

- (3) With ignition turned off, front oil pump is not running. If noise is still present and was not sensitive to engine speed, noise is in rear oil pump.
- (4) If doubt exists whether noise originates in rear oil pump or axles, proceed as in (a) through (g) below.
  - (a) Disconnect and remove transmission-to-transfer propeller shaft (par. 229c).
  - (b) Remove oil filler cap and oil level indicator from transmission.
  - (c) Start engine and move transmission control lever into F-1, HIGH RANGE position.
  - (d) Accelerate engine until transmission shifts into fourth speed. If noise is in rear oil pump, it will be heard at approximately same speed as when road testing in (1) and (2) above.
  - (e) This test definitely eliminates axles as being source of noise. Report condition to ordnance maintenance personnel.
  - (f) Install transmission-to-transfer propeller shaft as described in paragraph 230c.
  - (g) Install transmission oil filler cap and oil level indicator.

## 201. Front Band Adjustment

*a. General.* Reference must be made to paragraph 10 for front band adjustment intervals during break-in period on new or rebuilt vehicles. The need for additional adjustment may vary, depending upon the service to which vehicle is subjected. In every case, where the shift does not conform to the automatic shift pattern indicated in table X, an immediate adjustment of the front band must be accomplished.

**Caution:** Do not attempt to adjust the rear band. Rear band adjusts automatically with vehicle in normal operation. Rear band adjusting screw is used only for initial adjustment at transmission assembly or overhaul. Rear band adjusting screw is located toward rear of transmission (away from engine) and is equipped with a cap to prevent unintentional external adjustment.

### *b. Inspection.*

- (1) Fold back companion seat.
- (2) On late-type vehicles only, remove four bolts with lock-washers attaching foot rest to floor; then remove foot rest.
- (3) Remove 14 bolts attaching floor pan to cab floor and dash; then remove floor pan to gain access to front band adjusting screw (C, fig. 191).
- (4) Apply parking brake lever.
- (5) Clean indicator pin plug (B, fig. 191) and adjacent surface of transmission case; then run engine at idling speed with transmission control lever in F-1, HIGH RANGE position.

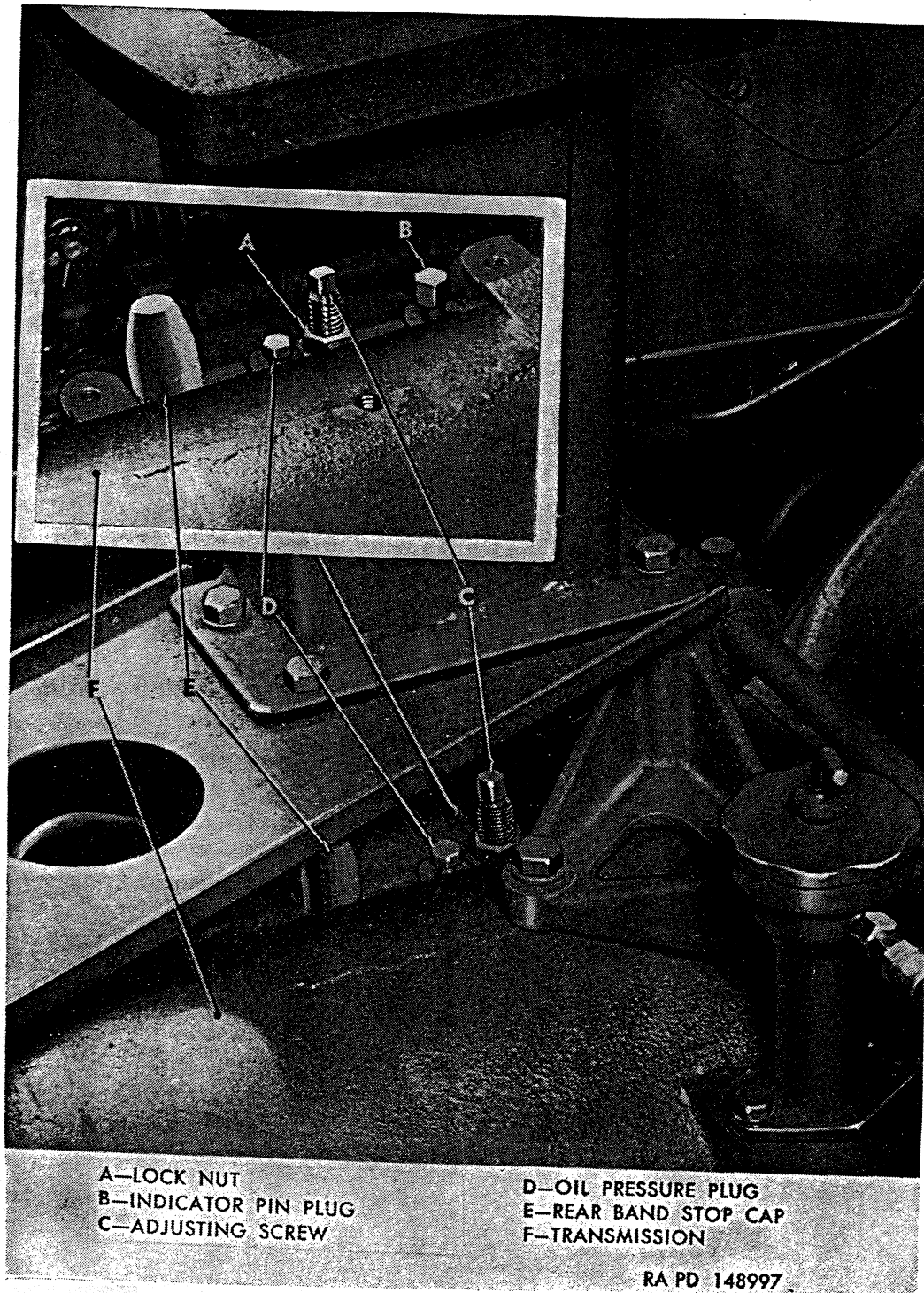

*Figure 191. Location of band adjusting screws.*

- (6) Unscrew indicator pin plug (B, fig. 191). Indicator pin should be flush ( $\pm \frac{1}{64}$  inch) with machined surface of transmission case. Use straightedge to check pin position (fig. 192).

*c. Adjustment.*

- (1) Loosen front band adjusting screw locknut (A, fig. 191).

*Note.* If end of indicator pin is more than one thirty-second inch above machined surface of transmission case, it is not necessary to loosen adjusting screw. In (2) below, if indicator pin checks high, turn adjusting screw in.

If indicator pin checks low, turn adjusting screw out.

- (2) Turn adjusting screw (C, fig. 191) until pin is **EXACTLY FLUSH** with machined surface of transmission case. Use straightedge (fig. 192) to check adjustment.
- (3) While holding adjusting screw (C, fig. 191) stationary, tighten adjusting screw locknut (A, fig. 191) to 40 to 50 pound-feet torque.
- (4) Use a straightedge (fig. 192) to recheck indicator pin position to **EXACTLY FLUSH** with machined surface of transmission case.
- (5) Install indicator pin plug (B, fig. 191) in transmission case. Tighten plug to 15 to 18 pound-feet torque.
- (6) Install cab floor pan, attaching with fourteen  $\frac{5}{16}$ -24 x  $\frac{5}{8}$  bolts and external-teeth lockwashers.
- (7) On late type vehicles only, position foot rest on cab floor. Attach foot rest to floor with four  $\frac{5}{16}$ -24 x  $\frac{3}{4}$  bolts with external-teeth lockwashers.

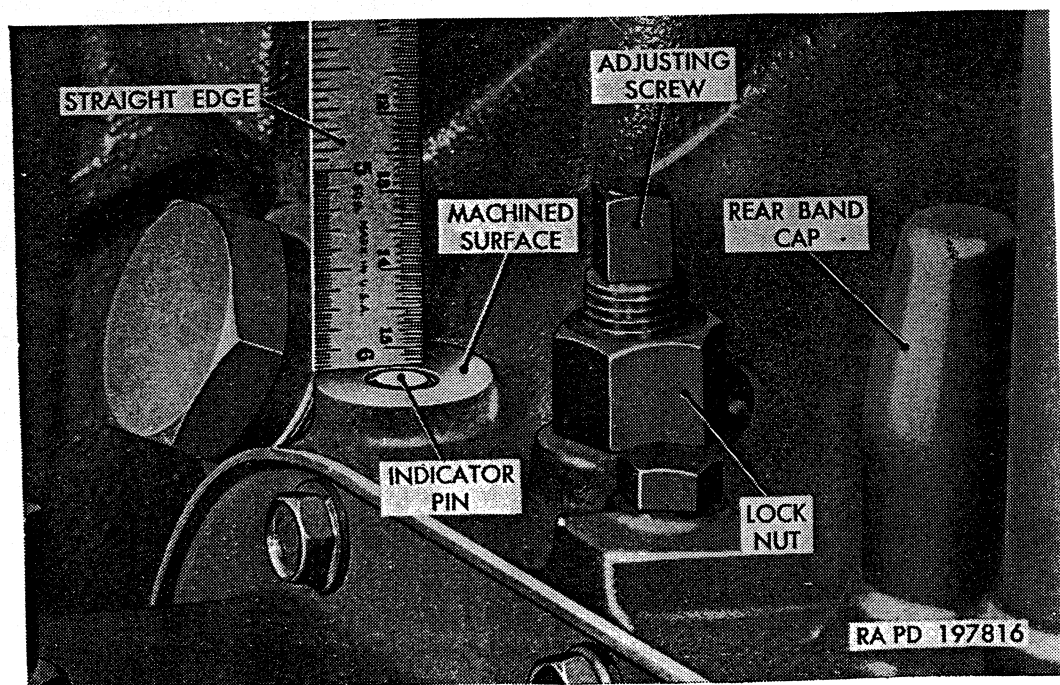

Figure 192. Checking position of indicator pin.

## 202. Transmission Manual and Throttle Linkage

*a. General.* Importance of correct transmission manual and throttle control linkage adjustments cannot be overemphasized. Performance of transmission is closely allied with performance of engine. Transmission shift pattern (table X) is balanced with and dependent upon inertia and torque characteristics of engine. Consequently, transmission and other controls must be correctly adjusted and maintained in order to provide correct performance. It should be kept in mind, that to assure efficient performance of power plant, transmission should be as carefully balanced with engine as are fuel and ignition systems.

### *b. Throttle Linkage Adjustment.*

- (1) *General.* Correct adjustment of throttle valve control lever on side of transmission is very important; therefore, gaging and bending procedures must be carefully performed. Always make adjustments in sequence listed. Before making throttle linkage adjustment, adjust engine idling speed (par. 127*b*) and thoroughly clean and oil all linkage adjustable yokes and clevis pins. Throttle valve control lever is connected to accelerator linkage as shown in figures 193 and 196.

**Caution:** Do not pry against or twist throttle valve control lever, as serious damage to transmission control valve assembly may result.

- (2) *On early type vehicles only.* Refer to figure 193.
  - (a) Disconnect throttle valve control rod from throttle valve lever by removing cotter pin and clevis pin.
  - (b) Hold transmission throttle valve lever gage B7950168 against machined surface of fly wheel housing rear half as shown in figure 194. Using clevis pin previously removed, check for free pin in closed position of throttle valve lever (C, fig. 194).
  - (c) If clevis pin cannot be freely inserted through hole in throttle valve lever and hole in gage B7950168, bend throttle valve lever with bending tool C7950171. Place bending tool on lever as shown in figure 195, or on opposite side of lever depending on direction bend is required. Turn screw in tool with wrench to bend lever.
  - (d) After correct adjustment is made, connect throttle valve control rod to throttle valve lever with clevis pin and cotter pin.
  - (e) Disconnect throttle valve control rod adjustable clevis from idler shaft outer lever by removing cotter pin and clevis pin.
  - (f) While holding throttle valve lever against stop, loosen adjustable yoke locknut on throttle valve control rod and

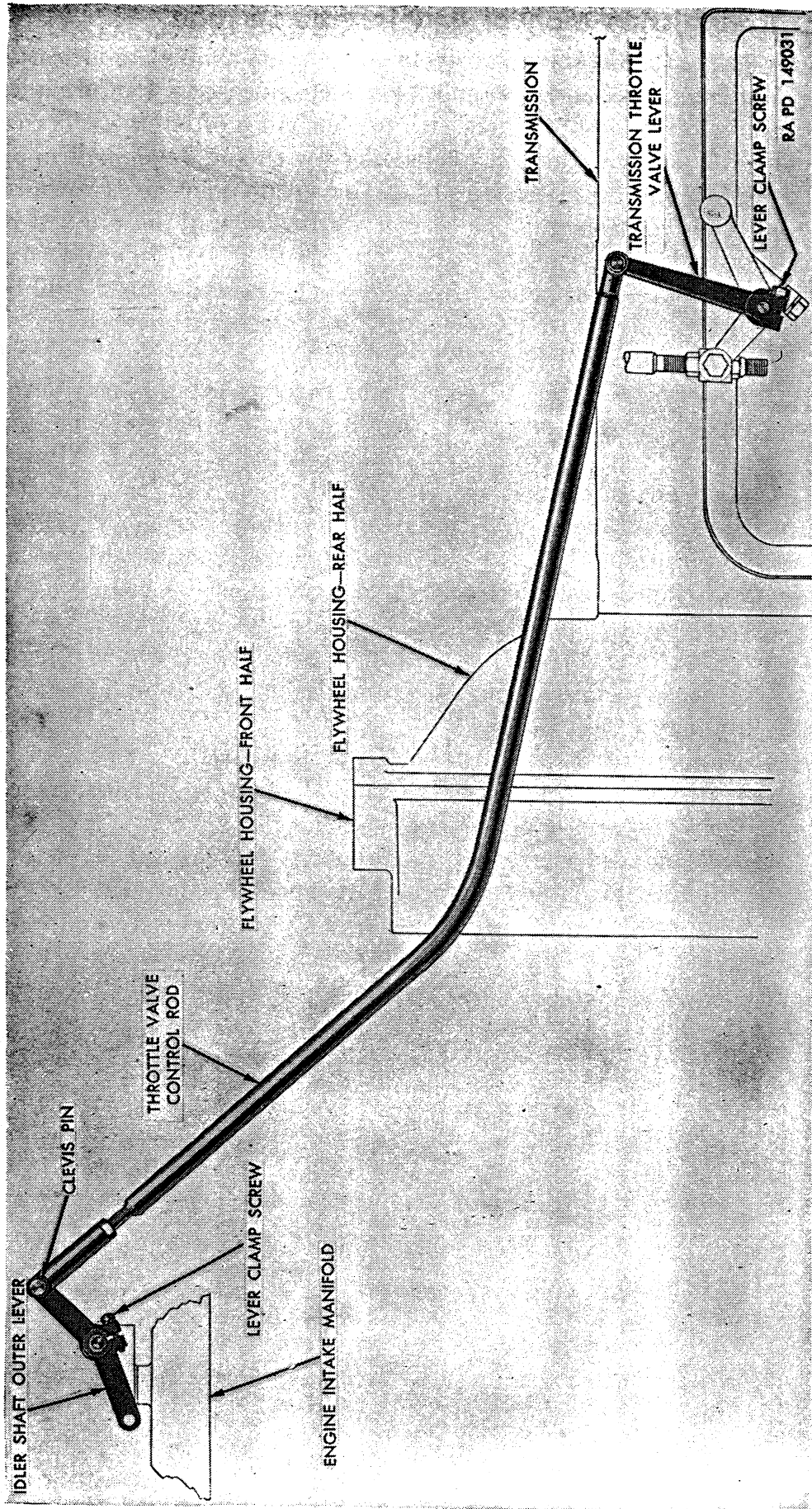

Figure 193. Throttle linkage arrangement (early type)

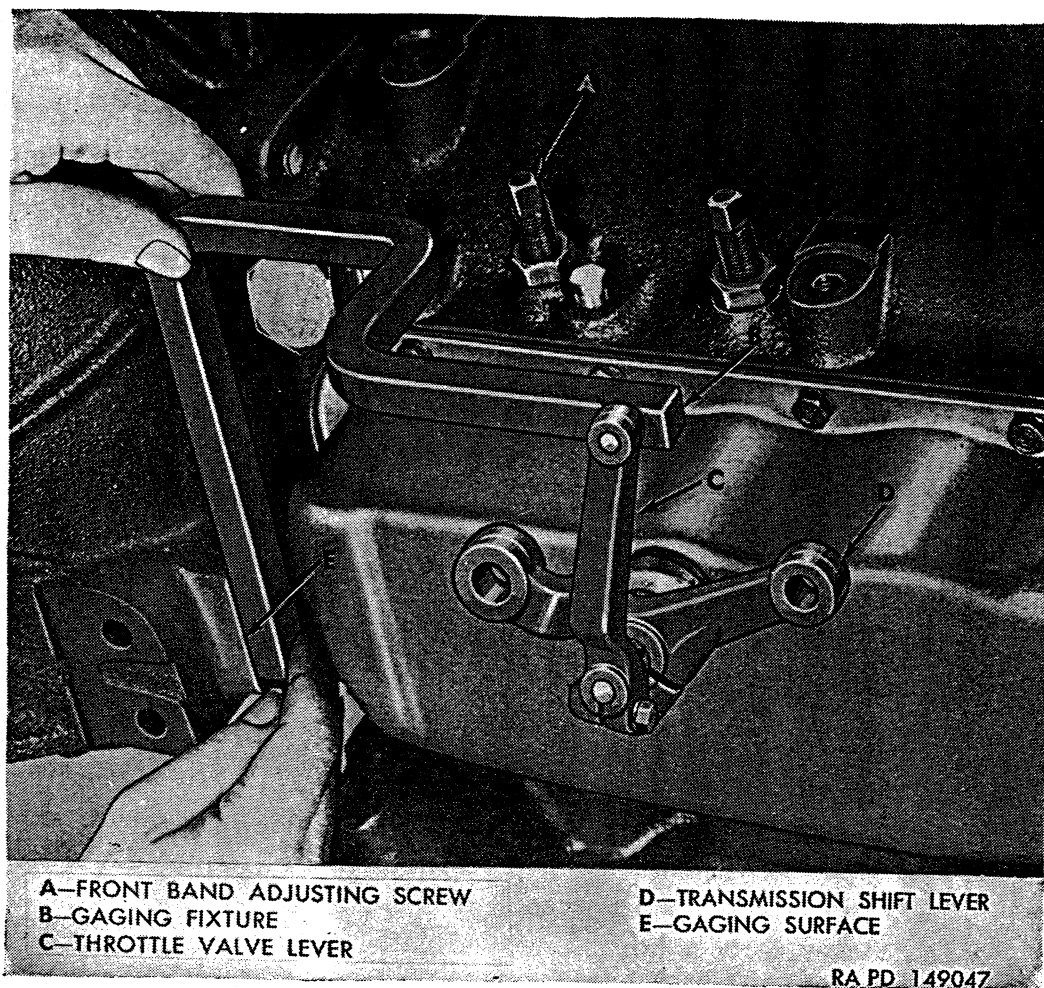

Figure 194. Using gage—B7950168 to adjust throttle valve lever.

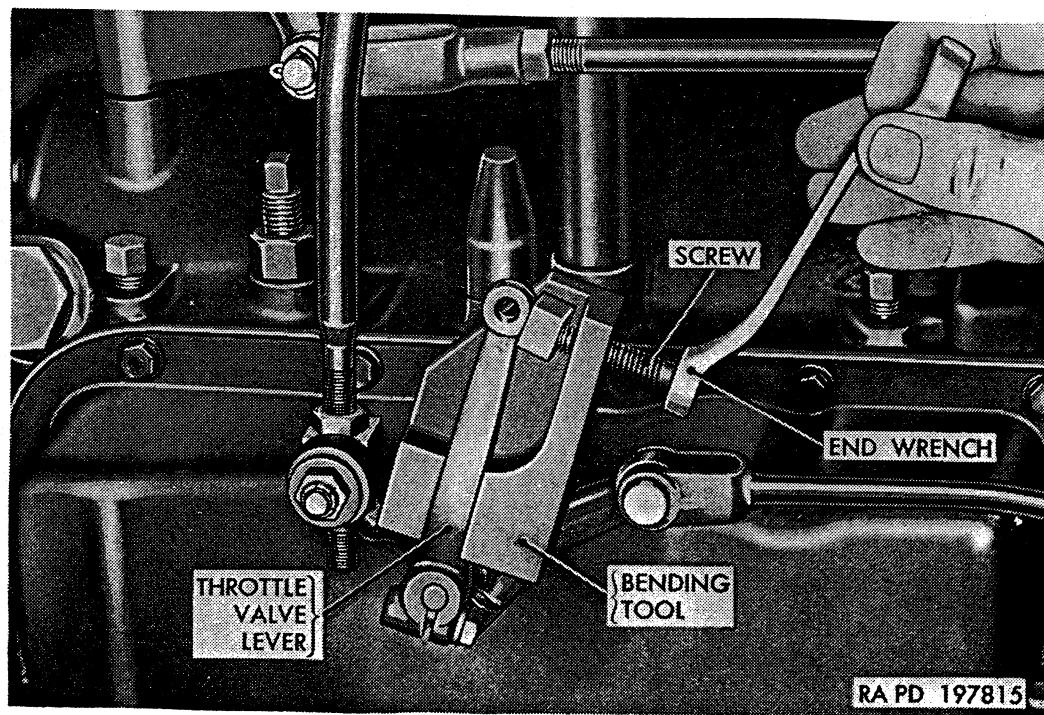

Figure 195. Using tool C7950171 to bend throttle valve lever.

adjust yoke on rod as necessary to obtain free installation of clevis pin through yoke and idler lever.

(g) After free pin adjustment is made, shorten throttle valve control rod by one to two turns of adjustable yoke; then secure clevis pin with cotter pin and tighten locknut against adjustable yoke.

(3) *On late type vehicles only.*

*Note.* The key letters noted in parentheses are in figure 196, except where otherwise indicated.

(a) Disconnect throttle valve control rod (K) from throttle valve lever (L) by removing cotter pin and clevis pin (M).

(b) Hold transmission throttle valve lever gage B7950168 against machined surface of flywheel housing rear half (N) as shown in figure 194. Using clevis pin (M) previously removed, check for free pin in closed position of throttle valve lever (L) as shown in figure 194.

(c) If clevis pin cannot be freely inserted through hole in throttle valve lever and hole in gage B7950168, bend throttle valve lever with bending tool C7950171. Place bending tool on lever as shown in figure 195, or on opposite side of lever, depending on direction bend is required. Turn screw in tool with wrench to bend lever.

(d) After correct adjustment is made, connect throttle valve control rod (K) to throttle valve lever (L) with clevis pin (M) and cotter pin.

(e) Disconnect throttle valve control rod adjustable yoke (H) from lever of throttle control cross shaft bracket (G) by removing cotter pin and clevis pin (F).

(f) Loosen jam nut (A) and turn adjusting screw (B) in as far as it will go; then push throttle cross shaft inner-lever-to-carburetor rod (C) against carburetor stop in open throttle position. While holding throttle cross shaft inner-lever-to-carburetor rod (C) in this position, back adjusting screw (B) out until it JUST TOUCHES stop on throttle cross shaft inner-lever-to-carburetor rod (C). Tighten adjusting screw jam nut (A).

(g) Push down on accelerator pedal (P) until carburetor throttle overrule spring (E) is compressed and spring sleeve (D) is against stop; then adjust yoke (H) so that transmission throttle valve lever (L) is against stop and clevis pins are free.

(h) Lengthen throttle valve control rod (K) by turning adjustable yoke (H) one turn; then tighten locknut. Secure clevis pin (F) with cotter pin.

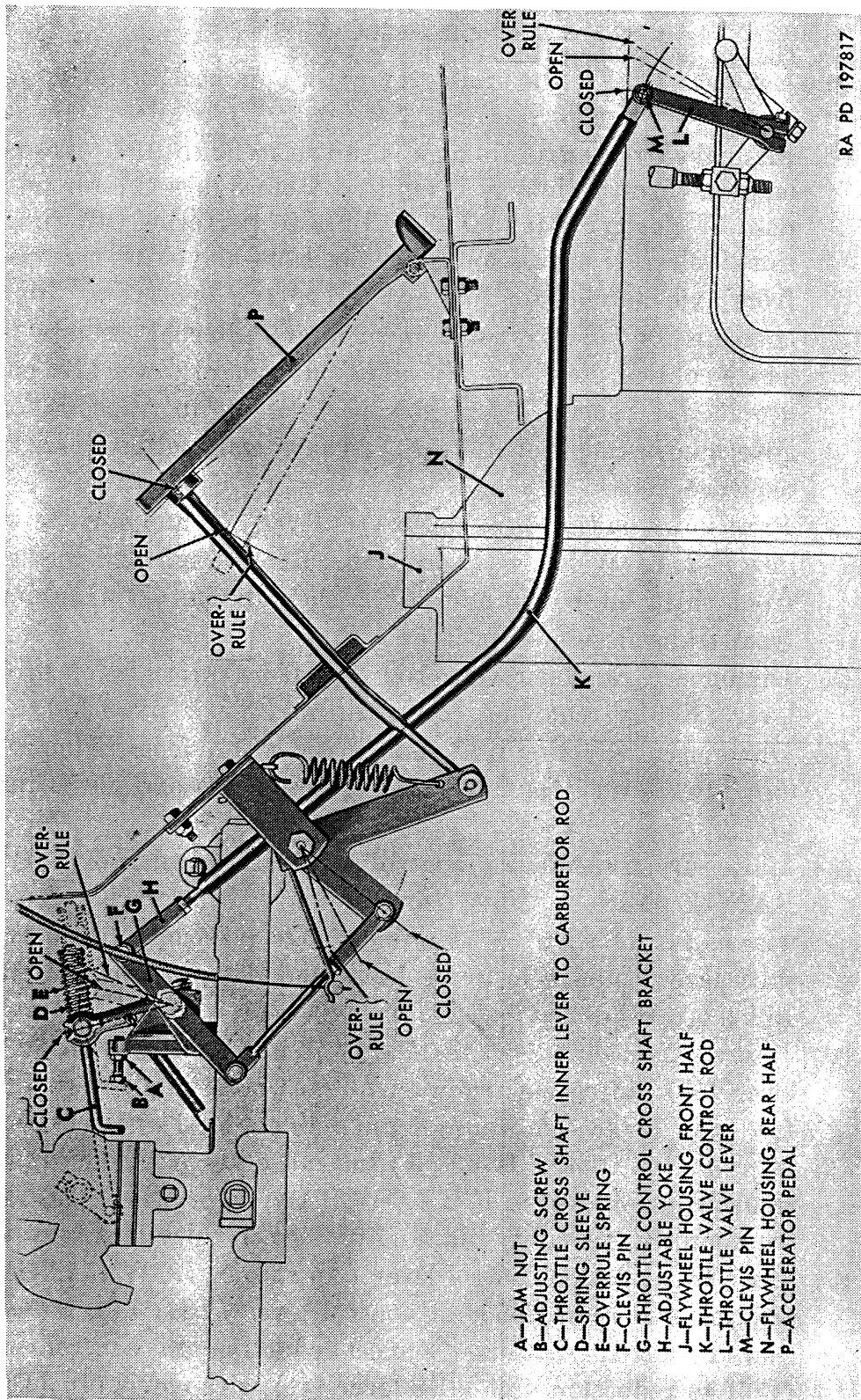

- A—JAM NUT
- B—ADJUSTING SCREW
- C—THROTTLE CROSS SHAFT INNER LEVER TO CARBURETOR ROD
- D—SPRING SLEEVE
- E—OVERRULE SPRING
- F—CLEVIS PIN
- G—THROTTLE CONTROL CROSS SHAFT BRACKET
- H—ADJUSTABLE YOKE
- J—FLYWHEEL HOUSING FRONT HALF
- K—THROTTLE VALVE CONTROL ROD
- L—THROTTLE VALVE LEVER
- M—CLEVIS PIN
- N—FLYWHEEL HOUSING REAR HALF
- P—ACCELERATOR PEDAL

Figure 196. Throttle linkage arrangement (late-type).



- (i) Recheck to make sure all clevis pins are secured with cotter pins.

*c. Manual Shift Control Linkage Adjustment.*

*Note.* The key letters noted in parentheses are in figure 197, except where otherwise indicated. Refer also to figure 198 for view of manual control linkage installed.

- (1) Manual shift control linkage is shown in figure 197. Transmission throttle linkage is omitted from figure 197 for purpose of clarity. Manual shift linkage performs two functions: selects transmission range positions and shifts transfer front axle clutches for forward and reverse operation. Both transmission and transfer incorporate internal detents to locate control positions. In addition, control tower also has detents for control lever; however, detents in transmission govern adjustment of linkage. Always make adjustments in sequence listed.
- (2) Press down on transmission control lever (A) and move lever into F-2, LOW RANGE position. Remove nut and washer from shift lever trunnion (J); then disconnect trunnion from transmission shift lever (K).
- (3) Disconnect transfer reverse rod (M) from transmission shift lever (K) by removing cotter pin and clevis pin (JJ).
- (4) Disconnect reduction unit control rod (CC) from reduction unit idler lever (G) by removing cotter pin and clevis pin (H).
- (5) Make sure transmission control lever (A) is in F-2, LOW RANGE position. Move transmission shift lever (K) clockwise as far as it will go into first detent position; then move shift lever counterclockwise to second detent position felt, which is third detent position from the rear.
- (6) Insert pin on shift lever trunnion (J) into transmission shift lever (K), adjusting trunnion nuts as necessary to provide free pin. Make sure trunnion pin does not bind when moving transmission control lever (A) into all other positions; then return control lever to F-2, LOW RANGE position. Install trunnion,  $\frac{5}{16}$ -24 safety nut, and 0.083-inch thick lockwasher.
- (7) Move transmission control lever (A) into N, LOW RANGE position and reduction unit control lever (DD) into reduction (forward) position. Connect reduction unit control rod (CC) to reduction unit idler lever (G) with clevis pin (H) and cotter pin, adjusting clevis as necessary to provide free pin. Clevis pin (H) should also be free with transmission control lever (A) in N, HIGH RANGE position.

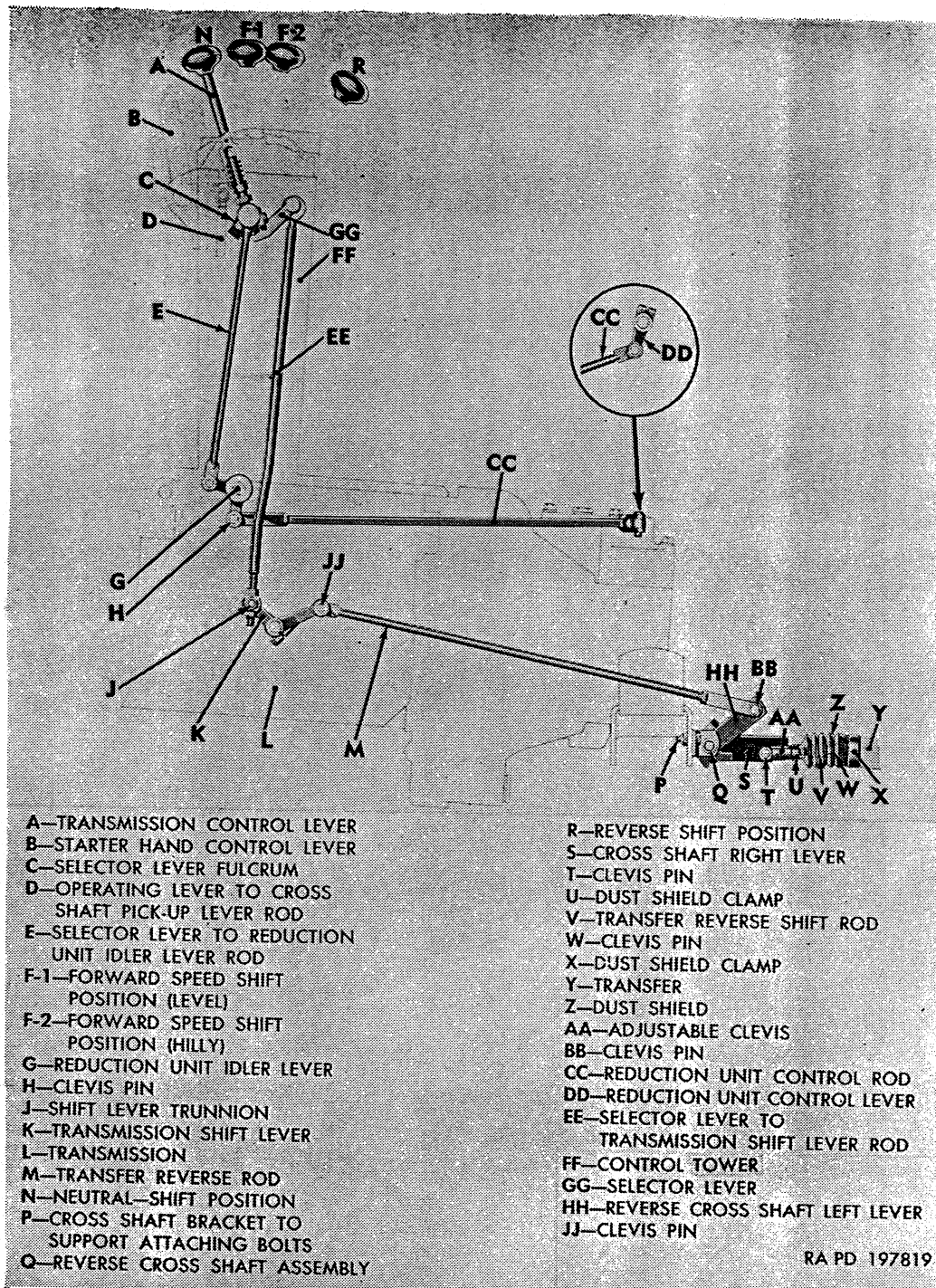
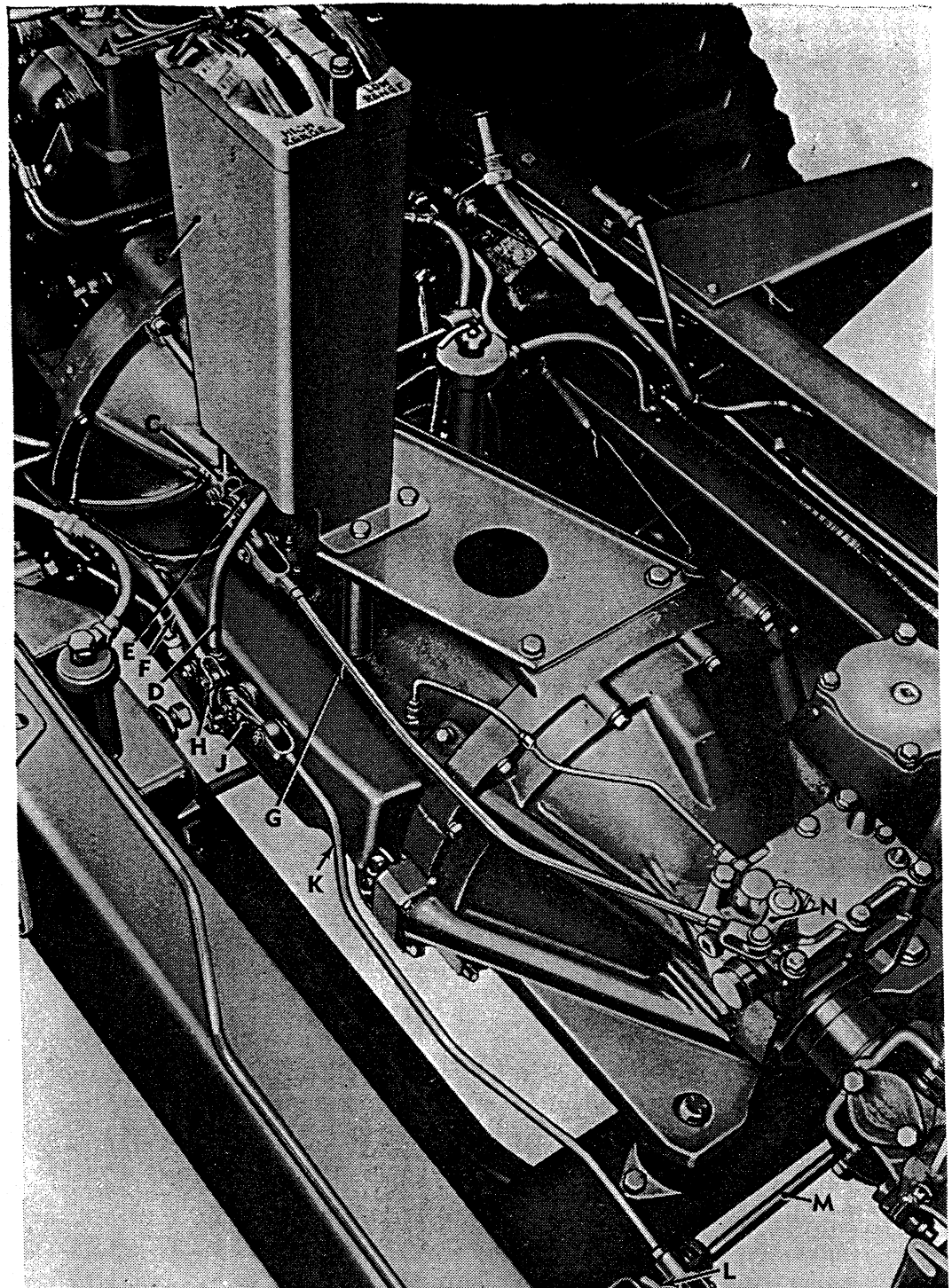

Figure 197. Transmission and transfer linkage arrangement.

- (8) On late type vehicles only, remove two dust shield clamps (U and X); then remove transfer reverse shifter shaft dust shield (Z).
- (9) Remove cotter pin and clevis pin (W) attaching transfer reverse shift rod assembly (V) to transfer shift rail.
- (10) With stop on transfer reverse cross shaft right lever (S) against yoke and transfer shift rail in forward (toward rear) position, adjust reverse shift rod assembly (V) to permit free



- |   |  |
|---|--|
| A—TRANSMISSION CONTROL LEVER                      | G—REDUCTION UNIT CONTROL ROD                   |
| B—CONTROL TOWER                                   | H—THROTTLE VALVE LEVER                         |
| C—CONTROL LEVER TO REDUCTION UNIT IDLER LEVER ROD | J—TRANSMISSION SHIFT LEVER                     |
| D—CONTROL LEVER TO TRANSMISSION SHIFT LEVER ROD   | K—TRANSFER REVERSE ROD                         |
| E—REDUCTION UNIT IDLER LEVER                      | L—TRANSFER REVERSE CROSS SHAFT LEFT-HAND LEVER |
| F—THROTTLE VALVE CONTROL ROD                      | M—CROSS SHAFT                                  |
|   | N—REDUCTION UNIT CONTROL LEVER                 |

RA PD 197820

Figure 198. Transmission shift linkage installed.

assembly of clevis pin (W). Secure clevis pin with cotter pin and tighten locknut against yoke.

(11) With cotter pin and clevis pin (BB) attaching transfer reverse rod (M) to reverse cross shaft left lever (HH) removed, move transmission control lever (A) into F-1 HIGH RANGE position and push transfer reverse cross shaft left lever (HH) against pick-up lever on cross shaft assembly (Q). Adjust transfer reverse rod yoke to permit free installation of clevis pin (BB). Secure clevis pin with cotter pin. Tighten locknut against yoke.

(12) Recheck, making sure all clevis pins are secured with cotter pins.

*d. Replacement of Rods and Levers.* Linkage rods are connected at each end by clevis pins as shown in figures 197 and 198. Linkage rods are easily removed by removing cotter pins and clevis pins. Levers are removed after loosening clamp screws. Before installing adjustable yoke or clevis pins, make sure parts are not worn excessively. Worn parts will not permit accurate linkage adjustment. Transmission throttle valve control lever and transmission shift lever are attached to control valve shaft by means of clamp screws. Serrations on levers and shafts position levers in relation to shafts. Do not force levers on shafts in wrong position.

## 203. Transmission Control Tower

### *a. Replacement.*

*Note.* The key letters noted in parentheses are in figure 199, except where otherwise indicated.

#### (1) *Removal.*

- (a) On late type vehicles only, remove four bolts with lockwashers attaching foot rest to floor; then remove foot rest.
- (b) Remove 14 bolts with lockwashers attaching cab front floor pan to cab floor; then remove floor pan from vehicle.
- (c) Disconnect transmission shift lever trunnion (F) from transmission shift lever (H) by removing safety nut (G) and washer.
- (d) Disconnect reduction unit control rod (L) from reduction unit idler lever (M) by removing cotter pin and clevis pin.
- (e) Disconnect transmission vent line (J, fig. 200) from oil filler tube by unscrewing fitting.
- (f) Unhook cross shaft lever pull back spring from extension hook; then disengage extension hook from cotter pin on control tower support. Remove pull back spring (K, fig. 200) from cross shaft lever (F, fig. 200).

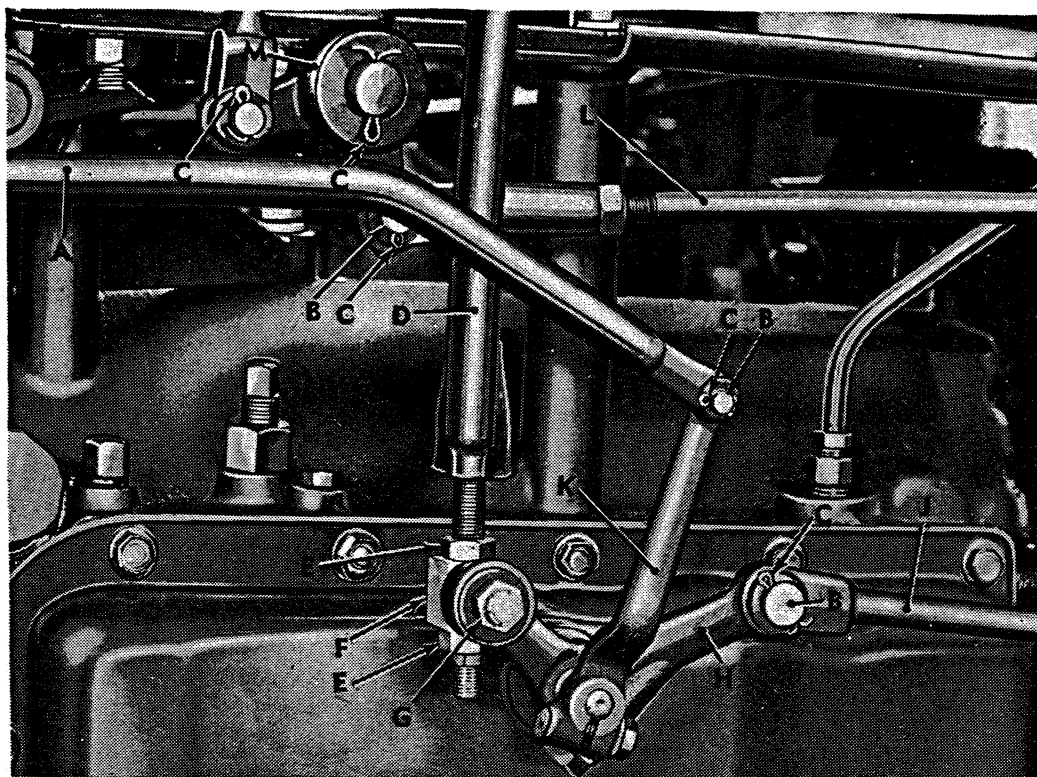

A—TRANSMISSION THROTTLE VALVE CONTROL ROD  
 B—CLEVIS PINS  
 C—COTTER PINS  
 D—TRANSMISSION SHIFT LEVER ROD  
 E—ADJUSTING NUTS  
 F—TRUNNION  
 G—SAFETY NUT

H—TRANSMISSION SHIFT LEVER  
 J—TRANSFER REVERSE ROD  
 K—TRANSMISSION THROTTLE VALVE LEVER  
 L—REDUCTION UNIT CONTROL ROD  
 M—REDUCTION UNIT IDLER LEVER

RA PD 197766

Figure 199. Transmission control linkage at side cover.

- (g) Remove three cap screws, one bolt, and four lockwashers attaching shift control tower and support to transmission (E, fig. 200); then remove control tower and support from transmission.
- (2) *Installation.*
- (a) Position transmission control tower and support (B and N, fig. 200) on transmission and attach with two  $\frac{7}{16}$ -14 x 1 cap screws, one  $\frac{3}{8}$ -16 x  $4\frac{1}{4}$  cap screw, one  $\frac{3}{8}$ -16 x  $5\frac{3}{4}$  bolt, two  $\frac{7}{16}$ -inch lockwashers, and two  $\frac{3}{8}$ -inch lockwashers.
- (b) Engage cross shaft lever pull back spring (K, fig. 200) with cross shaft lever (F, fig. 200). Engage extension hook with cotter pin on control tower support; then stretch spring and engage spring end with end of extension hook (M, fig. 200).
- (c) Attach transmission vent line (J, fig. 200) to oil filler tube (L, fig. 200). Tighten fitting.

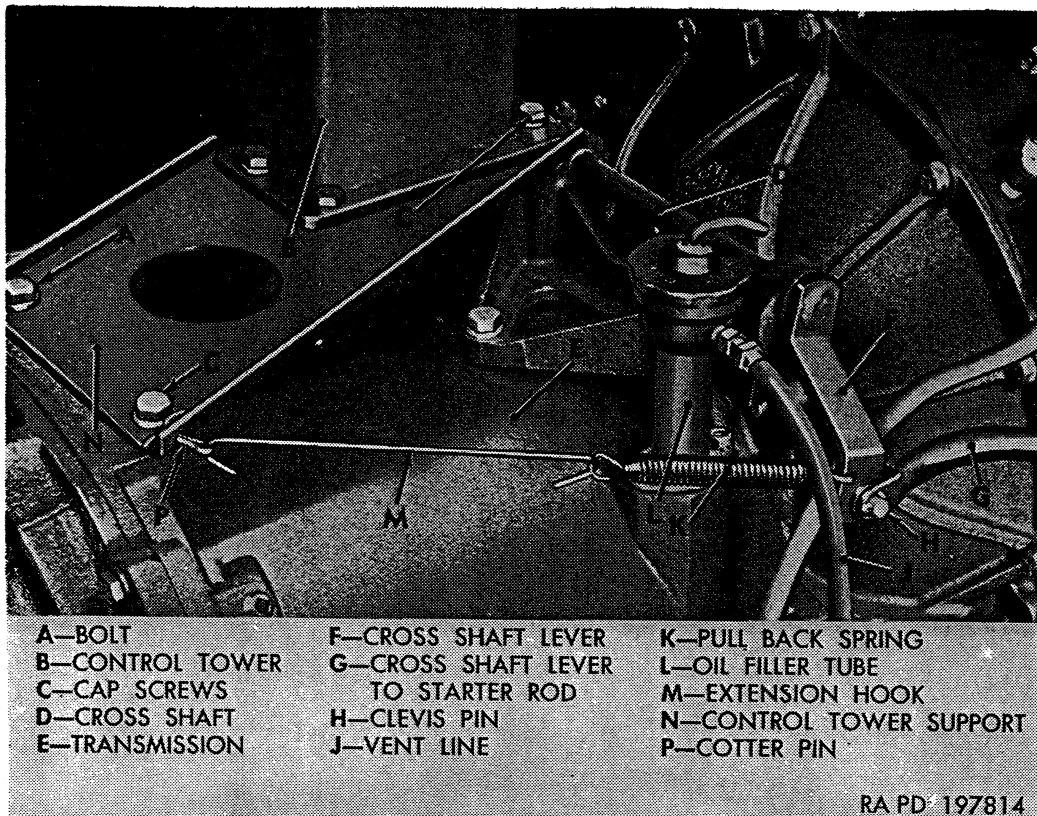

Figure 200. Control tower disconnect points.

- (d) Attach reduction unit control rod (L) to reduction unit idler lever (M) with clevis pin and cotter pin. Adjust rod if necessary (par. 202c).
- (e) Attach transmission shift lever trunnion (F) to transmission shift lever (H) with  $\frac{5}{16}$ -24 safety nut (G) and 0.083-inch thick lockwasher. Adjusting nuts (E) (par. 202c).
- (f) Position cab front floor pan on cab floor and attach with fourteen  $\frac{5}{16}$ -24 x  $\frac{5}{8}$  bolts and lockwashers.
- (g) On late type vehicles, position foot rest on cab floor and attach with four  $\frac{5}{16}$ -24 x  $\frac{3}{4}$  bolts and lockwashers.

*b. Disassembly.*

*Note.* The key letters noted in parentheses are in figure 201.

- (1) Remove transmission control tower assembly from vehicle (a(1) above).
- (2) Remove two screws (QQ) and two nuts (AM) attaching control tower support (AL) to control tower (SS).
- (3) Remove cotter pin and clevis pin (WW) attaching transmission-selector-lever-to-reduction-unit-idler-lever rod (AF) to idler lever (XX); then remove tower support (AL) from control tower (SS).
- (4) Remove cotter pin and flat washer (ZZ) attaching reduction unit idler lever (XX) to control tower support (AL); then remove idler lever from support.

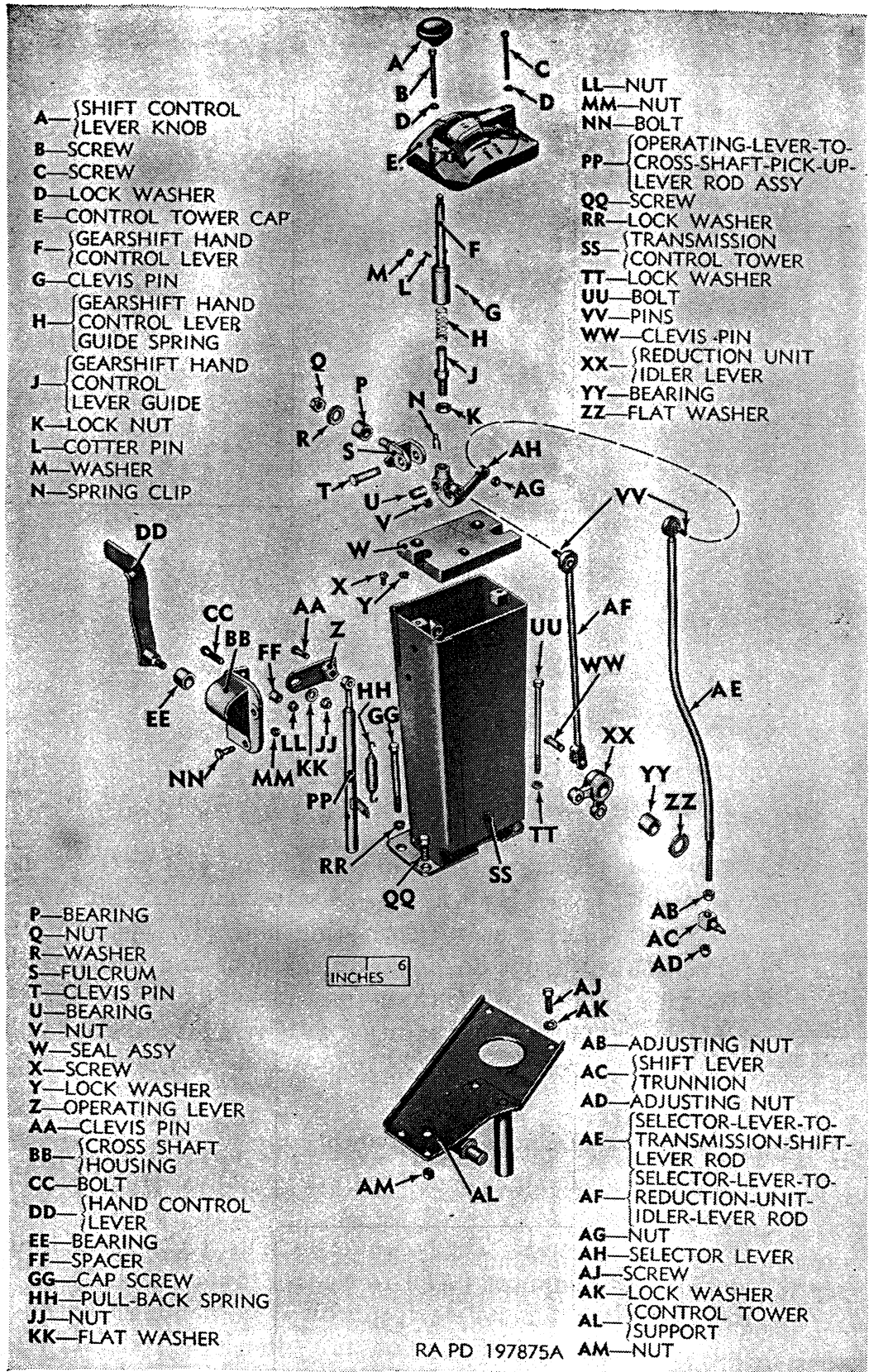

Figure 201. Control tower components.

- (5) Remove bushing-type bearing (YY) from reduction unit idler lever (XX) only if inspection shows necessity for replacement.
- (6) Remove cotter pin from control tower support (AL) only if new pin is to be installed.
- (7) Slide control-tower-to-cab-floor seal off control tower.
- (8) Remove adjusting nuts (AD and AB) and shift lever trunion (AC) from selector-lever-to-transmission-shift-lever rod (AE).
- (9) Unscrew transmission shift control lever knob (A) from gearshift hand control lever (F).
- (10) Remove two screws (B and C) and lockwashers (D); then remove control tower cap (E) from control tower (SS).
- (11) Remove bolt (CC), nut (LL), spacer (FF), two bolts (NN), and two nuts (MM) attaching cross shaft housing (BB) to control tower (SS).
- (12) Unhook pull-back spring (HH) from operating-lever-to-cross-shaft-pick-up-lever rod assembly (PP); then unhook spring from bracket inside control tower (SS). Remove spring (HH) from control tower.
- (13) Pull cross shaft housing (BB) away from control tower (SS) as shown in figure 202; then remove cotter pin and clevis pin (AA) attaching cross shaft housing (BB) and

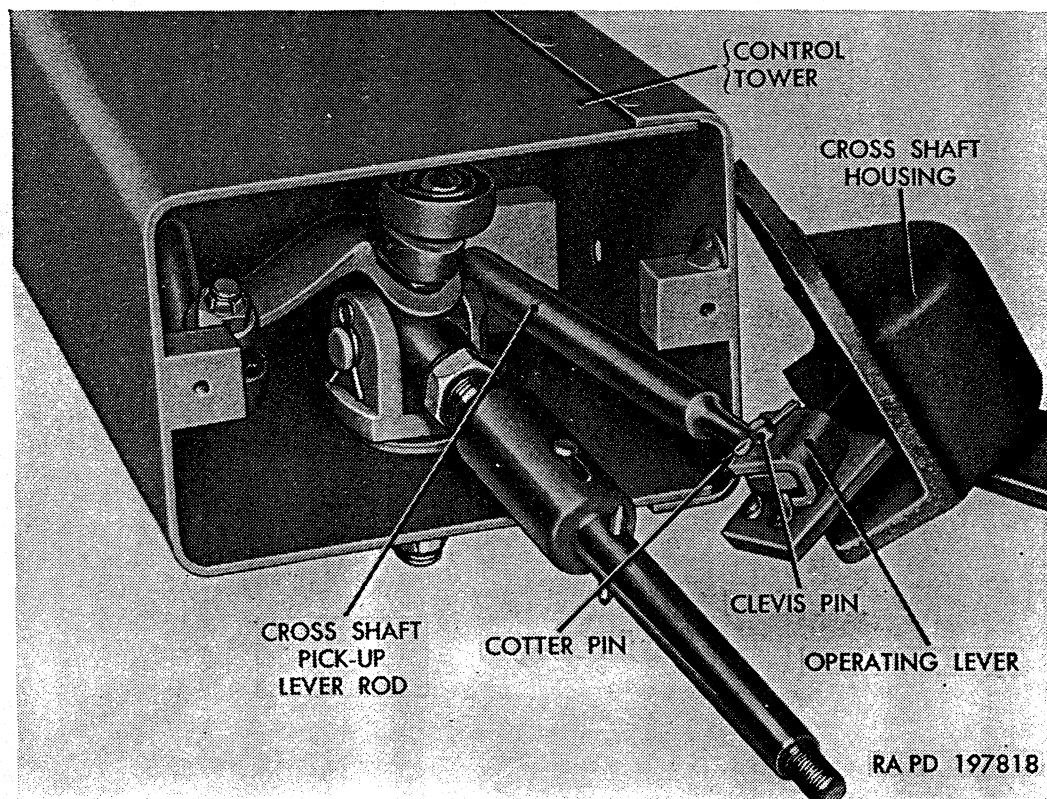
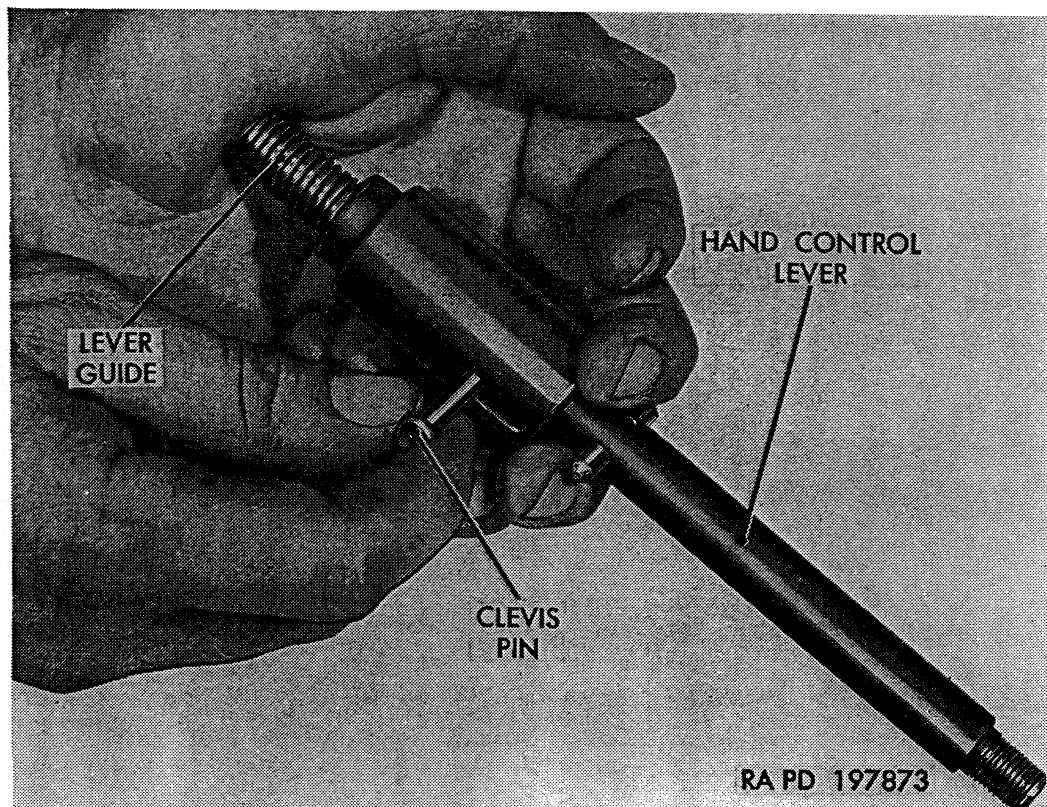

Figure 202. Removing cross shaft housing.



- operating lever (Z) to operating-lever-to-cross-shaft-pick-up-lever rod (PP). Remove housing and lever.
- (14) Remove nut (JJ) and flat washer (KK); then remove operating lever (Z) and hand control lever (DD) from cross shaft housing (BB).
  - (15) Remove bearing (EE) from cross shaft housing (BB) only if inspection shows necessity for replacement.
  - (16) Remove operating-lever-to-cross-shaft-pick-up-lever rod (PP) through opening at bottom of control tower (SS).
  - (17) Remove spring clip (N) from clevis pin (T); then remove clevis pin from fulcrum (S).
  - (18) Pull rods as an assembly from top of control tower (SS).
  - (19) Remove nut (AG); then remove selector-lever-to-transmission-shift-lever rod (AE) from selector lever (AH).
  - (20) Remove nut (V); then remove selector-lever-to-reduction-unit-idler-lever rod (AF) from selector lever (AH).
  - (21) Loosen locknut (K) and remove selector lever (AH) from gear-shift hand control lever guide (J). Remove bearing (U) from selector lever (AH) only if inspection shows necessity for replacement.
  - (22) Remove cotter pin (L) and washer (M); then while holding assembly against spring pressure as shown in figure 203, remove clevis pin (G) from gearshift hand control lever (F).



*Figure 203. Disassembling gearshift hand control lever.*

- (23) Remove gearshift hand control lever guide (J) and gearshift hand control lever guide spring (H) from gearshift hand control lever (F).
- (24) Remove nut (Q), washer (R), and fulcrum (S) from control tower (SS). Remove bearing (P) from control tower (SS) only if inspection shows necessity for replacement.
- (25) Remove two screws (X) and lockwashers (Y) attaching seal assembly (W) to control tower (SS). Remove seal assembly from control tower.

*c. Assembly (fig. 201).*

*Note.* When assembling transmission control tower, lubricate each moving part liberally with automotive and artillery grease (GAA) as part is installed. Replace all parts inspection shows to be worn or not in good condition.

- (1) Position seal assembly (W) in transmission control tower (SS) and attach with two  $\frac{1}{4}$ -28 x  $\frac{3}{8}$  cross-recess screws (X) and  $\frac{1}{4}$ -inch lockwashers (Y). Tighten screws.
- (2) If bushing-type bearing (P) was removed from control tower (SS), tap new bearing into place in tower, using plastic hammer.
- (3) Install fulcrum (S) in control tower (SS), attaching to tower with  $\frac{17}{32}$ -inch plain washer (R) and  $\frac{1}{2}$ -20 safety nut (Q). Tighten nut.

*Note.* Install fulcrum with lug on fulcrum aligned with slot in control tower as shown in figure 204.

- (4) Install  $\frac{1}{2}$ -20 locknut (K) on gearshift hand control lever guide (J); then thread guide into selector lever (AH) to  $1\frac{29}{32}$ -inch dimension shown in figure 205, measured from gearshift hand control lever guide spring (H) seat on gear shift hand control lever guide (J) to centerline of bearing hole in selector lever. Tighten locknut against selector lever.
- (5) If bearing (U) was removed from selector lever (AH), tap new bearing into place, using plastic hammer.
- (6) Position gearshift hand control lever guide spring (H) over end of gearshift hand control lever guide (J).
- (7) Install gearshift hand control lever guide spring (H) and guide (J) into end of gearshift hand control lever (F), aligning hole in guide with slot in lever.
- (8) While compressing assembly against spring pressure in manner shown in figure 203, install clevis pin (G) through slot in gearshift hand control lever (F) and into hole in gearshift hand control lever guide (J).
- (9) Retain clevis pin (G) in assembly by installing  $\frac{7}{32}$ -inch plain washer (M) and cotter pin (L) on end of clevis pin.

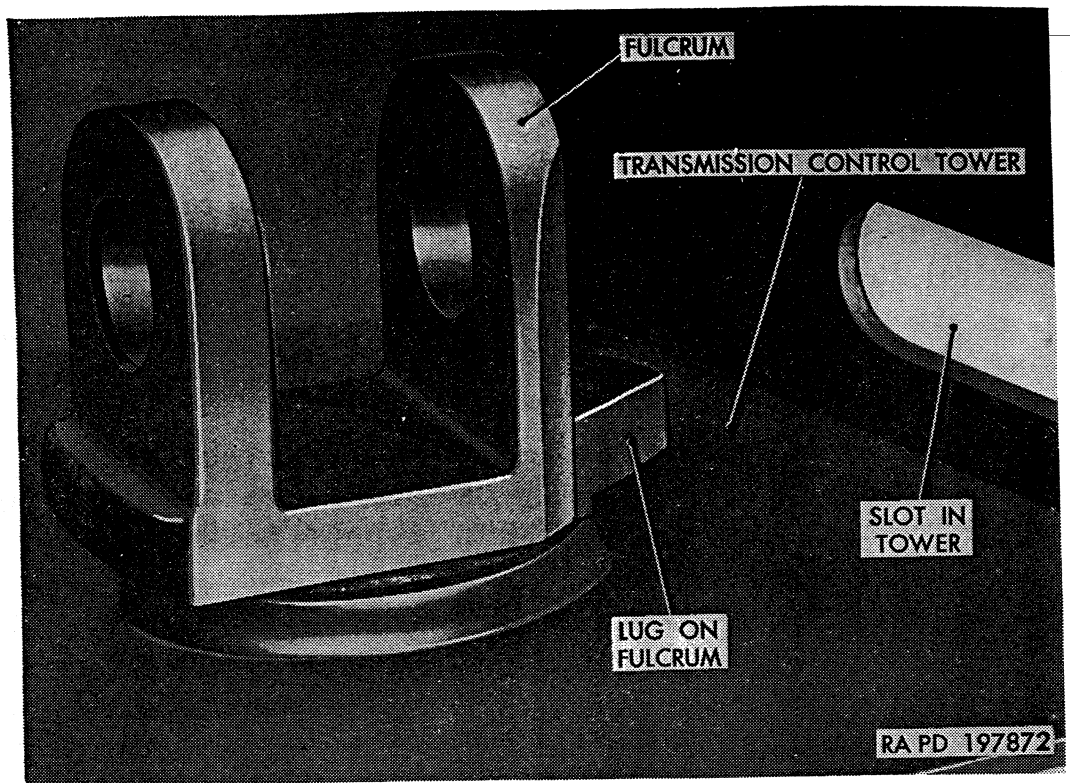

Figure 204. Positioning lug on fulcrum.

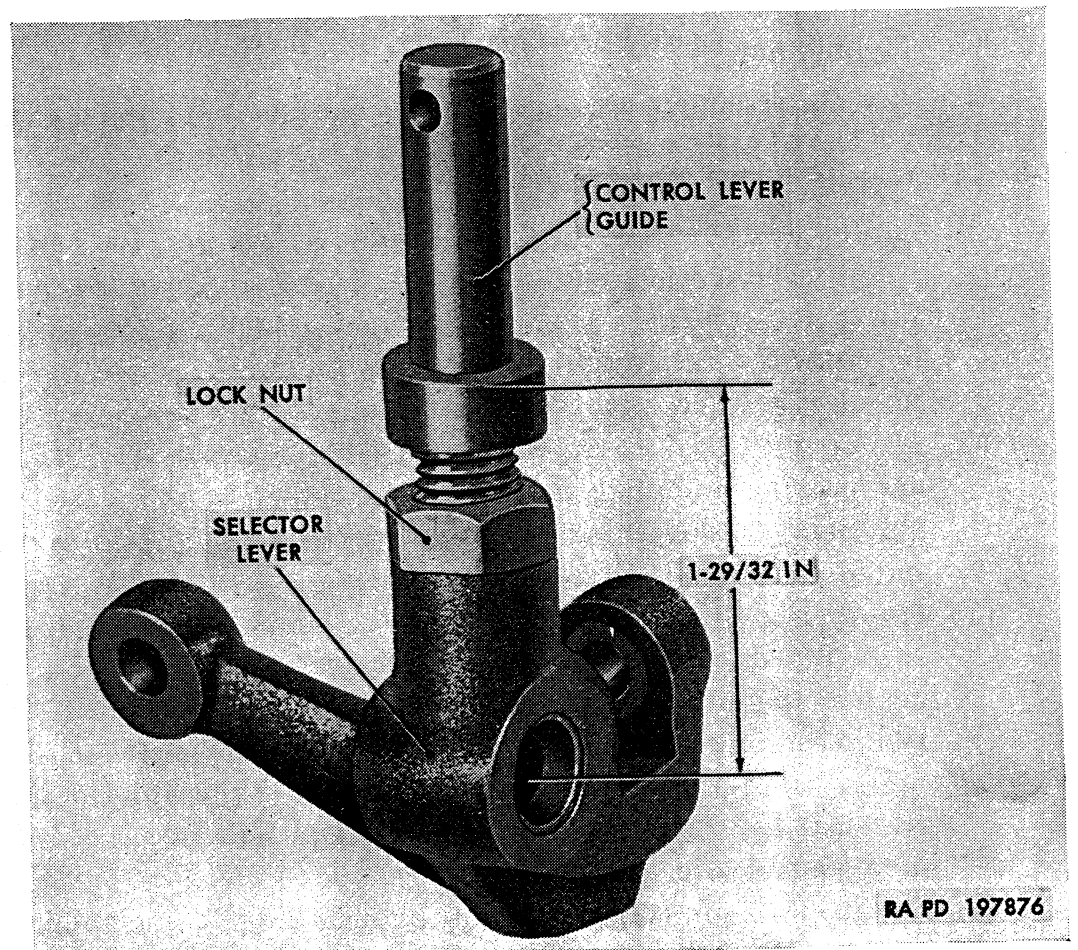

Figure 205. Adjusting guide and selector lever.

- (10) Insert pin (VV) on selector-lever-to-reduction-unit-idler-lever rod (AF) through hole in selector lever (AH); then attach rod to lever with  $\frac{5}{16}$ -inch locknut (V). Tighten locknut.
- (11) Insert pin (VV) on selector-lever-to-transmission-shift-lever rod (AE) through hole in selector lever (AH); then attach rod to lever with  $\frac{5}{16}$ -24 locknut (AG). Tighten locknut.
- (12) Install rod assembly through top of transmission control tower (SS).
- (13) With end of selector lever (AH) positioned in fulcrum (S), insert clevis pin (T) through hole in fulcrum and hole in selector lever. Secure clevis pin with spring clip (N).
- (14) Insert shaft of hand control lever (DD) through hole in cross shaft housing (BB); then position operating lever (Z) on shaft of hand control lever (DD). Attach operating lever to control lever with  $1\frac{13}{32}$ -inch flat washer (KK) and  $\frac{3}{8}$ -24 safety nut (JJ).
- (15) Insert operating-lever-to-cross-shaft-pick-up-lever rod assembly (PP) through opening at bottom of control tower (SS), positioning rod so pull-back spring bracket on rod is facing center of control tower and end of rod is inserted into hole in bottom of control tower.
- (16) With other end of operating-lever-to-cross-shaft-pick-up-lever rod assembly (PP) in operating lever (Z) attach rod to operating lever with clevis pin (AA) and cotter pin.
- (17) Hook one end of pull-back spring (HH) to bracket on operating-lever-to-cross-shaft-pick-up-lever rod (PP) and other end of spring to bracket inside control tower (SS).
- (18) Make sure end of operating-lever-to-cross-shaft-pick-up-lever rod (PP) is entered into hole in bottom of control tower (SS); then install  $\frac{5}{16}$ -24 x  $1\frac{1}{2}$  bolt (CC), spacer (FF), and  $\frac{5}{16}$ -24 locknut (LL) attaching cross shaft housing (BB) to control tower (SS). Before tightening bolt and nut, install two  $\frac{5}{16}$ -24 x  $\frac{7}{8}$  bolts (NN) and  $\frac{5}{16}$ -24 locknuts (MM). Tighten all attaching bolts and nuts.
- (19) Position control tower cap (E) on control tower (SS); then install one  $\frac{1}{4}$ -28 x 2 front screw (B), one  $\frac{1}{4}$ -28 x  $2\frac{3}{4}$  rear screw (C), and two  $\frac{1}{4}$ -inch lockwashers (D).
- (20) Install transmission shift control lever knob (A) on end of gearshift hand control lever (F).
- (21) Position control-tower-to-cab-floor seal on transmission control tower (SS).
- (22) Install reduction unit idler lever (XX) on control tower support (AL); then attach lever to support with  $2\frac{1}{32}$ -inch flat washer (ZZ) and cotter pin.

- (23) Mount control tower (SS) on tower support (AL); then attach tower to support with two  $\frac{3}{8}$ -24 x  $\frac{7}{8}$  screws (QQ) and  $\frac{3}{8}$ -24 safety nuts (AM). Tighten nuts.
- (24) Connect selector-lever-to-reduction-unit-idler-lever rod (AF) to reduction unit idler lever (XX) with clevis pin (WW) and cotter pin.
- (25) Install  $\frac{3}{8}$ -24 adjusting nut (AB), shift lever trunnion (AC), and  $\frac{5}{16}$ -24 adjusting nut (AD) on selector-lever-to-transmission-shift-lever rod (AE).
- (26) Install transmission control tower and support assembly on transmission in vehicle (a(2) above).
- (27) Adjust transmission manual control linkage (par. 202c).

## 204. Transmission Removal

a. *General.* The following procedures cover removal of transmission from vehicle with engine installed in vehicle. Procedures necessary to remove transmission from vehicle together with engine are covered in paragraph 117. Before removing transmission, make certain of necessity for transmission replacement by first accomplishing adjustments and tests described in this section, and by correct analysis of trouble symptoms as described in table VI.

b. *Coordination with Ordnance Maintenance Unit.* Refer to paragraph 2 for information on coordination with an ordnance maintenance unit.

c. *Preliminary Procedures.*

- (1) *Disconnect transmission control linkage and remove shift control tower.*
  - (a) Remove transmission control tower (par. 203a(1)).
  - (b) Disconnect transfer reverse rod from transmission shift lever by removing cotter pin and clevis pin (B and C, fig. 199).
  - (c) Remove reduction unit control rod (CC, fig. 197) from reduction unit control lever by removing cotter pin and clevis pin.
  - (d) Disconnect throttle valve control rod from throttle valve lever by removing cotter pin and clevis pin (M, fig. 196).
  - (e) Remove two bolts and locknuts attaching transfer control cross shaft left bracket to transmission rear support.
- (2) *Remove exhaust pipe rear section.*
  - (a) Remove rear exhaust pipe supporting strap (E, fig. 135) from transmission rear support by removing cap screw and nut.
  - (b) Loosen exhaust pipe clamp nuts at muffler and front exhaust pipe; then remove connecting clamps and seal (A, fig. 135) and rear exhaust pipe. Discard seals.

- (3) *Remove transmission-to-transfer propeller shaft.*
  - (a) Remove four bolts and nuts securing front and rear universal joints (fig. 240) together.
  - (b) Remove four bolts and nuts attaching rear universal joint flange to transfer flange; then remove rear universal joint flange.
  - (c) Slide front universal joint flange toward rear and off transmission output shaft.
- (4) *Detach power plant from rear support mountings.* Remove two bolts and lockwashers (X and Y, fig. 108) attaching transmission to rear mountings.
- (5) *Raise power plant from rear support.* Using a suitable floor jack, raise transmission just enough to relieve load from rear support cross member. Place blocking under engine to support power plant while removing transmission from engine.
- (6) *Disconnect transfer-to-front-axle propeller shaft.* Remove four bolts and nuts attaching front propeller shaft universal joint to transfer driving flange; then lower rear end of propeller shaft to floor.
- (7) *Remove transmission rear support cross member.* Remove four bolts and locknuts attaching transmission rear support cross member to support brackets; then remove transmission rear support.
- (8) *Disconnect starter control.* Remove cross-shaft-lever-to-starter rod from cross shaft lever by removing cotter pin and clevis pin (H, fig. 200).
- (9) *Drain coolant and disconnect cooler lines.*
  - (a) Drain water from cooling system as described in paragraph 142b.
  - (b) Remove cooler line nuts at transmission and pull lines free from fittings at oil pan and cooler assembly.
- (10) *Drain transmission oil.* Remove drain plugs (fig. 186) and drain transmission oil from transmission and fluid coupling (par. 194d).

*d. Transmission Removal from Engine.*

**Caution:** Make sure transmission is positioned on floor jack so there will be no danger of transmission falling during removal from engine. Be sure engine is properly supported with blocking during transmission removal.

- (1) *Remove torus-cover-to-flywheel attaching bolts.* Through opening provided previously by removal of flywheel housing lower cover, remove 30 torus-cover-to-flywheel attaching bolts (B, fig. 206) and lockwashers. Turn engine to turn flywheel to gain access to all bolts.

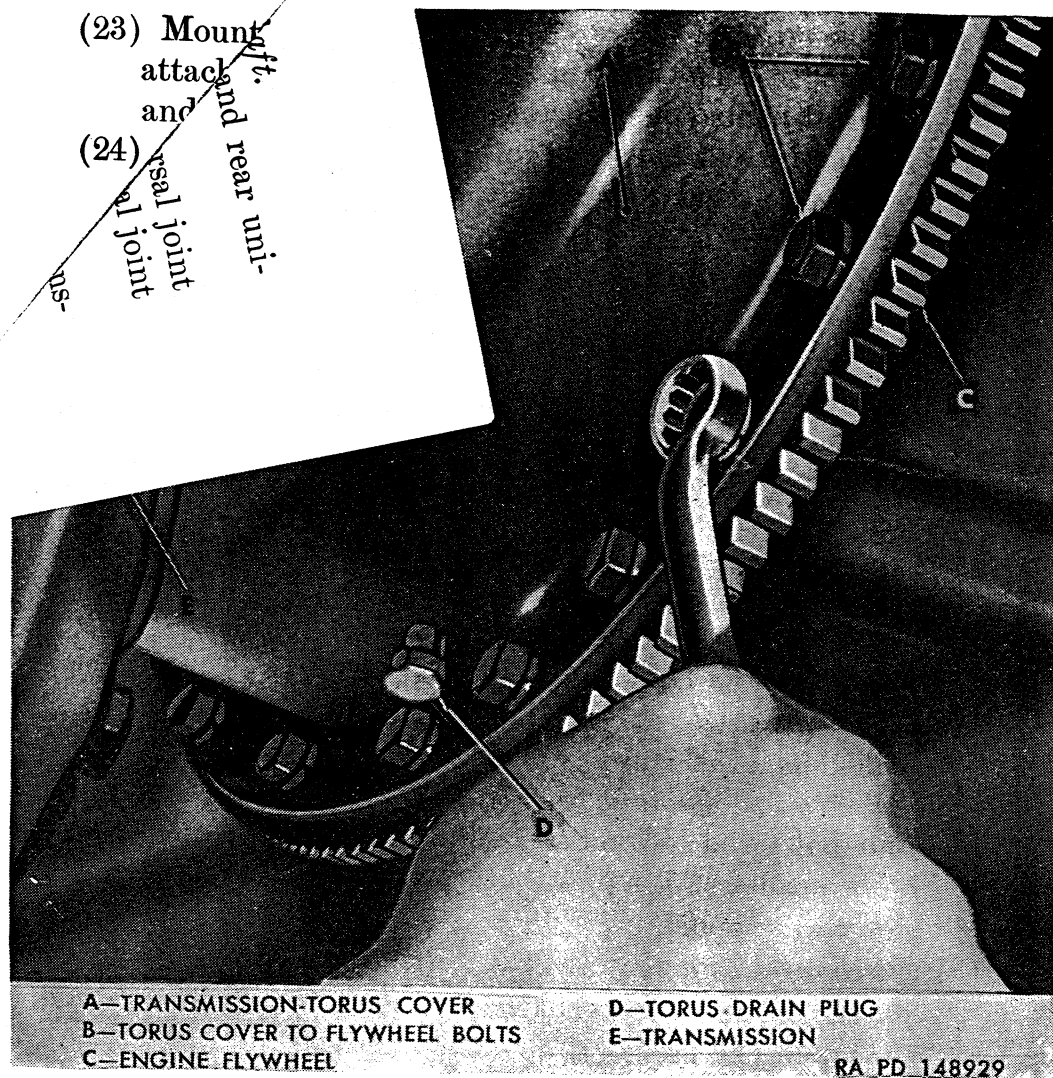

Figure 206. Removing torus-cover-to-flywheel bolt.

- (2) Remove flywheel housing rear half to front half attaching parts. With transmission positioned on saddle jack to support its weight, remove nine cap screws, one nut, and nine lockwashers attaching flywheel housing rear half to front half. Leave flywheel housing front half bolted to engine.

*Note.* On gasoline tank truck M217 and water tank truck M222, Mechanovac governor speed unit and bracket will come off when flywheel housing attaching parts are removed.

- (3) Remove transmission from vehicle. Carefully move transmission away from engine a short distance for clearance as shown in figure 207; then lower jack with transmission to floor. Remove transmission from beneath vehicle; then using lifting eye-bolts A266327 (fig. 76) in holes in top of transmission and reduction unit, lift transmission and position on work bench or suitable repair stand. Remove pilot bearing spacer from end of transmission input shaft.

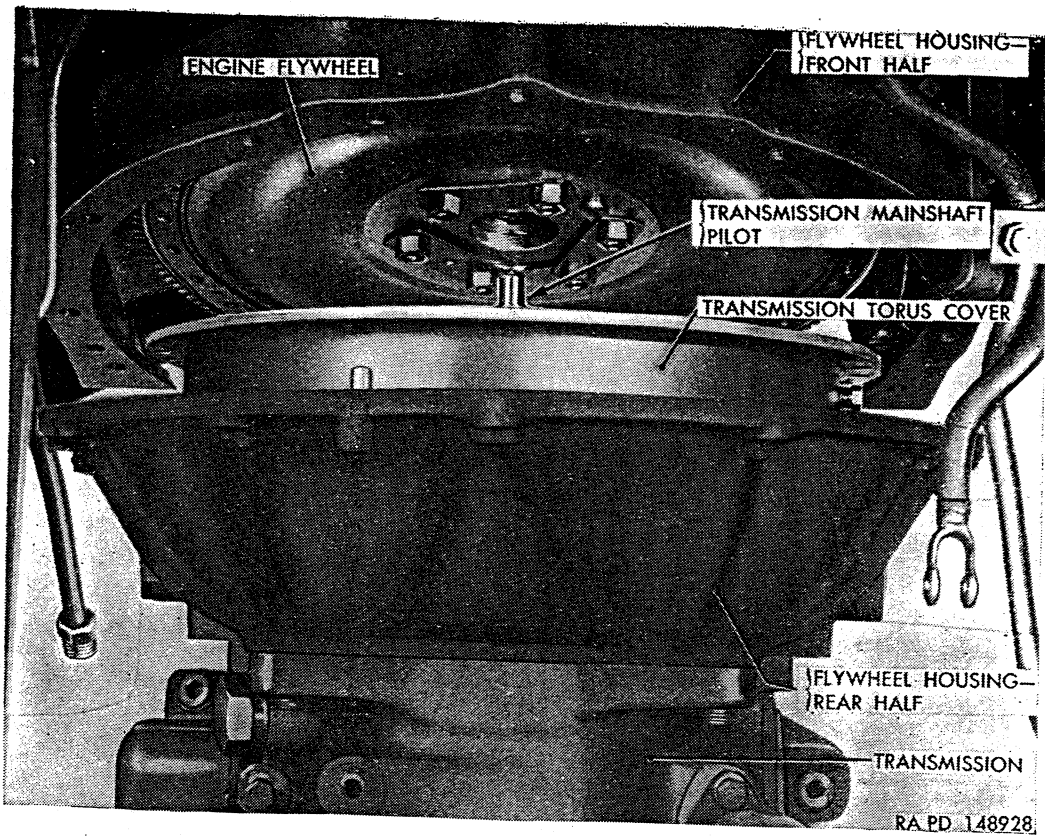

Figure 207. Removing transmission from engine.

- (4) Remove flywheel housing rear half. Flywheel housing rear half, attached to transmission case, is matched with flywheel housing front half attached to engine.

*Note.* Flywheel housing front and rear halves comprise a matched set which must remain with engine on which originally installed. A metal plate attached to each half of flywheel housing bears engine serial number (fig. 208). Operations described in (a) through (d) below must be performed if transmission is not to be reinstalled on engine from which it was removed, or if it is found necessary to remove flywheel rear housing from transmission.

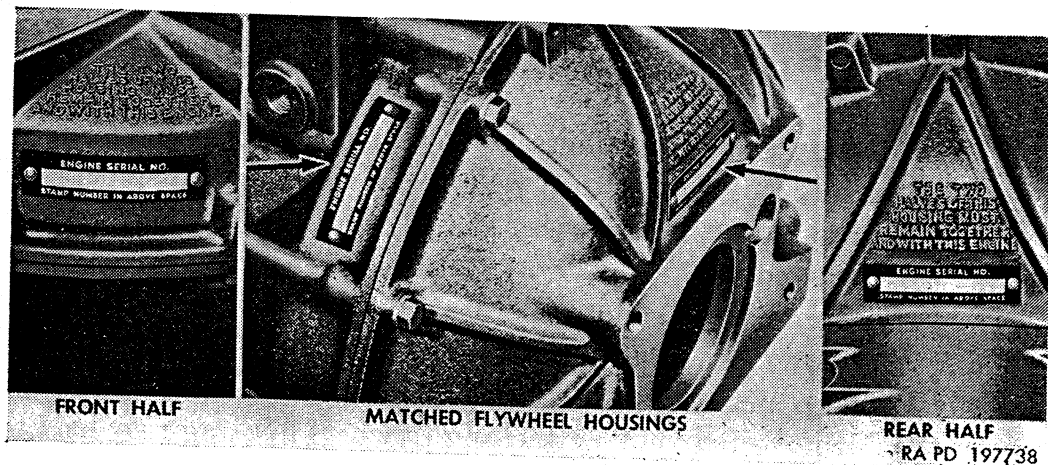

Figure 208. Location of engine serial number plates on flywheel housings.



(23) Mount  
attach  
and

(24) rear uni-  
versal joint  
al joint

way from transmission input shaft nut;  
fluid coupling with wrench B7950256  
-inch wrench and remove input shaft

torus member and pull driven torus  
put shaft. If torus member sticks,  
raft lightly with rawhide or plastic  
time pulling out at hub of driven

cles, torus check valve and check valve  
with driven torus or remained on trans-  
ve torus check valve and check valve  
y vehicles, torus check valve and check valve spring  
are held in position in driven torus by a retainer and two cap screws.

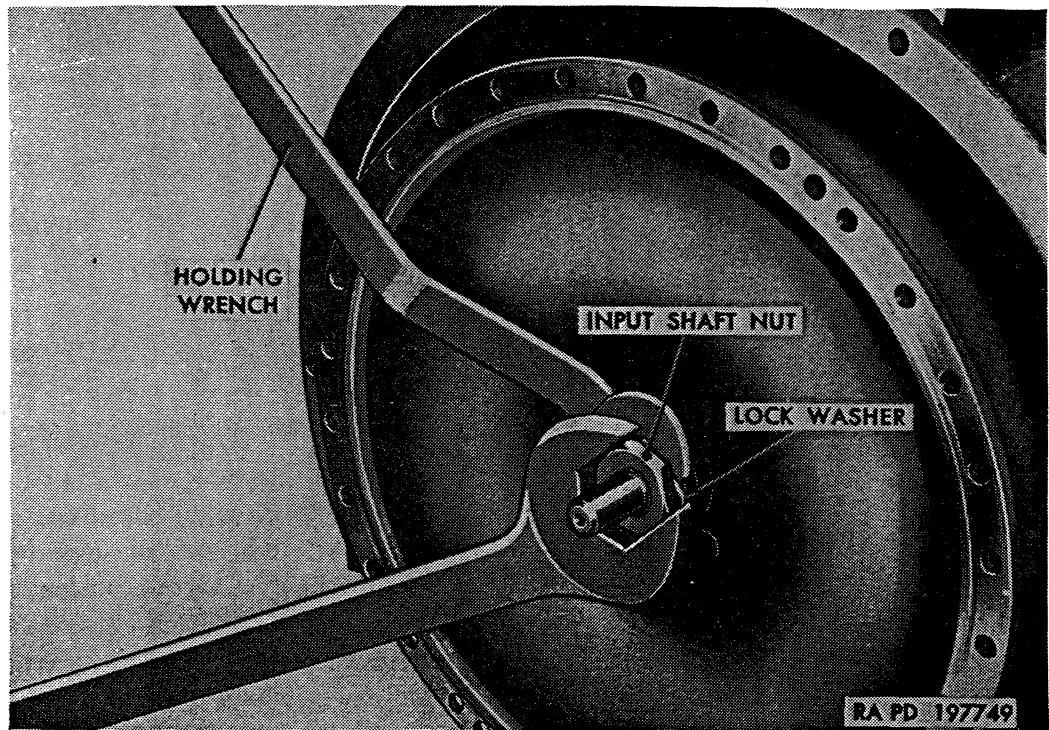

Figure 209. Using holding wrench B7950256 to hold fluid coupling.

(c) Using snap ring pliers, remove driving torus member re-  
tainer (fig. 210); then remove driving torus member and  
torus cover together by sharply pulling straight out on  
torus cover.

**Caution:** Do not rock torus cover from side to side when  
removing, as damage to oil seal or seal ring at front oil  
pump may result.

(d) Remove four bolts attaching flywheel housing rear half to  
transmission case. Remove flywheel housing rear half

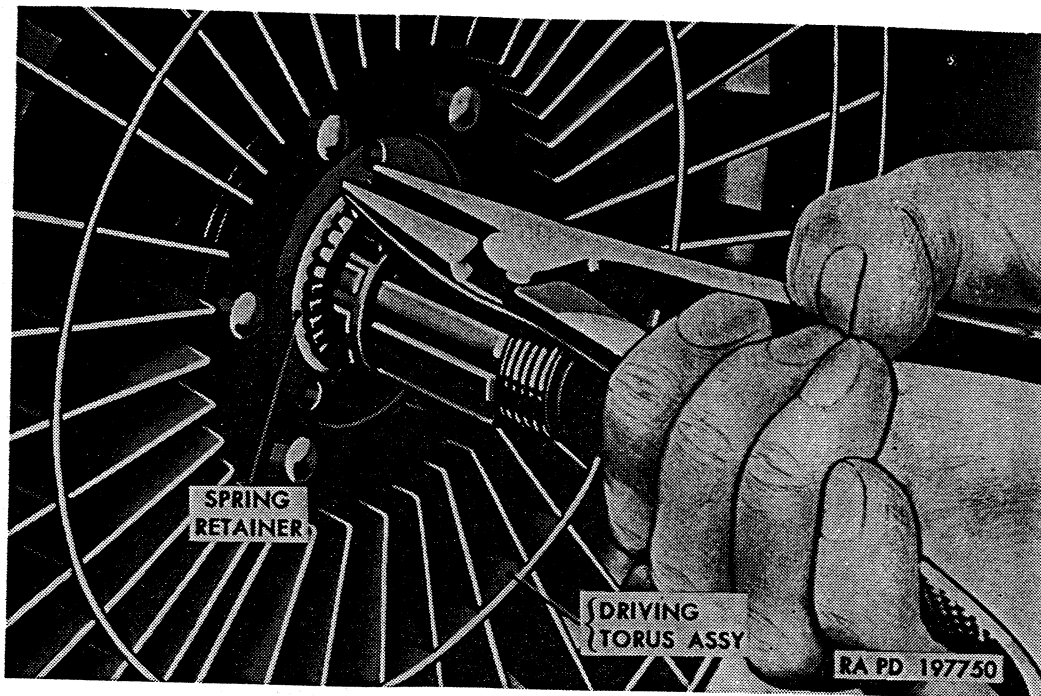

Figure 210. Removing driving torus member retainer.

from transmission and temporarily attach to flywheel housing front half installed on engine.

*Note.* Flywheel housing front and rear halves (fig. 208) must be kept together and with engine on which they were originally installed.

## 205. Transmission Installation

*a. General.* The following procedures cover installation of transmission with engine installed in vehicle. Procedures necessary to install transmission together with engine into vehicle are covered in paragraph 120. Before assembling flywheel housing rear half to transmission, accomplish procedures in *b* below.

### *b. Preliminary Procedures.*

- (1) Assemble torus cover to engine flywheel, using four  $\frac{5}{16}$ -24 x  $1\frac{1}{16}$  torus-cover-to-flywheel attaching bolts and  $\frac{5}{16}$ -inch lock-washers, two at dowels and two 90° from dowels. Torus must fit freely on dowels. Tighten bolts evenly to 12 to 15-pound-feet torque.

*Note.* On some early type vehicles, torus cover can be assembled to flywheel in one position only, because flywheel dowel pins have different diameters. On late vehicles, torus cover can be assembled to engine flywheel in either of two positions, 180° apart. On these vehicles, aline dowel pin with hole in cover marked as shown in figure 211.

- (2) Attach test indicator supporting bracket B7950331 (fig. 212) to flywheel housing front half, using two  $\frac{3}{8}$ -16 x 1 cap screws.

- (3) Assemble a suitable dial-type test indicator to supporting bracket B7950331 so tip of indicator set rocker arm attachment contacts oil seal area of torus cover neck as shown in figure 212.
- (4) Turn engine and observe reading on dial of indicator. Runout must not exceed 0.005 inch.
- (5) If runout exceeds 0.005 inch ((4) above), on vehicles having same size flywheel dowels only, remove torus cover from flywheel. Remount torus cover on flywheel 180° from original

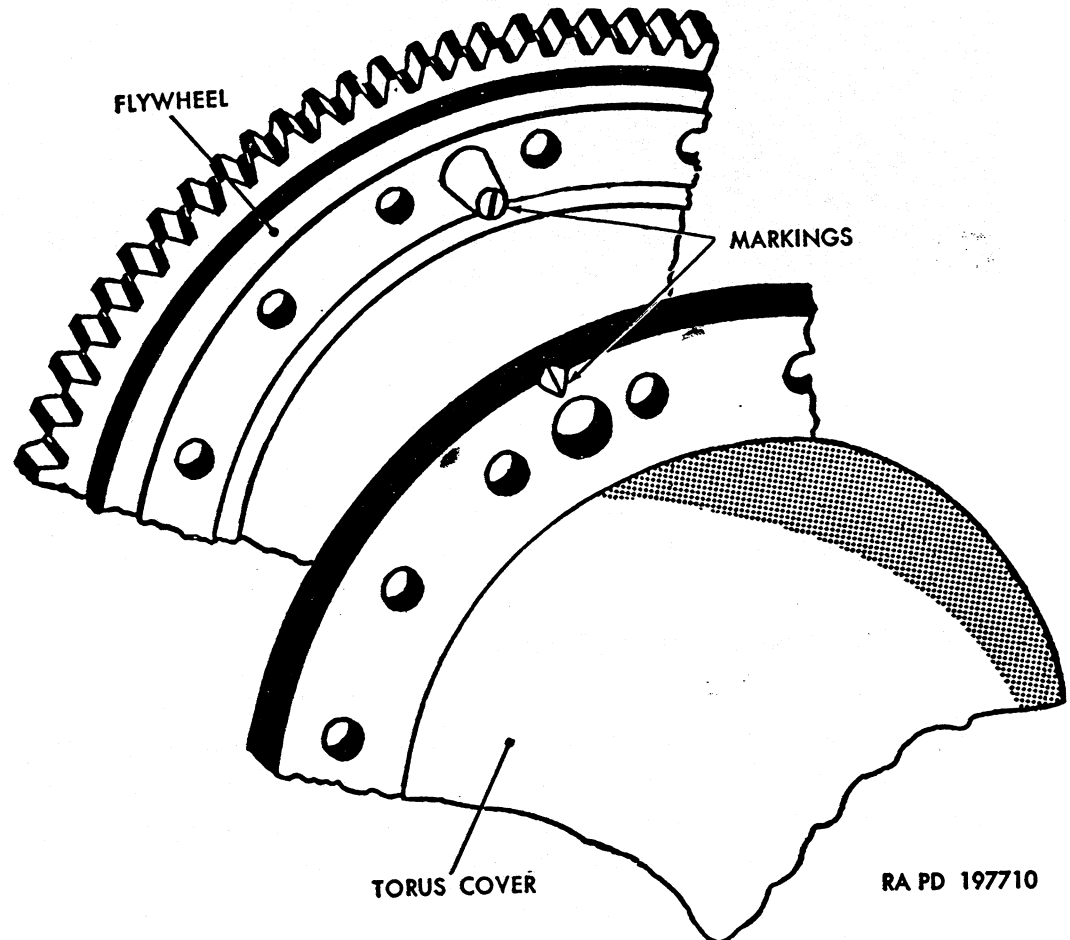

Figure 211. Flywheel and torus cover markings.

position and recheck runout. Runout must not exceed 0.005 inch. If runout checks satisfactorily with torus cover installed in the new position, remark torus cover and flywheel dowel so parts can be properly positioned when transmission is installed on engine. Be sure to use type of mark that will not become confused with previous mark (fig. 211).

- (6) If runout checked satisfactorily in (4) or (5) above, remove torus cover from flywheel. If runout exceeds 0.005-inch maximum, check engine flywheel runout as in (a), (b), and (c) below.

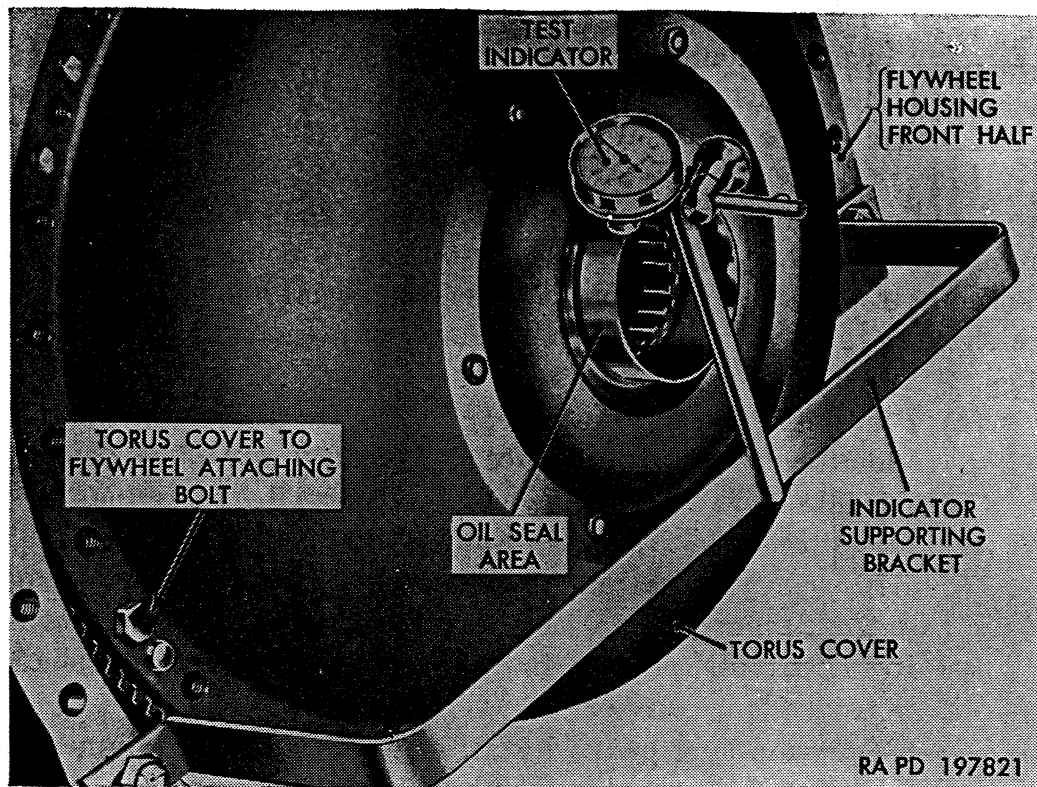

Figure 212. Checking torus cover runout, using test indicator and supporting bracket B7950331.

- (a) With torus cover removed, mount test indicator on flywheel housing front half so stem of indicator will contact sealing surface of flywheel, just inside the row of torus cover bolt holes as shown in figure 213.
- (b) Rotate engine to turn flywheel, noting reading on dial of indicator. Flywheel runout should not exceed 0.005 inch.

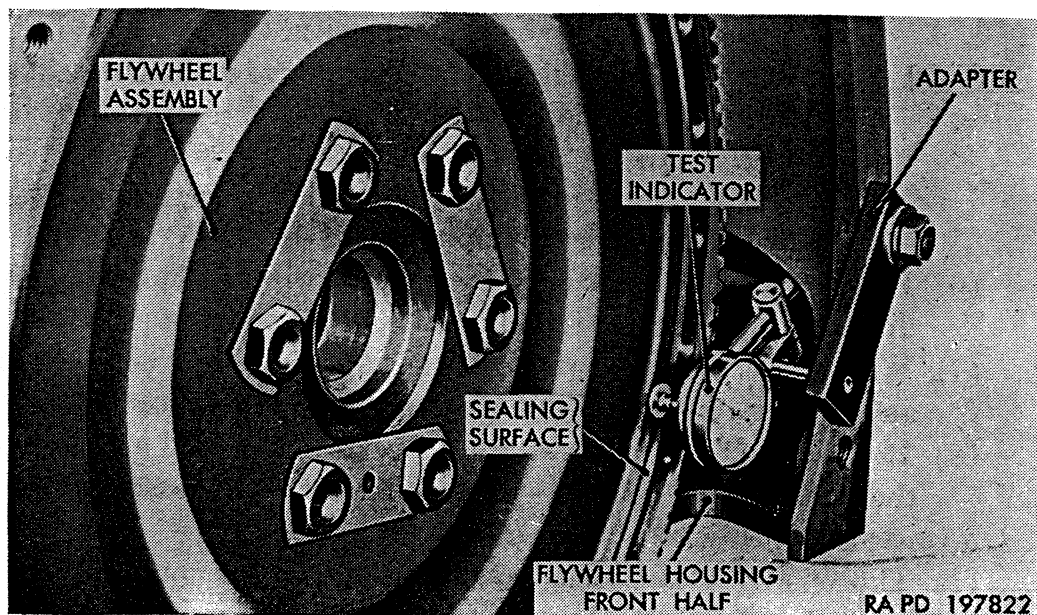

Figure 213. Checking engine flywheel runout.

(c) If flywheel runout exceeds 0.005 inch, report condition to ordnance maintenance personnel.

(7) If new torus cover is used, a final check for runout should be made before transmission is assembled to engine.

*c. Flywheel Housing Rear Half Installation.* Flywheel housing front and rear halves comprise a matched set which must remain with engine on which they were originally installed. A metal plate attached to each half of flywheel housing bears engine serial number (fig. 208) which must agree with serial numbers on plates and stamp on engine (figs. 24 and 25).

(1) Position flywheel housing rear half to transmission assembly and attach with four  $\frac{1}{2}$ -13 x  $1\frac{1}{2}$  self-locking bolts. Tighten opposite bolts alternately to 70 to 75 pound-feet torque.

(2) Push torus cover into place on splines of transmission front drive gear, using care to avoid damage to oil seal and oil ring at front pump cover as torus cover is pushed into place.

(3) Install driving torus assembly on splines of intermediate shaft of front planet carrier.

(4) Using snap ring pliers, install new driving torus retainer in groove of shaft to retain driving torus.

(5) On some early vehicles, torus check valve and spring are held in position in driven torus by a retainer and two bolts. On these vehicles, install driven torus on splines of transmission input shaft. On late vehicles not having the retainer and two bolts to hold torus check valve and spring in place, proceed as in (a) through (d) below.

(a) Slide torus check valve over driven torus hub to check for freeness, then remove torus check valve.

(b) Install torus check valve and check valve spring over transmission input shaft as shown in figure 214.

(c) Start driven torus member on input shaft. at the same time positioning torus check valve spring over hub of driven torus (fig. 214).

(d) Locate driven torus member against driven torus snap ring in groove of transmission input shaft.

(6) Place new lockwasher over transmission input shaft against driven torus member; then install  $\frac{7}{8}$ -16 input shaft nut.

(7) With torus holding wrench B7950256 (fig. 209), hold torus and tighten input shaft nut to 50 to 60 pound-feet torque.

(8) Bend lug of lockwasher against face of nut to hold nut tight; then install pilot bearing spacer on end of input shaft.

*d. Transmission Assembly to Engine.*

(1) Thoroughly clean torus cover gasket surface on flywheel, using dry-cleaning solvent or volatile mineral spirits.

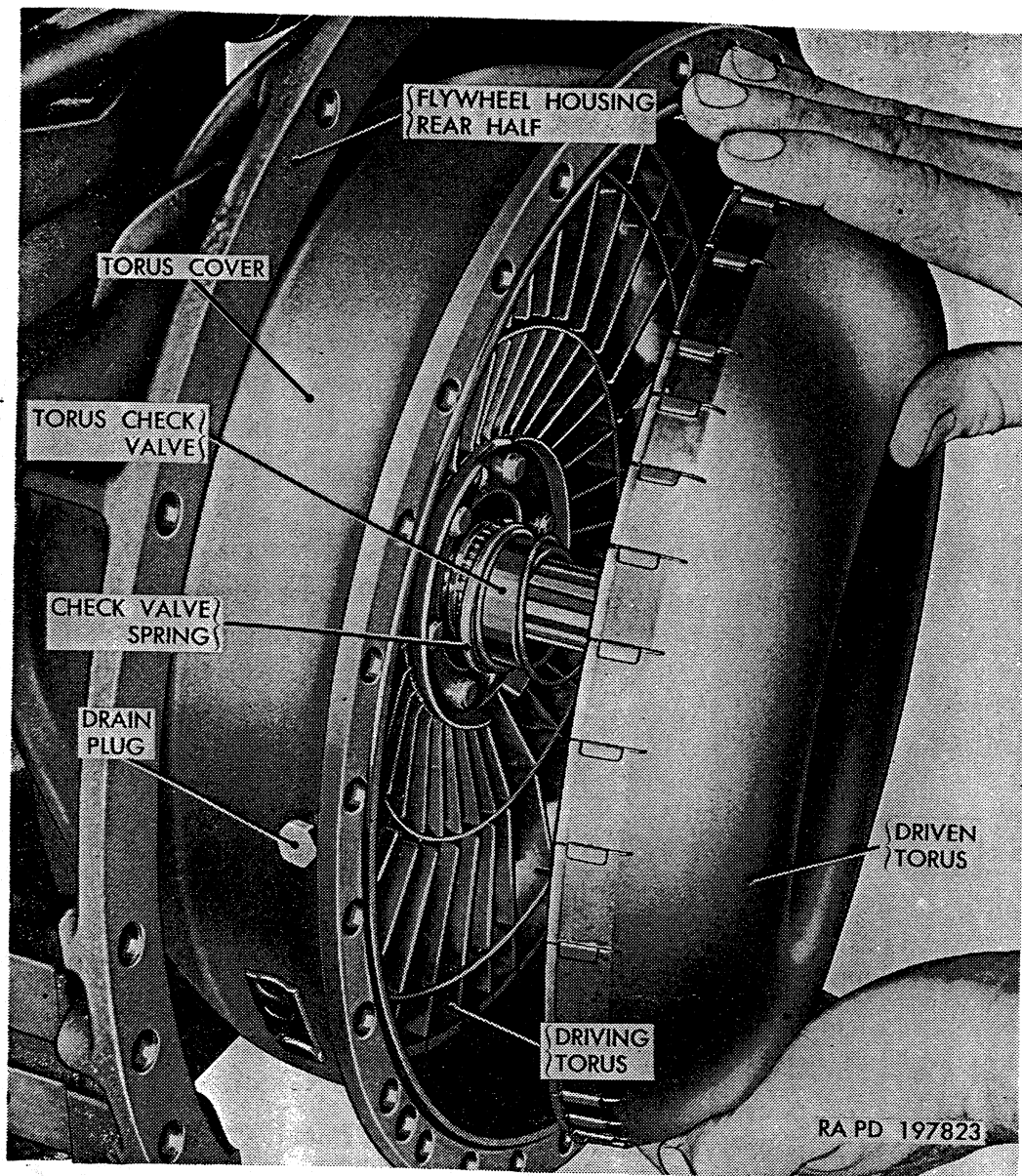

Figure 214. Installing driven torus member.

- (2) Coat torus cover gasket with automotive and artillery grease (GAA); then position gasket to flywheel, alining holes in gasket with holes in flywheel.

*Note.* Gasket must be free from creases or wrinkles, and there must be no nicks or burs at gasket surface on torus cover or flywheel.

- (3) Transmission installation can be facilitated by use of two guide studs in flywheel housing front half. Make guide studs by cutting off heads of two  $\frac{3}{8}$ -16 x 4 bolts and cutting screw-driver slots in ends of bolts. Install the guide studs, one in first or second hole to left and one in the third hole to the right of the dowel in top of flywheel housing front half.
- (4) Make sure pilot bearing spacer is installed on end of transmission input shaft; then with transmission seated on suit-

saddle jack, move transmission under vehicle and into position with engine.

transmission (fig. 207) so input shaft pilot is aligned with pilot bearing in crankshaft, and holes in flywheel housing rear half are aligned with guide studs.

Turn torus cover or flywheel until dowels in flywheel are aligned with dowel holes in torus cover.

*Note.* On some early vehicles, it will be necessary to align large dowel in flywheel with large hole in torus cover.

- (7) Move transmission toward engine so input shaft pilot enters pilot bearing, and dowel holes in flywheel housing rear half fit over dowels in flywheel housing front half. Remove guide studs.
- (8) Install two  $\frac{3}{8}$ -16 x 1 cap screws, six  $\frac{3}{8}$ -16 x  $1\frac{1}{8}$  cap screws, one  $\frac{3}{8}$ -24 x  $1\frac{1}{2}$  cap screw, one  $\frac{3}{8}$ -24 nut, and nine  $\frac{3}{8}$ -inch lockwashers attaching flywheel housing front and rear halves. Tighten cap screws and nut to 27 to 32 pound-feet torque.
- (9) Install thirty  $\frac{5}{16}$ -24 x  $1\frac{1}{16}$  torus-cover-to-flywheel attaching bolts and  $\frac{5}{16}$ -inch lockwashers. Tighten attaching bolts finger-tight only.
- (10) First tighten two bolts at dowels and two bolts 90° from dowels to 12 to 15 pound-feet torque. Tighten bolts alternately to avoid distorting torus cover.
- (11) Tighten all torus-cover-to-flywheel attaching bolts alternately and evenly to 25 to 28 pound-feet torque.
- (12) Make sure torus cover drain plug (fig. 186) is tightened to 6 to 7 pound-feet torque.
- (13) Position flywheel housing cover on housing and attach with eight  $\frac{3}{8}$ -16 x 1 cap screws and  $\frac{3}{8}$ -inch lockwashers. Tighten cap screws to 25 to 30 pound-feet torque.
- (14) Connect transmission oil cooler lines at each side of oil pan and cooler assembly. Tighten nuts.

*e. Final Procedures.*

- (1) *Connect starter control.* Align cross-shaft-lever-to-starter rod with cross shaft lever; then attach rod to lever with clevis pin (H, fig. 200) and cotter pin.
- (2) *Install transmission rear support cross member.* Position transmission rear support cross member on support brackets at each side member; then attach support to brackets with four  $\frac{1}{2}$ -20 x  $2\frac{1}{4}$  bolts and four  $\frac{1}{2}$ -20 safety nuts. Tighten nuts.
- (3) *Attach transfer control cross shaft.* Attach transfer control cross shaft left bracket to transmission rear support with two

$\frac{5}{16}$ -24 x  $\frac{7}{8}$  bolts (P, fig. 197) and  $\frac{5}{16}$ -24 safety nuts. Tighten nuts.

- (4) *Connect transfer-to-front-axle propeller shaft.* Raise rear end of transfer-to-front-axle propeller shaft into position; then attach propeller shaft universal joint to transfer driving flange with four  $\frac{7}{16}$ -20 x  $1\frac{3}{16}$  bolts and  $\frac{7}{16}$ -20 safety nuts. Tighten nuts.
- (5) *Install transmission-to-transfer propeller shaft.*
  - (a) Slide front universal joint flange on transmission output shaft.
  - (b) Attach rear universal joint flange to transfer flange with four  $\frac{1}{2}$ -20 x  $1\frac{3}{8}$  bolts and  $\frac{1}{2}$ -20 safety nuts. Tighten nuts.
  - (c) Install four  $\frac{1}{2}$ -20 x  $\frac{1}{2}$  bolts and  $\frac{1}{2}$ -20 safety nuts attaching front and rear universal joint. Tighten nuts.
- (6) *Attach power plant to transmission rear support.*
  - (a) With power plant carefully supported by saddle jack, lower power plant until weight rests on cushioned mountings at rear of transmission, installed on transmission rear support. Refer to figure 108.
  - (b) Attach transmission to rear support cushions with two  $\frac{1}{2}$ -20 x  $1\frac{3}{8}$  bolts and  $\frac{1}{2}$ -inch lockwashers. Tighten bolts. Remove saddle jack from beneath vehicle.
- (7) *Install exhaust pipe rear section.* Using a new seal at each end of exhaust pipe rear section, attach rear exhaust pipe to muffler and front exhaust strap to transmission rear support with a  $\frac{5}{16}$ -24 x  $1\frac{5}{8}$  cap screw and  $\frac{5}{16}$ -24 safety nut. Tighten nut firmly.
- (8) *Install transmission shift control tower and connect linkage.*
  - (a) Install transmission control tower (par. 203a (2)).
  - (b) Position throttle valve control rod at throttle valve lever and attach with cotter pin and clevis pin (M, fig. 196).
  - (c) Connect reduction unit control rod (CC, fig. 197) to reduction unit control lever with clevis pin and cotter pin.
  - (d) Aline transfer reverse rod with transmission shift lever, then attach rod to lever with clevis pin and cotter pin (B and C, fig. 199).
- (9) *Adjust linkage.* Adjust manual shift control linkage and transmission throttle linkage as described in paragraph 202.
- (10) *Fill cooling system.* Fill engine cooling system as described in paragraph 142a.
- (11) *Fill transmission with lubricant.* Fill transmission with oil as described in paragraph 194e.

f. *Record of Replacement.* Record the replacement on DA Form 478.



### III. TRANSFER AND CONTROLS

#### Data

Transfer is essentially a single-speed auxiliary gears, and output shafts for transferring driving axles. Mounted on frame cross of transmission, transfer is driven from ed propeller shaft. Transfer includes a ing axles from power plant, to permit ment without driving vehicle. Transfer incor- e jaw-type clutch in front axle drive gearing to pro- automatic engagement and disengagement of front driving axle. Except when required for tractive effort, front axle runs free. Open- ing is provided at left side of transfer case to accommodate a power- take-off assembly used to operate such equipment as winch, dump body hoist, and pumps on trucks with tank bodies. Parking brake mecha- nism is assembled at rear of transfer, and speedometer is driven by gears assembled at idler shaft front bearing retainer. The two shifter shafts mounted in support at front side of transfer case are operated by mechanical linkage. Lower shifter shaft is interconnected with transmission control and automatically positions front axle output shaft gear for forward and reverse driving. Upper shift shaft is con- nected to manually operated shift linkage connected to transfer lever in cab, which enables driver to place transfer case in neutral.

#### b. Data.

Type----- single-speed with automatic front axle declutching  
Make----- GMC Truck and Coach  
Ordnance number----- 7411327  
Ratio----- 1.16:1

### 207. Checking, Draining, and Filling Transfer

a. *General.* Refer to lubrication chart (par. 69) for type of lubri- cant and intervals of checking and draining.

b. *Checking Lubricant Level.* Remove filler plug (AA, fig. 83). Add sufficient lubricant to bring level to one-half inch below filler plug opening if unit is cold (before operation). If unit is hot, imme- diately after operation, lubricant level should be even with bottom of filler plug opening. Clean plug thoroughly and install new gasket if old gasket is damaged. Install and tighten plug.

c. *Draining and Filling.* Unit should be drained while hot, im- mediately after operation. Remove bottom plug (BB, fig. 83) in case to drain lubricant. If vehicle is equipped with a power-take-off, also remove plug at bottom of power-take-off to drain unit. Clean drain plug thoroughly. Install new gaskets. Install and tighten plugs. Re- fill to one-half inch of bottom of filler plug opening (b above).

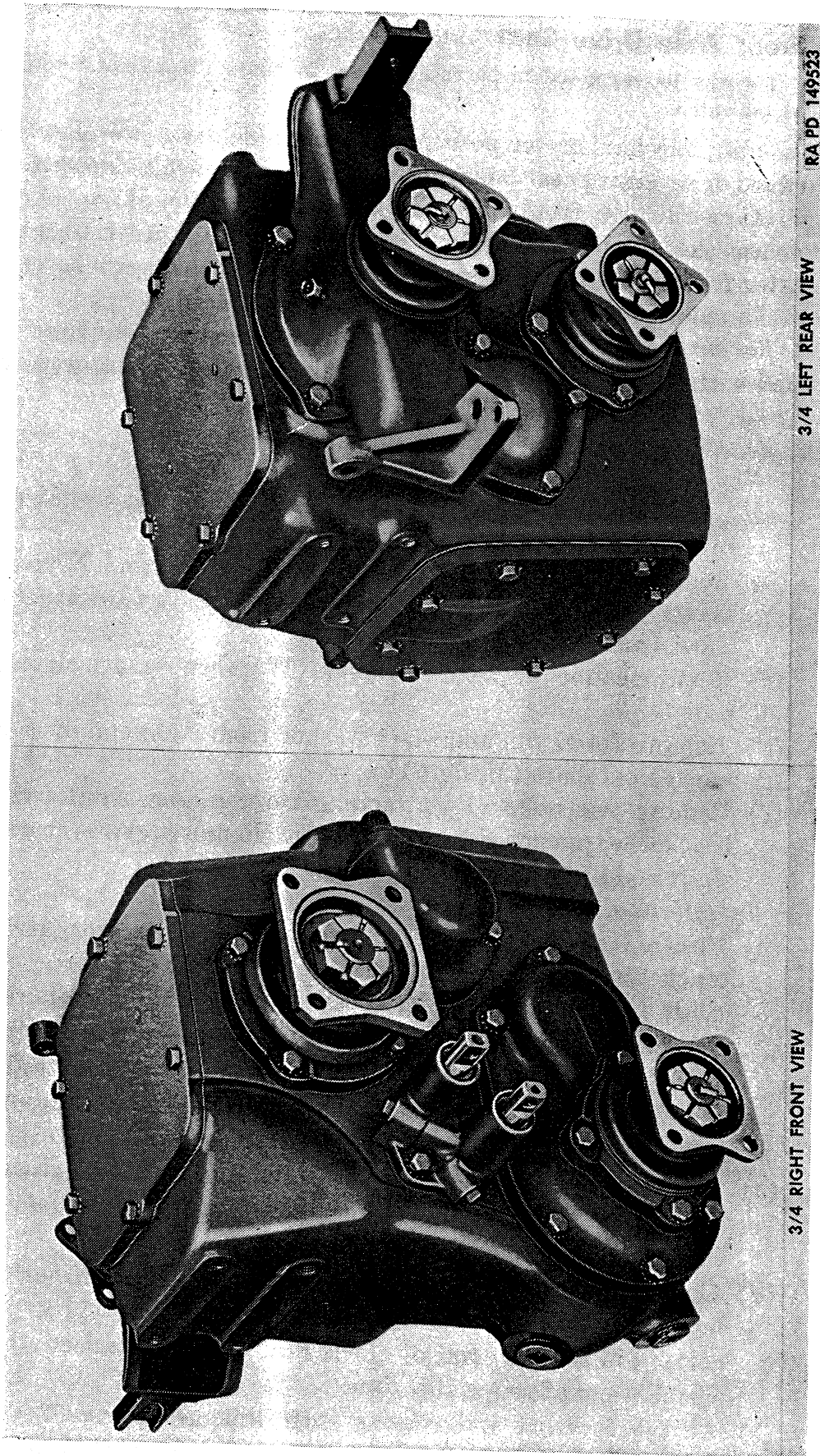

3/4 LEFT REAR VIEW RA PD 149523

3/4 RIGHT FRONT VIEW

*Figure 215. Front and rear external views of transfer assembly.*

## 208. Front Axle Drive Shift Linkage

*Note.* The key letters noted in parentheses are in figure 197, except where otherwise indicated.

*a. General.* Mechanism for positioning front axle drive jaw clutch for forward or reverse operation is interconnected to transmission shift linkage. Consequently, from driver's viewpoint, operation of transfer is automatic, except when necessary to place into neutral. Adjustment of transfer forward and reverse shift linkage must be made whenever transmission manual shift linkage is adjusted or replaced.

*b. Adjustment.* Since transfer forward and reverse linkage is interconnected with transmission manual shift linkage, refer to paragraph 202*c* for adjustment information.

*c. Replacement.*

(1) *Removal.*

- (a) Remove clevis pins (BB and JJ) at each end of transfer reverse rod (M); then remove rod.
- (b) Remove front and rear dust shield clamps (U and X) on reverse shifter shaft dust shield (Z). Slide dust shield toward front.
- (c) Remove cotter pin from clevis pin (W), then remove clevis pin.
- (d) Remove cotter pin and plain washer from right end of reverse cross shaft (M, fig. 217).
- (e) Remove two bolts (P) attaching reverse cross shaft left bracket to transmission rear support. Remove reverse cross shaft and bracket assembly.

(2) *Installation.*

- (a) Position reverse cross shaft assembly, with lever and bracket as a unit, at transmission rear support.
- (b) Slide right end of reverse cross shaft into right support bracket (L, fig. 217). Install two  $\frac{5}{16}$ -24 x  $\frac{7}{8}$  bolts (P) and  $\frac{5}{16}$ -24 locknuts which attach reverse cross shaft left support bracket to transmission rear support. Tighten locknuts to  $9\frac{1}{2}$  to 13 pound-feet torque.
- (c) Place  $1\frac{7}{32}$ -inch plain washer on right end of reverse cross shaft; then install  $\frac{1}{8}$  x  $\frac{7}{8}$  cotter pin through end of reverse cross shaft (M, fig. 217).
- (d) Connect transfer reverse rod (M) to transmission shift lever (K) with  $\frac{3}{8}$ -inch clevis pin (JJ). Install  $\frac{3}{32}$  x  $\frac{5}{8}$  cotter pin through end of clevis pin. Do not connect adjustable end of rod at this time.
- (e) Adjust forward and reverse shift linkage (par. 202*c*); then install  $\frac{3}{8}$ -inch clevis pin (BB). Secure clevis pin with  $\frac{3}{32}$  x  $\frac{5}{8}$  cotter pin.

- (f) Position reverse shifter shaft dust shield (Z) over clevis yoke and shifter shaft; then install and tighten front and rear dust shield clamps (U and X).

## 209. Manual Shift Linkage

*Note.* Key letters noted in parentheses are in figure 216.

*a. General.* Transfer is placed into neutral and driving positions with manually operated transfer lever, located above floor slightly to right of driver's seat (A). Through linkage, manually operated lever actuates power-take-off shifter shaft in transfer. With transfer lever raised to UP-ENGAGED position, transfer is in driving position. When transfer lever is lowered to DOWN-NEUTRAL position, transfer is in neutral.

*b. Adjustment.* With handoperated transfer control lever (S) in UP-ENGAGED position, and with lever resting on lower edge of guide slot in companion seat riser (T), make sure shifter shaft (H) in transfer is pulled out (forward) to detent stop. Loosen jam nut

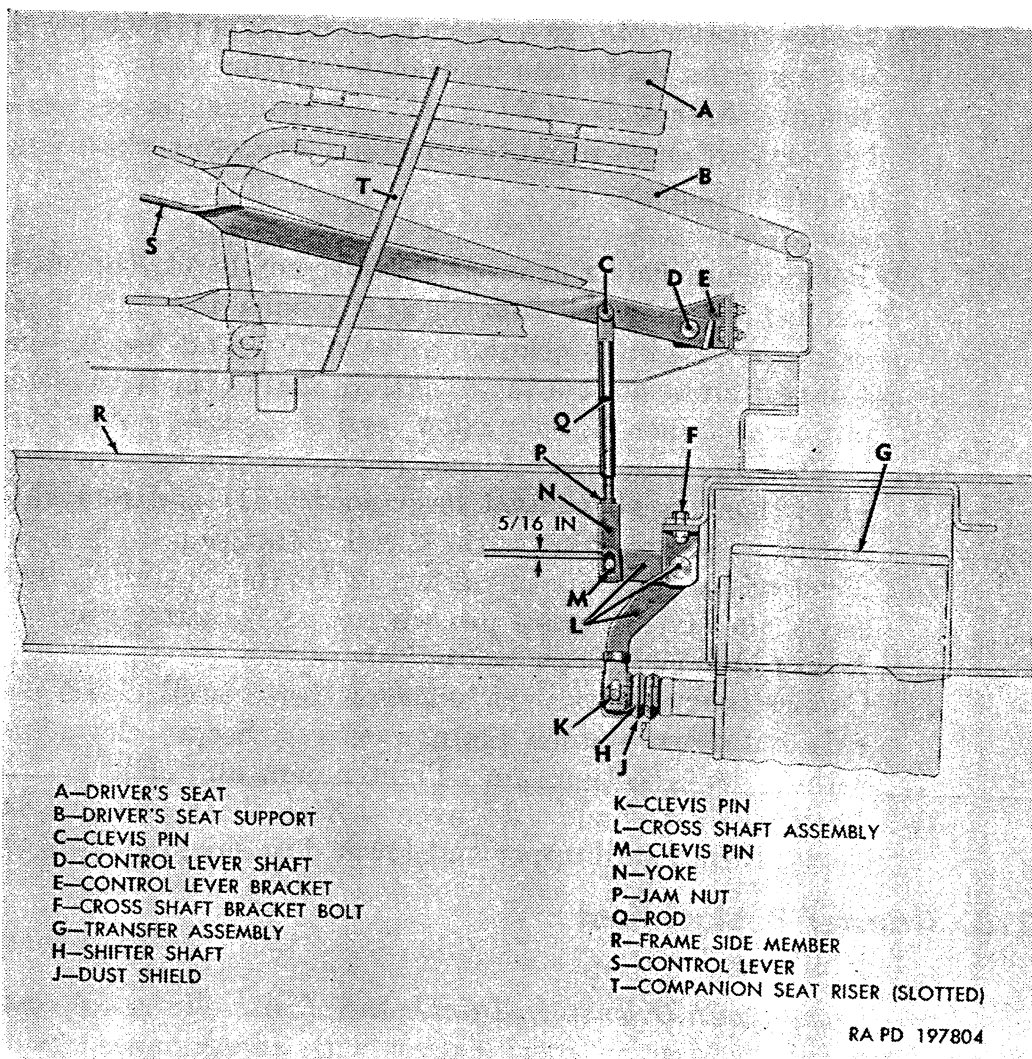

Figure 216. Transfer lever linkage.

(P), remove clevis pin (M); then adjust yoke (N) so that clevis pin (M) is five-sixteenths of an inch from top of elongated clevis pin holes in yoke (N). Tighten clevis jam nut (P). Install clevis pin (M) with two  $\frac{3}{8}$ -inch plain washers; then secure clevis pin with  $\frac{3}{32} \times \frac{5}{8}$  cotter pin.

*c. Replacement.*

(1) *Removal.*

- (a) Remove cotter pin and clevis pin (C) from transfer control lever and lever-to-cross-shaft rod.
- (b) Remove cotter pin, retaining washer, and shaft (D) which connect transfer control lever (S) to bracket (E); then remove lever.
- (c) Remove cotter pin, two washers, and clevis pin (M) from lower end of lever-to-cross-shaft-rod yoke (N); then remove rod and clevis assembly.
- (d) Remove upper and lower clamps from shifter shaft dust shield (J); then move dust shield back onto shifter shaft (H).
- (e) Remove cotter pin, two washers, and clevis pin (K) connecting cross shaft lever to transfer shifter shaft.
- (f) Remove four bolts (F) attaching transfer cross shaft brackets to cross member; then remove cross shaft and brackets assembly.

(2) *Installation.*

- (a) Position brackets and cross shaft assembly (L) on cross member; then install four  $\frac{3}{8}$ -24 x 1 bolts and four  $\frac{3}{8}$ -24 locknuts. Tighten locknuts to 20 to 27 pound-feet torque.
- (b) Connect cross shaft lever to shifter shaft (H) with clevis pin, two  $\frac{3}{8}$ -inch plain washer, and a  $\frac{3}{32} \times \frac{5}{8}$  cotter pin.
- (c) Position transfer control lever (S) in control lever bracket (E); then install control lever shaft (D) and retaining washer. Secure shaft with  $\frac{1}{8} \times 1$  cotter pin.
- (d) Position rod (Q) on control lever (S); then install  $\frac{3}{8}$ -inch clevis pin (C). Secure pin with  $\frac{3}{32} \times \frac{5}{8}$  cotter pin.
- (e) Adjust linkage as described in *b* above.
- (f) Connect rod to cross shaft lever; then install clevis pin (M) with two  $\frac{3}{8}$ -inch plain washers. Secure clevis pin with  $\frac{3}{32} \times \frac{5}{8}$  cotter pin. Tighten jam nut (P).
- (g) Position dust shield (J) over shifter shaft and end of clevis; then install upper and lower dust shield clamps.

## 210. Transfer Replacement

(fig. 217)

*a. Coordination with Ordnance Maintenance Unit.* Refer to paragraph 2 for information on coordination with an ordnance maintenance unit.

b. *General.* The transfer assembly, which includes parking brake and power-take-off (when used), is removed as an assembly. A suitable dolly jack is required to remove transfer assembly.

c. *Removal.*

- (1) Remove filler and drain plugs (Q and R) and allow lubricant to drain. Install and tighten plugs when drainage is complete.
- (2) Disconnect propeller shafts at transfer by removing bolts and nuts which attach propeller shaft flanges to transfer companion flanges (par. 229).
- (3) Disconnect vent line (C) at tee on cross member and at transfer.
- (4) Disconnect speedometer flexible shaft at transfer. Use pliers to unscrew knurled nut; then pull flexible shaft out of speedometer driven gear shaft.

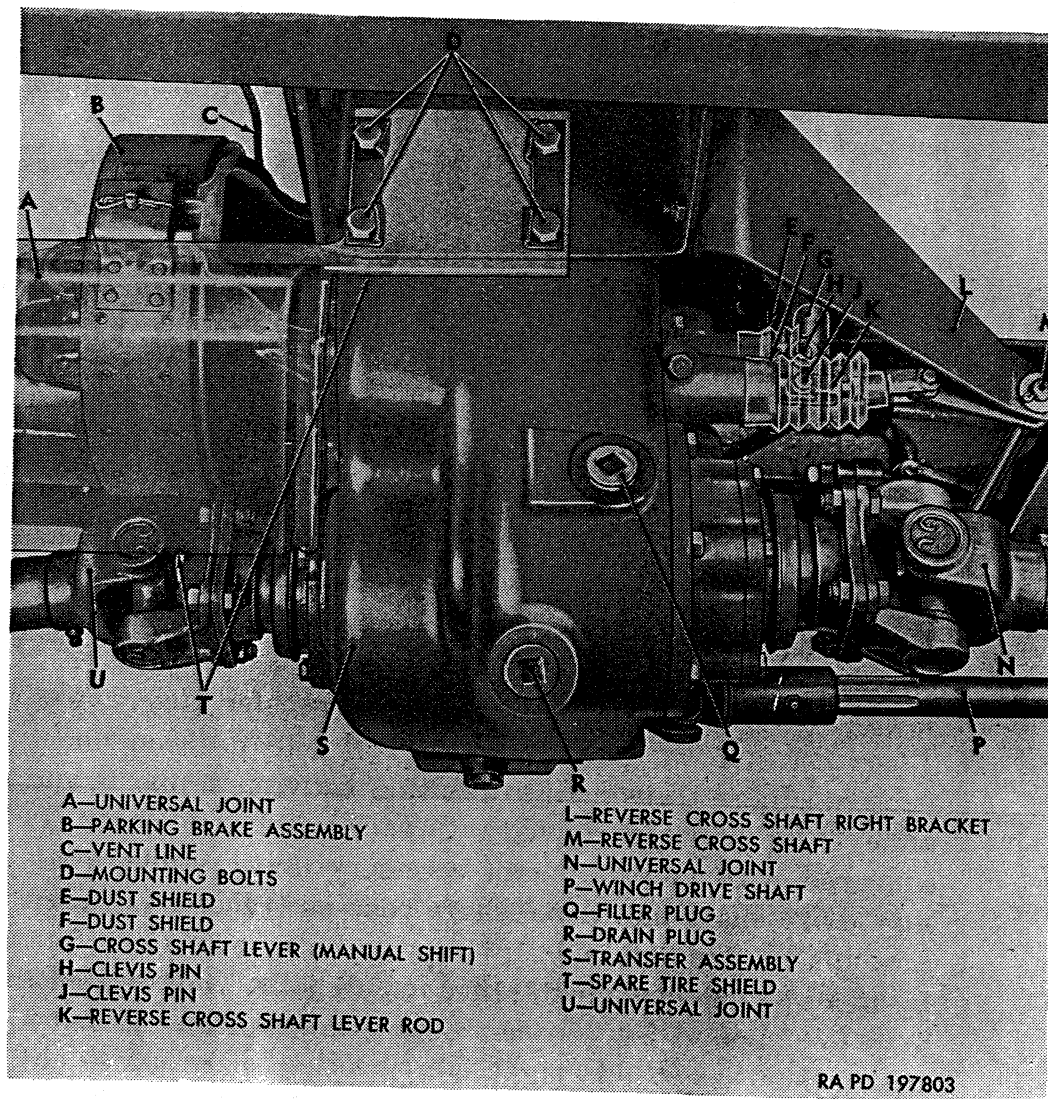

Figure 217. Transfer installed.

- (5) When vehicle is equipped with power-take-off and winch, disconnect winch drive shaft (par. 319*b*), and winch control cable (par. 321*b*) at power-take-off.
- (6) When vehicle is equipped with power-take-off and accessory drive assembly, remove cotter pin and clevis pin from shifting rod at accessory drive. Remove hex-socket setscrew from drive shaft universal joint yoke. Slide yoke toward end of accessory drive shaft as far as possible.
- (7) Remove cotter pin and clevis pin attaching parking brake rod to brake cam levers.
- (8) Remove upper and lower clamps from shifter shaft dust shield (F); then move dust shield back onto shifter shaft. Remove cotter pin, two washers, and clevis pin (H) connecting cross shaft lever (G) to transfer shifter shaft.
- (9) Remove front and rear dust shield clamps from reverse shifter shaft dust shield (E); then slide dust shield forward. Remove cotter pin from reverse cross shaft lever rod clevis pin (J); then remove clevis pin.
- (10) Position dolly jack under transfer and raise into position to support transfer.
- (11) Bend bolt locks away from bolt heads; then remove four mounting bolts (D) and two bolt locks from each side. Remove spare tire shield (T). Lower transfer on jack and withdraw from under vehicle. When power-take-off accessory drive is used, the drive shaft yoke can be removed from accessory drive as transfer is lowered.
- (12) Remove parking brake band from rear of transfer (par. 255*a*).
- (13) Remove power-take-off assembly (when used) from side of transfer (par. 212).

*d. Installation.*

- (1) Install power-take-off (when used) on side of transfer (par. 213).
- (2) Install parking brake band on rear of transfer (par. 255*b*).
- (3) Place transfer on dolly jack and roll into position under vehicle. Raise transfer into position between supports and align holes in supports with threaded holes in case. If equipped with power-take-off accessory drive, guide accessory drive shaft into drive shaft yoke as transfer is raised into place. On left side, place two bolt locks over four  $\frac{1}{2}$ -13 x  $1\frac{3}{16}$  mounting bolts; then install bolts. Tighten bolts to 60 to 85 pound-feet torque. Bend corners of bolt locks up against bolt heads. On right side, position spare tire shield (T) on transfer support. Place two bolt locks over four  $\frac{1}{2}$ -13 x  $1\frac{1}{16}$  mounting bolts; then install bolts (D) and

- tighten to 60 to 85 pound-feet torque. Bend corners of bolt locks up against bolt heads.
- (4) Adjust forward and reverse shift linkage (par. 202*c*). Position reverse shifter shaft rod clevis on transfer shifter shaft; then install  $\frac{3}{8}$ -inch clevis pin (J). Secure clevis pin with  $\frac{3}{32} \times \frac{5}{8}$  cotter pin. Position reverse shifter shaft dust shield (E), then install and tighten front and rear dust shield clamps.
  - (5) Adjust manual shift linkage (par. 209). Connect cross shaft lever (G) to shifter shaft with clevis pin (H), two  $\frac{3}{8}$ -inch plain washers, and a  $\frac{3}{32} \times \frac{5}{8}$  cotter pin. Position shifter shaft dust shield (F) over shifter shaft and end of clevis; then install upper and lower dust shield clamps.
  - (6) Attach parking brake rod to parking brake cam lever with a  $\frac{3}{8} \times \frac{15}{16}$  clevis pin. Secure clevis pin with a  $\frac{3}{32} \times \frac{5}{8}$  cotter pin.
  - (7) If vehicle is equipped with winch, connect winch drive shaft (par. 319*d*) and winch control cable (par. 321*c*) to power-take-off.
  - (8) If vehicle is equipped with power-take-off accessory drive, connect shifting rod to accessory drive with clevis pin. Secure clevis pin with  $\frac{1}{8} \times \frac{7}{8}$  cotter pin. Install and tighten setscrew in drive shaft yoke.
  - (9) Connect speedometer flexible shaft to transfer. Make sure that tongue on cable meshes with speedometer gear shaft. Tighten knurled nut with pliers.
  - (10) Connect vent line (C) at line tee on cross member and at transfer. Tighten tubing nut.
  - (11) Connect propeller shafts to transfer (par. 230).
  - (12) Examine condition of drain and filler plugs and gaskets and replace if necessary. Refer to lubrication chart (par. 69) for type of lubricant. Fill as described in paragraph 207.
- e. Record of Replacement.* Record the replacement on DA Form 478.

## **Section XIX. POWER-TAKE-OFF AND ACCESSORY DRIVE**

### **211. Description and Data**

*a. Description.* Power-take-off assembly, installed at left side of transfer, provides power for operation of winch only, winch and dump body hoist pump, and pump used with gasoline and water tanks. Power-take-off assemblies are single-speed-type and can be operated either with vehicle standing or moving. Some applications require an accessory drive, which is mounted on top of power-take-off.



- (1) *Power-take-off (winch only)*. Power-take-off used on vehicles equipped with winch only is illustrated in figure 218. This unit has a single output shaft at forward side of power-take-off. Control cable is also attached at forward side.
- (2) *Power-take-off (winch and dump body hoist)*. Power-take-off used on vehicles equipped with dump body and winch is illustrated in figure 219. This unit is equipped with an accessory drive, mounted at top of power-take-off, and provides means for driving dump body hoist pump. Accessory drive output shaft and control shaft are toward rear.
- (3) *Power-take-off (tank body pump)*. Power-take-off used on vehicles equipped with tank bodies is illustrated in figure 220. This unit is equipped with an accessory drive, mounted at top of power-take-off, and provides means for driving tank body pump. Accessory drive output shaft is toward rear and controls are toward front.

*b. Data.*

Make	-----	Chelsea
Type	-----	reversible
Speed	-----	single
Power take-off model :		
Winch only	-----	87C1
Winch and dump body hoist	-----	87C1
Tank body pump	-----	88C
Accessory drive model :		
Dump body	-----	82C
Tank body	-----	81C

## 212. Power-Take-Off Removal

*a. General.* The arrangement of power-take-off and accessory drive assemblies are similar in their mounting and controls as illustrated in figures 221, 222, and 223. Removal procedures for each type are described in *b, c, and d* below.

*b. Removal of Winch Power-Take-Off (fig. 221).*

- (1) Remove plug from bottom of power-take-off to drain lubricant.
- (2) Loosen setscrew securing universal joint yoke to power-take-off shaft; then slide yoke forward to remove from power-take-off shaft.
- (3) Remove control cable from power-take-off (par. 321*b*).
- (4) Remove six cap screws and lockwashers, and two stud nuts attaching power-take-off to transfer. Remove power-take-off assembly from transfer. Remove and discard gasket.

*c. Removal of Dump Body Hoist Power-Take-Off (fig. 222).*

- (1) Remove plug from bottom of power-take-off to drain lubricant.

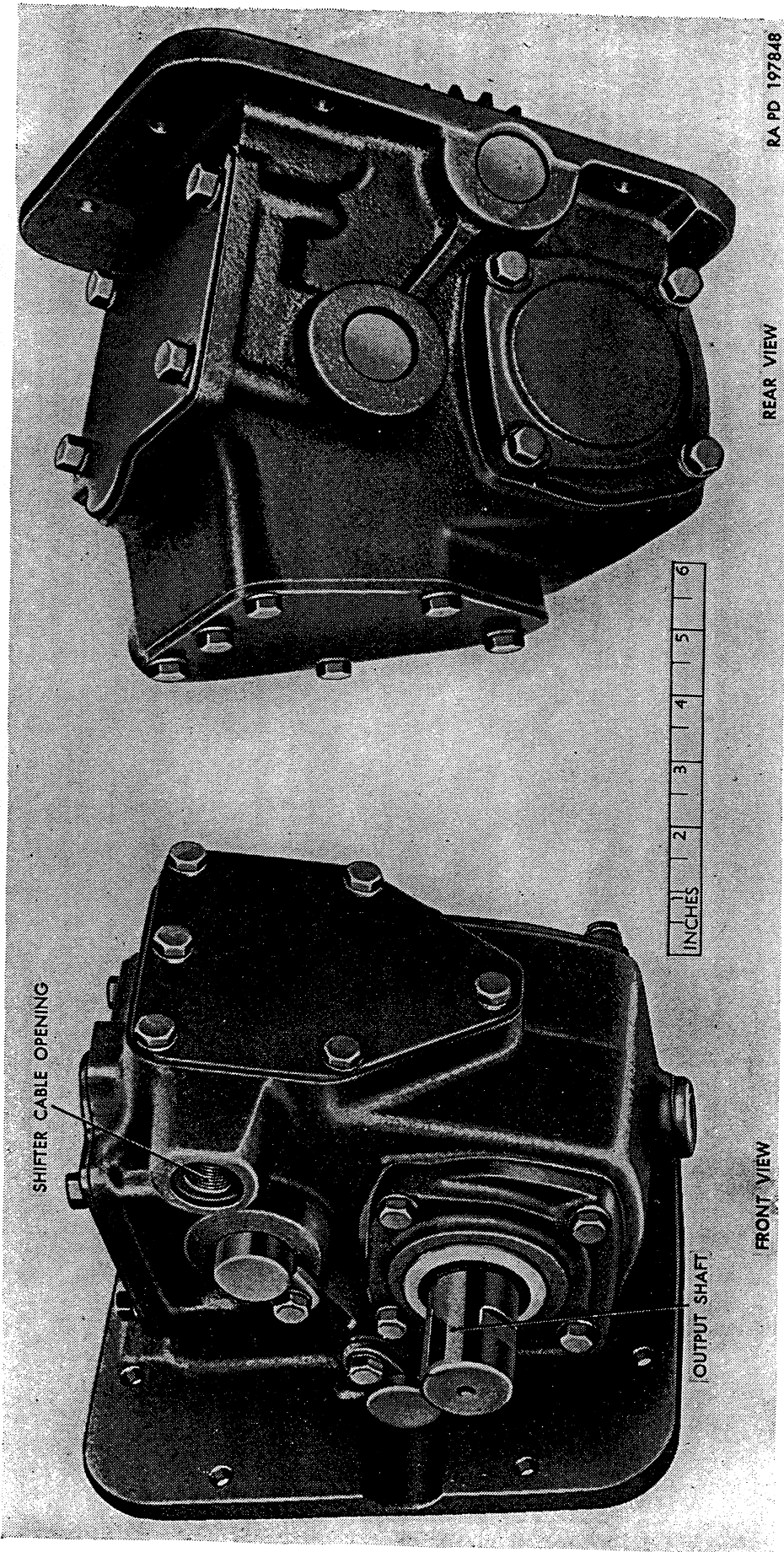

Figure 218. Front and rear views of winch power-take-off assembly.

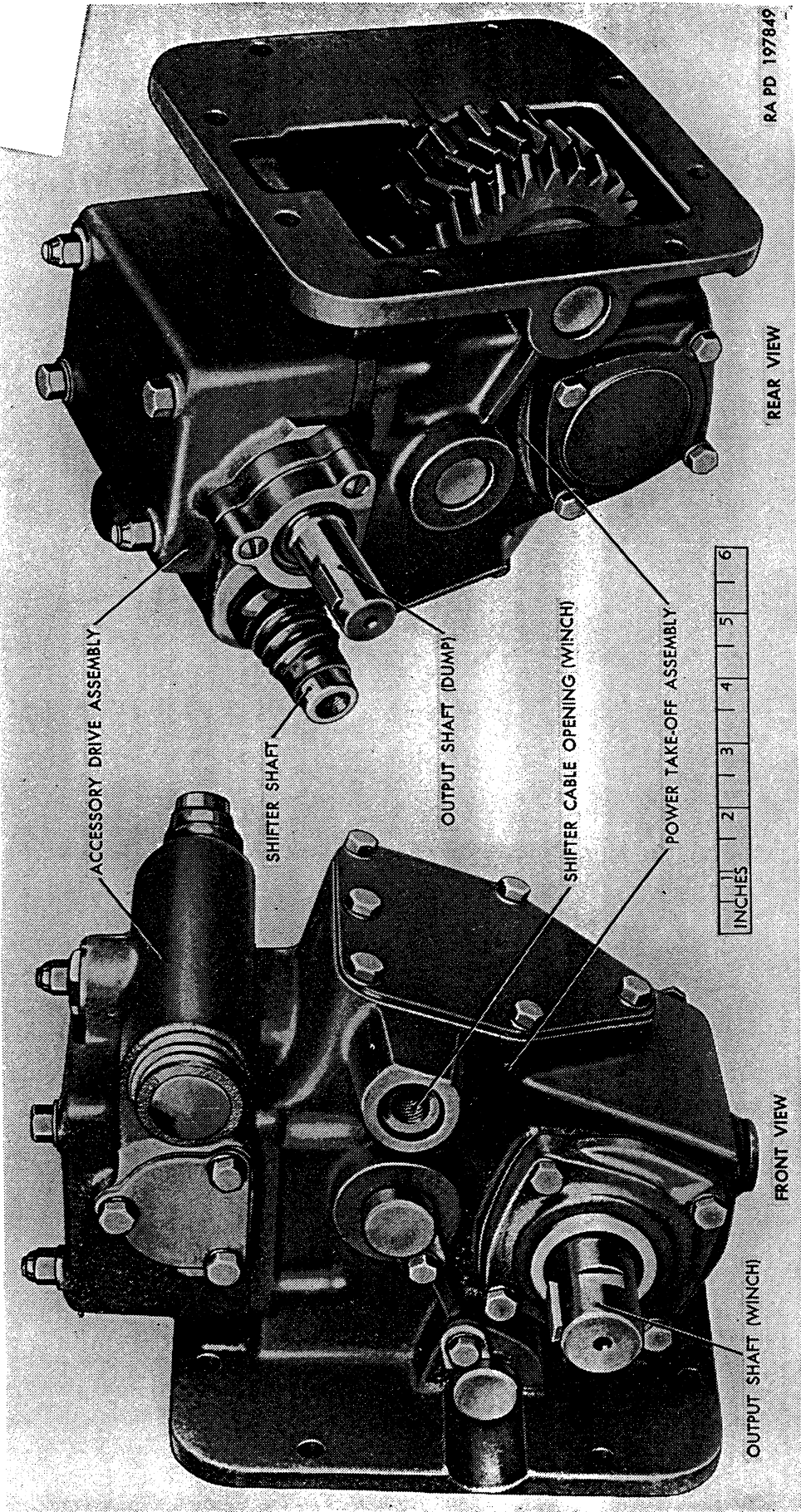

Figure 219. Front and rear views of dump body hoist and winch power-take-off and accessory drive assemblies.

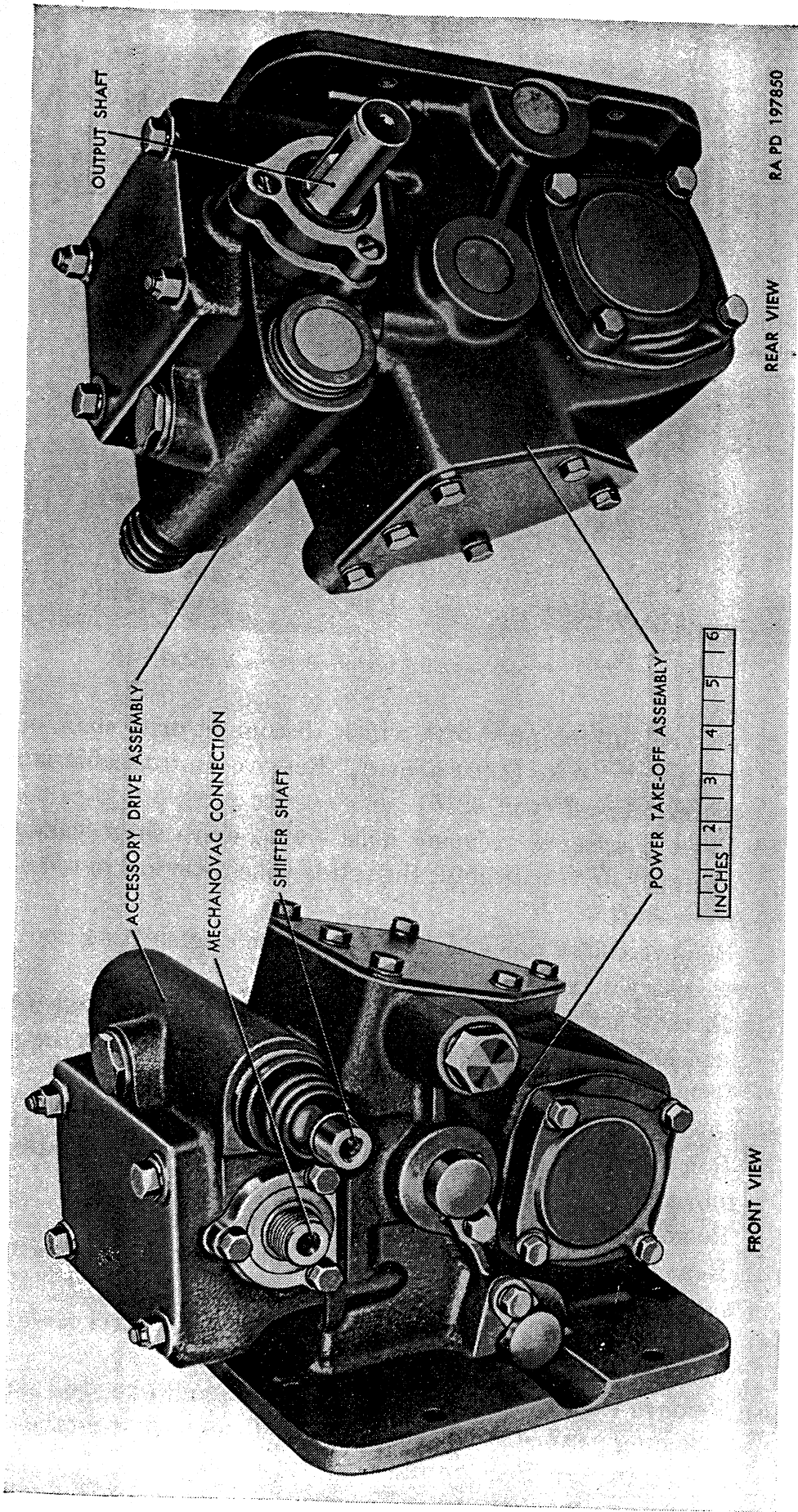

Figure 220. Front and rear views of tank body pump power-take-off and accessory drive assemblies.

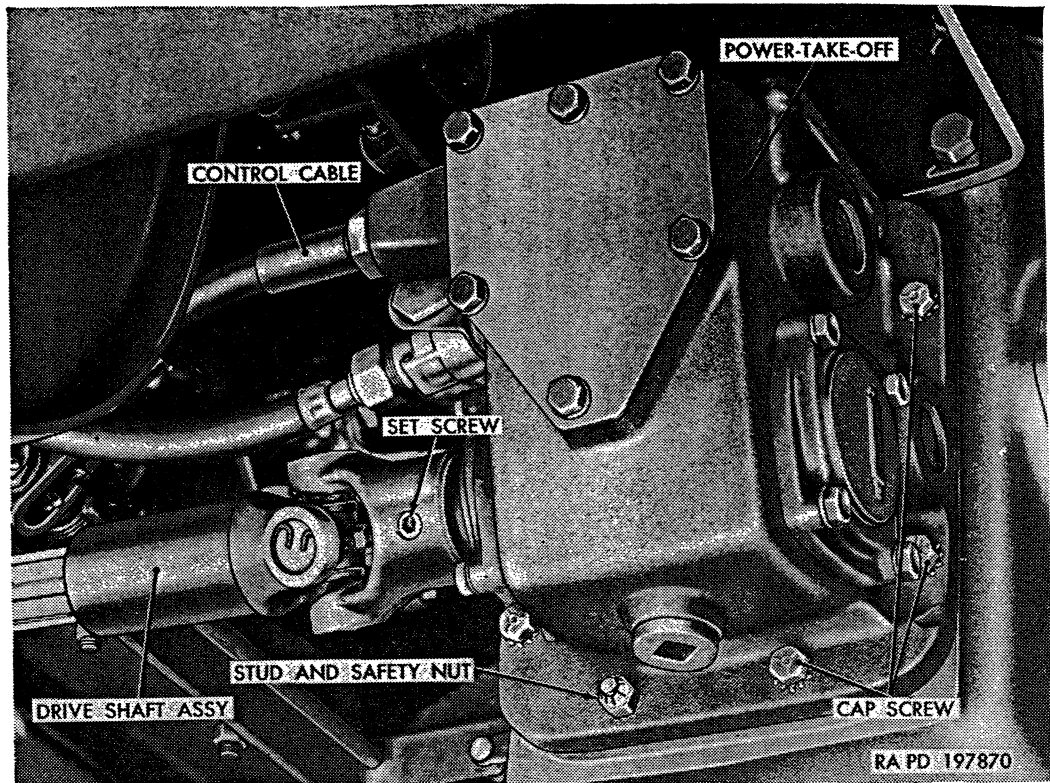

Figure 221. Power-take-off installed (winch only).

- (2) On vehicles equipped with winch, disconnect drive shaft universal joint yoke (b(2) above). Remove control cable from power-take-off (par. 321b).
  - (3) Remove setscrew securing hoist pump drive shaft yoke to accessory drive assembly; then slide yoke rearward to remove from shaft.
  - (4) Remove cotter pin and clevis pin attaching shifting rod to accessory drive shifter shaft.
  - (5) Remove six cap screws and lockwashers, and two stud nuts attaching power-take-off to transfer. Remove power-take-off from transfer. Remove and discard gasket.
- d. *Removal of Tank Body Pump Power-Take-Off* (fig. 223).
- (1) Remove plug from bottom of power-take-off to drain lubricant.
  - (2) Remove pump front propeller shaft (par. 345b).
  - (3) Remove cotter pin and clevis pin; then remove shift rod at accessory drive shift shaft.
  - (4) Remove nut attaching Mechanovac governor control cable to accessory drive assembly; then remove cable.
  - (5) Remove six cap screws and lockwashers, and two stud nuts attaching power-take-off to transfer. Remove power-take-off from transfer. Remove and discard gasket.

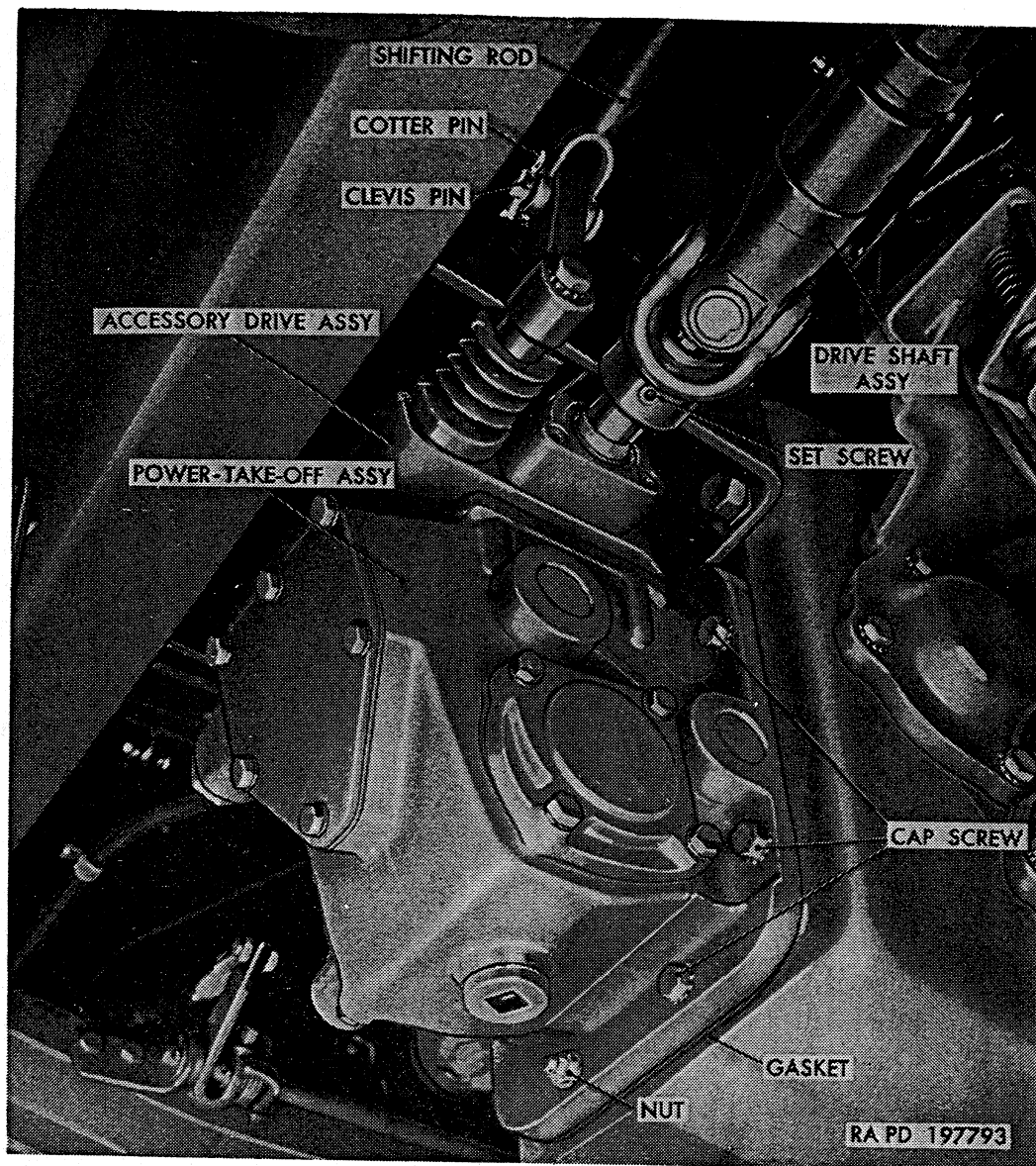

Figure 222. Power-take-off installed (dump body hoist).

### 213. Power-Take-Off Installation

*a. General.* Procedures for installation of each type are described in *b*, *c*, and *d* below.

*b. Installation of Winch Power-Take-Off* (fig. 221).

- (1) Position two new gaskets over studs and against transfer. Position power-take-off over two studs and against transfer. Install one  $\frac{3}{8}$ -24 nut on each of the two studs. Install six  $\frac{3}{8}$ -16 x  $1\frac{1}{8}$  cap screws and  $\frac{3}{8}$ -inch lockwashers. Tighten stud nuts and cap screws evenly and alternately.
- (2) Fill transfer with lubricant as directed in paragraph 207*c*.
- (3) Install control cable (par. 321*c*).
- (4) Install  $\frac{1}{4}$  x 1 woodruff key in power-take-off shaft keyway. Install rear universal joint on splined rear shaft; then slide joint rearward and onto power-take-off shaft, alining keyway

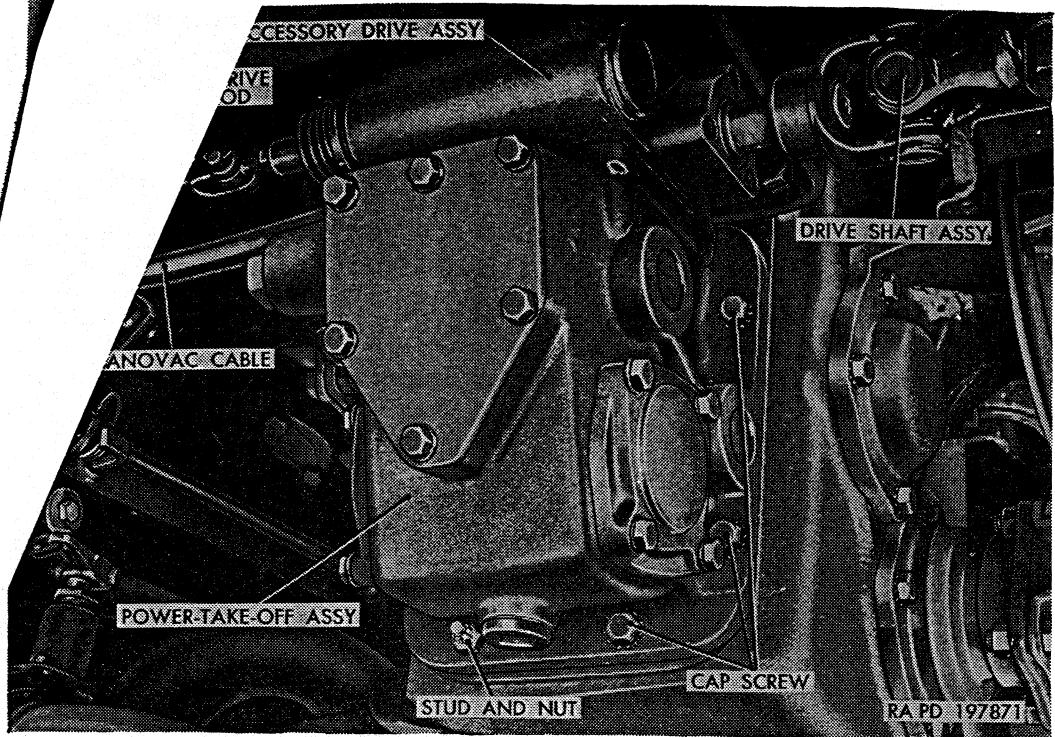

Figure 223. Power-take-off installed (gasoline and water tank pump).

and key. Install and tighten  $\frac{1}{2}$ -13 x  $\frac{1}{2}$  setscrew securing yoke to drive shaft.

*c. Installation of Dump Body Hoist Power-Take-Off (fig. 222).*

- (1) Install power-take-off (b(1) above); then fill transfer with lubricant as directed in paragraph 207c.
- (2) On vehicles equipped with winch, connect drive shaft universal joint to power-take-off (b(4) above). Connect control cable (par. 321c).
- (3) Connect shifting rod to accessory drive shift shaft, using  $\frac{1}{2}$  x  $1\frac{3}{64}$  clevis pin and  $\frac{1}{8}$  x  $\frac{7}{8}$  cotter pin.
- (4) Install one  $\frac{1}{4}$  x  $\frac{7}{8}$  woodruff key in accessory drive shaft. Aline drive shaft yoke keyway with drive shaft key; then tap yoke with soft hammer until in position on shaft. Install and tighten a  $\frac{3}{8}$ -16 x  $\frac{1}{2}$  socket-head setscrew which attaches yoke to shaft. Prick punch head of setscrew to prevent loosening.

*d. Installation of Tank Body Pump Power-Take-Off (fig. 223).*

- (1) Install power-take-off (b(1) above); then fill transfer with lubricant (par. 207c).
- (2) Connect shifting rod to accessory drive shift shaft eye, using  $\frac{3}{8}$  x  $\frac{15}{16}$  clevis pin and  $\frac{3}{32}$  x  $\frac{5}{8}$  cotter pin.
- (3) Insert end of Mechanovac governor control cable into opening in accessory drive; then tighten retaining nut.
- (4) Install pump front propeller shaft as directed in paragraph 345c.

## 214. Accessory Drive Replacement

*a. Removal.* Remove power-take-off and accessory drive assembly from transfer (par. 212). Remove two cap screws and lockwashers, also two stud nuts which attach accessory drive to power-take-off. Remove accessory drive assembly from power-take-off. Remove and discard gasket.

*b. Installation.* Install new gasket over studs on power-take-off. Position accessory drive assembly over studs on power-take-off. Install two  $\frac{3}{8}$ -24 stud nuts, and two  $\frac{3}{8}$ -16 x  $3\frac{3}{4}$  cap screws with  $\frac{3}{8}$ -inch lockwashers. Tighten stud nuts and cap screws evenly and alternately. Install power-take-off and accessory drive assembly to transfer (par. 213).

## Section XX. FRONT AXLE

### 215. Description and Data

*a. Description.*

- (1) *General.* Front axle assembly (fig. 224) is a hypoid, single-reduction-type axle consisting of a housing, differential and carrier assembly, axle shaft and universal joint assemblies, and steering knuckle support assemblies. Power is transmitted from transfer to drive pinion through a tubular propeller shaft. Power is transmitted from drive pinion to drive gear and differential assembly, then to the wheels through axle shaft and universal joint assemblies. Action of universal joints permits delivery of power to the wheels when they are turned from straightahead position. Front axle is automatically engaged and disengaged by action of a jaw-type clutch located in transfer unit. Front axle is disengaged, except when tractive effort is required.
- (2) *Axle housing.* The axle housing is of the conventional one-piece banjo-type with carrier assembly and cover openings near center of housing. The spherical shaped housing outer ends, torque rod brackets, spring seats, and steering knuckle stops are welded to the axle housing. Oil seals are used at outer ends of housing to prevent lubricant loss. External surface of housing outer ends are machined and polished to provide smooth surface for housing outer end oil and dust seals.
- (3) *Axle shaft and universal joint assemblies.* The axle shafts are full-floating-type with constant-velocity universal joints at steering knuckles. Each assembly consists of inner and outer shafts with integral yokes which form a universal joint around five steel balls. Outer shafts are the same for right and left sides and are splined at outer ends to engage drive



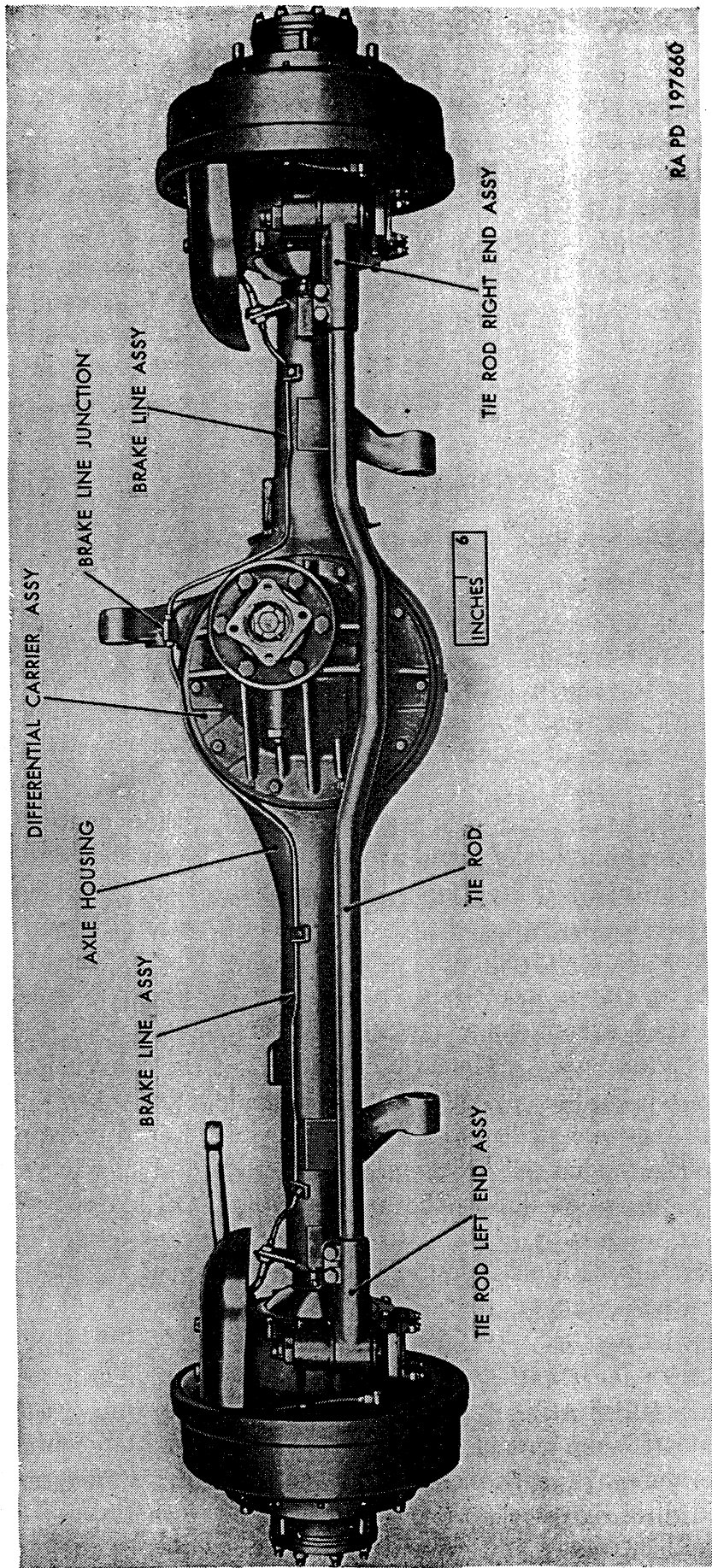

Figure 224. Front axle assembly removed.

flange. Inner shafts are of different lengths and are splined at inner ends to engage side gears at differential. Universal joint assemblies are completely inclosed within the steering knuckle supports.

- (4) *Steering knuckle supports.* Steering knuckle supports are supported at outer ends of housing by tapered roller bearings. Supports are held in position on the bearings by steering knuckle trunnions, which permit steering knuckle supports to turn as front wheels are turned to right or left. Steering arms, to which tie rod ends attach, are integral with steering knuckle supports. Housing outer end oil and dust seals are attached to inner side of steering knuckle supports and are held in place by suitable retainers.
- (5) *Steering knuckles.* Steering knuckles are attached to steering knuckle supports by bolts and lockwashers, which also serve to attach brake backing plate and brake anchor blocks. Steering knuckles act as spindles for mounting wheel hubs and bearings. A brake oil shield is installed at outer side of steering knuckle flange which prevents any escaping lubricant reaching brake linings.
- (6) *Tie rod assembly.* The tie rod is a solid rod, threaded at each end, and double offset to clear the differential carrier assembly. Rod has finer threads (16 per in.) on the left end than on the right end (12 per in.) to permit a finer degree of toe-in adjustment (par. 220). The tie rod is attached to integral arm on each steering knuckle support by a tapered stud installed in each tie rod end. Tie rod is threaded into tie rod ends and held by clamp bolts (and a lock at left end). In addition to controlling toe-in, tie rod also transmits the turning force from the left steering knuckle support to the right steering knuckle support.

*b. Data.*

Type----- hypoid, single-reduction  
 Ratio----- 6.17:1  
 Universal joints----- Bendix-Weiss

**216. Front Axle Alinement**

*a. General.* Front axle alinement factors, such as camber, caster, turning angle, and toe-in have a major effect on steering from the standpoint of control, ease of steering, and safety. Front axle mis-alinement is a major cause of premature and uneven tire wear.

*b. Caster.* Front axle caster (L, fig. 225) is the inclination of the centerline through the upper and lower steering knuckle support trunnion bearings toward the rear of the vehicle. Caster is established by design; therefore no adjustment can be made. The axle is given

this caster angle to provide a castering action at the front wheels when the vehicle is in motion. When the front axle has proper caster, the wheels will tend to point straightahead as long as the vehicle is in motion. Caster angle is affected by a twisted axle housing, loose spring U-bolts, or sagging springs. Insufficient caster will permit front wheels to wander out of straightahead position. Excessive caster will cause hard steering when turning.

*c. Camber.* Camber is the sidewise inclination of the front wheels. Positive camber is the outward inclination of the wheels as viewed from the front of the vehicle; that is, the wheels are farther apart at the top than at the bottom (H-G, fig. 225). Camber is established by design; therefore no adjustment can be made. A bent axle housing, bent steering knuckle, loose steering knuckle support trunnion bearings, or loose wheel bearings will affect camber. Unequal camber will cause vehicle to pull toward side having most camber. Camber may be measured with a square and rule in manner illustrated in figure 225. Camber dimensions given in *f* below are for straight-ahead position only and must be checked with axle installed on vehicle.

*d. Toe-in.* Toe-in is the amount which the front wheels are closer together at the front than at the rear (A-B, fig. 225). An adjustable tie rod, connecting the two steering knuckle supports, is used to adjust toe-in. Camber causes both wheels to tend to turn outward from the vehicle; however, by adjusting tie rod to give wheels proper toe-in, the tendency to turn outward is counteracted and the wheels roll straightahead with no scuffing action on tires. Toe-in is affected by loose wheel bearings, bent axle housing, bent steering knuckle, loose steering knuckle support trunnion bearings, or a bent or improperly adjusted tie rod. Improper toe-in causes excessive tire wear or scuffing. Unequal toe-in may cause the vehicle to pull toward the side having the least toe-in. When wheels are turned from straightahead to either right or left, toe-in changes, until at extreme right or left positions they are farther apart at the front than at the rear. This condition is termed toe-out. Always measure toe-in with wheels in straightahead position, by actually measuring A-B as shown in figure 225 and described in paragraph 220. Toe-in dimensions are given in *f* below.

*e. Turning Angle.* The turning angle is the maximum angle through which the front wheels may be turned to right or left from the straightahead position. This angle is greater for the inside wheel than the outside wheel on a turn. The turning angle for the inside wheel is shown as C, figure 225, and the turning angle for the outside wheel is shown as D, figure 225. Stop plugs, threaded and welded in housing, are provided to limit the angle through which the inside wheel can turn. Refer replacement and adjustment of stop plugs to ordnance maintenance personnel.

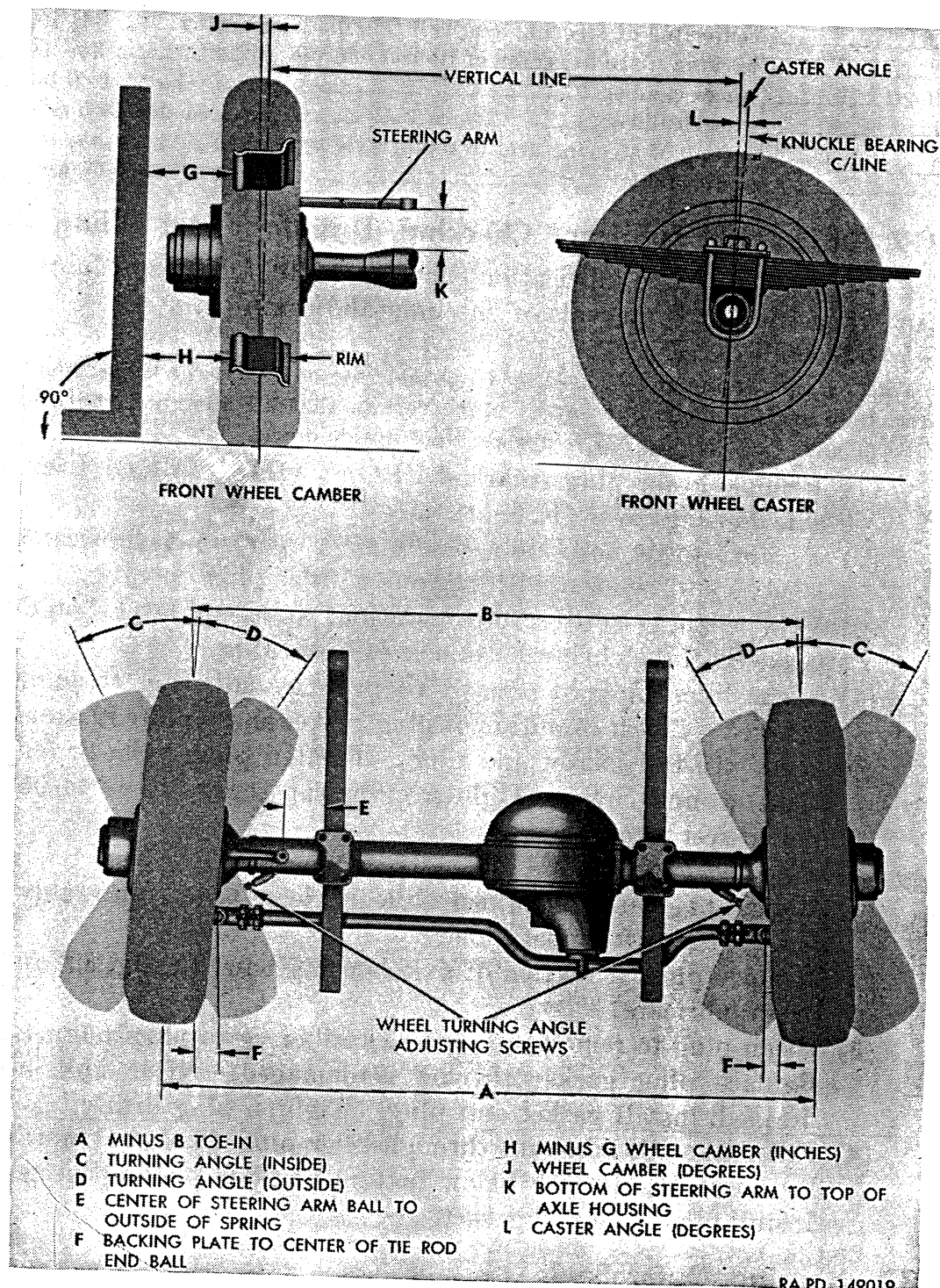

Figure 225. Front wheel and axle alignment chart.

*ment Data.*

-----	toe-in (at hub C/L)-----	5/32 to 7/32 in.
-----	turning angle—inside-----	28 deg+1 deg-0 deg
-----	turning angle—outside-----	26 deg
-----	centerline of steering arm ball to outside of spring-----	3 1/4 in.
-----	backing plate to center of tie rod end pin-----	3 1/4 in.
H-G-----	wheel camber-----	27/64 in. to 0 in.
J-----	wheel camber-----	3/4 deg to 0 deg
K-----	bottom of steering arm to top of axle housing-----	3 1/2 in.
L-----	caster angle-----	1 deg 45 min.

## 217. Differential Lubricant Checking, Draining, and Filling

*a. General.* Refer to lubrication chart (par. 69) for type of lubricant, capacities, and intervals of checking and draining.

*b. Checking Level.*

*Note.* Axle housing covers used on front and rear axles are the same; however, they are installed differently. Make certain that oil filler hole marked FRONT OIL LEVEL (fig. 82) is upright—not upside down.

- (1) Remove lower plug (marked FRONT OIL LEVEL) from axle housing cover (R, fig. 82).
- (2) If lubricant is hot (immediately after operation), lubricant level should be even with bottom of filler plug opening.
- (3) If lubricant is cold (before operation), lubricant level should be one-half inch below bottom of plug opening.
- (4) Clean filler plug to remove all particles adhering to plug magnet. Check condition of plug gasket and replace if damaged. Install gasket and plug. Tighten plug. Check for leaks around cover. Tighten cover cap screws to 45 to 55 pound-feet torque.

*c. Draining and Filling.*

- (1) Lubricant should be drained while lubricant is hot, preferably immediately after operation.
- (2) Remove plug at bottom of axle housing bowl (S, fig. 82) to drain lubricant.
- (3) Clean plug to remove all particles adhering to plug magnet. Replace plug gasket if part is damaged. After unit is drained, install gasket and plug. Tighten plug firmly.
- (4) Fill unit with lubricant through filler plug (*b* above) until level is one-half inch below bottom of filler plug opening. Install filler plug and gasket.

## 218. Housing Outer Seals

(fig. 226)

*a. General.* Axle housing outer seals are installed on inner side of each steering knuckle support around spherical surface of axle housing outer end. Each assembly consists of a gasket (G), oil seal outer retainer (F), felt oil seal (E), dust seal spring (D), dust seal (C),

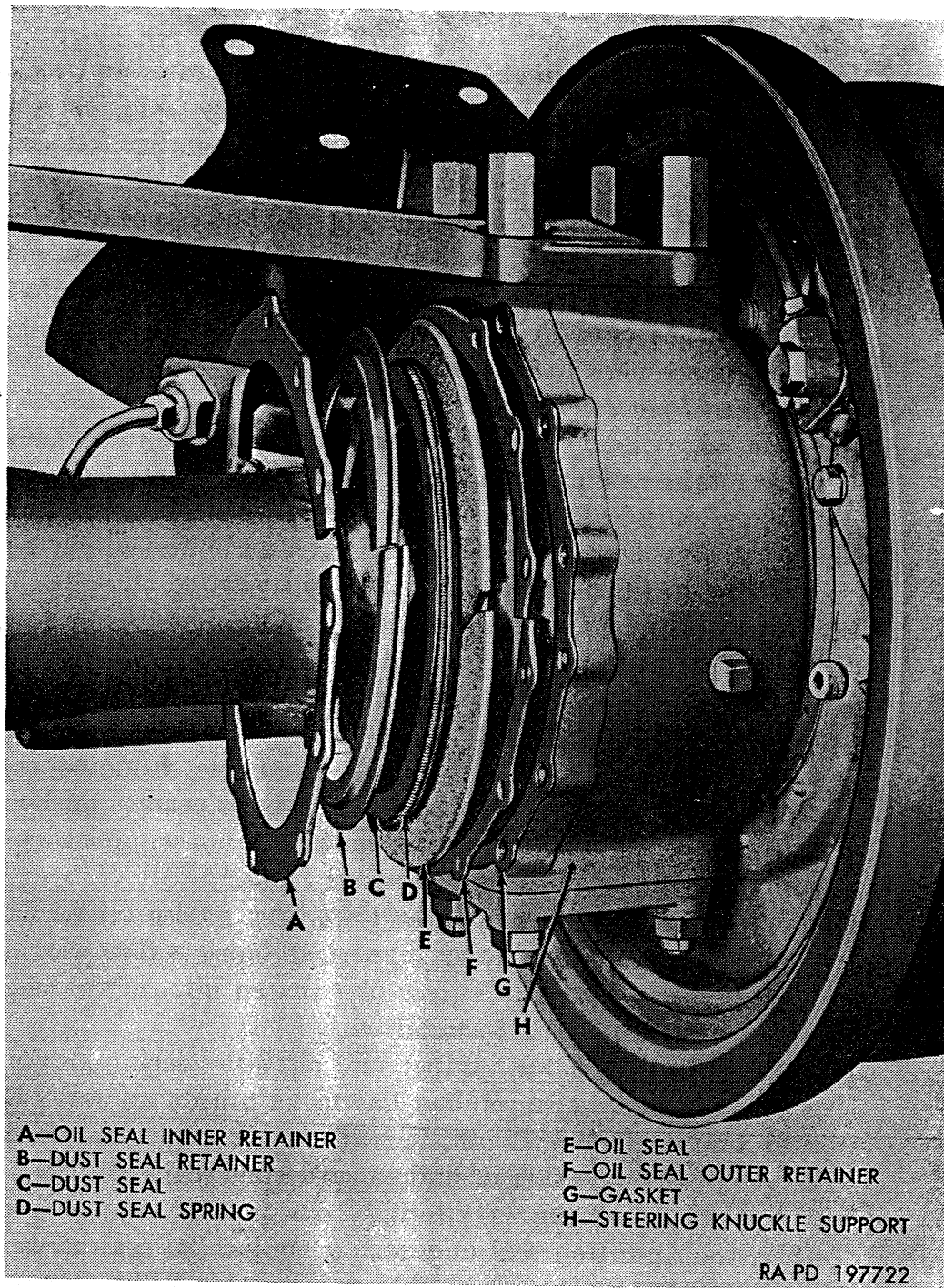

*Figure 226. Housing outer seal components.*

dust seal retainer (B), and oil seal inner retainers (A). The oil seal (E) is composition of felt and neoprene to prevent leakage of lubricant. The dust seal (C) is spring-loaded and bears tightly against spherical surface. When seals are in good condition and properly installed, lubricant leakage is prevented and entrance of dirt, water, or other contaminants is prevented. The dust seal (C) and dust seal spring (D) cannot be replaced without partial disassembly of axle; however the oil seal (E) and retainers are split and can be replaced with axle installed.

*inner retainers.* Remove 12 cap screws and lock-attaching two oil seal inner retainers (A), dust seal (B), and oil seal outer retainer (F) and gasket (G) to steering knuckle support (H). Discard gasket.

*oil seal.* Felt oil seal (E) is split and can be replaced in two parts. Dust seal (neoprene) (C) and dust seal spring (D) are not split and cannot be replaced at this time.

Report worn or damaged dust seal and spring to ordnance maintenance personnel.

*c. Cleaning and Inspection.*

- (1) *Cleaning.* Clean steering knuckle support (H) and oil seal outer retainer (F) to remove all gasket material. Clean axle housing spherical surface and retainers, using dry-cleaning solvent or volatile mineral spirits. Clean spherical surface with fine crocus cloth if surface is slightly pitted or rusty.
- (2) *Inspection.* Inspect dust seal (C) to determine if continued use is advisable. Report all worn or damaged conditions to ordnance maintenance personnel.

*d. Installation.*

- (1) Install new gasket (G) to steering knuckle support (H), using small quantity of plastic-type gasket cement on both sides of gasket; then position gasket on steering knuckle support with split in gasket toward front.
- (2) Apply a film of automotive and artillery grease (GAA) to spherical surface of housing, oil seal, and dust seal to provide initial lubrication when unit is first placed into service; also as a preservative after installation.
- (3) Position oil seal outer retainer (F) against steering knuckle support with split in retainer at top. Position oil seal (E) into retainer (F) with split in seal at right angles to split in retainer, and felt side of seal toward spherical ball.
- (4) Fit dust seal spring (D) into groove in edge of dust seal (C); then position seal and spring against oil seal as dust seal retainer (B) is positioned to retain seals. While holding dust seal retainer against seals, install two oil seal inner retainers (A) with splits on a horizontal line.

Align splits in the gasket (G), oil seal outer retainer (F), dust seal retainer (B), and oil seal inner retainer (A) when assembled.

Install 18 x 5/8 cap screws and 5/16-inch lockwashers. Tighten lockwashers just tight enough to hold parts in place. Retainers are in proper position as explained above; then make final tightening of cap

Fasten  
each set of  
outer retainers  
retainer (A)

405

## 219. Tie Rod

### a. Removal.

- (1) Place vehicle on a level surface and apply parking brake. Place a jack under front axle and raise enough to take weight of vehicle off front wheels.
- (2) Loosen two tie rod end clamp screw nuts at each end of tie rod; then remove inner clamp screws and nuts; also lock (fig. 227) at tie rod left end. Remove tie rod end stud nut at each end of tie rod. Tap steering knuckle support arm a sharp blow with hammer as downward pressure is applied to tie rod end with pinch bar. Move each tie rod end down, and at same time twist forward until free from steering

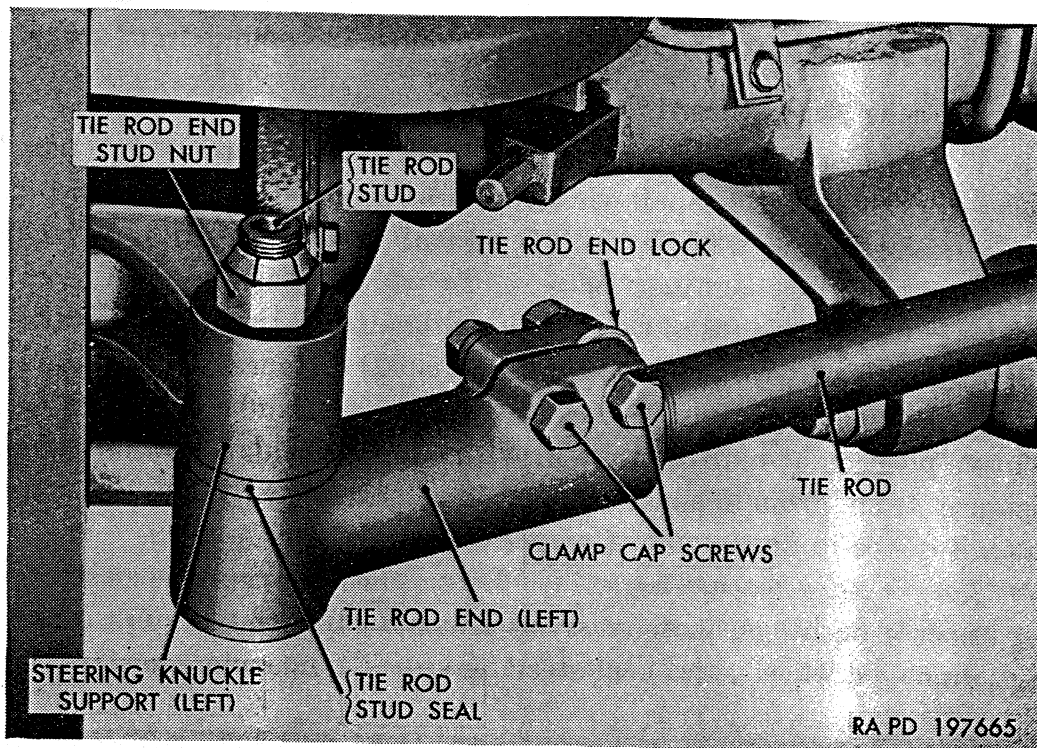

Figure 227. Tie rod installed (left side shown).

knuckle support arm. Remove tie rod ends when both ends are free. Remove and discard tie rod stud seals if deteriorated or damaged.

### b. Installation.

- (1) Thread tie rod ends onto tie rod an equal distance. Each tie rod end will engage tie rod a distance of 3 inches when in approximately correct location.
- (2) Carefully measure distance between centerline of tie rod end studs; then thread tie rod ends on or off until dimension is  $62\frac{17}{32}$  inches. This dimension will approximate correct toe-in after tie rod is installed.



- (3) Install two  $\frac{1}{2}$ -20 x  $2\frac{1}{2}$  cap screws and  $\frac{1}{2}$ -20 nuts used to clamp tie rod ends to tie rod. Also install tie rod lock at tie rod end (left) (fig. 227). Do not final tighten cap screw nuts until toe-in check is made.
- (4) Place tie rod stud seal (fig. 227) over each tie rod stud. Position tie rod assembly with end having coarse threads to right, and end with lock to the left. Insert tie rod end studs into tapered holes in support arms. Install  $\frac{7}{8}$ -14 safety nut on each tie rod end stud. Do not final tighten nuts.
- (5) Check and adjust toe-in (par. 220).
- (6) After toe-in adjustment has been made, final tighten tie rod end clamp screw nuts to 48 to 64 pound-feet torque. Final tighten tie rod end stud nuts to 85 to 125 pound-feet torque.

## 220. Toe-In Adjustment

*a. Toe-In Check* (fig. 228). Inflate tires to correct pressure (par. 258*b*) and check for proper wheel bearing adjustment (par. 265*a*); then position vehicle with the wheels in straightahead position. Place a toe-in wheel alinement gage between the wheels ahead of the axle at hub height with the ends of the gage bearing against the tire side walls and with ends of both pendant chains an equal distance from ground. Set gage so pointer registers zero. Remove gage and place at same relative position at rear of tire and with ends of pendant chains same distance from ground as at front. The pointer will indicate the amount of toe-in or toe-out. Correct toe-in is  $\frac{5}{32}$  to  $\frac{7}{32}$  inch.

*b. Toe-In Adjustment* (fig. 227). Loose wheel bearings, worn steering knuckle bushings, loose steering knuckle support trunnion bearings, damaged wheels, and bent steering knuckle, housing, and tie-rod

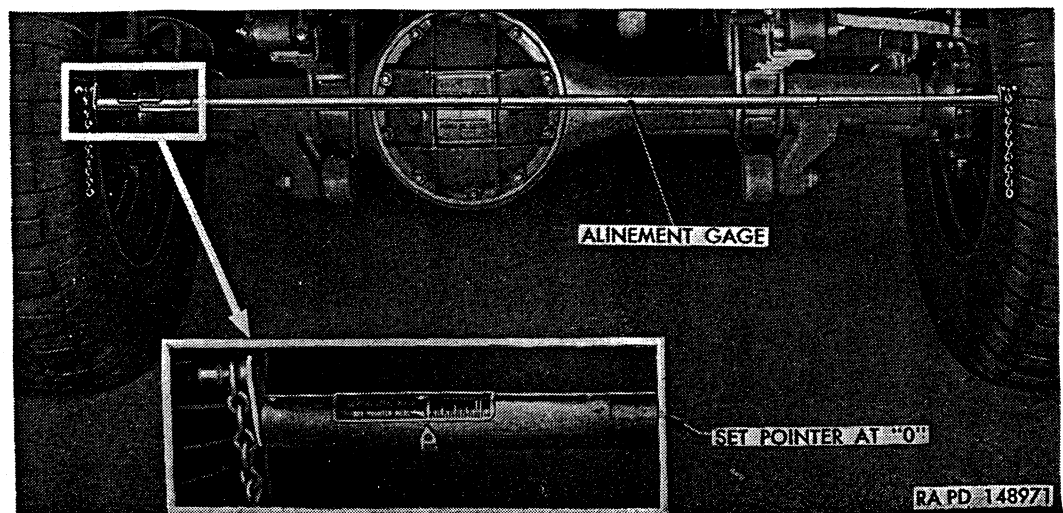

Figure 228. Checking toe-in.

will affect toe-in. Replace damaged parts and adjust wheel bearings (par. 265b) before adjusting the tie rod to correct toe-in.

- (1) *Remove tie-rod.* Position vehicle with wheels in straight-ahead position. Remove tie rod (par. 219a).
- (2) *Adjust tie-rod.* Loosen tie rod end clamp screw nuts at each end of tie rod. Remove inner clamp screws and tie rod end lock at left side. Screw tie rod ends onto or off tie rod to obtain correct toe-in.

*Note.* Tie rod right end has coarse threads, while tie rod left end has fine threads. This construction permits finer adjustment than would be possible if both ends were the same. Toe-in will be changed about one-eighth inch by each revolution of right (coarse thread) end, and slightly less by turning left (fine thread) end. In some instances, it may be necessary to adjust both ends to obtain correct toe-in.

- (3) *Check adjustment.* Temporarily install ends on steering knuckle supports. Measure toe-in (*a* above). Readjust if necessary. Install tie rod (par. 219b).

## **221. Axle Shaft and Universal Joint Assembly Replacement**

*a. Coordination with Ordnance Maintenance Unit.* Refer to paragraph 2 for information on coordination with an ordnance maintenance unit.

### *b. Removal.*

- (1) *Remove wheel.* Jack up axle; then remove wheel stud nuts, and remove tire and wheel assembly.
- (2) *Remove drive flange.* Remove eight stud nuts attaching drive flange to hub. Strike hub a sharp blow with a soft hammer to loosen tapered split dowels; then remove dowels from studs. Thread two  $\frac{1}{2}$ -20 cap screws into the tapped holes in drive flange. Turn screws in evenly and alternately until flange is removed. Remove and discard flange to hub gasket.
- (3) *Remove hub and drum.* Remove wheel hub and brake drum assembly (par. 266a).
- (4) *Loosen brake hose shield.* Remove three cap screws and lockwashers attaching brake hose shield to top of steering knuckle support to permit utilizing full length of brake flexible hose when brake backing plate and shoe assembly is removed.
- (5) *Remove brake backing plate and shoe assembly.* Remove 12 retaining screws and lockwashers attaching brake backing plate (fig. 229) to steering knuckle. Observe installed position of backing plate so that it can be reinstalled in its original location. Mark backing plate. Remove backing plate and shoe assembly from steering knuckle and swing over end of steering knuckle (fig. 230).

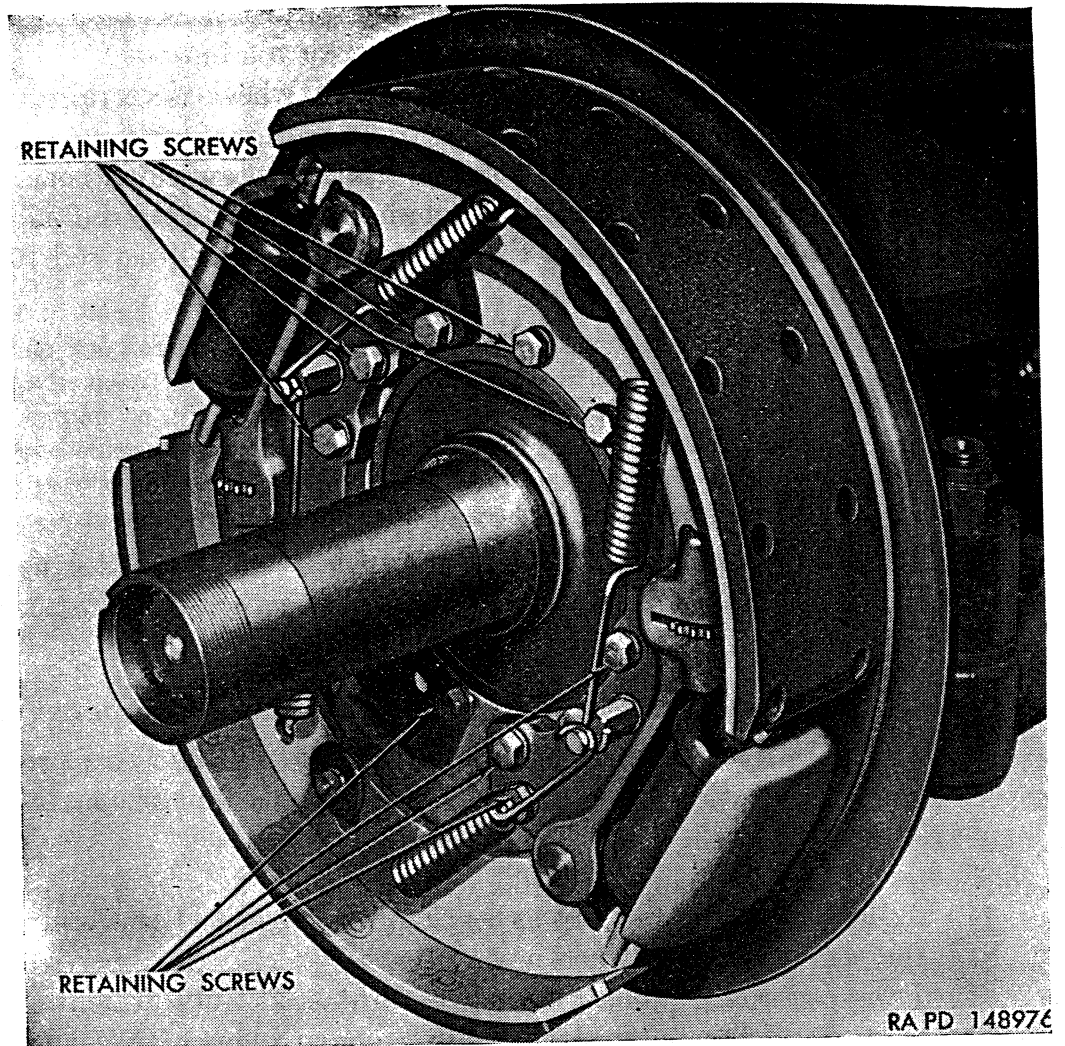

Figure 229. Brake backing plate and shoe assembly installed.

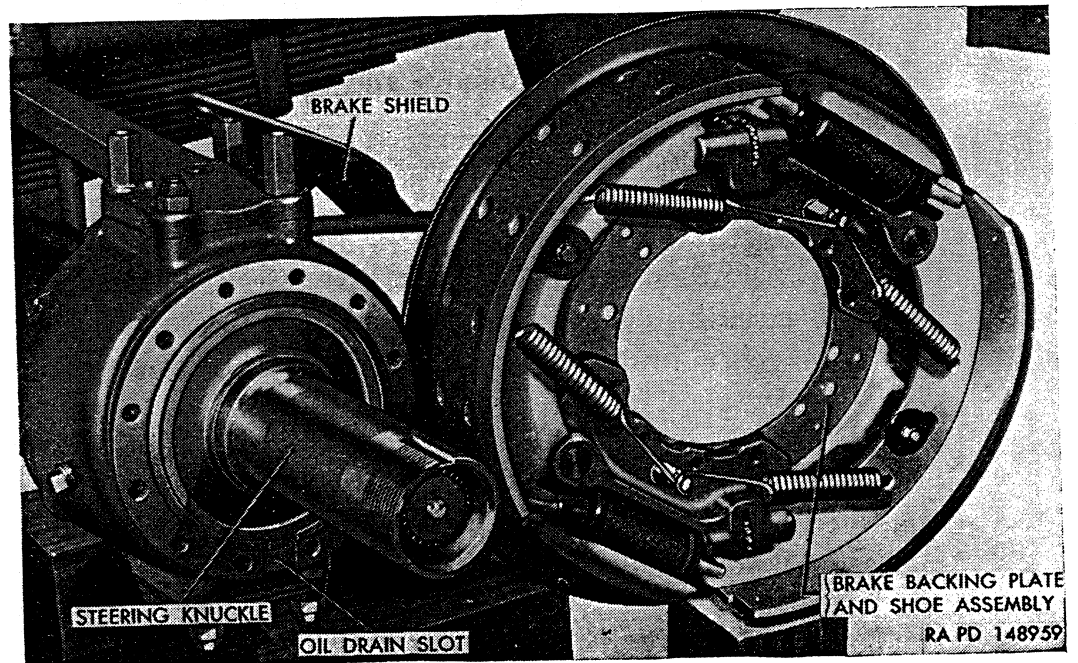

Figure 230. Brake backing plate and shoe assembly removed showing steering knuckle.

- (6) *Remove steering knuckle.* Tap steering knuckle with soft hammer as shown in figure 231 to loosen from steering knuckle support; then remove steering knuckle. Remove old gasket from steering knuckle and knuckle support.
- (7) *Remove axle shaft and universal joint.* Pull assembly straight out (fig. 232) as assembly is supported to avoid damage to axle shaft oil seal in housing.

c. *Cleaning, Inspection, and Lubrication.*

- (1) *Cleaning.* Thoroughly wash axle shaft and universal joint in dry-cleaning solvent or volatile mineral spirits to remove all old lubricant; also wash inside of steering knuckle support, steering knuckle, and housing outer end.
- (2) *Inspection.* Inspect balls and ball races for grooved, scratched, or pitted condition. To determine if excessive play or backlash exist in the universal joint, place the assembly in a vise having soft jaws, in a vertical position with the outer (short) shaft up, and with vise jaws gripping the inner shaft below the universal joint. Firmly push down on outer shaft so that it rests on center ball, and at the same time attempt to twist the joint in both directions. If any play or

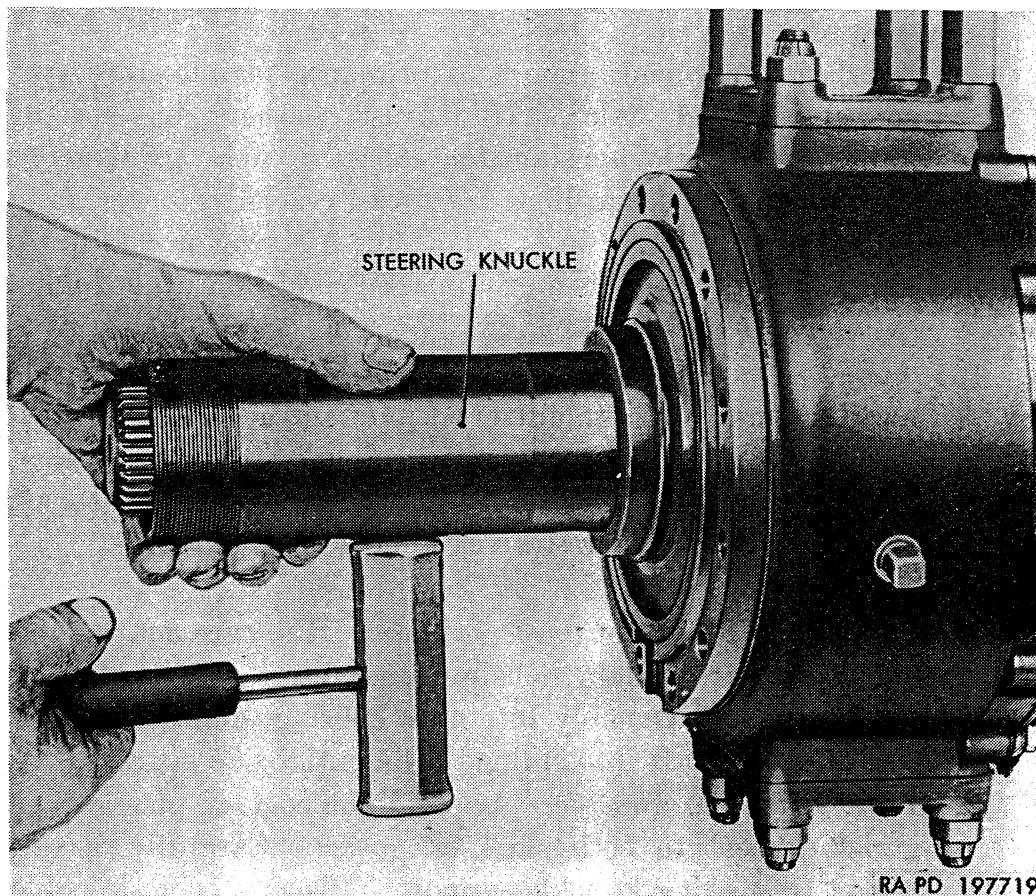

Figure 231. *Removing steering knuckle.*

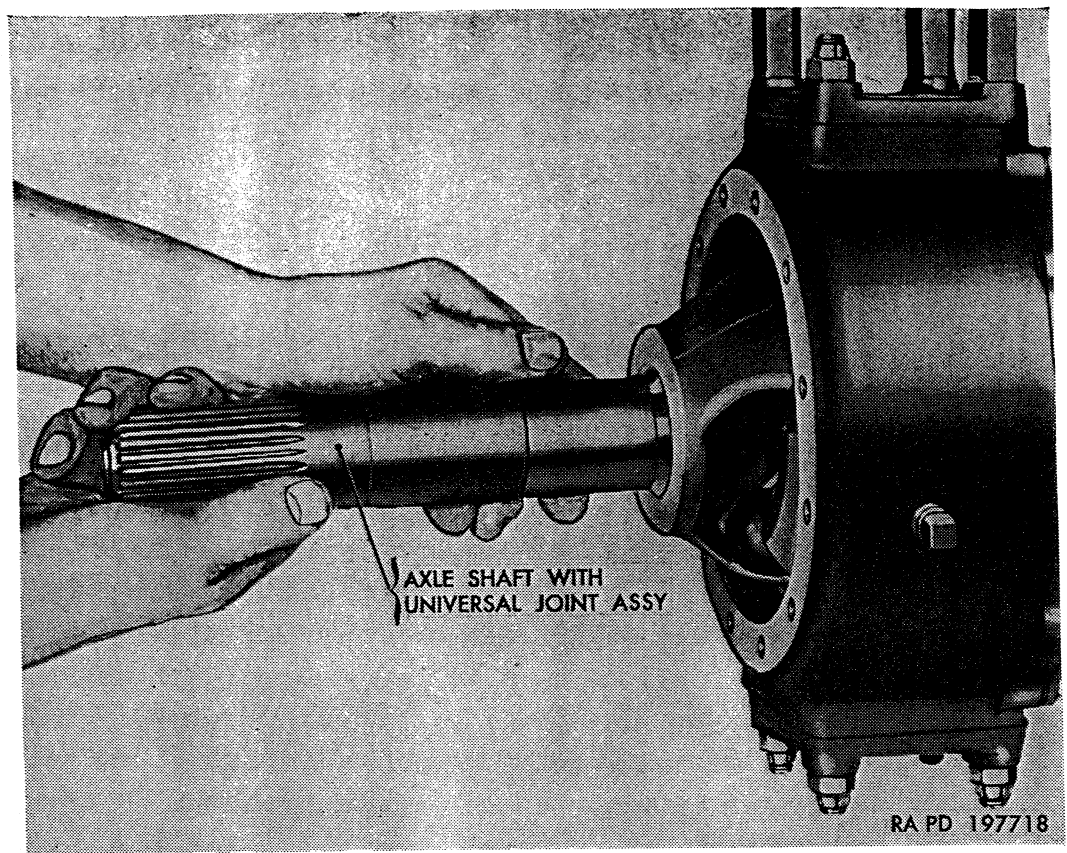

Figure 232. Removing or installing axle shaft and universal joint assembly.

backlash is evident, report to ordnance maintenance personnel. Inspect axle shaft thrust washers in steering knuckle and axle housing for excessive wear or damage. Examine axle shaft splines for nicks, cracks, or other damage. Inspect oil seal in axle housing for wear or cuts in lip of seal. Report all worn or damaged conditions to ordnance maintenance personnel.

- (3) *Lubrication.* Using universal gear lubricant (GO), pack new lubricant well into universal joint and around balls until it fills all space between balls and universal joint yokes. Also spread lubricant on surfaces which contact thrust washers and bushing in steering knuckle.

*d. Installation.*

- (1) *Install axle shaft and universal joint.* Use care not to damage axle shaft seal in housing, and insert axle shaft and universal joint assembly into axle housing, guiding splined end of inner shaft into splined differential side gear.
- (2) *Install steering knuckle.* Apply light coat of plastic-type gasket cement to both sides of gasket. Carefully install gasket to steering knuckle support. Place steering knuckle

over outer end of axle shaft and position against steering knuckle support with bolt holes in alinement.

*Note.* Milled oil drain slot (fig. 230) in steering knuckle flange must be at the bottom as shown.

- (3) *Install brake backing plate and shoe assembly.* Swing backing plate and shoe assembly over end of steering knuckle (fig. 230) and into place against steering knuckle, being sure plate is properly located as noted at time of removal. Aline bolt holes in plate with those in steering knuckle. Apply liquid-type gasket cement to female threads of steering knuckle and to threads of retaining bolts to insure a leakproof fit. Install four  $\frac{3}{8}$ -16 x  $1\frac{5}{16}$  bolts and  $\frac{3}{8}$ -inch lockwashers through brake backing plate and steering knuckle flange. Install eight  $\frac{3}{8}$ -16 x  $1\frac{11}{16}$  bolts and  $\frac{3}{8}$ -inch lockwashers through anchor block, backing plate, and steering knuckle flange. Tighten all 12 bolts to 27 to 30 pound-feet torque. Install brake flexible hose shield at top of steering knuckle arm studs, using three cap screws and lockwashers. Tighten cap screws.
- (4) *Install hub and drum.* Install wheel hub and brake drum assembly (par. 266g) and adjust hub bearings (par. 265b).
- (5) *Install drive flange.* Install drive flange over splined outer end of axle shaft, using a new gasket between flange and hub. Aline holes in flange with hub studs; then push flange in against hub. Install eight split tapered dowels and  $\frac{1}{2}$ -20 safety nuts on studs and tighten nuts to 55 to 65 pound-feet torque. When nuts have been tightened, inspect for slight clearance (approx.  $\frac{1}{16}$  in) between nut and flange. If no clearance exists, it indicates that dowels, tapered holes in flange, or studs are worn excessively and must be replaced with new parts.
- (6) *Install wheel.* Install wheel and tire on hub (par. 259c).

*e. Record of Replacement.* Record the replacement on DA Form 478.

## 222. Front Axle Assembly Replacement

(figs. 224 and 233)

*a. Coordination with Ordnance Maintenance Unit.* Refer to paragraph 2 for information on coordination with an ordnance maintenance unit.

*b. General.* Front axle assembly includes front axle housing, differential and carrier assembly, axle shaft and universal joint assemblies, steering knuckle support assemblies, hub and drum assemblies, tie rod with ends assembly, and brake line assemblies.

*c. Removal.*

- (1) *Position vehicle.* Place vehicle in a level surface and apply parking brake, or place blocks on each side of rear wheels to prevent vehicle rolling. Place a jack under front axle and raise front end of vehicle high enough to permit withdrawing axle. Place blocks under frame side members at rear of front spring hanger brackets. Lower jack until entire front end weight rests on blocks.
- (2) *Remove wheels.* Remove wheel stud nuts, and remove wheel and tire from each side.
- (3) *Disconnect propeller shaft.* Remove four bolts and nuts attaching propeller shaft universal joint flange to differential pinion flange. Tie propeller shaft up to prevent universal joint becoming damaged or filled with dirt.

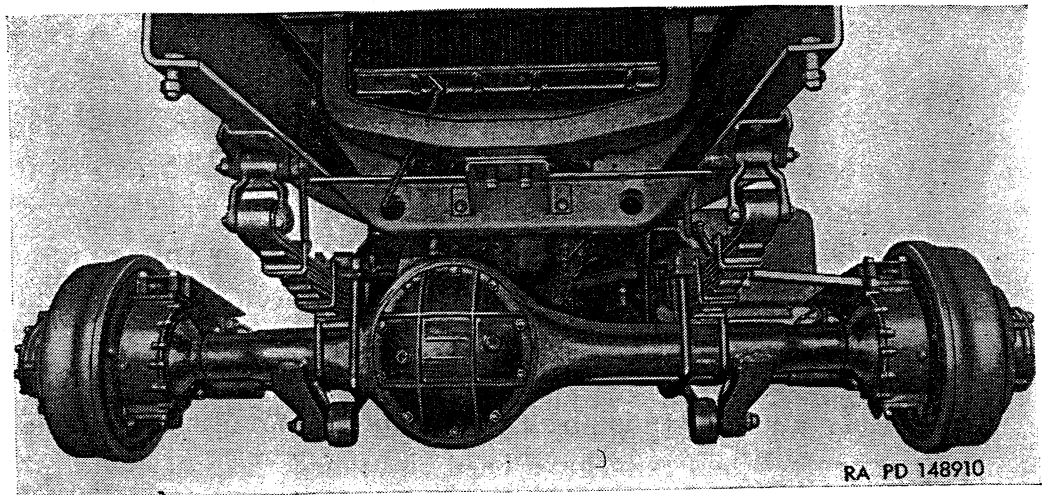

*Figure 233. Front axle assembly installed.*

- (4) *Disconnect drag link.* Remove nut at steering arm end of drag link. Use pry bar between steering arm and drag link; then strike arm a sharp blow with hammer to loosen tapered pin from arm.
- (5) *Disconnect lower torque rods.* Remove nuts and washers from torque rod end pins; then use soft metal hammer to drive pins from axle brackets.
- (6) *Disconnect shock absorber links.* Remove nut and disconnect shock absorber link from spring bumper block at each side of vehicle.
- (7) *Remove spring U-bolts.* Remove nuts from two spring U-bolts at each side of vehicle; then remove U-bolts.
- (8) *Disconnect flexible hose.* Lower jack under axle for better accessibility; then disconnect hydraulic brake and axle vent flexible hose at junction block on top of axle housing.

- (9) *Disconnect upper torque rod.* Remove nut and washer from torque rod end pin; then use soft metal hammer to drive pin from axle bracket.

**Caution:** Be sure axle is safely supported to prevent rolling off jack and resulting in injury to personnel.

- (10) *Remove axle assembly.* Lower jack until axle assembly clears under side of chassis and withdraw from under vehicle.

*d. Installation.*

- (1) *Position axle assembly.* Place axle assembly on dolly jack and move into position under vehicle.
- (2) *Connect upper torque rod.* Insert upper torque rod tapered pin into axle bracket and install nut and washer. Do not tighten nut.
- (3) *Connect flexible hose.* Connect hydraulic brake and axle vent flexible hose at junction on top of axle housing with two connector bolts and four new copper washers. Use one washer on each side of connector. Tighten connector bolts to 20 to 30 pound-feet torque.
- (4) *Connect axle to springs.* Lift axle until spring center bolt is located in hole of spring seat on top of axle. Install **U**-bolts and spring bumper block with shock absorber link eye at front. Install **U**-bolt nuts and tighten nuts to 170 to 200 pound-feet torque.
- (5) *Connect shock absorber links.* Install shock absorber link stud in spring bumper block and install nut. Tighten nut to 48 to 64 pound-feet torque.
- (6) *Connect lower torque rods.* Insert lower torque rod end pins into axle brackets and install washers and nuts. Tighten nuts on upper and lower torque rod end pins to 350 to 400 pound-feet torque.
- (7) *Connect drag link.* Install drag link tapered stud in steering arm and install nut. Tighten stud nut to 75 to 100 pound-feet torque. Install  $\frac{1}{8}$  x  $1\frac{3}{8}$  cotter pin.
- (8) *Connect propeller shaft.* Position propeller shaft joint flange to differential pinion flange and install four bolts and four  $\frac{7}{16}$ -20 safety nuts attaching these two flanges. Tighten nuts to 33 to 43 pound-feet torque.
- (9) *Install wheels.* Install wheels on hub (par. 259c).
- (10) *Bleed brakes.* Perform brake bleeding operation (par. 237).
- (11) *Lubricate.* Check lubricant level in axle differential and universal joints at outer end of housing. Check for lubricant leaks around housing cover. Tighten cover stud nuts to 45 to 55 pound-feet torque.
- (12) *Remove blocks and jack.* Raise front of vehicle with jack sufficiently to permit removal of blocks from under frame side



members. Lower jack and withdraw from under vehicle. Re-  
 spring U-bolt nuts for 170 to 200 pound-feet torque with  
 weight of vehicle resting on springs.  
*ord of Replacement.* Record the replacement on DA Form

## Section XXI. REAR AXLE

### 223. Description and Data (fig. 234)

*a. Description.*

(1) *General.* Both rear axles are hypoid, single-reduction-type, consisting of a housing, differential and carrier assembly, and axle shafts. Forward rear axle and rear rear axle are mounted in tandem with upper and lower torque rods connecting each axle to vehicle frame. The two rear axles are similar in design and construction; the major difference between the two is that the opening for the differential carrier in the forward rear axle is off-center. Power is transmitted from the transfer by two propeller shafts, one to each of the rear axles. Forward rear axle is driven direct from transfer by a single shaft, while drive to rear rear axle is through two propeller shafts and a pillow block mounted on a bracket attached to forward rear axle housing.

(2) *Axle housing.* Axle housings are conventional one-piece banjo-type. The carrier assembly and rear cover openings are in center of housing on rear rear axle, while the openings are offset near left side on forward rear axle. Ribbed cast rear covers provide maximum strength and accessibility to differential. Flanges which support brake assemblies are welded to outer ends of housings. External surfaces of housing outer ends are machined to provide accurate surfaces for mounting hub bearings. Spring pads and torque rod brackets are welded to axle housings; in addition, forward rear axle has a welded flange which supports pillow block.

(3) *Mounting.* Driving force is transmitted from axles to vehicle frame by six torque rods. Three torque rods are attached to each axle and take all driving and braking load at rear axles. Vehicle's load is transmitted to axles through main and secondary springs which are anchored to vehicle frame, with the spring ends riding on slipper-type brackets welded on axle housings.

*b. Data.*

Type of differential----- hypoid, single-reduction  
 Ratio----- 6.17 : 1  
 Type of axle shafts----- full-floating

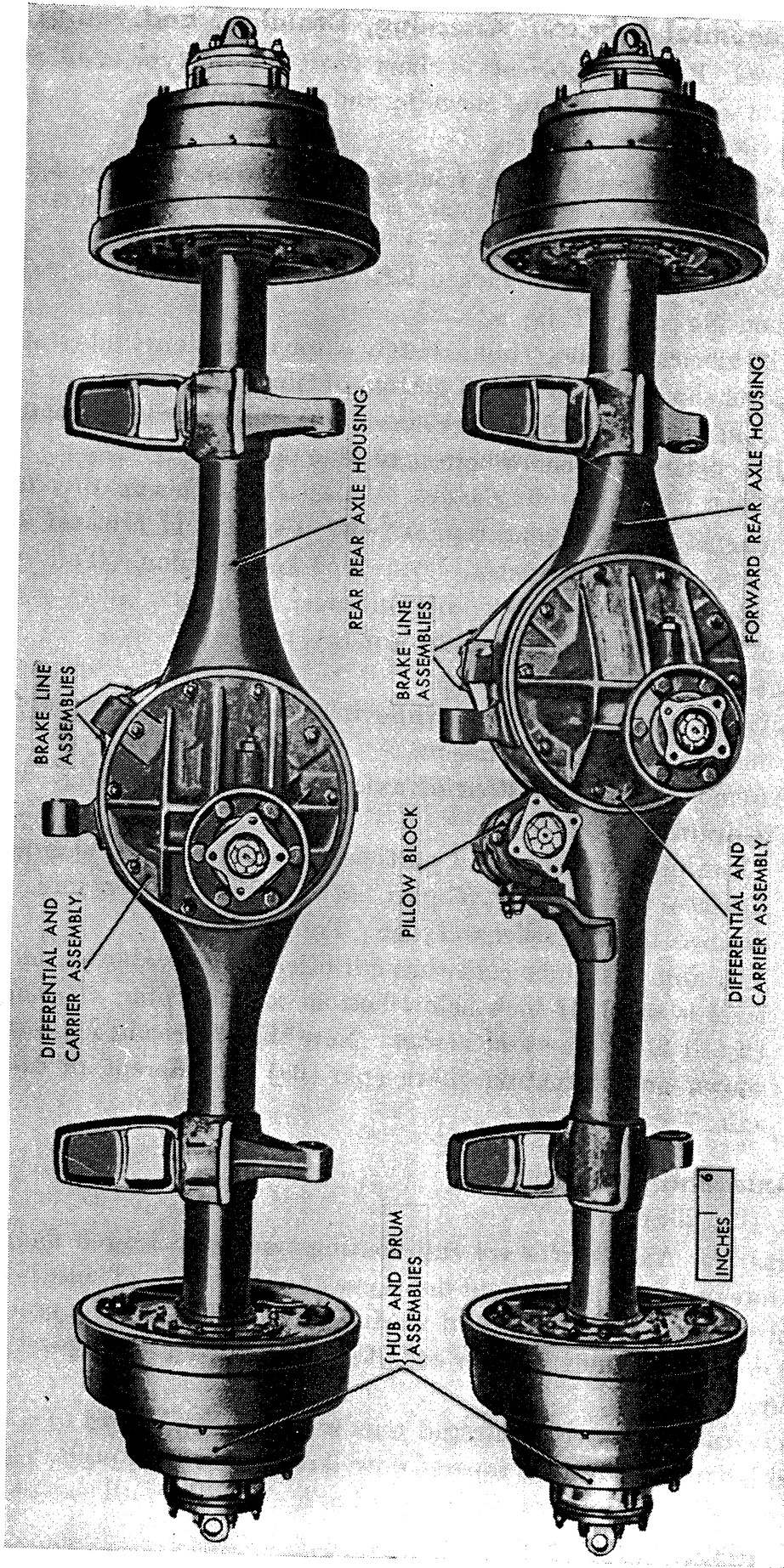

RA PD 197652

Figure 234. Forward and rear rear axle assemblies removed.

## \* Checking, Draining, and Filling

on chart (par. 69) for type of lubricating and draining.

and rear axles are the same; however, be certain that oil filler hole marked *a*, not upside down.

**223.** Marked REAR OIL LEVEL from axle (fig. 82).

*a* (immediately after operation), lubricant level should be even with bottom of plug opening.

If lubricant is cold (before operation), lubricant level should be one-half inch below bottom of plug opening.

Remove filler plug to remove all particles adhering to plug magnet. Check condition of plug gasket. If crushed or damaged, replace gasket. Install gasket and plug. Tighten plug. Check for leaks around cover. Tighten cover stud nuts to 45 to 55 pound-feet torque.

### *Draining and Filling.*

- (1) Unit should be drained while lubricant is hot, preferably immediately after operation.
- (2) Remove plug at bottom of axle housing bowl (U, fig. 82) to drain lubricant.
- (3) Clean plug to remove all particles adhering to plug magnet. Replace plug gasket if part is damaged. After unit is drained, install gasket and plug. Tighten plug.
- (4) Fill unit with lubricant through filler plug (*b* above) until level is one-half inch below bottom of filler plug opening. Install filler plug and gasket. Note that lubricant capacity shown on lubrication chart (par. 69) is different in each axle.

## **225. Axle Shafts**

(fig. 235)

*a. General.* Axle shafts are full-floating-type with forged flange having integral lifting-and-hold-down eye at outer end, and splines at differential end. Flanged end of shaft is attached to hub by studs, tapered dowels, and nuts. Inner end of shaft is splined to differential side gear.

*b. Removal.* Remove eight stud nuts at hub. Strike end of axle shaft with hammer to loosen tapered dowels; then remove dowels. Insert small steel bar through eye in end of axle shaft and pull shaft out of axle. Remove and discard gasket.

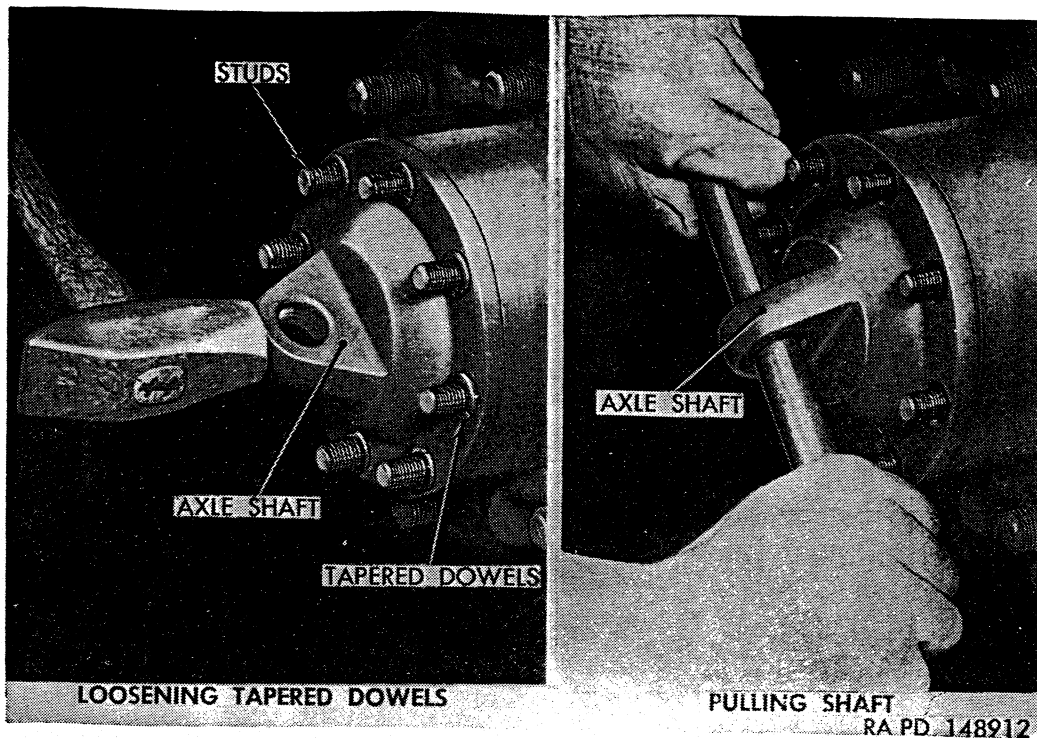

Figure 235. Removing axle shaft.

*c. Cleaning and Inspection.*

- (1) *Cleaning.* Clean axle shafts of all accumulated grease and dirt. Be sure splines are cleaned thoroughly. Remove all gasket particles from inside of flange.
- (2) *Inspection.* Inspect axle shafts for twisted, worn, or damaged splines. Inspect tapered dowel holes in flange of axle shaft for evidence of excessive wear by fitting new dowel in each hole.

*d. Installation.* Install new paper gasket over studs on hubs. Dip splined end of axle shaft in axle lubricant. Insert splined end into hub, guiding splines into differential side gear. Rotate shaft or wheel hub as necessary to aline hub studs with holes in shaft flange; then press shaft into place. Install split tapered dowel and  $\frac{1}{2}$ -20 safety nut on each stud and tighten nuts to 55 to 65 pound-feet torque. There should be slight clearance (approx.  $\frac{1}{16}$  in.) between nut and shaft flange. If no clearance exists, or if studs, dowels, or holes in flange are worn excessively, new parts must be installed.

## 226. Forward Rear Axle Replacement

*a. Coordination with Ordnance Maintenance Unit.* Refer to paragraph 2 for information on coordination with an ordnance maintenance unit.

*b. General.* Forward rear axle assembly includes axle housing, differential and carrier, axle shafts, hub and drum assemblies, and brake line assemblies. Pillow block is also removed and installed with the axle assembly (fig. 234).

c. *Removal* (fig. 236).

- (1) *Position vehicle.* Place vehicle on a level surface and block front wheels to prevent vehicle rolling. Place a jack under axle and raise vehicle until tires are off the ground.
- (2) *Remove wheels.* Remove wheels and tires from each side (par. 259b).
- (3) *Block vehicle.* Place blocks under torque rod support bracket at spring seat on each side to support vehicle after axle is removed.
- (4) *Disconnect flexible hose.* Disconnect hydraulic brake and axle vent flexible hose at junction block on top of axle housing.

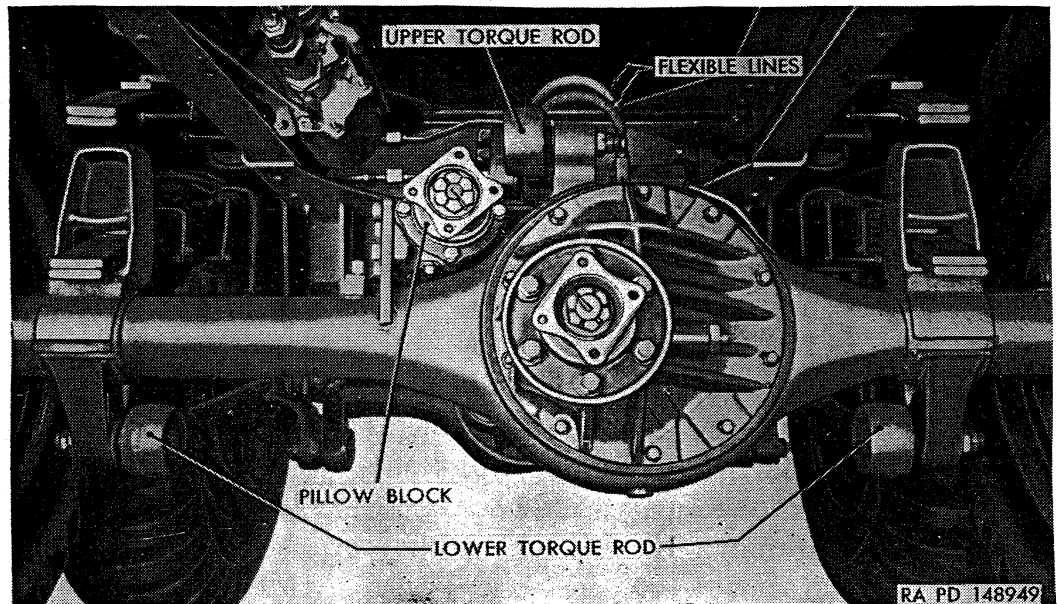

Figure 236. Forward rear axle installed.

- (5) *Disconnect propeller shafts.* Remove four bolts and nuts attaching propeller shaft universal joint flange to differential pinion flange. Remove bolts and nuts attaching propeller shafts to each end of propeller shaft pillow block on top of axle housing.
- (6) *Loosen torque rods.* Remove nuts and washers from three torque rod end pins; then use soft metal hammer to loosen torque rod end pins in axle brackets.
- (7) *Disconnect torque rods.* Remove torque rod end pins from each axle bracket.

**Caution:** Be sure axle is safely supported to prevent rolling off jack and resulting in injury to personnel.

- (8) *Remove axle.* Lower axle with jack and pull forward as necessary to disengage main spring ends from axle brackets; then completely remove axle assembly from under vehicle.

- (9) *Remove pillow block.* Remove pillow block from axle (par. 233b).

*Note.* If same axle assembly is to be installed, it is not necessary to remove pillow block assembly.

*d. Installation (fig. 236).*

- (1) *Install pillow block.* Install pillow block on axle (par. 233c).
- (2) *Position axle.* Move axle into position under vehicle and engage main spring ends in openings in brackets at each end of axle housing.
- (3) *Connect torque rods.* Attach three torque rods to axle brackets by installing torque rod end pins in axle brackets. Install washer and 1-14 safety nut on each pin and tighten to 350 to 400 pound-feet torque.
- (4) *Connect flexible hose.* Connect hydraulic brake and axle vent flexible hose at junction on top of axle housing with two connector bolts and four new copper washers. Use one washer on each side of connector. Tighten connector bolts to 20 to 30 pound-feet torque.
- (5) *Connect propeller shafts.* Position respective propeller shafts to differential pinion flange and to each end of pillow block assembly, with lubrication fittings in same plane as other shafts; then install four bolts and  $\frac{7}{16}$ -20 safety nuts at each location. Tighten nuts to 33 to 43 pound-feet torque.
- (6) *Install wheels.* Install wheels on hubs (par. 259c).
- (7) *Remove blocks and jack.* Raise vehicle with jack as necessary to remove block from under each torque rod support bracket at spring seat. Lower jack and withdraw from under vehicle.
- (8) *Bleed brakes.* Perform brake bleeding operation (par. 237).
- (9) *Lubricate.* Check lubricant level in axle differential (par. 224b). Lubricate propeller shaft universal joints and pillow block as directed on lubrication chart (par. 69).
- (10) *Check for lubricant leaks.* Check for lubricant leaks around housing cover. Tighten cover stud nuts to 45 to 55 pound-feet torque.

*e. Record of Replacement.* Record the replacement on DA Form 478.

## **227. Rear Rear Axle Replacement**

*a. Coordination with Ordnance Maintenance Unit.* Refer to paragraph 2 for information on coordination with an ordnance maintenance unit.

b. *General.* Rear rear axle assembly includes axle housing, differential and carrier, axle shafts, hub and drum assemblies, and brake line assemblies (fig. 234).

c. *Removal* (fig. 237).

- (1) *Position vehicle.* Place vehicle on a level surface and block front wheels to prevent vehicle rolling. Place a jack under axle and raise vehicle until tires are off the ground.
- (2) *Remove wheels.* Remove wheels and tires from each side (par. 259b).
- (3) *Block vehicle.* Place blocks under torque rod support bracket at spring seat at each side to support vehicle after axle is removed.

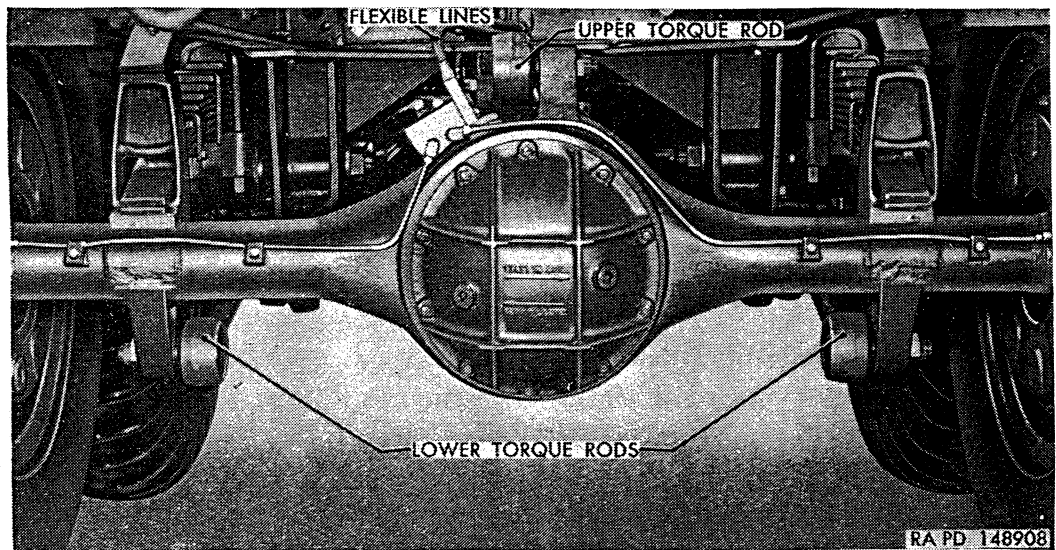

Figure 237. Rear rear axle assembly installed.

- (4) *Disconnect flexible hose.* Disconnect hydraulic brake and axle vent flexible hose at junction block on top of axle housing.
- (5) *Disconnect propeller shafts.* Remove four bolts and nuts attaching propeller shaft universal joint flange to differential pinion flange.
- (6) *Loosen torque rods.* Remove nuts and washers from three torque rod end pins. Use a soft metal hammer to loosen torque rod end pins in axle brackets.
- (7) *Disconnect torque rods.* Remove torque rod end pins from each axle bracket.

**Caution:** Be sure axle is safely supported to prevent rolling off jack and resulting in injury to personnel.

- (8) *Remove axle.* Lower axle with jack and pull assembly rearward as necessary to disengage main spring ends from axle brackets; then completely remove axle assembly.

*d. Installation (fig. 237).*

- (1) *Position axle.* Move axle into position under vehicle and engage main spring ends with openings in bracket at each end of axle housing.
- (2) *Connect torque rods.* Attach three torque rods to axle brackets by installing torque rod end pins in axle brackets. Install washer and 1-14 safety nut on each pin. Tighten nuts to 350 to 400 pound-feet torque.
- (3) *Connect flexible hose.* Connect hydraulic brake and axle vent flexible hose at junction on top of axle housing with two connector bolts and four new copper washers. Use one washer on each side of connector. Tighten connector bolts to 20 to 30 pound-feet torque.
- (4) *Connect propeller shaft.* Position propeller shaft joint flange to differential pinion flange, with lubrication fittings in same plane as other shafts; then install four bolts and  $\frac{7}{16}$ -20 safety nuts. Tighten nuts to 33 to 43 pound-feet torque.
- (5) *Install wheels.* Install wheels on hub (par. 259c).
- (6) *Remove blocks and jack.* Raise vehicle with jack as necessary to remove block from under each torque rod bracket; then lower jack and withdraw from under vehicle.
- (7) *Bleed brakes.* Perform brake bleeding operation (par. 237).
- (8) *Lubricate.* Check lubricant level in axle differential (par. 224b). Lubricate propeller shaft universal joints as directed on lubrication chart (par. 69).
- (9) *Check for lubricant leaks.* Check for lubricant leaks around housing cover. Tighten cover stud nuts to 45 to 55 pound-feet torque.

*e. Record of Replacement.* Record the replacement on DA Form 478.

## Section XXII. AXLE PROPELLER SHAFTS AND UNIVERSAL JOINTS

### 228. Description

*a. General.* This section includes replacement of axle drive propeller shafts and universal joints, pillow block, and repair of universal joint assemblies. Arrangement of axle drive propeller shafts is shown in figure 238.

*b. Axle Propeller Shafts.* Each of the four tubular propeller shafts has a universal joint at each end of shaft. In addition, each shaft has a slip joint at one end. The slip joint on the front-axle-to-transfer propeller shaft is at the rear of vehicle while on all other shafts the slip joint is toward front of vehicle. The purpose of the slip joint is to permit telescopic action of shaft during operation. One half



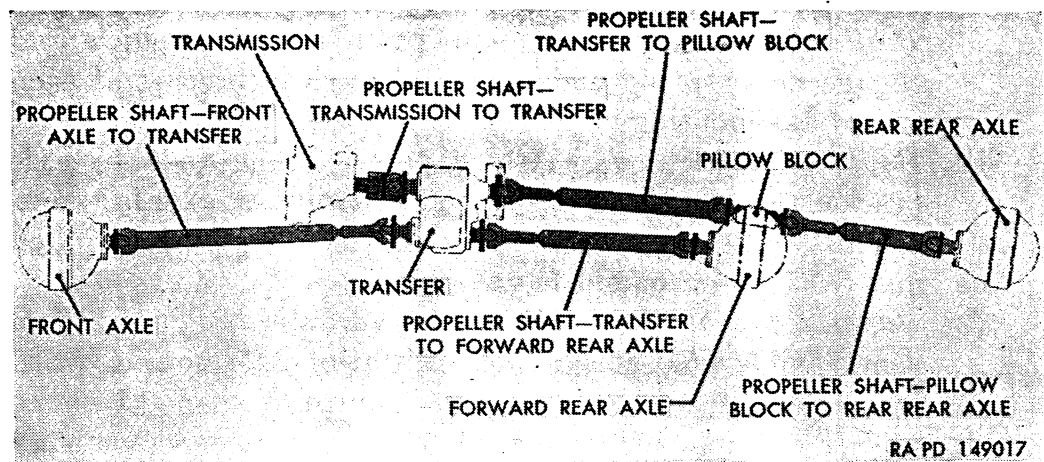

Figure 238. Propeller shafts and universal joint arrangement.

of slip joint is a splined solid stub shaft, having one blank spline for alinement at assembly, and is welded to tubular shaft, while opposite half is incorporated in universal joint yoke.

*c. Transmission-to-Transfer Propeller Shaft* (fig. 240). Power from transmission to transfer is through two universal joint assemblies which are bolted together, thus eliminating shaft usually used. Slip joint between transmission and transfer is through splined yoke which engages transmission output shaft.

*d. Universal Joints.* Universal joints permit angular movement of shaft during rotation. Movement between the shaft yoke and flange yoke is through bearings over each arm of a journal or cross. Seal at each journal arm prevents loss of lubricant or entry of dirt, water, or other foreign matter.

*e. Pillow Block* (fig. 243). Pillow block assembly, mounted on top of forward rear axle, connects and supports the two propeller shafts required to transmit power from transfer to rear rear axle.

## 229. Propeller Shaft and Universal Joint Removal

*a. General.* Propeller shafts used between transfer and respective drive units can be completely removed by disconnecting both ends; however, when service requirements permit, only one end can be disconnected from its respective unit.

*b. Axle Propeller Shaft Removal.* Remove four bolts and nuts at each end of shaft attaching universal joint flange to drive or driven unit flange; then remove complete shaft assembly (C, D, E, or F, fig. 239).

*c. Transmission-to-Transfer Propeller Shaft Removal.* Remove four bolts and nuts attaching two universal joints (fig. 240) together; also remove four bolts and nuts attaching rear universal joint flange to transfer flange. Remove rear universal joint. Slide front universal joint toward rear and off transmission output shaft.

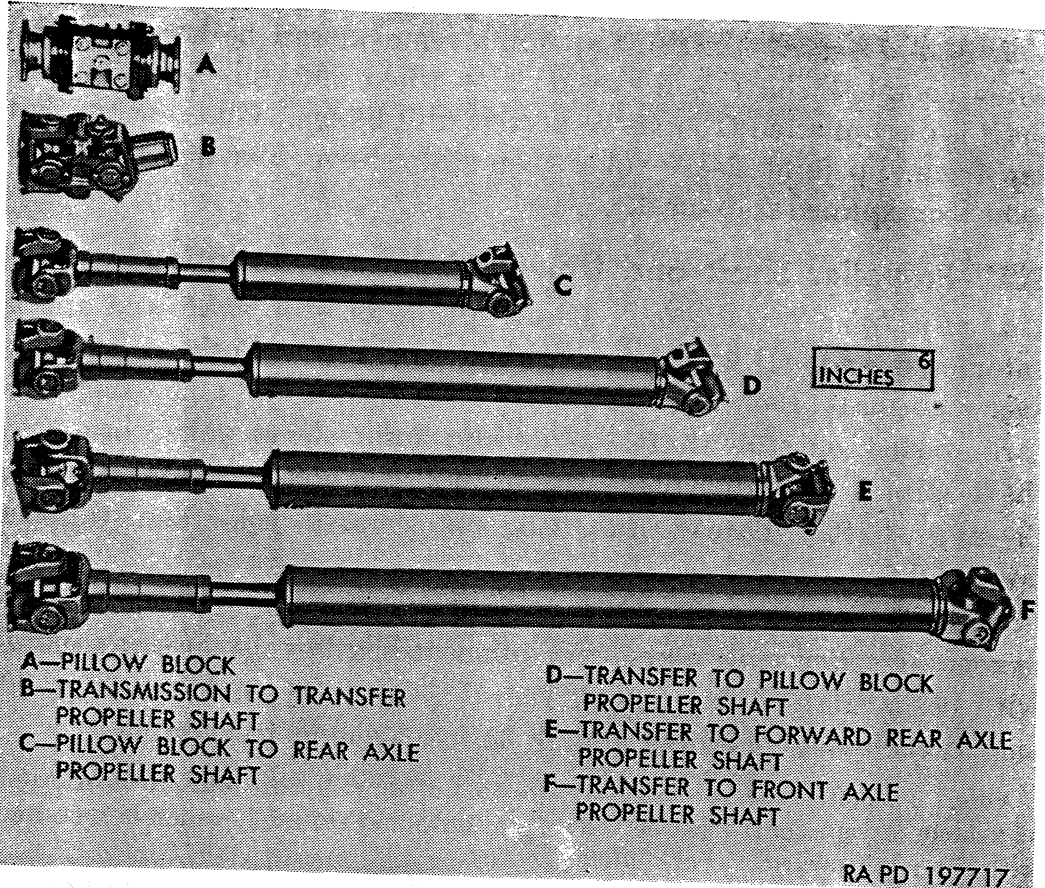

Figure 239. Pillow block and propeller shaft assemblies removed.

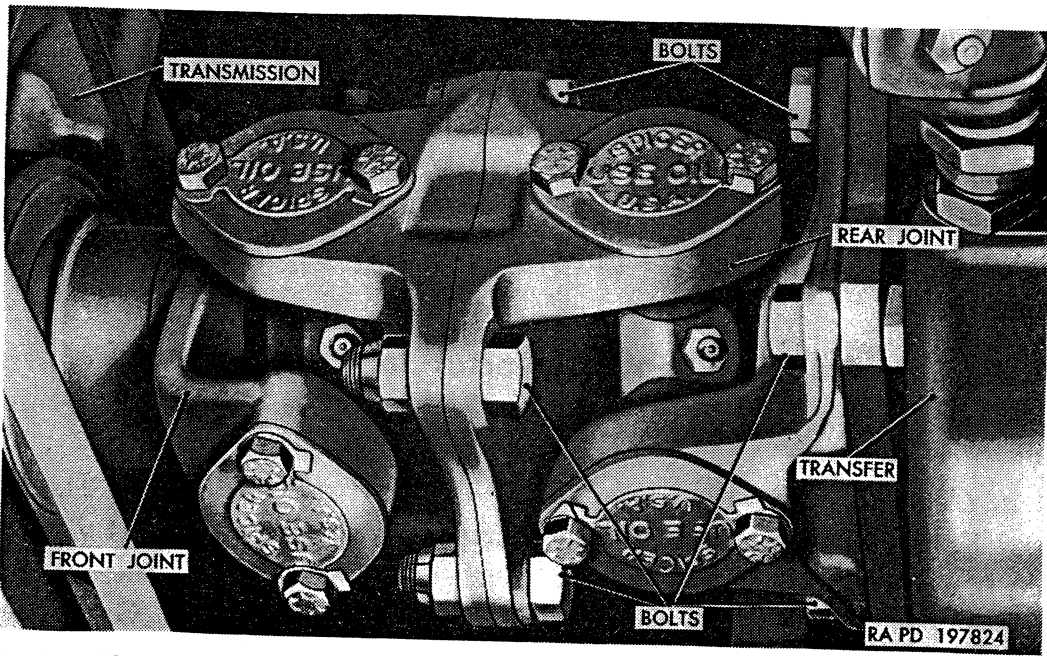

Figure 240. Transmission-to-transfer propeller shaft installed.

*d. Slip Joint Removal.* Slip joint removal can be accomplished while complete shaft is removed; also when only slip joint end of shaft is disconnected from its respective unit flange. Unscrew knurled cap from slip joint sleeve yoke; then slide sleeve yoke and universal joint from splined stub shaft.

### **230. Propeller Shaft and Universal Joint Installation**

*a. Slip Joint Installation.* Clean splines on stub shaft and apply automotive and artillery grease (GAA) to splines. Position dust cap over stub shaft; then install dust cap steel washer and a new dust cap cork washer on stub shaft. Slide slip joint sleeve yoke onto stub shaft splines, matching blank spline in sleeve yoke and blank spline in stub shaft. Thread dust cap onto sleeve yoke and tighten fingertight.

*b. Axle Propeller Shaft Installation.* Position shaft between flanges of connecting units with lubrication fittings in same plane with other shafts; then install four  $\frac{7}{16}$ -20 x  $1\frac{3}{16}$  bolts and  $\frac{7}{16}$ -20 nuts at each end. Tighten nuts to 33 to 43 pound-feet torque.

*Note.* Propeller shafts (fig. 238) are installed with slip joint toward front of vehicle, except shaft used between front axle and transfer, which is installed with slip joint toward rear of vehicle.

*c. Transmission-to-Transfer Propeller Shaft Installation* (fig. 240). Apply automotive and artillery grease (GAA) to sleeve yoke sleeve; then slide sleeve yoke over transmission output shaft, being careful that transmission rear seal is not damaged during installation. Move joint toward transmission to provide sufficient space to install rear universal joint. Locate rear joint between front joint and transfer flange with lubrication fittings in alignment; then install four  $\frac{1}{2}$ -20 x  $1\frac{3}{8}$  bolts and  $\frac{1}{2}$ -20 nuts attaching two universal joints together. Install four  $\frac{1}{2}$ -20 x  $1\frac{3}{8}$  bolts and  $\frac{1}{2}$ -20 nuts attaching rear joint to transfer flange. Tighten the eight nuts to 48 to 64 pound-feet torque.

### **231. Axle Propeller Shaft Universal Joint Assembly**

*Note.* The key letters noted in parentheses are in figure 241, except where otherwise indicated.

*a. General.* The four axle propeller shaft assemblies (C, D, E, and F, fig. 239) are identical in construction except lengths of tubular shaft and stub shaft assemblies. Each shaft has a slip joint at one end to permit telescopic action of shaft during operation. One half of the slip joint is a splined solid stub shaft welded to tubular shaft. The slip joint sleeve yoke assembly (G) fits over the stub shaft splines, thus forming the slip joint. Universal joints should be repaired whenever excessive wear is indicated by looseness in bearing

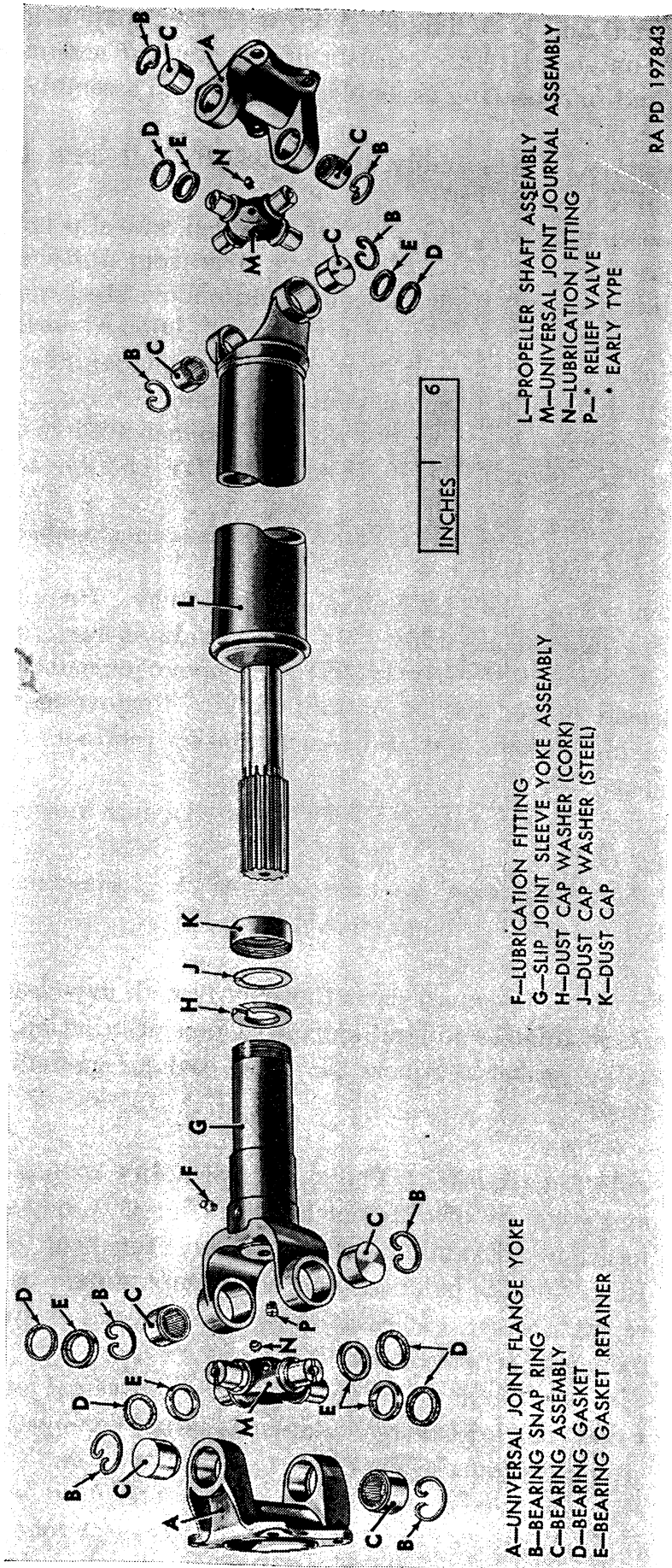

A—UNIVERSAL JOINT FLANGE YOKE  
 B—BEARING SNAP RING  
 C—BEARING ASSEMBLY  
 D—BEARING GASKET  
 E—BEARING GASKET RETAINER

F—LUBRICATION FITTING  
 G—SLIP JOINT SLEEVE YOKE ASSEMBLY  
 H—DUST CAP WASHER (CORK)  
 J—DUST CAP WASHER (STEEL)  
 K—DUST CAP

L—PROPELLER SHAFT ASSEMBLY  
 M—UNIVERSAL JOINT JOURNAL ASSEMBLY  
 N—LUBRICATION FITTING  
 P—RELIEF VALVE  
 \* EARLY TYPE

RA PD 197843

Figure 241. Axle propeller shaft and universal joint components.

between journal and yoke flange. A kit used for repair of axle propeller shaft universal joints consists of one journal assembly, four snap rings, and four bearing assemblies; the journal assembly includes gaskets and retainers.

*b. Disassembly.* Disassembly procedures for all axle propeller shaft assemblies are identical.

- (1) Loosen dust cap (K) which is threaded onto slip joint sleeve yoke assembly (G). Slide sleeve yoke from stub shaft.
- (2) Slide dust cap from stub shaft and remove steel washer (J) and cork washer (H) from dust cap. Discard cork washer.
- (3) Pinch ends of bearing snap rings (B) together; then remove four snap rings from each universal joint.
- (4) Strike the yokes sharply with lead hammer to force one roller bearing assembly (C) from yoke far enough to permit removal.

*Note.* The roller bearings are loose in the bearing retainer and may fall out when bearing assembly is removed.

- (5) Remove opposite roller bearing from yoke. Push universal joint journal assembly (M) to one side as far as possible. Tilt slip joint sleeve yoke (G) and remove journal from yoke. Repeat procedures on opposite yoke. Remove and discard bearing gaskets (D) and bearing gasket retainers (E) from journal.
- (6) Remove relief valve (P) (when used) and lubrication fitting (F).
- (7) Opposite universal joint assembly can be disassembled as explained in (3) through (6) above.

*c. Cleaning and Inspection.*

- (1) *Cleaning.* Clean all parts thoroughly with dry-cleaning solvent or volatile mineral spirits. Upon installation, use new bearing gasket retainers (E) and bearing gaskets (D) on journal.

(2) *Inspection.*

- (a) *Shaft assemblies.* The shaft assemblies with stub shaft and yoke are of different lengths (fig. 239), depending on location. Examine shaft assembly for bent condition. Each shaft is balanced and no attempt should be made to repair a shaft. If shaft is bent, or if yoke or splines are damaged, replace shaft.
- (b) *Universal joint flange yokes.* Inspect universal joint flange yokes (A) for damage. Replace yokes if damaged. Do not attempt to repair yokes.
- (c) *Slip joint sleeve yoke.* Thoroughly clean out interior of slip joint sleeve yoke assembly (G). Inspect yoke for dam-

age. Replace if yoke is distorted or damaged in any manner.

(d) *Universal joint journal assemblies.* Inspect bearing surfaces on universal joint journal assemblies (M) for roughness or scoring. Make certain that lubricant passages in journals are clean and free. Make certain that journal lubrication fittings (N) are clean and in good usable condition.

(e) *Bearing assemblies.* Examine bearings for bent condition; check for bent or missing rollers. There are 34 rollers mounted in retainer. If rollers are missing or retainer is bent, replace with new bearing assembly. If bearing snap rings (B) have been damaged or stretched at time of disassembly, replace rings.

d. *Assembly.* Procedures in (1) through (5) below apply to universal joint at both ends of shaft; procedure in (6) through (9) below apply only to slip joint end.

- (1) All parts should be thoroughly lubricated during assembly with automotive and artillery grease (GAA).
- (2) Install a new bearing gasket retainer (E) and a new bearing gasket (D) on each end of the universal joint journal assembly (M). Position journal in place in universal joint flange yoke (A).
- (3) Install 34 rollers in bearing retainer. Apply small quantity of grease to hold rollers in place. Install bearing assembly (C) into yoke over each end of journal.
- (4) Install relief valve (P) (when used) into end of slip joint sleeve yoke assembly (G). Position journal in place in yoke of slip joint sleeve yoke or shaft yoke. Install bearing assembly into yoke over each end of journal.
- (5) Install bearing snap ring (B) at each bearing, making certain snap rings engage grooves in yokes.
- (6) One splined tooth in slip joint sleeve yoke assembly (G) is blank. This blank spline must match with a similar blank spline on stub shaft of propeller shaft to assure proper universal joint alignment.
- (7) Position dust cap (K) over stub shaft; then install dust cap washer (steel) (J) and new dust cap washer (cork) (H). Insert slip joint sleeve yoke assembly (G) over stub shaft splines, matching blank spline of yoke with blank spline of shaft.
- (8) Thread dust cap (K) onto sleeve yoke. Do not use a wrench. Tighten with fingers.

- (9) Install lubrication fitting (F) in slip joint sleeve yoke, and install journal lubrication fittings (N) in universal joint journal assembly (M). Thoroughly lubricate universal joints with automotive and artillery grease (GAA).

### 232. Transmission-To-Transfer Propeller Shaft Assembly

*Note.* The key letters noted in parentheses are in figure 242, except where otherwise indicated.

*a. Description.* The propeller shaft assembly between transmission and transfer (B, fig. 239) consists of two universal joint assemblies bolted together to form a propeller shaft assembly. The sleeve yoke assembly (R) fits on splined output shaft of transmission to form a slip joint. The flange yoke (Q) bolts to a companion flange on transfer input shaft. Needle-type roller bearing assemblies are used at each universal joint. Universal joints should be repaired whenever excessive wear is indicated by looseness in bearings. A kit for repair of universal joints consists of one journal assembly, four bearing assemblies, four bearing caps (when used), two lubrication fittings, eight cap screws, and four lock straps; the journal assembly includes gaskets and retainers.

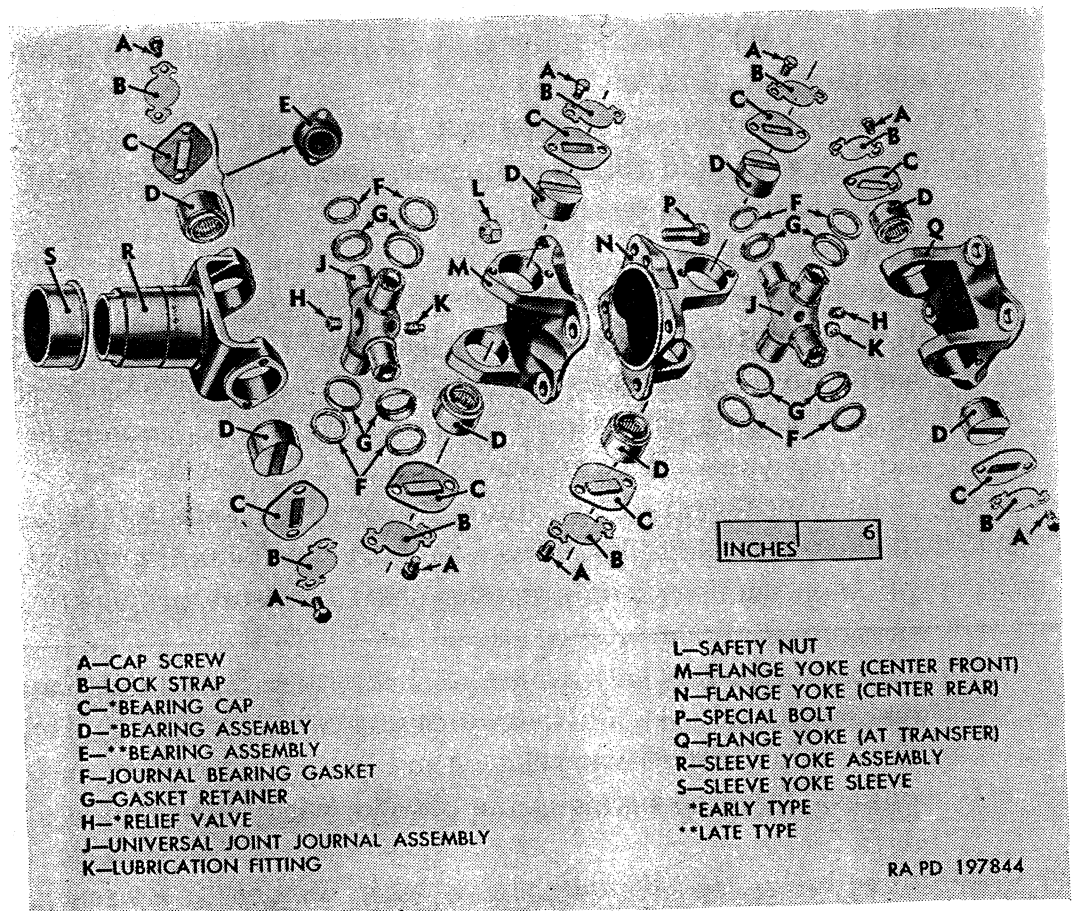

Figure 242. Transmission-to-transfer propeller shaft universal joint components.

*b. Disassembly.*

- (1) Remove four safety nuts (L) from special bolts (P). Separate flange yokes (M and N).
- (2) Remove lubrication fitting (K) from universal joint journal assembly (J) at the sleeve yoke.
- (3) Straighten lugs on lock straps (B). Remove two cap screws (A) from each journal bearing cap. On late type, the bearing cap is integral with the bearing assembly. Remove lock straps (B), and, on early type, remove journal bearing caps (C).
- (4) Strike either the flange yoke or sleeve yoke sharply with lead hammer to force a journal bearing assembly (D or E) out of yoke far enough to permit removal. Remove opposite bearing assembly from yoke.
- (5) Push universal joint journal assembly (J) to one side as far as possible. Tilt yoke and remove yoke from journal. Repeat procedures on opposite yoke. Remove and discard journal bearing gaskets (F) and gasket retainers (G) from journal.
- (6) Remove relief valve (H) (when used) from universal joint journal assembly (J).
- (7) Opposite universal joint assembly can be disassembled as explained in (2) through (6) above.

*c. Cleaning and Inspection.*

- (1) *Cleaning.* Thoroughly clean all parts with dry-cleaning solvent or volatile mineral spirits.
- (2) *Inspection.*
  - (a) *Flange yokes.* Inspect flange yokes (M, N, and Q) for distortion, damage, or stripped threads. Replace yokes if these conditions exist.
  - (b) *Sleeve yoke assembly.* Inspect splines of sleeve yoke assembly (R) for distortion, chipped condition, or excessively worn condition. If these conditions exist, replace sleeve yoke assembly. Examine sleeve yoke sleeve (S) for scoring, checking, or looseness. If sleeve is damaged, replace sleeve yoke assembly.
  - (c) *Journal bearing assemblies.* Examine bearing assemblies (D or E) for bent condition or missing rollers. There are 28 rollers for each bearing. Bearing rollers are held in place with a retainer. If retainer or rollers are damaged, replace bearing assembly.
  - (d) *Universal joint journal assemblies.* Inspect bearing surfaces on journal for roughness or scoring. Make certain that lubricant passages in journal are clean and free.



(e) *Journal bearing caps and lock straps.* Journal bearing caps (C) (when used) should be inspected for damage. As a general rule, lock straps (B) should be replaced at assembly; however, straps can be reused if one lug at each end has not been bent.

*d. Assembly.*

- (1) Thoroughly lubricate all parts with automotive and artillery grease (GAA).
- (2) Install relief valve (H) (when used) and lubrication fitting (K) in universal joint journal assembly (J).
- (3) Install new gasket retainer (G) and journal bearing gasket (F) on each end of journal.
- (4) Assemble front universal joint first. Place universal joint journal assembly (J) in sleeve yoke assembly (R).
- (5) Install a journal bearing assembly (D or E) into sleeve yoke over each end of journal cross.
- (6) Insert journal into center front flange yoke; then install journal bearing assembly (D or E) into flange yoke over each end of journal cross.
- (7) Install journal bearing cap (C) (when used) over journal bearing, making sure that lug on cap fits in slot in bearing retainer.
- (8) Position lock strap (B) over each cap. Install two  $\frac{5}{16}$ -24 x  $\frac{1}{2}$  cap screws (A) and tighten. Bend one lug of lock strap against face of cap screw.
- (9) Assemble opposite universal joint in the same manner ((1) through (8) above).
- (10) Bolt center front and center rear flange yokes (M and N) together, using four  $\frac{1}{2}$ -20 x  $1\frac{3}{8}$  special bolts (P) and  $\frac{1}{2}$ -20 safety nuts (L). Tighten nuts to 48 to 64 pound-feet torque.

*Note.* The front and rear universal joint assemblies must be in same plane when bolted together.

### **233. Pillow Block**

*a. Description.* Pillow block consists of a shaft supported by two ball bearings mounted in a housing. Pillow block is installed on forward rear axle housing as shown in figure 243. Double lip oil seals, supported in retainer, are used at each end to prevent loss of lubricant and entry of dirt, water, and other foreign matter.

*b. Removal.* Drain pillow block by removing bottom plug; then disconnect propeller shafts at front and rear of pillow block by removing four bolts and nuts at each end. Remove four mounting stud nuts and split tapered dowel wedges attaching pillow block to mounting bracket; then remove pillow block.

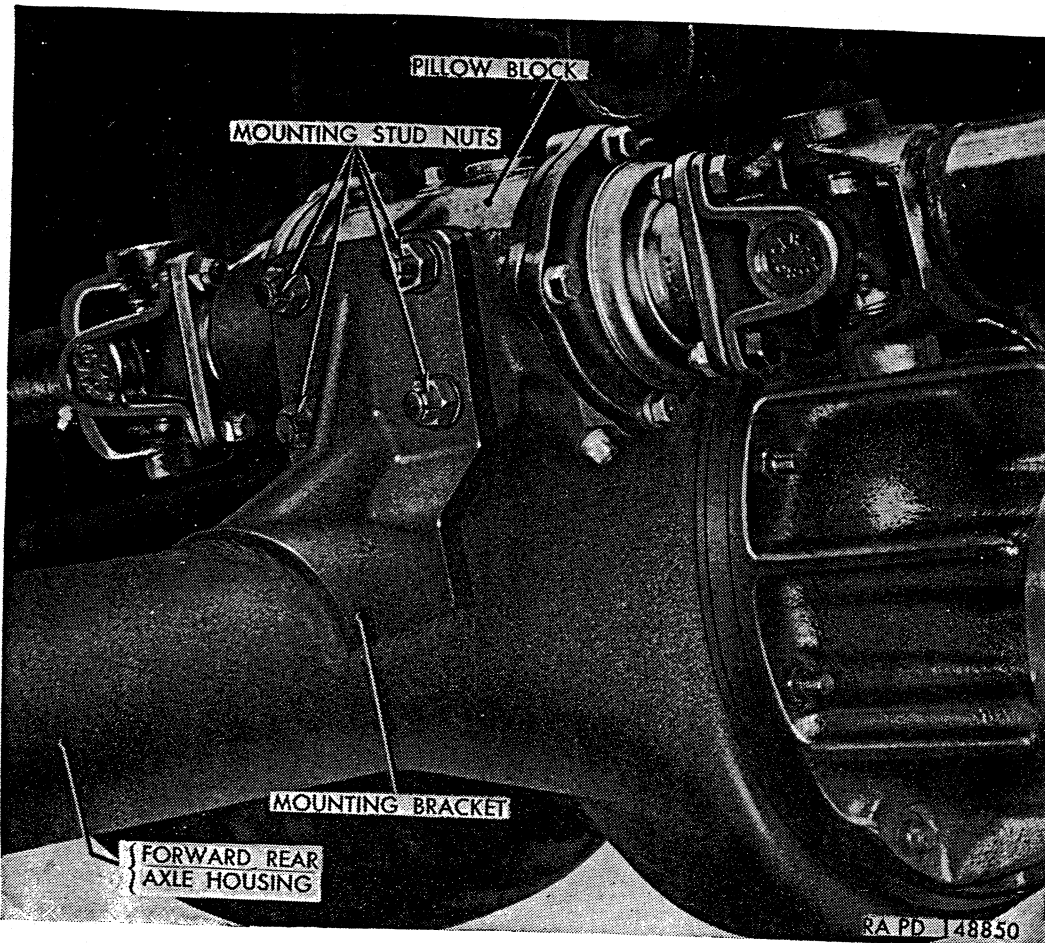

Figure 243. Pillow block installed.

*c. Installation.* Position pillow block assembly on inside (differential side) of mounting bracket, with drain plug toward front. Install four split tapered dowel wedges and  $\frac{1}{2}$ -20 safety nuts on mounting studs. Tighten nuts to 48 to 64 pound-feet torque. Connect propeller shafts (par. 230*b*). Lubricate pillow block and propeller shaft universal joints as instructed on lubrication chart (par. 69).

*d. Filling.* Remove plug at side of housing near lubrication fitting (KK, fig. 84); then apply lubricant through fitting until level with plug opening.

## Section XXIII. SERVICE BRAKE SYSTEM

### 234. Description and Operation

*a. Description.* The combined air-hydraulic brake system consists primarily of a pedal, interconnected to a hydraulic master cylinder to build up the initial hydraulic pressure; and air-hydraulic power cylinder to increase the hydraulic pressure; hydraulic wheel cylinders to transmit the hydraulic pressure to the brake assembly at each wheel; compressed air system which maintains a supply of compressed air for

operation of the air-hydraulic power cylinder; and interconnecting lines, fittings, and linkage.

*b. Operation.*

(1) *Application.* When brake pedal is depressed, hydraulic brake fluid is displaced from the master cylinder into the air-hydraulic cylinder, and through the air-hydraulic cylinder slave cylinder into the lines leading to the wheel cylinders. When hydraulic pressure against the air-hydraulic cylinder control valve hydraulic piston reaches a certain point, control valve functions to admit compressed air into the air-hydraulic cylinder behind the cylinder air piston, causing the piston to move forward in the cylinder. Forward movement of air piston forces slave cylinder piston forward in slave cylinder, displacing hydraulic brake fluid under high pressure into the lines leading to the wheel cylinders. Hydraulic brake fluid entering the wheel cylinders forces wheel cylinder pistons apart; outward movement of wheel cylinder pistons is transmitted to the brake shoes through push rods, forcing brake shoes into contact with brake drums.

(2) *Release.* When brake pedal is released, hydraulic pressure is removed from air-hydraulic cylinder control valve hydraulic piston; with pressure removed from control valve hydraulic piston, control valve functions to exhaust air pressure from power cylinder into the engine air cleaner manifold. With air pressure removed from behind air-hydraulic cylinder air piston, piston return spring forces air piston to rear of cylinder, at the same time pulling slave cylinder piston to rear of slave cylinder, removing pressure from hydraulic brake fluid in wheel cylinders. With hydraulic pressure removed from wheel cylinder pistons, brake shoe return springs pull brake shoes away from brake drums, forcing wheel cylinder pistons together. Hydraulic brake fluid is displaced from wheel cylinders and returns to the master cylinder via the air-hydraulic cylinder slave cylinder.

### 235. Service Brake System Data

*a. Air Compressor.*

Make----- Midland Steel Products Co  
Model----- N4119W  
Ordnance number----- 7350423  
Capacity----- 7 $\frac{1}{4}$  cu. ft. per min. at 1,250 rpm  
Governor cutout pressure----- 100 psi  
Governor cut-in pressure----- 75 to 80 psi

*b. Master Cylinder.*

Ordnance number..... 7410830  
Cylinder bore..... 1¾ in.  
Piston stroke..... 1⅞ in.

*c. Air-Hydraulic Cylinder.*

Make..... Bendix Products Division  
Model..... A35-15-154  
Tag number :  
    Early M135..... 375817  
    Late M135 and all other models..... 376440  
Ordnance number..... 7410860  
Cylinder shell diameter..... 4¼ in.  
Air piston stroke..... 3⅞ in.  
Slave cylinder bore..... 1⅞ in.  
Slave cylinder piston stroke..... 3¾ in.  
Control valve piston bore :  
    Early M135..... 1⅞ in.  
    Late M135 and all other models..... 2<sup>9</sup>/<sub>32</sub> in.

*d. Wheel Cylinders.*

Ordnance number..... 7412065  
Bore diameter..... 1¼ in.

*e. Brake Drums.*

Inside diameter..... 15 in.

*f. Brake Shoe Lining.*

Width..... 3 in.  
Thickness..... ⅜ in.

**236. Brake System Tests**

*a. Performance Tests.*

- (1) *Road test.* Road-test brakes by making a brake application at about 20 mph to determine if vehicle stops evenly and quickly. If pedal has a spongy feel when applying brakes, air is present in hydraulic system. Brake system must be bled to expel air (par. 237).
- (2) *Check pedal free-travel.* Press brake pedal down with hand until resistance other than that of the pedal pull-back spring is felt. Pedal movement should not be less than one-fourth inch or more than one-half inch before master cylinder piston cup covers bypass port in cylinder and power stroke commences. If free travel is not within one-fourth to one-half inch, pedal or master cylinder piston is not returning to fully released position, or the master cylinder piston cup is defective. Adjust brake pedal linkage (par. 241b) or replace master cylinder (par. 242).

(3) *Operating test.*

- (a) Build up air pressure in system to normal operating pressure (100 psi); then stop engine.
- (b) Apply brakes; then listen for sound of exhausting air pressure as brakes are released. Rapid release of air pressure indicates that air-hydraulic cylinder control valve is operating.
- (c) Depress brake pedal and hold pressure on pedal. If pedal gradually falls away under pressure, leakage in hydraulic system is indicated. Make hydraulic pressure tests (c below).
- (d) If stop washer on pedal shaft goes to within 2 inches of the toe pan when brakes are applied, brake shoes require adjustment (par. 238) or replacing (par. 239).

b. *Air Pressure Tests.*

- (1) Remove lubrication pipe plug from rear end of air-hydraulic cylinder and connect an air pressure test gage at this point. Build up air pressure in system to normal operating pressure (100 psi) as registered on air pressure gage in instrument cluster; then shut off engine.
- (2) Coat all air line connections with a solution of soap and water to check for leakage. Leakage can sometimes be corrected by tightening the connection. If this fails to correct leakage, air line or fittings must be replaced (par. 245b).
- (3) Disconnect air exhaust line from air-hydraulic cylinder exhaust port. Connect a flexible hose or a bent tube to exhaust port; hose or tube must be long enough to hang down over side of air-hydraulic cylinder. Hold a jar of water up under exhaust tube so that end of tube is immersed in water. Watch for bubbles to appear in water. The appearance of bubbles indicates a leaking control valve poppet air inlet seal, requiring replacement of the air-hydraulic cylinder (par. 243).
- (4) Apply brakes and hold pressure on pedal, observing action of air pressure test gage at rear of air-hydraulic cylinder. Air-hydraulic cylinder should hold maximum pressure registered on test gage without noticeable loss until the brake pedal is released. Loss of air pressure indicates a leaking control valve poppet exhaust seal, or leakage past the air-hydraulic cylinder air piston. Replace air-hydraulic cylinder (par. 243).
- (5) Depress and momentarily hold brake pedal to several positions between fully released and fully applied positions. Pressure registered on test air pressure gage should increase gradually according to brake pedal depression. Failure to

graduate the pressure evenly indicates a sticking control valve hydraulic piston, which necessitates replacing air-hydraulic cylinder (par. 243).

- (6) Make a full brake application; then observe action of air pressure test gage when brakes are released. If gage does not return to zero or is slow in returning, a sticking control valve hydraulic piston is indicated. Replace air-hydraulic cylinder (par. 243).

*c. Hydraulic Pressure Test.* A hydraulic pressure test gage capable of registering at least 1,200 psi and an air pressure test gage are required for making this test.

- (1) Connect hydraulic pressure gage to one of the wheel cylinder bleeder valve openings or at top of slave cylinder end fitting. Connect air pressure test gage to lubrication pipe plug opening at rear of air-hydraulic cylinder.
- (2) Apply brakes until approximately 60 psi is registered on air pressure test gage. Observe reading on hydraulic pressure gage. Hydraulic pressure should be 950 to 1,100 psi with 60 psi air pressure applied to air-hydraulic cylinder. If applied air pressure is higher or lower than 60 psi, hydraulic pressure will be proportionately higher or lower.
- (3) Apply brakes and hold applied for at least 1 minute, observing action of hydraulic pressure gage. A low pressure reading or a drop in hydraulic pressure indicates leakage in hydraulic lines, wheel cylinder, master cylinder, or air-hydraulic cylinder. Replace hydraulic lines (par. 245), wheel cylinders (par. 244), master cylinder (par. 242), or air-hydraulic cylinder (par. 243) as necessary.

## **237. Bleeding Brake System**

*a. General.* Master cylinder filler cap is accessible through inspection hole in left side of floor pan after removing inspection hole cover. Air-hydraulic cylinder bleeder valves are accessible from under vehicle and wheel cylinder bleeder valves are accessible at inner side of backing plate at each wheel (fig. 244). Bleeding brake system may be accomplished by one of two methods, pressure or manual. Engine must not be running and all air pressure must be exhausted from the air system before bleeding brakes.

*b. Pressure Bleeding.*

- (1) Clean dirt from around master cylinder cap. Unscrew bolt securing filler cap and vent line fitting to master cylinder filler pipe. Swing vent line and filler cap to one side. Bolt will remain in filler cap and fitting.

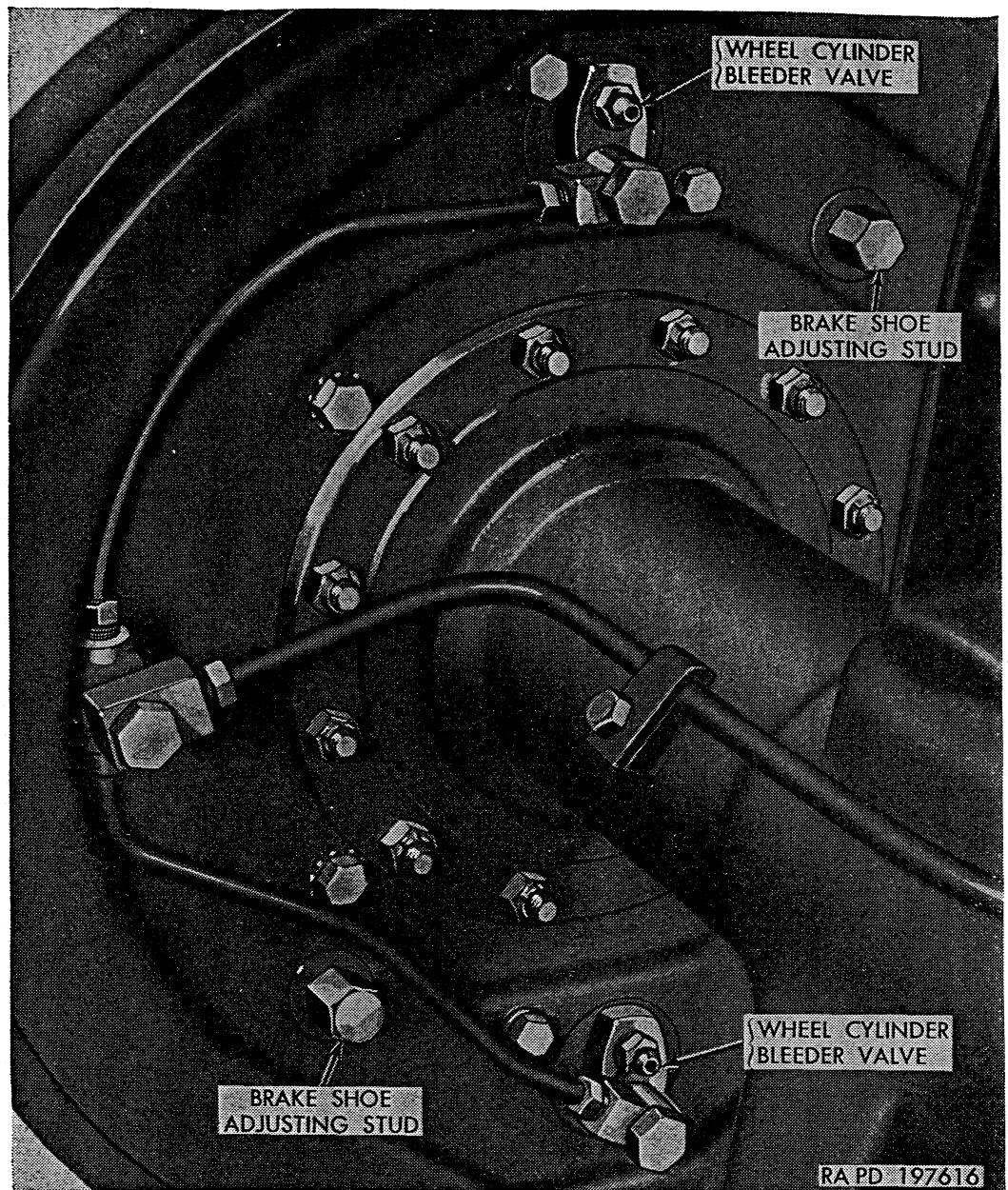

Figure 244. Brake bleeder valves and adjusting studs (rear wheel shown).

- (2) Make sure pressure bleeding tank contains sufficient hydraulic brake fluid and is properly charged with air pressure. Connect pressure tank to master cylinder filler pipe, bleeding all air from hose before tightening the connection.
- (3) Bleed air-hydraulic cylinder first. Slip end of bleeder hose over bleeder valve at top of air-hydraulic cylinder control valve and place other end in a glass jar containing sufficient hydraulic brake fluid to cover end of hose. Open bleeder valve and observe flow of fluid from end of hose. Close bleeder valve as soon as bubbles stop and fluid flows in a solid stream. Repeat this procedure at bleeder valve on top of slave cylinder end fitting.

- (4) Bleed both bleeder valves at each wheel (fig. 244), following same procedure used at air-hydraulic cylinder ((3) above). Make sure each bleeder valve is closed tightly after bleeding.
- (5) Disconnect bleeder tank hose from master cylinder filler pipe. Install filler cap and vent line fitting, tightening attaching bolt to a maximum of 30 pound-feet torque. Install cover plug in inspection hole in floor pan.

*c. Manual Bleeding.* Manual bleeding procedure is the same as pressure bleeding, except that the hydraulic brake fluid is forced through the lines by pumping the brake pedal instead of by air pressure. Two persons are required, one to pump the brake pedal and replenish fluid in master cylinder, the other to accomplish the bleeding operations at the air-hydraulic cylinder and wheel cylinders. Fluid in master cylinder must be replenished after bleeding at each bleeder valve. When pumping pedal, push it down slowly, let it snap back, and immediately start the downward stroke. After all air is expelled at each bleeder valve, close bleeder valve during the downstroke of brake pedal.

### **238. Brake Adjustment for Normal Wear**

*a. General.* Brake adjustments to compensate for normal lining wear are made at the brake shoes. These adjustments should be made before the brake pedal reserve travel becomes less than 2 inches. Adjustments (fig. 244) are made by turning adjusting pinion studs at inner side of backing plates. Always check wheel bearing adjustment and adjust if necessary (par. 265) before adjusting brakes. Do not adjust brake shoes while brake drums are hot.

#### *b. Adjustment.*

- (1) Jack up axle. Make a brake application and release to center brake shoes with brake drums.
- (2) Using a suitable wrench on brake shoe adjusting studs (fig. 245), turn studs in direction of forward rotation of wheel (fig. 245) until a heavy drag is felt as wheel is turned by hand; then turn studs in opposite direction one-half to one-third turn to provide running clearance between brake shoe lining and brake drum.
- (3) After completing adjustment at each wheel, make sure wheel turns freely. Remove jack from under axle.

### **239. Brake Shoes—Front and Rear**

*Note.* The key letters noted in parentheses are in figure 246, except where otherwise indicated.

*a. Description.* All brake shoes on vehicle are identical. Two brake shoes are mounted on each backing plate in conjunction with two anchor blocks and two wheel cylinders (L). Anchor blocks serve as shoe



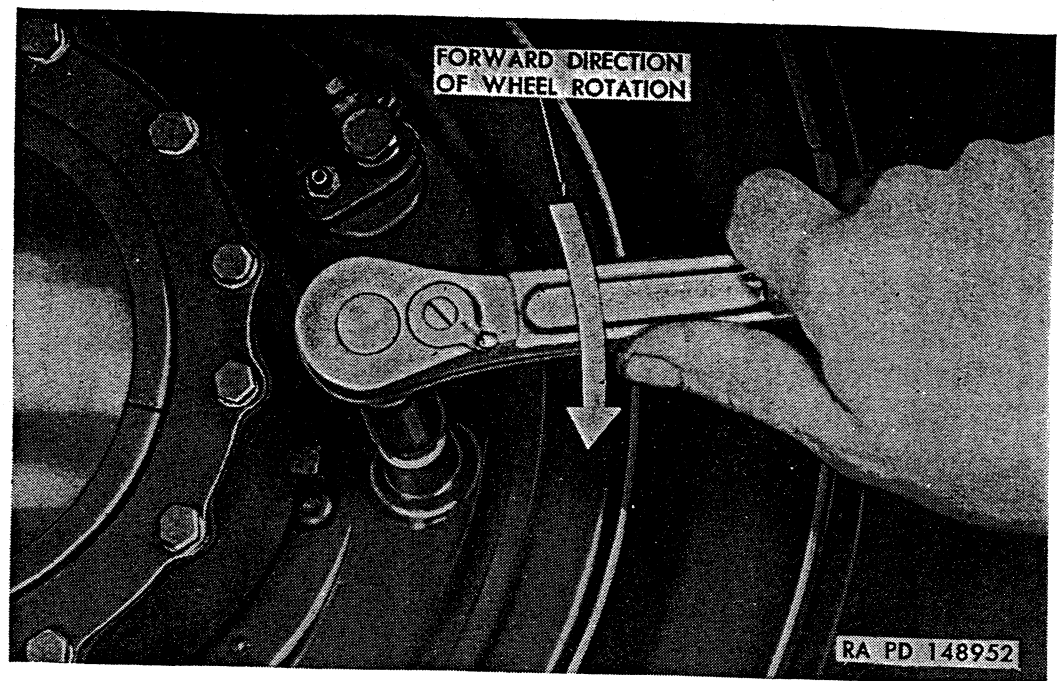

Figure 245. Adjusting brake shoes (front shown).

stops and shoe centering points, and provide the fulcrums around which the shoes pivot when brakes are applied. Four brake shoe return springs hold shoe ends firmly against anchors when brakes are released. Heel of each shoe anchors against steel pins which pivot in anchor blocks. Toe of each shoe anchors against adjusting screws which are threaded into the anchor blocks. Both shoes are always primary shoes, independently self-energized in either direction of brake drum rotation. Shoes anchor either at toe or at heel, depending upon direction of brake drum rotation when brakes are applied.

*b. Removal.*

- (1) Jack up axle and remove wheel (or wheels) (par. 259*b*).
- (2) At front axle, remove hub drive flange (par. 221*b*); at rear axle, remove axle shaft (par. 225*b*).
- (3) Remove hub and brake drum (par. 266*a*).
- (4) Using brake shoe spring remover and replacer B7950060 (fig. 247), unhook brake shoe return springs (D) from return spring pins. Remove springs from brake shoes.
- (5) Remove nut, lockwasher, guide washer (E), and sleeve from front brake shoe guide bolt (F) and remove guide bolt. Lift shoe ends out of anchor blocks (G) and wheel cylinder push rods to remove brake shoe, and lining assembly (B).
- (6) Remove guide bolt (F), lockwasher, guide washer (E), and sleeve attaching rear brake shoe to backing plate (A). Lift shoe ends out of anchor blocks (G) and wheel cylinder push rods to remove shoe.

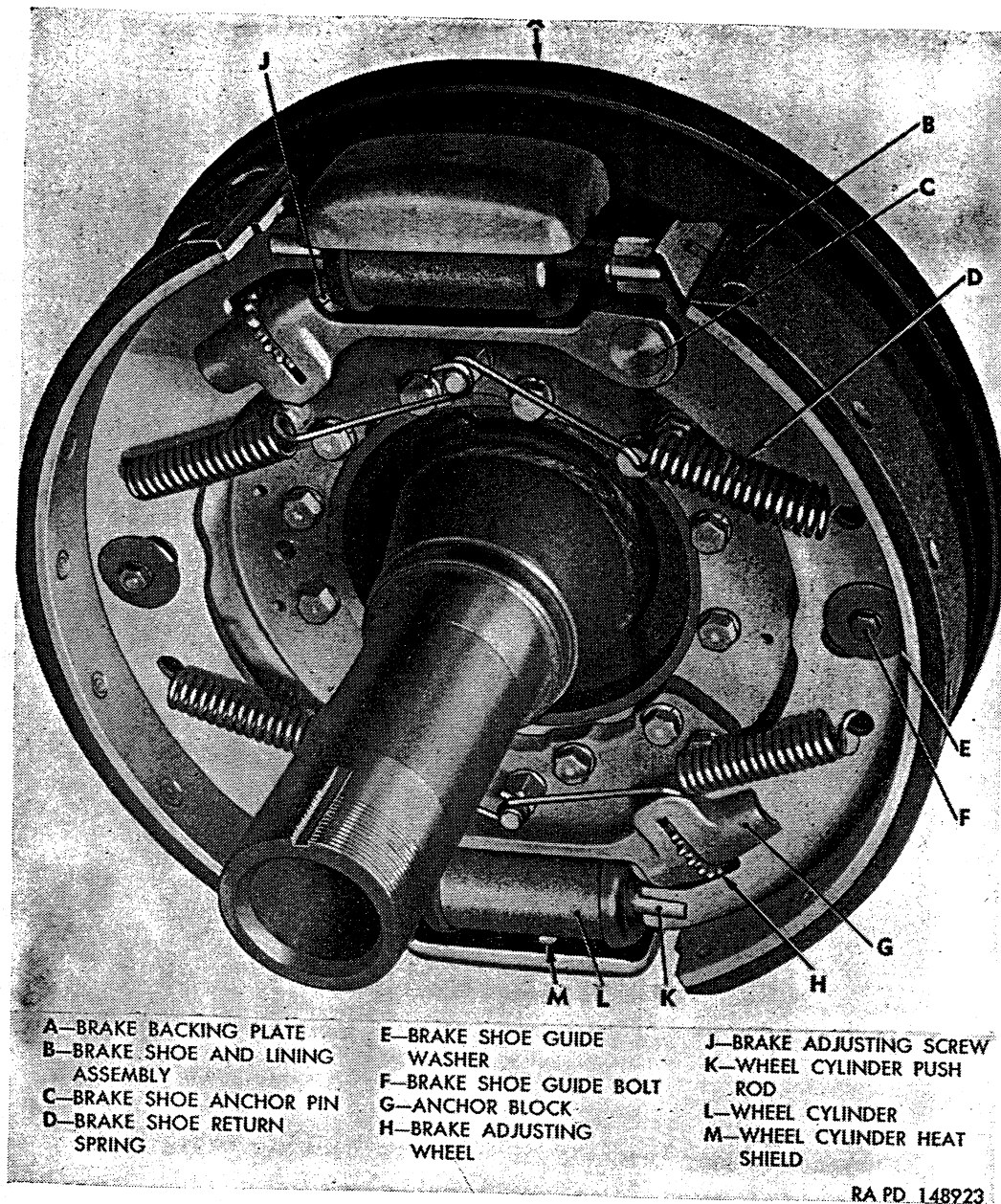

Figure 246. Brake shoes and wheel cylinders installed (rear shown).

### c. Installation.

*Note.* Large portion of brake shoe web which engages slots in anchor blocks is curved at one end and flat at the other end. Shoes must be installed with curved end at adjusting screw and flat end engaging groove in anchor pin in anchor block.

- (1) Position front brake shoe and lining assembly (B) on backing plate, with shoe web engaging slots in wheel cylinder push rods and anchor blocks (G), and with elongated hole in center of shoe web over guide bolt. Install sleeve, brake shoe guide washer (E), lockwasher, and nut on brake shoe guide bolt (F) and tighten.

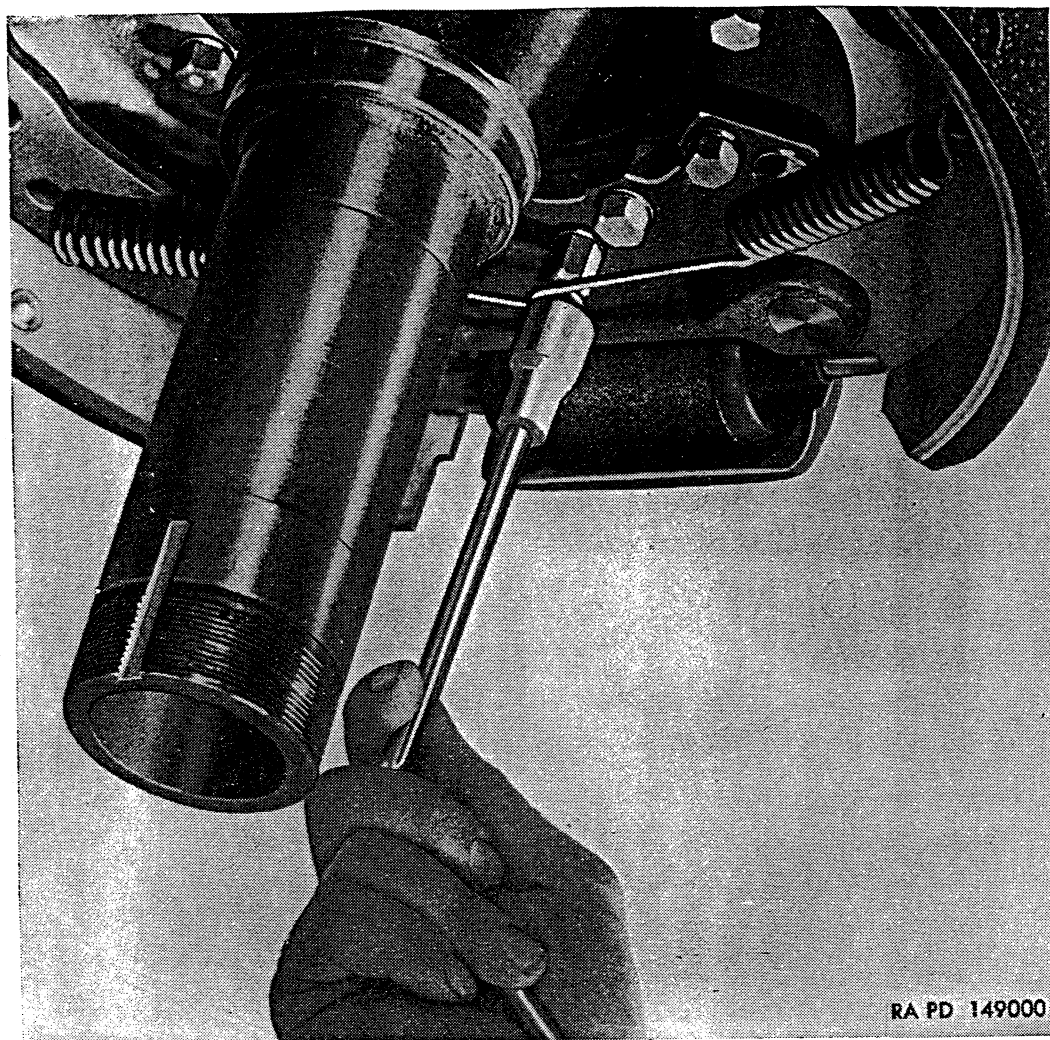

Figure 247. Removing brake shoe return springs, using remover and replacer B7950060.

- (2) Position rear brake shoe at brake backing plate (A), with shoe web engaging slots in wheel cylinder push rods and anchor blocks (G). Install lockwasher, guide washer (E), and sleeve on guide bolt (F); insert bolt through shoe web and backing plate, and thread bolt into hydraulic brake line distributor fitting at inner side of backing plate. Tighten bolt.
- (3) Install brake shoe return springs (D), placing end of each spring in brake shoe web; then hooking springs onto pins, using brake shoe spring remover and replacer B7950060 (fig. 248).
- (4) Install hub and brake drum assembly (par. 266g).
- (5) At front axle, install hub drive flange (par. 221d); at rear axle, install axle shaft (par. 225d).
- (6) Install wheel (or wheels) (par. 259c). Adjust brake shoes (par. 238b).



Figure 248. Installing brake shoe return springs, using remover and replacer B7950060.

## 240. Brake Drums

*a. General.* Brake drums may be either cast iron, or cast iron with steel back. Brake drums are attached to hub flanges by adapters (brake drum backs). Adapters are attached to inner side of hub flanges under heads of wheel studs which are pressed into hub drive flanges (fig. 270). Brake drum removal and installation procedures which follow apply with hub installed on axle; however, the same procedures will apply with hub removed from axle by omitting *b*(1) and *c*(2) below.

*b. Removal.*

- (1) Jack up axle and remove wheel (or wheels) (par. 259*b*).
- (2) Remove nuts and plain washers from 18 studs securing brake drum to brake drum adapter. Tap drum to loosen from adapter; then lift drum off adapter. Studs are pressed into adapter.

*c. Installation.*

- (1) Install brake drum on brake drum adapter, with studs in adapter inserted through holes in drum flange. Install plain washer and  $\frac{3}{8}$ -24 safety nut on each stud, and tighten nuts to 20 to 27 pound-feet torque.
- (2) Install wheel (or wheels) (par. 259c). Adjust brake shoes (par. 238b).

## 241. Brake Pedal and Linkage

(fig. 249)

*a. General.* Brake pedal shaft is welded to pedal and master cylinder bracket which is riveted to frame left side member. Brake pedal lower half is secured on shaft by the master cylinder brace and a cotter pin. Pedal upper half is secured in pedal lower half by a cap screw and nut.

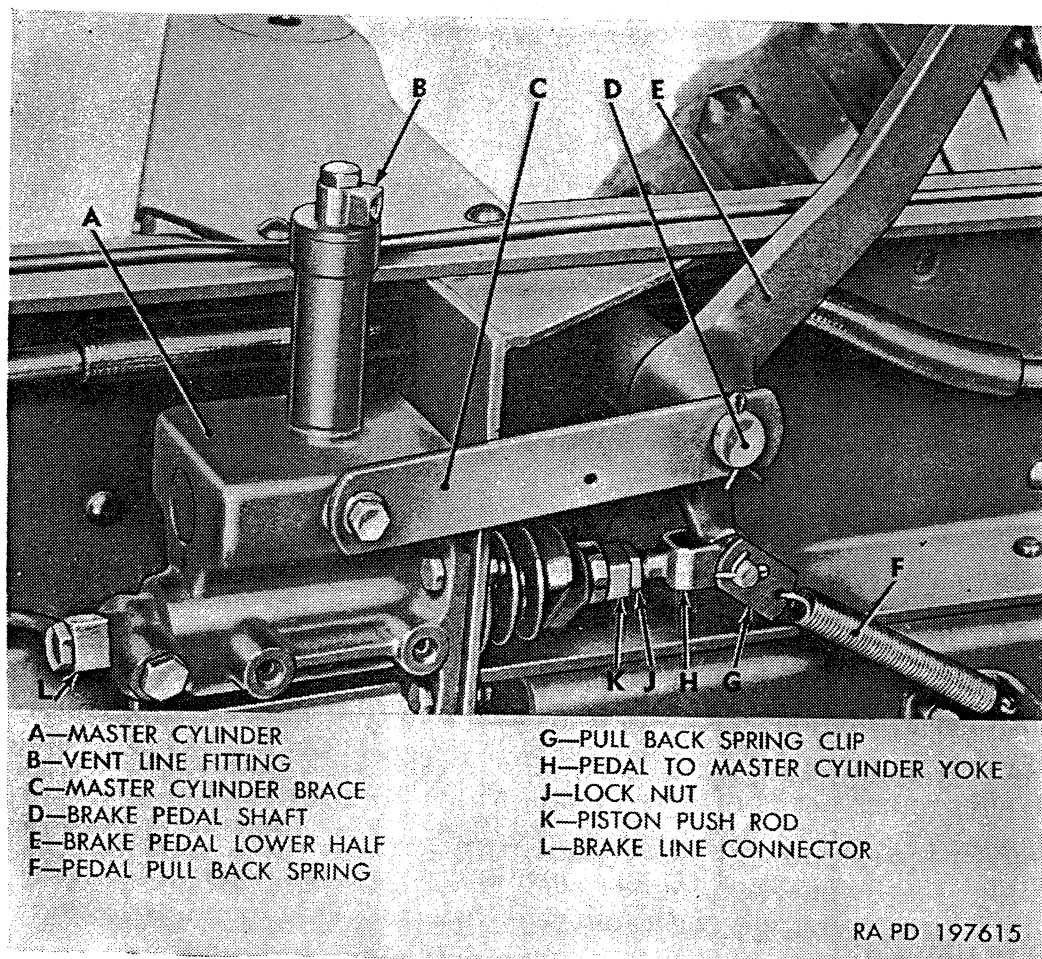

Figure 249. Brake pedal and master cylinder installed.

*b. Brake Pedal Linkage Adjustment.* Master cylinder piston must return to fully released position when brake pedal is released. If piston and cup do not return completely to end of cylinder, bypass port between cylinder and reservoir will be closed and fluid returning from

the wheel cylinders cannot enter the master cylinder reservoir. Proper brake pedal linkage adjustment must be maintained to insure return of master cylinder piston to end of cylinder. Adjustment is made at master cylinder piston push rod.

- (1) Loosen locknut (J) on pedal-to-master-cylinder yoke (H). Remove cotter pin and clevis pin attaching yoke and pedal pull-back spring clip (G) to pedal lower half.
- (2) With pedal-to-toe-panel bumper against under side of pedal upper plate and with master cylinder piston at extreme front end of cylinder, adjust yoke in master cylinder piston push rod (K) as necessary to aline holes in yoke and pedal; then turn yoke into push rod an additional one-half turn to provide slight clearance between push rod and piston.
- (3) Install clevis pin attaching pedal-to-master-cylinder yoke (H) to brake pedal, with pedal pull-back spring clip (G) installed on clevis pin, and secure with cotter pin. Tighten locknut (J) against master cylinder piston push rod.

*c. Brake Pedal Upper Half Replacement.*

- (1) *Removal.* Remove nut from cap screw securing brake pedal upper half in brake pedal lower half and remove cap screw. Pull brake pedal upper half up out of pedal lower half and hole in pedal upper plate.
- (2) *Installation.* Insert brake pedal upper half down through felt seal in pedal upper plate and into end of brake pedal lower half. Aline notch in pedal upper half with cap screw hole in pedal lower half, install  $\frac{3}{8}$ -24 x  $1\frac{5}{8}$  cap screw and  $\frac{3}{8}$ -24 safety nut, and tighten nut to 20 to 27 pound-feet torque.

*d. Brake Pedal Lower Half Replacement.*

- (1) *Removal.* Remove brake pedal upper half (*c* above). Remove cotter pin and clevis pin attaching pedal-to-master-cylinder yoke (H) and pedal pull-back spring clip (G) to brake pedal lower half (E). Remove cotter pin securing master cylinder brace (C) on brake pedal shaft (D). Loosen cap screw attaching brace to master cylinder (A) enough to permit removing brace from pedal shaft. Slide pedal lower half off shaft. Remove pedal-to-toe-pan bumper from pedal lower half.
- (2) *Installation.* Install pedal-to-toe-pan bumper on brake pedal lower half (E). Place pedal lower half on brake pedal shaft (D), position master cylinder brace (C) on shaft, and secure with cotter pin. Tighten cap screw attaching master cylinder brace (C) to master cylinder (A). Adjust linkage and connect to pedal lower half (*b*(2) and (3) above). Install brake pedal upper half (*c* above). Lubricate brake pedal at point shown on lubrication order (par. 69).

## 242. Master Cylinder

*Note.* The key letters noted in parentheses are in figure 249.

*a. General.* Master cylinder, with integral fluid reservoir, is mounted on pedal and master cylinder bracket which is riveted to left frame side member. Master cylinder piston push rod is connected to brake pedal lower half by a yoke and clevis pin. Hydraulic brake line connects to outlet at rear end of cylinder. Linkage connecting master cylinder piston push rod to brake pedal lower half is adjusted as described in paragraph 241*b*.

### *b. Removal.*

- (1) Remove bolt and gaskets attaching hydraulic brake line connector (L) to rear end of master cylinder (A).
- (2) Remove cotter pin and clevis pin attaching pedal-to-master-cylinder yoke (H) and pedal pull-back spring clip (G) to brake pedal lower half (E).
- (3) Disconnect master cylinder vent line from fitting (B) on master cylinder filler cap.
- (4) Remove cap screw and lockwasher attaching master cylinder brace (C) to master cylinder (A).
- (5) Remove four nuts and cap screws attaching master cylinder (A) to bracket. Remove master cylinder from bracket.
- (6) Remove pedal-to-master-cylinder yoke (H) and locknut from master cylinder piston push rod (K).

### *c. Installation.*

- (1) With locknut threaded onto pedal-to-master-cylinder yoke (H), thread yoke into end of master cylinder piston push rod (K).
- (2) Position master cylinder (A) at bracket, with push rod and yoke inserted through hole in bracket. Attach master cylinder to bracket with four  $\frac{3}{8}$ -24 x  $1\frac{1}{4}$  cap screws and  $\frac{3}{8}$ -24 safety nuts. Tighten nuts to 20 to 27 pound-feet torque.
- (3) Attach master cylinder brace (C) to side of master cylinder (A) with a  $\frac{7}{16}$ -20 x  $\frac{7}{8}$  cap screw and  $\frac{7}{16}$ -inch lockwasher.
- (4) Insert hydraulic brake line connector bolt through brake line connector (L), with copper gasket on both sides of connector, and thread bolt into rear end of master cylinder. Tighten bolt.
- (5) Connect master cylinder vent line to fitting (B) on master cylinder filler cap.
- (6) Connect pedal-to-master-cylinder yoke (H) to brake pedal lower half (E), making adjustment as described in paragraph 241*b*.
- (7) Bleed brake system (par. 237).

## 243. Air-Hydraulic Cylinder

(fig. 250)

*a. General.* Air-hydraulic cylinder is mounted on two brackets inside frame right side member above forward rear-axle. Front bracket is riveted to frame, and rear bracket is attached to frame by two cap screws and nuts. Hydraulic inlet line from master cylinder connects to bottom of control valve. Hydraulic outlet line to wheel cylinders connects to slave cylinder end fitting. Air line from air reservoir connects to control valve inlet port, air line to trailer brake service line coupling connects to control valve body, and air exhaust line connects to top of end plate.

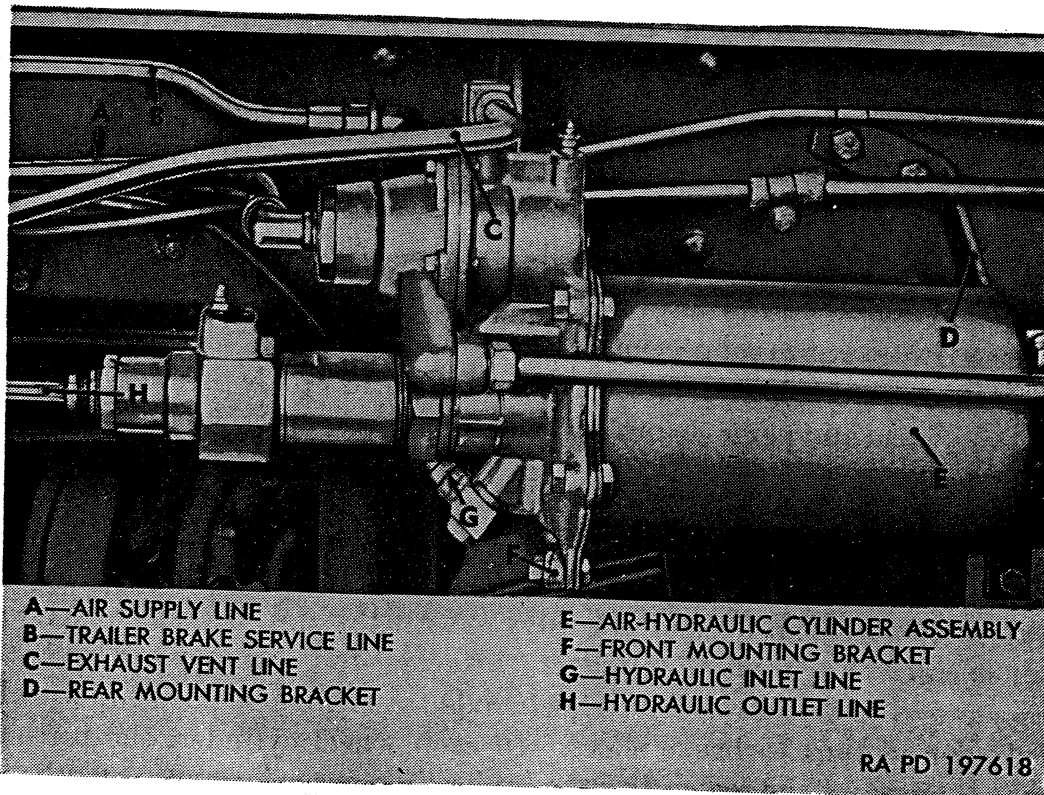

Figure 250. Air-hydraulic cylinder installed.

### *b. Removal.*

- (1) Exhaust air pressure from system. Disconnect air lines (A, B, and C) from air-hydraulic cylinder.
- (2) Disconnect hydraulic lines (G and H) from air-hydraulic cylinder.
- (3) Remove nuts from two cap screws securing air-hydraulic cylinder (E) to front mounting bracket (F).
- (4) Remove two nuts and cap screws attaching rear mounting bracket (D) to frame side member. Remove air-hydraulic cylinder and rear mounting bracket; then remove nut and plain washer attaching rear bracket to stud in rear of cylinder shell.



*c. Installation.*

- (1) Install rear mounting bracket (D) on stud at rear of air-hydraulic cylinder assembly (E) and secure with plain washer and  $\frac{5}{16}$ -24 safety nut. Do not tighten nut.
- (2) Position air-hydraulic cylinder and rear bracket at frame side member, with two end plate cap screws inserted through holes in front mounting bracket (F). Install  $\frac{5}{16}$ -24 safety nut on each cap screw and tighten to  $9\frac{1}{2}$  to 13 pound-feet torque.
- (3) Position rear mounting bracket at frame side member and secure with two  $\frac{3}{8}$ -24 x 1 cap screws and  $\frac{3}{8}$ -24 safety nuts, attaching hydraulic brake line clip under front cap screw head. Tighten nuts to 20 to 27 pound-feet torque; then tighten nut attaching rear bracket to cylinder to  $9\frac{1}{2}$  to 13 pound-feet torque.
- (4) Connect hydraulic inlet and outlet lines (G and H) to slave cylinder end fitting and end plate. Use copper gasket on both sides of hydraulic line fitting at bottom of end plate.
- (5) Connect air lines (A, B, and C) to air-hydraulic cylinder. Make sure connections are tightened.
- (6) Bleed brake system (par. 237). Build up air pressure in system and perform brake system tests (par. 236).

## 244. Wheel Cylinders

*a. General.* Two double-end wheel cylinders (L, fig. 246) are mounted on each backing plate between ends of brake shoes. Bleeder valves and hydraulic inlet openings extend through backing plate to inner side. Each wheel cylinder is attached to backing plate by two cap screws and lockwashers. Push rods transmit movement of wheel cylinder pistons to brake shoes. In each wheel cylinder, the piston which operates the toe end of the brake shoe has a longer stroke than the piston in the other end to compensate for the increased piston travel made necessary when brakes are adjusted to compensate for normal lining wear. Rubber boot at each end of cylinder keeps out water and dirt, and a heat shield at each cylinder deflects heat, created during brake application, away from cylinder.

*b. Removal.*

- (1) Remove brake shoes (par. 239b).
- (2) At inner side of backing plate, remove bolt attaching hydraulic connecting line fitting to wheel cylinder.
- (3) Remove two cap screws and lockwashers attaching wheel cylinder to backing plate. Remove wheel cylinder and heat shield from backing plate; then remove heat shield from wheel cylinder.

*c. Installation.*

- (1) Install heat shield on wheel cylinder. Place wheel cylinder and heat shield on backing plate with long end of cylinder adjacent to adjusting screw in anchor block. Attach wheel cylinder to backing plate with two  $\frac{5}{16}$ -18 x  $\frac{5}{8}$  cap screws and  $\frac{5}{16}$ -inch lockwashers, threading bolts into wheel cylinder from inner side of backing plate.
- (2) Insert bolt through hydraulic connecting line fitting, with new copper gaskets on both sides of fitting, and thread bolt into wheel cylinder at inner side of backing plate. Tighten bolt.
- (3) Install brake shoes (par. 239c).
- (4) Bleed brake system (par. 237).

## 245. Brake Lines and Connections

*a. Hydraulic Brake Lines.* Metal lines are used to carry hydraulic brake fluid from master cylinder to air-hydraulic cylinder; from air-hydraulic cylinder outlet to tee fitting at frame side member; from frame tee fitting to front and rear axle rubber line connections; from rubber line junctions at rear axles to distributor fitting on backing plates; and from rubber line junction at front axle to front brake rubber line connections. Flexible rubber lines (hose) are used between frame connections and axles, and from axle to distributor fitting on backing plate on front axle. Metal brake lines are made of special tubing with flared-type connections, designed to withstand high pressure and to resist corrosion; ordinary copper tubing is not satisfactory for use as hydraulic brake lines. When replacing metal brake lines, be sure replacement line is the same size as the one removed. Whenever any hydraulic line has been replaced or disconnected, make sure connections are tight, then bleed brake system (par. 237).

- (1) *Front axle to brake rubber line replacement* (fig. 251).
  - (a) *Removal.* Remove three cap screws and lockwashers attaching brake line shield to steering knuckle support and swing shield to one side. Disconnect metal brake line from rubber line fitting at bracket on outer end of axle housing. Remove nut and lockwasher securing rubber line fitting in bracket, remove end of rubber line from bracket on axle, and pull line through bracket on shield. Unscrew rubber brake line from distributor fitting at backing plate.
  - (b) *Installation.* Place plain copper washer on rubber line fitting, thread fitting into distributor fitting at backing plate, and tighten. Insert fitting at other end of rubber line through bracket on brake line shield, making sure rubber grommet is properly positioned in bracket on axle.

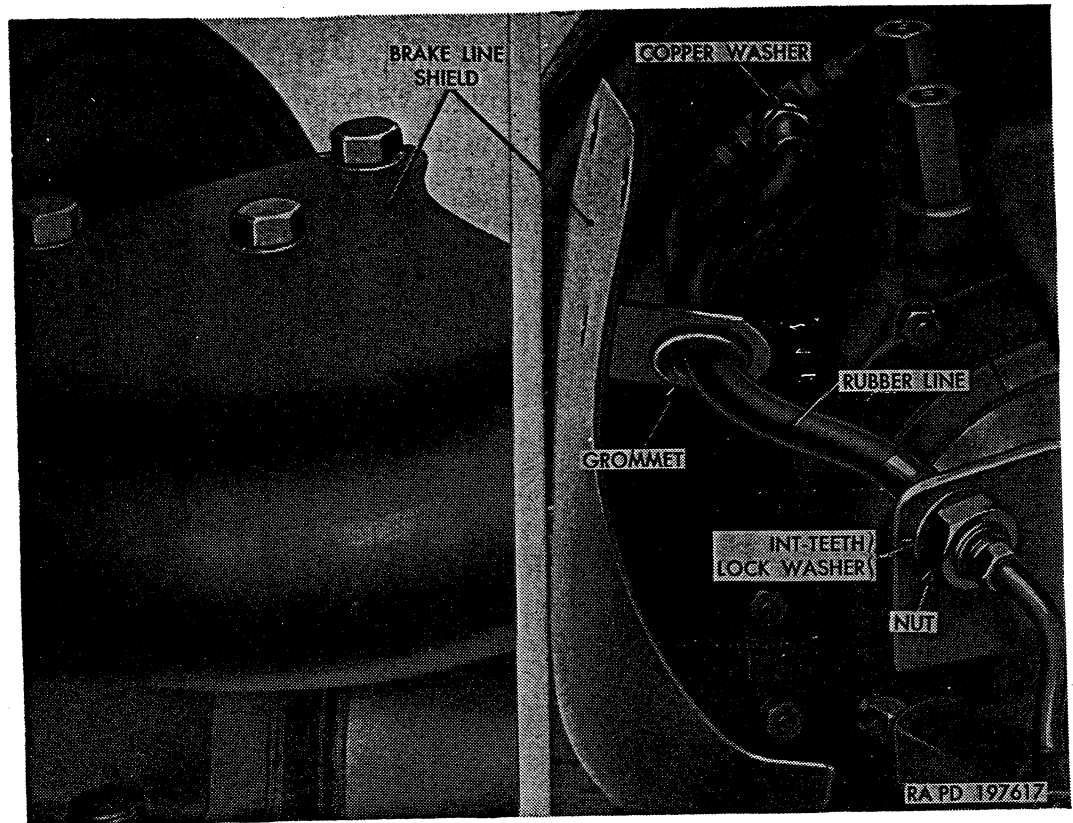

Figure 251. Front brake rubber line installed.

- Install  $\frac{3}{4}$ -inch internal-teeth lockwasher and  $\frac{3}{4}$ -16 nut on fitting, and tighten. Thread nut on metal brake line into rubber line fitting at bracket and tighten, using care not to overtighten. Position brake line shield on three spacer nuts on top of steering knuckle support and secure in place with three  $\frac{1}{2}$ -20 x  $\frac{1}{2}$  cap screws and  $\frac{1}{2}$ -inch internal-teeth lockwashers. Bleed brake system (par. 237).
- (2) *Frame to axle rubber line replacement* (fig. 252).
- (a) *Removal.* Disconnect metal brake line from rubber line fitting at bracket at frame. Remove nut and lockwasher securing rubber line fitting in bracket, and remove end of line from bracket. Remove wire clips securing brake rubber line and axle vent line in shield on torque rod. Unscrew rubber line fitting from connector at axle junction block.
- (b) *Installation.* Place copper washer on fitting at axle end of rubber line and thread fitting into connector at axle junction block. Insert fitting at other end of rubber line through bracket at frame and secure with  $\frac{5}{8}$ -inch internal-teeth lockwasher. Thread nut on metal brake line into rubber line fitting at frame bracket and tighten, using care not to overtighten. Place rubber brake line and axle vent line in shield on torque rod and secure with two wire clips. Bleed brake system (par. 237).

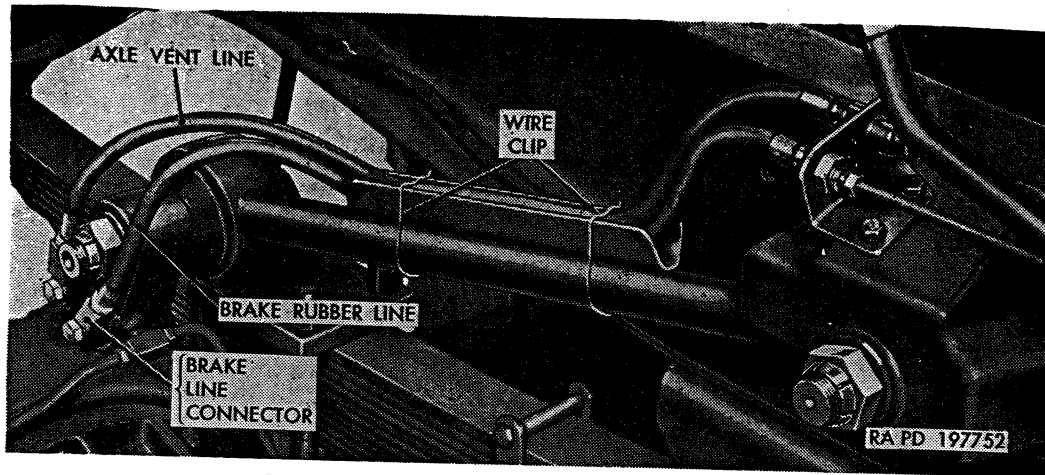

Figure 252. Frame to axle rubber line installed (front axle shown).

- (3) *Hydraulic brake metal line replacement.* To replace any metal brake line, disconnect line at both ends, disengage line from clips at frame, and remove line from vehicle. Install new line, connect at both ends, and tighten connections, using care not to overtighten. Make sure lines are clipped at frame, and that lines do not contact metal where they pass through frame cross members. Bleed brake system (par. 237).

*b. Air Lines.* Air lines are of seamless copper tubing with three-piece compression-type fittings. Air lines can be tested for leakage by building up air pressure in system to normal operating pressure (100 psi), then coating all air line connections with a solution of soap and water. Leakage will be indicated by the appearance of soap bubbles. Leakage can sometimes be corrected by tightening the connection. If tightening fails to correct leakage, new air line or connection must be installed. When replacing air lines, tubing must be free of burs, copper cuttings, and dirt. Blow line out with compressed air before installing. Any of the above mentioned particles will destroy sealing seats in air-hydraulic cylinder control valve. Replacement lines must be of the same size as the ones removed. Whenever air lines have been replaced or disconnected, tighten connections and check for leakage.

## 246. Air Compressor Governor

*a. General.* Air compressor governor controls pressure in air system by starting or stopping compression of air when system pressure reaches the desired minimum or maximum. Governor (E, fig. 254), mounted on air compressor cylinder head, consists primarily of a diaphragm-operated plunger which actuates a trigger to hold the air inlet valves off their seats, stopping compression, when pressure reaches maximum limit (100 psi). When pressure is reduced to minimum limit (75 to 80 psi), trigger releases inlet valves and compress-

sion of air is resumed. Governor diaphragm is subjected to air system pressure at all times by a flexible rubber line connected to air line junction fitting on cowl.

*b. Adjustment.* Adjustment points and method of checking and making adjustments are shown in figure 253. Adjustments must be made in the sequence given. Make sure cylinder head stud nuts are tightened ( $9\frac{1}{2}$  to 13 pound-feet torque) before adjusting governor.

- (1) *Governor trigger to stop.* With engine stopped and air pressure exhausted from system, remove cover from governor. Discard gasket. Depress trigger (fig. 253) by pressing with finger on end of trigger opposite trigger stop screw. Loosen locknut on trigger stop screw and adjust stop screw, to provide 0.065-inch clearance between heel of trigger and stop screw with trigger depressed. When correct clearance is obtained, tighten locknut on stop screw.
- (2) *Plunger housing to stop.* Insert a screwdriver between governor plunger housing (fig. 253) and diaphragm spring; then using side of governor base as a fulcrum, pry plunger housing up just enough to permit the plunger to trip the trigger downward. With plunger housing in this position, check clearance between top of plunger housing and stop. Bend stop if necessary to obtain  $\frac{1}{32}$ -inch clearance between housing and stop.
- (3) *Cutout pressure adjustment.* With cover removed from governor, start engine and build up air pressure in system. Observe reading on air pressure gage in instrument cluster when governor plunger trips trigger downward. Cutout pressure should be 100 psi. If necessary to adjust cutout pressure (fig. 253), turn adjusting screw to change tension on diaphragm spring. Turn adjusting screw clockwise to increase cutout pressure and counterclockwise to reduce cutout pressure. One complete turn of adjusting screw will change cutout pressure 14 psi.
- (4) *Cut-in pressure check.* Slowly reduce air pressure in system and note pressure reading on gage when governor plunger trips trigger upward. With correct cutout pressure setting (100 psi), cut-in pressure should be 75 to 80 psi. If governor does not cut in within these limits, check adjustment (1), (2), and (3) above, then repeat cut-in pressure check.
- (5) *Install governor cover.* Place new cover gasket on governor base. Install cover over governor attaching studs and secure with two  $\frac{1}{4}$ -28 safety nuts. Lubricate governor as shown on lubrication chart (par. 69).

*c. Air Compressor Governor Replacement.*

(1) *Removal.*

(a) Disconnect flexible rubber line from governor end cover.

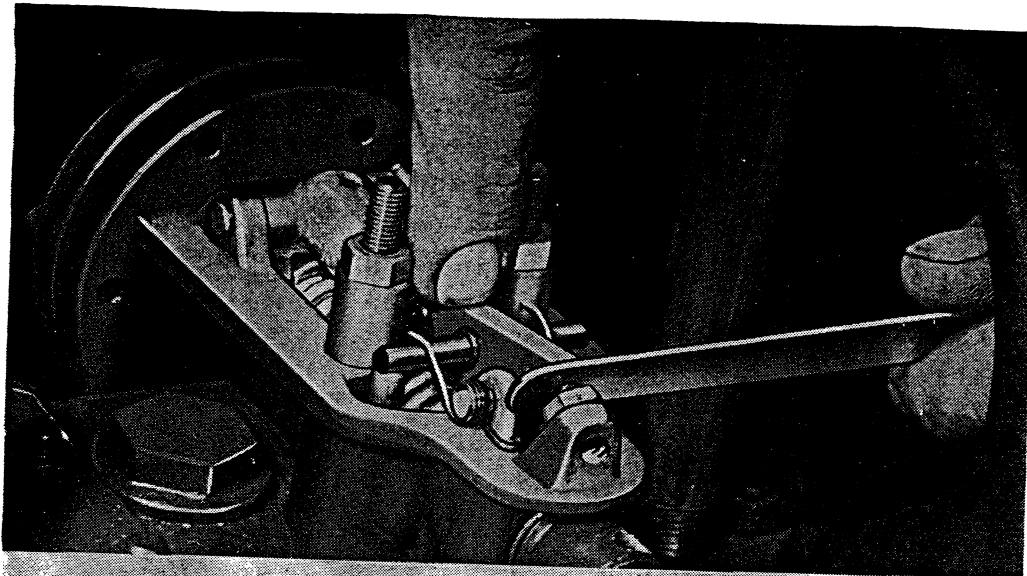

CHECKING TRIGGER TO STOP CLEARANCE

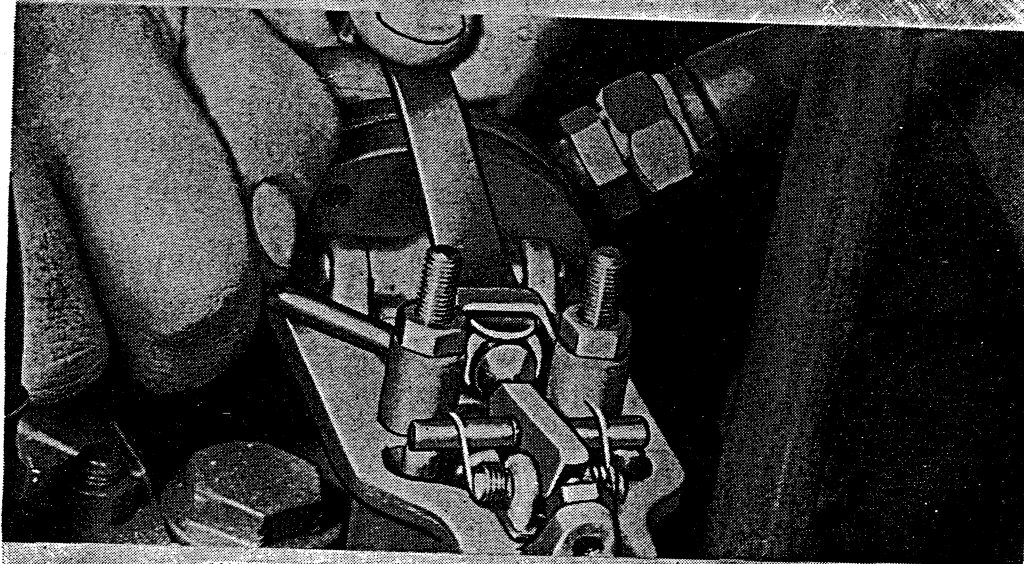

CHECKING PLUNGER HOUSING TO STOP CLEARANCE

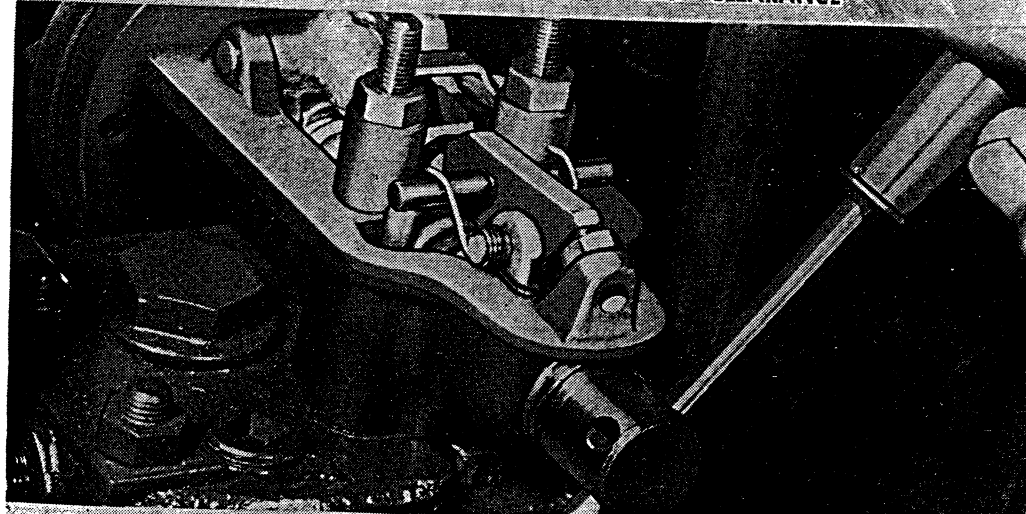

ADJUSTING CUT-OUT PRESSURE

RA PD 148922

Figure 253. Air compressor governor adjustments.

- (b) Remove two safety nuts attaching governor cover to governor base. Remove cover and cover gasket from base.
  - (c) Remove two nuts from governor attaching studs. Remove plunger housing stop and two spacers from studs. Lift governor assembly off studs and remove governor-to-cylinder-head gasket. Discard gasket.
  - (d) Lift inlet valve plungers and plunger springs out of cylinder head.
- (2) *Installation.*
- (a) Place inlet valve plunger springs over inlet valve plungers and insert plungers through openings in top of cylinder head onto inlet valves.
  - (b) Place new governor-to-cylinder-head gasket over governor attaching studs onto cylinder head.
  - (c) Carefully place governor assembly over studs, at the same time guiding inlet valve plungers and springs up through holes in governor base.
  - (d) Install a spacer on each governor attaching stud and place governor plunger housing stop over both studs, then install a  $\frac{1}{4}$ -28 nut on each stud. Tighten nuts to 5 to 7 pound-feet torque.
  - (e) Apply a few drops of engine oil to plunger and to plunger housing and trigger pivot points. Connect flexible rubber line to governor end cover. Before installing governor cover, adjust governor (*b* above).

## 247. Air Compressor Drive Belt

(fig. 254)

### *a. Adjustment.*

- (1) Loosen cap screws attaching air compressor adjusting arm to engine thermostat housing and to adjusting arm bracket on compressor cylinder head.
- (2) Loosen nut on cap screw (pivot bolt) attaching air compressor mounting base to engine front left inner mounting support bracket.
- (3) Move air compressor toward or away from engine as necessary to provide correct belt tension; tension is correct when a light pressure on belt midway between pulleys will cause  $\frac{1}{2}$  to  $\frac{3}{4}$ -inch deflection of belt.
- (4) When correct belt tension is obtained, tighten cap screw attaching adjusting arm to bracket on compressor cylinder head; then tighten cap screw attaching adjusting arm to engine thermostat housing, and tighten nut on cap screw (pivot bolt) attaching compressor mounting base to engine front left inner mounting support bracket.

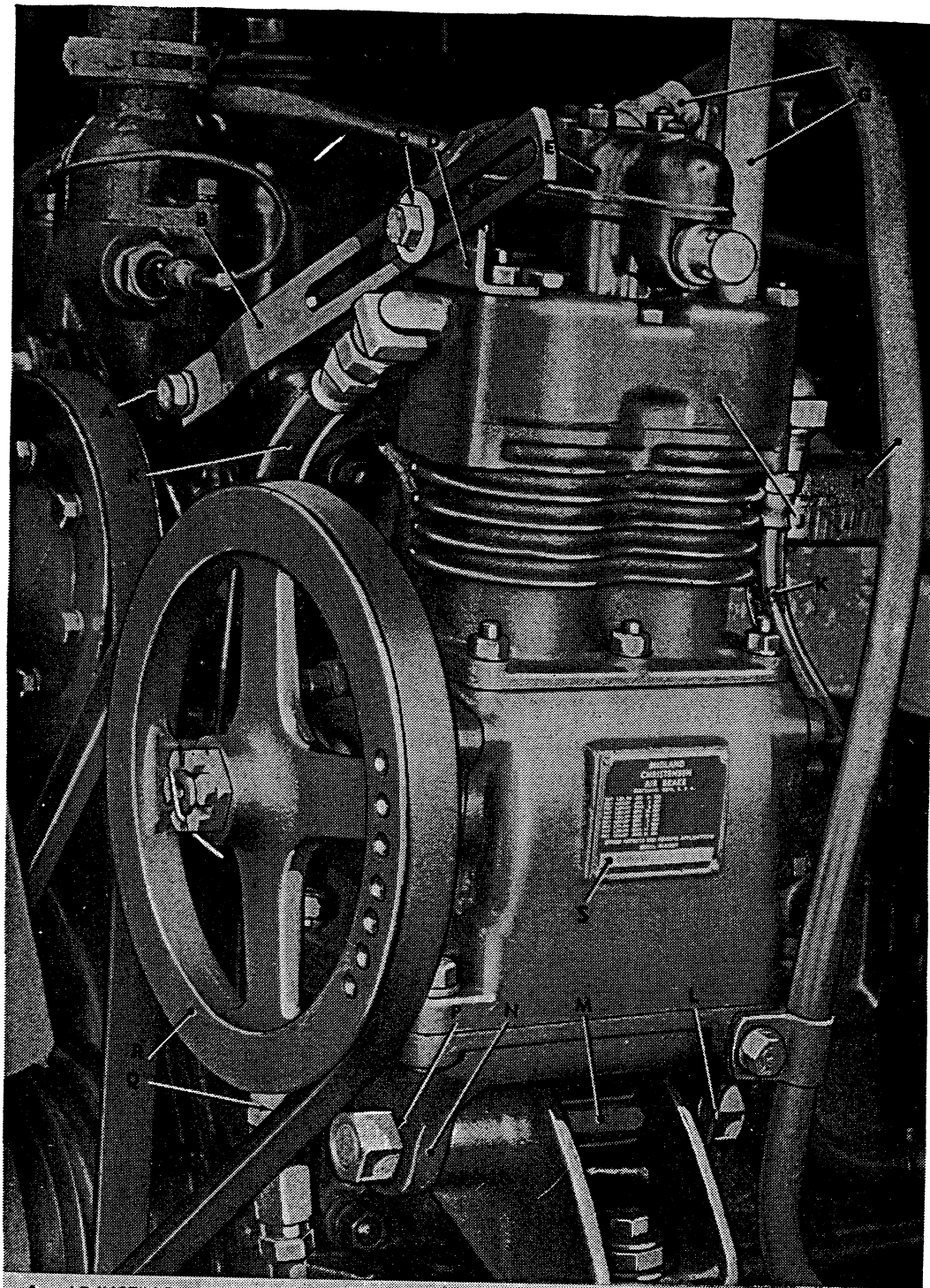

A—ADJUSTING ARM TO CYLINDER HEAD BOLT  
 B—ADJUSTING ARM  
 C—ADJUSTING ARM TO BRACKET BOLT  
 D—ADJUSTING ARM BRACKET  
 E—GOVERNOR ASSEMBLY  
 F—GOVERNOR AIR LINE  
 G—AIR INTAKE LINE  
 H—DISCHARGE LINE  
 J—COMPRESSOR ASSEMBLY

K—WATER LINES  
 L—LOCK WASHER  
 M—MOUNTING BOLT  
 N—MOUNTING BASE  
 P—MOUNTING BOLT NUT  
 Q—DRIVE BELT  
 R—DRIVE PULLEY  
 S—NAME PLATE

RA PD 197622

Figure 254. Air compressor installed.



*b. Replacement.*

- (1) Loosen cap screws attaching air compressor adjusting arm to engine thermostat housing and to adjusting arm bracket on compressor cylinder head.
- (2) Loosen nut on cap screw (pivot bolt) attaching air compressor mounting base to engine front left inner mounting support bracket.
- (3) Move air compressor toward engine and remove drive belt from compressor drive pulley and from engine crankshaft pulley.
- (4) Position new drive belt in groove in engine crankshaft pulley and in compressor drive pulley.
- (5) Adjust drive belt tension (a(3) and (4) above).

## **248. Air Compressor**

(fig. 254)

*a. General.* Air compressor, mounted on left front side of engine, is a two-cylinder, reciprocating-type unit. Air compressor is driven by belt from the engine crankshaft pulley, lubricated by the engine lubrication system, and the air compressor cylinder head is water-cooled by the engine cooling system. Air compressor crankshaft turns continuously while the engine is running, but actual compression of air is controlled by the air compressor governor which is mounted on the compressor cylinder head. Air compressor air intake port is connected to engine air intake system at the carburetor air inlet elbow. Oil is carried from the engine main oil gallery to the compressor crankshaft rear bearing cap by a flexible line, is forced through the drilled crankshaft, lubricating the connecting rods, piston pins, and cylinder walls. Oil drains into compressor mounting base and returns to the engine crankcase through the oil return line.

*b. Removal.*

- (1) Refer to paragraph 2 for information on coordination with an ordnance maintenance unit.
- (2) Exhaust air pressure from air system.
- (3) Disconnect oil inlet line from compressor crankshaft rear bearing cap, and disconnect oil return line from compressor mounting base.
- (4) Disconnect water inlet and outlet lines (K) from elbows on air compressor cylinder head.
- (5) Disconnect compressor copper discharge line (H) and air intake line (G) from fittings on compressor cylinder head. Disconnect governor air line (F) from compressor governor end cover. Remove cap screw and lockwasher attaching discharge line clip to compressor mounting base (N).
- (6) Remove bolt (C), plain washer, lockwasher, and nut attaching adjusting arm (B) to bracket (D) on compressor cyl-

inder head. Loosen nut (P) on mounting bolt (M) attaching compressor mounting base to engine front left inner mounting support bracket. Move compressor toward engine and remove drive belt (Q) from compressor drive pulley (R).

- (7) Remove nut, lockwasher, and mounting bolt (M) attaching compressor mounting base to engine front left inner mounting support bracket. Lift compressor and mounting base away from engine.
- (8) Remove four cap screws and lockwashers attaching compressor mounting base (N) to compressor crankcase, and remove mounting base and gasket. Discard gasket.
- (9) Remove cotter pin and nut securing drive pulley (R) on compressor crankshaft. Remove pulley from crankshaft, using a suitable puller.
- (10) Remove all air, oil, and water line elbows and fittings from air compressor for installation on replacement unit.
- (11) Remove nuts attaching adjusting arm bracket (D) to two cylinder head studs, and remove bracket for installation on replacement unit. Install nuts on cylinder head studs.

*c. Installation.*

- (1) Install air, oil, and water line elbows and fittings on air compressor, coating threads of each connector with plastic-type gasket cement. Tighten connectors, leaving elbows pointing in proper direction for connecting lines.
- (2) Install drive pulley (R) on compressor crankshaft, making sure woodruff key is in place in keyway in crankshaft. Secure pulley on crankshaft with nut and cotter pin.
- (3) Remove nuts from two cylinder head studs at front of air compressor. Install adjusting arm bracket (D) on studs and install nuts. Tighten nuts to 9½ to 13 pound-feet torque.
- (4) Install compressor mounting base (N) on bottom of compressor crankcase, using new base-to-crankcase gasket, and attach with four 7/16-14 x 1¼ cap screws and 7/16-inch lockwashers. Tighten cap screws to 50 to 55 pound-feet torque.
- (5) Position air compressor at engine and install ¾-16 x 6½ mounting bolt (M) attaching compressor mounting base to engine front left inner mounting support bracket. Install ¾-16 nut and ¾-inch lockwasher on mounting bolt, but do not tighten.
- (6) Attach adjusting arm (B) to bracket on air compressor cylinder head with 3/8-24 x 7/8 adjusting arm to bracket bolt (C), 7/16-inch plain washer, 3/8-inch lockwasher, and 3/8-24 nut. Do not tighten nut.

- (7) Connect oil inlet line to compressor crankshaft rear bearing cap, and connect oil return line to compressor mounting base. Use plastic-type gasket cement sparingly on connector threads.
- (8) Connect air discharge line (H) and air intake line (G) to compressor cylinder head, and connect governor air line (F) to governor end cover. Make sure connections are tight.
- (9) Connect water inlet and outlet lines (K) to elbows on compressor cylinder head, using plastic-type gasket cement sparingly on connector threads.
- (10) Adjust air compressor drive belt tension (par. 247a). Fill engine cooling system (par. 142a). Build up air pressure in system, check air compressor governor operation, and adjust if necessary (par. 246b).

*d. Record of Replacement.* Record the replacement on DA Form 478.

## 249. Air Reservoirs and Safety Valve

(fig. 255)

### *a. General.*

#### (1) *Air reservoirs.*

(a) Two air reservoirs are used on each vehicle. On cargo truck M135, one air reservoir is mounted on inside of each frame side member ahead of forward rear axle. On cargo truck M211, gasoline tank truck M217, shop van truck M220, and water tank truck M222, one air reservoir is mounted inside frame right side member ahead of forward rear axle, and one is mounted on support brackets below frame left side member ahead of forward rear axle. On dump truck M215 and truck tractor M221, one air reservoir is mounted on outside of frame right side member and one on support brackets below frame right side member, both ahead of forward rear axle. Each air reservoir is attached to frame side member or to support brackets by two U-bolts.

(b) The purpose of the air reservoirs is to provide a place to store compressed air so there will always be an ample supply available for immediate use for brake operation. They also provide storage for sufficient compressed air to permit several brake applications with the engine stopped. Another purpose of the air reservoirs is to provide a place where the air, heated during compression, may cool and the oil and water vapors condense. Drain cock is provided at bottom of each reservoir for draining condensation from reservoirs.

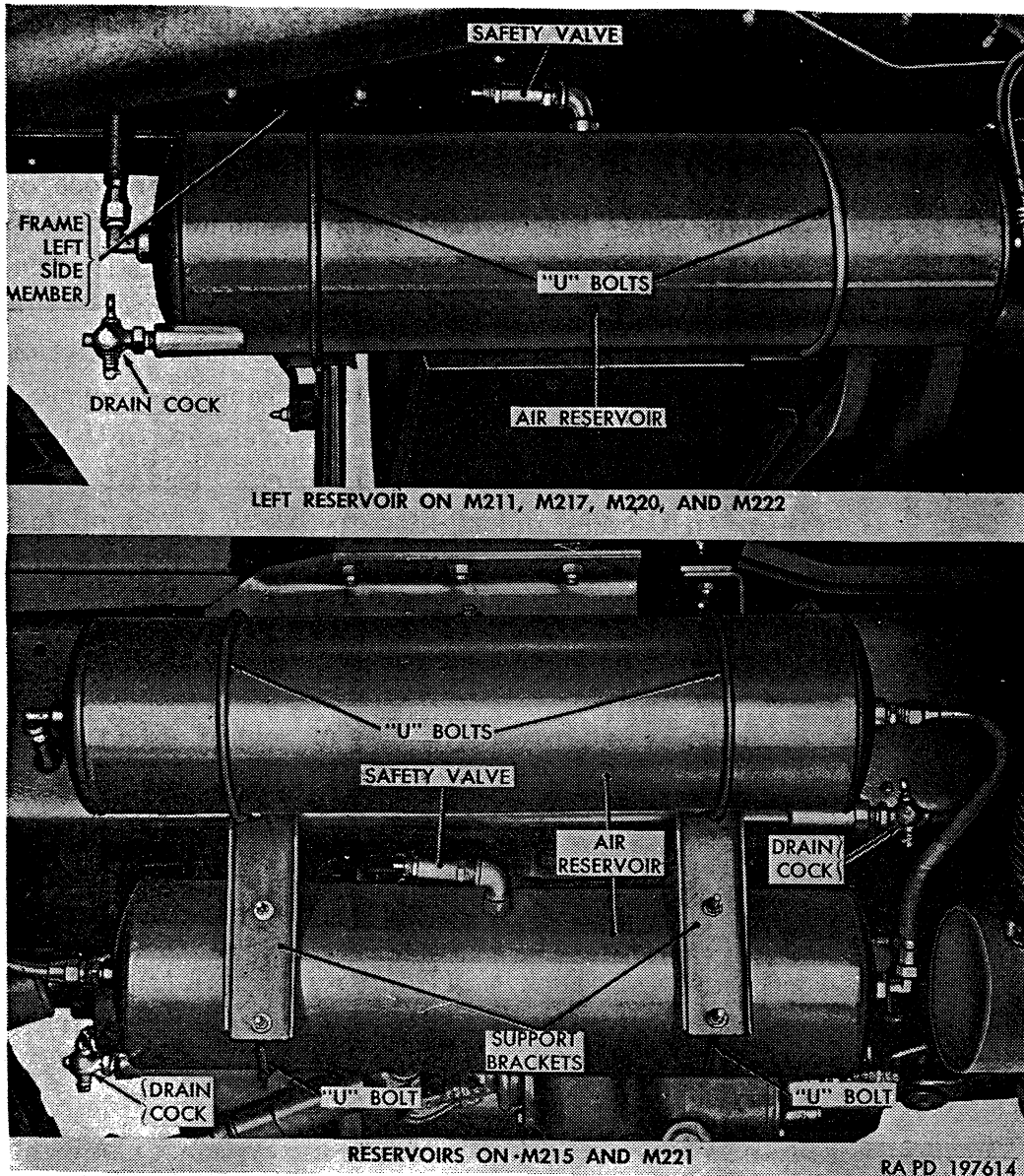

Figure 255. Air reservoir installations.

(2) *Safety valve.* Safety valve, installed on top of left air reservoir (bottom reservoir on M215 and M221), is provided to eliminate the possibility of air pressure building up in the system beyond a safe maximum in the event of failure of the air compressor governor. Safety valve permits air pressure in excess of 150 psi to escape.

b. *Air Reservoir Replacement.* The following procedure covers replacement of either tank on all vehicles.

(1) *Removal.* Exhaust air pressure from air system. Disconnect air lines from air reservoir. Remove nuts (and plain washers when reservoir is mounted on support brackets) from reservoir U-bolts. Remove reservoir and U-bolts (and reservoir support when reservoir is mounted inside frame side

member). Remove **U**-bolts and supports (when used) from air reservoir. Remove drain cock, safety valve (where used), and air line fittings from air reservoir for installation on replacement reservoir.

- (2) *Installation.* Install air line connectors and drain cock on air reservoir, using plastic-type gasket cement on threads. Also install safety valve on air reservoir (where used). Position **U**-bolts on air reservoir. If reservoir is mounted inside frame side member, place support over **U**-bolts. Position reservoir with **U**-bolts inserted through frame side member or support brackets. Place plain washers over ends of **U**-bolts if reservoir is mounted on support brackets. Install  $\frac{5}{16}$ -24 safety nuts on **U**-bolts and tighten to  $9\frac{1}{2}$  to 13 pound-feet torque. Connect air lines to reservoir and tighten connections. Build up air pressure in system and test connections for leakage, using soap and water solution.

*c. Safety Valve Replacement.* Unscrew safety valve from elbow on top of air reservoir. Coat threads of new or rebuilt safety valve sparingly with plastic-type gasket cement and thread into elbow on air tank, and tighten.

## **250. Trailer Connections**

*a. General.* Two air line couplings at rear end of vehicle on all models, except gasoline tank truck M217 and water tank truck M222 provide a means of connecting the trailer brake system to the truck brake system. Coupling on right side of vehicle, marked **EMERGENCY**, is connected directly to air reservoir on truck, and delivers a constant supply of air pressure to the trailer air system. Coupling on left side, marked **SERVICE**, is connected to the air-hydraulic cylinder control valve, and delivers air pressure to the trailer brake operating valve when truck brakes are applied. Dummy couplings, attached to frame brackets by chains, are provided to seal trailer air couplings against the entrance of dirt when not in use. A cutout cock at each trailer coupling provides a means of shutting off the trailer brake air lines when not connected to trailer. On truck tractor M221, two additional trailer couplings and cutout cocks are installed at rear of cab (fig. 258) for connecting truck brake system to semitrailer brake system. Couplings and identification markings are identical to those installed at rear of vehicle. Use of trailer brake couplings is described in paragraph 44. Figure 256 shows a sectional view of a single coupling and a view of two couplings connected. When the two couplings are connected together, pressure is placed on two rubber packing rings, making an airtight seal.

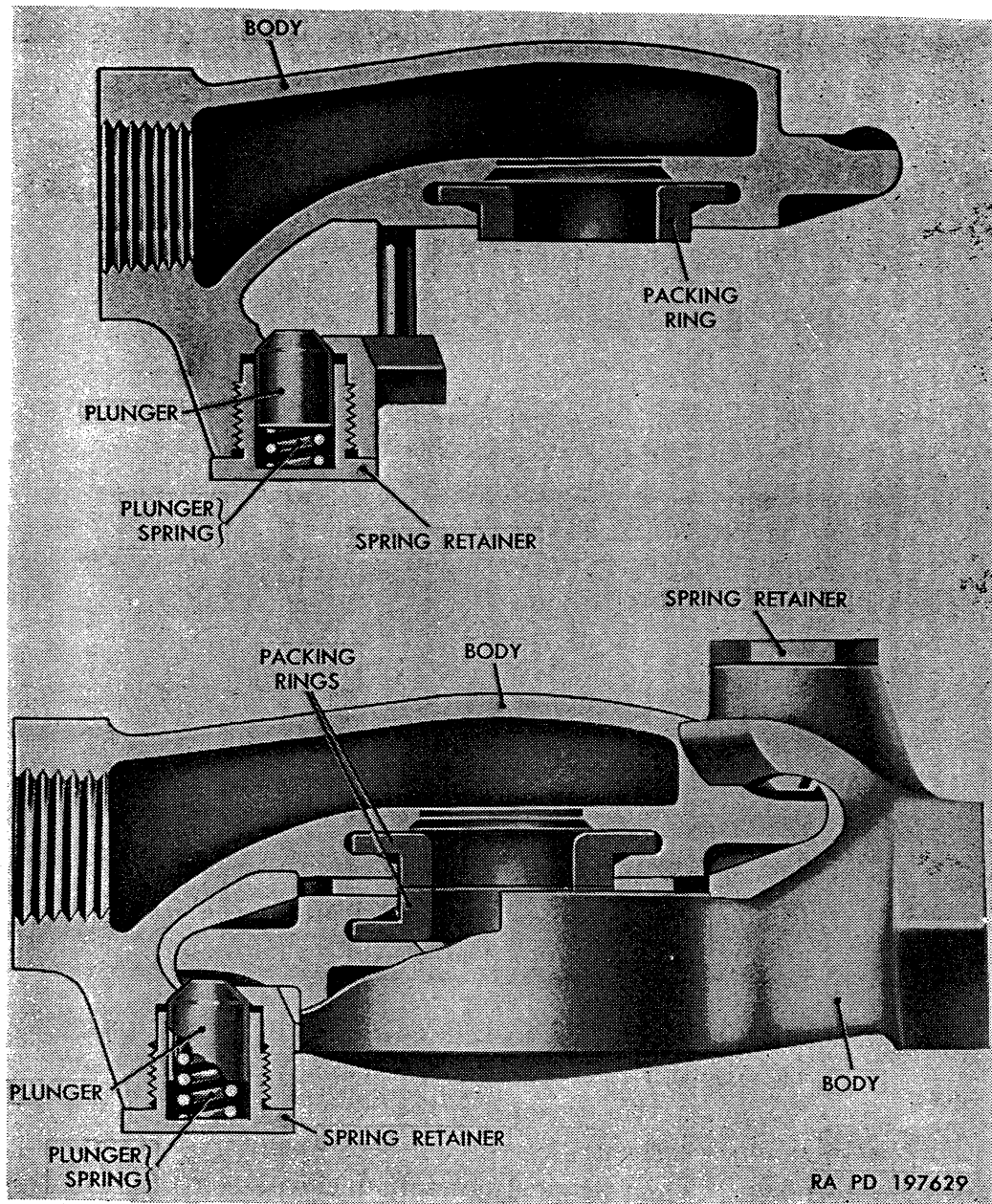

Figure 256. Sectional views of trailer brake hose coupling.

*b. Trailer Brake Coupling Replacement (fig. 257 or 258)*

- (1) *Removal.* Cutout cock must be closed. Remove dummy coupling from trailer coupling. Unscrew coupling from cutout cock connector.
- (2) *Installation.* Coat threads of cutout cock connector sparingly with plastic-type gasket cement. Thread trailer coupling onto connector and tighten. Assemble dummy coupling to trailer coupling.

*c. Trailer Brake Coupling Repair.*

- (1) *Packing ring replacement (fig. 259).* Pry old packing ring out of body with a screwdriver. Thoroughly clean packing ring groove, scraping if necessary to remove all particles of

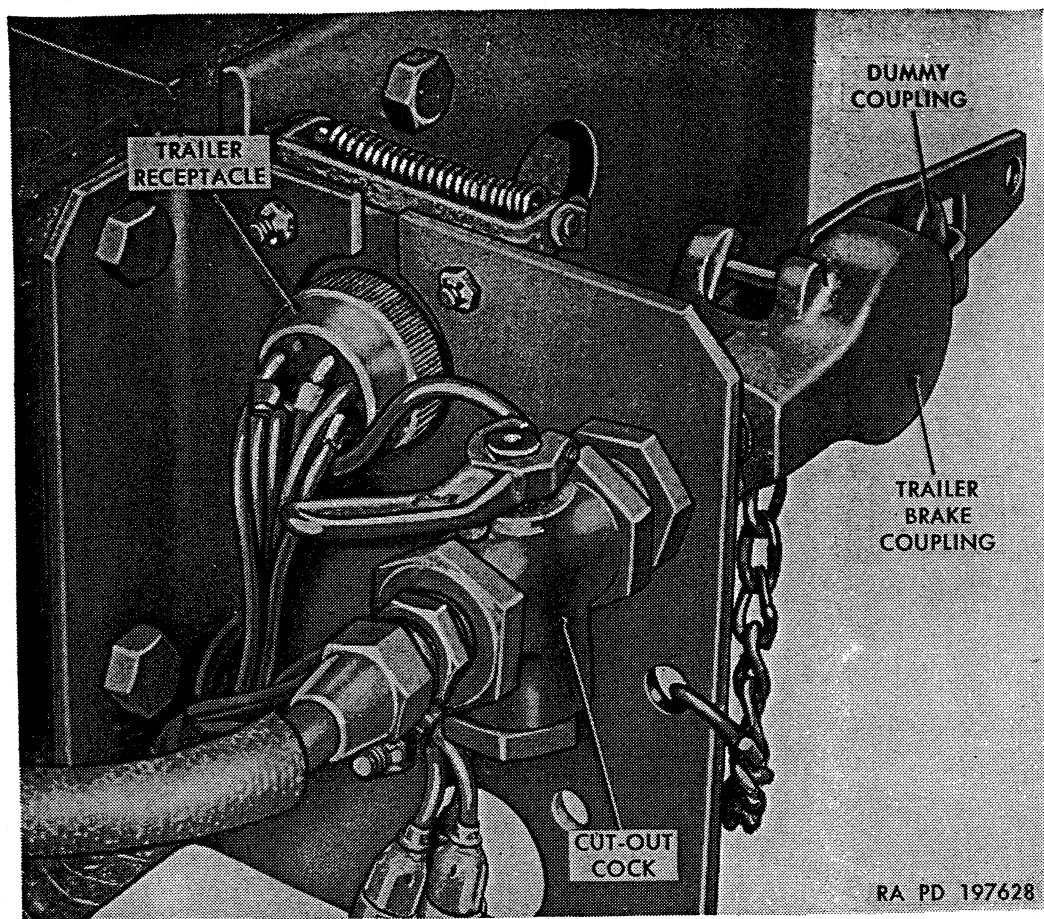

Figure 257. Trailer brake coupling and cutout cock installed at rear of frame (left side shown).

old packing ring. To install new packing ring, partially collapse ring with fingers and insert one side of the packing ring flange into the groove in the coupling body. Then use a blunt-nose screwdriver to complete pushing packing ring into place. When properly installed, the exposed face of the packing ring must be flat and not twisted or bulged at any point.

- (2) *Plunger and spring replacement* (fig. 256). Unscrew spring retainer from body of coupling and remove spring and plunger. Place new plunger and spring in spring retainer, thread retainer into coupling body, and tighten. Make sure nose of plunger extends through body.

*d. Trailer Brake Cutout Cock Replacement* (fig. 257 or 258).

- (1) *Removal.* Exhaust air pressure from system before removing cutout cock at trailer brake EMERGENCY line coupling. Disconnect air line from cutout cock. Unscrew cutout cock from connector.
- (2) *Installation.* Coat threads of cutout cock connector with plastic-type gasket cement. Thread cutout cock onto connec-

tor and tighten. Connect air line to cutout cock, tightening the connection. Build up air pressure in system and test connections for leakage. Truck brakes must be applied when testing the left (SERVICE) connection.

## 251. Trailer Brake Hand Control Valve (M221 Only)

*a. General.* Trailer brake hand control valve, mounted on steering column jacket, is used only on truck tractor M221 to provide a means of independent trailer brake control. Hand control valve inlet port is connected to constant pressure line at fitting below the air pressure gage sending unit on cowl. The hand control valve outlet port is connected to the trailer brake service line double check valve (fig. 175), mounted inside frame left side member at rear of cab. Exhaust check valve, installed in exhaust port, permits control valve to exhaust air

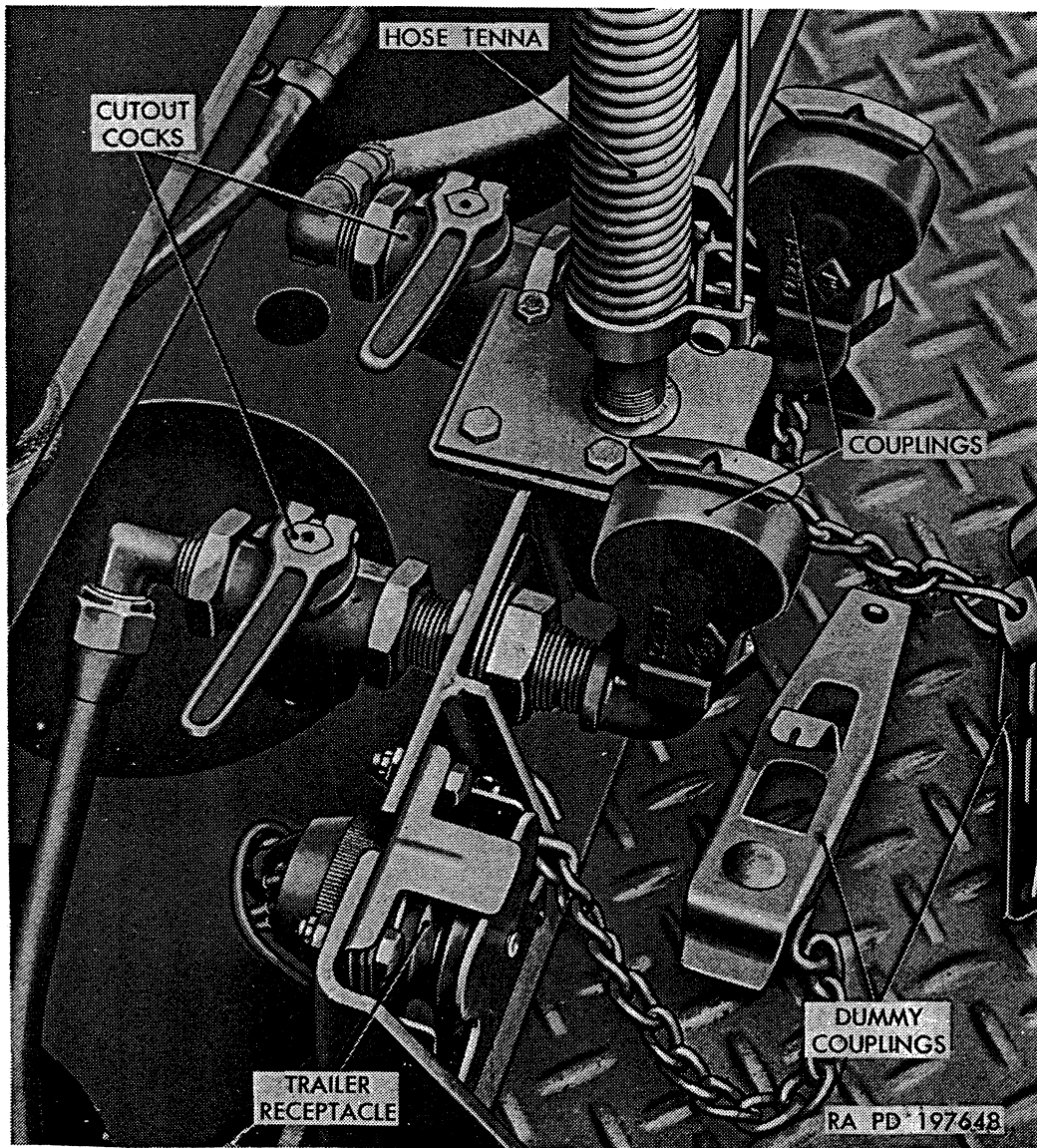

Figure 258. Trailer brake couplings and cutout cocks installed at rear of cab (M221).



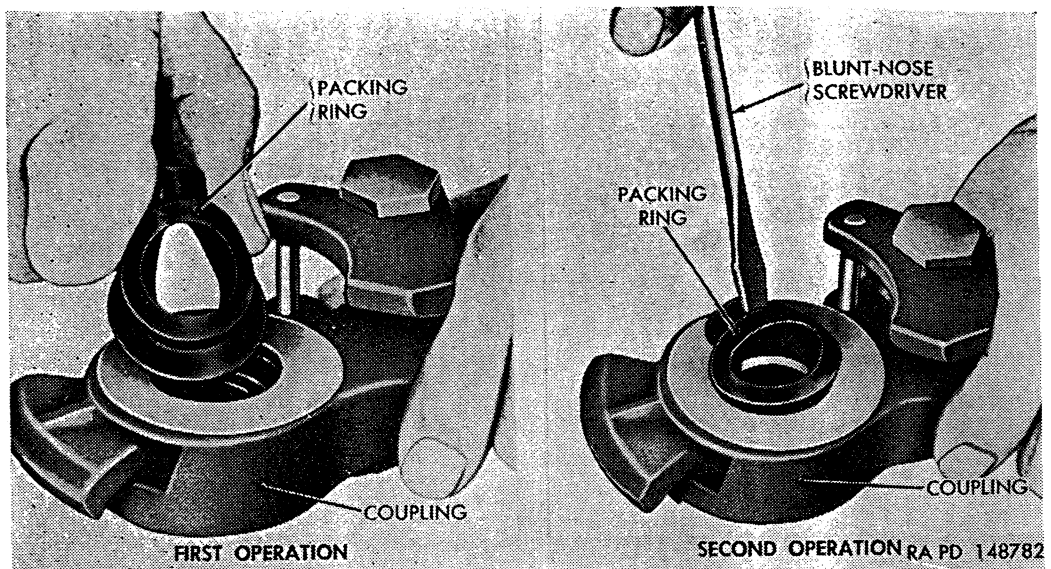

Figure 259. Replacing trailer brake coupling packing ring.

pressure from service line, but prevents entrance of water and dirt. Use of trailer brake hand control valve is described in paragraph 44.

*b. Tests.*

- (1) *Operating tests.* Check the delivery pressure of the hand control valve, using an accurate test gage. Test gage can be connected to trailer brake service line outlet at rear of vehicle. With valve handle moved to fully applied position, valve must deliver at least 75 psi pressure. Move the valve handle to several different positions between fully released and fully applied, and observe that the air pressure registered by the test gage varies in accordance with the position to which the handle is moved. Replace hand control valve assembly (*c* below) if it does not meet the above requirements.
- (2) *Leakage tests.* Coat the exhaust valve with soap and water solution with the control valve handle in fully released and in fully applied positions. If leakage in either test exceeds a 1-inch diameter bubble in 1 second, control valve assembly must be replaced.

*c. Replacement.*

(1) *Removal.*

- (a) Exhaust air pressure from air system.
- (b) Disconnect copper air line from control valve inlet port.
- (c) Remove two socket-head setscrews attaching mounting clamp to control valve body and lower valve from steering column.
- (d) Disconnect rubber air line from fitting at toe pan above steering column jacket and remove clip attaching line to steering column jacket; then unscrew line fitting from control valve outlet port.

- (e) Remove exhaust check valve from control valve exhaust port for installation in replacement unit.
- (2) *Installation.*
  - (a) Thread rubber air line fitting into control valve outlet port and tighten.
  - (b) Thread exhaust check valve into control valve exhaust port and tighten.
  - (c) Position control valve at steering column jacket, install mounting clamp, and secure with two socket-head setscrews. Tighten setscrew.
  - (d) Connect copper air line to control valve inlet port.
  - (e) Connect rubber air line to fitting at toe pan above steering column jacket. Secure line to steering column jacket with band-type clip.
  - (f) Build up air pressure in system and test control valve (b above).

## 252. Trailer Brake Service Line Double Check Valve (M221 Only)

*a. General.* Double check valve (fig. 175) mounted inside frame left side member is used only on truck tractor M221. Check valve is used to connect both the trailer brake service line from the air-hydraulic cylinder and the trailer brake control line from the hand control valve to the trailer brake service line leading to the trailer brake SERVICE coupling. When truck brakes are applied, air pressure from the air-hydraulic cylinder control valve forces the check valve disk over against the inlet from the hand control valve, and flows out the check valve outlet port into the trailer brake service line. When truck brakes are released and trailer brakes are applied by means of the trailer brake hand control valve, air pressure from the hand control valve forces the check valve disk over against the inlet from the air-hydraulic cylinder control valve, and flows out the check valve outlet port into the trailer brake service line.

### *b. Test.*

- (1) Disconnect air line from front side of check valve. Coat air line fitting at front side of check valve with soap and water solution, apply truck brakes, and check for leakage at front side of check valve.
- (2) Connect air line to front side of check valve and disconnect air line from elbow at rear of check valve. Coat open end of elbow with soap and water solution, move trailer brake hand control lever to fully applied position, and check for leakage at the open end of the check valve elbow.
- (3) Leakage in excess of a 1-inch diameter bubble in either of the above tests is not permissible. If leakage is excessive, replace double check valve (c below).

c. *Replacement* (fig. 175).

- (1) *Removal*. Disconnect cables from stop light switch and unscrew stop light switch from pipe nipple at side of check valve. Disconnect three air lines from check valve. Remove nut and cap screw attaching check valve to support bracket, and remove valve assembly. Remove elbow, pipe nipple, and two air line connectors from check valve for installation on replacement unit.
- (2) *Installation*. Coat threads of elbow, pipe nipple, and two air line connectors sparingly with plastic-type gasket cement, thread into check valve body, and tighten. Position check valve assembly at support bracket and attach with a  $\frac{3}{8}$ -24 x  $2\frac{3}{4}$  cap screw and  $\frac{3}{8}$ -24 nut. Tighten nut to 20 to 27 pound-feet torque. Connect three air lines to check valve, tightening the connections. Thread stop light switch onto pipe nipple at side of valve, tighten, and connect cables to stop light switch terminals.

## Section XXIV. PARKING BRAKE SYSTEM

### 253. Parking Brakes

a. *Mechanical Parking Brake*. Mechanical parking brake is an external-contracting one-piece band-type brake, located at rear of transfer assembly (fig. 260). Parking brake drum is installed between transfer-to-pillow-block propeller shaft flange and transfer output shaft flange. Brake band and lining assembly is supported around drum by a support bracket and anchor bracket which are integral with the transfer output gear bearing retainer. Parking brake hand lever (A, fig. 261) located at right of driver in cab, operates brake band through a relay lever and interconnecting rods.

b. *Temporary (Electric) Parking Brake*. Temporary (electric) parking brake system comprises a solenoid valve connected into the master cylinder hydraulic outlet line, operated by a two-position switch on instrument panel.

*Note*. This parking brake is for emergency use only in the event of failure of the mechanical parking brake, and should not be depended upon to hold the vehicle for extended periods.

c. *Data*.

(1) *Mechanical parking brake*:

Type	external-contracting band
Brake drum diameter	9½ in.
Brake lining width	3 in.
Brake lining thickness	5/16 in.

(2) *Temporary (electric) parking brake:*

Switch:

Manufacturer----- Delco-Remy  
Model----- 1997889

Solenoid valve:

Manufacturer----- Wagner Electric Corp  
Model----- FD-15018H

## 254. Mechanical Parking Brake Adjustment

*a. General.* Parking brake adjustment is required when hand lever requires more than three-quarters travel for full application. Adjustments are made at the brake band at rear of transfer, and at forward end of brake rod connecting brake cams to relay lever.

*b. Adjustment Procedure.*

- (1) Block wheels to prevent vehicle moving. Place hand lever in fully released position. Disconnect brake rod adjustable yoke (K, fig. 261) from relay lever by removing cotter pin and clevis pin.
- (2) Remove lock wire from anchor adjusting screw (C, fig. 260). Turn anchor adjusting screw as necessary to obtain a clearance of 0.015 inch between lining and drum. Install lock wire.
- (3) Loosen locknut on locating bolt (J, fig. 260). Draw up locating bolt until there is a clearance of 0.020 inch between lower end of lining and brake drum. Measure about 1½-inches clearance from end of lining. Tighten locknut on locating bolt.
- (4) Loosen locknut on adjusting bolt (M, fig. 260). Draw up adjusting bolt to obtain a clearance of 0.020 inch between upper end of lining and brake drum. Measure about 1½-inches clearance from end of lining. Tighten locknut on adjusting bolt.
- (5) Adjust yoke (K, fig. 261) on brake rod so that clevis pin may be freely inserted through yoke and relay lever. Install clevis pin and cotter pin, then tighten lock nut against yoke. Remove blocks from wheels.

## 255. Brake Band and Lining

(fig. 260)

*a. Removal.*

- (1) Block wheels to prevent vehicle moving. Disconnect relay-lever-to-brake rod (Q) from cams (P) by removing cotter pin and clevis pin. Remove cotter pin, clevis pin, and cams from upper end of adjusting bolt (M).
- (2) Remove nuts (F), washers, and tension spring (G) from lower end of adjusting bolt (M). Lift adjusting bolt

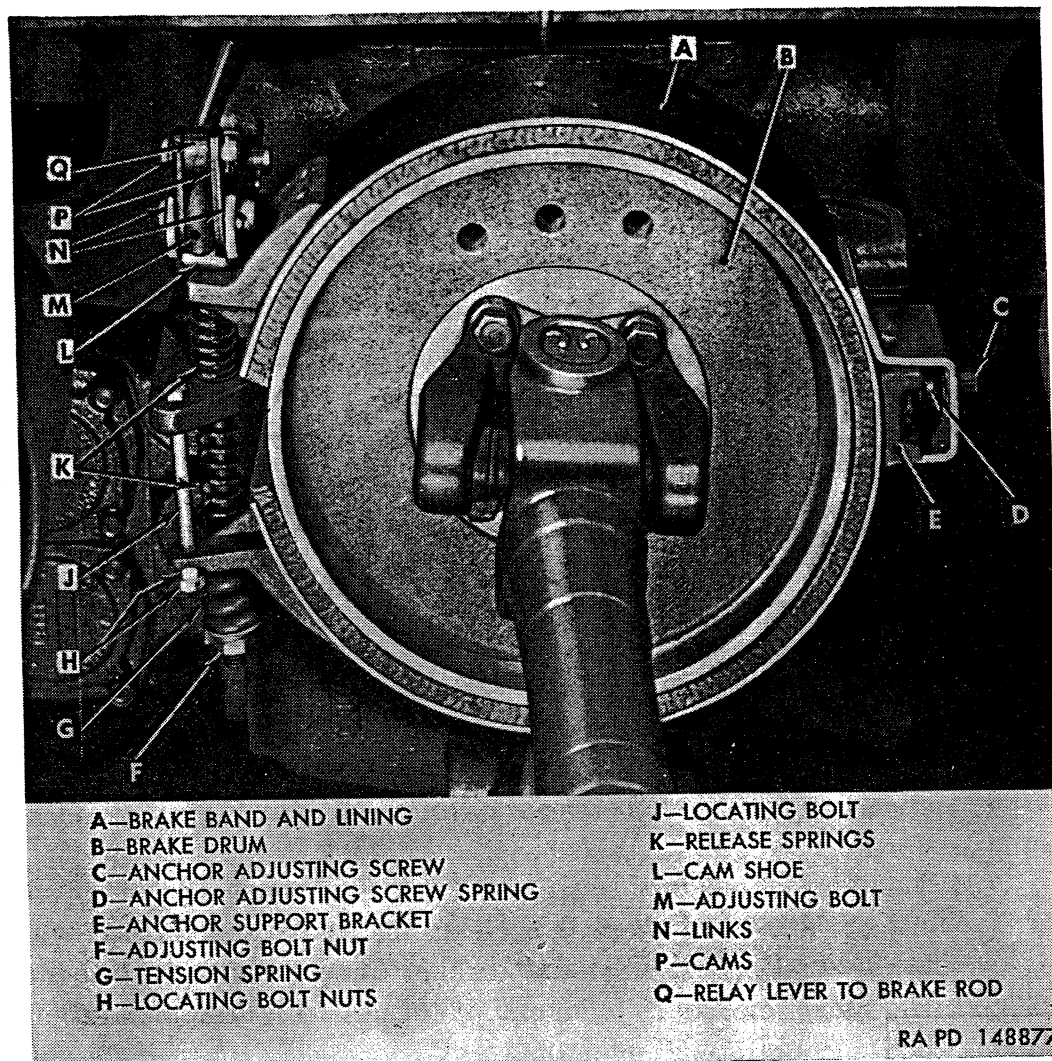

Figure 260. Parking brake drum, band, and linkage installed on transfer.

straight up out of brake band brackets and support bracket, stripping release springs (K) and cam shoe (L) from bolt as bolt is removed.

- (3) Remove nuts (H) from locating bolt (J) and remove bolt. Remove lock wire from anchor adjusting screw (C); then back screw out of anchor bracket.
- (4) Slide brake band and lining assembly (A) rearward off brake drum and anchor bracket, removing anchor adjusting screw spring (D) as band is removed. Pull band and lining assembly off over propeller shaft.

*b. Installation.*

- (1) Place brake band and lining over propeller shaft. Place anchor adjusting screw spring (D) in depression in anchor bracket, and compress spring as brake band and lining assembly (A) is placed over brake drum and anchor support.
- (2) Thread anchor adjusting screw (C) into anchor bracket until it contacts brake band. Insert locating bolt (J) down

through hole support bracket and brake band lower bracket. Install two nuts (H) on locating bolt.

- (3) Position cams (P) between links (N) and install clevis pin and cotter pin.
- (4) Insert threaded end of adjusting bolt (M) down between cams (P) with hook toward rear of vehicle; as bolt is lowered into place, it must pass through cam shoe (L), band upper bracket, upper release spring (K), support bracket, lower release spring (K), and band lower bracket. Install tension spring (G), flat washer, and two nuts (F) on adjusting bolt.
- (5) Connect relay-lever-to-brake rod (Q) to cams (P), using clevis pin and cotter pin. Adjust lining to drum clearance (par. 254b).

## 256. Parking Brake Linkage

(fig. 261)

### a. Hand Lever Replacement.

- (1) *Removal.* Remove cotter pin and clevis pin attaching adapter-to-relay-lever rod (G) to hand lever adapters (C). Remove nut from clamp bolt (F) securing hand lever on lever pin (E) and remove clamp bolt; then remove parking brake hand lever (A) from pin.
- (2) *Installation.* Install parking brake hand lever (A) on hand lever pin (E) with clamp bolt hole alined with groove in pin. Install hand lever clamp bolt (F) and nut and tighten to 20 to 27 pound-feet torque. Connect adapter-to-relay-lever rod (G) to hand lever adapters (C), using clevis pin and cotter

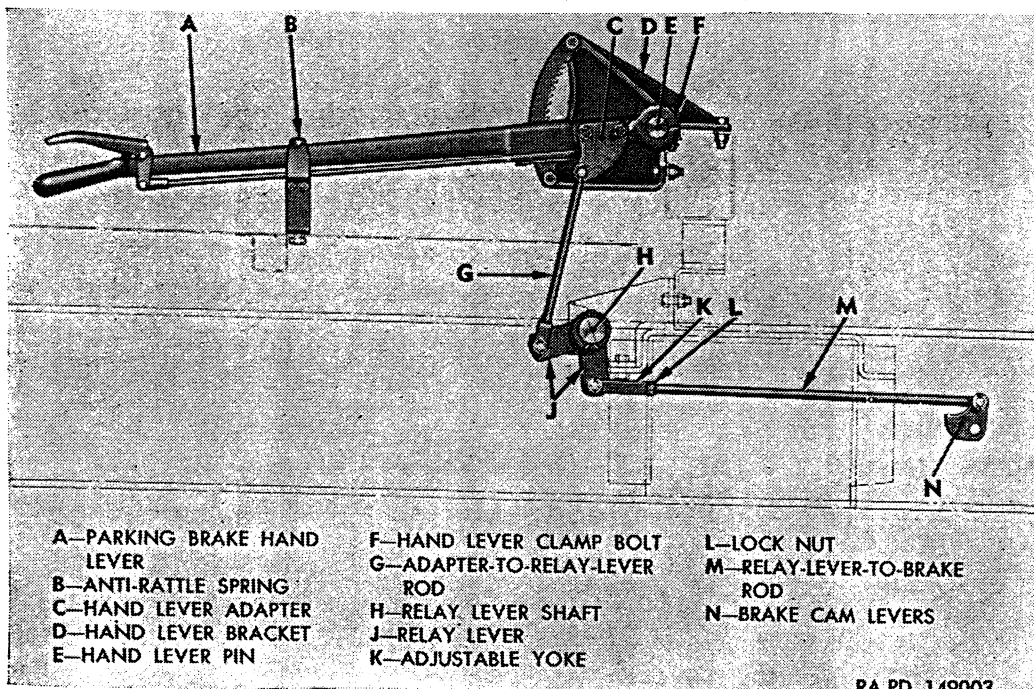

Figure 261. Parking brake linkage.

pin. Apply parking brake; if more than three-quarters of the hand lever travel is required for full application, adjust parking brake (par. 254b).

*b. Relay Lever Replacement.*

- (1) *Removal.* Disconnect brake rods (G and M) from relay lever (J) by removing cotter pins and clevis pins. Remove cotter pin from both ends of relay lever shaft (H). Remove shaft and lever from bracket.
- (2) *Installation.* Position relay lever (J) in bracket and insert relay lever shaft (H) through bracket and lever. Install cotter pin in both ends of shaft. Connect brake rods (G and M) to relay lever, using clevis pins and cotter pins. Apply parking brake; if more than three-quarters of the hand lever travel is required for full application, adjust parking brake (par. 254b).

## 257. Temporary (Electric) Parking Brake Valve

(fig. 262)

*a. Removal.*

- (1) Disconnect solenoid cables at bayonet-type connectors.
- (2) Unscrew hydraulic brake tube nut from fitting at each end of parking brake valve.

*Note.* Do not apply brakes with hydraulic tubes disconnected.

- (3) Remove nut and bolt attaching parking brake valve clamp to frame side member, and remove valve and clamp assembly; then remove clamp from valve.

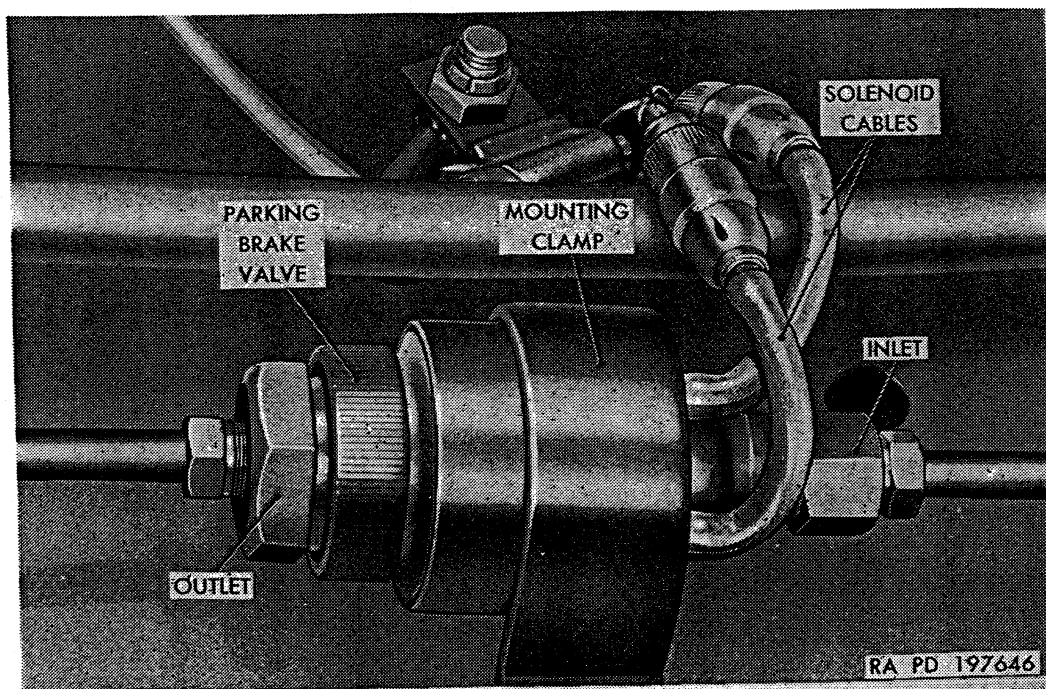

Figure 262. Temporary (electric) parking brake valve installed.

*b. Installation.*

- (1) Install clamp around parking brake valve, position valve and clamp assembly at frame side member, and attach to frame with  $\frac{3}{8}$ -24 x  $1\frac{1}{4}$  bolt and  $\frac{3}{8}$ -24 safety nut. Tighten nut to 20 to 27 pound-feet torque.
- (2) Connect hydraulic brake tube to each end of valve, threading tube nuts into fittings in valve.
- (3) Connect solenoid cables to harness cables at bayonet-type connectors.
- (4) Bleed hydraulic brake system (par. 237).

## Section XXV. WHEELS AND TIRES

### 258. Description and Data

*a. Description.*

- (1) *Wheels.* Single front wheels are used on all models. Single rear wheels are used on M135, and dual rear wheels are used on all other models. Wheels are secured on each hub by six studs and nuts. Studs are pressed into hub flange. Wheels do not pilot on hub; taper on wheel nuts engage chamfered holes in wheel, positioning wheel concentric with hub. Wheel studs and nuts on left side of vehicle all have left-hand threads; studs and nuts on right side have right-hand threads. Front wheel installation on hub is shown in figure 270, and both single and dual rear wheel installations are shown in figure 271. One tire bead seat and flange is integral with the wheel rim. The removable tire retaining ring forms the other tire bead seat and flange.
- (2) *Tires.* Tires are designed for high or low pressure operation. All tires have military-type tread. All M135 trucks are equipped with 11.00/20, 12-ply tires; all other models are equipped with 9.00/20, 8-ply tires. Tire flap is used between tube and wheel rim.

*b. Data.*

Wheels:	<i>M135</i>	<i>All Others</i>
Ordnance number.....	7389617	7389620
Rim size.....	20 x 7.50	20 x 7.50
Offset.....	5 $\frac{1}{8}$ in.	6 $\frac{3}{16}$ in.
Bolt circle diameter.....	8.743 to 8.757 in.	8.743 to 8.757 in.
Wheel bore diameter.....	6.469 to 6.473 in.	6.469 to 6.473 in.
<i>Tires:</i>		
Type.....	Military	Military
Size.....	11.00 x 20	9.00 x 20
<i>Operating pressure:</i>		
Highway operation.....	70 lb	45 lb.
Cross-country operation...	35 lb.	45 lb.
Mud, sand, or snow.....	15 lb.	15 lb.



## 259. Wheels

*a. Mounting.* All front wheels and single rear wheels are secured on hub by six hex cap nuts. On dual rear wheels, the inner wheel is secured on hub by six sleeve-type inner nuts having internal and external threads; the outer wheel is mounted over the inner nuts and secured by six hex cap nuts.

### *b. Removal.*

*Note.* Turn nuts on right side of vehicle counterclockwise and turn nuts on left side of vehicle clockwise to remove.

Using hex end of wheel stud nut wrench 7950664 (fig. 77), remove six cap nuts securing hex single wheel or outer dual wheel to hub; remove wheel. To remove inner dual wheel, remove six inner nuts using square end of wrench 7950664 (fig. 77).

### *c. Installation.*

- (1) Make sure mating surfaces of wheel and hub flange are clean, and that wheel studs and nuts are free of grease or oil.
- (2) If dual rear wheels are used, install inner wheel and secure with six inner nuts. Tighten nuts to 400 to 450 pound-foot torque. Install outer dual wheel or single wheel and secure with six cap nuts. Tighten nuts to 400 to 450 pound-foot torque.

## 260. Tires and Tubes

*a. Gaging and Inflating Tires.* Before tires are inflated to correct pressure, each tire should be gaged for pressure loss. If any appreciable loss is noted in a tire, that tire should be dismounted and examined for cause of pressure loss. When making pressure loss check, use the same gage on all tires so that any element of inaccuracy in the gage will be the same for all tires. Tires should be inflated to pressure shown in paragraph 258*b*, depending upon tire size and operating conditions. Pressure in all tires must be the same; unequal pressures will affect braking and steering. Use tire inflation hose (*b* below).

*b. Use of Tire Inflation Hose* (fig. 263). An air supply valve is provided at left side of dash panel inside cab, adjacent to cowl left side ventilator. Supply valve is connected to vehicle air system through junction fitting at center of dash panel. Tire inflation air hose is provided in vehicle tool kit. Remove cap from supply valve and thread hose fitting onto valve. Open valve by turning handle parallel to hose outlet. Air nozzle is attached to hose by a chain. Nozzle may be used for cleaning and drying parts.

*c. Matching Tires.* Replacement tires should be of the same design tread as other tires on the vehicle. Differences in design and tread in some instances result in unequal rolling radii. If tires do not have the same outside diameter within one-eighth inch, excessive tread scuf-

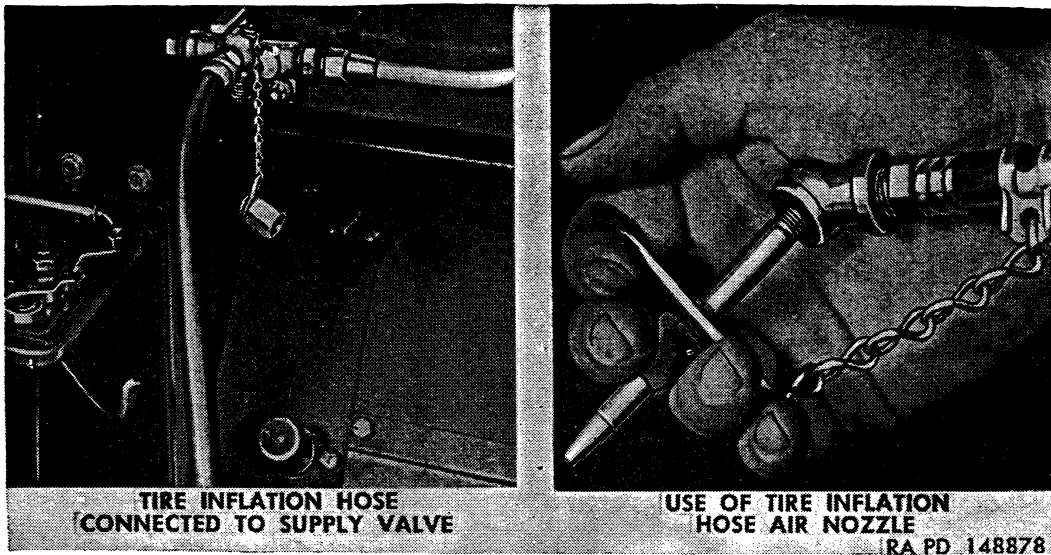

Figure 263. Use of tire inflation hose.

ing will result. When replacement tire is selected, one should be selected with outside diameter within one-eighth inch of other tires on the vehicle, particularly on the same axle. Measure outside diameter of tires with a conventional tire measuring gage.

d. *Valve Stem Replacement* (fig. 264). The valve stem is threaded onto an adapter which is vulcanized into the tube. This permits replacing the valve stem in the event it becomes broken or damaged and the tube is still serviceable. A new valve stem, or one removed from a damaged tube, can be installed.

- (1) To remove valve stem, position tube over vise as shown in figure 264; place foot inside tube at bottom and press down to stretch tube over vise. Turn valve stem counterclockwise to remove.

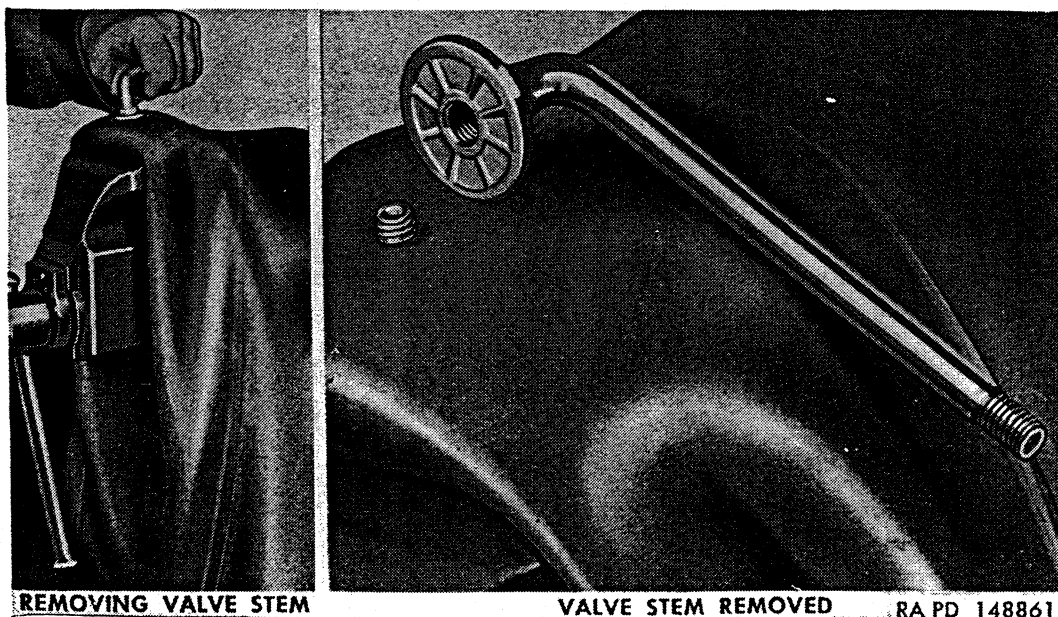

Figure 264. Valve stem replacement.

- (2) Make sure tube is clean around valve stem adapter. Wet area of tube contacted by valve stem with water to act as a lubricant while installing valve stem. Thread valve stem onto adapter. Stretch tube over vise while tightening valve stem. Do not use a pipe over valve stem to tighten.

## **261. Tire and Tube Replacement**

Removal and installation of tire and tube are illustrated, together with necessary instructions, in figures 265 and 266. When inflating tube (4, fig. 266), refer to paragraph 258*b* for correct operating pressure.

## **262. Spare Wheel and Carrier**

*a. General.* Spare wheel and tire (fig. 267) are mounted on carrier on frame right side member at rear of cab on cargo trucks M135 and M211, gasoline tank truck M217, shop van truck M220, and water tank truck M222. On dump truck M215, spare wheel and tire (fig. 268) are mounted in carrier on top of frame at rear of cab. No spare wheel and tire is mounted on chassis for truck tractor M221.

*b. Spare Wheel and Tire Removal (M135, M211, M217, M220, and M222)* (fig. 267).

- (1) Remove two nuts attaching spare wheel support bracket to frame bracket. Swing carrier and wheel out from under body and tip wheel and tire to upright position.
- (2) Remove four nuts attaching wheel to support bracket; then remove wheel and tire from support bracket.

*c. Spare Wheel and Tire Installation (M135, M211, M217, M220, and M222)* (fig. 267).

- (1) Position wheel and tire on support bracket and attach with four hex cap nuts. Tighten nuts.
- (2) Tip wheel and tire to horizontal position and swing in under body, with support bracket in place against frame bracket. Install hex cap nuts on two attaching studs and tighten.

*d. Spare Wheel and Tire Replacement (M215)* (fig. 268). To remove spare wheel and tire, loosen nut on hook bolt until bolt can be unhooked from carrier base, swing right clamp down, and roll wheel and tire down clamp. To install, position wheel and tire on base, swing right clamp up against tire, engage hooked end of hook bolt in hole in carrier base, and tighten nut on hook bolt.

## **263. Spare Tire Shield**

*a. General.* Some vehicles having spare wheel and tire mounted under body (fig. 267) are not equipped with spare tire shield. Spare tire on these vehicles may become deteriorated due to lubricant being deposited on the tire by the front universal joint of the rear axle pro-

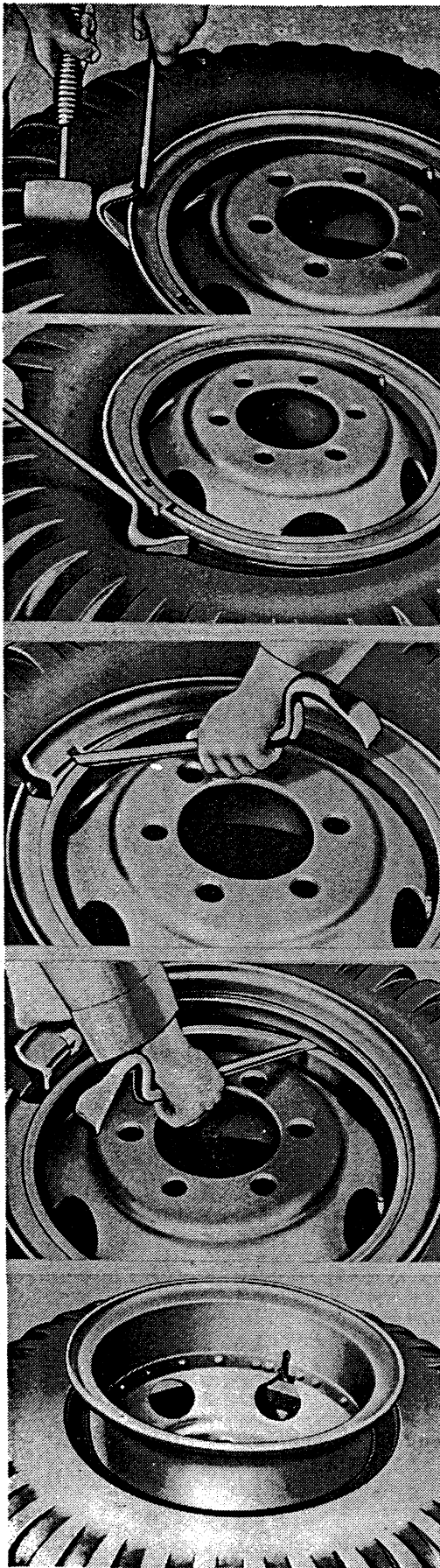

1—LAY WHEEL AND TIRE ON FLOOR WITH RETAINING RING UP. DEFLATE TUBE BY REMOVING VALVE CORE. DRIVE A "GOOSE-NECK" TYPE TIRE TOOL BETWEEN THE TIRE BEAD AND RETAINING RING.

2—PRY SIDeways ON TOOL TO CAUSE WIDE PART OF TOOL TO FORCE TIRE BEAD AWAY FROM RETAINING RING. REPEAT AT INTERVALS AROUND TIRE TO LOOSEN BEAD.

3—INSERT STRAIGHT END OF TIRE TOOL INTO PRY NOTCH NEXT TO SPLIT IN RETAINING RING; THEN, USING WHEEL AS A FULCRUM, PRY RETAINING RING UP OUT OF RIM GUTTER.

4—WHILE PULLING UP ON FREE END OF RETAINING RING, USE TIRE TOOL PROGRESSIVELY AROUND WHEEL TO FREE RETAINING RING FROM RIM.

5—TURN WHEEL AND TIRE OVER. PRY TIRE BEAD AWAY FROM RIM FLANGE AS IN 1 AND 2 ABOVE. DROP WHEEL AND TIRE OVER WOOD BLOCK WHICH IS 8 OR 10 INCHES HIGH AND SMALLER THAN WHEEL. TIRE WILL DROP OFF RIM. REMOVE FLAP AND TUBE FROM TIRE.

RA PD 197650

Figure 265. Removing tire from wheel.

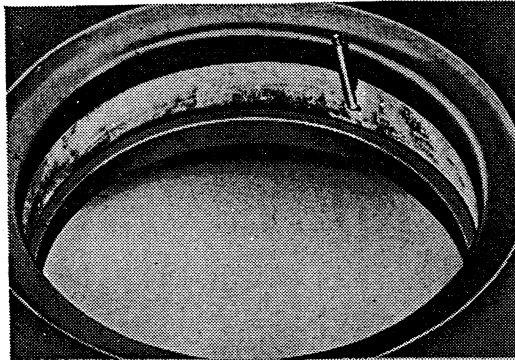

1—REMOVE ALL DIRT FROM INSIDE OF TIRE. MAKE SURE TUBE AND FLAP ARE CLEAN. CLEAN ALL DIRT AND RUST FROM WHEEL RIM, USING WIRE BRUSH IF NECESSARY. INSTALL TUBE AND FLAP IN TIRE, WITH VALVE STEM INSERTED THROUGH HOLE IN FLAP.

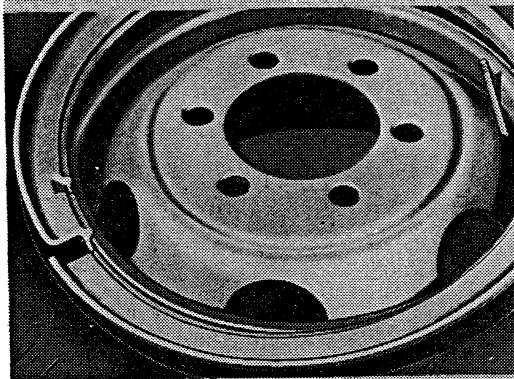

2—LAY WHEEL ON FLOOR, RETAINING RING SIDE UP. PLACE TIRE AND TUBE OVER WHEEL RIM, FORCING VALVE STEM DOWN AND INSERTING IT THROUGH HOLE IN RIM AS TIRE IS LOWERED INTO PLACE. PLACE RETAINING RING ON TIRE WITH SPLIT IN RING OPPOSITE VALVE STEM. FORCE TOE OF RETAINING RING BETWEEN TIRE BEAD AND RIM AT ONE END AND SEAT HEEL OF RETAINING RING IN RIM GUTTER.

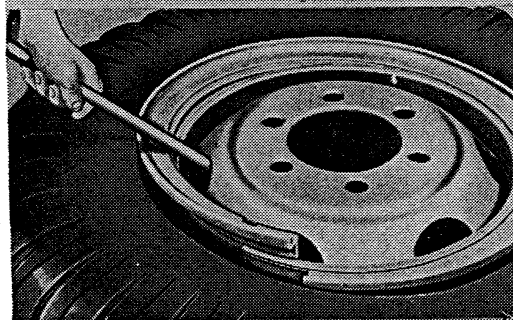

3—USING TIRE TOOL IN WHEEL SPOKE OPENINGS, WORK PROGRESSIVELY AROUND WHEEL PRYING RETAINING RING DOWN INTO RIM GUTTER. MAKE SURE RETAINING RING IS FULLY SEATED ALL THE WAY AROUND.

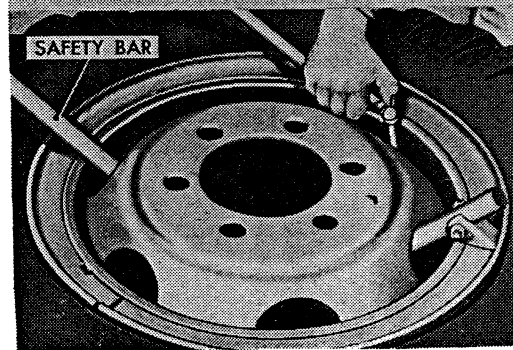

4—BEFORE INFLATING TUBE, PLACE SAFETY BAR THROUGH WHEEL SPOKES TO PREVENT RETAINING RING FROM BLOWING OFF IN THE EVENT IT IS NOT FULLY SEATED. INFLATE TUBE TO FULL OPERATING PRESSURE. COMPLETELY DEFLATE TUBE BY REMOVING VALVE CORE AND REINFLATE TO CORRECT PRESSURE. MAKE SURE RETAINING RING IS FULLY SEATED BEFORE REMOVING SAFETY BAR.

RA PD 197649

Figure 266. Installing tire on wheel.

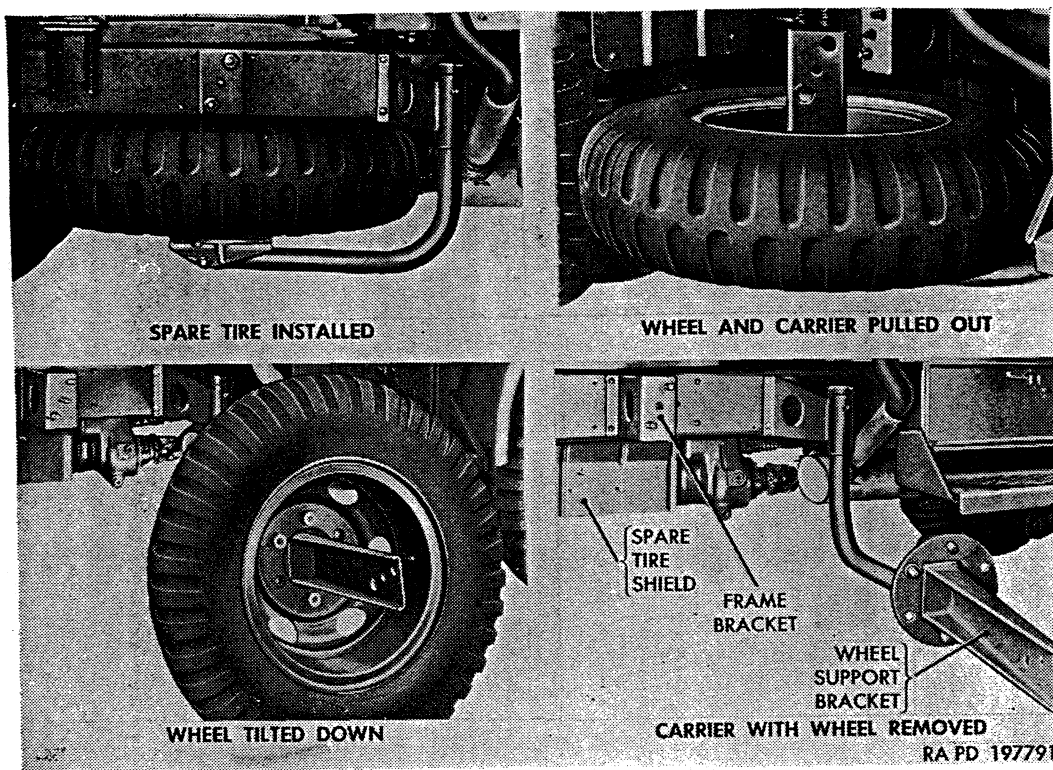
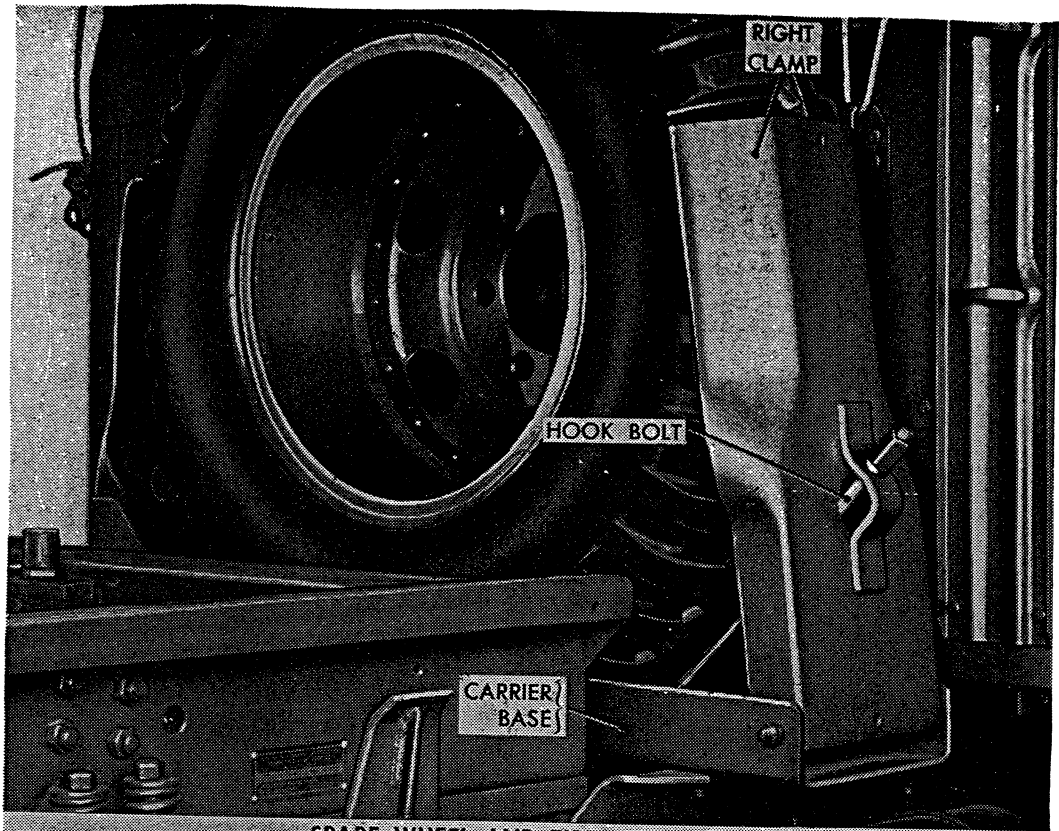

Figure 267. Spare wheel and tire carrier (M135, M211, M217, M220, and M222).

PELLER shaft. Shield should be fabricated and installed as directed in *b* below to prevent this deterioration of the spare tire.

*b. Procedure.*

- (1) Fabricate a spare tire shield, using a piece of 14 x 20 x No. 16-gage (0.0631 inch) steel. Cut a 4 x 5 section out of one corner of the shield as shown in A, figure 269.
- (2) Using two pieces of  $\frac{1}{4}$  x 1 x 29 bar stock, fabricate two brackets as shown in B, figure 269. Measure 4 inches from end of bar stock and make a 90° bend. Measure 12 inches from first bend and make a second 90° bend in the opposite direction. Shape the end beyond the second 90° bend to fit contour of tire. Drill three  $1\frac{1}{32}$ -inch holes in each bracket in accordance with B, figure 269.
- (3) Using a bracket as a template, lay out and drill an  $1\frac{1}{32}$ -inch hole through side of frame at center of spare tire frame bracket. Drill another  $1\frac{1}{32}$ -inch hole through frame 12 inches to the rear of the first hole. Paint the brackets. Secure each bracket to frame, using a  $\frac{5}{16}$ -18 x  $1\frac{1}{4}$  bolt, nut, and lock-washer.
- (4) Hold shield in position with the 4 x 5 cutaway section clearing the parking brake band. This will allow shield to cover the top of the universal joint. Using the brackets as templates, shape shield to fit contour of brackets and drill four  $1\frac{1}{32}$ -inch holes in shield to match holes in brackets. Paint



SPARE WHEEL AND TIRE INSTALLED

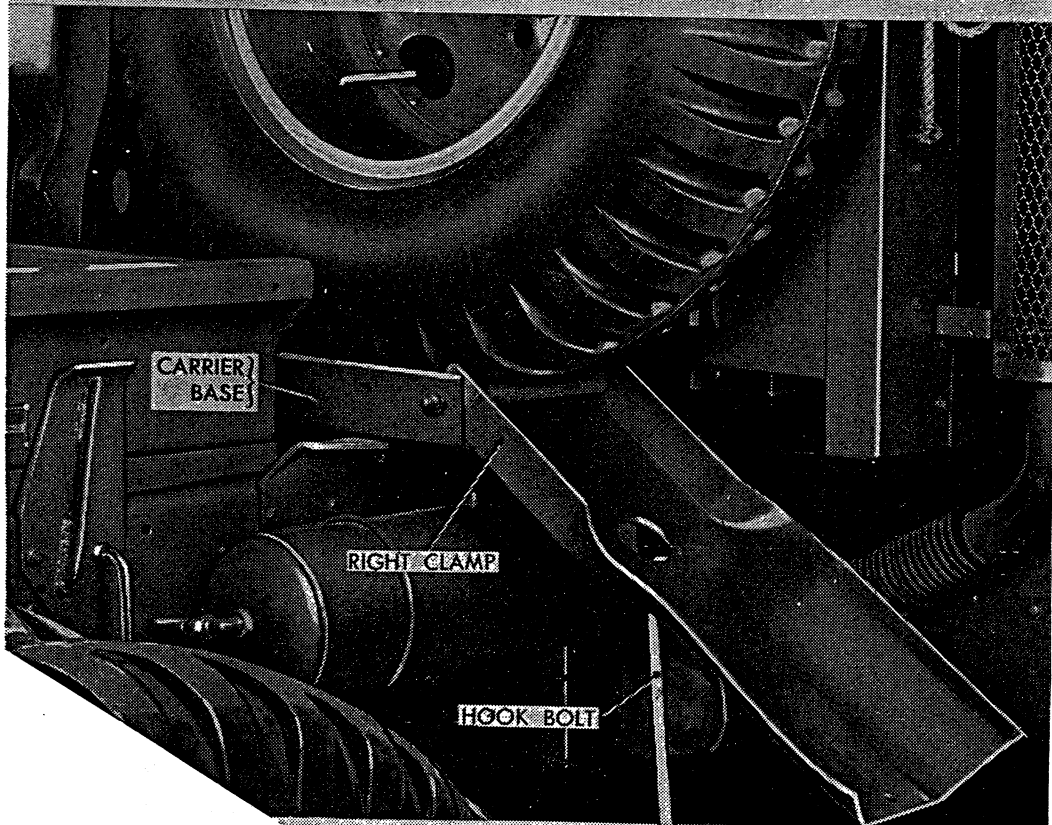

SPARE WHEEL AND TIRE REMOVAL

RA PD 197647

*spare wheel and tire carrier (M215).*

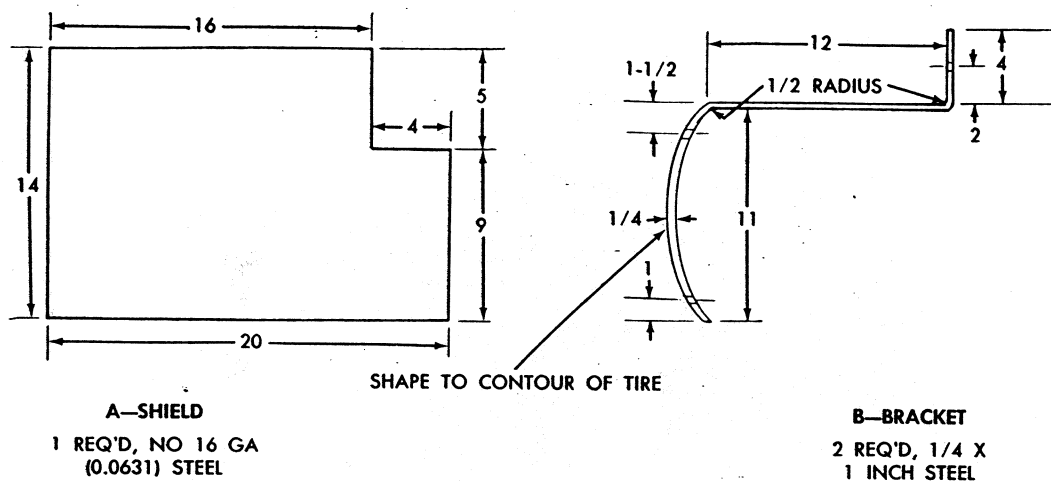

NOTES: 1—ALL HOLES SHOWN ARE 11/32 DIAM  
2—ALL DIMENSIONS SHOWN ARE IN INCHES

RA PD 197671

Figure 269. Spare tire shield and brackets.

and secure the shield to brackets, using four  $\frac{5}{16}$ -18 x  $\frac{3}{4}$  bolts, nuts, and plain and lockwashers.

## Section XXVI. WHEEL HUBS AND BEARINGS

### 264. Description

*a. Mounting.* Front and rear hubs are mounted on opposed tapered roller bearings. Front hub bearings are mounted on steering knuckles as shown in figure 270. Rear hub bearings are mounted on axle housing tube as shown in figure 271. Bearing adjustment is accomplished by means of the bearing adjusting nuts which are locked in place by the adjusting nut lock.

*b. Oil Seals.* A spring-loaded, lip-type oil seal is pressed into inner end of each hub to prevent wheel bearing lubricant leaking into the brake mechanism. Oil seal sleeves are pressed onto steering knuckle (front) and on axle housing (rear); seal lips wipe on these sleeves. Seals are also used at outer ends of hubs. Outer seals are installed between outer bearing and bearing adjusting nut. A tongue on inside of seal retainer engages groove in steering knuckle or axle housing to prevent seal turning; seal lip wipes on inside of hub as hub revolves. A cork seal is also installed in groove in rear axle housing.

### 265. Wheel Bearing Adjustment

#### *a. Bearing Adjustment Check.*

- (1) Jack up axle until tires are clear of floor. Before checking bearing adjustment, make sure brakes are fully released and do not drag.
- (2) At rear axles, remove axle shaft (par. 225b). At front axle, remove hub drive flange (par. 221b(2)).



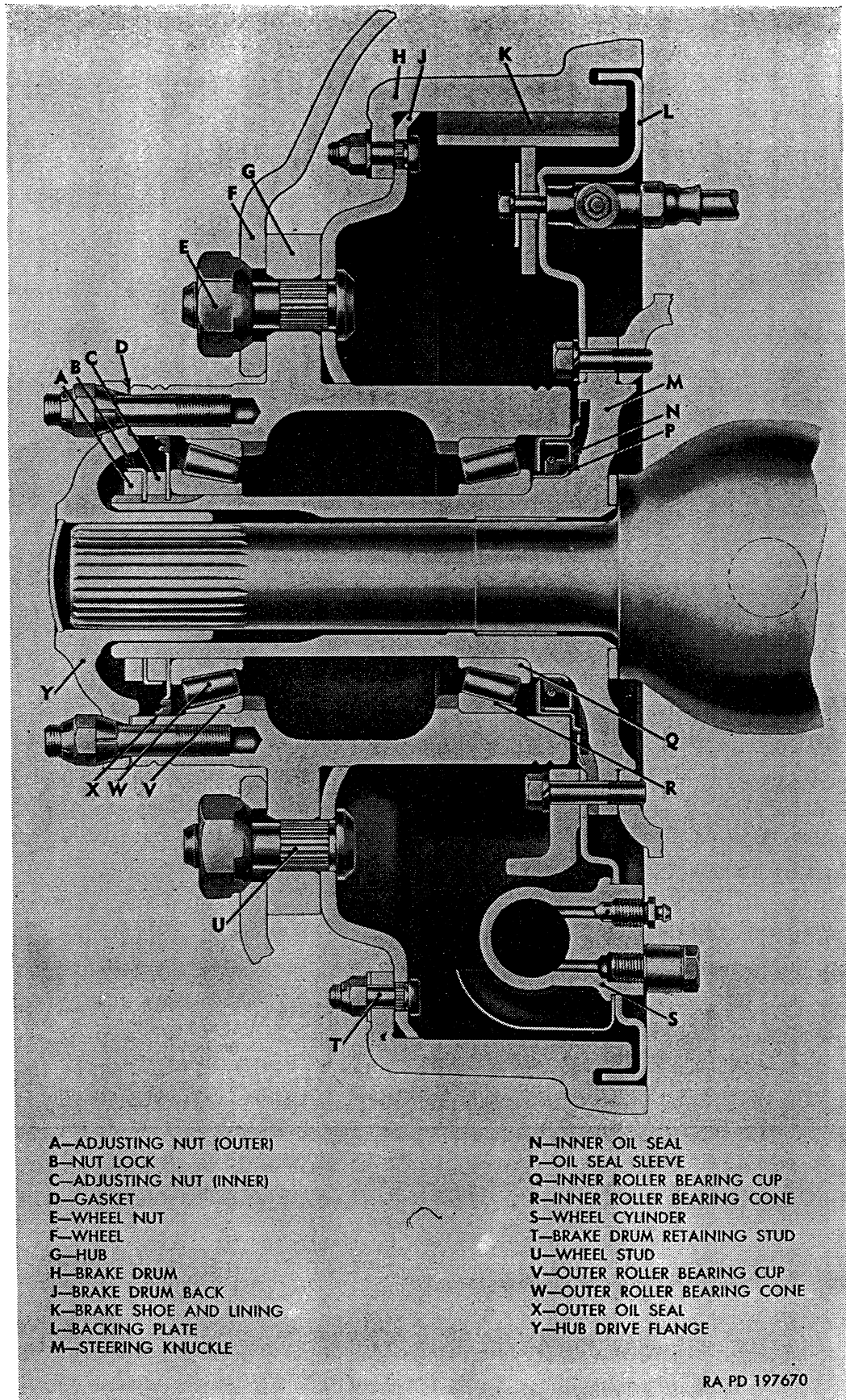

- A-ADJUSTING NUT (OUTER)
- B-NUT LOCK
- C-ADJUSTING NUT (INNER)
- D-GASKET
- E-WHEEL NUT
- F-WHEEL
- G-HUB
- H-BRAKE DRUM
- J-BRAKE DRUM BACK
- K-BRAKE SHOE AND LINING
- L-BACKING PLATE
- M-STEERING KNUCKLE

- N-INNER OIL SEAL
- P-OIL SEAL SLEEVE
- Q-INNER ROLLER BEARING CUP
- R-INNER ROLLER BEARING CONE
- S-WHEEL CYLINDER
- T-BRAKE DRUM RETAINING STUD
- U-WHEEL STUD
- V-OUTER ROLLER BEARING CUP
- W-OUTER ROLLER BEARING CONE
- X-OUTER OIL SEAL
- Y-HUB DRIVE FLANGE

RA PD 197670

Figure 270. Front hub, bearings, and oil seals.

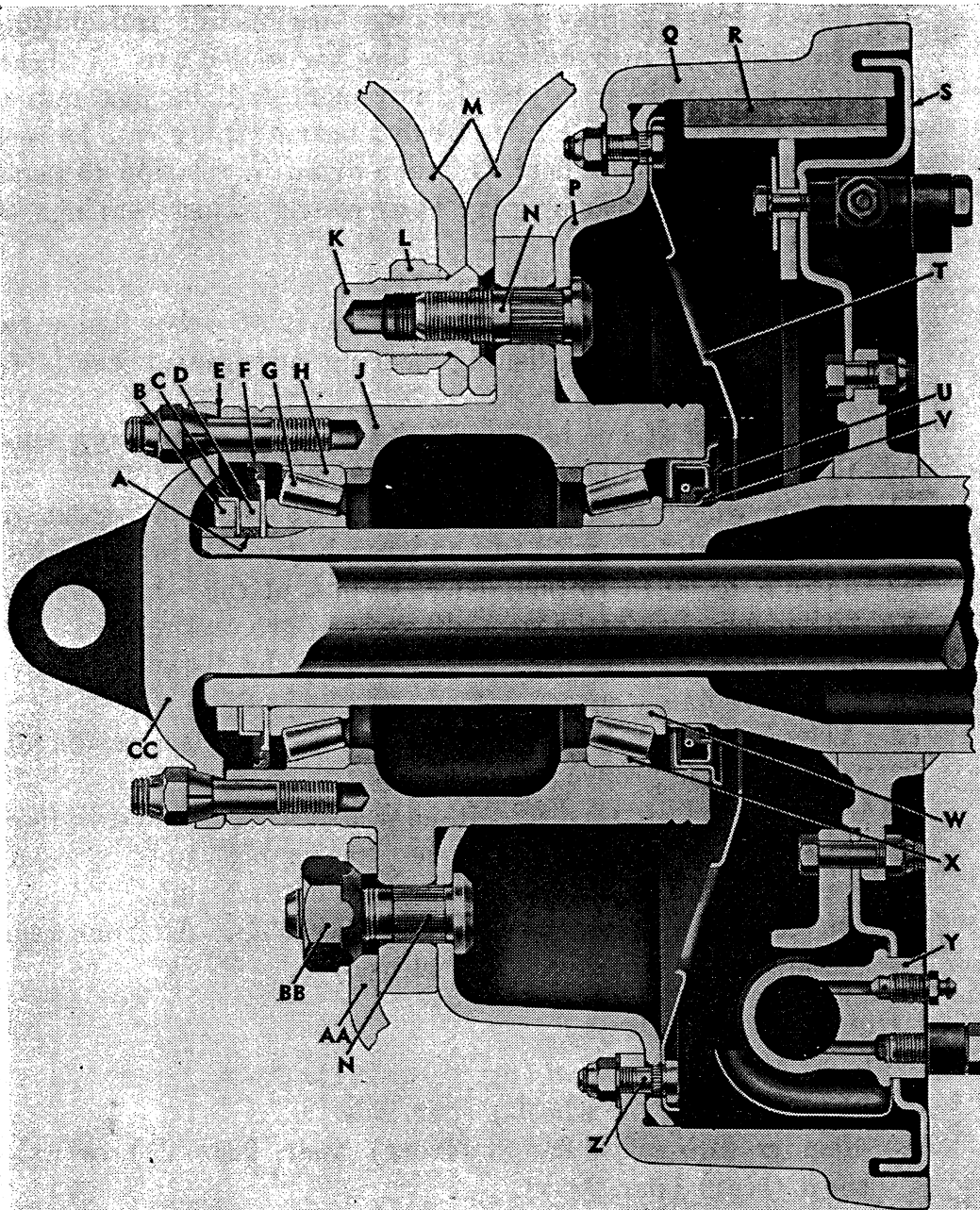

A—ADJUSTING NUT OIL SEAL  
 B—ADJUSTING NUT (OUTER)  
 C—NUT LOCK  
 D—ADJUSTING NUT (INNER)  
 E—GASKET  
 F—OUTER OIL SEAL  
 G—OUTER ROLLER BEARING CONE  
 H—OUTER ROLLER BEARING CUP  
 J—HUB  
 K—DUAL WHEEL INNER NUT  
 L—DUAL WHEEL OUTER NUT  
 M—DUAL WHEELS  
 N—WHEEL STUD  
 P—BRAKE DRUM BACK

Q—BRAKE DRUM  
 R—BRAKE SHOE AND LINING  
 S—BACKING PLATE  
 T—OIL SHIELD  
 U—INNER OIL SEAL  
 V—OIL SEAL SLEEVE  
 W—INNER ROLLER BEARING CUP  
 X—INNER ROLLER BEARING CONE  
 Y—WHEEL CYLINDER  
 Z—BRAKE DRUM RETAINING STUD  
 AA—SINGLE WHEEL  
 BB—SINGLE WHEEL STUD NUT  
 CC—AXLE SHAFT

RA PD 197669

Figure 271. Rear hub, bearings, and oil seals.

- (3) Check bearing play by grasping tire at top and pulling back and forth or by using a pry bar under tire. If bearings are properly adjusted, movement will be just noticeable and wheel will turn freely; bearing play can be seen by observing movement of brake drum in relation to backing plate. If bearing play is excessive, adjust bearings (*b* below).

*b. Bearing Adjustment* (fig. 270 or 271).

- (1) Axle will be jacked up and axle shaft or drive flange removed after accomplishing bearing adjustment check (*a* above).
- (2) Bend tangs of nut lock away from bearing adjusting nuts. Remove outer adjusting nut and nut lock.
- (3) Using wheel bearing nut wrench C8390299 at front or C8390302 at rear with torque wrench, tighten inner adjusting nut to 60 to 75 pound-feet torque, at the same time rotating wheel to make sure all surfaces are seating properly. Back off nut three-eighths of a turn, or the distance of three hub drive flange studs.
- (4) At rear axles, make sure cork oil seal is in place inside adjusting nut in groove in axle housing.
- (5) Install nut lock, then install outer adjusting nut and tighten to 100 to 150 pound-feet torque. Secure both nuts by bending two tangs of nut lock over flats of each nut.
- (6) At rear axles, install axle shaft (par. 225*d*). At front axle, install hub drive flange (par. 221*d*(5)).

## 266. Hubs and Bearings

*a. Hub and Bearing Removal* (fig. 270 or 271).

- (1) Remove wheel (or wheels) (par. 259*b*).
- (2) Remove hub drive flange (front) (par. 221*b*(2)) or axle shaft (rear) (par. 225*b*).
- (3) Bend tangs of adjusting nut lock away from bearing adjusting nuts. Remove outer adjusting nut, nut lock, and inner adjusting nut from steering knuckle (front) or axle housing (rear). Pull hub and brake drum assembly straight off steering knuckle or axle housing.
- (4) Lift outer oil seal and outer roller bearing cone out of outer end of hub.

*Note.* Inner oil seal should always be replaced with a new seal, particularly at the 12,000 mile or annual inspection. However, if new seals are not available or if old seals are still serviceable, use care when removing seals not to distort the seal case.

- (5) Using a flat blade screwdriver under oil seal flange, pry inner oil seal out of inner end of hub. After removing oil seal, lift inner roller bearing cone out of hub.

*b. Cleaning.* Clean bearings as directed in paragraph 70d(3) (a). Wash all old lubricant out of inside of hub and off steering knuckle (front) or axle housing (rear) with volatile mineral spirits or dry-cleaning solvent. After cleaning, wipe dry. Wipe grease off oil seal with clean rag.

*c. Inspection.*

- (1) Inspect bearings for cracks, chipped rollers, or rough operation. Replace bearings if any damage is evident.
- (2) Examine bearing cups in hub. If cups are pitted or cracked, they must be replaced (*d* below).
- (3) Examine oil seal sleeve on steering knuckle (front) or axle housing (rear). If surface against which seal lip bears is grooved or rough, replace sleeve (*e* below).
- (4) Inspect inner oil seal for distorted case and for worn or deteriorated seal lip. Replace seal, if any damage is evident.

*d. Bearing Cup Replacement.*

- (1) Using a brass drift through opposite end of hub, drive out each bearing cup. Four knockout notches are provided in each bearing flange on inside of hub. Alternately drive on opposite sides of bearing cup to prevent cocking bearing cup and damaging machined bore in hub.
- (2) Install new bearing cups in hub, driving them into place with replacer B7950766 as shown in figure 272. Make sure

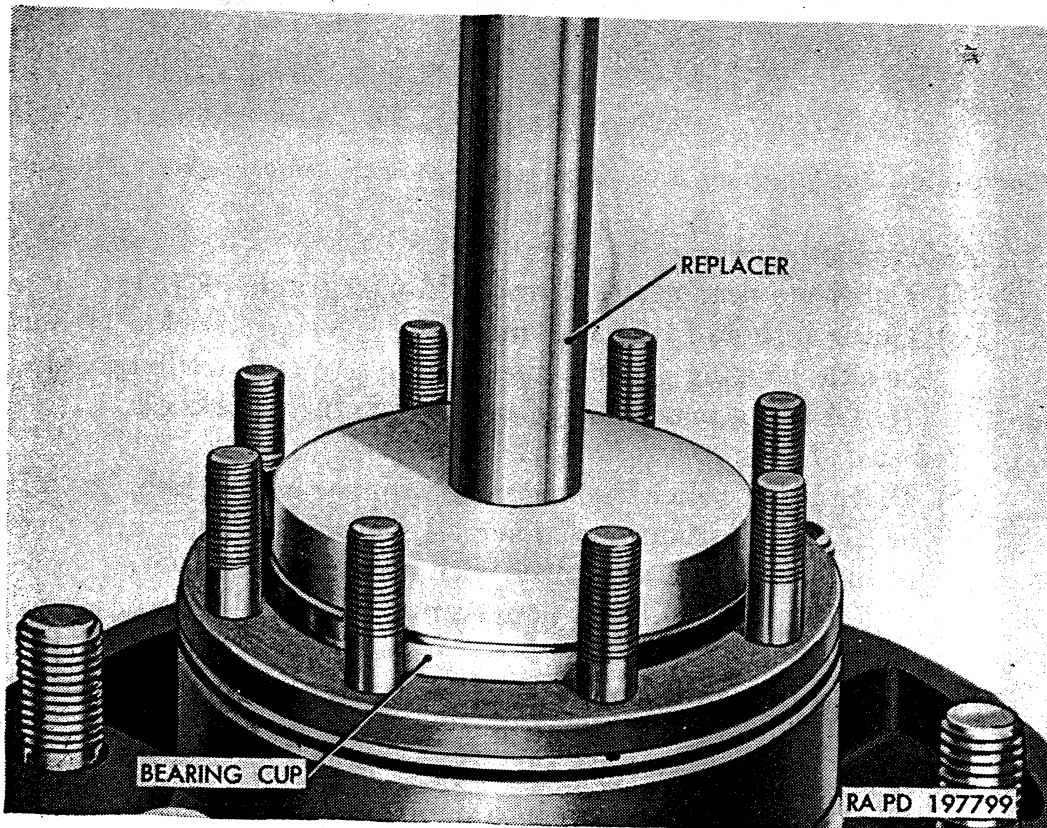

Figure 272. Installing bearing cups in hub with replacer B7950766.

cups are driven in squarely and are fully seated against flanges on inside of hub.

*e. Oil Seal Sleeve Replacement.*

- (1) Use ball peen hammer and tap entire circumference of outer surface of oil seal sleeve. Peening of this surface will cause metal in sleeve to stretch until sleeve can be removed from steering knuckle (front) or axle housing (rear).
- (2) Install new sleeve on steering knuckle or axle housing, driving it into place with oil seal sleeve replacer B7950063 (fig. 273). Replacer properly positions sleeve with outer edge flush with bearing shoulder on steering knuckle or axle housing.

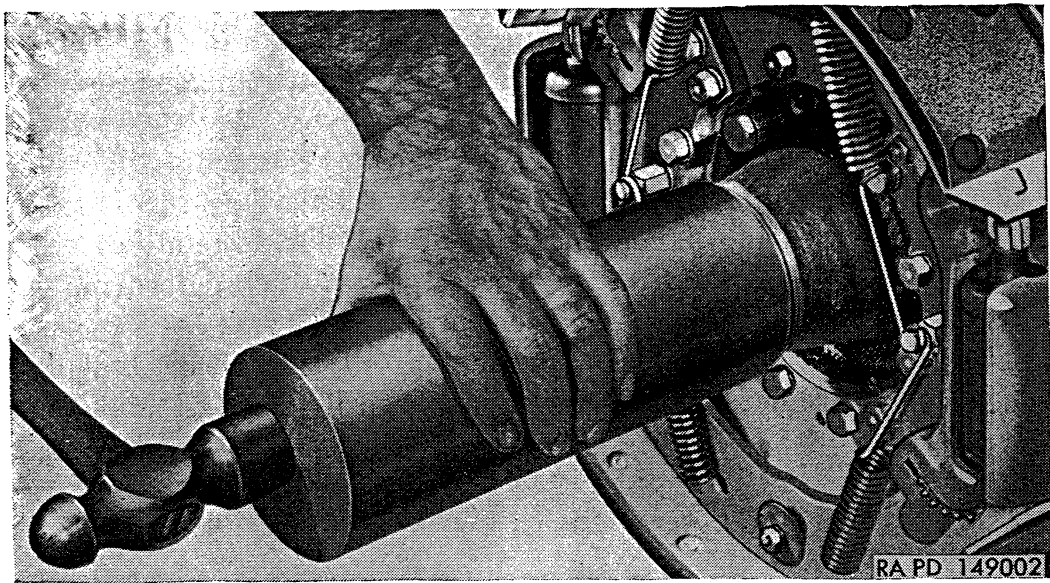

Figure 273. Installing oil seal sleeve (rear shown) using replacer B7950063.

*f. Lubrication.*

- (1) Lubricate bearings as directed in paragraph 70d(3)(b).
- (2) Cover inside of hub and outside of steering knuckle (front) or axle housing (rear) with automotive and artillery grease (GAA) to a maximum of one-eighth inch thickness.

*g. Hub and Bearing Installation.*

- (1) Place inner roller bearing cone in inner end of hub (fig. 270 or 271). Position new inner oil seal assembly on inner end of hub and drive into place with replacer B7950766 as shown in figure 274. Oil seal flange must seat firmly against inner end of hub.
- (2) Install hub and drum assembly on steering knuckle (front) or axle housing (rear), using care not to damage inner oil seal. Place outer roller bearing cone on steering knuckle or axle housing and press into outer end of hub with fingers. Install outer oil seal assembly on steering knuckle or axle

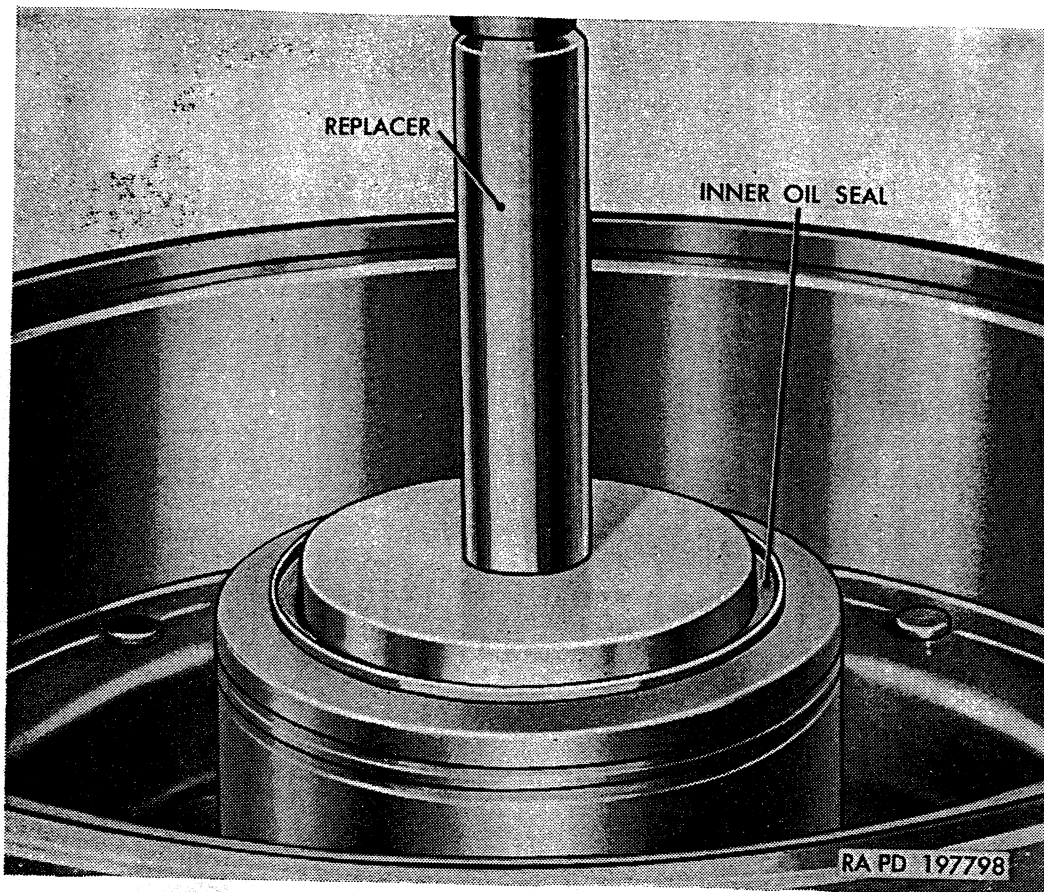

Figure 274. Installing inner oil seal with replacer B7950766.

housing and press into hub against bearing. On rear axles only, install adjusting nut cork oil seal in groove in axle housing.

- (3) Install bearing inner adjusting nut on steering knuckle or axle housing, using care not to dislodge adjusting nut cork oil seal on rear axle. Adjust bearings and complete the installation as directed in paragraph 265b(3) through (6). Install wheel (or wheels) (par. 259c).

## Section XXVII. STEERING SYSTEM

### 267. Description and Data

*a. Description.* The steering system consists of a recirculating-ball type steering gear assembly, mounted on frame left side member, interconnected from pitman arm to front axle left steering arm with a steering drag link (fig. 275). Movement of the steering wheel is transmitted through steering gear mechanism and drag link to the axle steering arm. Both wheels are turned by means of a tie rod interconnecting the front axle right and left steering knuckles. Components of the tie rod and front axle are described in paragraphs 215-222.

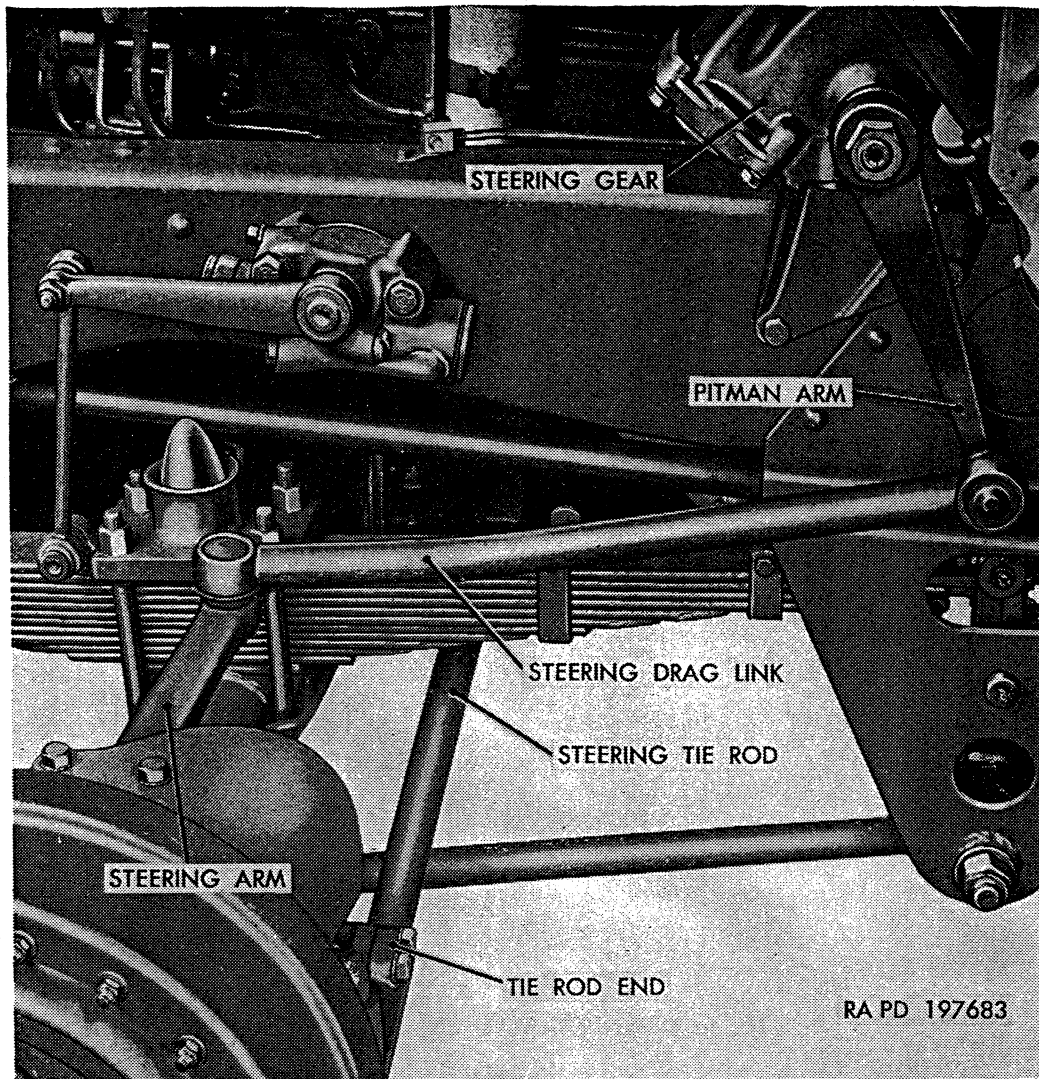

Figure 275. Steering linkage installed.

*b. Data.*

Manufacturer..... Saginaw Steering Gear Div  
 Model number..... 552-D-6  
 Ratio..... 28.14 : 1  
 Steering wheel diameter..... 20 in.

**268. Steering Gear Adjustments**

*a. General.* The steering gear is designed to provide for adjustments to compensate for normal wear at worm bearings, and at pitman arm shaft and mating parts. If steering action necessitates adjustment (par. 99), procedures for checking and adjusting steering gear must be performed in sequence outlined in *b*, *c*, and *d* below.

*b. Worm Bearing Adjustment Check.*

- (1) Check lubricant in housing and fill to proper level if necessary. Refer to lubrication chart (par. 69).
- (2) Check mounting bolt nuts for tightness (par. 272*d*(4)).

- (3) Disconnect drag link from pitman arm (par. 269*b*). Loosen two bolts on cowl bracket cap (fig. 284 or 285).
- (4) Check end cover cap screws (fig. 278) for tightness. Loosen jam nut on pitman arm shaft adjusting screw (fig. 276) and turn adjusting screw a few turns counterclockwise to provide clearance between pitman arm shaft sector and worm nut.

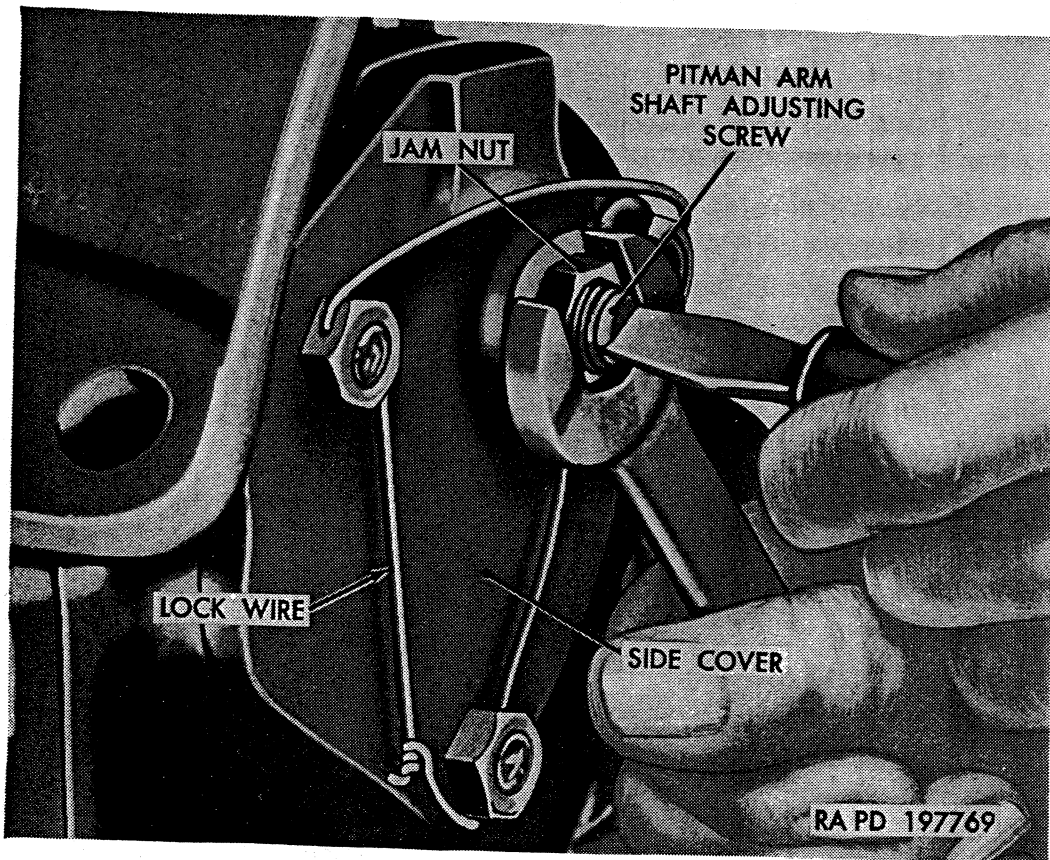

Figure 276. Adjusting pitman arm shaft lash.

- (5) Turn steering wheel gently in one direction until stopped by gear; then back away about one turn.
 

**Caution:** Approach end of gear travel cautiously either to the right or left to prevent damage to worm nut.
- (6) Measure pull required to keep wheel in motion by attaching scale B707918 to rim of steering wheel; then pull on scale to turn wheel as shown in figure 277. Pull on scale should be made on a line at right angle to wheel spoke.
- (7) If bearings are properly adjusted, the pull should be within 1½ to 2 pounds.
- (8) If pull is not within limits of 1½ to 2 pounds, worm bearings should be adjusted (*c* below). If bearings are in proper adjustment, proceed to adjust pitman arm shaft (*d* below).
- (9) If rough or lumpy action is noted during worm bearing check, the steering gear assembly should be replaced (par. 272), and report made to ordnance maintenance personnel.



*c. Worm Bearing Adjustment.*

- (1) Loosen worm bearing adjuster nut at bottom of end cover as shown in figure 278. Tighten worm bearing adjuster (clockwise) until all end play is removed.
- (2) With spring scale B707918 (fig. 277) attached to steering wheel (b(6) above), check wheel pull. Adjust by turning worm bearing adjuster as necessary to obtain  $1\frac{1}{2}$  to 2 pounds pull. Tighten adjuster nut and check again.

*Note.* After adjusting worm bearings, pitman arm shaft lash adjustment must always be made (*d* below).

*d. Pitman Arm Shaft Lash Adjustment.*

- (1) Remove lock wire (fig. 276) from side cover bolts and check tightness of bolts.
- (2) Center steering mechanism by gently turning wheel from right to left extreme position, being careful to approach end position lightly. Count number of turns of wheel while turning to extreme left. Turn wheel back exactly half way; then mark position on top or bottom of wheel with a piece of tape.

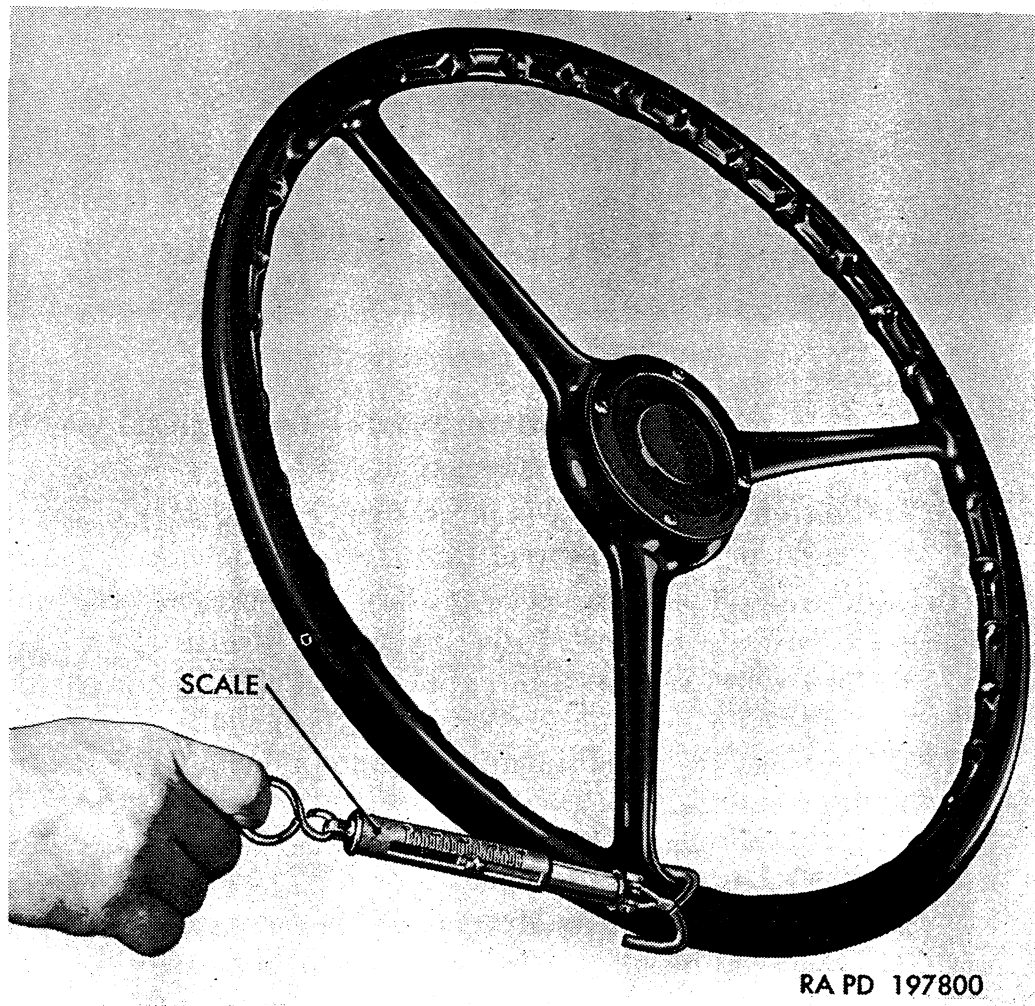

*Figure 277. Use of scale B707918 on steering wheel to check pull.*

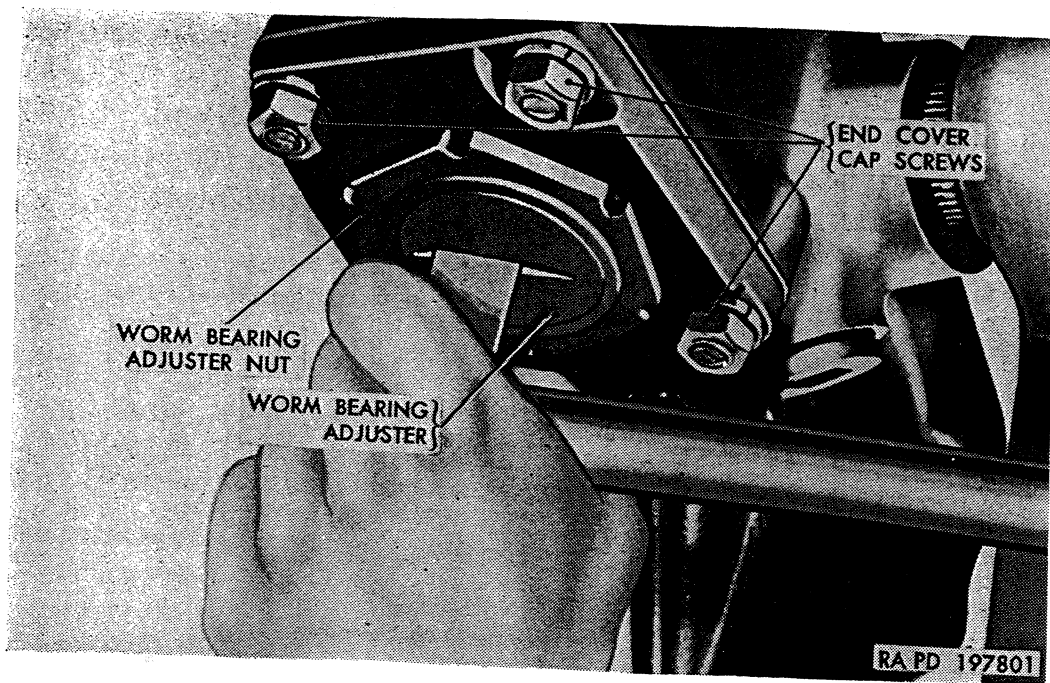

Figure 278. Adjusting worm bearings.

- (3) Turn pitman arm shaft adjusting screw (fig. 276) in to remove all lash between gear teeth. Amount of backlash can be determined by pushing backward and forward on lower end of pitman arm. When all backlash has been removed, tighten jam nut.
- (4) Check pull of steering wheel with a spring scale B707918 (fig. 277). Measure pull as wheel is pulled through center position. Pull should be  $2\frac{3}{4}$  to  $3\frac{1}{4}$  pounds.
- (5) If pull is not within proper limits ( $2\frac{3}{4}$  to  $3\frac{1}{4}$  lb.), loosen jam nut and turn adjusting screw as necessary to obtain proper pull. Tighten jam nut and again check pull. Always check pull after tightening jam nut.
- (6) Install lock wire (fig. 276) in heads of side cover screws.
- (7) Install drag link end to pitman arm (par. 269c).
- (8) Tighten two bolts on cowl bracket cap (fig. 284 or 285).

## 269. Steering Drag Link

(fig. 275)

*a. General.* Tubular-type steering drag link connects pitman arm to steering arm on left steering knuckle of front axle with tapered ball studs and nuts. Ball studs are mounted in drag link ends in bearings which require no lubrication. Rubber dust seals (fig. 279) fit tightly around taper of each ball stud, and seal against drag link ends.

*b. Removal.* Remove and discard cotter pin from slotted hex nut at each ball stud. Remove stud nuts; then drive out ball studs from pitman arm and steering arm.

*c. Installation.* Position drag link ball studs into pitman arm and steering arm. Make sure that rubber dust seal at each stud is in good condition and fits snugly over stud taper and drag link end. Install  $\frac{5}{8}$ -18 slotted hex nut on each stud and tighten to 75 to 100 pound-feet torque. Install new  $\frac{1}{8}$  x  $1\frac{3}{8}$  cotter pins and bend into place.

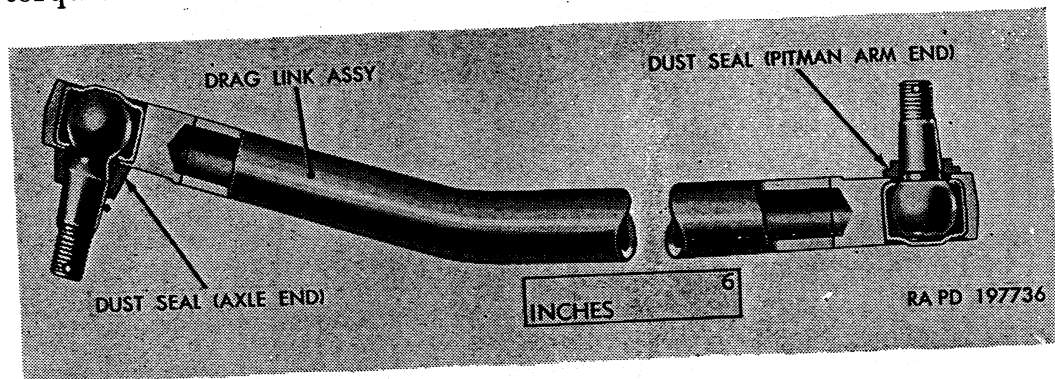

Figure 279. Steering drag link removed.

## 270. Pitman Arm

(fig. 280)

*a. General.* Pitman arm is retained on pitman arm shaft with nut and washer. Blank serration in pitman arm registers with blank serration on shaft.

*b. Removal.*

- (1) Remove left fender and skirt assembly (par. 304b).
- (2) Remove and discard cotter pin from slotted hex nut on steering drag link ball stud. Remove stud nut; then drive ball stud out of pitman arm.
- (3) Remove nut and lockwasher which retains arm or pitman shaft. Use a suitable puller to remove arm from shaft in manner shown in figure 280.

*c. Installation.*

- (1) Position pitman arm on pitman arm shaft, matching blank serration in arm with blank serration on shaft.
- (2) Install  $\frac{7}{8}$ -inch lockwasher and nut on shaft; then tighten nut to 115 to 155 pound-feet torque.
- (3) Position steering drag link ball stud in pitman arm. Install  $\frac{5}{8}$ -18 slotted hex nut on stud; then tighten nut to 75 to 100 pound-feet torque. Install new  $\frac{1}{8}$  x  $1\frac{3}{8}$  cotter pin and bend into place.
- (4) Install left fender and skirt assembly (par. 304c).

## 271. Steering Wheel

(fig. 281)

*a. General.* Steering wheel is retained on shaft with a nut. Horn button and contact fit in recess in center of wheel.

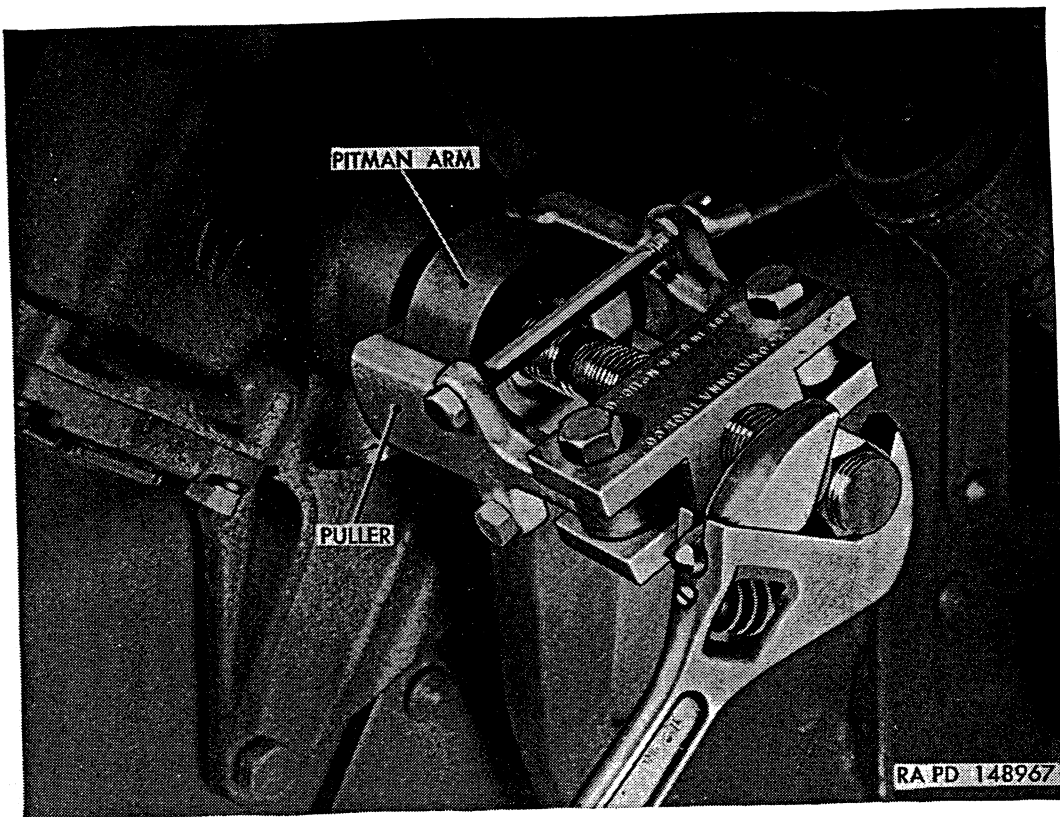

Figure 280. Removing pitman arm.

*b. Removal.*

- (1) Remove horn button and contact from steering wheel (par. 185*d*).
- (2) Remove steering wheel nut.
- (3) Install adapter A7950054 (fig. 281) with a suitable puller at steering wheel. Pull steering wheel from shaft.
- (4) Remove shaft bearing spring and shaft bearing spring seat from steering shaft.

*c. Installation.*

- (1) Position shaft bearing spring seat and shaft bearing spring on steering shaft.
- (2) Position steering wheel on shaft; then install wheel nut. Tighten nut to 40 to 55 pound-feet torque.
- (3) Install horn button and contact (par. 185*e*).

## 272. Steering Gear Replacement

(fig. 282)

*a. Coordination with Ordnance Maintenance Unit.* Refer to paragraph 2 for information on coordination with an ordnance maintenance unit.

*b. General.* Steering wheel, pitman arm, and drag link may remain on steering gear during removal. However, if only steering gear is to be replaced, remove steering wheel with steering gear

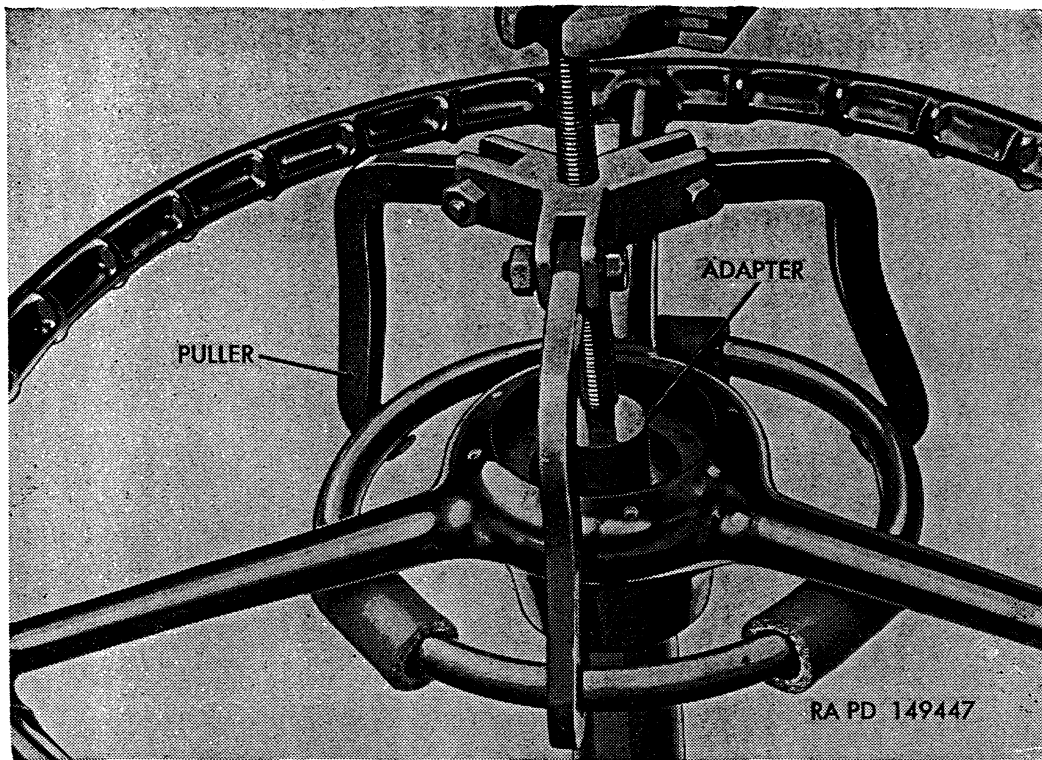

Figure 281. Removing steering wheel, using adapter A7950054 with puller.

mounted in vehicle, and disconnect steering drag link at pitman arm. Pitman arm should be removed with steering gear; otherwise it is necessary to remove left fender and skirt assembly to remove pitman arm.

*c. Removal.*

- (1) Remove steering wheel (par. 271b).
- (2) Remove and discard cotter pin from slotted hex nut on steering drag link ball stud. Remove stud nut, then drive ball stud out of pitman arm.

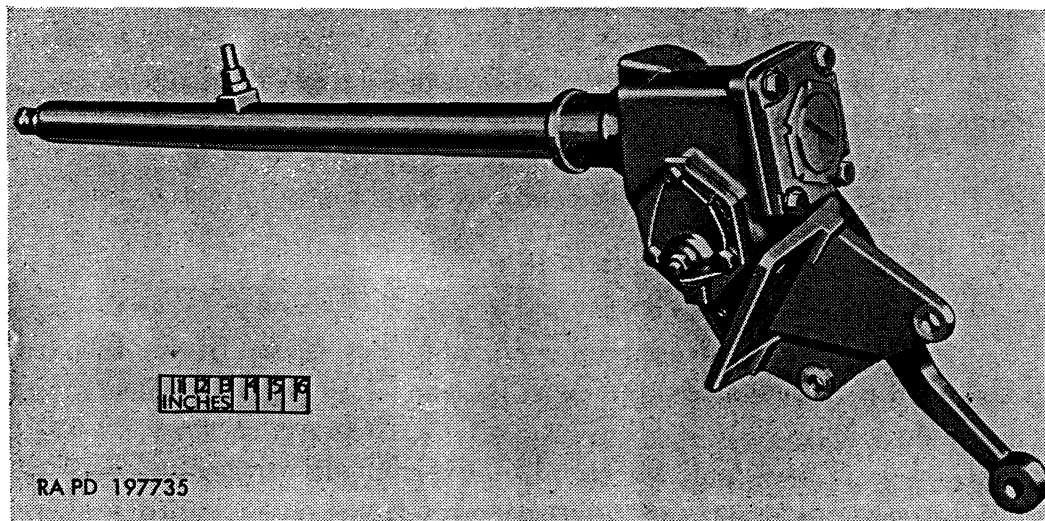

Figure 282. Steering gear assembly removed.

- (3) In cab, remove six bolts from upper and lower pedal plates; then remove plates. Remove horn cable connector from steering column. Remove two cap screws attaching cowl bracket cap (fig. 285) to cowl bracket.
- (4) Remove four cap screws (C and D, fig. 283) and nuts which mount steering gear to frame side member.
- (5) In cab, pull steering gear back until it clears cowl bracket; then pull steering gear straight up through floor and out through left door.
- (6) Remove nut and lockwasher which retains pitman arm on pitman shaft. Use a suitable puller (fig. 280) to remove arm from shaft.

*d. Installation.*

- (1) Position pitman arm on pitman arm shaft, matching blank serrations on shaft with blank serrations in arm.
- (2) Install  $\frac{7}{8}$ -inch lockwasher and nut on pitman shaft; then tighten nut to 115 to 155 pound-feet torque.
- (3) Guide steering gear and pitman arm assembly through opening in cab floor inside cab.
- (4) Position steering gear on frame side member; then install three  $\frac{1}{2}$ -20 x  $1\frac{1}{2}$  cap screws (D, fig. 283) and one  $\frac{1}{2}$ -20 x  $1\frac{7}{8}$  cap screw (C, fig. 283) with four  $\frac{1}{2}$ -30 safety nuts. Tighten nuts to 48 to 64 pound-feet torque.
- (5) On early models (fig. 284), loosen two nuts and bolts attaching spacer to cowl bracket. Position rubber grommet on steering column. Position steering column in cowl bracket; then install bracket cap with two  $\frac{3}{8}$ -24 x 2 cap screws and two  $\frac{3}{8}$ -24 safety nuts. Tighten nuts. With steering column positioned without bind, tighten the two bolts and nuts which attach cowl bracket to spacer. On late models (fig. 285), loosen two nuts and bolts attaching bracket support to dash brace. Position steering column in steering column bracket. Position bracket cap on bracket; then attach cap with two  $\frac{3}{8}$ -16 x 1 bolts and  $\frac{3}{8}$ -inch lockwashers. Tighten bolts. With steering column positioned without bind, tighten the two bolts and nuts attaching bracket support to dash brace.
- (6) In cab, position upper and lower pedal plates on cowl; then attach with six  $\frac{5}{16}$ -24 x  $\frac{5}{8}$  bolts with external-teeth lockwashers. Connect horn cable connector to steering column.
- (7) Position steering drag link ball stud in pitman arm. Install  $\frac{5}{8}$ -18 slotted nut on stud; then tighten to 75 to 100 pound-feet torque. Install new  $\frac{1}{8}$  x  $1\frac{3}{8}$  cotter pin to secure nut on stud.
- (8) Install steering wheel (par. 271c).
- (9) Check lubricant level and replenish if necessary as described on lubrication chart (par. 69).

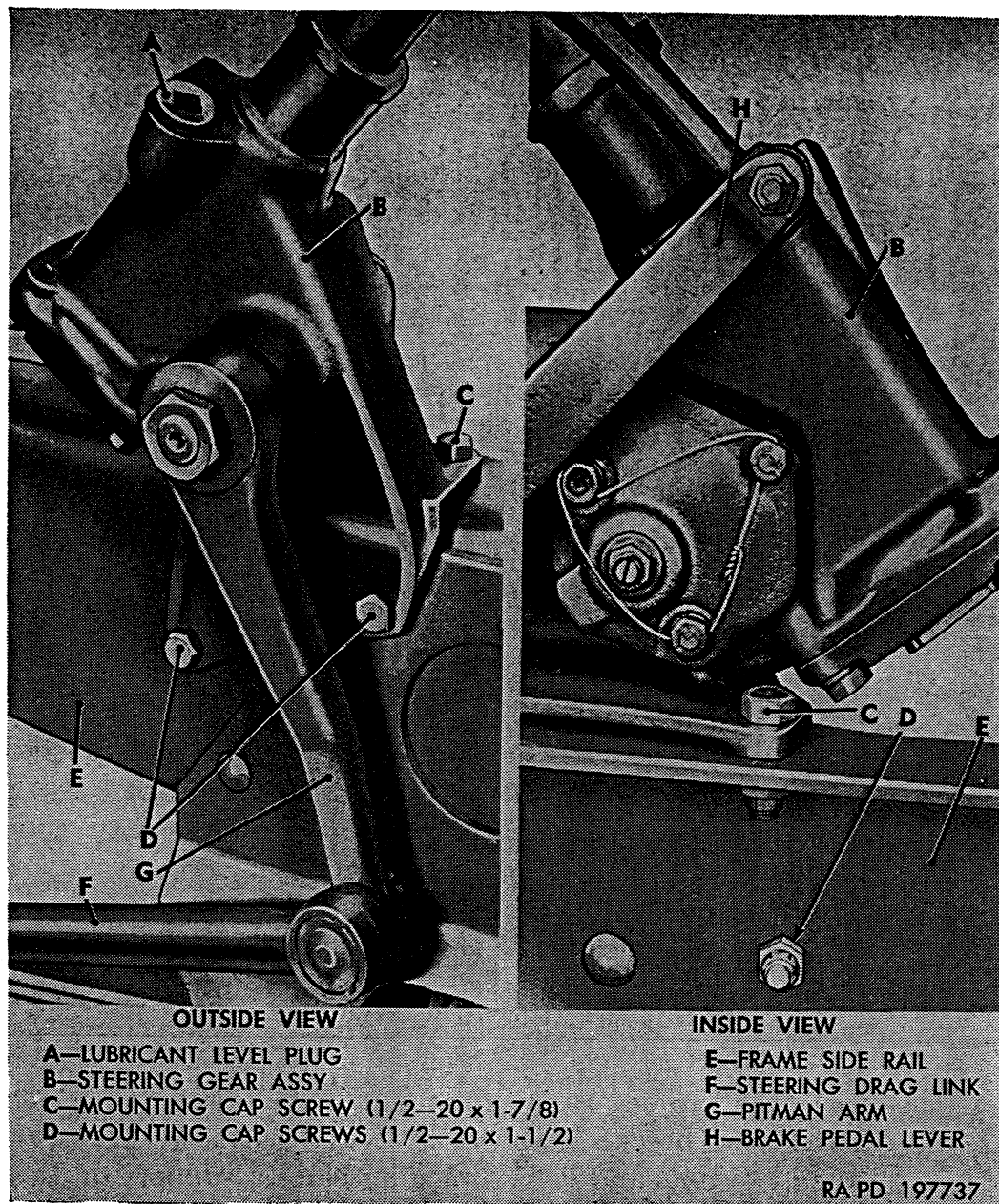

Figure 283. Steering gear mounted to frame.

e. *Record of Replacement.* Record the replacement on DA Form 478.

## Section XXVIII. FRONT SPRING SUSPENSION

### 273. Description and Data

#### a. *Description.*

(1) *General.* Front spring suspension system components comprise the front springs, spring shackles and brackets, torque rods, and shock absorbers. Front spring suspension components are illustrated in figure 286.

(2) *Front springs.* Semielliptic-type front springs carry only vertical and lateral loads and are secured to frame brackets

through shackles at both ends. Springs are mounted on axle housing and held in place with U-bolts and spring bumper blocks.

- (3) *Front spring shackles.* Shackles are secured in frame brackets by bolts and self-locking nuts. Each spring eye is secured in shackle with a straight pin which is held in place with a clamp bolt at both sides of shackle. Shackle bolts and pins are drilled to direct lubricant to spring eye and shackle bushings.
- (4) *Torque rods.* Three torque rods, two lower and one upper, transmit front axle driving and braking forces to frame. Lower torque rod frame brackets are integral with front spring rear brackets. Upper torque rod bracket is mounted inside frame right side member ahead of front spring rear bracket. Frame ends of torque rods are equipped with bushing type bearings mounted in material which requires no lubrication. Rods are secured to frame brackets with bolts and self-locking nuts. Axle ends of torque rods are equipped

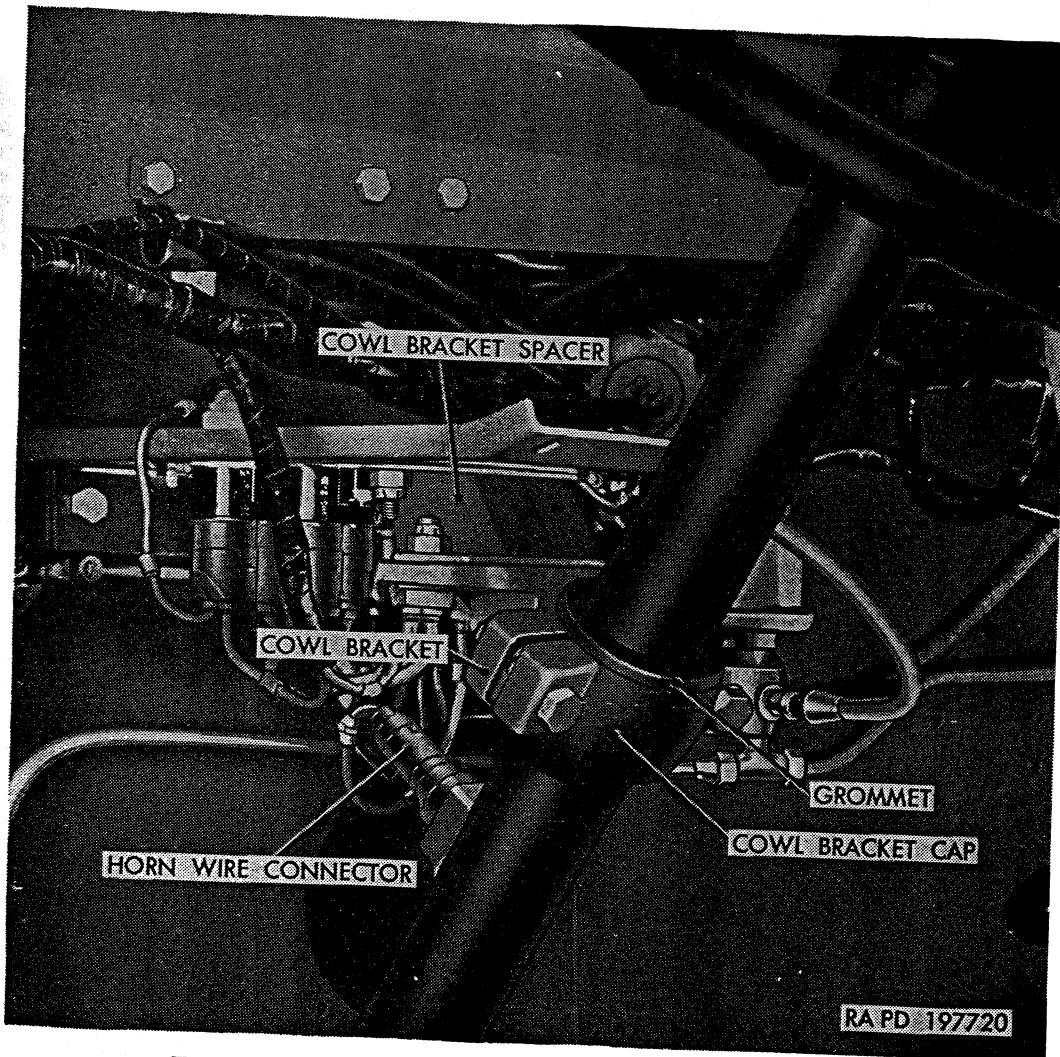

Figure 284. Steering mounting at cowl (early models).



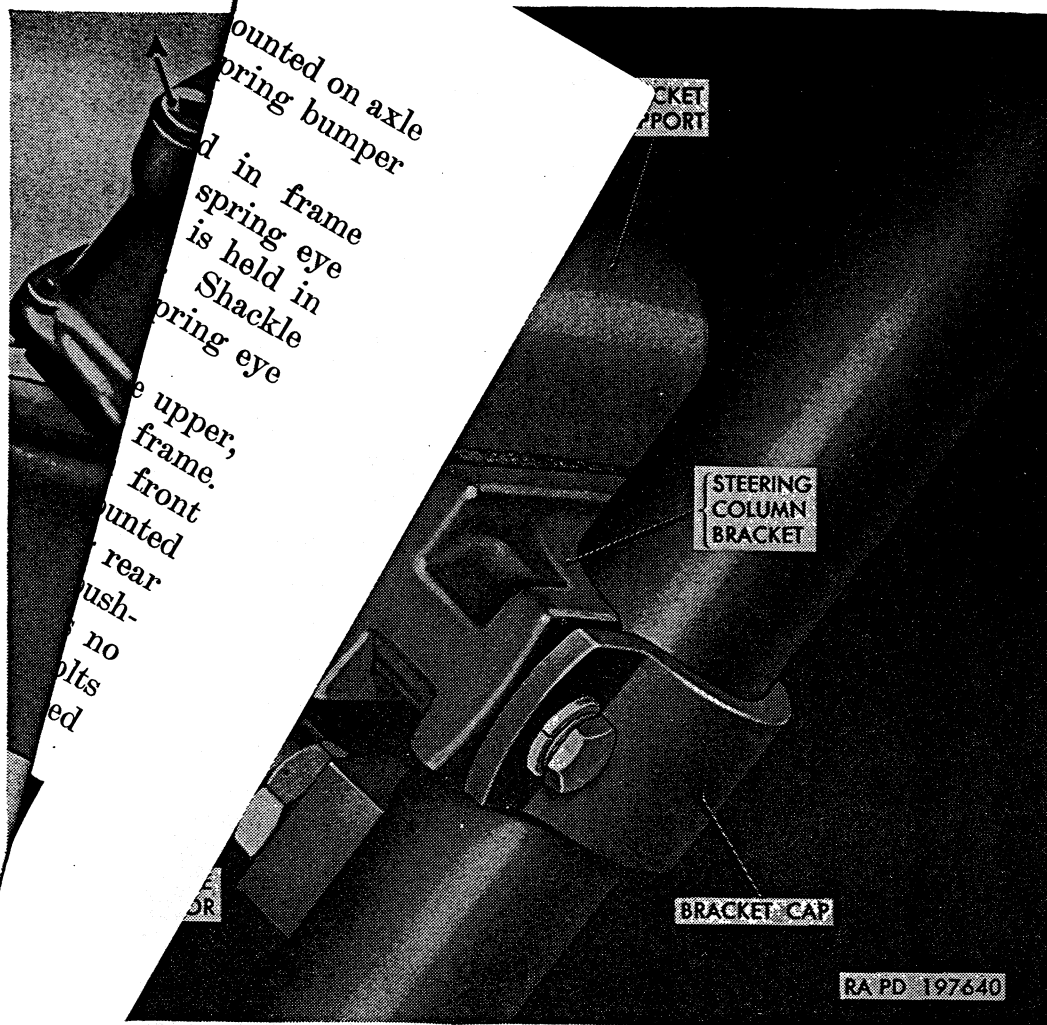

Figure 285. Steering mounting at cowl (late models).

with tapered end pins which are mounted in material requiring no lubrication.

- (5) *Shock absorbers.* Shock absorbers, used at front axle, are hydraulic, double-acting, opposed-cylinder-type. Filler plug is at top front end of shock absorber body. Shock absorber arms are connected to bumper blocks at axle through links which have tapered studs mounted in rubber at each end.

*b. Data.*

Front springs :

Length (center-to-center of spring eyes)	-----	50 in.
Width	-----	2½ in.
Number of leaves	-----	11
Thickness of leaves :		
1 at	-----	0.360 in.
4 at	-----	0.323 in.
6 at	-----	0.291 in.
Total thickness	-----	3.398 in.

Shock absorbers:

Manufacturer ----- Delco Products

Model:

Right side ----- 2009-H

Left side ----- 2009-G

## 274. Spring Shackles

(fig. 286)

*a. General.* The front shackle can be removed without removing front spring. Rear shackle pin and bolt can be replaced without removing spring, however, to replace rear shackle, the spring assembly must be removed.

### *b. Front Shackle Removal.*

- (1) Place jack under frame and raise enough to remove all tension from springs.
- (2) Remove clamp cap screw nuts and cap screws which secure shackle pin at both sides of shackle. Remove lubrication fitting from outer end of pin.
- (3) Remove shackle bolt nut.
- (4) From inside, drive shackle pin (Q) out of shackle (P) and spring eye. Drive shackle bolt (N) out of frame bracket and shackle.

### *c. Front Shackle Installation.*

- (1) Position shackle in frame bracket; then install front shackle bolt (N) through frame bracket and front shackle (P).

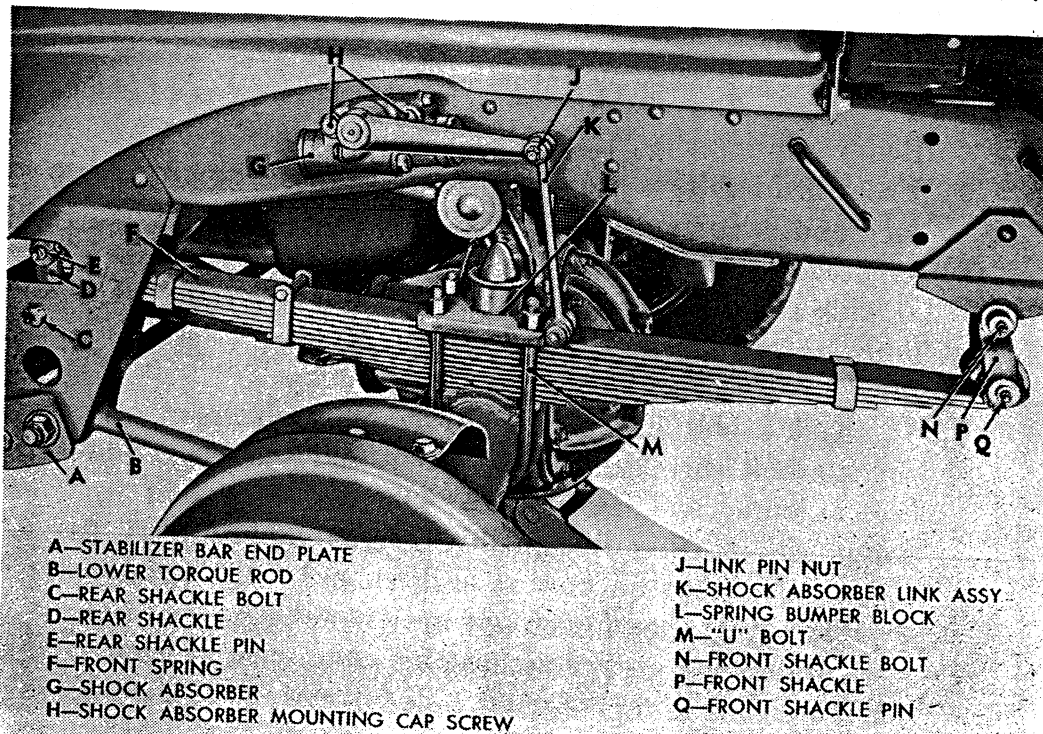

RA PD 197731

Figure 286. Front spring and shock absorber installed — right side shown.

Shank of bolt at outer end is serrated. Drive shackle bolt in from outer end, seating bolt firmly in frame bracket. Install  $\frac{3}{4}$ -16 safety nut on shackle bolt and tighten nut on bolt until shackle binds; then loosen nut until shackle swings free.

- (2) Aline holes in shackle with spring eye; then insert front shackle pin (Q) with flat milled portion of pin registering with clamp cap screw holes in shackle. Install two  $\frac{5}{16}$ -24 x  $1\frac{7}{8}$  cap screws through shackle and secure with two  $\frac{5}{16}$ -24 safety nuts. Tighten nuts to  $9\frac{1}{2}$  to 13 pound-feet torque.

*d. Rear Shackle Replacement.* The front spring must be removed (par. 275a) in order to remove and install rear shackle. However, rear shackle pin and bolt may be removed and installed without removing shackle, by following the same procedure as described in front shackle removal and installation (*b* and *c* above).

## 275. Front Spring Replacement

(fig. 286)

### *a. Removal.*

- (1) Place jack under frame and raise enough to remove all tension from springs.
- (2) Disconnect shock absorber link (K) from eye at spring bumper block (L).
- (3) Remove nuts from spring U-bolts (M); then remove spring bumper block (L) and U-bolts.
- (4) At each end of spring, remove clamp cap screw nuts and cap screws securing shackle pin (Q) at both sides of shackle. Remove lubrication fitting from outer end of each pin.
- (5) From inside, drive pin (Q) out of shackle and spring eye at each end. Spring can then be removed from axle housing.
- (6) If necessary to remove shackles, remove shackle bolt nuts at each shackle; then drive shackle bolts (N) out of frame brackets and shackles.

### *b. Installation.*

- (1) If shackle bolt has been removed at each shackle, install shackle bolt through frame bracket and shackle. Shank of bolt at outer end is serrated. Drive shackle bolt in from outer end, seating bolt firmly in frame bracket. Install  $\frac{3}{4}$ -16 safety nut on bolt at each shackle and tighten until shackle binds; then loosen nut until shackle swings free.
- (2) Position spring on spring seat on axle housing with center bolt head engaging locating hole in seat, and with spring eyes in place in shackles.
- (3) At each end of spring, aline holes in shackle with spring eye. Insert shackle pin with flat milled portion of pin registering

with clamp cap screw holes in shackle. Install two  $\frac{5}{16}$ -24 x  $1\frac{7}{8}$  clamp cap screws through shackle and secure with two  $\frac{5}{16}$ -24 safety nuts. Tighten nuts to  $9\frac{1}{2}$  to 13 pound-feet torque.

- (4) Install U-bolts (M) and spring bumper block (L), with shock absorber link assembly (K) eye in bumper block toward the front. Install nuts on U-bolts and tighten. Final tightening should be made with weight of vehicle on springs.
- (5) Insert shock absorber link (K) stud through eye in spring bumper block (L). Install  $\frac{1}{2}$ -20 safety nut on stud and tighten to 48 to 64 pound-feet torque.
- (6) Remove jack from under frame. With weight of vehicle on springs, tighten U-bolt nuts to 170 to 200 pound-feet torque.
- (7) Install lubrication fittings in shackle bolts and pins, and lubricate shackles. Refer to lubrication chart (par. 69).

## 276. Torque Rods

*a. General.* Replacement procedures for both lower torque rods is the same. Upper torque rod replacement is described separately in *d* and *e* below.

### *b. Lower Torque Rod Removal (fig. 287).*

- (1) Jack up frame enough to relieve tension from spring.
- (2) At frame bracket end of torque rod to be removed, remove nut from bolt. Drive bolt out of lower bracket and torque rod bearing, using a soft metal hammer and drift. The removal of both torque rod bolts also removes the stabilizer bar which is held in position on spring and torque rod brackets by the torque rod bolts.
- (3) At axle end of torque rod to be removed, remove nut and flat washer from torque rod tapered end pin. Using soft metal hammer, drive pin out of axle bracket.

*Note.* Rubber dust seals are used on both ends of torque rod bearings at frame brackets, and also between rod end and brackets at axle ends.

### *c. Lower Torque Rod Installation (fig. 287).*

- (1) Place dust seal on both sides of torque rod bearing at frame bracket end. Position dust seal over end pin at axle end of rod.
- (2) Position torque rod tapered pin in axle bracket, being careful not to dislodge dust seal from bearing.
- (3) Position torque rod end with seals in frame bracket; position stabilizer bar end plate on outside of frame bracket. From inside of frame bracket, insert torque rod bolt through frame bracket, torque rod, and stabilizer bar end plate. Drive bolt into place, using a soft metal hammer.

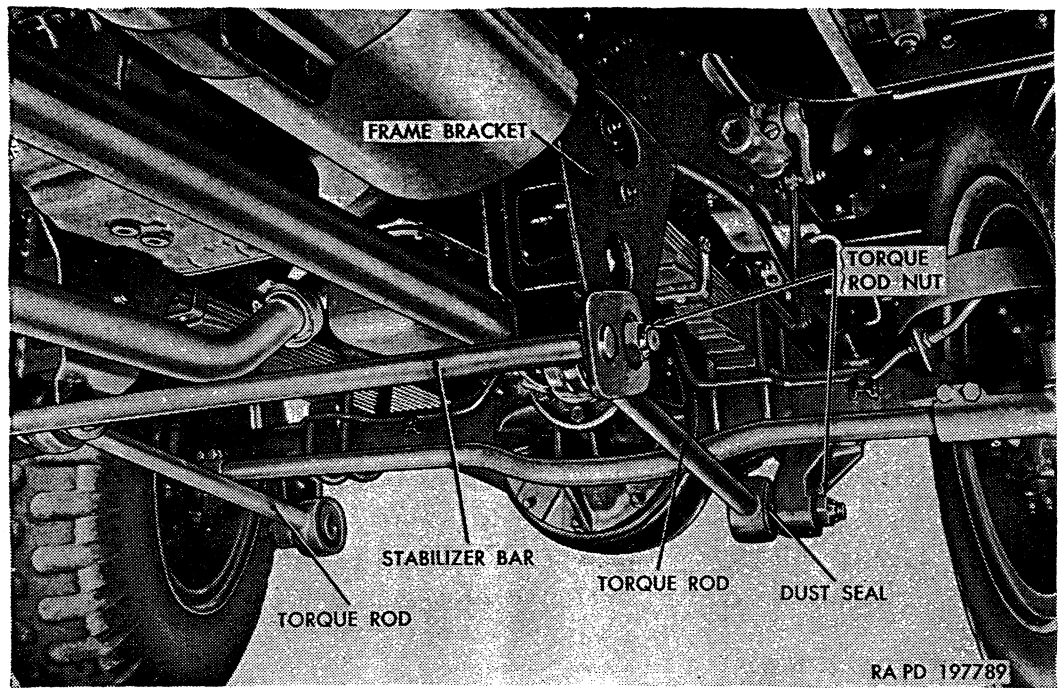

Figure 287. Right lower torque installed.

- (4) Install 1-14 safety nut on torque rod bolt. Tighten nut to 190 to 250 pound-feet torque.
- (5) Install flat washer and 1-14 safety nut on torque rod tapered pin at axle end. Tighten nut to 350 to 400 pound-feet torque.

d. Upper Torque Rod Removal (fig. 288).

- (1) Jack up frame enough to relieve tension from springs.
- (2) Remove right fender and skirt assembly (par. 304b).

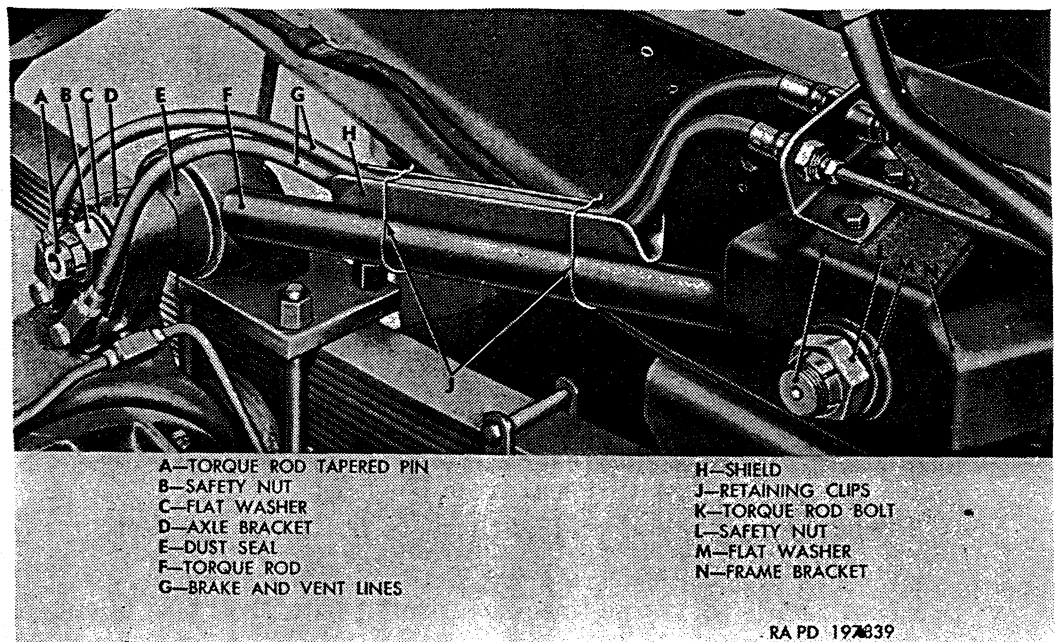

Figure 288. Upper torque rod installed.

- (3) Remove clips holding brake and vent lines in shield on top of torque rod, then lift lines from shield.
- (4) At frame bracket end of torque rod, remove nut from torque rod bolt.
- (5) Head of torque rod bolt is drilled and threaded for use of slide hammer to facilitate bolt removal. Pull bolt from torque rod and bracket.
- (6) At axle end of torque rod, remove nut and flat washer from torque rod tapered end pin. With soft metal hammer, drive pin out axle bracket.

*Note.* Rubber dust seals are used on both sides of torque rod bearings at frame bracket and between rod end and bracket at axle end.

*e. Upper Torque Rod Installation (fig. 288).*

- (1) Place dust seal on both sides of torque rod bearing at frame bracket end. Position dust seal (E) over end pin at axle end of torque rod (F).
- (2) Position torque rod tapered pin (A) in axle bracket (D), being careful not to dislodge dust seal (E) from bearing.
- (3) Position torque rod end with seals in frame bracket (N). Install flat washer on torque rod bolt (K); then insert bolt through frame side member, frame bracket, and torque rod bearing.
- (4) Using a soft metal hammer, drive bolt into place. As bolt is driven through inner side of frame bracket (N), install flat washer (M), and 1-14 safety nut (L). Nut must be started on torque rod bolt (K) before bolt is fully seated. Tighten nut to 190 to 250 pound-feet torque.
- (5) Install flat washer (C) and 1-14 safety nut (B) on torque tapered pin (A) at axle end; then tighten nut to 350 to 400 pound-feet torque.
- (6) Position brake and vent lines (G) in shield (H) on top of torque rod. Secure lines in shield with two retaining clips (J).
- (7) Install right fender and skirt assembly (par. 304c).

## **277. Shock Absorbers**

*Note.* The key letters noted in parentheses are in figure 286, except where otherwise indicated.

*a. Checking Action.*

- (1) If shock absorber action is not satisfactory (overflexible), disconnect link (K) at shock absorber arm. Move shock absorber arm up and down. Normal action requires resistance in both directions. If arm drops easily part way, stops, and then continues to move down slowly, refill with fluid as described in *b* below.

- (2) If leaks are evident around end caps or filler plug, replace gaskets. If unit has been operated with low fluid level, leaks may appear around shaft. Shock absorber should then be replaced.

*b. Adding Fluid.*

- (1) Refer to lubrication chart (par. 69) for type of fluid and intervals.
- (2) Remove plug at front of housing (N, fig. 82) and check fluid level. If fluid is not up to plug level, disconnect shock absorber link assembly (K) from arm by removing link stud nut; then remove link from arm.
- (3) Fill to plug level with hydraulic oil (OHA). Pump arm up and down slowly to expel air from shock absorber. Repeat pumping and filling operations until all air is removed and fluid is at filler plug opening. Install and tighten filler plug.
- (4) Install link to arm. Tighten link stud nut to 48 to 64 pound-feet torque.

*c. Removal.*

- (1) Remove nut (J) on link (K) pin at shock absorber arm, and drive pin from arm. If link also must be replaced, remove at spring bumper block (L).
- (2) Remove two mounting cap screws (H) and nuts securing shock absorber to frame side member. Remove reinforcing spacer.

*d. Installation.*

- (1) Position shock absorber at frame side member; then insert two  $\frac{9}{16}$ -18 x 3 shock absorber mounting cap screws (H) through shock absorber and frame side member.
- (2) Place a reinforcing spacer between inner side of frame side member and each cap screw nut. Install two  $\frac{9}{16}$ -18 safety nuts and tighten to 63 to 84 pound-feet torque.
- (3) Connect shock absorber link assembly (K) to shock absorber arm. Install  $\frac{1}{2}$ -20 safety nut on link pin and tighten to 48 to 64 pound-feet torque.
- (4) Fill absorber with fluid if necessary as described in *b* above.
- (5) Connect link (K) to spring bumper block (L). Install  $\frac{1}{2}$ -20 safety nut and tighten to 48 to 64 pound-feet torque.

## Section XXIX. REAR SPRING SUSPENSION

### 278. Description and Data

*a. Description.*

- (1) *General.* Rear spring suspension system components comprise the main spring assembly, main spring seat and bearings, secondary spring assembly, torque rod assemblies (fig. 289), and attaching parts.

- (2) *Main and secondary springs.* Main and secondary spring assemblies are identical. Each spring assembly consists of 10 spring leaves, secured together by a center bolt and four rebound clips. Main spring is mounted on spring seat which, in turn, is mounted on a shaft on opposed tapered roller bearings. Secondary spring is mounted rigidly to bracket on frame side rail. Slipper ends of main spring are inserted in brackets which are integral with axle housings; secondary spring ends contact top of brackets on axle housing under heavy load conditions.
- (3) *Main spring seat.* Main spring seat is mounted on tapered roller bearings on spring seat shaft. Tapered spring seat cross shaft is installed in spring seat and torque rod cross shaft bracket (M, fig. 298) and secured with a plain washer and safety nut. Outer end of shaft is threaded for bearing adjusting nuts, and grooved for tongue on adjusting nut lock. Spring seat inner oil seal, installed on spring seat shaft sleeve, wipes on inside of seal flange which is pressed into inner end of seat.
- (4) *Torque rods.* Six torque rod assemblies, two upper and four lower, transmit driving and braking forces of the two rear axles to the frame. Both ends of all rear torque rods are equipped with tapered end pins. Brake and vent line shield is welded to top of each upper torque rod.

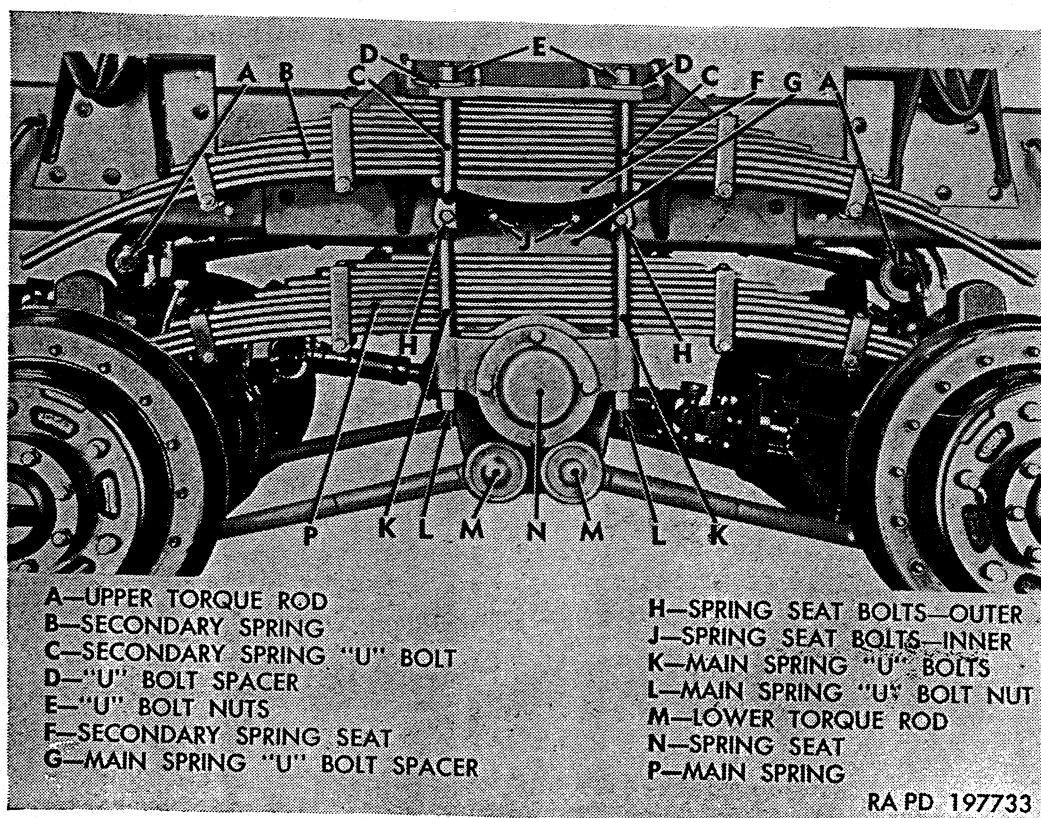

Figure 289. Rear springs and torque rods installed.



*b. Data.*

Main and secondary spring assemblies :

Overall length.....	55½ in.
Width.....	2½ in.
Number of leaves.....	10
Thickness of leaves :	
4.....	0.447 in.
6.....	0.401 in.
Total thickness.....	4.194 in.

## 279. Main Spring Replacement

*a. Removal.*

- (1) Apply parking brake or block wheels to prevent accidental movement of vehicle while spring is being removed and installed.
- (2) On side being serviced, place jack under frame bracket assembly; then jack up bracket until tension is relieved from main spring. Remove main spring U-bolt nuts (L, fig. 289).
- (3) Drive U-bolts up against auxiliary spring seat; then remove main spring U-bolt spacer (fig. 290).
- (4) Remove jack from under frame bracket assembly. This allows spring seat assembly to tilt forward and backward, so that the U-bolts can be removed from spring seat. Remove U-bolts (fig. 291).
- (5) Place jack under forward rear axle and raise axle until tires just clear ground. Slide spring forward into spring guide bracket on forward axle. Spring end will not quite clear spring guide bracket (fig. 292) on rear rear axle.

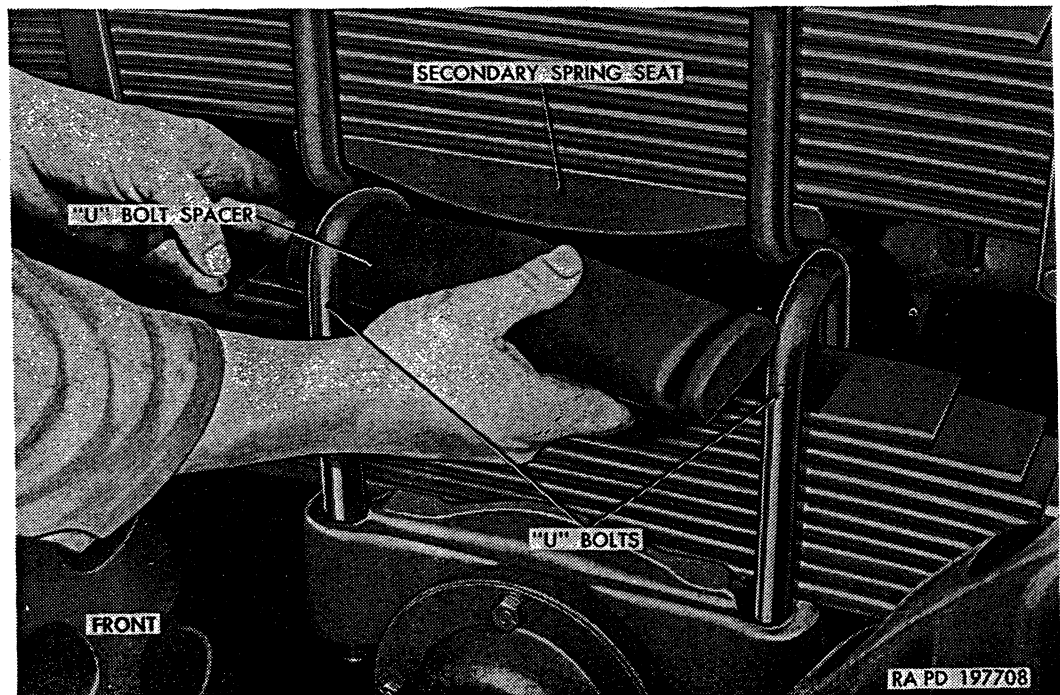

Figure 290. Removing or installing main spring U-bolt spacer.

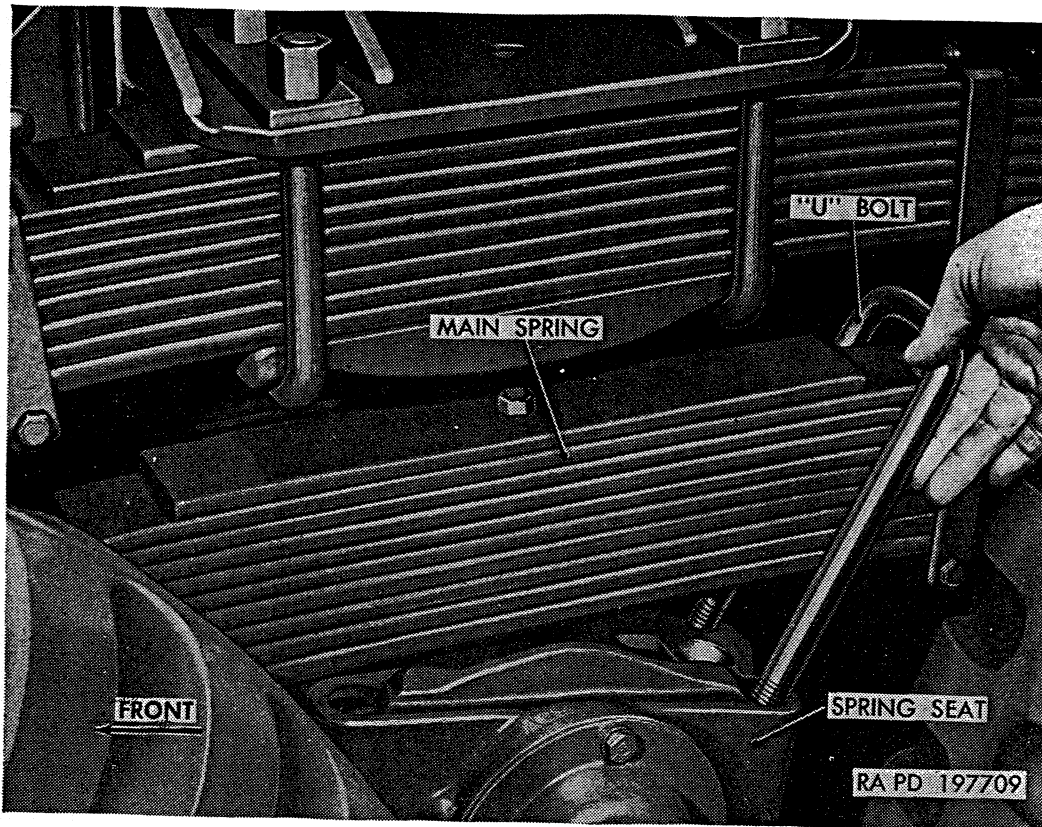

Figure 291. Removing or installing main spring U-bolts.

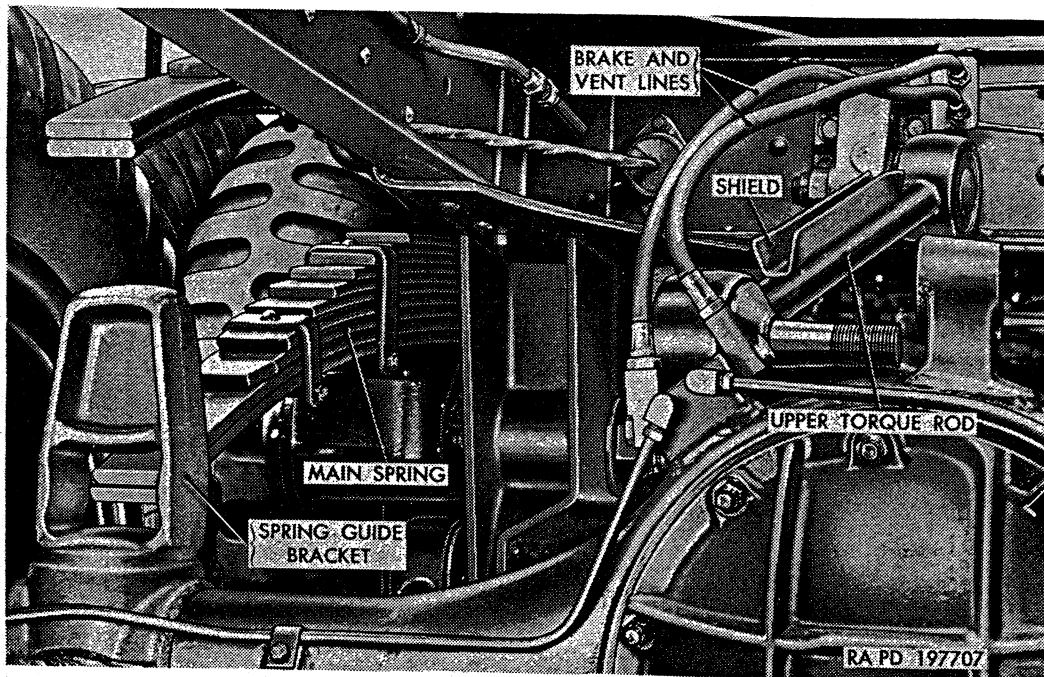
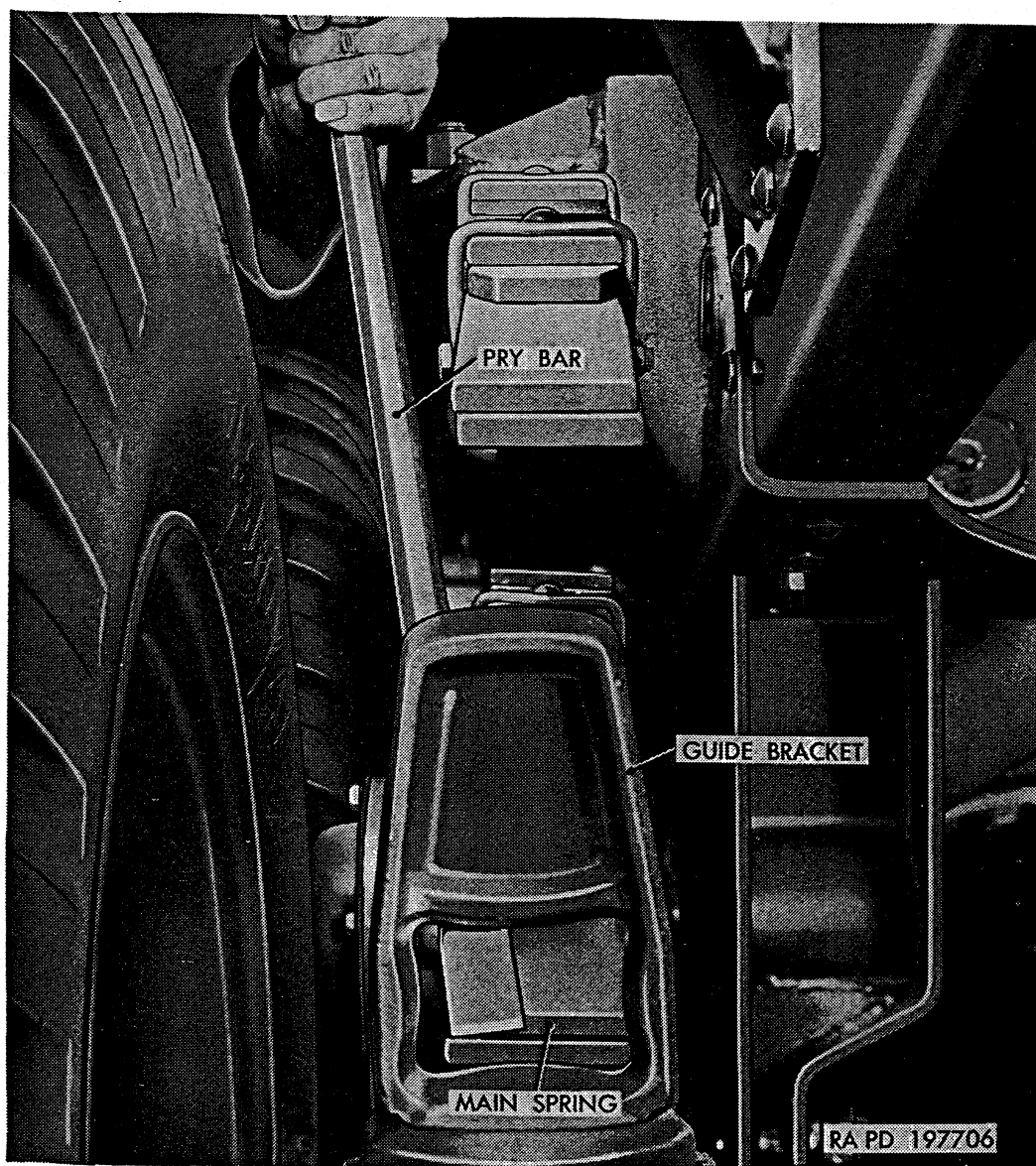

Figure 292. Main spring and upper torque rod disconnected.

- (6) Disconnect upper torque rod (fig. 292) at rear rear axle by removing nut from end of tapered pin; then driving pin from bracket using a soft metal hammer.
  - (7) Place end of short pry bar against end of main spring (fig. 293) and pry against spring guide bracket. This will rotate axle housing enough to allow spring to be removed from rear guide bracket.
  - (8) Tilt spring sidewise and withdraw out over rear rear axle housing past inside of spring guide bracket (fig. 294).
- b. Installation.*
- (1) Raise forward rear axle with a jack until tires clear ground. Position spring over rear rear axle housing (fig. 294). Slide front end of spring into spring guide bracket on forward axle. Rotate rear spring guide bracket with a pry bar to allow rear end of spring to enter rear spring guide.



*Figure 293. Removing main spring end from guide bracket.*

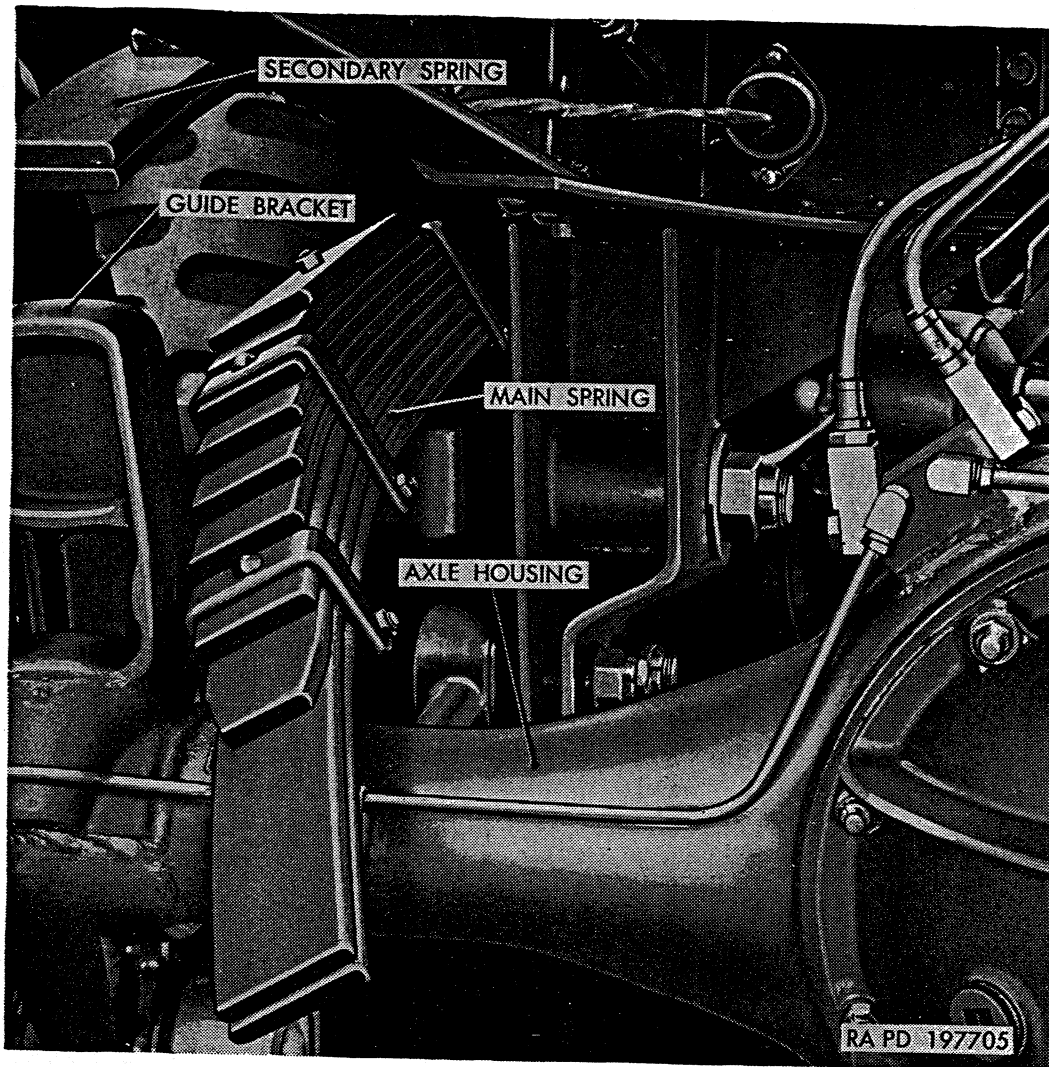

Figure 294. Main spring removal.

- (2) Remove jack from under forward rear axle. Position spring on spring seat assembly; then place U-bolts over spring and through spring seat.
- (3) Install U-bolt spacer (fig. 290). Place jack under frame bracket assembly and raise bracket until spring rests on spring seat.
- (4) Install U-bolt nuts and tighten to 375 to 400 pound-feet torque. Remove jack from under frame bracket.
- (5) Connect upper torque rod to rear rear axle bracket.

*Note.* Positioning of torque rod tapered pin in axle bracket is facilitated by jacking up axle; then rotating axle forward, using a pry bar between lower torque rod and axle housing.

Install flat washer and 1-14 safety nut on torque rod tapered pin. Tighten nut to 350 to 400 pound-feet torque.

## 280. Secondary Spring Replacement

### a. Removal.

- (1) Loosen secondary spring U-bolt nuts (E, fig. 289).

- (2) Remove four nuts and bolts (H and J, fig. 289) attaching secondary spring seat to frame bracket.
- (3) Support spring by blocking between ends of spring and spring guide brackets on axle housings.
- (4) Remove U-bolt nuts, spacers, and U-bolts.
- (5) With spring held up against frame bracket (fig. 295) lower spring seat until locating cavities in spring seat clear the locating projections on spring leaf; then slide spring seat to rear until it contacts flange of frame bracket.
- (6) Roll spring out of spring seat (fig. 296) by tilting top of spring in toward frame side member and pulling ends of spring out toward tires. Spring can then be lifted out of spring seat and removed out over wheels. Remove spring seat.

*b. Installation.*

- (1) If spring center bolt extends over a thread above bolt nut, cut off bolt (fig. 297) to give maximum clearance between bolt and frame bracket when installing spring.
- (2) Place secondary spring seat in position on top of main spring U-bolt spacer. Move spring seat to rear as far as possible until seat contacts flange of frame bracket.
- (3) Position spring on spring seat (fig. 296), with top of spring tilted towards frame and spring ends toward tires. When

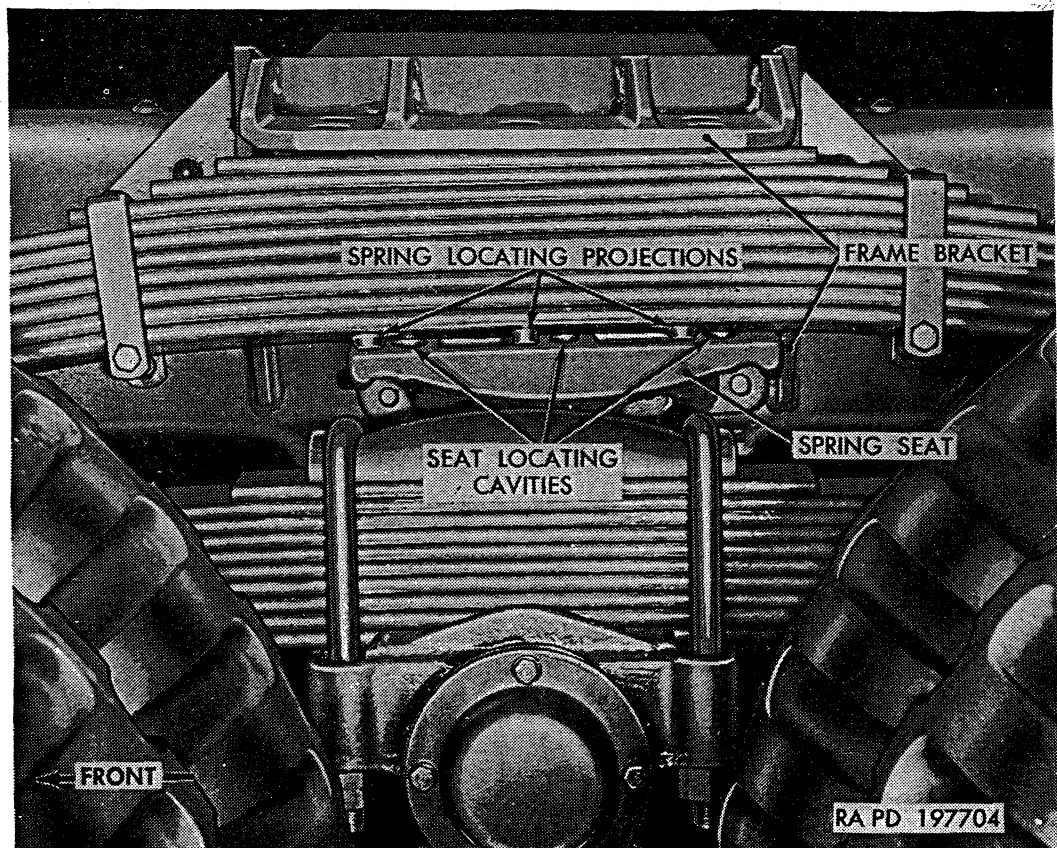
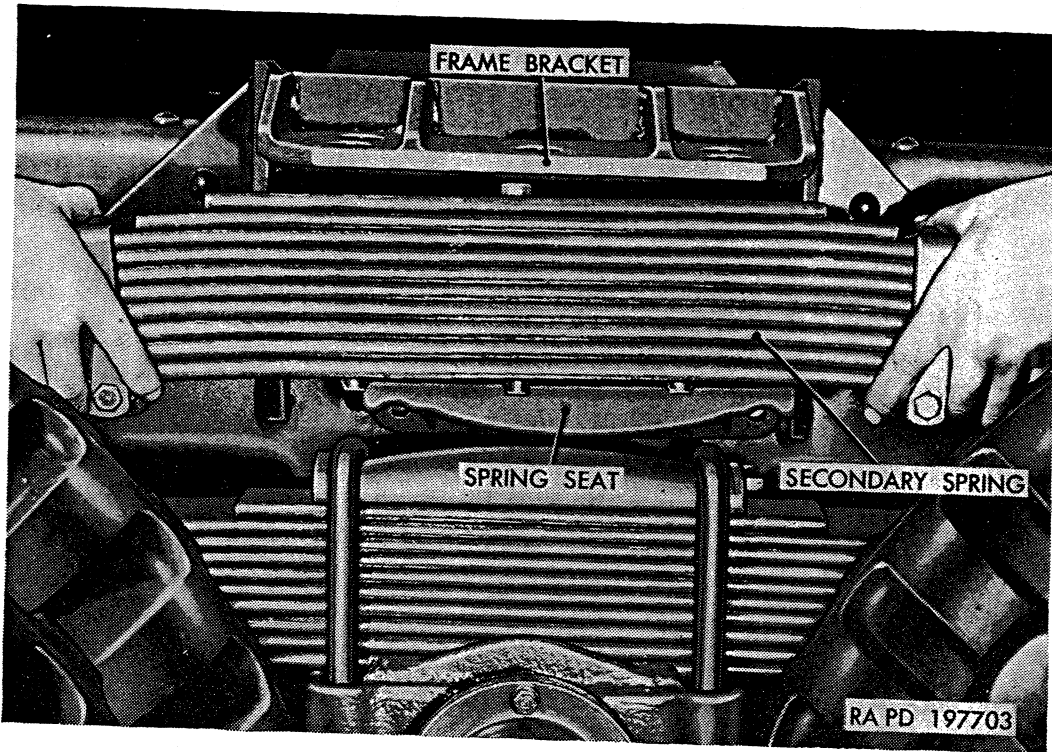
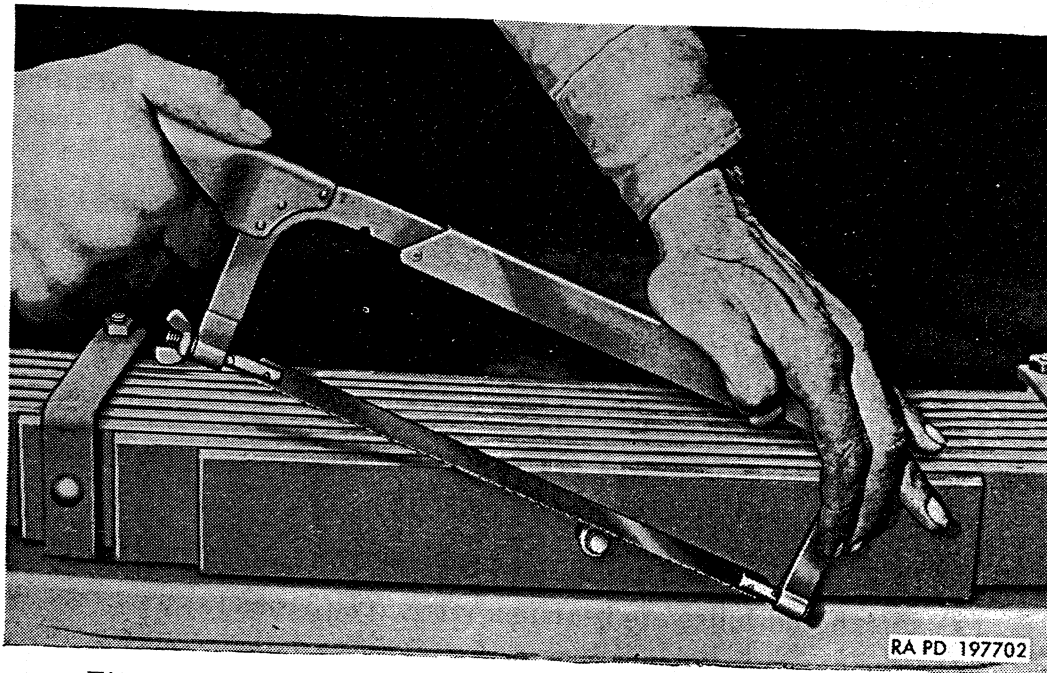

Figure 295. Secondary spring seat disconnected.



*Figure 296. Secondary spring seat removal.*



*Figure 297. Removing excess end of secondary spring center bolt.*

correctly positioned, spring and spring seat will roll into position in frame bracket (fig. 295).

- (4) With spring center bolt located in drilled locating hole in frame bracket, hold top of spring against bracket by blocking between spring ends and spring guide brackets on axle housing.
- (5) Move spring seat forward under spring until locating projections on spring leaf mate with locating cavities in spring seat.
- (6) Install U-bolts with two spacers and four nuts. Do not tighten U-bolt nuts at this time.
- (7) Align spring seat bolt holes with bolt holes in frame bracket. Install two  $\frac{7}{16}$ -20 x  $2\frac{1}{4}$  inner spring seat bolts (J, fig. 289) in inner bolt holes, and two  $\frac{7}{16}$ -20 x 2 outer spring seat bolts (H, fig. 289) in two outside bolt holes. Install four  $\frac{7}{16}$ -20 safety nuts and tighten to 33 to 43 pound-feet torque.
- (8) Tighten U-bolt nuts to 375 to 400 pound-feet torque. Remove blocks from between ends of spring and spring guide brackets.

## 281. Main Spring Seat Replacement

(fig. 298)

### *a. Removal.*

- (1) Remove main spring (par. 279a).
- (2) Remove four cap screws (B) and lockwashers attaching seat dust cap (A) to seat; remove cap and dust cap gasket (R). Discard gasket.
- (3) Bend tangs of nut lock away from locknut (V). Remove locknut, nut lock, adjusting nut (T), and washer (S) from shaft (J).
- (4) Slide seat assembly (E) off shaft. Inner and outer cones and rollers (C and G) seal flange (N) will be removed with seat. Remove outer cone and rollers from seat housing. With suitable puller, remove inner cone, roller and sleeve flange. Oil seal (P) and sleeve (H) will remain on shaft.
- (5) Pull seal from sleeve if necessary to replace (b(4) below).
- (6) Remove bearing cups (D and F) if necessary (b(3) below), with suitable puller or soft drift.

### *b. Cleaning and Inspection.*

- (1) Clean and lubricate bearings (par. 70d(3)(a)).
- (2) Clean all old lubricant out of spring seat and wipe dry. Remove old particles of gasket from outer side of spring seat. Wipe oil seal clean with a cloth dampened in dry-cleaning solvent or volatile mineral spirits. Wash all mounting parts in cleaning fluid.

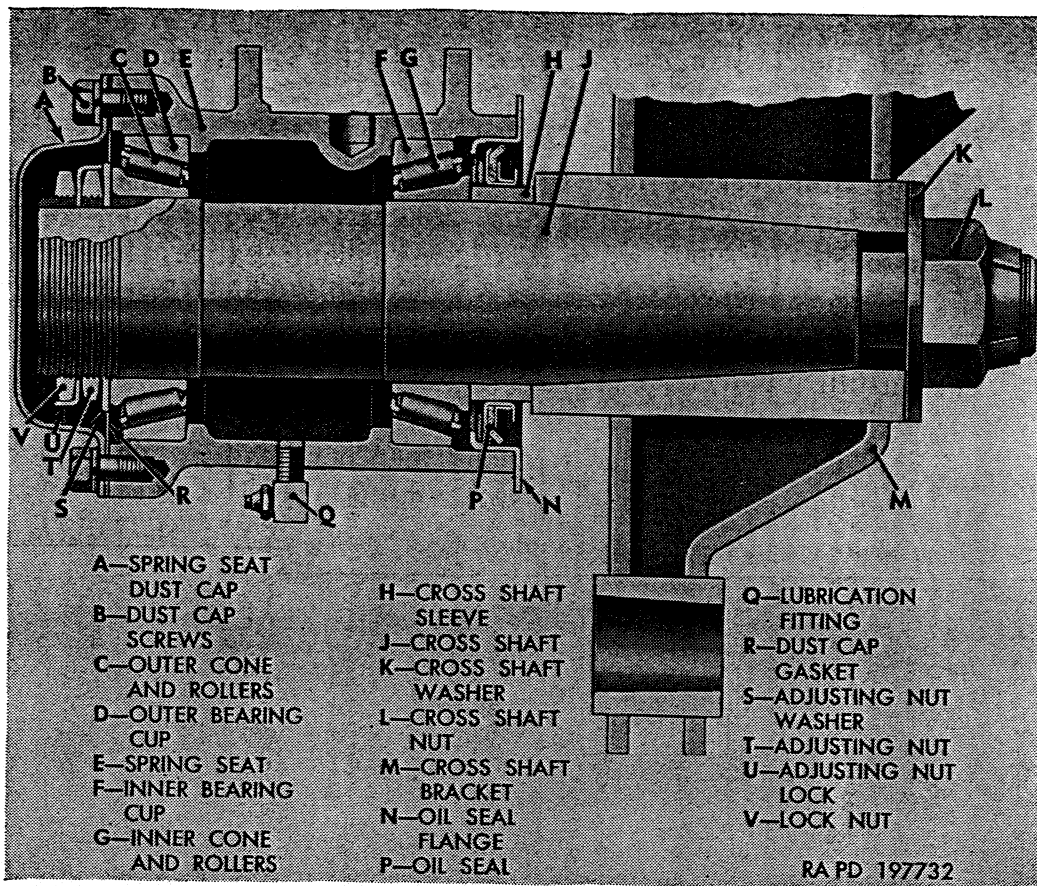

Figure 298. Rear spring seat—sectional view.

- (3) Inspect bearing rollers for wear or chipped edges. Examine bearing cups for pits and cracks. Polished lines will appear in cups indicating resting position of rollers. These lines are not harmful. Bearing cups should not be replaced unless cracked or pitted.
- (4) Examine oil seal. If lip is worn or deteriorated, replace seal. If inner diameter of seal flange is grooved, replace parts.
- (5) Examine cross shaft for damaged threads or distortion. Report to ordnance maintenance personnel if cross shaft requires replacement.

*c. Installation.*

- (1) Coat inner diameter of oil seal (P) with plastic-type gasket cement. Press seal over cross shaft sleeve (H) with lip of seal toward cross shaft bracket (M). Press on sleeve until inner edge of seal is one-quarter inch from inner edge of sleeve.
- (2) Install outer and inner bearing cups (D and F) (if removed) in seat, making certain that cups seat firmly against shoulder in seat.
- (3) Install inner cone and rollers (G) in spring seat (E).
- (4) Press oil seal flange (N) into spring seat.



- (5) Position outer cone and roller (C) into spring seat. Slide seat and bearings over cross shaft, with oil seal flange over oil seal lip.
- (6) Install adjusting nut washer (S) over cross shaft threads. Install adjusting nut (T) and tighten to 60 to 75 pound-feet torque, using adjusting nut wrench B7950946 with torque wrench (fig. 299) while oscillating spring seat to make sure bearings are properly seated. After tightening adjusting nut, back off one-quarter turn.
- (7) Install nut lock (U) and locknut (V). Tighten locknut to 100 to 150 pound-feet torque, using adjusting nut wrench B7950946 with torque wrench; then bend tangs of nut lock over flats on adjusting nut and locknut.

*Note.* Inner edge of trunnion shaft sleeve must be tight against cross shaft bracket when seat is installed and adjusted.

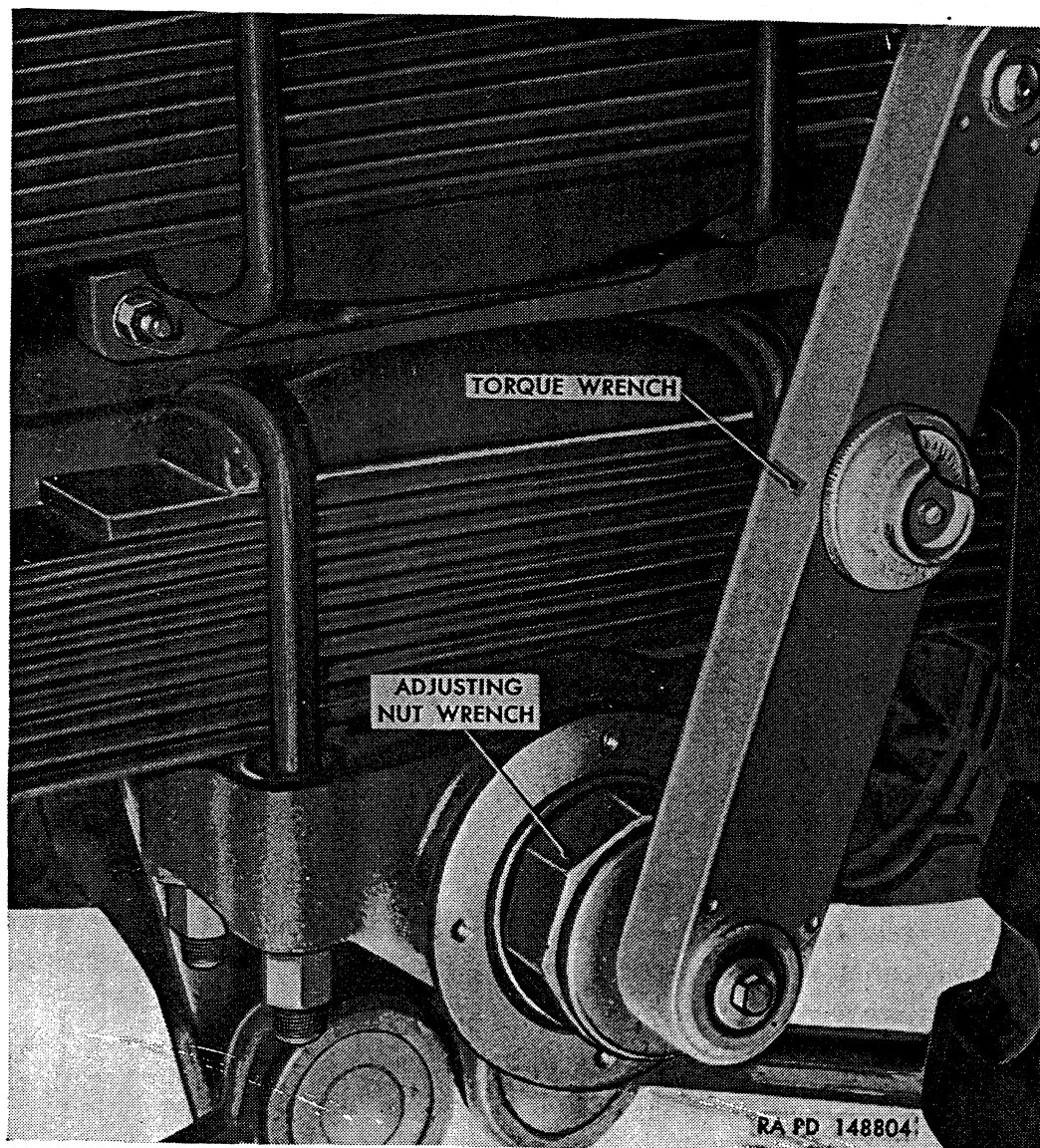

Figure 299. Tighten spring seat adjusting nut, using wrench B7950946 with torque wrench.

- (8) Install spring seat cap (A), using new dust cap gasket (R); attach with four  $\frac{3}{8}$ -16 x  $\frac{3}{4}$  dust cap screws (B) and  $\frac{3}{8}$ -inch lockwashers. Tighten cap screws.
- (9) Fill spring seat with lubricant through lubrication fitting (Q) until lubricant appears at seat on inner side. Refer to lubrication chart (par. 69).
- (10) Replace main spring (par. 279).

## 282. Torque Rod Replacement

(fig. 300)

*a. General.* Replacement procedure is the same for all six rear torque rods, with the exception that on two upper torque rods, it is also necessary to remove and install brake and vent line in shield on top of each torque rod.

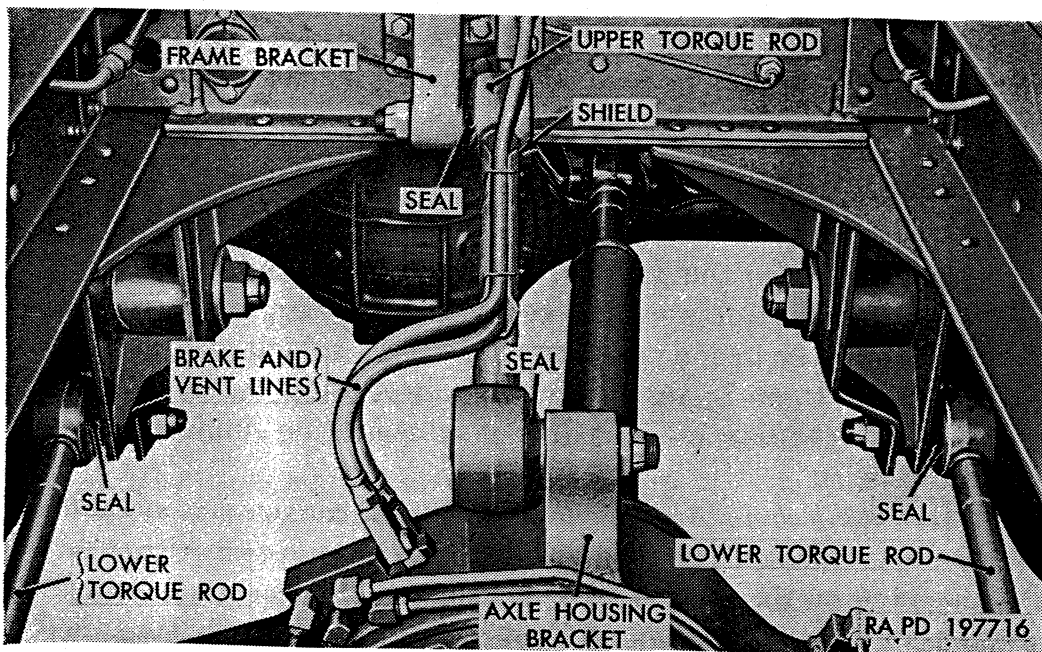

Figure 300. Rear torque rods installed—rear rear axle shown.

### *b. Removal.*

- (1) Remove two clips retaining brake and vent lines in shield on upper torque rod. Lift lines out of shield.
- (2) Jack up frame enough to relieve all strain from springs.
- (3) Remove nut and flat washer from pin at both ends of torque rod being removed. Drive pins from brackets, using soft metal hammer. Note that rubber dust shields are installed over pins between rod ends and brackets.

### *c. Installation.*

- (1) Place dust seals over torque rod tapered pins at both ends of rod being installed.

*Note.* Torque ends do not require lubrication.

- (2) Insert pins through frame bracket and axle brackets. Install flat washers and 1-14 safety nuts on pins. Tighten nuts to 350 to 400 pound-feet torque.
- (3) Position brake and vent lines in shield on upper torque rod only. Secure lines in shield with two clips.
- (4) Remove jack from under frame.

## Section XXX. FRAME

### 283. Description

The frame assembly consists of frame side members, cross members, gussets, and various brackets. Side members, cross members, gussets, and many other parts are pressed steel formed to meet their particular requirement. Parts which normally do not require removal are held in place by cold riveting; however, other parts which may require more frequent removal are held by bolts and safety nuts. In some instances, several pressed metal pieces are welded together to form a part.

### 284. Frame Alinement

(fig. 301)

*a. General.* Since the frame forms the foundation of the entire vehicle, proper functioning of the vehicle and its components is greatly dependent upon correct frame alinement. If vehicle has been in a collision, or if there is any reason to believe that frame is sprung, twisted, or otherwise misalined, report condition immediately to proper authority.

*b. Checking Frame Alinement.* The most convenient method to check frame alinement, particularly on vehicle equipped with a body, is by marking on the floor all points from which measurements are to be taken. This can be accomplished by tacking or cementing pieces of paper to the floor under each point of measurement. Start at front of vehicle (M, fig. 301) and drop a plumb bob from each point indicated in figure 301. Satisfactory checking is dependent upon accuracy of marks with relation to frame. When each point shown has been marked carefully and the vehicle moved away from the layout on the floor, proceed as directed in (1) through (5) below.

- (1) Check frame width at front and rear, using corresponding marks on floor. If widths correspond to dimensions given, draw centerline full length of vehicle halfway between marks indicating front and rear width. If frame widths are not correct, lay out centerline as directed in (4) below.
- (2) With centerline properly laid out, measure distance from opposite points marked over entire length of chassis. If frame is in proper alinement, measurements should not vary more than one-eighth inch at any point.

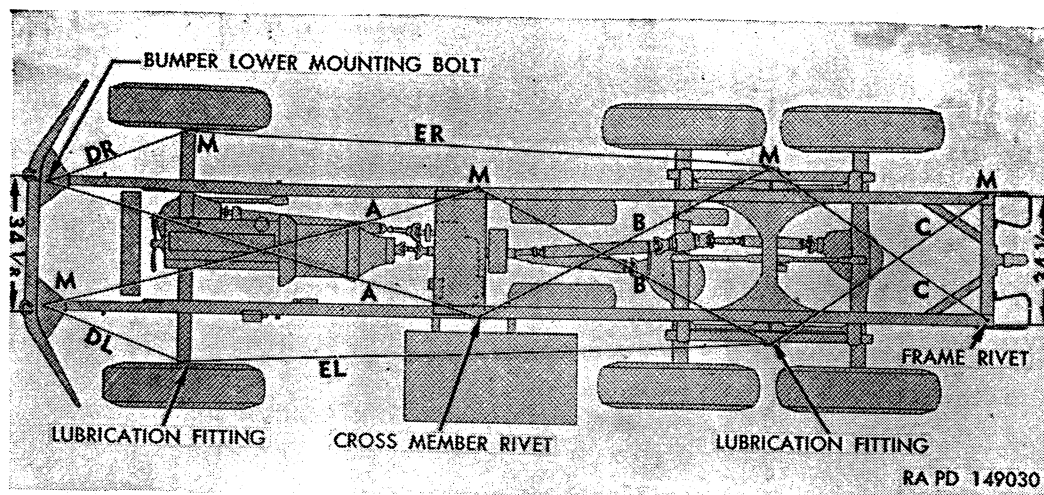

Figure 301. Method of checking frame alinement (M135 shown).

- (3) To locate point at which frame is sprung, measure diagonals marked A, B, and C. If diagonals in each pair are within one-eighth inch, that part of frame included between points of measurements may be considered in alinement, and these diagonals should intersect within one-eighth inch of centerline. Variations of more than one-eighth inch indicate misalinement.
- (4) If centerline cannot be laid out from points at ends of frame, it can be drawn through intersection of any pair of diagonal lines of equal length and center point of either end of frame. Centerline can also be laid out through points of intersection of any two pairs of equal diagonals. If extreme front end of frame is damaged, center of front of frame can be located from point exactly midway between radiator support bolts.
- (5) After it has been determined that frame is properly alined, front axle alinement with frame can be checked as indicated in (a), (b), and (c) below.
  - (a) Front axle is square with frame if ER equals EL, and DR equals DL.
  - (b) Front axle has shifted sideways if ER is less than EL, and DR is less than DL, or vice versa.
  - (c) Front axle is bent, twisted, or shifted if ER is less than EL, and DR is greater than DL, or vice versa.

## 285. Front Bumper

(fig. 302)

*a. Description.* Bumper is pressed steel channel, bolted to front end of frame side member. Gusset plates bolted to frame side member and bumper assist in providing rigidity to bumper mounting. Stone shields (C, F, and G) are of pressed metal and were not used on early models. On vehicles with winch, two stone shields are required.

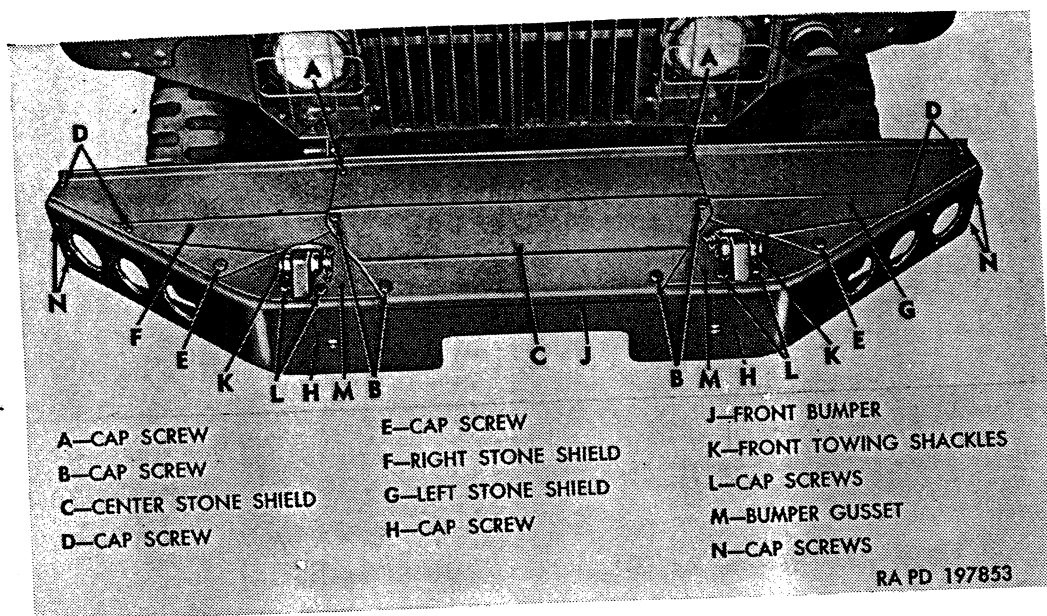

Figure 302. Front bumper and stone shields installed.

On vehicles less winch, three stone shields are required. Stone shield supports, located at each end of front bumper, are used to attach stone shields to front bumper assembly.

*b. Removal.*

- (1) Remove two nuts and cap screws (A) attaching center stone shield (C) to side member.
- (2) Remove four nuts and four cap screws (B) attaching center stone shield (C) to side member, bumper gusset (M), and front bumper (J); then remove shield.
- (3) Remove two nuts and cap screws (D) attaching right front stone shield (F) to stone shield support and front bumper (J).
- (4) Remove one nut and cap screw (E) attaching right front stone shield (F) to bumper gusset (M) and bumper (J); then remove shield.
- (5) To remove left stone shield (G), repeat (3) and (4) above.
- (6) Remove two nuts and cap screws (H) (one on each side) under bumper attaching bumper (J) to frame side member. Pull bumper (J) and gusset (M) forward to remove complete bumper.
- (7) If necessary to remove gussets, remove six nuts and cap screws (L) (three each side) attaching each gusset to bumper.
- (8) To remove stone shield supports, remove four nuts and cap screws (N) (two each side).

*c. Installation.* On vehicles equipped with winch, front bumper is installed with cable opening at top; however, on vehicles not equipped with winch, cable opening in bumper is down.

- (1) Install one stone shield support at each end of bumper, using four  $\frac{5}{16}$ -24 x  $\frac{7}{8}$  cap screws (N) and  $\frac{5}{16}$ -24 safety nuts (two each side).
- (2) If bumper gussets (M) have been removed, attach gussets to front bumper (J) with six  $\frac{5}{8}$ -18 x  $1\frac{3}{4}$  cap screws (L) and  $\frac{5}{8}$ -18 safety nuts (three each side).
- (3) Locate bumper (J) in place on front end of side members with attaching bolt holes in alinement; then install two  $\frac{5}{8}$ -18 x  $1\frac{3}{4}$  cap screws (H) and  $\frac{5}{8}$ -18 safety nuts under bumper (J) attaching bumper to frame side members.
- (4) Place right stone shield (F) in position; then install two  $\frac{5}{16}$ -24 x  $\frac{7}{8}$  cap screws (D) and  $\frac{5}{16}$ -24 safety nuts attaching shield to stone shield support and front bumper (J).
- (5) Install one  $\frac{5}{8}$ -18 x  $1\frac{3}{4}$  cap screw (E) and  $\frac{5}{8}$ -18 safety nut attaching right stone shield (F) to gusset (M) and bumper (J).
- (6) To install left stone shield (G), repeat (4) and (5) above.
- (7) Position center stone shield (C); then install two  $\frac{5}{16}$ -24 x  $\frac{7}{8}$  cap screws (A) and  $\frac{5}{16}$ -24 safety nuts attaching shield to side member.
- (8) Install four  $\frac{5}{8}$ -18 x  $1\frac{3}{4}$  cap screws (B) and  $\frac{5}{8}$ -18 safety nuts attaching center stone shield (C) to side member, gusset (M), and front bumper (J).
- (9) Tighten all cap screw nuts to the following torque:  $\frac{5}{16}$ -24 nuts to  $9\frac{1}{2}$  to 13 pound-feet torque, and  $\frac{5}{8}$ -18 nuts to 95 to 127 pound-feet torque.

## 286. Rear Bumpers

(fig. 303)

*a. General.* Two rear bumpers are used on all models, except tractor truck M221 and dump truck M215. Bumpers are formed from pressed steel and are attached to each rear corner of frame by cap screws and safety nuts. Bumpers also protect rear towing shackles.

### *b. Removal.*

- (1) On each bumper, remove four nuts and cap screws attaching bumper to side member.
- (2) On each bumper, remove two nuts and cap screws attaching bumper to rear cross member. Bumpers can then be removed.

### *c. Installation.*

- (1) Position rear bumper against frame side member and rear cross member with cap screw holes in alinement.
- (2) On each bumper, attach bumper to frame side member with four  $\frac{1}{2}$ -20 x  $1\frac{5}{8}$  cap screws and  $\frac{1}{2}$ -20 safety nuts.

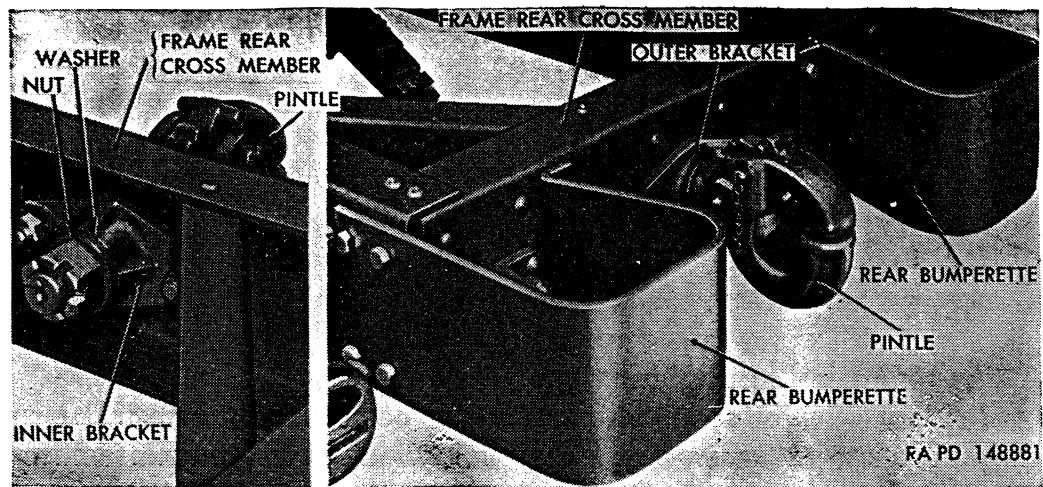

Figure 303. Pintle and rear bumper installation.

- (3) On each bumper, attach bumper to rear cross member with two  $\frac{1}{2}$ -20 x  $1\frac{1}{2}$  cap screws and  $\frac{1}{2}$ -20 safety nuts.
- (4) Tighten safety nuts to 48 to 64 pound-feet torque.

## 287. Towing Shackles

*a. General.* Four towing shackles are used on all vehicles, one at each corner. Front shackles are attached to bracket welded to front bumper gusset; rear shackles are attached to brackets riveted to frame rear cross member and are protected by rear bumpers (when used).

*b. Removal.* Remove cotter pin holding shackle pin in bracket; then remove shackle pin and shackle.

*c. Installation.* Position shackle over bracket and secure with shackle pin, then install cotter pin through hole in shackle pin.

## 288. Pintle

(fig. 303)

*a. General.* Pintle is installed at center of frame rear cross member. Instructions necessary for operation of pintle are covered in paragraph 46a.

*b. Removal.* At inside of frame rear cross member, remove cotter pin securing nut on pintle shaft. Insert bar through pintle jaw to prevent pintle assembly from turning, then remove nut and washer at end of pintle shaft. Pull pintle toward rear of vehicle to complete removal.

*c. Installation.* Lubricate pintle shaft with automotive and artillery grease (GAA); then insert shaft through cross member and brackets. Install washer and nut on shaft. Use bar through pintle jaw to prevent turning as nut is tightened. Tighten until pintle binds, then back off nut until cotter pin can be installed and pintle assembly can be turned by hand.

## 289. Tie-Down U-Bolts

(fig. 304)

*a. General.* Ten tie-down U-bolts are used on all vehicles except early M135, which has six U-bolts. Additional tie-down U-bolts must be added to early vehicles if vehicle is to be shipped by air. There must be four U-bolts added to the frame side members at front end, two on each side. The two rear tie-down U-bolts must be relocated.

*b. Installation of Additional Tie-Down U-Bolts.*

- (1) Remove all wheels from both sides (par. 259*b*).
- (2) Drill five  $1\frac{7}{32}$ -inch diameter holes in the side member, four at front and one at rear. Drill the existing pintle-brace bolt hole to seventeen thirty-seconds of an inch.
- (3) Thread  $\frac{1}{2}$ -20 nuts onto U-bolts; then install U-bolts in drilled holes in frame side member. Secure U-bolts with  $\frac{1}{2}$ -20 safety nuts, two at each U-bolt.
- (4) Remove U-bolts from frame rear cross member.
- (5) Thread two  $\frac{1}{2}$ -20 nuts onto U-bolt and position U-bolt in new location designated at rear end of side member. Install two  $\frac{1}{2}$ -20 safety nuts.
- (6) Repeat (2) through (5) above to install U-bolts on opposite side member.
- (7) Tighten all outside U-bolt nuts to 48 to 64 pound-feet torque.
- (8) Install wheels (par. 259*c*).

## 290. Tractor Truck Rear Fenders

*a. General.* Rear fenders are formed of pressed metal. Right fender is attached at top to front cover plate with four cap screws and nuts and at bottom to fender brace with three cap screws and nuts. Left fender is attached at top to front cover plate with four cap screws and nuts, and at bottom to fender-to-fuel-tank-support brace with three cap screws and nuts.

*b. Removal.*

- (1) Remove four nuts and cap screws attaching fender at top to front cover plate.
- (2) Remove three nuts and cap screws attaching fender at bottom to fender brace on right fender, or to fuel tank support brace on left fender.

*c. Installation.*

- (1) Position fender and install four  $\frac{3}{8}$ -24 x  $\frac{7}{8}$  cap screws and  $\frac{3}{8}$ -24 safety nuts attaching fender at top to front cover plate.
- (2) Install three  $\frac{3}{8}$ -24 x  $\frac{3}{4}$  cap screws and  $\frac{3}{8}$ -24 safety nuts attaching fender to fender brace on right fender, or to fuel tank support brace on left fender.
- (3) Tighten all nuts to 20 to 27 pound-feet torque.



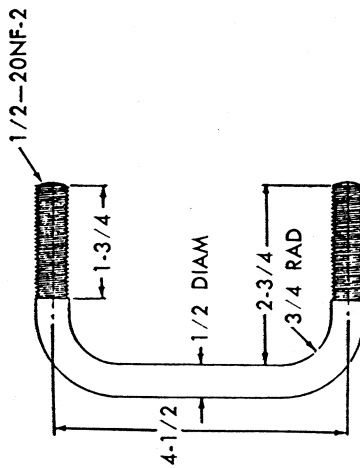
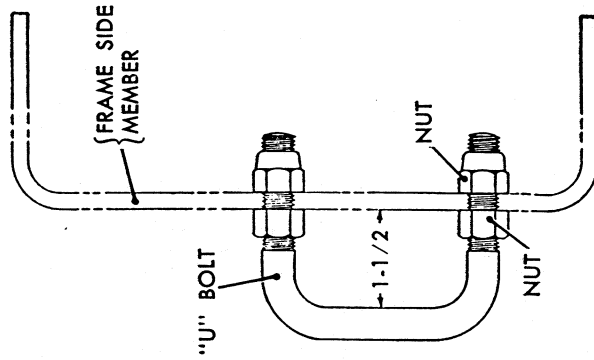
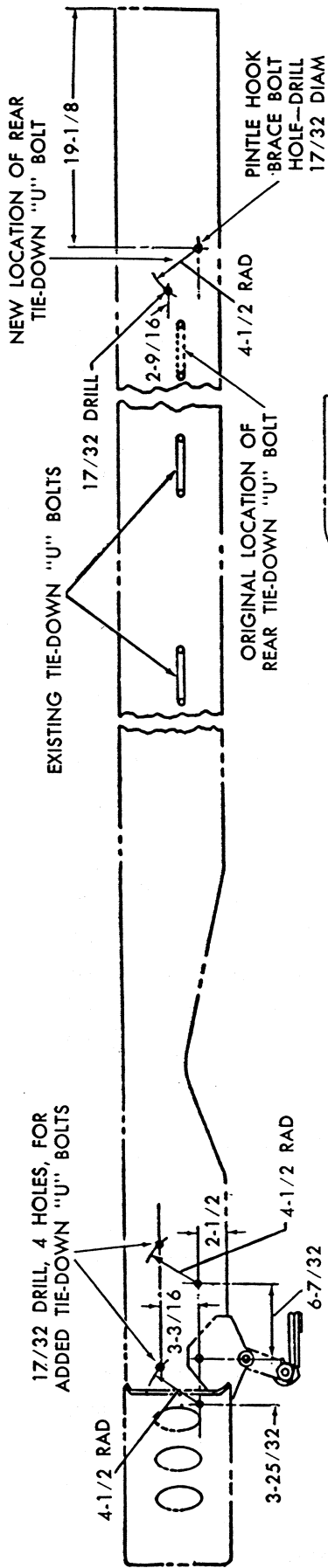

NOTES: 1—ALL DIMENSIONS SHOWN ARE IN INCHES  
 2—MATERIAL: COLD-ROLLED STEEL BAR STOCK (DEV LGH APRX 9-3/8)

RA PD 197854

Figure 304. Tie-down U-bolt installation (early M135).

## Section XXXI. CAB AND ASSOCIATED PARTS

### 291. Description

*a. General.* This section includes organizational maintenance procedures on soft-top cab and associated parts used on all vehicles, except shop van truck M220. Maintenance operations within the scope of organizational maintenance on hard-top cab used on shop van truck M220 are also included in this section.

*b. Soft-Top Cab.* All vehicles, except the shop van truck M220 are equipped with a three-man soft-top cab. The cab comprises a metal top inclosed around driver's compartment with metal doors hinged to cab structure on each side. Each door is equipped with glass windows which can be raised and lowered with conventional regulator mechanism. The two windshield sections can be positioned for ventilation, or the entire window frame can be lowered to horizontal position over hood. Canvas top and back curtain, lashed into position to cab structure, can be positioned or removed to provide accessibility. Cab also includes provision for a gun mount ring.

*c. Hard-Top Cab.* The shop van truck M220 is equipped with a hard-top cab which utilizes the same lower structure and doors used on the soft-top cab. A metal top and back replaces the canvas top and back curtain. Sliding windows are furnished at back of cab, and a fixed rear quarter-window on each side. The windshield can be tilted, but cannot be lowered to a horizontal position.

### 292. Cab Mountings

*Note.* The key letters noted in parentheses are in figure 305, except where otherwise indicated.

*a. Description.* Three-point-type mounting is used to attach cab to chassis frame on all models. Both front corners of cab are flexibly mounted by means of front mounting cushions (F) to cab supporting bracket (J). Rear mounting consists of a single through-bolt (N) and cushions (P) at rear center of cab, attaching cab to frame cross member. A heavy U-shaped cab mounting spring (Q) is mounted between cab and frame cross member at each side of rear center mounting bolt to prevent excessive rocking movement of cab.

*b. Adjustment.* Should mounting bolts be permitted to loosen sufficiently to allow cab to shift, steering gear may bind. If this condition exists, tightening procedure must be followed in sequence to insure correct mounting.

- (1) Loosen four cap screws attaching rubber spacer to dash brace and steering cowl brackets on early models (fig. 284). On later models, loosen two cap screws and nuts attaching bracket support to dash brace (fig. 285).
- (2) Tighten cap screws which attach steering gear to frame to 48 to 64 pound-feet torque.

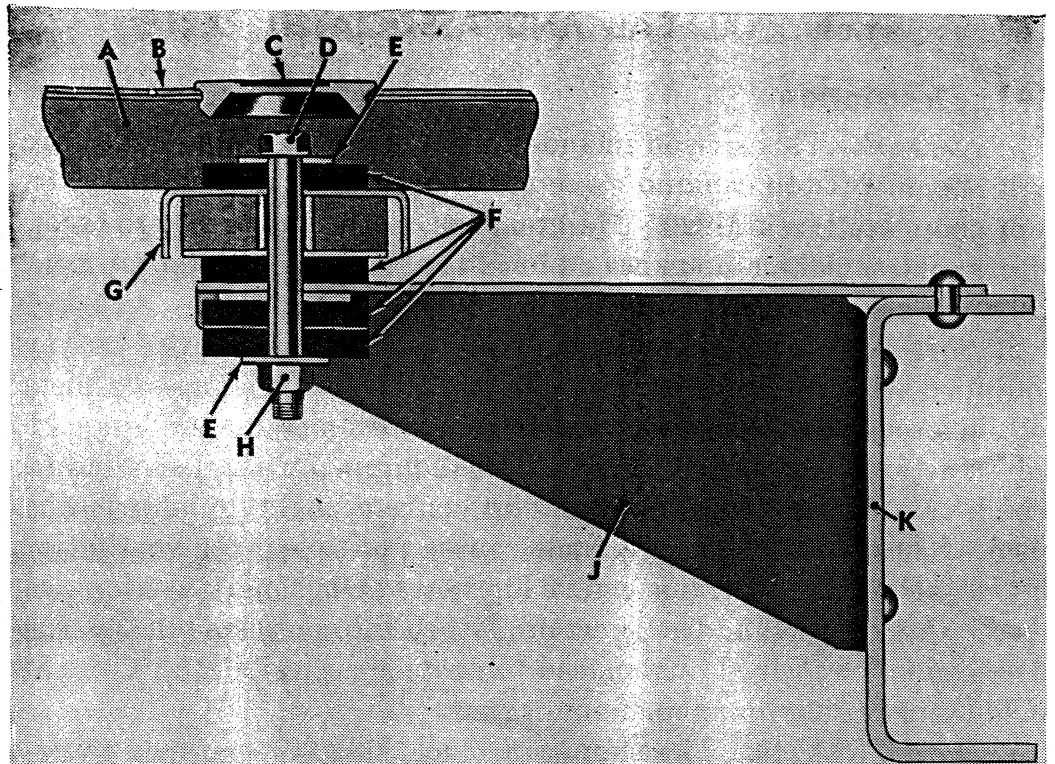

CAB FRONT MOUNTING (LEFT SIDE SHOWN)

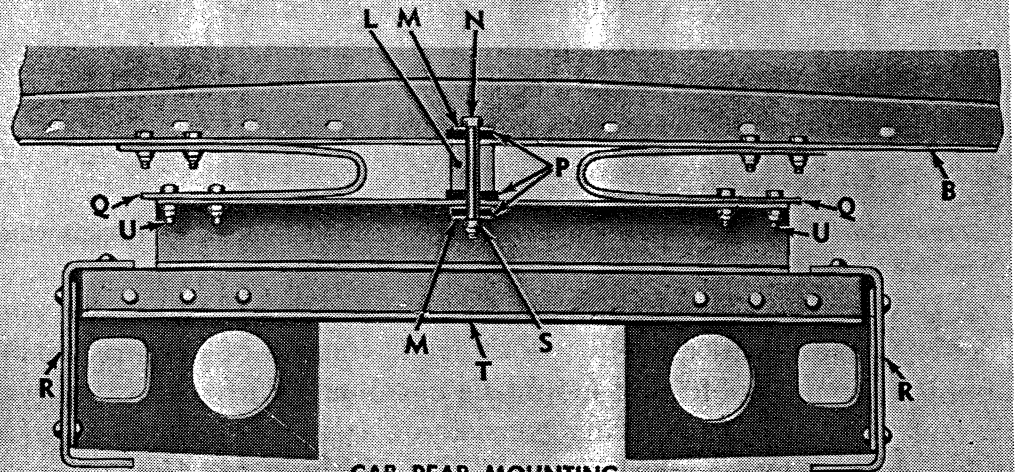

CAB REAR MOUNTING

- |                              |                             |
|------------------------------|-----------------------------|
| A—CAB SILL                   | L—STEEL SPACER              |
| B—CAB FLOOR                  | M—REAR MOUNTING BOLT WASHER |
| C—CLEARANCE HOLE COVER       | N—REAR MOUNTING BOLT        |
| D—FRONT MOUNTING BOLT        | P—REAR MOUNTING CUSHION     |
| E—FRONT MOUNTING BOLT WASHER | Q—CAB MOUNTING SPRING       |
| F—FRONT MOUNTING CUSHIONS    | R—FRAME SIDE MEMBER         |
| G—CAB SIDE SILL              | S—REAR MOUNTING BOLT NUT    |
| H—FRONT MOUNTING BOLT NUT    | T—NO. 2 CROSS MEMBER        |
| J—CAB SUPPORTING BRACKET     | U—CAP SCREW                 |
| K—FRAME SIDE MEMBER          |                             |

RA PD 197664

Figure 305. Cab mounting.