



**TM 9-2320-211-34-2-4**  
**T.O. 36A12-1C-422-2-2**

---

**TECHNICAL MANUAL**  
**PART 4 OF 4**  
**VOLUME 2 OF 2**  
**MAINTENANCE**  
**DIRECT SUPPORT AND GENERAL SUPPORT LEVEL**  
**5-TON, 6X6, M39 SERIES TRUCKS**  
**(MULTIFUEL)**

**Chapter 18**

**Body Accessory  
Items**

**Chapter 19**

**Material Used In  
Conjunction With  
Major Items**

**Appendix A  
References**

**TRUCK, CHASSIS: M40A2C,  
M61A2, M63A2; TRUCK, CARGO:  
M54A2, M54A2C, M55A2; TRUCK,  
DUMP: M51A2; TRUCK, TRACTOR:  
M52A2; TRUCK, WRECKER, MEDIUM: M543A2**

**NOTE:**

**THE STYLE OF THIS TM IS  
EXPERIMENTAL. IT IS BEING TRIED  
BY THE ARMY ONLY ON  
A LIMITED BASIS**

---

**DEPARTMENTS OF THE ARMY AND THE AIR FORCE**

**FEBRUARY 1981**



**WARNING**

**EXHAUST GASES CAN BE DEADLY**

Exposure to exhaust gases produces symptoms of headache, dizziness, loss of muscular control, apparent drowsiness, and coma. Permanent brain damage or death can result from severe exposure.

Carbon monoxide occurs in the exhaust fumes of fuel burning heaters and internal combustion engines, and becomes dangerously concentrated under conditions of inadequate ventilation. The following precautions must be observed to insure the safety of personnel whenever fuel burning heater(s) or engine of any vehicle is operated for maintenance purposes or tactical use.

Do not operate heater or engine of vehicle in an enclosed area unless it is adequately ventilated.

Do not idle engine for long periods without maintaining adequate ventilation in personnel compartments.

Do not drive any vehicle with inspection plates or cover plates removed unless necessary for maintenance purposes.

Be alert at all times during vehicle operation for exhaust odors and exposure symptoms. If either are present, immediately ventilate personnel compartments. If symptoms persist, remove affected personnel from vehicle and treat as follows: expose to fresh air; keep warm; do not permit physical exercise; if necessary, administer artificial respiration.

If exposed, seek prompt medical attention for possible delayed onset of acute lung congestion. Administer oxygen if available.

The best defense against exhaust gas poisoning is adequate ventilation.

**WARNING**

Serious or fatal injury to personnel may result  
if the following instructions are not complied with.

Dry cleaning solvent is flammable. Do not use near an open flame. Keep a fire extinguisher nearby when solvent is used. Use only in well-ventilated places. Failure to do this may result in injury to personnel and damage to equipment.

Eye shields must be worn when using compressed air. Eye injury can occur if eye shields are not used.

Smoking, flames, sparks and glowing or hot objects are not allowed within 50 feet of work area during maintenance of fuel burning heater systems. Fuel can explode, causing injury to personnel and damage to equipment.

Do not work on hot exhaust tube. Personnel can be badly burned.

Make sure that powerplant heater is off and cool before doing this task. Failure to do this may result in injury to personnel.

---

**WARNING - Cont**

---

Exhaust gases of any fuel are very poisonous. Be sure exhaust is directed out of work area. Be sure work area is well ventilated. Failure to do so could result in injury or death to personnel.

Use caution when working near hot coolant. Severe burns could result.

Do not inhale vapor from methyl-ethyl-ketone used on rear of panels. Always wear rubber gloves and use brush to put on methyl-ethyl-ketone. Place fans in and around cab to give ventilation.

Contact cement is flammable. Do not use near an open flame. Keep a fire extinguisher nearby when contact cement is used. Use only in well-ventilated places. Failure to do this may result in injury to personnel and damage to equipment.

Always wear leather gloves when handling winch cable. Never allow cable to run through hands. During winch operation or when stopping winch, tell all personnel to stand clear of winch and load. A snapped cable or shifting load can injure personnel or damage equipment.

**\*TM 9-2320-211-34-2-4**  
**T.O. 36A12-1C-422-2-2**

TECHNICAL MANUAL  
NO. 9-2320-211-34-2-4  
TECHNICAL ORDER  
NO. 36A12-1C-422-2-2

DEPARTMENTS OF THE ARMY  
AND  
THE AIR FORCE  
WASHINGTON, DC, 25 February 1981

TECHNICAL MANUAL

VOLUME 2 OF 2

PART 4 OF 4

## **MAINTENANCE**

DIRECT SUPPORT AND GENERAL SUPPORT LEVEL

### **5-TON, 6X6, M39 SERIES TRUCKS (MULTIFUEL)**

	Model	NSN without Winch	NSN with Winch
Truck, Chassis	M40A2C	2320-00-969-4114	
	M61A2	2320-00-055-9264	2320-00-965-0321
	M63A2	2320-00-226-6251	2320-00-285-3757
Truck, Cargo	M54A2	2320-00-055-9266	2320-00-055-9265
	M54A2C	2320-00-926-0874	2320-00-926-0874
	M55A2	2320-00-073-8476	2320-00-055-9259
Truck, Dump	M51A2	2320-00-055-9262	2320-00-055-9263
Truck, Tractor	M52A2	2320-00-055-9260	2320-00-055-9261
Truck, Wrecker, Medium	M543A2		2320-00-055-9258

Current as of 25 Jul 80.

\*This manual together with TM 9-2320-211-34-1, 25 February 1981; TM 9-2320-211-34-2-1, 25 February 1981; TM 9-2320-211-34-2-2, 25 February 1981 and TM 9-2320-211-34-2-3, 25 February 1981 supersedes so much of TM 9-2320-211-35, 13 September 1964 as pertains to multifuel vehicles including all changes.

**REPORTING OF ERRORS AND RECOMMENDING IMPROVEMENTS**

You can help improve this manual. If you find any mistakes or if you know of a way to improve the procedure, please let us know. Mail your letter, DA Form 2028 (Recommended Changes to Publications and Blank Forms), or DA Form 2028-2 located in the back of this manual direct to: Commander, US Army Tank-Automotive Command, ATTN: DRSTA-MB, Warren, Michigan 48090. A reply will be furnished to you.

**TABLE OF CONTENTS**

	Paragraph	Page
<b>CHAPTER 18. BODY ACCESSORY ITEMS GROUP MAINTENANCE</b>		
Section 1. Scope . . . . .		18-1
Equipment Items Covered . . . . .	18-1	18-1
Equipment Items Not Covered . . . . .	18-2	18-1
Equipment Items Not Covered . . . . .	18-2	18-1
Section II. Canvas Accessory Items . . . . .		18-1
Cab Top Cover Assembly Repair (Trucks M54A2, M54A2C, and M55A2) . . . . .	18-3	18-1
Cargo Body Curtain Repair (Trucks M54A2, M54A2C, and M55A2) . . . . .	18-4	18-1
Cargo Body Cover Repair (Trucks M54A2, M54A2C, and M55A2) . . . . .	18-5	18-1
<b>CHAPTER 19. MAINTENANCE OF MATERIAL USED IN CONJUNCTION WITH MAJOR ITEMS</b>		
Section I. Scope . . . . .		19-1
Equipment Items Covered . . . . .	19-1	19-1
Equipment Items Not Covered . . . . .	19-2	19-1
Section II. Winterization Kits . . . . .		19-1
Hot Water Personnel Heater Kit Installation, Test, and Adjustment . . . . .	19-3	19-1
Preliminary Procedures . . . . .	19-3a	19-1
Installation . . . . .	19-3b	19-1
Test and Adjustment . . . . .	19-3c	19-1
Hot Water Personnel Heater Functional Test . . . . .	19-4	19-2
Hot Water Personnel Heater Assembly, Removal, Repair and Replacement . . . . .	19-5	19-3
Preliminary Procedures . . . . .	19-5a	19-3
Removal . . . . .	19-5b	19-4
Cleaning . . . . .	19-5c	19-6
Repair . . . . .	19-5d	19-6
Replacement . . . . .	19-5e	19-7
Hot Water Personnel Heater Electrical Harness Removal, Repair and Replacement . . . . .	19-6	19-9
Preliminary Procedures . . . . .	19-6a	19-9
Removal . . . . .	19-6b	19-9
Inspection and Repair . . . . .	19-6c	19-13
Replacement . . . . .	19-6d	19-14

TABLE OF CONTENTS - CONT

	Paragraph	Page
Hot Water Personnel Heater		
Diverter Removal and Replacement .....	19-7	19-18
Hot Water Personnel Heater Ducting		
Removal and Replacement .....	19-8	19-18
Fuel Burning Personnel Heater Kit		
Installation .....	19-9	19-18
Fuel Burning Personnel Heater Air		
Diverter Removal and Replacement .....	19-10	19-19
Preliminary Procedure .....	19-10a	19-19
Removal .....	19-10b	19-19
Replacement .....	19-10c	19-20
Fuel Burning Personnel Heater		
Ducting Removal and Replacement .....	19-11	19-21
Preliminary Procedure .....	19-11a	19-21
Removal .....	19-11b	19-21
Replacement .....	19-11c	19-22
Fuel Burning Personnel Heater Control		
Cables Removal, Replacement, and		
Adjustment .....	19-12	19-24
Removal .....	19-12a	19-24
Replacement .....	19-12b	19-26
Adjustment .....	19-12c	19-28
Vehicular Coolant Heater Kit Installation .....	19-13	19-29
Vehicular Coolant Heater Hoses and		
Tubes Removal and Replacement .....	19-14	19-29
Preliminary Procedures .....	19-14a	19-29
Removal .....	19-14b	19-30
Replacement .....	19-14c	19-33
Vehicular Coolant Heater Exhaust		
Tube Removal and Replacement .....	19-15	19-37
Removal .....	19-15a	19-37
Replacement .....	19-15b	19-40
Vehicular Coolant Heater Oil Pan Shroud		
Assembly Removal, Repair and		
Replacement .....	19-16	19-43
Removal .....	19-16a	19-43
Replacement .....	19-16b	19-44
Vehicular Coolant Heater Hood Cover		
Assembly Repair .....	19-17	19-45
Removal .....	19-17a	19-45
Repair .....	19-17b	19-45
Replacement .....	19-17c	19-45
Vehicular Coolant Heater Radiator		
Cover Assembly .....	19-18	19-45
Removal .....	19-18a	19-45
Repair .....	19-18b	19-45
Replacement .....	19-18c	19-45

TABLE OF CONTENTS - CONT

	Paragraph	Page
Vehicular Coolant Heater Removal,		
Repair, Test, and Replacement . . . . .	19-19	19-46
Preliminary Procedures . . . . .	19-19a	19-46
Removal \ \ \ \ \	19-19b	19-47
Disassembly into Subassemblies . . . . .	19-19c	19-48
Cleaning and Inspection of		
Subassemblies . . . . .	19-19d	18-59
Assembly . . . . .	19-19e	19-81
Testing . . . . .	19-19f	19-93
Replacement . . . . .	19-19g	19-107
Thermal Barrier Kit Installation . . . . .	19-20	19-108
Preliminary Procedures . . . . .	19-20a	19-108
Installation . . . . .	19-20b	19-109
Thermal Barrier Panels, Floor mats and		
Covers Removal, Repair and		
Replacement . . . . .	19-21	19-123
Preliminary Procedures . . . . .	19-21a	19-123
Inspection and Repair . . . . .	19-21b	19-123
Removal . . . . .	19-21c	19-124
Cleaning . . . . .	19-21d	19-125
Replacement . . . . .	19-21e	19-125
Hard Top Closure Top Assembly		
Removal, Repair and Replacement . . . . .	19-22	19-126
Removal . . . . .	19-22a	19-127
Disassembly \ \ \ \ \	19-22b	19-130
Cleaning . . . . .	19-22c	19-136
Inspection and Repair . . . . .	19-22d	19-137
Assembly . . . . .	19-22e	19-140
Replacement . . . . .	19-22f	19-146
Hood Cover Assembly Installation . . . . .	19-23	19-150
Preliminary Procedure . . . . .	19-23a	19-150
Installation . . . . .	19-23b	19-150
Radiator Cover Assembly Installation . . . . .	18-24	19-155
Radiator Cover Assembly Repair . . . . .	19-25	19-160
Removal . . . . .	19-25a	19-160
Repair . . . . .	19-25b	19-160
Replacement . . . . .	19-25c	19-160
Slave Receptacle Kit Installation . . . . .	19-26	19-160
Preliminary Procedures . . . . .	19-26a	19-160
Installation . . . . .	19-26b	19-161
Slave Receptacle Kit (Trucks Without		
Winterization Kit) . . . . .	19-27	19-165
Preliminary Procedures . . . . .	19-27a	19-165
Installation . . . . .	19-27b	19-165
Section III. Special Purpose Kits . . . . .		19-169
Electric Brake Kit Installation,		
Test, and Adjustment . . . . .	19-28	19-169
Preliminary Procedures . . . . .	19-28a	19-169
Installation . . . . .	19-28b	19-170



TABLE OF CONTENTS - CONT

	Paragraph	Page
Electric Brake Controller Removal, Repair, and Replacement .....	19-29	19-186
Preliminary Procedure .....	19-29a	19-186
Removal .....	19-29b	19-186
Disassembly .....	19-29c	19-187
Inspection and Repair .....	19-29d	19-191
Assembly .....	19-29e	19-192
Replacement .....	19-29f	19-196
A-Frame Kit Installation (Trucks M54A2 with Winch, M54A2C with Winch, and M55A2 with Winch) .....	19-30	19-197
Preliminary Procedures .....	19-30a	19-197
Installation .....	19-30b	19-198
Decontamination Apparatus Stowage Bracket Installation .....	19-31	19-208
Engine Shipping and Storage Container Repair .....	19-32	19-211
Cleaning .....	19-32a	19-211
Disassembly .....	19-32b	19-211
Inspection and Repair .....	19-32c	19-213
Assembly .....	19-32d	19-215
Pressure Check .....	19-32e	19-217
Deep Water Fording Kit Installation .....	19-33	19-219
Deep Water Fording Kit Pressurization Valve Hand Control Assembly Removal and Replacement .....	19-34	19-219
Preliminary Procedure .....	19-34a	19-219
Removal .....	19-34b	19-219
Replacement .....	19-34c	19-221
Deep Water Fording Kit Control Valve Assembly Removal and Replacement .....	19-35	19-223
Preliminary Procedures .....	19-35a	19-223
Removal .....	19-35b	19-223
Replacement .....	19-35c	19-224
Deep Water Fording Kit Hoses and Tubes Removal and Replacement .....	19-36	19-225
Deep Water Fording Kit Snorkle Assembly Removal and Replacement .....	19-37	19-225
Removal .....	19-37a	19-225
Replacement .....	19-37b	19-226
Deep Water Fording Kit Air Pressurization System Regulator Valve Removal and Replacement .....	19-38	19-227
Preliminary Procedure .....	19-38a	19-227
Removal .....	18-38b	19-227
Replacement .....	19-38c	19-229
APPENDIX A. REFERENCES .....		A-1
INDEX .....		Index 1



## CHAPTER 18

### BODY ACCESSORY ITEMS GROUP MAINTENANCE

---

#### Section I. SCOPE

18-1. EQUIPMENT ITEMS COVERED. This chapter gives equipment maintenance procedures for canvas accessory items for which there are authorized corrective maintenance tasks at the direct and general support maintenance levels.

18-2. EQUIPMENT ITEMS NOT COVERED. All equipment items for which corrective maintenance is authorized at the direct and general support maintenance levels are covered in this chapter.

#### Section II. CANVAS ACCESSORY ITEMS

18-3. CAB TOP COVER ASSEMBLY REPAIR (TRUCKS M54A2, M54A2C, AND M55A2). Refer to FM 43-3 for repair of cab cover assembly.

18-4. CARGO BODY CURTAIN REPAIR (TRUCKS M54A2, M54A2C AND M55A2). Refer to FM 43-3 for repair of cargo body curtain.

18-5. CARGO BODY COVER REPAIR (TRUCKS M54A2, M54A2C, AND M55A2). Refer to FM 43-3 for repair of cargo body cover.



**CHAPTER 19**  
**MATERIAL USED IN CONJUNCTION WITH MAJOR ITEMS**  
**GROUP MAINTENANCE**

---

**Section I. SCOPE**

19-1. EQUIPMENT ITEMS COVERED. This chapter gives equipment maintenance procedures for winterization and special purpose kits for which there are authorized corrective maintenance tasks at the direct and general support maintenance levels.

19-2. EQUIPMENT ITEMS NOT COVERED. All equipment items for which corrective maintenance is authorized at the direct and general support maintenance levels are covered in this chapter.

**Section II. WINTERIZATION KITS**

19-3. HOT WATER PERSONNEL HEATER KIT INSTALLATION, TEST, AND ADJUSTMENT.

TOOLS: No special tools required

SUPPLIES: Hot water personnel heater kit.

PERSONNEL: One

EQUIPMENT CONDITIONS: Truck parked, engine off, handbrake set.

a. Preliminary Procedures.

(1) Remove negative and positive battery cables. Refer to TM 9-2320-211-20.

(2) Open hood and left side panel. Refer to TM 9-2320-211-10.

b. Installation.

(1) Install hot water personnel heater kit using instructions that come with the kit.

(2) Close hood and left side panel. Refer to TM 9-2320-211-10.

(3) Replace positive and negative battery cables. Refer to TM 9-2320-211-20.

c. Test and Adjustment. Refer to TM 9-2320-211-20.

**19-4. HOT WATER PERSONNEL HEATER FUNCTIONAL TEST.**

TOOLS: No special tools required

SUPPLIES: None

PERSONNEL: One

EQUIPMENT CONDITION: Truck parked, engine off, handbrake set.

FRAME 1

1. Start engine and bring to normal operating temperature. Refer to TM 9-2320-211-10.

**CAUTION**

In very cold weather, do not pull out DEFROSTER knob (1) until cab is warm. Sudden changes in temperature can damage windshield.

2. Pull out AIR knob (2).
3. Set HEATER switch (3) to LO position.
4. Very warm air should be felt coming out of diverter (4). Set HEATER switch (3) to HI position. Air from diverter should now be coming out faster.
5. Pull out DEFROSTER knob (1). Warm air should be coming from four deflectors (5).
6. Push in DEFROSTER knob and AIR knob (2). Little or no air should be felt from diverter (4) or deflectors (5).
7. Set HEATER switch (3) to OFF position. Stop engine. Refer to TM 9-2320-211-10.

END OF TASK

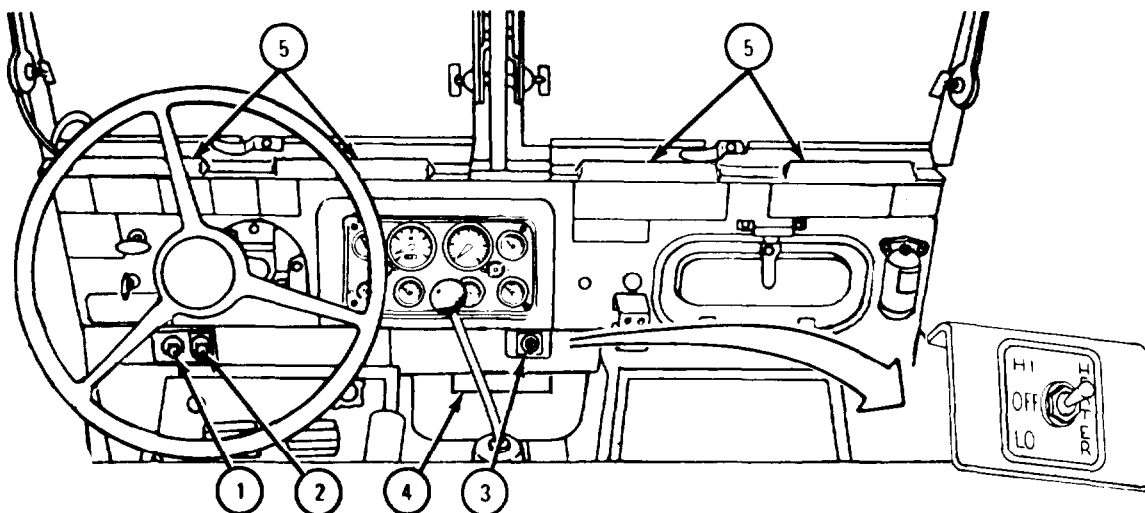

TA 087356

**19-5. HOT WATER PERSONNEL HEATER ASSEMBLY, REMOVAL, REPAIR, AND REPLACEMENT.**

TOOLS: No special tools required

SUPPLIES: None

PERSONNEL: One

EQUIPMENT CONDITION: Truck parked, engine off, handbrake set.

a. Preliminary Procedures.

- (1) Open hood. Refer to TM 9-2320-211-10.
- (2) Disconnect battery cables. Refer to TM 9-2320-211-20.
- (3) Drain coolant system. Refer to TM 9-2320-211-20.

b. Removal.

FRAME 1

1. Unplug heater motor electrical cable connector (1).
  2. Unplug two electrical cable connectors (2).
  3. Loosen screw (3) on clamp (4). Do again for second hose on heater assembly (5).
  4. Twist and pull off two heater hoses (6).
- GO TO FRAME 2

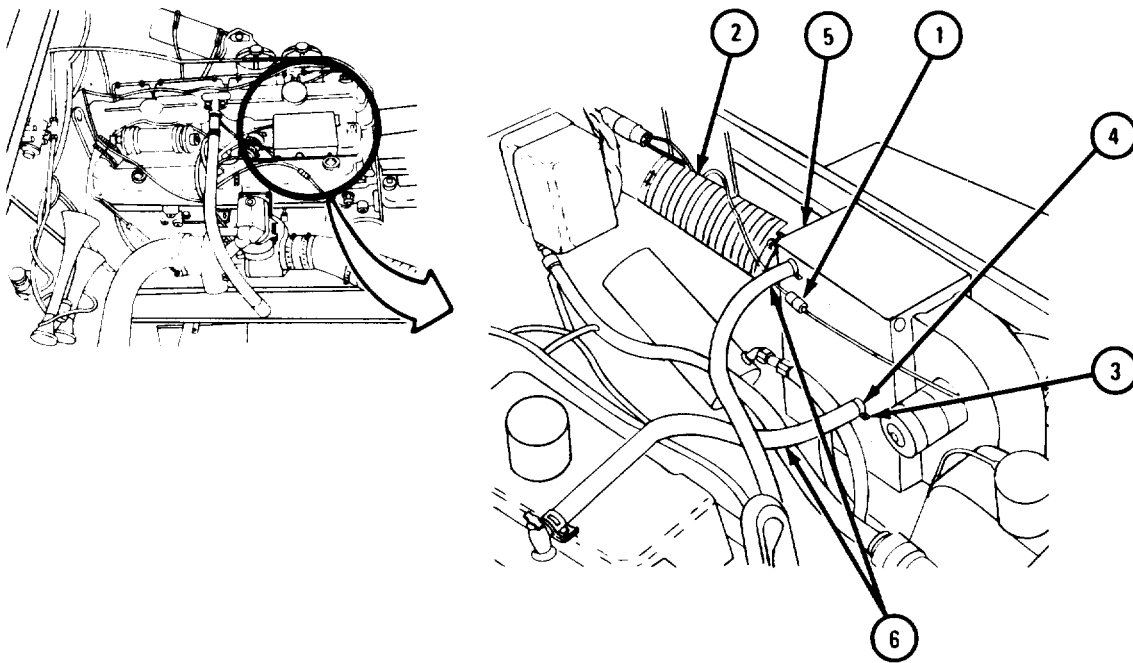

TA 087285



## FRAME 2

1. Take four screws (1) and washers (2) out of adapters (3 and 4). Take off adapters.
2. Take out four screws (5), washers, and nuts (6) holding heater assembly (7) to mounting brackets
3. Take heater assembly (7) out of truck.

END OF TASK

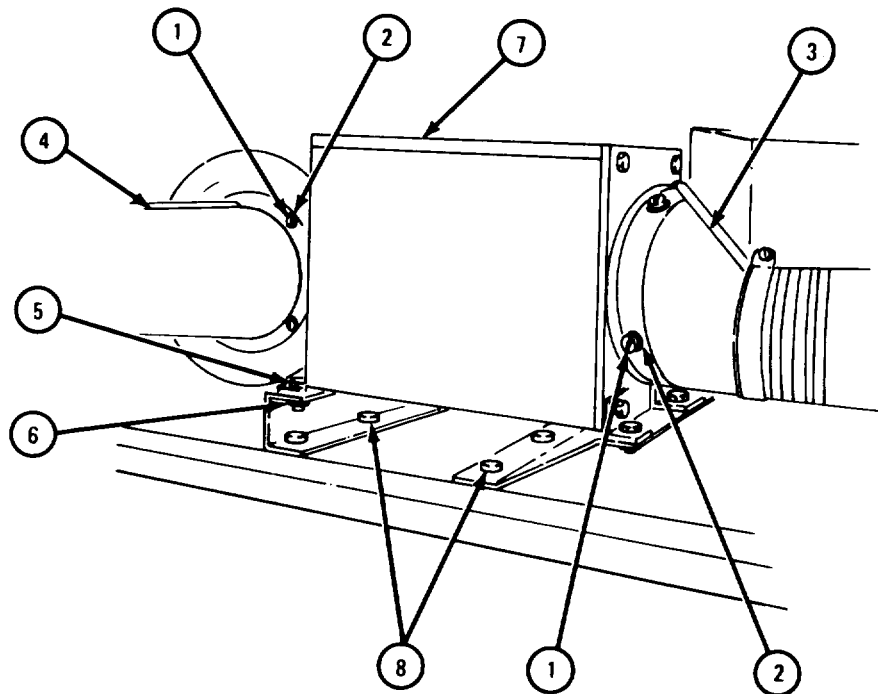

TA 087304

c. Cleaning. There are no special cleaning procedures needed. Refer to cleaning procedures given in Part 1, para 1-3.

d. Repair. A damaged or defective heater assembly must be replaced with a new heater assembly. Refer to para 19-5e for replacement procedures.

e. Replacement.

## FRAME 1

1. Place heater assembly (1) on mounting brackets (2). Aline holes in heater assembly with holes in brackets.
2. Put in four screws (3), washers, and nuts (4).
3. Put on adapters (5 and 6), alining mounting holes.
4. Put in four screws (7) and washers (8) holding each adapter (5 and 6) to heater assembly (1).

GO TO FRAME 2

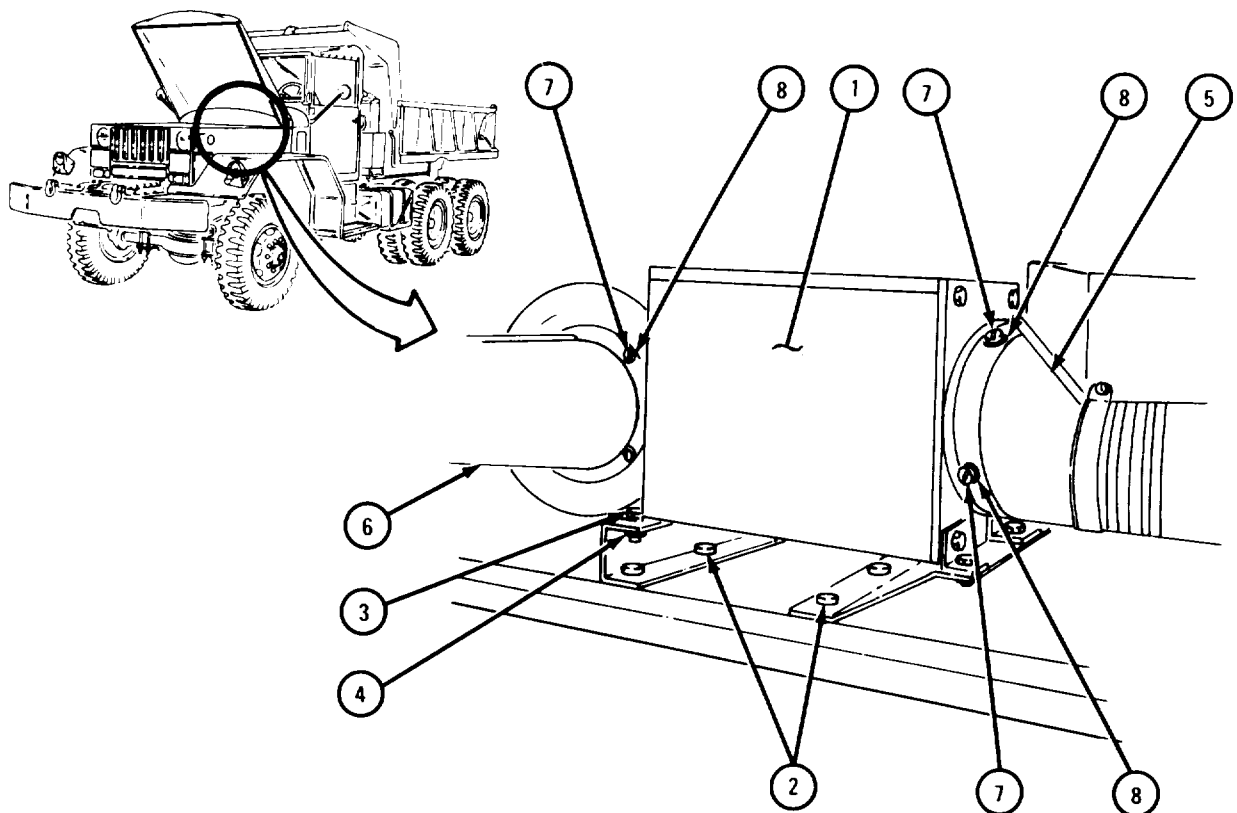

TA 087308

FRAME 2

1. Put on hoses (1).
2. Tighten two screws (2) on two clamps (3).
3. Join two electrical cable connectors (4).
4. Join heater motor electrical cable connector (5).

**NOTE**

Follow-on Maintenance Action Required:

1. Fill coolant system. Refer to TM 9-2320-211-20..
2. Connect battery cables. Refer to TM 9-2320-211-20.
3. Check hot water personnel heater kit for proper operation. Refer to TM 9-2320-211-10.
4. Close hood. Refer to TM 9-2320-211-10.

END OF TASK

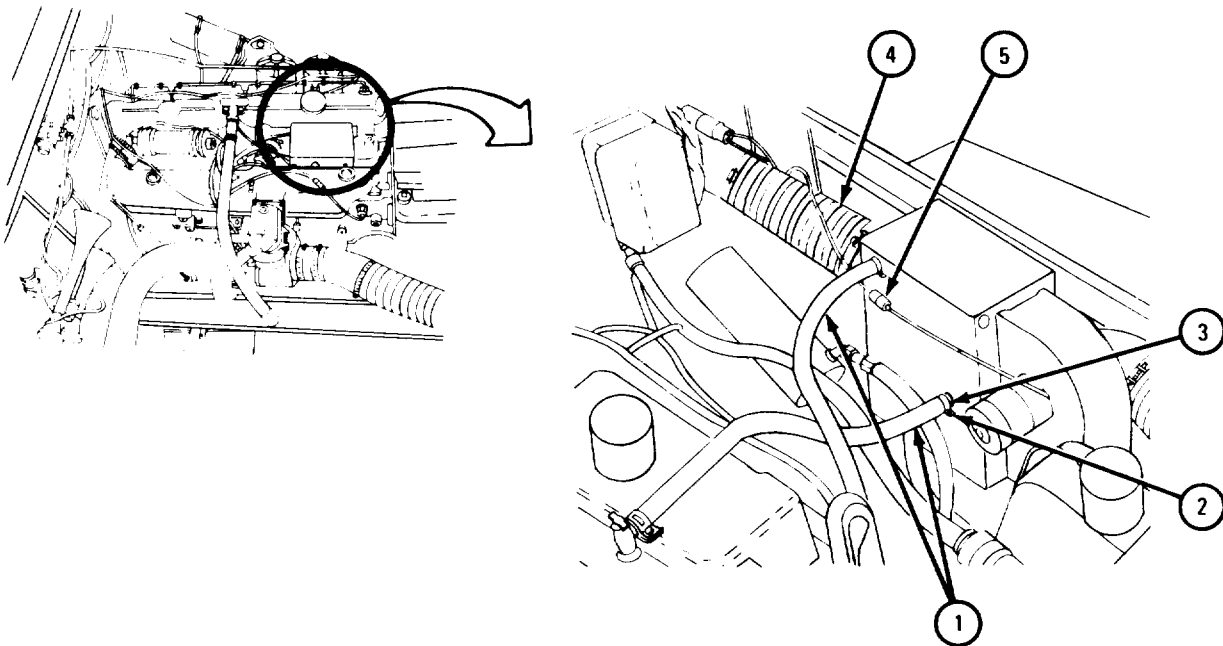

TA 087309

**19-6. HOT WATER PERSONNEL HEATER ELECTRICAL HARNESS REMOVAL, REPAIR, AND REPLACEMENT.**

TOOLS: No special tools required

SUPPLIES: None

PERSONNEL: One

EQUIPMENT CONDITION: Truck parked, engine off, handbrake set.

a. Preliminary Procedures.

(1) Disconnect battery ground cable. Refer to TM 9-2320-211-20.

(2) Open hood. Refer to TM 9-2320-211-10.

(3) Take off hose from diverter in truck cab. Refer to para 19-10.

b. Removal.

FRAME 1

1. Tag and take off cable (1) from hot water heater (2).
2. Take off screw (3) and washer (4).
3. Take off clamp (5).

GO TO FRAME 2

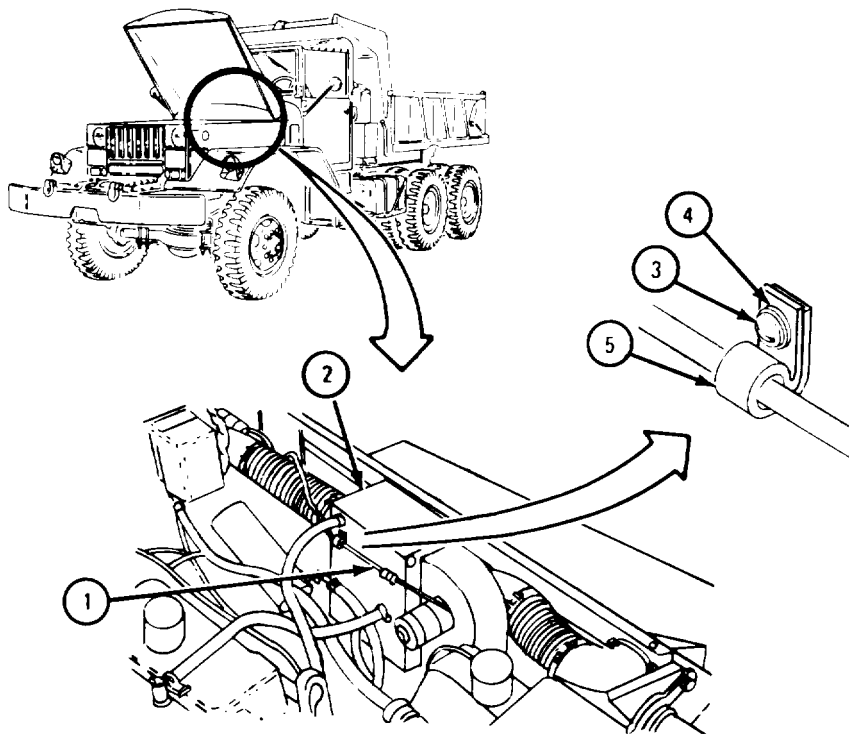

TA 084403

FRAME 2

1. Take off locking nut (1) and washer (2) from bracket (3).
2. Take off identification plate (4).
3. Take switch (5) out of bracket (6).
4. Take out three screws (7) and lockwashers (8).
5. Tag and take off four wires (9).

GO TO FRAME 3

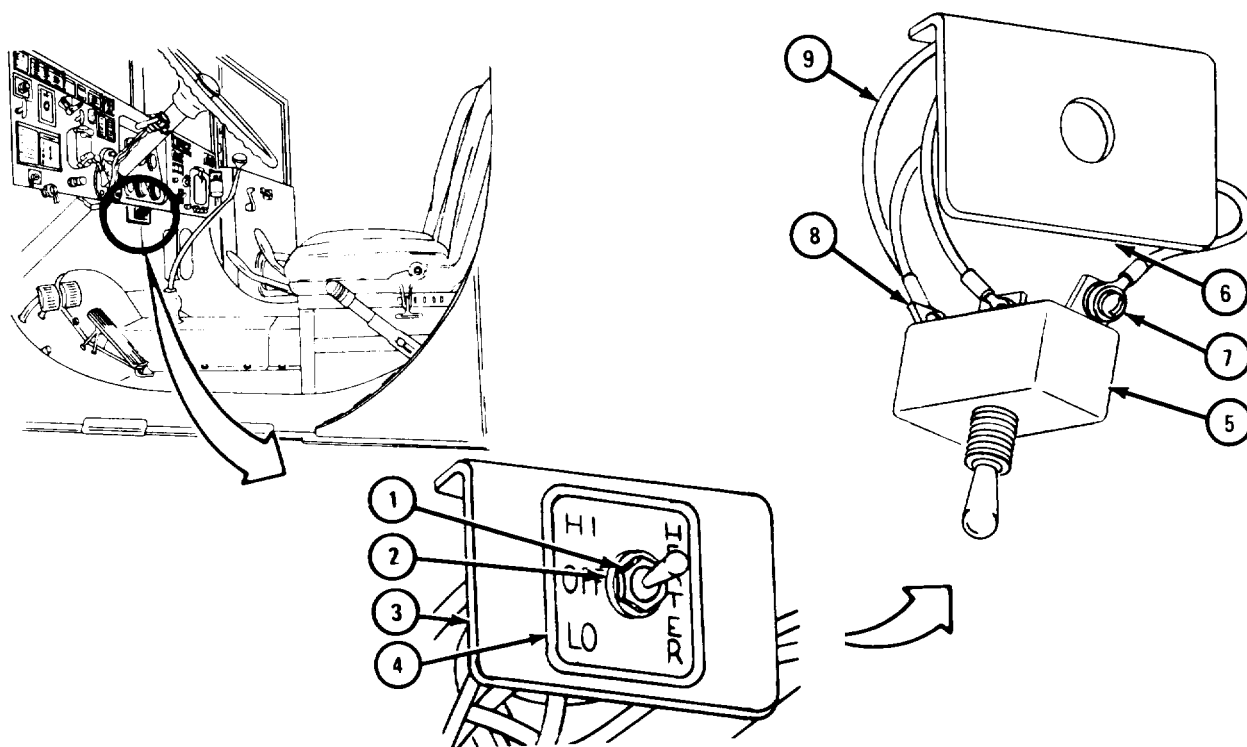

TA 084402

FRAME 3

1. Take out two screws (1), two washers (2), and resistor (3) from firewall (4).
2. Take out two screws (5), two washers (6), and circuit breaker (7) from instrument panel (8).
3. Tag and take out two cables (9 and 10).

GO TO FRAME 4

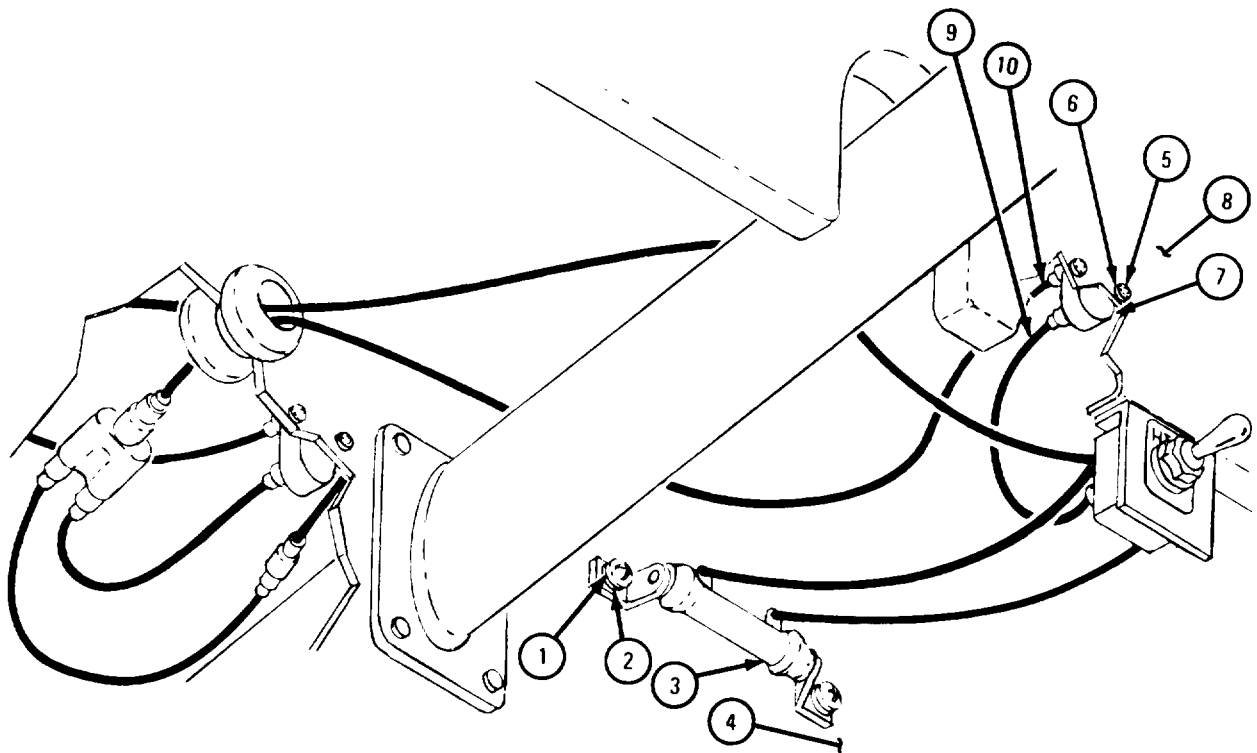

TA 103123

FRAME 4

**NOTE**

Note routing of cables so they are put back the same way.

1. Tag and pull cable (1) out of connector (2) and circuit breaker (3).
2. Tag and pull cable (4) out of connectors (2 and 5).
3. Tag and pull cables (6 and 7) out of truck.
4. Pull connector (2) off cable (7).

END OF TASK

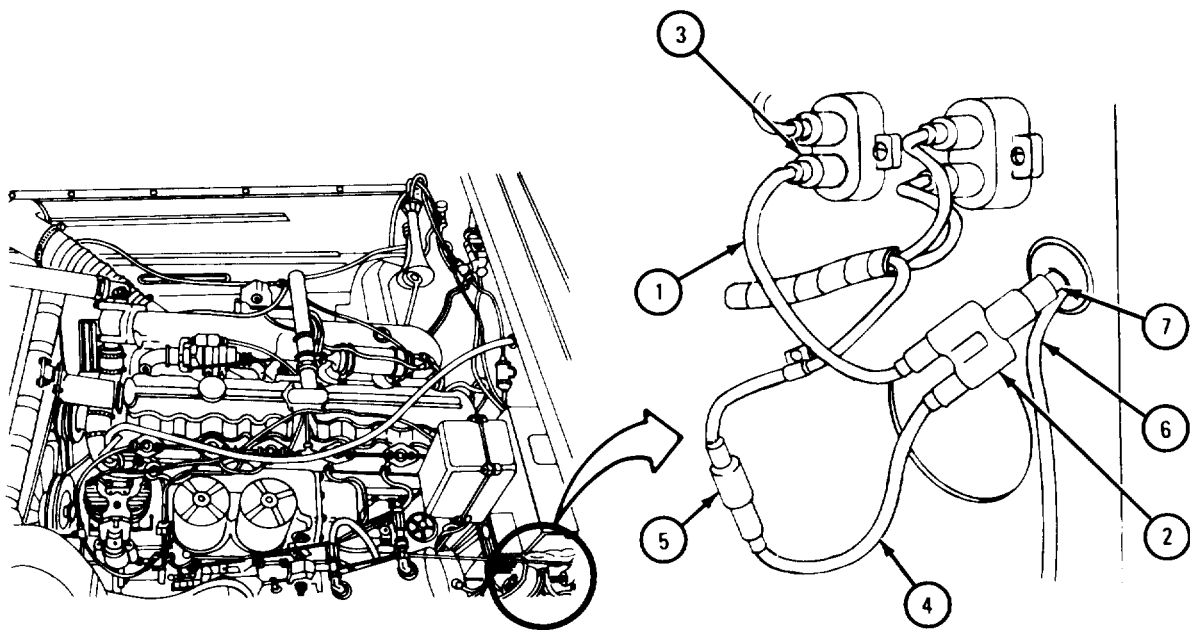

TA 103122



c. Inspection and Repair.

## FRAME 1

1. Check that wires (1) are not broken and that insulation is not burned or broken.
2. Check that ends of wires (1) are not corroded.
3. Check that resistor (2) is not burned, cracked or corroded.
4. Check that circuit breaker (3) and switch (4) are not damaged.
5. Check that connector (5) is not corroded.
6. If parts are damaged, get new ones.

END OF TASK

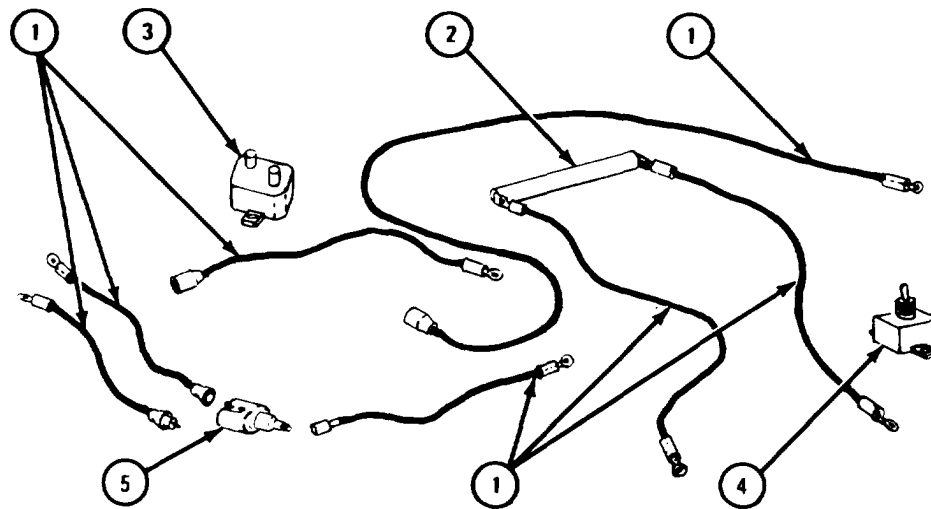

TA 089114

d. Replacement.

FRAME 1

1. Route cable (1) from heater unit (2) through grommet (3) in firewall (4) as noted.
2. Join cable (1) as tagged to connector (5). Take off tag.
3. Put clamp (6) on cable (1).
4. Put in screw (7) and washer (8).

GO TO FRAME 2

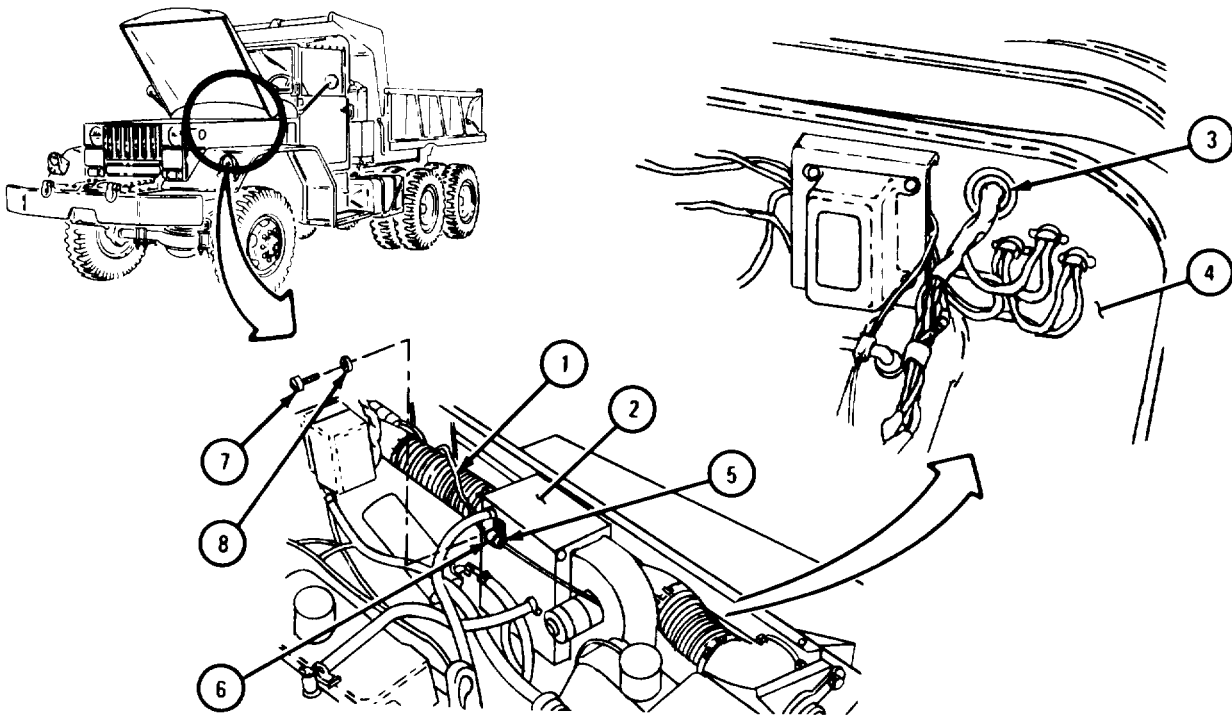

TA 089116

FRAME 2

1. Join connector (1) to cable (2).
2. Route cable (2) through grommet (3) in firewall (4) as noted.
3. Put two cables (5 and 6) into connector (1) as tagged. Take off tags,
4. Join cable (5) to circuit breaker (7) as tagged. Take off tag.
5. Join cable (6) to connector (8) as tagged. Take off tag.

GO TO FRAME 3

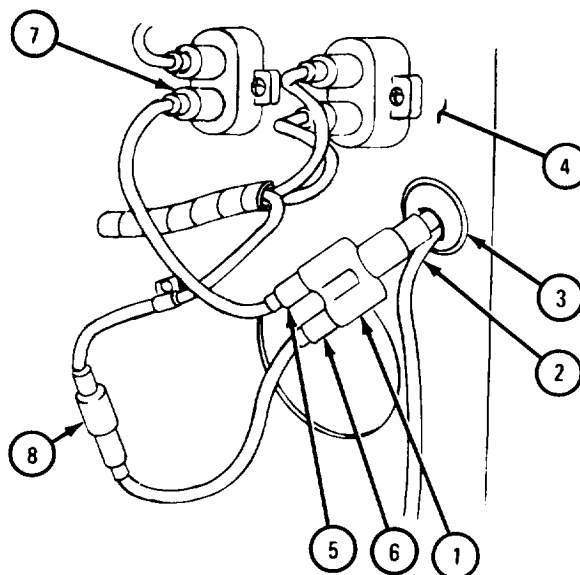

TA 089117

FRAME 3

1. Place resistor (1) on firewall (2) and put in two screws (3) and washers (4).
2. Place circuit breaker (5) on instrument panel (6) and put in two screws (7) and washers (8).
3. Join cables (9 and 10) to circuit breaker (5) as tagged. Take off tags.

GO TO FRAME 4

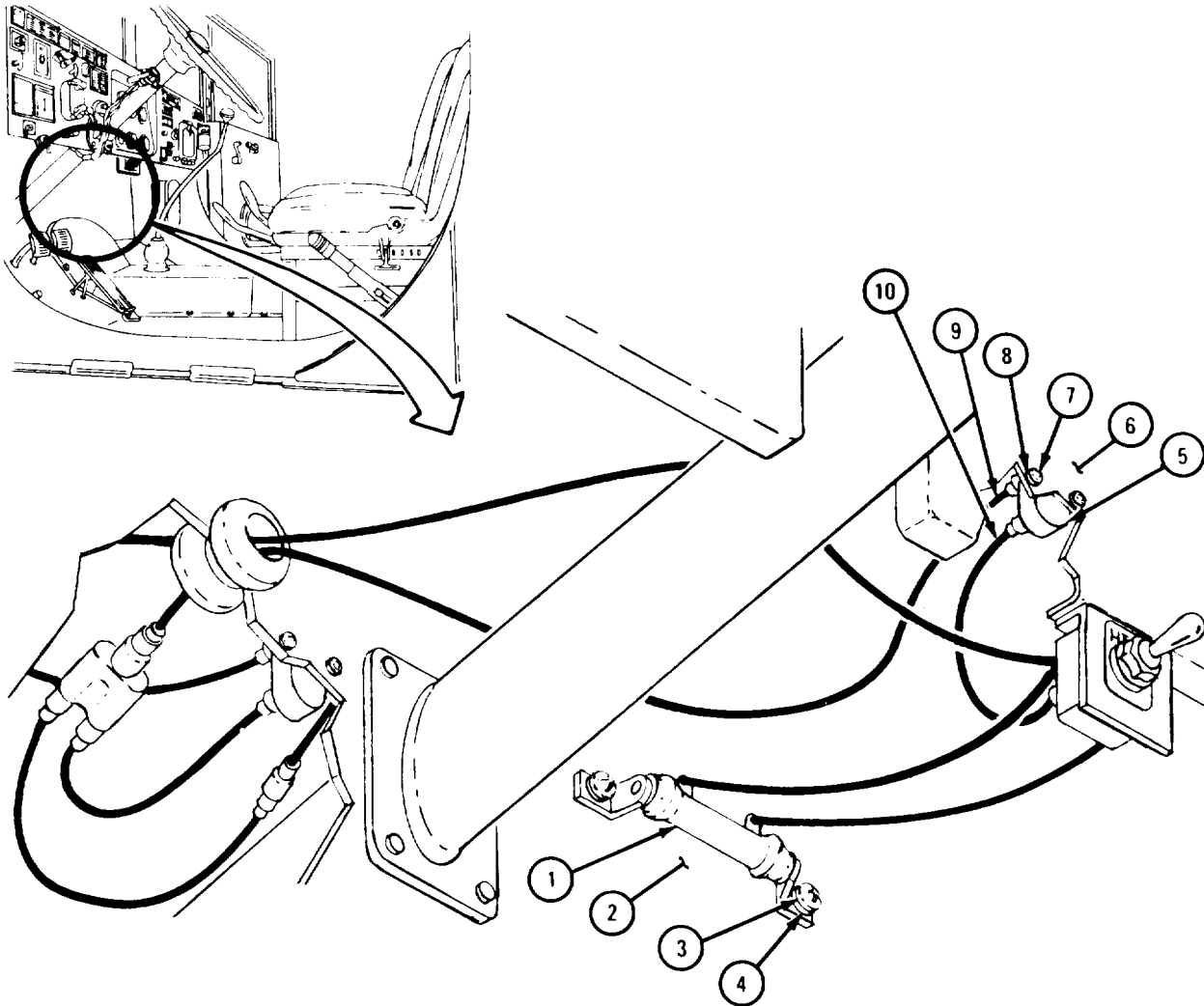

TA 089118

FRAME 4

1. Put four wires (1) on switch (2) as tagged. Put in three screws (3) and washers (4). Take off tags.
2. Put switch (2) in bracket (5).
3. Put on identification plate (6).
4. Put on washer (7) and locking nut (8).

**NOTE**

Follow-on Maintenance Action Required:

1. Put hose on diverter in truck cab. Refer to para 19-10.
2. Reconnect battery ground cable. Refer to TM 9-2320-211-20.
3. Close hood. Refer to TM 9-2320-211-10.

END OF TASK

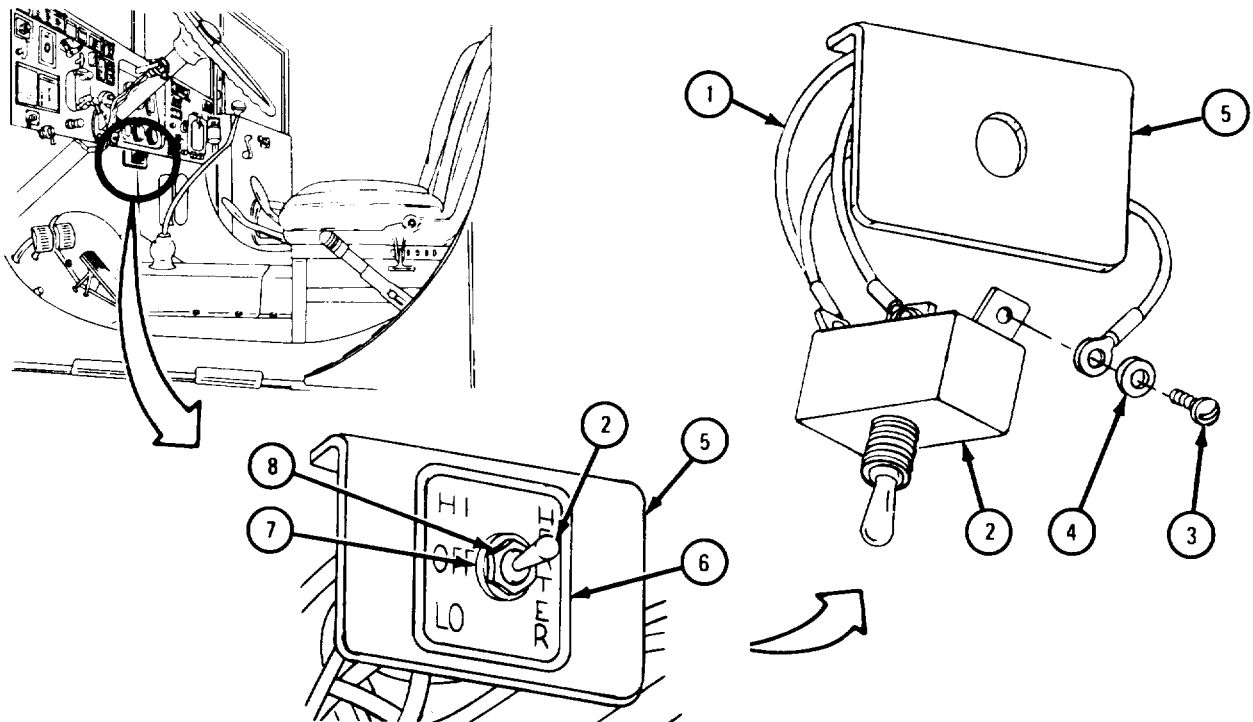

TA 089119

**19-7. HOT WATER PERSONNEL HEATER DIVERTER REMOVAL AND REPLACEMENT.**

Refer to fuel burning personnel heater air diverter removal and replacement, para 19-10.

**19-8. HOT WATER PERSONNEL HEATER DUCTING REMOVAL AND REPLACEMENT.**

Refer to fuel burning personnel heater ducting removal and replacement, para 19-11.

**19-9. FUEL BURNING PERSONNEL HEATER KIT INSTALLATION.** Install fuel burning personnel heater kit using instructions that come with kit.

**19-10. FUEL BURNING PERSONNEL HEATER AIR DIVERTER REMOVAL AND REPLACEMENT.**

TOOLS: No special tools required

SUPPLIES: None

PERSONNEL: Two

EQUIPMENT CONDITION: Truck parked, engine off, handbrake set.

Preliminary Procedure. Open hood and right side panel. Refer to TM 9-2320-211-10.

b. Removal.

FRAME 1

- Soldier A 1. Working inside cab, loosen three duct clamps (1).
2. Turn and pull off three diverter ducts (2).
3. Loosen screw (3) and take end of control cable (4) off shaft (5). Pull control cable out of diverter clamp (6).
4. Hold four screws (7). Tell soldier B when ready.
- Soldier B 5. Working under hood, take off four nuts (8) and washers (9).
- Soldier A 6. Take out heater diverter assembly (10).
- END OF TASK

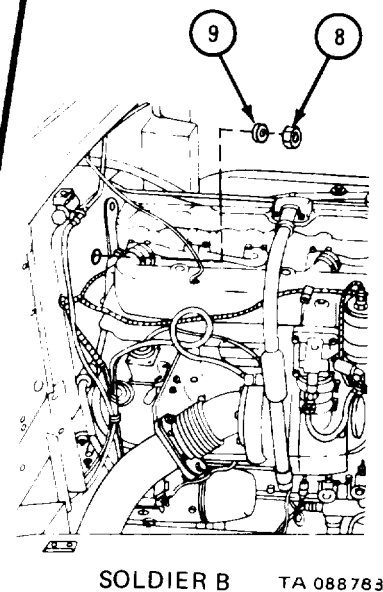
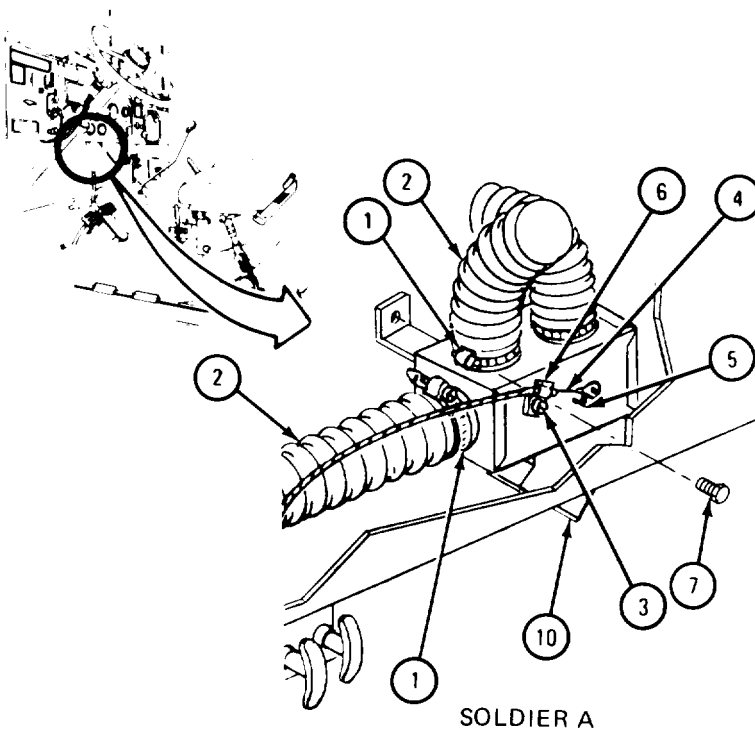

c. Replacement.

FRAME 1

- Soldier A 1. Working inside cab, put heater diverter assembly (1) in place and put four capscrews (2) in place. Hold four capscrews and tell soldier B when ready.
- Soldier B 2. Working under hood, screw in and tighten four nuts (3) and washers (4).
- Soldier A 3. Put on three heating ducts (5).
4. Tighten three duct clamps (6).
5. Put cable (7) through diverter clamp (8). Put looped end of control cable on shaft (9).
6. Tighten screw (10).

**NOTE**

Follow-on Maintenance Action Required:

1. Close hood and right side panel. Refer to TM 9-2320-211-10.
2. Adjust control cable. Refer to para 19-12.

END OF TASK

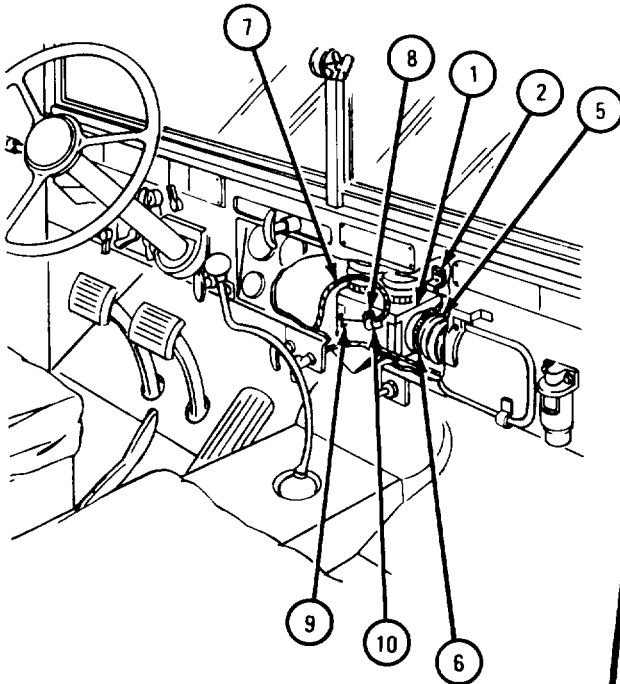

Soldier A

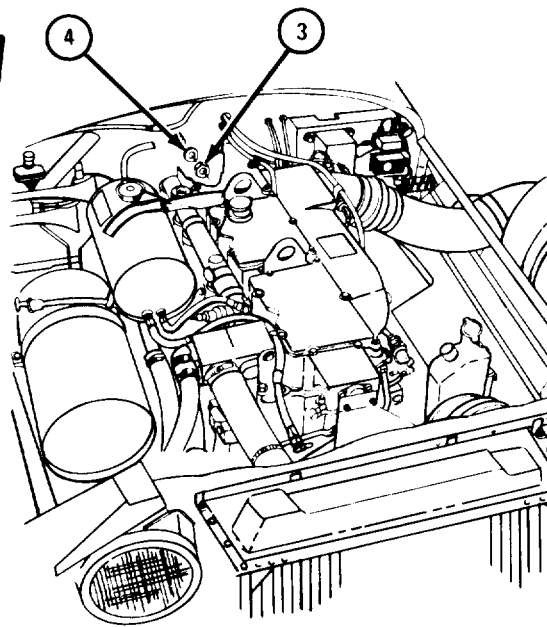

Soldier B

TA 088784



**19-11. FUEL BURNING PERSONNEL HEATER DUCTING REMOVAL AND REPLACEMENT.**

TOOLS: No special tools required

SUPPLIES: None

PERSONNEL: One

EQUIPMENT CONDITION: Truck parked, engine off, handbrake set.

a. Preliminary Procedure. Open hood and left side panel. Refer to TM9-2320-211-10.

b. Removal.

**FRAME 1**

1. Working inside cab, loosen six duct clamps (1).
2. Turn and pull off three diverter ducts (2, 3, and 4) and take off six duct clamps (1).
3. Working in engine compartment, loosen two heater duct clamps (5).
4. Turn and pull off heater duct (6) and take off two duct clamps (5).

END OF TASK

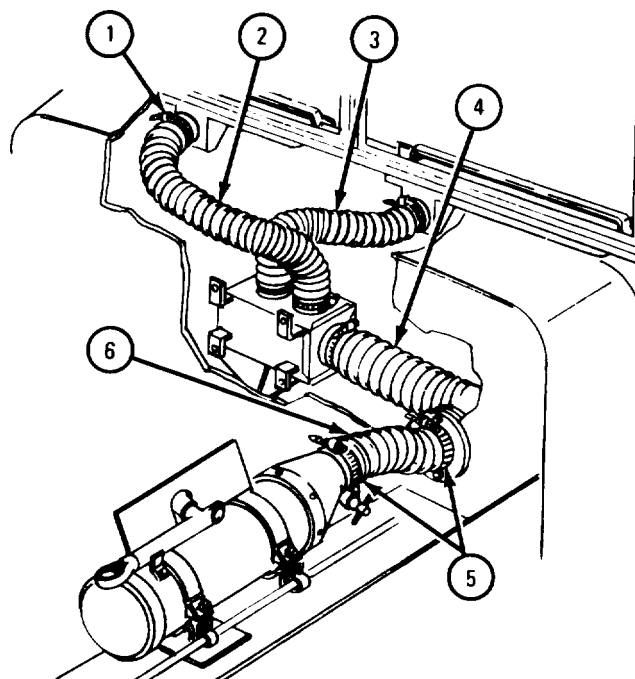
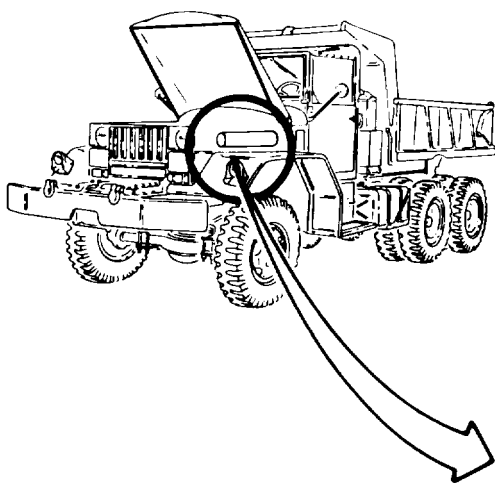

TA 088785

c. Replacement.

FRAME 1

1. Working in engine compartment, put two duct clamps (1) on 3 1/2-inch heater duct (2). Put heater duct in place and slide duct clamps to each end of duct as shown. Tighten two duct clamps.
2. Working inside cab, put two duct clamps (3) on 19 1/2-inch diverter duct (4). Put diverter duct in place and slide duct clamps to each end of duct as shown.
3. Tighten two duct clamps (3).

GO TO FRAME 2

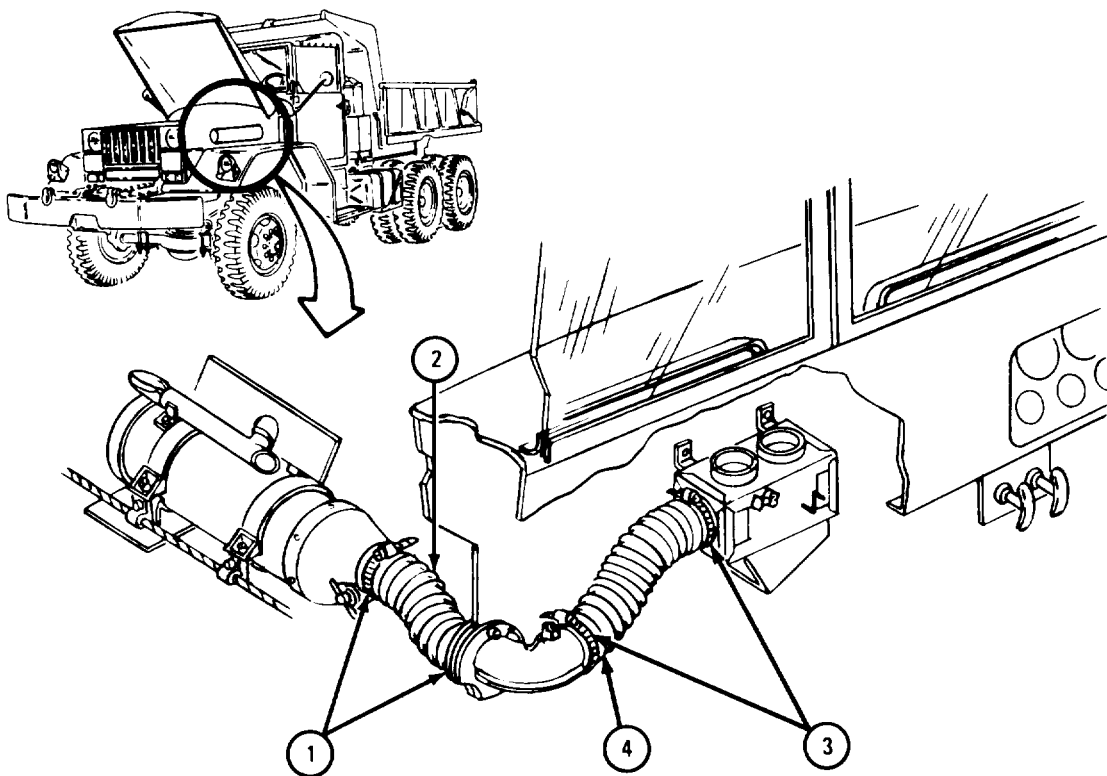

TA 088786

## FRAME 2

1. Working inside cab, put two duct clamps (1) on 29 1/2-inch diverter duct (2). Put one end of diverter duct on left port of diverter assembly (3) and put other end on left deflector (4). Slide duct clamps to each end of duct.
2. Tighten two duct clamps (1).
3. Put two duct clamps (5) on 26 1/2-inch diverter duct (6). Put one end of diverter duct on right port of diverter assembly (3) and put other end on right deflector (7). Slide duct clamp to each end of duct.
4. Tighten two duct clamps (5).

**NOTE**

Follow-on Maintenance Action Required:

Close hood and left side panel. Refer to TM 9-2320-211-10.

END OF TASK

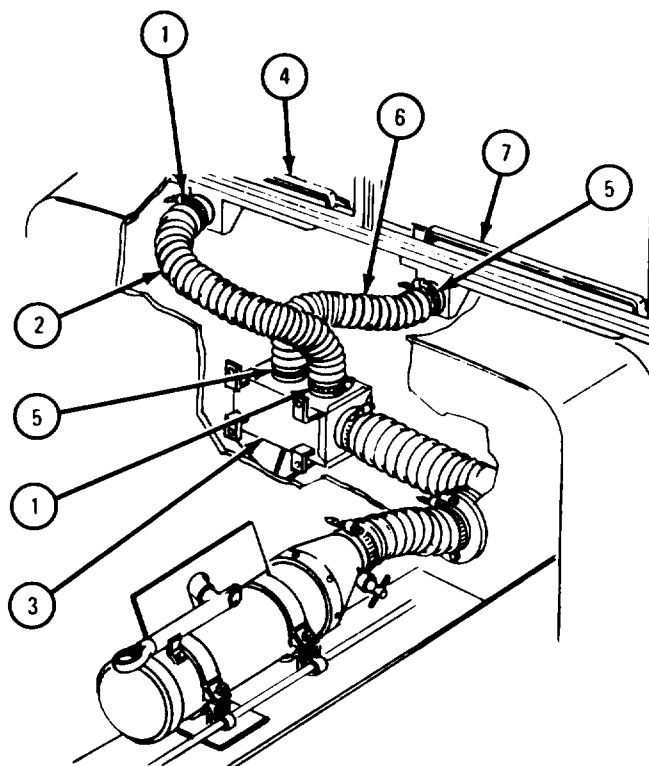
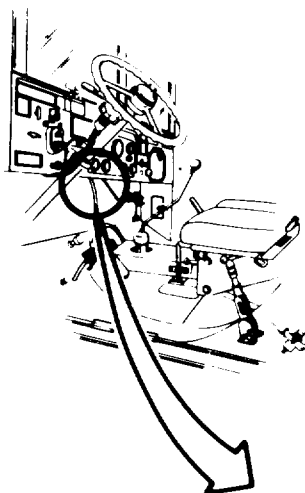

TA 088787

**19-12. FUEL BURNING PERSONNEL HEATER CONTROL CABLES REMOVAL, REPLACEMENT, AND ADJUSTMENT**

TOOLS: No special tools required

SUPPLIES: None

PERSONNEL: One

EQUIPMENT CONDITION: Truck parked, engine off, handbrake set.

a. Removal.

FRAME 1

1. Working from behind instrument panel, loosen screw 91) on adapter clamp (2). Take looped end of diverter adapter cable assembly (3) off shaft (4) and take cable out of adapter clamp.
2. Loosen screw (5) on diverter clamp (6). Take looped end of diverter cable (7) off shaft (8) and take cable out of diverter clamp.

GO TO FRAME 2

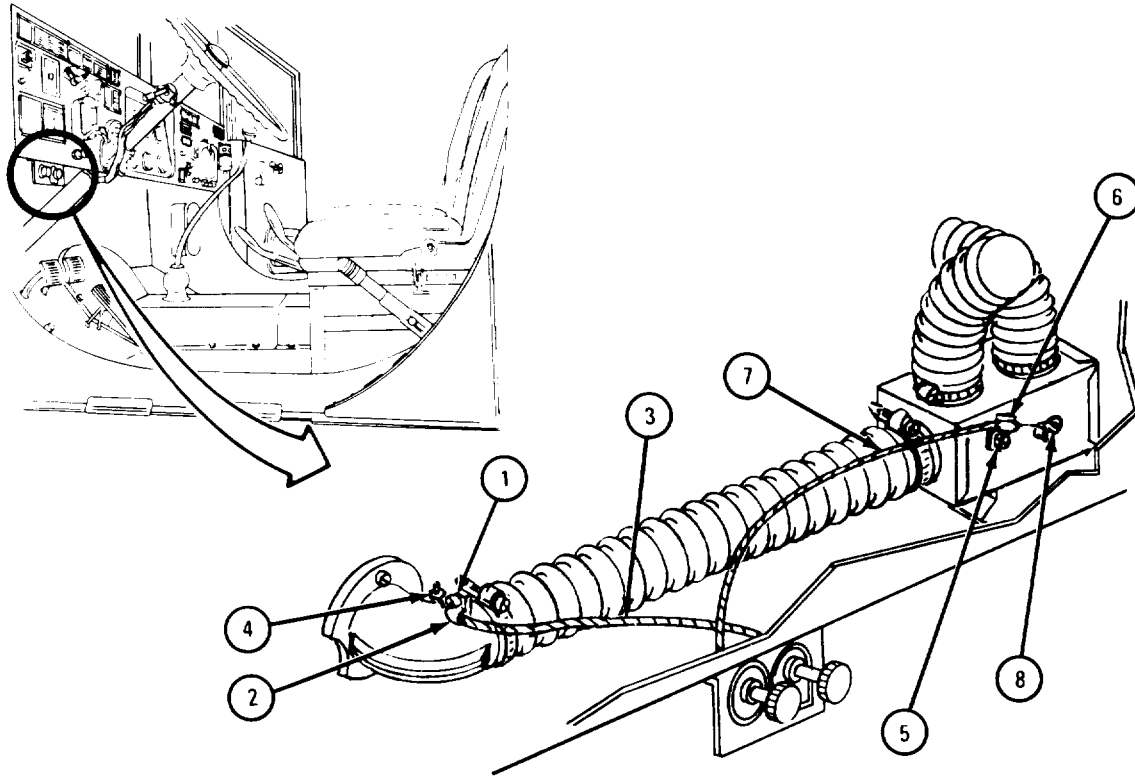

TA 088778

## FRAME 2

1. Take off nut and washer (1) and slide them off diverter adapter cable assembly (2).
2. Take off nut and washer (3) and slide them off diverter cable assembly (4).
3. Pull diverter adapter cable assembly (2), diverter cable assembly (4), AIR plate (5), and DEFROSTER plate (6) out of front of bracket (7).

END OF TASK

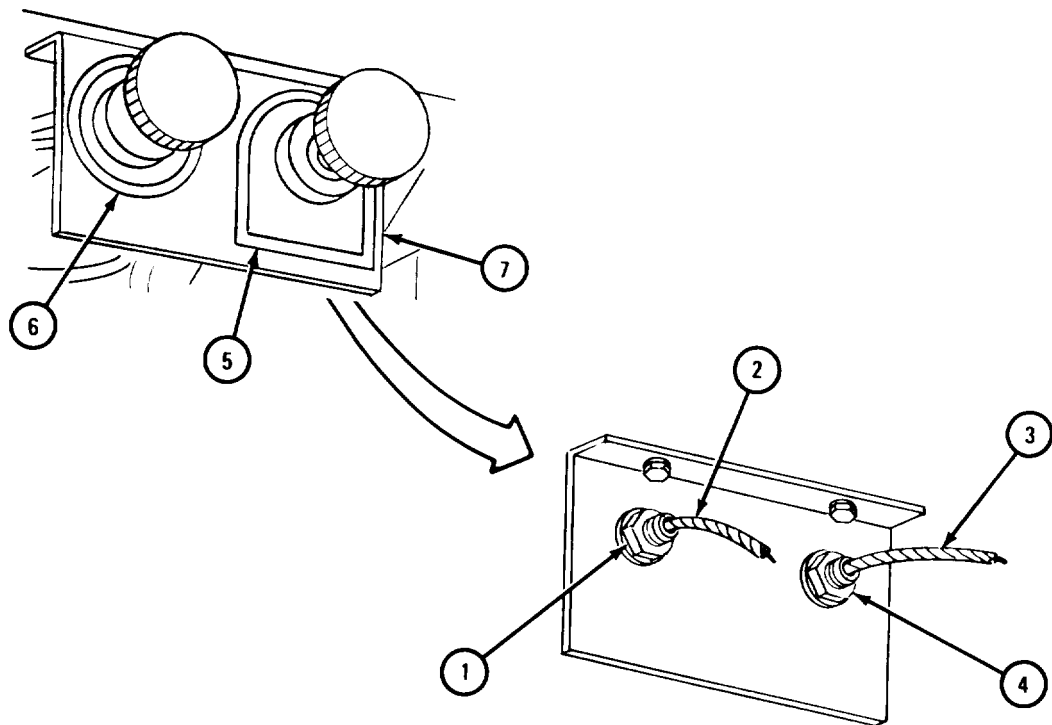

TA 088779

b. Replacement.

FRAME 1

1. Put identification plate marked AIR (1) over right hole in bracket (2) and put diverter adapter cable assembly (3) through hole as shown.
2. Slide nut and washer (4) over diverter adapter cable (3). Put on nut and washer.
3. Put identification plate marked DEFROSTER (5) over left hole in bracket (2) and put diverter cable assembly (6) through hole as shown.
4. Slide nut and washer (7) over diverter cable (6). Put on nut and washer.

GO TO FRAME 2

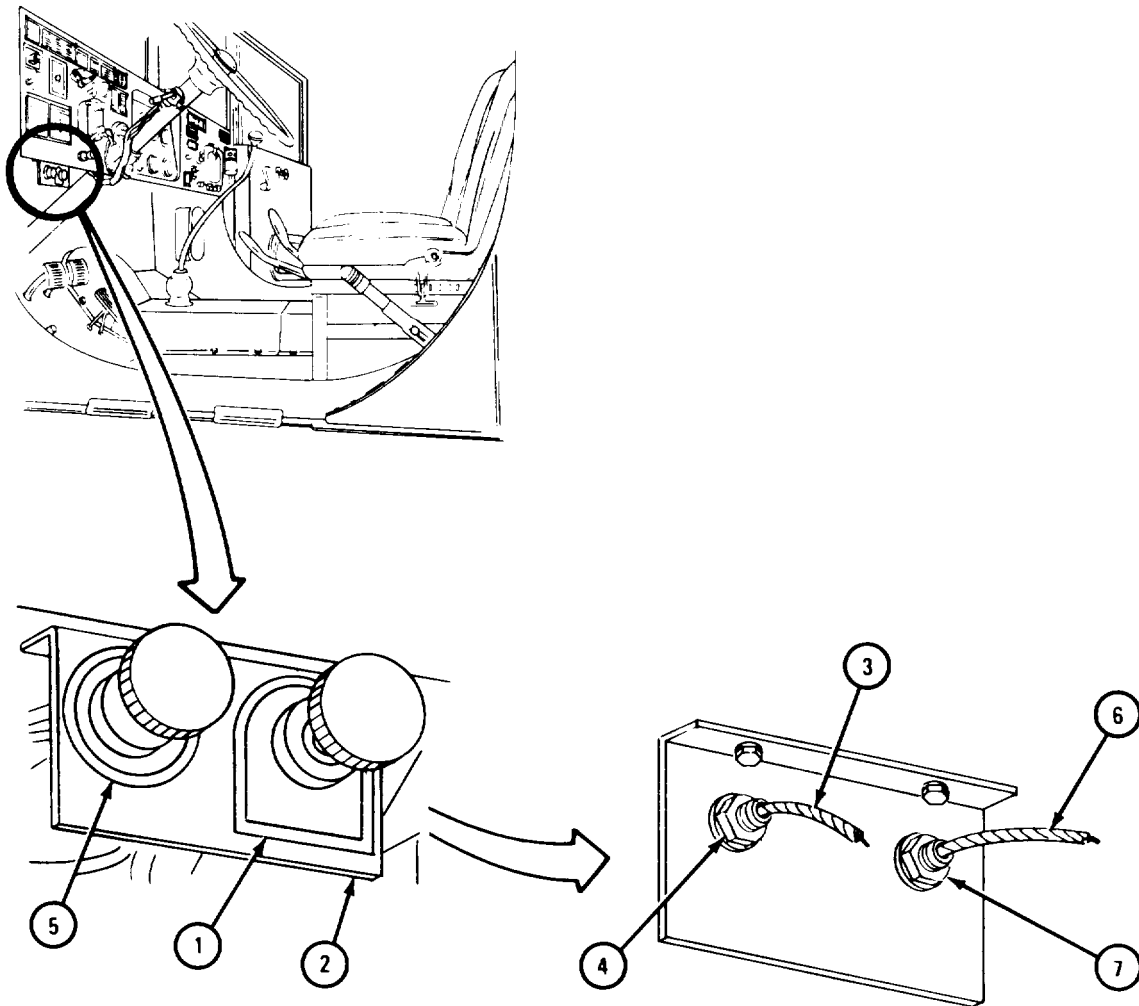

## FRAME 2

1. Working from behind instrument panel, put diverter adapter cable assembly (1) through adapter clamp (2) and put looped end of cable over shaft (3).
2. Tighten screw (4).
3. Put diverter cable assembly (5) through diverter clamp (6) and put looped end of cable over shaft (7).
4. Tighten screw (8).

END OF TASK

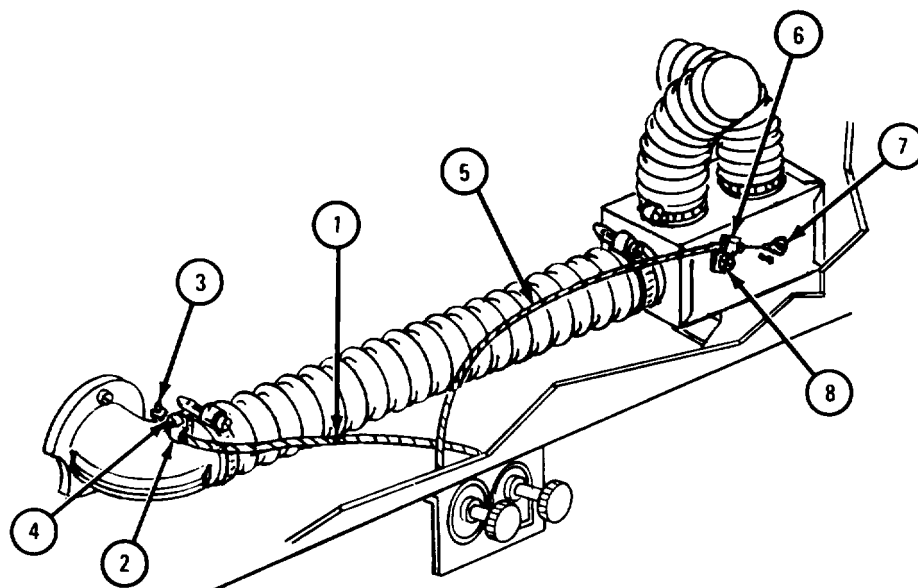

TA 088781

c. Adjustment.

FRAME 1

**NOTE**

This task is shown for one cable. This task is the same for both cables.

1. Loosen screw (1).
2. Pull knob (2) all the way out.
3. Pull shaft (3) all the way in towards cable clamp (4).
4. Using screwdriver, tighten screw (1). Do not let cable assembly (5) pull out of cable clamp (4).
5. Push in knob (2) and check that shaft (3) moves freely.

END OF TASK

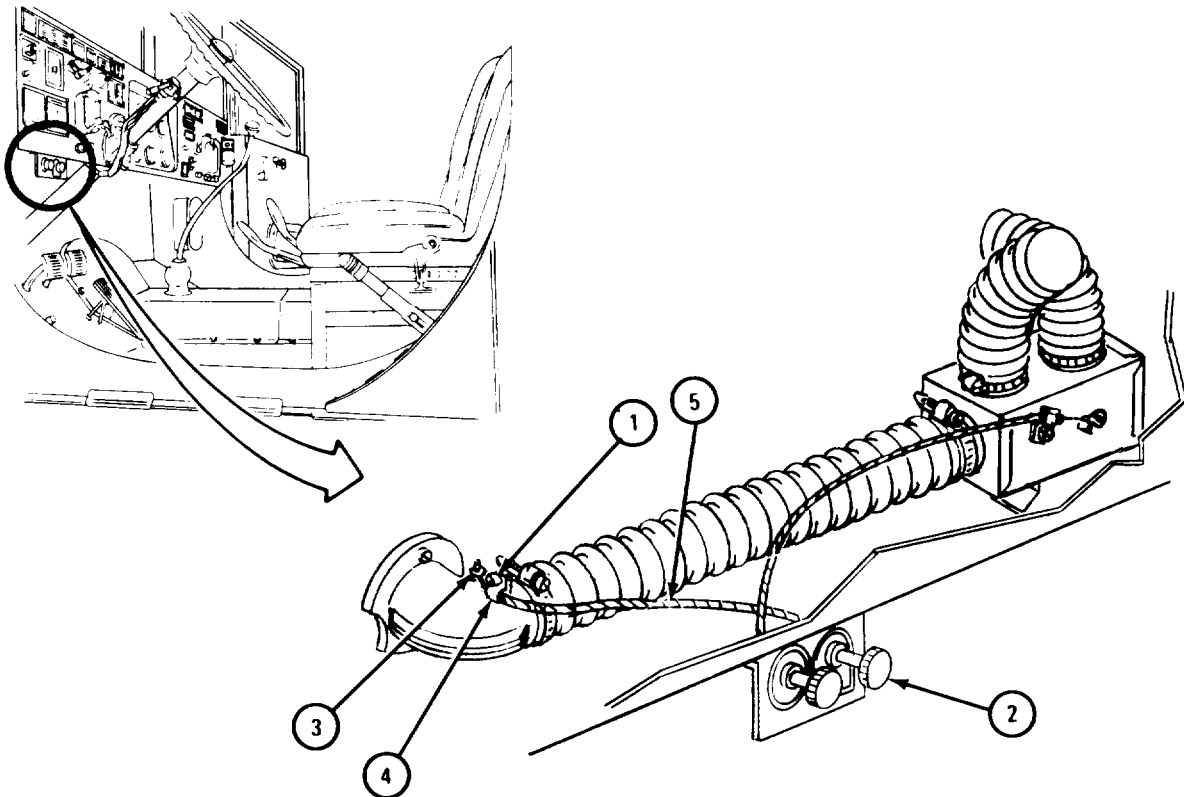

TA 088782



**19-13. VEHICULAR COOLANT HEATER KIT INSTALLATION.** Install vehicular coolant heater kit using instructions that come with kit.

**19-14. VEHICULAR COOLANT HEATER HOSES AND TUBES REMOVAL AND REPLACEMENT.**

TOOLS: No special tools required

SUPPLIES: Tags

PERSONNEL: One

EQUIPMENT CONDITION: Truck parked, engine off and cool, handbrake set.

a. Preliminary Procedures.

- (1) Disconnect battery ground cable. Refer to TM 9-2320-211-20.
- (2) Open hood. Refer to TM 9-2320-211-10.
- (3) Drain engine coolant. Refer to TM 9-2320-211-20.
- (4) Remove companion seat. Refer to TM 9-2320-211-20.
- (5) Remove batteries. Refer to TM 9-2320-211-20.
- (6) Remove center thermal barrier cover floormat. Refer to para 19-20.

b. Removal.

FRAME 1

1. Loosen two screws (1) on two clamps (2).
2. Tag and take off hoses (3 and 4). Take off two clamps (2).
3. Take out two screws (5) and washers (6). Take off two clamps (7).
4. Take out screw (8) and nut (9). Take off clamp (10).

GO TO FRAME 2

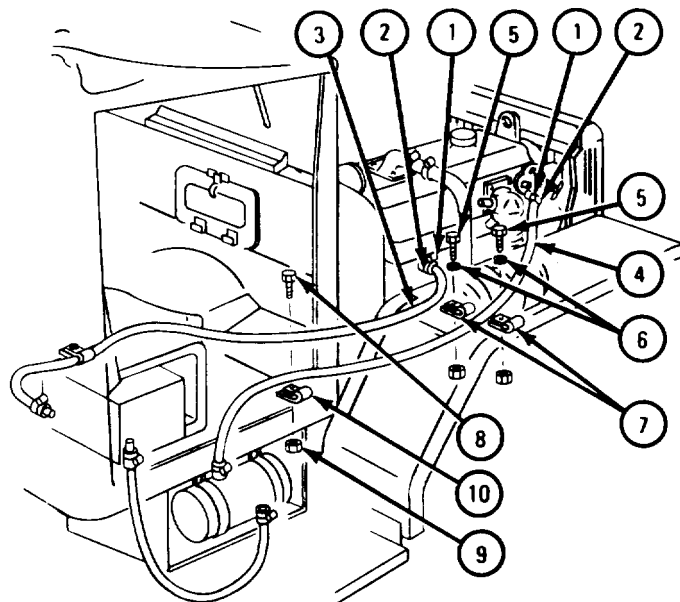

TA 088817

FRAME 2

1. Take out 11 screws (1) and lockwashers (2).
2. Take off cover (3).
3. Take out screw (4) and clamp (5) from shift lever cover (6).
4. Loosen clamp (7) on hose (8). Pull hose from battery pad inlet tube (9). Take off clamp.
5. Take out hose (8) and shield (10) from truck.
6. Take out hose (8) from shield (10).

GO TO FRAME 3

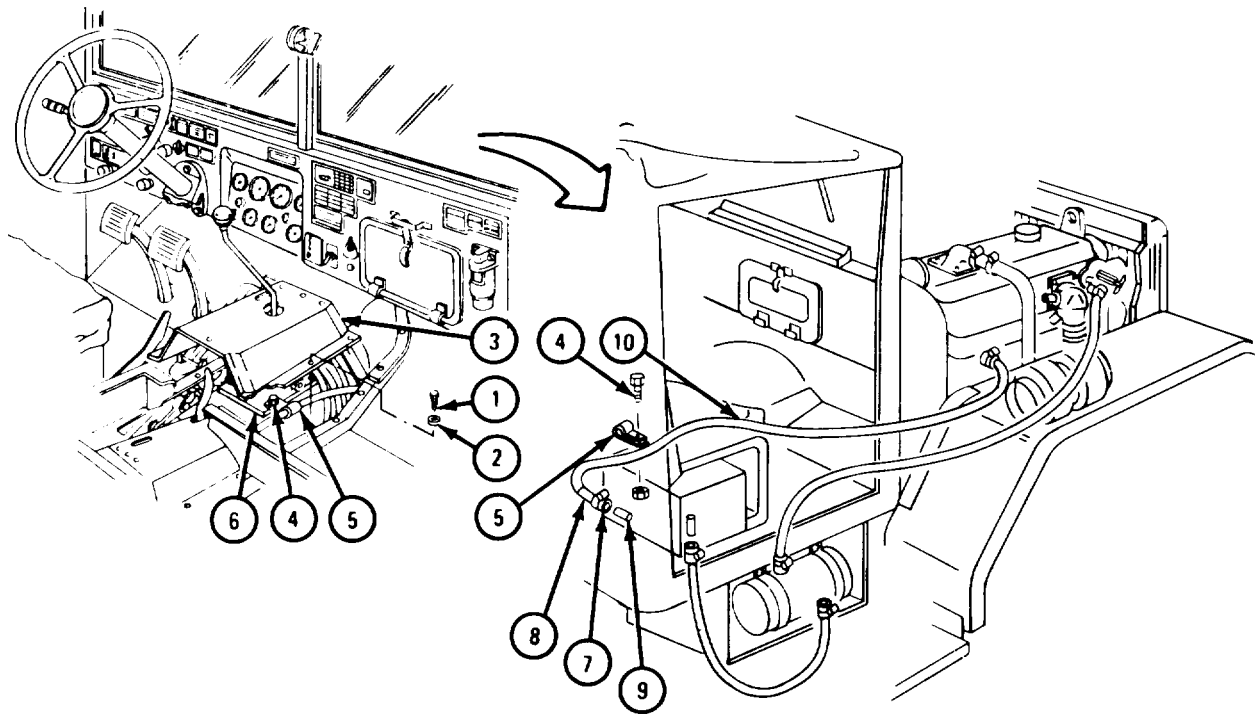

TA 088818

FRAME 3

1. Open door (1).
2. Loosen clamp (2). Take off hose (3) from battery pad outlet tube (4).
3. Loosen clamp (5). Take off hose (3) and shield (6).
4. Take off clamp (5).
5. Take hose (3) out of shield (6).
6. Loosen clamp (7). Take off hose (8) and shield (9).
7. Take off clamp (7).
8. Take hose (8) out of shield (9).

END OF TASK

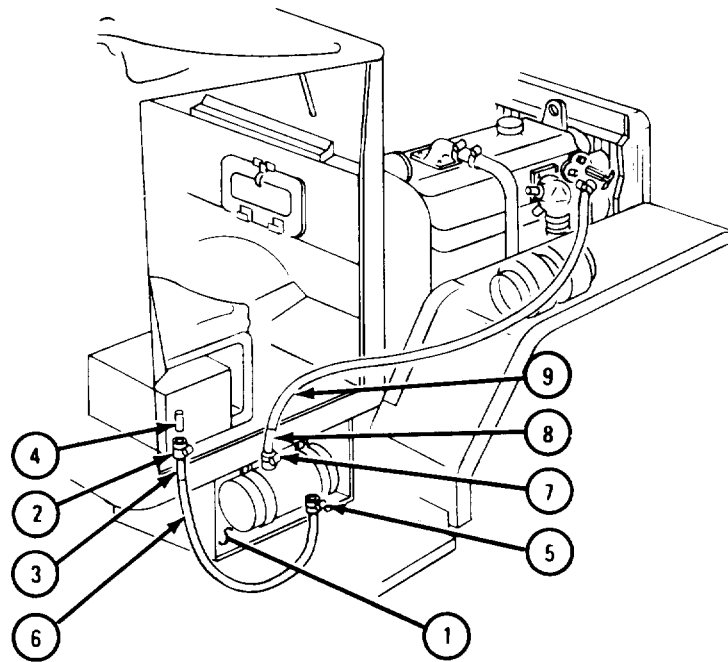

TA 088819

c. Replacement.

## FRAME 1

1. Put hose shields (1) on hoses (2 and 3).
2. Put clamp (4) on each end of hose (2).
3. Join hose (2) to battery pad outlet tube (5) and drain cock on engine coolant heater (6) as tagged. Tighten two clamps (4). Take off tag.
4. Place hose (3) in truck as tagged.
5. Put clamp (7) on hose (3).
6. Put hose (3) on elbow on engine coolant heater (6). Tighten clamp. Take off tag.

GO TO FRAME 2

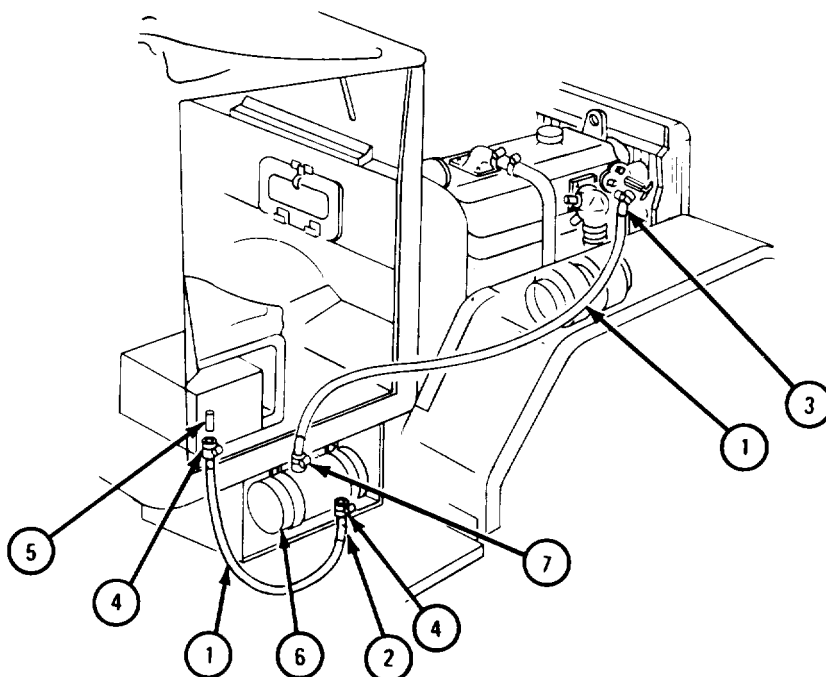

TA 088820

FRAME 2

1. Put hose shield (1) on hose (2).
2. Place hose (2) in truck as tagged.
3. Put clamp (3) on hose (2). Take off tag.
4. Put hose (2) on battery pad inlet tube (4). Tighten clamp.
5. Put clamp (5) on hose shield (1). Put screw (6) through clamp and shift lever cover (7).
6. Put on cover (8).
7. Put in 11 screws (9) and lockwashers (10).

GO TO FRAME 3

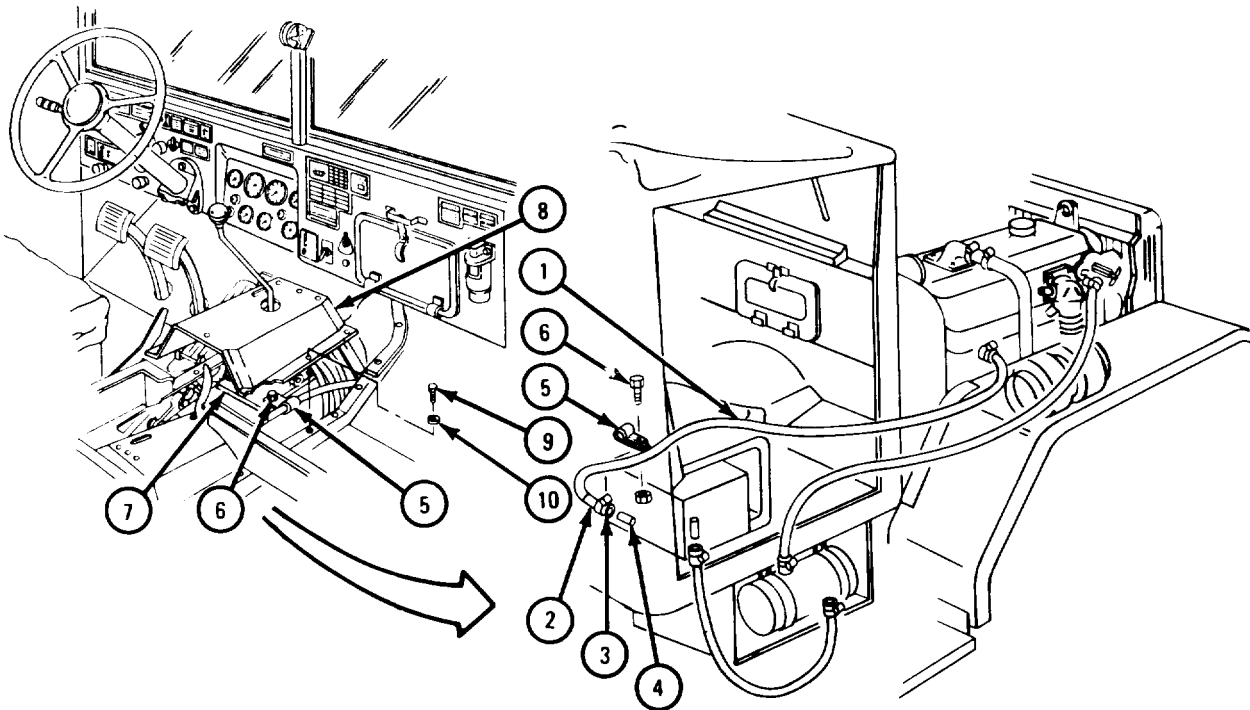

TA 088821

FRAME 3

1. Put on clamp (1) and put in screw (2) and nut (3).
  2. Put on two clamps (4) and put in two screws (5) and washers (6).
  3. Put two clamps (7) on hoses (8 and 9).
  4. Put hose (8) in place as tagged. Tighten clamp (7) and take off tag.
  5. Put hose (9) in place as tagged. Tighten clamp (7) and take off tag.
- GO TO FRAME 4

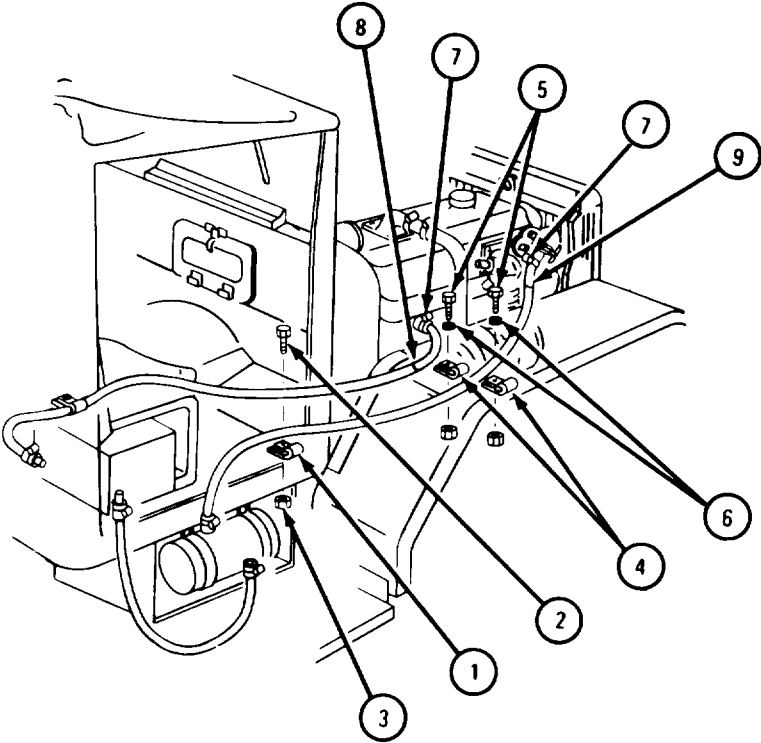

TA 088822

FRAME 4

**NOTE**

Follow-on Maintenance Action Required:

1. Replace center thermal barrier cover floormat. Refer to para 19-20.
2. Replace batteries. Refer to TM 9-2320-211-20.
3. Replace companion seat. Refer to TM 9-2320-211-20.
4. Check that all drain cocks are closed and fill cooling system with coolant. Refer to TM 9-2320-211-20.
5. Close hood. Refer to TM 9-2320-211-10.
6. Reconnect battery ground cables. Refer to TM 9-2320-211-20.

END OF TASK



**19-15. VEHICULAR COOLANT HEATER EXHAUST TUBE REMOVAL AND REPLACEMENT.**

TOOLS: No special tools required

SUPPLIES: None

PERSONNEL: One

EQUIPMENT CONDITION: Truck parked, engine off and cool, handbrake set.

a. Removal.

**FRAME 1**

1. Open vehicular coolant heater plant box door (1).
2. Take out and throw away cotter pin (2).

**WARNING**

Do not work on hot exhaust tube. Personnel can be badly burned.

3. Take exhaust tube (3) off exhaust pipe on heater (4).

GO TO FRAME 2

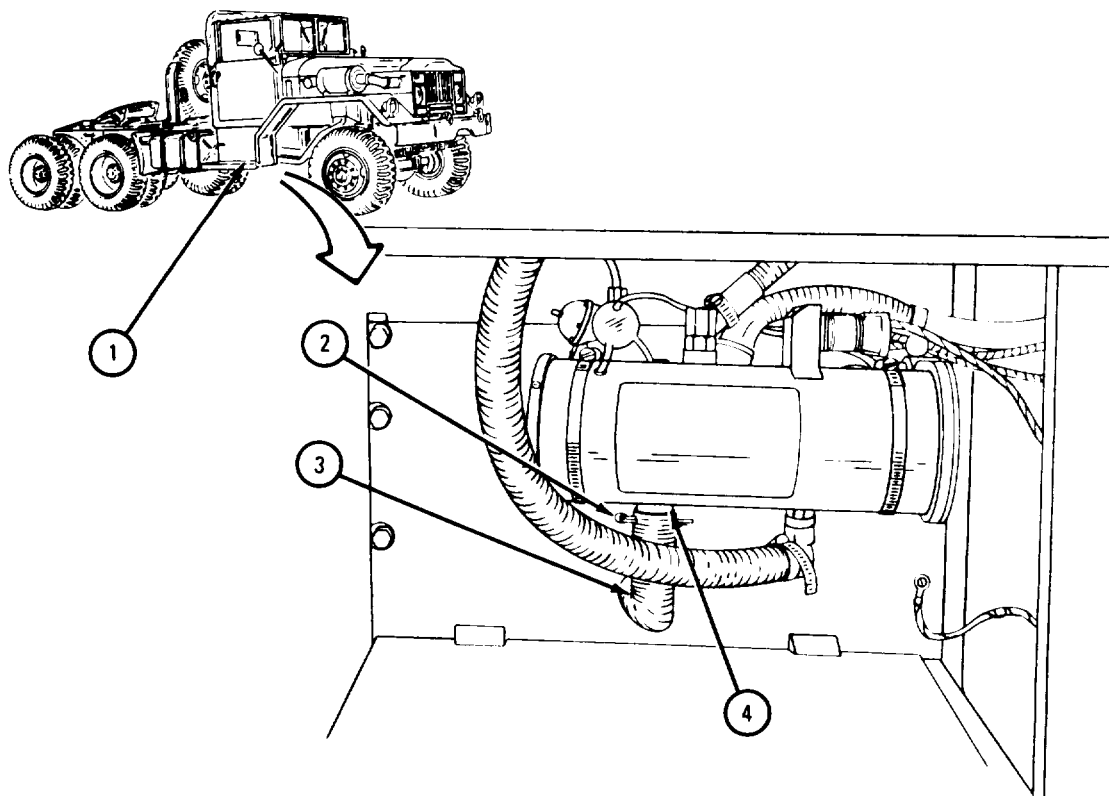

TA 088806

FRAME 2

1. Take out and throw away cotter pin (1). Take exhaust tube (2) out of oil pan shroud exhaust inlet (3).

GO TO FRAME 3

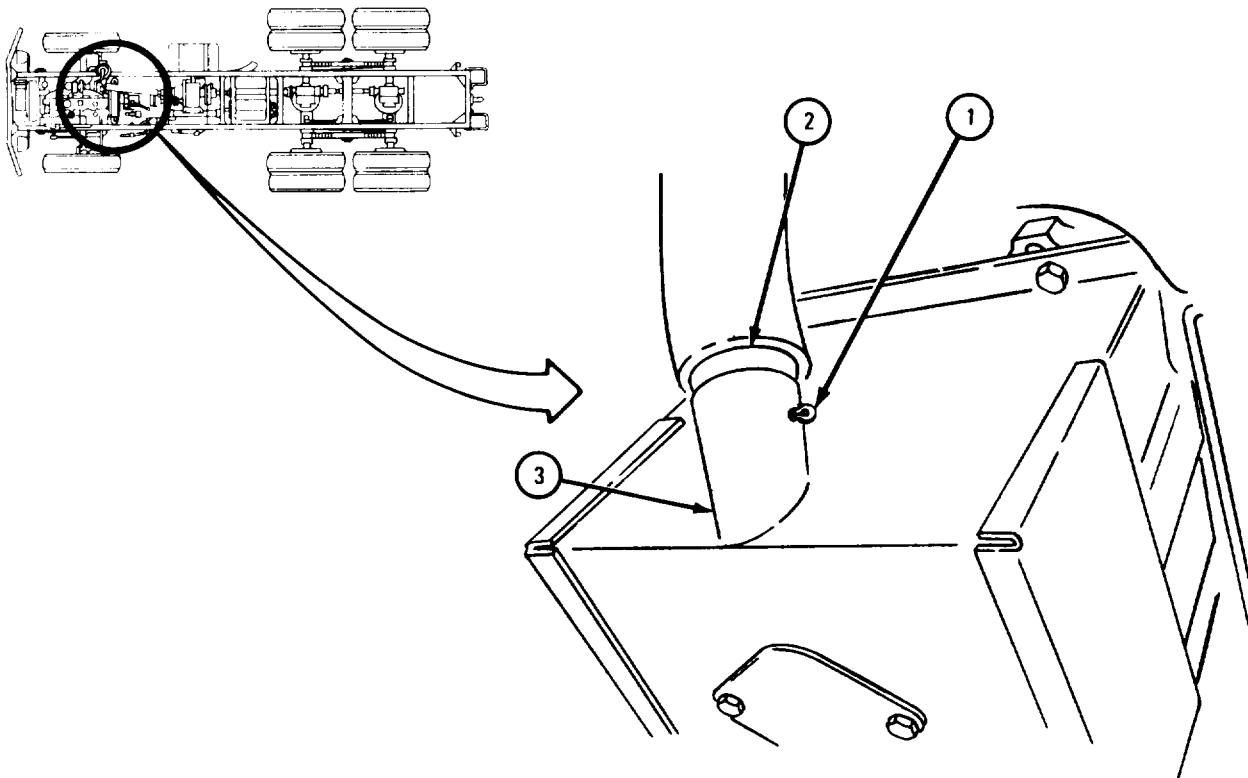

TA 088807

## FRAME 3

**NOTE**

Note position of exhaust tube (1) so it will be put back in the right position.

1. Take out screw (2), locknut (3), and clamp (4) from bracket (5) under running board support (6).
2. Take out exhaust tube (1).
3. Take off clamp (4).

END OF TASK

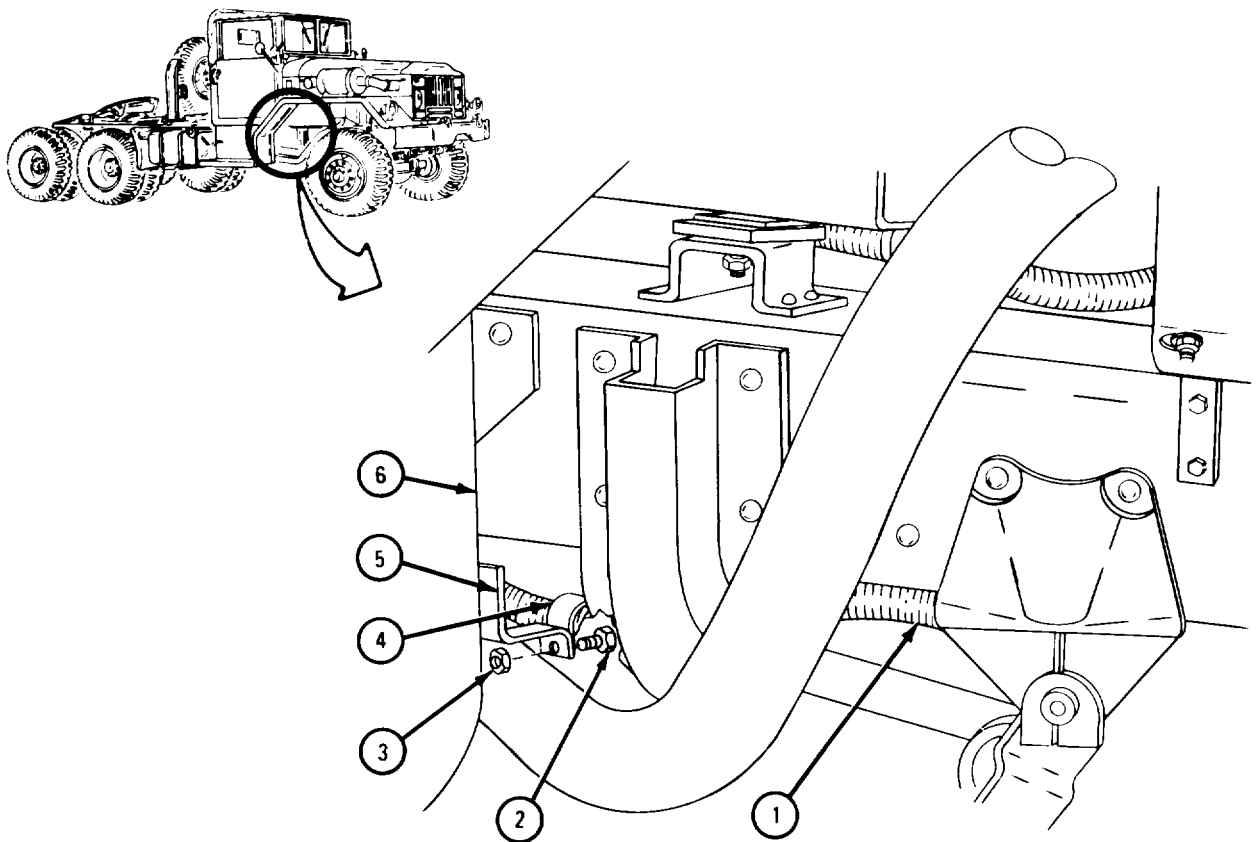

TA 088808

b. Replacement.

FRAME 1

1. Put exhaust tube (1) in place as noted in removal.
  2. Put exhaust tube (1) on exhaust pipe of heater (2), alining holes.
  3. Put in cotter pin (3).
- GO TO FRAME 2

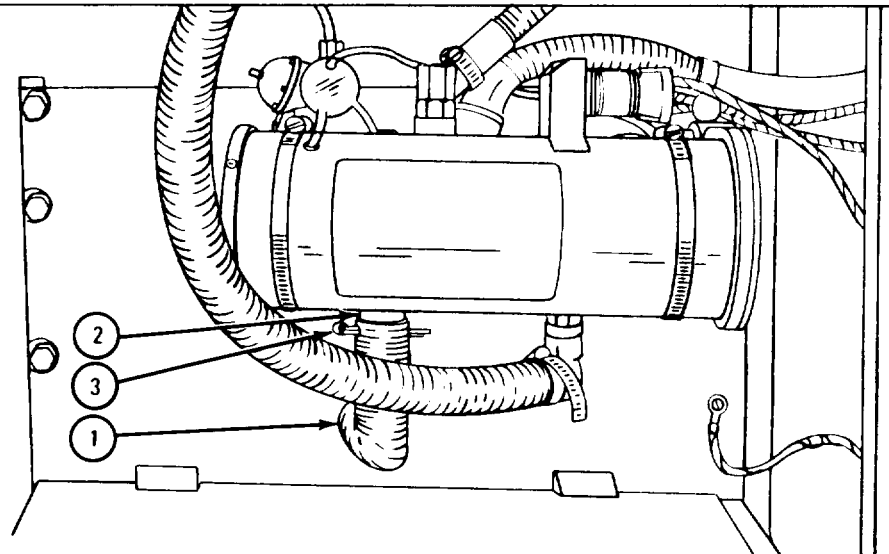
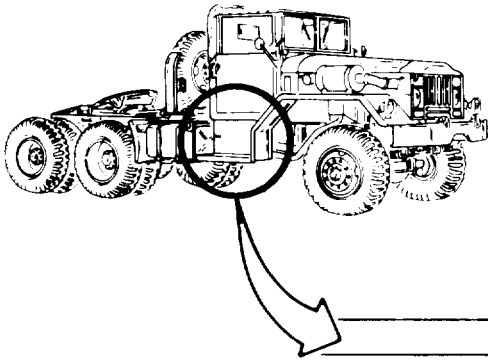

TA 088809

FRAME 2

1. Put exhaust tube (1) in oil pan shroud exhaust inlet (2), alining holes.
2. Put in cotter pin (3).

GO TO FRAME 3

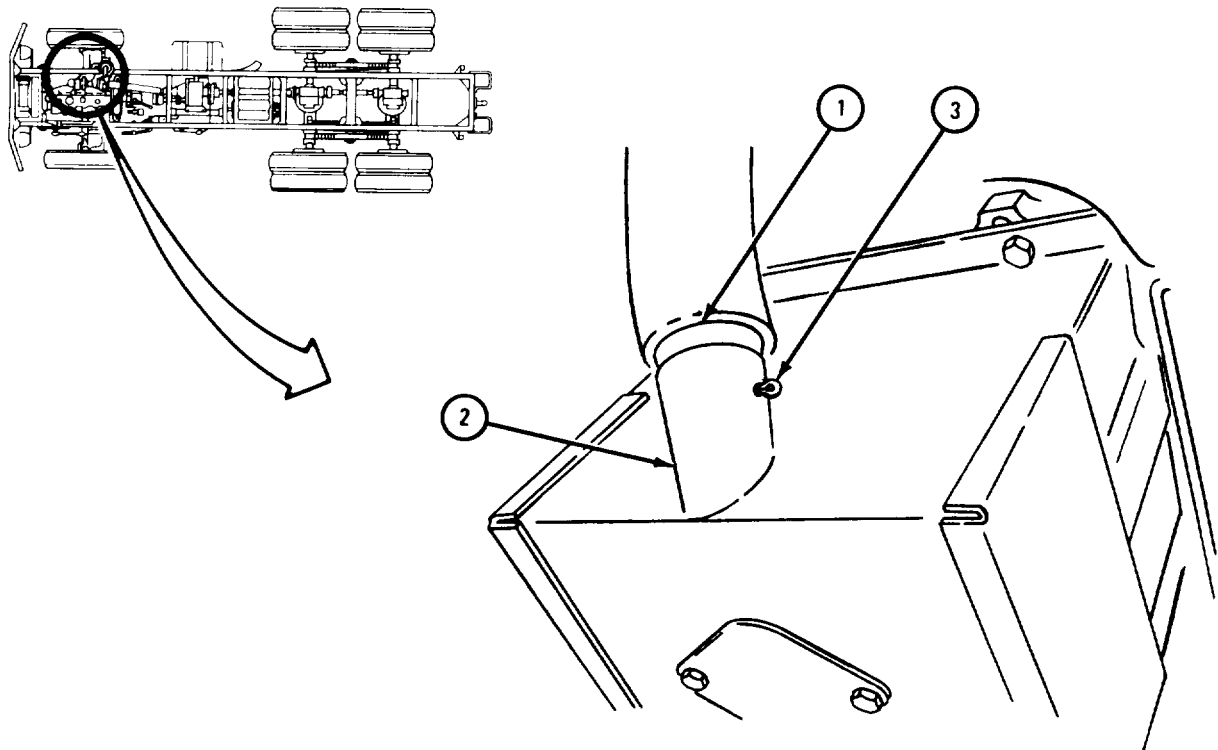

TA 088810

FRAME 3

1. Put clamp (1) on exhaust tube (2).
2. Put cap screw (3) into screw hole in clamp (1) and aline with screw hole in bracket (4) on right running board support (5).
3. Put on locknut (6).
4. Close vehicular coolant heater plant box door (7).

**NOTE**

Follow-on Maintenance Action Required:

At lowest point of exhaust tube, drill 1/8-inch diameter hole to drain condensation.

END OF TASK

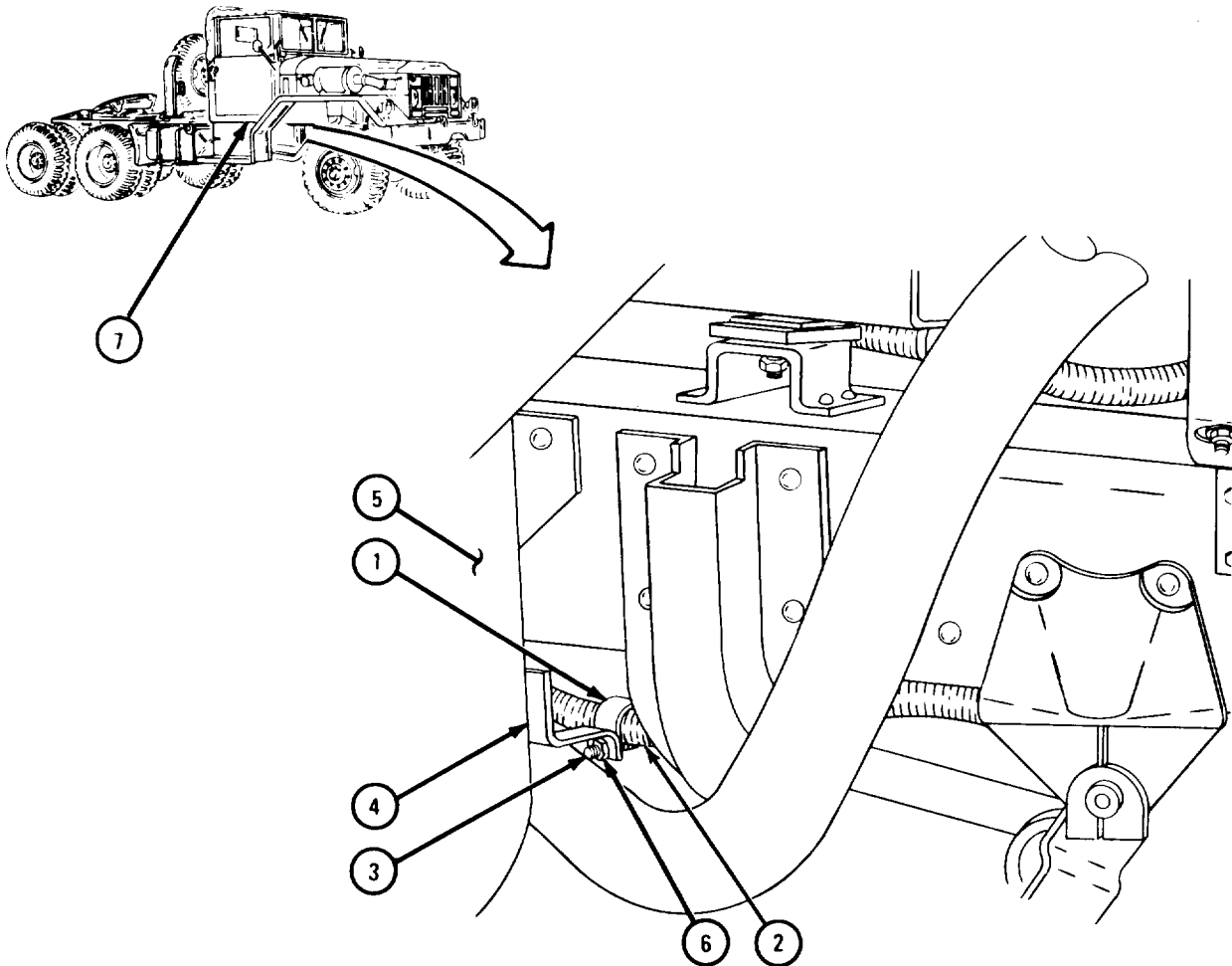

TA 088811

### 19-16. VEHICULAR COOLANT HEATER OIL PAN SHHROUD ASSEMBLY REMOVAL, REPAIR AND REPLACEMENT.

TOOLS: No special tools required.

SUPPLIES: None

PERSONNEL: One

EQUIPMENT CONDITION: Truck parked, engine off, handbrake set.

#### WARNING

Make sure powerplant heater is off and cool before doing this task. Failure to do this may result in injury to personnel.

#### a. Removal.

##### FRAME 1

1. Take out cotter pin (1) and pull out hose (2).
2. Hold oil pan shroud (3) in place and take out four screws (4) and washers (5).
3. Take down oil pan shroud (3).

END OF TASK

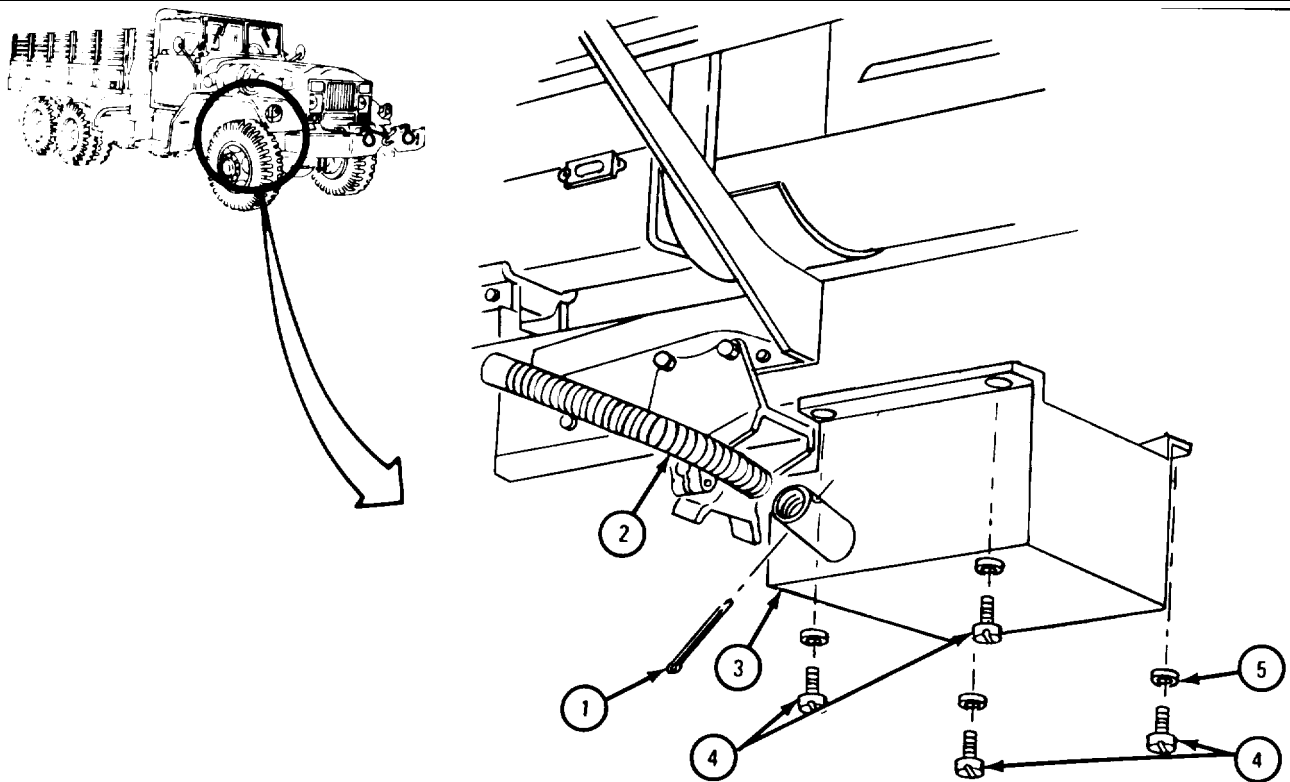

TA 101771

b. Replacement.

FRAME 1

1. Aline exhaust inlet on oil pan shroud (1) with exhaust tube (2) and aline four holes in bottom of oil pan with holes in shroud (1).
2. Push oil pan shroud (1) up and hold it in place. Put exhaust tube (2) in place.
3. Screw on and tighten four screws (3) and washers (4).
4. Put in cotter pin (5).

END OF TASK

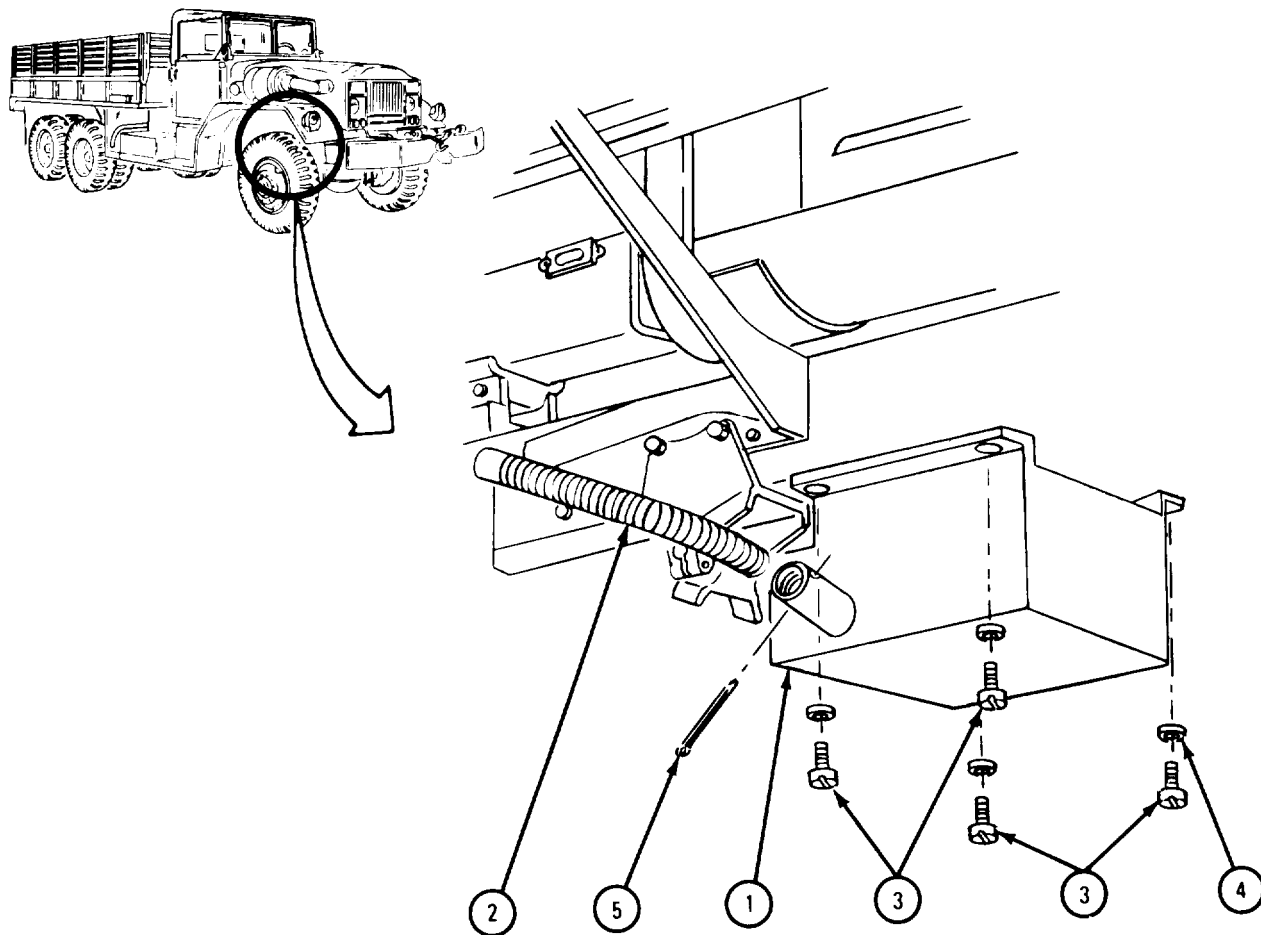

TA 101772



**19-17. VEHICULAR COOLANT HEATER HOOD COVER ASSEMBLY REPAIR.**

a. Removal. Take off vehicular coolant heater hood cover assembly. Refer to TM 9-2320-211-20.

b. Repair. Repair vehicular coolant heater hood cover assembly. Refer to FM 43-3.

Replacement. Put on vehicular coolant heater hood cover assembly. Refer to TM 9-2320-211-20.

**19-18. VEHICULAR COOLANT HEATER RADIATOR COVER ASSEMBLY.**

a. Removal. Take off vehicular coolant heater radiator cover assembly. Refer to TM 9-2320-211-20.

b. Repair. Repair vehicular coolant heater radiator cover assembly. Refer to FM 43-3.

Replacement. Put on vehicular coolant heater radiator cover assembly. Refer to TM 9-2320-211-20.

**19-19. VEHICULAR COOLANT HEATER REMOVAL, REPAIR, TEST, AND REPLACEMENT.**

TOOLS: Test stand, fuel burning heaters  
Graduate, 50cc-capacity  
Dry cleaning solvent, type II (SD-2), Fed. Spec P-D-680

SUPPLIES: Compressed air, 30 psi maximum  
Clean rags  
Burner gasket  
Burner, preformed packing  
Overheat thermostat preformed packing  
Fuel control valve gasket  
Fuel control valve gasket with screen  
Igniter  
Igniter gasket

PERSONNEL: One

EQUIPMENT CONDITION: Truck parked, engine off, handbrake set.

a. Preliminary Procedures.

- (1) Take off battery ground strap. Refer to TM 9-2320-211-20.
- (2) Take off coolant hoses at heater. Refer to TM 9-2320-211-20.

b. Removal.

## FRAME 1

**WARNING**

Smoking, sparks or open flames are not allowed within 50 feet of work area during this task. Fuel can explode, causing injury to personnel and damage to equipment.

1. Working in battery box, shut off fuel cock (1).
2. Unscrew fitting (2) and pull fuel line (3) from fuel control valve (4).
3. Take out cotter pin (5) and slide off exhaust pipe elbow (6) from heater (7).
4. Unscrew and unplug electrical connector (8) from heater (7).
5. Unscrew and open two heater retainer clamps (9) and take out heater assembly (7).

END OF TASK

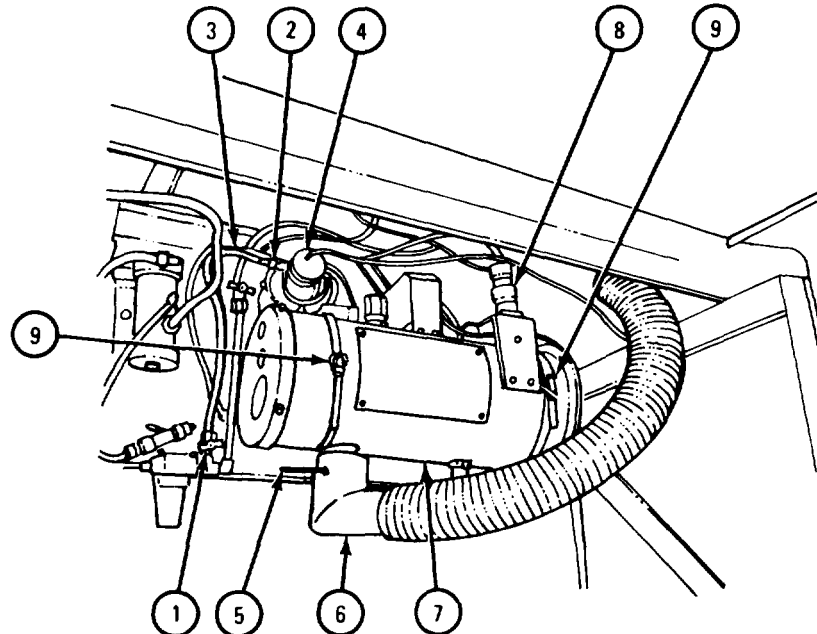
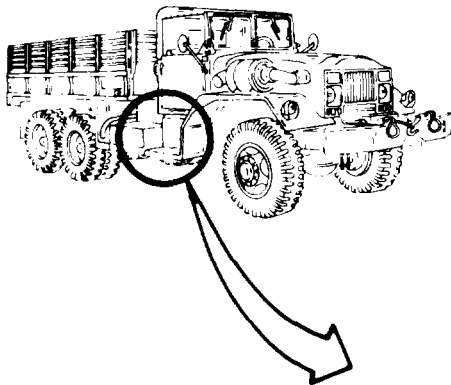

TA 117882

c. Disassembly into Subassemblies.

FRAME 1

1. Unscrew and take out four screws (1), two on each of guard (2). Take off guard (2).
2. Tag ground electrical lead (3). Unscrew and take off nut (4). Take off ground electrical lead (3).
3. Take off air inlet tube and elbows (5).

GO TO FRAME 2

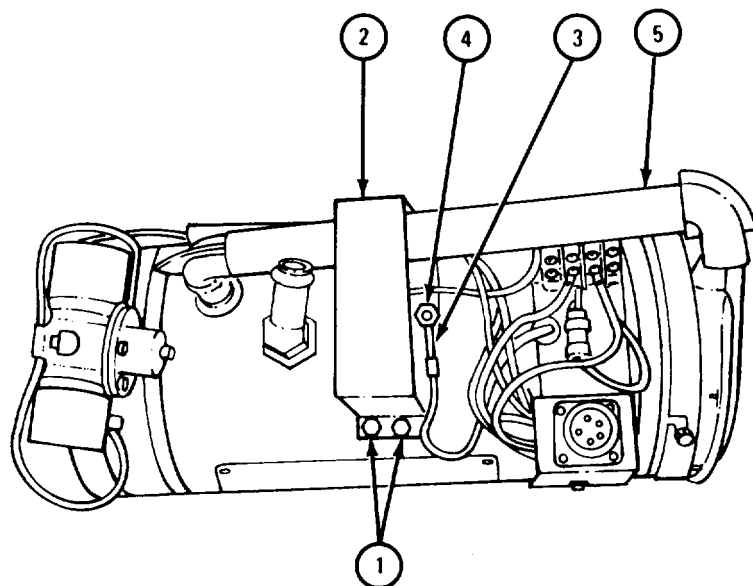

TA 117883

FRAME 2

1. Tag blower motor electrical lead (1). Unscrew and take out terminal screw (2). Take off blower motor electrical lead (1).
2. Tag terminal screw (2) the same as blower motor electrical lead (1). Screw in terminal screw (2).
3. Scratch a line (3) across blower assembly (4) and housing (5). Loosen four nuts (6) around blower assembly (4).
4. Turn blower assembly (4) so slots (7) clear studs (8). Take off blower assembly (4).

GO TO FRAME 3

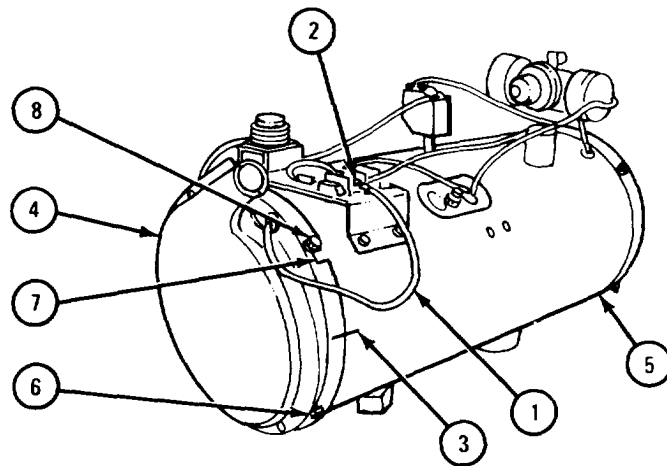

TA 117884

FRAME 3

1. Tag flame detector switch common electrical lead (1). Unscrew and take out terminal screw (2) from flame detector switch (3).
2. Tag terminal screw (2) the same as electrical lead (1). Screw terminal screw (2) with tag into flame detector switch (3).
3. Do steps 1 and 2 again for switch middle electrical leads (4 and 5) and switch end electrical leads (6 and 7).
4. Unscrew fitting (8) under flame detector switch (3).

**CAUTION**

Use care in pulling flame detector switch out. If switch is not pulled straight out, parts in switch will break.

5. Pull flame detector switch (3) out of housing (9).

GO TO FRAME 4

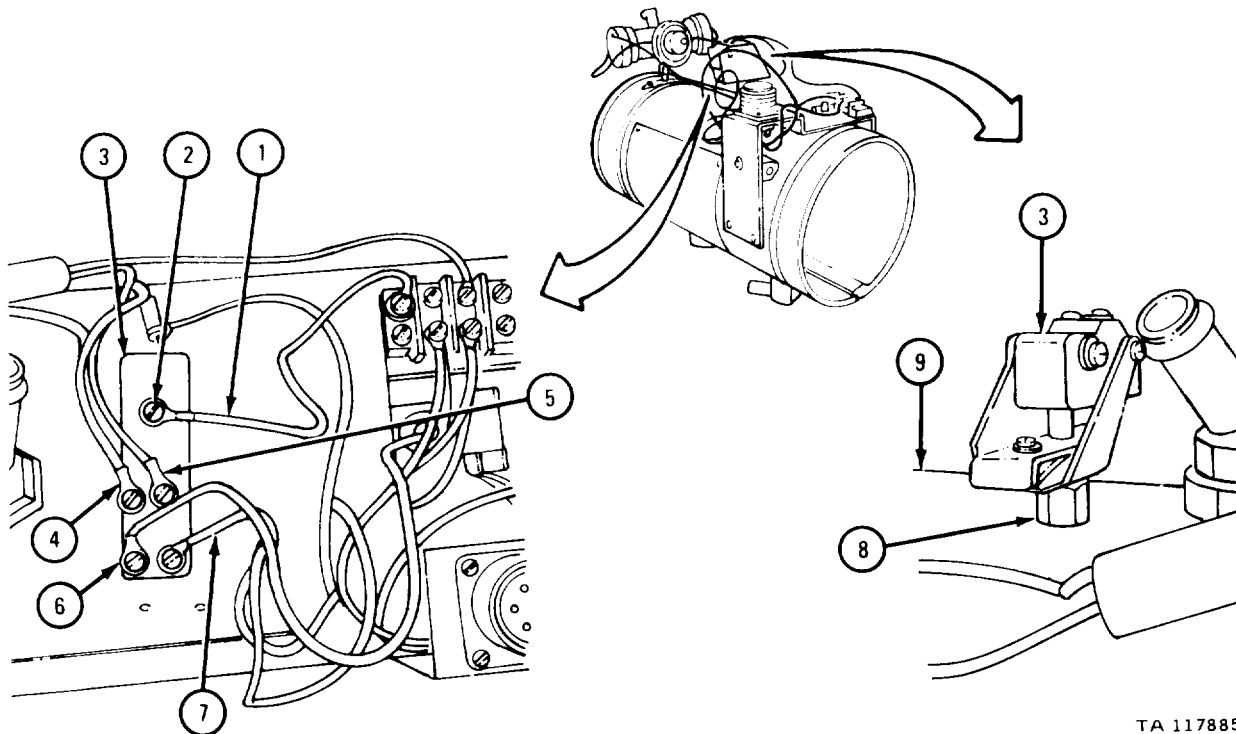

TA 117885

## FRAME 4

1. Tag fuel control valve electrical lead (1). Unscrew and take out terminal screw (2). Tag terminal screw (2) the same as electrical lead (1) and screw back into terminal strip (3).
2. Tag each of two overhear thermostat electrical leads (4 and 5) on overhear thermostat (6). Unscrew and take out terminal screw (7).
3. Tag terminal screw (7) the same as electrical leads (4 and 5) and screw terminal screw (1) back into overhear thermostat (6).
4. Do step 2 again for overhear thermostat electrical leads (8 and 9) on terminal screw (10). Take off electrical lead (9).

GO TO FRAME 5

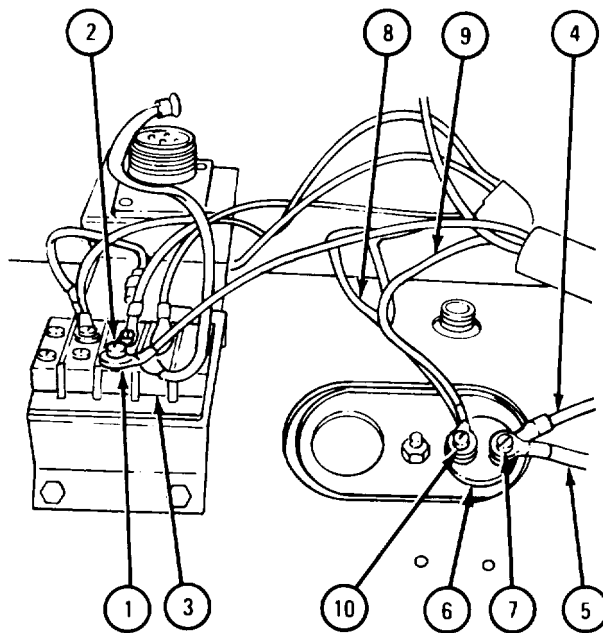

TA 117886

FRAME 5

1. Unscrew fitting (1) under fuel control valve (2).
2. Lift valve (2) from stand pipe (3).
3. Unscrew and take off nut (4), lockwasher (5), cover (6), and overheat thermostat (7).
4. Take off preformed packing (8) from overheat thermostat (7). Throw away preformed packing.

GO TO FRAME 6

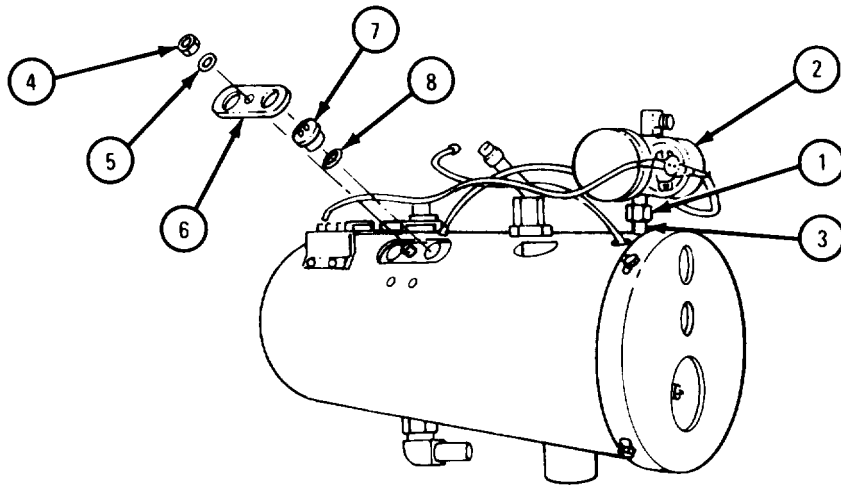

TA 117887



## FRAME 6

1. Scratch a line across end plate (1) and housing (2).
2. Loosen four nuts (3). Turn end plate (1) to clear slots (4) and pull end plate (1) off housing (2).

GO TO FRAME 7

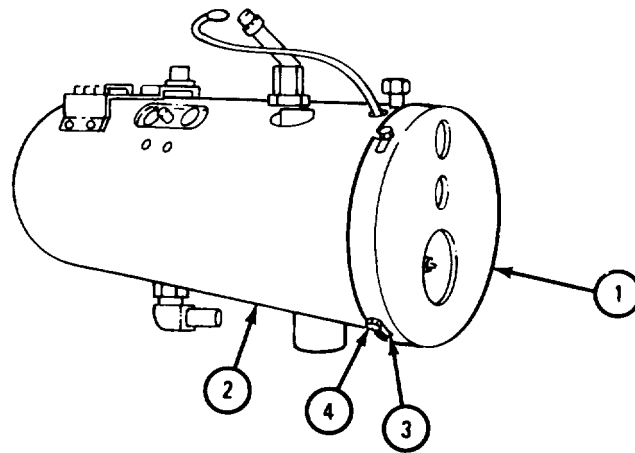

TA 117888

FRAME 7

1. Unscrew and take out screw, lockwasher, and nut (1). Take off preheat resistor electrical lead (2). Pull lead through hold in housing (3).
2. Tag preheat resistor terminal (4).
3. Unscrew and take off nut and lockwasher (5). Take off ground strap (6). Unscrew and take out screw, lockwasher, and nut (7). Take out ground strap (6) and take off igniter ground wire (8).
4. Unscrew and take off two nuts (9).

GO TO FRAME 8

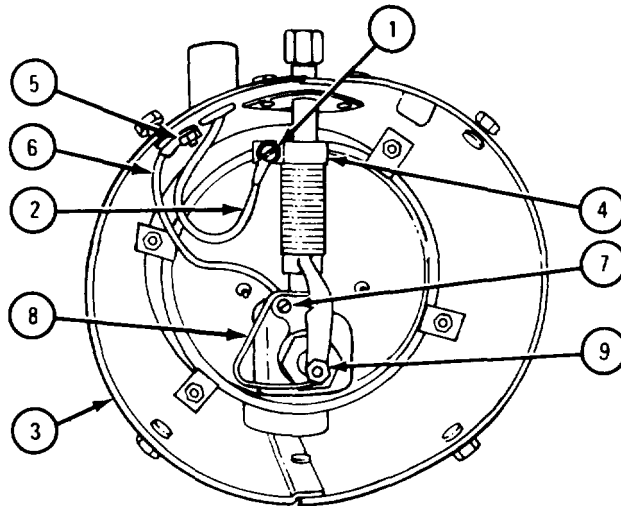

TA 117889

FRAME 8

1. Unscrew and take out two screws (1). Slide off plate (2).
  2. Unscrew fitting (3). Take out stand pipe and preheat resistor (4). Unscrew and take out igniter (5).
  3. Loosen four nuts (6). Turn tie downs (7) and lift off burner (8).
- GO TO FRAME 9

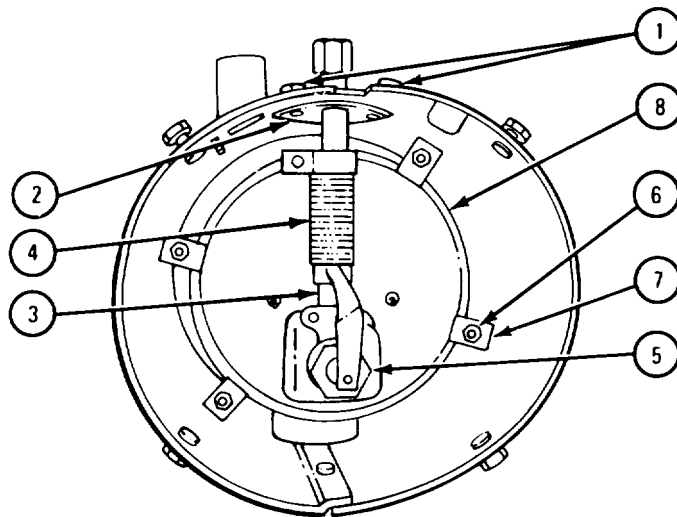

TA 117890

FRAME 9

1. Pull off two thermostat electrical leads (1). Pull leads through hole in housing (2). Tag both leads (1) together.
2. Unscrew and take off two nuts (3) and lockwashers (4). Take off thermostat (5) and two spacers (6).

**NOTE**

Spacers (6) are a special size. Tag them together so they can be reused when unit is assembled.

GO TO FRAME 10

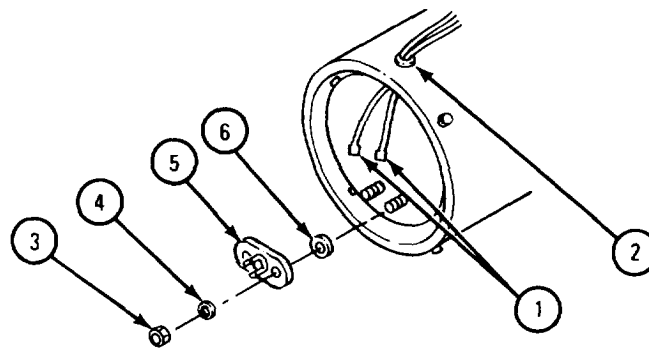

TA 117891

## FRAME 10

**NOTE**

Diode (1) must be put back in exactly as it is put in.  
Diode has an arrow on it. Mark end of the holder (2)  
that the arrow points to.

1. Take out diode (1) by snapping it out of holder (2).
2. Unscrew and take out four screws (3), two on each end of bracket (4). Take off bracket (4) with electrical leads.

GO TO FRAME 11

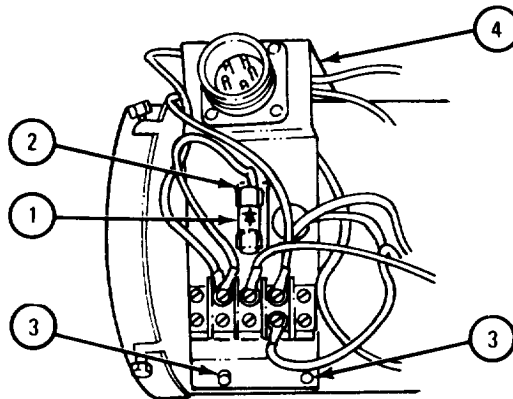

TA 117892

FRAME 11

1. Unscrew and take out three screws (1) along seam of housing (2).

**CAUTION**

Do not spread housing (2) apart any more than is needed to slide heat exchanger (3) out of housing. Overspreading will make permanent bends in the housing.

2. Spread housing (2) apart. Slide heat exchanger (3) out.

END OF TASK

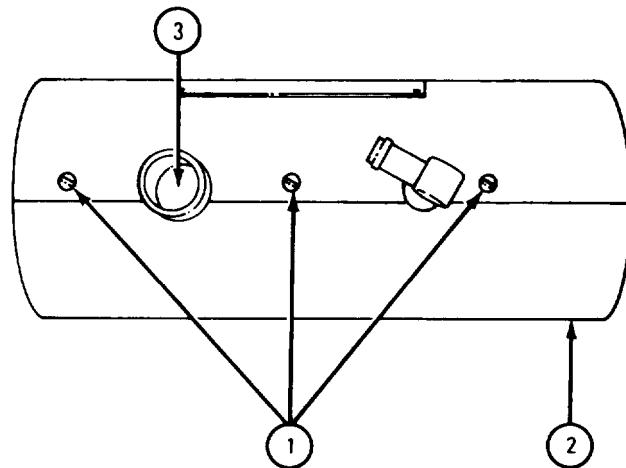

TA 117893

d. Cleaning and Inspection of Subassemblies.**WARNING**

Dry cleaning solvent is flammable. Do not use near an open flame. Keep a fire extinguisher nearby when solvent is used. Use only in well-ventilated places. Failure to do this may result in injury to personnel and damage to equipment.

Eye shields must be worn when using compressed air. Eye injury can occur if eye shields are not used.

**CAUTION**

Clean subassemblies exactly as instructed, using only tools and cleaning materials specified. Damage to equipment will result if this is not done.

**NOTE**

Parts and subassemblies not specifically referred to in this paragraph should be cleaned as outlined in Part 1, para 1-3.

- (1) Burner and heat exchanger.

FRAME 1

1. Take off gasket (1) from igniter (2). Throw away gasket (1). Make a note of the amount of carbon, light coating or heavy build-up on igniter (2). Throw igniter away.
2. Take off gasket (3) and preformed packing (4) from burner (5). Throw away gasket and preformed packing. Make a note of amount of carbon on burner (5). Do not take burner apart any further.

**CAUTION**

Do not damage screen or wick when scraping carbon. If they are damaged, get new burner assembly (5).

3. Scrape carbon from burner assembly (5), using a sharp tool.
4. Inspect heat exchanger (6) for dents or possible leaks. Get new heat exchanger (6) if it is dented or leaking.

**WARNING**

Eye shields must be worn when using compressed air. Eye injury can occur if eye shields are not used.

5. Soak heat exchanger (6) in water for a few minutes. Blow out with compressed air.

END OF TASK

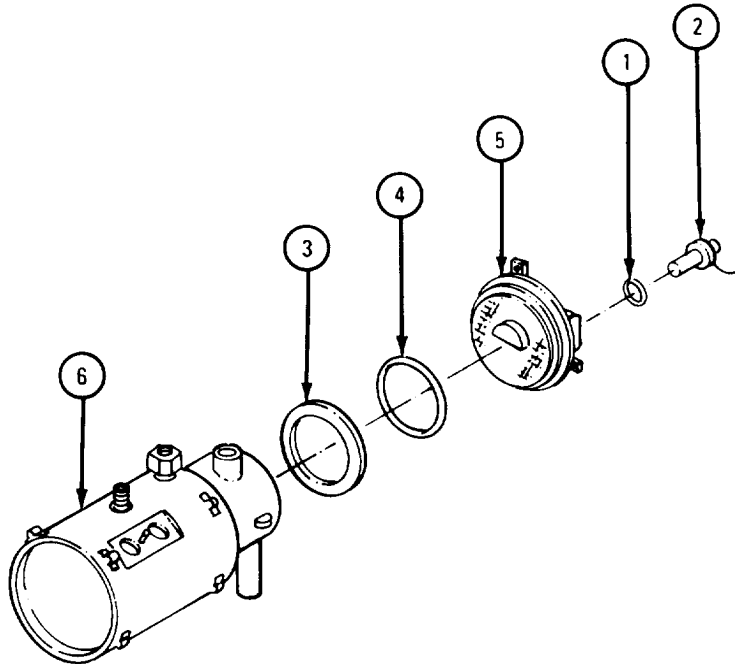

TA 117894



## (2) Blower assembly.

## FRAME 1

1. Unscrew and take out seven screws (1) and speed nuts (2). Lift off blower cover (3).
2. Loosen setscrew (4) in hub of blower wheel (5). Lift off blower wheel (5).
3. Carefully pull blower motor electrical lead (6) through grommets hole in blower plate (7).
4. Unscrew and take out three screws (8). Lift off blower plate (7). Take off three spacers (9) from blower motor (10).

**CAUTION**

Do not dip blower motor in solvent. Bearings will be damaged. Do not take blower motor apart. It cannot be repaired.

5. Wipe blower motor (10) clean with cloth. Inspect blower motor for broken housing, bent shaft, or signs of overheating. Inspect electrical lead (6) for broken or worn insulation.
6. Get new motor if any of the conditions in step 5 are found. Get new motor if:
  - a. Motor was known not to be working.
  - b. Heavy carbon was found on igniter or burner.
7. Clean the rest of blower parts in dry cleaning solvent and wipe dry.

GO TO FRAME 2

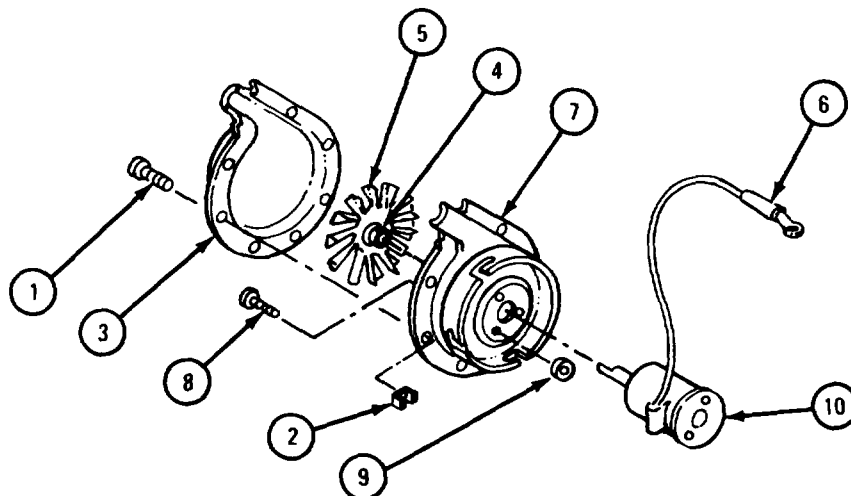

TA 117895

FRAME 2

1. Put three spacers (1) on bosses on blower motor (2).
2. Put blower plate (3) on spacers (1). Be sure grommetted hole (4) is near blower motor electrical lead (5).
3. Screw in and tighten three screws with starwashers (6).
4. Put on blower wheel (7) so that top of hub (8) is flush with motor shaft (9). Be sure setscrew (10) is opposite flat on motor shaft (9). Tighten setscrew (10).
5. Put electrical lead (5) through grommetted hole (4).

GO TO FRAME 3

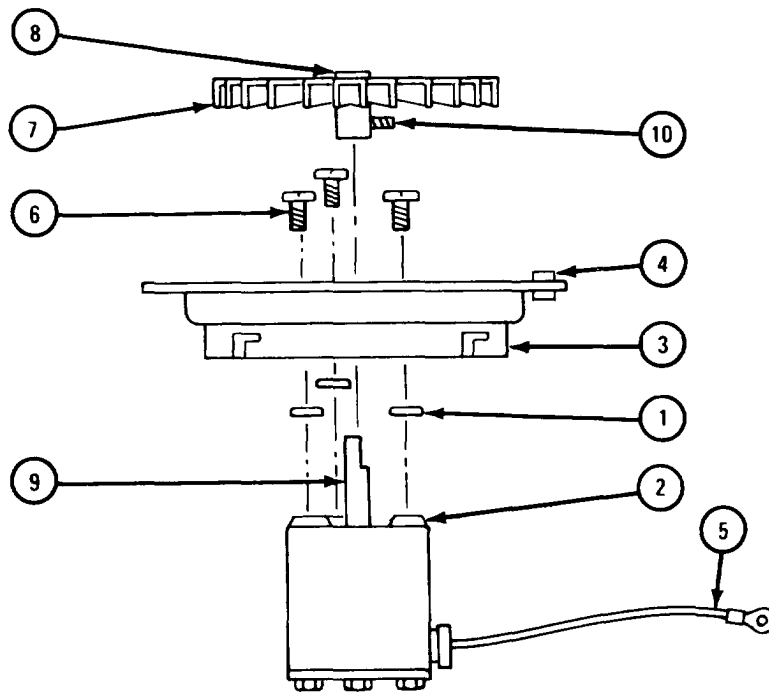

TA 117896

## FRAME 3

1. Put blower cover (1) in place on blower assembly (2). Using a stiff wire, turn the blower wheel (3) through the outlet opening (4). Be sure that blower wheel (3) spins freely.
2. If blower wheel (3) does not turn freely, take off blower cover (1). Change position of blower wheel as in frame 2, step 4. Do step 1 again.
3. Put on seven screws (5) and speed nuts (6). Tighten screws (5).

END OF TASK

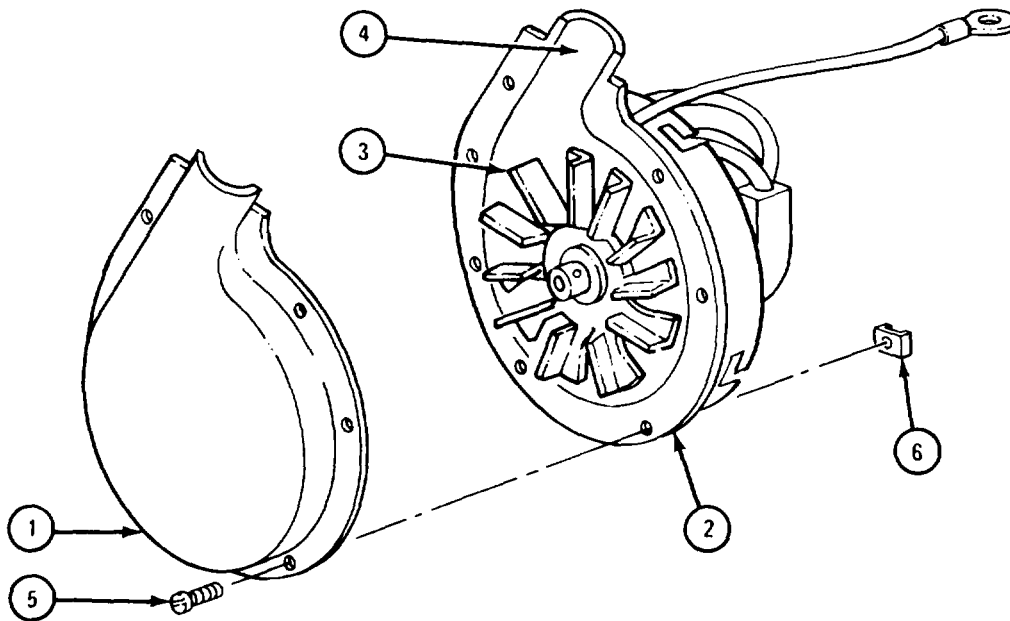

TA 117897

(3) Overheat thermostat, restriction thermostat, diode and electrical leads.

FRAME 1

**CAUTION**

Rough handling of thermostats can cause them not to work properly.

1. Clean overheat thermostat (1), restriction thermostat (2), and diode (3) with clean cloth.
2. Inspect overheat thermostat (1), restriction thermostat (2), and diode (3) for corrosion. If they are corroded, get new parts.
3. If overheat thermostat (1) or restriction thermostat (2) are known not to be working right get new ones.

**NOTE**

Thermostats and diode are not repairable. If they do not pass tests, get new ones.

4. Place leads of ohmmeter on each terminal (4 and 5) of overheat thermostat (1). Circuit should be closed.
5. Place one lead of ohmmeter on overheat thermostat case (1). Place other lead on terminal (4 or 5). Circuit should be open.
6. Get new overheat thermostat (1) if it does not pass tests in steps 4 and 5.
7. Do steps 4, 5, and 6 again for terminals (6 and 7) of restriction thermostat (2).
8. Place leads of ohmmeter on ends of diode (3). Note if circuit is open or closed. Switch leads on ends of diode. Note if circuit is open or closed.
9. Circuit must be closed in one test and open in the other. If circuit is open or closed in both directions, diode must be replaced.
10. Inspect electrical leads (8 and 9) for broken or worn insulation and broken terminals. Inspect ground strap (10) for broken terminals.
11. Check continuity through electrical leads (8 and 9) and ground strap (10) using an ohmmeter. Place an ohmmeter lead on each terminal of each lead. Get new electrical leads (8 and 9) or ground strap (10) if circuit is open.

END OF TASK

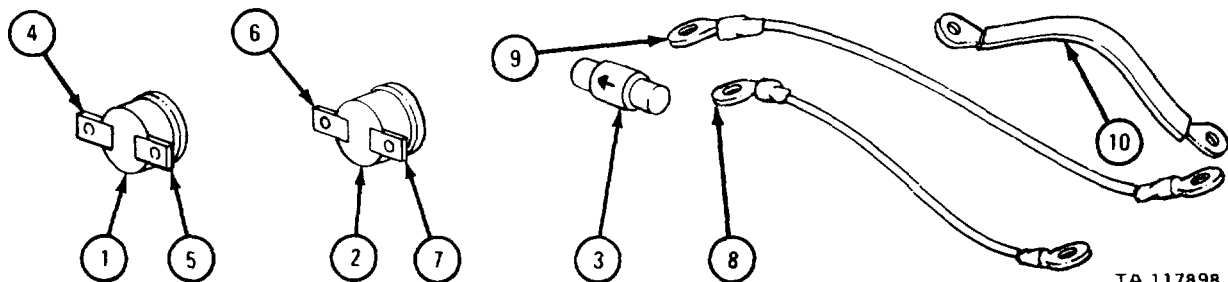

TA 117898

(4) Flame detector switch.

FRAME 1

1. Wipe flame detector switch (1) with cloth dipped in dry cleaning solvent. Do not dip switch into solvent because it may be damaged. Wipe flame detector switch dry.
2. Unscrew and take out adjusting screw and washer (2). Loosen two screws (3).
3. Flip up microswitch (4) and take off bar spring (5).

**CAUTION**

Do not let quartz rod (6) fall out of flame detector switch.  
Do not drop quartz rod. Doing so may break or chip quartz rod.

4. Turn flame detector switch (1) over and let quartz rod (6) slide out of tube (7). Tap bottom of tube (7) to get out any broken pieces of quartz rod.

GO TO FRAME 2

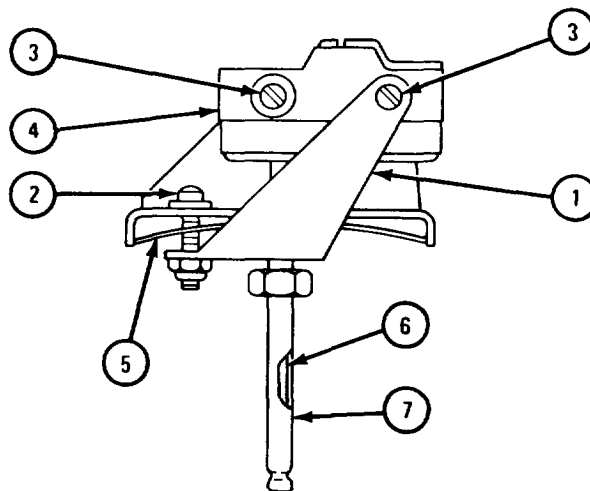

TA 117899

FRAME 2

1. Clean tube (1) of flame detector switch (2) with wire brush. Check tube for straightness. Get new flame detector switch (2) if tube (1) is not straight.
2. Clean bow spring (3) with wire brush. Bow spring (3) should be straight. Get new flame detector switch (2), if bow spring is bent.
3. Check to see if microswitch (4) clicks by pressing in on shaft (5). Microswitch (4) should also click when shaft (5) is let out. Get new flame detector switch (2), if microswitch (4) does not click.
4. Check that quartz rod (6) is not broken or chipped. Get new quartz rod (6), if it is broken or chipped.

GO TO FRAME 3

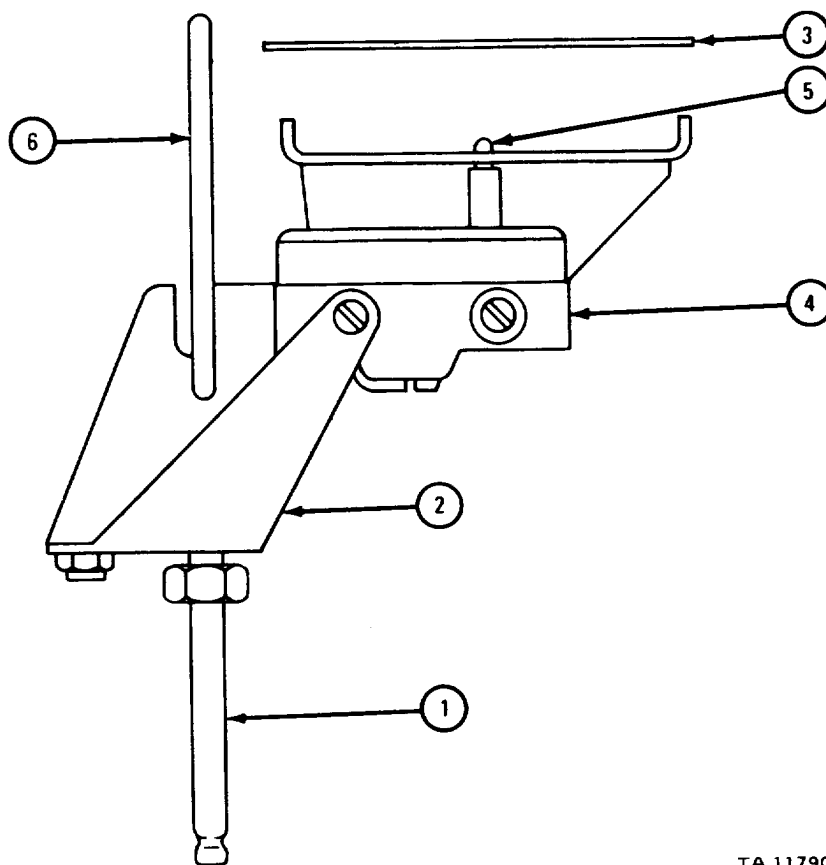

TA 117900

## FRAME 3

1. Slide quartz rod (1) into tube (2) of flame detector switch (3). Place bow spring (4) on microswitch frame (5). Flip microswitch (6) down into place.
2. Screw in adjusting screw and washer (7) and push up on bow spring (4) while tightening adjusting screw (7).
3. Tighten screws (8) just tight enough so microswitch (6) is held in place.
4. Slowly unscrew adjusting screw (7) until microswitch (6) clicks. Screw in adjusting screw (7) exactly three-fourths of a turn more.
5. Tighten screws (8).

END OF TASK

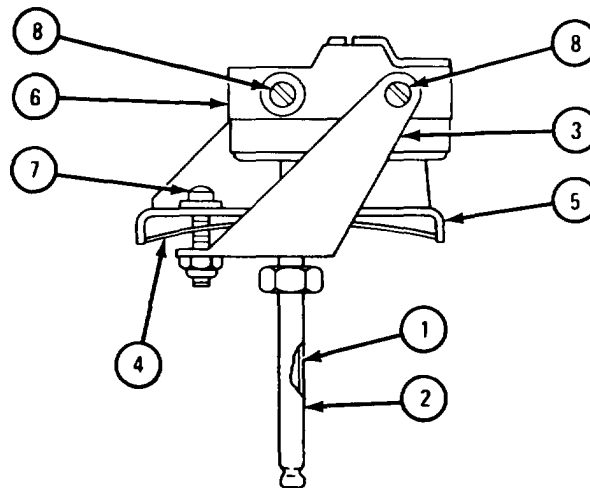

TA 117901

(5) Fuel control valve.

FRAME 1

**CAUTION**

Do not dip fuel control valve (1) in dry cleaning solvent. Electrical parts may be damaged by doing so.

1. Wipe fuel control valve (1) clean with a clean cloth dipped in dry cleaning solvent. Wipe fuel control valve (1) dry.
2. Inspect fuel control valve (1) for cracked or broken parts. Go to step 6 if cracks or breaks are found.
3. Inspect electrical leads (2, 3, 4, 5, 6, and 7) for broken or frayed insulation or damaged connectors on the end. Go to step 6 if any electrical leads or connectors are bad.
4. Using an ohmmeter, check continuity through heater. Place one ohmmeter lead on terminal (8) and the other ohmmeter lead on terminal (9). Circuit should be closed. If circuit is open, go to step 6.
5. If fuel control valve (1) passes tests, go to frame 2. If you must get a new fuel control valve, do step 6.

**NOTE**

Electrical leads (2 and 7) must be used on new fuel control valve.

6. Unscrew and take off nut (10). Take off electrical lead (2) and slide off electrical lead (7). Get new fuel control valve.

GO TO FRAME 2

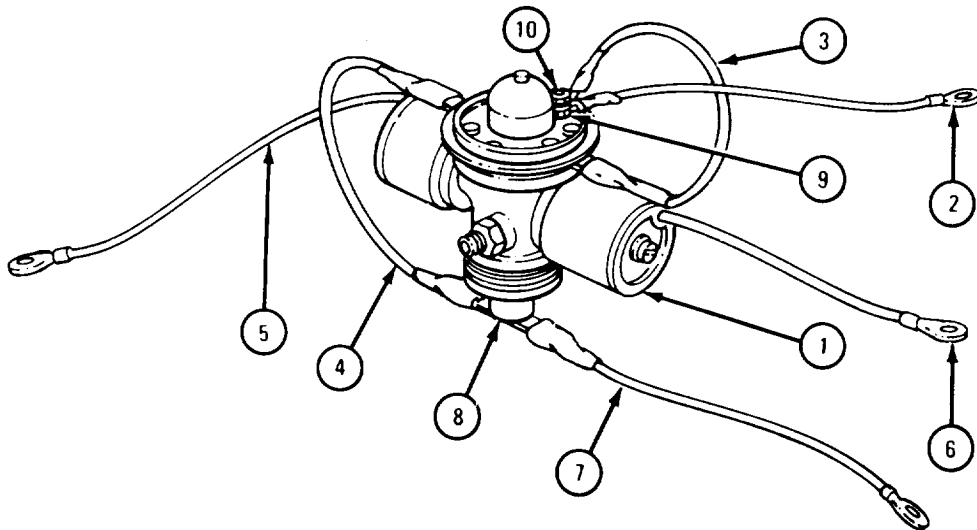

TA 117902



## FRAME 2

1. Fuel control valve (1) should be tested for leaks and proper fuel flow. Refer to para 19-19f (1), frames 1 through 6.

IF FUEL CONTROL VALVE (1) PASSES TESTS, GO TO FRAME 3.

IF FUEL CONTROL VALVE (1) FAILS TESTS, GET NEW FUEL CONTROL VALVE (1). GO TO FRAME 6

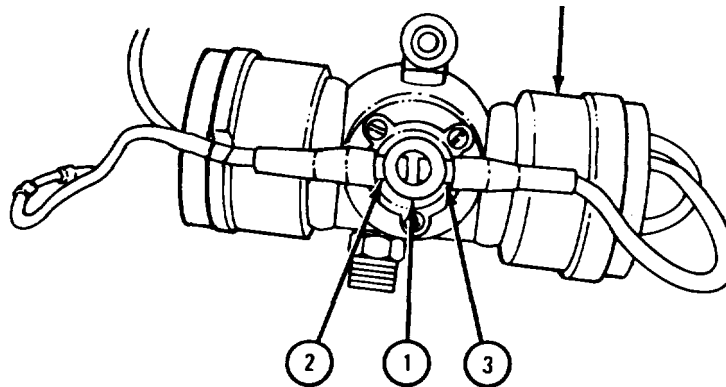

TA 117903

FRAME 3

**CAUTION**

Do not use anything but a warm hand to warm up thermostat (1). Flame or high heat will cause thermostat to lose calibration.

1. Hold warm hand on thermostat (1) for five minutes to warm it to 75°F or higher.
2. Using an ohmmeter, check continuity through thermostat (1). Place one ohmmeter lead on terminal (2) and other ohmmeter lead on terminal (3).
3. If circuit is open, go to step 4. If circuit is closed, go to frame 5.

**CAUTION**

Do not place thermostat (1) or fuel control valve (4) in any type of liquid to cool it. Thermostat and fuel control valve are not sealed from liquids.

4. Place fuel control valve (4) in refrigerator set to 20°F for 30 minutes.
5. Do step 2 again.

IF CIRCUIT IS OPEN, GO TO FRAME 5.

IF CIRCUIT IS CLOSED, GO TO FRAME 4

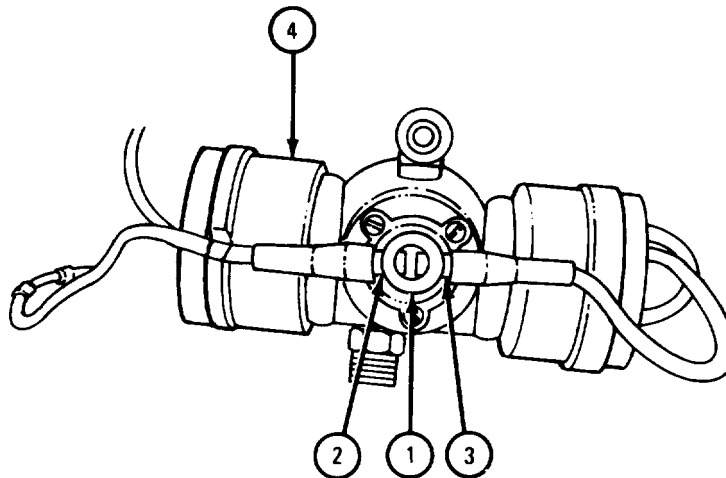

TA 104148

FRAME 4

1. Unscrew and take out fuel inlet fitting (1).
2. Check, but do not take out, screen (2) in fuel inlet (3).
3. If screen (2) is dirty or clogged, get new fuel control valve (4). Go to frame 7, step 1.
4. If screen (2) is not dirty or clogged, screw in and tighten fuel inlet fitting (1). Be sure opening of fuel inlet fitting points toward thermostat (5).

GO TO FRAME 7

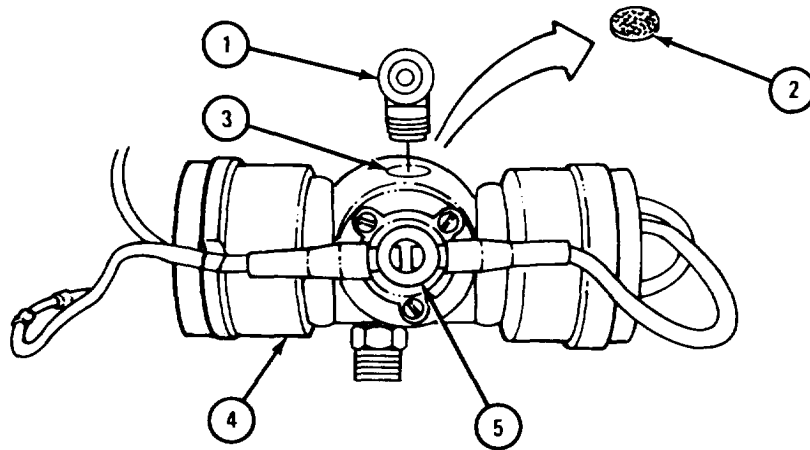

TA 121075

FRAME 5

**CAUTION**

Use clean tools, have clean hands, and work on clean surface when taking apart fuel control valve. Even the smallest piece of dirt will cause the valve not to work properly.

1. Pull off electrical leads (1 and 2) from thermostat (3).
2. Unscrew and take out three screws (4). Take off clamp (5) and thermostat (3).
3. Take off cover plate (6), gasket (7), orifice plate (8), and gasket (9). Throw away gaskets (7 and 9).

**CAUTION**

Do not force anything through the orifice plate (8) openings. The slightest change in the calibrated openings in the plate may cause serious overheating problems.

4. Clean orifice plate (8) and cover plate (6) with compressed air. Inspect orifice plate (8) with a magnifier. Check for cracks or burrs. Get new orifice plate if cracks or burrs are found.

GO TO FRAME 6

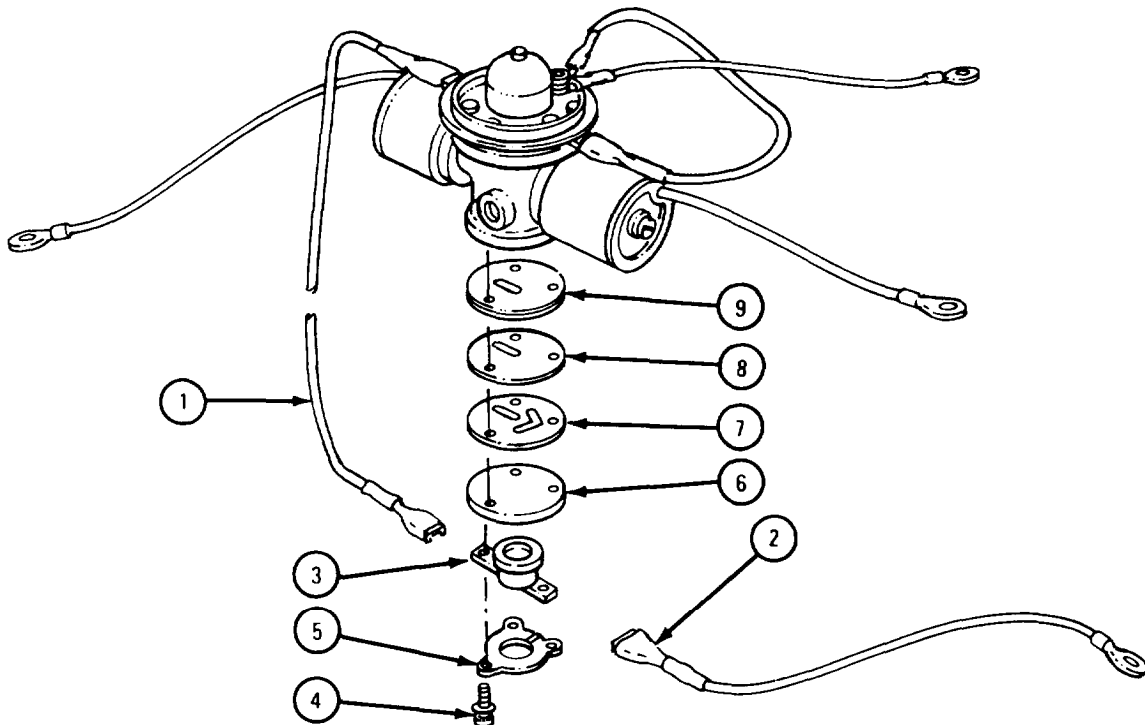

TA 117905

## FRAME 6

**CAUTION**

Do not use flame or high heat to warm up thermostat (1). Flame or high heat will cause thermostat to lose calibration.

1. Warm thermostat (1) to 75°F or higher.
2. Using an ohmmeter, check continuity through thermostat (1). Place one ohmmeter lead on terminal (2) and the other ohmmeter lead on terminal (3).
3. If circuit is closed, get new thermostat (1). Go to frame 7. If circuit is open, do step 4.

**CAUTION**

Do not place thermostat (1) in any type of liquid to cool it. Thermostat is not sealed from liquids.

4. Place thermostat (1) in refrigerator set to 20°F for 30 minutes.
5. Do step 2 again.
6. If circuit is open, get new thermostat (1).

GO TO FRAME 7

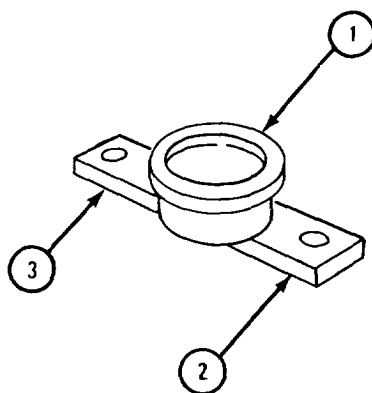

TA 121074

FRAME 7

**NOTE**

Put gasket (1), orifice plate (2), and gasket (3) on cover plate (4) exactly as shown. Put orifice plate and gasket assembly (5) on fuel control valve (6) exactly as shown.

1. Put new gasket (1), orifice plate (2), and new gasket (3) on cover plate (4).
2. Put orifice plate and gasket assembly (5) on fuel control valve body (6).
3. Put thermostat (7) and clamp (8) on orifice plate and gasket assembly (5).
4. Screw in three screws (9) finger tight. Tighten three screws evenly, tightening each one a little at a time.
5. Slide two electrical leads (10) on terminals of thermostat (7).
6. Do frame 2 again if fuel control valve did not pass fuel flow test. If fuel control valve-still does not pass fuel flow test, get new fuel control valve.

END OF TASK

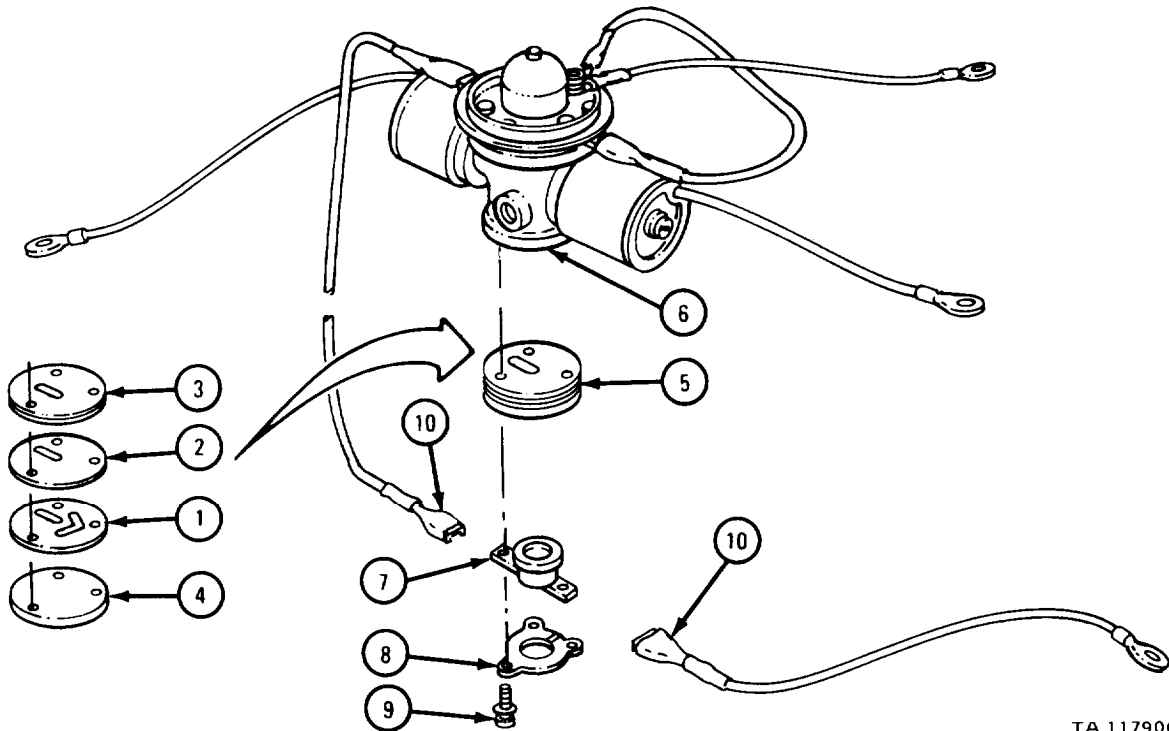

TA 117906

(6) Motor resistor, electrical leads, and connector.

FRAME 1

1. Wipe bracket (1) with electrical leads (2, 3, 4, and 5) with cloth dipped in dry cleaning solvent. Wipe bracket and electrical leads dry.
2. Inspect five electrical leads (2) for damaged insulation and connectors. Go to frame 2 if leads are bad.
3. Check continuity through electrical leads (2) by using an ohmmeter. Place one ohmmeter lead on end of electrical lead and the other ohmmeter lead on end of electrical lead pin (6). Go to frame 2, if an open circuit is found.
4. Inspect electrical leads (3, 4, and 5) for damaged insulation and connectors. Get new leads if leads are bad.
5. Check continuity through electrical leads (3, 4, and 5) by placing ohmmeter leads on each end of electrical lead. Get new lead if circuit is open.
6. Inspect terminal strip (7) and diode holder (8) for cracks and damaged threads. Go to frame 2, if any are found.
7. Check motor resistor by placing ohmmeter leads on outer terminals (9 and 10) of terminal strip (7).

IF CIRCUIT IS OPEN, GO TO FRAME 2.  
END OF TASK

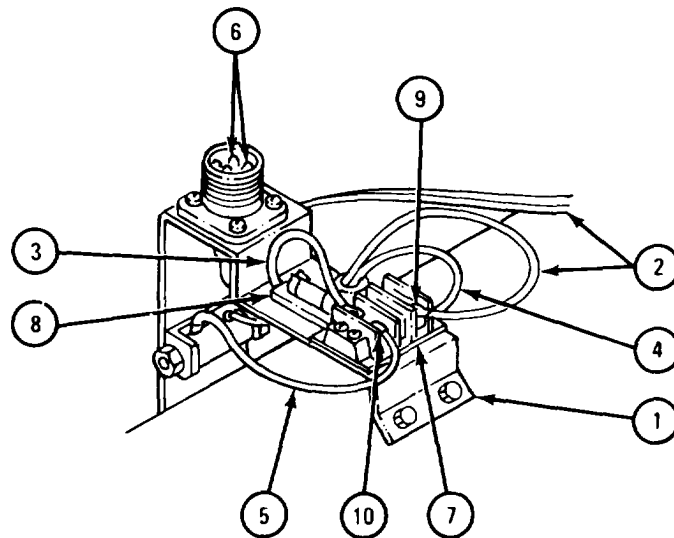

TA 117907

FRAME 2

1. Unscrew and take out four screws (1). Take off electrical connector (2) with electrical leads.
2. Unscrew and take out four screws (3). Take off terminal strip (4).
3. Unscrew and take out two screws (5). Take off diode holder (6).
4. Unscrew and take off nut (7). Pull out screw (8) and resistor (9).

GO TO FRAME 3

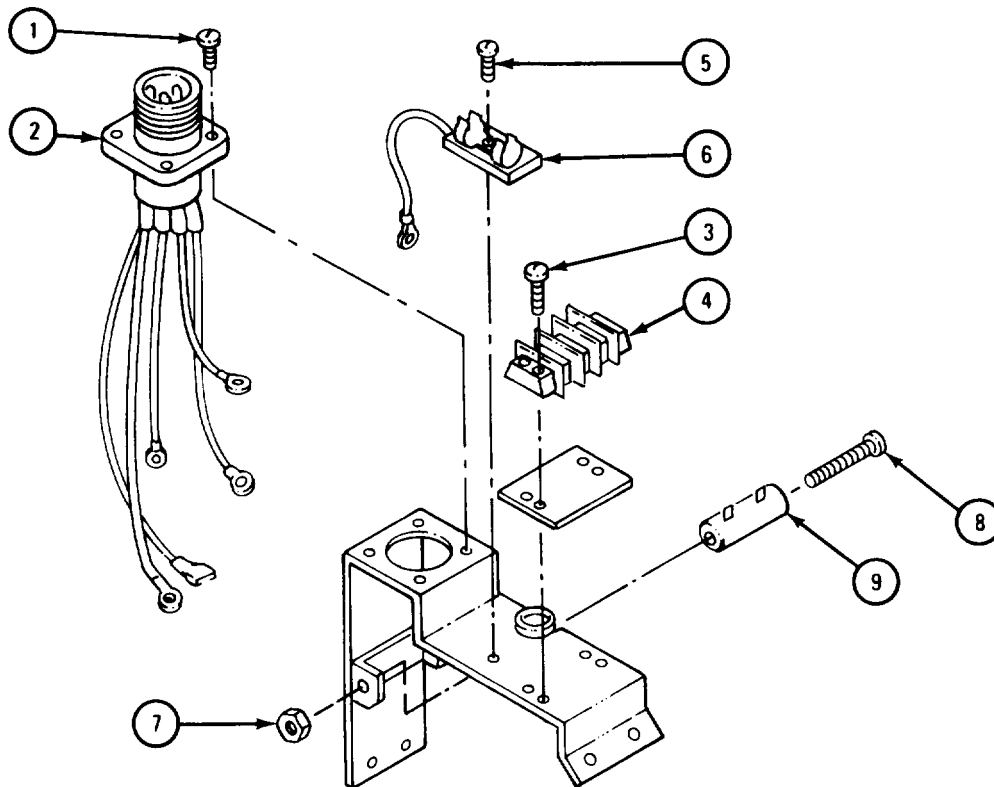

NOTE: PARTS WITHOUT CALLOUTS ARE SHOWN ONLY FOR REFERENCE PURPOSES.

TA 117908



FRAME 3

1. Put electrical connector (1) with electrical leads in place on bracket (2). Screw in and tighten four screws (3).
2. Put terminal strip (4) in place on bracket (2). Screw in and tighten four screws (5).
3. Put diode holder (6) in place on bracket (2). Screw in and tighten two screws (7).
4. Put motor resistor (8) in place on bracket (2). Put in screw (9). Screw on and tighten nut (10).

END OF TASK

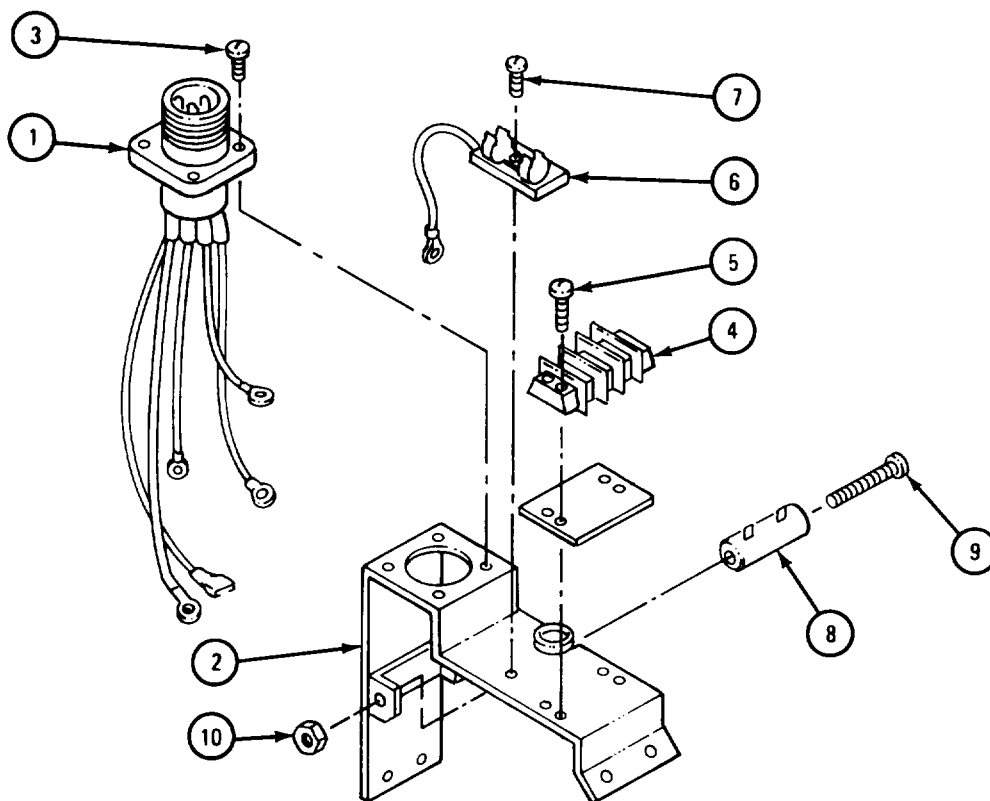

NOTE: PARTS WITHOUT CALLOUTS ARE SHOWN ONLY FOR REFERENCE PURPOSES.

TA 117909

(7) Fuel stand pipe and preheat resistor.

FRAME 1

1. Clean fuel stand pipe (1) with cloth dipped in dry cleaning solvent. Wipe fuel stand pipe dry.
2. Check continuity through preheat resistor (2) with an ohmmeter. Place ohmmeter leads on terminals (3 and 4). If circuit is open, get new preheat resistor (2).
3. Check compression fitting (5) and union nut (6) for damage.

IF ANY PARTS ARE DAMAGED, GO TO FRAME 2.  
END OF TASK

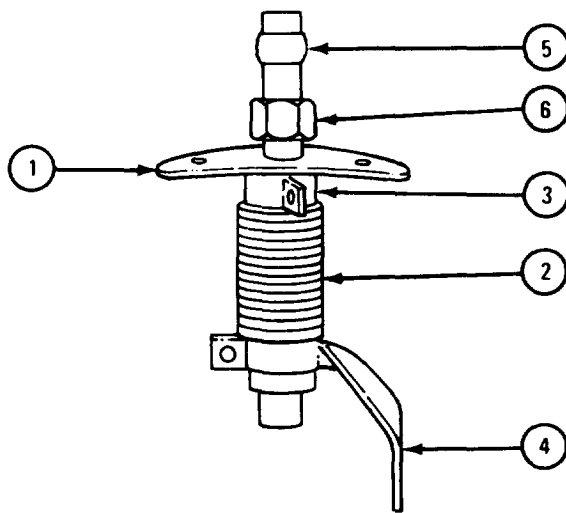

TA 117910

## FRAME 2

**CAUTION**

Use care in grinding or cutting compression fitting (1) from fuel standpipe (2). Damage to other parts of fuel standpipe could result.

1. Cut or grind compression fitting (1) from standpipe (2).
2. Slide off union nut (3), flange (4), and preheat resistor (5) from standpipe (2).

GO TO FRAME 3

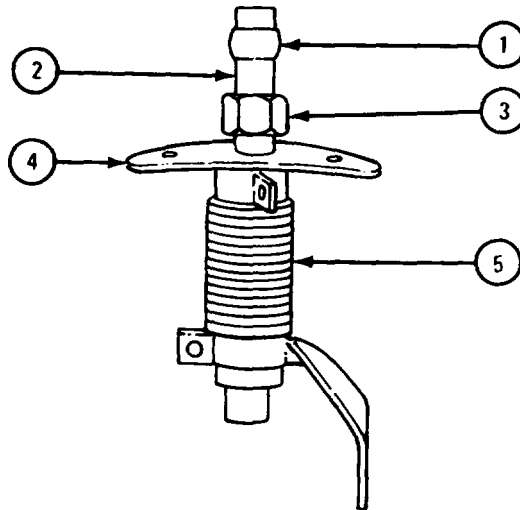

TA 117911

FRAME 3

1. Slide preheat resistor (1), flange (2), and union nut (3) on standpipe (4).
  2. Slide new compression fitting (5) on standpipe (4).
- END OF TASK

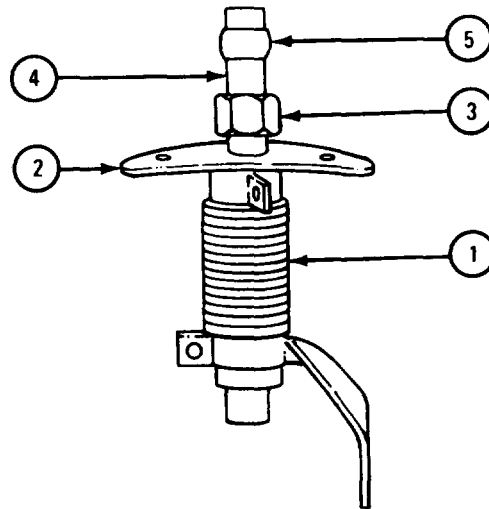

TA 117912

e. Assembly.

FRAME 1

**CAUTION**

Do not spread housing (1) apart any more than is needed to slide heat exchanger (2) into housing. Overspreading will make permanent bends in the housing.

1. Spread housing (1) apart. Slide in heat exchanger (2).
2. Screw in and tighten three screws (3) along seam of housing (1).

GO TO FRAME 2

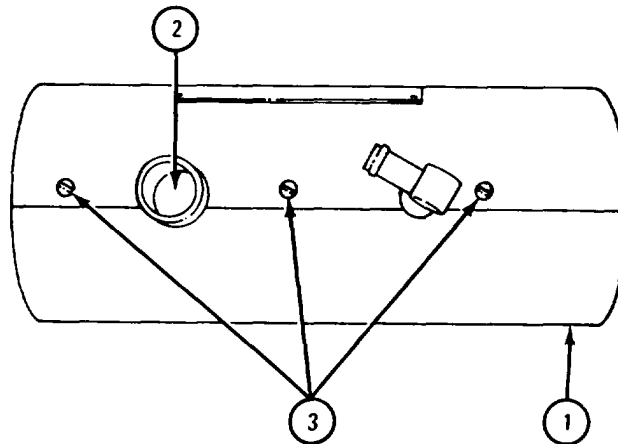

TA 117913

FRAME 2

**NOTE**

Match tags on electrical leads with tags on terminals when connecting electrical leads to terminals.

1. Put bracket (1) with electrical leads on housing (2). Screw in and tighten four screws (3), two on each end of bracket (1).
2. Put two restriction thermostat electrical leads (4) through grommetted hole (5).

**NOTE**

Diode (6) must be put back in exactly as it was taken out. End of holder (7) is marked. Arrow on diode must point to end of holder.

3. Snap diode (6) into holder (7).

GO TO FRAME 3

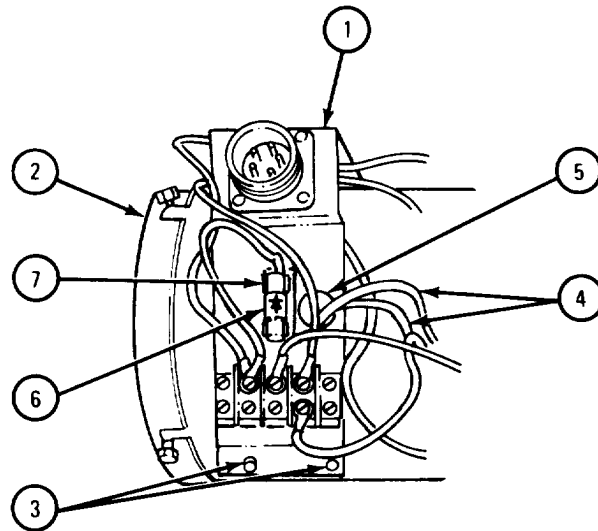

TA 117914

## FRAME 3

1. Put one spacer (1) on each stud (2). Put on restriction thermostat (3) and two lockwashers (4). Screw on and tighten two nuts (5).
  2. Slide two electrical leads (6) on terminals of restriction thermostat (3).
- GO TO FRAME 4

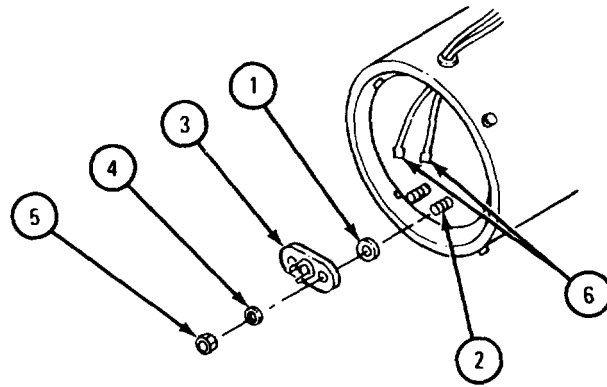

TA 117915

FRAME 4

1. Put new preformed packing (1) and gasket (2) on burner (3).
2. Put burner assembly (3) on heat exchanger (4) as shown. Turn tiedowns (5) and tighten nuts (6).
3. Screw in and tighten new igniter (7).

GO TO FRAME 5

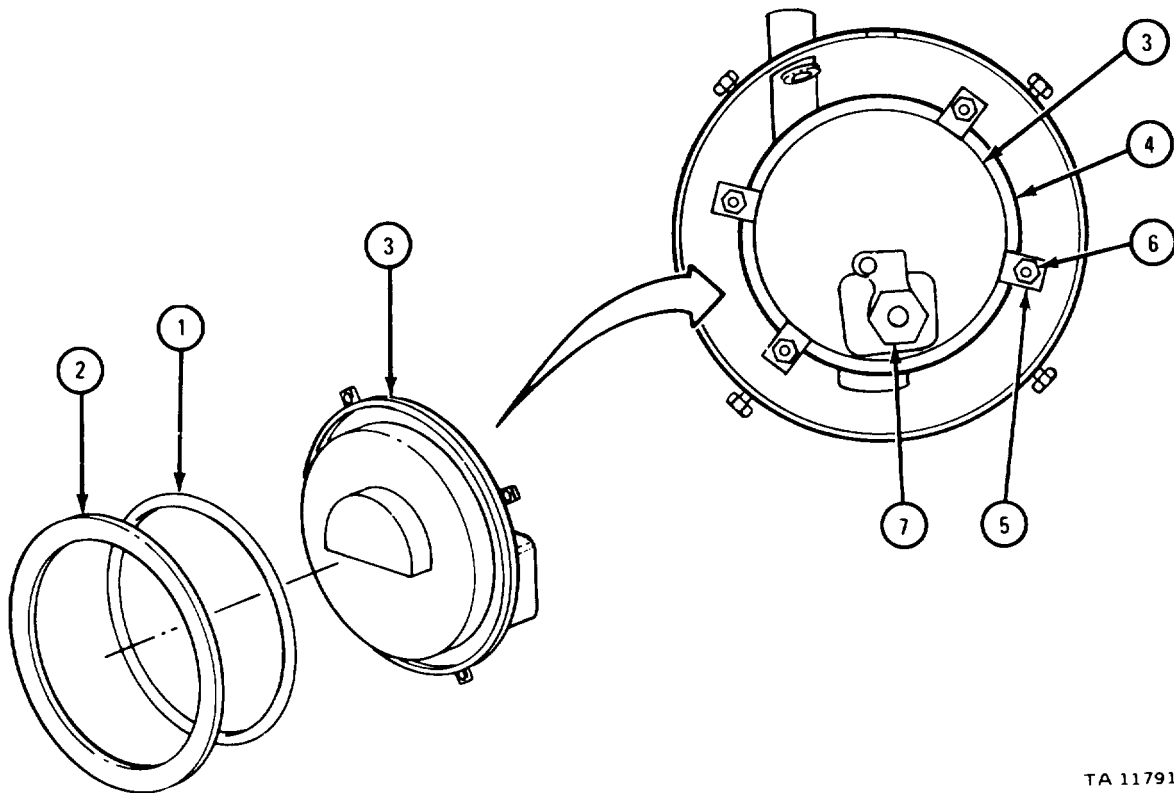

TA 117916



FRAME 5

1. Put fuel standpipe assembly (1) on burner (2). Screw on and tighten fitting (3).
  2. Put strap (4) on igniter (5). Screw on and tighten two nuts (6).
  3. Slide plate (7) around fuel standpipe (1). Screw in and tighten two screws (8).
  4. Put preheat resistor electrical lead (2) through grommetted hole (10).
- GO TO FRAME 6

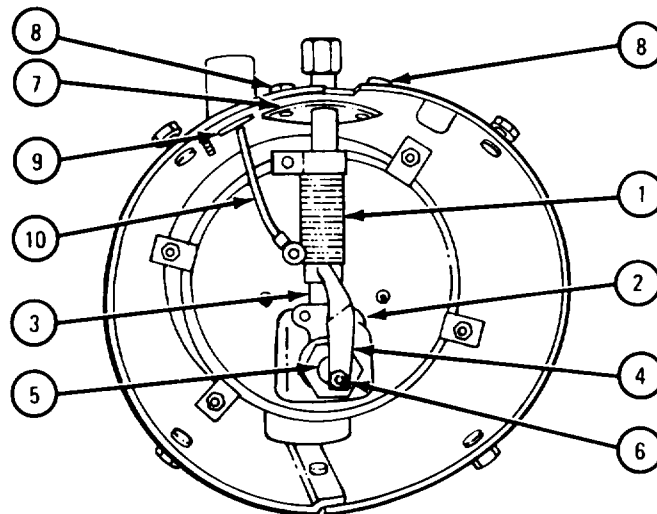

TA 117917

FRAME 6

1. Put igniter ground wire (1) and ground strap (2) in place on burner (3). Screw in and tighten screw, lockwasher, and nut (4).
2. Put ground strap (2) on stud (5). Screw on and tighten nut and lockwasher (6).
3. Put preheat resistor electrical lead (7) on preheat resistor terminal (8). Screw in and tighten screw, lockwasher, and nut (9).

GO TO FRAME 7

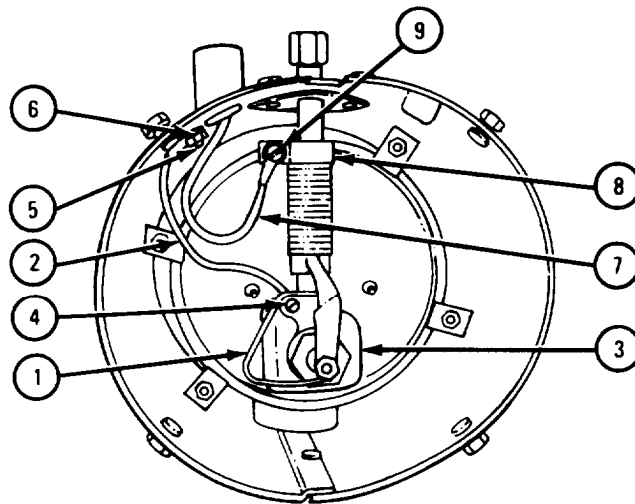

TA 117918

## FRAME 7

1. Put end plate (1) on housing (2) as shown. Be sure four slots (3) engage four studs (4).
2. Turn end plate (1) so studs (4) engage bayonet slots (5). Tighten four nuts (6).

GO TO FRAME 8

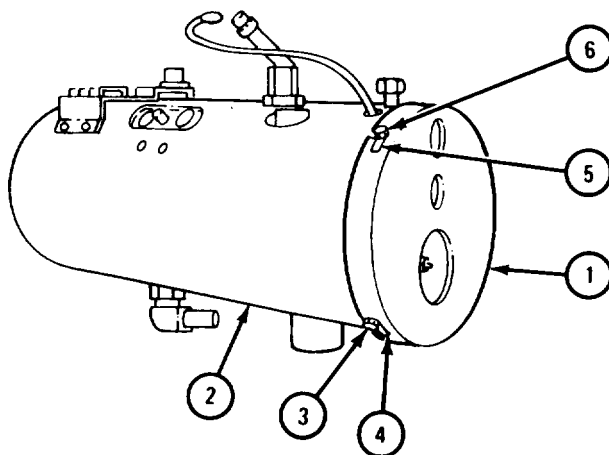

TA 117919

FRAME 8

1. Put new preformed packing (1) on overheat thermostat (2). Put overheat thermostat (2) and cover (3) on heater (4).
2. put lockwasher (5) on stud (6). Screw on and tighten nut (7).
3. Put fuel control valve (8) on fuel standpipe (9). Screw on and tighten fitting (10).

GO TO FRAME 9

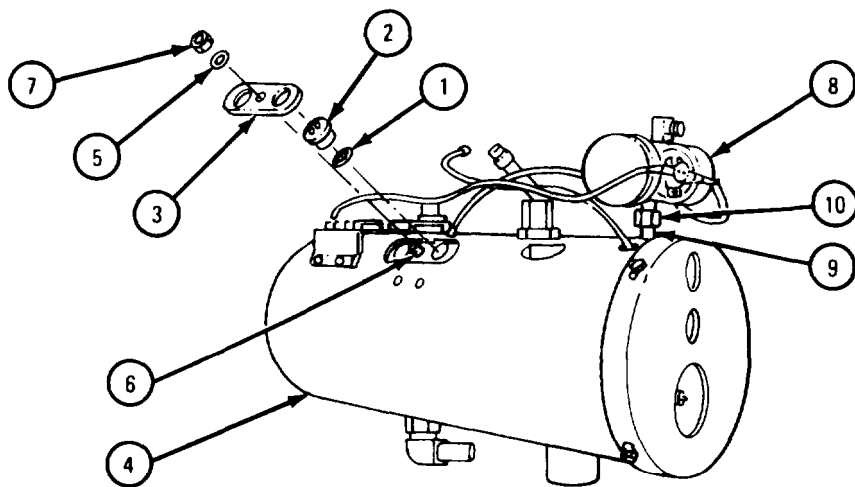

TA 117920

## FRAME 9

1. Take out terminal screw (1) on overhear thermostat (2). Put on two overhear thermostat electrical leads (3 and 4). Screw in and tighten terminal screw (1).
2. Do step 1 again for terminal screw (5) on overhear thermostat (2) and electrical leads (6 and 7).
3. Take out terminal screw (8) on terminal strip (9). Put on fuel control valve electrical lead (10) on terminal strip (9). Screw in and tighten terminal screw (8).

GO TO FRAME 10

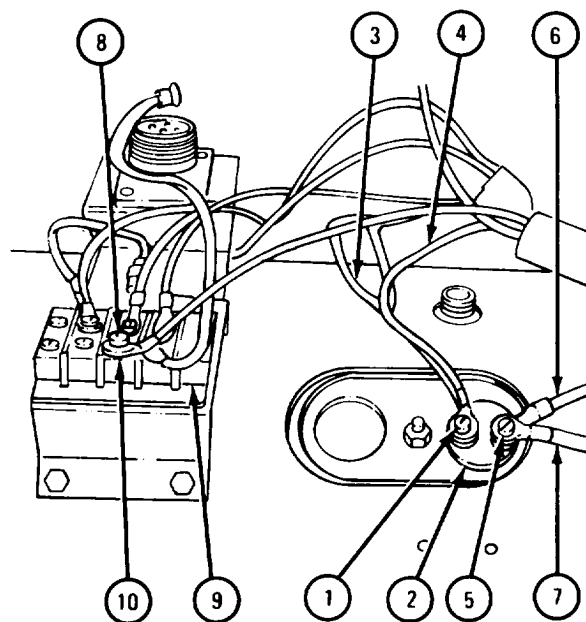

TA 117921

FRAME 10

**CAUTION**

Use care in putting flame detector switch (1) back into housing (2). Quartz rod in switch (1) may break if you are not careful.

1. Put flame detector switch (1) into housing (2). Screw on and tighten fitting (3) under flame detector switch (1).
2. Unscrew and take out terminal screw (4). Put flame detector switch common electrical lead (5) on common terminal of flame detector switch (1). Screw in and tighten terminal screw (4).
3. Do step 2 again for middle terminal screws (6 and 7) and end terminal screws (8 and 9) on flame detector switch (1).

GO TO FRAME 11

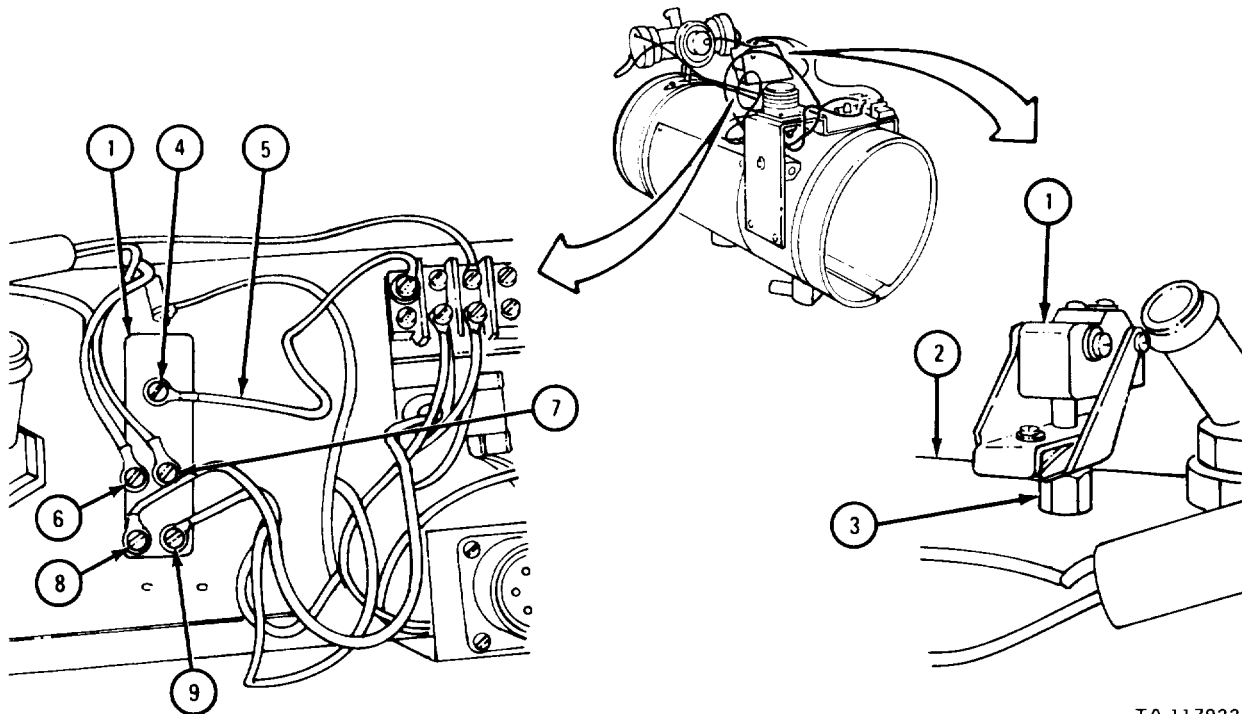

TA 117922

## FRAME 11

1. Aline scratch marks (1) on blower assembly (2) and housing (3). Put blower assembly (2) on housing (3).
2. Turn blower assembly (2) so studs (4) engage slots (5). Tighten nuts (6).
3. Unscrew and take out terminal screw (7). Put on blower motor electrical lead (8). Screw in and tighten terminal screw (7).

GO TO FRAME 12

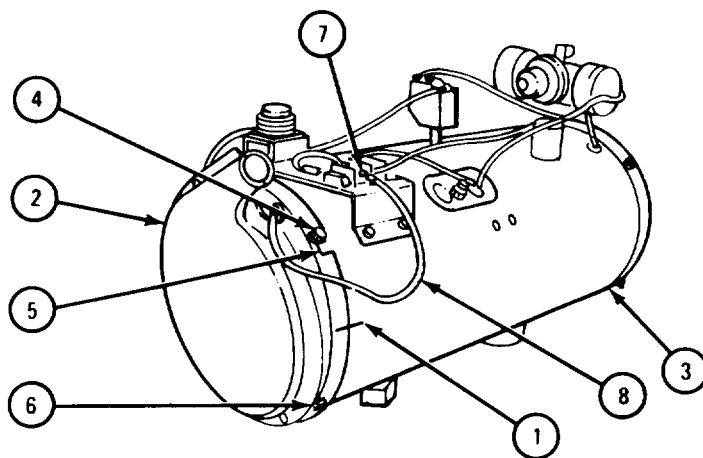

TA 117923

FRAME 12

1. Put on air inlet tube and elbows (1). Put on ground electrical lead (2). Screw on and tighten nut (3).
2. Put on guard (4). Screw in and tighten four screws (5), two on each end of guard (4).

END OF TASK

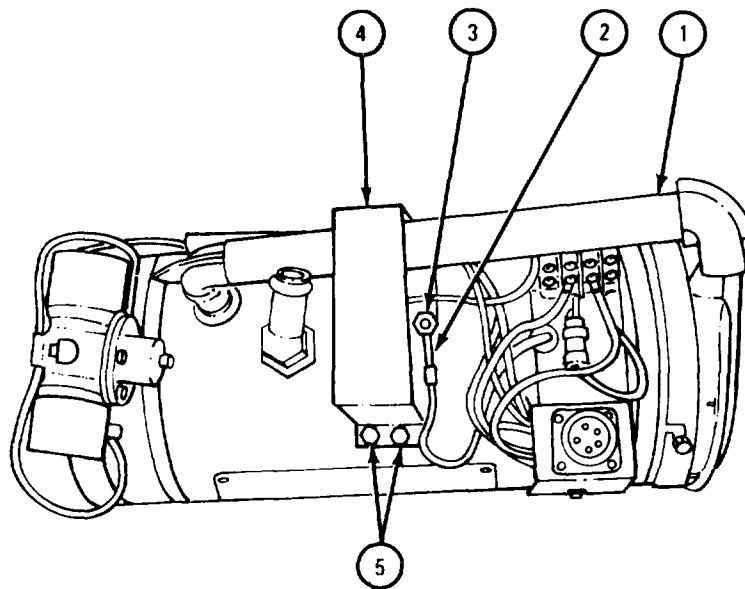

TA 117924



f. Testing.**WARNING**

Smoking, sparks or open flames are not allowed within 50 feet of work area during this task. Fuel can explode, causing injury to personnel and damage to equipment.

Exhaust gases of any fuel are very poisonous. Be sure exhaust is directed out of work area. Be sure work area is well ventilated. Failure to do so could result in injury or death to personnel.

**CAUTION**

Be sure test stand is equipped with proper control box. Proper control box is pn G-701633. Damage to equipment will result if improper control box is used. Test stand must also be equipped with a coolant container of about five-gallon capacity. Container should be higher than heater. Container must be vented. Coolant used must be of same type as used in engine. Pure water cannot be used. Failure to use proper coolant could cause overheating and improper operation of thermostats, damaging the heater.

**NOTE**

A fuel burning coolant heater test stand and stop watch is needed to perform these tests. Such a test stand can be fabricated. Refer to Special Test ST 9-194.

- (1) Fuel control valve.

**CAUTION**

Fuel flow and leak tests must be done with fuel control valve in the position it normally operates. Fuel used must be of the type normally used. Failure to do this could result in a wrong measurement, causing serious damage to equipment.

FRAME 1

**NOTE**

If fuel control valve (1) is already off heater, skip step 1.

1. Take fuel control valve (1) off heater. Refer to para 19-19c, frames 1 and 4, steps 1 and 2 and frame 5.
2. Connect fuel supply line (2) to fuel inlet fitting (3).
3. Using a suitable electrical lead (4), connect shutoff electrical lead (5) and restrictive electrical lead (6). Connect other end of lead (4) to pin "B" (7) of wiring harness connector (8).
4. Using another suitable electrical lead (9) connect body of fuel control valve (1) to pin "A" (10) of wiring harness connector (8).

GO TO FRAME 2

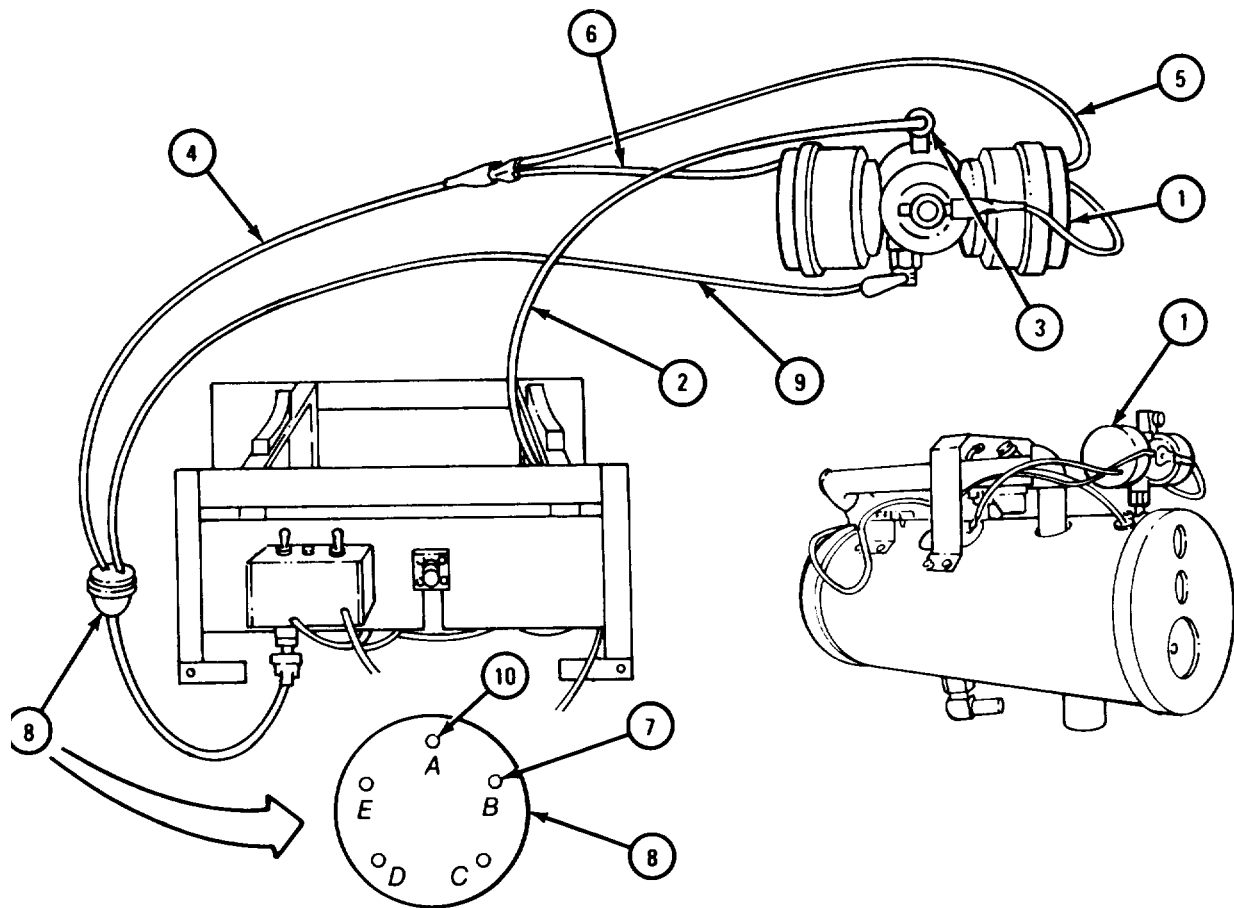

TA 120639

## FRAME 2

1. Put control switch (1) in OFF position. Put HI-LO switch (2) in LO position.
2. Connect power supply lead (3) to plus (+) battery terminal (4). Connect ground lead (5) to minus (-) battery terminal (6).

GO TO FRAME 3

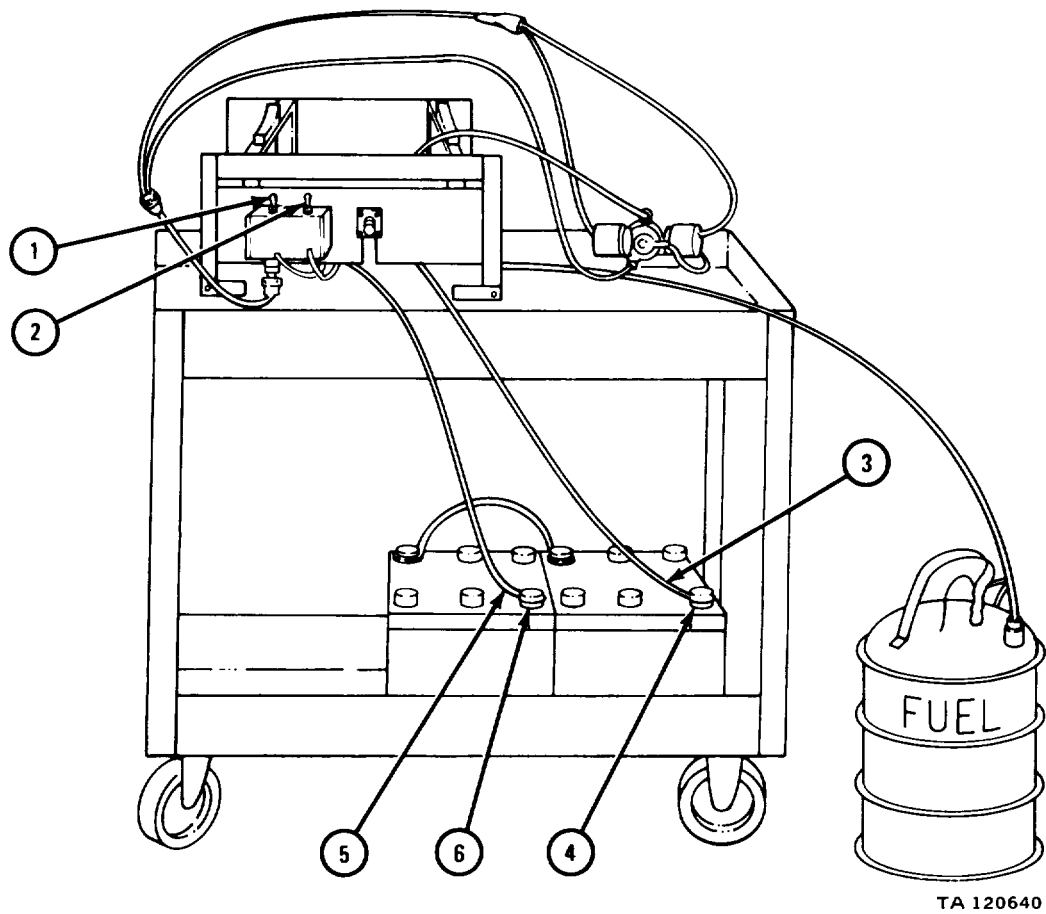

FRAME 3

**NOTE**

A suitable container (3) to catch overflow is needed for this test.

1. Hold fuel outlet (1) of fuel control valve (2) over overflow container (3).
2. Be sure HI-LO switch (4) is in LO position. Flip control switch (5) to RUN position. Fuel pump should be pumping.
3. Flip HI-LO switch (4) to HI position. Let fuel flow into overflow container (3) for a few seconds. Flip HI-LO switch (4) to LO position.
4. Look at fuel outlet (1) for one minute. One or two drops may form but fuel flow must be completely stopped.
5. Do steps 1 through 4 again. Flip control switch (5) to OFF position.
6. If fuel flow does not stop completely when HI-LO switch (4) is flipped to LO position, get a new fuel control valve.

IF FUEL CONTROL VALVE PASSES TEST, GO TO FRAME 4.

IF FUEL CONTROL VALVE FAILS TEST, GO TO FRAME 6

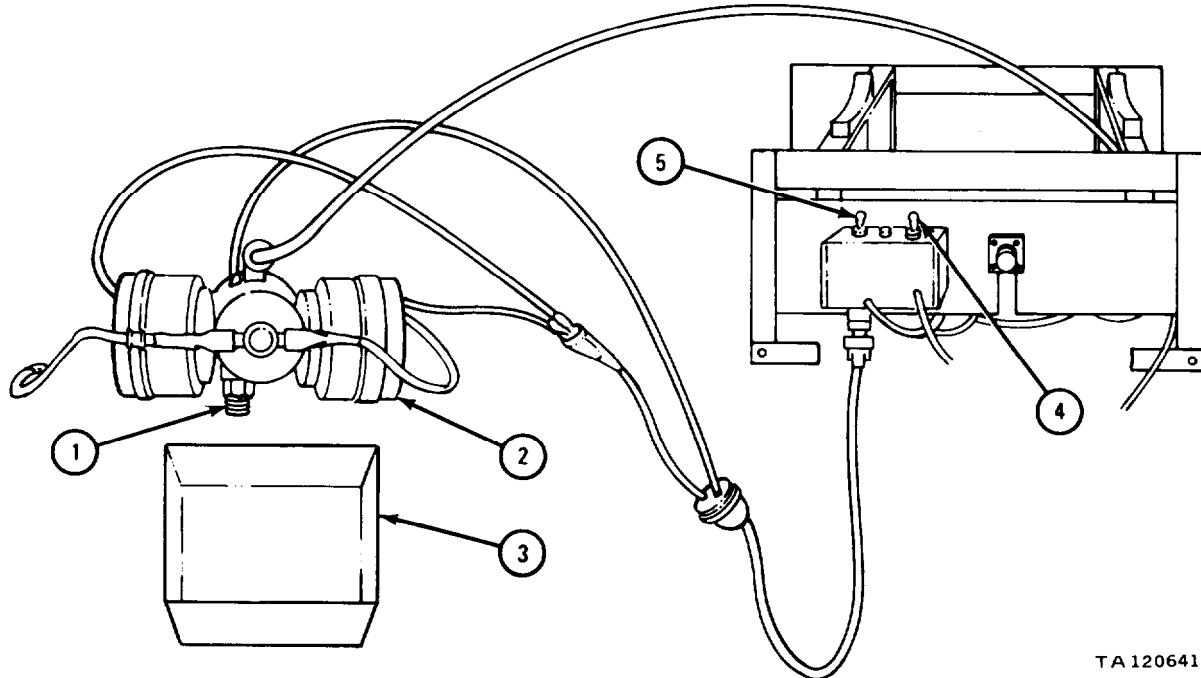

TA 120641

FRAME 4

**NOTE**

Fuel flow test and adjustment should be done even on a new fuel control valve. Fuel control valve must be adjusted for use with different fuels. A stopwatch or watch with a second hand is needed for this test.

1. Hold fuel outlet (1) of fuel control valve (2) over overflow container (3).
2. Be sure HI-LO switch (4) is in LO position. Flip control switch (5) to RUN position. Fuel pump should be pumping.
3. Flip HI-LO switch (4) to HI position. Let fuel flow into overflow container (3) for a few seconds.
4. Let fuel flow into graduate (6) for exactly one minute. Flip HI-LO switch (4) to LO position. Flip control switch (5) to OFF position.
5. Place graduate (6) on a level surface. Read level of fuel (7) as shown. Level of fuel should be as in table for type of fuel used.

Fuel Type	Diesel Fuel			Combat Gasoline
	DFA	DF1	DF2	
Flow Rate (cc/mm)	14 to 18	14 to 18	15 to 19	15 to 19

6. If fuel flow is not within range of table, get a new fuel control valve (2).  
GO TO FRAME 5

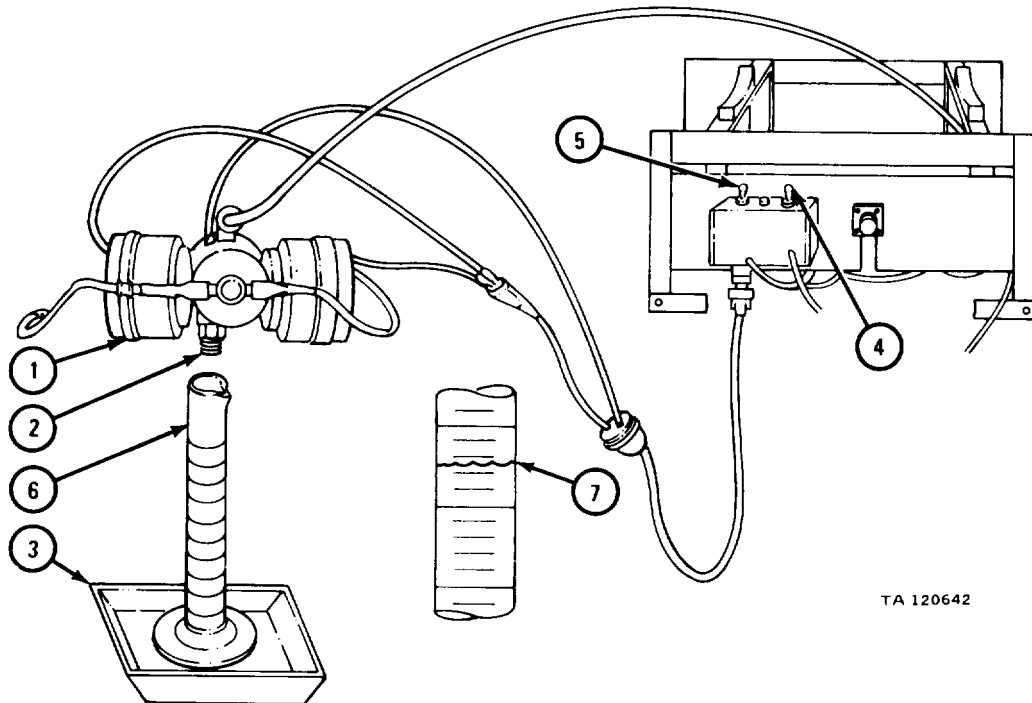

TA 120642

FRAME 5

1. Take restrictive electrical lead (1) out of clip (2).
2. Hold fuel outlet (3) of fuel control valve (4) over overflow container (5).
3. Be sure HI-LO switch (6) is in LO position. Flip control switch (7) to RUN position. Fuel pump should be pumping.
4. Flip HI-LO switch (6) to HI position. Let fuel into overflow container (5) for a few seconds.
5. Let fuel flow into graduate (8) for exactly one minute. Flip HI-LO switch (6) to LO position. Flip control switch (7) to OFF position.
6. Place graduate (8) on a level surface. Read level of fuel (9) as shown. Level of fuel should be as in table for type of fuel used.

Fuel Type	Diesel Fuel			Combat Gasoline
	DFA	DF1	DF2	
Flow Rate (cc/mm)	6 t0 8	6.5 t0 8.5	6.5 t0 8.5	7 t0 9

7. If fuel flow is not within range of table, get a new fuel control valve (4).
- GO TO FRAME 6

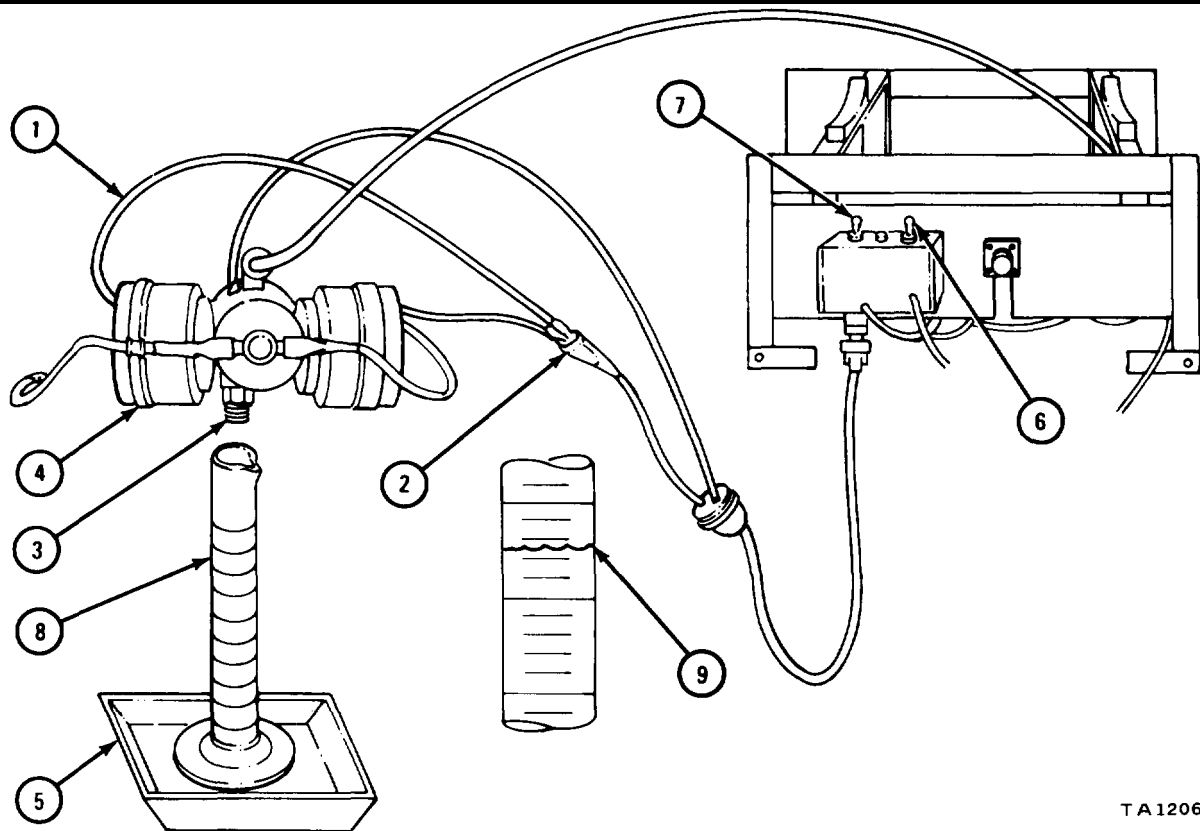

T A 120643

## FRAME 6

1. Take off electrical lead (1) from fuel control valve body (2) and from pin "A" (3) of wiring harness connector (4).
2. Take off electrical lead (5) from fuel control valve leads (6) and from pin "B" of wiring harness connector.
3. Take off fuel supply line (8) from fuel inlet fitting (9).

**NOTE**

If these tests on fuel control valve were done as part of cleaning, inspection and repair, skip step 4, go to para 19-19d (5), frame 2.

4. Put fuel control valve (2) on heater (10). Refer to para 19-19e, frame 8, step 3. frame 9, steps 2 and 3, and frame 12.

END OF TASK

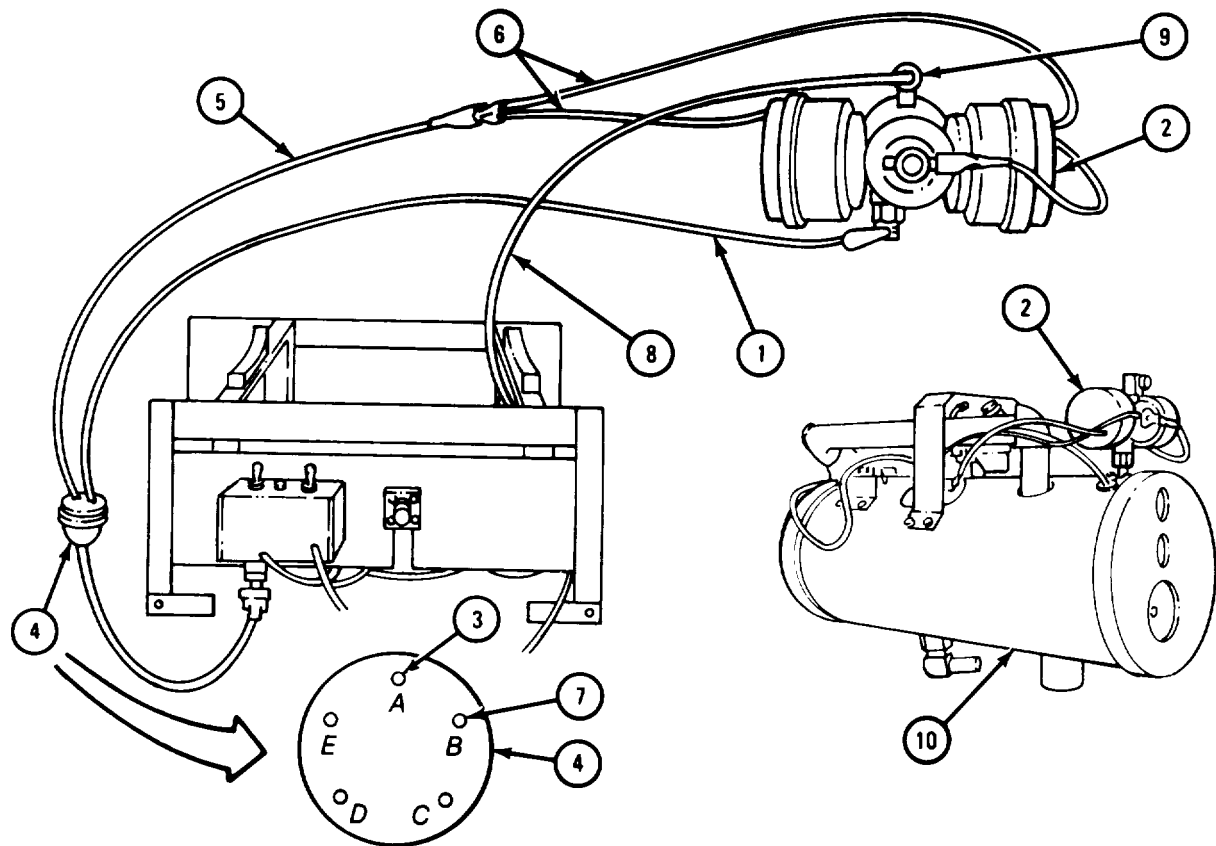

TA 120644

(2) Testing set-up.

FRAME 1

1. Mount heater assembly (1) on test stand (2).
2. Connect coolant inlet hose (3) and outlet hose (4) to heater (1). Connect exhaust pipe (5).
3. Connect fuel supply line (6) to fuel inlet fitting (7).
4. Connect wiring harness (8) to electrical connector (9).

GO TO FRAME 2

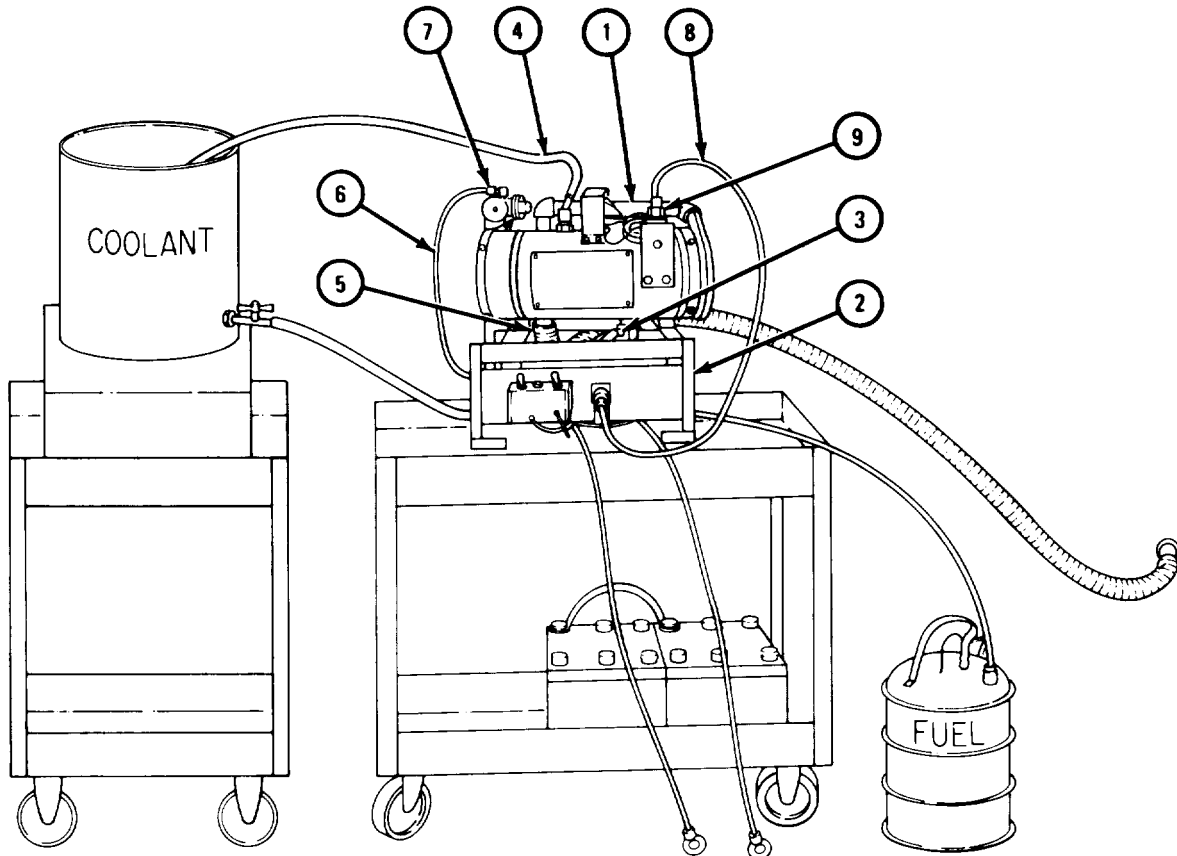

TA 120645



## FRAME 2

1. put control switch (1) in OFF position. Put HI-LO switch (2) in LO position  
Fill coolant container (3) with coolant.
2. Take off end cover plate (4). Refer to para 19- 19c, frame 6.
3. Inspect inside of heater (5) for coolant leaks. If leaks are testing. Take heater (5) apart. Refer to para 19-19c.
4. Connect power supply lead (6) to plus (+) battery terminal (7). Connect ground lead (8) to minus (-) battery terminal (9).

END OF TASK

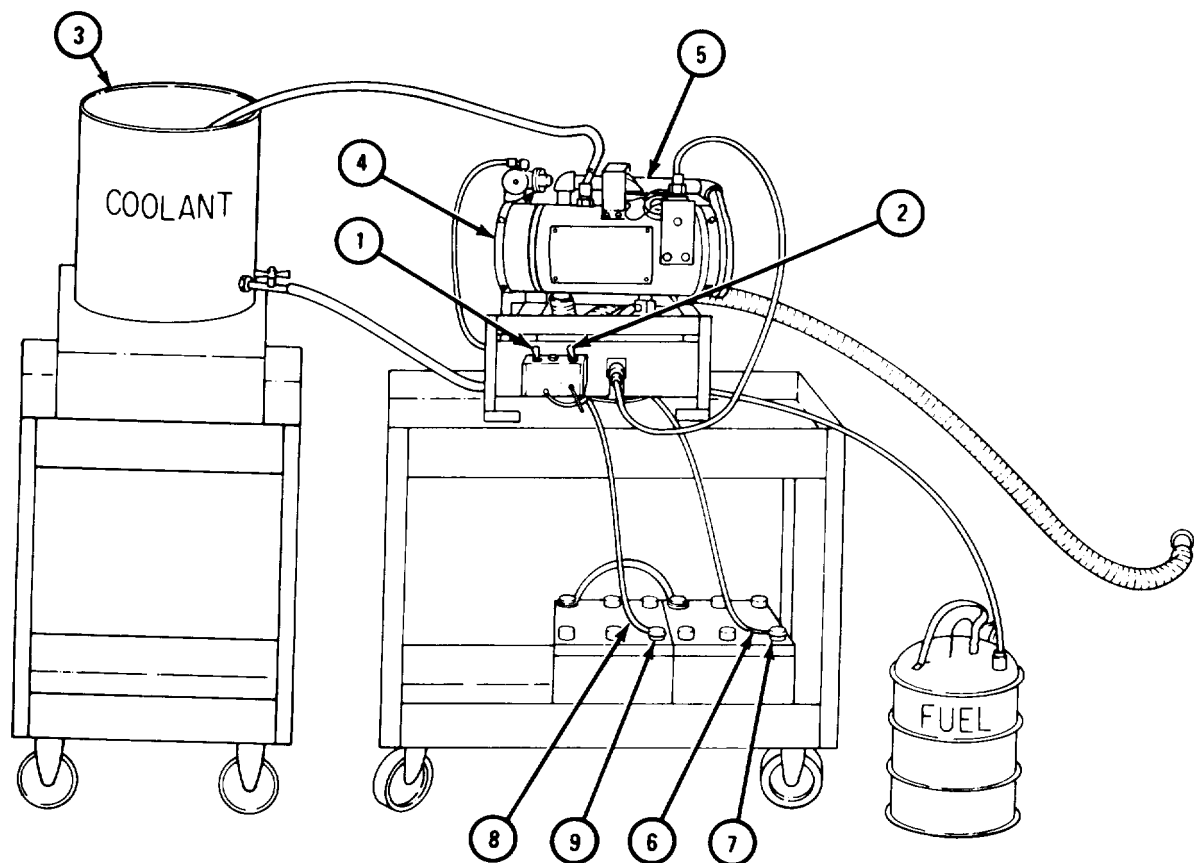

TA 120646

(3) Burn test.

FRAME 1

1. Be sure control switch (1) is in OFF position. Flip HI-LO switch (2) to HI position.
2. Start timing and hold control switch (1) in START position. Heater (3) should start in 40 seconds. Flip control switch (1) to RUN position.
3. If heater (3) does not start, replace igniter. Refer to paras 19-19c and e.
4. Look inside heater (3) for fuel leaks. If leaks are found, stop testing. Repair leak. Refer to para c, d, and e.
5. Flame detector switch should transfer in 200 seconds. Pilot lamp (4) will glow when transfer takes place.
6. If transfer does not take place, adjust or get new flame detector switch. Refer to para 19-19c, d, and e.
7. Let heater (3) burn on HI heat for about a minute. Flip HI-LO switch (2) to LO position. Burning should be less and blower motor should run slower.
8. If heater (3) goes out, a new fuel control valve must be put on. Refer to para 19-19c and d. Then do this frame again.
9. Flip control switch (1) to OFF position. Fuel flow should stop and burning should stop in 30 seconds. Blower should still run for more than one minute, but less than three minutes. Blower should stop all by itself.
10. If blower does not run as in step 9, do step 6.

END OF TASK

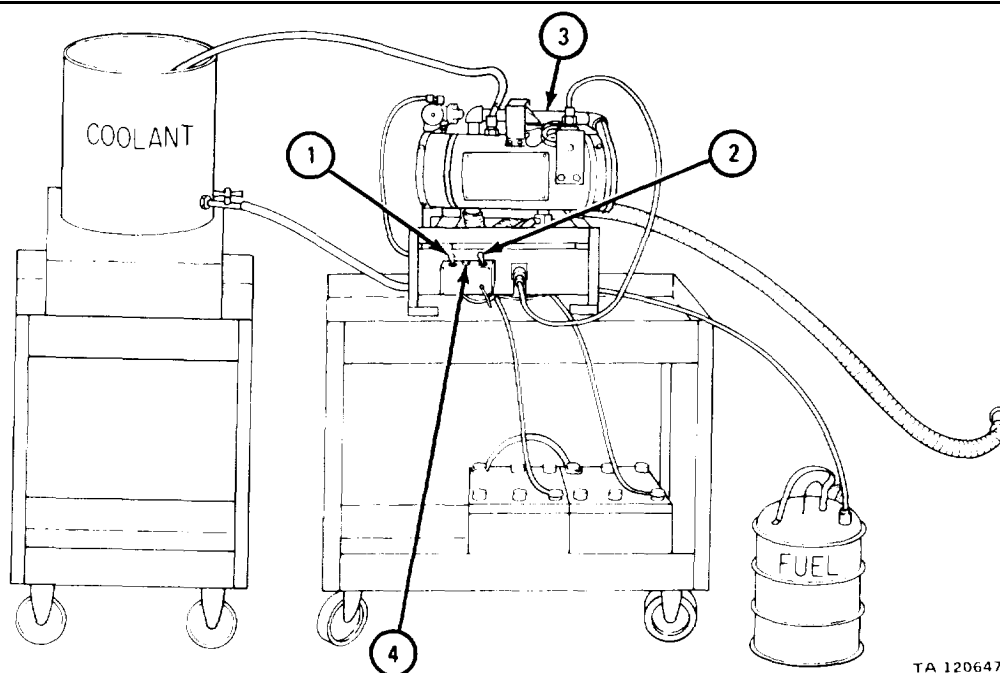

TA 120647

## (4) Cycling test.

## FRAME 1

1. Be sure control switch (1) is in OFF position. Flip HI-LO switch (2) to HI position. Start heater (3) and let it run until it transfers to LO heat all by itself.
2. Wait a few minutes after heater (3) transfers to LO heat. Measure temperature of coolant at outlet hose (4) by letting coolant run on thermometer.

**WARNING**

Coolant will be hot. Use caution when working near hot coolant. Severe burns could result.

3. Temperature should be between 170°F and 195°F.
4. Flip control switch (1) to OFF position. Let the blower motor stop.
5. If temperature is not specified, get new restriction thermostat. Refer to para 19-19c and e.

END OF TASK

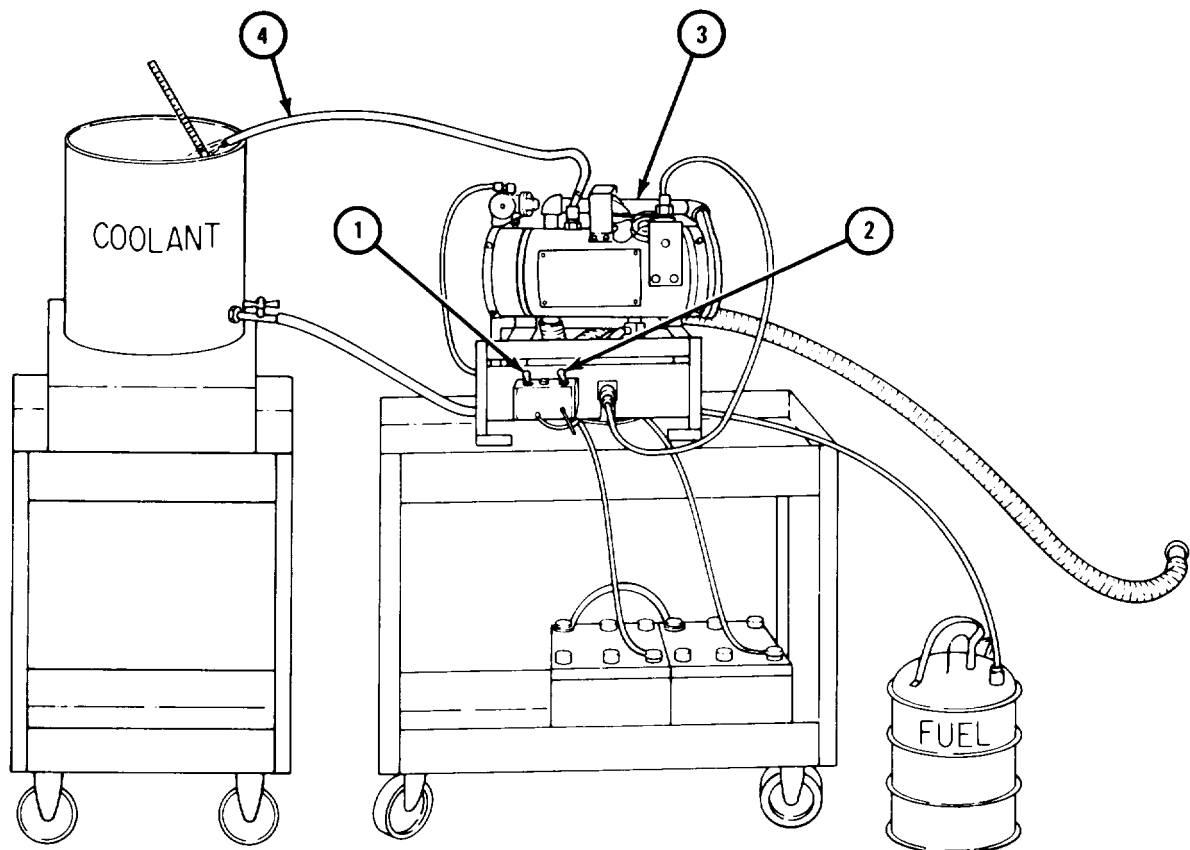

TA 120648

- (5) Overheat switch.

FRAME 1

1. Connect a jumper wire (1) by terminal screws (2 and 3).
2. Start heater (4) and let it run until pilot light (5) glows.

**NOTE**

The jumper wire (1) bypasses the restriction thermostat and keeps the heater on HI heat.

**WARNING**

Coolant will be hot. Use caution when working near hot coolant. Severe burns could result.

3. Measure temperature of coolant at outlet hose (6) by letting coolant run on thermometer.
4. Heater (4) will overheat and burning will stop. Make note of the coolant temperature when burning stops. Temperature should be between 220°F and 250°F.
5. Flip control switch (7) to OFF position. Let the blower motor stop. Take out jumper wire (1).
6. If temperature is not as specified, get new overheat thermostat. Refer to para 19-19c and e.

END OF TASK

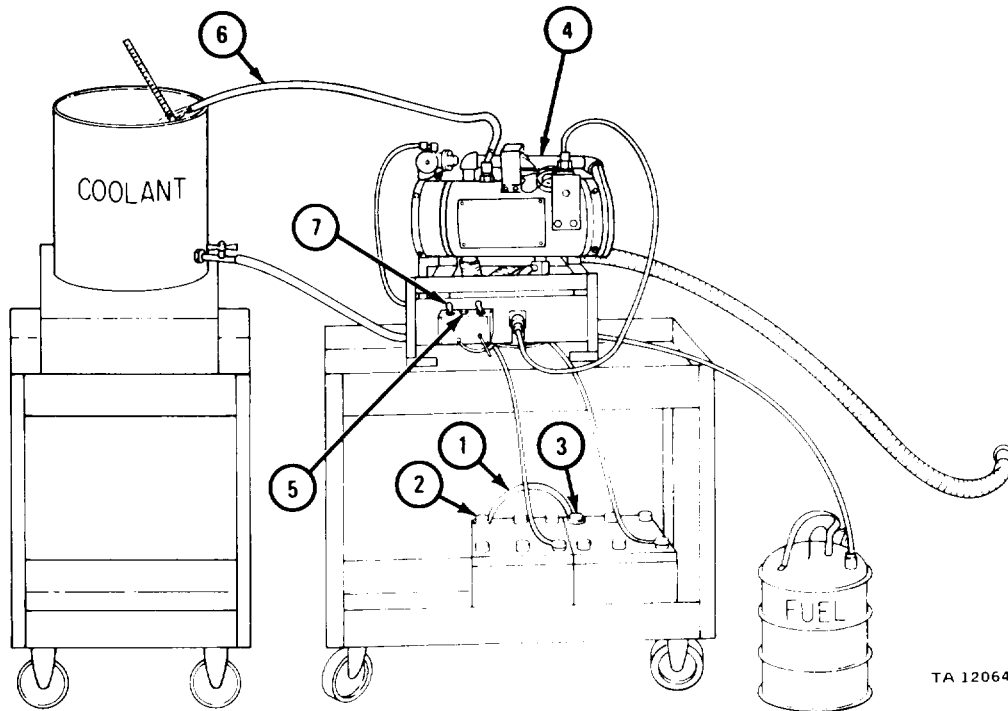

TA 120648

(6) Stopping test.

FRAME 1

1. Put control switch (1) in OFF position. Put HI-LO switch (2) in LO position. Take off ground lead (3) from minus (-) battery terminal (4). Take off Power supply lead (5) from plus (+) battery terminal (6).
2. Put on end cover plate (7). Refer to para 19-19e, frame 7.

**WARNING**

Coolant may be hot. Use caution when working near hot coolant. Severe burns could result.

3. Drain coolant from coolant container (8).

GO TO FRAME 2

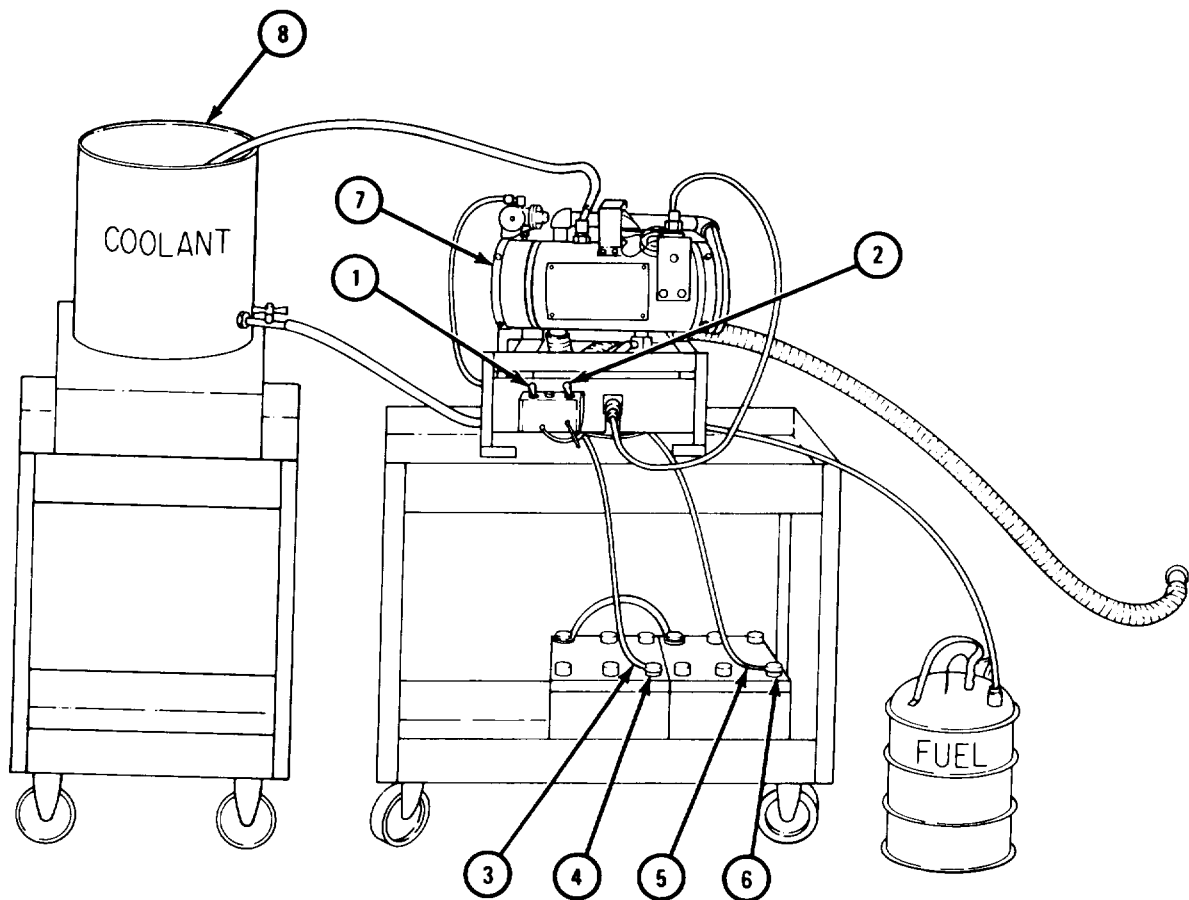

TA 120649

FRAME 2

1. Take off wiring harness (1) from electrical connector (2).
2. Take off fuel supply line (3) from fuel inlet fitting (4). Take off exhaust pipe (5).

**WARNING**

Coolant may be hot. Use caution when working near hot coolant. Severe burns could result.

3. Take off coolant outlet hose (6) and coolant inlet hose (7).
4. Take off heater (8) from test stand (9).

END OF TASK

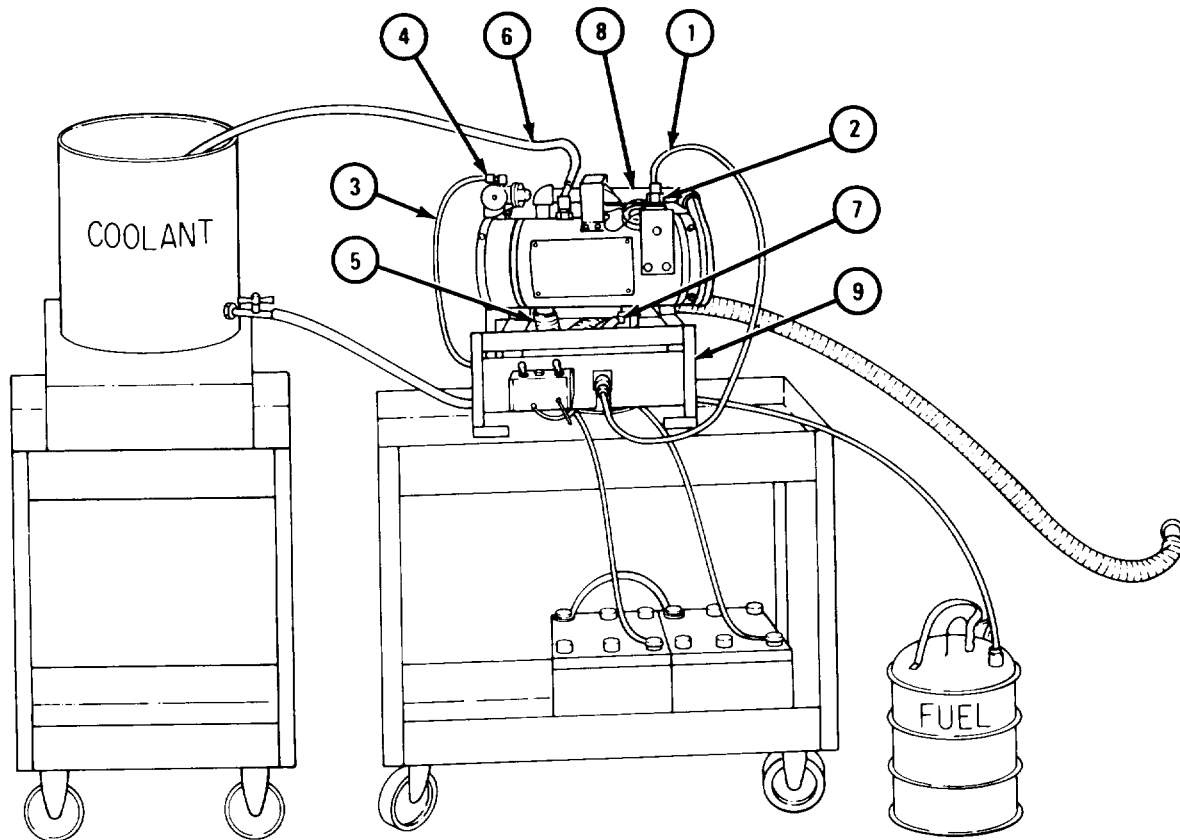

TA 120650

g. Replacement.

## FRAME 1

**WARNING**

Smoking, sparks or open flames are not allowed within 50 feet of work area during this task. Fuel can explode, causing injury to personnel and damage to equipment.

1. Working in battery box, put heater assembly (1) into two retainer clamps (2). Close and screw tight two retainer clamps (2).
2. Plug in and screw on tight electrical connector (3).
3. Slide exhaust pipe elbow (4) onto heater (1). Put in cotter pin (5). Bend over ends of cotter pin (5).
4. Put fuel line (6) on fuel control valve (7). Screw on and tighten fitting (8).
5. Turn on fuel cock (9).

**NOTE**

Follow-on Maintenance Action Required:

1. Put on coolant hoses at heater. Refer to TM 9-2320-211-20.
2. Put on battery ground strap. Refer to TM 9-2320-211-20.
3. Operate heater and check for coolant and fuel leaks. Refer to TM 9-2320-211-10.

END OF TASK

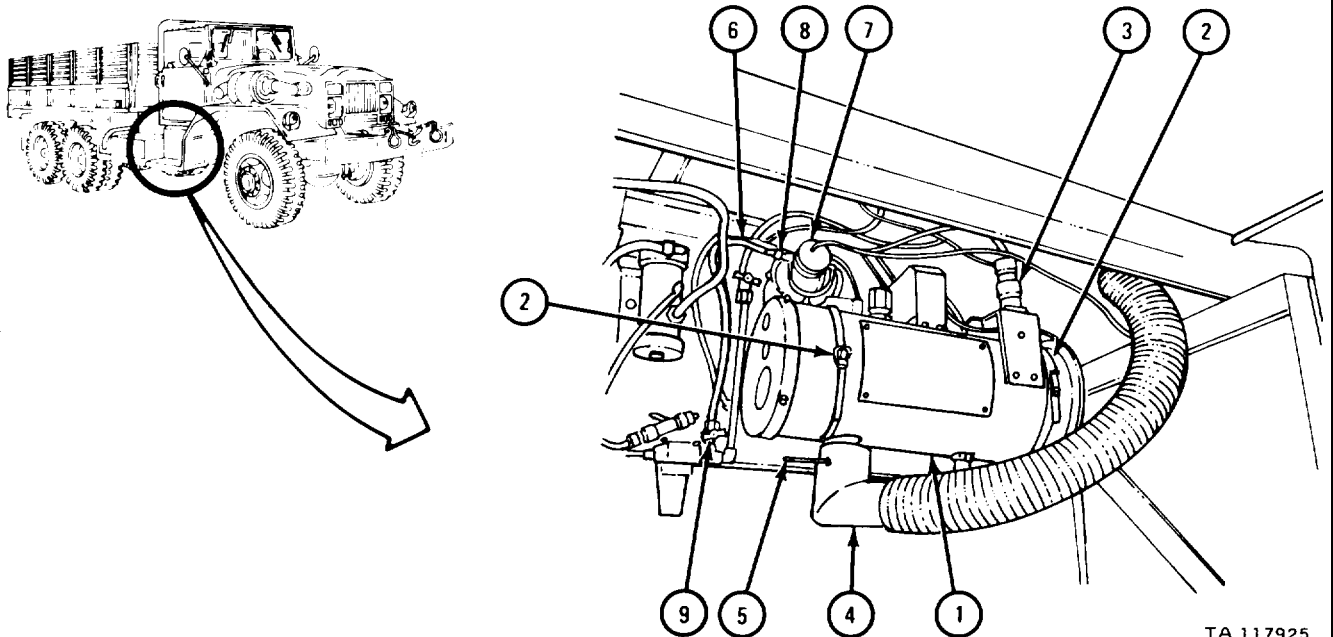

TA 117925

**19-20. THERMAL BARRIER KIT INSTALLATION.**

TOOLS: No special tools required

SUPPLIES: Thermal barrier kit  
Rubber gloves  
Brush  
Methyl-ethyl-ketone

PERSONNEL: One

EQUIPMENT CONDITION: Truck parked in well-ventilated area, engine off,  
handbrake set, cab interior cleaned.

a. Preliminary Procedures.

(1) Remove driver and companion seats. Refer to TM 9-2320-211-20.

(2) Remove map box from instrument panel. Refer to TM 9-2320-211-20.



b. Installation.**WARNING**

Do not inhale vapor from methyl-ethyl-ketone used on rear of panels. Always wear rubber gloves and use brush to put on methyl-ethyl-ketone. Place fans in and around cab to give ventilation.

**CAUTION**

Once a panel is coated with methyl-ethyl-ketone and put in place, it cannot be moved. Be careful to put panel in the right place.

**NOTE**

Thermal barrier kit will be used with hot water and fuel-burning heaters. Where needed, extra slits or cutouts will have to be made with sharp knife or scissors. All knockouts in thermal barrier panels must be taken out before installation. The shiny side of panels will face up.

FRAME 1

1. Put panel (1) in place over right vent door (2). Check to see that it fits and that no extra slits or cutouts have to be made.
2. Take away panel (1).
3. Coat back of panel (1) and right vent door (2) with methyl-ethyl-ketone and press it firmly in place.
4. Do steps 1 through 3 again on other side of cab.

GO TO FRAME 2

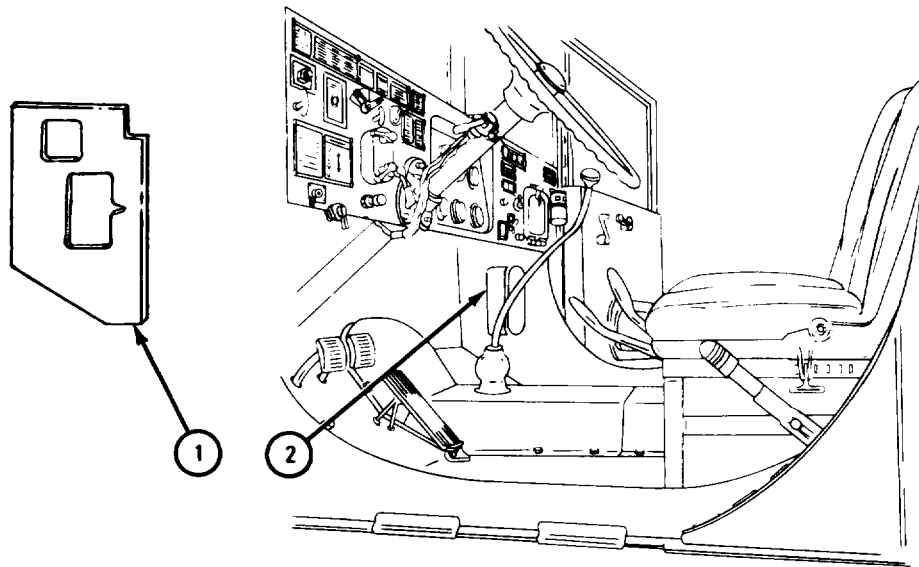

TA 088798

FRAME 2

1. Put panel (1) over right door support (2). Check to see that it fits.
2. Take away panel (1).
3. Coat back of panel (1) and right door support (2) with methyl-ethyl-ketone and press it firmly in place.
4. Do steps 1 through 3 again on other side of cab.

GO TO FRAME 3

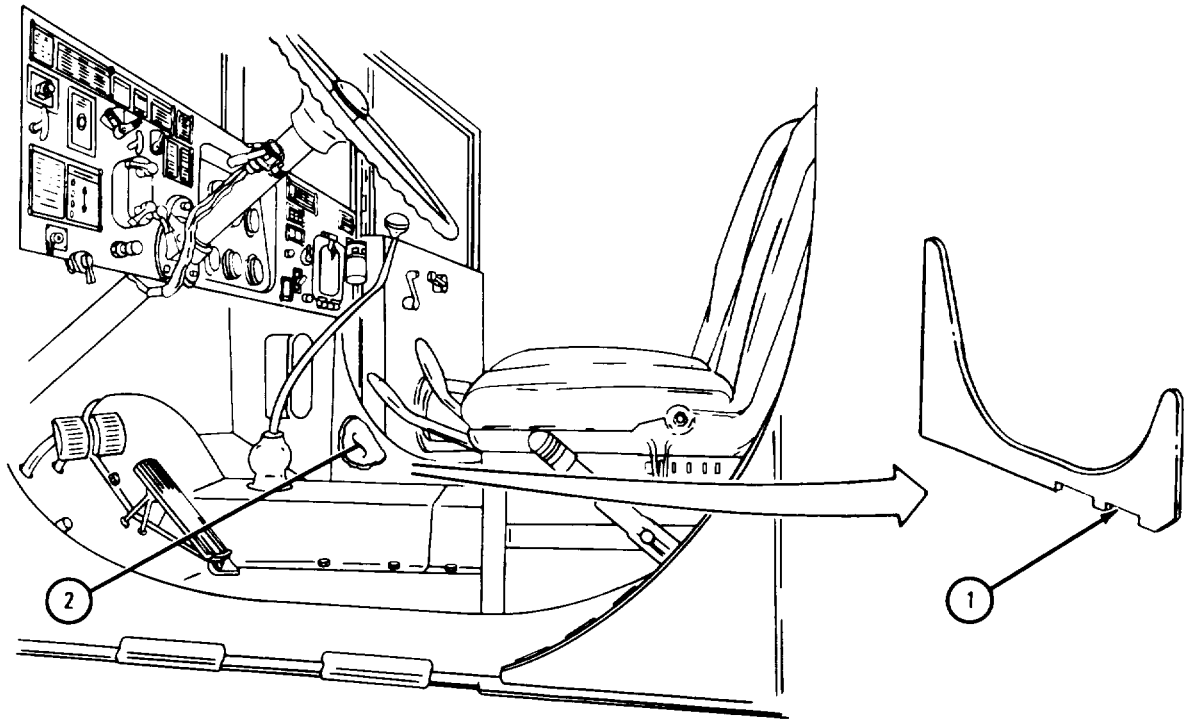

TA 088799

FRAME 3

1. Put panel (1) on front cover (2). Check to see that it fits.
2. Take away panel (1).
3. Coat back of panel (1) and front cover (2) with methyl-ethyl-ketone and press it firmly in place.

GO TO FRAME 4

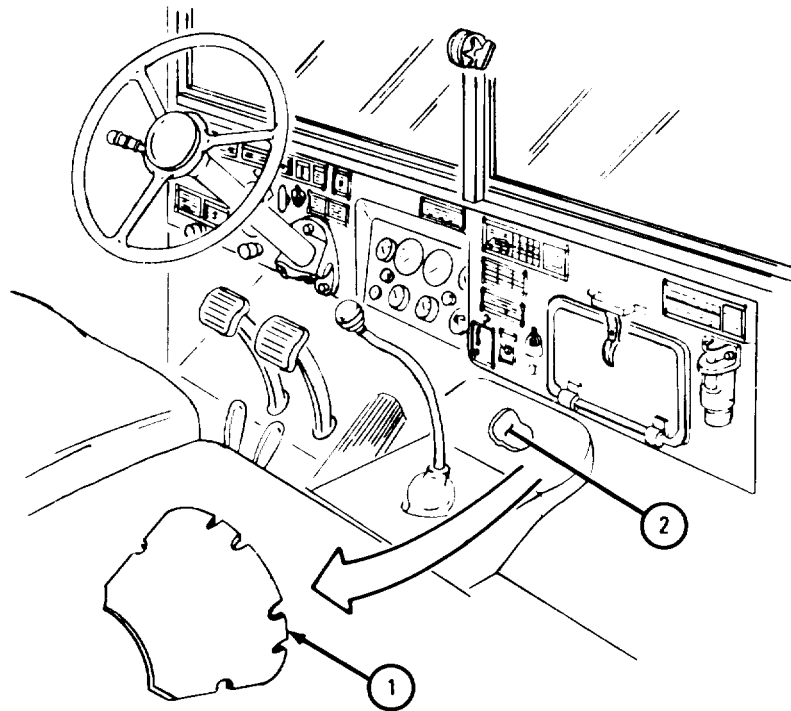

TA 088800

## FRAME 4

1. Put panel (1) on center cover (2). Check to see that it fits.
2. Take away panel (1).
3. Coat back of panel (1) and center cover (2) with methyl-ethyl-ketone and press it firmly in place.

GO TO FRAME 5

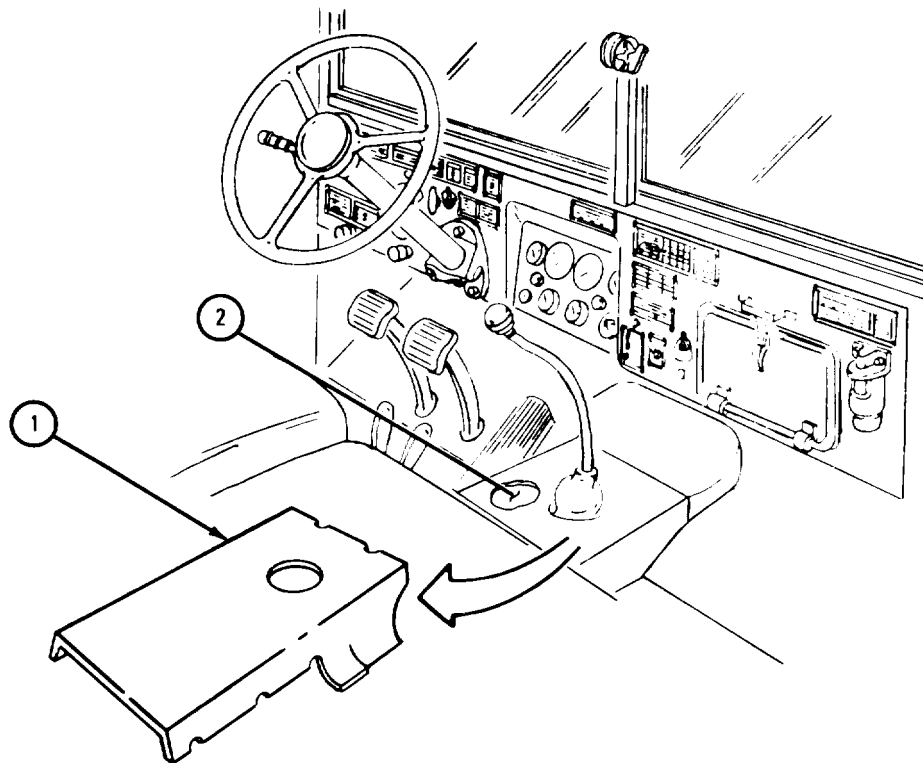

TA 088801

FRAME 5

1. Put panel (1) on rear cover (2). Check to see that it fits.
2. Take away panel (1).
3. Coat back of panel (1) and rear cover (2) with methyl-ethyl-ketone and press it firmly in place.

GO TO FRAME 6

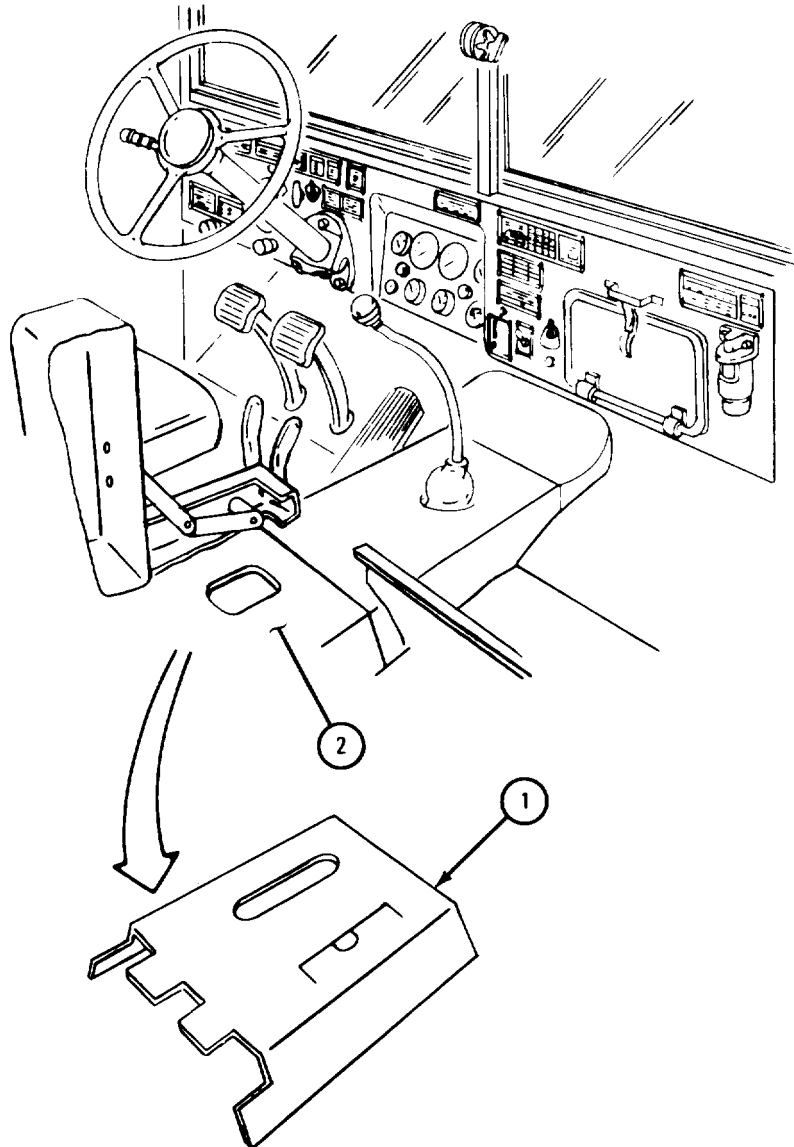

TA 087436

## FRAME 6

1. Put panel (1) on left side of floor (2). Check to see that it fits.
2. Take away panel (1).
3. Coat back of panel (1) and left side of floor (2) with methyl-ethyl-ketone and press it firmly in place.

GO TO FRAME 7

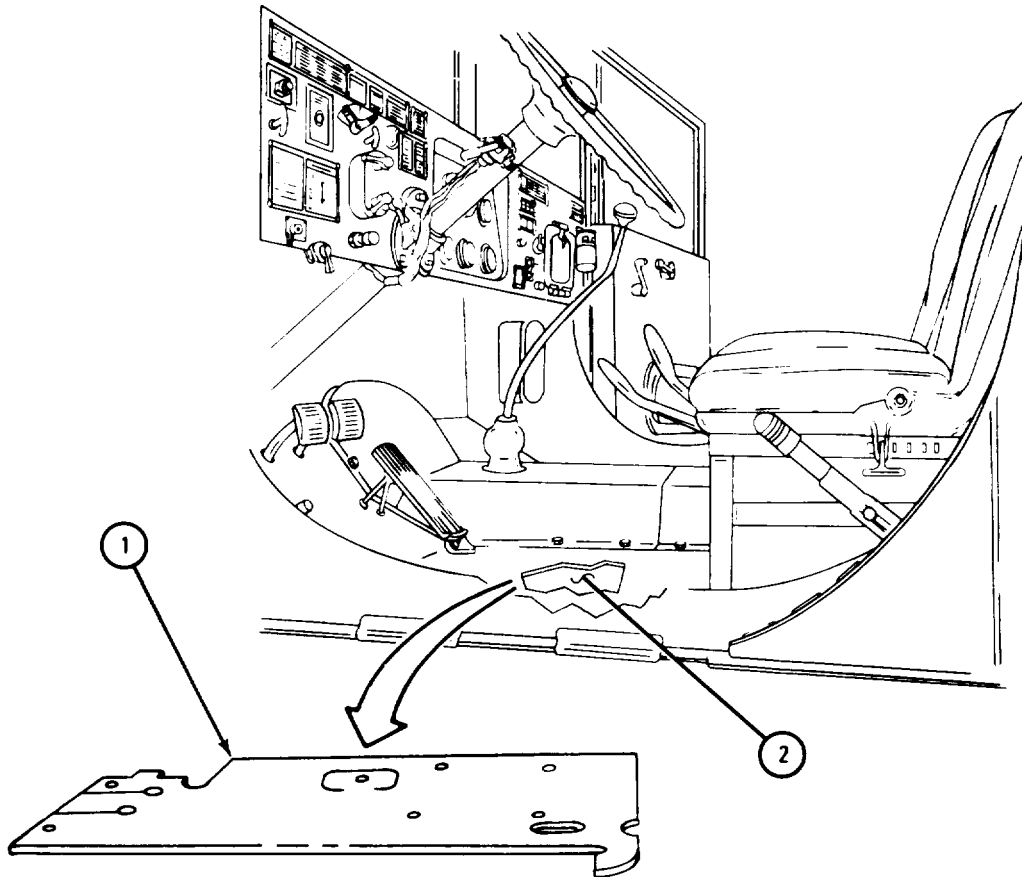

TA 088776

FRAME 7

1. Put panel (1) on accelerator pedal (2). Check to see that it fits.
2. Take away panel (1).
3. Coat back of panel (1) and accelerator pedal (2) with methyl-ethyl-ketone and press it firmly in place.

GO TO FRAME 8

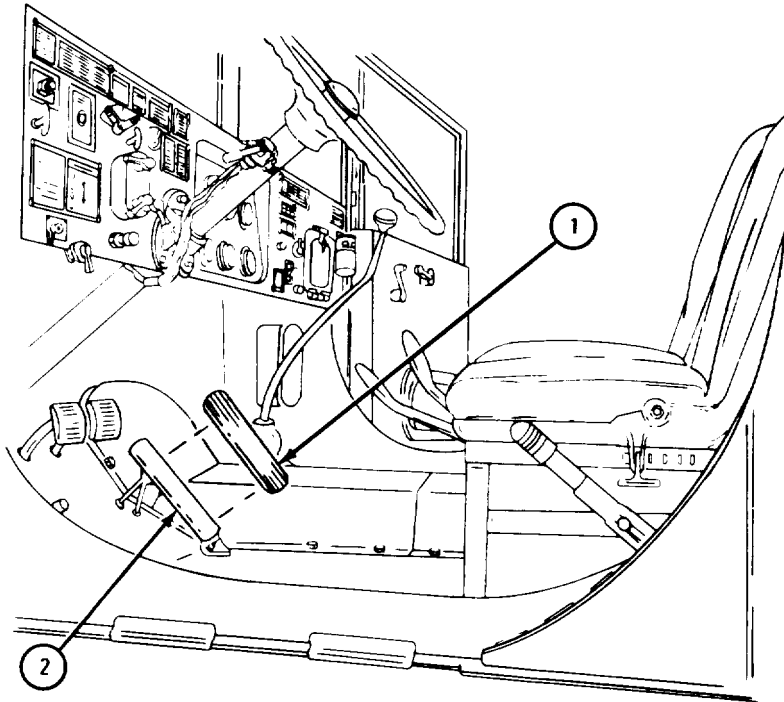

TA 088777



## FRAME 8

1. Put panel (1) on right side of floor (2). Check to see that it fits.
2. Take away panel (1).
3. Coat back of panel (1) and right side of floor (2) with methyl-ethyl-ketone and press it firmly in place.

GO TO FRAME 9

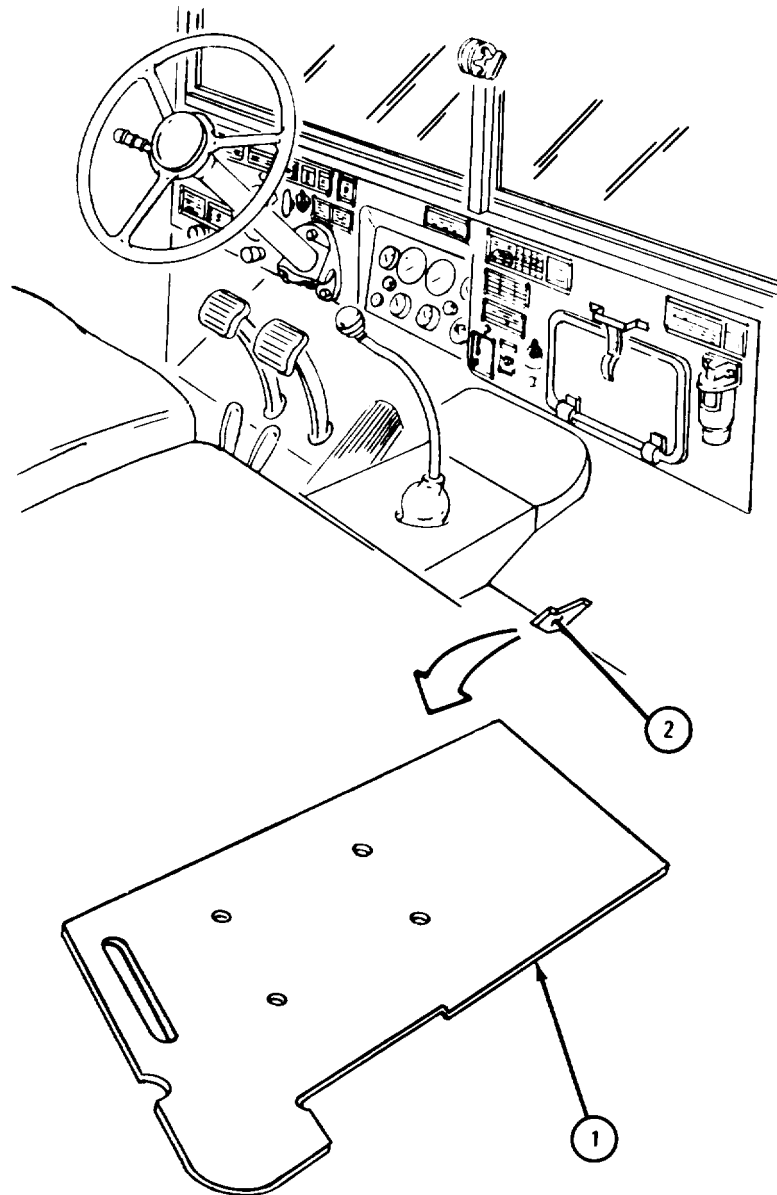

TA 088791

FRAME 9

1. Put panel (1) on right side of firewall (2). Check to see that it fits.
2. Take away panel (1).
3. Coat back of panel (1) and right side of firewall (2) with methyl-ethyl-ketone and press it firmly in place.

GO TO FRAME 10

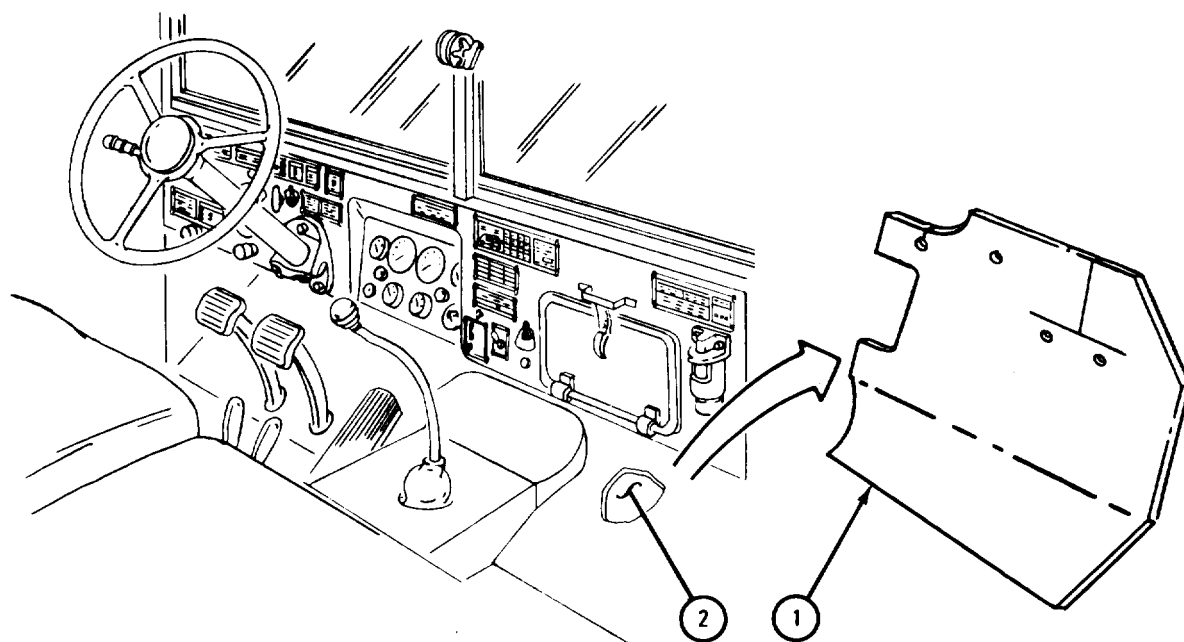

TA 088792

## FRAME 10

1. Put panels (1) on clutch and brake pedal (2). Check to see that they fit.
2. Take away panels (1).
3. Coat back of panels (1) and clutch and brake pedal (2) with methyl-ethyl-ketone and press them firmly in place.

GO TO FRAME 11

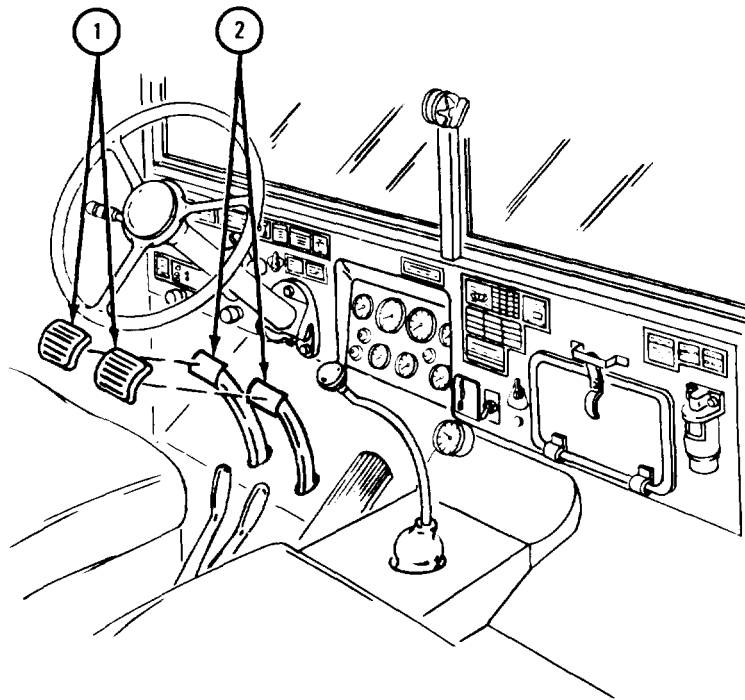

TA 088793

FRAME 1

1. Put panel (1) on left of firewall (2). Check to see that it fits.
2. Take away panel (1).
3. Coat back of panel (1) and left of firewall (2) with methyl-ethyl-ketone and press it firmly in place.

GO TO FRAME 12

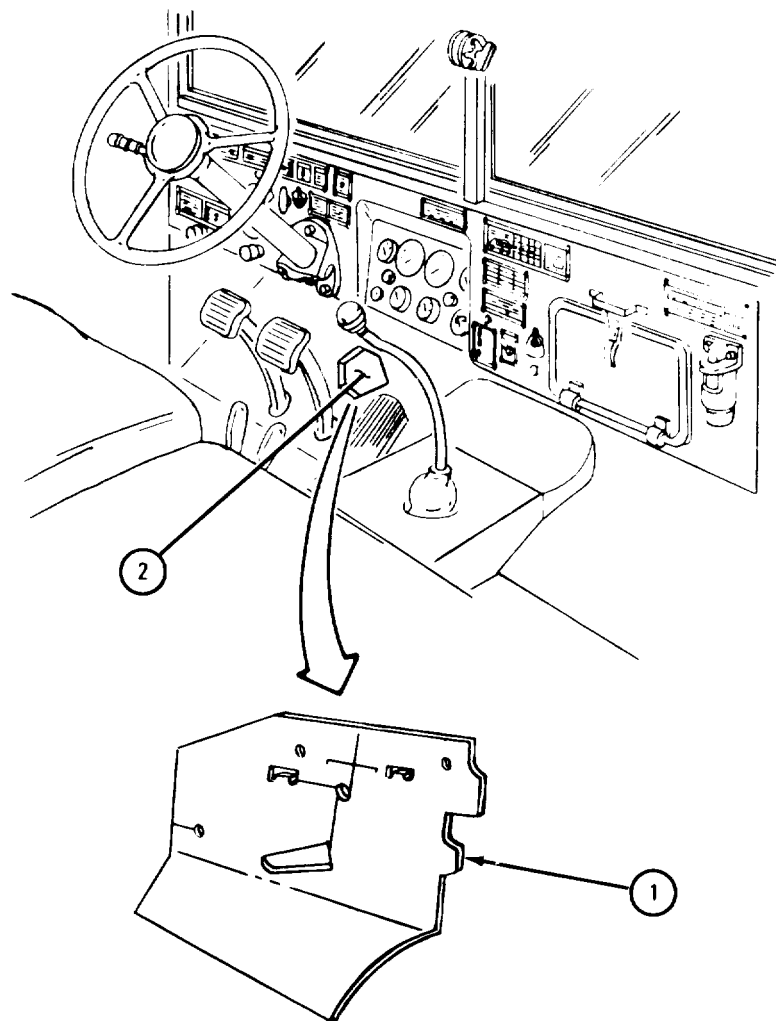

TA 088794

FRAME 12

1. put panel (1) on right lock pillar (2). Check to see that it fits.
2. Take away panel (1).
3. Coat back of panel (1) and right lock pillar (2) with methyl-ethyl-ketone and press it firmly in place.
4. Do steps 1 through 3 again on other side of cab.

GO TO FRAME 13

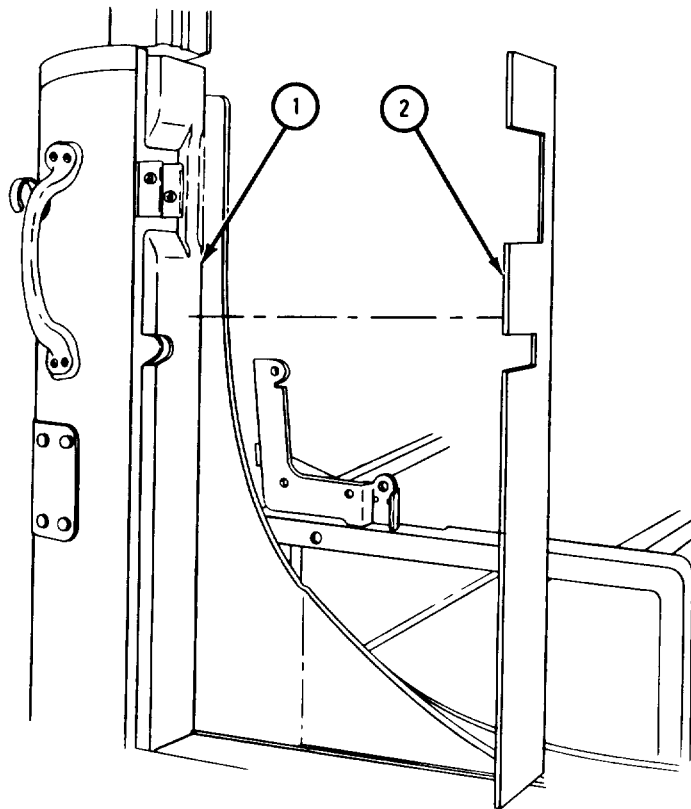

TA 088795

FRAME 13

1. Put panel (1) in right rear of cab (2). Check to see that it fits.
2. Take away panel (1).
3. Coat back of panel (1) and right rear of cab (2) with methyl-ethyl-ketone and press it firmly in place.

**NOTE**

Follow-on Maintenance Action Required:

1. Replace map box on instrument panel. Refer to TM 9-2320-211-20.
2. Replace driver's and companion seats. Refer to TM 9-2320-211-20.

END OF TASK

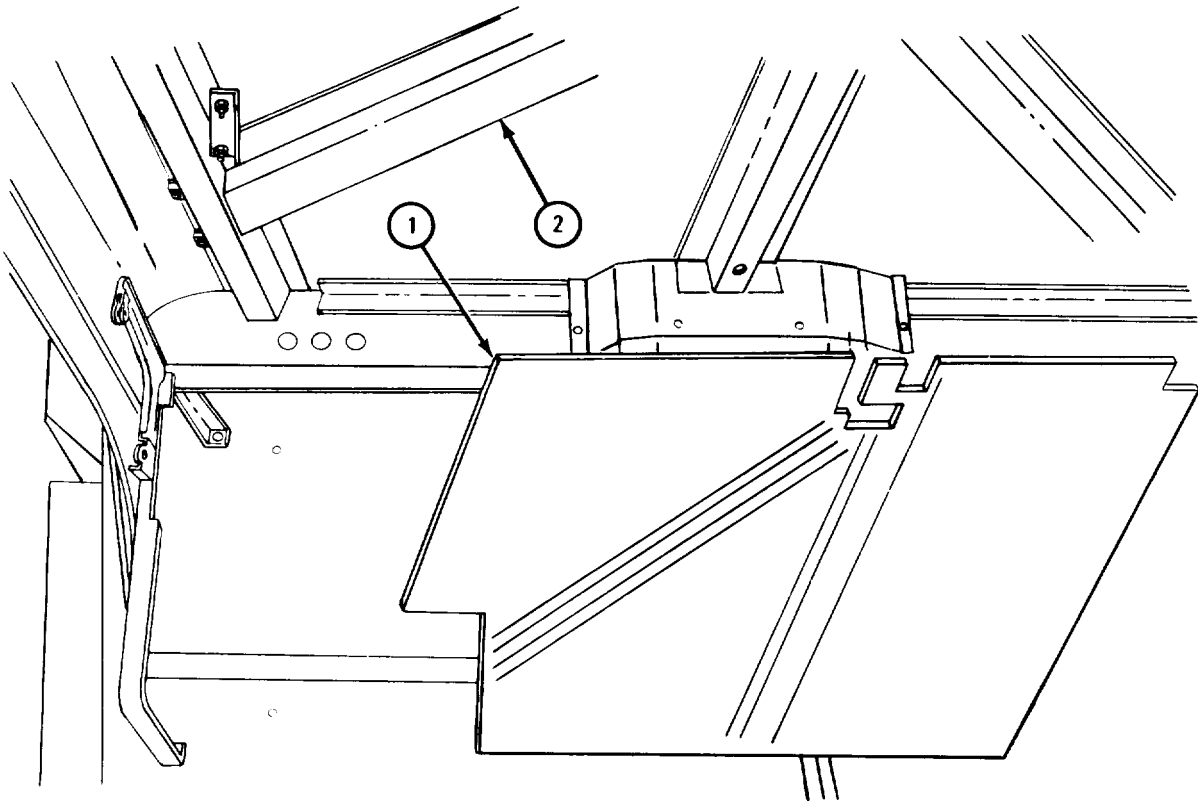

TA 088796

**19-21. THERMAL BARRIER PANELS, FLOORMATS, AND COVERS REMOVAL, REPAIR, AND REPLACEMENT.**

TOOLS: No special tools required

SUPPLIES: Thermal barrier kit  
Rubber gloves

EQUIPMENT CONDITION: Truck parked in well lighted and well-ventilated area, engine off, handbrake set.

a. Preliminary Procedures.

(1) Remove driver and companion seats. Refer to TM 9-2320-211-20.

(2) Remove map box from instrument panel. Refer to TM 9-2320-211-20.

b. Inspection and Repair.

(1) Clean cab floor.

(2) Check that thermal barrier panels are not damaged.

(3) If thermal barrier panels are damaged, get new ones in their place.

c. Removal.

FRAME 1

**NOTE**

This task is the same for all 18 thermal barrier panels.

1. Using putty knife, put blade under damaged thermal barrier panel (1) and pry and scrape off panel.

END OF TASK

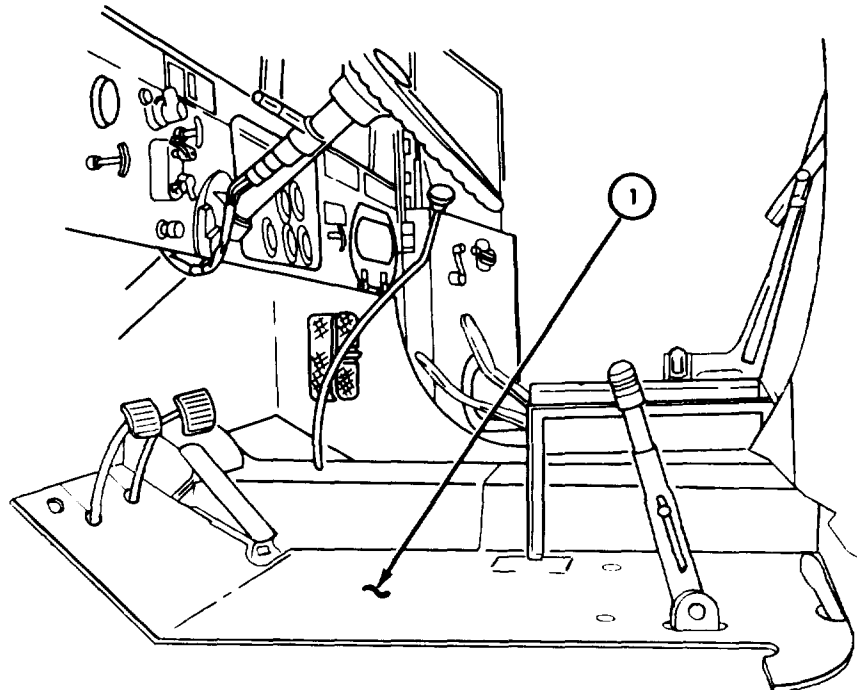

TA 088802



- d. Cleaning. There are no special cleaning procedures needed. Refer to cleaning procedures given in Part 1, para 1-3.
- e. Replacement. Put back thermal barrier panel. Refer to para 19-20.

**NOTE**

Follow-on Maintenance Action Required:

1. Replace map box. Refer to TM 9-2320-211-20.
2. Replace driver and companion seats. Refer to TM 9-2320-211-20.

**19-22. HARD TOP CLOSURE TOP ASSEMBLY REMOVAL, REPAIR, AND REPLACEMENT.**

**TOOLS:** No special tools required

**SUPPLIES:** Solvent, dry cleaning, type 11 (SD-2), Fed. Spec P-D-680  
Soapy water  
Clean lint -free cloth  
Contact cement  
Frame cap tape

**PERSONNEL:** Two

**EQUIPMENT CONDITION:** Truck parked, engine off, handbrake set.

a. Removal.

FRAME 1

1. Take out two screws (1) and two washers (2).
2. Take off two nuts (3) and take out two screws (4).
3. Pull out two angle washers (5).
4. Take off 14 nuts (6). Take out 14 screws (7) and 28 washers (8).
5. Lift roof panel (9) off back panel (10) and take off strip seal (11).

Soldiers  
A and B

GO TO FRAME 2

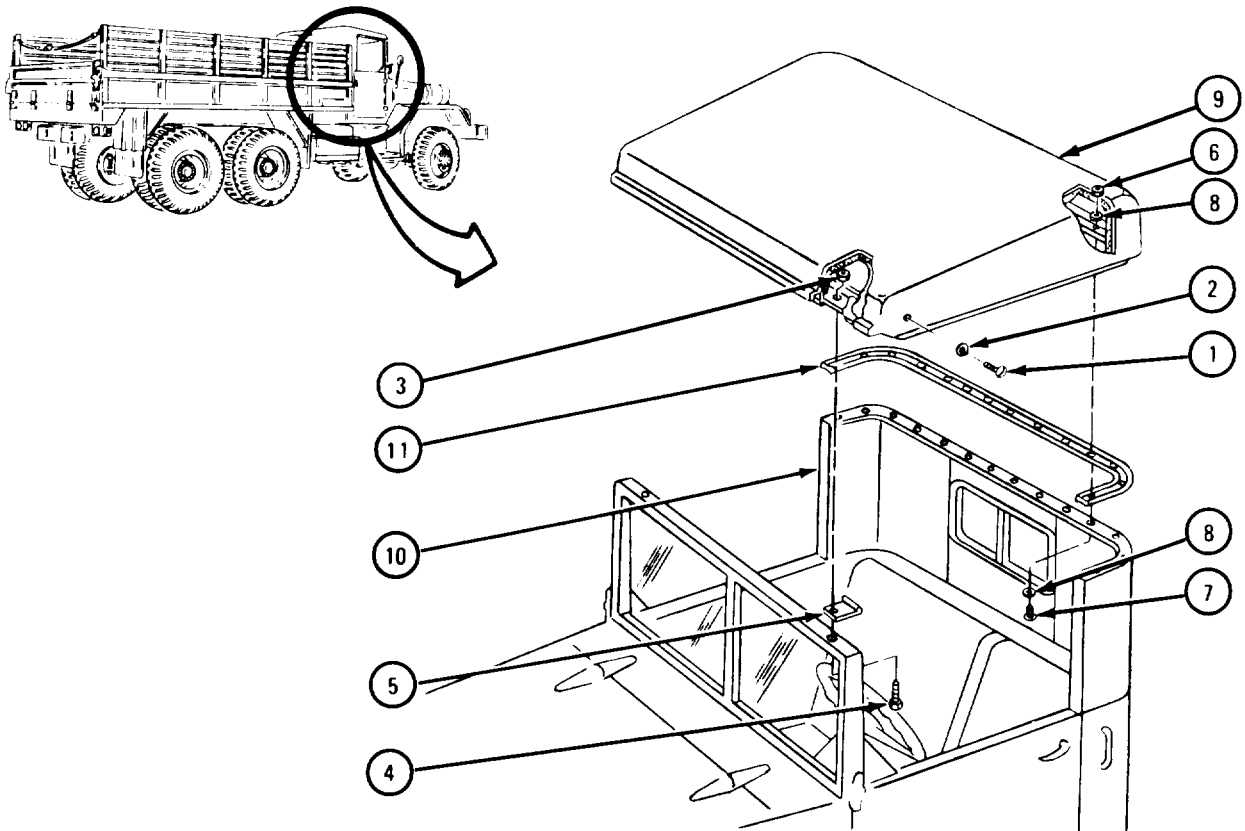

TA 085787

FRAME 2

1. Takeoff 14 nuts (1) and 14 washers (2). Take out 14 screws (3) and 14 washers (4).

Soldiers 2. Lift back panel (5) off cab body (6).  
A and B

GO TO FRAME 3

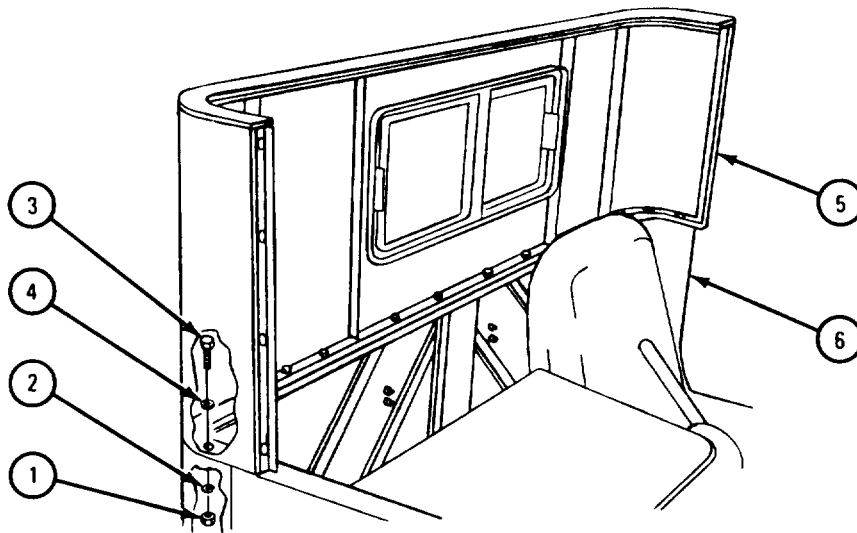

TA 085789

## FRAME 3

1. Take out eight screws (1), washers (2), and nuts (3).
2. Take off frame cap (4). Scrape off tape (5) and throw it away.
3. Take out 14 screws (6), nuts (7), and washers (8).
4. Take out window assembly (9).

END OF TASK

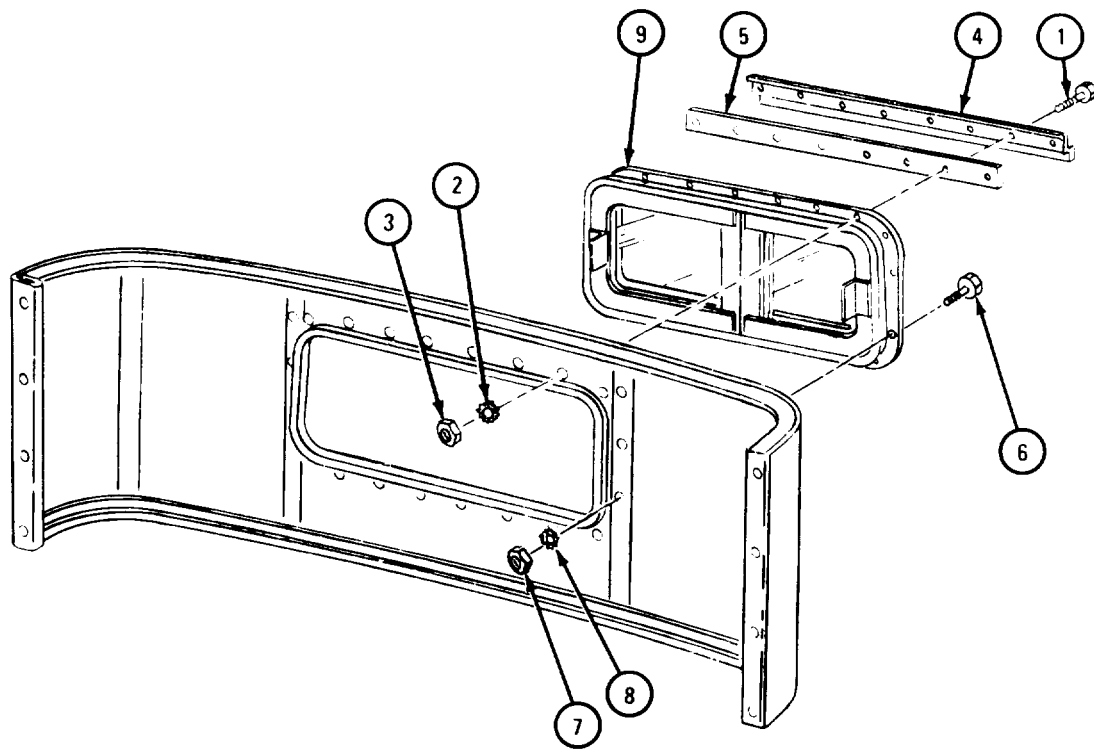

TA 085790

b. Disassembly.

FRAME 1

1. Take out three screws (1), three lockwashers (2), and three nuts (3). Take off front seal (4).
2. Take out five screws (5), five lockwashers (6), and five nuts (7). Take off side run retainer (8), side retainer run (9), and side run retainer (10).
3. Do step 2 again on other side of roof panel.

GO TO FRAME 2

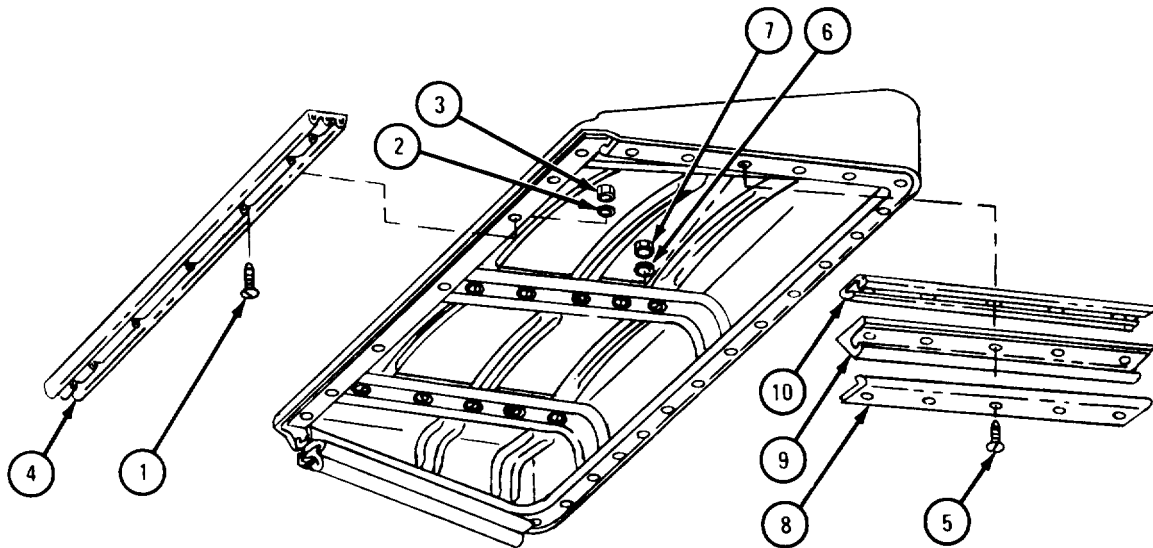

TA 085791

FRAME 2

1. Take out six screws (1) and six washers (2) from each of three top insulation retainers (3).
2. Take out three top insulation retainers (3) and three top retainers (4).
3. Take out screw (5) from each of two front side retainers (6) and take out two front side retainers.
4. Take out screw (7) from each of two top side rear retainers (8) and take out two top side rear retainers.

GO TO FRAME 3

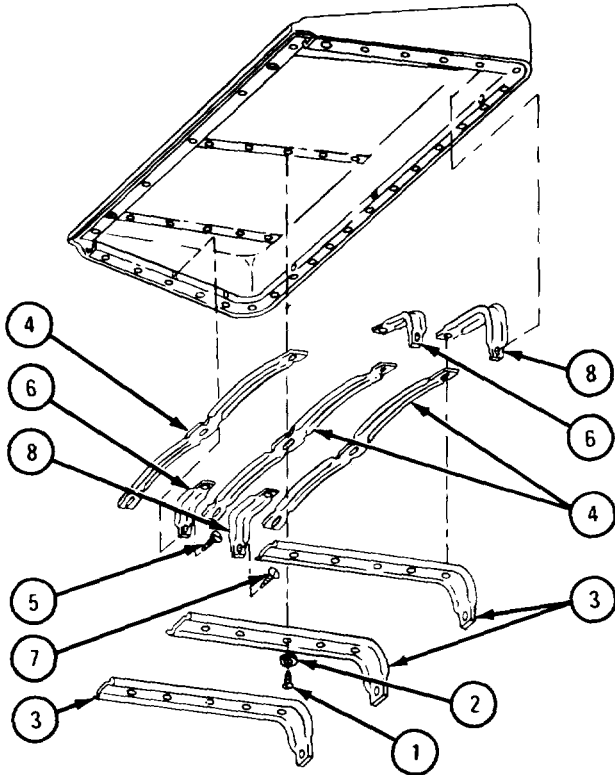

TA 085792

FRAME 3

**NOTE**

If insulation panels are damaged, do steps 1 and 2. If insulation panels are not damaged, go to frame 4.

1. Scrape off top left side insulation panel (1) and top right side insulation panel (2).
2. Take out two top panel insulation panels (3) and scrape off two top insulation panels (4).

GO TO FRAME 4

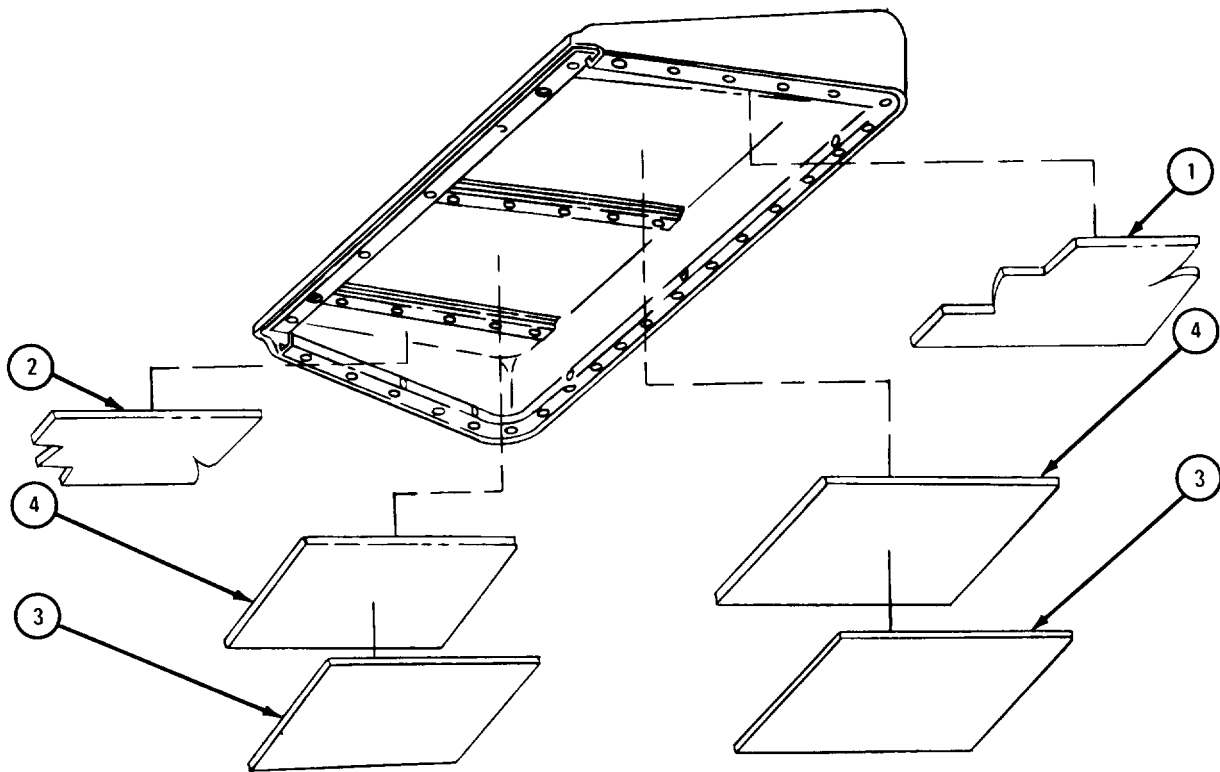

TA 085793



FRAME 4

1. Take out two screws (1) and two seal clips (2). Take off strip seal (3).
2. Take out four screws (4), four lockwashers (5), and four nuts (6). Take off left rear run retainer (7), left rear run (8), and left rear run retainer (9).
3. Do step 2 again on right side of panel.

GO TO FRAME 5

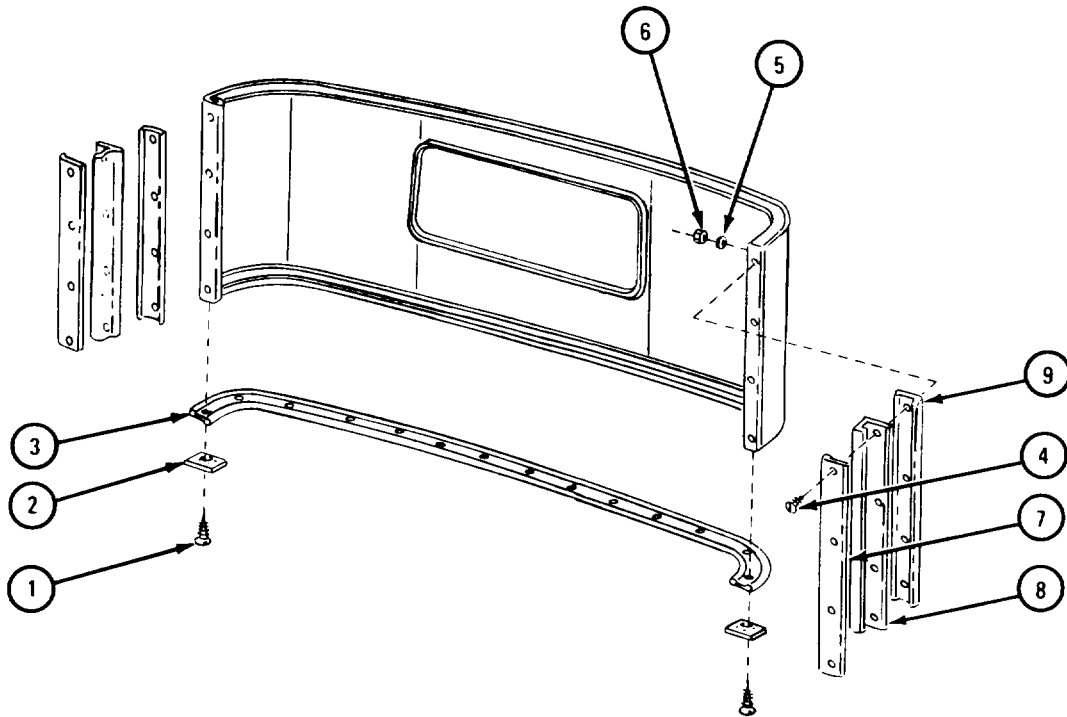

TA 085794

FRAME 5

**NOTE**

If insulation panels are damaged, do step 1. If insulation panels are not damaged, go to frame 6.

1. Scrape off two rear side insulation panels (1), two rear insulation panels (2), rear top center insulation panel (3), and rear bottom center insulation panel (4) from back panel (5).

GO TO FRAME 6

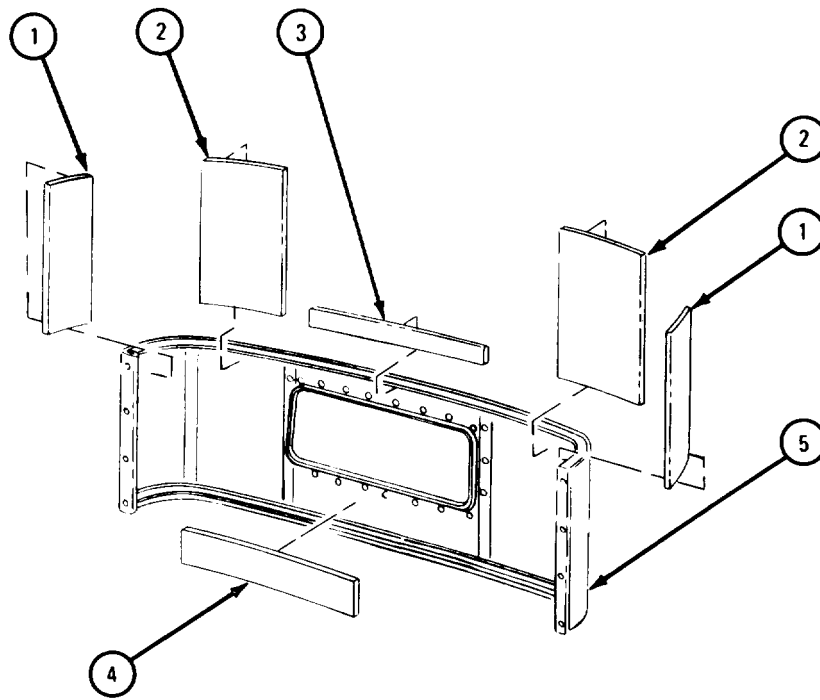

TA 085795

**FRAME 6**

1. Take out two screws (1).
  2. Spread frame (2) and take out two windows (3).
  3. Take out two screws (4) and sleeves (5).
  4. Take off end rail (6). Take seal (7) out of end rail.
  5. Carefully slide out glass (8).
  6. Take seal (9) out of rail (10).
- Do steps 3 through 6 again for other window (3).

**END OF TASK**

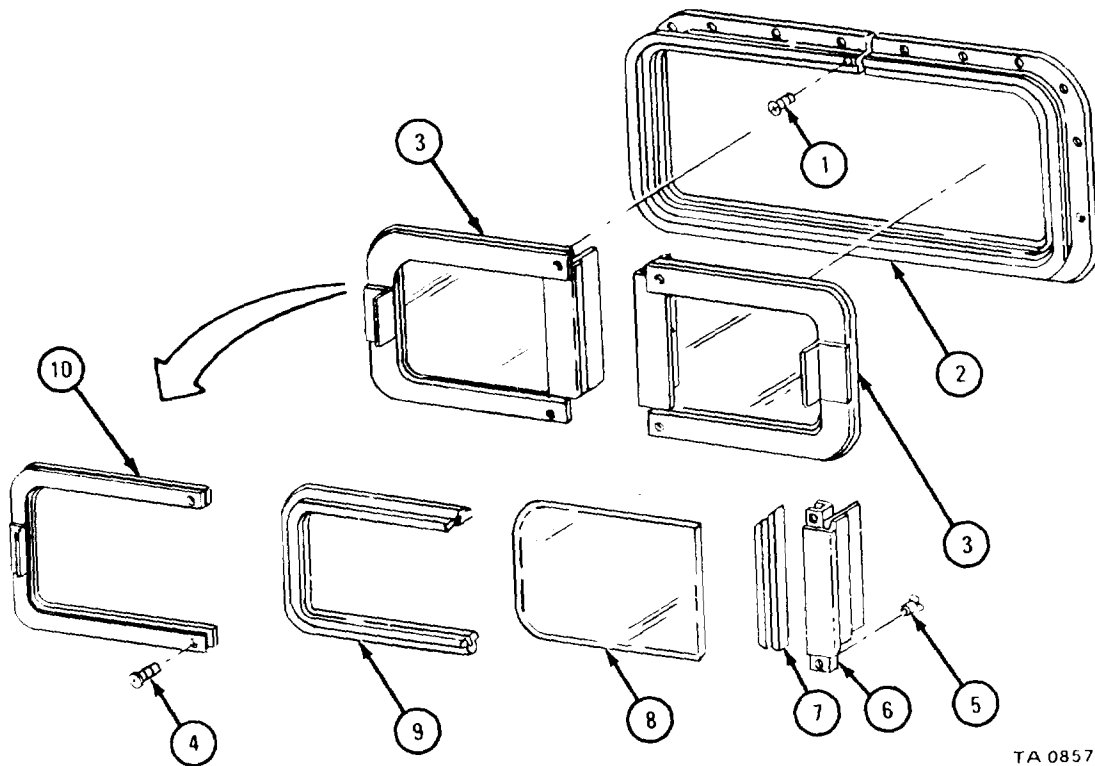

TA 085796

c. Cleaning.

**WARNING**

Dry cleaning solvent is flammable. Do not use near an open flame. Keep a fire extinguisher nearby when solvent is used. Use only in well-ventilated places. Failure to do this may result in injury to personnel and damage to equipment.

- (1) Clean all metal parts with dry cleaning solvent. Let parts air dry.
- (2) Clean glass with soap and water. Dry glass with clean lint-free cloth.

d. Inspection and Repair.

FRAME 1

1. Check that roof panel (1) is not bent, cracked or damaged in any other way. Repair by straightening or welding. Refer to TM 9-237. If more repair is needed, get a new panel.
2. Check that three top insulation retainers (2), three top retainers (3), two front side retainers (4), and two top side rear retainers (5) are not cracked or broken. If retainers are damaged, get new ones.
3. Check that six insulation panels (6) are not torn or broken. If panels are damaged, get new ones.
4. Check that top front seal (7) is not torn or worn. If seal is damaged, get new one.
5. Check that four side run retainers (8 and 9) and two side run retainers (10) are not cracked or bent. If parts are damaged, get new ones.

GO TO FRAME 2

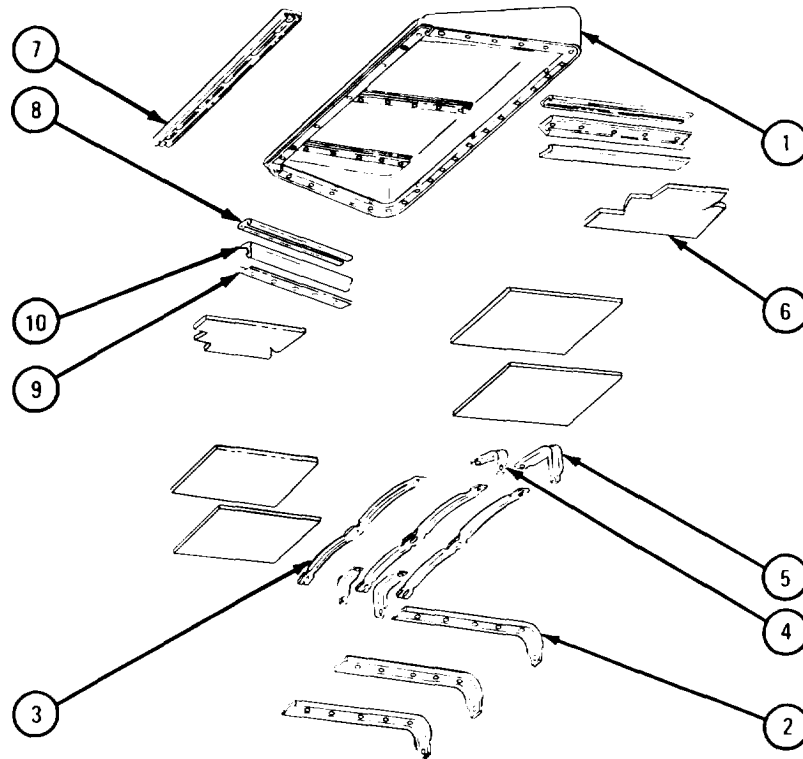

NOTE: CHECK ONLY THOSE PARTS WHICH ARE CALLED OUT IN THIS FRAME. PARTS WITHOUT CALLOUTS ARE SHOWN ONLY FOR REFERENCE PURPOSES OR ARE CHECKED IN ANOTHER FRAME.

TA 085797

FRAME 2

1. Check that rear seal (1) is not torn or worn. If seal is damaged, get a new one. Check that two rear seal clips (2) are not cracked or broken, If clips are damaged, get new ones.
2. Check that four rear run retainers (3) and two rear runs (4) are not cracked or broken. If parts are damaged, get new ones.
3. Check that six insulation panels (5) are not torn or broken. If panels are damaged, get new ones.
4. Check that back panel (6) is not cracked or bent. If panel is damaged, repair by straightening or welding. Refer to TM 9-237. If more repair is-needed, get a new back panel.

GO TO FRAME 3

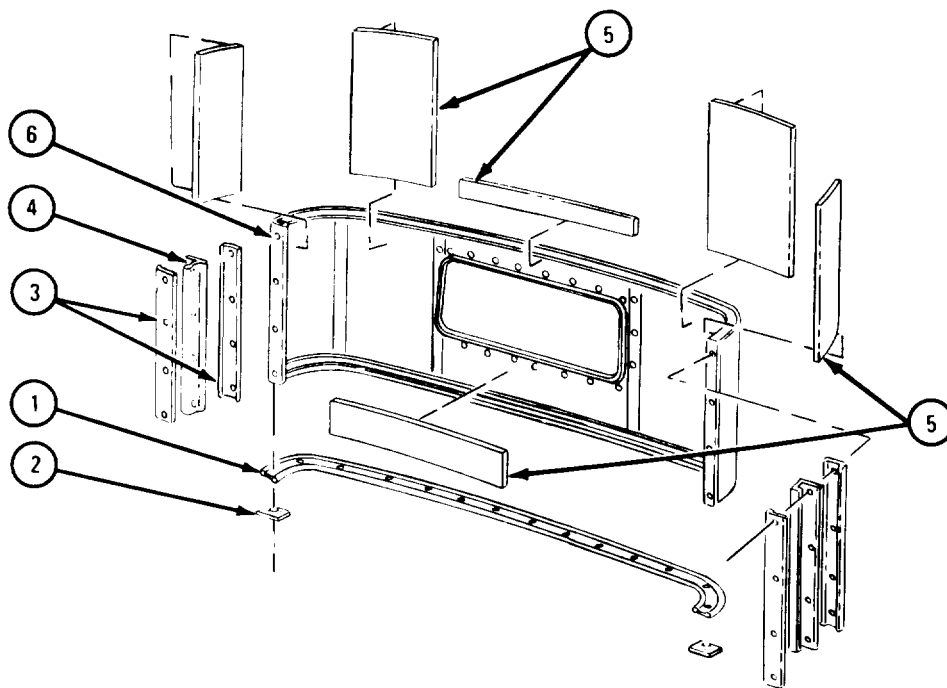

TA 085798

## FRAME 3

1. Check that frame assembly (1) is not cracked or bent. Repair by straightening. If more repair is needed, get a new frame assembly.
2. Check that two 36-inch seals (2) and two 12-inch seals (3) are not torn or worn. If seals are damaged, get new ones.
3. Check that two pieces of glass (4) are not chipped, cracked or broken. If glass is damaged, get a new piece.
4. Check that rail (5) and end rail (6) are not bent or damaged. If rails are damaged, get new ones.

END OF TASK

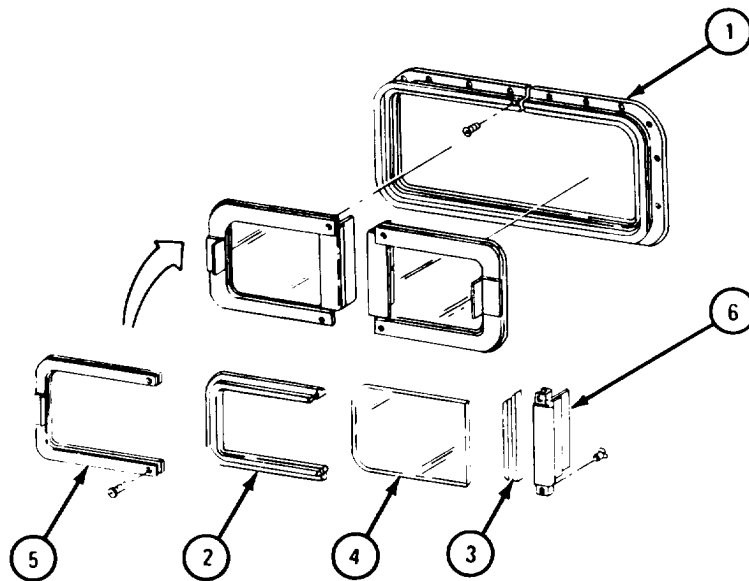

TA 085799

e. Assembly.

FRAME 1

---

**WARNING**

Contact cement is flammable. Do not use near an open flame. Keep a fire extinguisher nearby when contact cement is used. Use only in well-ventilated places. Failure to do this may result in injury to personnel and damage to equipment.

**NOTE**

If insulation panels are damaged, do steps 1 and 2. If insulation panels are not damaged, go to frame 2.

Put each insulation panel in place before putting on contact cement to be sure panel is in the proper position.

1. Put a coat of contact cement on six panels (1 through 4).
2. Press two rear insulation panels (1) into place. Press two rear side insulation panels (2) into place. Press rear bottom center insulation panel (3) into place. Press rear top center insulation panel (4) into place.

GO TO FRAME 2

---

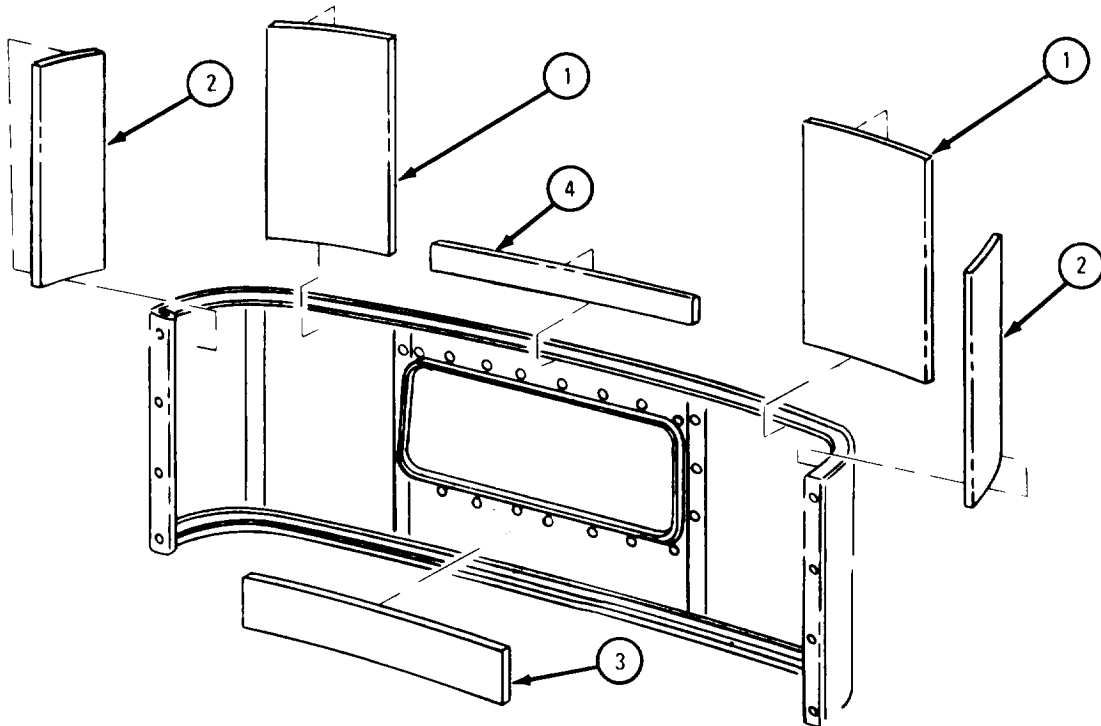

TA 085800



FRAME 2

1. Hold left rear run retainer (1), left rear run (2), and left rear run retainer (3) in place and put in four screws (4), four lockwashers (5), and four nuts (6).
2. Do step 1 again on right side of panel.
3. Hold rear seal (7) and rear seal clip (8) in place and put in screw (9).
4. Do step 3 again on right side of panel.

GO TO FRAME 3

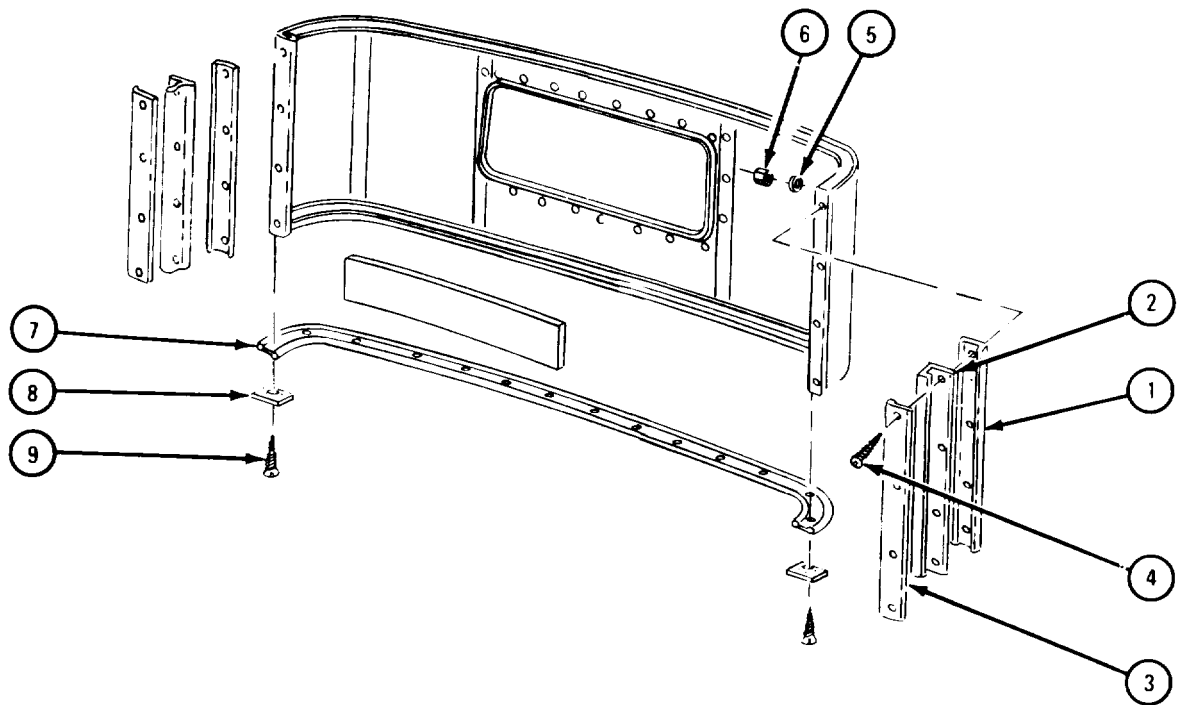

TA 085801

FRAME 3

**WARNING**

Contact cement is flammable. Do not use near an open flame. Keep a fire extinguisher nearby when contact cement is used. Use only in well-ventilated places. Failure to do this may result in injury to personnel and damage to equipment.

Do not breathe contact cement vapors. They can cause illness.

**NOTE**

If insulation panels are damaged, do steps 1 through 4. If insulation panels are not damaged, go to frame 4.

Put each insulation panel in place before putting on contact cement to be sure panel is in the proper position.

1. Put a coat of contact cement on backs of panels (1 through 3).
2. Press two top center insulation panels (1) into place. Press top left side insulation panel (2) into place. Press top right side insulation panel (3) into place.
3. Put a coat of contact cement on two panels (4).
4. Press two top center insulation panels (4) in place on the first two top center insulation panels (1).

**GO TO FRAME**

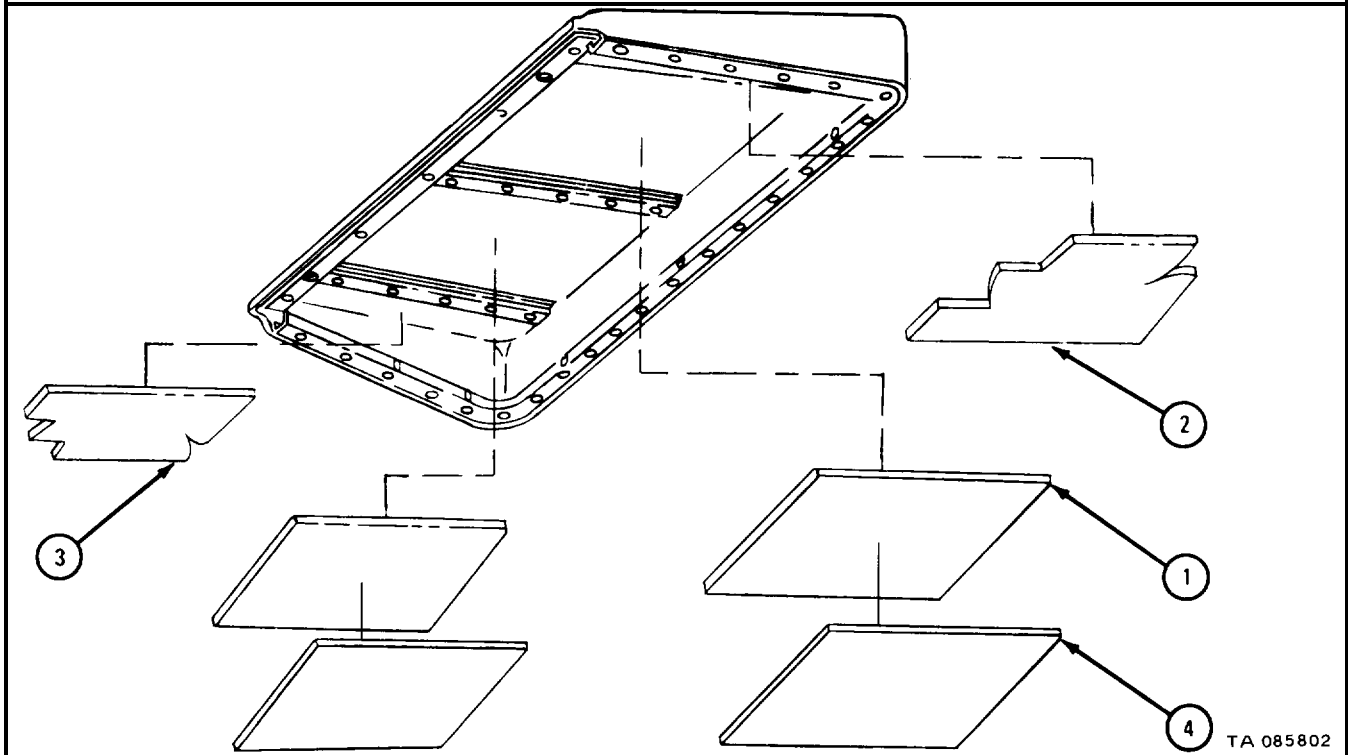

TA 085802

## FRAME 4

1. Hold top side rear retainer (1) in place and put in, but do not tighten, screw (2).
2. Do step 1 again on right side of roof panel.
3. Hold front side retainer (3) in place and put in, but do not tighten, screw (4).
4. Do step 3 again on right side of roof panel.
5. Put three retainers (5) with slotted holes in place. Put three top insulation retainers (6) in place and put in, but do not tighten, three screws (7).
6. Line up holes and put in 15 screws (8) and 15 washers (9).
7. Tighten two screws (2), two screws (4), and three screws (7).

GO TO FRAME 5

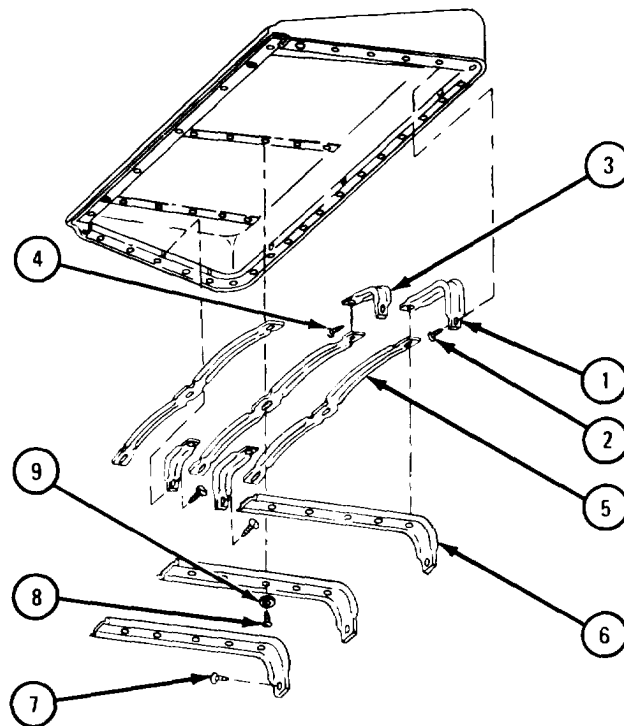

TA 085803

FRAME 5

1. Hold side run retainer (1), side run retainer (2), and side run retainer (3) in place and put in five screws (4), five washers (5), and five nuts (6).
2. Do step 1 again for right side of roof panel.
3. Hold front seal (7) in place and put in three screws (8), washers (9), and nuts (10).

GO TO FRAME 6

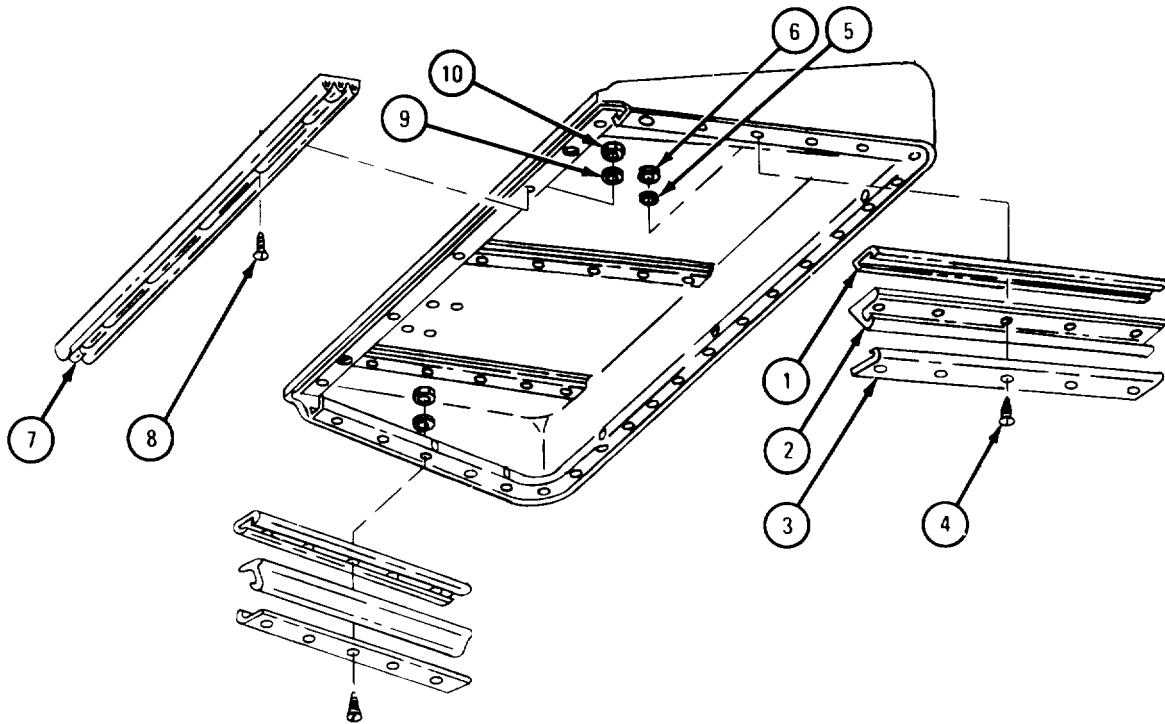

TA 085804

FRAME 6

1. Press seal (1) into rail (2).
2. Press seal (3) into end rail (4).
3. Carefully slide glass (5) into seal (1) and rail (2).
4. Put seal (3) and end rail (4) in place.
5. Put in two screws (6) and sleeves (7).
6. Do steps 1 through 5 again for other window (8).
7. Spread frame (9) and put two windows (8) in place.
8. Put in two screws (10).

END OF TASK

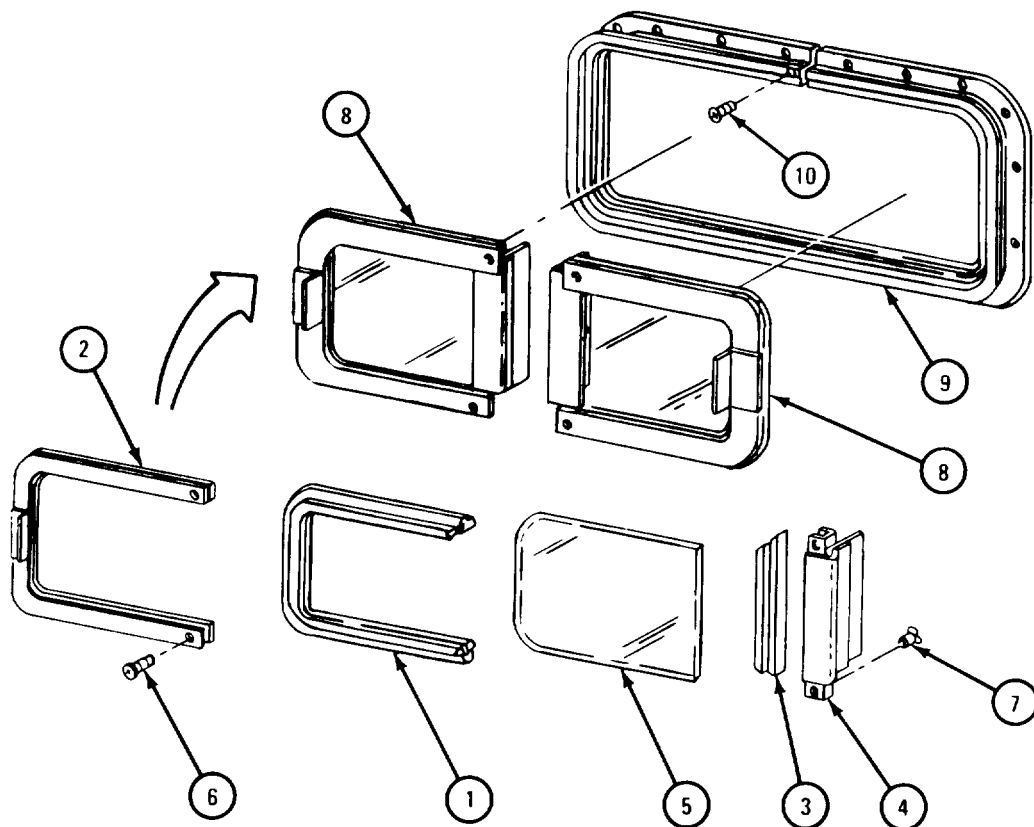

TA 085805

f. Replacement.

FRAME 1

1. Hold rear window assembly (1), frame cap tape (2), and frame cap (3) in place. Put in 22 screws (4), 22 lockwashers (5), and 22 nuts (6) through window (1).

GO TO FRAME 2

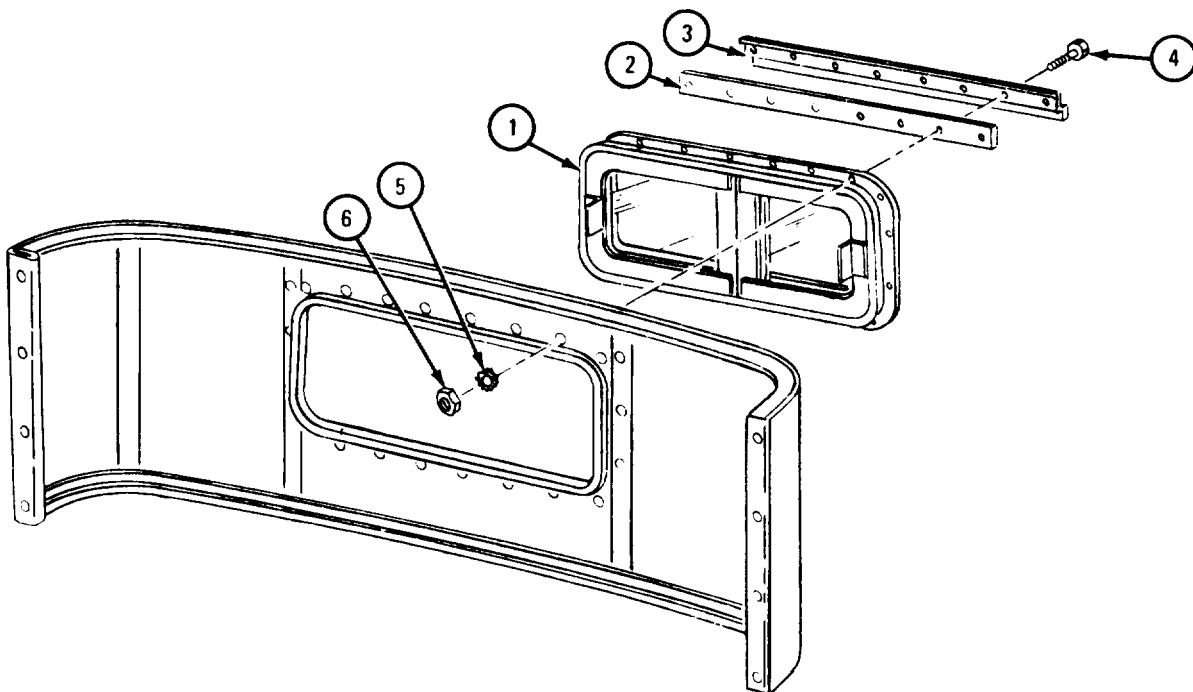

TA 085806

FRAME 2

1. Put strip seal (1) in place in cab body (2).
- Soldiers A and B 2. Put back panel (3) on strip seal (1) and cab body (2), alining holes.
- Soldier A 3. Hold back panel (3).
- Soldier B 4. Put in 14 screws (4), 14 washers (5), and 14 nuts (6).
- GO TO FRAME 3

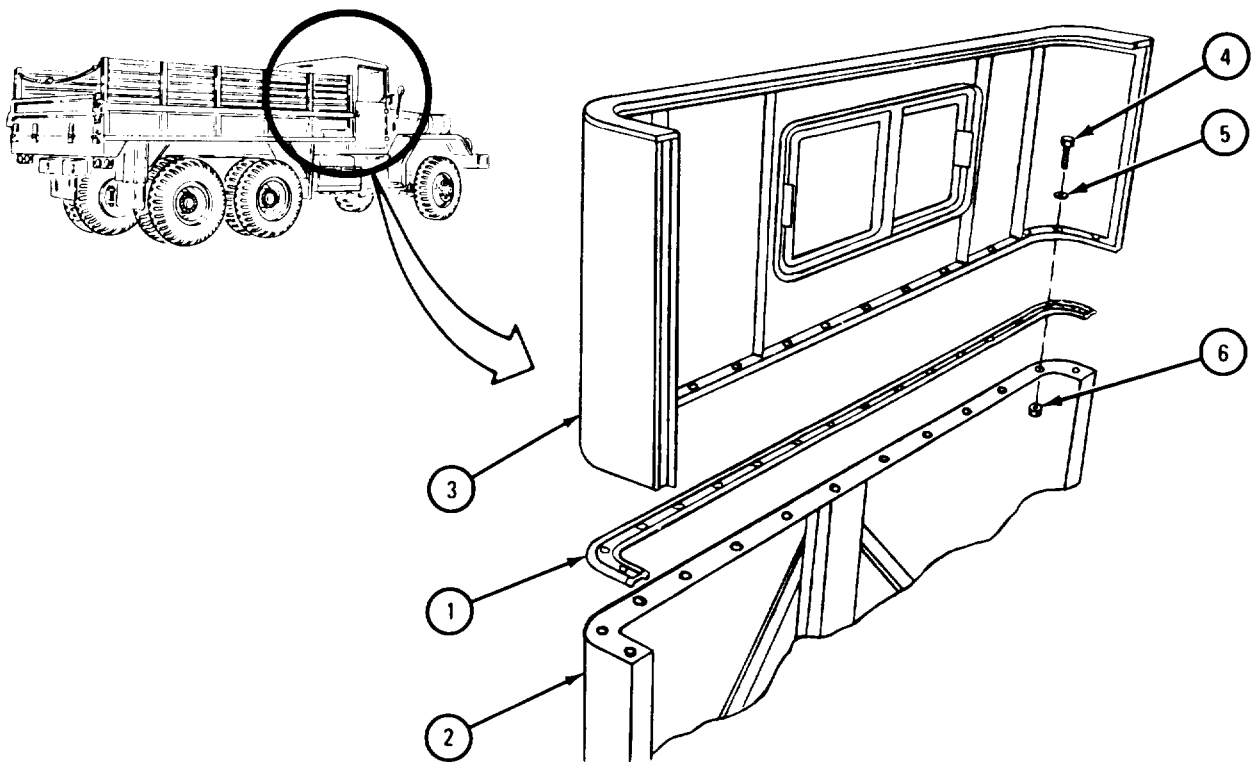

TA 085807

FRAME 3

Soldiers 1. Put roof panel (1) with strip seal (2) on back panel (3) and windshield (4) and aline holes.

Soldier A 2. Put in, but do not tighten, 14 screws (5), 28 washers (6), and 14 nuts (7).

3. Put in, but do not tighten, two screws (8) with two angle washers (9) and two nuts (10).

GO TO FRAME 4

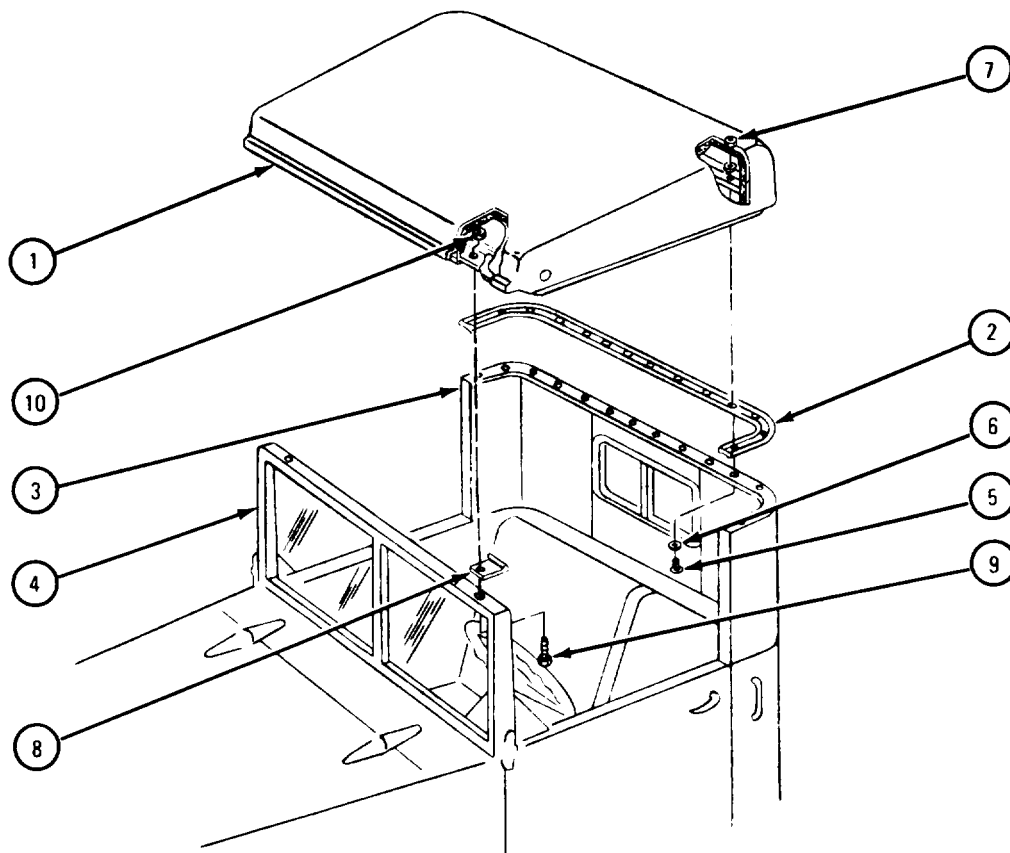

TA 085808



## FRAME 4

1. With cab windows (1) closed, tighten 14 nuts (2) and two nuts (3). Put in two screws (4) and two washers (5).
2. Open and close windows (1) to check seal and fit.

END OF TASK

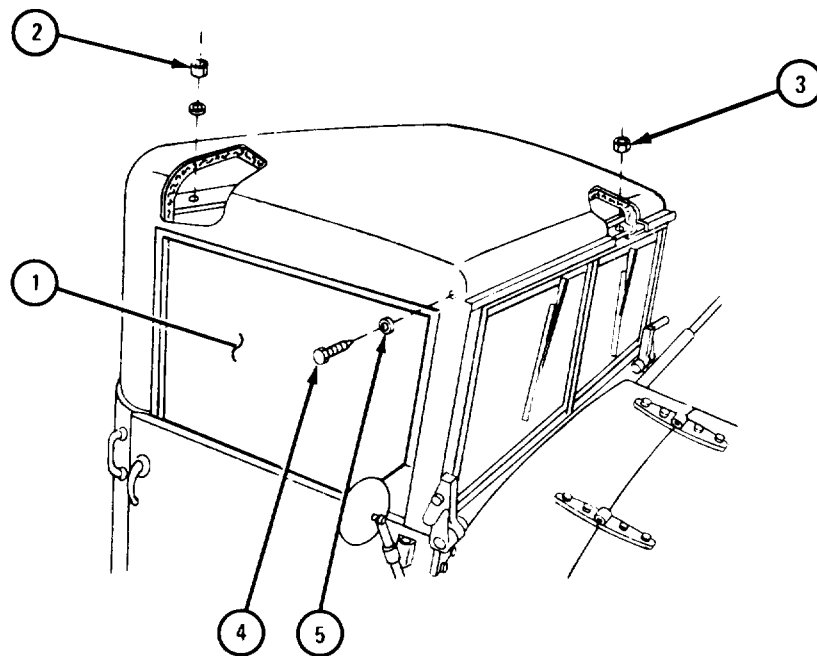

TA 085809

**19-23. HOOD COVER ASSEMBLY INSTALLATION.**

TOOLS : No special tools required

SUPPLIES : None

PERSONNEL : Two

EQUIPMENT CONDITION : Truck parked, engine off, handbrake set.

Preliminary Procedure. Remove air cleaner assembly. Refer to TM 9-2320-211-20.

b. Installation.

FRAME 1

Soldier A 1. Hold hood cover (1) in place on truck as shown.

Soldier B 2. Mark location of all grommets (2) on truck.

Soldier A 3. Take off hood cover (1).

GO TO FRAME 2

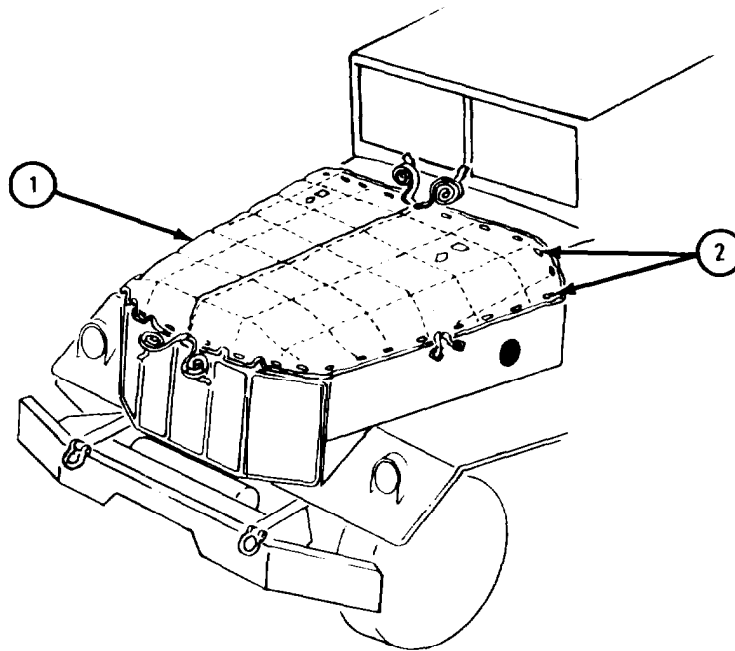

TA 089422

FRAME 2

Soldier A 1. Hold left side panel cover (1) in place on truck as shown.

Soldier B 2. Mark location of all grommets (2) on truck.

Soldier A 3. Take off left side panel cover (1).

Soldiers A and B 4. Do steps 1 through 3 again for right side panel (3).

GO TO FRAME 3

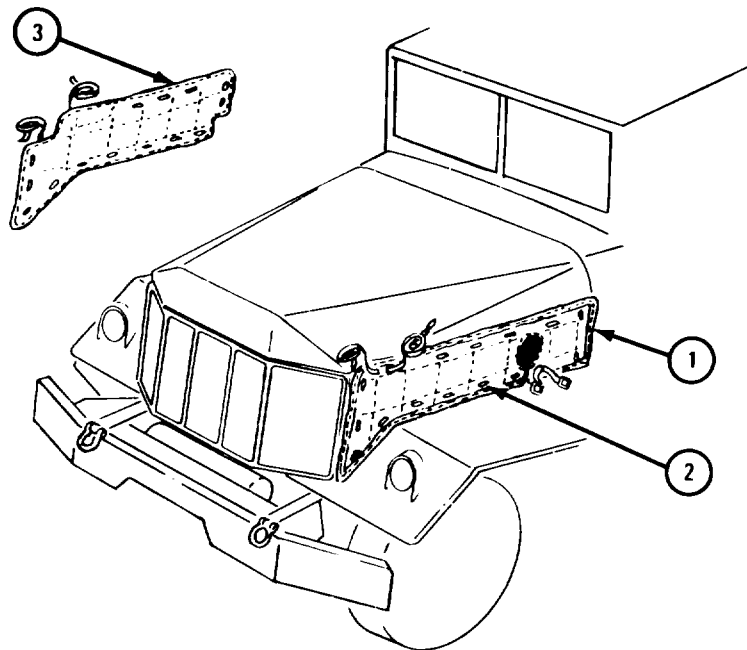

TA 089423

FRAME 3

**CAUTION**

Be sure there is clearance under hood and behind side panels so drill cannot damage parts in engine compartment.

1. Hold loop (1) against left side panel (2) with center of loop over mark (3),
2. Mark left side panel (2) at location of two screw holes in loop (1).
3. Center punch two screw hole locations marked in step 2.
4. Drill two screw holes at locations punched in step 3.
5. Hold loop (1) against left side panel (2) and align screw holes.
6. Put in two screws (4).
7. Do steps 1 through 6 again for all marks (3) on left side panel (2) and all marks (5) on hood (6) and right side panel (7).

GO TO FRAME 4

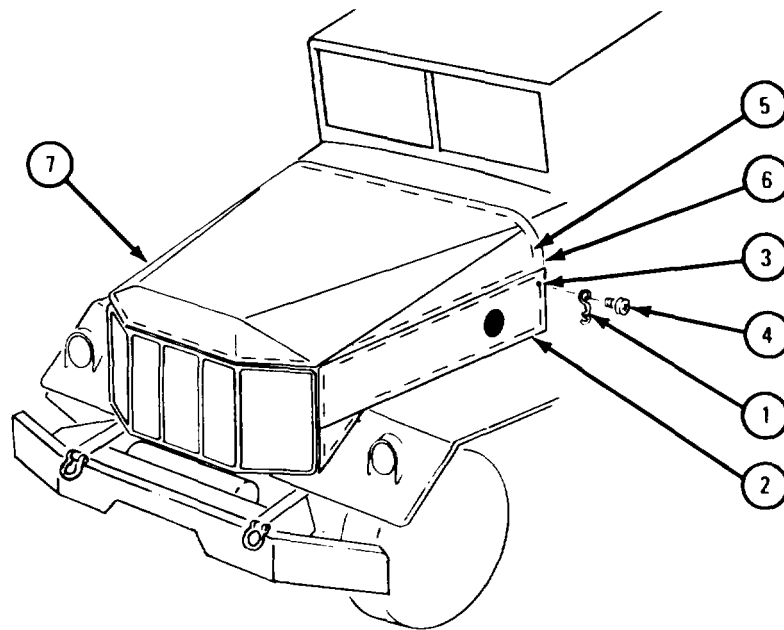

TA 089424

## FRAME 4

1. Put side panel cover (1) in place on truck as shown.
  2. Lace strap (2) through loops (3) and buckle (4) as shown.
  3. Lace strap (5) through loops (6) and buckle (7) as shown.
  4. Do steps 1 through 3 again for side panel cover on other side of truck.
- GO TO FRAME 5

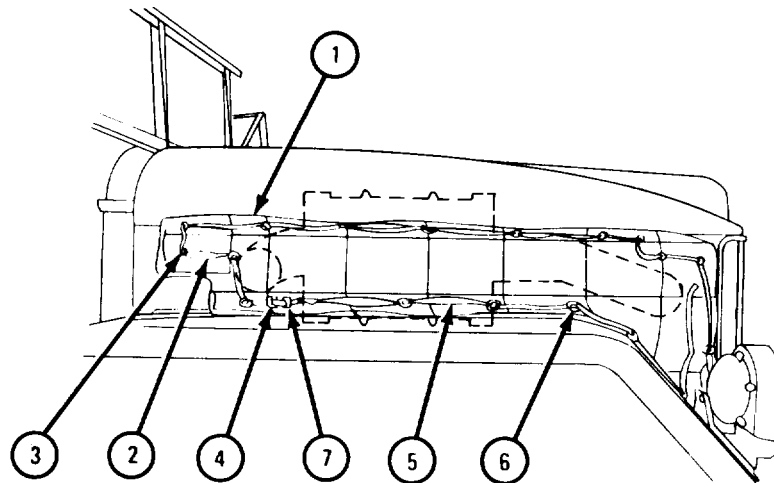

TA 089425

FRAME 5

1. Put hood cover (1) in place on truck as shown.
2. Lace strap (2) through loops (3) and buckle (4).
3. Lace strap (5) through loops (6) and buckle (7).
4. Do steps 2 and 3 again on other side of hood cover (1).

**NOTE**

Follow-on Maintenance Action Required:

Replace air cleaner assembly. Refer to TM 9-2320-211-20.

END OF TASK

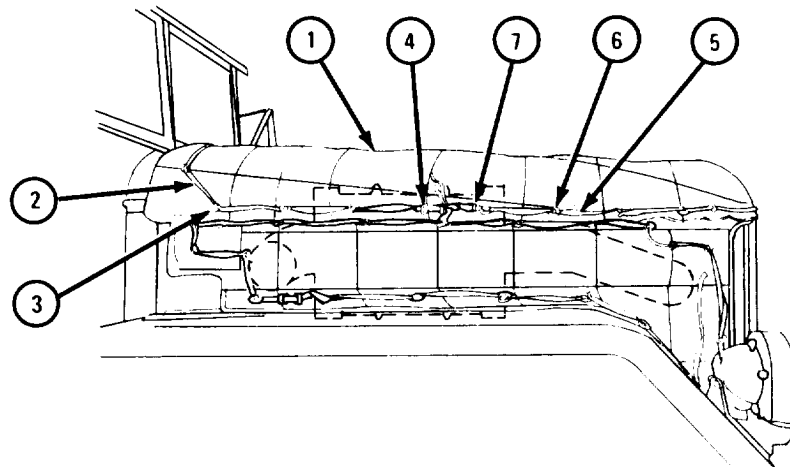

TA 089426

**19-24. RADIATOR COVER ASSEMBLY INSTALLATION.**

TOOLS: No special tools required

SUPPLIES: None

PERSONNEL: Two

EQUIPMENT CONDITION: Truck parked, engine off, handbrake set.

**FRAME 1**

Soldier A 1. Unlatch two hood latches (1). Put on and hold radiator cover (2) in place on truck as shown.

Soldier B 2. Mark location of 13 grommets (3) on radiator guard (4).

Soldier A 3. Take off radiator cover (2).

GO TO FRAME 2

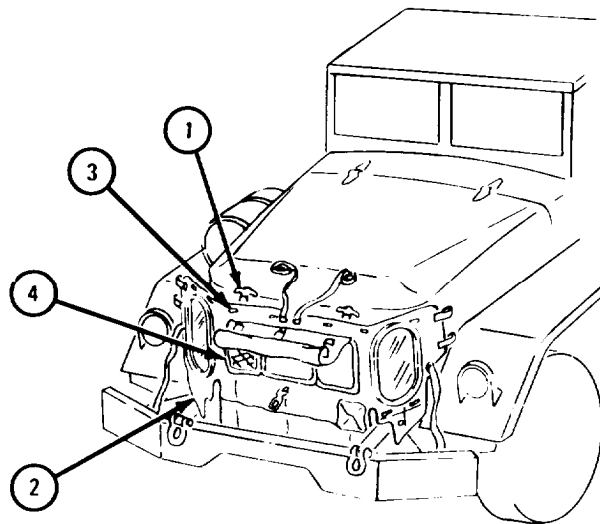

TA 089427

FRAME 2

1. Hold radiator cover loop (1) against brush guard (2) with center of loop over mark and ends of loop on brush guard.
2. Mark brush guard (2) at locations of two screw holes of loop (1). Take off loop.
3. Punch two screw hole locations marked in step 2.
4. Drill two screw holes at locations punched in step 3.
5. Hold loop (1) against brush guard (2) and align screw holes.
6. Put in two screws (3).
7. Do steps 1 through 6 again for 12 more loops (1).

GO TO FRAME 3

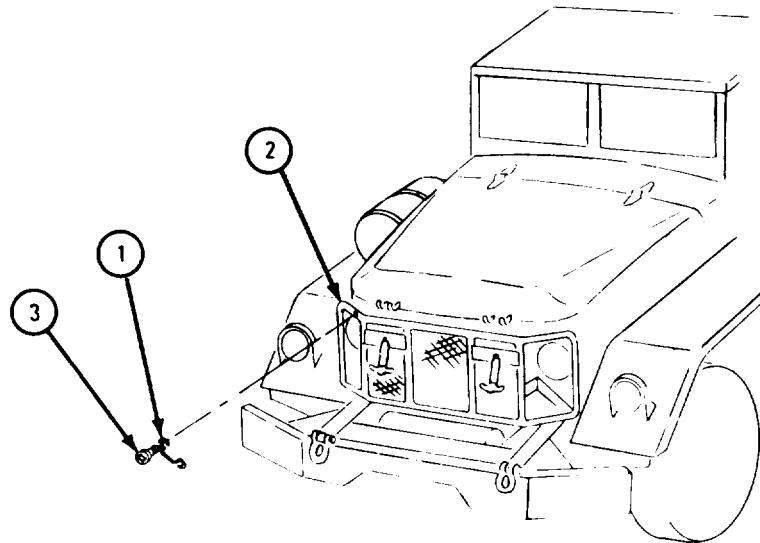

TA 089428



FRAME 3

1. Put radiator cover (1) in place on truck as shown.
2. Lace strap (2) through loops (3) and buckle (4) as shown.
3. Lace strap (5) through loops (6) and buckle (7) as shown.
4. Put long end of retaining spring (8) through grommet (9).
5. Put loose end of retaining spring (8) through hole in frame side rail (10).
6. Do steps 2 through 5 again for other side of radiator cover (1).

IF TRUCK HAS SIDE PANEL COVERS, GO TO FRAME 4.

IF TRUCK HAS NO SIDE PANEL COVERS, GO TO FRAME 5

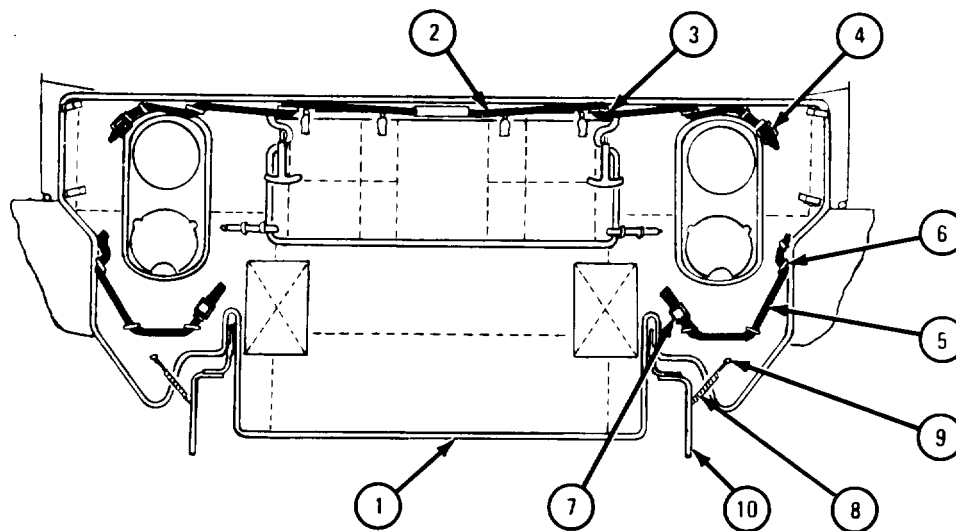

TA 089429

FRAME 4

1. Put short end of retaining spring (1) through cloth loop (2).
2. Put loose end of retaining spring (1) through side panel cover loop (3).
3. Put short end of retaining spring (4) through cloth loop (5).
4. Put loose end of retaining spring (4) through side panel cover loop (6).
5. Do steps 1 through 4 again for other side of radiator cover (7).
6. Close two hood latches (8).

END OF TASK

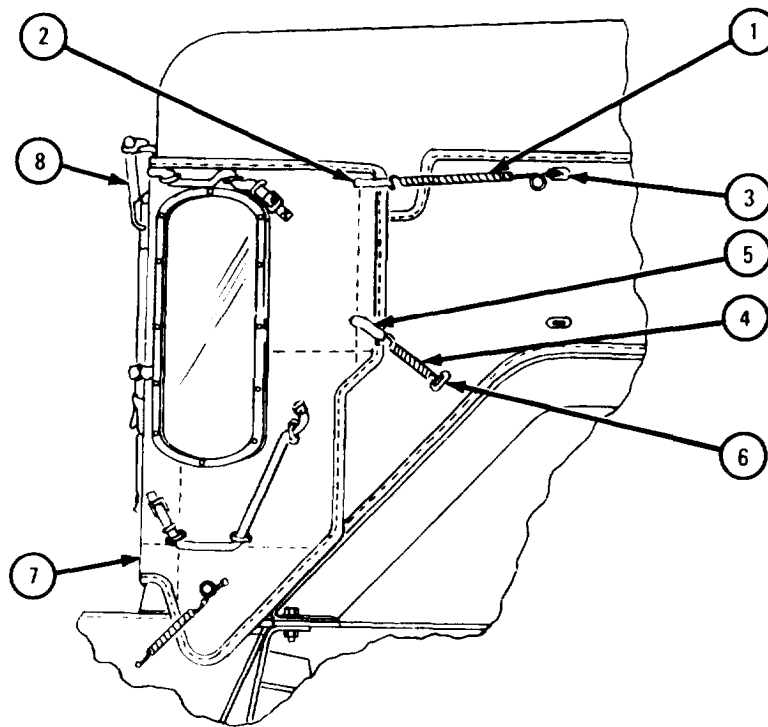

TA 089430

## FRAME 5

1. Put short end of retaining spring (1) through cloth loop (2).
2. Pull retaining spring (1) across side panel (3) as shown. Mark side panel at end of retaining spring. Let retaining spring hang from cloth loop (2).
3. Hold loop (4) against side panel (3) as shown, with center of loop over pen mark.
4. Mark locations of two screw holes of loop (4). Take off loop.
5. Punch two screw hole locations marked in step 4.
6. Drill two screw holes punched in step 5.
7. Hold loop (4) against side panel (3) and aline screw holes.
8. Put in two screws (5).
9. Put loose end of retaining spring (1) through cloth loop (4).
10. Do steps 1 through 9 again for retaining spring (6).
11. Do steps 1 through 10 again for other side of radiator cover (7).
12. Close two hood latches (8).

END OF TASK

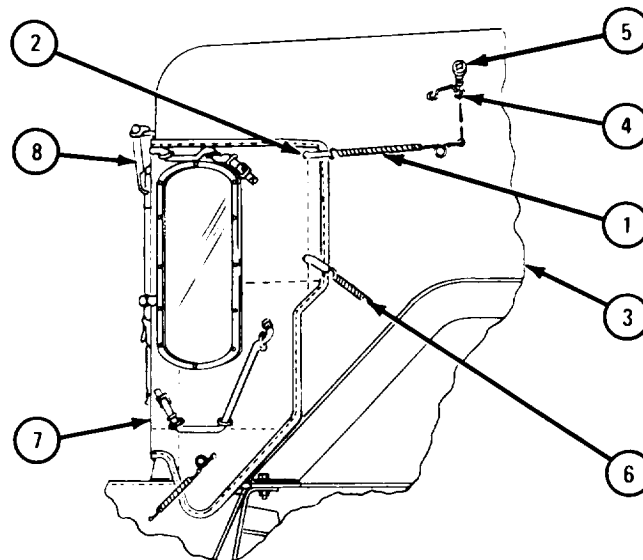

TA 089431

**19-25. RADIATOR COVER ASSEMBLY REPAIR.**

- a. Removal. For removal procedures, refer to TM 9-2320-211-20.
- b. Repair. For repair procedures, refer to FM 43-3.
- c. Replacement. For replacement procedures, refer to TM 9-2320-211-20.

**19-26. SLAVE RECEPTACLE KIT INSTALLATION.**

TOOLS: No special tools required

SUPPLIES: Slave receptacle kit

PERSONNEL: One

EQUIPMENT CONDITION: Truck parked, engine off, handbrake set.

- a. Preliminary Procedures.
  - (1) Open battery box cover. Refer to Battery Inspection, TM 9-2320-211-20.
  - (2) Disconnect battery ground cable. Refer to TM 9-2320-211-20.

b. Installation.

**NOTE**

Slave receptacle is part of fuel burning personnel heater kit. Battery box must be put in before slave receptacle kit is put in.

FRAME 1

1. Open right cab door.
2. Take out four screws (1) and nuts (2).
3. Take off cover plate (3).
4. Put cables of slave receptacle (4) through access hole (5) and hold slave receptacle in place.
5. Put in four screws (1) and nuts (2).

GO TO FRAME 2

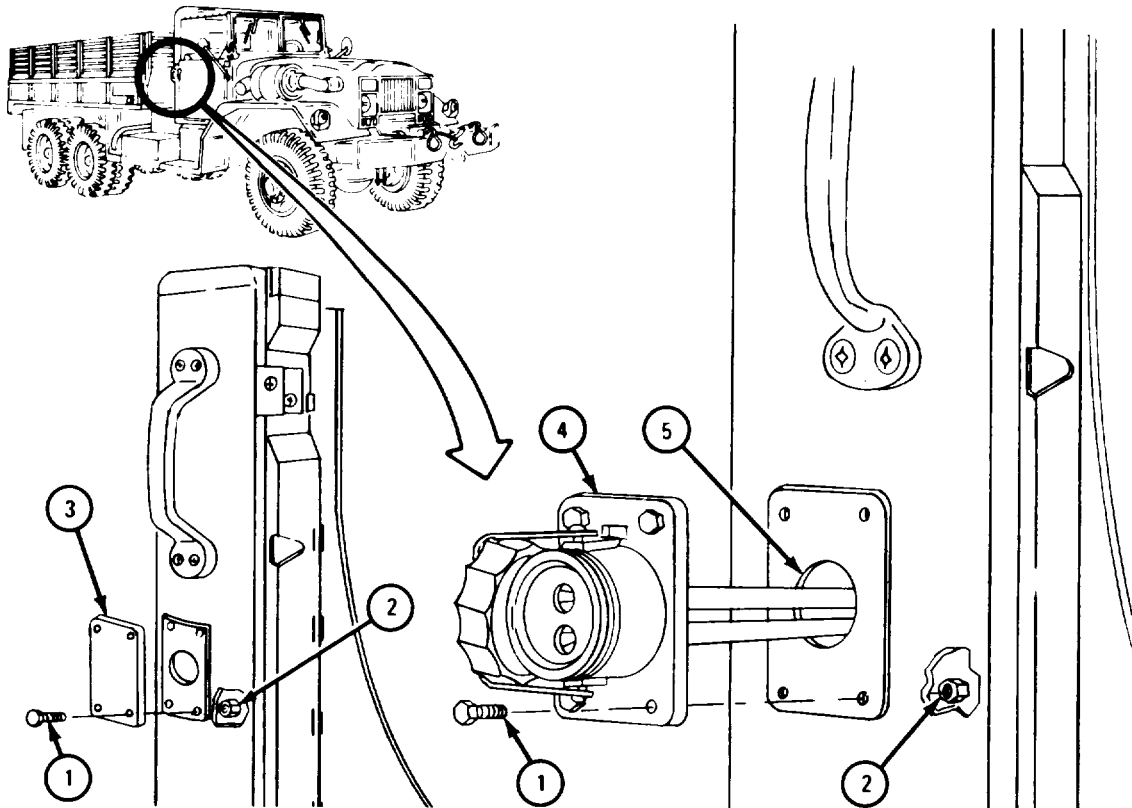

TA 101773

FRAME 2

1. Put two grommets (1) in place in two holes (2).
2. Push long (positive) receptacle cable (3) through hole (2) nearest door, under cab floor, and up through center hole in front edge of battery box (4).
3. Push short (negative) receptacle cable (5) down through other hole (2).

GO TO FRAME 3

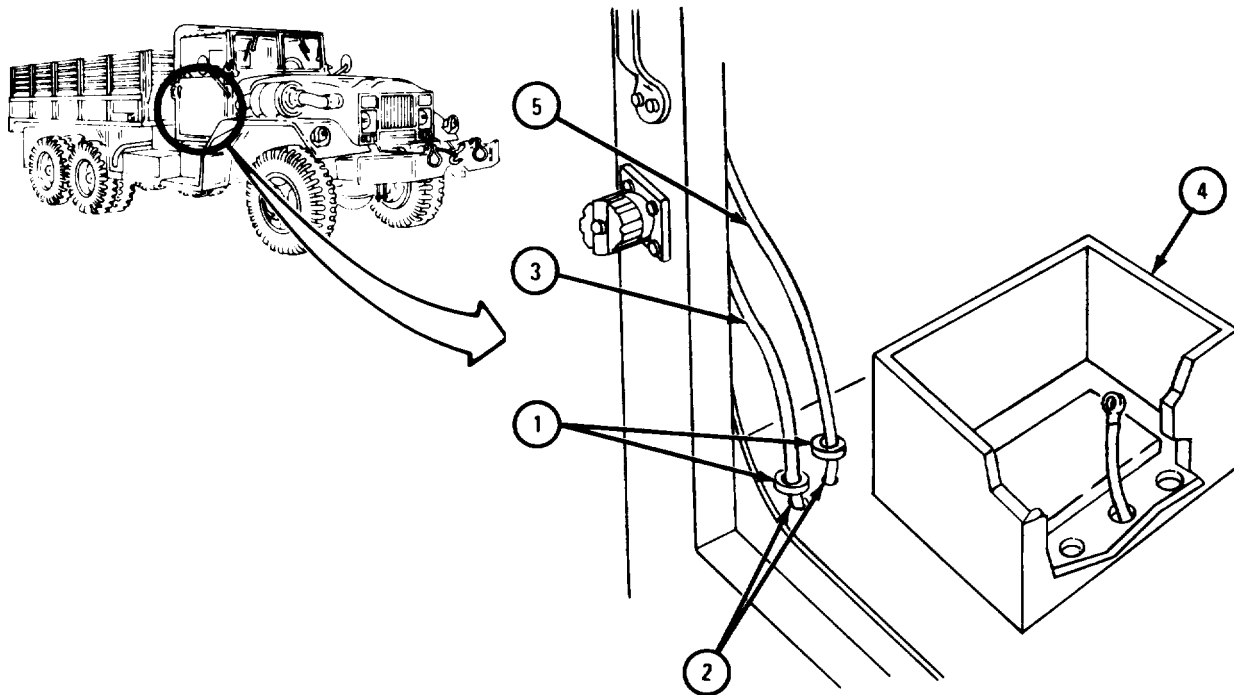

TA 101774

## FRAME 3

**NOTE**

Be sure cable-to-truck surface is free from dirt and paint before attaching cables.

1. Put bolt (1) and starwasher (2) through hole in short (negative) receptacle cable (3).
2. Put bolt (1), starwasher (2), and end of cable (3) into hole on rear running board bracket support and put on nut (4).
3. Put two clamps (5) around long (positive) and short (negative) cables above two grommets (6).
4. Put in screw (7), washer (8), and nut (9).

GO TO FRAME 4

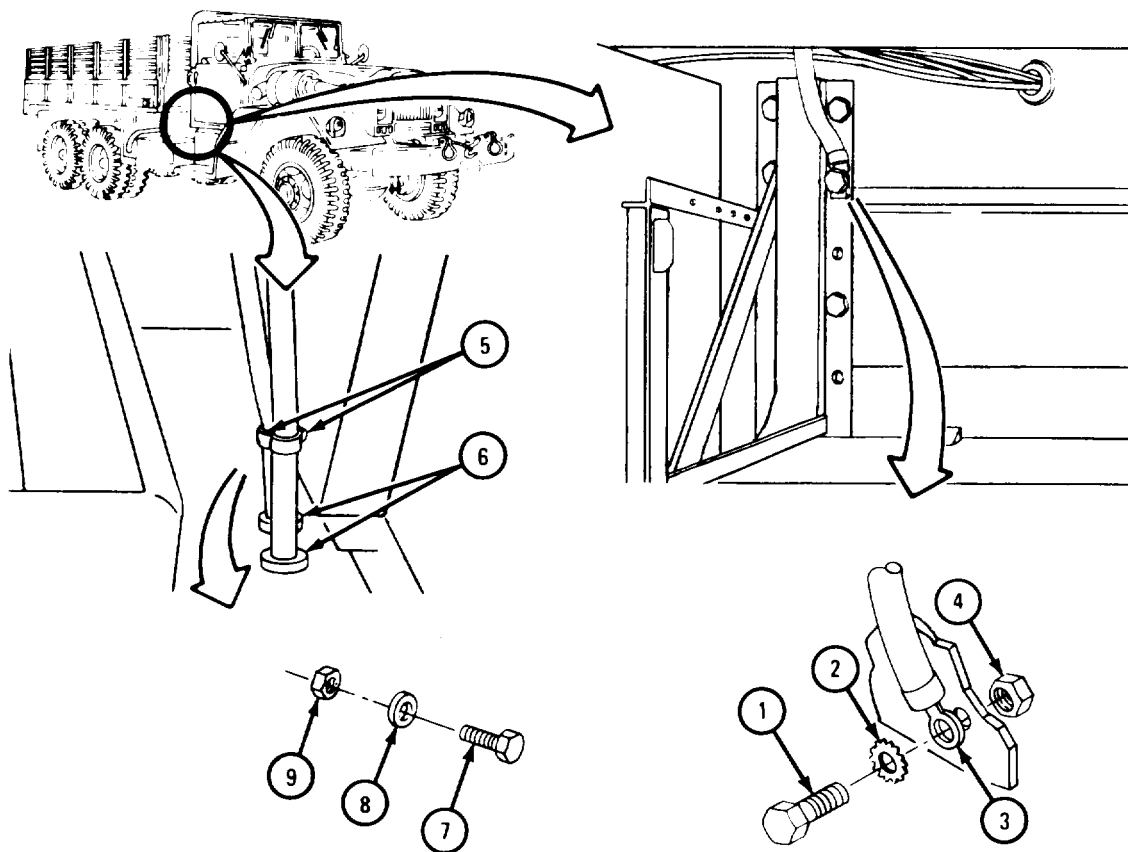

TA 087435

FRAME 4

1. Put long (positive) cable (1) on end of capscrew (2).
2. Hold capscrew (2) and put on nut (3).

**NOTE**

Follow-on Maintenance Action Required:

1. Reconnect battery ground cable. Refer to TM 9-2320-211-20.
2. Close battery box cover. Refer to Battery Inspection, TM 9-2320-211-20.

END OF TASK

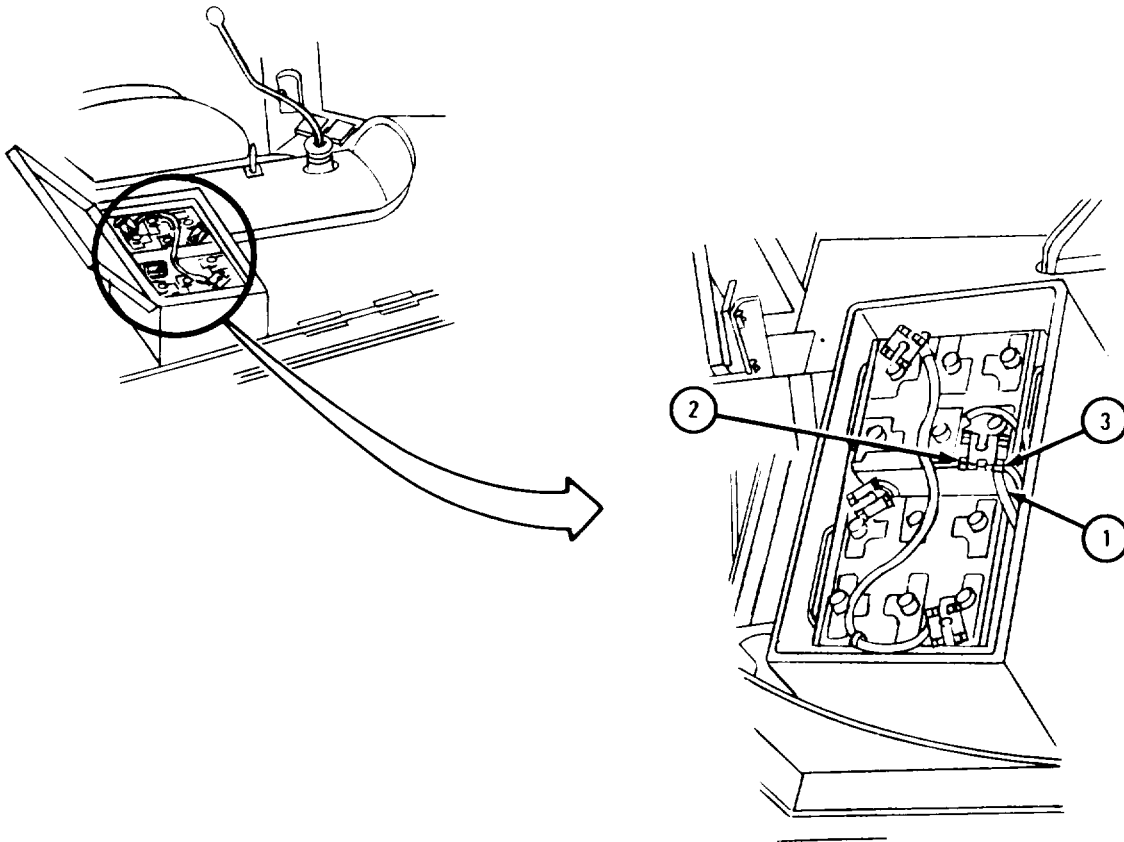

TA 101775



### 19-27. SLAVE RECEPTACLE KIT INSTALLATION (TRUCKS WITHOUT WINTERIZATION KIT).

TOOLS: No special tools required

SUPPLIES: Slave receptacle kit

PERSONNEL: Two

EQUIPMENT CONDITION: Truck parked, engine off, handbrake set.

a. Preliminary Procedures.

(1) Remove battery box cover. Refer to TM 9-2320-211-10.

(2) Disconnect battery ground cable. Refer to TM 9-2320-211-20.

b. Installation.

#### FRAME 1

1. Open right side cab door.
2. Take out four screws (1) and nuts (2).
3. Take off cover plate (3).
4. Put cables of slave receptacle (4) through access hole (5) and hold slave receptacle in place.
5. Put in four screws (1) and nuts (2).

GO TO FRAME 2

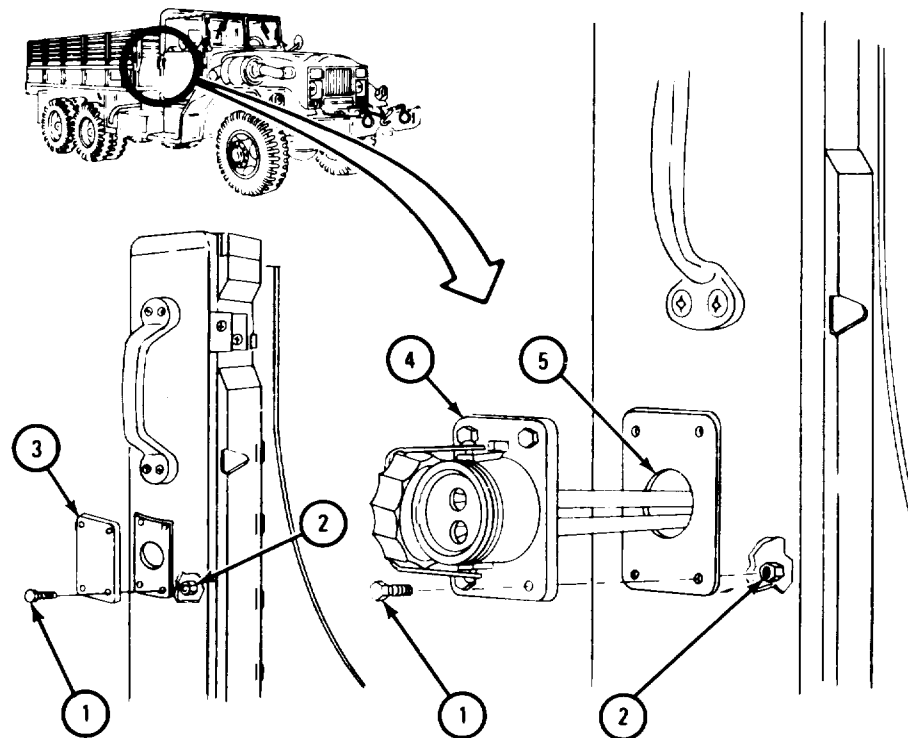

TA 103124

FRAME 2

1. Put two grommets (1) in place in two holes (2).
2. Push two cables (3) all the way through two holes (2).
3. Close cab door.

GO TO FRAME 3

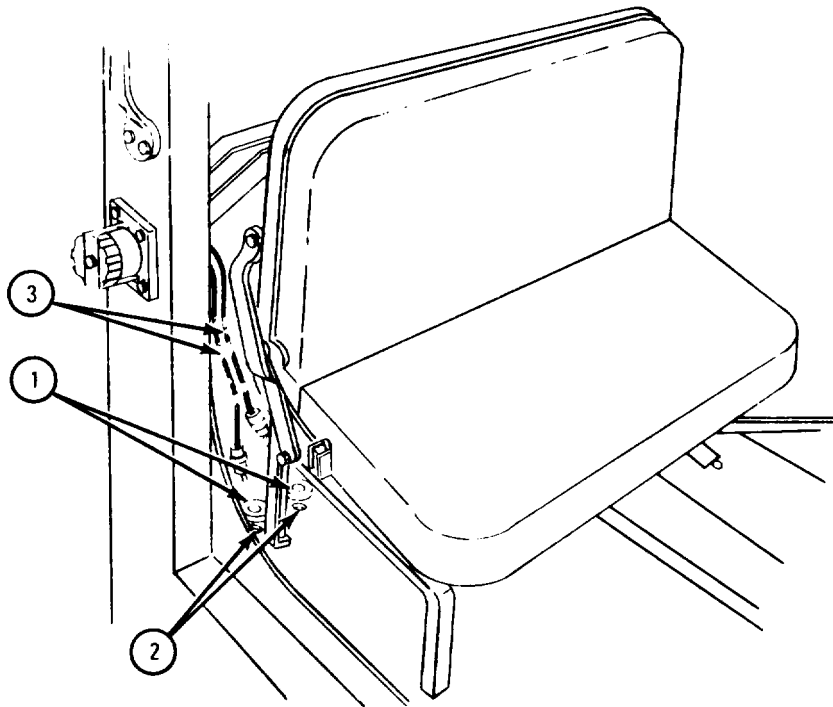

TA 103125

FRAME 3

Soldier A 1. Working under truck, hold screw (1).

Soldier B 2. Take off nut (2).

3. Take off nut (3).

GO TO FRAME 4

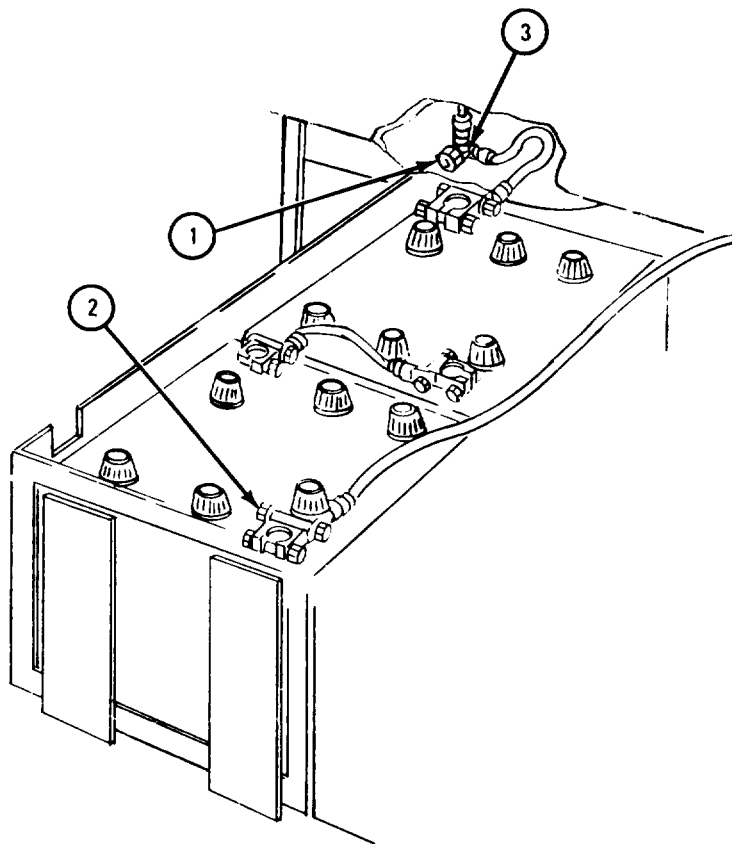

TA 103126

FRAME 4

- Soldier A 1. Working under truck, put in and hold screw (1).
- Soldier B 2. Put negative cable (2) (short cable) in place as shown.
3. Put on nut (3).
4. Put positive cable (4) (long cable) in place as shown.
5. Put on nut (5).

**NOTE**

Follow-on Maintenance Action Required:

1. Replace battery box cover. Refer to TM 9-2320-211-10.
2. Reconnect battery ground cable. Refer to TM 9-2320-211-20.

END OF TASK

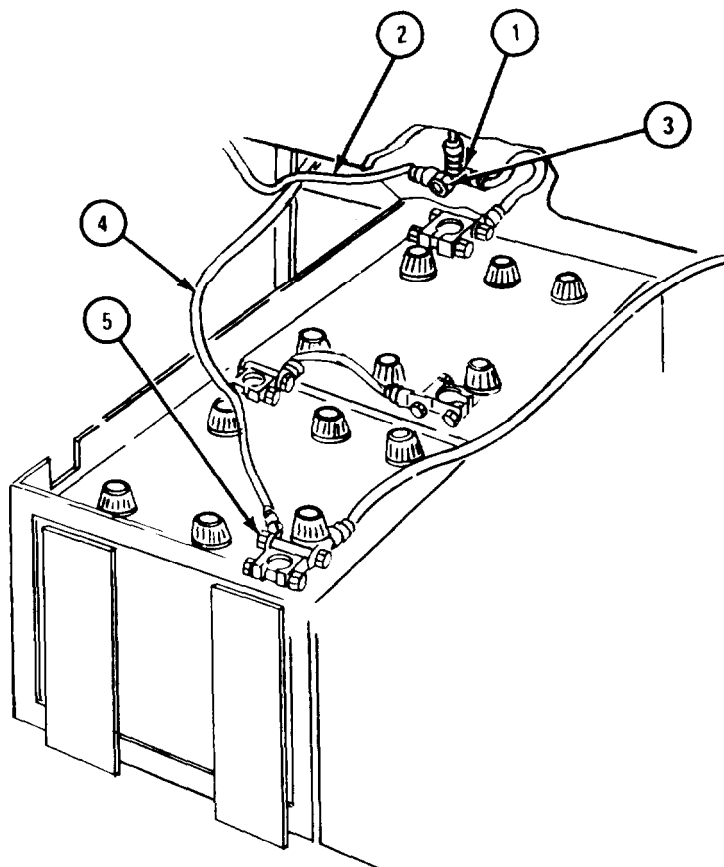

TA 103127

**Section III. SPECIAL PURPOSE KITS**

**19-28. ELECTRIC BRAKE KIT INSTALLATION, TEST, AND ADJUSTMENT.**

TOOLS: No special tools required

SUPPLIES: None

PERSONNEL: One

EQUIPMENT CONDITION: Truck parked, engine off, handbrake set.

a. Preliminary Procedures.

- (1) Disconnect battery ground cable. Refer to TM 9-2320-211-20.
- (2) Vent air system pressure. Refer to TM 9-2320-211-20.
- (3) Open hood and left side panel. Refer to TM 9-2320-211-10.
- (4) Take off front and intermediate cab tunnels. Refer to TM 9-2320-211-20.
- (5) On truck M543A2, remove fuel tank. Refer to TM 9-2320-211-20.

b. Installation.

FRAME 1

1. Working under truck, find transfer mounting bracket bolt (1).
  2. Measure distance A to find spot for bracket (2).
    - a. If working on trucks M51A2, M54A2, M54A2C or M55A2, distance A is 18 3/16 inches.
    - b. If working on truck M52A2, distance A is 13 5/16 inches.
    - c. If working on truck M543A2, distance A is 26 3/16 inches.
  3. Put bracket (2) on frame (3) as measured in step 2 and as shown.
  4. Center punch and drill out four 13/32-inch holes (4) through frame (3).
- GO TO FRAME 2

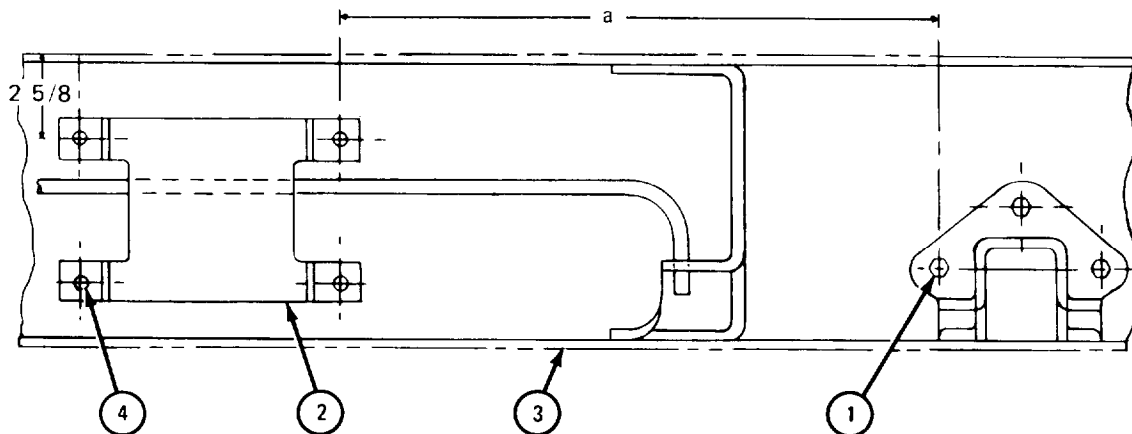
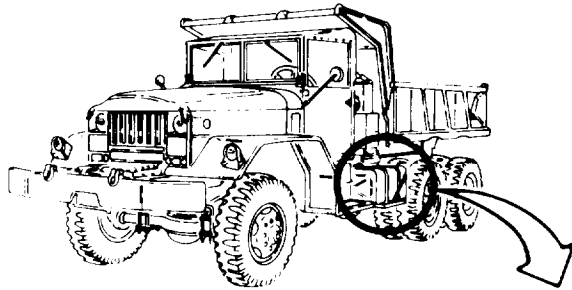

TA 103195

FRAME 2

1. Put on bracket (1) with four screws (2) and nuts (3).

**CAUTION**

Make sure to cut into air line (4) and not into hydraulic line.

2. Cut out air line (4) to dimensions shown.
3. Put controller assembly (5) on bracket (1) with three washers (6) and nuts (7).
4. Put on tee fitting (8).
5. Put air line (9) on tee fitting (8) and controller assembly (5).
6. Tighten four fittings (10).

GO TO FRAME 3

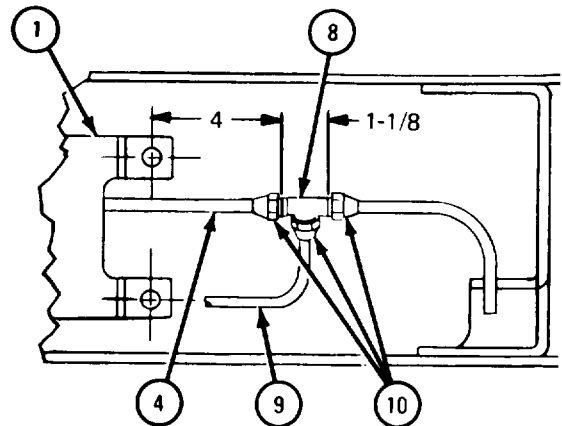
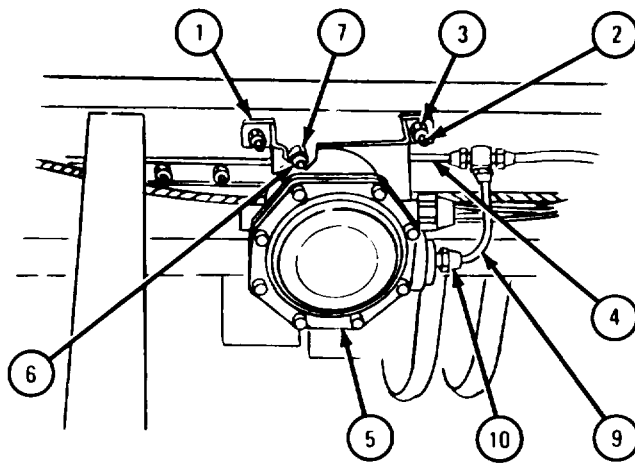

TA 103196

FRAME 3

1. Put rheostat bracket (1) in place on steering column (2).
2. Put in screw (3) and nut (4).
3. Put rheostat (5) into place in rheostat bracket (1).
4. Put in screw (6) and nut (7).

GO TO FRAME 4

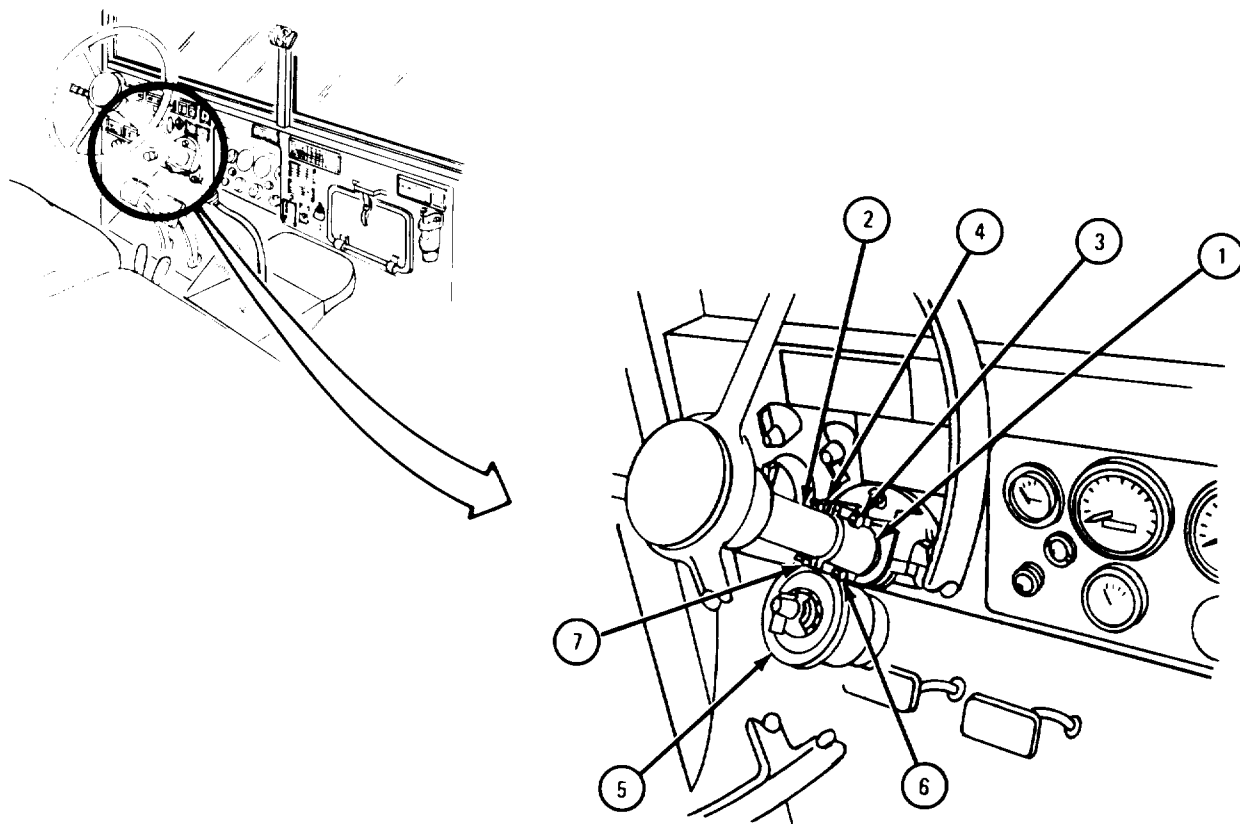

TA 103197



FRAME 4

1. Take out four screws (1), nuts (2), and washers (3). Take off receptacle cover (4).
2. Take out receptacle assembly (5).
3. Unscrew grommet retaining nut (6) and slide it back along cable (7).
4. Pull grommet (8) away from receptacle assembly (5). Be careful not to pull wire leads (9) out of receptacle assembly.

GO TO FRAME 5

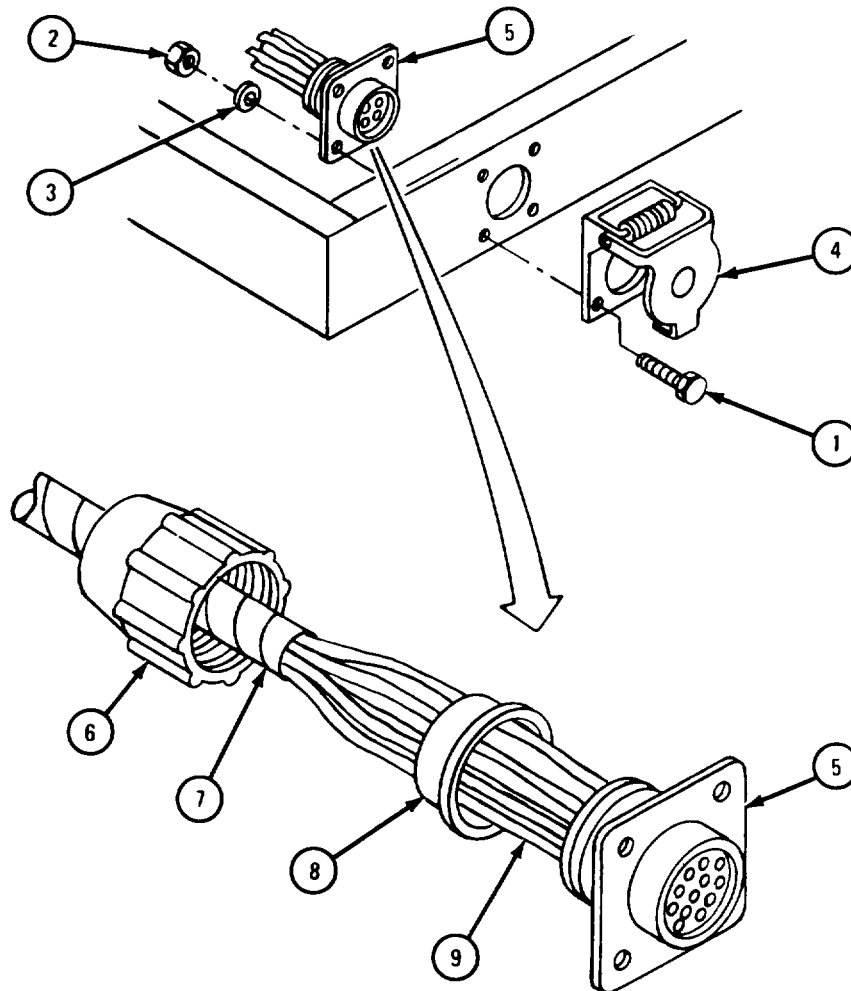

TA 103198

FRAME 5

1. Pass lead (1) with wire number 53B through grommet retaining nut (2) and empty hole in grommet (3). Aline lead with terminal N in receptacle assembly (4).
2. Solder lead (1) with wire number 53B to terminal N.
3. Pass lead (5) with wire number 53C through grommet retaining nut (2) and empty hole in grommet (3). Aline lead with terminal M in receptacle assembly (4).
4. Solder lead (5) with wire number 53C to terminal M.

GO TO FRAME 6

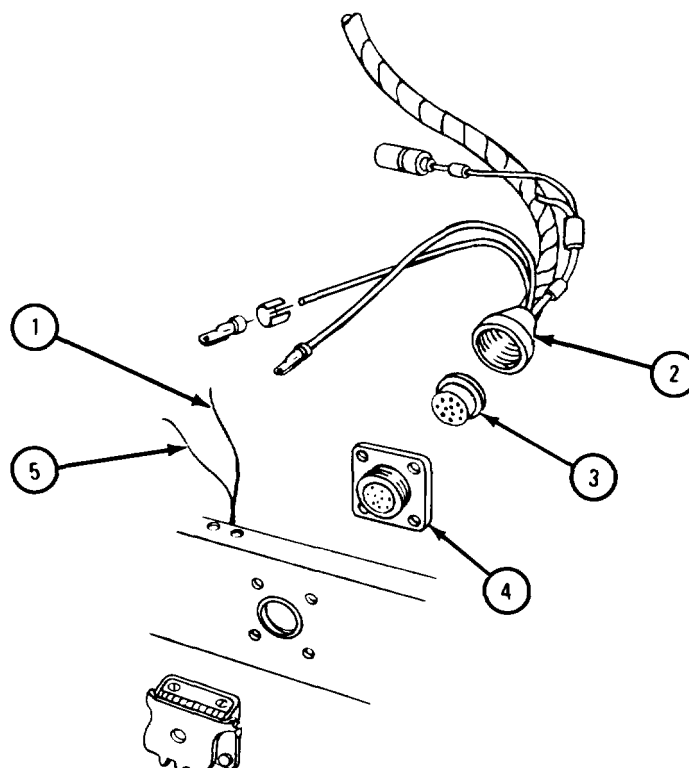

TA 103199

## FRAME 6

1. Push grommet (1) into receptacle assembly (2) until it is seated.
2. Screw grommet retaining nut (3) into receptacle assembly (2).
3. Put receptacle assembly (2) into place on rear frame member (4) and align screw holes.
4. Put receptacle cover (5) into place on rear frame member (4) and align screw holes.
5. Put in four screws (6), washers (7), and nuts (8).

GO TO FRAME 7

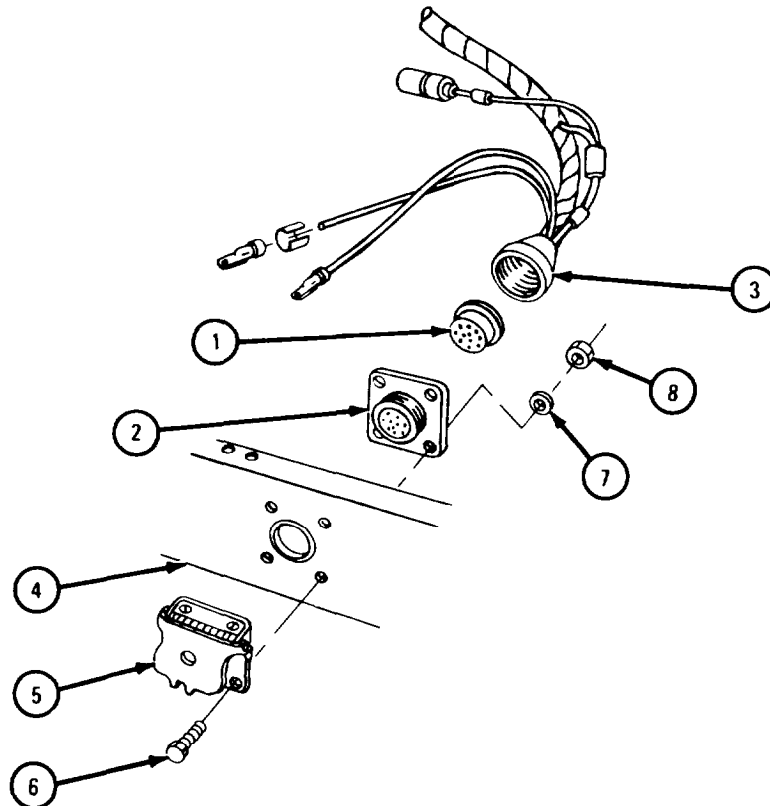

TA 103200

FRAME 7

1. Take out screw (1) and nut (2).
2. Spread open ends of electrical harness clamp (3).
3. Lay out rheostat-to-controller cable (4) along cable on inside of left frame member (5) and put rheostat-to-controller cable into electrical harness clamp (3).
4. Close ends of electrical harness clamp (3) and put it in place on inside of left frame member (5). Aline screw holes.
5. Put in screw (1) and nut (2).
6. Do steps 1 through 5 again along length of left frame member (5) and up firewall (6) as shown.

**NOTE**

Two leads (7) are only used on truck M52A2. Do not clamp these two leads along left frame member (5).

GO TO FRAME 8

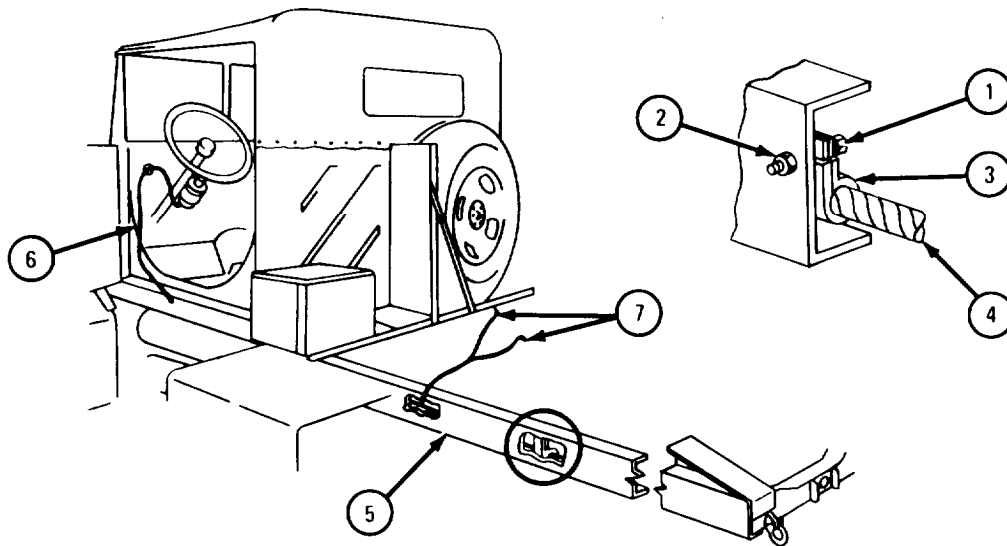

TA 103201

## FRAME 8

1. Push controller-to-rheostat cable (1) and plug (2) through electrical harness grommet (3).
2. Working inside cab, gently pull controller-to-rheostat cable (1) until it reaches rheostat (4).
3. Plug controller-to-rheostat plug (2) into rheostat (4).

FOR TRUCK M52A2, GO TO FRAME 9.  
FOR ALL OTHER TRUCKS, GO TO FRAME 12

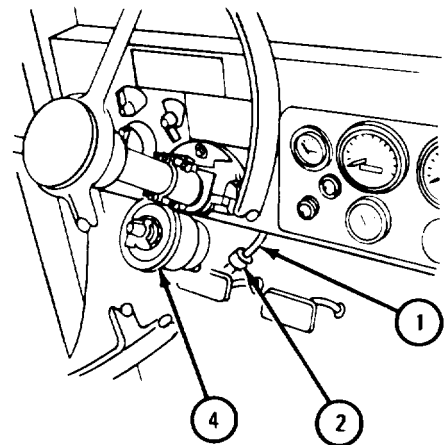
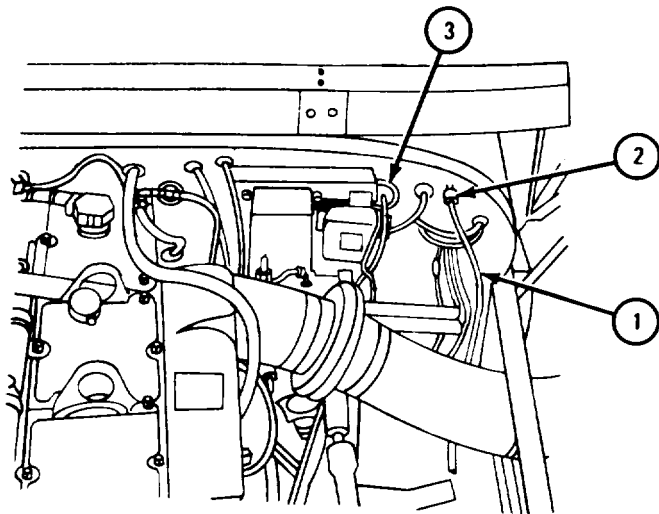

TA 103202

FRAME 9

1. Take out four screws (1) and nuts (2). Take off receptacle cover (3).
2. Take out receptacle assembly (4).
3. Unscrew grommet retaining nut (5) and slide it back along cable (6).
4. Pull grommet (7) away from receptacle assembly (4). Be careful not to pull wire leads (8) out of receptacle assembly.

GO TO FRAME 10

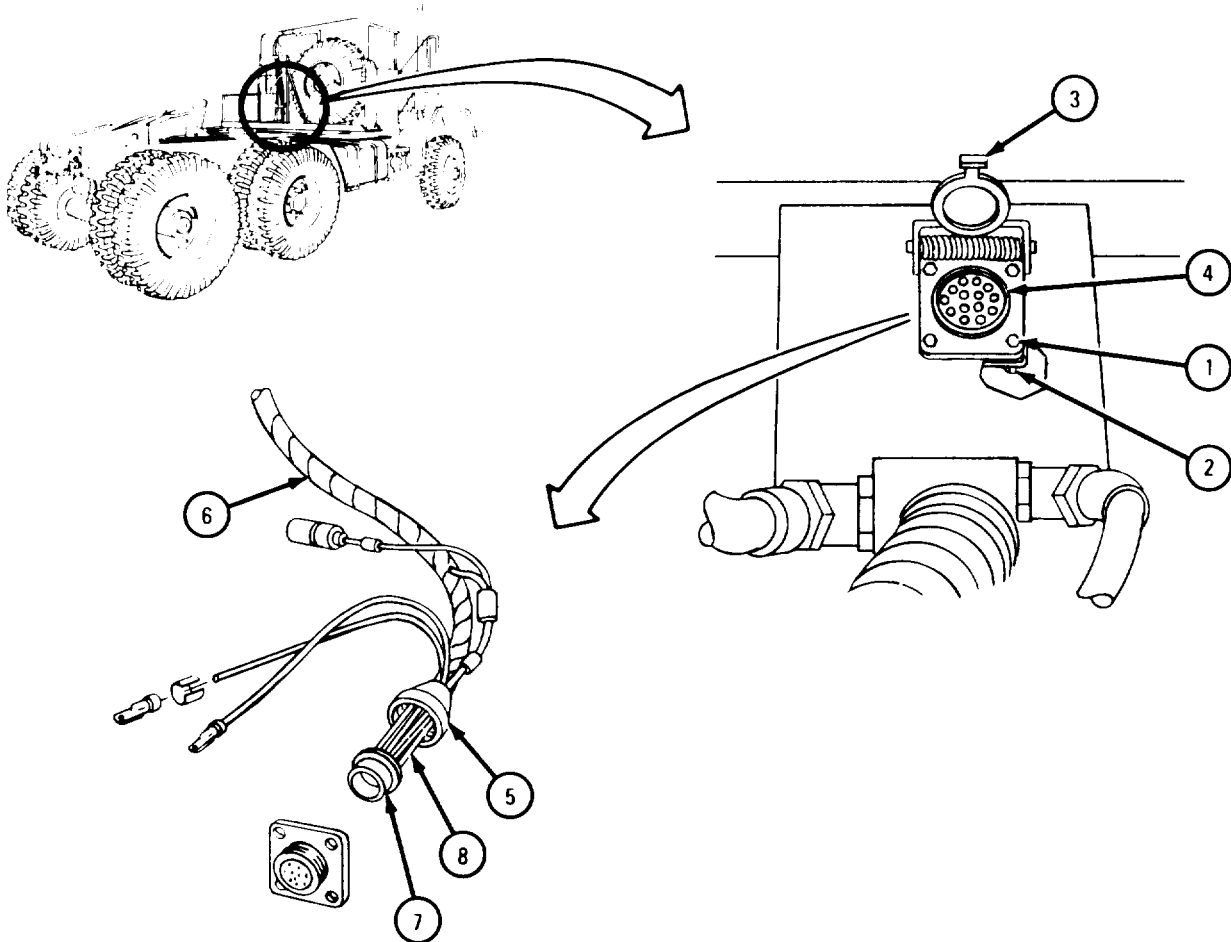

TA 103203



FRAME 11

1. Push grommet (1) into receptacle assembly (2) until it is seated.
2. Screw grommet retaining nut (3) into receptacle assembly (2).
3. Put receptacle assembly (2) in place under plate (4) as shown and aline screw holes.
4. Put receptacle cover (5) in place as shown and aline screw holes.
5. Put in four screws (6) and nuts (7).

GO TO FRAME 12

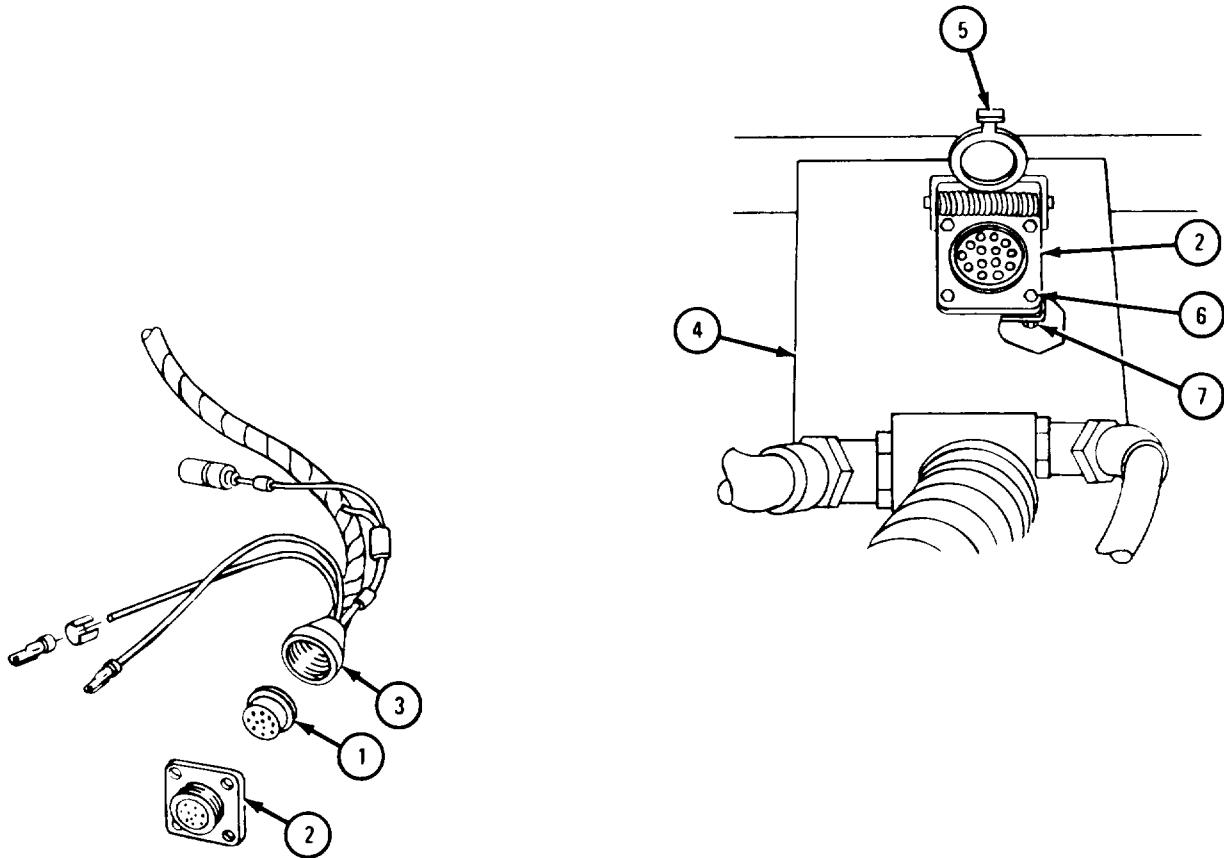

TA 103205



FRAME 12

1. Push battery-to-rheostat cable (1) and plug (2) through electrical harness grommet (3).
  2. Working inside cab, gently pull battery-to-rheostat cable (1) until it reaches rheostat (4).
  3. Plug battery-to-rheostat plug (2) into rheostat (4).
- GO TO FRAME 13

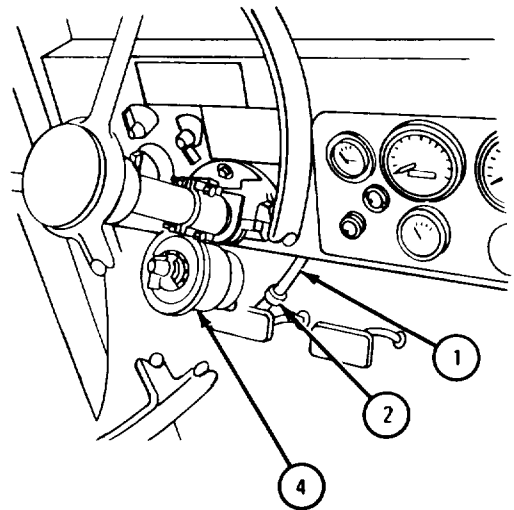
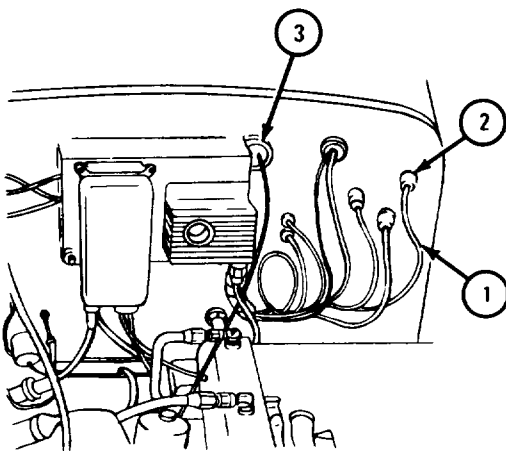

TA 103206

FRAME 13

1. Working in engine compartment, take out screw (1). Spread open clamp (2).
2. Put battery-to-rheostat cable (3) through clamp (2) and route it next to battery cable (4) toward top of transmission.
3. Close clamp (2). Put in screw (1).

GO TO FRAME 14

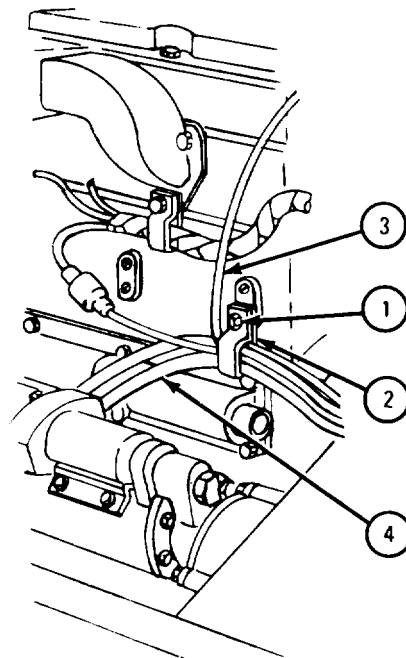
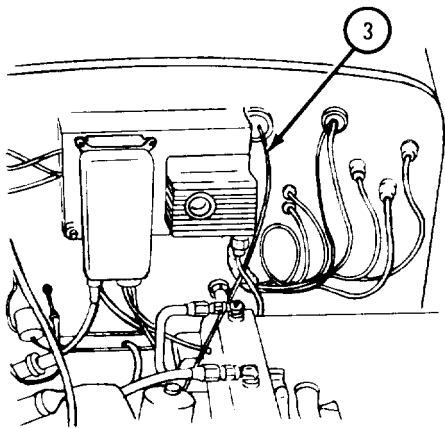

TA 103207

## FRAME 14

1. Take out two screws (1) and spread open two clamps (2).
2. Route battery-to-rheostat cable (3) next to battery cable (4) and through two clamps (2) toward battery box as shown.
3. Close two clamps (2).

GO TO FRAME 15

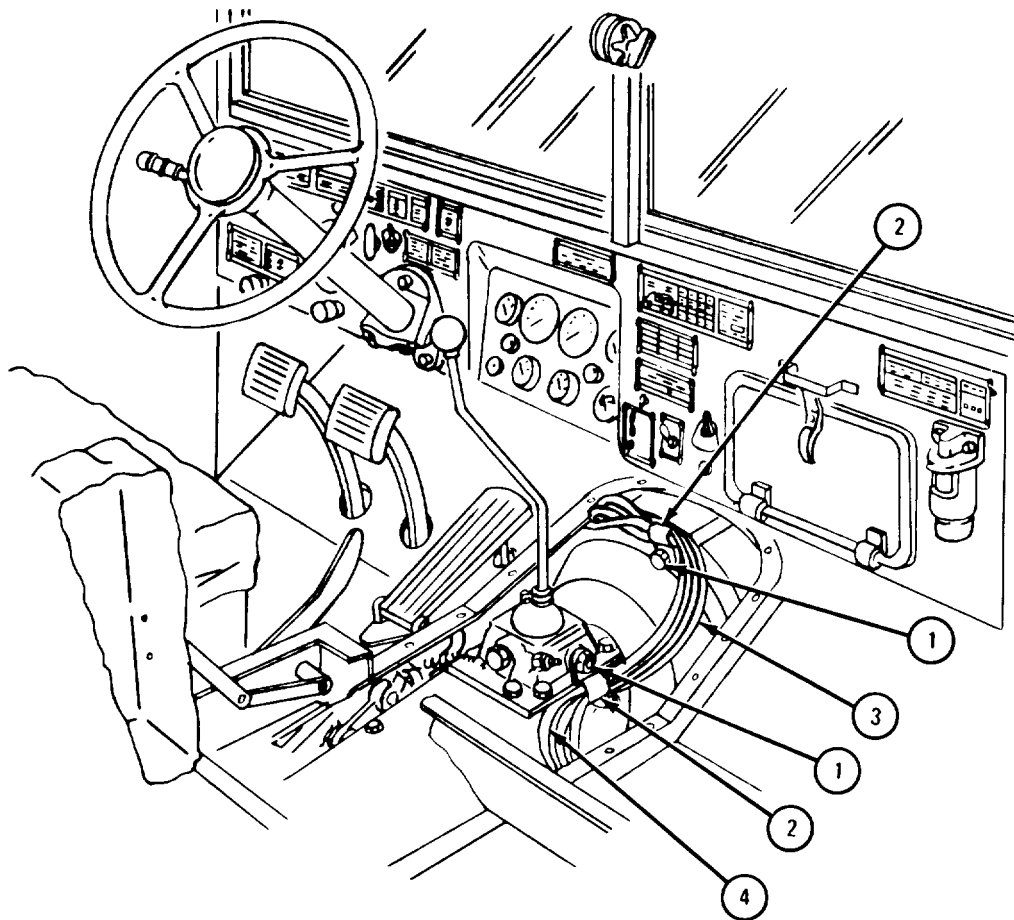

TA 103208

FRAME 15

1. Take off nut (1) and take out screw (2). Spread open clamp (3).
2. Pull battery-to-rheostat cable (4) through grommet (5) and route it next to battery cable (6) and through clamp (3).
3. Close clamp (3) and put screw (2) in place.
4. Put on nut (1).

GO TO FRAME 16

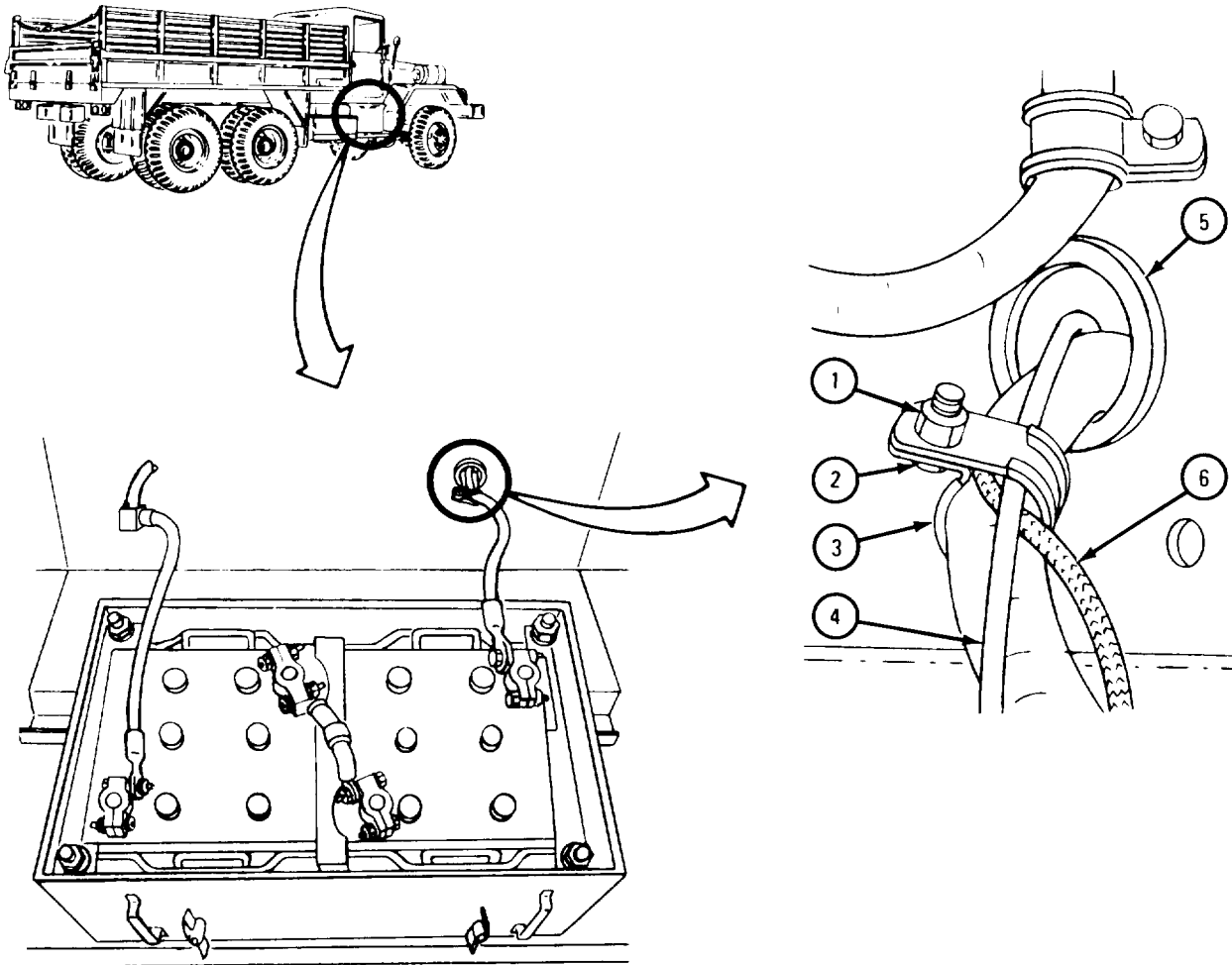

TA 103209

## FRAME 16

1. Take off nut (1). Take screw (2) out of battery terminal clamp (3).
2. Put screw (2) through battery-to-rheostat cable terminal (4). Put screw back in battery terminal clamp (3).
3. Put battery cable terminal (5) on screw (2).

**NOTE**

Adjustment of electric brake rheostat depends on towed load. The heavier the load, the higher the setting. Exact setting should be set by operation. For maintenance of controller, refer to para 19-29.

**NOTE**

Follow-on Maintenance Action Required:

1. On truck M543A2, install fuel tank. Refer to TM 9-2320-211-20.
2. Close hood and left side panel. Refer to TM 9-2320-211-10.
3. Put on front and intermediate cab tunnels. Refer to TM 9-2320-211-20.
4. Reconnect battery ground cable. Refer to TM 9-2320-211-20.

END OF TASK

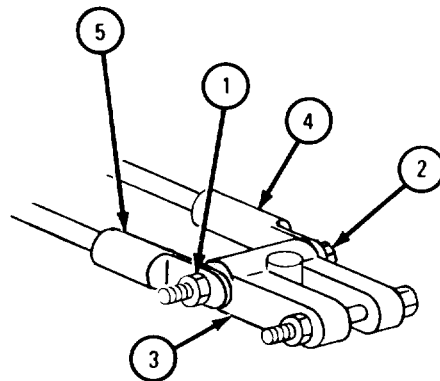
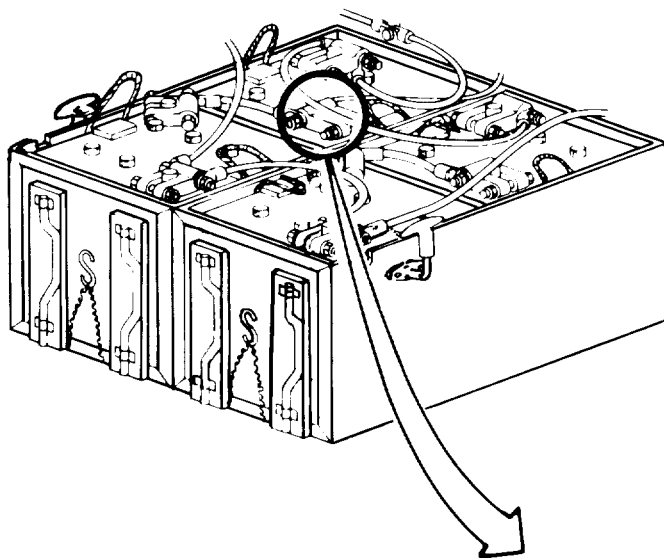

TA 103210

**19-29. ELECTRIC BRAKE CONTROLLER REMOVAL, REPAIR, AND REPLACEMENT.**

TOOLS: No special tools required

SUPPLIES: Solvent, dry cleaning, type 11 (SD-2), Fed. Spec P-D-680  
Insulating compound, MIL-C-47233  
Controller cover gasket  
Clean, dry rags  
Compressed air source, 30 psi max

PERSONNEL: One

EQUIPMENT CONDITION : Truck parked, engine off, handbrake set.

Preliminary Procedure. Vent air system pressure. Refer to TM 9-2320-211-20.

b. Removal.

FRAME 1

1. Working under truck, take off cable connector (1).
  2. Unscrew air line fitting (2).
  3. Take out three nuts (3) and washers (4). Take out controller assembly (5).
- END OF TASK

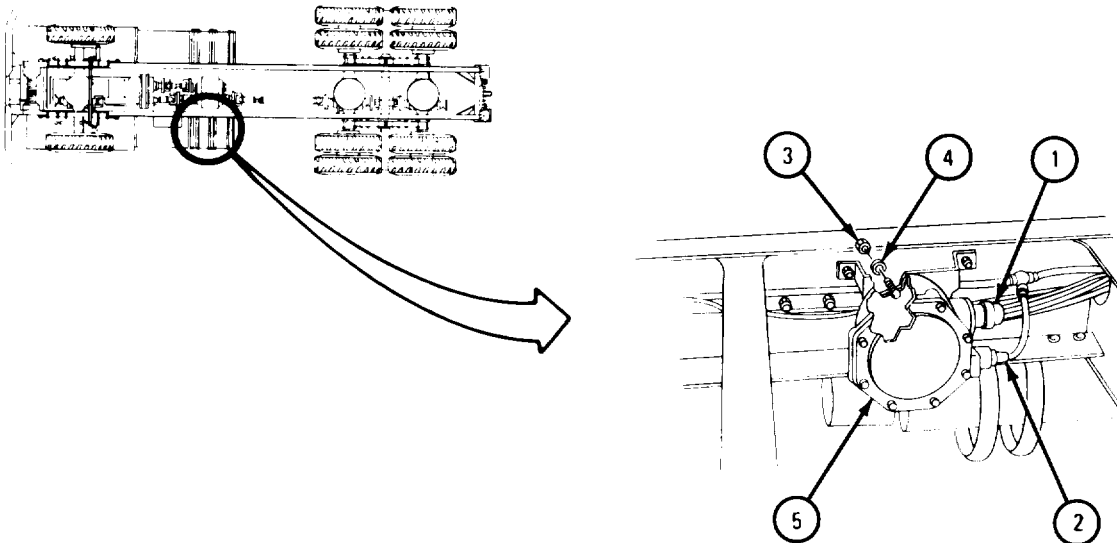

TA 103211

c. Disassembly.

## FRAME 1

**WARNING**

Dry cleaning solvent is flammable. Do not use near an open flame. Keep a fire extinguisher nearby when solvent is used. Use only in well-ventilated places. Failure to do this may result in injury to personnel and damage to equipment.

1. Using dry cleaning solvent, clean outside of controller (1).
2. Take out eight screws (2) with lockwashers (3). Take off diaphragm cover (4) and diaphragm (5).

GO TO FRAME 2

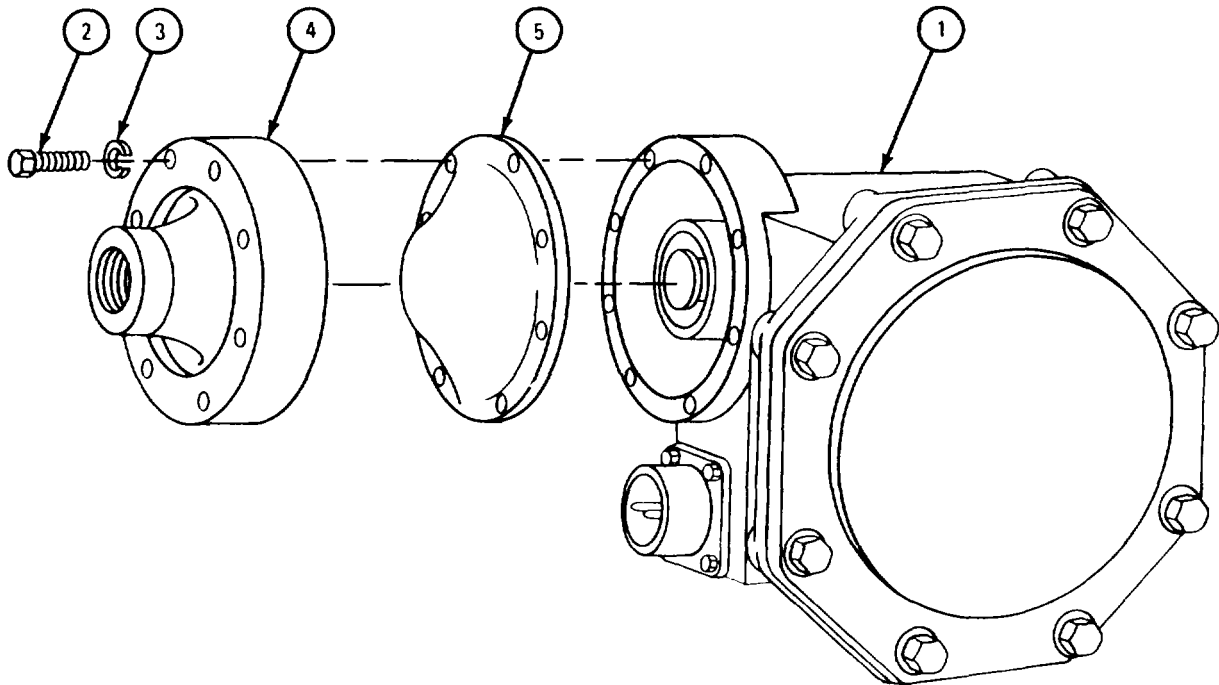

TA 103212

FRAME 2

1. Take out eight screws (1) and lockwashers (2).
2. Take off cover (3) and gasket (4). Throw away gasket.
3. Push in shaft head three or four times. Shaft head should come back with force. If it does not, refer to para 19-29f and put in new controller.

GO TO FRAME 3

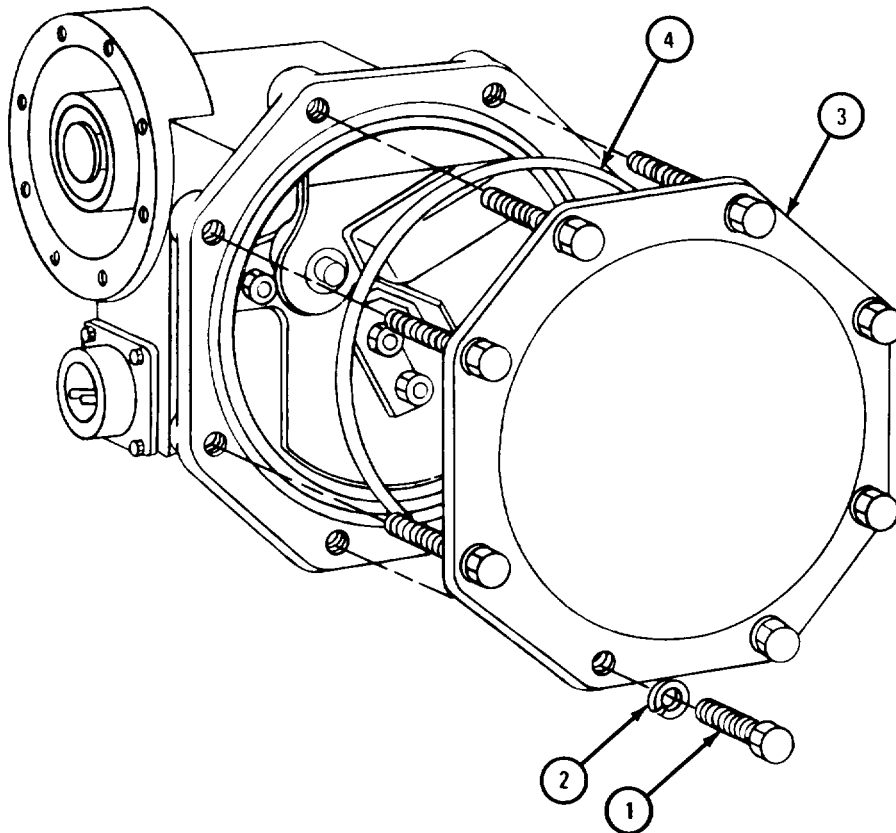

TA 103213



## FRAME 3

1. Push shaft head (1) in and check that arm (2) touches leaves (3). If arm does not touch leaves, get new resistor assembly (4).
2. Take off nut (5). Take off connecting cable (6).

GO TO FRAME 4

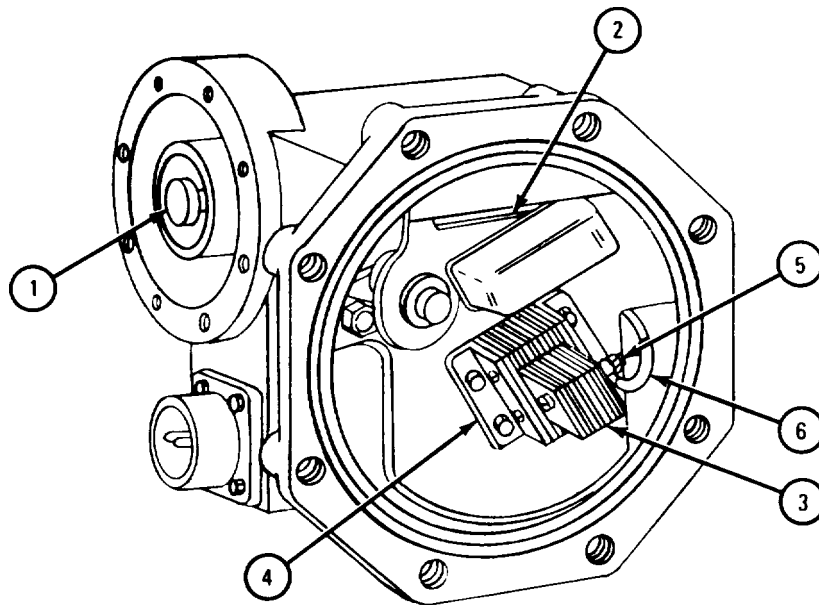

TA 103214

FRAME 4

1. Take out two nuts (1) with washers (2).
2. Take out mounting panel (3).
3. Take out two spacers (4) and mounting panel (5).

**WARNING**

Eye shields must be worn when using compressed air.  
Eye injury can occur if eye shields are not used.

4. Blow dust and flakes out of controller (6) with compressed air.

END OF TASK

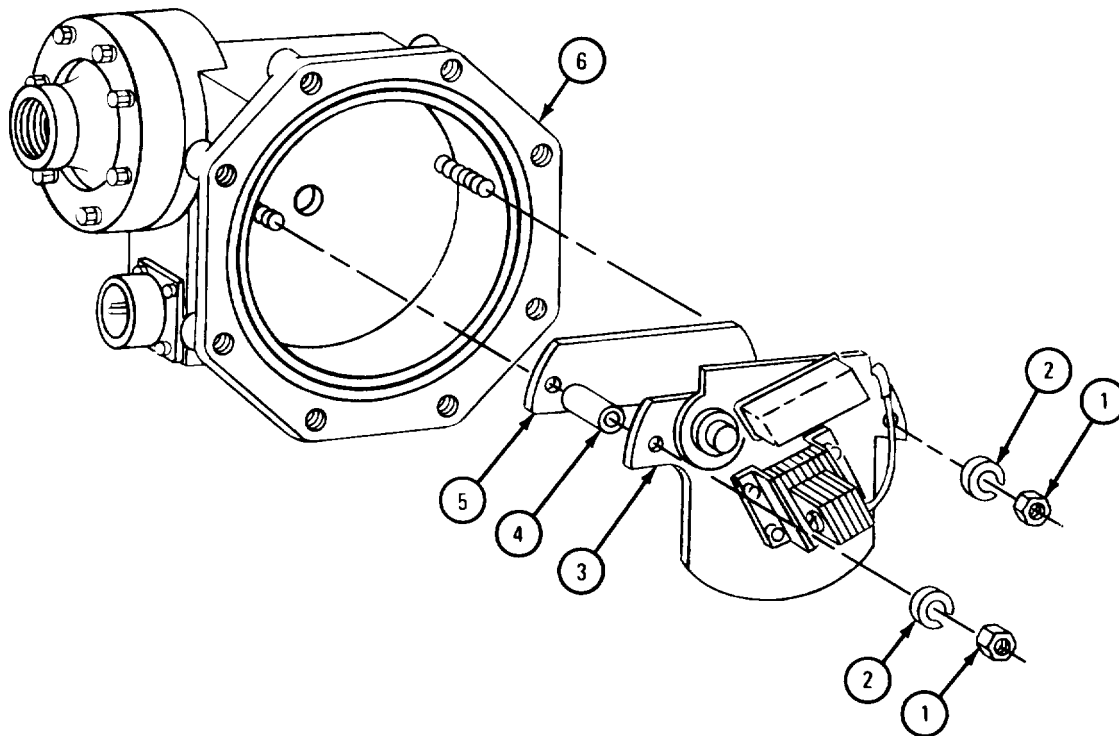

TA 103215

d. Inspection and Repair.

(1) Check that screw hole threads are not damaged. Retap screw holes if damaged.

(2) Check that there are no missing studs, screws, washers or plugs. Get new parts for missing parts.

(3) Check that controller housing and covers have no cracks or damage. If damage is found, get a new controller.

(4) Check that cable rivet on contact arm is not loose. Rerivet if needed.

(5) Check that diaphragm has no brittleness or cracks. If cracks or brittleness are found, get new diaphragm.

e. Assembly.

FRAME 1

1. Wipe off diaphragm (1) and shaft head (2). Put thin coat of insulating compound on shaft head.
2. Put diaphragm (1) and cover (3) in place. Put in eight screws (4) with washers (5).

GO TO FRAME 2

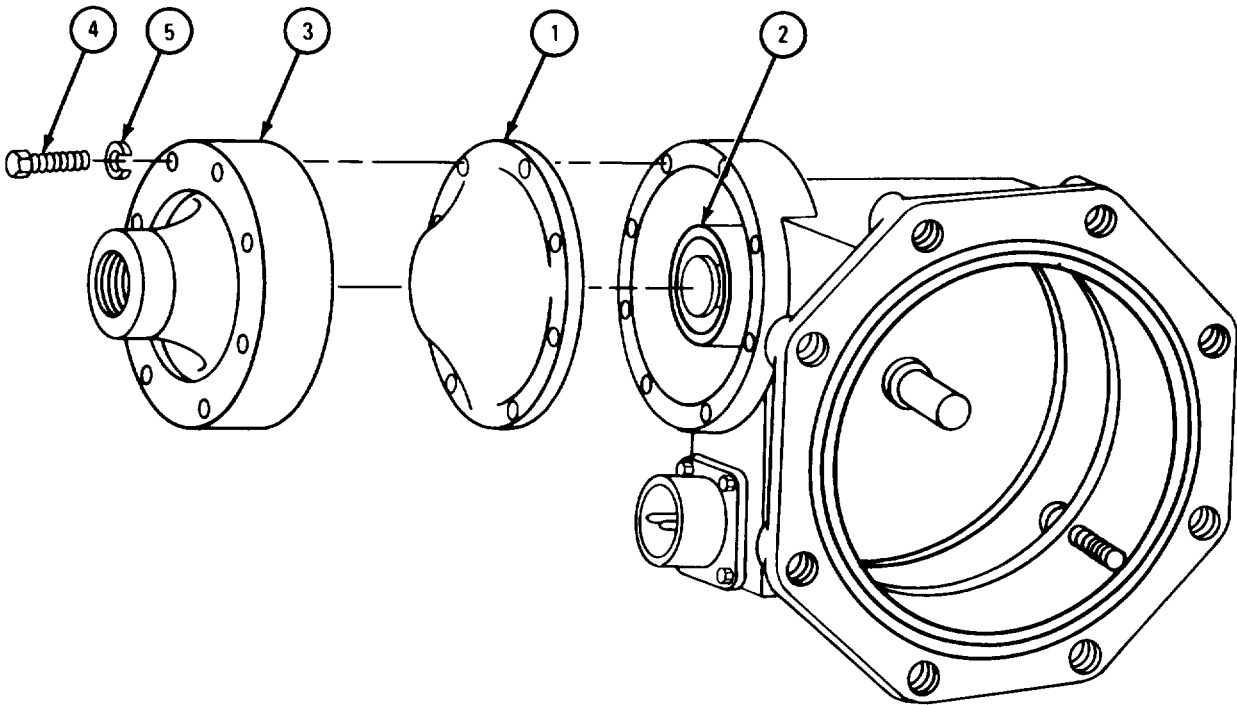

TA 103216

**FRAME 2**

1. Put in mounting panel (1) and two spacers (2).
2. Put in mounting panel (3).
3. Put on two nuts (4) with washers (5).

GO TO FRAME 3

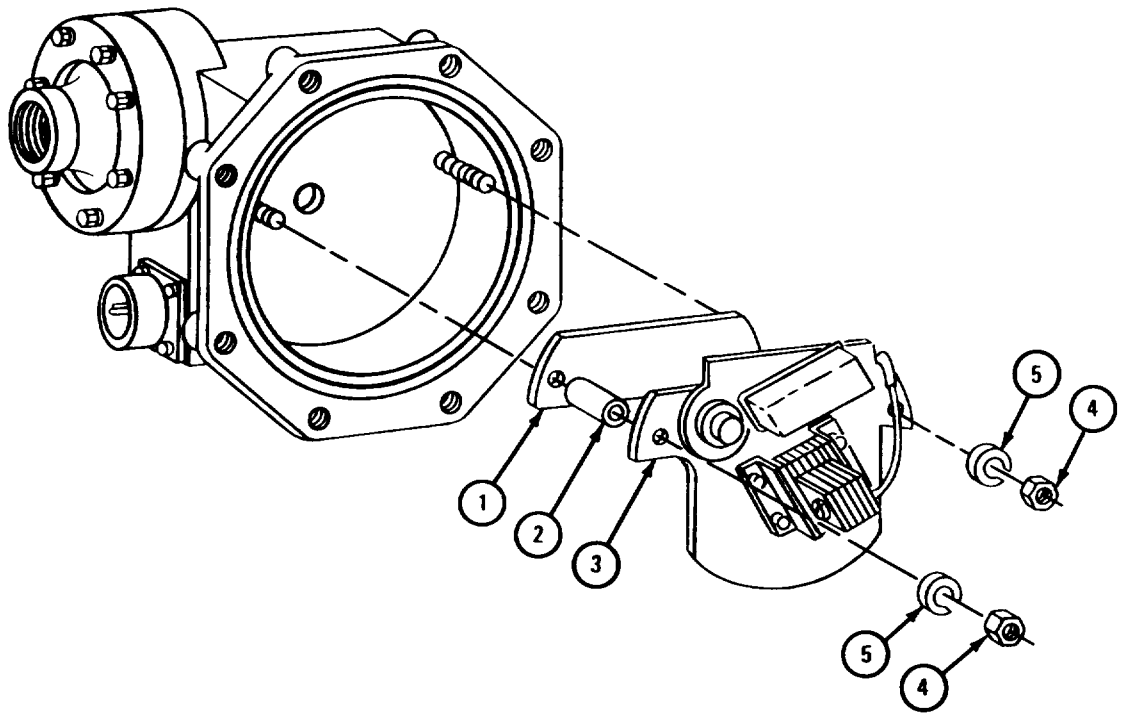

TA 103217

FRAME 3

1. Put cable (1) in place. Make sure sleeve (2) is against panel (3).
  2. Put on nut (2).
- GO TO FRAME 4

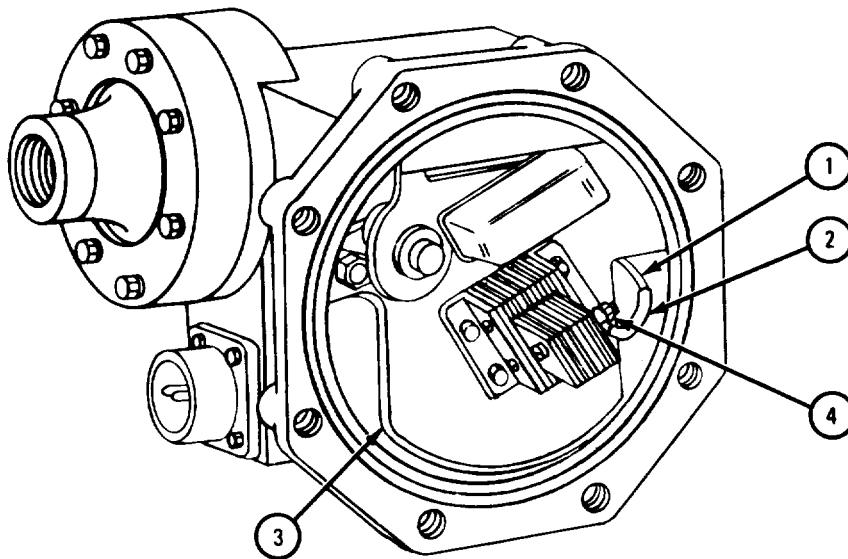

TA 103218

## FRAME 4

1. Put gasket (1) and cover (2) on controller (3), alining holes.
2. Put in eight screws (4) and lockwashers (5).

END OF TASK

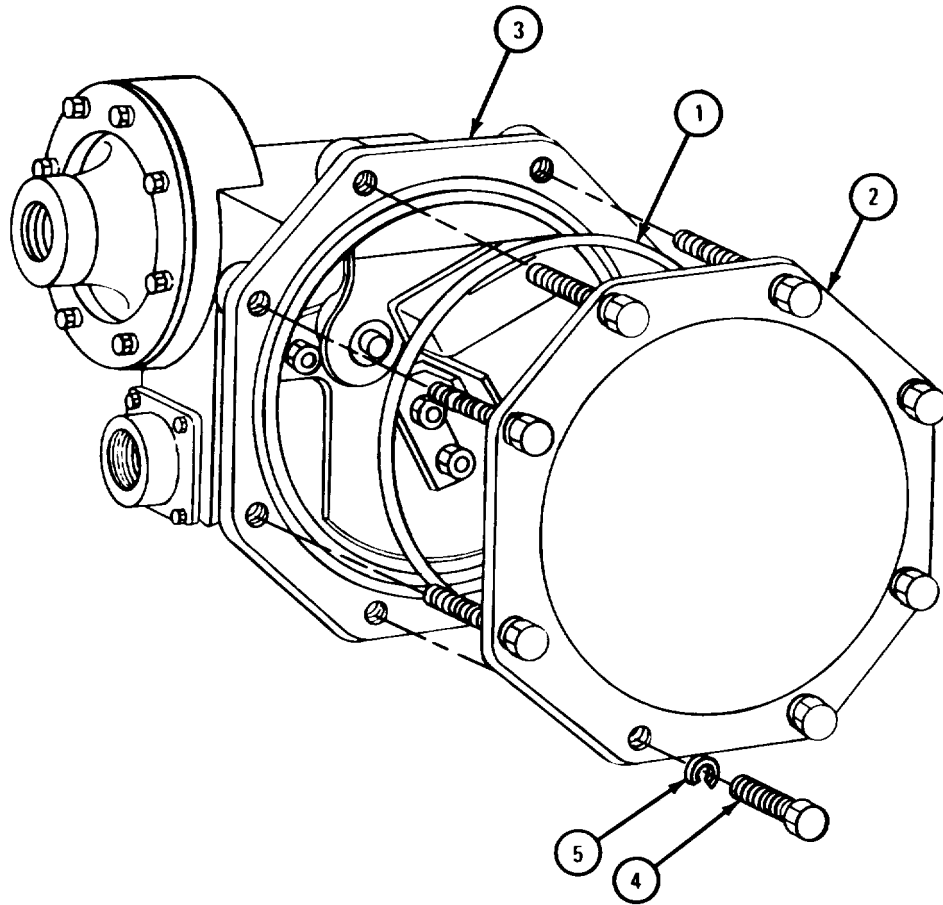

TA 103219

f. Replacement.

FRAME 1

1. Put controller (1) on bracket (2).
2. Put on three nuts (3) with washers (4).
3. Put on air line fitting (5).
4. Put on cable connection (6).

END OF TASK

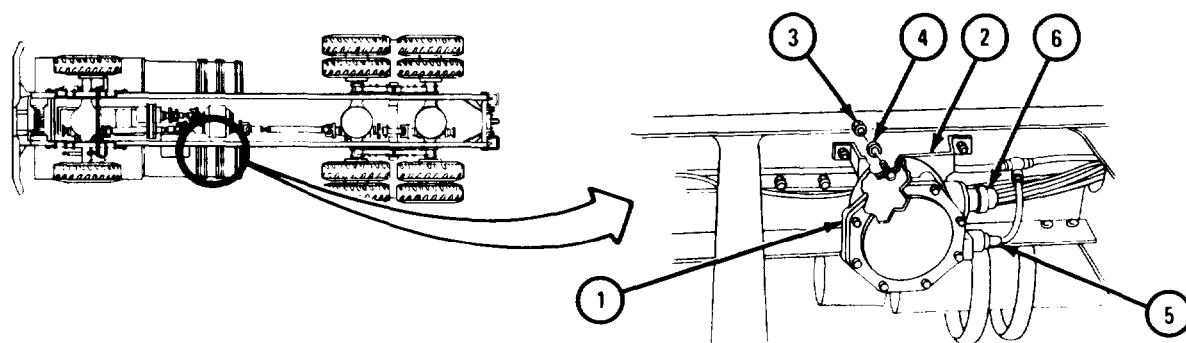

TA 103220



**19-30. A-FRAME KIT INSTALLATION (TRUCKS M54A2 WITH WINCH, M54A2C WITH WINCH, AND M55A2 WITH WINCH).**

TOOLS: No special tools required

SUPPLIES: A-frame kit  
Cotter pin

PERSONNEL: Three

EQUIPMENT CONDITION: Truck parked, engine off, handbrake set.

a. Preliminary Procedures.

(1) Remove tailgate. Refer to TM 9-2320-211-10.

(2) Remove cab cover. Refer to TM 9-2320-211-20.

(3) Lay windshield down on cowl and make it fast with safety latch. Refer to TM 9-2320-211-10.

b. Installation.

(1) Anchor plate.

FRAME 1

1. Center anchor plate (1) on cargo body bed (2) above pintle (3).
2. Mark cargo body bed (2) through hole in anchor plate (1). Take off anchor plate.
3. Drill 1/2-inch diameter hole on mark.
4. Put anchor plate (1) and eyebolt (4) in place.
5. Screw on and tighten washer (5) and nut (6).

END OF TASK

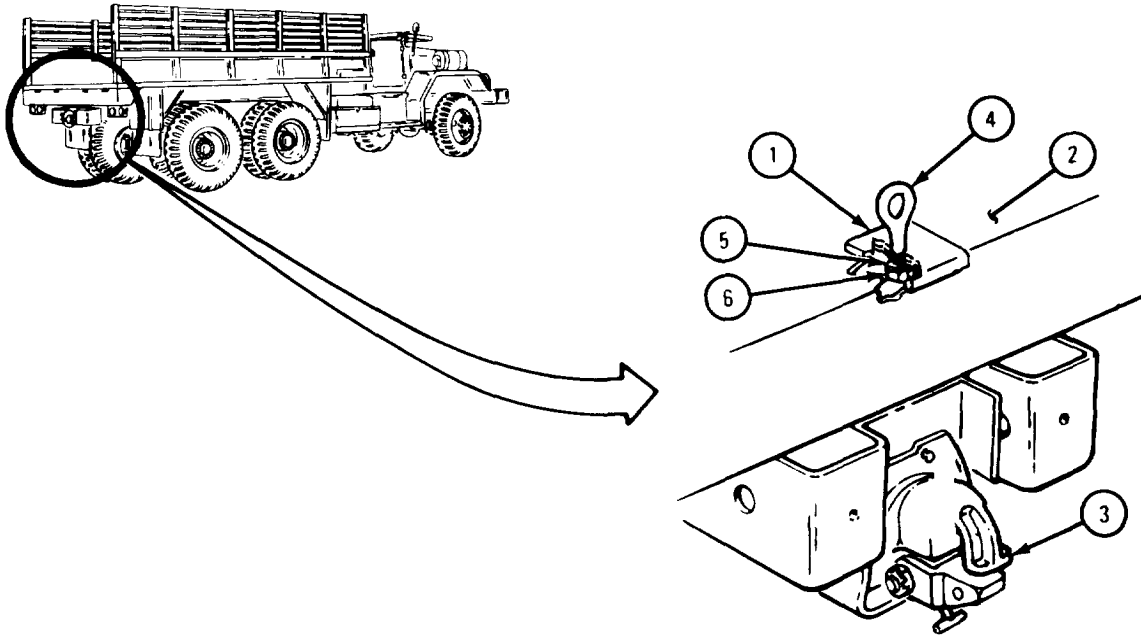

TA 105766

(2) A-frame legs.

FRAME 1

1. Unhook and take out two safety pins (1).
2. Take out two retaining pins (2).
3. Take off two shackles (3).
4. Take two shackles (3) off of chain and hook (4). Put chain and hook down on ground.

GO TO FRAME 2

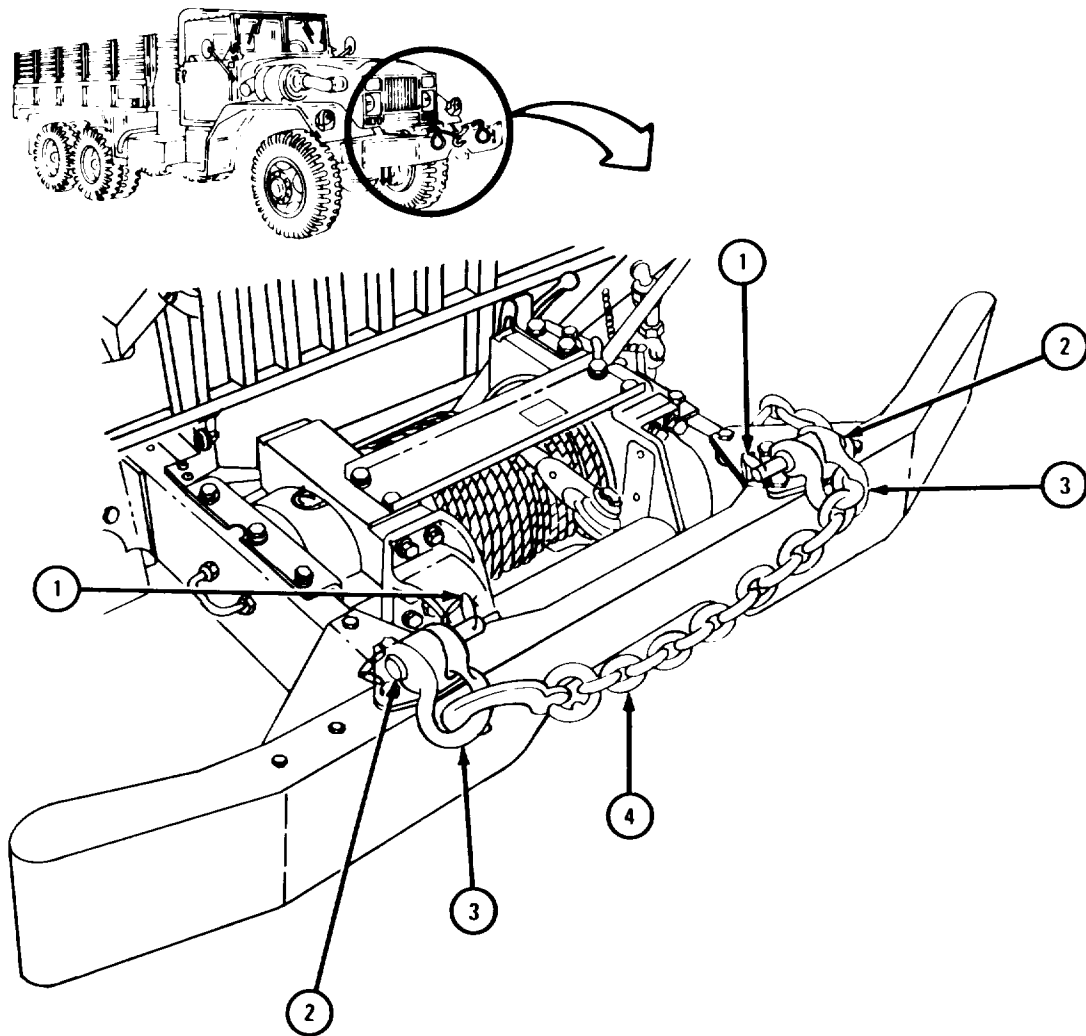

TA 105767

FRAME 2

1. Put two A-frame legs (1) on two shackle brackets (2) in place.
2. Put in two retaining pins (3).
3. Put in two safety pins (4).
4. Put two A-frame extensions (5) in place in A-frame legs (1).
5. Put in two pins (6).

END OF TASK

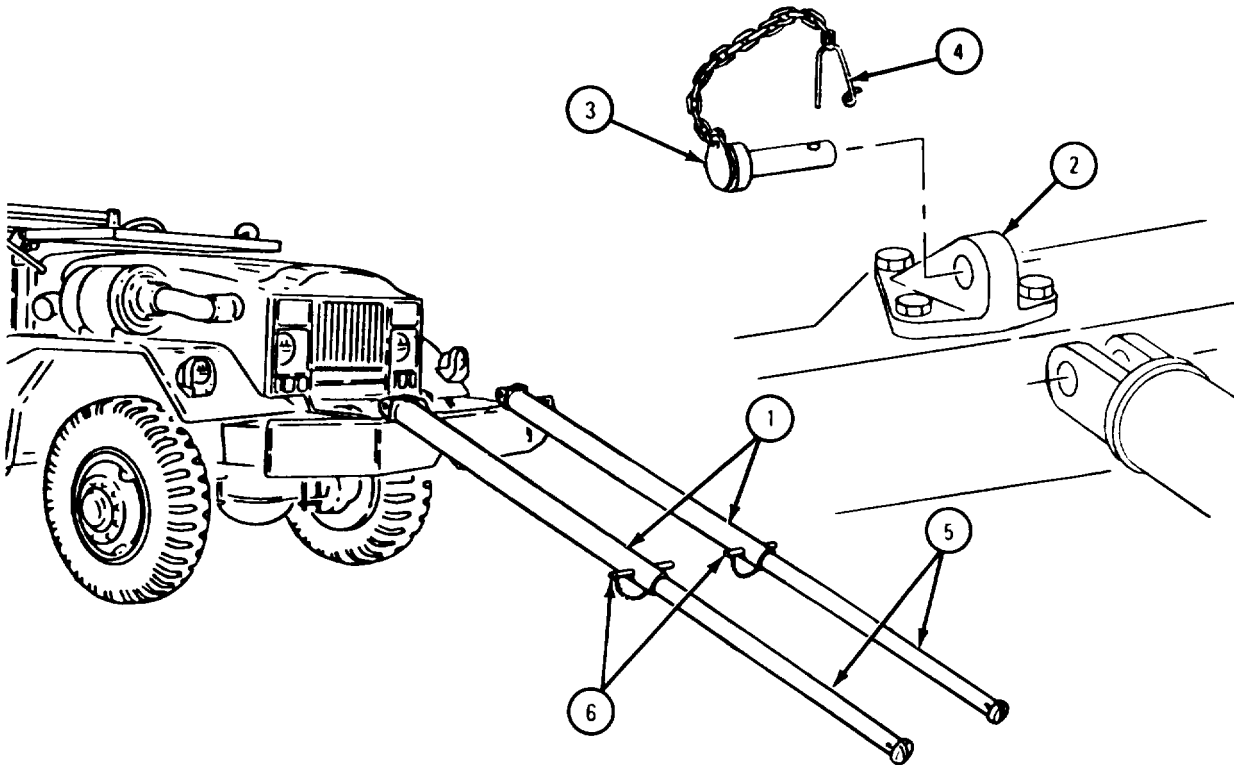

TA 105768

(3) A-frame spreader tube, harness, and cable.

**FRAME 1****WARNING**

Always wear leather gloves when handling winch cable. Never allow cable to run through hands. During winch operation or when stopping winch, tell all personnel to stand clear of winch and load. A snapped cable or shifting load can be extremely dangerous.

1. Put spreader stud (1) through outer spacer (2), extension (3), spreader tube (4), extension (5), and outer spacer (6).

GO TO FRAME 2

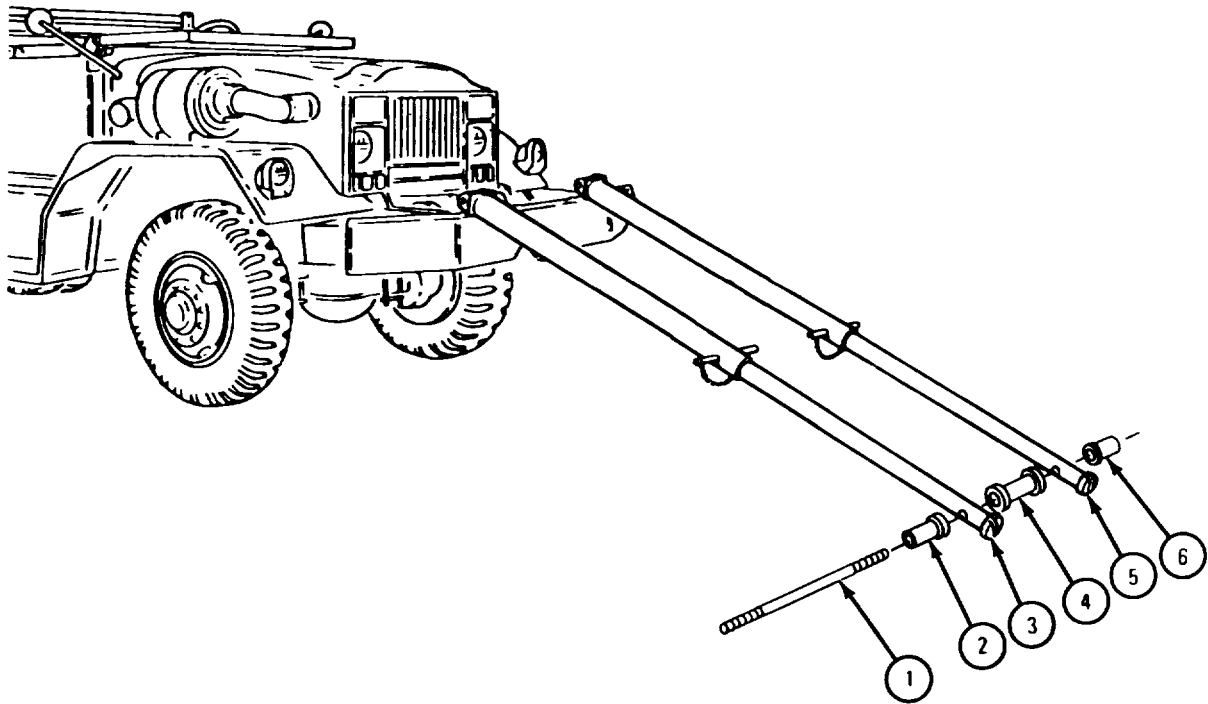

TA 105769

FRAME 2

1. Put each end of harness (1) on each end of spreader stud (2).
2. Put on two washers (3) and tighten nuts (4 and 5).

GO TO FRAME 3

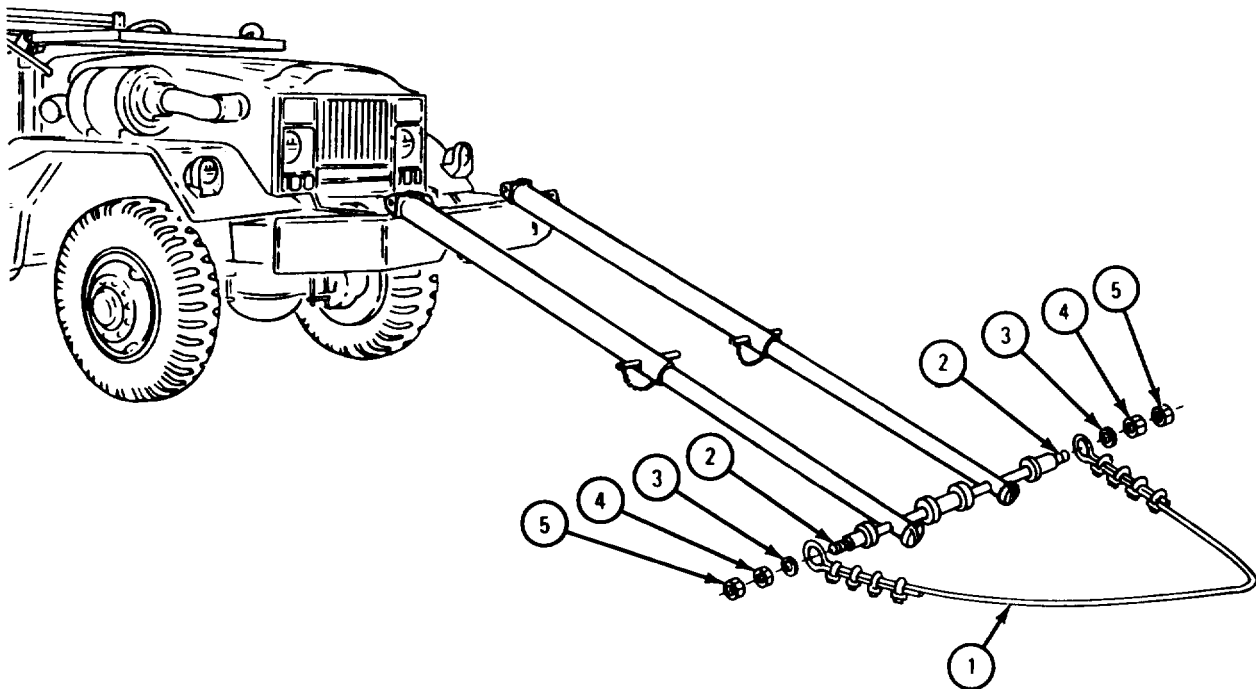

TA 105770

FRAME 3

1. Unscrew and take out four bolts (1) and four lockwashers (2).
2. Take off top channel (3).

GO TO FRAME 4

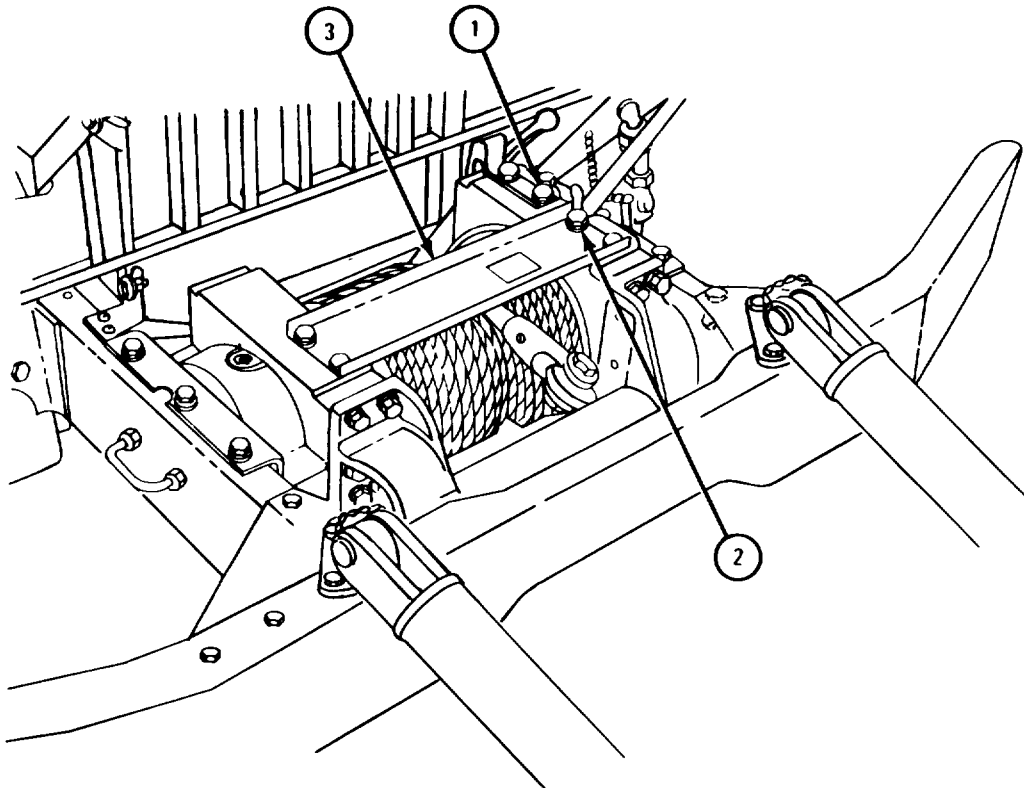

TA 105771

FRAME 4

1. Unwind 20 feet of winch cable (1). Refer to Operating Front Winch, TM 9-2320-211-10.
2. Open snatch block (2).
3. Put winch cable (1) in snatch block (2).
4. Close snatch block (2) and hook it on spreader tube (3).

GO TO FRAME 5

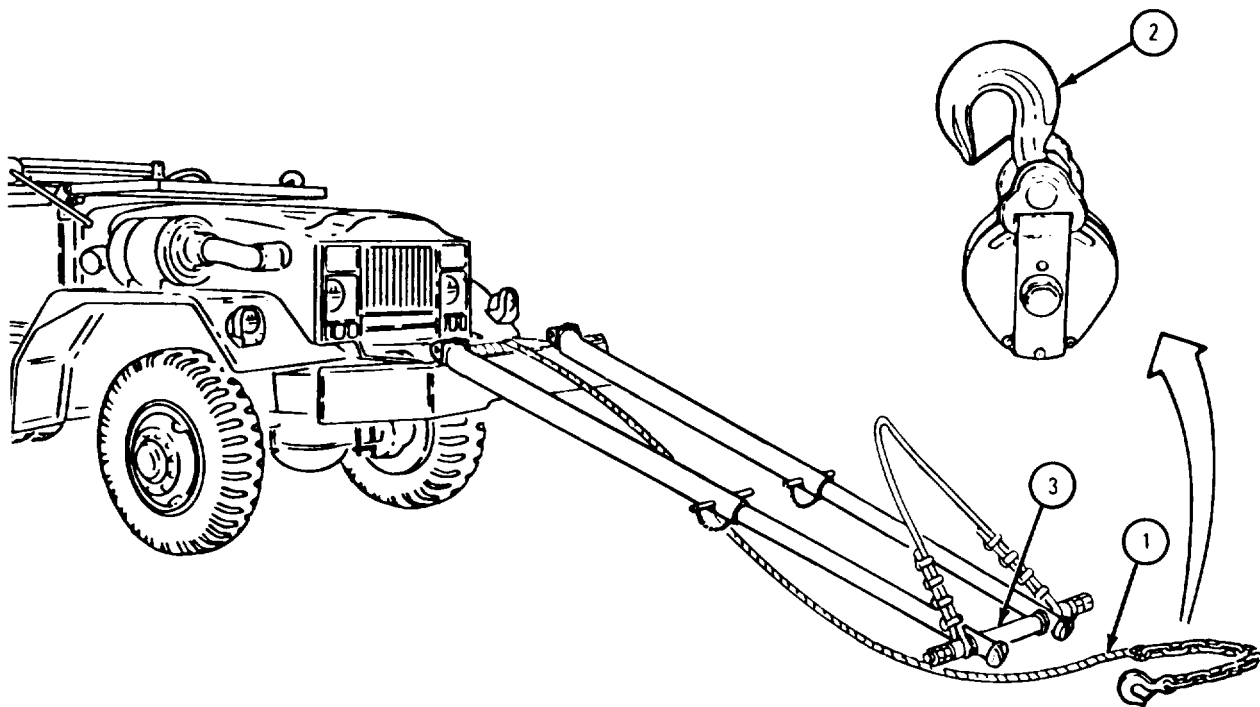

TA 105772



FRAME 5

1. Unscrew and take pin (1) out of hook (2).
2. Put hook (2) on small loop of cable (3).
3. Put cable (4) in hook (2).
4. Screw in and tighten pin (1).

GO TO FRAME 6

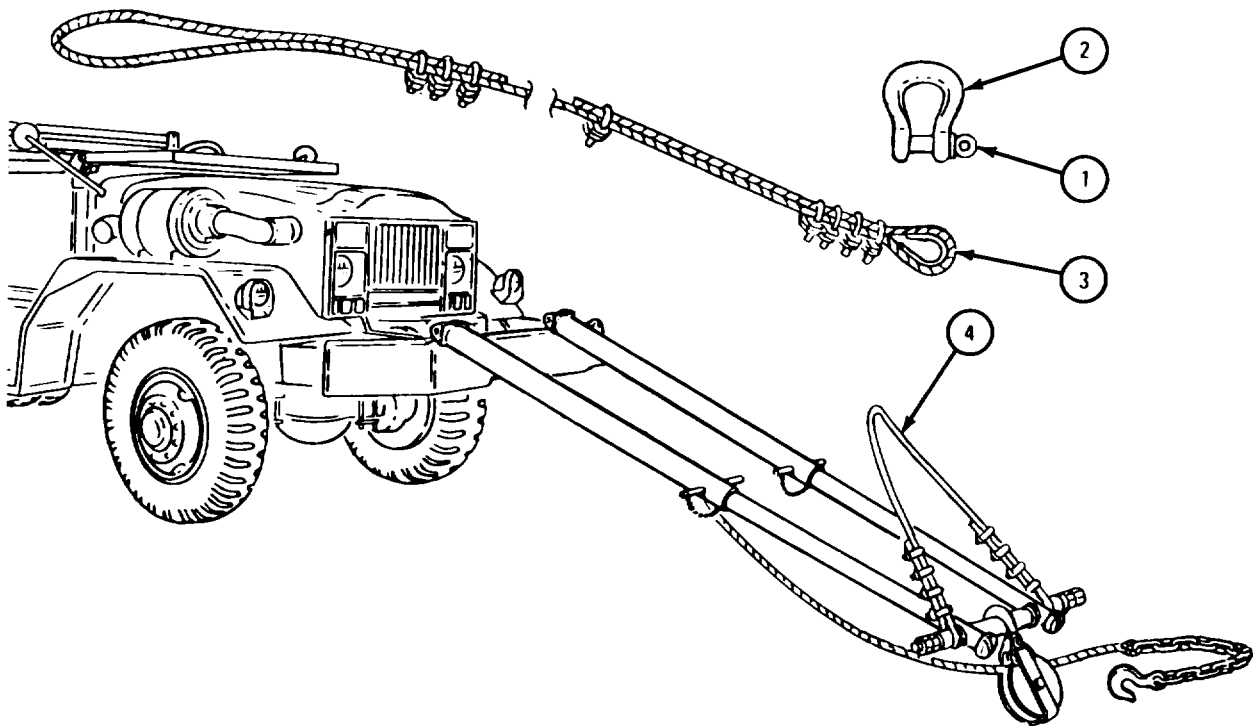

TA 105773

FRAME 6

- Soldiers A and B 1. Lift two A-frame legs (1) and hold them up until soldier C hooks end of cable (2).
- Soldier C 2. Take looped end of cable (2) to rear of truck and pass it through eyebolt (3).
3. Turn pintle hook (4) so lock (5) is on bottom. Pull out and throw away cotter pin (6) and open pintle hook.
4. Put loop of cable (2) in pintle hook (4). Close lock (5). Using pliers, put in and open ends of cotter pin (6).

GO TO FRAME 7

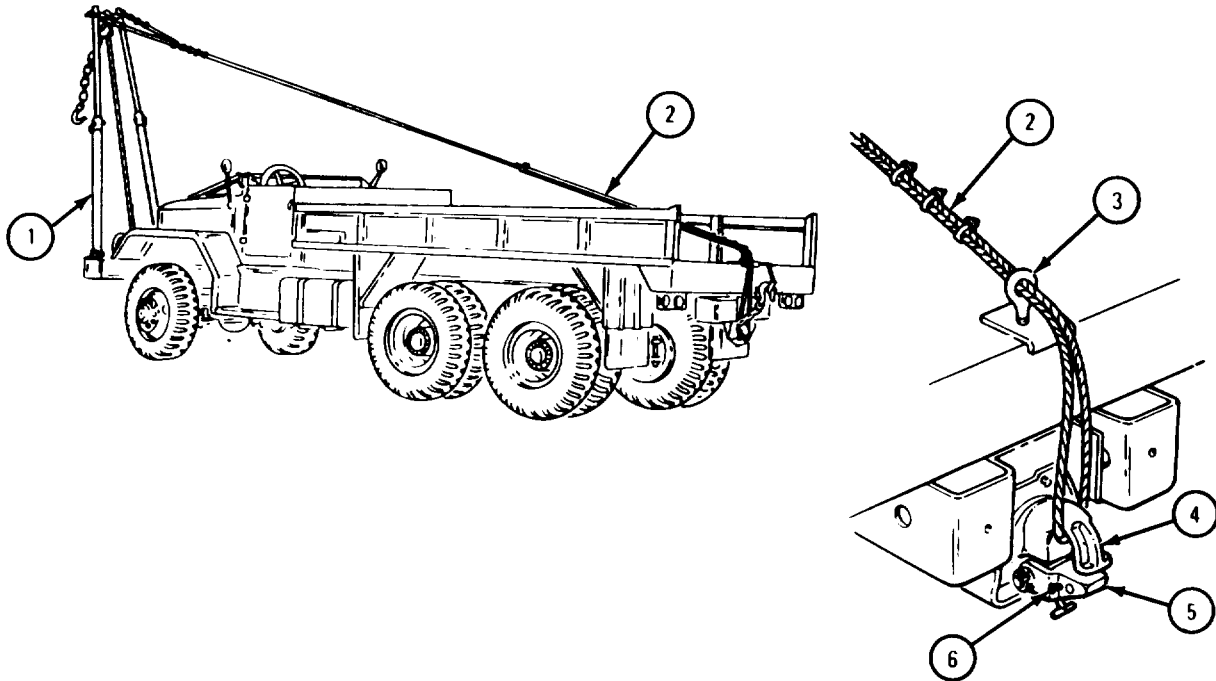

TA 105774

FRAME 7

- Soldiers A and B 1. Hold two A-frame legs (1) at 60° angle to ground while soldier C adjusts cable (2).
- Soldier C 2. Loosen eight nuts (3) on four clamps (4). Pull on end of cable (2) to take out slack. Tighten eight nuts (3).
3. Screw in adjusting screw (5) at bottom of each A-frame leg (1) until each adjusting screw is snug.

**NOTE**

Follow-on Maintenance Action Required:

1. Put on cab cover. Refer to TM 9-2320-211-20.
2. Put windshield back up in place and make it fast. Refer to TM 9-2320-211-10.

END OF TASK

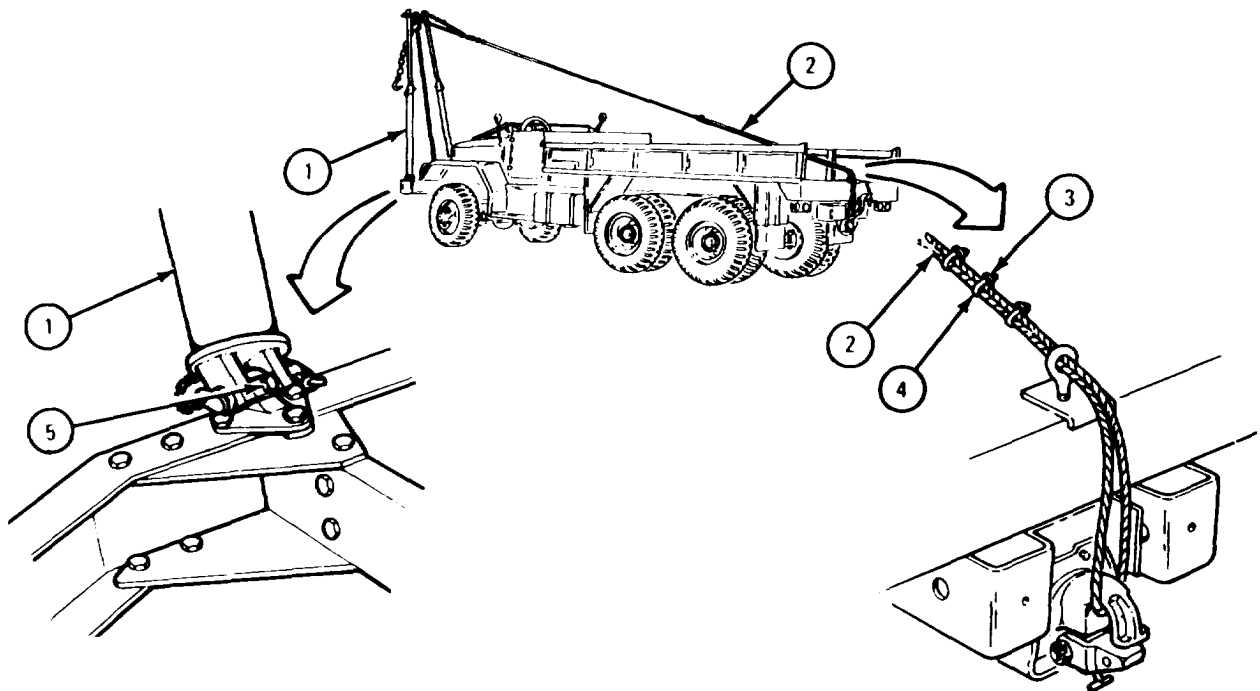

TA 105775

**19-31. DECONTAMINATION APPARATUS STOWAGE BRACKET INSTALLATION.**

TOOLS: No special tools required

SUPPLIES: Mounting bracket

PERSONNEL: One

EQUIPMENT CONDITION: Truck parked, engine off, handbrake set.

FRAME 1

1. Raise companion seat (1).
2. Take out 10 screws (2) with lockwashers (3) on tunnel (4).
3. Lift up and slide off tunnel (4).

GO TO FRAME 2

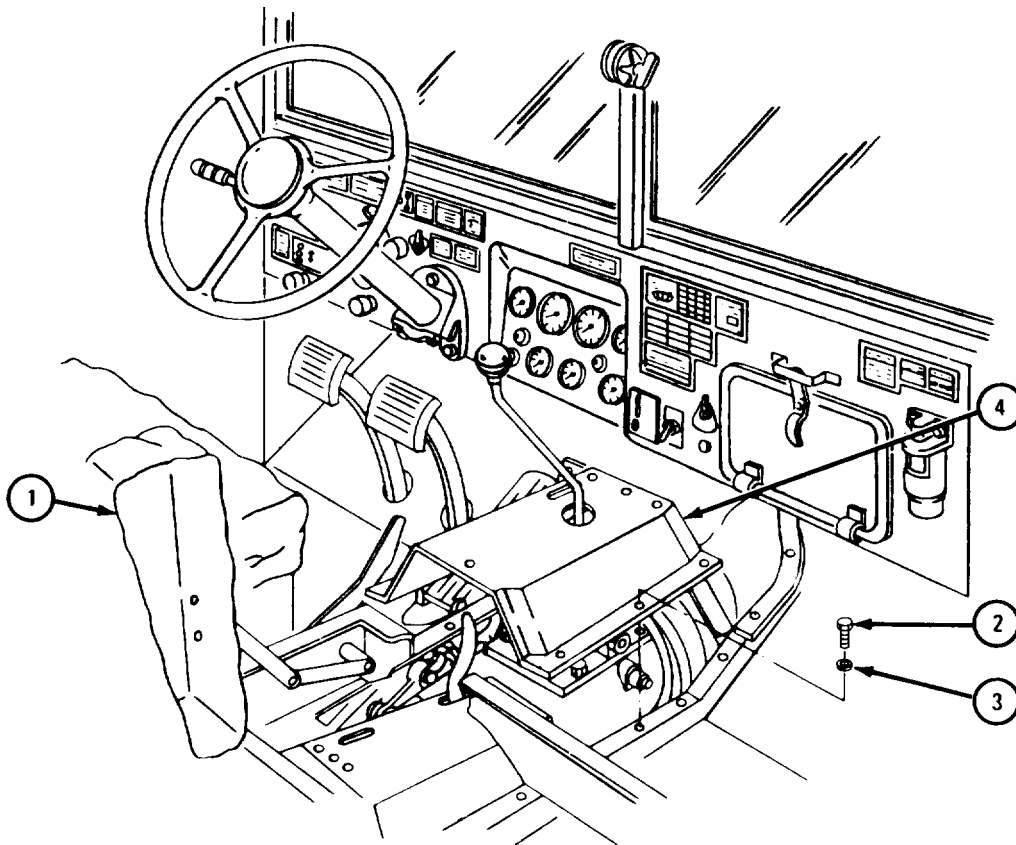

TA 103224

## FRAME 2

1. Put cab tunnel (1) on flat surface.
2. Draw line (2) through center of hole (3).
3. Put bracket (4) on tunnel (1). Aline front of bracket with line (2). Hole (5) goes over hole in tunnel.
4. Mark three holes (6). Take off bracket (4).
5. Drill three 0.280 inch holes (6) as marked.
6. Put on bracket (4).
7. Put in three capscrews (7) with washers (8).
8. Put on three nuts (9).

GO TO FRAME 3

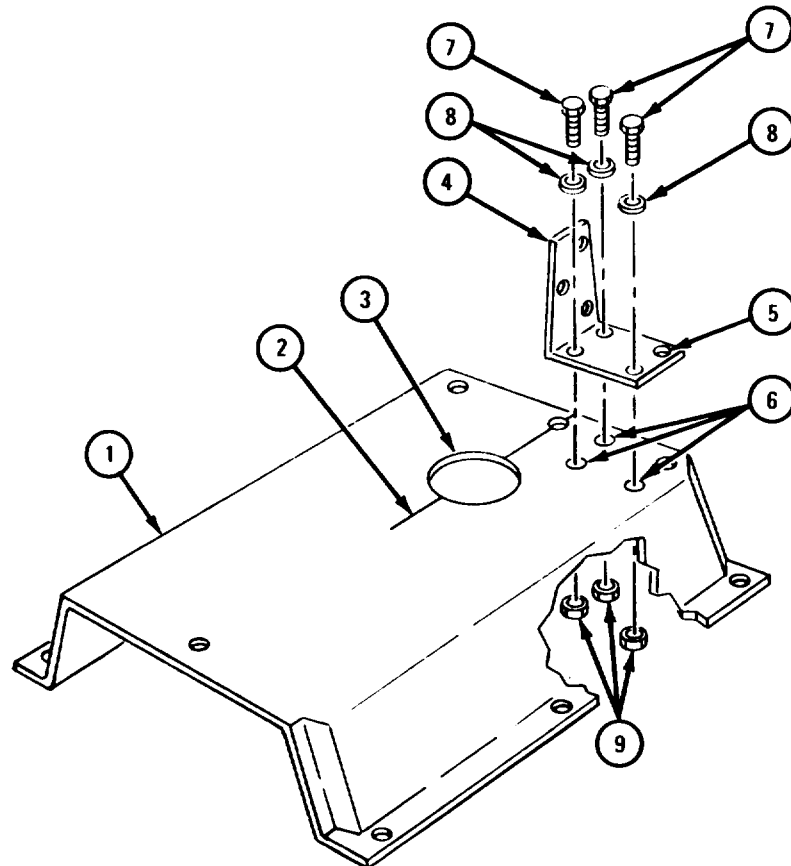

TA 103225

FRAME 3

1. Put cab tunnel (1) back in cab.
2. Put in capscrew (2) with lockwasher (3) through bracket (4).
3. Put in 8 capscrews (5) with lockwashers (6).
4. Put down companion seat (7).

END OF TASK

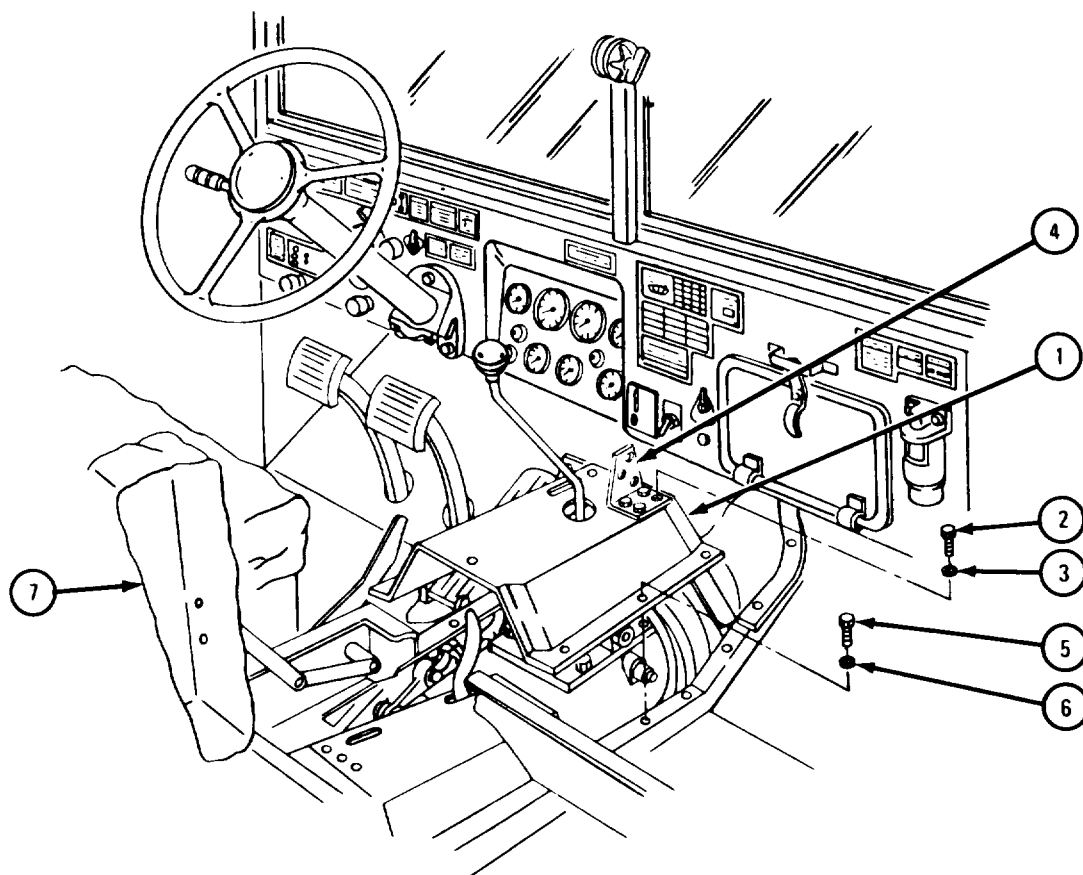

TA 103226

**19-32. ENGINE SHIPPING AND STORAGE CONTAINER REPAIR.**

TOOLS: Dial indicating pressure gage

SUPPLIES: Soapy water  
Sealing compound, MIL-S-8660

PERSONNEL: Two

EQUIPMENT CONDITION: Engine out of container.

a. Cleaning. There are no special cleaning procedures needed. Refer to Part 1, para 1-3.

b. Disassembly.

FRAME 1

1. Take out humidity indicator (1).
2. Take out safety relief valve (2).
3. Take out pneumatic tank valve (3).
4. Take off rubber seal (4).

GO TO FRAME 2

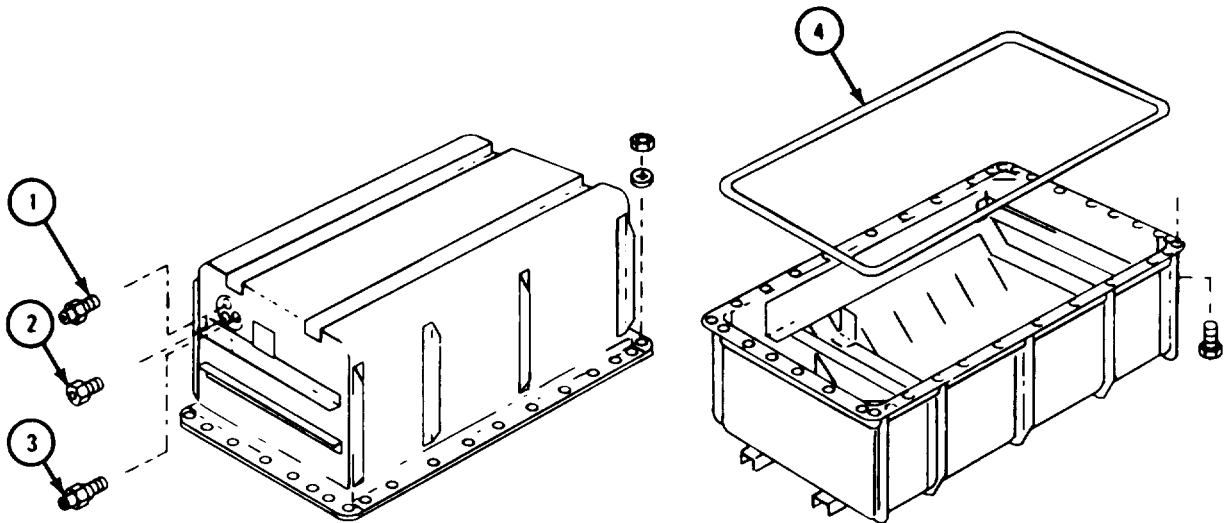

TA 116707

FRAME 2

Soldiers 1. Take off four screws (1) at four mounting plates (2) two on each side.

2. Take cradle (3) out of container (4).

END OF TASK

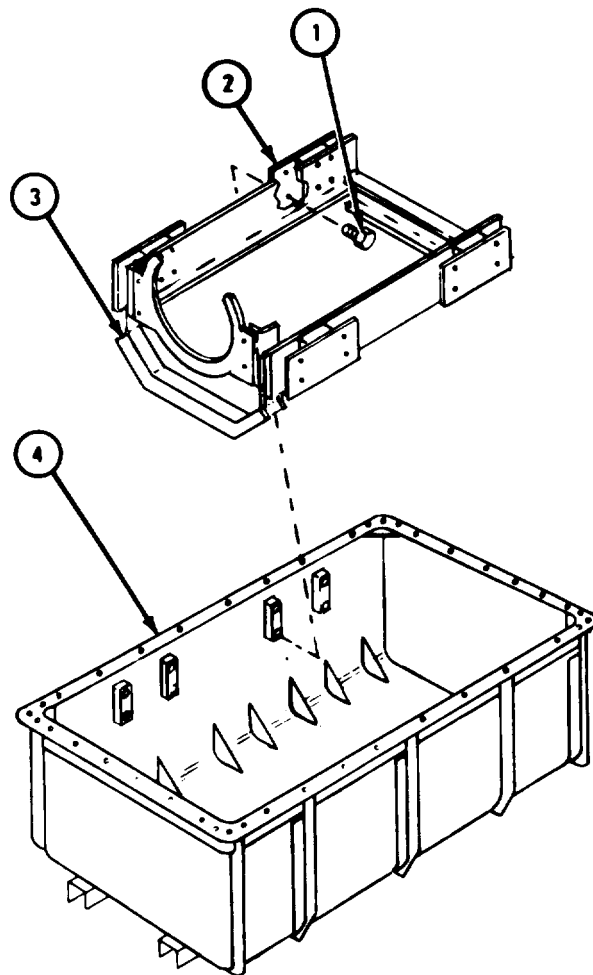

TA 116708



c. Inspection and Repair.

FRAME 1

1. Check that upper and lower parts of container (1) are not bent, dented, cracked or torn.
2. Check that cradle (2) is not bent, dented, cracked or torn. To repair bent or dented parts, refer to FM 43-2. To weld tears or cracks, refer to TM 9-237. If more repair is needed, get a new part.

GO TO FRAME 2

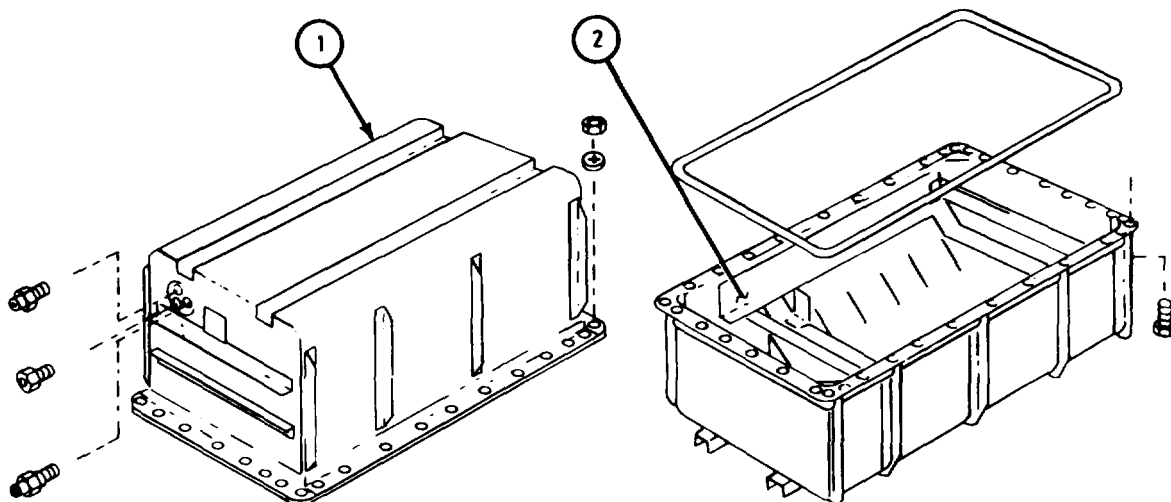

NOTE

CHECK ONLY THOSE PARTS WHICH ARE CALLED OUT IN THIS FRAME. PARTS WITHOUT CALLOUTS ARE SHOWN ONLY FOR REFERENCE PURPOSES OR ARE CHECKED IN ANOTHER FRAME.

TA 116709

FRAME 2

1. Check that rubber seal (1) is not torn or damaged. If damaged, get a new part.
2. Check that humidity indicator (2), safety relief valve (3), and pneumatic tank valve (4) are not damaged. If damaged, get a new part.
3. Check that all threaded parts are not stripped or crossthreaded. If damaged, get a new part.

END OF TASK

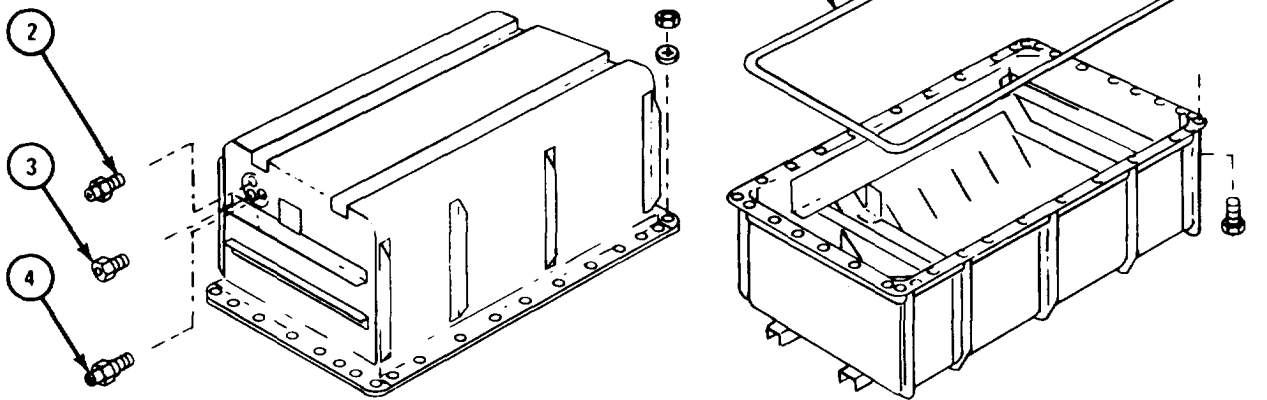

NOTE

CHECK ONLY THOSE PARTS WHICH ARE CALLED OUT IN THIS FRAME. PARTS WITHOUT CALLOUTS ARE SHOWN ONLY FOR REFERENCE PURPOSES OR ARE CHECKED IN ANOTHER FRAME.

TA 116710

d. Assembly.

FRAME 1

Soldiers 1. Put cradle (1) in container (2).  
A and B

Soldier A 2. Aline holes of mounting plate (3) to holes in container (2).

Soldier B 3. Put in four screws (4).

Soldiers 4. Do steps 2 and 3 again for three other mounting plates (2).  
A and B

GO TO FRAME 2

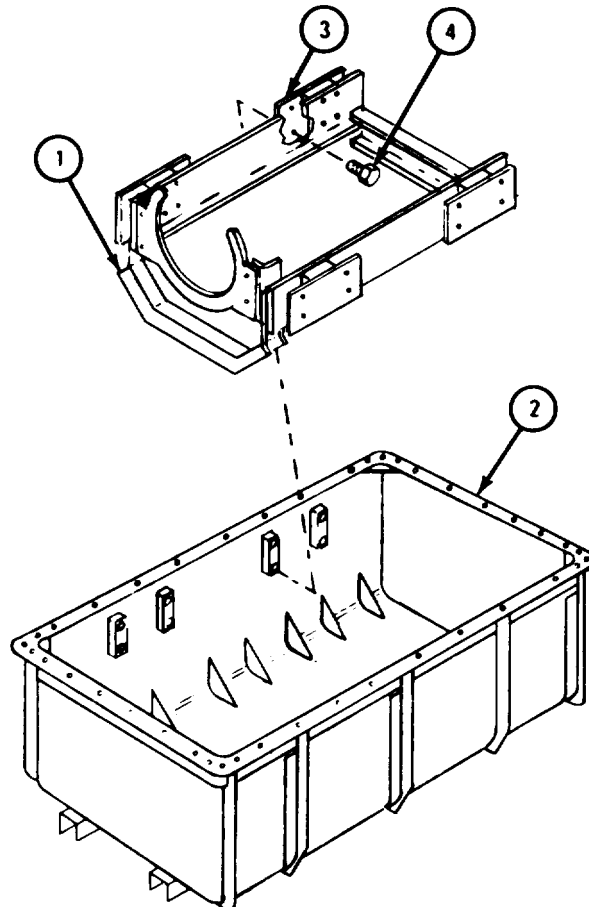

TA116711

FRAME 2

1. Put on rubber seal (1).
2. Put in pneumatic tank valve (2).
3. Put in safety relief valve (3).
4. Put in humidity indicator (4).

END OF TASK

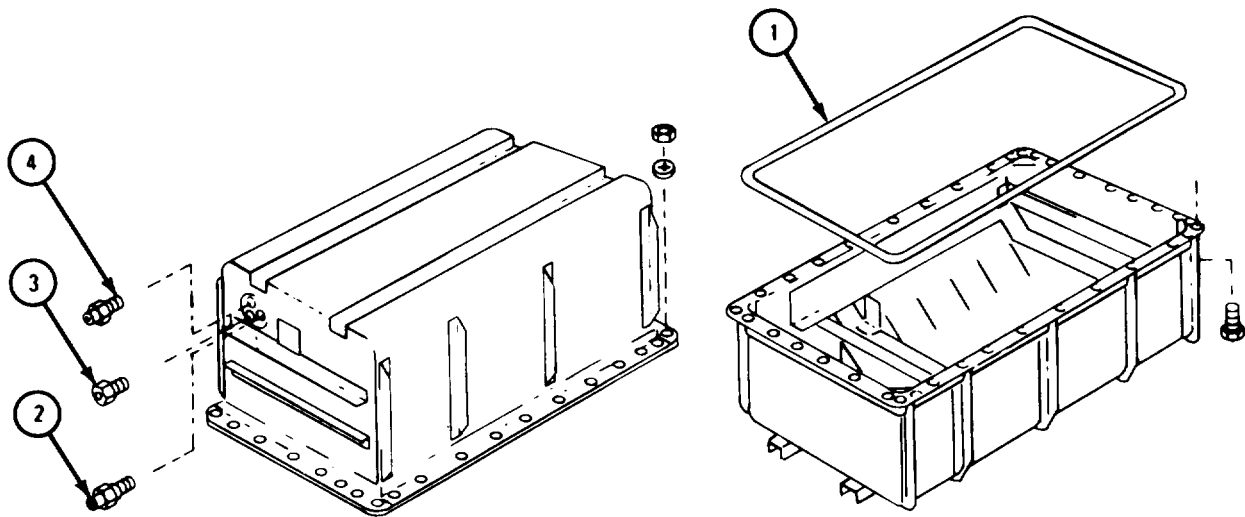

TA 116712

e. Pressure Check.

## FRAME 1

- Soldier A 1. Coat rubber seal (1) with sealing compound.
- Soldiers A and B 2. Put upper part of container (2) on lower part of container.
- Soldier A 3. Put in 40 screws (3).
- Soldier B 4. Put on 40 lockwashers (4) and nuts (5).
5. Using clean, dry air, pressurize container (2) through valve (6) 10 psi.

**NOTE**

Relief valve (7) should open between 7 to 10 psi.

6. If relief valve (7) does not open, replace relief valve.

GO TO FRAME 2

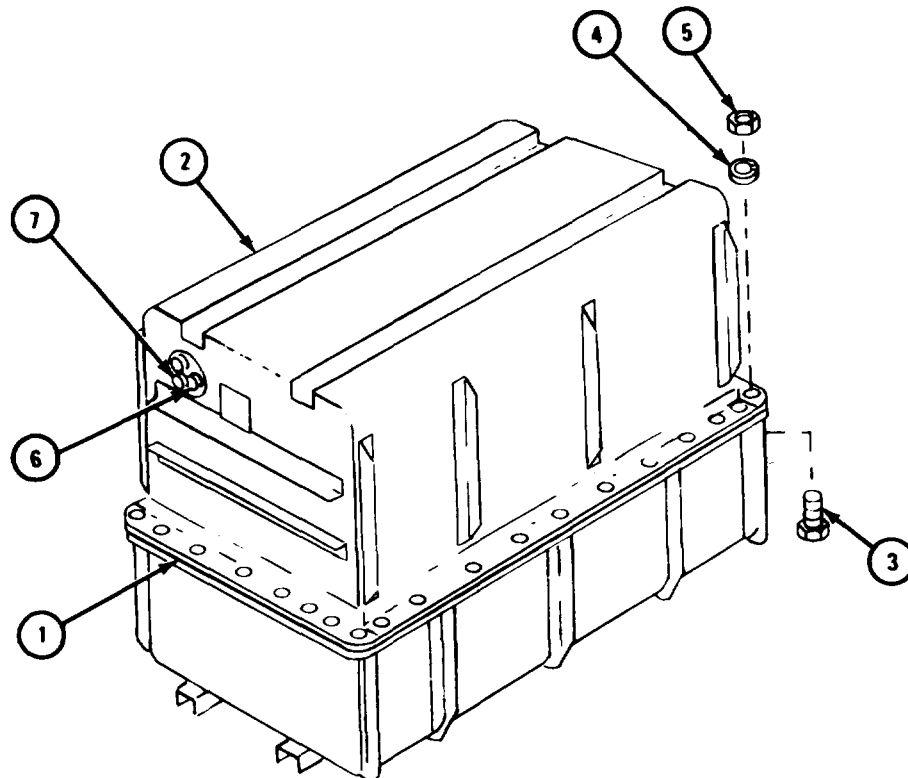

TA 116713

FRAME 2

1. Take out safety relief valve (1).
2. Put in air pressure gage (2).
3. Using clean, dry air, pressurize container (3) to 10 psi.
4. Put soapy water on container (3). Air bubbles or a drop in air pressure is a sign of air leak. To repair, refer to para 19-32c.
5. Take out air pressure gage (2).
6. Put in safety relief valve (1).

END OF TASK

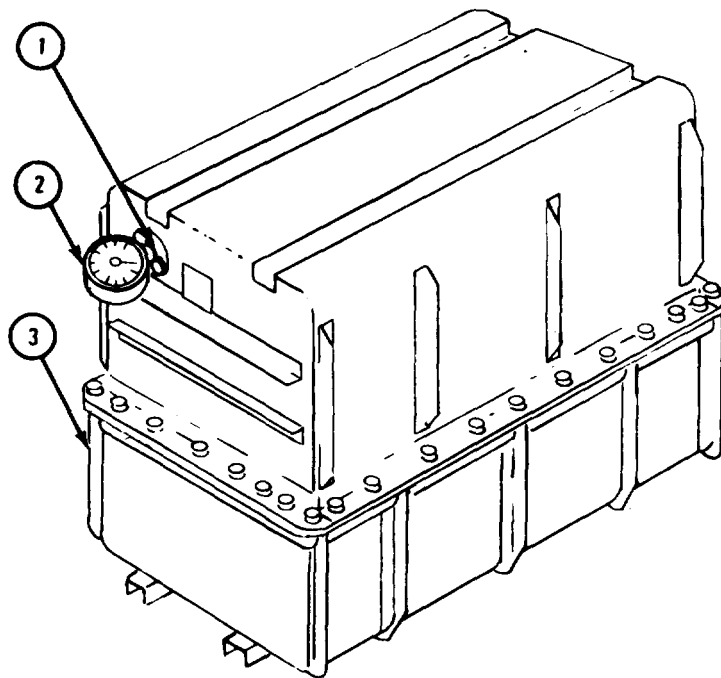

TA 116714

**19-33. DEEP WATER FORDING KIT INSTALLATION.** Install deep water fording kit using instructions that come with kit.

**19-34. DEEP WATER FORDING KIT PRESSURIZATION VALVE HAND CONTROL ASSEMBLY REMOVAL AND REPLACEMENT.**

TOOLS: No special tools required

SUPPLIES: None

PERSONNEL: One

EQUIPMENT CONDITION: Truck parked, engine off, handbrake set.

a. Preliminary Procedure. Open hood. Refer to TM 9-2320-211-10.

b. Removal.

FRAME 1

1. Loosen two setscrews (1).
2. Loosen capscrew and nut (2).

GO TO FRAME 2

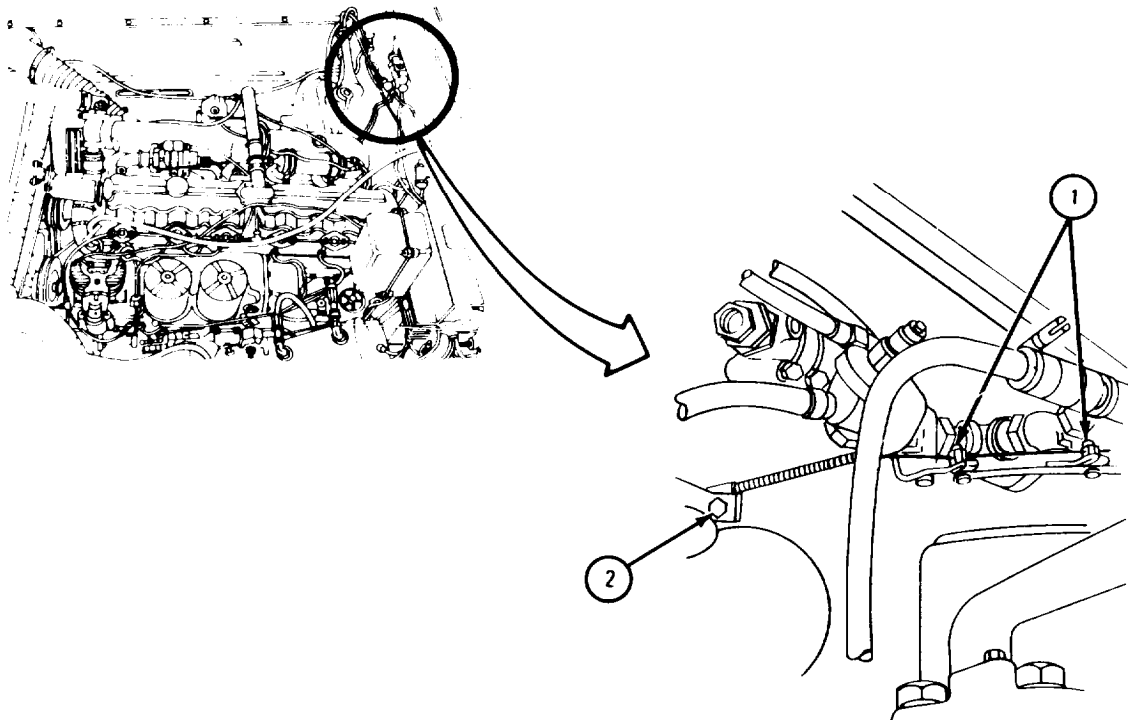

TA 121100

FRAME 2

1. Unscrew nut (1).
2. Pull pressurization valve hand control assembly (2) out of instrument panel (3) and take off nut (1) and washer (4).

END OF TASK

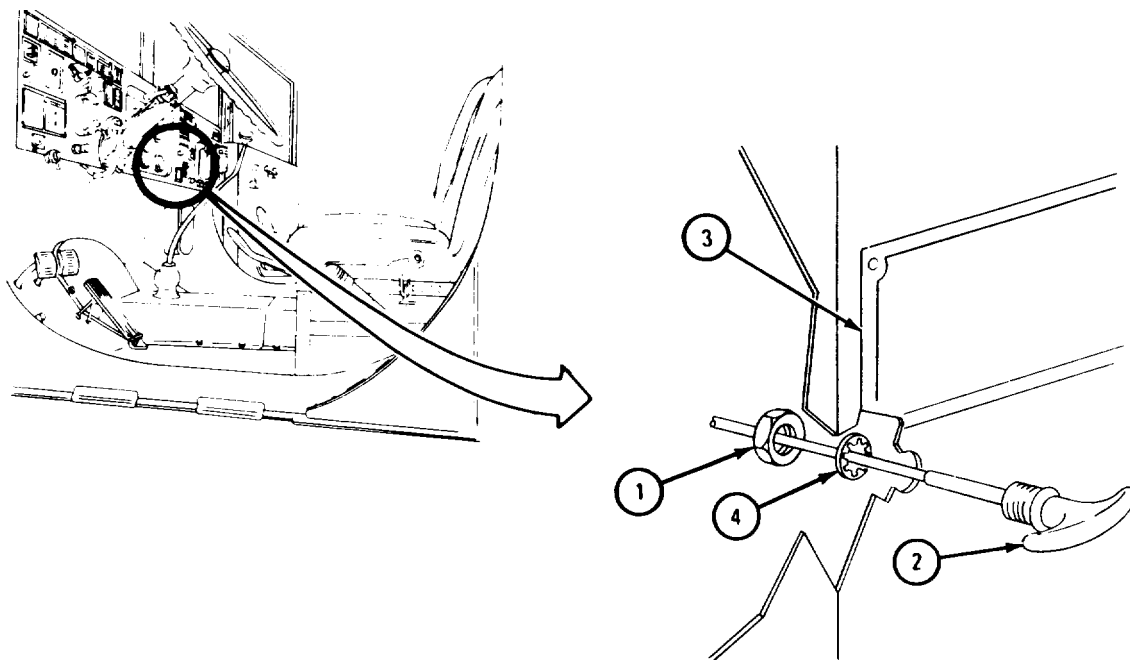

TA 121101



c. Replacement.

## FRAME 1

1. Put pressurization valve hand control assembly (1) through hole in instrument panel (2), washer (3), nut (4), and grommet (5).
2. Put knob (6) on pressurization valve hand control assembly (1) as shown. Screw on and tighten nut (4).
3. Push knob (6) all the way in.

GO TO FRAME 2

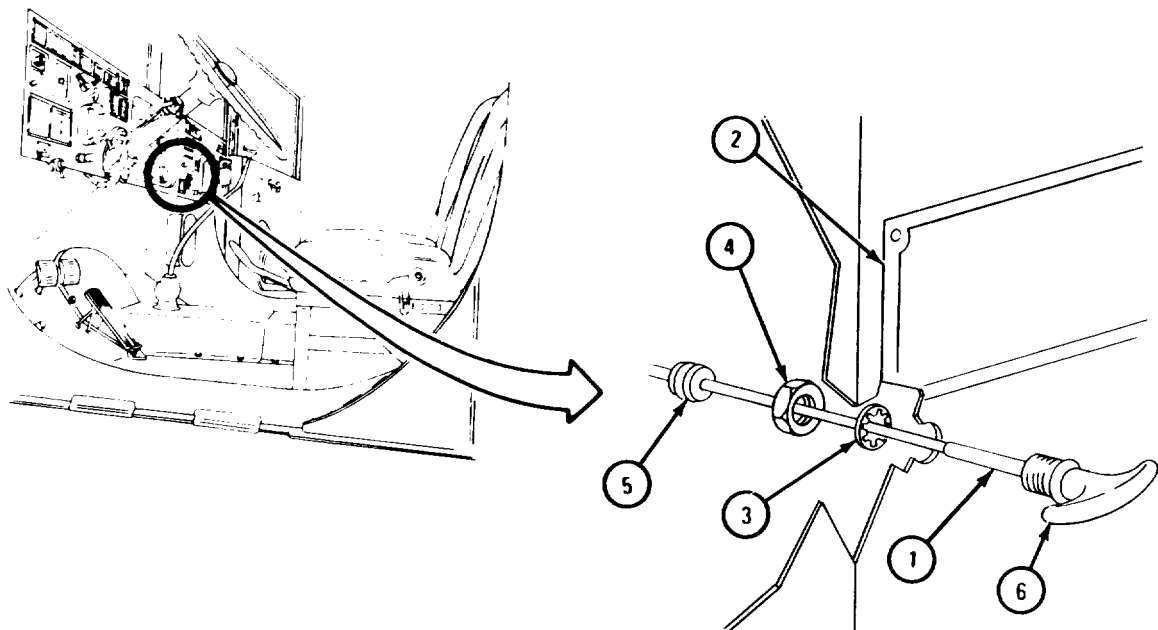

TA 121102

FRAME 2

1. Put pressurization valve hand control assembly cable housing (1) in clamp (2) and control cable (3) into two swivels (4).
2. Push swivels (4) all the way toward firewall (5).
3. Slide pressurization valve hand control assembly cable housing (1) in clamp (2) so there is no less than 112-inch between swivels (4) and Pressurization valve hand control assembly cable housing (1).
4. Tighten capscrew and nut (6). Push swivels (4) all the way away from firewall (5).
5. Tighten two setscrews (7).
6. From inside cab, move pressurization valve hand control knob (8) out and in several times to make sure all parts move smoothly without binding.

**NOTE**

Follow-on Maintenance Action Required:  
Close hood. Refer to TM 9-2320-211-10.

END OF TASK

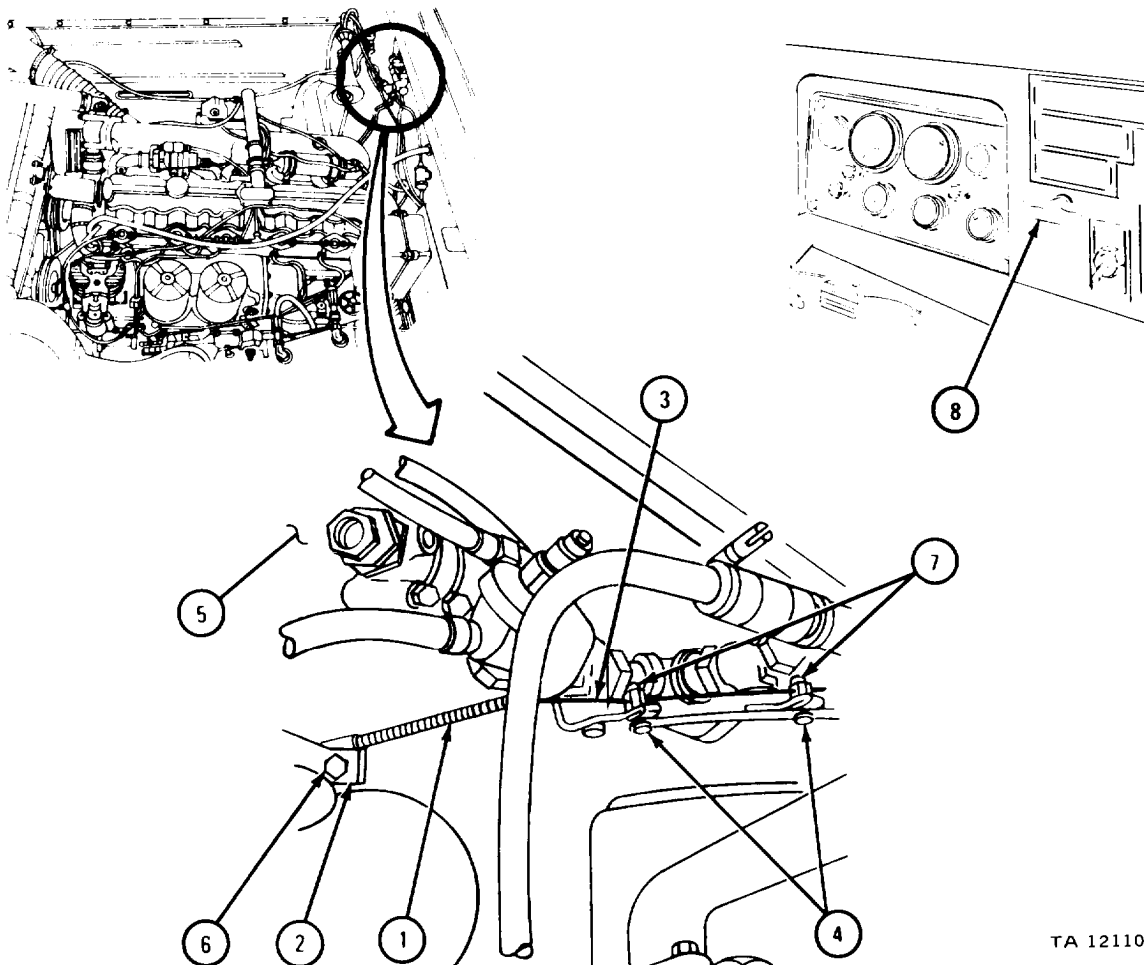

TA 121103

**19-35. DEEP WATER FORDING KIT CONTROL VALVE ASSEMBLY REMOVAL AND REPLACEMENT.**

TOOLS: No special tools required

SUPPLIES: None

PERSONNEL: One

EQUIPMENT CONDITION: Truck parked, engine off, handbrake set.

a. Preliminary Procedures.

(1) Open hood. Refer to TM 9-2320-211-10.

(2) Remove deep water fording kit pressurization valve hand control assembly. Refer to para 19-34.

b. Removal.

FRAME 1

1. Unscrew and take off fitting (1). Take off hose (2).
2. Unscrew and take off fitting (3). Take off tube (4).
3. Unscrew and take off four nuts (5) with lockwashers (6). Take off two U-bolts (7) and control valve assembly (8).

END OF TASK

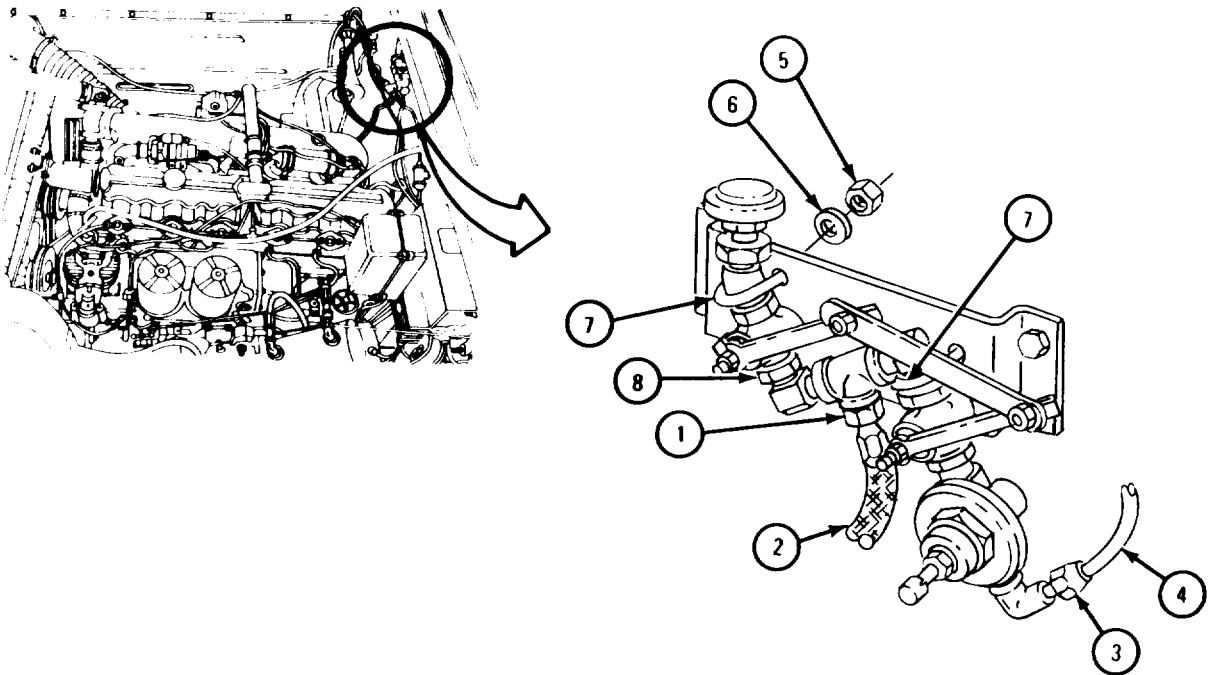

TA 121104

c. Replacement.

FRAME 1

1. Put control valve assembly (1) in place. Put in two U-bolts (2). Screw on and tighten four nuts (3) with lockwashers (4).
2. Put tube (5) in place. Screw on and tighten fitting (6).
3. Put hose (7) in place. Screw on and tighten fitting (8).

**NOTE**

Follow-on Maintenance Action Required:

1. Replace deep water fording kit pressurization valve hand control assembly. Refer to para 19-34.
2. Close hood. Refer to TM 9-2320-211-10.

END OF TASK

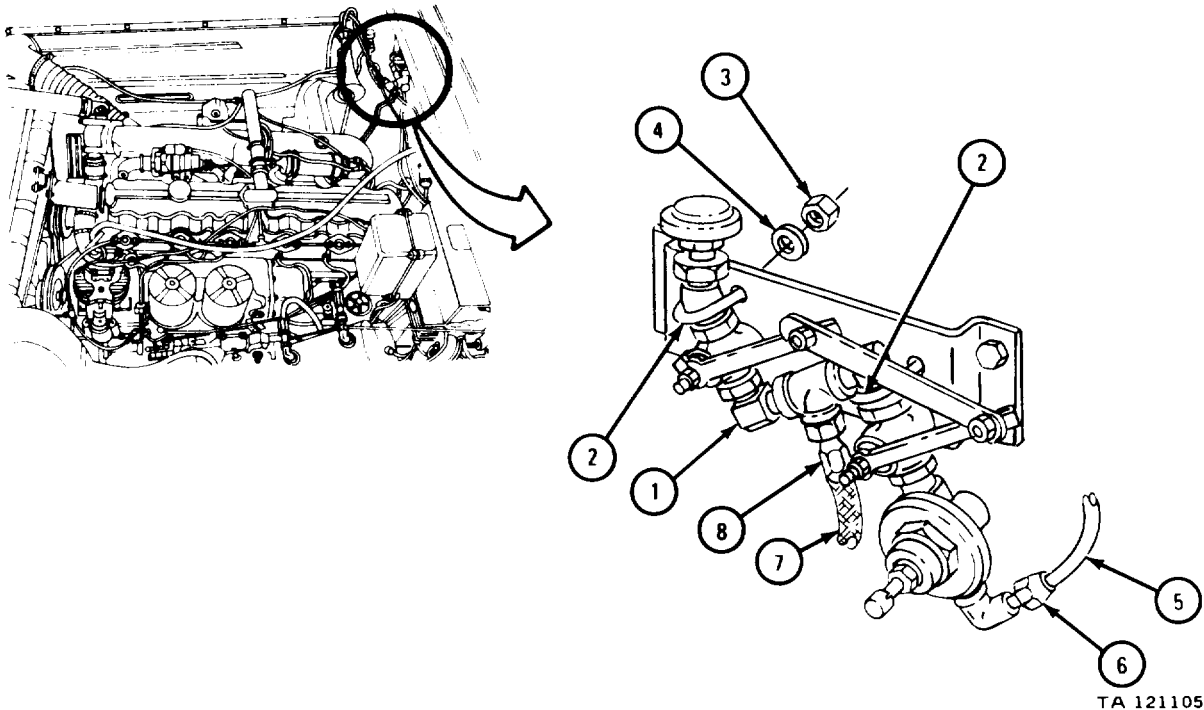

**19-36. DEEP WATER FORDING KIT HOSES AND TUBES REMOVAL AND REPLACEMENT.** Refer to hoses and tubes removal and replacement. Refer to para 19-35 and 19-37.

**19-37. DEEP WATER FORDING KIT SNORKLE ASSEMBLY REMOVAL AND REPLACEMENT.**

TOOLS: No special tools required

SUPPLIES: None

PERSONNEL: One

EQUIPMENT CONDITION: Truck parked, engine off, handbrake set.

a. Removal.

FRAME 1

1. Loosen clamp (1) and two hose clamps (2).
2. Take off cap (3), air cleaner snorkel (4), air cleaner hose (5), and two hose clamps (2).

END OF TASK

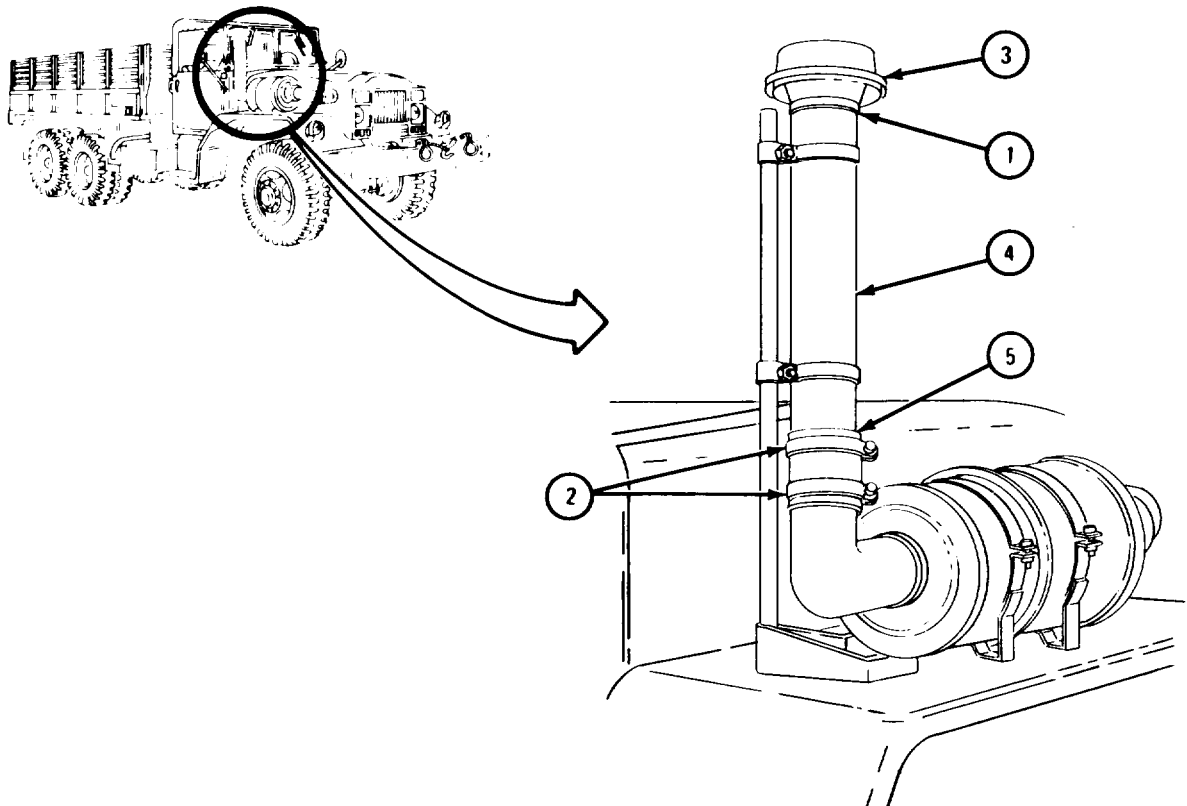

TA 121106

b. Replacement.

FRAME 1

1. Put air cleaner hose (1) and two hose clamps (2) on air cleaner assembly (3) as shown.
2. Put air cleaner snorkle (4) into air cleaner hose (1).
3. Put on two hose clamps (2), one on each end of air cleaner hose (1), and tighten two hose clamps.
4. Put cap (5) on air cleaner snorkle (4).
5. Tighten clamp (6).

END OF TASK

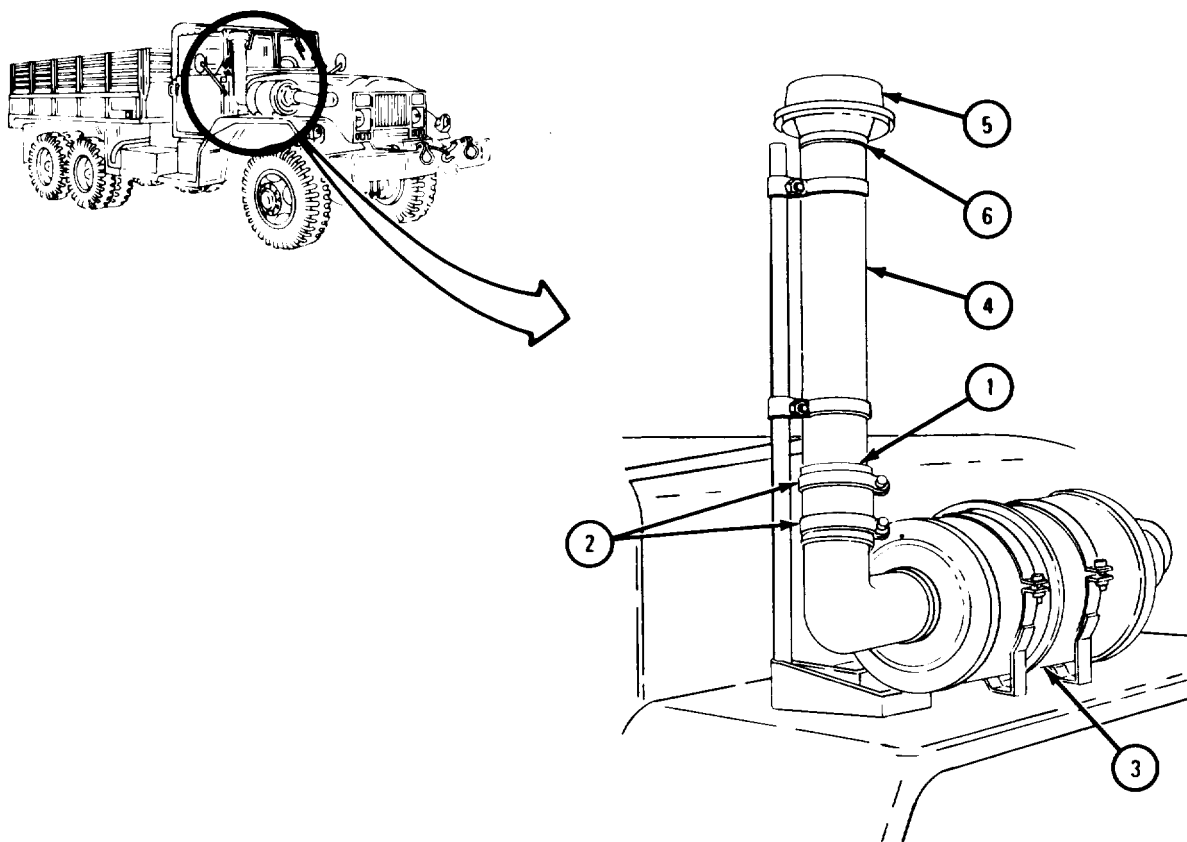

TA 121107

**19-38. DEEP WATER FORDING KIT AIR PRESSURIZATION SYSTEM REGULATOR VALVE REMOVAL AND REPLACEMENT.**

TOOLS: No special tools required

SUPPLIES: None

PERSONNEL: One

EQUIPMENT CONDITION: Truck parked, engine off, handbrake set.

- a. Preliminary Procedure. Open hood. Refer to TM 9-2320-211-10.
- b. Removal.

**FRAME 1**

1. Unscrew nut (1).
2. Take off hose (2) from valve inlet (3).
3. Take out valve outlet (4) from nipple (5).

GO TO FRAME 2

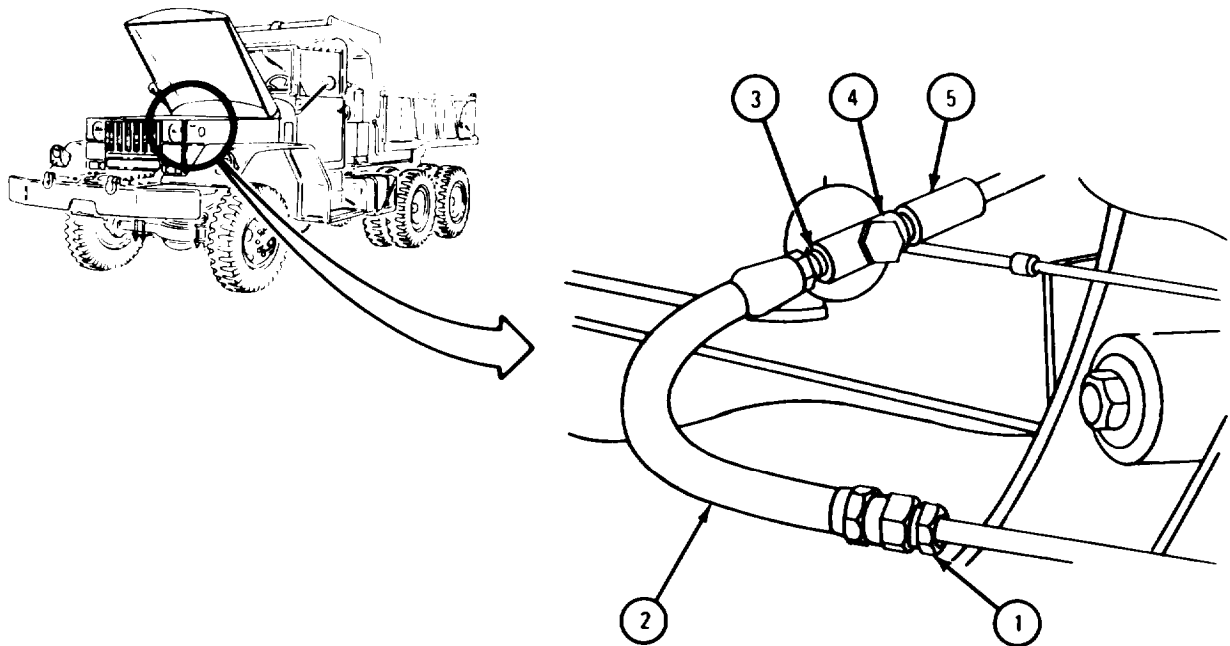

TA 121108

FRAME 2

1. Take off nut (1) and take out screw (2) and washer (3) from bracket (4) and clamp (5).
2. Take clamp (5) off nipple (6).
3. Take nipple (6) out of valve elbow (7).

END OF TASK

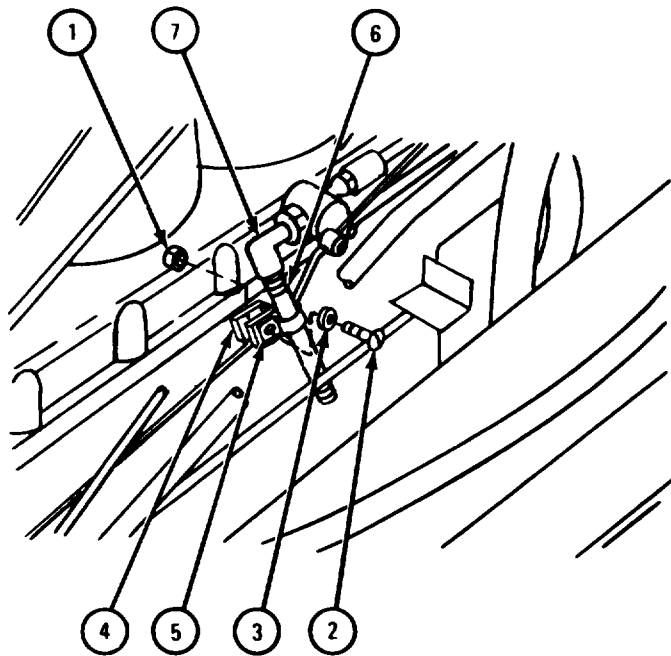

TA 089051



c. Replacement.

FRAME 1

1. Put nipple (1) into valve elbow (2).
  2. Put clamp (3) over nipple (1).
  3. Put screw and washer (4) through clamp (3) and bracket (5). Put on nut (6).
- GO TO FRAME 2

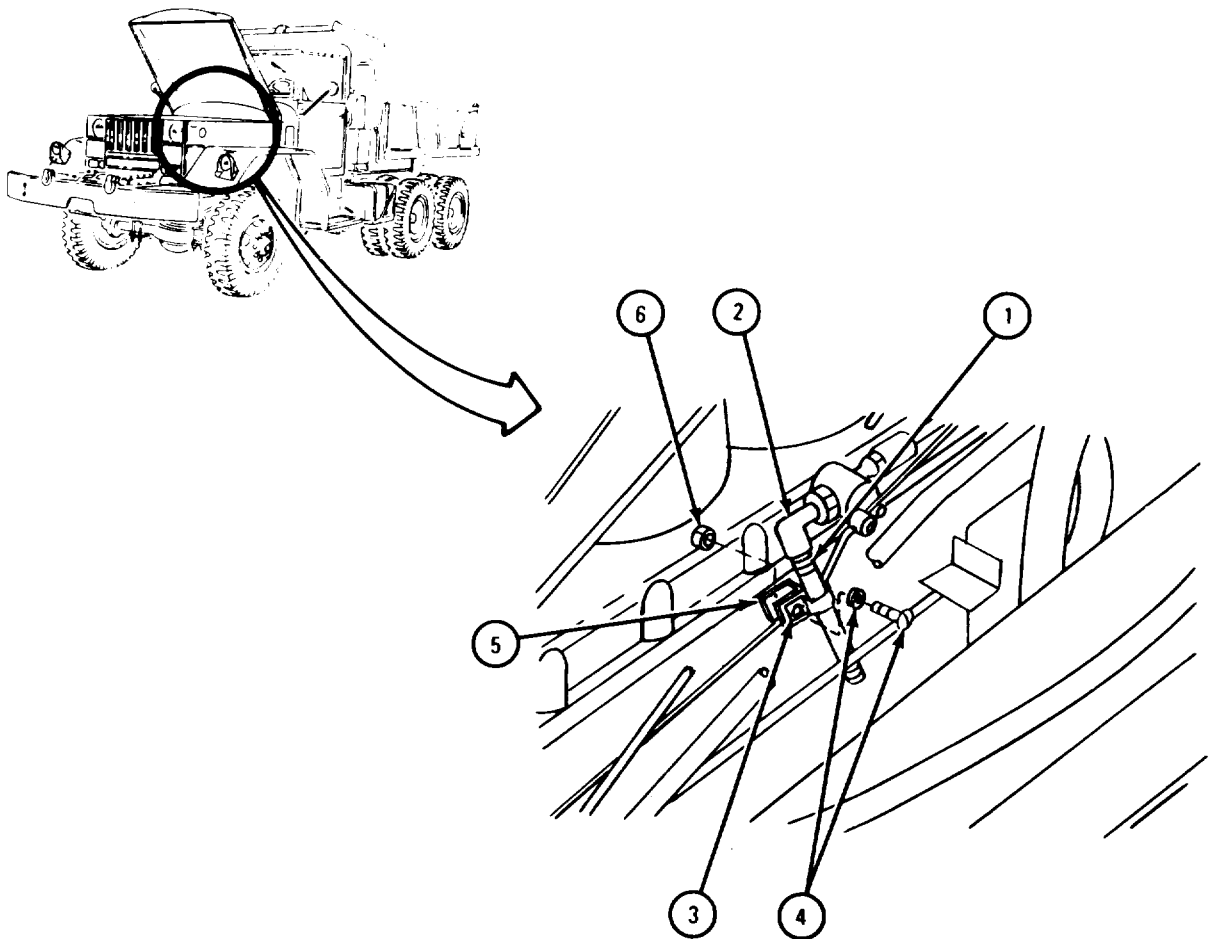

TA 121109

FRAME 2

1. Loosen jam nut (1) and unscrew adjusting screw (2) until it is free of spring seat (3).
2. Slowly tighten adjusting screw (2) until it touches spring seat (3). Tighten adjusting screw 1/4 turn more and tighten jamnut (1).

GO TO FRAME 3

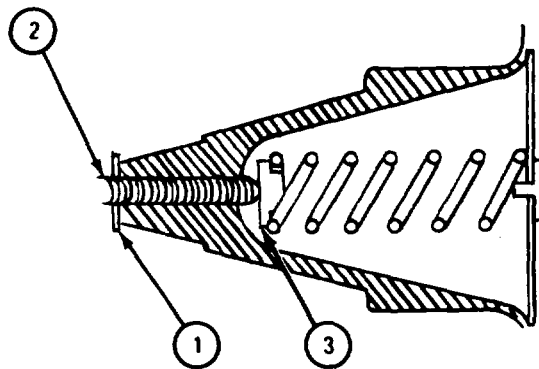

TA 089053

FRAME 3

1. Put regulator valve (1) onto nipple (2).
2. Put hose (3) into valve inlet (4).
3. Tighten nut (5).

**NOTE**

Follow-on Maintenance Action Required:  
Close hood. Refer to TM 9-2320-211-10.

END OF TASK

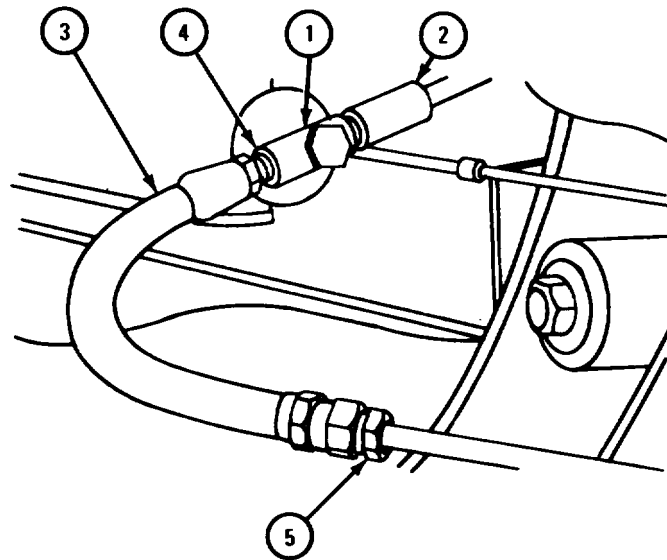

TA 089054



## APPENDIX A

### REFERENCES

#### A-1. PUBLICATION INDEXES AND GENERAL REFERENCE.

Indexes should be checked often for the latest changes or revisions of references given in this appendix and for new publications on materiel covered in this technical manual.

a. Military Publications Indexes.

Index of Army Motion Pictures  
and Related Audio-Visual Aids . . . . . DA Pam 108-1

Index of Administrative Publications . . . . . DA Pam 310- 1

Index of Blank Forms . . . . . DA Pam 310-2

Index of Doctrinal Training and  
Organizational Publications . . . . . DA Pam 310-3

Military Publications:

Index of Technical Manuals, Technical  
Bulletins, Supply Bulletins, and  
Lubrications Orders . . . . . DA Pam 310-4

Index of Supply Catalogs and  
Supply Manuals (excluding types  
7,8, and 9) . . . . . DA Pam 310-6

Index of Modification Work Orders . . . . . DA Pam 310-7

Common Tools and Equipment  
Supply Manuals . . . . . DA Supply Manuals  
SC-4910-95-CL-A01, A02,  
A50, A63, A64, A65, A67,  
A68, A72, A73, and A74.  
SC-5180-90-CL-N-23,  
SC-4910-95-CL-A31 and  
-A 32

b. General Reference.

Authorization Abbreviations and Brevity  
Codes . . . . . AR 310-50

Dictionary of United States Army Terms . . . . . AR 310-25

**A-2. FORMS.**

The following forms are for this materiel (refer to DA pamphlet 310-2 for index of blank forms and to TM 38-750 for explanation of their use).

Recommended Changes to Publications . . . . .	DA Form 2028
Maintenance Request - Continuation Sheet . . . . .	DA Form 2407-1
Equipment Log Assembly (Records) . . . . .	DA Form 2408
Processing and Reprocessing Records for Shipment, Storage, and Issue of Vehicles and Spare Engines . . . . .	DA Form 1397

**A-3. OTHER PUBLICATIONS.**

a. Vehicle Manuals

Lubrication Order . . . . .	LO 9-2320-211-12
operator's Manual . . . . .	TM 9-2320-211-10
Organizational Maintenance Manual . . . . .	TM 9-2320-211-20
Organizational Maintenance Repair Parts and Special Tool List . . . . .	TM 9-2320-211-20P
Direct Support and General Support Maintenance Repair Parts and Special Tool List . . . . .	TM 9-2320-211-34P
Transportability Guidance . . . . .	TM 55-2320-211-15-1

b. Engine Maintenance Manuals

DS, GS, and Depot Maintenance Manual:  
Engine, Diesel (Multifuel): Turbocharged  
(LD-465-1, LD-465-1C, LDS-465-1, LDT-465-1C,  
LDS-465-1A & LDS-465-2) . . . . . TM 9-2815-210-34

DS and GS Maintenance Repair Parts and Special  
Tools Lists (Including Depot Maintenance  
Parts and Special Tools): Engine, Diesel  
(Multifuel): Turbocharged (LD-465-1,  
LD-465-1C, LDT-465-1C, LDS-465-1,  
LDS-465-1A) . . . . . TM 9-2815-210-34P

co Engine Equipment Maintenance Manuals

DS and GS Maintenance Manual (Including DS and GS Maintenance Repair Parts List):  
 Pump Fuel, Metering and Distributing  
 Assembly . . . . . TM 9-2910-226-34&P

GS and Depot Maintenance Manual  
 (Including Repair Parts and Special  
 Tools List): Turbocharger, Engine  
 Assembly (Schwitzer Models 4-456,  
 4D-554, 4D454C, 4LD-354, 4LD-456) . . . . . TM 9-2990-201-40&P

d. Other Truck Equipment Maintenance Manuals

DS, GS, and Depot Maintenance Manual:  
 Transmissions, Transfers, and Power  
 Takeoffs . . . . . TM 9-2520-246-34

Ordnance Maintenance: Winches, Power  
 Takeoffs, Power Divider and Hydraulic  
 Equipment (Gar Wood) . . . . . TM 9-8617

Organizational Care, Maintenance and  
 Repair of Pneumatic Tires and Inner  
 Tubes . . . . . TM 9-2200-200-20

GS Maintenance Manual: Generator, Delco-  
 Remy Model 1117495 . . . . . TM 9-2920-214-34&P

GS Maintenance Manual: Generator, Presto-  
 lite Model GHA-4804JUT and Autolite Model  
 GHA-4802UT . . . . . TM 9-2920-247-34&P

e. General Manuals

Administrative Storage of Equipment . . . . . TM 740- 90-1

The Army Maintenance Management  
 System (TAMMS) . . . . . TM 38-750

Operator's Manual: Lathe, Brake Drum,  
 Floor Mounted, 60 Inch Rated Swing;  
 25 Inch Maximum Drum Diameter,  
 115-Volt, 60-Cycle, Single Phase  
 (Star Machine Tool Co. Model 1400)  
 (4910-516-6192) Change 1 . . . . . TM 9-4910-482-10

Operator's and Organizational Maintenance  
Manual (Including Repair Parts and Special  
Tools Lists) for Reliner, Brake and Clutch:  
Floor Mounted, 6- to 24-inch Brake Shoe Diameter,  
1/8 to 1/4-inch Drill Capacity; 1/3 Horsepower,  
115 Volts, 60 Cycle, Single Phase (Star Machine  
and Tool Company, Model 80V) (4910-802-1423)  
Changes 1, 2 ..... TM 9-4910-443-12

Inspection, Care and Maintenance of  
Antifriction Bearings ..... TM 9-214

Tactical Wheeled Vehicles, Repair  
of Frames ..... TB 9-2300-247-40

Safety Inspection and Testing of  
Lifting Devices ..... TB 43-0142

Operator's Manual: Welding Theory and  
Application (TO 34W4-1-5) ..... TM 9-237

General Repair for Canvas and Webbing ..... FM 43-3

Materials Used for Cleaning, Preserving,  
Abrading and Cementing Ordnance Materiel  
and Related Materials Including Chemicals ..... TM 9-247

Metal Body Repair and Related Operations ..... FM 43-2

Cooling Systems: Tactical Vehicles  
Changes 1, 2 ..... TB 750-254

Purging, Cleaning and Coating Interior  
Ferrous and Terne Sheet Vehicle Fuel Tanks ..... TB 43-0212

Painting Instructions for Field Use ..... TM 43-0139

Color, Marking and Camouflage Painting  
of Military Vehicles, Construction Equipment,  
and Materials Handling Equipment ..... TB 43-0209

(Rustproofing) ..... TB 43-0213

Security of Tactical Wheeled Vehicles ..... TM 9-2300-422-20

Operator's, Organizational, Direct Support  
and General Support Maintenance Manual  
for Lead-Acid Storage Batteries ..... TM 9-6140-200-14



## INDEX

	Paragraph	Page
A		
Accessory wiring circuit breakers . . . . .	6-10	6-15
Preliminary procedures . . . . .	6-10a	6-15
Removal . . . . .	6-10b	6-15
Replacement . . . . .	6-10c	6-16
Adapter assembly, control valve, dump body (truck M51A2) . . . . .	17-19	17-238.
Assembly . . . . .	17-19e	17-243
Cleaning, inspection, and repair . . . . .	17-19d	17-241
Disassembly . . . . .	17-19c	17-240
Preliminary procedures . . . . .	17-19a	17-238
Removal . . . . .	17-19b	17-239
Replacement . . . . .	17-19f	17-244
Administrative storage . . . . .	1-13	1-7
A-frame kit installation (trucks M54A 2 with winch, M54A2C with winch, and M55A2 with winch) . . . . .	19-30	19-197
Installation . . . . .	19-30b	19-198
Preliminary procedures . . . . .	19-30a	19-197
Air diverter, fuel burning personnel heater . . . . .	19-10	19-19
Preliminary procedure . . . . .	19-10a	19-19
Removal . . . . .	19-10b	19-19
Replacement . . . . .	19-10c	19-20
Air hydraulic cylinder repair . . . . .	11-7	11-18
Assembly . . . . .	11-7d	11-36
Cleaning, inspection, and repair . . . . .	11-7c	11-33
Disassembly . . . . .	11-7b	11-19
Preliminary procedure . . . . .	11-7a	11-18
Alinement, frame . . . . .	14-3	14-2
Alinement check . . . . .	14-3b	14-3
Inspection and repair . . . . .	14-3c	14-6
Preliminary procedures . . . . .	14-3a	14-2
Approach plates and center deck (truck M52A2) . . . . .	14-11	14-83
Cleaning . . . . .	14-11c	14-85
Inspection and repair . . . . .	14-11d	14-85
Preliminary procedure . . . . .	14-11a	14-83
Removal . . . . .	14-11b	14-83
Replacement . . . . .	14-11e	14-86
B		
Battery . . . . .	6-14	6-27
Removal . . . . .	6-14a	6-27
Repair . . . . .	6-14b	6-27
Replacement . . . . .	6-14c	6-27

INDEX - CONT

	Paragraph	Page
B - Cont		
Body assembly, cargo (trucks M54A2 and M54A2C) . . . . .	16-26	16-194
Assembly . . . . .	16-26f	16-200
Cleaning . . . . .	16-26d	16-199
Disassembly . . . . .	16-26c	16-197
Inspection and repair . . . . .	16-26e	16-199
Preliminary procedures . . . . .	16-26a	16-194
Removal . . . . .	16-26b	16-195
Replacement . . . . .	16-26g	16-202
Body assembly, dump truck (truck M51A2) . . . . .	16-28	16-214
Assembly . . . . .	16-28f	16-224
Cleaning . . . . .	16-28d	16-223
Disassembly . . . . .	16-28c	16-218
Inspection and repair . . . . .	16-28e	16-223
Preliminary procedures . . . . .	16-28a	16-214
Removal . . . . .	16-28b	16-215
Replacement . . . . .	16-28g	16-229
Body assembly, long cargo (truck M55A2) . . . . .	16-27	16-204
Assembly . . . . .	16-27f	16-209
Cleaning . . . . .	16-27d	16-208
Disassembly . . . . .	16-27c	16-207
Inspection and repair . . . . .	16-27e	16-208
Preliminary procedures . . . . .	16-27a	16-204
Removal . . . . .	16-27b	16-205
Replacement . . . . .	16-27g	16-211
Boom assembly (truck M543A2) . . . . .	17-44	17-548
Preliminary procedures . . . . .	17-44a	17-548
Removal . . . . .	17-44b	17-548
Replacement . . . . .	17-44c	17-558
Boom, crane inner (truck M543A2). . . . .	17-46	17-590
Assembly . . . . .	17-46f	17-596
Cleaning . . . . .	17-46c	17-594
Disassembly . . . . .	17-46b	17-591
Inspection . . . . .	17-46d	17-595
Preliminary procedures . . . . .	17-46a	17-590
Repair . . . . .	17-46e	17-596
Boom, crane outer (truck M543A2) . . . . .	17-45	17-569
Assembly . . . . .	17-45g	17-581
Cleaning . . . . .	17-45d	17-579
Disassembly . . . . .	17-45c	17-572
Inspection . . . . .	17-45e	17-579
Preliminary procedure . . . . .	17-45a	17-569
Removal of inner boom . . . . .	17-45b	17-570
Repair . . . . .	17-45f	17-581
Replacement of inner boom . . . . .	17-45h	17-588

## INDEX - CONT

	Paragraph	Page
B - Cont		
Bracket, gun mount . . . . .	16-10	16-81
Preliminary procedures . . . . .	16-10a	16-81
Removal . . . . .	16-10b	16-81
Replacement . . . . .	16-10c	16-83
Bracket, hold down, dump body (truck M51A2) . . . . .	14-8	14-49
Cleaning, inspection, and repair . . . . .	14-8b	14-52
Removal . . . . .	14-8a	14-50
Replacement . . . . .	14-8c	14-53
Bracket, mounting, rear axle bumper . . . . .	14-7	14-47
Cleaning, inspection, and repair . . . . .	14-7c	14-48
Preliminary procedure . . . . .	14-7a	14-47
Removal . . . . .	14-7b	14-47
Replacement . . . . .	14-7d	14-48
Bracket, mounting, transmission transfer case . . . . .	8-6	8-98
Cleaning and inspection . . . . .	8-6c	8-100
Preliminary procedures . . . . .	8-6a	8-98
Removal . . . . .	8-6b	8-98
Replacement . . . . .	8-6d	8-101
Bracket, stowage, decontamination apparatus, installation . . . . .	19-31	19-208
Bracket, support, main, brake actuating lever and clutch and brake lever . . . . .	11-9	11-49
Assembly . . . . .	11-9g	11-53
Cleaning . . . . .	11-9d	11-53
Disassembly . . . . .	11-9c	11-52
Inspection . . . . .	11-9e	11-53
Preliminary procedures . . . . .	11-9a	11-49
Removal . . . . .	11-9b	11-50
Repair . . . . .	11-9f	11-53
Replacement . . . . .	11-9h	11-54
Bracket, support, rear axle bogie (trucks M51A2 and M52A2) . . . . .	15-10	15-42
Cleaning . . . . .	15-10c	15-45
Inspection and repair . . . . .	15-10d	15-45
Preliminary procedures . . . . .	15-10a	15-42
Removal . . . . .	15-10b	15-43
Replacement . . . . .	15-10e	15-45
Brake, automatic, front winch . . . . .	17-8	17-42
Removal . . . . .	17-8a	17-42
Replacement and adjustment . . . . .	17-8b	17-45
Brake chamber assembly, cable tensioner, rear winch, (truck M543A2) . . . . .	17-13	17-98
Removal . . . . .	17-13a	17-98
Replacement . . . . .	17-13b	17-99
Brush guard repair . . . . .	16-9	16-80

INDEX - CONT

	Paragraph	Page
B - Cont		
Bumper and reinforcing gussets, front .....	14-5	14-40
Cleaning, inspection, and repair .....	14-5c	14-42
Preliminary procedure .....	14-5a	14-40
Removal .....	14-5b	14-40
Replacement .....	14-5d	14-42
Bumperette, bumper, rear (trucks M54A2 and M54A2C). . .	14-6	14-44
Cleaning, inspection, and repair .....	14-6c	14-45
Preliminary procedure .....	14-6a	14-44
Removal .....	14-6b	14-44
Replacement .....	14-6d	14-46
C		
Cab .....	16-7	16-50
Cleaning .....	16-7c	16-62
Inspection and repair .....	16-7d	16-62
Preliminary procedures .....	16-7a	16-50
Removal .....	16-7b	16-52
Replacement .....	16-7e	16-63
Cable tensioner assembly, rear winch, repair (truck M543A2) .....	17-14	17-100
Cleaning .....	17-14b	17-104
Disassembly .....	17-14a	17-100
Inspection and repair .....	17-14c	17-104
Replacement .....	17-14d	17-104
Camshaft and bushing type bearings .....	2-17	2-92
Cleaning .....	2-17c	2-95
Inspection .....	2-17d	2-95
Preliminary procedures .....	2-17a	2-92
Removal .....	2-17b	2-93
Repair .....	2-17e	2-95
Replacement .....	2-17f	2-96
Circuit breakers, accessor wiring .....	6-10	6-15
Preliminary procedures .....	6-10a	6-15
Removal .....	6-10b	6-15
Replacement .....	6-10c	6-16
Cleaning .....	1-3	1-1
Clutch assembly .....	3-3	3-1
Adjustment of clutch .....	3-3e	3-7
Cleaning .....	3-3c	3-3
Inspection .....	3-3d	3-4
Preliminary procedures .....	3-3a	3-1
Removal .....	3-3b	3-2
Replacement .....	3-3f	3-8

INDEX - CONT

	Paragraph	Page
C - Cont		
Control box assembly, hoist (truck M51A2) .....	17-20	17-245
Assembly .....	17-20f	17-256
Cleaning .....	17-20d	17-254
Disassembly .....	17-20c	17-249
Inspection and repair .....	17-20e	17-255
Preliminary procedures .....	17-20a	17-245
Removal .....	17-20b	17-246
Replacement .....	17-20g	17-262
Control cables, fuel burning personnel heater . . . . .	19-12	19-24
Adjustment .....	19-12c	19-28
Removal .....	19-12a	19-24
Replacement .....	19-12b	19-26
Controller, electric brake .....	19-29	19-186
Assembly .....	19-29e	19-192
Disassembly .....	19-29c	19-187
Inspection and repair .....	19-29d	19-191
Preliminary procedure .....	19-29a	19-186
Removal .....	19-29b	19-186
Replacement .....	19-29f	19-196
Control linkage, hoist (truck M51A2) . . . . .	17-22	17-275
Assembly .....	17-22e	17-284
Cleaning .....	17-22c	17-284
Disassembly .....	17-22b	17-281
Inspection and repair .....	17-22d	17-284
Removal .....	17-22a	17-275
Replacement .....	17-22f	17-288
Control linkage, power divider (truck M543A2) .....	17-53	17-675
Cleaning, inspection, and repair .....	17-53c	17-694
Preliminary procedures .....	17-53a	17-675
Removal .....	17-53b	17-676
Replacement .....	17-53d	17-695
Controls and linkage, transmission power takeoff . . . . .	17-59	17-801
Cleaning .....	17-59b	17-806
Inspection and repair .....	17-59c	17-806
Removal .....	17-59a	17-801
Replacement .....	17-59d	17-807
Control valve assembly repair (truck M51A2) .....	17-21	17-266
Assembly .....	17-21e	17-271
Cleaning .....	17-21c	17-269
Disassembly .....	17-21b	17-266
Inspection and repair .....	17-21d	17-270
Preliminary procedures . . . . .	17-21a	17-266

INDEX - CONT

Paragraph Page

C - Cont

Control valve bank (truck M543A2) . . . . .	17-51	17-620
Assembly of control valve bank . . . . .	17-51g	17-645
Assembly of subassemblies . . . . .	17-51f	16-637
Cleaning . . . . .	17-51d	17-633
Disassembly into subassemblies . . . . .	17-51b	17-621
Disassembly of subassemblies . . . . .	17-51c	17-625
Inspection and repair . . . . .	17-51e	17-634
Preliminary procedures . . . . .	17-51a	17-620
Cover assembly, cab top, repair (trucks M54A2, M54A2C, and M55A2) . . . . .	18-3	18-1
Cover assembly, hood . . . . .	19-23	19-150
Installation . . . . .	19-23b	19-150
Preliminary . . . . .	19-23a	19-150
Cover assembly, hood, vehicular coolant heater . . . . .	19-17	19-45
Removal . . . . .	19-17a	19-45
Repair . . . . .	19-17b	19-45
Replacement . . . . .	19-17c	19-45
Cover assembly, radiator . . . . .	19-25	19-160
Removal . . . . .	19-25a	19-160
Repair . . . . .	19-25b	19-160
Replacement . . . . .	19-25c	19-160
Cover assembly, radiator, installatlon . . . . .	19-24	19-155
Cover assembly, radiator, vehicular coolant heater . . . . .	19-18	19-45
Removal . . . . .	19-18a	19-45
Repair . . . . .	19-18b	19-45
Replacement . . . . .	19-18c	19-45
Cover, cargo body, repair (trucks M54A2, M54A2C, and M55A2) . . . . .	18-5	18-1
Crane body assembly repair (truck M543A2) . . . . .	16-32	16-268
Crane turntable assembly (truck M543A2) . . . . .	17-33	17-390
Assembly . . . . .	17-33g	17-403
Cleaning . . . . .	17-33d	17-402
Disassembly . . . . .	17-33c	17-397
Inspection . . . . .	17-33e	17-402
Preliminary procedures. . . . .	17-33a	17-390
Removal . . . . .	17-33b	17-391
Repair . . . . .	17-33f	17-403
Replacement . . . . .	17-33h	17-408
Crankshaft front seal . . . . .	2-7	2-37
Cleaning . . . . .	2-7c	2-39
Preliminary procedure . . . . .	2-7a	2-37
Removal . . . . .	2-7b	2-38
Replacement . . . . .	2-7d	2-40

INDEX - CONT

	Paragraph	Page
C - Cont		
Crankshaft gear and camshaft gear . . . . .	2-16	2-85
Cleaning, inspection, and repair . . . . .	2-16c	2-88
Preliminary procedures . . . . .	2-16a	2-85
Removal . . . . .	2-16b	2-86
Replacement . . . . .	2-16d	2-90
Crankshaft rear oil seal . . . . .	2-8	2-42
Cleaning, inspection and repair . . . . .	2-8c	2-43
Preliminary procedures . . . . .	2-8a	2-42
Removal . . . . .	2-8b	2-42
Replacement . . . . .	2-8d	2-44
Crankshaft vibration damper . . . . .	2-9	2-46
Cleaning . . . . .	2-9c	2-50
Inspection and repair . . . . .	2-9d	2-51
Preliminary procedures. . . . .	2-9a	2-46
Removal . . . . .	2-9b	2-47
Replacement . . . . .	2-9e	2-52
Crossmembers, brackets, and sidemembers, frame . . . . .	14-4	14-7
Crossmember . . . . .	14-4g	14-24
Crossmember frame . . . . .	14-41	14-31
Left and right cab mounting bracket . . . . .	14-4f	14-22
Radiator crossmember and engine support bracket. . .	14-4b	14-12
Rear axle bogie support bracket . . . . .	14-4k	14-30
Rear crossmember frame . . . . .	14-4m	14-33
Rear engine support brackets . . . . .	14-4e	14-20
Rear of transfer frame crossmember . . . . .	14-4i	14-26
Right and left angle bracket and brush guard hinges . . . . .	14-4a	14-8
Right and left front spring hangers . . . . .	14-4c	14-16
Steering gear bracket . . . . .	14-4d	14-18
Transfer case support . . . . .	14-4h	14-26
Transfer rear support crossmember frame . . . . .	14-4j	14-28
U-bolts . . . . .	14-4n	14-37
Cross tube, rear spring . . . . .	15-9	15-37
Preliminary procedures. . . . .	15-9a	15-37
Removal . . . . .	15-9b	15-37
Replacement . . . . .	15-9c	15-39
Curtain, cargo body, repair (trucks M54A2, M54A2C, and M55A2) . . . . .	18-4	18-1
Cylinder, boom crowd (truck M543A2) . . . . .	17-41	17-517
Assembly . . . . .	17-41f	17-524
Cleaning . . . . .	17-41d	17-522
Disassembly . . . . .	17-41c	17-519
Inspection and repair . . . . .	17-41e	17-523
Preliminary procedure . . . . .	17-41a	17-517
Removal . . . . .	17-41b	17-518
Replacement . . . . .	17-41g	17-527

INDEX - CONT

Paragraph Page

C - Cont

Cylinder, crane boom elevating (truck M543A2) .....	17-42	17-528
Assembly .....	17-42g	17-537
Cleaning .....	17-42d	17-536
Disassembly .....	17-42c	17-533
Inspection .....	17-42e	17-536
Preliminary procedures .....	17-42a	17-528
Removal .....	17-42b	17-529
Repair .....	17-42f	17-537
Replacement .....	17-42h	17-540
Cylinder head .....	2-6	2-30
Preliminary procedures .....	2-6a	2-30
Removal .....	2-6b	2-31
Repair .....	2-6c	2-32
Replacement .....	2-6d	2-32

D

Description .....	1-15	1-7
Destruction to prevent enemy use .....	1-12	1-7
Differential carrier assembly .....	9-4	9-14
Assembly and adjustment .....	9-4f	9-42
Cleaning .....	9-4d	9-31
Disassembly .....	9-4c	9-16
Inspection and repair .....	9-4e	9-31
Preliminary procedures .....	9-4a	9-14
Removal .....	9-4b	9-15
Replacement .....	9-4g	9-83
Diverter, hot water personnel heater .....	19-7	19-18
Door and weather seal, vent .....	16-8	16-74
Removal .....	16-8a	16-74
Replacement .....	16-8b	16-77
Door assembly, cab .....	16-6	16-24
Assembly .....	16-6f	16-39
Cleaning .....	16-6c	16-36
Disassembly .....	16-6b	16-24
Inspection .....	16-6d	16-37
Preliminary procedure .....	16-6a	16-24
Repair .....	16-6e	16-39
Drag link assembly .....	13-3	13-1
Assembly .....	13-3d	13-4
Cleaning .....	13-3b	13-3
Disassembly .....	13-3a	13-2
Inspection and repair .....	13-3c	13-3



INDEX - CONT

	Paragraph	Page
D - Cont		
Ducting, fuel burning personnel heater .....	19-11	19-21
Preliminary procedure .....	19-11a	19-21
Removal .....	19-11b	19-21
Replacement .....	19-11C	19-22
Ducting, hot water personnel heater .....	19-8	19-18
E		
Electric brake kit .....	19-28	19-169
Installation .....	19-28b	19-170
Preliminary procedures .....	19-28a	19-169
Engine assembly .....	2-5	2-12
Preliminary procedures .....	2-5a	2-12
Removal .....	2-5b	2-13
Replacement .....	2-5c	2-21
Engine generator .....	6-3	6-1
Removal .....	6-3a	6-1
Repair .....	6-3b	6-1
Replacement .....	6-3c	6-1
Engine generator regulator .....	6-5	6-4
Removal .....	6-5a	6-4
Repair .....	6-5b	6-4
Replacement .....	6-5c	6-4
Engine mounts and brackets, front .....	2-3	2-2
Cleaning .....	2-3c	2-5
Inspection and repair .....	2-3d	2-5
Preliminary procedures.. ..	2-3a	2-2
Removal .....	2-3b	2-2
Replacement .....	2-3e	2-6
Engine mounts and brackets, rear .....	2-4	2-7
Removal .....	2-4a	2-7
Replacement .....	2-4b	2-10
Engine oil pump assembly (trucks with engines LDS 465-1 and LDS 465-1A) .....	2-20	2-106
Adjustment and testing .....	2-20f	2-111
Assembly .....	2-20g	2-111
Cleaning .....	2-20d	2-111
Disassembly .....	2-20c	2-109
Inspection and repair .....	2-20e	2-111
Preliminary procedures. . . . .	2-20a	2-106
Removal .....	2-20b	2-107
Replacement .....	2-20h	2-116
Engine, starter solenoid .....	6-7	6-5
Removal .....	6-7a	6-5
Replacement .....	6-7b	6-7

INDEX - CONT

Paragraph Page

E - Cont

Equipment improvement report and maintenance digest (EIR MD) and improvement report and maintenance summary (EIRMS) . . . . .	1-9	1-2
Exhaust tube, vehicular coolant heater . . . . .	19-15	19-37
Removal . . . . .	19-15a	19-37
Replacement . . . . .	19-15b	19-40

F

Fan, engine cooling, cleaning, inspection, and repair . . . .	5-5	5-7
Cleaning, inspection, and repair . . . . .	5-5b	5-8
Preliminary procedure . . . . .	5-5a	5-7
Fender assembly, front . . . . .	16-11	16-85
Cleaning . . . . .	16-11d	16-107
Inspection and repair . . . . .	16-11e	16-107
Preliminary procedures . . . . .	16-11a	16-85
Removal of left front fender . . . . .	16-11b	16-86
Removal of right front fender . . . . .	16-11c	16-98
Replacement of left front fender . . . . .	16-11f	16-108
Replacement of right front fender . . . . .	16-11g	16-119
Fifth wheel assembly . . . . .	14-10	14-59
Assembly . . . . .	14-10f	14-72
Cleaning . . . . .	14-10c	14-69
Disassembly . . . . .	14-10b	14-60
Inspection . . . . .	14-10d	14-70
Preliminary procedure . . . . .	14-10a	14-59
Repair . . . . .	14-10e	14-72
Flame heater (side-mounted, uncovered and side-mounted, covered) . . . . .	4-9	4-31
Removal . . . . .	4-9a	4-31
Repair . . . . .	4-9b	4-31
Replacement . . . . .	4-9c	4-31
Floodlight assembly repair, (truck M543A2) . . . . .	6-11	6-17
Cleaning . . . . .	6-11b	6-17
Inspection and repair . . . . .	6-11c	6-18
Preliminary procedure . . . . .	6-11a	6-17
Flywheel . . . . .	2-10	2-57
Cleaning . . . . .	2-10c	2-60
Inspection and repair . . . . .	2-10d	2-60
Preliminary procedures . . . . .	2-10a	2-57
Removal . . . . .	2-10b	2-58
Replacement . . . . .	2-10e	2-61

INDEX - CONT

	Paragraph	Page
F - Cont		
Flywheel housing .....	2-12	2-65
Cleaning, inspection, and repair .....	2-12c	2-67
Final inspection .....	2-12e	2-71
Preliminary procedures .....	2-12a	2-65
Removal .....	2-12b	2-66
Replacement .....	2-12d	2-68
Flywheel ring gear .....	2-11	2-62
Preliminary procedures .....	2-11a	2-62
Removal .....	2-11b	2-62
Replacement .....	2-11c	2-64
Foot sheave, lower boom (truck M543A2) .....	17-43	17-543
Cleaning .....	17-43c	17-546
Inspection and repair .....	17-43d	17-546
Preliminary procedures .....	17-43a	17-543
Removal .....	17-43b	17-544
Replacement .....	17-43e	17-547
Fording kit, deep water, control valve assembly .....	19-35	19-223
Preliminary procedures .....	19-35a	19-223
Removal .....	19-35b	19-223
Replacement .....	19-35c	19-224
Fording kit, deep water, hoses and tubes . . . . .	19-36	19-225
Fording kit, deep water, installation .....	19-33	19-219
Fording kit, deep water, pressurization system		
regulator valve .....	19-38	19-227
Preliminary procedure .....	19-38a	19-227
Removal .....	19-38b	19-227
Replacement .....	19-38c	19-229
Fording kit, deep water, pressurization valve hand		
control assembly .....	19-34	19-219
Preliminary procedure .....	19-34a	19-219
Removal .....	19-34b	19-219
Replacement .....	19-34c	19-221
Fording kit, deep water, snorkle assembly .....	19-37	19-225
Removal .....	19-37a	19-225
Replacement .....	19-37b	19-226
Forms and records .....	1-8	1-2
Front axle assembly .....	9-3	9-1
Assembly .....	9-3f	9-8
Cleaning .....	9-3d	9-6
Disassembly .....	9-3c	9-4
Inspection and repair .....	9-3e	9-6
Preliminary procedures .....	9-3a	9-1
Removal .....	9-3b	9-2
Replacement .....	9-3h	9-11
Tests and Adjustment .....	9-3g	9-10

INDEX - CONT

	Paragraph	Page
F - Cont		
Front axle shafts, bearings, seals, knuckles, and arms . .	9-5	9-85
Cleaning . . . . .	9-5c	9-92
Inspection and repair . . . . .	9-5d	9-92
Preliminary procedure . . . . .	9-5a	9-85
Removal . . . . .	9-5b	9-86
Replacement . . . . .	9-5e	9-94
Tests and Adjustments . . . . .	9-5f	9-100
Fuel injector nozzle and holder . . . . .	4-3	4-1
Cleaning, inspection and repair . . . . .	4-3b	4-1
Removal . . . . .	4-3a	4-1
Replacement . . . . .	4-3c	4-1
Fuel injector pump . . . . .	4-4	4-1
Preliminary procedures . . . . .	4-4a	4-1
Removal . . . . .	4-4b	4-2
Repair . . . . .	4-4c	4-11
Replacement . . . . .	4-4d	4-11
Fuel injector pump timing . . . . .	4-5	4-19
Preliminary procedures . . . . .	4-5a	4-19
Timing . . . . .	4-5b	4-20
Fuel injector tubes repair . . . . .	4-6	4-26
Cleaning, inspection, and repair . . . . .	4-6b	4-26
Removal . . . . .	4-6a	4-26
Replacement . . . . .	4-6c	4-26
Fuel tank repair . . . . .	4-8	4-26
Assembly . . . . .	4-8d	4-30
Cleaning . . . . .	4-8b	4-28
Disassembly . . . . .	4-8a	4-27
Inspection and repair . . . . .	4-8c	4-29
G		
Gearcase assembly, crane swinger (truck M543A2) . . . . .	17-29	17-349
Preliminary procedure . . . . .	17-29a	17-349
Removal . . . . .	17-29b	17-349
Replacement . . . . .	17-29c	17-351
Gearcase assembly repair, crane swinger (truck M543A2) . . . . .	17-30	17-353
Assembly . . . . .	17-30f	17-362
Cleaning . . . . .	17-30c	17-360
Disassembly . . . . .	17-30b	17-354
Inspection . . . . .	17-30d	17-360
Preliminary procedure . . . . .	17-30a	17-353
Repair . . . . .	17-30e	17-362

INDEX - CONT

	Paragraph	Page
G - Cont		
Gearcase assembly, turntable bevel (truck M543A2) . . . . .	17-34	17-415
Assembly . . . . .	17-34f	17-429
Cleaning . . . . .	17-34d	17-426
Disassembly . . . . .	17-34c	17-418
Inspection and repair . . . . .	17-34e	17-427
Preliminary procedures . . . . .	17-34a	17-415
Removal . . . . .	17-34b	17-416
Replacement . . . . .	17-34g	17-439
General Shipping instructions . . . . .	1-16	1-7
Generator mounting bracket . . . . .	6-4	6-2
Cleaning . . . . .	6-4c	6-3
Inspection . . . . .	6-4d	6-3
Preliminary procedures. . . . .	6-4a	6-2
Removal . . . . .	6-4b	6-2
Replacement . . . . .	6-4e	6-3
Gondola assembly, wrecker (truck M543A2) . . . . .	17-52	17-649
Assembly . . . . .	17-52e	17-662
Cleaning, inspection, and repair . . . . .	17-52d	17-661
Disassembly . . . . .	17-52c	17-659
Preliminary procedures. . . . .	17-52a	17-649
Removal . . . . .	17-52b	17-650
Replacement . . . . .	17-52f	17-664
Guard, operator (truck M543A2) . . . . .	17-50	17-617
Cleaning, inspection, and repair . . . . .	17-50b	17-618
Removal . . . . .	17-50a	17-617
Replacement . . . . .	17-50c	17-619
H		
Handbrake drum assembly. . . . .	11-4	11-5
Assembly . . . . .	11-4e	11-9
Cleaning, inspection, and repair . . . . .	11-4d	11-7
Disassembly . . . . .	11-4c	11-6
Preliminary procedure . . . . .	11-4a	11-5
Removal . . . . .	11-4b	11-5
Handbrake linkage repair . . . . .	11-3	11-1
Assembly . . . . .	11-3d	11-4
Cleaning, inspection, and repair . . . . .	11-3c	11-3
Disassembly . . . . .	11-3b	11-2
Preliminary procedures. . . . .	11-3a	11-1
Handle, grab . . . . .	16-15	16-146
Removal . . . . .	16-15a	16-146
Replacement . . . . .	16-15b	16-147
Hanger, front spring . . . . .	15-4	15-6
Cleaning, inspection, and repair . . . . .	15-4c	15-8
Preliminary procedures. . . . .	15-4a	15-6
Removal . . . . .	15-4b	15-7
Replacement . . . . .	15-4d	15-9

INDEX - CONT

	Paragraph	Page
H - Cont		
Hardtop closure assembly .....	19-22	19-126
Assembly .....	19-22e	19-140
Cleaning .....	19-22c	19-136
Disassembly .....	19-22b	19-130
Inspection and repair . . . . .	19-22d	19-137
Removal .....	19-22a	19-127
Replacement .....	19-22f	19-146
Harness, electrical, hot water personnel heater .....	19-6	19-9
Inspection and repair . . . . .	19-6c	19-13
Preliminary procedures .....	19-6a	19-9
Removal .....	19-6b	19-9
Replacement .....	19-6d	19-14
Harness, starter relay .....	6-8	6-9
Preliminary procedures .....	6-8a	6-9
Removal .....	6-8b	6-10
Replacement .....	6-8c	6-12
Heater assembly, hot water personnel .....	19-5	19-3
Cleaning .....	19-5c	19-6
Preliminary procedures .....	19-5a	19-3
Removal .....	19-5b	19-4
Repair .....	19-5d	19-6
Replacement .....	19-5e	19-7
Heater, hot water personnel, functional test . . . . .	19-4	19-2
Heater kit, fuel burning personnel, installation . . . . .	19-9	19-18
Heater kit, hot water personnel .....	19-3	19-1
Installation .....	19-3b	19-1
Preliminary procedures .....	19-3a	19-1
Test and adjustment . . . . .	19-3c	19-1
Heater kit, vehicular coolant, installation .....	19-13	19-29
Hinge assembly, cab windshield .....	16-14	16-144
Removal .....	16-14a	16-144
Replacement . . . . .	16-14b	16-145
Hoist cylinder, dump body (truck M51A2) .....	17-24	17-302
Assembly .....	17-24g	17-310
Cleaning .....	17-24d	17-309
Disassembly .....	17-24c	17-304
Inspection .....	17-24e	17-309
Preliminary procedure.. . . . .	17-24a	17-302
Removal .....	17-24b	17-303
Repair .....	17-24f	17-310
Replacement .....	17-24h	17-315

INDEX - CONT

	Paragraph	Page
H - Cont		
Hoist frame assembly, dump body (truck M51A2) . . . . .	17-23	17-294
Cleaning . . . . .	17-23c	17-298
Inspection and repair . . . . .	17-23d	17-298
Preliminary procedures . . . . .	17-23a	17-294
Removal . . . . .	17-23b	17-295
Replacement . . . . .	17-23e	17-299
Hood . . . . .	16-5	16-13
Assembly . . . . .	16-5f	16-19
Cleaning . . . . .	16-5c	16-18
Disassembly . . . . .	16-5b	16-16
Inspection . . . . .	16-5d	16-18
Removal . . . . .	16-5a	16-13
Repair . . . . .	16-5e	16-19
Replacement . . . . .	16-5g	16-21
Horn assembly . . . . .	6-12	6-19
Assembly . . . . .	6-12e	6-22
Cleaning . . . . .	6-12c	6-20
Disassembly . . . . .	6-12b	6-19
Inspection and repair . . . . .	6-12d	6-21
Preliminary procedure.. . . . .	6-12a	6-19
Horn contact brush assembly . . . . .	6-13	6-23
Preliminary procedures. . . . .	6-13a	6-23
Removal . . . . .	6-13b	6-23
Replacement . . . . .	6-13c	6-25
Hoses and tubes, vehicular coolant heater . . . . .	19-14	19-29
Preliminary procedures. . . . .	19-14a	19-29
Removal . . . . .	19-14b	19-30
Replacement . . . . .	19-14c	19-33
Hydraulic brake lines repair . . . . .	11-8	11-49

I

Instrument panel . . . . .	6-9	6-14
Cleaning . . . . .	6-9b	6-14
Inspection and repair . . . . .	6-9c	6-14
Preliminary procedure . . . . .	6-9a	6-14

L

Lead and ring assembly, pump drive shaft, bevel gearcase (truck M543A2) . . . . .	17-31	17-370
Cleaning . . . . .	17-31c	17-374
Inspection and repair . . . . .	17-31d	17-375
Preliminary procedures. . . . .	17-31a	17-370
Removal . . . . .	17-31b	17-370
Replacement . . . . .	17-31e	17-376

INDEX - CONT

	Paragraph	Page
L - Cont		
Level wind, front .....	17-6	17-25
Preliminary procedure .....	17-6a	17-25
Removal .....	17-6b	17-25
Replacement .....	17-6c	17-27
Level wind, front winch .....	17-9	17-49
Removal .....	17-9a	17-49
Replacement .....	17-9b	17-51
M		
Maintenance, general .....	1-2	1-1
Maintenance of bearings .....	7-7	7-125
Cleaning of bearings .....	7-7e	7-129
Inspection .....	7-7f	7-130
Removal of bearing from housing by pressing .....	7-7c	7-127
Removal of bearing from housing by pulling .....	7-7d	7-128
Removal of bearing from shaft by pressing .....	7-7a	7-125
Removal of bearing from shaft by pulling .....	7-7b	7-126
Replacement of bearing into housing .....	7-7h	7-132
Replacement of bearing onto shaft .....	7-7g	7-131
Maintenance repair parts .....	1-18	1-7
Manifolds, intake and exhaust .....	2-24	2-144
Assembly .....	2-24f	2-152
Cleaning .....	2-24d	2-151
Disassembly .....	2-24c	2-148
Inspection and repair .....	2-24e	2-151
Preliminary procedures .....	2-24a	2-144
Removal .....	2-24b	2-145
Replacement .....	2-24g	2-155
Metric system .....	1-11	1-7
Motor assembly, hoist winch (truck M543A2) .....	17-17	17-177
Assembly .....	17-17f	17-190
Cleaning .....	17-17c	17-187
Disassembly .....	17-17b	17-180
Inspection .....	17-17d	17-188
Removal .....	17-17a	17-178
Repair .....	17-17e	17-190
Replacement .....	17-17g	17-198
Motor assembly, swing hydraulic (truck M543A2) .....	17-36	17-461
Assembly .....	17-36f	17-473
Cleaning .....	17-36e	17-470
Disassembly .....	17-36b	17-464
Inspection .....	17-36d	17-471
Removal .....	17-36a	17-462
Repair .....	17-36e	17-473
Replacement .....	17-36g	17-480



INDEX - CONT

	Paragraph	Page
O		
Oil cooler element and housing .....	2-22	2-126
Assembly .....	2-22f	2-133
Cleaning .....	2-22d	2-131
Disassembly .....	2-22c	2-130
Inspection and repair .....	2-22e	2-131
Preliminary procedures .....	2-22a	2-126
Removal .....	2-22b	2-127
Replacement .....	2-22g	2-134
Oil pan .....	2-21	2-119
Cleaning .....	2-21c	2-122
Inspection and repair .....	2-21d	2-122
Preliminary procedures .....	2-21a	2-119
Removal .....	2-21b	2-119
Replacement .....	2-21e	2-123
Oil pressure regulator .....	2-23	
Cleaning and inspection .....	2-23c	2-137
Preliminary procedures .....	2-23a	2-137
Removal .....	2-23b	2-138
Replacement .....	2-23d	2-141
Outrigger assemblies, front and rear (truck M543A2) . . . .	16-33	16-268
Assembly .....	16-33f	16-272
Cleaning .....	16-33d	16-272
Disassembly .....	16-33c	16-270
Inspection and repair .....	16-33e	16-272
Preliminary procedures .....	16-33a	16-268
Removal .....	16-33b	16-269
Replacement .....	16-33g	16-273
P		
Packing, boom crowd cylinder .....	17-39	17-511
Preliminary procedures .....	17-39a	17-511
Removal .....	17-39b	17-512
Replacement .....	17-39c	17-513
Packing, boom elevating cylinder piston rod (truck M543A2) .....	17-40	17-514
Preliminary procedures .....	17-40a	17-514
Removal .....	17-40b	17-515
Replacement .....	17-40c	17-516
Packing, hoist cylinder .....	17-26	17-327
Preliminary procedures .....	17-26a	17-327
Removal .....	17-26b	17-328
Replacement .....	17-26c	17-329
Painting .....	1-4	1-2

INDEX - CONT

Paragraph Page

P - Cont

Panels, floor mats, and covers, thermal barrier .....	19-21	19-123
Cleaning .....	19-21d	19-125
Inspection and repair .....	19-21b	19-123
Preliminary procedures .....	19-21a	19-123
Removal .....	19-21c	19-124
Replacement .....	19-21e	19-125
Panel, side, hood .....	16-3	16-1
Assembly .....	16-3f	16-5
Cleaning .....	16-3d	16-4
Disassemble .....	16-3c	16-3
Inspection and repair .....	16-3e	16-4
Preliminary procedures .....	16-3a	16-1
Removal .....	16-3b	16-2
Replacement .....	16-3g	16-6
Parking brakeshoe assemblies repair .....	11-5	11-11
Assembly .....	11-5e	11-13
Cleaning .....	11-5b	11-12
Disassembly .....	11-5a	11-11
Inspection .....	11-5c	11-12
Repair .....	11-5d	11-13
Pilot bearing .....	2-13	2-74
Preliminary procedures .....	2-13a	2 - 7 4
Removal .....	2-13b	2-74
Replacement .....	2-13c	2-75
Pintle hook repair .....	14-9	14-55
Assembly .....	14-9e	14-58
Cleaning .....	14-9c	14-57
Disassembly .....	14-9b	14-56
Inspection and repair .....	14-9d	14-57
Preliminary procedure.. .....	14-9a	14-55
Pioneer tool set bracket and stowage tool box (truck M51A2) .....	16-24	16-180
Cleaning .....	16-24c	16-184
Inspection and repair .....	16-24d	16-184
Preliminary procedure.. .....	16-24a	16-180
Removal .....	16-24b	16-180
Replacement .....	16-24e	16-184
Power divider assembly (truck M543A3) .....	17-54	17-714
Assembly .....	17-54g	17-744
Cleaning .....	17-54d	17-736
Disassembly, .....	17-54c	17-716
Inspection .....	17-54e	17-736
Preliminary procedures .....	17-54a	17-714
Removal .....	17-54b	17-715
Repair .....	17-54f	17-744
Replacement .....	17-54h	17-770

INDEX - CONT

	Paragraph	Page
P - Cont		
Power takeoff, transmission .....	17-60	17-812
Assembly .....	17-60f	17-829
Cleaning .....	17-60d	17-825
Disassembly .....	17-60c	17-814
Inspection and repair .....	17-60e	17-825
Preliminary procedures .....	17-60a	17-812
Removal .....	17-60b	17-813
Replacement .....	17-60g	17-844
Power takeoff, transmission transfer (truck M543A2) .....	17-56	17-774
Assembly .....	17-56g	17-785
Cleaning . . . . .	17-56d	17-784
Disassembly .....	17-56c	17-777
Inspection .....	17-56e	17-784
Preliminary procedures .....	17-56a	17-774
Removal .....	17-56b	17-774
Repair .....	17-56f	17-785
Replacement .....	17-56h	17-791
Pump assembly, hydraulic turntable (truck M543A2) . . . . .	17-35	17-441
Assembly .....	17-35g	17-452
Cleaning .....	17-35d	17-449
Disassembly .....	17-35c	17-444
Inspection .....	17-35e	17-449
Preliminary procedures.. . . . .	17-35a	17-441
Removal .....	17-35b	17-442
Repair .....	17-35f	17-452
Replacement .....	17-35h	17-459
Pump, hoist, repair (truck M51A2) .....	17-25	17-318
Assembly .....	17-25f	17-344
Cleaning .....	17-25c	17-322
Disassembly .....	17-25b	17-319
Inspection .....	17-25d	17-323
Preliminary procedures .....	17-25a	17-318
Repair .....	17-25e	17-344
Pump, hydraulic, power steering . . . . .	13-7	13-76
Assembly .....	13-7e	13-84
Cleaning, inspection, and repair .....	13-7d	13-83
Disassembly .....	13-7c	13-80
Preliminary procedures .....	13-7a	13-76
Removal .....	13-7b	13-77
Replacement .....	13-7f	13-87

INDEX - CONT

	Paragraph	Page
R		
Radiator assembly, engine cooling, repair .....	5-3	5-1
Removal .....	5-3a	5-1
Repair .....	5-3b	5-1
Replacement .....	5-3c	5-1
Relay lever assembly .....	13-4	13-5
Cleaning .....	13-4b	13-6
Disassembly .....	13-4a	13-5
Inspection and repair .....	13-4c	13-7
Relief valve, steering .....	13-9	13-94
Preliminary procedure .....	13-9a	13-94
Removal .....	13-9b	13-94
Replacement .....	13-9c	13-95
Reporting improvement recommendations .....	1-10	1-7
Reservoir, power steering hydraulic oil .....	13-8	13-90
Assembly .....	13-8f	13-93
Cleaning .....	13-8c	13-91
Disassembly .....	13-8b	13-90
Inspection .....	13-8d	13-91
Preliminary procedure .....	13-8a	13-90
Repair .....	13-8e	13-92
Reservoir, hydraulic oil repair (truck M543A2) .....	17-37	17-482
Assembly .....	17-37g	17-493
Cleaning .....	17-37d	17-490
Disassembly .....	17-37c	17-487
Inspection .....	17-37e	17-491
Preliminary procedure .....	17-37a	17-482
Removal .....	17-37b	17-482
Repair .....	17-37f	17-493
Replacement .....	17-37h	17-497
Rocker arm assembly .....	2-15	2-80
Adjustment .....	2-15e	2-83
Cleaning, inspection, and repair .....	2-15c	2-82
Preliminary procedures .....	2-15a	2-80
Removal .....	2-15b	2-81
Replacement .....	2-15d	2-82
Rod and clip, hood support .....	16-4	16-7
Preliminary procedure .....	16-4a	16-7
Removal .....	16-4b	16-7
Replacement .....	16-4c	16-10
Roller arm assembly, hoist (truck M51A2). . . . .	17-28	17-340
Assembly .....	17-28f	17-345
Cleaning .....	17-28d	17-344
Disassembly .....	17-28c	17-343
Inspection and repair .....	17-28e	17-344
Preliminary procedure .....	17-28a	17-341
Removal .....	17-28b	17-342
Replacement .....	17-28g	17-346

INDEX - CONT

	Paragraph	Page
R - Cont		
Roller assemblies, boom and shipper, repair		
(truck M543A2) .....	17-38	17-502
Assembly .....	17-38e	17-508
Cleaning .....	17-38c	17-506
Disassembly .....	17-38b	17-504
Inspection and repair .....	17-38d	17-507
Removal .....	17-38a	17-503
Replacement .....	17-38f	17-510
Roller assembly, front winch. ....	17-3	17-1
Assembly .....	17-3f	17-6
Cleaning .....	17-3d	17-5
Disassembly .....	17-3c	17-3
Inspection and repair .....	17-3e	17-5
Preliminary procedure .....	17-3a	17-1
Removal .....	17-3b	17-2
Replacement .....	17-3g	17-8
Rotochamber (truck M543A2) .....	17-47	17-599
Preliminary procedure .....	17-47a	17-599
Removal .....	17-47b	17-599
Replacement .....	17-47c	17-601
Running board .....	16-12	16-130
Cleaning .....	16-12b	16-132
Inspection and repair .....	16-12c	16-132
Removal .....	16-12a	16-130
Replacement .....	16-12d	16-133
S		
Safety inspection and testing of lifting devices .....	1-7	1-2
Seal, driveshaft, bevel gearcase .....	17-32	17-382
Preliminary procedures .....	17-32a	17-382
Removal .....	17-32b	17-382
Replacement .....	17-32c	17-382
Seal, power takeoff, transmission (all trucks		
except M51A2) .....	17-57	17-794
Preliminary procedures .....	17-57a	17-794
Removal .....	17-57b	17-794
Replacement .....	17-57c	17-795
Seal, power takeoff, transmission (truck M51A2) . . . . .	17-58	17-796
Preliminary procedures .....	17-58a	17-796
Removal .....	17-58b	17-796
Replacement .....	17-58c	17-799
Seat, companion .....	16-20	16-168
Cleaning .....	16-20b	16-171
Inspection and repair .....	16-20c	16-172
Removal .....	16-20a	16-168
Replacement .....	16-20d	16-173

INDEX - CONT

	Paragraph	Page
S - Cont		
Seat cushion repair .....	16-21	16-176
Removal .....	16-21a	16-176
Repair .....	16-21b	16-176
Replacement .....	16-21c	16-176
Seat, driver's .....	16-19	16-156
Cleaning .....	16-19b	16-161
Inspection and repair .....	16-19c	16-162
Removal .....	16-19a	16-156
Replacement .....	16-19d	16-163
Service brake drum and brakeshoe assembly .....	11-6	11-14
Repair of brake drum .....	11-6a	11-14
Repair of brakeshoe assembly .....	11-6b	11-15
Sheave and trolley, level wind, front winch, repair (truck M543A2) .....	17-5	17-11
Assembly .....	17-5d	17-19
Cleaning .....	17-5b	17-18
Disassembly .....	17-5a	17-12
Inspection and repair .....	17-5c	17-18
Sheave and trolley, level wind, rear winch, repair (truck M543A2) .....	17-15	17-108
Assembly .....	17-15d	17-114
Cleaning .....	17-15b	17-113
Disassembly .....	17-15a	17-108
Inspection and repair .....	17-15c	17-113
Sheave and trolley, level wind, rear winch (truck M543A2) .....	17-11	17-89
Removal .....	17-11a	17-89
Replacement .....	17-11b	17-90
Sheaves and guard, upper boom head and upper boom foot, hoist cable (truck M543A2) .....	17-27	17-330
Assembly .....	17-27f	17-335
Cleaning .....	17-27d	17-334
Disassembly .....	17-27c	17-333
Inspection and repair .....	17-27e	17-334
Preliminary procedures .....	17-27a	17-330
Removal .....	17-27b	17-330
Replacement .....	17-27g	17-336
Shipping container, engine and storage, repair .....	19-32	19-211
Assembly .....	18-32d	19-215
Cleaning .....	17-32a	19-211
Disassembly .....	19-32b	19-211
Inspection and repair .....	19-32c	19-213
Pressure check .....	19-32e	19-217
Shroud assembly, oil pan, vehicular coolant heater .....	19-16	19-43
Removal .....	19-16a	19-43
Replacement .....	19-16b	19-44

INDEX - CONT

	Paragraph	Page
S - Cont		
Slave receptacle kit .....	19-26	19-160
Installation .....	19-26b	19-161
Preliminary procedures .....	19-26a	19-160
Slave receptacle kit (without winterization) .....	19-27	19-165
Installation .....	19-27b	19-165
Preliminary procedures .....	19-27a	19-165
Snatch block assembly (double) (truck M543A2) .....	17-48	17-603
Assembly .....	17-48e	17-607
Cleaning .....	17-48c	17-606
Inspection and repair .....	17-48d	17-606
Preliminary procedure .....	17-48a	17-603
Snatch block assembly (single) (truck M543A2) .....	17-49	17-610
Assembly .....	17-49e	17-614
Cleaning .....	17-49c	17-613
Disassembly .....	17-49b	17-610
Inspection and repair .....	17-49d	17-613
Preliminary procedure .....	17-49a	17-610
Solenoid, engine starter .....	6-7	6-5
Removal .....	6-7a	6-6
Replacement .....	6-7b	6-8
Special tools and equipment .....	1-6	1-2
Splash shield assembly (trucks M54A2, M54A2C, and M55A2) .....	16-17	16-150
Removal .....	16-17a	16-150
Replacement .....	16-17b	16-152
Splash shield, rear (truck M52A2) .....	16-18	16-154
Removal .....	16-18a	16-154
Replacement .....	16-18b	16-155
Splash shield, rear (truck M543A2) .....	16-16	16-148
Removal .....	16-16a	16-148
Replacement .....	16-16b	16-149
Spring, leaf, front, repair .....	15-3	15-1
Assembly .....	15-3d	15-4
Cleaning, inspection, and repair .....	15-3c	15-3
Disassembly .....	15-3b	15-2
Preliminary procedure .....	15-3a	15-1
Spring, leaf, rear, repair .....	15-5	15-10
Assembly .....	15-5d	15-12
Cleaning, inspection, and repair .....	15-5c	15-11
Disassembly .....	15-5b	15-10
Preliminary procedure .....	15-5a	15-10

INDEX - CONT

	Paragraph	Page
S - Cont		
Spring seat, rear .....	15-6	15-14
Preliminary procedure .....	15-6a	15-14
Removal .....	15-6b	15-14
Replacement and adjustment .....	15-6c	15-19
Starter .....	6-6	6-4
Removal .....	6-6a	6-4
Repair .....	6-6b	6-4
Replacement .....	6-6c	6-4
Steering gear .....	13-5	13-9
Adjustment .....	13-5j	13-62
Assembly from subassemblies .....	13-5h	13-49
Assembly of subassemblies .....	13-5g	13-39
Cleaning .....	13-5e	13-29
Disassembly into subassemblies .....	13-5c	13-13
Disassembly of subassemblies .....	13-5d	13-21
Inspection and repair .....	13-5f	13-30
Preliminary procedures .....	13-5a	13-9
Removal .....	13-5b	13-10
Replacement .....	13-5i	13-59
Steering gear tube and jacket .....	13-6	13-66
Assembly .....	13-6f	13-72
Cleaning .....	13-6d	13-70
Disassembly .....	13-6c	13-69
Inspection and repair .....	13-6e	13-71
Preliminary procedures .....	13-6a	13-66
Removal .....	13-6b	13-67
Replacement .....	13-6g	13-73
Suspension axle assembly, forward-rear and rear-rear .....	10-3	10-1
Preliminary procedures .....	10-3a	10-1
Removal .....	10-3b	10-2
Replacement .....	10-3c	10-3
Suspension axle assembly repair, forward-rear and rear-rear .....	10-4	10-5
Assembly .....	10-4e	10-9
Cleaning .....	10-4c	10-7
Disassembly .....	10-4b	10-6
Inspection and repair .....	10-4d	10-8
Preliminary procedures .....	10-4a	10-5



INDEX - CONT

	Paragraph	Page
T		
Tabulated Data .....	1-14	1-7
Tailgate assembly (trucks M54A2, M54A2C, and M55A2) .....	16-29	16-233
Assembly .....	16-29d	16-237
Cleaning, inspection, and repair .....	16-29c	16-236
Disassembly .....	16-29b	16-235
Removal .....	16-29a	16-233
Replacement .....	16-29e	16-238
Tailgate control linkage (truck M51A2) .....	16-31	16-246
Cleaning .....	16-31c	16-254
Inspection .....	16-31d	16-254
Preliminary procedure.. ..	16-31a	16-246
Removal .....	16-31b	16-247
Repair .....	16-31e	16-258
Replacement .....	16-31f	16-258
Tailgate, dumptruck (truck M51A2) .....	16-30	16-240
Assembly .....	16-30f	16-244
Cleaning .....	16-30d	16-243
Disassembly .....	16-30c	16-242
Inspection and repair .....	16-30e	16-243
Preliminary procedure .....	16-30a	16-240
Removal .....	16-30b	16-241
Replacement .....	16-30g	16-245
Tappet chamber cover.. ..	2-18	2-99
Cleaning, inspection, and repair .....	2-18c	2-100
Preliminary Procedures. ....	2-18a	2-99
Removal .....	2-18b	2-99
Replacement .....	2-18d	2-101
Tensioner Assembly, front winch .....	17-4	17-9
Preliminary procedure .....	17-4a	17-9
Removal .....	17-4b	17-9
Replacement .....	17-4c	17-10
Tension sheave assembly, front winch, repair (truck M543A2) .....	17-7	17-29
Assembly .....	17-7d	17-36
Cleaning .....	17-7b	17-35
Disassembly .....	17-7a	17-29
Inspection and repair .....	17-7c	17-35
Tension sheave assembly, rear winch (truck M543A2) .....	17-12	17-91
Preliminary procedure .....	17-12a	17-91
Removal .....	17-12b	17-91
Replacement .....	17-12c	17-95

INDEX - CONT

Paragraph Page

T - Cont

Thermal barrier kit, installation .....	19-20	19-108
Installation .....	19-20b	19-109
Preliminary procedures .....	19-20a	19-108
Timing, fuel injector pump .....	4-5	4-19
Preliminary procedures .....	4-5a	4-19
Timing .....	4-5b	4-20
Tire repair .....	12-3	12-1
Removal .....	12-3a	12-1
Repair .....	12-3b	12-1
Replacement .....	12-3c	12-1
Tool box assembly, left .....	16-22	16-176
Assembly .....	16-22e	16-177
Cleaning .....	16-22c	16-177
Disassembly .....	16-22b	16-176
Inspection and repair .....	16-22d	16-177
Preliminary procedure .....	16-22a	16-176
Tool box assembly, pioneer .....	16-25	16-188
Cleaning .....	16-25c	16-191
Inspection and repair .....	16-25d	16-191
Preliminary procedures .....	16-25a	16-188
Removal .....	16-25b	16-188
Replacement .....	16-25e	16-191
Tool box, pioneer .....	16-23	16-178
Assembly .....	16-23e	16-179
Cleaning .....	16-23c	16-179
Disassembly .....	16-23b	16-178
Inspection and repair .....	16-23d	16-179
Preliminary procedure .....	16-23a	16-178
Torque rod assembly .....	15-8	15-32
Preliminary procedure .....	15-8a	15-32
Removal .....	15-8b	15-32
Replacement .....	15-8c	15-35
Torque rod brackets, upper and lower .....	15-7	15-27
Preliminary procedures .....	15-7a	15-27
Removal .....	15-7b	15-27
Replacement .....	15-7c	15-29
Torque valves .....	1-5	1-2
Trailer connector cable harness .....	6-17	6-56
Inspection .....	6-17b	6-57
Removal .....	6-17a	6-56
Replacement .....	6-17c	6-57

INDEX - CONT

	Paragraph	Page
T - Cont		
Transmission assembly .....	7-3	7-1
Assembly of subassemblies into transmission .....	7-3h	7-85
Assembly of transmission subassemblies .....	7-3g	7-64
Cleaning .....	7-3e	7-46
Disassembly of transmission into subassemblies .....	7-3c	7-6
Disassembly of transmission subassemblies .....	7-3d	7-28
Inspection and repair .....	7-3f	7-47
Preliminary procedures .....	7-3a	7-2
Removal .....	7-3b	7-3
Replacement .....	7-3i	7-105
Transmission input shaft seal .....	7-5	7-109
Preliminary procedures .....	7-5a	7-109
Removal .....	7-5b	7-110
Replacement .....	7-5c	7-115
Transmission output shaft seal .....	7-6	7-120
Preliminary procedure .....	7-6a	7-120
Removal .....	7-6b	7-121
Replacement .....	7-6c	7-123
Transmission power test .....	7-4	7-107
Preliminary procedures .....	7-4a	7-107
Test .....	7-4b	7-108
Transmission transfer assembly rear seal .....	8-5	8-94
Preliminary procedures .....	8-5a	8-94
Removal .....	8-5b	8-94
Replacement .....	8-5c	8-96
Transmission transfer assembly repair .....	8-4	8-13
Assembly of subassemblies .....	8-4g	8-72
Cleaning .....	8-4d	8-48
Disassembly into subassemblies .....	8-4b	8-16
Disassembly of subassemblies .....	8-4c	8-34
Inspection .....	8-4e	8-48
Transmission transfer .....	8-3	8-1
Preliminary procedures .....	8-3a	8-1
Removal .....	8-3b	8-2
Replacement .....	8-3c	8-7
Mounting transmission transfer assembly in stand .....	8-4a	8-14
Repair .....	8-4f	8-70
Replacement of subassemblies .....	8-4h	8-87
Transmission transfer case mounting brackets .....	8-6	8-98
Cleaning and inspection .....	8-6c	8-100
Preliminary procedure .....	8-6a	8-98
Removal .....	8-6b	8-98
Replacement .....	8-6d	8-101

INDEX - CONT

	Paragraph	Page
T - Cont		
Transmission transfer controls and linkage (trucks with front winch) .....	8-8	8-113
Assembly .....	8-8e	8-118
Cleaning .....	8-8c	8-117
Disassembly .....	8-8b	8-116
Inspection and repair .....	8-8d	8-117
Removal .....	8-8a	8-113
Replacement .....	8-8f	8-119
Transmission transfer controls and linkage (trucks without front winch) .....	8-7	8-103
Assembly .....	8-7e	8-109
Cleaning .....	8-7c	8-108
Disassembly .....	8-7b	8-107
Inspection and repair .....	8-7d	8-108
Removal .....	8-7a	8-103
Replacement .....	8-7f	8-110
Transportability guidance .....	1-17	1-7
Turbocharger repair .....	4-7	4-26

v

Valve, governor, power divider (truck M543A2)..	17-55	17-771
Adjustment .....	17-55d	17-773
Preliminary procedures .....	17-55a	17-771
Removal .....	17-55b	17-771
Replacement .....	17-55c	17-772
Valve rocker arm pushrod .....	2-14	2-76
Inspection .....	2-14c	2-78
Preliminary procedures .....	2-14a	2-76
Removal .....	2-14b	2-77
Replacement .....	2-14d	2-79
Valve, swivel (truck M543A2) .....	17-61	17-845
Assembly .....	17-61f	17-853
Cleaning .....	17-61d	17-852
Disassembly .....	17-61c	17-849
Inspection and repair .....	17-61e	17-852
Preliminary procedure .....	17-61a	17-845
Removal .....	17-61b	17-846
Replacement .....	17-61g	17-857
Valve tappets .....	2-19	2-102
Cleaning .....	2-19c	2-104
Inspection and repair .....	2-19d	2-104
Preliminary procedures .....	2-19a	2-102
Removal .....	2-19b	2-103
Replacement .....	2-19e	2-105

INDEX - CONT

	Paragraph	Page
V - Cont		
Vehicular coolant heater. . . . .		
Assembly. . . . .	19-19	19-46
Cleaning and inspection of subassemblies . . . . .	19-19e	19-81
Disassembly into subassemblies. . . . .	19-19d	19-59
Preliminary procedures. . . . .	19-19c	18-48
Removal. . . . .	19-19a	19-46
Testing. . . . .	19-19b	19-47
	19-19f	19-93
W		
Water pump assembly repair . . . . .		
Assembly . . . . .	5-4	5-1
Cleaning . . . . .	5-4f	5-6
Disassembly . . . . .	5-4c	5-3
Inspection . . . . .	5-4b	5-2
Preliminary procedures . . . . .	5-4d	5-4
Repair . . . . .	5-4a	5-2
Winch assembly, front, repair . . . . .	5-4e	5-5
Assembly . . . . .	17-10	17-53
Cleaning . . . . .	17-10f	17-73
Disassembly . . . . .	17-10c	17-70
Inspection . . . . .	17-10b	17-54
Preliminary procedures . . . . .	17-10d	17-71
Repair . . . . .	17-10a	17-53
Winch assembly, rear, repair (truck M543A2) . . . . .	17-10e	17-73
Assembly . . . . .	17-16	17-119
Cleaning . . . . .	17-16f	17-150
Disassembly . . . . .	17-16c	17-141
Inspection . . . . .	17-16b	17-119
Preliminary procedures . . . . .	17-16d	17-142
Repair . . . . .	17-16a	17-119
Winch, hoist (truck M543A2) . . . . .	17-16e	17-149
Assembly . . . . .	17-18	17-200
Cleaning . . . . .	17-18f	17-219
Disassembly . . . . .	17-18d	17-215
Inspection and repair . . . . .	17-18c	17-202
Preliminary procedures . . . . .	17-18e	17-216
Removal . . . . .	17-18a	17-200
Replacement . . . . .	17-18b	17-201
Windshield assembly, vehicle . . . . .	17-18g	17-236
Assembly . . . . .	16-13	16-135
Cleaning . . . . .	16-13e	16-140
Disassembly . . . . .	16-13c	16-139
Inspection and repair . . . . .	16-13b	16-135
Preliminary procedure . . . . .	16-13d	16-139
	16-13a	16-135

INDEX - CONT

	Paragraph	Page
W - Cont		
Wire clamps .....	6-15	6-28
Removal . . . . .	6-15a	6-28
Replacement .....	6-15b	6-29
Wiring harness, front .....	6-16	6-30
Preliminary procedure .....	6-16a	6-30
Removal .....	6-16b	6-30
Replacement .....	6-16c	6-43
Wiring harness, rear .....	6-18	6-58
Preliminary procedure .....	6-18a	6-58
Removal .....	6-18b	6-59
Replacement .....	6-18c	6-60

By Order of the Secretaries of the Army and the Air Force:

**E. C. MEYER**  
General, United States Army  
Chief of Staff

Official:

**J. C. PENNINGTON**  
Major General, United States Army  
The Adjutant General

**LEW ALLEN, JR., General, USAF**  
Chief of Staff

Official:

**VAN L. CRAWFORD, JR Colonel, USAF**  
Director of Administration

Distribution:

To be distributed in accordance with DA Form 12-38, Direct and General Support Maintenance requirements for 5-Ton Truck Chassis: 5-Ton, 6x6, M39A2.







THEN... JOT DOWN THE DOPE ABOUT IT ON THIS FORM, CAREFULLY TEAR IT OUT, FOLD IT AND DROP IT IN THE MAIL!

SOMETHING WRONG WITH THIS PUBLICATION?

FROM (PRINT YOUR UNIT'S COMPLETE ADDRESS)

CDR, 1st Bn, 65th ADA  
Attn: SP4 Jane Idone  
Key West, FL 33040

DATE SENT

Date sent in

PUBLICATION NUMBER

TM 9-2320-211-34-2-4

PUBLICATION DATE

25 Feb 1981

PUBLICATION TITLE

DIR. & GEN. SUPPORT MAINT. MANUAL

BE EXACT PIN-POINT WHERE IT IS

PAGE NO	PARA. GRAPH	FIGURE NO	TABLE NO
19-42	19-15 b		
19-133	19-22 b		
19-223	19-35		

IN THIS SPACE TELL WHAT IS WRONG AND WHAT SHOULD BE DONE ABOUT IT:

FRAME 3, add Follow-on Maintenance Action to read "At lowest point of exhaust tube, drill 1/8-inch diameter hole to drain condensation."

FRAME 4, change illustration callouts. Reason: callouts for seal clip (2) and strip seal (3) are reversed.

Subparagraph a, second sentence refers to para 9-34. Should refer to para 19-34.

SAMPLE

PRINTED NAME GRADE OR TITLE AND TELEPHONE NUMBER

SP4 Jane Idone Autovon 222-2224

SIGN HERE

Jane Idone

FILL IN YOUR  
UNIT'S ADDRESS

FOL

DEPARTMENT OF THE ARMY

OFFICIAL BUSINESS

**SAMPLE**

TEAR ALONG PERFORATED LINE

Commander  
U.S. Army Tank-Automotive Command  
ATTN: DRSTA-MB  
Warren, MI 48090



THEN... JOT DOWN THE DOPE ABOUT IT ON THIS FORM, CAREFULLY TEAR IT OUT, FOLD IT AND DROP IT IN THE MAIL!

**SOMETHING WRONG WITH THIS PUBLICATION?**

FROM (PRINT YOUR UNIT'S COMPLETE ADDRESS)

DATE SENT

PUBLICATION NUMBER

TM 9-2320-211-34-2-4

PUBLICATION DATE

25 Feb 1981

PUBLICATION TITLE

DIR. & GEN. SUPPORT MAINT. MANUAL

BE EXACT... PIN-POINT WHERE IT IS

PAGE NO

PARA-GRAPH

FIGURE NO

TABLE NO

IN THIS SPACE TELL WHAT IS WRONG AND WHAT SHOULD BE DONE ABOUT IT:

PRINTED NAME GRADE OR TITLE AND TELEPHONE NUMBER

SIGN HERE

FILL IN YOUR  
UNIT'S ADDRESS

FOLD BACK

TEAR ALONG PERFORATED LINE

DEPARTMENT OF THE ARMY

OFFICIAL BUSINESS

Commander  
U.S. Army Tank-Automotive Command  
ATTN: DRSTA-MB  
Warren, MI 48090



THEN... JOT DOWN THE DOPE ABOUT IT ON THIS FORM, CAREFULLY TEAR IT OUT, FOLD IT AND DROP IT IN THE MAIL!

**SOMETHING WRONG WITH THIS PUBLICATION?**

FROM (PRINT YOUR UNIT'S COMPLETE ADDRESS)

DATE SENT

PUBLICATION NUMBER

TM 9-2320-211-34-2-4

PUBLICATION DATE

25 Feb 1981

PUBLICATION TITLE

DIR. & GEN. SUPPORT MAINT. MANUAL

BE EXACT . . . PIN-POINT WHERE IT IS

PAGE NO

PARA-GRAPH

FIGURE NO

TABLE NO

IN THIS SPACE TELL WHAT IS WRONG AND WHAT SHOULD BE DONE ABOUT IT:

PRINTED NAME GRADE OR TITLE AND TELEPHONE NUMBER

SIGN HERE

FILL IN YOUR  
UNIT'S ADDRESS

FOLD BACK

DEPARTMENT OF THE ARMY

OFFICIAL BUSINESS

Commander  
U.S. Army Tank-Automotive Command  
ATTN: DRSTA-MB  
Warren, MI 48090

TEAR ALONG PERFORATED LINE

RECOMMENDED CHANGES TO EQUIPMENT TECHNICAL PUBLICATIONS



THEN... JOT DOWN THE DOPE ABOUT IT ON THIS FORM, CAREFULLY TEAR IT OUT, FOLD IT AND DROP IT IN THE MAIL!

SOMETHING WRONG WITH THIS PUBLICATION?

FROM (PRINT YOUR UNIT'S COMPLETE ADDRESS)

DATE SENT

PUBLICATION NUMBER

TM 9-2320-211-34-2-4

PUBLICATION DATE

25 Feb 1981

PUBLICATION TITLE

DIR. & GEN. SUPPORT MAINT. MANUAL

BE EXACT. PIN-POINT WHERE IT IS

PAGE NO

PARA-GRAPH

FIGURE NO

TABLE NO

IN THIS SPACE TELL WHAT IS WRONG AND WHAT SHOULD BE DONE ABOUT IT:

PRINTED NAME GRADE OR TITLE AND TELEPHONE NUMBER

SIGN HERE

FILL IN YOUR  
UNIT'S ADDRESS

FOLD BACK

DEPARTMENT OF THE ARMY

OFFICIAL BUSINESS

Commander  
U.S. Army Tank-Automotive Command  
ATTN: DRSTA-MB  
Warren, MI 48090

TEAR ALONG PERFORATED LINE



## THE METRIC SYSTEM AND EQUIVALENTS

### LINEAR MEASURE

1 Centimeter = 10 Millimeters = 0.01 Meters = 0.3937 Inches  
 1 Meter = 100 Centimeters = 1000 Millimeters = 39.37 Inches  
 1 Kilometer = 1000 Meters = 0.621 Miles

### WEIGHTS

1 Gram = 0.001 Kilograms = 1000 Milligrams = 0.035 Ounces  
 1 Kilogram = 1000 Grams = 2.2 Lb  
 1 Metric Ton = 1000 Kilograms = 1 Megagram = 1.1 Short Tons

### LIQUID MEASURE

1 Milliliter = 0.001 Liters = 0.0338 Fluid Ounces  
 1 Liter = 1000 Milliliters = 33.82 Fluid Ounces

### SQUARE MEASURE

1 Sq Centimeter = 100 Sq Millimeters = 0.155 Sq Inches  
 1 Sq Meter = 10,000 Sq Centimeters = 10.76 Sq Feet  
 1 Sq Kilometer = 1,000,000 Sq Meters = 0.386 Sq Miles

### CUBIC MEASURE

1 Cu Centimeter = 1000 Cu Millimeters = 0.06 Cu Inches  
 1 Cu Meter = 1,000,000 Cu Centimeters = 35.31 Cu Feet

### TEMPERATURE

$5/9 (^{\circ}\text{F} - 32) = ^{\circ}\text{C}$   
 212<sup>o</sup> Fahrenheit is equivalent to 100<sup>o</sup> Celsius  
 90<sup>o</sup> Fahrenheit is equivalent to 32.2<sup>o</sup> Celsius  
 32<sup>o</sup> Fahrenheit is equivalent to 0<sup>o</sup> Celsius  
 $9/5 \text{ C}^{\circ} + 32 = \text{F}^{\circ}$

### APPROXIMATE CONVERSION FACTORS

<u>TO CHANGE</u>	<u>TO</u>	<u>MULTIPLY BY</u>
Inches . . . . .	Centimeters . . . . .	2.540
Feet . . . . .	Meters . . . . .	0.305
Yards . . . . .	Meters . . . . .	0.914
Miles . . . . .	Kilometers . . . . .	1.609
Square Inches . . . . .	Square Centimeters . . . . .	6.451
Square Feet . . . . .	Square Meters . . . . .	0.093
Square Yards . . . . .	Square Meters . . . . .	0.836
Square Miles . . . . .	Square Kilometers . . . . .	2.590
Acres . . . . .	Square Hectometers . . . . .	0.405
Cubic Feet . . . . .	Cubic Meters . . . . .	0.028
Cubic Yards . . . . .	Cubic Meters . . . . .	0.765
Fluid Ounces . . . . .	Milliliters . . . . .	29.573
Pints . . . . .	Liters . . . . .	0.473
Quarts . . . . .	Liters . . . . .	0.946
Gallons . . . . .	Liters . . . . .	3.785
Ounces . . . . .	Grams . . . . .	28.349
Pounds . . . . .	Kilograms . . . . .	0.454
Short Tons . . . . .	Metric Tons . . . . .	0.907
Pound-Feet . . . . .	Newton-Meters . . . . .	1.356
Pounds per Square Inch . . . . .	Kilopascals . . . . .	6.895
Miles per Gallon . . . . .	Kilometers per Liter . . . . .	0.425
Miles per Hour . . . . .	Kilometers per Hour . . . . .	1.609

<u>TO CHANGE</u>	<u>TO</u>	<u>MULTIPLY BY</u>
Centimeters . . . . .	Inches . . . . .	0.394
Meters . . . . .	Feet . . . . .	3.280
Meters . . . . .	Yards . . . . .	1.094
Kilometers . . . . .	Miles . . . . .	0.621
Square Centimeters . . . . .	Square Inches . . . . .	0.155
Square Meters . . . . .	Square Feet . . . . .	10.764
Square Meters . . . . .	Square Yards . . . . .	1.196
Square Kilometers . . . . .	Square Miles . . . . .	0.386
Square Hectometers . . . . .	Acres . . . . .	2.471
Cubic Meters . . . . .	Cubic Feet . . . . .	35.315
Cubic Meters . . . . .	Cubic Yards . . . . .	1.308
Milliliters . . . . .	Fluid Ounces . . . . .	0.034
Liters . . . . .	Pints . . . . .	2.113
Liters . . . . .	Quarts . . . . .	1.057
Liters . . . . .	Gallons . . . . .	0.264
Grams . . . . .	Ounces . . . . .	0.035
Kilograms . . . . .	Pounds . . . . .	2.205
Metric Tons . . . . .	Short Tons . . . . .	1.102
Newton-Meters . . . . .	Pound-Feet . . . . .	0.738
Kilopascals . . . . .	Pounds per Square Inch . . . . .	0.145
Kilometers per Liter . . . . .	Miles per Gallon . . . . .	2.354
Kilometers per Hour . . . . .	Miles per Hour . . . . .	0.621

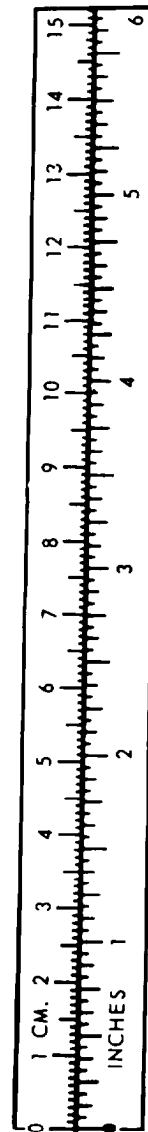

TA089991

