

**MANUAL FOR
THE WHEELED
VEHICLE DRIVER**

**HEADQUARTERS
DEPARTMENT OF THE ARMY
DEPARTMENT OF THE AIR FORCE**

MANUAL FOR THE WHEELED VEHICLE DRIVER

TABLE OF CONTENTS

	Page
PREFACE	vii
CHAPTER 1 BASIC REGULATIONS AND RESPONSIBILITIES	1-1
Official Use Requirement	1-1
Identification Card	1-1
Qualification Record	1-1
Authorization Form	1-2
Driver Qualifications	1-2
Driver Responsibilities	1-6
Fuel Efficient Operation	1-7
CHAPTER 2 TRAFFIC CONTROLS	2-1
Traffic Controllers	2-1
Signals	2-1
Traffic Signals	2-3
Traffic Signs	2-3
Pavement Markings	2-8
CHAPTER 3 SPEED CONTROL	3-1
Stopping	3-1
Avoiding Collisions	3-2

DISTRIBUTION RESTRICTION: Approved for public release; distribution is unlimited.

* This publication supersedes FM 21-305, 24 September 1984.

CHAPTER 4	GOOD DRIVING PRACTICES	4-1
	Obeying the Rules of the Road	4-1
	Driving on the Right	4-2
	Handling Curves	4-2
	Using Selective Vision	4-3
	Turning Left	4-3
	Turning Right	4-4
	Abstaining from Alcohol and Other Drugs	4-4
	Resting	4-4
CHAPTER 5	SAFE DISTANCES AND PASSING	5-1
	Managing Space	5-1
	Night Driving	5-1
	Passing	5-2
	Being Passed	5-3
CHAPTER 6	INTERSECTIONS	6-1
	Intersections Without Traffic Controls	6-1
	Intersections With Traffic Controls	6-1
	Turns at Intersections	6-2
	Special Intersections	6-2
	Private Driveways	6-3
CHAPTER 7	PEDESTRIANS, BICYCLISTS, AND ANIMALS	7-1
	Pedestrians	7-1
	Bicyclists	7-2
	Animals	7-2
CHAPTER 8	OPERATING PRACTICES AND MANUEVERS	8-1
	Driving Practices	8-1
	Starting	8-1
	Steering and Turning	8-1
	Braking and Stopping	8-2
	Ground Guide Safety Procedures	8-3
	Backing	8-3
	Turning Around	8-4

	Parking	8-5
	Elements of Safe Driving	8-8
CHAPTER 9	EMERGENCIES	9-1
	Blowouts	9-1
	Skids	9-1
	Running Off the Pavement	9-2
	Brake Failure	9-2
	Downhill Braking	9-2
	Less Serious Accidents	9-2
	Vehicle Fires	9-3
CHAPTER 10	ACCIDENT CAUSES AND REPORTS	10-1
	Primary Causes of Accidents	10-1
	Procedure in Case of an Accident	10-1
	Precautionary Measures	10-1
	Preparation of Accident Forms	10-2
CHAPTER 11	HAZARDS AND SAFETY MEASURES	11-1
	Night Driving	11-1
	Weather	11-2
	Seasonal Hazards	11-3
	Secondary Roads	11-3
	Smoking, Eating, and Drinking	11-4
	Overloading and Crowding	11-4
	School Buses	11-4
	Emergency Vehicles	11-4
	Breakdowns	11-5
	Safety	11-5
CHAPTER 12	GRIDS AND STRIP MAPS	12-1
	Using the Military Grid Reference System	12-1
	Estimating the Distance	12-2
	Estimating the Time	12-5
	Recognizing Military Signs	12-5
	Using a Strip Map	12-5

CHAPTER 13	OPERATION OF GOVERNMENT VEHICLES OFF POST/BASE	13-1
	Dispatcher's Responsibility	13-1
	Off Post/Base Driving Items and Equipment	13-1
	Off Post/Base Repair Service	13-4
CHAPTER 14	PROCEDURES FOR TRANSPORTING PERSONNEL	14-1
	General Procedures	14-1
	Special Situations	14-1
CHAPTER 15	MAINTENANCE RESPONSIBILITIES	15-1
	Preventive Maintenance	15-1
	Inspections	15-1
	Equipment and Maintenance Forms and Records	15-2
CHAPTER 16	SPARK IGNITION AND COMPRESSION IGNITION ENGINES	16-1
	Spark Ignition Engines	16-1
	Compression Ignition Engines	16-1
CHAPTER 17	MANUAL SHIFT AND AUTOMATIC TRANSMISSIONS	17-1
	Manual Shift Operation	17-1
	Automatic Transmission Operation	17-2
	Jump Starting Vehicles	17-4
CHAPTER 18	TRUCKS, TRACTORS, SEMITRAILERS, AND SPECIAL-PURPOSE VEHICLES	18-1
	Starting/Stopping the Tractor-Semitrailer	18-1
	Using the Engine Retarder (Jacobs Brake)	18-3
	Placing the Chock Blocks	18-4
	Coupling/Uncoupling the Tractor and Semitrailer	18-4
	Maneuvering the Tractor-Semitrailer	18-8
	Connecting and Disconnecting Pintle-Connected Trailer	18-9
	Loading Trucks and Semitrailers	18-11
	Operating Special-Purpose Vehicles	18-14

CHAPTER 19	DANGEROUS/HAZARDOUS CARGO AND MATERIALS	19-1
	General Safety Measures	19-1
	Transporting Dangerous/Hazardous Cargo	19-5
	Transporting Hazardous Materials by Highway	19-7
	Detecting Fuel Leakage Occurring on a Public Highway	19-8
	Detecting Fuel Leakage Occurring Off the Road	19-9
	Using Safety Procedures	19-9
CHAPTER 20	VEHICLE CAMOUFLAGE AND NUCLEAR, BIOLOGICAL, AND CHEMICAL OPERATIONS	20-1
	Vehicle Camouflage Operations	20-1
	Operations Under Nuclear, Biological, and Chemical (NBC) Conditions	20-10
CHAPTER 21	OFF-ROAD AND WINTER DRIVING	21-1
	Off-Road Driving	21-1
	Winter Driving	21-4
CHAPTER 22	VEHICLE RECOVERY	22-1
	Recovery Procedure	22-1
	Towing Vehicles	22-1
	Anchoring Vehicles	22-1
	Winch Recovery	22-2
	Man Power Recovery	22-5
	A-Frame Recovery	22-6
	Field Expedients	22-6
CHAPTER 23	NIGHT VISION GOGGLE DRIVING TECHNIQUES AND PROCEDURES AND OPERATIONS UNDER BLACKOUT CONDITIONS	23-1
	Night Vision Goggles	23-1
	Driving with Night Vision Goggles	23-4
	Training Programs	23-12
	Operations Under Blackout Conditions	23-14
CHAPTER 24	MOTOR MARCHES AND CONVOYS	24-1
	Proper Speed and Gap	24-1
	Vehicle Failures	24-1

Vehicle Halts	24-1
Aircraft-Loading and Convoy Control Signals	24-2
NATO Convoy Flags	24-2
CHAPTER 25 OPERATION OF MOTOR VEHICLES ON AIR FORCE FLIGHT LINES (FOR AIR FORCE ONLY)	25-1
Authorizations	25-1
Flight Line Safety Precautions	25-1
Control Tower Signals	25-3
“Follow Me” Vehicles	25-3
Refueling Vehicles and Servicing Equipment	25-4
Aircraft-Towing Vehicle Operator’s Responsibilities and Qualifications	25-4
Forklift Operator’s Instructions	25-5
APPENDIX A INTERNATIONAL MILITARY ROUTE SIGNS (NATO) AND ROAD SIGNS	A-1
APPENDIX B EXTRACT OF STANAG 2025, BASIC MILITARY ROAD TRAFFIC REGULATIONS (EDITION 5)	B-1
APPENDIX C EXTRACT OF STANAG 2002, MARKING OF CONTAMINATED OR DANGEROUS LAND AREAS, COMPLETE EQUIPMENTS, SUPPLIES AND STORES (EDITION 6)	C-1
APPENDIX D NIGHT VISION PRINCIPLES	D-1
GLOSSARY	Glossary-1
REFERENCES	References-1
INDEX	Index-1

PREFACE

This manual covers the general principles of nontactical wheeled vehicle operation. It also describes special instructions for tactical vehicle operation. Military and civilian drivers of government-owned vehicles will use this manual as a guide for safe and efficient operation of a vehicle.

Instructions in this manual will help the wheeled vehicle driver maintain a high degree of driving efficiency. This manual does not restrict its contents to any particular vehicle. It is a guide to normal everyday operations and to driving under difficult conditions. When more information is needed for a specific vehicle, check the technical manual written for that vehicle.

The proponent of this publication is the US Army Transportation School. Send comments and recommendations on DA Form 2028 (Recommended Changes to Publications and Blank Forms) directly to Commandant, US Army Transportation School, ATTN: ATSP-TDR Fort Eustis, VA 23604-5389. Air Force personnel submit AF Form 847 (Recommendation for Change of Publication) to HQ USAF/LGTV, The Pentagon, Room 4B238, Washington, D. C. 20330-5130.

This publication implements the following international agreements:

STANAG 2002, Marking of Contaminated or Dangerous Load Areas, Complete Equipments, Supplies and Stores (Edition 6).

STANAG 2025, Basic Military Road Traffic Regulations (Edition 5).

Unless this publication states otherwise, masculine nouns and pronouns do not refer exclusively to men.

CHAPTER 1

BASIC REGULATIONS AND RESPONSIBILITIES

The military and civilian vehicle driver must meet specific qualifications to be certified. He must know his responsibilities and be familiar with the forms that pertain to vehicle operation.

OFFICIAL USE REQUIREMENT

“Official use” is defined as the employment or authorization of employment of a government motor vehicle (owned, leased, or rented, if required) in the discharge or performance of an official duty, function, or service. (Certain restrictions on using government vehicles are also contained in AR 58-1 and AFM 77-310, Volume 1.)

The law provides penalties for the willful use or authorization of any government-owned, government-leased, or government-rented motor vehicle for other than official purposes. Civilian employees who misuse government vehicles will have action taken in accordance with the Civilian Personnel Manual. Penalties for military personnel are prescribed in the Uniform Code of Military Justice.

IDENTIFICATION CARD

A valid motor vehicle license issued in any of the 50 states, the District of Columbia, Puerto Rico, or similar licensing jurisdiction will be sufficient qualification for military and civilian personnel to operate commercially-designed, general-purpose vehicles up to 1 1/2-ton cargo trucks. Personnel who operate vehicles in excess of 14,000 pounds gross vehicle weight (GVW) must possess an AF Form 2293 (US Air Force Motor Vehicle Operator Identification Card) (Figure 1-1), a DA Form 5984-E (Operator's Identification Card) (Figure 1-2), or an OF 346 (US Government Motor Vehicle Operator's Identification Card) (Figure 1-3), if units do not possess Computer Assisted Transportation Systems (CATS) or Unit Level Logistics System (ULLS) hardware

and software. Personnel performing either temporary or permanent change-of-station duty in United States Air Forces in Europe (USAFE) require an AF Form 2293 or OF 346.

The OF 346 or AF Form 2293 is your official operator's card. Your card shows types of vehicles you are qualified to operate. All limitations may also be indicated on your operator ID card, such as “Valid Only with Glasses.” Do not operate vehicles you have not been trained on or authorized to operate. Be sure to sign your card when it is issued to you and keep it with you whenever you drive. The OF 346 or AF Form 2293 is good only for operating government vehicles that have been properly dispatched. It is not valid for operating privately owned vehicles or for driving when your state operator's permit has been revoked or suspended. Keep your OF 346 or AF Form 2293 current at all times.

For Army Only: DA Form 5984-E is your official operator's card if you are a ULLS user. See the ULLS users manual ADSM-18-L3N-AWA-ZTH-EUM for complete information concerning maintenance.

QUALIFICATION RECORD

DA Form 348 (Figure 1-4) or ULLS computer-generated DA Form 5983-E (Equipment Operator Qualification Record [Except Aircraft]) (Figure 1-5), and AF Form 22% (Vehicle Operator Information [Part 3]) (Figure 1-6) provide the means for recording the complete history of your driving qualifications and equipment-operating experience. Required for each equipment operator, DA Form 348, DA Form 5983-E, or AF Form 22% reflects your qualifications, experience, performance, and test results. (For complete information concerning maintenance of DA Form 348, refer to AR 600-55. For information concerning maintenance of DA Form 5983-E refer to ULLS end user manual ADSM-18-L3N-AWA-ZTH-EUM.)

U. S. Air Force Motor Vehicle		Card Type	----- CUT HERE
Operator Identification Card		STANDARD	
A U T H O R I Z E D F O R F L I G H T L I N E			
Name of Operator	LARRY D	Sex	Date Issued
PENN		M	06-02-92
Height	Weight	Date of Birth	SSAN
73	197	05/07/50	
		Date Expire	INDEFINITE
Color of	Signature of Operator		
Hair	_____		
Eyes	_____		
BLK	_____		
	Signature of Official		
Name/Loc Issue Unit	_____		
1 TFW/LGTO	_____		
LAFB VA 23665	_____		
NOT TRANSFERABLE: CARD MUST BE CARRIED WHEN OPERATING GOV			
AF Form 2293, Feb 1987 (Computer Generated)			
----- FOLD HERE			
RESTRICTIONS: NONE			
QUALIFIED VEHICLES			
SC SW CA TK-1 1/2T;MCI/EAGLE 41-51 PX;BUS 29PAX DED			
BUS 45PAX DED; WNSE TUG 4-6K; BUS MOTOR 16PX 4X2			
TRK TRACTOR 5TON D;TRK TRACTOR 10TG&D;TRK F/L 50K AT CH			
TRK FANLFT 25K DED;TRL FB W/TILT 5-6T;TRK WRK 2.5 TON			
TRK WRKR 5 TON; TRK WRK 10 TON; FKLFT GAS 2-6K ST			
FKLFT 6-10K PT GED;FKLFT GAS 10-15K; F/L 10K AT 463L			
SEMITRLR 20T/25FT; SMITRLR 20T/40FT; M-35 TRK CGO 6X6 D			
TRK FUEL R-98R-11; TRK FUEL R-5; TRK ACFT TOW MB-4			
TRK AC/LD 25K 463L;TRK AC/LD 40K 463L;TRK AC/LD 10K 463L			
CRANE H-11 2 TON;TRL VAN 30FT&OVER;VANW/CAB2400G4X2D			
LIFTGATE QUALIFIED;ARMOREDTRK CONVOY;TRK FIRE CRAS P-10			
CRN HYD 7 1/5 TON;TRAC ACFT TOW MB-2;TRK BORTAIL G/D			
DISTR W 1500G 6X4D;TRK AMB MOD 4X4;TRLR CARGO M101			
TRLR CARGO M105;TRK TRACT. 7 1/2 D;PINTLE HOOK QUAL			
M151 JEEP 4X4;TRL40FT W/CONV KIT;2.5T WRKR W/2-LIFT			
----- CUT HERE			
CUT HERE			

FIGURE 1-1. Sample AF Form 2293.

AUTHORIZATION FORM

Vehicles are assigned to drivers by means of a dispatch form. This form is issued to you when you are dispatched on any type of motorized vehicle. It is your authorization to operate that particular vehicle, and it must be kept current. You must have a valid authorization in your vehicle whenever you are on dispatch.

For Army Only: DD Form 1970 (Motor Equipment Utilization Record) (or for ULLS users, DA Form 5983-E) is your dispatch authorization form for Army vehicles.

DRIVER QUALIFICATIONS

To be a military or civilian driver, you must-

- Be qualified and licensed.
- Be physically, mentally, and emotionally stable.
- Be informed about the vehicle and the local traffic laws.
- Have sound knowledge of driving techniques.
- Have sufficient experience, evidenced by good safety habits and driving skills.
- Have a courteous and responsible driver attitude.

The mission of the armed services depends on you and your vehicle for mobility. Your unit's success depends to a great extent on how good you are at your job. Apply yourself, your knowledge, and your

skills. Obey instructions given to you by your commander or supervisor and the person delegated to relay them. Maintain a neat appearance and practice courtesy.

OPERATOR'S PERMIT AWAY-493

U.S. ARMY GOVT VEHICLE
OPERATOR'S IDENTIFICATION CARD

Name of Operator: **DOE JOHN** Sex: **M** Date Issued: **30-SEP-93**
 Height: **5 10** Weight: **150** Date of Birth: **21-SEP-45** SSN: **444-47-1234** Date expired: **21-SEP-93**
 Color of Hair: **BRN** Eyes: **BLU**

John R. Doe
SIGNATURE OF OPERATOR

Name/Loc Issue Unit: **B CO 2020 SPT BN**
 APO 09028 LICENSE EXAMINER: **JOHN BROWN**

NOT TRANSFERABLE: CARD REQUIRED TO OPERATE GOVT VEHICLE:
 PRIVACY ACT OF 1974 APPLIES OF 346E

QUALIFICATIONS/RESTRICTIONS

EYEGASSES REQUIRED COXN VEH OVER 10,000 LBS
 BUS 48 PASS AND BELOW CRANE 7 1/2 TON
 GENR 60 KW AND BELOW BUS FAMILY EXC M548
 M60 FAMILY & AVLB, M728 10 TON AND BELOW

-DA Form 5984-E

Figure 1-2. Sample DA Form 5984-E.

OF 346 11/85 USOPM FPM Chapter 930		U.S. Government Vehicle Operator's Identification Card		Card No C-6018	Restrictions HEAVY C-6018
Name of Operator (Not Transferable) CALDWELL, JOHN		Sex M	Signature of Operator (Not valid until signed) <i>John Caldwell</i>		QUALIFIED TO OPERATE
Date of Birth 20MAY65	Social Security No. 278686018	Name and Location of Issuing Unit 6th BN DVR TESTING FT EUSTIS, VA 23604		Type Vehicle and/or Equipment M923A2 TRK CGO	Capacity HI
Height 5 7"	Weight 170	Hair Color BRN	Eye Color BLU	Qualifying Official <i>[Signature]</i>	
Date Issued 25SEPT92	Date Expires 25SEPT96	Signature and Title of Issuing Official <i>Mark A. Peterson</i> Peterson, Mark A. CMDR.		OTHER RECORDS (Optional)	
The holder of this card is qualified to operate U.S. Government vehicles and/or equipment specified, subject to the restrictions set forth on the other half of this card. Card must be carried at all times when operating Government vehicles.					NSN 7540-00-634-3999 50346-101

FIGURE 1-3. Sample OF 346.

NAME (Last, First, Initial) AND SERVICE NUMBER				PERMIT (Initial)		
CALDWELL, JOHN 278-68-6018				NUMBER C-6018	DATE ISSUED 25 SEPT 92	
				TYPE ARMY STANDARD	LIMITATIONS (Physical or operational) Light/Heavy	
SEX Male	DATE OF BIRTH 20 May 65	COLOR HAIR Brown	COLOR EYES Blue	HEIGHT 5'7"	WEIGHT 170	POSITION TITLE (If civilian) N/A
SECTION I - OFFICIAL QUALIFICATIONS						
TYPE OF EQUIPMENT	SIZE	SPECIAL QUALIFICATION ¹	DATE QUALIFIED	QUALIFIED AT	NAME OF EXAMINER	
M923A2 TRK CGO	HI	SEE SECTION III	25 SEPT 92	FT EUSTIS, VA	<i>[Signature]</i>	
SECTION II - BACKGROUND AND EXPERIENCE						
TYPE OF EQUIPMENT	SIZE	TYPE OF DRIVING OR OPERATION ²	ADDITIONAL DRIVER'S LICENSES (State or agency)	NUMBER OF OTHER DRIVER'S LICENSES	SATISFACTORY EXPERIENCE VERIFIED BY	
SEDAN	5-8 PASS	CITY/RURAL	OH 5/95	QC825505	<i>[Signature]</i>	
¹ Special equipment, special operations or conditions ² City, rural, long haul, etc.						
SECTION III - PERFORMANCE RECORD						
(List chronologically as "credits" - awards, training, retraining, testing, retesting, roadtests, permit renewal, relicensing, etc; and as "debits" - accidents, arrests, violations, warnings, revocations, suspensions, etc.)						
DATE	CREDITS	DEBITS	TYPE OR NATURE	ACTION TAKEN		
4 AUG 92	2½ hrs.		ACCIDENT	Acciden Avoidance Trng completed on the ARMY DRIVER IMPROVEMENT PROGRAM Trng Film Video Tape		
			AVOIDANCE	TF 20-6367 thru 20-6377 and 20-6381. Battery II Testing waived in Section IV (Examination & Findings) IAW AR 600-55, Para 1-5b. <i>[initials]</i>		
			BATTERY II			
			WAIVER			
5 Aug 92	4 hrs.		DDC CLASS	Completed a 4 hour DDC training class given at FT Eustis, VA DDC CARD# FE-9854 <i>[initials]</i>		
25 SEPT 92	40 hrs.		TRAINED/TESTED	Completed Driver Training Class given by 6th Bn Driver Training & Testing Academy on the M923A2 Trk Cgo. Class#8-92 21-25 SEPT 92		

EQUIPMENT OPERATOR'S QUALIFICATION RECORD (EXCEPT AIRCRAFT)
(AR 58-1, AR 600-55 and AR 385-55)

DA FORM 348
1 OCT 64

REPLACES DA FORM 348, 1 AUG 60, WHICH WILL BE USED, AND DD FORM 1360 WHICH IS OBSOLETE FOR ARMY USE.

(Extract from personnel file to maintain at operating level.)

FIGURE 1-4. Sample DA Form 348 (front).

SECTION IV - EXAMINATION FINDINGS					
BATTERY I - (Administered as a part of reception processing, at reception stations)		BATTERY II - (To be administered to all applicants for Driver Permit SF 46) (To transfer raw score to standard score see DA Pamphlet 611-119)			
		DA FORM 6122	RAW SCORE	STANDARD SCORE	
ENTER SCORE FROM ITEM 24 OF INDIVIDUAL'S DA FORM 20		DA FORM 6123			
		DA FORM 6124			
		TOTAL STANDARD SCORE			
		STANDARD SCORE FOR BATTERY II (Divide Total Standard Score by 3)			
STANDARD SCORE		SUCCESSFUL COMPLETION <input type="checkbox"/> YES <input type="checkbox"/> NO	EXAMINATION ADMINISTERED BY (Last name - first name - middle initial)		
I PHYSICAL EVALUATION MEASURES			<input checked="" type="checkbox"/> IF QUALIFIED <input type="checkbox"/> IF SUBSTAND.	SIGNATURE OF EXAMINER	COMMENTS AND RECOMMENDATIONS ON SUBSTANDARD ITEMS
1. VISUAL ACUITY	LEFT EYE 20/20	RIGHT EYE 20/20	<input checked="" type="checkbox"/>	<i>[Signature]</i>	
2. FIELD OF VISION	LEFT EYE 90°	RIGHT EYE 90°	<input checked="" type="checkbox"/>		
3. HEARING	LEFT EAR 15/20	RIGHT EAR 15/20	<input checked="" type="checkbox"/>		
4. REACTION TIME	40/100 SEC	45/100 SEC	<input checked="" type="checkbox"/>		
5. DEPTH PERCEPTION	[Patterned Box]		NORMAL		
6. COLOR PERCEPTION			NORMAL		
II DRIVING PERFORMANCE TEST (Check "✓" if successful, "x" if failed and corrective training is needed)					
A. ROAD TEST - PREREQUISITE					
1. INSTRUMENTS (Location, correct reading, action for abnormal reading)	<input checked="" type="checkbox"/> OIL LEVEL STICK	<input checked="" type="checkbox"/> TEMPERATURE GAGE	<input checked="" type="checkbox"/> OIL PRESSURE GAGE	<input checked="" type="checkbox"/> VOLT METER	
	<input checked="" type="checkbox"/> AMP METER	<input checked="" type="checkbox"/> TACHOMETER	<input checked="" type="checkbox"/> FUEL GAGE	<input checked="" type="checkbox"/> AIR PRESSURE GAGE	
2. BEFORE OPERATION CHECK	<input checked="" type="checkbox"/> VEHICLE DAMAGE	<input checked="" type="checkbox"/> CONDITION OF TIRES	<input checked="" type="checkbox"/> CLEAN HEADLIGHTS	<input checked="" type="checkbox"/> OIL LEVEL	<input checked="" type="checkbox"/> BATTERY
	<input checked="" type="checkbox"/> MIRROR ADJUSTMT.	<input checked="" type="checkbox"/> HORN	<input checked="" type="checkbox"/> HAND BRAKES	<input checked="" type="checkbox"/> FOOT BRAKES	<input checked="" type="checkbox"/> WATER LEVEL
3. EMERGENCY EQUIPMENT (Location and use)	FIRE EXTINGUISHER		HIGHWAY WARNING KIT	OTHER (Describe)	
4. CONTROLS - "DRY RUN"	GEARS <input checked="" type="checkbox"/>	BRAKE <input checked="" type="checkbox"/>	CLUTCH <input checked="" type="checkbox"/>	FRONT AXLE <input checked="" type="checkbox"/>	
5. DEPTH PERCEPTION (Two feet from target)	FIRST TRY <input checked="" type="checkbox"/>		SECOND TRY	THIRD TRY	
6. PRACTICE RUN (1/2 mile)	START <input checked="" type="checkbox"/>	PULL OUT <input checked="" type="checkbox"/>	SHIFT <input checked="" type="checkbox"/>	3 STOPS	TURN S BACKING
7. ADDITIONAL REQUIREMENTS FOR LICENSE	<input checked="" type="checkbox"/> LOCAL LAWS	<input checked="" type="checkbox"/> OPERATING PROCEDURES	<input checked="" type="checkbox"/> ACCIDENT REPORTING	<input checked="" type="checkbox"/>	
	OTHER (Describe)				
HAS SUCCESSFULLY DEMONSTRATED PREPARATION OF DA FORM 2404					
B. ROAD TEST - SCORED PHASE (DA PRT 2678)				100	
SAMPLE			COMMENTS AND RECOMMENDATIONS OF ROAD TEST EXAMINER		NUMBER OF TALLY MARKS ON CHECK LIST PRT 2678 (Subtract)
					99
					75%
			SIGNATURE OF ROAD TEST EXAMINER		
MY DRIVING WEAKNESSES HAVE BEEN MAKE KNOWN TO ME AND I HAVE BEEN SHOWN HOW TO OVERCOME OR ADJUST THEM.			DATE 25 Sep 92	SIGNATURE OF APPLICANT <i>[Signature]</i>	

FIGURE 1-4. Sample DA Form 348 (back).

DATE: 30-SEP-91		OPERATOR QUALIFICATION RECORD		AWAMF468	
LAST NAME: DOE		FIRST NAME: JOHN		INITIAL: R	
DOB: 21-SEP-45	SEX: M	WT: 150	HT: FT 5 IN 10	HAIR: BRN	EYES: BLU
SOCIAL SECURITY NUMBER: 444-47-1234			LICENSE EXPIRATION DATE: 21-SEP-93		
MILES SINCE LAST ACTION: 000000			HOURS SINCE LAST ACTION: 000000		
DAYS SINCE LAST ACTION: 000000			TOTAL MILES DRIVEN: 046211		
EQUIPMENT QUALIFICATIONS					
EQ	CLS	CD	CODE DESCRIPTION	DATE QUALIFIED	
A2			COMM VEH OVER 10,000 #	20-AUG-77	
B3			BUS 48 PASS AND BELOW	30-SEP-80	
C2			CRANE 7 1/2 TON	21-MAY-77	
E2			GENR 60 KW AND BELOW	15-JAN-90	
T3			M113 FAMILY EXC M548	20-FEB-80	
T4			M60 FAMILY & AVLB, M728	30-SEP-91	
W4			10 TON AND BELOW	18-DEC-78	
RESTRICTIONS/ACTIONS					
RMK	CD	DATE	DESCRIPTION OF REMARK	VERIFIER	
R1		27-JUL-90	EYSGLASSES REQUIRED	SGT J. BROWN	

FIGURE 1-5. Sample DA Form 5983-E.

DRIVER RESPONSIBILITIES

As a driver, you are responsible for-

- Safely operating your vehicle and complying with applicable federal, state, local and host-nation laws and regulations.
- Doing before-, during-, and after-operation inspections of your vehicle.
- Following all operator maintenance outlined in the appropriate vehicle technical manual (Army) or order (Air Force).
- Caring for and cleaning your vehicle and its equipment at all times.
- Ensuring the safety and comfort of your passengers (includes ensuring that seat and shoulder belts are fastened). The senior occupant will ensure that passengers comply. For nontactical vehicles, passengers are seated with safety strap in place.
- Ensuring the security of the vehicle and cargo entrusted to you.

- Exercising common sense.
- Notifying your supervisor/NCO of any change in your status, for example, inability to drive due to physical condition or withdrawal of your state operator's license.

The life expectancy and capability of your vehicle depend on you. Remember, you are subject to corrective action by your commander for incidents of abuse, misuse, and damage to unit-assigned vehicles (AR 58-1, AFR 77-4).

CAUTION

For Air Force Only: As a vehicle operator you may be required to operate two-way radio equipment. Do not attempt to operate the two-way radio equipment in your vehicle unless you have been instructed to do so. Your supervisor will determine whether you are qualified to efficiently operate this equipment. He will furnish local standard procedures, codes, and so forth which may be published in base directives or Air Force publication supplements.

```

"PERSONAL DATA - PRIVACY ACT OF 1974 ( 5 USC 552a)"
=====
: VEHICLE OPERATOR INFORMATION Page 1:
LASTNAME :PENN FIRSTNAME :LARRY MI :D JR :
GRADE :SSGT ORG.CD :0A OFFSYM :1TRS/TRV DUTY.PH :47505 :
SSAN :XXXXXXXXX DOB :05/07/50 DAFSC :60370 :
SEX :M HAIR :BLK EYES :BRN HT (in):73 WT :197 :
-----
TYPE.DR :RC(r/c) ST :VA DR.LICH :229748197 EXPIR.DT :
RESTRICT :NONE SF46.DT :10/18/83 VERIFY.DT :10/18/83
COURSE1.DT :09/01/72 COURSE2.DT :10/18/83 COURSE3.DT :10/01/75
BASE :Y (y/n/s/r) FLTLINE :Y (auth y/n) ORIG46.DT :06/17/73
-----
VEHICLE QUALIFICATIONS MGT.CODES :
--MGT.CODE-- --DATE-- --MGT.CODE-- --DATE-- |from Vol II|
: Q1 :BXX1 DT1 :06/13/73 : Q2 :B139 DT2 :09/08/75 :AFM 77-310 :
: Q3 :B121 DT3 :09/08/75 : Q4 :B130 DT4 :09/08/75 :are used... :
: Q5 :E801 DT5 :04/14/75 : Q6 :B184 DT6 :06/12/73 :See Main :
: Q7 :B353 DT7 :09/08/75 : Q8 :B363 DT8 :09/08/75 :Menu's MGT :
: Q9 :E979 DT9 :07/01/87 : Q10 :XB499 DT10 :09/08/75 :CODE option|
REMARK :
AWARD.ELG :N (y/n) ELG.DT :10/18/89 PREV.AWARD :NONE
-----
VEHICLE QUALIFICATIONS Page 2:
--MGT.CODE-- --DATE-- --MGT.CODE-- --DATE--
: Q11 :B442 DT11 :03/04/88 Q12 :C104 DT12 :11/08/79 :
: Q13 :C108 DT13 :11/08/79 Q14 :C114 DT14 :11/08/79 :
: Q15 :E830 DT15 :11/19/79 Q16 :E832 DT16 :11/19/79 :
: Q17 :E834 DT17 :11/19/79 Q18 :E958 DT18 :11/19/79 :
: Q19 :B407 DT19 :10/17/79 Q20 :B409 DT20 :10/17/79 :
: Q21 :K248 DT21 :09/08/75 Q22 :L275 DT22 :11/19/79 :
: Q23 :L273 DT23 :11/19/79 Q24 :L351 DT24 :11/19/79 :
: Q25 :E935 DT25 :04/06/79 Q26 :E941 DT26 :04/06/79 :
: Q27 :E957 DT27 :04/06/79 Q28 :C510 DT28 :11/19/79 :
: Q29 :B423 DT29 :11/19/79 Q30 :C203 DT30 :11/19/79 :
: Q31 :LIFT DT31 :11/19/79 Q32 :C507 DT32 :11/19/79 :
: Q33 :L146 DT33 :11/19/79 Q34 :D515 DT34 :11/19/79 :
: Q35 :L350 DT35 :11/19/79 Q36 :C355 DT36 :11/19/79 :
: Q37 :B731 DT37 :11/19/79 Q38 :B163 DT38 :11/19/79 :
: Q39 :K452 DT39 :11/19/79 Q40 :K454 DT40 :11/19/79 :
: Q41 :B361 DT41 :11/19/79 Q42 :ABC1 DT42 :10/15/83 :
: Q43 :K199 DT43 :11/19/79 Q44 :E975 DT44 :10/15/83 :
: Q45 :ZACKL DT45 :10/03/88 45 QUALIFICATIONS IS MAXIMUM ALLOWED :
"PERSONAL DATA - PRIVACY ACT OF 1974 ( 5 USC 552a)"
=====
AF Form 2296, Feb 87 (Computer Generated)

```

FIGURE 1-6. Sample AF Form 2296.

FUEL-EFFICIENT OPERATION

As a qualified vehicle operator, you should operate your vehicle in the most fuel-efficient manner. To do so, you must adopt a fuel-conservation attitude. Applying these tips will help develop this attitude:

- Plan trips to avoid unnecessary "cold starts." Consolidate short trips whenever possible.
- Reduce vehicle's cool-down time, and select your route with consideration for terrain, weather, and type of vehicle.

- Maintain your vehicle with particular attention to proper tire inflation, brakes grabbing or pulling, oil and lubrication specifications, and tune-ups.
- Adhere to speed limits when driving lower speeds not only reduce air resistance but also are safer.

CHAPTER 2

TRAFFIC CONTROLS

This chapter implements STANAG 2025.

Except when specifically directed otherwise, military and civilian drivers must comply with all civil traffic laws and ordinances. Civilian traffic police have full authority for regulating all traffic in towns and on public roads. Military police have full authority over all military vehicles wherever they may be.

TRAFFIC CONTROLLERS

Civilian and military police normally control traffic using a system of signs, signals, devices, and markings. When an authorized official (police, traffic warden military police) is directing traffic, obey his signals rather than traffic lights or signs. A traffic official usually signals traffic to stop by holding up his hands, palms toward traffic, and by giving a long blast on his whistle. To start traffic, he motions with his hand and arm toward the direction of travel, giving two initial short blasts on his whistle. He uses three blasts or a series of short blasts on his whistle to warn any motorists or pedestrians of unusual or dangerous conditions, approaching emergency, and so forth. At night, visual signals may be given with a flashlight or lighted traffic baton or wand. Flagmen at railroad crossings or road construction sites use flags or color-coded sign paddles. When driving in host nations, drivers need to understand the visual and audible signals used by traffic control personnel. (See Appendix A.)

SIGNALS

You must be familiar with three categories of signals commonly used to control traffic. First, you must know the meaning and proper use of those hand signals common to both military and civilian drivers. Second, you must know the hand signals used by police to control traffic. Third, you must know the signals used to control military vehicles in convoy. (See Appendix B.)

Signaling Distance

Always signal in advance of making a turn or stopping. If you do not signal until you have already started to turn or stop, you might as well not signal. By that time, it is too late for other drivers to take whatever action may be necessary. The law usually requires you to signal at least 100 feet in advance. This is the minimum distance. The faster you are going the farther in advance you should signal. Your signaling distance should never be less than the distance required for stopping or slowing down sufficiently to make a turn. For example, a signal for a stop when you are traveling 40 MPH should never be given less than 140 feet in advance of the stop. When driving on the open highway, a good rule is to give all signals at least 300 feet in advance.

Hand Signals

Hand signals are given with the left hand and arm out the driver's window of left-hand drive vehicles (Figure 2-1). The signal for stopping and slowing down is given by pointing the arm and hand down, palm back. The left turn signal is given by pointing the arm and hand straight out, palm forward. The right turn signal is given by pointing the arm and hand straight up from the elbow, palm forward.

Make your signals clearly. You cannot be understood if you merely put your hand lazily out of the window. Be careful not to give signals that you do not mean. Some drivers rest their elbows on the windowsill and idly tap the top of the vehicle with their fingers. To drivers behind them, this may look like a right-turn signal. Other drivers let their hands trail out the window holding a cigarette. If you do this, the driver behind may think you are slowing down or stopping. If the vehicle you are driving has no turn signals and the cargo bed is wider than the cab, stretch your arm out as far as possible when signaling to make sure your signal is visible to the

driver following you. When giving a hand signal for a turn, finish signaling before you actually make the turn so that you can have both hands on the wheel.

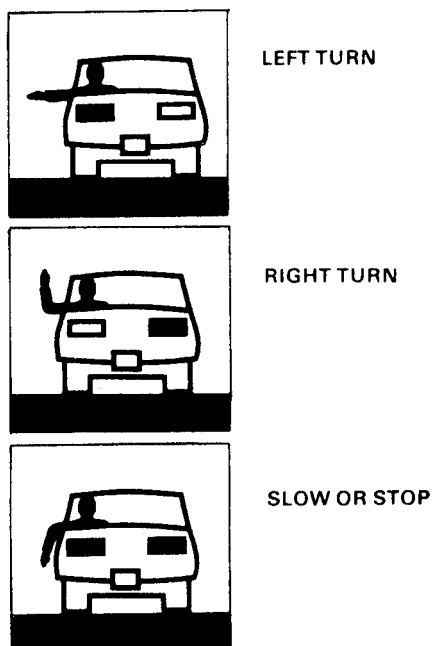

FIGURE 2-1. Driver Hand Signals.

Electrical Signals

Almost all vehicles have at least one electrical signal—the stoplight at the rear which goes on when the driver depresses the brake pedal. The stoplight does not always take the place of the hand signal for stopping or slowing down. Many times you slow down without using your brakes. Many other times, especially if you are a good driver, you start using your brakes only in the last feet of travel. Furthermore, the stoplight may not be visible except to the driver of the vehicle immediately behind you.

Turn Signals

These flashing-light signals are usually legal substitutes for hand signals, but there are times when they are hard to see. In late afternoon and early evening, the lenses may reflect the light of the sun, making it very difficult to tell whether the signals are flashing or not. On the other hand, a flashing-light signal is much more likely to be seen at night than a hand signal. The important thing is that the signal be clearly seen. Therefore, the method of signaling should depend on light conditions and legal requirements. A good rule is to use both hand

signals and flashing-light signals in the daytime (especially when the sun is low) and to use flashing-light signals at night.

Emergency Flashers

Four-way flasher lights are used to warn other traffic of a vehicle halted due to an emergency in a traffic lane or on the shoulder adjacent to a traffic lane. When a vehicle halts in an authorized space, flasher lights are normally not used. Most states prohibit their use on a vehicle in motion except on emergency vehicles. Four-way flasher lights are not a substitute for warning devices contained in the highway warning kit.

For Air Force Only: Vehicles operating on the flight line, such as maintenance servicing vehicles, may use the four-way flasher where authorized instead of nonrevolving, pulsating hazard warning lights prescribed by TO 36-1-3.

Horn

What should you do if you see a vehicle coming from the opposite direction turn suddenly out into your lane? Apply your brakes and blow your horn at the same time. Your horn is the best means you have of alerting a temporarily inattentive driver to your presence. It immediately enlists his aid in attempting to avoid a collision instead of leaving the whole burden on you. Use your horn also whenever you have to come out of a blind alley or driveway, when you come to curves on mountainous roads where visibility is limited, and immediately before backing.

Use your horn courteously. A long blast is usually unnecessary. Pressing the horn button lightly once or twice will ordinarily serve to get the attention of another driver or pedestrian. The only lawful use of the horn is as a reasonable warning device. Never use it to greet friends or express irritation at a delay or at another driver's errors.

Other Signals

In addition to hand and electrical signals, drivers are constantly signaling to each other merely by the position of their vehicles on the road. When you see a driver move toward the center of the road you assume that he is about to turn left or pull out to pass. When you see him move toward the right, you assume that he is going to turn right or stop.

Whether you realize it or not, you are guided by the position signaling of other drivers. Misleading position signals are as dangerous as misleading hand signals. The driver who pulls to the right before turning left is inviting an accident because he is, in effect, misinforming other drivers of his intentions.

TRAFFIC SIGNALS

No traffic signal is more important than the traffic light (Figure 2-2). Few drivers actually run through red lights. Their common sense usually keeps them from that. They speed up as they approach a green light to make sure they get through before it turns red; or when stopped at a red light, they watch the green light showing in the opposite direction and start to move into the intersection as soon as the yellow appears. This practice often results in an accident.

TRAFFIC SIGNS

The United States is moving toward an international system of traffic signs that emphasizes pictures and symbols rather than written messages. Symbolic signs are not entirely new. The familiar curve and crossroad symbols have been used for many years. Symbols have several advantages over word messages. They provide almost instant communication to the driver since they can be

understood at a glance without having to be read. Also, they overcome language barriers. Familiarity with the symbolic signs will help military drivers operating in overseas areas. International signs and markings are discussed in Appendixes A and B (STANAG 2025).

On signs that contain messages in words, color and shape provide the driver with information at first glance before he is close enough to read the words (Figures 2-5 through 2-6).

International Traffic Signs

This system of road signs was agreed upon at the United Nations Conference on Road and Motor Transport in September 1949. It was the United Nations' desire to ensure safety and to facilitate international road traffic by adopting a uniform system of road signaling. Although these signs are not military, Army personnel should be familiar with them since they are used in most overseas areas. Dimensions of signs are standardized in each country to ensure maximum uniformity. (See Appendix A.)

International Military Route Signs (NATO)

North Atlantic Treaty Organization countries have standardized road signs. These signs are shown and explained in GTA 55-3-20. (See Appendixes A and B.)

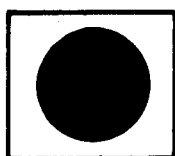

RED
Stop—come to a complete stop before you reach the intersection, stop line, or crosswalk, and remain stopped as long as the light is red.



FLASHING RED LIGHT
You must come to a complete stop, yield to oncoming traffic or pedestrians, then go when the way is clear.

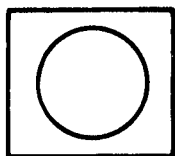

YELLOW
Caution—an amber or yellow light is a warning that the light is about to change. If you have not entered the intersection, you should come to a safe stop. If you are already in the intersection, you should continue moving and clear it safely. Speeding up to "beat the light" is illegal and could cause an accident.

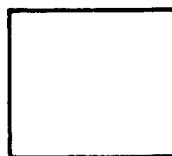

FLASHING YELLOW LIGHT
You should slow down and proceed with caution.





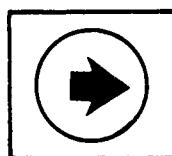



GREEN
Go—you may go through an intersection in the direction indicated by the signal if the roadway is clear.



GREEN ARROW
You may proceed in the direction of the arrow if you are in the proper lane.

FIGURE 2-2. Traffic Signals.

	RED Stop, yield, do not enter, or wrong way.
	YELLOW General warning of what to expect ahead.
	WHITE Regulatory, such as speed limits.

	ORANGE Construction warning.
	GREEN Guide information, such as distance or direction.
	BLUE Motorist services.
	BROWN Recreation and scenic areas.

USE OF COLOR IN SIGNS

Sign Shapes

The shape of a traffic sign can tell you as much about the sign's message as its color. In poor visibility conditions, such as heavy fog, you may be able to make out only the shape of a sign.

OCTAGON: STOP

The octagonal (eight-sided) shape always means stop. You must come to a complete stop at the sign, stop line, pedestrian crosswalk or curb before entering an intersection.



TRIANGLE: YIELD

Slow down—or stop if necessary—and give the right of way to vehicles crossing your path.



DIAMOND: WARNING

These signs warn you of special conditions or hazards ahead. You may have to slow down, so be ready.

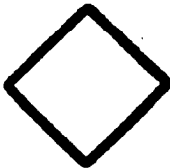

RECTANGLE: REGULATORY OR GUIDE

Vertical signs are generally used to give instructions or tell you the law. In the horizontal position, the signs may give directions or information.



PENTAGON: SCHOOL AND SCHOOL CROSSING

The pentagon (five-sided) shape marks school zones and warns you about school crossings.



CROSSBUCK & CIRCLE: RAILROAD CROSSING

Both of these signs mean you are approaching a railroad crossing and should slow down, look and listen for trains.



Figure 2-4. Use of Shape in Signs.



Figure 2-5. Regulatory Signs.

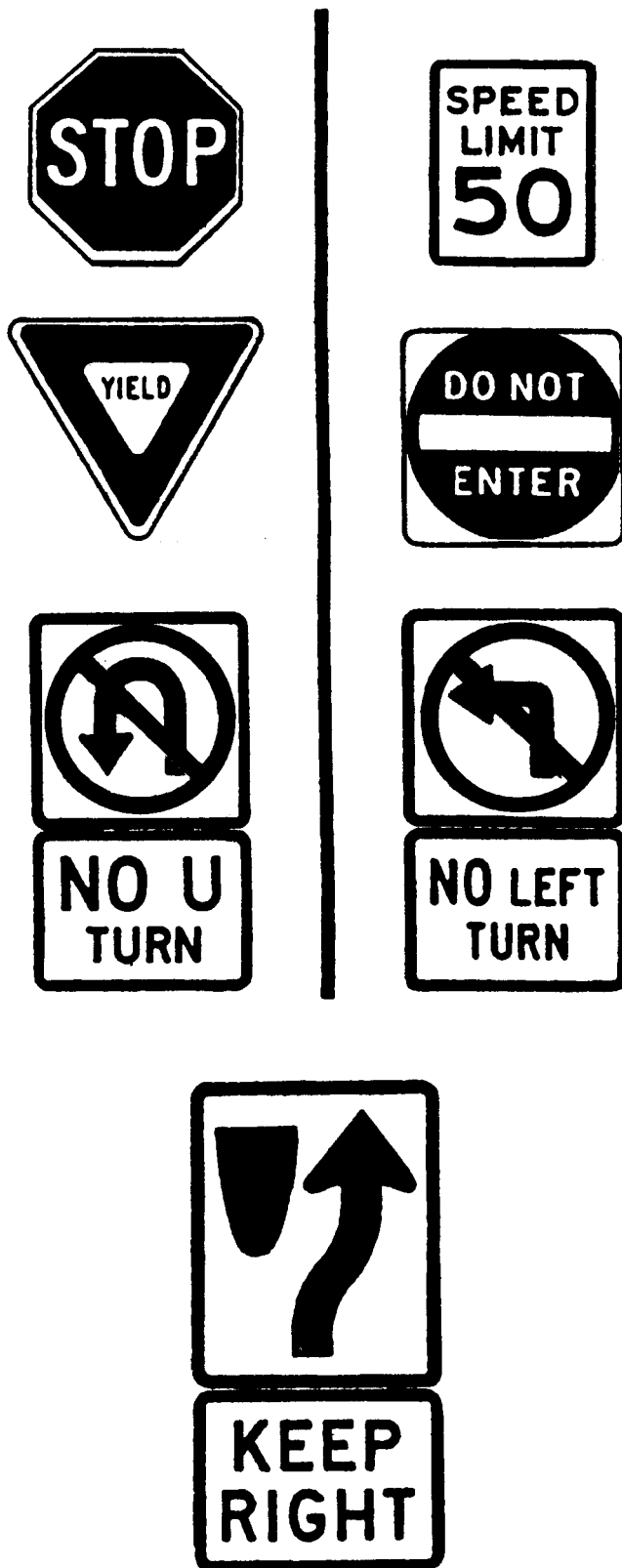

Figure 2-5. Regulatory Signs (Continued).

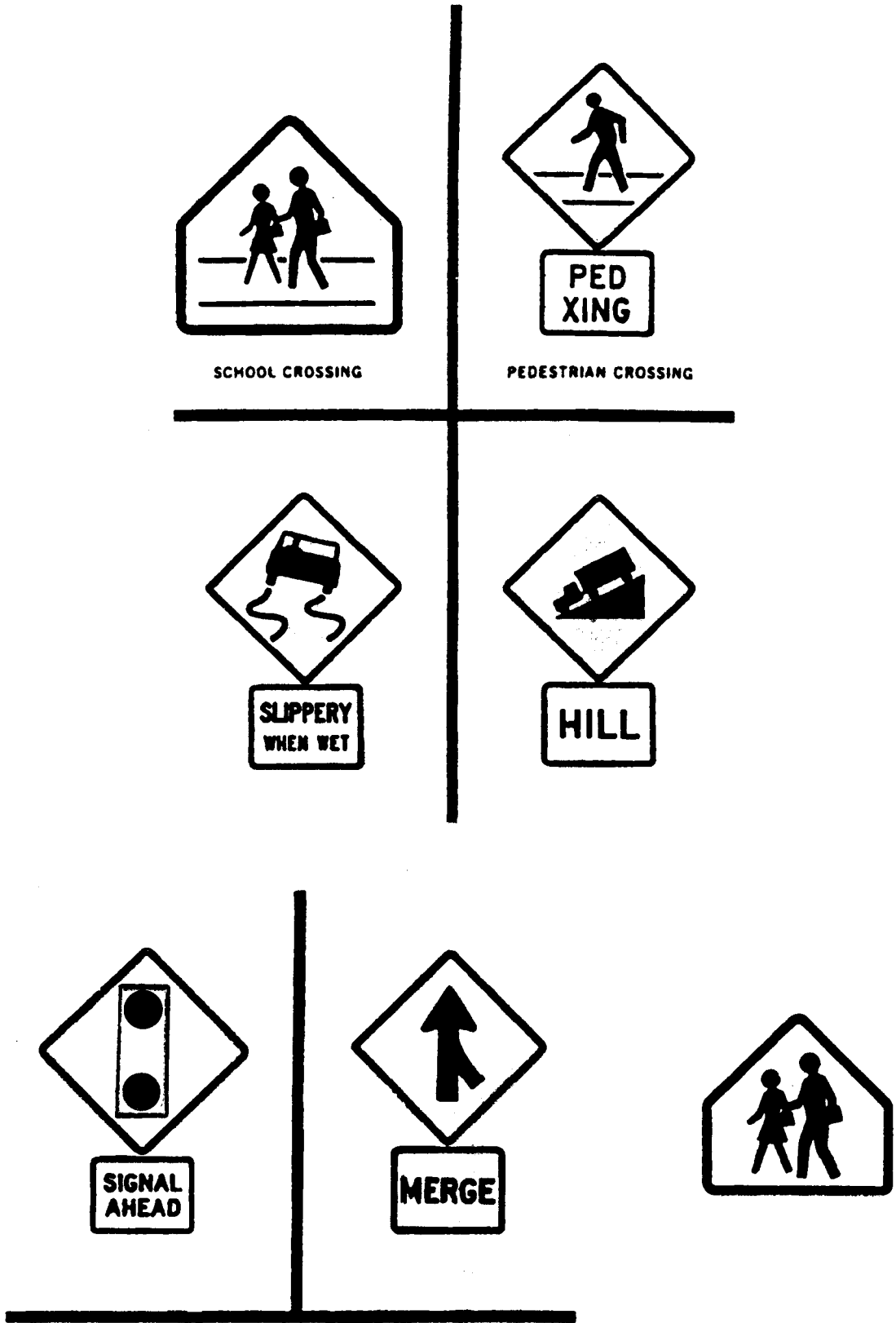

Figure 2-6. Warning Signs.

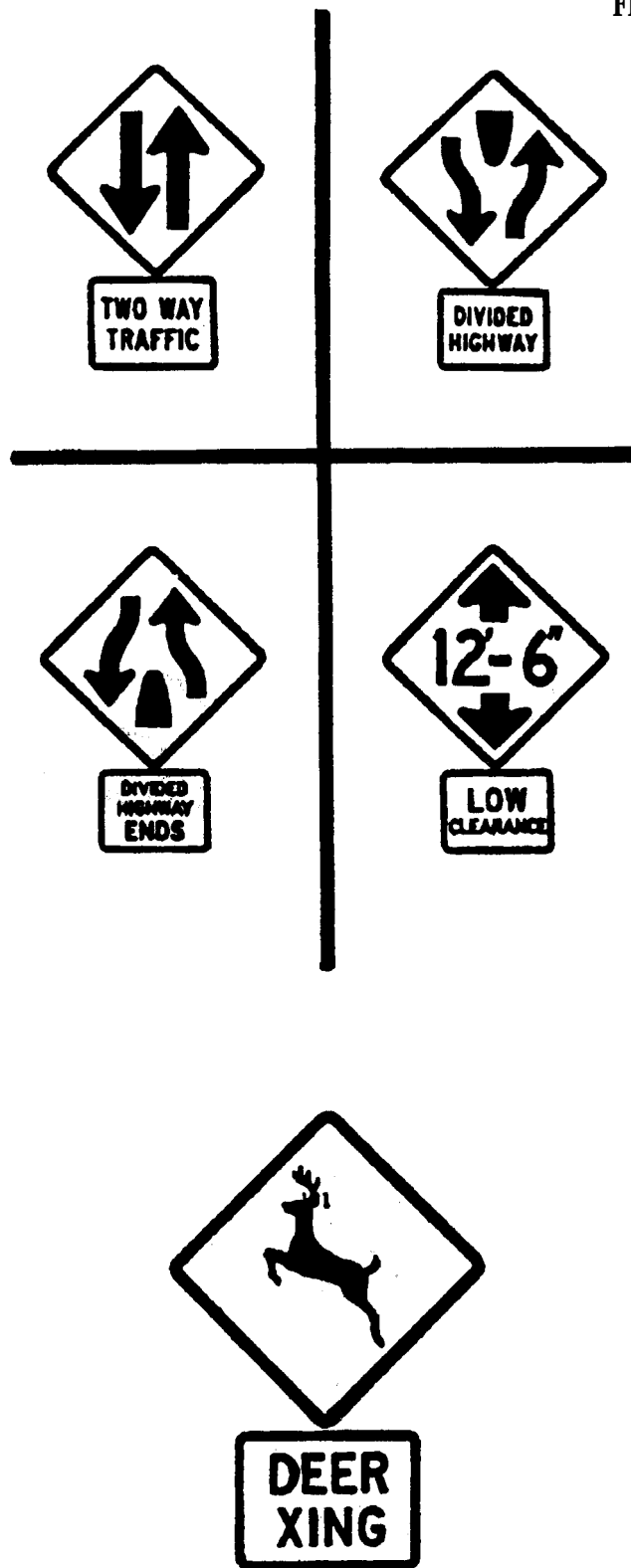

Figure 2-6. Warning Signs (Continued).

PAVEMENT MARKINGS

Road markings guide and warn drivers, as well as regulate traffic. Markings may be either yellow or white and used alone or in combination. Each has a different meaning. Yellow centerlines indicate that there is two-way traffic flowing in opposite directions. White lines separate lanes of traffic going in the same direction.

Pavement markings are widely used to control the flow of traffic (Figure 2-7). These markings may be used to indicate—

- The middle of the road.
- Nonpassing and passing zones by using a solid line for a nonpassing zone and a broken line for a passing zone.
- Crosswalks, reduced speed zones, school zones, and approaches to railroad crossings.

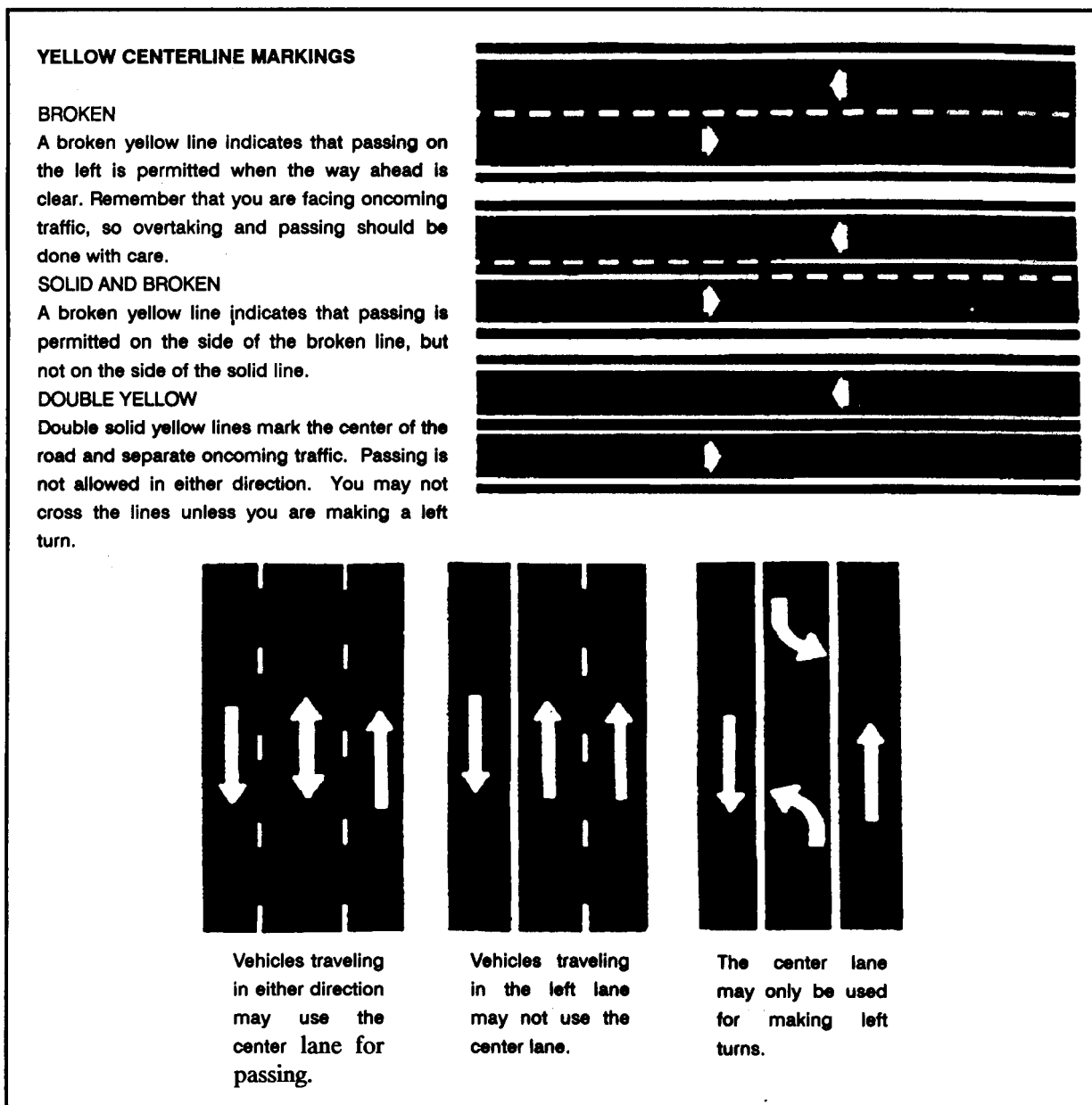

FIGURE 2-7. Pavement Markings.

WHITE LINE MARKINGS**BROKEN**

Broken white lines separate lanes of traffic going in the same direction and may be crossed with care.

**SOLID WITH TURN-LANE ARROW**

Solid white lines are used for turn lanes and to prevent lane changes near intersections. Arrows are often used with the white lines to indicate which turn may be made from the lane.

If you are in a lane marked with a curved arrow and the word **ONLY**, you must turn in the direction of the arrow. If your lane is marked with both a curved and a straight arrow, you may either turn or go straight.

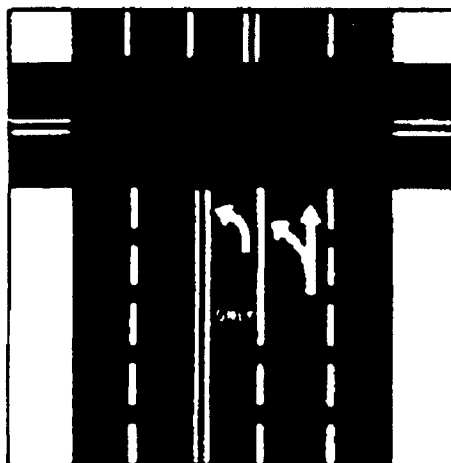

FIGURE 2-7. Pavement Markings (Continued).

CHAPTER 3

SPEED CONTROL

Speed not only makes accidents more likely, but also makes death in accidents more likely. There are several statutes in the law book dealing with speed. The most important and common sense rule is: **NO PERSON SHALL DRIVE A VEHICLE ON A HIGHWAY AT A SPEED GREATER THAN IS REASONABLE AND PRUDENT UNDER THE EXISTING CONDITIONS.** However, conditions are constantly changing and it may be necessary to drive slower than the posted speed limit.

Although many improvements have been made in safety equipment on vehicles, the most important safety factor in any vehicle is the control the driver has over the machine. The faster the vehicle goes and the more of that control the driver gives up, the less chance he has of avoiding an accident and the more deadly the accident will be. Accident statistics show that speed is a factor in one-fifth of all accidents and in almost half of the fatal accidents. Speed affects your ability to turn, pass, slow down, and stop. Nothing is more important to safe driving than careful control of speed.

STOPPING

The following factors affect your ability to bring your vehicle to a stop:

- Type and condition of road surface, such as concrete, asphalt, or gravel.
- Foreign material on the road, such as ice, snow, leaves, or mud.
- Road configuration, such as uphill or downhill, straight, curve, high crown, or dip.
- Tire condition, such as type and condition of tread and tire inflation.
- Brakes, such as type and state of repair and adjustment.

For any speed, the distance required to stop a vehicle in an emergency depends on three things—driver perception time, driver reaction time, and vehicle stopped time. During driver perception time and driver reaction time, the vehicle slows down very little because the brakes have not yet been applied.

Perception Distance

Perception distance is that distance traveled between the time a dangerous situation is first seen by the driver and the time he actually recognizes it as being dangerous. This time varies widely in different situations. The distance traveled will vary with the speed of the vehicle and the individual mental response of the driver.

Reaction Distance

Reaction distance is that distance traveled by a vehicle during which the driver determines the preventive action to be taken and actually sets the vehicle controls in motion. In stopping, it would include the time required to move the foot from the accelerator to the brake pedal. Some emergencies require complex reactions involving decisions to turn, increase speed, or stop and consequently require increased time for the driver to decide how to react.

Braking Distance

Ability to slow down depends on how hard and steadily the operator presses the brake, how efficient the brakes are compared to the weight of the vehicle and its load and how slippery the road surface is. Most vehicles can be stopped on a dry road surface within the distance required by state laws, but snow, ice, rain, and gravel reduce the vehicle's stopping ability and increase the distance necessary to bring the vehicle to a complete stop.

Vehicles equipped with air brakes take additional time because it takes the air time to travel through

the system to engage the brakes. This is called brake lag. The distance the vehicle travels during the brake lag is called brake lag distance.

AVOIDING COLLISIONS

Many times you can avoid a collision merely by slowing down. Even after it is too late to stop or slow

down, a driver may often avoid a collision by swerving to one side. It is normally safer to swerve to the right than to the left. It is better to run off the road to the right than to collide head on. However, a speeding vehicle cannot be turned sharply without the risk of turning over. The faster a vehicle is going the more distance it takes to turn safely from a straight path.

CHAPTER 4

GOOD DRIVING PRACTICES

Fifty years ago, when there were few vehicles and roads were narrow, there were two simple traffic rules. One required a driver to turn to the right when meeting a vehicle coming from the opposite direction. The other required him to turn to the left when overtaking and passing a vehicle going in the same direction. At other times, a driver could use the center or any other part of the road. It is easy to imagine the confusion and wreckage that would result if these were the only rules followed today.

OBEYING THE RULES OF THE ROAD

Rules of the road are standardized throughout the United States to promote highway safety. However, they may be modified by local laws and ordinances or by appropriate civil or military authority. Such modifications will be normally indicated by traffic control personnel or by signs or markings. Drivers will be informed of applicable rules and variations when operating outside the continental United States.

The following are the general rules of the road for military and civilian drivers:

- Operate vehicles on the right of the highway, giving approaching traffic at least one-half of the road unless conditions or directions indicate otherwise. When overtaking and passing other vehicles, pass to the left and remain on the left until safely clear of the overtaken vehicle. However, **DO NOT** overtake and pass another vehicle unless the left side of the road is clearly visible and free of oncoming traffic. Ensure that you have sufficient distance to pass and safely return to the right without coming within 100 feet of an approaching vehicle. You may pass on the right when the vehicle you are passing has signaled and is making a left turn. Be cautious because the vehicle may block your view and another driver's view of you. You may also pass on the right if you are on a street or highway designed for two or more lanes of traffic in both directions or on a one-way street with at least two lanes. Under such
- conditions, keep movement from one lane to another to the minimum. If you must change lanes, signal your intentions, and then ensure that such movement can be made safely and does not interfere with the movement of traffic in other lanes. You may not pass on the right if you must drive off the pavement or the main portion of the roadway to get around another vehicle.
- **DO NOT** start, stop, or turn a vehicle from its course on the highway without ensuring that making such a change is reasonably safe. Also, give adequate warning of your intentions. Make a visual survey of the traffic that may be affected by the movement of your vehicle. You must know how to judge the speed of oncoming vehicles and the effect of your movement upon either their speed or direction. Give clear warning signals that are standard, appropriate to your intentions, and timed to give reasonable warning. A proper signal of intention to turn right or left will be given continuously during not less than the last 100 feet traveled by the vehicle before turning. To turn right at an intersection, approach the turn at the extreme right of the traveled way and make the turn itself as close to the right as practicable. To turn left, approach the turn to the right of, and close to, the centerline, leaving the intersection to the right of the centerline of the entered road. An exception is a one-way road which will be entered to the left of the centerline. A turn to reverse the direction of a vehicle will not be made unless a vehicle approaching from either direction can see the movement from a distance of 500 feet.
- Observe the rules of right-of-way with judgment and courtesy. The safe driver gives the right-of-way rather than taking it. In general, when two vehicles enter an intersection at about the same time, the vehicle on the left yields the right-of-way to the vehicle on the right. Always yield right-of-way to the first vehicle arriving at an intersection. When entering a through highway from a secondary road, give the right-of-way to traffic on the main thoroughfare. Fire, police,

and emergency vehicles have the right-of-way over all other vehicles. However, military emergency vehicles are required to be operated with due regard for life, property, and traffic laws. Obey directions given by traffic control personnel or signs regardless of conflict with the general rules quoted.

Highway speeds to be observed under normal conditions vary somewhat from state to state. These speeds are generally posted on regulatory signs with warnings where reduction in speed is directed. Safe highway speeds are determined by analysis of traffic, highway design, and population densities. Posted speed indicates the results of such analysis under conditions of average traffic, dry pavement, and good visibility. At no time should vehicles be operated in excess of posted limits. Driver judgment should be consciously developed to determine speeds suitable to other conditions. Safe driving requires constant adjustment to changing driving conditions. The military driver will be trained to judge and maintain safe following distances to ensure adequate reaction time and stopping distances at any speed and under varying conditions.

DRIVING ON THE RIGHT

On two-lane roads, the law requires you to drive on the right-hand side of the road, not only when meeting another vehicle, but also as a general rule. Driving on the left-hand side of the road is permitted only in certain situations, such as passing. The danger of ignoring this law is obvious. Yet, more than one-seventh of fatal accidents are the result of head-on and sideswipe collisions, the kind that occur because a driver is on the wrong side of the road. Driving with a portion of your vehicle on the wrong side is a violation of this law.

Why do people drive on the wrong side of the road? One reason is speed. When a person is driving fast, he wants to be sure that he has plenty of room. Because he senses the danger of running off the side of the road, he instinctively moves toward the center. In avoiding one danger, the driver exposes himself to another. A second reason people drive on the wrong side of the road is that they fail to concentrate on driving. Their minds are occupied with conversation, with settling a quarrel, worrying, or trying to remember detailed instructions given by

their supervisors – everything except driving. Their eyes may be off the road and on a passenger in the back seat. The military vehicle driver will refrain from unnecessary conversation while driving. When you are driving, give all your attention to it.

HANDLING CURVES

When thinking of vehicle accidents, people are likely to think of one vehicle crashing into another. Thousands of people are killed each year in collisions between vehicles, but more are killed in one-vehicle accidents. A driver loses control of his vehicle, skids off the road and careens into a telephone pole, or his vehicle turns over and over as it rolls down an embankment into a ditch. A curve is a likely place for this kind of accident.

If you took physics in school you learned two rules about moving bodies:

- Moving bodies tend to remain in motion.
- Moving bodies tend to follow a straight path.

To make a moving body follow a curved path, you have to use force to overcome its natural tendency to follow a straight one. A vehicle on a curve is a moving body with a natural tendency to go straight ahead. At each point on the curve the driver must use force to keep the vehicle turning. The natural tendency to go straight ahead increases much more rapidly than the speed. At 60 MPH, it takes nine times as much force to keep a vehicle turning as it does at 20 MPH.

More important, effective steering depends on the traction between the road and the tires. Traction refers to the tendency of the rubber of the tire to stick to the road instead of slipping and sliding over it. The part of a tire in contact with the road at any one time is about the size of the sole of a shoe. Four small patches of rubber are the only connection between the road and the vehicle.

Anyone who has ever been in a skid knows that traction can be broken. Whenever the tendency of the vehicle to travel in a straight line becomes too powerful for the traction holding the vehicle on the curve, the tires slide on the road and the vehicle starts to skid.

The force represented by the natural tendency of the vehicle to follow a straight line is opposed by the force you place on the steering wheel to turn the vehicle. These opposing forces can cause you to lose control of the vehicle. The only thing you can do to prevent skidding is to drive slowly enough to make the curve safely. (Chapter 9 discusses what to do if you go into a skid.)

When driving on a curve, do the following:

- As you approach a curve, slow down enough so that after you are in the curve, you can keep your engine pulling and maintain your speed.
- Do not wait until you are in the curve to apply your brakes.
- If you must apply your brakes in a curve, be careful. Use a gentle pumping motion until you are sure it is safe to keep continuous pressure on the pedal.
- Start turning your wheels just before you reach the point at which the road begins to turn.
- Once in a curve, stay on your own side of the road and stay as far over as you reasonably can. Do not try to make a curve easier by cutting across the lane of oncoming traffic.
- Maintain a moderate speed and the curve will be easy enough to handle on your side of the road.

You cannot judge the next curve by the last one. Roads with uniformly sharp or gentle curves are probably safer than roads with curves of varying degrees. But on most roads, curves vary a good deal. Assume that unfamiliar curves are sharp. You can always speed up if you are wrong, but you may not always be able to slow down.

USING SELECTIVE VISION

Safe drivers must know what is going on at all times around their vehicle. Not looking properly is a major cause of accidents. All drivers look ahead, but many do not look far enough ahead. Stopping or changing lanes can take a lot of distance; so you must know what the traffic is doing on all sides of

you. You must look far ahead to be sure you have room to move safely.

Most good drivers look 12 to 15 seconds ahead. That means looking ahead the distance you will travel in 12 to 15 seconds. At lower speeds, that is about one block; at highway speeds, about a quarter of a mile. If you do not look that far ahead, you may have to stop too quickly or change lanes quickly. Looking 12 to 15 seconds ahead does not mean not paying attention to closer things. Good drivers shift their attention back and forth, near and far.

Look for vehicles coming onto the highway, into your lane, or turning. Watch for brake lights from slow moving vehicles. By seeing these things far enough ahead, you can change your speed or change lanes if necessary to avoid a problem. Look for hills, curves, or anything for which you must slowdown or change lanes. Pay attention to traffic signals and signs. If a light has been green for a long time, it will probably change before you get there. Start slowing down and be ready to stop. Traffic signs may alert you to road conditions where you may have to change speed.

TURNING LEFT

Sometimes when you are making a left turn at an intersection, your vision of traffic coming from the right will be obstructed by a passenger sitting beside you on the front seat. If your vehicle is equipped with individual bucket seats, adjusting the passenger seat several inches backward of the driver's seat will give you a better view to the right. If the vehicle has a standard seat, you may have to lean forward to see around your passenger. If necessary, ask him to lean back to give you a better view.

Be sure there is enough space to turn left. When turning left –

- Signal your intent to turn and slow down.
- If there are two left turn lanes, take the right-hand turn lane.
- Be sure you are in the center of the intersection. Start to turn only after you are sure your vehicle's rear will clear the centerline.

- Be sure there is an adequate gap to turn in front of traffic.
- Watch your vehicle's progress in the side mirrors.
- Steer the vehicle wide of the lane, if necessary.
- When the vehicle's wheels are into the lane, steer left to put the vehicle in the lane and straighten up.
- If applicable, watch for oncoming traffic.
- Cancel your signal.

TURNING RIGHT

Before making any turns, signal your intention at least 100 feet ahead of the intersection. When making a right turn -

- Be sure there is enough space to turn right.
- Signal your intent to turn and slow down gradually as you approach the turn.
- Be sure to let oncoming traffic clear before you make your turn.
- Stay as close as possible to the right edge of the road or street.
- Never swerve to the left before turning right.
- Position your vehicle in the right-hand lane. Keep your vehicle's rear close to the curb. Do not turn wide to the left as you start the turn; the driver behind you might think you are turning left.
- Pull forward into the intersection past the right corner; you must do this so the vehicle's rear wheels can clear the curb. Turn the steering wheel hard to the right.
- Check your vehicle's progress using the right side mirrors.
- Watch oncoming cars if swinging wide into the left or oncoming lane.
- Cancel your signal.

If the speed is right the turn should be easily made without swerving. If your tires squeal when you turn, it is likely that you are trying to take the turn too fast.

ABSTAINING FROM ALCOHOL AND OTHER DRUGS

Drinking is a factor in at least half of the fatal motor vehicle accidents in the United States. Most of the people involved in these accidents did not have enough to drink to be considered drunk, but there is reason to believe that the driver who has had a drink or two may be more dangerous than the one who is clearly drunk. He usually does not realize that his driving ability is impaired. He often thinks he can drive better. "Whiskey courage" is an old story. On the highway, it is a tragic one.

Alcohol is not the only drug that impairs driving ability. Barbiturates, antihistamines, and other medicines in common use may cause drowsiness. If you are uncertain about the effects of a particular medicine, check with your doctor or druggist before taking it. If he says that it may make you sleepy, do not take it before driving. You must stay alert to stay alive.

Narcotics may dull the senses, induce profound sleep, or cause stupor, coma, or convulsions. Effects on the central nervous system include hilarity, carelessness, talkativeness, euphoria, distortion of sensation and perception, impairment of judgment and memory, distortion of emotional responsiveness, irritability, and confusion. You cannot take drugs and operate your vehicle safely.

RESTING

If you have experienced loss of sleep or for some other reason feel an unusual sleepiness to the point that you think your driving may be unsafe, notify your supervisor. He will adjust your duties accordingly. This does not excuse you from keeping yourself physically capable of performing your duty, and repeated incidents will require a physical checkup and/or disciplinary action.

For Army Only: Drivers will not be assigned to drive military vehicles for more than 10 continuous hours. They will not have a combined duty period (driving plus other duties) longer than 12 hours in

any 24-hour period without at least 8 consecutive hours of rest (AR 385-55).

CHAPTER 5

SAFE DISTANCES AND PASSING

A driver who tailgates does not give himself enough time or distance to handle emergency situations. Running into the vehicle ahead happens often because many drivers do not allow a safe stopping distance between their vehicles and those in front of them. Safe passing requires that drivers know not only how to pass, but also when and when not to pass.

MANAGING SPACE

To be a safe driver, you need space all around your vehicle. When things go wrong, space gives you time to think and act. To have space available when something goes wrong, you need to manage space. While this is true for all drivers, it is very important for large vehicles. They take up more space and require more space for stopping and turning.

Of all the space around your vehicle, the area ahead of the vehicle — the space you are driving into — is most important. You need space ahead in case you must suddenly stop. According to accident reports, trucks and buses most often run into the vehicle that is in front of them. The most frequent cause is following too closely. Remember, if the vehicle ahead of you is smaller than yours, it can probably stop faster than you can. This may cause you to crash into it if you are following too closely.

How much space should you keep in front of you? One good rule is to keep at least one second for each 10 feet of vehicle length at speeds below 40 MPH. At greater speeds, you must add one second for safety. For example, if you are driving at a speed below 40 MPH in a 40-foot vehicle, you should leave 4 seconds between you and the vehicle ahead; in a 60-foot vehicle, 6 seconds. If the 40-foot vehicle is moving faster than 40 MPH, you would need 5 seconds; for the 60-foot vehicle, 7 seconds.

To know how much space you have, wait until the vehicle ahead passes a shadow on the road, a pavement marking, or some other clear landmark. Then count off the seconds — one thousand and one, one thousand and two, and so on — until you reach the

same spot. Compare your count with the rule of one second for every 10 feet of length. If you are driving a 40-foot truck and only counted up to 2 seconds, you are too close. Drop back a little and count again until you have 4 seconds of following distance (or 5 seconds, if you are going faster than 40 MPH). After a little practice, you will know how far back you should drive. Also remember that when the road is slippery, you need more space to stop.

Specific following distances are determined for certain vehicles:

- When driving outside of cities and towns, a bus or truck should not travel closer than 200 feet behind another bus or truck.
- When a fire engine is answering an alarm, the minimum safe following distance is 500 feet. Violators can be prosecuted.

NIGHT DRIVING

Headlights are a poor substitute for daylight. Never drive so fast that you cannot stop within the distance you can see ahead with your lights. At twilight, as soon as light begins to fade, turn on your headlights, not parking lights. To make your vehicle more visible to others, you must use headlights from sunset to sunrise according to most states. Be aware that some other drivers may not have turned on their lights. Use low beams when driving in cities and towns, except on streets where there is no other lighting. Use high-beam headlights on highways only when it is safe and legal to do so, such as when no other vehicle is coming toward you. Use low beams whenever you are following a vehicle. Switch to low beams whenever you meet oncoming traffic to avoid blinding the other driver. If the high beams of an oncoming car are not dimmed, avoid looking directly at the bright lights. Glance toward the side of the road; then quickly look ahead to determine the other vehicle's position. Keep doing this until you have passed each other. Drive defensively at night.

PASSING

You must decide whether to pass or not to pass again and again every time you drive. Do not take chances. Do not move out into the left-hand lane as soon as you see any possibility of getting by the vehicle ahead. On the other hand, do not let opportunities for safe passing go by while irritably following a slow-moving vehicle for mile after mile.

Safe Passing

Safe passing depends mainly on your knowing three things: when to pass, when not to pass, and how to pass. You cannot pass safely unless you can see far enough ahead to be sure that you can get back in line before you meet any traffic coming from the opposite direction. You must also be able to get back into line before meeting any traffic crossing or turning onto the road on which you are driving.

Give yourself and the driver of the vehicle you are passing plenty of room. Start to pass from a safe following distance. If the vehicle you want to pass is traveling at 30 MPH, start from at least 60 feet behind it. Drift over to the left and speed up quickly. Do not speed up directly behind a vehicle and then turn out suddenly just before you get to it. This interferes with your view of the road ahead. The other driver may slow down or stop, and he can do so much more quickly than you can because his speed is lower. If he does, you will almost certainly be unable to slow down or stop in time. If you try to avoid a collision by turning sharply aside, you may skid off the road, turn over, or smash into another vehicle.

As you go by another vehicle, be sure there is plenty of distance between the right side of your vehicle and the left side of the other vehicle. The law in most localities requires a minimum clearance of 2 feet.

You have not finished passing until you get back onto your own side of the road or in the lane where you belong, leaving the vehicle you have just passed at a safe following distance behind you. If the vehicle you are passing is traveling at 30 MPH, leave 60 feet clear before returning to your own side of the road (20 feet for every 10 MPH of speed). If you force the driver of the vehicle you have just passed to slow down as you get back into line, you have not passed safely. Of course, it is difficult to see the vehicle you have just passed and estimate the distance. A good

rule of thumb is that you can usually be sure it is safe to return to the right side of the road when you can see the vehicle you have passed in your rearview mirror.

As a general rule, do not attempt to pass more than one vehicle at a time. Passing several vehicles increases the danger because it increases the time you spend and the distance you cover while out of your own lane. If you come up behind a long line of vehicles, you can almost be sure that every driver except the first one is waiting for an opportunity to pass. The safe and courteous thing to do is to wait your turn. On the other hand, if you are next in line behind a slow-moving vehicle, it is discourteous to the drivers behind you not to pass when you have the opportunity.

Unsafe Passing

There are some situations where passing is always dangerous or unlawful:

- On any curve or hill where you cannot see at least 500 feet ahead.
- At intersections and railway crossings.
- Whenever there is a single or double solid line between lanes or when your lane's side of a double line is solid.
- At crosswalks where a vehicle has stopped to allow a pedestrian to cross.
- Whenever a stopped school bus has its warning flashers on.
- Whenever you cannot see that the road is free of traffic far enough ahead to pass safely.

The last statement above sums up all the others and raises the question. How far ahead is far enough? This distance depends on you own speed, on the speed of the vehicle you are passing, and on the lengths of the vehicles involved. Suppose you want to pass a vehicle traveling at 30 MPH. You would have to travel whatever distance it travels while you are passing and an additional distance besides. Since the other vehicle's speed is 30 MPH, the additional distance in this case would be about 160 feet.

It is generally a good idea to pass at a speed at least 10 to 15 MPH faster than the speed of the vehicle being passed. If your speed is only 5 MPH faster, it will take you twice the time and almost twice the distance to completely pass the other vehicle.

On the other hand, there is no point in passing at too fast a speed. In passing at 20 MPH faster instead of 15 MPH faster than the speed of the vehicle being passed, the advantage amounts to only 1 or 2 seconds gained. It is usually offset by the danger of increased speed. If too much increased speed is required to pass and return to your lane, the wise decision is not to pass.

As a general rule, your passing speed should be from 10 to 15 MPH faster than the speed of the vehicle you are passing. Suppose, however, that you want to pass a vehicle traveling at 50 MPH when the speed limit is 55 MPH. In this case, driving your vehicle 10 to 15 MPH faster would be unlawful because passing is no excuse for exceeding the speed limit. Yet if you pass at 55 MPH, you will need 2,640 feet or exactly half a mile to pass the other vehicle. When the driver ahead of you is traveling just under the speed limit, the safest thing to do is forget about passing. Settle down behind him at a safe following distance. You may reach your destination a few minutes later than if you had attempted to pass, but at least you will not have broken the law.

Passing on the Right. Passing on the right, except as explained, is usually dangerous and unlawful. It puts you on the other driver's blind side. He may be intending to make a right turn or to pull over to the right side of the road. In either case, an accident is almost certain. There are, however, three situations in which passing on the right is permissible and reasonably safe:

- If the highway has at least two lanes going in each direction.
- If all lanes of traffic move in the same direction (one-way street).
- If the vehicle you are passing is in a left-turn lane.

Passing On Three-Lane Highways. Passing on a three-lane highway demands extra caution. Do not pass except in the center lane, and then only when the center lane is marked for passing in your direction.

The center lane may be so marked that it is open for passing in both directions. Before passing, make sure that none of the vehicles coming from the opposite direction are moving out to pass. Never use the center lane to pass if your view of the road ahead is obstructed by a hill or curve. The one exception to using only the center lane for passing is that you may pass in the right lane if the vehicle in the center lane is making a left turn.

Signaling

When passing, do not just pull out and start around. Look ahead and behind to be sure it is safe to pass. Let the driver of the vehicle ahead know what you intend to do. He may be getting ready to pass the vehicle ahead of him or to turn left. Blow your horn as a signal to him. At night, give the driver ahead an additional signal by flashing your headlights from low to high beam and back to low. However, do not use the light signal as a substitute for the horn signal. The horn signal is required by law in most localities, and it puts the driver of the vehicle being passed under a legal obligation to help you pass.

The driver of the vehicle behind you also needs to know what you are going to do. He may be pulling out to pass you. Give a left-turn signal to let him know that you are about to pull out to pass.

BEING PASSED

When you are being passed, the law requires you to help the other driver get by. When the driver of the passing vehicle blows his horn, you must do one thing: give way to the right. Even if you are already on your own side of the road, move over as close as safety will permit to the right-hand edge of the road. The law does not permit you to increase your speed. Speeding up forces the passing driver to cover more distance and take more time to get by you. It exposes both of you to unnecessary danger.

When you are being passed, it is usually safest to maintain a steady speed. By doing this, you allow the passing driver to judge passing distance with greater accuracy. If you slow down, you may mislead him into overestimating his speed. Nevertheless, if an attempt to pass you becomes dangerous, you may be able to make it safer for everyone by slowing down and allowing the passing vehicle to get back into the proper lane in less time and distance.

If, however, you see that a driver is trying to get back into line behind you, rather than ahead of you, do not slow down. In this case, it is much safer to speed

up a little to give him more room. When danger develops in passing, do not stand on your rights. Use all driving skill to avoid an accident.

CHAPTER 6

INTERSECTIONS

The most dangerous place on a street or highway is an intersection. An elementary law of physics says that two bales cannot occupy the same space at the same time. Hundreds of thousands of drivers and pedestrians have demonstrated the truth of this law by losing their lives at intersections. An intersection is any place where two or more roads join or cross each other. You are required to slow down when approaching all intersections – whether or not you have the right-of-way. The following rules of the road are normal; however, state and local laws take precedence. The main question faced by drivers at an intersection is “Who has the right-of-way?”

INTERSECTIONS WITHOUT TRAFFIC CONTROLS

When approaching a major road from a minor road, you must yield to the traffic on the major road. If you are entering an intersection with traffic already in it, you must yield to that traffic regardless of the type of road.

When two vehicles approach an intersection at the same time, which one has the right-of-way? The law states that when two vehicles enter an intersection from different highways at the same time, the driver on the left must yield to the driver on the right. The law does not give right-of-way to anyone; it only states who must yield it. Therefore, you should always be alert for those who fail to yield, and you must do everything possible to avoid an accident.

INTERSECTIONS WITH TRAFFIC CONTROLS

Traffic Lights

Traffic lights greatly simplify right-of-way problems since the traffic on one road is stopped while the traffic on the other is permitted to proceed. For vehicles coming from opposite directions on the road which has the green light, the right-of-way rules

are the same as those that would apply in the absence of traffic signals. At some intersections, however, you may not make a left turn unless a special left-turn green light is showing. Sometimes the sign is in the form of a traffic light showing a green arrow, however, these rules may vary from state to state.

At other intersections where there are signs permitting you may make a right turn on a red light. To turn right on a red light at one of these intersections, you must be in the right-turn lane and must give a right-turn signal. You ordinarily have the right-of-way over pedestrians who are crossing the street you are turning into because the light is red for them. Nevertheless, it is unlawful for you to do anything that might endanger them, even if they refuse to yield the right-of-way to you.

Traffic Signs

At an intersection where stop signs have been erected, you must come to a complete stop. You may not enter the intersection, whether to go straight through or to turn right or left, until you are sure that the movement can be made safely.

When required to stop at an intersection where a line has been painted on the street indicating the place to stop, stop there (Figure 6-1). When the place to stop is not marked by a line, stop close enough to the intersection so that you can see any traffic that may be approaching from your right or left. **Do not, however, block a crosswalk.** Pedestrians crossing at an intersection have the right-of-way over vehicles. Do not start again until you are sure the way is clear. Do not enter the intersection if there is traffic on the intersecting street that will reach the intersection before you have cleared it.

Stop signs are sometimes placed at intersections where lights have also been erected. When traffic lights are in operation, obey them instead of the signs. Furthermore, a traffic officer's signaling must be obeyed regardless of traffic lights or signs.

At intersections governed by yield signs, you must slow down to a speed reasonable for the conditions and yield the right-of-way.

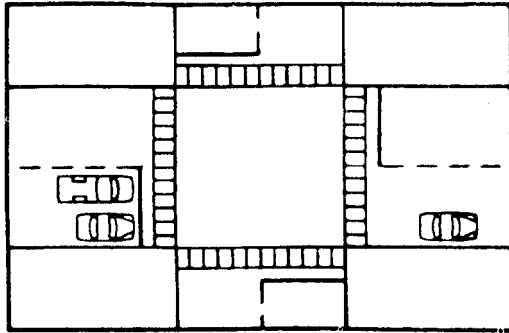

FIGURE 6-1. Proper Stopping Places at Crosswalks.

URNS AT INTERSECTIONS

Before making any turn, signal your intention at least 100 feet ahead of the intersection. Never turn or change lanes without first looking to make sure that it can be done safely.

When you make a right turn at an intersection, stay as close as possible to the right edge of the road or street. Never swerve to the left before turning right (Figure 6-2).

Never swerve to the right before turning left (Figure 6-3). When making a left turn—

- First, get into the lane nearest the centerline in advance of the turn.
- Then slow down gradually as you approach the turn.
- Be sure to let oncoming traffic clear before you make your turn. Then enter the lane to the right of the centerline of the street into which you are turning.

Many drivers swerve in the opposite direction before turning to make the turn easier. If the speed is right, the turn should be easily made without swerving. If your tires squeal when you turn, it may mean your tires are underinflated, but it is more likely that you are trying to take the turn too fast.

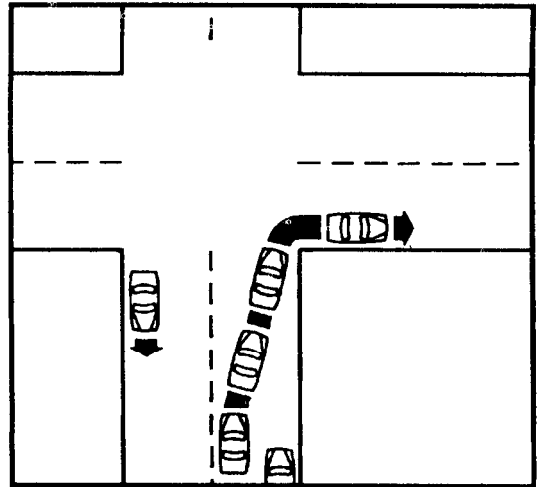

FIGURE 6-2. Making a Right-Hand Turn.

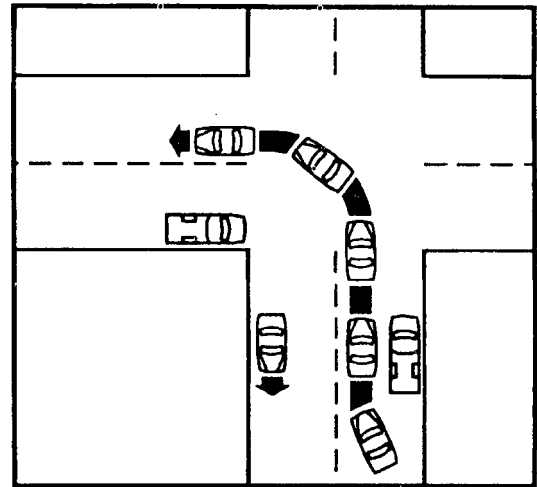

FIGURE 6-3. Making a Left-Hand Turn.

NOTE: Swerving in the opposite direction before making a turn is likely to mislead other drivers and cause an accident.

SPECIAL INTERSECTIONS

On new highways, an increasing number of intersections are designed so that one road passes over the other instead of crossing it. To turn right or left at such intersections, it is necessary to use connecting roads to get onto the crossroads. These elevated

intersections and their connecting roads are often confusing to drivers who are not used to them, and the method of making turns may vary from one to the other. Whenever you come to an intersection where one road passes over or under the other, slow down and pay careful attention to the signs that tell you how to make the turn you want to make.

Cloverleaves

Intersections where the roads cross each other at different levels may be designed in a number of ways. The most common type is the cloverleaf design (Figure 6-4). To turn right, you take a right turn before you get to the bridge that carries one road over the other. To turn left, you take the right turn just after the bridge. This road will carry you around to join the crossroad in a three-quarter circle at an ordinary intersection. The advantage of cloverleaves and similar intersections is that you do not have to cross the path of other traffic to make a turn.

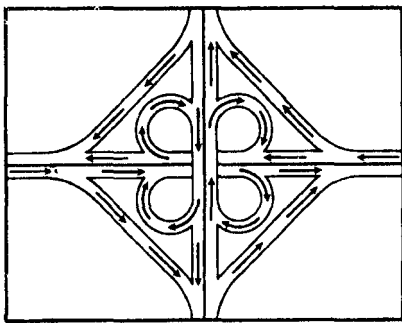

FIGURE 6-4. A Cloverleaf Intersection.

Traffic Circles

A rather common type of special intersection is the traffic circle. Upon entering the traffic circle, all vehicles turn in the same direction – to the right. Almost all traffic circles have at least two lanes, and some have more. You simply continue around the circle in a counterclockwise direction until you come to the road or street you want. Then you leave the traffic circle by making a right turn.

As you travel around the circle, use the inside lane if practicable, but be sure to get in the outside lane well before you come to the place where you intend to leave the circle. Never attempt to make a right turn from the inside lane. Look and signal before you turn or change lanes.

At traffic circles, the whole circle is considered an intersection. The vehicles already in the traffic circle have the right-of-way over those approaching the circle on the roads leading into it unless traffic signs indicate otherwise.

Railroad Crossings

To move safely through a railroad crossing, develop the following habits:

- Identify all warning signs, signals, and protective devices.
- Before crossing the tracks, look both ways and listen for approaching trains.
- After a train has passed, be sure no other train is approaching from either direction before starting across.
- Never stop on railroad tracks.
- Do not rely on mechanical equipment (flashing lights) to be sure the way is safe to cross.
- Never take familiar crossings for granted or assume that no train is coming.
- Be particularly alert for trains after dark when crossings are not protected by gates or flashing lights. Frequently drivers drive into the sides of trains at such crossings.
- Stop your vehicle between 15 and 50 feet from a railroad crossing when transporting hazardous materials or passengers (in a vehicle designed to transport 16 or more persons including the driver).
- When driving a bus, open your forward door if it will help you see or hear an approaching train.

PRIVATE DRIVEWAYS

When coming out of a private driveway, yield the right-of-way to all vehicles on the street or highway you are entering. Stop for any pedestrians who may be on the sidewalk and about to cross the driveway.

CHAPTER 7

PEDESTRIANS, BICYCLISTS, AND ANIMALS

Pedestrians, bicyclists, and animals pose special problems for drivers. It is often difficult to see pedestrians, bicyclists, and animals on the road. You must be alert to avoid collisions with them.

PEDESTRIANS

Pedestrians are a poor match for the automobile. In the United States, about 10,000 of them are killed in traffic accidents each year. When pedestrians are involved in collisions, speeds of no greater than 15 or 20 MPH often prove fatal.

It is true that pedestrians often violate laws passed for their protection. They may walk along highways with their backs to oncoming traffic. They often ignore crosswalks and cross in the middle of a block. Children dart out into the street without looking for traffic. Nevertheless, after one has killed a child, it is not much comfort to know that the child was at least partly to blame. Pedestrians will be safe on streets and highways only when drivers are willing to be their brothers' keepers.

You should let the pedestrian know your intentions. Whenever a pedestrian may be affected by you turning, stopping, or starting, the law requires you to blow your horn regardless of which of you has the right-of-way. Be careful how you blow your horn. A long, loud blast can frighten and confuse a pedestrian, increasing instead of minimizing the danger. Use your horn as a warning signal, not as a command to get out of your way. Whenever you blow your horn to warn a pedestrian, your foot should be off the accelerator and ready to depress the brake pedal.

Anticipate the pedestrian's intentions. If you see a person in the street, slowdown and get ready to stop. He may be able to take care of himself, but do not depend on it. He may get confused and walk right in front of you. Never pass another vehicle that has stopped to permit a pedestrian to cross.

Watch people on the sidewalks and at the side of the road. They may not stay there. Leave room between your vehicle and a row of parked vehicles. Someone may step out from between them at any moment. When near pedestrians, drive slowly.

If you should come upon a pedestrian walking with his back to you on your side of the highway, blow your horn well before you get to him. If he is warned of your approach, he is unlikely to step out in front of you. When you pass a pedestrian walking along a highway, allow plenty of room between him and your vehicle.

In school zones, slowdown to the posted speed limit and watch for children. Obey the directions given by members of the school safety patrol or by school Crossing guards.

When stopped by the stop signal of a school bus, do not move until the bus is placed in motion and the highway is clear of students.

Observe these rules at intersections:

- At intersections with no traffic lights, pedestrians have the right-of-way.
- A blind pedestrian is entitled by law to special consideration at intersections with no traffic lights. If a blind pedestrian holds out a white cane or a white cane tipped with red or if he is accompanied by a guide dog, all vehicles approaching the intersection must stop. They must remain stopped until the blind pedestrian has completed his crossing.
- At intersections controlled by ordinary traffic lights, pedestrians obey the same signals as drivers. When crossing on a green light, they have the right-of-way. If a light changes to yellow or red while a pedestrian is still in the street, drivers must allow him to complete his crossing safely.

- At some intersections, special lights instruct pedestrians either to walk or to wait. Where these lights are in operation, pedestrians must obey them instead of the regular traffic lights. Pedestrians crossing on a special pedestrian signal have the right-of-way just as they do when crossing on a green light.
- If you are going through an intersection on a green light and a pedestrian starts to cross in front of you against a red light, warn him with your horn. If he does not stop, then you must stop. If you save a life, losing your right-of-way will be worthwhile. The safe driver yields the right-of-way to a pedestrian when the pedestrian is entitled to it and even when he is not.

Obey traffic rules when you are a pedestrian. As a military vehicle driver, you will frequently find yourself in this role. When you walk, be as careful as you want pedestrians to be when you are driving.

When you cross a street, cross at an intersection or crosswalk if one is available. Before you cross, stop and look in both directions. Be sure that you can get all the way across or to a safety island before the light changes.

Remember, pedestrians as well as drivers must obey traffic lights. Never start to cross on a red or yellow light. Do not start to cross on a green light if you know it is just about to change.

When walking or jogging along a road without sidewalks, use the left shoulder and face oncoming traffic. When a vehicle approaches, get off as far as necessary for safety. At night, carry a flashlight or a

light-reflecting object that will enable drivers to see you better. The lights of an oncoming vehicle may be bright enough to blind you, but its driver may not see you.

BICYCLISTS

The number of bicycles being used on streets and highways is growing daily, both for exercise purposes and for transportation in city areas. Bicyclists are expected to obey the same traffic rules and regulations as vehicle drivers, but many are children who may not obey or even know the rules.

A major problem for drivers is their inability to see bicyclists, especially at night. Sometimes they may be in the blind spot of your vehicle. Keep on the lookout and slow down when you approach bicyclists. Tap your horn lightly if necessary to let them know where you are. Give them plenty of room when passing and be prepared to stop suddenly.

ANIMALS

Stock laws vary from state to state and in some instances are not properly enforced. Therefore, a vehicle operator should always be alert to the possibility of a collision with an animal. Collision with even a small animal can cause serious vehicle damage and endanger human life. As a vehicle operator, you must be thoroughly familiar with and obey all local laws. You must also exercise your best judgment and drive defensively at all times to avoid endangering animals, human life, and property.

CHAPTER 8

OPERATING PRACTICES AND MANEUVERS

The objective of your training as a military driver is to teach you how to do your job efficiently with maximum safety, comfort, and economy. Good driving habits are attained through constant practice. During your daily driving, review the techniques discussed below. Test yourself occasionally to see how you measure up. In this way, you can avoid slipping into bad, perhaps dangerous habits.

DRIVING PRACTICES

Make the following general practices part of your routine daily driving methods:

- Always sit in an erect, comfortable position with your shoulders parallel to the back of the driver's seat.
- Adjust the seat if necessary so that you can easily manipulate the vehicle controls and have a clear view to the front.
- Adjust side and rearview mirrors so that they give unobstructed views.
- Fasten shoulder and seat belts.
- Lock doors, if applicable.

The position of the hands on the steering wheel is of prime importance for vehicle control particularly in emergencies. Place your hands on opposite sides of the steering wheel at 10 and 2 o'clock or 10 and 4 o'clock positions. Hold the rim, not the spokes. Maintain a firm, but comfortable grip. Remove hands from the wheel only when signaling, adjusting controls, or performing other acts essential to driving. A driver should be ready for a complete, controlled turn of the wheel in a fraction of a second at all times.

Before putting the vehicle into motion, carefully check traffic conditions, particularly the immediate front and rear of the vehicle where children or objects difficult to see could be located.

Try to anticipate future situations. Continually glance far ahead and be prepared for other drivers' errors or unsafe maneuvers. Keep a close watch at all times on conditions behind your vehicle by regularly glancing at the rearview mirrors. Anticipation and good judgment can preclude a large percentage of emergency situations - drive defensively.

STARTING

Instructions on starting both manual and automatic shift vehicles are found in Chapter 16. However, the following points are given on specific starting conditions.

On Hills

When you have to start on an upgrade, use your parking brake to keep the vehicle from rolling backward. Keep the parking brake on while you shift into low gear and begin to release the clutch pedal slowly. When the vehicle begins to pull against the brake, release the brake slowly. In this way, you can start without danger of rolling back and losing control of your vehicle. It may not be necessary to use the parking brake in vehicles equipped with automatic transmission or special devices that prevent rolling back on hills.

On Slippery Surfaces

If you have to start on a slippery surface, such as ice or loose dirt, use second or a higher gear instead of low gear. Feed the gas and release the clutch pedal very slowly to avoid spinning the rear wheels.

STEERING AND TURNING

The best and safest position of the hands on the steering wheel is on either side of the wheel a little above the center (the 10 and 2 o'clock positions) or the right hand can be positioned a little below the center (10 and 4 o'clock positions). Two hands are necessary both for beginners and for experienced

drivers. Your grip on the wheel should be firm, but not tight.

When you round a corner or make any other sharp turn, use the hand-over-hand steering method (Figure 8-1). If you are turning to the right, begin by placing your right hand near the top of the wheel and pull the wheel down to the right. As the right hand nears the bottom of the circle, let the left hand take over, starting at a position on the left of the wheel, a little below the top. As the left hand nears the bottom of the circle, again place the right hand at the top of the wheel to continue the turn, if necessary. As you complete the turn and release pressure on the steering wheel it will slide through your hands because the front wheels tend to return to their normal straightforward position. At low speeds and on some old vehicles, the wheels must be brought back to their normal position by reversing the direction of steering.

Do not turn sharply to change lanes. Light pressure on the steering wheel will allow you to drift gradually from one lane to another. Before you change lanes, remember to look for traffic that may be coming up behind you and to give a turn signal.

BRAKING AND STOPPING

The proper use of brakes is one of the most important elements of good driving as well as one of the best indicators of driving capability. Your brakes are used in all stopping procedures, but they are seldom used alone. Emergency stops may be exceptional for the professional driver, but being prepared for them should be routine.

The heavier the vehicle, the more work the brakes must do to stop it, and the more heat they absorb. But the brakes, tires, springs, and shock absorbers on heavy vehicles are designed to work best when the vehicle is fully loaded. Empty trucks require greater stopping distances because they have less traction. They can bounce and lock up their wheels, braking poorly. This is not usually the case with buses.

Use these general procedures for braking:

- Release the accelerator pedal.
- Downshift within the operating range of the engine (RPM) (if manual transmission).
- Depress the brake pedal.
- As the vehicle begins to reduce speed, decrease brake pedal pressure.
- Stop smoothly by releasing the brake pressure gradually as the stopping rate increases.
- As the vehicle halts, push in the clutch pedal (manual transmission), and release the brake pedal.
- After stopping, shift to neutral and reapply the brake just enough to keep the vehicle stationary. Now release the clutch pedal (manual transmission).
- Use the engine retarder for descending grades, in city traffic, or in any situation where slowing is required but not on slippery road surfaces (such as rain, snow, sleet, or ice).

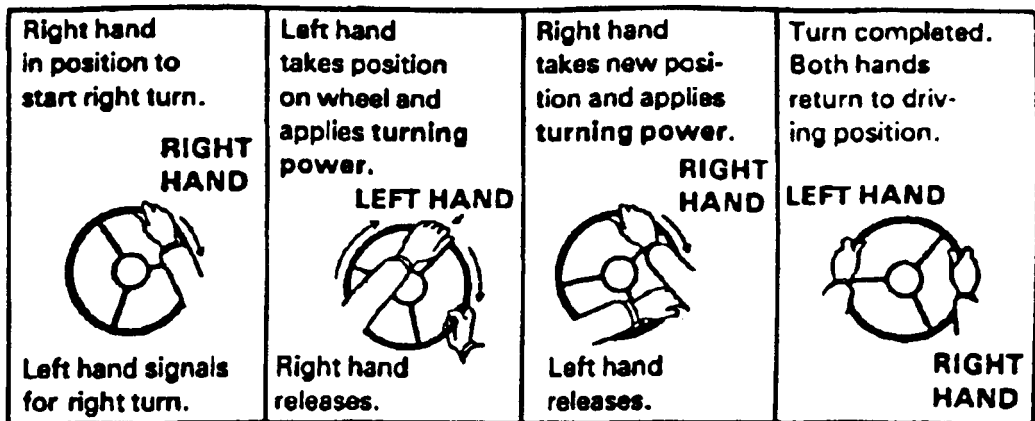

FIGURE 8-1. Hand-Over-Hand Steering Method.

NOTE: Apply the Jacobs brake (Chapter 18) only if wheels have good traction.

GROUND GUIDE SAFETY PROCEDURES

Ground guides must be trained in standard hand and arm signals and flashlight signals before guiding a wheeled vehicle. Hand and arm signals are the basic method used for ground guiding. Drivers and ground guides will coordinate signals before ground guide operations. Examples of hand and arm signals are in Appendixes A and B. Additional hand and arm signals are in FM 21-60. Voice signals between a ground guide and driver can be misunderstood and should not be used except in an emergency.

Before a wheeled vehicle is started for movement, a member of the crew or the driver must walk completely around the vehicle to ensure no one or no object is in danger from the vehicle's movement. At no time will ground guides run or walk backwards while guiding a vehicle.

CAUTION

The ground guides should keep 10 yards between themselves and the vehicle front or rear and corners. They should never be directly behind the vehicle. Ground guides will not position themselves between the vehicle being guided and another object where an inadvertent engine surge or momentary loss of vehicle control could cause injury. Drivers of vehicles will immediately stop their vehicles if they lose sight of ground guides or note that the guide is dangerously positioned between the vehicle and another object. Drivers of vehicles in such cases will secure their vehicle, dismount, and make an on-the-spot correction before commencing operations.

Use the procedure below when there is only one ground guide or when a ground guide is not available, such as in the civilian domain. The ground guide or the vehicle driver will dismount and walk completely around the vehicle to -

- Determine visual clear distance with a ground reference point from the cab of the vehicle.
- Mount the vehicle, sound the horn, and back to the rear of the preselected ground reference point. Stop and repeat the process as necessary until the desired vehicle position is obtained.

Only one ground guide gives signals to the driver. Be sure that everyone involved (the driver and ground guides) understand who will give the signal and who will receive it before any movement is done. If sight between the driver and the ground guide making the signal is lost, the driver must stop the vehicle until the signal is again visible or the confusion is cleared up.

During movement within an assembly area, wheeled vehicles require ground guides when moving forward and when backing. Ground guides are also required when vehicles enter a field site operations area.

At night the best method to ground guide a vehicle into the area is to use a screened flashlight. Guides move forward to make sure the way is clear, then turn around to face the vehicle, and give the proper signal with the flashlight. The driver moves the vehicle forward until the flashlight signal goes out. Then he stops the vehicle. This process is repeated as the vehicle is moved forward to its final stop.

Ground guides are required when wheeled vehicles are backed. However, the number of ground guides used is determined by visibility restrictions (cargo, darkness, and so forth). The horn will be sounded before any backing operation is done. When backing at night, use the same flashlight procedures to safely back the vehicle.

Figure 8-2 shows where the ground guides will be positioned when backing and moving vehicles forward.

BACKING

To turn while backing, turn the steering wheel in the same direction as you would if you were going forward. To back to the right, turn the wheel to the right. To back to the left, turn the wheel to the left. Back slowly. In a vehicle with standard gears, you cannot control your speed safely while backing

- Verify clearance.

unless you use the clutch as well as the accelerator. Always come to a full stop before shifting into forward gear.

Keep looking back until you have stopped. If you shift your eyes to the front as soon as you are ready to stop, you will be backing blindly for several feet. When backing in very close quarters such as a driveway or when visibility through the rear window is poor, you may find it necessary to use your right hand on the steering wheel while you look out the left window to see where you are going.

WARNING

NEVER OPEN EITHER DOOR WHILE YOUR VEHICLE IS IN MOTION. At best, backing is more dangerous than going forward. You cannot see as well and your vehicle is harder to control. Before you back even a short distance, make sure there are no children around. Many youngsters have been crushed under the wheels of the family car while playing in their own backyards or driveways. Never back long distances unless absolutely necessary. It is much safer to turn around and cover the distance going forward.

TURNING AROUND

The best, safest, and often quickest way to turn around is to drive around the block, making three right turns and a final left turn. This eliminates the problems of most left turns. In some cases, however, such as a dead-end street or other tight space, you have to turn the vehicle completely around. Carefully follow these suggestions:

- Select a place where you have at least 500 feet of clear visibility in each direction.
- Do not attempt any turnaround near hills or curves or where visibility is limited.
- Be sure there are no signs prohibiting the turn.
- Be sure there is enough space to complete the turn safely.
- Check for vehicular and pedestrian traffic before and during the turn.

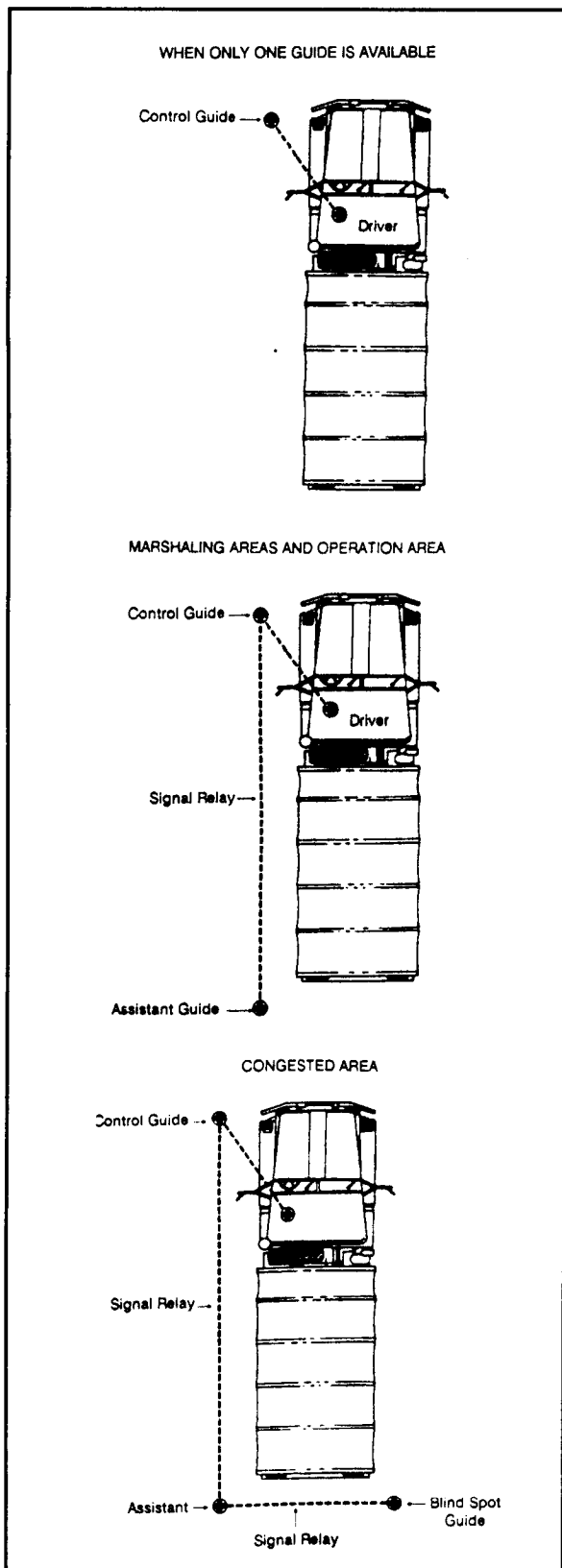

FIGURE 8-2. Recommended Ground Guide Positions.

Remember that the responsibility for avoiding an accident rests with you. Neither of the following turns should be made on roads with heavy traffic.

U-Turns

U-turns are not legal everywhere, so be sure to look for prohibiting signs before making one. **IN CITIES AND TOWNS, U-TURNS ARE ALLOWED AT INTERSECTIONS ONLY.** To make a U-turn, follow these steps (Figure 8-3):

- Move into the proper lane. On a two-lane street move as far right as possible. On four-lane and divided streets, move into the left-turn lane.
- Check for traffic signal, stop, and then signal a left turn.
- Check for oncoming traffic and for room to complete the turn; then make a sharp left turn.
- Slowly finish your turn, positioning your vehicle in the far right lane. Straighten your wheels and proceed.

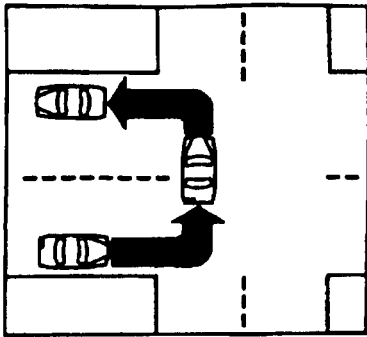

FIGURE 8-3. U-Turn.

Road Turns

If you cannot make a U-turn and no side road is available, use the road turn. There are two ways of making a road turn. The easiest is to come to a complete stop at the right curb or edge of the road, using the shoulder if available. After checking to see that the road is clear of traffic in both directions, start turning to the left. Turn your steering wheel as quickly as possible as far to the left as it will go. Just before you get into the opposite curb or edge, reverse the steering wheel as far to the right as it will go. Now back up, keeping the steering wheel to the

right. AS you approach the opposite curb or edge, turn your steering wheel back again to the left. By going forward and keeping your wheel to the left, you should now be able to clear the curb or edge on your right and complete your turn. If the road is very narrow, you may have to repeat the above steps.

You can also make a road turn by stopping close to the right curb or road edge and backing to the left. Just before you get to the opposite curb or edge, turn your wheel hard to the right and then go forward. When you use this method, you have to be careful to start far enough away from the right curb or edge so that your front wheels will not run into the curb or go off the road when you start backing to the left. When you make these turns, it is not necessary to reverse your steering wheel just before you stop moving. You can do this after you have stopped. However, turning the wheels while you are still moving is easier and saves wear on the tires and steering mechanism.

In business districts, where traffic is usually heavy, no method of turning around may be practical or safe. In such places, the best way to reverse your direction is to drive around the block.

NOTE: Use turn signals, four-way flashers, and if possible, a ground guide/road guard.

PARKING

Parallel Parking

Parallel parking to the curb between vehicles is difficult for many, if not most, drivers. You can parallel park easily if you follow this step-by-step method (Figures 8-4 and 8-5):

- Select a large enough space. You need at least 6 feet more than the length of your vehicle. About 1 1/2 car lengths or 25 feet are adequate for a sedan in almost any case. The width of the parking space should be approximately 8 feet for 1/2-ton vehicles or sedans.
- Give the hand signal for stopping. Pull up alongside the vehicle parked in the space ahead of the space you intend to use. Your vehicle should be 1 to 2 feet away from that vehicle, and the rear bumpers of both vehicles should be even.

- Start backing slowly. Turn your steering wheel as hard as you can to the right as soon as your vehicle starts moving. With your wheel all the way over to the right, continue backing until your vehicle is at a 45-degree angle to the curb. At this point your right front door will be opposite the rear bumper of the other vehicle.
- Straighten the front wheels. Go straight back a short distance until the right end of your front bumper is opposite the left end of the rear bumper of the other vehicle.
- Pause a moment. Now turn your steering wheel hard to the left and back slowly the rest of the way into the space, straightening your front wheels just as they approach the curb. (If you find that you cannot get all the way into the space, usually the best thing to do is to drive all the way out, get your vehicle ahead of the space, and start all over again.)
- Pull forward Your vehicle should divide the parking space, leaving as much distance between your vehicle and the vehicle ahead as there is between your vehicle and the vehicle behind. Your front and rear wheels should be an equal distance from the curb and no more than a foot away from it.
- Turn off the engine. Before you leave your vehicle, turn off the engine, set the hand brake, and put the vehicle in reverse gear. If your vehicle has an automatic transmission, place the lever in the park position. For multifuel (diesel) engine vehicles, pull the engine fuel stop out and set the gearshift in the neutral position. Otherwise, the engine may start if the vehicle moves slightly while the transmission is in gear. When parking on a downgrade, if there is a curb, turn your wheels so that the front of your right tire is against the curb. When parking on an upgrade, turn the wheels left away from the curb so that the back of the right front tire locks against the curb. Doing this will ensure that your vehicle does not roll. When parking uphill without a curb, use chocks behind the front tires. When parking downhill without a curb, place chocks in front of the front tires.

- The parking brake is the primary safety item. Only use chock blocks as a secondary safety item in conjunction with the parking brake. Using chock blocks alone is not safe or effective. The parking brake must be set at all times when the vehicle is parked.

Except on one-way streets, always park on the right side of the street. Remember to lock the ignition switch on vehicles of commercial design and take the key with you. Turn off the master switch on tactical vehicles. (Exceptions may be directed by local commanders.)

Diagonal Parking

Diagonal or angle parking is easy enough for most drivers. However, you should remember the following:

- Give the hand signal for stopping.
- Begin turning into the parking space from a position about 5 feet from the row of parked vehicles.
- Turn your steering wheel in the direction of the space and enter the space with your vehicle as straight as possible with the angle of the space.
- Use the parked vehicle or line marking on the left as a guide, but be very careful to allow enough clearance between your vehicle and the vehicles parked on either side.

When coming out of a diagonal parking space, back very slowly until you are out far enough to see traffic that may be coming and stop if necessary. Turn your steering wheel sharply when your left front wheel is opposite the rear bumper of the vehicle parked on your left. If you turn sooner, you are likely to side-swipe the other vehicle as you back out.

Improper Parking

Parking improperly may inconvenience and endanger other drivers. Do not park -

- In violation of local traffic laws.
- In an intersection or in front of a driveway.

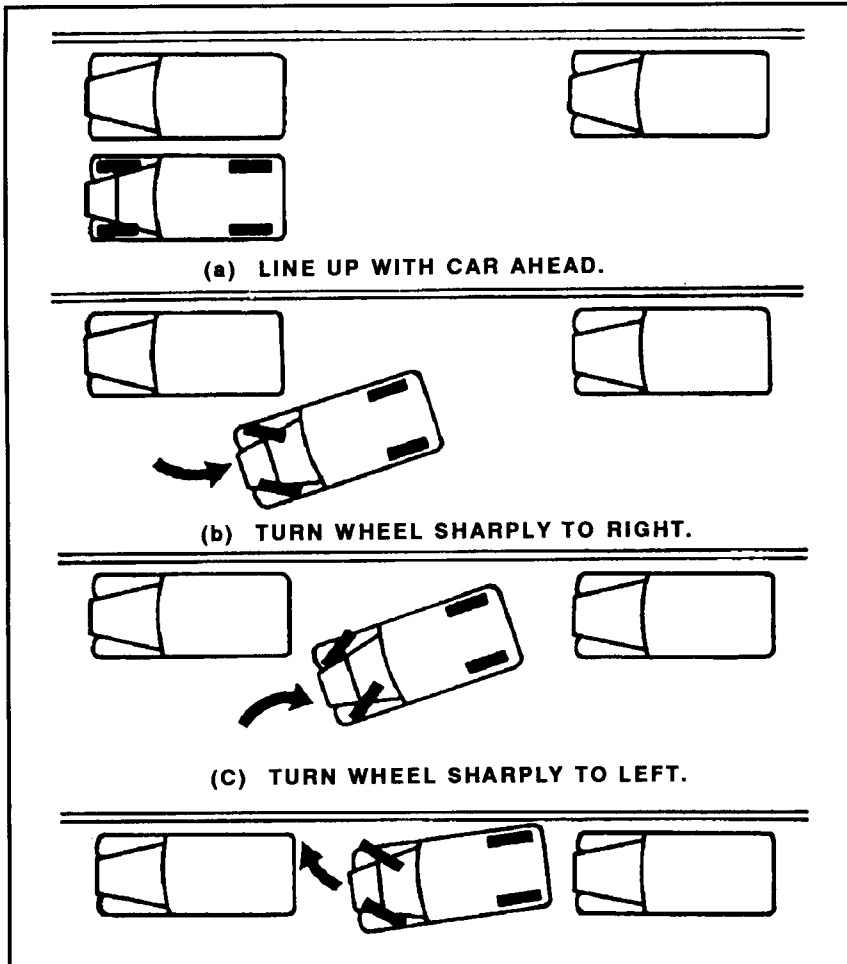

FIGURE 8-4. Parking Parallel to a Curb.

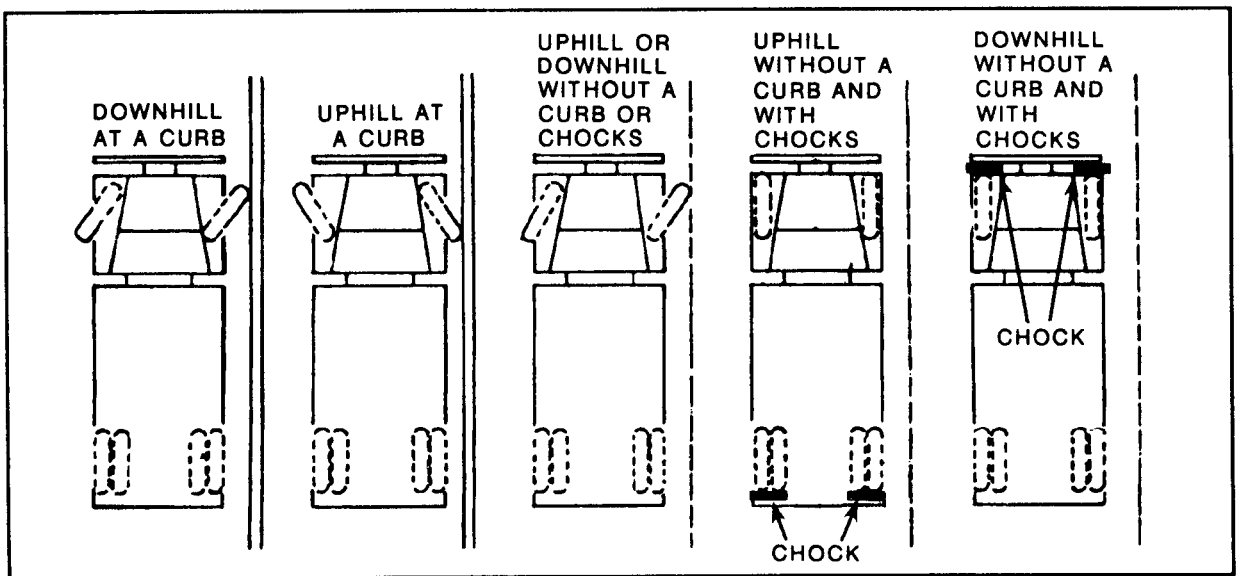

FIGURE 8-5. Parking on a Hill.

ELEMENTS OF SAFE DRIVING

The ability to mechanically operate a motor vehicle is not the only qualification of the safe driver. This skill must be augmented by a definite sense of personal responsibility and by a knowledge of and unceasing respect for the laws of physics, physiology, and psychology as they affect the driver and his vehicle. Since safety is a command responsibility, it is the duty of commanders at all levels to ensure compliance with these nonstatutory laws. Instruction for military drivers should include an explanation of these elements and examples of the results of common violations.

Physiological Considerations

To operate a vehicle with the maximum degree of safety, the driver must maintain top physical condition. Any deterioration in physical condition will reduce this degree of safety. Prospective drivers having physical defects that will interfere with safe vehicle operation should be eliminated from the driver training program. Instructors and supervisors should be constantly alert to evidence of any incapacitating disease such as heart trouble, asthma, or epilepsy; of vision deficiencies not detected in physical examination and of dangerously slow reaction time. Although temporary, the effects of fatigue, drugs, and alcohol seriously impair the physical condition of the driver and may be regarded as a contributing factor to accidents.

Psychological Considerations

To drive properly and safely, a driver must have a proper attitude toward driving and must have emotional control. Faulty attitudes toward driving may often be detected by instructors and supervisory personnel. These attitudes may be eliminated to some degree through instruction and counseling. If the driver does not respond to corrective measures and continues to show evidence of faulty attitudes, it is advisable to drop him from the program.

Other psychological considerations include overconfidence, egotism, rationalization, and impatience. Overconfidence encourages the taking of unnecessary chances. Egotism disregards the rights of others. Rationalization prevents the driver from recognizing and correcting his own faults. Impatience leads to unsafe driving through refusal to adjust to driving conditions.

Since emotions such as anger, fear, and grief affect the driver's ability to think clearly and react promptly, safe driving requires a high degree of emotional control. Emotional control may be developed in the driver through self-discipline. This, however, requires his full cooperation and the will to overcome emotional instability. Avoid selecting drivers who show evidence of unregulated emotion.

Effect of Physical Laws

The laws of nature are constant and automatic. It is impossible to drive properly and safely without recognizing such natural forces as gravity, friction, centrifugal force, and kinetic energy. Instructions for the military driver should include, but not be limited to, the following paragraphs.

Gravity. Gravity is the force that pulls a body toward the center of the earth. It is measured in terms of weight. Without the force of gravity, the wheeled vehicle would be weightless and impossible to control by conventional means (starting, stopping, or steering). The force of gravity increases downhill speeds and stopping distances. It exerts a rearward pull on upgrades requiring increased power to the vehicle at rest, making it necessary to take precautions while parking. Absolutely level terrain is the exception rather than the rule. Therefore, the driver must always be aware of the power of gravity (Figure 8-6).

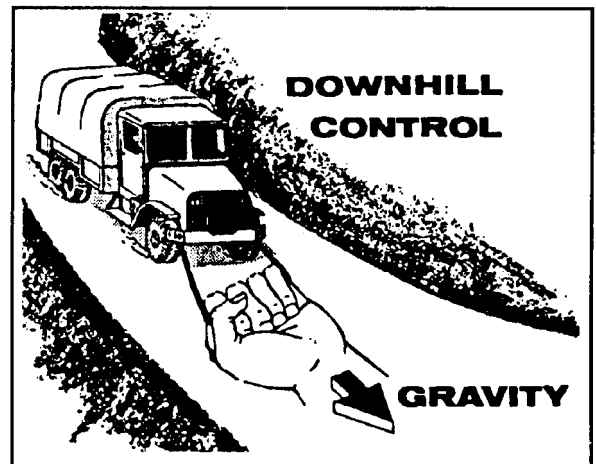

FIGURE 8-6. Gravity Increases Downhill Speed.

Friction. Friction is the resistance to motion caused by contact between two surfaces (Figure 8-7). It results from the interlocking of slight irregularities on surfaces in contact. When an attempt is made to

slide one surface over another, the grip of the interlocked irregularities resists the motion. The greater the contact pressure and the coarser the surfaces, the greater the friction. More road friction is produced by a heavy vehicle than a light one because there is greater contact pressure. More driving control is possible on a dry road than on an icy one because the dry surface is rougher. Thus, although friction is responsible for many maintenance problems and necessitates the use of lubricants, without friction it would be impossible to get the vehicle in motion, control its direction, or stop it.

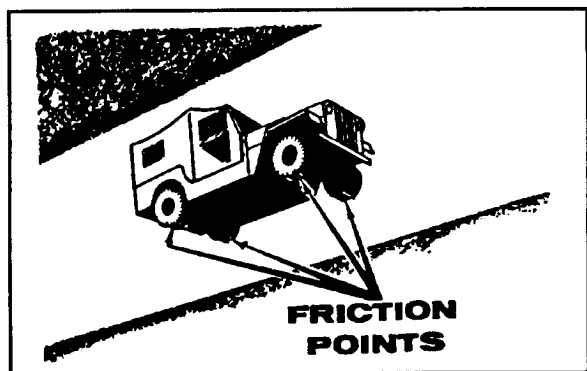

FIGURE 8-7. Friction Points Between Vehicle and Road Surface.

Kinetic Energy. Kinetic energy is the energy of motion. It is the kind of energy that a body has because it is moving. Weight and speed determine the kinetic energy of a vehicle. The kinetic energy does not increase uniformly with speed, but with the square of the speed. In other words, if the speed is doubled, the kinetic energy becomes four times as

great. A vehicle cannot be stopped until all of its kinetic energy is dissipated. The only safe way this can be done is by the controlled use of friction (proper braking) and engine compression. The speed with which the kinetic energy is dissipated has a direct relation with the force of impact when a moving vehicle strikes another object.

Centrifugal Force. Centrifugal force is that force which, acting upon an object traveling in a curve, tends to force it from the curved path into a straight one. The magnitude of centrifugal force depends upon the degree of the curve and the weight and speed of the object. In driving, road curvature and vehicle weight are fixed. The only variable is speed. The following example illustrates the effect of speed. An 11,000-pound vehicle, making a turn of 500-foot radius at 20 MPH has to overcome centrifugal force of only about 583 pounds. At 30 MPH, the force is increased to 1,312 pounds. At 60 MPH, it is over 3,644 pounds – six times as great as at 20 MPH. The vehicle is prevented from skidding off the road by friction. If the wheels hit a patch of ice or water, friction may be reduced to the point where it cannot hold the vehicle against centrifugal force. If the vehicle enters the curve at too great a speed, centrifugal force will overcome friction even if the road is dry and free of ice. Whenever centrifugal force is greater than friction, the vehicle will skid. Centrifugal force also tends to tip over large vehicles on curves. This tendency is caused by loss of tire-road friction holding the tires on the road on the inside of the curve while centrifugal force pulls the upper part of the vehicle toward the outside of the curve.

CHAPTER 9

EMERGENCIES

Although some emergencies are unavoidable, most of them are created by drivers who are driving carelessly or too fast or who fail to take proper care of their vehicles. Yet, once in danger, the important thing is not how you got into it, but how you get out of it. The techniques discussed here are not foolproof, but they will give you a better chance of avoiding a serious accident.

BLOWOUTS

A driver seldom gets a warning before a blowout. There is usually a loud report before the vehicle immediately starts swerving to one side or swaying dangerously. Use all your strength on the steering wheel to keep the vehicle going straight ahead. Do not apply the brakes until the engine has slowed the vehicle down and you are sure you have it under control. If you are in a passing lane when a blowout occurs, do not attempt to get to the highway shoulder until the lanes on your right are clear. The chances are your tire has already been damaged beyond repair, so do not risk an accident in an effort to bring your vehicle to a halt.

SKIDS

Almost all skids can be avoided if you drive slowly enough and if you stop, start, and turn slowly enough on slippery surfaces. If you start to skid, you may be able to regain control if you ease up slowly on the accelerator and do not apply the brakes. Keep your vehicle in gear. If the skid occurs when you are braking, take your foot off the brake. It may be necessary to feed gas carefully to reduce the braking effect of the engine. In either case, the reason for reducing the brake action is to keep the wheels from slowing down too quickly and making the skid worse.

At the same time, turn your wheels in the direction of the skid. If the rear end of your vehicle is skidding to the right, turn your steering wheel to the right. If it is skidding to the left, turn your steering wheel to the left. If you start to skid to the left and turn your wheels to the left, you may steer into oncoming

traffic on the other side of the road. Do not turn the steering wheel too sharply or keep it turned too long. If you do, you may start skidding in the opposite direction. Ease the steering wheel back to the center position as you recover from the skid and regain control of your vehicle.

Let the engine slow your vehicle down gradually. If you use your brakes to stop, do not hold the pedal down, but pump it gently until you come almost to a complete stop. Figure 9-1 shows how to recover from a skid.

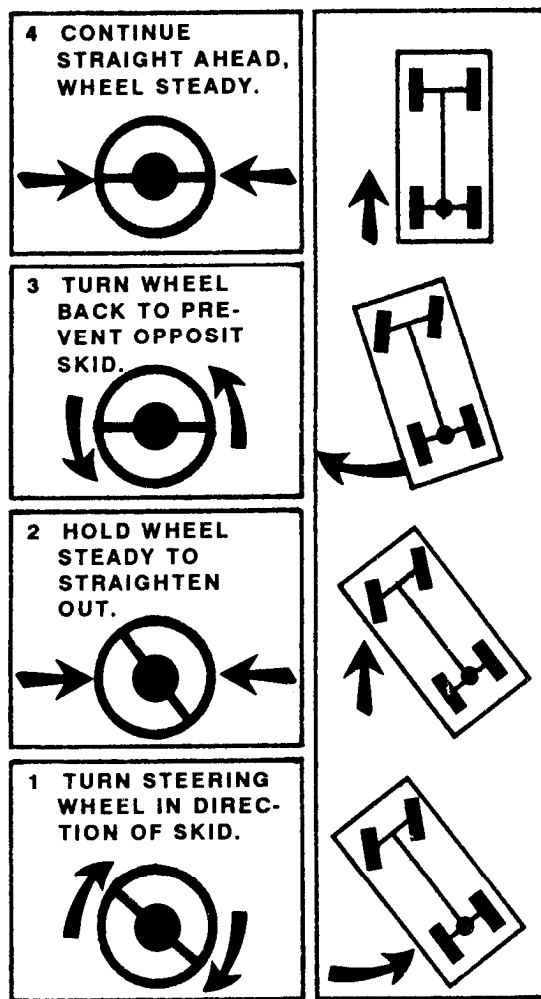

FIGURE 9-1. Recovering from a Skid.

RUNNING OFF THE PAVEMENT

At some point, your vehicle may drift off the roadway onto the shoulder or you may steer onto the shoulder to avoid a collision. There may be a drop-off of several inches from the edge of the road to the shoulder. Most shoulders provide less traction than the roadway surface. They may be quite narrow and consist of loose gravel, grass, or mud. Despite these variables, pulling off onto the shoulder and returning to the roadway can be done safely. Practice the proper procedures:

- If you run the two right or left wheels off the paved roadway, keep a firm grip on the steering wheel. Keep the vehicle traveling straight ahead. Straddle the edge of the pavement. You must fight the tendency of the wheels to pull toward soft shoulders. You also must resist the urge to immediately whip the vehicle back onto the pavement.
- Next, ease off the accelerator pedal so the vehicle slows down. Avoid braking, if possible; if braking is necessary, use a gentle squeeze braking application so you can control steering.
- Before returning to the pavement, visually check ahead, to the sides, and to the rear. Unless some object beside the road poses a serious threat of a collision, avoid trying to return to the roadway immediately. Move the off-road tires out about 1 1/2 to 2 feet away from the pavement edge. When it is safe and your speed is under control, turn the wheel quickly about a quarter turn to the right or left as necessary. This lets the tire climb the pavement edge and get back on the roadway.
- As soon as the front tires are back on the roadway, counter steer quickly to maintain your proper lane.

BRAKE FAILURE

If your brakes fail and the failure is not related to engine failure, pump the brake pedal rapidly (if vehicle has hydraulic brakes) to restore braking action long enough to get off the highway. If this does not work, apply steady pressure to the parking brake that controls the rear wheels. (Be careful if you use the parking brake to stop. Be prepared

to release the brake if the rear wheels lock. Then reapply the parking brake if needed.) Downshifting your vehicle also serves as a braking force. Find an escape ramp or a safe exit from the highway. Communicate your emergency to other drivers by sounding your air horns and flashing your lights. In more extreme cases, you may need severe methods to slow your vehicle. You may have to run along an embankment, scrape against a curve, or drive into bushes, hedges, or other obstructions.

DOWNHILL BRAKING

To maintain control of a vehicle (especially loaded) while descending downhill, make sure that downhill braking procedures are used as indicated in the applicable -10 technical manual.

NOTE: As a rule of thumb, you should go down the hill at least one gear lower than you used to come up the hill. The brakes are used with the engine and transmission to keep the vehicle under control.

LESS SERIOUS ACCIDENTS

Sometimes you can avoid a serious accident only by deliberately choosing a less serious one. Suppose you are driving at about 50 MPH on a two-lane road. Two vehicles are approaching from the opposite direction on the other side of the road. When they are fairly close to you, the second one suddenly pulls out to pass the first one. If you cannot stop or slow down in time, the only thing for you to do is to head for the right shoulder, even if it means an accident. If you stay where you are, you will have a head-on collision with the vehicle on the wrong side of the road. If you swerve to the left, you will probably have ahead-on collision with the other vehicle. The right shoulder may be dangerous, but almost any kind of accident is preferable to a head-on collision.

As another example, suppose you are being passed by one vehicle and there is another vehicle not far behind you. As the passing vehicle draws even with you, a small animal runs out on the road ahead of you. You must make an unpleasant decision and make it quickly. If you swerve to the right, the soft surface of the shoulder may turn your vehicle over. If you stop suddenly, you will probably be hit by the vehicle behind you. You do not want to hit the

animal, but it is the safest thing to do. If you do anything else, the animal may be killed anyway as well as several human beings.

VEHICLE FIRES

Preventing Vehicle Fires

Switch the vehicle engine off during refueling. Do not allow smoking or open flames within 50 feet of a vehicle during fueling or at an accident scene where there is danger from spilled gasoline or other flammables.

CAUTION

Keep the gasoline nozzle in contact with the gas tank when fueling.

When flares are authorized, issue instructions for their handling and storage on the vehicle. Since flares are a potential fire hazard, it is imperative that drivers take the prescribed precautions when handling them.

NOTE: Ignited flares will not be attached to a vehicle. Further information concerning warning devices is contained in Chapter 13.

When transporting explosives or flammable cargo, do not allow smoking within 50 feet of your vehicle. Also, do not allow your vehicle to become exposed to open flames or explosives when it is loaded with flammables or explosives. Flares are prohibited on vehicles transporting explosives or flammable cargo.

Vehicles designed for transporting bulk flammable liquids will be permanently marked with warning signs. When a general-purpose vehicle is used to transport liquid fuels or other dangerous cargo, it is your responsibility to place the prescribed warning signs on your vehicle. When you are dispatched to transport dangerous cargo, ask your supervisor for special instructions and warning signs for your truck. TM 9-1300-206 prescribes the warning signs for vehicles transporting hazardous cargo in the continental United States (CONUS). When operating overseas, be sure you have the required

warning signs for all the countries in which you will be driving. Emergency measures to be taken when bulk fuel transporters develop leaks are given in Chapter 19.

CAUTION

When dispensing fuel to another vehicle or a tank, a ground cable must be secured to the dispensing vehicle and the vehicle or tank being filled.

Fighting Vehicle Fires

You have only limited resources for fighting a vehicle fire, so send for help from professional fire fighters when possible. Your fire fighting equipment usually consists of a hand fire extinguisher and any natural materials that may be available, such as sand and water. Those resources, when applied at the start of a fire, have a good chance of bringing it under control. However, once the fire has become major, you place yourself in danger with little possibility for success when you attempt to extinguish it with inadequate equipment.

When you discover your vehicle is on fire, pull it off the road in an open area away from buildings, trees, brush, or vehicles, or anything that might catch fire. Do not pull into a service station. Notify the fire and police departments. Keep the fire from spreading. Before trying to put out the fire, be sure it does not spread any further. With an engine fire, turn off the engine as soon as possible. Do not open the hood if you can avoid it. Discharge fire extinguishers through louvers, the radiator, or from the underside of the vehicle.

Use the right type of fire extinguisher. B:C rating is designed to work on electrical and liquid fires. The A:B:C: type is designed to work on burning wood, paper, and cloth as well as electrical and liquid fires.

Know how to use the fire extinguisher. Stay far away from the fire. Aim at the source or the base of the fire, not up in the flames. Position yourself upwind; let the wind carry the extinguisher to the fire rather than carry the flames to you. Only try to extinguish the fire if you know what you are doing.

CAUTION

When attempting to extinguish a fire, keep the wind to your back. In this position, the flames and poisonous fumes from the chemical extinguisher will be blown away from you.

You usually discover cargo fires in trucks and trailers by smelling or observing smoke escaping from around doors and/or from under the tarpaulin. Unless an adequate source of fire fighting equipment is available, do not open the cargo doors or remove the tarpaulin until you have moved your vehicle to a safe location where help can be obtained, preferably from a fire department. After help has been obtained, the doors may be opened cautiously or the tarpaulin partially removed and the source of the fire located. You may have to remove part of the cargo to find the source of the fire. Fires in a closed van or under a secure tarpaulin can only smother due to lack of oxygen.

Underinflated tires generate excessive heat during operation, a condition which, especially on dual wheels, may result in the tires igniting. Tires dragged along the road surface because of a locked wheel may begin to burn. Fires resulting from these conditions may be prevented by keeping your tires

properly inflated, recognizing any difference in the performance of your vehicle that would indicate a locked wheel, and promptly taking corrective action. If a tire does start burning on your vehicle, you may not be able to extinguish it with your fire fighting equipment; however, you may prevent further damage by employing the following measures:

- When possible, remove the wheel from your vehicle and attempt to extinguish the fire by covering it with sand, mud, or water.
- When the wheel cannot be safely removed, drive your vehicle into sand, mud, or water and cover any exposed parts with mud or a similar substance.
- When the fire cannot be controlled by the above procedures, use your vehicle fire fighting equipment or other suitable substance to prevent the fire from spreading.

CAUTION

Do not attempt to transport a burned tire on your truck unless the fire is completely extinguished and the tire has cooled to normal temperature.

CHAPTER 10

ACCIDENT CAUSES AND REPORTS

The driver rather than the machine is at fault in the greatest percentage of motor vehicle accidents. If you cause an accident, you may be as effective as an enemy would be in disabling a vehicle and inflicting casualties. The minimum cost to the government is loss of use of the vehicle, but there are almost always additional costs. For instance, parts for repairs are expensive; maintenance personnel must expend additional unplanned time; and you may be injured and require medical attention. An accident could cost your life.

PRIMARY CAUSES OF ACCIDENTS

In most accidents, the driver has violated traffic regulations. The most common causes of vehicle accidents are —

- Traveling at a speed too fast for conditions.
- Following too closely.
- Driving while fatigued or under the influence of alcohol or drugs.
- Wrongfully assuming right-of-way.
- Misjudging clearances on turns, in passing, and so forth.
- Backing without exercising caution.

PROCEDURE IN CASE OF AN ACCIDENT

If you are involved in a motor vehicle accident, take certain steps to protect your own interest and that of the government and to aid others involved in the accident. Some steps to take follow.

- If anyone seems injured, render first aid. Then summon the nearest military or civilian doctor or ambulance, whichever can be secured in less time. Military personnel with only minor

injuries should be sent to a military hospital when practicable.

- If fire breaks out and you cannot put it out with a fire extinguisher or sand, send for the fire department.
- If civil police are not present, send for them. State laws require that police be summoned to all motor vehicle accidents. In such matters, the military cooperates with civil authorities who are responsible for investigating all accidents on public highways.
- If you are in an area controlled by armed services police, send for them or ask someone to do so. The armed services police must complete their own investigation of the accident. You should cooperate and assist them in every way.
- When there are enough people available, you may be able to get aid more quickly by sending one person to summon doctors; another, firemen; and still another, police.
- Whenever practical, report the accident to your commanding officer by telephone as soon as you have finished your duties at the scene of the accident. If an assistant driver is present, have him phone while you attend to other matters. In an emergency, you can usually get permission to use a nearby telephone without charge. Your unit headquarters will accept a collect toll charge if you must report an accident by long distance.

PRECAUTIONARY MEASURES**Precautions Against Further Accidents**

After a motor vehicle accident, the vehicle or vehicles involved are frequently in dangerous locations. Often a crowd collects in the road. To prevent additional accidents, damage, or injury, be sure to post guards, flags, flares, or lights (except in a blackout) to warn all other traffic to proceed with caution.

If civil or armed forces police are present, they will direct traffic. If troops are present, they should be asked to act as guards. If neither police nor troops are present, civilians should act as guards. Cargo, glass, or other debris spilled on the highway as a result of the accident will be cleared from the road surface as soon as possible.

Precautions Against Fire

Gasoline exposed to the air forms a highly flammable vapor. Avoid this danger by shutting off all engines and prohibiting smoking whenever there is spilled gasoline or whenever vehicles are badly wrecked. Permit no open flame within 50 feet of the wreck. Spread sand or dirt over spilled gasoline as soon as possible. A fire extinguisher is your first defense against fire. If you need to supplement the fire extinguisher with other methods, use sand or dirt. However, remember that water cannot be used on gasoline fires as it causes them to spread

Removal of Vehicle From Accident Scene

Moving the vehicle from the scene of the accident must be governed by laws or regulations of the state or area where the accident occurred. Obtain all the necessary data relating to the accident before moving the vehicle. Make sure to mark the exact position of all vehicles and objects before moving them.

PREPARATION OF ACCIDENT FORMS

DD Form 518 (Accident-Identification Card)

The purpose of DD Form 518 is to give any persons involved in an accident all of the information that they require from you. You fill this form out at the scene of the accident or as promptly as possible and give it to the person directly concerned. If the accident involves a parked vehicle and the person concerned is not present, place the DD Form 518 in the vehicle or secure on the windshield. Notify local authorities and then stand by the scene of the accident for their arrival, if practical. Figure 10-1 is a properly completed DD Form 518.

ACCIDENT-IDENTIFICATION CARD	
<i>(THIS FORM IS SUBJECT TO THE PRIVACY ACT OF 1974-SEE REVERSE)</i>	
Any correspondence regarding accident should be addressed to: COMMANDING GENERAL ABERDEEN PROVING GROUND, MD 21005-5201	
MAKE REFERENCE TO	
DATE OF ACCIDENT 11 NOV 88	
MAKE AND TYPE OF VEHICLE TRK, UTIL, 1/4T, M998	
REGISTRATION NO. NPO68CU	
DRIVER (Last name - first name - initial) HODGES, JAMES L.	
SSN 123-45-6789	GRADE SFC
ORGANIZATION HHC 61ST ORD BDE	
DD FORM 518 1 OCT 76 PREVIOUS EDITION IS OBSOLETE.	

FIGURE 10-1. DD Form 518.

NOTE: Disclosure of social security number (SSN) is voluntary. No disciplinary action is taken in cases where the SSN is not provided.

SF 91 (Operator's Report of Motor Vehicle Accident)

Always stop and investigate any accident in which you are involved. The only possible exception to this rule might be in combat or in case of military necessity when you are operating under definite orders not to stop. Even though an accident is minor or not your fault, you must report it so that the facts will be clearly presented and so that you can give the names of witnesses. This protects both you and your government against claims and exaggerations. For the purpose of reporting an accident, use SF 91. Figure 10-2 is a sample form filled out. Study it so that you will know how to fill it out in case the need arises.

In completing SF 91, keep the following general instructions in mind:

- Secure hard-to-get facts first. After making sure that your vehicle will not cause another accident and that the injured are cared for and other precautions are taken, your first responsibility is to get the names and addresses of the people involved in the accident and of all witnesses. If you do not do this promptly, you may not be able to get the information at all.
- Do not leave the scene of the accident until you have carefully noted facts that would be hard to get later, such as condition of the road, position of the vehicles, amount of damage, and other details.
- Fill in items that you know or can easily get, such as your own name, the make of your vehicle, and so forth, after you have done everything else. This can even be done after you have left the scene of the accident.
- Be exact. Be sure that your report gives a clear picture of what actually happened. If another vehicle is involved, your diagram of the accident should show exactly where the vehicles were before and after the crash and exactly what obstacles blocked either driver's view. Every name should be spelled correctly and every street address listed by number. On highways where there are no house numbers, use mileage markers, power line or telephone pole numbers, or intersecting roads to pinpoint the location of the accident. State damage you can see; for example, crushed right rear wheel, bent or broken axle, crumpled fender. If someone claims that you have damaged property, but you cannot see the damage, note only that he claims bent frame. Follow the same procedures with injuries. Report cuts, burns, broken bones, and so forth, of which you are certain and note only that a person claims an injury when you have no way of knowing the truth, such as a strained back or internal injuries. If you cannot get the exact information on some item, write unknown and if there is a blank that does not pertain to your accident, write NA or none. By making an entry in every blank, the reviewer will be assured you did not overlook anything.
- Never express an opinion either orally or in writing to claimants or their agents concerning liability, investigation findings, or the possibility of claim approval.
- Use more paper if necessary. If you need more space, use a separate sheet of paper to answer a question. Write see attached in the space by the question on your report and attach the extra sheet securely to the report form.
- Check each item. In securing information for the report, remember that you are an agent of the US government. As you fill in each item of the report, check it against what you can observe and against your common sense. When the other driver gives you his name, make sure it is the same as the name on his driver's permit. If not, find out why. If somebody gives you an address that you think is incorrect or does not exist, question him further as tactfully as you can. If you have reason to doubt any information that you write on your report, be sure to call attention to your doubts by a note.
- Check the entire report. After you have finished, look over the entire report to make sure that it is complete and accurate. Imagine yourself as the investigating officer. He must form his picture of the accident from your report. His decision concerning the accident will be based on the information in your report. In fairness to yourself, you must make sure that all your answers are clear before you turn in the form. If you are satisfied that this is so, sign the report and turn it in to the commanding officer or immediate supervisor.

NOTE: An employee of a federal agency who fails to report accurately a motor vehicle accident involving a federal vehicle may be subject to administrative sanctions.

OPERATOR'S REPORT OF MOTOR VEHICLE ACCIDENT
 This form is to be completed by the driver or operator of the motor vehicle involved in the accident. It should be completed at the time and place of the accident. See the Privacy Act Statement on page 2.

1. OPERATOR DATA
 SUPERVISOR OR AGENCY: U.S. ARMY
 NAME AND LOCATION OF FACILITY TO WHICH YOU ARE ASSIGNED: HHC 61ST ORD BDE
 LAST NAME: ARG, MD. 21005
 FIRST NAME: JAMES
 MIDDLE INITIAL: L
 SEX: 35
 NAME: HODGES
 SERVICE NUMBER OR SOCIAL SECURITY NO.: 419-98-9839
 TYPE OF MOTOR VEHICLE: H-4834
 MAKE, MODEL OR TYPE: SFC
 HOME TELEPHONE NO.: 7212 ROSEBERG CIRCLE APT A
 HOME TELEPHONE NO.: 679-2314
 DATE OF ACCIDENT: 7/11/88
 DAY OF WEEK: Monday
 NUMBER OF OCCASIONS: 2
 PLACE OF ACCIDENT (City, State, County, Street, RFD and Box, if remote) (Do not use "G-WAY" or "SHACK")
MAIN GATE ENTRANCE, HWY 22, BLDG 270
EDGEWOOD AREA, APG, BLDG 318, APG
 ESTIMATE
 RETURNING TO: FOR TESTING ANALYSIS
 MAKE: M 918
 TYPE: TAK, UTB4
 REGISTRATION NUMBER OR STATE IDENTIFICATION: NG 08PF
 NUMBER OF VEHICLE LICENSES (Drivers): 1
 OCCASIONS ESTIMATED: 1,000
 NUMBER OF PASSENGERS: 0
 2. OCCIDENT TYPE AND LOCATION
TAIL GATE SMASHED
 3. VEHICLE MAKE, MODEL AND TYPE
 MAKE: FORD
 MODEL: F150
 YEAR: 1986
 OPERATOR'S MAKE, MODEL AND TYPE: PICK UP
 REGISTRATION NUMBER AND STATE: NYM-724 VA.
 4. OTHER VEHICLE INVOLVED
 MAKE: SSG GAOVER R. FLATFOOT
 MODEL: HHC 61ST ORD BDE, APG, MD. 21005
 MAKE: SSG GAOVER R. FLATFOOT
 MODEL: HHC 61ST ORD BDE, APG, MD. 21005
 MAKE: FRONT GRAYLE, Hood, Headlights
 MODEL: 1200 AD
 5. OTHER PROPERTY DAMAGED (List item if more than is needed, continue on item 12, page 2.)
NONE

81-108
 STANDARD FORM 91, PAGE 1 (REV. 11-76)
 Prescribed by GSA, FPMR (41 CFR) 101-11.6

FIGURE 10-2. Example of Operator's Report of Motor Vehicle Accident (Page 1 of 4).

1. PERSONS INVOLVED
 NAME: NONE
 HOME ADDRESS: _____

2. OCCUPANTS IN YOUR VEHICLE
 NAME: NONE

3. OCCUPANTS IN OTHER VEHICLES
 NAME: NONE

4. OCCIDENT TYPE AND LOCATION
 NAME: PVT JOE SCHMEDLAPP
 HOME ADDRESS: 2nd Co. 601st MP Co.
 NAME: PFC THERESA BLUM
 HOME ADDRESS: A Co. 601st ORD Bn.

5. WITNESSES AND POLICE
 NAME: PVT WAYNE JOHNS
 HOME ADDRESS: 62519
 HOME PHONE NO.: 601st MP Co.
 (Include number of other witnesses, if any)
 NAME: EAST BOUND, HWY 22
 HOME ADDRESS: EAST BOUND, HWY 22
 NAME: LEFT LANE, ENTERING GATE
 HOME ADDRESS: LEFT LANE, ENTERING GATE
 NAME: STOPPED (0)
 HOME ADDRESS: STOPPED (0)
 TYPE OF ROADWAY (Interstate, State, Local, etc.)
 TYPE OF SURFACE (Asphalt, Concrete, etc.)
 TYPE OF WEATHER (Sun, Cloud, Rain, Snow, etc.)
 TYPE OF LIGHTS (On, Off, etc.)
 TYPE OF VEHICLE (Car, Truck, etc.)
 TYPE OF DAMAGE (Collision, etc.)
 TYPE OF DAMAGE (Collision, etc.)
 TYPE OF DAMAGE (Collision, etc.)

6. ACCIDENT CONDITIONS
 TYPE OF DAMAGE (Collision, etc.): SLASH/ICE
 TYPE OF DAMAGE (Collision, etc.): CLEAR/ICY
 TYPE OF DAMAGE (Collision, etc.): ASPHALT
 TYPE OF DAMAGE (Collision, etc.): STOPPED IN LANE FOR GATE GUARD TO CHECK DISPATCH. LIGHTS ON BECAUSE IT WAS STILL DARK.

STANDARD FORM 91, PAGE 2 (REV. 11-76)

FIGURE 10-2. Example of Operator's Report of Motor Vehicle Accident (Page 2 of 4).

CHAPTER 11

HAZARDS AND SAFETY MEASURES

As a military driver, you will have to face many hazardous driving situations. Hazards may be the result of weather, time of day, or season of the year. They may be caused by conditions of the road or of your vehicle or other vehicles.

NIGHT DRIVING

Darkness increases driving dangers. Although traffic is not as heavy at night, the fatality rate for nighttime drivers is double that for daytime drivers. On the basis of mileage driven, night driving is two to three times more dangerous than day driving. Fatigue and sharply reduced vision are primarily responsible for this greater danger. Also, drinking drivers are more likely to be on the road at night.

Reduced Vision

In the daytime, a driver can often see several thousand feet ahead if the road is straight and there are no obstructions. At night, even with good headlights, a driver can usually see no more than a few hundred feet ahead. The headlights may be powerful, but the amount of the beam reflected by an object or a pedestrian may be very small, and it decreases very rapidly as the distance increases. An object 100 feet away reflects only one-fourth as much light as an object 50 feet away, and an object 200 feet away, only one-sixteenth as much.

Hills and curves reduce vision during the daytime, but not nearly as much as they do at night. In the daytime, a driver going downhill can ordinarily see the level road at the bottom and/or the upgrade of the next hill. At night, his headlight beams slant downward with his vehicle, illuminating only the road directly ahead. Curves have a similar effect. As a driver rounds a curve at night, his headlights do not follow the path of the curve. They shine across the road, leaving most of the curve in darkness.

Vision to the sides and the rear is also greatly restricted at night. It is especially important at night that rearview mirrors be properly adjusted. If they

are not, a driver may have little warning of vehicles coming from behind.

Glare from the headlights of other vehicles often results in several seconds of near blindness. This is especially true if the headlights of the other vehicle are out of adjustment or if the other driver fails to lower or dim his beams. However, even the glare from properly adjusted and dimmed headlights may affect some drivers. The light from buildings or signs along the road may also be blinding. It takes most drivers at least 2 or 3 seconds to recover from the effects of glare. At 50 MPH, 3 seconds means 219 feet.

A dirty windshield multiplies the effect of glare. In the headlight beams of an approaching vehicle, the specks of dirt on your windshield seem to glow and turn the windshield into a wall of light that is almost impossible to see through. You cannot drive safely, especially at night, without a clean windshield.

When parking at night, never leave your headlights on. They are just as likely to blind approaching drivers when your vehicle is standing still as they are when it is moving. They may also confuse approaching drivers about the exact position of the road. This danger is increased if you are parked on the wrong side of the road. Whenever you park on or along a highway at night, turn on your parking lights or four-way emergency flasher.

NOTE: Emergency vehicles may leave headlights on when they are required to illuminate an area in an emergency.

Seeing is especially difficult at dusk. There is no longer enough natural light to see clearly without using headlights, but there is too much natural light for the eyes to adjust properly for night driving. The twilight hazard is especially serious in the fall as the days grow shorter and it begins to get dark as people are driving home from work. Many of them do not notice the darkness increasing from day to day and fail to take it into account in their driving.

Fatigue

Many drivers on the road after dark are likely to be tired. The majority of them have done a day's work. Others have been driving all day and are trying to add a few more miles before they stop for the night. Seeing things through a drowsy haze, a tired driver may need several seconds to recognize danger and decide what to do about it. His decisions may be wrong and his reactions slow.

When you are tired, it takes longer to recover from the effects of glare and also your eyes often play tricks on you. More than one driver has been killed or seriously injured trying to avoid a collision with a pedestrian or animal that existed only in his imagination. Tired drivers greatly increase the hazards of night driving.

Safe Night Driving

Speed. The basic rule for safe night driving is NEVER OUTFRAN YOUR HEADLIGHTS. Your stopping distance should always be less than your sight distance. The law requires headlights that will enable you to see clearly any person on the highway for as much as 200 feet ahead of your vehicle. (Since the effectiveness of headlights diminishes greatly as the distance increases, headlights must be in good working order to meet legal requirements.) What effect should this rule have on your speed? At 55 MPH, the stopping distance for a vehicle with brakes meeting the legal stopping distance requirements is 307 feet, or 107 feet more than the distance you can see. At 50 MPH, the stopping distance is 258 feet, or 58 feet more than the distance you can see. At 45 MPH, it is 217 feet, or 17 feet more than the distance you can see.

Speeds of 50 and 55 MPH, safe and legal under good conditions in the daytime, are very often unsafe and illegal at night. They may be unsafe because by the time your headlights reveal a dangerous condition, it may be too late to stop. These speeds may also be illegal under the basic provisions of the speed law which makes it unlawful to drive at a speed greater than is reasonable and prudent under existing conditions.

As a general rule, keep your speed under 50 MPH at night. On curves or hills, your speed should be even lower - low enough so that you are always able to stop within the range of your headlights.

Some drivers, preparing for long trips, prefer to drive at night because traffic is lighter, and they can make better time. Traffic is lighter, but on a mileage basis, the chances of getting killed or killing someone are two to three times as great. Plan trips so that you can drive during daylight hours rather than at night. Unnecessary night driving does not make sense.

Lights. Most state laws require you to turn your headlights on from sunset to sunrise. In the daytime, turn on your lights whenever rain, fog, or snow impairs visibility or if there is not enough light for you to see an object clearly 200 feet ahead of you. Keep your headlights on low beam when driving in places where enough light is provided by street lamps. Where there is no street illumination, use your high beams except when meeting or following another vehicle.

Lower your high beams when you are approaching a vehicle coming toward you. As you meet another vehicle at night, watch the road ahead of you. Do not look directly at the lights of the other vehicle. If the driver of the other vehicle fails to lower his headlights, do not flick your lights to remind him. Avoid looking directly at the bright lights, glance to the right side of the road, then quickly look ahead to determine the other vehicle's position.

As soon as you have met and passed a vehicle, switch on your high beams again. It is dangerous to meet another vehicle with high beams, but it is also dangerous to drive along with low beams when there is no reason for it.

NOTE: Never drive with only your parking lights on. If conditions are such that there is reduced visibility, your headlights should be on.

WEATHER

Bad weather means poor driving conditions. Rain, snow, and sleet reduce visibility and make pavements dangerous. In fog, and sometimes in heavy rain or snow, you may be able to see only a few feet ahead. Braking distances on slippery pavements may be from 2 to 10 times as great as on dry pavement. The danger of swerving sharply to one side or the other when you apply your brakes is much greater on slippery pavements,

especially if the brakes are out of adjustment and the pressure is not equalized.

Rain

Most drivers slow down or pull off the road in a heavy downpour, but many do not realize that roads are likely to be especially slick just after rain or drizzle begins. The first few drops loosen grease and dirt accumulated on the road surface. Loosened grease and dirt mix with raindrops, quickly covering the road with an extremely dangerous, slippery film. Later on, after the water has washed some of the grease and dirt away, the road is likely to be less slippery. To the safe driver, the first few drops of rain are danger signals telling him to slowdown and be extra cautious. On wet pavements, allow at least twice the normal following distance. For example, when following on wet pavement, use a 4-second instead of a 2-second rule.

In wet weather, extra caution is necessary on mountain roads. Rocks, loosened by water seepage, may fall onto the road. Water beneath the pavement may freeze during a cold snap and cause the pavement to buckle. A driver may suddenly find broken pavement or rocks in his path as he rounds a curve. Unless he is driving slowly, he may not be able to avoid them. Wet roads may also cause hydroplaning, a condition in which directional control is partially or totally lost.

Snow and Ice

Snow and ice reduce traction even more than a wet pavement does. A thin layer of soft snow that allows tires to sink through to the road can be negotiated by a careful driver. Packed snow or ice is another matter. When driving on snow or ice, make sure your vehicle is equipped with chains, snow tires, or studded tires. Even then, you must use extreme caution to maintain traction and keep from skidding when you attempt to stop or turn. When roads are dangerous because of weather, drive with extra alertness at reduced speed according to conditions.

Even when a road is generally clear of ice, you may suddenly come upon unexpected patches of it. Melting snow running down from the upper side of a banked curve may freeze on the pavement as the sun sets. Because the decks of bridges cool much more rapidly than other road surfaces, moisture often condenses on them and freezes quickly into

thin sheets of ice when the temperature drops. A good winter driving rule is to slow down before you come to bridges and shaded places. Be especially careful in late afternoon and after dark.

Fog

Fog is dangerous at any time, but particularly so at night. Fog can sometimes be so thick that a driver can barely see the front of his own vehicle. The only thing to do in dense fog is to get off the road as quickly as possible.

Sometimes, on otherwise fairly clear nights, thick fog collects in small pockets at the bottom of hills. When you run into one of these pockets, slow down as quickly as you can and switch on your low-beam headlights. When you have passed through the fog, continue to drive slowly. One pocket of fog is usually a warning. There will probably be more fog at the bottom of the next hill. Continue to drive slowly until you are sure you are completely out of the fog area.

SEASONAL HAZARDS

Fallen leaves often make roads dangerous because tires are likely to skid on them when a driver applies his brakes, especially if the leaves are wet. In winter and spring, dirt roads are likely to be muddy. The wheels of vehicles turning from dirt roads onto paved roads track mud and dirt onto the pavement. At such places, there is an increased danger of skidding. When you see leaves, mud, loose dirt, or sand on the road ahead of you, slow down.

Spring and summer foliage may greatly reduce sight distances, especially on curves and at intersections. A driver, though familiar with a road, may not realize how quickly sight distances have been reduced when spring foliage appears. Unless he adjusts his speed to the changed conditions, he may have an accident.

SECONDARY ROADS

Secondary roads, built for local transportation and not as main highways, may be hazardous, depending largely on how you drive on them. The fact that a road is paved does not necessarily mean that it was designed for heavy traffic or regular highway speeds. So-called "farm-to-market" roads are much more

serviceable than the dirt roads they have replaced. However, they were still built for local transportation. On these roads, hills are likely to be steeper and curves sharper than on primary roads. Sight distances are often very short.

You can recognize secondary roads by their rectangular route signs. A driver who is unfamiliar with one of these roads must be on his guard for sudden bends and sharp dips. You cannot drive them safely at speeds that would be normal on primary highways. Probably the highest reasonable speed on most of them is 40 to 45 MPH. These roads are not unsafe, but the person who drives on them as though they were express highways is on his way to an accident.

Gravel roads are particularly dangerous because of their loose surface and flat (unbanked) curves. Stopping distances at all speeds are greater and skids and spinouts are more likely to occur. On gravel roads, you must keep your vehicle under close control and drive at a much lower speed than would be safe on a paved road.

SMOKING, EATING, AND DRINKING

The use of tobacco and alcohol reduces your ability to see. Eating and smoking impair senses. Never eat or smoke when operating a vehicle, and do not drink alcoholic beverages 8 hours before or when driving.

OVERLOADING AND CROWDING

No vehicle is safe when it is overloaded or crowded to the point that the driver's normal vision of the road is obstructed and he has difficulty operating the vehicle. As a general rule, you cannot drive safely if you allow more than three persons, including yourself, in the front seat of a vehicle with the gearshift lever on the steering column or more than two persons with the gearshift on the floor of the vehicle. In some compact vehicles, the maximum safe limit may be only two, regardless of where the gearshift is. Overcrowding in the back seat (more than three persons) is dangerous because it is likely to interfere with the line of sight from the rearview mirror. When a vehicle is equipped with seat belts, the number of passengers should not exceed the number of seat belts provided.

Do not use a car as a truck. A heavy load decreases performance and increases stopping distances. It may damage the springs, shock absorbers, tires, and transmission. A heavy load or one that is not evenly distributed may upset the trim and balance of a vehicle, making curves and stops more dangerous. Loads on trucks and trailers should be securely fastened to prevent any part of them from falling off. (See Chapter 18 for loading instructions.)

Never drive a motorcycle, motor scooter, or motorbike without wearing a safety helmet and eye protectors (nonshattering). Keep your lights on, day or night, so that other drivers can see you more easily. Never carry more than the number of riders for which the vehicle was designed.

SCHOOL BUSES

Except on highways with a median strip, all traffic in both directions must come to a complete stop whenever a school bus stops to take on passengers or let them off (Figure 11-1). In some localities, this rule applies to certain other vehicles, such as city, church, or Sunday school buses. Traffic must remain stopped until the bus driver turns off the special stop lights on the front and rear and/or withdraws the special stop sign located on the left side of the bus.

EMERGENCY VEHICLES

Police cars, ambulances, and fire engines are entitled to the right-of-way whenever they give an audible warning of their approach. The warning is usually a siren, sometimes a bell. Additional warning is usually given by a flashing red or blue light. The law requires you to drive to the right-hand curb or edge of the road and come to a complete stop. You must remain stopped until the emergency vehicle has passed or until you are directed to start again by a police officer.

Though laws and regulations require you to pull to the right side of the road, they do not require you to do it carelessly or without regard to consequences. Be sure to look before you turn your steering wheel. If you turn suddenly to the right without looking, you may collide with the emergency vehicle or with some other vehicle.

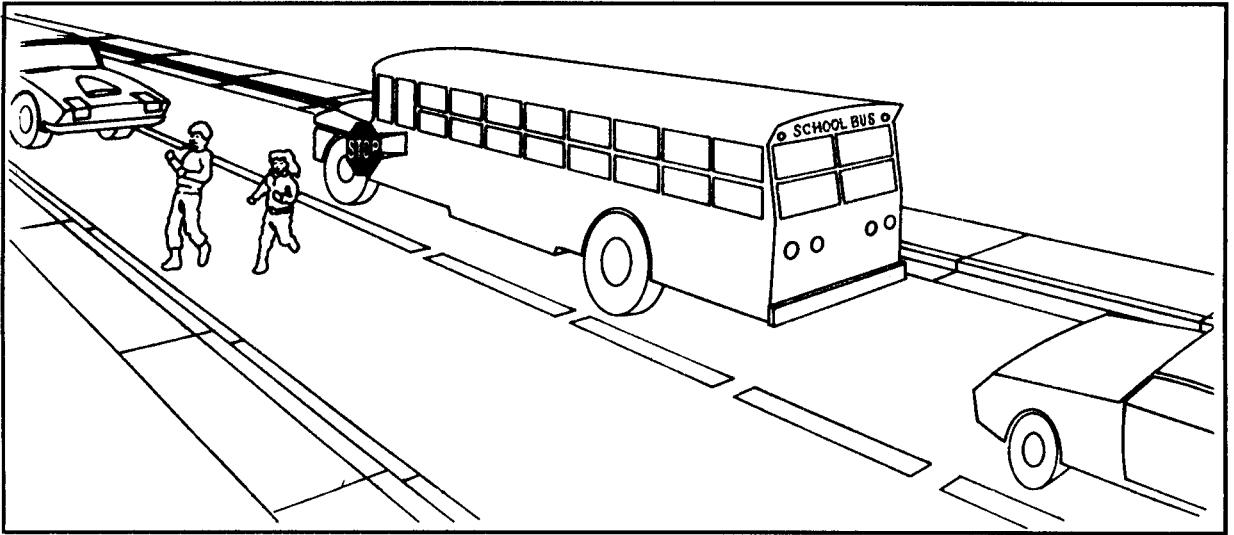

FIGURE 11-1. Stopping for a School Bus.

Never follow within 500 feet of a fire truck or other emergency vehicle. Never drive into or park in a block where an emergency vehicle has stopped in answer to a fire alarm. If you do, you will expose yourself to unnecessary danger and may hinder the work of the fire department. Never drive over a fire hose unless directed to do so by a fireman or police officer.

BREAKDOWNS

If your vehicle breaks down, get it off the main traveled portion of the road if possible. If you have a flat tire, you may damage the tire beyond repair if you drive on it, but you should take this risk if necessary to avoid greater danger. When your vehicle is disabled at night, always leave your parking lights on as a warning to other drivers. Day or night, turn on your four-way flasher warning lights.

Place warning devices contained in the highway warning kit as prescribed in the kit instructional manual. If the instructions are not with the kit, follow the procedures in Chapter 13.

If you cannot get your vehicle off the road and it is obstructed from view by a curve or hill, walk back along the shoulder of the road to a position where you can signal approaching drivers to stop in time.

Do not attempt to make repairs on your vehicle while it is in an exposed position on the road.

For Army Only: Make limited repairs, if possible, or notify your unit maintenance personnel according to the operating procedure of your unit.

For Air Force Only: For disabled vehicles on base, notify vehicle maintenance through your unit vehicle control officer during normal duty hours. After normal duty hours, notify the on-duty vehicle operation dispatcher. For off-base vehicle disabilities, contact the vehicle operations officer/superintendent to obtain vehicle repair instructions (AFR 77-4 and AFM 77-310, Volume 1).

SAFETY

Safety is a command responsibility. The driver must receive adequate instruction on safe practices when vehicles are operated. Safety, properly taught and constantly emphasized, will prevent much needless manpower equipment loss during critical military operations. The AR 385-series of Army regulations defines safety responsibility. A few of the safety hazards that you should avoid are as follows:

- Moving vehicles without first checking on both sides, front, rear, and underneath to ensure that you can maneuver without endangering personnel or equipment. Always post ground guides when maneuvering a vehicle in a motor pool or bivouac area, especially at night and under blackout conditions in any off-road area when it is too dark to see your surroundings.

- Running engines in closed areas without adequate ventilation.
- Using cutting wheels or torches without wearing protective goggles.
- Using defective or improper tools.
- Wearing rings or watches when working around the vehicle.
- Failing to use proper support when changing wheels.
- Climbing over bumpers and running boards without first removing ice or frost.
- Maneuvering vehicles with vision obscured by frost or dirt on windshield and mirrors.
- Driving too fast for roads or traffic conditions.
- Backing without a ground guide.
- Smoking during refueling operations.
- Failing to wear seat belt, helmet, and hearing and eye protection.

CHAPTER 12

GRIDS AND STRIP MAPS

An easy way to become familiar with the area in which you are operating is by studying a map. From the map you can determine the major roads and where they go. Also, you can find obvious landmarks such as mountains, valleys, coastlines, rivers, cities, railroads, crossroads, and bridges. The two basic types of maps are the grid map and the strip map. FM 21-26 covers map reading.

USING THE MILITARY GRID REFERENCE SYSTEM

To keep from getting lost, you have to know how to find out where you are. There are no street addresses in a combat area, but a military map can spot your location accurately. The map has lines running up and down (north and south) and across (east and west). These lines form small squares 1,000 meters on each side called grid squares.

The lines that form grid squares are numbered along the outside edge of the map picture. No two grid squares will have the same number. The precision of a point location is shown by the number of digits in the coordinates the more digits, the more precise the location; for example—

1181 is a 1,000 meter grid square.

115813 is to the nearest 100 meters.

11508133 is to the nearest 10 meters.

For instance, suppose your address is grid square 1181. How do you know this? Start from the left and read right until you come to 11, the first half of your address. Then read up to 81, the other half. Your address is somewhere in gridsquare 1181 (Figure 12-1).

Grid square 1181 gives your general neighborhood, but there is a lot of ground inside that grid square. To make your address more accurate, just add another number to the first half and another number to the other half, so your address has six numbers instead of four.

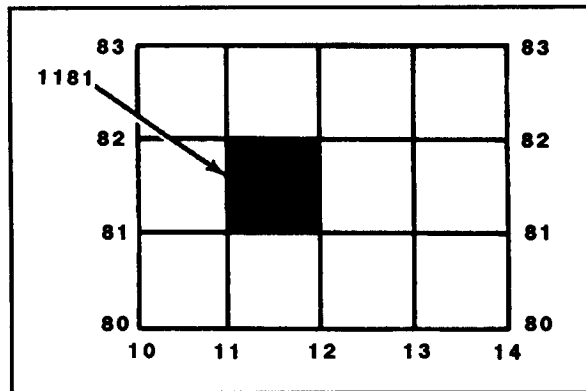

FIGURE 12-1. Grid Square.

To get those extra numbers pretend that each grid square has 10 lines inside it running north and south and another 10 running east and west. This makes 100 smaller squares. You can estimate where these imaginary lines are.

If you are halfway between line 11 and line 12, the next number is 5 and the first half of your address is 115. If you are also three-tenths of the way between line 81 and line 82, then the second half of your address is 813. (If you are exactly on line 81, the second half would be 810.) Figure 12-2 shows that if you were where the dot is in the grid square 1181, then your address would be 115813.

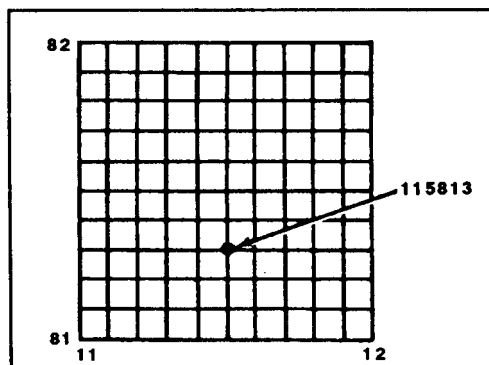

FIGURE 12-2. Point on Grid Square.

The most accurate way to determine the coordinates of a point on a map is to use a coordinate scale (Figure 12-3). You do not have to use imaginary lines because you can find the exact coordinates on the coordinate scale and protractor or the plotting scale. Located on both of these devices are two coordinate scales: 1:25,000 and 1:50,000 meters. When you use either of these devices, be sure to use the correct scale.

Use the coordinate scales to determine the coordinates of a point (Point A) already plotted on a map (Figure 12-4). First, locate the grid square in which the point is located. The number of the vertical grid line on the left (west) side of the grid square will be the first and second digits of the coordinates (11). The number of the horizontal grid line on the bottom (south) side of the grid square will be the fourth and fifth digits of the coordinates (81).

To determine the third and sixth digits of the coordinates, place the coordinate scale on the bottom grid square containing point A. Be sure the zeros of the coordinate scale are in the lower left-hand (south-west) corner of the grid square. Slide the coordinate scale to the right, keeping the bottom of the scale on the bottom grid line until point A is under the vertical (right-hand) scale.

To determine a six-digit coordinate, the 100-meter mark on the bottom scale, which is nearest the north-south grid line, is the third digit, 5. The 100-meter mark on the right-hand scale, which is nearest point A, is the sixth digit, 3. Putting these together, you have 115813.

To determine an eight-digit coordinate, which locates a point on the ground to within 10 meters, keep in mind that there are 100 meters between each 100-meter mark (number) on the scale. A short tick mark indicates 50 meters between each 100-meter mark. As shown in Figure 12-2, the grid line crosses the bottom scale on the 500-meter mark, this makes the third and fourth digits 50. If the grid line crossed the scale between the 500- and 600-meter mark, you must interpolate how many meters it is beyond 500 meters. To determine the seventh and eighth digits, read the right-hand scale where the point is on the scale. As shown, the point is between the 300- mark

and the 50-meter tick mark. You must estimate how many 10s the point is beyond the 300 mark. In this case it is 3, which makes the seventh and eighth digits, 33. Putting these together, you have 11508133.

To determine the correct two-letter 100,000-meter square identifier, look at the grid reference box in the margin of the map. Place the 100,000 - meter square identifier in front of the coordinate GL 11508133 (Figures 12-5 through 12-7).

ESTIMATING THE DISTANCE

Maps are drawn to scale so by measuring the distance on the map you can estimate the distance on the ground. This scale may be indicated by a note such as "3 inches equals 1 mile." This means that 3 inches on the map equals 1 mile on the ground. You can then use a 3-inch strip of paper as a ruler to measure the number of miles on the map. Sometimes instead of a note, a ruler is printed on the map for you. Another way to show the scale is by a representative fraction; for instance, 1/63,360 or 1:63,360. This means that one unit of distance on the map equals 63,360 units on the ground. For instance, 1 inch on the map equals 63,360 inches on the ground which equals 5,280 feet or 1 mile.

United States units for measuring distance are in terms of miles, yards, and feet. In most overseas areas, the metric system is used. You need to know metric measurements and how they compare to ours because your speedometer and odometer will measure in miles. A kilometer equals a little over six-tenths of a mile. The following conversion method shows how to convert (approximately) to the metric system

- Kilometers (km) to miles (mi): multiply km by .62.

Example: 37 km x .62 = 22.94 or 23 mi.

- Miles to kilometers: multiply mi by 1.6.

Example: 23 mi x 1.6 = 36.8 or 37 km.

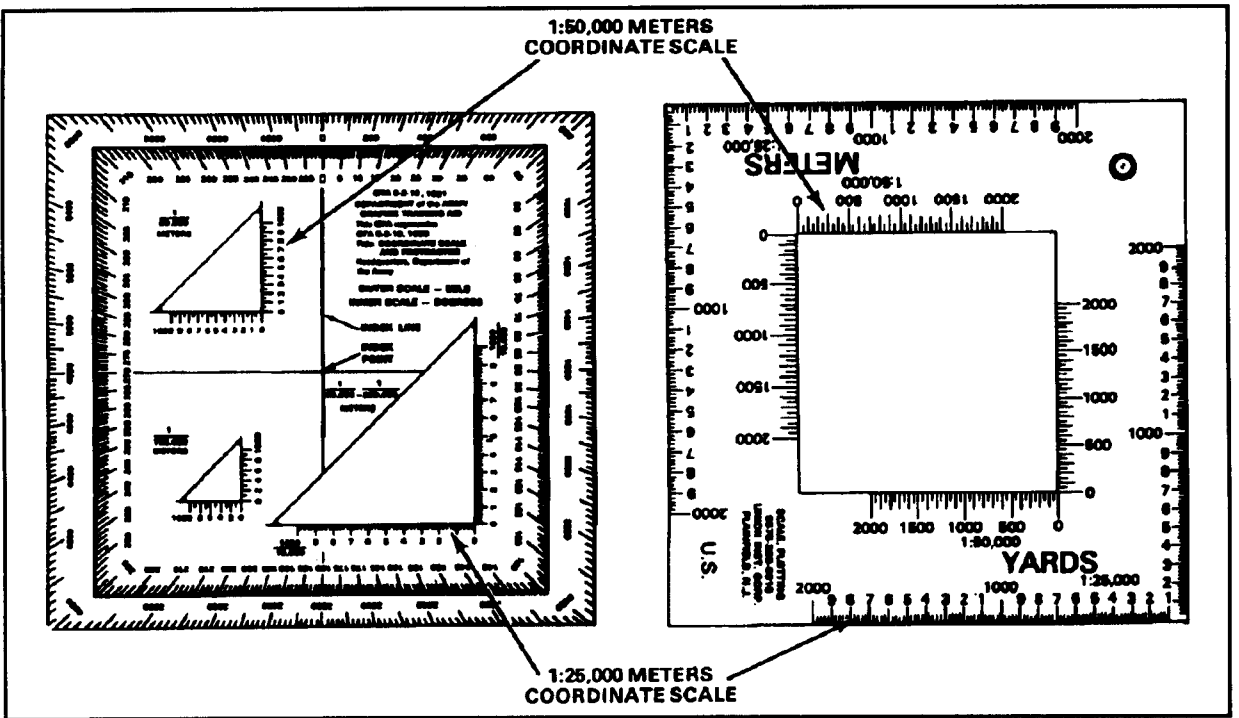

FIGURE 12-3. Coordinate Scales.

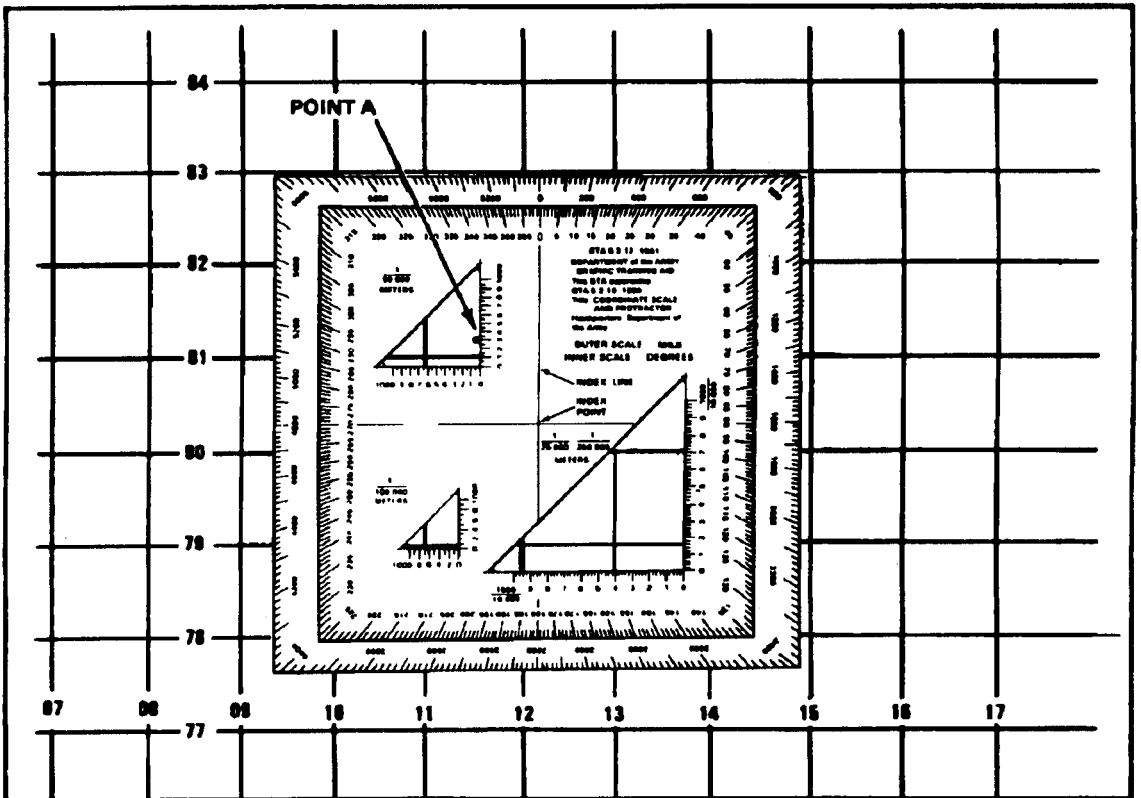

Figure 12-4. Determining Coordinates of a Point Using Coordinate Scale.

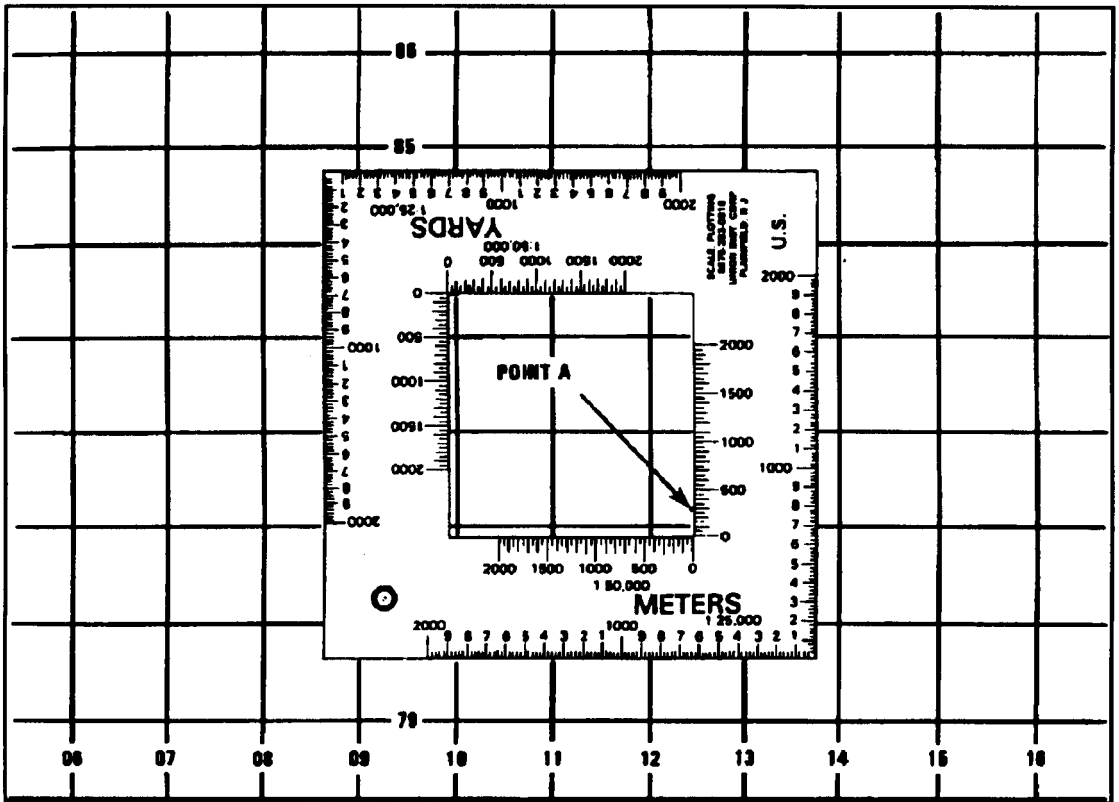

FIGURE 12-5. Locating a Point on a Grid Square.

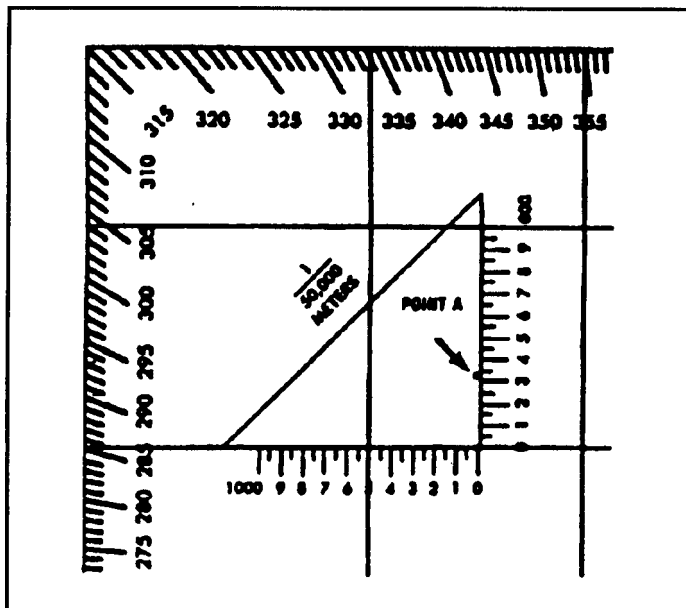

FIGURE 12-6. Coordinate Scale.

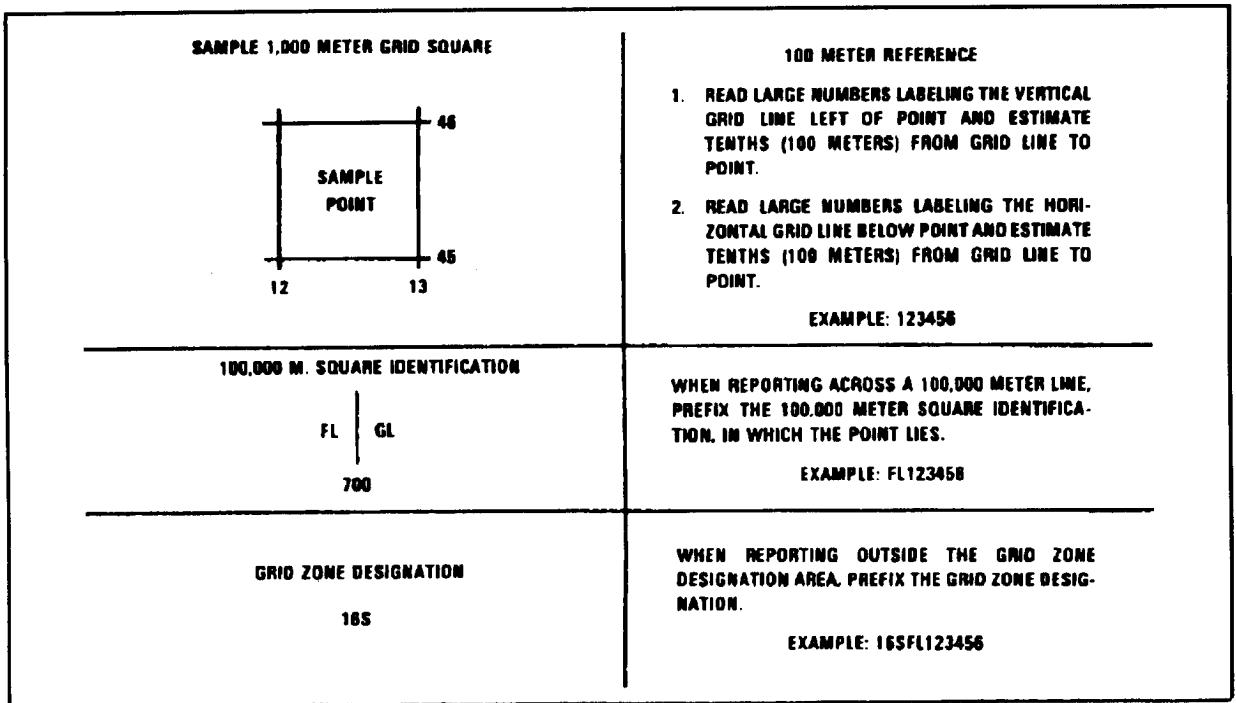

FIGURE 12-7. Grid Reference Box.

ESTIMATING THE TIME

Having estimated the distance, the next step is to figure the time you will need. In estimating time, remember that your maximum allowable speed must not exceed that shown on the caution plate in the cab or that specified by your commander. Your average speed will be less than your maximum speed, as average speed includes halts and traffic slowdowns. For detailed information, refer to FM 55-30.

RECOGNIZING MILITARY SIGNS

In addition to the signs and devices normally encountered in civilian and military driving, you must know signs peculiar to the military service. These include signs or symbols and installation markers. Military signs and symbols can be found in FM 101-5-1.

USING A STRIP MAP

The strip map (Figures 12-8 and 12-9) is a sketch of a route of march. It may or may not be drawn to scale, but it should show the identifying landmarks.

A strip map may include varying degrees of information, such as —

- Start point and release point.
- Routes and route numbers.
- Major towns.
- Major roads and crossroads.
- Mileage between points.
- Bivouac, rest, halt, and petroleum, oils, and lubricants (POL) areas.
- Directional arrows.
- Legend.

When you are assigned a driving mission, you are told which route to follow. However, you must study the map and check the road system for alternate routes so that you can make detours when necessary.

If you turn on the wrong road, your sense of direction should help you find your way. The task is much easier if you have oriented yourself properly in the beginning and have picked out landmarks along the way. Check your road map to find the road you are on and either select a new route or return to the one you were following originally.

At times, the simplest way to get on the right road may be to ask directions, but do not follow suggested shortcuts. Make your questions specific. Ask the way to a particular town or definite route. Again, a knowledge of the country is vital. Armed services police, if available, are a valuable and authorized source of information.

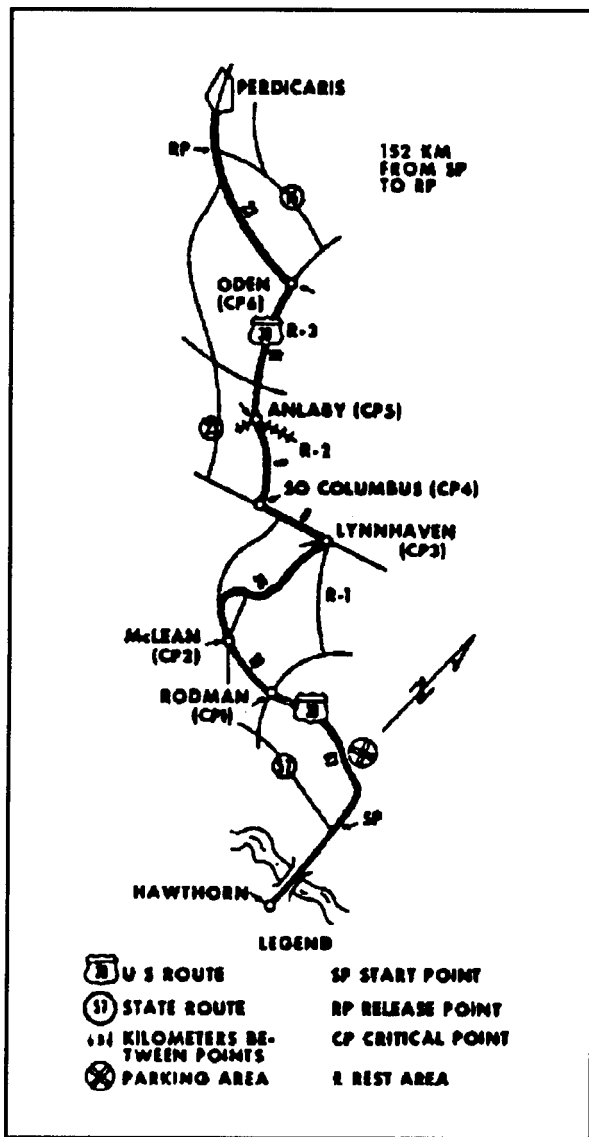

FIGURE 12-8. Strip Map.

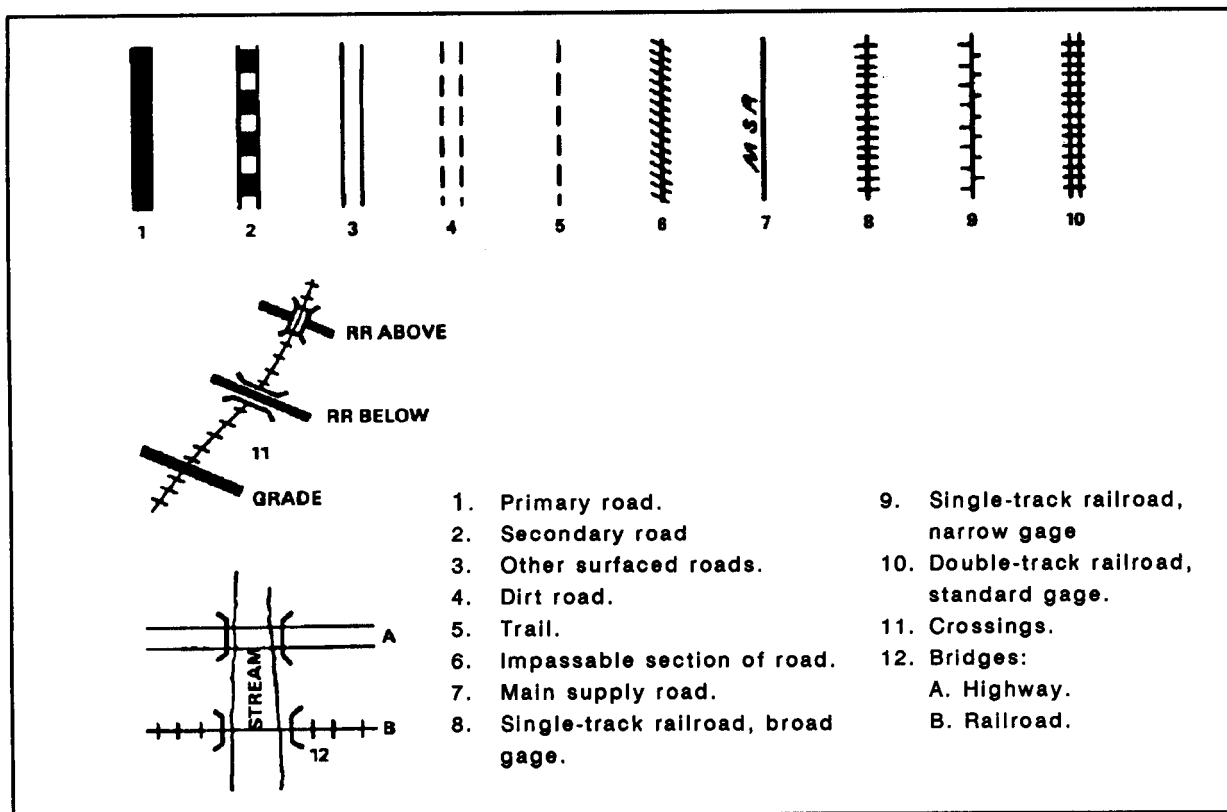

FIGURE 12-9. Strip Map Symbols.

CHAPTER 13

OPERATION OF GOVERNMENT VEHICLES OFF POST/BASE

Off post/base dispatches may be limited to those approved by the motor transport officer or his designated representative. Off post/base operation of a government vehicle involves driver responsibility additional to on post/base operation. Previous chapters contain guidance on general techniques and methods of highway driving. This chapter gives instructions that you should follow closely while on an off post/base dispatch. If the instructions are not clear to you or if you desire more detailed instructions, discuss the matter with your supervisor or dispatcher before starting on an off Post/base dispatch.

DISPATCHER'S RESPONSIBILITY

The unit vehicle control officer/dispatcher will provide you with required items for an off post/base dispatch, along with necessary instructions and information regarding the route. He will recommend a route to follow and furnish a map indicating the route. The recommended route will offer the best repair facilities and communication services. He will give you a list of these facilities with telephone numbers. The location of the repair facility, as well as locations of roadside telephone booths, when considered necessary, will be marked on the map furnished.

OFF POST/BASE DRIVING ITEMS AND EQUIPMENT**Proof of Authorization**

To prove you are authorized to take a government vehicle off post/base, you must have in your possession a valid state driver's license, your OF 346, and your dispatch document (For Army Only; DD Form 1970). Check local procedures for other authorizations required for off post/base dispatches.

Credit Card

The US Government National Credit Card is controlled since it could possibly be misused if lost and then found by dishonest persons. You will be expected to sign for this item and to limit its use to an absolute minimum. Proper servicing of vehicles before departure from the post/base will reduce the need for credit card purchases.

When required, you may procure the following items and services with the credit card:

- Gasoline (regular unleaded, premium unleaded, special unleaded).
- Gasoline (aviation grade, unleaded for boats, diesel marine fuel oil, and aviation turbine fuel).
- Gasohol.
- Diesel fuels.

NOTE: Drivers of government vehicles will use self-service pumps when available at commercial service stations to purchase the fuels noted above.

- Lubricating service and lubricants (including differential and transmission lubricant).
- Oil filter elements and servicing.
- Ethylene glycol antifreeze.
- Brake fluid.
- Air filters (replacement of throwaway type only, cleaning of permanent type).
- Battery charging.
- Tire and tube repairs.
- Mounting and dismounting snow tires or chains.

- Emergency replacement of spark plugs, fan and generator belts, windshield wiper arms and blades, lamps, and so forth.
- Washing, waxing, and cleaning services when the overall in-house cost exceeds the cost of obtaining like services through commercial resources.
- Other emergency repairs, known in the automobile trade as “road repairs.”

Emergency roadside repair involves replacing or repairing automotive accessories at the point of breakdown. Repair is limited to the guidelines of the region responsible for that TMP and/or the local installation policies. Repairs of this type include tires, tubes, batteries, and automotive accessories. When government facilities are nearby, use them instead of commercial facilities if possible. Normally, the dispatcher will advise you if a government facility is readily available or if you must use a commercial source. You may be held liable for the bill if this procedure is not followed.

Remember, you are responsible for the control and purchases made with the card issued to you. Credit card purchases must be substantiated by a copy of the service station delivery receipt. In addition to the information normally shown on delivery receipts, ensure that the speedometer reading and the registration (or license) number of the vehicle and your name, grade, and organization are put on the receipt. The receipt must also show the credit card number; date of purchase; name and address of the station; the grade, quantity, and price per gallon of fuel; and the total amount charged. Whenever a purchase is made by credit card, you will turn in a copy of the purchase receipt to the dispatcher with your credit card when you return to your post/base.

Toll Tickets

When routes off post/base include locations where passage would require a toll, tickets may be furnished to you at the time of dispatch if available. If not, follow local policy for being reimbursed for tolls and parking fees. Upon your return, you will turn in to the dispatcher the ticket receipt given to you by the toll keeper or any unused tickets.

Accident Forms

Use SF 91 (Operator’s Report of Motor Vehicle Accident) according to instructions in Chapter 10. DD Form 518 (Accident-Identification Card) is completed and furnished as identification according to instructions in Chapter 10.

Spare Tire and Tool Kit

You must be sure that the vehicle is equipped, as a minimum with a suitable jack, lug wrench, and screwdriver, as well as any additional tools based on conditions such as bad weather, difficult terrain, warfare, and so forth. The unit vehicle control officer will provide a spare tire and tool kit.

Route Maps and Driver Information

The map may be cut from an ordinary road map and securely attached to a card in order to reduce bulk and provide a map which is ready to read. Additional maps of cities along the route will be included if necessary. The map or card should be marked to show the north direction and the scale, if necessary. You may be furnished a strip map with map symbols to assist you in reading it.

Attached to the route map will be a list of suggested repair stations and their telephone numbers. These stations will be numbered and indicated by location markings on the map. See illustrations on maps in Chapter 12. (Specific and detailed instructions from the dispatcher should be written and clipped to the map along with the listing, or you should write the instructions in your personal note pad. Do not rely on remembering these details while driving.)

A military operator should have a copy of this manual during an off post/base dispatch so that he can refer to its instructions. However, this does not eliminate his responsibility to understand its instructions before the trip.

Government Invoice

Emergency roadside repairs, materials, supplies, and labor services may be obtained by using SF 44 (Purchase Order Invoice Voucher). If necessary, the off post dispatcher will furnish you appropriate forms at the time of dispatch. You will sign for them since they are controlled items. Emergency

roadside repairs include the repair or replacement of minor assemblies, such as starters, generators, distributors, fuel pumps, water pumps, carburetors, and similar minor component assemblies. When you make purchases using a government invoice, turn in a copy of the invoice to the dispatcher upon your return to your post/base.

For Army Only : Drivers of Army vehicles must be authorized at the time of dispatch to pay parking fees in order to obtain reimbursement.

Highway Warning Kit

This kit has reflectors that can be used in all cases where warning is necessary (Figure 13-1). All Air Force or Army motor vehicles capable of carrying 10 or more persons or with a rated capacity of more than 4 tons will be equipped with approved highway warning kits. Vehicles of lesser capacity that regularly operate over public highways will also be equipped with warning kits. These kits stay with vehicles regularly used on public highways. Additional kits are stored in post/base motor pools. They are issued for specific trips when required, such as when vehicles are used for accident investigation. Convoys will be equipped with one kit for each 10 vehicles, with a minimum of two kits per convoy. Of the total kits, at least one will be carried in the trail vehicle. Instructions for use will accompany each kit when issued.

For Air Force Only: The unit vehicle control officer/NCO will furnish the highway warning kit through unit supply channels (AFR 77-4).

Whenever a vehicle is inoperative or unable to move on a traveled portion of any highway or the shoulder, the following instructions will be complied with immediately (except in blackouts or within business or residential districts where traffic conditions do not permit or warrant the placing of warning devices):

- Make every reasonable effort to move the vehicle from the traveled portion of the roadway completely onto the shoulder if possible.
- When lights are required (sunset to sunrise), place a reflector in the obstructed lane, or on the shoulder of the road if the vehicle is on or over the shoulder, between the vehicle and the approaching traffic using that lane. Do this

before trying to repair the vehicle. Place the reflectors as follows:

- One reflector in the center of the lane of traffic occupied by the vehicle, not less than 40 paces (about 100 feet) from the vehicle in the direction of traffic approaching in that lane. If the vehicle is on or over the shoulder and does not occupy a traffic lane, place the warning device alongside the edge of the roadway to avoid obstructing the traffic lane.
- One reflector on the traffic side of the vehicle four paces (about 10 feet) to its rear, in the direction of traffic approaching in that lane.
- One reflector not less than 40 paces from the vehicle in the opposite direction.
- If the motor vehicle is stopped within 300 feet of a curve, crest of a hill, or other obstruction to view, one reflector not less than 40 paces nor more than 120 paces from the vehicle to afford ample warning to other highway users.
- When lights are not required (sunrise to sunset), place red flags or reflectors with flags mounted on them as prescribed for night. (Since most warning kits contain only two flags, the reflector placed 20 feet behind the vehicle will have no flag mounted on it.)

Whenever convoys or convoy components must stop on or near the traveled roadway, the convoy commander or the person in charge must immediately ensure that emergency warning devices are correctly placed

A basic vehicle highway warning kit containing three sets of reflectors and two red flags is acceptable in most states. Some states also require items such as flares in the kit. However, vehicles transporting compressed gases, explosives, or flammable liquids will use three red electric flashing lanterns instead of flares. Check the kit and/or additional items periodically to ensure compliance with local legal requirements.

For Air Force Only : Obtain highway warning kit and/or items through local purchase or base supply.

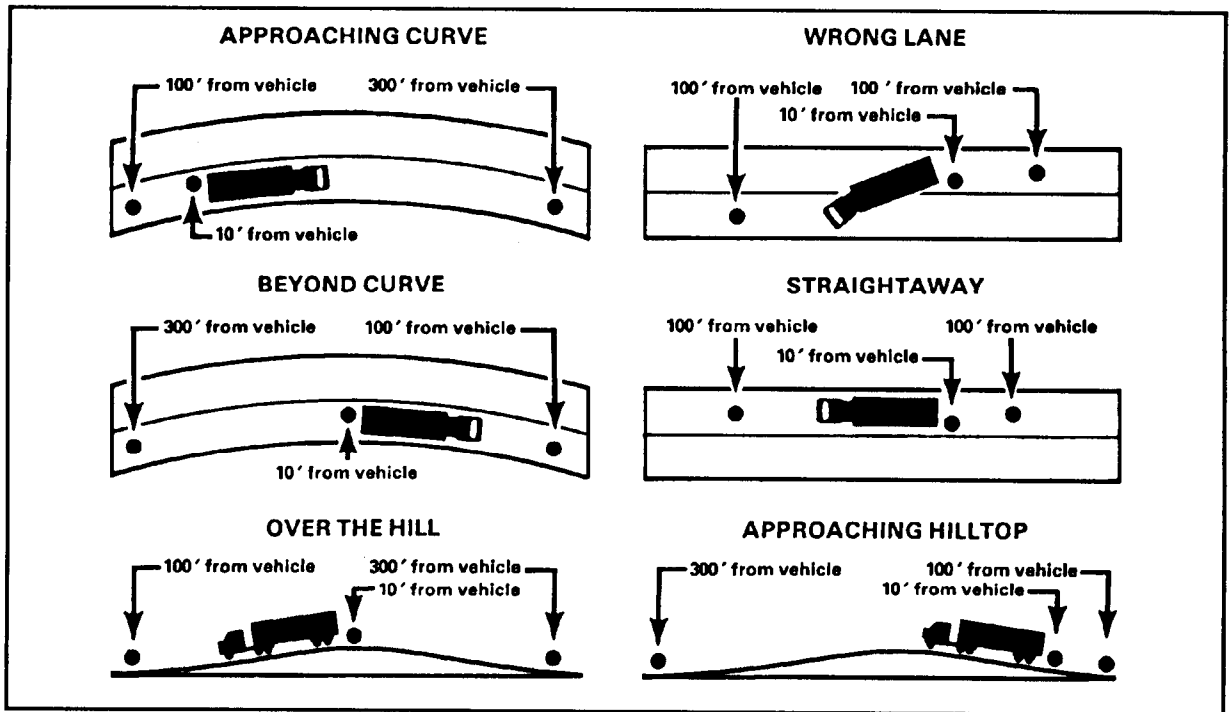

FIGURE 13-1. Use of Highway Warning Kits.

OFF POST/BASE REPAIR SERVICE

Your supervisor or dispatcher can furnish local procedures and policies on the off post/base area to be served by your installation's vehicle maintenance crew. When your vehicle needs service at an off post/base location and you are too far away for practical vehicle maintenance furnished from the post/base, proceed according to the instructions below.

If the nearest suggested repair station will accept a collect telephone call, use this method to obtain service. If the station will not accept a collect telephone call, call your post/base motor transport officer, to contact a repair station or to help in some other way. When acceptable service from other than suggested repair stations is more convenient and timesaving, be sure the credit card or government invoice will be honored before requesting service be performed. The government invoice used is SF 44.

Contact the nearest military installation for major repairs not listed in the paragraph above when it is determined that such assistance would be advantageous to the government. For instance, when the mission requires repair or service without delay

or when the vehicle must be towed for safety reasons, it would be advantageous to request service from a suggested repair station or some other acceptable service station. If in doubt on what to do, contact your motor transport officer or officer of the day at your home post/base or activity.

For Air Force Only: Use AF Form 15 (United States Air Force Invoice) to get emergency repairs, materials, supplies, and labor services. Use it for services that are not authorized to be procured on a credit card. The form was originally intended for use with aircraft. Some modification of the form is required for use with vehicles. Emergency roadside repairs include the repair or replacement of minor assemblies, such as starters, generators, distributors, fuel pumps, water pumps, and similar component assemblies. AF Form 15A (Invoice Envelope) is used with the AF Form 15. A credit card can also be used for service normally acquired with an AF Form 15 when the vendor refuses to accept an AF Form 15. A statement concerning the refusal of the AF Form 15 must accompany the delivery receipt. When purchases are made using a government invoice, turn in a copy of the invoice to the dispatcher when you return to your post/base. For additional guidance, refer to Career Development Course, CDC 603X0.

CHAPTER 14

PROCEDURES FOR TRANSPORTING PERSONNEL

As the driver of a government vehicle transporting military or civilian personnel, you have special obligations to your passengers. These are in addition to the responsibilities previously described for operating your vehicle.

GENERAL PROCEDURES

Many passengers transported will be from other posts/bases, or they may be visiting dignitaries from nearby cities. The first impression of your installation a person gets is usually the one he will remember most. How you perform your duties when transporting personnel reflects the type of motor transportation operation you have. No matter who you are transporting (officers, non-commissioned officers, enlisted personnel, or civilians), you should always –

- Report promptly to the person requesting transportation.
- Show courtesy to all passengers regardless of grade.
- Open and close the vehicle door for passengers especially at the destination.
- See that all passengers have secured seat and shoulder belts.
- Park your vehicle so passengers load and unload on the curbside. (Never arrange for passengers to enter or dismount on the traffic side.)

NOTE: Ordinarily, the passenger seating arrangement needs no assistance from the driver. Expect the lowest-ranking person to enter the vehicle first and dismount last. The highest-ranking person enters the vehicle last and dismounts first. Remember this when positioning your vehicle to allow your passengers to dismount.

SPECIAL SITUATIONS**Off Post/Base**

You may have to transport personnel to off post/base destinations such as airports, train stations, and bus stations. When picking up personnel off post/base, park as near the exit or entrance as possible. Then report to the information section and publicly page your passengers. If you parked the vehicle a block or more from the station, tell your passengers to meet you at the front of the entrance; then go for the vehicle. When transporting personnel to stations, you must only deliver them to the station entrance.

Very Important Persons

As a military driver, you may have the opportunity to transport very important persons (VIPs) –high-ranking officers or civilians— who visit your Post/base. If you are chosen to drive for VIPs, you will usually be assigned this job for their entire visit, usually 1 to 3 days. A group of VIPs will normally consist of three to eight persons. They will be accompanied by one person to whom you report and from whom you take orders. He will have all the information on where and when you should be available with your vehicle. Between runs, be sure that your vehicle is ready for further service. Keep the vehicle wiped off, windows clean, floor swept, and ash trays emptied. You and your vehicle must be neat and clean at all times. If your vehicle is needed past normal duty hours, a change of uniform is in order.

Salute when you report to an officer to tell him his transportation is available. When the officer reports to your vehicle, you must only stand at attention and open the door. If, however, additional officers accompany the officer to whom you reported, salute when the other officers report to the vehicle.

If, when you report to an officer, your request is relayed by an NCO or civilian, return to the vehicle.

Stand at parade rest by the vehicle door the officer will enter. When you see him coming, open the door, stand at attention, and salute.

Once you have saluted the officer and are touring the post/base on inspection, you must only open (or close) the door and stand at attention when he enters and leaves the vehicle.

When personnel on an inspection tour leave the vehicle, your position is at the vehicle door they will enter when they return. Stand at parade rest. Do not wait inside the vehicle.

When transporting general officers, uncase the appropriate star plates and flags. When a general officer is not present, plates and flags will be cased.

For Army Only: When you hear the sound of retreat, halt your vehicle. If you are driving a bus or truck, only the senior occupant dismounts and renders the appropriate courtesy. If you are driving any other vehicle, you and all other occupants dismount and render the appropriate courtesy.

CAUTION

When dismounting on the traffic side, watch for traffic coming and going.

For Air Force Only : When you hear the sound of retreat, stop your vehicle and remain seated.

NOTE: The above applies when the American flag is passing.

Buses, Trucks, and Panel Vans

Buses. When transporting personnel on buses –

- Secure all equipment to prevent possible injury to passengers.
- Permit only authorized passengers to ride in your vehicle.
- Permit passengers to board or leave the vehicle only when the vehicle is stopped.

- Do not permit passengers to extend legs or arms outside the vehicle when it is in motion.
- Never permit a passenger to obstruct your clear view of the road. You must have maximum Visibility to drive safely.
- See that baggage, if carried, is safely stowed and secured and not in the way of your passengers. Obey the regulations prohibiting the overload of vehicles.
- Place the vehicle next to the curb or to the extreme right of the roadway when receiving or discharging passengers.
- Do not allow smoking on shuttle vehicles.
- Stop the vehicle between 15 and 50 feet before railroad crossings. Listen and look in both directions for trains. Before crossing after a train has passed, be sure another train is not coming in the other direction on other tracks. If the vehicle has manual transmission, do not change gears while crossing the tracks.
- Slow down and carefully check for other vehicles at these locations:
 - Streetcar crossings.
 - Railroad tracks used only for industrial switching within a business district.
 - Where a policeman or flagman is directing traffic.
 - Where a traffic signal shows green.
 - Crossings marked exempt crossing.
- Avoid sudden stops and starts or any jerky movement.
- Comply with federal, state, municipal, and area laws and regulations pertaining to the operation of buses and mass personnel carrying vehicles when your vehicle is used over public streets or highways.

- Stop at drawbridges that do not have a signal light or traffic control attendant. Stop at least 50 feet before the draw of the bridge.
- Be sure the draw is completely closed before crossing.
- Slow down and be sure it is safe to cross when there is a traffic light showing green or there is an attendant or traffic officer that controls traffic whenever the bridge opens.

Trucks and Panel Vans. Permit passengers to be carried only in trucks equipped with sideboards and end enclosures (to include safety straps) at least 36 inches above the standing surface of the vehicle body. Require all passengers to be seated when the vehicle is in motion. Safety straps must be connected when transporting personnel. When your vehicle is hauling cargo, do not carry passengers other than members of the work crew handling the cargo or maintenance personnel with their toolboxes and maintenance materials. In such cases, be sure your passengers have enough room to stay seated within the vehicle. You must lower the tailgate when loading or unloading personnel and secure it before moving the vehicle.

When transporting personnel, you are responsible for delivering them to their destinations safely and on time. You should -

- Be courteous and responsive to the instructions of official passengers, troop commanders, and cargo security personnel who may travel with you. Talk as little as possible while en route. When loading or discharging officer personnel observe the rules of military courtesy.
- Not exceed the passenger limit of your vehicle except in an emergency or as directed by your supervisor. Generally, when all passengers are seated and the weight limit of the vehicle is not exceeded, the passengers may be carried safely.
- Walk to the rear of the vehicle before starting to ensure the tailgate and safety strap are in place and all passengers are seated.
- Walk to the rear of the vehicle after stopping, release the safety strap, and lower the tailgate before allowing passengers to dismount.

Do not move your vehicle if any personnel are in unsafe positions, such as standing; attempting to ride between the cab and body; hanging on sideboards, running boards, or fenders; or sitting on the tailgate or sides of the truck.

Adjust the vehicle tarpaulin according to the weather or as directed by your supervisor. Always ensure there is proper ventilation to prevent the accumulation of exhaust gases in the cargo compartment.

For Air Force Only: You may transport personnel in the cargo bed of 1/4- or 3/4-ton general-purpose pickup trucks if you follow these safety procedures:

- Be sure vehicle is equipped with a working tailgate.
- Be sure passengers are seated on the cargo deck with no portion of their bodies overhanging the vehicle sides or rear.
- Do not operate the vehicle off base.
- Be cautious when entering and exiting pickup trucks. Tailgates do not have to be lowered for personnel to enter and exit the cargo deck of the vehicle.

Emergency Vehicles

You may be designated as a driver of an ambulance or other emergency vehicle. However, you must still conform to normal traffic regulations unless otherwise directed by your supervisor. Emergency runs will be restricted to actual emergencies.

The speed of emergency vehicles will be reasonable and proper with due regard for actual and potential hazards. At no time during operation on or off post/base will the speed of ambulances exceed the legal speed limit for regular vehicles. Police vehicles will exceed the posted speed limits only in emergencies and as directed by the provost marshal or security police directives.

Certain emergency vehicles are equipped with warning devices. Use these warning devices, usually a siren and red or blue flashing light, to request that other vehicles yield the right-of-way. Under no circumstances assume that these signals give full clearance to operate the vehicle without suitable regard for life, property, and traffic laws.

Unless ordered otherwise by the medical officer in charge, do not use the sirens on ambulances. Except when responding to an emergency call, observe all traffic laws carefully during the transfer of patients. When responding to an emergency, emergency vehicles may proceed through a stop sign or light (if not in violation of local law), only after slowing down or stopping to assure safe operation.

Police vehicles responding to emergency calls use sirens and flashing lights according to local directives or as directed by the provost marshal or chief of the Air Force security police.

The foregoing provisions do not relieve emergency vehicle operators from the responsibility to drive with regard for the safety of all persons and property.

Nor do any of these provisions protect the driver from the consequence of any reckless disregard for the safety and well-being of others.

As an emergency vehicle operator, you will receive additional driver training and must be licensed in accordance with AR 600-55 to operate emergency vehicles. You should gain as much knowledge as possible in the operation of emergency vehicles and be fully familiar with local operating procedures for such vehicles. The safe operation of emergency vehicles and the transportation of personnel on such vehicles demand more driving skill and knowledge than ordinary vehicle operation requires. Remember at all times that emergency vehicle accidents are possible and are, in fact, quite frequent and serious.

CHAPTER 15

MAINTENANCE RESPONSIBILITIES

The responsibilities of a military vehicle driver include keeping the vehicle in safe operating condition and maintaining its mechanical efficiency.

PREVENTIVE MAINTENANCE

Preventive maintenance checks and services (PMCS) is commonly known as operator maintenance. It is that part of the overall maintenance program that the using organization must perform on its assigned equipment. PMCS is the systematic care of a vehicle, including daily cleaning, servicing, and inspecting for maintenance discrepancies. Its purpose is to maintain serviceability at reduced cost. Detecting and correcting defects in their early stages before they develop into major defects results in lower maintenance costs and less vehicle out-of-commission time. Unless regulations direct otherwise, the vehicle operator performs organizational maintenance.

As the driver, you must properly and safely operate your vehicle. You are the most important single factor in preventive maintenance. Daily maintenance of your vehicle includes -

- Inspecting servicing adjusting and cleaning the vehicle according to procedures outlined in the vehicle technical manual (Army) or technical order (Air Force).
- Recording any deficiencies and shortcomings, both those that you correct by replacing parts and those that you do not correct. Deficiencies are malfunctions that may result in an unsafe condition to personnel or serious damage to the vehicle for example, loose battery connections or a missing or broken rearview mirror or wiper blade on the driver's side. Shortcomings are defects or malfunctions that must be corrected to make the vehicle completely serviceable; for example, a missing battery cap or broken speedometer.

(For Army Only: Use DA Form 2404.) (For Air Force Only : Use AF Form 1800 series, as appropriate, as specified by AFM 77-310, Volume 2, Chapter 6, for your particular vehicle.)

- Lubricating your vehicle according to procedures outlined in the vehicle lubrication order (Army) or -1 technical order (Air Force).
- Helping your unit maintenance personnel perform scheduled periodic services on your vehicle.

You must be thoroughly familiar with the technical manual and lubrication order (Army) and technical order (Air Force) for your vehicle. Refer to them frequently when maintaining your equipment. Do not tinker — an enthusiastic operator with inadequate knowledge and skills can cause serious damage.

INSPECTIONS

You must perform before-, during-, and after-operation inspections, and provide routine service and repairs on your vehicle.

Before Operation

Before-operation inspection is a visual inspection to make sure the vehicle is safe and in good operating condition before it is driven. Many defects, especially leaks, are more apparent after the vehicle has been parked overnight.

Proper before-operation inspection and servicing and proper starting procedures will increase the useful life of your vehicle. Refer to the vehicle technical manual (Army) and Chapter 16 of this manual for before-operation and starting procedures.

During Operation

During-operation inspection consists of the operator being alert to indications of vehicle

malfunction while driving, such as unusual vibrations, noise, and odors; abnormal instrument readings; and erratic brake and steering operations.

Good drivers habitually inspect their vehicles at each halt. A walk-around inspection to check the tires, suspension, and load (an abbreviated after-operation check) is appropriate. During this inspection, you may discover and correct equipment faults that might cause a breakdown. Maintenance personnel are normally available in the rear element of convoys to help you make repairs beyond your capabilities or to provide vehicle recovery if required. However, you must also notify your supervisor as soon as possible of your problem and keep him informed of its status. Unusual noises, vibrations, and changes in engine performance detected en route but not identified should be reported to your supervisor.

After Operation

After-operation inspection consists of all daily vehicle services and correction, if possible, of any deficiencies found. This inspection prepares the vehicle for operation on a moment's notice. After-operation maintenance procedures are prescribed in your vehicle technical manual (Army).

NOTE: As a vehicle operator, you are ultimately liable for the proper operation and care of your vehicle. Therefore, the importance of performing before-, during-, and after-operation checks cannot be overstressed. You could be held liable for damages to your vehicle if you fail to properly inspect for and annotate discrepancies.

EQUIPMENT AND MAINTENANCE FORMS AND RECORDS

Army

When you are dispatched, you will be given an equipment record folder containing all records and forms pertaining to your vehicle. The equipment and maintenance records found in this folder are —

- DD Form 1970 (Motor Equipment Utilization Record) (or for ULLS users, DA Form 5983-E). This is a dispatch form and is further explained

in DA Pam 738-750. (When using this form, you will not maintain the automatic data processing (ADP) card mentioned below.)

- DA Form 2404 (Equipment Inspection and Maintenance Worksheet) (or for ULLS users, DA Form 5988-E). When using DD Form 1970, you may be required to maintain two DA Forms 2404. A daily form is used to record deficiencies noted during vehicle inspection. It must be with the vehicle whenever it is being operated. A deferred maintenance form is carried only when items on the vehicle are on deferred maintenance. These forms are further explained in DA Pam 738-750.
- Automatic data processing (ADP) card. This is a dispatch form issued by a transportation motor pool (TMP) using an ADP system. When using this system, you will not use DD Form 1970 or the daily DA Form 2404. (You may still be required to maintain the deferred maintenance form, DA Form 2404.)
- SF 91 (Operator's Report of Motor Vehicle Accident). You must complete this form whenever you are involved in a motor vehicle accident. This form is further explained in Chapter 10 (Army/Air Force).
- DD Form 518 (Accident-Identification Card). You must complete this form whenever you are involved in a motor vehicle accident. This form is further explained in Chapter 10 (Army/Air Force).

Air Force

Use the information below to perform inspections and maintenance required by your operator's inspection guide and trouble report (AF Forms 1800, 1806, 1807, 1810, 1812, and 1819).

Damage. Inspect the general condition of the vehicle. Check for tampering or damage that may have occurred since the vehicle was last operated. Inspect doors, windows, windshields, seats, and upholstery. Examine paint condition and legibility of markings.

Leaks. Inspect the engine compartment and look under the vehicle for evidence of leaks.

Tire, Jack, and Lug Wrench. Be sure lugs are tight, and tires have correct air pressure and at least 4/32 inch (military) and 2/32 inch (commercial) tread remaining. The spare tire must also have the appropriate tread remaining in accordance with TM 9-2610-200-24.

NOTE: When a vehicle is supported on a jack stand, chock at least one wheel. When both front wheels are in a raised position chock the rear wheels.

Fuel, Oil, and Coolant. Check fuel, engine oil, and coolant. Add amounts necessary to bring them to the correct levels. Do not overfill. Add only premixed coolant solution.

Battery. Inspect fluid levels, terminal, clamps, hold down, and so forth for security and corrosion. Add water, clean surfaces, and tighten any loose connections.

WARNING

Personnel should remove watches, rings, ID tags, and all jewelry before checking or inspecting the batteries.

Horn. Inspect the horn for security of mounting and operation.

Lights and Reflectors. Inspect all lights and reflectors for condition and proper operation.

Instruments. During operation, monitor all instrument readings for indications of malfunctions. Do not continue to operate the vehicle if instrument readings are not within acceptable limits or if warning lights are lit.

Windshield Wipers. Inspect for condition of blades and proper operation of blades and wiper assembly.

Windshield. Clean windshield and other glass daily. Inspect for cracks or discoloration that would obstruct your visibility. Fill windshield washer reservoir.

Cargo and Mounted Equipment. Inspect for security, proper operation, and damage of mounted equipment. Mounted equipment will receive the same type of service and inspection as the vehicle.

Vehicle Components. Clean inside and outside of vehicle as needed

Steering. During operation, check for abnormal steering.

Safety Devices. Inspect condition and operation of all safety devices, such as seat belts, horn, lights, warning buzzer, warning decals, and fire extinguisher.

Drive Belts and Pulley. Inspect belts for deterioration, wear, and proper tension.

Brakes. Inspect brake pedal free travel. Brake pedal should have some free travel, but it should not exceed one-half of the total pedal travel distance. Inspect parking brake for operation and effectiveness. For special-purpose vehicles, inspect (daily when used) and adjust levels of hydraulic fluid in the master cylinder reservoir as necessary.

Lube and Oil Change. Maintain lube and oil at the prescribed levels. This includes any special (daily, weekly) lubrication requirements specified for your vehicle or mounted equipment. Make sure that lubrication and oil changes are done at established intervals (miles or month).

Other. The "other" space on the operator's inspection guide and trouble report is provided for inspections and the recording of defects found during vehicle inspections that are not otherwise covered by the form.

Defects. If no defects are found during the before-operation checks and all cleaning and servicing requirements have been met, you are ready to start operating the vehicle. If you do find vehicle defects, enter the details in the appropriate space on the operator's inspection guide and trouble report. When correction of these defects exceeds the operator's responsibility, take the AF form and the vehicle to the vehicle diagnostic and quality assurance section for corrective action. In some cases, required maintenance of your vehicle may be delayed by maintenance control due to the type of defect or to maintenance work backlog. When maintenance is deferred maintenance control will enter the status code and initial your form to show that defects have been reported and maintenance delayed. You must retain this form in the vehicle as a record of defects that have been reported to maintenance control. Any new maintenance defects not

previously reported and identified as delayed maintenance must be reported to maintenance control. Maintenance control will update your inspection guide when delayed maintenance items have been

completed. (Refer to AFM 77-310, Volume 2, for more specific information on reporting a vehicle for maintenance.)

CHAPTER 16

SPARK IGNITION AND COMPRESSION IGNITION ENGINES

Conventional gasoline-fueled, spark ignition engines and multipurpose diesel-fueled engines differ in their principles of operation. Before-, starting-, and during-operation procedures also differ for conventional and diesel engines.

SPARK IGNITION ENGINES**Operating Principles**

In spark ignition engines, the vehicle's ignition provides the spark that ignites the fuel-air mixture in the engine's cylinder. The battery provides current to produce the spark. Once the current leaves its source, it flows in a definite path to the cylinders. When the fuel mixture ignites, it causes the expanding gases of the burning fuel to force the piston down on its power stroke.

Starting Procedures

It is always a good policy to check your technical manual or manufacturer's instructions before trying to operate an unfamiliar vehicle.

Before beginning the starting procedure, make sure the seat is adjusted so you can comfortably manipulate the vehicle controls. Be sure the parking brake is set and the transmission is in the neutral or park position. If the vehicle is equipped with special attachments, be sure all power control levers are in neutral. Then -

- Depress the clutch pedal to release the transmission load.
- Turn on the ignition key or switch.
- Pull out the choke if applicable. During warm weather or when the engine is warm, you generally do not need to use the choke. In extremely cold weather, pull the choke control out all the way. (Some vehicles have an automatic choke that you can set by pressing the accelerator to the floor and releasing it before starting the engine.)

- Engage the starter. If the engine does not start within 10 seconds, release the starter and check to see if you have performed the other operations correctly. (If the 10- to 15-second time limit is exceeded the battery and starting motor may be damaged. If the starter has been engaged without results, wait at least 30 seconds; then engage the starter again. Notify your supervisor if your engine fails to start after repeated attempts.)
- As soon as the engine starts, push in the choke control partway and adjust the throttle for a smooth idle. Use the choke only as necessary to start the engine and bring it to operating temperature. (Do not race a cold engine. It takes time for the oil to circulate to all parts. If the engine is raced while cold, the lack of lubrication may seriously damage the pistons, bearings, and cylinder walls. Racing the engine also wastes fuel.)
- Note the oil pressure and charging system indicators. The charging system shows some charge unless the engine is idling slowly. The oil pressure indicator should show some pressure. In vehicles with oil pressure and generator light indicator the lights should go out immediately after the engine is started. If the gauges do not show the proper indication or the light indicators do not go out after the engine has started, stop the engine and notify your supervisor.

COMPRESSION IGNITION ENGINES**Operating Principles**

Multifuel Engines. The multifuel engine is a diesel (compression ignition) engine (Figure 16-1). Unlike the conventional gasoline engine, it has no spark plugs. The heat of compression ignites the fuel. A piston coming up on the compression stroke compresses the air in the cylinder until it reaches an extremely high temperature. At this time, fuel is injected into the cylinder under high

pressure. The temperature within the cylinder ignites the fuel. The expanding gases of the burning fuel force the piston down on its power stroke.

CAUTION

Always park a diesel/multifuel-powered vehicle in neutral with the emergency brake applied (except in extreme cold weather) and chock the wheels. If you parked it in gear, a slight bump by another vehicle may start the engine, causing the vehicle to move out of control. Complete details on the operation of diesel multifuel engines are in TM 9-2815-210-34-1.

A variety of fuels may be used in multifuel engines. Acceptable types are as follows. First choices are VV-F-800 diesel fuel, MIL-F-16884 marine fuel oil, and CITE MIL-F-46005 compression ignition fuel. Second choices are SPEC MIL-J-5624 jet fuel and jet A and jet A-1 commercial aviation kerosene. The

third choice is MIL-G-3056 combat gasoline. (This is considered emergency fuel since it does not perform as well as other acceptable fuels in multifuel engines. It may even shorten the life of the engine.)

Figure 16-2 shows the multifuel engine models found in 2 1/2-ton and 5-ton trucks. The four engines shown in Figure 16-2 operate similarly. One important difference, however, is the fuel filter arrangement. Both multifuel engines have three filters – primary, secondary, and final. The location and type of filters are different in some cases. Figure 16-3 shows the locations of filters on the different model engines shown in Figure 16-2.

Diesel Fuel Engines. Figure 16-4 shows the diesel fuel engines found in 5-ton trucks. Diesel fuel engines-use grades DF1 or DF2 diesel fuel.

On the M939-series vehicles, the filter is located under the left-front fender. On the M915, the filter is located on the left side of the engine. Both require daily maintenance.

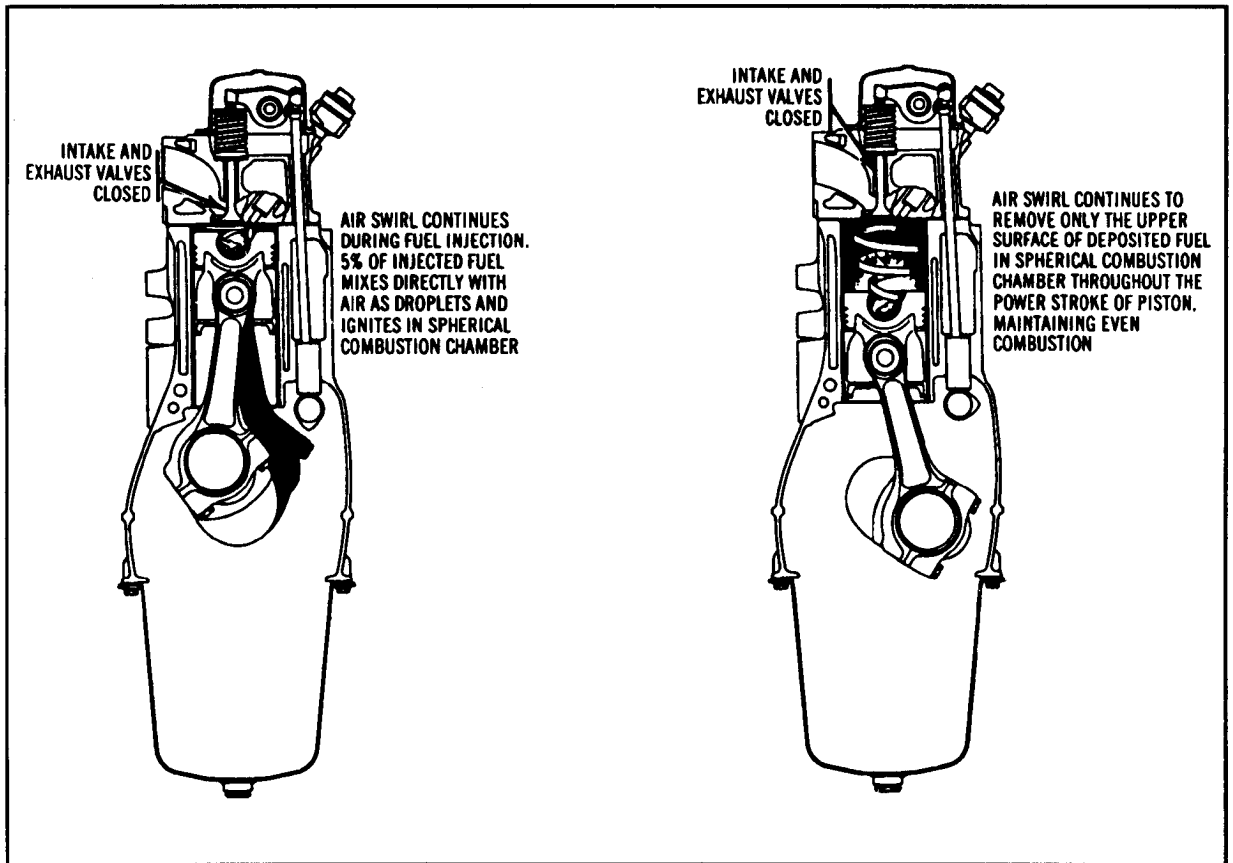

FIGURE 16-1. Injection and Combustion of Fuel in a Multifuel Engine.

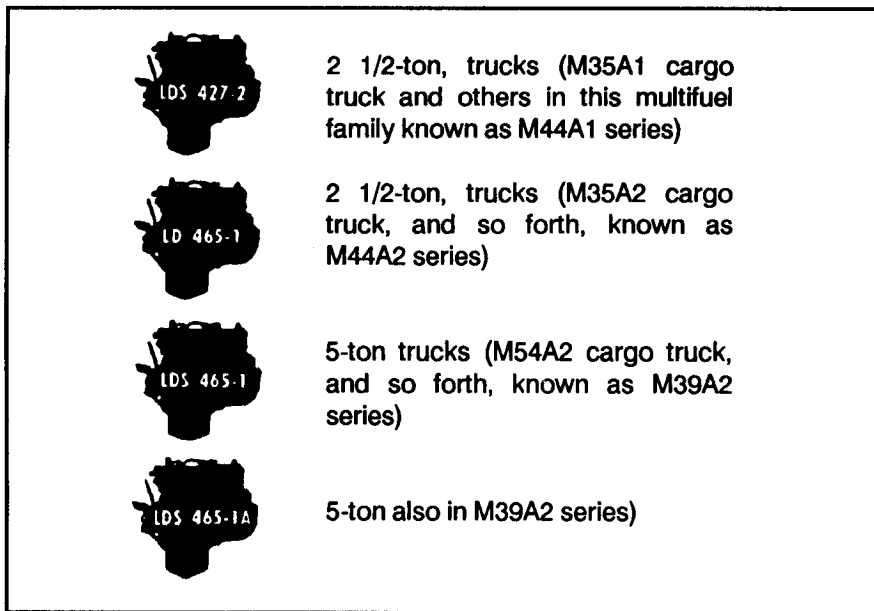

FIGURE 16-2. Multifuel Engines.

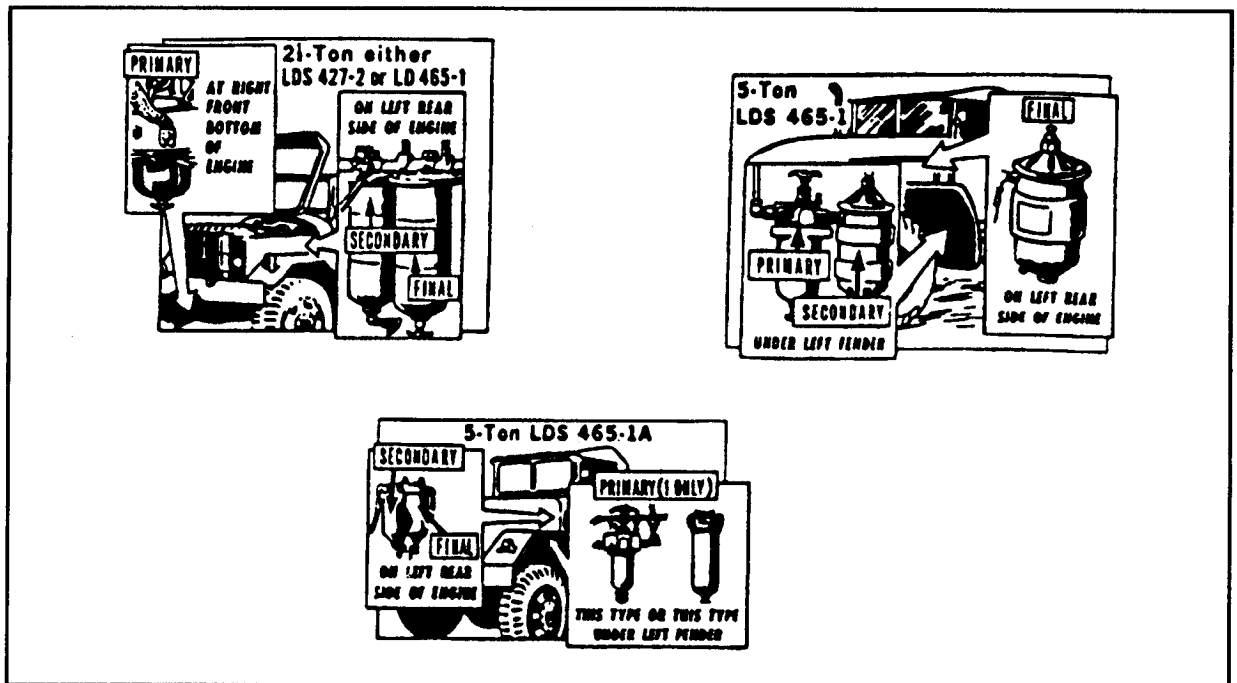

FIGURE 16-3. Location of Fuel Filters on Multifuel Engines.

Before-, Starting-, and During-Operation Procedures

Drivers converting from vehicles powered by conventional spark ignition gasoline engines to vehicles powered by compression ignition engines

should become thoroughly familiar with the before-, starting-, and during-operation procedures required by compression ignition engines. Consult the vehicle technical manual before trying to start or operate the vehicle.

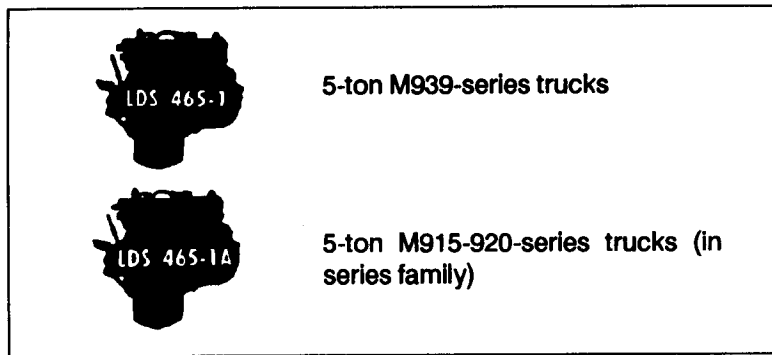

FIGURE 16-4. Diesel Fuel Engines.

Before-Operation Procedures. The vehicle technical manual prescribes before-operation services. Most of these apply to both gasoline and multifuel vehicles. The fuel falters, however, require special attention. Before operating a multifuel vehicle, the following filter service is mandatory

- After ensuring that the engine stop lever is pulled out, turn on the vehicle accessory switch to start the in-tank fuel pump.
- Open the drain cock on the bottom of the primary fuel filter. (On scraper types, give the handle on top of the filter two complete turns to loosen any foreign matter in the filter element.) Drain off 1 pint of the contents into a clean jar or can. Examine the drained-off fuel for dirt or water. (Water will form as small globules or blobs.)
- If fuel drained from the primary filter is contaminated with dirt or water, drain the secondary filter.
- If the final filter shows that the fuel is contaminated, turn off the accessory switch and report the condition to your supervisor.

Hydrostatic lock occurs when fuel, water, or other liquid is on top of one or more of the pistons. When the piston rams this fluid against the cylinder head, it can ruin or seriously damage the engine. The procedure to check for hydrostatic lock is simple. With the gearshift in neutral, hand brake applied, fuel off, and accessory switch on, push the clutch pedal to the floor. Then depress the starter button with a hard, firm push for 2 or 3 seconds. Look for these signs of hydrostatic lock: hard thud in the

engine as it turns over, engine turning over and quitting with a thunk, or engine not turning over at all. If there is any evidence of hydrostatic lock, remove your fingers from the starter button at once and report the problem to your supervisor.

Starting-Operation Procedures. After determining the engine is free of hydrostatic lock, start the engine. Follow these procedures:

- Make sure that the transmission is in neutral and the parking brake is applied.
- Push the engine stop lever all the way in.
- Turn the accessory switch to the on position.
- Depress the clutch while operating the starter.
- Press the starter button with a hard, firm push. (Not firmly closing the starter switch may damage the starting motor and switch.) Release the starter button as soon as the engine fires. Never depress the starter switch for longer than 10 seconds at one time. Usually 10 seconds is sufficient. If the engine does not start, wait at least 2 minutes and try again. If the multifuel engine does not start in three tries, report the condition to your supervisor. Do not start multifuel engines by towing or pushing, except in an emergency.
- After the engine has started, let it idle for 3 to 5 minutes or until the engine heat reaches 140°F. Engine idling speed should not exceed the RPM prescribed in the vehicle technical manual. Too slow an idle creates vibrations that will loosen some parts and may break others. The warm-up benefits the

entire engine, but it is especially important for the turbo-supercharger. Exhaust gas turns the turbo-supercharger at approximately 30,000 RPM at idle speed and up to 60,000 RPM at operating speed. Idling at a low speed allows time for the oil to circulate.

Observe the oil pressure gauge closely during the first 20 seconds of idling. If pressure does not reach 15 pounds per square inch (psi) at 800 to 1,000 RPM, stop the engine immediately and report the condition to your supervisor.

Allow engine coolant temperature to reach 140°F before putting the vehicle in motion. Drive at moderate speed until the temperature reaches 170° to 200°F.

Heavy black smoke, engine missing, and power loss may indicate a dirty air cleaner. When the red flag in the air cleaner is up over halfway, cleaning is required. Follow instructions in your vehicle technical manual or technical order when cleaning the air cleaner.

If the vehicle is equipped with air or air hydraulic brakes, do not move it until the air pressure reaches the required level. When the buzzer stops, there is enough pressure to operate the brakes. Changes in air pressure are registered on the pressure gauge. The vehicle manual specifies the amount of air pressure that should be maintained.

(For Air Force Only: Operating instructions and operating maintenance requirements are contained in the -1 technical order for each vehicle.)

During-Operation Procedures. Do not idle the engine of a parked vehicle except when necessary to keep the engine warm in extremely cold weather.

WARNING

Keep windows, curtains, and tarps open to prevent dangerous accumulation of carbon monoxide inside vehicle while the engine is idling.

Never let the vehicle idle for long periods of time. In addition to wasting fuel, excess idling allows carbon formation and oil dilution to take place in the engine. Never run the engine to recharge a rundown battery unless your immediate supervisor specifically instructs you to do so. Never leave a vehicle unattended with the engine running.

Do not exceed allowable speeds indicated on the vehicle instruction plate (if applicable) or operate at an engine speed low enough to cause the engine to labor. Vehicle instruction plates are usually located on the instrument panel.

CHAPTER 17

MANUAL SHIFT AND AUTOMATIC TRANSMISSIONS

The vehicle driver must be prepared to drive vehicles with either manual or automatic transmission. Each transmission type requires specific methods to ensure smooth operation.

MANUAL SHIFT OPERATION

Clutch Operation

A clutch provides the means to apply engine power to the wheels smoothly and gradually. Learn where the clutch starts to engage, how far the pedal moves to become fully engaged, how much free play the pedal has, and how fast you should engage the clutch.

Keep your foot off the clutch pedal except when actually starting, stopping, or shifting gears. Even a slight constant pressure on the clutch pedal causes excessive wear. For this reason, when stopped on a hill, never slip your clutch to keep from rolling backward. Instead use your brakes. While waiting for a long line at traffic lights or when halted for other reasons, depress the clutch pedal and move the transmission shift lever into neutral. Release the clutch after shifting into neutral.

When slowing a government vehicle to stop or to turn, be sure to reduce speed to 15 MPH or less before depressing the clutch pedal. Coasting a vehicle at a high speed with the clutch pedal depressed is dangerous. Vehicle control becomes more difficult, and the clutch may be damaged. Damage resulting from this practice is considered vehicle abuse.

Skill in manual shifting is a requirement of good driving. Poor manual shifting results in poor vehicle performance and can damage the vehicle. Know the gearshift lever positions so well that you can shift to any gear without looking at the shift lever. The gearshift pattern is usually diagramed on the vehicle caution plate. Never move the gear shift lever from one position to another while the engine is running until you have fully depressed the clutch pedal with your left foot. To shift gears smoothly and quietly,

keep the pedal fully depressed until the shift has been completed. When shifting gears in a 1 1/2-ton or larger truck, you may be required to use the double-clutching instructions.

Clutch Shifting Procedure. After acquainting yourself with the vehicle's instruments and controls, you are ready to begin driving operations. Start and warm the engine with the transmission in neutral. Then start moving the vehicle in low or first gear. Follow these steps:

- Depress the clutch pedal and shift into low gear.
- Check the inside and outside rearview mirrors.
- Check blind spots and give signal.
- Let the clutch pedal up slowly, pausing at friction point or when you feel it taking hold. Hesitate; then check mirrors again for traffic.
- Release the parking brake.
- Slowly release the clutch pedal and at the same time slightly depress the accelerator.
- When driving operation is underway, remove your left foot from the clutch pedal completely.

Double-Clutch Shifting Procedure. Good driving practice in trucks (1 1/2-ton or larger) often requires double-clutching to properly engage the gears and to prevent loss of momentum. To shift to a lower gear by double-clutching—

- Release pressure from the accelerator as you begin depressing the clutch pedal.
- When the clutch pedal is fully depressed, move the gearshift lever to the neutral position.
- Release the clutch pedal and at the same time depress the accelerator to speed up the engine.
- Let up on the accelerator and depress the clutch pedal.

- While the clutch pedal is depressed, move the gearshift lever to the next lower gear speed
- Release the clutch pedal and at the same time depress the accelerator to maintain engine speed as the load is again connected to the engine.

The procedure is the same for shifting to a higher gear speed, except that the engine is not accelerated while the gear is in neutral.

CAUTION

When shifting gears in rough terrain and on hills, never let your vehicle slow down to a point where the engine begins to labor or jerk before shifting into a lower gear ratio. Always anticipate the need for extra power and shift gears accordingly. When descending a hill, with or without a heavy cargo, always drive with your vehicle in gear and the clutch pedal out.

Spark Ignition Engine Braking Operation

If the hill is steep enough to require using brakes to reduce speed, shift into the next lower gear at the crest of the hill and use the engine compression as a brake. Take extreme care to prevent excessive engine speed while descending a hill. Judge the necessary gear and shift, if necessary, at the crest of the hill **BEFORE SPEED HAS INCREASED FROM DOWNHILL MOVEMENT**. Ordinarily, the gear required to ascend a hill is proper to use to descend it. **GEARING DOWN AFTER ENGINE SPEED HAS INCREASED MAY EXTENSIVELY DAMAGE THE ENGINE**. Except when used to compensate for brake failure, damage resulting from this practice is considered vehicle abuse. With proper gear selection, intermittent application of brakes will reduce the speed of the vehicle to safe limits.

CAUTION

The preceding paragraph applies to spark ignition engines only. Compression ignition (multifuel/diesel) engines should not be used to reduce speed. This practice will damage compression ignition engines.

When preparing to stop the vehicle, remove your foot from the accelerator and use the engine compression as a brake to help stop the vehicle. Do not depress the clutch pedal until the motor is operating at low speed and is no longer serving as a brake. Then depress the clutch pedal before the engine begins to labor from slow speed. Apply the foot brake to help this braking action. When preparing to turn or stop, avoid downshifting above 20 MPH. (Braking on icy roads requires a special technique which is discussed in Chapter 21.)

NOTE: The above rules apply to most vehicles. To meet the military's transportation needs for moving heavy equipment and traveling over rough terrain, new vehicles are constantly being developed. These vehicles may have more complicated transmissions, such as multi-gear ranges and dual-speed axles or other special features. Be sure you understand how a new vehicle operates. Read the vehicle operator's technical manual before trying to operate it.

AUTOMATIC TRANSMISSION OPERATION

Selector Lever Positions

While some military vehicles are equipped with manual transmission, an increasing number are equipped with automatic transmissions. Though operation of automatic shift vehicles is quite simple, the good driver must learn to operate them smoothly and properly.

In vehicles equipped with automatic transmissions, initial gear selection is controlled with a selector lever. When in drive (D or DR), shifting from drive to low (L) and returning to drive is controlled automatically by engine speed. Acquaint yourself with the vehicle and learn the selector lever positions, since there are a number of different automatic transmissions. The selector lever positions are as follows:

- P (park position) is used to lock the transmission so the vehicle will not roll while parked, on light vehicles such as sedans and pickups. In some heavier vehicles, the park position does not lock the transmission. In vehicles with a park position, start the engine from the park position.

- N (neutral position) is used to start engines of vehicles without a park position. In the neutral position, the engine is disengaged from the drive shaft of the vehicle.
- D or DR (drive position) is used to move the vehicle forward. With the shift lever at D or DR, the vehicle moves forward as you depress the accelerator. After starting the engine in the neutral or park position, change the selector to D or DR to move forward. To avoid premature forward movement, apply the brake while in the drive position until you are ready to move the vehicle. The transmission automatically shifts to higher gears as the speed increases.
- L (low or power position) is used to negotiate steep grades and rough terrain or when the braking power of the engine is required. The transmission will not shift automatically to higher gear ratios when the lever is in the low position. When the low range is no longer needed, release the accelerator temporarily and move the shift lever to the drive position for normal gear progression. In the drive position, the low range is engaged automatically when the engine speed is reduced. If the accelerator is suddenly fully depressed when the vehicle is in the drive position, the low range becomes engaged. (This procedure may be used to provide a sudden burst of speed for passing.) When a predetermined engine speed has been attained, the transmission automatically returns to driving range.
- R (reverse position) is used to move the vehicle in reverse. Some shift levers must be raised slightly to be moved to the reverse position. Others require you to depress a button on the end of the lever before moving to R. Park vehicles without a park position in the reverse position. Bring your vehicle to a full halt before placing it in R; then set the parking brake.

A good driver will become thoroughly familiar with the vehicle instruments and controls before driving it. He will always check the selector positions before he moves the lever. Serious accidents can happen if you do not follow these rules. For example, R or reverse is on the

extreme right on some shift selectors, on the extreme left on others, and in an intermediate position on others. From force of habit, if you are in a different vehicle from the one you have been driving, you could move the selector to R, thinking you were moving it to D or L. The vehicle would move in an entirely opposite direction than you anticipated.

A good driver will shift from D or DR according to driving needs. Never shift from D or DR to L at a high rate of speed because this will seriously damage the transmission and could result in a severe accident by causing a skid on wet or slippery pavement.

Dual-Range Driving Positions

Tactical vehicles may be equipped with automatic transmissions. Due to the diverse conditions under which they may be required to operate, tactical vehicle automatic transmissions are designed for greater flexibility than commercial types. Flexibility is attained with low and high transmission ranges. The vehicle technical manual contains instructions for your particular vehicle. Consult it frequently.

Vehicles equipped with dual-range driving positions offer the operator a selection of two ranges in driving pattern D or DR. Use them according to your driving needs as prescribed below. (On some vehicles, these positions are F1 and F2.)

D (F1) position is used for all ordinary driving. It -

- Provides four forward speeds.
- Shifts automatically to fourth gear.
- Increases economy by reducing engine speed

DR (F2) position is used for congested areas, rough terrain, and mountain driving. It -

- Provides three forward speeds automatically.
- Will not shift into fourth speed unless the engine is accelerated to a very high RPM.
- Uses the engine as a brake on long, steep downgrades.

Operating Procedure

To put the vehicle in motion -

- Apply the foot brake.
- Select the proper transmission lever position — forward or reverse.
- Place the transfer shift lever in the appropriate range.
- Check traffic conditions front and rear, using mirrors if necessary.
- Release the parking brake.
- Check again for traffic blind spots to the left or right rear. Signal if pulling away from a curb.
- Release the foot brake.
- Depress the accelerator pedal gradually for a smooth start.

CAUTION

Government vehicle operators are not permitted to tow or push automatic shift vehicles for the purpose of starting them.

(For Air Force Only: During normal duty hours, contact the maintenance control section of vehicle maintenance to start the vehicle with a booster battery, jumper cables, or other equipment. After duty hours, contact vehicle operations for wrecker service. For detailed instructions, see your supervisor.)

JUMP STARTING VEHICLES

Thousands of people are injured each year from auto battery explosions. Nearly two-thirds of these injuries involve the eyes. Most soldiers, at one time or another, will use jumper cables to start a vehicle, and chances are they are not aware of the danger involved. As a commander or supervisor, you are responsible for the safety of your troops, both on and off duty. Stress that they should use one of the procedures below to jump start a vehicle.

Using Jumper Cables to Start Engine

Use the following procedure to start an engine using jumper cables on a 12-volt system (Figure 17-1):

- Position the jump starting vehicle with batteries opposite the batteries of the disabled vehicle.
- Stop the engine of the jump starting vehicle.
- Open battery compartment doors of both vehicles. Pull both battery boxes onto running boards.

WARNING

One jumper cable must connect positive terminals. The other jumper cable must connect the negative terminal of the jump starting vehicle to the body of the disabled vehicle away from the batteries. Failure to do so may cause batteries to explode, injuring or killing personnel.

- Clamp one jumper cable (2) to the positive terminal (1) of the jump starting vehicle and the positive terminal (3) of the disabled vehicle.
- Clamp the other jumper cable (5) to the negative terminal (6) of the jump starting vehicle and the body (4) of the disabled vehicle.
- Start the engine of the jump starting vehicle.
- Start the engine of the disabled vehicle. If the engine does not start after four tries, notify your supervisor.

WARNING

Be sure jumper cable clamps do not contact other jumper cable clamps or terminals. Failure to do so may cause batteries to explode, injuring or killing personnel.

- Remove jumper cables (2) and (5).

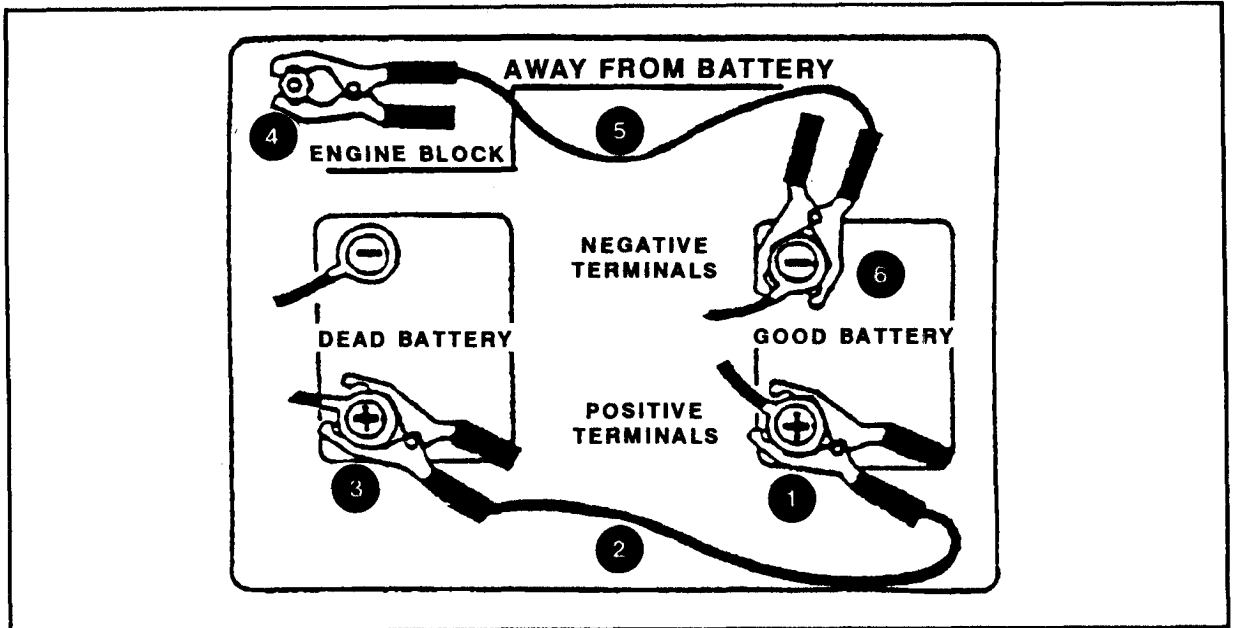

FIGURE 17-1. Jumper Cable Hookup.

Using Slave Cables to Start Engine

Use the following procedure to start an engine using NATO slave cables (Figure 17-2):

- Position the right side of the slaving (recharging) vehicle to the right side of the vehicle needing slave start.
- Stop the slaving vehicle engine.
- Pull the cover (4) from the slave receptacle (3) of the disabled vehicle. The receptacle (3) is located below the grab handle (1) on the right side of the vehicle.

CAUTION

When slaving, always connect the slave cable to the disabled vehicle first. Damage to the batteries or cable may result from improperly connecting hot batteries before connecting the cable to the receptacle of the disabled vehicle.

- Connect the slave cable (2) to the disabled vehicle. Connect the slave cable (2) to the slaving vehicle.

NOTE: Turn off all unnecessary electrical switches in both vehicles.

- Start the slaving vehicle engine. Pull out the hand throttle control until idle speed is between 700 to 800 RPM.
- Start the slaved vehicle engine.
- After the engine starts, disconnect the slave cable (2) from both vehicles.
- Put the covers (4) back over the receptacles (3).
- Clean and stow the slaving cable (2).
- Operate the slaved vehicle. If the voltmeter (6) is not in the green area, notify organizational maintenance.

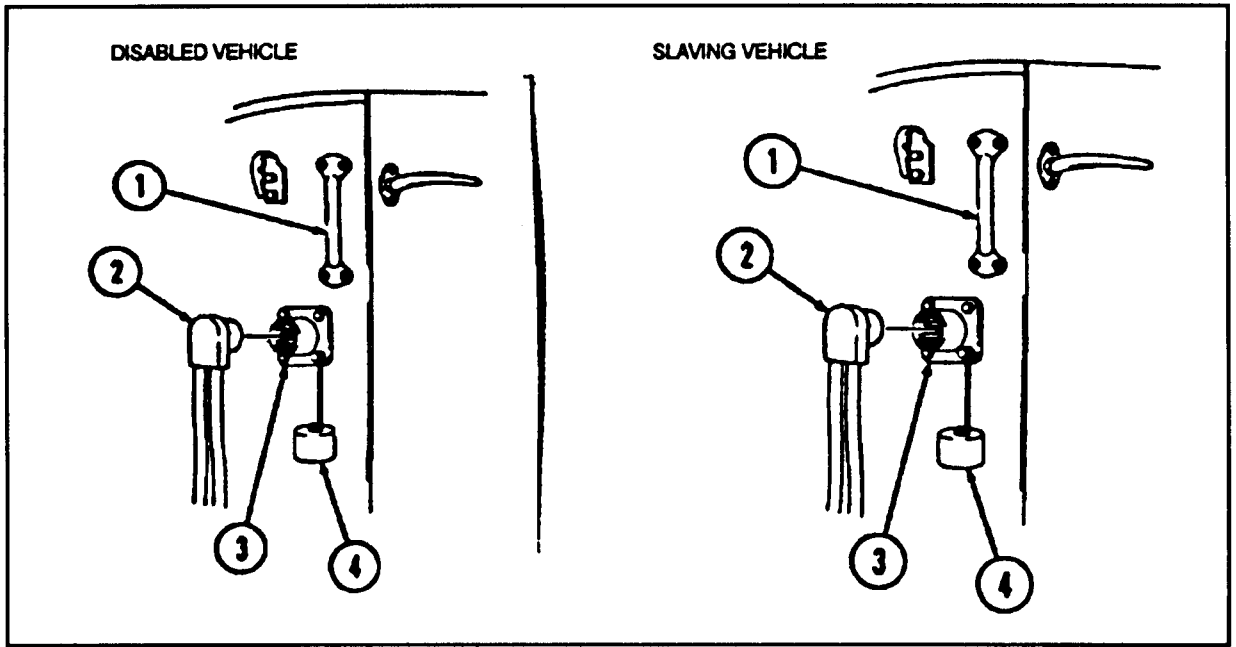

FIGURE 17-2. Parts Used in Slave Cable Hookup.

CHAPTER 18

TRUCKS, TRACTORS, SEMITRAILERS, AND SPECIAL-PURPOSE VEHICLES

The operation instructions and traffic regulations found elsewhere in this manual will generally apply to trucks, tractors, semitrailers, and other special-purpose vehicles. However, there are additional special instructions for operating and loading this equipment.

STARTING/STOPPING THE TRACTOR-SEMITRAILER

Starting the Engine and Putting the Vehicle in Motion

Start the engine following instructions contained in the operator's manual for the vehicle concerned. Then do the following:

- Check all instruments, including ammeter, heat, and fuel, air, and oil pressure gauges.

CAUTION

Always build up air pressure to **FULL TANK CAPACITY** before moving the vehicle.

- Be sure all seat belts or restraining devices are secured.
- With the engine warmed up and the air pressure gauge at the correct pressure, depress the clutch pedal and move the gearshift lever to the lowest forward gear.

NOTE: When using a tractor equipped with a two-speed axle, be sure the selector button is down or in the low-range position. When using a tractor equipped with an auxiliary transmission be sure the gearshift for auxiliary transmission is in the low-range position. These procedures are for when your vehicle is

heavily loaded or additional power is needed. The gearshift lever for an auxiliary transmission is to the right of the main gearshift lever.

- With the gearshift lever in the lowest forward gear, locate the semitrailer hand brake lever on the steering post just behind the steering wheel. Pull it toward you. This applies brakes to the trailer only.
- Release the tractor emergency brake. Push the semitrailer brake lever away from you. As you push it away, release the clutch GENTLY and accelerate slightly. Doing so lets you start off without rolling backward, even on an upgrade. This step is very important.
- Accelerate further and release the clutch pedal completely. Remove your foot from the pedal so you do not ride the clutch and cause unnecessary wear on the clutch plate.

Operation of Gears When Starting Out (Shifting Up). The vehicle is now moving. After building up enough speed to overcome any lugging of the engine in first gear, shift to the next higher gear as follows:

- Depress the clutch pedal and release the accelerator at the same time.
- When the engine idles down bring the gearshift lever to the neutral position.
- Release the clutch pedal.
- Depress the clutch pedal and put the gearshift lever in the next higher gear.
- Release the clutch pedal GENTLY and accelerate at the same time (double-clutching). To smoothly shift, double-clutching is essential on all transmissions except synchromesh transmissions.

CAUTION

If gears fail to mesh because of faulty timing **DO NOT USE FORCE TO MOVE THE LEVER.** Instead, return the gearshift lever to the neutral position, release the clutch, reaccelerate the engine, depress the clutch pedal, and try again. Repeat these steps until the lever goes into the next higher gear smoothly. If the gears fail to mesh after two or three tries, stop the vehicle safely and start over. Continue up through the gears until you reach the allowed road speed Remember to always accelerate enough to overcome any lugging of the engine before shifting to the next higher gear.

Operation of Gears When Going Upgrade (Shifting Down). When necessary, shift from a higher to a lower gear as follows:

- Depress the clutch pedal and release the accelerator. At the same time, move the gearshift lever to the neutral position.
- Release the clutch pedal.
- With the clutch released and the gearshift in neutral, accelerate enough to mesh the next gear without clashing.
- Immediately after accelerating depress the clutch pedal and move the gearshift to the next lower gear.
- Release the clutch GENTLY. At the same time take up the clutching shock by accelerating enough to smoothly shift.

DO NOT FORCE THE GEAR. Remember, you must accelerate to a slightly higher RPM than required for the lower gear to smoothly shift. Properly using the clutch compensates for any difference in speed between the engine and transmission. **UNLESS THE CLUTCH IS RELEASED GENTLY, IT CANNOT DO WHAT IT IS SUPPOSED TO DO.** Force is never necessary to properly shift.

Operation of Interaxle Differential. The interaxle differential may be locked or unlocked at any

speed. However, be sure all axles are turning at the same rate before engaging the differential. Be sure to lock the axle only at low speeds and when easing upon the throttle.

Vehicles equipped with interaxle differentials normally operate on a paved surface in an unlocked position to prolong tire life.

At the first sign of a slippery or icy highway, lock the interaxle differential. The locked position is used for normal operation on a dirt road to assure maximum traction and to prevent overworking of the differential. Always use the locked position for the following conditions:

- When ice or snow is on the highway (with or without tire chains).
- When loose sand, mud, or other slippery off-highway road conditions exist.
- When operating on a dynamometer is required or when you are blocked up.
- When loss of traction is anticipated.

Stopping the Vehicle

Smoothly stop the vehicle by following these steps:

- Wait until the vehicle has slowed down almost to idling speed before depressing the clutch pedal.
- Apply the brakes firmly. Then as the vehicle slows down, release the brakes gradually. When the vehicle is about to stop, there will not be much force on the brakes.
- The instant the vehicle stops, release the brakes completely. This prevents a jerk or rebound. Then reapply the brakes to hold the vehicle in place.

Do not intermittently apply (fan) brakes in normal slowing or stopping; this wastes air pressure and does not help you make a good stop. In normal operation use the foot (service) brakes alone since they control the tractor and trailer simultaneously. Except when necessary, avoid sudden stops to prevent possible damage to cargo and vehicle.

Skidding or locked wheels, normally due to hard braking in emergency or hazardous conditions, causes jackknifing. Locked or skidding wheels will tend to take the lead or come around.

Tractor jackknifing occurs when the rear tractor wheels lock and skid to the left or right. To gain control, steer in the direction of the skid.

Semitrailer jackknifing occurs when the semitrailer wheels lock and skid to the left or right. Control must be regained immediately if it is to be regained at all. To regain control, quickly release the brakes to get the wheels turning. **DO NOT USE THE SEMITRAILER HAND BRAKE.**

NOTE: Use the semitrailer hand brake **ALONE ONLY** to prevent roll while stopped on an incline and when coupling the tractor and trailer.

WARNING

Do not use the semitrailer hand brake in driving because you may make the trailer skid or jackknife. Also, never use the semitrailer hand brake for parking because all the air may leak out, unlocking the brakes (in trailers that do not have spring valves).

USING THE ENGINE RETARDER (JACOBS BRAKE)

Many military vehicles are equipped with an engine retarder system that lets the engine act as a brake. Use the engine retarder for descending grades in city traffic or in any situation where slowing is required. Do not use it on slippery road surfaces (such as rain, snow, sleet, or ice). Using the engine brake on slippery surfaces can cause the vehicle to skid. The engine retarder is most effective between RPMs specified in the vehicle's TM.

Do not use the engine retarder in any gear except those outlined in the vehicle's TM when descending steep grades. Never let the engine speed drop below the RPM specified in the vehicle's TM with the engine retarder applied or it will seriously damage the transmission. Do not engage the engine retarder when shifting or when the transmission is in neutral.

Use the following procedures when the towing vehicle tires have good traction:

- Select a gear that lets the engine with the engine retarder applied control the truck speed with the engine at or below the recommended RPM and service brakes not applied. Thus, as you approach a downgrade, progressively select a gear that when combined with the engine retarder lets you maintain an engine speed at the recommended RPM.
- As the engine speed exceeds the recommended vehicle RPM, apply the service brakes once to slow the engine speed to the recommended RPM. Release the engine retarder. Downshift one gear (for example, if you are in 10th gear, downshift to 9th gear) and reapply the engine retarder. Repeat this procedure until you can maintain the engine speed at the RPM listed in the vehicle operator's TM.
- If the engine speeds above the RPM specified in the vehicle's TM, apply the service brakes once to slow the vehicle speed and regain control.

WARNING

Failure to follow the downhill driving procedures may cause you to lose vehicle control and result in severe injury or death. .

CAUTION

Excessive use of the service brake to control downhill speed will cause the loss of braking power due to heat buildup.

If the transmission speeds above the RPM specified in the vehicle's TM and the transmission totally disengages, do the following:

- Release the engine retarder.
- Upshift the transmission to the next higher gear (for example, if you are in 10th gear, upshift to 11th gear).
- Apply the service brakes once to slow the vehicle speed and help regain control of the vehicle.

If the transmission totally disengages from the engine due to a shift being made with the engine retarder applied and the engine speed returns to low idle free wheeling, accelerate the engine to reengage the transmission.

If a total loss of braking occurs due to heat buildup-

- Apply the engine retarder (place switch in high mode).
- Upshift as the engine speed approaches the RPM specified in the vehicle's TM. Before each upshift, release the engine retarder.
- In the gear specified in the vehicle's TM, continue to apply the engine retarder and maintain directional control of the vehicle.

The driver must understand the importance of the proper downhill braking procedures and the use of the engine retarder especially on slippery surfaces as outlined above. Drivers must know that if these procedures are not followed death or serious injury can result. Also the driver must know that braking ability and braking techniques are different when loaded. The driver must think and plan ahead. The driver must increase his following distance and reduce his speed consistent with road and traffic conditions.

PLACING THE CHOCK BLOCKS

When on level ground place one chock block in front of the rear duals. Place the other chock block behind the rear duals of the side wheel (Figure 18-1). For single-axle trailers, place one chock block in front of the left wheel and the other chock block behind the opposite rear wheels.

When uncoupling place chock blocks firmly behind wheels on both sides of the semitrailer when parking uphill. Place blocks in front of wheels on a downgrade. On level ground wheels should be blocked on one side in front and one side in rear.

COUPLING/UNCOUPLING THE TRACTOR AND SEMITRAILER

The tractor and semitrailer are separate units joined together by the tractor's fifth wheel and the

semitrailer kingpin. The fifth wheel on the tractor and the kingpin on the semitrailer form a coupling held together by the fifth wheel coupling jaws. When not joined to the tractor, the semitrailer is held upright by two legs that support the front end.

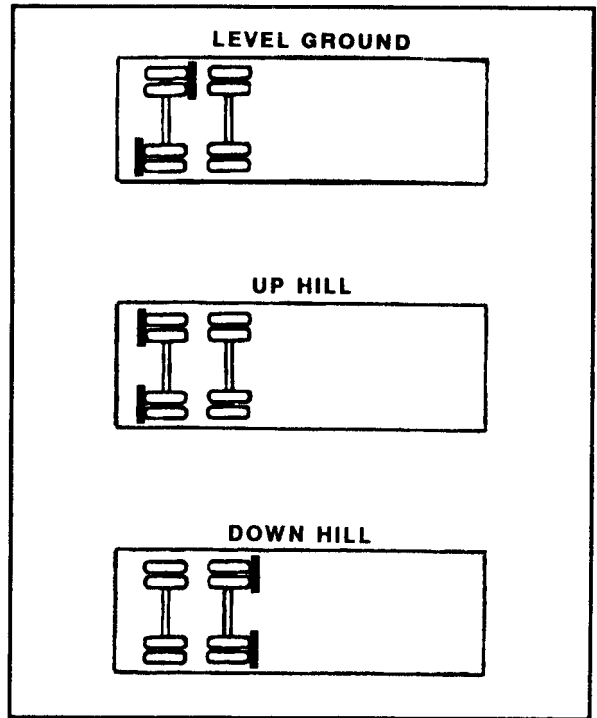

FIGURE 18-1. Chock Block Placement.

Coupling

NOTE: Due to the different types of vehicles and fifth wheels, these procedures may differ slightly from vehicle to vehicle.

To couple the tractor and semitrailer-

- Check all coupling devices on the tractor and semitrailer for condition and working order.
- Set the coupling jaws by swinging the locking plunger right or left to free the locking plunger lever. Move the locking plunger lever toward the front of the truck until it stays in the forward position. Coupler jaws are now unlocked.
- Position the tractor so that the fifth wheel coupler jaws line up with the semitrailer kingpin.

- Check the fifth wheel wedge adjustment (if appropriate) for the type of terrain. Position wedges fully below the walking beam for highway operations and back and away from the walking beam for cross-country operations. To position wedge—
 - Remove the two cap screws from each wedge.
 - Remove the wedges and reverse the position.
 - Using the same holes, reinstall and tighten the cap screws.
- Be sure chock blocks are properly placed at semitrailer wheels. If chock blocks are not in place, properly position them (Figure 18-1).
- Be sure all moving parts and the top of the fifth wheel (semitrailer coupler) are properly lubricated.
- After checks are completed, start the tractor and line it up with the semitrailer in a straight line. Sound the horn before backing. When backing use ground guides.
- Back the tractor up slowly and maneuver so the kingpin of the semitrailer is in line with the coupling jaws of the tractor's fifth wheel (Figure 18-2).
- Stop the tractor in front of the semitrailer. Place the transmission shift lever in neutral. Apply the tractor's parking brake.
- Adjust the height of the semitrailer to the height of the tractor's fifth wheel. Use the crank handle on the semitrailer to raise or lower the landing legs, so the semitrailer's approach ramps are slightly lower than the tractor's fifth wheel.
- Pull the fifth wheel plunger handle forward and then out to open the coupler jaws.
- Remove dummy couplings from the air connections on the semitrailer.
- Connect air line hoses from the tractor to the semitrailer:
 - Attach the emergency hose on the tractor (color coded red) to the emergency coupling on the semitrailer.
 - Attach the service hose (color coded yellow or blue) to the service coupling on the semitrailer.

CAUTION

Be sure the service air hose from the tractor is connected to the service coupling, the emergency air hose, to the emergency coupling on the semitrailer.

Semitrailer Kingpin (1) must be in locks (2) in center of fifth wheel (3).

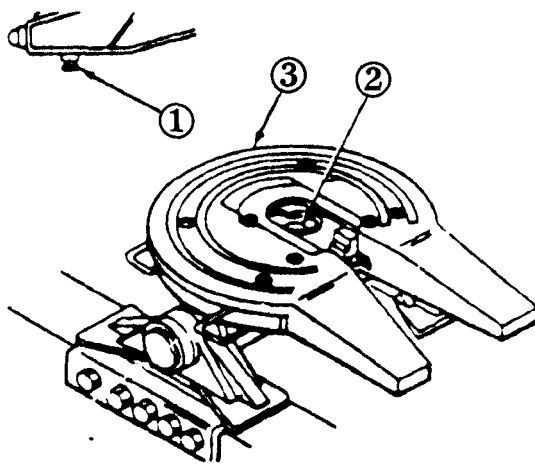
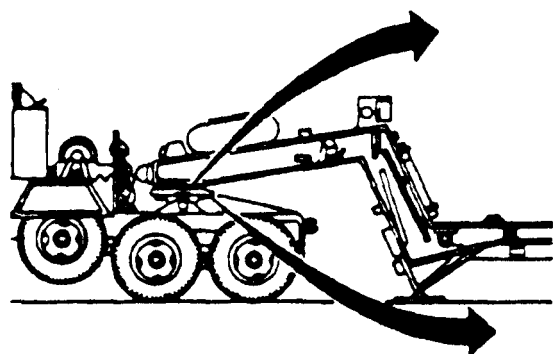

FIGURE 18-2. Coupling.

WARNING

Air brake hose shut-off valves must be open at all times during the normal operation of the tractor and the semitrailer, and the semitrailer brakes must be functional. Failure to do this will cause injury or death.

- The tractor may come with either the lever shut-off valves or the handle shut-off valves. To position the valves—
 - Open the lever shut-off valves; place the levers in the down position. Place the lever in the up position to close the shut-off valves.
 - Open the handle shut-off valves; place the handles in the vertical (up) position. Place the handles in the horizontal (down) position to close the shut-off valves.

Press in the trailer air supply valve; hold it in place for 15 seconds. Release the valve. The valve should stay in the engaged position indicating the semitrailer air brake system has proper air pressure. If the valve does not stay in the engaged position, disconnect the air couplings and notify your supervisor.

- Pull down the trailer air brake hand control lever to engage the semitrailer brakes (Figure 18-3).
- Release the parking brake lever (Figure 18-4). Place the transmission selector lever in reverse. Resume backing up.
- Stop the vehicle when the coupling jaws close around the semitrailer kingpin.
- Place the transmission selector lever in neutral and apply the parking brake lever.
- Visually check to make sure the jaws have completely closed.

- With the trailer air brake control handle engaged, release the parking brake lever, place the transmission selector lever in first, and slightly depress the accelerator pedal. The tractor will not move forward if the fifth wheel is properly connected to the semitrailer.

CAUTION

Stop the vehicle immediately if the tractor moves forward and repeat previous six steps.

- Place the transmission selector lever in neutral and apply the parking brake lever.
- Connect the electrical cable to the electric receptacle on the semitrailer (Figure 18-5).
- Check the semitrailer lights:
 - Turn the light switch to service drive.
 - Operate the turn signal switch and direct the ground guides to check for the proper operation of the semitrailer signal lights.
 - Depress the brake pedal and direct the ground guides to check for the proper operation of the semitrailer stoplights.
- Turn the crank to raise the landing gear on the semitrailer. Be sure the crank handle is stowed securely.
- Stow the landing gear float pads in the racks; remove and stow the chock blocks.
- Check the operation of the semitrailer brakes using the trailer brake hand control in the cab.

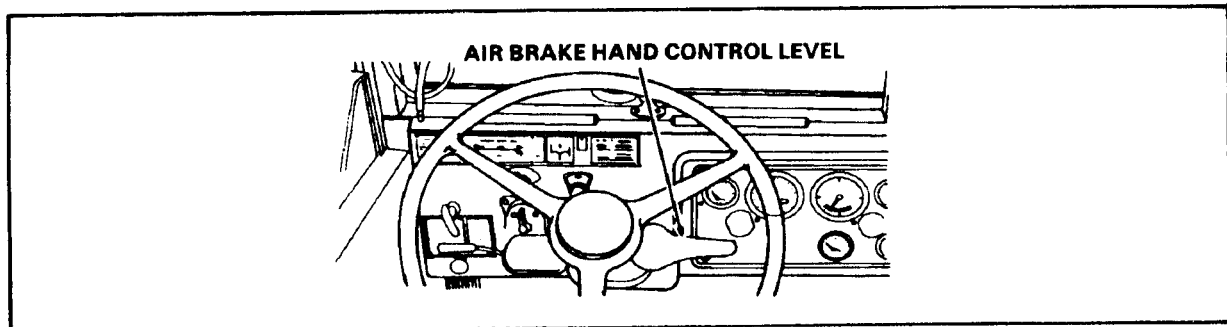

FIGURE 18-3. Air Brake Hand Control Lever.

1. Transmission selector lever.
2. Lockout switch.
3. Transfer case shift lever.
4. Parking brake lever.
5. Accelerator pedal.
6. Service brake pedal.

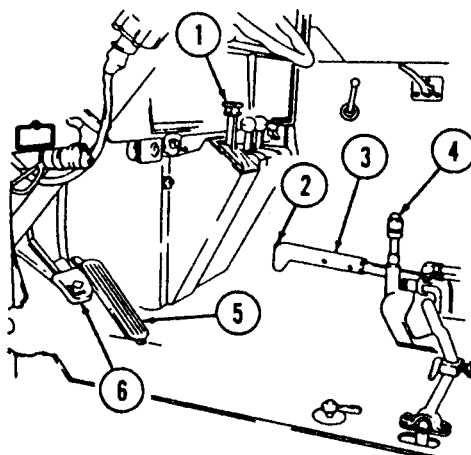

FIGURE 18-4. Tractor Interior.

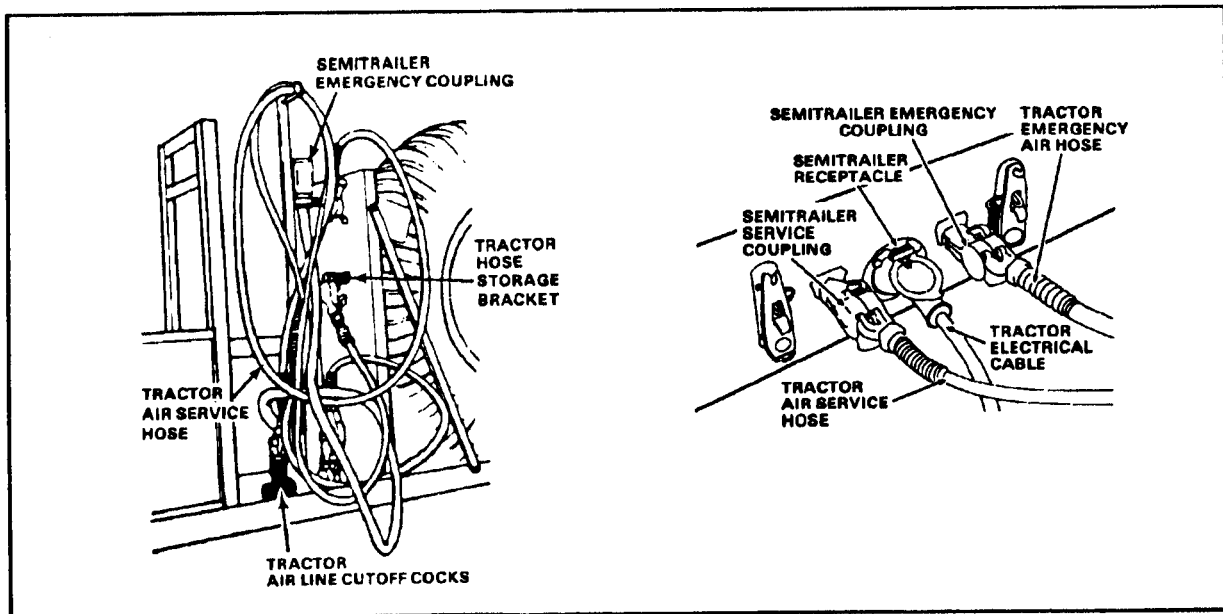

FIGURE 18-5. Coupling Receptacles and Intervehicular Cables.

Uncoupling

WARNING

Use ground guides when backing up to park the semitrailer. Failure to do so could damage the vehicle or cause injury or death.

To uncouple the tractor and semitrailer-

- Place the semitrailer in the proper location. Place the transmission selector lever in neutral. Engage the air brake hand control lever. Apply the parking brake.
- Place wheel chocks in front of and behind the semitrailer wheels.
- Place the landing gear float pads on the ground under the semitrailer landing gear.
- Turn the crank handle until the landing gear firmly contacts the float pads.
- Disconnect and remove the electrical cable from the semitrailer and secure the cable on the tractor.
- Turn the air brake hose shut-off valve levers to the closed position.

NOTE: The trailer air supply valve inside the vehicle cab will automatically pop back and disengage when the air couplings are disconnected.

- Disconnect the air couplings from the semitrailer and secure the air hose on the tractor.
- Install dummy couplings on the semitrailer air couplings.
- Release the semitrailer kingpin by pulling the plunger handle forward then out to open the fifth wheel coupling jaws.
- Place the transmission selector lever in drive and release the parking brake.
- Enter the cab and move the tractor forward until the trailer kingpin is free from the lock

guard and the landing gear is supporting the trailer weight. Then stop for a moment. Do not pull all the way from under the trailer yet to ensure the landing gear will support the trailer. If it collapses, the rear frame area of your truck can catch the front of the trailer before equipment is damaged.

- Have a crew member observe the semitrailer kingpin to be sure it clears properly during separation of the vehicles. Be sure the kingpin will clear the rear three cross-member when you pull the tractor out from under the trailer.
- Pull slowly forward to allow the semitrailer gooseneck and kingpin to totally clear the rear frame area of the tractor.

MANEUVERING THE TRACTOR-SEMITRAILER

The tractor (towing vehicle) is usually equipped with air brakes. The semitrailer may be controlled by hand-controlled trailer brakes or by automatically controlled semitrailer brakes. When driving a towing vehicle and semitrailer, keep in mind the overall length of the unit when you pass other vehicles and when you turn. Remember, the unit is hinged in the middle and therefore turns and backs differently than a truck. Further, the distribution of weight will affect stopping.

When driving a tractor/semitrailer, you must allow for offtracking on it. Therefore, when entering a right-hand curve, position the front of the vehicle as close to the centerline as possible (without letting your semitrailer tire cross the centerline) to keep the semitrailer tires from running off the pavement. When driving into a left-hand curve, move as close as possible to the shoulder of the road (without running off the road) to keep the semitrailer tires from crossing the centerline. Do not brake while in a curve. Brake before entering the curve.

Backing

Sound horn before backing. Back a semitrailer by reversing the direction you use to back a truck. Always use ground guides to help backing operations.

Backing to the Left. Turn the steering wheel to the right until the trailer is headed in the desired direction. Then turn the tractor wheels to the left to put the tractor on the same line of travel as the semitrailer. This method is known as backing sight side (Figure 18-6). Use this method whenever possible.

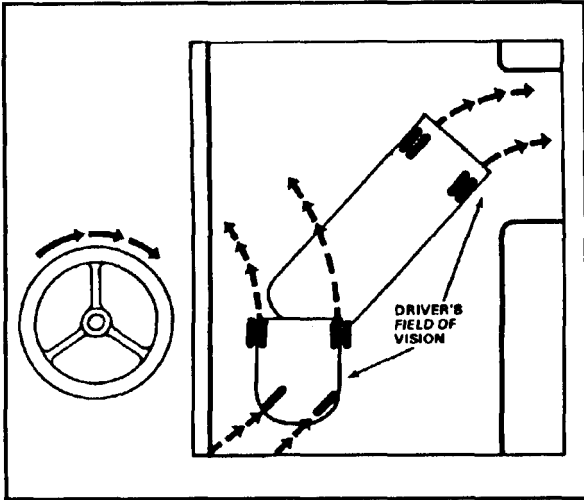

FIGURE 18-6. Backing the Semitrailer (Sight Side).

Backing to the Right. Reverse the procedure described above. This is known as backing blind side (Figure 18-7). Use it only when there is not enough space to manipulate your vehicle for backing sight side.

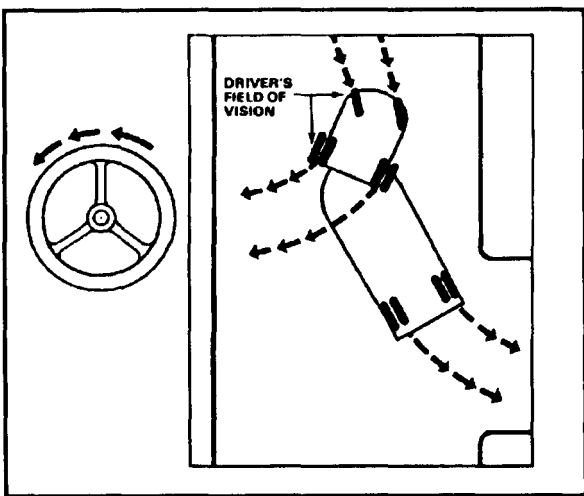

FIGURE 18-7. Backing the Semitrailer (Blind Side).

Parking

Do not use the trailer hand brake control as a parking brake. Using the semitrailer hand control to park can cause all the air to leak out.

CONNECTING AND DISCONNECTING PINTLE-CONNECTED TRAILER

Refer to the appropriate trailer technical manual for complete trailer operation procedures.

Connecting

To connect the trailer to the vehicle -

- Align tow pintle with trailer lunette.
 - Remove the cotter pin raise the latch, and open the pintle hook lock.
 - Use ground guides.
 - Sound horn before backing.
 - Back up the vehicle until the trailer lunette can be lowered onto the pintle hook.
 - Close the pintle hook lock, close the latch, and replace the cotter pin.
 - Pass the left safety chain under the trailer lunette and secure it to the right lifting shackle of the towing vehicle. Pass the right safety chain under the lunette and secure it to the left lifting shackle of the towing vehicle.
 - Raise the landing (support) legs and secure properly.
- NOTE:** Crossing the chains under the trailer lunette in an X figure decreases the distance the trailer pintle will travel if dropped
- Connect the intervehicular service brake hose, emergency brake hose, and electrical cable.

NOTE: The location of the service air couplings, emergency air couplings, and trailer electrical outlet may vary from model to model.

- Turn on both the service and emergency brakes air cutoff cocks.
- Release trailer hand brakes.
- Check the operation of the trailer brakes and lights.

WARNING

Failure to turn on the air cutoff cocks will cause loss of brakes on the trailer. This may injure personnel.

Disconnecting

To disconnect the trailer from the vehicle (Figure 18-8)-

- Sound horn before backing.
- Use ground guides.
- Lower landing (support) legs.

- Park the trailer and apply the vehicle and trailer hand brakes.
- Turn off both the service and emergency brakes air cutoff cocks completely.

WARNING

Failure to turn off the air cutoff cocks completely may cause loss of vehicle brakes. This may injure personnel.

- Disconnect the intervehicular service brake and emergency brake hoses, the electrical cable, and safety chains.
- Remove the cotter pin. Raise the latch. Open the pintle hook lock.
- Disconnect the lunette from the pintle hook.
- Close the pintle hook lock and the latch. Replace the-cotter pin.
- Set trailer brake.

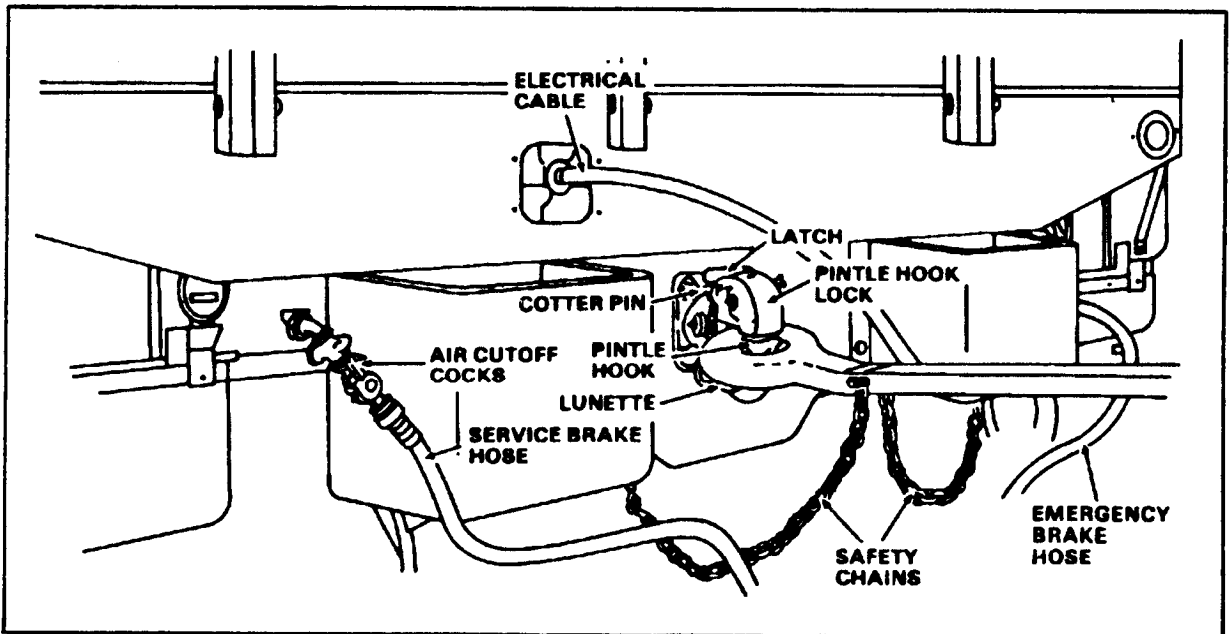

FIGURE 18-8. Vehicle and Trailer Attachment Point.

LOADING TRUCKS AND SEMITRAILERS

Distribution of Cargo

The distribution of cargo definitely bears on the life of the tires, axles, frame, and other vehicle parts. Although a vehicle may not be overloaded beyond its weight capacity, individual tires and axles may still be overloaded due to faulty cargo distribution. When loading be sure the maximum capacity of the vehicle is not exceeded over anyone of the axles. If possible, distribute the load to reduce the maximum axle loading (Figure 18-9).

WARNING

The driver must be sure the vehicle hand brake is set and wheel chocks are placed under the rear wheels to prevent any forward or rear movement of the vehicle while being loaded.

Learn the capacity of any vehicle assigned to you before you leave the dispatcher's office. No vehicle should be loaded beyond its rated capacity without written authority from your supervisor. You can usually get the weight of the load from the shipping agency. If in doubt about the weight of special loads, contact your supervisor for instruction before moving.

Responsibility for Cargo

The driver should help load his vehicle to ensure the load is properly secured to avoid damage during movement. Inspect all cargo loaded in your vehicle; be sure that its weight does not exceed the vehicle's capacity and that it is secured against falling or shifting.

Shippers must ensure they have adequate chains, cables, or special tools required to secure a load when blocking, bracing, or banding. After the load has been secured to the vehicle, recheck security before covering the load. This may prevent shifting or loss of load en route. The driver covers the load with the tarpaulin and lashes the tarpaulin in place.

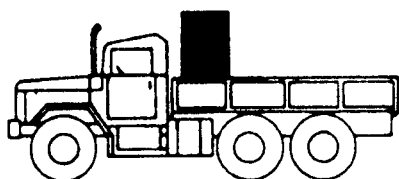

WRONG

This will bend the frame, overload front tires, make steering harder.

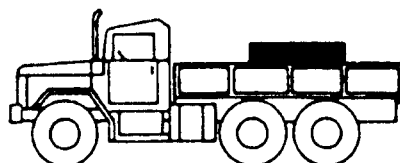

RIGHT

Place heavy part of load near rear axle for proper tire loading and to keep frame from bending.

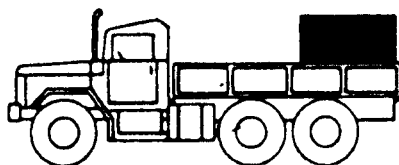

WRONG

This kind of weight distribution bends the frame, overloads rear tires, and makes steering almost impossible.

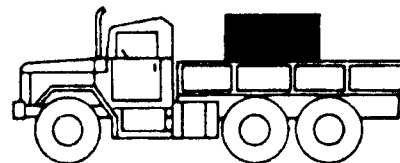

RIGHT

Set a concentrated load just ahead of the rear axle with the longest side on the floor, if possible.

FIGURE 18-9. Procedures for Loading Trucks and Semitrailers.

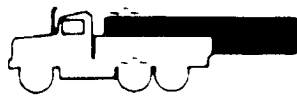

WRONG



RIGHT

Use the right vehicle for the job.

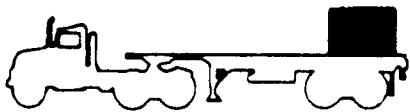

WRONG

This overloads trailer rear wheels. Brakes won't brake properly, rubber scuffs away. Distribute the load over the fulltrailer floor.

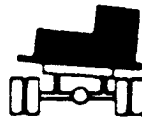

WRONG

This overloads one spring and set of tires. Brakes lock on the light side, cause skids.

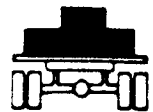

RIGHT

Nothing overloaded. Frame won't twist and loosen cross-member rivets.



WRONG

This overloads and shortens tire life, bends the truck rear axle housing. Applying the trailer brakes may lock the wheels, cause flat spots and skidding.



RIGHT

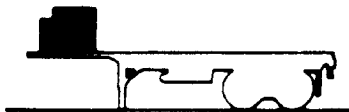

WRONG

If you are not careful, this will happen.

FIGURE 18-9. Procedures for Loading Trucks and Semitrailers (Continued).

The driver is responsible for the cargo from the loading point to receipt at destination. The information below will help you protect the load

Protection Against the Weather. Use the sides, tailgate, tarpaulin, curtains, and ropes on the vehicle whenever needed to protect the load from rain, snow, sun, sand, or dust. Draw tarpaulins tight over the bows or sides. Tie them down to the proper cleats with the tie-down ropes, using two half hitches. If properly tied down the canvas will look neat and will be free from wrinkles and bulges. If improperly placed on the vehicle, the canvas will develop rubbed spots and tears that will soon make it worthless. If the canvas is not in use, it should be folded during transport. However, the canvas should not be stored if it is wet. As soon as practicable after the job is done, spread out the wet canvas and let it dry before storing it.

Protection Against Pilferage. When cargo is protected against the weather, you also protect it to some degree against pilferage. However, you must stay constantly aware of this danger. Keeping close watch of people approaching your vehicle provides the best protection. Loads may be pilfered while moving as well as while halted. If your cargo is particularly valuable or you are operating in an area where theft is common, you may be given armed guards to help you.

Load Lashing. Two 60-to 70-foot lengths of 3/8-inch rope will usually be enough to secure the tarpaulin. Use the following procedure (Figure 18-10):

- Fasten the end of one rope to one of the front lash hooks or rings (A1).
- Pass the rope diagonally across the top of the load through or under the second rope support on the opposite side (A2). Pull the rope tight.
- Pass the rope diagonally back across the top of the load through or under the third rope support (A3). Pull the rope tight.
- Continue this process until you reach the rear of the vehicle. Secure the rope.
- With the second rope, repeat the entire process, starting at the front lash hook or ring (B1).

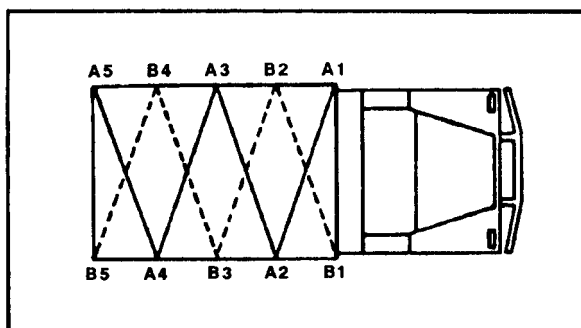

FIGURE 18-10. How to Lash a Load.

Special Loads. When transporting a load that extends beyond the sides or more than 4 feet beyond the front or rear, mark the part of the load that extends beyond the truck body with red flags (measuring not less than 12 inches square) in daytime and with red lights at night. On loads extending one-third the length of the cargo bed, determine if a special permit is required as explained below.

Vertical Height of Load. When vehicles are loaded with substantial weight concentrated high above the ground, the possibility of a high center of gravity exists. This situation becomes critical when you try to drive around a corner or make a short-radius turn at too great a speed. When this occurs, centrifugal force, which is always present in turns, joined by the high center of gravity point, results in an increased tendency of the load to tip over. To preclude this and possible damage to your vehicle and cargo—

- Load the heaviest items on the bottom of your vehicle.
- Avoid stacking heavy items too high.
- Slow your vehicle before turning and watch for possible load leaning.

Oversize and Overweight Vehicles. Before operating a truck or trailer loaded with unusually heavy or odd-size loads check with your supervisor to determine if the load is within state and local laws limiting load weight and dimensions on public highways. Your supervisor must arrange to obtain special permits before moving oversize or overweight vehicles on public highways.

Overhead Vehicle Clearance. Know the overhead clearance of your vehicle. Signs on most overpasses indicate the clearance in feet and inches. When transporting an unusual load, if you are not completely sure of the clearance, drive very slowly when you approach the underpass so that you can stop in time if the load or vehicle will not clear. Be aware of other low hanging objects, such as electrical wires, stop lights, and tree limbs.

Hazardous Cargo. Ammunition, gasoline, and liquid fuels require special handling. When carrying hazardous cargo, take the following precautions:

- Handle cargo with care and avoid overloading.
- Keep the engine turned off during loading and unloading.
- Do not allow smoking within 50 feet of the vehicle during loading and unloading or in the vehicle while it is moving.
- Carry the prescribed number and type of serviceable fire extinguishers.
- Secure the load against shifting.
- Post dangerous cargo warning devices on the front, rear, and both sides of the vehicle.
- Load unpalletized shells with their sides parallel to the vehicle body.
- Inspect gasoline cans for leaks. Do not permit defective cans to be loaded
- Keep gasoline cans, whether full or empty, tightly closed.
- Remove tarpaulins from gasoline cans unless otherwise instructed. If you use tarpaulins, air and dry them before folding and storing.
- Maintain safe distances from other traffic. Avoid sudden stops or turns. (See Chapter 8.)

NOTE: Under normal driving conditions on an open highway, the safe following distance for trucks, tractor and semitrailer

combinations, and similar vehicles is 300 feet daytime and 500 feet nighttime. Increase the following distance in adverse weather and under other poor driving conditions. In some localities, the legal required minimum following distance may increase to 1,000 feet under normal driving conditions. Check with local authorities for the required minimum following distance.

- Have your vehicle technically inspected when transporting ammunition explosives, or other hazardous material. You will get a copy of the inspection report, DD Form 626 (Motor Vehicle Inspection).
- Never drive a vehicle transporting hazardous cargo through a tunnel.
- Never park a vehicle loaded with hazardous cargo overnight in a building or a populated area.
- Always have your protective mask and protective ointment kit with you when carrying chemical ammunition.

Perishable Cargo. Perishable cargo normally consists of fresh foods. Prompt delivery is essential. Vehicles that transport fresh foodstuffs must be kept clean and free from contamination and odors.

OPERATING SPECIAL-PURPOSE VEHICLES

The driving principles learned for regular vehicles also apply to special-purpose vehicles. However, each special-purpose vehicle may require additional training for operation; some, for instance, ambulances, require training not directly related to driving. The applicable vehicle technical manual or manufacturer's manual furnishes information on special-purpose vehicles and their operation.

DO NOT operate special equipment until your OF 346 or AF Form 2293 has been validated to indicate that you are qualified to operate that particular vehicle or equipment. Your supervisor can tell you how to obtain this information.

CHAPTER 19

DANGEROUS/HAZARDOUS CARGO AND MATERIALS

This chapter implements STANAG 2002.

Transporting dangerous/hazardous cargo is perhaps the most demanding job a military driver will ever perform. Much of the cargo that trucks move is dangerous, delicate, or unwieldy. It may be explosive, radioactive, sensitive to shock, or simply oversize or overweight. Rules covering these special cargoes are special themselves. Before dispatching a vehicle to the loading site, the truckmaster or operations officer ensures the driver is properly trained in the correct procedures to load, block, and brace the special or hazardous cargo.

Various forms are necessary for transporting special cargo. The driver must keep these forms safely on board the vehicle when transporting special cargo.

Although the driver need not fill out any of these forms, he must be familiar with their purpose and where he needs to sign them:

- DD Form 836 (Special Instructions for Motor Vehicle Drivers) (Figure 19-1).
- DD Form 626 (Motor Vehicle Inspection Report) (Figure 19-2).

GENERAL SAFETY MEASURES

Observe these safety measures when dealing with hazardous materials:

- Establish a safety program (AR 385-10) for loading, unloading and handling hazardous materials. Be sure each person involved in the operation is familiar with its contents.
- Provide qualified supervisors to direct and control the loading, unloading and handling of hazardous materials. Supervisors must thoroughly understand the hazards involved and will indoctrinate subordinates on special precautions and emergency situations that may arise.
- Designate specific segregated areas for container restowing activities, if available, and for in-transit storage purposes.
- Mark hazardous materials operating and storage areas with appropriate warning signs. (See Appendix C, extract of STANAG 2002.)
- When appropriate, initiate security measures to prevent theft, sabotage, and so forth.
- When handling explosives or flammable materials -
 - Prohibit smoking except in an established smoking area and provide facilities for safe disposal of smoking materials.
 - Prohibit matches, lighters, or other sparking or open-flame producing items in the hazardous area.
 - Prohibit footwear strengthened with nails or other spark-producing metal, unless the footwear is covered with rubber, leather, or other nonsparking material.
 - Establish fire fighting and other emergency plans and provide for fire fighting and other emergency equipment.
 - Avoid jars or shocks, particularly with sensitive explosives used in detonators. Subject nuclear weapons to minimum handling and minimum exposure to shock.
- Ensure that protective clothing and/or equipment is used during handling of toxic oxidizers, fuels, or chemical agents. This may include masks, goggles, gloves, or other garments. Suitable neutralizing agents should be available for personnel handling toxic gases, etiologic agents, and white phosphorus.

SPECIAL INSTRUCTIONS FOR MOTOR VEHICLE DRIVERS		DATE
TO: (Carrier's Name and Trailer Number) Miller Motor Express		1 Feb 1991
FROM: (Installation Issuing Instructions) Fort Eustis, Virginia 23604		
BILL OF LADING NUMBER E-9, 879, 418	THIS TRUCK IS LOADED WITH (Commodity description) Rocket Ammunition with Empty Projectiles and Radioactive Material N.V.S.	
TYPE PLACARDS REQUIRED		
IN CASE OF FIRE 1. If any part of the vehicle outside of actual contents catches fire, take vehicle to a clear or uninhabited area, if practicable, and/or attempt to put fire out immediately with hand extinguishers or other available means. If practicable, ask someone to notify the fire department. Call to the attention of fire or police personnel at the scene of the fire the information on this form. 2. Fires may be fought until the flames reach the cargo, at which time firemen and other personnel should be withdrawn to a safe distance, as noted in 5 and 6 below. 3. If in convoy, other trucks proceed to safe distance. 4. Water may be used on this cargo <input checked="" type="checkbox"/> Yes <input type="checkbox"/> No (See Other Specific Precautions or Instructions below) 5. Firemen should not approach closer than <u>500</u> feet* from the fire when the fire has reached the cargo. (See Other Specific Precautions or Instructions below) 6. Public should not approach closer than <u>500</u> feet* from fire. 7. As soon as practical, notify the nearest military installation.		IN CASE OF ACCIDENT 1. Set brake and block vehicle to prevent movement. 2. Post flags by day, and red electric lanterns or reflectors by night, warning traffic approaching from each direction. 3. Call for ambulance, if necessary. 4. Notify nearest police. 5. Notify nearest military installation if cargo is damaged. ADDITIONAL NOTIFICATION REQUIRED (By phone or wire as soon as possible) Transportation Officer Fort Eustis, VA 23604 877-4181 Ext 2235
		IN CASE OF BREAKDOWN 1. Do not attempt to tow loaded vehicle. 2. Post flags by day and red electric lanterns by night, warning traffic from each direction.
GENERAL PRECAUTIONS		
1. While operating over public roads, keep at least 300 feet from trucks loaded with explosives or other dangerous articles; a greater minimum distance must be maintained if required by state or municipal regulations. 2. Protect the public from the hazards of the cargo. 3. Do not allow smoking or use of matches or lighters in or near the vehicle. 4. Obey all state and local traffic regulations. 5. Do not exceed posted speed limits.		6. Stop at all railroad crossings. 7. Use designated routes. Whenever possible avoid congested residential or business areas. 8. Do not permit unauthorized persons to ride on vehicles. 9. At other than carrier rest stops or interchange points, select safe parking space at stopping locations designated by the carrier. Vehicles carrying explosives should not group together at these stopping locations.
OTHER SPECIFIC PRECAUTIONS OR INSTRUCTIONS		
Remain at least 1500 feet upwind of fire		
SAMPLE		
These instructions must be transferred to each subsequent driver for turn-in at final destination. If more than 3 drivers are involved, the additional signatures should be made on an extra sheet and attached hereto.	SIGNATURE OF SHIPPER REPRESENTATIVE <i>John C Williams</i>	SIGNATURE OF FIRST DRIVER <i>Nancy A. Bair</i>
	SIGNATURE OF SECOND DRIVER	SIGNATURE OF THIRD DRIVER
<small>* The distances shown are minimum; greater distances should be used whenever possible.</small>		

DD FORM 836

REPLACES EDITION OF 1 JUN 66, WHICH MAY BE USED.

GPO : 1967 O - 195-150

FIGURE 19-1. Example of DD Form 836.

NOTE: This is an extremely important form used whenever you have dangerous or hazardous cargo. Read it carefully before you sign it.

MOTOR VEHICLE INSPECTION (TRANSPORTING HAZARDOUS MATERIAL)								
SCL. NO.		ORIGIN		DESTINATION				
NAME OF CARRIER		Miller Motor Express						
NAME OF DRIVER		Harvey A. Bain						
DATE AND HOUR		1 Feb 88 0800 Hrs.						
INSTALLATION/ACTIVITY		Ft. Eustis, VA.						
DRIVER'S STATE PERMIT NO.		246882145 VA.						
MEDICAL EXAMINER'S CERTIFICATE AND DATE								
VEHICLE								
TYPE OF VEHICLE <input type="checkbox"/> TRUCK <input type="checkbox"/> TRUCK AND FULL TRAILER <input type="checkbox"/> TRACTOR AND DOUBLE TRAILERS <input checked="" type="checkbox"/> TRACTOR AND CLOSED SEMI-TRAILER <input type="checkbox"/> TRACTOR AND FLAT-BED TRAILER		TRUCK NUMBER T-462-187 ORIGIN	TRAILER/SEM NUMBER 27A-883 ORIGIN	SLEEPER CAB <input type="checkbox"/> YES <input checked="" type="checkbox"/> NO VALID LEASE <input checked="" type="checkbox"/> YES <input type="checkbox"/> NO I.C.C. NUMBER 3274 A				
		DESTINATION	DESTINATION					
NOTE: All of the following items shall be checked on empty equipment prior to loading. Items with an asterisk(*) shall be checked on incoming loaded equipment.								
ITEM NO.	CHECK APPROPRIATE COLUMN (See reverse side for explanatory notes)	ORIGIN		DESTINATION		REMARKS (Explain unsatisfactory items; see reverse side if necessary)		
		SAT	UNSAT	SAT	UNSAT			
1.	ENGINE, BODY, CAB AND CHASSIS CLEAN	✓		✓				
2.	STEERING MECHANISM	✓		✓				
3.	HORN OPERATIVE	✓		✓				
4.	WINDSHIELD AND WIPERS	✓		✓				
5.	SPARE ELECTRIC FUSES AVAILABLE	✓		✓				
6.	REAR VIEW MIRRORS INSTALLED	✓		✓				
7.	HIGHWAY WARNING EQUIPMENT	✓		✓				
* 8.	FULL FIRE EXTINGUISHER INSTALLED	✓		✓				
9.	LIGHTS AND REFLECTORS OPERATIVE	✓		✓				
10.	EXHAUST SYSTEM	✓		✓				
* 11.	LIQUID PETROLEUM GAS POWERED VEHICLES	✓		✓				
* 12.	FUEL TANK, LINE AND INLET	✓		✓				
13.	COUPLING DEVICES - KINGPIN LOCK	✓		✓				
* 14.	ALL BRAKES OPERATIVE	✓		✓				
* 15.	LANDING GEAR ASSEMBLY OPERATIVE	✓		✓				
16.	SPRINGS AND ASSOCIATED PARTS	✓		✓				
* 17.	TIRES	✓		✓				
18.	CARGO SPACE	✓		✓				
* 19.	ELECTRIC WIRING	✓		✓				
* 20.	TAIL GATE AND DOORS SECURED	✓		✓				
* 21.	FIRE AND WATER RESISTANT TARPULIN							
22.	ANY OTHER DEFECTS (Specify)							
<input type="checkbox"/> APPROVED (If rejected give reasons on reverse under "Remarks". Equipment shall be approved if deficiencies are corrected prior to loading.)		SIGNATURE (of Inspector)		SIGNATURE (of Inspector)				
<input type="checkbox"/> REJECTED		ORIGIN		DESTINATION				
		<i>John Coulter</i>		<i>Thomas Smith</i>				
ITEMS TO BE CHECKED PRIOR TO RELEASE OF LOADED VEHICLE						ORIGIN	DESTINATION	
* 23.	HAZARDOUS MATERIAL PROHIBITED BY DOT REGS. ARE NOT LOADED ONTO THIS VEHICLE							
* 24.	LOAD IS SECURED TO PREVENT MOVEMENT							
25.	WEIGHT IS PROPERLY DISTRIBUTED AND VEHICLE IS NOT OVERWEIGHT							
* 26.	SEALS APPLIED TO CLOSED VEHICLE, FIRE AND WATER RESISTANT TARPULIN APPLIED ON OPEN VEHICLE							
* 27.	SPECIAL INSTRUCTIONS (DD Form 836) FURNISHED DRIVER							
* 28.	COPY OF VEHICLE INSPECTION (DD Form 626) FURNISHED DRIVER							
* 29.	PROPER PLACARDS APPLIED							
* 30.	SHIPMENT MADE UNDER DOT EXCEPTION 665							
SIGNATURE (of Inspector) ORIGIN				SIGNATURE (of Driver) ORIGIN				
<i>John Coulter</i>				<i>Harvey A. Bain</i>				
SIGNATURE (of Inspector) DESTINATION				SIGNATURE (of Driver) DESTINATION				
<i>Thomas Smith</i>				<i>Harvey A. Bain</i>				

DD FORM 626
APR 78

REPLACES EDITION OF 1 JUN 72, WHICH IS OBSOLETE.

FIGURE 19-2. Example of DD Form 626.

EXPLANATORY NOTES

REFERENCES IN ITALICS BELOW ARE THE APPLICABLE PORTIONS OF THE DOT MOTOR CARRIER SAFETY REGULATIONS (M.C.S.R.) AND THE CODE OF FEDERAL REGULATIONS (C.F.R.). DOD REQUIREMENTS ARE ESTABLISHED BY THE DEPARTMENT OF DEFENSE (DOD)

THE INSPECTOR MUST BE FAMILIAR WITH THE CITED PORTIONS OF THE SAFETY AND EXPLOSIVE REGULATIONS

MEDICAL EXAMINER'S CERTIFICATE - Certificate must not be over 24 months old. (M.C.S.R.)

Item 1, ENGINE, BODY, CAB, AND CHASSIS CLEAN (i.e., no excessive oil or grease) - Inspect to see that engine and compartment are clean, check cab to see that no excessive grease is on cab and cab floor is free of debris; check under cab and chassis for excessive grease. (DOD Requirement)

Item 2, STEERING MECHANISM - Inspect to see that steering mechanism is in good condition, in proper adjustment, correctly and securely mounted, and whether the steering gear case is leaking lubricant. Pay particular attention to the pitman arm and tie rod assembly to see that they are securely mounted and not bent out of normal shape. (DOD Requirement)

Item 3, HORN OPERATIVE - Inspect to see that horn is securely mounted and of sufficient volume to serve its purpose. (M.C.S.R.)

Item 4, WINDSHIELD AND WIPERS - Inspect to see that the windshields of the tractors are free from breaks, cracks or defects which would make operation of the vehicle unsafe, that the view of the driver is not obscured by stickers, that wipers operate properly, and that wiper blades are of proper kind and in good condition. Defroster operative when conditions require it. (M.C.S.R.)

Item 5, SPARE ELECTRIC FUSES AVAILABLE - Check to see that at least one spare fuse for each kind and type of installed fuse is carried on vehicle as a spare, or it is equipped with an overload protective device (circuit breaker) (M.C.S.R.)

Item 6, REAR VIEW MIRRORS INSTALLED - Every truck and truck tractor shall have installed two rear vision mirrors, one at each side, firmly attached and so located as to reflect to the driver a view of the highway to the rear along both sides of the vehicle. Mirrors must not be cracked or dirty. (M.C.S.R.)

Item 7, HIGHWAY WARNING EQUIPMENT - This equipment must include either three red electric lanterns in operating condition and two red flags or three red emergency reflectors and two red flags with standards adequate to maintain them in an upright position, or three red emergency reflective triangles or three bidirectional emergency reflective triangles. Flame producing equipment is prohibited. (M.C.S.R.)

Item 8, FULL FIRE EXTINGUISHER INSTALLED - Inspect to see that one full fire extinguisher having an Underwriters' Laboratories rating of 10 B:C or more is securely mounted and readily accessible. (M.C.S.R.)

Item 9, LIGHTS AND REFLECTORS OPERATIVE - (Head-Stop-Tail-Front and Rear Clearance) - Inspect all lights and switches, including clearance lights and turn signals; make sure they are not obscured by dirt or grease or have broken lens; high and low beam switch must be operative. **EMERGENCY** flashers operating on front and rear of vehicle. (M.C.S.R.)

Item 10, EXHAUST SYSTEM - Inspect the exhaust system to see that no part is so located as would be likely to result in burning, charring, or damaging the electrical wiring, the fuel supply, or any combustible part of the vehicle. The exhaust system shall discharge to the atmosphere at a location to the rear of the cab or, if the exhaust projects above the cab, at a location near the rear of the cab. (M.C.S.R.)

Item 11, LIQUID PETROLEUM GAS POWERED VEHICLES - Inspect LPG burning system to insure compliance with DOT standards prescribed in 49 CFR 393.69. (M.C.S.R.)

Item 12, FUEL TANK, LINE, AND INLET - Inspect tanks and fuel lines to see that they are in completely serviceable condition. Free from leaks or evidence of leakage and securely mounted. Examine caps for defective gaskets or plugged vents. Inspect the filler necks to see that they are in completely serviceable condition, securely supported and not leaking at joints. (M.C.S.R.)

Item 13, COUPLING DEVICES - KINOPIN LOCK - Inspect without uncoupling to see that the fifth wheel rocker plate and bed are in good condition, properly assembled and mounted, and adequately lubricated. Kinopin lock must operate freely and properly, lock securely, and not show excessive wear. (M.C.S.R.)

Item 14, ALL BRAKES OPERATIVE - (Including hand brakes and air pressure warning devices) - Inspect for oil or grease leaks around drum flanges, pedal travel, air or vacuum line leaks, moisture in tanks, compressor build up and governor cut off. Test for proper and adequate brake application. (M.C.S.R.)

Item 15, LANDING GEAR ASSEMBLY OPERATIVE - Landing gear assembly must be in good condition, correctly assembled, adequately lubricated, and properly mounted.

Item 16, SPRINGS AND ASSOCIATED PARTS - Examine visually the springs, suspension hanger mechanisms, torsion bar assemblies, and auxiliary parts such as U-bolts, shackles, center bolts and hangers, for breakage, improper adjustment, and, as appropriate, lack of lubrication. Air suspensions should not be leaking. (DOD Requirement)

Item 17, TIRES - Examine all tires for cuts, bruises, breaks, and blisters. All tires with cuts or injuries extending into the cord body and those worn smooth in the center of the tread are not acceptable. Insure that stones are removed from between duals. Tires must be properly matched on dual-equipped tractors and trailers. (M.C.S.R.)

Item 18, CARGO SPACE - Inspect to see that cargo space is clean and in good condition to prevent damage to lading from exposed bolts, nuts, screws, nails, or other inwardly projecting parts. Check floor to make sure it is tight and free of holes. Floors shall not be permeated with oil or gasoline. (C.F.R.)

Item 19, ELECTRIC WIRING - Electric wiring must be clean and properly secured, insulation must not be frayed or otherwise in poor condition. There must be no uninsulated wires or improper splices or connections. Wires and electric fixtures inside the body must be protected from the lading. (M.C.S.R.)

Item 20, TAILGATE AND DOORS ON CLOSED EQUIPMENT SECURED - Inspect to see that all hinges are tight in body. Check for broken latches and safety chains. Doors must close securely. (M.C.S.R.)

Item 21, FIRE AND WATER RESISTANT TARPULIN - If shipment is made on open equipment, check to make sure the lading is properly covered with a fire and water resistant tarpaulin. Explosive material packed in fire and water resistant containers and transported on flat-bed vehicles are not required to be covered with fire and water resistant tarpaulins. (C.F.R.)

Item 22, ANY OTHER DEFECTS (Specify) - Self Explanatory. **Item 23, MIXTURES OF MATERIAL PROHIBITED BY DOT REGS. ARE NOT LOADED ONTO THIS VEHICLE** - Check carefully to prevent loading of incompatible explosives. (C.F.R.)

Item 24, LOAD IS SECURED TO PREVENT MOVEMENT - Self Explanatory.

Item 25, WEIGHT IS PROPERLY DISTRIBUTED AND VEHICLE IS NOT OVERLOADED - Lading shall be distributed in accordance with the approved load plan, when available, or when not available, a plan agreed upon by the shipper and the carrier. The weight of the load shall not exceed the capacity of the vehicle established by the carrier. The gross axle weights and the gross vehicle weight shall not exceed the limits imposed by the states through which the vehicle is routed. The carrier shall inform the shipper of the state's law requirements. (DOD Requirement)

Item 26, 27, and 28 - Self Explanatory.

Item 29, PROPER PLACARDS APPLIED - Four standard placards applicable to the load will be furnished the carrier and insure they are conspicuously displayed, one in front, rear, and each side. (C.F.R.)

Item 30, SHIPMENT MADE UNDER DOT EXCEPTION 666 - This item will be checked when a shipment is made under the provisions of DOT Exception 666. When checked, it signifies that the shipment was loaded in compliance with carrier's notes on maximum weight and that the driver is released from certifying to Items 22, 24, and 25. (DOD Requirement)

REMARKS

FIGURE 19-2. Example of DD Form 626 (Continued).

- Keep personnel clear of loads being lifted by terminal or marshaling yard equipment.
- Keep roadways and marshaling yard aisles in good repair to minimize the danger of toppling container-bearing transporters.
- Chock the semitrailer when separated from the tractor.
- Turn off the vehicle's motor unless it is providing power to the vehicle accessories used to load or unload.

TRANSPORTING DANGEROUS/ HAZARDOUS CARGO

In addition to the rules that apply to general cargo, these general rules apply to most dangerous/hazardous cargo:

- Inspect vehicles that carry dangerous/hazardous cargo according to DD Form 626. The inspector checks to see that the vehicle can be operated safely and is free of grease accumulations that can cause a fire.
- Once the vehicle passes inspection, attach the proper placards to the vehicle front, rear, and sides to identify its cargo (Figure 19-3). (Use bilingual placards when outside of CONUS.)
- When loading and unloading, the driver must –
 - Set the vehicle's brakes.
 - Chock at least one wheel if the vehicle is on a grade.

- When driving with dangerous/hazardous cargo, keep a safe distance from the other traffic. Avoid sudden stops and turns. Do not smoke inside the vehicle. Do not enter tunnels or park overnight in populated areas.

Unless there is no practicable alternative, a motor vehicle which contains hazardous materials must be operated over routes which do not go through or near heavily populated areas, places where crowds are assembled, tunnels, narrow streets, or alleys. Operating convenience does not determine the practicability to operate a motor vehicle according to this paragraph. This paragraph does not apply to radioactive materials.

Except as provided below, the driver or another individual qualified to operate the vehicle must attend a motor vehicle which contains Class A or B explosives at all times. The driver of a motor vehicle which contains hazardous materials other than Class A or B explosives and which is located on a public street or highway must attend it. However, the

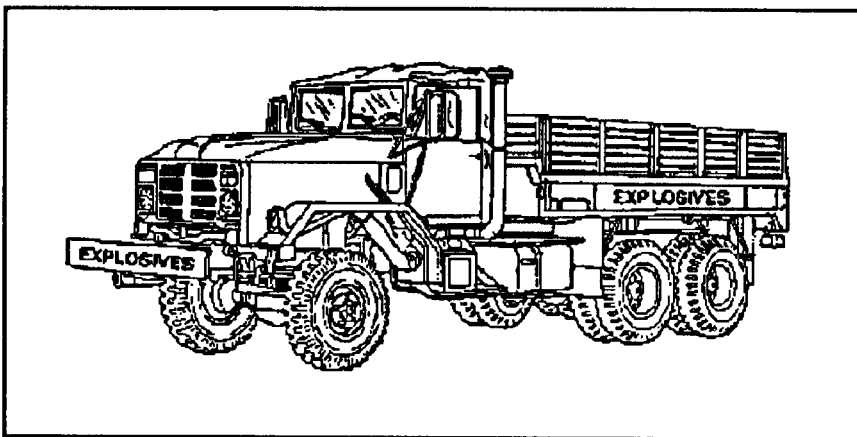

FIGURE 19-3. Placarding a Vehicle.

vehicle need not be attended while its driver is performing duties which are incident and necessary to his duties as the operator of the vehicle.

For purposes of this section –

- A motor vehicle is attended when the person in charge of it is awake in it (not in the sleeper berth) or is within 100 feet of it and has an unobstructed field of view of it.
- A qualified representative of the unit is a person who meets all these criteria
 - The unit has designated him to attend the vehicle.
 - He is aware of the nature of the hazardous materials contained in the vehicle.
 - He has been instructed on the procedures to follow in emergencies.
 - He is authorized and has the ability to move the vehicle.
- A safe haven is an area specially approved in writing by local, state, or federal governmental authorities for the parking of unattended vehicles containing Class A or B explosives.

These rules do not relieve a driver from any legal obligation relating to placing warning devices when a motor vehicle is stopped on a public street or highway. A motor vehicle which contains Class A or B explosives must not be parked under any of these circumstances:

- On or within 5 feet of the traveled portion of a public street or highway.
- On private property (including premises of a fueling or eating facility) without the knowledge and consent of the person who is in charge of the property and who is aware of the nature of the hazardous materials the vehicle contains.
- Within 300 feet of a bridge, tunnel, dwelling, building or place where people work, congregate, or assemble except for brief periods when the necessities of operation require the vehicle to be parked and make it impracticable to park the vehicle in any other place.

A motor vehicle which contains hazardous materials other than Class A or B explosives must not be parked on or within 5 feet of the traveled portion of public streets or highways except for brief periods when the necessities of operation require the vehicle to be parked and make it impracticable to park the vehicle in any other place.

These rules do not apply to motor vehicles which contain Class A or B explosives if all the following conditions exist:

- The vehicle is located in the unit motor pool, on the property of the shipper or consignee of the explosives, in a safe haven, or in the case of a vehicle containing 50 pounds of either Class A or B explosives, on a construction or survey site.
- The responsible individual of the explosives is aware of the nature of the explosives the vehicle contains and has been instructed on the procedures to follow in emergencies.
- The vehicle is within the responsible individual's unobstructed field of view or is located in a safe haven.

Missiles

Missiles are very different from most items the Army transports because they can be at the same time overweight, sensitive, and flammable. These complex characteristics call for special loading procedures. In fact, the procedures are so special that the Army publishes detailed loading and bracing drawings for each missile system.

Ammunition and Explosives

Army motor vehicles often transport ammunition and explosives. Although safety is always important, it is especially so when the cargo itself is dangerous.

A vehicle carrying explosives must be equipped with two fully charged dry chemical fire extinguishers. One of them must be mounted on the outside of the cab on the driver's side; the other mounted inside the cab.

NOTE: All fire extinguisher's must be inspected monthly to make sure they have not been damaged and the hose nozzles are not clogged. The inspection date and the initials

or name of the inspector must be recorded on a tag; the tag must be attached to the extinguisher. Another tag, indicating the date of the last weight-test, must also be attached to the extinguisher. Obtain instructions on these procedures from your local or military fire station.

Block and brace the load well to prevent its shifting during travel. Drawings of approved methods of blocking and bracing are available from the US Army Ammunition Procurement and Supply Agency. Refer to FM 55-17 before loading, blocking, or bracing any ammunition or explosive load. Be sure that detonating caps for such explosives as dynamite are not carried in the same vehicle as the explosives. While loading or unloading, handle explosives with care.

CAUTION

The truck's tailboard or tailgate must be closed and secured to be sure all ammunition or explosives stay inside the cargo compartment.

Chemical Agents

Federal agencies govern and regulate the transport of hazardous chemicals and related items within the United States. A brief summary of the regulations and safety standards to be used to load and unload this kind of cargo follows.

The Vehicle. The cargo compartment of the vehicle must be a closed body or one covered with a fire resistant tarpaulin. The vehicle must be equipped with red lanterns, red reflectors, red cloths, and two fire extinguishers for use in emergencies.

Loading and Unloading Safely. In addition to those precautions already explained, load containers with valves or fittings so damage to valves or fittings during transit is prevented. Vehicles, once unloaded, should be swept clean. The sides and floors should be tested for contamination and decontaminated if necessary.

Driver Instructions. Each driver of a motor vehicle transporting dangerous chemicals must be given full and complete information about the shipment to help him safely deliver the cargo to its destination.

When the vehicle is loaded, the driver is informed of necessary safety precautions verbally and in writing, using DD Form 836.

Liquid Fuels

When carrying gasoline or other liquid fuels, you need two fully charged fire extinguishers. (The same as for ammunition.)

Inspect gasoline cans for leaks. Do not let defective cans be loaded. Keep all gasoline cans, full or empty, tightly closed. When hauling gasoline in a cargo truck, remove tarpaulins unless otherwise instructed. If you must use tarpaulins, carefully air and dry them before they are folded and stored.

TRANSPORTING HAZARDOUS MATERIALS BY HIGHWAY

Because the transportation of ammunition, explosives, flammables, chemical agents, and radioactive materials is dangerous, it is essential that personnel involved know and observe applicable safety regulations.

A vehicle transporting Class A or B ammunition, explosives, or other hazardous material is inspected at —

- The origin of shipment. At this time deficiencies are corrected before the transporter enters a sensitive area.
- At trailer transfer points (when prime movers are exchanged).
- At destination, before delivery is accepted.

In CONUS, the shipper uses DD Form 626 as a guide to and record of the inspection. In an overseas theater, DD Form 626 (modified appropriately) may be used or may serve as a model for a locally produced inspection form.

In CONUS, military shippers use DD Form 836 to instruct drivers of military and commercial vehicles transporting dangerous material. Sections of the form outline actions to be taken in case of fire, accident, and breakdown and provide for entry of specific information by the shipper or transportation officer. This form (appropriately modified) may

also be used in an overseas theater or may serve as a model for a locally produced instruction form. The driver must have shipping papers available at all times. (See CFR 49 177.817.)

In CONUS, military vehicles transporting ammunition, flammable materials, or toxic chemicals must comply with DOT regulations governing highway movement of these materials. In an overseas theater, such movement must comply with theater policies and host-nation requirements.

Follow these general safety guidelines for motor transport of ammunition and explosives:

- To prevent accidental movement of the transporter while it is being loaded or unloaded, stop the engine, place the vehicle in gear, and set the parking brake and block the wheels.
- Handle the explosives with care. Do not jar or shock them.
- Prohibit smoking within 50 feet of a transporter loaded with explosive or flammable liquids. (The driver will not smoke during transport.)
- Prohibit open flames, such as matches, cigarette lighters, and torches, within 100 feet of a transporter loaded with explosives or flammable liquids.
- Each truck hauling explosives or flammables must have two dry chemical fire extinguishers, one inside the truck cab and one outside on the driver's side. Be sure drivers know how to check the serviceability of the extinguishers and how to use them.
- Vehicles will be driven at a safe distance from other traffic. Caution drivers against sudden stops or turns.
- Clearly label or placard vehicles to warn other traffic.

During highway movement of chemical agents, hazardous chemicals, and chemical ammunition, the driver should have a protective mask, protective clothing, and appropriate protective and first aid items, such as burn ointment, as necessary.

The driver must know the hazardous nature of his cargo, such as symptoms produced by toxic chemical agents and action to take in case of fire, spillage, or other emergency.

DETECTING FUEL LEAKAGE OCCURRING ON A PUBLIC HIGHWAY

Immediately upon detecting a leak in the cargo tank-

- Turn off the vehicle's electrical system. Extinguish any cigarettes or open flames in the vicinity. Remove the vehicle's fire extinguisher from its bracket and keep it close at hand. If an assistant driver or other person is available, tell him to man the fire extinguisher.
- Notify police of the hazardous situation by the most expeditious means.
- Inspect the leak. Determine if a field expedient, for example, a wooden plug or rubber matting, can be used to control the leak.
- Place highway warning devices at prescribed locations. Do not use flares.
- Keep spectators away from areas where flammable liquids are spilled or toxic fumes have accumulated.
- Guard against smoking by spectators or passing motorists. If personnel are available, post guards to warn passing vehicle drivers of the fire hazard.
- Notify nearby residents when spillage may place them in danger.

When civilian police and/or fire fighting personnel arrive, tell them the nature of the cargo. Follow instructions issued by fire or police department personnel until the hazard is neutralized. Military personnel will inform civilian investigators and cooperate with civilian authorities in clearing the damaged equipment from the highway.

DETECTING FUEL LEAKAGE OCCURRING OFF THE ROAD

Emergency Procedures

Immediately upon detecting a leak in the cargo tank -

- Turn off the vehicle's electrical system. Extinguish all sources of ignition in the area.
- If the tanker is a semitrailer, lower the landing legs, disconnect the semitrailer from the tractor, and drive the tractor a safe distance from the semitrailer.
- Remove the vehicle fire extinguisher from its bracket and keep it close at hand. If an assistant driver or other person is available, tell him to man the fire extinguisher.
- Inspect the leak. Determine if a field expedient, for example, a wooden plug or rubber matting, can be used to control the leak.
- If space is available in another compartment of the tanker, transfer the fuel from the leaking compartment to the secure one. However, this procedure is not recommended when fumes have accumulated around the tanker pump.

Fuel Transfer

When other fuel-transporting vehicles are available and not filled to capacity, you may transfer fuel from the leaking compartment to their cargo compartments. When this method is used, use only the pump on the secure vehicle and separate the vehicles the maximum distance allowed by the available hose.

Fuel Jettisoning

When fuel cannot be transferred from the leaking compartment, contact your nearest hazardous material protection facility (local fire station) for permission to locate a proper location to jettison fuel.

CAUTION

Army, Department of Defense, and federal regulations prohibit routine discharge of

USING SAFETY PROCEDURES

If you use petroleum tank vehicles, know and observe the safety precautions in this section and those in the chapters dealing with specific vehicles and operations. These procedures apply to all the vehicles in this manual. When refueling aircraft, however, follow the additional instructions in FM 10-68.

Whenever you operate a tank vehicle or transfer a product, follow these safety procedures:

- Position the tank vehicle in the transfer area so that it is headed toward the nearest exit and away from buildings or other obstructions. Do not let other vehicles block exit routes.
- When possible, conduct petroleum operations on level ground. Always stop the engine and set the brakes. If you are on a grade, chock the wheels.
- Keep at least 25 feet between the tank vehicles during receipt and issue operations. To avoid congestion during transfers to other vehicles, maintain a distance of 100 feet between the tank vehicles engaged in transfer operations. Also, be sure you have a clear escape route when the tank vehicles are parked overnight in the designated parking area.
- During all loading, unloading, and fuel-servicing operations, keep the tractor coupled to the tank semitrailer. However, if the semitrailer is used for temporary storage, you may keep it uncoupled from the tractor.
- Keep the manhole cover open during all loading, unloading, and fuel-servicing operations. Do this so the tank shell does not collapse if a vent fails. When opening the manhole cover, stand on the windward side of the vehicle.

- When transferring a product, the driver of the receiving vehicle operates the dispensing nozzle of the discharge hose. By doing this, the driver can top off his own vehicle at the proper level.
- When the transfer operation is completed, carry the nozzle and the discharge hose back to the fuel tank vehicle. Do not drag it on the ground
- Keep the canvas top and rear curtain of the tractor in place whenever the vehicle is carrying, loading, or unloading a product. The top and curtain keep the tractor from being splashed with fuel from the vehicle catwalks.
- Check the pressure vacuum relief valves frequently in cold weather to be sure they are operating properly.

Fire Prevention

Aside from enemy attack, fire is the greatest danger during fuel tank vehicle operations. To prevent fires -

- Post NO SMOKING signs around the area of operation. Observe no smoking rules. Do not let anyone carry matches or lighters when working around a fuel tank vehicle.
- Keep a dry chemical fire extinguisher manned and ready for use during all petroleum tank vehicle operations. At permanent fueling installations, build a covered storage point in which a carbon dioxide, foam, or dry chemical fire extinguisher and sand may be kept. Keep this storage point close to the loading and unloading area. Inspect all fire extinguishers at this storage point monthly to be sure they have not been damaged and the hose nozzles are not clogged. Record the inspection date and the initials or name of the inspector on a tag; attach the tag to the extinguisher.
- Bond and ground all vehicles and equipment before you start any petroleum tank vehicle operation.
- Stop all petroleum operations if there is an enemy attack, electrical storm, or a fire in the area.

- Keep all possible sources of vapor ignition away during fuel tank vehicle operations.
- Be sure the drop tube or discharge hose is close to the bottom of the tank during top loading. This cuts down on vapors and static electricity. When top loading jet fuel, start pumping at a reduced flow rate until the lower end of the drop tube or discharge hose is covered with the product.
- Use explosion-proof extension lights, flashlights, and electric lanterns. Be sure all electrical equipment used is explosion-proof and in good operating condition.
- Do not drag hoses across the rear decks of combat vehicles or near their exhaust systems. Armor plates and exhaust pipes get hot during operation, could damage hoses, and could cause a fire.
- Do not drive past or near a fire until it is safe to do so.
- Stop the flow of fuel and close the manhole cover if a fire is in a tank compartment.
- Wash immediately with soap and water if you get fuel on your skin.
- Wet fuel-soaked clothes with water and remove them immediately. If you do not have any water, temporarily ground yourself by holding a piece of grounded equipment with both hands. Then remove your hands from grounded equipment and take off your clothes. This grounding action removes the danger of a static spark igniting your clothes.

Bonding and Grounding

Bonding is the process of electrically connecting two units to equalize any static potential that might exist between them. Bonding also forms a path for any static potential that might develop while the operation is in progress.

Grounding is the process of electrically connecting single or bonded units to ground rods so that any static potential that might exist at the beginning of

the operation or that might develop during the operation, is discharged into the earth.

Always bond and ground both vehicles and equipment before you start petroleum operations. To do this, first ground the tank vehicle and the other unit involved to the ground rod. If you use only one ground rod to do this, you do not need to bond. If you use two rods, bond the tank vehicle to the other unit by running a cable between them. Then touch the hose, drop tube, or discharge nozzle to fill the cap before you remove it. During the operation, keep the nozzle in contact with the fill opening at all times. When the operation is completed, close the fill cover before disconnecting the bonding and grounding cables.

Spill Control

Fuel spills or overflows at tank vehicle receipt and issue points can pollute the soil, create a fire hazard, and cause a loss of fuel. To prevent spills or overflows —

- Gauge both the receiving tank and the tank vehicle before and after a transfer. When traveling cross-country, use a gauge stick to measure the amount of product in the tank compartment.
- Attend all discharge nozzles or loading arms constantly while refueling. Also do not use nozzles with notched handles. If you find a nozzle with a notched handle, modify-it so the handle cannot be held open in the locked position.
- Do not exceed safe refueling rates. Also, top off all containers at a reduced flow rate and fill containers only to prescribed levels. At the completion of every operation, drain all hose sections into an appropriate container.
- Keep nozzles, hoses, or drop tubes inside containers to avoid spray.
- Try to keep the product from entering streams or sewers except as directed by police or fire department personnel.
- Fill drums and cans on the ground or on a ground rack.
- Use the pressure control when filling a 500-gallon collapsible drum. If you do not have a pressure control or meter, leave a 1 1/2-inch depression in the top of the drum to allow for product expansion. Whenever the drums are air-lifted, you MUST use the pressure control.
- Park loaded bulk petroleum transporting vehicles under shade whenever possible. Heat from the sun will cause the POL to expand. If natural cover is not available, use a camouflage screen system to shade the tanker.

CHAPTER 20

VEHICLE CAMOUFLAGE AND NUCLEAR, BIOLOGICAL, AND CHEMICAL OPERATIONS

This chapter implements STANAG 2002.

Actual operations prove that what you do in training you will also do during warfare. Part of this training will come through field exercises and maneuvers simulating warlike conditions. You must know what to do during passive defense and blackout driving and when driving under nuclear, biological, and chemical (NBC) conditions. The unit SOP contains warning systems; actions to take when under aircraft, guerrilla, and NBC attack; and conduct in a motor march or convoy. Learn what is expected of you so that you will automatically do the right thing at the right time.

VEHICLE CAMOUFLAGE OPERATIONS

Stationary Vehicle Camouflage and Concealment

A stationary vehicle can best be camouflaged by placing it under vegetation to break up the regular pattern of shadows and by covering all parts likely to reflect light noticeably. Use blankets, shelter halves, or pieces of dark burlap to cover the windshield, cab window, a wet vehicle body, light paint on insignia, and so forth. Use foliage to cover headlights. Fishnet or chicken wire scattered with artificial material or with vegetation can be used to cover the vehicle when trees or bushes are not available. When snow is on the ground, cover the vehicle with white cloth. Be sure that color and texture blend with the surrounding area. For information on drape net sizes, refer to TM 5-1080-200-13&P.

Camouflage Screen System

The camouflage screen system is the principal artificial expedient for camouflaging vehicles. Use it when concealment by natural methods or materials is not possible or to supplement natural

methods and materials in sparsely vegetated or barren areas such as deserts, predominantly snow-covered areas, and thinly wooded areas.

The modular system consists of a hexagon screen, a diamond-shaped screen, a support system, and a repair kit. The screens are made of synthetic, lightweight, water-resistant material. Any number of screens can be joined together to cover an area. The screens are fastened together by a quick-connect-disconnect system to facilitate their joining or separation.

Radar-transparent screens (Type I screens) are identified by a five-sided tag attached to the screens at every other corner. (The tag identifies the screen as either woodland, snow, or desert.) The radar-transparent camouflage screen system, designed for use over active radar equipment, inhibits detection of the concealed items by visual and photographic means.

CAUTION

The radar-transparent screen can be placed over most active radar equipment. Camouflage screens induce interference in continuous-wave radar systems. Consult appropriate end item technical manual/order for any restrictions or limitations.

Radar-scattering screens (Type II screens) are identified by a rectangular tag attached to the screen at every other corner. (The tag identifies the screen as either woodland, snow, or desert.) The radar-scattering camouflage screen system can be temporarily placed over halted vehicles, weapons, and materials, and over semipermanent positions and installations. It prevents the enemy from locating and identifying the camouflaged items with visual, photographic, or radar devices.

NOTE: The woodland and desert screens come in seasonal patterns. One side of the screen has a spring-summer pattern; the other side, a fall-winter pattern. The desert screen has arid and semiarid sides.

Radar-scattering screens and radar-transparent screens are not visually different. The only difference between the two screens is that the radar-scattering screens have stainless steel filaments impregnated in the garnish material. Because of their minute size the steel filaments cannot be detected, but give the radar-scattering screen its radar-reflective capabilities. The procedures to erect, strike, or repair the radar-scattering and radar-transparent screens are the same.

The only difference between the woodland and desert screens are the pattern, incising, and colors. Use woodland screens in woodland environments; desert screens, in desert environments. The procedures to erect, strike, or repair the woodland and desert screens are the same.

The support system is used with radar-scattering or radar-transparent screen systems (Figure 20-1). The support system consists of —

- 12 aluminum pole sections (4-foot), which can be extended to various heights.
- 18 aluminum stakes.

- 18 batten spreaders, which support the screens. (Batten spreaders can be of different designs and are interchangeable.)
- A locking device called a spreader adapter assembly. (Batten spreaders and spreader adapter assemblies are made from a plastic material.)
- A carrying case for the support system.

The repair kit contains sufficient material for operator/crew personnel to repair the screen (Figure 20-2).

The screen system and support system have separate carrying cases. The camouflage screen systems should be stored in a cool, dry place.

Combat support units and combat troop units use the camouflage screen system to conceal stationary target signatures, weapons, vehicles, and semi-permanent positions when natural cover or concealment may be inadequate or absent.

The lightweight camouflage screen system can also help to conceal permanent noticeable objects and objects in a fixed pattern or array that present obvious targets. However, permanent installation camouflage usually requires construction of concealment features, such as false roofs, dummy buildings, and garnished wire netting.

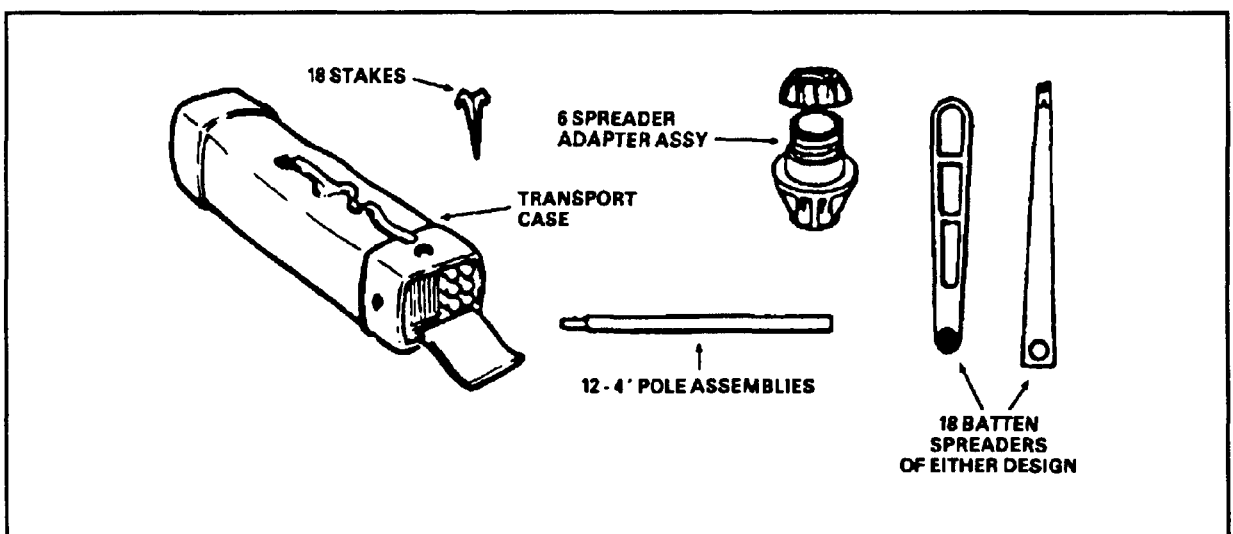

FIGURE 20-1. Support System Transport and Storage Case (With Components).

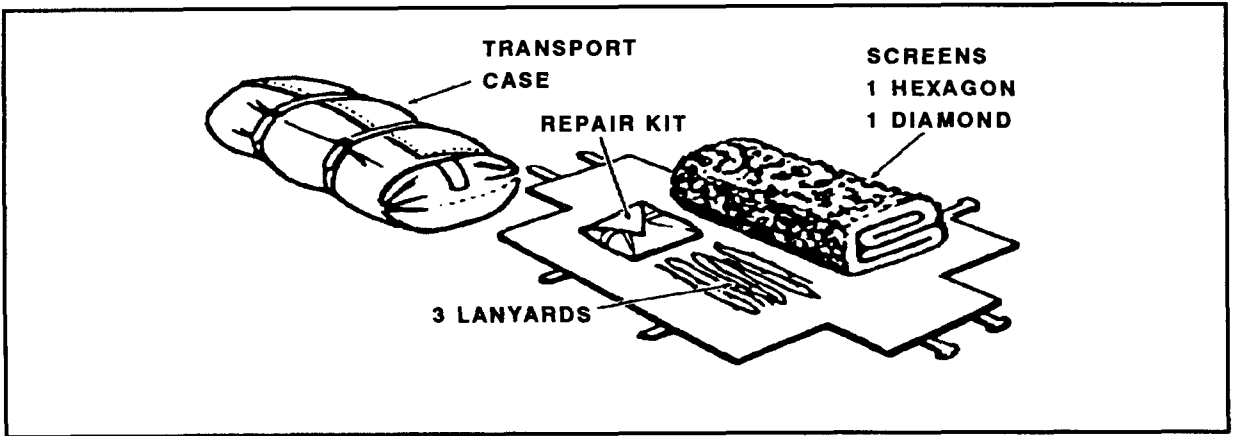

FIGURE 20-2. Screen Transport and Storage Case (With Components).

Dimensions of the screen system and support system are —

- Weight and cube of the packaged camouflage screen system: 70 pounds, 5.0 cubic feet.
- Weight and cube of the packaged support system 70 pounds, 3.1 cubic feet.

Erection of Camouflage Screens Over Vehicle

When erecting the camouflage screen over a vehicle, take extreme care to prevent the screen from snagging and tearing on any sharp corners or vehicle accessories, such as mirrors, bumpers, mounted armament, and so forth. When joining multiple screens, first spread the screens to be joined over a level ground site free from large rocks and sharp objects. Be sure the same pattern design on all screens is facing the same way.

CAUTION

Keep screens away from all exhaust systems including those on vehicles, heaters, and stoves. Screens can be damaged if not struck and removed from the back blast area of field artillery before firing.

To effectively conceal a vehicle, maintain a minimum space of 2 feet between the screen and the top of the vehicle. Never drape screens over a vehicle. Use the support system at all times. Draping the

screen shows the outline of the vehicle underneath and lets the enemy immediately recognize the vehicle, thus defeating the purpose of camouflage. Disguise the shape of the screens as much as possible by placing the support assemblies beneath the screens at various positions and heights.

To ease assembly and disassembly of the support pole sections, keep both ends of the pole free from dirt, mud, and foreign matter. Wipe both ends clean before assembly. Take care to prevent damage to the pole ends, which could cause an improper fit. Inspect the pole ends for burrs or damage before assembly.

If you must erect the screens in muddy area provide the support poles with a firm footing by placing them on top of any appropriate material available, such as a flat rock, boards, or brush. If such material is not available, you may need to add another 4-foot pole section in order to reach firm footing and then reposition the pole assemblies as required.

CAUTION

When multimodule configuration is used (8 feet high or more), the camouflage screens can be blown down when winds exceed 20 MPH. Equipment would be damaged.

After screens are erected, check them daily for proper erection and retighten as required. Check the screens more frequently during high winds and heavy snowfalls. Do not let lots of snow or ice accumulate on screens. Remove snow or ice from the

screen as soon as it starts to sag and begins to show signs of stress or strain due to excessive weight.

Follow these special precautions when erecting the radar-scattering screen over whip antennas used on the AN/GRC-106 radio sets or similar radios with whip antennas:

- Mark a 16-inch diameter circle in the garnish material over the antenna. Use the antenna as the center of the circle.
- Cut the garnish material for a distance of approximately three-fourths of the circle's circumference. Do not completely cut the garnish material around the circle's circumference. Do not cut the netting.
- Lay the garnish material flap back to expose the netting. Temporarily secure the flap to the screen with plastic straps provided in the repair kit.
- Place the screen so that the radio antenna is located in the center of the exposed netting. Be sure to maintain approximately 8 inches between the antenna and garnish material at all times.
- Place all aluminum support poles at least 4 feet from the antenna.

- After the antenna is removed repair the screen by removing the plastic straps holding down the garnish flap. Reposition the **garnish flap** to its original position and secure it in place with plastic straps.

WARNING

FLAMMABLE MATERIAL: The radar-scattering screen will ignite and burn if it comes near or touches the whip antennas on the AN/GRC-106 radio sets or similar sets with whip antennas when the radio is transmitting.

CAUTION

Do not place the radar-scattering screen system over active radar equipment. It will seriously interfere with the operation of any radar equipment.

The procedures to erect a two-module camouflage screen system are shown in Figure 20-3. Figures 20-4 and 20-5 show how to fold screens for storage.

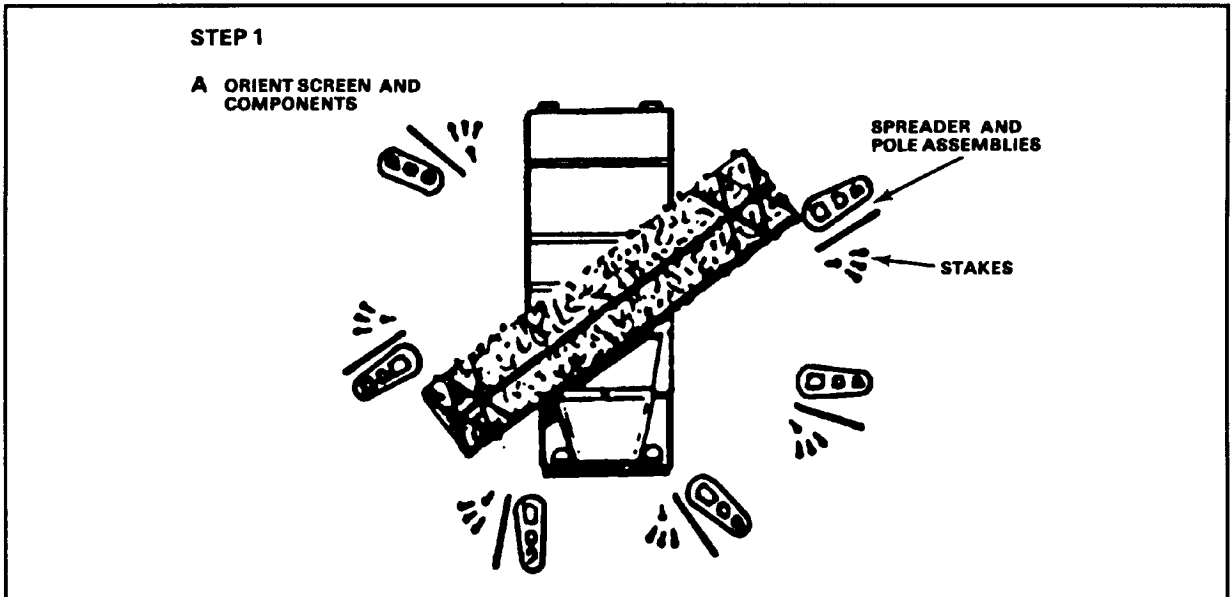
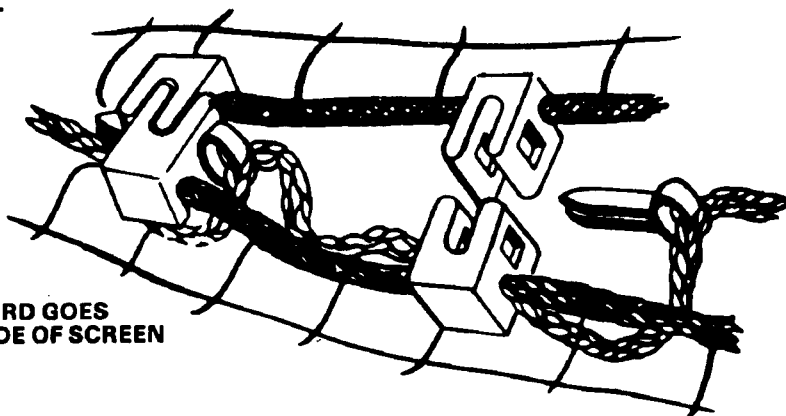

FIGURE 20-3. Procedures for Erecting a Two-Module Camouflage Screen System.

STEP 1 (Cont)

NOTE: WHEN USING MULTIPLE MODULE TECHNIQUE, CONNECT ALL SCREENS TO BE USED BEFORE ERECTING.

B TO JOIN SCREENS, CLIP EDGES TOGETHER WITH LANYARD CORD. ALL PINS SHOULD POINT IN THE SAME DIRECTION.



LANYARD CORD GOES ON UNDERSIDE OF SCREEN

STEP 2

A TO EXTEND POLES TO DESIRED LENGTH, REMOVE SECTIONS FROM TRANSPORT CASE AND INSERT SMALL END OF ONE POLE INTO LARGE END OF OTHER POLE.

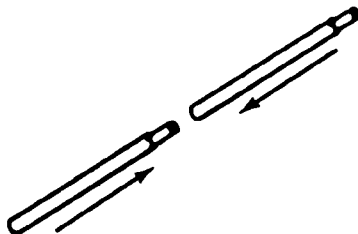

B PLACE SPREADER OVER TOP OF POLE. PUSH DOWN UNTIL SPREADER IS FIRMLY SEATED.

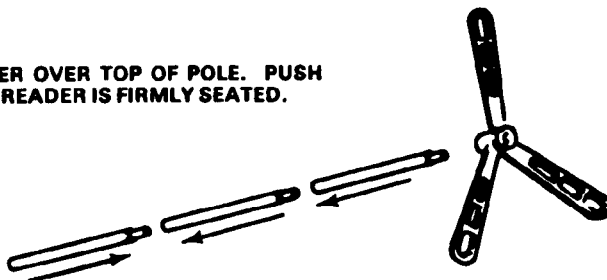

C TO INSTALL SPREADERS, LOOSEN TOP NUT.

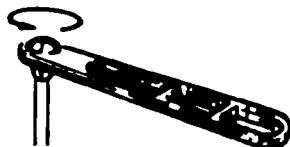

EXTEND ARMS OF SPREADER AND TIGHTEN TOP NUT.



FIGURE 20-3. Procedures for Erecting a Two-Module Camouflage Screen System (Continued).

STEP 3

A SPREAD OUT SCREEN AND STAKE CORNERS.

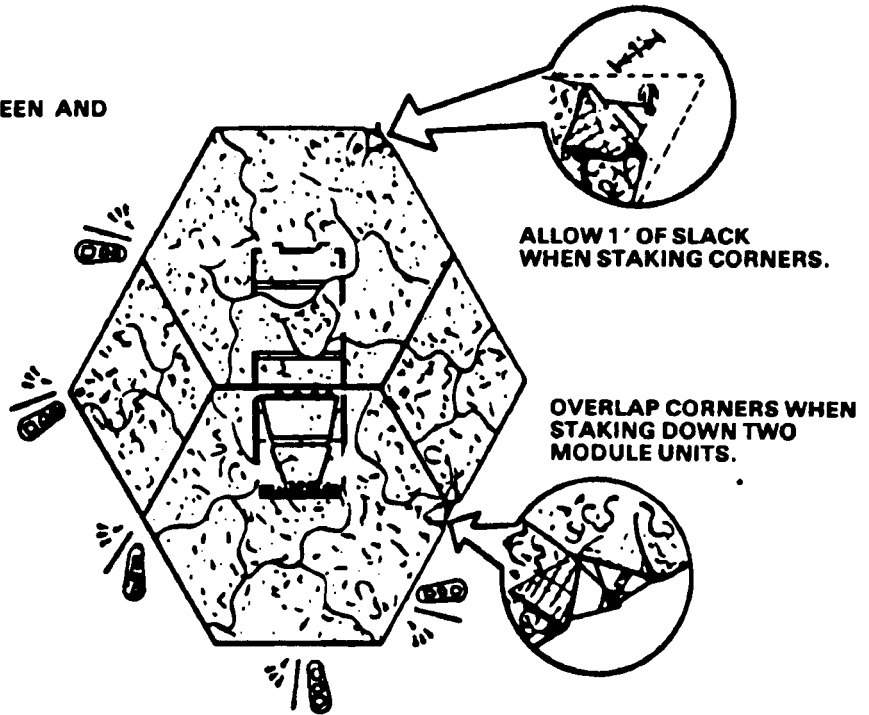

B PLACEMENT OF SPREADERS

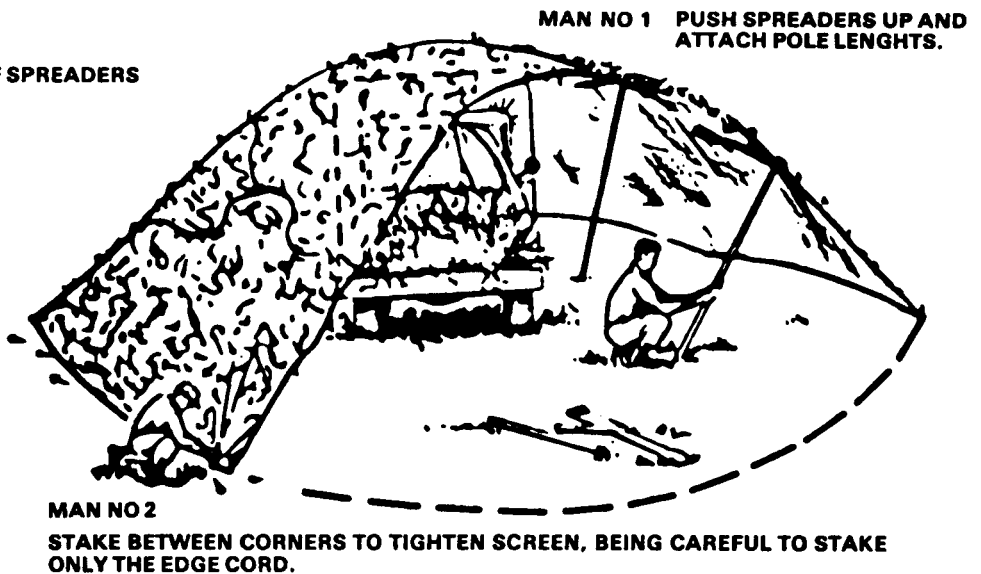

FIGURE 20-3. Procedures for Erecting a Two-Module Camouflage Screen System (Continued).

STEP 3 (Cont)

CAUTION: IF THIS 2-FT MINIMAL SPACE BETWEEN SCREEN AND VEHICLE IS NOT MAINTAINED, SCREEN WILL NOT CONCEAL

STAGGER POLES TO DISRUPT STRAIGHT LINES.

LOWER CANVAS FLAP TO HIDE THE SHADOW.

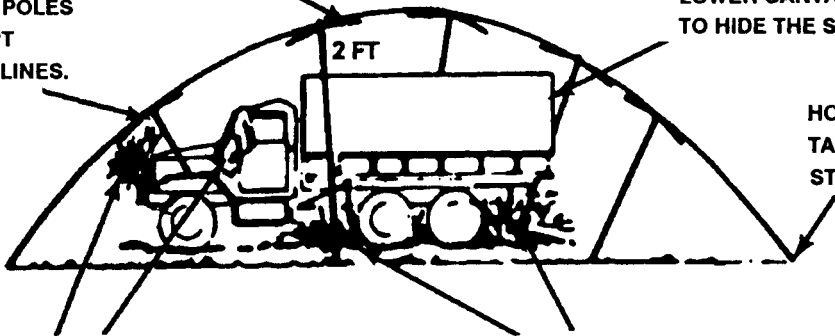

COVER LIGHTS WITH BRUSH, WINDSHIELD WITH TARPULIN.

BREAK UP RECOGNIZABLE SHADOWS WITH BRUSH.

FIGURE 20-3. Procedures for Erecting a Two-Module Camouflage Screen System (Continued).

THE METHOD OF FOLDING A SINGLE SCREEN.

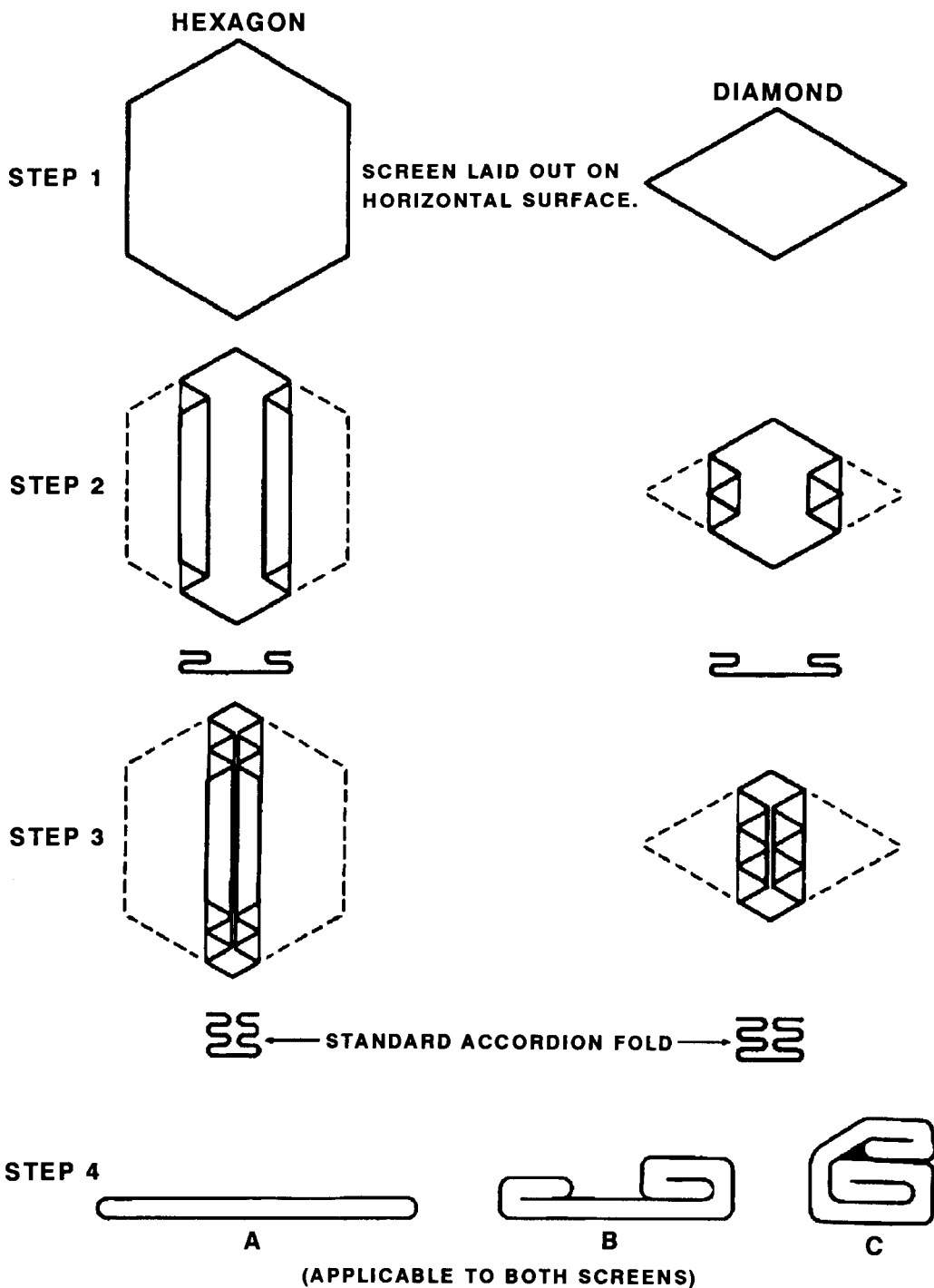

NOTE: AFTER STEP 4, PLACE BOTH SCREENS IN COVER AND SECURE.

FIGURE 20-4. Method of Folding a Single Screen.

THE METHOD OF FOLDING SCREENS FOR STORAGE.

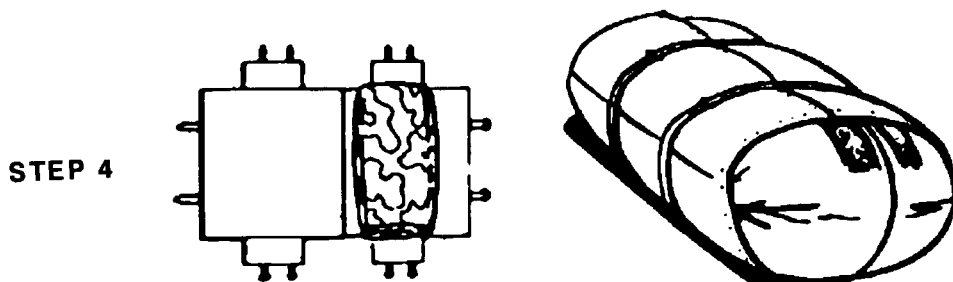
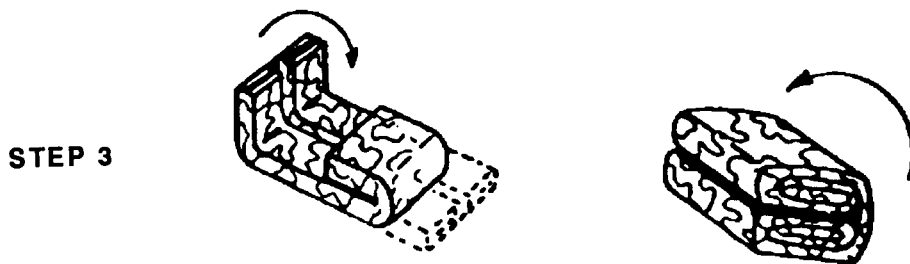
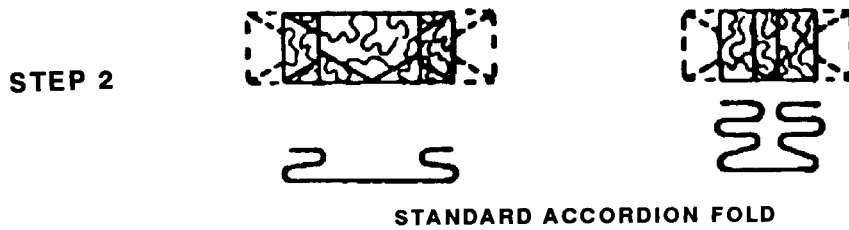
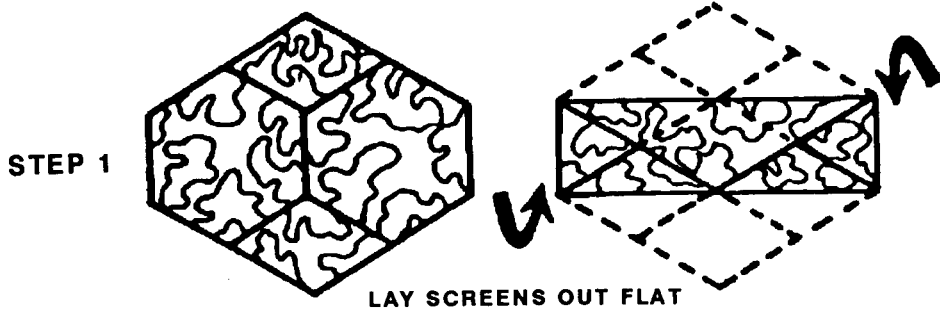

FIGURE 20-5. Method of Folding Screens for Storage.

OPERATIONS UNDER NUCLEAR, BIOLOGICAL, AND CHEMICAL (NBC) CONDITIONS

After a suitable period following NBC contamination of an area, you may operate your vehicle through the area safely using the protective measures you have been taught. Time limits vary depending on the use of protective clothing, temperature, nature of the contaminant, type of soil and terrain, and task to be performed. If your mission requires you to operate your vehicle in a radiologically contaminated area, your commanding officer must decide the maximum dose to which you will be exposed.

Practices for Operating Vehicle in Contaminated Area

The following practices are helpful in carrying out your mission:

- Before entering chemically contaminated areas, put on protective clothing and the protective mask.
- Use hard-surface roads, if available.
- Avoid unnecessary splashing if roads are muddy.
- Clean the wheels of your vehicle after crossing the area.
- Guard against splashes from tree branches.
- Move through the area as rapidly as safety rules will allow.

Vehicle Operation While Wearing Protective Masks

Under combat conditions, situations change. You may be moving forward with assault troops, in a foxhole, or standing by in a replacement area some distance from the combat area. In any of these situations, you are subject to enemy gas attack. Therefore, always remember your mission comes first. Thus, you may be operating your vehicle while wearing your protective mask. Although wearing your protective mask may be inconvenient

and slightly uncomfortable, the ease with which you can wear it for an extended period improves with practice and self-discipline. Train yourself to drive while wearing the mask. Above all, keep it on until instructed to remove it. The undisciplined soldier, feeling terribly sick, uncomfortable, and ill at ease, will remove his mask and die. A well-trained disciplined soldier will keep his mask on and live. Trucks must move. If you remain calm and do not panic, you have a much better chance of completing your mission.

Marker Descriptions

Use the triangular signs described in this chapter and Appendix C (STANAG 2002) to mark NBC contaminated areas, chemical minefield, booby traps, and unexploded munitions unless the area is to be abandoned to threat forces. The colors of the signs indicate the nature of the contamination or danger. These include the primary color and the secondary color (Figure 20-6). The primary color is used for the background of the front surface and for the entire back surface. The secondary color is used for additional markings and inscriptions on the front surface.

Areas containing more than one type of contamination or other hazard are marked with the relevant signs placed close to each other. However, the sign GAS MINES is assumed to include the presence of high-explosive mines and booby traps as well as chemical mines. Simulated contaminated areas are marked exactly as if they were real.

The signs are the shape of a right isosceles triangle (90 degrees by 45 degrees by 45 degrees). They are made of plastic, wood, metal, or other rigid material with holes or "ears" that are used to hang them above the ground. They are placed on wire boundary fences, poles, trees, or rocks. STANAG 2002 prescribes the coloring and markings of the signs. The signs may be mass-produced by major commands for distribution to subordinate units or may be made locally. The base of the triangle is about 28 centimeters (11 inches); the opposite sides, about 20 centimeters (8 inches) each (Figure 20-7).

Chemical Contamination Marker. This triangle is yellow on both sides. The word GAS in red 5-centimeter (2-inch) block letters is placed on the front side of the marker facing away from the

contamination. Use fluorescent paint, if available. Place the name of the agent (if known) and the date and time of detection on the front of the marker with paint, marking pencil, or grease pencil at the time of emplacement.

Biological Contamination Marker. This triangle is blue on both sides. The letters BIO in red 5-centimeter (2-inch) block letters are placed on the front side of the marker facing away from the contamination. Use fluorescent paint, if available. Place the name of the agent (if known) and the date and time of detection on the front of the marker at the time of emplacement.

Radiological Contamination Marker. This triangle is white on both sides. The word ATOM in black 5-centimeter (2-inch) block letters is placed on the front side of the marker facing away from the contamination. Place the dose rate, date and time of reading, and the date and time of burst (if known) on the front of the marker at the time of emplacement.

Chemical Minefield Marker. This triangle is red on both sides. The words GAS MINES in yellow 2.5-centimeter (1-inch) block letters with a horizontal yellow 2.5-centimeter (1-inch) stripe underneath the lettering are placed on the front side of the marker facing away from the contamination. Use fluorescent paint, if available. You may inscribe the name of the chemical agent in the mines and the date of emplacement on the front of the marker if the commander desires.

Booby Trap Marker. This triangle is red on both sides. A white 4-centimeter (1.6-inch) horizontal stripe is painted on the front side of the marker facing away from the booby-trapped area.

Unexploded Munition Marker. This triangle is red on both sides. A white bomb at least 10 centimeters (4 inches) tall is painted on the front side of the marker facing away from the dangerous area.

Special Radiological Marking Procedures

The marking of radiologically contaminated areas merely indicates a hazard. Newly arrived troops must determine its extent using instrument readings, surveys, and information from other units.

At the commander's discretion, a radiologically contaminated area need not be marked when it is a military advantage to not do so. In this case, take positive measures to warn other friendly forces of the radiologically contaminated area.

Place signs on all probable routes leading into contaminated areas at the points where the dose rate reaches 1 rad per hour (rad/hr) measured 1 meter above the ground.

Levels of radiation less than 1 rad/hr normally are not marked even though long stays in areas of old contamination might produce significant doses. Units planning prolonged stays in any area during a nuclear war must check the area with radiac instruments even if it is marked.

DANGER	PRIMARY COLORS	SECONDARY COLORS	
		MARKINGS	INSCRIPTIONS
RADIOLOGICAL CONTAMINATION	WHITE	NONE	BLACK
BIOLOGICAL CONTAMINATION	BLUE	NONE	RED
CHEMICAL CONTAMINATION	YELLOW	NONE	RED
CHEMICAL MINEFIELDS	RED	YELLOW STRIPE	YELLOW
BOOBY-TRAPPED AREAS	RED	WHITE STRIPE	NONE
UNEXPLODED MUNITIONS	RED	WHITE (BOMB)	NONE

FIGURE 20-6. Primary and Secondary Colors.

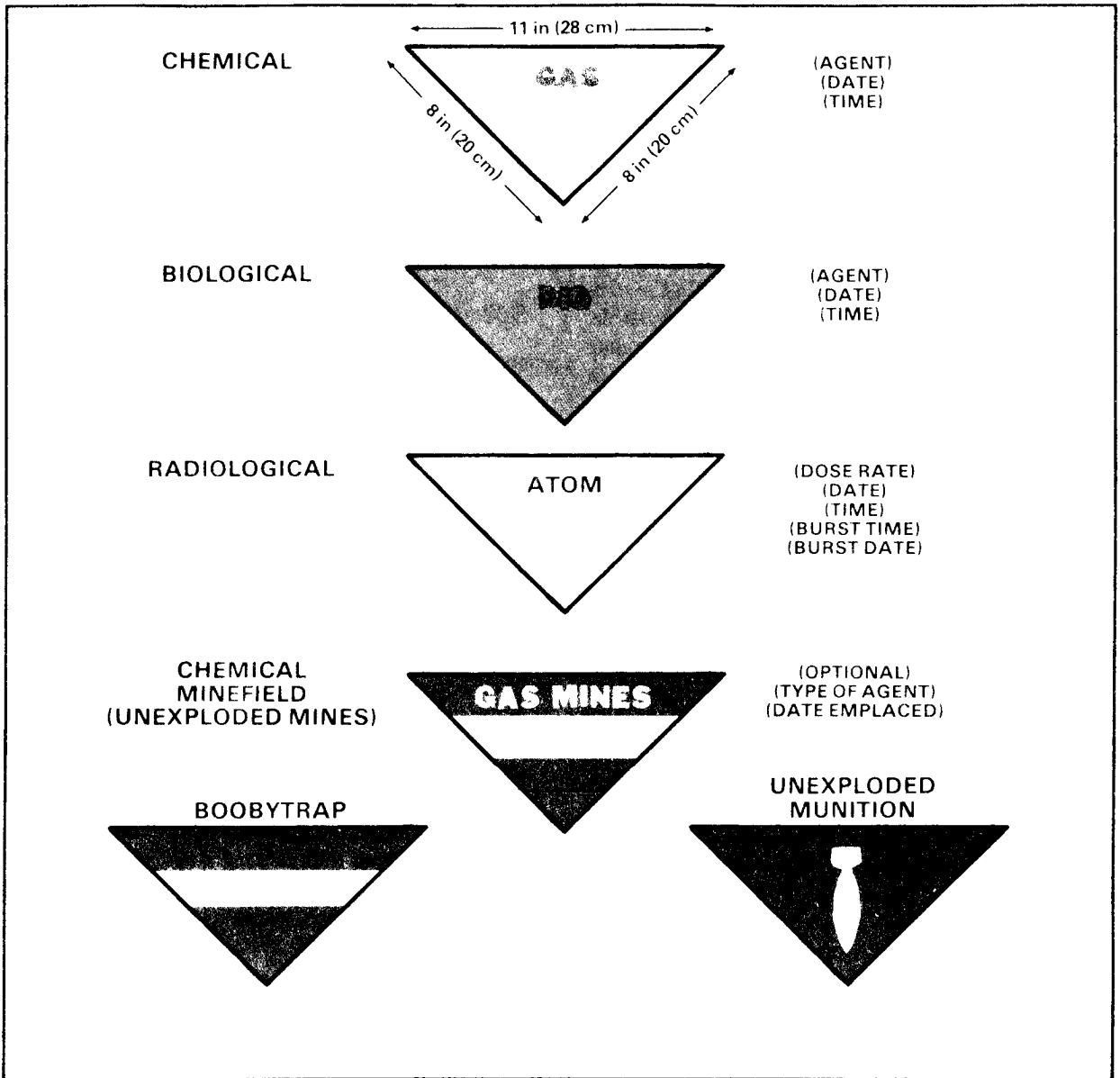

FIGURE 20-7. Markers of Contaminated or Dangerous Land Areas.

NOTE: The unit responsible for the area corrects or moves signs periodically to account for radioactive decay.

Commanders leaving an area or otherwise giving up responsibility for an area should leave perimeter signs in place - unless the area is being abandoned to threat forces. The commander taking over the responsibility for the area will continue the periodic correction or movement of the signs and remove them when they are no longer necessary.

Mark dumps for radiologically contaminated material at intervals around the perimeter with signs that are visible from one another.

Equipment Decontamination

As soon after contamination as the situation permits, decontaminate unit equipment as follows.

Vehicles. Each tactical vehicle is authorized one M11 portable decontaminating apparatus that will hold 1 ½ quarts of decontaminating agent DS2.

The M11 apparatus is not intended to decontaminate of the entire vehicle. One filling of DS2 is sufficient for emergency decontamination of the operator controls. Tank crews and armored personnel carrier drivers use the M11 to decontaminate those parts of their vehicles that personnel will touch during a mission; for example, areas touched when entering or leaving the vehicle. If sufficient DS2 is not available, use mud rags or any other expedient. Decontaminate contaminated wood surfaces and tires with slurry.

NOTE: If the driver of a vehicle realizes the vehicle is contaminated, all occupants mask and continue their mission until the situation permits decontamination.

Decontaminate the vehicle with DS2, soapy water, solvents, or slurry. (Lightly contaminated vehicles may be decontaminated by airing.)

Crew-Served Weapons. Decontaminate these weapons using the methods described above. If considered necessary, decontaminate the bore by using cleaning solvent or hot soapy water. Decontaminate ammunition DS2 solution, wiped with gasoline-soaked rags, and then dried.

If DS2 is not available, ammunition may be washed with cool soapy water, rinsed, and dried thoroughly. Dispose of ammunition corroded from contact with chemical agents, particularly if the brass cannot be cleaned. Do not use dry super tropical bleach (STB) on ammunition contaminated with mustard-type blister agents because when mixed they may ignite and start a fire.

Optical Instruments. Decontaminate optical instruments by blotting with rags, wiping with an organic solvent (only lens-cleaning solvent is used for the lens), and then allowing them to air-dry. If available, hot air may be used to decontaminate most optical instruments.

Communications and Radar Equipment. Decontaminate communications and radar equipment using hot air, if available. The next best method is by airing or weathering. The metal parts of field telephones and radios are decontaminated by the heat given off during operation.

NOTE: Any metal surface decontaminated with DS2 must then be cleaned to remove the DS2, which is corrosive.

Support-Level Equipment Decontamination Stations

Equipment decontamination stations are located as far forward as possible. A specialized decontamination team or unit normally runs them. A typical layout for such a station is described in FM 3-100. Collapsible tanks may be used to store water. Use standard decontaminating materials and equipment, if available. Brooms, mops, and pails may be used if the standard equipment is not available. Dispose of contaminated wash water in such a way that it is not a hazard. (A sump pit is one means of disposing of the wash water.)

Personnel Decontamination Stations (PDSs)

Large-scale personnel decontamination stations (Figure 20-8) may be of three types: permanent, semipermanent, and field expedient. The permanent PDS is located in a building specifically designed and built for this purpose only. The semipermanent PDS is normally set up in an existing structure that has been modified to serve the purpose. These two types of PDSs are usually established at higher levels of command where locations will be relatively static. See FM 3-100 for details and sample layouts of these two PDSs.

The field expedient PDS may be established in many configurations depending on the available equipment and location. If water is not available, a mobile PDS can be established using the M12A1 power-driven decontamination apparatus (PDDA). The field expedient personnel decontamination stations are normally located as far forward as possible and near a medical aid station, if possible. A clothing exchange facility and a first aid and monitoring facility are operated in conjunction with the field expedient PDS. In addition, the field expedient PDS should be located in an area that provides concealment from air and ground observation and where contaminated water can be disposed of safely.

In an emergency when a PDDA is not available, you may need to establish a field expedient PDS to

decontaminate personnel units that cannot be withdrawn from combat. The PDS provides fresh clothing, equipment, and a means to dispose of contaminated clothing, equipment, and water.

An uncontaminated area near a source of water (such as a stream, well, or water storage facility) is selected, if possible. If the area is contaminated

first decontaminate it by turning or removing a top layer of soil or sand or by using available decontaminating agents. Preferably, the area selected should have overhead cover. If not, provide this cover to protect against chemical attack. The area should be located to take advantage of any available cover and concealment and camouflaged to hinder enemy detection.

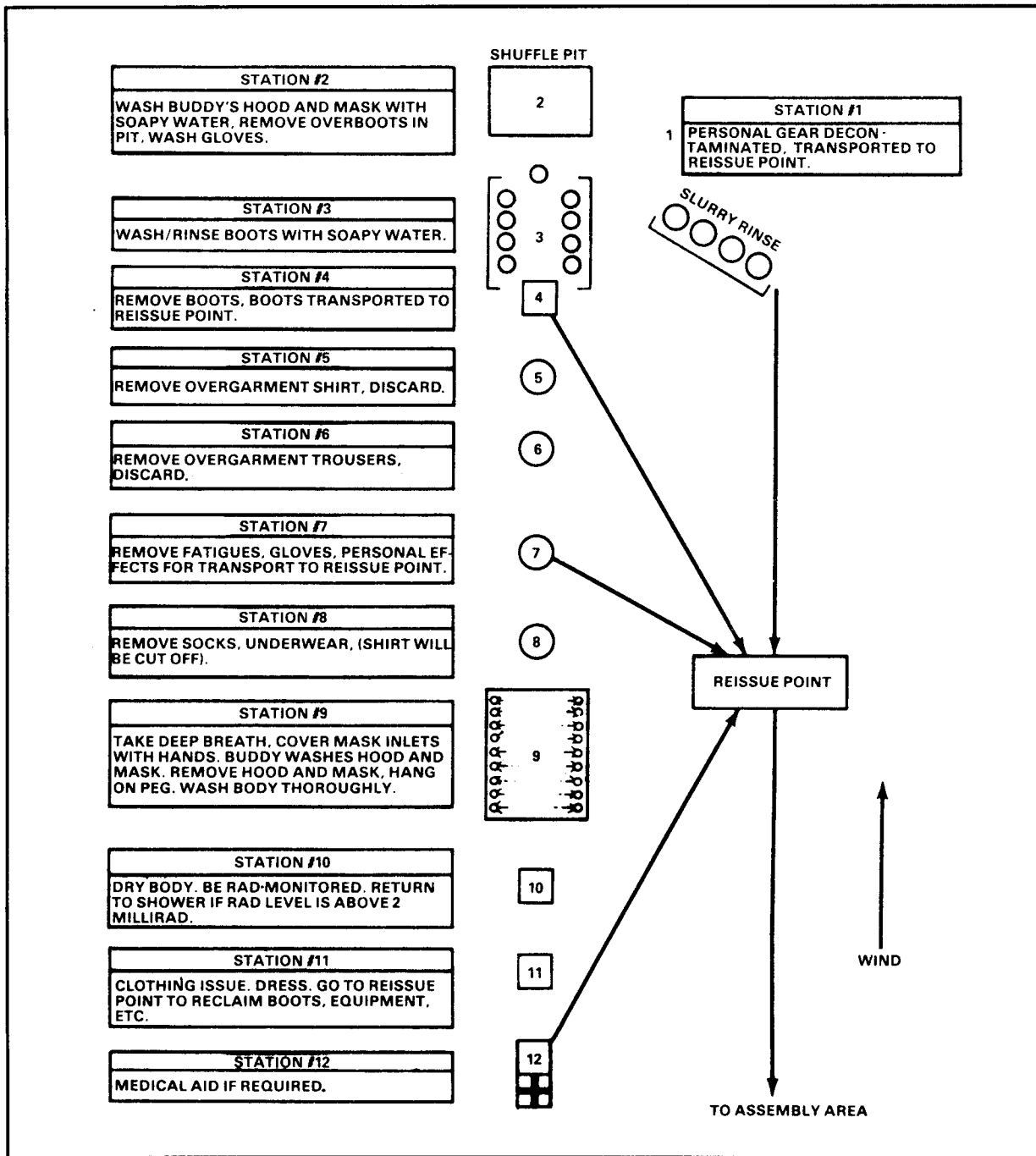

FIGURE 20-8. Personal Decontamination Station.

The following materials and equipment can be used

- Containers (such as GI cans, boxes, or plastic bags) in which to put contaminated clothing as it is removed.
- Water pump and hose (if PDDA is not available).
- Water heater, improvised (if an M1 or M2 water heater is not available).
- An overhead pipe with shower heads (ordinary pipe or rubber hose with holes can be used).
- Lumber and nails for benches and walks.
- Pails of soapy water and clear water with brushes to decontaminate of boots and masks.
- Tarpaulin or any other material to use as overhead cover.
- Medical tent or substitute.
- Clothing exchange tent or substitute.

Assistants are required at the various stations within the PDS to supervise and help personnel going through the line.

FM 3-100 details a recommended undressing procedure. However, the undressing procedure should be modified according to the facilities and conditions at the specific PDS.

The unit SOP should include a personnel decontamination station annex that gives guidance on the following

- Organization of the decontamination line.
- Personnel required at stations on the line and their duties.
- Supplies required.

- Description of boot-cleaning buckets and instructions for use, frequency of contents renewal, disposal of contaminated waste, and replenishing buckets.
- Undressing procedure, including a practical unmasking procedure for personnel going through the line.
- Procedures for decontaminating individual equipment and reissue before departure from the PDS.
- Coordination for disposing of contaminated clothing.

If units with both male and female personnel need to be decontaminated, the PDS may be set up to provide separate facilities for males and females. To do this, establish two lines of decontamination points (shower heads) separated by a canvas tarpaulin. Female assistants, if available, would assist the females; and male assistants, the males. **HOWEVER, IF SUCH ARRANGEMENTS ARE NOT AVAILABLE, THE PRIMARY CONCERN MUST BE THE PRESERVATION OF LIFE AND THE IMMEDIATE REMOVAL OF THE CONTAMINANT FROM ALL PERSONNEL WITHOUT REGARD TO GENDER.** In either case, once personnel have departed the shower area (are no longer in a life-death situation), separate dressing areas should be provided for men and women.

Decontamination Materials and Their Use

STB Decontaminating Agent (Bleach). Super tropical bleach can be applied undiluted but should be used either as a dry mix (with earth) or a wet mix (with water). Do not leave it on contaminated surfaces for longer than 24 hours because it corrodes metals. STB neutralizes liquid chemical agents by chemical action. Dry bleach in direct contact with liquid blister agents reacts violently and can cause flame and heavy vapor. STB is chemically active, causing vigorous corrosion of metals. Wet mix is effective against biological agents.

DS2 Decontaminating Agent. Ready-to-use solution is available in 1 1/3-quart cans and 5-gallon drums. DS2 can be applied easily with the M11 decontaminating apparatus, a broom, or a swab. One application of DS2 should be made to the contaminated surface and flushed with water after 30 minutes. The solution is effective at temperatures from -26° to 52° C (-15° to 125° F). DS2 neutralizes all known chemical agents and most biological agents. It reacts with G-agents, V-agents, and blister agents to reduce their hazards within 30 minutes after application.

Washing Soda (Sodium Carbonate). Make a solution by stirring 2 pounds of washing soda into 2 1/2 gallons of water. Then apply it to the contaminated surface. Washing soda neutralizes most chemical agents and is especially effective against G-agents. It is used as a washing agent for blister agents. Decontamination is faster with concentrated solutions.

Caustic Soda (Lye). Make a 5 percent solution by stirring 1 pound of lye into 2 1/2 gallons of water. Then apply it to the contaminated surface. Caustic soda neutralizes chemical agents and biological agents. It is especially effective against G-agents. Decontamination is faster with concentrated solutions.

Fuels and Solvents. Fuel is applied to contaminated areas and ignited. Solvents (like gasoline, kerosene, or carbon tetrachloride) are applied with swabs, taking care not to spread

the contamination. Ignited fuels destroy agents. Solvents merely remove them, but sufficient solvent can dilute most dangerous contamination.

Water or Steam. Water or steam is applied under high pressure. The action of hot water is speeded by using soap or other detergent. Hot water may also be applied with swabs. Water or steam removes dirt or grease containing chemical agents or radioactive material. Hot soapy water removes G-agents and physically removes other chemical and radiological contamination.

CAUTION

Use temperature and air velocities that are safe for the particular equipment involved. Effluent air will be contaminated.

Hot Air. Hot air is used in special situations, such as decontamination of delicate instruments contaminated with liquid agents or decontamination of aircraft cabins, using the engine heaters. Hot air evaporates liquid chemical contaminants.

WARNING

Drain water and condensed steam into a properly marked sump pit. If you must drain into a stream, notify friendly units downstream.

CHAPTER 21

OFF-ROAD AND WINTER DRIVING

Off-road and winter driving conditions present special challenges for the vehicle driver. This chapter gives guidance on driving off-road and during winter conditions.

OFF-ROAD DRIVING

CAUTION

The operator should first check the vehicle technical manual for the equipment operated and follow instructions for driving under other than normal conditions. Driving techniques differ for rear-wheel drive, front-wheel drive, and all-wheel drive vehicles.

Ditches

Cross shallow ditches by shifting into low gear or range and proceeding slowly. Enter the ditch obliquely so that one wheel leaves the ditch as the other wheel on the same side enters it. When crossing deep ditches, use the lowest forward gear and four-wheel drive if the vehicle is so equipped. When you reach the bottom, accelerate the motor enough to keep rolling as you go up the other side. If the ditch is deep and has very steep sides, you may have to cut away the tops of the banks before trying to cross.

Gullies and Ravines

Gullies and ravines are natural formations caused by running water. Look these formations over carefully to find a place to cross and to ensure that your vehicle can get across. Examine both banks. If water is flowing in the ravine, check its depth. Put your vehicle in low gear and slowly approach the ravine at a right angle to the edge. Using the foot brake, ease the front wheels into the gully; take care to have them strike the bottom at the same time. Bring your engine up to normal operating speed as your wheels hit the bottom. Accelerate enough to climb as your front wheels touch the opposite bank.

Woods

Woods help to conceal you and your vehicle from air observation, but they present certain problems. Fairly open woods with trees at least as far apart as the width of your vehicle will allow passage if you can maneuver your vehicle around the trees. Use an established trail if possible. Do not plan to return on the same route because these same saplings may stop or damage your vehicle when braced against it. If the trees are too dense and prevent your passage, drive as closely as possible to the edge of the woods using shadows for concealment. Although woods can be an obstacle to vehicles, they are not to the foot soldier. Wooded areas are likely spots for guerrillas, partisans, or enemy troops. Be alert to the possibility of an ambush.

Stumps. A high tree stump, if straddled by your vehicle, can seriously damage the vehicle axles and other low parts. Moreover, stumps can injure your tires. Check ground clearances and drive with caution.

Low Limbs. When you drive through wooded areas, whether on country roads or cross-country, low-hanging limbs may break your tarp bows or rip your top and radio antennas. (It is usually best to remove the canvas top and the bows for field operation.) Survey the route to determine if your vehicle can proceed without damage from low-hanging limbs or if it is practicable to remove obstructing limbs.

Timber. Fallen trees may often be crossed by piling dirt or other material on each side and then driving over it if required and if angle crossings cannot be achieved.

Rocky Terrain

Do not try to straddle large boulders; they will damage axles and other low parts of your vehicle. Move very slowly when driving in very rocky terrain. Carry an extra spare tire if one is available as there is greater danger of flats. Remove stones between dual tires as often as possible to prevent breaking the sidewalls of the tires.

Mud and Swamps

Every military vehicle has enough power in its lowest gear to pull out of mud if it gets traction. Try to pull out slowly in low gear or low range if your vehicle is equipped with an automatic transmission. Placing boards, brush, or similar material under the vehicle's wheels can increase traction. Remember the following points:

- Select the gear that will get you through. Roll onto the soft area at a medium speed for the selected gear. Carefully maintain a steady throttle until you reach solid ground.
- If stopped by mud rolling up in front of your wheels, you may have to back off and hit it again with regained momentum. Under most conditions, this technique requires prompt action. Otherwise, the mud will fill the tracks behind your wheels and slow or stop your backing. You must have solid footing within reach of your vehicle to do this.
- If you get stuck in a vehicle equipped with an automatic transmission, try to pull out slowly in low gear or low range. If you cannot pull out and if brush or boards do not provide the needed traction, get another vehicle to pull you out. When other vehicles are not available and your vehicle is equipped with a winch, attach your winch cable to a tree or solid object and pull yourself out with winch power. Do not rock your vehicle; it will only dig in.

Streams

Your vehicle technical manual/order contains specific instructions on fording streams. In addition to those instructions, follow these precautions before fording

- Check the stream bottom to determine how firm a support you can expect.
- If you expect some sinking, determine if this sinking added to the water depth will exceed your vehicle's fording limit. If the fording limit will be exceeded, find another crossing point.

After reaching dry land, test your brakes while moving at a reduced speed. If your brakes do not

operate properly, continue at a slow speed while maintaining a light steady pressure on the brake pedal to cause a slight drag on them. The heat should dry your brakes.

NOTE: See the appropriate vehicle -10 TM for correct procedure.

Sand

Procedures. The main objective when driving in sand is to maintain movement with the least amount of strain on the vehicle, its engine, and its power train. To do this—

- Estimate if a sandy area is drivable.
- Adjust the tire pressure to meet changing conditions.
- Use various aids to improve bearing surfaces.
- Exercise sound driving techniques.

Your ability to do these things well comes only through experience.

Tire Pressure. Reduce tire pressure when driving in soft sand and over dunes. This increases the amount of tire surface in contact with the sand to provide better flotation (support). However, never reduce tire pressure so much that the tire slips on the rim. Refer to your vehicle technical manual/order for proper tire pressure. When operating with reduced tire pressure, drive at low speed. Inflate tires to normal pressure (for cross-country or hard surface, as appropriate) as soon as the situation permits.

Accessories. To help you meet, take proper action for, and overcome the many difficult conditions associated with extended driving in sand, you should be provided with —

- A tire gauge.
- The means to inflate tires if your vehicle is not so equipped.
- Spare valve cores.
- Readily available material for use under wheels in extremely soft areas.

- Shovels and tow chains or cables.
- Vehicle lubrication and servicing at more frequent intervals as specified by your unit commander.

Driving. To start on sand-

- Be sure tires have proper tire pressure.
- Follow normal engine-starting procedures.
- Select a gear or range that will start you with a minimum of, or no, clutch slippage and wheel spinning.
- Accelerate gradually.

To drive on sand -

- Maintain a steady and even rate of movement.
- Avoid unnecessary shifting of gears. If your vehicle is equipped with an automatic transmission, keep it in low range.
- Anticipate difficult spots and try to bypass them.
- Head for a small stretch of soft sand with increased speed, when necessary, to take advantage of momentum.
- Stop before entering an extensive stretch of soft sand. Reduce the tire pressure, if necessary. Start off in a gear or range that you think will take you through with little need for further shifting and a minimum of clutch slippage and wheel spinning. As soon as the need for low tire pressure ceases, stop and reinflate to appropriate pressure.
- Approach a dune (hill of sand piled up by the wind) from the windward (most gradual) slope at a 90-degree angle. Select the proper gear or range to avoid shifting while on the slope. Maintain as much momentum as possible while going up the slope; be prepared to change direction as you reach the crest. Ride the crest if necessary to seek a safe route. If you must use the lee (steepest) slope, select a point where the angle of approach will allow the front bumper to clear.

- Follow in the tracks of preceding vehicles or break a new path depending on conditions.
- Make wide turns. Sharp turns can stall or even overturn your vehicle.

To stop in sand -

- Let your vehicle roll to a halt if practicable. Otherwise, brake gradually. This prevents tires from digging in, which happens when brakes are used.
- Try to stop on a downhill slope. This gives you an advantage when starting.

Freeing Vehicle. At the first sign that your vehicle is bogging down, try a lower gear. If it still bogs down -

- Stop power to the driving wheels. If you continue to use the motor to force the vehicle out of the sand, it will only sink deeper. It will be more difficult to get out.
- Check tires for sand operation inflation. High temperature may have built up the pressure.
- Lower the tire pressure, if necessary, for emergency movement over a short distance. (Check the vehicle technical manual/order for the allowable minimum tire pressure.)
- As soon as the need for low tire pressure ceases, stop and reinflate tire to appropriate pressure.
- Try to drive on.

If lowered tire pressure is not enough to free the vehicle, use any or all of the following procedures:

- Shovel a clear path ahead of the wheels.
- Lay boards, brush channels, canvas, wire netting rope ladders, or some similar material under and in front of the tires for better flotation and traction.
- Use the winch or a tow if you see that continued operation of the vehicle under its own power will only cause it to sink deeper into the sand.

- If a vehicle is bellied down and must be pulled out, unload the vehicle to the extent needed.
- As soon as the need for low pressure ceases, stop and reinflate tire to appropriate pressure.

Vehicle Care. In addition to responsibilities contained in your vehicle technical manual/order, you must —

- Keep valve caps on all tires.
- Check engine temperature and oil pressure frequently.
- If overheating occurs, check for loose or broken fan belt. Correct as necessary.
- Clean the oil spout before adding oil. Remove any accumulation of sand or dirt around the filler hole.
- Clean the spouts of gasoline containers before using them for refueling. Under extremely dirty conditions, falter gasoline when filling tank.
- Inspect nuts, bolts, springs, mountings, and accessories frequently for evidence of looseness or damage.
- When halted overnight or for any extended period, park with the rear of the vehicle toward the wind. If this is not possible, cover the windshield and radiator with a tarpaulin to prevent sand from accumulating in the engine compartment and damage to the windshield.

WINTER DRIVING

Particularly during cold weather, exercise extreme care starting and operating your vehicle. Keep your vehicle in the best mechanical condition possible. Otherwise, it will not operate properly. Carbon monoxide poisoning is an added hazard. This poisoning from inhaling the exhaust fumes of the vehicle usually results in death. To avoid it, never sleep in the cab of your vehicle with the engine or heater running. Whenever the heater is used while driving, leave a window open slightly. Inspect the vehicle exhaust manifold, muffler, and tail pipe for serviceability and tightness daily. Never leave the

engine ruining while working on the vehicle in a closed building. Remember these points:

- Vehicles equipped with mud and snow tires will slide more on icy road surfaces than those with commercial tread. Mud and snow treads are more effective on roads covered with loosely packed snow.
- All-wheel drive vehicles without chains generally perform better than two-wheel drive vehicles with chains on rear wheels.
- Chains give a good bite in snow or mud but tend to slide and slip on ice and packed snow.
- Sand, cinders, or dirt scattered on icy road surfaces gives more traction than chains.
- Fresh snow may conceal an icy road surface.
- Although snow or ice may be melting on roads, it may remain solidly packed or frozen on bridges.
- Better traction is gained when the load is distributed evenly on all wheels.
- Three to eleven times more distance is required to stop a vehicle on pavement covered with ice or snow.
- Isolated patches of ice may be on an otherwise clear road, especially in shaded areas.

Cold weather engine starting and warm-up procedures apply. Avoid excessive use of the choke because unburned gasoline will wash down the cylinder walls, destroying the oil film and diluting the engine oil. Do not race a cold engine.

As a last resort when the engine will not start, tow the vehicle with another or call your unit maintenance crew according to unit policies. Do not push the vehicle.

Start driving in second or third gear rather than first or low. Engage the clutch gradually (or in D2, high, with automatic transmission), and accelerate no more than necessary to keep from stalling.

Avoid quick acceleration on slick roads. It will probably cause you to skid.

Driving methods and practices discussed in Chapter 8 apply, modified as follows:

- Drive at reduced speeds so you can stop quicker.
- Give turn signals sooner than usual. This gives other drivers more time to react.
- Pump your brakes to warn early of your intention to stop.
- Maintain at least double the normal distance from the vehicle ahead.

Good all-around visibility is the first requirement for safe driving. Keep windshields, windows, mirrors, headlights, spotlights, and body lights clean and free of snow and ice. If defrosters are not available, keep windshields clean by using the windshield wiper, wedging the rear of the hood open so motor heat is vented toward the windshield, or thoroughly ventilating inside the vehicle. Cover windshields of vehicles parked in open lots with cardboard or canvas to prevent overnight frosting.

Descend moderate grades in the gear normally used to climb the same grade. On steep or very slippery grades, use at least one gear lower and go slower.

When visibility is poor, use low-beam headlights to warn other drivers of your position. Stop, park off the roadway, and wait for conditions to improve if visibility is zero. If you absolutely must continue, have an assistant driver or passenger walk in front of the vehicle as a guide.

Avoid vehicle tracks, rocks, and other objects that might throw the vehicle sideways and start a skid.

Keep the cab door open when crossing frozen streams. You may need to get out in a hurry if the ice thins.

After driving through slush or water, test your brakes while moving at a reduced speed. If your brakes do not operate normally, continue at a slow speed while maintaining moderate pressure on your brake pedal to create a slight drag. The heat generated by friction between the brake shoe and brake drum will dry your brakes.

On roads that slope toward side ditches, you may need to straddle the center or crown to avoid sliding to the side. Watch carefully for approaching traffic.

WARNING

Drivers of large vehicles should be aware that the shoulder of the road may give way due to vehicle weight.

If unsure about a difficult stretch of road, stop and inspect it carefully before going across. Select a gear that will get you through. If following a vehicle, wait until it crosses. You may need to render assistance if it gets stuck.

To drive through heavy slush, shift down before entering it and keep moving. If wheels begin to spin, disengage the clutch at once, back up, and try again or try rocking by shifting rapidly between forward and reverse gears.

At traffic stops -

- Gradually ease up on the gas. Leave vehicle in gear.
- Apply brakes intermittently and lightly. Use engine compression as much as possible to assist braking.
- Disengage the clutch at the last possible moment to prevent stalling.
- Avoid sudden braking on slick roads so you will not skid.

When parking -

- Place brush, boards, or other suitable material beneath wheels when parking for an extended period on wet, slushy, or muddy surfaces. This keeps the tires from freezing to the ground or being "pocketed" in ice.
- Do not set the parking brake when parking brake linings may freeze to the brake drums. Instead, block the wheels and place the transmission in the appropriate gear for parking as directed by the vehicle technical manual/order.

Tire Chains

Chains are designed to creep or move on the tires. Tighten them by hand, never with tools. Creeping or moving of chains reduces the possibility of the links gouging into tires. When using chains continuously, check their fit and condition at each halt. Install repair links as soon as one of the cross chains is broken.

When installing tire chains under normal conditions —

- Check the chains' condition. Eliminate twists.
- On some vehicles, tire chains must be installed on all driving wheels. Check the vehicle operator's TM.
- Drape chains over tires with OPEN ENDS OF CROSS CHAIN HOOKS AWAY FROM THE TIRE and with fasteners on the trailing ends of the side chains.
- Tuck the first cross chain under the front of the tire. Move the vehicle forward until the fasteners are hub high.
- Straighten and center the chains.
- Lift the ends of the side chains to determine which links will be hooked into the fasteners.
- If installing on duals, first fasten chains between wheels, then inner chains, and finally the outer chain. If installing on singles, fasten the inner chain before the outer chain.

When the vehicle is mired —

- Determine if you want to install your chains with a forward or backward wheel motion.
- Check the chains' condition. Eliminate twists.
- Drape chains over tires with OPEN ENDS OF CROSS CHAIN HOOKS AWAY FROM THE TIRE and with fasteners on the trailing ends of the side chains.
- Locate the first cross chain near mud or snow line.

- If the chains are dual, fold the inner half of the chain over top of the outer half. This makes a doubled chain on the outer wheel. For this reason, the methods listed below then apply to either dual or single wheels.
- Secure one end of each side chain to the wheel by a strong wire, cord, or chain passed through the opening in the wheel and fasten to the inner and outer side chains adjacent to the first cross chain.
- Pull the chain back to take up slack and align with tire. To keep the loose chain from one wheel from being caught up by the other, pile it close behind the wheel to which it is secured.
- Revolve wheels slowly to draw chains around tires. Stop when fasteners are at the top of the tires.
- Pull side chains up tight to select links to be hooked into fasteners. Hook the inner side chain first.
- When the vehicle has been moved to solid ground, loosen and remove the temporary wires, cords, or chains. Adjust the chains to their proper position.

Vehicle Care

In addition to the responsibilities contained in your vehicle technical manual/order, follow these procedures for vehicle care in cold weather.

Keep all fuel tanks and containers as nearly full as possible to keep moisture from condensing inside the fuel tanks and containers. Moisture not only contaminates the gasoline but also may freeze in the fuel lines. Filter the gasoline through a chamois to remove water.

Drain the air tanks in your vehicle each time it is stopped long enough for the tanks to become cold. This reduces the chance of moisture collecting in the tanks, entering the brake lines, freezing and making the brakes inoperative.

On brief halts during extremely cold weather, let the engine run at a fast idle so that the ammeter shows a charge. A fast idle results in better

burning of fuel and a more even engine temperature. Under normal operating conditions, stop the engine during brief halts. This will prevent plug fouling and overheating.

On long halts, park your vehicle with the rear end toward the wind to keep snow out of the engine.

When it is very cold, cover the radiator and hood with a tarpaulin or other suitable material.

In severe cold, start the engine frequently between operating periods to keep it warm.

CHAPTER 22

VEHICLE RECOVERY

This chapter describes a few of the more common field vehicle recovery procedures – operations you can perform with limited resources. In any of these operations, remember to use brainpower to make up for a lack of available horsepower. Take your time in figuring your rigging and include a reasonable factor for safety. Sloppy planning results in wasted time and may further damage your vehicle and equipment as well as injure yourself and others. Recovery failures are often the direct result of haste.

(For Army Only : Refer to FM 20-22 for further information.)

RECOVERY PROCEDURE

Remember the steps in Figure 22-1 to improve chances of vehicle recovery:

Reconnoiter the area.
Estimate the situation.
Calculate the ratio.
Obtain the resistance.
Verify the solution.
Erect the rigging.
Recheck the rigging.
You are ready.

FIGURE 22-1. Vehicle Recovery.

TOWING VEHICLES

Before towing any vehicle, refer to the vehicle technical manual/order. The following are general rules for towing

- Move towed loads at slow speed. Avoid quick stops.
- Mark towing vehicles with warning lights or flags.

- Use a wrecker whenever possible. It is designed for towing.
- Use a tow bar in preference to chains, ropes or cables. Tow bars keep the towed vehicle from running into the towing vehicle.
- Connect cables, chains, or ropes, if used, to the pintle of the towing vehicle and to the lifting shackles of the towed vehicle.
- In cities or heavy traffic, tie the front lifting shackles of the towed vehicle tightly to the rear lifting shackles of the towing vehicle and connect the air brakes.
- Proceed slowly at 5 to 10 MPH because the towed vehicle will skid on turns at higher speeds.
- When using a tow bar, connect a chain between the two vehicles for safety in case the bar breaks or becomes disconnected.
- Be sure a driver is in every motor vehicle being towed to control it, unless a wrecker is towing the vehicle.

CAUTION

Always use rigger's gloves when handling chains, cables, and wire rope.

ANCHORING VEHICLES

Trees, stumps, or rocks are natural anchors. Always attach your lines near the ground when using a tree or a stump as an anchor. You should lash the first tree or stump to a second one to provide added support for the line. When using a rock as an anchor, be sure it is large and firmly embedded in the ground.

Construct anchors when natural ones are not available. The deadman is one of the best types of constructed anchors and can be used for heavy loads (Figure 22-2). It consists of a log timber, steel beam, or other similar object buried in the ground with a deadline connected to it at the center. To construct a deadman, follow these steps:

- Select a place where the direction of pull is as nearly horizontal as possible, such as a sharp bank or crest. Thus, you obtain more holding power with less digging.
- When digging slant the bank at least 15 degrees from the vertical and undercut toward the disabled vehicle.
- Drive stakes in front of the deadman at each end to hold it in place.
- Tie the deadline to the center of the deadman so the main or standing part of the line leads from the bottom of the deadman. Dig a narrow trench for the deadline; bear to the center of the deadman. If the deadline has a tendency to cut into the ground, place a log or plank under the line at the outlet from the inclined trench.
- Tie the deadline to the center of the deadman so the main part of the line leads to the bottom. This will keep the deadman from rotating out of the hold.

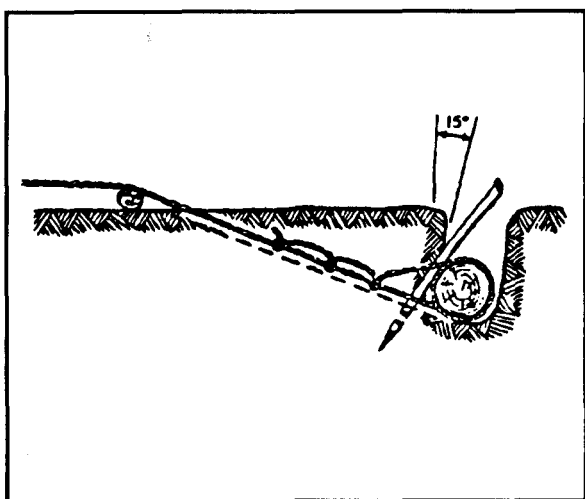

FIGURE 22-2. Log Deadman (Anchor).

WINCH RECOVERY

Many military trucks are equipped with winches. How to get the most from a winch without danger to personnel or abuse to the equipment.

For Army Only: Your vehicle technical manual completely describes the winch on your vehicle and details of its operation, care, and maintenance. FM 20-22 explains general characteristics, effective capacities, and details for use.

To ensure your safety, the protection of your equipment, and the success of your recovery operation, use the following as a guide:

- Check the capacity of your winch. The capacity shown on the manufacturer's plate is the maximum with one layer of cable on the drum. Each successive layer increases the diameter of the drum and reduces the winch capacity to as little as 50 percent of the rated capacity when the last layer is being wound on the drum.
- Check the cable for rust, kinks, or frays.
- Estimate the total resistance. Consider grade or slope, weight of the vehicle, and type of terrain. Then add a reasonable factor for safety.
- Check your equipment. Be sure you rig safely to overcome the resistance with the equipment available.
- Select or provide a suitable anchor. Remember, the purpose of this operation is to recover a vehicle, not to pull stumps.
- Rig and check rigging. Do not put power on your winch until you check every element in your rigging and are satisfied that you made no mistakes.
- Clear personnel from the danger area. All persons observing the operation should stand outside the angle formed by the cable under stress at a distance at least equal to the distance between the two most distant points in the rigging. Clear personnel away before tightening the cable.

Single-Vehicle Winch Operation

If you have been individually dispatched and get into a spot where your traction is not enough to get you through, use your winch and suitable rigging to pull you through or get you back to solid footing. Working alone or with your crew, recovery may take time, but do not skimp on planning. Your training should keep you out of the really bad spots, and if you remain calm, you should get through by applying a little extra effort.

Vehicle With Winch. Select or construct a strong anchor. Attach a snatch block to the anchor with your tow chain. Run the winch cable through the block and back to the truck (Figure 22-3). Take up the slack gradually and pull the truck forward with its winch. Power may be applied to the wheels at the same time. Your vehicle technical manual/order technical order gives details on the operation.

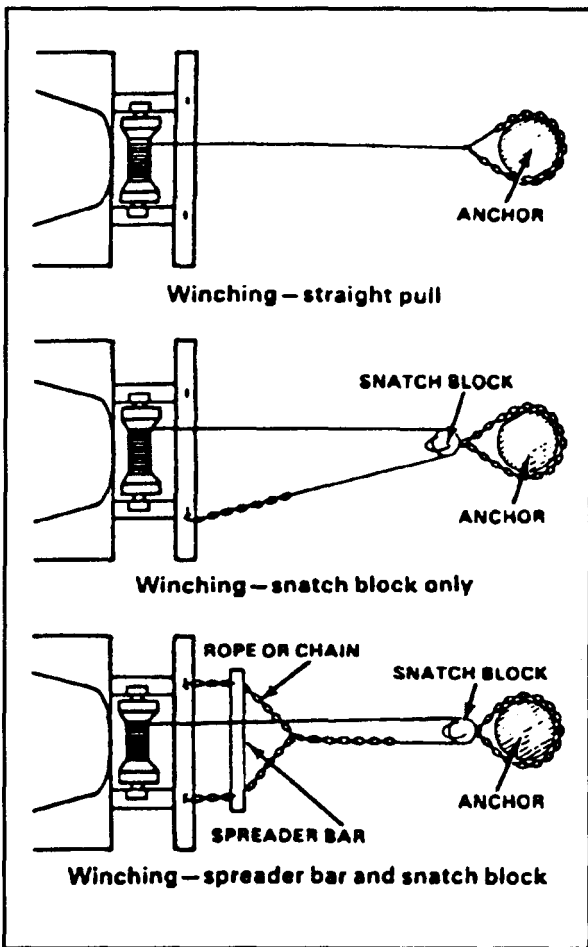

FIGURE 22-3. Vehicle Winching.

Vehicle Without Winch (Dual Wheels). Dual wheels and ropes may be used to winch out vehicles not equipped with winches (Figure 22-4). Fasten one end of each rope to a rear wheel hub and the other to an anchor. Place the rope between the duals and through one of the holes in the wheel disk. Tie the rope around the hub where it will be clear of the valve stem. Move the vehicle in reverse gear to wind the rope.

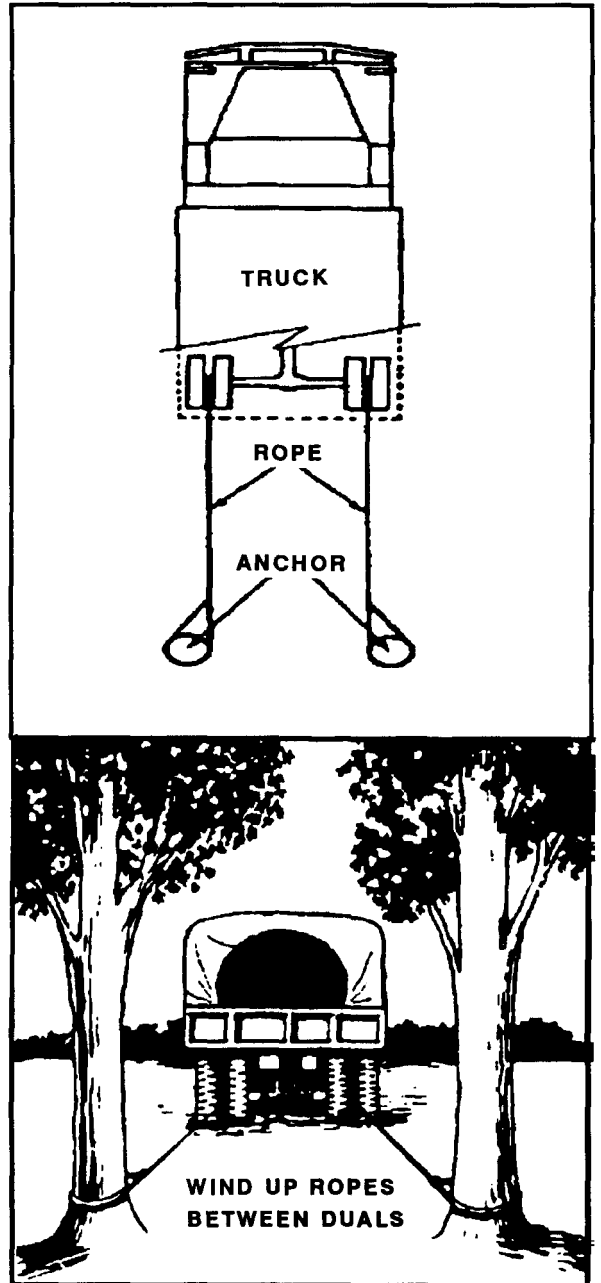

FIGURE 22-4. Dual Wheels and Rope Used as a Winch.

Vehicle Without Winch (Single Wheels). Place a bar through the hole in the end of the axle flange of each rear wheel. On each wheel, fasten one end of the rope to the bar and the other to an anchor. Move the vehicle in reverse gear to wind the rope in behind the bar (File 22-5). This procedure cannot be used on vehicles equipped with a Center Tire Inflation System (CTIS).

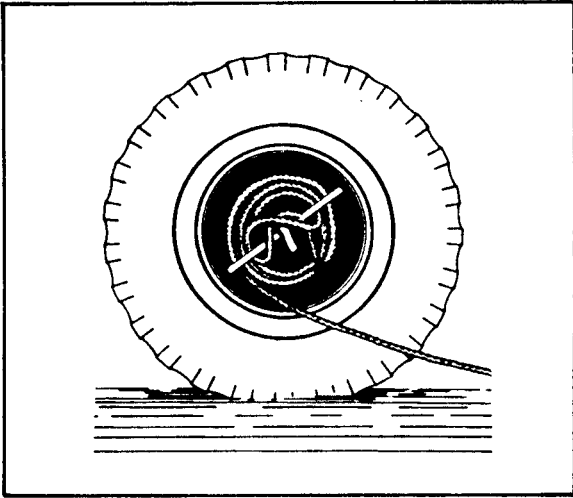

FIGURE 22-5. Single-Wheel Winch.

Two-Vehicle Winch Operation

Mechanical advantage is gained by using a mechanism to transmit force. A small force, when moved through a long distance by one or more mechanisms (pulleys), will move a large weight (vehicle) for a short distance. Use one of the following procedures when rigging for greater mechanical advantage.

Two-Part Line. This simple hookup gives a 2:1 mechanical advantage (Figure 22-6). Attach a snatch block to the load. Next, run your winch cable through the block and secure the cable to the winch vehicle. Place a log in front of the towing vehicle to help hold its ground.

Three-Part Line. To get a mechanical advantage of 3:1, use two snatch blocks – one at the load and one on the winch vehicle (Figure 22-7). Thread the winch cable first through the block on the load, back through the block on the winch, and then again to the load where it is secured.

Four-Part Line. To get a 4:1 mechanical advantage, use two snatch blocks – a double-sheave block for the load and a single-sheave block for the winch vehicle (Figure 22-8). Thread the winch cable through one sheave of the double block attached to the load back through the single sheave on the winch vehicle, and again to the load through the second sheave of the double block. Finally secure it to the winch vehicle.

Winch Safety

Cable. Recovery operations take time. Do not hurry. A broken winch line reacts like a whip. When hooking to a vehicle, use both shackles whenever possible so effort is applied equally and damage to the vehicle is minimized.

Never bend the wire cable at a sharp angle. Straighten out all kinks and twists as you take up the slack. Do not let tractors or vehicles with metal tracks run over the cable. Such abuse flattens the cable, exposes the Manila hemp core, and lets water enter, causing internal rust and weakening the cable.

WARNING

Stand clear of a winch cable before it is tightened. A cable being tightened may break and whip back with enough force to seriously maim or kill.

After using the winch, have one person or preferably two pull back on the cable while it is wound slowly and evenly on the drum in accordance with the appropriate vehicle operator -10 TM. Keep the cable lubricated according to the vehicle lubrication order.

Shear Pin. When the winch is overloaded, the shear pin breaks to protect the cable. Never use makeshift shearing of unknown strength to replace a broken pin. Too strong a pin may snap the cable and damage the winch. Use only authorized replacement pins. Do not depend on the shear pin for protection. Even with the proper pin installed, a kinked, damaged, or weakened cable may snap. Vehicles with electric winches have circuit breakers to protect the winch from overloading. Check the appropriate vehicle operator -10 TM for correct winch.

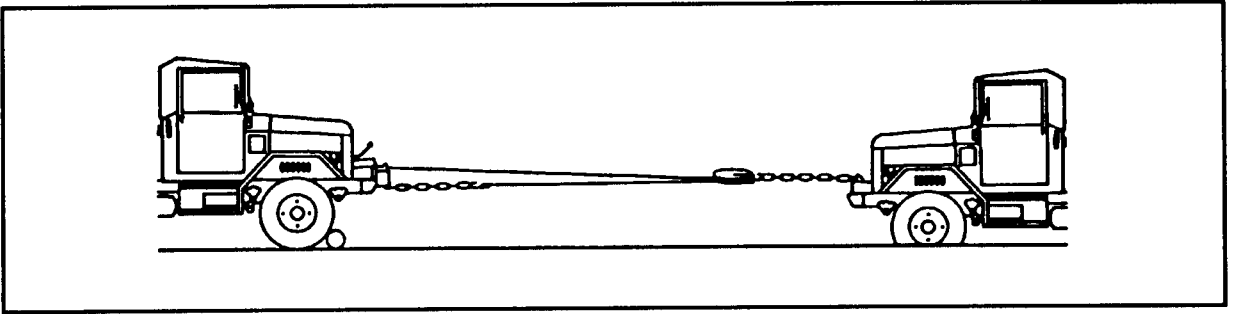

FIGURE 22-6. Two-Part Line.

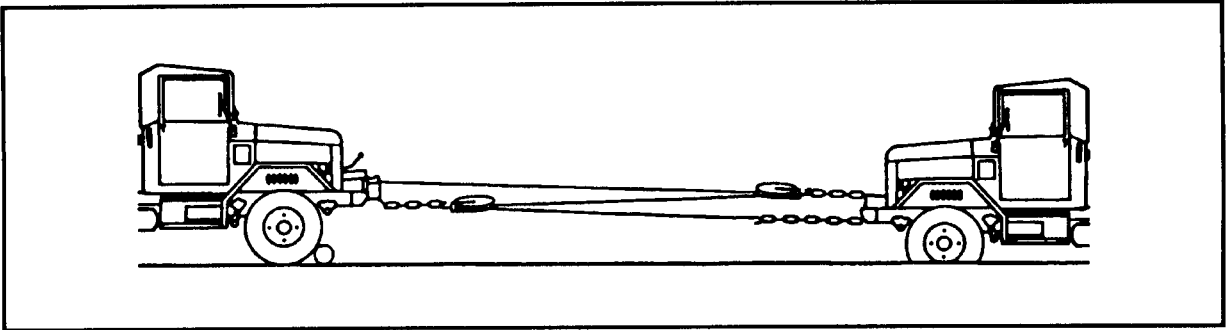

FIGURE 22-7. Three-Part Line.

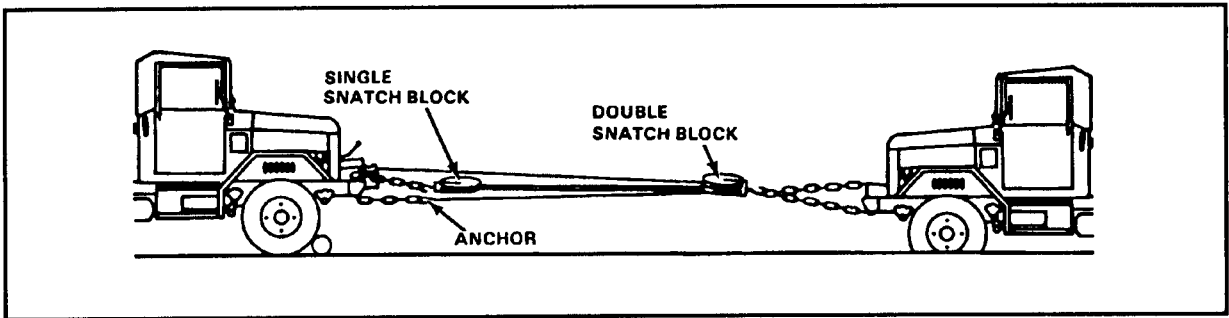

FIGURE 22-8. Four-Part Line.

MAN POWER RECOVERY

Recovery operations with limited man power and material at hand can be successful if you have enough time.

If your vehicle has dropped into a hole or ditch, man power can get it out. First, find an 8-foot length of timber or similar material with a diameter that available personnel can handle. Place a suitable fulcrum near the point of lift — a log or rock that will not move when pressure is applied. Rig the lever under the bumper for the first lift.

Block when you have gained all you can. Rerig for a second lift with the point of the lever under the axle if possible. Lift and block. Repeat these steps until the vehicle can be backed off without too much trouble.

If you are alone and must move a light vehicle a short distance without power, use a lever. You will need a fairly long pole or crowbar, a rope, cable, or chain, and a suitable anchorage for the point of the bar. The distance from the lever to the point of attachment of the tow rope must be quite short to give you enough advantage. You will not move very far at each try, but you will be able to move slowly.

A-FRAME RECOVERY

Narrow ditches, slit trenches, and shell holes can quickly stop your truck. They are common obstacles to off-road movement and maybe hard to see. If your front wheels should drop into one, the A-frame is a very useful recovery tool (Figures 22-9 and 22-10). It is not very difficult to put together nor too complicated to use. You need two 8-foot poles with a large enough diameter to support the front end of your truck. Lash them together near the top with a figure eight or girth knot; use your tow chain or a length of rope. Dig two 10- to 12-inch holes 5 or 6 feet apart to hold the legs in position when power is applied. Rest the upper end of the A-frame on the hood of the truck with the legs in the anchor holes. Select a suitable anchor in front of the truck. Tie a line from the A-frame joint to the anchor, bringing the frame up to a position where the frame joint is directly over or slightly to the rear of the bumper. Move your winch line through a snatch block fastened to the A-frame joint and secure it to the front bumper.

Winch up the front end of the truck until the wheels clear the ditch. Then slowly back the vehicle off to solid ground. When safely away from the edge of the ditch, lower the wheels and unhitch your rig. If you have no winch, another vehicle may be used for power, though more rigging will be required.

FIELD EXPEDIENTS

Field expedients are one-time emergency operations or procedures that you may use to get out of tight spots during tactical operations. Use expedients only under unusual or emergency conditions. The equipment is usually prepared as needed from materials at hand, most of which are designed or intended to serve another purpose. For instance, tire chains used as tow chains are a field expedient. A truck tarpaulin used to wrap a 1/4-ton truck to float it across a river is another example. The list of field expedients that have been successfully used is long. It is beyond the scope of this text to describe all of them. However, the few described below give you an idea of the possibilities.

Substitutes for a Jack

If an outside dual is flat, a practical substitute for a jack is to run the inside dual up on a small rock or log. This lifts the outside tire off the ground so you can change the tire.

Another simple method, good for any wheel on an all-wheel drive vehicle, is to rig an inclined plane with two logs of suitable size (or a stone and a log) (Figure 22-11). When the vehicle is driven ahead the axle is pushed up the log until the wheel clears the ground. Set brakes and block the vehicle securely. You can easily back off when your job is completed.

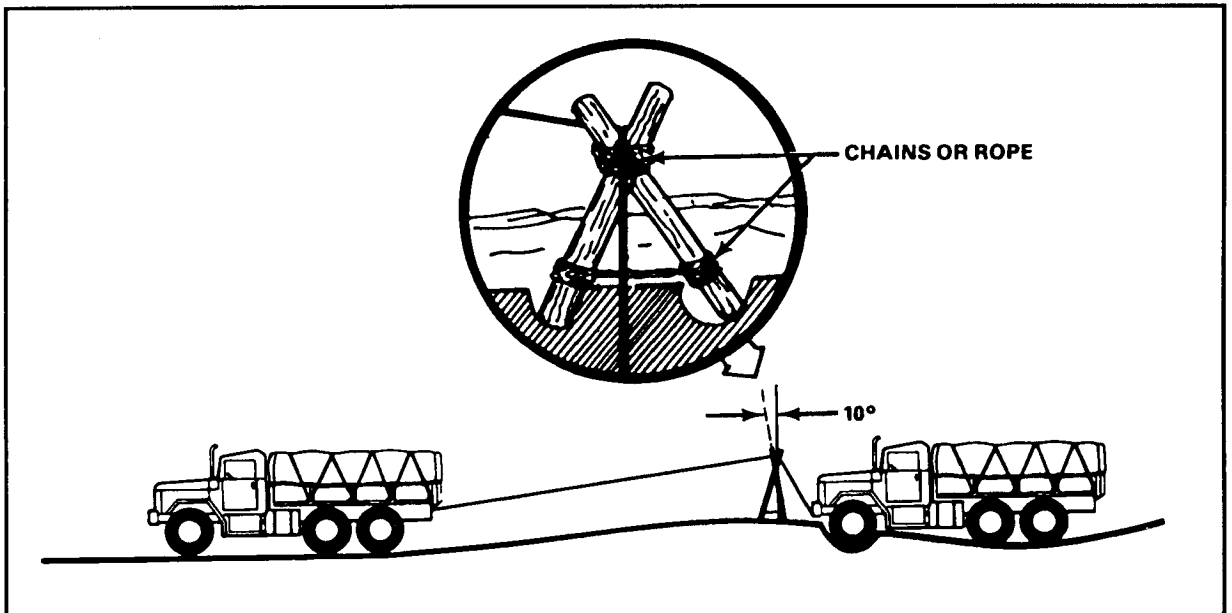

FIGURE 22-9. An A-Frame Supplying Lifting Force.

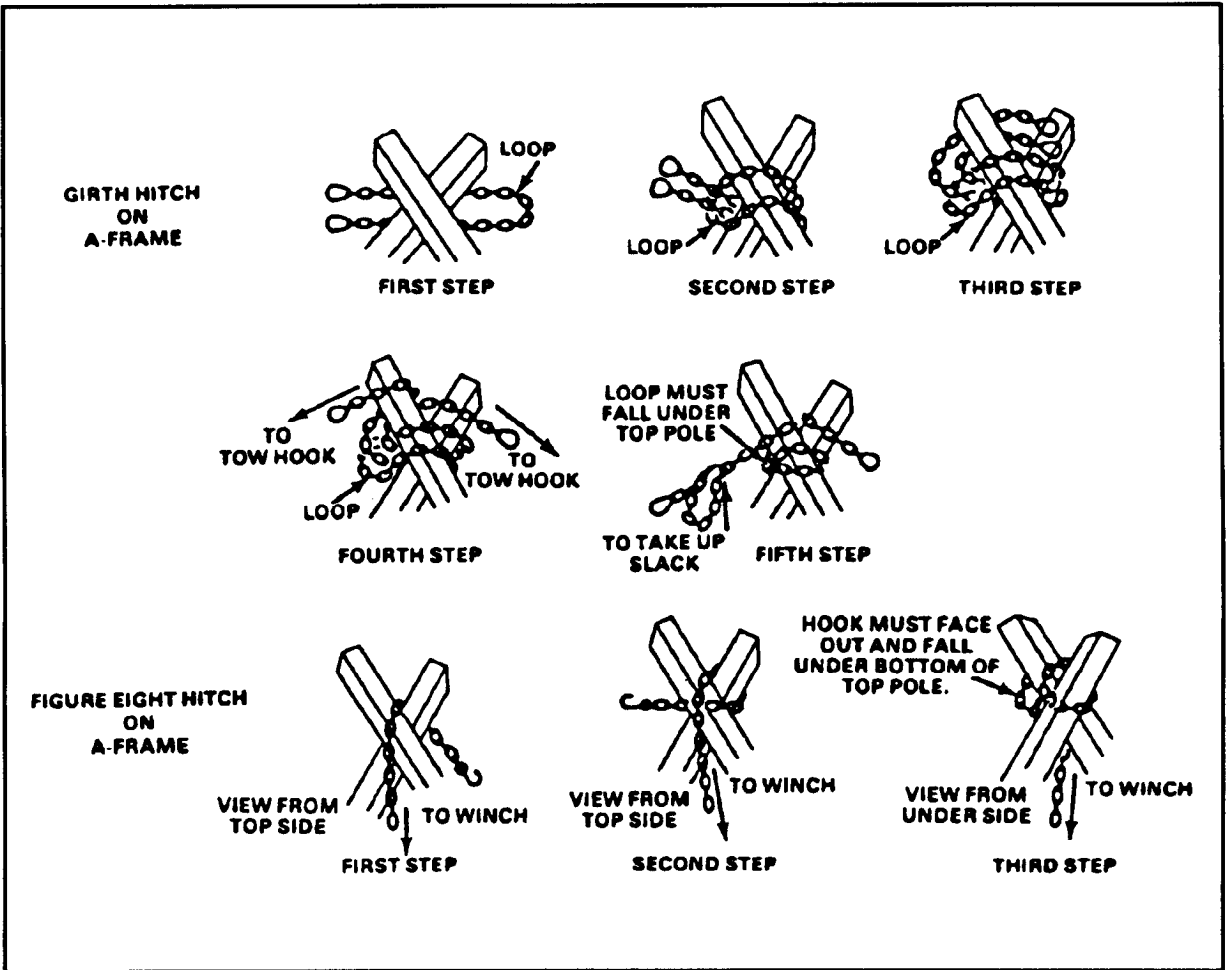

FIGURE 22-10. Lashing an A-Frame With a Girth Hitch and a Figure Eight Hitch.

To raise the front end, make your own bumper jack by fastening a 5-foot piece of timber at an angle to the front bumper with a chain or rope (Figure 22-12). Move your vehicle backward until the timber is vertical and the wheel clears the ground. Set brakes and block the vehicle securely before working on the tire. When through, pull forward and unhitch.

Method for Raising a Wheel

If one of your driving wheels falls in a deep hole, you can get out with a log and a chain (Figure 22-13). Chain the log to the wheel and move forward slowly to prevent spinning. If the wheel spins, the log will damage the fender or other parts of your vehicle. After clearing the hole, force the log under the wheel to keep it from falling back into the hole.

Use of a Skid

A flat tire or bad wheel that you cannot repair should not stop your four-wheel drive (4 x 4)

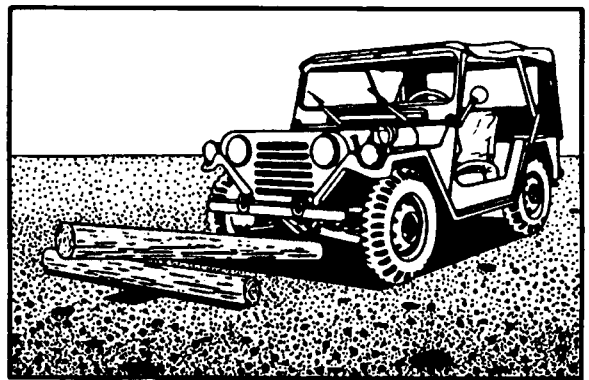

FIGURE 22-11. Substitute for a Jack (Logs).

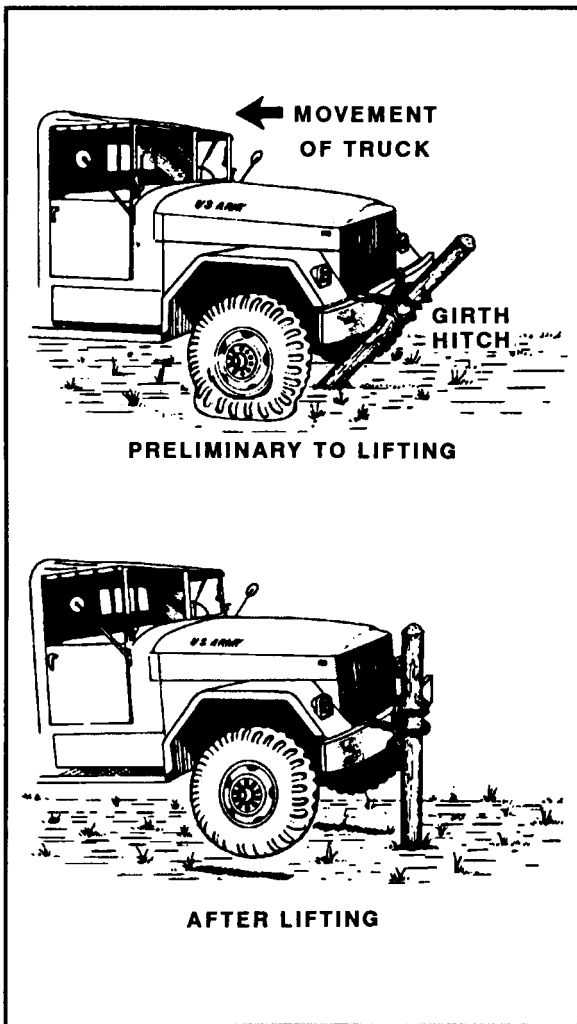

FIGURE 22-12. Substitute for a Jack (Bumper).

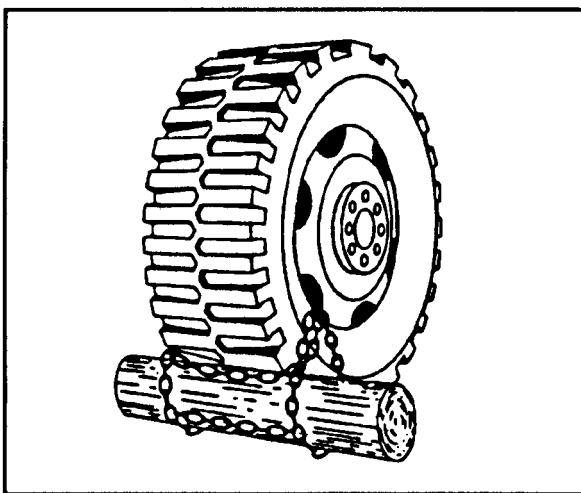

FIGURE 22-13. Raising a Wheel.

vehicle. Use a skid on the rear wheels only (Figure 22-14). If necessary, change wheels from one hub to another. Use a skid in the following manner:

- Obtain a pole 4 inches in diameter and 6 to 8 feet long.
- Place one end of the pole above the cross member near the transmission and the other end on the ground.
- Pass the pole under the spring U-bolts, align it with the spring and lash it securely to the spring.
- Move the vehicle, using front-wheel drive. Starting will be difficult, but once moving, the vehicle will ride and handle surprisingly well.

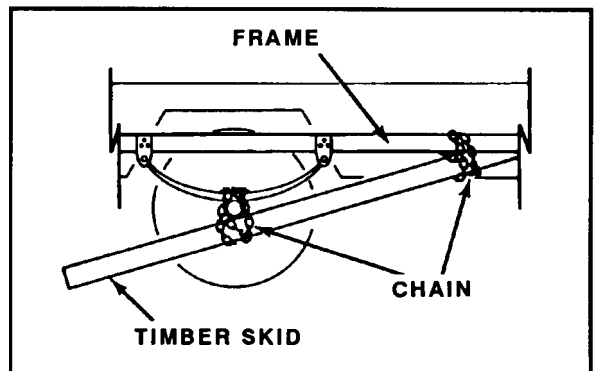

FIGURE 22-14. Skid Arrangement.

Substitutes for Tire Chain

Rope or tow chains can be wrapped around the wheels as tire chain substitutes. Fasten them securely, but leave slack around the tires to prevent damage. Remember, these are only temporary substitutes. Remove them as soon as possible.

Engine Failures During Field Driving

Fuel or ignition troubles commonly cause engine failures in the field. You can correct some of these by field expedients, but remember, these are only field expedients, not repairs. Inform your unit maintenance personnel as soon as possible so that proper repairs can be made, if necessary. A few of these field expedients are described below.

(For Army Only): More field expedients are explained in FM 20-22 and appropriate operator vehicle -10 TM.)

Shorted Distributor Cap. A cracked distributor cap will cause your engine to miss and backfire, particularly in damp weather when the crack is filled with moisture. To correct this, carefully clean and dry the distributor cap, scrape the crack or runner, and fill the crack with tar or other sticky material (Figure 22-15).

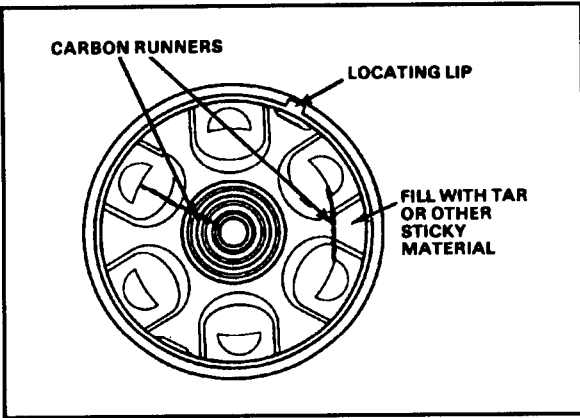

FIGURE 22-15. Shorted Distributor Cap Repair.

Broken Distributor Point Spring. If your engine cuts out, stops, and cannot be restarted, the cause may be a broken distributor point spring. Take off the distributor cap and if this is the cause, cut a piece of rubber from a tire and double it behind the spring (Figure 22-16). The engine will then start and operate at slow speeds. The rubber substitute cannot close the point fast enough for high-speed operation.

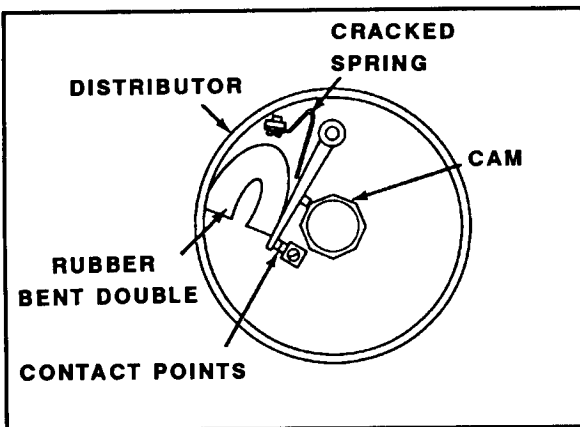

FIGURE 22-16. Broken Distributor Point Spring Repair.

Frozen Fuel Lines. Condensation in your fuel tank may get into the fuel lines and freeze in cold weather. This effectively cuts off the fuel supply to your carburetor. Thaw out these spots using hot water. Never use a flame or any device that could cause a spark directly on the line.

Leaking Line Fitting. Leaks at fuel line fittings can develop from the vibrations caused by cross-country operation and may result in an extremely dangerous condition if not discovered and corrected promptly. To correct this deficiency, unscrew the coupling nut, wind a piece of string clockwise behind the flare, slide the coupling nut over this temporary gasket, and tighten with a wrench (Figure 22-17).

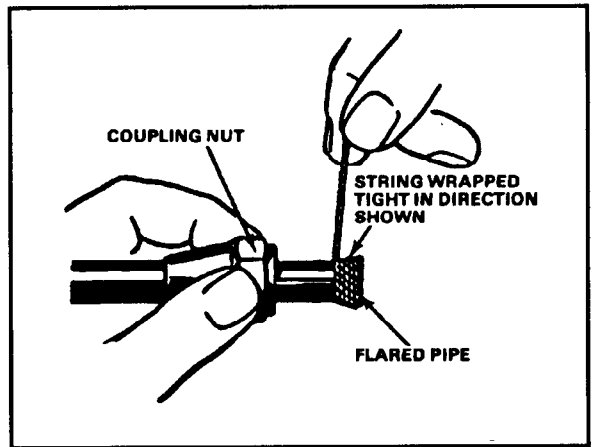

FIGURE 22-17. Leaking Fuel Line Repair.

Fuel Pump Vapor Lock High temperatures vaporizing gasoline in the fuel line causes this failure. The fuel pump will not pump vapor. Soak a cloth in water and place it over the fuel pump (Figure 22-18) to cool the fuel pump and condensate the vapor. The evaporation of moisture from the cloth has a refrigerating action that is most effective in hot, dry climates.

Other. Two other common occurrences that can damage your engine are a punctured radiator and a broken fan belt.

If you have a punctured radiator, cut the cooling fins. Push them back from the tubes in front of the leaky tubes so you have enough room to work. Cut the leaking tube in half and fold the ends back three-quarters of an inch. Close the ends by pressing them flat with pliers. This repair may hold permanently,

but radiator efficiency is reduced when several tubes are cut, and the engine may overheat.

If you have a broken fan belt and no available replacement, use a fiber rope from the vehicle

tarpaulin or a piece of field telephone wire. Loop the rope around the pulley three or four times and tie with a square knot. Find and replace faulty fan belts during your daily maintenance service and inspection.

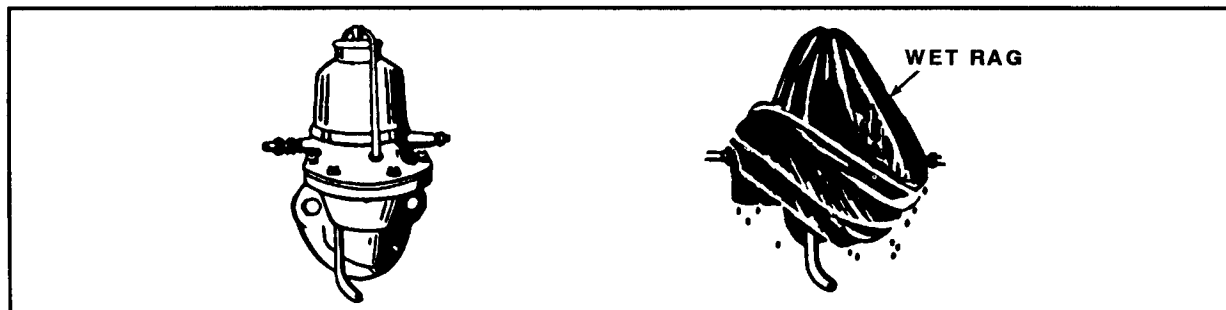

FIGURE 22-18. Fuel Pump Vapor Lock Correction.

CHAPTER 23

NIGHT VISION GOGGLE DRIVING TECHNIQUES AND PROCEDURES AND OPERATIONS UNDER BLACKOUT CONDITIONS

Night operations in combat, combat support, and combat service support units have played an important role in many US Army battles. In fact, the ability to conduct effective tactical transportation operations during hours of darkness and limited visibility is a long-standing Army objective. Today's technology provides the wheeled vehicle operator with the ability to meet these objectives using night vision goggles (NVGs). Your ability to safely and effectively drive using NVGs depends on your understanding the device's limitations and capabilities, the amount of ambient (available) light, driving ability, proficiency with NVGs, familiarity with the terrain, and availability of NVGs.

NIGHT VISION GOGGLES

General Characteristics

Night vision goggles are image-intensification devices that improve visibility during periods of low light levels. They amplify available ambient light, such as moonlight and starlight. NVGs, however, do not magnify an image. An object viewed through the goggles looks the same size as if it were seen in the day without the goggles. Objects that are hard to see during the day are also hard to see at night through the goggles. NVG performance is directly related to the amount of ambient light. During periods of high ambient light, resolution is improved and objects can be identified at greater distances. However, visual acuity (the accuracy with which an object is seen) with NVGs will never be as good as it is with the naked eye during daylight conditions.

Rain, haze, fog, snow, or smoke and viewing into shadows and other darkened areas greatly reduce the effectiveness of NVGs.

Vision using NVGs equals the vision of an unaided driver with less than perfect vision. The best case for a driver with 20/20 vision wearing the goggles is 20/40 with the AN/PVS-7 and 20/50 with the AN/PVS-5.

The goggles affect depth perception and distance estimation. For the first 20 feet in front of the user, the NVG decreases depth perception. From 20 to 500 feet, depth discrimination roughly equals that of the unaided eye. NVGs reduce depth perception beyond 500 feet and distance viewing. This is due mainly to reduced visual acuity and lack of peripheral vision. Peripheral vision lets a person see things on the side of the field of vision while concentrating on looking straight ahead at an object. Color discrimination is absent when goggles are used.

Single Color Vision. The picture seen with NVGs is green. It is also less distinct than normal daylight vision. As a result, it is hard to distinguish between certain objects or features. Shadows, for example, are hard to distinguish from puddles of water, walls, or ditches and vice versa when viewed through the goggles at night.

Color Adaptation. Because of the green color in NVGs, you may see one of two things when you remove the goggles after several minutes. If you look at the lighter of two backgrounds, you may see the complement or opposite of the green color to which you had become adapted. If you look at the darker of the two backgrounds, you might see an after-image of the green light to which you had become adapted. Do not be concerned about this after-image. It is a normal physical reaction.

Second Versus Third Generation Night Vision Goggles

NVGs have been produced over a period of 25 years. There are two distinct generations (models) of devices with militarily significant performance differences. AN/PVS-5 devices are second generation.

AN/PVS-7 devices have been produced in both second and third generation versions. External examination will not determine if a PVS-7 is second or third generation. Commanders should ask supporting maintenance units to identify second and third generation PVS-7 devices during routine

maintenance checks. (PVS-7 devices can be upgraded from second to third generation by changing the tubes. However, the cost of changing the tube is high and is not necessary unless the tube is not functioning properly.)

Third generation devices have increased performance and longer tube life. Normally, a second generation device operating under quarter moon conditions and a third generation device operating under starlight conditions provide the operator with equal quality images. Under bright light (full moon) conditions, the performance of the two devices will seem exactly alike.

Second generation devices have a tube life projected at 2,500 hours. They tend to fail slowly, so maintenance personnel must periodically check the devices to ensure they are performing at a satisfactory level. An operator may not notice the gradual loss of performance normal for second generation devices.

Third generation devices have a tube life designed to last 7,500 hours. When they eventually fail, they tend to fail quickly. Check them periodically in accordance with the applicable technical manual and local policies.

Second generation devices are sensitive to all visible light as well as light in the near infrared spectrum. All flashlights, even those with blue-green filters, will be seen by second generation devices and may make it harder to see other objects in the field of view.

Third generation devices are sensitive to yellow and red visible light as well as light in the near infrared. They have reduced sensitivity to blue or green light. Flashlights with blue-green filters minimally affect the performance of third generation devices.

Operational Characteristics and Care Considerations

Take special care in dusty, sandy, and humid conditions. Never store NVGs wet or in a wet carrying case.

Moisture may form on the eyepieces when they are first placed on the head. This is caused by heat and moisture given off by the body. It is more noticeable in cold temperatures when there is a significant temperature difference between the goggles and the

body. Demisting shields are provided to prevent collection of moisture on the lenses. Do not use antimisting chemicals or chemically treated cloths on the demisting shield or lenses.

Install the lens covers when not wearing the goggles. Do not hang the goggles from your neck by the safety strap without covering the objective lenses (the objective lenses may be scratched).

When installing or removing a battery, be sure the selector switch is in the OFF position. If the switch is on, intermittent electrical contact is made when unscrewing or screwing the battery cap. This causes a flicker or power surge to the tubes, which may cause burn spots on the tubes.

Always remove the battery before storing the goggles to avoid turning the switch on accidentally when placing the goggles in the case. If the goggles are stored for a long period of time with the battery installed, corrosion can develop.

CAUTION

For lithium batteries, this increases the possibility of battery venting, which can cause serious injury to personnel and equipment.

Avoid rough treatment of the NVGs. Mistreatment may cause the tubes or the electrical system to fail. If the goggles do not operate when the switch is turned on and the battery is fully charged, check the wiring for breaks or the battery terminals for the presence of oxidation.

Never operate the NVGs during daylight hours. Doing so commonly causes tube failure.

You may use the infrared (IR) light on the goggles to illuminate the instrument panel or to read maps when you do not want to turn on the interior light. However, continuous use of the IR light shortens the battery life.

CAUTION

Use of the IR light makes the NVG an active system. As such, it can be detected by the enemy and will severely limit vision outside the vehicle.

Resolution checks are required on NVGs every 180 days using either the TS-3895U/V test set or the alternate test method (direct support level). Perform this test as instructed in the applicable systems' technical manual:

- AN/PVS-5 (A, B, C models): TM 11-5855-238-10.
- AN/PVS-7A TM 11-5855-262-10-1.
- AN/PVS-7B: TM 11-5855-262-10-2.

Proper Focusing Procedures

Improper focusing adjustments significantly reduce visual acuity and increase eye fatigue.

Eye Relief. Eye relief is the distance between the NVG eyepiece lens and the eye. It is recommended that the eye relief for the NVG be 1 inch. This distance may not be achievable because of helmet/-helmet liner configurations and facial features, such as deep set eyes or protruding foreheads. If eye relief is too little, an unnecessary strain is placed upon the eyes, which accelerates fatigue. However, if the eye relief is too large, a significant loss of field of view can occur.

Interpupillary Distance (IPD). IPD is the distance between the pupils of the eyes. It is also called eye span. The center of the intensifier tubes should align with the pupil of the eyes. The distance between the center of the tubes should equal the user's IPD. If the tubes are not aligned, the eyes tend to drift towards the center of the tubes. This leads to focusing problems and eye fatigue. It has also been attributed as the cause of short-term reduction of near depth perception.

IPD is adjusted with the interpupillary lever clamp on the AN/PVS-5 series. On the AN/PVS-7 series, it is adjusted by moving the eyepieces apart or closer together. The common method of aligning the tubes is the subjective overlapping of the images until a single, clear, circular field of view is reached. This procedure, however, makes most people bring the tubes too close together. A more objective and accurate method involves using a millimeter ruler to measure from the outside edge of one objective lens (or eyepiece lens) to the inside edge of the other.

This will require all NVG users to be measured for their distant IPD at their clinic. Record and memorize this value given in millimeters.

Eyepiece Lens Adjustment. The eyepiece focus rings, also referred to as the diopter adjustment rings, focus the image at the eyepiece lens. They allow those who wear corrective lenses to accommodate for certain problems, such as farsightedness. However, they will not correct astigmatism. It is recommended that corrective lenses be worn with the NVG. (Eyeglasses can only be worn with the AN/PVS-7 series. AN/PVS-5 users may wear contact lenses.)

Objective Lens Adjustment. The objective focus knob is adjusted as a function of distance (called focal range) from the object. The focal range of the NVGs is between 10 inches and infinity. The vast majority of driving with NVGs requires the optical infinity setting. You must focus the goggles outdoors at night or indoors with a small light source, such as a 7 1/2-watt light bulb. Focusing on a small light source or lettering on a nearby sign is not sufficient for proper adjustment! You need a visual acuity chart that can be hung on a tree at slightly lower than eyesight. Because it is closer to the optical infinity distance, 20 feet is the desired distance between the user and the chart.

Focus one knob at a time. DO NOT close the other eye. Instead, block the eye with the palm of your hand or with a 3 x 5 card. First, rotate the objective focus ring to get the clearest focus on the eye chart. Next, position the eyepiece focus ring at its full counterclockwise setting. (For reading use, first turn to full clockwise setting.) Rotate the eye focus ring clockwise (counterclockwise for reading). STOP when the image is clear. Do not continue clockwise because the image will remain clear at the expense of eye fatigue. If you feel you have gone too far clockwise, start the ring back counterclockwise until the image blurs; then start again clockwise until the clearest image is reached.

The appropriate line on the visual acuity chart should now be readable at the distances given below.

	<u>10 Feet</u>	<u>20 Feet</u>
AN/PVS-5 Series	20/25	20/50
AN/PVS-7 Series	20/20	20/40

Failure of the visual performance checks is determined when the following lines on the eye chart are not readable at the distances given below.

	<u>10 Feet</u>	<u>20 Feet</u>
AN/PVS-5 Series	20/30	20/70
AN/PVS-7 Series	20/25	20/50

Defective Tubes

Tube operation must be checked before each mission. If any of the following tube conditions exist (Figure 23-1), take the appropriate action before using the goggles.

Shading. Both tubes should show a perfect circle. If shading is present, you will not see a fully circular image (Figure 23-1A). Shading always begins on the edge and moves inward. Replace the tubes if this condition exists.

Edge Glow. This is a bright area in the outer portion of the viewing area (Figure 23-1B). To check for this defect, cup your hand over the lens to block out all light. Replace the tubes if this condition exists.

Bright Spots (White Dots). A pinhole in the phosphorous screen causes this condition. Spots may flicker or appear constant (Figure 23-1C). Check by cupping your hand over the lens to block out all light. If bright spots or white dots are visible, turn in the NVG to direct support (DS)

maintenance where it can be properly checked with a TS-3895U/V test set.

Dark Spots. Black marks that may look like spots or streaks are acceptable as long as they do not interfere with the mission. No action is required when such dark spots occur (Figure 23-1D).

Fixed Pattern Noise (Honeycomb). A faint honeycomb pattern occurs most often in high light levels. This condition is acceptable as long as the pattern does not interfere with the mission (Figure 23-1E).

Flashing, Flickering, or Intermittent Operation. The NVG may appear to flicker on and off, or the output may flash. This can occur in one or both tubes. If you see more than one flicker, consult the troubleshooting chart in the operator's manual.

DRIVING WITH NIGHT VISION GOGGLES

Threat Night Capability

Threat forces consider darkness an advantage. They do not stop operations at night but continue to operate using night vision devices. Most threat night vision devices are infrared. They include driving aids on vehicles. (FM 17-95 discusses this topic in detail.)

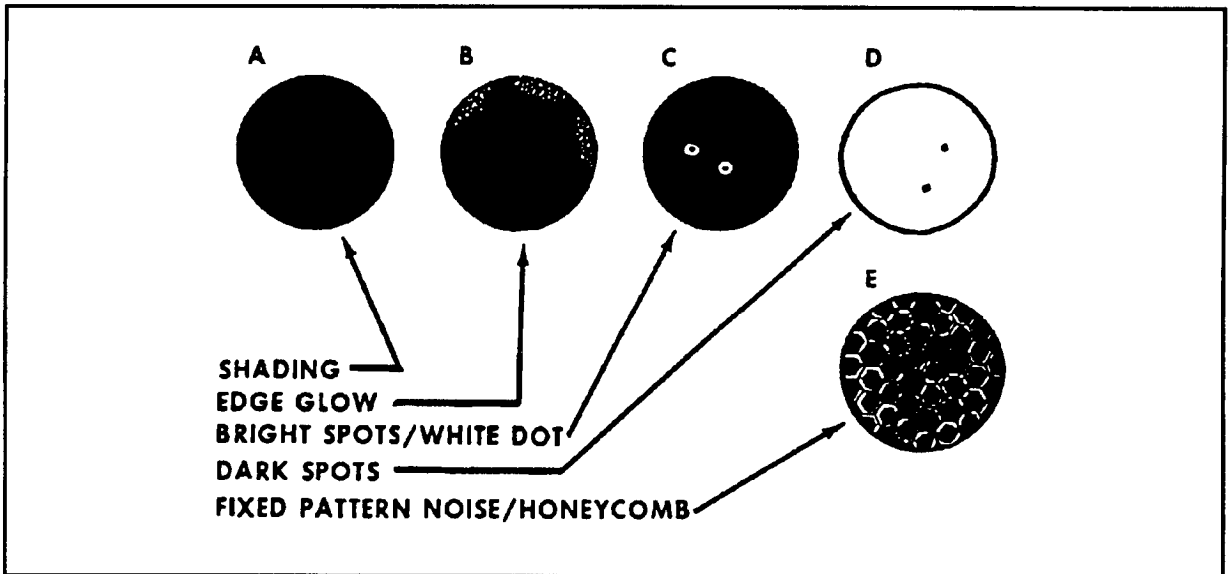

FIGURE 23-1. Tube Defects.

Effects of Light

Any detectable light source in the vehicle's cab may affect your ability to see with NVGs. The adverse effect of panel lights on the goggles is greatest during low ambient light conditions.

Vehicle Lighting System. NVG compatibility is best achieved by eliminating all interior and exterior light sources. Tape lights that cannot be controlled to reduce the amount of light they emit. Instruments and gauges can normally be read with NVGs without instrument lighting.

WARNING

Vehicles without NVGs may not see you. Ensure the route selected is in an area where other traffic (commercial and tactical) is precluded. If the route does not preclude this, establish some form of traffic control.

Dark Adaptation. No dark adaptation period is necessary for effective viewing through NVGs. In fact, viewing through goggles for a short period of time lessens the normal dark adaptation period. After using NVGs, it takes about 2 minutes to reach the 30-minute dark adaptation level.

Lasers. Lasers are used on the battlefield, both in training and in combat. Lasers affect NVGs much as other light sources do. Most lasers will not cause permanent damage to NVGs. In fact, the goggles protect the operator's eyes from the damaging effects of lasers, even if the laser is bright enough to damage the goggles. If the goggles are damaged, you can probably continue to use the goggles with a bright or dark spot at the point where the tube was damaged. If you think that a laser is being directed at you, look away to reduce the effects of the laser on the goggles and eyesight.

Object Identification. Viewing an area lit by artificial lights, such as flares, will limit your ability to see objects outside the lighted area. Your ability to see objects within the lighted area depends on the brightness of the light and the object's distance

from you. Try to keep the light source outside the field of view of the goggles.

Using goggles will enable you to detect light sources that are not visible to the unaided eye. You can detect light from vehicles, flashlights, IR light sticks, and burning cigarettes at great distances. The capability of goggles to detect these light sources improves as the ambient light level DECREASES.

When using NVGs, some objects will be more difficult to distinguish (low contrast against the background) than during the day when color clues are available.

Weather Considerations

Rain, haze, fog, snow, or smoke greatly reduces NVG effectiveness. As visibility decreases, you will notice a gradual reduction in light and visual sharpness. When you realize your visibility is reduced, try to determine the severity of the Condition. If driving can be conducted safely with the goggles, continue the mission. If not, adjust your driving speed, remove the goggles, and turn on your headlights or switch to blackout drive lights. Use NVGs only when the situation permits and it is safe to do so. Table 23-1 lists countermeasures to use when faced with specific vehicle lighting conditions that degrade NVG performance, such as using NVGs in conjunction with blackout drive.

Visual clues to the presence of visibility restrictions include —

- A halo around artificial lights when using goggles. The halo effect tends to increase when atmospheric obscurations are present. Note the size of this halo effect around lights in the staging area. If the halo becomes noticeably larger, a restriction could be developing.
- An increase in "image noise" when atmospheric interference is present or when ambient light level is low. This is similar in appearance to the "snow" seen on television with poor reception.

TABLE 23-1. NVG Lighting Countermeasures.

Specific Conditions	Impact on NVGs	Countermeasures
Driving with external and internal lights off. (Vehicles without NVGs may not see you.)	None.	NA.
Blue-green instrument panel lights on. (Vulnerable to threat detection with NVGs.)	Minimal on third generation tubes; will degrade performance of second generation tubes.	Turn to lowest light level or turn off. Tape over noncritical lights. (May allow warning lights to go unnoticed.)
Instrument panel lights on. (Vulnerable to threat detection with NVGs.)	Will degrade all NVG performance.	Turn to lowest light level or turn off. Tape over noncritical lights. (May allow warning lights to go unnoticed.)
Headlights on. (Vulnerable to threat detection.)	Not recommended. Will shorten life of NVGs and blind oncoming drivers with NVGs.	Use blackout (BO) lights.
Chemlights on front of lead vehicle and rear of trail vehicle. (Vulnerable to threat detection.)	Will degrade lead vehicle's distance vision to some degree under low light conditions.	Tape over part of chemlight. Use BO lights.
Blackout marker lights on. (Vulnerable to threat detection with NVGs.)	At low light levels (heavy overhead canopy or starlight), will degrade NVG performance.	Tape over all but one of four markers on rear of vehicle. Tape over brake marker.
Blackout markers with blackout drive. (Threat detection easy with NVGs.)	Will enhance near vision, but degrade distance vision. May blind oncoming drivers with NVGs.	Turn off BO drive or ensure BO hood is adjusted so light only shines down.
Normal parking/brake lights. (Vulnerable to threat detection.)	Will seriously degrade all NVG performance and may blind oncoming drivers with NVGs.	Use BO lights.

Ground Speed Limitations

Most drivers tend to overdrive their capability to see. To avoid obstacles, you must understand the relationship between the NVG visual range capability and speed.

Different light levels affect the distance at which you can identify an object. This, in turn, limits the ground speed at which you can safely drive. The range limitation graph (Figure 23-2) shows how to determine the maximum range that an object can be identified. It also gives the commander a good rough estimate of the goggle's working range. The graph addresses a hazard 3 meters in length and 15 centimeters in diameter (the size of a small pole or a bare tree limb) with 30 percent contrast.

To find the minimum range at which an object can be detected in a given ambient light condition,

follow the chart along the top at a point representing the ambient light condition. Move down until the range curve is intercepted. Read the minimum range (meters) an object can be identified at the left.

After computing the range at which an object can be detected, use the ground speed limitation graph (Figure 23-3) to determine a safe speed for driving with goggles. This graph gives the commander a good rough estimate of ground speed limitations for nonconvoy movements. Follow the graph along the left side at the predetermined detection range. Move right until the 10-second driver response line is intercepted. (This line measures the time it takes for the operator to react to an object at a given distance and a given speed.) From the intersection, move down and read the safe ground speed for driving with the AN/PVS-5 or AN/PVS-7.

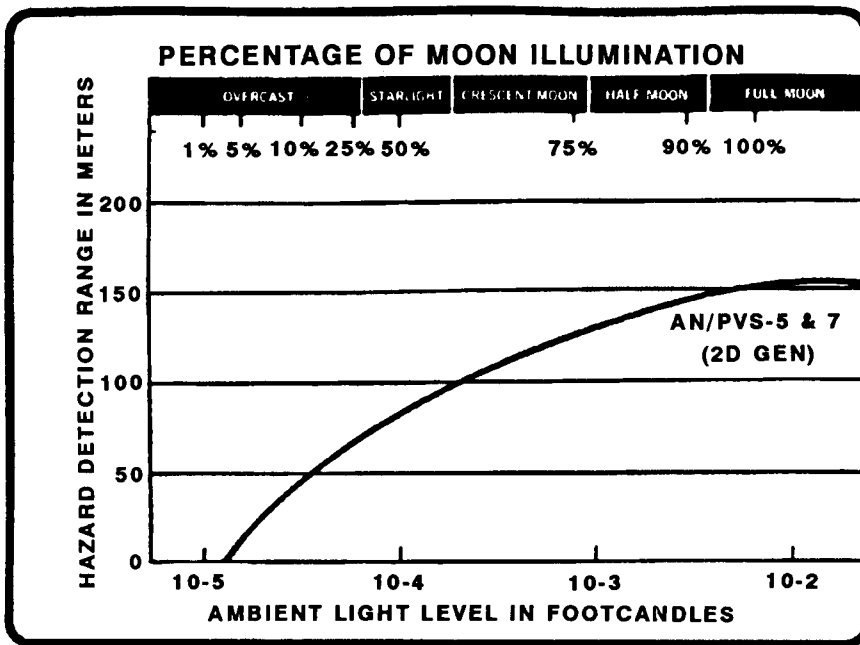

THIS GRAPH IS NOT EXACT.

FIGURE 23-2. Minimum Hazard Recognition Range.

AR 600-55, Chapter 8, requires commanders to establish speed limitations for all modes of driving while wearing the NVG. In deciding what those limitations are, they must consider the following factors as a minimum:

- The type of NVG being used for driving, the age of the tubes, and the generation of tubes (second or third) of the goggles. For example, an AN/PVS-7 equipped with third generation tubes will outperform an AN/PVS-5 with second generation tubes in terms of improved resolution.
- The type of vehicle used for training.
- Weather conditions.
- Mode of driving, such as convoy, off-road, and cross-country.
- Terrain.
- Amount of light available (Appendix D).
- Type of mission.

NOTE: As a general rule, driving with NVGs should never exceed 25 MPH under any circumstance. Speed under convoy conditions should not exceed the limitations established for normal convoy movement without NVGs.

Vehicle Preparation

The design of some Army vehicles will affect your ability to see outside the windshield. To reduce the loss of night vision because of vehicle shortcomings, properly prepare the vehicle for night driving with NVGs.

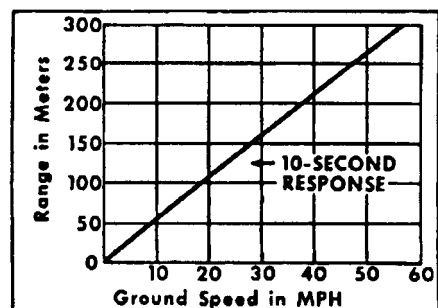

THIS GRAPH IS NOT EXACT.

FIGURE 23-3. Ground Speed Limitations.

Dirty windshields can reduce your ability to see outside your vehicle. Keep them clean. Remove dirt, grease, bugs, and scratches before each mission.

Vehicle instruments are easier to read under high levels of instrument lighting. However, the level of light needed for the best reading interferes with the goggle's ability to see dim objects OUTSIDE the vehicle. Interior lights also interfere with goggle performance. They reflect off the windshield, reduce outside visibility, and are subject to enemy detection. To minimize these effects, turn off all interior lights and turn off or tape all exterior lights.

Driver Preparation

Proper preparation of the vehicle and ground facilities for driving with NVGs will contribute greatly to the success of a night mission. The mission, however, may fail unless you are physically and mentally prepared. To ensure your readiness —

- Keep physically fit.
- Eat a well-balanced diet.
- Get enough rest.
- Avoid self-medication.
- Avoid the use of tobacco and alcohol.
- Learn and apply night vision principles (Appendix D).
- Avoid all bright lights (including sunlight) during the day. Wear sunglasses when outside.
- Participate in frequent night driving.

Driving With Goggles and Emergency Procedures

The ability to drive with NVGs is developed through training. The more you drive with goggles, the more you learn about them. As a result, you gain confidence in your ability and in the capability of the device. On the other hand, overconfidence is a main fault associated with NVG use. After

wearing the device for only a short time, you may feel you have complete visual acuity and depth perception when in fact you do not.

Driving techniques and visual clues used during unaided night driving (without NVGs) also apply to aided night driving (with NVGs). The advantage of NVG use is improved ground reference and object identification. However, the field of view is greatly reduced. Use a continual scanning pattern to make up for this. To view an area while using NVGs, turn your head slowly until the goggles point in the desired direction. Rapid head movement can induce vertigo, which may lead to dizziness and nausea.

WARNING

Never use NVGs on public highways. The effect of oncoming headlights on the device may cause some very dangerous situations; the operator will be unable to see other objects in the field of view. If the light is sufficiently bright, the devices all have a bright source protection feature that shuts down the NVG to protect it. If the bright source protection is activated, the NVG will be off for at least 2 seconds.

Although unlikely to occur, drivers with NVGs may face the situation described above in an NVG-controlled training area. To minimize the effect of headlights from an oncoming vehicle on NVGs, SLOW DOWN. Look away so that the light source is just outside the goggle's field of view. Pull off to the far right-hand side of the road, and stop the vehicle. NVG training at this point is now compromised as other vehicles with headlights on may appear. DO NOT CONTINUE DRIVING WITH NVGs unless authorized by a responsible officer or individual, such as the range control officer.

If your vehicle malfunctions while you are driving with NVGs, or if the goggles fail or begin to fail, SLOW DOWN. Pull off to the far right-hand side of the road, and stop the vehicle. Immediately WARN approaching NVG-equipped drivers with hand and arm signals and NVG-compatible light sources, such as an IR light stick or tactical flashlight. DO NOT turn on your four-way emergency flasher lights; they may blind approaching drivers with NVGs. If your vehicle breaks down on a road

hidden from approaching drivers by a curve or hill, walk back along the shoulder of the road to a position where you can signal them to slow down in time. Do not try to repair your vehicle while it is in an exposed position on the road! If you are in a vehicle and see the scene described above, SLOW DOWN and proceed with caution.

If the NVG's low battery indicator turns on, REPLACE the batteries. DO NOT WAIT until the goggles shut down due to a weak or dead battery while driving. Slow down, pull off to the far right-hand side of the road, and stop the vehicle. You (or the assistant operator if accompanied by one) must warn approaching traffic FIRST before you try to switch batteries from another NVG or replace the batteries if spares are available. DO NOT switch goggles or you will have to refocus the device to suit your eyesight.

Operating a vehicle while wearing the goggles (AN/PVS-7 series only) over the NBC protective mask further reduces the field of view to about 20 degrees and is not recommended.

Driving with one lens focused inside and one focused outside the vehicle can cause spatial disorientation (dizziness, nausea) and is not recommended.

The assistant (shotgun) operator plays an important role in driving with NVGs. The driver must focus the goggles for distance vision even though this makes instrument reading difficult. An assistant operator wearing NVGs can compensate for this by alternating between distance and close-up viewing and telling the driver the status of warning lights, speedometer, fuel gauge, and other instrument readings. Depending on the vehicle configuration, the assistant operator may need to sit directly behind the driver to gain a better view of the instrument panel. The assistant operator must also use a slow scanning pattern and tell the driver of any obstacles inside or outside his field of view.

When parking vehicles in areas where NVG tactical lighting is used, trained ground guides equipped with NVGs should direct drivers to parking spots. Neither drivers nor guides should remove their NVGs until the vehicle is in the desired parking spot. Modify flashlights used by ground guides for NVG compatibility (Table 23-2). Alternative light sources for use during tactical operations are available in the Army supply system. Table 23-2 lists NVG-compatible items and their stock numbers.

Table 23-2. NVG-Compatible Light Sources.

ITEM	NSN
30-min high-intensity light stick (yellow), 6"	6260-01-074-4230
12-hour low-intensity light stick (green), 6"	6260-01-074-4229
3-hour IR light stick, 1 1/2"	6260-01-247-0364
3-hour IR light stick, 6"	6260-01-195-9752
3-hour IR light stick, 15"	6260-01-247-0366
3-hour IR flexible band, 7 1/2"	6260-01-247-0365
IR transmitter (battery-operated)	6240-01-275-8080
IR paper	6230-01-074-4230
Filter, flashlight (green)	6230-00-504-8341
Filter, flashlight (blue)	6230-01-189-1480

Convoy Driving

Convoy driving with the NVG presents some unique problems, some influenced by the type of terrain and road surface. The major concern is keeping a safe distance between the vehicles in the convoy. Resolution, bar patterns, or IR light sticks affixed to the rear center of each vehicle are valuable aids to keeping safe distances between vehicles.

Convoy movement over winding or hilly terrain can cause the loss of visual contact with the lead vehicle. Therefore, a high degree of speed discipline is required to maintain safe distances. Dirt or extremely dusty surfaces also cause problems keeping visual contact with the lead vehicle. When driving on these surfaces, the convoy's speed must be reduced. Convoys composed of different types of vehicles should proceed at the speed of the slowest vehicle. As a general rule, the speed limit should not exceed that established for blackout driving without the use of NVGs.

For safety reasons, permit convoy driving with NVGs only if every driver and assistant operator are NVG-equipped. If insufficient quantities of NVGs prohibit this, a mix of NVG and blackout drive may be used. Group the NVG-equipped vehicles together at the rear of the convoy. Do not disperse and intermix them with other vehicles not equipped with NVGs. If grouped in this manner, be sure the last non-NVG-equipped vehicle has its rear blackout drive lights off.

Motorcycle and All-Terrain Vehicle (ATV) Operation

Motorcycles and ATVs may be operated with NVGs. Since a motorcycle or ATV operator does not have an assistant driver, the limitations of NVGs may require him to slow down proportionately more than a wheeled vehicle operator when using the goggles. A motorcycle or ATV operator usually requires much more training with NVGs than a wheeled vehicle operator to achieve equal levels of proficiency and safety. The additional weight that the goggles place on the operator's head and the position of this weight may require the motorcycle or ATV operator to redevelop his sense of balance during training.

In general, operate the motorcycle or ATV with headlights off, or at most, with blackout marker

lights on. Turn instrument lights off. Users of AN/PVS-5 goggles should focus both tubes for distance vision, even though this makes instrument reading difficult.

The limited field of view of NVGs will have a greater impact on motorcycle and ATV users than on other vehicles. Operators must practice and train to turn their heads from side to side to make up for the loss of peripheral vision.

NVG Training Mission Planning and Briefings

Night driving operations are more easily conducted when ambient light sources provide the greatest amount of hemispherical illumination. Try to schedule qualification training on a night when the moon offers NOT LESS THAN 25 PERCENT ILLUMINATION (quarter moon) and is positioned at least 30 degrees above the horizon.

Every NVG training mission should be planned and briefed with all possible situations considered, to include deteriorating weather, disorientation, loss of depth perception, and equipment failure. All primary and assistant drivers must know their responsibilities under each situation. Communication between driver and vehicle commander is critical. The driver must constantly advise the vehicle commander of any reduction in vision.

At a minimum these subjects should be discussed during a night vision goggle briefing:

- Weather, including winds, sunset, moonrise, moonset, percent moon available, ambient light level, and effect of cloud coverage on ambient light levels. Weather forecasts should cover from 1 hour before training begins through 1 hour after training ends. If actual weather conditions deteriorate, modify night training as necessary.
- Light-level planning calendar. The commander, helped by supporting weather personnel, can develop a light-level calendar to predict when optimum levels of ambient light will exist. Further, a computer program termed NIGHTVIS provides NVG users with accurate forecasts of favorable/unfavorable times of use. You can get this user-friendly software

program by writing to Commander, US Army Atmospheric Sciences Laboratory, ATTN: ALCAS-AE-A, White Sands Missile Range, NM 88002-5501.

- Visibility restrictions, such as smoke, haze, or fog.
- Hazard map review for obstructions located in the training area.
- Mission to be performed.
- Vehicle and site preparation/lighting.
- Driver and assistant driver duties and responsibilities.
- Parking and recovery plans.
- Emergency procedures, such as what to do if a tube fails while driving.
- Medical evacuation/fire support.
- Personal equipment.
- Safety.

Draw all charts, drawings, and diagrams to scale as accurately as possible. Conduct a reconnaissance of the selected route during the day and night. The area should have a variety of road and terrain conditions available; for example, heavy/little overhead canopy, hilly roads, off-road terrain, unimproved roads, and good and poor contrast. It should also be an area where other traffic is precluded.

Conduct the formal briefing far enough in advance of the scheduled departure to allow time to resolve any problems raised during the briefing. Schedule a final briefing just before departure time to—

- Update weather conditions.
- Confirm time schedule.
- Discuss any mission changes.
- Ensure goggles are properly focused.
- Ensure a sufficient quantity of spare batteries are available.

- Review safety precautions and emergency procedures.
- Give the commander time to reemphasize important aspects of the mission.

Commanders/team leaders should hold individual briefings after the formal briefing. Each driver should be required to discuss the entire mission.

Support Requirements

Support requirements for conducting safe NVG driver training include the following:

- Before driving a route at night, check it during the day for obstructions. Post a hazard map in the briefing room. Update it when a new obstruction is detected.
- Set up the tactical site/staging area lighting system for night training. Tactical lights for both aided and unaided vision are required when operating at a tactical site.
- A command and control vehicle equipped with NVGs must be on the route during qualification and refresher training. Establish communication between the command and control vehicle and the TOC. MEDEVAC and fire support personnel must be on site or on standby.
- Get an eye chart from your servicing medical company. Make it available for drivers to properly focus the NVG before the start of actual driving.
- If the route selected does not preclude other traffic, such as commercial traffic, military police support may be needed for traffic control purposes.

WARNING

Before training begins, all support personnel not involved with NVG training should be briefed on what will be going on and what they should and should not do; for example, random use of flashlights or other lights and walking around and between vehicles.

TRAINING PROGRAMS

Command Considerations

Commanders must fully understand the limitations and requirements of night driving operations. The success of any night operation depends on the amount and quality of preparation and training conducted before the mission. Night operations require extensive training and maximum support and attention from commanders.

Commanders must establish and support night training programs. Mission goals must be realistic and developed around the proficiency and experience of the unit in night operations.

Using drivers in day and night roles reduces their ability to operate effectively at night. Because night driving is more tiring than day driving, commanders must ensure that personnel get every opportunity to rest. When drivers are scheduled for night driving, commanders should consider limiting workloads to night driving only.

Maintenance requirements for day and night driving are greater than those required for day operations alone. To allow enough time for maintenance, commanders should decrease day operations when night missions are scheduled. Maintenance personnel may have to be divided into two shifts to support day and night operations.

Commanders should be alert to signs of fatigue, overconfidence, or carelessness that personnel engaged in night driving display. A carefully planned and executed night driving safety awareness program is essential for accident-free operations. Commanders must ensure that leaders at the lowest level emphasize and enforce the spirit and the standards of this program.

Commanders must ensure that proper facilities are available for night training. Failure to provide the proper training environment reduces an individual's ability to perform night driving and creates an unsafe situation.

Until the entire unit is fully trained in all aspects of night missions, commanders may consider dedicating a platoon or company solely to tactical night operations. Once established and proficient,

this element can then help train the remainder of the organization.

Since the introduction of NVGs, many units have established aggressive NVG training programs. Their experience has shown that night tactical missions are much more effective under ALL ambient light levels when conducted with the use of NVGs.

Psychological and Physiological Training Considerations

Training with NVGs is relatively new and challenging. Initially, some drivers may be bothered by sore neck muscles, headaches, and fatigue. Some may develop anxiety due to reduced depth perception. Most of the mental and physical effects of NVGs can be reduced if the following considerations are included in NVG training programs.

The first NVG driving lesson should be conducted over a short range, for example, 3 to 5 kilometers, and when a high ambient light level exists. This procedure introduces the driver to NVGs during ideal conditions; the short route helps prevent fatigue. As training progresses, conduct longer training periods in lower ambient light levels. Using these procedures increases the student's endurance and confidence.

Students experience greater fatigue during night driving. Duty hours for drivers, instructors, data collectors, and support personnel undergoing night training should not exceed 8 continuous hours a day. (Instructors conducting NVG training should be restricted to 4 hours of instruction within a 24-hour period.) A typical duty day would be 1600 to 0200 hours. To comply with this requirement, duty should be limited to driving and academic training only. Additional duty, requiring a soldier's presence during the day, should be avoided when possible.

NOTE: Aviation experience has shown that 1 hour of flying with NVGs equals 3 hours of flying without them.

Commanders should consider using reversed cycle training for personnel selected to receive NVG training. This procedure means training at night and resting during the day. It enables the soldier to physically and mentally adjust to night operations

and provides continuity to a unit night training effort. Individual soldiers require at least 5 days to begin physical adaptation to a night training cycle. Physical adaptation is essentially complete after 2 to 3 weeks, but training efficiency is again reduced during the period of adjustment back to day cycle.

Training Prerequisites

Driving proficiency with NVGs can be maintained only through a training program that requires frequent NVG driving. Drivers who do not maintain NVG proficiency must receive refresher training.

In accordance with AR 600-55, Chapter 8, students must be licensed motor vehicle operators, receive NVG academic subjects before receiving hands-on training in a vehicle, and pass a written exam. Academic training makes students aware of the limitations of NVG driving and ensures a safer operating environment.

AR 600-55, Appendix J contains a list of mandatory academic subjects and driving (hands-on) tasks for driver qualification or refresher training, as well as instructor qualification requirements.

An NVG-equipped instructor must be in the cab of the vehicle at all times during qualification/refresher training.

Exportable Training Package

TC 21-305-2 is an exportable training package for units authorized either the AN/PVS-5 or AN/PVS-7 series NVG. It is available through normal publication channels. This training circular includes lesson plans, advance sheets, paper copies of viewgraph transparencies, a sample training calendar, eye charts, written examination and quizzes with answer sheets, and a performance evaluation checklist (road test). Lesson plans contain the conditions and standards for those mandatory academic and hands-on tasks outlined in AR 600-55, Appendix J.

Two training videotapes support this training and must be ordered separately through your local training and audiovisual center (TASC). The videotapes provide instruction on operational functions, care, preventive maintenance,

and proper wear of the AN/PVS-5 series and AN/PVS-7B NVG. TC 21-305-2 provides instructions for ordering either video.

Standing Operating Procedures

Standing operating procedures should cover all aspects of a unit's training program. Each operator should become thoroughly familiar with the contents of the SOP and of this chapter. The information that follows is minimal and is provided for guidance only. Each SOP must be developed to meet the particular training needs of the unit. The following information should be addressed:

- Hemispherical illumination limitations for NVG training.
- Rest requirements for personnel undergoing NVG training.
- Vehicle lighting configurations for night and NVG driving.
- Command and control vehicle for tactical operations.
- Additional light sources authorized for NVG driving.
- Care and security of the NVG.
- Weather requirements for night and NVG training.
- Vehicle speed limitations.
- Emergency procedures while driving with NVGs, such as goggle failure and vehicle breakdowns.
- Driver and assistant driver responsibilities.
- Qualification/refresher training requirements.
- NVG instructor qualification requirements.
- NVG licensing procedures (SF 46/OF 346).
- NVG-related accident reporting procedures.

OPERATIONS UNDER BLACKOUT CONDITIONS

When operating under blackout conditions, be sure your blackout marker lights are functioning properly. Lower the windshield to improve visibility. Drive at reduced speeds. If in a column, watch the rear blackout marker lights of the vehicle ahead to be sure you are following at the correct distance. Remember, the white blackout stoplight of the vehicle ahead is on the right and left side.

Blackout Marker Lights

To show the location of vehicles during blackouts, military vehicles are equipped with four blackout marker lights. Two of these lights are on the rear corners of the vehicles and the other two are on the front (Figures 23-4 and 23-5). They do not illuminate the road but indicate the position of a vehicle as much as 250 yards ahead, depending on the weather. They cannot be seen from an airplane flying higher than 400 feet.

When operating a vehicle in a convoy under blackout conditions, if practicable post a person equipped with a screened flashlight or large white piece of material in the rear of your vehicle to warn the following driver if he approaches too closely. An alert rear guard can usually detect a vehicle at a reasonable distance, even one with no lamps. In blackout operation, vehicles will maintain a speed of 5 to 10 MPH (8 to 16 kilometers per hour).

NOTE: When a vehicle is disabled on the side of the road, the driver is posted at the rear of the disabled vehicle with a screened flashlight or large white piece of material to warn approaching vehicles of the danger.

Taillights. Each rear lamp has two pairs of "cat's eyes" that show red when on. Each pair appears as one red light when you are 60 to 180 feet (20 to 60 yards) away and as two pairs of cat's eyes in each light at less than 60 feet.

Remember, one point of light tells you that you are too far behind the vehicle ahead. Two lights assure you that you are following at a proper distance. Four lights warn that you are getting too close.

Normally, the blackout stoplight is a separate unit mounted on the right and left taillights. It flashes a white light when brakes are applied.

Front Lights Each front light has one pair of cat's eyes. They show white when on. Each pair appears as one light when you are more than 60 feet away. When you are 60 feet away, you can see one pair of cat's eyes in each light. This warns you that the vehicle is near.

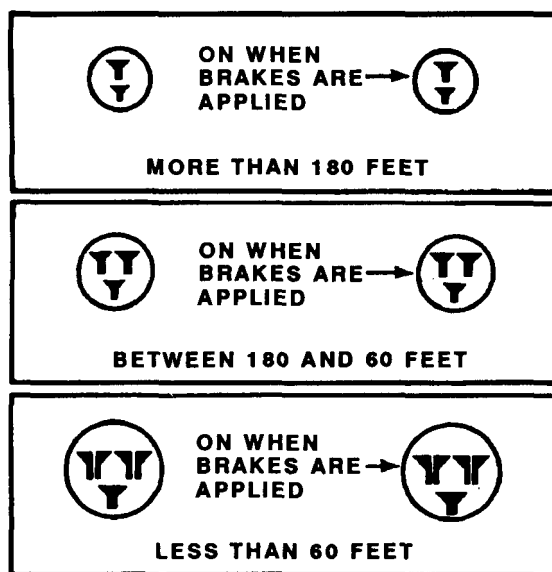

FIGURE 23-4. Rear Blackout Marker Lights.

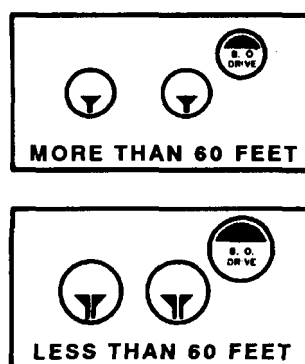

FIGURE 23-5. Front Blackout Marker Lights and Blackout Driving Lights.

Blackout Driving Light

The blackout driving light is mounted to the left of the left headlight (Figure 23-5). It furnishes a diffused light beam for limited illumination when you are driving under blackout conditions.

CHAPTER 24

MOTOR MARCHES AND CONVOYS

The wheeled vehicle driver must know specific procedures for maintaining convoy speed, halting, and handling breakdowns. The driver must also know convoy and aircraft loading signals as well as NATO convoy flags.

PROPER SPEED AND GAP

The road, weather, and amount of space needed between vehicles to allow for stopping without rear-end collisions and for letting faster-moving vehicles pull into the column after passing determine speed and gap.

Of all the space around your vehicle, the area ahead of the vehicle – the space you are driving into – is most important. You need space ahead in case you must suddenly stop. According to accident reports, trucks and buses most often run into the vehicle in front of them. The most frequent cause is following too closely. If the vehicle ahead of you is smaller than yours, it can probably stop faster than you can. This may cause you to crash into it if you follow too closely.

One good rule to determine how much space to keep in front of you is to allow at least one second for each 10 feet of vehicle length at speeds below 40 MPH. At greater speeds, add one second for safety. For example, if you are driving a 40-foot vehicle, leave 4 seconds between you and the vehicle ahead; in a 60-foot vehicle, 6 seconds. Over 40 MPH, you need 5 seconds for a 40-foot vehicle; 7 seconds for a 60-foot vehicle.

To know how much space you have, wait until the vehicle ahead passes a shadow on the road, a pavement marking, or some other clear landmark. Then count the seconds, one thousand and one, one thousand and two, and so on, until you reach the same spot. Compare your count with the rule of one second for every 10 feet of length. If you are driving a 40-foot truck and only count two seconds, you are too close. Drop back a little and recount until you have the right number of seconds of following distance. After some practice, you

will know how far back you should drive. When the road is slippery, you need more space to stop.

Maintain your proper place in the convoy. If you have no other orders, a good general rule is to keep a distance in yards that is twice the rate of speed at which you are driving. For example, if you are traveling at 25 MPH, leave 50 yards between your vehicle and the one just ahead at 30 MPH, 60 yards; at 35 MPH, 70 yards; and so forth. Remember, this distance is in yards, not feet. The number by which you multiply, in this case, 2, is called the speedometer multiplier (SM). The convoy commander may set a speedometer multiplier greater than 2.

In applying the speedometer multiplier, you must be able to judge distances. You can do this more easily if you practice estimating distances. Take a known distance, such as the length of a truck or the distance between telephone poles; observe carefully how that distance looks to you. Try this in different light conditions, such as day, night, and dusk. You will soon be able to estimate distances accurately.

VEHICLE FAILURES

If your vehicle fails while you are driving in a convoy, remember these basic rules:

- Signal a stop and pull off the road.
- Signal vehicles behind you to proceed.
- Correct the trouble if possible and fall back in the column at one of the breaks (halts). If you or a mechanic left with you cannot repair the trouble, wait for the trail officer and tell him your difficulties. He will make the necessary arrangements.

VEHICLE HALTS

A convoy halt is made for your personal convenience and for checking your vehicle. Make the at-halt

preventive maintenance check at each halt. Be sure to keep off the road if possible while checking your vehicle. If you must halt on the road, designate your assistant driver as a guard to warn other traffic.

AIRCRAFT-LOADING AND CONVOY CONTROL SIGNALS

Use and obey hand signals in a convoy just as you would when driving individually. In addition to the signals for right and left turns, stopping, and so forth, you must learn convoy control signals. (Signals used by personnel directing the loading of vehicles on aircraft are the same as those used for convoy control.) Whenever a march column is halted on a curve or downgrade, or whenever some drivers cannot see the signal, signals may be relayed along the column or transmitted by messenger to all concerned.

NATO CONVOY FLAGS

Mark each march unit of a convoy with flags 12 inches high and 18 inches long. The lead vehicle has a blue flag; the rear vehicle, a green flag. Mount the flags on the left front of the lead and trail vehicles, respectively. There they will not interfere with the driver's vision or with any functional component of the vehicle.

The convoy commander and march unit commander's vehicle must have a white and black flag on the left front bumper. This flag is divided diagonally from the lower left corner to the upper right corner. The upper left triangle is white; the lower right triangle, black. See FM 55-312 for additional information. OCONUS convoys must comply with MACOM and host nation regulations.

CHAPTER 25

OPERATION OF MOTOR VEHICLES ON AIR FORCE FLIGHT LINES (FOR AIR FORCE ONLY)

Motor vehicles operating on the flight line are necessary to normal operations and maintenance. However, they present a clear and possible danger, both to aircraft and ground personnel. Carelessness, haste, and disregard of existing safety standards by flight line vehicle operators are inexcusable and are primary sources of aircraft collisions and personnel injury. This chapter discusses applicable directives covering flight line vehicle traffic.

NOTE: For the purpose of this chapter, the term “flight line” includes runways, taxiways, aircraft parking ramps, hangars, and associated maintenance/-servicing areas where aircraft may be encountered, excluding aircraft on permanent static display.

AUTHORIZATIONS

Only operators and vehicles designated by the installation chief of airfield management, as prescribed in this manual and AFR 55-48, will be given access to the flight line. Before driving on the flight line, these operators will be given special instructions on standard flight line traffic controls and tower signals, advised of the particular hazards involved, and tested to ensure the instructions are understood. These operators will complete local flight line drivers' familiarization training and possess proper documentation authorizing flight line driving.

The individual's commander will certify on AF Form 171 (Request for Driver's Training and Additions to US Government Motor Vehicle Operator's Permit) that the individual has attended the flight line driving familiarization program. Certification of completion will be entered on the operator's record, AF Form 483 (Certificate of Competency).

No other person will be allowed to operate a vehicle on the flight line except for specified short

periods and only by temporary written permission and instruction of the installation chief of airfield management as prescribed in AFR 55-48. Permits for driving on flight lines will be kept to a minimum, consistent with operations requirements.

The installation chief of airfield management should periodically review the instructional material being presented to potential flight line vehicle operators to ensure that the material is current.

Vehicle operators performing on-the-job training (OJT) for flight line duties will not operate a vehicle within 50 feet of aircraft. This restriction does not apply to fire fighting vehicles and equipment, OJT operators who are towing aircraft, loading/unloading materials-handling equipment (MHE), and aircraft-servicing vehicles. In all cases, drivers on OJT must be qualified to operate the vehicle, and the qualified instructor must accompany him.

FLIGHT LINE SAFETY PRECAUTIONS

Careful attention and strict adherence to flight line safety precautions will prevent accidental damage to aircraft and possible injury to both flight and ground personnel. Bicycle operators on the flight line will also conform to these measures. Observe the following precautions at all times when operating vehicles on the flight line:

- Do not drive vehicles within 10 feet of a parked aircraft, except when the aircraft is being serviced, loaded, or off-loaded. Then use spotters to guide the vehicle's approach to the aircraft. Never drive vehicles under any part of the aircraft. Also, do not back or drive vehicles forward directly toward any aircraft, except as authorized in certain loading, unloading, or fueling operations. In these cases, place pre-positioned wheel chocks between the aircraft and the approaching vehicle to keep vehicles from striking the aircraft. Post guides as a required

safety measure. Keep chocks in position until vehicles leave from within the 10-foot safety distance requirement. When parked on the flight line, do not point vehicles directly toward an aircraft. Chock all powered vehicles and all equipment mounted on wheels that do not have an integral braking system when left unattended on the flight line. Leave vehicles unlocked with keys in the ignition when parked on the flight line.

CAUTION

All vehicles must approach parked aircraft with the driver's side of the vehicle toward the aircraft.

- For maximum safety, do not park or drive any vehicle closer than 25 feet in front or 200 feet to the rear of any aircraft when engines are operating or are about to be started. Vehicles parked at the side of the aircraft will be located clear of the wing tips and will be clearly visible to personnel in the aircraft cockpit.
- Under no circumstances will vehicles stand in front of, or drive into, the path of taxiing aircraft except "guide" or "follow me" vehicles. No vehicle will be driven between the aircraft and the "follow me" guide.
- Operators must be particularly cautious when they must drive across runways. They will completely stop at the runway holdline (two yellow parallel stripes painted on the taxiway surface). This marking is normally at least 100 feet from the runway edge. Installation airfield management officers will survey vehicle runway crossing procedures annually to ensure that flight safety is not being compromised. If runway crossing conditions require it, traffic signals, electrically controlled from the tower, will be installed.
- All flight line vehicles will fully stop before they enter or cross a taxiway. Before proceeding the operator will determine visually that the way is clear.
- Vehicles on the flight line are a major source of foreign objects that damage aircraft tires and are ingested into jet engines with disastrous results. Before airfield operations, operators will ensure all equipment carried on their vehicles is properly stowed and secured and the vehicles are inspected for objects that could damage aircraft. When dual-wheeled vehicles are operated on unpaved surfaces, they frequently pick up rocks between the tires. Operators will stop when reaching the airfield pavement and remove any rocks that are wedged between the tires or treads.
- A serious mishap potential exists when vehicles are operated in the path of radio beams used for aircraft navigation. Flight line vehicle operators will be instructed on the location and necessary precautions to be taken when operating near such equipment.
- General-purpose vehicles will not tow compressors, auxiliary power units, and similar equipment unless properly equipped with hitches designed for that purpose. Tugs or other vehicles with suitable trailer hitches will normally be used. Equipment will never be towed faster than 15 MPH. Safety chains will not be required on aerospace ground equipment (AGE). Pintle hook safety pins will be used in all pintle hook towing operations. Vehicle and wheeled equipment that do not have integral braking systems, when parked within 25 feet of any aircraft, will have one rear wheel chocked fore and aft.
- Except in unusual places, general-purpose vehicles will not operate at a speed greater than 15 MPH while on the flight line. Special-purpose vehicles will not exceed 10 MPH. No vehicle will operate in excess of 5 MPH when near aircraft. Aircraft will not be towed at speeds greater than 5 MPH at any time. During emergencies, fire and crash equipment and ambulances may exceed speed limits with prudence only when personnel and property are not endangered. Drivers will stop when emergency vehicles are seen or heard.
- Headlights shining toward a moving aircraft at night will be turned off immediately so the

pilot will not be blinded or his night vision affected. The vehicle's parking lights will be turned on so its position will be known. The headlights will remain off until the aircraft is out of range. During hours of darkness or inclement weather, all motor vehicles will normally use emergency warning flashers (directional lights front and rear) when parked on the airfield's aircraft movement areas. Unit commanders may waive this requirement at locations where aircraft parking ramp lighting is otherwise ample or when vehicles are parked within clearly designated areas within the unit's own ramp or in any other areas that have been coordinated with the airfield manager.

- Passengers in or on government vehicles will be particularly cautious. They will remain seated while the vehicle is moving and keep their arms and legs within the vehicle body. Passengers will not ride on tugs or towing vehicles unless a suitable seat with back and side guard is installed. They will not ride on any part of moving equipment not designed especially for passengers. Passenger-carrying vehicles will stop only at the side of aircraft when actually loading or unloading personnel.
- When the driver's seat is vacated, turn off the ignition, set the brakes, and place the gear lever in reverse gear. Use park if the vehicle has automatic transmission.
- Use chocks to secure all vehicles and wheeled equipment that do not have an integral braking system when they are left parked unattended on the aircraft parking ramp.

Aircraft-servicing support vehicles that require the vehicle engine to operate as the power source for auxiliary components may be left unattended while the engine is running. When the driver's seat is not occupied set the parking brake, place the transmission in neutral or park, and chock the rear wheels. Applicable equipment includes lavatory-servicing trucks, vehicle-mounted aircraft baggage, belt conveyors, water tank trucks, truck-mounted aircraft baggage, truck-mounted air conditioners, fleet-sinking high-lift trucks, refuelers, ambulances, and staircase trucks.

Emergency vehicles that must remain in operation at the scene of an emergency may be parked with the engine running, the parking brake set, the transmission in neutral or park, and the rear wheels chocked when the driver's seat is not occupied.

AGE-towing vehicles may be placed in neutral and left running while the driver completes hookup operations. This facilitates movement of the AGE-towing vehicle by hand to align pintle and tongue. Drivers must shut off the vehicle, set the parking brake, and place the vehicle in park or reverse if they do not drive off with the AGE equipment immediately following hookup.

CONTROL TOWER SIGNALS

Tower personnel control all vehicles operating on the flight line. Vehicle operators will observe and obey their light signals and radio instructions. Control tower light signals will be posted in plain view of vehicle operators on either the dash panel or other appropriate location.

The following light signals flashed from the control tower are designed to control flight time vehicle traffic:

- Steady green light – clear to cross.
- Steady red light – stop. Do not move vehicle
- Flashing red light – clear runway/taxiway.
- Flashing white light – return to starting point.
- Red and green light – general warning. Exercise extreme caution.

“FOLLOW ME” VEHICLES

“Follow me” vehicles used to guide aircraft will be equipped with signs easily visible at night reading STOP and FOLLOW ME. They should also be equipped with two-way radio facilities for communication on control tower frequencies. When approaching the parking spot, the “follow me” vehicle operator should illuminate the stop signal, move the vehicle from the intended path of

aircraft travel, and position it laterally, clear to the aircraft wing tip. The marshal, who may be the vehicle operator, will then guide the aircraft to the parking spot using marshaling signals contained in applicable Air Force directives. To accommodate the optimum safe taxiing speed of aircraft, guiding "follow me" vehicles can exceed the normal 15 MPH flight line speed limit. Tugs will not be used as "follow me" vehicles at any time.

REFUELING VEHICLES AND SERVICING EQUIPMENT

Operators of vehicles and servicing equipment will approach the aircraft so that the operator's side is adjacent to the aircraft. At no time, except in certain backing operations, will you drive your vehicle or equipment directly toward the parked aircraft. A sudden brake failure could result in collision. Where backing is absolutely necessary in the approach to aircraft, post a guide and place chocks to prevent your vehicle from backing into the aircraft. Even with this precaution, do not back toward the aircraft at a speed too fast for the bumper chocks to efficiently stop the vehicle in case of brake failure.

When approaching an aircraft to be fueled or defueled by a truck, the operator will approach the aircraft parallel to the wings (except in instances where single point locations of the aircraft require a different approach). Check with your supervisor for specific instructions. Always remember to leave the vehicle door ajar while servicing operations are performed so that you can move the vehicle more quickly in an emergency.

Stop the fuel-servicing equipment at least 20 feet from the aircraft, upwind if possible, and move into servicing position cautiously upon signal from directing personnel. Keep a distance of 20 feet between the fueling unit and aircraft fuel intake and/or vents. Keep a minimum of 10 feet at all times between the fueling unit and any portion of the aircraft. Check to see that suitable fire extinguishers are in position before beginning fuel transfer operations. When servicing aircraft with vehicles equipped with power takeoff in lieu of a pumping engine, keep a 10-foot minimum clearance between the vehicle and the leading edge of the wing. Do not back these vehicles toward the trailing edge of the wing. Exercise caution to make sure

that the prime mover exhaust system is outside the minimum 20-foot separation distance from the aircraft filler points or vents.

Never drive or park fuel-servicing vehicles under any portion of the aircraft.

TO 00-25-172 has additional guidance on positioning refueling vehicles and servicing equipment for aircraft.

AIRCRAFT-TOWING VEHICLE OPERATOR'S RESPONSIBILITIES AND QUALIFICATIONS

Towing aircraft is, in itself, not a hazardous operation when done properly. Experience has proven that inexperienced personnel and failure to follow established towing procedures contained in applicable rules and regulations usually cause towing mishaps.

As a towing operator, you must operate your vehicle in a safe manner. Follow the instructions your team supervisor issues. Also obey emergency-stop instructions given by any team member.

The OJT operator will receive special towing equipment training in his organization by qualified instructor personnel who are thoroughly familiar with the type of equipment and operating procedures to be performed. The OJT operator will possess a current AF Form 2293 or OF 346 when operating special-purpose vehicles with more than 14,000 GVW. A current AF Form 2296 will be on file in the base driver evaluation section.

An authorized, qualified instructor will be in the towing vehicle when training is conducted. Operators will receive training on each specific type of towing vehicle that they are to operate. Qualifications will be entered on their AF Form 2296 and OF 346. Training will be conducted for each specific piece of equipment towed by pintle hook on/off base. Qualifications will be entered in the appropriate training records.

Vehicle operators will not tow aircraft unless accompanied by a qualified operator in an authorized seated position who is certain that the student has been sufficiently instructed and trained

on the type of towing vehicle being used and aircraft to be moved.

When approaching the aircraft to be moved, the tow vehicle operator will stop at least 50 feet from the aircraft. He will proceed only on specific instruction from the noncommissioned officer in charge (NCOIC) of the towing team. The tow bar will be unhooked from the towing vehicle and moved into the aircraft hookup position by hand. The operator will not exceed a maximum speed of 5 MPH. Before the towing vehicle is unhooked from the aircraft, put chocks in place and set the aircraft brakes.

Towing equipment will not be dispatched to or operated by personnel not having a current operator's permit (properly authenticated for the type of vehicle being requested).

FORKLIFT OPERATOR'S INSTRUCTIONS

The forklift in its various sizes and capacities is the basic piece of aircraft cargo-handling equipment. It is used mainly for moving cargo to and from aircraft and for raising and lowering loads between the ground and the aircraft. Forklifts will be operated at all times only by licensed drivers. They will never be driven faster than 10 MPH on ramps or 5 MPH close to aircraft.

Forklift Maneuvers

When maneuvering forklifts close to aircraft, use a guide to help the driver determine safe clearances. Use bumper blocks placed on ramps to prevent unintentional contact with aircraft. Before lifting *or* lowering a load, completely stop the forklift. At no time will forklift drivers raise or lower a load while moving. Forklifts will never be driven under any part of an aircraft except when the type of aircraft involved requires it. When long distances must be traveled or when bulky loads are carried, the forklift will be driven in reverse so the operator has a less obstructed field of vision. The forks of parked forklifts will be lowered flat on the ground to prevent injury to personnel working or walking in the area. On parked and unattended forklifts, the operating levers will be in neutral, the ignition switched off, and the hand brake set. This will be done whenever the forklift is unattended.

Forklift Operation and Safety

WARNING

Operating forklifts with extension tines will change the center of balance and lessen the weight that can be safely lifted. OSHA standards should be met or a variance to the OSHA standards should be approved before use.

Use the following general guide for safe and efficient operation of forklifts in cargo handling:

- Stay within rated capacity.
- Lift with mast vertical or tilted slightly back, never forward.
- Keep loaded fork tines as low as practicable while moving.
- Do not raise or lower load while traveling.
- Watch rear-end swinging.
- Proceed slowly and cautiously around corners.
- Watch blind corners; signal with horn.
- Select lower gears before descending ramps.
- Avoid sudden stops or starts.
- Do not descend ramps with load in front. Back down slowly.
- Watch overhead clearances.
- For better vision, drive backwards with bulky loads.
- Ensure floor strength is adequate to support both vehicle and load.
- Use care in high-piling watch for falling stock.
- Be careful when handling long lengths of bar stock, lumber, and so forth. Watch swing, and if necessary, use a walking guide.

- Keep load against carriage.
- Keep load balanced laterally.
- Spread forks according to load width.
- Lower heavy loads slowly; stop them slowly.
- Keep clear of loading dock edges.
- Check bridge plates between loading docks, trucks, and cars for sufficient width, strength, and security.
- When loading or unloading highway trucks or trailers, be sure vehicle brakes are set and/or wheels chocked and support vehicle body with jacks or braces if springs are weak.
- Never tilt an elevated load forward except to place it on a stockpile.
- Be sure all objects of irregular shape, including aircraft engines, are securely chained to the forklift frame before being raised lowered, or moved. Normally, place large irregularly shaped objects on pallets for stability before raising or transporting them.
- Do not exceed 5 MPH around aircraft.
- Let only the operator on the forklift.
- Check foot brakes and hand brakes for effective operation.
- Do not load or unload cargo while aircraft is being serviced with fuel or oxygen. (For exception, refer to TO 00-25-172.)
- Keep an adequate fire extinguisher available.
- Have tail stand installed on tricycle-landing gear-type aircraft (ii equipped).
- Have adequate lighting.
- Remove ice and snow from area before loading and unloading or make the area safe by using appropriate materials.
- Use extreme care when operating on loading docks that are wet and slippery.

APPENDIX A

INTERNATIONAL MILITARY ROUTE SIGNS (NATO) AND ROAD SIGNS

The international military route sign system can be used with any existing civil system to meet military requirements in areas where North Atlantic Treaty Organization (NATO) military forces are operating.

INTERNATIONAL MILITARY ROUTE SIGNS (NATO)

Standard military signs include hazard (warning) signs, regulatory signs, and guide signs (Figures A-1 through A-6).

Hazard Signs

These signs indicate traffic hazards, such as road junctions and dangerous curves. They are normally used only in areas under military authority. Hazard signs are square and placed with one corner pointing downward. A purely military sign not included in the host-nation's system will have a yellow background with the legend or symbol in black. In the case of a sign included in the Geneva Convention or host nation's system, the appropriate sign is shown on the same yellow background.

Regulatory Signs

Regulatory signs are used to regulate and control traffic. They are square and have a black background on which the legend is shown in white with the following exceptions which are in different colors: bridge classification signs, stop signs, no entry signs, and signs erected by the military for the control of civilians under specified circumstances.

Guide Signs

Guide signs are used to indicate locations, distances, directions, routes, and similar information. Guide signs for routes are rectangular with the long axis vertical. The appropriate legend or symbol and route number are shown in white on a black background. Guide signs for casualty evacuation routes are either rectangular or shaped like a cross with red symbols on a white background.

Directional discs are used with other guide signs to indicate the direction of a route or with any major unit or formation sign to indicate the route to that unit. The disc is less than 16 inches in diameter and bears a black arrow on a white background. Eight equally spaced holes around the rim allow the disc to be nailed with the arrow pointing in any desired direction.

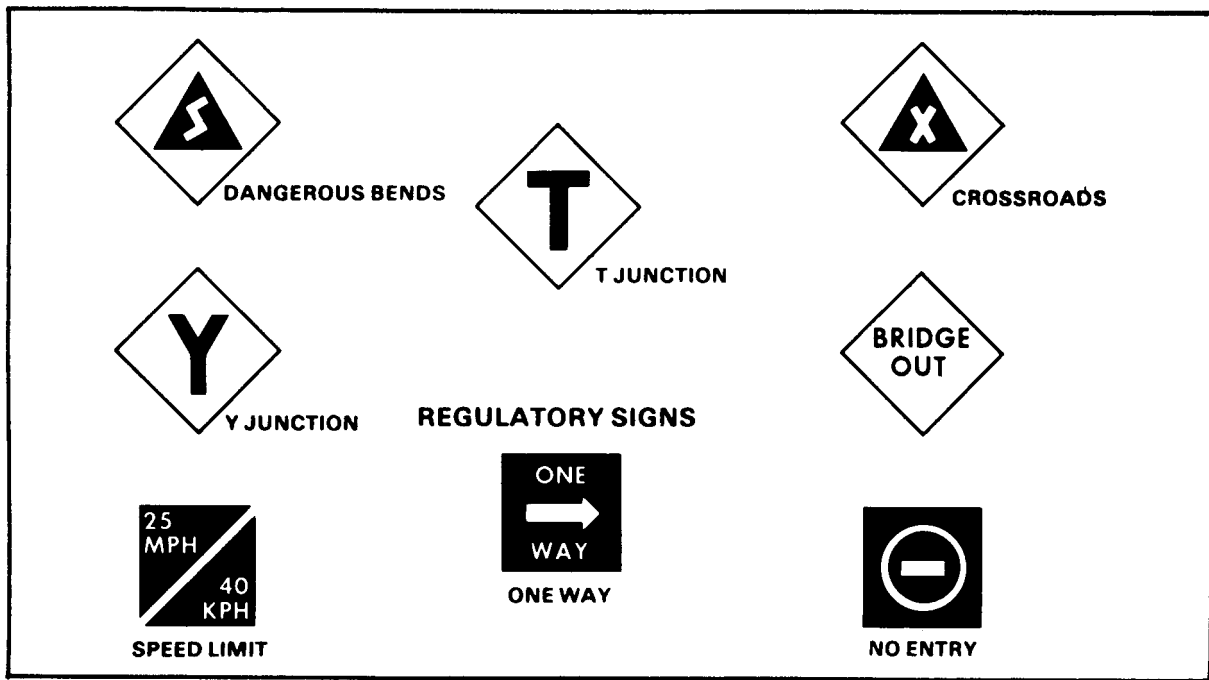

FIGURE A-1. Hazard and Regulatory Signs.

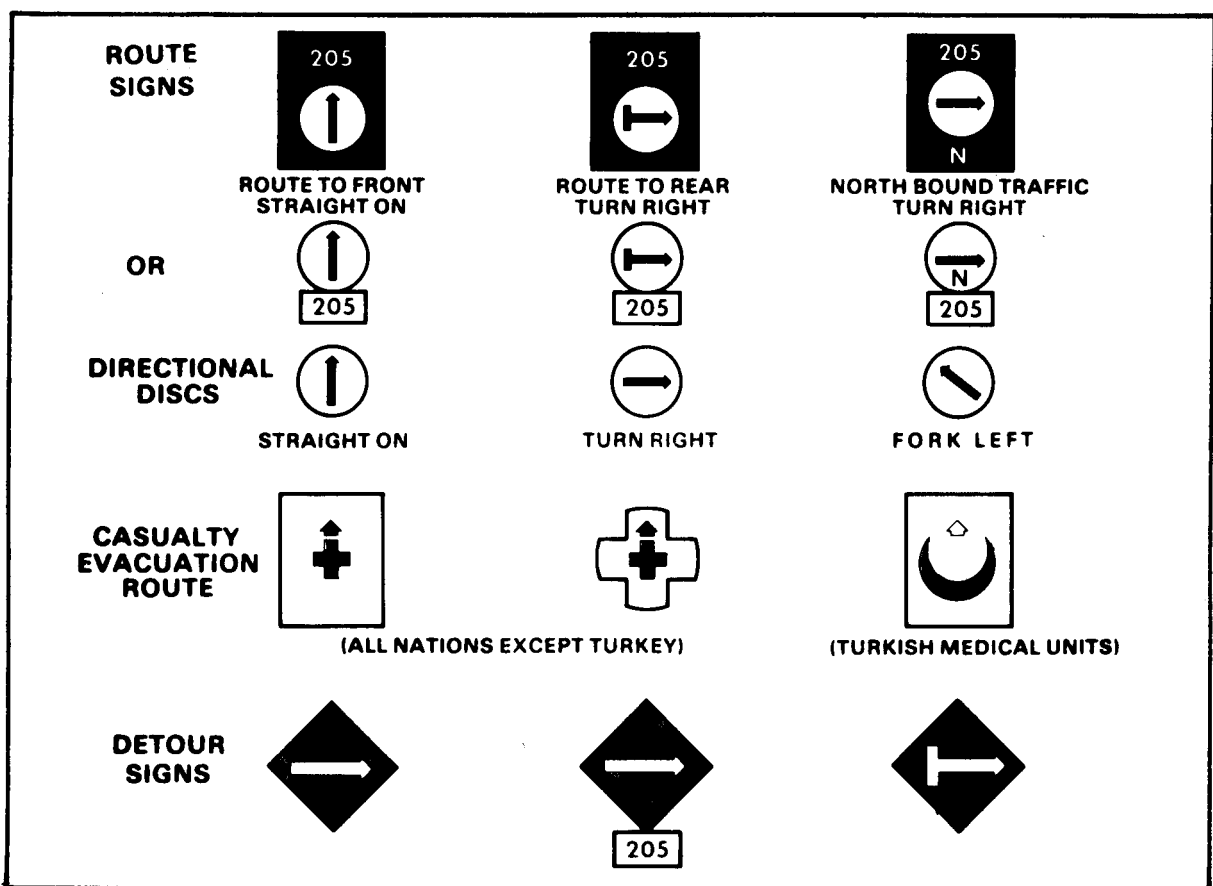

FIGURE A-2. NATO Guide Markings.













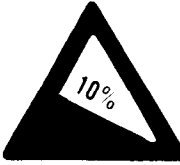

 <p>Danger</p>	 <p>STRASSENBAHN</p>	 <p>Oncoming Traffic</p>	 <p>Crossroads</p>
 <p>Bicycle Crossing</p>	 <p>Dangerous Downgrade</p>	 <p>Dangerous Upgrade</p>	 <p>Rough Road</p>
 <p>Signal Lights Ahead</p>	 <p>Stop</p>	 <p>Yield Right of Way</p>	 <p>Maximum Height Allowed</p>
 <p>Temporary 'GO' Sign</p>	 <p>Prohibited For All Vehicles</p>	 <p>Entry Prohibited</p>	 <p>240m 160m 80m</p> <p>Distance to Guarded Railroad Crossing</p>
 <p>Restricted No Stopping</p>	 <p>No Stopping</p>	 <p>No Passing</p>	 <p>End of No Passing Zone</p>

FIGURE A-3. International Road Signs.





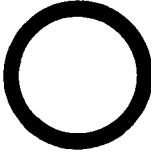
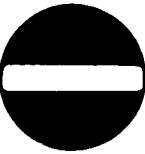
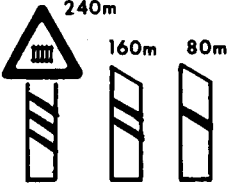
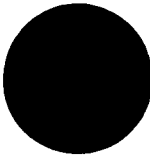
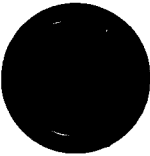













 <p>Single Curve</p>	 <p>Double Curve</p>	 <p>Road Narrows</p>	 <p>Road Narrows</p>
 <p>Slippery Road</p>	 <p>Children</p>	 <p>Construction Site</p>	 <p>Drawbridge Ahead</p>
 <p>Maximum Width Allowed</p>	 <p>Maximum Weight Allowed</p>	 <p>No Vehicles Carrying more than 3000 Liters of Pollutants</p>	 <p>Vehicles Above a Specific Axle Weight Prohibited</p>
 <p>Distance to Unguarded Railroad Crossing</p>	 <p>Railroad Crossing</p>	 <p>R.R. Crossing</p>	 <p>Guarded R.R. Crossing</p>
 <p>No Passing for Trucks in Excess of 2.8 Tons Authorized Weight</p>	 <p>End of No Passing Zone</p>	 <p>Limited Parking Place 'Clock Card' in Windshield</p>	 <p>End of No Stopping Zone</p>

FIGURE A-3. International Road Signs (Continued).

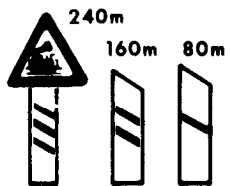

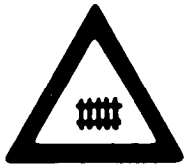



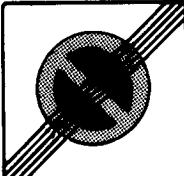











 <p>Quay or River Bank</p>	 <p>Low Flying Aircraft</p>	 <p>Pedestrian Crosswalk Ahead</p>	 <p>Pedestrian Crosswalk</p>
 <p>Wild Animal Crossing</p>	 <p>Domestic Animal Crossing</p>	 <p>Side Wind</p>	 <p>Falling Rocks</p>
 <p>Motor Vehicles Prohibited</p>	 <p>Tractors and trucks with an authorized loaded weight of more than 2.8 tons (3.08 US tons) prohibited</p>	 <p>Customs Control</p>	 <p>SMOG. Motor Vehicle Traffic Prohibited</p>
 <p>Unguarded R.R. Crossing</p>	 <p>Maximum Speed Limit</p>	 <p>End of Speed Limit</p>	 <p>Oncoming Traffic has Right of Way</p>
 <p>End of Restriction</p>	 <p>Soft Shoulder</p>	 <p>No Stopping on Shoulder</p>	 <p>Oncoming Traffic Must Wait</p>

FIGURE A-3. International Road Signs (Continued).



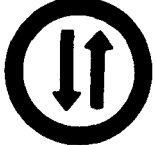
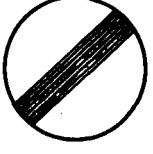







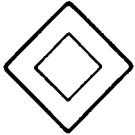
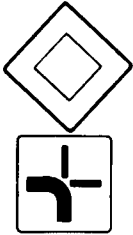
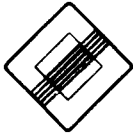

 <p>Priority Road</p>	 <p>Priority Road</p>	 <p>End of Priority Road</p>	 <p>Right of Way</p>
 <p>Snow Chains Mandatory</p>	 <p>Horsemen Only</p>	 <p>Pedestrians Only</p>	 <p>Bicycle Only</p>
 <p>Autobahn</p>	 <p>End of Autobahn</p>	 <p>Motor Vehicles Only</p>	 <p>End of Motor Vehicles Only</p>
 <p>Autobahn Detour</p>	 <p>Detour Route Marker</p>	 <p>Autobahn Direction Sign</p>	 <p>Direction to Autobahn</p>
 <p>White Center Lines</p>	 <p>Lane Markings (Painted on Pavement)</p>	 <p>Pedestrian Crosswalk</p>	

FIGURE A-3. International Road Signs (Continued).





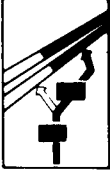
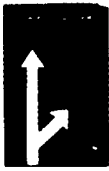
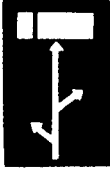
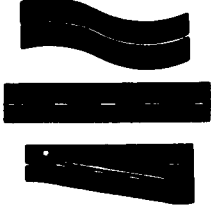





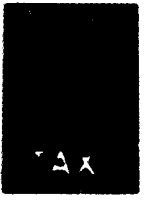



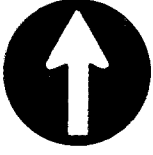
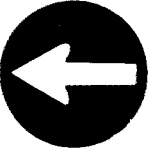
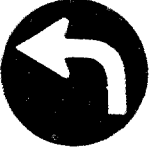

 <p>Priority Road Ahead</p>	 <p>Taxi Parking Only</p>	 <p>One-Way Street In Direction of Arrow</p>	 <p>One-Way Street</p>
 <p>Mandatory Direction of Travel</p>	 <p>Mandatory Direction of Travel</p>	 <p>Mandatory Direction of Travel</p>	 <p>Mandatory Direction of Travel</p>
 <p>Entrance to Autobahn</p>  <p>Exit from Autobahn</p>	 <p>Direction to Autobahn</p>	 <p>First Aid Station</p>	 <p>Telephone</p>
 <p>Change of Traffic Lanes</p>	 <p>Bypass Routing</p>	 <p>Detour</p>	 <p>Direction of Travel</p>
 <p>No Parking</p>	 <p>Streetcar Stop</p>  <p>Bus Stop</p>	 <p>Place Name</p>	 <p>Federal Highway Number</p>

FIGURE A-3. International Road Signs (Continued).

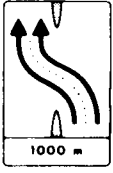
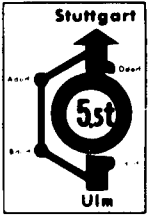
 <p>Dead End</p>	 <p>(Children Playing)</p>	 <p>Compulsory Minimum Speed</p>	 <p>End of Compulsory Minimum Speed Zone</p>
 <p>Mandatory Direction of Travel</p>	 <p>Mandatory Direction of Travel</p>	 <p>Water Protection Area</p>	 <p>Traffic Directed by School Guard</p>
 <p>Police</p>	 <p>Recommended Minimum and Maximum Speeds</p>	 <p>Parking on Curb Permitted</p>	 <p>Parking Area</p>
 <p>Direction Marker</p>	  <p>Direction Marker</p>	 <p>Built-Up Area (Front)</p>	 <p>Built-Up Area (Reverse)</p>
 <p>European Highway</p>			

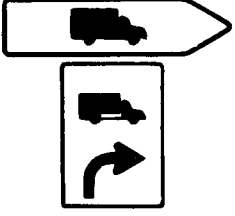
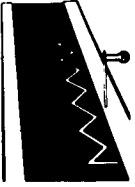
FIGURE A-3. International Road Signs (Continued).

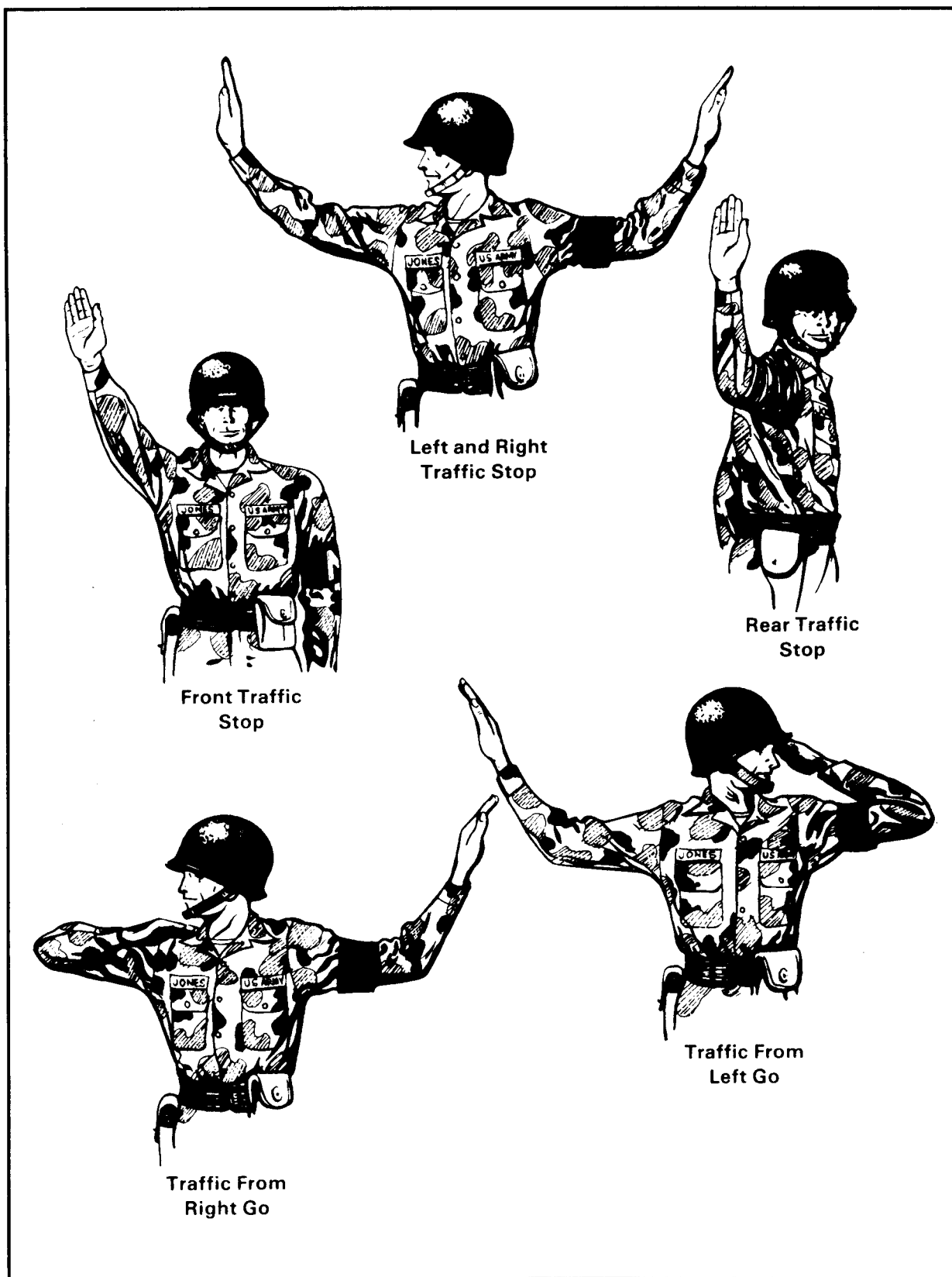
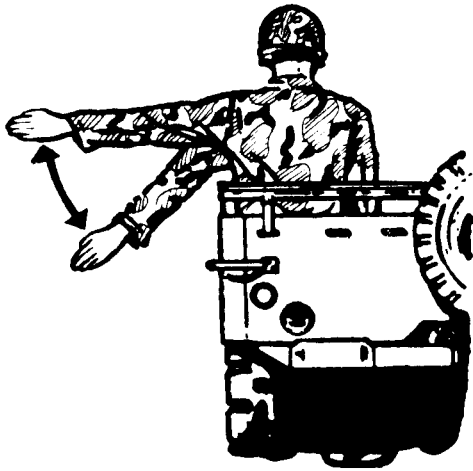
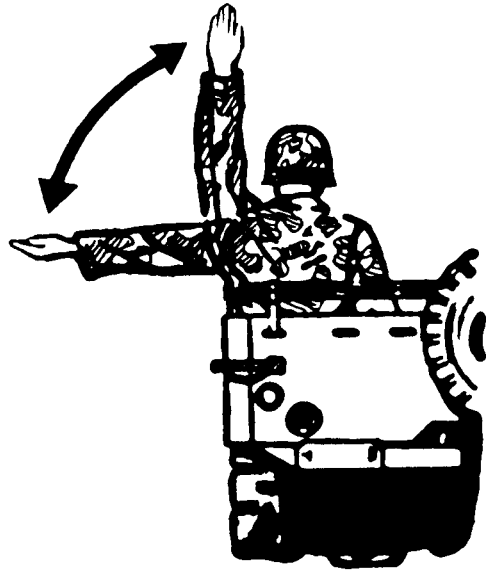

FIGURE A-4. Signals Given by Traffic Control Personnel.



1. **OPEN UP (EXTEND DISTANCE BETWEEN VEHICLES).** Extend left arm horizontally to the side, palm to the front, then move arm downward to an angle 45° below horizontal. Repeat several times.



2. **CLOSE UP.** Extend the left arm sideward to the horizontal, palm up, and raise it to the vertical. Repeat several times.

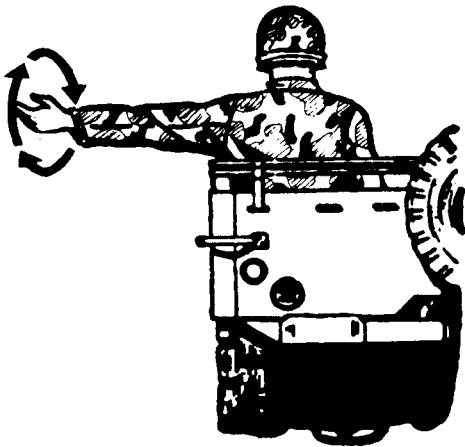

3. **PASS AND KEEP GOING.** Extend left arm horizontally to the side, palm to the front, and describe large circles to the front by rotating arm clockwise from the elbow.

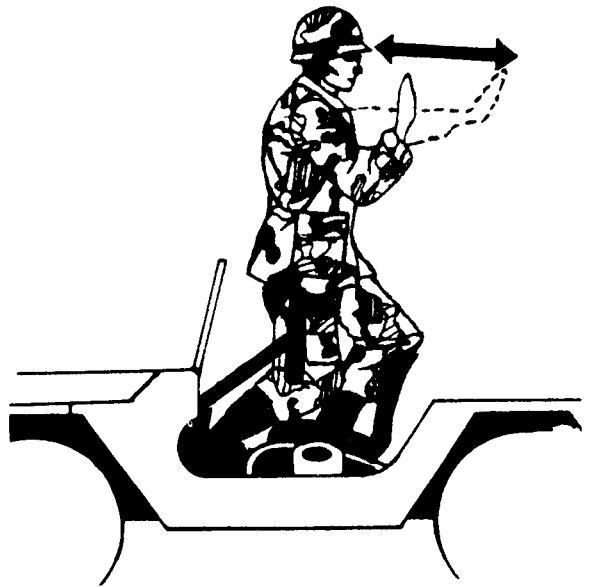

4. **MOVE IN REVERSE.** Face the unit being signaled and raise hand to shoulder level in front of the body, palm to the front; extend arm forward to the full extent in a pushing motion, keeping the palm to the front.

FIGURE A-5. Convoy Signals Given From a Vehicle.

DAY

NIGHT

Signal No 1 - Come Ahead



Flashlights on only when motioning in desired vehicle direction. When using conventional flashlights, direct lights forward.

Signal No 2 - Slow Down

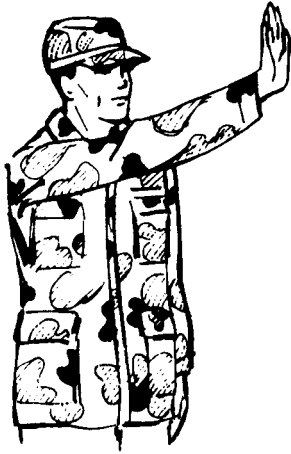

FIGURE A-6. Convoy Control and Aircraft-Loading Signals.

DAY

NIGHT

Signal No 3 - Stop or Halt



Light in right hand pointed upward, blinking. When using conventional flashlights, direct light in right hand forward, blinking.

Signal No 4 - Move in Reverse



Lights on only when motioning in desired vehicle direction. When using conventional flashlights, direct lights forward.

FIGURE A-6. Convoy Control and Aircraft-loading Signals (Continued).

DAY

NIGHT

Signal No 5 - Turn Left



When using conventional flashlights, direct light in right hand forward.

Signal No 6 - Turn Right

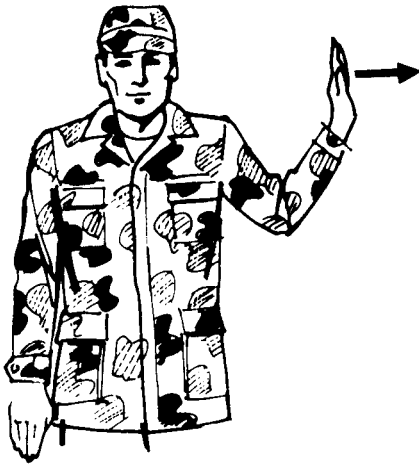

When using conventional flashlights, direct light in left hand forward.

FIGURE A-6. Convoy Control and Aircraft-loading Signals (Continued).

DAY

Signal No 7 - Turn Off Engine

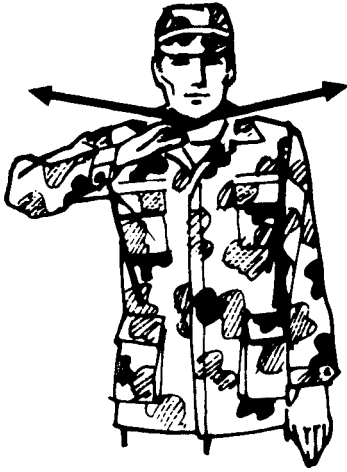

NIGHT

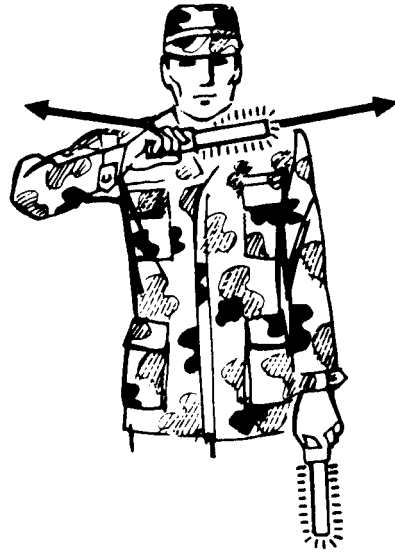

When using conventional flashlights, direct light in right hand forward.

Signal No 8 - Increase Speed



When using conventional flashlights, direct light in right hand forward.

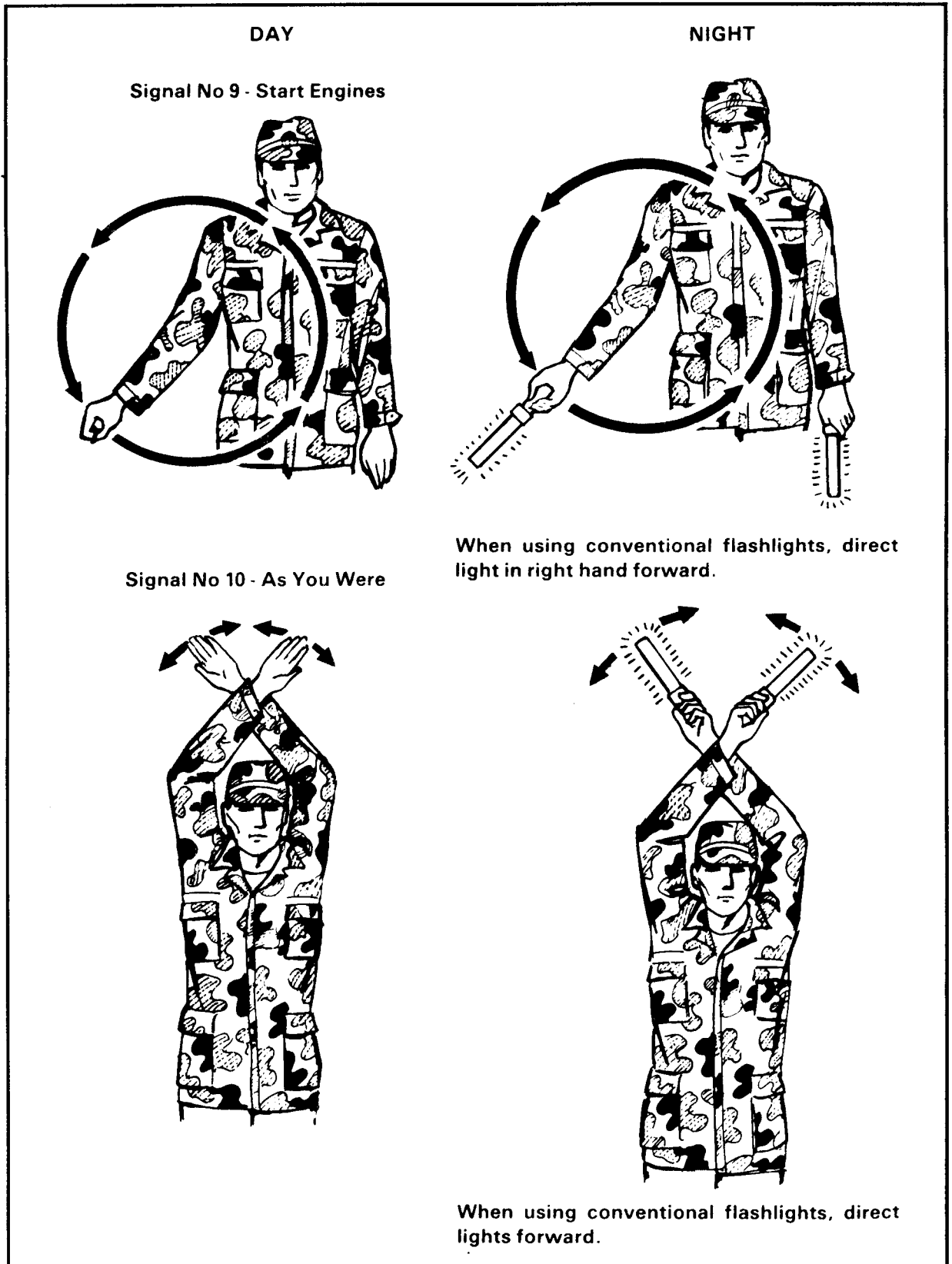

FIGURE A-6. Convoy Control and Aircraft-loading Signals (Continued).

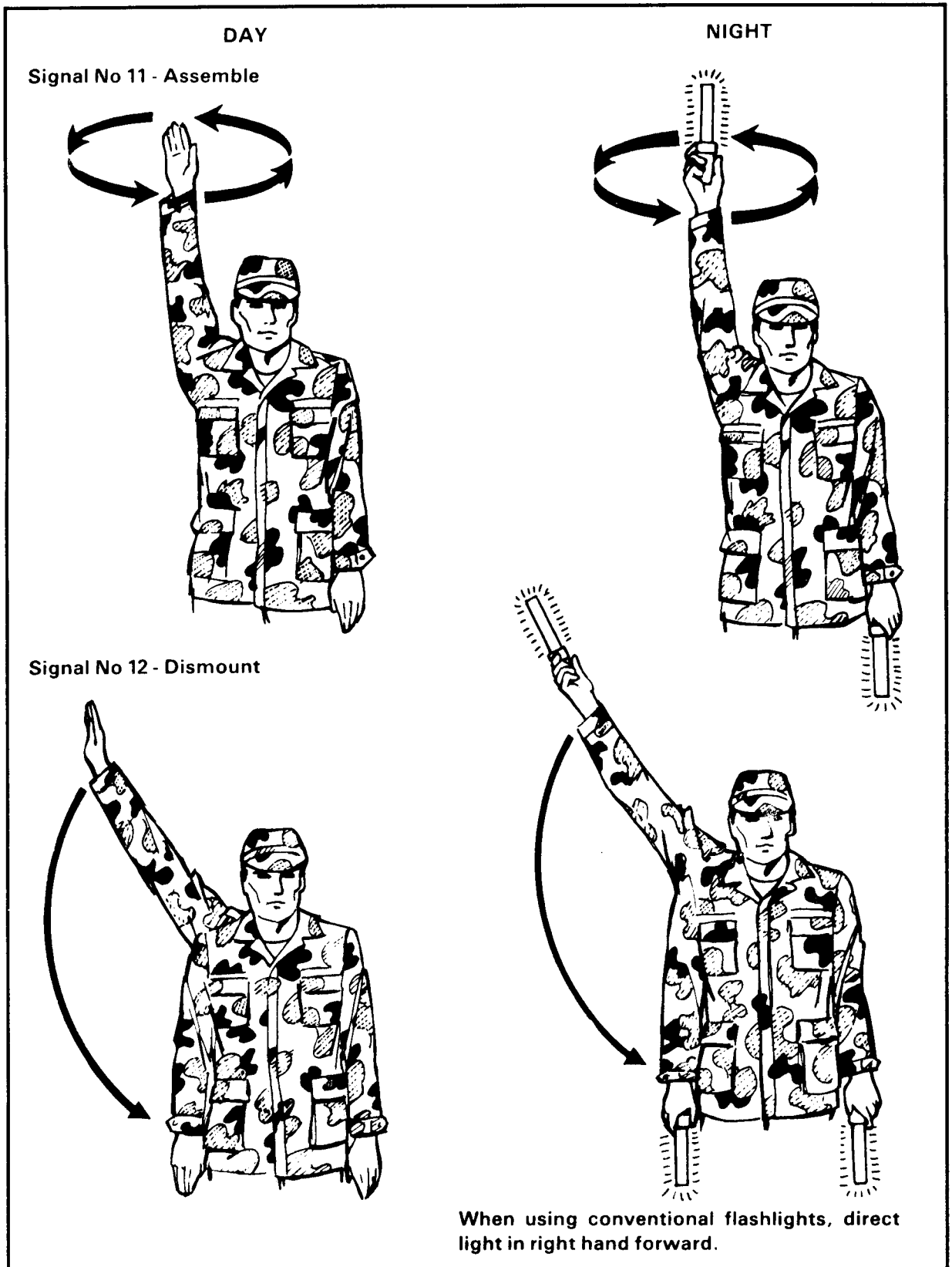

FIGURE A-6. Convoy Control and Aircraft-loading Signals (Continued).

Signal No 13 - Mount

DAY



NIGHT



When using conventional flashlights, direct light in right hand forward.

FIGURE A-6. Convoy Control and Aircraft-loading Signals (Continued).

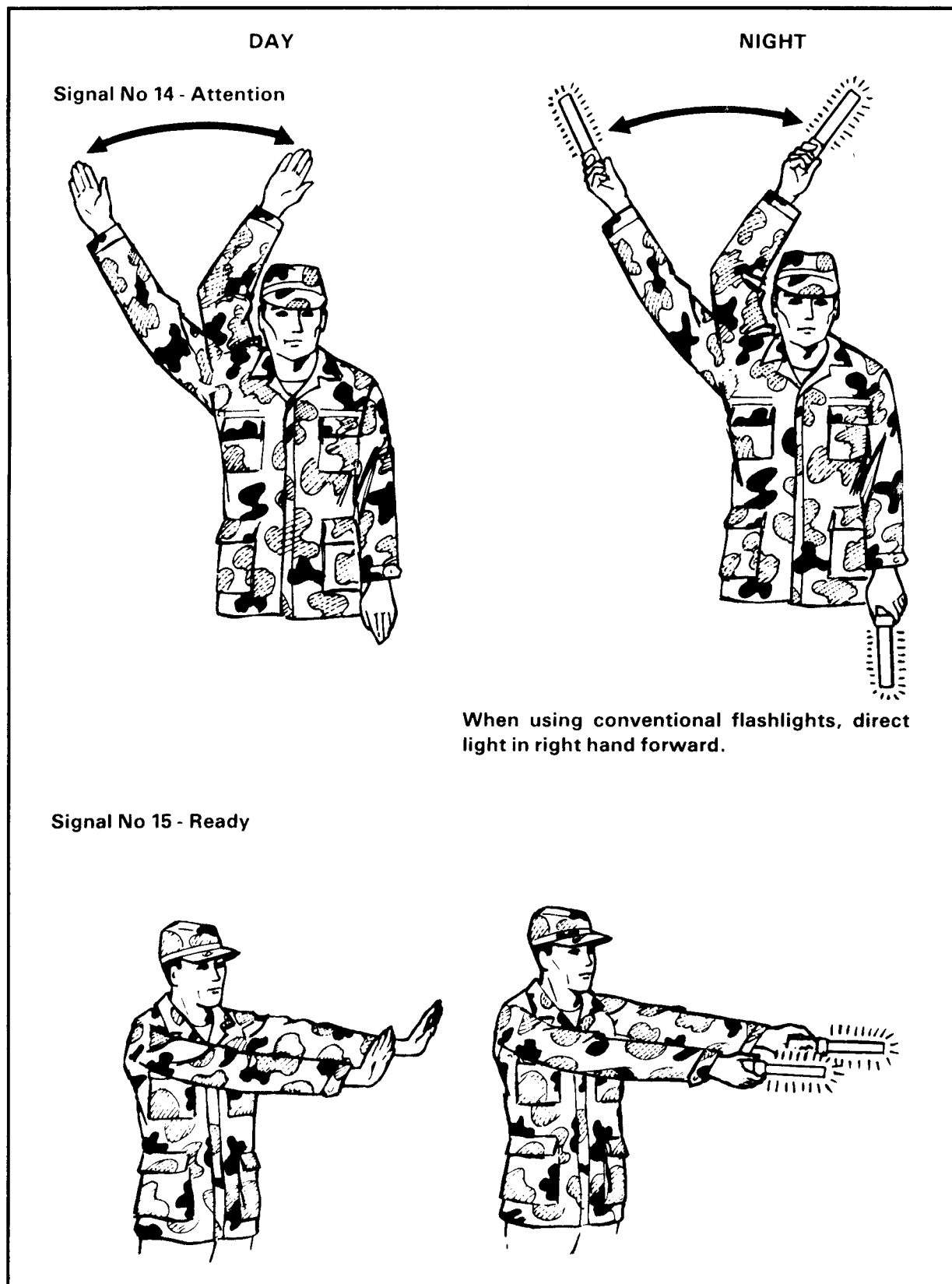

FIGURE A-6. Convoy Control and Aircraft-loading Signals (Continued).

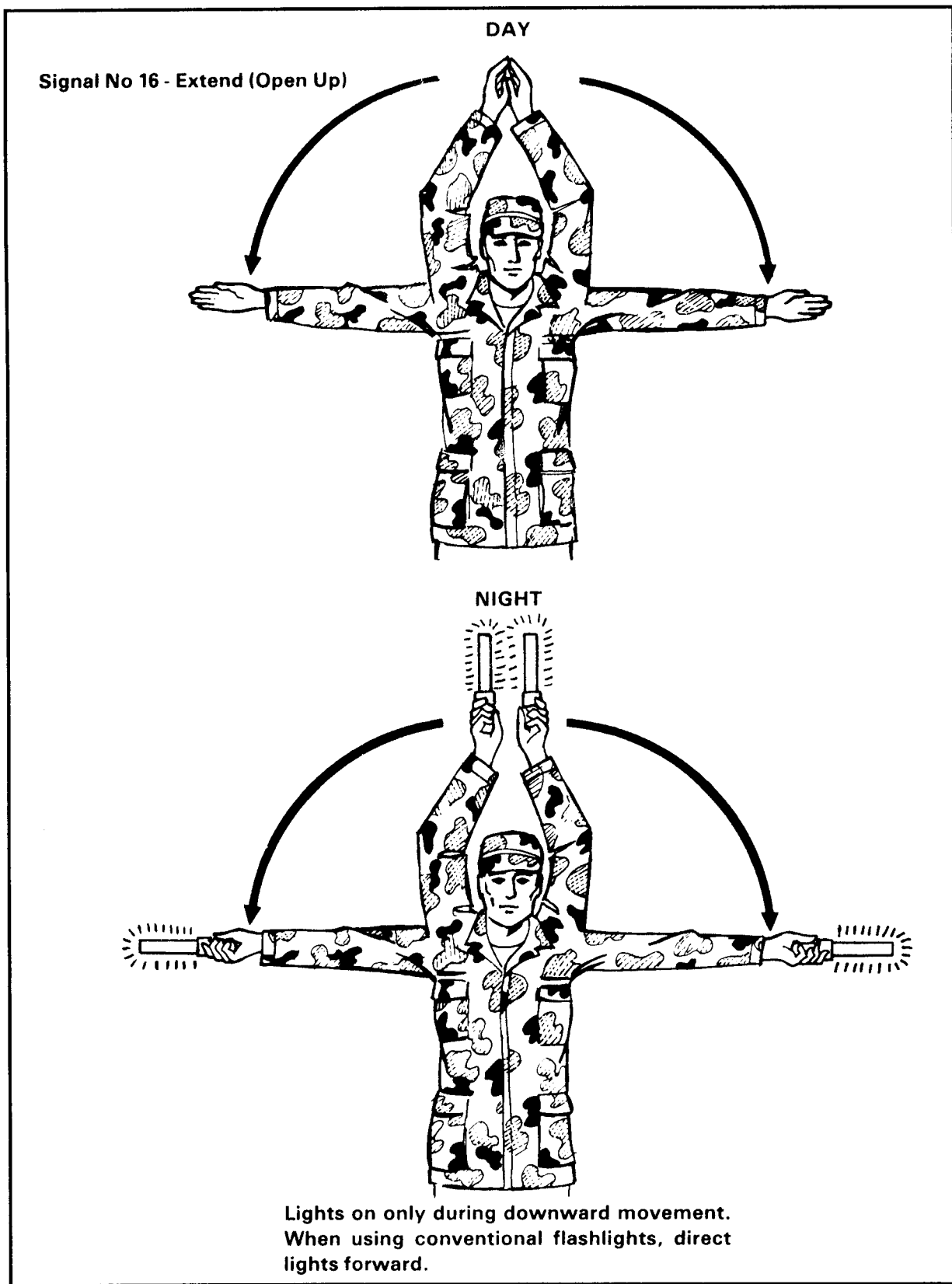

FIGURE A-6. Convoy Control and Aircraft-loading Signals (Continued).

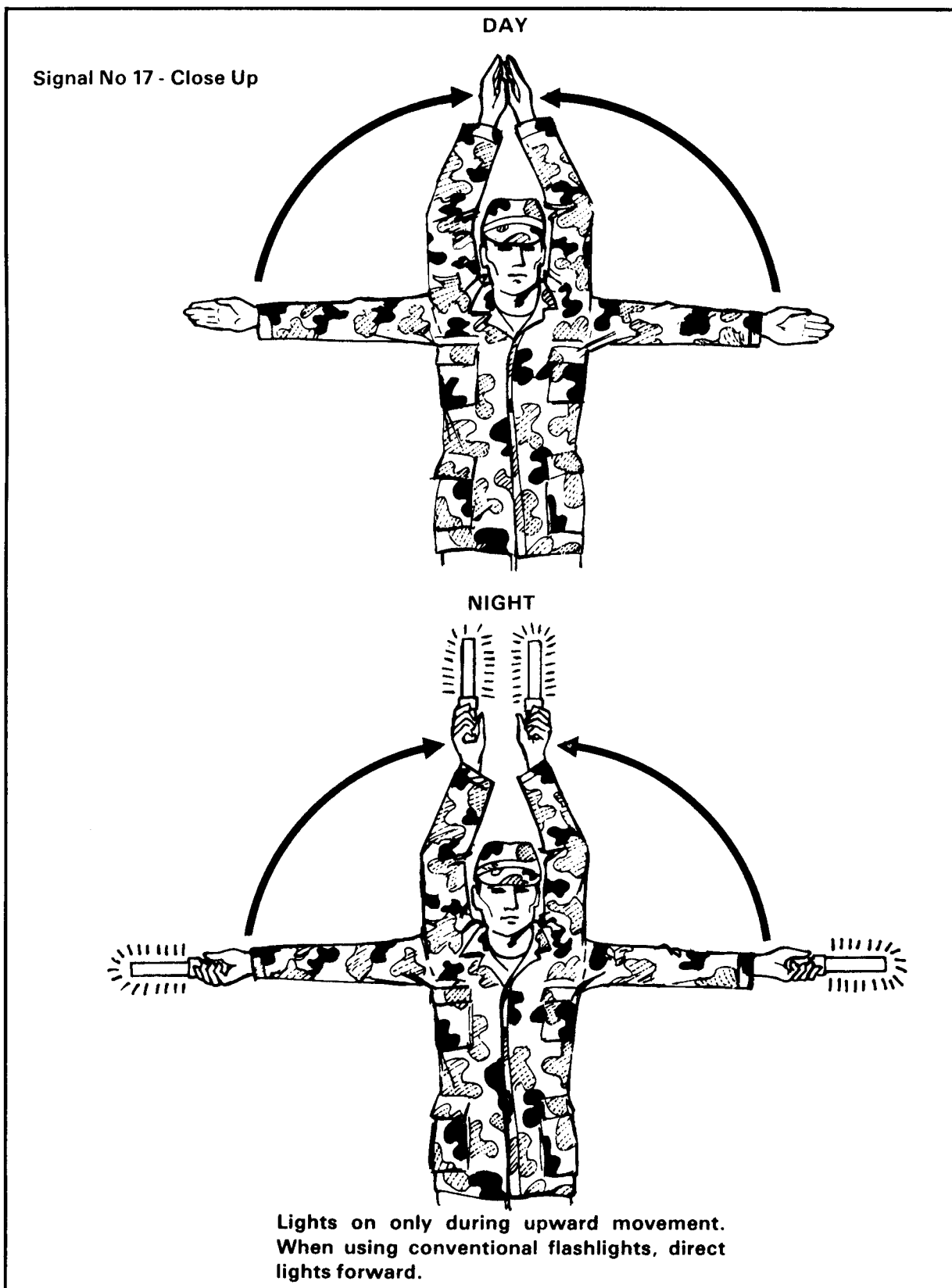

FIGURE A-6. Convoy Control and Aircraft-loading Signals (Continued).

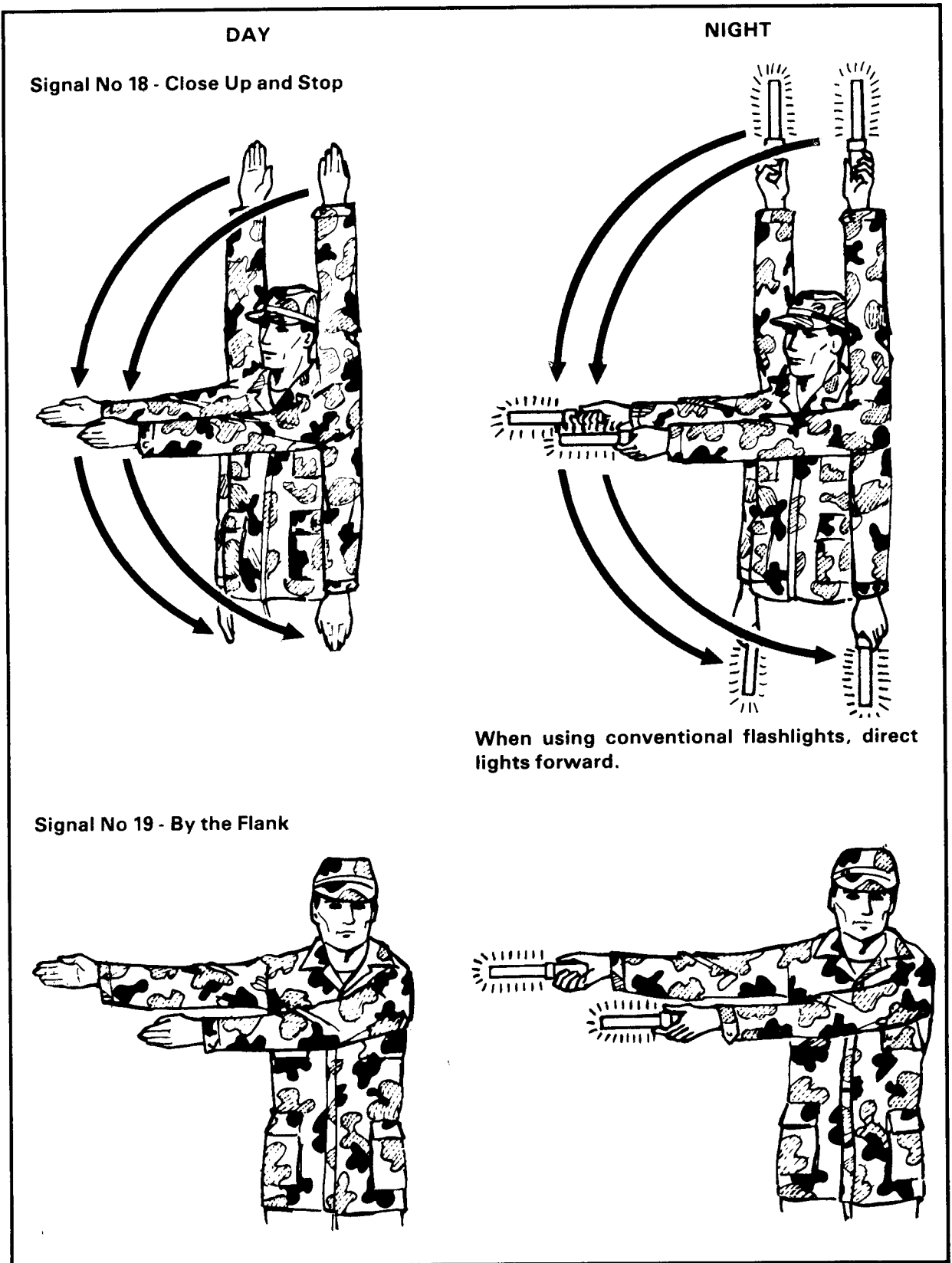

FIGURE A-6. Convoy Control and Aircraft-loading Signals (Continued).

APPENDIX B

**EXTRACT OF STANAG 2025
BASIC MILITARY ROAD TRAFFIC REGULATIONS
(EDITION 5)**

- Annexes:**
- A. Driver Hand Signals to Be Used by Drivers of Left Hand Drive Military Vehicles
 - B. Driver Hand Signals to Be Used by Drivers of Right Hand Drive Military Vehicles
 - C. Hand Signals to Be Used by Military Traffic Control Personnel
 - D. Standard Layout for Offence Report to Be Used by NATO Traffic Control Personnel
 - E. Example of Distinguishing Cuffs
 - F. (Part I) - Hand Signals for Guiding or Marshalling Single Vehicles by Day
(Part II) - Hand Signals for Guiding or Marshalling Single Vehicles when Visibility Precludes the Use of Day Signals

- Related Documents:**
- STANAG 2010 ENGR - Military Load Classification Markings
 - STANAG 2021 ENGR - Computation of Bridge, Raft and Vehicle Classifications
 - STANAG 2027 OP - Marking of Military Vehicles
 - STANAG 2154 M&T - Regulations for Military Motor Vehicle Movement by Road
 - STANAG 2174 M&T - Military Routes and Route/Road Networks

AIM

1. The aim of this Agreement is to standardize basic military road traffic regulations for NATO forces.

AGREEMENT

2. Participating nations agree to adopt the basic military road traffic regulations in particular as regards to the movements of vehicles or columns in an area under the control of a different authority.

NATO UNCLASSIFIED

GENERAL

3. This agreement is divided into five parts:
- Part 1 - General Regulations for Military Road Traffic Control Organization
 - Part 2 - Action by Road Traffic Control Elements
 - Part 3 - Road Traffic Regulations to Be Observed by Drivers of Military Vehicles
 - Part 4 - Traffic Control Personnel and their Relationship with Military Road Users
 - Part 5 - Signals for Guiding and Marshalling a Single Vehicle

DETAILS OF THE AGREEMENT

PART 1 - GENERAL REGULATION FOR MILITARY ROAD TRAFFIC CONTROL ORGANIZATION

4. The Military Road Traffic Control Organization is intended to regulate control and facilitate the movement of military vehicles and columns of vehicles by road.
5. Within each area of responsibility, the overall steps taken by the appropriate authority to organize and control Military Movement by Road constitute a Road Traffic Plan which serves as the basis for preparing road movements orders and instructions.
6. The Road Traffic Plan and related orders must enable those concerned to ascertain:
- a. General traffic regulations affecting military vehicles in particular.
 - b. The layout of the routes which it will be required to follow, and the details relating to those routes:
 - (1) Controlled routes
 - (2) One way route sections
 - (3) Authorized or prescribed speeds
 - (4) Special orders applicable to certain route sections or to certain critical points
 - (5) Location of traffic control posts

NATO UNCLASSIFIED

- c. Priorities allocated to certain vehicles or columns.
- d. Various prohibitions or restrictions (parking, overtaking, etc).
- e. Regulations relating to day or night traffic and in particular:
 - (1) The lines beyond which the movement of vehicles and the lighting of signs are subject to reduced lighting conditions or blackout conditions.
 - (2) If appropriate, route sections on which road markings are used.
- f. The conditions under which the appropriate authority wishes to be kept informed of the execution of movements.

PART 2 - ACTION BY ROAD TRAFFIC CONTROL ELEMENTS

7. To ensure implementation of the Road Traffic Plan and the execution of related orders as well as for the purpose of being kept informed of the execution of current movements, the responsible national territorial authority has Road Traffic Control elements at its disposal.

8. These elements are the representatives of the responsible national territorial authority. As such, the orders and instructions given by them must be obeyed by all military road users, irrespective of nationality. In accordance with NATO alert measures, responsibility for military traffic will be transferred to the appropriate military commanders in the combat zone.

9. Road Traffic Control elements can be:

- a. Military or Civil Police Units.
- b. Special Military Units.

10. These units discharge their task by means of:

- a. Traffic Control Posts set up along the routes as necessary and staffed by Traffic Control personnel.
- b. Mobile patrols (may be air patrols) or guides.

NATO UNCLASSIFIED

- c. Erection of the signs and equipment described in STANAG 2174 and any other temporary device for the purpose of regulating the flow of traffic.

11. Their primary duties are to:

- a. Apply traffic regulations by enforcing the Road Traffic Regulations, the instructions given by military and civil road signs and the instructions contained in the Road Traffic Plan. (For this purpose, they are empowered to prohibit access to controlled routes for which a movement credit is required to any military column and/or independent military vehicle not in possession of one.)
- b. Take appropriate action to prevent or reduce congestion. (For this purpose they must be familiar with their allocated area and available detours.)
- c. Supply military road users with all information and guidance which they may require.

12. When these units have the task of keeping the responsible national territorial authority informed of the execution of movements, they set up on the routes Traffic Control Posts equipped with necessary means of communication and in possession of the movement plan for these routes.

13. These Traffic Control Posts are indicated by panels of the type defined in STANAG 2174 erected along the route at a suitable distance on either side of and close by the Control Post.

14. Action by column commanders on passing Traffic Control Posts is given in STANAG 2154.

15. When the movement of a column of one nationality is controlled by an authority of a different nationality, representatives of the National Command to which the column belongs may be posted alongside the Control Post Commanders.

16. Action by the Traffic Control elements is facilitated by the erection of the signs and equipment stated in STANAG 2174, and any other temporary device for the purpose of easing the flow of columns, at particularly difficult points along routes.

NATO UNCLASSIFIEDPART 3 - ROAD TRAFFIC REGULATIONS TO BE OBSERVED BY DRIVERS OF MILITARY VEHICLES17. Civil Traffic Regulations

- a. Road Traffic Regulations. The drivers of military motor vehicles are at all times subject to the road traffic regulations of the country in which they are driving.
- b. Road Traffic Signs. Except in the cases referred to in STANAG 2174 drivers of military motor vehicles must at all times obey the civil road traffic signs of the country in which they are driving.
- c. Training. All drivers of military motor vehicles must be instructed on the traffic regulations of the country in which they are to drive including the signals given by civilian and/or military personnel engaged in traffic control as well as the civil road traffic signs, including in particular, the right of way signs used at road intersections.

18. Military Road Traffic Regulationsa. Speed Limits

- (1) Military vehicles, whether moving in columns or as single vehicles, must abide by the speed limits laid down by the responsible national military territorial authority controlling road movements in the area concerned. These speed limits will, in principle, exceed or, in the case of minimum speed limits, be less than civil speed limits applying to the roads in question.
- (2) In all inter-allied orders relating to road movement (e.g. standing orders, movement orders), speeds must be described both in "kilometres per hour" (km/h) and "miles per hour" (MPH).

b. Signals by Drivers of Military Vehicles

- (1) All drivers of military vehicles must indicate changes in direction by the use of the illuminated direction indicators with which vehicles are equipped except when their use is prohibited (in particular forward of the light line).

NATO UNCLASSIFIED

- (2) When the use of illuminated direction indicators is prohibited, or where the technical manufacturing and usage characteristics of vehicles are incompatible with the fitting of illuminated direction indicators, all drivers of military vehicles must indicate changes of direction by use of hand signals.
- (a) In countries where traffic normally drives on the right hand side of the road, drivers must use the signals described and illustrated in Annex A to this STANAG for Left Hand Drive vehicles and in Annex B to this STANAG for Right Hand Drive vehicles.
- (b) In countries where traffic normally drives on the left hand side of the road, these signals will not apply, and drivers must use the signals given in the Road Traffic Regulations of the nation concerned.
- (3) In addition, indication of intention will be given by the use of the signals described and illustrated in Annexes A and B of this STANAG where applicable.
- c. Stopping of Single Military Vehicles. When the driver of a single military vehicle has to stop his vehicle:
- (1) He must indicate to drivers behind that he is stopped and that it is safe they may pass.
- (2) He must place a reflective warning triangle, if he is equipped with one, beside the road at least 100 metres behind his vehicle to warn approaching traffic of its presence. He must then stand in a safe position where he can best signal traffic around his parked vehicle when parking off the road is not possible and if no Traffic Control personnel are present.
- d. Movement over Bridges, etc.
- (1) STANAG 2021 indicates the relationship between the classification number of a vehicle and those of bridges and rafts. No driver must move his vehicle on to a bridge or raft if his vehicle bears a classification number higher than that of the bridge or raft as established by STANAG 2010, unless directed to do so by Traffic Control personnel.

FATO UNCLASSIFIED

(2) All military traffic approaching or crossing bridges under repair, temporary bridges and rafts must move with particular care.

e. Military Road Signs

(1) All drivers of military vehicles must be taught and, where appropriate, must obey the military route signs given in STANAG 2174.

(2) When responsibility for military traffic in a combat zone is transferred to a military commander, military road signs will take precedence over civilian road signs.

f. Priority Vehicles. All drivers of military vehicles must facilitate the movement of any vehicle which has priority on the road. Military priority vehicles are marked in accordance with the provisions of STANAG 2027.

PART 4 - TRAFFIC CONTROL PERSONNEL AND THEIR RELATIONSHIP WITH MILITARY ROAD USERS

19. Traffic Control Personnel. For the purpose of this agreement the term "Traffic Control Personnel" is used to denote any person acting under the orders of the national territorial authority responsible for traffic control and instructed by this authority to facilitate the movement of traffic and to prevent and/or report any breach of road traffic regulations.

20. Distinguishing Cuffs

a. All military traffic control personnel, when on duty, must wear and be distinguished by a reflective white cuff, with longitudinal light-reflecting stripes, given a white or yellow effect to be worn on each sleeve.

b. As a guide, refer to Annex E.

NATO UNCLASSIFIED

21. Duties and Powers of Traffic Control Personnel. Traffic Control personnel when on duty, must be empowered to give the drivers of military vehicles:

- a. Any order designed to ensure that the traffic regulations imposed by the national military territorial authorities responsible for the preparation of the Road Traffic Plan and/or the appropriate Road Traffic Regulations are observed. These must include but are not restricted to:
 - (1) Direction of traffic.
 - (2) Speed limits.
 - (3) Authority or prohibition to move on certain roads.
 - (4) Lighting regulations.
 - (5) Application of priority of movements.
- b. Any order designed to facilitate road movement or to prevent accidents. This must include, but is not restricted to the following:
 - (1) To stop, to slow, to part, to speed up, etc.
 - (2) Not to overtake.
 - (3) Not to enter a certain route.
 - (4) To facilitate the movement of traffic at cross roads.
 - (5) To be concerned with the evacuation of broken down vehicles.

22. Indication of Direction to Be Followed. Drivers of single military vehicles or column commanders are responsible for finding their own way. The only exceptions to this rule are:

- a. Important movement serials planned by movement staffs, for which Traffic Control personnel may be ordered to direct traffic on a given route.
- b. Local diversions reconnoitred and identified by responsible Traffic Control personnel.

NATO UNCLASSIFIED

23. Information to Drivers, etc. Traffic Control personnel on duty may be authorized to give certain specific information to drivers of military vehicles, with the object of assisting them, in particular as regards to their routes, the location of supply points, recovery posts, emergency posts, etc. Where Traffic Control personnel are asked for information which they are not authorized to give, or where they are not satisfied that the enquirer is competent to receive such information, they must refer the enquiry to the next superior officer or the nearest Traffic Control Posts.

24. Breaches of Regulations. Where a member of the Traffic Control personnel has reason to believe that a breach of regulations has taken place, he must report the matter on the standard Offence Report Form described in paragraph 25 below to the Offender's Commanding officer through the normal military channels.

25. Offence Report. Traffic Control personnel must report any breach of regulations by means of a form of the type shown at Annex D to the STANAG. The layout of this form will be the same in all languages.

26. Traffic Control Signals. Road traffic may be controlled by one of the following means:

- a. Hand signals, if necessary with signalling disc or luminous appliance (lamp), using the signals described and illustrated in Annex C to this STANAG; whistles may be used for the purpose of attracting attention to such signals.
- b. Traffic and road signs.
- c. By verbal orders, where necessary.

27. Duties of Military Road Users in Regard to Military or Civil Traffic Control Personnel.

- a. All orders given by Traffic Control personnel to military road users are to be regarded as being orders given by the national territorial authority responsible for road movement in the area concerned.
- b. All military road users, when called upon to do so by Traffic Control personnel, must be prepared to show:
 - (1) Their own identity documents.
 - (2) The documents concerning their vehicles and/or mission.

NATO UNCLASSIFIED

- c. Similarly, Traffic Control personnel must themselves be prepared to show their identity documents, if required.

PART 5 - SIGNALS FOR GUIDING AND MARSHALLING A SINGLE VEHICLE

28. General rules for using hand signals:

- a. All signals must be given correctly and clearly to avoid confusion.
- b. The signals must be given from a place, in full view of the driver of the guided vehicle.
- c. If the guide has to move, the guided vehicle must be stopped beforehand; this refers specifically to the guiding of vehicles on flat wagons or rafts in order to avoid accidents by walking backwards on the flat wagons or rafts.
- d. The signals must be given with the guide facing the vehicle to be guided.
- e. The signals must be repeated as long as the guided vehicle is moving or has to move into the given direction.
- f. When the visibility is such that day signals are impracticable, the signal must be given by means of an illuminating device (torch, flash light, signal lamp, etc.) with the light pointing towards the vehicle.
- g. During darkness if the illuminating device fails to function, the guided vehicles must stop immediately.
- h. During the guiding or marshalling, the vehicle must move slowly.
- j. Day signals may be combined, by the guide, according to circumstances and the size of the marshalling area.

29. All signals are illustrated and described in Annex F.

IMPLEMENTATION OF AGREEMENT

- 30. This STANAG is implemented when the necessary orders/instructions have been issued directing the forces concerned to put the content of this agreement into effect.

NATO UNCLASSIFIEDANNEX A TO STANAG 2025
(Edition 5)SIGNALS TO BE USED BY DRIVERS OF LEFT HAND DRIVE MILITARY VEHICLES
(only when illuminated direction indicators cannot be used)

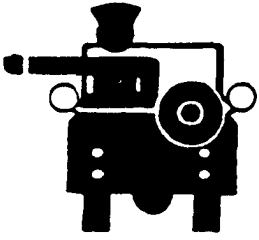
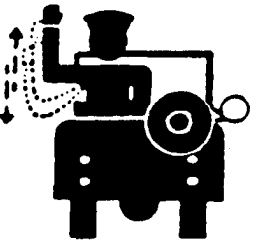
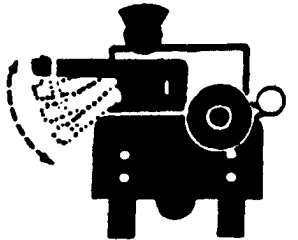
SERIAL	ILLUSTRATION OF SIGNAL	DESCRIPTION OF SIGNAL	MEANING OF SIGNAL
1	(REAR VIEW) 	a. Use of left direction indicator b. Or, left arm extended horizontally c. See note(1)	"I am going to turn to my LEFT"
2	(REAR VIEW) 	a. Left arm extended forearm raised vertically and then moved slowly down and up several times. b. Same signal when vehicle is moving	"I am MOVING OFF" "I am ACCELERATING"
3	(REAR VIEW) 	a. Left arm extended horizontally & then moved slowly down and up several times in the vertical plane. b. The arm is then stopped at the lowest position.	"I am SLOWING DOWN..." "... and STOPPING"

Note(1): An arm signal "I am going to turn right" has not been established because it is not clear enough.

A-1

NATO UNCLASSIFIED

NATO UNCLASSIFIED

SERIAL	ILLUSTRATION OF SIGNAL	DESCRIPTION OF SIGNAL	MEANING OF SIGNAL
4	<p>(SIDE VIEW)</p> 	<p>The palm of the hand is placed on, or in the normal position of the windscreen.</p>	<p>"I am going STRAIGHT ON" (Normally a signal given to Traffic Control personnel)</p>

NATO UNCLASSIFIEDANNEX B TO STANAG 2025
(Edition 5)SIGNALS TO BE USED BY DRIVERS OF RIGHT HAND DRIVE MILITARY VEHICLES
(only when illuminated direction indicators cannot be used)

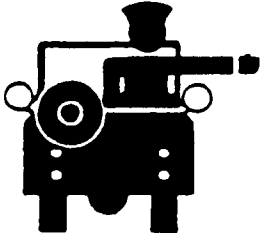
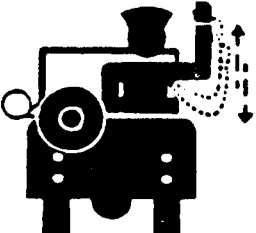
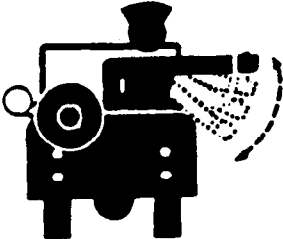
SERIAL	ILLUSTRATION OF SIGNAL	DESCRIPTION OF SIGNAL	MEANING OF SIGNAL
1	(REAR VIEW) 	a. Use of right direction indicator b. Or, right arm extended horizontally c. See note(1)	"I am going to turn to my RIGHT"
2	(REAR VIEW) 	a. Right arm extended forearm raised vertically and then slowly extended up several times. b. Same signal when vehicle is moving	"I am MOVING OFF" "I am ACCELERATING"
3	(REAR VIEW) 	a. Right arm extended horizontally and then moved slowly up and down several times in the vertical plane. b. The arm is then stopped at the lowest position.	"I am SLOWING DOWN..." "... and STOPPING"

Note(1): An arm signal "I am going to turn left" has not been established because it is not clear enough.

B-1

NATO UNCLASSIFIED



NATO UNCLASSIFIED

SERIAL	ILLUSTRATION OF SIGNAL	DESCRIPTION OF SIGNAL	MEANING OF SIGNAL
4	<p>(SIDE VIEW)</p> 	<p>The palm of the hand is placed on, or in the normal position of the windscreen.</p>	<p>"I am going STRAIGHT ON" (Normally a signal given to Traffic Control personnel)</p>

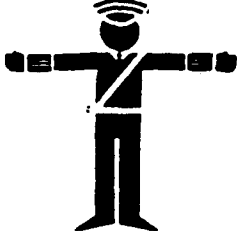

NATO UNCLASSIFIED

ANNEX C TO STANAG 2025
(Edition 5)

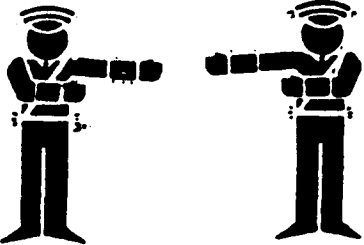
SIGNALS TO BE USED BY MILITARY TRAFFIC CONTROL PERSONNEL

SERIAL	ILLUSTRATION OF SIGNAL	DESCRIPTION OF SIGNAL	MEANING OF SIGNAL
1		<p>a. Arm raised vertically palm forward, body facing the traffic to be stopped.</p> <p>b. Red light signal used similarly.</p>	<p>b. "STOP" (to traffic coming from all directions faced)</p>
2		<p>Both arms raised horizontally, body facing one of the lines of traffic to be stopped.</p> <p>(Use only during good visibility).</p>	<p>"STOP" (to traffic approaching in front and behind)</p>
3		<p>One arm horizontal other forearm held vertically, body facing one of the lines of traffic to be stopped.</p> <p>(Use only during good visibility).</p>	<p>ALTERNATIVE SIGNAL with the same meaning as that at Serial 2 above.</p>
4		<p>The left arm extended horizontally, the right arm folded across the body to the left.</p> <p>(A green light may be used with this signal).</p>	<p>"FORK" or "TURN TO YOUR RIGHT" (to traffic approaching from the direction faced.)</p>
5	<p>The sign given at Serial 4 above may be used equally to direct traffic to the left by reversing the relative positions of the arms.</p>		

NATO UNCLASSIFIED

SERIAL	ILLUSTRATION OF SIGNAL	DESCRIPTION OF SIGNAL	MEANING OF SIGNAL
6		<p>The signal may, or may not, be started from either of the "Stop" positions at serials 1 or 2 above. In any case, the hand and arm are first extended horizontally with fingers pointed towards the stream for which the signal is intended. The forearm then describes an arc in the vertical plane and stops, fingers pointing towards the direction to be taken by the vehicle(s). (A green light may be used with this signal.)</p>	<p>"GO"</p> <p>Signal to either a stopped or moving vehicle to proceed.</p>
7		<p>The arm extended horizontally and then moved slowly up and down.</p> <p>(A red light may be held in the moving hand.)</p>	<p>"SLOW DOWN"</p>
8		<p>The fist raised and lowered quickly, above the right shoulder.</p> <p>(A green light may held in the moving hand.)</p>	<p>"SPEED UP"</p>

NATO UNCLASSIFIED

ANNEX D TO STANAG 2025
(Edition -)

ANNEX D AU STANAG 2025
(Edition -)

STANDARD LAYOUT FOR OFFENCE REPORT TO BE USED BY NATO TRAFFIC CONTROL
PERSONNEL

PRESENTATION STANDARD DE LA FICHE D'INFRACTION A EMPLOYER PAR LES AGENTS
DE LA CIRCULATION DE L'OTAN
OFFENCE REPORT/FICHE D'INFRACTION

This form will be sent through the normal military channels to the driver's Commanding Officer.

Cette fiche sera transmise par la voie hiérarchique à l'autorité dont dépend le conducteur en faute.

-
1. Date, time, place of offence(1)/Date, heure et lieu de l'infraction (1)
.....
-
2. Driver's name(1) Nationality (if military) Rank, Service No(3) & Unit
Nom du conducteur(1) Nationalité (pour les militaires)
Grade, No Matricule(3) & Unité
.....
(if civilian) address of employer
(pour les civils) adresse de l'employeur
-
3. Name of vehicle Nationality (if military) Rank, Service No(3) & Unit
Commander Nationalité (pour les militaires)
Nom du Chef de Grade, No Matricule(3) & Unité
voiture
.....
(if civilian) address
(pour les civils) adresse
-
4. Particulars of vehicle checked/Caracteristiques du véhicule contrôlé
a. Make/Marque
b. Type/Type
c. Registration No/No D'immatriculation
d. (Address of unit or civil owner)
(Affectation du véhicule ou adresse du propriétaire)
.....
-
5. Offense observed Infraction constatée
(Detailed statement of evidence (Constat détaillé)
to be given)
(2)
-
6. Action taken Mesures prises
(X)
-
7. Name, rank, service No & Unit / Nom, grade, No Matricule et Unité de
of traffic control policeman(1) l'agent de circulation(1)

signature: Witnessed:
(Person rendering the report) Témoigné par:
(de l'agent établissant la fiche)

NOTE: (1) all names will be written in block letters.
tous les noms propres seront écrits en capitales d'imprimerie.

- (2) further details may be added on the reverse side.
tous détails supplémentaires pourront être indiqués au dos.
- (3) French officers have no Service No.
les officiers français n'ont pas de No Matricule.

NATO UNCLASSIFIED

ANNEX E TO STANAG 2025
(Edition 5)

EXAMPLE OF DISTINGUISHING CUFFS

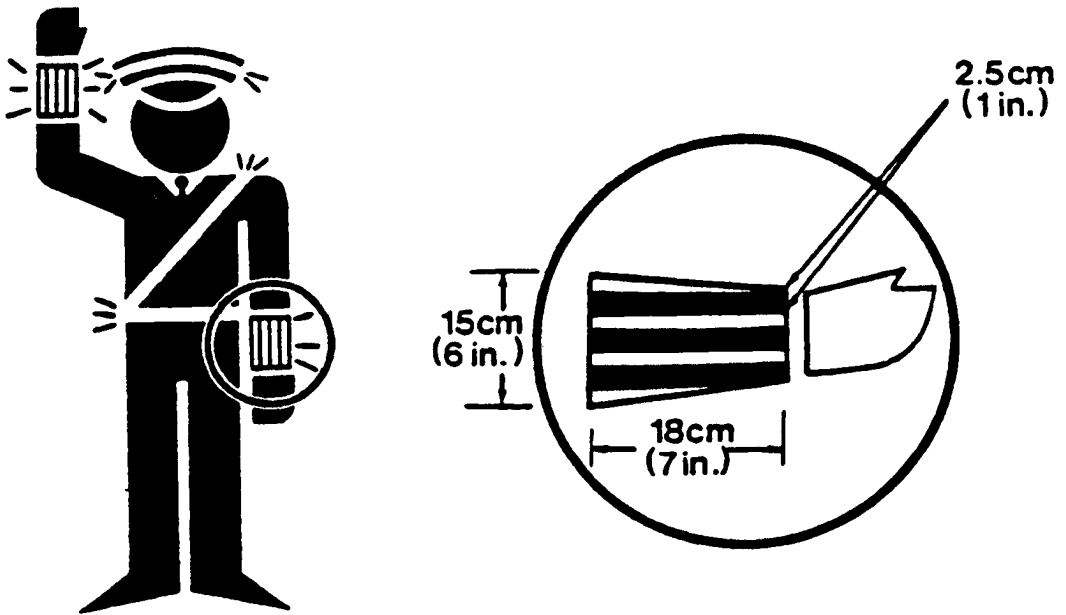



NOTE 1: The cuff may be approximately the following dimensions, the stripes being parallel with the arm:

- (a) width of widest part - 15 cm (6 inches)
- (b) length - 18 cm (7 inches)
- (c) width of stripes - 2.5 cm (1 inch)

E-1

NATO UNCLASSIFIED



NATO UNCLASSIFIEDANNEX F TO STANAG 2025
(Edition 5)I. SIGNALS FOR GUIDING OR MARSHALLING SINGLE VEHICLES BY DAY.

SERIAL	ILLUSTRATION OF SIGNAL	DESCRIPTION OF SIGNAL	MEANING OF SIGNAL
1		<p>a. With both hands moving backwards and forward;</p> <p>b. Palms of the hands turned to the breast;</p> <p>c. As "pulling" the vehicle</p>	COME FORWARD
2		<p>a. With both hands moving forward and backwards;</p> <p>b. Palms of the hands turned to the vehicle;</p> <p>c. As "pushing off" the vehicle.</p>	REVERSE
3		<p>a. Hand moving, from shoulder, horizontally into the direction into which the vehicle must be turned.</p> <p>b. "Turn to the left" is given with the right arm;</p> <p>c. "Turn to the right" is given with the left arm;</p>	TURN TO THE LEFT/RIGHT



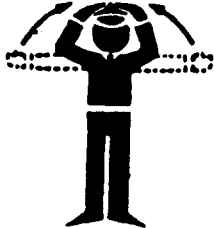

F-1

NATO UNCLASSIFIED

NATO UNCLASSIFIED

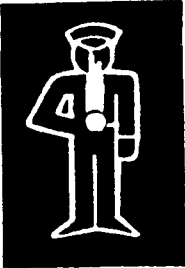
SERIAL	ILLUSTRATION OF SIGNAL	DESCRIPTION OF SIGNAL	MEANING OF SIGNAL
3 (CONT'D)		d. The speed, in which the hand is moved, indicates the speed of turning the vehicle.	
4		a. With both hands; b. Palms of the hands facing each other; c. Distance between hands indicates the distance between the guided vehicle and an obstacle to be approached; d. Touching hands means: the distance between the guided vehicle and the obstacle has become nil.	INDICATING DISTANCE
5		a. One or both arms raised vertically; b. Palms of the hands turned to the vehicle.	STOP
6		Proceeding from the "Arms horizontal" position, both hands are placed on the head or steel helmet, the elbows being extended towards the side.	SWITCH OFF

NATO UNCLASSIFIEDII. SIGNALS FOR GUIDING OR MARSHALLING SINGLE VEHICLES WHEN VISIBILITY PRECLUDES THE USE OF DAY SIGNALS

SERIAL	ILLUSTRATION OF SIGNAL	DESCRIPTION OF SIGNAL	MEANING OF SIGNAL
1		a. With an illuminating device moving vertically from chin to waist.	COME FORWARD
2		a. With an illuminating device, at least chest level, rotating slowly in a circular motion (clockwise or anti-clockwise to the driver).	TURN a. Clockwise - turn right. b. Anti-clockwise turn left.
3		a. Move the illuminating device horizontally in front of the body. b. Switch off or cover the illuminating device.	a. STOP b. STOP ENGINE
4		Cause the light to flicker by switching it on and off.	REVERSE

F-3

NATO UNCLASSIFIED

APPENDIX C

**EXTRACT OF STANAG 2002
MARKING OF CONTAMINATED OR DANGEROUS LAND AREAS,
COMPLETE EQUIPMENTS, SUPPLIES AND STORES
(EDITION 6)**

Related documents: STANAG 2019 - Military Symbols.
STANAG 2029 - Method of Describing Ground Locations,
Areas and Boundaries.
STANAG 2036 - Land Minefield Laying, Recording, Reporting
and Marking Procedures.

AIM

1. The aim of this agreement is to standardize those procedures which are to be used by the NATO Forces to mark contaminated or dangerous land areas, complete equipments, supplies and stores.

AGREEMENT

2. Participating nations agree that the procedures contained herein for marking contaminated or dangerous land areas, complete equipments, supplies and stores will be used by the NATO Forces.

PART I - MARTIAL CONTAMINATIONSGENERAL

3. For the purpose of this STANAG, martial contaminations will include such dangers as radiological contamination, biological contamination, chemical contamination, chemical minefields (or barriers), minefields (or barriers) other than chemical, booby-trapped areas and unexploded munitions. These dangers, except where protective minefields are concerned, will always be marked by triangular signs (right-angled isosceles triangle) unless the area is to be abandoned to the enemy. The details of marking protective minefields are described in STANAG 2036.

4. The relevant procedures and marking systems are designed both for the protection of personnel of the units responsible for the areas, complete equipments, supplies and stores concerned and for the prevention of casualties or unnecessary exposures among individuals or units of other commands resulting from unknowingly traversing contaminated areas or handling contaminated equipments, supplies or stores.

5. The provisions of this agreement do not preclude additional marking or signposting over and above that required by this STANAG when the commander concerned believes it is necessary.

NATO UNCLASSIFIED

COLOUR OF SIGNS

6. The nature of the contamination or danger of the considered area is to be indicated by the colours of the signs. These include:

- a. The primary colour, used for the background of the front surface and for the entire back surface of the sign.
- b. A secondary colour, used for additional markings and/or inscriptions on the front surface.

These colours are:

DANGER	PRIMARY COLOUR	SECONDARY COLOURS	
		MARKINGS	INSCRIPTIONS
Radiological contamination	WHITE	NONE	BLACK
Biological contamination	BLUE	NONE	RED
Chemical contamination	YELLOW	NONE	RED
Chemical minefields (or barriers)	RED	YELLOW (STRIPE)	YELLOW
Minefields (or barriers) other than chemical	RED	NONE	WHITE
Booby-trapped areas	RED	WHITE (STRIPE)	WHITE
Unexploded munition	RED	WHITE (BCMB)	NONE

CHEMICAL MINEFIELDS (OR BARRIERS), BOOBY-TRAPS AND UNEXPLODED MUNITIONS

7. In the case of danger due to chemical minefields (or barriers), booby-traps and unexploded munitions, the front surface of the sign which faces away from the dangerous area has two colours and will be marked thus:

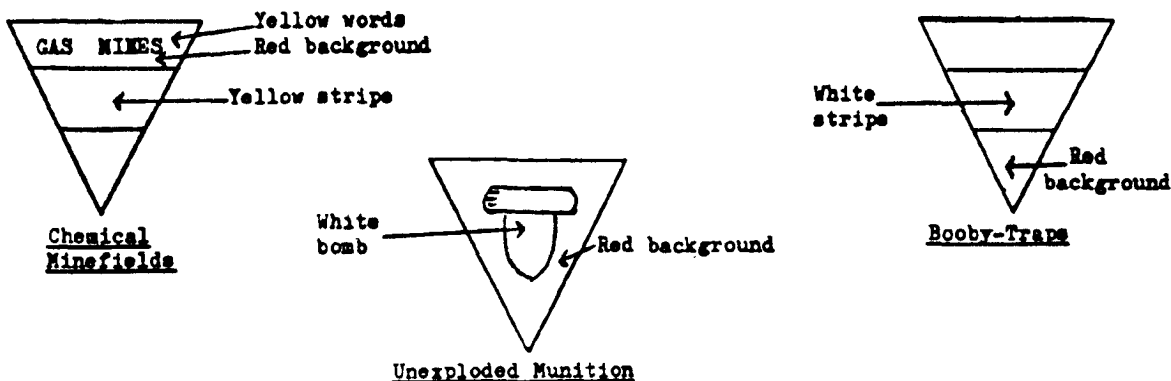

NATO UNCLASSIFIEDMINEFIELDS (OR BARRIERS) AND BIOLOGICAL, RADIOLOGICAL AND CHEMICAL CONTAMINATIONS

8. In the case of danger due to minefields (or barriers) (other than chemical) and of danger due to biological, chemical and radiological contamination, the primary colour and the pattern of the signs by themselves will be the principal means of recognizing the type of contamination. As a safeguard, the words "MINES", "GAS MINES", "GAS", "BIO", (for biological contamination) or "ATOM", with the optional addition of a symbol such as a trefoil (for radiological contamination) where required by national authorities, will be painted or written with the secondary colour on the front surface. The language to be used for these inscriptions will be selected by the forces erecting the sign. These inscriptions will be written parallel to the longer side of the sign, for example:

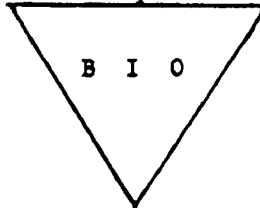
INSCRIPTION OF SIGNS

9. In addition, details if known, of biological, chemical and radiological contaminations are to be written on each sign, preferably on the front surface. For biological contamination and for persistent or moderately persistent chemical agents, the name of the agent used, when known, and the date and time of detection are required. In cases of radiological contamination, the following information will be inserted on each sign:

- a. The dose rate.
- b. Date and time of reading.
- c. The date and time of the detonation that produced the contamination (if known).

MULTIPLE HAZARDS

10. Areas which contain more than one type of contamination or other hazard will be marked with the relevant signs placed near to each other. However, the sign "GAS MINES" will be assumed to include the attendant presence of High Explosive Mines and/or Booby Traps.

MARKING OF PHONEY CONTAMINATED AREAS

11. Marking of phoney contaminated areas (for example, a phoney minefield) shall be exactly the same as for those which are real.

NATO UNCLASSIFIEDSPECIAL RADIOLOGICAL MARKING PROCEDURES

12. The marking of radiologically contaminated areas, complete equipments, supplies and stores merely indicates the presence of a hazard, the extent of which must be determined by newly arrived troops by means of instrument readings, surveys, or information from other units.
13. At the discretion of the commander, a radiologically contaminated area need not be marked when a military advantage would be obtained by not doing so. In such cases positive measures will be taken to warn other friendly forces of the existence of the radiologically contaminated area.
14. Signs are to be placed on all probable routes leading into contaminated areas at the points where the dose rate reaches 1 rad per hour measured at 1 metre above the ground and on supplies and stores within these areas. When the dose rate is above 1 rad per hour, signs showing the actual dose rate are to be placed on all probable routes leading into the contaminated area at the boundary.
15. Lower levels normally are not marked even though significant doses might be produced by long stays in areas of old contamination. Units planning prolonged stays in an area during a nuclear war should check the area with radiac instruments regardless of whether it is marked.
16. Signs should be corrected or moved periodically to account for radioactive decay.
17. Commands leaving an area or otherwise giving up responsibility for an area are to leave perimeter signs in place. The command taking over responsibility for the area will continue the periodic correction or movement of the signs or remove them when they are no longer necessary.
18. Dumps for radiologically contaminated material are to be marked at intervisible intervals around the perimeter.

SIZE AND SHAPE OF SIGNS

19. Existing stocks of coloured triangular signs of slightly divergent shapes and sizes will be retained and used until stocks are exhausted.
20. The triangle will be a right-angled isosceles triangle.
21. The base of the triangle will be approximately 28 cm (11½ ins) and the opposite sides will be approximately 20 cm (8 ins).
22. Triangles will be made of metal, wood, plastic, composition board, or any other adequate material available.

PLACING OF SIGNS

23. Signs will be placed above the ground, right-angled apex downwards on wire boundary fences, trees, rocks, poles or by putting the apex into the ground. This latter method should not be used if the other methods can be adopted as the signs might well be obscured by grass and other undergrowth. Further, they can be readily knocked down. The front

NATO UNCLASSIFIED

side of the signs is to be posted facing away from the area being marked. In those cases where signs are posted within a contaminated area, the sign is to face away from the area of higher dose rate, or higher concentration, if such can be determined.

SIGNS FOR COMPLETE EQUIPMENTS, SUPPLIES AND STORES

24. At least one sign will be placed centrally on one side of a complete equipment or unit load pallet right-angled apex downwards. Non-palletized stores will be marked in the most obvious and convenient position.

NIGHT SIGNING

25. No standardization of lighting of signs is specified. Each army will provide lighting or reflecting devices where deemed necessary.

PART II - NON-MARTIAL CONTAMINATIONS

26. Non-martial contamination consists of that contamination resulting from latrines, garbage, soakage and refuse. These forms of contaminations will always be marked by rectangular signs which may be of any colour and any convenient size.

27. When closed, earth mounds will be placed on top of non-martial contaminations and the rectangular sign will be placed on the top of the mound. The sign will indicate the type of pit, the date closed and, in non-operational areas, the unit designation.

IMPLEMENTATION OF THE AGREEMENT

28. This STANAG will be considered to have been implemented when the necessary orders/instructions putting the procedures detailed in this agreement into effect have been issued for the forces concerned.

APPENDIX D

NIGHT VISION PRINCIPLES

Vision is the most important sense you use while driving. It makes you aware of the position of your vehicle in relation to the road. You need good depth perception to determine height and distance, good visual acuity to identify terrain features and obstacles that lie along the road and good night vision techniques to be efficient in night operations. When driving during daylight hours, eyes can rapidly identify and interpret visual clues. During hours of darkness, however, illumination is reduced, and vision is limited. Wheeled vehicle operators with 20/20 daylight vision may not have adequate night vision.

To increase your capability to operate at night, you must understand night vision principles and the use of night vision techniques for viewing at night. This appendix includes information about the anatomy of the eye, types of vision, visual problems that affect night vision, differences between day and night vision, target detection, dark adaptation, night vision scanning techniques, distance estimation and depth perception visual illusions, measures used to protect night vision, self-imposed stresses, the effect of nerve agents on night vision, sources of ambient light and meteorological considerations.

EVALUATION OF NIGHT VISION

Your ability to drive at night is based on your ability to see at night and how well you train your night vision. Although the limits of night vision vary from person to person, most drivers never learn to use their night vision to its fullest capacity. A person with average night vision who uses night vision techniques is more effective than someone with superior night vision who does not use these techniques.

ANATOMY AND PHYSIOLOGY OF THE EYE

The eye is similar to a camera. The cornea, lens, and iris combination gathers and controls the amount of light that enters the retina (Figure D-1).

The parts of the eye are described as follows:

- The CORNEA is a transparent tissue covering the front of the eye like a watch crystal covers a watch. (Contact lenses are fitted over the cornea.)
- The IRIS is a thin circular curtain which is the colored part of the eye. A person's eye color depends on the amount of pigment in the iris. Light blue has the least amount and dark brown the most.
- The PUPIL is a hole in the center of the iris. It is black because the inside of the eye is dark. The size varies with the amount of light entering the eye. It gets smaller with increased light.
- The LENS is a transparent, semisoft material about half the size of a dime. It can change shape to focus on objects at different distances from the eye.
- The RETINA is the lining at the back of the eye where the image is formed. It consists of rod cells, which see black and white, and cone cells, which see colors. The picture seen by the retina is sent to the brain along the optic nerve.

Light enters your eye through the pupil. The iris controls the amount of light entering the eye. The light passes through the lens which focuses it onto the retina at the back of the eye. The picture seen by the retina is upside down the brain turns it right side up. The brain gets a slightly different picture from each eye and usually combines them to make one picture.

TYPES OF VISION

There are three types of vision. Each type requires different sensory perceptors to identify an image.

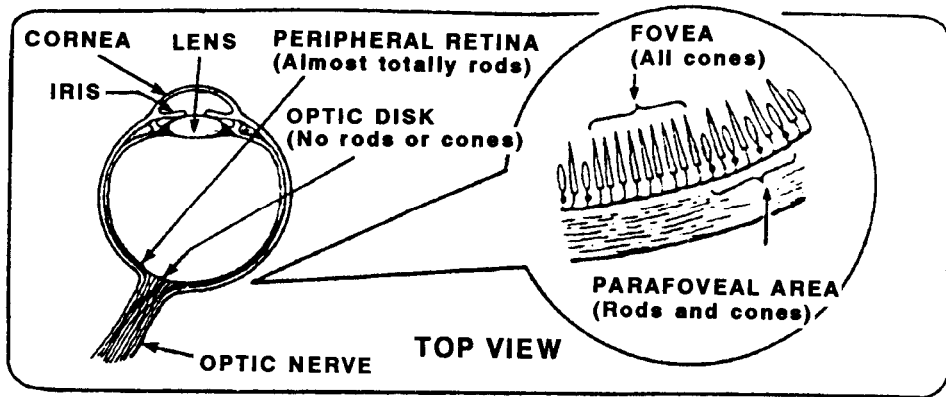

FIGURE D-1. Anatomy of the Eye.

Photopic Vision

Photopic vision is experienced during daylight hours or when a high level of artificial light exists. Under these conditions, sight is achieved primarily by the cones, especially those concentrated in the fovea. Due to the high light condition, rod cells are bleached out and become less effective. Sharp image interpretation (fine resolution of detail) and color vision are characteristic of photopic vision. Under these conditions, objects are detected with peripheral vision but are viewed primarily with central (foveal) vision.

Mesopic Vision

Mesopic vision is experienced at dawn and dusk and during periods of mid-level light. Vision is achieved by a combination of the rods and cones. Visual acuity steadily decreases; the available light decreases. A reduction in color vision occurs as the light level decreases; the cones become less effective. Due to gradual loss of cone sensitivity, greater emphasis is placed on off-center vision and scanning to detect objects.

Scotopic Vision

Scotopic vision is experienced in low-level light conditions. Cone cells become ineffective causing poor resolution of detail. Visual acuity decreases to 20/200 or less. Color perception is totally lost. A central blind spot occurs due to the loss of cone sensitivity. Objects must be viewed using off-center viewing and scanning. The natural reflex of looking directly at an object must be

reoriented by night vision training. The use of scotopic vision demands searching movements of the eyes to locate an object and small eye movements to keep the object in sight. Characteristically, in this type of vision a dim image may fade away if your eyes are held stationary for more than a few seconds.

VISUAL PROBLEMS AFFECTING NIGHT VISION

Two visual deficiencies that may become more apparent at night are presbyopia and night myopia. Another visual problem that affects night vision is astigmatism.

Presbyopia

This deficiency, which commonly occurs in individuals over 40 years of age, is due to hardening of the lens. It involves a loss of the eye's ability to focus diverging light rays from near objects. As a result, light transmission from the lens to the retina decreases light scattering or glare increases. As presbyopia increases, instruments, maps, and checklists become more difficult to read, especially in red light. Certain types of bifocal lenses that compensate for this condition can correct this deficiency.

Night Myopia

At night, the spectrum of available light changes; blue wavelengths of light are dominant. Therefore, a person who is slightly nearsighted (myopic) will

find it hard to see at night; blurred vision could occur. Special lenses can be prescribed to correct myopia.

Astigmatism

Astigmatism is an irregularity of the eye that produces an out-of-focus condition. For example, if you focus on power poles (vertical), the wires (horizontal) will be out of focus in most cases. The typical prescription for glasses is written showing three numbers for each eye. The first number is the spherical portion of your prescription, which can be compensated for by NVGs. The second number is the astigmatism in degrees, and the third number is the axis of the astigmatism in degrees.

Detail

Perception of fine detail is impossible at night. Low light conditions greatly reduce visual acuity. At 0.1 footcandle (level of full moonlight), acuity is one-seventh as good as it is in average daylight. Therefore, objects must be rather large or nearby to be seen at night. Identification at night must depend on the perception of generalized contours and outlines and not on small distinguishing features.

Retinal Sensitivity

Another important distinction between night vision and day vision is the difference in the sensitivity of various parts of the retina under these two conditions.

The central part of the eye is not sensitive to starlight levels. During darkness or with low-level light, central vision becomes less effective, and a relative blind spot (5 to 10 degrees wide) develops. This is due to the concentration of cones in the area immediately surrounding the fovea of the retina.

Since the central fields of vision for each eye are laid over each other for binocular (two-eyed) vision, a night blind spot occurs during periods of low-level illumination. If an object is viewed directly, it may not be detected because of this blind spot (Figure D-2).

Because of the central blind spot, as distance increases, larger and larger objects will not be seen. To see things clearly at night, use off-center vision and scanning techniques.

DIFFERENCES BETWEEN DAY AND NIGHT VISION

Color

One way night vision differs from day vision is in color vision. As light levels decrease, the eyes shift from photopic vision (cones) to scotopic vision (rods). With this shift, the eyes become less sensitive to the red end of the spectrum and more sensitive to the blue part of the spectrum. Color perception is not possible with the rods. Colors of nonlighted objects cannot be determined at night under very low light conditions. You can distinguish between light and dark colors at night only in terms of the brightness of reflected light. If, however, the brightness of a color is above the threshold for cone vision, the color can be seen.

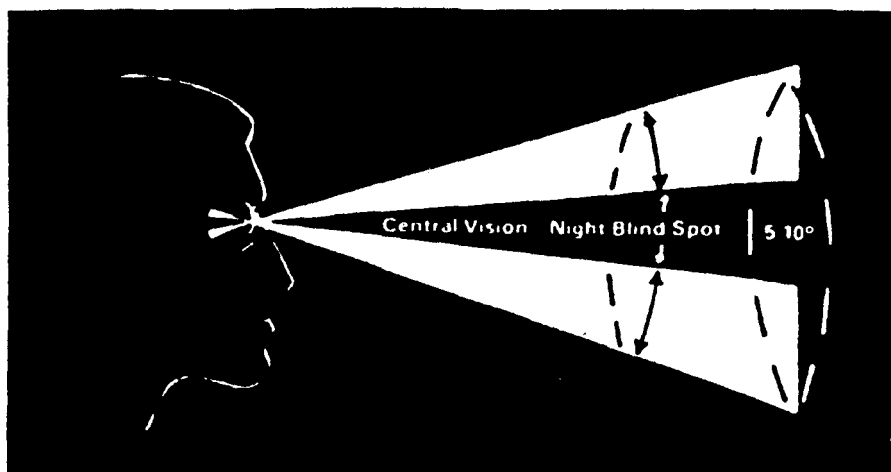

FIGURE D-2. Night Blind Spot.

TARGET DETECTION

With 20/20 vision detection of a target depends on several factors including-

- Target size and distance (relative target size).
- Overall brightness (luminance).
- Brightness and color contrast between target and background.
- Location of eye focus.
- Angle between central visual axis and target.

DARK ADAPTATION

Dark adaptation is the process by which your eyes increase their sensitivity to low-light levels. People dark-adapt to varying degrees and at different rates. During the first 30 minutes, the sensitivity of the eye increases roughly ten thousandfold, with little further increase after that time.

Going suddenly from bright light into darkness occurs often; for example, when you enter a movie theater during the day or leave a brightly lit room at night. In both cases, the sensations are the same. At first you see very little, if anything. After several minutes you can see dim forms and very large outlines. As time passes you see more details of the surroundings.

The lower the level of light, the more rapidly you complete dark adaptation. For example, you need less time to completely dark-adapt after being exposed to a darkened theater than after being exposed to the brightness of day.

Maximum dark adaptation is reached in 30 to 45 minutes under minimal lighting conditions. If the dark-adapted eye is exposed to a bright light, the sensitivity of that eye is temporarily impaired. The amount of impairment depends on the intensity and duration of the exposure. Exposure to a flare or lightning may seriously impair your night vision. Recovery to dark adaptation could take from 5 to 45 minutes in continued darkness.

Night vision goggles affect dark adaptation. If you dark-adapt before donning the goggles and remove them in a darkened environment, expect to regain full dark adaptation in 2 to 10 minutes.

NIGHT VISION SCANNING TECHNIQUES

Dark adaption is only the first step to maximize your ability to see at night. Applying night vision techniques will help you to overcome many of the physical limitations of your eyes.

Scanning techniques are important to identify an object at night. To scan effectively, scan from right to left or left to right using a slow, regular scanning movement (Figure D-3).

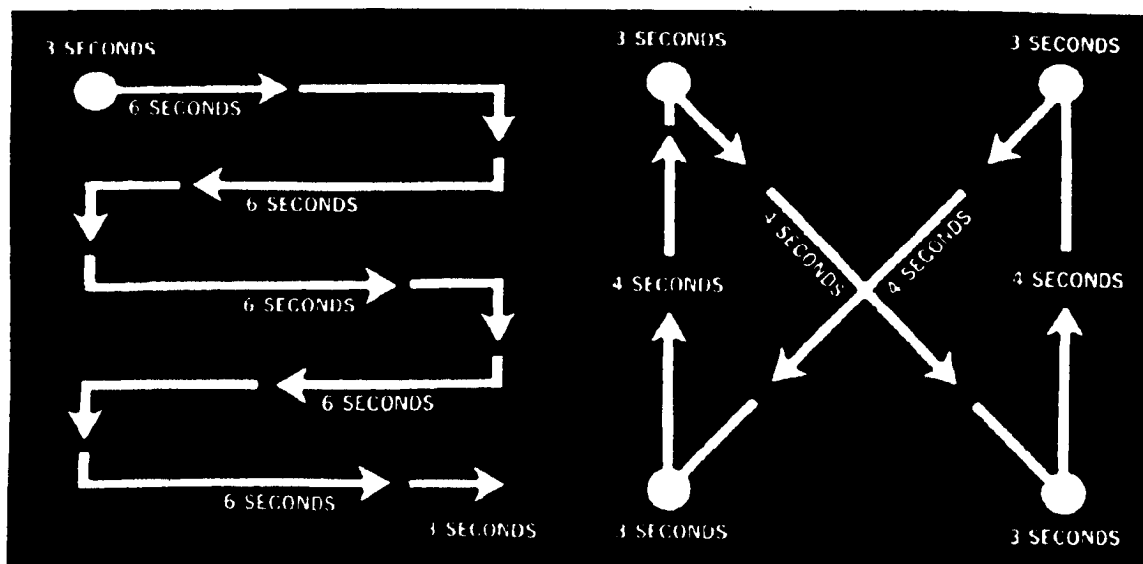

FIGURE D-3. A Typical Scanning Pattern.

Viewing an object using central vision during daylight poses no limitation. If you use the same technique at night, you may not see the object. This is due to the night blind spot that exists during periods of low light. To make up for this limitation use off-center vision. This technique requires you to view an object by looking 10 degrees above, below, or to either side of, rather than directly at an object. This lets your peripheral vision maintain contact with an object.

Even when off-center viewing is practiced, the image of an object viewed longer than 2 to 3 seconds tends to bleach out and become a solid tone. As a result, the object is no longer visible. This produces a potentially unsafe operating condition. To overcome this limitation, be aware of the phenomenon. Avoid looking at an object longer than 2 or 3 seconds.

Visual acuity is greatly reduced at night. Therefore, objects must be identified by their shape or outline. Your familiarity with the architectural design of the structures common to the area will determine your success using this technique. For example, the outline of a building with a high roof and a steeple can be easily recognized in the United States as a church. Churches in other parts of the world may have entirely different distinguishing features. Man-made features depicted on your map can help you recognize outlines during night driving,

DISTANCE ESTIMATION AND DEPTH PERCEPTION

Distance estimation and depth perception clues are easily recognized using central vision during periods of good lighting. But as light levels decrease, your ability to correctly judge distances decreases, and you tend to have visual illusions. A knowledge of distance estimation and depth perception clues will help you to better judge distance at night.

Distance and depth perception clues may be monocular (one-eyed) or binocular (two-eyed). The binocular clues depend on the slightly different view each eye has of the object. Consequently, binocular perception is useful only when the object is close enough to make the viewing angle of the two eyes obviously different. Because they are rarely improved by study and training, binocular clues are not discussed here. Monocular clues used to help distance estimation and depth perception are discussed below.

Geometric Perspective

An object has an apparent different shape depending on the distance and angle from which it is seen (Figure D-4). Geometric perspective clues include linear perspective, apparent foreshortening vertical position in the field, and motion parallax.

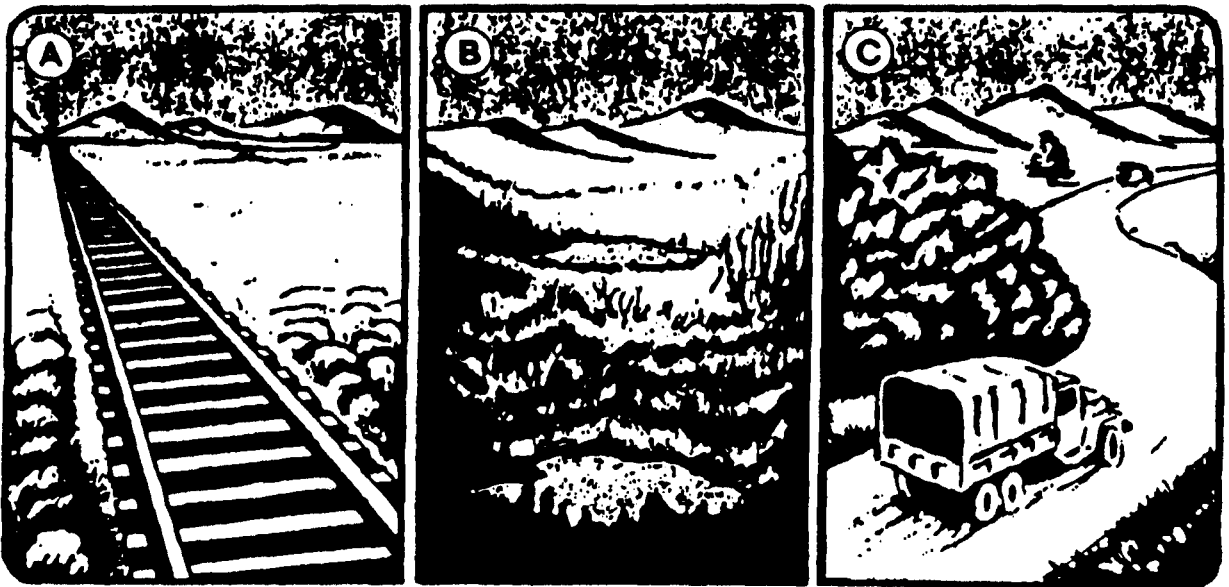

FIGURE D-4. Geometric Perspective.

Linear Perspective. Parallel lines such as railroad tracks or runway lights (Figure D-4A) tend to converge as distance from the observer increases.

Apparent Foreshortening. The true shape of an object or terrain feature seems oval when seen from a distance. As the distance to the object or terrain feature decreases, the apparent perspective changes to its true shape or form. Figure D-4B illustrates how the shape of a body of water changes when viewed at different distances at the same altitude.

Vertical Position in the Field. Objects or terrain features at a distance from the observer seem higher on the horizon than objects or terrain features that are closer to the observer. The highest vehicle in Figure D-4C looks the closest to the top and is judged to be the greatest distance from the observer.

Motion Parallax. This clue to depth perception is often considered the most important. Motion parallax is the apparent relative motion of still objects as seen by an observer moving across the landscape. Near objects seem to move backward, past, or opposite the path of motion. Far objects seem either to move in the direction of motion or remain fixed. The rate of apparent movement depends on the distance the observer is from the object. For example, as you drive along a road, a picket fence whizzes by while a tree further away from the road passes more slowly. Mountains in the distance seem to be freed or to move with the vehicle.

Retinal Image Size

The brain perceives the size of an image focused on the retina to be a certain size. To determine distance using the retinal image, consider three factors: known size of objects, increasing/decreasing size of objects, and land associations.

Known Size of Objects. The nearer an object is to the observer, the larger its retinal image. The brain learns from experience to associate the distance of familiar objects by the size of their retinal image. A structure will fix a specific angle on the retina based on the distance from the observer. If the angle is small, the observer judges the structure to be at a great distance. If the angle is large, the building is

judged as being close. To use this clue, you must know the actual size of the object and have seen it before. If you have not seen it before, determine an object's distance primarily by motion parallax.

Increasing/Decreasing Size of Objects. If the retinal image size of an object increases, it is getting closer. If the image size decreases the object is moving farther away. If the image size is constant, the object is at a fixed distance.

Land Associations. Comparing an object, such as a motor pool, with an object of known size, such as a 5-ton truck will help determine the object's relative size and apparent distance from the observer. Objects ordinarily associated together are judged to be about the same distance.

VISUAL ILLUSIONS

As visual information decreases, the probability of spatial disorientation increases. Reduced visual references also create illusions that can cause spatial disorientation.

Autokinesis

When a person stares at a still light in the dark, the light seems to move. This occurrence can be rapidly demonstrated by staring at a lighted cigarette in a dark room. Apparent movement will start after 8 to 10 seconds. Although the cause is not known, it seems to be related to the loss of surrounding references that normally serve to stabilize your visual perceptions. This illusion can be eliminated or reduced by visual scanning, increasing the number of lights, or varying the brightness of the light. The most important of the three solutions is visual scanning.

Relative Motion

A person sitting in a car at a railroad crossing waiting for a train to pass often experiences the illusion of relative motion. Even though the car is not moving, the person feels that it is moving. The only way to correct this illusion is to understand that such illusions do occur and to not react to them on the vehicle's controls. Using proper scanning techniques can help prevent this illusion.

Reversible Perspective Illusion

A vehicle may seem to be moving away when it is in fact approaching you. This illusion is often experienced when a vehicle is driving parallel to your course. To determine its direction, watch its lights. If the brightness of the lights increases, the vehicle is approaching you. If the lights dim, the vehicle is retreating.

Structural Illusions

Heat waves, rain, snow, sleet, or other factors that block vision cause structural illusions. For example, a straight line may appear to be curved when seen through a desert heat wave.

Size-Distance Illusion

This illusion results from staring at a point of light that approaches and then retreats from the observer. Instead of seeing the light advancing or receding, the lights may seem to expand and contract at a fixed distance. Without additional distance clues, accurate range estimation is extremely difficult. Using proper scanning techniques can help prevent this illusion.

NIGHT VISION PROTECTION

Night vision should be protected whenever possible. There are various precautions you can take.

Sunglasses

Repeated exposure to bright sunlight has an increasingly negative effect on dark adaptation. This effect is intensified by reflective surfaces, such as sand and snow. Exposure to bright sunlight for 2 to 5 hours definitely decreases your scotopic visual sensitivity for as long as 5 hours. Additionally, your rate of dark adaptation and degree of night vision will decrease. These effects combine with each other and may persist for several days.

If night driving is expected, use military neutral density (N-15) sunglasses or equivalent falter lenses when exposed to bright sunlight. This precaution will maximize your rate of dark adaptation at night and improve your night vision sensitivity.

Night Tactical Operations Precautions

During a night tactical mission, expect to experience battlefield condition such as artillery flashes, flares, and searchlight as well as oncoming vehicle headlights and lightning. These conditions will cause total or partial loss of your night vision. When you are confronted with these conditions, use the following techniques:

- If a flash or high-intensity light is expected from a certain direction, turn the vehicle away from the light source. When such a condition occurs unexpectedly and cannot be avoided, save your dark adaptation by closing one eye. Once the light source is no longer a factor, the eye that was closed will provide enough night vision to continue driving. This is possible because dark adaptation occurs independently in each eye. Viewing with one dark-adapted eye, however, will cause depth perception problems.
- Select routes to avoid built-up areas with heavy concentrations of light. If you encounter these conditions, alter your route to avoid brightly lighted areas. A decrease in dark adaptation from a single light source, such as a farmhouse or an automobile can be reduced; turn your head and eyes away from the light.
- When flares are used to light the viewing area or if they are set off near your position, maneuver the vehicle away from the flare to the edge of the lighted area. Thus your exposure to the light source is minimized.
- Use short bursts of fire when firing automatic weapons. Close one eye or look away from the firing to minimize loss of dark adaptation.

SELF-IMPOSED STRESSES

Many self-imposed stresses limit night vision. Be aware of these restrictions to ensure that you avoid them before driving at night.

Smoking

Smoking significantly increases the amount of carbon monoxide carried by the hemoglobin of red blood cells. This reduces the blood's ability to combine with oxygen. The smoker effectively loses 20 percent of his night vision at sea level.

Alcohol

Alcohol is a sedative that impairs coordination and judgment. As a result, you will fail to apply the proper night vision techniques. You begin to stare at objects, and your Scanning techniques become disorganized.

Fatigue

You will not be mentally alert if you are tired when performing night driving. Your response to night situations that require immediate reaction will slow down. Depending on the degree of fatigue, your performance may become a safety hazard.

Nutrition

Missing or postponing meals can negatively affect night driving performance. The resulting hunger pains cause unpleasant feelings, distraction, breakdown inhabit pattern, shortened attention span, and other physical changes.

Failure to eat foods that provide sufficient vitamin A can reduce night vision. Food high in vitamin A include eggs, butter, cheese, carrots, squash, peas, and all types of green vegetables. A balanced diet normally provides an adequate amount of vitamin A. Excess amounts of vitamin A will not increase your night vision ability and may be harmful.

Physical Conditioning and Sleep and Rest Requirements

Because of the physical stresses of night driving, you will tire more easily. To overcome this, exercise daily. Good physical fitness will help you conduct night driving with less fatigue and will improve your night scanning efficiency. However, too much exercise in one day may leave you too tired for night driving.

Night driving is more tiring and stressful than day driving. Therefore, get adequate rest and sleep before driving.

NERVE AGENTS AND NIGHT VISION

Exposure of the eyes to very small amounts of nerve agents negatively affects night vision. Chemical alarms are not sensitive enough to detect the low levels of nerve agent gas that can cause miosis (contracting of the pupils). Miosis may occur gradually through exposure to low levels of nerve agent gas over a long period of time. However, exposure to a high level can cause miosis in the few seconds it takes to put on a protective mask.

The onset of miosis is tricky in that it is not always immediately painful. Miotic subjects may not realize their condition even when carrying out tasks requiring vision in low ambient light. After an attack by nerve agents, especially the more lasting types, commanders should assume there will be some loss in night vision among personnel otherwise fit for duty. No drug can cure the effects of miosis without causing other visual problems that may be just as severe.

SOURCES OF AMBIENT LIGHT

Sources of ambient light include the moon, background illumination, artificial light, and solar light.

The Moon

The moon provides the greatest source of ambient light at night. It rises in the east and sets in the west. The time at which it rises and sets changes continually. The moon angle changes approximately 1.5 degrees per hour (1 degree every 4 minutes). Light from the moon is brightest when the moon is at its highest point.

Background Illumination

Natural light sources provide background illumination at night. Besides the light provided by the sun and moon, the following natural light sources add to night brightness:

- Airglow (also called night-sky luminance).
- Aurora (also called Northern Lights in the Northern Hemisphere and Southern Aurora in the Southern Hemisphere).
- Starlight.
- Zodiacal light (also called counter glow).

Artificial Light

Lights from cities, automobiles, fires, and flares normally are sources of small amounts of artificial light. The lights of a large metropolitan area will, however, increase the light level around the city. The light from these sources is most pronounced in overcast conditions.

Solar Light

Ambient solar light is usable for certain periods following sunset and before sunrise. After sunset, solar light steadily decreases until the level of light is not usable to the unaided eye. This occurs when the sun is 12 degrees below the horizon. Before sunrise, solar light becomes usable when the rising sun is 12 degrees below the horizon.

METEOROLOGICAL CONSIDERATIONS

Atmospheric conditions can affect hemispherical illumination. Because weather conditions vary, light levels cannot always be accurately predicted. An awareness of these factors will help to evaluate the available ambient light. Some meteorological conditions that restrict hemispherical illumination are discussed below.

Due to reduced vision at night, you may fail to detect a gradual increase in cloud coverage. At night, you must be alert for the following indications that clouds are present:

- A gradual reduction in light level.
- Obscuration of the moon and stars.
- Shadows resulting in varying levels of ambient light.

Humidity reduces transmission of light through the atmosphere. When humidity is high, ambient light is greatly reduced. High dew point temperatures indicate high humidity. An increase in the humidity content of the air will decrease the brightness of ground lights.

Restrictions, such as fog, dust, haze, or smoke, reduce hemispherical illumination. These conditions are greater at lower altitudes and intensify as temperatures decrease and the dew point spread approaches zero.

At least one weather occurrence **INCREASES** illumination. Lightning flashes have an effect similar to that of a bright flare. The brightness of the illumination depends on the closeness of the thunderstorm.

GLOSSARY

ADP	automatic data processing	N	neutral
AF	Air Force	NATO	North Atlantic Treaty Organization
AFM	Air Force Manual	NBC	nuclear, biological, and chemical
AFR	Air Force Regulation	NCO	noncommissioned officer
AFTO	Air Force Technical Order	NCOIC	noncommissioned officer in charge
AR	Army Regulation	NVG	night vision goggle
ATTN	attention	OF	Optional Form
ATV	all-terrain vehicle	OIC	officer in charge
C	Celsius	OJT	on-the-job training
CAR	customer account representative	OSHA	Occupational Safety and Health Act
CATS	Computer-Assisted Transportation Systems	P	park
CFR	Code of Federal Regulations	PDDA	power-driven decontamination apparatus
CONUS	continental United States	PDS	personnel decontamination station
D	drive	PMCS	preventive maintenance checks and services
DA	Department of the Army	POL	petroleum, oils, and lubricants
DA Pam	Department of the Army Pamphlet	psi	pounds per square inch
DD Form	Department of Defense Form	R	reverse
DOT	Department of Transportation	rad/hr	rads per hour
DS	direct support	RPM	revolutions per minute
F	Fahrenheit	SF	Standard Form
FM	Field Manual	SM	speedometer multiplier
GI	government issue	SOP	standing operating procedures
GTA	graphic training aid	SSN	social security number
GVW	gross vehicle weight	STANAG	standardization agreement
IPD	interpupillary distance	STB	super tropical bleach
IR	infrared	TAMMS	The Army Maintenance Management System
km	kilometer	TC	Training Circular
L	low	TM	Technical Manual
MHE	materials-handling equipment	TMP	transportation motor pool
mi	mile	TO	Technical Order
MPH	miles per hour	UCMJ	Uniform Code of Military Justice
		ULLS	Unit Level Logistics System
		USAFE	United States Air Forces in Europe
		VIP	very important person

REFERENCES

SOURCES USED

These are the sources quoted or paraphrased in this publication.

ARMY PUBLICATIONS

Army Regulations

AR 190-5. Motor Vehicle Traffic Supervision. 8 July 1988.

AR 310-25. Dictionary of United States Army Terms. 15 October 1983.

AR 310-50. Authorized Abbreviations and Brevity Codes. 15 November 1985.

AR 746-1. Packaging of Army Materiel for Shipment and Storage. 8 October 1985.

Department of the Army Form

DA Form 2028. Recommended Changes to Publications and Blank Forms. February 1974.

Field Manuals

FM 8-35. Evacuation of the Sick and Wounded. 22 December 1983.

FM 10-68. Aircraft Refueling. 29 May 1987.

FM 17-95. Cavalry Operations. 14 February 1986.

FM 55-15. Transportation Reference Data. 9 June 1986.

FM 55-30. Army Motor Transport Units and Operations. 14 March 1980.

Technical Manuals

TM 5-1080-200-13&P. Operator's, Organizational, and Direct Support Maintenance Manual, Including Repair Parts and Special Tools List, for Lightweight Camouflage Screen Systems and Support Systems. 29 January 1987.

TM 9-1300-206. Ammunition and Explosives Standards. 30 August 1973.

TM 9-2320-272-10. Operator's Manual for Truck 5-Ton, 6 X 6, M939 and M939A1 Series (Diesel), 25 July 1984.

TM 9-2815-210-34-1. Troubleshooting Direct Support and General Support Level Engine Assembly, Diesel (Multifuel). 3 April 1981.

TM 9-2815-210-34-2-1. Maintenance, Direct Support and General Support Level Engine Assembly, Diesel (Multifuel). 3 April 1981.

TM 9-2815-210-34-2-2. Maintenance, Direct Support and General Support Level Engine Assembly, Diesel (Multifuel). 3 April 1981.

AIR FORCE PUBLICATIONS

Air Force Forms

AF Form 15. United States Air Force Invoice. May 1987.

AF Form 15A. Invoice Envelope.

AF Form 847. Recommendation for Change of Publication.

INTERNATIONAL STANDARDIZATION AGREEMENTS

STANAG 2002 (Edition 6). NBC, Marking of Contaminated or Dangerous Land Areas, Complete Equipment, Supplies and Stores. 12 October 1976.

STANAG 2025 (Edition 5). Basic Military Road Traffic Regulations. September 1975.

DOCUMENTS NEEDED

These documents must be available to the intended users of this publication.

ARMY PUBLICATIONS

Army Regulations

*AR 55-29. Military Convoy Operations in CONUS. 3 September 1971.

*AR 55-162. Permits for Oversize, Overweight or Other Special Military Movements on Public Highways in the United States. 1 January 1979.

*AR 55-355. Defense Traffic Management Regulation. 31 July 1986.

*AR 385-10. Army Safety Program. 23 May 1988.

*AR 385-40. Accident Reporting and Records. 1 April 1987.

*AR 385-55. Prevention of Motor Vehicle Accidents. 12 March 1987.

*AR 600-55. Motor Vehicle Driver and Equipment Operator Selection Training, Testing, and Licensing. 26 September 1986.

Department of the Army Forms

*DA Form 348. Equipment Operator's Qualification Record (Except Aircraft). October 1964.

*DA Form 2401. Organization Control Record for Equipment. April 1982.

*This source was also used to develop this publication.

*DA Form 2404. Equipment Inspection and Maintenance Worksheet. April 1979.

*DA Form 2408. Equipment Log Assembly (Records). January 1986.

*DA Form 2408-14. Uncorrected Fault Record January 1984.

*DA Form 5983-E. Equipment Operator Qualification Record (EGA). March 1991.

*DA Form 5984-E. Operator's Permit Record. March 1991.

Department of the Army Pamphlet

*DA Pam 738-750. Functional User's Manual for the Army Maintenance Management System (TAMMS).
31 October 1989.

Field Manuals

*FM 3-100. NBC Operations. 17 September 1985.

*FM 5-20. Camouflage. 20 May 1968.

*FM 5-36. Route Reconnaissance and Classification. 10 May 1985.

*FM 20-22. Vehicle Recovery Operations. 18 September 1990.

*FM 21-26. Map Reading and Navigation. 30 September 1987.

*FM 21-60. Visual Signals. 30 September 1987.

FM 55-312. Military Convoy Operations in the Continental United States. 3 April 1991.

FM 101-5-1. Operational Terms and Symbols. 21 October 1985.

Technical Manual

TM 9-2610-200-24. Organizational, Direct Support, and General Support Maintenance Care,
Maintenance, and Repair of Pneumatic Tires and Inner Tubes. 1 February 1985.

Training Circular

*TC 21-305-2. Night Vision Goggles: Training Program for Night Vision Goggle Driving Operations.
14 November 1990.

AIR FORCE PUBLICATIONS

Air Force Forms

*AF Form 171. Request for Driver's Training and Additions to US Government Motor Vehicle Operator's
Permit. May 1987.

*AF Form 483. Certificate of Competency. February 1985.

*This source was also used to develop this publication.

FM 21-305/AFMAN 24-306

*AF Form 1800. Operator's Inspection Guide and Trouble Report (General Purpose Vehicles). April 1987.

AF Form 1806 (Currently AFTO 373). Operator's Inspection Guide and Trouble Report (Aircraft Towing, Base Maintenance, Deicers, High Reach and Snow Removal). July 1986.

AF Form 1807 (Currently AFTO 421). Operator's Inspection Guide and Trouble Report (Fuel Servicing). September 1987.

AF Form 1812. Operator's Inspection Guide and Trouble Report (530A/B, 750A, P-6, P-8, P-12 P-13, 1,000/1,500-Gallon Water Distributors, F6/F7). November 1979.

AF Form 1819. Operator's Inspection Guide and Trouble Report (P2/4, 0-IIA/B, P-10, P-10A, RP2, P-15, Firefighting Vehicles). November 1979.

*AF Form 2293. US Air Force Motor Vehicle Operator Identification Card (Computer Generated). February 1987.

AF Form 2296. Vehicle Operator Information (Part 3) (Computer Generated). February 1987.

Air Force Manuals.

AFM 77-310, Vol. 1. Vehicle Operations, Acquisition, Management, and Use of Motor Vehicles. July 1987.

AFM 77-310, Vol. 2. Vehicle Maintenance Management. April 1987.

Air Force Regulations

AFR 55-48. Airfield Management and Base Operations. February 1988.

AFR 77-4. Vehicle Control. January 1989.

Career Development Course

*CDC 603XO, Skill Levels 3,5,7,9.

Technical Orders

TO 00-20-B-5. USAF Motor Vehicle and Vehicular Equipment Inspection. 7 April 1988.

*TO 00-25-172. Ground Servicing of Aircraft and Static Grounding/Bonding (ATOS). 1 February 1988.

TO 36-1-3. Painting Marking and Lighting Requirements for USAF Vehicles. 7 November 1988.

DEPARTMENT OF DEFENSE PUBLICATIONS

Department of Defense Forms

*DD Form 314. Preventive Maintenance Schedule and Record. December 1953.

*DD Form 518. Accident Identification Card. October 1978.

*This source was also used to develop this publication.

Reference-4

*DD Form 626. Motor Vehicle Inspection. April 1978.

*DD Form 836. Special Instructions for Motor Vehicle Drivers. May 1971.

*DD Form 1360. Operator Qualifications and Record of Licensing, Examination, and Performance (Air Force).

*DD Form 1970. Motor Equipment Utilization Record. April 1981.

MISCELLANEOUS PUBLICATIONS

*Civilian Personnel Manual.

GTA 55-3-20. Know Your European International Road Signs. March 1983.

Code of Federal Regulations

Title 31. Money and Finance: Treasury. July 1990.

Title 49.177.817. Shipping Papers. 1 October 1989.

Optional Form

*OF 346. US Government Motor Vehicle Operator's Identification Card. November 1985.

Uniform Code of Military Justice (UCMJ).

Unit Level Logistics System Users Manual ADSM-18-L3N-AWA-ZTH-EUM. 15 February 1989.

STANDARD FORMS

*SF 44. Purchase Order Invoice Voucher. October 1983.

*SF 91. Operator's Report of Motor Vehicle Accident. November 1976.

READINGS RECOMMENDED

These readings contain relevant supplemental information.

ARMY PUBLICATIONS

Army Regulation

AR 58-1. Management, Acquisition, and Use of Administrative Use Motor Vehicles. 15 December 1979.

Department of the Army Pamphlet

DA Pam 25-30. Consolidated Index of Army Publications and Blank Forms. 30 September 1990.

* This source was also used to develop this publication.

Field Manual

FM 19-25. Military Police Traffic Operations. 30 September 1977.

Technical Manual

TM 9-500. Data Sheets for Ordnance Type Materiel. 11 September 1972.

NOTE: Personnel can obtain applicable publications through their unit customer account representative (CAR).

INDEX

- Accessories (for driving in sand) 21-2, 21-3
- Accidents
 - causes of 10-1
 - identification card (DD Form 518) 10-2, 13-2
 - operator's report of (SF 91) 10-2 thru 10-5, 13-2
 - precautions against 10-1, 10-2
 - procedure in case of 10-1
 - reporting of (by telephone) 10-1
- Aerospace ground equipment 25-2, 25-3
- Air cleaner, dirt in 16-5
- Aircraft
 - servicing of 25-3, 25-4
 - towing of 25-3
- Alcohol and drugs
 - abstaining from 4-4, 11-4
 - as causes of accidents 10-1
 - effects of 4-4, 11-4
- Anchors 22-1, 22-2
- Animals 7-2
- Authorization, flight line 25-1

- Bicyclists 7-2
- Blackouts 23-6, 23-10, 23-14
- Blowouts 9-1
- Brake failure 9-2
- Braking 8-2, 8-3
- Breakdowns 11-5
- Buses
 - backing of 8-3, 8-4
 - school 11-4
 - transporting of personnel on 14-2, 14-3

- Cargo
 - dangerous 19-5 thru 19-7
 - distribution of 18-11, 18-12
 - hazardous 18-14, 19-6, 19-7
 - lashing of 18-13
 - perishable 18-14
 - protection of 18-11 thru 18-13
 - responsibility for 18-11 thru 18-14
- Contaminated area, marking of 20-10
- Controllers, traffic 2-1, 6-1
- Convoy
 - driving speed of 24-1
 - flags (NATO) 24-2
- Credit card 13-1, 13-2
- Curves, safe driving on 4-2, 4-3

- Deadman, log 22-2
- Decontamination
 - agents 20-15, 20-16
 - materials and use 20-15, 20-16
 - of communications and radar equipment 20-13
 - of crew-served weapons 20-13
 - of equipment 20-12, 20-13
 - of optical instruments 20-13
 - of vehicles 20-13
- Decontamination stations
 - equipment 20-13
 - personnel 20-13 thru 20-15
 - field expedient 20-13 thru 20-15
- Dispatch form 13-1
- Dispatcher, responsibility of 13-1
- Distance, estimating of 12-2
- Driver
 - fatigue of 11-1, 11-2
 - identification card 1-1 thru 1-3
 - qualification record of 1-1, 1-4 thru 1-6
 - responsibilities of 1-6
 - rest requirements for 4-4
- Drives, private 6-3
- Driving
 - across ditches 21-1
 - across gullies and ravines 21-1
 - across streams 21-2
 - blackout 23-6, 23-10, 23-14
 - fuel-efficient 1-7
 - general practices 8-1
 - in mud and swamps 21-2
 - in sand 21-2, 21-3
 - night 5-1, 11-1, 11-2, 23-1 thru 23-11
 - off post/base 13-1 thru 13-4
 - off road 21-1 thru 21-4
 - on icy roads 21-4, 21-5
 - on the right 4-2
 - over rocky terrain 21-1, 21-2
 - through woods 21-1
 - winter 21-4 thru 21-7

- Engine
 - before-operation procedures 16-3 thru 16-5
 - compression ignition (diesel/multifuel) 16-1, 16-2
 - during-operation procedures 16-5
 - filters in 16-2, 16-3
 - fuels used in 16-2

Engine (continued)

- hydrostatic lock in 16-4
- multifuel models of 16-1, 16-2
- operating principles of 16-1, 16-2
- spark ignition 16-1
- starting of 16-1, 16-4, 16-5
- used as a brake 17-2

Engine, failures of

- distributor cap, shorted 22-9
- distributor point spring, broken 22-9
- during field driving 22-8 thru 22-10
- fuel lines, frozen 22-9
- fuel pump vapor lock 22-9
- line fitting, leaking 22-9
- substitutes for tire chains 22-8

Equipment

- decontamination 20-13
- fuel-servicing 25-4
- inspection and maintenance work sheet (DA Form 2404) 15-1, 15-2

Fatigue, effect of 11-1, 11-2

Field expedients 22-6 thru 22-10

- for a jack 22-6
- personnel decontamination station 20-13 thru 20-15

Fifth wheel 18-4, 18-5

Fire

- in accidents 10-1, 10-2
- in vehicle 9-3, 9-4
- precautions against 9-3, 10-2

First aid 10-1

Following distance 5-1

- at night 5-1
- too close 5-1, 10-1

Fording 21-2

Forklift

- maneuvers 25-5
- operations 25-5
- safety 25-5, 25-6

Fuel

- as a decontaminant 20-16
- jettisoning of 19-9
- leakage of 19-8
- transfer of 19-9

Gap, proper speed and 24-1

Grid

- military, reference system 12-1, 12-2
- reference box 12-5

Guides, use of 8-3, 8-4

Hazards, seasonal 11-3

Headlights 11-2

Highway warning kit 13-3

Interaxle differential 18-2

Intersections

- cloverleafs 6-3
- pedestrian rules at 7-1, 7-2
- special 6-2, 6-3
- traffic circles 6-3
- turns at 6-2
- with traffic controls 6-1, 6-2
- with traffic signs 6-1, 6-2
- without traffic controls 6-1

Jack substitutes 22-6

Jumper cables 17-4

Lights

- blackout 23-6, 23-14
- driving light 23-6, 23-14
- front lights 23-6, 23-14
- marker lights 23-6, 23-14
- taillights 23-6, 23-14

Load

- lashing of 18-13
- special 18-13
- vertical height of 18-13

Maintenance

- after operation 15-2
- before operation 15-1
- driver 15-1
- during operation 15-1, 15-2
- forms and records 15-2 thru 15-4
- inspections 15-1, 15-2
- lubrication 15-1
- operator 15-1, 15-2
- organizational 15-1
- preventive 15-1

Manual shift 17-1, 17-2

Map

- grid, use of 12-1 thru 12-5
- route 13-2
- strip, use of 12-5 thru 12-7

Markers

- biological contamination 20-11
- booby trap 20-11
- chemical contamination 20-10, 20-11
- chemical minefield 20-11
- description of 20-10
- radiological contamination 20-11
- unexploded munitions 20-11

Marking procedures, special radiological 20-11, 20-12

Markings, pavement 2-8, 2-9

- Masks, protective 20-10
- Night driving 11-1, 11-2
- Night vision goggles 23-1 thru 23-4
 - convoy driving 23-10
 - driver preparation 23-8
 - driving 23-4 thru 23-12
 - exportable training package 23-13
 - ground speed limitations 23-6, 23-7
 - operation and care 23-2 thru 23-4
 - training 23-12, 23-13
 - vehicle preparation 23-7, 23-8
 - weather considerations 23-5
- Nuclear, biological, and chemical conditions 20-10 thru 20-16
- Operator, aircraft-towing vehicle 25-4, 25-5
- Operator, forklift 25-5
- Overloading 11-4
- Parking 8-5 thru 8-7, 18-9
 - diagonal 8-6, 8-7
 - improper 8-6, 8-7
 - on a hill 8-5, 8-7
 - parallel 8-5 thru 8-7
- Parking fees 13-2
- Passing
 - being passed 5-3, 5-4
 - on the right 5-3
 - on three-lane highways 5-3
 - safe 5-2
 - signaling when 5-3
 - unsafe 5-2, 5-3
- Pedestrians 7-1, 7-2
- Personnel, transporting of
 - general procedures 14-1
 - in emergency vehicles 14-3, 14-4
 - off post/base 14-1
 - on buses 14-2, 14-3
 - on panel vans 14-3
 - on post/base 14-1
 - on trucks 14-3
 - very important persons 14-1, 14-2
- Police
 - armed services 10-1
 - civil 10-1
- Railroad crossings 6-3
- Repairs, off post/base 13-2, 13-4
- Road turn 8-5
- Roads, secondary 11-3, 11-4
- Safety, flight line 25-1 thru 25-3
 - and aircraft engine runup 25-2
- Safety, flight line (continued)
 - and aircraft navigation equipment 25-2
 - and emergency vehicles 25-3
 - and foreign object damage prevention 25-2
 - and parked aircraft 25-2
 - and passengers 25-3
 - and taxiing aircraft 25-2
 - and use of chocks 25-2, 25-3
 - and vehicle lights 25-2, 25-3
 - and wheeled equipment 25-3
 - when crossing runways 25-2
 - when crossing taxiways 25-2
- Safety, forklift 25-5, 25-6
- Scales, coordinate 12-2, 12-3
- School buses 11-4, 11-5
- Screens, camouflage 20-1 thru 20-10
 - desert 20-1, 20-2
 - erection of 20-3 thru 20-7
 - folding of 20-4, 20-8, 20-9
 - radar-scattering 20-1, 20-2
 - radar-transparent 20-1, 20-2
 - snow 20-1
 - woodland 20-1, 20-2
- Seatbelts 11-6
- Signals
 - aircraft loading and convoy control 24-1, A-11 thru A-22
 - control tower 25-3
 - convoy (from vehicle) A-10
 - driver 2-1, 2-2
 - electrical 2-2
 - emergency flashing 2-2
 - hand 2-1
 - horn 2-2
 - traffic 2-3
 - traffic control personnel A-9
 - turn 2-1, 2-2
- Signs, international A-1
- Signs, military 12-5
- Signs, NATO
 - guide A-1, A-2
 - hazard and regulatory 2-4 thru 2-7, A-1, A-2
 - route signs 2-3
- Signs, traffic color in 2-3, 2-4
 - international 2-3, A-3 thru A-8
 - shape in 2-3, 2-4
- Skid, pole, use of 22-7, 22-8
- Skid, recovery from 9-1
- Speed
 - control of 3-6
 - convoy 24-1
 - night driving 11-1, 11-2
 - on secondary roads 11-3, 11-4

Starting

engine, procedures for 16-1, 16-4, 16-5,
17-1, 17-4

on hills 8-1

on slippery surfaces 8-1

Steering, hand-over-hand 8-1, 8-2

Stopping

distances 3-1, 3-2

effect of braking distance on 3-1, 3-2

effect of perception distance on 3-1

effect of reaction distance on 3-1

factors affecting 3-1

Symbols, strip map 12-5, 12-6

Time, estimating of 12-5

Tire chains

fit of 21-6

installation of 21-6

Tire, pressure 21-2

Toll tickets 13-2

Tractor-semitrailer

backing of 18-8, 18-9

coupling/uncoupling 18-4 thru 18-8

fifth wheel on 18-4, 18-5

loading of 18-11 thru 18-14

maneuvering of 18-8, 18-9

parking of 18-9

Transmission, automatic

dual-range driving positions 17-3, 17-4

selector lever positions 17-2, 17-3

Transmission, manual shift

clutch, operation of 17-1, 17-2

double clutching 17-1, 17-2

shifting down 18-2

shifting up 18-1

Trucks, transporting personnel in 14-3

Turbosupercharger 16-5

Turning around 8-4, 8-5

U-turn 8-5

Vapor lock, fuel pump 22-9

Vehicle

aircraft-refueling 25-4

anchoring of 22-1, 22-2

backing of 8-3, 8-4

breakdowns 11-5

camouflaging of 20-1 thru 20-7

capacity of 18-11

Vehicle (continued)

care of when driving in sand 21-4

care of when driving in winter 21-4, 21-5

decontamination of 20-12, 20-13

emergency 11-4

failures (convoy) 24-1

fires 9-3, 9-4

"follow me" 25-3, 25-4

freeing of from sand 21-3, 21-4

halts (convoy) 24-1

loading of 18-11 thru 18-14

multifuel 16-1

official use of 1-1

operation of in blackout conditions 23-14

operation of in contaminated areas 20-10

operator's identification card 1-1 thru 1-3

overhead clearances for 18-14

overloading of 11-4

oversize 18-13

overweight 18-13

penalties for unauthorized use of 1-1

removal of from accident scene 10-2

restriction on use 1-1

special-purpose 18-14

stopping 3-1

towing of, general rules for 22-1

Vehicle, recovery of

with A-frame 22-6

with manpower 22-5

with winch 22-2 thru 22-5

VIPs, transporting of 14-1, 14-2

Vision

reduced 11-1

selective 4-3

Warning kit, highway 11-5, 13-3

use of 13-3

Weather 11-2

fog 11-3

ice 11-3

rain 11-3

snow 11-3

Wheel, raising of 22-7

Winch

safety 22-2

use with single vehicle 22-3, 22-4

use with two vehicles 22-4, 22-5

vehicle recovery by use of 22-2 thru 22-5

By Order of the Secretary of the Army:

Official:

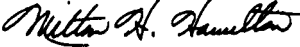
MILTON H. HAMILTON
*Administrative Assistant to the
Secretary of the Army*
04640

GORDON R. SULLIVAN
*General, United States Army
Chief of Staff*

By Order of the Secretary of the Air Force:

Official:

MERRILL A. McPEAK
*General, United States Air Force
Chief of Staff*

EDWARD A. PARDINI
*Colonel, United States Air Force
Director of Information Management*

Distribution:

Active Army, USAR, and ARNG: To be distributed in accordance with DA Form 12-11 E requirements for FM 21-305, Manual for the Wheeled Vehicle Driver (Qty rqr block no. 1055).

PIN: 007205-000