

TECHNICAL MANUAL

FIELD AND SUSTAINMENT MAINTENANCE

FOR

2-1/2 TON, 6X6, M44A2 SERIES TRUCKS (MULTIFUEL)

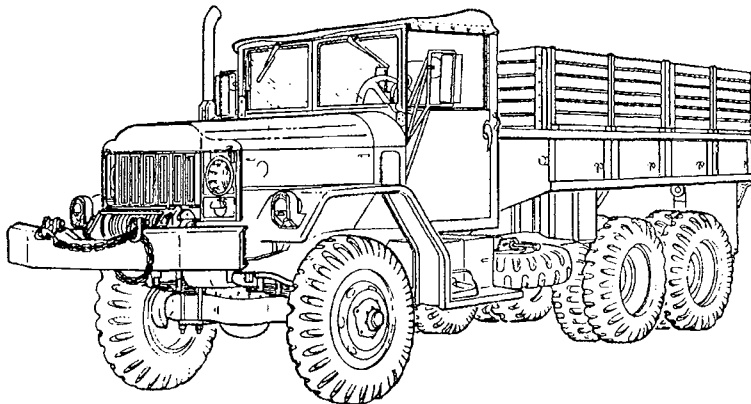

CHAPTER 3 (Contd)
FIELD MAINTENANCE
INSTRUCTIONS

CHAPTER 4
FIELD MAINTENANCE
INSTRUCTIONS FOR SPECIAL
PURPOSE KITS

CHAPTER 5
SUSTAINMENT MAINTENANCE
INSTRUCTIONS

CHAPTER 6
SUPPORTING INFORMATION

TRUCK, CARGO, M35A2 (2320-00-077-1616) (EIC: BMA)
(2320-00-077-1617) (EIC: BMB)

TRUCK, CARGO, XLWB, M36A2 (2320-00-077-1618) (EIC: BMC)
(2320-00-077-1619) (EIC: BMD)

TRUCK, CARGO, DROPSIDE, M35A2C (2320-00-926-0873) (EIC: BMR)
(2320-00-926-0875) (EIC: BMS)

TRUCK, TANK, FUEL SERVICING, M49A2C (2320-00-077-1631) (EIC: BME)
(2320-00-077-1632) (EIC: BMF)

TRUCK, TANK, WATER, M50A3 (2320-00-937-4036) (EIC: BMT)
(2320-00-937-5264) (EIC: BMU)

TRUCK, VAN, SHOP, M109A3 (2320-00-077-1636) (EIC: BMJ)
(2320-00-077-1637) (EIC: BMK)

TRUCK, VAN, REPAIR, M185A3 (4940-00-077-1638) (EIC: BMW)

DISTRIBUTION STATEMENT A: Approved for public release; distribution is unlimited.

HEADQUARTERS, DEPARTMENTS OF THE ARMY
AND THE AIR FORCE

AUGUST 2006

WARNING

EXHAUST GASES CAN KILL

1. DO NOT operate vehicle engine in enclosed area.
 2. DO NOT idle vehicle engine with vehicle windows closed.
 3. DO NOT drive vehicle with inspection plates or cover plates removed.
 4. BE ALERT at all times for exhaust odors.
 5. BE ALERT for exhaust poisoning symptoms. They are:
 - Headache
 - Dizziness
 - Sleepiness
 - Loss of muscular control
 6. If YOU SEE another person with exhaust poisoning symptoms:
 - Remove person from area
 - Expose to open air
 - Keep person warm
 - Do not permit person to move
 - Administer artificial respiration * or CPR if necessary
- * For artificial respiration, refer to FM 4-25.11.
7. BE AWARE, the field protective mask for Nuclear-Biological-Chemical (NBC) protection will not protect you from carbon monoxide poisoning. **THE BEST DEFENSE AGAINST EXHAUST POISONING IS ADEQUATE VENTILATION.**

WARNING SUMMARY

- Hearing protection is required for the driver and co-driver. Hearing protection is also required for all personnel working in and around this vehicle while the engine is running (reference AR 40-5 and DA PAM 40-501).
- If required to remain inside the vehicle during extreme heat, occupants should follow the water intake, work/rest cycle, and other heat stress preventive medicines measures contained in FM 21-10, Field Hygiene and Sanitation.
- Vehicle will become charged with electricity if A-frame contacts or breaks high voltage line. Do not attempt to leave vehicle while voltage line is in contact with A-frame or vehicle. Leaving the vehicle may result in injury to personnel.
- Air compressor becomes hot during operation. Allow air compressor to cool before handling, or injury to personnel may result.
- Do not disconnect air couplings before draining air reservoirs. Small parts under pressure may shoot out with high velocity, causing injury to personnel.
- Do not disconnect air lines before draining air reservoirs. Small parts under pressure may shoot out with high velocity, causing injury to personnel.
- Alternator must be supported during removal. Failure to support alternator may cause injury to personnel or damage to equipment.
- Do not use a dry brush or compressed air to clean brakeshoes. There may be asbestos dust on brakeshoes, which can be dangerous to your health if you breathe it. (Brakeshoes must be wet and a soft bristle brush must be used).
- Leaves and plates of assembled spring are under tension. Restrain all leaves and plates while removing center bolt. Release tension slowly. Failure to comply may result in injury to personnel.
- When assembling plates and leaves with C-clamp, the plates and leaves will be under tension. Use care not to disturb the assembly until center bolt and nut are tightened. Failure to do so may result in injury to personnel.
- Axle is heavy. Ensure axle is balanced and personnel are clear before lowering axle. Failure to do so may result in injury to personnel.
- Battery acid (electrolyte) is extremely harmful. Always wear safety goggles and rubber gloves when performing battery maintenance. Severe injury will result if acid contacts eyes or skin.
- Do not smoke, have open flame, or make sparks when performing battery maintenance. Batteries may explode causing severe injury to personnel.
- Remove all jewelry such as rings, identification tags, and bracelets. If jewelry or disconnected battery ground cable contacts battery post, a direct short can result, causing damage to equipment or severe injury to personnel.
- When disconnecting battery cables, disconnect the ground cable first. Do not allow tools to come in contact with vehicle when disconnecting cable clamps. A direct short can result, causing instant heating of tools, tool damage, battery damage, or battery explosion, and severe injury to personnel.
- Ensure new longer front brake hoses, currently used on 5-ton trucks, are installed on all 2 1/2 ton trucks. Old shorter front brake hoses are subject to failure during full steering travel and must be replaced with new longer front brake hoses. Failure to do this may result in injury or death to personnel.
- Never stand between test vehicles. Assistant must remain in secondary vehicle to engage service brake if cable snaps or automatic brake fails. Failure to do so may result in injury to personnel.
- All personnel must stand clear during removal of cargo body dropside. Cargo body dropside will swing free when pins are removed and injury to personnel may result.
- Eye protection is required when using wire brush for cleaning. Failure to do so may result in injury to personnel.

WARNING SUMMARY (Contd)

- Compressed air used for cleaning must not exceed 30 psi (207 kPa). Wear goggles/face shield and gloves when cleaning with compressed air. Failure to do so may result in injury to personnel.
- Do not remove inlet hose and outlet hose when engine is hot. Failure to comply may result in injury to personnel.
- All personnel must stand away from engine during crank test. Wear eye protection during crank test. Failure to stand clear and wear eye protection may cause injury or death to personnel.
- Discharge valve internal spring is compressed in cap. Eye protection must be worn when removing screws and cap from valve housing. Failure to do this may cause injury to personnel.
- Eye protection must be worn during spring and cap installation. Failure to do this may result in injury to personnel.
- Stay clear of drive gear area during inspection of input drive shaft seal when engine is operating. Failure to stay clear of drive gear area may result in injury to personnel.
- Ensure engine compartment is free of all tools and working materials before starting engine. Failure to do so may result in damage to equipment and injury to personnel.
- Do not perform engine coolant heater testing while smoking or within 50 feet of sparks or open flames. Fuel is flammable and can explode easily causing injury or death to personnel and damage to equipment.
- Allow time for heater to cool before removing from test equipment. Failure to do so may result in injury to personnel or damage to equipment.
- Keep hands clear of supported engine during placement of engine mounts. Failure to do so may result in injury to personnel.
- Hand protection must be worn during nut retightening. Engine surface is hot and can cause injury to personnel.
- Diesel fuel is flammable. Do not perform fuel system procedures near open flames. Injury or death to personnel may result.
- Before performing fuel system procedures, allow engine to cool. Failure to do so may result in injury or death to personnel.
- Flywheel is heavy. Use care when removing flywheel. Failure to do so may result in injury to personnel.
- Do not put fingers between frame and engine support. Jack failure may result in injury to personnel.
- Do not perform fuel burning personnel heater testing while smoking or within 50 feet of sparks or open flame. Fuel is flammable and can explode, causing injury or death to personnel and damage to equipment.
- Eye protection is required during inspection of fuel injection pump and drive gear input shaft seal with engine operating. Oil may spray or splash from gear area. Failure to wear eye protection may result in injury to personnel.
- There is enough fuel pressure to penetrate skin when removing injector tubes. Wear hand protection at all times when removing injector tubes. Failure to do so may result in injury to personnel.
- Ensure fuel shutoff valve is OFF and remove throttle cable before cranking engine. Failure to do so may result in injury to personnel.
- Eye protection is required when performing fuel system troubleshooting checks. Failure to wear eye protection may result in injury to personnel.

WARNING SUMMARY (Contd)

- Ignition switch must remain OFF during fuel system troubleshooting checks. Failure to verify that ignition system is turned off may result in injury to personnel.
- Keep fingers clear of hood and cowling when replacing hinge. Failure to do so may result in injury to personnel.
- Hot coolant is under pressure. Care should be used when removing coolant filler cap or inspecting hot engine coolant leaks. Steam or hot coolant under pressure may cause severe injury to personnel.
- Do not touch hot exhaust system components with bare hands. Severe injury to personnel may result.
- Short front flexible hydraulic brake lines are subject to failure during full steering travel and must be replaced with new, longer flexible hydraulic brake lines P/N 7409330. Failure to comply may cause injury or death to personnel.
- Weight of vehicles must be supported on jack stands at all times. Do not attempt to support weight of vehicle on hydraulic jack. Failure to comply may result in injury or death to personnel.
- Ensure lifting capacity is greater than weight of cargo body. Failure to do so may result in injury to personnel or damage to equipment.
- Ensure lifting capacity is greater than 5,535 lb (2513 kg). Failure to do so may result in injury to personnel or damage to equipment.
- All personnel must stand clear during lifting operations. A swinging or shifting load may cause injury to personnel.
- Do not detach lifting device from engine until all engine weight is equally distributed and engine is stable. An improperly supported engine may cause injury to personnel.
- Lifting device must have a weight capacity greater than the weight of the engine and transmission to prevent damage to equipment and injury to personnel.
- Stay clear of moving parts. Failure to do so may result in injury or death to personnel.
- Exhaust gases can kill. Do not operate personnel heater in enclosed areas. Ensure work area is well ventilated and exhaust fumes are directed away from the test area.
- Failure to perform preliminary inspection on a deadlined vehicle may result in injury to personnel and/or damage to equipment.
- Pressure plate is heavy. Support pressure plate during removal. Failure to do so may result in injury to personnel.
- Use prybar to free engine during lifting operations. Failure to do so may result in injury to personnel.
- Turn vehicle engine off before installing pulse tachometer. Failure to do so may result in injury to personnel.
- Do not remove radiator cap when engine is hot. Wait until engine cools. Failure to wait may cause injury to personnel.
- Do not place fingers between frame and crossmember while replacing mount. Doing so may result in injury to personnel.
- Support cab body while in raised position for mount replacement. Failure to do so may result in injury to personnel.
- If rod clevis is not positioned tightly against cover window bearing screw, fuel shutoff rod may be binding. Verify fuel shutoff rod travels freely before adjusting clearance between rod clevis and bearing screw. Failure to verify fuel shutoff rod condition may result in governor sticking under acceleration and injury to personnel.
- Gloves, eyeshields, and dust mask must be worn during panel removal and installation. Failure to do so may result in injury to personnel.

WARNING SUMMARY (Contd)

- Skysol 100 solvent is combustible; DO NOT use or store near heat, sparks, flame, or other ignition sources. Use mechanical ventilation whenever product is used in a confined space, heated above ambient temperatures, or agitated. Keep container sealed when not in use.

Contact with Skysol 100 may cause skin irritation. Use chemical resistant gloves. In case of skin contact, remove any contaminated clothing and wash skin thoroughly with soap and water. Wash contaminated clothing before reuse. Eye contact may cause irritation, tearing, or blurring of vision. Use face shield or goggles when eye contact may occur. In case of eye contact, flush eyes with large amounts of water for at least 15 minutes or until irritation subsides. Inhalation may cause irritation to upper respiratory passages. DO NOT have food or drink in the vicinity. Failure to comply may result in injury to personnel.

- Do not remove slave receptacle before disconnecting battery ground cables. If energized battery cables contact cab, a direct short will result and may cause injury to personnel.
- Wear leather gloves when handling cable. Do not let cable run through hands. Broken or rusty wires can cause injury to personnel.
- Ensure vehicle is firmly supported while spring seat is removed. Failure to comply may result in injury to personnel.
- Eye protection must be worn when removing or installing springs under tension. Failure to do so may result in injury to personnel.
- When using steam cleaning equipment, do not come in direct contact of spray. Burns or severe injury to personnel may result.
- All sunshields must be rolled up and properly secured prior to vehicle operation. Failure to do so may result in injury or death to personnel.
- Support capacity must be greater than weight of van body. Ensure that support capacity is not less than 5,535 lb (2,513 kg). Failure to comply may result in injury to personnel and damage to equipment.
- Place support under radiator before removing support plate. Failure to do so may result in injury to personnel and damage to equipment.
- Tandem axle is heavy. Support tandem axle during removal and installation. Failure to do so may result in injury to personnel or damage to equipment.
- Ensure lifting capacity is greater than weight of tank body. Failure to do so may result in injury to personnel.
- Be careful when working under tank body placed on supports. Tank body may fall causing injury to personnel.
- Use caution when testing thermostat, hot water may cause injury to personnel.
- Never inflate a tire without a tire inflation cage. Injury or death to personnel may result from exploding wheel components.
- Always use tire inflation equipment specified in TM 9-2610-200-14. Warn personnel to stand 10 ft (3.1 m) clear of tire inflation cage while inflating tire. Injury or death may result from exploding wheel components.
- Never rest or lean against tire inflation cage while tire is being inflated or injury or death to personnel may result.
- Never remove tire lock ring without first deflating tire. Lock ring may explode off, causing injury or death to personnel.
- Lock ring must be properly seated around wheel when installed. If lock ring is not correctly installed, it may explode off when tire is inflated, causing injury or death to personnel.

WARNING SUMMARY (Contd)

- Never attempt to correct seating of lock ring by hammering, striking, or forcing while tire is inflated. Lock ring may explode off, causing injury or death to personnel.
- Ensure transfer case is securely mounted to jack with safety chain or strap. Failure to do so may result in injury to personnel.
- Transfer case is heavy and bulky. Allow adequate clearance to remove transfer case from vehicle. Failure to do so may result in injury to personnel.
- Hand protection must be worn at all times when handling heated vibration damper and pulley. Failure to do so may cause injury to personnel.
- Completely deflate tires before removing from axles if there is obvious damage to wheel components. Injury or death to personnel may result from exploding wheel components.
- Always use hand throttle to control engine speed when operating winch. Avoid sudden change in engine speed. Rough or jerky operations may cause broken shearpins and snapped cables. Injury to personnel or damage to equipment may result.
- Ensure rear closure assembly is supported when removing screws. Failure to do so may allow rear closure assembly to drop unexpectedly causing injury to personnel.
- If NBC exposure is suspected, all air filter media must be handled by personnel wearing protective equipment. Consult your NBC officer or NBC noncommission officer for appropriate handling and disposal instructions.

NBC contaminated filters must be handled using adequate precautions and must be disposed of by trained personnel. Failure to do so may result in injury to personnel.

- Accidental or intentional introduction of liquid contaminants into the environment is a violation of state, federal, and military regulations. Refer to Army POL (WP 0001 00) for information concerning storage, use, and disposal of these liquids. Failure to do so may result in damage to environment and health of personnel.
- Eye protection must be worn during fuel tank replacement. Failure to do so may result in injury to personnel.
- Steering gear is heavy. Support steering gear during removal and installation. Failure to do so may result in injury to personnel or damage to equipment.
- Windshield glass may be sharp. Wear gloves and protective clothing during windshield glass removal and installation. Failure to do so may result in injury to personnel.

LIST OF EFFECTIVE PAGES/WORK PACKAGES

Date of issue for the original manual is:

Original 18 AUGUST 2006

TOTAL NUMBER OF PAGES FOR FRONT AND REAR MATTER IS 28,

TOTAL NUMBER OF WORK PACKAGES IS 279,

CONSISTING OF THE FOLLOWING:

<u>PAGE/WP NO.</u>	<u>*CHANGE NO.</u>
Title	0
warning a-f	0
i-x	0
Chapter 3 (Contd) title page (4 pgs)	0
WP 0194 00 – 0349 00 (536 pgs)	0
Chapter 4 title page (2 pgs)	0
WP 0350 00 – 0436 00 (342 pgs)	0
Chapter 5 title page (2 pgs)	0
WP 0437 00 – 0464 00 (134 pgs)	0
Chapter 6 title page (2 pgs)	0
WP 0465 00 – 0473 00 (80 pgs)	0
Index (12 pgs)	0

***Zero in this column indicates an original page.**

HEADQUARTERS,
DEPARTMENT OF THE ARMY
WASHINGTON, D.C., 18 August 2006

**TECHNICAL MANUAL
(VOLUME 2 OF 2)
FIELD AND SUSTAINMENT MAINTENANCE MANUAL
FOR
2-1/2 TON, 6X6, M44A2 SERIES TRUCKS (MULTIFUEL)**

MODEL	NSN W/O WINCH	NSN W/WINCH
Truck, Cargo, M35A2	2320-00-077-1616	2320-00-077-1617
Truck, Cargo, XLWB, M36A2	2320-00-077-1618	2320-00-077-1619
Truck, Cargo, Drop Side, M35A2C	2320-00-926-0873	2320-00-926-0875
Truck, Tank, Fuel Servicing, M49A2C	2320-00-077-1631	2320-00-077-1632
Truck, Tank, Water, M50A3	2320-00-937-4036	2320-00-937-5264
Truck, Van, Shop, M109A3	2320-00-077-1636	2320-00-077-1637
Truck, Van, Repair, M185A3	4940-00-077-1638	

REPORTING ERRORS AND RECOMMENDING IMPROVEMENTS

You can help improve this publication. If you find any mistakes or if you know of a way to improve the procedures, please let us know. Submit your DA Form 2028 (Recommended Changes to Publications and Blank Forms), through the Internet, on the Army Electronic Product Support (AEPS) website. The Internet address is <https://aeps.ria.army.mil>. If you need a password, scroll down and click on "ACCESS REQUEST FORM". The DA Form 2028 is located in the ONLINE FORMS PROCESSING section of the AEPS. Fill out the form and click on SUBMIT. Using this form on the AEPS will enable us to respond quicker to your comments and better manage the DA Form 2028 program. You may also mail, fax or E-mail your letter or DA Form 2028 direct to: AMSTA-LC-LPIT/Tech Pubs, TACOM-RI, 1 Rock Island Arsenal, Rock Island, IL 61299-7630. The E-mail address is TACOM-TECH-PUBS@ria.army.mil. The fax number is DSN 793-0726 or Commercial (309) 782-0726.

CURRENT AS OF 12 MAY 2006

*This publication supersedes all portions of the M44A2 series vehicles data published in TM 9-2320-361-20, 25 October 1991, TM 9-2320-361-34, 8 May 1992, and all changes.

Distribution Statement A - Approved for public release; distribution is unlimited.

TABLE OF CONTENTS
VOLUME 2 OF 2

WP Sequence No.

CHAPTER 3 – FIELD MAINTENANCE INSTRUCTIONS (Contd)

STEERING SYSTEM

Toe-In Check and Adjustment	WP 0190 00
Pitman Arm Replacement	WP 0191 00
Steering Gear Replacement	WP 0192 00
Steering Gear Adjustment	WP 0193 00
Tie Rod and Tie Rod End Replacement	WP 0194 00
Drag Link Replacement	WP 0195 00
Steering Wheel Replacement	WP 0196 00

FRAME

Front Shackle (W/O Winch) Replacement	WP 0197 00
Front Shackle (W/ Winch) Replacement	WP 0198 00
Pintle Hook Maintenance	WP 0199 00
Rear Shackle Replacement	WP 0200 00
Rear Bumperette Replacement	WP 0201 00
Spare Tire Carrier Maintenance	WP 0202 00
Brush Guard, Stone Shield, and Headlight Guard Replacement	WP 0203 00
Front Bumper Replacement	WP 0204 00
Front Winch Extension Replacement	WP 0205 00
Frame Alignment Inspection	WP 0206 00

BODY, CAB, AND ACCESSORIES

Cab Door Inspection Hole Cover Replacement	WP 0207 00
Cab Door Dovetail Wedge Replacement	WP 0208 00
Cab Door and Hinges Replacement	WP 0209 00
Cab Door Glass Assembly and Weatherseal Replacement	WP 0210 00
Door Glass Replacement	WP 0211 00
Door Glass Channel Replacement	WP 0212 00
Cab Door Window Regulator and Handle Replacement	WP 0213 00
Outside Door Handle, Inside Door Handle, and Cab Door Lock Replacement	WP 0214 00
Cab Door Check Rod Replacement	WP 0215 00
Cab Door Catch Replacement	WP 0216 00
Cab Door Weatherseals Replacement	WP 0217 00
Side Panel Replacement	WP 0218 00
Headlight Bracket and Rubber Radiator Shield Replacement	WP 0219 00
Hood Fasteners Replacement	WP 0220 00
Hood Maintenance	WP 0221 00
Hood Hinges Replacement	WP 0222 00
Cab Handle Replacement	WP 0223 00
Cab Cowl Vent Replacement	WP 0224 00
Glove Compartment Replacement	WP 0225 00
Toolbox (Under Cab) Replacement	WP 0226 00
Windshield Glass Replacement	WP 0227 00
Windshield Assembly Maintenance	WP 0228 00
Windshield Arm, Glass Assembly, and Handle Replacement	WP 0229 00
Cab Tunnel, Rear Tunnel, and Toeboard Replacement	WP 0230 00
Rear Cab Mount and Bracket Replacement	WP 0231 00
Water Can Bracket and Running Board Replacement	WP 0232 00
Cab Soft Top Turnbuttons and Lashing Hooks Replacement	WP 0233 00

TABLE OF CONTENTS (Contd)
VOLUME 2 OF 2 (Contd)

WP Sequence No.

CHAPTER 3 – FIELD MAINTENANCE INSTRUCTIONS (Contd)

BODY, CAB, AND ACCESSORIES (Contd)

Companion Seat Maintenance	WP 0234 00
Driver's Seat Base Maintenance	WP 0235 00
Driver's Seat Replacement	WP 0236 00
Driver's Seat Cushion, Backrest, Frame, and Seat Adjuster Replacement	WP 0237 00
Front Fenders Maintenance	WP 0238 00

ACCESSORIES

Windshield Washer Reservoir, Tubing, Jet, and Pump Replacement	WP 0239 00
Windshield Wiper Switch, Motor, and Conlink Covers Replacement	WP 0240 00
Left and Right Conlinks Maintenance	WP 0241 00
Windshield Wiper Idler Shaft and Housing Replacement	WP 0242 00
Windshield Wiper Blade and Arm Replacement	WP 0243 00
Mirror and Brackets Replacement	WP 0244 00
Data Plate Replacement	WP 0245 00
Personnel Heater Supply Hose Replacement	WP 0246 00
Personnel Heater Diverter Replacement	WP 0247 00
Personnel Heater Air Vent Replacement	WP 0248 00
Personnel Heater Control Cables Maintenance	WP 0249 00
Personnel Hot Water Heater Replacement	WP 0250 00
Personnel Heater Defroster Hoses Replacement	WP 0251 00
Reflector Replacement	WP 0252 00

CARGO BODIES

Cargo Body Rack and Troop Seat Maintenance	WP 0253 00
Cargo Body Tailgate Replacement	WP 0254 00
Cargo Body Tailgate Replacement (M35A2C)	WP 0255 00
Cargo Body Upper and Lower Rear Splash Guard Replacement	WP 0256 00
Front Splash Guard Replacement	WP 0257 00
Cargo Body Front Rack Maintenance (M35A2C)	WP 0258 00
Cargo Body Dropside Replacement (M35A2C)	WP 0259 00
Cargo Body Front Rack Maintenance (M35A2 and M36A2)	WP 0260 00
Cargo Bodies Tailgate Maintenance	WP 0261 00
Cargo Bodies Maintenance	WP 0262 00

TANK BODIES

Discharge Valve Replacement (M49A2C)	WP 0263 00
Discharge Valve Control Levers Maintenance (M49A2C)	WP 0264 00
Discharge Valve Repair	WP 0265 00
Front and Rear Fuel Tank Discharge Tubes Replacement (M49A2C)	WP 0266 00
Automatic Dump Valve and Sump Assembly Maintenance (M49A2C)	WP 0267 00
Fuel Tank Manhole Cover Maintenance (M49A2C)	WP 0268 00
Fuel Hose and Nozzle Replacement (M49A2C)	WP 0269 00
Water Tank Nozzle Holder Replacement	WP 0270 00
Overturn Tubes Replacement (M49A2C)	WP 0271 00
Globe Valve Replacement (M49A2C)	WP 0272 00
Filter Separator-to-Sump Pipe Replacement (M49A2C)	WP 0273 00
Cable Retractor Replacement (M49A2C)	WP 0274 00
Meter-to-Filter Tube Replacement (M49A2C)	WP 0275 00

TABLE OF CONTENTS (Contd)
VOLUME 2 OF 2

WP Sequence No.

CHAPTER 3 – FIELD MAINTENANCE INSTRUCTIONS (Contd)

TANK BODIES (Contd)

Gallon Meter Replacement (M49A2C)	WP 0276 00
Delivery Pump Outlet Tube Replacement (M49A2C)	WP 0277 00
Delivery Pump Inlet Tube Replacement (M49A2C)	WP 0278 00
Water Pump Manifold Replacement (M50A3)	WP 0279 00
Delivery Pump Replacement	WP 0280 00
Delivery Pump Drain Valve Replacement	WP 0281 00
Meter Outlet Tube Replacement (M49A2C)	WP 0282 00
Gate Valve Replacement	WP 0283 00
Delivery Pump Strainer Replacement	WP 0284 00
Separator Element Test Valve, Gauge, and Lines Maintenance (M49A2C)	WP 0285 00
Filter Separator Maintenance (M49A2C)	WP 0286 00
Water Tank Filler Cover Replacement (M50A3)	WP 0287 00
Rear Compartment Door Maintenance	WP 0288 00
Water Tank Discharge Tube, Cover, and Valve Replacement (M50A3)	WP 0289 00
Water Tank Discharge Valve Control Levers Maintenance (M50A3)	WP 0290 00
Water Tank Manhole Cover Replacement (M50A3)	WP 0291 00
Delivery Pump Front Propeller Shaft Maintenance	WP 0292 00
Delivery Pump Rear Propeller Shaft Maintenance	WP 0293 00
Speed Control Cable Maintenance	WP 0294 00
Tank Bodies Front Splash Guard Replacement	WP 0295 00
Tank Bodies Upper and Lower Rear Splash Guard Replacement	WP 0296 00
Tank Bodies Frame Sill Maintenance	WP 0297 00
Fuel and Water Tank Bodies Maintenance	WP 0298 00

VAN BODY

Rear Splash Guard Replacement	WP 0299 00
Safety Switch Fuse Replacement	WP 0300 00
Exhaust Blower Motor and Bracket Replacement	WP 0301 00
Dome Lamp and Housing Replacement	WP 0302 00
Van Door Replacement	WP 0303 00
Van Door Seals Replacement	WP 0304 00
Van Door Maintenance	WP 0305 00
Van Body Cabinet and Work Bench Table Replacement	WP 0306 00
Van Body Ceiling Panel Replacement	WP 0307 00
Van Body Side Panel Replacement	WP 0308 00
115-Volt AC Receptacle Replacement	WP 0309 00
24-Volt DC Receptacle Replacement (M185A3)	WP 0310 00
115-Volt Receptacle Replacement	WP 0311 00
115-Volt Receptacle Strip Replacement	WP 0312 00
115-Volt Wiring Harness Replacement	WP 0313 00
Wire Plug Wiring Harness Replacement (M109A3)	WP 0314 00
115- and 24-Volt Wiring Harness Replacement	WP 0315 00
Blackout Master Switch Replacement (M109A3)	WP 0316 00
Multibreaker Box Replacement	WP 0317 00
Safety Switch Box Replacement	WP 0318 00
Circuit Breaker Harness Replacement	WP 0319 00

TABLE OF CONTENTS (Contd)
VOLUME 2 OF 2 (Contd)

WP Sequence No.

CHAPTER 3 – FIELD MAINTENANCE INSTRUCTIONS (Contd)

VAN BODY (Contd)

Front Window Sash Maintenance	WP 0320 00
Side Window Sash Maintenance	WP 0321 00
Van Body Access Door Replacement	WP 0322 00
Van Body Access Plate, Access Cover, and Retainer Assembly Replacement	WP 0323 00
24-Volt Circuit Breaker Replacement	WP 0324 00
Vehicle Boarding Ladder Replacement	WP 0325 00
Converter Selector Switch Replacement	WP 0326 00
Exhaust Blower Switch Replacement	WP 0327 00
Converter Replacement	WP 0328 00
Van Bodies Front Splash Guard Replacement	WP 0329 00
Van Body Tool Replacement (M185A3)	WP 0330 00
Converter Receptacle Replacement	WP 0331 00
Floodlight Bracket Replacement	WP 0332 00
Access Door Molding and Access Plate Replacement	WP 0333 00
Power Switch Maintenance	WP 0334 00
Door Holder Assembly and Bracket Replacement	WP 0335 00
Door Check Replacement	WP 0336 00
Exhaust Blower Duct Assembly Replacement	WP 0337 00
Blower Motor Receptacle Replacement	WP 0338 00
Blackout Switch Replacement	WP 0339 00
Fuel Line Adapter Replacement	WP 0340 00
Side Rail Maintenance	WP 0341 00

WINCH AND POWER TAKEOFF

Front Winch Drag Brake Test and Adjustment	WP 0342 00
Front Winch Cable Replacement	WP 0343 00
Automatic Brake Test and Adjustment	WP 0344 00
Front Winch Replacement	WP 0345 00
Front Winch Propeller Shaft Replacement	WP 0346 00
Transmission Power Takeoff (PTO) Shift Linkage Maintenance	WP 0347 00
Transfer Case Power Takeoff (PTO) Maintenance	WP 0348 00
Transmission Power Takeoff (PTO), Cover, and Gasket Maintenance	WP 0349 00

CHAPTER 4 – FIELD MAINTENANCE INSTRUCTIONS FOR SPECIAL PURPOSE KITS

PIONEER TOOL BRACKET KIT

Pioneer Tool Bracket Replacement	WP 0350 00
--	------------

WINTERIZATION KIT

Fuel Burning Personnel Heater Replacement	WP 0351 00
Personnel Heater Control Box Replacement	WP 0352 00
Personnel Heater Fuel Pump Replacement	WP 0353 00
Personnel Heater Fuel Filter Replacement	WP 0354 00
Exhaust Tube Replacement	WP 0355 00
Oil Pan Shroud and Exhaust Tube Replacement	WP 0356 00
Engine Coolant Heater Replacement	WP 0357 00
Engine Coolant Heater Harness Replacement	WP 0358 00
Thermal Barrier Insulation Replacement	WP 0359 00

TABLE OF CONTENTS (Contd)
VOLUME 2 OF 2 (Contd)

WP Sequence No.

CHAPTER 4 – FIELD MAINTENANCE INSTRUCTIONS FOR SPECIAL PURPOSE KITS (Contd)

WINTERIZATION KIT (Contd)

Battery Box and Heater Pad Replacement	WP 0360 00
Transmission Gearshift and Transfer Case Lever Cover Replacement.	WP 0361 00
Hood and Radiator Cover Replacement	WP 0362 00
Hardtop Maintenance	WP 0363 00
Alcohol Evaporator Maintenance	WP 0364 00
Slave Receptacle Replacement	WP 0365 00
Cargo Body Personnel Heater Replacement	WP 0366 00
Cargo Body Personnel Heater Mounting Bracket Maintenance.	WP 0367 00
Cargo Body Personnel Heater Fuel Pump Replacement.	WP 0368 00
Cargo Body Personnel Heater Fuel Filter Replacement.	WP 0369 00
Cargo Body Personnel Heater Control Box Replacement.	WP 0370 00
Cargo Body Personnel Heater Fuel Line Replacement.	WP 0371 00
Cargo Body Personnel Heater Diverter and Duct Replacement.	WP 0372 00

VAN BODY PRIMARY AND SECONDARY HEATER KIT

Primary Heater Fuel Pump Replacement	WP 0373 00
Primary Heater Fuel Pump Cover Replacement.	WP 0374 00
Primary Heater Fuel Filter Replacement	WP 0375 00
Primary Heater Fuel Lines Replacement	WP 0376 00
Primary Heater Fuel Shutoff and Coupling Replacement	WP 0377 00
Primary and Secondary Heater Exhaust Tube Replacement	WP 0378 00
Primary Heater Air Inlet Duct Replacement.	WP 0379 00
Primary Heater and Duct Replacement.	WP 0380 00
Primary and Secondary Heater Switches Replacement	WP 0381 00
Primary Heater Auxiliary Duct Replacement	WP 0382 00
Secondary Heater Fuel Lines Replacement.	WP 0383 00
Secondary Heater and Duct Replacement	WP 0384 00

DEEP WATER FORDING KIT

Deep Water Fording Kit Air Intake Tubes Replacement.	WP 0385 00
Deep Water Fording Kit Control Valve Replacement	WP 0386 00
Deep Water Fording Kit Regulator Valve Replacement	WP 0387 00

A-FRAME KIT

A-Frame Kit Maintenance.	WP 0388 00
----------------------------------	------------

MOUNTING KITS

Machine Gun Mount Kit Replacement.	WP 0389 00
Rifle Mounting Kit Replacement	WP 0390 00
Decontamination Mounting Kit Replacement	WP 0391 00
Chemical Agent Alarm Mounting Kit Replacement	WP 0392 00
Fire Extinguisher and Mounting Kit Replacement.	WP 0393 00
Bumper Step Kit Replacement	WP 0394 00

TROOP SEAT MOUNTING AND SEATBELT KITS

Troop Seat Center Mounted Kit Replacement.	WP 0395 00
Fixed Seatbelt Kit Replacement	WP 0396 00
Floating Seatbelt Kit Replacement.	WP 0397 00

TABLE OF CONTENTS (Contd)
VOLUME 2 OF 2 (Contd)

WP Sequence No.

CHAPTER 4 – FIELD MAINTENANCE INSTRUCTIONS FOR SPECIAL PURPOSE KITS (Contd)

COMPANION SEAT KIT

Companion Seat and Leg Extension Replacement WP 0398 00

SWINGFIRE HEATER KIT

Swingfire Heater and Mounting Brackets Replacement. WP 0399 00

Swingfire Heater Battery Box Tube Replacement. WP 0400 00

Swingfire Heater Water Jacket Replacement WP 0401 00

Swingfire Heater Water Hoses Replacement WP 0402 00

Swingfire Heater Water Jacket Brackets Replacement WP 0403 00

Swingfire Heater Wiring Harness and Receptacle Replacement WP 0404 00

AIR BRAKE KIT

Air Brake Rotary Valve and Air Line Replacement WP 0405 00

Air Brake Harness Replacement WP 0406 00

Air Brake Check Valve, Pressure Switch, and Air Line Replacement WP 0407 00

STEERING ASSIST KIT

Steering Assist Cylinder Maintenance. WP 0408 00

Steering Assist Regulator Replacement. WP 0409 00

ARCTIC ENCLOSURE KIT

Arctic Cargo Body Enclosure Replacement WP 0410 00

Speaking Tube Replacement (M35A2) WP 0411 00

CARGO BODY TIEDOWN KIT

Cargo Body Tiedown Replacement WP 0412 00

LOW PRESSURE AIR WARNING LIGHT KIT

Low Air Pressure Indicator and Lamp Replacement WP 0413 00

CAB REINFORCEMENT KIT

Cab Reinforcement Replacement WP 0414 00

SUNSHIELD KIT

Sunshield Replacement (Soft Top) WP 0415 00

Sunshield Replacement (Hard Top) WP 0416 00

ENGINE COOLANT HEATER KIT

Engine Coolant Heater Flame Detector Switch Maintenance WP 0417 00

Engine Coolant Heater Blower Motor Maintenance WP 0418 00

Engine Coolant Heater Restriction Thermostat Maintenance WP 0419 00

Engine Coolant Heater Component Bracket Maintenance. WP 0420 00

Engine Coolant Heater Fuel Control Valve Replacement. WP 0421 00

Engine Coolant Heater Overheat Switch and Igniter Maintenance WP 0422 00

Engine Coolant Heater Fuel Tube and Preheater Resistor Replacement WP 0423 00

Engine Coolant Heater Burner Maintenance WP 0424 00

Engine Coolant Heater Housing Replacement WP 0425 00

Engine Coolant Heater Testing. WP 0426 00

PERSONNEL HEATER KIT

Personnel Heater Guard and Blower Motor Replacement WP 0427 00

Personnel Heater Fuel Control Valve Maintenance WP 0428 00

Personnel Heater Igniter and Ignition Control Unit Replacement WP 0429 00

Personnel Heater Fuel Line and Blower Housing Replacement WP 0430 00

TABLE OF CONTENTS (Contd)
VOLUME 2 OF 2 (Contd)

WP Sequence No.

CHAPTER 4 – FIELD MAINTENANCE INSTRUCTIONS FOR SPECIAL PURPOSE KITS (Contd)

PERSONNEL HEATER KIT

Personnel Heater Flame Detector Switch Maintenance	WP 0431 00
Personnel Heater Burner Maintenance	WP 0432 00
Personnel Heater Overheat Switch and Receptacle Replacement	WP 0433 00
Personnel Heater Heat Exchanger Maintenance	WP 0434 00
Fuel Burning Personnel Heater Testing.	WP 0435 00

HARDTOP REAR PANEL WINDOW KIT

Hardtop Rear Panel Window Maintenance	WP 0436 00
---	------------

CHAPTER 5 – SUSTAINMENT MAINTENANCE INSTRUCTIONS

ENGINE

Engine Repair	WP 0437 00
Cylinder Head Repair	WP 0438 00
Cylinder Sleeve Replacement	WP 0439 00
Crankshaft Replacement	WP 0440 00
Flywheel Repair	WP 0441 00
Piston and Connecting Rod Replacement	WP 0442 00
Intake and Exhaust Valves, Guides, and Springs Replacement.	WP 0443 00
Camshaft and Bearing Replacement	WP 0444 00
Oil Pump Repair	WP 0445 00

FUEL SYSTEM

Fuel Injector Pump Maintenance	WP 0446 00
--	------------

COOLING SYSTEM

Radiator Repair	WP 0447 00
---------------------------	------------

ELECTRICAL SYSTEM

60-Ampere Alternator Repair	WP 0448 00
Starter Repair	WP 0449 00

TRANSMISSION

Transmission Repair	WP 0450 00
-------------------------------	------------

TRANSFER CASE

Transfer Case Repair.	WP 0451 00
-------------------------------	------------

FRONT AND REAR AXLE

Front Axle Assembly Overhaul	WP 0452 00
Forward-Rear and Rear-Rear Axle Assembly Overhaul	WP 0453 00
Differential Carrier Replacement.	WP 0454 00
Differential Carrier Repair	WP 0455 00

BRAKE SYSTEM

Parking and Service Brakedrum Repair	WP 0456 00
Parking and Service Brakeshoe Repair	WP 0457 00

STEERING GEAR

Steering Gear Repair.	WP 0458 00
-------------------------------	------------

CARGO BODIES

Cargo Bodies Repair	WP 0459 00
-------------------------------	------------

TABLE OF CONTENTS (Contd)
VOLUME 2 OF 2 (Contd)

	<u>WP Sequence No.</u>
CHAPTER 5 – SUSTAINMENT MAINTENANCE INSTRUCTIONS (Contd)	
TANK BODIES	
Tank Bodies Repair	WP 0460 00
Delivery Pump Repair	WP 0461 00
VAN BODY	
Van Body Maintenance	WP 0462 00
WINCH	
Front Winch Repair	WP 0463 00
POWER TAKEOFF	
Transmission Power Takeoff (PTO) Repair	WP 0464 00
CHAPTER 6 – SUPPORTING INFORMATION	
References	WP 0465 00
Maintenance Allocation Chart (MAC) Introduction	WP 0466 00
Maintenance Allocation Chart (MAC)	WP 0467 00
Expendable and Durable Items List	WP 0468 00
Tool Identification List	WP 0469 00
Mandatory Replacement Parts	WP 0470 00
Manufactured Items List	WP 0471 00
Torque Limits	WP 0472 00
Schematics and Wiring Diagrams	WP 0473 00
Index	INDEX-1

CHAPTER 3

FIELD MAINTENANCE INSTRUCTIONS (Contd)

2-1/2 TON, 6X6, M44A2 SERIES TRUCKS (MULTIFUEL)

	<u>WP Sequence No.</u>
STEERING SYSTEM	
Toe-In Check and Adjustment	WP 0190 00
Pitman Arm Replacement	WP 0191 00
Steering Gear Replacement	WP 0192 00
Steering Gear Adjustment	WP 0193 00
Tie Rod and Tie Rod End Replacement	WP 0194 00
Drag Link Replacement	WP 0195 00
Steering Wheel Replacement	WP 0196 00
FRAME	
Front Shackle (W/O Winch) Replacement	WP 0197 00
Front Shackle (W/ Winch) Replacement	WP 0198 00
Pintle Hook Maintenance	WP 0199 00
Rear Shackle Replacement	WP 0200 00
Rear Bumperette Replacement	WP 0201 00
Spare Tire Carrier Maintenance	WP 0202 00
Brush Guard, Stone Shield, and Headlight Guard Replacement	WP 0203 00
Front Bumper Replacement	WP 0204 00
Front Winch Extension Replacement	WP 0205 00
Frame Alignment Inspection	WP 0206 00
BODY, CAB, AND ACCESSORIES	
Cab Door Inspection Hole Cover Replacement	WP 0207 00
Cab Door Dovetail Wedge Replacement	WP 0208 00
Cab Door and Hinges Replacement	WP 0209 00
Cab Door Glass Assembly and Weatherseal Replacement	WP 0210 00
Door Glass Replacement	WP 0211 00
Door Glass Channel Replacement	WP 0212 00
Cab Door Window Regulator and Handle Replacement	WP 0213 00
Outside Door Handle, Inside Door Handle, and Cab Door Lock Replacement	WP 0214 00
Cab Door Check Rod Replacement	WP 0215 00
Cab Door Catch Replacement	WP 0216 00
Cab Door Weatherseals Replacement	WP 0217 00
Side Panel Replacement	WP 0218 00
Headlight Bracket Replacement	WP 0219 00
Hood Fasteners and Rubber Radiator Shield Replacement	WP 0220 00
Hood Maintenance	WP 0221 00
Hood Hinges Replacement	WP 0222 00
Cab Handle Replacement	WP 0223 00
Cab Cowl Vent Replacement	WP 0224 00
Glove Compartment Replacement	WP 0225 00
Toolbox (Under Cab) Replacement	WP 0226 00
Windshield Glass Replacement	WP 0227 00

CHAPTER 3

FIELD MAINTENANCE INSTRUCTIONS (Contd)

	<u>WP Sequence No.</u>
BODY, CAB, AND ACCESSORIES (Contd)	
Windshield Assembly Maintenance	WP 0228 00
Windshield Arm, Glass Assembly, and Handle Replacement	WP 0229 00
Cab Tunnel, Rear Tunnel, and Toeboard Replacement	WP 0230 00
Rear Cab Mount and Bracket Replacement	WP 0231 00
Water Can Bracket and Running Board Replacement	WP 0232 00
Cab Soft Top Turnbuttons and Lashing Hooks Replacement	WP 0233 00
Companion Seat Maintenance	WP 0234 00
Driver's Seat Base Maintenance	WP 0235 00
Driver's Seat Replacement	WP 0236 00
Driver's Seat Cushion, Backrest, Frame, and Seat Adjuster Replacement	WP 0237 00
Front Fenders Maintenance	WP 0238 00
ACCESSORIES	
Windshield Washer Reservoir, Tubing, Jet, and Pump Replacement	WP 0239 00
Windshield Wiper Switch, Motor, and Conlink Covers Replacement	WP 0240 00
Left and Right Conlinks Maintenance	WP 0241 00
Windshield Wiper Idler Shaft and Housing Replacement	WP 0242 00
Windshield Wiper Blade and Arm Replacement	WP 0243 00
Mirror and Brackets Replacement	WP 0244 00
Data Plate Replacement	WP 0245 00
Personnel Heater Supply Hose Replacement	WP 0246 00
Personnel Heater Diverter Replacement	WP 0247 00
Personnel Heater Air Vent Replacement	WP 0248 00
Personnel Heater Control Cables Maintenance	WP 0249 00
Personnel Hot Water Heater Replacement	WP 0250 00
Personnel Heater Defroster Hoses Replacement	WP 0251 00
Reflector Replacement	WP 0252 00
CARGO BODIES	
Cargo Body Rack and Troop Seat Maintenance	WP 0253 00
Cargo Body Tailgate Replacement	WP 0254 00
Cargo Body Tailgate Replacement (M35A2C)	WP 0255 00
Cargo Body Upper and Lower Rear Splash Guard Replacement	WP 0256 00
Front Splash Guard Replacement	WP 0257 00
Cargo Body Front Rack Maintenance (M35A2C)	WP 0258 00
Cargo Body Dropside Replacement (M35A2C)	WP 0259 00
Cargo Body Front Rack Maintenance (M35A2 and M36A2)	WP 0260 00
Cargo Bodies Tailgate Maintenance	WP 0261 00
Cargo Bodies Maintenance	WP 0262 00
TANK BODIES	
Discharge Valve Replacement (M49A2C)	WP 0263 00
Discharge Valve Control Levers Maintenance (M49A2C)	WP 0264 00
Discharge Valve Repair	WP 0265 00
Front and Rear Fuel Tank Discharge Tubes Replacement (M49A2C)	WP 0266 00
Automatic Dump Valve and Sump Assembly Maintenance (M49A2C)	WP 0267 00
Fuel Tank Manhole Cover Maintenance (M49A2C)	WP 0268 00

CHAPTER 3

FIELD MAINTENANCE INSTRUCTIONS (Contd)

	<u>WP Sequence No.</u>
TANK BODIES (Contd)	
Fuel Hose and Nozzle Replacement (M49A2C)	WP 0269 00
Water Tank Nozzle Holder Replacement	WP 0270 00
Overturn Tubes Replacement (M49A2C)	WP 0271 00
Globe Valve Replacement (M49A2C)	WP 0272 00
Filter Separator-to-Sump Pipe Replacement (M49A2C)	WP 0273 00
Cable Retractor Replacement (M49A2C)	WP 0274 00
Meter-to-Filter Tube Replacement (M49A2C)	WP 0275 00
Gallon Meter Replacement (M49A2C)	WP 0276 00
Delivery Pump Outlet Tube Replacement (M49A2C)	WP 0277 00
Delivery Pump Inlet Tube Replacement (M49A2C)	WP 0278 00
Water Pump Manifold Replacement (M50A3)	WP 0279 00
Delivery Pump Replacement	WP 0280 00
Delivery Pump Drain Valve Replacement	WP 0281 00
Meter Outlet Tube Replacement (M49A2C)	WP 0282 00
Gate Valve Replacement	WP 0283 00
Delivery Pump Strainer Replacement	WP 0284 00
Separator Element Test Valve, Gauge, and Lines Maintenance (M49A2C)	WP 0285 00
Filter Separator Maintenance (M49A2C)	WP 0286 00
Water Tank Filler Cover Replacement (M50A3)	WP 0287 00
Rear Compartment Door Maintenance	WP 0288 00
Water Tank Discharge Tube, Cover, and Valve Replacement (M50A3)	WP 0289 00
Water Tank Discharge Valve Control Levers Maintenance (M50A3)	WP 0290 00
Water Tank Manhole Cover Replacement (M50A3)	WP 0291 00
Delivery Pump Front Propeller Shaft Maintenance	WP 0292 00
Delivery Pump Rear Propeller Shaft Maintenance	WP 0293 00
Speed Control Cable Maintenance	WP 0294 00
Tank Bodies Front Splash Guard Replacement	WP 0295 00
Tank Bodies Upper and Lower Rear Splash Guard Replacement	WP 0296 00
Tank Bodies Frame Sill Maintenance	WP 0297 00
Fuel and Water Tank Bodies Maintenance	WP 0298 00
VAN BODY	
Rear Splash Guard Replacement	WP 0299 00
Safety Switch Fuse Replacement	WP 0300 00
Exhaust Blower Motor and Bracket Replacement	WP 0301 00
Dome Lamp and Housing Replacement	WP 0302 00
Van Door Replacement	WP 0303 00
Van Door Seals Replacement	WP 0304 00
Van Door Maintenance	WP 0305 00
Van Body Cabinet and Work Bench Table Replacement	WP 0306 00
Van Body Ceiling Panel Replacement	WP 0307 00
Van Body Side Panel Replacement	WP 0308 00
115-Volt AC Receptacle Replacement	WP 0309 00
24-Volt DC Receptacle Replacement (M185A3)	WP 0310 00
115-Volt Receptacle Replacement	WP 0311 00
115-Volt Receptacle Strip Replacement	WP 0312 00

CHAPTER 3

FIELD MAINTENANCE INSTRUCTIONS (Contd)

	<u>WP Sequence No.</u>
VAN BODY (Contd)	
115-Volt Wiring Harness Replacement	WP 0313 00
Wire Plug Wiring Harness Replacement (M109A3)	WP 0314 00
115- and 24-Volt Wiring Harness Replacement.	WP 0315 00
Blackout Master Switch Replacement (M109A3)	WP 0316 00
Multibreaker Box Replacement	WP 0317 00
Safety Switch Box Replacement.	WP 0318 00
Circuit Breaker Harness Replacement	WP 0319 00
Front Window Sash Maintenance	WP 0320 00
Side Window Sash Maintenance	WP 0321 00
Van Body Access Door Replacement.	WP 0322 00
Van Body Access Plate, Access Cover, and Retainer Assembly Replacement	WP 0323 00
24-Volt Circuit Breaker Replacement	WP 0324 00
Vehicle Boarding Ladder Replacement	WP 0325 00
Converter Selector Switch Replacement	WP 0326 00
Exhaust Blower Switch Replacement	WP 0327 00
Converter Replacement.	WP 0328 00
Van Bodies Front Splash Guard Replacement	WP 0329 00
Van Body Tool Replacement (M185A3)	WP 0330 00
Converter Receptacle Replacement	WP 0331 00
Floodlight Bracket Replacement	WP 0332 00
Access Door Molding and Access Plate Replacement	WP 0333 00
Power Switch Maintenance.	WP 0334 00
Door Holder Assembly and Bracket Replacement.	WP 0335 00
Door Check Replacement	WP 0336 00
Exhaust Blower Duct Assembly Replacement.	WP 0337 00
Blower Motor Receptacle Replacement	WP 0338 00
Blackout Switch Replacement	WP 0339 00
Fuel Line Adapter Replacement.	WP 0340 00
Side Rail Maintenance	WP 0341 00
WINCH AND POWER TAKEOFF	
Front Winch Drag Brake Test and Adjustment.	WP 0342 00
Front Winch Cable Replacement	WP 0343 00
Automatic Brake Test and Adjustment	WP 0344 00
Front Winch Replacement.	WP 0345 00
Front Winch Propeller Shaft Replacement	WP 0346 00
Transmission Power Takeoff (PTO) Shift Linkage Maintenance.	WP 0347 00
Transfer Case Power Takeoff (PTO) Maintenance	WP 0348 00
Transmission Power Takeoff (PTO), Cover, and Gasket Maintenance	WP 0349 00

FIELD MAINTENANCE INSTRUCTIONS

2-1/2 TON, 6X6, M44A2 SERIES TRUCKS (MULTIFUEL)

TOE-IN CHECK AND ADJUSTMENT

TOE-IN CHECK AND TOE-IN ADJUSTMENT

INITIAL SETUP:

Applicable Models

All

Equipment Condition

Parking brake set (TM 9-2320-361-10).

Tires inflated to proper pressure and uniform wear (TM 9-2320-361-10).

Equipment Condition (Contd)

Wheel bearings adjusted properly (WP 0189 00).

Steering gear adjusted properly (WP 0193 00).

TOE-IN CHECK AND ADJUSTMENT (Contd)

TOE-IN CHECK

NOTE

- Ensure vehicle is on a level surface when performing this procedure.
- Ensure all steering system components are tight. If any steering component is damaged, replace. If loose, tighten.
- Steps 1 through 3 will determine centerline of tire.
- “Point of Measurement” for checking toe-in will be where lines marked in steps 1 and 3 intersect.

1. Mark line (1) on center tread (2) of tire (3) 18.3 in. (46.5 cm) from ground.
2. Measure total width of tire tread (4) and record.
3. Mark line (5) on center tread (2) at one-half total tread width (4).
4. Repeat steps 1 through 3 for opposite tire.
5. Measure distance between “Points of Measurement” on front side of tires (3) and record.
6. Rotate tires (3) by moving vehicle forward until “Points of Measurement” are 18.3 in. (46.5 cm) above the ground at rear side of tires (3).
7. Measure distance between “Points of Measurement” on rear side of tires (3) and record.

NOTE

- If measurement is larger on front side of tires than measurement on rear side of tires, tires have toe-out.
- If toe-in alignment does not meet specifications, repeat checking procedures to eliminate any possible reading errors.

8. Subtract measurement from front side of tires (3) step 5, from measurement from rear side of tires (3) step 7. The result of this subtraction represents inches of toe-in. Proper toe-in is 0.13 in. \pm 0.06 in. (3.2 mm \pm 1.6 mm).

TOE-IN ADJUSTMENT

1. Loosen two nuts (7) at each end of tie rod (6).
2. Turn tie rod (6) in 1/2 turn increments and measure toe-in until toe-in of 0.13 in. \pm 0.06 in. (3.2 mm \pm 1.6 mm) is obtained.
3. When correct toe-in is obtained, tighten two nuts (7) 60 lb-ft (81 N•m).
4. Release parking brake (TM 9-2320-361-10).

TOE-IN CHECK AND ADJUSTMENT (Contd)

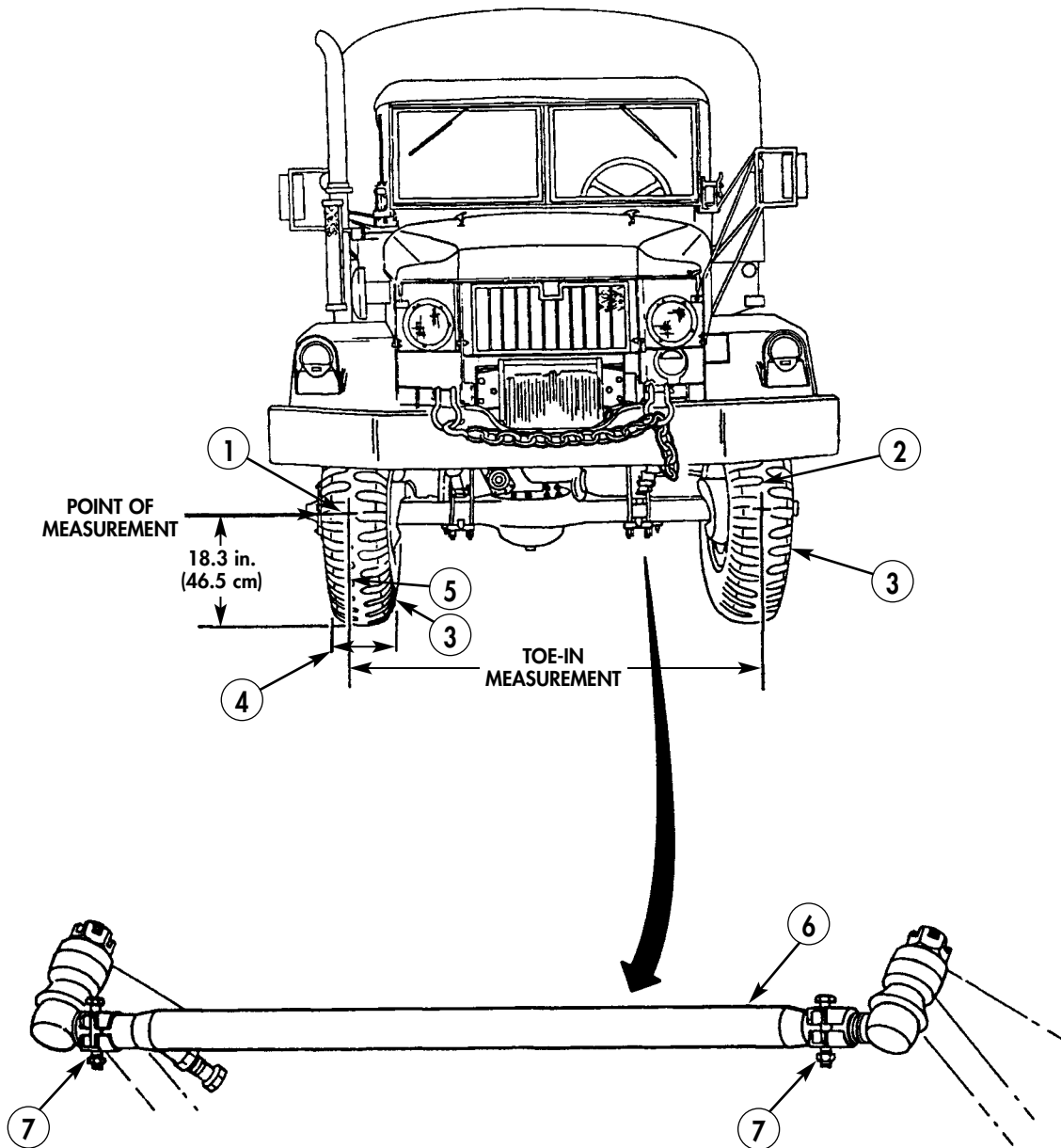

END OF WORK PACKAGE

FIELD MAINTENANCE INSTRUCTIONS

2-1/2 TON, 6X6, M44A2 SERIES TRUCKS (MULTIFUEL)

PITMAN ARM REPLACEMENT

REMOVAL AND INSTALLATION

INITIAL SETUP:

Applicable Models

All

Materials/Parts

Cotter pin (item 22, WP 0470 00)

Lockwasher (item 228, WP 0470 00)

References

WP 0020 00

Equipment Condition

Parking brake set and wheels chocked
(TM 9-2320-361-10).

Battery ground cable disconnected
(WP 0126 00).

PITMAN ARM REPLACEMENT (Contd)

REMOVAL

1. Remove cotter pin (6) from drag link (5). Discard cotter pin (6).
2. Unscrew adjusting plug (10) until it is almost out of drag link (5) end.
3. Turn steering wheel one-half turn right.

NOTE

Be careful not to let inner parts fall out of drag link when drag link is removed.

4. Remove drag link (5) from pitman arm (3).
5. Remove nut (1) and lockwasher (2) from shaft (4). Discard lockwasher (2).
6. Remove pitman arm (3) from shaft (4).

INSTALLATION

1. Align marks on pitman arm (3) and splined shaft (4) and slide pitman arm (3) on shaft (4) until screw end of shaft (4) comes through.
2. Install new lockwasher (2) and nut (1). Tighten nut (1) 180–200 lb-ft (244–271 N•m).
3. Remove adjusting plug (10), safety plug (9), spring (8), and ball seat (7) from drag link (5).
4. Install ball of pitman arm (3) in slot of drag link (5). Install ball seat (7), spring (8), and safety plug (9), and start to screw in adjusting plug (10).
5. Lubricate drag link (5) (WP 0020 00).
6. Screw in adjusting plug (10) until seated, then back plug (10) off enough to install new cotter pin (6).
7. Connect battery ground cable (WP 0126 00).
8. Release parking brake and remove wheel chocks (TM 9-2320-361-10).

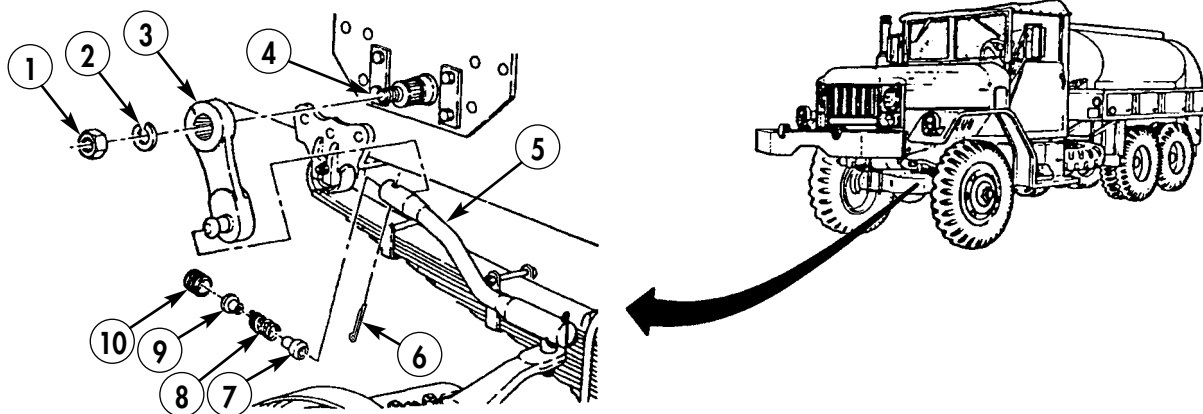

END OF WORK PACKAGE

FIELD MAINTENANCE INSTRUCTIONS

2-1/2 TON, 6X6, M44A2 SERIES TRUCKS (MULTIFUEL)

STEERING GEAR REPLACEMENT

REMOVAL AND INSTALLATION

INITIAL SETUP:

Applicable Models

All

References

WP 0193 00

Tools and Special Tools

General mechanic's tool kit
(item 116, WP 0469 00)
Torque wrench, 1/2-in. drive
(item 136, WP 0469 00)

Equipment Condition

Parking brake set and wheels chocked
(TM 9-2320-361-10).
Hood raised and secured (TM 9-2320-361-10).
Battery ground cable disconnected
(WP 0126 00).
Steering wheel removed (WP 0196 00).
Horn cable removed (WP 0113 00).
Turn signal control removed (WP 0102 00).
Airbrake hand control valve removed
(if installed) (WP 0178 00).
Front winch propeller shaft removed
(if installed) (WP 0346 00).
Fuel injection pump removed (WP 0069 00).
Pitman arm removed (WP 0191 00).
Steering gear drained (WP 0020 00).

Materials/Parts

Four locknuts (item 145, WP 0470 00)
Four lockscrews (item 185, WP 0470 00)
Screw-assembled lockwasher
(item 249, WP 0470 00)
Tiedown strap (item 40, WP 0468 00)

WARNING

Steering gear is heavy. Support steering gear during removal and installation. Failure to do so may result in injury to personnel or damage to equipment.

STEERING GEAR REPLACEMENT (Contd)

REMOVAL

1. Remove four screws (13) and washers (14) from pad (15).
2. Remove pad (15) from firewall (17) and steering column (3).
3. Turn four studs (7) 1/4 turn counterclockwise and pull instrument cluster (8) away from instrument panel (16).
4. Remove two locknuts (18), washers (19), screws (12), and bracket (11) from collar (2). Discard locknuts (18).
5. Remove two locknuts (20), washers (21), and screws (1) from collar (2). Discard locknuts (20).
6. Remove screw-assembled lockwasher (10) from bracket (9). Discard screw-assembled lockwasher (10).
7. Remove bushing (6) from steering column (3).
8. Remove spring (4) and retainer (5) from steering column (3).

CAUTION

Do not bind or bend steering column. Permanent damage to column may result.

9. Remove tiedown strap (23) and engine stop control cable (22) from steering column (3). Discard tiedown strap (23).
10. Remove air line (24) from air compressor (30).
11. Remove four lockscrews (26) and two spacers (27) from frame support (29) and steering gear (25). Discard lockscrews (26).
12. Remove pitman shaft end (28) from hole in frame support (29).
13. Remove steering gear (25) and steering column (3) from firewall (17).

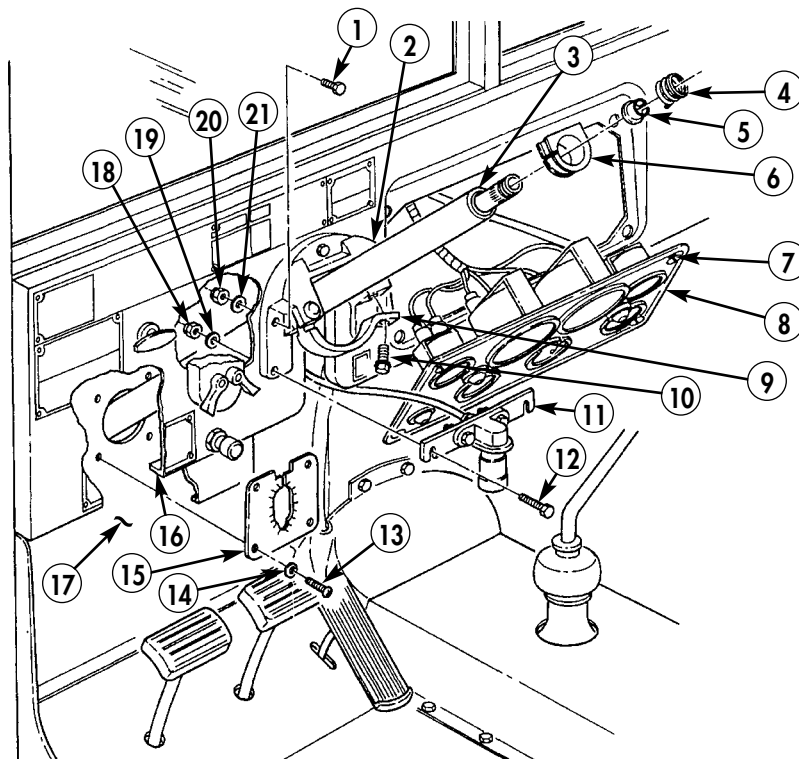

STEERING GEAR REPLACEMENT (Contd)

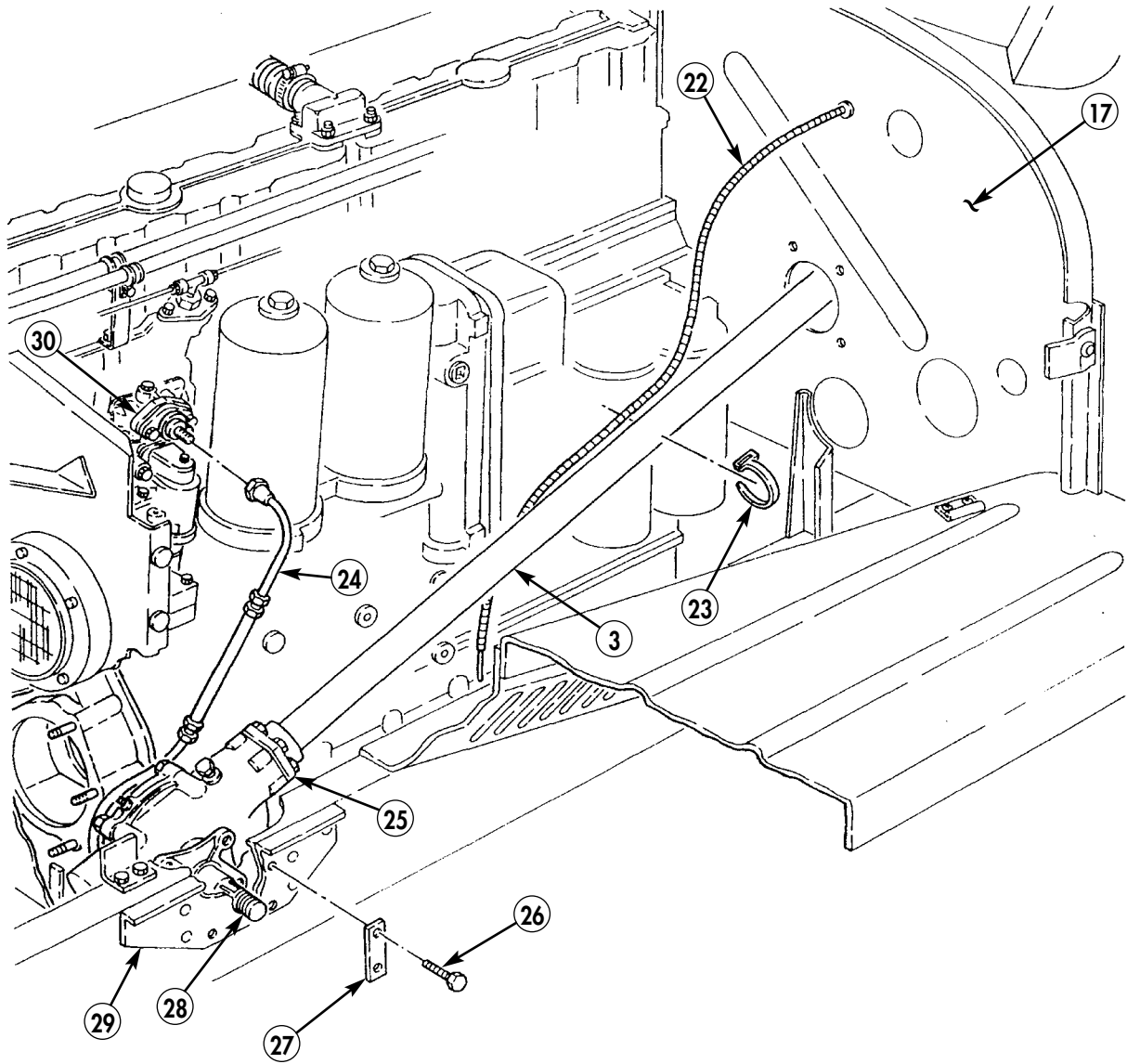

STEERING GEAR REPLACEMENT (Contd)

INSTALLATION

CAUTION

Do not bind or bend steering column. Permanent damage to column may result.

1. Install steering column (5) through firewall (3).
2. Insert pitman shaft end (10) through frame support (11).
3. Install steering gear (7) on frame support (11) with two spacers (9) and four new lockscrews (8). Tighten four lockscrews (8) 62–68 lb-ft (84–92 N•m).
4. Install air line (6) on air compressor (1).
5. Install new tiedown strap (4) around engine stop control cable (2) and steering column (5).
6. Install bushing (20) over steering column (5) into collar (17) and fasten bracket (23) with new screw assembled lockwasher (24).
7. Install two screws (16) through collar (17) and instrument panel (30) with two washers (15) and new locknuts (14).
8. Install bracket (25) on collar (17) with two screws (26), washers (13), and new locknuts (12).
9. Install pad (29) on steering column (5) and firewall (3) with four washers (28) and screws (27).
10. Position instrument cluster (22) on instrument panel (30) and lock in place by turning four studs (21) 1/4 turn clockwise.
11. Install retainer (19) and spring (18) on steering column (5).
12. Fill steering gear to proper oil level (WP 0020 00).
13. Install pitman arm (WP 0191 00).
14. Install left front engine mount bracket (WP 0026 00).
15. Install fuel injection pump (WP 0069 00).
16. Install front winch propeller shaft, if removed (WP 0346 00).
17. Install personnel heater (WP 0366 00).
18. Install airbrake hand control, if removed (WP 0178 00).
19. Install turn signal control (WP 0102 00).
20. Install horn cable (WP 0113 00).
21. Install steering wheel (WP 0196 00).
22. Adjust steering gear (WP 0193 00).
23. Connect battery ground cable (WP 0126 00).
24. Lower and secure hood (TM 9-2320-361-10).
25. Release parking brake and remove wheel chocks (TM 9-2320-361-10).

STEERING GEAR REPLACEMENT (Contd)

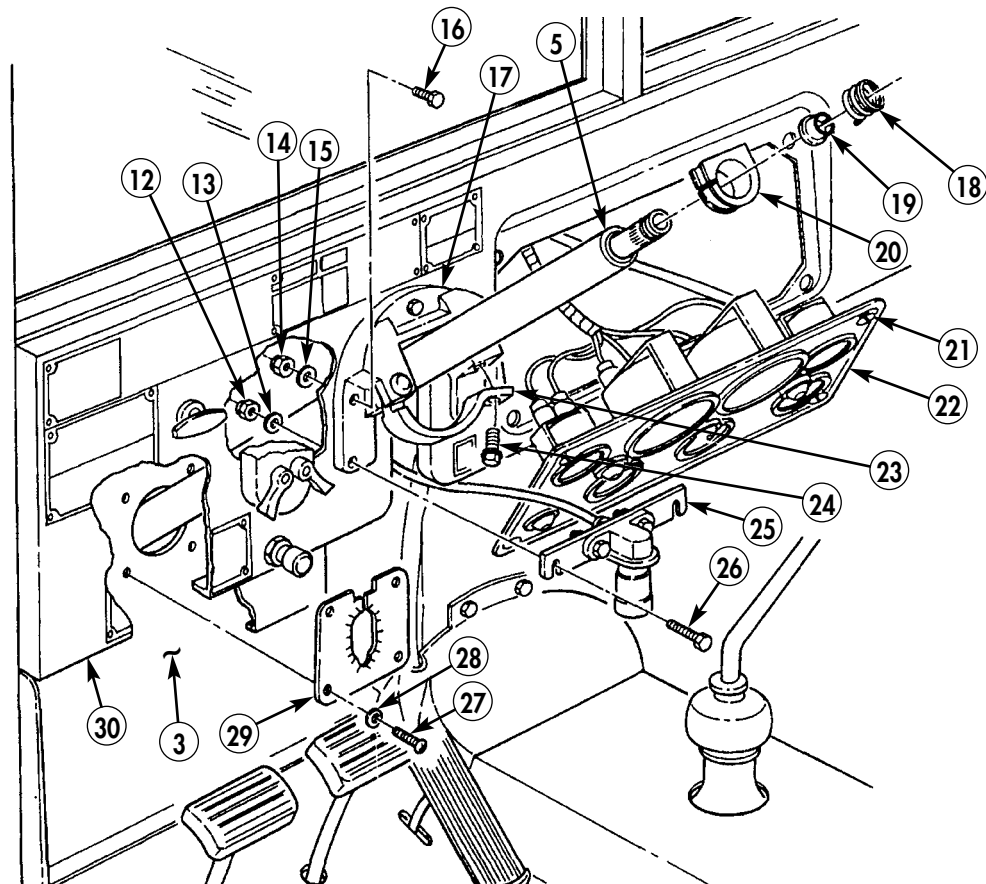
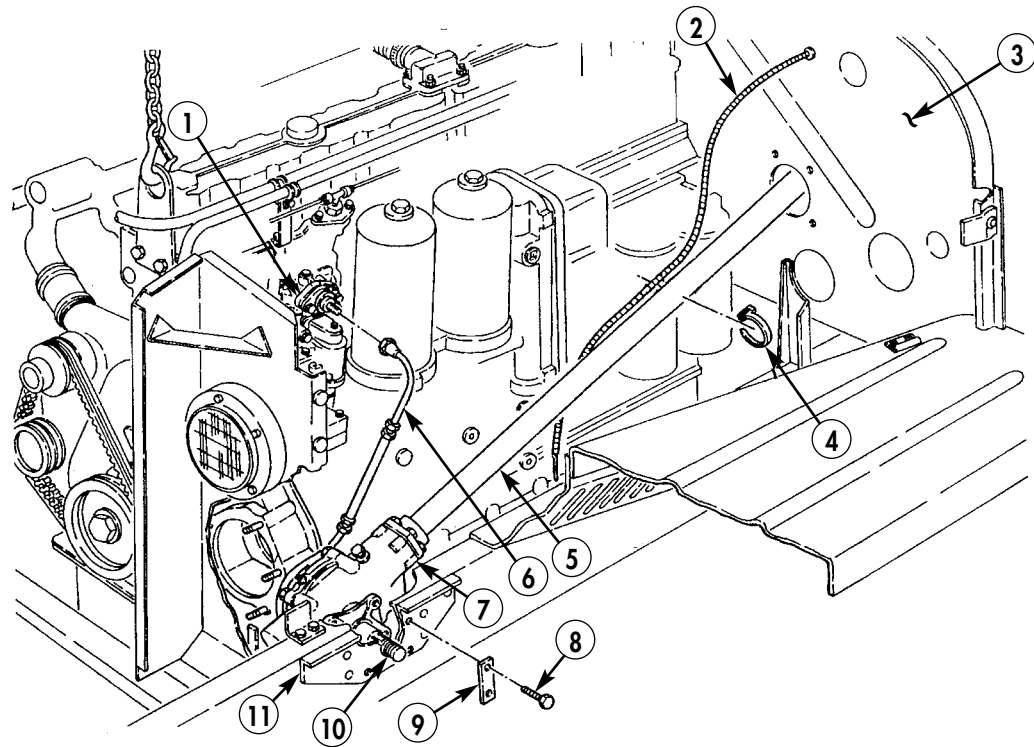

END OF WORK PACKAGE

FIELD MAINTENANCE INSTRUCTIONS

2-1/2 TON, 6X6, M44A2 SERIES TRUCKS (MULTIFUEL)

STEERING GEAR ADJUSTMENT

INITIAL SETUP:

Applicable Models

All

Personnel Required

Two

Equipment Condition

Parking brake set and wheels chocked
(TM 9-2320-361-10).

Hood raised and secured (TM 9-2320-361-10).

Battery ground cable disconnected
(WP 0126 00).

Drag link removed from pitman arm
(WP 0195 00).

Horn button removed (WP 0113 00).

STEERING GEAR ADJUSTMENT (Contd)**NOTE**

Ensure all steering system components are tight. If any steering component is damaged, replace. If loose, tighten.

1. Hold screw (4) still, loosen nut (5), then loosen screw (4).
2. Turn steering wheel (2) completely to right, then completely to left, counting number of turns each way.
3. Turn steering wheel (2) right, half the number of turns counted.
4. Tighten screw (4) until it is slightly snug, and tighten nut (5).
5. Turn steering wheel (2) one turn each way around mid-position.

NOTE

Assistant will help with step 6.

6. With steering wheel (2) at mid-position, hold screw (4) still and loosen nut (5). Tighten screw (4) until torque at nut (3) on steering column (1) reads 9–35 lb-in (1.0–4.0 N•m).
7. Hold screw (4) still and tighten nut (5).
8. Install drag link on pitman arm (WP 0195 00).
9. Install horn button (WP 0113 00).
10. Connect battery ground cable (WP 0126 00).
11. Lower and secure hood (TM 9-2320-361-10).
12. Release parking brake and remove wheel chocks (TM 9-2320-361-10).

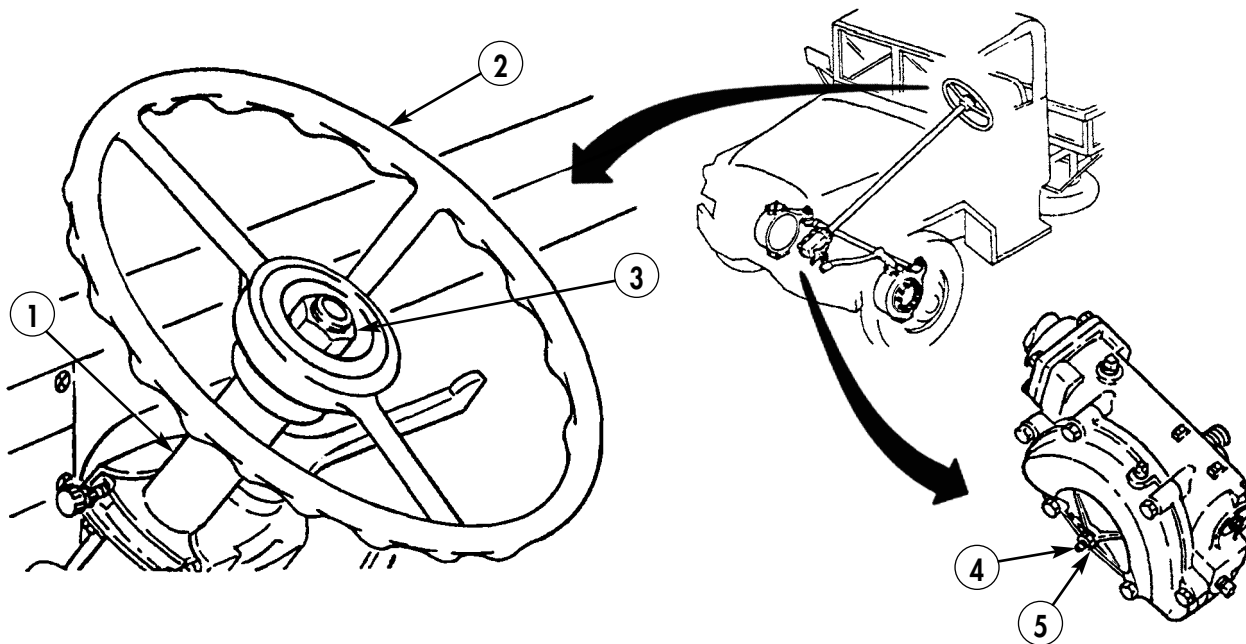

END OF WORK PACKAGE

FIELD MAINTENANCE INSTRUCTIONS

2-1/2 TON, 6X6, M44A2 SERIES TRUCKS (MULTIFUEL)

TIE ROD AND TIE ROD END REPLACEMENT

REMOVAL AND INSTALLATION

INITIAL SETUP:

Applicable Models

All

Reference

WP 0190 00

Materials/Parts

Cotter pin (item 21, WP 0470 00)

Equipment Condition

Parking brake set and wheels chocked
(TM 9-2320-361-10).

Personnel Required

Two

Battery ground cable disconnected
(WP 0126 00).

TIE ROD AND TIE ROD END REPLACEMENT (Contd)

WARNING

Tie rods are heavy. An assistant is required during removal and installation to prevent injury to personnel.

REMOVAL

NOTE

Left tie rod end has left-hand threads. Right tie rod end has right-hand threads. Left and right tie rod ends are removed the same way. This procedure covers the left end only.

1. Lift front axle enough to take weight off front wheels (TM 9-2320-361-10).
2. Loosen nut (5) on clamp (4).
3. Remove cotter pin (3) and nut (1) from tie rod end (6). Discard cotter pin (3).
4. Remove tie rod end (6) from steering knuckle (7).

NOTE

Count how many turns it takes to unscrew tie rod end.

5. Remove tie rod end (6) from tie rod (2).
6. Remove boot (8) from tie rod end (6).

INSTALLATION

CAUTION

Be careful when screwing in tie rod end, or damage to dust cover may result.

1. Screw tie rod end (6) into tie rod (2), using same number of turns as in removal.
2. Install boot (8) on tie rod end (6).
3. Install tie rod end (6) in steering knuckle (7) with nut (1) and new cotter pin (3). Tighten nut (1) 165–180 lb-ft (224–244 N•m), and bend back ends of cotter pin (3).
4. Tighten nut (5) on clamp (4) 170 lb-ft (231 N•m).
5. Lower front axle (TM 9-2320-361-10).
6. Adjust toe-in (WP 0190 00).
7. Connect battery ground cable (WP 0126 00).
8. Release parking brake and remove wheel chocks (TM 9-2320-361-10).

TIE ROD AND TIE ROD END REPLACEMENT (Contd)

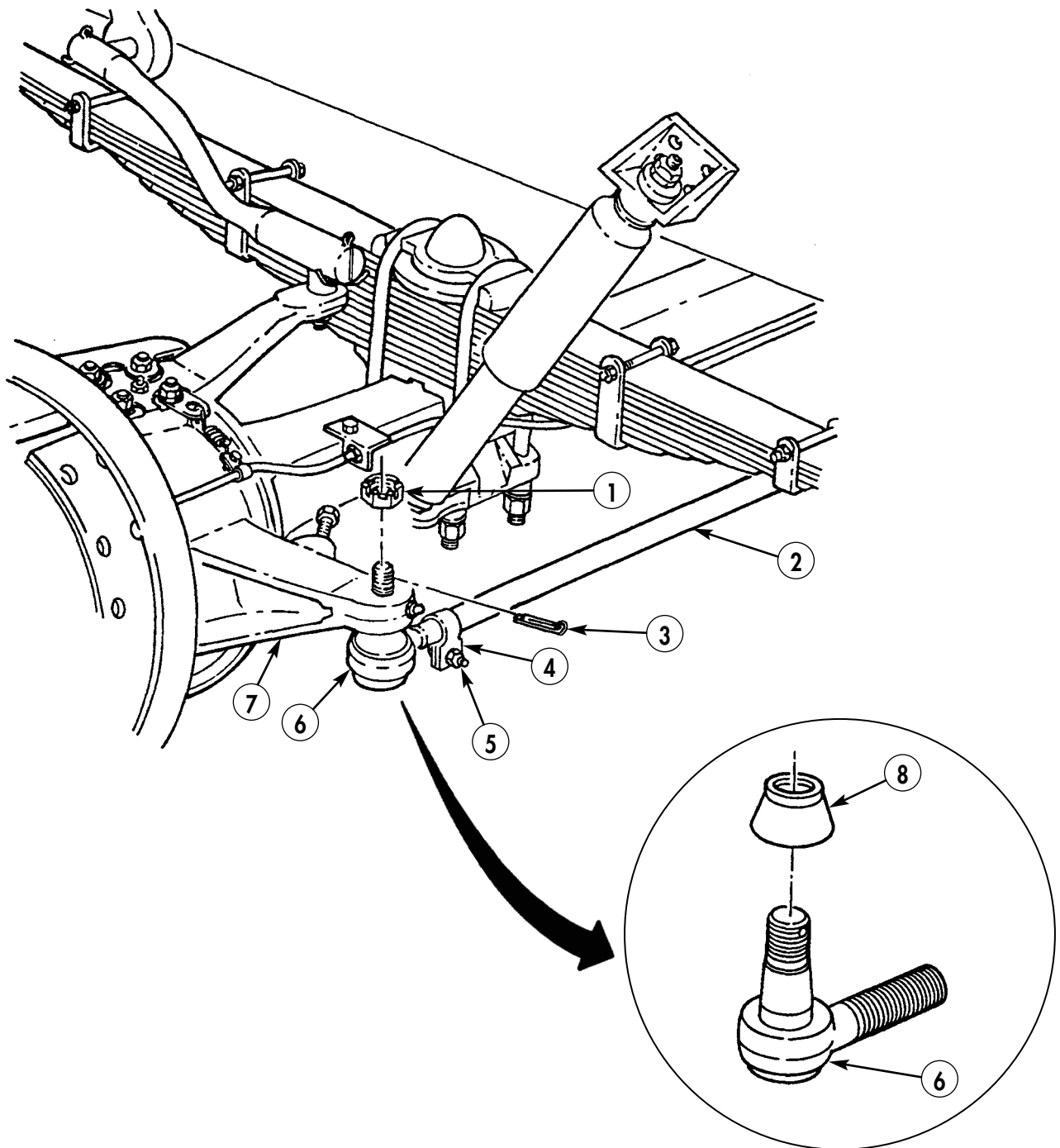

END OF WORK PACKAGE

FIELD MAINTENANCE INSTRUCTIONS

2-1/2 TON, 6X6, M44A2 SERIES TRUCKS (MULTIFUEL)

DRAG LINK REPLACEMENT

REMOVAL AND INSTALLATION

INITIAL SETUP:

Applicable Models

All

References

WP 0020 00

Materials/Parts

Two cotter pins (item 22, WP 0470 00)

Equipment Condition

Parking brake set and wheels chocked
(TM 9-2320-361-10).

Battery ground cable disconnected
(WP 0126 00).

DRAG LINK REPLACEMENT (Contd)

REMOVAL

1. Remove two cotter pins (6) and adjusting plugs (1) and (12) from drag link (7). Discard cotter pins (6).
2. Turn steering wheel as needed, and remove safety plug (2).
3. Remove drag link (7) from pitman arm (17), then lower end of drag link (7). Remove spring (3) and ball seats (4) and (5).
4. Remove ball seat (11) and lift drag link (7) from steering arm (13). Lower end of drag link (7) and remove ball seat (10), spring (9), and safety plug (8).
5. Remove two grease fittings (15) from drag link (7).

INSTALLATION

CAUTION

Ensure drag link components are properly installed, or damage to equipment may result.

NOTE

The steering arm end of drag link is the side with the opening closest to end.

1. Install two grease fittings (15) on drag link (7).
2. Install safety plug (8), spring (9), and ball seat (10) in steering arm end of drag link (7).
3. Install drag link (7) on steering arm (13). Ensure ball seat (10) is caught on steering arm ball (14).
4. Install ball seat (11) and adjusting plug (12) in drag link (7).
5. Install ball seat (5) in pitman arm end of drag link (7).
6. Install drag link (7) on pitman arm (17). Ensure ball seat (5) is caught on pitman arm ball (16).
7. Install ball seat (4), spring (3), safety plug (2), and adjusting plug (1) in drag link (7).
8. Lubricate drag link (7) (WP 0020 00).
9. Tighten adjusting plugs (1) and (12) until seated, then back off plugs (1) and (12) until cotter pins (6) can be installed.
10. Install two new cotter pins (6) through drag link (7) and plugs (1) and (12). Secure cotter pins (6) by bending ends.
11. Connect battery ground cable (WP 0126 00).
12. Release parking brake and remove wheel chocks (TM 9-2320-361-10).

DRAG LINK REPLACEMENT (Contd)

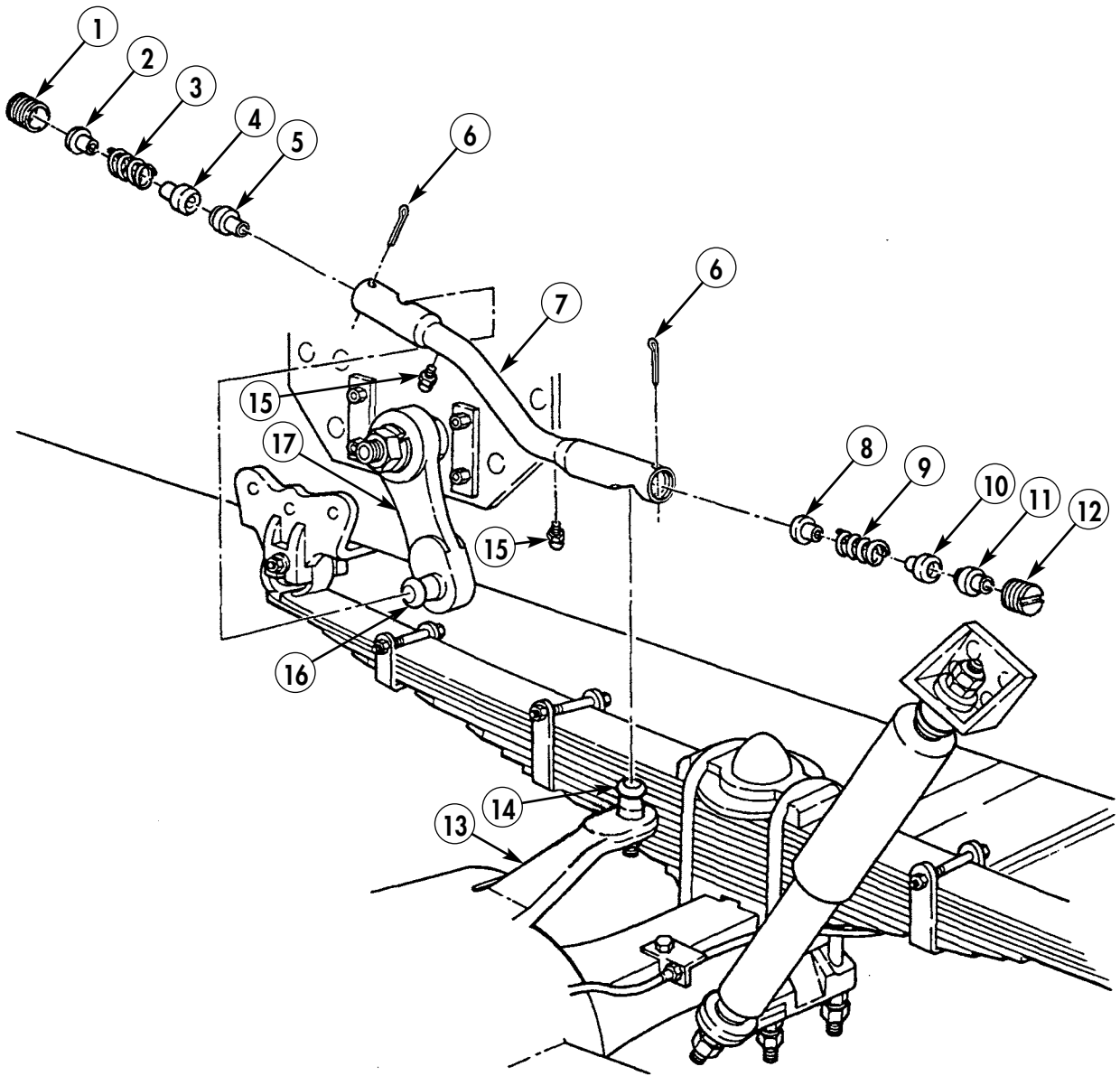

END OF WORK PACKAGE

FIELD MAINTENANCE INSTRUCTIONS

2-1/2 TON, 6X6, M44A2 SERIES TRUCKS (MULTIFUEL)

STEERING WHEEL REPLACEMENT

REMOVAL AND INSTALLATION

INITIAL SETUP:

Applicable Models

All

Tools and Special Tools

Steering puller (item 58, WP 0469 00)

Equipment Condition

Parking brake set and wheels chocked
(TM 9-2320-361-10).

Battery ground cable disconnected
(WP 0126 00).

Horn button removed (WP 0113 00).

Wheels in straight-ahead position.

STEERING WHEEL REPLACEMENT (Contd)

REMOVAL

1. Loosen screw (6) and slide turn control (7) down steering column (8).

NOTE

Perform step 2 only if truck has airbrake hand control lever.

2. Loosen two screws (5) and slide airbrake hand control lever (4) down steering column (8).
3. Unscrew nut (2) until it is level with top of shaft (3).
4. Turn steering wheel (1) to straight-ahead position. Install adapter (10) on steering wheel nut (2), and adapter (11) on steering column (8).
5. Position steering puller on adapters (10) and (11), and screw in steering puller screw (9) until steering wheel (1) pops loose.
6. Remove steering puller, adapters (10) and (11), nut (2), and steering wheel (1).

INSTALLATION

1. Place steering wheel (1) on shaft (3) in 10 o'clock, 2 o'clock, and 6 o'clock positions, and tap evenly on wheel (1) until nut (2) can be installed.
2. Install nut (2) and tighten.

NOTE

Perform step 3 only if truck has airbrake hand control lever.

3. Slide airbrake hand control valve (4) up steering column (8) and tighten two screws (5).
4. Slide turn signal control (7) up steering column (8) and tighten screw (6).
5. Install horn button (WP 0113 00).
6. Connect battery ground cable (WP 0126 00).
7. Release parking brake and remove wheel chocks (TM 9-2320-361-10).

STEERING WHEEL REPLACEMENT (Contd)

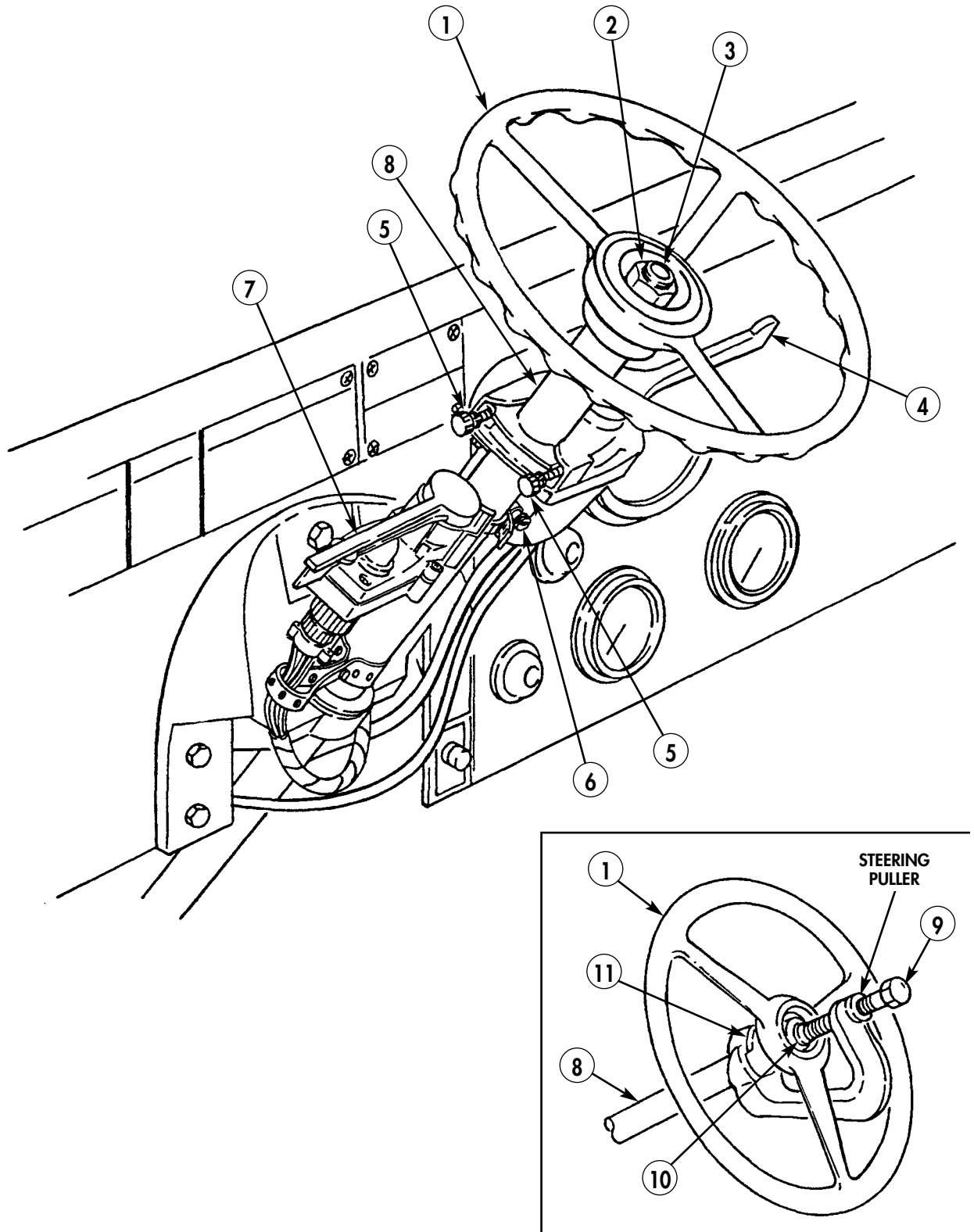

END OF WORK PACKAGE

FIELD MAINTENANCE INSTRUCTIONS

2-1/2 TON, 6X6, M44A2 SERIES TRUCKS (MULTIFUEL)

FRONT SHACKLE (W/O WINCH) REPLACEMENT

REMOVAL AND INSTALLATION

INITIAL SETUP:

Applicable Models

All

Materials/Parts

Two locknuts (item 136, WP 0470 00)

Two locknuts (item 147, WP 0470 00)

Equipment Condition

Parking brake set and wheels chocked
(TM 9-2320-361-10).

Battery ground cable disconnected
(WP 0126 00).

Brush guard removed (WP 0203 00).

FRONT SHACKLE (W/O WINCH) REPLACEMENT (Contd)

REMOVAL

1. Remove retaining pin (6) from pin (4).
2. Remove pin (4) and shackle (5) from bracket (12).
3. Remove locknuts (9) and screws (1) and (2). Discard locknuts (9).
4. Remove locknuts (7) and screws (3), bracket (12), and brush guard bracket (11) from bumper (8) and frame rail (10). Discard locknuts (7).

INSTALLATION

1. Install brush guard bracket (11) and bracket (12) on frame rail (10) with screws (1) and (2) and two new locknuts (9).
2. Install bracket (12) on bumper (8) with two screws (3) and new locknuts (7).
3. Install shackle (5) and pin (4) on bracket (12).
4. Install retaining pin (6) on pin (4). Latch retaining pin (6).
5. Install brush guard (WP 0203 00).
6. Connect battery ground cable (WP 0126 00).
7. Release parking brake and remove wheel chocks (TM 9-2320-361-10).

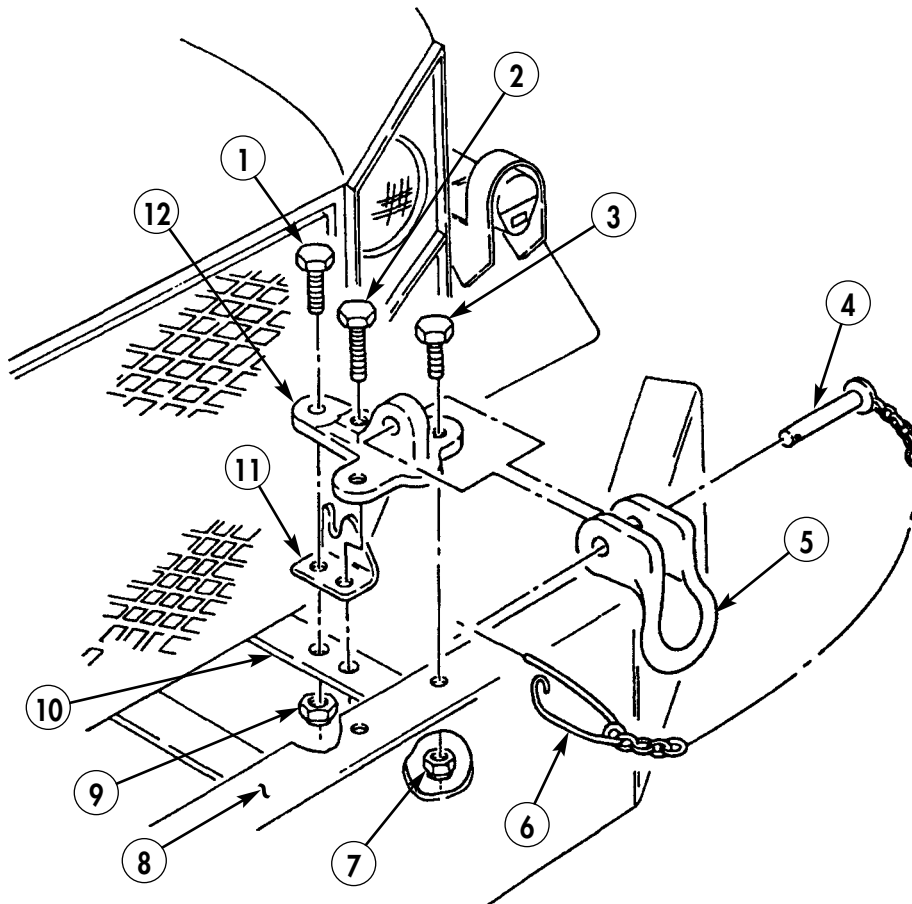

END OF WORK PACKAGE

FIELD MAINTENANCE INSTRUCTIONS

2-1/2 TON, 6X6, M44A2 SERIES TRUCKS (MULTIFUEL)

FRONT SHACKLE (W/WINCH) REPLACEMENT

REMOVAL AND INSTALLATION

INITIAL SETUP:

Applicable Models

All

Materials/Parts

Two locknuts (item 136, WP 0470 00)

Two locknuts (item 147, WP 0470 00)

Equipment Condition

Parking brake set and wheels chocked
(TM 9-2320-361-10).

Battery ground cable disconnected
(WP 0126 00).

NOTE

Left shackle has two spacers and right shackle has only one.
This procedure covers the left shackle and bracket.

REMOVAL

1. Remove retaining pin (6) from pin (5).
2. Remove pin (5), and shackle (4) from bracket (3).
3. Remove three locknuts (7), screws (2), and two spacers (9) from bracket (3) and bumper (8). Discard locknuts (7).
4. Remove locknut (10), screw (1), and bracket (3) from bumper (8). Discard locknut (10).

INSTALLATION

1. Install bracket (3) on bumper (8) with screw (1) and new locknut (10).
2. Install two spacers (9), three screws (2), and new locknuts (7) on bracket (3) and bumper (8).
3. Install shackle (4) on bracket (3) with pin (5).
4. Install retaining pin (6) on pin (5). Latch retaining pin (6).
5. Connect battery ground cable (WP 0126 00).
6. Release parking brake and remove wheel chocks (TM 9-2320-361-10).

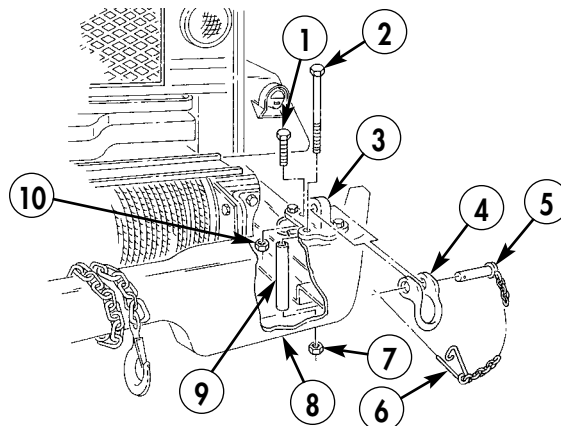

END OF WORK PACKAGE

0198 00-1/2 blank

FIELD MAINTENANCE INSTRUCTIONS

2-1/2 TON, 6X6, M44A2 SERIES TRUCKS (MULTIFUEL)

PINTLE HOOK MAINTENANCE

PINTLE HOOK REMOVAL, PINTLE HOOK LATCH REMOVAL,
CLEANING AND INSPECTION, PINTLE HOOK LATCH INSTALLATION, PINTLE HOOK INSTALLATION

INITIAL SETUP:

Applicable Models

All

Materials/Parts

Two locknuts (item 164, WP 0470 00)
Cotter pin (item 23, WP 0470 00)
Cotter pin (item 421, WP 0470 00)
Cotter pin (item 34, WP 0470 00)

Materials/Parts

Rags (item 27, WP 0468 00)
Skysol 100 (item 13, WP 0468 00)

References

WP 0020 00

Equipment Condition

Parking brake set and wheels chocked
(TM 9-2320-361-10).
Battery ground cable disconnected
(WP 0126 00).

PINTLE HOOK MAINTENANCE (Contd)

PINTLE HOOK REMOVAL

1. Remove cotter pin (21) from pintle hook (14) and nut (1). Discard cotter pin (21).
2. Remove nut (1), washer (2), and pintle hook (14) from rear crossmember (4).
3. Remove two locknuts (20), inner bracket (3), two screws (18), and outer bracket (19) from rear crossmember (4). Discard locknuts (20).

PINTLE HOOK LATCH REMOVAL

1. Remove cotter pin (16) from lock (11). Discard cotter pin (16).
2. Remove two grease fittings (13) and (5) from drive pin (12) and screw (6).
3. Remove cotter pin (10) from screw (6) and slotted nut (9). Discard cotter pin (10).
4. Remove slotted nut (9), screw (6), and lock (11) from pintle hook (14).
5. Remove drive pin (12), latch (7), and spring (8) from lock (11).

CLEANING AND INSPECTION

WARNING

Skysol 100 solvent is combustible; DO NOT use or store near heat, sparks, flame, or other ignition sources. Use mechanical ventilation whenever product is used in a confined space, heated above ambient temperatures, or agitated. Keep container sealed when not in use.

Contact with Skysol 100 may cause skin irritation. Use chemical-resistant gloves. In case of skin contact, remove any contaminated clothing and wash skin thoroughly with soap and water. Wash contaminated clothing before reuse. Eye contact may cause irritation, tearing, or blurring of vision. Use face shield or goggles when eye contact may occur. In case of eye contact, flush eyes with large amounts of water for at least 15 minutes or until irritation subsides. Inhalation may cause irritation to upper respiratory passages. DO NOT have food or drink in the vicinity. Failure to comply may result in injury to personnel.

1. Clean all parts with Skysol 100 and dry with clean rag.
2. Inspect all parts for breaks and cracks. Replace all damaged parts.
3. Inspect drivescrew (15) and chain (17) for damage. Replace drivescrew (15) or chain (17) if damaged.
4. Inspect spring (8) for breaks or collapsed coils. Replace if damaged.
5. Inspect for broken or missing chain (17) and drivescrew (15). Replace any broken or missing parts.
6. Replace grease fittings (5) and (13) if broken or missing.

PINTLE HOOK LATCH INSTALLATION

1. Install drive pin (12) until flush with inside edge of lock (11).
2. Install spring (8) and latch (7) in lock (11) until drive pin (12) is flush with outside edge of lock (11).
3. Stake both edges of lock (11) in four places to hold drive pin (12) in place.

PINTLE HOOK MAINTENANCE (Contd)

PINTLE HOOK LATCH INSTALLATION (Contd)

4. If removed, install drivescrew (15) and chain (17) on pintle hook (14) with new cotter pin (16).
5. Install lock (11) on pintle hook (14) with screw (6), slotted nut (9), and new cotter pin (10). Ensure lock (11) and latch (7) move freely.
6. Install two grease fittings (13) and (5) in drive pin (12) and screw (6).

PINTLE HOOK INSTALLATION

1. Install inner bracket (3) and outer bracket (19) on rear crossmember (4) with two screws (18) and new locknuts (20).
2. Install pintle hook (14) on crossmember (4) with washer (2), and slotted nut (1). Tighten slotted nut (1) to obtain 0.003–0.017 in. (0.076–0.432 mm) clearance between washer (2) and bracket (3).
3. Install new cotter pin (21).
4. Lubricate pintle hook (WP 0020 00).
5. Connect battery ground cable (WP 0126 00).
6. Release parking brake and remove wheel chocks (TM 9-2320-361-10).

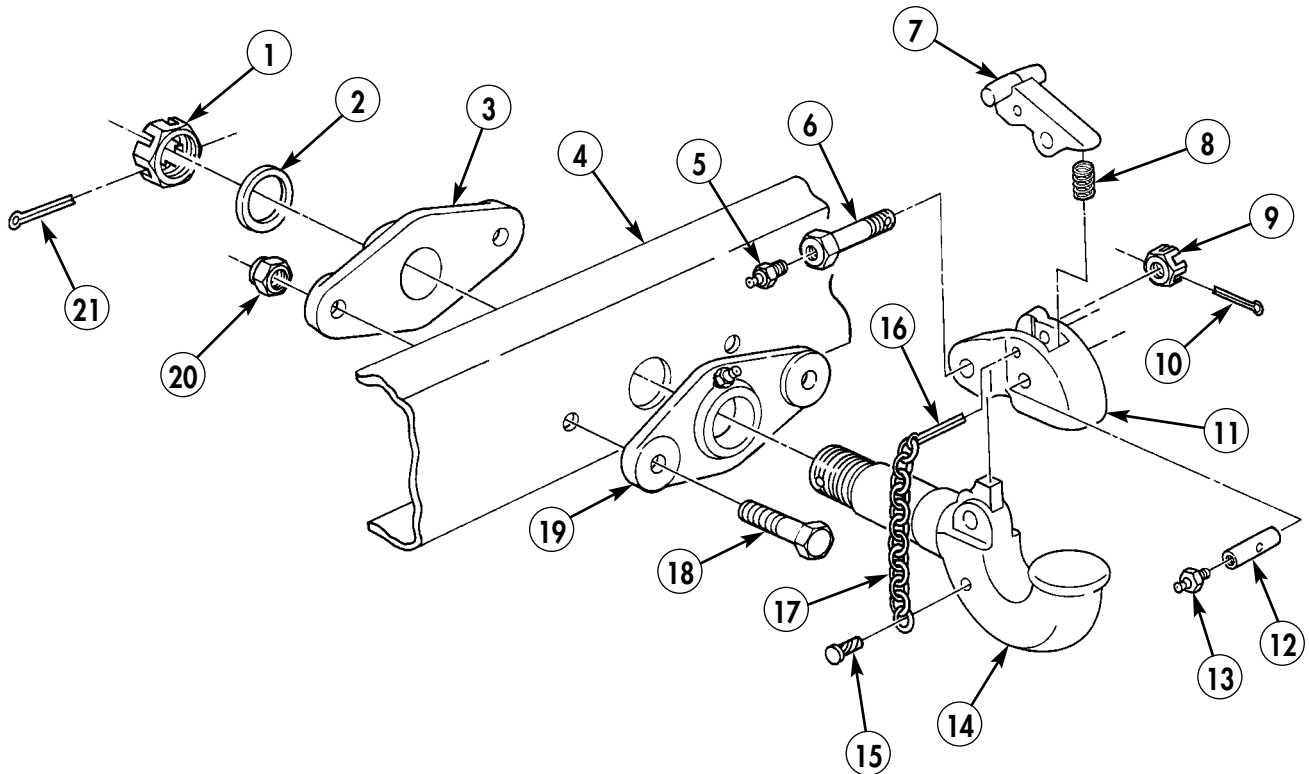

END OF WORK PACKAGE

FIELD MAINTENANCE INSTRUCTIONS

2-1/2 TON, 6X6, M44A2 SERIES TRUCKS (MULTIFUEL)

REAR SHACKLE REPLACEMENT

REMOVAL AND INSTALLATION

INITIAL SETUP:

Applicable Models

All

Materials/Parts

Three locknuts (item 422, WP 0470 00)

Cotter pin (item 20, WP 0470 00)

Equipment Condition

Battery ground cable disconnected
(WP 0126 00).

Parking brake set and wheels chocked
(TM 9-2320-361-10).

Rear bumperettes removed (WP 0201 00).

REMOVAL

1. Remove cotter pin (3) from pin (5). Discard cotter pin (3).
2. Remove pin (5) and shackle (4) from bracket (2).
3. Remove three locknuts (7), screws (6), and bracket (2) from crossmember (1). Discard locknuts (7).

INSTALLATION

1. Install bracket (2) on crossmember (1) with three screws (6) and new locknuts (7).
2. Install shackle (4) on bracket (2) with pin (5).
3. Install new cotter pin (3) in pin (5).
4. Install rear bumperettes (WP 0201 00).
5. Connect battery ground cable (WP 0126 00).
6. Release parking brake and remove wheel chocks (TM 9-2320-361-10).

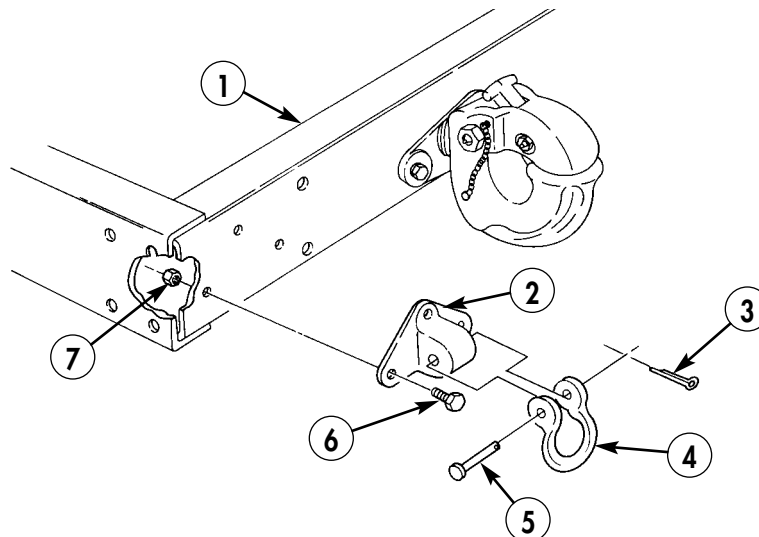

END OF WORK PACKAGE

0200 00-1/2 blank

FIELD MAINTENANCE INSTRUCTIONS

2-1/2 TON, 6X6, M44A2 SERIES TRUCKS (MULTIFUEL)

REAR BUMPERETTE REPLACEMENT

REMOVAL AND INSTALLATION

INITIAL SETUP:

Applicable Models

All

Materials/Parts

Four locknuts (item 132, WP 0470 00)

Two locknuts (item 147, WP 0470 00)

Equipment Condition

Parking brake set and wheels chocked
(TM 9-2320-361-10).

Battery ground cable disconnected
(WP 0126 00).

Rear composite light removed (WP 0125 00).

REAR BUMPERETTE REPLACEMENT (Contd)

REMOVAL

NOTE

Perform step 1 for right side.

1. Remove two locknuts (2) and screws (4) from crossmember (3) and rear bumperette (5). Discard locknuts (2).

NOTE

Perform step 2 for left side.

2. Remove four locknuts (1), screws (7), composite light bracket (6), clamp (9), and rear bumperette (5) from frame (8). Discard locknuts (1).

INSTALLATION

NOTE

Perform step 1 for right side.

1. Install rear bumperette (5) on rear crossmember (3) with two screws (4) and new locknuts (2).

NOTE

Perform step 2 for left side.

2. Install composite light bracket (6) and clamp (9) on bumperette (5) and frame (8) with four screws (7) and new locknuts (1).
3. Install rear composite light (WP 0125 00).
4. Connect battery ground cable (WP 0126 00).
5. Release parking brake and remove wheel chocks (TM 9-2320-361-10).

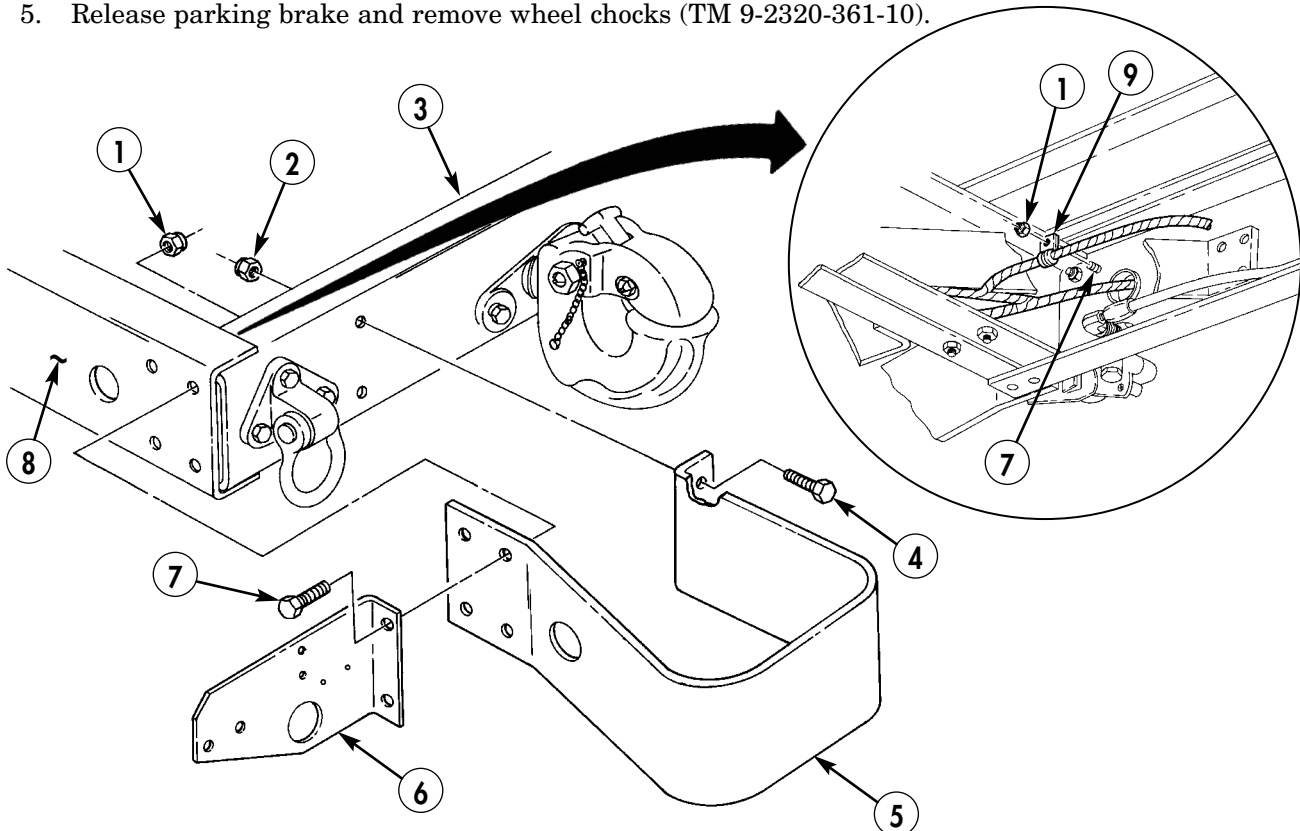

END OF WORK PACKAGE

FIELD MAINTENANCE INSTRUCTIONS

2-1/2 TON, 6X6, M44A2 SERIES TRUCKS (MULTIFUEL)

SPARE TIRE CARRIER MAINTENANCE

REMOVAL, DISASSEMBLY, INSPECTION, ASSEMBLY, AND INSTALLATION

INITIAL SETUP:

Applicable Models

All

Materials/Parts

Four locknuts (item 147, WP 0470 00)

Four lockwashers (item 207, WP 0470 00)

Cotter pin (item 24, WP 0470 00)

Equipment Condition

Parking brake set and wheels chocked
(TM 9-2320-361-10).

Battery ground cable disconnected
(WP 0126 00).

Spare tire removed (TM 9-2320-361-10).

SPARE TIRE CARRIER MAINTENANCE (Contd)

REMOVAL

Remove four locknuts (3), screws (1), and spare tire carrier (2) from frame (4). Discard locknuts (3).

DISASSEMBLY

1. Remove four nuts (10), lockwashers (11), two U-bolts (13), and ends of cable (7) from pickup member (14). Discard lockwashers (11).

WARNING

Wear leather gloves when handling cable. Do not let cable run through hands. Broken or rusty wires can cause injury to personnel.

2. Remove cable (7) from shaft (8).
3. Remove cotter pin (5) from shaft (8) and remove shaft (8) from housing (6). Discard cotter pin (5).

INSPECTION

1. Inspect housing (6) for cracks, breaks, and broken welds. Replace housing (6) if cracked, bent, or welds are broken.
2. Inspect pickup member (14) for cracks, breaks, and loose studs (12). Replace pickup member (14) if cracked, broken, or studs (12) are loose.
3. Inspect shaft (8) and ratchet (9) for cracks, breaks, bends, and broken teeth. Replace shaft (8) or ratchet (9) if cracked, broken, bent, or teeth are broken.
4. Inspect cable (7) for breaks and frays. Replace cable (7) if broken or frayed.

ASSEMBLY

1. Install shaft (8) and ratchet (9) in housing (6) with new cotter pin (5).
2. Install ends of cable (7) through holes in shaft (8), and feed ends of cable (7) through hole in bottom of housing (6).

NOTE

Ensure cable ends are of equal length through shaft.

3. Install two U-bolts (13) on pickup member (14) with four new lockwashers (11) and nuts (10). Do not tighten nuts (10).

NOTE

Ensure cable ends extend through both U-bolts before tightening nuts in step 4.

4. Install ends of cable (7) through holes in pickup member (14) and U-bolts (13). Tighten nuts (10).

INSTALLATION

1. Install spare tire carrier (2) on frame (4) with four screws (1) and new locknuts (3). Tighten locknuts (3) 30–35 lb-ft (41–47 N•m).
2. Install spare tire (TM 9-2320-361-10).
3. Connect battery ground cable (WP 0126 00).
4. Release parking brake and remove wheel chocks (TM 9-2320-361-10).

SPARE TIRE CARRIER MAINTENANCE (Contd)

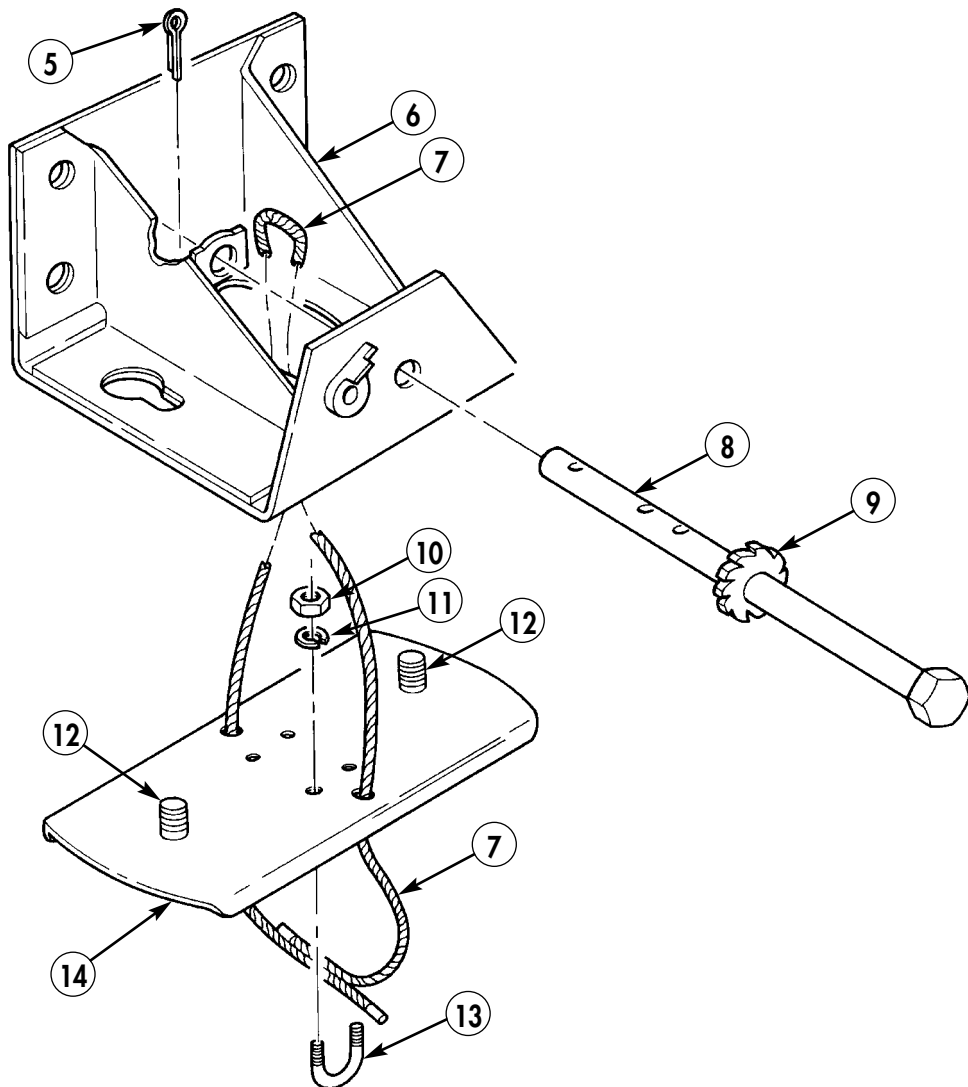
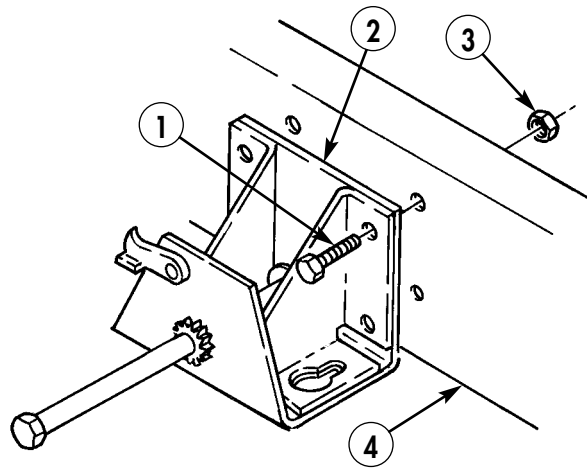

END OF WORK PACKAGE

FIELD MAINTENANCE INSTRUCTIONS

2-1/2 TON, 6X6, M44A2 SERIES TRUCKS (MULTIFUEL)

BRUSH GUARD, STONE SHIELD, AND HEADLIGHT GUARD REPLACEMENT

STONE SHIELD REMOVAL, BRUSH GUARD REMOVAL, HEADLIGHT GUARD REMOVAL,
HEADLIGHT GUARD INSTALLATION, BRUSH GUARD INSTALLATION, AND STONE SHIELD INSTALLATION

INITIAL SETUP:

Applicable Models

All

Materials/Parts

Three locknuts (item 145, WP 0470 00)
Eight locknuts (item 129, WP 0470 00)
Twelve locknuts (item 147, WP 0470 00)

Equipment Condition

Parking brake set and wheels chocked
(TM 9-2320-361-10).
Hood raised and secured (TM 9-2320-361-10).
Parking brake set and wheels chocked
(TM 9-2320-361-10).
Hood holddown fasteners removed
(WP 0220 00).

BRUSH GUARD, STONE SHIELD, AND HEADLIGHT GUARD REPLACEMENT (Contd)

STONE SHIELD REMOVAL

NOTE

- Radiator stone shield consists of an upper and lower stone shield. Vehicles with a front winch do not use lower stone shield.
- Some vehicles may have washers between brush guard and brush guard bracket.

1. Remove four locknuts (19), screws (10), two washers (15), and lower stone shield (9) from brush guard (4) and upper stone shield (7). Discard locknuts (19).
2. Remove three locknuts (5), screws (8), brackets (6), and upper stone shield (7) from brush guard (4). Discard locknuts (5).

HEADLIGHT GUARD REMOVAL

NOTE

This procedure can also be done with brush guard installed on vehicle.

1. Remove four locknuts (1), screws (20), and washers (21) from brush guard (4). Discard locknuts (1).
2. If brush guard (4) was not removed from vehicle, remove two locknuts (22), washers (14), screws (13), and headlight guard (2) from brush guard (4). Discard locknuts (22).

BRUSH GUARD REMOVAL

1. Remove two locknuts (16) and screws (18) from brush guard (4) and frame rail brackets (17). Discard locknuts (16).
2. Remove four locknuts (1) and (22), four washers (21) and (14), screws (20) and (13), and brush guard (4) from angle brackets (3). Discard locknuts (1) and (22).

NOTE

- Vehicles without front winch have an additional brush guard bracket.
- If vehicle is equipped with lower stone shield, proceed to step 4.

3. Remove two locknuts (19), screws (10), washers (15), and upper brush guard bracket (12) from brush guard (4). Discard locknuts (19).
4. Remove two locknuts (19), screws (10), washers (15), and lower brush guard bracket (11) from brush guard (4). Discard locknuts (19).

BRUSH GUARD INSTALLATION

1. Install upper brush guard bracket (12) on brush guard (4) with two screws (10), washers (15), and new locknuts (19).
2. Install lower brush guard bracket (11) on brush guard (4) with two screws (10), washers (15), and new locknuts (19).
3. Position brush guard (4) on two frame rail brackets (17) and install with two screws (18) and new locknuts (16). Do not tighten locknuts (16).
4. Position brush guard (4) on angle brackets (3). Install four screws (13) and (20), washers (2) and (14), and locknuts (1) and (22) on brush guard (4), headlight guard (2), and two angle brackets (3). Tighten locknuts (16).

BRUSH GUARD, STONE SHIELD, AND HEADLIGHT GUARD REPLACEMENT (Contd)

HEADLIGHT GUARD INSTALLATION

1. Install two headlight guards (2) on brush guard (4) with four screws (20) and (13), washers (21) and (14), and new locknuts (1) and (22).
2. Install inner ends of headlight guards (2) on brush guard (4) with two screws (13) and new locknuts (22).

STONE SHIELD INSTALLATION

1. Install upper stone shield (7) on brush guard (4) with three screws (8), brackets (6), and new locknuts (5).
2. Install lower stone shield (9) on brush guard (4) with four screws (10), two washers (14), and new locknuts (19).
3. Install hood holddown fasteners (WP 0220 00).
4. Connect battery ground cable (WP 0126 00).
5. Lower and secure hood (TM 9-2320-361-10).
6. Release parking brake and remove wheel chocks (TM 9-2320-361-10).

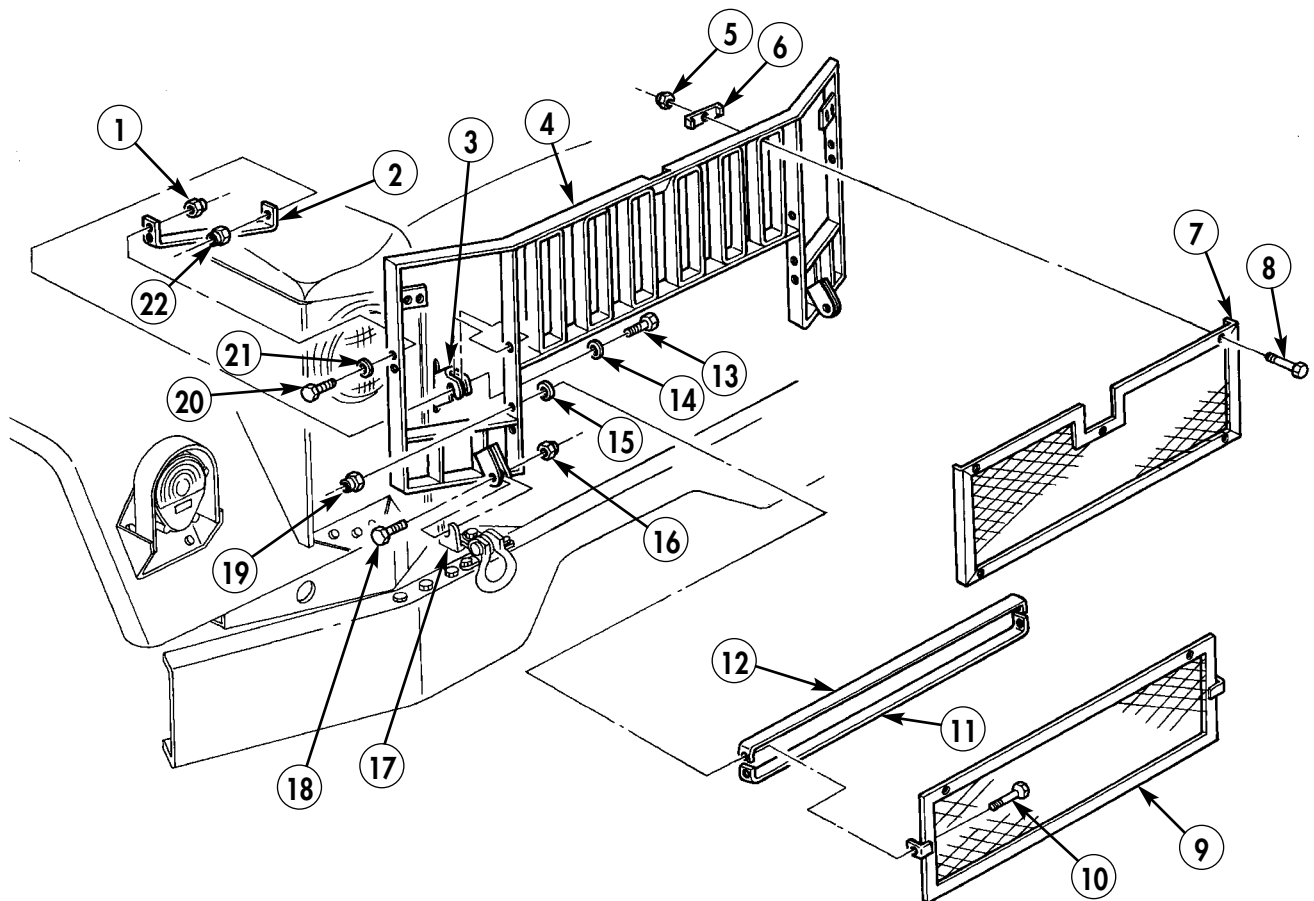

END OF WORK PACKAGE

0203 00-3/4 blank

FIELD MAINTENANCE INSTRUCTIONS

2-1/2 TON, 6X6, M44A2 SERIES TRUCKS (MULTIFUEL)

FRONT BUMPER REPLACEMENT

REMOVAL AND INSTALLATION

INITIAL SETUP:

Applicable Models

All

Personnel Required

Two

Materials/Parts

Twenty-four locknuts (item 147, WP 470 00)

Ten locknuts (without winch)
(item 132, WP 0470 00)

Four locknuts (with winch)
(item 132, WP 0470 00)

Equipment Condition

Parking brake set and wheels chocked
(TM 9-2320-361-10).

Battery ground cable disconnected
(WP 0126 00).

Front lifting brackets and shackles removed
(WP 0197 00 for vehicles without winch)
(WP 0198 00 for vehicles with winch).

FRONT BUMPER REPLACEMENT (Contd)

WARNING

Front bumper is heavy. An assistant is required during removal and installation to prevent injury to personnel.

REMOVAL

NOTE

- Perform step 1 for vehicles without winch.
- Assistant is required to support bumper.

1. Remove six locknuts (5) and screws (7) from bottom of bumper (2) and frame (4). Discard locknuts (5).

NOTE

Perform step 2 for vehicles with winch.

2. Remove four locknuts (5), screws (7), and two lower plates (8) from frame (4). Discard locknuts (5).
3. Remove bumper (2), two plates (3) and two plates (8) from frame (4).

NOTE

Prior to removal, mark plates for installation.

4. Remove twelve locknuts (6), screws (1), and two upper plates (3) from bumper (2). Discard locknuts (6).
5. Remove twelve locknuts (9), screws (10), and two lower plates (8) from bumper (2). Discard locknuts (9).

INSTALLATION

1. Install two upper plates (3) on bumper (2) with twelve screws (1) and new locknuts (6).
2. Install two lower plates (8) on bumper (2) with twelve screws (10) and new locknuts (9).

NOTE

- Assistant is required to support bumper.
- Perform step 3 for vehicles without winch.

3. Install bumper (2), two plates (3), and two plates (8) on frame (4) with six screws (7) and new locknuts (5). Do not tighten screws (7).

NOTE

Perform step 4 for vehicles with winch.

4. Install bumper (2) and two plates (3), and (8) on frame (4) with four screws (7) and new locknuts (5). Do not tighten screws (7).
5. Install brackets and shackles on bumper (2) and frame (4) (WP 0197 00 and WP 0198 00).
6. Tighten six screws (7) and locknuts (5).
7. Install front lifting brackets and shackles (WP 0197 00 for vehicles without winch) (WP 0198 00 for vehicles with winch).
8. Connect battery ground cable (WP 0126 00).
9. Release parking brake and remove wheel chocks (TM 9-2320-361-10).

FRONT BUMPER REPLACEMENT (Contd)

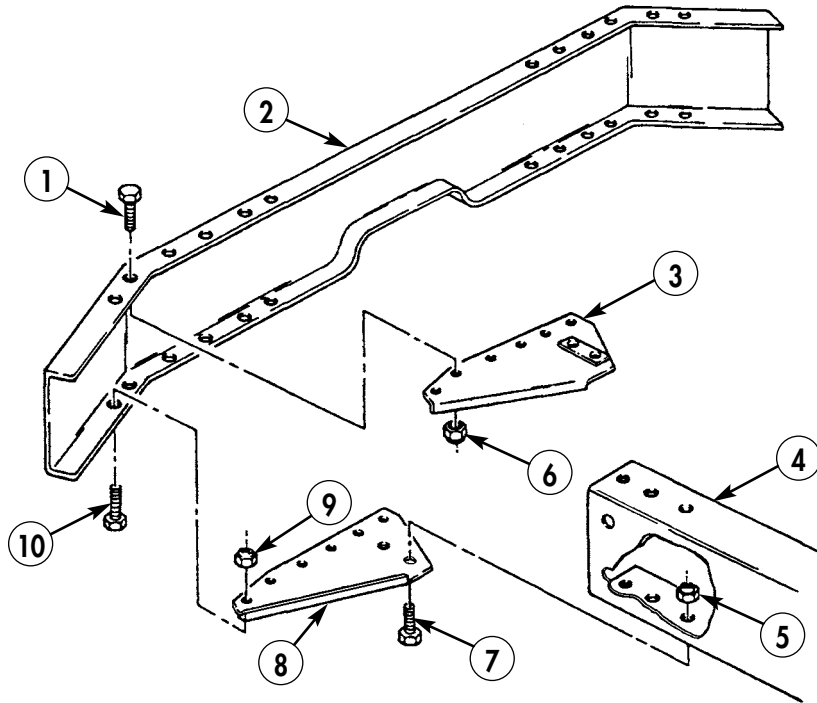

WITHOUT WINCH

WITH WINCH

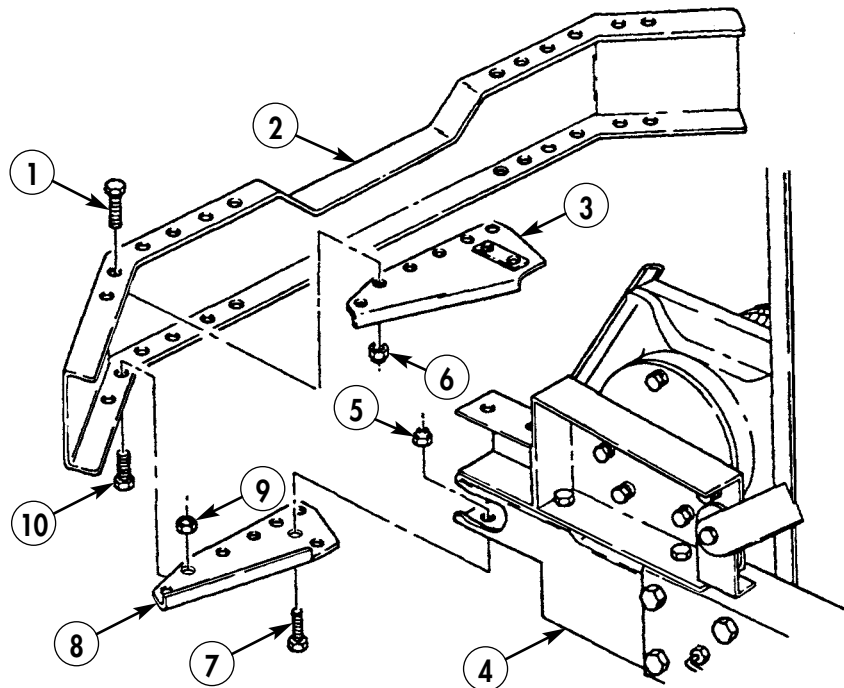

END OF WORK PACKAGE

FIELD MAINTENANCE INSTRUCTIONS

2-1/2 TON, 6X6, M44A2 SERIES TRUCKS (MULTIFUEL)

FRONT WINCH EXTENSION REPLACEMENT

REMOVAL AND INSTALLATION

INITIAL SETUP:

Applicable Models

All

Materials/Parts

Ten locknuts (item 147, WP 0470 00)

Equipment Condition

Parking brake set and wheels chocked
(TM 9-2320-361-10).

Battery ground cable disconnected
(WP 0126 00).

Front winch removed (WP 0345 00).

Brush guard removed (WP 0203 00).

REMOVAL

1. Remove four locknuts (4) and screws (3) from bottom of frame rail (2). Discard locknuts (4).
2. Remove six locknuts (5), screws (7), loop tiedown (1), and front winch extension (6) from frame rail (2). Discard locknuts (5).

INSTALLATION

1. Install front winch extension (6), and loop tiedown (1) on frame rail (2) with six screws (7) and new locknuts (5). Do not tighten nuts (5).
2. Install four screws (3) and new locknuts (4) through bottom of frame rail (2) and front winch extension (6). Tighten nuts (4).
3. Install brush guard (WP 0203 00).
4. Install front winch (WP 0345 00).
5. Connect battery ground cable (WP 0126 00).
6. Release parking brake and remove wheel chocks (TM 9-2320-361-10).

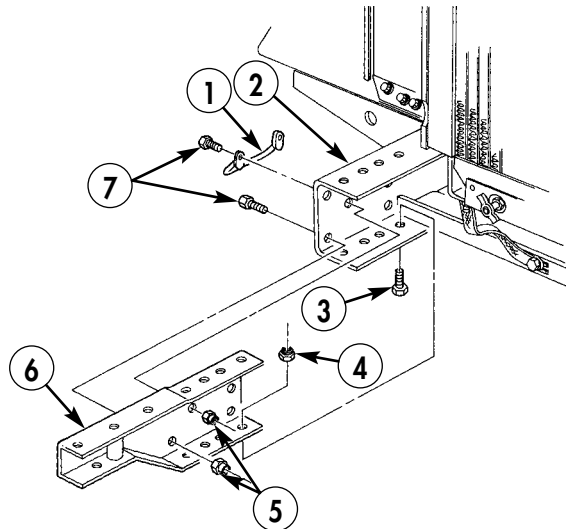

END OF WORK PACKAGE

0205 00-1/2 blank

FIELD MAINTENANCE INSTRUCTIONS

2-1/2 TON, 6X6, M44A2 SERIES TRUCKS (MULTIFUEL)

FRAME ALIGNMENT INSPECTION

FRAME LEVELING, HORIZONTAL BOW INSPECTION, FRAME SQUARENESS, AND VERTICAL BOW INSPECTION

INITIAL SETUP:

Applicable Models

All

Personnel Required

Two

Tools and Special Tools

General mechanic's tool kit
(item 116, WP 0469 00)
Plumb bob (item 55, WP 0469 00)
Tape measure (item 106, WP 0469 00)
Two straight edges (item 105, WP 0469 00)
Hydraulic jack (item 47, WP 0469 00)
Jack stands

References

TB 9-2300-247-40

Equipment Condition

Parking brake set and wheels chocked
(TM 9-2320-361-10).
Set parking brake (TM 9-2320-361-10).
Vehicle undercarriage clean and free of mud
and debris (TM 9-2320-361-10).
Tires checked for proper air pressure
(TM 9-2320-361-10).
Battery ground cable disconnected
(WP 0126 00).

Materials/Parts

Chalk (item 11, WP 0468 00)
Tape, masking (item 44, WP 0468 00)
Tape, transparent (item 45, WP 0468 00)
Twine (item 47, WP 0468 00)

FRAME ALIGNMENT INSPECTION (Contd)

NOTE

- Any loose or missing cross member rivets, loose or broken crossmembers, or damaged frame rails must be repaired prior to inspection.
- Ensure inspection procedure is performed on a flat level surface.

FRAME LEVELING

1. Drive vehicle into inspection position from a 12 ft (3.7 m) straight line of travel. Apply parking brake and chock wheels (TM 9-2320-361-10).
2. Using tape measure, determine distance from floor (3) to bottom of front frame rails (1) in front of crossmember (4). If one frame rail (1) is lower, use hydraulic jack and raise one side of front axle to level frame rails (1) to within 1/8 in. (3 mm) of each other.
3. Using tape measure, determine distance from floor (3) to bottom of rear frame rails (1) at crossmember (2). If one frame rail (1) is lower, use hydraulic jack and raise one side of rear-rear axle to level frame rails (1) to within 1/8–5/16 in. (3-8 mm) of each other.

HORIZONTAL BOW INSPECTION

NOTE

On vehicles with a frame longer than 20 ft (6 m), the front 20 ft (6 m) of frame rail (measured from front to rear) and the rear 20 ft (6 m) of frame rail (measured from rear to front) are measured separately. This will cause an overlap in measurement. Perform the following procedure for each 20 ft (6 m) section of left and right frame rail.

1. Tape one 8 x 10-1/2 in. (20x 27 cm) sheet of white paper to floor (3) under each end of frame crossmembers (5) and in front of crossmember (4) where attached to frame rails (1).
2. Tape one 8 x 10-1/2 in. (20x 27 cm) sheet of white paper to floor (3) under each front bogie bracket (6).

NOTE

Ensure plumb bob string is placed flat against frame rails free of obstructions such as bolts, rivets, brackets, and rear springs. Allow plumb bob to stop swinging before making mark on paper.

3. Hold string with plumb bob to outside of frame rails (1), above paper, and 4 in. (10 cm) up from bottom of frame rails (1). Accurately locate point of paper directly below plumb bob.
4. Carefully mark spot on each paper directly below plumb point.

FRAME ALIGNMENT INSPECTION (Contd)

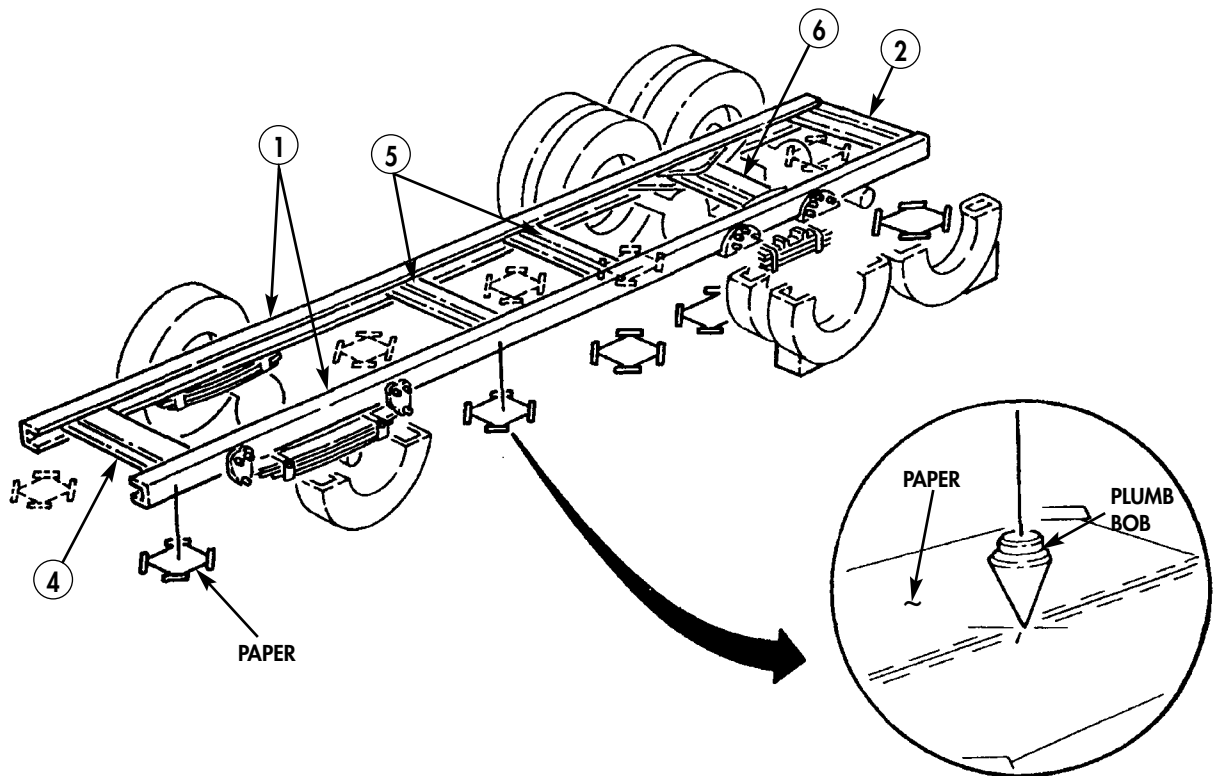
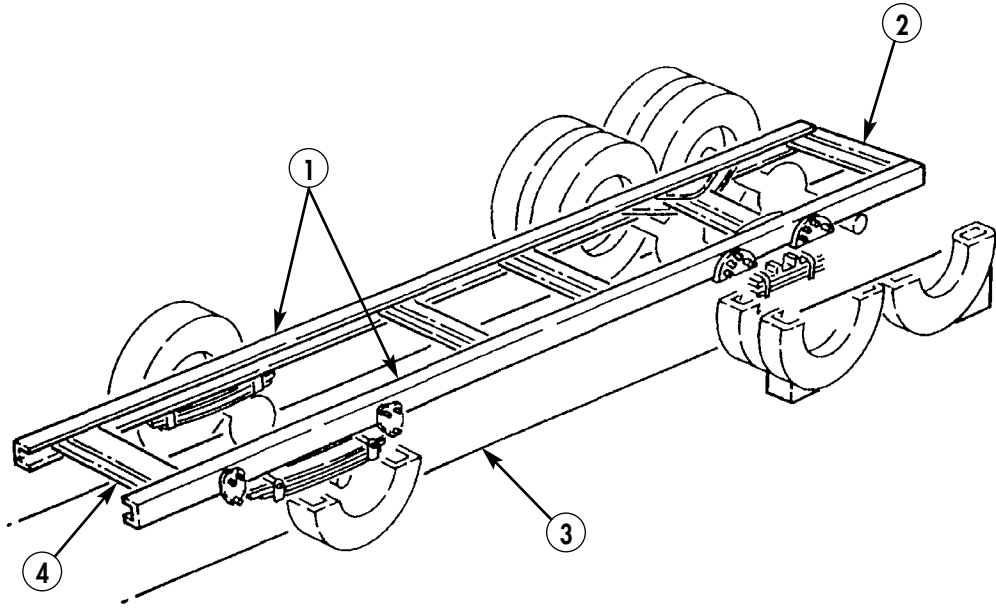

FRAME ALIGNMENT INSPECTION (Contd)

HORIZONTAL BOW INSPECTION (Contd)

NOTE

Strings used for horizontal bow measurement will remain in place until the frame squareness procedure is completed. On frames longer than 20 ft (6 m), the two front and rear strings will be used.

5. Stretch string tightly on floor (5) between front and rear plumb bob marks (2) under each frame rail (1). Place weights on string to keep it taut or tie ends of string to jack stands.

NOTE

- For frame rail sections with added fishplate, subtract 5/16 in. (7.94 mm) from plumb bob marks to compensate for the fishplate added to frame rail.
- If measured frame rails are out of tolerance, notify supervisor. If frame rails are verified to be out of tolerance, vehicle will be classified as unserviceable.

6. Measure distance between string and each plumb bob mark (2). If distance is more than 1/2 in. (13 mm) from bow (3), or 1/2 in. (13 mm) from bow (4), frame rails (1) are out of tolerance.

FRAME ALIGNMENT INSPECTION (Contd)

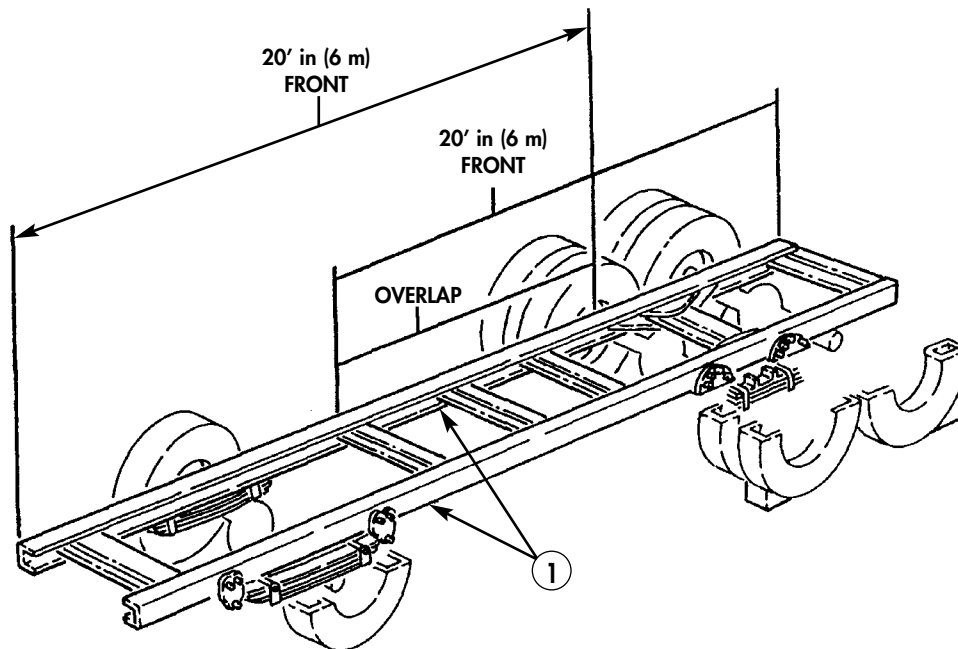
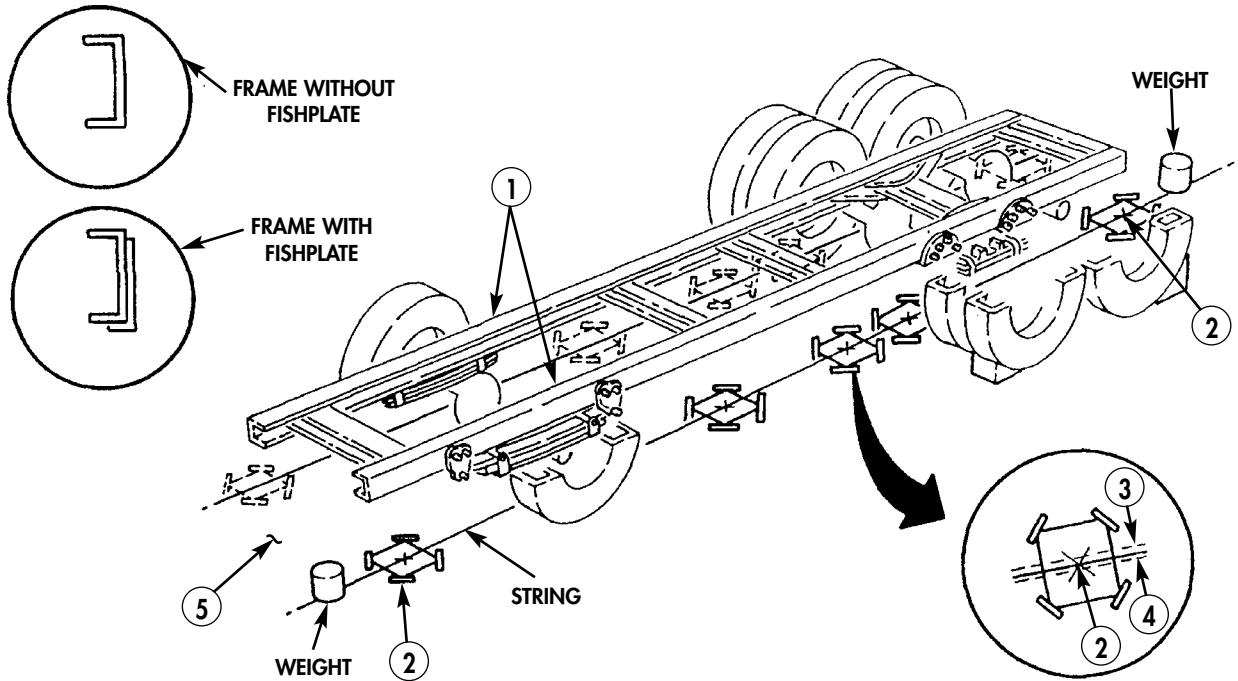

FRAME ALIGNMENT INSPECTION (Contd)

FRAME SQUARENESS

1. Locate and clean two front grease fittings (2) on right and left front spring shackles (1).
2. Tape an 8 x 10-1/2 in. (20 x 27 cm) sheet of white paper to floor (4) under right and left front spring shackles (1).

NOTE

Ensure plumb bob is placed toward front of vehicle on both right and left grease fittings. If not, inaccurate measurement of frame squareness will result.

3. Place string over grease fitting (2) on right front spring shackle (1) with plumb bob toward front of vehicle. Lower plumb bob and locate a point on paper below spring shackle (1).

NOTE

Do not mark paper until plumb bob has stopped swinging and is close to, but not touching paper.

4. Mark spot (3) on paper directly below plumb bob point.
5. Place one edge of square along horizontal line (7) used to measure horizontal bow on right side of vehicle and other edge of square touching plumb bob mark (3).
6. Stretch string along edge of square to left side of vehicle. Allow string to extend 6 in. (15 cm) beyond left horizontal line (6). Tape or secure string to floor (4).

NOTE

Ensure plumb bob is placed toward front of vehicle on both right and left grease fittings. If not, inaccurate measurement of frame squareness will result.

7. Place string over grease fitting (2) on left front spring shackle (1) with plumb bob toward front of vehicle. Lower plumb bob and locate a point on paper below spring shackle (1).

NOTE

Do not mark paper until plumb bob has stopped swinging and is close to, but not touching paper.

8. Mark spot (3) on paper directly below plumb bob point.

NOTE

- If measured frame rails are out of tolerance, notify supervisor. If frame rails are verified to be out of tolerance, vehicle will be classified as unserviceable.

- At end of inspection, remove plumb bob and string.

9. Measure distance between left side plumb bob mark (3) and string on floor (4). If distance is more than 1/4 in. (6 mm), frame rails (6) are out of tolerance.

FRAME ALIGNMENT INSPECTION (Contd)

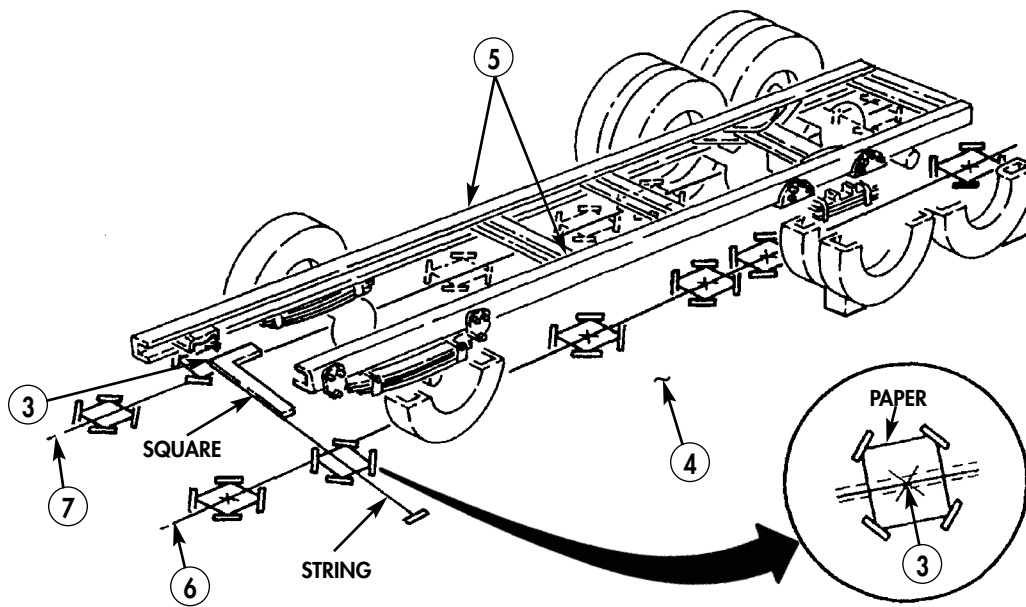
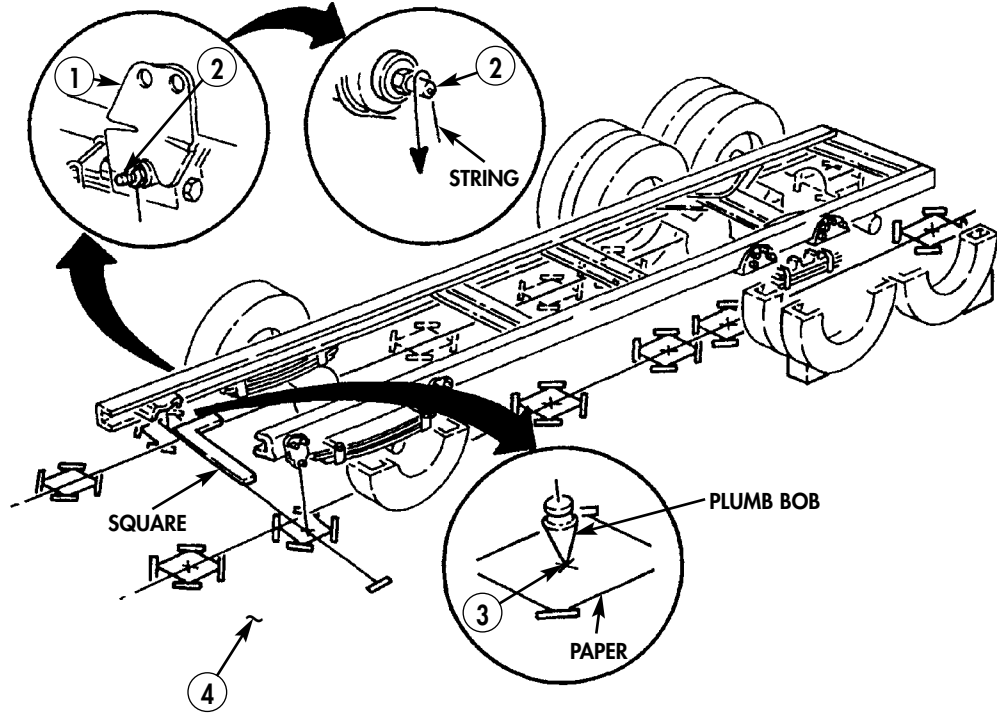

FRAME ALIGNMENT INSPECTION (Contd)

VERTICAL BOW INSPECTION

NOTE

On vehicles with a frame longer than 20 ft (6 m), the front 20 ft (6 m) of frame rail (measured from front to rear) and the rear 20 ft (6 m) of frame rail (measured from rear to front) are measured separately. This will cause an overlap in measurement. Perform the following procedure for each 20 ft (6m) section of left and right frame rails.

1. Stretch string on floor and position weight under bottom and at front of frame rail (1) or tie ends of string to jack stands. Pull string tight. Position weights or jack stands at 20 ft (6 m) measurement.
2. Measure distance between string and bottom of frame rail (1) at closest point to each weight or jack stand. Adjust string height until each measurement is the same and the entire length of string is unobstructed.

NOTE

If measured frame rails are out of tolerance, notify supervisor. If frame rails are verified to be out of tolerance, vehicle will be classified as unserviceable.

3. Measure distance between string and bottom of frame rail (1) near crossmembers (2) and as close to the midway point as possible. If frame rail (1) bows more than 1/8–5/16 in. (3–8 mm) up or down, the frame rail (1) is out of tolerance.
4. Connect battery ground cable (WP 0126 00).
5. Release parking brake and remove wheel chocks (TM 9-2320-361-10).

FRAME ALIGNMENT INSPECTION (Contd)

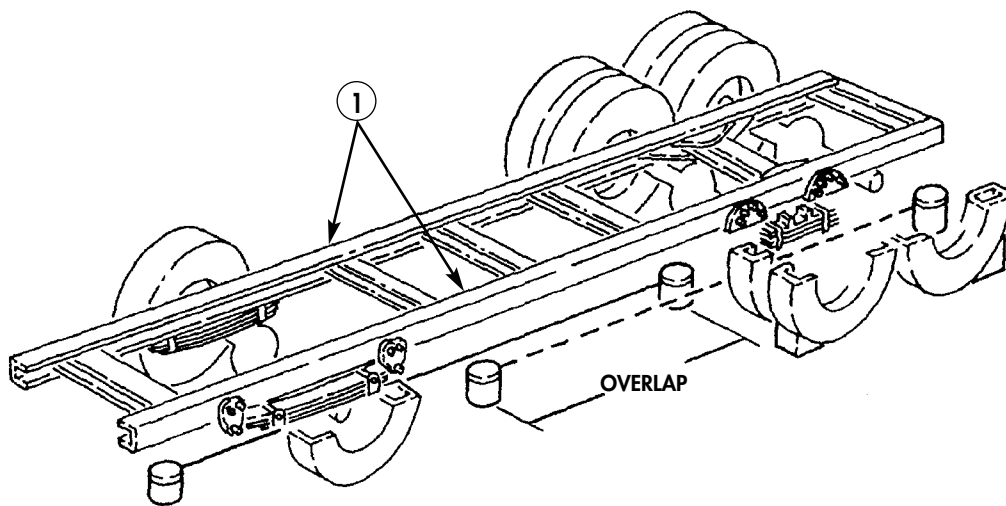
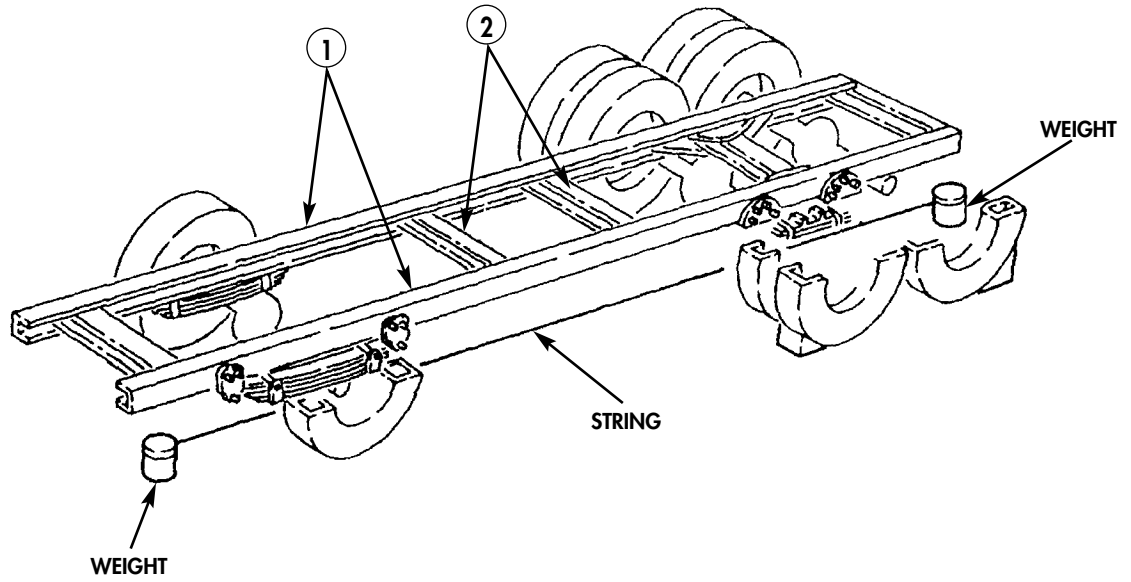

END OF WORK PACKAGE

FIELD MAINTENANCE INSTRUCTIONS

2-1/2 TON, 6X6, M44A2 SERIES TRUCKS (MULTIFUEL)

CAB DOOR INSPECTION HOLE COVER REPLACEMENT

REMOVAL AND INSTALLATION

INITIAL SETUP:

Applicable Models
All

Equipment Condition
Parking brake set and wheels chocked
(TM 9-2320-361-10).

REMOVAL

Remove six screws (2) and cab door inspection hole cover (3) from cab door (1).

INSTALLATION

1. Install cab door inspection hole cover (3) on cab door (1) with six screws (2).
2. Release parking brake and remove wheel chocks (TM 9-2320-361-10).

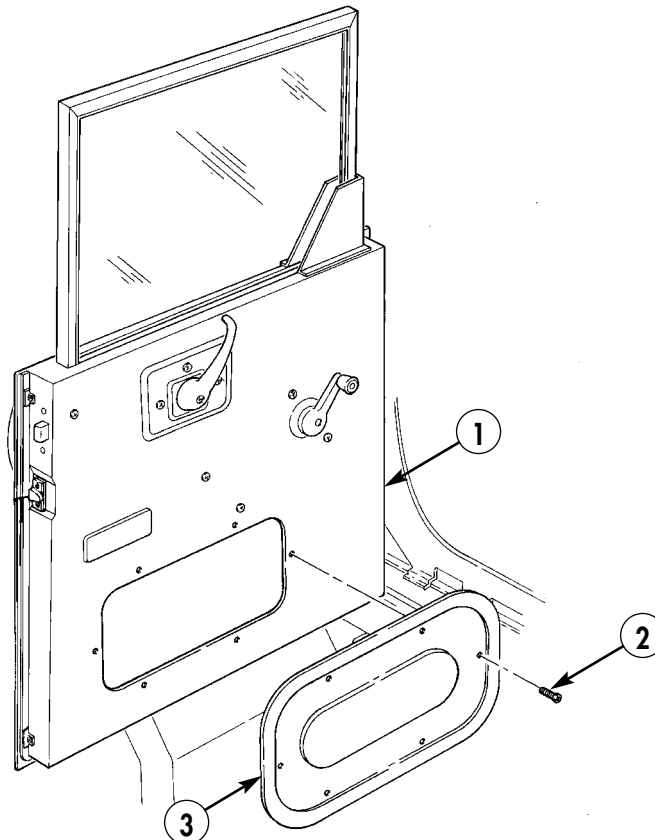

END OF WORK PACKAGE

0207 00-1/2 blank

FIELD MAINTENANCE INSTRUCTIONS

2-1/2 TON, 6X6, M44A2 SERIES TRUCKS (MULTIFUEL)

CAB DOOR DOVETAIL WEDGE REPLACEMENT

REMOVAL AND INSTALLATION

INITIAL SETUP:

Applicable Models

All

Materials/Parts

Two screw-assembled lockwashers
(item 258, WP 0470 00)

Equipment Condition

Parking brake set and wheels chocked
(TM 9-2320-361-10).

Battery ground cable disconnected
(WP 0126 00).

REMOVAL

Remove two screw-assembled lockwashers (1), dovetail wedge (2), and shim (3) from cab door (4). Discard screw-assembled lockwashers (1).

INSTALLATION

1. Install shim (3) and dovetail wedge (2) on cab door (4) with two new screw-assembled lockwashers (1).
2. Connect battery ground cable (WP 0126 00).
3. Release parking brake and remove wheel chocks (TM 9-2320-361-10).

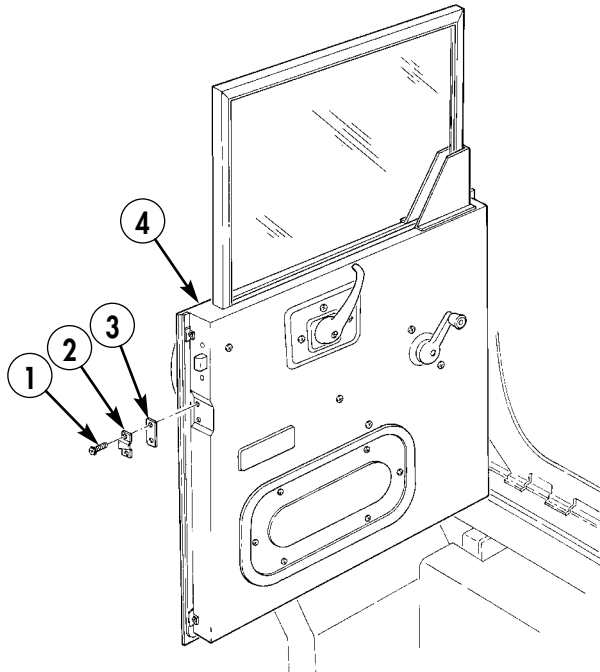

END OF WORK PACKAGE

0208 00-1/2 blank

FIELD MAINTENANCE INSTRUCTIONS

2-1/2 TON, 6X6, M44A2 SERIES TRUCKS (MULTIFUEL)

CAB DOOR AND HINGES REPLACEMENT

CAB DOOR REMOVAL, CAB DOOR HINGES REMOVAL,
CAB DOOR HINGES INSTALLATION, AND CAB DOOR INSTALLATION

INITIAL SETUP:

Applicable Models

All

Materials/Parts

Two locknuts (item 152, WP 0470 00)

Personnel Required

Two

Equipment Condition

Parking brake set and wheels chocked
(TM 9-2320-361-10).

Battery ground cable disconnected
(WP 0126 00).

Cab door lock removed (WP 0214 00).

Cab door dovetail wedge removed
(WP 0208 00).

Cab door weatherseal removed
(WP 0217 00).

Cab door window regulator removed
(WP 0213 00).

Cab door check rod removed (WP 0215 00).

Side panel removed (WP 0218 00).

CAB DOOR AND HINGES REPLACEMENT (Contd)

WARNING

Cab door is heavy. An assistant is required during removal and installation to prevent injury to personnel.

CAB DOOR REMOVAL

NOTE

Assistant will help with steps 1 and 2.

1. Remove two locknuts (6), washers (7), and hinge screws (1) from three mirror braces (2) and two cab door hinges (4). Discard locknuts (6).
2. Remove cab door (5) from hinges (9) mounted on cab (8) A-pillar (10).

CAB DOOR HINGES REMOVAL

Remove sixteen screws (3) and cab door hinges (4) and (9) from cab door (5) and cab (8) A-pillar (10).

CAB DOOR HINGES INSTALLATION

Install two cab door hinges (4) on cab door (5) and two hinges (9) on cab (8) A-pillar (10) with sixteen screws (3).

CAB DOOR INSTALLATION

NOTE

Assistant will help with steps 1 and 2.

1. Lift cab door (5) and position cab door hinges (4) to hinges (9) mounted on cab (8) A-pillar (10) and align three mirror braces (2) to hinges (4) and (9).
2. Install two hinge screws (1) through three mirror braces (2) and hinges (4) and (9).
3. Install two washers (7) and two new locknuts (6) on hinge screws (1). Tighten locknuts (6).
4. Install cab door weatherseal (WP 0217 00).
5. Install cab door check rod (WP 0215 00).
6. Install cab door window regulator (WP 0213 00).
7. Install cab door dovetail wedge (WP 0208 00).
8. Install cab door lock (WP 0214 00).
9. Install side panel (WP 0218 00).
10. Connect battery ground cable (WP 0126 00).
11. Release parking brake and remove wheel chocks (TM 9-2320-361-10).

CAB DOOR AND HINGES REPLACEMENT (Contd)

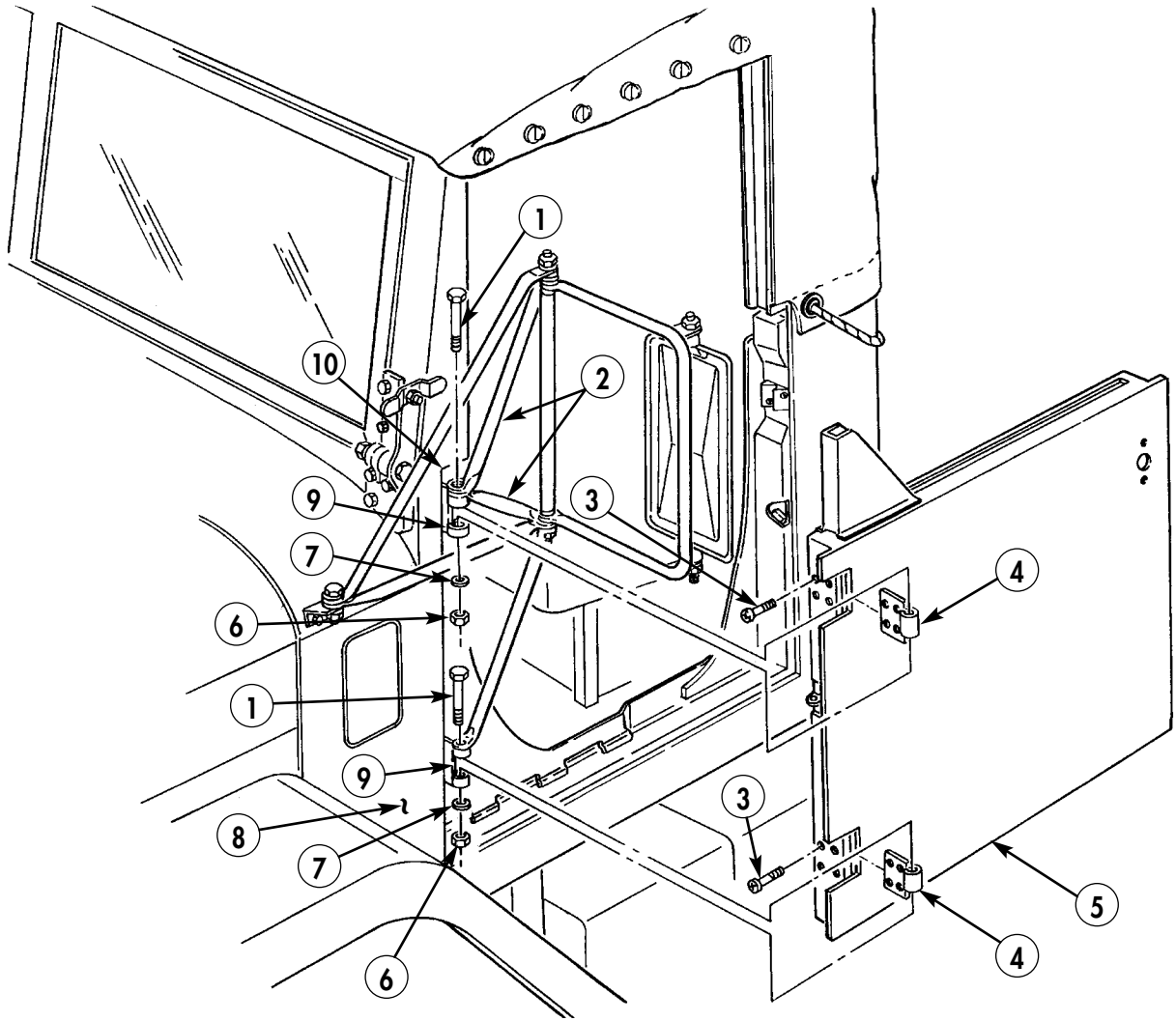

END OF WORK PACKAGE

FIELD MAINTENANCE INSTRUCTIONS

2-1/2 TON, 6X6, M44A2 SERIES TRUCKS (MULTIFUEL)

CAB DOOR GLASS ASSEMBLY AND WEATHERSEAL REPLACEMENT REMOVAL, INSTALLATION, AND CAB DOOR GLASS ADJUSTMENT

INITIAL SETUP:

Applicable Models

All

Materials/Parts

Four lockwashers (item 197, WP 0470 00)

Two fasteners (item 39, WP 0470 00)

Equipment Condition

Parking brake set and wheels chocked
(TM 9-2320-361-10).

Battery ground cable disconnected
(WP 0126 00).

Cab door inspection hole cover removed
(WP 0207 00).

CAB DOOR GLASS ASSEMBLY AND WEATHERSEAL REPLACEMENT (Contd)

REMOVAL

1. Lower cab door glass (9) so regulator channels (2) are accessible through cab door (4) inspection hole (7).

NOTE

Prior to removal, mark position of regulator stop brackets for installation.

2. Remove four screws (8), lockwashers (6), and two window regulator stop brackets (5) from regulator channels (2). Discard lockwashers (6).
3. Remove two fasteners (1) from window regulator arm studs (3). Discard two fasteners (1).
4. Pull two regulator arm studs (3) out of two regulator channels (2) and slide cab door glass (9) out of cab door (4).
5. Remove weatherseal (11) from cab door (4).
6. Remove five clips (10) from weatherseal (11).

INSTALLATION

1. Install five clips (10) to weatherseal (11) and align clips (10) with panel slots (12).
2. Install weatherseal (11) and clips (10) on cab door (4) so clips (10) snap into corresponding panel slots (12).
3. Slide cab door glass (9) into cab door (4) and install two window regulator arm studs (3) through two regulator channels (2).
4. Install two new fasteners (1) on window regulator arm studs (3).
5. Install two window regulator stop brackets (5) on regulator channels (2) with four new lockwashers (6) and screws (8). Do not tighten screws (8).

CAB DOOR GLASS ADJUSTMENT

1. Raise cab door glass (9) to full up position.

NOTE

Ensure cab door glass meets glass seal at top with door in closed position.

2. Lower cab door glass (9) and tighten screws (8).
3. Install door inspection hole cover (WP 0207 00).
4. Connect battery ground cable (WP 0126 00).
5. Release parking brake and remove wheel chocks (TM 9-2320-361-10).

CAB DOOR GLASS ASSEMBLY AND WEATHERSEAL REPLACEMENT (Contd)

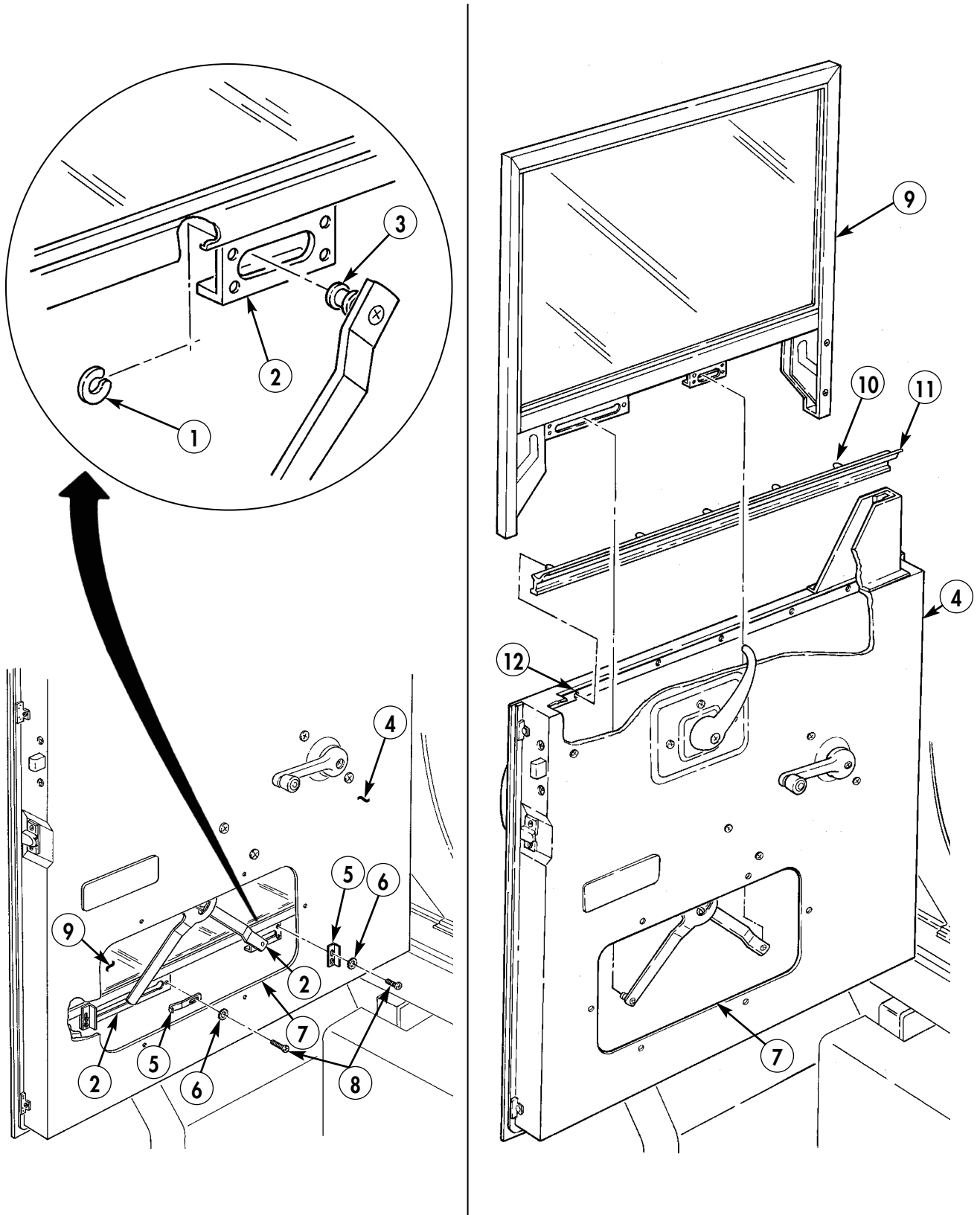

END OF WORK PACKAGE

FIELD MAINTENANCE INSTRUCTIONS

2-1/2 TON, 6X6, M44A2 SERIES TRUCKS (MULTIFUEL)

DOOR GLASS REPLACEMENT

REMOVAL AND INSTALLATION

INITIAL SETUP:

Applicable Models

All

Equipment Condition

Cab door glass and frame removed
(WP 0210 00).

Tools and Special Tools

General mechanic's tool kit
(item 116, WP 0455 00)

Materials/Parts

Channel lift filler (item 347, WP 0470 00)
Channel lift seal (item 348, WP 0470 00)
Frame seal (item 350, WP 0470 00)

DOOR GLASS REPLACEMENT (Contd)

REMOVAL

1. Remove four screws (4) from channel lift (5) and frame (3).
2. Remove channel lift (5), channel lift filler (6), and channel lift seal (7) from frame (3). Discard channel lift filler (6) and channel lift seal (7).
3. Slide glass (1) out of frame (3).
4. Remove frame seal (2) from frame (3). Discard frame seal (2).

INSTALLATION

1. Install new frame seal (2) in frame (3).
2. Install glass (1) in frame (3). Tap glass (1) gently into position.
3. Install new channel lift seal (7) on bottom of glass (1).
4. Install new channel lift filler (6) on channel lift (5).
5. Install channel lift (5) on frame (3) with four screws (4).
6. Install cab door glass and frame (WP 0210 00).

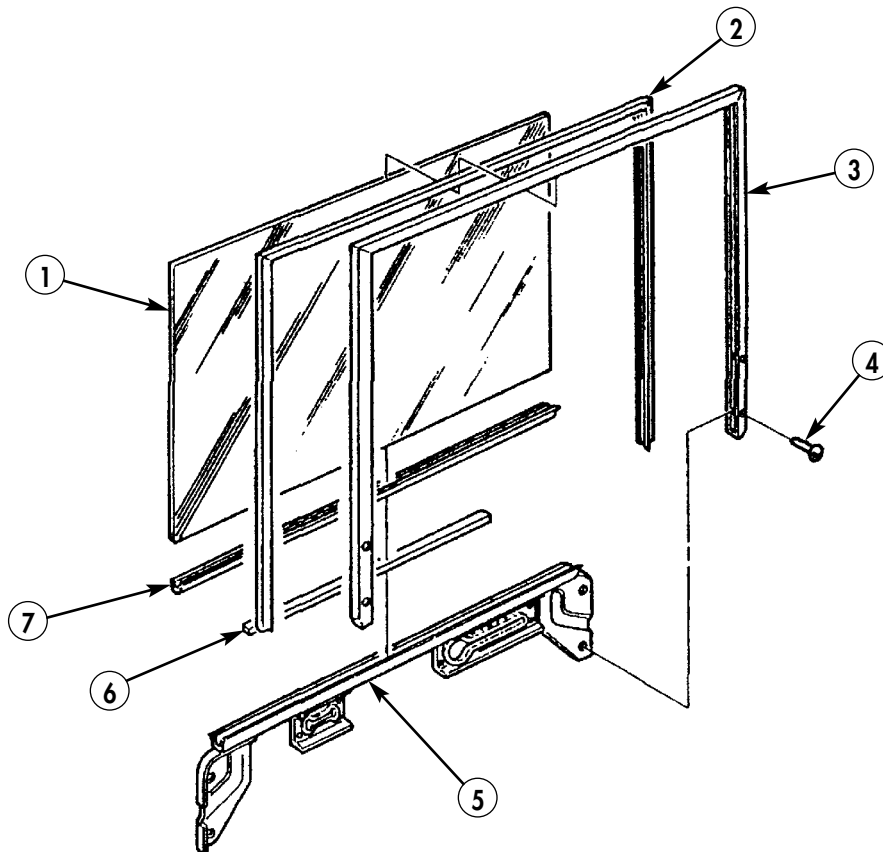

FIELD MAINTENANCE INSTRUCTIONS

2-1/2 TON, 6X6, M44A2 SERIES TRUCKS (MULTIFUEL)

DOOR GLASS CHANNEL REPLACEMENT

REMOVAL AND INSTALLATION

INITIAL SETUP:

Applicable Models

All

Tools and Special Tools

General mechanic's tool kit
(item 116, WP 0469 00)

Hand riveting tool (item 86, WP 0469 00)

Materials/Parts

Pop rivet (item 313, WP 0470 00)

Equipment Condition

Parking brake set and wheels chocked
(TM 9-2320-361-10).

Battery ground cable disconnected
(WP 0126 00).

Cab door glass and frame removed
(WP 0210 00).

REMOVAL

1. Remove screw (2) and channel (3) from cab door (4).
2. Remove pop rivet (5) and channel (1) from cab door (4). Discard pop rivet (5).

INSTALLATION

1. Install channel (1) in cab door (4) with new pop rivet (5).
2. Install channel (3) in cab door (4) with screw (2).
3. Install cab door glass and frame (WP 0210 00).
4. Connect battery ground cable (WP 0126 00).
5. Release parking brake and remove wheel chocks (TM 9-2320-361-10).

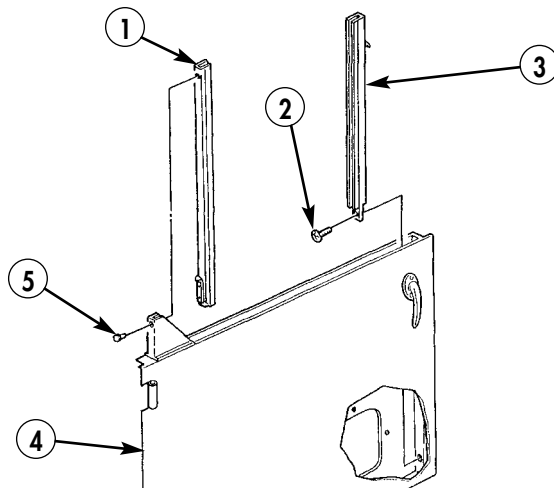

END OF WORK PACKAGE

0212 00-1/2 blank

FIELD MAINTENANCE INSTRUCTIONS

2-1/2 TON, 6X6, M44A2 SERIES TRUCKS (MULTIFUEL)

CAB DOOR WINDOW REGULATOR AND HANDLE REPLACEMENT

WINDOW REGULATOR HANDLE REMOVAL, CAB DOOR WINDOW REGULATOR REMOVAL,
CAB DOOR WINDOW REGULATOR INSTALLATION, AND WINDOW REGULATOR HANDLE INSTALLATION

INITIAL SETUP:

Applicable Models

All

Equipment Condition

Parking brake set and wheels chocked
(TM 9-2320-361-10).

Battery ground cable disconnected
(WP 0126 00).

Cab door glass removed (WP 0210 00).

CAB DOOR WINDOW REGULATOR AND HANDLE REPLACEMENT (Contd)

WINDOW REGULATOR HANDLE REMOVAL

Remove screw (6), window regulator handle (5), and washer (4) from cab door window regulator (7).

CAB DOOR WINDOW REGULATOR REMOVAL

NOTE

Cab door window regulator must be supported as last screw is removed.

1. Remove four screws (3) from inner door panel (2) and cab door window regulator (7).
2. Slide regulator arm stud (8) out of stationary track (9) and remove cab door window regulator (7) through cab door (1) inspection hole.

CAB DOOR WINDOW REGULATOR INSTALLATION

1. Install window regulator (7) through cab door (1) inspection hole and slide regulator arm stud (8) into stationary track (9).

NOTE

Regulator arm stud must be held in stationary track when installing window regulator to inner door panel.

2. Install window regulator (7) on inner door panel (2) with four screws (3).

WINDOW REGULATOR HANDLE INSTALLATION

1. Install washer (4) and window regulator handle (5) on window regulator (7) with screw (6).
2. Install cab door glass (WP 0210 00).
3. Connect battery ground cable (WP 0126 00).
4. Release parking brake and remove wheel chocks (TM 9-2320-361-10).

CAB DOOR WINDOW REGULATOR AND HANDLE REPLACEMENT (Contd)

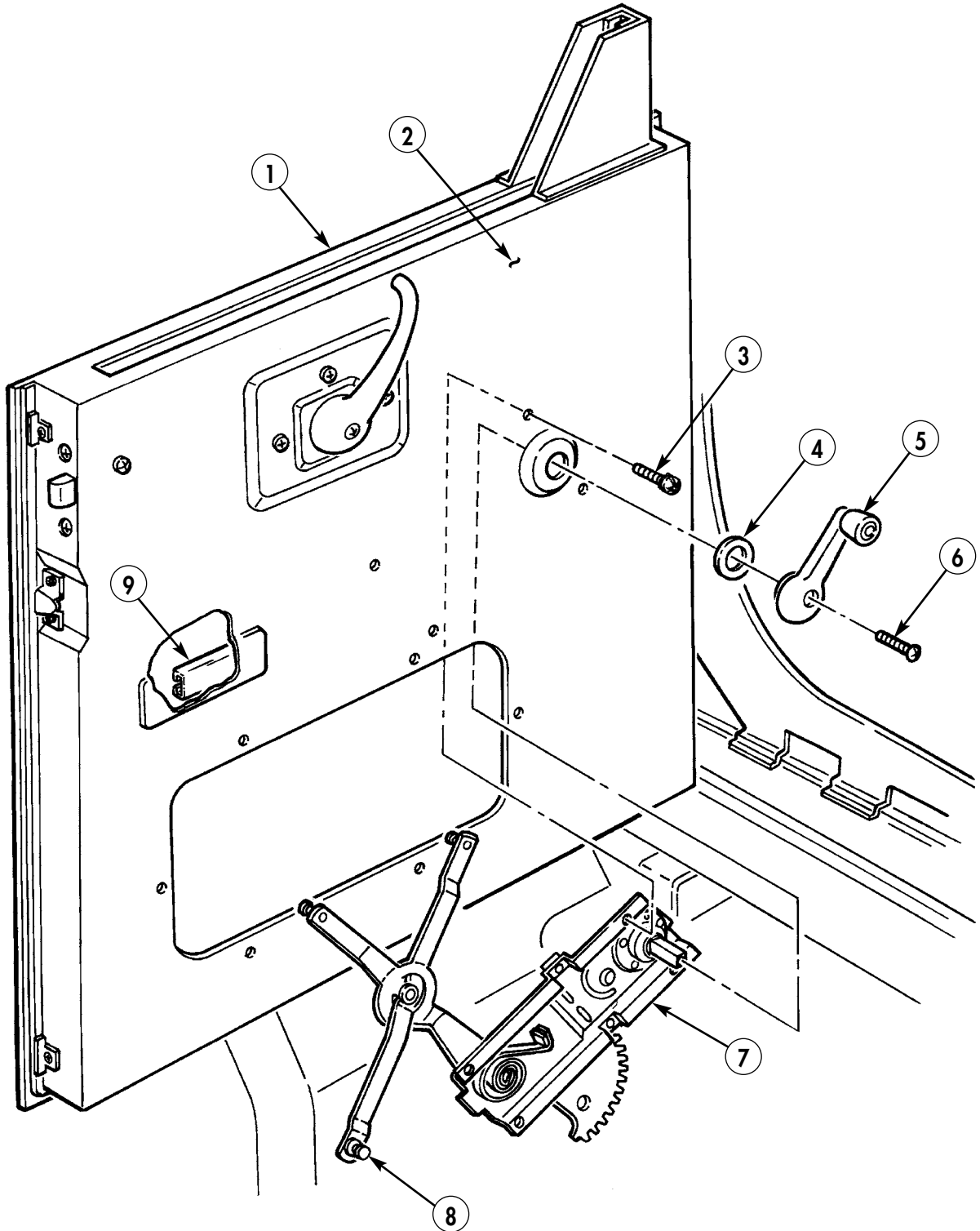

END OF WORK PACKAGE

FIELD MAINTENANCE INSTRUCTIONS

2-1/2 TON, 6X6, M44A2 SERIES TRUCKS (MULTIFUEL)

OUTSIDE DOOR HANDLE, INSIDE DOOR HANDLE, AND CAB DOOR LOCK REPLACEMENT

OUTSIDE DOOR HANDLE REMOVAL, INSIDE DOOR HANDLE REMOVAL, CAB DOOR LOCK REMOVAL, CAB DOOR LOCK INSTALLATION, INSIDE DOOR HANDLE INSTALLATION, OUTSIDE DOOR HANDLE INSTALLATION

INITIAL SETUP:

Applicable Models

All

Materials/Parts

Six screw-assembled lockwashers
(item 260, WP 0470 00)

Equipment Condition

Parking brake set and wheels chocked
(TM 9-2320-361-10).

Battery ground cable disconnected
(WP 0126 00).

Cab door inspection hole cover removed
(WP 0207 00).

OUTSIDE DOOR HANDLE, INSIDE DOOR HANDLE, AND CAB DOOR LOCK REPLACEMENT (Contd)

OUTSIDE DOOR HANDLE REMOVAL

1. Remove two screws (1) from door handle (9) and door (4).
2. Rotate door handle (9) 1/4 turn counterclockwise and remove from cab door (4).

INSIDE DOOR HANDLE REMOVAL

Remove screw (5), door handle (3), and washer (2) from cab door lock (8).

CAB DOOR LOCK REMOVAL

1. Remove six screw-assembled lockwashers (6) from cab door (4). Discard screw-assembled lockwashers (6).
2. Remove cab door lock (8) through inspection hole (7) in cab door (4).

CAB DOOR LOCK INSTALLATION

1. Install cab door lock (8) through inspection hole (7) in cab door (4).
2. Install cab door lock (8) on cab door (4) with six new screw-assembled lockwashers (4).

INSIDE DOOR HANDLE INSTALLATION

Install washer (2) and door handle (3) on cab door lock (8) with screw (5).

OUTSIDE DOOR HANDLE INSTALLATION

1. Install outside door handle (9) on cab door (4) with two screws (1).
2. Install cab door inspection hole cover (WP 0207 00).
3. Connect battery ground cable (WP 0126 00).
4. Release parking brake and remove wheel chocks (TM 9-2320-361-10).

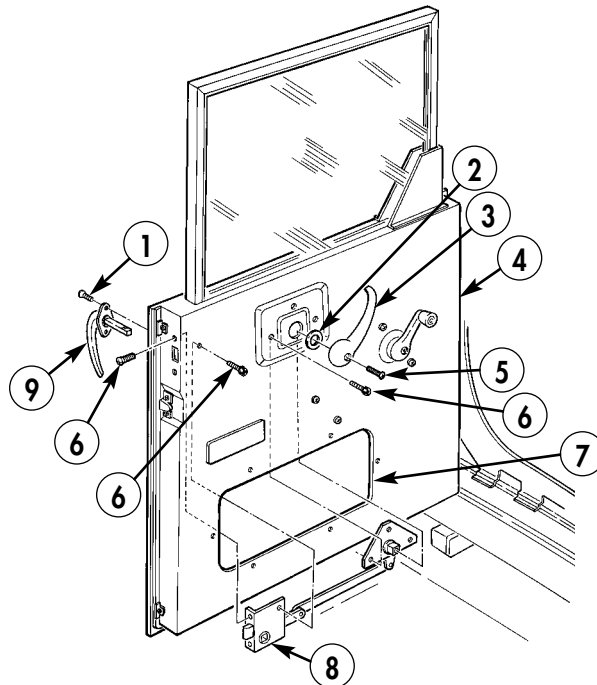

END OF WORK PACKAGE

FIELD MAINTENANCE INSTRUCTIONS

2-1/2 TON, 6X6, M44A2 SERIES TRUCKS (MULTIFUEL)

CAB DOOR CHECK ROD REPLACEMENT

REMOVAL AND INSTALLATION

INITIAL SETUP:

Applicable Models

All

Materials/Parts

Cotter pin (item 19, WP 0470 00)

Equipment Condition

Parking brake set and wheels chocked
(TM 9-2320-361-10).

Battery ground cable disconnected
(WP 0126 00).

REMOVAL

1. Remove cotter pin (1) from cab door check rod (2), pillar (4), and cab door (3). Discard cotter pin (1).
2. Open air vent door (6) and remove cab door check rod (2) and pad (5).
3. Remove pad (5) from rod (2).

INSTALLATION

1. Install pad (5) on cab door check rod (2), and insert cab door check rod (2) through pillar (4).
2. Connect cab door check rod (2) to cab door (3) with new cotter pin (1).
3. Close air vent door (6).
4. Connect battery ground cable (WP 0126 00).
5. Release parking brake and remove wheel chocks (TM 9-2320-361-10).

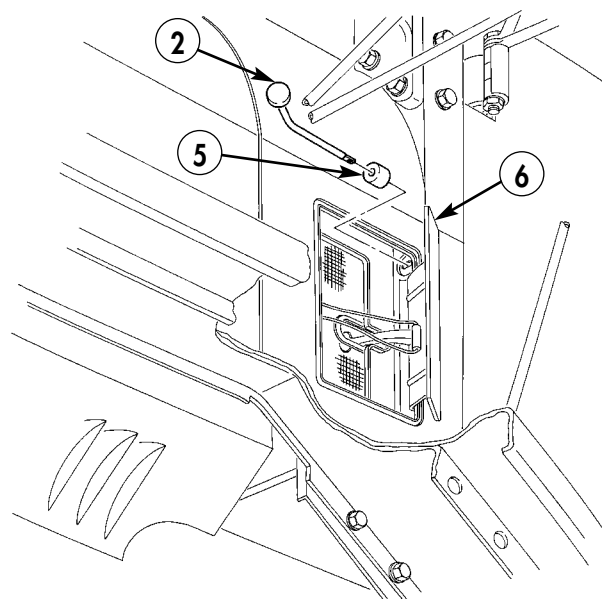
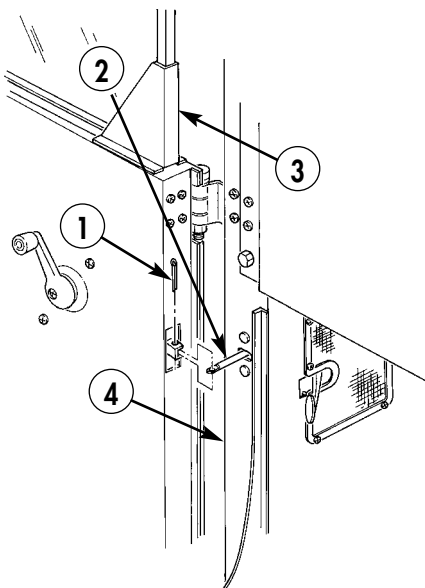

END OF WORK PACKAGE

0215 00-1/2 blank

FIELD MAINTENANCE INSTRUCTIONS

2-1/2 TON, 6X6, M44A2 SERIES TRUCKS (MULTIFUEL)

CAB DOOR CATCH REPLACEMENT

REMOVAL AND INSTALLATION

INITIAL SETUP:

Applicable Models

All

Materials/Parts

Two screw-assembled washers
(item 258, WP 0470 00)

Equipment Condition

Parking brake set and wheels chocked
(TM 9-2320-361-10).

Battery ground cable disconnected
(WP 0126 00).

REMOVAL

Remove two screw-assembled washers (3) and cab door catch (1) from cab body (2). Discard screw assembled washers (3).

INSTALLATION

1. Install cab door catch (1) on cab body (2) with two new screw-assembled washers (3).
2. Connect battery ground cable (WP 0126 00).
3. Release parking brake and remove wheel chocks (TM 9-2320-361-10).

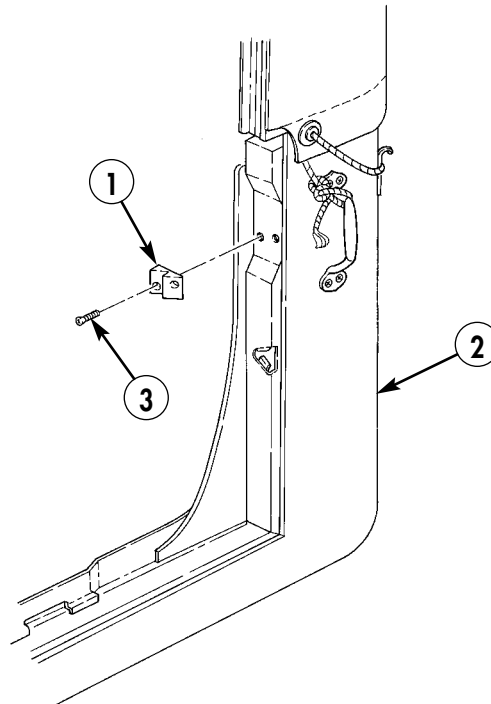

END OF WORK PACKAGE

0216 00-1/2 blank

FIELD MAINTENANCE INSTRUCTIONS

2-1/2 TON, 6X6, M44A2 SERIES TRUCKS (MULTIFUEL)

CAB DOOR WEATHERSEALS REPLACEMENT

CAB DOOR WEATHERSEALS REMOVAL, CAB DOOR HEAD WEATHERSEAL REMOVAL,
CAB DOOR PILLAR POSTS WEATHERSEALS REMOVAL, CAB DOOR PILLAR POSTS WEATHERSEALS INSTALLATION,
CAB DOOR HEAD WEATHERSEAL INSTALLATION, AND CAB DOOR WEATHERSEALS INSTALLATION

INITIAL SETUP:

Applicable Models

All

Materials/Parts

Adhesive (item 2, WP 0468 00)

Equipment Condition

Parking brake set and wheels chocked
(TM 9-2320-361-10).

Battery ground cable disconnected
(WP 0126 00).

CAB DOOR WEATHERSEALS REPLACEMENT (Contd)

CAB DOOR WEATHERSEALS REMOVAL

1. Remove five screws (12), clips (11), and cab door weatherseal (13) from cab door (14).
2. Remove cab door weatherseal (10) from cab door (14) and clean weatherseal (10) remains from cab door (14).

CAB DOOR HEAD WEATHERSEAL REMOVAL

1. Remove cab door head weatherseal (4) from retainer (3).
2. Remove nine screws (2) and retainer (3) from cab soft top post (6).

CAB DOOR PILLAR POSTS WEATHERSEALS REMOVAL

1. Remove pillar post weatherseals (7), (15), and (8) from retainers (17), (1), and (5).
2. Remove twelve screws (9) and (16) and retainers (1), (5), and (17) from pillar post (18) and cab soft top post (6).

CAB DOOR PILLAR POSTS WEATHERSEALS INSTALLATION

1. Install retainers (1), (5), and (17) on pillar post (18) and cab soft top post (6) with twelve screws (9) and (16).
2. Install pillar post weatherseals (7), (15), and (8) on retainers (17), (1), and (5).

CAB DOOR HEAD WEATHERSEAL INSTALLATION

1. Install retainer (3) on cab soft top post (6) with nine screws (2).
2. Install cab door head weatherseal (4) on retainer (3).

CAB DOOR WEATHERSEALS INSTALLATION

1. Apply adhesive to mounting side of cab door weatherseal (13) and cab door (14) mounting surface.
2. Install cab door weatherseal (13) on cab door (14) with five screws (12) and clips (11).
3. Apply adhesive to mounting side of cab door weatherseal (10) and cab door (14) mounting surface.
4. Install cab door weatherseal (10) on cab door (14).
5. Connect battery ground cable (WP 0126 00).
6. Release parking brake and remove wheel chocks (TM 9-2320-361-10).

CAB DOOR WEATHERSEALS REPLACEMENT (Contd)

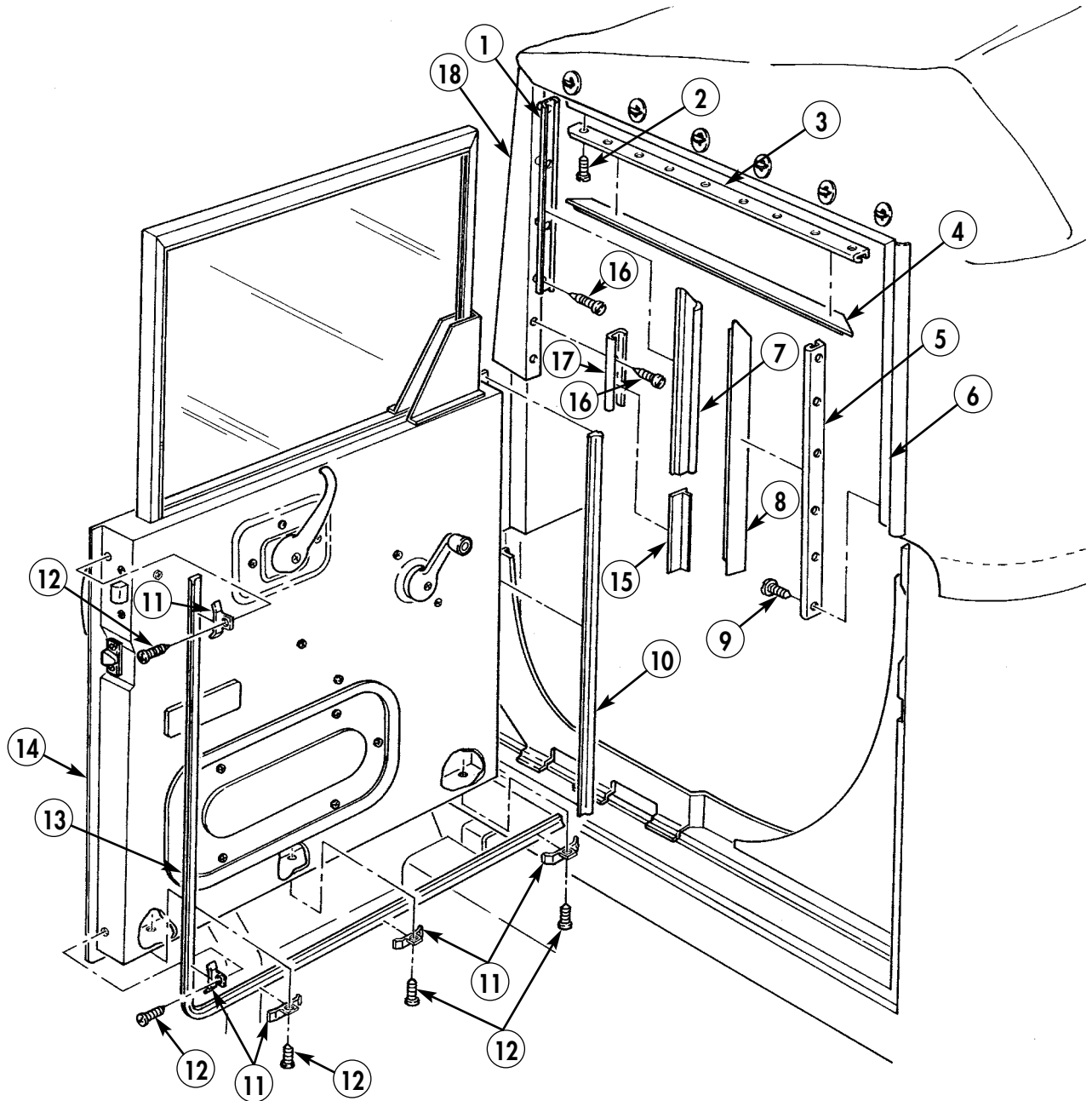

END OF WORK PACKAGE

FIELD MAINTENANCE INSTRUCTIONS

2-1/2 TON, 6X6, M44A2 SERIES TRUCKS (MULTIFUEL)

SIDE PANEL REPLACEMENT

SIDE PANEL REMOVAL, SIDE PANEL HINGES REMOVAL, THUMB CRANKS REMOVAL,
THUMB CRANKS INSTALLATION, SIDE PANEL HINGES INSTALLATION, AND SIDE PANEL INSTALLATION

INITIAL SETUP:

Applicable Models

All

Materials/Parts

Twelve locknuts (item 145, WP 0470 00)

Equipment Condition

Parking brake set and wheels chocked
(TM 9-2320-361-10).

Hood raised and secured (TM 9-2320-361-10).

Battery ground cable disconnected
(WP 0126 00).

SIDE PANEL REPLACEMENT (Contd)

SIDE PANEL REMOVAL

1. Loosen clamp (15) and remove rain hood (17) from air intake (16).
2. Turn thumb cranks (2) to unlock side panel (4) from fender (9).
3. Raise spring clip (7) and remove side panel (4) from fender (9) by sliding side panel (4) forward until free from vehicle.

SIDE PANEL HINGES REMOVAL

1. Remove four locknuts (5), washers (6), screws (14), spring clip (7), and two hinges (8) from side panel (4). Discard locknuts (5).
2. Remove four locknuts (11), washers (10), screws (13), and two hinges (12) from fender (9). Discard locknuts (11).

THUMB CRANKS REMOVAL

NOTE

Perform step 1 if side panel has not been removed.

1. Turn thumb cranks (2) to unlock side panel (4) from fender (9).
2. Remove four locknuts (3), screws (1), and two thumb cranks (2) from side panel (4). Discard locknuts (3).

THUMB CRANKS INSTALLATION

1. Install two thumb cranks (2) on side panel (4) with four screws (1) and new locknuts (3).

NOTE

Perform step 2 if side panel was removed.

2. Lock side panel (4) to fender (9) by turning thumb cranks (2).

SIDE PANEL HINGES INSTALLATION

1. Install two hinges (12) on fender (9) with four screws (13), washers (10), and new locknuts (11).
2. Install two hinges (8) and spring clip (7) on side panel (4) with four screws (14), washers (6), and new locknuts (5).

SIDE PANEL INSTALLATION

1. With hinges (8) and (12) aligned, raise spring clip (7), and install side panel (4) on fender (9) by sliding side panel (4) to rear until in place.
2. Lock side panel (4) to fender (9) by turning thumb cranks (2).
3. Install rain hood (17) on air intake (16) with clamp (15).
4. Connect battery ground cable (WP 0126 00).
5. Lower and secure hood (TM 9-2320-361-10).
6. Release parking brake and remove wheel chocks (TM 9-2320-361-10).

SIDE PANEL REPLACEMENT (Contd)

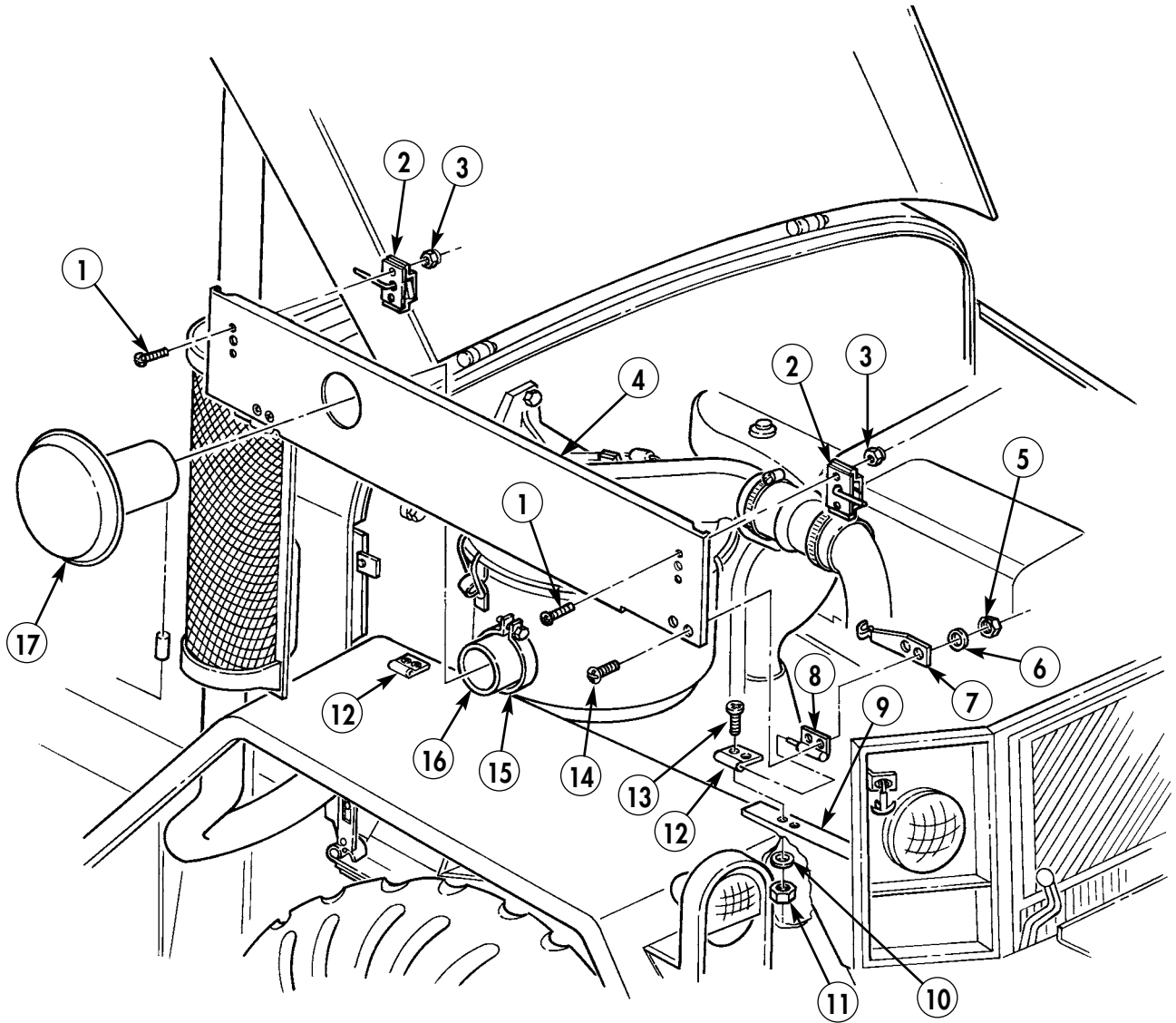

END OF WORK PACKAGE

FIELD MAINTENANCE INSTRUCTIONS

2-1/2 TON, 6X6, M44A2 SERIES TRUCKS (MULTIFUEL)

HEADLIGHT BRACKET AND RUBBER RADIATOR SHIELD REPLACEMENT

REMOVAL AND INSTALLATION

INITIAL SETUP:

Applicable Models

All

Materials/Parts

Six rivets (item 435, WP 0470 00)

References

TM 9-2320-361-10

Equipment Condition

Parking brake set and wheels chocked
(TM 9-2320-361-10).

Battery ground cable disconnected
(WP 0126 00).

Brush guard removed (WP 0203 00).

Sealed beam and headlight housing removed
(WP 0120 00).

Blackout drive lamp and housing removed
(WP 0123 00).

HEADLIGHT BRACKET REPLACEMENT (Contd)

REMOVAL

1. Remove two screws (5), washers (4), and brace (7) from front fender (1) and headlight bracket (11).
2. Remove three nuts (17), washers (16) and (13), and screws (12) from headlight bracket (11).
3. Remove two nuts (15), washers (14), and screws (6) from front hinge (2) and side panel (3).
4. Remove two nuts (18), washers (19), screws (8), and headlight bracket (11) from front fender (1).
5. Remove three rivets (9) and rubber radiator shield (10) from headlight bracket (11).

INSTALLATION

1. Install rubber radiator shield (10) on headlight bracket (11) with three rivets (9).
2. Install headlight bracket (11) on front fender (1) with two nuts (18), washers (19), and screws (8).
3. Install front hinge (2) on side panel (3) with two nuts (15), washers (14), and screws (6).
4. Install headlight bracket (11) on front fender (1) with three nuts (17), washers (16) and (13), and screws (12).
5. Install brace (7) on headlight bracket (11) and front fender (1) with two washers (4) and screws (5).
6. Install blackout drive lamp and housing (WP 0123 00).
7. Install sealed beam and headlight housing (WP 0120 00).
8. Install brush guard (WP 0203 00).
9. Connect battery ground cable (WP 0126 00).
10. Release parking brake and remove wheel chocks (TM 9-2320-361-10).

HEADLIGHT BRACKET REPLACEMENT (Contd)

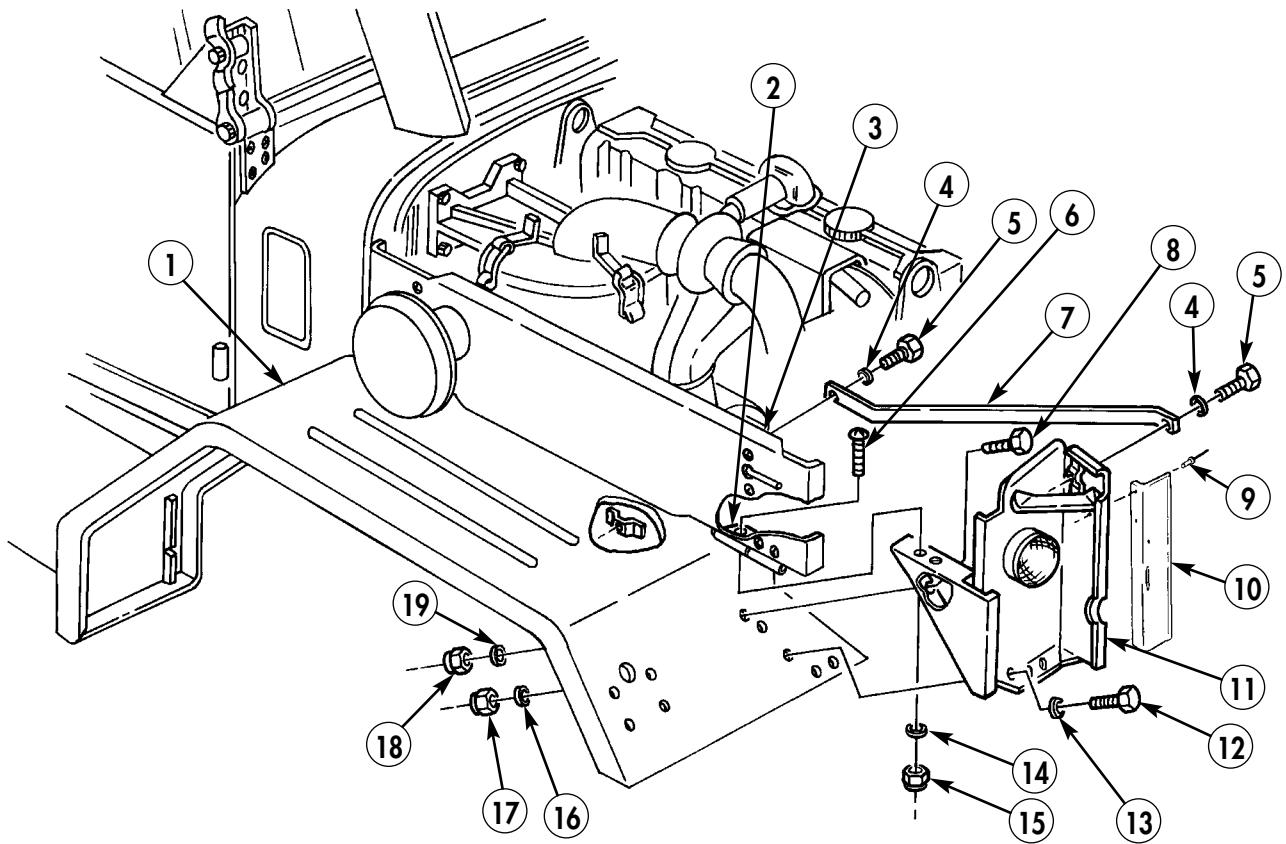

END OF WORK PACKAGE

FIELD MAINTENANCE INSTRUCTIONS

2-1/2 TON, 6X6, M44A2 SERIES TRUCKS (MULTIFUEL)

HOOD FASTENERS REPLACEMENT

HOOD HOLDDOWN FASTENER AND BRACKET REMOVAL, SAFETY LATCH REMOVAL,
HOOD SUPPORT HOOK REMOVAL, HOOD SUPPORT HOOK INSTALLATION,
SAFETY LATCH INSTALLATION, AND HOOD HOLDDOWN FASTENER AND BRACKET INSTALLATION

INITIAL SETUP:

Applicable Models

All

Materials/Parts

Four locknuts (item 144, WP 0470 00)

Two locknuts (item 145, WP 0470 00)

Two locknuts (item 155, WP 0470 00)

Equipment Condition

Parking brake set and wheels chocked
(TM 9-2320-361-10).

Battery ground cable disconnected
(WP 0126 00).

Left side panel lowered (TM 9-2320-361-10).

HOOD FASTENERS REPLACEMENT (Contd)

NOTE

Hood holddown, companion seat fastener, and windshield holddown fasteners are replaced basically the same. Some fasteners have additional hardware and reinforcements. This procedure covers the hood holddown fastener only.

HOOD HOLDDOWN FASTENER AND BRACKET REMOVAL

1. Unlatch fastener (15) from bracket (13).
2. Raise and secure hood (10).
3. Remove two locknuts (11), screws (16), and fastener (15) from brush guard (17) Discard locknuts (11).
4. Remove two locknuts (12), screws (14), and bracket (13) from hood (10). Discard locknuts (12).

SAFETY LATCH REMOVAL

Remove two locknuts (20), screws (18), and safety latch (19) from hood (10). Discard locknuts (20).

HOOD SUPPORT HOOK REMOVAL

1. Lower hood (10).
2. Remove hook (7) from clip (9).
3. Remove screw (8) and clip (9) from cowling (1).
4. Remove locknut (3), washer (4), nut (6), and hook (7) from bolt (5). Discard locknut (3).
5. Remove locknut (2) and bolt (5) from cowling (1). Discard locknut (2).

HOOD SUPPORT HOOK INSTALLATION

1. Install nut (6), bolt (5), washer (4), and new locknut (3) on hook (7). Install assembled hook (7) on cowling (1) with new locknut (2).
2. Install clip (9) on cowling (1) with screw (8).
3. Install hook (7) on clip (9).

SAFETY LATCH INSTALLATION

1. Raise and secure hood (10).
2. Install safety latch (19) on hood (10) with two screws (18) and new locknuts (20).

HOOD HOLDDOWN FASTENER AND BRACKET INSTALLATION

1. Install bracket (13) on hood (10) with two screws (14) and new locknuts (12).
2. Install fastener (15) on brush guard (17) with two screws (16) and new locknuts (11).
3. Lower and secure hood (10).
4. Latch fastener (15) on bracket (13).
5. Raise left side panel and secure (TM 9-2320-361-10).
6. Connect battery ground cable (WP 0126 00).
7. Release parking brake and remove wheel chocks (TM 9-2320-361-10).

HOOD FASTENERS REPLACEMENT (Contd)

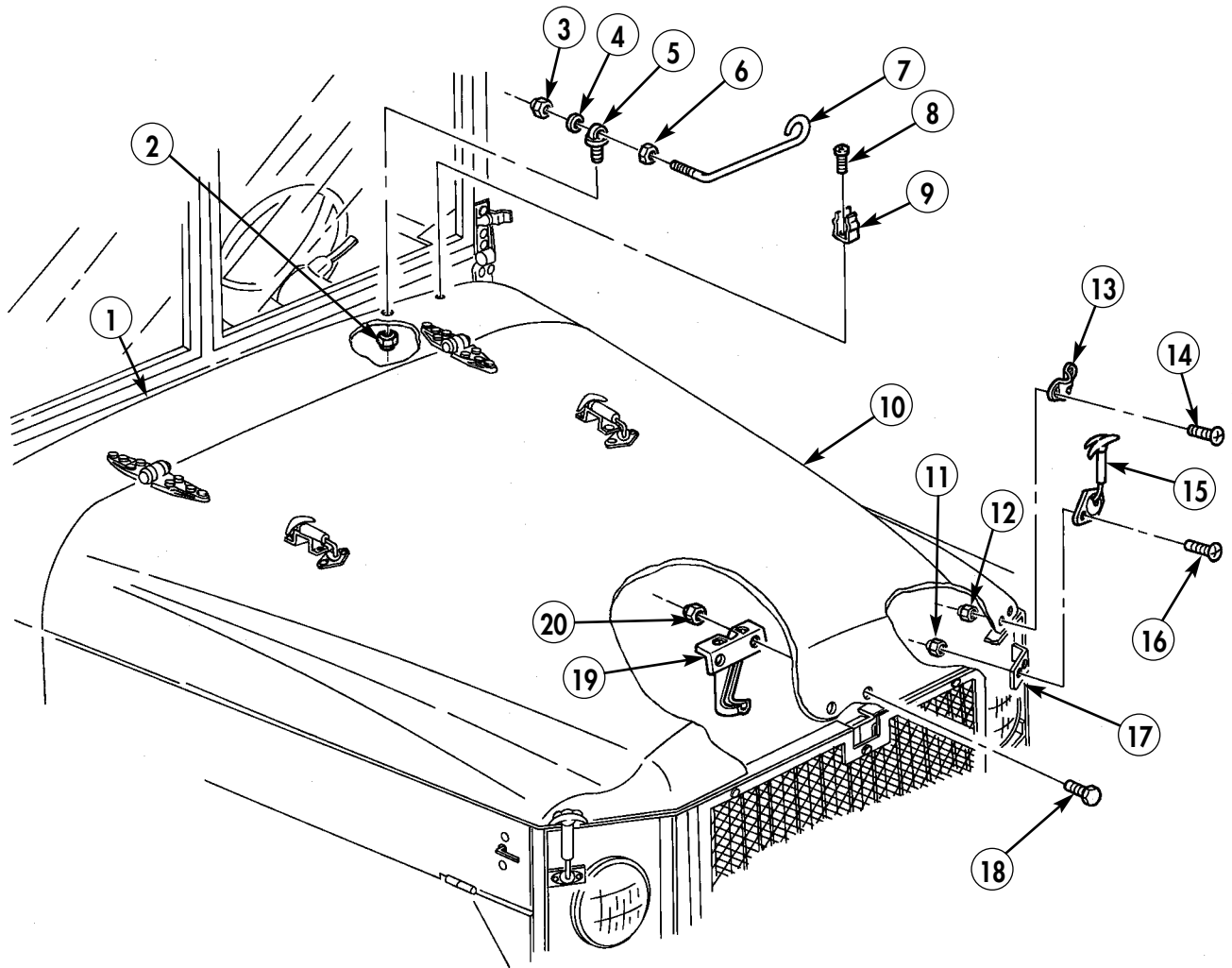

END OF WORK PACKAGE

FIELD MAINTENANCE INSTRUCTIONS

2-1/2 TON, 6X6, M44A2 SERIES TRUCKS (MULTIFUEL)

HOOD MAINTENANCE

REMOVAL, REPAIR, AND INSTALLATION

INITIAL SETUP:

Applicable Models

All

Materials/Parts

Eight locknuts (item 145, WP 0470 00)
Eight lockwashers (item 411, WP 0470 00)
Eight split rivets (item 320, WP 0470 00)
Adhesive (item 3, WP 0468 00)

Personnel Required

Two

References

TB 43-0209
TC 9-510
TC 9-237

Equipment Condition

Parking brake set and wheels chocked
(TM 9-2320-361-10).
Battery ground cable disconnected
(WP 0126 00).
Hood holddown fasteners and brackets
removed (WP 0220 00).
Windshield holddown fasteners and brackets
removed (WP 0228 00).

HOOD MAINTENANCE (Contd)

WARNING

Hood is large and heavy. An assistant is required during removal and installation to prevent injury to personnel.

REMOVAL

1. Raise hood (9) and remove eight split rivets (13) and two rubber bumpers (12) from hood (9). Discard split rivets (7).

NOTE

Assistant will help with step 2.

2. Remove eight screws (1), lockwashers (2), two reinforcements (4), and hood (9) from two hinges (3). Discard lockwashers (2).
3. Unlatch windshield holddown fastener (7) from bracket (6).
4. Remove two locknuts (11), screws (5), and bracket (6) from hood (9). Discard locknuts (11).
5. Remove two locknuts (11), screws (8), fastener (7) and reinforcement (10) from hood (9). Discard locknuts (11).
6. Remove adhesive remains from hood.

REPAIR

1. Refer to TM 9-237 for welding repair.
2. Refer to TC 9-510 for metal body repair.
3. Refer to TB 43-0209 for rustproofing instructions.

INSTALLATION

NOTE

Assistant will help with step 4.

1. Install windshield holddown fastener (7) on hood (9) with two screws (8), reinforcement (10), and new locknuts (11).
2. Install bracket (6) on hood (9) with two screws (5) and new locknuts (11).
3. Latch windshield holddown fastener (7) to bracket (6).
4. Install hood (9) on two hinges (3) with two reinforcements (4), eight new lockwashers (2), and screws (1).
5. Apply adhesive to rubber bumpers (12).
6. Install two rubber bumpers (12) on hood (9) with eight new split rivets (13).
7. Install windshield holddown fasteners and brackets (WP 0228 00).
8. Install hood holddown fasteners and brackets (WP 0220 00).
9. Connect battery ground cable (WP 0126 00).
10. Release parking brake and remove wheel chocks (TM 9-2320-361-10).

HOOD MAINTENANCE (Contd)

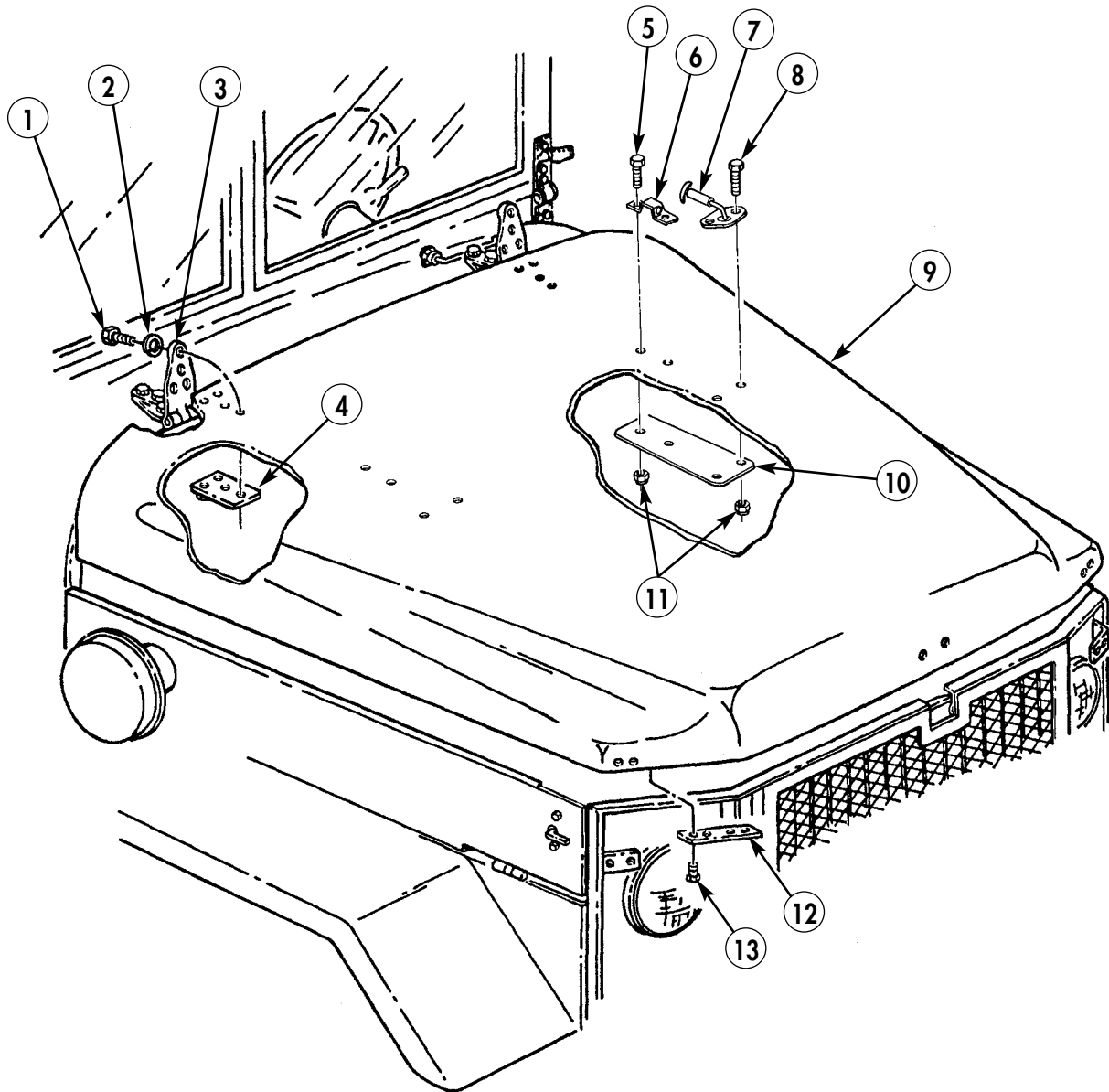

END OF WORK PACKAGE

FIELD MAINTENANCE INSTRUCTIONS

2-1/2 TON, 6X6, M44A2 SERIES TRUCKS (MULTIFUEL)

HOOD HINGES REPLACEMENT

REMOVAL AND INSTALLATION

INITIAL SETUP:

Applicable Models

All

Personnel Required

Two

Materials/Parts

Eight lockwashers (item 411, WP 0470 00)

Equipment Condition

Parking brake set and wheels chocked
(TM 9-2320-361-10).

Hood raised and secured (TM 9-2320-361-10).

Battery ground cable disconnected
(WP 0126 00).

Glove compartment removed (WP 0225 00).

HOOD HINGES REPLACEMENT (Contd)

WARNING

Keep fingers clear of hood and cowling when replacing hinge.
Failure to do so may result in injury to personnel.

REMOVAL

NOTE

Assistant will help with step 1.

1. Remove four screws (1), lockwashers (9), and reinforcement (8) from hinge (9) and cowling (3). Discard lockwashers (9).
2. Remove four screws (2), lockwashers (5), reinforcement (6), and hinge (9) from hood (4) and cowling (3). Discard lockwashers (5).

INSTALLATION

1. Install hinge (9) and reinforcement (6) on hood (4) with four new lockwashers (5) and screws (2).

NOTE

Assistant will help with step 2.

2. Install hinge (9) and reinforcement (8) on cowling (3) with four new lockwashers (9) and screws (1).
3. Install glove compartment (WP 0225 00).
4. Connect battery ground cable (WP 0126 00).
5. Lower and secure hood (TM 9-2320-361-10).
6. Release parking brake and remove wheel chocks (TM 9-2320-361-10).

HOOD HINGES REPLACEMENT (Contd)

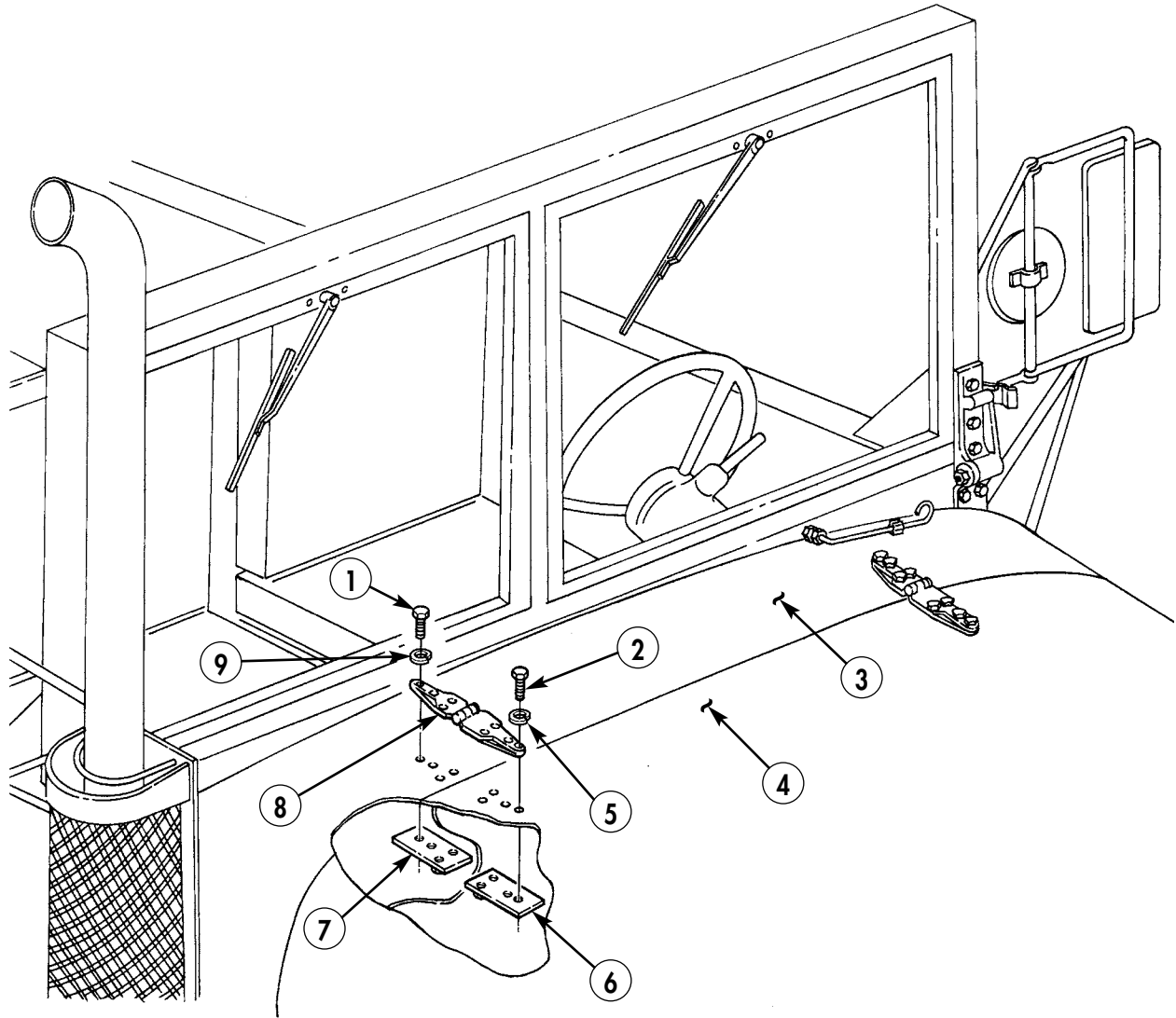

END OF WORK PACKAGE

FIELD MAINTENANCE INSTRUCTIONS

2-1/2 TON, 6X6, M44A2 SERIES TRUCKS (MULTIFUEL)

CAB HANDLE REPLACEMENT

REMOVAL AND INSTALLATION

INITIAL SETUP:

Applicable Models

All

Equipment Condition

Parking brake set and wheels chocked
(TM 9-2320-361-10).

Materials/Parts

Four locknuts (item 145, WP 0470 00)

REMOVAL

1. Remove soft top rope (2) from cab handle (4).
2. Remove four screws (5), locknuts (6), plate (1), and cab handle (4) from cab (3). Discard locknuts (6).

INSTALLATION

1. Install cab handle (4) and plate (1) on cab (3) with four screws (5) and new locknuts (6).
2. Tie soft top rope (2) on cab handle (4).
3. Release parking brake and remove wheel chocks (TM 9-2320-361-10).

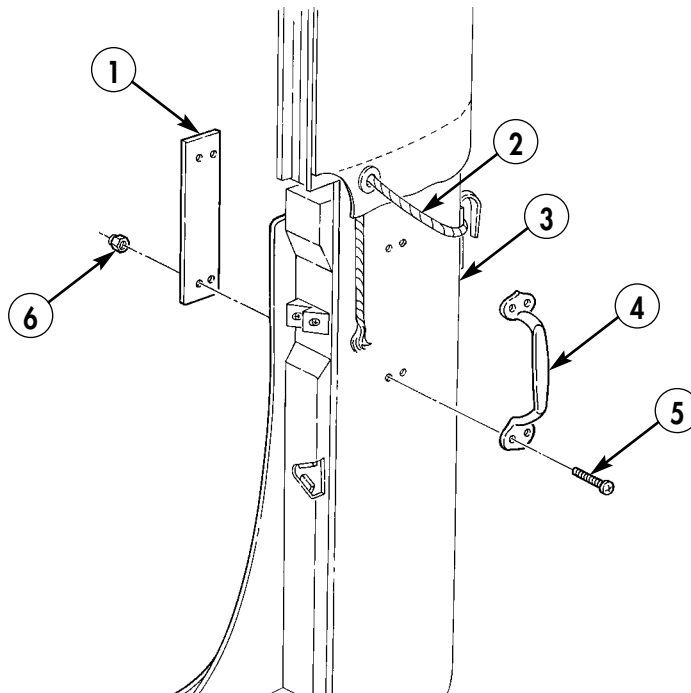

END OF WORK PACKAGE

0223 00-1/2 blank

FIELD MAINTENANCE INSTRUCTIONS

2-1/2 TON, 6X6, M44A2 SERIES TRUCKS (MULTIFUEL)

CAB COWL VENT REPLACEMENT

REMOVAL AND INSTALLATION

INITIAL SETUP:

Applicable Models

All

Materials/Parts

Cotter pin (item 30, WP 0470 00)

Adhesive (item 5, WP 0468 00)

Equipment Condition

Parking brake set and wheels chocked
(TM 9-2320-361-10).

Battery ground cable disconnected
(WP 0126 00).

CAB COWL VENT REPLACEMENT (Contd)

REMOVAL

1. Remove nine screws (4) and cowl vent screen (5) from kick panel (1).
2. Remove cotter pin (8), hinge pin (3), and cab cowl vent door (6) from bracket (2). Discard cotter pin (8).
3. Inspect cab cowl vent door seal (7). If damaged, clean cab cowling seal mounting surface (9) free of seal (7) debris and replace seal (7).

INSTALLATION

NOTE

Perform steps 1 and 2 only if seal was removed.

1. Apply adhesive to mounting side of seal (7) and cowling seal mounting surface (9).
2. Install seal (7) on cab cowling seal mounting surface (9).
3. Install cab cowl vent door (6) and hinge pin (3) on bracket (2) with new cotter pin (8).
4. Install cab cowl vent screen (5) on kick panel (1) with nine screws (4).
5. Connect battery ground cable (WP 0126 00).
6. Release parking brake and remove wheel chocks (TM 9-2320-361-10).

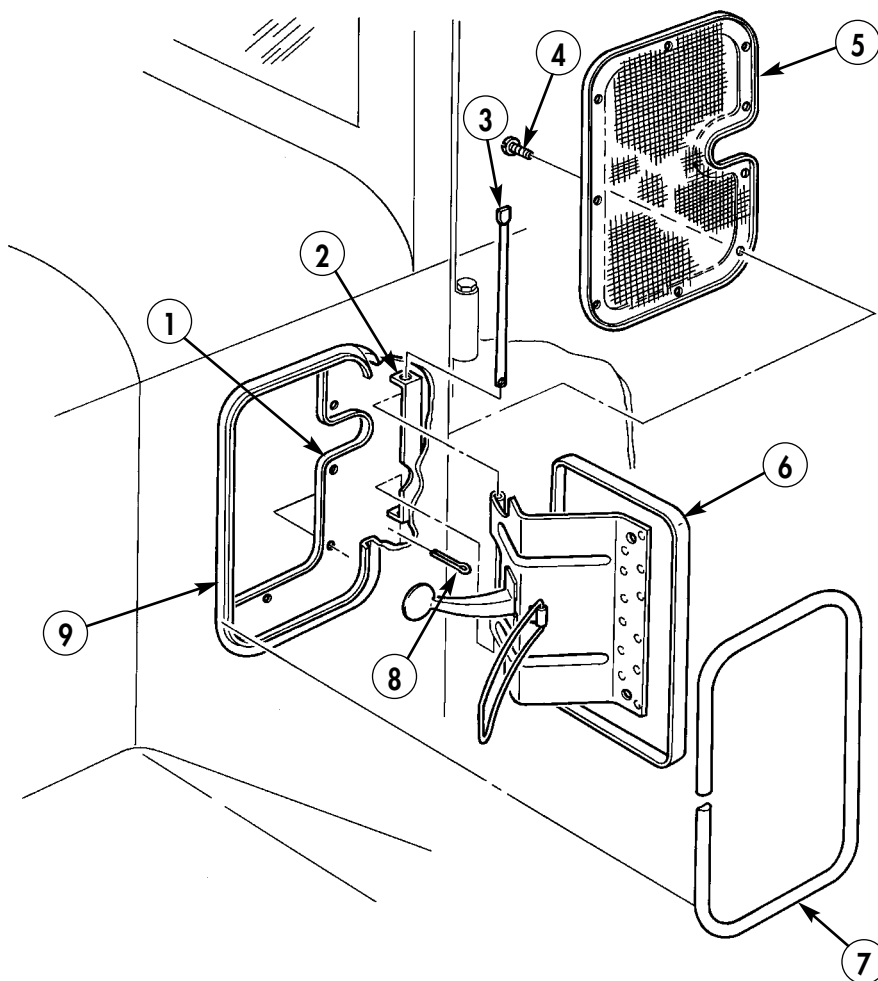

END OF WORK PACKAGE

FIELD MAINTENANCE INSTRUCTIONS

2-1/2 TON, 6X6, M44A2 SERIES TRUCKS (MULTIFUEL)

GLOVE COMPARTMENT REPLACEMENT

REMOVAL AND INSTALLATION

INITIAL SETUP:

Applicable Models

All

Materials/Parts

Adhesive (item 5, WP 0468 00)

Equipment Condition

Parking brake set and wheels chocked
(TM 9-2320-361-10).

Battery ground cable disconnected
(WP 0126 00).

GLOVE COMPARTMENT REPLACEMENT (Contd)

REMOVAL

1. Remove two screws (2) and bracket (3) from instrument panel (4).
2. Remove ten screws (9) and glove compartment (1) from instrument panel (4).
3. Remove four nuts (5), screws (7), and glove compartment door (6) from instrument panel (4).

NOTE

Perform step 4 if glove compartment door is damaged.

4. Inspect glove compartment door seal (8). If damaged, clean glove compartment door (6) seal mounting surface free of seal (8) debris and replace seal (8).

INSTALLATION

NOTE

Perform steps 1 and 2 only if seal was removed.

1. Apply adhesive to glove compartment door (6) seal mounting surface and mounting side of seal (8).
2. Install seal (8) on glove compartment door (6).
3. Install bracket (3) on instrument panel (4) with two screws (2).
4. Install glove compartment door (6) on instrument panel (4) with four screws (7) and nuts (5).
5. Install glove compartment (1) on instrument panel (4) with ten screws (9).
6. Connect battery ground cable (WP 0126 00).
7. Release parking brake and remove wheel chocks (TM 9-2320-361-10).

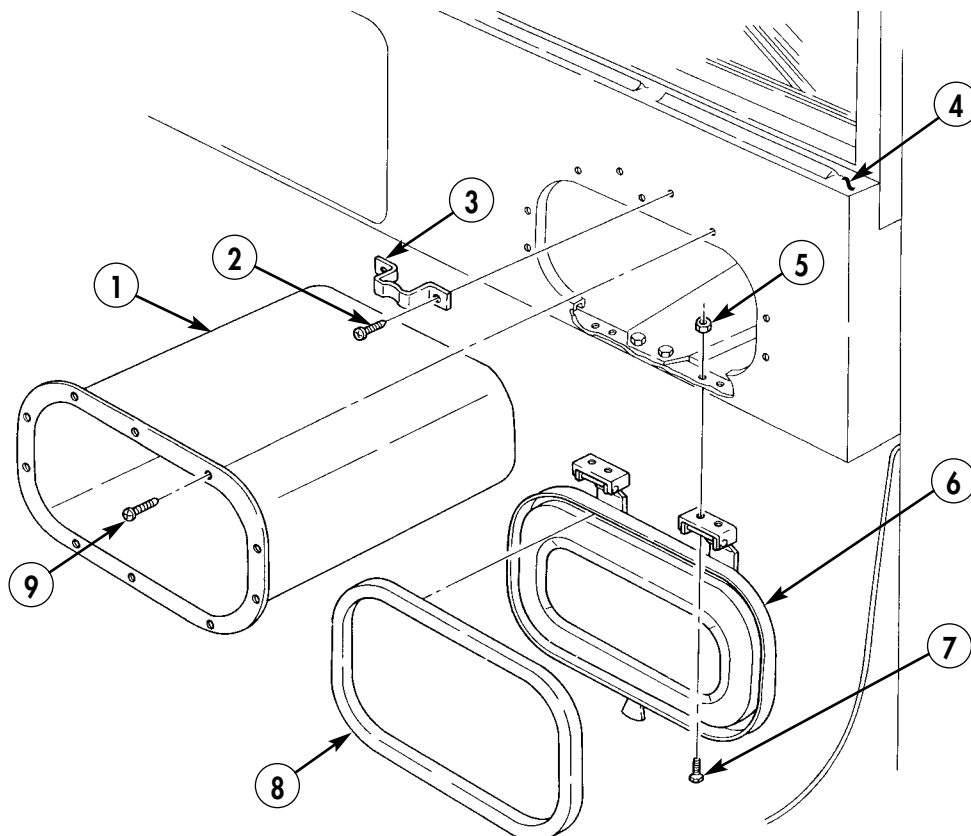

END OF WORK PACKAGE

FIELD MAINTENANCE INSTRUCTIONS

2-1/2 TON, 6X6, M44A2 SERIES TRUCKS (MULTIFUEL)

TOOLBOX (UNDER CAB) REPLACEMENT

REMOVAL AND INSTALLATION

INITIAL SETUP:

Applicable Models

All

Materials/Parts

Eighteen locknuts (item 145, WP 0470 00)

Equipment Condition

Parking brake set and wheels chocked
(TM 9-2320-361-10).

Battery ground cable disconnected
(WP 0126 00).

Water can bracket and running board removed
(WP 0232 00).

REMOVAL

Remove eighteen locknuts (3), screws (4), and toolbox (1) from two supports (2). Discard locknuts (3).

INSTALLATION

1. Install toolbox (1) on two supports (2) with eighteen screws (4) and new locknuts (3).
2. Install water can bracket and running board (WP 0232 00).
3. Connect battery ground cable (WP 0126 00).
4. Release parking brake and remove wheel chocks (TM 9-2320-361-10).

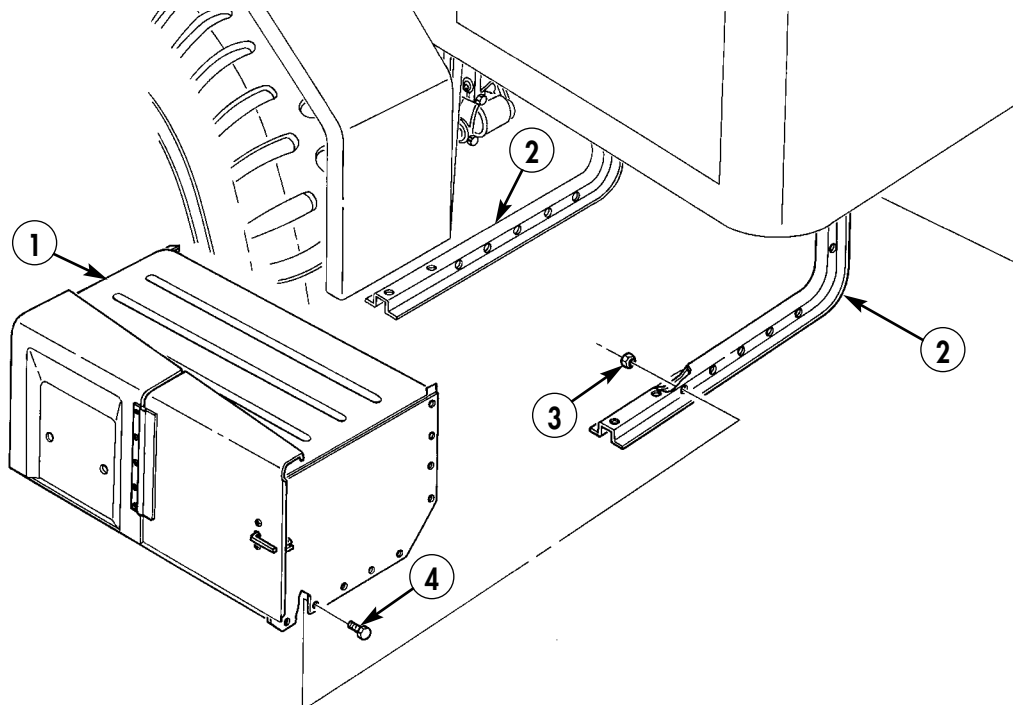

END OF WORK PACKAGE

0226 00-1/2 blank

FIELD MAINTENANCE INSTRUCTIONS

2-1/2 TON, 6X6, M44A2 SERIES TRUCKS (MULTIFUEL)

WINDSHIELD GLASS REPLACEMENT

REMOVAL AND INSTALLATION

INITIAL SETUP:

Applicable Models

All

Tools and Special Tools

General mechanic's tool kit
(item 116, WP 0469 00)

Materials/Parts

Two lockwashers (item 215, WP 0470 00)
Four filler strips (item 423, WP 0470 00)
Adhesive (item 3, WP 0468 00)

Equipment Condition

Windshield arm, glass, and handle removed
(WP 0229 00).

WINDSHIELD GLASS REPLACEMENT (Contd)

REMOVAL

1. Remove six screws (1), two nuts (4), four washers (9), and two lockwashers (3) from windshield frame (8). Discard lockwashers (3).
2. Remove crosspiece (2) from windshield frame (8).

NOTE

Prior to removal, measure old frame filler strips for installation.

3. Remove crosspiece filler strip (5) from crosspiece (2). Discard crosspiece filler strip (5).
4. Remove glass (6) and frame filler strips (7) from windshield frame (8). Discard frame filler strips (7).

INSTALLATION

NOTE

Cut four new filler strips to size.

1. Apply adhesive to new frame filler strips (7). Install new frame filler strips (7) on glass (6).
2. Install glass (6) in windshield frame (8). Tap glass (6) gently into position.
3. Apply adhesive to new crosspiece filler strip (5). Install new crosspiece filler strip (5) on glass (6).
4. Install crosspiece (2) on windshield frame (8) and gently tap until screw holes align.
5. Install crosspiece (2) on windshield frame (8) with six screws (1), four washers (9), two new lockwashers (3), and nuts (4). Trim excess filler strips (7) and (5) and adhesive from around glass (6).
6. Install windshield arm, glass, and handle (WP 0229 00).

WINDSHIELD GLASS REPLACEMENT (Contd)

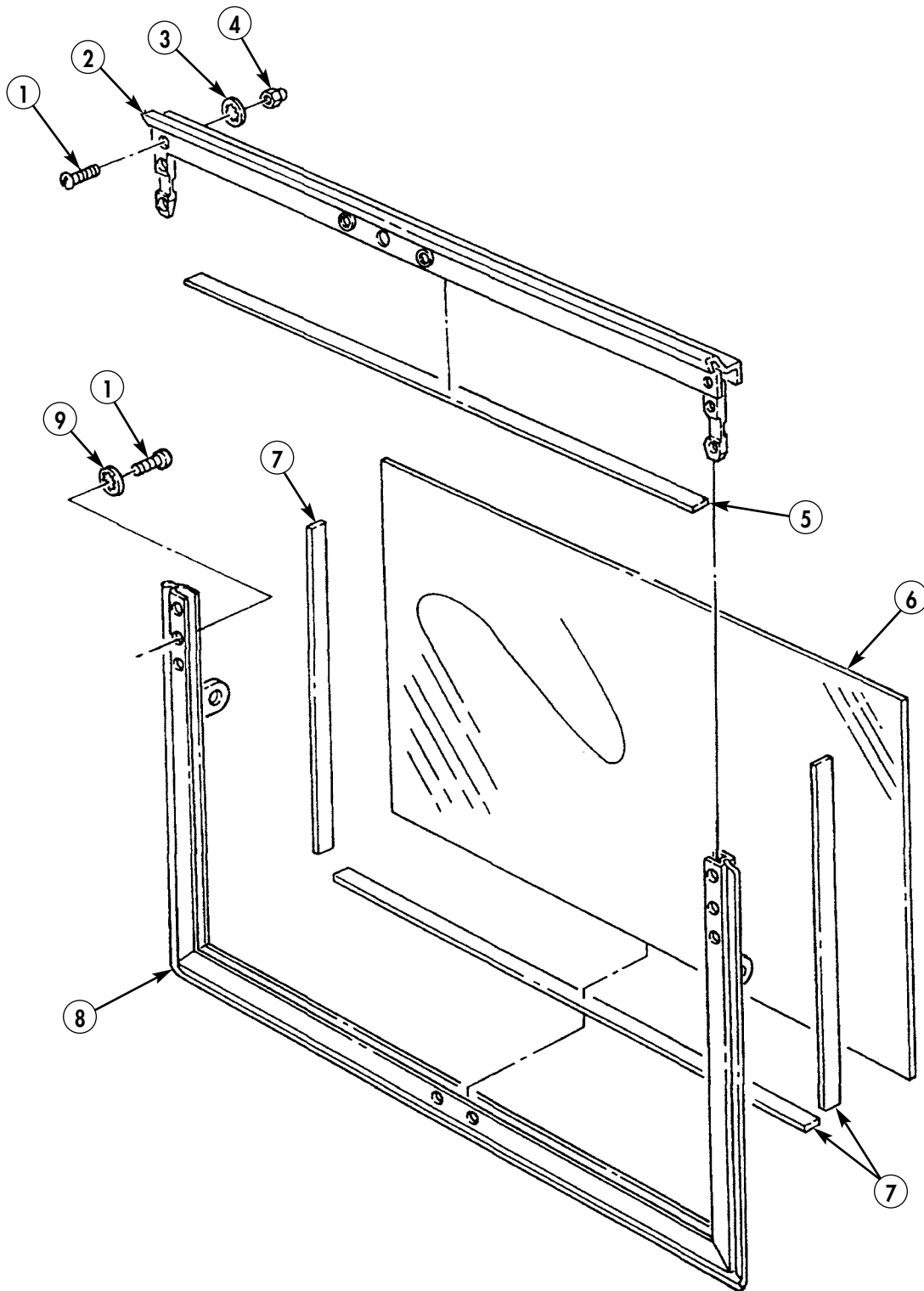

END OF WORK PACKAGE

0227 00-3/4 blank

FIELD MAINTENANCE INSTRUCTIONS

2-1/2 TON, 6X6, M44A2 SERIES TRUCKS (MULTIFUEL)

WINDSHIELD ASSEMBLY MAINTENANCE REMOVAL, DISASSEMBLY, ASSEMBLY, AND INSTALLATION

INITIAL SETUP:

Applicable Models

All

Personnel Required

Two

Materials/Parts

Lockwasher (item 195, WP 0470 00)
Two lockwashers (item 198, WP 0470 00)
Two locknuts (item 129, WP 0470 00)
Weatherstrip (item 379, WP 0470 00)
Two weatherstrips (item 378, WP 0470 00)

Materials/Parts (Contd)

Six screw-assembled lockwashers
(item 273, WP 0470 00)
Twelve screw-assembled lockwashers
(item 255, WP 0470 00)
Adhesive (item 5, WP 0468 00)

Equipment Condition

Parking brake set and wheels chocked
(TM 9-2320-361-10).
Battery ground cable disconnected
(WP 0126 00).
Soft top removed (TM 9-2320-361-10).
Windshield wiper switch, motor, and conlink
covers removed (WP 0240 00).
Conlinks removed (WP 0241 00).

WINDSHIELD ASSEMBLY MAINTENANCE (Contd)

WARNING

Windshield is heavy. An assistant is required during removal and installation to prevent injury to personnel.

REMOVAL

NOTE

Perform steps 1 through 3 for vehicles equipped with hardtop kit.

1. Remove two screws (12) and lockwashers (11) from cab hardtop (13) and windshield frame (5). Discard lockwashers (11).
2. Remove two screws (2), spacers (3), and locknuts (4) from cab hardtop (13) and windshield frame (5). Discard locknuts (4).
3. Loosen two knobs (22).

NOTE

- Two lower hinges are attached to cab by six screw-assembled lockwashers. Exhaust support is attached to lower right hinge and cab by a longer screw and lockwasher.
- Assistant will help with step 4.

4. Remove six screw-assembled lockwashers (28) and windshield frame (5) from left (29) and right (31) upper hinges and cab (32). Discard screw-assembled lockwashers (28).
5. Remove six screw-assembled lockwashers (26) and lower left hinge (25) from cab (32). Discard screw assembled lockwashers (26).
6. Remove six screw-assembled lockwashers (35) from lower right hinge (30) and cab (32). Discard screw-assembled lockwashers (35).
7. Remove screw (34), lockwasher (33), and lower right hinge (30) from exhaust support (36) and cab (32). Discard lockwasher (33).
8. Remove four screws (17) and two brackets (18) from windshield frame (5).
9. Remove four screws (21), two plates (19), and weatherstrips (20) from two brackets (18). Discard weatherstrips (20).
10. Remove weatherstrip (1) from windshield frame (5). Discard weatherstrip (1). Clean windshield frame (5) of all weatherstrip (1) remains.
11. Remove snap fastener stud (7) and retainer nut (6) from windshield frame (5).
12. Remove seal (10), four screws (9) and retainer (8) from windshield frame (5).
13. Remove seal (14), two screws (15) and retainer (16) from windshield frame (5).

DISASSEMBLY

1. Remove two knobs (22) and studs (23) from upper hinges (29).
2. Remove two nuts (27), hinge bolts (24), and upper hinges (29) from lower hinges (25).

WINDSHIELD ASSEMBLY MAINTENANCE (Contd)

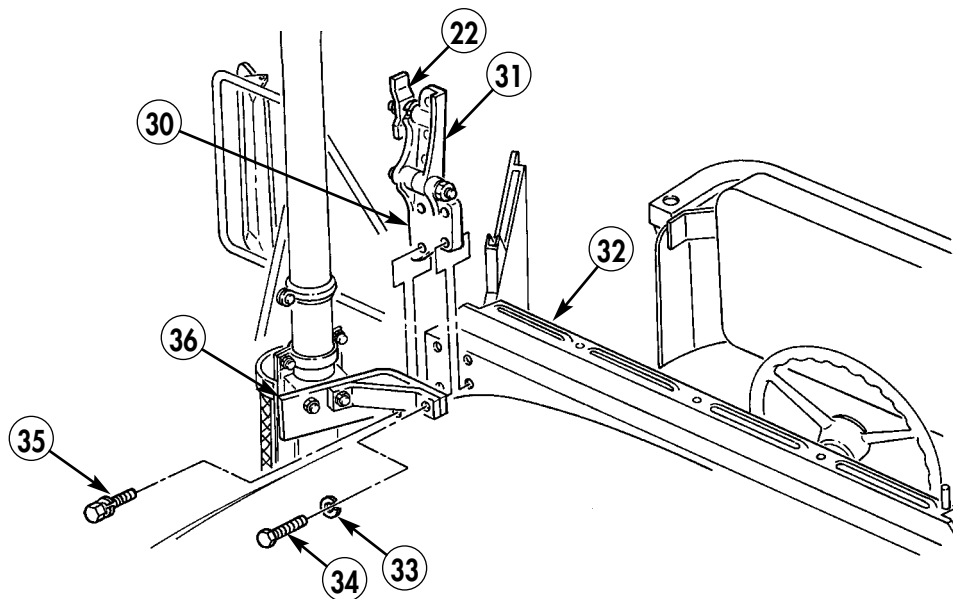
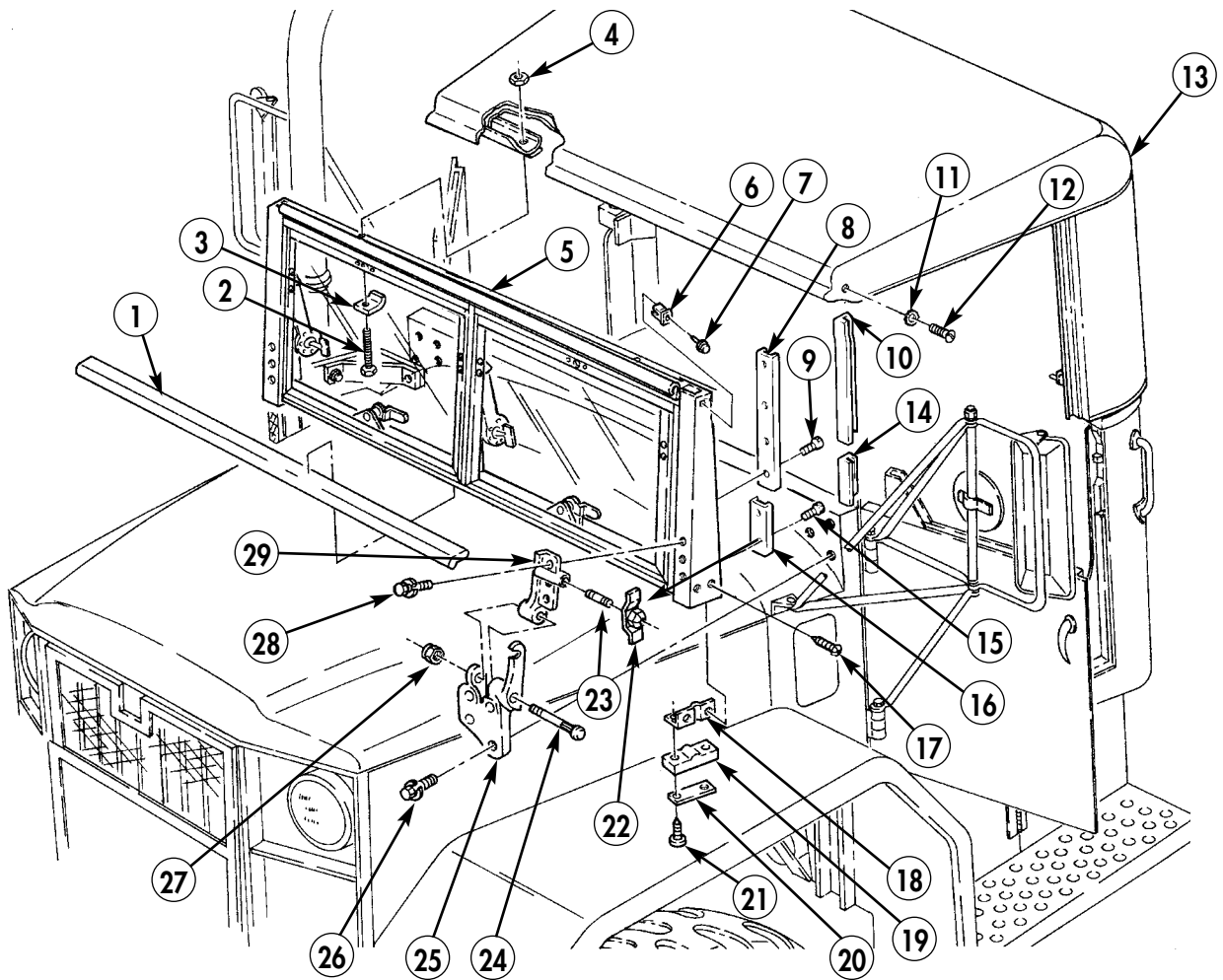

WINDSHIELD ASSEMBLY MAINTENANCE (Contd)

ASSEMBLY

1. Install two upper hinges (29) on lower hinges (25) with hinge bolts (24) and nuts (27).
2. Install two studs (23) and knobs (22) in upper hinges (29). Do not tighten knobs (22) if vehicle is equipped with hardtop kit.

INSTALLATION

1. Install retainer (16) on windshield frame (5) with two screws (15) and seal (14).
2. Install retainer (8) on windshield frame (5) with four screws (9) and seal 10).
3. Install retainer nut (6) and snap fastener stud (7) on windshield frame (5).
4. Apply adhesive to mounting side of new weatherstrip (1) and windshield frame (5) mounting surface. Install weatherstrip (1) on windshield frame (5) mounting surface.
5. Install two new weatherstrips (20) and plates (19) on two brackets (18) with four screws (21).
6. Install two brackets (18) on windshield frame (5) with four screws (17).

NOTE

- Two lower hinges are attached to cab by six screw-assembled lockwashers. Exhaust support is attached to lower right hinge and cab by a longer screw and lockwasher.
- Assistant will help with step 4.

7. Install windshield frame (5) in place on cab (32), and install hinges (29) and (31) on windshield frame (5) with six new screw-assembled lockwashers (28).
8. Install lower right hinge (30) on exhaust support (36) and cab (32) with new lockwasher (33) and screw (34).
9. Install lower right hinge (30) on cab (32) with six new screw-assembled lockwashers (35).

NOTE

Perform steps 7 through 9 on vehicles equipped with hardtop kit.

10. Tighten knobs (22) against hinges (29) and (31).
11. Install cab hardtop (13) on windshield frame (5) with two screws (2), spacers (3), and new locknuts (4).
12. Install cab hardtop (13) on windshield frame (5) with two screws (12) and new lockwashers (11).
13. Install conlinks (WP 0241 00).
14. Install wiper switch, motor, and conlink covers (WP 0240 00).
15. Install cab soft top (TM 9-2320-361-10).
16. Connect battery ground cable (WP 0126 00).
17. Release parking brake and remove wheel chocks (TM 9-2320-361-10).

WINDSHIELD ASSEMBLY MAINTENANCE (Contd)

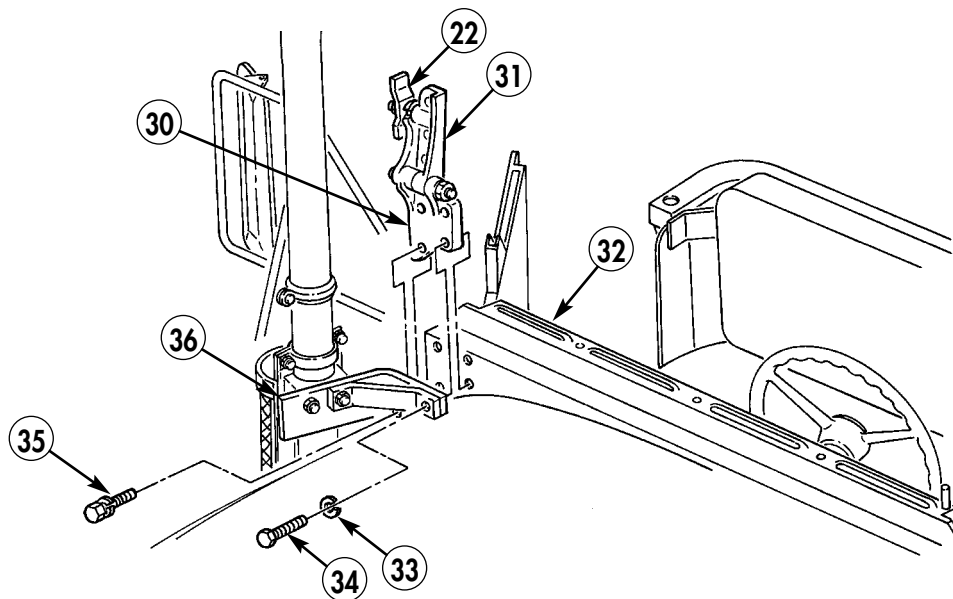
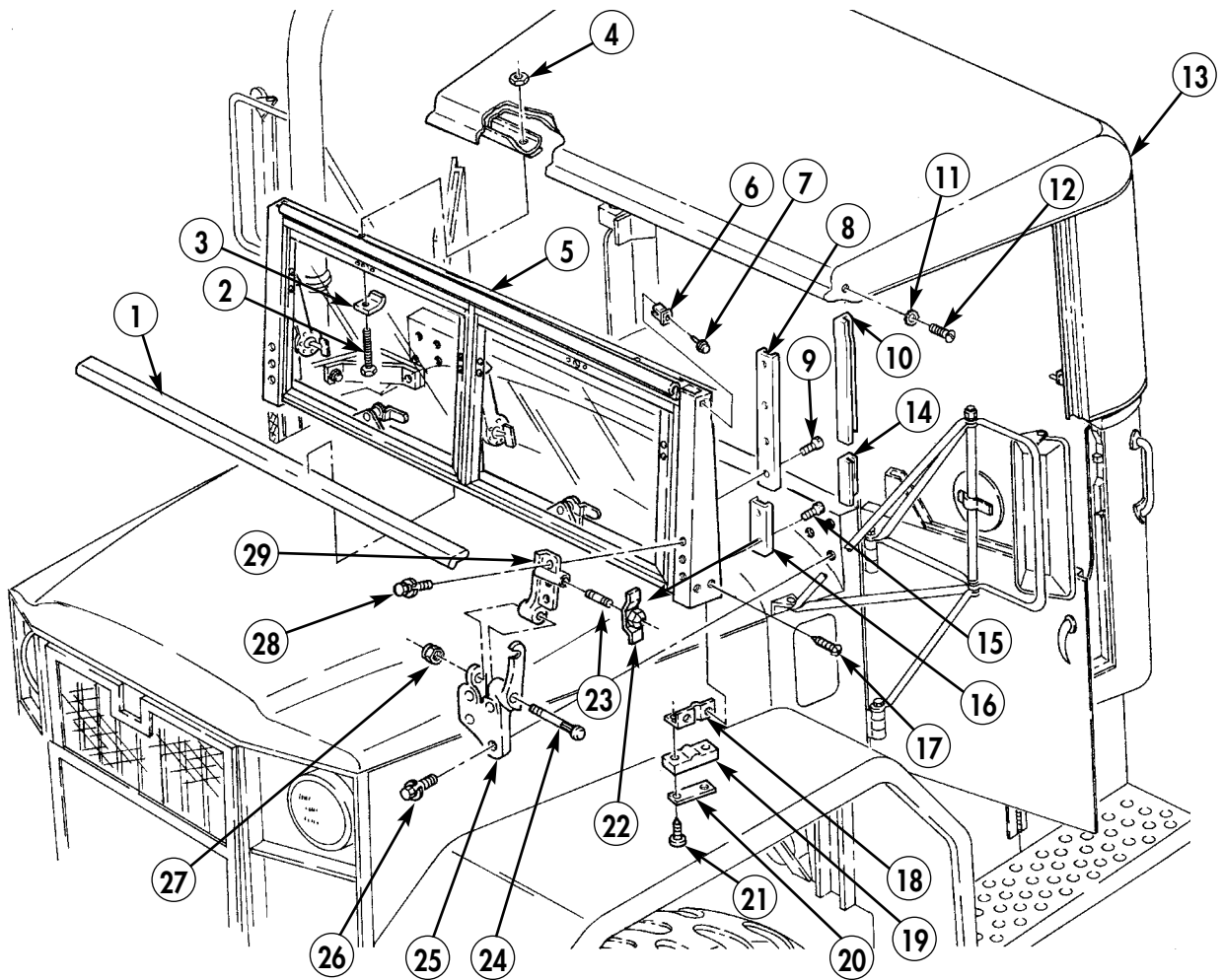

END OF WORK PACKAGE

FIELD MAINTENANCE INSTRUCTIONS

2-1/2 TON, 6X6, M44A2 SERIES TRUCKS (MULTIFUEL)

WINDSHIELD ARM, GLASS ASSEMBLY, AND HANDLE REPLACEMENT

ARM REMOVAL, GLASS ASSEMBLY REMOVAL, HANDLE REMOVAL,
HANDLE INSTALLATION, GLASS ASSEMBLY INSTALLATION, AND ARM INSTALLATION

INITIAL SETUP:

Applicable Models

All

Materials/Parts

Nine screw-assembled lockwashers
(item 251, WP 0470 00)
Lockwasher (item 225, WP 0470 00)
Seal (item 367, WP 0470 00)

Materials/Parts (Contd)

Seal (item 339, WP 0470 00)
Adhesive (item 2, WP 0468 00)

Equipment Condition

Parking brake set and wheels chocked
(TM 9-2320-361-10).
Battery ground cable disconnected
(WP 0126 00).
Windshield wiper switch, motor, and conlink
covers replacement (WP 0240 00).
Conlinks removed (WP 0241 00).

WINDSHIELD ARM, GLASS, AND HANDLE REPLACEMENT (Contd)

ARM REMOVAL

Remove two screws (7) and spring washers (8) from arm (9), outer frame bracket (4), lever (10), and glass frame bracket (11).

GLASS ASSEMBLY REMOVAL

1. Remove seven screw-assembled lockwashers (17) from windshield hinge (2) and windshield outer frame (3). Discard screw-assembled lockwashers (17).
2. Remove hinge seal (1) from windshield hinge (2).
3. Remove seal (12) from windshield inner frame (18). Discard seals (1) and (12).

HANDLE REMOVAL

1. Remove two screws (16), nuts (14), and handle (15) from windshield inner frame (18).
2. Remove lockwasher (13) from handle (15). Discard lockwasher (13).
3. Remove two screw-assembled lockwashers (5) and plate (6) from windshield outer frame (3). Discard screw-assembled lockwashers (5).

HANDLE INSTALLATION

1. Install new lockwasher (13) in handle (15).
2. Install handle (15) on windshield inner frame (18) with two screws (16) and nuts (14).
3. Install plate (6) on windshield outer frame (3) with two new screw-assembled lockwashers (5).

GLASS ASSEMBLY INSTALLATION

1. Apply adhesive to mounting side of new hinge seal (1) and on hinge (2).
2. Install new hinge seal (1) on hinge (2).
3. Install new seal (12) on windshield inner frame (18).
4. Install hinge (2) on windshield outer frame (3) with seven new screw-assembled lockwashers (17).
5. Install windshield inner frame (18) on hinge (2).

ARM INSTALLATION

1. Install arm (9) on outer frame bracket (4) and lever (10) on glass frame bracket (11) with two screws (7) and spring washers (8).
2. Install conlinks (WP 0241 00).
3. Install wiper switch, motor, conlink covers (WP 0240 00).
4. Release parking brake and remove wheel chocks (TM 9-2320-361-10).

WINDSHIELD ARM, GLASS, AND HANDLE REPLACEMENT (Contd)

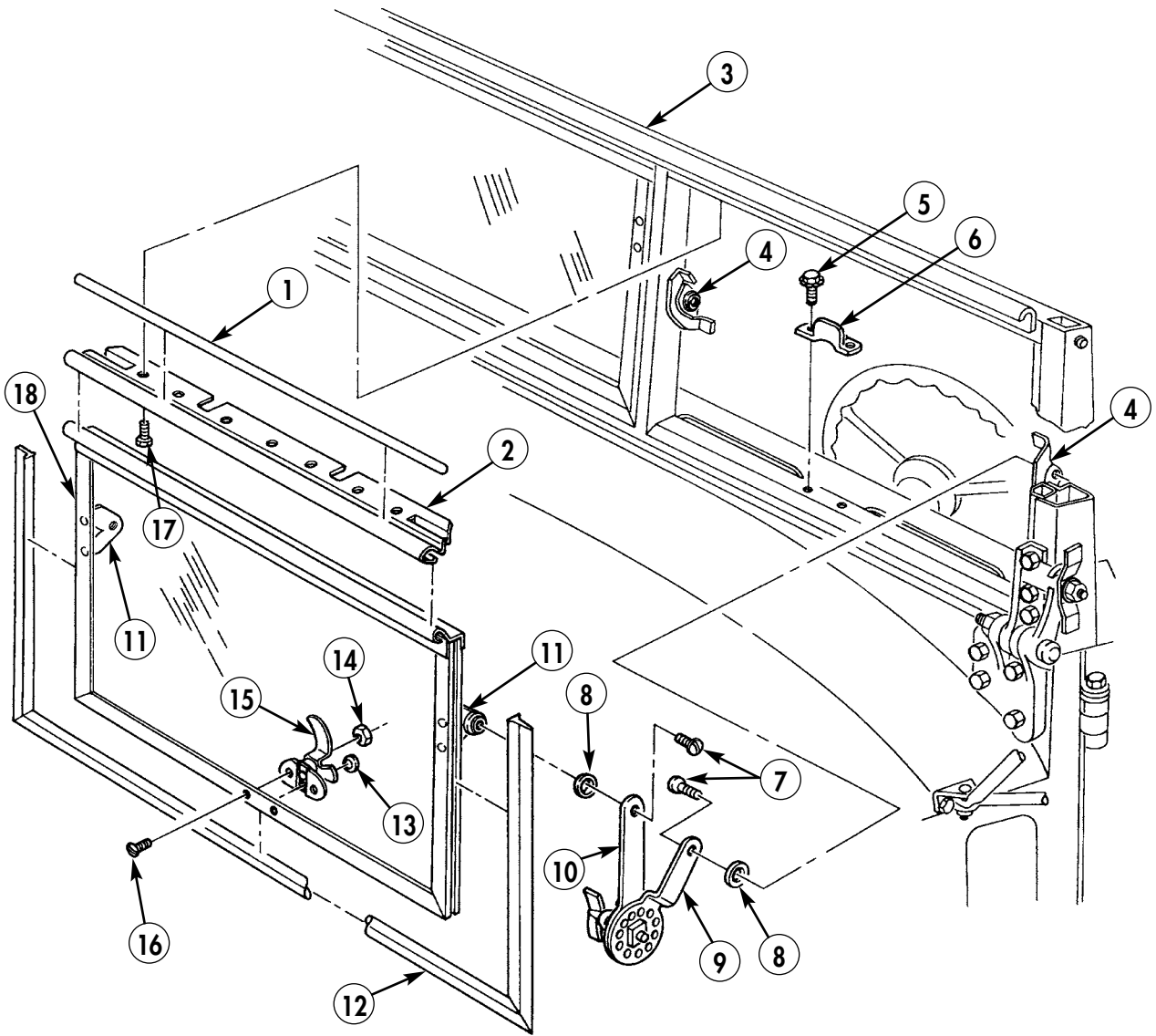

END OF WORK PACKAGE

FIELD MAINTENANCE INSTRUCTIONS

2-1/2 TON, 6X6, M44A2 SERIES TRUCKS (MULTIFUEL)

CAB TUNNEL, REAR TUNNEL, AND TOEBOARD REPLACEMENT

CAB TUNNEL REMOVAL, REAR TUNNEL REMOVAL, TOEBOARD REMOVAL,
TOEBOARD INSTALLATION, REAR TUNNEL INSTALLATION, AND CAB TUNNEL INSTALLATION

INITIAL SETUP:

Applicable Models

All

Materials/Parts

Thirty bolt-assembled lockwashers
(item 246, WP 0470 00)

Equipment Condition

Parking brake set and wheels chocked
(TM 9-2320-361-10).

Battery ground cable disconnected
(WP 0126 00).

Companion seat removed (WP 0234 00).

CAB TUNNEL, REAR TUNNEL, AND TOEBOARD REPLACEMENT (Contd)

CAB TUNNEL REMOVAL

Remove fourteen bolt-assembled lockwashers (3) and tunnel (2) from rear tunnel (4), toeboard (1), and cab floor (5). Discard bolt-assembled lockwashers (3).

REAR TUNNEL REMOVAL

Remove eight bolt-assembled lockwashers (3) and rear tunnel (4) from cab floor (5). Discard bolt-assembled lockwashers (3)

TOEBOARD REMOVAL

Remove eight bolt-assembled lockwashers (3) and toeboard (1) from cab floor (5). Discard bolt-assembled lockwashers (3)

TOEBOARD INSTALLATION

Install toeboard (1) on cab floor (5) with eight new bolt-assembled lockwashers (3)

REAR TUNNEL INSTALLATION

Install rear tunnel (4) on cab floor (5) with eight new bolt-assembled lockwashers (3).

CAB TUNNEL INSTALLATION

1. Install tunnel (2) on rear tunnel (4), toeboard (1), and cab floor (5) with fourteen new bolt-assembled lockwashers (3).
2. Install companion seat (WP 0234 00).
3. Connect battery ground cable (WP 0126 00).
4. Release parking brake and remove wheel chocks (TM 9-2320-361-10).

CAB TUNNEL, REAR TUNNEL, AND TOEBOARD REPLACEMENT (Contd)

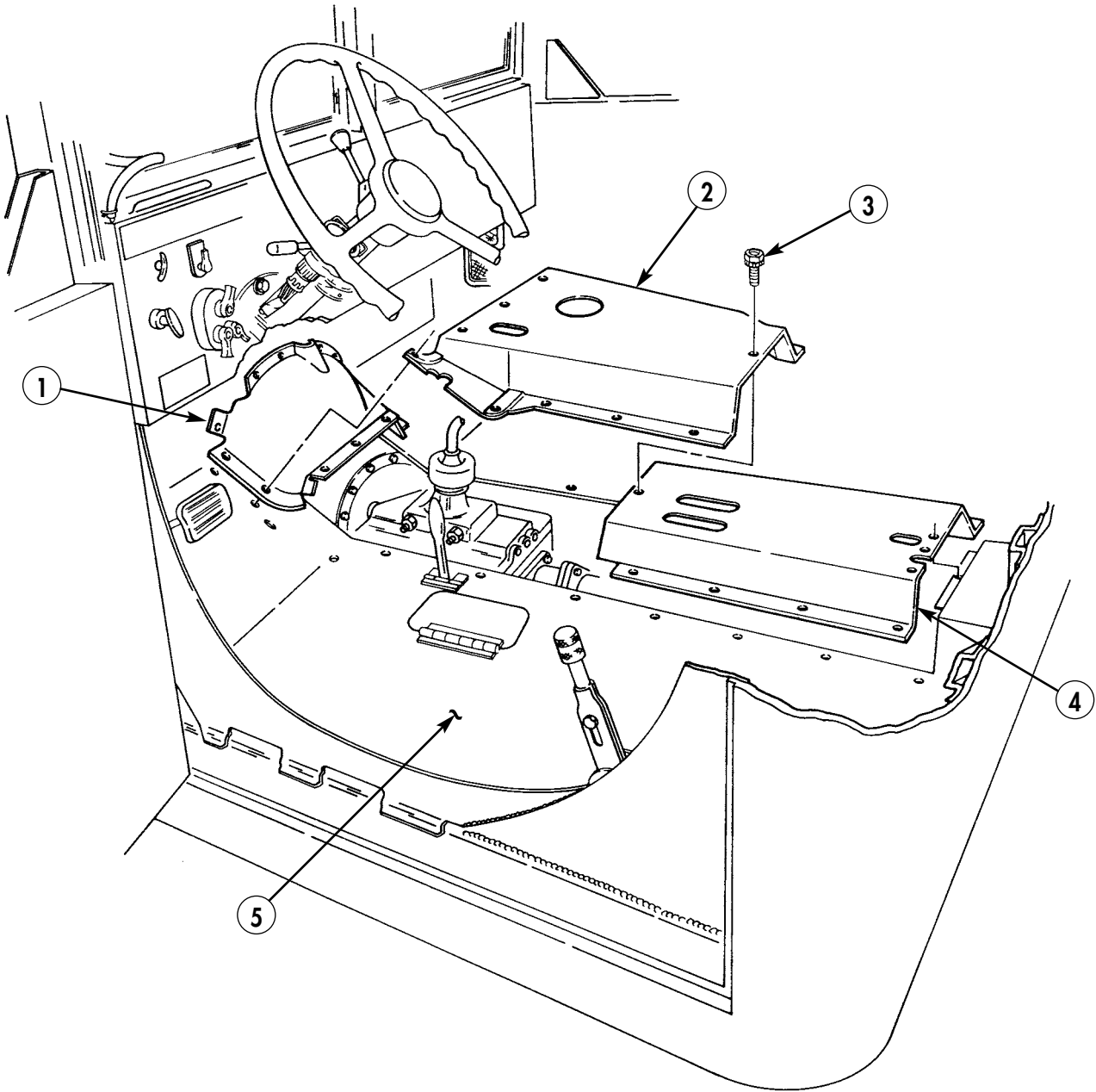

END OF WORK PACKAGE

FIELD MAINTENANCE INSTRUCTIONS

2-1/2 TON, 6X6, M44A2 SERIES TRUCKS (MULTIFUEL)

REAR CAB MOUNT AND BRACKET REPLACEMENT

REMOVAL AND INSTALLATION

INITIAL SETUP:

Applicable Models

All

Personnel Required

Two

Materials/Parts

Two locknuts (item 136, WP 0470 00)

Four screw-assembled lockwashers
(item 424, WP 0470 00)

Equipment Condition

Parking brake set and wheels chocked
(TM 9-2320-361-10).

Battery ground cable disconnected
(WP 0126 00).

REAR CAB MOUNT REPLACEMENT (Contd)

WARNING

Do not place fingers between frame and crossmember while replacing mount. Doing so may result in injury to personnel.

NOTE

Assistant will help with entire procedure.

REMOVAL

1. Remove two rear cab mount locknuts (9), washers (8), screws (2), springs (4), and four washers (3) from bracket (5) and frame (7). Discard locknuts (9).

WARNING

Support cab body while in raised position for mount replacement. Failure to do so may result in injury to personnel.

CAUTION

Do not raise rear of cab too high when removing mounts.
Damage to cab may result.

2. Raise cab (1) to provide clearance and remove two mounts (6) from frame (7).
3. Remove four screw-assembled lockwashers (10) and bracket (5) from lower cab (1). Discard screw-assembled lockwashers (10).

INSTALLATION

1. Install bracket (5) on lower cab (1) with four new screw-assembled lockwashers (10).
2. Install two new mounts (6) on frame (7).
3. Lower cab (1) on mounts (6).
4. Install two springs (4) and four washers (3) on two screws (2), and install screws (2) through bracket (5), mounts (6), and frame (7).
5. Install two washers (8) and two new locknuts (9) on screws (2). Tighten locknuts (9) to compress springs (4) to height of 1.78 in. (4.52 cm).
6. Connect battery ground cable (WP 0126 00).
7. Release parking brake and remove wheel chocks (TM 9-2320-361-10).

REAR CAB MOUNT REPLACEMENT (Contd)

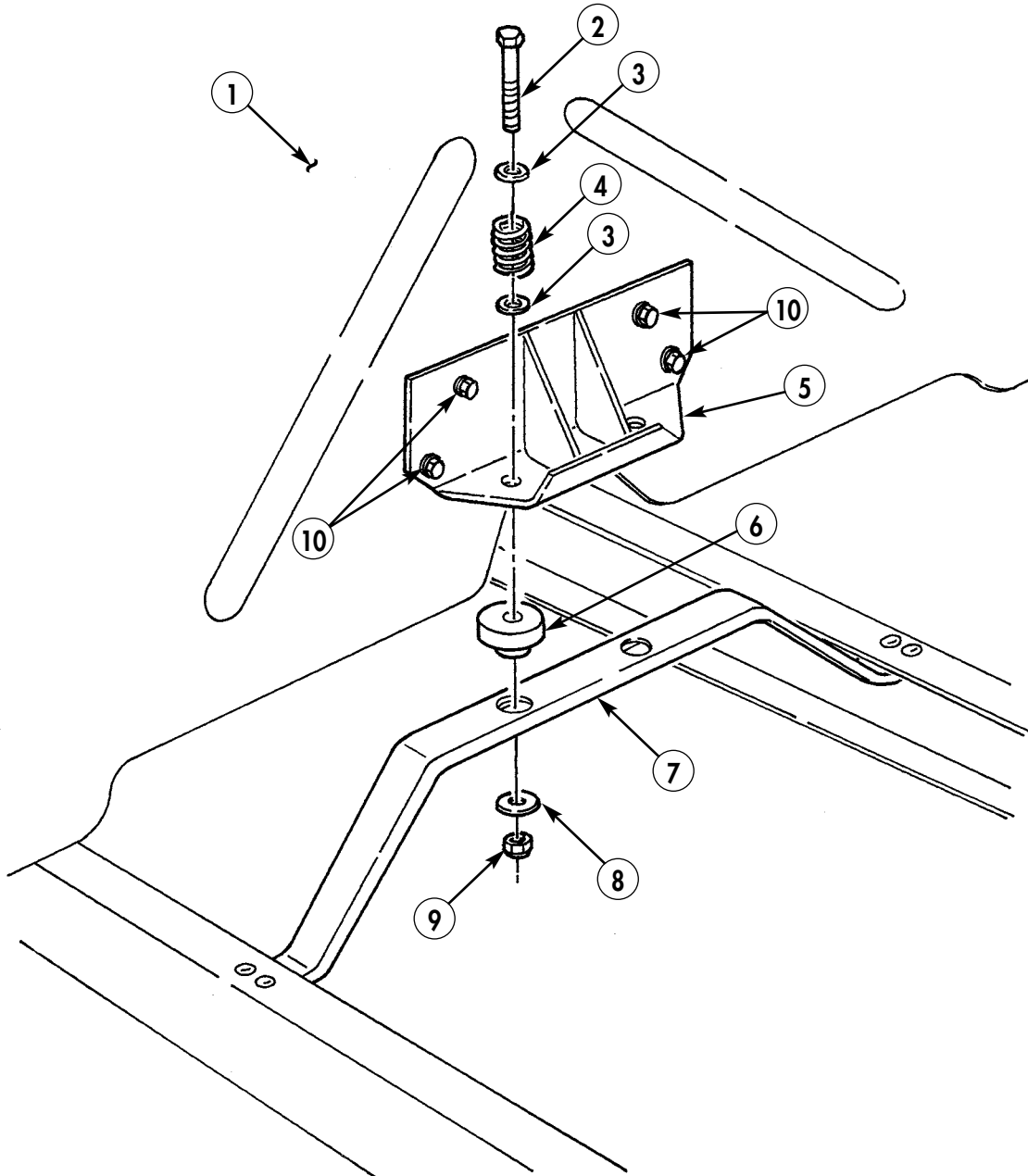

END OF WORK PACKAGE

FIELD MAINTENANCE INSTRUCTIONS

2-1/2 TON, 6X6, M44A2 SERIES TRUCKS (MULTIFUEL)

WATER CAN BRACKET AND RUNNING BOARD REPLACEMENT

WATER CAN BRACKET REMOVAL, RUNNING BOARD REMOVAL,
RUNNING BOARD INSTALLATION, AND WATER CAN BRACKET INSTALLATION

INITIAL SETUP:

Applicable Models

All

Materials/Parts

Six locknuts (item 129, WP 0470 00)

Four locknuts (item 174, WP 0470 00)

Equipment Condition

Parking brake set and wheels chocked
(TM 9-2320-361-10).

Battery ground cable disconnected
(WP 0126 00).

WATER CAN BRACKET AND RUNNING BOARD REPLACEMENT (Contd)

WATER CAN BRACKET REMOVAL

1. Remove strap (9) from water can bracket (2).
2. Remove six screws (1), locknuts (3), and water bracket (2) from toolbox (4) and running board (8). Discard locknuts (3).

RUNNING BOARD REMOVAL

Remove four screws (6), locknuts (7), and running board (8) from two supports (5). Discard locknuts (7).

RUNNING BOARD INSTALLATION

Install running board (8) on two supports (5) with four screws (6) and new locknuts (7).

WATER CAN BRACKET INSTALLATION

1. Install water can bracket (2) on running board (8) and toolbox (4) with six screws (1) and new locknuts (3).
2. Install strap (9) on water can bracket (2).
3. Connect battery ground cable (WP 0126 00).
4. Release parking brake and remove wheel chocks (TM 9-2320-361-10).

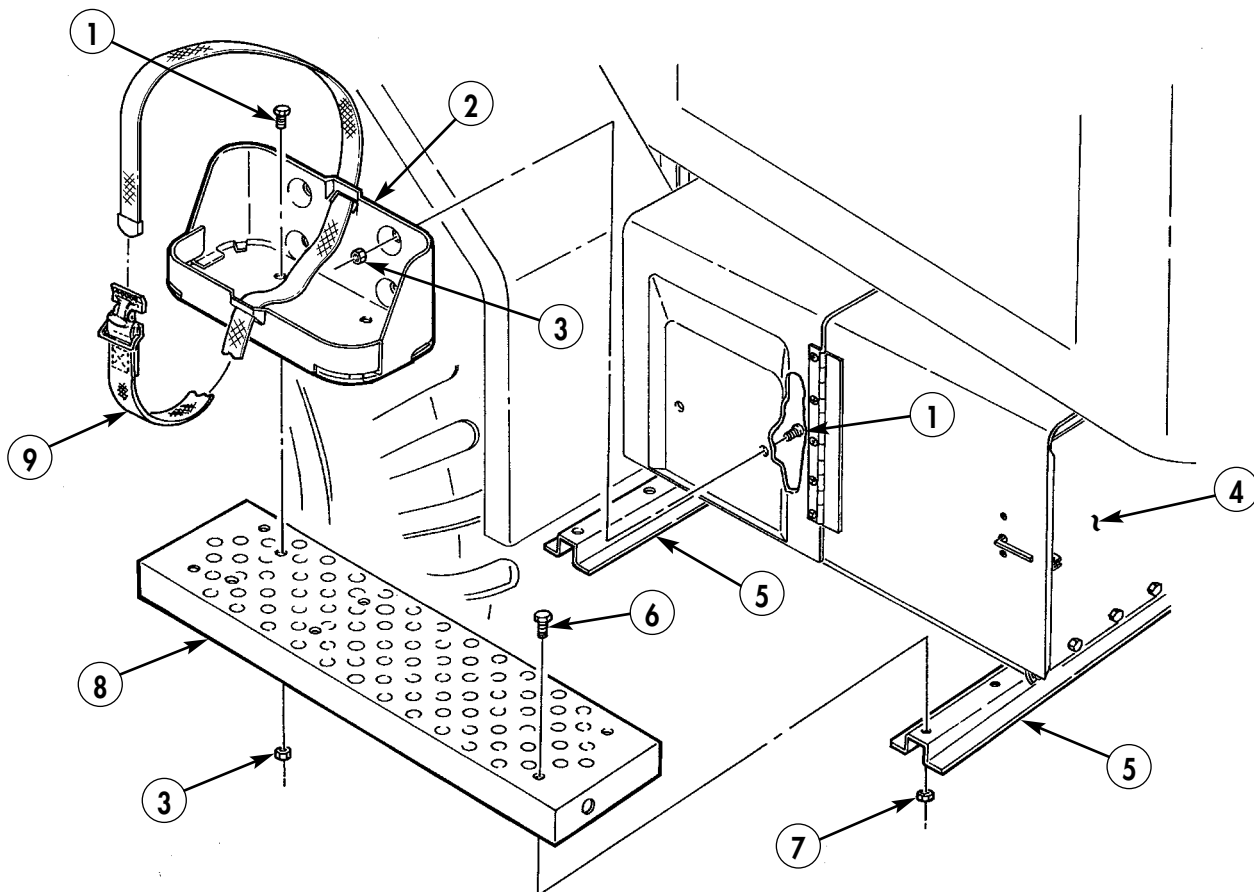

END OF WORK PACKAGE

FIELD MAINTENANCE INSTRUCTIONS

2-1/2 TON, 6X6, M44A2 SERIES TRUCKS (MULTIFUEL)

CAB SOFT TOP TURNBUTTONS AND LASHING HOOKS REPLACEMENT

TURNBUTTONS AND SNAP SHANK REMOVAL, LASHING HOOKS REMOVAL,
LASHING HOOKS INSTALLATION, AND TURNBUTTONS AND SNAP SHANK INSTALLATION

INITIAL SETUP:

Applicable Models

All

Materials/Parts

Twelve locknuts (item 155, WP 0470 00)

Equipment Condition

Parking brake set and wheels chocked
(TM 9-2320-361-10).

Battery ground cable disconnected
(WP 0126 00).

CAB SOFT TOP TURNBUTTONS AND LASHING HOOKS REPLACEMENT (Contd)

TURNBUTTONS AND SNAP SHANK REMOVAL

1. Remove twelve turnbuttons (2) from cab (1).
2. Remove two snap shanks (8) from windshield frame (7).

LASHING HOOKS REMOVAL

1. Remove rope (6) from lashing hooks (3).
2. Remove twelve locknuts (4), screws (5), and six lashing hooks (3) from cab (1). Discard locknuts (4).

LASHING HOOKS INSTALLATION

1. Install six lashing hooks (3) on cab (1) with twelve screws (5) and new locknuts (4).
2. Install rope (6) on lashing hooks (3).

TURNBUTTONS AND SNAP SHANK INSTALLATION

1. Install two snap shanks (8) on windshield frame (7).
2. Install twelve turnbuttons (2) on cab (1).
3. Connect battery ground cable (WP 0126 00).
4. Release parking brake and remove wheel chocks (TM 9-2320-361-10).

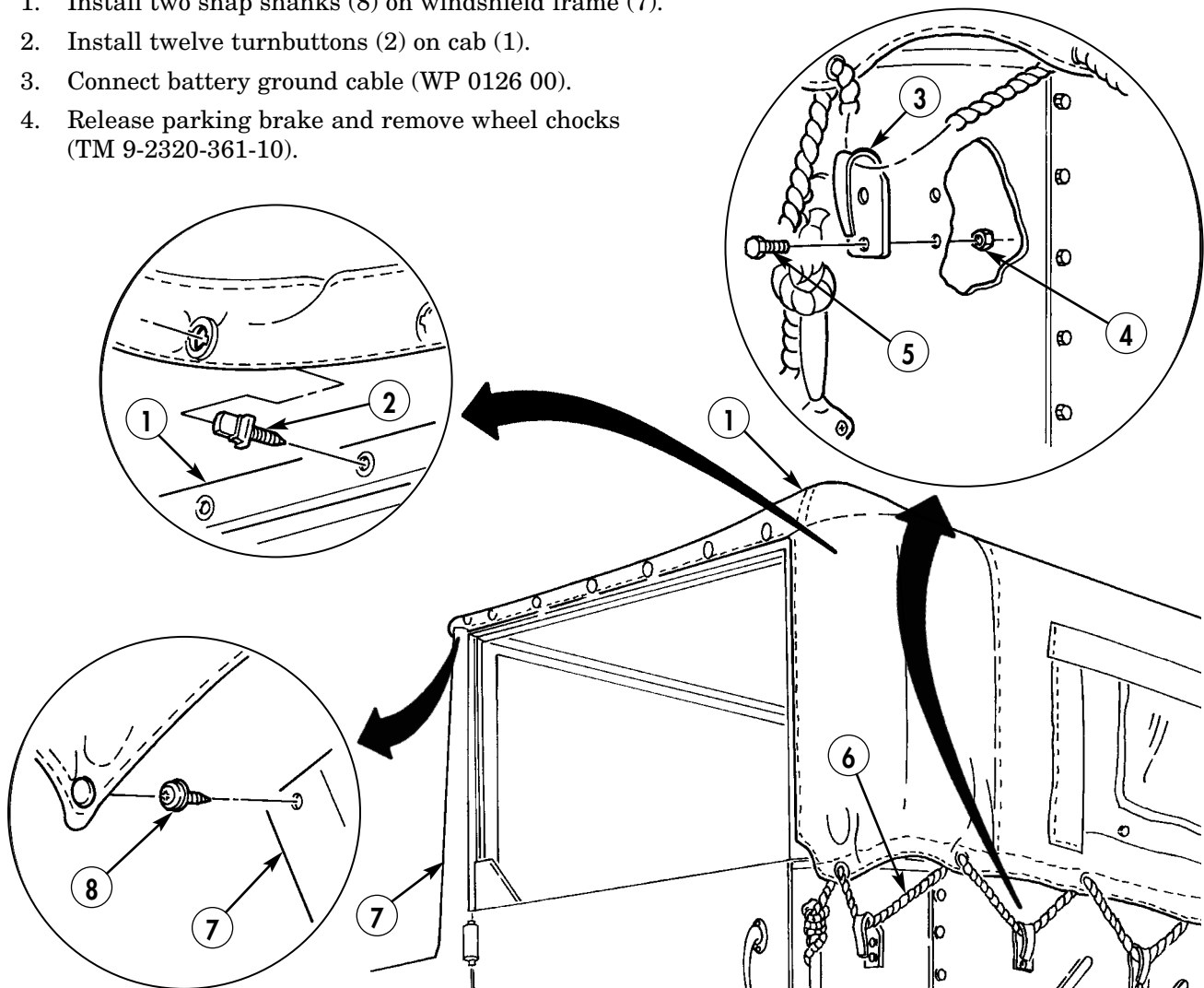

END OF WORK PACKAGE

FIELD MAINTENANCE INSTRUCTIONS

2-1/2 TON, 6X6, M44A2 SERIES TRUCKS (MULTIFUEL)

COMPANION SEAT MAINTENANCE

COMPANION SEAT BACKREST REMOVAL, COMPANION SEAT CUSHION REMOVAL, COMPANION SEAT FASTENER REMOVAL, COMPANION SEAT REMOVAL, FRAME DISASSEMBLY, FRAME ASSEMBLY, COMPANION SEAT INSTALLATION, COMPANION SEAT CUSHION INSTALLATION, COMPANION SEAT FASTENER INSTALLATION, AND COMPANION SEAT BACKREST INSTALLATION

INITIAL SETUP:

Applicable Models

All

Materials/Parts

Seven cotter pins (item 25, WP 0470 00)
Five locknuts (item 153, WP 0470 00)
Four screw-assembled lockwashers
(item 255, WP 0470 00)
Four locknuts (item 152, WP 0470 00)
Locknut (item 139, WP 0470 00)

Equipment Condition

Parking brake set and wheels chocked
(TM 9-2320-361-10).
Battery ground cable disconnected
(WP 0126 00).

COMPANION SEAT MAINTENANCE (Contd)

COMPANION SEAT BACKREST REMOVAL

Remove backrest (1) from backrest frame (29).

COMPANION SEAT CUSHION REMOVAL

1. Remove screw (4) and locknut (17) from link (15) and cushion (18). Discard locknut (17).
2. Remove cotter pin (25), washers (27), pin (28), and cushion (18) from cushion frame (21). Discard cotter pin (25).

COMPANION SEAT FASTENER REMOVAL

1. Unlatch fastener (7) from backrest frame (29).
2. Remove two locknuts (32), bolts (30), and fastener (7) from cab rail (31). Discard locknuts (32).

COMPANION SEAT REMOVAL

1. Unlatch fastener (7) from backrest frame (29).
2. Remove four screw-assembled washers (20) and cushion frame (21) from cab floor (13). Discard screw-assembled washers (20).

FRAME DISASSEMBLY

1. Remove four cotter pins (3), washers (2), pins (6), and backrest frame (29) from link (5), link (26), and cushion frame (21). Discard cotter pins (3).
2. Remove locknut (19), screw (24), two washers (22), sleeve (23), and link (26) from cushion frame (21). Discard locknut (19).
3. Remove cotter pin (12), pin (16), and link (15) from cushion frame (21). Discard cotter pin (12).
4. Remove cotter pin (9), washer (8), and link (5) from cushion frame (21). Discard cotter pin (9).
5. Remove four locknuts (14), screws (10), and leg (11) from cushion frame (21). Discard locknuts (14).

FRAME ASSEMBLY

1. Install leg (11) on cushion frame (21) with four screws (10) and new locknuts (14).
2. Install link (5) on cushion frame (21) with washer (8) and new cotter pin (9).
3. Install link (15) on cushion frame (21) with pin (16) and new cotter pin (12).
4. Install link (26) on cushion frame (21) with screw (24), two washers (22), sleeve (23), and new locknut (19).
5. Install link (5) and link (26) on backrest frame (29) with four pins (6), washers (2), and new cotter pins (3).

COMPANION SEAT INSTALLATION

1. Install backrest (1) on frame (29).
2. Install cushion frame (21) on cab floor (13) with four screw-assembled washers (20).
3. Latch fastener (7) on backrest frame (29).

COMPANION SEAT CUSHION INSTALLATION

1. Install cushion (18) on cushion frame (21) with pin (28), washer (27), and new cotter pin (25).
2. Install link (15) on cushion (18) with screw (4) and new locknut (17).

COMPANION SEAT MAINTENANCE (Contd)

COMPANION SEAT FASTENER INSTALLATION

1. Install fastener (7) on cab rail (31) with two bolts (30) and new locknuts (32).
2. Latch fastener (7) on backrest frame (29).

COMPANION SEAT BACKREST INSTALLATION

1. Install backrest (1) on backrest frame (29).
2. Connect battery ground cable (WP 0126 00).
3. Release parking brake and remove wheel chocks (TM 9-2320-361-10).

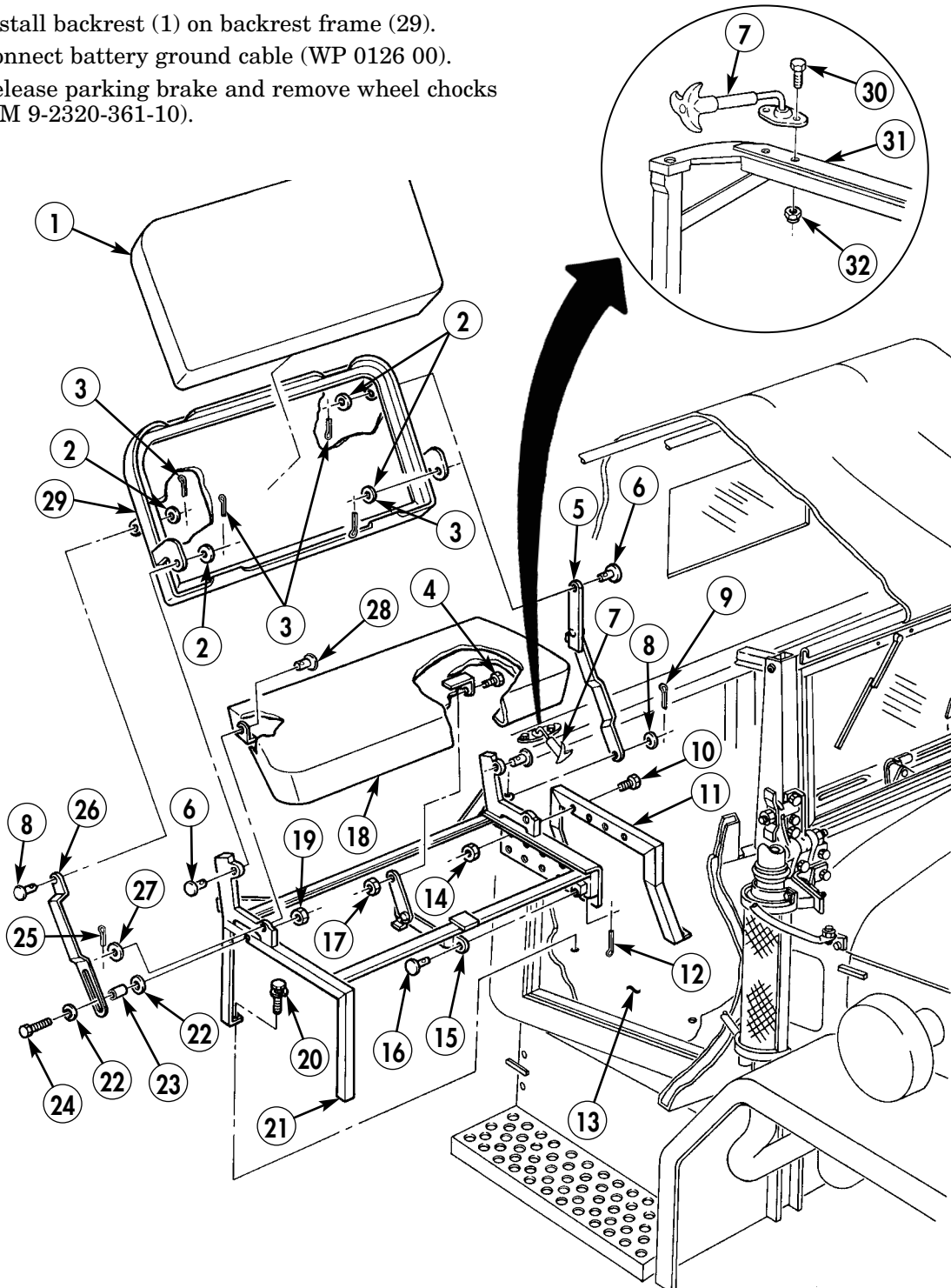

END OF WORK PACKAGE

FIELD MAINTENANCE INSTRUCTIONS

2-1/2 TON, 6X6, M44A2 SERIES TRUCKS (MULTIFUEL)

DRIVER'S SEAT BASE MAINTENANCE REMOVAL, INSPECTION AND REPAIR, AND INSTALLATION

INITIAL SETUP:

Applicable Models

All

Materials/Parts

Eight lockwashers (item 206, WP 0470 00)

Four lockwashers (item 216, WP 0470 00)

Pin (item 306, WP 0470 00)

GAA grease (item 17, WP 0468 00)

Personnel Required

Two

References

TC 9-237

WP 0023 00

Equipment Condition

Parking brake set and wheels chocked
(TM 9-2320-361-10).

Battery ground cable disconnected
(WP 0126 00).

Driver's seat removed (WP 0236 00).

Driver's seat cushion, backrest, frame, and seat
adjuster removed (WP 0237 00).

DRIVER'S SEAT BASE MAINTENANCE (Contd)**NOTE**

Assistant will help with entire procedure.

REMOVAL

1. Turn crank (2) counterclockwise to remove tension on spring (3).
2. Remove two nuts (1), screws (7), and shock absorber (5) from seat base (4) and top frame (6).
3. Remove four nuts (8), lockwashers (9), screws (11), and two brackets (10) from seat base (4). Discard lockwashers (9).
4. Remove spring (3) from seat base (4) and top frame (6).

NOTE

Prior to removal, tag lower struts and upper struts for installation.

5. Remove four nuts (18), lockwashers (13), screws (17), and lower strut (19) from top frame (6) and seat base (4). Discard lockwashers (13).
6. Remove two top nuts (16), lockwashers (15), torque rod (14), spring (26), sleeve (27), and spring (26) from top frame (6) and upper strut (23). Discard lockwashers (15).
7. Remove two nuts (22), lockwashers (21), screws (20), and upper strut (23) from seat base (4). Discard lockwashers (21).
8. Remove pin (24) from crank (2). Discard pin (24).
9. Remove crank (2) and washer (25) from swivel nut (12) and top frame (6).

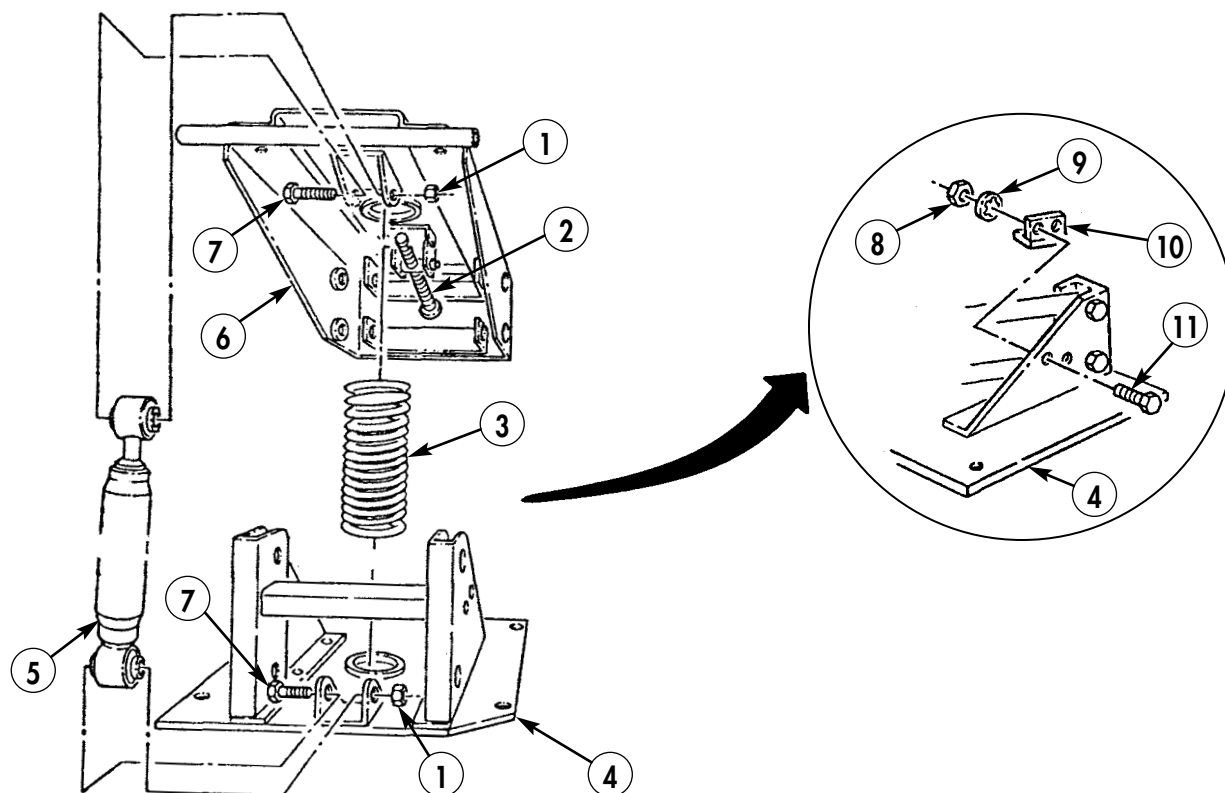

DRIVER'S SEAT BASE MAINTENANCE (Contd)

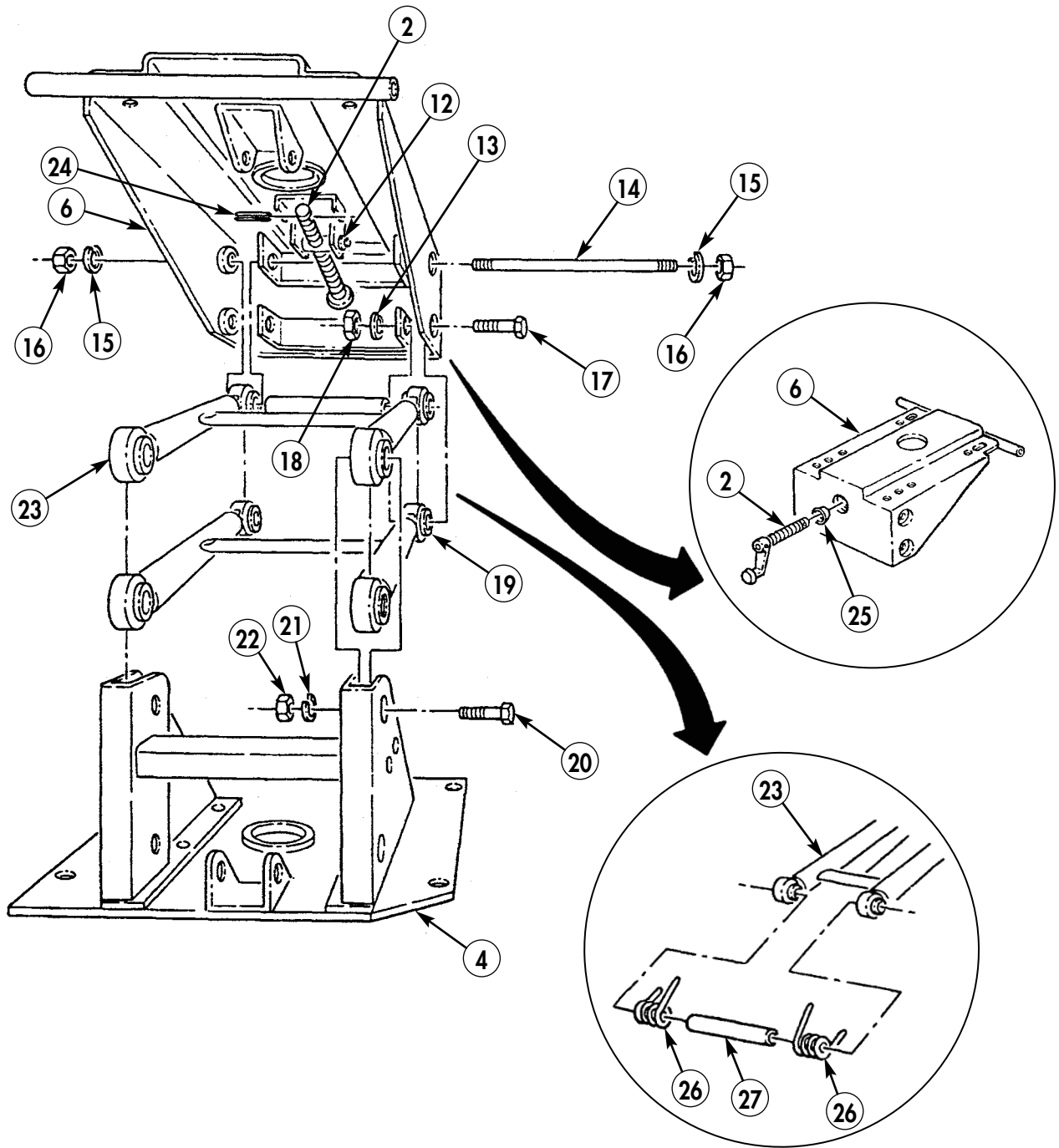

DRIVER'S SEAT BASE MAINTENANCE (Contd)**INSPECTION AND REPAIR**

1. Refer to WP 0023 00 for general inspection.
2. Refer to TC 9-237 for welding.
3. Inspect seat base (3), top frame (2), upper strut (6), lower strut (7), and sleeve (9) for cracks, bends, and breaks. Repair if cracked, bent, or broken.
4. Inspect torque rod (5), spring (4), crank (1), and two springs (8) for cracks, bends, and breaks. Replace if cracked, bent, or broken.
5. Inspect shock absorber (10) for cracks, bends, breaks, and leakage. Replace if cracked, bent, broken, or leaking.

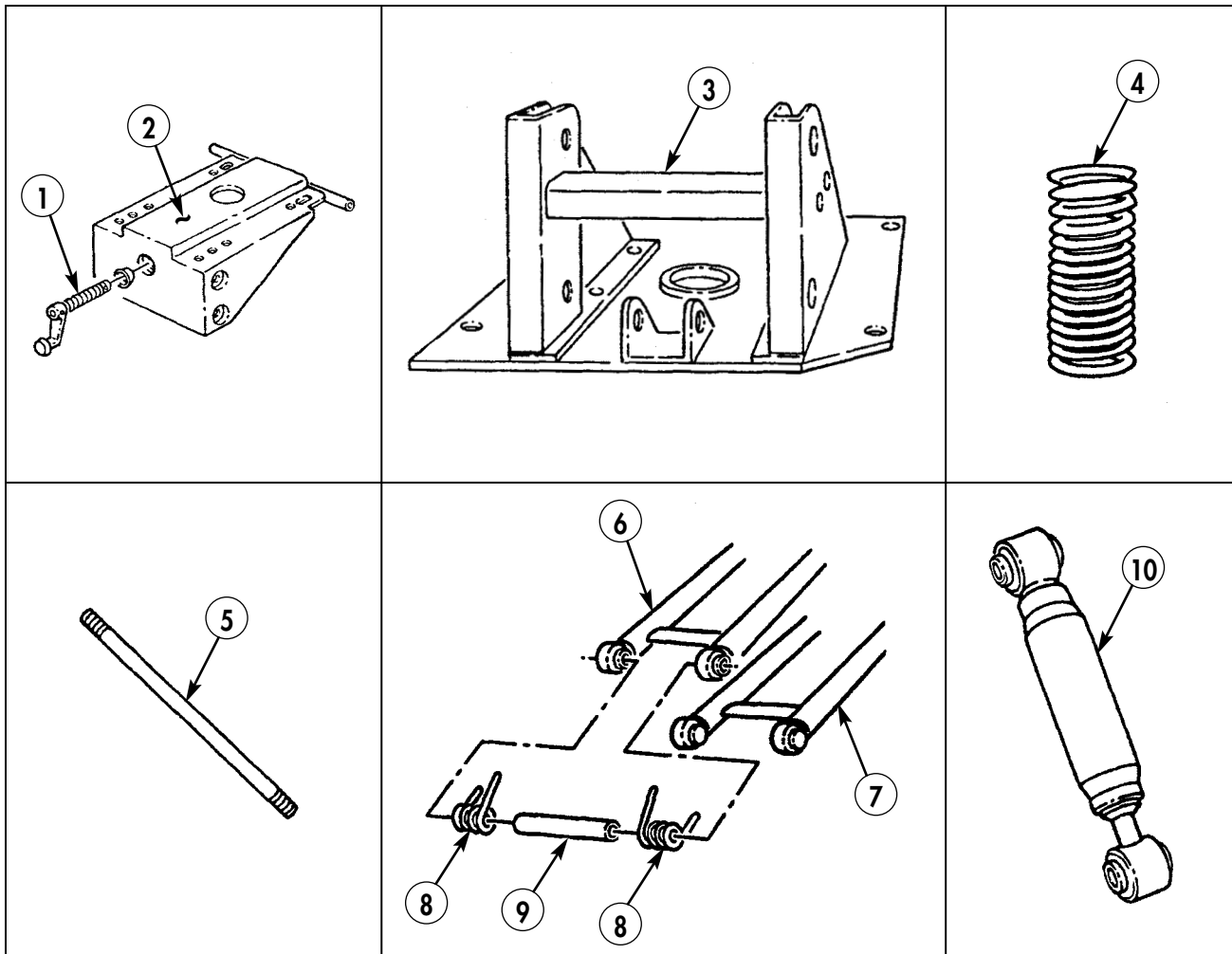

DRIVER'S SEAT BASE MAINTENANCE (Contd)

INSTALLATION

1. Install crank (1) and washer (21) in top frame (2) and swivel nut (11).
2. Install new pin (20) in crank (1).
3. Apply light coat of GAA grease to crank (1) threads.
4. Apply GAA grease to upper strut bushings (6), lower strut bushings (7), and torque rod (5).
5. Install upper strut (6), sleeve (9), and two springs (8) on top frame (2) with torque rod (5), two new lockwashers (13), and nuts (14).
6. Install lower strut (7) on top frame (2) and seat base (3) with four screws (15), new lockwashers (12), and nuts (16).
7. Install upper strut (6) on seat base (3) with two screws (17), new lockwashers (18), and nuts (19).

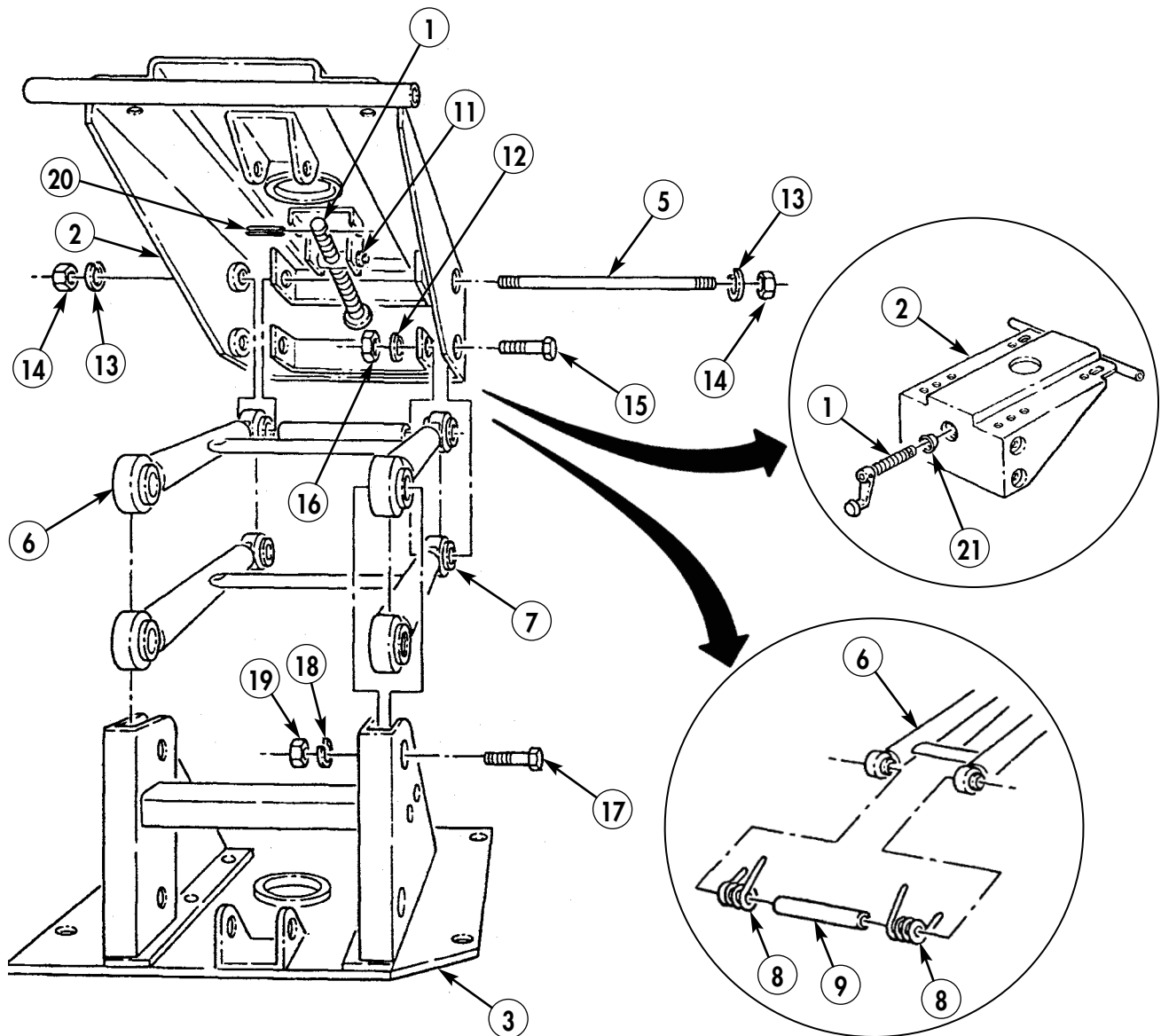

DRIVER'S SEAT BASE MAINTENANCE (Contd)**INSTALLATION (Contd)**

8. Install spring (2) in seat base (3) and top frame (6).
9. Install two brackets (9) on seat base (3) with four screws (10), new lockwashers (8), and nuts (7).
10. Install shock absorber (5) on top frame (6) and seat base (3) with two screws (4) and nuts (1).
11. Install seat cushion, backrest, frame, and seat adjuster (WP 0237 00).
12. Install driver's seat (WP 0236 00).
13. Connect battery ground cable (WP 0126 00).
14. Release parking brake and remove wheel chocks (TM 9-2320-361-10).

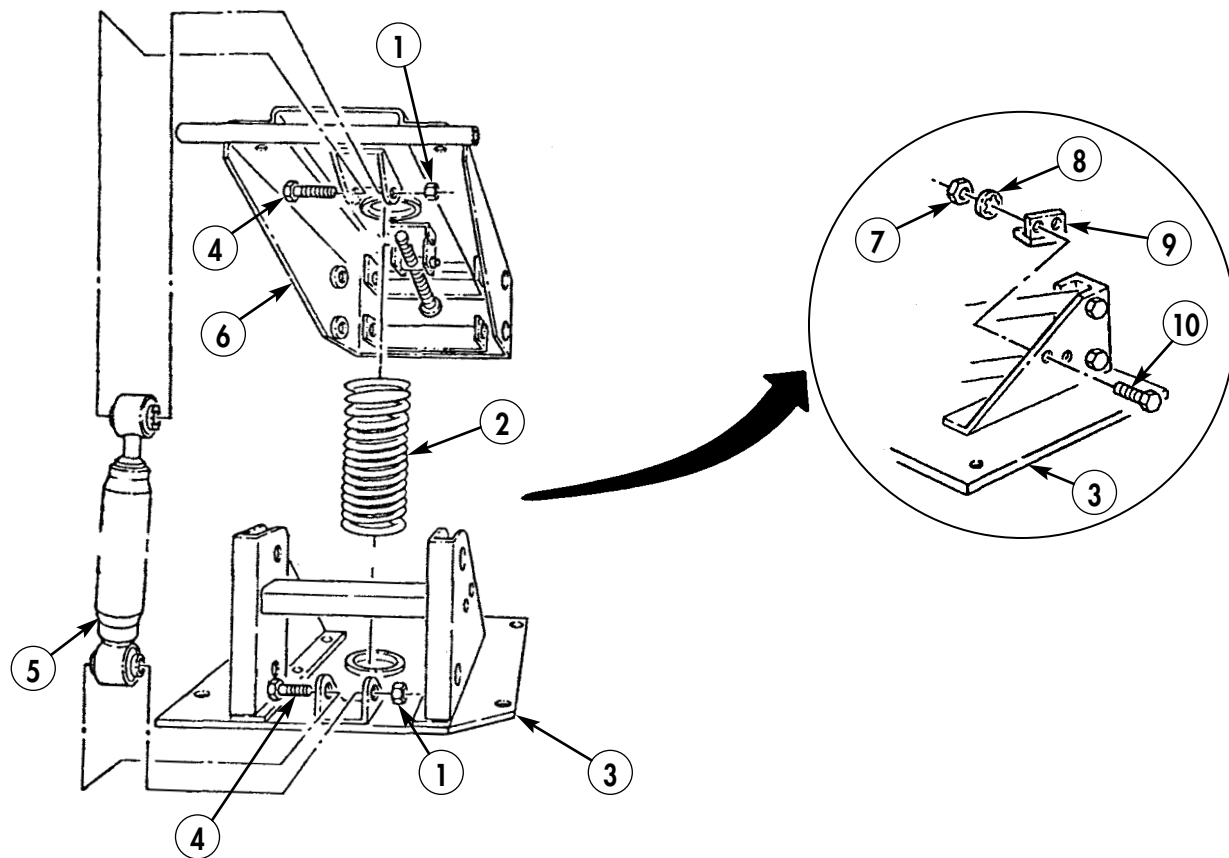
**END OF WORK PACKAGE**

FIELD MAINTENANCE INSTRUCTIONS

2-1/2 TON, 6X6, M44A2 SERIES TRUCKS (MULTIFUEL)

DRIVER'S SEAT REPLACEMENT

REMOVAL AND INSTALLATION

INITIAL SETUP:

Applicable Models

All

Materials/Parts

Four screw-assembled lockwashers
(item 255, WP 0470 00)

Equipment Condition

Parking brake set and wheels chocked
(TM 9-2320-361-10).

Battery ground cable disconnected
(WP 0126 00).

REMOVAL

Remove four screw-assembled lockwashers (1) and driver's seat and base (2) from cab floor (3). Discard screw-assembled lockwashers (1).

INSTALLATION

1. Install driver's seat and base (2) on cab floor (3) with four new screw-assembled lockwashers (1).
2. Connect battery ground cable (WP 0126 00).
3. Release parking brake and remove wheel chocks (TM 9-2320-361-10).

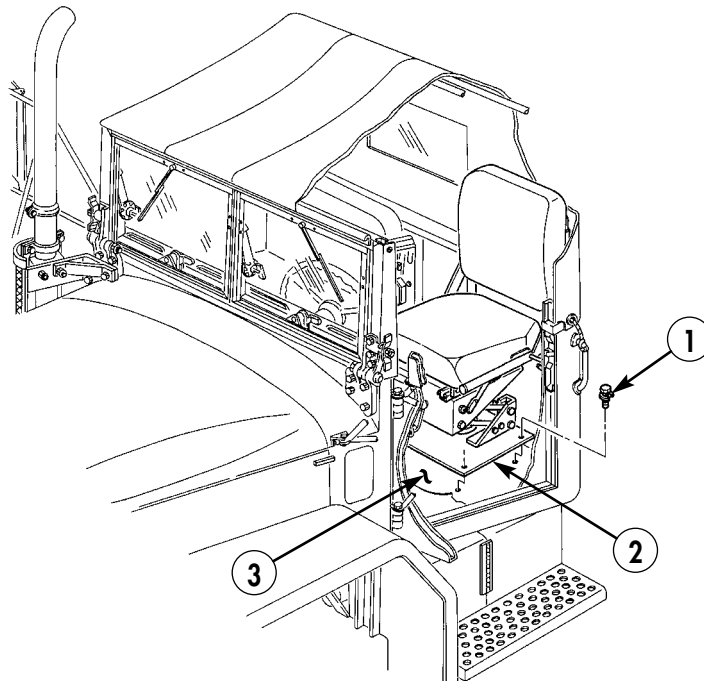

END OF WORK PACKAGE

0236 00-1/2 blank

FIELD MAINTENANCE INSTRUCTIONS

2-1/2 TON, 6X6, M44A2 SERIES TRUCKS (MULTIFUEL)

DRIVER'S SEAT CUSHION, BACKREST, FRAME, AND SEAT ADJUSTER REPLACEMENT

DRIVER'S SEAT CUSHION REMOVAL, DRIVER'S SEAT BACKREST REMOVAL, DRIVER'S SEAT FRAME REMOVAL,
DRIVER'S SEAT ADJUSTER REMOVAL, DRIVER'S SEAT ADJUSTER INSTALLATION, DRIVER'S SEAT FRAME
INSTALLATION, DRIVER'S SEAT BACKREST INSTALLATION, AND DRIVER'S SEAT CUSHION INSTALLATION

INITIAL SETUP:

Applicable Models

All

Materials/Parts

Eight locknuts (item 155, WP 0470 00)
Six lockwashers (item 216, WP 0470 00)

Equipment Condition

Parking brake set and wheels chocked
(TM 9-2320-361-10).
Battery ground cable disconnected
(WP 0126 00).

DRIVER'S SEAT CUSHION, BACKREST, FRAME, AND SEAT ADJUSTER REPLACEMENT (Contd)

DRIVER'S SEAT CUSHION REMOVAL

Remove four screws (14), lockwashers (15), two seat cushion brackets (16), and washers (13) from seat cushion (17) and seat frame (3). Remove seat cushion (17) from seat frame (3). Discard lockwashers (15).

DRIVER'S SEAT BACKREST REMOVAL

1. Remove two screws (6), lockwashers (5), and clips (4) from seat backrest (1) and seat frame (3). Discard lockwashers (5).
2. Remove four screws (7), backrest (1), and plate (2) from seat frame (3).

DRIVER'S SEAT FRAME REMOVAL

Remove four locknuts (8) and seat frame (3) from seat adjusters (11). Discard locknuts (8).

DRIVER'S SEAT ADJUSTER REMOVAL

Remove four locknuts (10), two seat adjusters (11), and release wire (12) from seat base (9). Discard locknuts (10).

DRIVER'S SEAT ADJUSTER INSTALLATION

Install two seat adjusters (11) and wire (12) on seat base (9) with four new locknuts (10).

DRIVER'S SEAT FRAME INSTALLATION

Install seat frame (3) on seat adjusters (11) with four new locknuts (8).

DRIVER'S SEAT BACKREST INSTALLATION

1. Install plate (2) and backrest (1) on seat frame (3) with four screws (7).
2. Install two clips (4) on seat frame (3) and backrest (1) with two new lockwashers (5) and screws (6).

DRIVER'S SEAT CUSHION INSTALLATION

1. Position two washers (13), seat cushion brackets (16), and seat cushion (17) on frame (3).
2. Install two seat cushion brackets (16), two washers (13), and seat cushion (17) on seat frame (3) with four screws (14) and new lockwashers (15).
3. Connect battery ground cable (WP 0126 00).
4. Release parking brake and remove wheel chocks (TM 9-2320-361-10).

DRIVER'S SEAT CUSHION, BACKREST, FRAME, AND SEAT ADJUSTER REPLACEMENT (Contd)

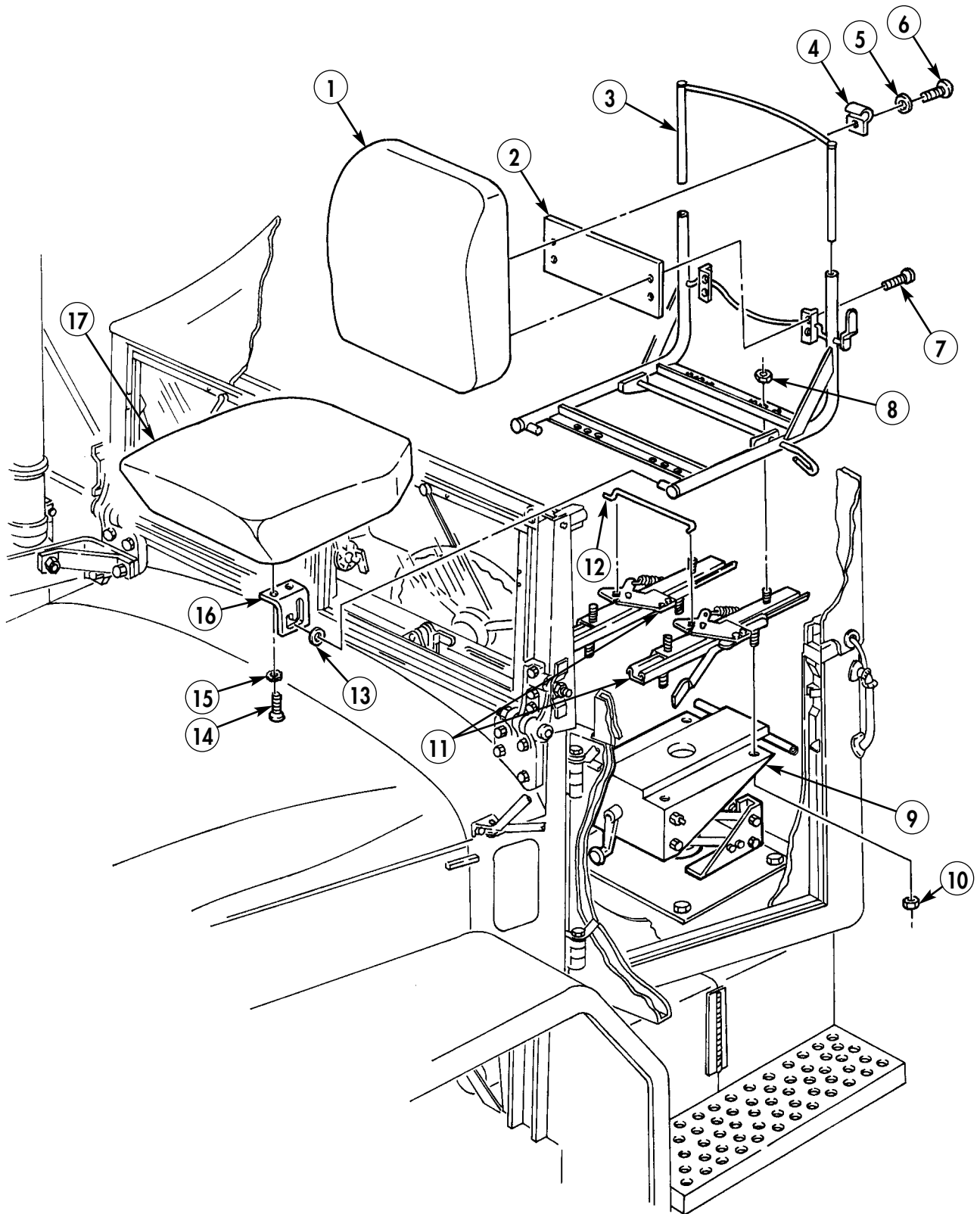

END OF WORK PACKAGE

FIELD MAINTENANCE INSTRUCTIONS

2-1/2 TON, 6X6, M44A2 SERIES TRUCKS (MULTIFUEL)

FRONT FENDERS MAINTENANCE

REMOVAL, INSPECTION AND REPAIR, AND INSTALLATION

INITIAL SETUP:

Applicable Models

All

Materials/Parts

Five locknuts (item 129, WP 0470 00)
Five locknuts (item 145, WP 0470 00)
Three locknuts (item 174, WP 0470 00)
Three screw-assembled lockwashers
(item 270, WP 0470 00)
Screw-assembled lockwasher
(item 253, WP 0470 00)
Anti-squeak material (item 1, WP 0470 00)
Adhesive (item 3, WP 0468 00)

References

TB 43-0213
TC 9-510
TC 9-237
WP 0020 00

Equipment Condition

Parking brake set and wheels chocked
(TM 9-2320-361-10).
Battery ground cable disconnected
(WP 0126 00).
Hood raised and secured (TM 9-2320-361-10).
Front wheels removed (TM 9-2320-361-10).
Side panel removed (WP 0218 00).
Front composite lamp housing and brackets
removed (WP 0122 00).
Exhaust system removed (right side only)
(WP 0073 00 or WP 0074 00).
Air horn removed (right side only)
(WP 0114 00).

FRONT FENDERS MAINTENANCE (Contd)

NOTE

Right and left fenders are replaced the same. This procedure covers right side.

REMOVAL

1. Remove two screws (30), locknuts (28), clamps (29), and wiring harness (25) from fender support (21). Discard locknuts (28).
2. Remove three screw-assembled lockwashers (16) from fender (13) and cowl (4). Discard screw-assembled lockwashers (16).
3. Remove three locknuts (22), screws (26), fender mount springs (27), and nine washers (23) from fender (13) and fender support (21). Discard locknuts (22).
4. Remove two locknuts (12), screws (7), and washers (6) from light support bracket (10) and fender (13). Discard locknuts (12).
5. Remove three locknuts (11), washers (9), screws (8), and washers (9) from fender (13) and light support bracket (10). Discard locknuts (11).
6. Remove screw-assembled lockwasher (19), locknut (14), screw (17), and brace (18) from flame (5). Discard screw-assembled lockwasher (19) and locknut (14).

NOTE

Assistant will help with step 7.

7. Remove two locknuts (3), screws (15), washers (2), fender (13), and fender mount spacer (24) from fender support (21), bracket (20), cowl (4), and light support bracket (10). Discard locknuts (3).
8. Remove anti-squeak material (1) from cowl (4). Discard anti-squeak material (1).

INSPECTION AND REPAIR

1. Inspect fender for rust, dents, bends, and cracks.
2. Refer to WP 0020 00 for general inspection procedure.
3. Refer to TC 9-237 for welding instructions.
4. Refer to TC 9-510 for metal body repair.
5. Refer to TB 43-0213 for rustproofing instructions.

FRONT FENDERS MAINTENANCE (Contd)

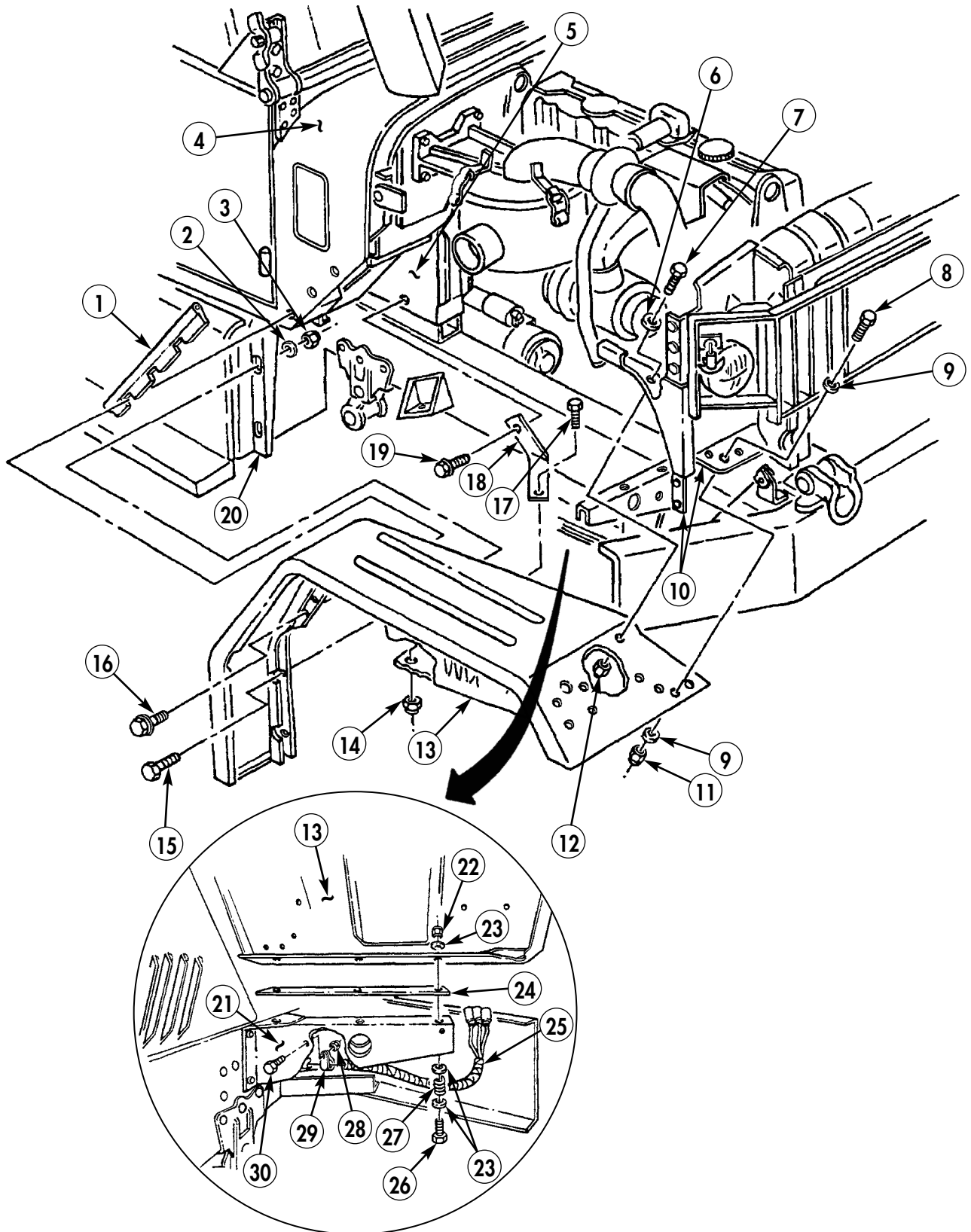

FRONT FENDERS MAINTENANCE (Contd)

INSTALLATION

NOTE

Assistant will help with step 1.

1. Install fender mount spacer (24), new anti-squeak material (1), and fender (13) on cowl (4) and fender support (21) with three new screw-assembled lockwashers (16), springs (27), nine washers (23), screws (26), and new locknuts (22). Do not tighten locknuts (22) or screw-assembled lockwashers (16).
2. Install brace (18) on frame (5) and fender (13) with new screw-assembled lockwasher (19), screw (17), and new locknut (14). Do not tighten screw-assembled lockwasher (19) or locknut (14).
3. Install two screws (15), washers (2), and new locknuts (3) on brace (20) and fender (13). Do not tighten locknuts (3).
4. Install fender (13) to light support bracket (10) with two screws (7), washers (6), and new locknuts (12). Do not tighten locknuts (12).
5. Install fender (13) to light support bracket (10) with three washers (9), screws (8), washers (9), and new locknuts (11). Do not tighten locknuts (11).

NOTE

Assistant will help with step 6.

6. Align fender (13) with cowl (4), brace (20), support (21), and light support bracket (10). Tighten screw-assembled lockwashers (16) and (19) and locknuts (22), (3), (11), (12), and (14).
7. Install wiring harness (25) on fender support (21) with two clamps (29), screws (30), and new locknuts (28).
8. Install exhaust system (right side only) (WP 0073 00 or WP 0074 00).
9. Install air horn (right side only) (WP 0114 00).
10. Install front composite light housing and brackets (WP 0122 00).
11. Install side panel (WP 0218 00).
12. Install front wheels (TM 9-2320-361-10).
13. Connect battery ground cable (WP 0126 00).
14. Lower and secure hood (TM 9-2320-361-10).
15. Release parking brake and remove wheel chocks (TM 9-2320-361-10).

FRONT FENDERS MAINTENANCE (Contd)

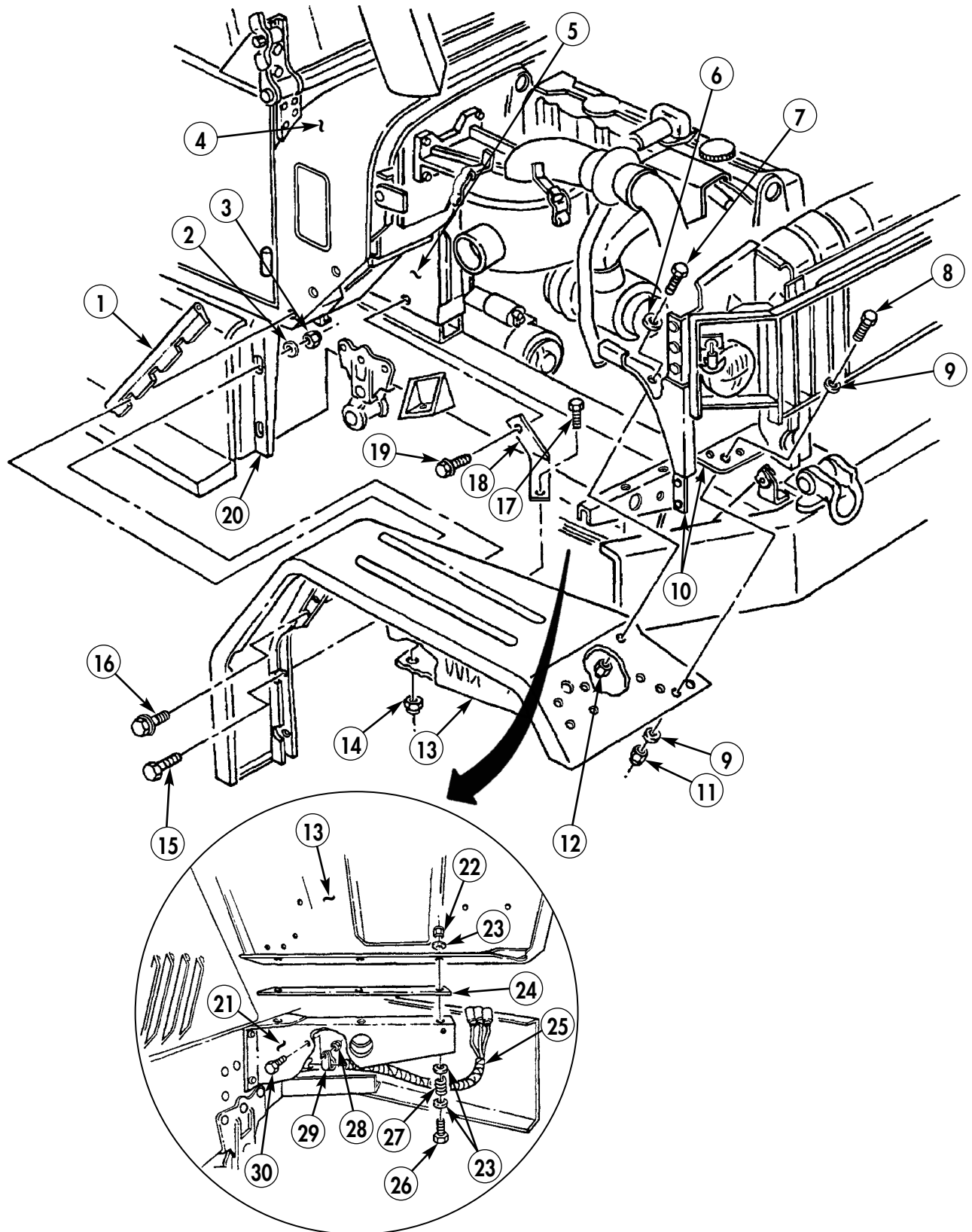

END OF WORK PACKAGE

FIELD MAINTENANCE INSTRUCTIONS

2-1/2 TON, 6X6, M44A2 SERIES TRUCKS (MULTIFUEL)

WINDSHIELD WASHER RESERVOIR, TUBING, JET, AND PUMP REPLACEMENT

WINDSHIELD WASHER RESERVOIR REMOVAL, WINDSHIELD WASHER TUBING REMOVAL, WINDSHIELD WASHER JET REMOVAL, WINDSHIELD WASHER PUMP REMOVAL, WINDSHIELD WASHER PUMP INSTALLATION, WINDSHIELD WASHER JET INSTALLATION, WINDSHIELD WASHER TUBING INSTALLATION, AND WINDSHIELD WASHER RESERVOIR INSTALLATION

INITIAL SETUP:

Applicable Models

All

Materials/Parts

Four locknuts (item 145, WP 0470 00)

Equipment Condition

Parking brake set and wheels chocked
(TM 9-2320-361-10).

Battery ground cable disconnected
(WP 0126 00).

Hood raised and secured (TM 9-2320-361-10).

WINDSHIELD WASHER RESERVOIR, TUBING, JET, AND PUMP REPLACEMENT (Contd)

WINDSHIELD WASHER RESERVOIR REMOVAL

1. Remove cover (17) with grommet (16) from reservoir (19). Remove strainer (18) from hose (7) and hose (7) from grommet (16) and cover (17).
2. Remove three locknuts (24), two clamps (23), plate (22), two screws (21), washers (20), and reservoir (19) from steering column (25). Discard locknuts (24).

WINDSHIELD WASHER TUBING REMOVAL

NOTE

Tag hose and tubes for installation.

1. Disconnect tubes (4), (6), and (28) from valve (29).
2. Disconnect hose (7) and tubes (6) and (9) from tee connector (8).
3. Remove grommet (27) and hose (7) from dash panel (26).

WINDSHIELD WASHER JET REMOVAL

Remove nut (5), washer (2), and jet (3) from cowling (1).

WINDSHIELD WASHER PUMP REMOVAL

Remove locknut (10), washer (11), windshield washer pump (13), washer (14), and screw (15) from instrument panel (12). Discard locknut (10).

WINDSHIELD WASHER PUMP INSTALLATION

Install windshield washer pump (13) on instrument panel (12) with washer (14), screw (15), washer (11), and new locknut (10).

WINDSHIELD WASHER JET INSTALLATION

Install washer (2) and jet (3) on cowling (1) with nut (5).

WINDSHIELD WASHER TUBING INSTALLATION

1. Install grommet (27) and hose (7) on dash panel (26).
2. Install tubing (28) on jet (3) and install tubing (4) and (9) on pump (13).
3. Install hose (7) and tubing (9) and (6) on tee connector (8).
4. Install tubing (4), (6), and (28) on valve (29).

WINDSHIELD WASHER RESERVOIR INSTALLATION

1. Install two clamps (23) on steering column (25).
2. Install plate (22) and reservoir (19) on clamps (23) with three screws (21), washers (20), and new locknuts (24).
3. Install grommet (16) in cover (17).
4. Install tube (7) through grommet (16) and connect to strainer (18). Position strainer (18) at bottom of reservoir (19) and install cover (17) on reservoir (19).
5. Connect battery ground cable (WP 0126 00).
6. Lower and secure hood (TM 9-2320-361-10).
7. Release parking brake and remove wheel chocks (TM 9-2320-361-10).

WINDSHIELD WASHER RESERVOIR, TUBING, JET, AND PUMP REPLACEMENT (Contd)

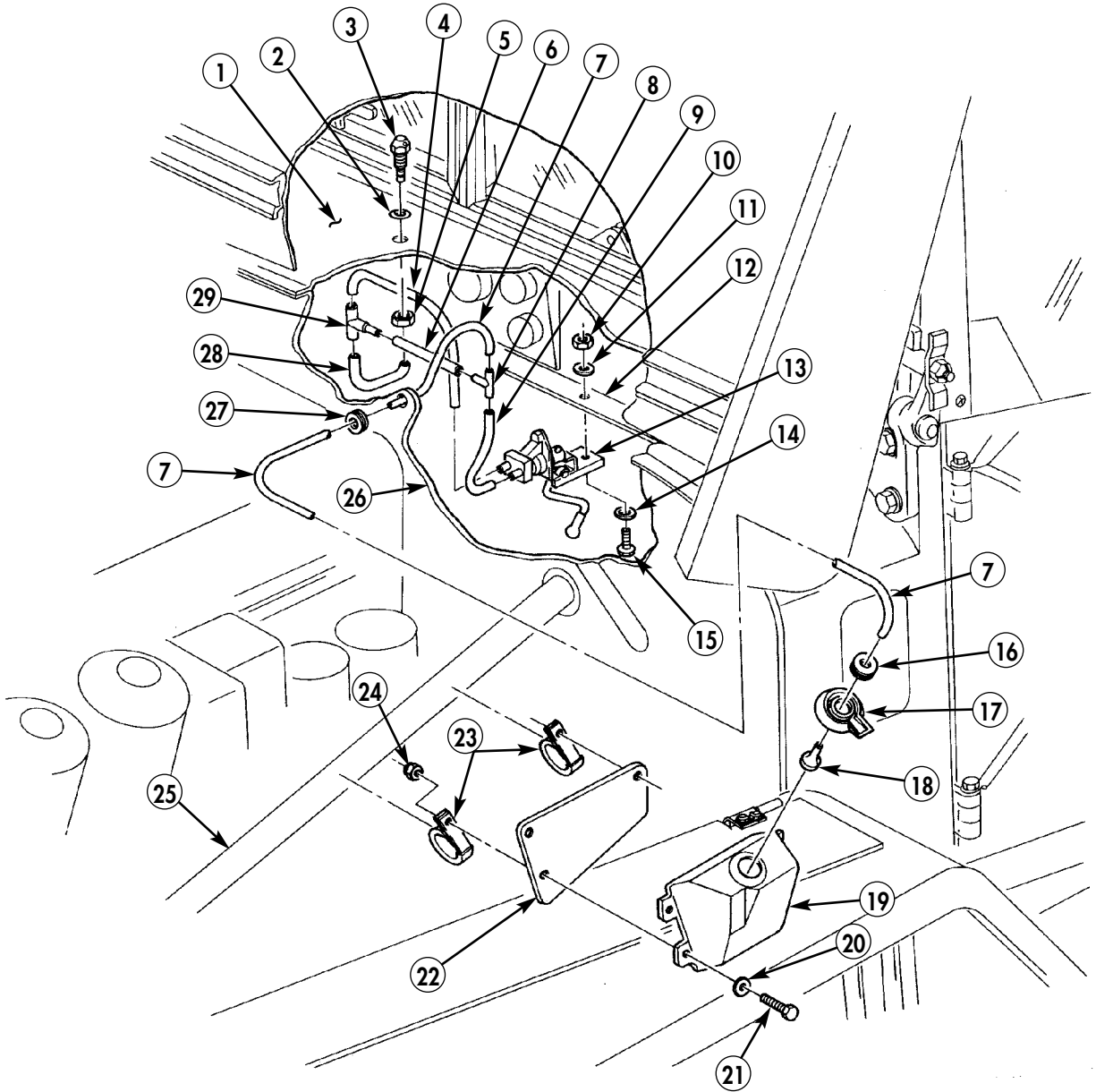

FIELD MAINTENANCE INSTRUCTIONS

2-1/2 TON, 6X6, M44A2 SERIES TRUCKS (MULTIFUEL)

WINDSHIELD WIPER SWITCH, MOTOR, AND CONLINK COVERS REPLACEMENT

REMOVAL AND INSTALLATION

INITIAL SETUP:

Applicable Models

All

Materials/Parts

Three locknuts (item 172 ,WP 0470 00)
Locknut (item 173, WP 0470 00)
Lockwasher (item 426, WP 0470 00)
Lockwasher (item 212, WP 0470 00)

Materials/Parts (Contd)

Lockwasher (item 216, WP 0470 00)
Seven lockwashers (item 425, WP 0470 00)

Equipment Condition

Parking brake set and wheels chocked
(TM 9-2320-361-10).
Battery ground cable disconnected
(WP 0126 00).

WINDSHIELD WIPER SWITCH, MOTOR, AND CONLINK COVERS REPLACEMENT (Contd)

REMOVAL

1. Remove four screws (3), lockwashers (4), washers (2), two screws (7), and lockwashers (8) from left conlink cover (1), right conlink cover (9), and windshield frame (11). Discard lockwashers (4) and (8).
2. Disconnect harness leads 27 and 71 (19) from wiper switch (18).
3. Remove screw (21), lockwasher (22), ground (GND) wire 57 (20), and lockwasher (23) from wiper motor (27). Discard lockwashers (22) and (23).
4. Remove screw (16) and lockwasher (15) from mounting bracket (10) and windshield frame (11). Discard lockwasher (15).
5. Remove left (1) and right (9) conlink covers, wiper motor (27), wiper switch (18), and mounting bracket (10) from windshield frame (11) as an assembly.
6. Remove three locknuts (12), screws (5), washers (6), left conlink cover (1), and right conlink cover (9) from wiper motor (27) and mounting bracket (10). Discard locknuts (12).
7. Remove locknut (14), retainer bracket (13), and wiper motor (27) from mounting bracket (10). Discard locknut (14).
8. Disconnect wiper switch lead (17) from wiper motor (27).
9. Depress retaining clip on knob (26) and remove knob (26), nut (25), lockwasher (24), and wiper switch (18) from wiper motor (27). Discard lockwasher (24).

INSTALLATION

1. Install wiper switch (18) on wiper motor (27) with new lockwasher (24) and nut (25). Tighten nut (25) 35 lb-in (4 N•m).
2. Depress retaining clip on knob (26) and install knob (26) on wiper switch (18).
3. Connect wiper switch lead (17) to wiper motor (27).
4. Install wiper motor (27) and retainer bracket (13) on mounting bracket (10) with new locknut (14).
5. Install left conlink cover (1) and right conlink cover (9) on wiper motor (27) and mounting bracket (10) with three washers (6), screws (5), and new locknuts (12).
6. Position left conlink cover (1) and right conlink cover (9), wiper motor (27), wiper switch (18), and mounting bracket (10) on windshield frame (11) as an assembly.
7. Install four washers (2), new lockwashers (4), screws (3), two new lockwashers (8), and screws (7) on left conlink cover (1), right conlink cover (9), and windshield frame (11).
8. Install mounting bracket (10) and wiper motor (27) on windshield frame (11) with new lockwasher (15) and screw (16).
9. Install new lockwasher (23), ground (GND) wire 57 (20), new lockwasher (22), and screw (21) on wiper motor (27).
10. Connect harness leads 27 and 71 (19) to wiper switch (18).
11. Connect battery ground cable (WP 0126 00).
12. Release parking brake and remove wheel chocks (TM 9-2320-361-10).

WINDSHIELD WIPER SWITCH, MOTOR, AND CONLINK COVERS REPLACEMENT (Contd)

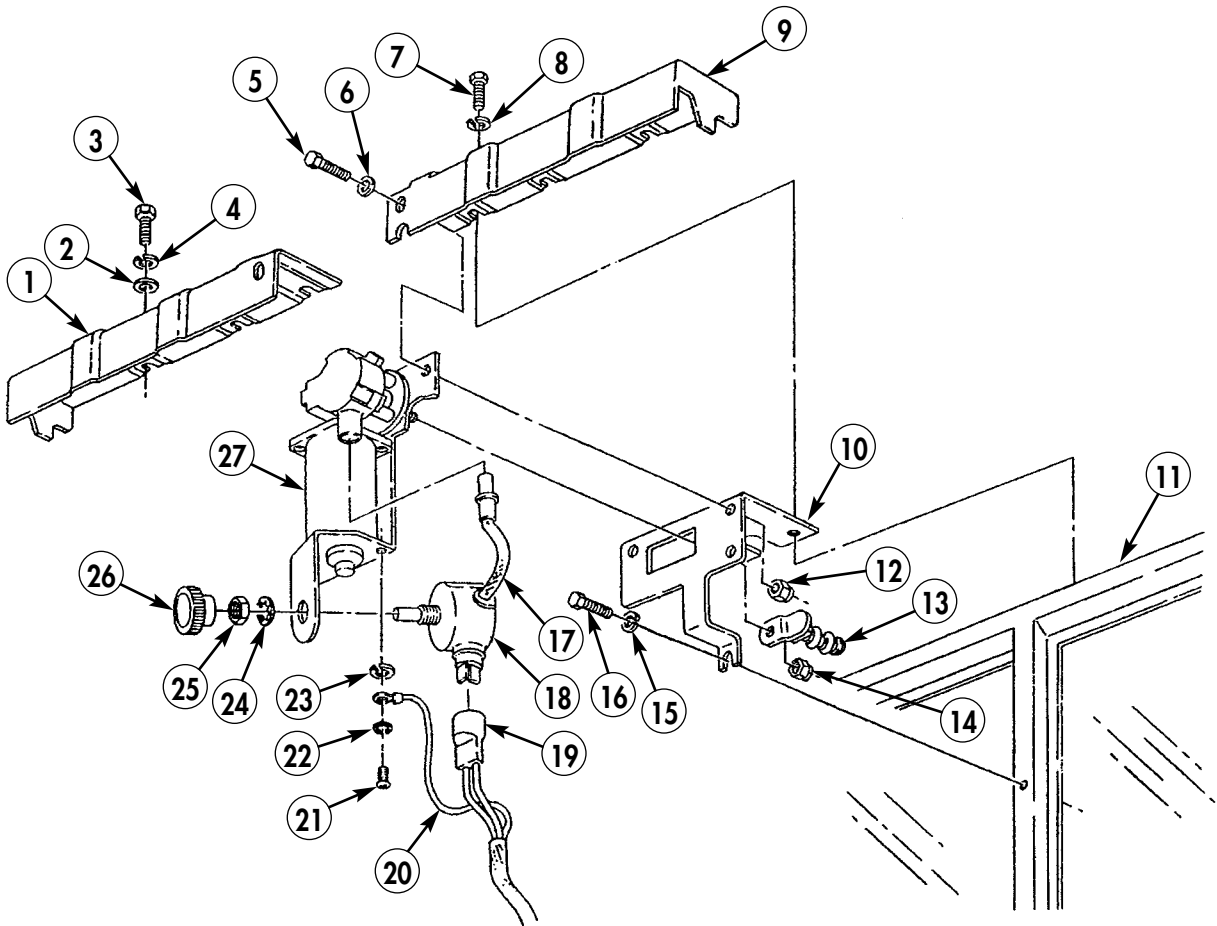

END OF WORK PACKAGE

FIELD MAINTENANCE INSTRUCTIONS

2-1/2 TON, 6X6, M44A2 SERIES TRUCKS (MULTIFUEL)

LEFT AND RIGHT CONLINKS MAINTENANCE REMOVAL, INSTALLATION, AND ADJUSTMENT

INITIAL SETUP:

Applicable Models

All

Materials/Parts

Two lockwashers (item 189, WP 0470 00)

Equipment Condition

Parking brake set and wheels chocked
(TM 9-2320-361-10).

Battery ground cable disconnected
(WP 0126 00).

Conlink covers removed (WP 0240 00).

LEFT AND RIGHT CONLINKS MAINTENANCE (Contd)

REMOVAL

1. Remove two nuts (8), lockwashers (7), left conlink (4), and right conlink (2) from idler shaft links (6). Discard lockwashers (7).
2. Remove left conlink (4) and right conlink (2) from wiper motor drive link (3).

INSTALLATION

CAUTION

The right conlink is longer than the left conlink. Ensure conlinks are installed in the correct locations. Failure to do so will result in damage to equipment.

1. Install left conlink (4) and right conlink (2) on wiper motor drive link (3).
2. Install left conlink (4) and right conlink (2) to idler shaft links (6) with two new lockwashers (7) and nuts (8).

ADJUSTMENT

1. Remove two nuts (8), lockwashers (7), left conlink (4), and right conlink (2) from idler shaft links (6). Discard lockwashers (7).
2. Position wiper arms (9) approximately 2 in. (5 cm) from edge of windshield frame (10).
3. Loosen two jamnuts (1) on locking ball joints (5) and on right conlink (2) and left conlink (4).
4. Shorten or lengthen locking ball joints (5) until they align with holes in idler shaft links (6).

NOTE

Check operation of windshield wipers to ensure correct wiper travel and linkage is free of binding.

5. Tighten jamnuts (1) on right conlink (2) and left conlink (4).
6. Install left conlink (4) and right conlink (2) on two idler shaft links (6) with two new lockwashers (7) and nuts (8).
7. Install conlink covers (WP 0240 00).
8. Connect battery ground cable (WP 0126 00).
9. Release parking brake and remove wheel chocks (TM 9-2320-361-10).

LEFT AND RIGHT CONLINKS MAINTENANCE (Contd)

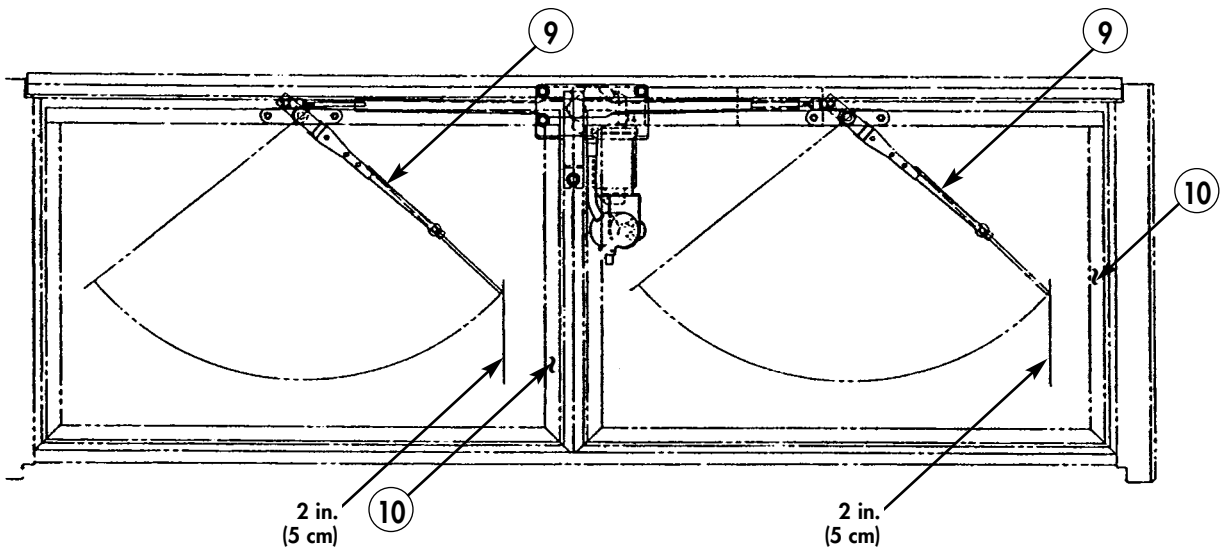
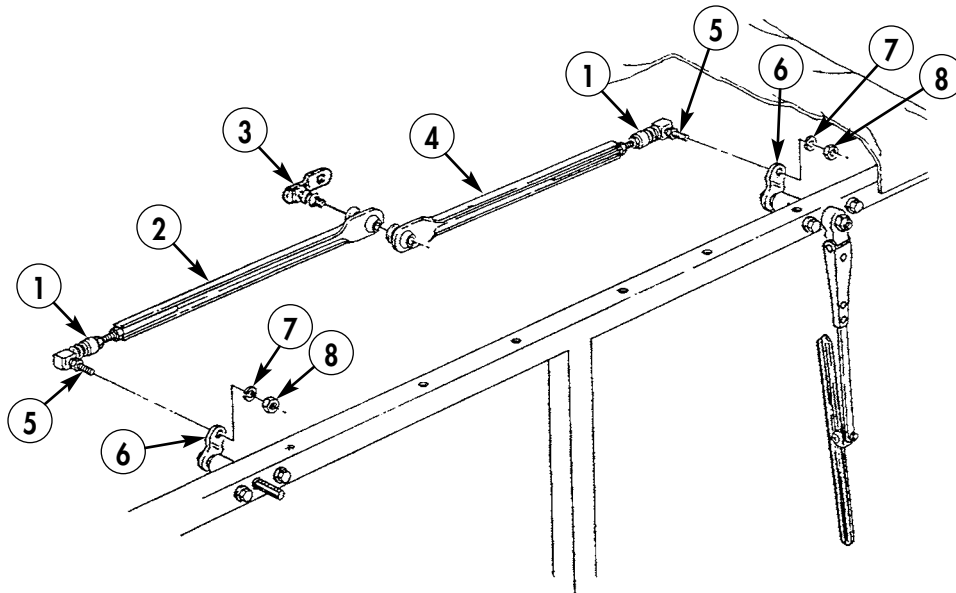

END OF WORK PACKAGE

FIELD MAINTENANCE INSTRUCTIONS

2-1/2 TON, 6X6, M44A2 SERIES TRUCKS (MULTIFUEL)

WINDSHIELD WIPER IDLER SHAFT AND HOUSING REPLACEMENT

REMOVAL AND INSTALLATION

INITIAL SETUP:

Applicable Models

All

Materials/Parts

Four locknuts (item 427, WP 0470 00)

GAA Grease (item 17, WP 0468 00)

Equipment Condition

Parking brake set and wheels chocked
(TM 9-2320-361-10).

Battery ground cable disconnected
(WP 0126 00).

Wiper blade and arm removed (WP 0243 00).

Left and right conlinks removed (WP 0240 00).

WINDSHIELD WIPER IDLER SHAFT AND HOUSING REPLACEMENT (Contd)

NOTE

The replacement procedure for the left and right idler shaft and housing assembly is basically the same. This procedure covers the left idler shaft and housing assembly.

REMOVAL

Remove two screws (4), locknuts (1), and idler shaft and housing assembly (2) from windshield frame (5). Discard locknuts (1).

INSTALLATION

1. Apply grease to surface of shaft (3).
2. Install idler shaft and housing assembly (2) on windshield frame (5) with two screws (4) and new locknuts (1).
3. Install left and right conlinks (WP 0240 00).
4. Install wiper blade and arm (WP 0243 00).
5. Connect battery ground cable (WP 0126 00).
6. Release parking brake and remove wheel chocks (TM 9-2320-361-10).

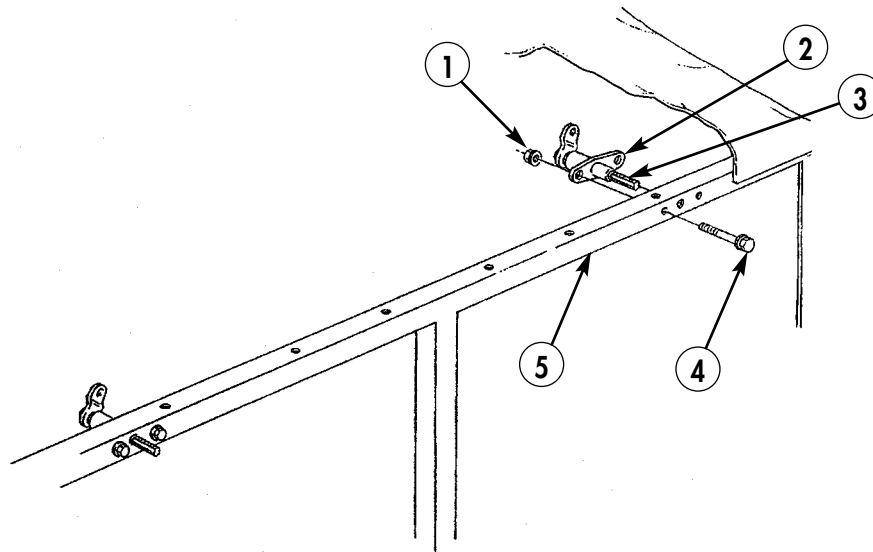

END OF WORK PACKAGE

FIELD MAINTENANCE INSTRUCTIONS

2-1/2 TON, 6X6, M44A2 SERIES TRUCKS (MULTIFUEL)

WINDSHIELD WIPER BLADE AND ARM REPLACEMENT REMOVAL AND INSTALLATION

INITIAL SETUP:

Applicable Models

All

Equipment Condition

Parking brake set and wheels chocked
(TM 9-2320-361-10).

Materials/Parts

Locknut (item 135, WP 0470 00)

Locknut (item 150, WP 0470 00)

WINDSHIELD WIPER BLADE AND ARM REPLACEMENT (Contd)

NOTE

Left and right windshield wiper blades and arms are replaced the same. This procedure covers left windshield wiper blade and arm.

REMOVAL

1. Remove locknut (5), screw (6), and wiper blade (7) from wiper arm (4). Discard locknut (5).
2. Remove locknut (3), wiper arm (4), and arm driver (2) from idler shaft (1). Discard locknut (3).

INSTALLATION

NOTE

Install wiper arm in line with idler shaft link.

1. Install arm driver (2) and wiper arm (4) on idler shaft (1) with new locknut (3). Tighten locknut (3) 90–110 lb-in (10–12 N•m).
2. Install wiper blade (7) on wiper arm (4) with screw (6) and new locknut (5). Tighten locknut (5) 15–20 lb-in (1.7–2.3 N•m).
3. Release parking brake and remove wheel chocks (TM 9-2320-361-10).

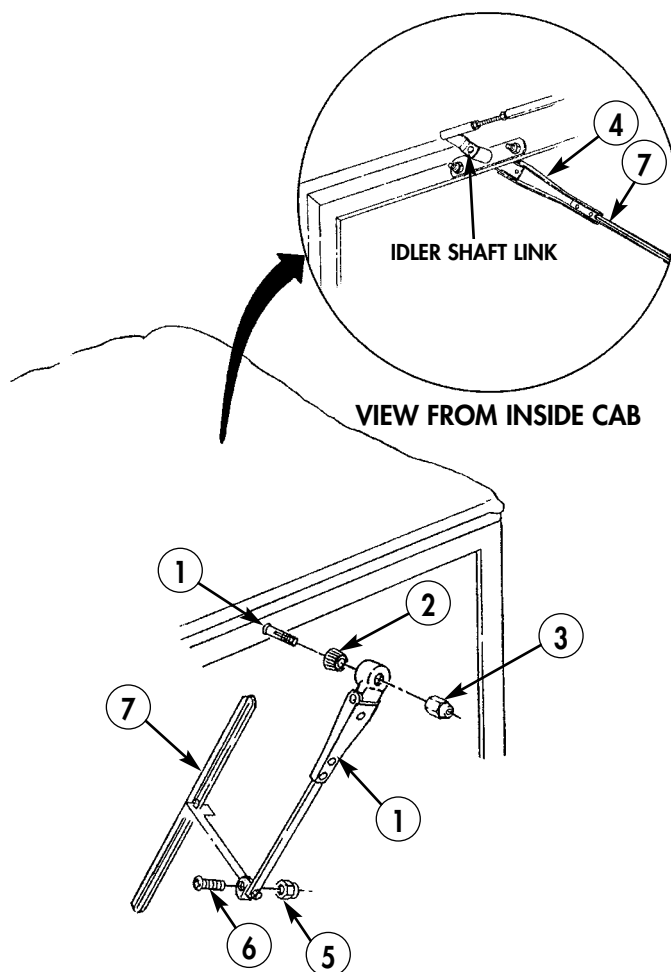

END OF WORK PACKAGE

FIELD MAINTENANCE INSTRUCTIONS

2-1/2 TON, 6X6, M44A2 SERIES TRUCKS (MULTIFUEL)

MIRROR AND BRACKETS REPLACEMENT

REMOVAL AND INSTALLATION

INITIAL SETUP:

Applicable Models

All

Materials/Parts

Seven locknuts (item 152, WP 0470 00)

Two locknuts (item 136, WP 0470 00)

Locknut (item 130, WP 0470 00)

Equipment Condition

Parking brake set and wheels chocked
(TM 9-2320-361-10).

Battery ground cable disconnected
(WP 0126 00).

MIRROR AND BRACKETS REPLACEMENT (Contd)

REMOVAL

1. Remove bolt (26), convex mirror (17), locknut (16), washer (15), two brackets (23), and screw (25) from brace (24). Discard locknut (16).
2. Remove two locknuts (18), washers (19), spacers (20), and mirror (21) from bracket (22). Discard locknuts (18).
3. Remove two locknuts (10), four washers (11) and (14), rod (30), brace (24), and bracket (22) from braces (12), (13), (27), (28), and (29). Discard locknuts (10).
4. Remove locknut (7), washer (6), hinge bolt (9), and braces (13) and (27) from upper door hinge (5). Discard locknut (7).
5. Install hinge bolt (9) in upper door hinge (5).
6. Remove locknut (7), washer (6), hinge bolt (9), and brace (29) from top of lower door hinge (31). Discard locknut (7).
7. Install hinge bolt (9) in lower door hinge (31).
8. Remove locknut (7), washer (6), screw (8), and braces (12) and (28) from clip (4). Discard locknut (7).
9. Remove two locknuts (1), plate (2), clip (4), and screws (32) from cowling (3). Discard locknuts (1).

INSTALLATION

1. Install clip (4) and plate (2) on cowling (3) with two screws (32) and new locknuts (1).
2. Install braces (12) and (28) on clip (4) with screw (8), washer (6), and new locknut (7).
3. Remove hinge bolt (9) from lower door hinge (31).
4. Install brace (29) on top of lower door hinge (31) with hinge bolt (9), washer (6), and new locknut (7).
5. Remove hinge bolt (9) from upper door hinge (5).
6. Install braces (13) and (27) on upper door hinge (5) with hinge bolt (9), washer (6), and new locknut (7).
7. Install bracket (22), brace (24), and rod (30) on braces (12), (13), (27), (28), and (29) with four washers (11) and (14) and two new locknuts (10).
8. Install two spacers (20) on mirror (21) and install mirror (21) on bracket (22) with two washers (19) and new locknuts (18).
9. Install convex mirror (17) on brace (24) with two brackets (23), screw (25), washer (15), new locknut (16), and bolt (26).
10. Connect battery ground cable (WP 0126 00).
11. Release parking brake and remove wheel chocks (TM 9-2320-361-10).

MIRROR AND BRACKETS REPLACEMENT (Contd)

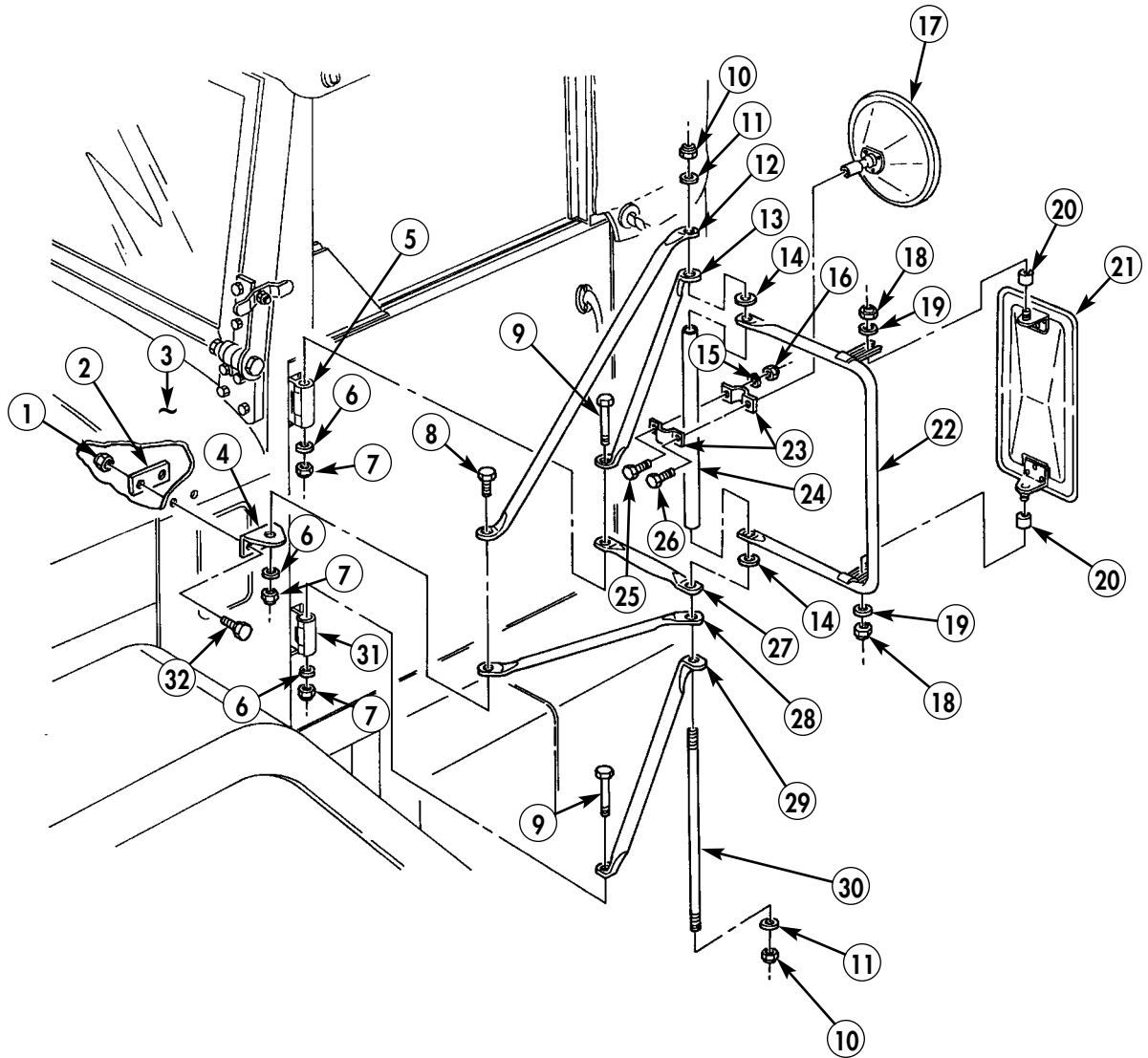

END OF WORK PACKAGE

0244 00-3/4 blank

FIELD MAINTENANCE INSTRUCTIONS

2-1/2 TON, 6X6, M44A2 SERIES TRUCKS (MULTIFUEL)

DATA PLATE REPLACEMENT

REMOVAL AND INSTALLATION

INITIAL SETUP:

Applicable Models

All

Equipment Condition

Parking brake set and wheels chocked
(TM 9-2320-361-10).

Materials/Parts

Four drivescrews (item 327, WP 0470 00)

NOTE

- Data plates are installed with rivets, screws, drivescrews, or adhesive. This procedure covers a data plate installed with drivescrews.
- All data plate replacement procedures are basically the same. This procedure covers a front winch data plate replacement.

REMOVAL

Remove four drivescrews (3) and data plate (2) from support (1). Discard drivescrews (3).

INSTALLATION

1. Install data plate (2) on support (1) with four new drivescrews (3).
2. Release parking brake and remove wheel chocks (TM 9-2320-361-10).

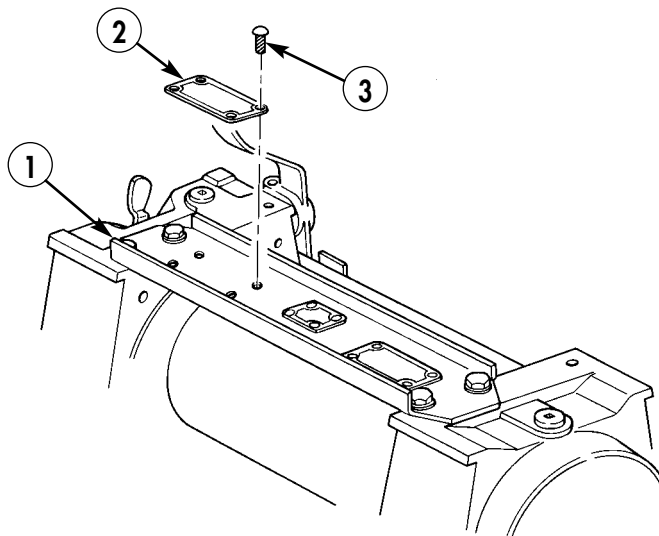

END OF WORK PACKAGE

0245 00-1/2 blank

FIELD MAINTENANCE INSTRUCTIONS

2-1/2 TON, 6X6, M44A2 SERIES TRUCKS (MULTIFUEL)

PERSONNEL HEATER SUPPLY HOSE REPLACEMENT

REMOVAL AND INSTALLATION

INITIAL SETUP:

Applicable Models
All

Equipment Condition

Parking brake set and wheels chocked
(TM 9-2320-361-10).

Battery ground cable disconnected
(WP 0126 00).

REMOVAL

1. Loosen clamp (5) and remove supply hose (4) from air vent (1).
2. Loosen clamp (3) and remove supply hose (4) from diverter (2).

INSTALLATION

1. Install supply hose (4) on diverter (2) with clamp (3). Tighten clamp (3).
2. Connect supply hose (4) on air vent (1) with clamp (5). Tighten clamp (5).
3. Connect battery ground cable (WP 0126 00).
4. Release parking brake and remove wheel chocks (TM 9-2320-361-10).

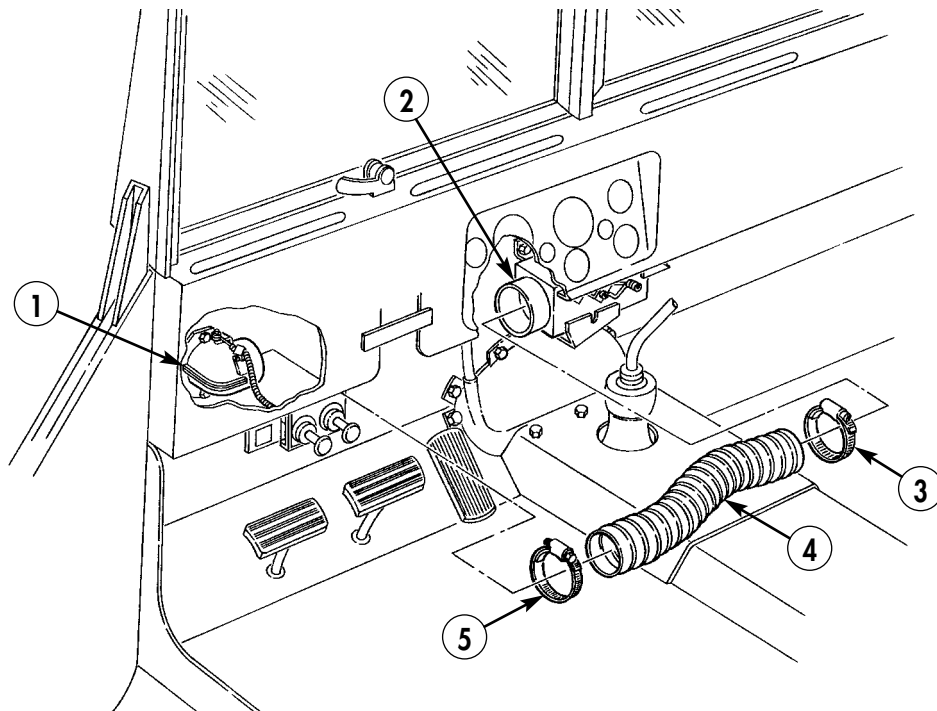

END OF WORK PACKAGE

FIELD MAINTENANCE INSTRUCTIONS

2-1/2 TON, 6X6, M44A2 SERIES TRUCKS (MULTIFUEL)

PERSONNEL HEATER DIVERTER REPLACEMENT

REMOVAL AND INSTALLATION

INITIAL SETUP:

Applicable Models

All

References

WP 0249 00

Materials/Parts

Four lockwashers (item 428, WP 0470 00)

Equipment Condition

Parking brake set and wheels chocked
(TM 9-2320-361-10).

Hood raised and secured (TM 9-2320-361-10).

Battery ground cable disconnected
(WP 0126 00).

PERSONNEL HEATER DIVERTER REPLACEMENT (Contd)

REMOVAL

1. Loosen clamp (11) and disconnect supply hose (13) from diverter (9).
2. Loosen two clamps (4) and disconnect two defroster hoses (3) from diverter (9).
3. Loosen screw (7) and holddown clamp (8) and disconnect cable (10) from shaft handle (6).
4. Remove four nuts (1), lockwashers (2), screws (5), and diverter (9) from firewall (12). Discard lockwashers (2).

INSTALLATION

1. Install diverter (9) on firewall (12) with four screws (5), new lockwashers (2), and nuts (1).
2. Install cable (10) through holddown clamp (8) and on shaft handle (6). Tighten holddown clamp (8) with screw (7).
3. Install two defroster hoses (3) on diverter (9) with two clamps (4).
4. Install supply hose (13) on diverter (9) with clamp (11).
5. Adjust control cable (WP 0249 00).
6. Connect battery ground cable (WP 0126 00).
7. Lower and secure hood (TM 9-2320-361-10).
8. Release parking brake and remove wheel chocks (TM 9-2320-361-10).

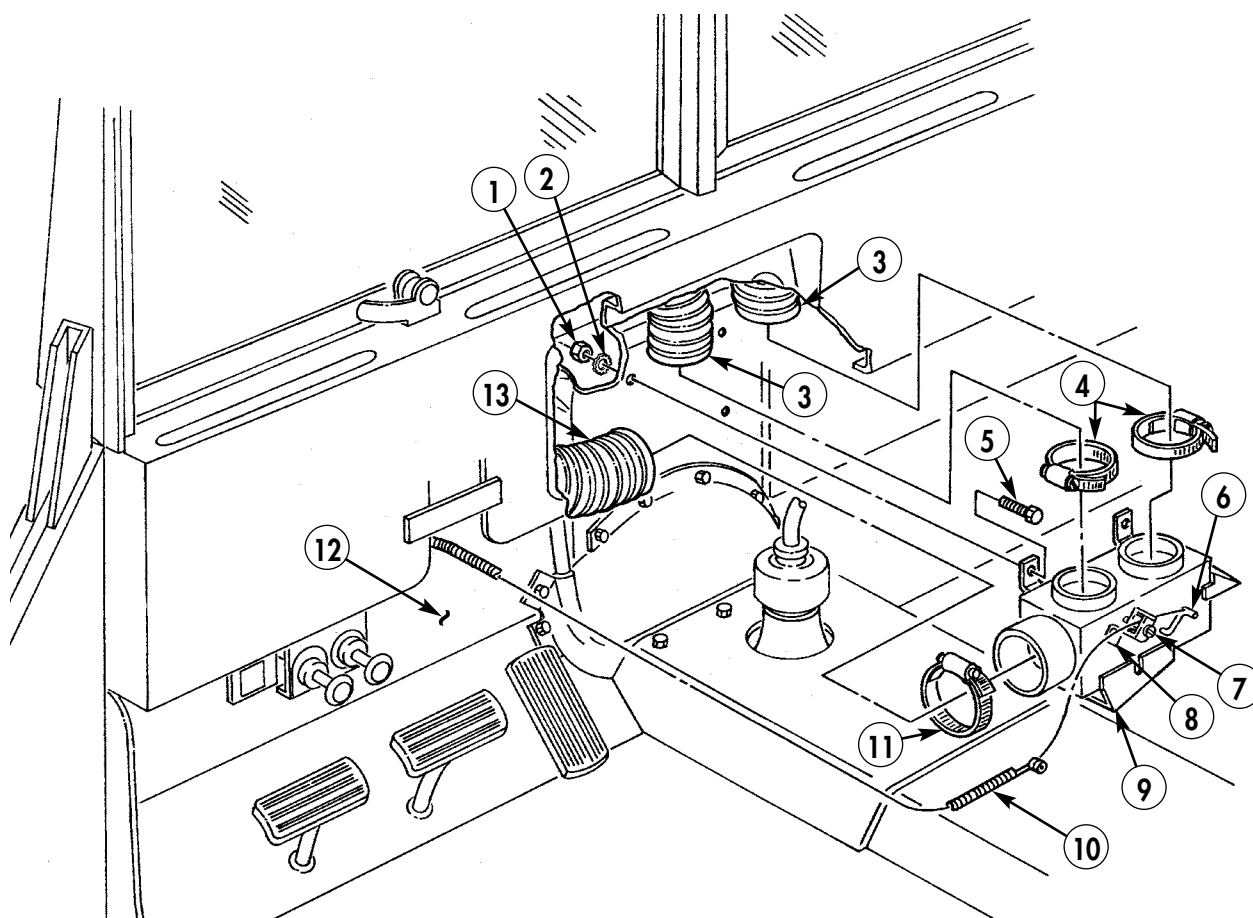

END OF WORK PACKAGE

FIELD MAINTENANCE INSTRUCTIONS

2-1/2 TON, 6X6, M44A2 SERIES TRUCKS (MULTIFUEL)

PERSONNEL HEATER AIR VENT REPLACEMENT

REMOVAL AND INSTALLATION

INITIAL SETUP:

Applicable Models

All

Materials/Parts

Four lockwashers (item 225, WP 0470 00)

References

WP 0249 00

Equipment Condition

Parking brake set and wheels chocked
(TM 9-2320-361-10).

Hood raised and secured (TM 9-2320-361-10).

Battery ground cable disconnected
(WP 0126 00).

REMOVAL

1. Loosen clamp (4) and remove supply hose (1) from air vent (9).
2. Loosen screw (8) and remove cable (5) from shaft (2) and clamp (3).
3. Remove two nuts (6), lockwashers (7), screws (12), lockwashers (11), and air vent (9) from firewall (10). Discard lockwashers (7) and (11).

INSTALLATION

1. Install air vent (9) on firewall (10) with two new lockwashers (11), screws (12), new lockwashers (7), and nuts (6).
2. Insert cable (5) through clamp (3) and install on shaft (2) with screw (8).
3. Install supply hose (1) on air vent (9) with clamp (4). Tighten clamp (4).
4. Adjust control cable (WP 0249 00).
5. Connect battery ground cable (WP 0126 00).
6. Lower and secure hood (TM 9-2320-361-10).
7. Release parking brake and remove wheel chocks (TM 9-2320-361-10).

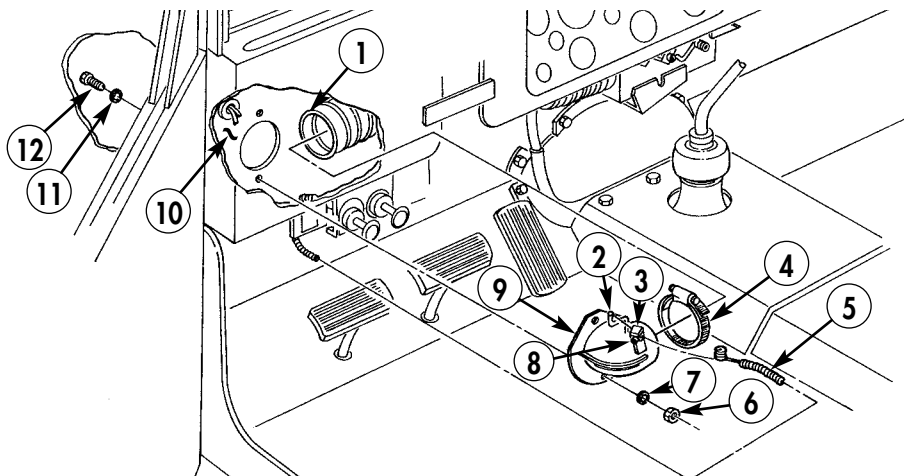

END OF WORK PACKAGE

0248 00-1/2 blank

FIELD MAINTENANCE INSTRUCTIONS

2-1/2 TON, 6X6, M44A2 SERIES TRUCKS (MULTIFUEL)

PERSONNEL HEATER CONTROL CABLES MAINTENANCE REMOVAL, INSTALLATION, AND ADJUSTMENT

INITIAL SETUP:

Applicable Models

All

Materials/Parts

Four lockwashers (item 203, WP 0470 00)

Equipment Condition

Parking brake set and wheels chocked
(TM 9-2320-361-10).

Battery ground cable disconnected
(WP 0126 00).

PERSONNEL HEATER CONTROL CABLES REPLACEMENT (Contd)

REMOVAL

1. Loosen screw (6) and remove cable (7) from shaft (5) and clamp (4) on diverter (3).
2. Loosen screw (16) and remove cable (8) from shaft (18) and clamp (19) on adapter (17).
3. Remove two nuts (1), lockwashers (2), screws (10), and bracket (9) from instrument panel (15). Discard lockwashers (2).
4. Remove nut (13), lockwasher (11), and cable (8) from bracket (9). Discard lockwasher (11).
5. Remove nut (14), lockwasher (12), and cable (7) from bracket (9). Discard lockwasher (12).

INSTALLATION

1. Install cable (7) in bracket (9) with new lockwasher (12) and nut (14).
2. Install cable (8) in bracket (9) with new lockwasher (11) and nut (13).
3. Install bracket (9) to instrument panel (15) with two screws (10), new lockwashers (2), and nuts (1).
4. Insert cable (8) through clamp (19) and install on shaft (18) of adapter (17).
5. Insert cable (7) through clamp (4) and install on shaft (5) of diverter (3).

ADJUSTMENT

1. Loosen screw (16) and slide cable (8) through clamp (19).
2. Push shaft (18) of adapter (17) forward and tighten screw (16).
3. Loosen screw (6) and slide cable (7) through clamp (4).
4. Push shaft (5) of diverter (3) to the right, and tighten screw (6).
5. Connect battery ground cable (WP 0126 00).
6. Release parking brake and remove wheel chocks (TM 9-2320-361-10).

PERSONNEL HEATER CONTROL CABLES REPLACEMENT (Contd)

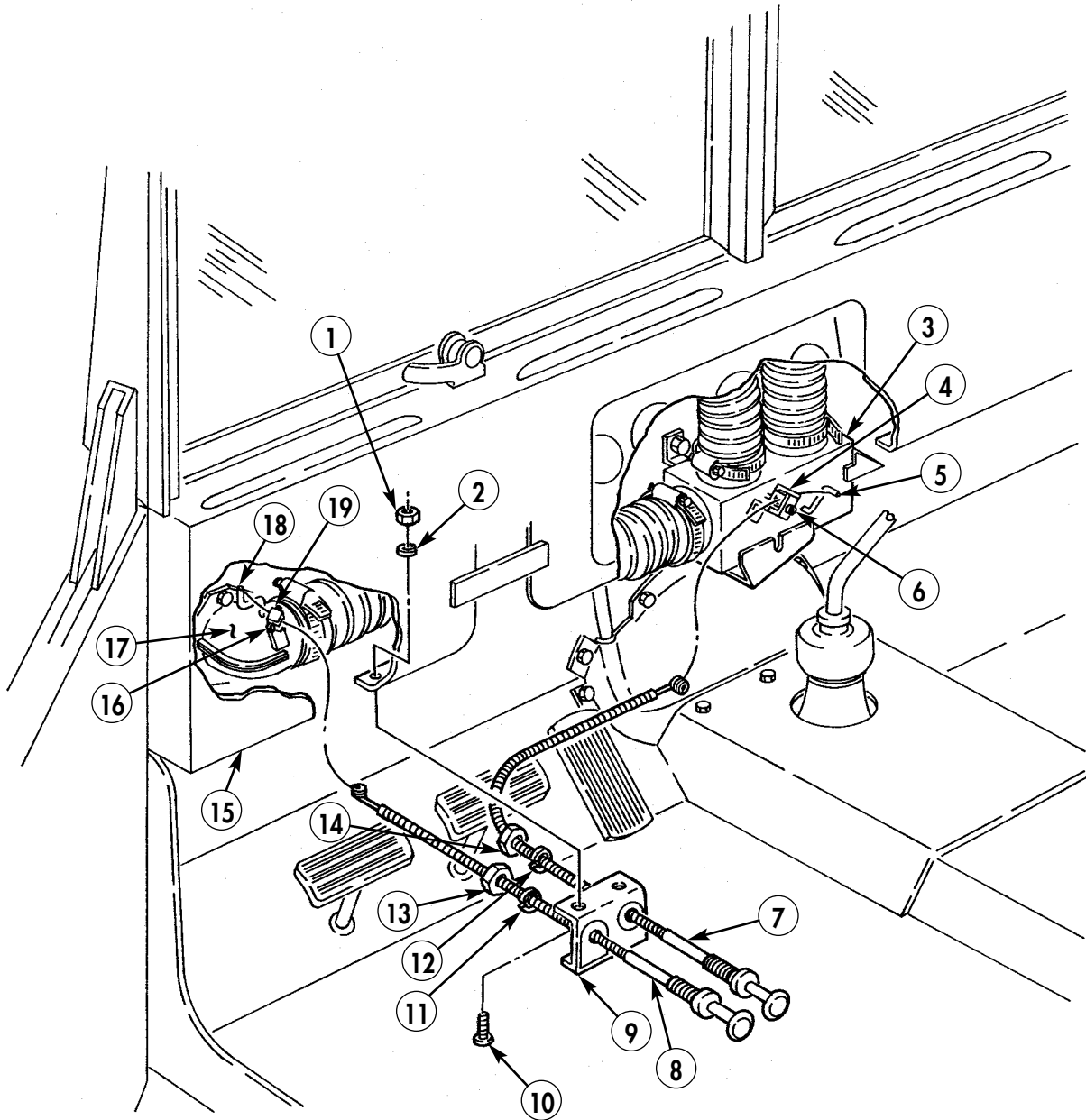

END OF WORK PACKAGE

FIELD MAINTENANCE INSTRUCTIONS

2-1/2 TON, 6X6, M44A2 SERIES TRUCKS (MULTIFUEL)

PERSONNEL HOT WATER HEATER REPLACEMENT

HOSES AND ADAPTERS REMOVAL, HEATER REMOVAL, BRACKETS REMOVAL, BRACKETS INSTALLATION,
HEATER INSTALLATION, AND HOSES AND ADAPTERS INSTALLATION

INITIAL SETUP:

Applicable Models

All

Materials/Parts

Eleven locknuts (item 155, WP 0470 00)
Three locknuts (item 145, WP 0470 00)
Eight lockwashers (item 215, WP 0470 00)
Four lockwashers (item 216, WP 0470 00)

Equipment Condition

Parking brake set and wheels chocked
(TM 9-2320-361-10).
Hood raised and secured (TM 9-2320-361-10).
Battery ground cable disconnected
(WP 0126 00).
Two engine coolant heater hoses removed
(WP 0079 00).

PERSONNEL HOT WATER HEATER REPLACEMENT (Contd)

NOTE

In some installations, fresh air hood, screen, and elbow are mounted on left side panel.

HOSES AND ADAPTERS REMOVAL

1. Loosen two clamps (1) and remove inlet hose (14) from elbow (24) and adapter (17).
2. Loosen two clamps (1) and remove outlet hose (13) from adapters (9) and (12).
3. Remove eight screws (11), lockwashers (10), and adapter (12) from heater (4). Discard lockwashers (10).
4. Remove four screws (15), lockwashers (16), and adapter (17) from heater (4). Discard lockwashers (16).
5. Remove three locknuts (2), elbow (24), screen (23), hood (20), and three screws (19) from hood side panel (21). Discard locknuts (2).

HEATER REMOVAL

1. Disconnect electrical plugs (5).
2. Remove screw (7), clamp (6), and wire (8) from heater (4).
3. Remove four locknuts (18), heater (4), and screws (3) from bracket (22). Discard locknuts (18).

PERSONNEL HOT WATER HEATER REPLACEMENT (Contd)

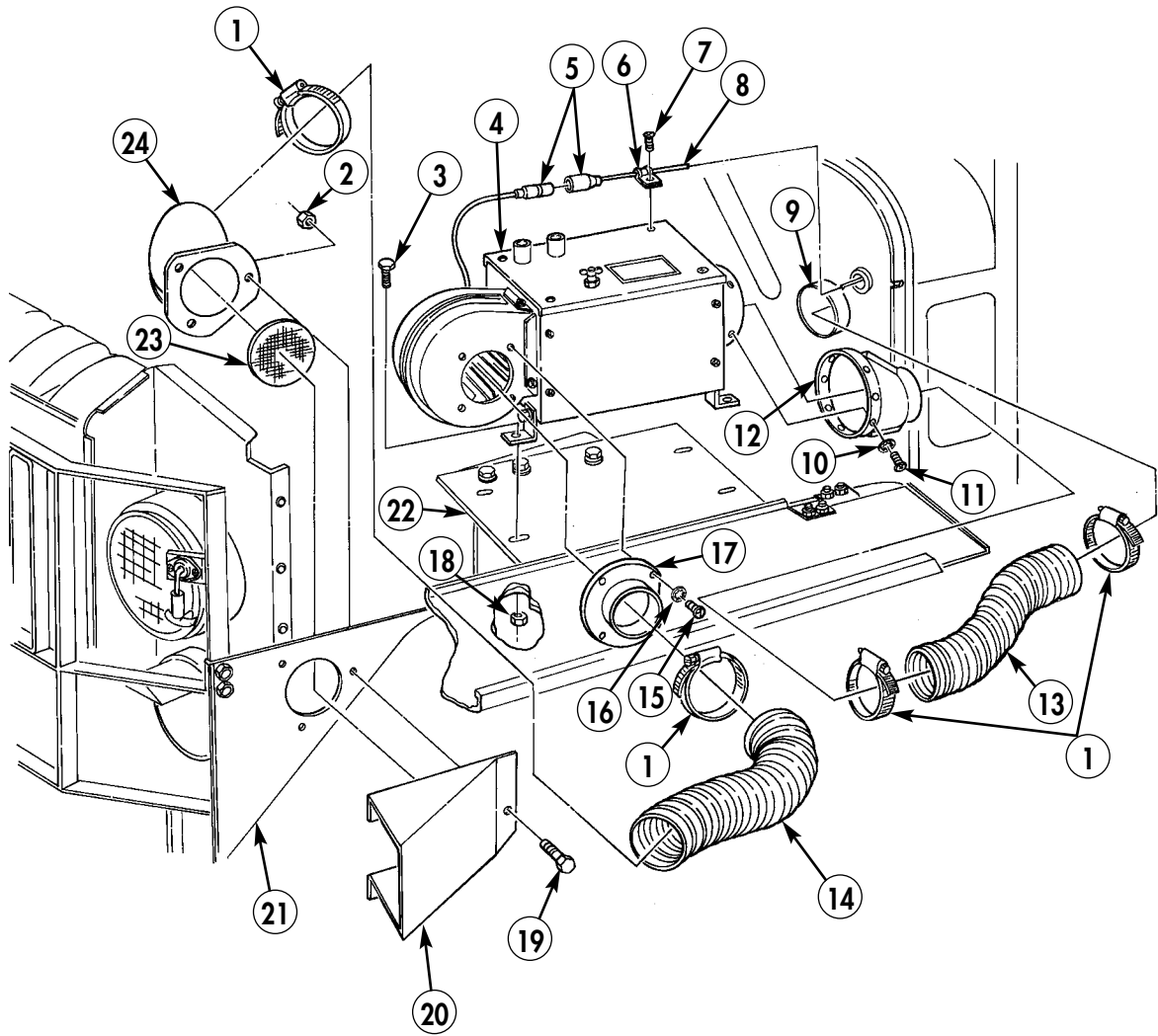

PERSONNEL HOT WATER HEATER REPLACEMENT (Contd)

BRACKETS REMOVAL

1. Remove five locknuts (1), ten washers (2), five screws (6), and bracket (5) from fender (13) and bracket (4). Discard locknuts (1).
2. Remove two locknuts (1), four washers (2), bracket (4), and two screws (3) from frame (14). Discard locknuts (1).

BRACKETS INSTALLATION

1. Install bracket (4) on frame (14) with two screws (3), four washers (2), and two new locknuts (1).
2. Install bracket (5) on fender (13) and bracket (4) with five screws (6), ten washers (2), and five new locknuts (1).

HEATER INSTALLATION

1. Install heater (7) on bracket (5) with four screws (12) and new locknuts (1).
2. Install wire (11) and clamp (9) on heater (7) with screw (10).

PERSONNEL HOT WATER HEATER REPLACEMENT (Contd)

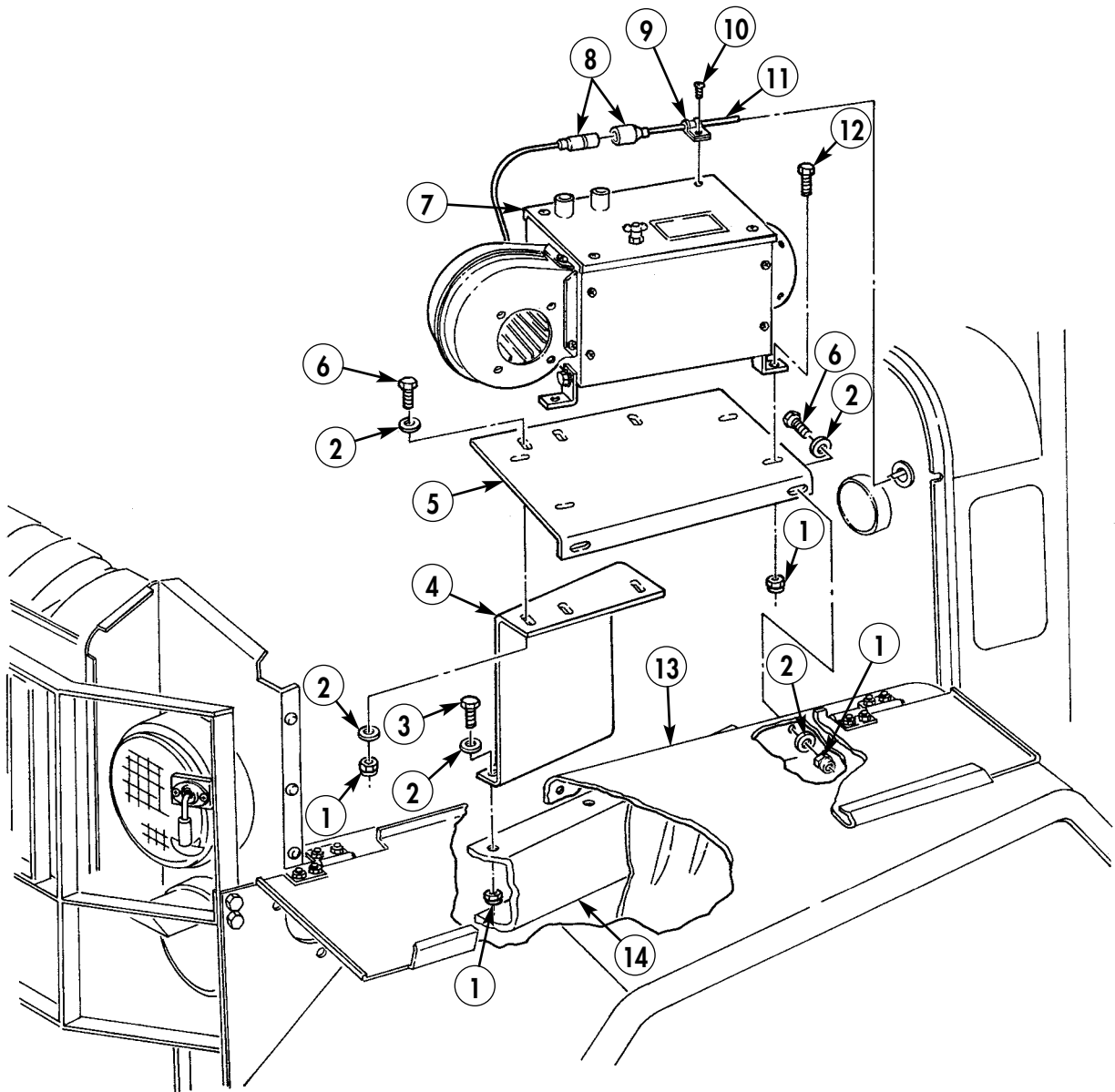

PERSONNEL HOT WATER HEATER REPLACEMENT (Contd)

HOSES AND ADAPTERS INSTALLATION

1. Install screen (17), elbow (1), and hood (15) on hood side panel (16) with three screws (14) and new locknuts (3).
2. Install adapter (13) on heater (4) with four screws (11) and new lockwashers (12).
3. Install adapter (5) on heater (4) with eight screws (8) and new lockwashers (7).
4. Install outlet hose (9) on adapters (5) and (6) with two clamps (2).
5. Install inlet hose (10) on adapter (13) and elbow (1) with two clamps (2).
6. Install two engine coolant heater hoses (WP 0079 00).
7. Connect battery ground cable (WP 0126 00).
8. Lower hood and secure (TM 9-2320-361-10).
9. Release parking brake and remove wheel chocks (TM 9-2320-361-10).

PERSONNEL HOT WATER HEATER REPLACEMENT (Contd)

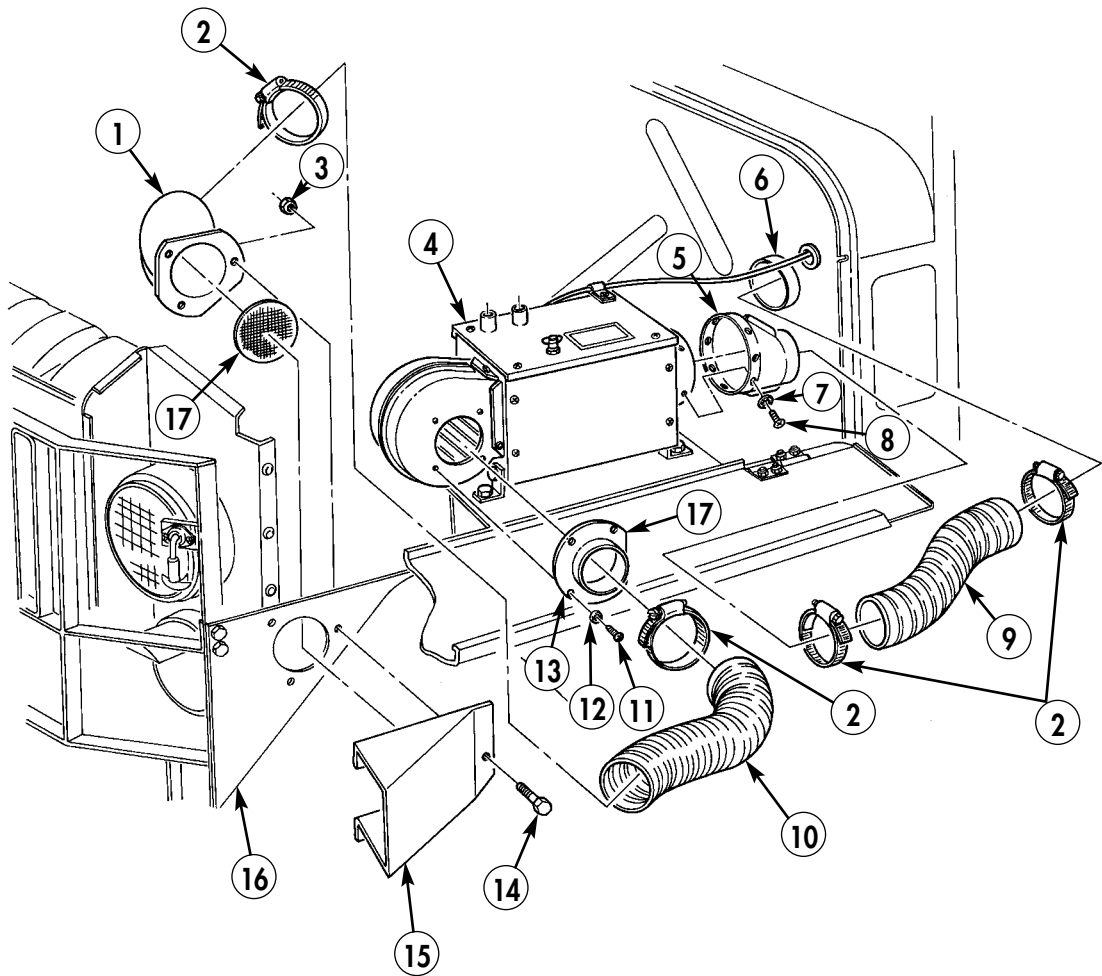

FIELD MAINTENANCE INSTRUCTIONS

2-1/2 TON, 6X6, M44A2 SERIES TRUCKS (MULTIFUEL)

PERSONNEL HEATER DEFROSTER HOSES REPLACEMENT

REMOVAL AND INSTALLATION

INITIAL SETUP:

Applicable Models

All

Equipment Condition

Parking brake set and wheels chocked
(TM 9-2320-361-10).

Battery ground cable disconnected
(WP 0126 00).

REMOVAL

1. Loosen clamp (4) and remove defroster hose (3) from diverter (2).
2. Loosen clamp (5) and remove defroster hose (3) from defroster duct (1).

INSTALLATION

1. Install defroster hose (3) on defroster duct (1) with clamp (5).
2. Install defroster hose (3) on diverter (2) with clamp (4).
3. Connect battery ground cable (WP 0126 00).
4. Release parking brake and remove wheel chocks (TM 9-2320-361-10).

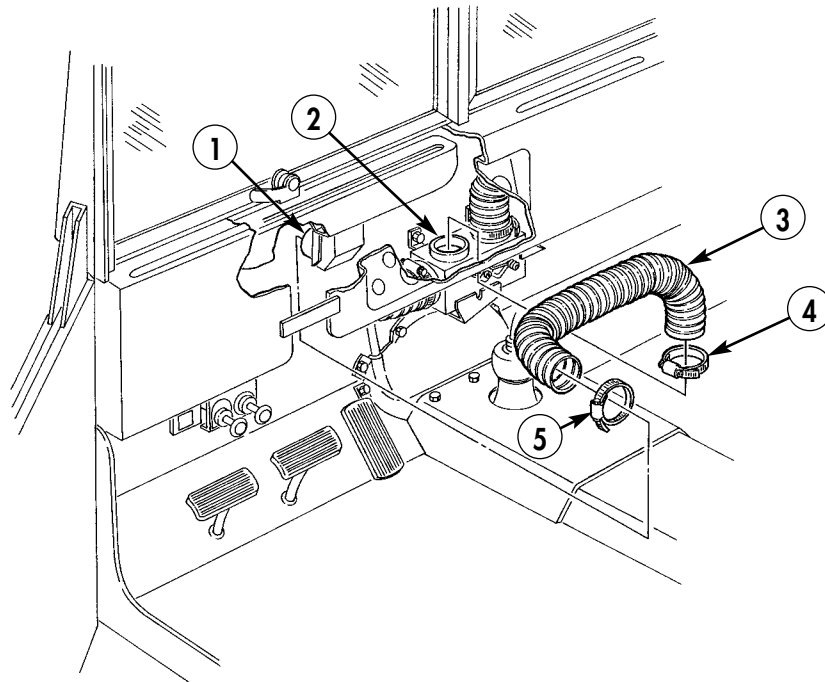

END OF WORK PACKAGE

0251 00-1/2 blank

FIELD MAINTENANCE INSTRUCTIONS

2-1/2 TON, 6X6, M44A2 SERIES TRUCKS (MULTIFUEL)

REFLECTOR REPLACEMENT

REMOVAL AND INSTALLATION

INITIAL SETUP:

Applicable Models

All

Materials/Parts

Six locknuts (item 165, WP 0470 00)

Equipment Condition

Parking brake set and wheels chocked
(TM 9-2320-361-10).

Battery ground cable disconnected
(WP 0126 00).

REMOVAL

1. Remove two locknuts (1), screws (4), and yellow reflector (3) from forward cargo body side (2). Discard locknuts (1).
2. Remove two locknuts (8), screws (5), and red reflector (6) from rear cargo body side (7). Discard locknuts (8).
3. Remove two locknuts (12), screws (11), and red reflector (10) from rear cargo body (9). Discard locknuts (12).

INSTALLATION

1. Install red reflector (10) on rear cargo body (9) with two screws (11) and new locknuts (12).
2. Install red reflector (6) on rear cargo body side (7) with two screws (5) and new locknuts (8).
3. Install yellow reflector (3) on forward cargo body side (2) with two screws (4) and new locknuts (1).
4. Connect battery ground cable (WP 0126 00).
5. Release parking brake and remove wheel chocks (TM 9-2320-361-10).

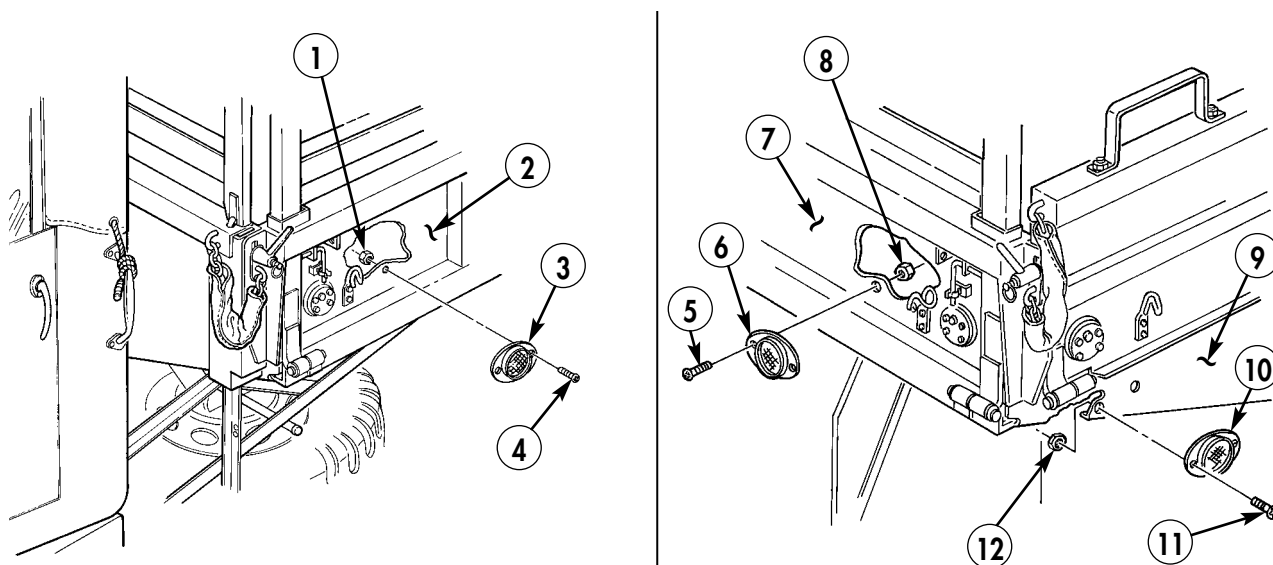

END OF WORK PACKAGE

0252 00-1/2 blank

FIELD MAINTENANCE INSTRUCTIONS

2-1/2 TON, 6X6, M44A2 SERIES TRUCKS (MULTIFUEL)

CARGO BODY RACK AND TROOP SEAT MAINTENANCE

TROOP SEAT REMOVAL, CARGO RACK DISASSEMBLY, TROOP SEAT DISASSEMBLY, INSPECTION, TROOP SEAT ASSEMBLY, CARGO RACK ASSEMBLY, AND TROOP SEAT INSTALLATION

INITIAL SETUP:

Applicable Models

M35A2, M35A2C, M36A2

Materials/Parts

Five cotter pins (item 25, WP 0470 00)

Nine locknuts (item 139, WP 0470 00)

Equipment Condition

Parking brake set and wheels chocked
(TM 9-2320-361-10).

Battery ground cable disconnected
(WP 0126 00).

Troop seat and side rack removed
(TM 2320-361-10).

CARGO BODY RACK AND TROOP SEAT MAINTENANCE (Contd)

NOTE

Maintenance procedures for M36A2, M35A2, and M35A2C cargo body racks are the same. This procedure covers M35A2 and M35A2C.

TROOP SEAT REMOVAL

Remove five cotter pins (4), pins (3), and troop seat (2) from cargo rack (1). Discard cotter pins (4).

CARGO RACK DISASSEMBLY

1. Remove two locknuts (10), washers (8), clamps (7), washers (8), and screws (9) from cargo rack slats (5). Discard locknuts (10).
2. Remove sixteen nuts (12), screws (6), and five bow pockets (11) from two cargo rack slats (5).

TROOP SEAT DISASSEMBLY

1. Remove five locknuts (13), screws (15), and legs (14) from three channels (18) and two end channels (20). Discard locknuts (13).
2. Remove two locknuts (23), screws (16), and hinges (21) from end channels (20). Discard locknuts (23).
3. Remove twenty-four nuts (22), screws (19), five hinges (21), two end channels (20), and three channels (18) from troop seat slats (17).

INSPECTION

1. Inspect legs (14), channels (18) and (20), and hinges (21) for cracks, bends, and excessive rust. Replace legs (14), channels (18) and (20), or hinges (21) if cracked, bent, or excessively rusted.
2. Inspect wood slats (17) and (5) for splinters, warp, and excessive rotting. Replace slats (17) and (5) if splintered, warped, or excessively rotted.

TROOP SEAT ASSEMBLY

1. Install two end channels (20), three channels (18), and five hinges (21) on slats (17) with twenty-four screws (19) and nuts (22).
2. Install hinges (21) on end channels (20) with two screws (16) and new locknuts (23).
3. Install leg (14) on three channels (18) and two end channels (20) with five screws (15) and new locknuts (13).

CARGO RACK ASSEMBLY

1. Install five bow pockets (11) on two cargo rack slats (5) with sixteen screws (6) and nuts (12).
2. Install clamps (7) on two cargo rack slats (5) with screws (9), washers (8), and new locknuts (10).

TROOP SEAT INSTALLATION

1. Install troop seat (2) on cargo rack (1) with five pins (3) and new cotter pins (4).
2. Install troop seat and side rack (TM 9-2320-361-10).
3. Connect battery ground cable (WP 0126 00).
4. Release parking brake and remove wheel chocks (TM 9-2320-361-10).

CARGO BODY RACK AND TROOP SEAT MAINTENANCE (Contd)

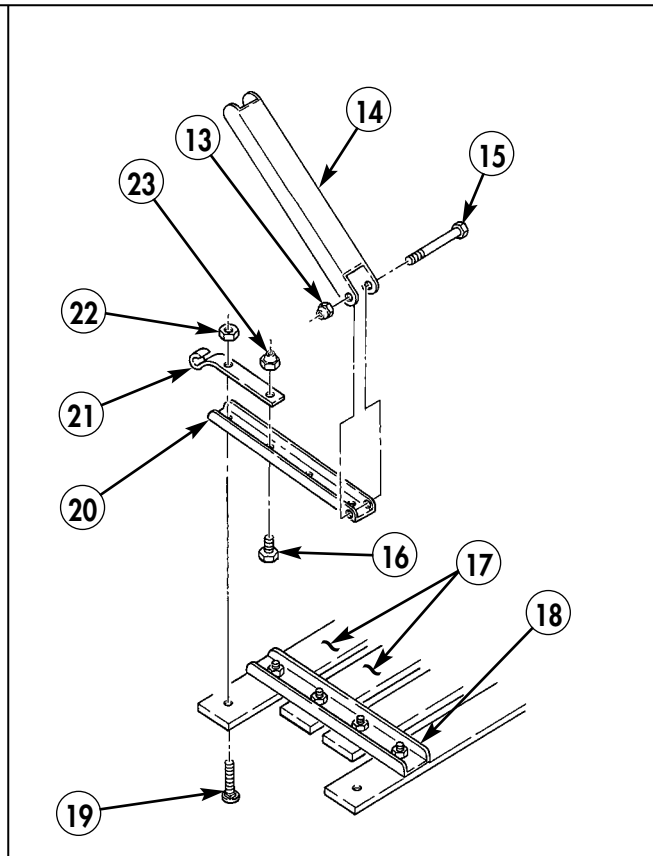
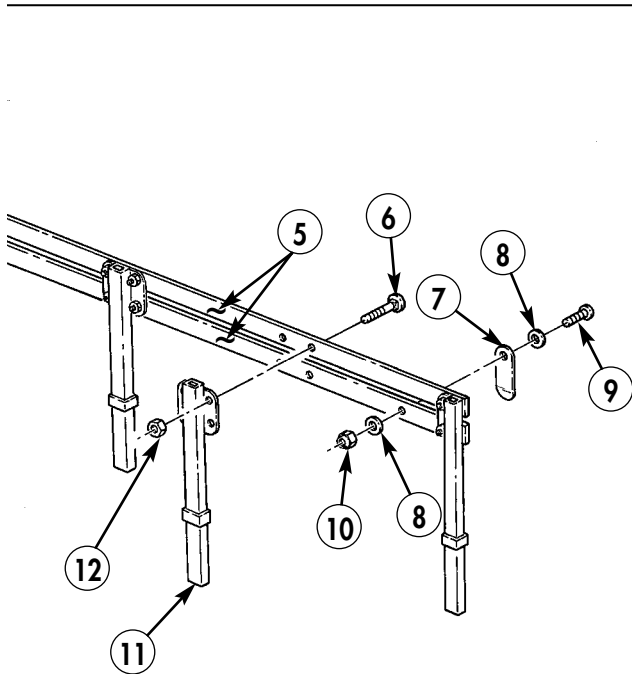
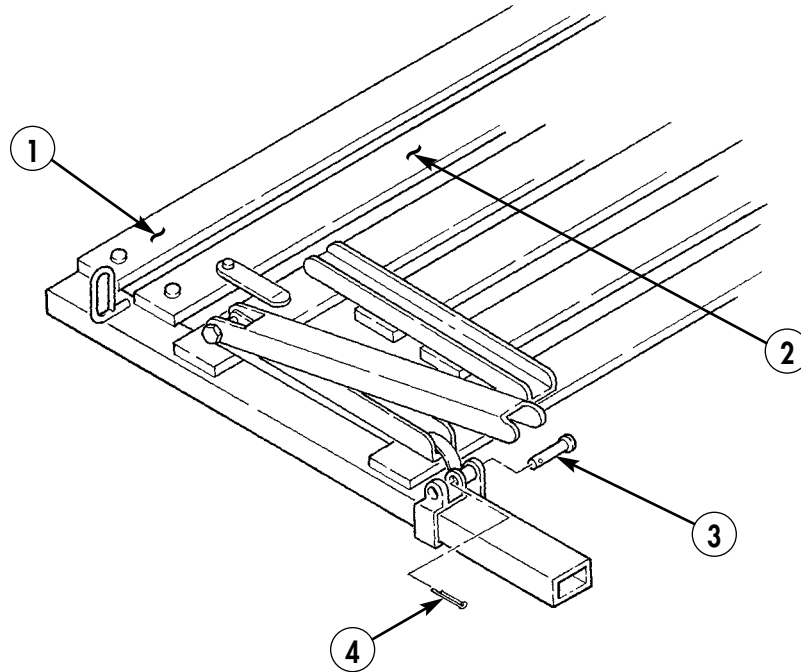

END OF WORK PACKAGE

0253 00-3/4 blank

FIELD MAINTENANCE INSTRUCTIONS

2-1/2 TON, 6X6, M44A2 SERIES TRUCKS (MULTIFUEL)

CARGO BODY TAILGATE REPLACEMENT REMOVAL AND INSTALLATION

INITIAL SETUP:

Applicable Models

M35A2, M36A2

Personnel Required

Two

Materials/Parts

Ten cotter pins (item 28, WP 0470 00)

Equipment Condition

Parking brake set and wheels chocked
(TM 9-2320-361-10).

Battery ground cable disconnected
(WP 0126 00).

CARGO BODY TAILGATE REPLACEMENT (Contd)

REMOVAL

1. Install chain sling (2) on tailgate (1).
2. Install lifting device (3) on chain sling (2) and raise lifting device (3) until slack is removed from chain sling (2).
3. Remove hook (8) from each side of tailgate (1).

WARNING

All personnel must stand clear during lifting operations.
A swinging or shifting load may result in injury to personnel.

4. Remove ten cotter pins (7), washers (6), and five pins (5) from hinges (4). Discard cotter pins (7).
5. Lower tailgate (1) to ground and remove chain sling (2).

INSTALLATION

1. Attach chain sling (2) to tailgate (1) and lifting device (3) to chain sling (2).

NOTE

Assistant will help with steps 2 and 3.

2. Raise tailgate (1) and position on vehicle hinges (4).
3. Install tailgate (1) with five pins (5), ten washers (6), and ten new cotter pins (7).
4. Install hook (8) in each side of tailgate (1).
5. Remove lifting device (3) and chain sling (2) from tailgate (1).
6. Connect battery ground cable (WP 0126 00).
7. Release parking brake and remove wheel chocks (TM 9-2320-361-10).

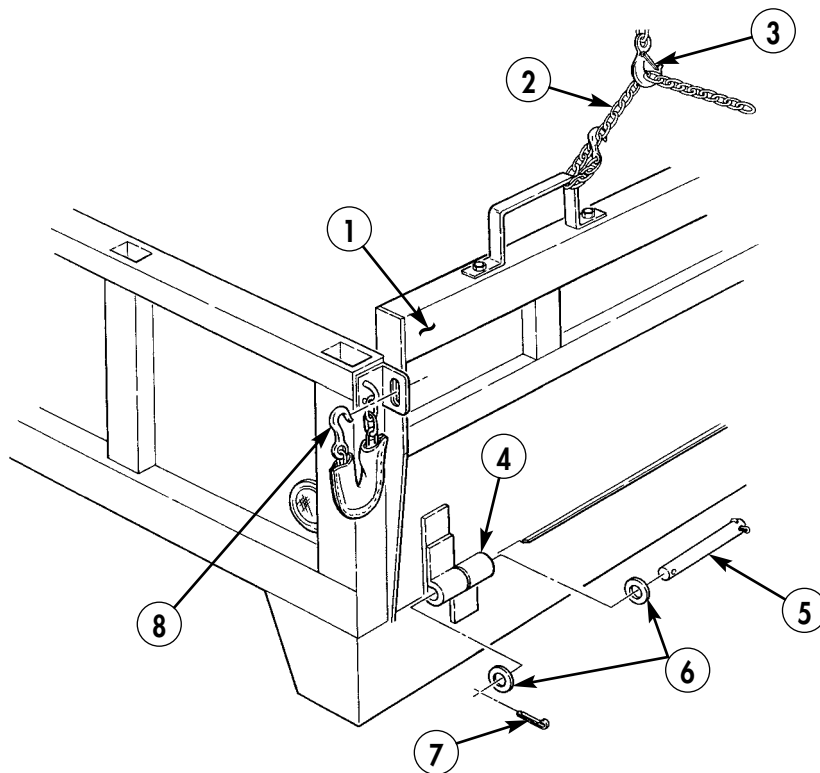

END OF WORK PACKAGE

FIELD MAINTENANCE INSTRUCTIONS

2-1/2 TON, 6X6, M44A2 SERIES TRUCKS (MULTIFUEL)

CARGO BODY TAILGATE REPLACEMENT (M35A2C)

REMOVAL AND INSTALLATION

INITIAL SETUP:

Applicable Models

M35A2C

Materials/Parts

Eight cotter pins (item 28, WP 0470 00)

Personnel Required

Two

Equipment Condition

Parking brake set and wheels chocked
(TM 9-2320-361-10).

Battery ground cable disconnected
(WP 0126 00).

CARGO BODY TAILGATE REPLACEMENT (M35A2C) (Contd)

REMOVAL

1. Install chain sling (4) on tailgate (2) and attach lifting device (3) to chain sling (4).
2. Raise lifting device (3) until slack is removed from chain sling (4).
3. On each side of tailgate (2) loosen handle (9) and remove lockbar (10) from vehicle dropside (1).

WARNING

All personnel must stand clear during lifting operations.
A swinging or shifting load may cause injury to personnel.

4. Remove eight cotter pins (8), washers (7), and four pins (6) from hinges (5). Discard cotter pins (8).
5. Lower tailgate (2) to ground and remove lifting device (3) and chain sling (4).

INSTALLATION

1. Attach chain sling (4) to tailgate (2) and lifting device (3) to chain sling (4).

NOTE

Assistant will help with steps 2 and 3.

2. Raise tailgate (2) and position on vehicle hinges (5).
3. Install tailgate (2) with four pins (6), eight washers (7), and eight new cotter pins (8).
4. On each side of tailgate (2), install lockbar (10) and tighten handle (9) on vehicle dropside (1).
5. Remove lifting device (3) and chain sling (4) from tailgate (2).
6. Connect battery ground cable (WP 0126 00).
7. Release parking brake and remove wheel chocks (TM 9-2320-361-10).

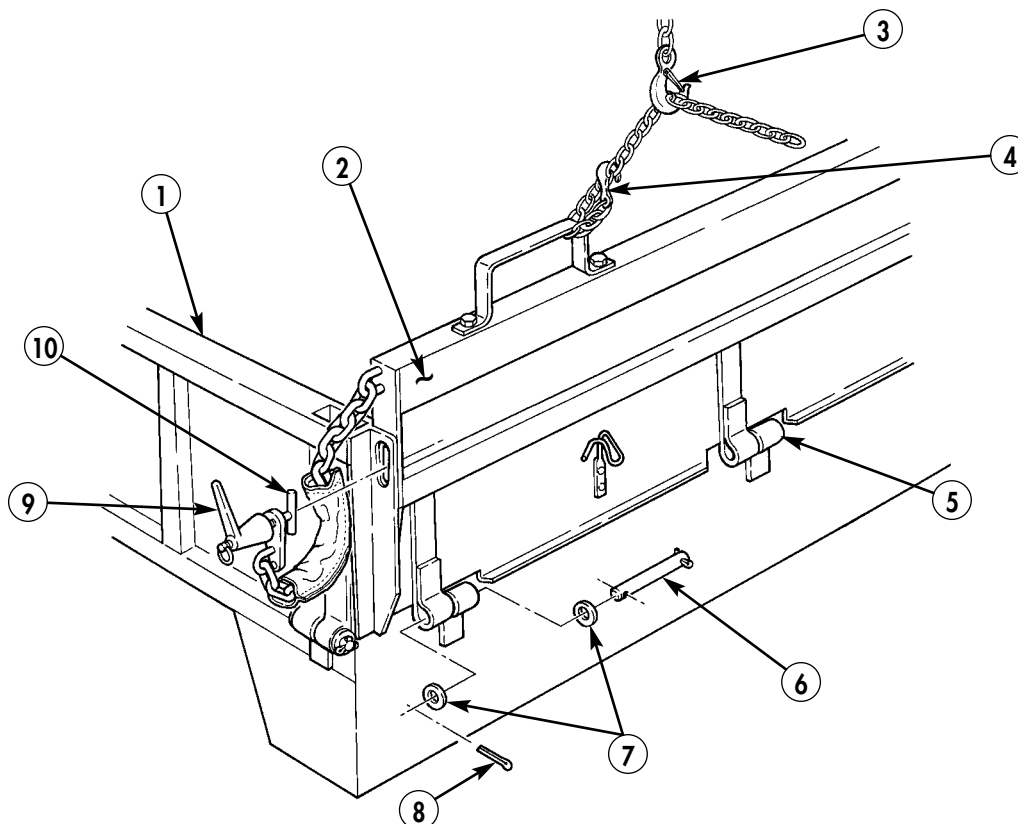

FIELD MAINTENANCE INSTRUCTIONS

2-1/2 TON, 6X6, M44A2 SERIES TRUCKS (MULTIFUEL)

CARGO BODY UPPER AND LOWER REAR SPLASH GUARD REPLACEMENT

LOWER SPLASH GUARD REMOVAL, UPPER SPLASH GUARD REMOVAL,
UPPER SPLASH GUARD INSTALLATION, AND LOWER SPLASH GUARD INSTALLATION

INITIAL SETUP:

Applicable Models

M35A2, M35A2C, M36A2

Equipment Condition

Parking brake set and wheels chocked
(TM 9-2320-361-10).

Materials/Parts

Eleven locknuts (item 129, WP 0470 00)

CARGO BODY UPPER AND LOWER REAR SPLASH GUARD REPLACEMENT (Contd)

LOWER SPLASH GUARD REMOVAL

Remove five locknuts (8), screws (11), retaining strip (9), and lower splash guard (10) from upper splash guard (7). Discard locknuts (8).

UPPER SPLASH GUARD REMOVAL

1. Remove two locknuts (6) and screws (12) from upper splash guard braces (16) and upper splash guard (7). Discard locknuts (6).
2. Remove two locknuts (3), screws (4), and braces (16) from frame (5). Discard locknuts (3).
3. Remove two locknuts (18) and screws (2) from top of upper splash guard (7) and frame (1). Remove upper splash guard (7). Discard locknuts (13).

UPPER SPLASH GUARD INSTALLATION

1. Install upper splash guard (7) on frame (1) with two screws (2) and new locknuts (13).
2. Install two braces (16) on frame (5) with two screws (4) and new locknuts (3).
3. Install upper splash guard braces (16) on upper splash guard (7) with two screws (12) and new locknuts (6).

LOWER SPLASH GUARD INSTALLATION

1. Place lower splash guard (10) in retaining strip (9) and install on upper splash guard (7) with five screws (11) and new locknuts (8).
2. Release parking brake and remove wheel chocks (TM 9-2320-361-10).

CARGO BODY UPPER AND LOWER REAR SPLASH GUARD REPLACEMENT (Contd)

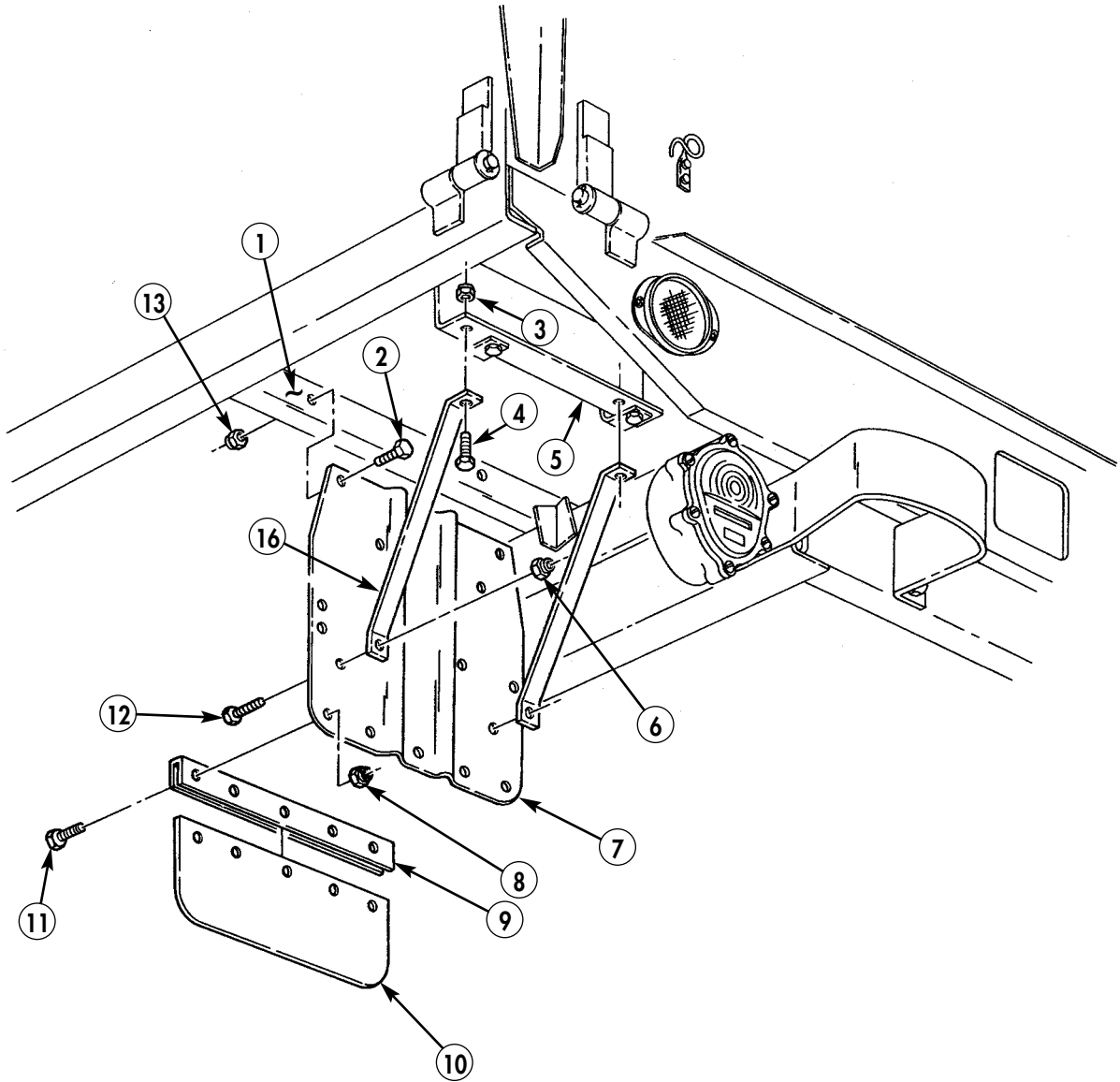

FIELD MAINTENANCE INSTRUCTIONS

2-1/2 TON, 6X6, M44A2 SERIES TRUCKS (MULTIFUEL)

FRONT SPLASH GUARD REPLACEMENT

REMOVAL AND INSTALLATION

INITIAL SETUP:

Applicable Models

M35A2, M35A2C, M36A2

Equipment Condition

Parking brake set and wheels chocked
(TM 9-2320-361-10).

Materials/Parts

Eight locknuts (item 129, WP 0470 00)

Two locknuts (item 155, WP 0470 00)

M35A2C series vehicles

FRONT SPLASH GUARD REPLACEMENT (Contd)

NOTE

Left and right front splash guards are removed the same. This procedure covers the left front splash guard.

REMOVAL

1. Remove two locknuts (13) and screws (8) from splash guard braces (6) and front splash guard (14). Discard locknuts (13).
2. Remove two locknuts (4), screws (5), and splash guard braces (6) from frame (2). Discard locknuts (4).

NOTE

Perform step 3 only if pioneer tool kit is on vehicle.

3. Remove two locknuts (15) and screws (7) from front splash guard (14) and pioneer tool kit bracket (1). Discard locknuts (15).
4. Remove two locknuts (3), screws (16), and splash guard (14) from frame (2). Discard locknuts (3).

NOTE

Perform step 5 for M35A2C series vehicles.

5. Remove two locknuts (9), screws (12), plate (10), and bumper (11) from front splash guard (14). Discard locknuts (9).

INSTALLATION

NOTE

Perform step 1 for M35A2C series vehicles.

1. Install bumper (11) and plate (10) on front splash guard (14) with two screws (12) and new locknuts (9).
2. Install front splash guard (14) on frame (2) with two screws (16) and new locknuts (3).

NOTE

Perform step 3 only if pioneer tool kit is installed on vehicle.

3. Install front splash guard (14) on pioneer tool kit bracket (1) with two screws (7) and new locknuts (15).
4. Install two splash guard braces (6) on frame (2) with two screws (5) and new locknuts (4).
5. Install two splash guard braces (6) on front splash guard (14) with screws (8) and new locknut (13).
6. Release parking brake and remove wheel chocks (TM 9-2320-361-10).

FRONT SPLASH GUARD REPLACEMENT (Contd)

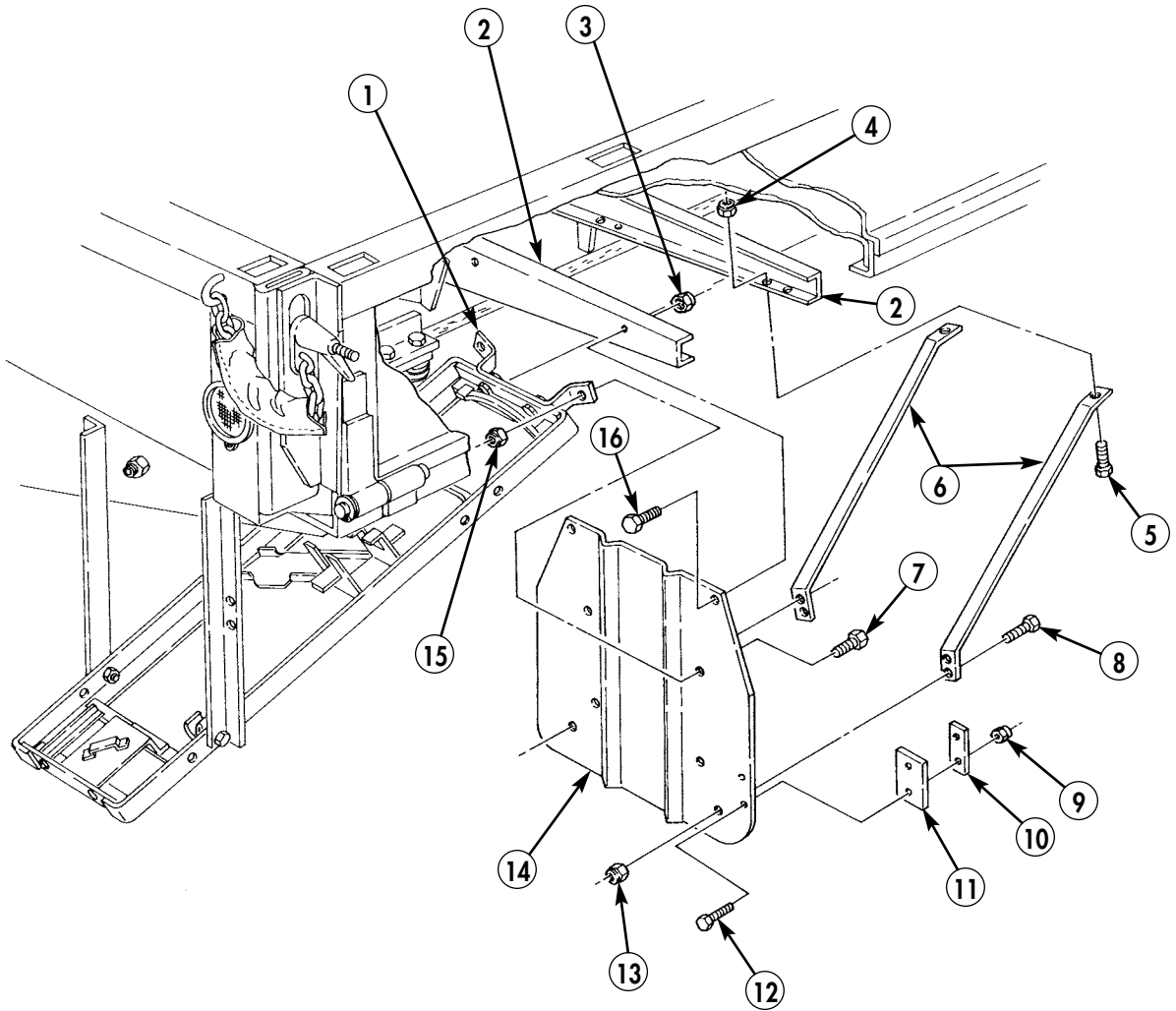

FIELD MAINTENANCE INSTRUCTIONS

2-1/2 TON, 6X6, M44A2 SERIES TRUCKS (MULTIFUEL)

CARGO BODY FRONT RACK MAINTENANCE (M35A2C) REMOVAL, INSPECTION, AND INSTALLATION

INITIAL SETUP:

Applicable Models
M35A2C

Equipment Condition
Parking brake set and wheels chocked
(TM 9-2320-361-10).
Cargo body front rack removed
(TM 9-2320-361-10).

CARGO BODY FRONT RACK MAINTENANCE (M35A2C) (Contd)

REMOVAL

1. Remove twenty nuts (2), screws (5), two stake bow retainers (1), and two body post stakes (11) from front rack slats (10).
2. Remove two wood fillers (4) from body post stakes (11).
3. Remove twelve nuts (9), screws (8), and end stakes (3) from six rack slats (10).
4. Remove chain hook (7) and locking pin assembly (6) from second rack slat (10).

INSPECTION

1. Inspect stake bow retainers (1), body post stakes (11), and end stakes (3) for cracks, bends, and excessive rust. Replace stake bow retainers (1), body post stakes (11), and end stakes (3) if cracked, bent, or excessively rusted.
2. Inspect all cargo body rack slats (10). Replace if excessively splintered, warped, or rotted.

INSTALLATION

NOTE

Position body post stakes with double thickness of metal towards outside of body.

1. Install two wood fillers (4) in body post stakes (11).

NOTE

Do not tighten nuts until all screws are installed.

2. Install two body post stakes (11) and stake bow retainers (1) on rack slats (10) with twenty screws (5) and nuts (2). Do not tighten nuts (2).
3. Install stakes (3) on ends of rack slats (10) with twelve screws (8) and nuts (9). Do not tighten nuts (9).
4. Install chain hook (7) and locking pin assembly (6) on second rack slat (10).
5. Tighten all nuts (2) and (9).
6. Install cargo body front rack (TM 9-2320-361-10).
7. Release parking brake and remove wheel chocks (TM 9-2320-361-10).

CARGO BODY FRONT RACK MAINTENANCE (M35A2C) (Contd)

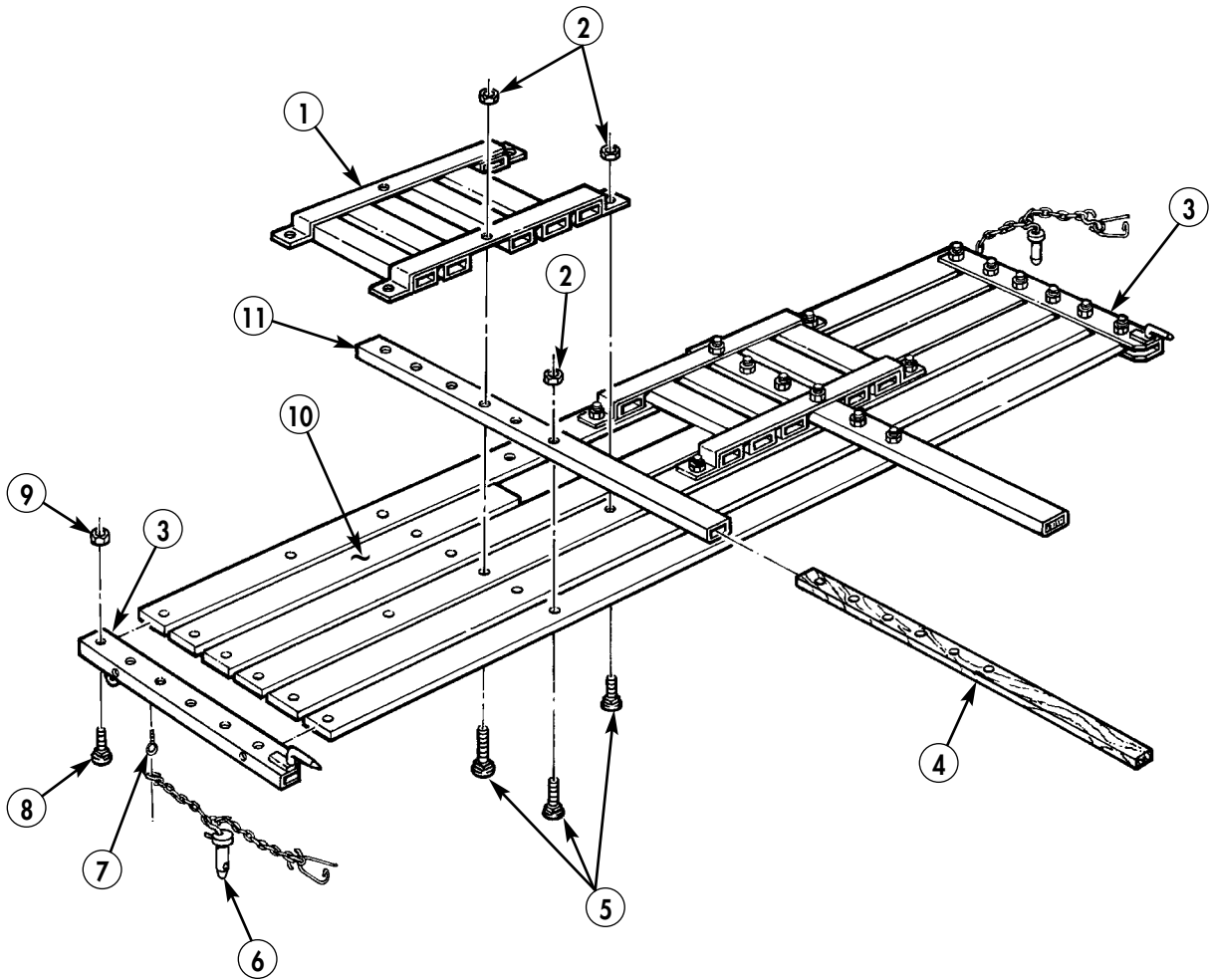

FIELD MAINTENANCE INSTRUCTIONS

2-1/2 TON, 6X6, M44A2 SERIES TRUCKS (MULTIFUEL)

CARGO BODY DROPSIDE REPLACEMENT (M35A2C)

REMOVAL AND INSTALLATION

INITIAL SETUP:

Applicable Models

M35A2C

Materials/Parts

Ten cotter pins (item 28, WP 0470 00)

Personnel Required

Two

Equipment Condition

Parking brake set and wheels chocked
(TM 9-2320-361-10).

Battery ground cable disconnected
(WP 0126 00).

Troop seat and cargo body side rack removed
(TM 9-2320-361-10).

Tailgate lowered (TM 9-2320-361-10).

Cargo body dropsides lowered
(TM 9-2320-361-10).

Bow and tarp removed (if installed)
(TM 9-2320-361-10).

CARGO BODY DROPSIDE REPLACEMENT (M35A2C) (Contd)

REMOVAL

1. With cargo body dropside (7) in lowered position, attach sling (1) to lifting device (2) and cargo body dropside (6).
2. Raise lifting device (2) until cargo body dropside (7) is raised to vertical position.

WARNING

- All personnel must stand clear during lifting operations. A swinging or shifting load may result in injury to personnel.
 - All personnel must stand clear during removal of cargo body Dropside. Cargo body dropside will swing free when pins are removed and injury to personnel may result.
3. Remove ten cotter pins (3), washers (4), and five pins (5) from hinges (6). Discard cotter pins (3).
 4. Lower dropside (7) to ground and remove lifting device (2) and chain sling (1) from dropside (7).

INSTALLATION

1. Attach chain sling (1) to cargo dropside (7) and attach lifting device (2) to chain sling (1).

NOTE

Assistant will help with steps 2 and 3.

2. Raise cargo body dropside (7) and position to hinges (6).
3. Install cargo body dropside (7) on hinges (6) with five pins (5), ten washers (4), and ten new cotter pins (3).
4. Lower cargo body dropside (7) to the lowered position and remove lifting device (2) and chain sling (1).
5. Raise cargo body dropsides (TM 9-2320-361-10).
6. Raise tailgate (TM 9-2320-361-10).
7. Install troop seat and cargo body side rack (TM 9-2320-361-10).
8. Install bow and tarp (if removed) (TM 9-2320-361-10).
9. Connect battery ground cable (WP 0126 00).
10. Release parking brake and remove wheel chocks (TM 9-2320-361-10).

CARGO BODY DROPSIDE REPLACEMENT (M35A2C) (Contd)

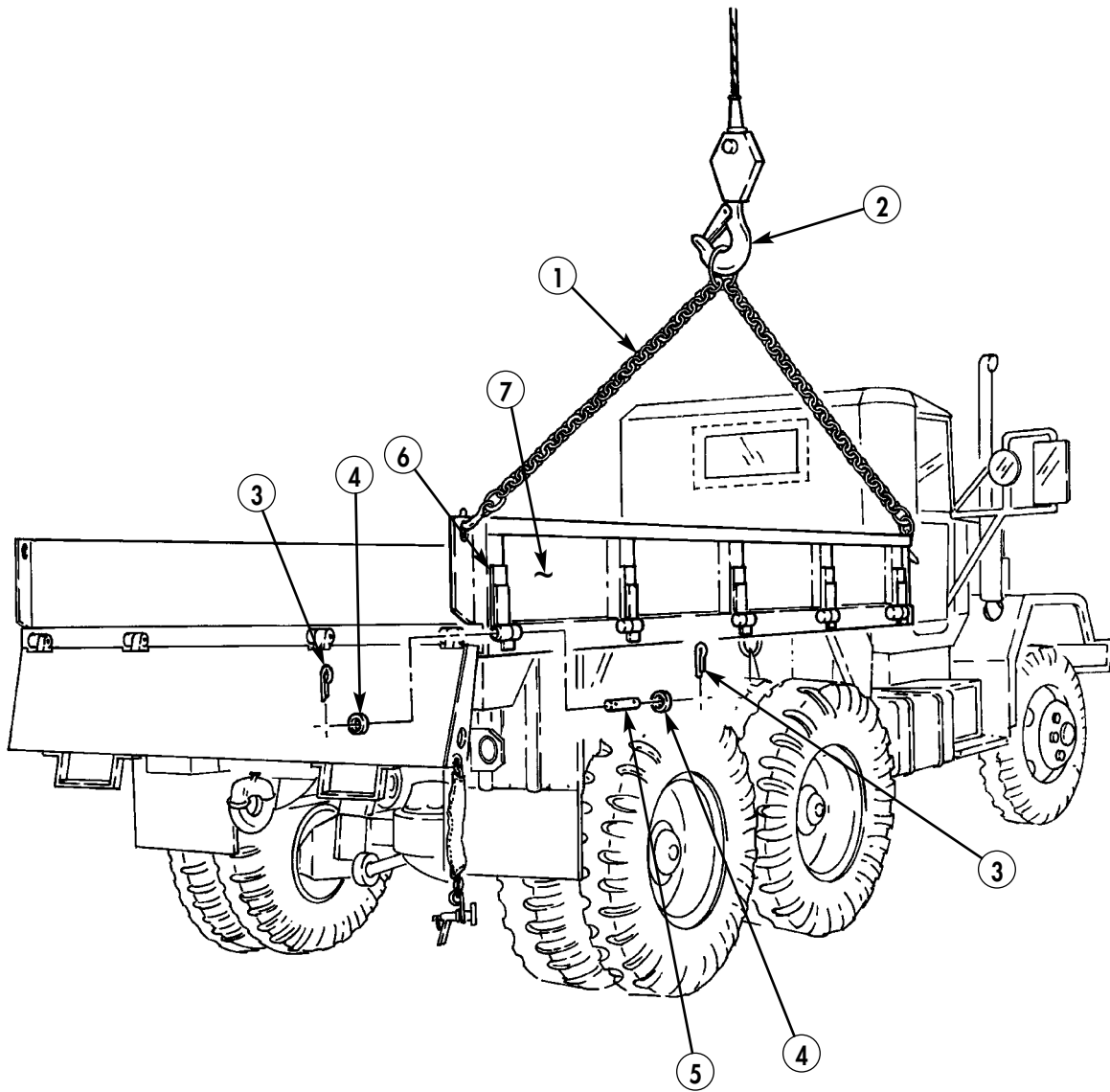

FIELD MAINTENANCE INSTRUCTIONS

2-1/2 TON, 6X6, M44A2 SERIES TRUCKS (MULTIFUEL)

CARGO BODY FRONT RACK MAINTENANCE (M35A2 and M36A2)

DISASSEMBLY, INSPECTION, AND ASSEMBLY

INITIAL SETUP:

Applicable Models

M35A2, M36A2

Equipment Condition

Parking brake set and wheels chocked
(TM 9-2320-361-10).

Cargo body front rack removed
(WP 0253 00).

CARGO BODY FRONT RACK MAINTENANCE (M35A2 and M36A2) (Contd)

DISASSEMBLY

1. Remove two nuts (1), and screws (4), from cargo front rack end channels (6).
2. Remove twelve nuts (1), screws (4), and two posts (2) from cargo body front rack slats (5).
3. Remove two wood fillers (3) from two posts (2).
4. Remove ten nuts (1), screws (4), and two end channels (6) from cargo body front rack slats (5).

INSPECTION

1. Inspect two posts (2) and end channels (6) for cracks, bends, and excessive rust. Replace posts (2) or end channels (6) if cracked, bent, or excessively rusted.
2. Inspect cargo body front rack wood slats (5) for splinters, warps, or excessive rotting. Replace front rack wood slats (5) if splintered, warped, or excessively rotted.

ASSEMBLY

NOTE

Do not tighten nuts until all screws are installed.

1. Install two end channels (6) on front rack slats (5) with ten screws (4) and nuts (1).
2. Insert two wood fillers (3) in posts (2).
3. Install two posts (2) on front rack slats (5) with twelve screws (4) and nuts (1). Do not tighten nuts (1).
4. Install two end channels (6) on cargo body front rack slats (5) with two screws (4) and nuts (1).
5. Tighten twenty-two nuts (1).
6. Install cargo body front rack (WP 0253 00).
7. Release parking brake and remove wheel chocks (TM 9-2320-361-10).

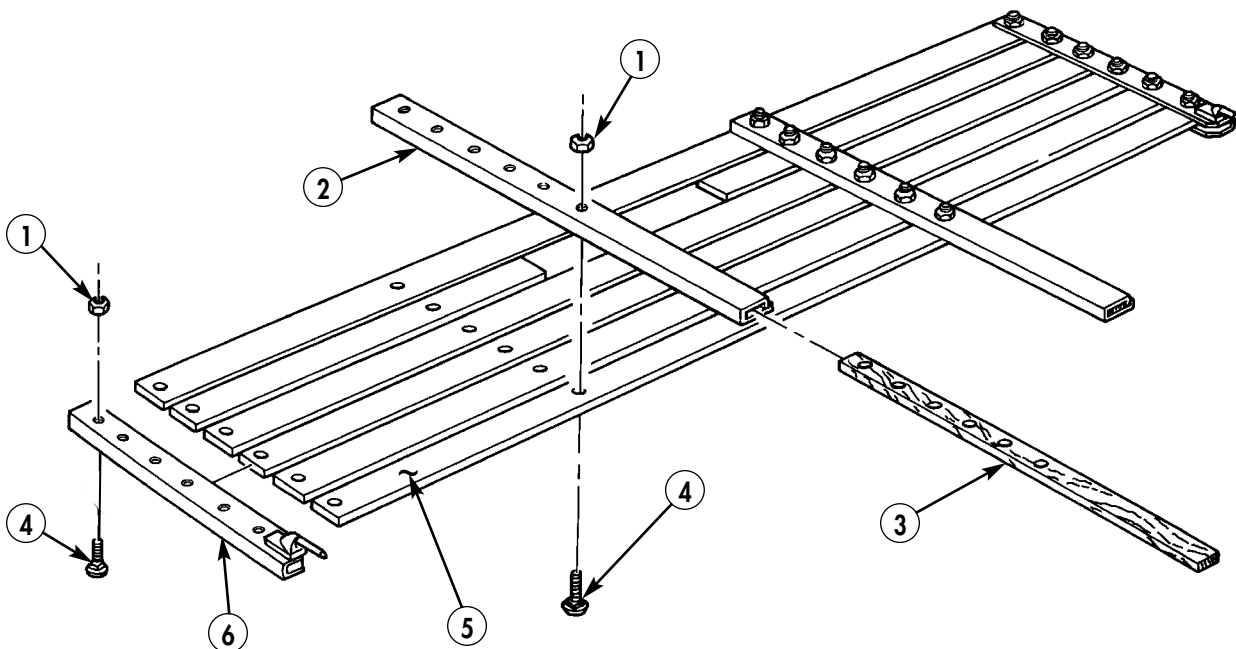

END OF WORK PACKAGE

FIELD MAINTENANCE INSTRUCTIONS

2-1/2 TON, 6X6, M44A2 SERIES TRUCKS (MULTIFUEL)

CARGO BODIES TAILGATE MAINTENANCE

CLEANING AND INSPECTION AND REPAIR

INITIAL SETUP:

Applicable Models

M35A2, M35A2C, M36A2

References

TB 43-0209
TC 9-510
TC 43-0139
TC 9-237

Equipment Condition

Parking brake set and wheels chocked
(TM 9-2320-361-10).
Battery ground cable disconnected
(WP 0216 00).
Cargo body tailgate removed (WP 0254 00 and
WP 0255 00).

CLEANING AND INSPECTION

1. Clean cargo body tailgate (1) (TB 43-0209 and TM 43-0139).
2. Inspect cargo body tailgate (1) for structural damage or rust. Replace if damage or rust is severe and exceeds available repair procedures.

REPAIR

1. Remove and install lashing hooks and/or data plate(s) in area(s) to be repaired or painted (WP 0254 00 and WP 0255 00).
2. Remove paint and/or rust from area(s) to be welded or repaired (TC 9-237).

NOTE

Refer to TM 43-0139 and TB 43-0209 for body repainting and camouflaging.

3. Repair cargo body tailgate (1) (TC 9-510). If welding is necessary, refer to TC 9-237.
4. Install cargo body tailgate (WP 0254 00 and WP 0255 00).
5. Connect battery ground cable (WP 0126 00).
6. Release parking brake and remove wheel chocks (TM 9-2320-361-10).

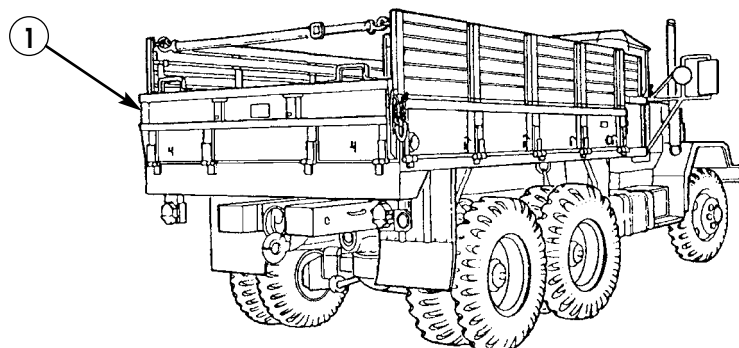

END OF WORK PACKAGE

0261 00-1/2 blank

FIELD MAINTENANCE INSTRUCTIONS

2-1/2 TON, 6X6, M44A2 SERIES TRUCKS (MULTIFUEL)

CARGO BODIES MAINTENANCE

REMOVAL, CLEANING AND INSPECTION, AND INSTALLATION

INITIAL SETUP:

Applicable Models

M35A2, M35A2C, M36A2

Personnel Required

Two

Tools and Special Tools

General mechanic's tool kit
(item 116, WP 0469 00)
Torque wrench, 3/4-in. drive
(item 137, WP 0469 00)
1-1/8-in. socket, 3/4-in. drive
(item 99, WP 0469 00)
Breaker bar, 3/4-in. drive
(item 8, WP 0469 00)
Handle, socket wrench, 3/4-in. drive
(item 41, WP 0469 00)
1-1/16-in. socket, 3/4-in. drive
(item 94, WP 0469 00)
Lifting device (item 48, WP 0469 00)
Guide lines
Utility chains

References

WP 0021 00
WP 0255 00
WP 0259 00

Equipment Condition

Parking brake set and wheels chocked
(TM 9-2320-361-10).
Battery ground cable disconnected
(WP 0126 00).
Troop seat and cargo body side racks removed
(TM 9-2320-361-10).
Cargo body front rack removed
(TM 9-2320-361-10).
Cargo body front splash guards removed
(WP 0257 00).
Cargo body upper and lower rear splash guards
removed (WP 0256 00).

Materials/Parts

Six locknuts (item 164, WP 0470 00)
Four locknuts (item 129, WP 0470 00)
Four locknuts (item 161, WP 0470 00)
Four locknuts (item 166, WP 0470 00)

CARGO BODIES MAINTENANCE (Contd)

REMOVAL

1. Remove four locknuts (2), screws (3), and trailer receptacle (5) from cargo body (4). Discard locknuts (2).
2. Attach utility chains around subframe (1) with chain hooks between chain links.

WARNING

- All personnel must stand clear during lifting operations. A swinging or shifting load may cause injury to personnel.
- Ensure lifting capacity is greater than weight of cargo body. Failure to do so may result in injury to personnel or damage to equipment.

3. Attach lifting device in center of chains and raise lifting device to remove slack in chains.
4. Attach two guide lines to lashing hooks.

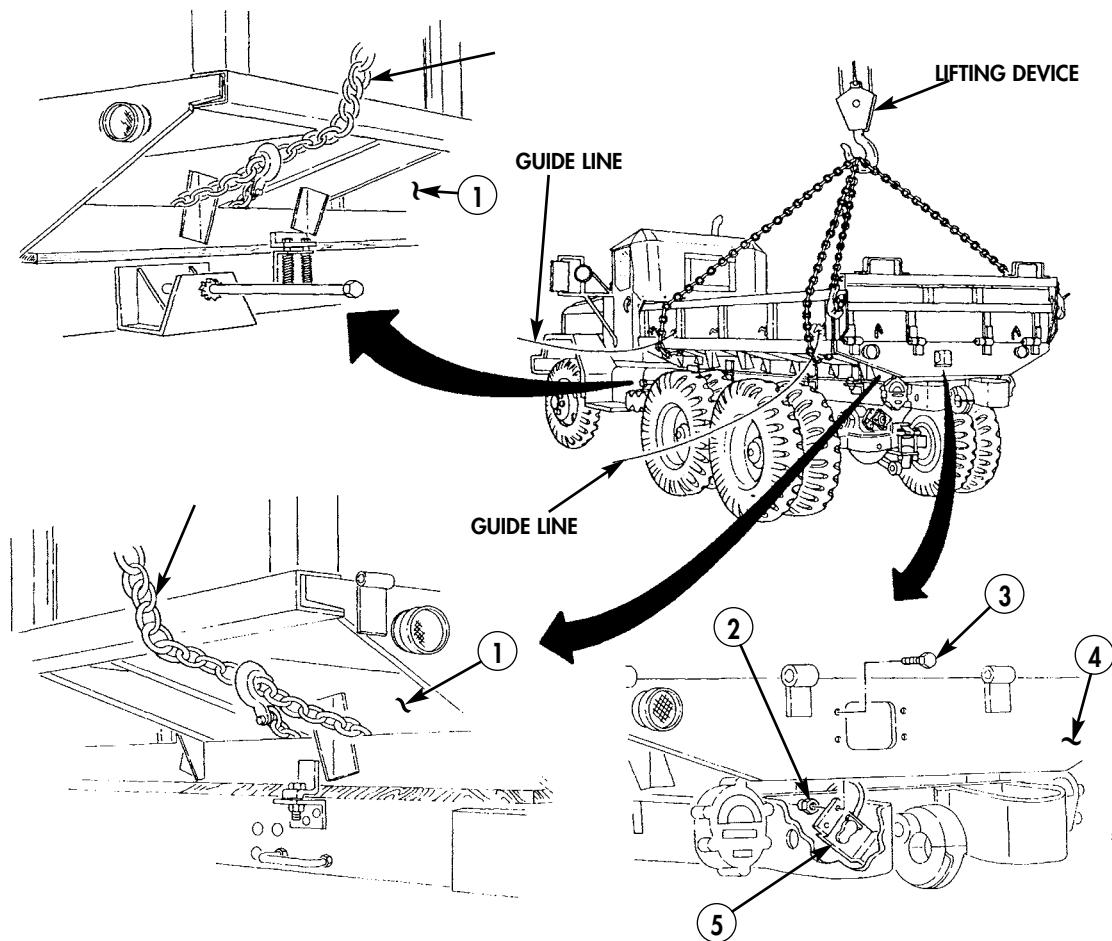

CARGO BODIES MAINTENANCE (Contd)

REMOVAL (Contd)

5. Remove four locknuts (19), washers (20), springs (21) and (22), and screws (17) from two brackets (6) and brackets (18). Discard locknuts (19).
6. Remove six locknuts (11), washers (12), and screws (9) from six brackets (7) and brackets (10). Discard locknuts (11).

NOTE

M36A2 long wheelbase models have two additional sets of body and frame brackets. For hardware removal, perform step 7.

7. Remove four locknuts (15), washers (16), and screws (13) from two brackets (8) and brackets (14). Discard locknuts (15).

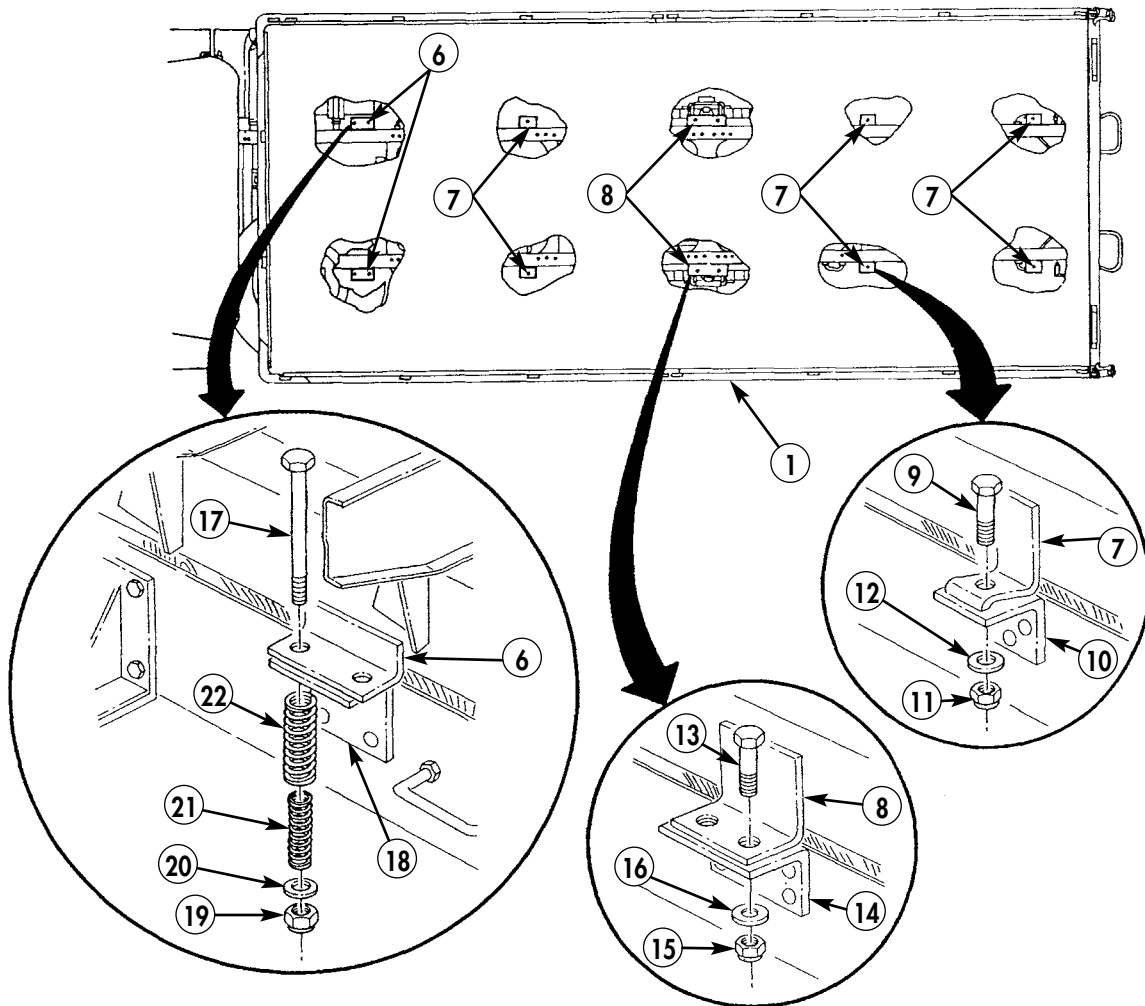

CARGO BODIES MAINTENANCE (Contd)

REMOVAL (Contd)

WARNING

All personnel must stand clear during lifting operations.
A swinging or shifting load may cause injury to personnel.

NOTE

Assistant will help guide cargo body during lifting operations.

8. Remove cargo body (1) and place on wooden supports.

NOTE

Perform steps 9 and 10 if replacing cargo body.

9. Remove cargo body tailgate (3) (WP 0255 00).
10. Remove cargo body dropside (2) (M35A2C) (WP 0259 00).
11. Remove one frame sill (4) from each frame rail (5) for inspection.

CLEANING AND INSPECTION

1. For general cleaning instructions of cargo body (1), refer to WP 0021 00.
2. Inspect all screws, washers, and springs for defects. Replace if defective.
3. Inspect frame sills (4) for end splits or rotting. Replace if end split(s) exceeds width of frame sill or frame sill is rotting.
4. Inspect cargo body (1) for structural damage or rust. Replace if damage or rust is severe and exceeds available repair procedures.

INSTALLATION

WARNING

All personnel must stand clear during lifting operations.
A swinging or shifting load may cause injury to personnel.

NOTE

- Use breaker bar to align body and frame brackets.
- Assistant will help guide cargo body during lifting operations.

1. Place one frame sill (4) on each frame rail (5).

NOTE

Perform steps 2 and 3 if installing new cargo body.

2. Install cargo body dropside (2) (M35A2C) (WP 0259 00).
3. Install cargo body tailgate (3) (WP 0255 00).
4. Lift cargo body (1) off supports and lower onto frame rails (5).

CARGO BODIES MAINTENANCE (Contd)

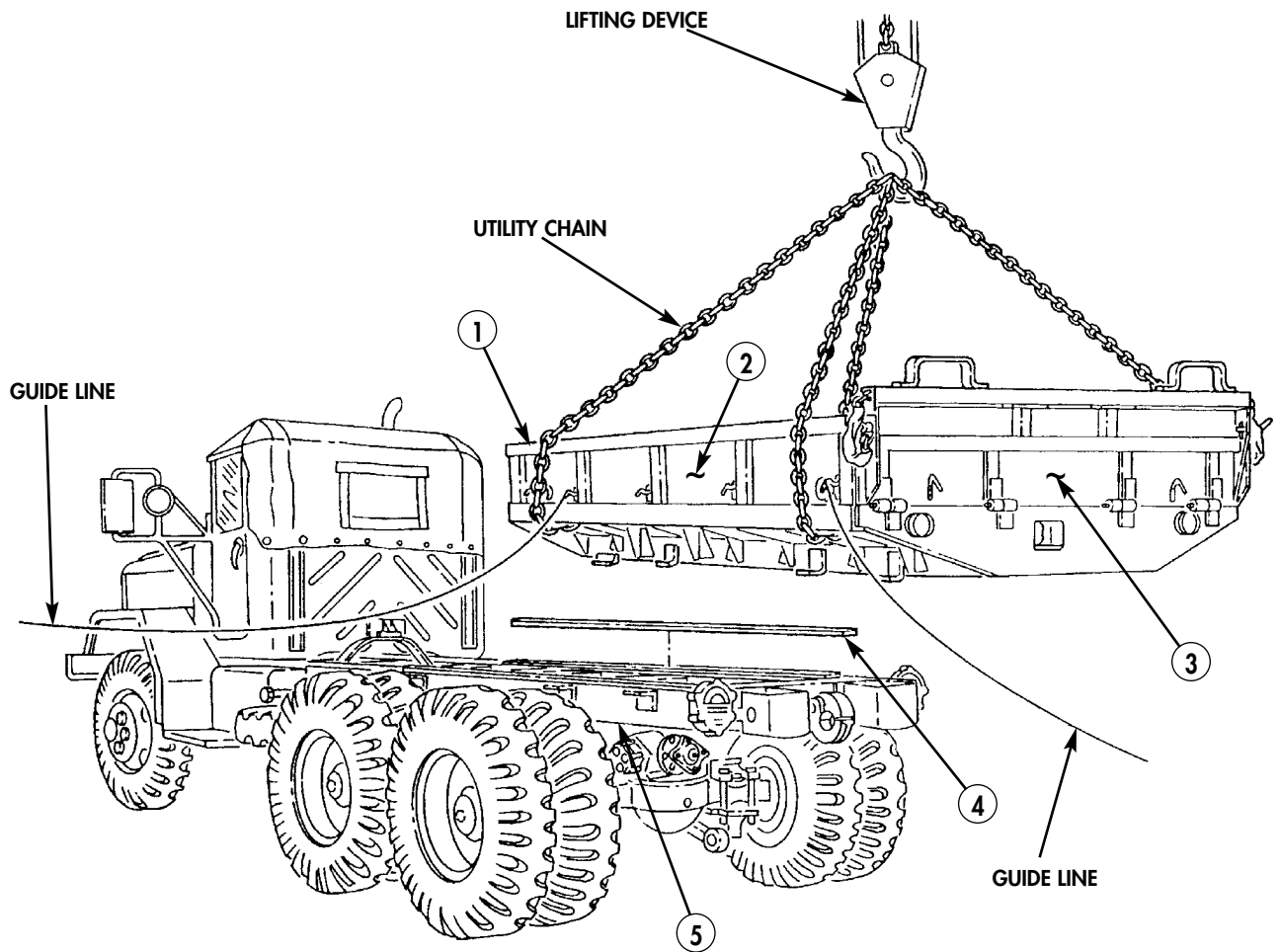

CARGO BODIES MAINTENANCE (Contd)

INSTALLATION (Contd)

5. Install trailer receptacle (3) behind cargo body (2) with four screws (1) and new locknuts (4).

NOTE

M35A2 front right side bracket mounting screws secure two sets of springs positioned on top of body brackets. Left side spring sets are the same and are secured below frame brackets.

6. Install four screws (16) in two brackets (5) and brackets (17). Install four springs (20) inside four springs (21) and over four screws (16) with four washers (19) and new locknuts (18).
7. Adjust spring screws (16) to set springs (20) and (21) height to 6.375 in. (16.19 cm).

NOTE

M36A2 long wheelbase models have two additional body and frame brackets. Perform step 8 for hardware installation.

8. Install four screws (12) in two brackets (7) and brackets (13) with four washers (15) and new locknuts (14). Tighten locknuts (14) 105–145 lb-ft (142–197 N•m).
9. Install six screws (8) to six brackets (6) and brackets (9) with six washers (11) and new locknuts (10). Tighten locknuts (10) 125–165 lb-ft (170–224 N•m).
10. Remove lifting device, chains, and guide lines from cargo body (2).
11. Install cargo body upper and lower rear splash guards (WP 0256 00).
12. Install cargo body front splash guards (WP 0257 00).
13. Install cargo body front rack (TM 9-2320-361-10).
14. Install troop seat and cargo body side racks (TM 9-2320-361-10).
15. Connect battery ground cable (WP 0126 00).
16. Release parking brake and remove wheel chocks (TM 9-2320-361-10).

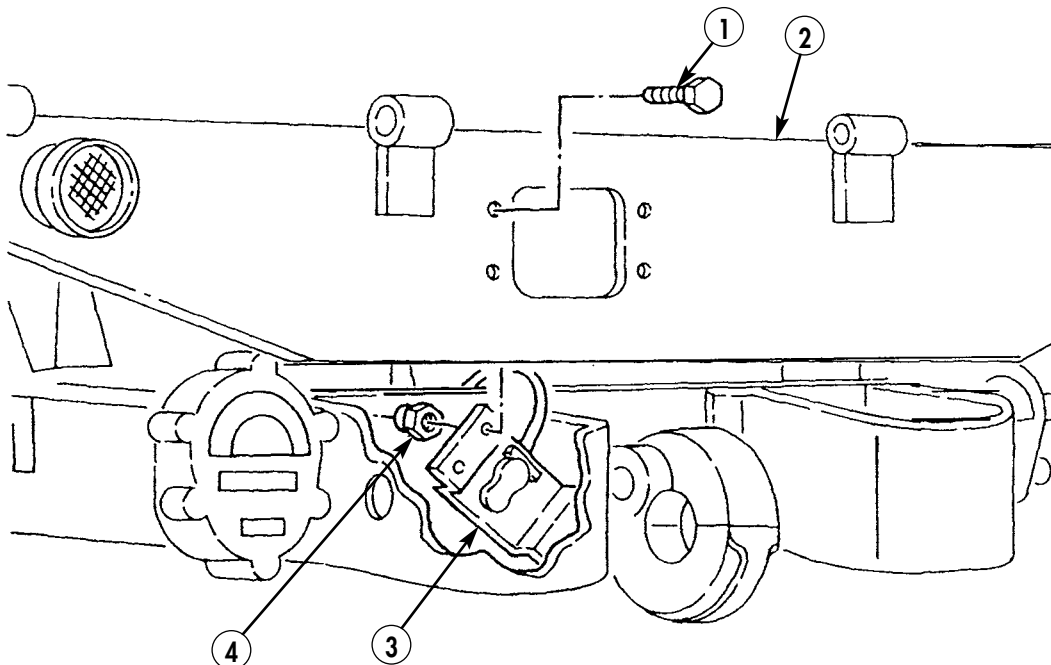

CARGO BODIES MAINTENANCE (Contd)

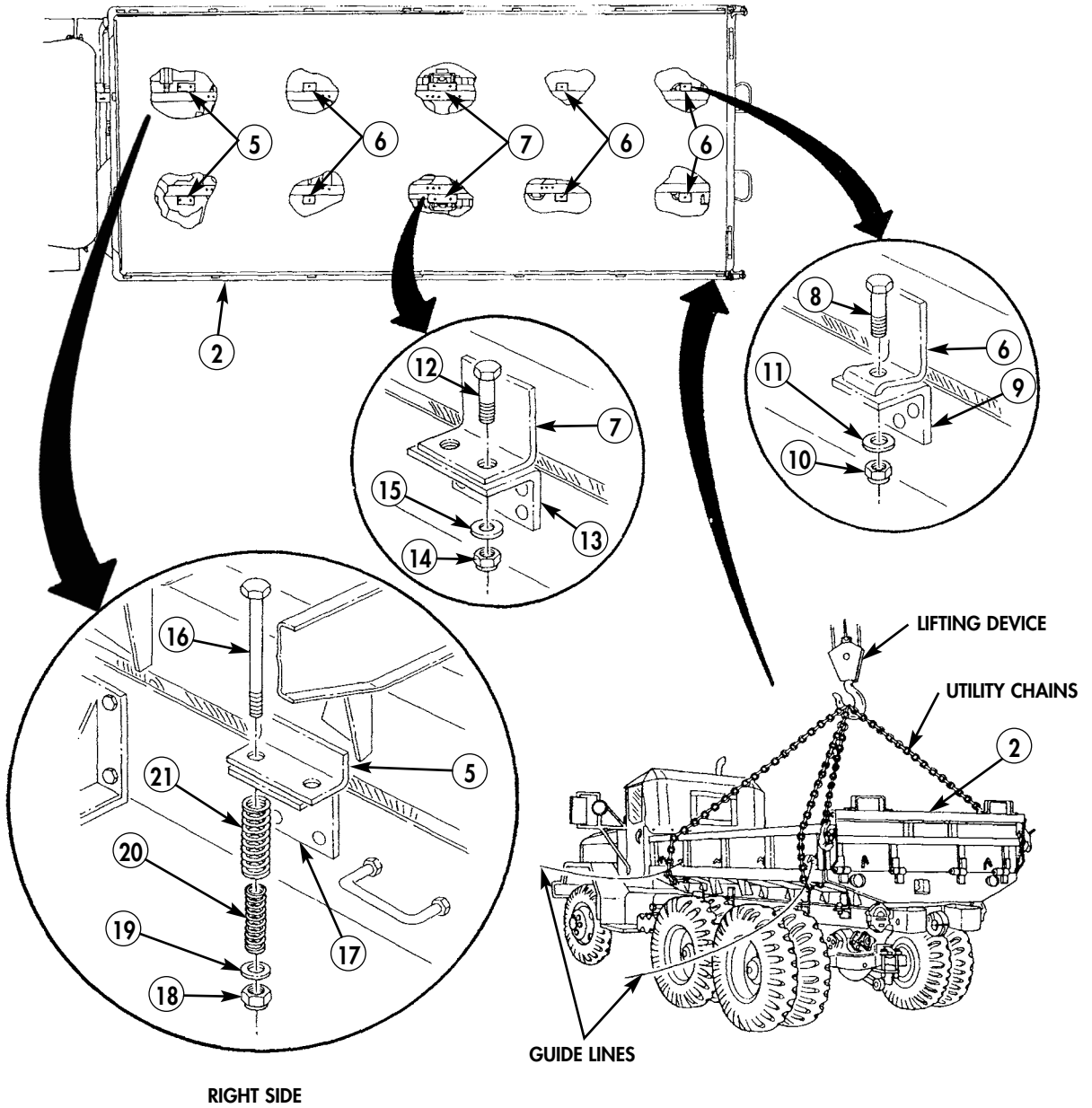

FIELD MAINTENANCE INSTRUCTIONS

2-1/2 TON, 6X6, M44A2 SERIES TRUCKS (MULTIFUEL)

DISCHARGE VALVE REPLACEMENT (M49A2C)

REMOVAL AND INSTALLATION

INITIAL SETUP:

Applicable Models

M49A2C

Materials/Parts

Six locknuts (item 137, WP 0470 00)
Four locknuts (item 165, WP 0470 00)
Locknut (item 145, WP 0470 00)
Gasket (item 51, WP 0470 00)
Gasket (item 54, WP 0470 00)

Equipment Condition

Parking brake set and wheels chocked
(TM 9-2320-361-10).
Battery ground cable disconnected
(WP 0126 00).
Fuel tanks drained (TM 9-2320-361-10).

DISCHARGE VALVE REPLACEMENT (M49A2C) (Contd)

WARNING

- Diesel fuel is flammable. Do not perform fuel system procedures near open flames. Injury or death to personnel may result.
- Accidental or intentional introduction of liquid contaminants into the environment is a violation of state, federal, and military regulations. Refer to Army POL (WP 0001 00) for information concerning storage, use, and disposal of these liquids. Failure to do so may result in damage to environment and health of personnel.

NOTE

- Both discharge valves are removed the same way.
- Use a drain pan to capture any draining fuel. Dispose of fluids in accordance with local policy and ordinances. Ensure all spills are cleaned up.

REMOVAL

1. Remove two locknuts (10), plates (9), U-bolt (7), and discharge valve cable (8) from discharge lever (5). Discard locknuts (10).
2. Remove locknut (6), screw (4), and lever (5) from discharge valve (16). Discard locknut (6).
3. Remove two locknuts (13), screws (15), coupling (14), and gasket (12) from discharge valve (16) and drain tube (11). Discard locknuts (13) and gasket (12).
4. Remove six locknuts (1), discharge valve (16), and gasket (2) from bottom of tank (3). Remove gasket remains from mating surfaces. Discard gasket (2) and locknuts (1).

INSTALLATION

1. Install new gasket (2) and discharge valve (16) on bottom of tank (3) with six new locknuts (1).
2. Install new gasket (12) and drain tube (11) on discharge valve (16) with coupling (14), two screws (15), and new locknuts (13).
3. Install lever (5) on discharge valve (16) with screw (4) and new locknut (6).
4. Install cable (8) on lever (5) with U-bolt (7), two plates (9), and two new locknuts (10). Remove slack in cable (8) and tighten nuts (10).
5. Fill fuel tanks (TM 9-2320-361-10) and check for leaks (TM 9-2320-361-10).
6. Connect battery ground cable (WP 0126 00).
7. Release parking brake and remove wheel chocks (TM 9-2320-361-10).

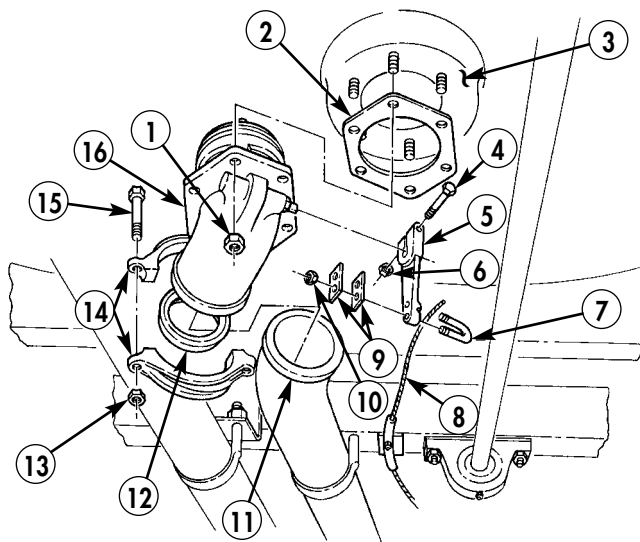

END OF WORK PACKAGE

FIELD MAINTENANCE INSTRUCTIONS

2-1/2 TON, 6X6, M44A2 SERIES TRUCKS (MULTIFUEL)

DISCHARGE VALVE CONTROL LEVERS MAINTENANCE (M49A2C)

REMOVAL, DISASSEMBLY, CLEANING AND INSPECTION, ASSEMBLY, AND INSTALLATION

INITIAL SETUP:

Applicable Models

M49A2C

References

WP 0020 00

WP 0021 00

Materials/Parts

Six locknuts (item 429, WP 0470 00)

Three cotter pins (item 29, WP 0470 00)

Three lockwashers (item 195, WP 0470 00)

Three lockwashers (item 229, WP 0470 00)

Equipment Condition

Parking brake set and wheels chocked
(TM 9-2320-361-10).

Battery ground cable disconnected
(WP 0126 00).

WARNING

Diesel fuel is flammable. Do not perform fuel system procedures near open flames. Injury or death to personnel may result.

REMOVAL

1. Unscrew three coupling nuts (1) from adapters (13) and slide back on tubes (2).
2. Unscrew three adapters (13) from plate (10).
3. Remove three nuts (8) and bolts (3), from levers (9), and pull cables (12) out of bolts (3), plate (10), and adapters (13).
4. Remove six locknuts (7), screws (4), discharge valve control assembly (5), and spacer (6) from compartment (11). Discard locknuts (7).

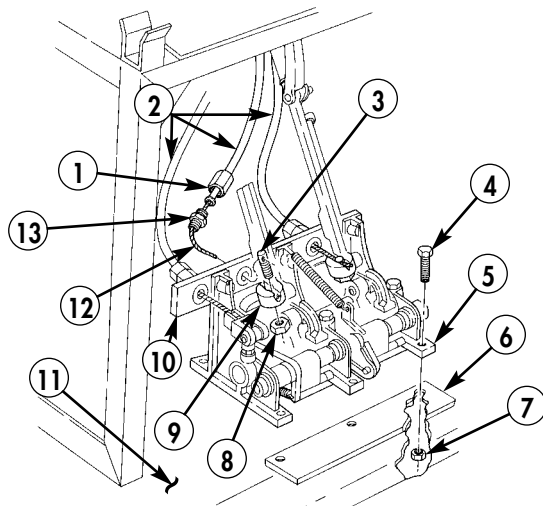

DISCHARGE VALVE CONTROL LEVERS MAINTENANCE (M49A2C) (Contd)**DISASSEMBLY****CAUTION**

Do not strike levers or brackets during lever shaft removal.
Striking levers or brackets may result in damage to components.

NOTE

Prior to removal, tag all components for assembly.

1. Remove springs (31) and (22) from lever arms (14) and (21) and brackets (30) and (23).
2. Remove three screws (6) and lockwashers (7) from brackets (5), (30), and (23). Discard lockwashers (7).
3. Remove lever shaft (8) and levers (4) and (28) from between brackets (5), (30), and (23).
4. Remove cotter pins (15) and (16) and fusible link (17) from lever arm (14) and bracket (30). Discard cotter pins (15) and (16).
5. Remove setscrews (12) and (20) in cams (13) and (19). Remove shaft (9) from bushing (24), lever arm (21), cam (20), bushing (29), lever arm (14), cam (13), and bushing (10). Remove cams (13) and (20).
6. Remove rollers (18) and (11) from bushings (10) and (29).
7. Remove lever arms (14) and (21) from bushings (29) and (24).
8. Remove cotter pin (27) from pin (25) and remove pin (25) and clevis (26) from lever arm (21). Discard cotter pin (27).
9. Remove three screws (2), lockwashers (3), and spacer bar (1) from brackets (5), (30), and (23). Discard lockwashers (3).

CLEANING AND INSPECTION

1. Refer to WP 0021 00 for general cleaning instructions.
2. Refer to WP 0020 00 for general inspection instructions.
3. Inspect clevis (26) and pin (25) for cracks or pin hole damage. Replace clevis (26) and pin (25) if cracked or pin hole is damaged.
4. Inspect shaft (9) for twists, cracks, or breakage. Replace shaft, (9) if twisted, cracked, or broken.

Table 1. M49A2C Discharge Valve Control Lever Wear Limits.

ITEM NO	ITEM/POINT OF MEASUREMENT	WEAR LIMITS/TOLERANCE	
		INCHES	MILLIMETERS
21	Lever arm (inner diameter at shaft hole)	0.433–0.463	11.25–11.76
14	Lever arm (inner diameter at shaft hole)	0.430–0.454	10.92–11.53
4 and 28	Levers (inner diameter at shaft hole)	0.868–0.922	22.05–23.42
10, 24, and 29	Bushings end exposed (diameter)	0.430–0.438	10.92–11.13
8	Lever shaft (diameter)	0.860–0.885	21.84–22.48
11 and 18	Roller (outer diameter)	0.750	19.05
11 and 18	Roller (inner diameter)	0.440–0.444	11.18–11.28

DISCHARGE VALVE CONTROL LEVERS MAINTENANCE (M49A2C) (Contd)

CLEANING AND INSPECTION (Contd)

5. Inspect lever arms (14) and (21) for wear, cracks, or pin hole damage. Refer to table 1, M49A2C Discharge Valve Control Lever Wear Limits, for measurements. Replace lever arms (14) and (21) if not within wear limits.
6. Inspect cams (13) and (20) for cracks or broken tabs. Replace cams (13) and (19) if cracked or tabs are broken.
7. Inspect rollers (11) and (18) for flat spots or wear. Refer to table 1, M49A2C Discharge Valve Control Lever Wear Limits, for measurements. Replace rollers (11) and (18) if not within wear limits.
8. Inspect brackets (5), (30), and (23) for cracks or damage. Replace brackets (5), (30), and (23) if cracked or damaged.
9. Inspect installed bushings (10), (24), and (29) for grooves or wear. Refer to table 1, M49A2C Discharge Valve Control Lever Wear Limits, for measurements. Replace bushings (10), (24), and (29) if not within wear limits.

NOTE

Perform steps 10 through 12 if bushings or brackets are damaged or not within wear limits.

10. Press bushings (10), (24), and (29) from brackets (5), (23), and (30).
11. Install bushings (10) and (24) in brackets (5) and (23) with press until bushings (10) and (24) ends are flush with inward side surface of brackets (5) and (23).
12. Install bushing (29) in bracket (30) with press until bushing (29) ends extend 0.5 in. (12.7 mm) from bracket (30) sides.
13. Inspect levers (4) and (28) for wear, latch, handle, or rod change. Refer to table 1, M49A2C Discharge Valve Control Lever Wear Limits, for measurements. Replace levers (4) and (28) if not within wear limits.
14. Inspect lever shaft (8) for grooves or wear. Refer to table 1, M49A2C Discharge Valve Control Lever Wear Limits, for measurements. Replace lever shaft (8) if not within wear limits.
15. Inspect springs (22) and (31) for distorted or broken coils. Replace springs (22) and (31) if distorted or coils are broken.
16. Inspect spacer bar (1) for cracks or damage. Replace spacer bar (1) if cracked or damaged.
17. Inspect six screws (2) and (6) and two setscrews (12) and (19). Replace screws (2) and (6) and setscrews (12) and (19) if threads are damaged.

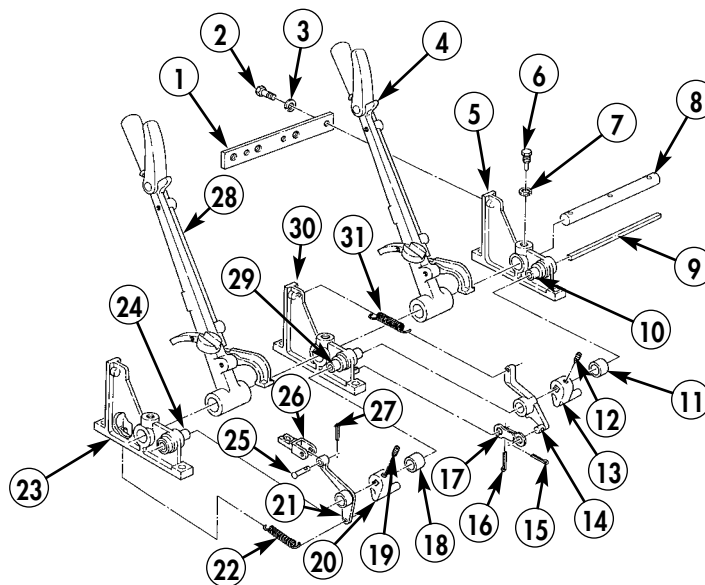

DISCHARGE VALVE CONTROL LEVERS MAINTENANCE (M49A2C) (Contd)

ASSEMBLY

1. Install clevis (26) on lever arm (21) with pin (25) and new cotter pin (27).
2. Install spacer bar (1) on brackets (5), (30), and (23) with three new lockwashers (3) and screws (2). Do not tighten screws (2).
3. Install lever shaft (8) through bracket (5), lever (4), bracket (30), lever (28), and bracket (23) with three new lockwashers (7) and screws (6).
4. Place lever arm (14) on bushing (29), lever arm (21) on bushing (24), roller (11) on bushing (10), and roller (18) on bushing (29).
5. Position cam (13) with tab down between lever arm (14) and roller (11). Install cam (13) by inserting shaft (9) through bushing (10) and cam (13) and into bushing (29).
6. Position cam (19) with tab down between lever arm (21) and roller (18). Install cam (19) by inserting shaft (9) through bushing (29) and cam (19) and into bushing (24).
7. Install setscrews (12) and (20) in cams (13) and (19).
8. Install fusible link (17) on bracket (30) and lever arm (14) with new cotter pins (15) and (16).
9. Install spring (31) on bracket (30) and lever arm (14).
10. Install spring (22) on bracket (23) and lever arm (21).
11. Tighten three screws (2).

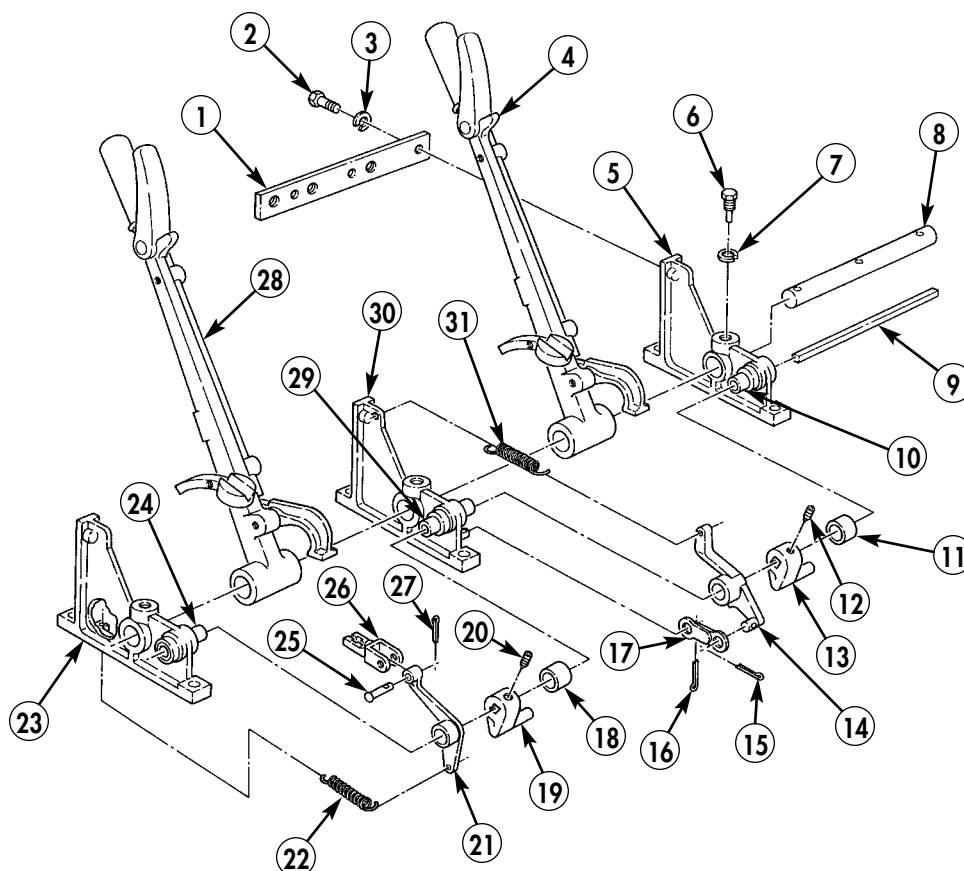

DISCHARGE VALVE CONTROL LEVERS MAINTENANCE (M49A2C) (Contd)**INSTALLATION**

1. Install three cables (43) through adapters (44) and plate (42).
2. Install discharge valve control assembly (36) and spacer (37) in compartment (40) with six screws (35) and new locknuts (38).
3. Install three adapters (44) to plate (42).
4. Thread three cables (43) through holes in bolts (34).
5. Install three bolts (34) on levers (41) with nuts (39). Do not tighten nuts (39).
6. Install three coupling nuts (32) and tubes (33) on adapters (44).
7. Remove slack in three cables (43) and tighten nuts (39).
8. Connect battery ground cable (WP 0126 00).
9. Release parking brake and remove wheel chocks (TM 9-2320-361-10).

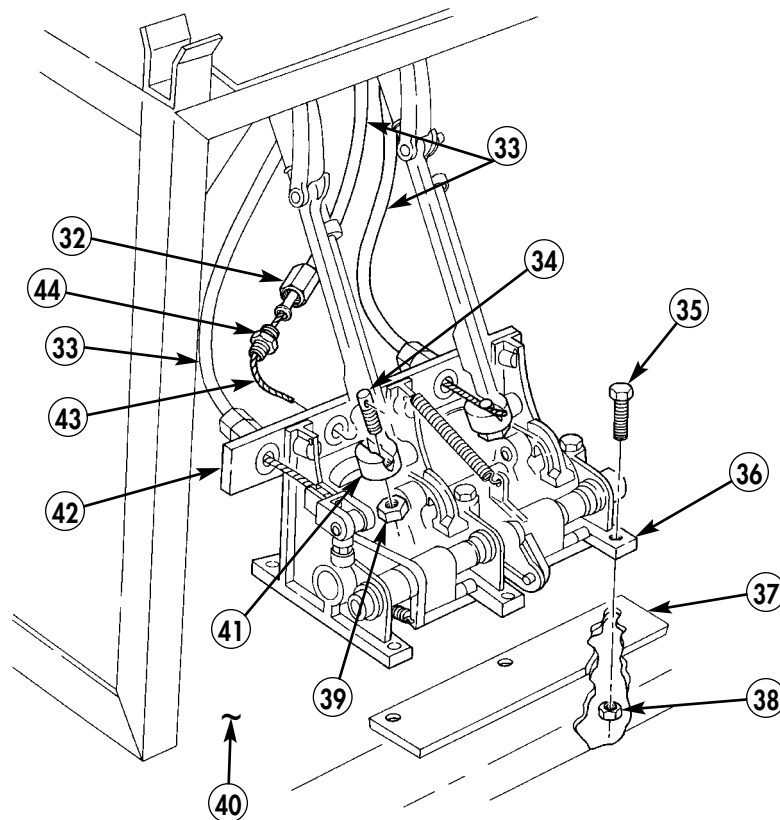

END OF WORK PACKAGE

0264 00-5/6 blank

FIELD MAINTENANCE INSTRUCTIONS

2-1/2 TON, 6X6, M44A2 SERIES TRUCKS (MULTIFUEL)

DISCHARGE VALVE REPAIR

DISASSEMBLY, CLEANING AND INSPECTION, AND ASSEMBLY

INITIAL SETUP:

Applicable Models

M49A2C, M50A3

Tools and Special Tools

General mechanic's tool kit
(item 116, WP 0469 00)
Multimeter (item 51, WP 0469 00)
Torque wrench, 1/2-in. drive
(item 138, WP 0469 00)
Spring tester (item 110, WP 0469 00)

Materials/Parts

Two O-rings (item 291, WP 0470 00)
Disc (item 37, WP 0470 00)
Gasket (item 120, WP 0470 00)
Antiseize tape (item 42, WP 0468 00)
Rag (item 27, WP 0468 00)
Skysol 100 (item 13, WP 0468 00)

Equipment Condition

Discharge valve removed (WP 0263 00).

DISCHARGE VALVE REPAIR (Contd)

DISASSEMBLY

WARNING

Discharge valve internal spring is compressed in cap. Eye protection must be worn when removing screws and cap from valve housing. Failure to do so may cause injury to personnel.

1. Remove strainer (2) from valve housing (7).
2. Remove four setscrews (15) from valve housing (7).
3. Remove cap (3) and spring (4) from stem (5).
4. Remove stem (5) with holder (1), disc (17), and retainer (16) from valve housing (7).
5. Remove retainer (16), disc (17), and holder (1) from stem (5). Discard disc (17).
6. Remove nut (13) from bore (8) in valve housing (7).
7. Remove seals (11) and (14) from bore (12) in nut (13). Discard seals (11) and (14).
8. Remove cam stem (10) from cam (6) and valve housing (7).
9. Remove cam (6) from valve housing (7).
10. Remove gasket (9) from bore (8) in valve housing (7). Discard gasket (9).

DISCHARGE VALVE REPAIR (Contd)

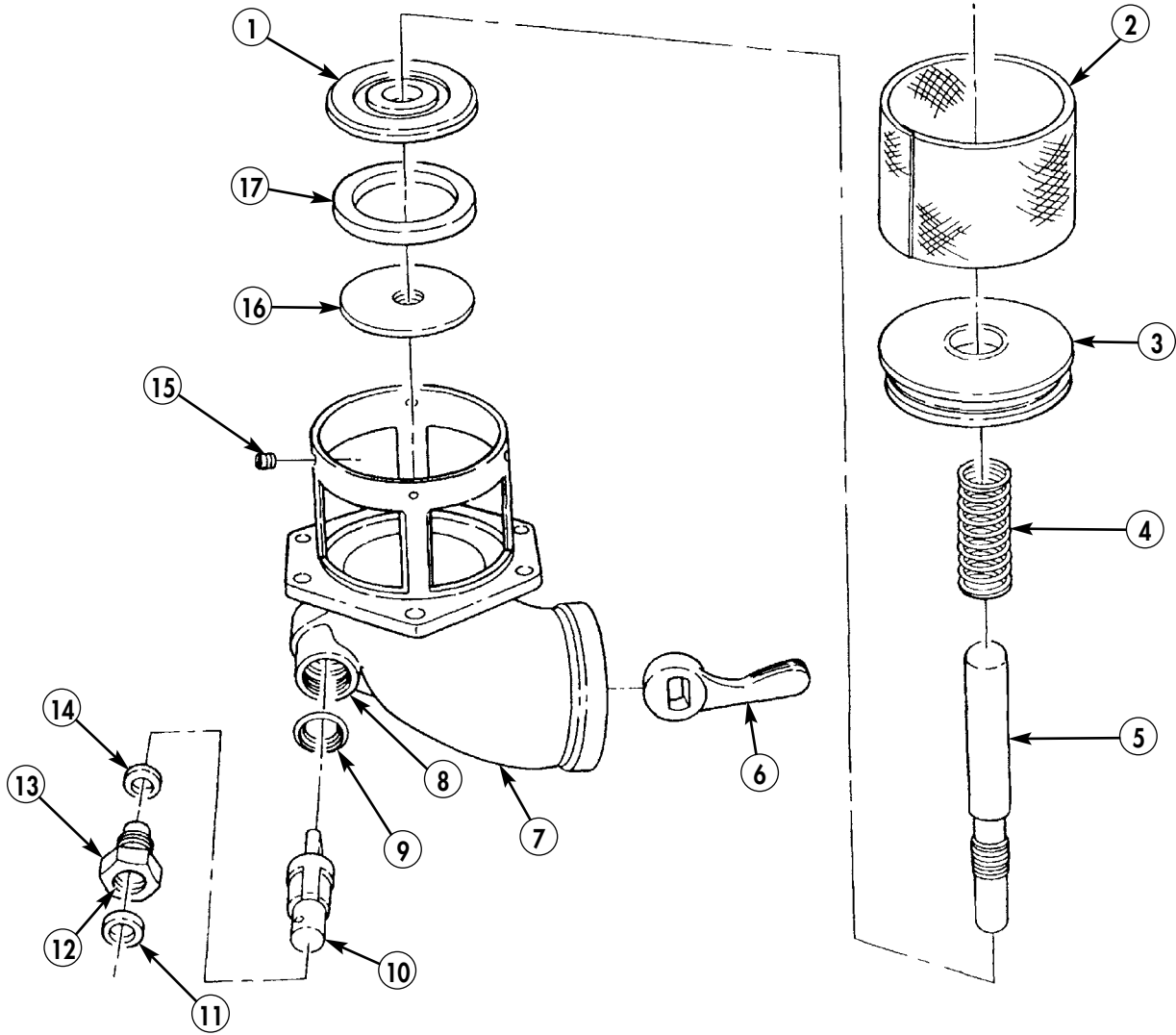

DISCHARGE VALVE REPAIR (Contd)

CLEANING AND INSPECTION

WARNING

Skysol 100 solvent is combustible; DO NOT use or store near heat, sparks, flame, or other ignition sources. Use mechanical ventilation whenever product is used in a confined space, heated above ambient temperatures, or agitated. Keep container sealed when not in use.

Contact with Skysol 100 may cause skin irritation. Use chemical-resistant gloves. In case of skin contact, remove any contaminated clothing and wash skin thoroughly with soap and water. Wash contaminated clothing before reuse. Eye contact may cause irritation, tearing, or blurring of vision. Use face shield or goggles when eye contact may occur. In case of eye contact, flush eyes with large amounts of water for at least 15 minutes or until irritation subsides. Inhalation may cause irritation to upper respiratory passages. DO NOT have food or drink in the vicinity. Failure to comply may result in injury to personnel.

NOTE

- Perform step 1 for cleaning M49A2C fuel tank discharge valves.
- Perform step 2 for cleaning M50A3 water tank discharge valves.

1. Wash all parts with Skysol 100 solvent and allow to air dry.
2. Wash all parts with soap and hot water. Rinse all parts with hot water and dry using a clean, soft rag.

Table 1. Discharge Valve Wear Limits.

ITEM NO.	ITEM/POINT OF MEASUREMENT	WEAR LIMITS/TOLERANCE	
		INCHES	MILLIMETERS
4	Spring (free length)	5.0	127.0
7	Cam stem:		
	Inside stem bore end diameter	0.422–0.437	10.72–11.10
	Plug end diameter	0.644–0.648	16.36–16.46
	Machined with square	0.497–0.500	11.00–12.70
9	Discharge valve housing:		
	Inside stem bore/inner diameter	0.433–0.443	10.99–11.25
	Outer stem bore/inner diameter	0.651–0.661	16.53–16.79

3. Inspect cam stem (7) for scoring or cracks and wear. Refer to table 1, Discharge Valve Wear Limits, for measurements. Replace if damaged or worn past limits.
4. Inspect strainer (2) for tears. Replace if damaged.
5. Inspect valve housing (9) for cracks, stripped threads, scoring, or worn bores. Refer to table 1, Discharge Valve Wear Limits, for measurements. Replace if damaged or worn past limits.
6. Inspect cap (3) for wear or cracks at stem hole. Replace if damaged.
7. Inspect holder (1) for wear or cracks at tapered stem hole. Replace if damaged.
8. Inspect retainer (10) for cracks or damaged threads. Replace if damaged.

DISCHARGE VALVE REPAIR (Contd)**CLEANING AND INSPECTION (Contd)**

9. Inspect stem (5) for cracks, scoring, damaged threads, or wear. Replace if damaged or worn.
10. Inspect cam (6) for wear at stem hole and curved driving surface. Replace if worn.
11. Inspect nut (8) for wear at stem hole and thread damage. Replace if damaged or worn.
12. Inspect spring (4) for weak or collapsed coils. Replace if damaged.
13. Inspect spring (4) free length. Refer to table 1, Discharge Valve Wear Limits, for measurements. Replace spring (4) if worn past limits.

WARNING

Eye protection must be worn during load test of internal spring. Failure to do so may cause injury to personnel.

NOTE

Perform step 14 for test of new or used internal spring prior to assembly.

14. Check load on spring (4). Spring load must be 5.5–6.4 lb-ft (7.5–8.7 N•m) when compressed to 3 in. (76.2 mm).

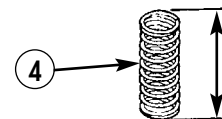
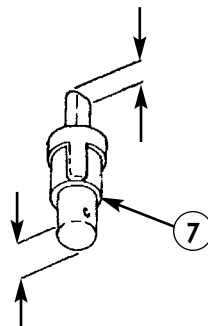
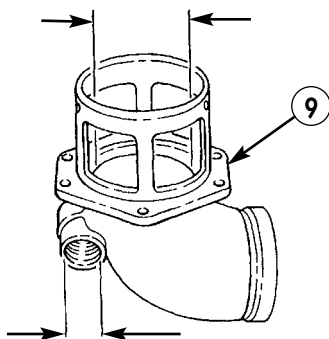
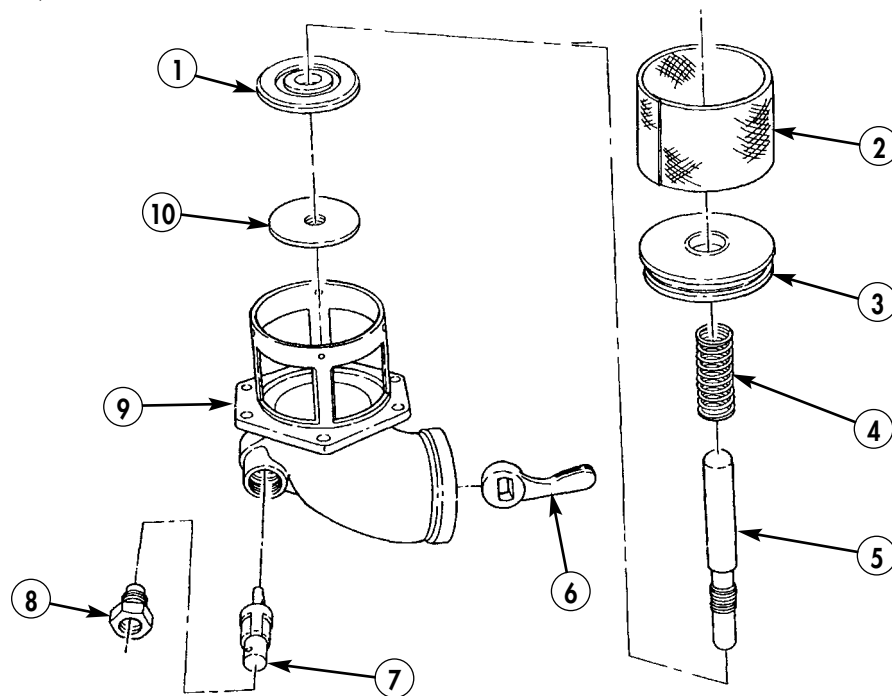

DISCHARGE VALVE REPAIR (Contd)

ASSEMBLY

1. Install new gasket (9) in bore (8) of valve housing (7).
2. Position cam (6) inside valve housing (7) with rounded edge facing up.
3. Insert cam stem (10) in bore (8) through cam (6) until seated.
4. Install two new O-rings (11) and (14) in bore (12) of nut (13). Wrap nut (13) threads with antiseize tape and install nut (13) over cam stem (10) into valve housing (7).
5. Install holder (1) and new disc (17) on stem (5) with retainer (16).
6. Position stem (5) with holder (1), new disc (17), and retainer (16) in valve housing (7) until seated.

WARNING

Eye protection must be worn during spring and cap installation.
Failure to do so may result in injury to personnel.

7. Position spring (4) over stem (5) on holder (1).
8. Install cap (3) on stem (5), compressing spring (4) into valve housing (7), with four setscrews (15).
9. Install strainer (2) over valve housing (7).
10. Install discharge valve (WP 0263 00).

DISCHARGE VALVE REPAIR (Contd)

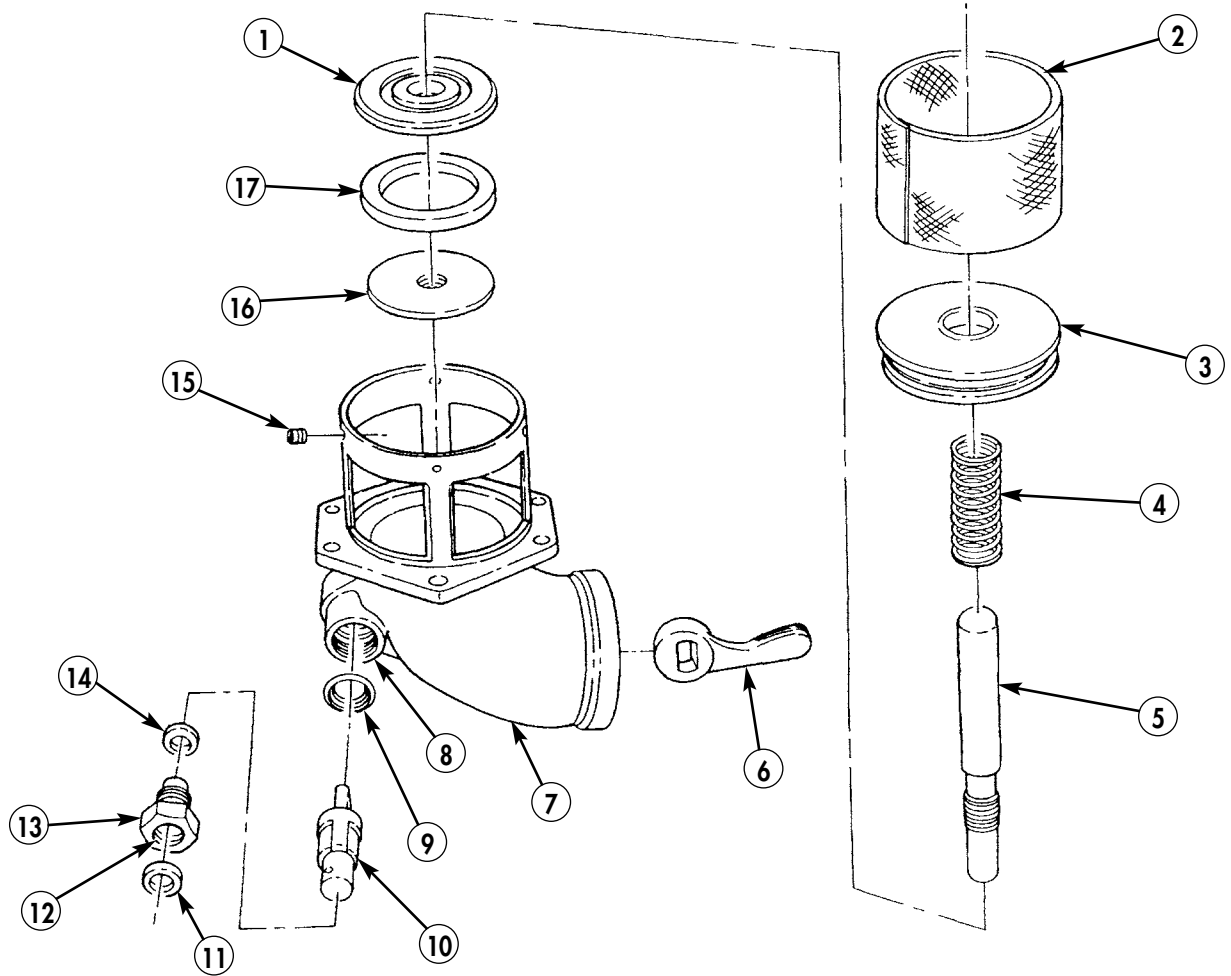

FIELD MAINTENANCE INSTRUCTIONS

2-1/2 TON, 6X6, M44A2 SERIES TRUCKS (MULTIFUEL)

FRONT AND REAR FUEL TANK DISCHARGE TUBES REPLACEMENT (M49A2C)

REMOVAL AND INSTALLATION

INITIAL SETUP:

Applicable Models

M49A2C

Materials/Parts

Six locknuts (item 163, WP 0470 00)

Gasket (item 99, WP 0470 00)

Gasket (item 100, WP 0470 00)

Equipment Condition

Parking brake set and wheels chocked
(TM 9-2320-361-10).

Battery ground cable disconnected
(WP 0126 00).

Fuel tanks drained (TM 9-2320-361-10).

FRONT AND REAR FUEL TANK DISCHARGE TUBES REPLACEMENT (M49A2C) (Contd)

REMOVAL

WARNING

Diesel fuel is flammable. Do not perform fuel system procedures near open flames. Injury or death to personnel may result.

NOTE

- Removal and installation of front and rear fuel tank discharge tubes is the same except for two U-bolts on the rear tube and three U-bolts on the front tube. This procedure describes removal and installation of the front tube.
- Access to nuts, screws, coupling, and gasket for removal and installation is through vehicle rear compartment.

1. Remove two nuts (2), screws (3), coupling (1), and gasket (6) from discharge tube (4) and manifold (5). Discard gasket (6).
2. Remove six locknuts (9) and three U-bolts (16) from discharge tube (7) and frame (8). Discard locknuts (9).
3. Remove two nuts (15), screws (10), coupling (11), and gasket (13) from discharge tube (7) and discharge valve (12). Discard gasket (13).
4. Remove discharge tube (7) from discharge valve (12), manifold (5), and frame (8).

INSTALLATION

1. Position discharge tube (7) on discharge valve (12).
2. Install new gasket (6) and discharge tube (7) on manifold (5) with coupling (1), two screws (3), and nuts (2).
3. Install new gasket (13) and discharge tube (7) on discharge valve (12) with coupling (1), two screws (10), and nuts (15).
4. Install discharge tube (7) on frame (8) with three U-bolts (16) and six new locknuts (9).
5. Fill fuel tanks (TM 9-2320-361-10) and check for leaks.
6. Connect battery ground cable (WP 0126 00).
7. Release parking brake and remove wheel chocks (TM 9-2320-361-10).

FRONT AND REAR FUEL TANK DISCHARGE TUBES REPLACEMENT (M49A2C) (Contd)

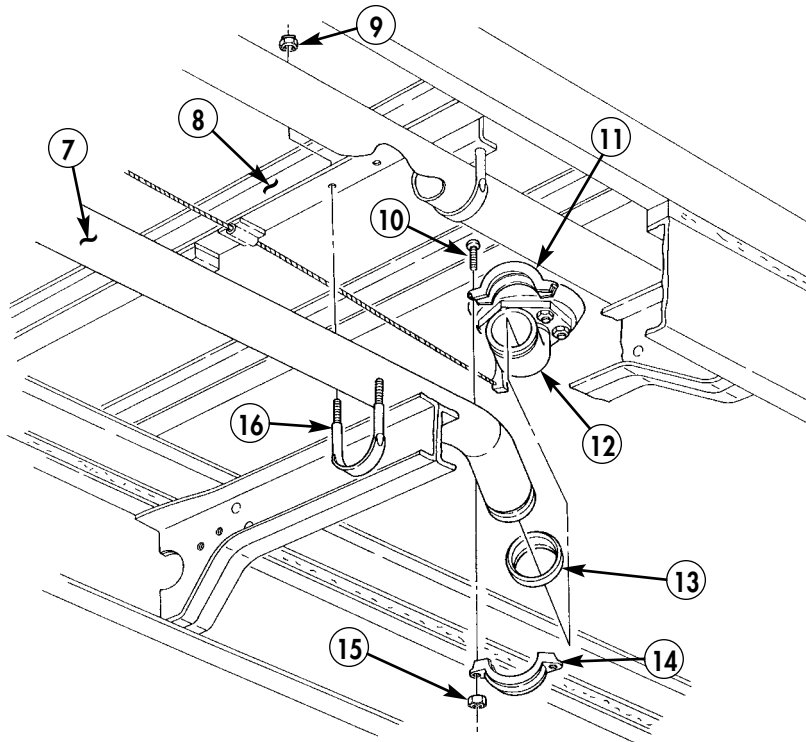
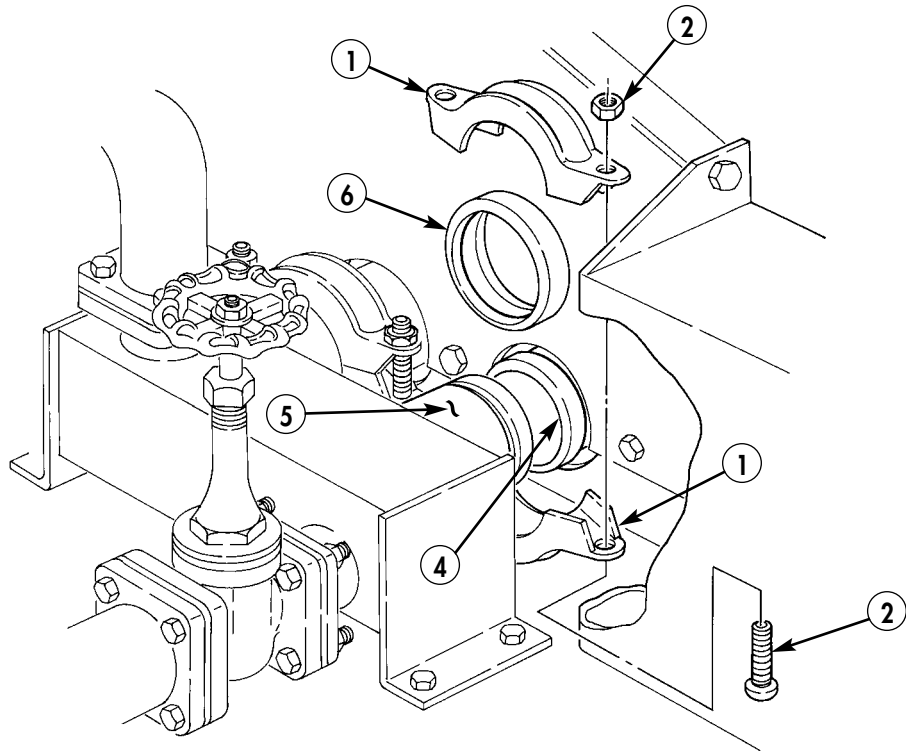

END OF WORK PACKAGE

FIELD MAINTENANCE INSTRUCTIONS

2-1/2 TON, 6X6, M44A2 SERIES TRUCKS (MULTIFUEL)

AUTOMATIC DUMP VALVE AND SUMP ASSEMBLY MAINTENANCE (M49A2C)

SUMP VALVE REMOVAL, DRAIN TUBES AND DRAIN VALVES REMOVAL,
AUTOMATIC DUMP VALVE REMOVAL, CLEANING AND INSPECTION, AUTOMATIC DUMP VALVE INSTALLATION,
DRAIN TUBES AND DRAIN VALVES INSTALLATION, AND SUMP VALVE INSTALLATION

INITIAL SETUP:

Applicable Models

M49A2C

Tools and Special Tools

General mechanic's tool kit
(item 116, WP 0469 00)

Materials/Parts

Six locknuts (item 129, WP 0470 00)
Gasket (item 101, WP 0470 00)
Antiseize tape (item 42, WP 0468 00)
Skysol 100 (item 13, WP 0468 00)

References

WP 0002 00
WP 0021 00

Equipment Condition

Parking brake set and wheels chocked
(TM 9-2320-361-10).
Battery ground cable disconnected
(WP 0126 00).
Filter separator-to-sump pipe removed
(WP 0273 00).

SUMP VALVE, DRAIN VALVES, AND DRAIN TUBES MAINTENANCE (M49A2C) (Contd)**SUMP VALVE REMOVAL****NOTE**

Prior to removal, mark location of two holes on sump cover where it attaches to support.

1. Remove two screws (12) from sump valve (5) and support (11).
2. Remove two locknuts (15), screws (13), and support (11) from cabinet (14). Discard locknuts (15).
3. Remove two locknuts (6), screws (3), collar (7), and pad (4) from sump valve (5) and bracket (2). Discard locknuts (6).
4. Remove two locknuts (16), screws (1), and bracket (2) from cabinet (14). Discard locknuts (16).
5. Remove sump valve (5) and drain tubes (8) and (9) from cabinet floor (10).

SUMP VALVE, DRAIN VALVES, AND DRAIN TUBES MAINTENANCE (M49A2C) (Contd)

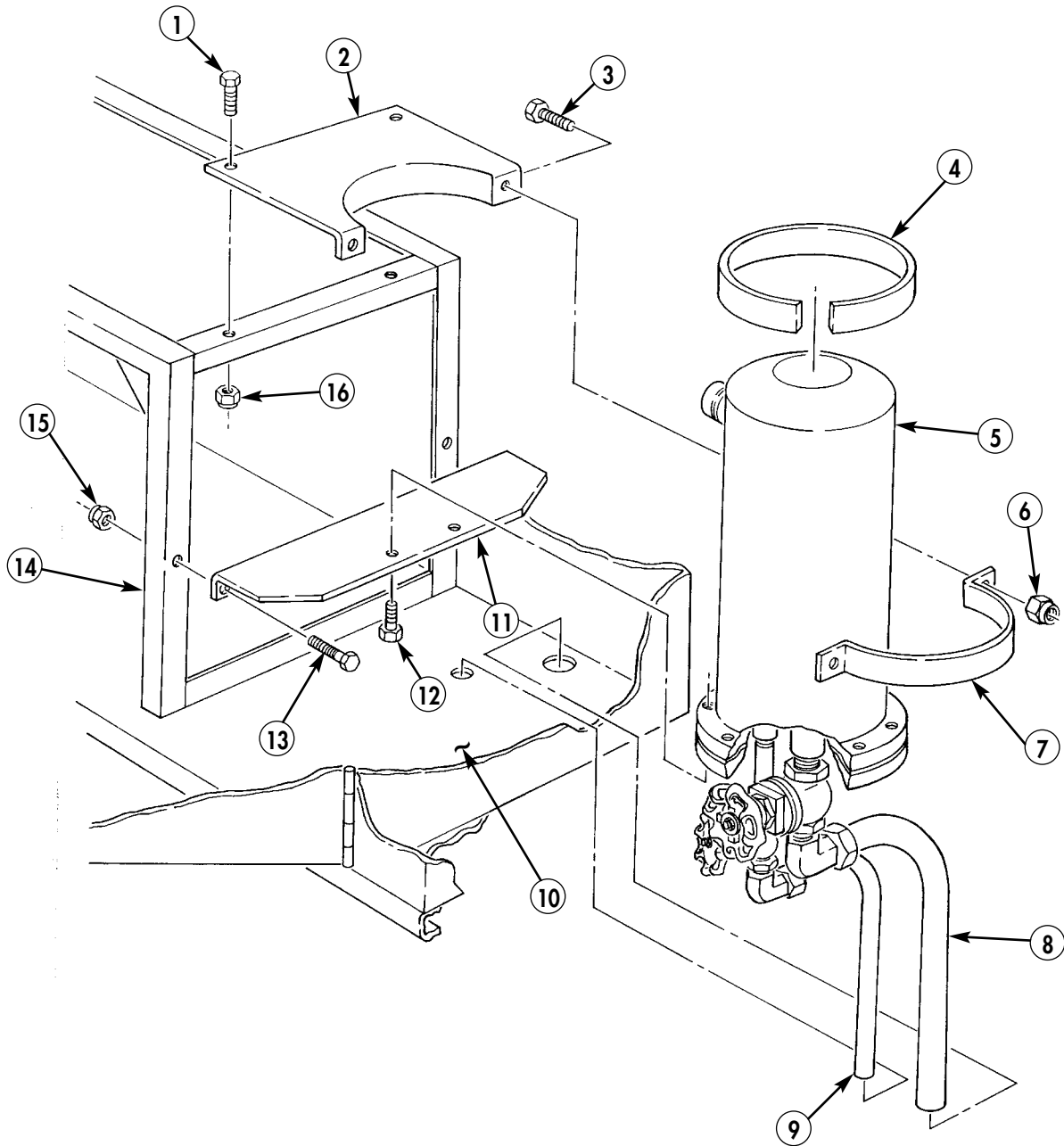

SUMP VALVE, DRAIN VALVES, AND DRAIN TUBES MAINTENANCE (M49A2C) (Contd)

DRAIN TUBES AND DRAIN VALVES REMOVAL

1. Disconnect tube nuts (7) and (11) from elbows (5) and (13).
2. Remove elbow (13), drain valve (14), and nipple (1) from sump valve (3).

NOTE

The short nipple should be removed if defective or damaged.

3. Remove elbow (5) and drain valve (4) from nipple (9).

AUTOMATIC DUMP VALVE REMOVAL

1. Remove six screws (19), cover (18), and gasket (17) from sump valve tank (15). Discard gasket (17).
2. Remove sump valve assembly (16) from cover (18).

CLEANING AND INSPECTION

1. For general cleaning and inspection instructions, refer to WP 0021 00.
2. Inspect pad (2) for tears or dry rot. Replace pad (2) if damaged.
3. Inspect sump valve tank (15) for cracks or damaged threads. Replace sump valve tank (16) if damaged.
4. Inspect cover (18) for cracks or damaged threads. Replace cover (18) if damaged.
5. Inspect drain valve (4), and (14) for damaged threads, leakage, or cracks. Replace drain valve (4), or (14) if damaged.
6. Inspect nipple (9) in cover (18) and nipple (1) for damaged threads or cracks. Replace cover (18) or nipples (9) and (1) if damaged.
7. Inspect elbows (5) and (13) for cracks, damaged sleeve contact surface, or damaged threads. Replace elbow (5) or (13) if damaged.
8. Inspect tube nuts (7) and (11) on tubes (8) and (10) for cracks or damaged sleeve contact surfaces or damaged threads. Replace tube (8) or (10) if damaged.
9. Inspect sleeves (6) and (12) on tubes (8) and (10) for cracks or defects. Remove sleeves (6) and (12) from tubes (8) and (10) and replace if damaged.
10. Inspect tubes (8) and (10) for kinks, cracks, or other damage. Replace tube (8) or (10) if damaged.

SUMP VALVE, DRAIN VALVES, AND DRAIN TUBES MAINTENANCE (M49A2C) (Contd)

CLEANING AND INSPECTION (Contd)

WARNING

Skysol 100 solvent is combustible; DO NOT use or store near heat, sparks, flame, or other ignition sources. Use mechanical ventilation whenever product is used in a confined space, heated above ambient temperatures, or agitated. Keep container sealed when not in use.

Contact with Skysol 100 may cause skin irritation. Use chemical-resistant gloves. In case of skin contact, remove any contaminated clothing and wash skin thoroughly with soap and water. Wash contaminated clothing before reuse. Eye contact may cause irritation, tearing, or blurring of vision. Use face shield or goggles when eye contact may occur. In case of eye contact, flush eyes with large amounts of water for at least 15 minutes or until irritation subsides. Inhalation may cause irritation to upper respiratory passages. DO NOT have food or drink in the vicinity. Failure to comply may result in injury to personnel.

11. Submerge sump valve float (16) in Skysol 100 solvent and check for internal leakage. Replace sump valve (16) if damaged.

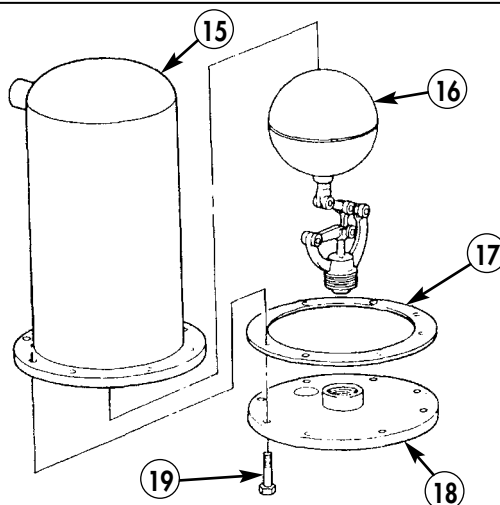
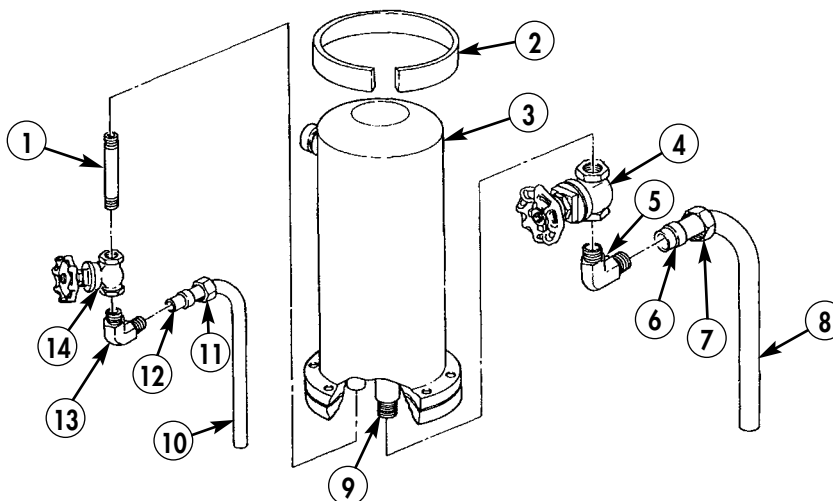

SUMP VALVE, DRAIN VALVES, AND DRAIN TUBES MAINTENANCE (M49A2C) (Contd)

AUTOMATIC DUMP VALVE INSTALLATION

1. Install sump valve assembly (2) on cover (4).

CAUTION

Do not install screws in two marked holes of cover where support attaches. If screws are in place, sump valve cannot be attached on support.

2. Install new gasket (3) and cover (4) on sump valve tank (1) with six screws (5).

NOTE

A new sump valve tank will require decal installation on exterior.

3. Install new decal(s) (WP 0002 00).

DRAIN TUBES AND DRAIN VALVES INSTALLATION

1. Wrap antiseize tape on all exposed pipe and fitting threads.
2. Install nipple (6) on sump valve (7) fitting threads.
3. Install valve (8) on nipple (13).
4. Install elbow (9) on valve (8).
5. Install valve housing (18) on nipple (6).
6. Install elbow (17) on valve (18).
7. Position sleeves (10) and (16), with tubes (12) and (14) attached, on elbows (9) and (17).
8. Install tubes (12) and (14) on elbows (9) and (17) with tube nuts (11) and (15).

SUMP VALVE, DRAIN VALVES, AND DRAIN TUBES MAINTENANCE (M49A2C) (Contd)

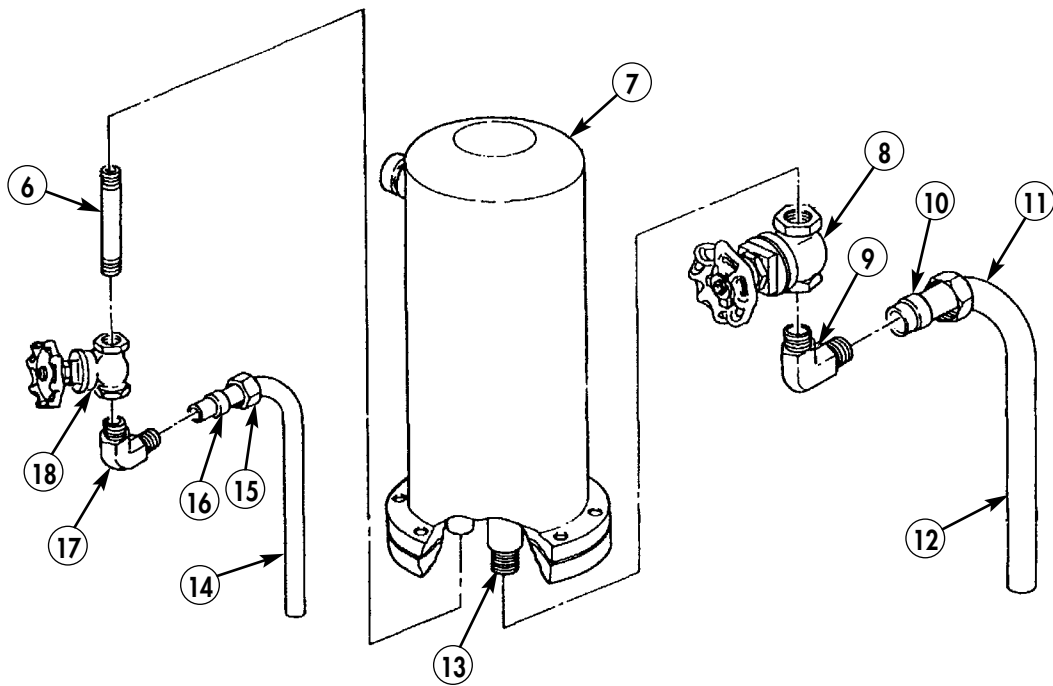
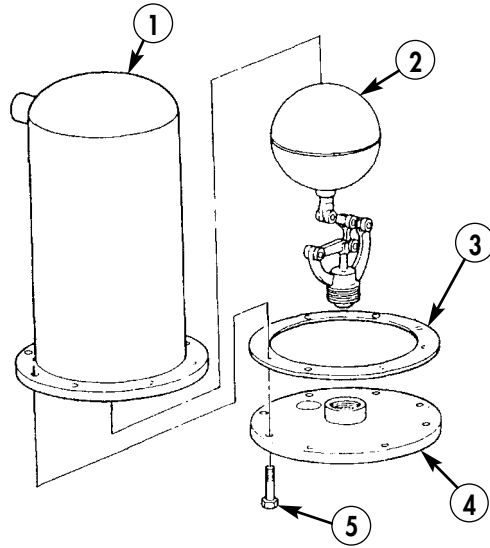

SUMP VALVE, DRAIN VALVES, AND DRAIN TUBES MAINTENANCE (M49A2C) (Contd)

SUMP VALVE INSTALLATION

1. Install support (16) on cabinet (13) with two screws (12) and new locknuts (14).
2. Place sump valve (5) on support (16) with drain tubes (8) and (9) through two holes in cabinet floor (10).
3. Install sump valve (5) on support (16) with two screws (11). Do not tighten two screws (11).
4. Position pad (4) around sump valve (5).
5. Install bracket (2) on cabinet (13) against pad (4) with two screws (1) and new locknuts (15).
6. Install collar (7) around pad (4) and on bracket (2) with two screws (3) and new locknuts (6).
7. Tighten two screws (11).
8. Install filter separator-to-sump pipe (WP 0273 00).
9. Connect battery ground cable (WP 0126 00).
10. Release parking brake and remove wheel chocks (TM 9-2320-361-10).

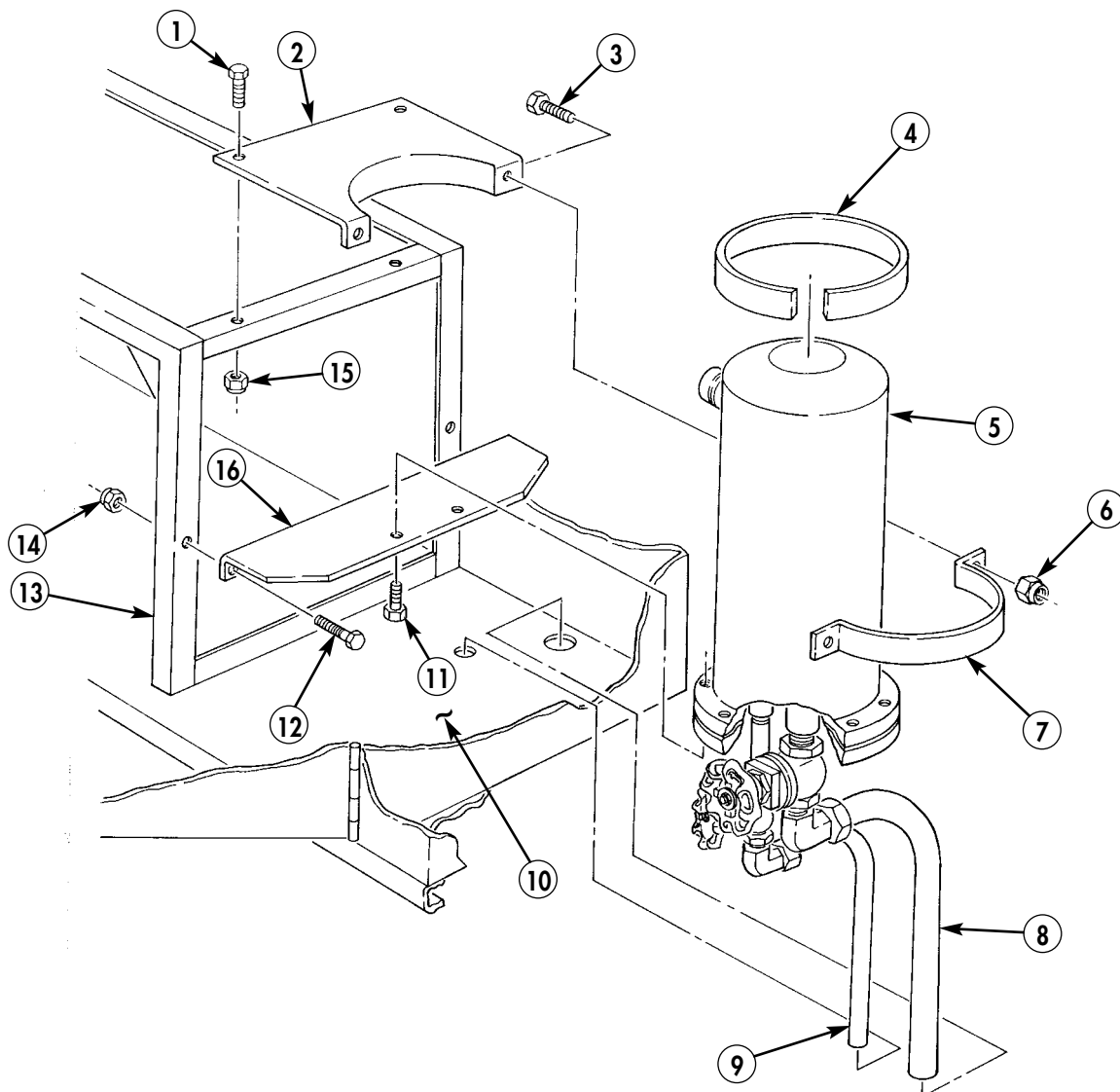

END OF WORK PACKAGE

0267 00-8

FIELD MAINTENANCE INSTRUCTIONS

2-1/2 TON, 6X6, M44A2 SERIES TRUCKS (MULTIFUEL)

FUEL TANK MANHOLE COVER MAINTENANCE (M49A2C) REMOVAL, DISASSEMBLY, INSPECTION, ASSEMBLY, AND INSTALLATION

INITIAL SETUP:

Applicable Models

M49A2C

Materials/Parts

Fill gasket (item 121, WP 0470 00)

Gasket (item 47, WP 0470 00)

Gasket (item 48, WP 0470 00)

Equipment Condition

Parking brake set and wheels chocked
(TM 9-2320-361-10).

Battery ground cable disconnected
(WP 0126 00)

Fuel tanks drained (TM 9-2320-361-10).

FUEL TANK MANHOLE COVER MAINTENANCE (M49A2C) (Contd)

WARNING

Diesel fuel is flammable. Do not perform fuel system procedures near open flames. Injury or death to personnel may result.

NOTE

Cover manhole opening in tank to avoid contamination.

FILLER CAP REMOVAL

1. If equipped, remove antipliferage seal (19) from filler cap (16) and tank body (20).
2. Remove S hook (17) and chain (18) from fuel tank (20).
3. Remove S hook (17) from filler cap (16).
4. Remove filler cap (16) from filler hole (21).

MANHOLE COVER REMOVAL

1. Remove nut (14), washer (15), screw (9) and clamp ring (12) from manhole cover (10) and tank body (13).
2. Remove manhole cover (10) and gasket (11) from tank body (13). Discard gasket (11)

MANIFOLD MANHOLE COVER REMOVAL

1. Remove nut (22), washer (23), screw (26), and clamp ring (25) from manhole cover (28) and tank body (24).
2. Remove manhole cover (28) and gasket (27) from tank body (24). Discard gasket (27).

DISASSEMBLY

1. Remove nut (31), springwell (30), spring (29), and screw (8) from fill cover (6) and latch (7).
2. Unscrew vent valve (1), and remove washer (2), gasket (3), fill retainer (4), fill gasket (5), and fill cover (6). Discard fill gasket (5) and gasket (3).

INSPECTION

1. Inspect manhole cover (28), spring (29), and clamp ring (25) for cracks, bends, and damage. Replace manhole cover (28), spring (29), or clamp ring (25) if cracked, bent, or damaged.
2. Inspect vent valve (1) for stripped threads. Replace vent valve (1) if threads are stripped or damaged.

ASSEMBLY

1. Install new fill gasket (5), fill retainer (4), new gasket (3), washer (2), and vent valve (1) on fill cover (6).
2. Install springwell (30) and spring (29) on fill cover (6) and latch (7) with screw (8) and nut (31).

MANIFOLD MANHOLE COVER INSTALLATION

1. Install new gasket (27) and manhole cover (28) on tank body (24).
2. Install clamp ring (25) around manhole cover (28) and tank body (24) with screw (26), washer (23), and nut (22).
3. Fill fuel tanks (TM 9-2320-361-10) and check for leaks.

FUEL TANK MANHOLE COVER MAINTENANCE (M49A2C) (Contd)

MANHOLE COVER INSTALLATION

1. Install manhole cover (10) and new gasket (11) on tank body (13).
2. Install screw (9), washer (15), nut (14), and clamp ring (12) on manhole cover (10) and tank body (13).

FILLER CAP INSTALLATION

1. Install filler cap (16) on filler hole (21).
2. Install S hook (17) on filler cap (16).
3. Install S hook (17) and chain (18) on fuel tank (20).
4. Install S hook and chain on fuel tank.
5. Fill fuel tanks (TM 9-2330-361-10) and check for leaks.
6. Install antipliferage seal (19) on filler cap (16) and tank body (20).
7. Connect battery ground cable (WP 0126 00).
8. Release parking brake and remove wheel chocks (TM 9-2330-361-10).

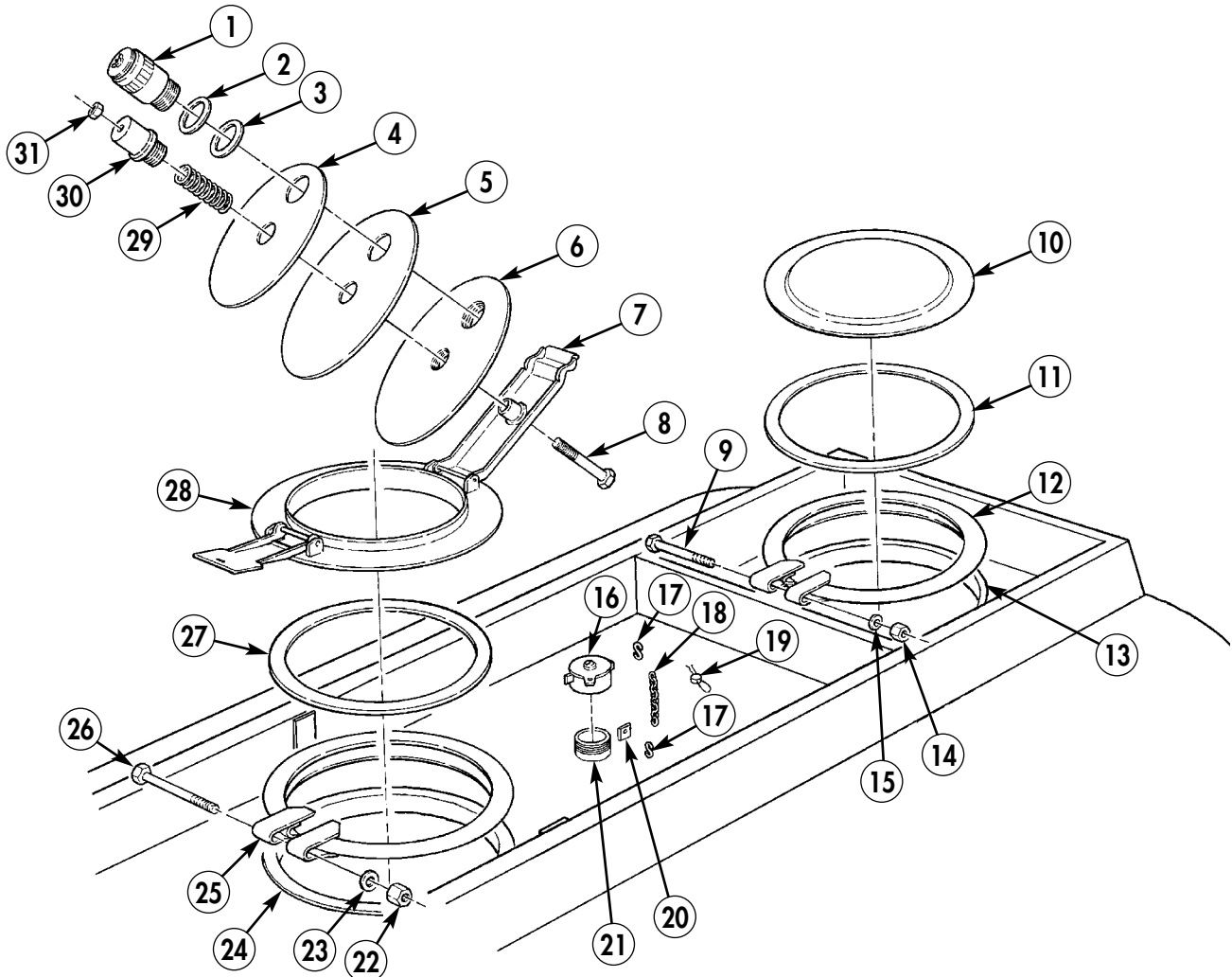

END OF WORK PACKAGE

0268 00-3/4 blank

FIELD MAINTENANCE INSTRUCTIONS

2-1/2 TON, 6X6, M44A2 SERIES TRUCKS (MULTIFUEL)

FUEL HOSE AND NOZZLE REPLACEMENT (M49A2C)

FUEL NOZZLE HOLDER REMOVAL, FUEL HOSE AND NOZZLE REMOVAL,
FUEL HOSE AND NOZZLE INSTALLATION, FUEL NOZZLE HOLDER INSTALLATION

INITIAL SETUP:

Applicable Models

M49A2C

Materials/Parts

Two locknuts (item 129, WP 0470 00)
Locknut (item 155, WP 0470 00)
Gasket (item 103, WP 0470 00)
Antiseize tape (item 42, WP 0468 00)

Equipment Condition

Parking brake set and wheels chocked
(TM 9-2320-361-10).
Battery ground cable disconnected
(WP 0126 00).

FUEL HOSE AND NOZZLE RPELACEMENT (M49A2C) (Contd)

WARNING

Diesel fuel is flammable. Do not perform fuel system procedures near open flames. Injury or death to personnel may result.

CAUTION

To prevent fuel from leaking, all valves must be in off position. Failure to comply may result in injury to personnel.

FUEL NOZZLE HOLDER REMOVAL

1. Remove nozzle strap (17) from nozzle (5).
2. Remove nozzle (5) from nozzle holder (18).
3. Remove locknut (19), screw (15), washer (16), and strap (17) from nozzle holder (18). Discard locknut (19).
4. Remove two locknuts (13), screw (14), and nozzle holder (18) from tanker body (12). Discard locknuts (13).

FUEL HOSE AND NOZZLE REMOVAL

1. Remove nut (4) and electrostatic discharger (6) from nozzle (5).
2. Remove nozzle (5) from bushing (3).
3. Remove bushing (3) from fitting (2).
4. Remove fitting (2) from hose (1).
5. Remove two nuts (11), screws (8), coupling (7), and gasket (9) from meter outlet tube (10) and tube (5). Discard gasket (9).
6. Remove tube (20) from fitting (21).
7. Remove fitting (21) from swivel (22).
8. Remove swivel (22) from bushing (23).
9. Remove bushing (23) from hose (1).

FUEL HOSE AND NOZZLE INSTALLATION

NOTE

Male pipe threads must be wrapped with antiseize tape before installation.

1. Install bushing (23) on hose (1).
2. Install swivel (22) on bushing (23).
3. Install fitting (21) on swivel (22).
4. Install tube (20) on fitting (21).
5. Install tube (20) and new gasket (9) on meter outlet tube (10) with coupling (7), two screws (8), and nuts (11).
6. Install fitting (2) on hose (1).
7. Install bushing (3) on fitting (2).
8. Install nozzle (5) on bushing (3).
9. Install electrostatic discharger (6) on nozzle (5) with nut (4).

FUEL HOSE AND NOZZLE RPELACEMENT (M49A2C) (Contd)

FUEL NOZZLE HOLDER INSTALLATION

1. Install nozzle holder (18) on tanker body (12) with two screws (14), and new locknuts (13).
2. Install strap (17) on nozzle holder (18) with screw (15) and new locknut (19).
3. Install nozzle (5) on nozzle holder (18).
4. Install nozzle strap (17) on nozzle (5).
5. Connect battery ground cable (WP 0126 00).
6. Release parking brake and remove wheel chocks (TM 9-2320-361-10).

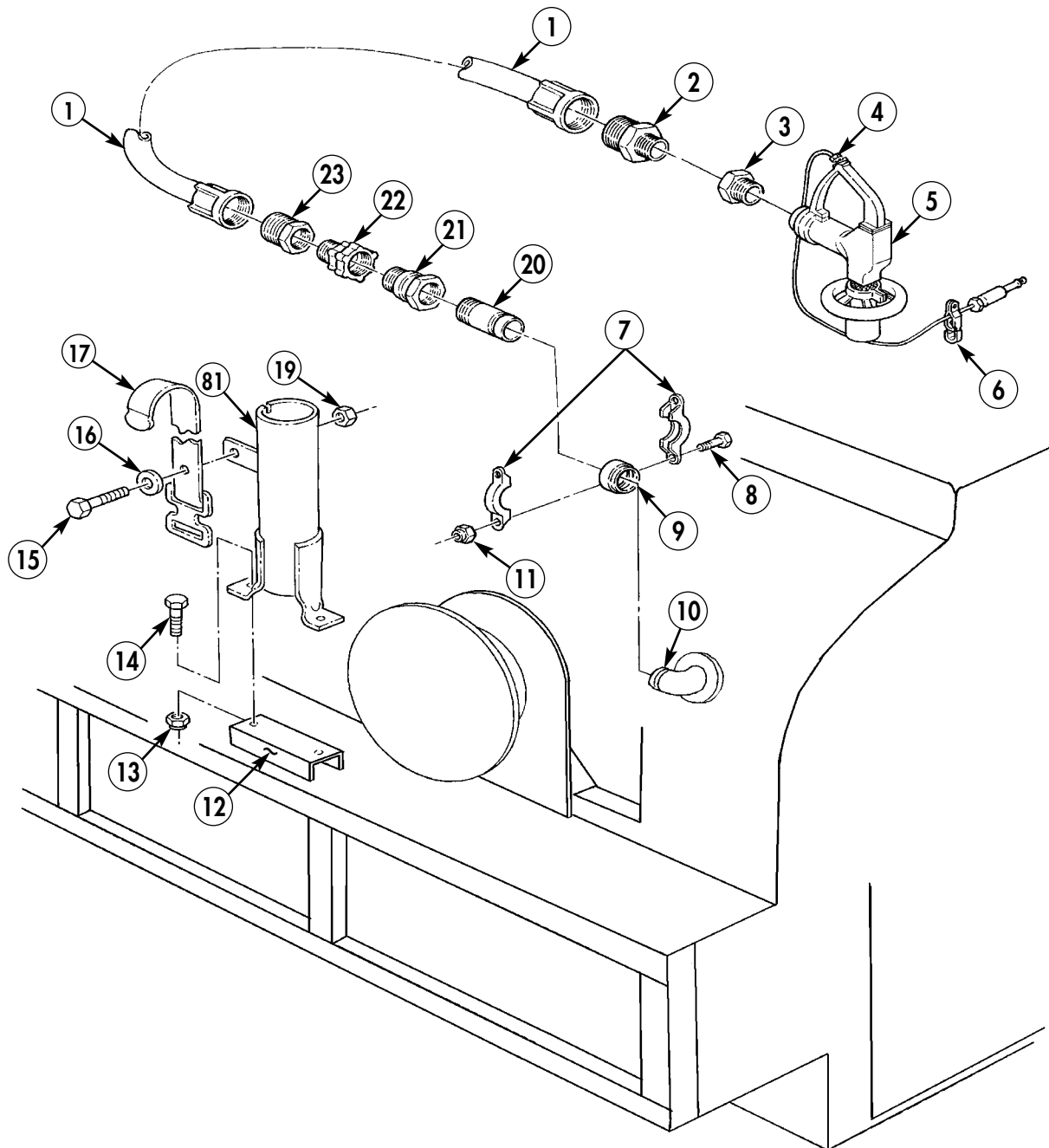

END OF WORK PACKAGE

0269 00-3/4 blank

FIELD MAINTENANCE INSTRUCTIONS

2-1/2 TON, 6X6, M44A2 SERIES TRUCKS (MULTIFUEL)

WATER TANK NOZZLE HOLDER REPLACEMENT

REMOVAL AND INSTALLATION

INITIAL SETUP:

Applicable Models

M50A3

Materials/Parts

Six locknuts (item 130, WP 0470 00)

Equipment Condition

Parking brake set and wheels chocked
(TM 9-2320-361-10).

Battery ground cable disconnected
(WP 0126 00).

REMOVAL

1. Remove two locknuts (4), screws (2), and nozzle hanger (3) from tank body (1).
2. Remove two locknuts (10), screws (13), and nozzle holder (12) from angle bracket (11). Discard locknuts (10).
3. Remove two locknuts (4), screws (9) and angle bracket (11) from tank body (1). Discard locknuts (4).
4. Remove screw (7), washer (8) and strap (6) from tank body (1).

INSTALLATION

1. Install strap (6) on tank body (1) with screw (7) and washer (8).
2. Install angle bracket (11) on tank body (1) with two screws (9) and new locknuts (4).
3. Install nozzle holder (12) on angle bracket (11) with two screws (13) and new locknuts (10).
4. Install nozzle hanger (3) on tank body (1) with two screws (2) and new locknuts (4).
5. Connect battery ground cable (WP 0126 00).
6. Release parking brake and remove wheel chocks (TM 92320-361-10).

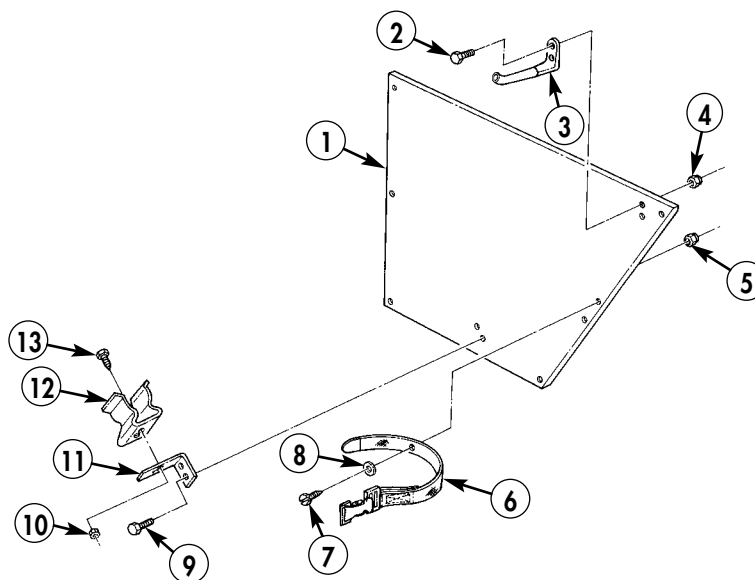

END OF WORK PACKAGE

0270 00-1/2 blank

FIELD MAINTENANCE INSTRUCTIONS

2-1/2 TON, 6X6, M44A2 SERIES TRUCKS (MULTIFUEL)

OVERTURN TUBES REPLACEMENT (M49A2C)

REMOVAL AND INSTALLATION

INITIAL SETUP:

Applicable Models

M49A2C

Equipment Condition

Parking brake set and wheels chocked
(TM 9-2320-361-10).

Battery ground cable disconnected
(WP 0126 00).

OVERTURN TUBES REPLACEMENT (M49A2C) (Contd)

WARNING

Diesel fuel is flammable. Do not perform fuel system procedures near open flames. Injury or death to personnel may result.

REMOVAL

1. Loosen clamps (1) on top and bottom of overturn tube (3).
2. Push tube (3) down, onto bottom adapter (4) as far as possible, and remove from adapter (2).
3. Remove tube (3) from adapter (4).

INSTALLATION

1. Install clamps (1) on top and bottom of tube (3).
2. Install tube (3) and push down as far as possible on bottom adapter (4).
3. Install top of tube (3) on top adapter (2). Adjust tube (3) evenly on top adapter (2) and bottom adapter (4) and tighten clamps (1).
4. Connect battery ground cable (WP 0126 00).
5. Release parking brake and remove wheel chocks (TM 9-2320-361-10).

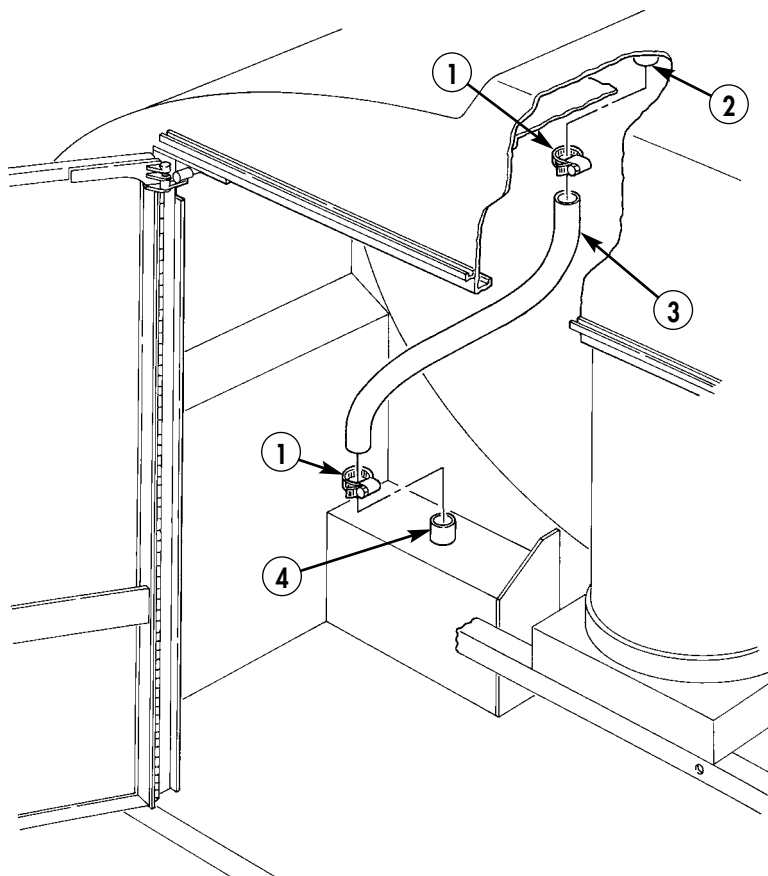

FIELD MAINTENANCE INSTRUCTIONS

2-1/2 TON, 6X6, M44A2 SERIES TRUCKS (MULTIFUEL)

GLOBE VALVE REPLACEMENT (M49A2C)

REMOVAL AND INSTALLATION

INITIAL SETUP:

Applicable Models

M49A2C

Materials/Parts

Antiseize tape (item 42, WP 0468 00)

Equipment Condition

Parking brake set and wheels chocked
(TM 9-2320-361-10).

Battery ground cable disconnected
(WP 0126 00).

GLOBE VALVE REPLACEMENT (M49A2C) (Contd)

WARNING

- Diesel fuel is flammable. Do not perform fuel system procedures near open flames. Injury or death to personnel may result.
- Accidental or intentional introduction of liquid contaminants into the environment is a violation of state, federal, and military regulations. Refer to Army POL (WP 0001 00) for information concerning storage, use, and disposal of these liquids. Failure to do so may result in damage to environment and health of personnel.

NOTE

Use a drain pan to capture any draining fuel. Dispose of fluids in accordance with local policy and ordinances. Ensure all spills are cleaned up.

REMOVAL

1. Open globe valve (3) and allow fuel to drain from piping (1).
2. Remove fitting (4) from hose (5) and globe valve (3).
3. Remove globe valve (3) from fitting (2).
4. Remove fitting (2) from pipe (1).

INSTALLATION

1. Apply antiseize tape to threads on fittings (2) and (4).
2. Install fitting (2) to pipe (1).
3. Install globe valve (3) to fitting (2).
4. Install fitting (4) to globe valve (3) and hose (5).
5. Connect battery ground cable (WP 0126 00).
6. Release parking brake and remove wheel chocks (TM 9-2320-361-10).

GLOBE VALVE REPLACEMENT (M49A2C) (Contd)

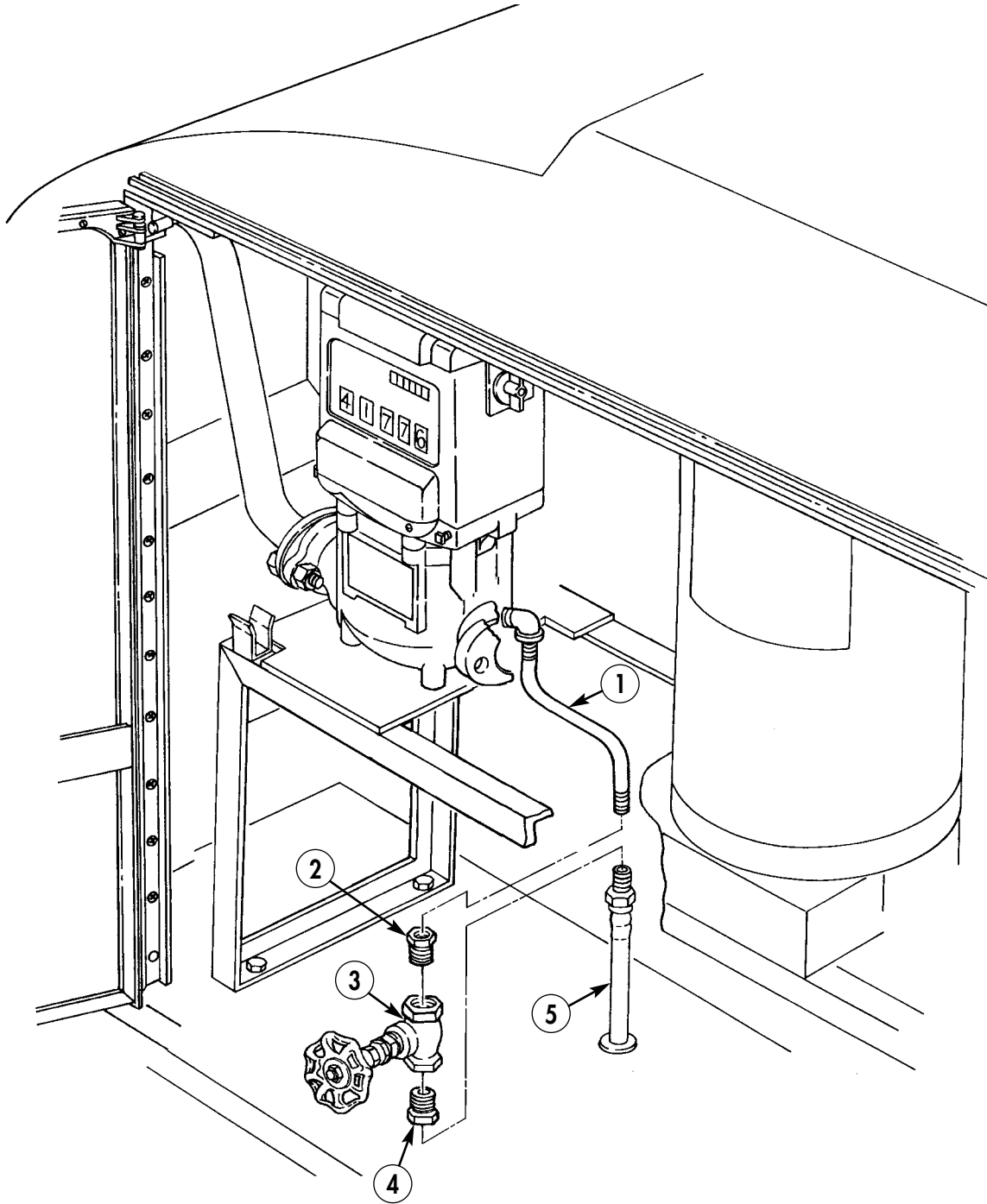

END OF WORK PACKAGE

FIELD MAINTENANCE INSTRUCTIONS

2-1/2 TON, 6X6, M44A2 SERIES TRUCKS (MULTIFUEL)

FILTER SEPARATOR-TO-SUMP PIPE REPLACEMENT (M49A2C)

REMOVAL AND INSTALLATION

INITIAL SETUP:

Applicable Models

M49A2C

Materials/Parts

Two gaskets (item 103, WP 0470 00)

Equipment Condition

Parking brake set and wheels chocked
(TM 9-2320-361-10).

Battery ground cable disconnected
(WP 0126 00).

FILTER SEPARATOR-TO-SUMP PIPE REPLACEMENT (M49A2C) (Contd)**WARNING**

- Diesel fuel is flammable. Do not perform fuel system procedures near open flames. Injury or death to personnel may result.
- Accidental or intentional introduction of liquid contaminants into the environment is a violation of state, federal, and military regulations. Refer to Army POL (WP 0001 00) for information concerning storage, use, and disposal of these liquids. Failure to do so may result in damage to environment and health of personnel.

NOTE

Use a drain pan to capture any draining fuel. Dispose of fluids in accordance with local policy and ordinances. Ensure all spills are cleaned up.

REMOVAL

Remove four screws (2), nuts (5), two couplings (3), filter separator-to-pump pipe (1), and two gaskets (6) from sump valve housing (4) and filter separator (7). Discard gaskets (6).

INSTALLATION

1. Install two new gaskets (6) and filter separator-to-sump pipe (1) on sump valve housing (4) and filter separator (7) with two couplings (3), four screws (2), and nuts (5).
2. Connect battery ground cable (WP 0126 00).
3. Release parking brake and remove wheel chocks (TM 9-2320-361-10).

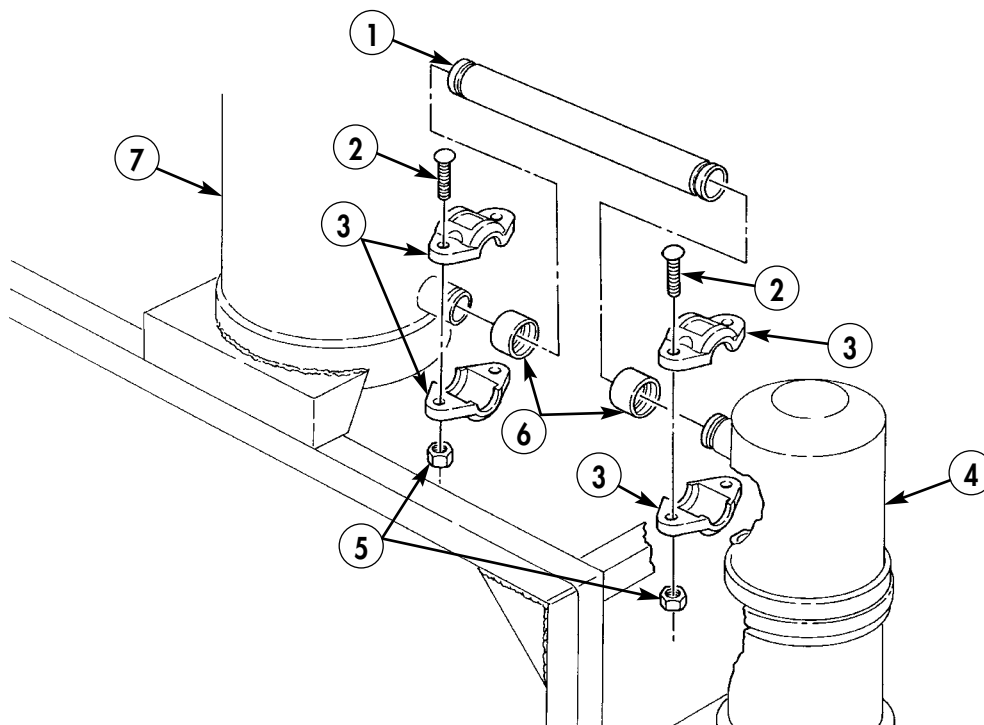
**END OF WORK PACKAGE**

FIELD MAINTENANCE INSTRUCTIONS

2-1/2 TON, 6X6, M44A2 SERIES TRUCKS (MULTIFUEL)

CABLE RETRACTOR REPLACEMENT (M49A2C)

REMOVAL AND INSTALLATION

INITIAL SETUP:

Applicable Models

M49A2C

Materials/Parts

Two locknuts (item 129, WP 0470 00)

Equipment Condition

Parking brake set and wheels chocked
(TM 9-2320-361-10).

Battery ground cable disconnected
(WP 0126 00).

REMOVAL

Remove two locknuts (3), screws (4), and static reel (1) from shelf (2). Discard locknuts (3).

INSTALLATION

1. Install static reel (1) on shelf (2) with two screws (4) and new locknuts (3).
2. Connect battery ground cable (WP 0126 00).
3. Release parking brake and remove wheel chocks (TM 9-2320-361-10).

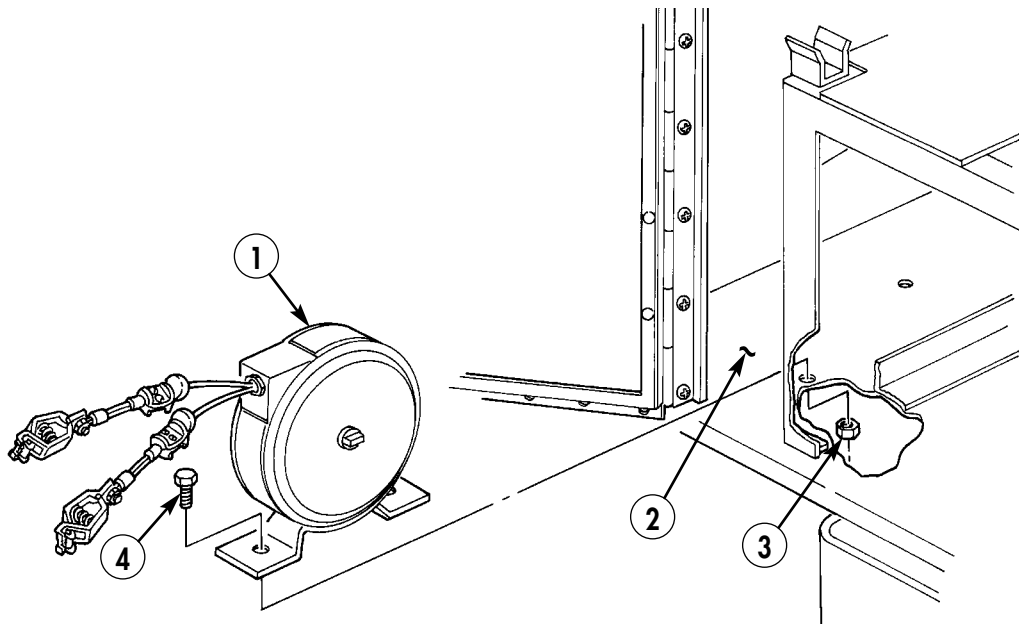

END OF WORK PACKAGE

0274 00-1/2 blank

FIELD MAINTENANCE INSTRUCTIONS

2-1/2 TON, 6X6, M44A2 SERIES TRUCKS (MULTIFUEL)

METER-TO-FILTER TUBE REPLACEMENT (M49A2C)

REMOVAL AND INSTALLATION

INITIAL SETUP:

Applicable Models

M49A2C

Materials/Parts

Two locknuts (item 132, WP 0470 00)

Gasket (item 102, WP 0470 00)

Gasket (item 103, WP 0470 00)

Equipment Condition

Parking brake set and wheels chocked
(TM 9-2320-361-10).

Battery ground cable disconnected
(WP 0126 00).

METER-TO-FILTER TUBE REPLACEMENT (M49A2C) (Contd)**WARNING**

- Diesel fuel is flammable. Do not perform fuel system procedures near open flames. Injury or death to personnel may result.
- Accidental or intentional introduction of liquid contaminants into the environment is a violation of state, federal, and military regulations. Refer to Army POL (WP 0001 00) for information concerning storage, use, and disposal of these liquids. Failure to do so may result in damage to environment and health of personnel.

NOTE

Use a drain pan to capture any draining fuel. Dispose of fluids in accordance with local policy and ordinances. Ensure all spills are cleaned up.

REMOVAL

1. Remove two nuts (6), screws (3), and coupling (4) from tube (8) and filter separator (2).
2. Remove two locknuts (10), screws (7), tube (8), and gaskets (9) and (5) from meter (1) and filter separator (2). Discard locknuts (10) and gaskets (9) and (5).

INSTALLATION

1. Install new gasket (9), tube (8), and new gasket (5) on filter separator (2) and meter (1) with two screws (7) and new locknuts (10). Do not tighten locknuts (10).
2. Install coupling (4) on filter separator (2) and gasket (5) with two screws (3) and nuts (6). Tighten locknuts (10).
3. Connect battery ground cable (WP 0126 00).
4. Release parking brake and remove wheel chocks (TM 9-2320-361-10).

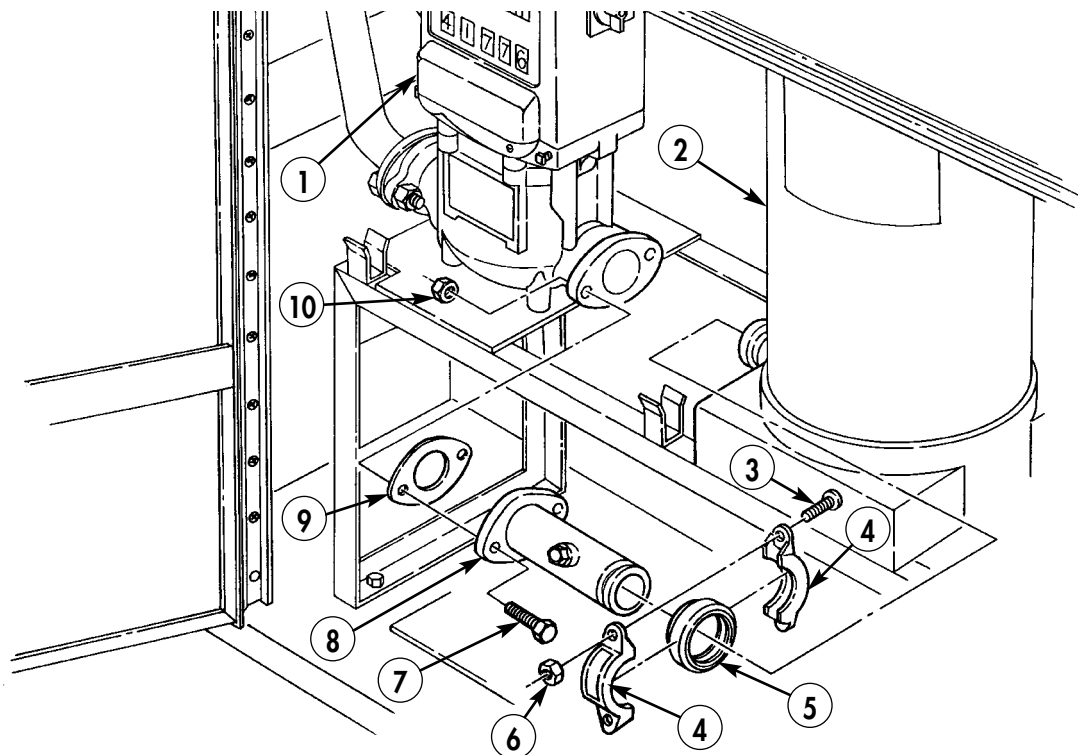

END OF WORK PACKAGE

FIELD MAINTENANCE INSTRUCTIONS

2-1/2 TON, 6X6, M44A2 SERIES TRUCKS (MULTIFUEL)

GALLON METER REPLACEMENT (M49A2C)

REMOVAL AND INSTALLATION

INITIAL SETUP:

Applicable Models

M49A2C

Materials/Parts

Three lockwashers (item 195, WP 0470 00)

Equipment Condition

Parking brake set and wheels chocked
(TM 9-2320-361-10).

Battery ground cable disconnected
(WP 0126 00).

Meter outlet tube removed (WP 0282 00).

Globe valve removed (WP 0272 00).

Meter-to-filter tube removed (WP 0275 00).

REMOVAL

1. Remove three screws (4), lockwashers (5), and gallon meter (1) from shelf (6). Discard lockwashers (5).
2. Remove pipe (3) from elbow (2) and elbow (2) from gallon meter (1).

INSTALLATION

NOTE

Clean all male pipe threads and wrap with antiseize tape before installation.

1. Install elbow (2) on gallon meter (1) and pipe (3) on elbow (2).
2. Install gallon meter (1) on shelf (6) with three screws (4) and new lockwashers (5).
3. Install meter-to-filter tube (WP 0275 00).
4. Install globe valve (WP 0272 00).
5. Install meter outlet tube (WP 0282 00).
6. Connect battery ground cable (WP 0126 00).
7. Release parking brake and remove wheel chocks (TM 9-2320-361-10).

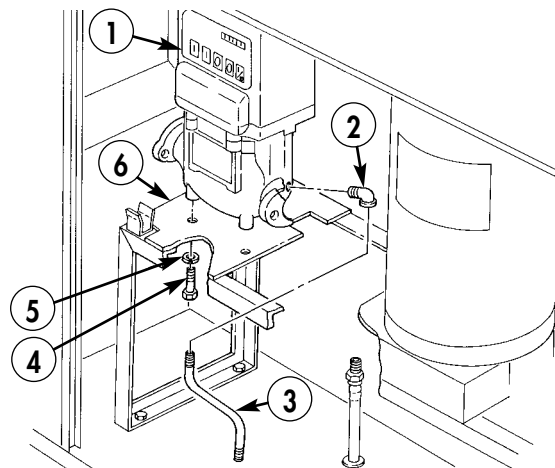

END OF WORK PACKAGE

0276 00-1/2 blank

FIELD MAINTENANCE INSTRUCTIONS

2-1/2 TON, 6X6, M44A2 SERIES TRUCKS (MULTIFUEL)

DELIVERY PUMP OUTLET TUBE REPLACEMENT (M49A2C)

REMOVAL AND INSTALLATION

INITIAL SETUP:

Applicable Models

M49A2C

Materials/Parts

Four locknuts (item 147, WP 0470 00)
Four lockwashers (item 195, WP 0470 00)
Gasket (item 76, WP 0470 00)
Gasket (item 111, WP 0470 00)

Equipment Condition

Parking brake set and wheels chocked
(TM 9-2320-361-10).
Battery ground cable disconnected
(WP 0126 00).

DELIVERY PUMP OUTLET TUBE REPLACEMENT (M49A2C) (Contd)**WARNING**

- Diesel fuel is flammable. Do not perform fuel system procedures near open flames. Injury or death to personnel may result.
- Accidental or intentional introduction of liquid contaminants into the environment is a violation of state, federal, and military regulations. Refer to Army POL (WP 0001 00) for information concerning storage, use, and disposal of these liquids. Failure to do so may result in damage to environment and health of personnel.

NOTE

Use a drain pan to capture any draining fuel. Dispose of fluids in accordance with local policy and ordinances. Ensure all spills are cleaned up.

REMOVAL

1. Remove four screws (7), lockwashers (8), and gasket (9) from outlet tube (5) and delivery pump (1). Discard lockwashers (8) and gasket (9). Remove gasket remains from mating surfaces.
2. Remove four screws (6), locknuts (2), gasket (4), and outlet tube (5) from gate valve (3). Discard locknuts (2) and gasket (4). Remove gasket remains from mating surfaces.

INSTALLATION

1. Install new gasket (9) and outlet tube (5) on delivery pump (1) with four screws (7) and new lockwashers (8).
2. Install new gasket (4) and outlet tube (5) on gate valve (3) with four screws (6) and new locknuts (2).
3. Release parking brake and remove wheel chocks (TM 9-2320-361-10).

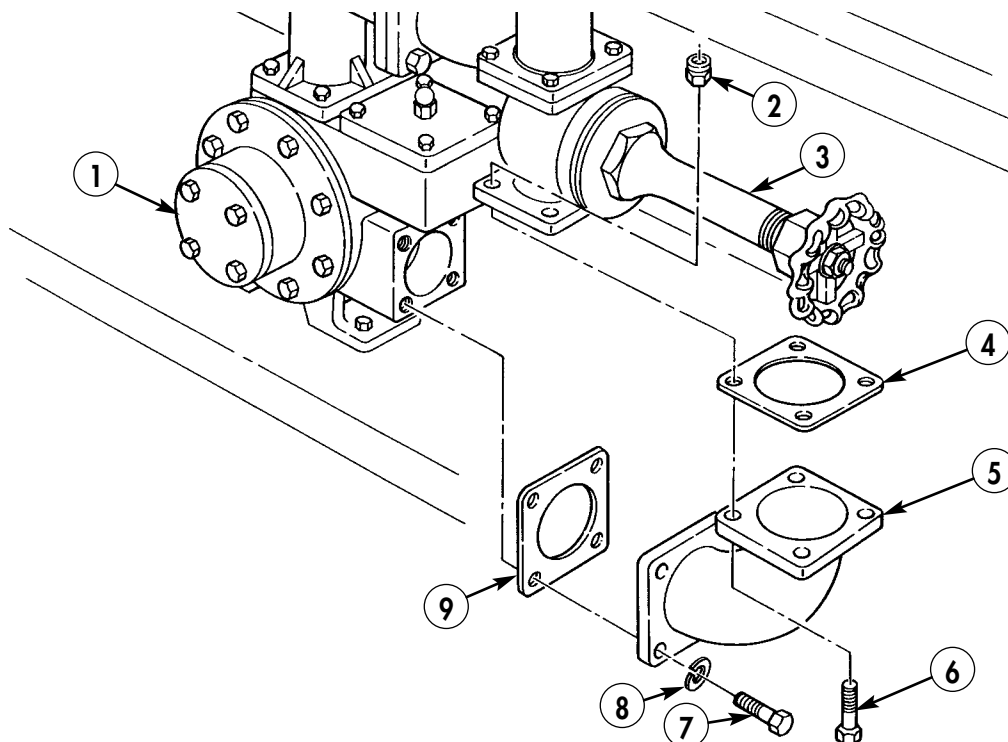

END OF WORK PACKAGE

FIELD MAINTENANCE INSTRUCTIONS

2-1/2 TON, 6X6, M44A2 SERIES TRUCKS (MULTIFUEL)

DELIVERY PUMP INLET TUBE REPLACEMENT (M49A2C)

REMOVAL AND INSTALLATION

INITIAL SETUP:

Applicable Models

M49A2C

Materials/Parts

Four locknuts (item 147, WP 0470 00)
Four lockwashers (item 206, WP 0470 00)
Gasket (item 111, WP 0470 00)
Gasket (item 78, WP 0470 00)

Equipment Condition

Parking brake set and wheels chocked
(TM 9-2320-361-10).
Battery ground cable disconnected
(WP 0126 00).

DELIVERY PUMP INLET TUBE REPLACEMENT (M49A2C) (Contd)**WARNING**

- Diesel fuel is flammable. Do not perform fuel system procedures near open flames. Injury or death to personnel may result.
- Accidental or intentional introduction of liquid contaminants into the environment is a violation of state, federal, and military regulations. Refer to Army POL (WP 0001 00) for information concerning storage, use, and disposal of these liquids. Failure to do so may result in damage to environment and health of personnel.

NOTE

Use a drain pan to capture any draining fuel. Dispose of fluids in accordance with local policy and ordinances. Ensure all spills are cleaned up.

REMOVAL

1. Loosen two clamps (5) on hose (6).
2. Remove four locknuts (11), screws (7), elbow (8), and gasket (9) from discharge manifold (10). Discard locknuts (11) and gasket (9).
3. Remove two clamps (5) and hose (6) from inlet tube (2) and elbow (8).
4. Remove four screws (4), lockwashers (3), inlet tube (2), and gasket (1) from delivery pump (12). Discard lockwashers (3) and gasket (1).

INSTALLATION

1. Install new gasket (1) and inlet tube (2) on delivery pump (12) with four screws (4) and new lockwashers (3).
2. Install hose (6) and two clamps (5) on inlet tube (2) and elbow (8). Do not tighten clamps (5).
3. Install new gasket (9) and elbow (8) on discharge manifold (10) with four screws (7) and new locknuts (11). Tighten clamps (5).
4. Connect battery ground cable (WP 0126 00).
5. Release parking brake and remove wheel chocks (TM 9-2320-361-10).

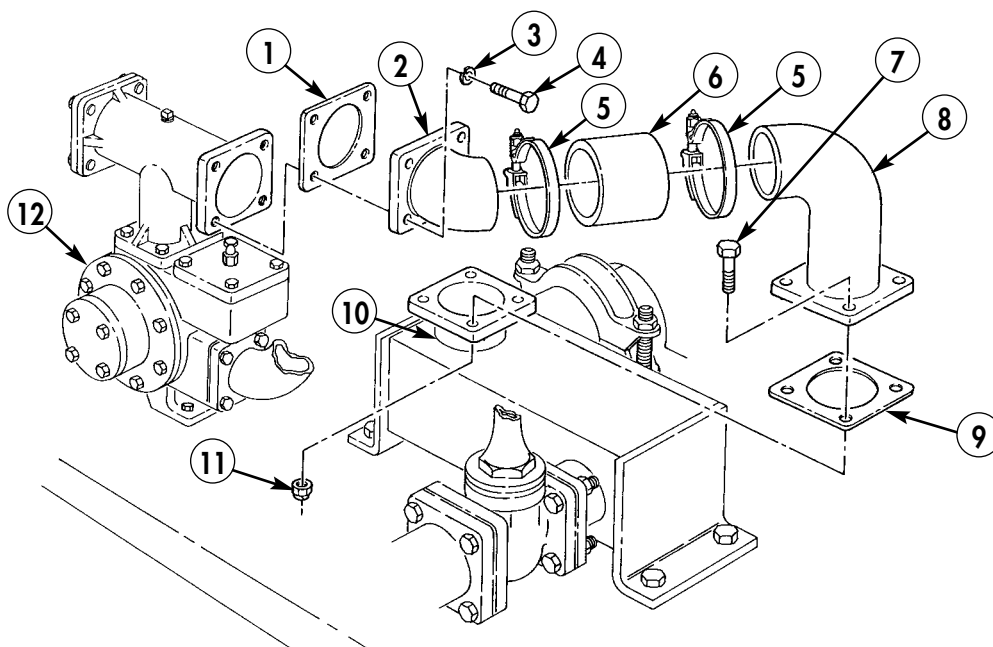
**END OF WORK PACKAGE**

FIELD MAINTENANCE INSTRUCTIONS

2-1/2 TON, 6X6, M44A2 SERIES TRUCKS (MULTIFUEL)

WATER PUMP MANIFOLD REPLACEMENT (M50A3)

REMOVAL AND INSTALLATION

INITIAL SETUP:

Applicable Models

M50A3

Materials/Parts

Four locknuts (item 129, WP 0470 00)

Four locknuts (item 147, WP 0470 00)

Gasket (item 100, WP 0470 00)

Gasket (item 111, WP 0470 00)

Gasket (item 51, WP 0470 00)

Equipment Condition

Parking brake set and wheels chocked
(TM 9-2320-361-10).

Battery ground cable disconnected
(WP 0126 00).

WATER PUMP MANIFOLD REPLACEMENT (M50A3) (Contd)

REMOVAL

1. Remove two nuts (19), screws (16), coupling (17), and gasket (18) from elbow (1) and manifold (11). Discard gasket (18).
2. Remove two nuts (5), screws (3), coupling (2), and gasket (10) from discharge tube (4) and manifold (11). Discard gasket (10).
3. Remove four locknuts (9), screws (14), gasket (13), and gate valve (15) from manifold flange (12). Discard gasket (13) and locknuts (9).
4. Remove four locknuts (7), screws (8), and manifold (11) from compartment (6). Discard locknuts (7).

INSTALLATION

1. Install manifold (11) on compartment (6) with four screws (8) and new locknuts (7).
2. Install new gasket (13) and gate valve (15) on manifold flange (12) with four screws (14) and new locknuts (9).
3. Install manifold (11) on discharge tube (4) with new gasket (10), coupling (2), two screws (3), and nut (5).
4. Install new gasket (18) and elbow (1) on manifold (11) with coupling (17), two screws (16), and nuts (19).
5. Connect battery ground cable (WP 0126 00).
6. Release parking brake and remove wheel chocks (TM 9-2320-361-10).

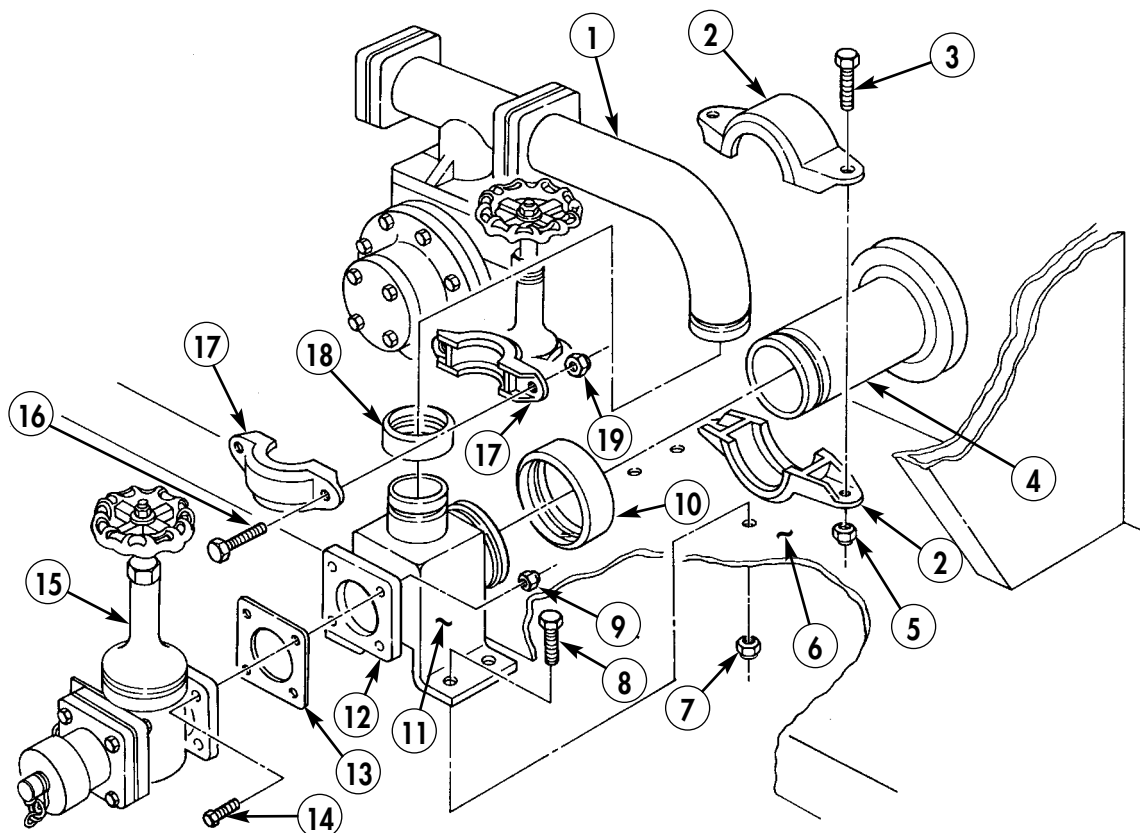

END OF WORK PACKAGE

FIELD MAINTENANCE INSTRUCTIONS

2-1/2 TON, 6X6, M44A2 SERIES TRUCKS (MULTIFUEL)

DELIVERY PUMP REPLACEMENT

REMOVAL AND INSTALLATION

INITIAL SETUP:

Applicable Models

M49A2C, M50A3

Materials/Parts

Four locknuts (item 129, WP 0470 00)

Woodruff key (item 385, WP 0470 00)

References

WP 0020 00

Equipment Condition

Parking brake set and wheels chocked
(TM 9-2320-361-10).

Battery ground cable disconnected
(WP 0126 00).

Delivery pump drain valve removed
(WP 0281 00).

Delivery pump inlet tube (WP 0278 00).

Delivery pump outlet tube removed
(WP 0277 00).

DELIVERY PUMP REPLACEMENT (Contd)**WARNING**

- Diesel fuel is flammable. Do not perform fuel system procedures near open flames. Injury or death to personnel may result.
- Accidental or intentional introduction of liquid contaminants into the environment is a violation of state, federal, and military regulations. Refer to Army POL (WP 0001 00) for information concerning storage, use, and disposal of these liquids. Failure to do so may result in damage to environment and health of personnel.

NOTE

Use a drain pan to capture any draining fuel. Dispose of fluids in accordance with local policy and ordinances. Ensure all spills are cleaned up.

REMOVAL

1. Remove setscrew (1) from delivery pump rear propeller shaft (8) and delivery pump shaft (5).
2. Remove four locknuts (6), screws (3), and delivery pump (2) from compartment shelf (4). Discard locknuts (6).
3. Remove woodruff key (7) from delivery pump shaft (5). Discard woodruff key (7).

INSTALLATION

1. Install new woodruff key (7) in delivery pump shaft (5).
2. Position delivery pump (2) on compartment (4).
3. Install delivery pump rear propeller shaft (8) on delivery pump shaft (5) with setscrew (1).
4. Install delivery pump (2) on compartment shelf (4) with four screws (3) and new locknuts (6).
5. Install delivery pump outlet tube (WP 0277 00).
6. Install delivery pump inlet tube (WP 0278 00).
7. Install delivery pump drain valve (WP 0281 00).
8. Lubricate pump and shaft (WP 0020 00).
9. Connect battery ground cable (WP 0126 00).
10. Release parking brake and remove wheel chocks (TM 9-2320-361-10).

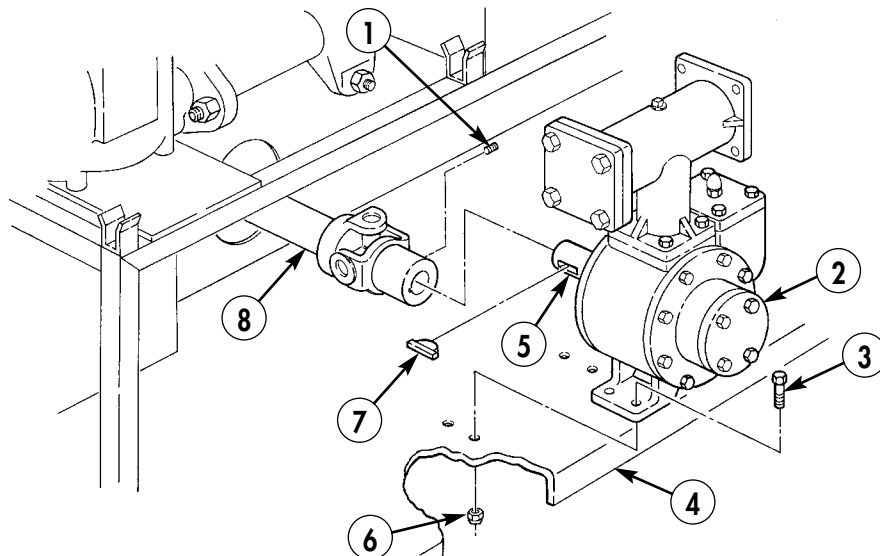
**END OF WORK PACKAGE**

FIELD MAINTENANCE INSTRUCTIONS

2-1/2 TON, 6X6, M44A2 SERIES TRUCKS (MULTIFUEL)

DELIVERY PUMP DRAIN VALVE REPLACEMENT REMOVAL AND INSTALLATION

INITIAL SETUP:

Applicable Models

M49A2C, M50A3

Materials/Parts

Drain valve (M49A2C)
(item 371, WP 0470 00)

Equipment Condition

Parking brake set and wheels chocked
(TM 9-2320-361-10).

Battery ground cable disconnected
(WP 0126 00).

DELIVERY PUMP DRAIN VALVE REPLACEMENT (Contd)

WARNING

- Diesel fuel is flammable. Do not perform fuel system procedures near open flames. Injury or death to personnel may result.
- Accidental or intentional introduction of liquid contaminants into the environment is a violation of state, federal, and military regulations. Refer to Army POL (WP 0001 00) for information concerning storage, use, and disposal of these liquids. Failure to do so may result in damage to environment and health of personnel.

NOTE

Use a drain pan to capture any draining fuel. Dispose of fluids in accordance with local policy and ordinances. Ensure all spills are cleaned up.

REMOVAL

1. Remove drain valve (2) and rubber seal (3) from pump adapter (4). Discard rubber seal (3).
2. Remove pump adapter (4) from drain pipe (1).

INSTALLATION

1. Install pump adapter (4) on pump drain pipe (1).
2. Install new rubber seal (3) and drain valve (2) on pump adapter (4).
3. Connect battery ground cable (WP 0126 00).
4. Release parking brake and remove wheel chocks (TM 9-2320-361-10).

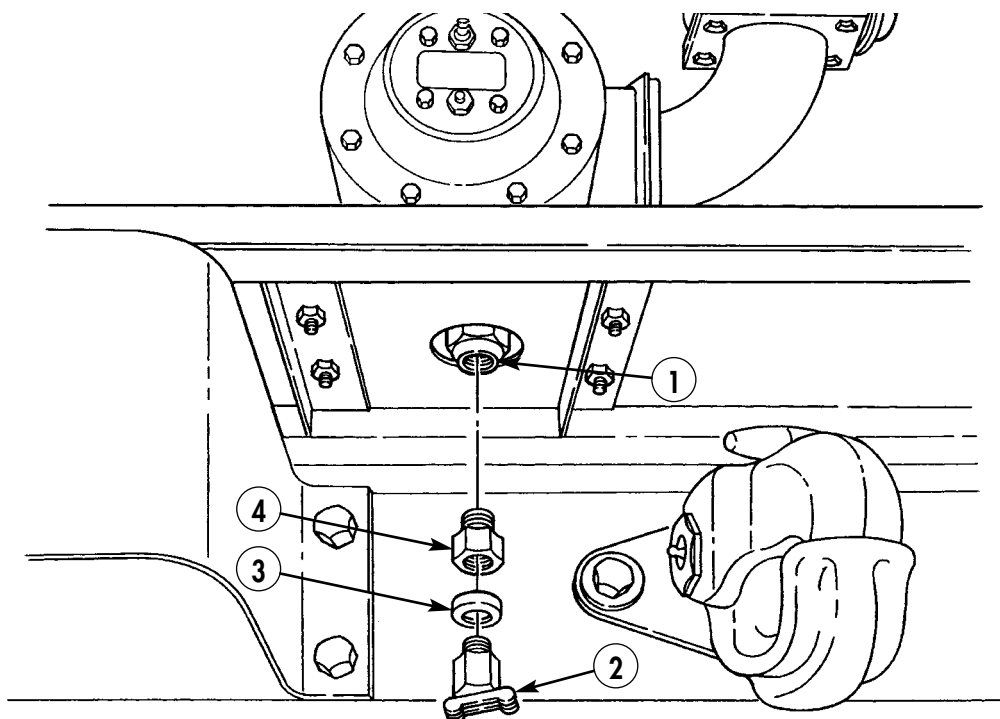

END OF WORK PACKAGE

FIELD MAINTENANCE INSTRUCTIONS

2-1/2 TON, 6X6, M44A2 SERIES TRUCKS (MULTIFUEL)

METER OUTLET TUBE REPLACEMENT (M49A2C)

REMOVAL AND INSTALLATION

INITIAL SETUP:

Applicable Models

M49A2C

Materials/Parts

Four locknuts (item 145, WP 0470 00)

Two locknuts (item 132, WP 0470 00)

Gasket (item 102, WP 0470 00)

Gasket (item 103, WP 0470 00)

Equipment Condition

Parking brake set and wheels chocked
(TM 9-2320-361-10).

Battery ground cable disconnected
(WP 0126 00).

Fuel hose and nozzle removed (WP 0269 00).

METER OUTLET TUBE REPLACEMENT (M49A2C) (Contd)

WARNING

- Diesel fuel is flammable. Do not perform fuel system procedures near open flames. Injury or death to personnel may result.
- Accidental or intentional introduction of liquid contaminants into the environment is a violation of state, federal, and military regulations. Refer to Army POL (WP 0001 00) for information concerning storage, use, and disposal of these liquids. Failure to do so may result in damage to environment and health of personnel.

NOTE

Use a drain pan to capture any draining fuel. Dispose of fluids in accordance with local policy and ordinances. Ensure all spills are cleaned up.

REMOVAL

1. Remove two locknuts (6), screws (8), and gasket (7) from outlet tube (13) and meter (5). Discard locknuts (6) and gasket (7).
2. Remove two nuts (15), screws (2), coupling (3), and gasket (14), from meter outlet tube (13) and fuel hose tube (1). Discard gasket (14).
3. Remove four locknuts (9), screws (12), plate (11), and grommet (10) from tank body (4). Discard locknuts (9).
4. Remove meter outlet tube (13) from tank body (4).

INSTALLATION

1. Install grommet (10) and plate (11) on tank body (4) with four screws (12) and new locknuts (9).
2. Install meter outlet tube (13) through hole in tank body (4).
3. Install new gasket (14) and coupling (3) on meter outlet tube (13) and fuel hose tube (1) with two screws (2) and nuts (15).
4. Install meter outlet tube (13) and new gasket (7) on meter (5) with two screws (8) and new locknuts (6).
5. Install fuel hose and nozzle (WP 0269 00).
6. Connect battery ground cable (WP 0126 00).
7. Release parking brake and remove wheel chocks (TM 9-2320-361-10).

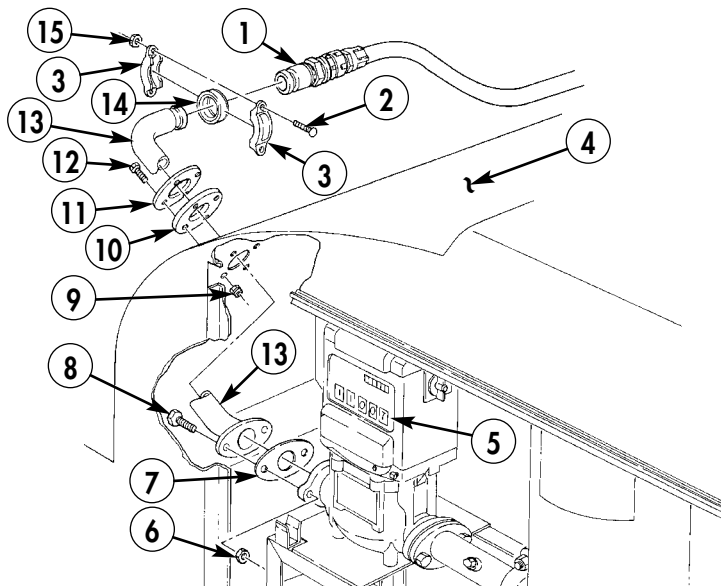

END OF WORK PACKAGE

FIELD MAINTENANCE INSTRUCTIONS

2-1/2 TON, 6X6, M44A2 SERIES TRUCKS (MULTIFUEL)

GATE VALVE REPLACEMENT

REMOVAL AND INSTALLATION

INITIAL SETUP:

Applicable Models

M49A2C, M50A3

Materials/Parts

Eight locknuts (item 147, WP 0470 00)

Two gaskets (item 111, WP 0470 00)

Equipment Condition

Parking brake set and wheels chocked
(TM 9-2320-361-10).

Battery ground cable disconnected
(WP 0126 00).

GATE VALVE REPLACEMENT (Contd)

WARNING

- Diesel fuel is flammable. Do not perform fuel system procedures near open flames. Injury or death to personnel may result.
- Accidental or intentional introduction of liquid contaminants into the environment is a violation of state, federal, and military regulations. Refer to Army POL (WP 0001 00) for information concerning storage, use, and disposal of these liquids. Failure to do so may result in damage to environment and health of personnel.

NOTE

- Use a drain pan to capture any draining fuel. Dispose of fluids in accordance with local policy and ordinances. Ensure all spills are cleaned up.
- Both gate valves are removed the same way.

REMOVAL

1. Remove four locknuts (9), screws (7), cover (6), and gasket (8) from gate valve (1). Discard locknuts (9) and gasket (8). Remove gasket remains from mating surfaces.
2. Remove four locknuts (2), screws (5), valve (1), and gasket (4) from manifold flange (3). Discard locknuts (2) and gasket (4). Remove gasket remains from mating surfaces.

INSTALLATION

1. Install new gasket (4) and valve (1) on manifold flange (3) with four screws (5) and new locknuts (2).
2. Install new gasket (8) and cover (6) on valve (1) with four screws (7) and new locknuts (9).
3. Connect battery ground cable (WP 0126 00).
4. Release parking brake and remove wheel chocks (TM 9-2320-361-10).

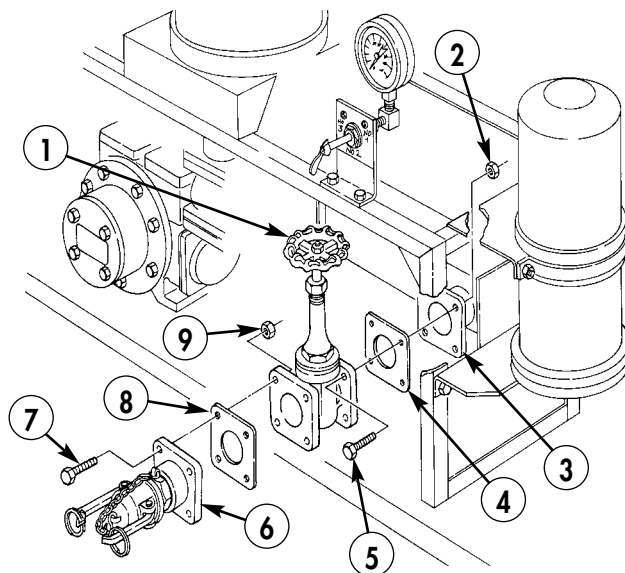

END OF WORK PACKAGE

FIELD MAINTENANCE INSTRUCTIONS

2-1/2 TON, 6X6, M44A2 SERIES TRUCKS (MULTIFUEL)

DELIVERY PUMP STRAINER REPLACEMENT

REMOVAL AND INSTALLATION

INITIAL SETUP:

Applicable Models

M49A2C, M50A3

Materials/Parts

Four lockwashers (item 232, WP 0470 00)

Gasket (item 78, WP 0470 00)

Equipment Condition

Parking brake set and wheels chocked
(TM 9-2320-361-10).

Battery ground cable disconnected
(WP 0126 00).

WARNING

Diesel fuel is flammable. Do not perform fuel system procedures near open flames. Injury or death to personnel may result.

REMOVAL

Remove four screws (1), lockwashers (2), cover (6), gasket (5), and strainer (4) from strainer body (3). Discard lockwashers (2) and gasket (5).

INSTALLATION

1. Install strainer (4), new gasket (5) and cover (6) on strainer body (3) with four new lockwashers (2) and screws (1).
2. Connect battery ground cable (WP 0126 00).
3. Release parking brake and remove wheel chocks (TM 9-2320-361-10).

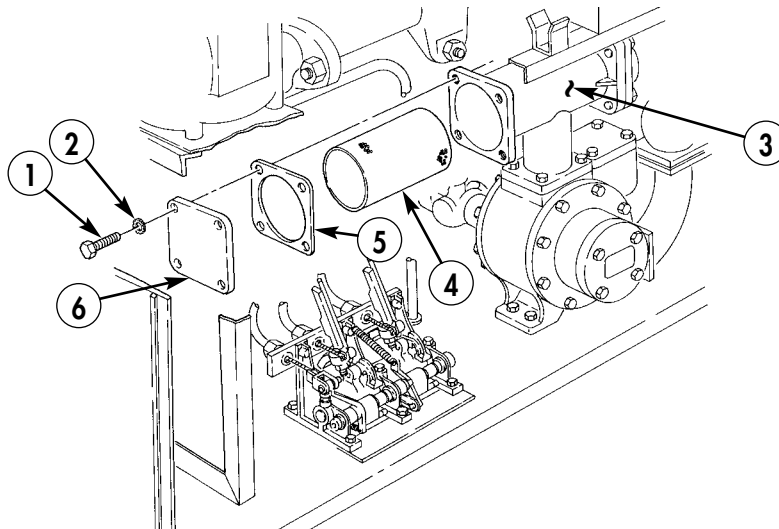

END OF WORK PACKAGE

0284 00-1/2 blank

FIELD MAINTENANCE INSTRUCTIONS

2-1/2 TON, 6X6, M44A2 SERIES TRUCKS (MULTIFUEL)

SEPARATOR ELEMENT TEST VALVE, GAUGE, AND LINES MAINTENANCE (M49A2C) REMOVAL, INSPECTION, AND INSTALLATION

INITIAL SETUP:

Applicable Models

M49A2C

Materials/Parts

Two locknuts (item 129, WP 0470 00)

Two locknuts (item 145, WP 0470 00)

Antiseize tape (item 42, WP 0468 00)

Equipment Condition

Parking brake set and wheels chocked
(TM 9-2320-361-10).

Battery ground cable disconnected
(WP 0126 00).

Filter separator drained (TM 9-2320-361-10).

SEPARATOR ELEMENT TEST VALVE, GAUGE, AND LINES MAINTENANCE (M49A2C) (Contd)**WARNING**

Diesel fuel is flammable. Do not perform fuel system procedures near open flames. Injury or death to personnel may result.

REMOVAL

1. Remove two tubes (14), line (15), five adapters (3), and elbow (11) from filter separator (1) and selector valve (9).
2. Remove two locknuts (10), screws (6), instruction plate (7), and selector valve (9) from bracket (8). Discard locknuts (10).
3. Remove two locknuts (16), screws (5), and bracket (8) from shelf (2). Discard locknuts (16).
4. Remove gauge (12) from elbow (13) and elbow (13) from selector valve (9).

INSPECTION

Clean and inspect fittings (4) for cracks or stripped threads. Replace fittings (4) if threads are cracked or stripped.

INSTALLATION**NOTE**

Male pipe threads must be wrapped with antiseize tape before installation.

1. Install elbow (13) on selector valve (9).
2. Install gauge (12) on elbow (13).
3. Install bracket (8) on shelf (2) with two screws (5) and new locknuts (16).
4. Install selector valve (9) and instruction plate (7) on bracket (8) with two screws (6) and new locknuts (10).
5. Install elbow (11), five adapters (3), line (15), and two tubes (14) on filter separator (1) and selector valve (9).
6. Fill filter separator (TM 9-2320-361-10).
7. Connect battery ground cable (WP 0126 00).
8. Release parking brake and remove wheel chocks (TM 9-2320-361-10).

SEPARATOR ELEMENT TEST VALVE, GAUGE, AND LINES MAINTENANCE (M49A2C) (Contd)

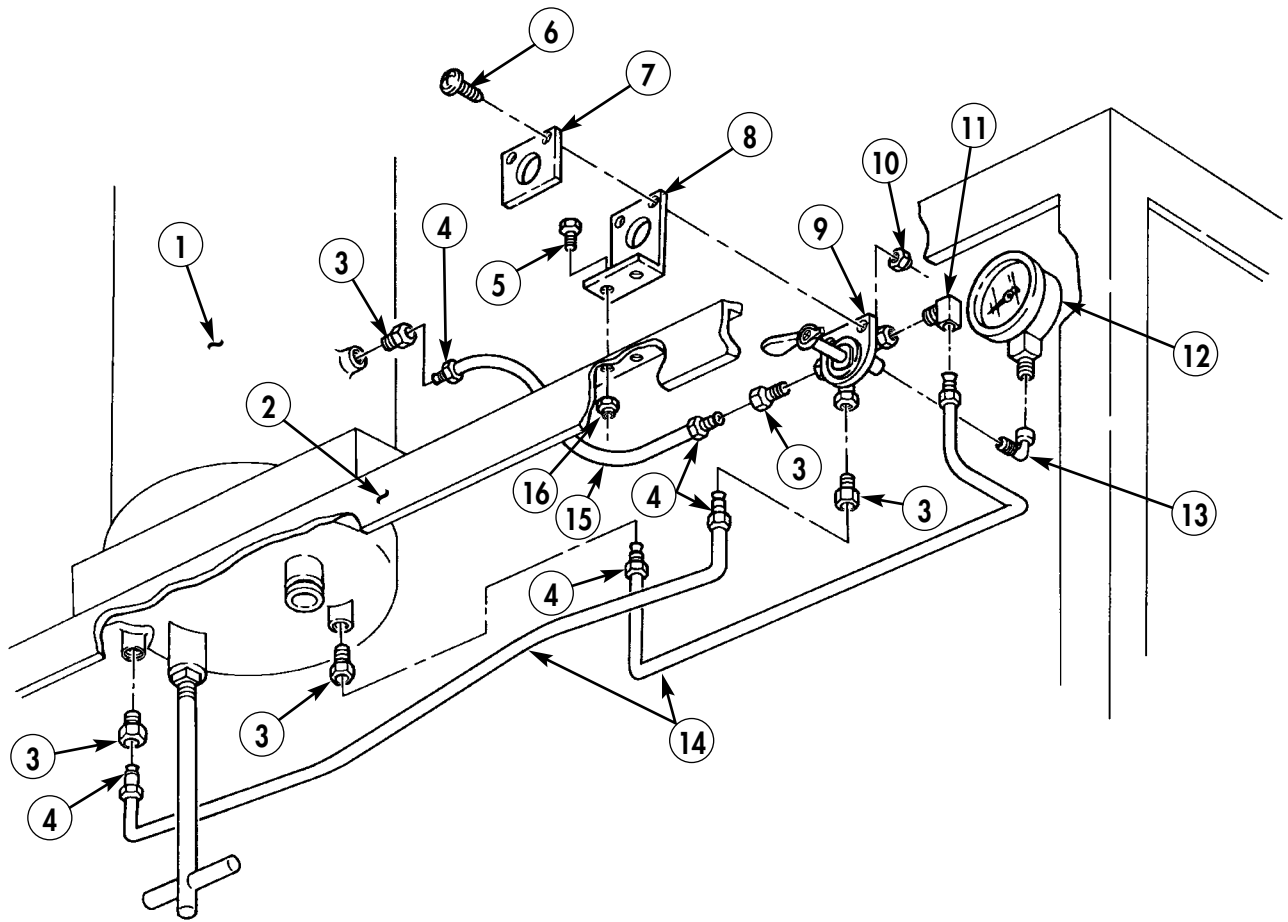

END OF WORK PACKAGE

FIELD MAINTENANCE INSTRUCTIONS

2-1/2 TON, 6X6, M44A2 SERIES TRUCKS (MULTIFUEL)

FILTER SEPARATOR MAINTENANCE (M49A2C)

REMOVAL, DISASSEMBLY, CLEANING AND INSPECTION, ASSEMBLY, AND INSTALLATION

INITIAL SETUP:

Applicable Models

M49A2C

Personnel Required

Two

Materials/Parts

Four locknuts (item 129, WP 0470 00)
Three filter elements (item 40, WP 0470 00)
Three filter elements (item 41, WP 0470 00)
Cotter pin (item 25, WP 0470 00)
Gasket (item 103, WP 0470 00)
Gasket (item 62, WP 0470 00)
Antiseize tape (item 42, WP 0468 00)
Skysol 100 (item 13, WP 0468 00)

Equipment Condition

Parking brake set and wheels chocked
(TM 9-2320-361-10).
Battery ground cable disconnected
(WP 0126 00).
Meter-to-filter tube removed (WP 0275 00).
Separator element test valve, gauge, and lines
removed (WP 0285 00).

FILTER SEPARATOR MAINTENANCE (M49A2C) (Contd)

WARNING

- Diesel fuel is flammable. Do not perform fuel system procedures near open flames. Injury or death to personnel may result.
- Accidental or intentional introduction of liquid contaminants into the environment is a violation of state, federal, and military regulations. Refer to Army POL (WP 0001 00) for information concerning storage, use, and disposal of these liquids. Failure to do so may result in damage to environment and health of personnel.

NOTE

Use a drain pan to capture any draining fuel. Dispose of fluids in accordance with local policy and ordinances. Ensure all spills are cleaned up.

REMOVAL

1. Remove two nuts (19), screws (21), and coupling halves (18) from gasket (16) and filter separator (11).
2. Disconnect nipple (2) and air eliminator hose (1) from cover (3).

NOTE

Assistant will help with step 3.

3. Remove four locknuts (17), screws (12), filter separator (11), and gasket (16) from separator pipe (20) and shelf (13). Discard locknuts (17) and gasket (16).

DISASSEMBLY

1. Remove nut (24), coupling clamp (25), cover (3), and gasket (23) from filter separator (11). Discard gasket (23).
2. Remove cotter pin (27) and vent valve (26) from cover (3). Discard cotter pin (27).
3. Remove six nuts (4), three washers (5), and plate (6) from filter separator (11).
4. Remove three nuts (7), screws (10), and washers (9) from filter separator brackets (8).
5. Remove three canisters (14) and filter elements (15) and (22) from filter separator (11). Discard filter elements (15) and (22).

CLEANING AND INSPECTION

WARNING

Skysol 100 solvent is combustible; DO NOT use or store near heat, sparks, flame, or other ignition sources. Use mechanical ventilation whenever product is used in a confined space, heated above ambient temperatures, or agitated. Keep container sealed when not in use.

Contact with Skysol 100 may cause skin irritation. Use chemical-resistant gloves. In case of skin contact, remove any contaminated clothing and wash skin thoroughly with soap and water. Wash contaminated clothing before reuse. Eye contact may cause irritation, tearing, or blurring of vision. Use face shield or goggles when eye contact may occur. In case of eye contact, flush eyes with large amounts of water for at least 15 minutes or until irritation subsides. Inhalation may cause irritation to upper respiratory passages. DO NOT have food or drink in the vicinity. Failure to comply may result in injury to personnel.

1. Clean canisters (14) and inside of filter separator (11) with Skysol 100 solvent.
2. Inspect canisters (14) for cracks. Replace canisters (14) if cracked.

FILTER SEPARATOR MAINTENANCE (M49A2C) (Contd)

ASSEMBLY

1. Install three new filter elements (15), three new filter elements (22), and canisters (14) on filter separator (11).
2. Install three screws (10), washers (9), and nuts (7) on filter separator brackets (8).
3. Install plate (6) on filter separator (11) with three washers (5) and six nuts (4).
4. Install valve (26) on cover (3) with new cotter pin (27).
5. Install new gasket (23) and cover (3) on filter separator (11) with coupling clamp (25) and nut (24).

INSTALLATION

NOTE

Male pipe threads must be wrapped with antiseize tape before installation.

1. Install new gasket (16) on separator pipe (20).
2. Install filter separator (11) on shelf (13) and separator pipe (20) with four screws (12) and new locknuts (17).
3. Install coupling (18) on gasket (16), filter separator (11), and separator pipe (20) with two screws (21) and nuts (19).
4. Connect air eliminator hose (1) and nipple (2) to cover (3).
5. Install filter separator element test valve, gauge, and lines (WP 0285 00).
6. Install meter-to-filter tube (WP 0275 00).
7. Connect battery ground cable (WP 0126 00).
8. Release parking brake and remove wheel chocks (TM 9-2320-361-10).

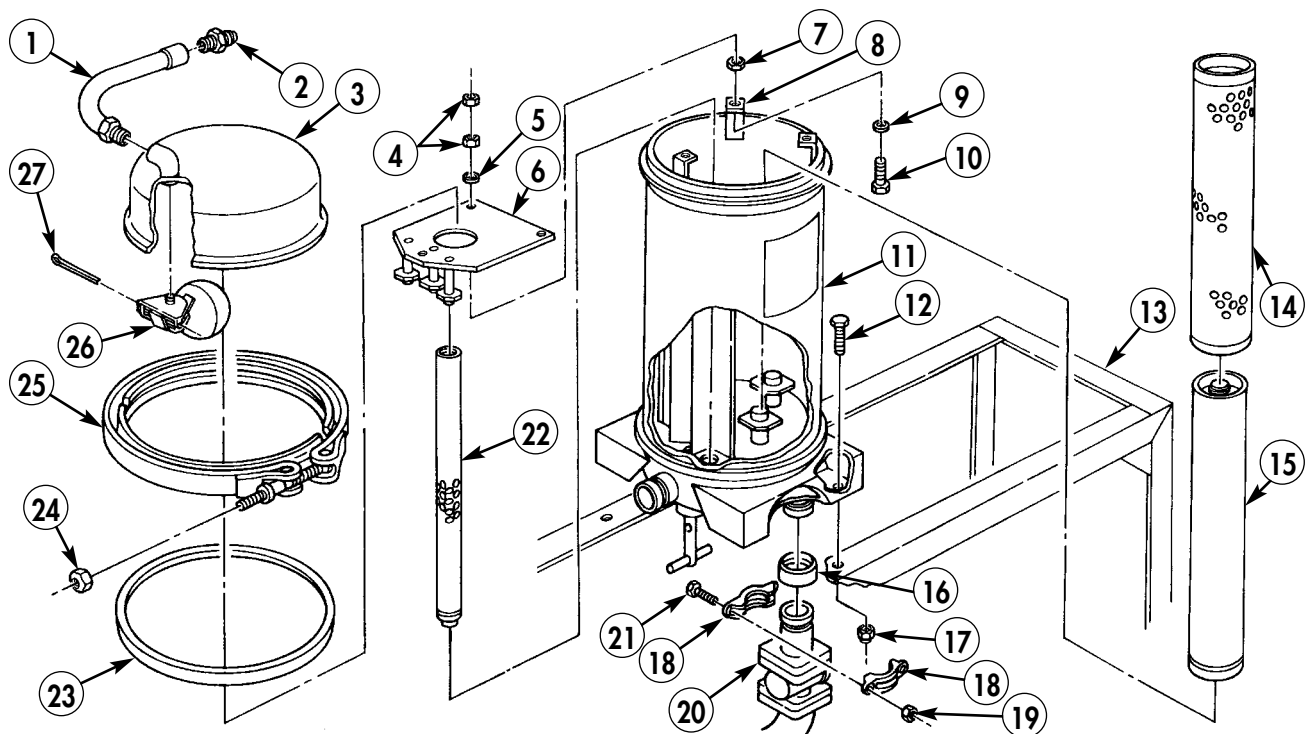

END OF WORK PACKAGE

FIELD MAINTENANCE INSTRUCTIONS

2-1/2 TON, 6X6, M44A2 SERIES TRUCKS (MULTIFUEL)

WATER TANK FILLER COVER REPLACEMENT (M50A3)

REMOVAL AND INSTALLATION

INITIAL SETUP:

Applicable Models

M50A3

Materials/Parts

Four locknuts (item 436, WP 0470 00)

Gasket (item 93, WP 0470 00)

Equipment Condition

Parking brake set and wheels chocked
(TM 9-2320-361-10).

Battery ground cable disconnected
(WP 0126 00).

WATER TANK FILLER COVER REPLACEMENT (M50A3) (Contd)

REMOVAL

1. Remove padlock (7) and open clamps (5) on filler cover (1).
2. Remove filler cover (1) and gasket (2) from tank body (6). Discard gasket (2). Remove gasket remains from mating surfaces.
3. Remove screen (3) from strainer (4).
4. Remove four locknuts (8) and strainer (4) from tank body (6).

INSTALLATION

1. Install strainer (4) on tank body (6) with four new locknuts (8).
2. Install screen (3) on strainer (4).
3. Install new gasket (2) and filler cover (1) on tank body (4).
4. Close clamps (3) and secure with padlock (5).
5. Connect battery ground cable (WP 0126 00).
6. Release parking brake and remove wheel chocks (TM 9-2320-361-10).

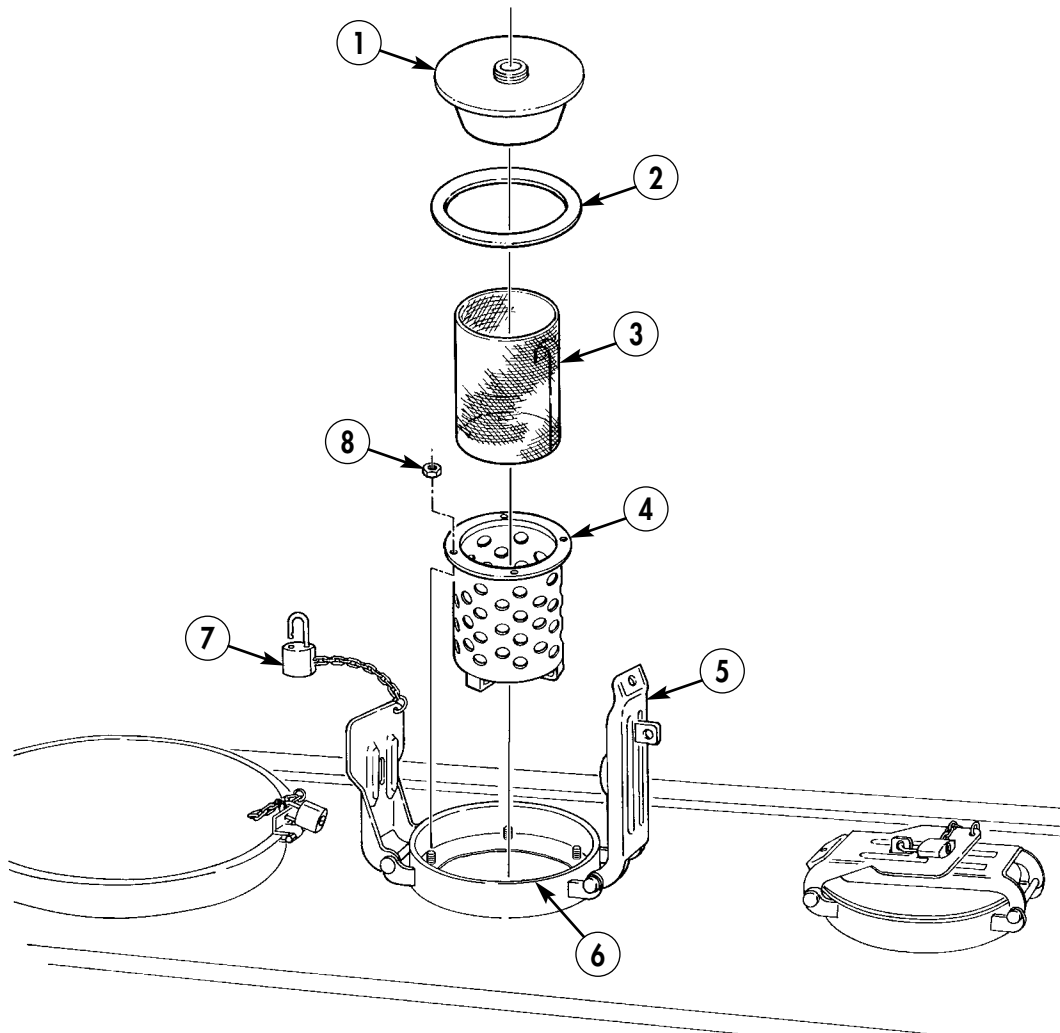

END OF WORK PACKAGE

FIELD MAINTENANCE INSTRUCTIONS

2-1/2 TON, 6X6, M44A2 SERIES TRUCKS (MULTIFUEL)

REAR COMPARTMENT DOOR MAINTENANCE

DOOR REMOVAL, ARM AND STOP REMOVAL, LOCK REMOVAL, CLEANING AND INSPECTION,
DOOR REPAIR, LOCK INSTALLATION, ARM AND STOP INSTALLATION, AND DOOR INSTALLATION

INITIAL SETUP:

Applicable Models

M49A2C, M50A3

Materials/Parts

Ten locknuts (item 145, WP 0470 00)
Seven locknuts (item 144, WP 0470 00)
Four rivets (item 437, WP 0470 00)

Personnel Required

Two

References

TC 9-237
TC 9-510
TM 43-0139
WP 0021 00
WP 0245 00
WP 0233 00
TB 43-0209

Equipment Condition

Parking brake set and wheels chocked
(TM 9-2320-361-10).
Battery ground cable disconnected
(WP 0126 00).

REAR COMPARTMENT DOOR MAINTENANCE (Contd)

WARNING

Diesel fuel is flammable. Do not perform fuel system procedures near open flames. Injury or death to personnel may result.

DOOR REMOVAL

1. Remove three locknuts (4), screws (16), and arm and stop (2) from door (3). Discard locknuts (4).

NOTE

Assistant will help with step 2.

2. Remove ten locknuts (5), screws (6), and door (3) from tank body (1). Discard locknuts (5).

ARM AND STOP REMOVAL

1. Remove two screws (17), and remove arm and stop (2) from tank body (1).
2. Remove three locknuts (4), screws (16), and arm and stop (2) from door (3). Discard locknuts (4).

LOCK REMOVAL

1. Remove four locknuts (11), screws (9), two straps (8), spacers (7), and lock pins (10) from door (3) and lock (13). Discard locknuts (11)
2. Remove four rivets (12) and lock (13) from door (3). Discard rivets (12).

CLEANING AND INSPECTION

1. Refer to WP 0021 00 for general cleaning instructions.
2. Inspect compartment door(s) (3) for dents, rust, or damage. Replace compartment door(s) (3) if dented, extensively rusted, or damaged.

DOOR REPAIR

1. Remove instruction plates (WP 0245 00) from area(s) to be painted/repaired.
2. Remove paint or rust from area to be repaired (TM 43-0139).
3. Repair compartment door(s) (3) (TC 9-237 and TC 9-510).
4. Paint compartment door(s) (3) as required (TB 43-0209).
5. Install instruction plates (WP 0245 00).

LOCK INSTALLATION

1. Install lock (13) on door (3) with four new rivets (12).
2. Install two lock pins (10) on lock (13) and door (3) with two screws (9), straps (8), spacers (7), and four new locknuts (11).

ARM AND STOP INSTALLATION

1. Install arm and stop (2) on door (3) with three screws (16), new locknuts (4).
2. Install arm and stop (2) on tank body (1), with two screws (17).

DOOR INSTALLATION

1. Install door (3) on tank body (1) with ten screws (6) and locknuts (5).

NOTE

Assistant will help with step 2.

2. Install arm and stop (2) on door (3) with three screws (16) and locknuts (4).
3. Connect battery ground cable (WP 0126 00).
4. Release parking brake and remove wheel chocks (TM 9-2320-361-10).

REAR COMPARTMENT DOOR MAINTENANCE (Contd)

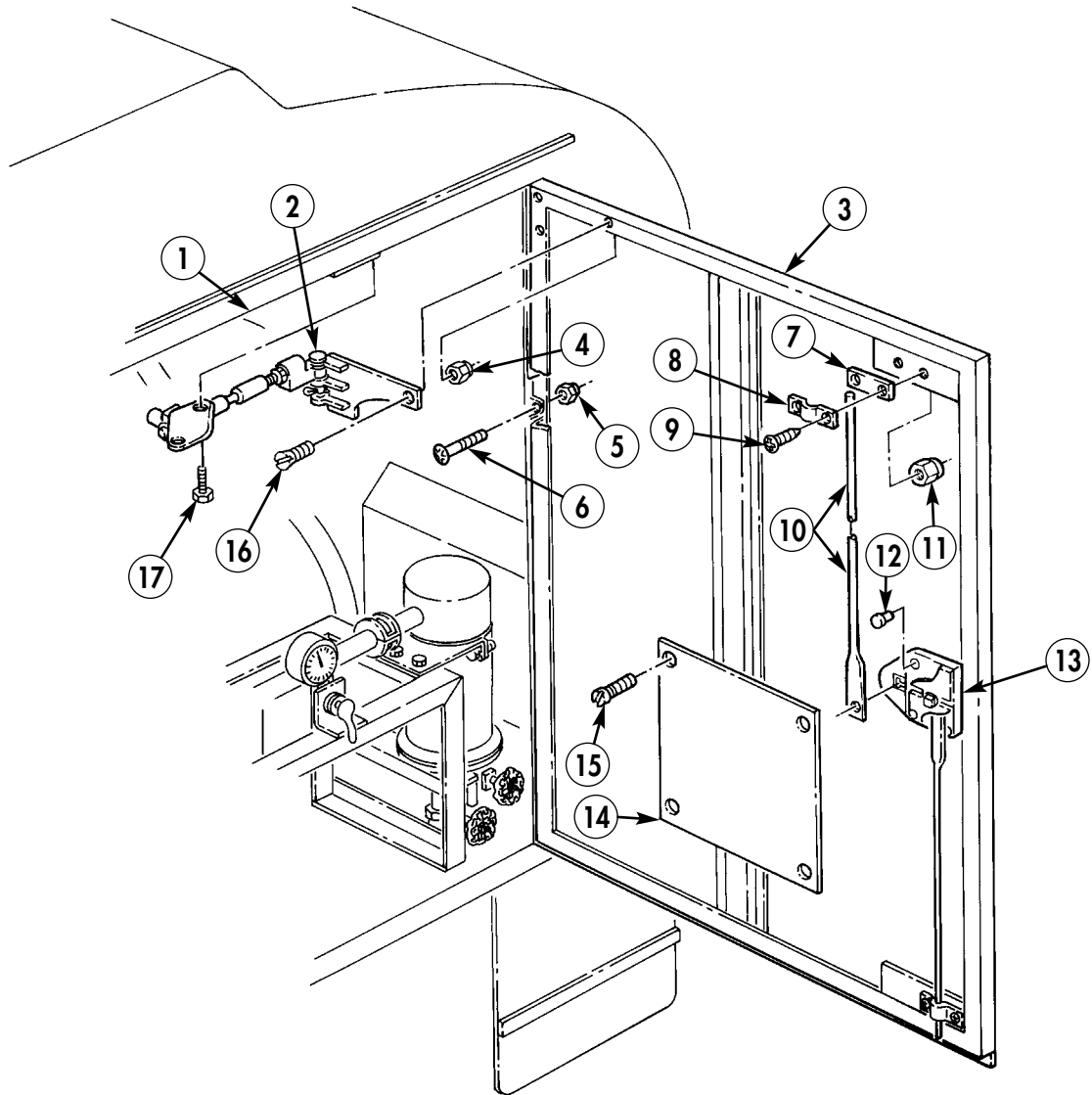

END OF WORK PACKAGE

FIELD MAINTENANCE INSTRUCTIONS

2-1/2 TON, 6X6, M44A2 SERIES TRUCKS (MULTIFUEL)

WATER TANK DISCHARGE TUBE, COVER, AND VALVE REPLACEMENT (M50A3)

DISCHARGE TUBE COVER REMOVAL, DISCHARGE TUBE REMOVAL, DISCHARGE VALVES REMOVAL, DISCHARGE VALVES INSTALLATION, DISCHARGE TUBE INSTALLATION, AND DISCHARGE TUBE COVER INSTALLATION

INITIAL SETUP:

Applicable Models

M50A3

Materials/Parts

Gasket (item 430, WP 0470 00)
Three gaskets (item 51, WP 0470 00)
Four locknuts (item 165, WP 0470 00)
Four locknuts (item 438, WP 0470 00)
Twelve locknuts (item 137, WP 0470 00)
Gasket (item 54, WP 0470 00)

Equipment Condition

Parking brake set and wheels chocked
(TM 9-2320-361-10).
Battery ground cable disconnected
(WP 0126 00).
Water tanks drained (TM 9-2320-361-10).

WATER TANK DISCHARGE TUBE, COVER, AND VALVE REPLACEMENT (M50A3) (Contd)

DISCHARGE TUBE COVER REMOVAL

1. Remove fifty-two screws (3) from discharge tube cover (2).
2. Slide discharge tube cover (2) left to access discharge valves (13) and discharge tube (23).

DISCHARGE TUBE REMOVAL

1. Remove four locknuts (16), two holders (15), U-bolts (14), and cables (17) and (26) from two discharge valves (13). Discard locknuts (16).
2. Remove two cables (17) and (26) from two guides (18) and (24).
3. Remove two nuts (10), screws (7), coupling (8) and gasket (9) from discharge tube (23). Discard gasket (9).
4. Remove four locknuts (4), screws (11), ring spacer (6), and gasket (5) from discharge tube (23). Discard gasket (5) and locknuts (4).
5. Remove four nuts (19), guides (18) and (24), four screws (22), two couplings (21), two gaskets (20), and discharge tube (23) from two discharge valves (13). Discard gaskets (20).

DISCHARGE VALVES REMOVAL

NOTE

Both discharge valves are replaced the same way.

Remove six locknuts (25), discharge valve (13), and gasket (12) from bottom of tank (1). Discard gasket (12) and locknuts (25).

DISCHARGE VALVES INSTALLATION

Install new gasket (12) and discharge valve (13) on bottom of tank (1) with six new locknuts (25).

DISCHARGE TUBE INSTALLATION

1. Install discharge tube (23) on two discharge valves (13) with two new gaskets (20), two couplings (21), four screws (22), and four nuts (19).
2. Install ring spacer (6) on discharge tube (23) with new gasket (5), four screws (11) and new locknuts (4).
3. Install new gasket (9) and coupling (8) on discharge tube (23) with two screws (7) and nuts (10).
4. Install two cables (17) and (26) through guides (18) and (24).
5. Install two cables (17) and (26) on two discharge valves (13) with two U-bolts (14), holders (15), and four new locknuts (16).

DISCHARGE TUBE COVER INSTALLATION

1. Slide discharge tube cover (2) right and cover discharge tube (23) and valves (13).
2. Install cover (2) with fifty-two screws (3).
3. Fill water tanks (TM 9-2320-361-10).
4. Connect battery ground cable (WP 0126 00).
5. Release parking brake and remove wheel chocks (TM 9-2320-361-10).

WATER TANK DISCHARGE TUBE, COVER, AND VALVE REPLACEMENT (M50A3) (Contd)

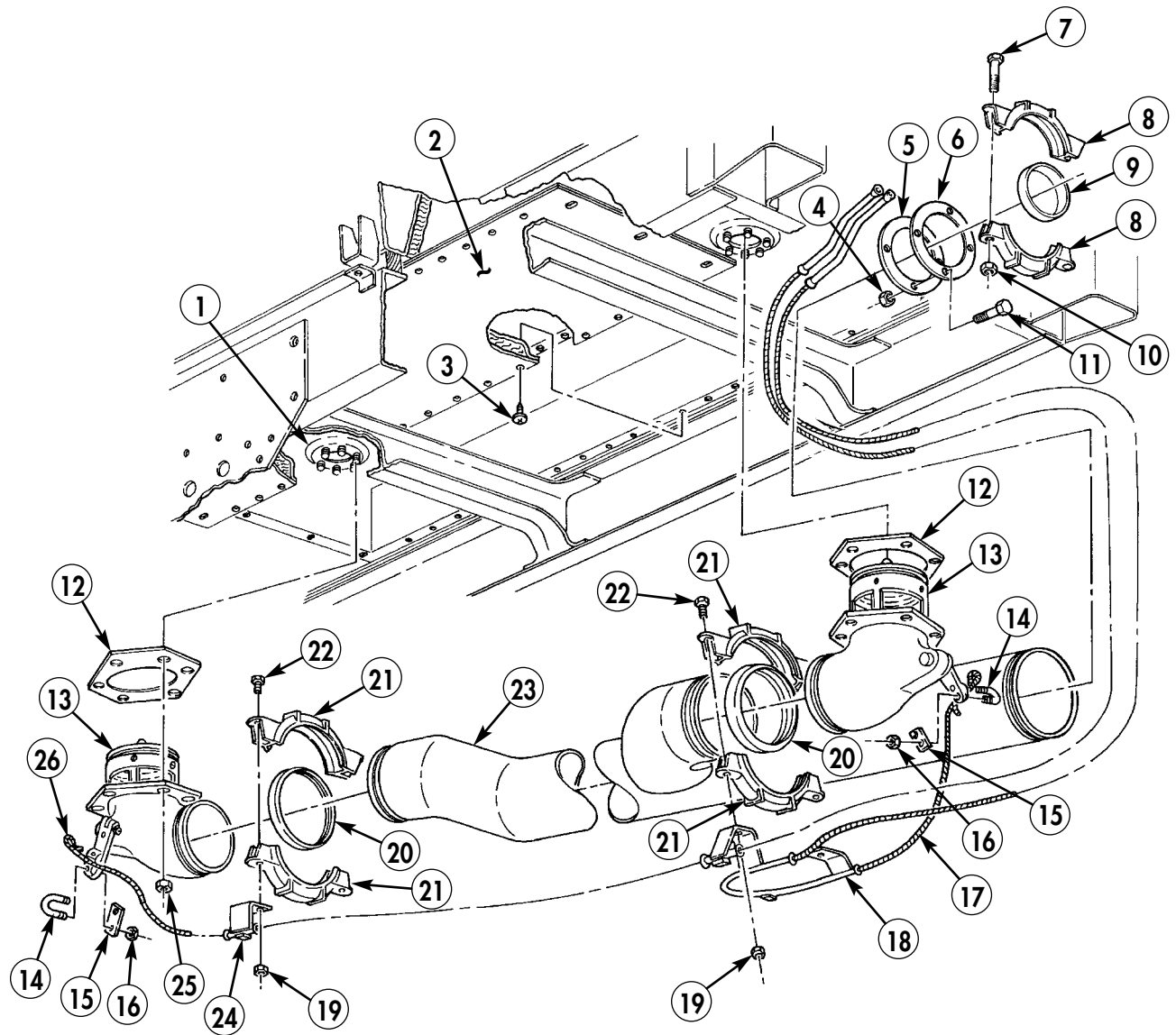

END OF WORK PACKAGE

FIELD MAINTENANCE INSTRUCTIONS

2-1/2 TON, 6X6, M44A2 SERIES TRUCKS (MULTIFUEL)

WATER TANK DISCHARGE VALVE CONTROL LEVERS MAINTENANCE (M50A3)

REMOVAL, CONTROL LEVERS DISASSEMBLY, LEVER DISASSEMBLY, CLEANING AND INSPECTION,
LEVER ASSEMBLY, CONTROL LEVERS ASSEMBLY, INSTALLATION, AND ADJUSTMENT

INITIAL SETUP:

Applicable Models

M50A3

References

WP 0021 00

Materials/Parts

Six locknuts (item 145, WP 0470 00)
Three lockwashers (item 195, WP 0470 00)
Three lockwashers (item 229, WP 0470 00)

Equipment Condition

Parking brake set and wheels chocked
(TM 9-2320-361-10).
Battery ground cable disconnected
(WP 0126 00).

WARNING

Wear leather gloves when handling cable. Do not let cable run through hands. Broken or rusty wires can cause injury to personnel.

REMOVAL

1. Unscrew two coupling nuts (5) from adapters (6) and slide back on tubes (4).
2. Unscrew two adapters (6) from spacer bar (8).
3. Remove two nuts (11) and screws (9) from discharge valve control levers (10), and pull cables (7) out of screws (9), spacer bar (8), and two adapters (6).
4. Remove six locknuts (12), screws (1), and discharge valve control assembly (3) from shelf (2). Discard locknuts (12).

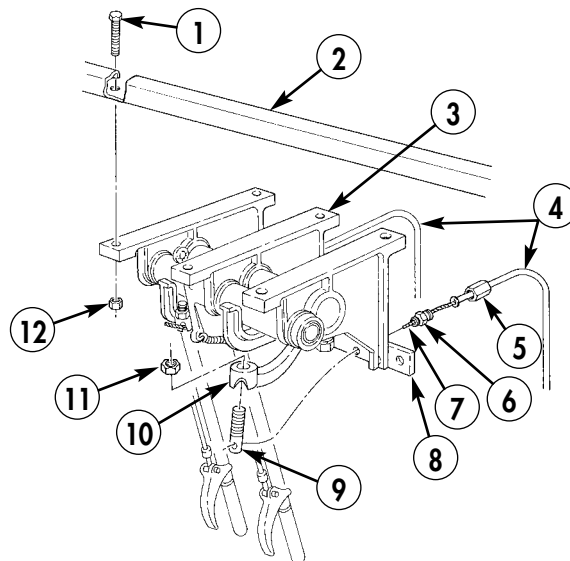

WATER TANK DISCHARGE VALVE CONTROL LEVERS MAINTENANCE (M50A3) (Contd)

CONTROL LEVERS DISASSEMBLY

CAUTION

Do not strike levers or brackets during lever shaft removal. Striking levers or brackets may result in damage to components.

1. Remove three screws (14) and lockwashers (15) from brackets (16), (20), and (24). Discard lockwashers (15).

NOTE

Prior to removal, tag all component locations for assembly.

2. Remove lever shaft (21) from bracket (24), lever (25), bracket (20), lever (5), and bracket (16). Remove levers (5) and (25).
3. Remove three screws (1), lockwashers (2), and spacer bar (3) from brackets (16), (20), and (24). Discard lockwashers (2).
4. Remove spacers (18) and (22) from bushings (17), (19), and (23).

LEVER DISASSEMBLY

1. Remove cotter pin (7), straight pin (4) and control handle (6) from lever (5).
2. Remove straight pin (8), connecting links (9) and (12), from lever (5).
3. Remove shoulder screw (13), spring (10), and lock release lever (11) from lever (5).

CLEANING AND INSPECTION

1. Refer to WP 0021 00 for general cleaning and inspection instructions.
2. Refer to table 1 for lever assembly area limits.

Table 1. M50A3 Water Tank Discharge Valve Control Levers Wear Limits.

ITEM NO.	ITEM/POINT OF MEASUREMENT	WEAR LIMITS/TOLERANCES	
		INCHES	MILLIMETERS
21	Lever shaft (diameter)	0.860–0.885 in.	21.84–22.48 mm
5 and 25	Levers (inner diameter at shaft hole)	0.868–0.992 in.	22.05–23.42 mm
17, 19, and 23	Bushings (outer diameter)	0.436–0.438 in.	11.07–11.13 mm
18 and 22	Spacers (inner diameter)	0.440–0.444 in.	11.18–11.28 mm
18 and 22	Spacers (outer diameter)	0.720–0.780 in.	18.29–19.81 mm

3. Inspect spacers (18) and (22) for flat spots or wear. Refer to table 1 for measurements. Replace spacers (18) and (22) if not within wear limits.
4. Inspect bushings (17), (19), and (23) for grooves or wear. Refer to table 1 for measurements. Replace bushings (17), (19), and (23) if not within wear limits.
5. Inspect brackets (16), (20), and (24) for cracks or damage. Replace brackets (16), (20), and (24) if cracked or damaged.

NOTE

Perform steps 6 through 8 if bushings or brackets are damaged or not within wear limits.

6. Press bushings (17), (19), and (23) from brackets (16), (20), and (24). Discard bushings (17), (19), and (23).
7. Install new bushings (17) and (23) in brackets (16) and (24) with press until bushings (17) and (23) ends are flush with brackets (16) and (24).

WATER TANK DISCHARGE VALVE CONTROL LEVERS MAINTENANCE (M50A3) (Contd)

CLEANING AND INSPECTION (Contd)

8. Install new bushings (19) in bracket (20) with press until bushing (19) ends extend 0.5 in. (12.7 mm) from bracket (20) sides.
9. Inspect levers (5) and (25) for wear, latch, handle, or rod damage. Refer to table 1 for measurements. Replace levers (5) and (25) if not within wear limits.
10. Inspect lever shaft (21) for grooves or wear. Refer to table 1, for measurements. Replace lever shaft (21) if not within wear limits.
11. Inspect spacer bar (3) for cracks or damage. Replace spacer bar (3) if cracked or damaged.

LEVER ASSEMBLY

1. Install lock release lever (11) and spring (10) on lever (5) with shoulder screw (13).
2. Install connecting links (9) and (12) and straight pin (8) on lever (5).
3. Install control handle (6) on lever (5) with straight pin (4) and cotter pin (7).

CONTROL LEVERS ASSEMBLY

1. Place spacers (18) and (22) on exposed ends of bushings (17), (19), and (23).
2. Install spacer bar (3) on brackets (16), (20), and (24) with three new lockwashers (2) and screws (1). Do not tighten screws (1).
3. Place lever shaft (21) through bracket (16), lever (5), bracket (20), lever (25), and bracket (24), and install with three new lockwashers (15) and screws (14).
4. Tighten three screws (1).

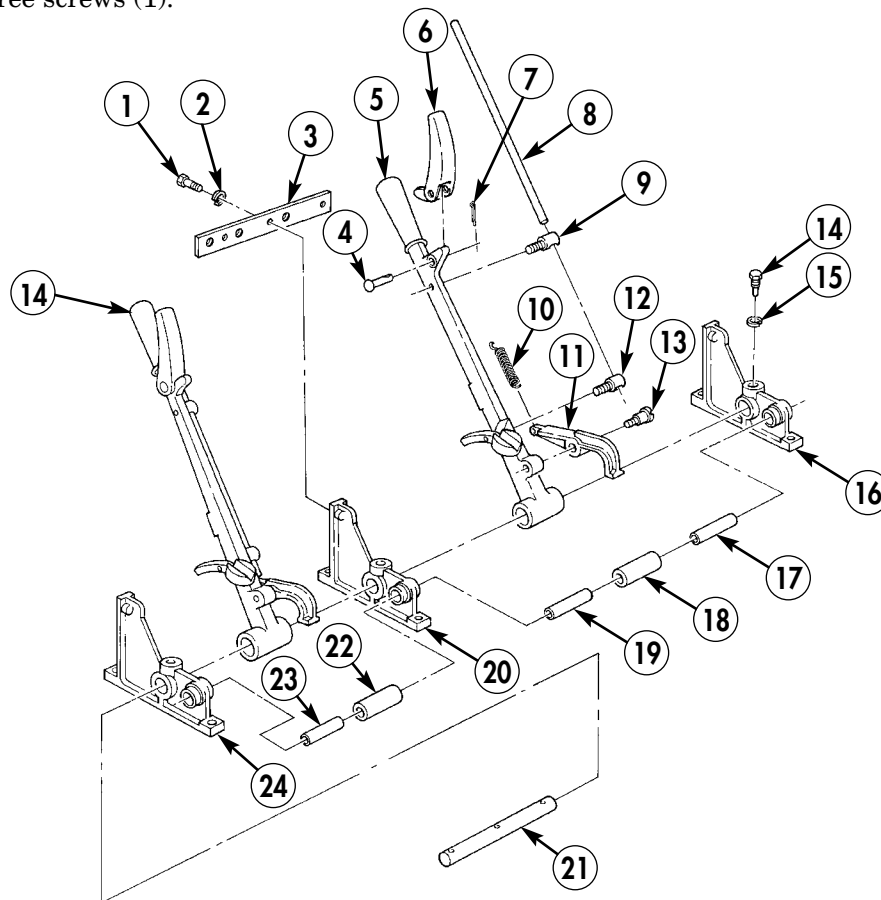

WATER TANK DISCHARGE VALVE CONTROL LEVERS MAINTENANCE (M50A3) (Contd)

INSTALLATION

1. Install two cables (6) through adapters (5) and plate (7).
2. Install discharge valve control assembly (3) under shelf (2) with six screws (1) and new locknuts (11).
3. Install two adapters (5) to plate (7).
4. Insert two screws (8) in two valve control levers (9) and install nuts (10). Do not tighten nuts (10).
5. Thread cables (6) through holes in screws (8).
6. Install two coupling nuts (4) on adapters (5).
7. Remove slack in two cables (6) and tighten nuts (10).

ADJUSTMENT

NOTE

Hold end of cable securely before loosening nuts. Cable may be under tension.

1. Loosen two nuts (10).
2. Remove slack in two cables (6) and tighten nuts (10).
3. Connect battery ground cable (WP 0126 00).
4. Release parking brake and remove wheel chocks (TM 9-2320-361-10).

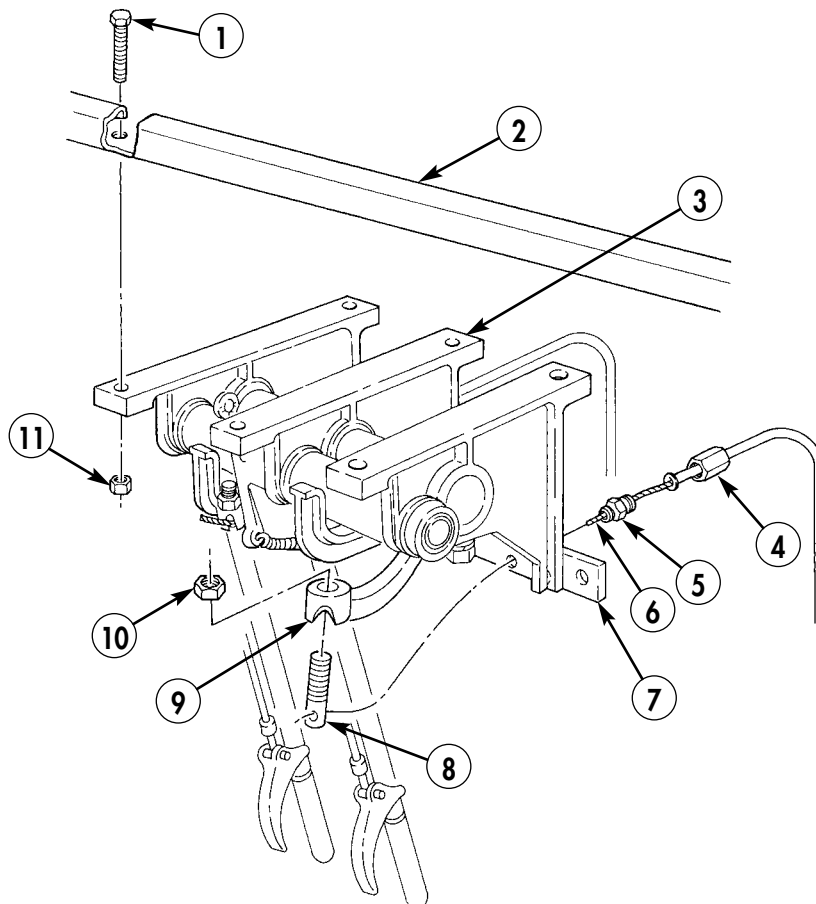

END OF WORK PACKAGE

FIELD MAINTENANCE INSTRUCTIONS

2-1/2 TON, 6X6, M44A2 SERIES TRUCKS (MULTIFUEL)

WATER TANK MANHOLE COVER MAINTENANCE (M50A3)

REMOVAL AND INSTALLATION

INITIAL SETUP:

Applicable Models

M50A3

Materials/Parts

Gasket (item 58, WP 0470 00)

Equipment Condition

Parking brake set and wheels chocked
(TM 9-2320-361-10).

Battery ground cable disconnected
(WP 0126 00).

REMOVAL

1. Remove padlock (2) and clamping ring (1) from manhole cover (5) and tank body (3).
2. Remove manhole cover (5) and gasket (4). Discard gasket (4).
3. Remove five screws (3) and shut off valve assembly (4) from tank body (5).

INSTALLATION

1. Install shutoff valve assembly (4) on tank body (5) with five screws (3).
2. Install new gasket (4) on cover (5). Install cover (5) on tank body (3).
3. Place clamping ring (1) around manhole cover (5) and tank body (3). Install padlock (2) on cover (5).
4. Connect battery ground cable (WP 0126 00).
5. Release parking brake and remove wheel chocks (TM 9-2320-361-10).

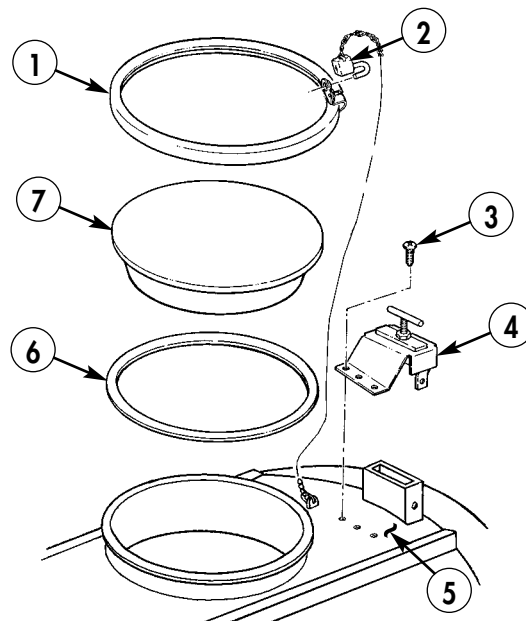

END OF WORK PACKAGE

0291 00-1/2 blank

FIELD MAINTENANCE INSTRUCTIONS

2-1/2 TON, 6X6, M44A2 SERIES TRUCKS (MULTIFUEL)

DELIVERY PUMP FRONT PROPELLER SHAFT MAINTENANCE REMOVAL, INSPECTION, AND INSTALLATION

INITIAL SETUP:

Applicable Models

M49A2C, M50A3

Materials/Parts

Four locknuts (item 129, WP 0470 00)

Key (item 125, WP 0470 00)

References

WP 0141 00

Equipment Condition

Parking brake set and wheels chocked
(TM 9-2320-361-10).

Battery ground cable disconnected
(WP 0126 00).

Discharge tube cover removed
(M50A3 only) (WP 0289 00).

DELIVERY PUMP FRONT PROPELLER SHAFT MAINTENANCE (Contd)

WARNING

Diesel fuel is flammable. Do not perform fuel system procedures near open flames. Injury or death to personnel may result.

REMOVAL

1. Remove four screws (3) and locknuts (1) from power takeoff flange (2) and delivery pump front propeller shaft (4). Discard locknuts (1).
2. Remove setscrew (7) and delivery pump front propeller shaft (4) from intermediate shaft (6).
3. Remove key (5) from intermediate shaft (6). Discard key (5).

INSPECTION

Inspect U-joints (8) for wear or damage. Replace U-joints (8) if worn or damaged (WP 0141 00).

INSTALLATION

1. Install new key (5) in intermediate shaft (6).
2. Install delivery pump front propeller shaft (4) on intermediate shaft (6) with setscrew (7).
3. Install delivery pump front propeller shaft (4) on power takeoff flange (2) with four screws (3) and new locknuts (1).
4. Install discharge tube cover (M50A3 only) (WP 0289 00).
5. Connect battery ground cable (WP 0126 00).
6. Release parking brake and remove wheel chocks (TM 9-2320-361-10).

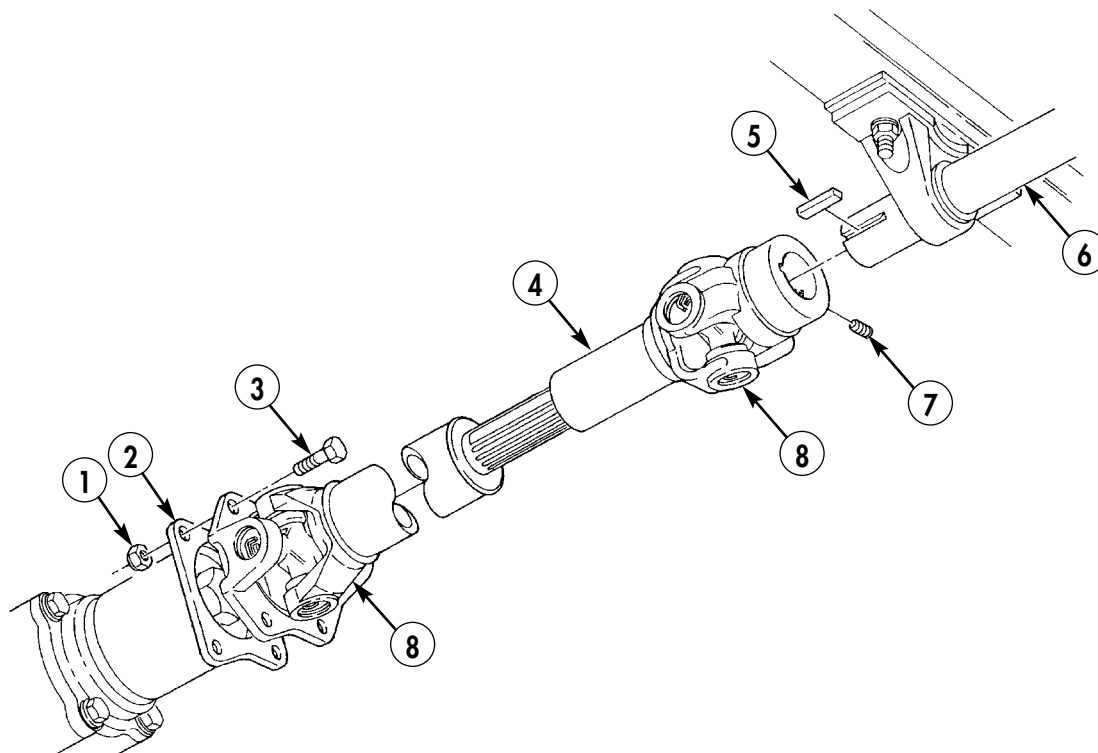

END OF WORK PACKAGE

FIELD MAINTENANCE INSTRUCTIONS

2-1/2 TON, 6X6, M44A2 SERIES TRUCKS (MULTIFUEL)

DELIVERY PUMP REAR PROPELLER SHAFT MAINTENANCE REMOVAL, INSPECTION, AND INSTALLATION

INITIAL SETUP:

Applicable Models

M49A2C, M50A3

Materials/Parts

Key (item 125, WP 0470 00)

Woodruff key (item 385, WP 0470 00)

References

WP 0141 00

Equipment Condition

Parking brake set and wheels chocked
(TM 9-2320-361-10).

Battery ground cable disconnected
(WP 0126 00).

Discharge tube cover removed (M50A3 only)
(WP 0289 00).

Delivery pump front propeller shaft removed
(WP 0292 00).

DELIVERY PUMP REAR PROPELLER SHAFT MAINTENANCE (Contd)

WARNING

Diesel fuel is flammable. Do not perform fuel system procedures near open flames. Injury or death to personnel may result.

REMOVAL

1. Remove setscrew (5) and intermediate shaft (6) from delivery pump rear propeller shaft (8).
2. Remove key (7) from intermediate shaft (6). Discard key (7).
3. Remove setscrew (3) and delivery pump rear propeller shaft (8) from delivery pump shaft (2).
4. Remove woodruff key (1) from delivery pump shaft (2). Discard woodruff key (1).

INSPECTION

Inspect U-joints (4) for wear or damage. Replace U-joints (4) if worn or damaged (WP 0141 00).

INSTALLATION

1. Install new woodruff key (1) in delivery pump shaft (2).
2. Install delivery pump rear propeller shaft (8) on delivery pump shaft (2) with setscrew (3).
3. Install new key (7) in intermediate shaft (6).
4. Install intermediate shaft (6) on delivery pump rear propeller shaft (8) with setscrew (5).
5. Install delivery pump front propeller shaft (WP 0292 00).
6. Install discharge tube cover (WP 0289 00).
7. Connect battery ground cable (WP 0126 00).
8. Release parking brake and remove wheel chocks (TM 9-2320-361-10).

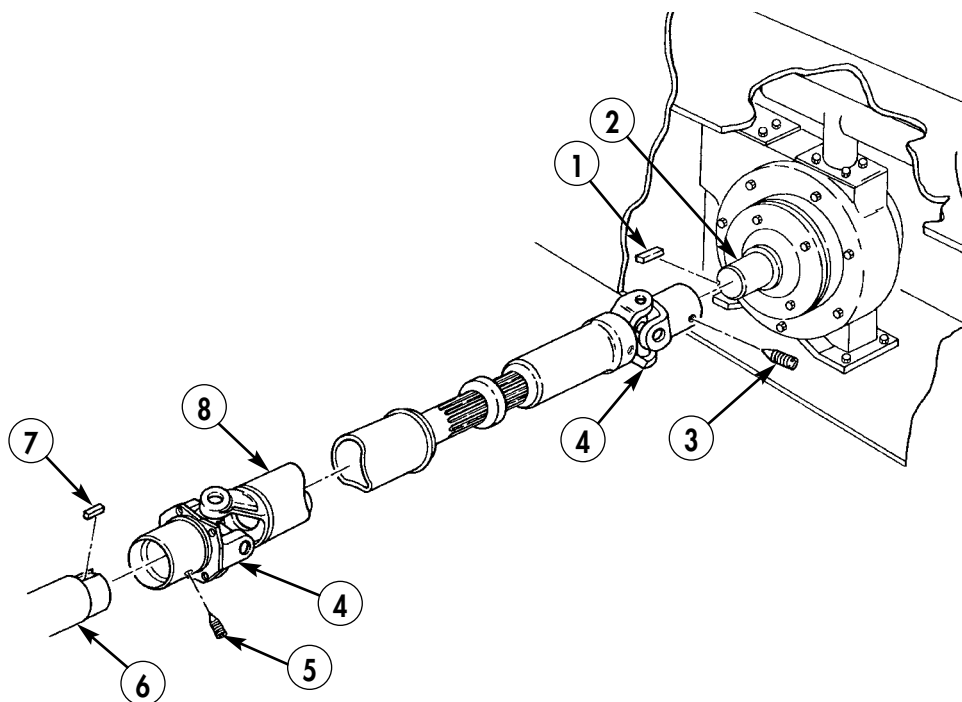

END OF WORK PACKAGE

FIELD MAINTENANCE INSTRUCTIONS

2-1/2 TON, 6X6, M44A2 SERIES TRUCKS (MULTIFUEL)

SPEED CONTROL CABLE MAINTENANCE REMOVAL, INSPECTION, AND INSTALLATION

INITIAL SETUP:

Applicable Models

M49A2C, M50A3

Tool and Test Equipment

STE/ICE-R

Materials/Parts

Two lockwashers (item 207, WP 0470 00)

Cotter pin (item 15, WP 0470 00)

Cotter pin (item 32, WP 0470 00)

Equipment Condition

Parking brake set and wheels chocked
(TM 9-2320-361-10).

Battery ground cable disconnected
(WP 0126 00).

SPEED CONTROL CABLE MAINTENANCE (Contd)

WARNING

Diesel fuel is flammable. Do not perform fuel system procedures near open flames. Injury or death to personnel may result.

REMOVAL

1. Remove cotter pin (16) and pin (17) from eye (18) and fuel pump lever (2). Discard cotter pin (16).
2. Loosen two nuts (14) and remove cable assembly (15) from bracket (3).
3. Remove cotter pin (9) and pin (12) from eye (10) and rod assembly (7). Discard cotter pin (9).
4. Remove two screws (5), lockwashers (6), and bracket (8) from cab frame (4). Discard lockwashers (6).
5. Loosen two nuts (13) and remove cable (15) from bracket (8).
6. Loosen two nuts (11) and remove two eyes (10) and (18) from cable (15).

INSPECTION

Inspect bracket (8) for cracks and bends. Replace bracket (8) if cracked or bent.

INSTALLATION

1. Install two eyes (10) and (18) on cable assembly (15) and tighten two nuts (11).

NOTE

Access to bracket is through door in cab floor in front of driver's seat.

2. Install bracket (8) on frame (4) with two screws (5) and new lockwashers (6).
3. Install cable (15) on fuel pump lever (2) with pin (17) and new cotter pin (16).
4. Install cable (15) on rod assembly (7) with pin (12) and new cotter pin (9).

NOTE

Loosen nuts to adjust cable so fuel pump lever is in curb idle position.

5. Install cable (15) on two brackets (3) and (8) and tighten two nuts (14) and (13).

ADJUSTMENT

1. Start engine and engage PTO (TM 9-2320-361-10). Monitor rpm with STE/ICE-R.
2. Adjust screw (1) and wire (19) to obtain fuel pump lever (2) position for RPMs specified for each vehicle. Refer to table 1 for settings.

Table 1. Speed Control Adjustment.

MODEL	ENGINE RPM	TRANSMISSION GEAR	PTO RPM
M49A2C	1150	2nd	413
M50A3	1100	4th	1100

3. Connect battery ground cable (WP 0126 00).
4. Release parking brake and remove wheel chocks (TM 9-2320-361-10).

SPEED CONTROL CABLE MAINTENANCE (Contd)

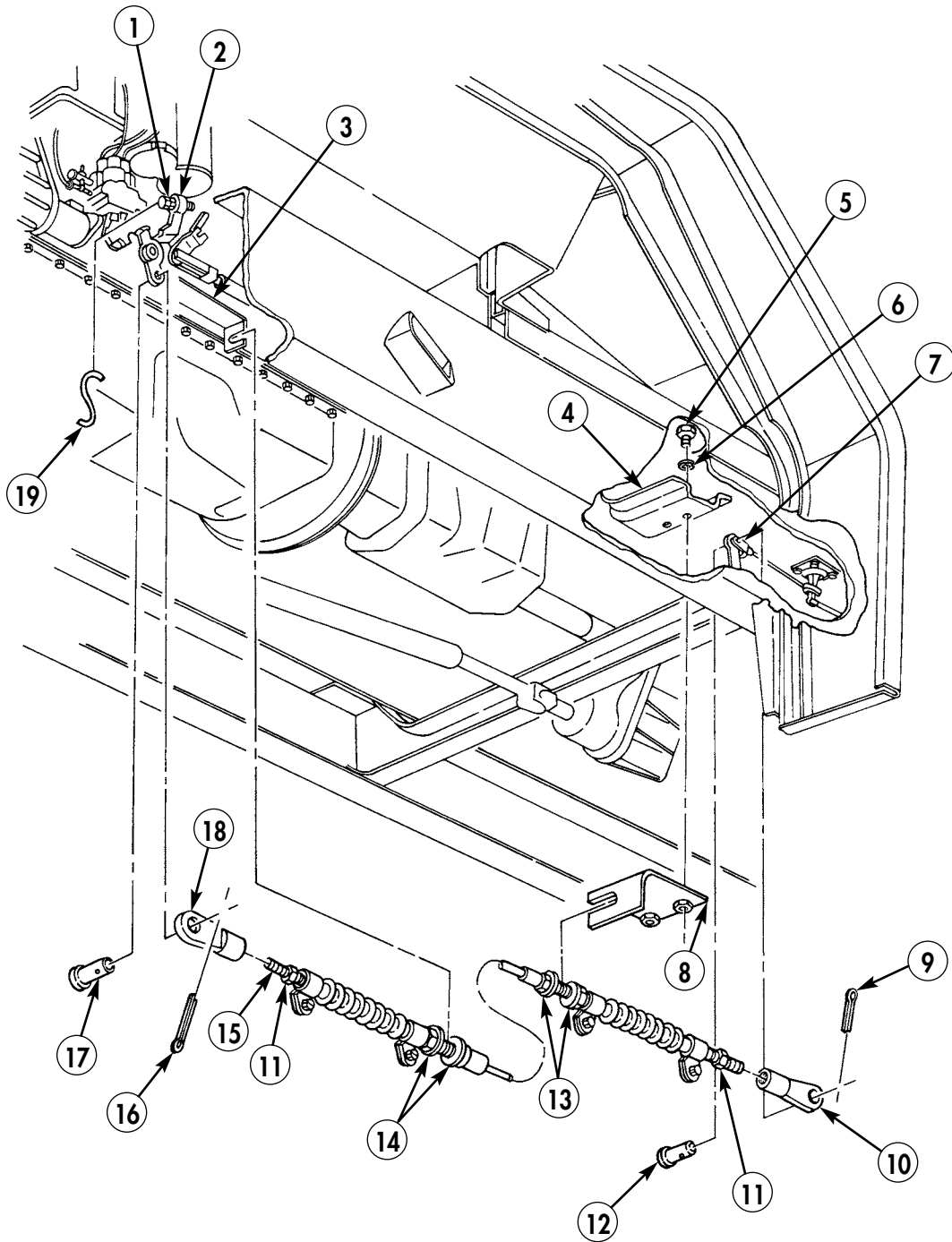

END OF WORK PACKAGE

FIELD MAINTENANCE INSTRUCTIONS

2-1/2 TON, 6X6, M44A2 SERIES TRUCKS (MULTIFUEL)

TANK BODIES FRONT SPLASH GUARD REPLACEMENT

REMOVAL AND INSTALLATION

INITIAL SETUP:

Applicable Models

M49A2C, M50A3

Materials/Parts

Nine locknuts (item 129, WP 0470 00)

Equipment Condition

Parking brake set and wheels chocked
(TM 9-2320-361-10).

Battery ground cable disconnected
(WP 0126 00).

TANK BODIES FRONT SPLASH GUARD REPLACEMENT (Contd)

WARNING

Diesel fuel is flammable. Do not perform fuel system procedures near open flames. Injury or death to personnel may result.

NOTE

Left and right front splash guards are replaced the same way.

REMOVAL

1. Remove two locknuts (8) and screws (9) from braces (7) and splash guard (10). Discard locknuts (8).
2. Remove two locknuts (6), screws (5), and braces (7) from frame (4). Discard locknuts (6).

NOTE

Perform step 3 on left side of vehicle if vehicle is equipped with pioneer tool kit.

3. Remove two locknuts (13) and screws (1) from pioneer tool bracket (12) and splash guard (10). Discard locknuts (13).
4. Remove three locknuts (11), screws (3), and splash guard (10) from frame (2). Discard locknuts (11).

INSTALLATION

1. Install splash guard (10) on frame (2) with three screws (3) and new locknuts (11).

NOTE

Perform step 2 on left side of vehicle if vehicle is equipped with pioneer tool kit.

2. Install pioneer tool bracket (12) on splash guard (10) with two screws (1) and new locknuts (13).
3. Install two braces (7) on frame (4) with two screws (5) and new locknuts (6).
4. Install two braces (7) on splash guard (10) with two screws (9) and new locknuts (8).
5. Connect battery ground cable (WP 0126 00).
6. Release parking brake and remove wheel chocks (TM 9-2320-361-10).

TANK BODIES FRONT SPLASH GUARD REPLACEMENT (Contd)

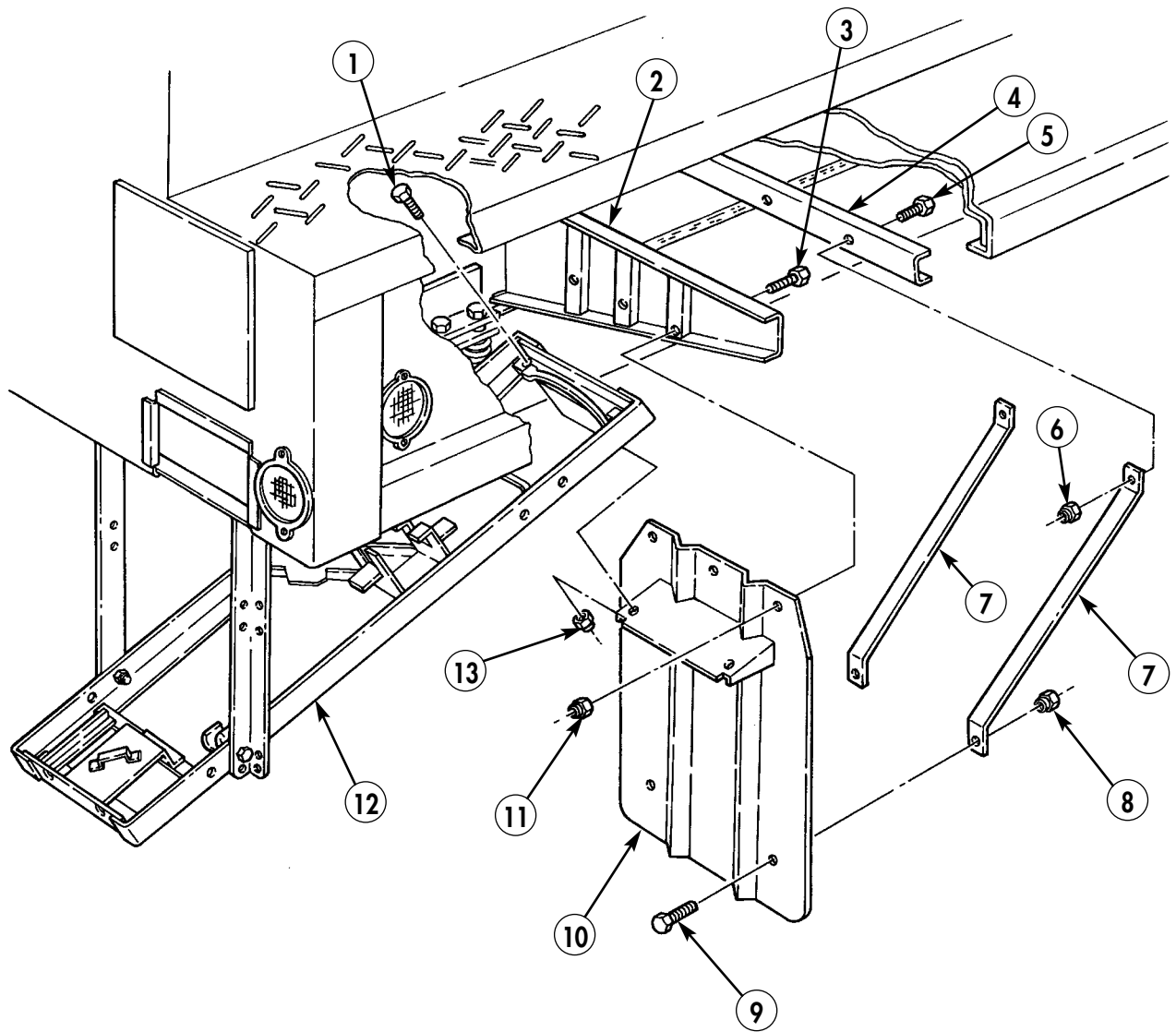

END OF WORK PACKAGE

FIELD MAINTENANCE INSTRUCTIONS

2-1/2 TON, 6X6, M44A2 SERIES TRUCKS (MULTIFUEL)

TANK BODIES UPPER AND LOWER REAR SPLASH GUARD REPLACEMENT

LOWER SPLASH GUARD REMOVAL, UPPER SPLASH GUARD REMOVAL,
UPPER SPLASH GUARD INSTALLATION, AND LOWER SPLASH GUARD INSTALLATION

INITIAL SETUP:

Applicable Models

M49A2C, M50A3

Materials/Parts

Ten locknuts (item 129, WP 0470 00)

Equipment Condition

Parking brake set and wheels chocked
(TM 9-2320-361-10).

Battery ground cable disconnected
(WP 0126 00).

TANK BODIES UPPER AND LOWER REAR SPLASH GUARD REPLACEMENT (Contd)

WARNING

Diesel fuel is flammable. Do not perform fuel system procedures near open flames. Injury or death to personnel may result.

LOWER SPLASH GUARD REMOVAL

Remove three locknuts (6), screws (8), retainer strip (9), and lower splash guard (10) from upper splash guard (4). Discard locknuts (6).

UPPER SPLASH GUARD REMOVAL

1. Remove two locknuts (7) and screws (12) from braces (11) and upper splash guard (4). Discard locknuts (7).
2. Remove two locknuts (13), screws (2), and braces (11) from crossmember (1). Discard locknuts (13).
3. Remove three locknuts (5), screws (3), and upper splash guard (4) from crossmember (14). Discard locknuts (5).

UPPER SPLASH GUARD INSTALLATION

1. Install upper splash guard (4) on crossmember (14) with three screws (3) and new locknuts (5).
2. Install two braces (11) on crossmember (1) with two screws (2) and new locknuts (13).
3. Install two braces (11) on upper splash guard (4) with two screws (12) and new locknuts (7).

LOWER SPLASH GUARD INSTALLATION

1. Install retainer strip (9) and lower splash guard (10) on upper splash guard (4) with three screws (8) and new locknuts (6).
2. Connect battery ground cable (WP 0126 00).
3. Release parking brake and remove wheel chocks (TM 9-2320-361-10).

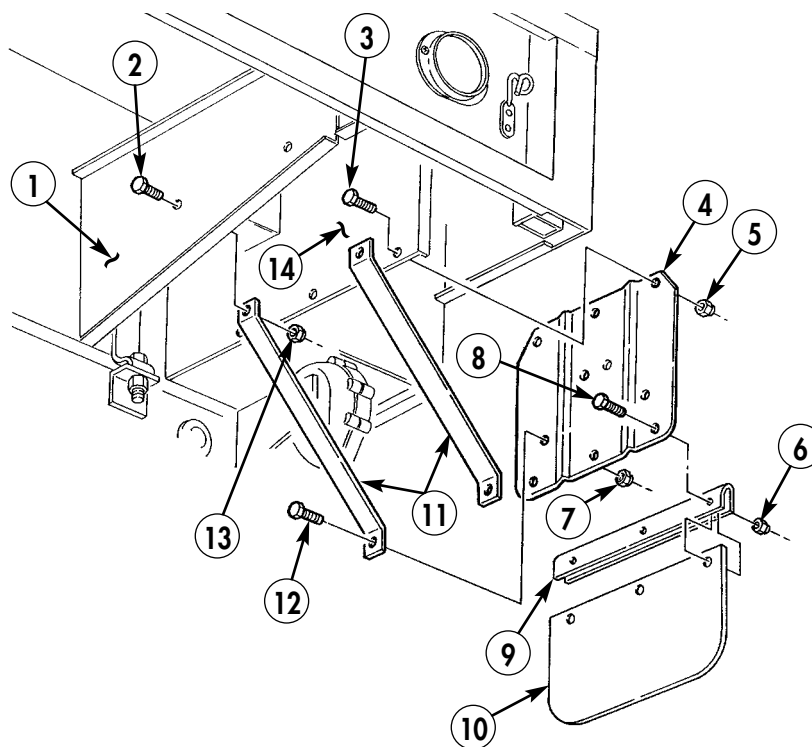

END OF WORK PACKAGE

FIELD MAINTENANCE INSTRUCTIONS

2-1/2 TON, 6X6, M44A2 SERIES TRUCKS (MULTIFUEL)

TANK BODIES FRAME SILL MAINTENANCE REMOVAL, INSPECTION, AND INSTALLATION

INITIAL SETUP:

Applicable Models

M49A2C, M50A3

Tools and Special Tools

General mechanic's tool kit
(item 116, WP 0469 00)

Breaker bar, 1/2-in. drive
(item 6, WP 0469 00)

1-1/8-in. socket, 1/2-in. drive
(item 98, WP 0469 00)

1-1/4-in. socket, 1/2-in. drive
(item 96, WP 0469 00)

Tools and Special Tools (Contd)

Torque wrench, 1/2-in. drive
(item 136, WP 0469 00)

Materials/Parts

Two locknuts (item 129, WP 0470 00)

Equipment Condition

Tank body removed (WP 0298 00).

TANK BODIES FRAME SILL MAINTENANCE (Contd)

WARNING

- Be careful when working under tank body placed on supports. Tank body may fall causing injury to personnel.
- Ensure lifting capacity is greater than weight of tank body. Failure to do so may cause injury to personnel.

REMOVAL

Remove two locknuts (2), washers (3), screws (4), and frame sill (5) from tank body (1). Discard locknuts (2).

INSPECTION

Inspect each frame sill (5) for end splits or rotting. Replace if end split exceeds width of frame sill (5) or frame sill (5) is damaged.

INSTALLATION

NOTE

Assistant will help with installation of frame sill.

1. Install frame sill (5) on tank body (1) with two screws (4), washers (3), and new locknuts (2).
2. Install tank body (WP 0298 00).

TANK BODIES FRAME SILL MAINTENANCE (Contd)

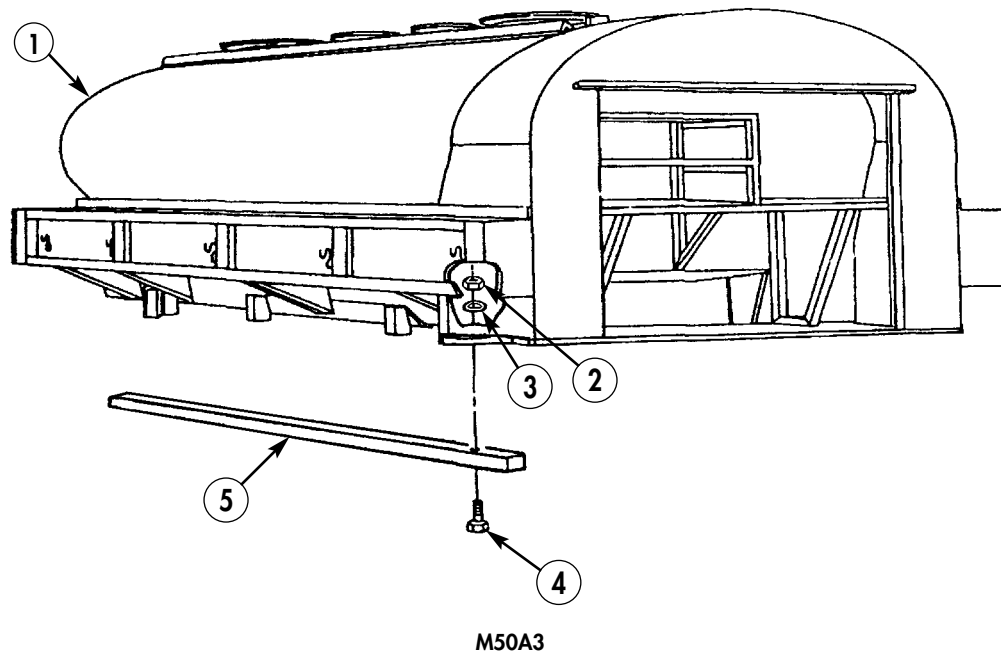
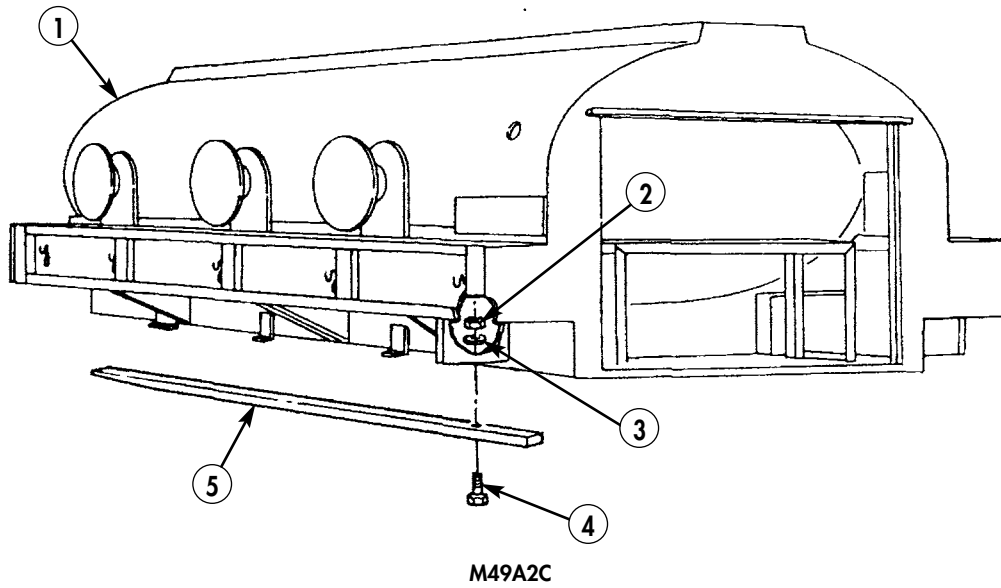

FIELD MAINTENANCE INSTRUCTIONS

2-1/2 TON, 6X6, M44A2 SERIES TRUCKS (MULTIFUEL)

FUEL AND WATER TANK BODIES MAINTENANCE

REMOVAL, CLEANING AND INSPECTION, AND INSTALLATION

INITIAL SETUP:

Applicable Models

M185A3, M109A3

Tools and Special Tools

General mechanic's tool kit
(item 116, WP 0469 00)
Torque wrench, 3/4-in. drive
(item 137, WP 0469 00)
Torque wrench, 1/2-in. drive
(item 136, WP 0469 00)
1-1/8-in. socket, 3/4-in. drive
(item 99, WP 0469 00)
Breaker bar, 3/4-in. drive (item 8, WP 0469 00)
Handle, socket wrench, 3/4-in. drive
(item 41, WP 0469 00)
1-1/4-in. socket, 3/4-in. drive
(item 97, WP 0469 00)
Lifting device (item 48, WP 0469 00)
Guide lines
Utility Chains

Materials/Parts

Four locknuts (M50A3) (item 162, WP 0470 00)
Four locknuts (M50A3) (item 166, WP 0470 00)
Six locknuts (M49A2C) (item 162, WP 0470 00)
Four locknuts (M49A2C) (item 166, WP 0470 00)

Personnel Required

Two

References

WP 0297 00

Equipment Condition

Parking brake set and wheels chocked
(TM 9-2320-361-10).
Battery ground cable disconnected
(WP 0126 00).
Tank body drained (TM 9-2320-361-10).
Tank body purged (M49A2C) (TB 43-0212).
Tank body upper and lower splash guards
removed (WP 0296 00).
Tank body front splash guards removed
(WP 0295 00).
Water tank manhole cover removed (M49A2C)
(WP 0268 00).

Equipment Condition (Contd)

Fuel tank manhole cover removed (M49A2C)
(WP 0268 00).
Water tank manhole cover removed (M50A3)
(WP 0291 00).
Water tank filler cover removed (M50A3)
(WP 0287 00).
Fuel tank nozzle holder removed (M49A2C)
(WP 0269 00).
Water tank nozzle holder removed (M50A3)
(WP 0270 00).
Exhaust system removed (M49A2C)
(WP 0073 00).
Exhaust system removed (M50A3) (WP 0074 00).
Tank body rear compartment doors removed
(WP 0288 00).
Water tank discharge tubes and valves removed
(M50A3) (WP 0289 00).
Fuel tank discharge valves removed (M49A2C)
(WP 0263 00).
Fuel tank discharge tubes removed (M49A2C)
(WP 0266 00).
Delivery pump rear propeller shaft removed
(WP 0293 00).
Delivery pump front propeller shaft removed
(WP 0292 00).
Cable retractor removed (M49A2C)
(WP 0274 00).
Fuel tank discharge valve control levers removed
(M49A2C) (WP 0264 00).
Water tank discharge control valves removed
(M50A3) (WP 0290 00).
Gallon meter removed (M49A2C)
(WP 0276 00).
Delivery pump strainer removed (WP 0284 00).
Filter separator removed (M49A2C)
(WP 0286 00).
Sump assembly, drain valves, and tubes removed
(WP 0267 00).
Gate valves removed (WP 0283 00).
Water tank pump manifold removed (M50A3)
(WP 0279 00).
Overturn tubes removed (M49A2C)
(WP 0271 00).
Water cans and brackets removed (WP 0232 00).
Fire extinguishers removed (M49A2C)
(WP 0393 00).

FUEL AND WATER TANK BODIES MAINTENANCE (Contd)

REMOVAL

WARNING

Eye protection must be worn when removing or installing springs under tension. Failure to do so may result in injury to personnel.

NOTE

The fuel (M49A2C) and water (M50A3) tank bodies are replaced basically the same. The fuel tank body has six sets of body and frame brackets, and the water tank body has four sets of body and frame brackets. This procedure covers the water tank body.

1. Remove four locknuts (5), washers (6), two springs (7) and (8), and four screws (3) from two brackets (1) and brackets (4). Discard locknuts (5).
2. Remove four locknuts (12), washers (11), and screws (9) from four brackets (2) and brackets (10). Discard locknuts (12).

FUEL AND WATER TANK BODIES MAINTENANCE (Contd)

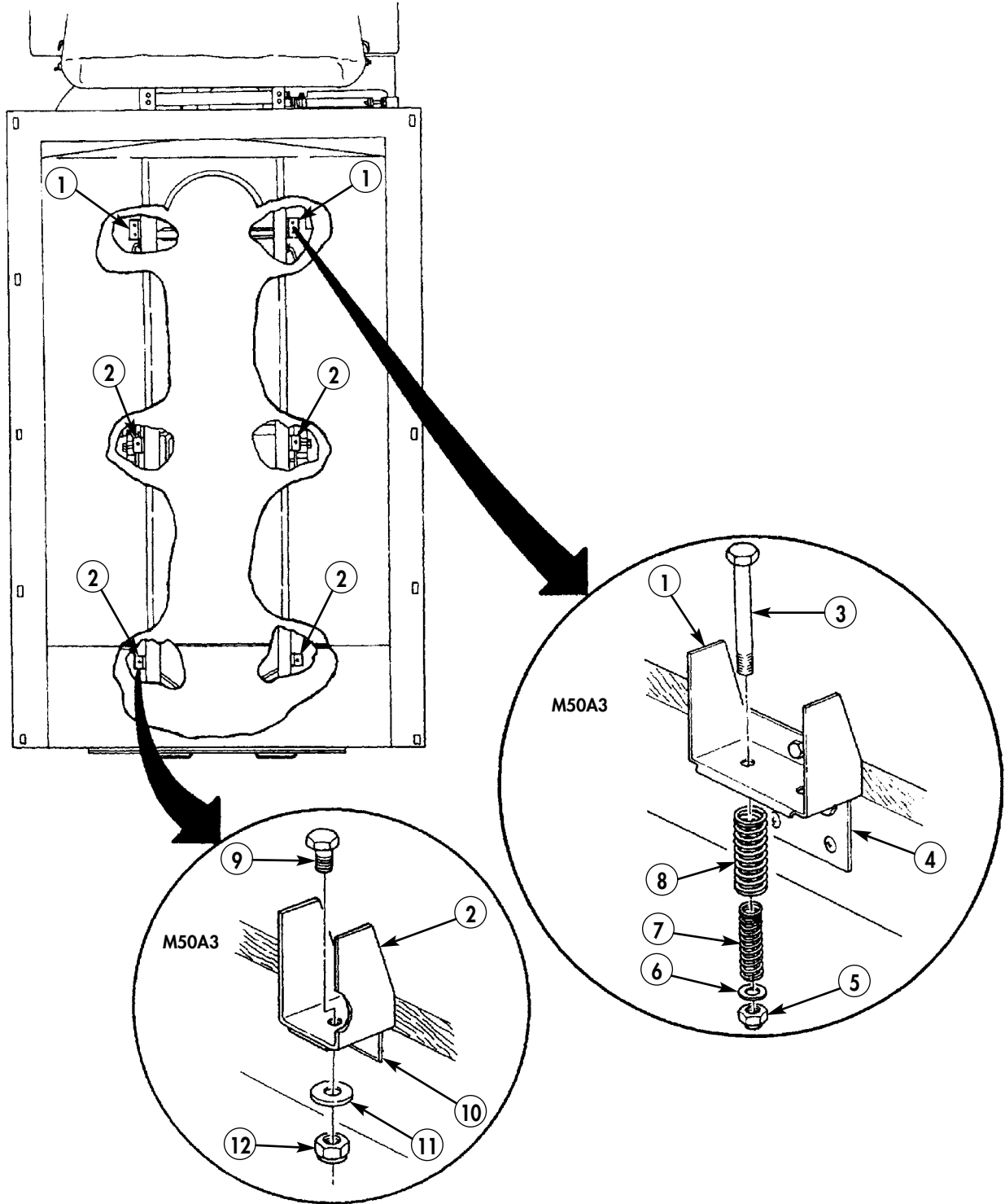

FUEL AND WATER TANK BODIES MAINTENANCE (Contd)

REMOVAL (Contd)

3. Attach utility chains to tank body (1) and position lifting device in center of utility chains. Raise lifting device and remove slack in utility chains.
4. Attach guide lines on lashing hooks (3).

WARNING

- All personnel must stand clear during lifting operations. A swinging or shifting load may cause injury to personnel.
- Ensure lifting and support capacity are greater than weight of tank body. Failure to do so may result in injury to personnel or damage to equipment.

NOTE

Assistant will help guide tank body during lifting operations.

5. Remove tank body (1) and place on wooden supports.
6. Remove lifting device, chains, and guide lines from tank body (1).

CLEANING AND INSPECTION

WARNING

When using steam cleaning equipment, do not come in direct contact of spray. Burns or severe injury to personnel may result.

CAUTION

When steam cleaning tank body, do not apply steam on rustproofing unless area needs repair.

NOTE

- Refer to TB 43-0212 for internal cleaning of fuel tank.
- Perform steps 1 through 3 for internal cleaning of water tank.

1. Place steam nozzle in manhole and direct spray within compartment(s) from top to bottom.
2. Wash all sludge and scale down to bottom of each compartment and remove. Rinse inside of each compartment thoroughly with fresh water.
3. Inspect tank body (1) for damage or rust. Replace tank body (1) if damage or rust is on tank body (1) is excessive and beyond available repair procedures.
4. Inspect frame sills (WP 0297 00).

FUEL AND WATER TANK BODIES MAINTENANCE (Contd)

INSTALLATION

WARNING

- All personnel must stand clear during lifting operations. A swinging or shifting load may cause injury to personnel.
- Ensure lifting capacity is greater than weight of tank body. Failure to do so may result in injury to personnel.

NOTE

Use breaker bar to align body and frame brackets.
Assistant will help guide tank body during lifting operations.

1. Attach utility chains to tank body (1).
2. Attach lifting device to utility chains and install guide lines to tank body (1).
3. Lift tank body (1) off wooden supports and lower onto vehicle frame (2).
4. Remove lifting device from chains. Remove utility chains from tank body (1).
5. Remove guide lines from lashing hooks (3).

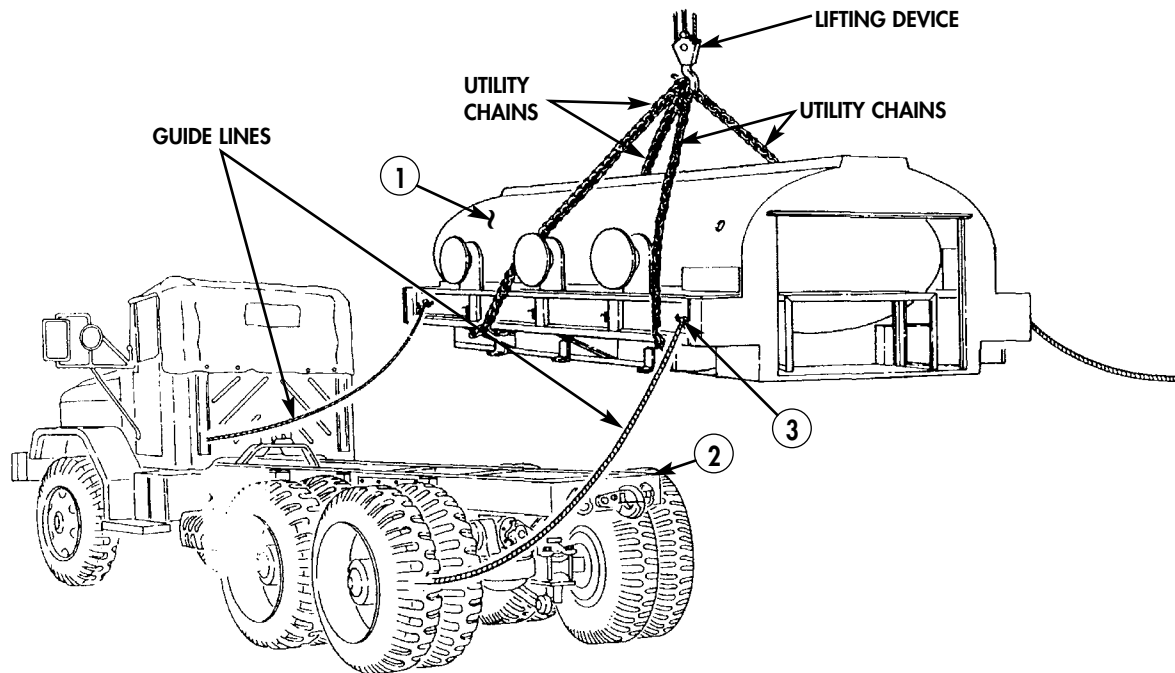

FUEL AND WATER TANK BODIES MAINTENANCE (Contd)

INSTALLATION (Contd)

NOTE

Fuel tank models have two additional sets of body and frame brackets.

6. Install four screws (9) in four brackets (2) and brackets (10) with four washers (11) and new locknuts (12). Tighten locknuts (12) 105–145 lb-ft (142–197 N•m).

WARNING

Eye protection must be worn when removing or installing springs under tension. Failure to do so may result in injury to personnel.

7. Place four screws (3) in two brackets (1) and brackets (4). Install springs (7) inside springs (8) and over screws (3) with four washers (6) and new locknuts (5).

NOTE

- Fuel tank bracket springs installed height is 6.4 in. (163 mm).
- Water tank bracket springs installed height is 6.5 in. (165 mm).

8. Tighten four locknuts (5) and adjust springs (7) and (8) to height specification.
9. Install fire extinguishers (M49A2C) (WP 0393 00).
10. Install water cans and brackets (WP 0232 00).
11. Install overturn tubes (M49A2C) (WP 0271 00).
12. Install water tank pump manifold (M50A3) (WP 0279 00).
13. Install gate valves (WP 0283 00).
14. Install sump assembly, drain valves, and tubes (M49A2C) (WP 0267 00).
15. Install filter separator (M49A2C) (WP 0286 00).
16. Install gallon meter (M49A2C) (WP 0276 00).
17. Install water tank discharge valve control levers (M50A3) (WP 0290 00).
18. Install fuel tank discharge valve control levers (WP 0264 00).
19. Install cable retractor (M49A2C) (WP 0274 00).
20. Install delivery pump front propeller shaft (WP 0292 00).
21. Install delivery pump rear propeller shaft (WP 0293 00).
22. Install fuel tank discharge tubes (M49A2C) (WP 0266 00).
23. Install fuel tank discharge valves (M49A2C) (WP 0263 00).
24. Install water tank discharge tubes and valves (M50A3) (WP 0289 00).
25. Install tank body rear compartment doors (WP 0288 00).
26. Install exhaust system (M49A2C) (WP 0073 00).
27. Install exhaust system (M50A3) (WP 0074 00).
28. Install fuel tank nozzle holder (M49A2C) (WP 0269 00).
29. Install water tank nozzle holder (M50A3) (WP 0270 00).
30. Install water tank filler cover (M50A3) (WP 0287 00).
31. Install fuel tank manhole cover (M49A2C) (WP 0268 00).

FUEL AND WATER TANK BODIES MAINTENANCE (Contd)

INSTALLATION (Contd)

32. Install water tank manhole cover (M50A3) (WP 0291 00).
33. Install tank body front splash guards (WP 0295 00).
34. Install tank body upper and lower splash guards (WP 0296 00).
35. Connect battery ground cable (WP 0126 00).
36. Release parking brake and remove wheel chocks (TM 9-2320-361-10).

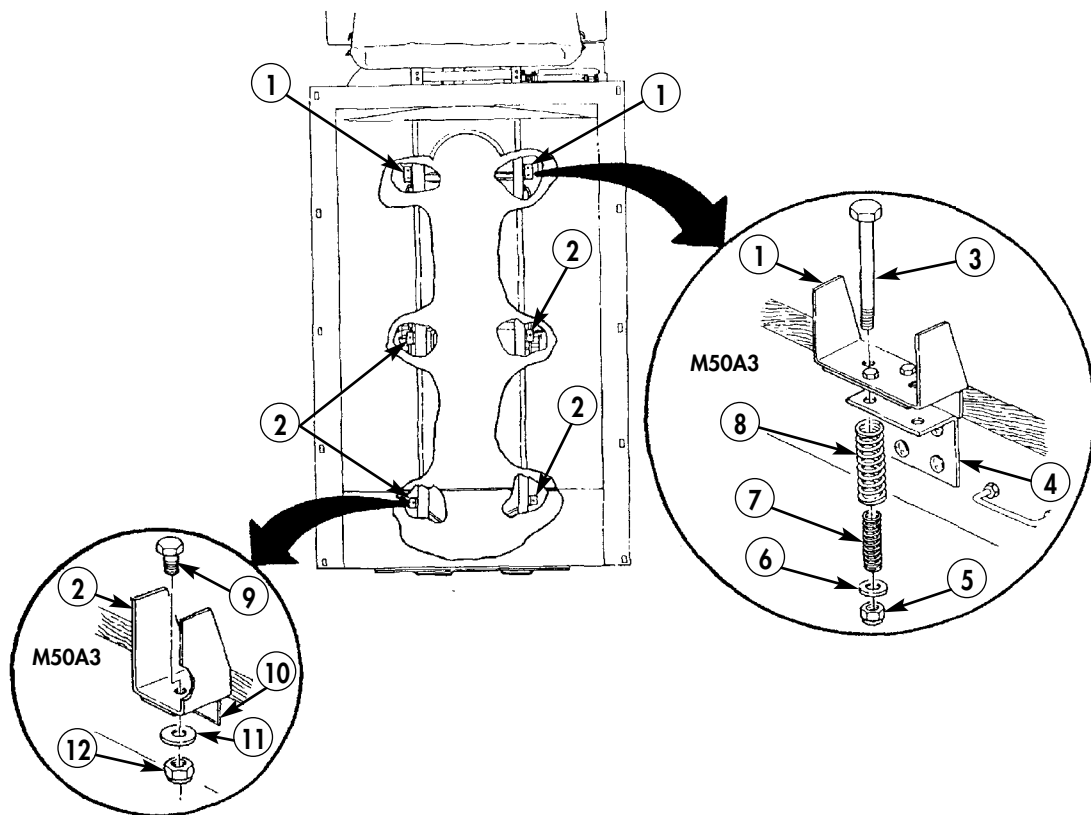

FIELD MAINTENANCE INSTRUCTIONS

2-1/2 TON, 6X6, M44A2 SERIES TRUCKS (MULTIFUEL)

REAR SPLASH GUARD REPLACEMENT

LOWER SPLASH GUARD, UPPER SPLASH GUARD REMOVAL,
UPPER SPLASH GUARD INSTALLATION, LOWER SPLASH GUARD INSTALLATION

INITIAL SETUP:

Applicable Models

M185A3, M109A3

Materials/Parts

Ten locknuts (item 129, WP 0470 00)

Equipment Condition

Parking brake set and wheels chocked
(TM 9-2320-361-10).

Battery ground cable disconnected
(WP 0126 00).

REAR SPLASH GUARD REPLACEMENT (Contd)

LOWER SPLASH GUARD REMOVAL

Remove four locknuts (9), screws (5), retainer strip (8), and lower splash guard (7) from upper splash guard (10). Discard locknuts (9).

UPPER SPLASH GUARD REMOVAL

1. Remove two locknuts (11) and screws (6) from two splash guard braces (12). Discard locknuts (11).
2. Remove two locknuts (1), screws (4), and splash guard braces (12) from frame (2). Discard locknuts (1).
3. Remove two locknuts (13), screws (3), and upper splash guard (10) from frame (2). Discard locknuts (13).

UPPER SPLASH GUARD INSTALLATION

1. Install upper splash guard (10) on frame (2) with two screws (3) and new locknuts (13).
2. Install two splash guard braces (12) on frame (2) with two screws (4) and new locknuts (1).
3. Install splash guard braces (12) on upper splash guard (10) with two screws (6) and new locknuts (11).

LOWER SPLASH GUARD INSTALLATION

1. Align holes in lower splash guard (7) to holes in retainer strip (8).
2. Install retainer strip (8) and lower splash guard (7) on upper splash guard (10) with four screws (5) and new locknuts (9).
3. Connect battery ground cable (WP 0126 00).
4. Release parking brake and remove wheel chocks (TM 9-2320-361-10).

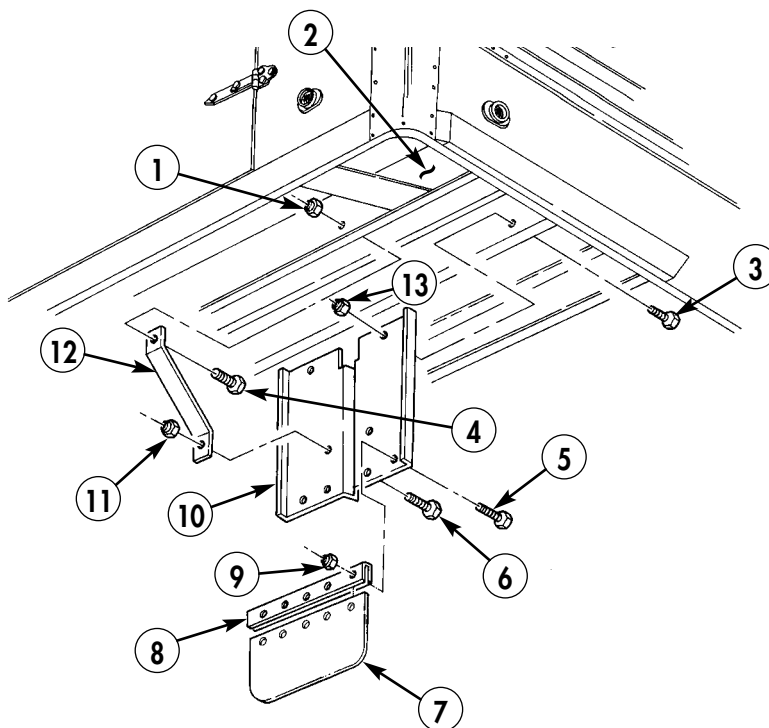

END OF WORK PACKAGE

FIELD MAINTENANCE INSTRUCTIONS

2-1/2 TON, 6X6, M44A2 SERIES TRUCKS (MULTIFUEL)

SAFETY SWITCH FUSE REPLACEMENT

REMOVAL AND INSTALLATION

INITIAL SETUP:

Applicable Models

M185A3, M109A3

Materials/Parts

Two 250V fuses (item 43, WP 0470 00)

Equipment Condition

Parking brake set and wheels chocked
(TM 9-2320-361-10).

Battery ground cable disconnected
(WP 0126 00).

REMOVAL

1. Pull safety switch box handle (2) down to off position and open cover (4).
2. Remove two 250V fuses (3) from safety switch box (1). Discard fuses (3).

INSTALLATION

1. Install two new 250V fuses (3) in safety switch box (1).
2. Close cover (4) and push safety switch box handle (2) up to ON position.
3. Connect battery ground cable (WP 0126 00).
4. Release parking brake and remove wheel chocks (TM 9-2320-361-10).

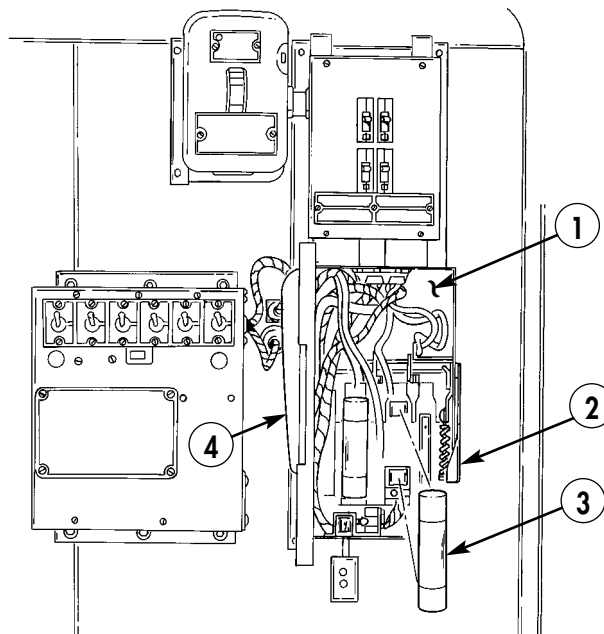

END OF WORK PACKAGE

0300 00-1/2 blank

FIELD MAINTENANCE INSTRUCTIONS

2-1/2 TON, 6X6, M44A2 SERIES TRUCKS (MULTIFUEL)

EXHAUST BLOWER MOTOR AND BRACKET REPLACEMENT

REMOVAL AND INSTALLATION

INITIAL SETUP:

Applicable Models

M185A3, M109A3

Materials/Parts

Six screw-assembled lockwashers
(item 275, WP 0470 00)

Two screw-assembled lockwashers
(item 267, WP 0470 00)

Equipment Condition

Parking brake set and wheels chocked
(TM 9-2320-361-10).

Battery ground cable disconnected
(WP 0126 00).

REMOVAL

1. Remove blower motor cable (4) from receptacle (9).
2. Remove two screw-assembled lockwashers (2) from bracket (3) and ceiling (1). Discard screw-assembled lockwashers (2).
3. Remove six screw-assembled lockwashers (6) and blower motor assembly (5) from adapter (8). Discard screw-assembled lockwashers (6).
4. Remove two nuts (7) and bracket (3) from blower motor (5).

INSTALLATION

1. Install bracket (3) on blower motor (5) with two nuts (7).
2. Install blower motor assembly (5) on adapter (8) with six new screw-assembled lockwashers (6).
3. Install bracket (3) on ceiling (1) with two new screw-assembled lockwashers (2).
4. Insert blower motor cable (4) into receptacle (9).
5. Connect battery ground cable (WP 0126 00).
6. Release parking brake and remove wheel chocks (TM 9-2320-361-10).

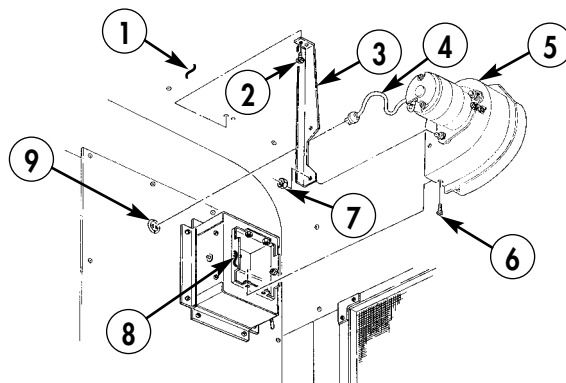

END OF WORK PACKAGE

0301 00-1/2 blank

FIELD MAINTENANCE INSTRUCTIONS

2-1/2 TON, 6X6, M44A2 SERIES TRUCKS (MULTIFUEL)

DOME LAMP AND HOUSING REPLACEMENT

REMOVAL AND INSTALLATION

INITIAL SETUP:

Applicable Models

M185A3, M109A3

Materials/Parts

Gasket (item 107, WP 0470 00)

Adhesive (item 2, WP 0468 00)

Equipment Condition

Parking brake set and wheels chocked
(TM 9-2320-361-10).

Battery ground cable disconnected
(WP 0126 00).

DOMELAMP AND HOUSING REPLACEMENT (Contd)

REMOVAL

1. Loosen screw (5) from dome light housing (12) and open dome light door (4).

NOTE

For 24V lamp replacement, push in lamp to unscrew.

2. Remove lamp (10) from dome light housing (12).
3. Remove screw (5), clip (6), washer (7), and lens (8) from dome light door (4).
4. Remove gasket (9) from dome light housing (12). Discard gasket (9).

NOTE

- Hold dome light assembly up to keep weight off wires.
- Tag wires for installation.

5. Remove four screws (11) and dome light housing (12) from ceiling (1).
6. Remove two screws (3) and wires (2) from dome light housing (12).

INSTALLATION

1. Install lens (8) on dome light door (4) with clip (6), washer (7), and screw (5).
2. Apply adhesive to new gasket (9) and install on dome light housing (12).
3. Install lamp (10) on dome light housing (12).
4. Install two wires (2) on dome light housing (12) with two screws (3).
5. Install dome light housing (12) on ceiling (1) with four screws (11).
6. Close dome light door (4) and tighten screw (5).
7. Connect battery ground cable (WP 0126 00).
8. Release parking brake and remove wheel chocks (TM 9-2320-361-10).

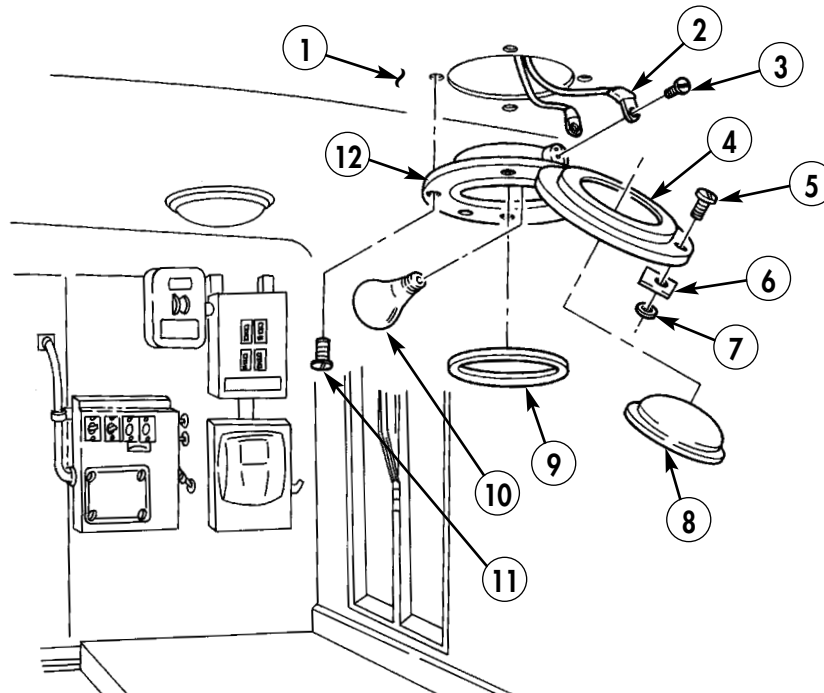

END OF WORK PACKAGE

FIELD MAINTENANCE INSTRUCTIONS

2-1/2 TON, 6X6, M44A2 SERIES TRUCKS (MULTIFUEL)

VAN DOOR REPLACEMENT

REMOVAL AND INSTALLATION

INITIAL SETUP:

Applicable Models

M185A3, M109A3

Materials/Parts

Six lockwashers (item 229, WP 0470 00)

Three locknuts (item 155, WP 0470 00)

Personnel Required

Two

Equipment Condition

Parking brake set and wheels chocked
(TM 9-2320-361-10).

Battery ground cable disconnected
(WP 0126 00).

Ladder removed (WP 0325 00).

Door handle and lock assembly removed
(WP 0305 00).

WARNING

Van door is heavy. An assistant is required during removal and installation to prevent injury to personnel.

VAN DOOR REPLACEMENT (Contd)

REMOVAL

1. Remove two screws (2) and pull door check (1) away from van door (8).
2. Remove six screws (6) and lockwashers (5) from three hinges (3) and van door (8). Discard lockwashers (5).

NOTE

Assistant will help with step 3.

3. Remove three locknuts (7), screws (4), and van door (8) from three hinges (3). Discard locknuts (7).

INSTALLATION

NOTE

Assistant will help with step 1.

1. Install van door (8) on three hinges (3) with three screws (4) and new locknuts (7).
2. Install six screws (6) and new lockwashers (5) on three hinges (3) and van door (8).
3. Install door check (1) to van door (8) with two screws (2).
4. Install door handle and lock assembly (WP 0305 00).
5. Install ladder (WP 0325 00).
6. Connect battery ground cable (WP 0126 00).
7. Release parking brake and remove wheel chocks (TM 9-2320-361-10).

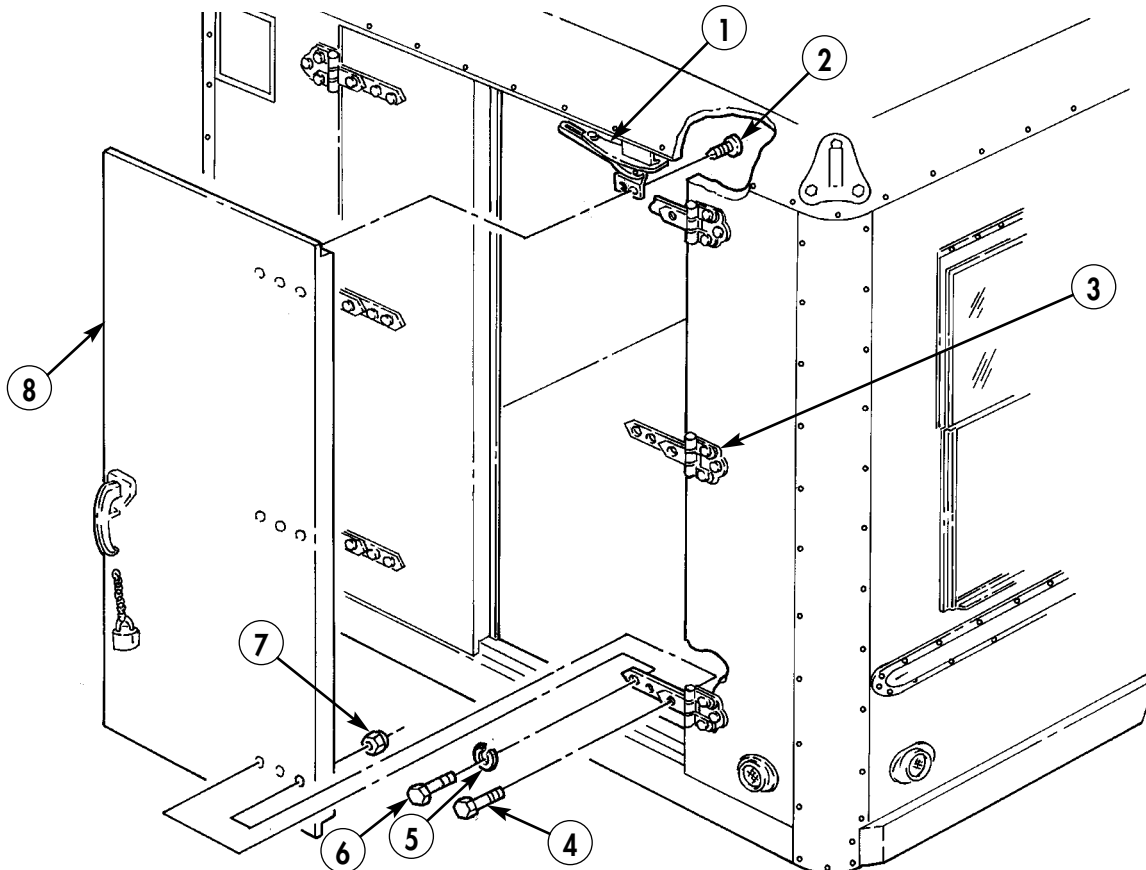

END OF WORK PACKAGE

FIELD MAINTENANCE INSTRUCTIONS

2-1/2 TON, 6X6, M44A2 SERIES TRUCKS (MULTIFUEL)

VAN DOOR SEALS REPLACEMENT REMOVAL, CLEANING, AND INSTALLATION

INITIAL SETUP:

Applicable Models

M185A3, M109A3

Materials/Parts

Two seals (item 344, WP 0470 00)
Seal (item 343, WP 0470 00)
Seal (item 345, WP 0470 00)
Seal (item 346, WP 0470 00)
Adhesive (item 5, WP 0468 00)
Skysol 100 (item 13, WP 0468 00)

Equipment Condition

Parking brake set and wheels chocked
(TM 9-2320-361-10).
Battery ground cable disconnected
(WP 0126 00).
Van doors open (TM 9-2320-361-10).
Ladder removed (WP 0325 00).

VAN DOOR SEALS REPLACEMENT (Contd)

NOTE

Secure van doors in open position.

REMOVAL

1. Remove four seals (2) from bottom, top, and side channels (3). Discard seals (2).
2. Remove seal (5) from channel (4) on left van door (1). Discard seals (5).

CLEANING

WARNING

Skysol 100 solvent is combustible; DO NOT use or store near heat, sparks, flame, or other ignition sources. Use mechanical ventilation whenever product is used in a confined space, heated above ambient temperatures, or agitated. Keep container sealed when not in use.

Contact with Skysol 100 may cause skin irritation. Use chemical-resistant gloves. In case of skin contact, remove any contaminated clothing and wash skin thoroughly with soap and water. Wash contaminated clothing before reuse. Eye contact may cause irritation, tearing, or blurring of vision. Use face shield or goggles when eye contact may occur. In case of eye contact, flush eyes with large amounts of water for at least 15 minutes or until irritation subsides. Inhalation may cause irritation to upper respiratory passages. DO NOT have food or drink in the vicinity. Failure to comply may result in injury to personnel.

Clean adhesive remains from all four sides of channel (3) and channel (4) on left van door with Skysol 100 solvent.

INSTALLATION

1. Apply adhesive to top, bottom, and side channels (5) and (4) on left van door (1).
2. Install four new seals (2) on top, bottom, and side channels (3).
3. Install new seal (5) on channel (4) on left van door (1).
4. Install ladder (WP 0325 00).
5. Close van door (TM 9-2320-361-10).
6. Connect battery ground cable (WP 0126 00).
7. Release parking brake and remove wheel chocks (TM 9-2320-361-10).

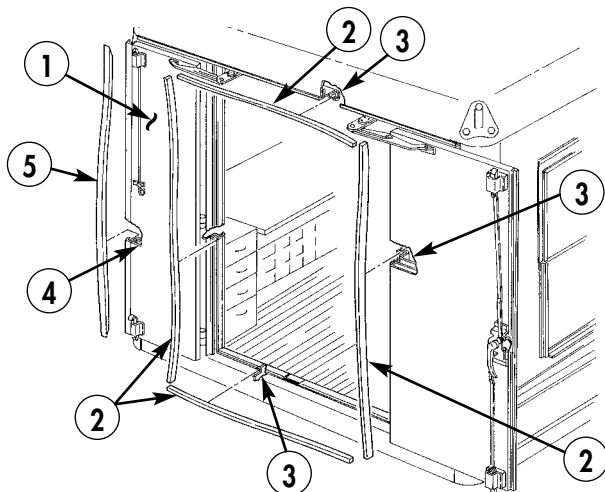

END OF WORK PACKAGE

FIELD MAINTENANCE INSTRUCTIONS

2-1/2 TON, 6X6, M44A2 SERIES TRUCKS (MULTIFUEL)

VAN DOOR MAINTENANCE

LEFT VAN DOOR DISASSEMBLY, RIGHT VAN DOOR DISASSEMBLY,
CLEANING AND INSPECTION, RIGHT VAN DOOR ASSEMBLY, AND LEFT VAN DOOR ASSEMBLY

INITIAL SETUP:

Applicable Models

M185A3, M109A3

Materials/Parts

Seventeen lockwashers (item 216, WP 0470 00)
Two screw-assembled lockwashers
(item 267, WP 0470 00)
Two cotter pins (item 27, WP 0470 00)
Cotter pin (item 35, WP 0470 00)
Skysol 100 (item 13, WP 0470 00)

Equipment Condition

Parking brake set and wheels chocked
(TM 9-2320-361-10).
Battery ground cable disconnected
(WP 0126 00).
Van door(s) removed (WP 0303 00).

VAN DOOR MAINTENANCE (Contd)

LEFT VAN DOOR DISASSEMBLY

1. Remove four screws (7), lockwashers (8), and latch (9) from van door (6). Discard lockwashers (8).
2. Remove two screws (12), lockwashers (11), and plate (10) from van door (6). Discard lockwashers (11).
3. Remove two screw-assembled lockwashers (13) and guide (14) from rod (15) and van door (6). Discard screw-assembled lockwashers (13).
4. Remove four screws (3), lockwashers (4), lock (5), and rod (15) from van door (6). Discard lockwashers (4).
5. Remove two screws (2) and holder (1) from van door (6).

RIGHT VAN DOOR DISASSEMBLY

1. Remove eight screws (32), four spacers (25), and two guides (31) from van door (24).
2. Remove cotter pin (37) and inside door handle (36) from van door (24). Discard cotter pin (37).
3. Remove four screws (30), lockwashers (29), and lock (28) from van door (24). Discard lockwashers (29).
4. Remove two screws (33), upper rod (26), and lower rod (34) from two guides (31).
5. Remove two cotter pins (27) and (35), upper rod (26), and lower rod (34) from lock (28). Discard cotter pins (27) and (35).
6. Remove two screws (17) and holder (16) from van door (24).
7. Remove three screws (18), lockwashers (19), spacer (21), and outside handle (20) from van door (24). Discard lockwashers (19).
8. Remove screw (23) and padlock (22) from van door (24).

CLEANING AND INSPECTION

1. Inspect latch (9), plates (10), guides (14) and (31), lock (28), rods (34), (15), and (26), handles (36) and (20), and doors (6) and (24) for cracks, bends, and excessive wear. Replace cracked, bent, or excessively worn components.

WARNING

Skysol 100 solvent is combustible; DO NOT use or store near heat, sparks, flame, or other ignition sources. Use mechanical ventilation whenever product is used in a confined space, heated above ambient temperatures, or agitated. Keep container sealed when not in use.

Contact with Skysol 100 may cause skin irritation. Use chemical-resistant gloves. In case of skin contact, remove any contaminated clothing and wash skin thoroughly with soap and water. Wash contaminated clothing before reuse. Eye contact may cause irritation, tearing, or blurring of vision. Use face shield or goggles when eye contact may occur. In case of eye contact, flush eyes with large amounts of water for at least 15 minutes or until irritation subsides. Inhalation may cause irritation to upper respiratory passages. DO NOT have food or drink in the vicinity. Failure to comply may result in injury to personnel.

2. Clean latch (9), plates (10), guides (14) and (31), lock (28), rods (26), (15), and (34), and handles (36) and (20) with Skysol 100 solution. Air dry all parts.

VAN DOOR MAINTENANCE (Contd)

LEFT SIDE

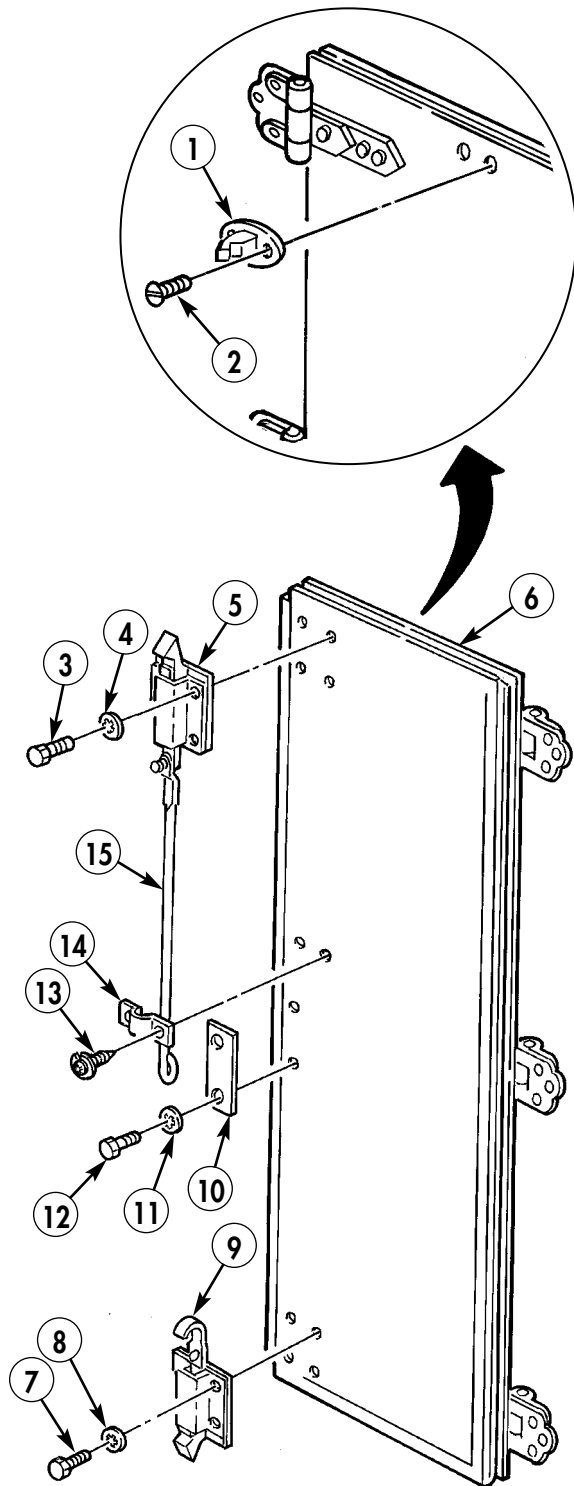

RIGHT SIDE

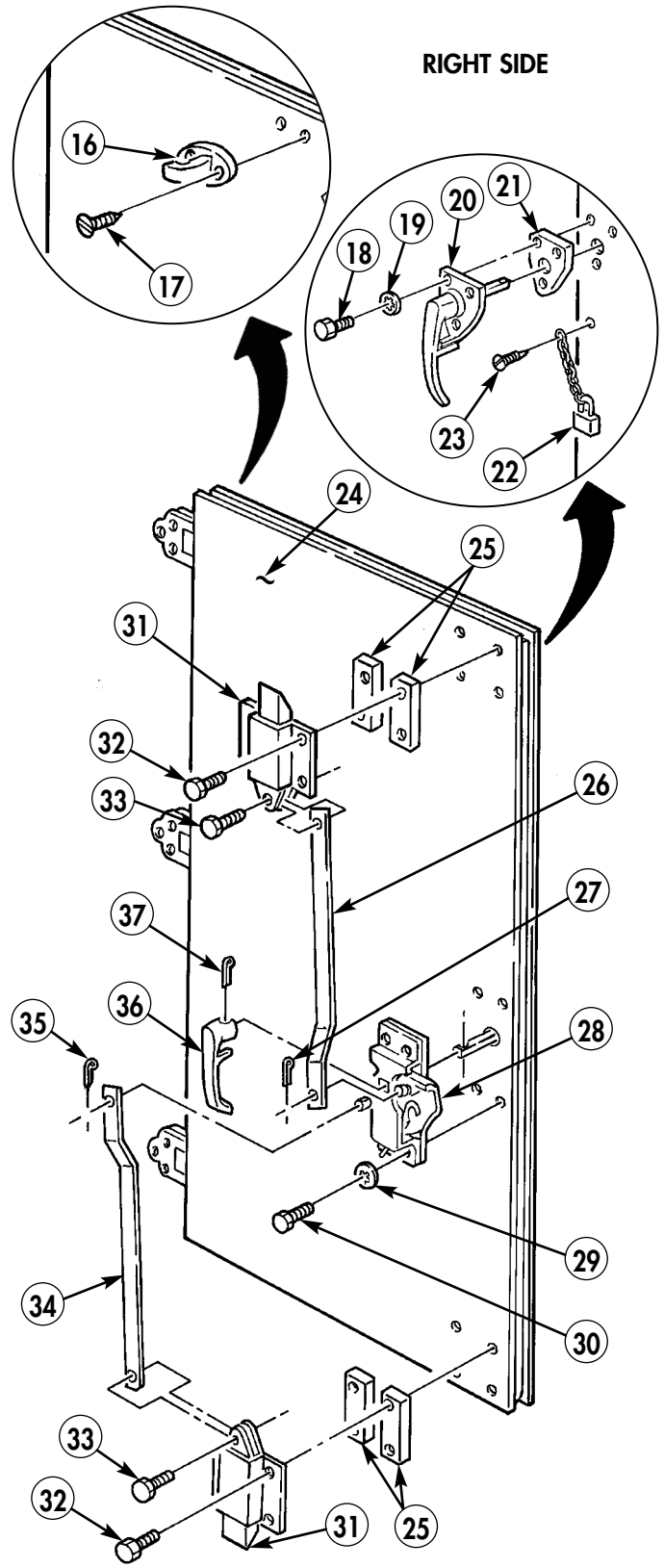

VAN DOOR MAINTENANCE (Contd)

RIGHT VAN DOOR ASSEMBLY

1. Install padlock (21) on van door (1) with screw (22).
2. Install spacer (20) and outside door handle (19) on van door (1) with three screws (17) and new lockwashers (18).
3. Install holder (16) on van door (1) with two screws (15).
4. Install upper and lower rods (11) and (3) on lock (5) with two new cotter pins (4) and (12).
5. Install rods (3) and (11) on two guides (8) with two screws (10).
6. Install lock (5) on van door (1) with four screws (7) and new lockwashers (6).
7. Install inside door handle (13) on van door (1) with new cotter pin (14).
8. Install four spacers (2) and two guides (8) on van door (1) with eight screws (9).

LEFT VAN DOOR ASSEMBLY

1. Install holder (37) on van door (26) with two screws (36).
2. Install lock (25) and rod (35) on van door (26) with four screws (23) and new lockwashers (24).
3. Install guide (34) on van door (26) with two new screw-assembled lockwashers (33).
4. Install plate (32) on van door (26) with two screws (30) and new lockwashers (31).
5. Install latch (27) on van door (26) with four screws (28) and new lockwashers (29).
6. Install van doors (WP 0303 00).
7. Connect battery ground cable (WP 0126 00).
8. Release parking brake and remove wheel chocks (TM 9-2320-361-10).

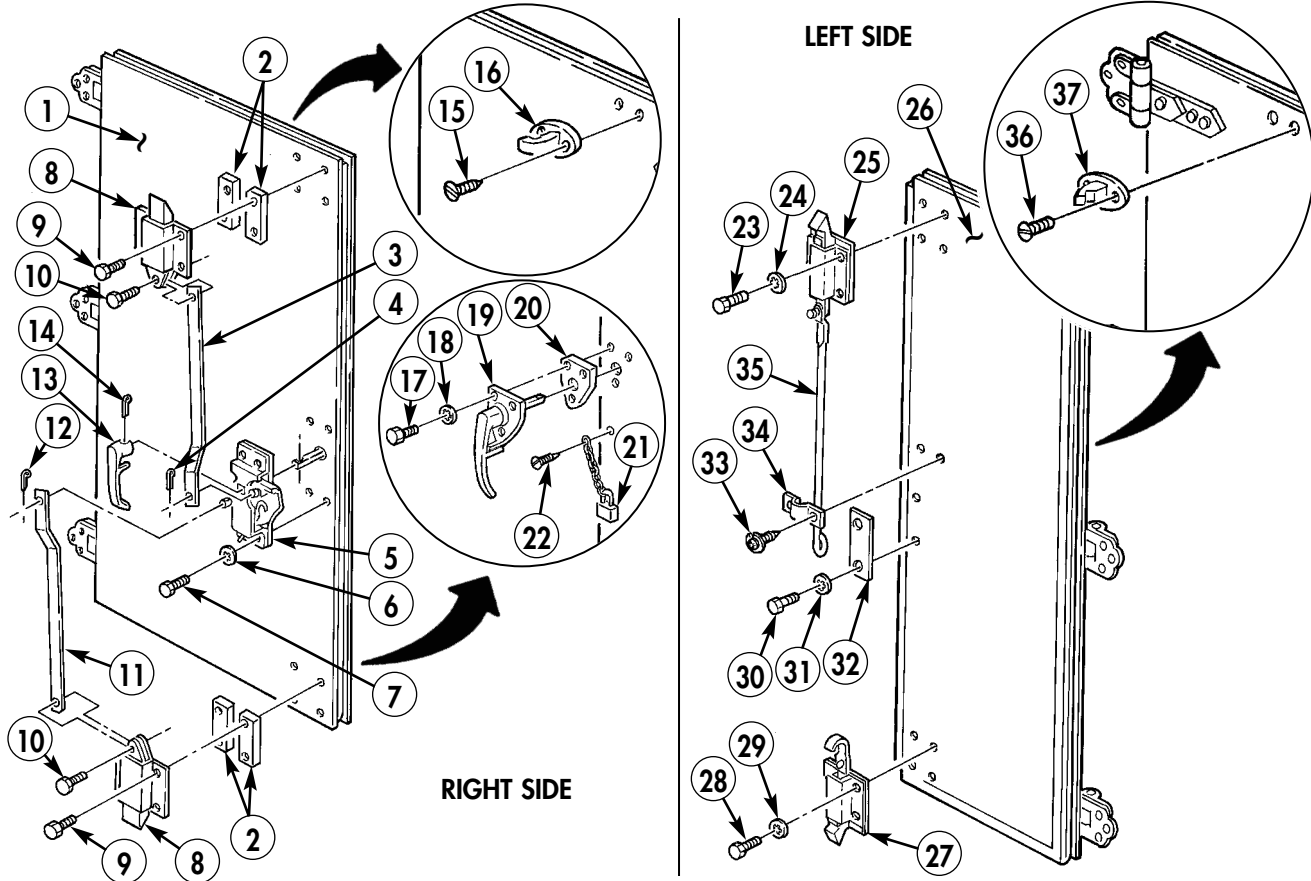

END OF WORK PACKAGE

FIELD MAINTENANCE INSTRUCTIONS

2-1/2 TON, 6X6, M44A2 SERIES TRUCKS (MULTIFUEL)

VAN BODY CABINET AND WORK BENCH TABLE REPLACEMENT

BRACKET REMOVAL, CABINET REMOVAL, DRAWER TABLE REMOVAL, SHELF TABLE REMOVAL, SHELF TABLE INSTALLATION, DRAWER TABLE INSTALLATION, CABINET INSTALLATION, AND BRACKET INSTALLATION

INITIAL SETUP:

Applicable Models

M185A3, M109A3

Tools and Special Tools

General mechanic's tool kit
(item 116, WP 0469 00)

Materials/Parts

Twelve locknuts (item 129, WP 0470 00)
Twelve locknuts (item 170, WP 0470 00)
Eight lockwashers (item 200, WP 0470 00)
Four lockwashers (item 207, WP 0470 00)

Personnel Required

Two

Equipment Condition

Parking brake set and wheels chocked
(TM 9-2320-361-10).
Battery ground cable disconnected
(WP 0126 00).

VAN BODY CABINET AND WORK BENCH TABLE REPLACEMENT (Contd)

BRACKET REMOVAL

1. Remove twelve screws (7), washers (6), washers (4), and locknuts (3) from bracket (5) and van wall (8). Discard locknuts (3).
2. Remove eight screws (25), lockwashers (24), washers (23), and bracket (5) from cabinet (14), drawer table (22), and shelf table (2). Discard lockwashers (24).

CABINET REMOVAL

1. Remove bottom cabinet drawer (17) and four screws (20) from van body floor (16).
2. Remove four nuts (9), lockwashers (10), washers (11), screws (13), brackets (12), cabinet (14), and spacer (15) from van body floor (16). Discard lockwashers (10).

DRAWER TABLE REMOVAL

NOTE

- Locknuts are removed from underside of van body.
- Assistant will help with drawer table removal.

Remove six locknuts (18), washers (19), screws (21), and drawer table (22) from van body floor (16). Discard locknuts (18).

SHELF TABLE REMOVAL

NOTE

- Locknuts are removed from underside of van body.
- Assistant will help with shelf table removal.

Remove six locknuts (27), washers (26), screws (1), and shelf table (2) from van body floor (16). Discard locknuts (27).

SHELF TABLE INSTALLATION

NOTE

- Locknuts are installed from underside of van body.
- Assistant will help with shelf table installation.

Install shelf table (2) on van body floor (16) with six screws (1), washers (26), and new locknuts (27).

DRAWER TABLE INSTALLATION

NOTE

- Locknuts are installed from underside of van body.
- Assistant will help with drawer table installation.

Install drawer table (22) on van body floor (16) with six screws (21), washers (19), and new locknuts (18).

VAN BODY CABINET AND WORK BENCH TABLE REPLACEMENT (Contd)

CABINET INSTALLATION

1. Install spacer (15) and cabinet (14) on van body floor (16) with four screws (13), brackets (12), washers (11), new lockwashers (10), nuts (9), and screws (20).
2. Install lower cabinet drawer (17) in cabinet (14).

BRACKET INSTALLATION

1. Install bracket (5) on cabinet (14), drawer table (22), and shelf table (2) with eight washers (23), new lockwashers (24), and screws (25).
2. Install twelve screws (7), washers (6), washers (4), and new locknuts (3) in bracket (5) and van body wall (8).
3. Connect battery ground cable (WP 0126 00).
4. Release parking brake and remove wheel chocks (TM 9-2320-361-10).

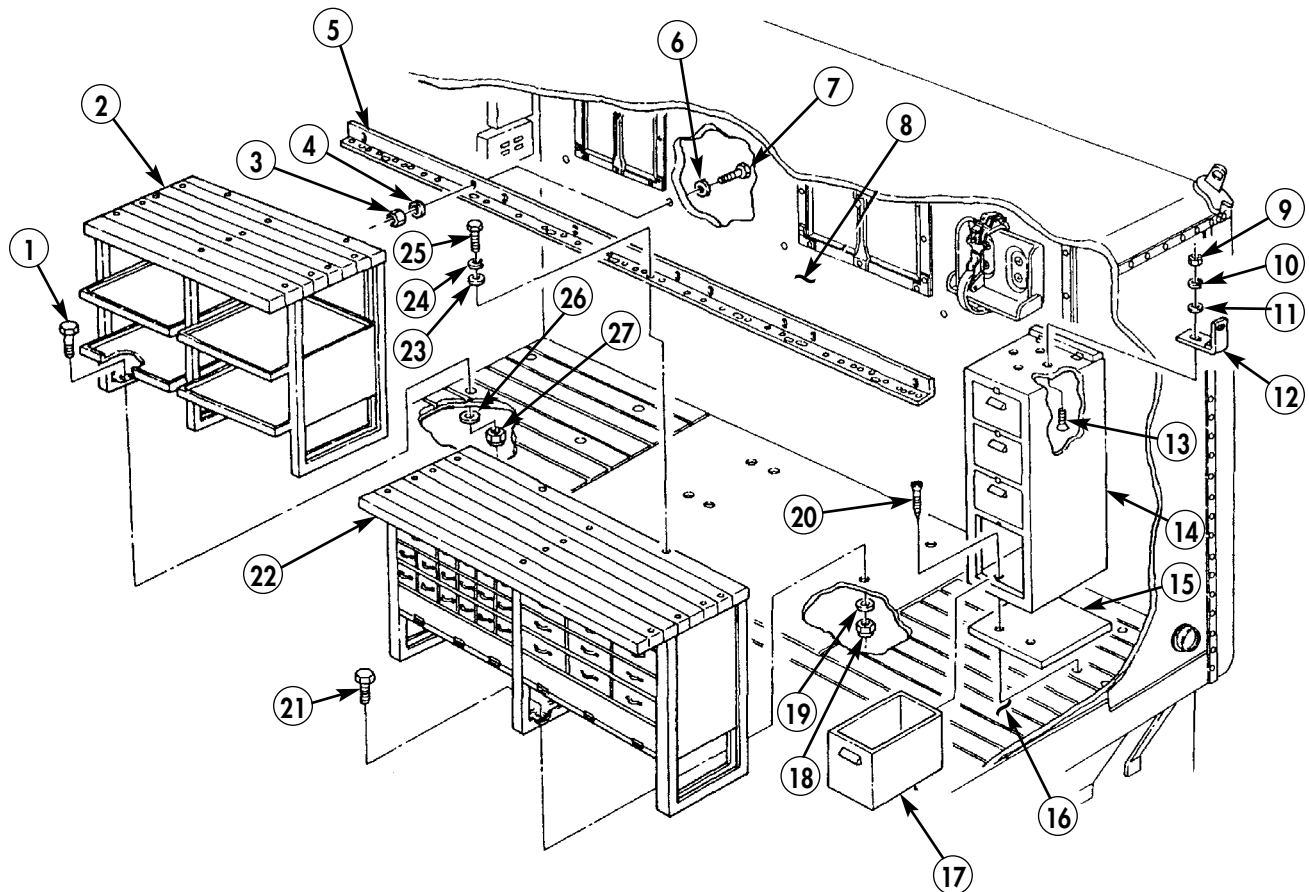

END OF WORK PACKAGE

0306 00-3/4 blank

FIELD MAINTENANCE INSTRUCTIONS

2-1/2 TON, 6X6, M44A2 SERIES TRUCKS (MULTIFUEL)

VAN BODY CEILING PANEL REPLACEMENT

REMOVAL AND INSTALLATION

INITIAL SETUP:

Applicable Models

M185A3, M109A3

Tools and Special Tools

General mechanic's tool kit
(item 116, WP 0469 00)

Personnel Required

Two

Equipment Condition

Parking brake set and wheels chocked
(TM 9-2320-361-10).
Battery ground cable disconnected
(WP 0126 00).

Equipment Condition (Contd)

Dome lights removed (WP 0302 00).
Front and side window sashes removed
(WP 0320 00 and WP 0321 00).
Exhaust blower motor and bracket removed
(WP 0301 00).
Multibreaker and safety switch boxes removed
(WP 0317 00 and WP 0318 00).
115-Volt receptacle strip removed
(WP 0312 00).
Primary or secondary van body heaters
removed (WP 0384 00).

VAN BODY CEILING PANEL REPLACEMENT (Contd)

WARNING

Gloves, eyeshields, and dust mask must be worn during panel removal and installation. Failure to do so may result in injury to personnel.

NOTE

Ceiling panels on both sides of van ceiling are removed and installed the same. This procedure covers the passenger side.

REMOVAL

1. Remove twenty screws (5) and center ceiling panel (6) from two ceiling panels (1), ceiling panel (8), and frame (2).
2. Remove thirty-two screws (7), two ceiling panels (1), and ceiling panel (8) from frame (2).

INSTALLATION

1. Position two ceiling panels (1) and ceiling panel (8) on frame (2) and align panel (1) screw holes (4) with screw holes (3) in frame (2).
2. Install two ceiling panels (1) and ceiling panel (8) with thirty-two screws (7).
3. Install center ceiling panel (6) on frame (2), two ceiling panels (1), and ceiling panel (8) with twenty screws (5).
4. Install primary or secondary van body heaters (if removed) (WP 0384 00).
5. Install 115-volt receptacle strip (WP 0312 00).
6. Install multibreaker and safety switch boxes (WP 0317 00 and WP 0318 00).
7. Install exhaust blower motor and bracket (WP 0301 00).
8. Install front and side window sashes (WP 0320 00 and WP 0321 00).
9. Install dome lights (WP 0302 00).
10. Connect battery ground cable (WP 0126 00).
11. Release parking brake and remove wheel chocks (TM 9-2320-361-10).

VAN BODY CEILING PANEL REPLACEMENT (Contd)

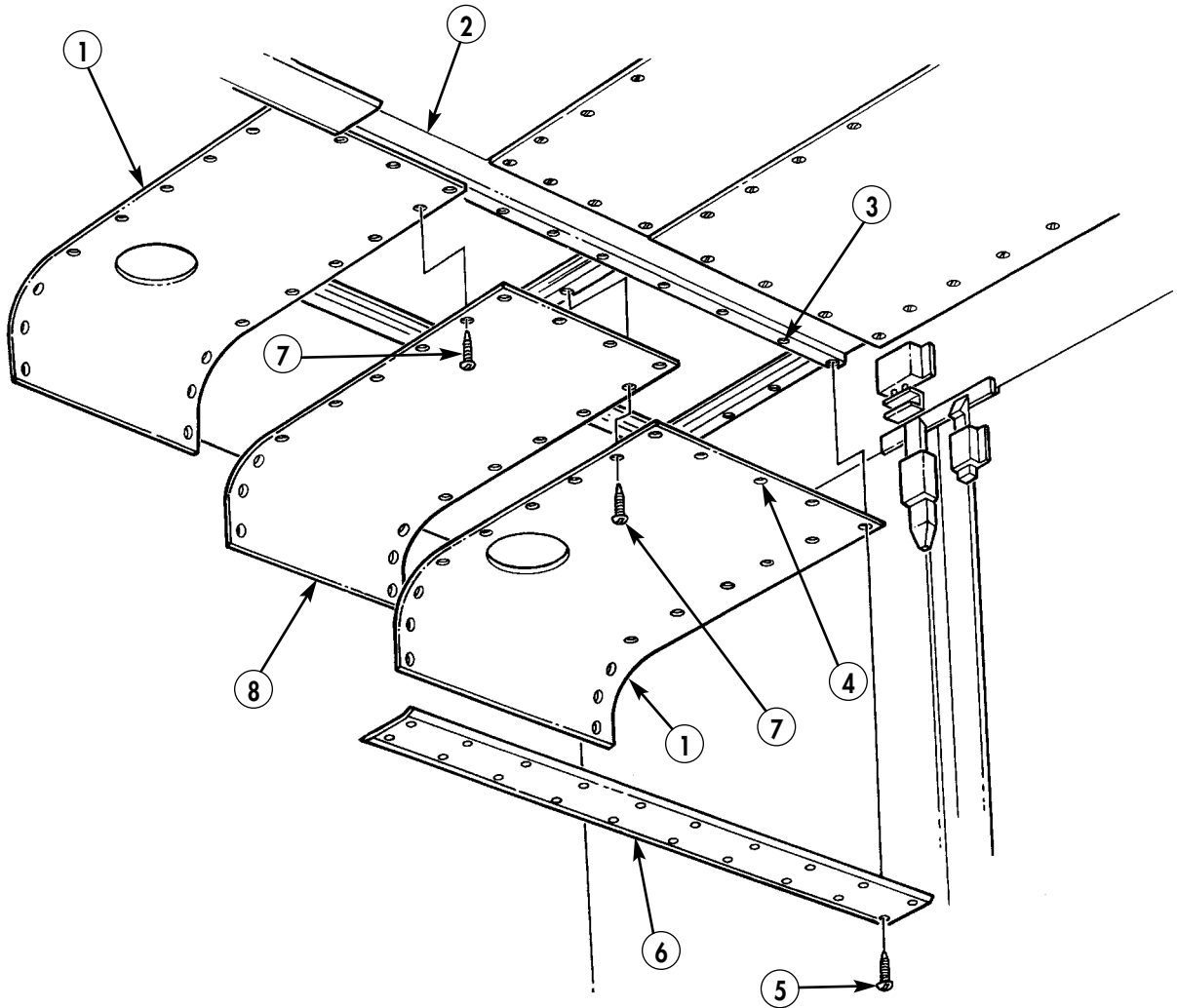

END OF WORK PACKAGE

0307 00-3/4 blank

FIELD MAINTENANCE INSTRUCTIONS

2-1/2 TON, 6X6, M44A2 SERIES TRUCKS (MULTIFUEL)

VAN BODY SIDE PANEL REPLACEMENT

REMOVAL AND INSTALLATION

INITIAL SETUP:

Applicable Models

M185A3, M109A3

Tools and Special Tools

General mechanic's tool kit
(item 116, WP 0469 00)

Personnel Required

Two

Equipment Condition

Parking brake set and wheels chocked
(TM 9-2320-361-10).

Battery ground cable disconnected
(WP 0126 00).

Van body cabinet and work benches removed
(WP 0306 00).

VAN BODY SIDE PANEL REPLACEMENT (Contd)

REMOVAL

WARNING

Gloves, eyeshields, and dust mask must be worn during panel removal and installation. Failure to do so may result in injury to personnel.

NOTE

All van body side panels are removed and installed basically the same.

Remove twenty-four screws (3) and side panel (5) from van body wall (1).

INSTALLATION

1. Place side panel (5) on van body wall (1) and align panel screw holes (4) with screw holes (2) in frame (6).
2. Install side panel (5) with twenty-four screws (3).
3. Install van body cabinet and work benches (WP 0306 00).
4. Connect battery ground cable (WP 0126 00).
5. Release parking brake and remove wheel chocks (TM 9-2320-361-10).

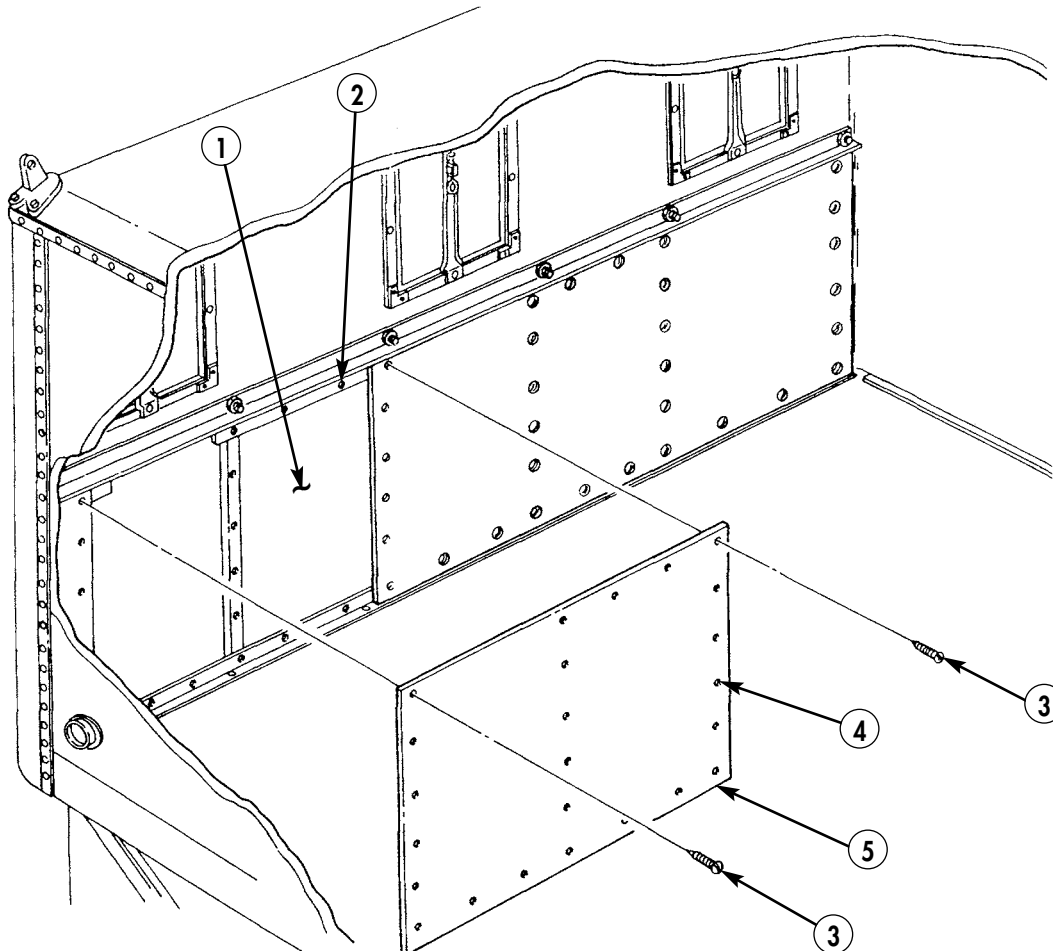

END OF WORK PACKAGE

FIELD MAINTENANCE INSTRUCTIONS

2-1/2 TON, 6X6, M44A2 SERIES TRUCKS (MULTIFUEL)

115-VOLT AC RECEPTACLE REPLACEMENT

REMOVAL AND INSTALLATION

INITIAL SETUP:

Applicable Models

M185A3, M109A3

Personnel Required

Two

Tools and Special Tools

General mechanic's tool kit
(item 116, WP 0469 00)
Electrical tool kit (item 114, WP 0469 00)

Equipment Condition

Parking brake set and wheels chocked
(TM 9-2320-361-10).
Battery ground cable disconnected
(WP 0126 00).

Materials/Parts

Gasket (item 118, WP 0470 00)
Safety wire (item 50, WP 0468 00)
Electrical tape (item 43, WP 0468 00)

115-VOLT AC RECEPTACLE REPLACEMENT (Contd)

CAUTION

Use care when removing or installing wiring harness. Excessive snagging or pulling may damage wires.

REMOVAL

NOTE

Prior to removal, tag lead wires and terminals for installation.

1. Slide handle (3) on safety switch box (2) to OFF position and open cover (5).

NOTE

Perform step 2 for M109A3 vehicles.

2. Loosen two screws (1) and remove two wires (4) from safety switch box (2).

NOTE

Perform step 3 for M185A3 vehicles.

3. Loosen two screws (7) and remove two wires (6) and two wires (4) from safety switch box (2).
4. Using electrical tape, attach safety wire (8) to two wires (4).
5. Remove four screws (11), receptacle (10), wires (4), and gasket (9) from van body (12). Discard gasket (9).
6. Remove safety wire (8) from two wires (4).

INSTALLATION

1. Using electrical tape, attach safety wire (8) to two wires (4).

NOTE

Assistant will help with step 2.

2. Pull safety wire (8) and two wires (4) through van body (12).
3. Install new gasket (9) and receptacle (10) on van body (12) with four screws (11).
4. Remove safety wire (8) from two wires (4).

NOTE

Perform step 5 for M185A3 vehicles.

5. Install two wires (4) and two wires (6) on safety switch box (2) by tightening two screws (7).

NOTE

Perform step 6 for M109A3 vehicles.

6. Install two wires (4) on safety switch box (2) by tightening two screws (1).
7. Close cover (5) on safety switch box (2) and slide handle (3) to ON position.
8. Connect battery ground cable (WP 0126 00).
9. Release parking brake and remove wheel chocks (TM 9-2320-361-10).

115-VOLT AC RECEPTACLE REPLACEMENT (Contd)

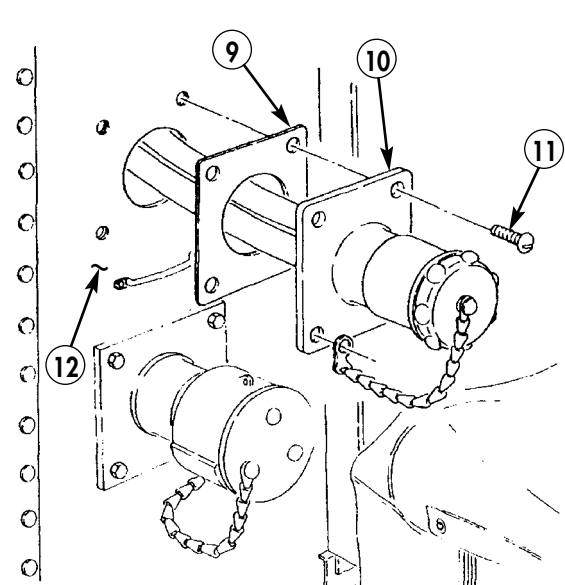
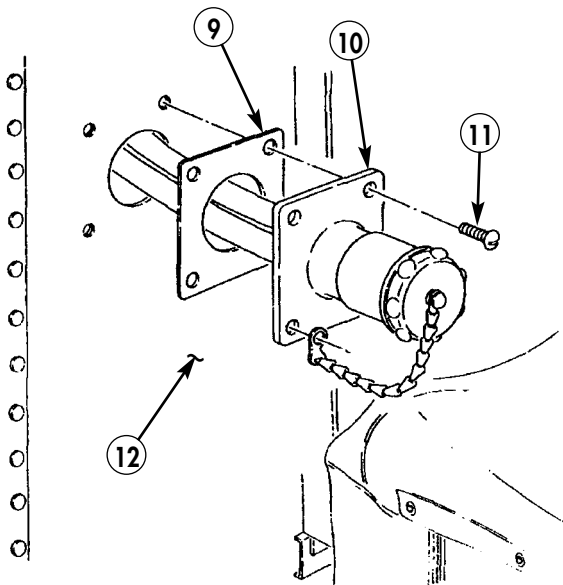
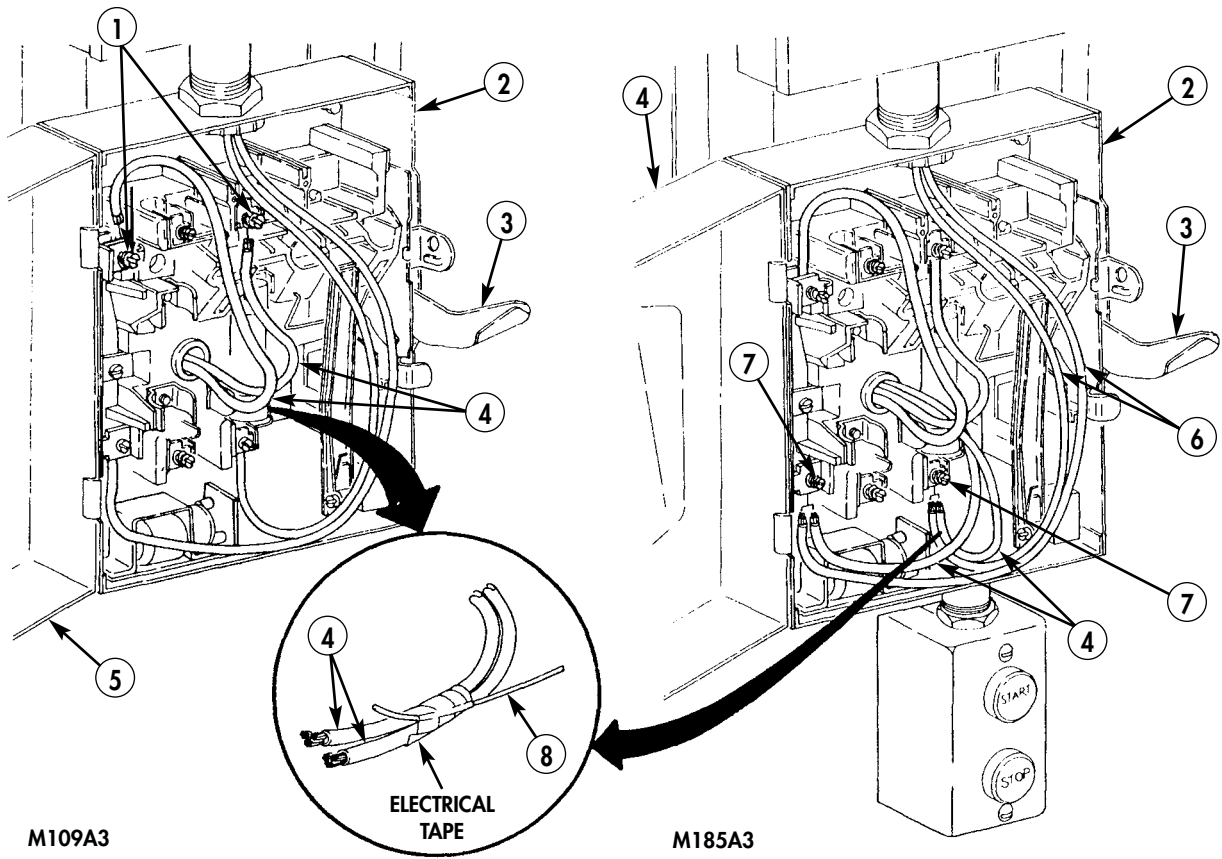

END OF WORK PACKAGE

SUSTAINMENT MAINTENANCE INSTRUCTIONS

2-1/2 TON, 6X6, M44A2 SERIES TRUCKS (MULTIFUEL)

24-VOLT DC RECEPTACLE REPLACEMENT (M185A3)

REMOVAL AND INSTALLATION

INITIAL SETUP:

Applicable Models

M185A3

Personnel Required

Two

Tools and Special Tools

General mechanic's tool kit

(item 116, WP 0469 00)

Electrical tool kit (item 114, WP 0469 00)

Equipment Condition

Parking brake set and wheels chocked

(TM 9-2320-361-10).

Battery ground cable disconnected

(WP 0126 00).

Materials/Parts

Four lockwashers (item 226, WP 0470 00)

Gasket (item 118, WP 0470 00)

Safety wire (item 49, WP 0468 00)

Electrical tape (item 43, WP 0468 00)

24-VOLT DC RECEPTACLE REPLACEMENT (M185A3) (Contd)

CAUTION

Use care when removing or installing wiring harnesses.
Excessive snagging or pulling may damage wires.

REMOVAL

NOTE

Prior to removal, tag lead wires and terminals for installation.

1. Slide handle (4) on safety switch box (3) to OFF position and open cover (1).
2. Loosen two screws (2) and remove two wires (5) from safety switch box (3).
3. Remove two screws (10) and cover (9) from START/STOP switch (8).
4. Remove three screws (7) and wires (6) from START/STOP switch (8).
5. Using electrical tape, attach safety wire (11) to two wires (5) and three wires (6).
6. Remove four screws (15), lockwashers (14), receptacle (13), two wires (5), three wires (6), and gasket (12) from van body (16). Discard gasket (12) and lockwashers (14).
7. Remove two wires (5) and three wires (6) from safety wire (11).

INSTALLATION

1. Using electrical tape, attach safety wire (11) to two wires (5) and three wires (6).

NOTE

Assistant will help with step 2.

2. Pull two wires (5) and three wires (6) through van body (16).
3. Install new gasket (12) and receptacle (13) on van body (16) with four new lockwashers (14) and screws (15).
4. Remove safety wire (11) from two wires (5) and three wires (6).
5. Install two wires (5) on safety switch box (3) by tightening two screws (2).
6. Install three wires (6) on START/STOP switch (8) with three screws (7).
7. Install cover (9) on START/STOP switch (8) with two screws (10).
8. Close cover (1) on safety switch box (3) and slide handle (4) to ON position.
9. Connect battery ground cable (WP 0126 00).
10. Release parking brake and remove wheel chocks (TM 9-2320-361-10).

24-VOLT DC RECEPTACLE REPLACEMENT (M185A3) (Contd)

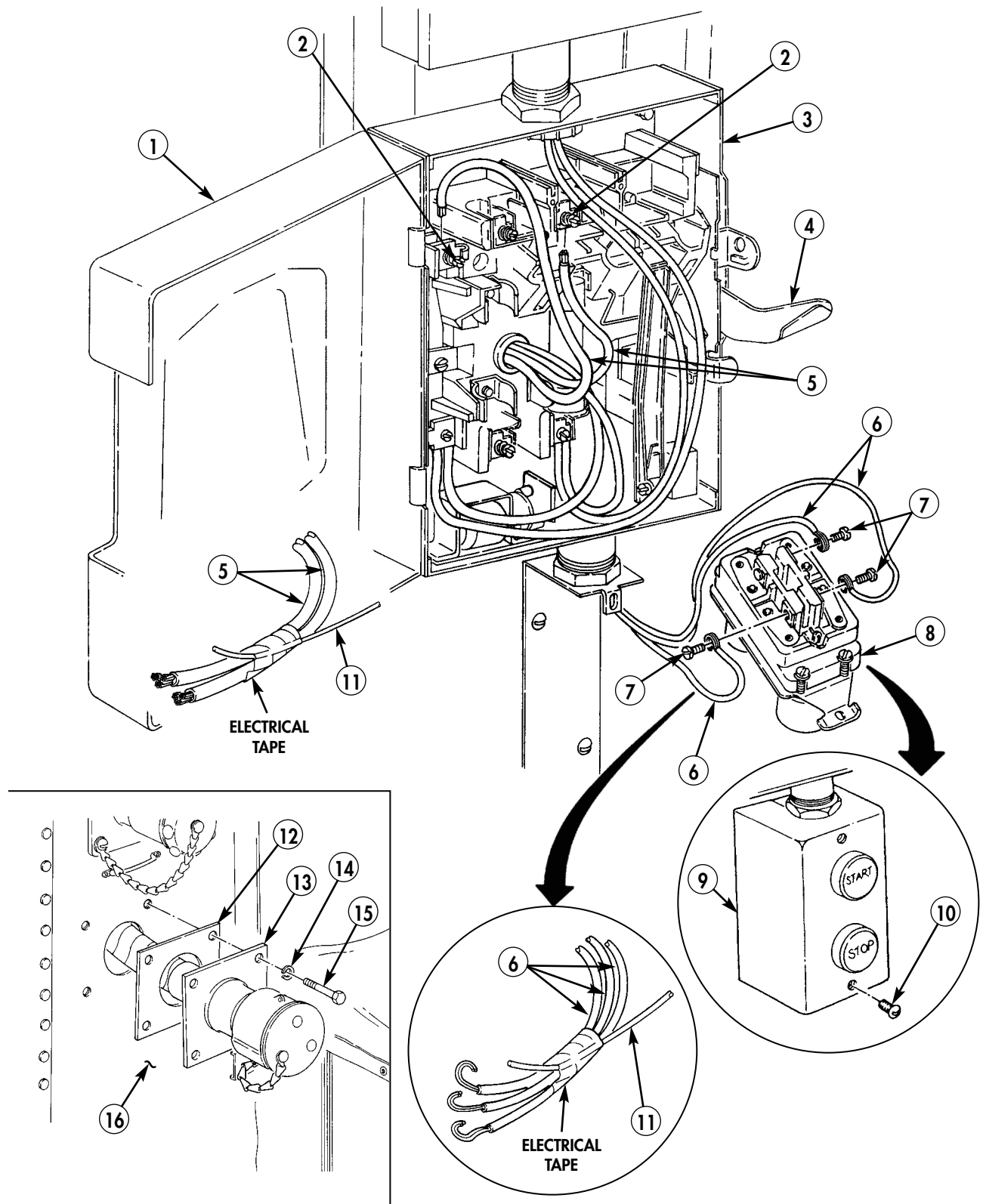

END OF WORK PACKAGE

FIELD MAINTENANCE INSTRUCTIONS

2-1/2 TON, 6X6, M44A2 SERIES TRUCKS (MULTIFUEL)

115-VOLT RECEPTACLE REPLACEMENT

REMOVAL AND INSTALLATION

INITIAL SETUP:

Applicable Models

M185A3, M109A3

Tools and Special Tools

General mechanic's tool kit

(item 116, WP 0469 00)

Electrical tool kit (item 114, WP 0469 00)

Equipment Condition

Parking brake set and wheels chocked

(TM 9-2320-361-10).

Battery ground cable disconnected

(WP 0126 00).

Safety switch in OFF position

(TM 9-2320-361-10).

115-VOLT RECEPTACLE REPLACEMENT (Contd)

REMOVAL

NOTE

Prior to removal, tag lead wires, terminals, and cables for installation.

1. Remove cap (1), clip (2), and cover (3) from base (5) on van wall (4).
2. Remove two screws (7) from receptacle (6) and retainers (8).
3. Pull receptacle (6) away from van wall (4).
4. Loosen three screws (10) and remove six wire leads (9) from receptacle (6).
5. Remove receptacle (6) from van wall (4).
6. Remove two retainers (8) from base (5).

INSTALLATION

1. Install two retainers (8) on base (5).
2. Install six wire leads (9) on receptacle (6) by tightening three screws (10).
3. Install receptacle (6) on two retainers (8) with two screws (7).
4. Install cover (3), clip (2), and cap (1) on base (5).
5. Connect battery ground cable (WP 0126 00).
6. Place safety switch in ON position (TM 9-2320-361-10).
7. Release parking brake and remove wheel chocks (TM 9-2320-361-10).

115-VOLT RECEPTACLE REPLACEMENT (Contd)

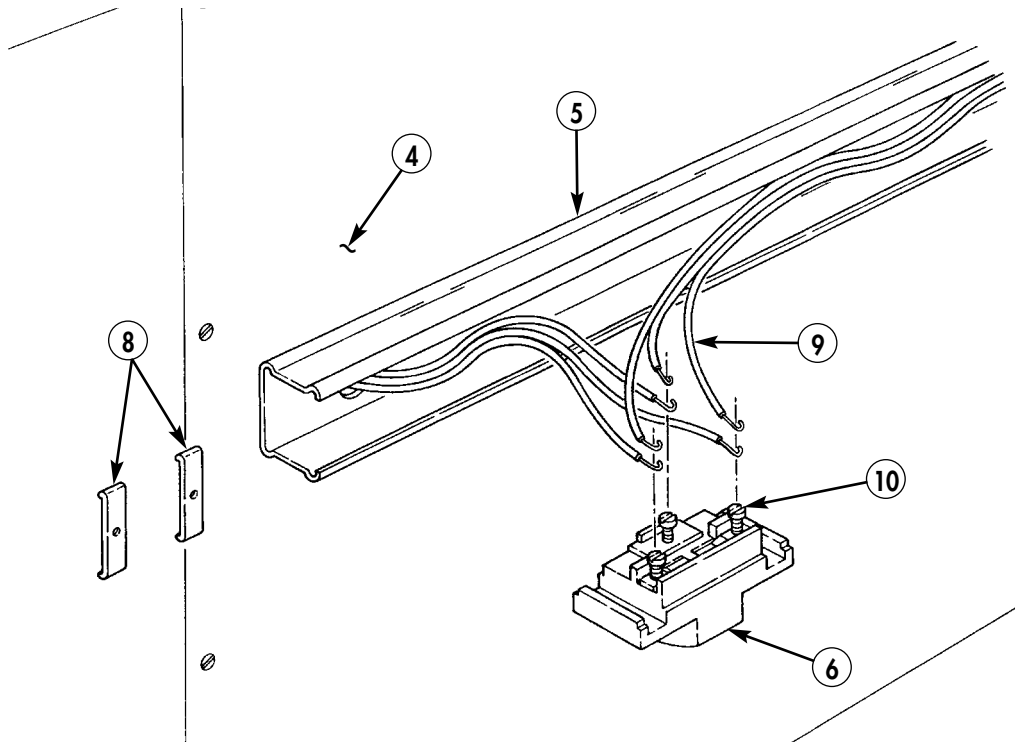
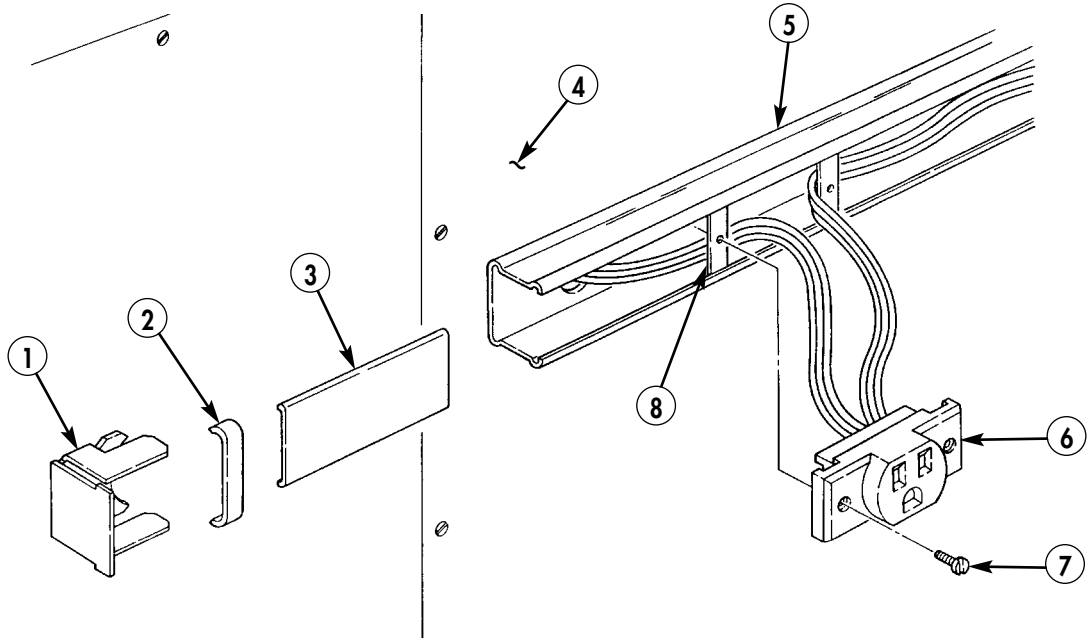

END OF WORK PACKAGE

FIELD MAINTENANCE INSTRUCTIONS

2-1/2 TON, 6X6, M44A2 SERIES TRUCKS (MULTIFUEL)

115-VOLT RECEPTACLE STRIP REPLACEMENT

REMOVAL AND INSTALLATION

INITIAL SETUP:

Applicable Models

M185A3, M109A3

Tools and Special Tools

General mechanic's tool kit
(item 116, WP 0469 00)

Equipment Condition

Parking brake set and wheels chocked
(TM 9-2320-361-10).

Battery ground cable disconnected
(WP 0126 00).

115-Volt receptacles removed (WP 0311 00).

REMOVAL

1. Remove five screws (3) from receptacle strip (1).
2. Remove receptacle strip (1) from van wall (2).

INSTALLATION

1. Position receptacle strip (1) on van wall (2).
2. Install receptacle strip (1) on van wall (2) with five screws (3).
3. Install 115-volt receptacles (WP 0311 00).
4. Connect battery ground cable (WP 0126 00).
5. Release parking brake and remove wheel chocks (TM 9-2320-361-10).

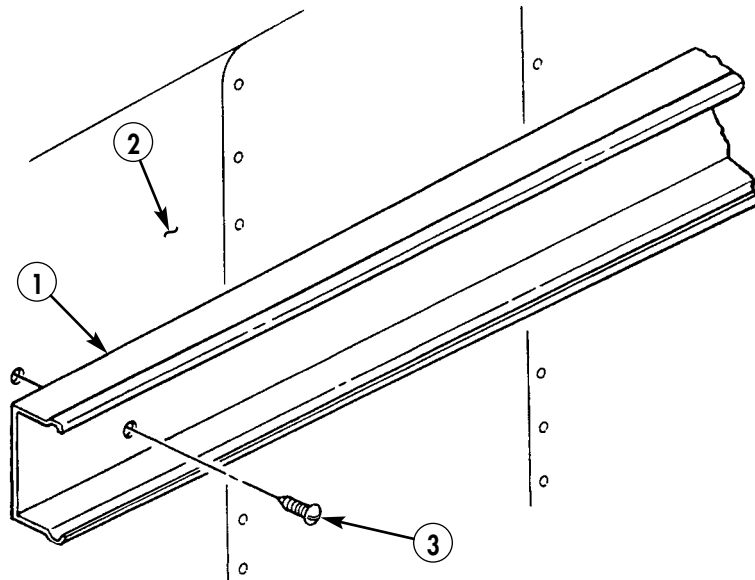

END OF WORK PACKAGE

0312 00-1/2 blank

FIELD MAINTENANCE INSTRUCTIONS

2-1/2 TON, 6X6, M44A2 SERIES TRUCKS (MULTIFUEL)

115-VOLT WIRING HARNESS REPLACEMENT

REMOVAL AND INSTALLATION

INITIAL SETUP:

Applicable Models

M185A3, M109A3

Tools and Special Tools

General mechanic's tool kit
(item 116, WP 0469 00)
Electrical tool kit (item 114, WP 0469 00)

Materials/Parts

Electrical tape (item 43, WP 0468 00)

Equipment Condition

Parking brake set and wheels chocked
(TM 9-2320-361-10).
Battery ground cable disconnected
(WP 0126 00).
115-Volt receptacles removed (WP 0311 00).

NOTE

Both 115-volt receptacle wiring harnesses are replaced the same way. This procedure covers one harness.

REMOVAL

NOTE

Prior to removal, tag lead wires, cables, and terminals for installation.

1. Remove electrical tape from connectors (4).
2. Cut receptacle wiring harness (3) from main wiring harness (1) at connectors (4).
3. Remove receptacle wiring harness (3) from receptacle strip (2).

INSTALLATION

1. Place receptacle wiring harness (3) in receptacle strip (2).
2. Connect receptacle wiring harness (3) to main wiring harness (1) at connectors (4).
3. Wrap connectors (4) with electrical tape.
4. Install 115-volt receptacles (WP 0311 00).
5. Connect battery ground cable (WP 0126 00).
6. Release parking brake and remove wheel chocks (TM 9-2320-361-10).

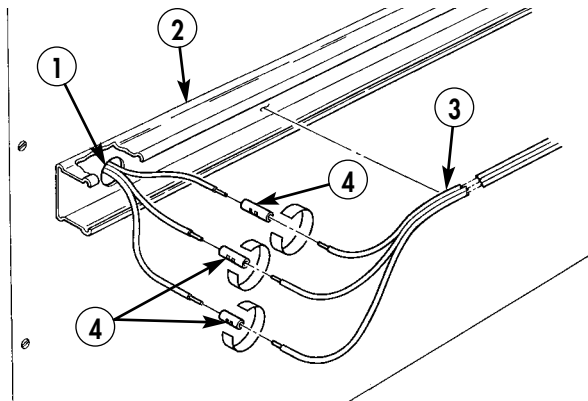

END OF WORK PACKAGE

0313 00-1/2 blank

FIELD MAINTENANCE INSTRUCTIONS

2-1/2 TON, 6X6, M44A2 SERIES TRUCKS (MULTIFUEL)

WIRE PLUG WIRING HARNESS REPLACEMENT (M109A3)

REMOVAL AND INSTALLATION

INITIAL SETUP:

Applicable Models

M109A3

Tools and Special Tools

General mechanic's tool kit
(item 116, WP 0469 00)

Materials/Parts

Electrical tape (item 43, WP 0468 00)
Safety wire (item 49, WP 0468 00)

Equipment Condition

Parking brake set and wheels chocked
(TM 9-2320-361-10).
Battery ground cable disconnected
(WP 0126 00).
Safety switch in OFF position
(TM 9-2320-361-10).

WIRE PLUG WIRING HARNESS REPLACEMENT (M109A3) (Contd)

CAUTION

Use care when removing or installing wiring harnesses.
Excessive snagging or pulling may damage wires.

REMOVAL

NOTE

Prior to removal, tag leads wires, cables, and terminals for installation.

1. Remove eight screws (1) from two housings (2) and van wall (3).
2. Remove two snaprings (8) from two wire plugs (7).
3. Remove two wire plugs (7) from two housings (2).

NOTE

Safety wire will be used to install new wiring harness. Do not cut safety wire from spool until wiring harness has been pulled through van wall and proper length has been obtained.

4. Using electrical tape, attach safety wire (5) to one end of wiring harness (4).
5. Pull on other end of wiring harness (4) and remove wiring harness (4) from van wall (3).
6. Remove wiring harness (4) from safety wire (5).
7. Cut safety wire (5) from spool (6).

INSTALLATION

1. Attach safety wire (5) to one end of wiring harness (4).
2. Pull safety wire (5) and wiring harness (4) through van wall (3).
3. Remove safety wire (5) from wiring harness (4).
4. Position two snaprings (8) on two wire plugs (7).
5. Install two snaprings (8) and two wire plugs (7) in two housings (2).
6. Install two housings (2) on van wall (3) with eight screws (1).
7. Connect battery ground cable (WP 0126 00).
8. Place safety switch in ON position (TM 9-2320-361-10).
9. Release parking brake and remove wheel chocks (TM 9-2320-361-10).

WIRE PLUG WIRING HARNESS REPLACEMENT (M109A3) (Contd)

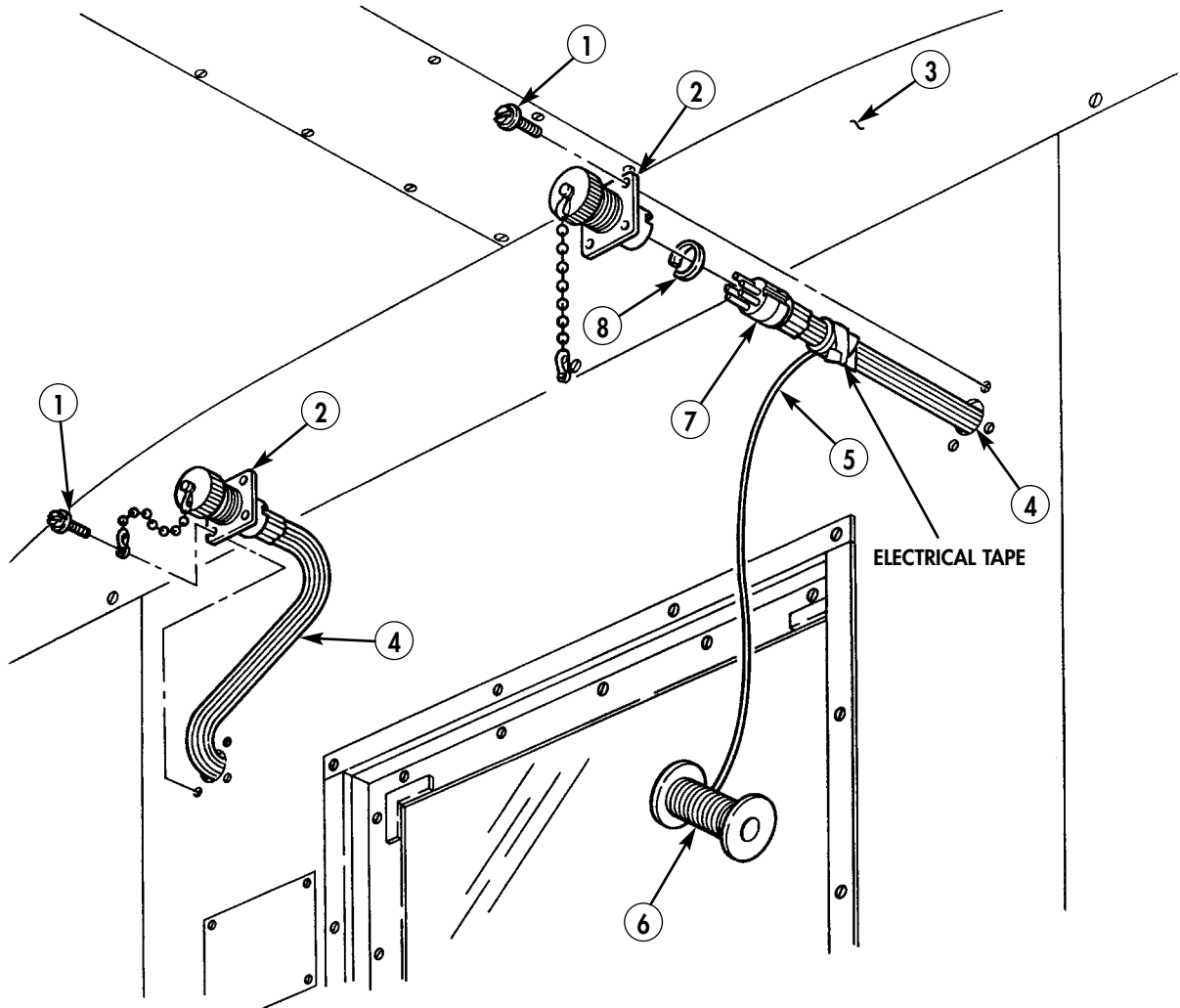

END OF WORK PACKAGE

0314 00-3/4 blank

FIELD MAINTENANCE INSTRUCTIONS

2-1/2 TON, 6X6, M44A2 SERIES TRUCKS (MULTIFUEL)

115- AND 24-VOLT WIRING HARNESS REPLACEMENT

REMOVAL AND INSTALLATION

INITIAL SETUP:

Applicable Models

M185A3, M109A3

Tools and Special Tools

General mechanic's tool kit
(item 116, WP 0469 00)
Electrical tool kit (item 114, WP 0469 00)
Pipe wrench (item 132, WP 0469 00)
1-1/4-in. Open-end wrench
(item 127, WP 0469 00)

Materials/Parts

Twenty-one lockwashers
(item 242, WP 0470 00)
Electrical tape (item 43, WP 0468 00)
Safety wire (item 49, WP 0468 00)

Equipment Condition

Parking brake set and wheels chocked
(TM 9-2320-361-10).
Battery ground cable disconnected
(WP 0126 00).
Lamp and dome light assemblies removed
(WP 0302 00).
24-Volt DC receptacle removed (M185A3)
(WP 0310 00).
115-Volt AC receptacle removed (WP 0309 00).
Power switch removed (WP 0334 00).
Blower motor receptacle removed
(WP 0338 00).
Converter receptacle removed (WP 0331 00).
Blackout light switches removed (WP 0339 00).

115- AND 24-VOLT WIRING HARNESS REPLACEMENT (Contd)

CAUTION

Use care when removing wiring harnesses. Excessive snagging or pulling may damage wires.

NOTE

Prior to removal, tag lead wires, cables, and terminals for installation.

REMOVAL

NOTE

All three ceiling panels are removed the same. This procedure covers the removal of one ceiling panel.

1. Remove ten screws (3) and center ceiling panel (4) from van body ceiling (1).

NOTE

- Safety wire will be used to install new wiring harness. Do not cut safety wire from spool until harness has been pulled from van and proper length has been obtained.
- Safety wire must be attached to wires with electrical tape.

2. Attach safety wire (8) to wires (7), (10), and (11).
3. Bend tabs (2) out of the way.
4. Pull wiring harness (6) out of van body rear wall (5).
5. Remove safety wire (8) from wires (7), (10), and (11). Cut safety wire (8) from spools (9).

115- AND 24-VOLT WIRING HARNESS REPLACEMENT (Contd)

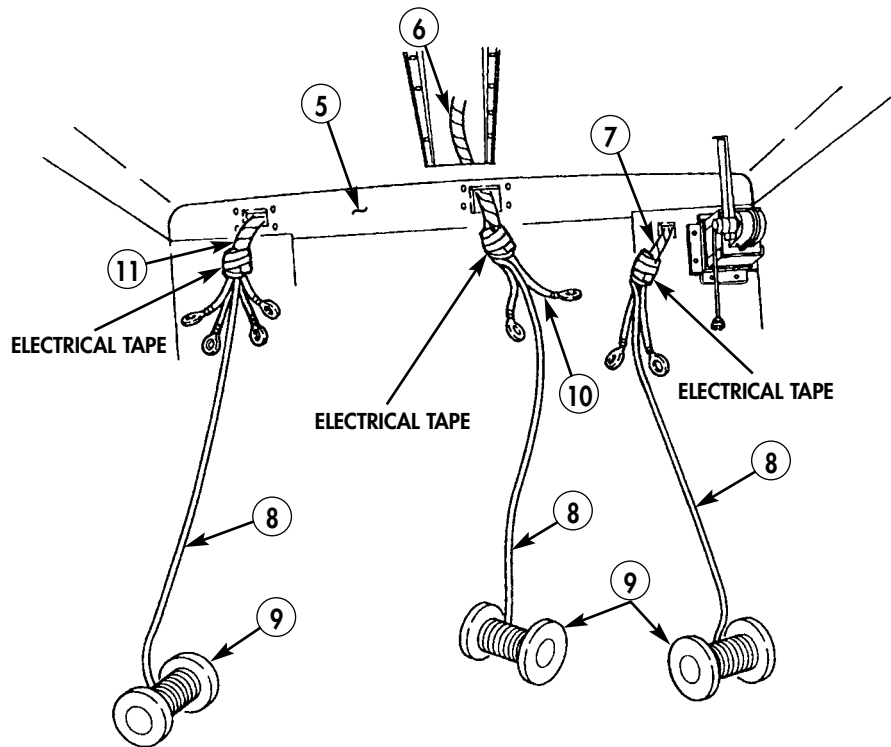
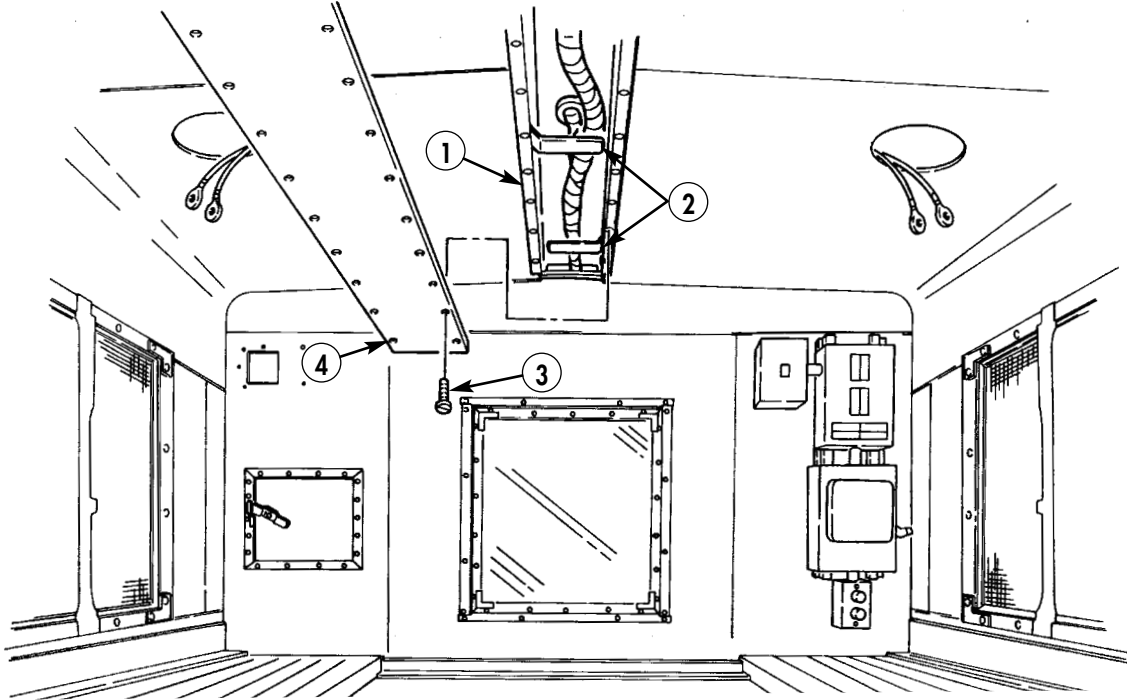

115- AND 24-VOLT WIRING HARNESS REPLACEMENT (Contd)

REMOVAL (Contd)

NOTE

Perform steps 6 and 7 on each side of van.

6. Remove cap (1), clip (2), and cover (3) from receptacle strip (4).
7. Pull receptacle wires (6) forward, remove electrical tape from connectors (7) and cut receptacle wires (6) from main wiring harness (5).

NOTE

Safety wire must be used to install new wiring harness. Do not cut safety wire from spool until harness has been pulled from van and proper length has been obtained.

8. Attach safety wire (15) to 115-volt domelight wires (13).
9. Pull 115-volt domelight wires (13) out of van body (8).
10. Remove safety wire (15) from 115-volt domelight wires (13).
11. Cut safety wire (15) from spool (14).
12. Attach safety wire (15) to 24-volt domelight wires (12).
13. Pull 24-volt domelight wires (12) out of van body (8).
14. Remove safety wire (15) from 24-volt domelight wires (12).
15. Cut safety wire (15) from spool (14).
16. Attach safety wire (15) to 115-volt domelight wires (11).
17. Pull 115-volt domelight wires (11) out of van body (8).
18. Remove safety wire (15) from 115-volt domelight wires (11).
19. Cut safety wire (15) from spool (14).
20. Attach safety wire (15) to 24-volt domelight wires (10).

NOTE

Both 115-volt receptacle connections are removed the same.
This procedure covers one connection.

21. Attach safety wire (15) to 115-volt receptacle connections (16).
22. Pull 24-volt domelight wires (10) and 115-volt receptacle connections (16) out of van body (8).
23. Remove safety wire (15) from wires (10) and 115-volt receptacle connections (16).
24. Cut safety wire (15) from spool (14).
25. Attach safety wire (15) to 115-volt domelight wires (9).
26. Pull 115-volt domelight wires (9) out of van body (8).
27. Remove safety wire (15) from wires (9).
28. Cut safety wire (15) from spool (14).

115- AND 24-VOLT WIRING HARNESS REPLACEMENT (Contd)

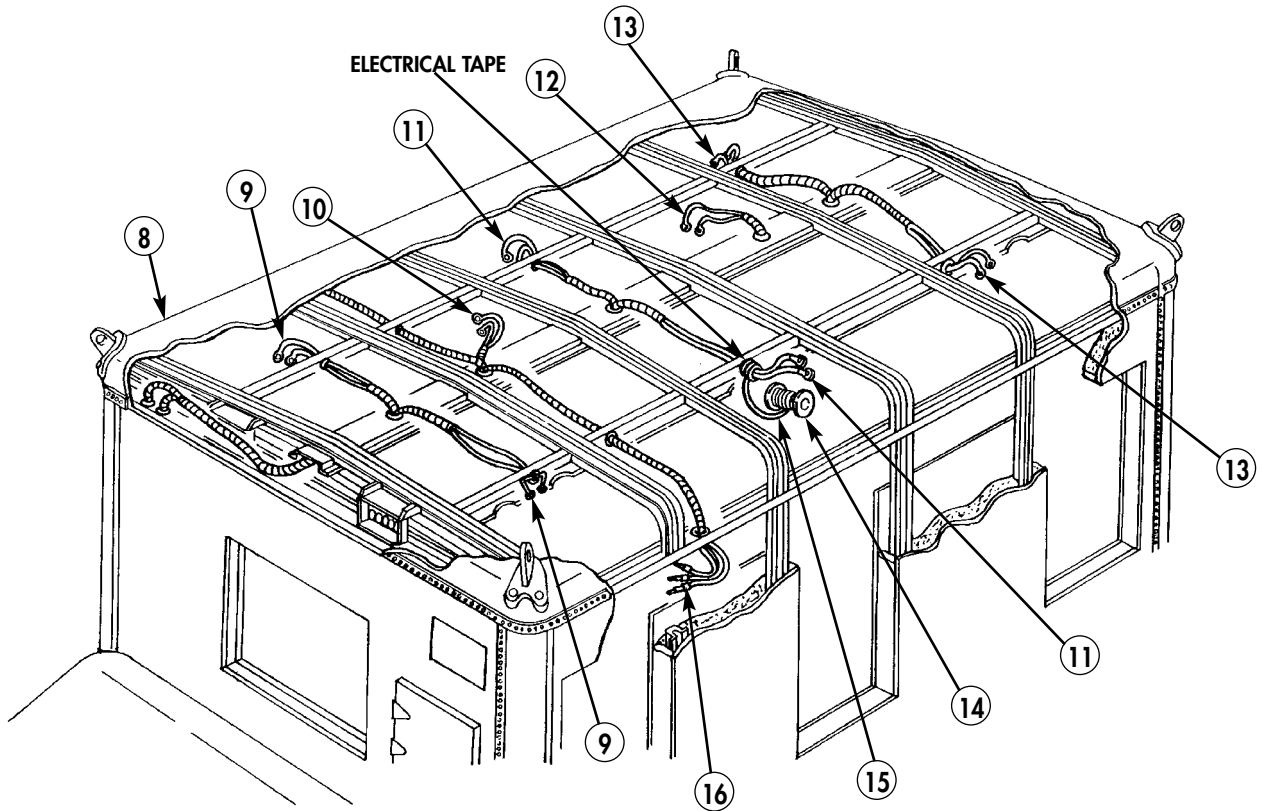
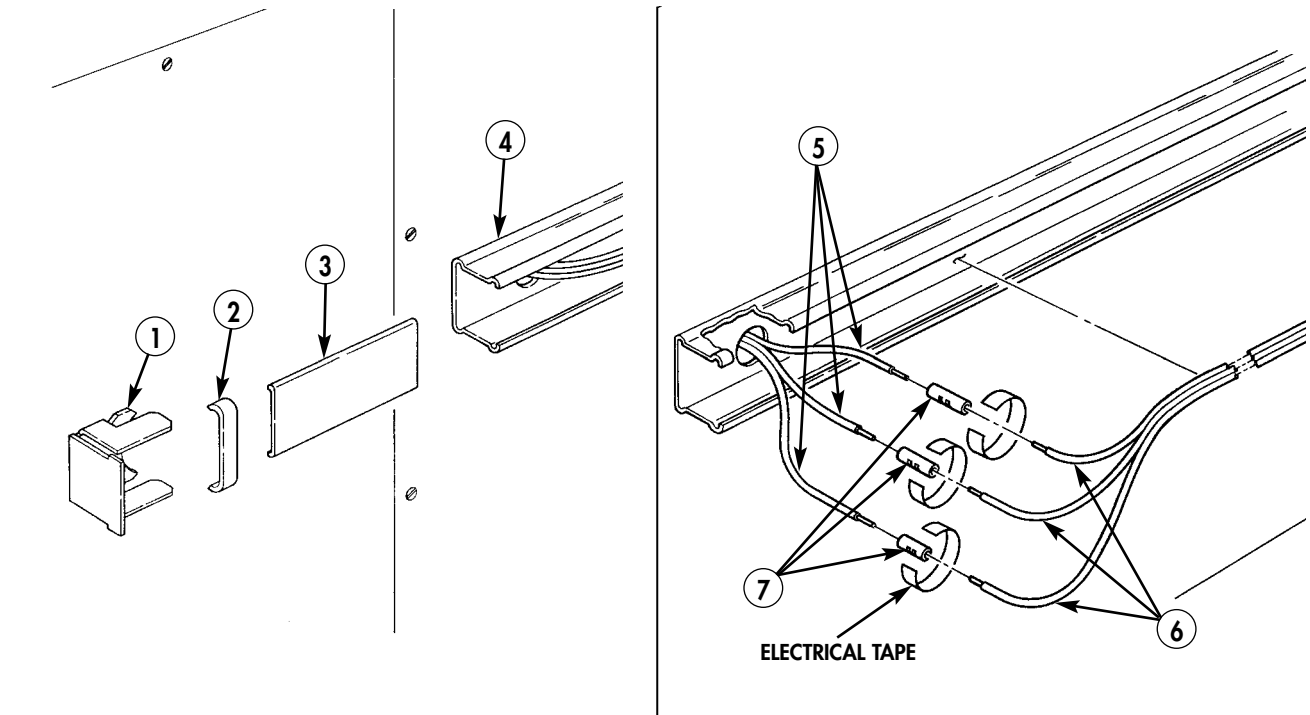

115- AND 24-VOLT WIRING HARNESS REPLACEMENT (Contd)

REMOVAL (Contd)

29. Remove four screws (4), lockwashers (3), and cover (5) from multibreaker box (2). Discard lockwashers (3).
30. Remove four screws (6), lockwashers (7), and cover (8) from blackout switch (1). Discard lockwashers (7).
31. Remove five screws (12), lockwashers (11), and wires (9), (10), (13), (14), (15), (16), and (17) from blackout switch (1).

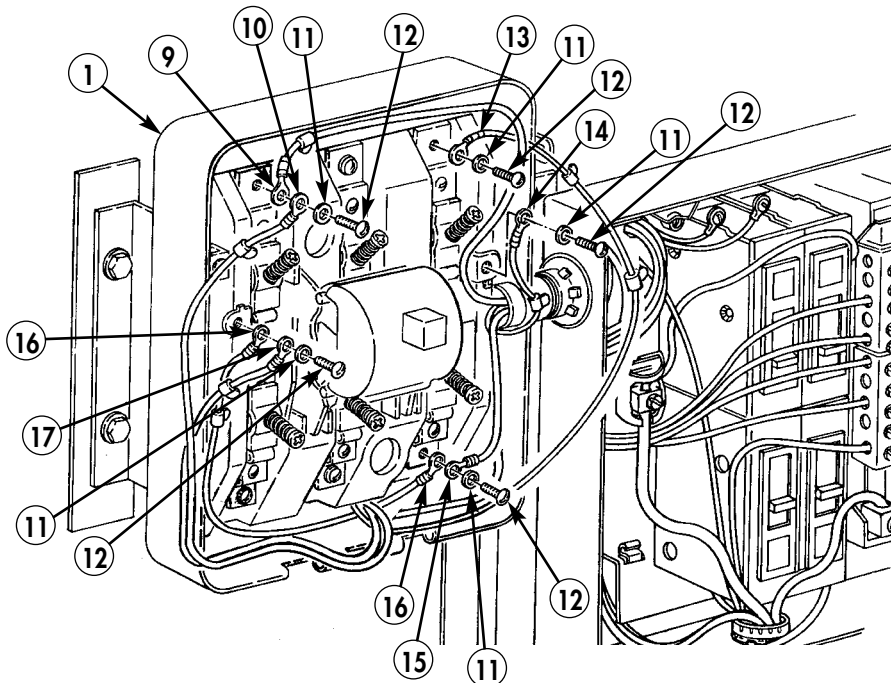
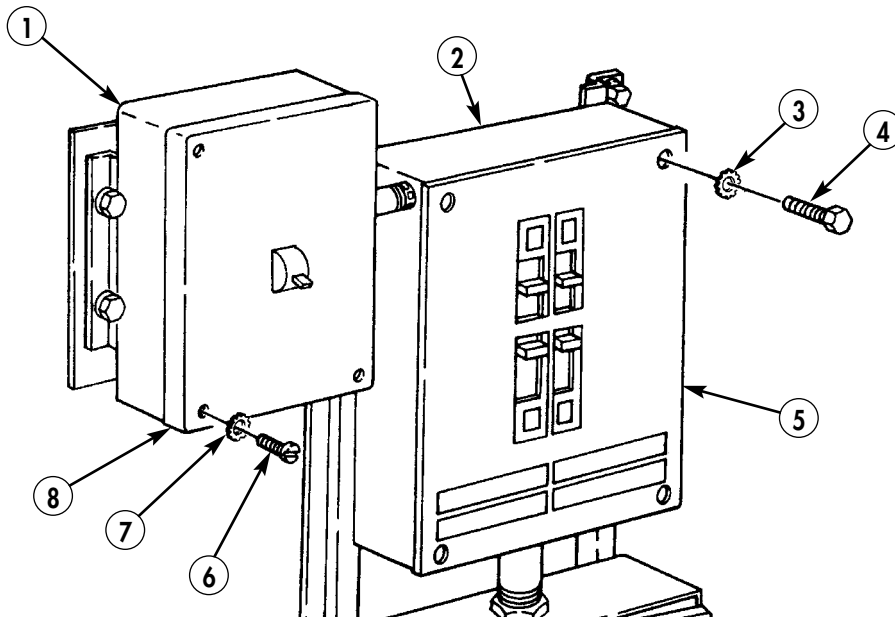

115- AND 24-VOLT WIRING HARNESS REPLACEMENT (Contd)

REMOVAL (Contd)

32. Remove four screws (20) and wires (18) from multibreaker box (2).
33. Loosen five screws (22) and remove five wires (19) from multibreaker box (2).
34. Loosen two screws (23) and remove three wires (21) from multibreaker box (2).
35. Remove capnut (28), wires (27) and (26), and nut (25) from safety switch box (24).

NOTE

Perform step 36 for M109A3 vehicles.

36. Loosen two screws (29) and remove wires (30) and (31) from safety switch box (24)

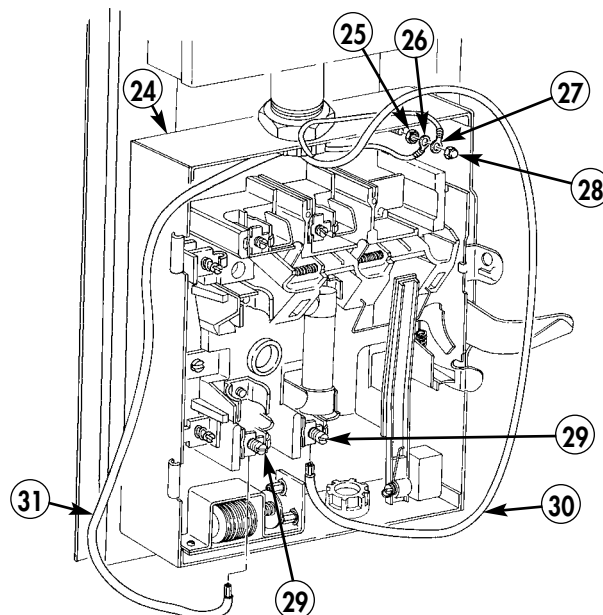
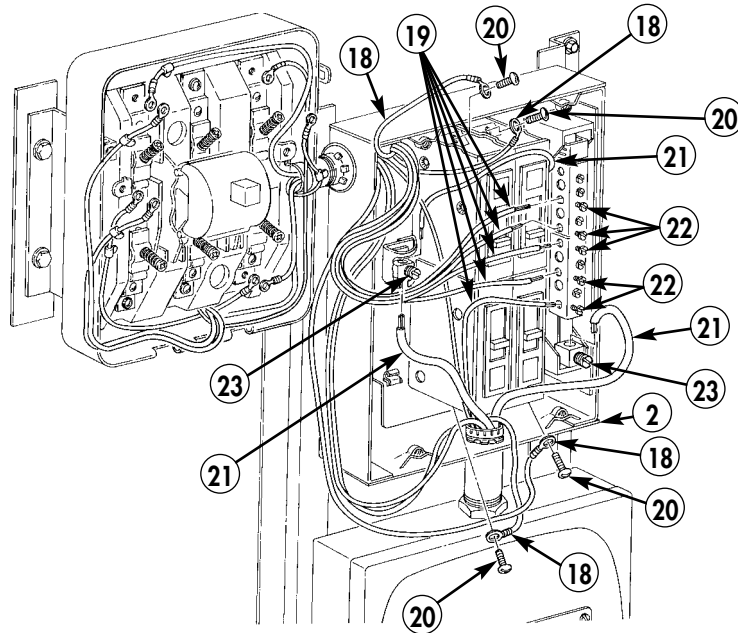

115- AND 24-VOLT WIRING HARNESS REPLACEMENT (Contd)

REMOVAL (Contd)

37. Remove bushing (3) from nipple (2) and blackout switch (4).
38. Remove two nuts (5), lockwashers (6), and blackout switch (4) from mounting bracket (1). Discard lockwashers (6).
39. Remove bushing (9) from nipple (12) and multibreaker box (8).
40. Remove two nuts (10), lockwashers (11), and multibreaker box (8) from mounting brackets (7) and nipple (12). Discard lockwasher (11).

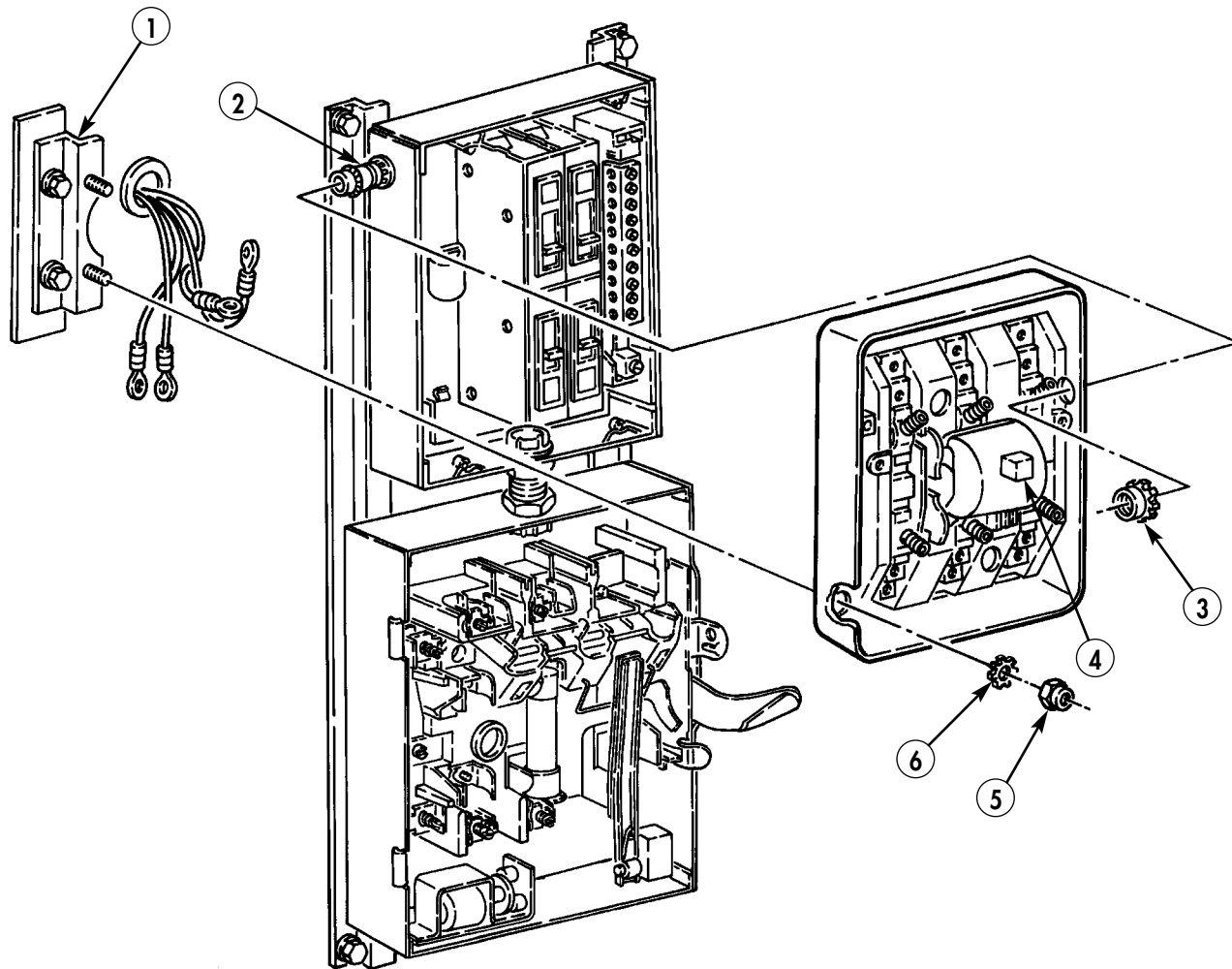

115- AND 24-VOLT WIRING HARNESS REPLACEMENT (Contd)

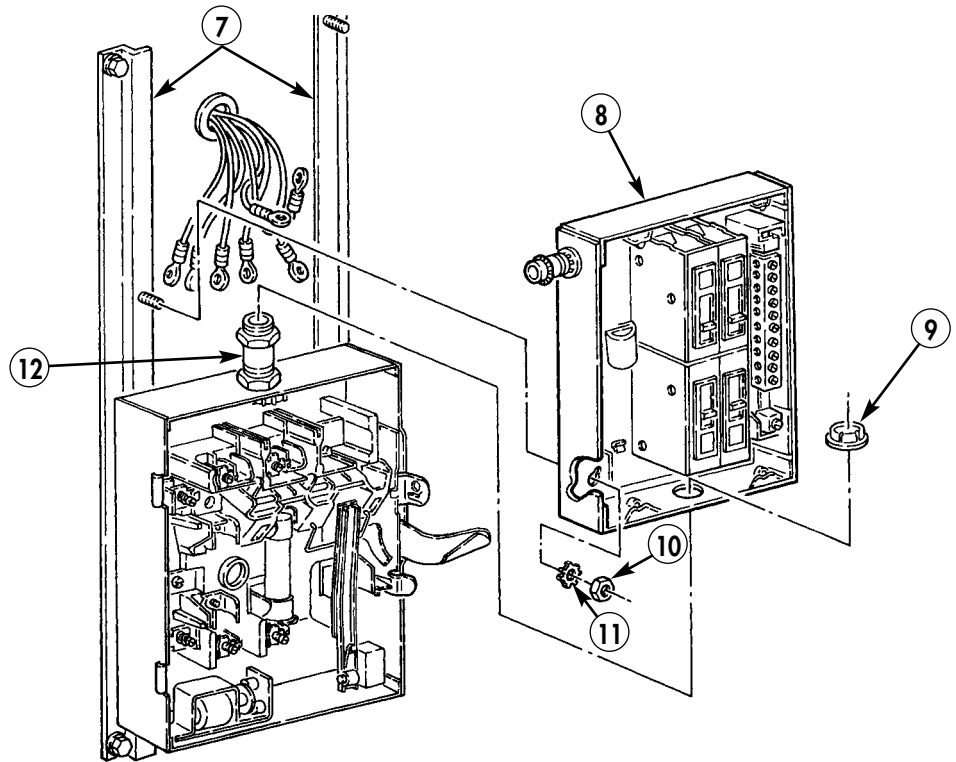

MI09A3

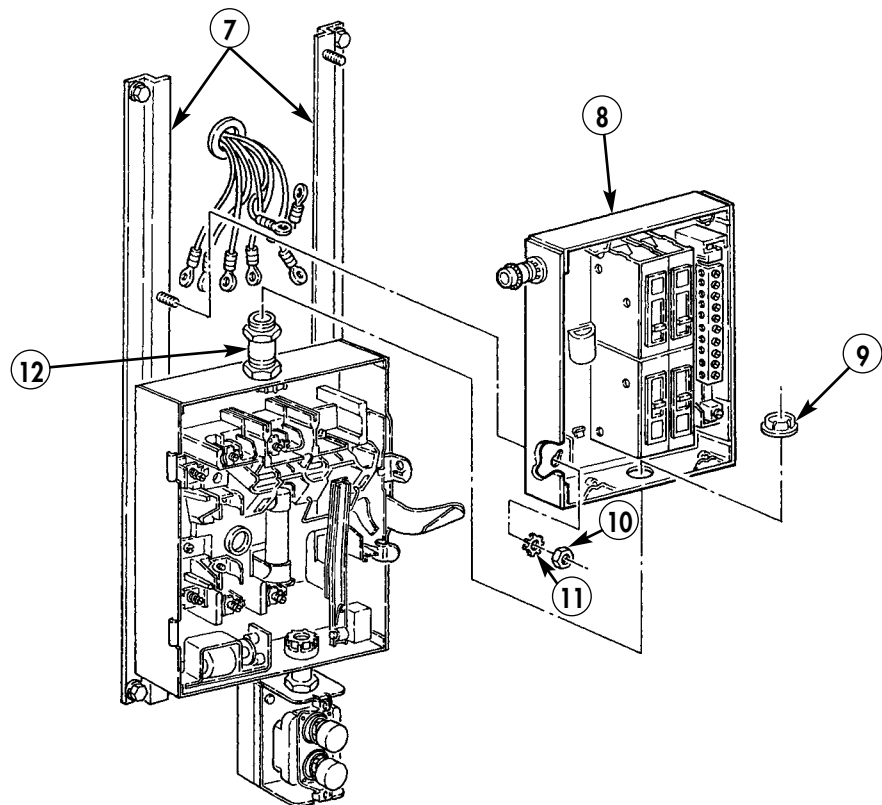

MI85A3

115- AND 24-VOLT WIRING HARNESS REPLACEMENT (Contd)

REMOVAL (Contd)

NOTE

Perform steps 41 and 42 for M185A3 vehicles.

41. Remove bushing (5) from nipple (6) and safety switch box (2).
42. Remove START/STOP switch (9), two screws (7), switch bracket (8), and spacer (10) from van wall (11).
43. Remove four nuts (4), lockwashers (3), and safety switch box (2) from two mounting brackets (1). Discard lockwashers (3).

NOTE

Safety wire will be used to install new wiring harness. Do not cut safety wire from spool until harness has been pulled from van and proper length has been obtained.

44. Attach safety wires (14) to wire leads (12), (13), (16), (18), and (19).
45. Remove three grommets (17) from van wall (11) and wire leads (12), (13), and (16).
46. Remove two grommets (20) from van wall (11) and wire leads (18) and (19).
47. Pull wire leads (12), (13), (16), (18), and (19) out of van wall (11).
48. Remove safety wires (14) from wire leads (12), (13), (16), (18), and (20).
49. Cut safety wires (14) from spools (15).

115- AND 24-VOLT WIRING HARNESS REPLACEMENT (Contd)

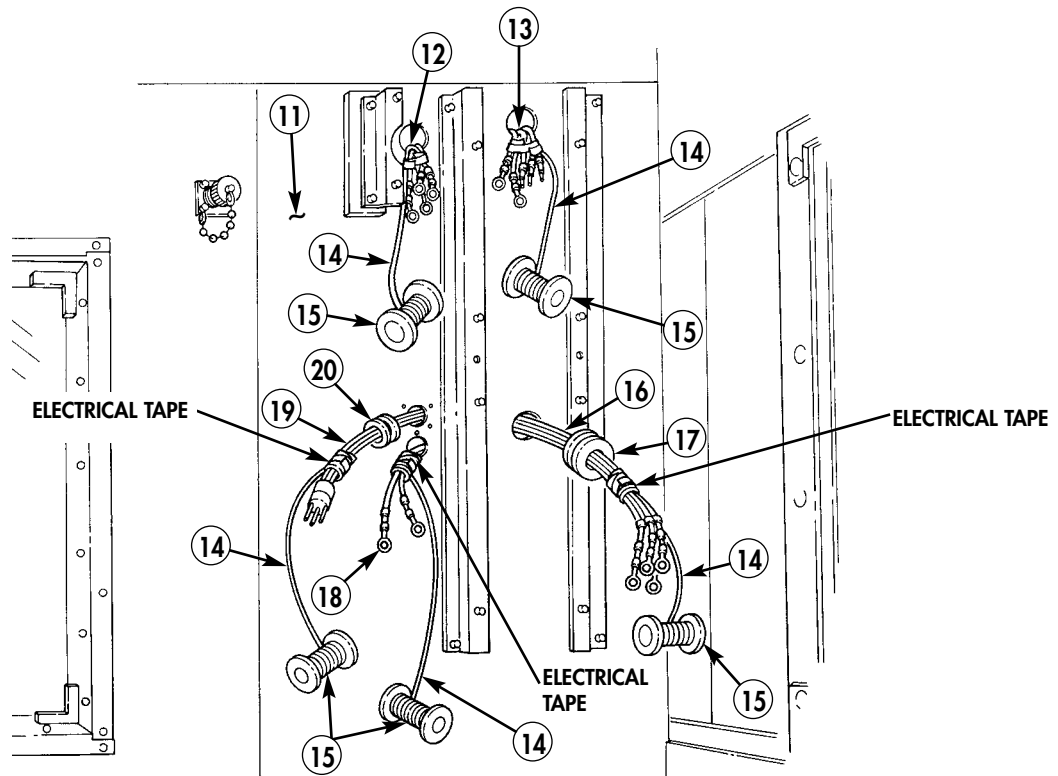
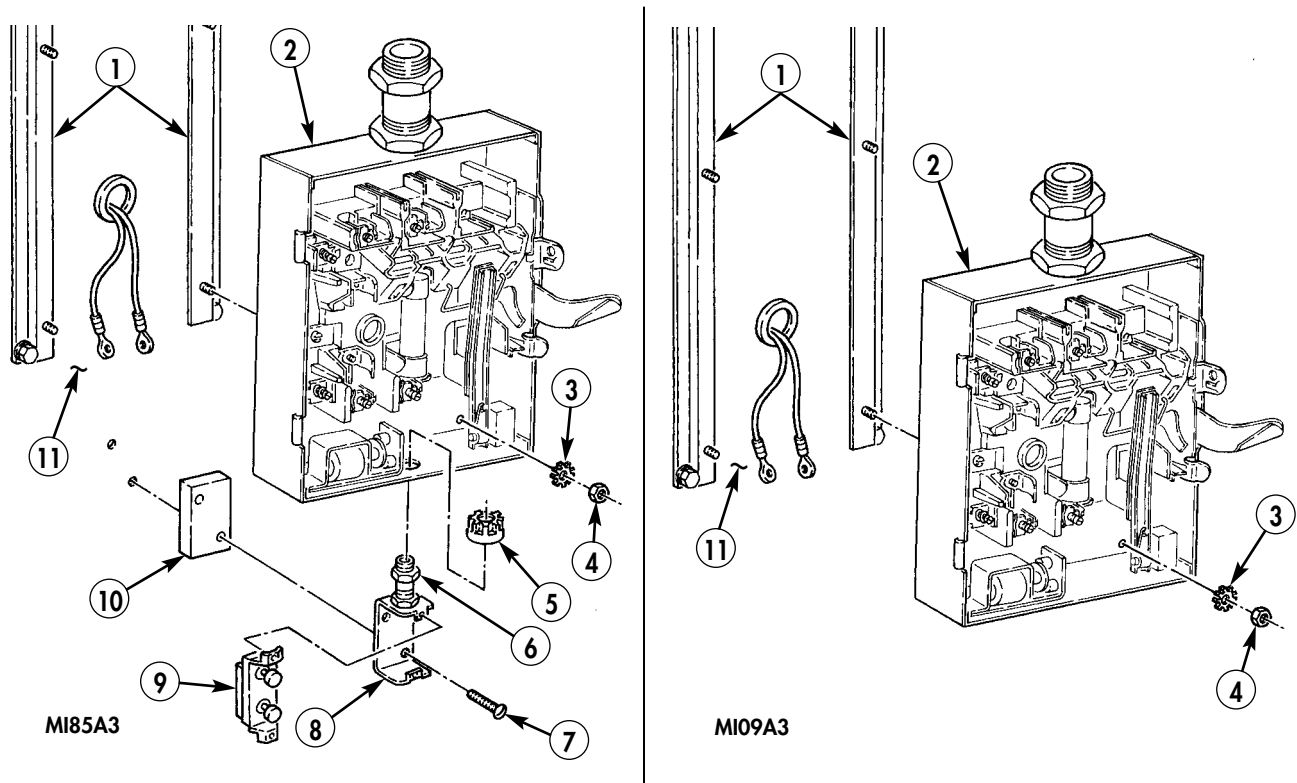

115- AND 24-VOLT WIRING HARNESS REPLACEMENT (Contd)

INSTALLATION

CAUTION

Use care when installing wiring harnesses. Excessive snagging or pulling may damage wires.

NOTE

Safety wire must be secured to wiring harnesses with electrical tape.

1. Position main wiring harness (2) in roof (3).
2. Secure main wiring harness (2) by closing tabs (1).
3. Install three grommets (9) and two grommets (13) in van wall (4).
4. Attach safety wires (7) to five wire leads (5), (6), (8), (11), and (12).

NOTE

Do not remove safety wire from wire leads until wires are connected.

5. Pull safety wires (7) so that wire leads (5), (6), (8), (11), and (12) are pulled through van wall (4).

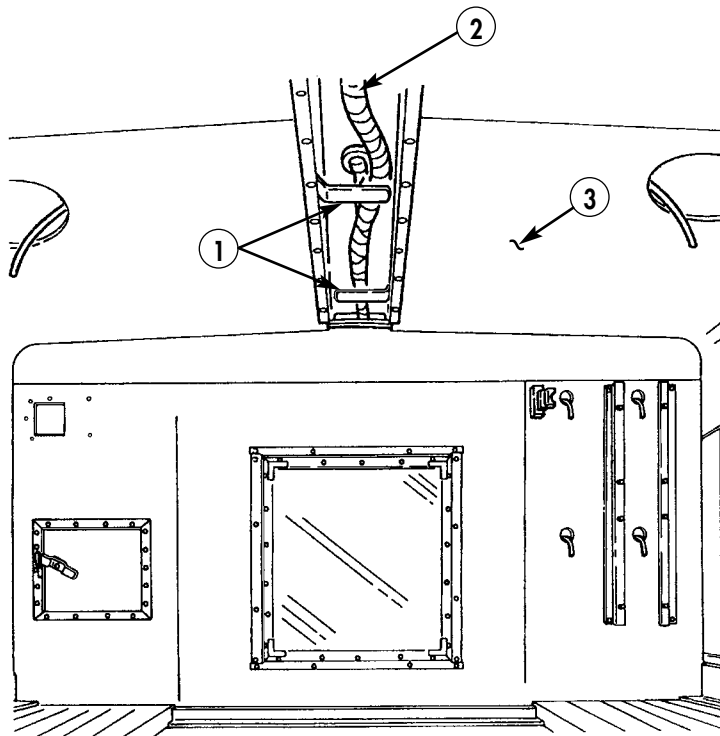

115- AND 24-VOLT WIRING HARNESS REPLACEMENT (Contd)

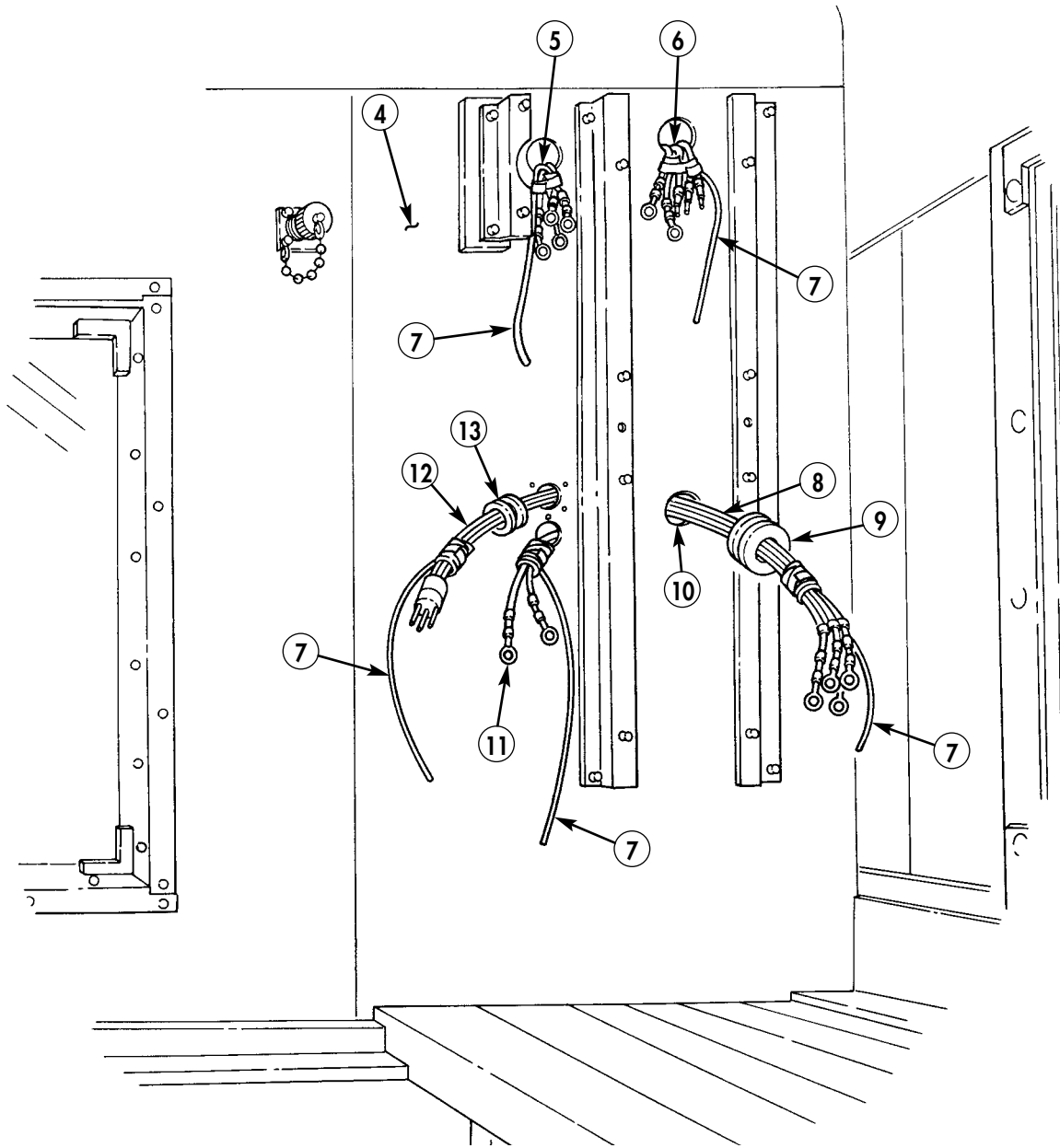

115- AND 24-VOLT WIRING HARNESS REPLACEMENT (Contd)

INSTALLATION (Contd)

6. Attach safety wires (5) to six 115-volt domelight wire leads (1).
7. Attach safety wires (5) to two 24-volt domelight wire leads (2).
8. Attach safety wires (5) to two 115-volt receptacle connectors (6).

NOTE

Do not remove safety wire from wire leads until wire leads are connected.

9. Pull safety wires (5) so that six 115-volt domelight wire leads (1) and two 24-volt domelight wire leads (2) are pulled through van body ceiling rails (3) and two 115-volt receptacle connector wire leads (6) are pulled through van body ceiling rails (3) and side rails (4).

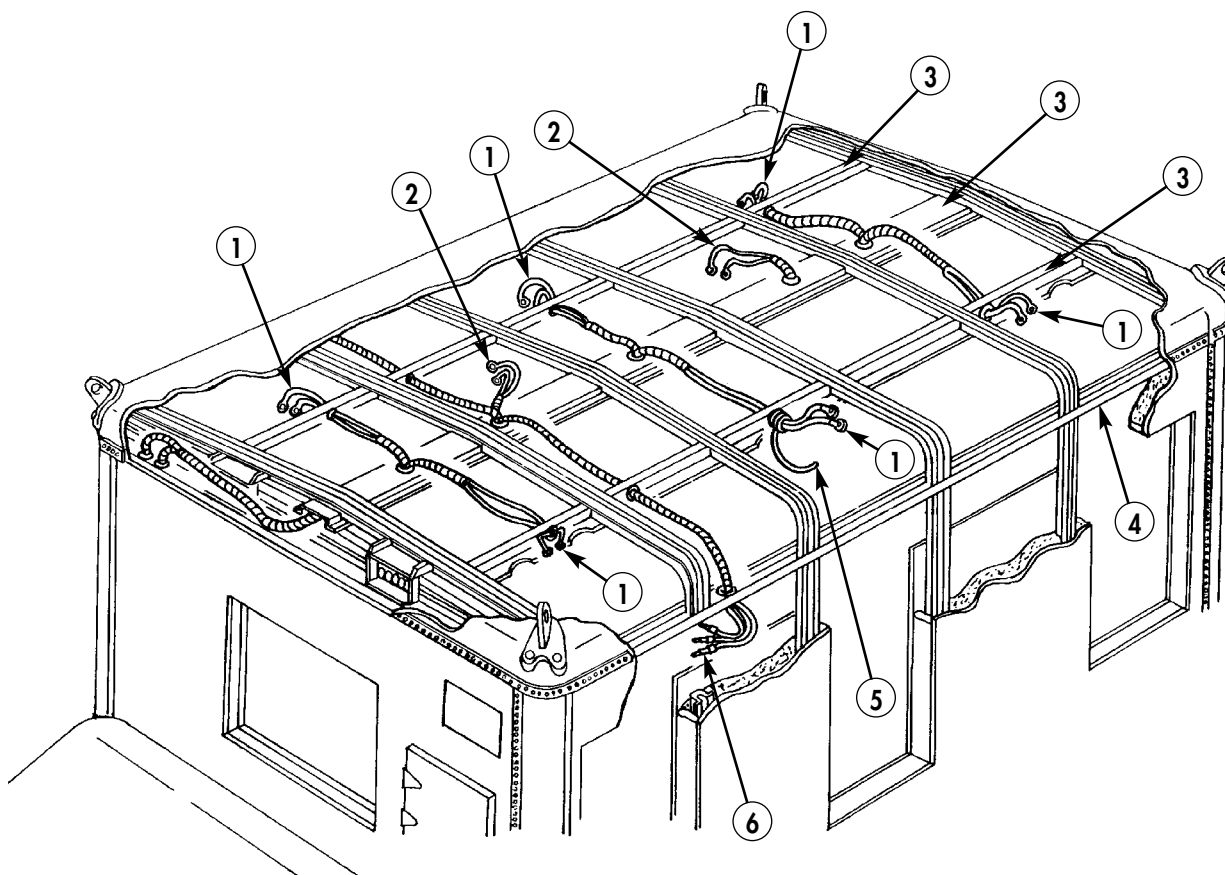

115- AND 24-VOLT WIRING HARNESS REPLACEMENT (Contd)

INSTALLATION (Contd)

NOTE

Do not remove safety wire from wire leads until wire leads are connected.

10. Attach safety wires (11) to four power switch wires (8), two blackout switch wires (9), and blower receptacle wires (10).
11. Pull three safety wires (11) so that wires (8), (9), and (10) are pulled through van body rear wall (7).

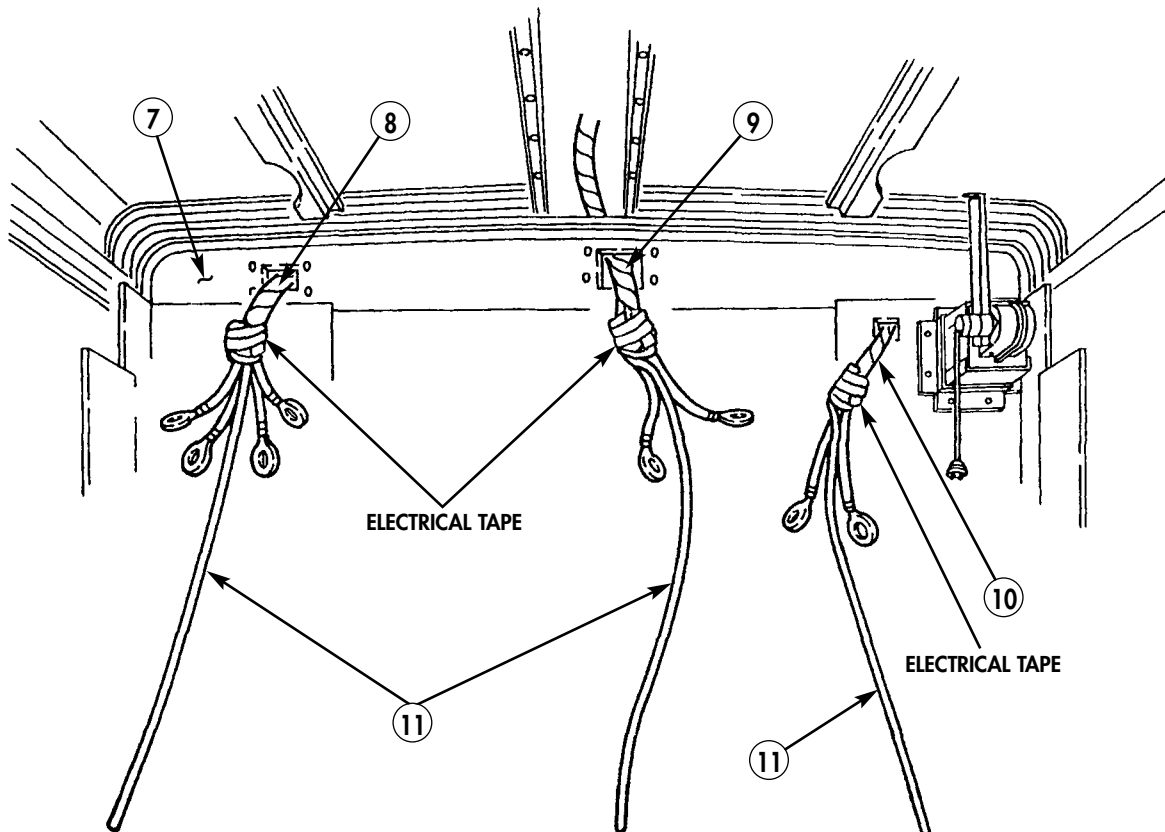

115- AND 24-VOLT WIRING HARNESS REPLACEMENT (Contd)

INSTALLATION (Contd)

12. Remove safety wire (3) from wire bunches (1), (2), and (4).
13. Insert wires (4) through access hole in safety switch box (6).
14. Install safety switch box (6) on mounting brackets (5) with four new lockwashers (7) and nuts (8).

NOTE

Perform steps 15 through 17 for M185A3 vehicles.

15. Position nipple (10) with switch bracket (12) through safety switch box (6) and secure nipple (10) with bushing (9).
16. Install spacer (15) and switch bracket (12) on van wall (14) with two screws (11).
17. Install start/stop switch (13) into switch bracket (12).
18. Insert wires (2) in access hole of multibreaker box (16).
19. Secure multibreaker box (16) on nipple (20) with bushing (17).
20. Install multibreaker box (16) on mounting brackets (5) with two new lockwashers (19) and nuts (18).
21. Insert wires (1) through access hole in blackout switch (23).
22. Position blackout switch (23) on nipple (21) and secure with bushing (22).
23. Install blackout switch (23) on mounting bracket (26) with two new lockwashers (25) and nuts (24).

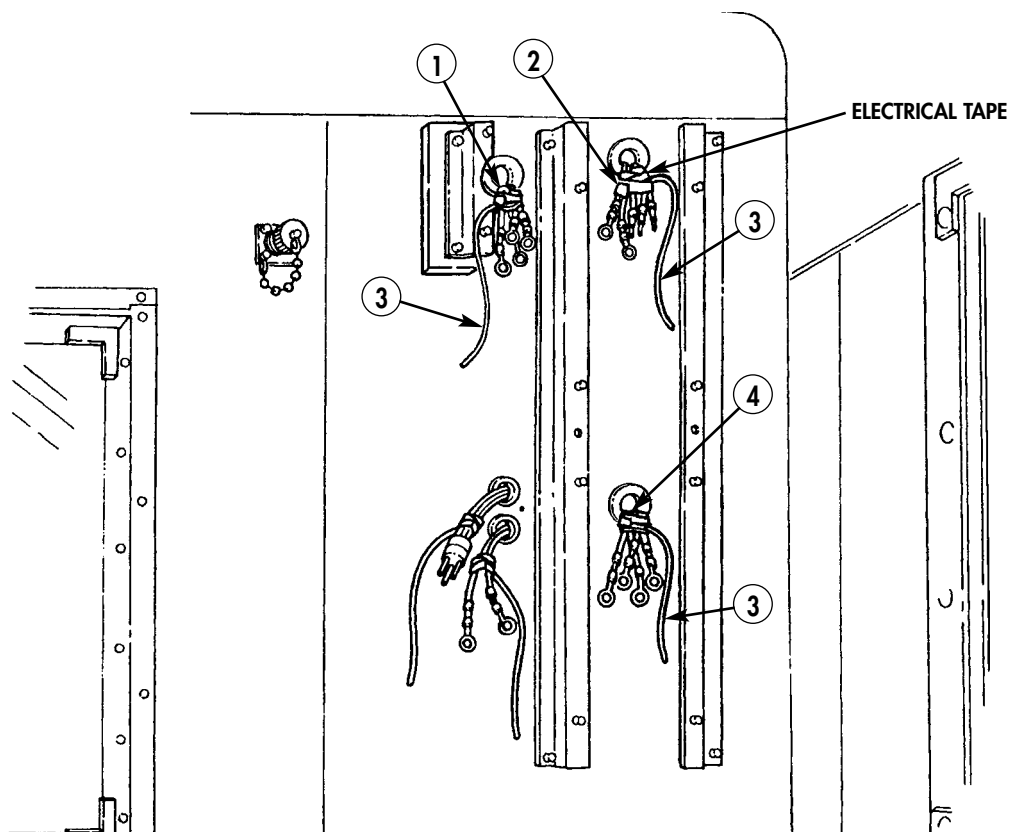

115- AND 24-VOLT WIRING HARNESS REPLACEMENT (Contd)

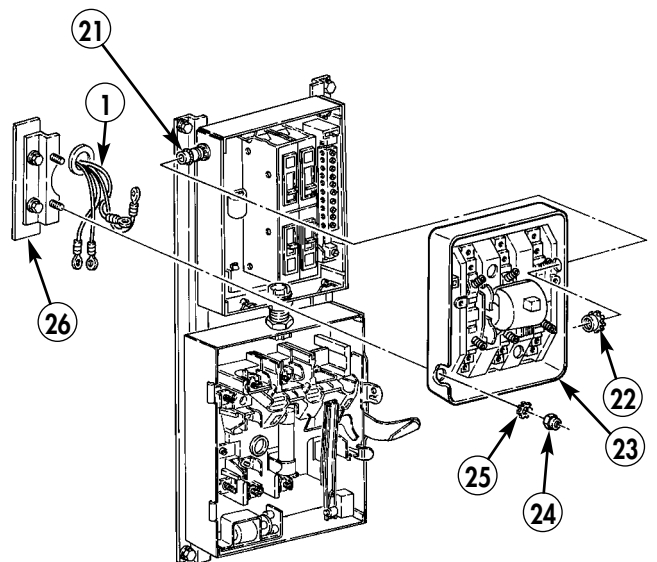
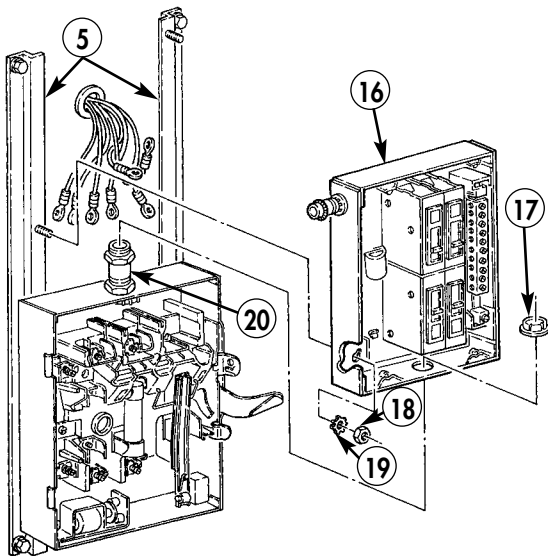
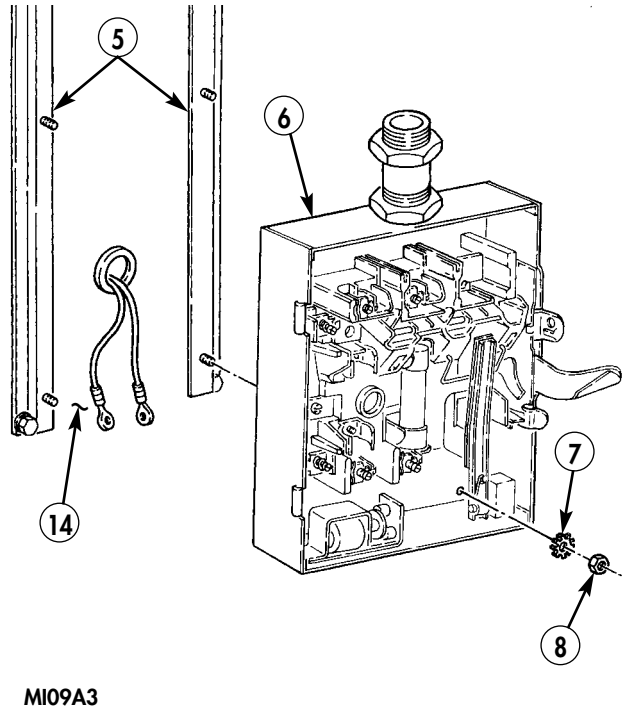
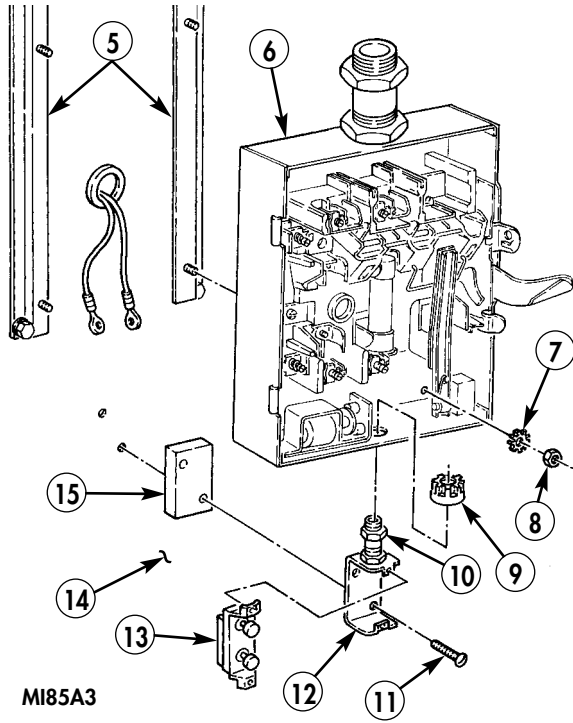

115- AND 24-VOLT WIRING HARNESS REPLACEMENT (Contd)

INSTALLATION (Contd)

24. Install nut (2) and wires (3) and (4) on safety switch box (1) with capnut (5).
25. Back out nut (2) to tighten leads (3) and (4) against capnut (5).
26. Install two wires (6) on fuse block (8) and tighten two screws (7).
27. Insert wires (18) and (25) through nipple (23) and into multibreaker box (10).
28. Insert wire (27) through nipple (23), multibreaker box (10), nipple (9) and into blackout switch (26).
29. Insert wires (24) through nipple (23), multibreaker box (10), nipple (9), and into blackout switch (26).
30. Install wire (21) on multibreaker box (10) with screw (22).
31. Insert opposite end of wire (21) through nipple (9) and into blackout switch (26).
32. Position wire (18) in multibreaker box (10) and tighten screw (19).
33. Position wires (25) and (14) in multibreaker box (10) and tighten screw (28).
34. Insert wire (20) in bridge (15) and tighten screw (17).
35. Install three wires (12) on multibreaker box (10) with three screws (13).
36. Insert four wires (11) in bridge (15) and tighten four screws (16).

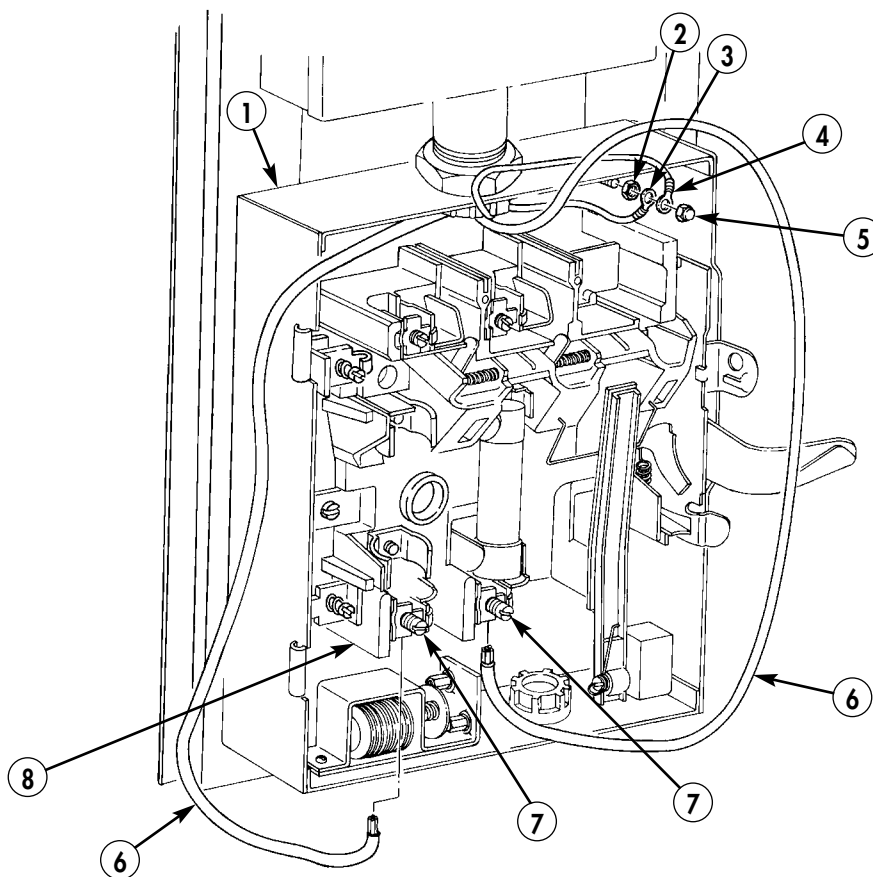

115- AND 24-VOLT WIRING HARNESS REPLACEMENT (Contd)

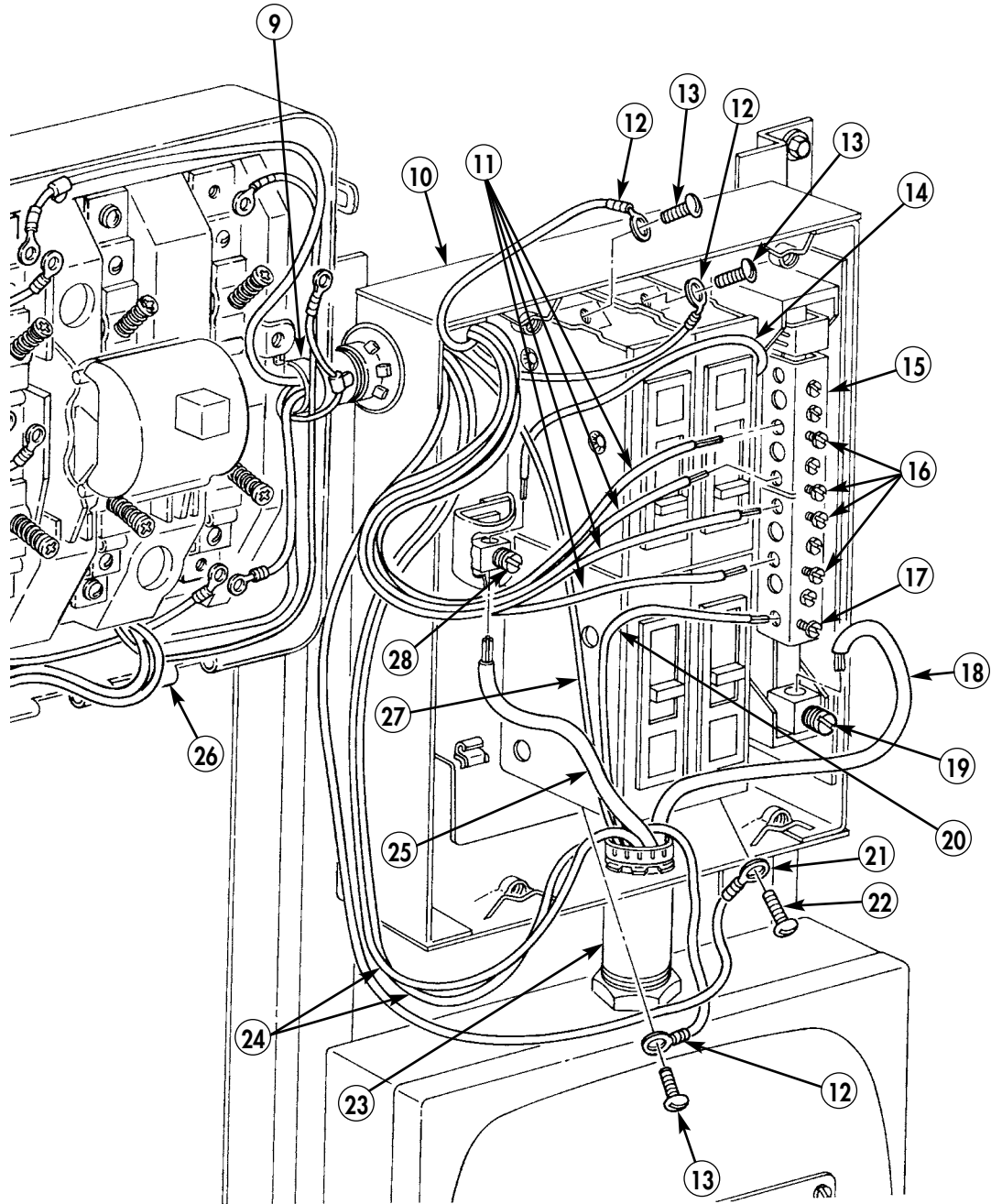

115- AND 24-VOLT WIRING HARNESS REPLACEMENT (Contd)

INSTALLATION (Contd)

37. Install wires (1), (2), (5), (6), (7), and one end of wire (8) on blackout switch (10) with four new lockwashers (3) and screws (4).
38. Install opposite end of wire (8) and wire (9) on blackout switch (10) with new lockwasher (3) and screw (4).

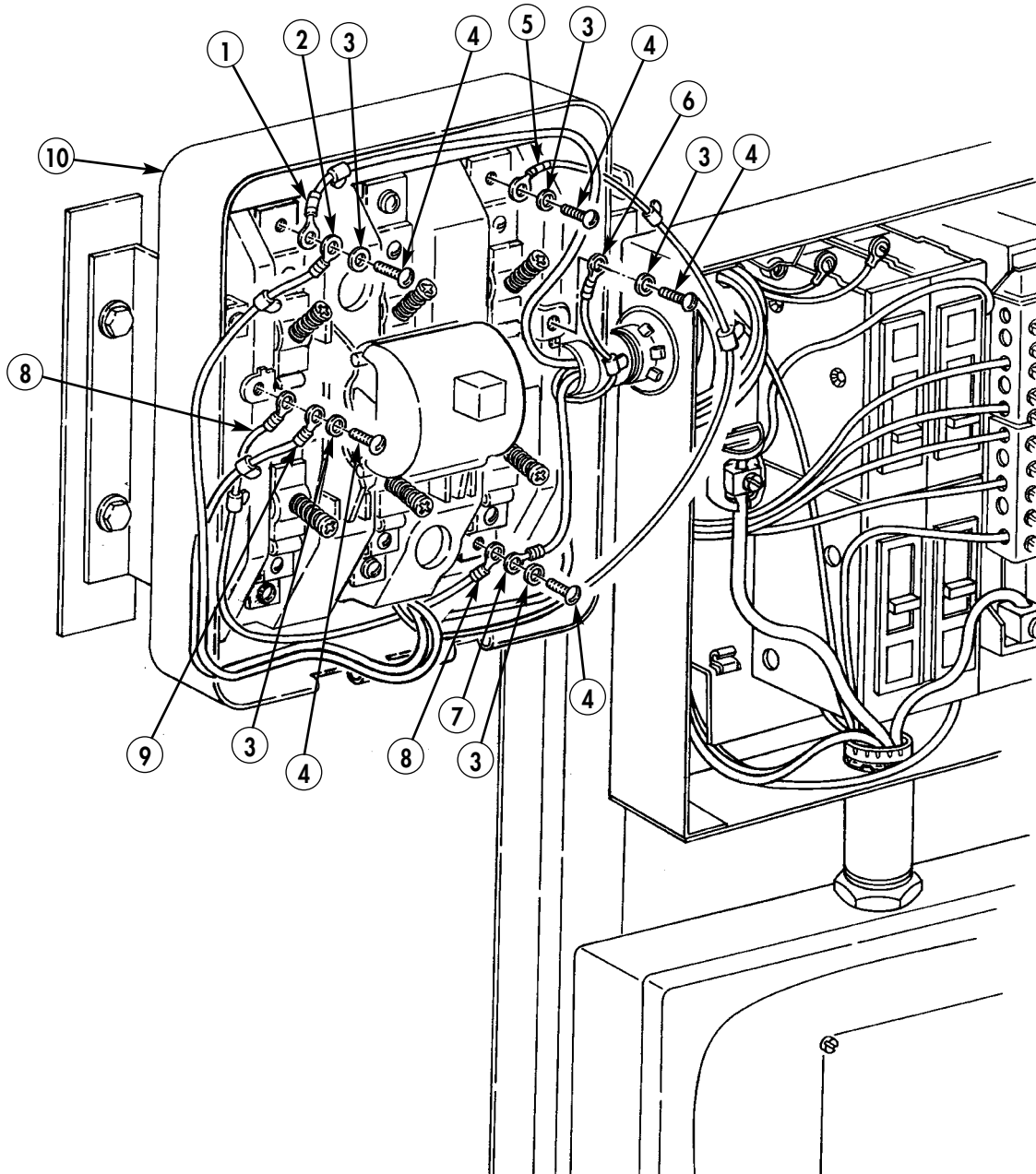

115- AND 24-VOLT WIRING HARNESS REPLACEMENT (Contd)

INSTALLATION (Contd)

39. Install cover (15) on multibreaker box (12) with four new lockwashers (13) and screws (14).
40. Install cover (11) on blackout switch (10) with four new lockwashers (17) and screws (16).
41. Install blackout light switch (WP 0339 00).
42. Install converter receptacle (WP 0331 00).
43. Install blower motor receptacle (WP 0338 00).
44. Install power switch (WP 0334 00).
45. Install 24-volt DC receptacle (M185A3) (WP 0310 00).
46. Install 115-volt AC receptacle (WP 0309 00).
47. Install lamp and domelight assemblies (WP 0302 00).
48. Connect battery ground cable (WP 0126 00).
49. Release parking brake and remove wheel chocks (TM 9-2320-361-10).

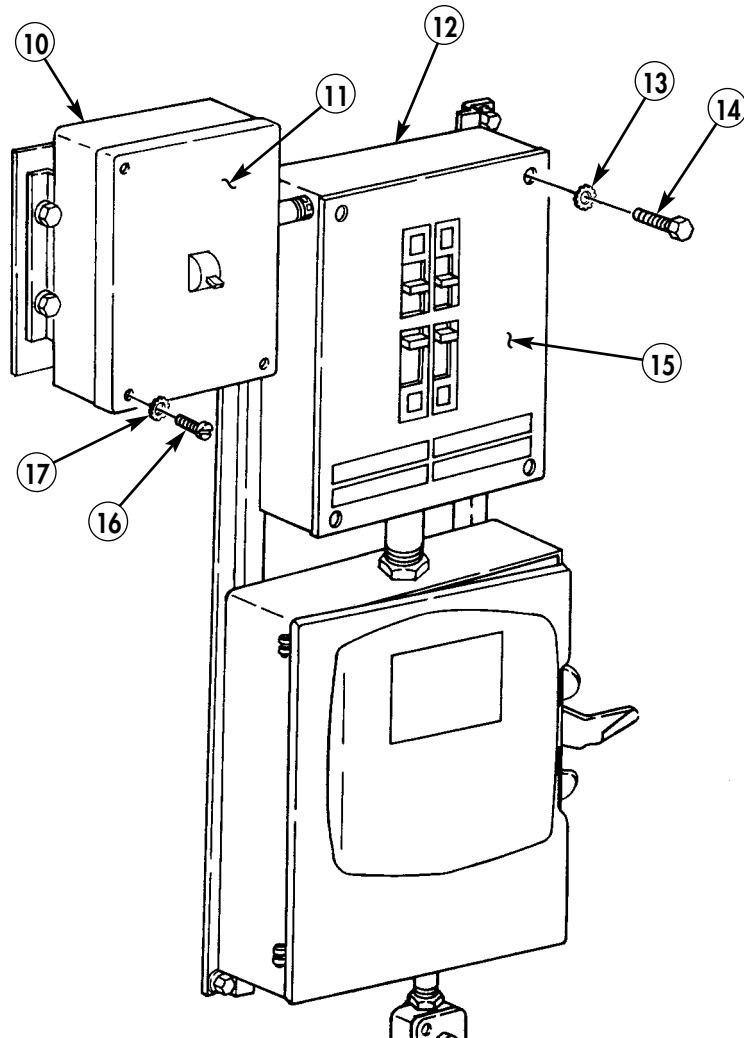

END OF WORK PACKAGE

0315 00-21/22 blank

FIELD MAINTENANCE INSTRUCTIONS

2-1/2 TON, 6X6, M44A2 SERIES TRUCKS (MULTIFUEL)

BLACKOUT MASTER SWITCH REPLACEMENT (M109A3)

REMOVAL AND INSTALLATION

INITIAL SETUP:

Applicable Models

M109A3

Tools and Special Tools

General mechanic's tool kit
(item 116, WP 0469 00)

Electrical tool kit (item 114, WP 0469 00)

Pipe wrench (item 132, WP 0469 00)

Materials/Parts

Eleven lockwashers (item 242, WP 0470 00)

Equipment Condition

Parking brake set and wheels chocked
(TM 9-2320-361-10).

Battery ground cable disconnected
(WP 0126 00).

BLACKOUT MASTER SWITCH REPLACEMENT (M109A3) (Contd)

REMOVAL

1. Remove four screws (3), lockwashers (4), and cover (1) from blackout master switch (2). Discard lockwashers (4).

NOTE

Prior to removal, tag lead wires and terminals for installation.

2. Remove five screws (8), lockwashers (7), and wires (5), (6), (9), (10), (11), (12), and (13) from blackout master switch (2). Discard lockwashers (7).
3. Remove bushing (16) from nipple (15).
4. Remove two nuts (17), lockwashers (18), and blackout master switch (2) from mounting bracket (14). Discard lockwashers (18).

INSTALLATION

1. Install blackout master switch (2) on mounting bracket (14) with two new lockwashers (18) and nuts (17).
2. Install blackout master switch (2) on nipple (15) with bushing (16).
3. Install wires (5), (6), (9), (10), (11), and one end of (12) on blackout master switch (2) with four lockwashers (7) and screws (8).
4. Install wire (13) and other end of wire (12) on blackout master switch (2) with new lockwasher (7) and screw (8).
5. Install cover (1) on blackout master switch (2) with four new lockwashers (4) and screws (3).
6. Connect battery ground cable (WP 0126 00).
7. Check blackout light operations (TM 9-2320-361-10).
8. Release parking brake and remove wheel chocks (TM 9-2320-361-10).

BLACKOUT MASTER SWITCH REPLACEMENT (M109A3) (Contd)

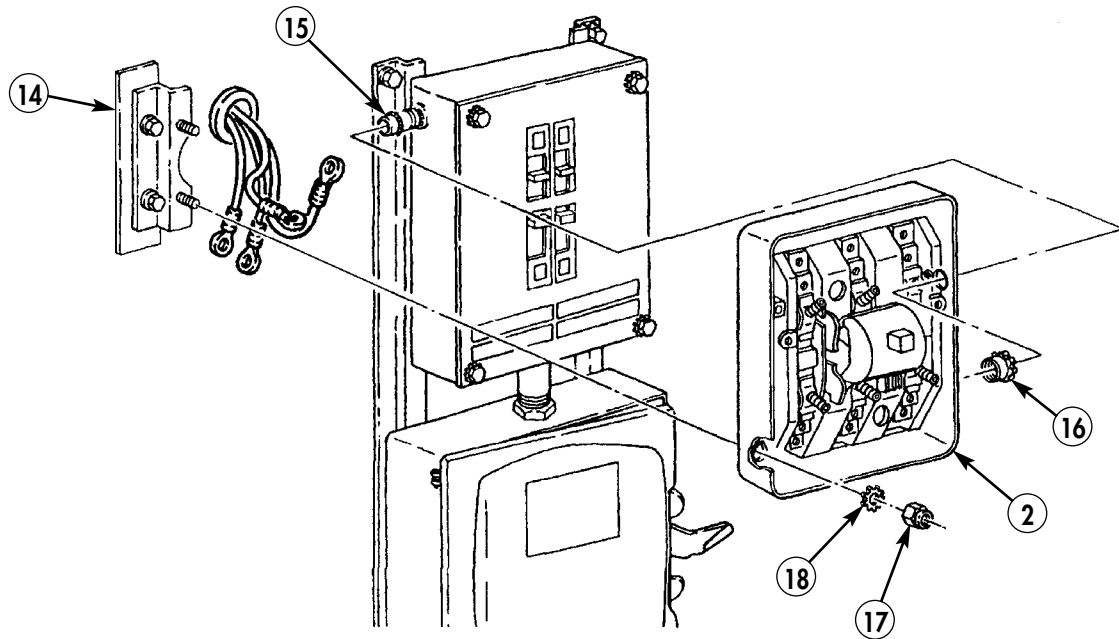
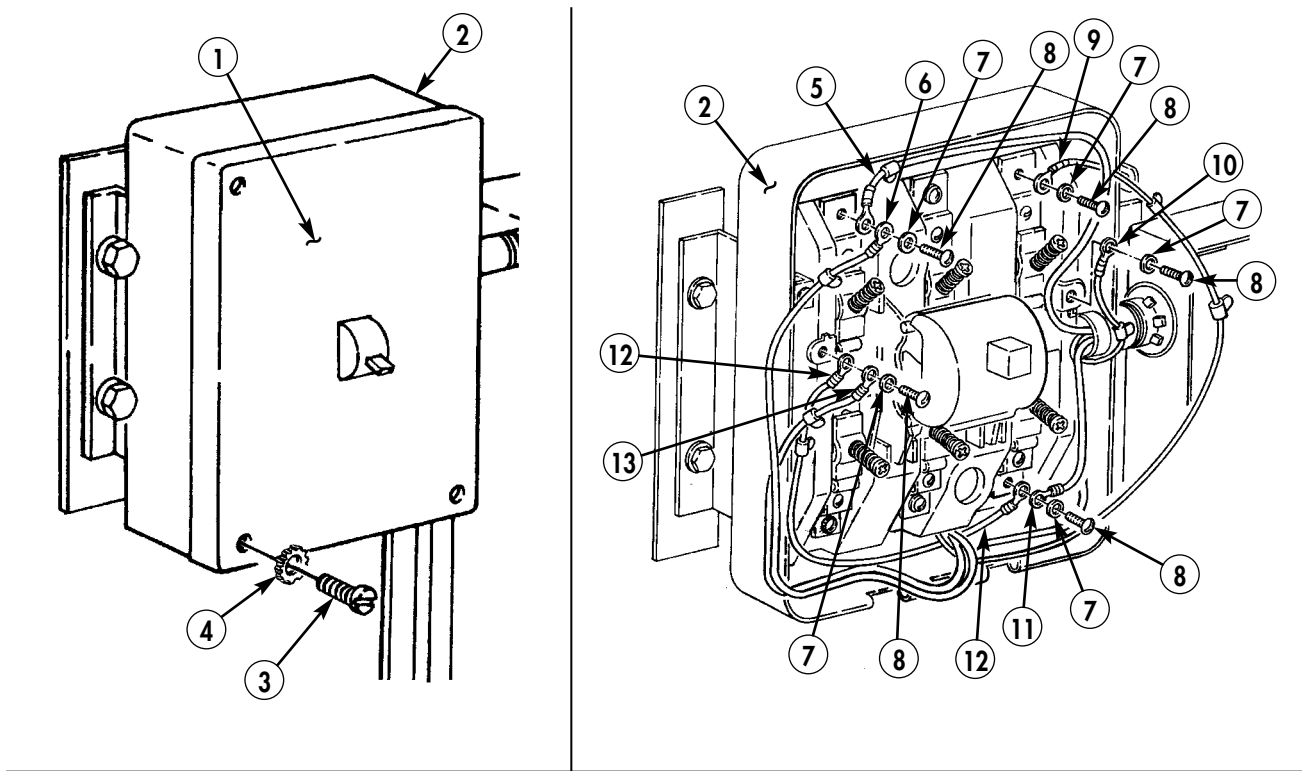

END OF WORK PACKAGE

FIELD MAINTENANCE INSTRUCTIONS

2-1/2 TON, 6X6, M44A2 SERIES TRUCKS (MULTIFUEL)

MULTIBREAKER BOX REPLACEMENT

REMOVAL AND INSTALLATION

INITIAL SETUP:

Applicable Models

All

Tools and Special Tools

General mechanic's tool kit
(item 116, WP 0469 00)
Multimeter (item 51, WP 0469 00)
Pipe wrench (item 132, WP 0469 00)
1-1/4-in. open-end wrench
(item 127, WP 0469 00)

Materials/Parts

Six lockwashers (item 242, WP 0470 00)

Equipment Condition

Parking brake set and wheels chocked
(TM 9-2320-361-10).
Battery ground cable disconnected
(WP 0126 00).
Safety switch in OFF position
(TM 9-2320-361-10).

MULTIBREAKER BOX REPLACEMENT (Contd)

REMOVAL

NOTE

Prior to removal, tag lead wires and terminals for installation.

1. Remove four screws (7), lockwashers (6), and cover (5) from multibreaker box (12). Discard lockwashers (6).
2. Remove four screws (16) and wires (15) from multibreaker box (12).
3. Loosen five screws (17) and remove five wires (20).
4. Loosen two screws (19) and remove three wires (18).
5. Remove bushing (4) from nipple (1).
6. Remove bushing (8) from nipple (13).
7. Remove two nuts (10) and lockwashers (11) from studs (3) on mounting bracket (2).
8. Remove multibreaker box (12) and nut (9) from nipple (13) and van body (14). Discard lockwashers (11).

INSTALLATION

1. Route wires through access hole in multibreaker box (12).
2. Install nut (9) on nipple (13) and position multibreaker box (12) on nipples (13) and (1).
3. Install multibreaker box (12) on studs (3) of mounting bracket (2) and van body (14) with two new lockwashers (11) and nuts (10).
4. Install multibreaker box (12) on nipple (13) with bushing (8).
5. Install multibreaker box (12) on nipple (1) with bushing (4).
6. Install three wires (18) in multibreaker box (12) and tighten two screws (19).
7. Install five wires (20) in multibreaker box (12) by tightening five screws (17).
8. Install four wires (15) in multibreaker box (12) with four screws (16).
9. Install cover (5) on multibreaker box (12) with four new lockwashers (6) and screws (7).
10. Connect battery ground cable (WP 0126 00).
11. Place safety switch in ON position (TM 9-2320-361-10).
12. Release parking brake and remove wheel chocks (TM 9-2320-361-10).

MULTIBREAKER BOX REPLACEMENT (Contd)

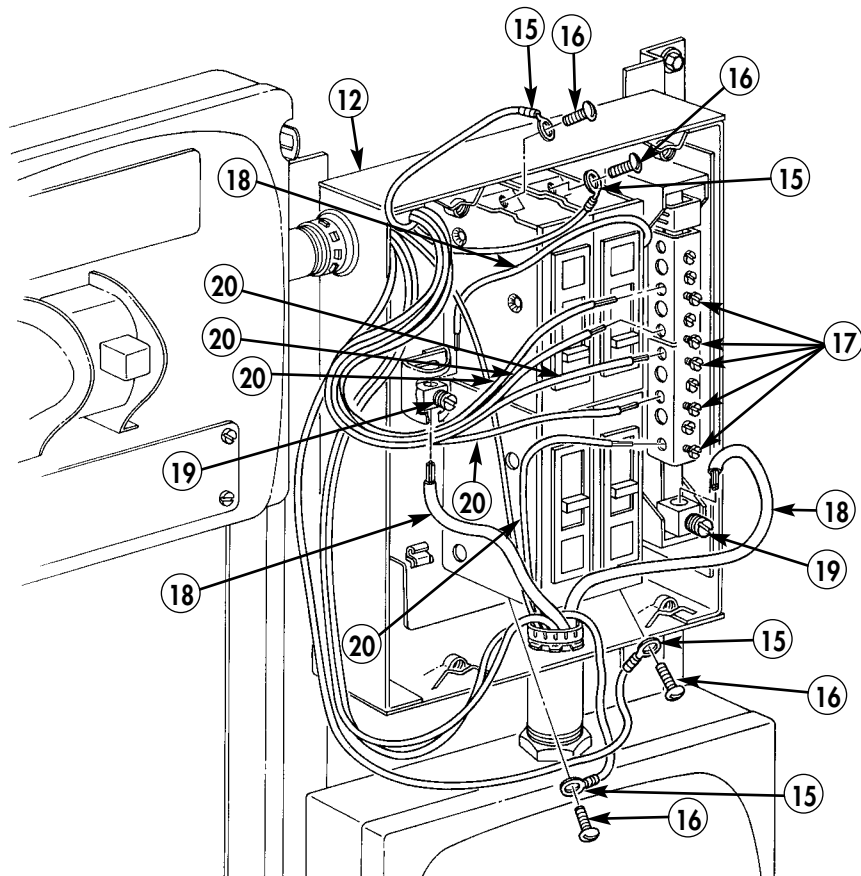
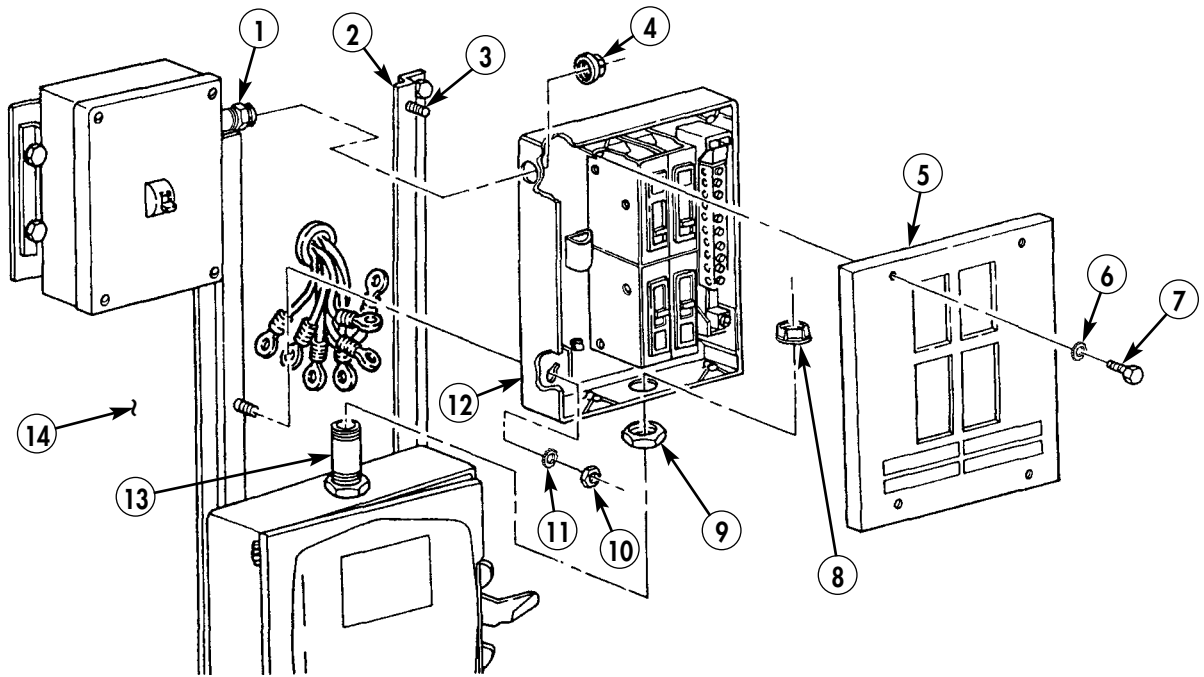

END OF WORK PACKAGE

FIELD MAINTENANCE INSTRUCTIONS

2-1/2 TON, 6X6, M44A2 SERIES TRUCKS (MULTIFUEL)

SAFETY SWITCH BOX REPLACEMENT

REMOVAL AND INSTALLATION

INITIAL SETUP:

Applicable Models

M185A3, M109A3

Tools and Special Tools

General mechanic's tool kit

(item 116, WP 0469 00)

Electrical tool kit (item 114, WP 0469 00)

Multimeter (item 51, WP 0469 00)

Equipment Condition

Parking brake set and wheels chocked
(TM 9-2320-361-10).

Battery ground cable disconnected
(WP 0126 00).

Safety switch in OFF position
(TM 9-2320-361-10).

Materials/Parts

Four lockwashers (item 242, WP 0470 00)

SAFETY SWITCH BOX REPLACEMENT (Contd)

REMOVAL

NOTE

Prior to removal, tag lead wires, cables, and terminals for installation.

1. Open cover (1) on safety switch box (2).

NOTE

Perform step 2 on M185A3 vehicles.

2. Remove two screws (4) and cover (3) from START/STOP switch (5).

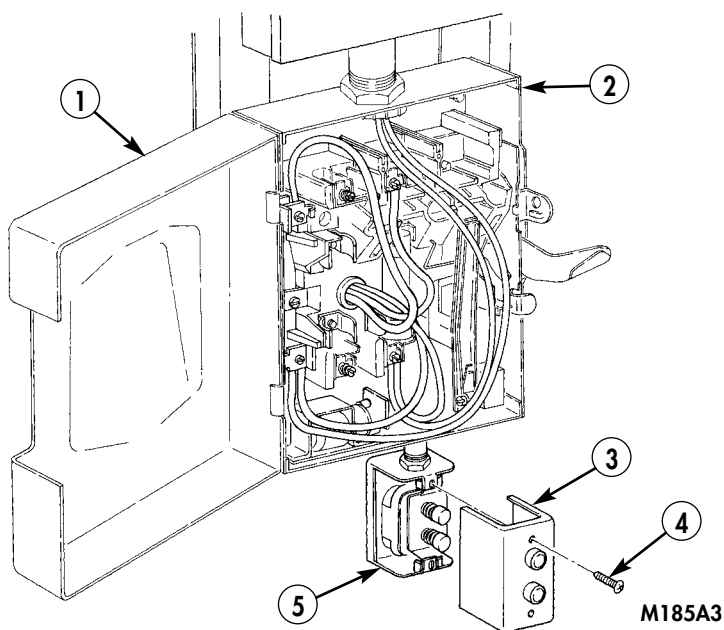
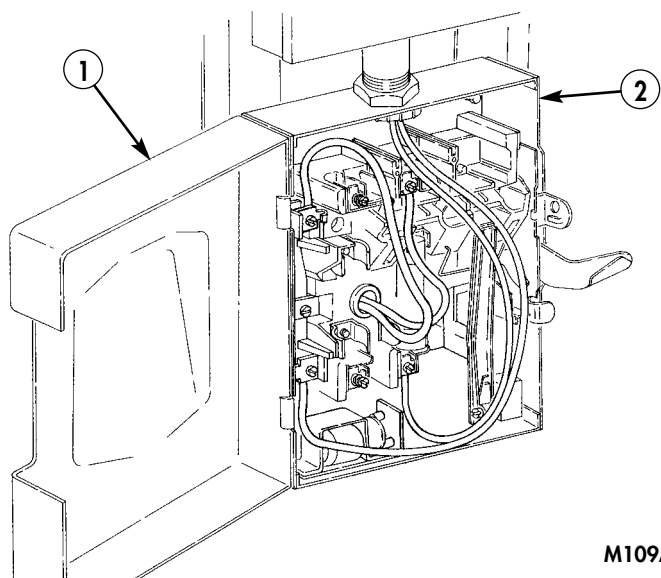

SAFETY SWITCH BOX REPLACEMENT (Contd)

REMOVAL (Contd)

NOTE

Perform step 3 for M109A3 vehicles.

- Loosen four screws (6) and remove two wires (7) and wires (8) from safety switch box (2).

NOTE

Perform steps 4 and 5 on M185A3 vehicles.

- Loosen four screws (6) and remove two wires (9), wires (10), and wires (11) from safety switch box (2).
- Remove three screws (13) and three wires (12) from START/STOP switch (14).

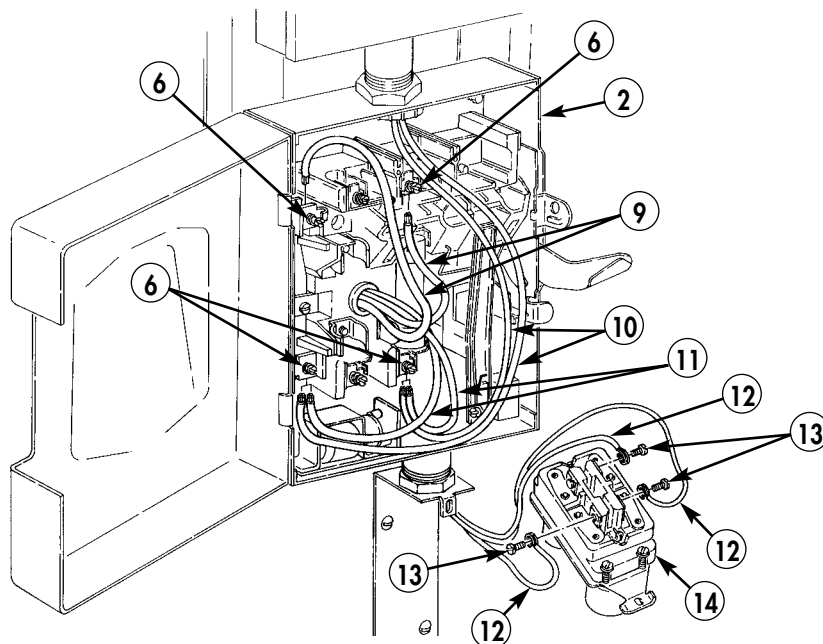
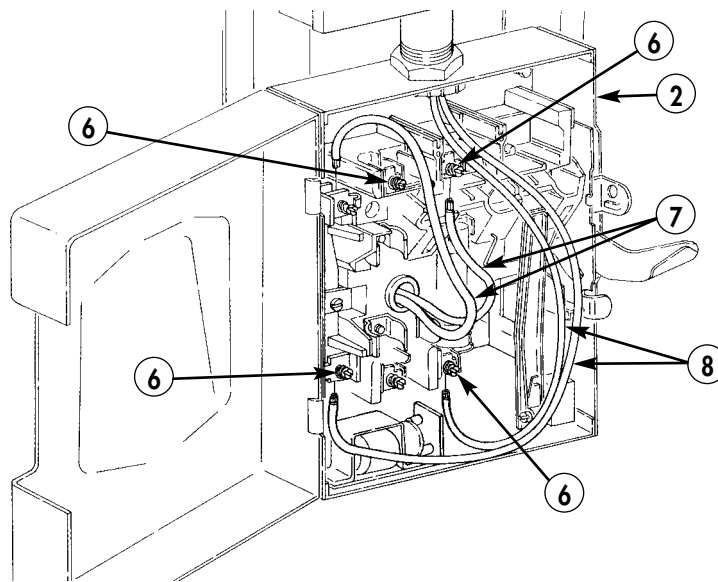

SAFETY SWITCH BOX REPLACEMENT (Contd)

REMOVAL (Contd)

6. Remove bushing (3) from nipple (1) and safety switch box (4).
7. Remove four nuts (6) and lockwashers (5) from studs (2) and remove safety switch box (4) from mounting brackets (9) and van body wall (8). Discard lockwashers (5).

NOTE

Perform steps 8 through 10 on M185A3 vehicles.

8. Remove bushing (10) from nipple (11) and safety switch box (4).
9. Remove START/STOP switch (14) from switch bracket (13).
10. Remove two screws (12), switch bracket (13), and spacer (15) from van body wall (8).

INSTALLATION

1. Pull wires (7) through access hole in safety switch box (4).
2. Install safety switch box (4) on nipple (1) and studs (2) of mounting brackets (9) with bushing (3), four new lockwashers (5), and nuts (6).

NOTE

Perform steps 3 through 7 on M185A3 vehicles.

3. Install spacer (15), switch bracket (13), and nipple (11) on safety switch box (4) and van body wall (8) with bushing (10) and two screws (12).
4. Install START/STOP switch (14) in switch bracket (13).

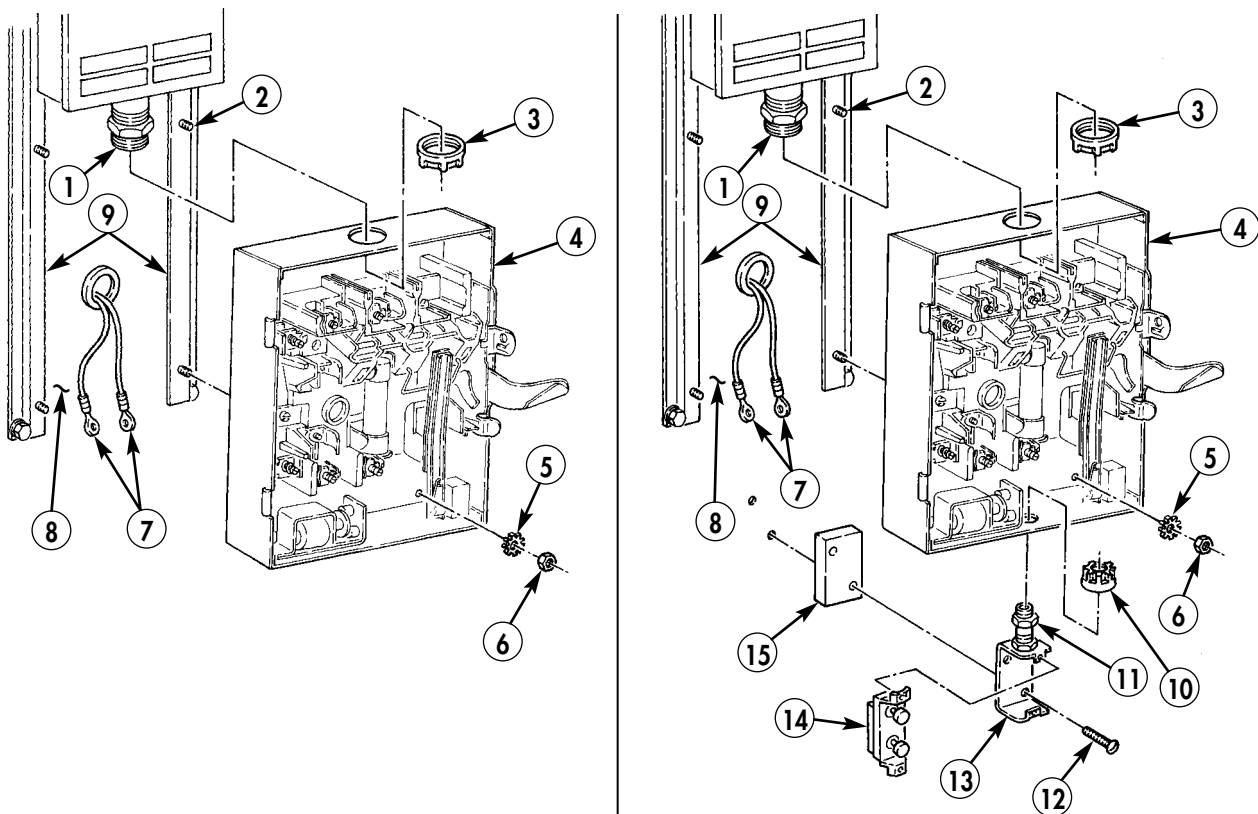

SAFETY SWITCH BOX REPLACEMENT (Contd)

INSTALLATION (Contd)

5. Install two wires (17), wires (18), and wires (22) on safety switch box (4) by tightening four screws (16).
6. Install three wires (19) on START/STOP switch (21) with three screws (20).
7. Install cover (24) on START/STOP switch (21) with two screws (25).

NOTE

Perform step 8 on M109A3 vehicles.

8. Install two wires (26) and wires (27) on safety switch box (4) by tightening four screws (16).
9. Close cover (23) on safety switch box (4).
10. Connect battery ground cable (WP 0126 00).
11. Place safety switch to ON position (TM 9-2320-361-10).
12. Release parking brake and remove wheel chocks (TM 9-2320-361-10).

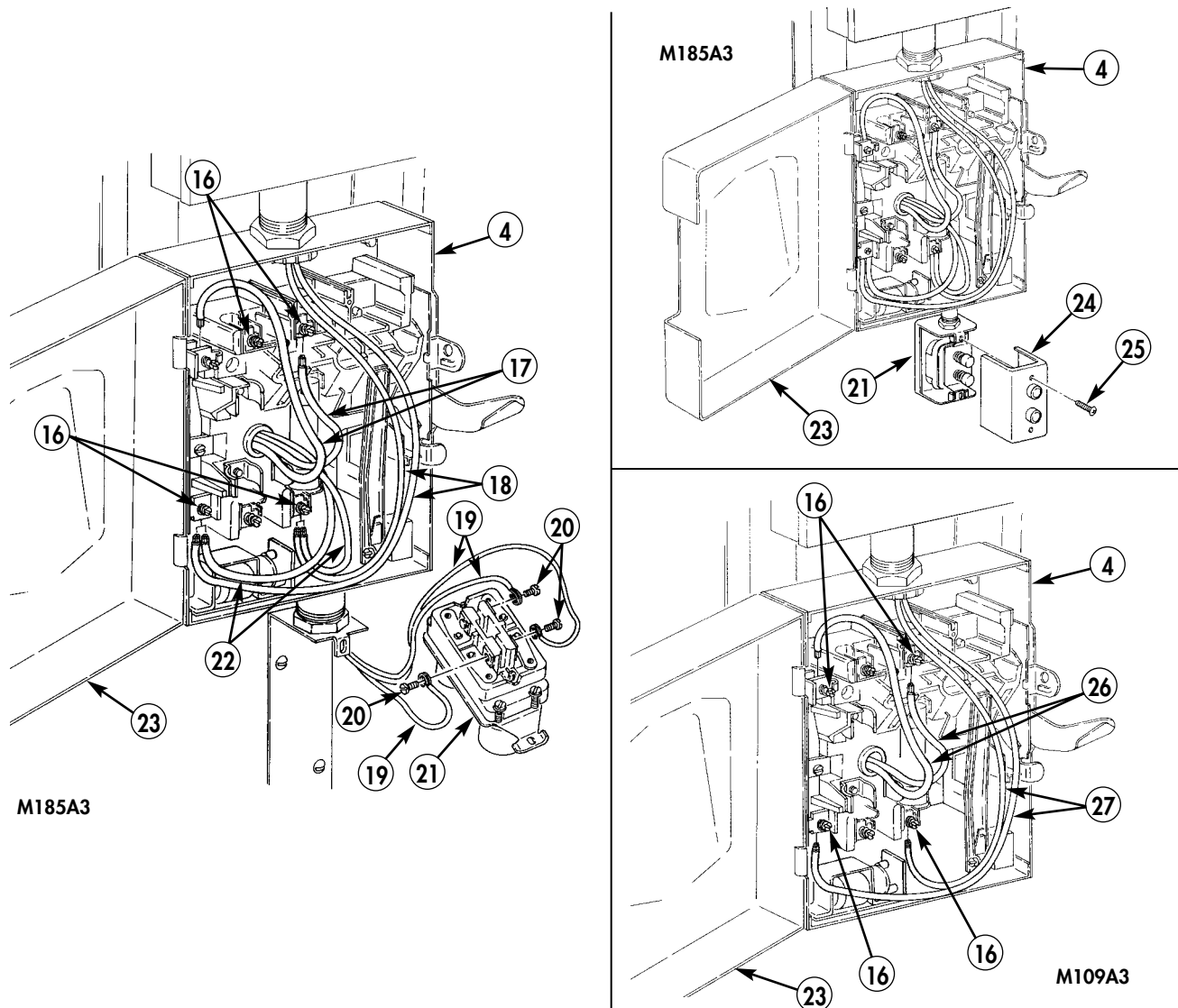

FIELD MAINTENANCE INSTRUCTIONS

2-1/2 TON, 6X6, M44A2 SERIES TRUCKS (MULTIFUEL)

CIRCUIT BREAKER HARNESS REPLACEMENT

REMOVAL AND INSTALLATION

INITIAL SETUP:

Applicable Models

M185A3, M109A3

Tools and Special Tools

General mechanic's tool kit
(item 116, WP 0469 00)

Equipment Condition

Parking brake set and wheels chocked
(TM 9-2320-361-10).
Battery ground cable disconnected
(WP 0126 00).

CIRCUIT BREAKER HARNESS REPLACEMENT (Contd)

REMOVAL

NOTE

Prior to removal, tag lead wires for installation.

1. Remove harness (3) from receptacle (2).
2. Remove cables (6) and (7) from 24V circuit breaker (11).
3. Remove six screws (5), harness mounting clamps (4), and harness (3) from van body (1).
4. Disconnect cable (7) from battery terminal (8).

NOTE

Perform step 5 if van body heater fuel pump is installed on vehicle.

5. Remove cable (9) from fuel pump (10).

INSTALLATION

1. Install harness (3) on receptacle (2).
2. Install cables (6) and (7) on 24V circuit breaker (11).
3. Install six harness mounting clamps (4) and harness (3) on van body (1) with six screws (5).
4. Connect cable (7) to battery terminal (8).

NOTE

Perform step 5 if van body heater fuel pump is installed on vehicle.

5. Connect cable (9) to fuel pump (10).
6. Connect battery ground cable (WP 0126 00).
7. Release parking brake and remove wheel chocks (TM 9-2320-361-10).

CIRCUIT BREAKER HARNESS REPLACEMENT (Contd)

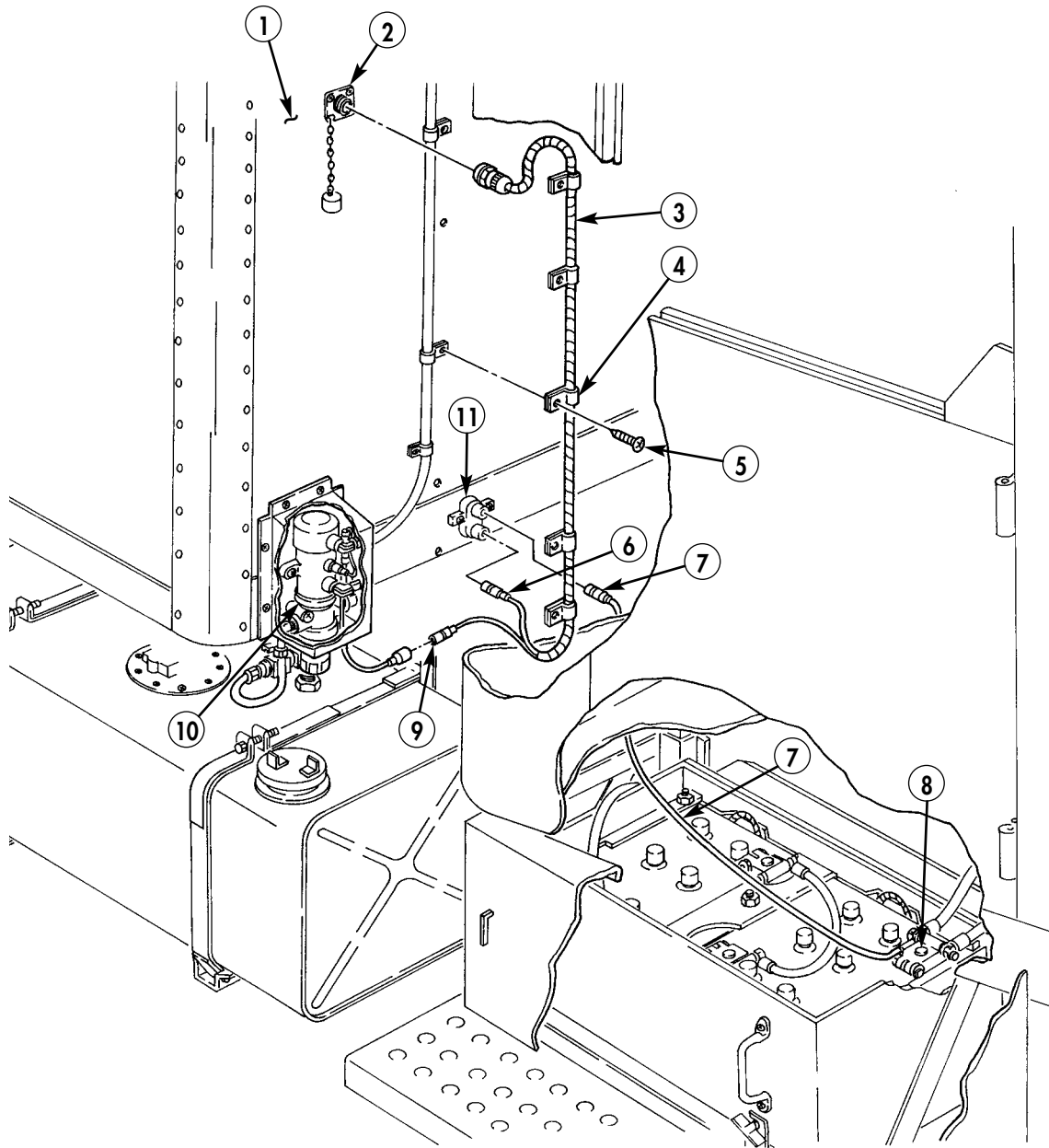

FIELD MAINTENANCE INSTRUCTIONS

2-1/2 TON, 6X6, M44A2 SERIES TRUCKS (MULTIFUEL)

FRONT WINDOW SASH MAINTENANCE REMOVAL, INSPECTION AND REPAIR, AND INSTALLATION

INITIAL SETUP:

Applicable Models

M185A3, M109A3

Tools and Special Tools

General mechanic's tool kit
(item 116, WP 0469 00)

Materials/Parts

Eighteen screw-assembled lockwashers
(item 263, WP 0470 00)

Eight screw-assembled lockwashers
(item 262, WP 0470 00)

Equipment Condition

Parking brake set and wheels chocked
(TM 9-2320-361-10).

Battery ground cable disconnected
(WP 0126 00).

FRONT WINDOW SASH MAINTENANCE (Contd)

REMOVAL

1. Slide blackout panel (1) open and remove eight screw-assembled lockwashers (3) and upper and lower guides (2), with blackout panel (1) attached, from van body wall (4). Discard screw-assembled lockwashers (3).
2. Remove eighteen screw-assembled lockwashers (10) and sash frames (5) and (9) from van body wall (4). Discard screw-assembled lockwashers (10).
3. Remove twenty-two screws (6), sash frame (5), weatherstrip (8), and window glass (7) from sash frame (9).

INSPECTION AND REPAIR

1. Inspect blackout panel (1), guides (2), and sash frames (5) and (9) for bends, dents, and tears. Replace blackout panel (1), guide(s) (2), and sash frame(s) (5) and (9) if bent, dented, or torn.
2. Inspect window glass (7) for cracks. Inspect weatherstrip (8) for tears and wear. Replace cracked window glass (7) and torn or worn weatherstrip (8).

INSTALLATION

1. Install weatherstrip (8) on window glass (7).
2. Install window glass (7) between sash frames (5) and (9) with twenty-two screws (6).
3. Install sash frames (5) and (9) on van body wall (4) with eighteen new screw-assembled lockwashers (10).
4. Install upper and lower guides (2) with blackout panel (1) on van body wall (4) with eight new screw-assembled lockwashers (3).
5. Release parking brake and remove wheel chocks (TM 9-2320-361-10).

FRONT WINDOW SASH MAINTENANCE (Contd)

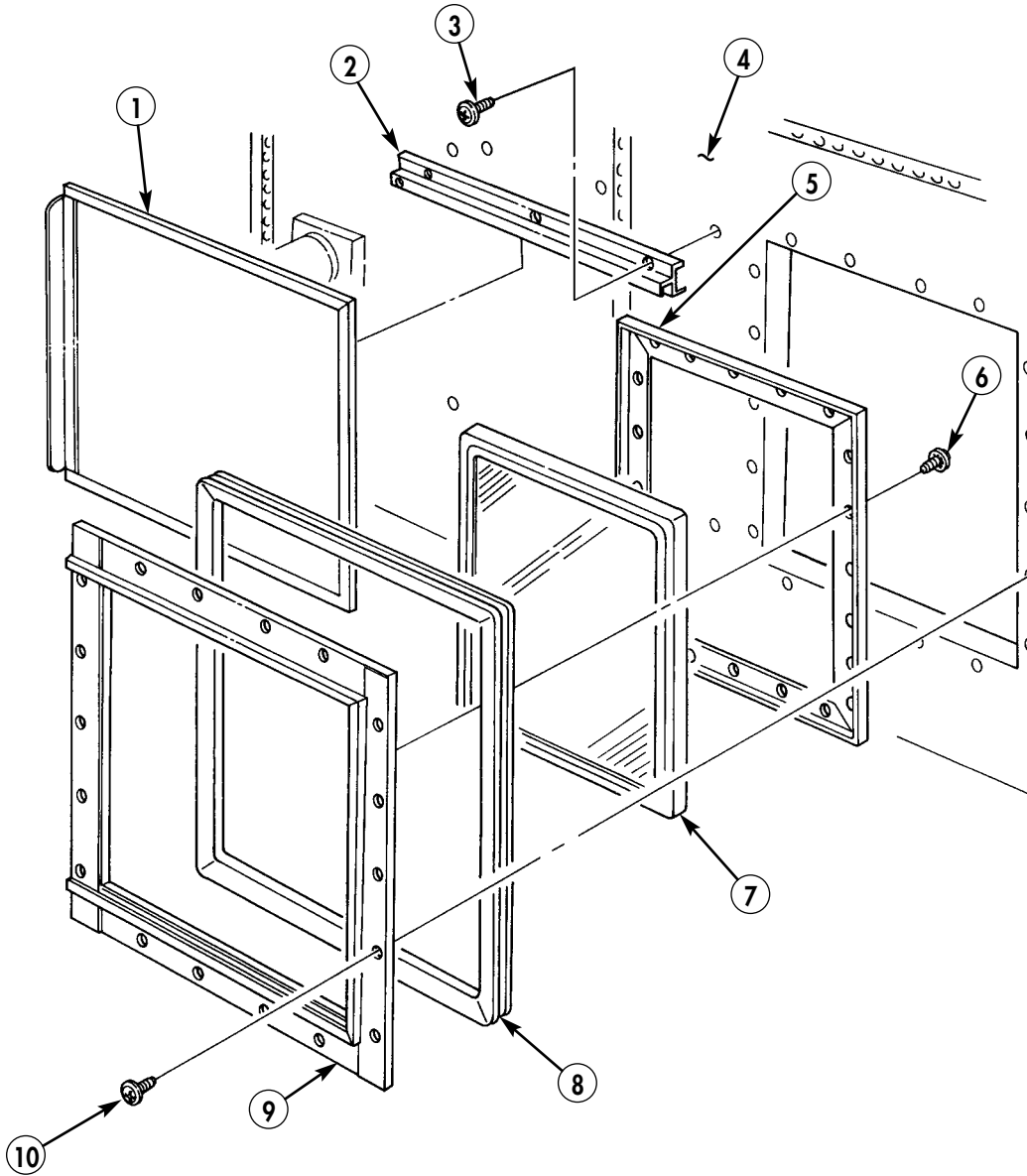

FIELD MAINTENANCE INSTRUCTIONS

2-1/2 TON, 6X6, M44A2 SERIES TRUCKS (MULTIFUEL)

SIDE WINDOW SASH MAINTENANCE REMOVAL, INSPECTION AND REPAIR, AND INSTALLATION

INITIAL SETUP:

Applicable Models

M185A3, M109A3

Tools and Special Tools

General mechanic's tool kit

(item 116, WP 0469 00)

Hand riveting tool (item 86, WP 0469 00)

Materials/Parts

Eighteen screw-assembled lockwashers

(item 262, WP 0470 00)

Eight screw-assembled lockwashers

(item 264, WP 0470 00)

Materials/Parts (Contd)

Six screw-assembled lockwashers

(item 266, WP 0470 00)

Two screw-assembled lockwashers

(item 265, WP 0470 00)

Rivet (item 314, WP 0470 00)

Equipment Condition

Parking brake set and wheels chocked

(TM 9-2320-361-10).

Battery ground cable disconnected

(WP 0126 00).

SIDE WINDOW SASH MAINTENANCE (Contd)

REMOVAL

1. Remove lever ring (9), eighteen screw-assembled lockwashers (10), and screen (8) from sash frames (1) and (4). Discard screw-assembled lockwashers (10).

NOTE

Pull down blackout panel from outside van body.

2. Remove eight screw-assembled lockwashers (14), two screw-assembled lockwashers (17), two guides (15), and blackout panel (16) from van body wall (6). Discard screw-assembled lockwashers (14) and (17).
3. Remove six screw-assembled lockwashers (12) and hinge (13) from van body wall (6). Discard screw-assembled lockwashers (12).
4. Remove twenty-two screws (11), sash frames (1) and (4), weatherstrip (2), and window glass (3) from van body wall (6).
5. Drill rivet (5) out of arm (7) and remove arm (7) from sash frame (4). Discard rivet (5).

INSPECTION AND REPAIR

Inspect screen (8), blackout panel (16), two guides (15), and window glass (3) for holes, bends, dents, or cracks. Repair screen (8) by patching. Replace cracked window glass (3). Replace blackout panel (16) or guide(s) (15) if bent, dented, or cracked.

INSTALLATION

1. Install arm (7) on sash frame (4) with new rivet (5).
2. Install weatherstrip (2) on window glass (3).
3. Install window glass (3) and sash frame (4) on sash frame (1) with twenty-two screws (11).
4. Install hinge (13) on van body wall (6) with six new screw-assembled lockwashers (12).
5. Install two guides (15) and blackout panel (16) on van body wall (6) with eight new screw-assembled lockwashers (14) and two new screw-assembled lockwashers (17).
6. Install screen (8) on sash frames (1) and (4) with eight new screw-assembled lockwashers (10).
7. Install lever ring (9) on arm (7).
8. Connect battery ground cable (WP 0126 00).
9. Release parking brake and remove wheel chocks (TM 9-2320-361-10).

SIDE WINDOW SASH MAINTENANCE (Contd)

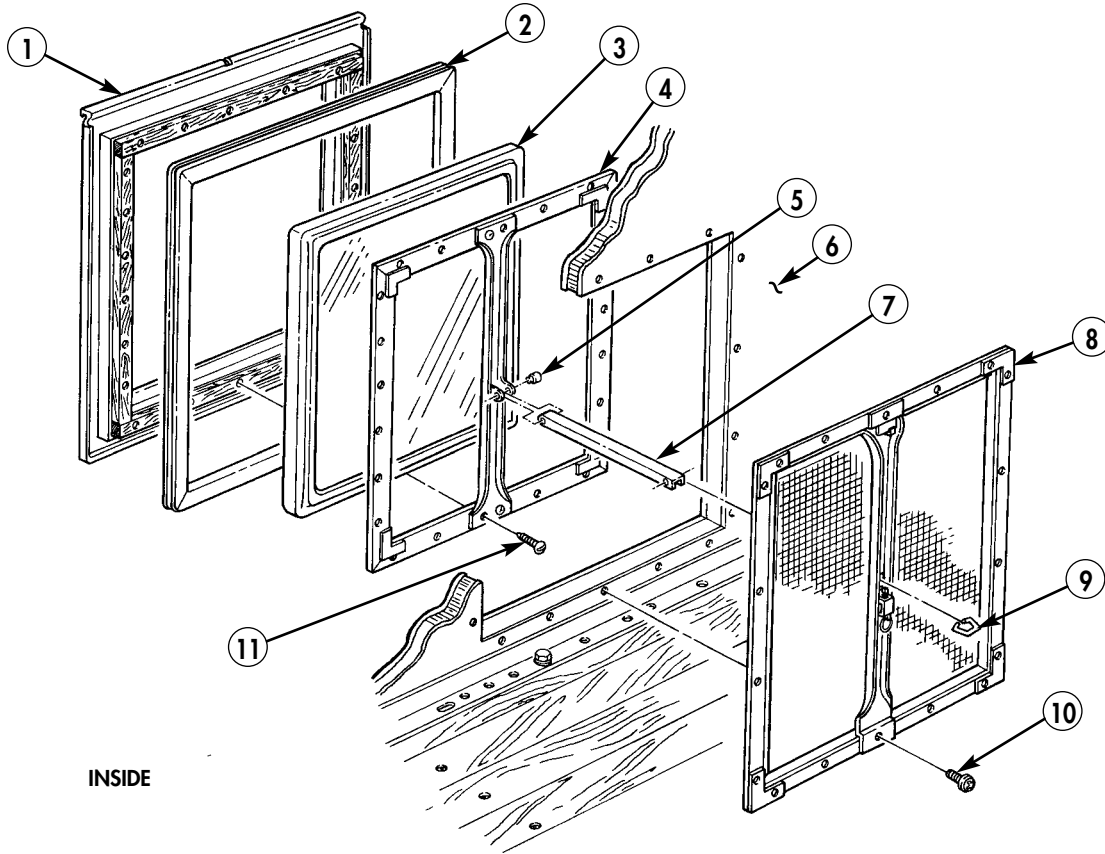

INSIDE

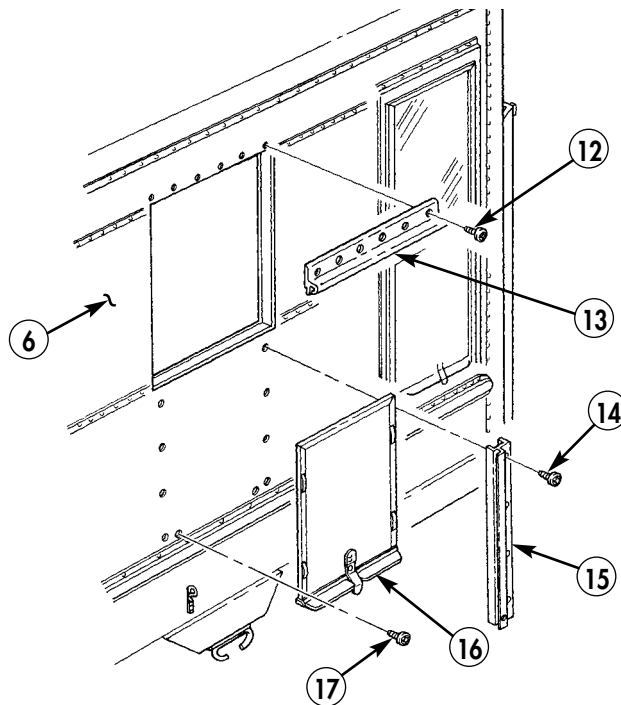

OUTSIDE

END OF WORK PACKAGE

0321 00-3/4 blank

FIELD MAINTENANCE INSTRUCTIONS

2-1/2 TON, 6X6, M44A2 SERIES TRUCKS (MULTIFUEL)

VAN BODY ACCESS DOOR REPLACEMENT

REMOVAL AND INSTALLATION

INITIAL SETUP:

Applicable Models

M185A3, M109A3

Tools and Special Tools

General mechanic's tool kit

(item 116, WP 0469 00)

Hand riveting tool (item 86, WP 0469 00)

Materials/Parts

Five plugs (item 310, WP 0470 00)

Five rivets (item 315, WP 0470 00)

Equipment Condition

Parking brake set and wheels chocked
(TM 9-2320-361-10).

Battery ground cable disconnected
(WP 0126 00).

VAN BODY ACCESS DOOR REPLACEMENT (Contd)

REMOVAL

1. Open access door (2).
2. Drill plug (5) and rivet (4) out of van wall (1) and chain (3). Discard plug (5) and rivet (4).
3. Unfasten two hinges (6) from two latch locks (9).
4. Remove access door (2) from van wall (1).
5. Drill out four plugs (7) and rivets (8) from van wall (1) and latch locks (9). Discard plugs (7) and rivets (8).
6. Remove two latch locks (9) and spacers (10) from van wall (1).
7. Remove screw (11), handle (12), and washer (13) from access door (2).

INSTALLATION

1. Install washer (13) and handle (12) on access door (2) with screw (11).
2. Install two spacers (10) and latch locks (9) on van wall (1) with four new rivets (8) and new plugs (7).
3. Position access door (2) on van wall (1).
4. Fasten two hinges (6) on two latch locks (9).
5. Install new rivet (4) and new plug (5) through chain (3) and on van wall (1).
6. Close access door (2).
7. Connect battery ground cable (WP 0126 00).
8. Release parking brake and remove wheel chocks (TM 9-2320-361-10).

VAN BODY ACCESS DOOR REPLACEMENT (Contd)

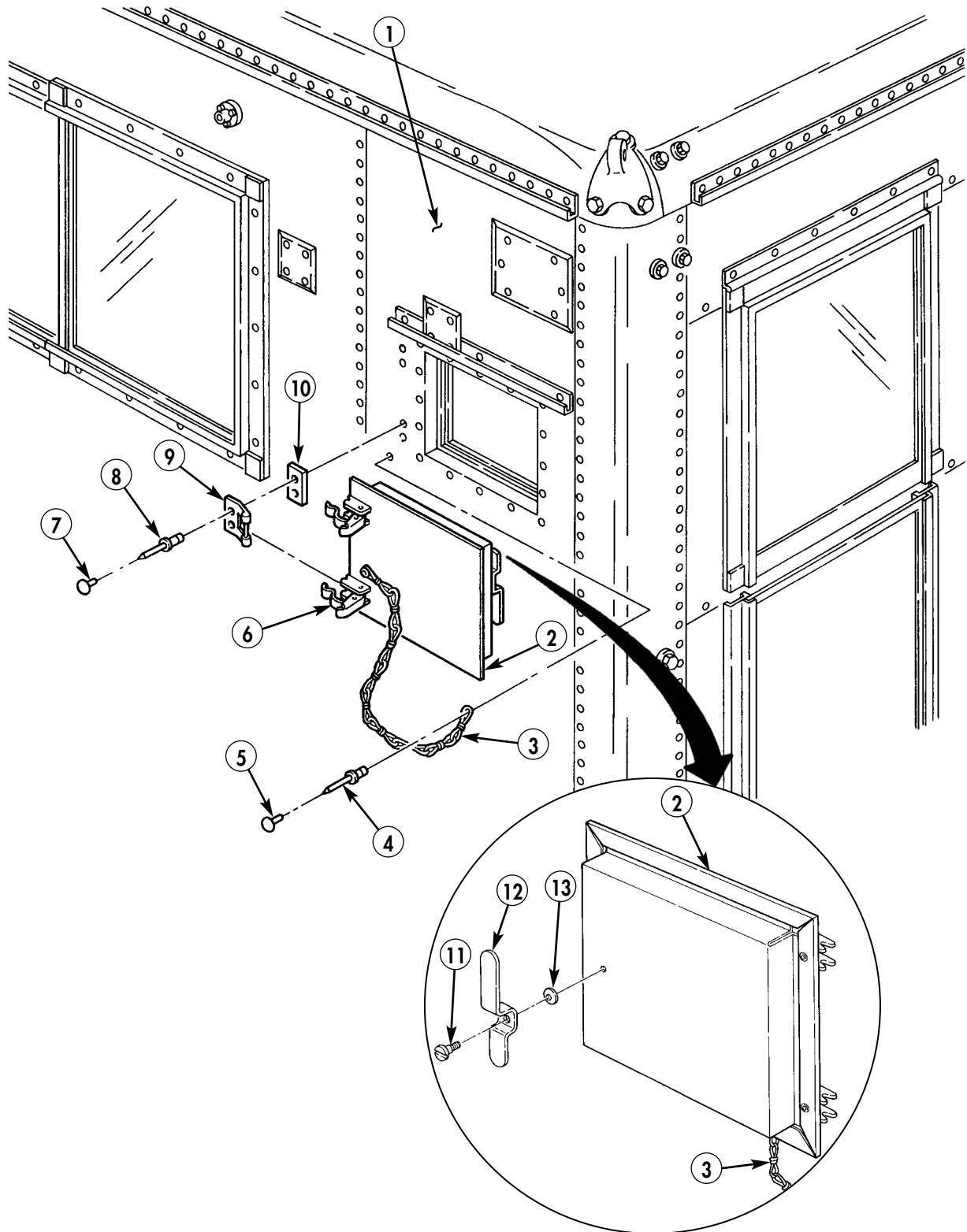

END OF WORK PACKAGE

0322 00-3/4 blank

FIELD MAINTENANCE INSTRUCTIONS

2-1/2 TON, 6X6, M44A2 SERIES TRUCKS (MULTIFUEL)

VAN BODY ACCESS PLATE, ACCESS COVER, AND RETAINER ASSEMBLY REPLACEMENT

ACCESS PLATE REMOVAL, ACCESS PLATE INSTALLATION, ACCESS COVER REMOVAL,
ACCESS COVER INSTALLATION, RETAINER ASSEMBLY REMOVAL, AND RETAINER ASSEMBLY INSTALLATION

INITIAL SETUP:

Applicable Models

M185A3, M109A3

Tools and Special Tools

General mechanic's tool kit
(item 116, WP 0469 00)

Materials/Parts

Eighteen screw-assembled lockwashers
(item 259, WP 0470 00)

Six screw-assembled lockwashers
(item 269, WP 0470 00)

Four screw-assembled lockwashers
(item 268, WP 0470 00)

Equipment Condition

Parking brake set and wheels chocked
(TM 9-2320-361-10).

Battery ground cable disconnected
(WP 0126 00).

VAN BODY ACCESS PLATE, ACCESS COVER, AND RETAINER ASSEMBLY (Contd)

ACCESS PLATE REMOVAL

Remove four screw-assembled lockwashers (2) and access plate (3) from van wall (4). Discard screw-assembled lockwashers (2).

ACCESS PLATE INSTALLATION

Install access plate (3) on van wall (4) with four new screw-assembled lockwashers (2).

ACCESS COVER REMOVAL

Remove six screw-assembled lockwashers (1) and access cover (10) from van wall (4). Discard screw-assembled lockwashers (1).

ACCESS COVER INSTALLATION

Install access cover (10) on van wall (4) with six new screw-assembled lockwashers (1).

RETAINER ASSEMBLY REMOVAL

1. Remove ten screw-assembled lockwashers (7) and two retainers (6) from van wall (4). Discard screw-assembled lockwashers (7).
2. Remove four screw-assembled lockwashers (7) and retainer (9) from van wall (4). Discard screw-assembled lockwashers (7).
3. Remove four screw-assembled lockwashers (7), retainer with door catch (8), and weather seal (5) from van wall (4). Discard screw-assembled lockwashers (7).

RETAINER ASSEMBLY INSTALLATION

1. Install weather seal (5) and retainer with door catch (8) on van wall (4) with four new screw-assembled lockwashers (7).
2. Install retainer (9) on van wall (4) with four new screw-assembled lockwashers (7).
3. Install two retainers (6) on van wall (4) with ten new screw-assembled lockwashers (7).
4. Connect battery ground cable (WP 0126 00).
5. Release parking brake and remove wheel chocks (TM 9-2320-361-10).

VAN BODY ACCESS PLATE, ACCESS COVER, AND RETAINER ASSEMBLY (Contd)

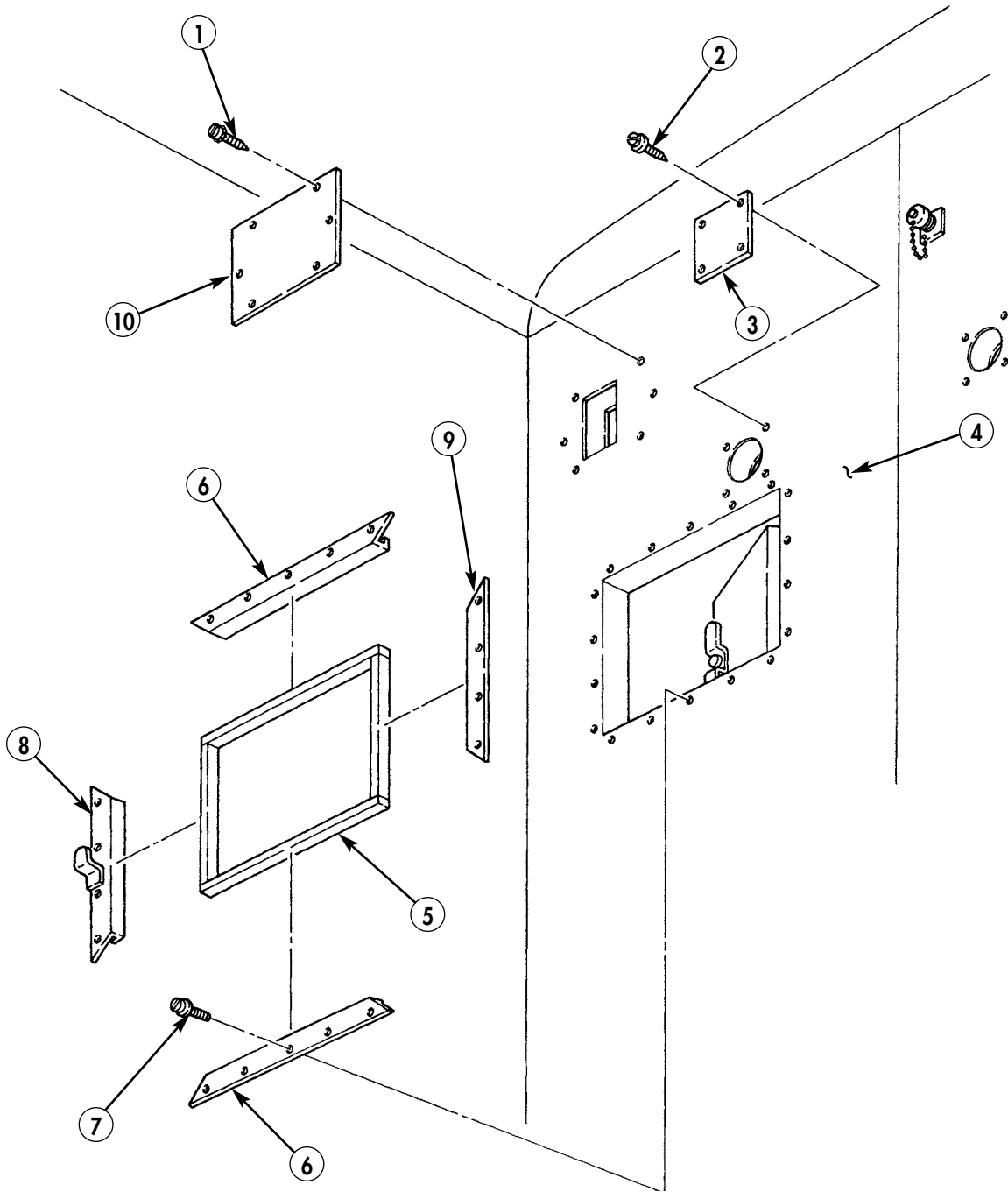

FIELD MAINTENANCE INSTRUCTIONS

2-1/2 TON, 6X6, M44A2 SERIES TRUCKS (MULTIFUEL)

24-VOLT CIRCUIT BREAKER REPLACEMENT

REMOVAL AND INSTALLATION

INITIAL SETUP:

Applicable Models

M185A3, M109A3

Materials/Parts

Two lockwashers (item 245, WP 0470 00)

Equipment Condition

Parking brake set and wheels chocked
(TM 9-2320-361-10).

Battery ground cable disconnected
(WP 0126 00).

REMOVAL

1. Disconnect two wires (4) from circuit breaker (3).
2. Remove two nuts (1), lockwashers (2), screws (5), and circuit breaker (3) from van body (6). Discard lockwashers (2).

INSTALLATION

1. Install circuit breaker (3) on van body (6) with two screws (5), new lockwashers (2), and nuts (1).
2. Connect two wires (4) to circuit breaker (3).
3. Connect battery ground cable (WP 0126 00).
4. Release parking brake and remove wheel chocks (TM 9-2320-361-10).

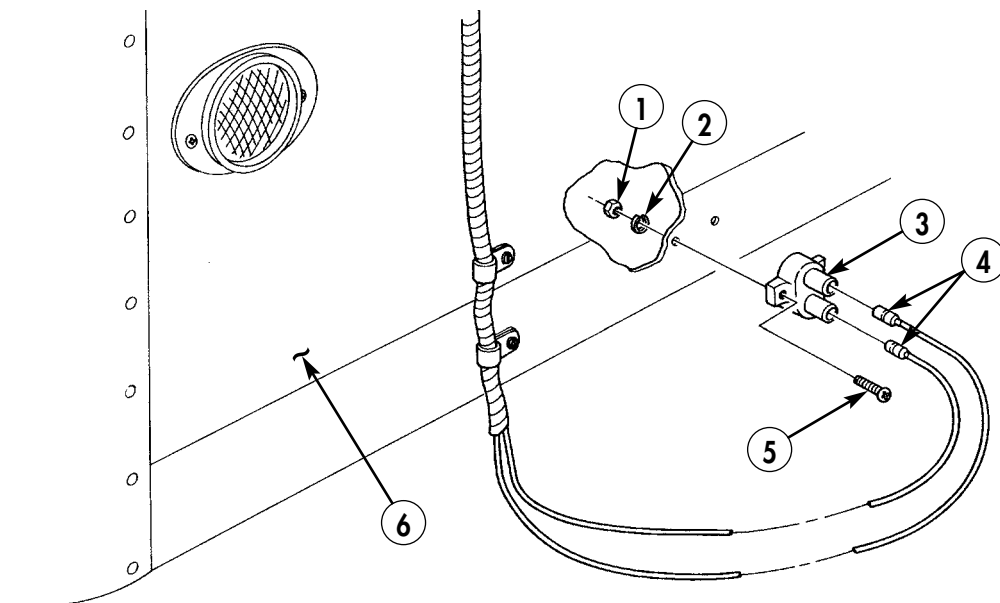

END OF WORK PACKAGE

0324 00-1/2 blank

FIELD MAINTENANCE INSTRUCTIONS

2-1/2 TON, 6X6, M44A2 SERIES TRUCKS (MULTIFUEL)

VEHICLE BOARDING LADDER REPLACEMENT

REMOVAL AND INSTALLATION

INITIAL SETUP:

Applicable Models

M185A3, M109A3

Materials/Parts

Six locknuts (item 148, WP 0470 00)

Four locknuts (item 146, WP 0470 00)

Equipment Condition

Parking brake set and wheels chocked
(TM 9-2320-361-10).

Battery ground cable disconnected
(WP 0126 00).

VEHICLE BOARDING LADDER REPLACEMENT (Contd)

REMOVAL

1. Remove fastener (9) from catch (5) and ladder (3).
2. Remove ladder (3) from brackets (4) and retainer (12).
3. Remove four locknuts (11), screws (7), two spacers (10), and brackets (4) from van body (1). Discard locknuts (11).
4. Remove three locknuts (8) and fastener (9) from bracket (4). Discard locknuts (8).
5. Remove two screws (2) and retainer (12) from van body (1).
6. Remove three locknuts (6) and catch (5) from ladder (3). Discard locknuts (6).

INSTALLATION

1. Install catch (5) on ladder (3) with three new locknuts (6).
2. Install retainer (12) on van body (1) with two screws (2).
3. Install fastener (9) on bracket (4) with three new locknuts (8).
4. Install two spacers (10) and brackets (4) on van body (1) with four screws (7) and new locknuts (11).
5. Install ladder (3) on brackets (4) and attach fastener (9) on catch (5).
6. Connect battery ground cable (WP 0126 00).
7. Release parking brake and remove wheel chocks (TM 9-2320-361-10).

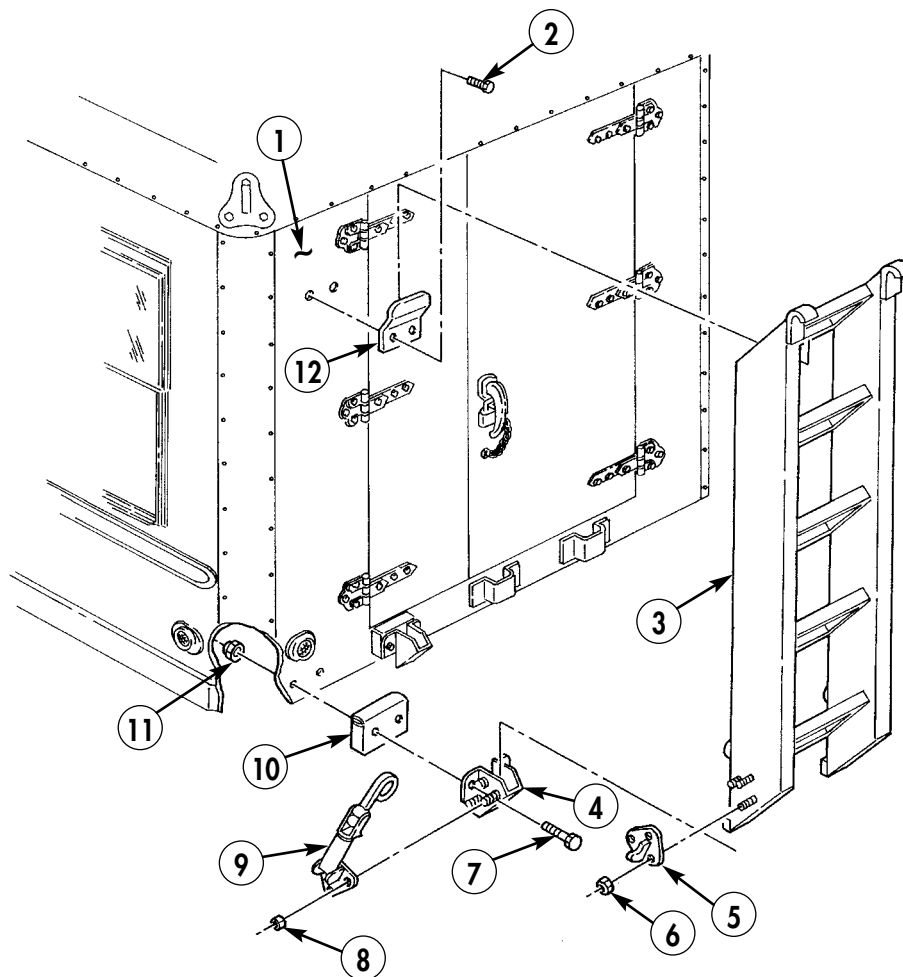

END OF WORK PACKAGE

FIELD MAINTENANCE INSTRUCTIONS

2-1/2 TON, 6X6, M44A2 SERIES TRUCKS (MULTIFUEL)

CONVERTER SELECTOR SWITCH REPLACEMENT

REMOVAL AND INSTALLATION

INITIAL SETUP:

Applicable Models

M185A3, M109A3

Materials/Parts

Five lockwashers (item 208, WP 0470 00)

Equipment Condition

Parking brake set and wheels chocked
(TM 9-2320-361-10).

Battery ground cable disconnected
(WP 0126 00).

Converter removed (WP 0328 00).

CONVERTER SELECTOR SWITCH REPLACEMENT (Contd)

REMOVAL

1. Remove fourteen screws (11) from converter front panel (3) and converter (6).
2. Turn screw (9) and open door (10). Pull converter front panel (3) away from converter (6).
3. Remove two screws (1), selector switch (4), and identification plate (2) from converter front panel (3).

NOTE

Prior to removal, tag lead wires for installation.

4. Remove five screws (8), lockwashers (5), and six wires (7) from selector switch (4). Discard lockwashers (5).

INSTALLATION

1. Install six wires (7) on selector switch (4) with five new lockwashers (5) and screws (8).
2. Install identification plate (2) and selector switch (4) on converter front panel (3) with two screws (1).
3. Install converter front panel (3) on converter (6) with fourteen screws (11).
4. Close door (10) and turn screw (9).
5. Install converter (WP 0328 00).
6. Connect battery ground cable (WP 0126 00).
7. Release parking brake and remove wheel chocks (TM 9-2320-361-10).

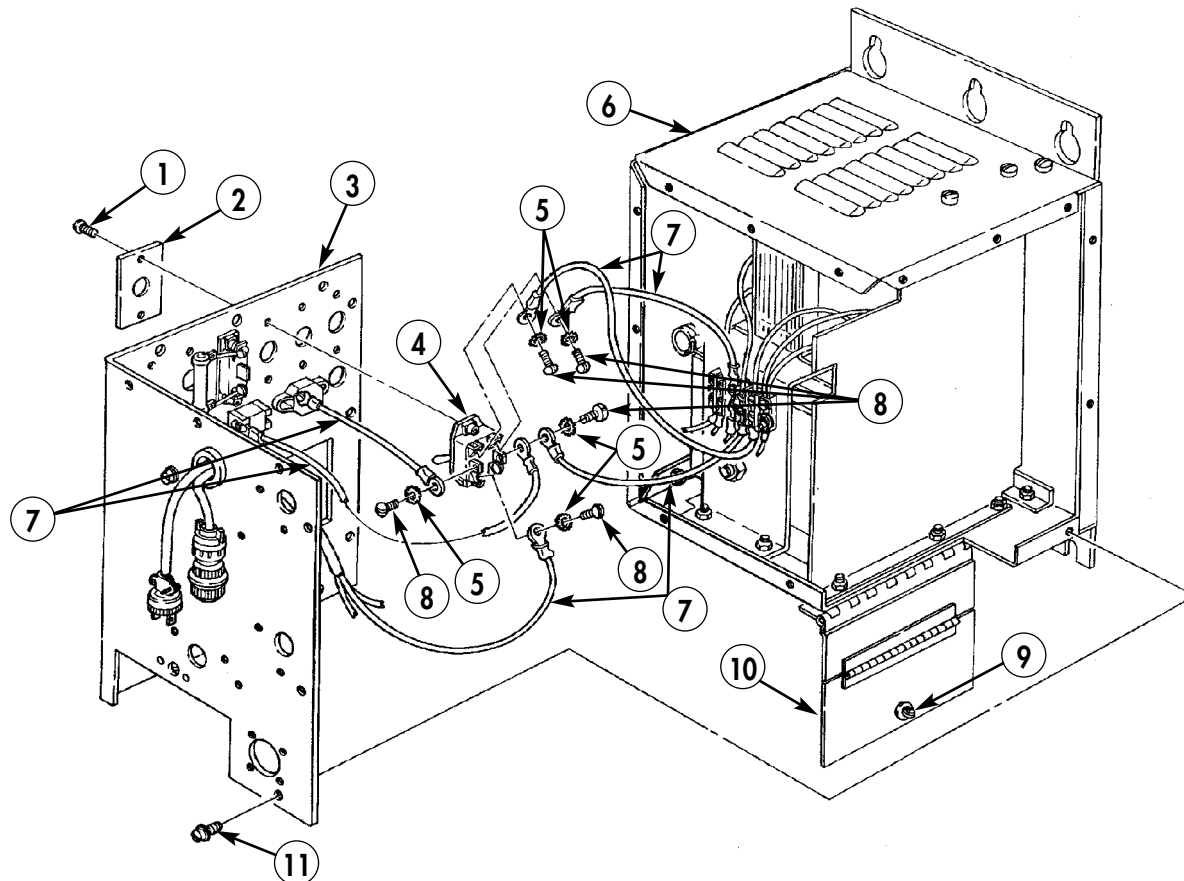

END OF WORK PACKAGE

FIELD MAINTENANCE INSTRUCTIONS

2-1/2 TON, 6X6, M44A2 SERIES TRUCKS (MULTIFUEL)

EXHAUST BLOWER SWITCH REPLACEMENT

REMOVAL AND INSTALLATION

INITIAL SETUP:

Applicable Models

M185A3, M109A3

Materials/Parts

Three lockwashers (item 208, WP 0470 00)

Equipment Condition

Parking brake set and wheels chocked
(TM 9-2320-361-10).

Battery ground cable disconnected
(WP 0126 00).

Converter removed (WP 0328 00).

EXHAUST BLOWER SWITCH REPLACEMENT (Contd)

REMOVAL

1. Remove fourteen screws (13) from converter front panel (3) and converter (6).
2. Turn screw (9) and open door (10). Pull converter front panel (3) away from converter (6).
3. Remove two screws (1), exhaust blower switch (4), and identification plate (2) from converter front panel (3).

NOTE

Prior to removal, tag all lead wires for installation.

4. Remove three screws (8), lockwashers (7), resistor (5), and two wires (11) and (12) from exhaust blower switch (4). Discard lockwashers (7).

INSTALLATION

1. Install wire (12) on exhaust blower switch (4) with new lockwasher (7) and screw (8).
2. Install resistor (5) and wire (11) on exhaust blower switch (4) with two new lockwashers (7) and screws (8).
3. Install exhaust blower switch (4) and identification plate (2) on converter front panel (3) with two screws (1).
4. Install converter front panel (3) on converter (6) with fourteen screws (13).
5. Close door (10) and turn screw (9).
6. Install converter (WP 0328 00).
7. Connect battery ground cable (WP 0126 00).
8. Release parking brake and remove wheel chocks (TM 9-2320-361-10).

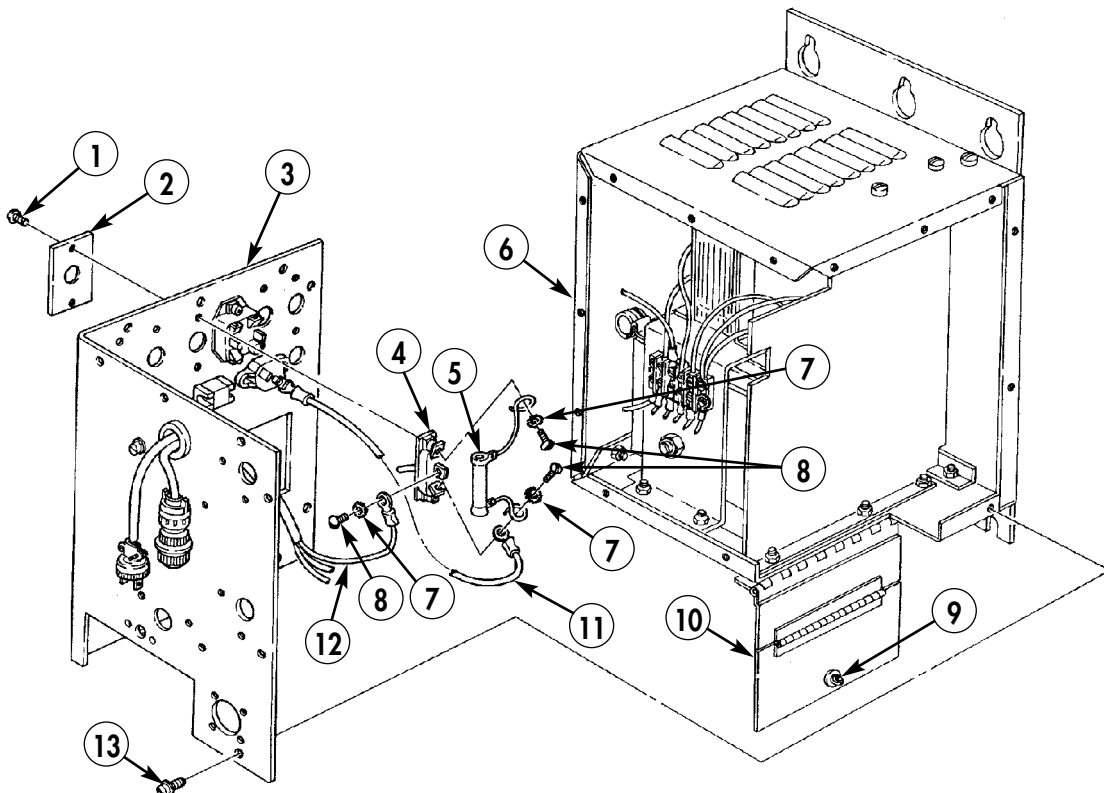

END OF WORK PACKAGE

FIELD MAINTENANCE INSTRUCTIONS

2-1/2 TON, 6X6, M44A2 SERIES TRUCKS (MULTIFUEL)

CONVERTER REPLACEMENT

REMOVAL AND INSTALLATION

INITIAL SETUP:

Applicable Models

M185A3, M109A3

Materials/Parts

Six lockwashers (item 242, WP 0470 00)

Equipment Condition

Parking brake set and wheels chocked
(TM 9-2320-361-10).

Battery ground cable disconnected
(WP 0126 00).

REMOVAL

1. Remove plug (5) from receptacle (6).
2. Remove plug (8) from receptacle (7).
3. Loosen six screws (1) and remove converter (9) from van body (4).
4. Remove six screws (1), lockwashers (2), and washers (3), from van body (4). Discard lockwashers (2).

INSTALLATION

1. Install six washers (3), new lockwashers (2), and screws (1) on van body (4). Do not tighten screws (1).
2. Install converter (9) on van body (4) and tighten six screws (1).
3. Install plug (8) on receptacle (7).
4. Screw plug (5) into receptacle (6).
5. Connect battery ground cable (WP 0126 00).
6. Release parking brake and remove wheel chocks (TM 9-2320-361-10).

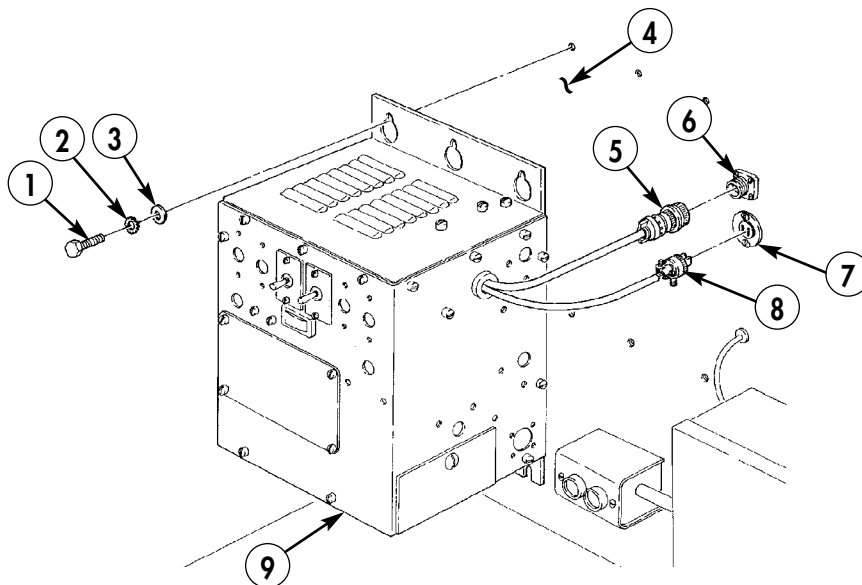

END OF WORK PACKAGE

FIELD MAINTENANCE INSTRUCTIONS

2-1/2 TON, 6X6, M44A2 SERIES TRUCKS (MULTIFUEL)

VAN BODIES FRONT SPLASH GUARD REPLACEMENT

REMOVAL AND INSTALLATION

INITIAL SETUP:

Applicable Models

M185A3, M109A3

Equipment Condition

Parking brake set and wheels chocked
(TM 9-2320-361-10).

Materials/Parts

Eight locknuts (item 129, WP 0470 00)

Battery ground cable disconnected
(WP 0126 00).

NOTE

Left and right front splash guards are removed the same, except for two additional screws for the pioneer tool bracket on the left side. This procedure is for the left front splash guard.

REMOVAL

1. Remove two locknuts (6) and screws (3) from two braces (9) and frame (4). Discard locknuts (6).
2. Remove two locknuts (11), screws (8), and two braces (9) from splash guard (10). Discard locknuts (11).
3. Remove two locknuts (12) and screws (7) from pioneer tool bracket (13) and splash guard (10). Discard locknuts (12).
4. Remove two locknuts (1), screws (5), and splash guard (10) from frame (2). Discard locknuts (1).

INSTALLATION

1. Install splash guard (10) on frame (2) with two screws (5) and new locknuts (1).
2. Install pioneer tool bracket (13) on splash guard (10) with two screws (7) and new locknuts (12).
3. Install two braces (9) on frame (4) with two screws (3) and new locknuts (6).
4. Install two braces (9) on splash guard (10) with two screws (8) and new locknuts (11).
5. Connect battery ground cable (WP 0126 00).
6. Release parking brake and remove wheel chocks (TM 9-2320-361-10).

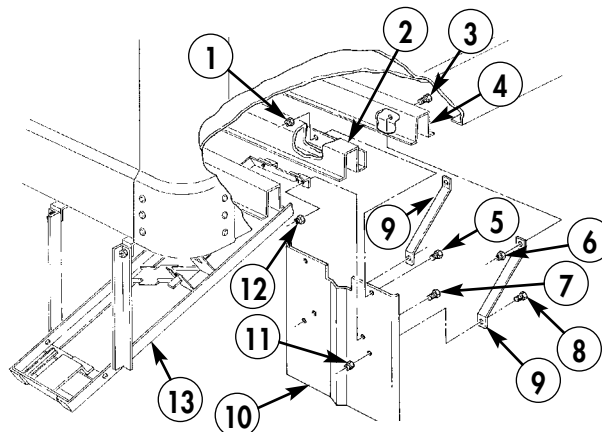

END OF WORK PACKAGE

0329 00-1/2 blank

FIELD MAINTENANCE INSTRUCTIONS

2-1/2 TON, 6X6, M44A2 SERIES TRUCKS (MULTIFUEL)

VAN BODY TOOL REPLACEMENT (M185A3)

COMPRESSOR REMOVAL, VICE AND MACHINE SWIVEL BASE REMOVAL,
FIRE EXTINGUISHER BRACKET REMOVAL, GRINDING MACHINE REMOVAL, DRILL AND STAND REMOVAL,
DRILL AND STAND INSTALLATION, GRINDING MACHINE INSTALLATION, FIRE EXTINGUISHER BRACKET
INSTALLATION, VICE AND MACHINE SWIVEL BASE INSTALLATION, COMPRESSOR INSTALLATION

INITIAL SETUP:

Applicable Models

M185A3

Personnel Required

Two

Materials/Parts

Eight lockwashers (item 229, WP 0470 00)
Seven lockwashers (item 207, WP 0470 00)
Four lockwashers (item 206, WP 0470 00)
Two lockwashers (item 209, WP 0470 00)

Equipment Condition

Parking brake set and wheels chocked
(TM 9-2320-361-10).
Battery ground cable disconnected
(WP 0126 00).

VAN BODY TOOL REPLACEMENT (M185A3) (Contd)

COMPRESSOR REMOVAL

1. Remove wingnut (14), washer (15), and lockwasher (16) from compressor mounting base (12). Discard lockwasher (16).
2. Remove wingnut (2), two lockwashers (1), screw (4), ground strap (3), and lockwasher (1) from compressor mounting base (12) and angle (5). Discard lockwashers (1).
3. Remove top cabinet drawer (38) and two screws (7) from cabinet (6).
4. Remove compressor (13), two nuts (11), washers (10), lockwashers (9), and block (8) from cabinet (6). Discard lockwashers (9).

VICE AND MACHINE SWIVEL BASE REMOVAL

Remove four nuts (39), lockwashers (40), screws (35), washers (37), and vice and machine swivel case (34) from table (20). Discard lockwashers (40).

FIRE EXTINGUISHER BRACKET REMOVAL

1. Remove fire extinguisher (36) from fire extinguisher mounting bracket (31).
2. Remove four nuts (29), washers (30), screws (17), lockwashers (18), and fire extinguisher mounting bracket (31) from van body wall (19). Discard lockwashers (18).

GRINDING MACHINE REMOVAL

Remove four wingnuts (27), lockwashers (28), screws (33), washers (32), and grinding machine (26) from table (20). Discard lockwashers (28).

DRILL AND STAND REMOVAL

Remove four nuts (25), washers (24), screws (22), lockwashers (23), and drill and stand (21) from table (20). Discard lockwashers (23).

DRILL AND STAND INSTALLATION

Install drill and stand (21) on table (20) with four new lockwashers (23), screws (22), washers (24), and nuts (25).

GRINDING MACHINE INSTALLATION

Install grinding machine (26) on table (20) with four screws (33), washers (32), new lockwashers (28), and wingnuts (27).

FIRE EXTINGUISHER BRACKET INSTALLATION

NOTE

Assistant will help with step 1.

1. Install fire extinguisher mounting bracket (31) on van body wall (19) with four new lockwashers (18), screws (17), washers (30), and nuts (29).
2. Install fire extinguisher (36) on mounting bracket (31).

VICE AND MACHINE SWIVEL BASE INSTALLATION

Install vice and machine swivel base (34) on table (20) with four washers (37), screws (35), new lockwashers (40), and nuts (39).

VAN BODY TOOL REPLACEMENT (M185A3) (Contd)

COMPRESSOR INSTALLATION

1. Install block (8) on cabinet (6) with two screws (7), new lockwashers (9), washers (10), and nuts (11).
2. Install top cabinet drawer (38) in cabinet (6).
3. Install compressor (13) on block (8) with new lockwasher (16), washer (15), and wingnut (14).
4. Install new lockwasher (1), ground strap (3), new lockwasher (1), and wingnut (2) on screw (7).
5. Install ground strap (3) on angle (5) with screw (4) and new lockwasher (1).
6. Connect battery ground cable (WP 0126 00).
7. Release parking brake and remove wheel chocks (TM 9-2320-361-10).

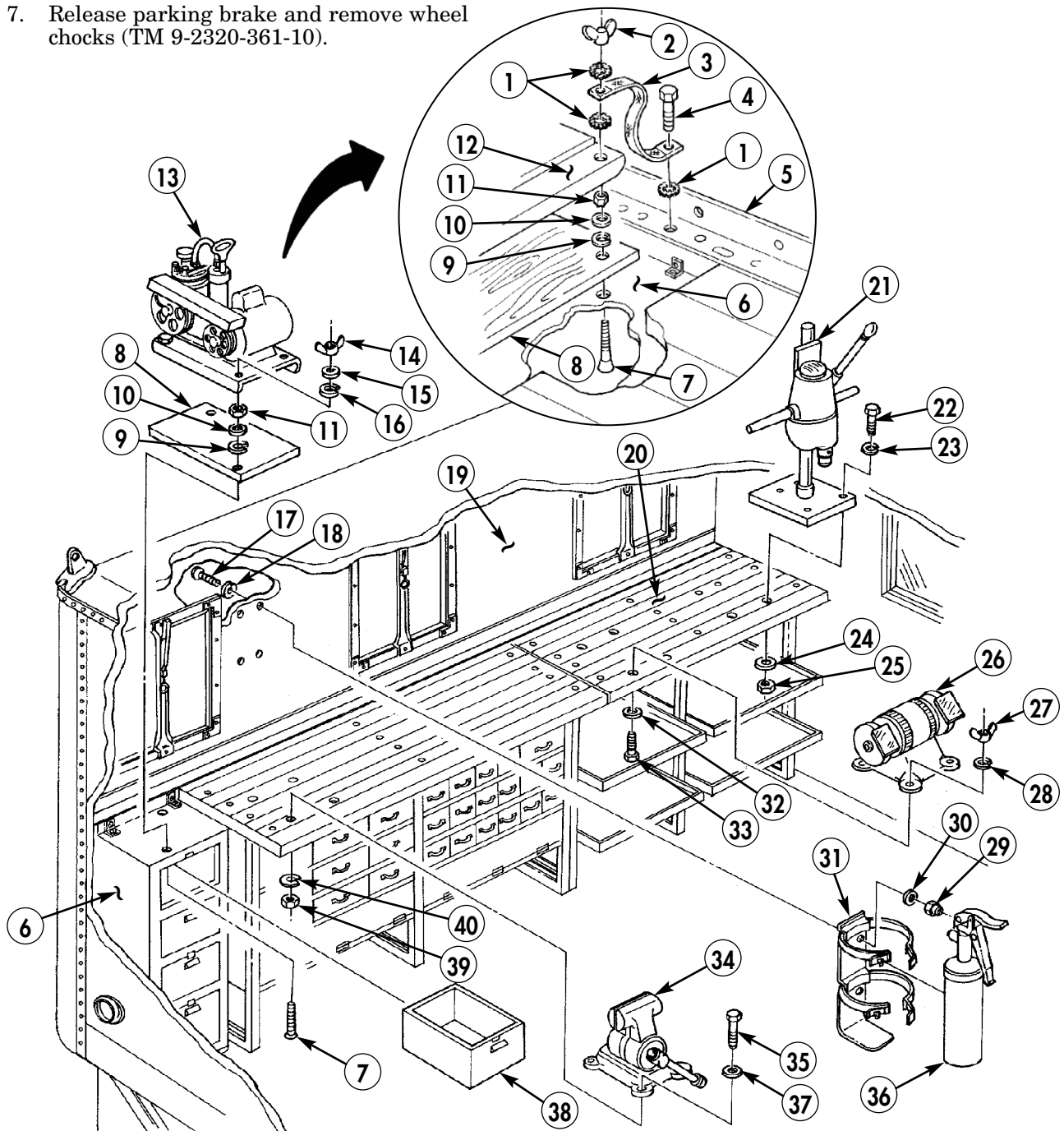

FIELD MAINTENANCE INSTRUCTIONS

2-1/2 TON, 6X6, M44A2 SERIES TRUCKS (MULTIFUEL)

CONVERTER RECEPTACLE REPLACEMENT

24-VOLT CONVERTER RECEPTACLE REMOVAL, 24-VOLT CONVERTER RECEPTACLE INSTALLATION,
115-VOLT CONVERTER RECEPTACLE REMOVAL, AND 115-VOLT CONVERTER RECEPTACLE INSTALLATION

INITIAL SETUP:

Applicable Models

M185A3, M109A3

Materials/Parts

Four screws (item 328, WP 0470 00)

References

TC 9-237

Equipment Condition

Parking brake set and wheels chocked
(TM 9-2320-361-10).

Battery ground cable disconnected
(WP 0126 00).

Van body primary heater removed
(WP 0380 00).

CONVERTER RECEPTACLE REPLACEMENT (Contd)

NOTE

Prior to removal, tag all lead wires for installation.

24-VOLT CONVERTER RECEPTACLE REMOVAL

1. Remove socket (12) from receptacle (2).
2. Remove four machine screws (1) and receptacle (2) from van wall (6). Discard machine screws (1).
3. Pull back three insulation tubings (5) from three receptacle pins (3).
4. Unsolder and remove three wires (4) from three receptacle pins (3) (TC 9-237).

24-VOLT CONVERTER RECEPTACLE INSTALLATION

1. Insert three wires (4) into three receptacle pins (3) and solder in place (TC 9-237).
2. Install three insulation tubings (5) on three receptacle pins (3).
3. Install receptacle (2) on van wall (6) with four new machine screws (1).
4. Install socket (12) on receptacle (2).
5. Install van body primary heater (WP 0380 00).

115-VOLT CONVERTER RECEPTACLE REMOVAL

1. Remove plug (11) from receptacle (9).
2. Remove two screws (10) and receptacle (9) from van wall (6).
3. Remove two screws (7) and wires (8) from receptacle (9).

115-VOLT CONVERTER RECEPTACLE INSTALLATION

1. Install two wires (8) on receptacle (9) with two screws (7).
2. Install receptacle (9) on van wall (6) with two screws (10).
3. Install plug (11) on receptacle (9).
4. Install van body primary heater (WP 0380 00).
5. Connect battery ground cable (WP 0126 00).
6. Release parking brake and remove wheel chocks (TM 9-2320-361-10).

CONVERTER RECEPTACLE REPLACEMENT (Contd)

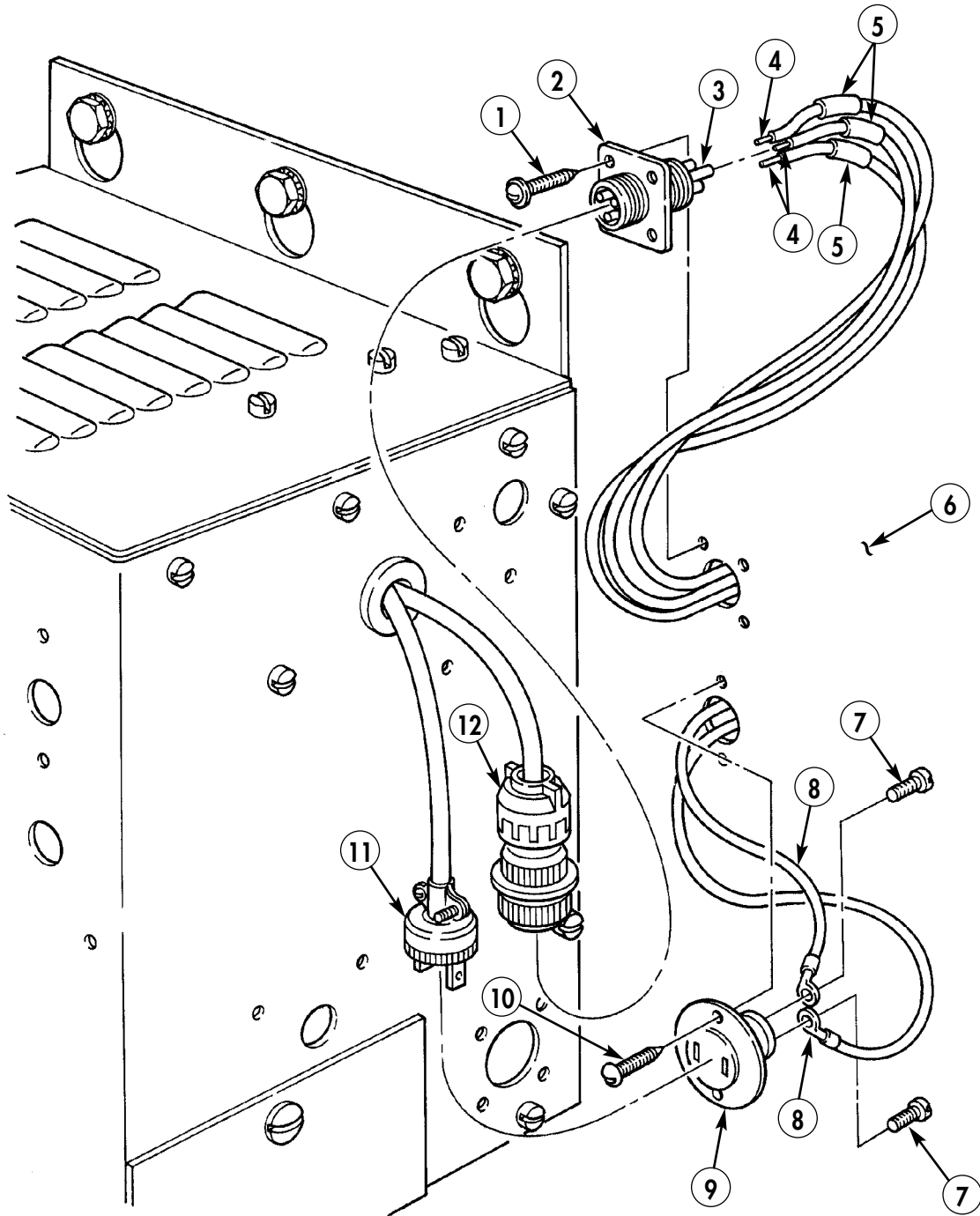

END OF WORK PACKAGE

FIELD MAINTENANCE INSTRUCTIONS

2-1/2 TON, 6X6, M44A2 SERIES TRUCKS (MULTIFUEL)

FLOODLIGHT BRACKET REPLACEMENT

REMOVAL AND INSTALLATION

INITIAL SETUP:

Applicable Models
M185A3, M109A3

Equipment Condition
Parking brake set and wheels chocked
(TM 9-2320-361-10).
Battery ground cable disconnected
(WP 0126 00).

NOTE

All brackets are removed and installed the same. This procedure covers two brackets.

REMOVAL

1. Remove two screws (6) and bracket (1) from van roof (2).
2. Remove two screws (4) and bracket (5) from van wall (3).

INSTALLATION

1. Install bracket (5) on van wall (3) with two screws (4).
2. Install bracket (1) on van roof (2) with two screws (6).
3. Release parking brake and remove wheel chocks (TM 9-2320-361-10).

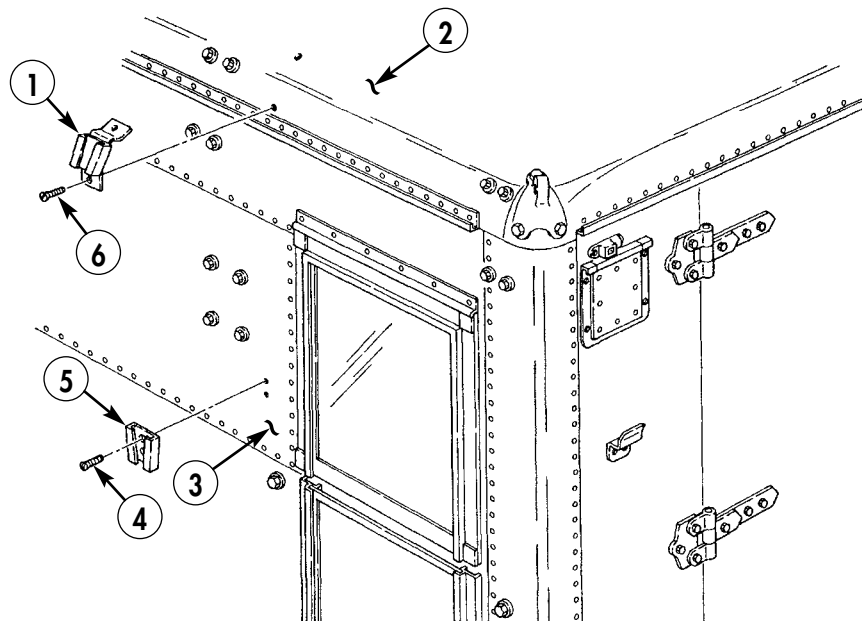

END OF WORK PACKAGE

0332 00-1/2 blank

FIELD MAINTENANCE INSTRUCTIONS

2-1/2 TON, 6X6, M44A2 SERIES TRUCKS (MULTIFUEL)

ACCESS DOOR MOLDING AND ACCESS PLATE REPLACEMENT

REMOVAL AND INSTALLATION

INITIAL SETUP:

Applicable Models

M185A3, M109A3

Materials/Parts

Three rivets (item 315, WP 0470 00)

Three plugs (item 310, WP 0470 00)

Equipment Condition

Parking brake set and wheels chocked
(TM 9-2320-361-10).

Battery ground cable disconnected
(WP 0126 00).

REMOVAL

1. Remove four screws (1) and plate (2) from van wall (3).
2. Drill three rivets (5) and plugs (6) out of molding (4) and van wall (3). Discard rivets (5) and plugs (6).
3. Remove molding (4) from van wall (3).

INSTALLATION

1. Install molding (4) on van wall (3) with three new rivets (5) and plugs (6).
2. Install plate (2) on van wall (3) with four screws (1).
3. Connect battery ground cable (WP 0126 00).
4. Release parking brake and remove wheel chocks (TM 9-2320-361-10).

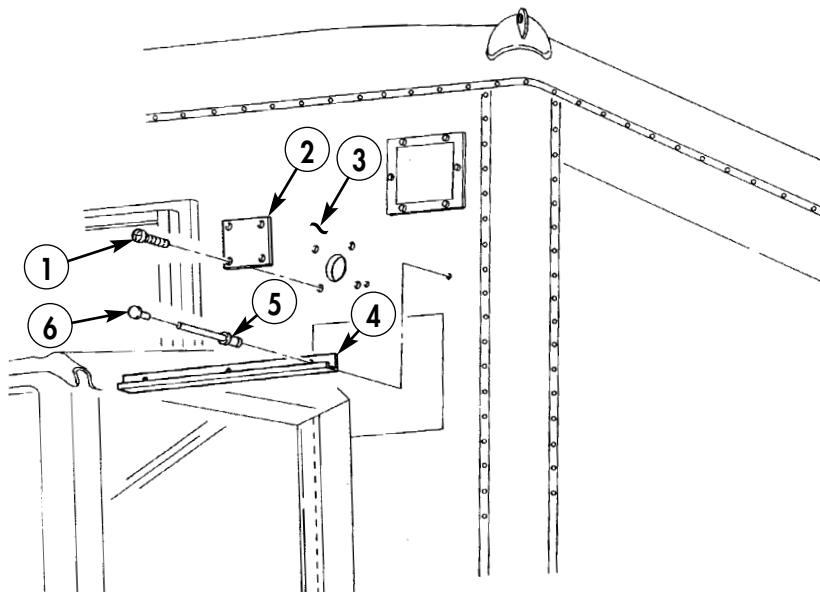

END OF WORK PACKAGE

0333 00-1/2 blank

FIELD MAINTENANCE INSTRUCTIONS

2-1/2 TON, 6X6, M44A2 SERIES TRUCKS (MULTIFUEL)

POWER SWITCH MAINTENANCE REMOVAL, DISASSEMBLY, ASSEMBLY, AND INSTALLATION

INITIAL SETUP:

Applicable Models

All

Materials/Parts

Four lockwashers (item 208, WP 0470 00)

Two lockwashers (item 212, WP 0470 00)

Two lockwashers (item 245, WP 0470 00)

Equipment Condition

Parking brake set and wheels chocked
(TM 9-2320-361-10).

Battery ground cable disconnected
(WP 0126 00).

POWER SWITCH MAINTENANCE (Contd)

NOTE

Prior to removal, tag all lead wires and terminals for installation.

REMOVAL

1. Remove four screws (1) and power switch cover (3) from van body (2).
2. Remove two screws (9), lockwashers (8), and wires (4) and (10) from switch (11). Discard lockwashers (8).
3. Remove two screws (7), lockwashers (6), and wires (4), (5), (12) and (13) from switch (14). Discard lockwashers (6).

DISASSEMBLY

1. Remove two nuts (18), lockwashers (17), and power switch cover (3) from switches (11) and (14). Discard lockwashers (17).
2. Remove two lockwashers (15) and nuts (16) from switches (11) and (14). Discard lockwashers (15).

ASSEMBLY

1. Install two nuts (16) and new lockwashers (15) on switches (14) and (11).
2. Install switches (14) and (11) on power switch cover (3) with two new lockwashers (17) and nuts (18).

INSTALLATION

1. Install wires (4), (5), (12), and (13) on switch (14) with two new lockwashers (6) and screws (7).
2. Install wires (4) and (10) on switch (11) with two new lockwashers (8) and screws (9).
3. Install power switch cover (3) on van body (2) with four screws (1).
4. Connect battery ground cable (WP 0126 00).
5. Release parking brake and remove wheel chocks (TM 9-2320-361-10).

POWER SWITCH MAINTENANCE (Contd)

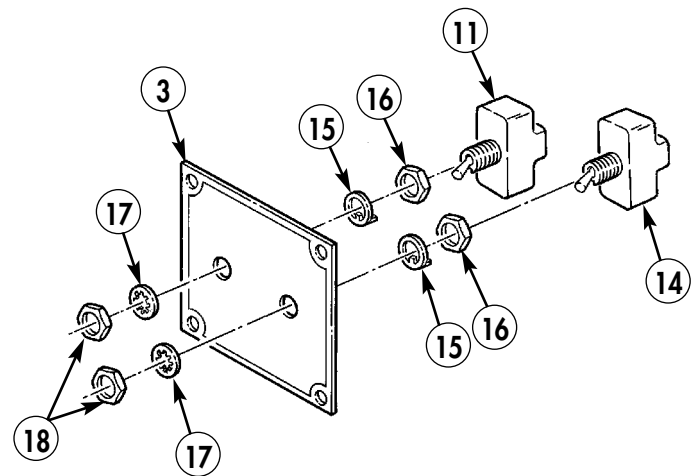
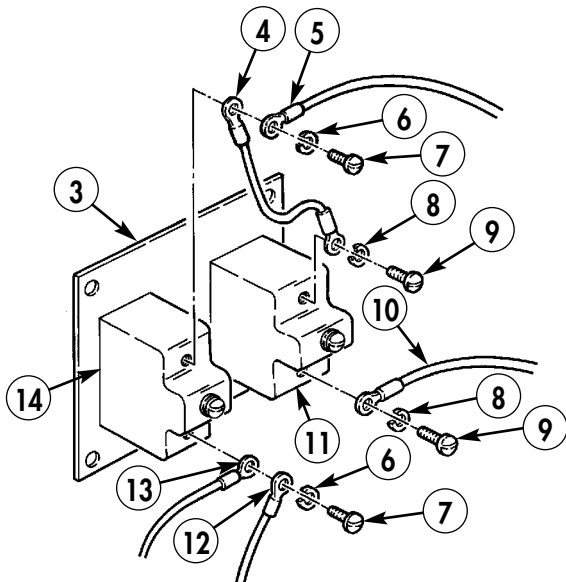
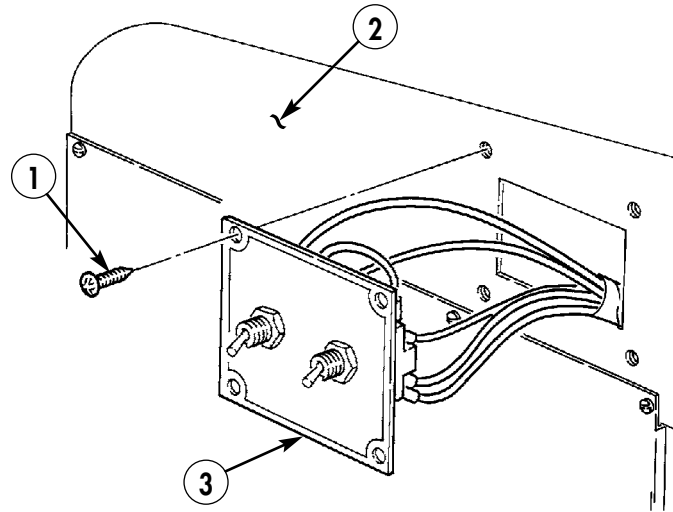

FIELD MAINTENANCE INSTRUCTIONS

2-1/2 TON, 6X6, M44A2 SERIES TRUCKS (MULTIFUEL)

DOOR HOLDER ASSEMBLY AND BRACKET REPLACEMENT

REMOVAL AND INSTALLATION

INITIAL SETUP:

Applicable Models

M185A3, M109A3

Materials/Parts

Eight lockwashers (item 235, WP 0470 00)

Four lockwashers (item 236, WP 0470 00)

Equipment Condition

Parking brake set and wheels chocked
(TM 9-2320-361-10).

Battery ground cable disconnected
(WP 0126 00).

REMOVAL

1. Remove four screws (5), lockwashers (4), and door holder (3) from van wall (2). Discard lockwashers (4).
2. Remove four screws (7), lockwashers (6), and catch (8) from bracket (11). Discard lockwashers (6).
3. Remove four screws (9), lockwashers (10), and bracket (11) from van door (1). Discard lockwashers (10).

INSTALLATION

1. Install bracket (11) on van door (1) with four new lockwashers (10) and screws (9).
2. Install catch (8) on bracket (11) with four new lockwashers (6) and screws (7).
3. Install door holder (3) on van wall (2) with four new lockwashers (4) and screws (5).
4. Connect battery ground cable (WP 0126 00).
5. Release parking brake and remove wheel chocks (TM 9-2320-361-10).

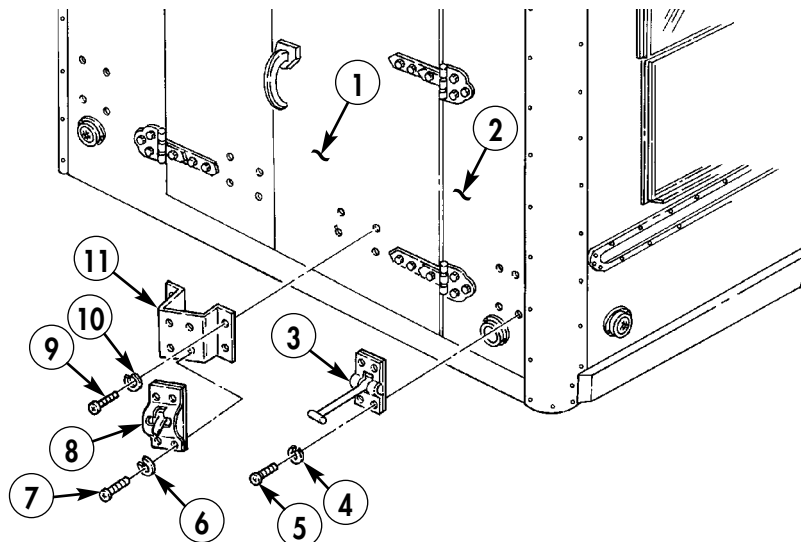

END OF WORK PACKAGE

0335 00-1/2 blank

FIELD MAINTENANCE INSTRUCTIONS

2-1/2 TON, 6X6, M44A2 SERIES TRUCKS (MULTIFUEL)

DOOR CHECK REPLACEMENT

REMOVAL AND INSTALLATION

INITIAL SETUP:

Applicable Models

M185A3, M109A3

Materials/Parts

Two locknuts (item 145, WP 0470 00)

Adhesive (item 5, WP 0468 00)

Equipment Condition

Parking brake set and wheels chocked
(TM 9-2320-361-10).

Battery ground cable disconnected
(WP 0126 00).

NOTE

Left and right door checks are removed and installed the same.
This procedure covers the right door check.

REMOVAL

1. Pull back door seal (3) from door channel (5).
2. Remove two locknuts (7), screws (6), and door check (1) from door channel (5). Discard locknuts (7).
3. Remove two screws (2) and door check (1) from van door (4).

INSTALLATION

1. Install door check (1) on van door (4) with two screws (2).
2. Install door check (1) on door channel (5) with two new locknuts (7) and screws (6).
3. Apply adhesive to door channel (5) and place door seal (3) on door channel (5).
4. Connect battery ground cable (WP 0126 00).
5. Release parking brake and remove wheel chocks (TM 9-2320-361-10).

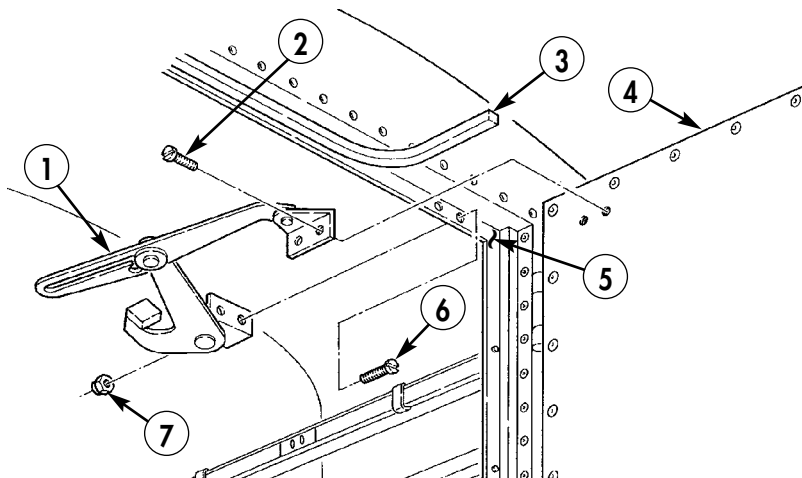

END OF WORK PACKAGE

0336 00-1/2 blank

FIELD MAINTENANCE INSTRUCTIONS

2-1/2 TON, 6X6, M44A2 SERIES TRUCKS (MULTIFUEL)

EXHAUST BLOWER DUCT ASSEMBLY REPLACEMENT

REMOVAL AND INSTALLATION

INITIAL SETUP:

Applicable Models
M185A3, M109A3

Equipment Condition

Parking brake set and wheels chocked
(TM 9-2320-361-10).

Battery ground cable disconnected
(WP 0126 00).

Exhaust blower motor and bracket removed
(WP 0301 00).

REMOVAL

1. Remove four screws (1) and adapter (3) from duct assembly (2).
2. Remove eight screws (5) and four angles (4) from van wall (7).
3. Remove four screws (6) and duct assembly (2) from van wall (7).

INSTALLATION

1. Install duct assembly (2) on van wall (7) with four screws (6).
2. Install four angles (4) on van wall (7) with eight screws (5).
3. Install adapter (3) on duct assembly (2) with four screws (1).
4. Install exhaust blower motor and bracket (WP 0301 00).
5. Connect battery ground cable (WP 0126 00).
6. Release parking brake and remove wheel chocks (TM 9-2320-361-10).

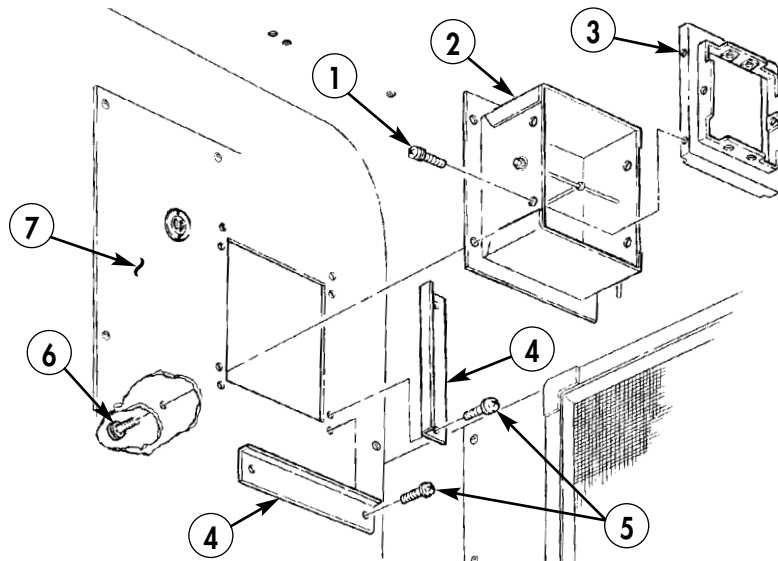

END OF WORK PACKAGE

FIELD MAINTENANCE INSTRUCTIONS

2-1/2 TON, 6X6, M44A2 SERIES TRUCKS (MULTIFUEL)

BLOWER MOTOR RECEPTACLE REPLACEMENT REMOVAL AND INSTALLATION

INITIAL SETUP:

Applicable Models
M185A3, M109A3

Materials/Parts
Two lockwashers (item 216, WP 0470 00)

Equipment Condition
Parking brake set and wheels chocked
(TM 9-2320-361-10).
Battery ground cable disconnected
(WP 0126 00).

NOTE

Prior to removal, tag all lead wires for installation.

REMOVAL

1. Remove two screws (3) from blower motor receptacle (4) and van wall (1).
2. Pull blower motor receptacle (4) forward and remove two screws (6), lockwashers (5), and wires (2) from blower motor receptacle (4). Discard lockwashers (5).

INSTALLATION

1. Install two wires (2) on blower motor receptacle (4) with two screws (6) and new lockwashers (5).
2. Install blower motor receptacle (4) on van wall (1) with two screws (3).
3. Connect battery ground cable (WP 0126 00).
4. Release parking brake and remove wheel chocks (TM 9-2320-361-10).

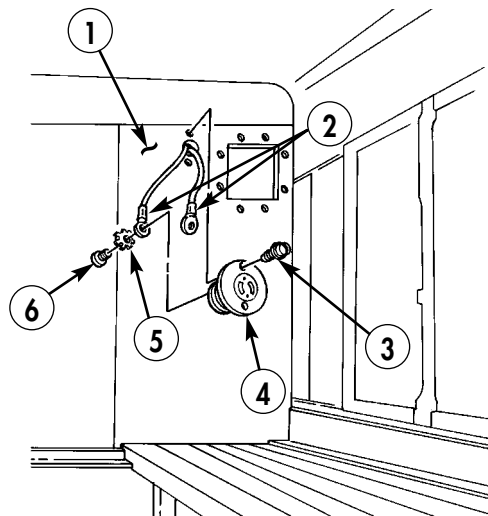

END OF WORK PACKAGE

0338 00-1/2 blank

FIELD MAINTENANCE INSTRUCTIONS

2-1/2 TON, 6X6, M44A2 SERIES TRUCKS (MULTIFUEL)

BLACKOUT SWITCH REPLACEMENT REMOVAL, DISASSEMBLY, ASSEMBLY, AND INSTALLATION

INITIAL SETUP:

Applicable Models

M185A3, M109A3

Materials/Parts

Four lockwashers (item 216, WP 0470 00)

Equipment Condition

Parking brake set and wheels chocked
(TM 9-2320-361-10).

Battery ground cable disconnected
(WP 0126 00).

BLACKOUT SWITCH REPLACEMENT (Contd)

NOTE

Prior to removal, tag all lead wires for installation.

REMOVAL

1. Remove four screws (6) and cover (5) from van body (1).
2. Remove four screws (4), lockwashers (3), two wires (2), and wires (11) from two switches (10). Discard lockwashers (3).
3. Remove four screws (8) and bracket (9) from van body (1).

DISASSEMBLY

Remove two nuts (7) and switches (10) from bracket (9).

ASSEMBLY

Install two switches (10) on bracket (9) with two nuts (7).

INSTALLATION

1. Install bracket (9) on van body (1) with four screws (8).
2. Install two wires (2) and wires (11) on two switches (10) with four new lockwashers (3) and screws (4).
3. Install cover (5) on van body (1) with four screws (6).
4. Connect battery ground cable (WP 0126 00).

50340

.Release parking brake and remove wheel chocks (TM 9-2320-361-10).

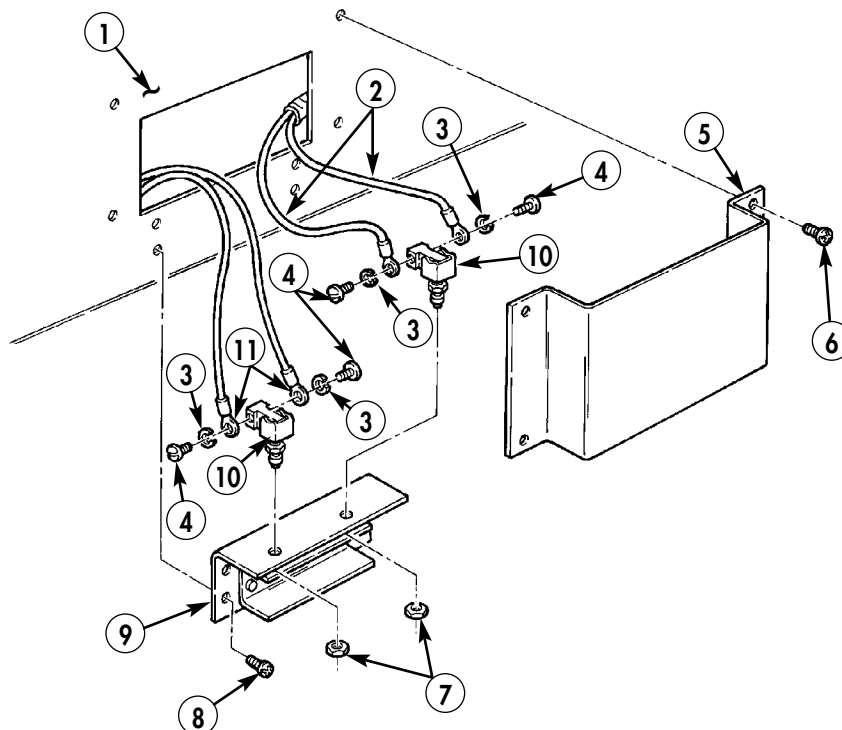

END OF WORK PACKAGE

FIELD MAINTENANCE INSTRUCTIONS

2-1/2 TON, 6X6, M44A2 SERIES TRUCKS (MULTIFUEL)

FUEL LINE ADAPTER REPLACEMENT

REMOVAL AND INSTALLATION

INITIAL SETUP:

Applicable Models
M185A3, M109A3

Equipment Condition
Parking brake set and wheels chocked
(TM 9-2320-361-10).
Battery ground cable disconnected
(WP 0126 00).

REMOVAL

1. Remove three screws (1) and fuel line adapter (4) from van body front wall (2).
2. Remove two plugs (3) from fuel line adapter (4).

INSTALLATION

1. Install two plugs (3) in fuel line adapter (4).
2. Install fuel line adapter (4) in van body front wall (2) with three screws (1).
3. Connect battery ground cable (WP 0126 00).
4. Release parking brake and remove wheel chocks (TM 9-2320-361-10).

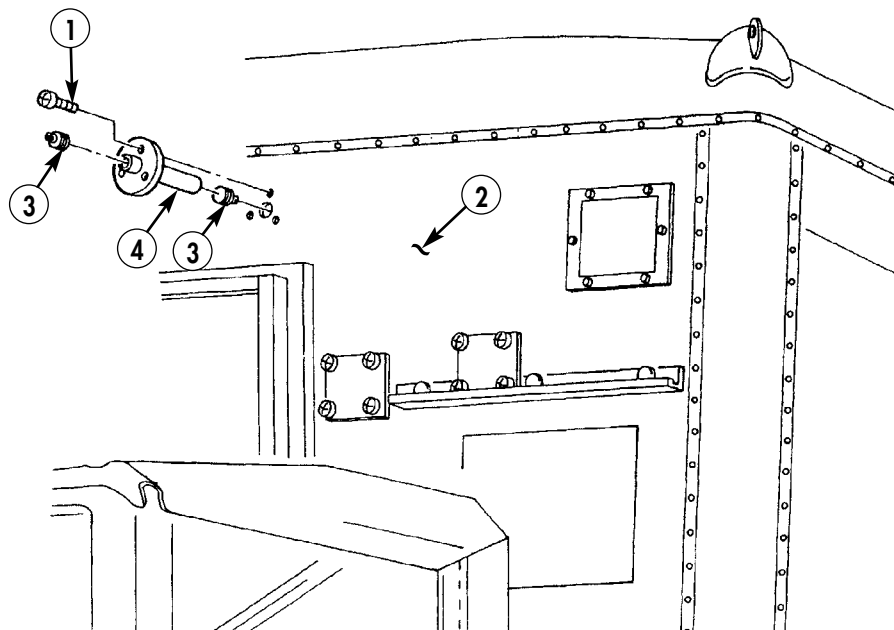

END OF WORK PACKAGE

0340 00-1/2 blank

FIELD MAINTENANCE INSTRUCTIONS

2-1/2 TON, 6X6, M44A2 SERIES TRUCKS (MULTIFUEL)

SIDE RAIL MAINTENANCE REMOVAL, CLEANING, AND INSTALLATION

INITIAL SETUP:

Applicable Models

M185A3, M109A3

Tools and Special Tools

General mechanic's tool kit
(item 116, WP 0469 00)

Materials/Parts

Fifty-four rivets (item 315, WP 0470 00)

Materials/Parts (Contd)

Fifty-four plugs (item 310, WP 0470 00)
Tar (item 52, WP 0468 00)

Equipment Condition

Parking brake set and wheels chocked
(TM 9-2320-361-10).
Battery ground cable disconnected
(WP 0126 00).

NOTE

Side rails on both sides of van body are removed and installed the same. This task covers one side.

REMOVAL

1. Drill fifty-four plugs (3) and rivets (2) out of side rail (4) and van wall (1).
2. Remove two side rails (4) from van wall (1).

CLEANING

Clean all tar out of rivet holes (5) and side rail (4).

INSTALLATION

NOTE

A sealer coat of hot tar must be applied to inside of rail in area of rivet holes before installation.

1. Install two side rails (4) on van wall (1) with fifty-four new rivets (2) and fifty-four plugs (3).
2. Connect battery ground cable (WP 0126 00).
3. Release parking brake and remove wheel chocks (TM 9-2320-361-10).

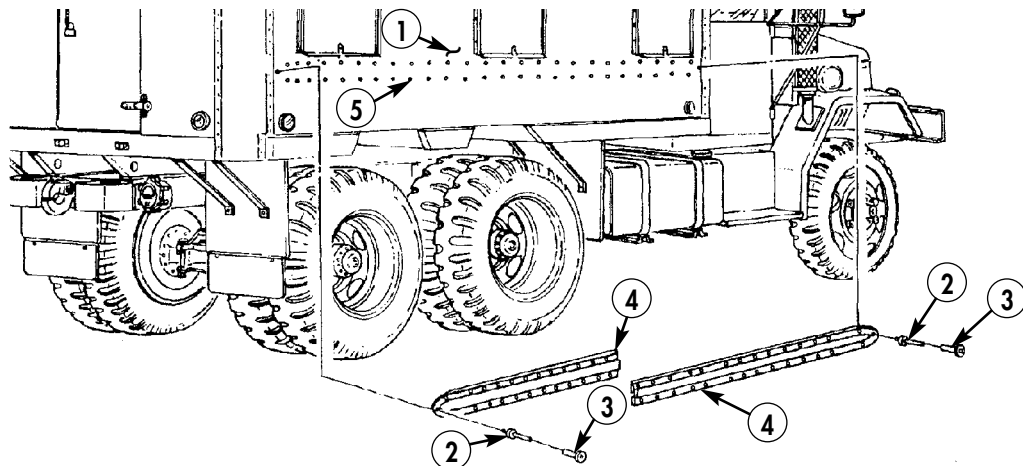

END OF WORK PACKAGE

0341 00-1/2 blank

FIELD MAINTENANCE INSTRUCTIONS

2-1/2 TON, 6X6, M44A2 SERIES TRUCKS (MULTIFUEL)

FRONT WINCH DRAG BRAKE TEST AND ADJUSTMENT

TESTING AND ADJUSTMENT

INITIAL SETUP:

Applicable Models

All

Tools and Special Tools

General mechanic's tool kit
(item 116, WP 0469 00)

Equipment Condition

Parking brake set and wheels chocked
(TM 9-2320-361-10).
Battery ground cable disconnected
(WP 0126 00).

WARNING

Wear leather gloves when handling cable. Do not let cable run through hands. Broken or rusty wires may cause injury to personnel.

TESTING

1. Pull out drum lock lever (1) and turn 90° clockwise to unlocked position.
2. Pull winch cable (3) out three to four feet. Winch drum (2) should stop turning when cable (3) is released. If drum (2) does not stop turning, adjust drag brake.

ADJUSTMENT

NOTE

When performing step 1, turn adjusting screw in 1/2 turn increments until proper drag adjustment is accomplished.

1. Turn adjusting screw (4) clockwise to increase drag.
2. Repeat drag test to make sure drag is adjusted correctly.
3. Connect battery ground cable (WP 0126 00).
4. Release parking brake and remove wheel chocks (TM 9-2320-361-10).

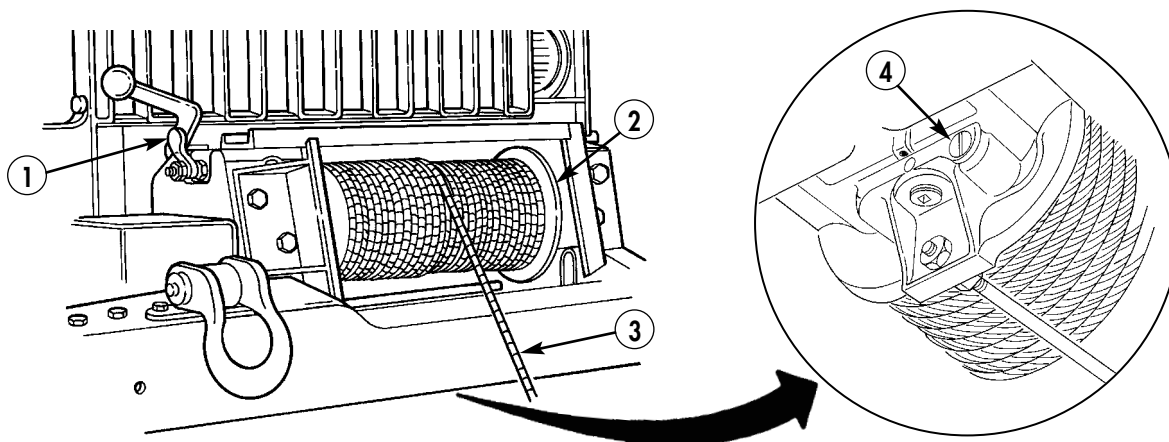

END OF WORK PACKAGE

0342 00-1/2 blank

FIELD MAINTENANCE INSTRUCTIONS

2-1/2 TON, 6X6, M44A2 SERIES TRUCKS (MULTIFUEL)

FRONT WINCH CABLE REPLACEMENT

REMOVAL AND INSTALLATION

INITIAL SETUP:

Applicable Models

All

References

WP 0020 00

Tools and Special Tools

General mechanic's tool kit
(item 116, WP 0469 00)

Equipment Condition

Parking brake set and wheels chocked
(TM 9-2320-361-10).
Front winch cable unwound
(TM 9-2320-361-10).

WARNING

Wear leather gloves when handling cable. Do not let cable run through hands. Broken or rusty wires may cause injury to personnel.

REMOVAL

1. Loosen setscrew (2) and remove front winch cable (3) from drum (1).
2. Remove nut (4) and screw (6) from clevis (7) and remove chain (5).

INSTALLATION

1. Install chain (5) on clevis (7) with screw (6) and nut (4).
2. Install front winch cable (3) in drum (1) and tighten setscrew (2).
3. Wind front winch cable on front winch drum (TM 9-2320-361-10).
4. Lubricate winch cable (WP 0020 00).
5. Release parking brake and remove wheel chocks (TM 9-2320-361-10).

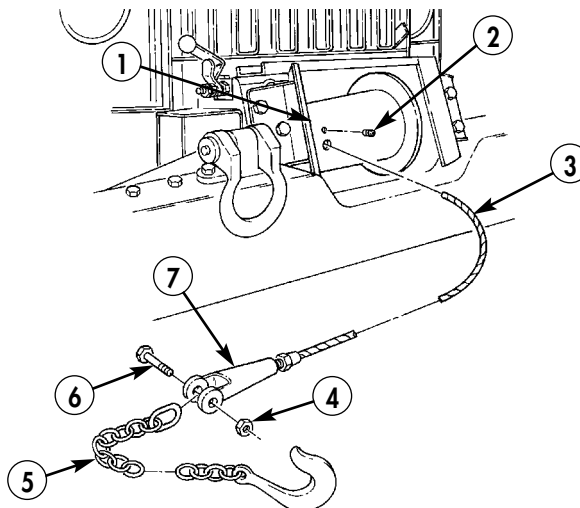

END OF WORK PACKAGE

0343 00-1/2 blank

FIELD MAINTENANCE INSTRUCTIONS

2-1/2 TON, 6X6, M44A2 SERIES TRUCKS (MULTIFUEL)

AUTOMATIC BRAKE TEST AND ADJUSTMENT

TESTING AND ADJUSTMENT

INITIAL SETUP:

Applicable Models

All

Personnel Required

Two

Tools and Special Tools

General mechanic's tool kit
(item 116, WP 0469 00)

Equipment Condition

Parking brake set and wheels chocked
(TM 9-2320-361-10).

AUTOMATIC BRAKE TEST AND ADJUSTMENT (Contd)

TESTING

1. Park test vehicle (1) at top of steep grade facing downhill and chock wheels (refer to TM 9-2320-361-10).
2. Park secondary vehicle (2) at bottom of steep grade facing test vehicle (1).

WARNING

- Wear leather gloves when handling cable. Do not let cable run through hands. Broken or rusty wires may cause injury to personnel.
 - Never stand between test vehicles. Assistant must remain in secondary vehicle to engage service brake if cable snaps or automatic brake fails. Failure to comply may result in injury to personnel.
3. Pull out drum lock lever (4) and turn 90° clockwise to unlocked position. Unwind cable (5) and connect to secondary vehicle (2).
 4. Place secondary vehicle's (2) transmission lever in neutral position. Disengage parking brake and disengage front wheel drive lever if engaged.

CAUTION

Do not use front winch to pay out line loads greater than 3,000 lb (1,362 kg) for any distance greater than 10 ft (3.1 m). Failure to comply may cause damage to equipment.

NOTE

Refer to TM 9-2320-361-10 for safe working loads.

5. Place winch drum clutch lever (3) in engage position.
6. Place transfer case shift lever (7) to neutral position and transmission power takeoff lever (8) to low position on test vehicle (1).

WARNING

Always use hand throttle to control engine speed when operating winch. Avoid sudden changes in speed. Rough or jerky operation may cause broken shearpins and snapped cables. Failure to comply may cause injury to personnel or damage to equipment.

7. Press clutch pedal (9) and start test vehicle (1). Place transmission gearshift lever (6) in 4th gear position.
8. Release clutch pedal (9) slowly. Using hand throttle (10), pull secondary vehicle (2) halfway up grade. Press clutch pedal (9) If secondary vehicle (2) rolls back down grade, adjust automatic brake.

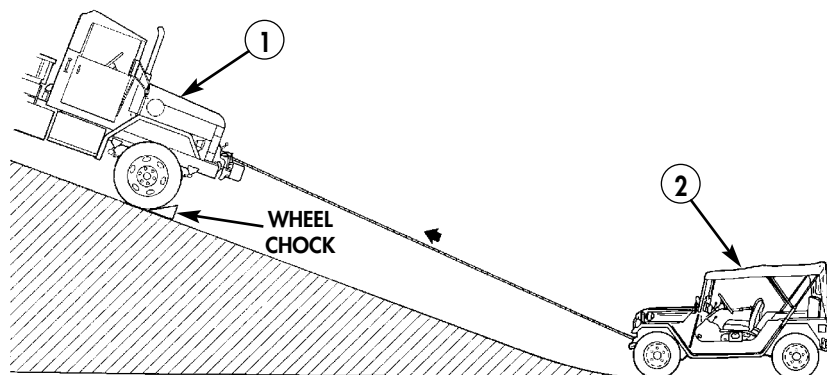

AUTOMATIC BRAKE TEST AND ADJUSTMENT (Contd)

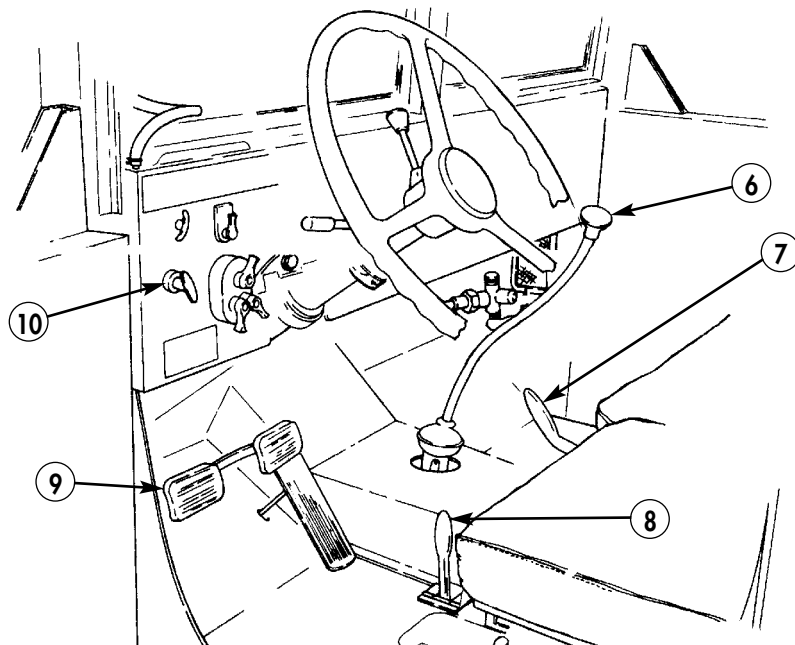
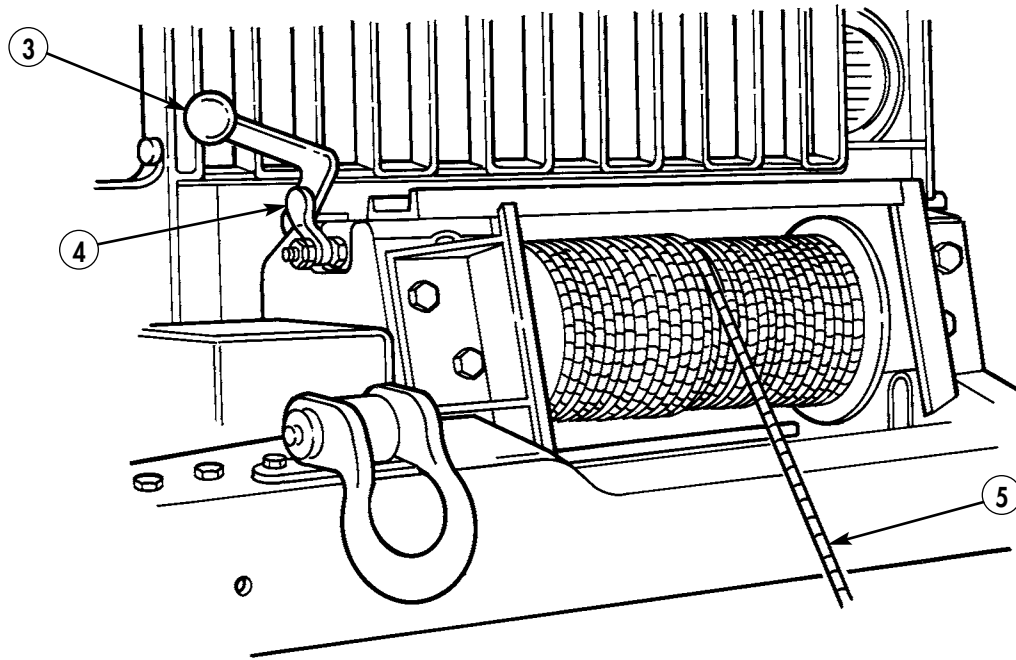

AUTOMATIC BRAKE TEST AND ADJUSTMENT (Contd)

ADJUSTMENT

1. Disengage hand throttle (3) on vehicle (1). Press clutch pedal (7) and place PTO lever (6) in reverse position. Release clutch pedal (7) and unwind secondary vehicle (2) back to level ground and set parking brake.
2. Place PTO lever (6) in neutral position and disengage drum clutch lever (8).
3. Adjust brake band by turning adjusting screw (10) in 1/2-turn clockwise increments to increase braking action.
4. Repeat testing and adjustment until correct adjustment is obtained.

NOTE

Perform steps 5 through 7 only when new winch is installed.

5. Extend winch cable (9) for 5 minutes at engine idle (TM 9-2320-361-10).
6. Allow brake band to cool for approximately 1-1/2 hours.
7. Repeat brake band adjustment procedure.
8. Release parking brake and remove wheel chocks (TM 9-2320-361-10).

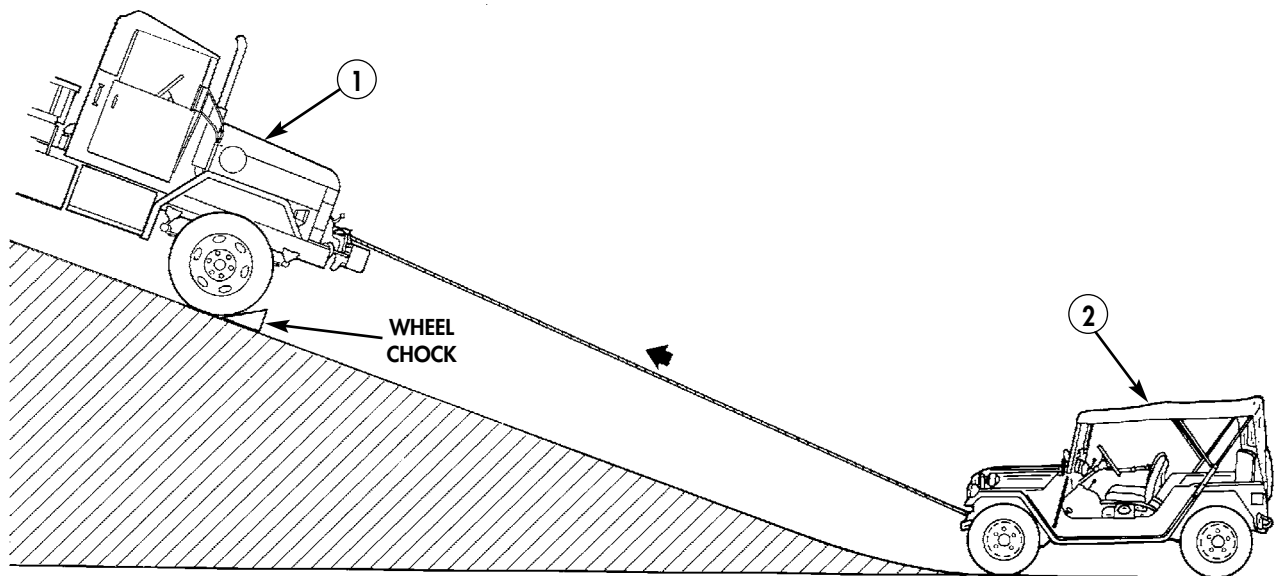

AUTOMATIC BRAKE TEST AND ADJUSTMENT (Contd)

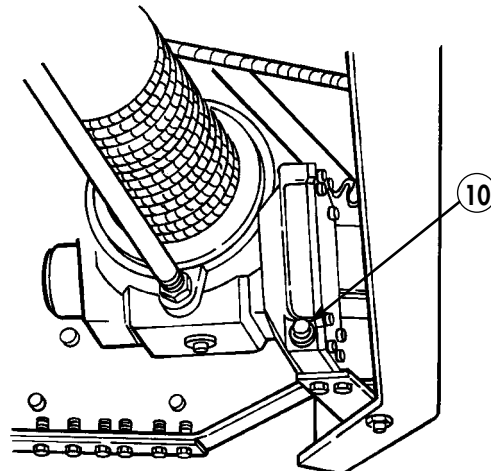
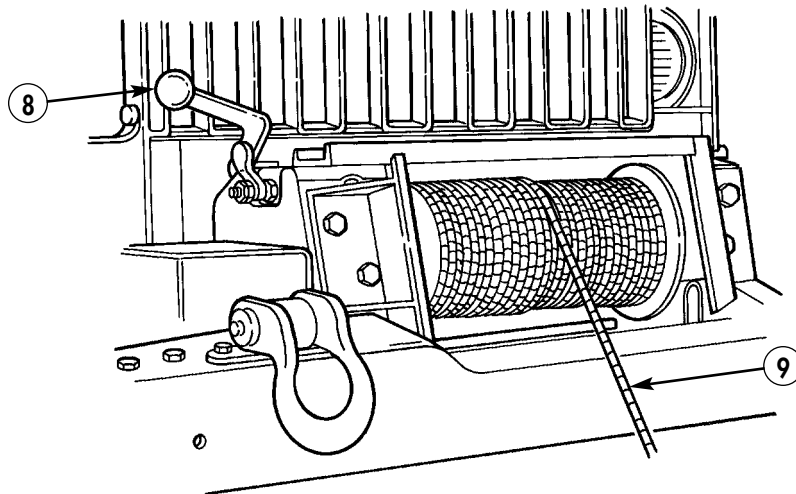
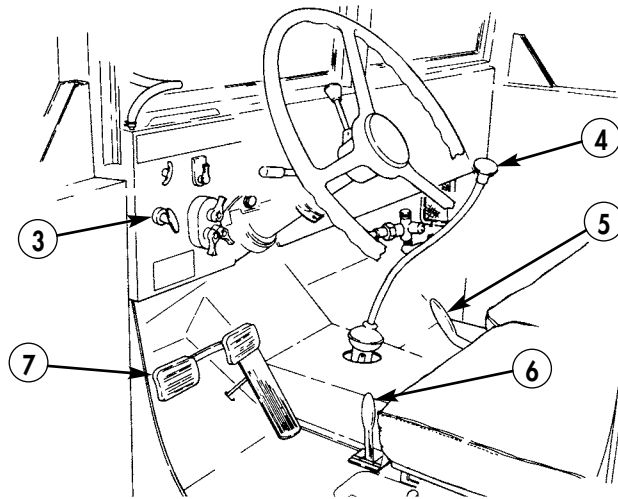

END OF WORK PACKAGE

FIELD MAINTENANCE INSTRUCTIONS

2-1/2 TON, 6X6, M44A2 SERIES TRUCKS (MULTIFUEL)

FRONT WINCH REPLACEMENT

REMOVAL AND INSTALLATION

INITIAL SETUP:

Applicable Models

All

Personnel Required

Two

Tools and Special Tools

General mechanic's tool kit
(item 116, WP 0469 00)

Materials/Parts

Four locknuts (item 166, WP 0470 00)
Six locknuts (item 147, WP 0470 00)
Twelve lockwashers (item 202, WP 0470 00)
Six lockwashers (item 200, WP 0470 00)

References

WP 0344 00

Equipment Condition

Parking brake set and wheels chocked
(TM 9-2320-361-10).
Battery ground cable disconnected
(WP 0126 00).
Front winch propeller shaft removed
(WP 0346 00).
Front winch cable removed (WP 0343 00).
Front bumper removed (WP 0204 00).
Brush guard removed (WP 0203 00).
Drain oil from winch (WP 0020 00).

FRONT WINCH REPLACEMENT (Contd)

WARNING

All personnel must stand clear of winch during lifting operations. A swinging or shifting load may result in injury to personnel.

REMOVAL

NOTE

Perform step 1 only if front winch requires repair.

1. Remove four locknuts (7), screws (3), two washers (5) and brush guard brackets (4) from frame rail (6). Discard locknuts (7).
2. Secure chain sling (1) to front winch (11) and lifting device (2). Raise lifting device (2) enough to remove slack from chain sling (1).

NOTE

Assistant will help with step 3.

3. Remove six locknuts (9), screws (10), and front winch (11) from frame extensions (8). Discard locknuts (9).
4. Lower front winch (11) approximately 1 in. (2.5 cm) from ground and remove twelve screws (15), lockwashers (16), washers (17), and two winch supports (18) from front winch (11). Discard lockwashers (16).
5. Lower front winch (11) to ground and remove chain sling (1) from lifting device (2) and front winch (11).
6. Remove six screws (20), lockwashers (19), and two cable guards (21) from front winch (11). Discard lockwashers (19).

INSTALLATION

NOTE

Perform steps 1 and 2 if installing new or repaired front winch.

1. Rotate winch drum (14) on front winch (11) one complete revolution to ensure front winch (11) moves freely without binding. Replace or repair front winch (11) if winch drive (14) binds.
2. Operate drum clutch lever (13) and drum lock lever (12) to ensure both operate correctly. Replace or repair front winch (11) if levers (12) or (13) do not operate correctly.
3. Install two cable guards (21) on front winch (11) with six new lockwashers (19) and screws (20).
4. Secure chain sling (1) around front winch (11) and lifting device (2). Raise front winch (11) approximately 1 in. (2.5 cm) off ground.
5. Install two winch supports (18) on front winch (11) with twelve washers (17), new lockwashers (16), and screws (15).

NOTE

Assistant will help with step 7.

6. Install front winch (11) and two winch supports (18) on two frame extensions (8) with six screws (10) and new locknuts (9).
7. Install two brush guard brackets (4) and washers (5) to frame rail (6) with four screws (3) and new locknuts (7).
8. Install front winch propeller shaft (WP 0346 00).
9. Install brush guard (WP 0203 00).
10. Install front winch cable (WP 0343 00).

FRONT WINCH REPLACEMENT (Contd)

INSTALLATION (Contd)

11. Install front bumper (WP 0204 00).
12. Fill winch to proper oil level (WP 0020 00).
13. Adjust automatic brake (WP 0344 00).
14. Connect battery ground cable (WP 0126 00).
15. Release parking brake and remove wheel chocks (TM 9-2320-361-10).

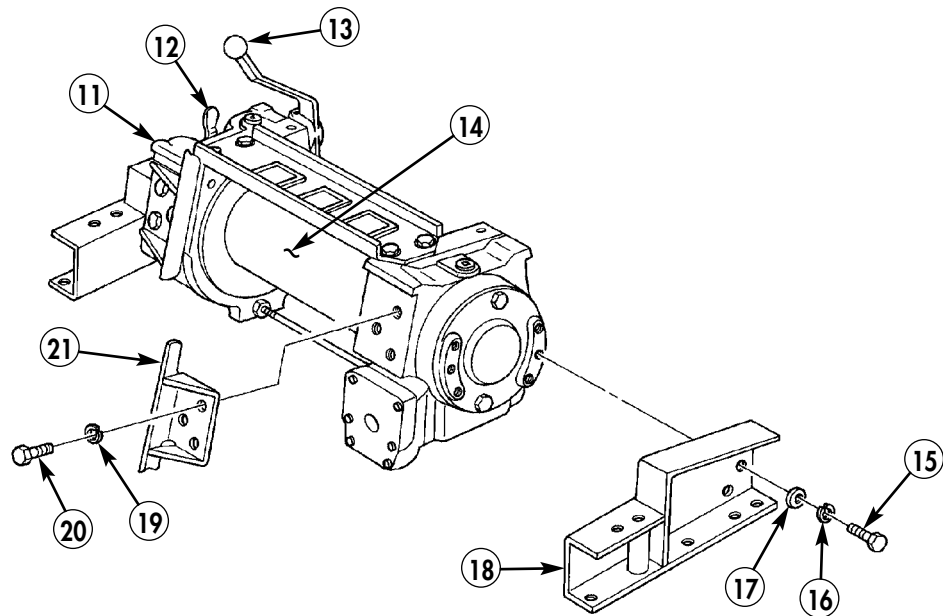
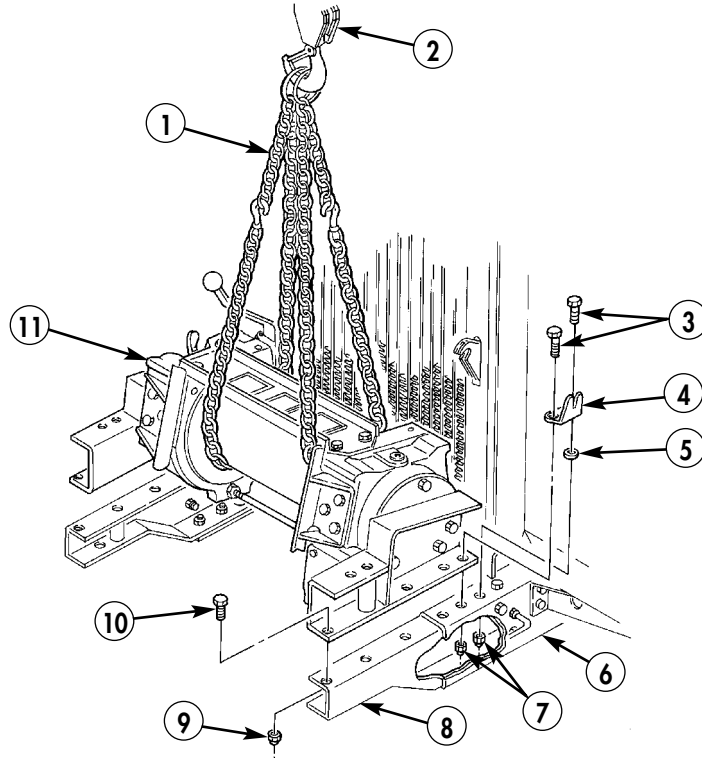

END OF WORK PACKAGE

FIELD MAINTENANCE INSTRUCTIONS

2-1/2 TON, 6X6, M44A2 SERIES TRUCKS (MULTIFUEL)

FRONT WINCH PROPELLER SHAFT REPLACEMENT REMOVAL, INSPECTION, AND INSTALLATION

INITIAL SETUP:

Applicable Models

All

Tools and Special Tools

General mechanic's tool kit
(item 116, WP 0469 00)

Materials/Parts

Four locknuts (item 169, WP 0470 00)
Two cotter pins (item 30, WP 0470 00)
GAA grease (item 17, WP 0468 00)

References

WP 0020 00
WP 0141 00

Equipment Condition

Parking brake set and wheels chocked
(TM 9-2320-361-10).
Battery ground cable disconnected
(WP 0126 00).

FRONT WINCH PROPELLER SHAFT REPLACEMENT (Contd)

REMOVAL

NOTE

Place front winch control lever in low position to remove screws, then in neutral position to gain access to remaining screws.

1. Remove four screws (3), locknuts (1), and rear flange (11) from transmission power takeoff flange (2). Discard locknuts (1).
2. Remove two cotter pins (6), pin (5), propeller shaft (4), and yoke (8) from front winch shaft (7).
3. Slide rear yoke (10) off propeller shaft (4).

INSPECTION

Inspect two universal joints (9) for looseness or roughness. If damaged, replace universal joint (9) (WP 0141 00).

INSTALLATION

1. Place a light coat of GAA grease on propeller shaft (4) splines and install rear yoke (10) and rear flange (11) on propeller shaft (4).
2. Install front yoke (8) and propeller shaft (4) on front winch shaft (7) and align pin (5) hole with front winch shaft (7) hole. Install pin (5) through front yoke (8) and winch shaft (7) and secure with two new cotter pins (6).
3. Install rear yoke (10) and rear flange (11) to transmission PTO flange (2) with four screws (3) and new locknuts (1).
4. Lubricate front winch propeller shaft (WP 0020 00).
5. Connect battery ground cable (WP 0126 00).
6. Release parking brake and remove wheel chocks (TM 9-2320-361-10).

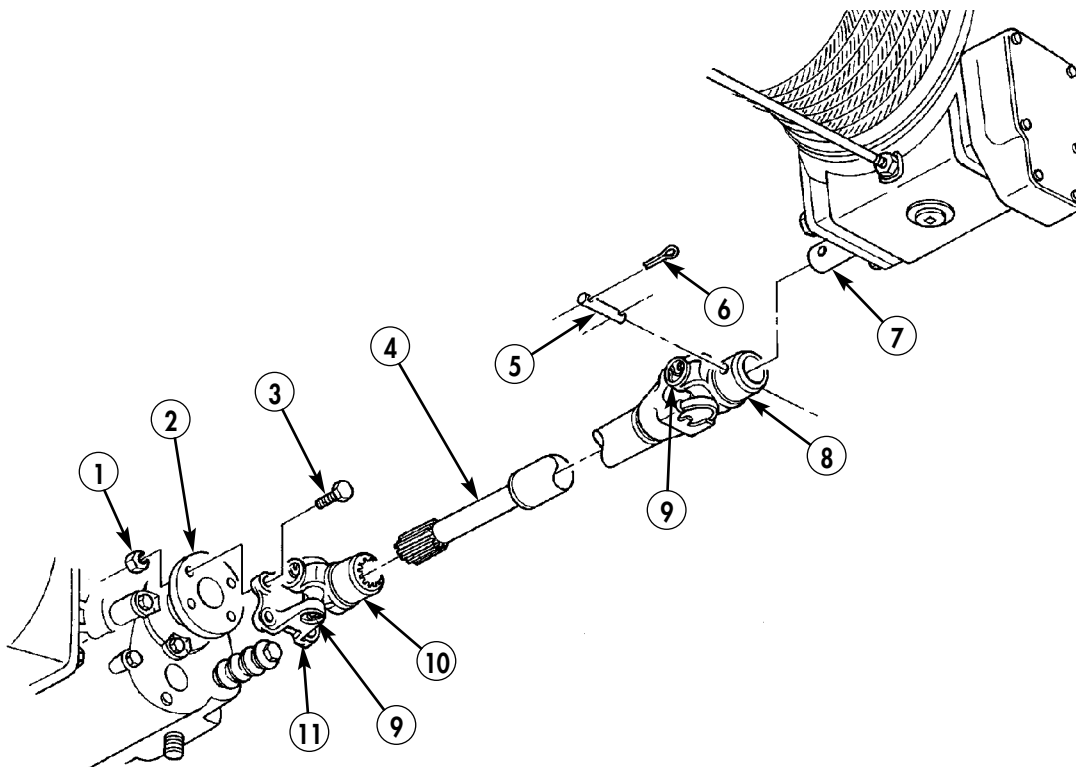

END OF WORK PACKAGE

FIELD MAINTENANCE INSTRUCTIONS

2-1/2 TON, 6X6, M44A2 SERIES TRUCKS (MULTIFUEL)

TRANSMISSION POWER TAKEOFF (PTO) SHIFT LINKAGE MAINTENANCE REMOVAL, INSPECTION, ADJUSTMENT, AND INSTALLATION

INITIAL SETUP:

Applicable Models

All

Tools and Special Tools

General mechanic's tool kit
(item 116, WP 0469 00)

Materials/Parts

Cotter pin (item 28, WP 0470 00)
Two locknuts (item 145, WP 0470 00)

Materials/Parts (Contd)

Locknut (item 147, WP 0470 00)
Screw-assembled lockwasher
(item 256, WP 0470 00)

Equipment Condition

Parking brake set and wheels chocked
(TM 9-2320-361-10).
Battery ground cable disconnected
(WP 0126 00).

TRANSMISSION POWER TAKEOFF (PTO) SHIFT LINKAGE MAINTENANCE (Contd)

REMOVAL

1. Remove screw-assembled lockwasher (4) from vehicle floor (6) and open master cylinder access door (5). Discard screw-assembled lockwasher (4).
2. Remove two locknuts (3), screws (2), and hinge lock (1) from cab floor (6). Discard locknuts (3).
3. Remove cotter pin (10) and clevis pin (18) from shift rod (12) and transmission PTO lever (19) and clevis (11). Discard cotter pin (10).
4. Remove locknut (9), screw (8), and transmission PTO lever (19) from support (21). Discard locknut (9).
5. Remove two screws (7) and support (21) from master cylinder (20).
6. Pull clevis pin (17) out far enough to allow shifting rod (12) to be removed from PTO arm (14).
7. Remove clevis pin (17), ball (15), and spring (16) from clevis (13). Remove shift rod (12).

INSPECTION

Inspect all parts for bends, breaks, or cracks, and ball (15) for roundness. Replace damaged parts.

ADJUSTMENT

Install spring (16), ball (15), and clevis pin (17) to clevis (13) and PTO arm (14) and adjust shift rod (12) to measure 5.63 in. (14.3 cm) from centers of clevis (13) and clevis (11).

INSTALLATION

1. Install shift rod (12) on PTO arm (14) with clevis pin (17).
2. Install support (21) on master cylinder (20) with two screws (7).
3. Install transmission PTO lever (19) to support (21) with screw (8) and new locknut (9).
4. Connect shift rod (12) on transmission PTO lever (19) with clevis pin (18) and new cotter pin (10).
5. Install hinge lock (1) on cab floor (6) with two screws (2) and new locknuts (3).
6. Close master cylinder access door (5) and secure to vehicle floor (6) with new screw-assembled lockwasher (4).
7. Connect battery ground cable (WP 0126 00).
8. Release parking brake and remove wheel chocks (TM 9-2320-361-10).

TRANSMISSION POWER TAKEOFF (PTO) SHIFT LINKAGE MAINTENANCE (Contd)

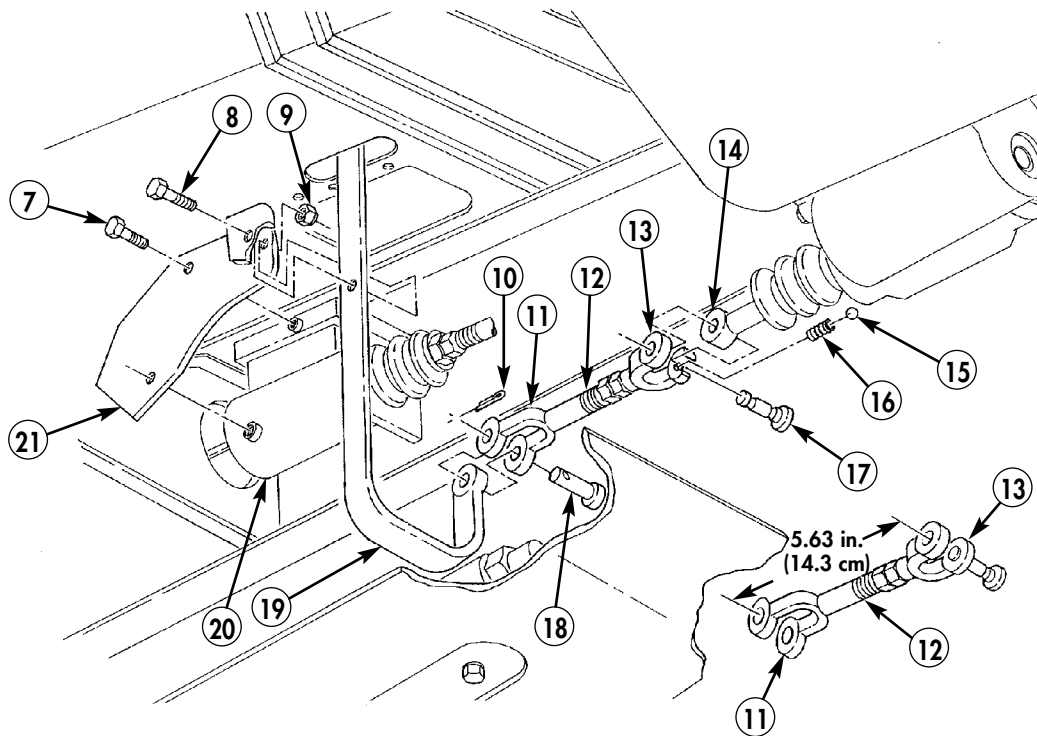
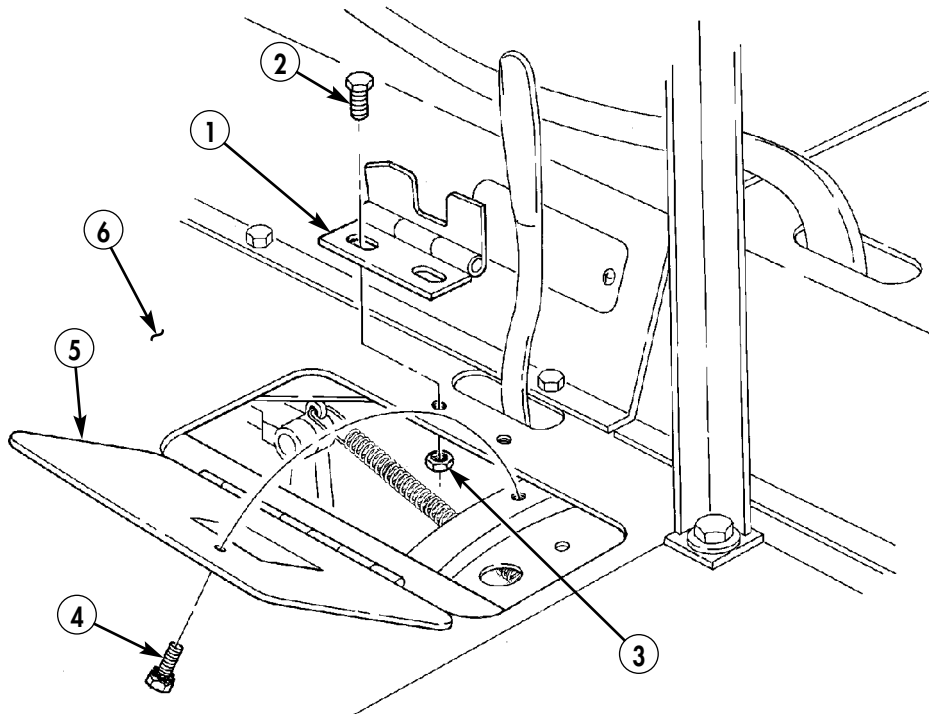

END OF WORK PACKAGE

0347 00-3/4 blank

FIELD MAINTENANCE INSTRUCTIONS

2-1/2 TON, 6X6, M44A2 SERIES TRUCKS (MULTIFUEL)

TRANSFER CASE POWER TAKEOFF (PTO) MAINTENANCE REMOVAL, CLEANING, INSPECTION AND REPAIR, AND INSTALLATION

INITIAL SETUP:

Applicable Models

M49A2C, M50A3

Tools And Special Tools

General mechanic's tool kit
(item 116, WP 0469 00)

Torque wrench 3/4-in. drive
(item 137, WP 0469 00)

Mechanical puller kit (item 64, WP 0469 00)

1-1/2-in. socket, 3/4-in. drive
(item 95, WP 0469 00)

Materials/Parts

Six lockwashers (item 234, WP 0470 00)

Cotter pin (item 25, WP 0470 00)

Gasket (item 113, WP 0470 00)

Woodruff key (item 431, WP 0470 00)

Sealing compound (item 31, WP 0468 00)

References

TM 9-2520-246-34-1

WP 0021 00

Equipment Condition

Transfer case removed (WP 0138 00).

TRANSFER CASE POWER TAKEOFF (PTO) MAINTENANCE (Contd)

REMOVAL

1. Loosen setscrew (6) and remove cotter pin (9), nut (8), yoke (7), and woodruff key (11) from PTO spindle (10). Discard cotter pin (9) and woodruff key (11).
2. Disconnect line (1) from oil pump (12).
3. Remove four screws (13), lockwashers (14), two nuts (4), lockwashers (3), PTO (5), and gasket (15) from transfer case (2). Discard lockwashers (14) and (3) and gasket (15).
4. Remove screw (19), washer (18), and clamp (17) from transfer case (2).
5. Remove line (1) and elbow (16) from transfer case (2).

CLEANING

Remove gasket material and debris from transfer case (2) and PTO (5) mating surface.

INSPECTION AND REPAIR

1. Check PTO (5) and transfer case (2) mating surface for scratches, cracks, and galling. Refer to TM 9-2520-246-34-1 if scratched, cracked, or galled.
2. Check PTO gear for wear, cracks, and discoloration. Refer to TM 9-2520-246-34-1 if gear teeth are worn, cracked, or discolored.
3. Inspect studs (20). Replace studs (20) if damaged (WP 0021 00).

INSTALLATION

NOTE

Prior to installation, coat threads of elbow with sealing compound.

1. Install elbow (16) on transfer case (2).
2. Connect line (1) to elbow (16) and install line (1) on transfer case (2) with clamp (17), washer (18), and screw (19). Tighten screw (19) 60–77 lb-ft (81–104 N•m).
3. Install new gasket (15) and PTO (5) on transfer case (2) with two new lockwashers (3), nuts (4), four new lockwashers (14), and screws (13). Tighten nuts (4) 32–40 lb-ft (43–54 N•m). Tighten screws (13) 60–77 lb-ft (81–104 N•m).
4. Connect line (1) on oil pump (12).
5. Install new woodruff key (11), yoke (7), and nut (8) on spindle (10). Tighten nut (8) 150–250 lb-ft (203–339 N•m) and install new cotter pin (9) and tighten setscrew (6).
6. Install transfer case (WP 0138 00).

TRANSFER CASE POWER TAKEOFF (PTO) MAINTENANCE (Contd)

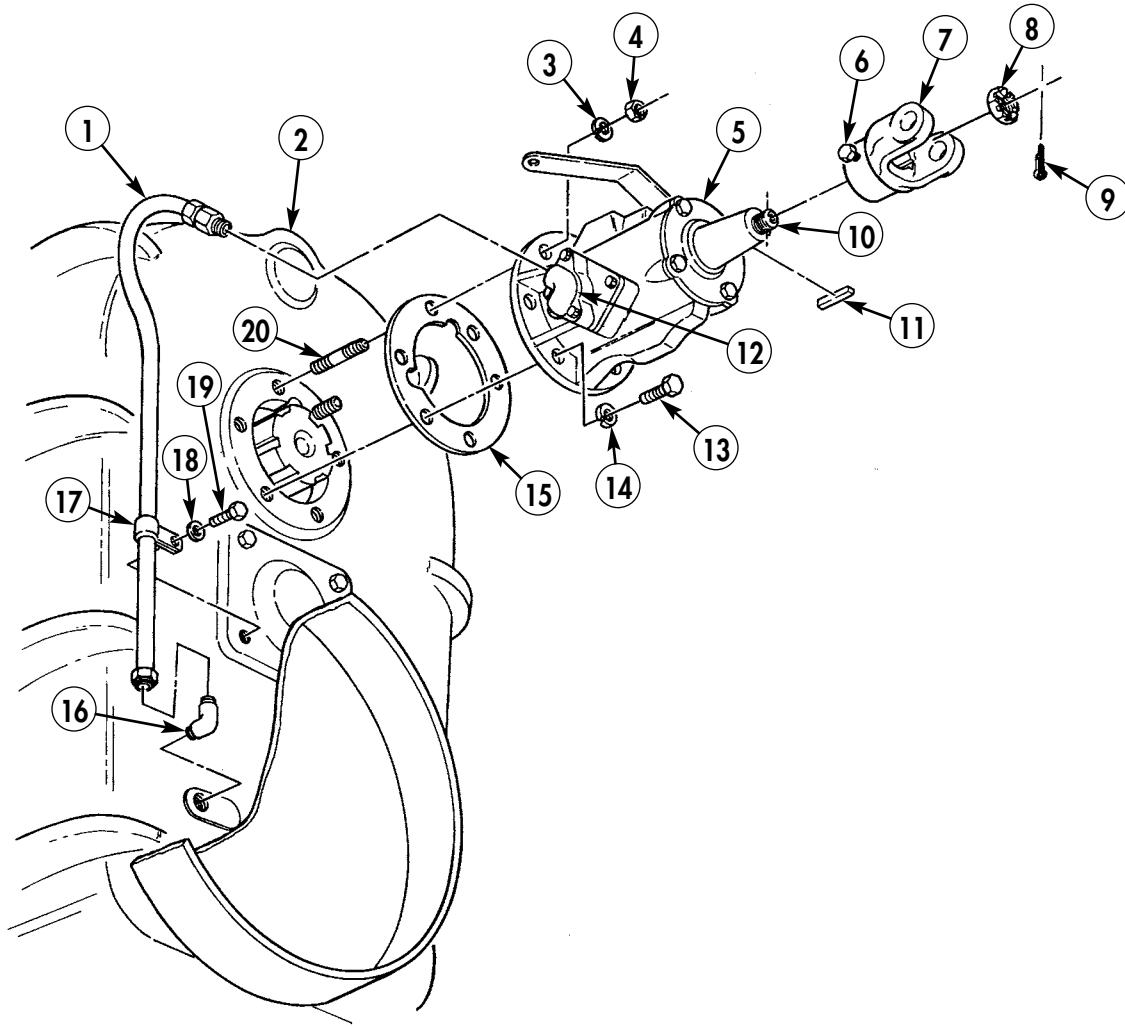

END OF WORK PACKAGE

FIELD MAINTENANCE INSTRUCTIONS

2-1/2 TON, 6X6, M44A2 SERIES TRUCKS (MULTIFUEL)

TRANSMISSION POWER TAKEOFF (PTO), COVER, AND GASKET MAINTENANCE REMOVAL, INSPECTION, AND INSTALLATION

INITIAL SETUP:

Applicable Models

All

Tools and Special Tools

General mechanic's tool kit
(item 116, WP 0469 00)
Torque wrench (item 136, WP 0469 00)
Dial indicator (item 43, WP 0469 00)

Materials/Parts

Twelve lockwashers (item 195, WP 0470 00)
Two gaskets (item 110, WP 0470 00)
Sealing compound (item 73, WP 0468 00)

References

TM 9-2320-361-10
TM 9-2520-246-34-1
WP 0021 00
WP 0132 00

Equipment Condition

Parking brake set and wheels chocked
(TM 9-2320-361-10).
Battery ground cable disconnected
(WP 0126 00).
Transmission oil drained (WP 0020 00).

REMOVAL

1. Remove six screws (5), lockwashers (4), cover (3), and gasket (2) from transmission PTO (1). Discard gasket (2) and lockwashers (4).
2. Clean mating surfaces between cover (3) and PTO (1).

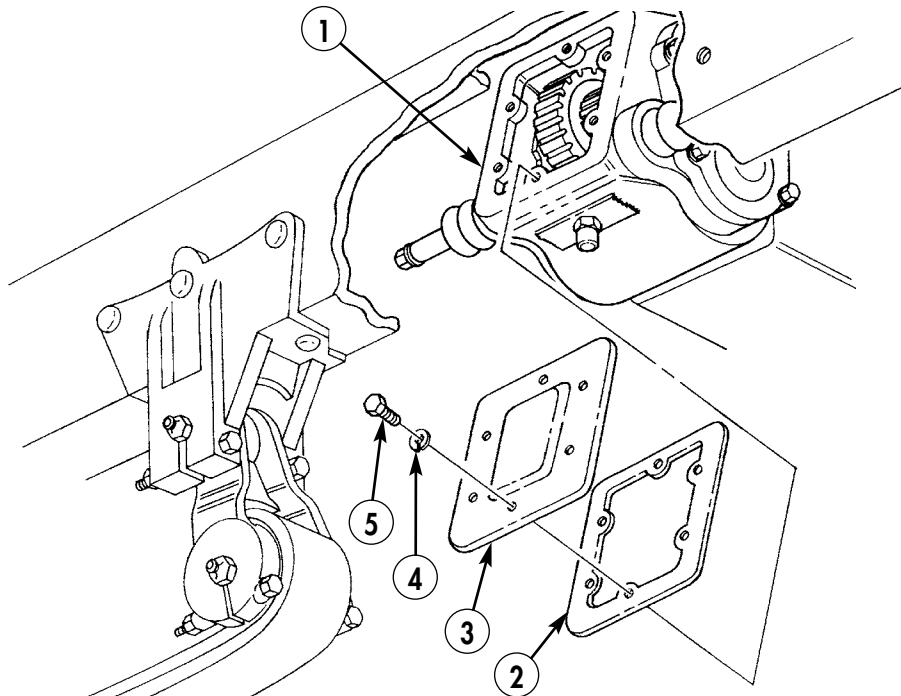

TRANSMISSION POWER TAKEOFF (PTO), COVER, AND GASKET MAINTENANCE (Contd)**REMOVAL (Contd)****CAUTION**

Prevent dirt from entering transmission and power takeoff (PTO). Failure to do so may cause damage to equipment.

3. Remove six nuts (6), lockwashers (7), PTO (5), and gasket (4) from transmission (1). Discard gasket (4) and lockwashers (7).
4. Remove gasket material and debris from transmission (1) and PTO (5) mating surfaces.

INSPECTION

1. Check PTO (5) and transmission (1) mating surfaces for scratches, cracks, and galling. Refer to TM 9-2520-246-34-1 if scratched, cracked, or galled.
2. Check transmission gear teeth (2) for wear, cracks, and discoloration. Refer to TM 9-2520-246-34-1 if gear teeth are worn, cracked, or discolored.
3. Inspect stud(s) (3). Replace stud(s) (3) if damaged (WP 0021 00).

INSTALLATION**NOTE**

Ensure transmission output gear is stabilized while measuring backlash.

1. Shift into second gear (TM 9-2320-361-10).
2. Install new gasket (4) and PTO (5) on transmission (1) with six nuts (6). Tighten nuts (6) 15–20 lb-ft (20–27 N•m).
3. Set dial indicator on PTO (5) to measure PTO input gear (8) backlash.
 - a. Check PTO backlash. Backlash should be 0.008–0.012 in. (0.203–0.305 mm).
 - b. If backlash is 0.008–0.012 in. (0.203–0.305 mm), perform steps 5 through 7.

NOTE

It may be necessary to use more than one gasket to obtain 0.008–0.012 in. (0.203–0.305 mm) backlash. Each gasket will change backlash approximately 0.006 in. (0.152 mm).

- c. If backlash is less than 0.008 in. (0.203 mm), remove dial indicator and PTO (5) from transmission (1) and continue with step 7 using two new gaskets (4) to obtain 0.008–0.012 in. (0.203–0.305 mm) measurement.
 - d. If 0.008–0.012 in. (0.203–0.305 mm) backlash measurement cannot be obtained, replace (WP 0132 00) or repair (TM 9-2520-246-34-1) transmission (1).
4. Remove dial indicator from PTO (5).
5. Remove six nuts (6), PTO (5), and gasket (4) from transmission (1).
6. Apply sealing compound on gasket (4) and transmission (1) mating surfaces.
7. Install new gasket(s) (4) and PTO (5) on transmission (1) with six new lockwashers (7) and nuts (6). Tighten nuts (6) 15–20 lb-ft (20–27 N•m).

TRANSMISSION POWER TAKEOFF (PTO), COVER, AND GASKET MAINTENANCE (Contd)

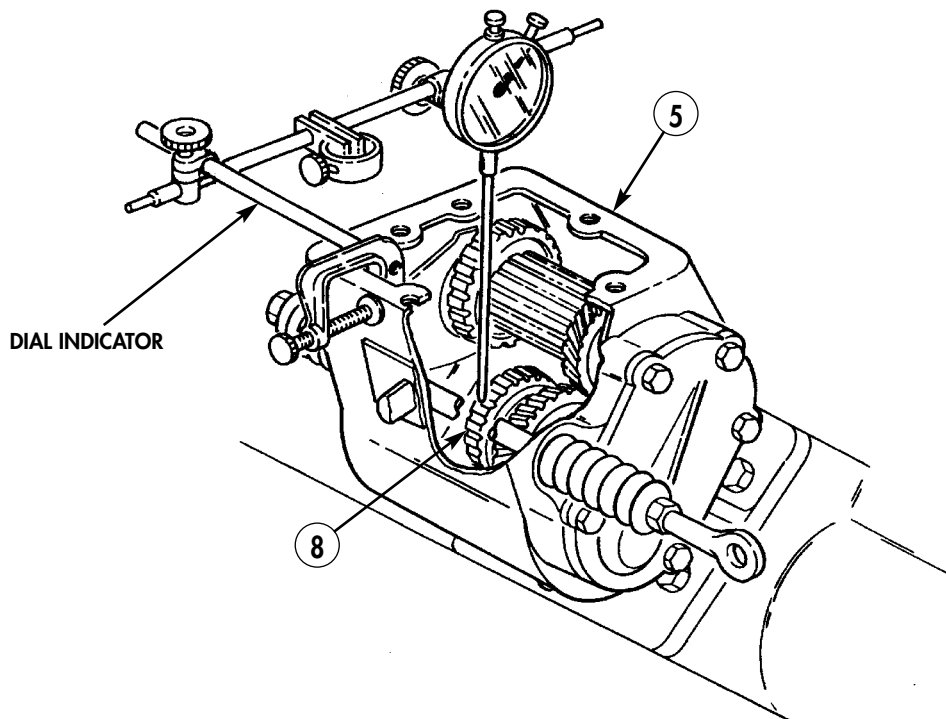
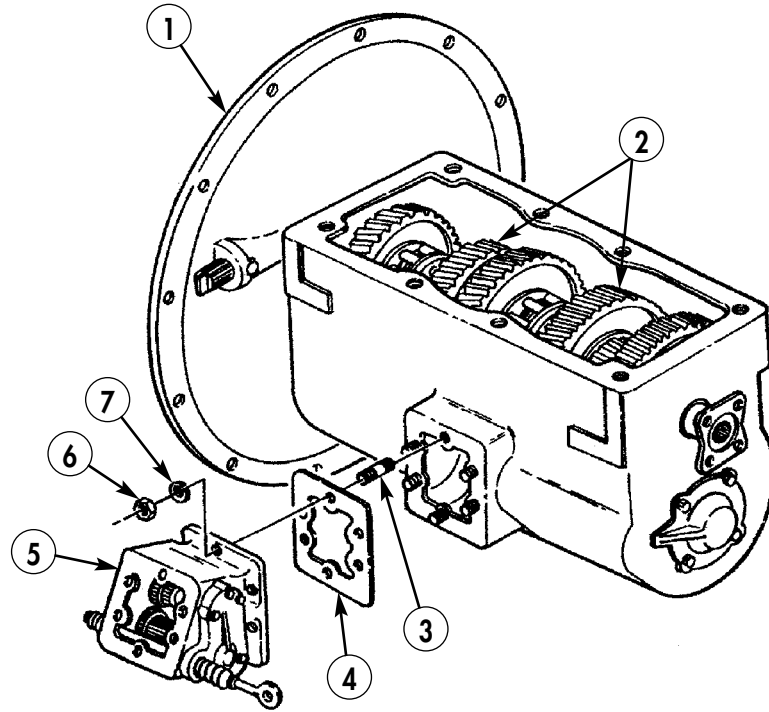

TRANSMISSION POWER TAKEOFF (PTO), COVER, AND GASKET MAINTENANCE (Contd)**INSTALLATION (Contd)**

8. Install new gasket (2) and cover (3) on PTO (1) with six new lockwashers (4) and screws (5).
9. Fill transmission to proper fluid level (WP 0018 00).
10. Connect battery ground cable (WP 0126 00).
11. Release parking brake and remove wheel chocks (TM 9-2320-361-10).

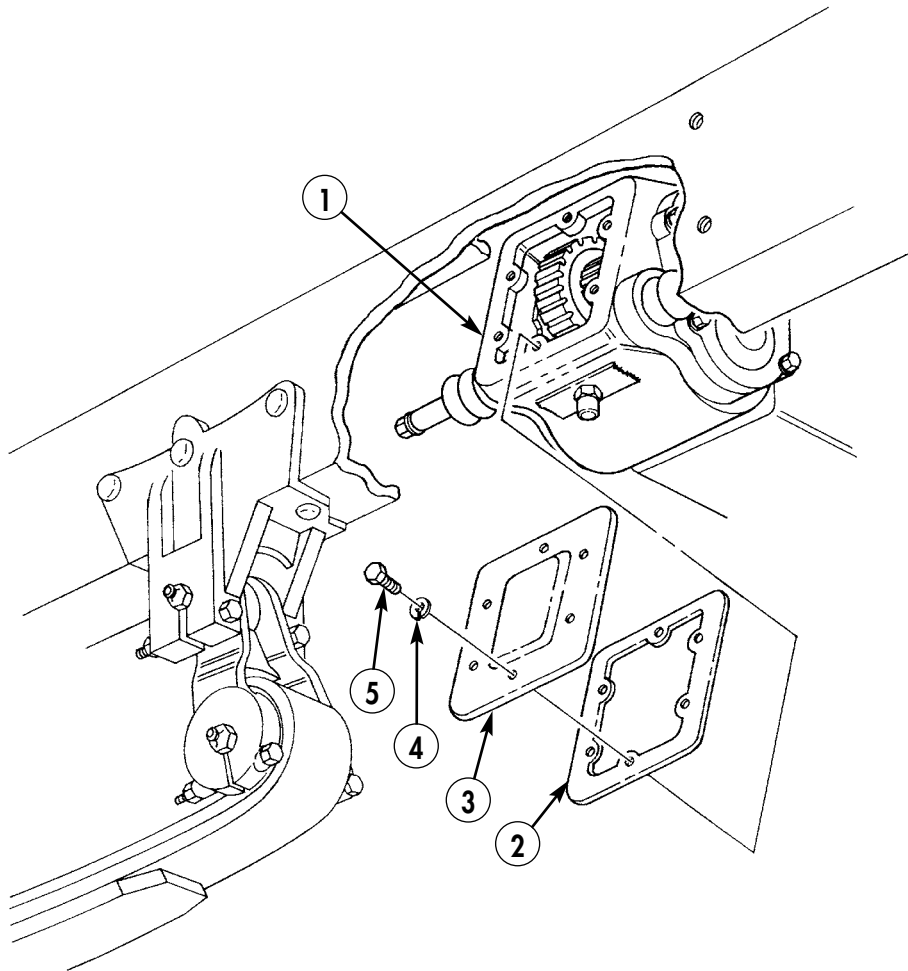
**END OF WORK PACKAGE**

CHAPTER 4

FIELD MAINTENANCE INSTRUCTIONS FOR SPECIAL PURPOSE KITS

**2-1/2 TON, 6X6, M44A2 SERIES TRUCKS
(MULTIFUEL)**

	<u>WP Sequence No.</u>
PIONEER TOOL BRACKET KIT	
Pioneer Tool Bracket Replacement	WP 0350 00
WINTERIZATION KIT	
Fuel Burning Personnel Heater Replacement	WP 0351 00
Personnel Heater Control Box Replacement	WP 0352 00
Personnel Heater Fuel Pump Replacement	WP 0353 00
Personnel Heater Fuel Filter Replacement	WP 0354 00
Exhaust Tube Replacement	WP 0355 00
Oil Pan Shroud and Exhaust Tube Replacement	WP 0356 00
Engine Coolant Heater Replacement	WP 0357 00
Engine Coolant Heater Harness Replacement	WP 0358 00
Thermal Barrier Insulation Replacement	WP 0359 00
WINTERIZATION KIT (Contd)	
Battery Box and Heater Pad Replacement	WP 0360 00
Transmission Gearshift and Transfer Case Lever Cover Replacement	WP 0361 00
Hood and Radiator Cover Replacement	WP 0362 00
Hardtop Maintenance	WP 0363 00
Alcohol Evaporator Maintenance	WP 0364 00
Slave Receptacle Replacement	WP 0365 00
Cargo Body Personnel Heater Replacement	WP 0366 00
Cargo Body Personnel Heater Mounting Bracket Maintenance	WP 0367 00
Cargo Body Personnel Heater Fuel Pump Replacement	WP 0368 00
Cargo Body Personnel Heater Fuel Filter Replacement	WP 0369 00
Cargo Body Personnel Heater Control Box Replacement	WP 0370 00
Cargo Body Personnel Heater Fuel Line Replacement	WP 0371 00
Cargo Body Personnel Heater Diverter and Duct Replacement	WP 0372 00
VAN BODY PRIMARY AND SECONDARY HEATER KIT	
Primary Heater Fuel Pump Replacement	WP 0373 00
Primary Heater Fuel Pump Cover Replacement	WP 0374 00
Primary Heater Fuel Filter Replacement	WP 0375 00
Primary Heater Fuel Lines Replacement	WP 0376 00
Primary Heater Fuel Shutoff and Coupling Replacement	WP 0377 00
Primary and Secondary Heater Exhaust Tube Replacement	WP 0378 00
Primary Heater Air Inlet Duct Replacement	WP 0379 00
Primary Heater and Duct Replacement	WP 0380 00
Primary and Secondary Heater Switches Replacement	WP 0381 00
Primary Heater Auxiliary Duct Replacement	WP 0382 00
Secondary Heater Fuel Lines Replacement	WP 0383 00
Secondary Heater and Duct Replacement	WP 0384 00

CHAPTER 4

FIELD MAINTENANCE INSTRUCTIONS FOR SPECIAL PURPOSE KITS (Contd)

	<u>WP Sequence No.</u>
DEEP WATER FORDING KIT	
Deep Water Fording Kit Air Intake Tubes Replacement	WP 0385 00
Deep Water Fording Kit Control Valve Replacement	WP 0386 00
Deep Water Fording Kit Regulator Valve Replacement	WP 0387 00
A-FRAME KIT	
A-Frame Kit Maintenance	WP 0388 00
MOUNTING KITS	
Machine Gun Mount Kit Replacement	WP 0389 00
Rifle Mounting Kit Replacement	WP 0390 00
Decontamination Mounting Kit Replacement	WP 0391 00
Chemical Agent Alarm Mounting Kit Replacement	WP 0392 00
Fire Extinguisher and Mounting Kit Replacement	WP 0393 00
Bumper Step Kit Replacement	WP 0394 00
TROOP SEAT MOUNTING AND SEATBELT KITS	
Troop Seat Center Mounted Kit Replacement	WP 0395 00
Fixed Seatbelt Kit Replacement	WP 0396 00
Floating Seatbelt Kit Replacement	WP 0397 00
COMPANION SEAT KIT	
Companion Seat and Leg Extension Replacement	WP 0398 00
SWINGFIRE HEATER KIT	
Swingfire Heater and Mounting Brackets Replacement	WP 0399 00
Swingfire Heater Battery Box Tube Replacement	WP 0400 00
Swingfire Heater Water Jacket Replacement	WP 0401 00
Swingfire Heater Water Hoses Replacement	WP 0402 00
Swingfire Heater Water Jacket Brackets Replacement	WP 0403 00
Swingfire Heater Wiring Harness and Receptacle Replacement	WP 0404 00
AIR BRAKE KIT	
Air Brake Rotary Valve and Air Line Replacement	WP 0405 00
Air Brake Harness Replacement	WP 0406 00
Air Brake Check Valve, Pressure Switch, and Air Line Replacement	WP 0407 00
STEERING ASSIST KIT	
Steering Assist Cylinder Maintenance	WP 0408 00
Steering Assist Regulator Replacement	WP 0409 00
ARCTIC ENCLOSURE KIT	
Arctic Cargo Body Enclosure Replacement	WP 0410 00
Speaking Tube Replacement (M35A2)	WP 0411 00
CARGO BODY TIEDOWN KIT	
Cargo Body Tiedown Replacement	WP 0412 00
LOW PRESSURE AIR WARNING LIGHT KIT	
Low Air Pressure Indicator and Lamp Replacement	WP 0413 00
CAB REINFORCEMENT KIT	
Cab Reinforcement Replacement	WP 0414 00

CHAPTER 4

FIELD MAINTENANCE INSTRUCTIONS FOR SPECIAL PURPOSE KITS (Contd)

	<u>WP Sequence No.</u>
SUNSHIELD KIT	
Sunshield Replacement (Soft Top)	WP 0415 00
Sunshield Replacement (Hard Top)	WP 0416 00
ENGINE COOLANT HEATER KIT	
Engine Coolant Heater Flame Detector Switch Maintenance	WP 0417 00
Engine Coolant Heater Blower Motor Maintenance	WP 0418 00
Engine Coolant Heater Restriction Thermostat Maintenance	WP 0419 00
Engine Coolant Heater Component Bracket Maintenance	WP 0420 00
Engine Coolant Heater Fuel Control Valve Replacement	WP 0421 00
Engine Coolant Heater Overheat Switch and Igniter Maintenance	WP 0422 00
Engine Coolant Heater Fuel Tube and Preheater Resistor Replacement	WP 0423 00
Engine Coolant Heater Burner Maintenance	WP 0424 00
Engine Coolant Heater Housing Replacement	WP 0425 00
Engine Coolant Heater Testing	WP 0426 00
PERSONNEL HEATER KIT	
Personnel Heater Guard and Blower Motor Replacement	WP 0427 00
Personnel Heater Fuel Control Valve Maintenance	WP 0428 00
Personnel Heater Igniter and Ignition Control Unit Replacement	WP 0429 00
Personnel Heater Fuel Line and Blower Housing Replacement	WP 0430 00
PERSONNEL HEATER KIT	
Personnel Heater Flame Detector Switch Maintenance	WP 0431 00
Personnel Heater Burner Maintenance	WP 0432 00
Personnel Heater Overheat Switch and Receptacle Replacement	WP 0433 00
Personnel Heater Heat Exchanger Maintenance	WP 0434 00
Fuel Burning Personnel Heater Testing	WP 0435 00
HARDTOP REAR PANEL WINDOW KIT	
Hardtop Rear Panel Window Maintenance	WP 0436 00

FIELD MAINTENANCE INSTRUCTIONS FOR SPECIAL PURPOSE KITS

2-1/2 TON, 6X6, M44A2 SERIES TRUCKS (MULTIFUEL)

PIONEER TOOL BRACKET REPLACEMENT REMOVAL AND INSTALLATION

INITIAL SETUP:

Applicable Models

All

Materials/Parts

Fourteen locknuts (M36A2)

(item 129, WP 0470 00)

Eight locknuts (M35A2, M35A2C)

(item 129, WP 0456 00)

Materials/Parts (Contd)

Eight locknuts (M109A3, M185A3)

(item 129, WP 0470 00)

Six locknuts (M49A2C, M50A3)

(item 129, WP 0470 00)

Equipment Condition

Parking brake set and wheels chocked

(TM 9-2320-361-10).

Battery ground cable disconnected

(WP 0126 00).

PIONEER TOOL BRACKET REPLACEMENT (Contd)

REMOVAL

NOTE

Perform steps 1 through 4 for M35A2 and M35A2C vehicles.

1. Remove two locknuts (6) and screws (10) from support (9) and front splash shield (7). Discard locknuts (6).
2. Remove two locknuts (11), screws (13), and bracket (12) from two supports (1). Discard locknuts (11).
3. Remove two locknuts (5), screws (8), and support (9) from bracket (12). Discard locknuts (5).
4. Remove two locknuts (3), screws (2), and supports (1) from cargo bed sill (4). Discard locknuts (3).

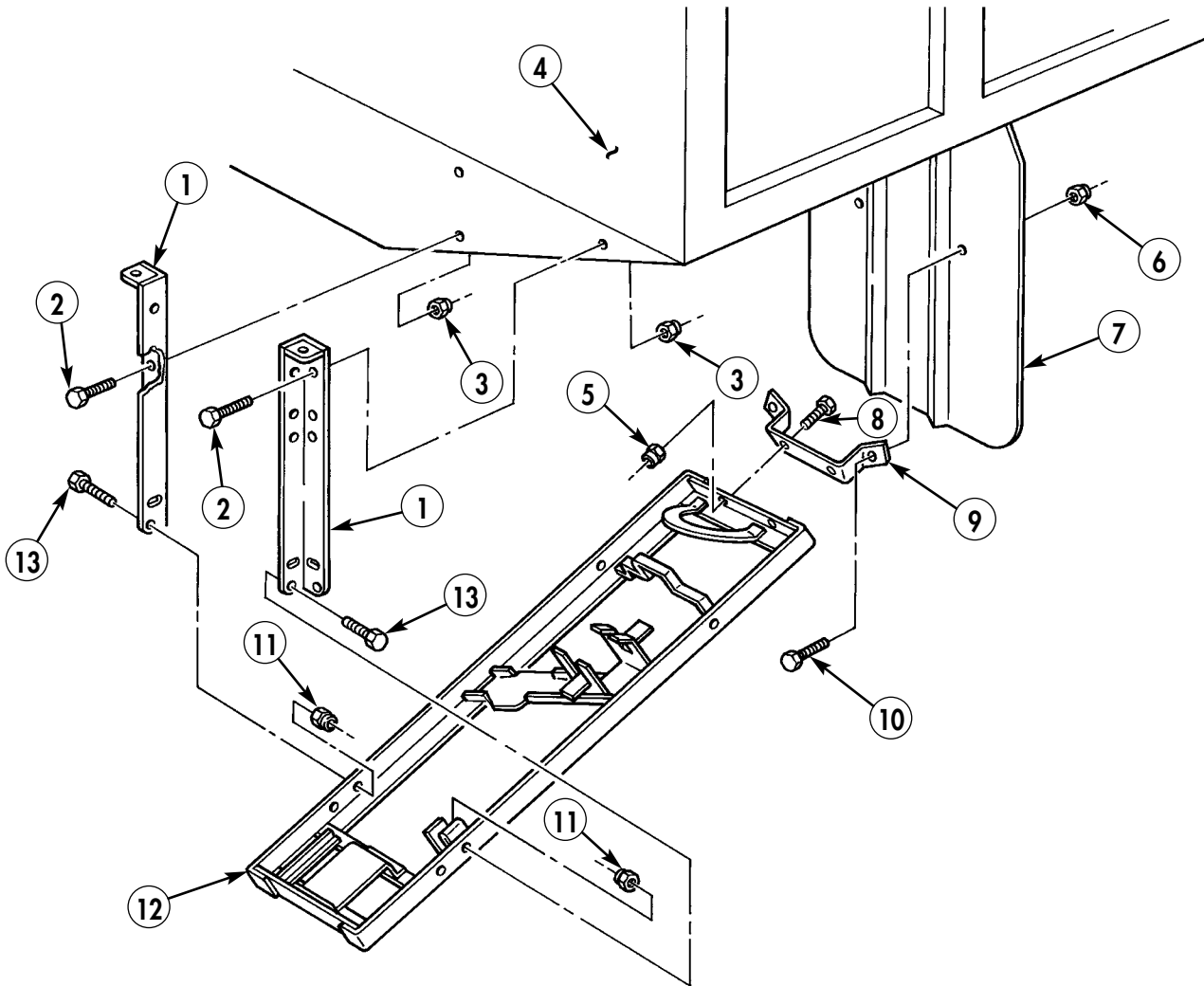

M35A2, M35A2C

PIONEER TOOL BRACKET REPLACEMENT (Contd)

REMOVAL (Contd)

NOTE

Perform steps 5 through 10 for M36A2 vehicles.

5. Remove two locknuts (6) and screws (10) from support (9) and front splash shield (7). Discard locknuts (6).
6. Remove two locknuts (22), screws (21), and bracket (12) from supports (20). Discard locknuts (22).
7. Remove two locknuts (5), screws (8), and support (10) from bracket (12). Discard locknuts (5).
8. Remove two locknuts (17) and screws (15) from supports (19) and cargo bed crossmember (16). Discard locknuts (17).
9. Remove two locknuts (23) and screws (18) from supports (19) and (20). Discard locknuts (23).
10. Remove four locknuts (24), screws (14), and two supports (20) from supports (19). Discard locknuts (24).

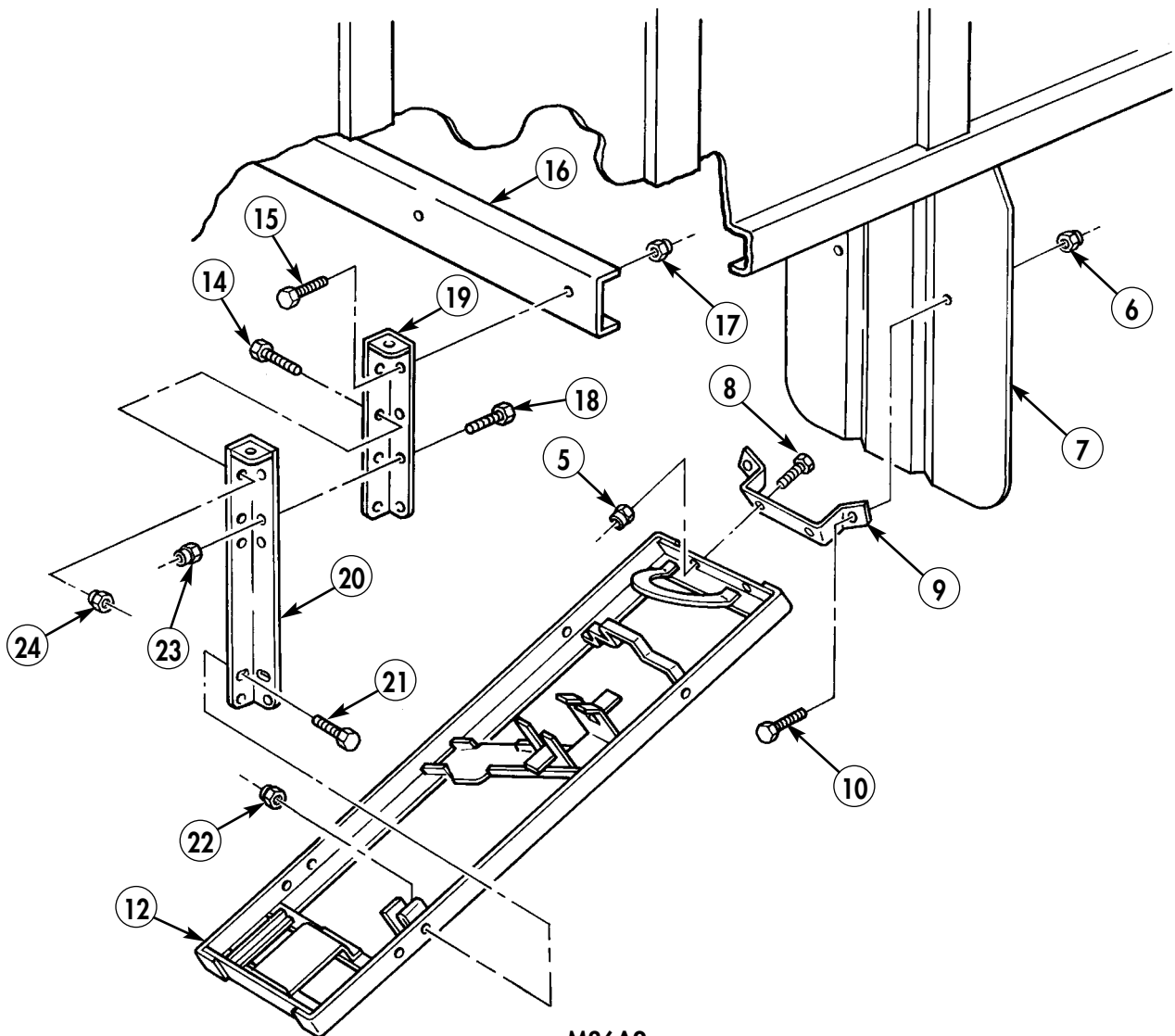

M36A2

PIONEER TOOL BRACKET REPLACEMENT (Contd)

REMOVAL (Contd)

NOTE

Perform steps 11 through 13 for M49A2C and M50A3 vehicles.

11. Remove two locknuts (5) and screws (3) from bracket (7) and front splash shield support (4). Discard locknuts (5).
12. Remove two locknuts (6), screws (8), and bracket (7) from supports (9). Discard locknuts (6).
13. Remove two locknuts (10), screws (2), and supports (9) from tank body sill (1). Discard locknuts (10).

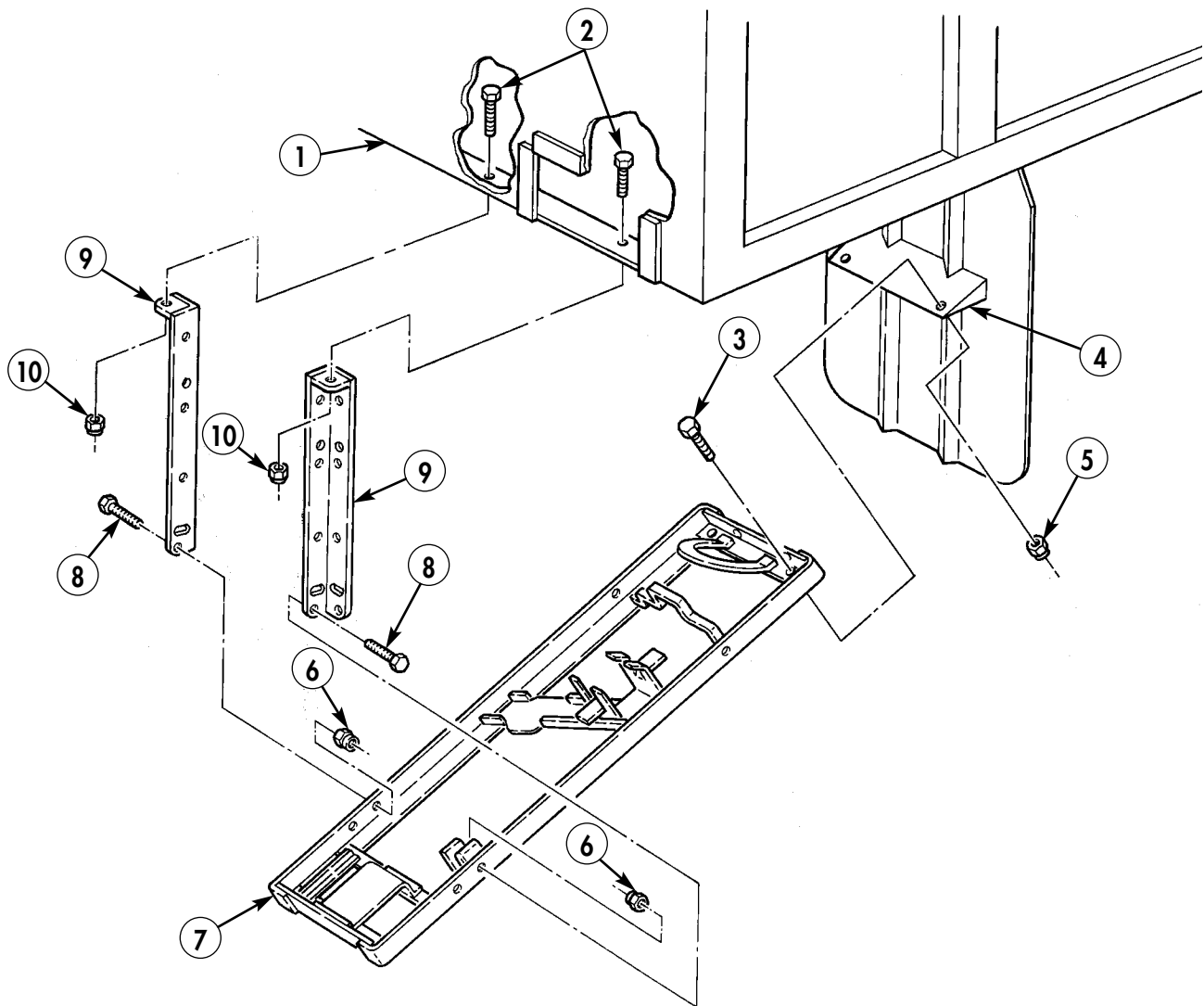

M49A2C, M50A3

PIONEER TOOL BRACKET REPLACEMENT (Contd)

REMOVAL (Contd)

NOTE

Perform steps 14 through 17 for M109A3 and M185A3 vehicles.

14. Remove two locknuts (14) and screws (17) from supports (16) and front splash shield (15). Discard locknuts (14).
15. Remove two locknuts (6), screws (8), and bracket (7) from supports (9). Discard locknuts (6).
16. Remove two locknuts (18), screws (13), and supports (16) from bracket (7). Discard locknuts (18).
17. Remove two locknuts (12), screws (19), and supports (9) from van body sill (11). Discard locknuts (12).

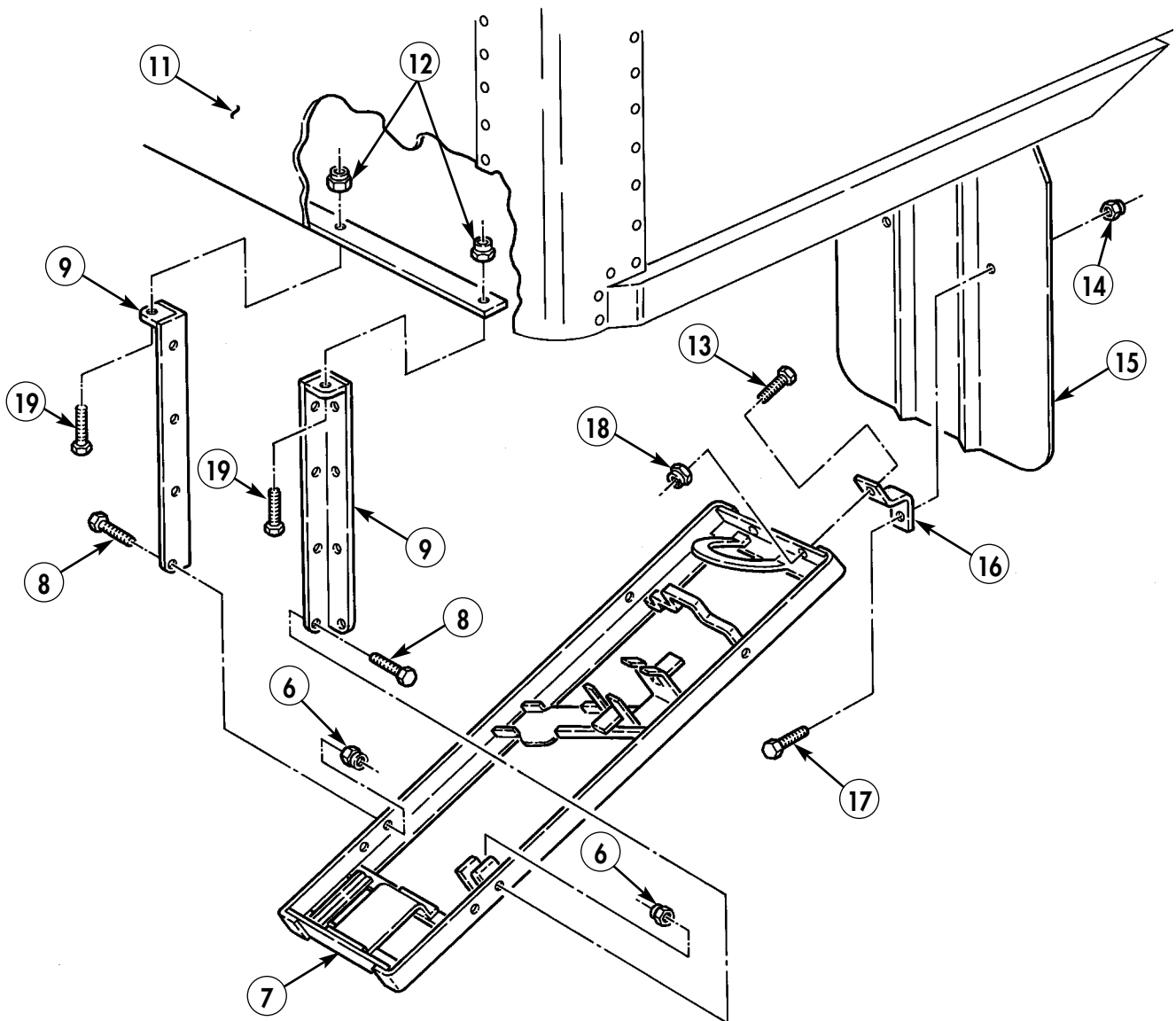

M109A3, M185A3

PIONEER TOOL BRACKET REPLACEMENT (Contd)

INSTALLATION

NOTE

Perform steps 1 through 5 for M109A3 and M185A3 vehicles.

1. Install two supports (1) on van body sill (2) with two screws (13) and new locknuts (3). Do not tighten locknuts (3).
2. Install two supports (8) on bracket (11) with two screws (5) and new locknuts (4).
3. Install bracket (11) on supports (1) with two screws (12) and new locknuts (10). Do not tighten locknuts (10).
4. Install two supports (8) on front splash shield (7) with two screws (9) and new locknuts (6).
5. Tighten locknuts (3) and (10).

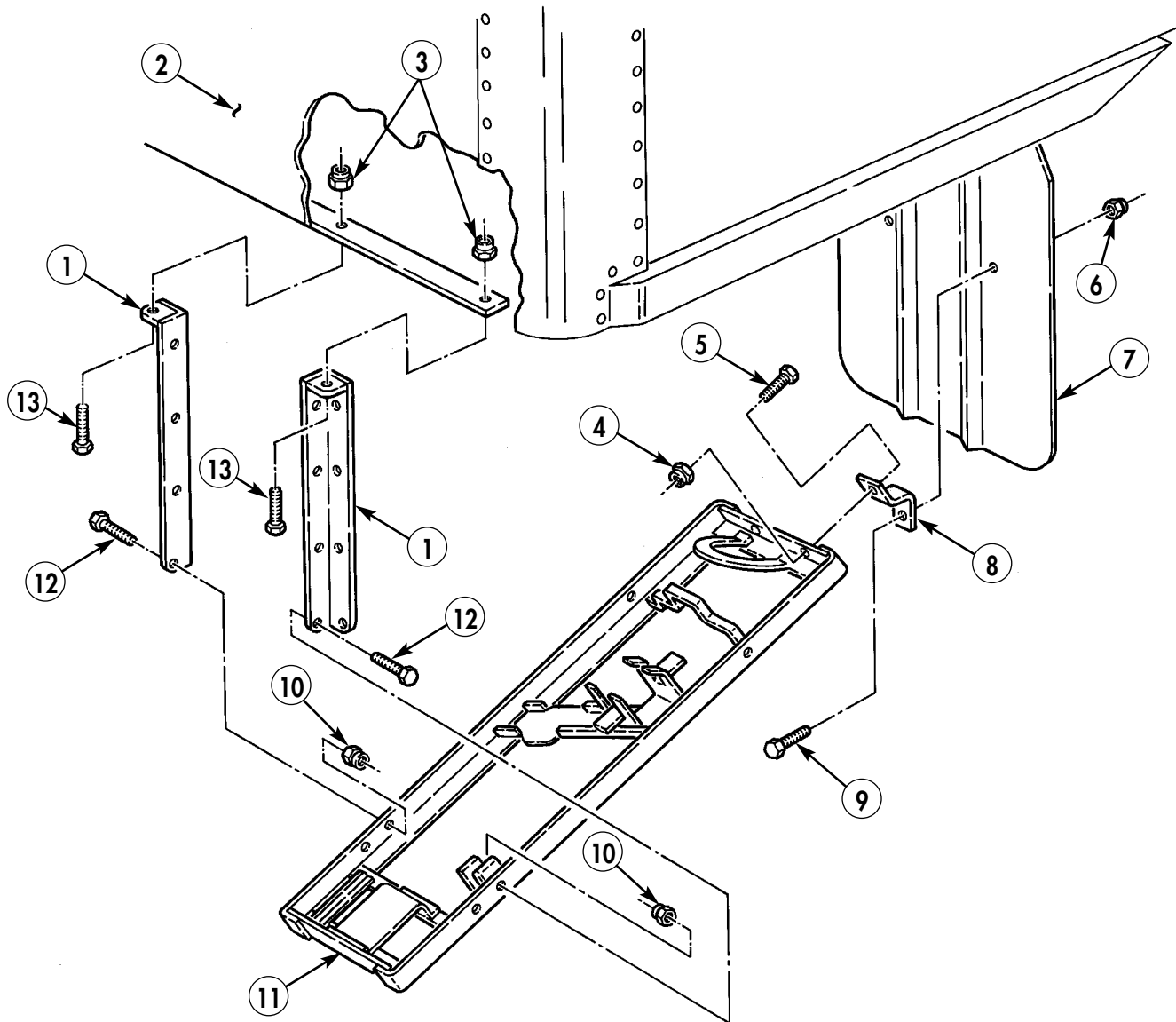

M109A3, M185A3

PIONEER TOOL BRACKET REPLACEMENT (Contd)

INSTALLATION (Contd)

NOTE

Perform steps 6 through 9 for M49A2C and M50A3 vehicles.

6. Install two supports (1) on front tank body sill (14) with two screws (15) and new locknuts (19). Do not tighten locknuts (19).
7. Install bracket (11) on two supports (1) with screws (12) and new locknuts (10). Do not tighten locknuts (10).
8. Install bracket (11) on front splash shield support (16) with two screws (18) and new locknuts (17).
9. Tighten locknuts (19) and (10).

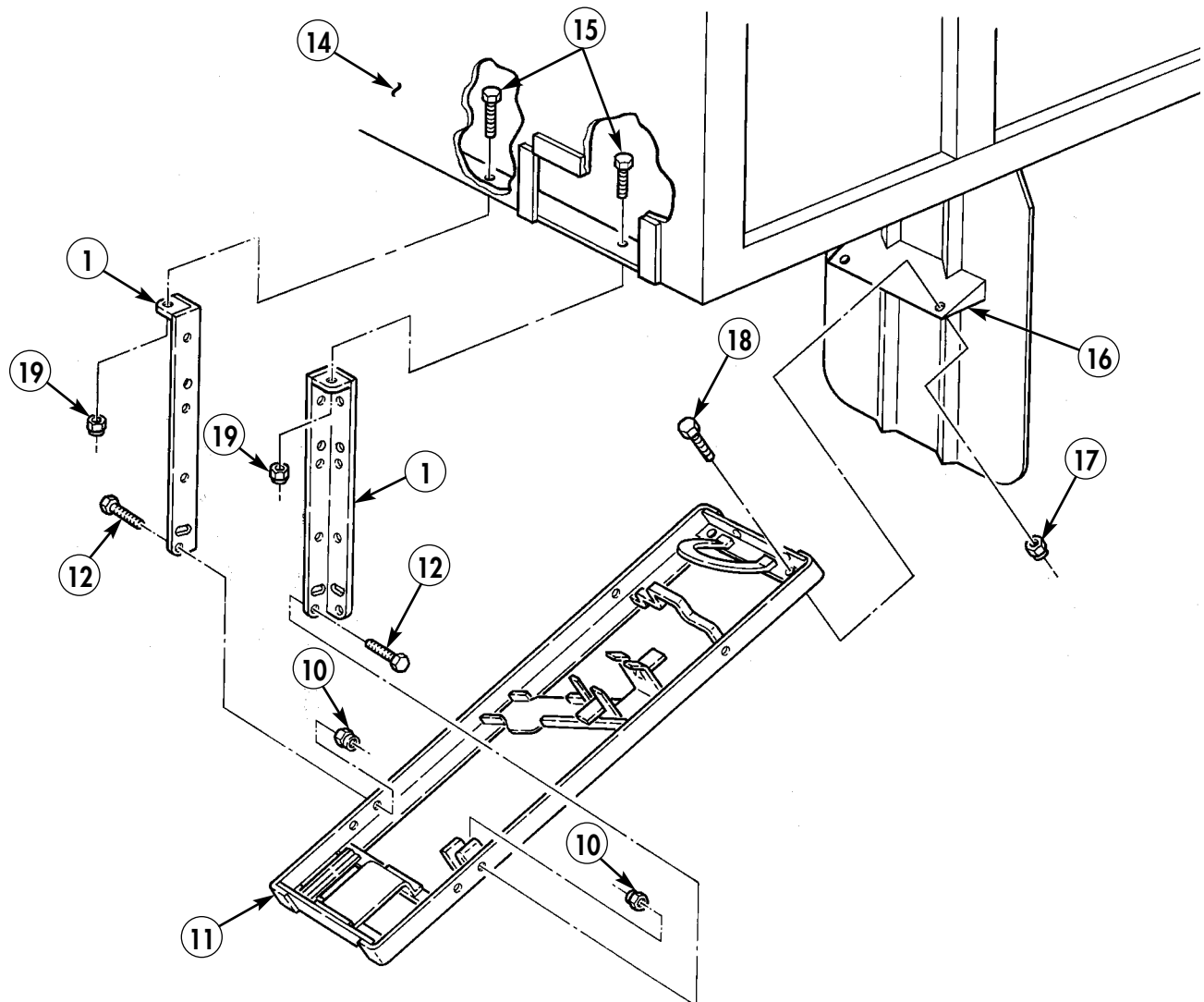

M49A2C, M50A3

PIONEER TOOL BRACKET REPLACEMENT (Contd)

INSTALLATION (Contd)

NOTE

Perform steps 10 through 16 for M36A2 vehicles.

10. Install two supports (2) on supports (13) with four screws (18) and new locknuts (17). Do not tighten locknuts (17).
11. Install two supports (2) on supports (13) with screws (15) and new locknuts (16). Do not tighten locknuts (16).
12. Install two supports (2) on cargo bed crossmember (3) with two screws (1) and new locknuts (4). Do not tighten locknuts (4).
13. Install support (7) on bracket (10) with two screws (8) and new locknuts (14). Do not tighten locknuts (14).
14. Install bracket (10) on two supports (13) with screws (12) and new locknuts (11). Do not tighten locknuts (11).
15. Install support (7) on front splash shield (6) with two screws (9) and new locknuts (5).
16. Tighten locknuts (17), (16), (4), (14), and (11).

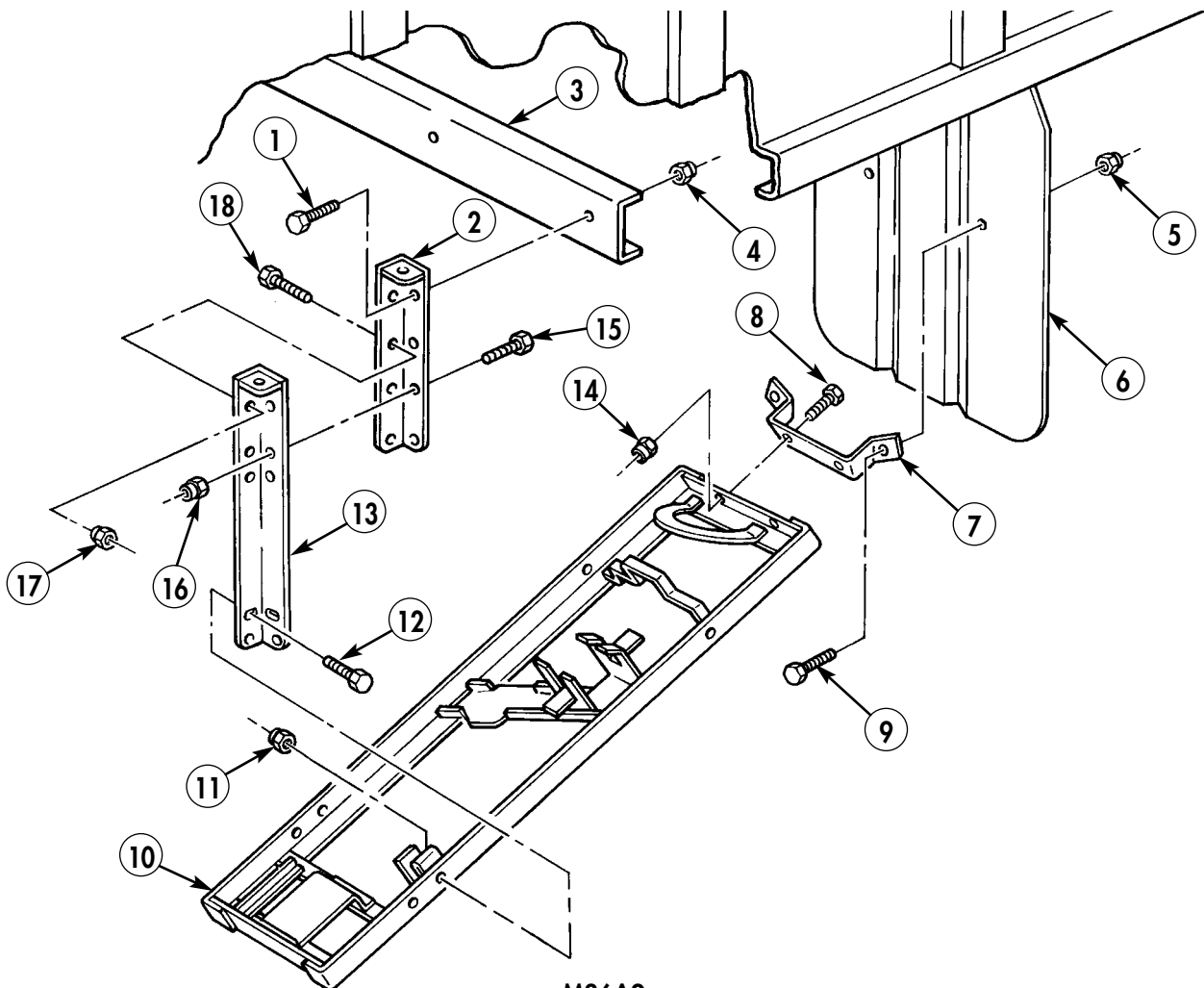

M36A2

PIONEER TOOL BRACKET REPLACEMENT (Contd)

INSTALLATION (Contd)

NOTE

Perform steps 17 through 21 for M35A2 and M35A2C vehicles.

17. Install two supports (21) on cargo bed sill (19) with two screws (24) and new locknuts (20). Do not tighten locknuts (20).
18. Install support (7) on bracket (10) with two screws (8) and new locknuts (14).
19. Install bracket (10) on two supports (21) with screws (22) and new locknuts (23). Do not tighten locknuts (23).
20. Install support (7) on front splash shield (6) with two screws (9) and new locknuts (5).
21. Tighten locknuts (20) and (23).
22. Connect battery ground cable (WP 0126 00).
23. Release parking brake and remove wheel chocks (TM 9-2320-361-10).

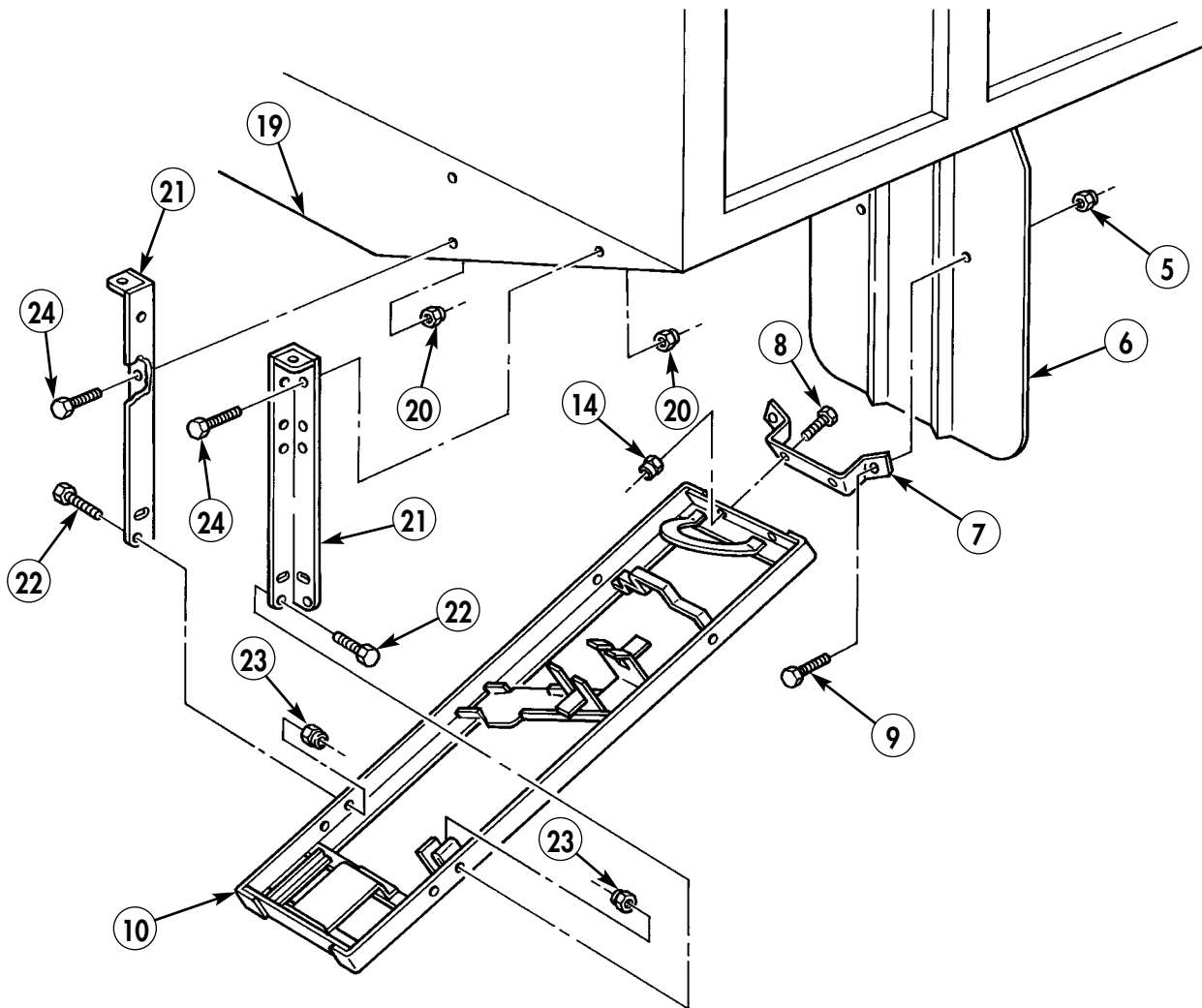

M35A2, M35A2C

END OF WORK PACKAGE

0350 00-9/10 blank

FIELD MAINTENANCE INSTRUCTIONS FOR SPECIAL PURPOSE KITS

2-1/2 TON, 6X6, M44A2 SERIES TRUCKS (MULTIFUEL)

FUEL BURNING PERSONNEL HEATER REPLACEMENT REMOVAL AND INSTALLATION

INITIAL SETUP:

Applicable Models

All

Tools and Special Tools

General mechanic's tool kit
(item 116, WP 0469 00)

Materials/Parts

Cotter pin (item 17, WP 0470 00)

Four lockwashers (item 190, WP 0456 00)

Equipment Condition

Parking brake set and wheels chocked
(TM 9-2320-361-10).

Hood raised and secured (TM 9-2320-361-10).

Battery ground cable disconnected
(WP 0126 00).

FUEL BURNING PERSONNEL HEATER REPLACEMENT (Contd)

REMOVAL

1. Disconnect wiring harness (1) from personnel heater (2).
2. Remove fuel line (4) from elbow (3) and personnel heater (2).
3. Remove elbow (3) from personnel heater (2).
4. Remove cotter pin (9) and disconnect exhaust tube (10) from personnel heater (2). Discard cotter pin (9).
5. Remove four screws (6), lockwashers (7), and adapter (5) from personnel heater (2). Discard lockwashers (7).
6. Remove two clamps (8) and personnel heater (2) from mount (11).

INSTALLATION

1. Install heater (2) on mount (11) with two clamps (8).
2. Install adapter (5) on personnel heater (2) with four new lockwashers (7) and screws (6).
3. Install elbow (3) on personnel heater (2).
4. Install exhaust tube (10) on personnel heater (2) and insert new cotter pin (9) through tube (10) and personnel heater (2).
5. Install fuel line (4) on elbow (3).
6. Connect wiring harness (1) to personnel heater (2).
7. Connect battery ground cable (WP 0126 00).
8. Start heater and check operation (TM 9-2320-361-10).
9. Release parking brake and remove wheel chocks (TM 9-2320-361-10).

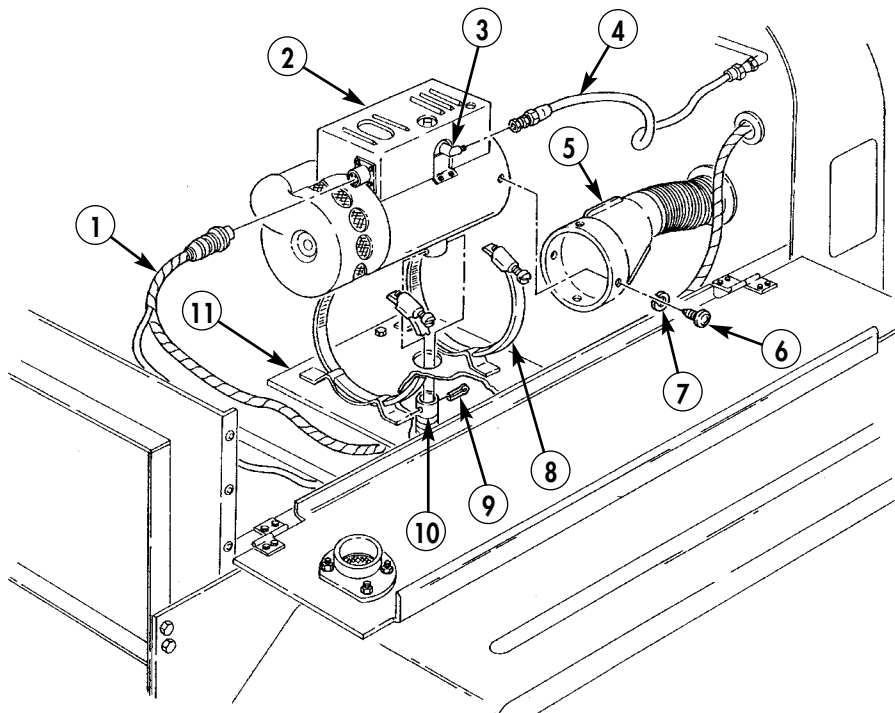

FIELD MAINTENANCE INSTRUCTIONS FOR SPECIAL PURPOSE KITS

2-1/2 TON, 6X6, M44A2 SERIES TRUCKS (MULTIFUEL)

PERSONNEL HEATER CONTROL BOX REPLACEMENT REMOVAL AND INSTALLATION

INITIAL SETUP:

Applicable Models

All

Materials/Parts

Two lockwashers (item 242, WP 0470 00)

Tools and Special Tools

General mechanic's tool kit
(item 116, WP 0469 00)

Equipment Condition

Parking brake set and wheels chocked
(TM 9-2320-361-10).
Battery ground cable disconnected
(WP 0126 00).

NOTE

This procedure is the same for the engine coolant heater control box.

REMOVAL

1. Disconnect wiring harness (4) from control box (7).
2. Disconnect wire (6) from wire (5).
3. Remove two nuts (2), lockwashers (1), and control box (7) from bracket (3). Discard lockwashers (1).

INSTALLATION

1. Install control box (7) on bracket (3) with two new lockwashers (1) and nuts (2).
2. Connect wire (6) to wire (5).
3. Connect wiring harness (4) to control box (7).
4. Connect battery ground cable (WP 0126 00).
5. Release parking brake and remove wheel chocks (TM 9-2320-361-10).

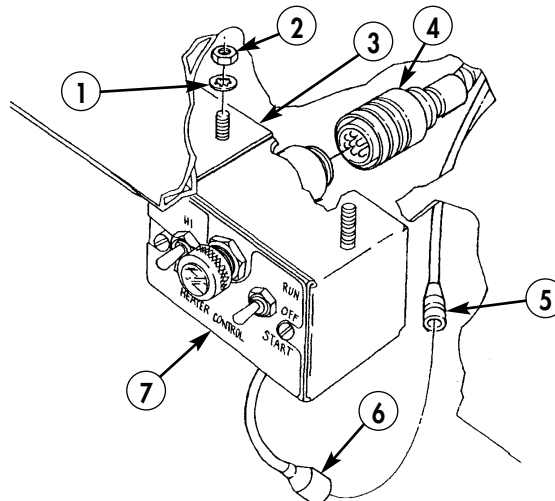

END OF WORK PACKAGE

0352 00-1/2 blank

**FIELD MAINTENANCE INSTRUCTIONS
FOR SPECIAL PURPOSE KITS**

2-1/2 TON, 6X6, M44A2 SERIES TRUCKS (MULTIFUEL)

**PERSONNEL HEATER FUEL PUMP REPLACEMENT
REMOVAL AND INSTALLATION**

INITIAL SETUP:

Applicable Models

All

Tools and Special Tools

General mechanic's tool kit
(item 116, WP 0469 00)

Materials/Parts

Two lockwashers (item 212, WP 0470 00)
Cap and plug set (item 10, WP 0468 00)

Equipment Condition

Parking brake set and wheels chocked
(TM 9-2320-361-10).
Battery ground cable disconnected
(WP 0126 00).

PERSONNEL HEATER FUEL PUMP REPLACEMENT (Contd)WARNING

Diesel fuel is flammable. Do not perform fuel system procedures near open flames. Injury or death may result.

REMOVAL

1. Disconnect wire (6) from wire (5).

CAUTION

Cap or plug all hoses, connections, and openings immediately after disconnection to prevent contamination. Failure to do so may result in damage to equipment.

2. Disconnect inlet line (3) from fuel pump (11).
3. Disconnect outlet line (1) from elbow (2).
4. Remove elbow (2) from fuel pump (11).
5. Remove two screws (7), lockwashers (8), clamp (10), ground wire (9), and fuel pump (11) from plate (4). Discard lockwashers (8).

INSTALLATIONCAUTION

Remove caps or plugs from hoses, connections, and openings before reconnection. Failure to do so may result in damage to equipment.

1. Install fuel pump (11), ground wire (9), and clamp (10) on plate (4) with two new lockwashers (8) and screws (7).
2. Install elbow (2) on fuel pump (11).
3. Connect outlet line (1) to elbow (2).
4. Connect inlet line (3) to fuel pump (11).
5. Connect wire (6) to wire (5).
6. Connect battery ground cable (WP 0126 00).
7. Release parking brake and remove wheel chocks (TM 9-2320-361-10).

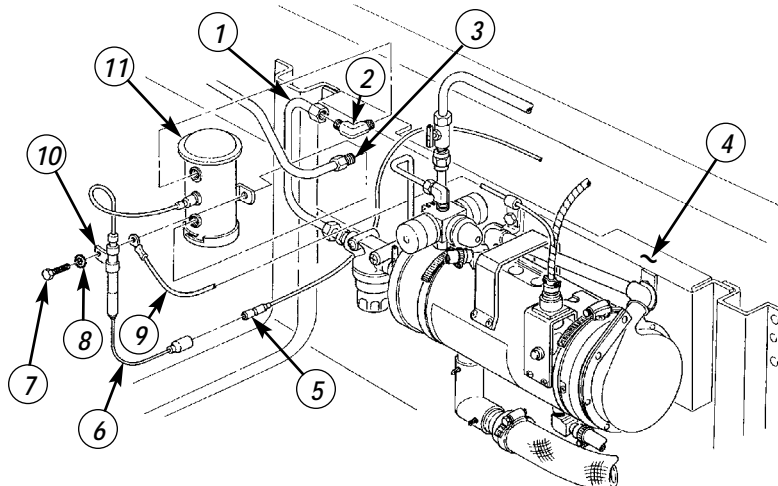
**END OF WORK PACKAGE**

FIELD MAINTENANCE INSTRUCTIONS FOR SPECIAL PURPOSE KITS

2-1/2 TON, 6X6, M44A2 SERIES TRUCKS (MULTIFUEL)

PERSONNEL HEATER FUEL FILTER REPLACEMENT REMOVAL AND INSTALLATION

INITIAL SETUP:

Applicable Models

All

Tools and Special Tools

General mechanic's tool kit
(item 116, WP 0469 00)

Materials/Parts

Two lockwashers (item 203, WP 0470 00)
Anitseize tape (item 42, WP 0468 00)

Equipment Condition

Parking brake set and wheels chocked
(TM 9-2320-361-10).
Hood raised and secured (TM 9-2320-361-10).
Battery ground cable disconnected
(WP 0126 00).

PERSONNEL HEATER FUEL FILTER REPLACEMENT (Contd)

REMOVAL

1. Disconnect tube (11) from fuel pump elbow (1) and adapter (10).
2. Disconnect fuel line (3) from tube (4).
3. Disconnect tube (4) from elbow (5).
4. Remove elbow (5) from tee (6).

NOTE

Perform step 5 if vehicle is equipped with engine coolant heater.

5. Disconnect fuel line (12) from tee (6).
6. Remove tee (6) from fuel filter (7).
7. Remove two screws (8), lockwashers (9), and fuel filter (7) from plate (2). Discard lockwashers (9).
8. Remove adapter (10) from fuel filter (7).

INSTALLATION

NOTE

Wrap male pipe threads with antiseize tape prior to installation.

1. Install adapter (10) on fuel filter (7).
2. Install fuel filter (7) on plate (2) with two new lockwashers (9) and screws (8).
3. Install tee (6) on fuel filter (7).
4. Install elbow (5) on tee (6).
5. Connect fuel line (3) to tube (4).

NOTE

Perform step 6 if vehicle is equipped with engine coolant heater.

6. Connect two fuel lines (12) and (4) to tee (6).
7. Connect tube (11) to fuel pump elbow (1) and adapter (10).
8. Connect battery ground cable (WP 0126 00).
9. Lower and secure hood (TM 9-2320-361-10).
10. Release parking brake and remove wheel chocks (TM 9-2320-361-10).

PERSONNEL HEATER FUEL FILTER REPLACEMENT (Contd)

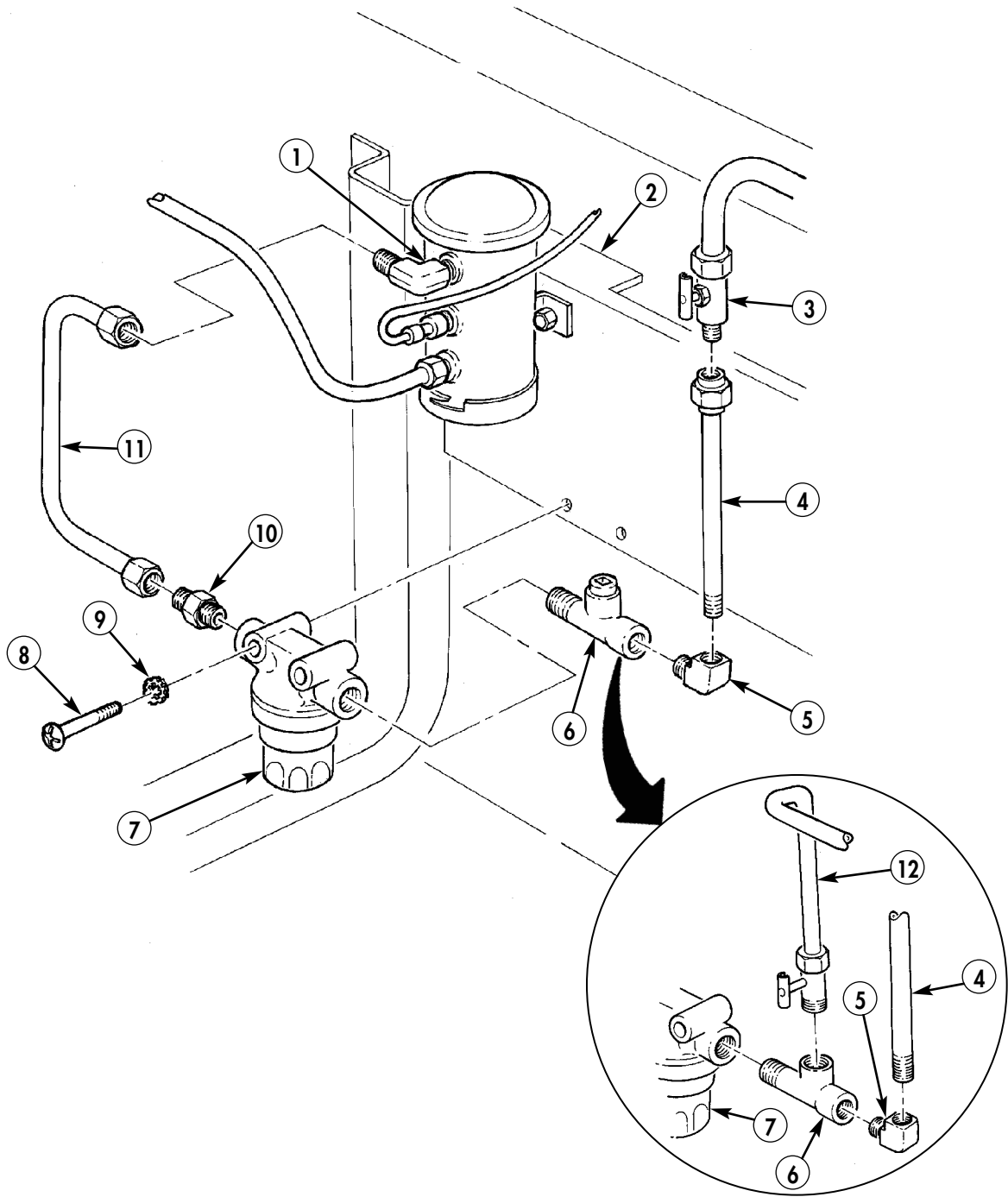

END OF WORK PACKAGE

FIELD MAINTENANCE INSTRUCTIONS FOR SPECIAL PURPOSE KITS

2-1/2 TON, 6X6, M44A2 SERIES TRUCKS (MULTIFUEL)

EXHAUST TUBE REPLACEMENT REMOVAL AND INSTALLATION

INITIAL SETUP:

Applicable Models

All

Tools and Special Tools

General mechanic's tool kit
(item 116, WP 0469 00)

Materials/Parts

Cotter pin (item 17, WP 0470 00)

Locknut (item 145, WP 0470 00)

Equipment Condition

Parking brake set and wheels chocked
(TM 9-2320-361-10).

Battery ground cable disconnected
(WP 0126 00).

WARNING

Do not touch hot exhaust system components with bare hands.
Severe injury to personnel will result.

REMOVAL

1. Remove cotter pin (2) and exhaust tube (7) from personnel heater elbow (1). Discard cotter pin (2).
2. Remove two nuts (5), screws (3), clamps (4), and exhaust tube (7) from left front fender (6).
3. Remove locknut (8), screw (10), clamp (9), and exhaust tube (7) from splash shield (11). Discard locknut (8).
4. Remove exhaust tube (7) from vehicle.

INSTALLATION

1. Install exhaust tube (7) on personnel heater elbow (1) with new cotter pin (2) through elbow (1) and tube (7).
2. Install exhaust tube (7) on left front fender (6) with two clamps (4), screws (3), and nuts (5).
3. Install exhaust tube (7) on splash shield (11) with clamp (9), screw (10), and new locknut (8).
4. Connect battery ground cable (WP 0126 00).
5. Release parking brake and remove wheel chocks (TM 9-2320-361-10).

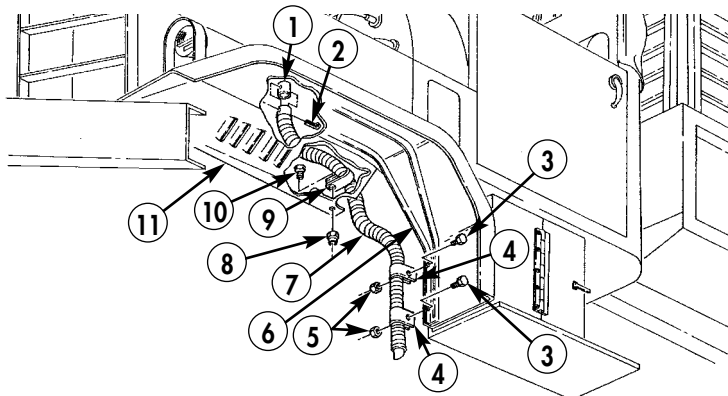

END OF WORK PACKAGE

0355 00-1/2 blank

FIELD MAINTENANCE INSTRUCTIONS FOR SPECIAL PURPOSE KITS

2-1/2 TON, 6X6, M44A2 SERIES TRUCKS (MULTIFUEL)

OIL PAN SHROUD AND EXHAUST TUBE REPLACEMENT REMOVAL AND INSTALLATION

INITIAL SETUP:

Applicable Models

All

Tools and Special Tools

General mechanic's tool kit
(item 116, WP 0469 00)

Materials/Parts

Four lockwashers (item 195, WP 0470 00)
Three cotter pins (item 18, WP 0470 00)
Locknut (item 145, WP 0470 00)

Equipment Condition

Parking brake set and wheels chocked
(TM 9-2320-361-10).
Battery ground cable disconnected
(WP 0126 00).

OIL PAN SHROUD AND EXHAUST TUBE REPLACEMENT (Contd)

WARNING

Do not touch hot exhaust system components with bare hands.
Severe injury to personnel will result.

REMOVAL

1. Remove cotter pin (9) and exhaust tube (10) from oil pan shroud (6). Discard cotter pin (9).
2. Remove two cotter pins (12), elbow (13), and exhaust tube (10) from heater (14). Discard cotter pins (12).
3. Remove locknut (1), screw (3), clamp (2), and exhaust tube (10) from splash shield (4). Discard locknut (1).
4. Remove exhaust tube (10) from vehicle.
5. Remove four screws (8), lockwashers (7), and oil pan shroud (6) from engine oil pan (5). Discard lockwashers (7).

INSTALLATION

1. Install oil pan shroud (6) on engine oil pan (5) with four new lockwashers (7) and screws (8).
2. Install exhaust tube (10) on oil pan shroud (6) with new cotter pin (9).
3. Insert exhaust tube (10) through hole (11) in toolbox.
4. Install elbow (13) and exhaust tube (10) on heater (14) with two new cotter pins (12).
5. Install exhaust tube (10) on splash shield (4) with clamp (2), screw (3), and new locknut (1).
6. Connect battery ground cable (WP 0126 00).
7. Release parking brake and remove wheel chocks (TM 9-2320-361-10).

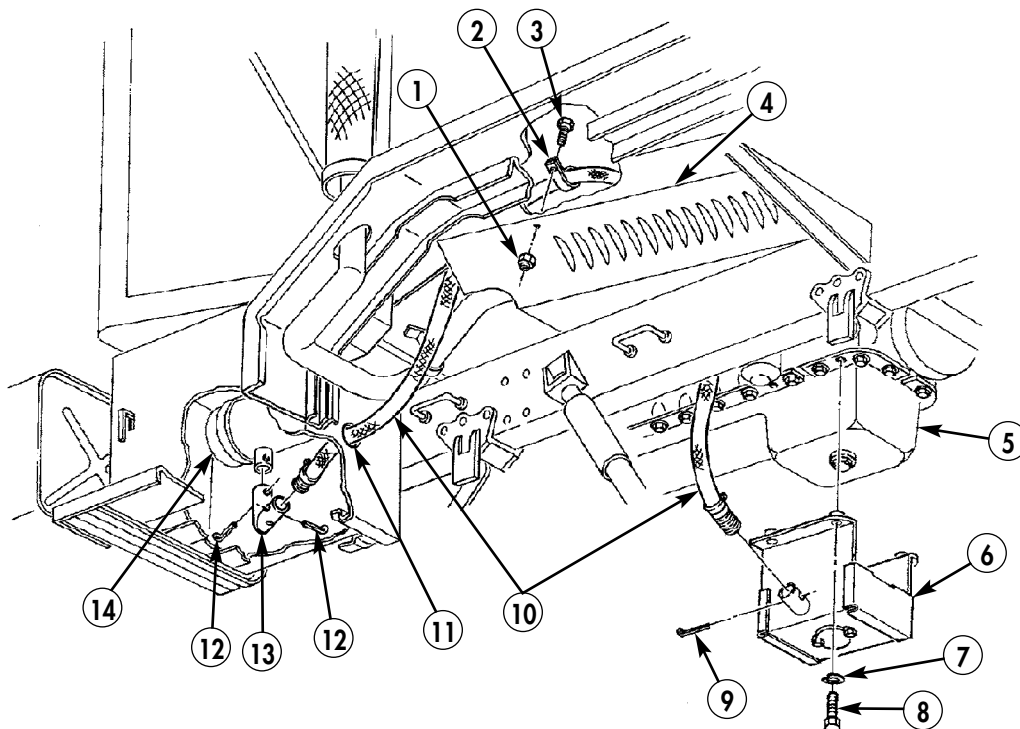

FIELD MAINTENANCE INSTRUCTIONS FOR SPECIAL PURPOSE KITS

2-1/2 TON, 6X6, M44A2 SERIES TRUCKS (MULTIFUEL)

ENGINE COOLANT HEATER REPLACEMENT REMOVAL AND INSTALLATION

INITIAL SETUP:

Applicable Models

All

Materials/Parts

Cotter pin (item 18, WP 0470 00)

Tools and Special Tools

General mechanic's tool kit
(item 116, WP 0469 00)

Equipment Condition

Parking brake set and wheels chocked
(TM 9-2320-361-10).
Battery ground cable disconnected
(WP 0126 00).

ENGINE COOLANT HEATER REPLACEMENT (Contd)

REMOVAL

WARNING

Accidental or intentional introduction of liquid contaminants into the environment is a violation of state, federal, and military regulations. Refer to Army POL (WP 0001 00) for information concerning storage, use, and disposal of these liquids. Failure to do so may result in damage to environment and health of personnel.

NOTE

- Prior to removal, close fuel shutoff, engine oil, and water manifold valves.
- Use a drain pan to capture any draining fluids. Dispose of fluids in accordance with local policy and ordinances. Ensure all spills are cleaned up.

1. Disconnect harness (3) from heater (4).
2. Disconnect fuel line (1) from elbow (14).
3. Remove clamp (13) and hose (12) from elbow (11).
4. Remove cotter pin (10) and elbow (8) from heater (4). Discard cotter pin (10).
5. Remove clamp (6) and hose (5) from elbow (7).
6. Remove two clamps (9) and heater (4) from saddle brackets (2).

INSTALLATION

1. Install heater (4) on saddle brackets (2) with two clamps (9).
2. Install hose (5) on elbow (7) with clamp (6).
3. Install elbow (8) on heater (4) with new cotter pin (10).
4. Install hose (12) on elbow (11) with clamp (13).
5. Connect fuel line (1) to elbow (14).
6. Connect harness (3) to heater (4).
7. Connect battery ground cable (WP 0126 00).
8. Release parking brake and remove wheel chocks (TM 9-2320-361-10).

ENGINE COOLANT HEATER REPLACEMENT (Contd)

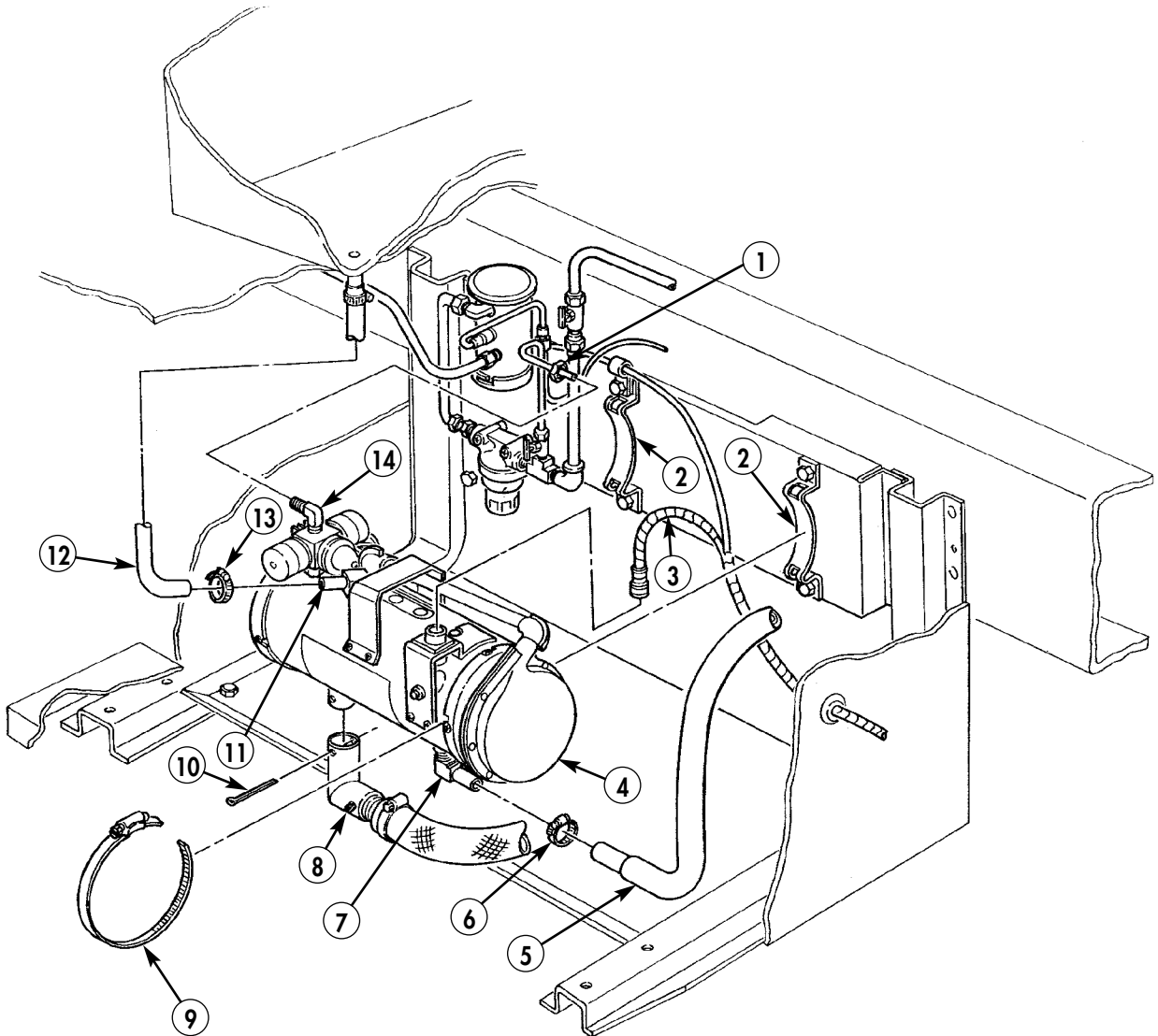

END OF WORK PACKAGE

0357 00-3/4 blank

**FIELD MAINTENANCE INSTRUCTIONS
FOR SPECIAL PURPOSE KITS**

2-1/2 TON, 6X6, M44A2 SERIES TRUCKS (MULTIFUEL)

**ENGINE COOLANT HEATER HARNESS REPLACEMENT
REMOVAL AND INSTALLATION**

INITIAL SETUP:

Applicable Models

All

Materials/Parts

Cotter pin (item 18, WP 0470 00)

Tools and Special Tools

General mechanic's tool kit
(item 116, WP 0469 00)

Equipment Condition

Parking brake set and wheels chocked
(TM 9-2320-361-10).
Battery ground cable disconnected
(WP 0126 00).

ENGINE COOLANT HEATER HARNESS REPLACEMENT (Contd)

REMOVAL

WARNING

Accidental or intentional introduction of liquid contaminants into the environment is a violation of state, federal, and military regulations. Refer to Army POL (WP 0001 00) for information concerning storage, use, and disposal of these liquids. Failure to do so may result in damage to environment and health of personnel.

NOTE

- Prior to removal, close fuel shutoff, engine oil, and water manifold valves.
- Use a drain pan to capture any draining fluids. Dispose of fluids in accordance with local policy and ordinances. Ensure all spills are cleaned up.

1. Disconnect harness (3) from heater (4).
2. Disconnect fuel line (1) from elbow (14).
3. Remove clamp (13) and hose (12) from elbow (11).
4. Remove cotter pin (10) and elbow (8) from heater (4). Discard cotter pin (10).
5. Remove clamp (6) and hose (5) from elbow (7).
6. Remove two clamps (9) and heater (4) from saddle brackets (2).

INSTALLATION

1. Install heater (4) on saddle brackets (2) with two clamps (9).
2. Install hose (5) on elbow (7) with clamp (6).
3. Install elbow (8) on heater (4) with new cotter pin (10).
4. Install hose (12) on elbow (11) with clamp (13).
5. Connect fuel line (1) to elbow (14).
6. Connect harness (3) to heater (4).
7. Connect battery ground cable (WP 0126 00).
8. Release parking brake and remove wheel chocks (TM 9-2320-361-10).

ENGINE COOLANT HEATER HARNESS REPLACEMENT (Contd)

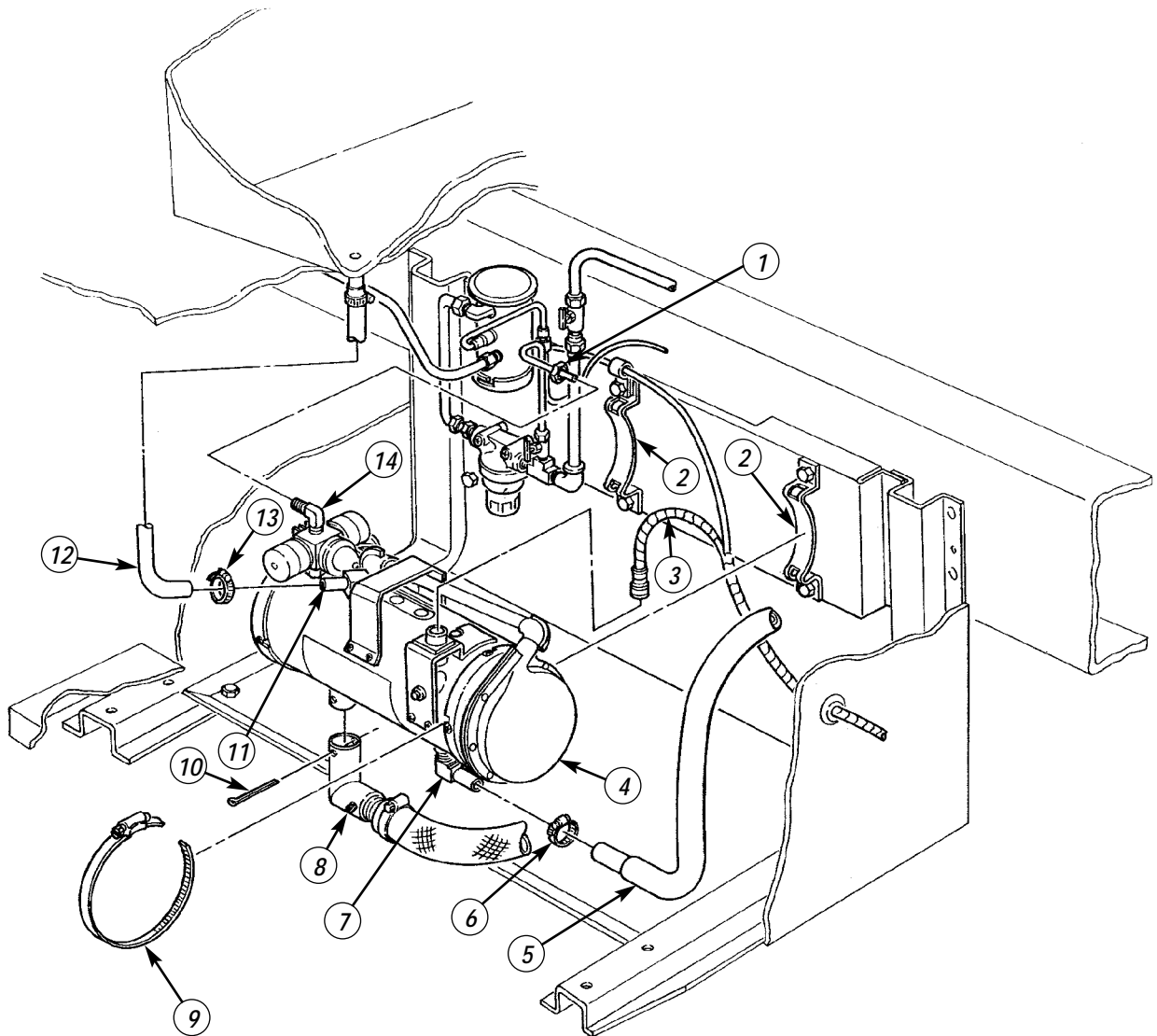

END OF WORK PACKAGE

0358 00-3/4 blank

FIELD MAINTENANCE INSTRUCTIONS FOR SPECIAL PURPOSE KITS

2-1/2 TON, 6X6, M44A2 SERIES TRUCKS (MULTIFUEL)

THERMAL BARRIER INSULATION REPLACEMENT REMOVAL AND INSTALLATION

INITIAL SETUP:

Applicable Models

All

Materials/Parts

Adhesive sealant (item 1, WP 0468 00)
Methylethylketone (item 22, WP 0468 00)

Equipment Condition

Parking brake set and wheels chocked
(TM 9-2320-361-10).
Battery ground cable disconnected
(WP 0126 00).
Driver's seat removed (WP 0236 00).
Companion seat removed (WP 0234 00).

THERMAL BARRIER INSULATION REPLACEMENT (Contd)

REMOVAL

NOTE

All thermal barrier insulation is removed the same way. This procedure covers replacement of left rear insulation panel only. Other panels are shown for reference only.

1. Remove panel (2) from cab interior (1). Discard panel (2) if irreparable damage occurs when removing.
2. Remove all remaining insulating material and adhesive from contact surface areas.

INSTALLATION

CAUTION

Once panel is coated with methylethylketone and put in place, it cannot be moved. Be careful not to place panel in the wrong position.

NOTE

- Make all necessary cutouts and slits in panels before installation.
 - Shiny side of panel must face outward.
1. Place panel (2) on cab (1) to check for fit.
 2. Remove panel (2) and coat contact areas with methylethylketone.
 3. Install panel (2) on cab (1) and press firmly into place.

NOTE

If additional adhesive sealant is required, perform steps 4 and 5.

4. Remove panel (2) and coat contact areas with adhesive sealant.
5. Install panel (2) on cab (1) and press firmly into place.
6. Install driver's seat (WP 0236 00).
7. Install companion seat (WP 0234 00).
8. Connect battery ground cable (WP 0126 00).
9. Release parking brake and remove wheel chocks (TM 9-2320-361-10).

THERMAL BARRIER INSULATION REPLACEMENT (Contd)

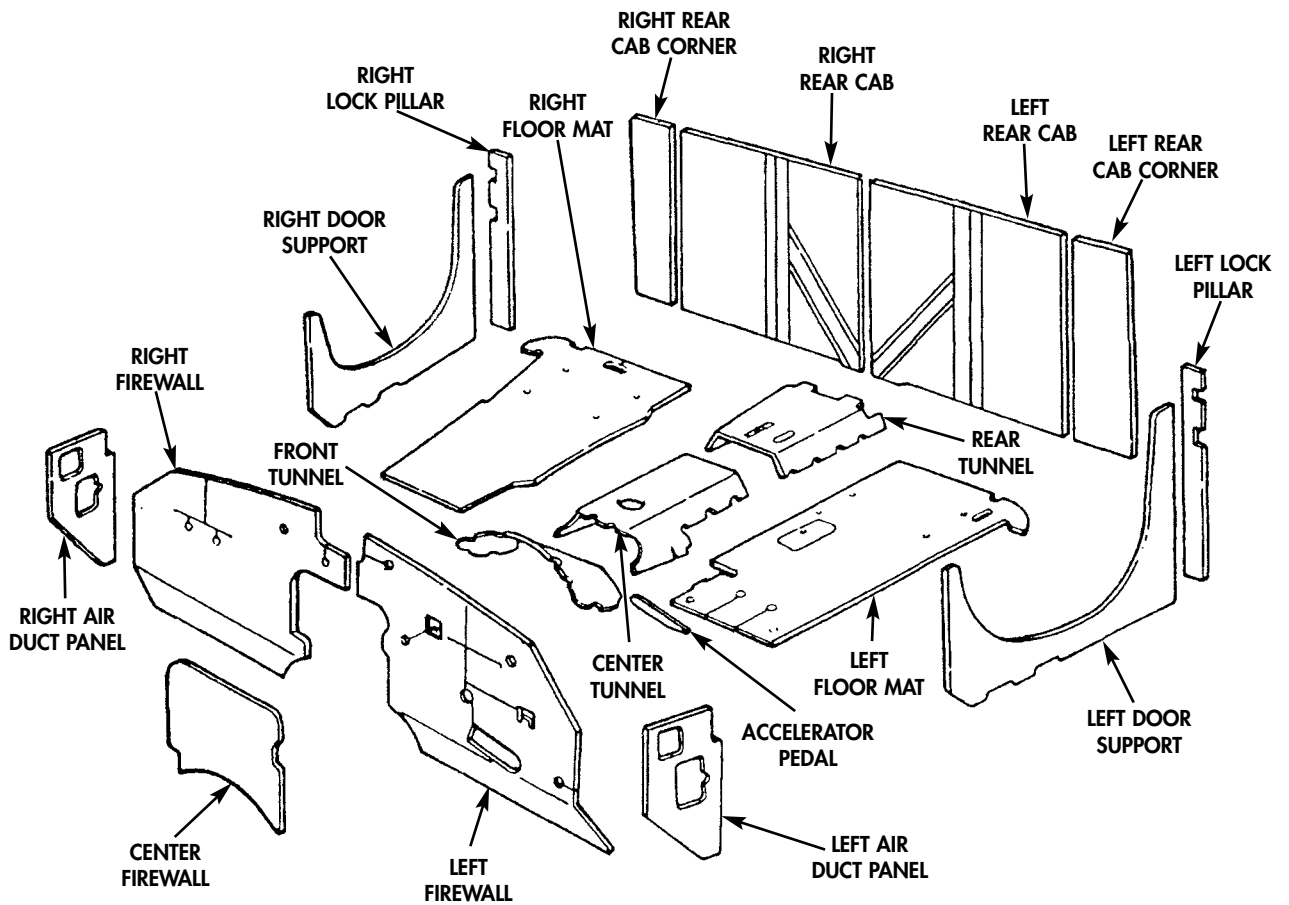
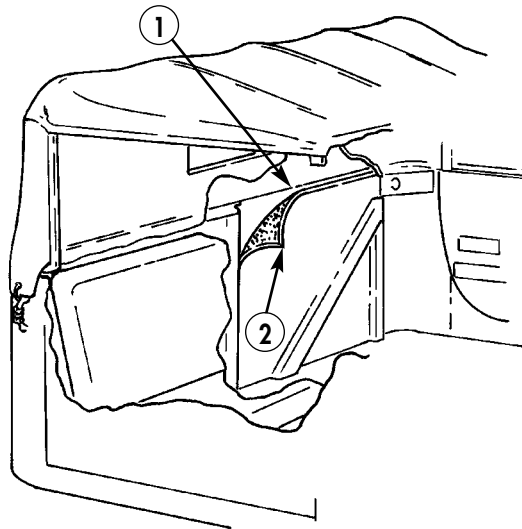

END OF WORK PACKAGE

FIELD MAINTENANCE INSTRUCTIONS FOR SPECIAL PURPOSE KITS

2-1/2 TON, 6X6, M44A2 SERIES TRUCKS (MULTIFUEL)

BATTERY BOX AND HEATER PAD REPLACEMENT

HEATER PAD REMOVAL, BATTERY BOX REMOVAL, BATTERY BOX INSTALLATION,
AND HEATER PAD INSTALLATION.

INITIAL SETUP:

Applicable Models

All

Tools and Special Tools

General mechanic's tool kit
(item 116, WP 0469 00)

Materials/Parts

Four lockwashers (item 195, WP 0470 00)

Equipment Condition

Parking brake set and wheels chocked
(TM 9-2320-361-10).

Companion seat removed (WP 0234 00).
Batteries removed (WP 0127 00).

BATTERY BOX HEATER PAD REPLACEMENT (Contd)

HEATER PAD REMOVAL

WARNING

Accidental or intentional introduction of liquid contaminants into the environment is a violation of state, federal, and military regulations. Refer to Army POL (WP 0001 00) for information concerning storage, use, and disposal of these liquids. Failure to do so may result in damage to environment and health of personnel.

NOTE

- Prior to removal, close water manifold valve.
- Use a drain pan to capture any draining coolant. Dispose of fluids in accordance with local policy and ordinances. Ensure all spills are cleaned up.

1. Loosen two clamps (6) and remove exhaust inlet hose (9) and outlet hose (7) from heater pad (1).
2. Remove heater pad (1) from battery box (3).

BATTERY BOX REMOVAL

1. Remove two rubber grommets (2) from battery box (3) and battery cables.
2. Remove four screws (4), lockwashers (5), spacers (8), and battery box (3) from cab floor (10). Discard lockwashers (5).

BATTERY BOX INSTALLATION

1. Install battery box (3) on cab floor (10), with four spacers (8), new lockwashers (5) and screws (4).
2. Install two rubber grommets (2) on battery cables and battery box (3).

HEATER PAD INSTALLATION

1. Install heater pad (1) in battery box (3).
2. Install exhaust inlet hose (9) and outlet hose (7) on heater pad (1). Tighten clamps (6).
3. Install batteries (WP 0127 00).
4. Install companion seat (WP 0234 00).
5. Release parking brake and remove wheel chocks (TM 9-2320-361-10).

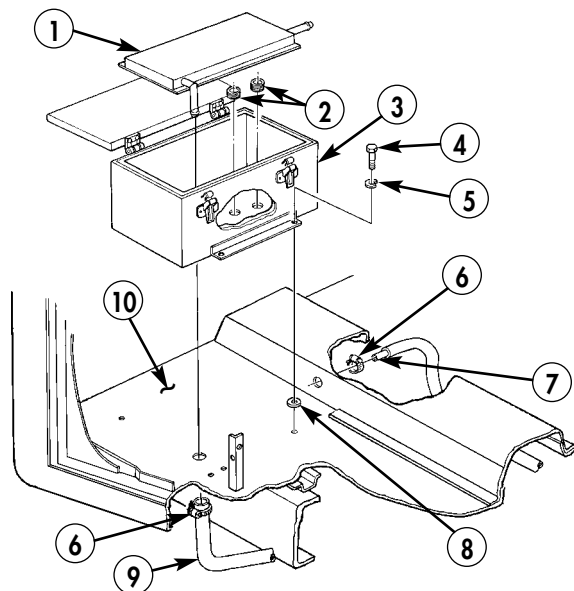

END OF WORK PACKAGE

**FIELD MAINTENANCE INSTRUCTIONS
FOR SPECIAL PURPOSE KITS**

2-1/2 TON, 6X6, M44A2 SERIES TRUCKS (MULTIFUEL)

**TRANSMISSION GEARSHIFT AND TRANSFER CASE LEVER COVER REPLACEMENT
REMOVAL AND INSTALLATION**

INITIAL SETUP:

Applicable Models

All

Tools and Special Tools

General mechanic's tool kit
(item 116, WP 0469 00)

Equipment Condition

Parking brake set and wheels chocked
(TM 9-2320-361-10).

Battery ground cable disconnected
(WP 0126 00).

TRANSMISSION GEARSHIFT AND TRANSFER CASE LEVER COVER REPLACEMENT (Contd)**REMOVAL**

1. Remove gearshift knob (1) from gearshift lever (5).
2. Remove four screws (2) and gearshift cover (3) from intermediate tunnel (4). Slide gearshift cover (3) from gearshift lever (5).
3. Remove four screws (8) and transfer case lever cover (7) from intermediate tunnel (4) and transfer case lever (6). Slide transfer case lever cover (7) from transfer case lever (6).

INSTALLATION

1. Place transfer case lever cover (7) over transfer case lever (6) and install on intermediate tunnel (4) with four screws (8).
2. Place gearshift cover (3) over gearshift lever (5) and install on intermediate tunnel (4) with four screws (2).
3. Install gearshift knob (1) on gearshift lever (5).
4. Connect battery ground cable (WP 0126 00).
5. Release parking brake and remove wheel chocks (TM 9-2320-361-10).

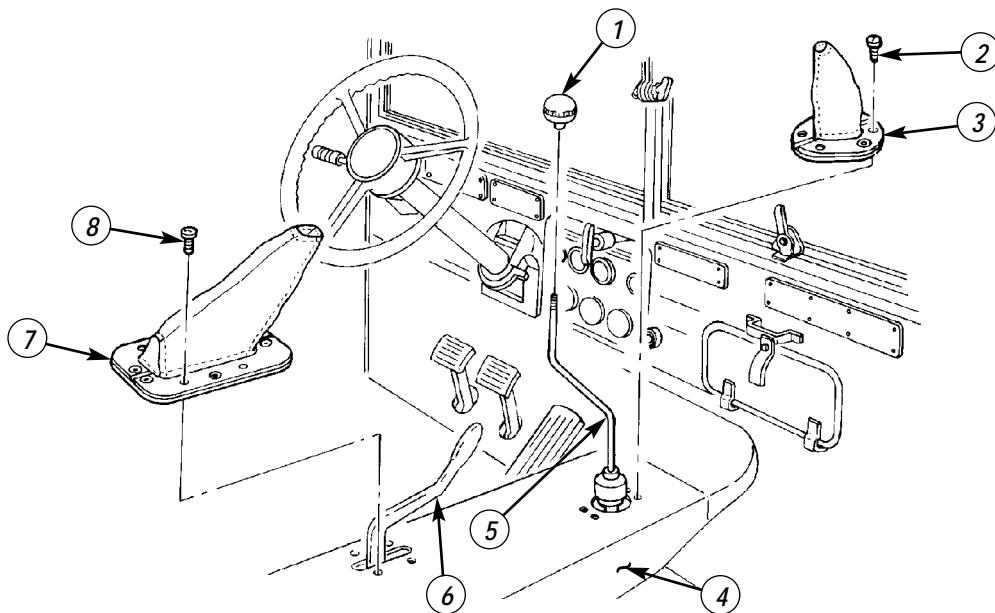

**FIELD MAINTENANCE INSTRUCTIONS
FOR SPECIAL PURPOSE KITS**

2-1/2 TON, 6X6, M44A2 SERIES TRUCKS (MULTIFUEL)

**HOOD AND RADIATOR COVER REPLACEMENT
REMOVAL AND INSTALLATION**

INITIAL SETUP:

Applicable Models

All

Equipment Condition

Parking brake set and wheels chocked
(TM 9-2320-361-10).

Battery ground cable disconnected
(WP 0126 00).

Air cleaner removed (WP 0053 00).

HOOD AND RADIATOR COVER REPLACEMENT (Contd)

REMOVAL

1. Remove three retaining springs (7) from front fender (12) and side panel loops (11). Repeat for the opposite side.
2. Unfasten buckles (3) and pull straps (1) through loops (2).
3. Unfasten buckle (6) and pull strap (5) through loops (4). Repeat for the opposite side.
4. Remove radiator cover (8) from brush guard (9).
5. Unfasten buckles (15) and pull straps (14) through loops (13). Repeat for the opposite side.
6. Remove hood cover (16) from hood (10).
7. Unfasten buckles (20) and pull straps (19) through loops (18).
8. Remove side panel cover (17) from side panel (21). Repeat for the opposite side.

INSTALLATION

1. Install side panel cover (17) on side panel (21) and insert loops (18) through side panel cover (17).
2. Thread straps (19) through loops (18) and fasten buckles (20). Repeat for the opposite side.
3. Install hood cover (16) on hood (10) and insert loops (13) through hood cover (16).
4. Thread straps (14) through loops (13) and fasten buckles (15). Repeat for the opposite side.
5. Install radiator cover (8) on brush guard (9) and insert loops (2) and (4) through radiator cover (8).
6. Thread straps (1) through loops (2) and fasten buckles (3).
7. Thread strap (5) through loops (4) and fasten buckle (6). Repeat for the opposite side.
8. Install three retaining springs (7) on front fender (12) and side panel loops (11). Repeat for the opposite side.
9. Install air cleaner (WP 0053 00).
10. Connect battery ground cable (WP 0126 00).
11. Release parking brake and remove wheel chocks (TM 9-2320-361-10).

HOOD AND RADIATOR COVER REPLACEMENT (Contd)

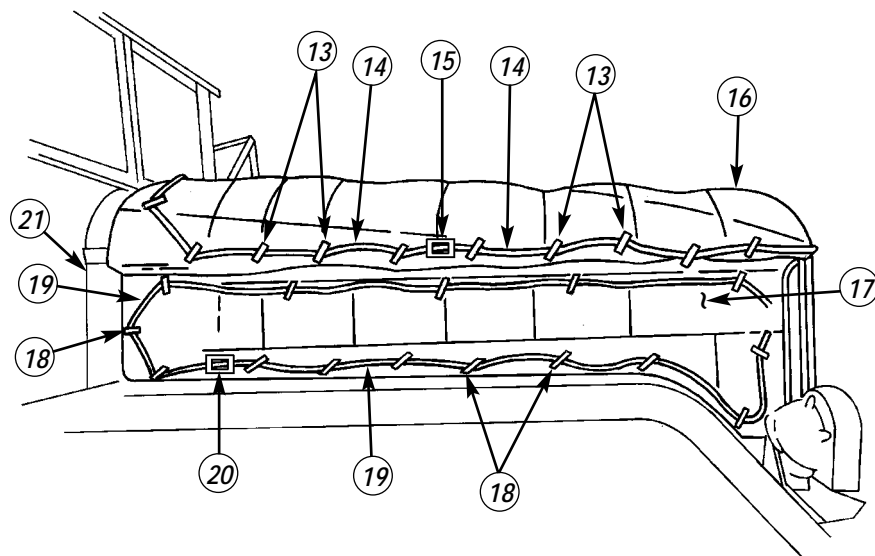
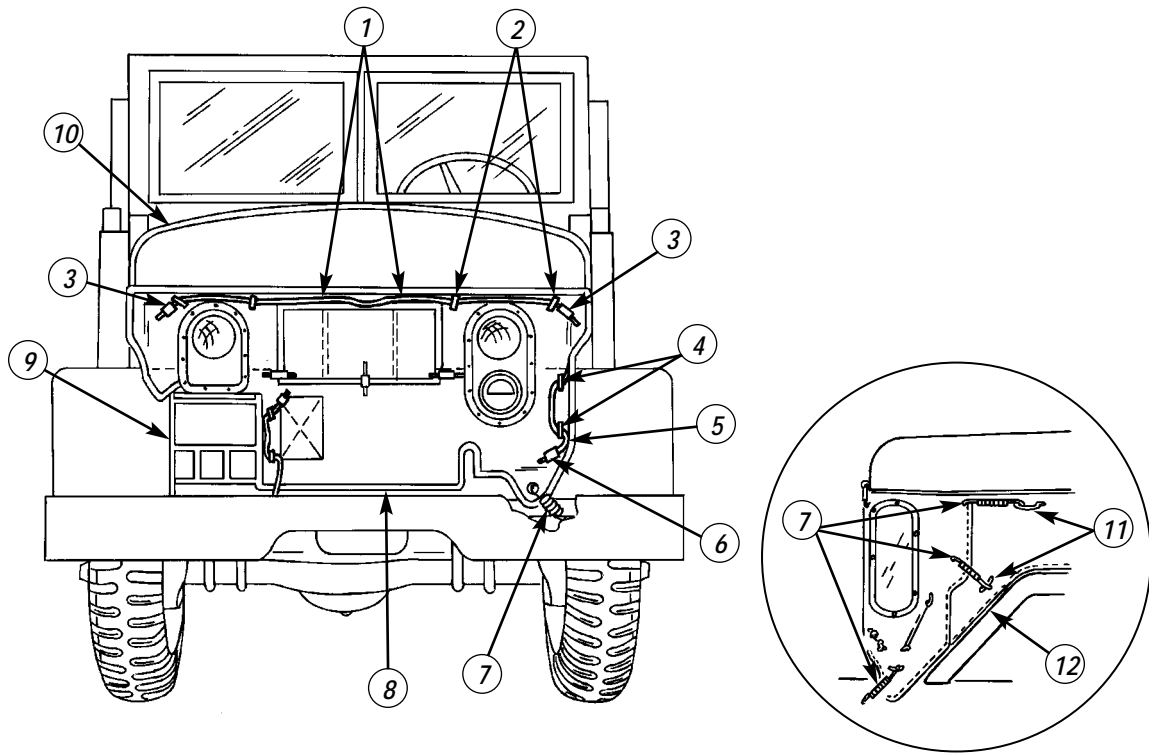

END OF WORK PACKAGE

FIELD MAINTENANCE INSTRUCTIONS FOR SPECIAL PURPOSE KITS

2-1/2 TON, 6X6, M44A2 SERIES TRUCKS (MULTIFUEL)

HARDTOP MAINTENANCE

REMOVAL, DISASSEMBLY, INSPECTION, ASSEMBLY, AND INSTALLATION

INITIAL SETUP:

Applicable Models

All

Tools and Special Tools

General mechanic's tool kit
(item 116, WP 0469 00)

Materials/Parts

Twenty-eight locknuts
(item 165, WP 0470 00)
Two locknuts (item 129, WP 0470 00)

Materials/Parts (Contd)

Two lockwashers (item 198, WP 0470 00)
Five lockwashers (item 197, WP 0470 00)

Personnel Required

Two

Equipment Condition

Parking brake set and wheels chocked
(TM 9-2320-361-10).
Battery ground cable disconnected
(WP 0126 00).

HARDTOP MAINTENANCE (Contd)

WARNING

Hardtop is heavy. An assistant is required during removal and installation to prevent injury to personnel.

REMOVAL

1. Remove two screws (1) and lockwashers (2) from each side of hardtop (3) and windshield frame (14). Discard lockwashers (2).
2. Remove capscrew (12), washer (13), and locknut (5) from each side of hardtop (3) and windshield frame (14). Discard locknut (5).
3. Remove fourteen screws (11), locknuts (6), and washers (7) and (10) from hardtop (3). Discard locknuts (6).

NOTE

Assistant will help with step 4.

4. Remove hardtop (3) and seal (8).
5. Remove two screws (23) and retainers (22) from back panel (9).
6. Remove fourteen locknuts (24), screws (19), and washers (20) from back panel (9) and cab (18). Discard locknuts (24).
7. Remove back panel (9) and seal (21) from cab (18).

DISASSEMBLY

Remove five nuts (4), lockwashers (16), screws (15), and seal (17) from hardtop (3). Discard lockwashers (16).

INSPECTION

Inspect seals (8), (17), and (21) for rips, tears, or other damage. Replace seals (8) and (21) if ripped, torn, or damaged.

ASSEMBLY

Install seal (17) on hardtop (3) with five screws (15), new lockwashers (16), and nuts (4).

INSTALLATION

NOTE

Do not tighten any screws or nuts until kit is fully installed.

1. Install seal (21) to back panel (9) with two retainers (22) and screws (23).
2. Install back panel (9) to cab (18) and align holes.
3. Install fourteen washers (20), screws (19), and new locknuts (24) on back panel (9) and cab (18).

NOTE

Assistant will help with step 4.

4. Place seal (8) on back panel (9). Install hardtop (3) on back panel (9) and align holes.
5. Install fourteen washers (7), screws (11), washers (10), and new locknuts (6) on back panel (9) and hardtop (3). Do not tighten.
6. Install washer (13), capscrew (12), and new locknut (5) on each side of hardtop (3) and windshield frame (14).

HARDTOP MAINTENANCE (Contd)

INSTALLATION (Contd)

7. Close cab windows and inspect all panels for alignment and seating. Adjust panels as required.
8. Tighten capscrews (12) and fourteen screws (11).
9. Install two screws (1) and new lockwashers (2) on each side of hardtop (3) and windshield frame (14).
10. Connect battery ground cable (WP 0126 00).
11. Release parking brake and remove wheel chocks (TM 9-2320-361-10).

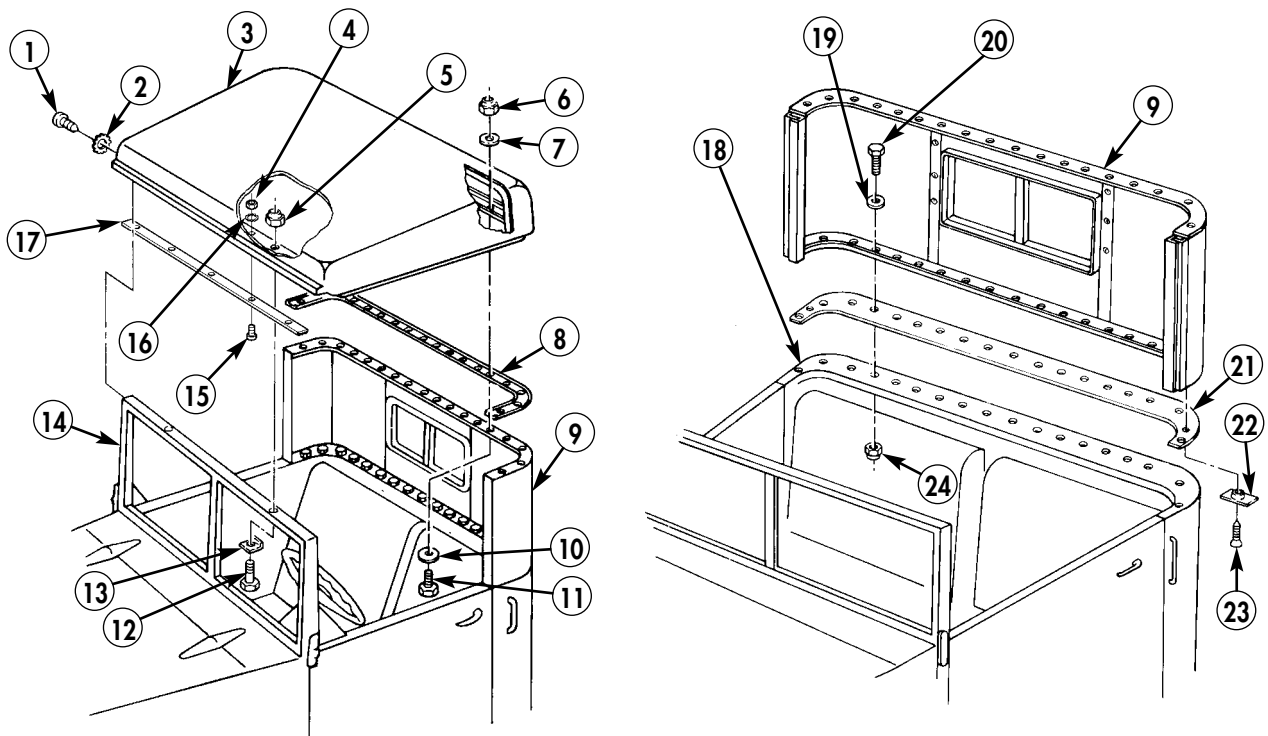

**FIELD MAINTENANCE INSTRUCTIONS
FOR SPECIAL PURPOSE KITS**

2-1/2 TON, 6X6, M44A2 SERIES TRUCKS (MULTIFUEL)

**ALCOHOL EVAPORATOR MAINTENANCE
REMOVAL, INSPECTION, AND INSTALLATION**

INITIAL SETUP:

Applicable Models

All

Tools and Special Tools

General mechanic's tool kit
(item 116, WP 0469 00)

Materials/Parts

Three locknuts (item 145, WP 0470 00)
Sealing compound (item 28, WP 0468 00)

Equipment Condition

Parking brake set and wheels chocked
(TM 9-2320-361-10).
Hood raised and secured (TM 9-2320-361-10).
Battery ground cable disconnected
(WP 0126 00).

ALCOHOL EVAPORATOR MAINTENANCE (Contd)

WARNING

Diesel fuel is flammable. Do not perform fuel system procedures near open flames. Injury or death to personnel may result.

REMOVAL

1. Remove jar (9) and O-ring (8) from evaporator body (7).
2. Disconnect tube (5) from compressor elbow (13) and adapter (6).
3. Remove three locknuts (11), screws (12), and evaporator body (7) from bracket (1). Discard locknuts (11).
4. Disconnect adapter (6) from evaporator body (7).
5. Disconnect tube (3) from outlet manifold (2).
6. Remove two screws (4), outlet manifold (2), and bracket (1) from compressor (10).

INSPECTION

Inspect O-ring (8) for rips, tears, or other damage. Replace O-ring (8) if ripped, torn, or damaged.

INSTALLATION

1. Install bracket (1) and outlet manifold (2) on compressor (10) with two screws (4).
2. Connect tube (3) to outlet manifold (2).

NOTE

Apply sealing compound to adapter prior to installation.

3. Install adapter (6) on evaporator body (7).
4. Install evaporator body (7) on bracket (1) with three screws (12) and new locknuts (11).
5. Connect tube (5) to compressor elbow (13) and adapter (6).
6. Install O-ring (8) and jar (9) on evaporator body (7).
7. Fill evaporator jar, start engine (TM 9-2320-361-10), and check alcohol evaporator operation.
8. Connect battery ground cable (WP 0126 00).
9. Lower and secure hood (TM 9-2320-361-10).
10. Release parking brake and remove wheel chocks (TM 9-2320-361-10).

ALCOHOL EVAPORATOR MAINTENANCE (Contd)

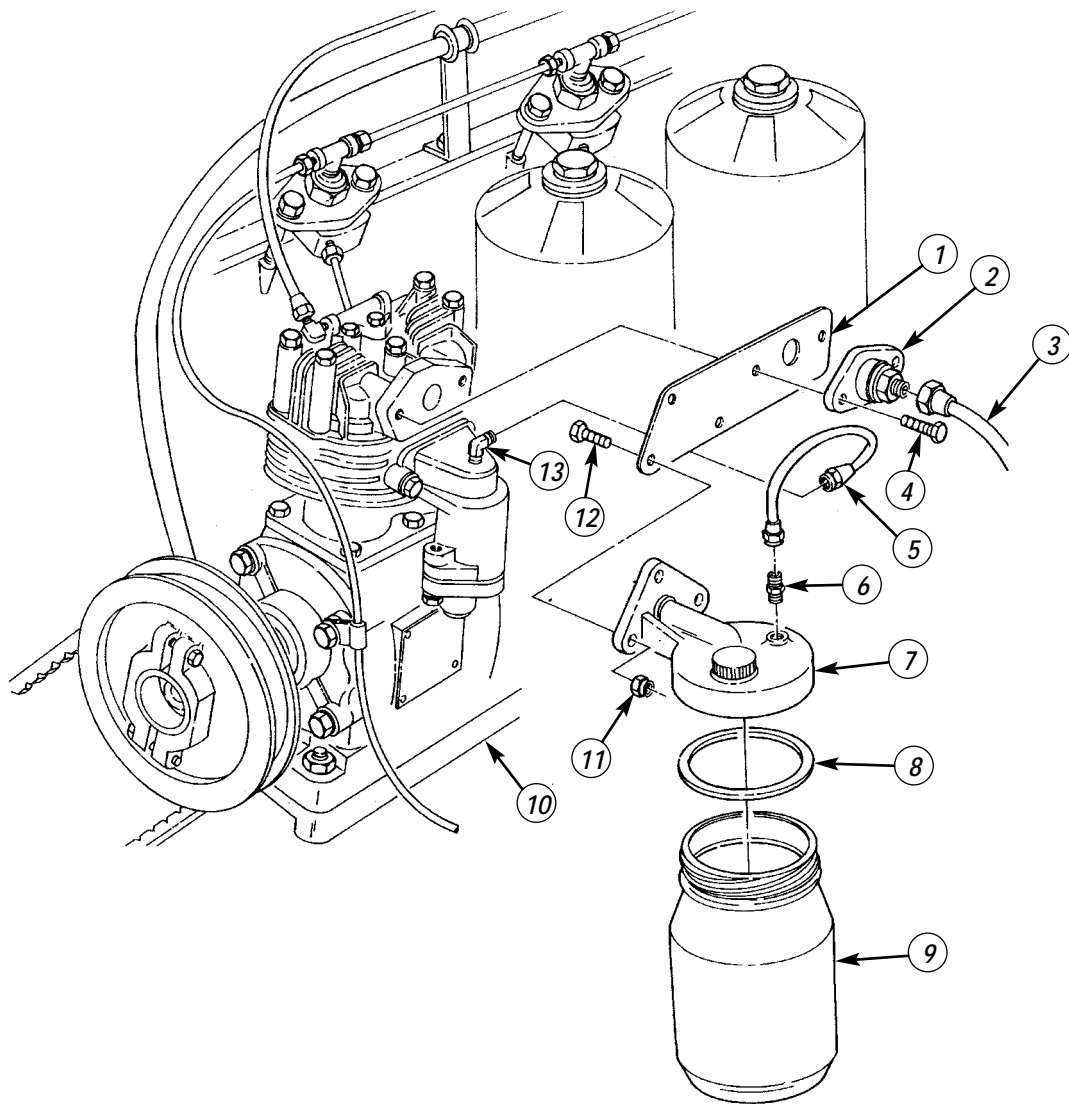

END OF WORK PACKAGE

FIELD MAINTENANCE INSTRUCTIONS FOR SPECIAL PURPOSE KITS

2-1/2 TON, 6X6, M44A2 SERIES TRUCKS (MULTIFUEL)

SLAVE RECEPTACLE REPLACEMENT

REMOVAL AND INSTALLATION

INITIAL SETUP:

Applicable Models

All

Tools and Special Tools

General mechanic's tool kit
(item 116, WP 0469 00)

Equipment Condition

Parking brake set and wheels chocked
(TM 9-2320-361-10).

Battery ground cable disconnected
(WP 0126 00).

Materials/Parts

Five lockwashers (item 225, WP 0470 00)
Two lockwashers (item 210, WP 0470 00)
Five locknuts (item 180, WP 0470 00)

SLAVE RECEPTACLE REPLACEMENT (Contd)

REMOVAL

1. Remove locknut (19), two lockwashers (18), ground cable (5), and screw (17) from rear battery support hanger (16). Discard locknut (19) and lockwashers (18).
2. Remove nut (33), screw (31), and positive cables (22) and (34) from positive battery terminal (32).
3. Remove screw (27) washer (26), lockwasher (25), two clamps (24), ground cable (5), and positive cable (22) from cab back panel support (23). Discard lockwasher (25).
4. Remove two grommets (24), positive cable (22), and ground cable (5) from cab floor (29).
5. Remove four locknuts (20) and screws (21) from cab (9) and reinforcement plate (10). Discard locknuts (20).
6. Remove four locknuts (14), lockwashers (15), screws (1), lockwashers (2), slave receptacle cap (30), seal (8), reinforcement plate (10), seal (11), plate (12) and slave receptacle (4) from cab (9). Discard locknuts (14), lockwashers (15), and lockwashers (2).
7. Remove cover (13), two screws (6), washers (7), positive cable (22), and ground cable (5) from slave receptacle (4).
8. Remove positive cables (22), and ground cable (5) from cab (9).

INSTALLATION

1. Install positive cables (22), and ground cable (5) on cab (9).
2. Install positive cable (22), and ground cable (5) on cab (9) with two screws (6), washers (7) and cover (13).
3. Install slave receptacle (4), slave receptacle cap (30), seal (8), reinforcement plate (10), seal (11), plate (12), with four screws (1), new lockwashers (2), new lockwashers (15), and new locknuts (14) on cab (9)
4. Install four screws (21) and locknuts (20) on slave receptacle (4) and reinforcement plate (10).
5. Install two grommets (24), positive cable (22), and ground cable (5) on cab floor (29).
6. Install ground cable (5), and positive cable (22) on cab back panel support (23) with screw (27) washer (26), lockwasher (25), and two clamps (24).
7. Install positive cables (22) and (34) on positive battery terminal (32) with screw (31) and nut (33).
8. Install ground cable (5) on rear battery support hanger (16) with screw (17), two lockwashers (18), and locknut (19).
9. Release parking brake and remove wheel chocks (TM 9-2320-361-10).

SLAVE RECEPTACLE REPLACEMENT (Contd)

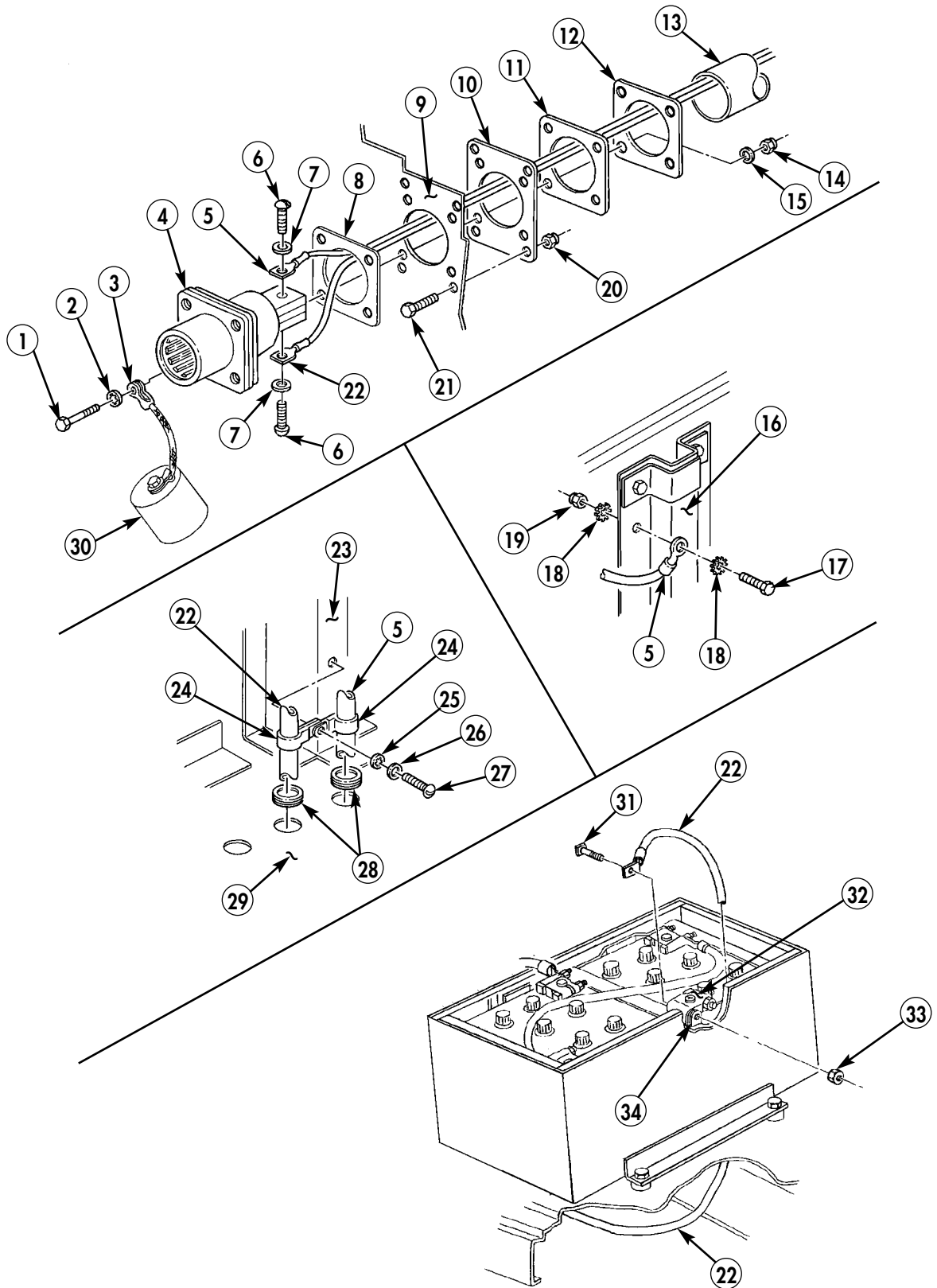

END OF WORK PACKAGE

FIELD MAINTENANCE INSTRUCTIONS FOR SPECIAL PURPOSE KITS

2-1/2 TON, 6X6, M44A2 SERIES TRUCKS (MULTIFUEL)

CARGO BODY PERSONNEL HEATER REPLACEMENT REMOVAL AND INSTALLATION

INITIAL SETUP:

Applicable Models

All

Tools and Special Tools

General mechanic's tool kit
(item 116, WP 0469 00)

Materials/Parts

Four lockwashers (item 239, WP 0470 00)
Gasket (item 122, WP 0470 00)

Equipment Condition

Parking brake set and wheels chocked
(TM 9-2320-361-10).
Battery ground cable disconnected
(WP 0126 00).

CARGO BODY PERSONNEL HEATER REPLACEMENT (Contd)

REMOVAL

1. Close fuel shutoff valve (20).
2. Release four latches (1) and remove cover (2) from four plate assemblies (13).
3. Disconnect wiring harness (5) from heater (4).
4. Disconnect fuel line (14) from heater elbow (3).
5. Remove clamp (18) and duct (19) from inlet adapter (17).
6. Remove two clamps (11) and heater (4) from mounting bracket (12).
7. Remove inlet adapter (17) from heater (4).
8. Remove four screws (8), lockwashers (7), and outlet adapter (6) from heater (4). Discard lockwashers (7).
9. Remove extension (10), gasket (9), and spacer (15) from heater exhaust (16). Discard gasket (9).

INSTALLATION

1. Install spacer (15), new gasket (9), and extension (10) on heater exhaust (16).
2. Install outlet adapter (6) on heater (4) with four new lockwashers (7) and screws (8).
3. Install inlet adapter (17) on heater (4).
4. Install heater (4) on mounting bracket (12) with two clamps (11).
5. Install duct (19) on inlet adapter (17) with clamp (18).
6. Connect fuel line (14) to heater elbow (3).
7. Connect wiring harness (5) to heater (4).
8. Install cover (2) on four plate assemblies (13) and close four latches (1).
9. Open fuel shutoff valve (20).
10. Connect battery ground cable (WP 0126 00).
11. Release parking brake and remove wheel chocks (TM 9-2320-361-10).

CARGO BODY PERSONNEL HEATER REPLACEMENT (Contd)

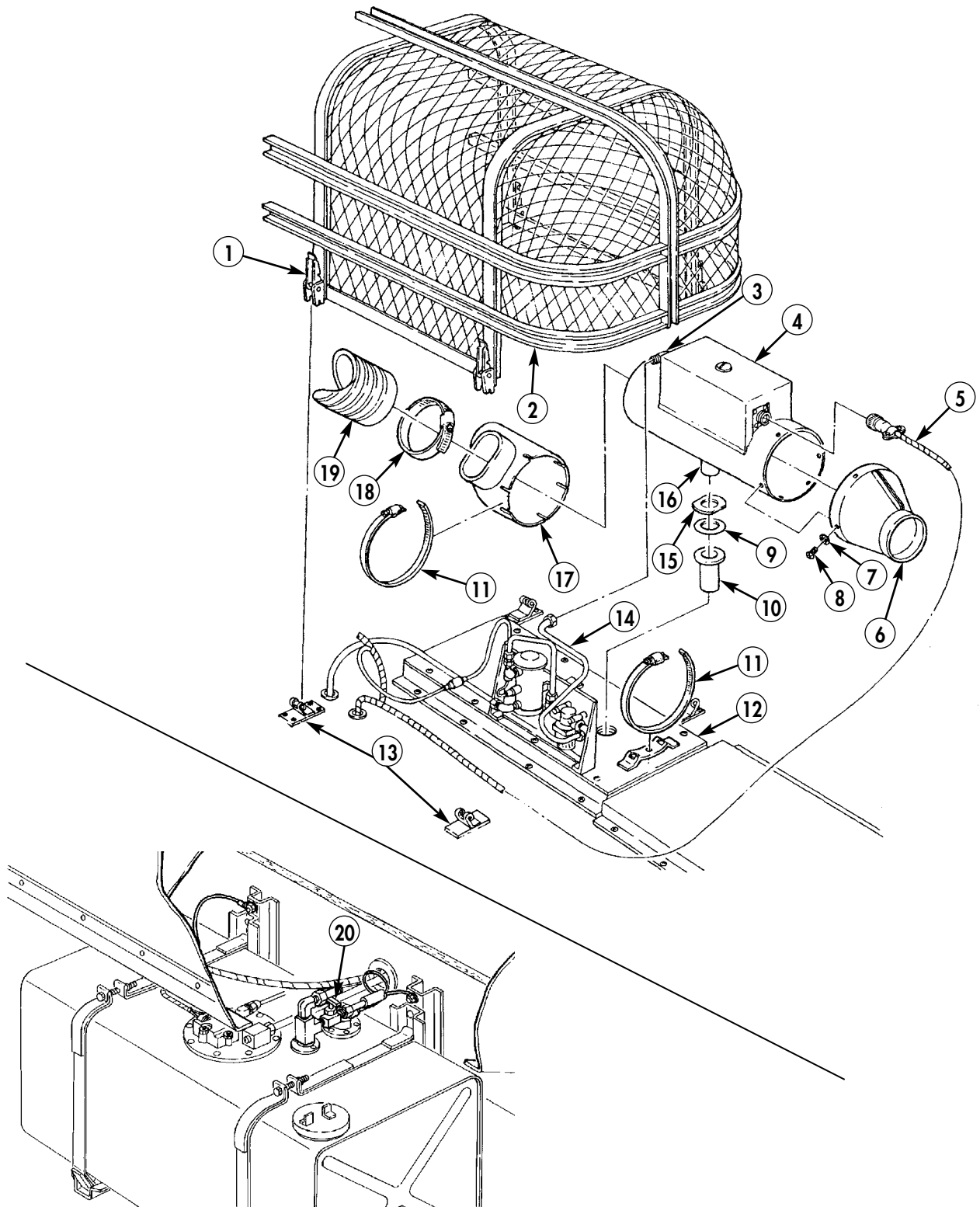

END OF WORK PACKAGE

FIELD MAINTENANCE INSTRUCTIONS FOR SPECIAL PURPOSE KITS

2-1/2 TON, 6X6, M44A2 SERIES TRUCKS (MULTIFUEL)

CARGO BODY PERSONNEL HEATER MOUNTING BRACKET MAINTENANCE REMOVAL, INSPECTION, AND INSTALLATION

INITIAL SETUP:

Applicable Models

M35A2, M35A2C, M36A2

Tools and Special Tools

General mechanic's tool kit
(item 116, WP 0469 00)

Equipment Condition

Parking brake set and wheels chocked
(TM 9-2320-361-10).

Battery ground cable disconnected
(WP 0126 00).

Heater removed (WP 0366 00).

Heater fuel pump removed (WP 0368 00).

Heater fuel filter removed (WP 0369 00).

CARGO BODY PERSONNEL HEATER MOUNTING BRACKET MAINTENANCE (Contd)

REMOVAL

1. Remove eight screws (4) and deflector bracket (5) from cargo body floor (7).
2. Remove eight screws (3) and mounting support (2) from mounting plate (10).
3. Remove eight screws (1), mounting plate (10), and gasket (6) from cargo body floor (7).
4. Remove sixteen screws (9) and four plates (8) from cargo body floor (7).

INSPECTION

Inspect gasket (6) for rips, tears, or other damage. Replace gasket (6) if ripped, torn, or damaged.

INSTALLATION

1. Install four plates (8) on cargo body floor (7) with sixteen screws (9).
2. Install gasket (6) and mounting plate (10) on cargo body floor (7) with eight screws (1).
3. Install mounting support (2) on mounting plate (10) with eight screws (3).
4. Install deflector bracket (5) on cargo body floor (7) with eight screws (4).
5. Install heater fuel filter (WP 0369 00).
6. Install heater fuel pump (WP 0368 00).
7. Install heater (WP 0366 00).
8. Connect battery ground cable (WP 0126 00).
9. Release parking brake and remove wheel chocks (TM 9-2320-361-10).

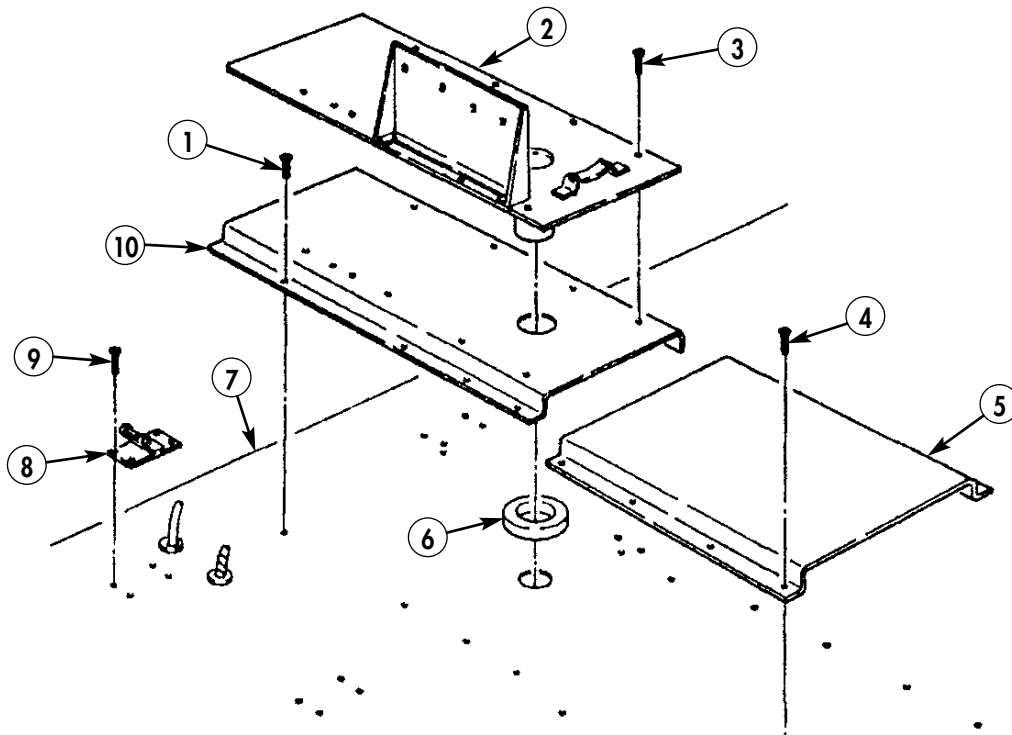

END OF WORK PACKAGE

FIELD MAINTENANCE INSTRUCTIONS FOR SPECIAL PURPOSE KITS

2-1/2 TON, 6X6, M44A2 SERIES TRUCKS (MULTIFUEL)

CARGO BODY PERSONNEL HEATER FUEL PUMP REPLACEMENT REMOVAL AND INSTALLATION

INITIAL SETUP:

Applicable Models

M35A2, M35A2C, M36A2

Tools and Special Tools

General mechanic's tool kit
(item 116, WP 0469 00)

Materials/Parts

Two lockwashers (item 207, WP 0470 00)

Equipment Condition

Parking brake set and wheels chocked
(TM 9-2320-361-10).
Battery ground cable disconnected
(WP 0126 00).

CARGO BODY PERSONNEL HEATER FUEL PUMP REPLACEMENT (Contd)

REMOVAL

1. Close fuel shutoff valve (1).
2. Disconnect wire (14) from wire (2).
3. Disconnect fuel inlet tube (3) from elbow (8).
4. Disconnect fuel outlet tube (4) from nipple (13) and filter elbow (5).
5. Remove two screws (9), lockwashers (10), wire clamp (11), and fuel pump (7) from plate (6). Discard lockwashers (10).
6. Remove nipple (13) and elbow (12) from fuel pump (7).

INSTALLATION

1. Install elbow (12) and nipple (13) on fuel pump (7).
2. Position fuel pump (7) on plate (6) and install wire clamp (11), two new lockwashers (10), and screws (9).
3. Connect fuel outlet tube (4) on nipple (13) and filter elbow (5).
4. Connect fuel inlet tube (3) on elbow (8).
5. Connect wire (14) to wire (2).
6. Open fuel shutoff valve (1).
7. Connect battery ground cable (WP 0126 00).
8. Start heater and check operation (TM 9-2320-361-10).
9. Release parking brake and remove wheel chocks (TM 9-2320-361-10).

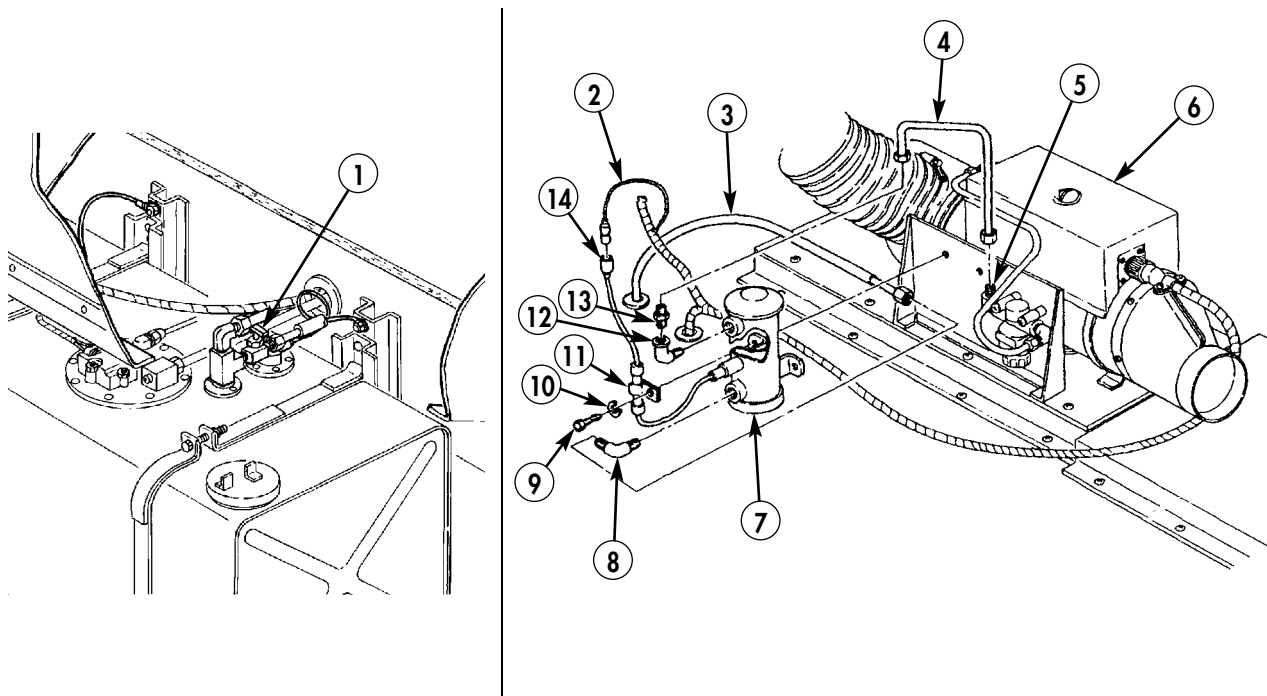

FIELD MAINTENANCE INSTRUCTIONS FOR SPECIAL PURPOSE KITS

2-1/2 TON, 6X6, M44A2 SERIES TRUCKS (MULTIFUEL)

CARGO BODY PERSONNEL HEATER FUEL FILTER REPLACEMENT REMOVAL AND INSTALLATION

INITIAL SETUP:

Applicable Models

M35A2, M35A2C, M36A2

References

TM 9-2320-361-10

Materials/Parts

Two lockwashers (item 203, WP 0470 00)
Antiseize tape (item 42, WP 0468 00)

Equipment Condition

Parking brake set and wheels chocked
(TM 9-2320-361-10).

CARGO BODY PERSONNEL HEATER FUEL FILTER REPLACEMENT

REMOVAL

1. Close fuel shutoff valve (1).
2. Disconnect fuel inlet tube (2) from nipple (3) and elbow (6).
3. Disconnect fuel outlet tube (12) from elbow (9) and heater (4).
4. Remove two screws (10), lockwashers (11), fuel filter (8), and two spacers (7) from mounting plate (5). Discard lockwashers (11).
5. Remove elbows (6) and (9) from fuel filter (8).

INSTALLATION

NOTE

Male pipe threads must be wrapped with antiseize tape prior to installation.

1. Install elbows (6) and (9) on fuel filter (8).
2. Install two spacers (7) and fuel filter (8) on mounting plate (5) with two new lockwashers (11) and screws (10).
3. Connect fuel outlet tube (12) to elbow (9) and heater (4).
4. Connect fuel inlet tube (2) to nipple (3) and elbow (6).
5. Open fuel shutoff valve (1).
6. Release parking brake and remove wheel chocks (TM 9-2320-361-10).

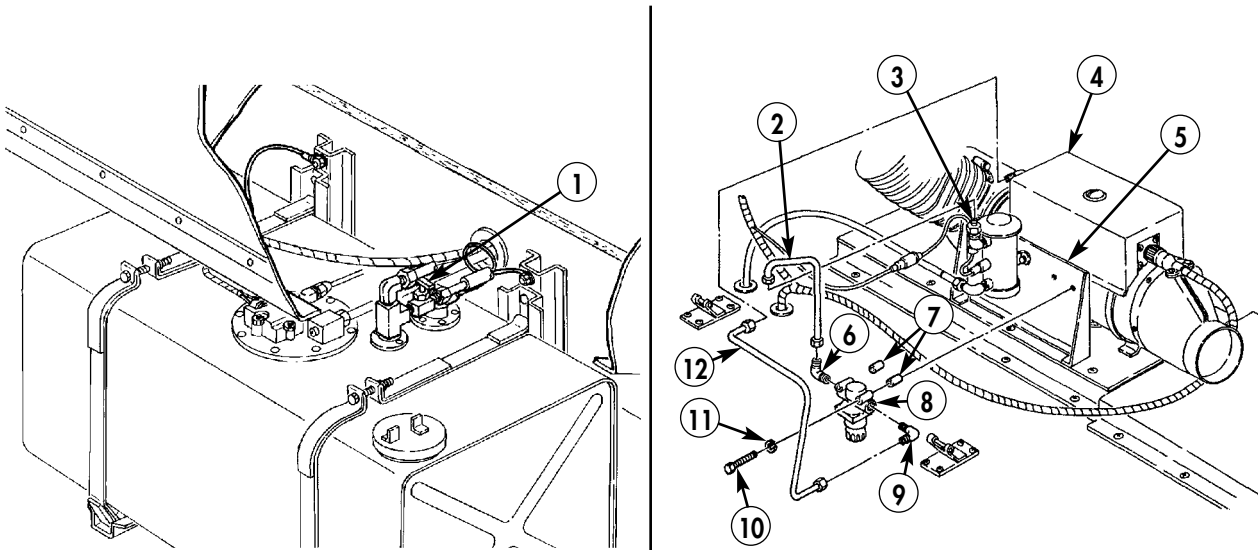

FIELD MAINTENANCE INSTRUCTIONS FOR SPECIAL PURPOSE KITS

2-1/2 TON, 6X6, M44A2 SERIES TRUCKS (MULTIFUEL)

CARGO BODY PERSONNEL HEATER CONTROL BOX REPLACEMENT REMOVAL AND INSTALLATION

INITIAL SETUP:

Applicable Models

M35A2, M35A2C, M36A2

Materials/Parts

Two lockwashers (item 242, WP 0470 00)

Equipment Condition

Parking brake set and wheels chocked
(TM 9-2320-361-10).

Battery ground cable disconnected
(WP 0126 00).

REMOVAL

1. Disconnect harness (6) from control box (7).
2. Disconnect wire (4) from wire (5).
3. Remove two nuts (1), lockwashers (2), ground wires (8), and control box (7) from bracket (10). Discard lockwashers (2).
4. Remove four screws (9) and bracket (10) from front cargo rack (3).

INSTALLATION

1. Install bracket (10) on front cargo rack (3) with four screws (9).
2. Install control box (7) and two ground wires (8) on bracket (10) with two new lockwashers (2) and nuts (1).
3. Connect wire (5) to wire (4).
4. Connect harness (6) to control box (7).
5. Connect battery ground cable (WP 0126 00).
6. Release parking brake and remove wheel chocks (TM 9-2320-361-10).

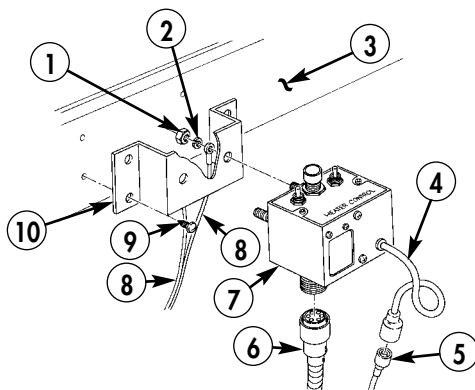

END OF WORK PACKAGE

FIELD MAINTENANCE INSTRUCTIONS FOR SPECIAL PURPOSE KITS

2-1/2 TON, 6X6, M44A2 SERIES TRUCKS (MULTIFUEL)

CARGO BODY PERSONNEL HEATER FUEL LINE REPLACEMENT REMOVAL AND INSTALLATION

INITIAL SETUP:

Applicable Models

All

Equipment Condition

Parking brake set and wheels chocked
(TM 9-2320-361-10).

Materials/Parts

Locknut (item 145, WP 0470 00)

CARGO BODY PERSONNEL HEATER FUEL LINE REPLACEMENT (Contd)

REMOVAL

1. Close fuel shutoff valve (9).
2. Disconnect fuel line (12) and elbow (11) from tee (10).
3. Disconnect fuel line (2) from shutoff valve (9).
4. Remove shutoff valve (9) and tee (10) from fuel tank (8).
5. Remove locknut (4), screw (14), two clamps (5), wiring harness(6), and fuel line (2) from front cargo body panel (7). Discard locknut (4).
6. Remove sleeve (15) from fuel line (2) and hole (3) in cargo body floor (13).
7. Disconnect fuel line (2) from heater fuel pump (1).
8. Straighten fuel line (2) and pull through cargo body floor (13).

INSTALLATION

1. Install fuel line (2) through hole (3) in cargo body floor (13).
2. Bend fuel line (2) and connect to heater fuel pump (1).
3. Place sleeve (15) on fuel line (2) and install in hole (3).
4. Install tee (10) and shutoff valve (9) on fuel tank (8).
5. Connect fuel line (2) to shutoff valve (9).
6. Connect elbow (11) and fuel line (12) to tee (10).
7. Install fuel line (2) and wiring harness (6) on front cargo body panel (7) with two clamps (5), screw (14), and new locknut (4).
8. Open fuel shutoff valve (9).
9. Start heater and check operation (TM 9-2320-361-10).
10. Release parking brake and remove wheel chocks (TM 9-2320-361-10).

CARGO BODY PERSONNEL HEATER FUEL LINE REPLACEMENT (Contd)

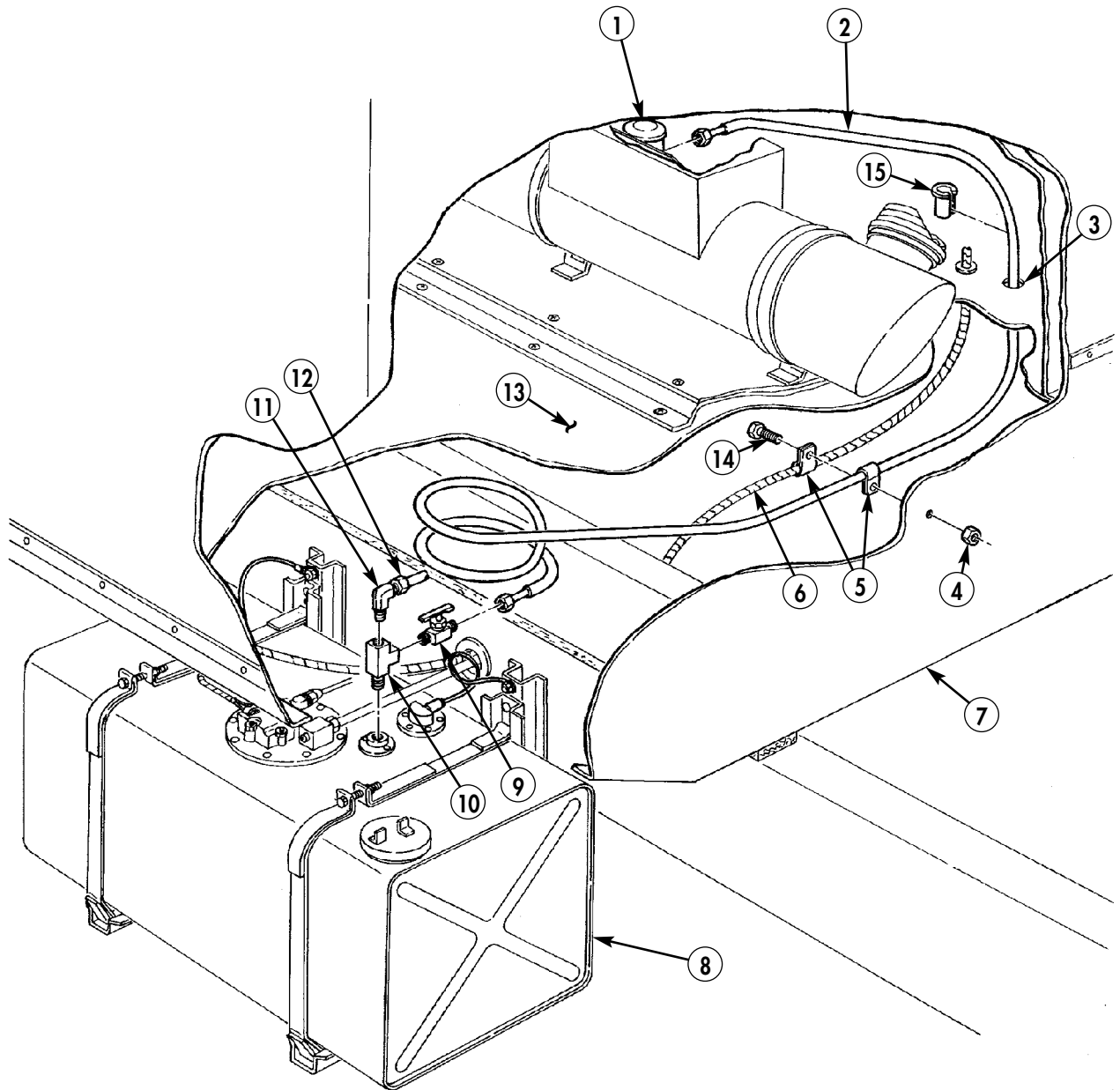

END OF WORK PACKAGE

0371 00-3/4 blank

**FIELD MAINTENANCE INSTRUCTIONS
FOR SPECIAL PURPOSE KITS**

2-1/2 TON, 6X6, M44A2 SERIES TRUCKS (MULTIFUEL)

**CARGO BODY PERSONNEL HEATER DIVERTER AND DUCT REPLACEMENT
REMOVAL AND INSTALLATION**

INITIAL SETUP:

Applicable Models

M35A2, M35A2C, M36A2

Equipment Condition

Parking brake set and wheels chocked
(TM 9-2320-361-10).

Battery ground cable disconnected
(WP 0126 00).

CARGO BODY PERSONNEL HEATER DIVERTER AND DUCT REPLACEMENT (Contd)

REMOVAL

1. Remove two clamps (12) and duct (13) from outlet adapter (16) and diverter (10).
2. Remove screw (14), clamp (15), and duct (13) from front cargo rack (1).
3. Remove two clamps (3) and duct (6) from diverter (10) and heater (2).
4. Remove screw (4), clamp (5), and duct (6) from front cargo rack (1).
5. Remove plug (7) and screw (8) from diverter (10).
6. Rotate handle (11) counterclockwise to close damper (9) and expose second screw (8).
7. Remove screw (8) and diverter (10) from front cargo rack (1).

INSTALLATION

1. Position diverter (10) on front cargo rack (1) and install screw (8) and plug (7).
2. Rotate handle (11) clockwise to open damper (9) and install second screw (8).
3. Install duct (6) on heater (2) and diverter (10) with two clamps (3).
4. Install duct (6) on front cargo rack (1) with clamp (5) and screw (4).
5. Install duct (13) on diverter (10) and outlet adapter (16) with two clamps (12).
6. Install duct (13) on front cargo rack (1) with clamp (15) and screw (14).
7. Connect battery ground cable (WP 0126 00).
8. Release parking brake and remove wheel chocks (TM 9-2320-361-10).

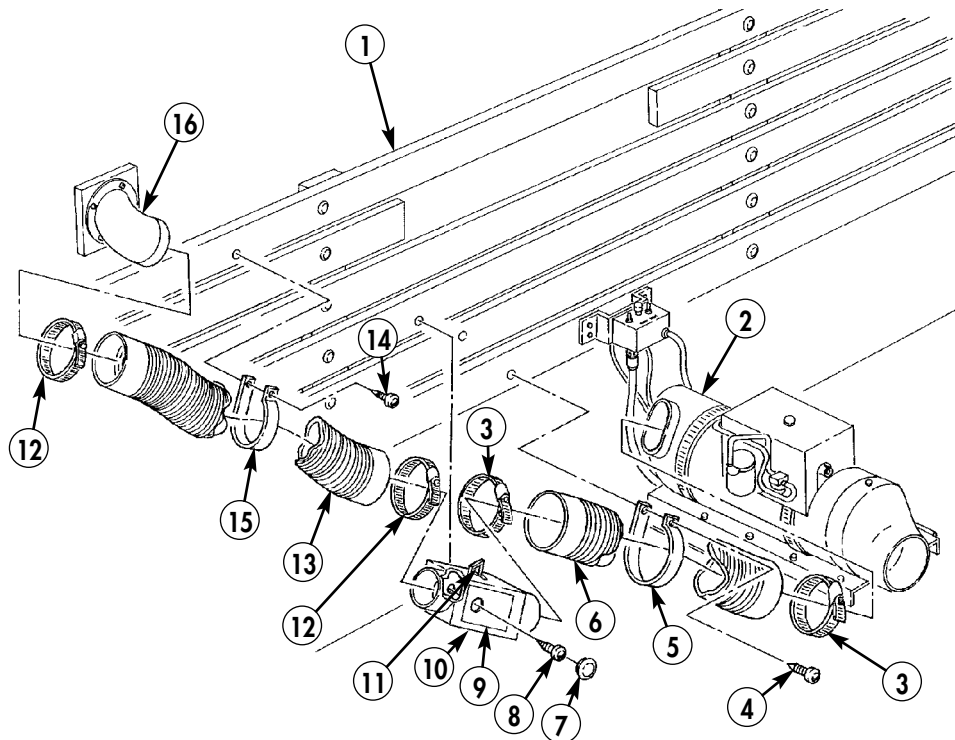

END OF WORK PACKAGE

FIELD MAINTENANCE INSTRUCTIONS FOR SPECIAL PURPOSE KITS

2-1/2 TON, 6X6, M44A2 SERIES TRUCKS (MULTIFUEL)

PRIMARY HEATER FUEL PUMP REPLACEMENT REMOVAL AND INSTALLATION

INITIAL SETUP:

Applicable Models

M109A3, M185A3

Materials/Parts

Antiseize tape (item 42, WP 0468 00)

Equipment Condition

Parking brake set and wheels chocked
(TM 9-2320-361-10).

Pump cover removed (WP 0374 00).

Battery ground cable disconnected
(WP 0126 00).

PRIMARY HEATER FUEL PUMP REPLACEMENT (Contd)

WARNING

Diesel fuel is flammable. Do not perform fuel system procedures near open flames. Injury or death to personnel may result.

REMOVAL

1. Disconnect wire connector (7) from connector (8).
2. Remove fuel lines (9) from elbows (6).
3. Remove two elbows (6) from heater fuel pump (1).
4. Remove two screws (5), washers (4), clamp (2), wire (3), and heater fuel pump (1) from van body (10).

INSTALLATION

NOTE

Wrap male pipe threads with antiseize tape prior to installation.

1. Install heater fuel pump (1), clamp (2), and wire (3) on van body (10) with two washers (4) and screws (5).
2. Install two elbows (6) on heater fuel pump (1).
3. Install two fuel lines (9) on elbows (6).
4. Connect wire connector (7) to connector (8).
5. Install pump cover (WP 0374 00).
6. Connect battery ground cable (WP 0126 00).
7. Release parking brake and remove wheel chocks (TM 9-2320-361-10).

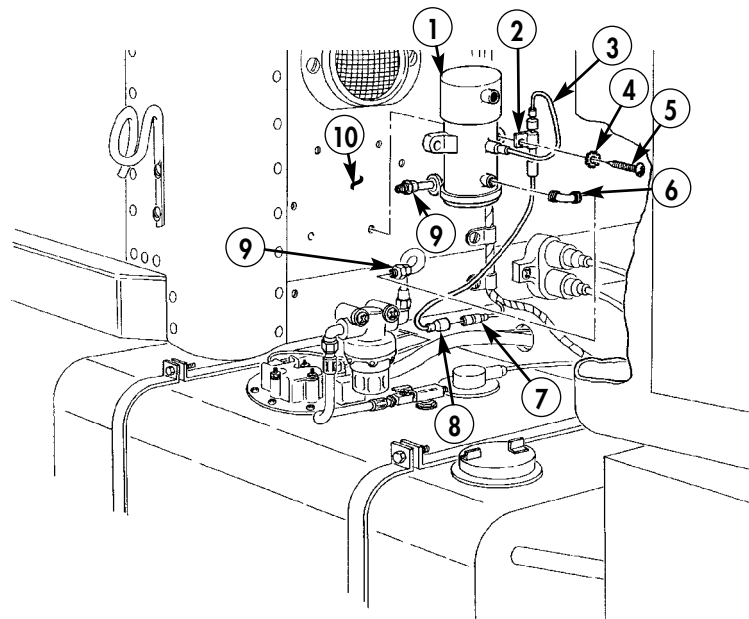

FIELD MAINTENANCE INSTRUCTIONS FOR SPECIAL PURPOSE KITS

2-1/2 TON, 6X6, M44A2 SERIES TRUCKS (MULTIFUEL)

PRIMARY HEATER FUEL PUMP COVER REPLACEMENT REMOVAL AND INSTALLATION

INITIAL SETUP:

Applicable Models
M109A3, M185A3

Equipment Condition
Parking brake set and wheels chocked
(TM 9-2320-361-10).

REMOVAL

Remove seven screws (2) and fuel pump cover (3) from van body (1).

INSTALLATION

1. Install fuel pump cover (3) on van body (1) with seven screws (2).
2. Release parking brake and remove wheel chocks (TM 9-2320-361-10).

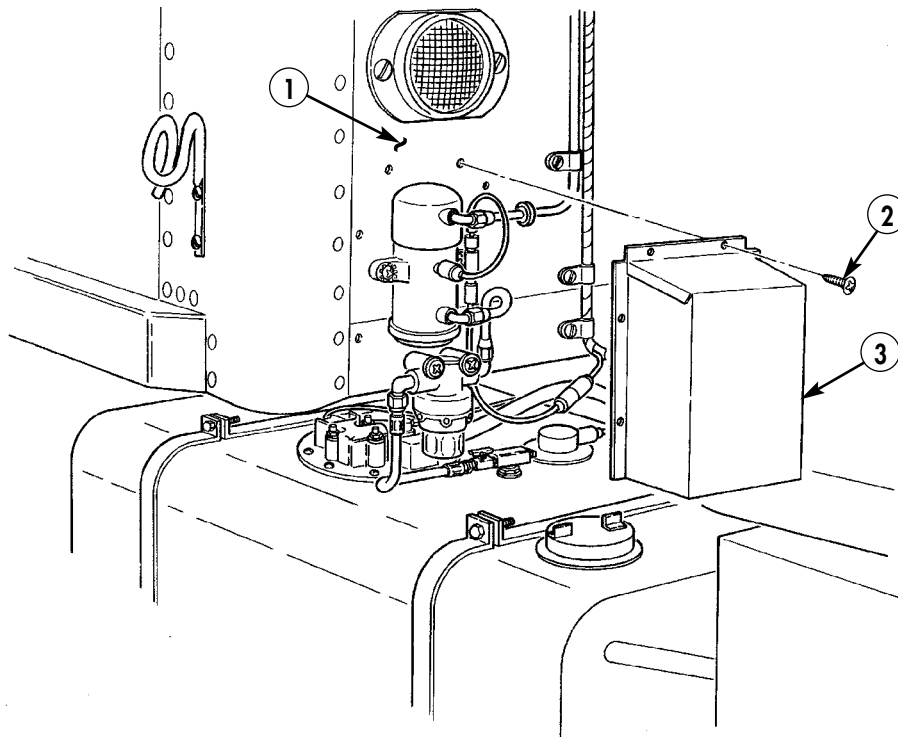

END OF WORK PACKAGE

0374 00-1/2 blank

FIELD MAINTENANCE INSTRUCTIONS FOR SPECIAL PURPOSE KITS

2-1/2 TON, 6X6, M44A2 SERIES TRUCKS (MULTIFUEL)

PRIMARY HEATER FUEL FILTER REPLACEMENT REMOVAL AND INSTALLATION

INITIAL SETUP:

Applicable Models

M109A3, M185A3

Equipment Condition

Parking brake set and wheels chocked
(TM 9-2320-361-10).

Materials/Parts

Antiseize tape (item 42, WP 0468 00)

Battery ground cable disconnected
(WP 0126 00).

REMOVAL

WARNING

Diesel fuel is flammable. Do not perform fuel system procedures near open flames. Injury or death to personnel may result.

1. Remove fuel line (8) from elbow (7) and fuel tube (2) from elbow (3).
2. Remove elbows (3) and (7) from filter (6).
3. Remove two screws (5), washers (4), and filter (6) from van body (1).

INSTALLATION

NOTE

Wrap male pipe threads with antiseize tape prior to installation.

1. Install filter (6) on van body (1) with two washers (4) and screws (5).
2. Install elbows (3) and (7) on filter (6).
3. Install fuel tube (2) on elbow (3) and fuel line (8) on elbow (7).
4. Connect battery ground cable (WP 0126 00).
5. Release parking brake and remove wheel chocks (TM 9-2320-361-10).

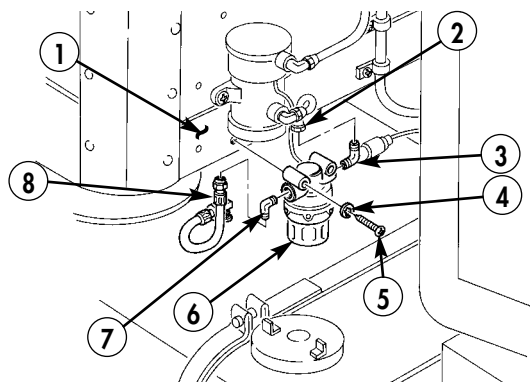

END OF WORK PACKAGE

0375 00-1/2 blank

FIELD MAINTENANCE INSTRUCTIONS FOR SPECIAL PURPOSE KITS

2-1/2 TON, 6X6, M44A2 SERIES TRUCKS (MULTIFUEL)

PRIMARY HEATER FUEL LINES REPLACEMENT

FUEL TANK SHUTOFF-TO-FILTER HOSE REMOVAL, FUEL TANK SHUTOFF-TO-FILTER HOSE INSTALLATION,
FILTER-TO-PUMP INLET TUBE REMOVAL, FILTER-TO-PUMP INLET TUBE INSTALLATION, PUMP
OUTLET-TO-ADAPTER TUBE REMOVAL, PUMP OUTLET-TO-ADAPTER TUBE INSTALLATION,
FUEL HEATER-TO-ADAPTER TUBE REMOVAL, AND FUEL HEATER-TO-ADAPTER TUBE INSTALLATION

INITIAL SETUP:

Applicable Models

M109A3, M185A3

Materials/Parts

Antiseize tape (item 42, WP 0468 00)

Equipment Condition

Parking brake set and wheels chocked
(TM 9-2320-361-10).

Battery ground cable disconnected
(WP 0126 00).

PRIMARY HEATER FUEL LINES REPLACEMENT (Contd)

WARNING

Diesel fuel is flammable. Do not perform fuel system procedures near open flames. Injury or death to personnel may result.

FUEL TANK SHUTOFF-TO-FILTER HOSE REMOVAL

NOTE

Have drainage container ready to catch fuel.

1. Remove hose (5) from fuel shutoff (4) and allow fuel to drain.
2. Remove hose (5) from elbow (6).

FUEL TANK SHUTOFF-TO-FILTER HOSE INSTALLATION

NOTE

Wrap male pipe threads with antiseize tape prior to installation.

1. Install hose (5) on elbow (6).
2. Install hose (5) on fuel shutoff (4).
3. Install pump cover (WP 0308 00).
4. Release parking brake (TM 9-2320-361-10).

FILTER-TO-PUMP INLET TUBE REMOVAL

Remove tube (2) from elbow (1) and elbow (3).

FILTER-TO-PUMP INLET TUBE INSTALLATION

NOTE

Wrap male pipe threads with antiseize tape prior to installation.

1. Install tube (2) on elbow (1) and elbow (3).
2. Install pump cover (WP 0374 00).
3. Connect battery ground cable (WP 0126 00).
4. Release parking brake and remove wheel chocks (TM 9-2320-361-10).

PRIMARY HEATER FUEL LINES REPLACEMENT (Contd)

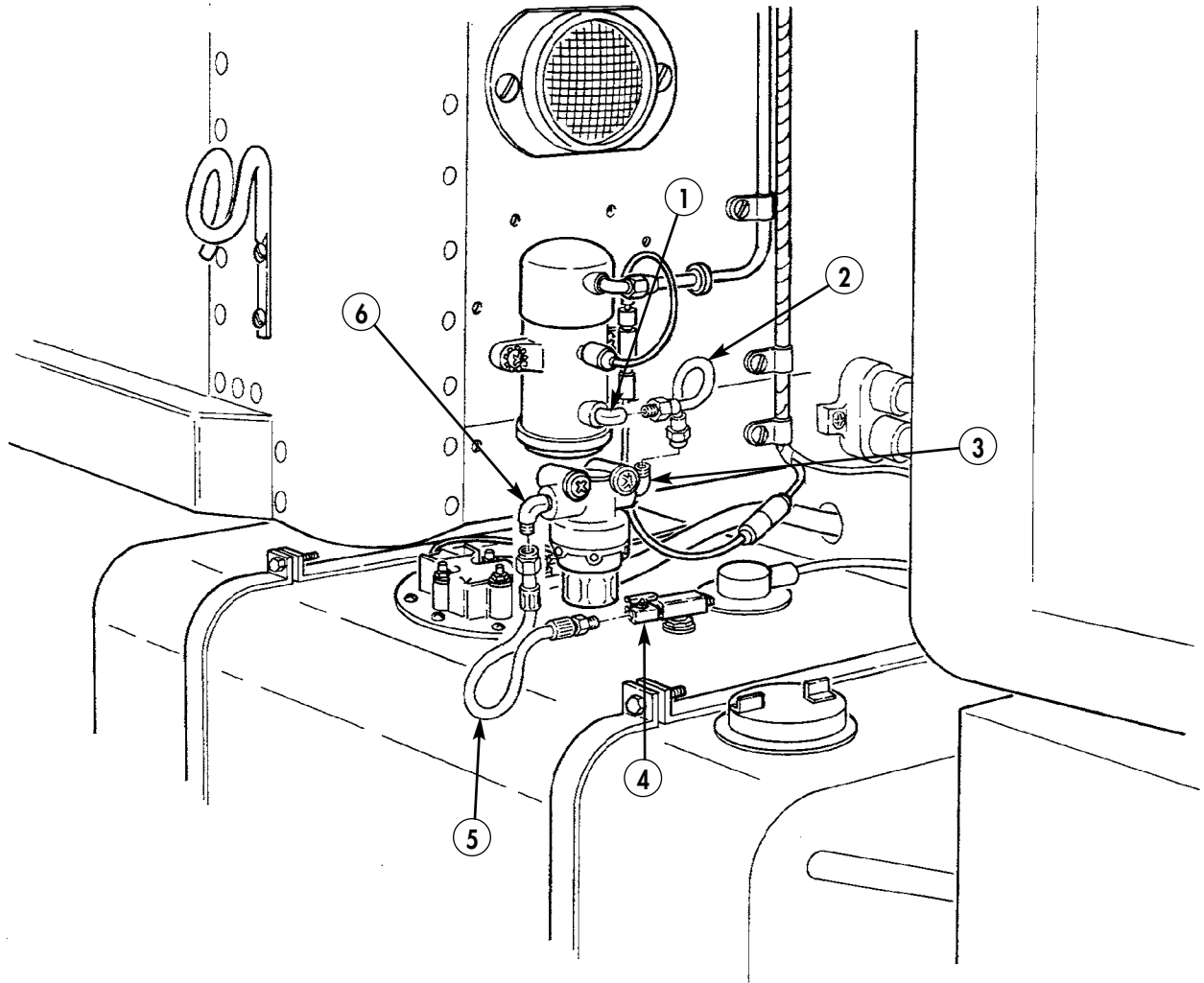

PRIMARY HEATER FUEL LINES REPLACEMENT (Contd)

PUMP OUTLET-TO-ADAPTER TUBE REMOVAL

1. Remove screw (4) and clamp (5) from fuel line (6) and van body (1).
2. Remove fuel line (6) from elbows (3) and (7).
3. Remove elbow (3) from adapter (2) and elbow (7) from pump outlet (8).

PUMP OUTLET-TO-ADAPTER TUBE INSTALLATION

NOTE

Wrap male pipe threads with antiseize tape prior to installation.

1. Install elbow (3) on adapter (2) and elbow (7) on pump outlet (8).
2. Install fuel line (6) on elbows (3) and (7).
3. Install clamp (5) and fuel line (6) on van body (1) with screw (4).
4. Install pump cover (WP 0374 00).
5. Connect battery ground cable (WP 0126 00).
6. Release parking brake and remove wheel chocks (TM 9-2320-361-10).

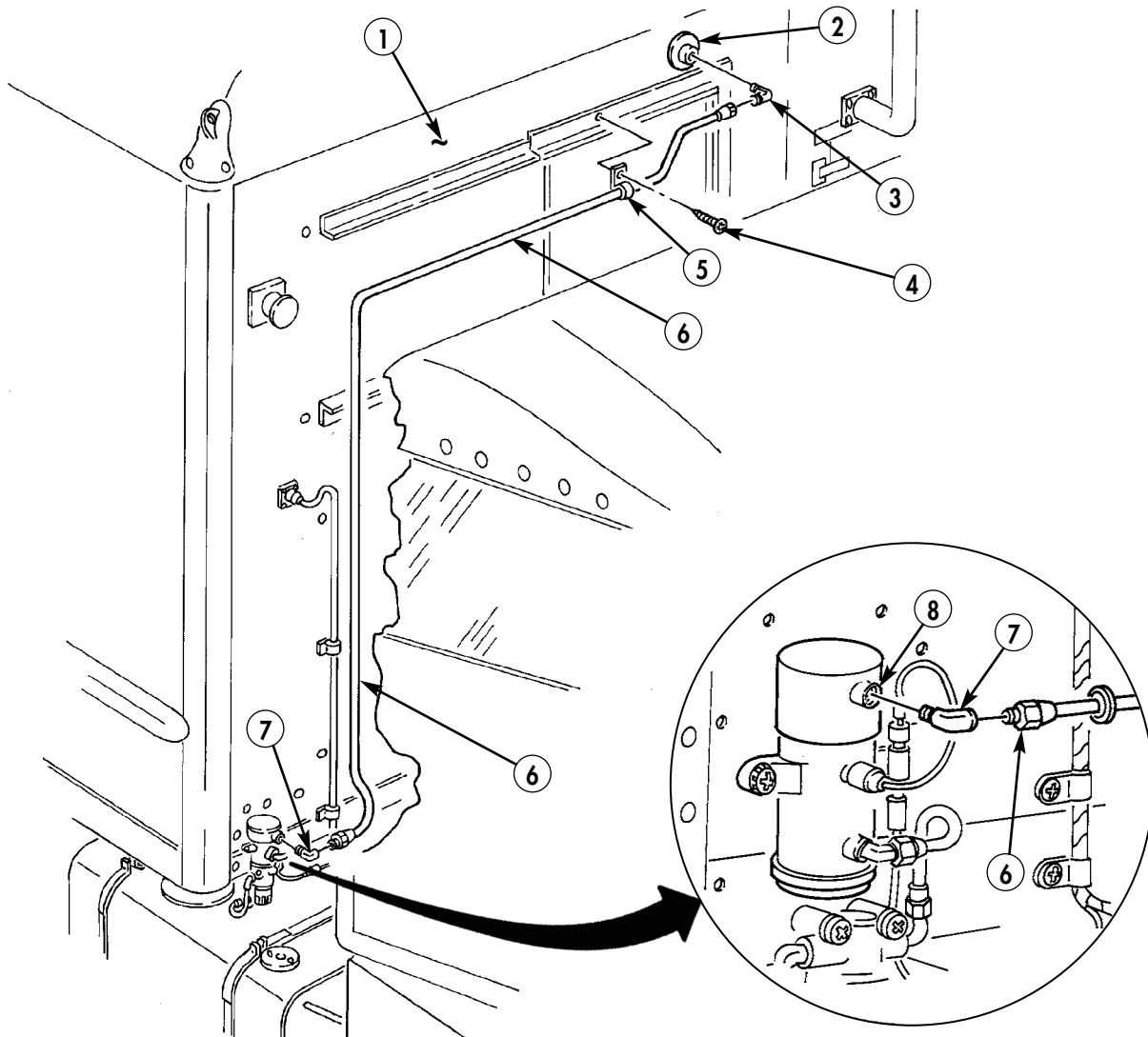

PRIMARY HEATER FUEL LINES REPLACEMENT (Contd)

FUEL HEATER-TO-ADAPTER TUBE REMOVAL

1. Remove tube (9) from elbows (11) and (13).
2. Remove elbow (11) from adapter (10) and elbow (13) from nipple (12).

FUEL HEATER-TO-ADAPTER TUBE INSTALLATION

NOTE

Wrap male pipe threads with antiseize tape prior to installation.

1. Install elbow (11) on adapter (10) and elbow (13) on nipple (12).
2. Install tube (9) on elbows (11) and (13).
3. Install pump cover (WP 0374 00).
4. Connect battery ground cable (WP 0126 00).
5. Release parking brake and remove wheel chocks (TM 9-2320-361-10).

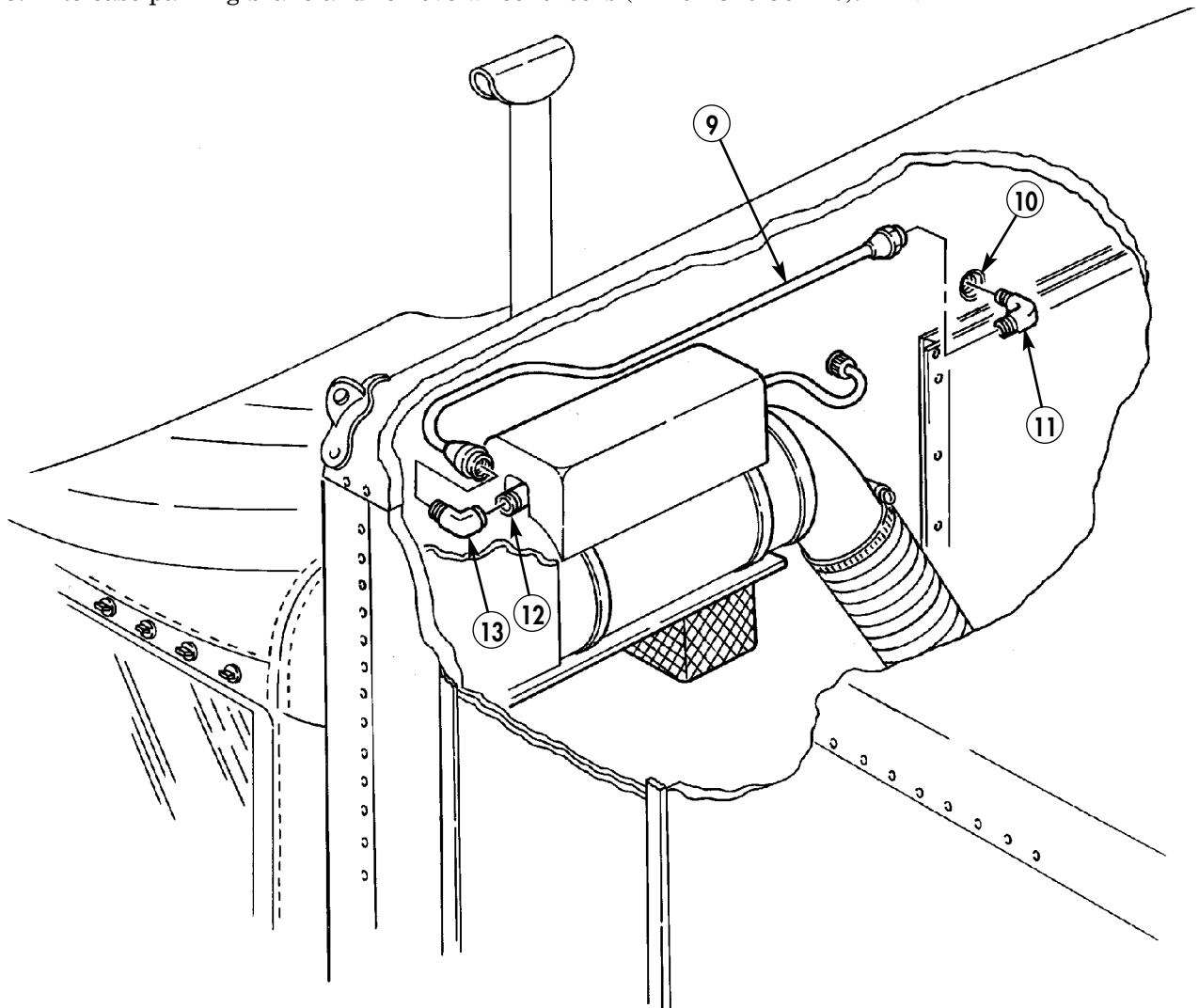

END OF WORK PACKAGE

0376 00-5/6 blank

FIELD MAINTENANCE INSTRUCTIONS FOR SPECIAL PURPOSE KITS

2-1/2 TON, 6X6, M44A2 SERIES TRUCKS (MULTIFUEL)

PRIMARY HEATER FUEL SHUTOFF AND COUPLING REPLACEMENT REMOVAL AND INSTALLATION

INITIAL SETUP:

Applicable Models

M109A3, M185A3

Materials/Parts

Three gaskets (item 96, WP 0470 00)
Antiseize tape (item 42, WP 0468 00)

Equipment Condition

Parking brake set and wheels chocked
(TM 9-2320-361-10).
Battery ground cable disconnected
(WP 0126 00).
Fuel tank drained (WP 0060 00).
Fuel tank filler cap and sleeve removed
(WP 0058 00).

PRIMARY HEATER FUEL SHUTOFF AND COUPLING REPLACEMENT (Contd)

WARNING

Diesel fuel is flammable. Do not perform fuel system procedures near open flames. Injury or death to personnel may result.

NOTE

Have drainage container ready to catch fuel.

REMOVAL

1. Remove hose (8) from shutoff (1) and allow fuel to drain from hose (8).
2. Remove shutoff (1) from nipple (2).
3. Remove nipple (2) and plug (3) from tee (4).
4. Remove tee (4) from coupling (5).
5. Reach through fuel fill port (10) and remove nut (12), sleeve (13), and tube (11) from adapter (14).
6. Remove adapter (14) from nut (15).
7. Remove nut (15), two gaskets (7), washer (6), coupling (5), gasket (7), and washer (6) from fuel tank (9). Discard gaskets (7).

INSTALLATION

NOTE

Wrap male pipe threads with antiseize tape prior to installation.

1. Reach through fuel tank fill port (10) and install nut (15), two new gaskets (7), washers (6), new gasket (7), and coupling (5) on fuel tank (9).
2. Install adapter (14) on nut (15).
3. Install sleeve (13), nut (12), and tube (11) on adapter (14).
4. Install tee (4) on coupling (5).
5. Install nipple (2) and plug (3) on tee (4).
6. Install shutoff (1) on nipple (2).
7. Install hose (8) on shutoff (1).
8. Fill fuel tank (TM 9-2320-361-10).
9. Install fuel tank filler cap and sleeve (WP 0058 00).
10. Connect battery ground cable (WP 0126 00).
11. Release parking brake and remove wheel chocks (TM 9-2320-361-10).

PRIMARY HEATER FUEL SHUTOFF AND COUPLING REPLACEMENT (Contd)

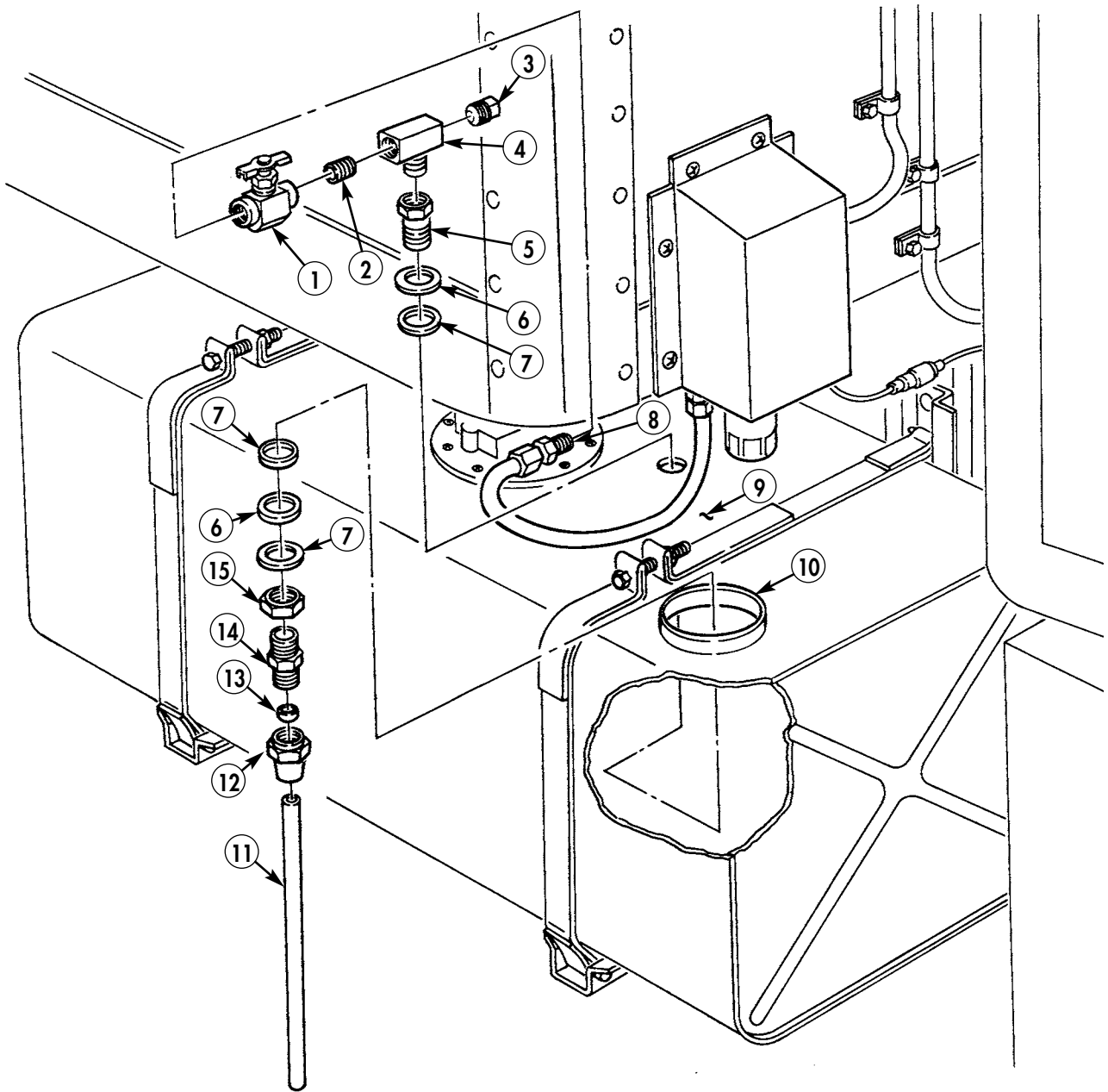

FIELD MAINTENANCE INSTRUCTIONS FOR SPECIAL PURPOSE KITS

2-1/2 TON, 6X6, M44A2 SERIES TRUCKS (MULTIFUEL)

PRIMARY AND SECONDARY HEATER EXHAUST TUBE REPLACEMENT

REMOVAL AND INSTALLATION

INITIAL SETUP:

Applicable Models

M109A3, M185A3

Equipment Condition

Parking brake set and wheels chocked
(TM 9-2320-361-10).

Materials/Parts

O-ring (item 122, WP 0470 00)

Battery ground cable disconnected
(WP 0126 00).

REMOVAL

WARNING

Do not touch hot exhaust system components with bare hands.
Severe injury to personnel will result.

1. Remove two screws (4) and washers (2) from clamp (3) and van body (7).
2. Remove nut (1), washer (2), screw (9), and clamp (3) from outside exhaust tube (5).
3. Remove four screws (8), O-ring (6), and outside exhaust tube (5) from van body (7). Discard O-ring (6).

INSTALLATION

1. Install new O-ring (6) and outside exhaust tube (5) on van body (7) with four screws (8).
2. Install clamp (3) on outside exhaust tube (5) with screw (9), washer (2), and nut (1).
3. Install clamp (3) on van body (7) with two screws (4) and washers (2).
4. Connect battery ground cable (WP 0126 00).
5. Release parking brake and remove wheel chocks (TM 9-2320-361-10).

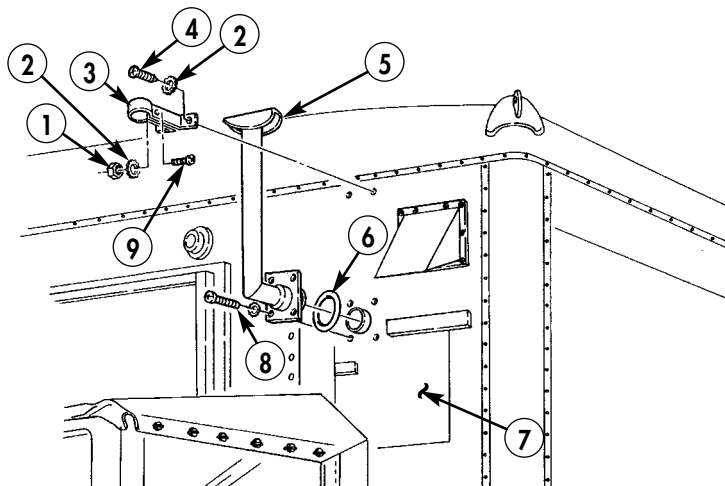

END OF WORK PACKAGE

0378 00-1/2 blank

FIELD MAINTENANCE INSTRUCTIONS FOR SPECIAL PURPOSE KITS

2-1/2 TON, 6X6, M44A2 SERIES TRUCKS (MULTIFUEL)

PRIMARY HEATER AIR INLET DUCT REPLACEMENT REMOVAL AND INSTALLATION

INITIAL SETUP:

Applicable Models
M109A3, M185A3

Equipment Condition
Parking brake set and wheels chocked
(TM 9-2320-361-10).

REMOVAL

Remove four screws (1) and duct (2) from van body (3).

INSTALLATION

1. Install duct (2) on van body (3) with four screws (1).
2. Release parking brake and remove wheel chocks (TM 9-2320-361-10).

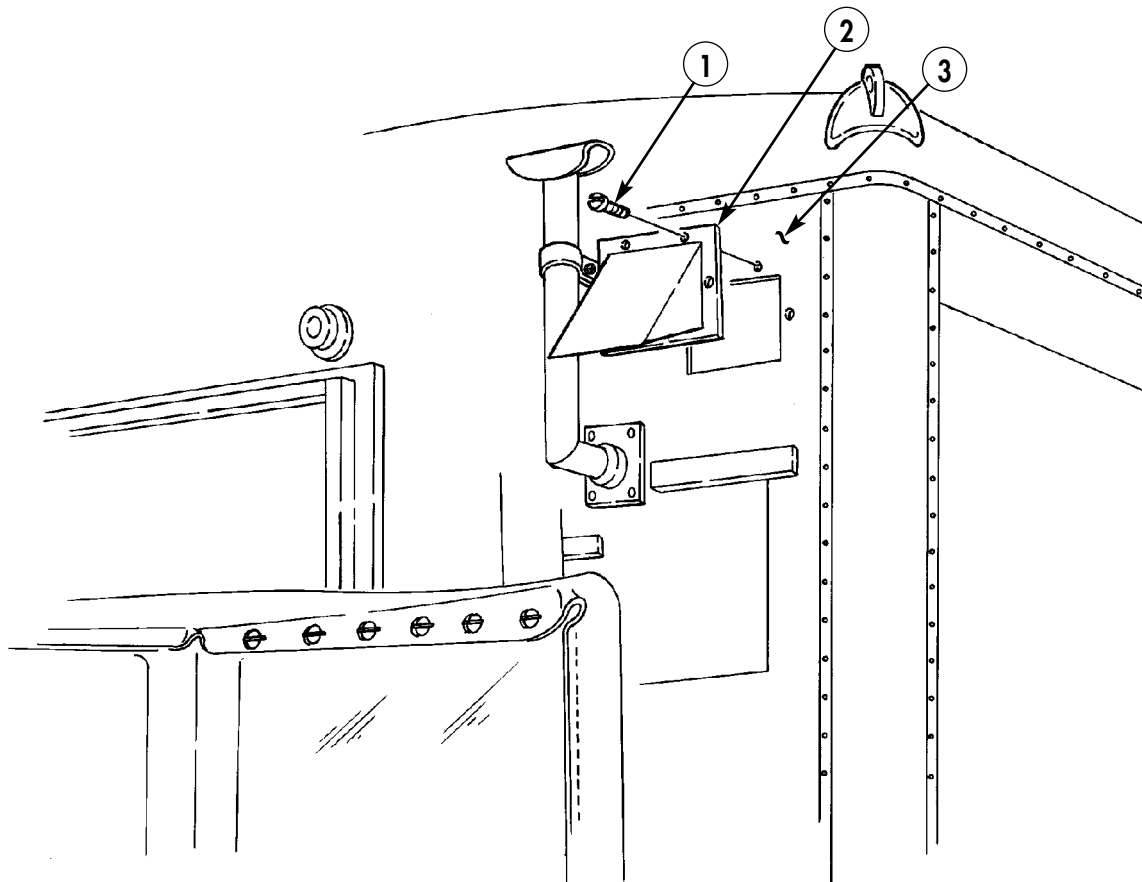

END OF WORK PACKAGE

0379 00-1/2 blank

FIELD MAINTENANCE INSTRUCTIONS FOR SPECIAL PURPOSE KITS

2-1/2 TON, 6X6, M44A2 SERIES TRUCKS (MULTIFUEL)

PRIMARY HEATER AND DUCT REPLACEMENT

HEATER REMOVAL, DUCT REMOVAL, DUCT INSTALLATION, AND HEATER INSTALLATION

INITIAL SETUP:

Applicable Models

M109A3, M185A3

Materials/Parts

Gasket (item 108, WP 0470 00)

Gasket (item 109, WP 0470 00)

O-ring (item 122, WP 0470 00)

Equipment Condition

Parking brake set and wheels chocked
(TM 9-2320-361-10).

Battery ground cable disconnected
(WP 0126 00).

PRIMARY HEATER AND DUCT REPLACEMENT (Contd)

HEATER REMOVAL

1. Remove heater harness (7) from heater (3).
2. Remove clamp (5) and duct (6) from adapter (4).
3. Remove four screws (10) and adapter (4) from heater (3).
4. Remove three screws (2) and cover (1) from heater box (23).
5. Remove two clamps (9), heater (3), washer (11), and O-ring (12) from support (14). Discard O-ring (12).
6. Remove screw (21) and two screws (22) from guard (20).
7. Remove guard (20) from support (14) and van wall (8).
8. Remove four screws (18) from exhaust tube (17) and support (14). Remove four screws (16) from exhaust tube (17) and van wall (8).
9. Remove exhaust tube (17) and gaskets (19) and (15) from support (14) and van wall (8). Discard gaskets (15) and (19).
10. Remove four screws (13) and support (14) from van wall (8).

PRIMARY HEATER AND DUCT REPLACEMENT (Contd)

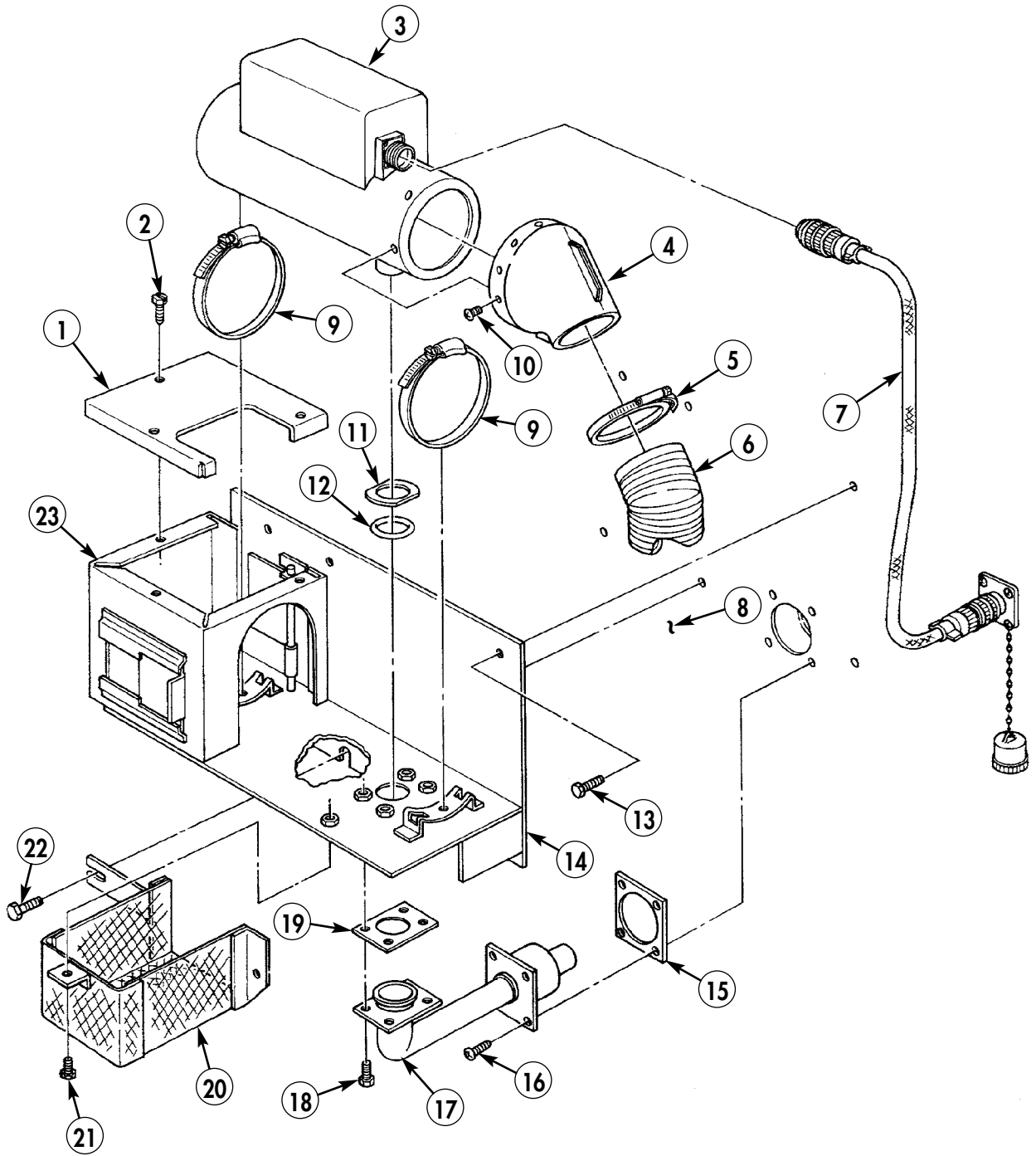

PRIMARY HEATER AND DUCT REPLACEMENT (Contd)

DUCT REMOVAL

1. Remove screw (3) and strap (2) from frame (1).
2. Remove two screws (8), screw (9), and strap (7) from deflector (11) and van wall (13).
3. Remove three screws (10) and deflector (11) from floor (12).
4. Remove clamp (5) and adapter (6) from duct (4).

DUCT INSTALLATION

1. Install adapter (6) and clamp (5) on duct (4).
2. Install deflector (11) on floor (12) with three screws (10).
3. Install strap (7) and deflector (11) on van wall (13) with two screws (8) and screw (9). Buckle strap (7) on adapter (6).
4. Install strap (2) on frame (1) with screw (3). Buckle strap (2) on duct (4).

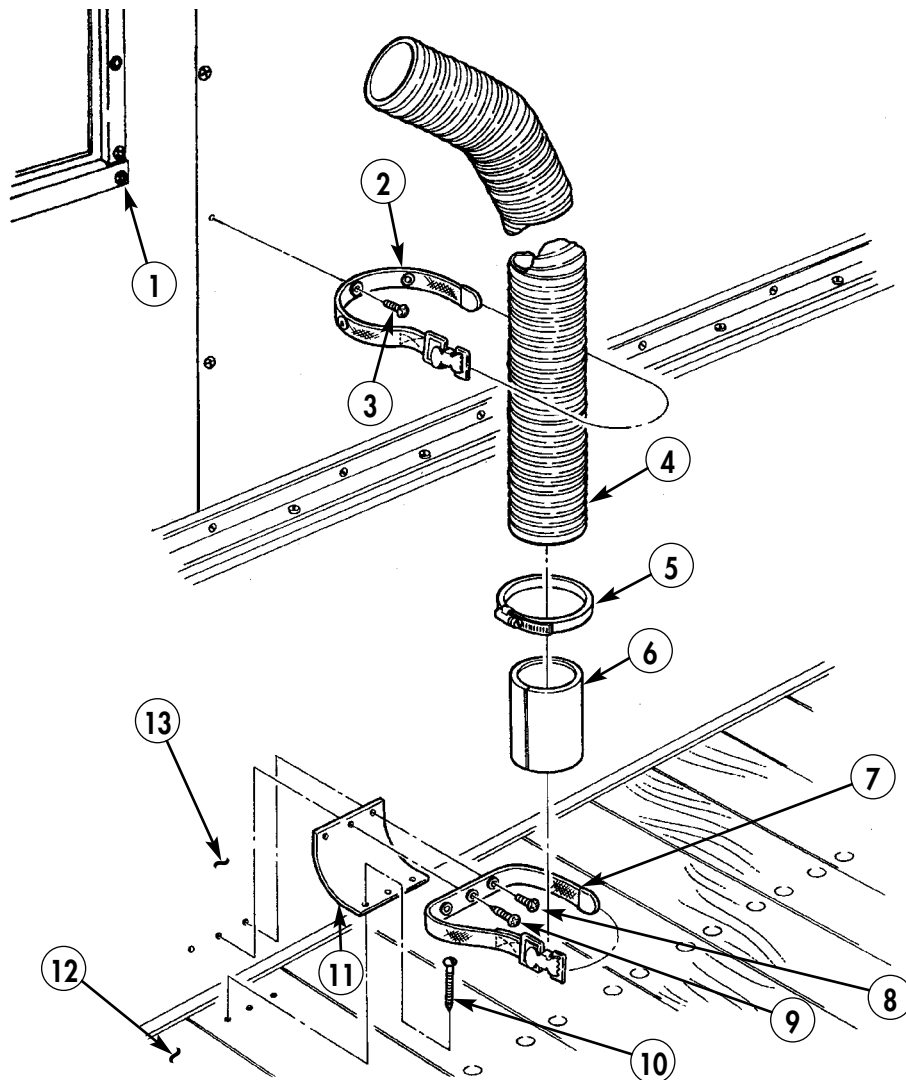

PRIMARY HEATER AND DUCT REPLACEMENT (Contd)

HEATER INSTALLATION

1. Install support (22) on van wall (13) with four screws (21).
2. Install exhaust tube (25) and new gasket (23) on van wall (13) with four screws (24).
3. Install exhaust tube (25) and new gasket (27) on support (22) with four screws (26).
4. Install guard (28) on van wall (13) with two screws (30).
5. Install guard (28) on support (22) with screw (29).
6. Install new O-ring (34), washer (35), and heater (16) on support (22) with two clamps (32).
7. Install cover (14) on heater box (31) with three screws (15).
8. Install adapter (17) on heater (16) with four screws (33).
9. Install duct (19) on adapter (17) with clamp (18).
10. Install heater harness (20) on heater (16).
11. Check heater for proper operation (TM 9-2320-361-10).
12. Connect battery ground cable (WP 0126 00).
13. Release parking brake and remove wheel chocks (TM 9-2320-361-10).

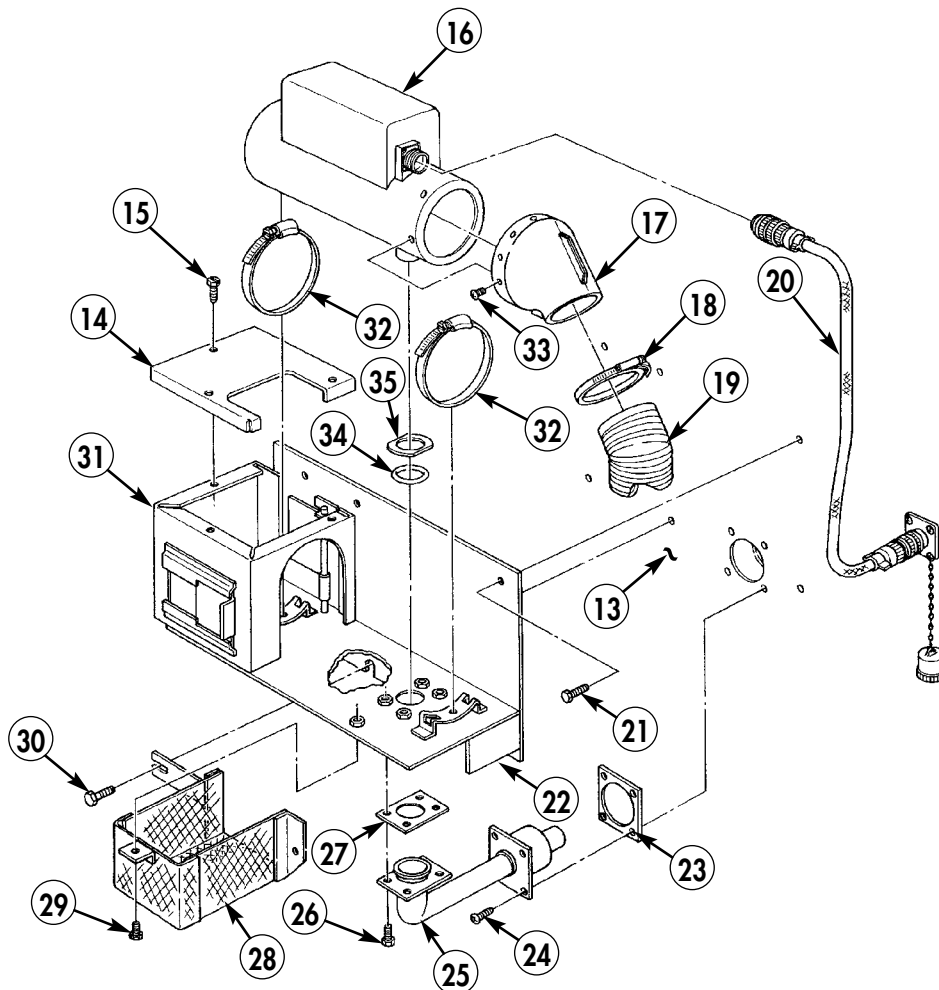

END OF WORK PACKAGE

0380 00-5/6 blank

FIELD MAINTENANCE INSTRUCTIONS FOR SPECIAL PURPOSE KITS

2-1/2 TON, 6X6, M44A2 SERIES TRUCKS (MULTIFUEL)

PRIMARY AND SECONDARY HEATER SWITCHES REPLACEMENT REMOVAL AND INSTALLATION

INITIAL SETUP:

Applicable Models

All

Equipment Condition

Parking brake set and wheels chocked
(TM 9-2320-361-10).

Battery ground cable disconnected
(WP 0126 00).

PRIMARY AND SECONDARY HEATER SWITCHES REPLACEMENT (Contd)

NOTE

Primary and secondary heater switches replacement procedures are the same.

REMOVAL

NOTE

Prior to removal, tag all lead wires for installation.

1. Loosen six screws (6) and remove converter (5) from screws (6) and van wall (7).
2. Remove fourteen screws (14) and cover (15) from converter (5).
3. Remove two screws (18), washers (17), and wires (3) and (19) from HI/LOW switch (16).
4. Remove four screws (10), washers (9), and wires (4), (11), (3), and (12) from START/OFF/RUN switch (13).
5. Remove jumper (8) from START/OFF/RUN switch (13).
6. Remove two screws (1), mounting plate (2), and START/OFF/RUN switch (13) from cover (15).
7. Remove two screws (1), mounting plate (2), and HI/LOW switch (16) from cover (15).

INSTALLATION

1. Install HI/LOW switch (16) and mounting plate (2) on cover (15) with two screws (1).
2. Install START/OFF/RUN switch (13) and mounting plate (2) on cover (15) with two screws (1).
3. Install jumper (8) on START/OFF/RUN switch (13).
4. Install wires (4), (11), (3), and (12) on START/OFF/RUN switch (13) with four washers (9) and screws (10).
5. Install wires (3) and (19) on HI/LOW switch (16) with two washers (17) and screws (18).
6. Install cover (15) on converter (5) with fourteen screws (14).
7. Install converter (5) on van wall (7) with six screws (6). Tighten screws (6).
8. Connect battery ground cable (WP 0126 00).
9. Release parking brake and remove wheel chocks (TM 9-2320-361-10).

PRIMARY AND SECONDARY HEATER SWITCHES REPLACEMENT (Contd)

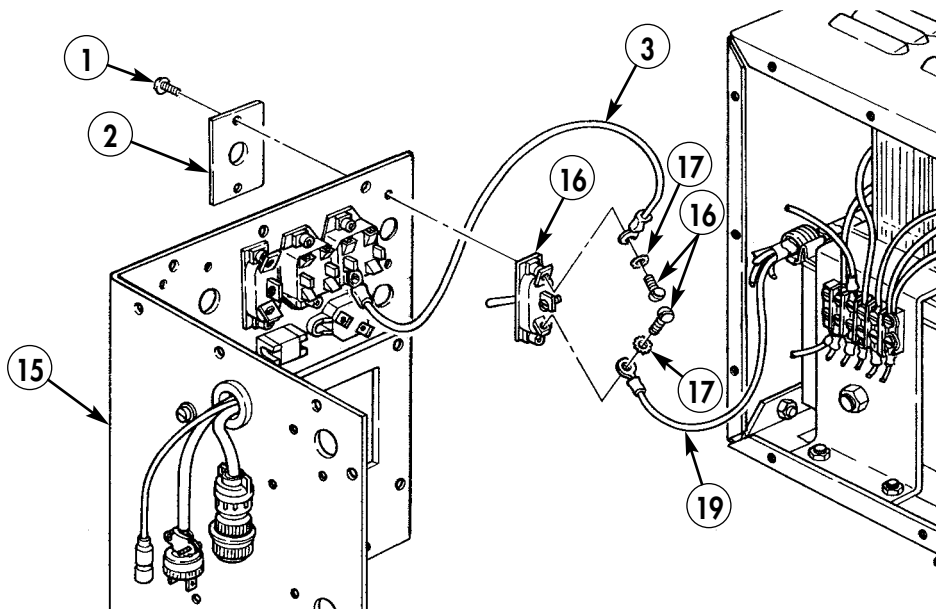
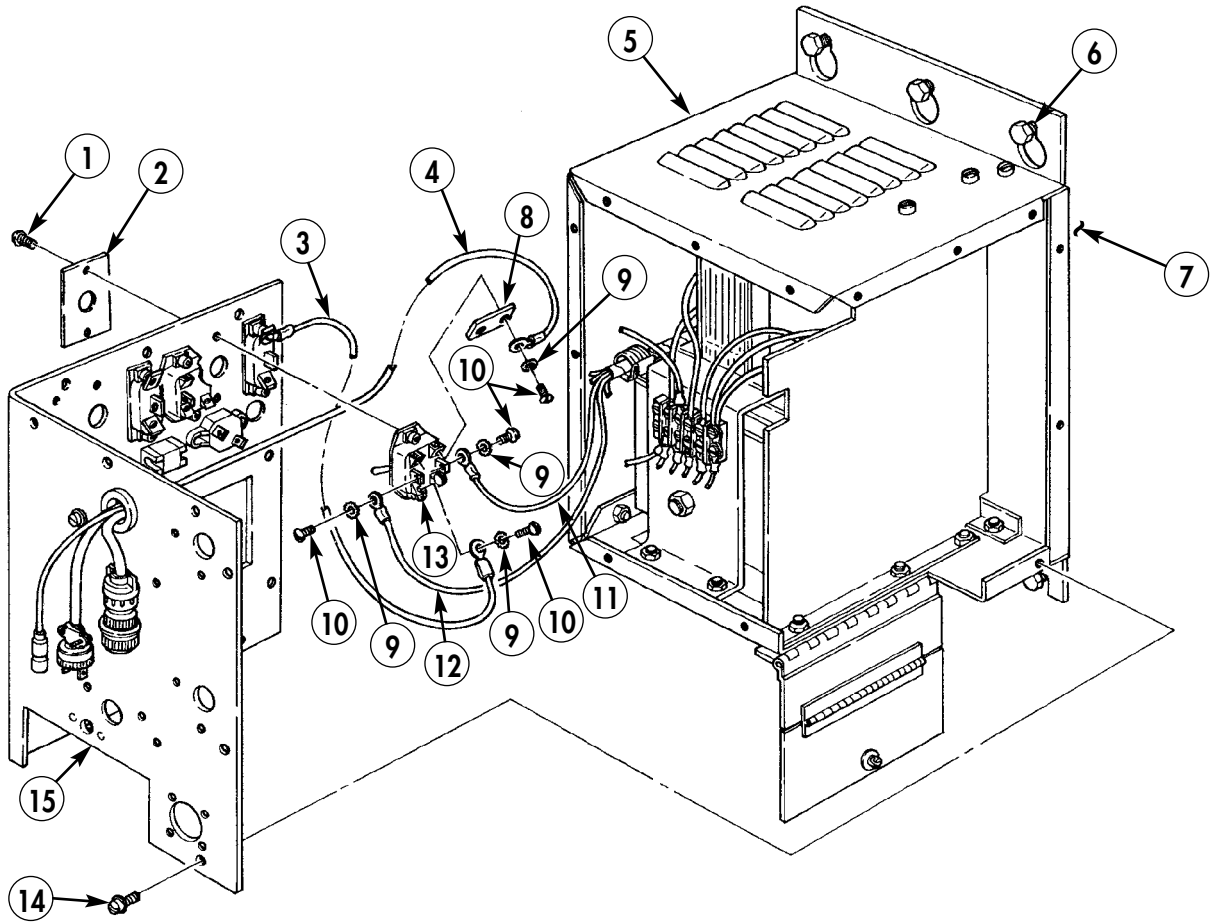

END OF WORK PACKAGE

FIELD MAINTENANCE INSTRUCTIONS FOR SPECIAL PURPOSE KITS

2-1/2 TON, 6X6, M44A2 SERIES TRUCKS (MULTIFUEL)

PRIMARY HEATER AUXILIARY DUCT REPLACEMENT REMOVAL AND INSTALLATION

INITIAL SETUP:

Applicable Models
M109A3, M185A3

Equipment Condition
Parking brake set and wheels chocked
(TM 9-2320-361-10).
Battery ground cable disconnected
(WP 0126 00).

NOTE

Auxiliary duct is normally located on van front wall prior to secondary heater installation.

REMOVAL

1. Unbuckle three straps (2) and remove auxiliary duct (1) from van ceiling (4).
2. Remove three screws (3) and straps (2) from van ceiling (4).

INSTALLATION

1. Install three straps (2) on van ceiling (4) with three screws (3).
2. Install auxiliary duct (1) on van ceiling (4) with three straps (2).
3. Connect battery ground cable (WP 0126 00).
4. Release parking brake and remove wheel chocks (TM 9-2320-361-10).

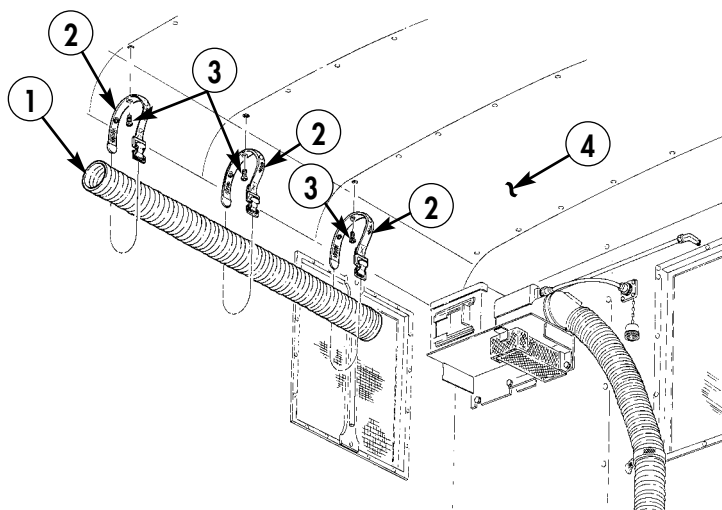

END OF WORK PACKAGE

0382 00-1/2 blank

FIELD MAINTENANCE INSTRUCTIONS FOR SPECIAL PURPOSE KITS

2-1/2 TON, 6X6, M44A2 SERIES TRUCKS (MULTIFUEL)

SECONDARY HEATER FUEL LINES REPLACEMENT REMOVAL AND INSTALLATION

INITIAL SETUP:

Applicable Models

M109A3

Materials/Parts

Antiseize tape (item 42, WP 0468 00)

Equipment Condition

Parking brake set and wheels chocked
(TM 9-2320-361-10).

Battery ground cable disconnected
(WP 0126 00).

SECONDARY HEATER FUEL LINES REPLACEMENT (Contd)

REMOVAL

WARNING

Diesel fuel is flammable. Do not perform fuel system procedures near open flames. Injury or death to personnel may result.

NOTE

Have drainage container ready to catch coolant.

1. Remove tubing (3) from elbow (4) and tee (2).
2. Remove elbow (4) from nipple (5).
3. Remove tubing (1) from tee (2).
4. Remove tee (2) from van body wall (6).

INSTALLATION

NOTE

Wrap male pipe threads with antiseize tape prior to installation.

1. Install tee (2) on van body wall (6).
2. Install tubing (1) on tee (2).
3. Install elbow (4) on nipple (5).
4. Install tubing (3) on elbow (4) and tee (2).
5. Connect battery ground cable (WP 0126 00).
6. Release parking brake and remove wheel chocks (TM 9-2320-361-10).

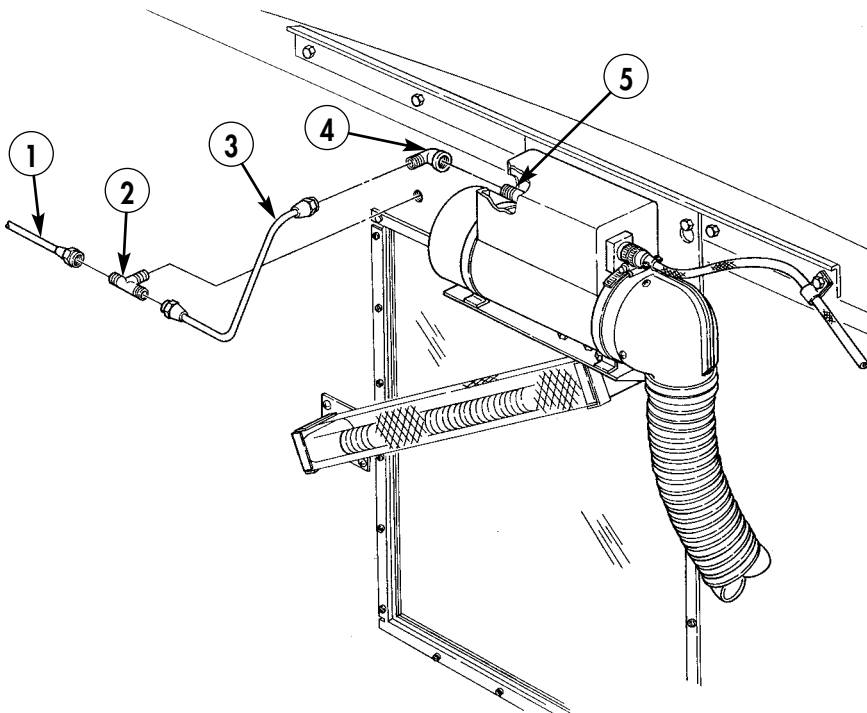

END OF WORK PACKAGE

FIELD MAINTENANCE INSTRUCTIONS FOR SPECIAL PURPOSE KITS

2-1/2 TON, 6X6, M44A2 SERIES TRUCKS (MULTIFUEL)

SECONDARY HEATER AND DUCT REPLACEMENT

HEATER, EXHAUST TUBE, AND GUARD REMOVAL; DUCT REMOVAL; DUCT INSTALLATION;
AND HEATER, EXHAUST TUBE, AND GUARD INSTALLATION

INITIAL SETUP:

Applicable Models

M109A3, M185A3

Materials/Parts

Six lockwashers (item 226, WP 0470 00)
Four lockwashers (item 241, WP 0470 00)
Two lockwashers (item 225, WP 0470 00)

Materials/Parts (Contd)

Gasket (item 108, WP 0470 00)
Gasket (item 109, WP 0470 00)
O-ring (item 122, WP 0470 00)

Equipment Condition

Parking brake set and wheels chocked
(TM 9-2320-361-10).
Battery ground cable disconnected
(WP 0126 00).

SECONDARY HEATER AND DUCT REPLACEMENT (Contd)

HEATER, EXHAUST TUBE, AND GUARD REMOVAL

1. Disconnect heater harness (7) from heater (3).
2. Remove clamp (10) and duct (13) from adapter (8).
3. Remove eight screws (9) and adapter (8) from heater (3).
4. Remove two clamps (2), heater (3), washer (11), and O-ring (12) from support (14). Discard O-ring (12).
5. Remove screws (16) and (22), lockwasher (23), washer (24), and guard (21) from exhaust tube (20), tube adapter (27), and support (14). Discard lockwasher (23).
6. Remove clamp (26) from exhaust tube (20) and tube adapter (27).
7. Remove three screws (22), lockwashers (23), tube adapter (27), and gasket (28) from van wall (29). Discard lockwashers (23) and gasket (28).
8. Remove four screws (16), gasket (15), and exhaust tube (20) from support (14). Discard gasket (15).
9. Remove two screws (6), lockwashers (25), washers (5), two screws (17), lockwashers (18), washers (19), and support (14) from bracket (1). Discard lockwashers (18) and (25).
10. Remove four screws (6), lockwashers (25), three flat washers (5), clamp (4), and bracket (1) from van wall (29). Discard lockwashers (25).

SECONDARY HEATER AND DUCT REPLACEMENT (Contd)

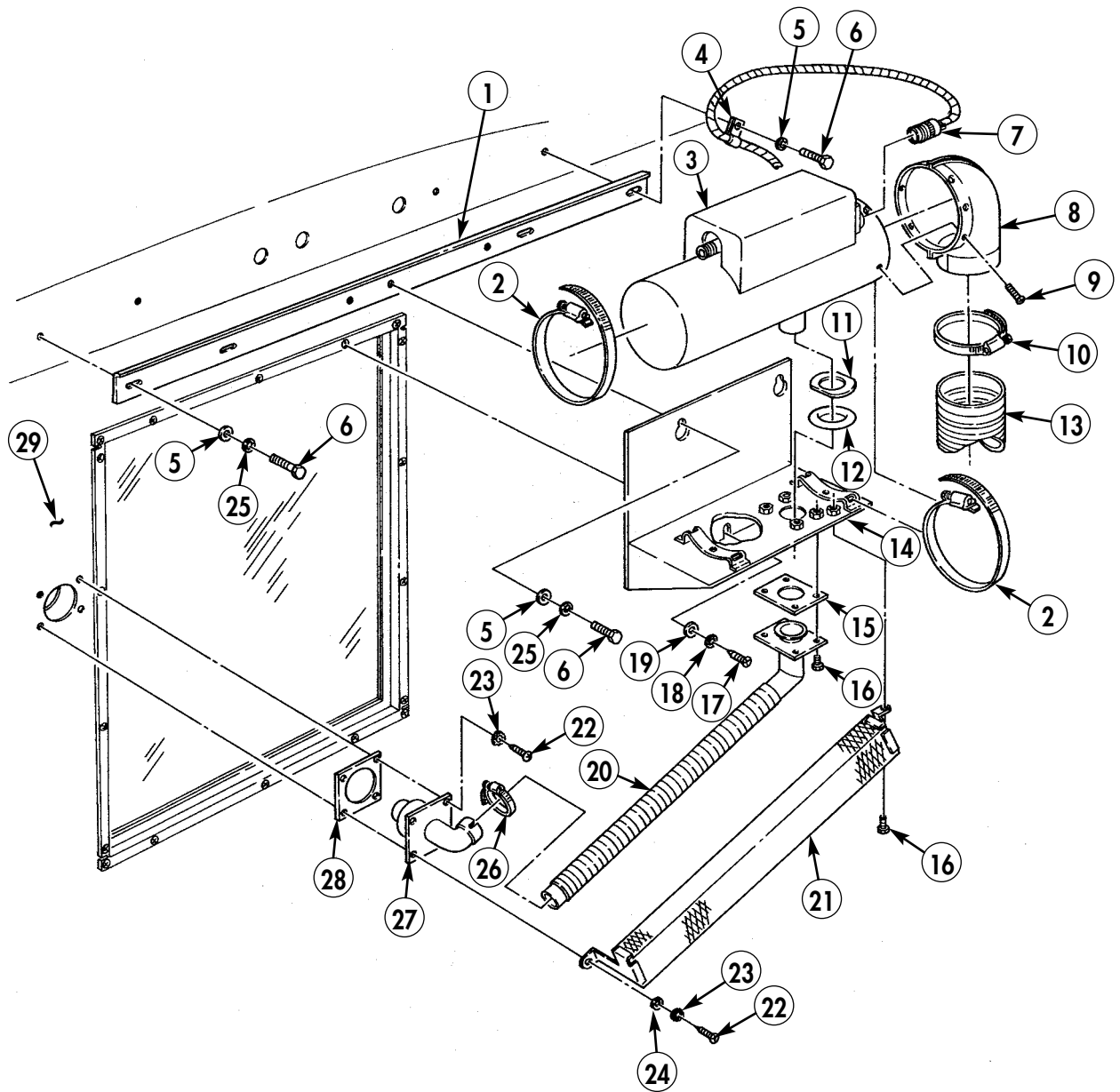

SECONDARY HEATER AND DUCT REPLACEMENT (Contd)

DUCT REMOVAL

1. Unbuckle strap (2) and remove duct (4) from strap (2). Remove screw (3) and strap (2) from van wall (1).
2. Unbuckle strap (7) and remove adapter (6). Remove two screws (8), screw (9), strap (7), and deflector (12) from van wall (1).
3. Remove three screws (10) and deflector (12) from van floor (11).
4. Remove clamp (5) and adapter (6) from duct (4).

DUCT INSTALLATION

1. Install adapter (6) and clamp (5) on duct (4).
2. Install deflector (12) on van floor (11) with three screws (10).
3. Install strap (7) and deflector (12) on van wall (1) with two screws (8) and screw (9). Buckle strap (7) on adapter (6).
4. Install strap (2) on van wall (1) with screw (3). Buckle strap (2) on duct (4).

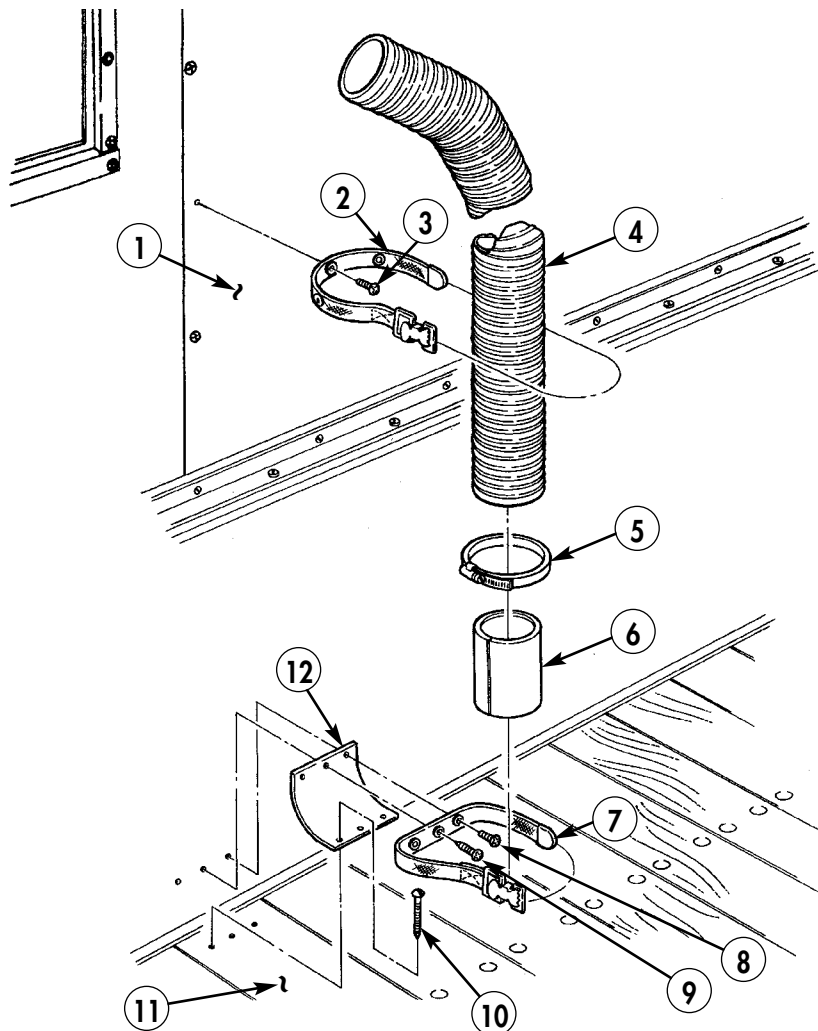

SECONDARY HEATER AND DUCT REPLACEMENT (Contd)

HEATER, EXHAUST TUBE, AND GUARD INSTALLATION

1. Install bracket (13) on van wall (37) with clamp (16), three washers (38), four new lockwashers (17), and screws (18).
2. Install support (26) on bracket (13) with two washers (38), new lockwashers (17), screws (18), washers (38), new lockwashers (17), and screws (39).
3. Install new gasket (27) and exhaust tube (28) on support (26) with four screws (28).
4. Install new gasket (36) and tube adapter (35) on van wall (37) with three lockwashers (32) and screws (33).
5. Install exhaust tube (29) on tube adapter (35) with clamp (34).
6. Install guard (30) on exhaust tube (29), support (26), and tube adapter (35) with washer (31), new lockwasher (32), and two screws (28) and (33).
7. Install new O-ring (24), washer (23), and heater (15) on support (26) with two clamps (14).
8. Install adapter (20) on heater (15) with eight screws (21).
9. Install duct (25) on adapter (20) with clamp (22).
10. Install heater harness (19) on heater (15).
11. Connect battery ground cable (WP 0126 00).
12. Release parking brake and remove wheel chocks (TM 9-2320-361-10).

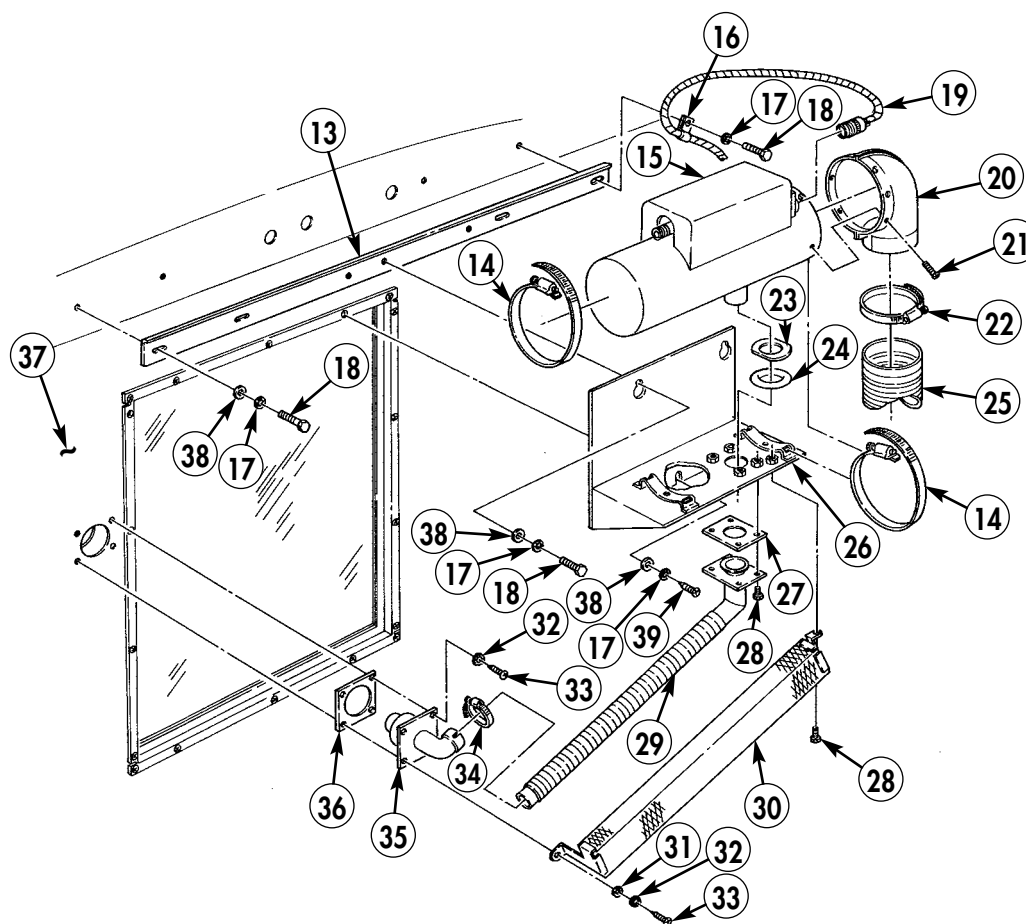

END OF WORK PACKAGE

0384 00-5/6 blank

FIELD MAINTENANCE INSTRUCTIONS FOR SPECIAL PURPOSE KITS

2-1/2 TON, 6X6, M44A2 SERIES TRUCKS (MULTIFUEL)

DEEP WATER FORDING KIT AIR INTAKE TUBES REPLACEMENT REMOVAL AND INSTALLATION

INITIAL SETUP:

Applicable Models

All

Materials/Parts

Four locknuts (item 129, WP 0470 00)
Tiedown strap (item 40, WP 0468 00)

Equipment Condition

Parking brake set and wheels chocked
(TM 9-2320-361-10).
Hood raised and secured (TM 9-2320-361-10).
Battery ground cable disconnected
(WP 0126 00).

DEEP WATER FORDING KIT AIR INTAKE TUBES REPLACEMENT (Contd)

REMOVAL

1. Loosen clamp (18) and remove air tube (19) from air cleaner body (2).
2. Loosen three clamps (14) and remove hose (15), elbow (16), and hose (17) from crankcase breather tube (13).
3. Loosen clamp (9) and remove hood (7) and sleeve (8) from air tube (19).
4. Remove four locknuts (12), screws (20), two retaining clamps (11), air tube (19), and hose (17) from supports (10). Discard locknuts (12).
5. Remove four nuts (22), two supports (10), U-bolt (23), and clamp half (24) from exhaust pipe (21).
6. Remove tiedown strap (4), loosen two clamps (3), and remove hose (6) from air compressor (1), steering column (5), and air cleaner body (2). Discard tiedown strap (4).

INSTALLATION

1. Install hose (6) on air cleaner body (2) and air compressor (1). Tighten two clamps (3).
2. Install hose (6) on steering column (5) with new tiedown strap (4).
3. Install two supports (10) on exhaust pipe (21) with U-bolt (23), clamp half (24), and four nuts (22).
4. Install hose (17), air tube (19), and two retaining clamps (11) on supports (10) with four screws (20) and new locknuts (12).
5. Install hose (17), elbow (16), and hose (15) on crankcase breather tube (13). Tighten three clamps (14).
6. Install air tube (19) through right side panel and on air cleaner (1) with clamp (18).
7. Install sleeve (8) and hood (7) on air tube (19). Tighten clamp (9).
8. Connect battery ground cable (WP 0126 00).
9. Lower and secure hood (TM 9-2320-361-10).
10. Release parking brake and remove wheel chocks (TM 9-2320-361-10).

DEEP WATER FORDING KIT AIR INTAKE TUBES REPLACEMENT (Contd)

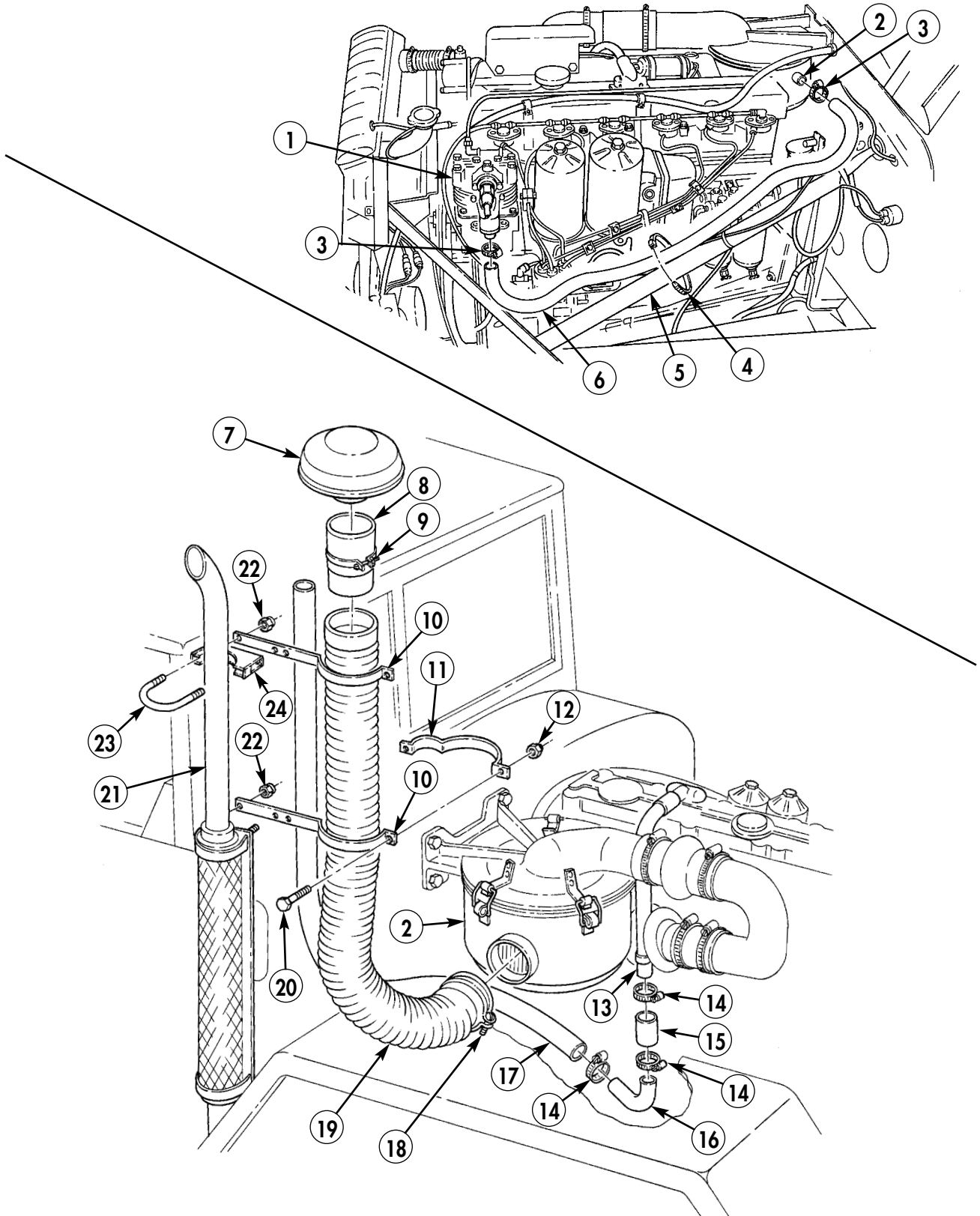

END OF WORK PACKAGE

FIELD MAINTENANCE INSTRUCTIONS FOR SPECIAL PURPOSE KITS

2-1/2 TON, 6X6, M44A2 SERIES TRUCKS (MULTIFUEL)

DEEP WATER FORDING KIT CONTROL VALVE REPLACEMENT REMOVAL AND INSTALLATION

INITIAL SETUP:

Applicable Models

All

Materials/Parts

Two locknuts (item 145, WP 0470 00)

Antiseize tape (item 42, WP 0468 00)

Equipment Condition

Parking brake set and wheels chocked
(TM 9-2320-361-10).

Battery ground cable disconnected
(WP 0126 00).

Air reservoirs drained (TM 9-2320-361-10).

DEEP WATER FORDING KIT CONTROL VALVE REPLACEMENT (Contd)**WARNING**

Do not disconnect air lines before draining air reservoirs. Small parts under pressure may shoot out with high velocity, causing injury to personnel.

REMOVAL

1. Remove tubes (1) and (3) from elbows (2).
2. Remove two locknuts (8), screws (10), and bracket (5) from instrument panel (9). Discard locknuts (8).
3. Remove two screws (7), plate (6), and bracket (5) from valve (4).
4. Remove two elbows (2) from valve (4).

INSTALLATION**NOTE**

Wrap male pipe threads with antiseize tape prior to installation.

1. Install two elbows (2) on valve (4).
2. Install bracket (5) and plate (6) on valve (4) with two screws (7).
3. Install bracket (5) on instrument panel (9) with two screws (10) and new locknuts (8).
4. Install tubes (1) and (3) on elbows (2).
5. Start engine (TM 9-2320-361-10) and allow air pressure to build up to normal operating range; check for air leaks at valve.
6. Connect battery ground cable (WP 0126 00).
7. Release parking brake and remove wheel chocks (TM 9-2320-361-10).

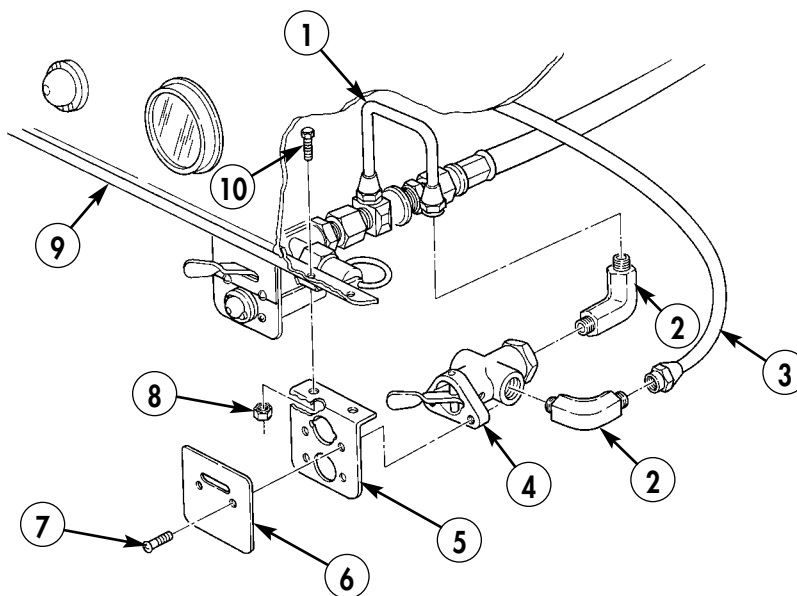
**END OF WORK PACKAGE**

FIELD MAINTENANCE INSTRUCTIONS FOR SPECIAL PURPOSE KITS

2-1/2 TON, 6X6, M44A2 SERIES TRUCKS (MULTIFUEL)

DEEP WATER FORDING KIT REGULATOR VALVE REPLACEMENT REMOVAL AND INSTALLATION

INITIAL SETUP:

Applicable Models

All

Materials/Parts

Lockwasher (item 222, WP 0470 00)

Antiseize tape (item 42, WP 0468 00)

Equipment Condition

Parking brake set and wheels chocked
(TM 9-2320-361-10).

Battery ground cable disconnected
(WP 0126 00).

DEEP WATER FORDING KIT REGULATOR VALVE REPLACEMENT (Contd)

REMOVAL

WARNING

Do not disconnect air lines before draining air reservoirs. Small parts under pressure may shoot out with high velocity, causing injury to personnel.

1. Remove hose (5) from elbow (4) on engine compartment firewall (1).
2. Remove tube (8) from regulator valve (7).
3. Remove regulator valve (7) from coupling (6).
4. Remove elbow (4), nut (3), lockwasher (2), coupling (6) from firewall (1). Discard lockwasher (2).

INSTALLATION

NOTE

Wrap male pipe threads with antiseize tape prior to installation.

1. Install coupling (6) and elbow (4) on firewall (1) with new lockwasher (2) and nut (3).
2. Install regulator valve (7) on coupling (6).
3. Install tube (8) on regulator valve (7).
4. Install hose (5) on elbow (4).
5. Start engine (TM 9-2320-361-10) and allow air pressure to build up to normal operating range; check for air leaks.
6. Connect battery ground cable (WP 0126 00).
7. Release parking brake and remove wheel chocks (TM 9-2320-361-10).

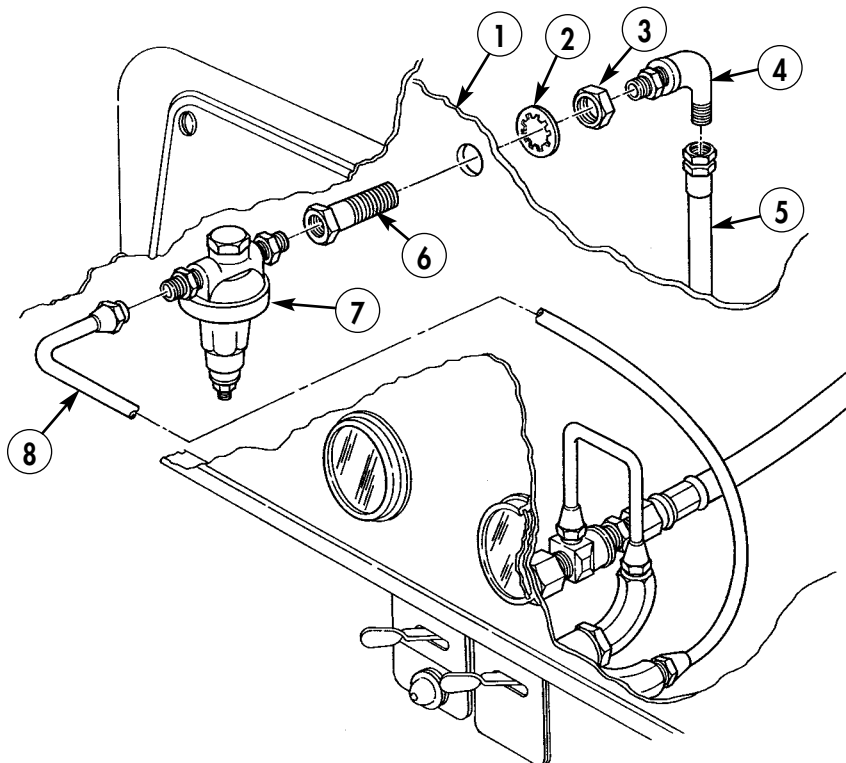

END OF WORK PACKAGE

FIELD MAINTENANCE INSTRUCTIONS FOR SPECIAL PURPOSE KITS

2-1/2 TON, 6X6, M44A2 SERIES TRUCKS (MULTIFUEL)

A-FRAME KIT MAINTENANCE REMOVAL, INSPECTION, AND INSTALLATION

INITIAL SETUP:

Applicable Models

M35A2, M35A2C, M36A2

Materials/Parts

Lockwasher (item 206, WP 0470 00)

Personnel Required

Two

Equipment Condition

Parking brake set and wheels chocked
(TM 9-2320-361-10).

Battery ground cable disconnected
(WP 0126 00).

Front lifting shackle removed, if required,
w/ winch (WP 0198 00) (installation only).

Tailgate removed, if required, M35A2, M36A2
(WP 0254 00), M35A2C (WP 0255 00)
(installation only).

A-FRAME KIT MAINTENANCE (Contd)

WARNING

Vehicle will become charged with electricity if A-frame contacts or breaks high voltage line. Do not attempt to leave vehicle while high voltage line is in contact with A-frame or vehicle. Leaving the vehicle may result in death or injury to personnel.

REMOVAL

1. Remove adjusting screw (10) from bottom of each A-frame leg (9) and shackle bracket (11).

NOTE

Assistant will help with steps 2 through 4.

2. Push A-frame (12) towards cab (13).
3. Remove cable (4) from pintle hook (5) and lower A-frame (12) to ground.
4. Open snatch block (2) and remove winch cable (3).
5. Remove snatch block (2) from A-frame spreader tube (1).
6. Remove shackle pin (8), cable (4), and harness (7) from shackle (6).
7. Remove nut (17), lockwasher (16), two washers (15), eyebolt plate (19), and eyebolt (14) from rear cargo bed (18). Discard lockwasher (16).
8. Remove two nuts (27), nuts (20), washers (21), harness (7), two spacers (22), spreader tube (1), and two studs (23) from leg extensions (24).
9. Remove two pins (26) and leg extensions (24) from A-frame legs (9).
10. Remove two pins (25) and A-frame legs (9) from shackle brackets (11).

A-FRAME KIT MAINTENANCE (Contd)

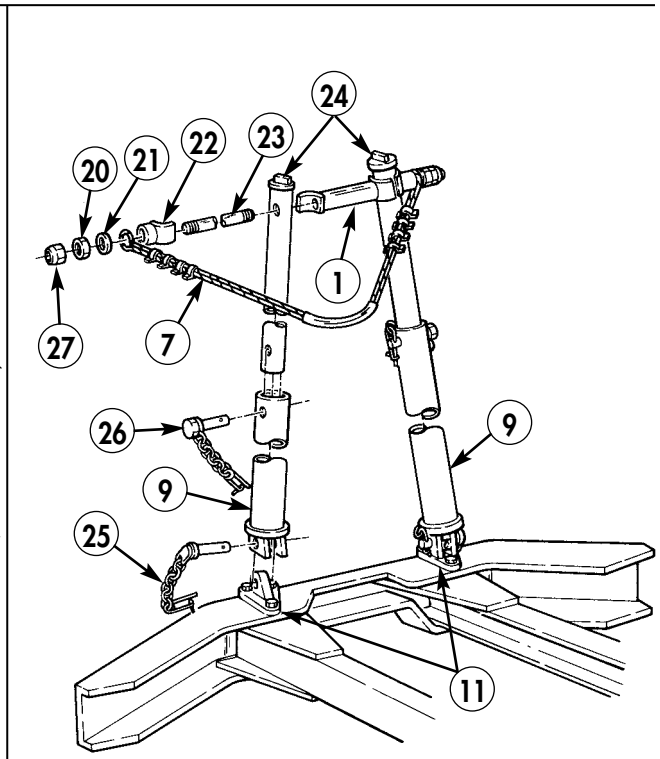
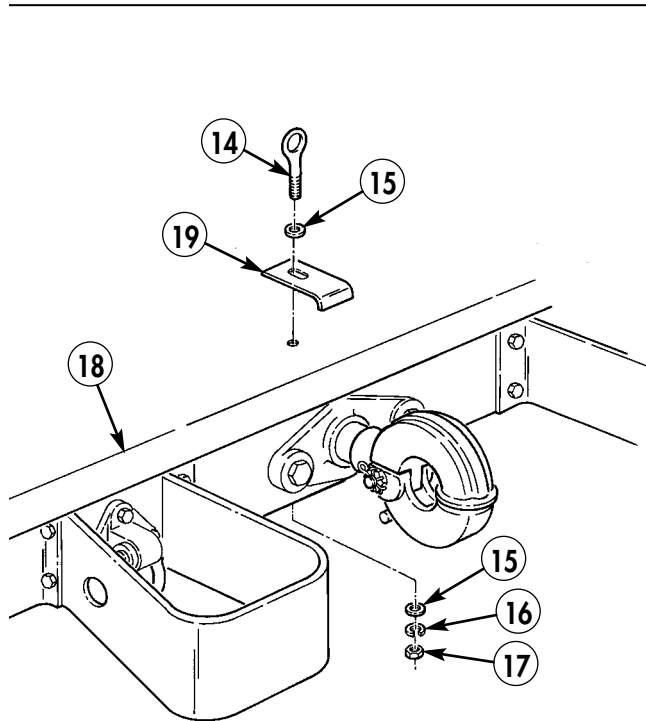
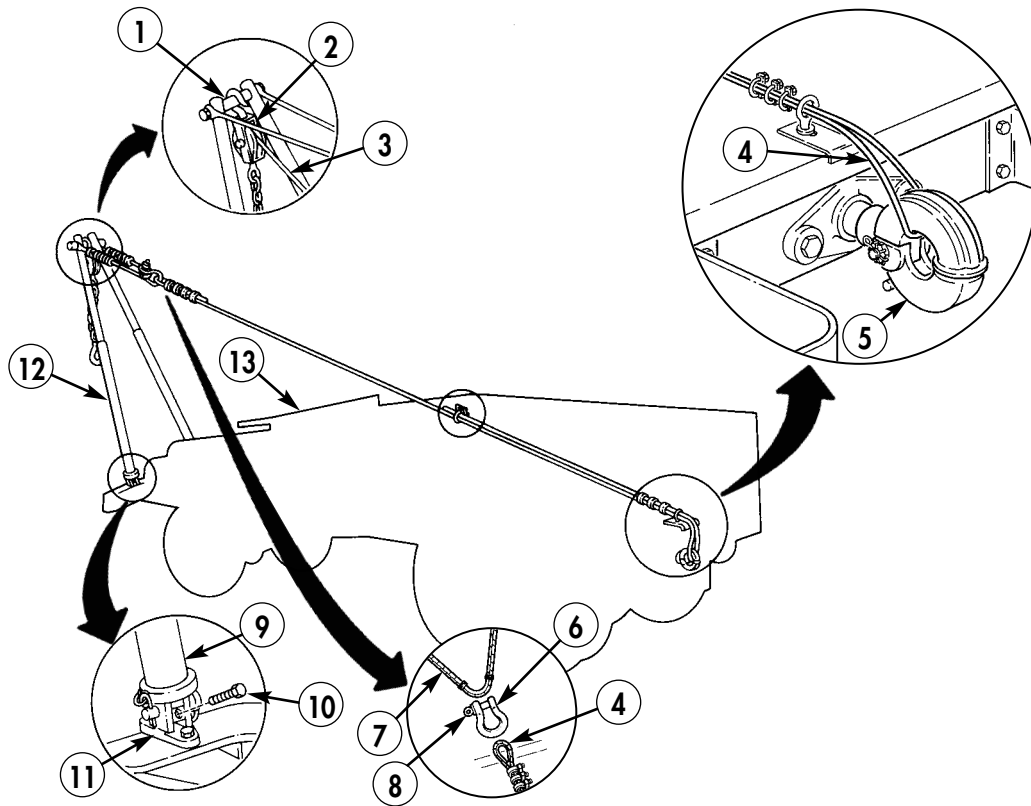

A-FRAME KIT MAINTENANCE (Contd)

INSPECTION

1. Inspect all metal components for bends, cracks, and breaks. Replace if damaged.
2. Inspect harness (17) and cable (22) for any fraying, breaks, and loose or missing clamps. Repair or replace if necessary.

NOTE

If A-frame kit is not to be installed, proceed to steps 13 and 14.
Do not continue to next step.

INSTALLATION

1. Install eyebolt plate (6), washer (2), and eyebolt (1) on rear cargo bed (5) with washer (2), new lockwasher (3), and nut (4).
2. Install two A-frame legs (13) on shackle brackets (14) with two pins (15).
3. Insert two leg extensions (11) into A-frame legs (13), align holes equally, and install with pins (16).
4. Install spreader tube (12) and two spreader tube studs (10) on leg extensions (11). Position spreader tube stud (12) so ends extend equally through holes in leg extensions (11).
5. Install two leg spacers (9) and harness (17) on each end of spreader tube studs (12) with two washers (8), nuts (7), and nuts (18).
6. Install cable (22), harness (17), and shackle pin (27) on shackle (26).
7. Install snatch block (19) on spreader tube (12).
8. Open snatch block (19) and install winch cable (20) on roller, then close snatch block (19).

NOTE

Assistant will help with steps 9 and 10.

9. Raise A-frame (24) towards cab (25).
10. Thread cable (22) through eyebolt (1) and install on pintle hook (23).

NOTE

A-frame must be angled at approximately 60° from horizontal.
Do not insert adjusting screws until all necessary adjustments
have been made.

11. Loosen clamp (21) at end of cable (22). Adjust until 60° angle is obtained, then tighten clamp (21).
12. Install adjusting screw (28) on each A-frame leg (13).

NOTE

Do not perform steps 13 and 14 if A-frame has been installed.

13. Install tailgate M35A2 and M36A2 (WP 0254 00) and M35A2C (WP 0255 00), if removed.
14. Install lifting shackles w/winch (WP 0198 00), (if removed).
15. Connect battery ground cable (WP 0126 00).
16. Release parking brake and remove wheel chocks (TM 9-2320-361-10).

A-FRAME KIT MAINTENANCE (Contd)

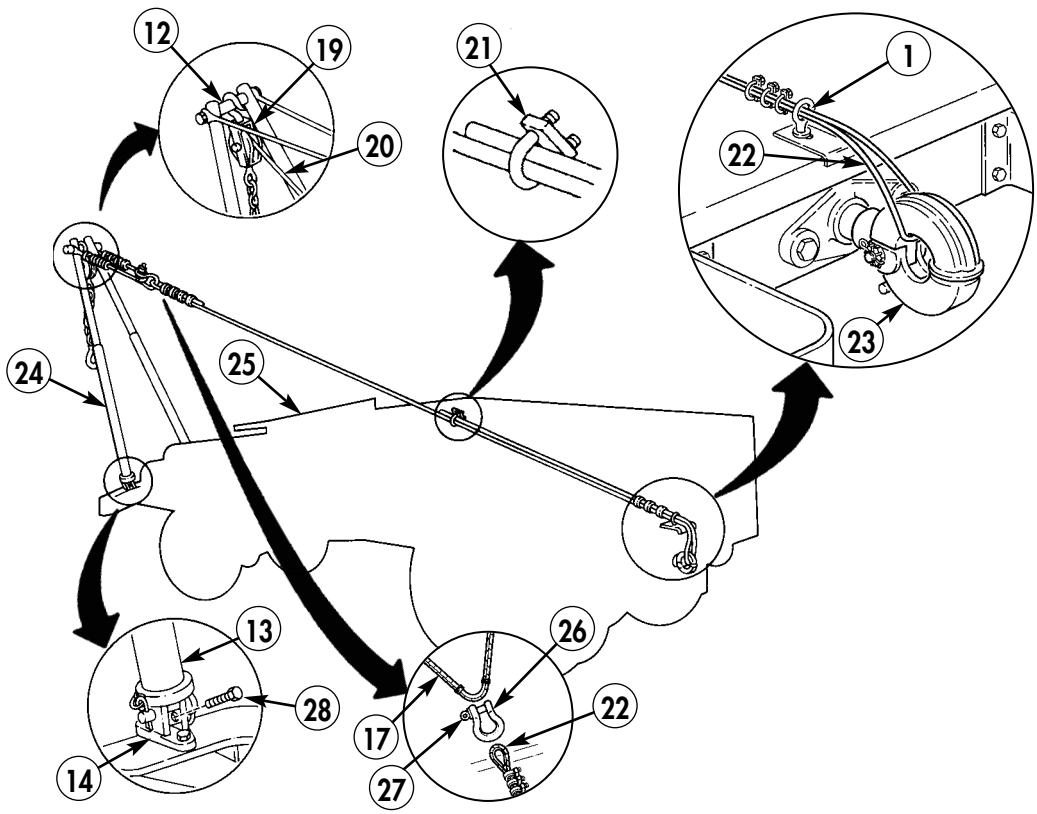
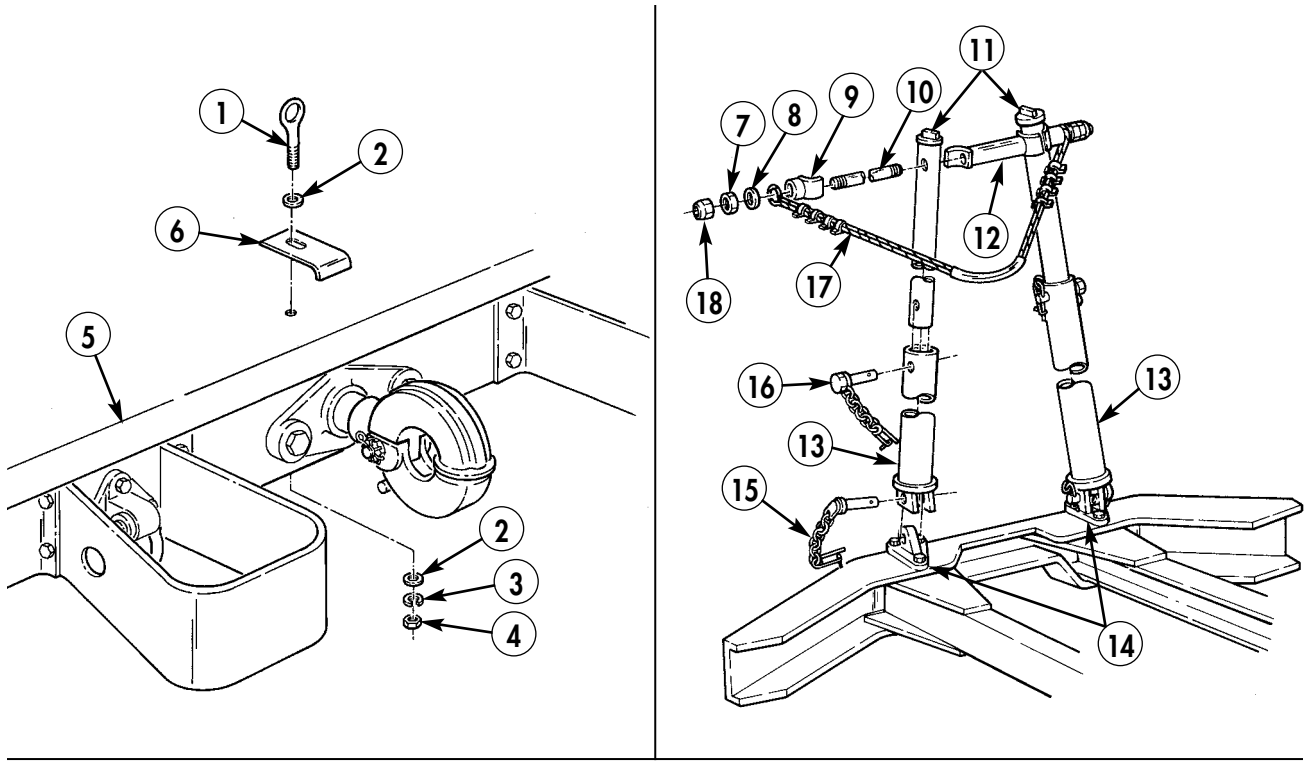

END OF WORK PACKAGE

FIELD MAINTENANCE INSTRUCTIONS FOR SPECIAL PURPOSE KITS

2-1/2 TON, 6X6, M44A2 SERIES TRUCKS (MULTIFUEL)

MACHINE GUN MOUNT KIT REPLACEMENT REMOVAL, DISASSEMBLY, ASSEMBLY, AND INSTALLATION

INITIAL SETUP:

Applicable Models

All

Materials/Parts

Sixteen locknuts (item 161, WP 0470 00)
Eight locknuts (item 147, WP 0470 00)
Eight locknuts (item 129, WP 0470 00)
Two cotter pins (item 25, WP 0470 00)

Personnel Required

Two

Equipment Condition

Parking brake set and wheels chocked
(TM 9-2320-361-10).
Battery ground cable disconnected
(WP 0126 00).
Cab top removed, hardtop (WP 0363 00) or
soft top (TM 9-2320-361-10).
Cab reinforcement kit installed (WP 0414 00).

MACHINE GUN MOUNT KIT REPLACEMENT (Contd)

REMOVAL

NOTE

Clamp down latch on ring mount to prevent rotation during removal.

1. Remove twelve locknuts (5), screws (2), and twenty-four washers (3) from ring mount (1), adapter (4), front bracket post (6), and rear bracket posts (7) and (8). Discard locknuts (5).

NOTE

Assistant will help with steps 2 through 4.

2. Remove ring mount (1) from front bracket post (6), rear bracket posts (7) and (8), and adapter (4).
3. Loosen four screws (13) and remove front bracket post (6) from front gun mount bracket (11). Retighten four screws (13).

WARNING

Bracket posts must be held in position before removing U-bolts.
Failure to do so may cause injury to personnel.

4. Remove eight locknuts (10), four U-bolts (9) and two rear bracket posts (7) and (8) from two rear gun mount brackets (12). Discard locknuts (10).

MACHINE GUN MOUNT KIT REPLACEMENT (Contd)

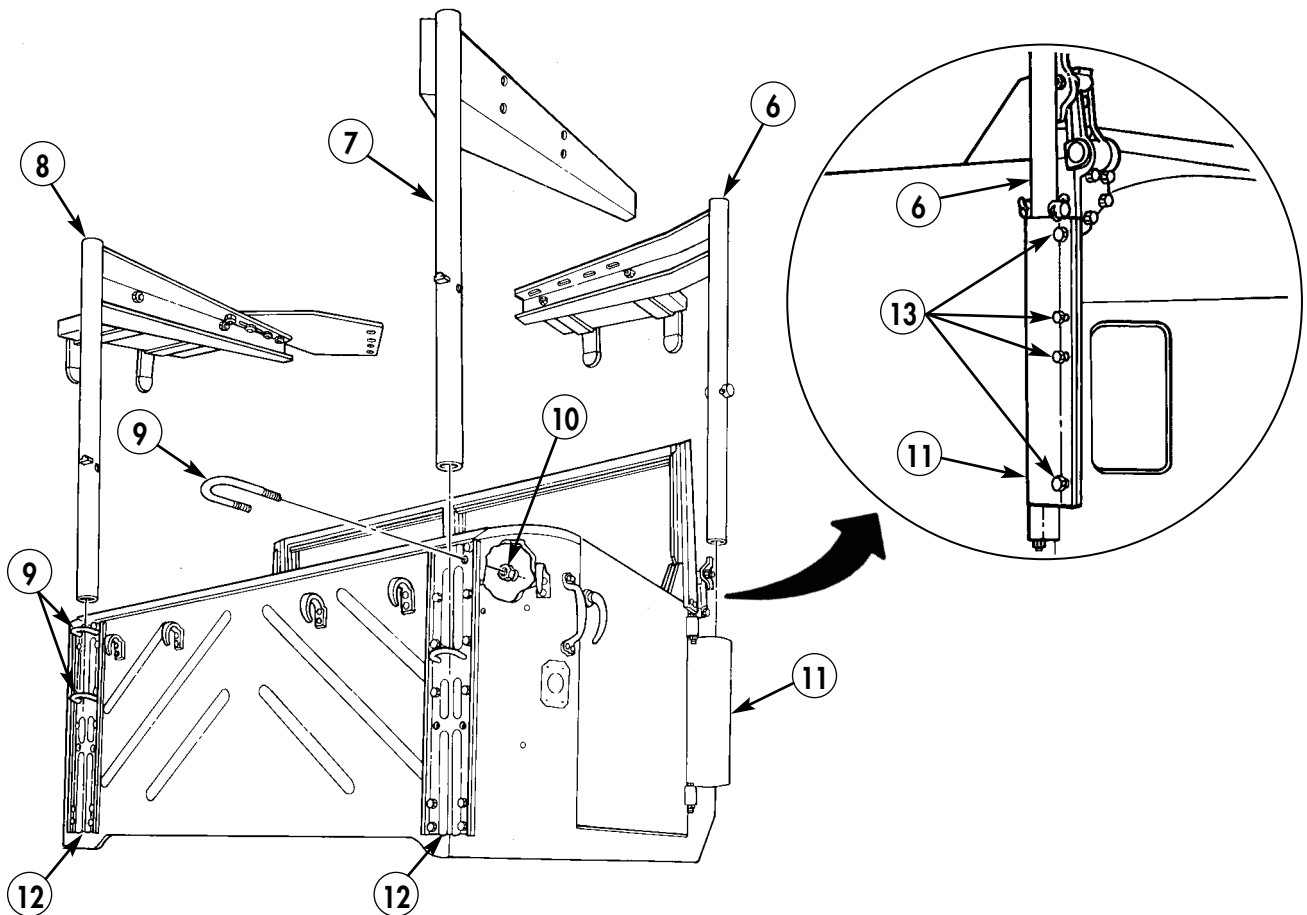
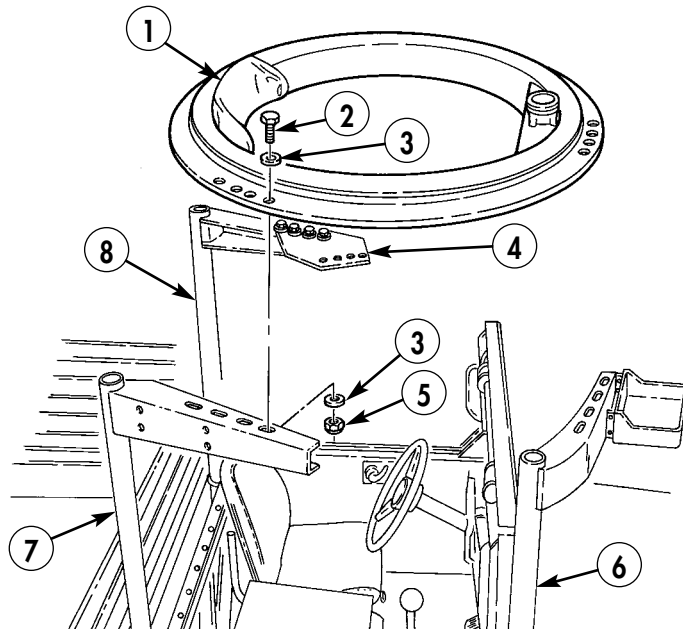

MACHINE GUN MOUNT KIT REPLACEMENT (Contd)

DISASSEMBLY

NOTE

Steps 1, 2, and 3 are identical for removing ammunition trays from both front bracket post and left rear bracket post. This procedure is for the front bracket post.

1. Remove two straps (6) from ammunition tray (7).
2. Remove four locknuts (1), washers (2), screws (4), and ammunition tray (7) from front bracket post (11). Discard locknuts (1).
3. Remove four locknuts (9), washers (8), screws (10), and two tray brackets (3) from ammunition tray extensions (5). Discard locknuts (9).
4. Remove four locknuts (17), screws (14), eight washers (15), and left rear adapter (16) from left rear bracket post (18). Discard locknuts (17).
5. Remove two cotter pins (13) and straight pins (12) from right rear bracket post (19) and front bracket post (11). Discard cotter pins (13).

ASSEMBLY

1. Install left rear adapter (16) on first four holes in left rear bracket post (18) with four screws (14), eight washers (15), and four new locknuts (17). Finger tighten screws (14).
2. Install two straight pins (12) on front bracket post (11) and right rear bracket post (19) with two new cotter pins (13).

NOTE

Steps 3, 4, and 5 are identical for assembling ammunition trays on both front bracket post and left rear bracket post. This procedure is for the front bracket post.

3. Install two tray brackets (3) on ammunition tray extensions (5) with four screws (10), washers (8), and new locknuts (9).
4. Install ammunition tray (7) on front bracket post (11) with four screws (4), washers (2), and new locknuts (1).
5. Install two straps (6) on ammunition tray (7).

MACHINE GUN MOUNT KIT REPLACEMENT (Contd)

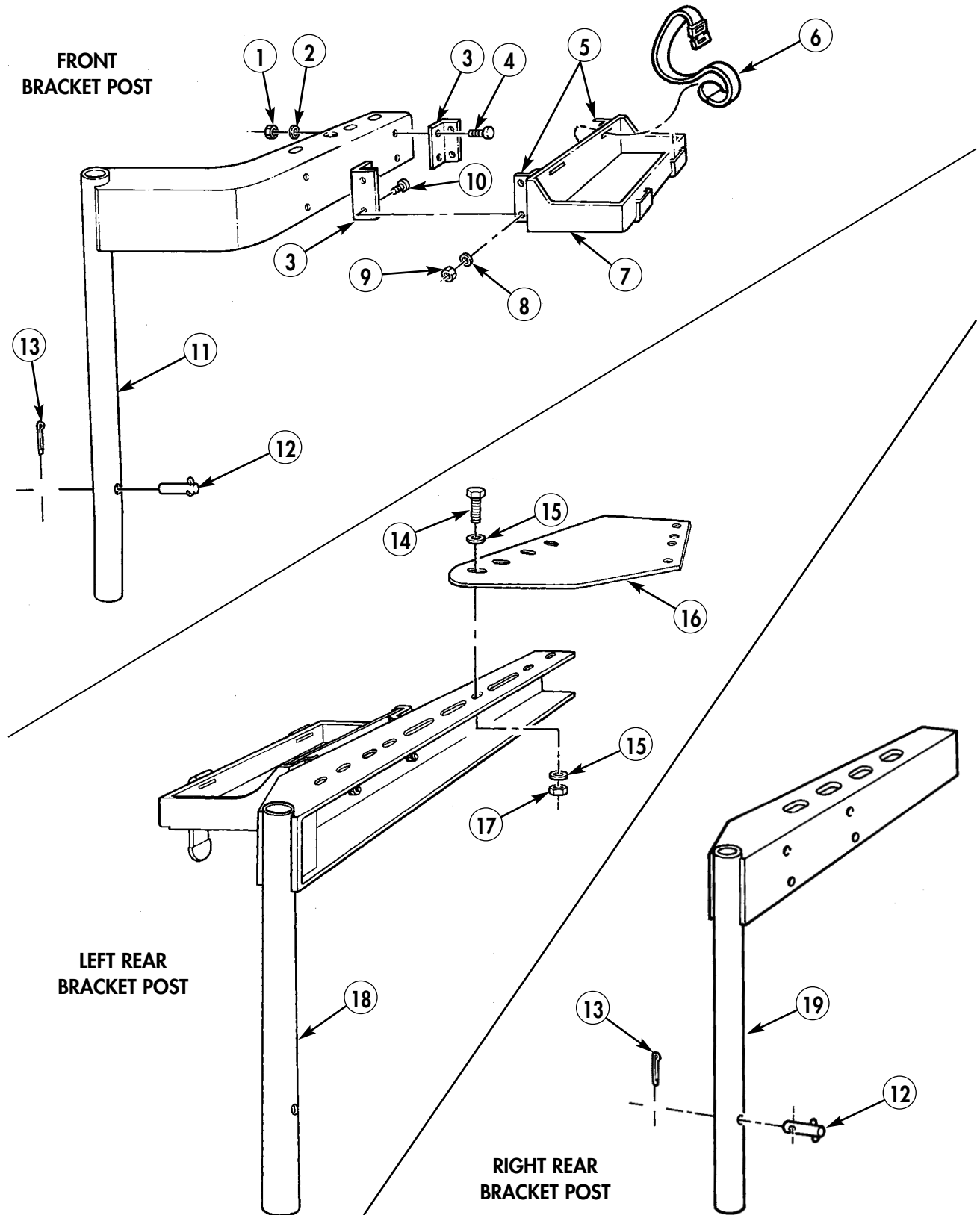

MACHINE GUN MOUNT KIT REPLACEMENT (Contd)

INSTALLATION

NOTE

- Assistant will help with steps 2 through 8.
 - If machine gun mount kit is not to be installed, proceed to cab top installation.
1. Install four U-bolts (8) on two rear gun mount brackets (7) with eight new locknuts (3). Finger tighten locknuts (3).
 2. Install right rear bracket post (1) through U-bolts (8) and rear gun mount bracket (7). Ensure pin (2) rests on top of U-bolt (8) and bracket post (1) turns freely.
 3. Install left rear bracket post (9) through U-bolts (8) and rear gun mount bracket (7). Ensure weld post pin (10) rests on top of U-bolt (8) and bracket post (9) turns freely.
 4. Loosen four screws (11) on front gun mount bracket (6).
 5. Install front bracket post (4) in front gun mount bracket (6). Ensure pin (5) rests on top of gun mount bracket (6).
 6. Position ring mount (12) on front bracket post (4), right rear bracket post (1), and left rear bracket post adapter (15).
 7. Align ring mount locating hole (18) to locating hole in right rear adapter (17).
 8. Install ring mount (12) with twelve screws (13), twenty-four washers (14), and twelve new locknuts (16).
 9. Tighten all four right front gun mount screws (11).
 10. Tighten all remaining gun mount hardware.
 11. Install cab top, hardtop (WP 0363 00), or soft top (TM 9-2320-361-10).
 12. Connect battery ground cable (WP 0126 00).
 13. Release parking brake and remove wheel chocks (TM 9-2320-361-10).

MACHINE GUN MOUNT KIT REPLACEMENT (Contd)

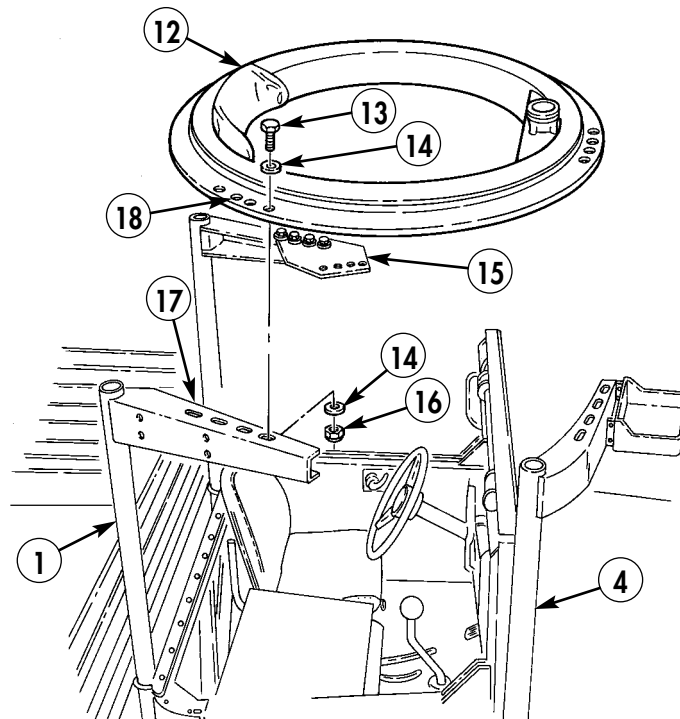
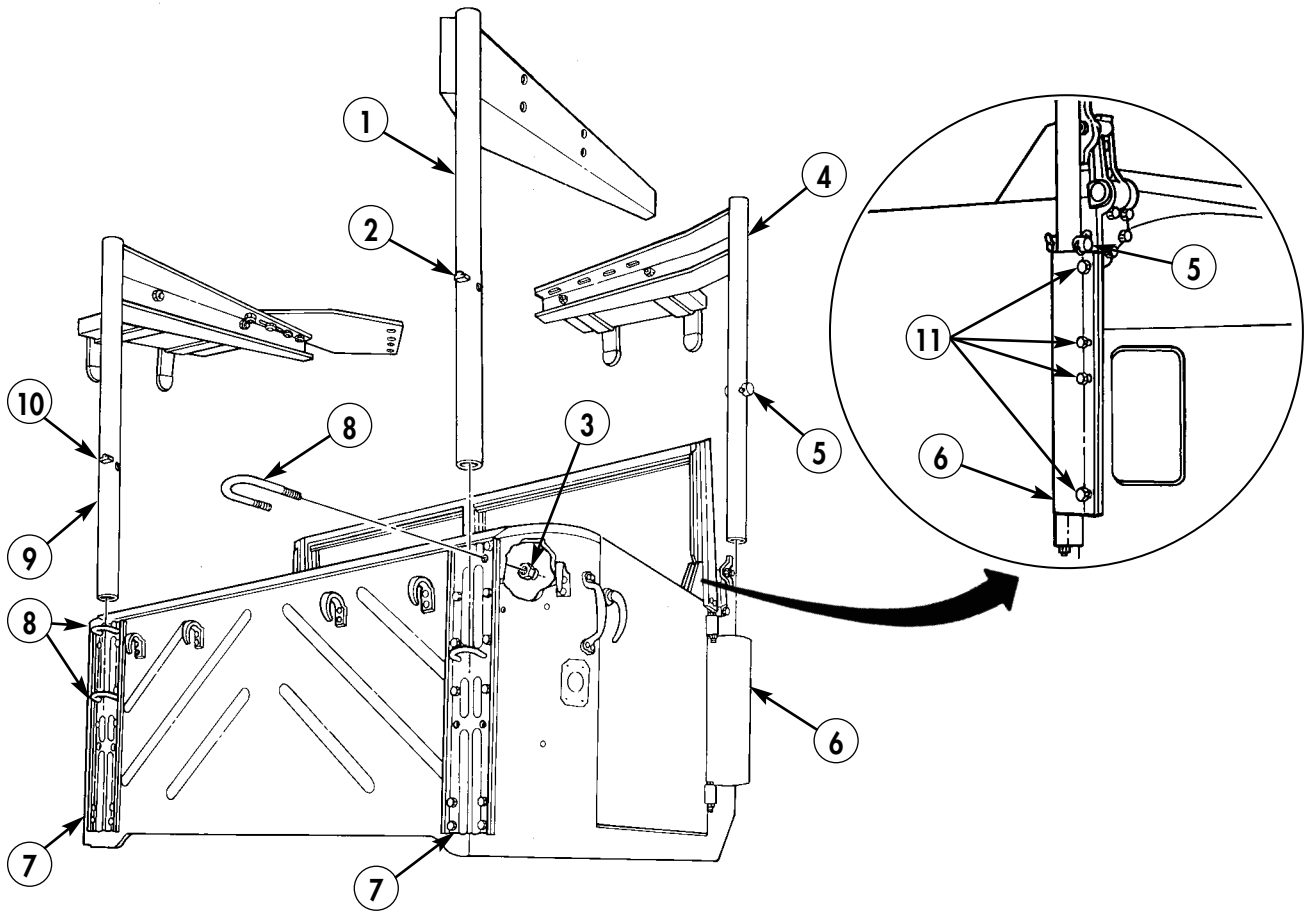

END OF WORK PACKAGE

FIELD MAINTENANCE INSTRUCTIONS FOR SPECIAL PURPOSE KITS

2-1/2 TON, 6X6, M44A2 SERIES TRUCKS (MULTIFUEL)

RIFLE MOUNTING KIT REPLACEMENT REMOVAL AND INSTALLATION

INITIAL SETUP:

Applicable Models

All

Personnel Required

Two

Tools and Special Tools

General mechanic's tool kit
(item 116, WP 0469 00)

Equipment Condition

Parking brake set and wheels chocked
(TM 9-2320-361-10).
Battery ground cable disconnected
(WP 0126 00).

Materials/Parts

Eleven locknuts (item 145, WP 0470 00)

RIFLE MOUNTING KIT REPLACEMENT (Contd)

REMOVAL

1. Remove four locknuts (2), screws (8), two catches (7), and brackets (6) from mounting bracket (5). Discard locknuts (2).
2. Remove three locknuts (3), screws (1), and mounting bracket (5) from instrument panel (4). Discard locknuts (3).

NOTE

Assistant will help with step 3.

3. Remove four locknuts (11), screws (9), and two supports (10) from cab floor (12). Discard locknuts (11).

INSTALLATION

NOTE

Assistant will help with step 1.

1. Install two supports (10) on cab floor (12) with four screws (9) and new locknuts (11).
2. Install mounting bracket (5) on instrument panel (4) with three screws (1) and new locknuts (3).
3. Install two brackets (6) and catches (7) on mounting bracket (5) with four screws (8) and new locknuts (2).
4. Connect battery ground cable (WP 0126 00).
5. Release parking brake and remove wheel chocks (TM 9-2320-361-10).

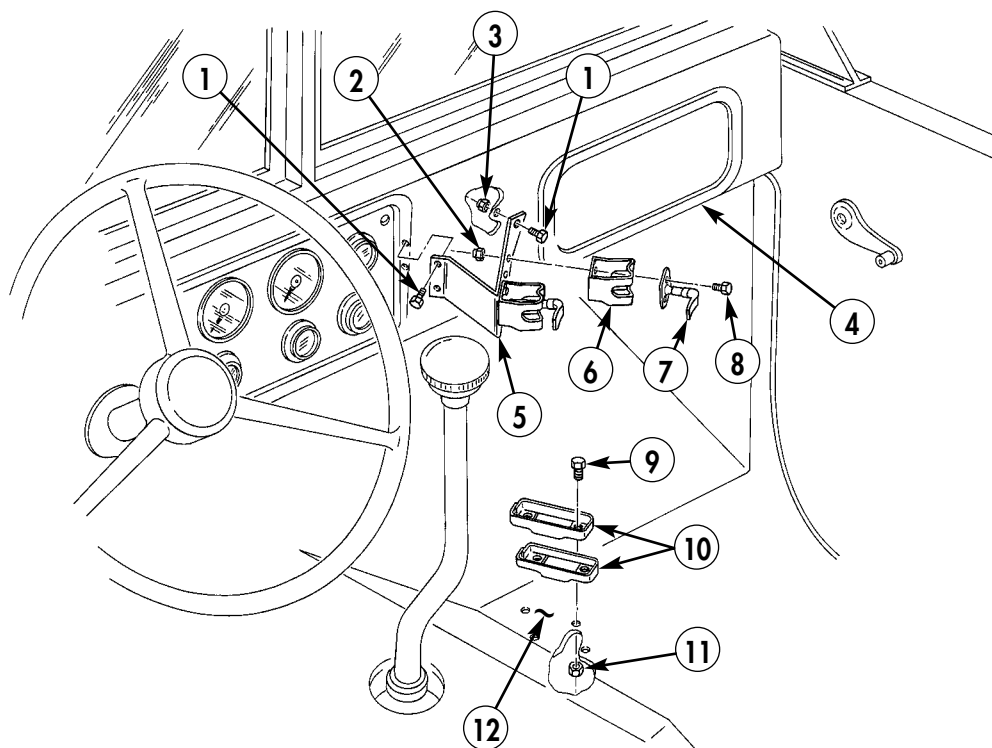

FIELD MAINTENANCE INSTRUCTIONS FOR SPECIAL PURPOSE KITS

2-1/2 TON, 6X6, M44A2 SERIES TRUCKS (MULTIFUEL)

DECONTAMINATION MOUNTING KIT REPLACEMENT REMOVAL AND INSTALLATION

INITIAL SETUP:

Applicable Models

All

Tools and Special Tools

General mechanic's tool kit
(item 116, WP 0469 00)

Materials/Parts

Thirteen bolt-assembled lockwashers
(item 246, WP 0470 00)
Four locknuts (item 145, WP 0470 00)

Equipment Condition

Parking brake set and wheels chocked
(TM 9-2320-361-10).
Battery ground cable disconnected
(WP 0126 00).
Decontamination apparatus removed
(TM 3-4230-204-12&P).

DECONTAMINATION MOUNTING KIT REPLACEMENT (Contd)

REMOVAL

1. Slide boot (5) up gearshift lever (6).
2. Remove nut (4), screw (2), washer (1), and gearshift lever (6) from transmission stud shaft (3).
3. Remove thirteen bolt-assembled lockwasher (8) and intermediate tunnel (7) from cab floor (9).
4. Remove four locknuts (12), capscrews (10), and decontamination mounting bracket (11) from intermediate tunnel (7). Discard locknuts (12).

INSTALLATION

1. Install decontamination mounting bracket (11) on intermediate tunnel (7) with four capscrews (10) and new locknuts (12).
2. Install intermediate tunnel (7) on cab floor (9) with thirteen new bolt-assembled lockwashers (8).
3. Install gearshift lever (6) on transmission stud shaft (3) with washer (1), screw (2), and nut (4).
4. Slide boot (5) down over end of gearshift lever (6).
5. Install decontamination apparatus (TM 3-4230-204-12&P).
6. Connect battery ground cable (WP 0126 00).
7. Release parking brake and remove wheel chocks (TM 9-2320-361-10).

DECONTAMINATION MOUNTING KIT REPLACEMENT (Contd)

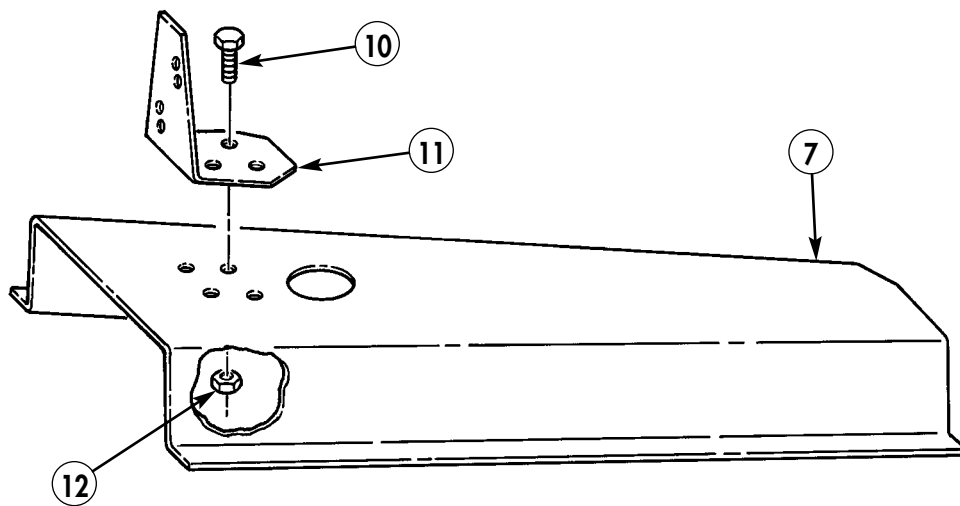
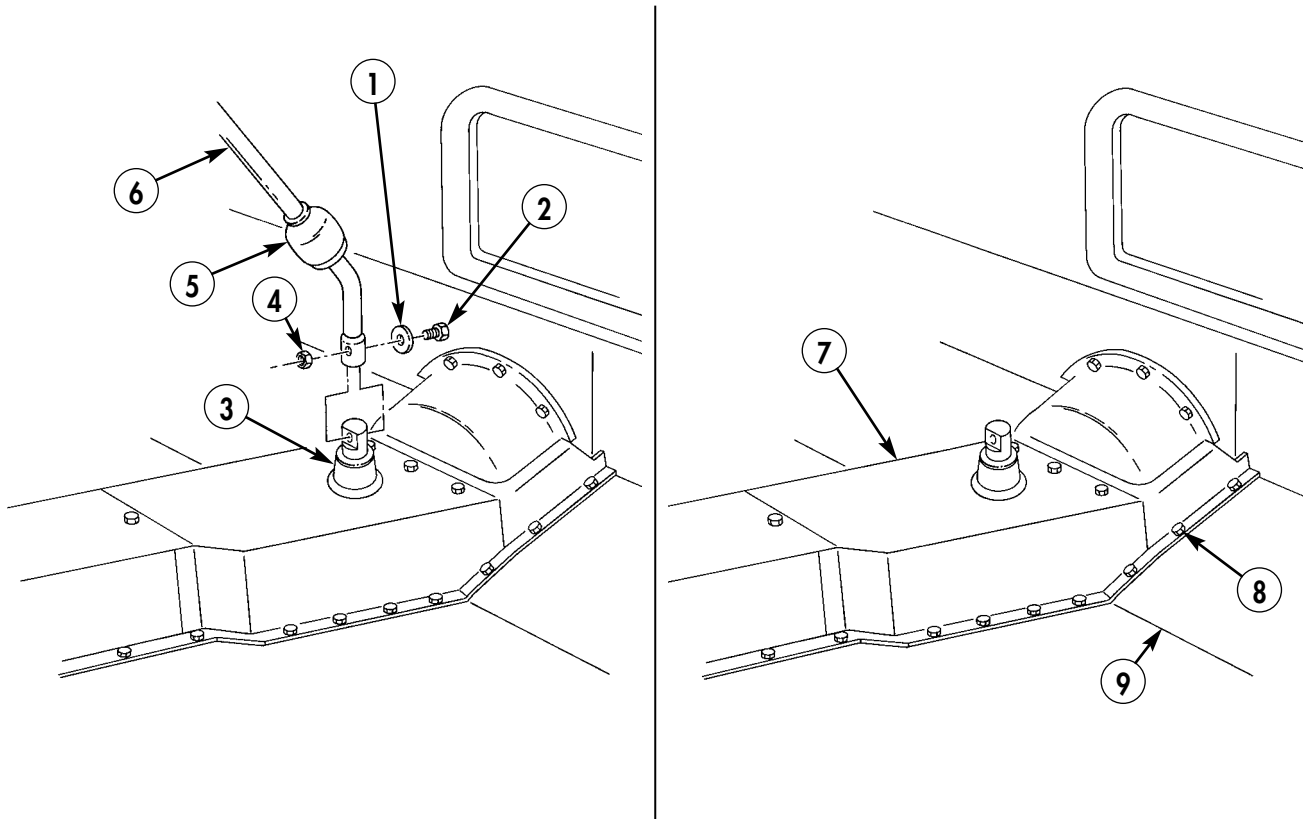

END OF WORK PACKAGE

0391 00-3/4 blank

FIELD MAINTENANCE INSTRUCTIONS FOR SPECIAL PURPOSE KITS

2-1/2 TON, 6X6, M44A2 SERIES TRUCKS (MULTIFUEL)

CHEMICAL AGENT ALARM MOUNTING KIT REPLACEMENT REMOVAL AND INSTALLATION

INITIAL SETUP:

Applicable Models

All

Personnel Required

Two

Tools and Special Tools

General mechanic's tool kit
(item 116, WP 0455 00)

Equipment Condition

Parking brake set and wheels chocked
(TM 9-2320-361-10).
Hood raised and secured (TM 9-2320-361-10).
Battery ground cable disconnected
(WP 0126 00).
M43 detector and M42 alarm unit removed
(TM 3-6665-225-12).

Materials/Parts

Four tiedown straps (item 40, WP 0468 00)
Two locknuts (item 145, WP 0470 00)
Two locknuts (item 160, WP 0470 00)
Three locknuts (item 155, WP 0470 00)

CHEMICAL AGENT ALARM MOUNTING KIT REPLACEMENT (Contd)

REMOVAL

1. Remove nut (3) and harness receptacle (5) from bracket (2).
2. Remove three locknuts (10), support (9), three screws (4), and detector unit bracket (1) from left front fender (8). Discard locknuts (10).
3. Remove screw (6) and clamp (7) from front fender (8).
4. Disconnect wire (16) from connector (17).
5. Remove locknut (11), washer (12), screw (19), harness ground wire (18), ground strap (15), and washer (14) from right side of turn signal flasher box (13). Discard locknut (11).
6. Remove four tiedown straps (28) from main wiring harness (27). Discard tiedown straps (28).

NOTE

Assistant will help with steps 7 through 13.

7. Remove locknut (31), screw (30), and clamp (29) from firewall (32). Discard locknut (31).
8. Loosen two screws (25) and remove harness (22) from clamps (26).
9. Remove screw (39) and clamp (38) from rear cab panel (20).
10. Remove grommet (37) from cab floor hole (36).
11. Remove two screws (33) and clamps (34) from frame (35).
12. Remove harness (22) from firewall (32).
13. Remove two locknuts (21), screws (24), and alarm unit bracket (23) from rear cab panel (20). Discard locknuts (21).

CHEMICAL AGENT ALARM MOUNTING KIT REPLACEMENT (Contd)

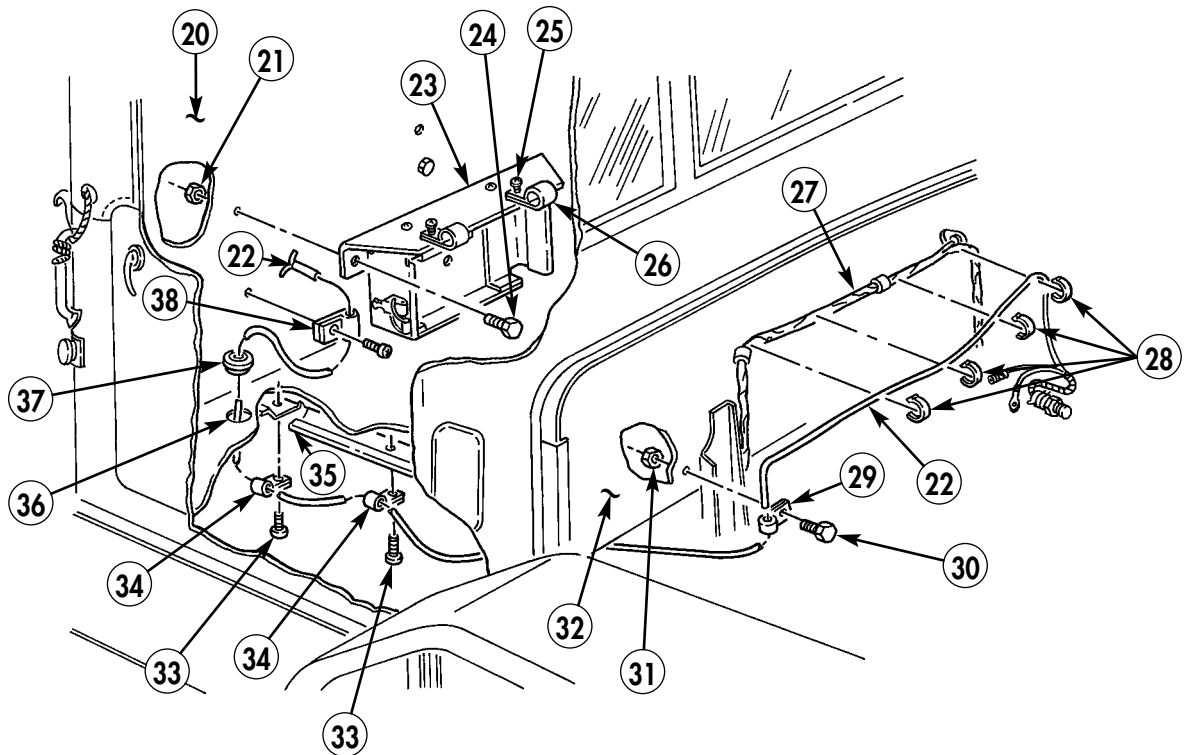
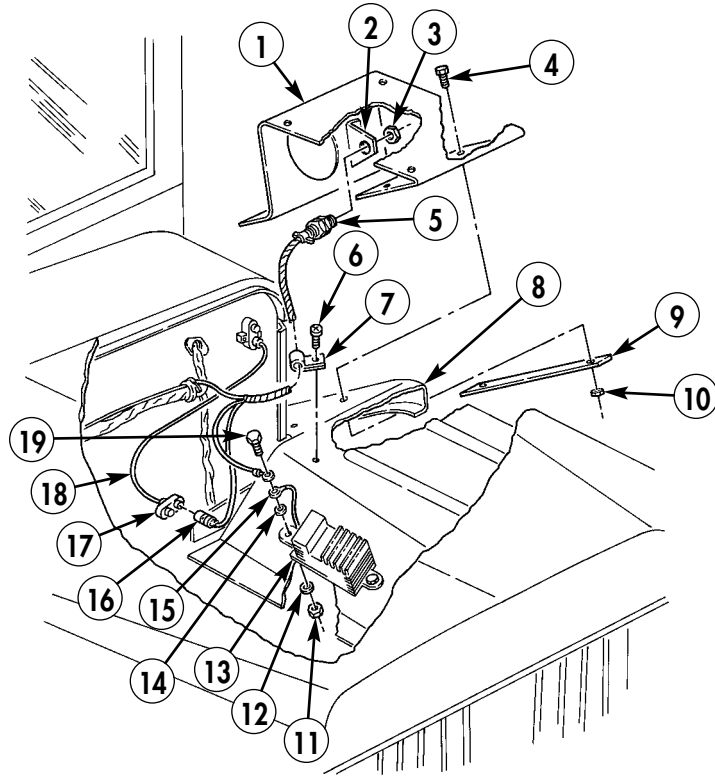

CHEMICAL AGENT ALARM MOUNTING KIT REPLACEMENT (Contd)

INSTALLATION

1. Position detector unit bracket (1) on left front fender (8) and install with three screws (4), support (9), and three new locknuts (10).
2. Install harness receptacle (5) on bracket (2) with nut (3).
3. Install harness (20) on left front fender (8) with clamp (7) and screw (6).
4. Feed harness (20) into engine compartment.
5. Install washer (14), ground strap (15), and harness ground wire (18) on right side of turn signal flasher box (13) with screw (19), washer (12), and new locknut (11).
6. Connect wire (16) to connector (17).
7. Feed harness (20) along main wiring harness (27), under cab, along cab frame (35), and through cab floor hole (36).
8. Position alarm unit bracket (23) on rear cab panel (21) and install with two screws (24) and new locknuts (22).
9. Insert harness (20) through two clamps (26) and tighten screws (25).
10. Install harness (20) on rear cab panel (21) with clamp (38) and screw (39).

NOTE

Assistant will help with steps 11 through 14.

11. Insert harness (20) in grommet (37) and install in cab floor hole (36).
12. Install harness (20) on frame (35) with two clamps (34) and screws (33).
13. Install harness (20) on main wiring harness (27) with four new tiedown straps (28).
14. Install harness (20) on firewall (32) with clamp (29), screw (30), and new locknut (31).
15. Install M43 detector and M42 alarm unit (TM 3-6665-225-12).
16. Connect battery ground cable (WP 0126 00).
17. Lower and secure hood (TM 9-2320-361-10).
18. Release parking brake and remove wheel chocks (TM 9-2320-361-10).

CHEMICAL AGENT ALARM MOUNTING KIT REPLACEMENT (Contd)

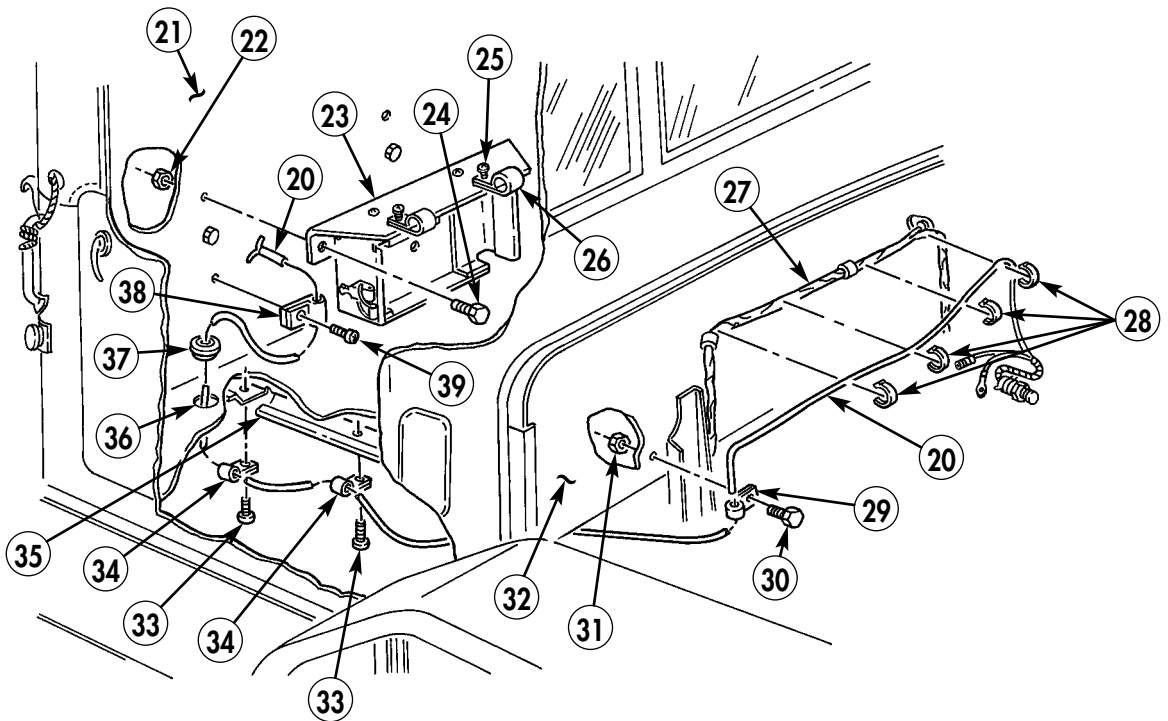
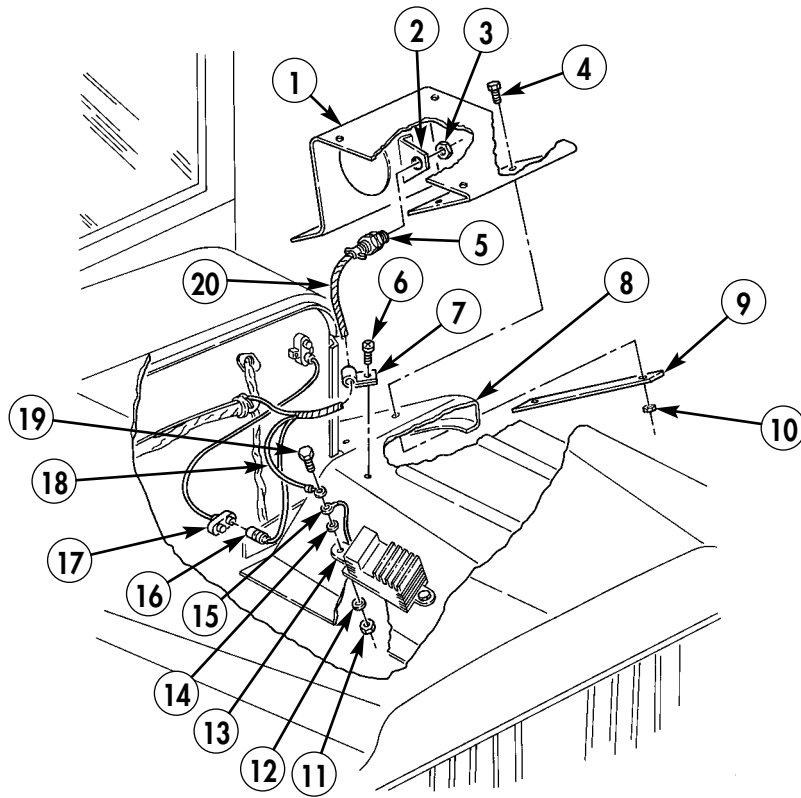

END OF WORK PACKAGE

FIELD MAINTENANCE INSTRUCTIONS FOR SPECIAL PURPOSE KITS

2-1/2 TON, 6X6, M44A2 SERIES TRUCKS (MULTIFUEL)

FIRE EXTINGUISHER AND MOUNTING KIT REPLACEMENT REMOVAL AND INSTALLATION

INITIAL SETUP:

Applicable Models

All

Materials/Parts

Four locknuts (item 130, WP 0470 00)

Tools and Special Tools

General mechanic's tool kit
(item 116, WP 0469 00)

Equipment Condition

Parking brake set and wheels chocked
(TM 9-2320-361-10).

FIRE EXTINGUISHER AND MOUNTING KIT RELACEMENT (Contd)**REMOVAL**

1. Open two clamps (6), and remove fire extinguisher (8) from mounting bracket (7).
2. Remove four locknuts (3), screws (1), washers (2), and mounting bracket (7) from cab (4). Discard locknuts (3).

INSTALLATION

1. Install mounting bracket (7) on cab (4) with four washers (2), screws (1), and new locknuts (3).
2. Install fire extinguisher (8) on mounting bracket (7) and close two clamps (6).
3. Tighten or loosen adjusting screws (5) to hold fire extinguisher (8) in place.
4. Release parking brake and remove wheel chocks (TM 9-2320-361-10).

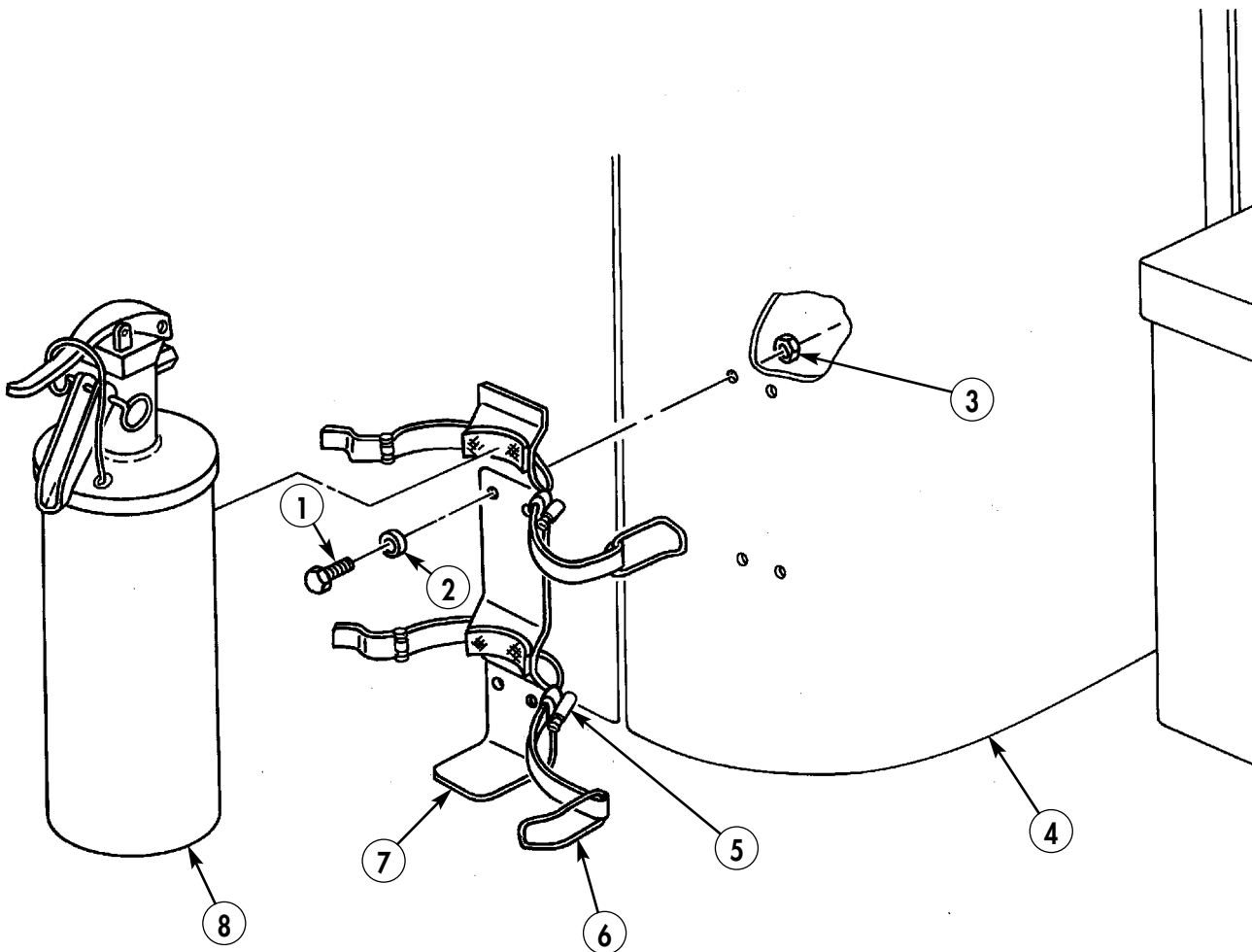

FIELD MAINTENANCE INSTRUCTIONS FOR SPECIAL PURPOSE KITS

2-1/2 TON, 6X6, M44A2 SERIES TRUCKS (MULTIFUEL)

BUMPER STEP KIT REPLACEMENT REMOVAL AND INSTALLATION

INITIAL SETUP:

Applicable Models

All

Tools and Special Tools

General mechanic's tool kit
(item 116, WP 0469 00)

Materials/Parts

Two locknuts (item 161, WP 0470 00)
Two locknuts (item 147, WP 0470 00)
Two lockwashers (item 206, WP 0470 00)

Equipment Condition

Parking brake set and wheels chocked
(TM 9-2320-361-10).
Battery ground cable disconnected
(WP 0126 00).

BUMPER STEP KIT REPLACEMENT (Contd)

REMOVAL

1. Remove safety pin (8) from pin (10).
2. Remove pin (10) from bumper step (9) and bracket (3).
3. Remove S-hook (11) from bumper step (9).
4. Remove two locknuts (5), lockwashers (6), washers (7), screws (12), and bumper step (9) from bracket (3). Discard lockwashers (6) and locknuts (5).
5. Remove two locknuts (2), screws (4), and bracket (3) from bumper (1). Discard locknuts (2).

INSTALLATION

1. Install bracket (3) on bumper (1) with two screws (4) and new locknuts (2).
2. Install bumper step (9) on bracket (3) with two screws (12), washers (7), new lockwashers (6), and new locknuts (5).
3. Install S-hook (11) on bumper step (9).
4. Install pin (10) on bumper step (9) and bracket (3).
5. Install safety pin (8) in pin (10).

NOTE

Ensure step is in stowed position before truck is mobilized.

6. Connect battery ground cable (WP 0126 00).
7. Release parking brake and remove wheel chocks (TM 9-2320-361-10).

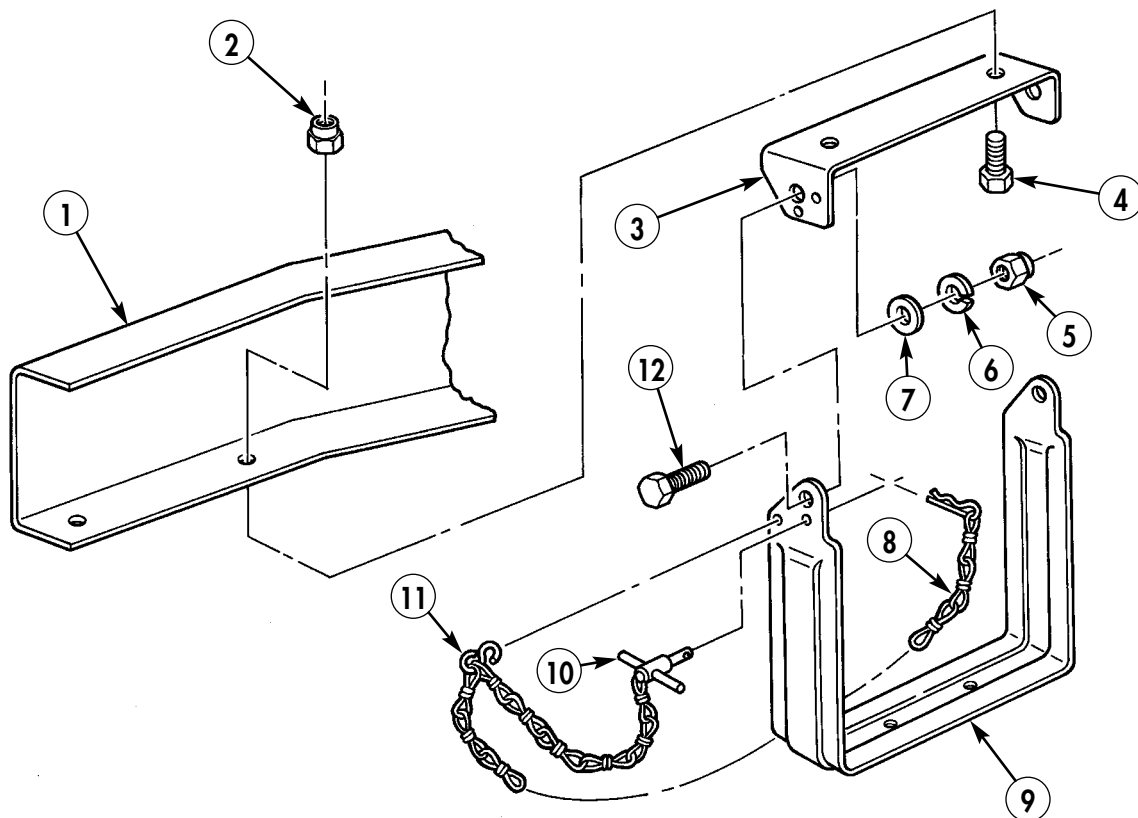

END OF WORK PACKAGE

FIELD MAINTENANCE INSTRUCTIONS FOR SPECIAL PURPOSE KITS

2-1/2 TON, 6X6, M44A2 SERIES TRUCKS (MULTIFUEL)

TROOP SEAT CENTER MOUNTED KIT REPLACEMENT REMOVAL AND INSTALLATION

INITIAL SETUP:

Applicable Models

M35A2, M35A2C

Personnel Required

Two

Tools and Special Tools

General mechanic's tool kit
(item 116, WP 0469 00)

Equipment Condition

Parking brake set and wheels chocked
(TM 9-2320-361-10).
Battery ground cable disconnected
(WP 0126 00).

Materials/Parts

Twenty locknuts (item 129, WP 0470 00)
Five cotter pins (item 25, WP 0470 00)

TROOP SEAT CENTER MOUNTED KIT REPLACEMENT (Contd)

REMOVAL

1. Remove five cotter pins (5) and pins (3) from hinges of troop seat (1) and side rack (2). Discard cotter pins (5).
2. Rotate two latches (4) and remove troop seat (1) from side rack (2).
3. Remove side rack (2) from pockets (6), (7), (8), (11), and (21).

NOTE

Assistant will help with steps 4 through 6.

4. Remove eight locknuts (19), washers (20), screws (23), washers (22), and pockets (6) and (21) from cargo body floor (15). Discard locknuts (19).
5. Remove four locknuts (17), washers (18), two reinforcements (16), four screws (24), washers (25), and pocket (11) from cargo body floor (15). Discard locknuts (17).
6. Remove eight locknuts (14), washers (13), two reinforcements (12), eight screws (9), washers (10), and pockets (7) and (8) from cargo body floor (15). Discard locknuts (14).

INSTALLATION

NOTE

Assistant will help with steps 1 through 5.

1. Position pockets (7) and (8) on cargo body floor (15) with eight washers (10) and screws (9).
2. Install two reinforcements (12) on eight screws (9) with eight washers (13) and new locknuts (14).
3. Position pocket (11) on cargo body floor (15) with four washers (25) and screws (24).
4. Place two reinforcements (16) on four screws (24) and install with four washers (18) and new locknuts (17).
5. Position pockets (6) and (21) on cargo body floor (15) with eight washers (22) and screws (23). Install with eight washers (20) and new locknuts (19).
6. Install side rack (2) in pockets (6), (7), (8), (11), and (21).
7. Install troop seat (1) on side rack (2) with five pins (3) and new cotter pins (5).
8. Raise troop seat (1) in stow position and hold in place with two latches (4).
9. Connect battery ground cable (WP 0126 00).
10. Release parking brake and remove wheel chocks (TM 9-2320-361-10).

TROOP SEAT CENTER MOUNTED KIT REPLACEMENT (Contd)

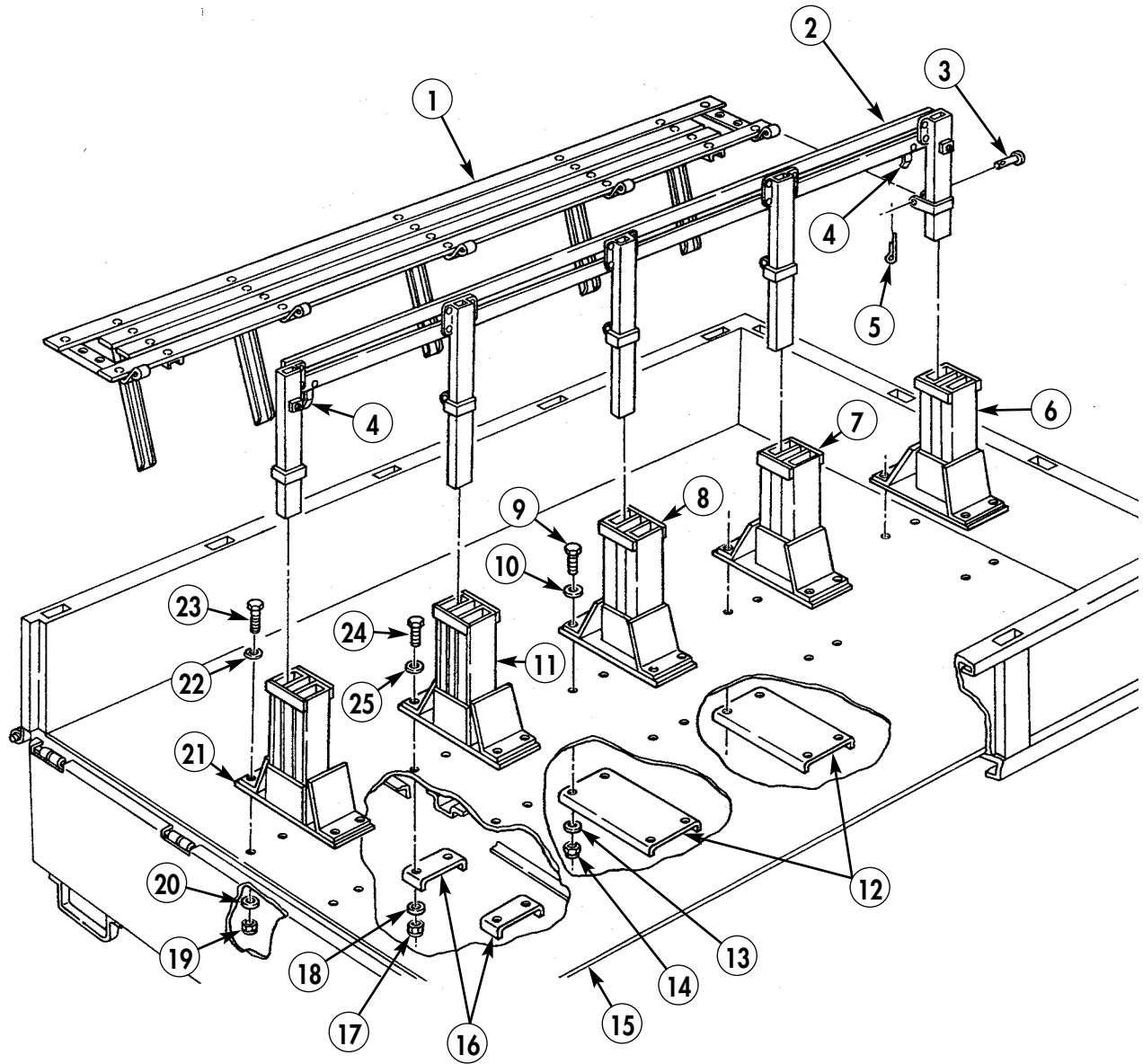

END OF WORK PACKAGE

0395 00-3/4 blank

FIELD MAINTENANCE INSTRUCTIONS FOR SPECIAL PURPOSE KITS

2-1/2 TON, 6X6, M44A2 SERIES TRUCKS (MULTIFUEL)

FIXED SEATBELT KIT REPLACEMENT

REMOVAL OF DRIVER'S SEATBELTS, INSTALLATION OF DRIVER'S SEATBELTS,
REMOVAL OF COMPANION SEATBELTS, AND INSTALLATION OF COMPANION SEATBELTS

INITIAL SETUP:

Applicable Models

All

Personnel Required

Two

Tools and Special Tools

General mechanic's tool kit
(item 116, WP 0469 00)

Equipment Condition

Parking brake set and wheels chocked
(TM 9-2320-361-10).
Battery ground cable disconnected
(WP 0126 00).
Companion seat removal (WP 0234 00).

Materials/Parts

Four locknuts (item 133, WP 0470 00)
Eight locknuts (item 161, WP 0470 00)

FIXED SEATBELT KIT REPLACEMENT (Contd)

REMOVAL OF DRIVER'S SEATBELTS

1. Pull driver's seat (1) to full forward position.
2. Remove locknut (5), screw (2), two washers (3), and seatbelt (4) from back cab panel channel (6). Discard locknut (5).
3. Remove locknut (8), washer (9), screw (25), seatbelt (7), and spacer (26) from back cab panel channel (6). Discard locknut (8).

NOTE

Assistant will help with step 4.

4. Remove four locknuts (24), screws (10), and eight washers (11) from back cab panel channel (6). Discard locknuts (24).

INSTALLATION OF DRIVER'S SEATBELTS

1. Install seatbelt (4) on back cab panel channel (6) with two washers (3), screw (2), and new locknut (5).
2. Install spacer (26) and seatbelt (7) on back cab panel channel (6) with screw (25), washer (9), and new locknut (8).

NOTE

Assistant will help with step 3.

3. Install eight washers (11), four screws (10), and new locknuts (24) on back cab panel channel (6).

REMOVAL OF COMPANION SEATBELTS

1. Remove locknut (16), seatbelt (17), spacer (22), screw (12), and washer (13) from back cab panel channel (6). Discard locknut (16).
2. Remove locknut (21), seatbelt (18), screw (19), and washer (20) from back cab panel channel (6). Discard locknut (21).

NOTE

Assistant will help with step 3.

3. Remove four locknuts (23), screws (14), and eight washers (15) from back cab panel channel (6).

INSTALLATION OF COMPANION SEATBELTS

1. Install seatbelt (18) on back cab panel channel (6) with screw (19), washer (20), and new locknut (21).
2. Install spacer (22) and seatbelt (17) on back cab panel channel (6) with screw (12), washer (13), and new locknut (16).

NOTE

Assistant will help with step 3.

3. Install eight washers (15), four screws (14), and new locknuts (23) on back cab panel channel (6).
4. Install companion seat (WP 0234 00).
5. Connect battery ground cable (WP 0126 00).
6. Release parking brake and remove wheel chocks (TM 9-2320-361-10).

FIXED SEATBELT KIT REPLACEMENT (Contd)

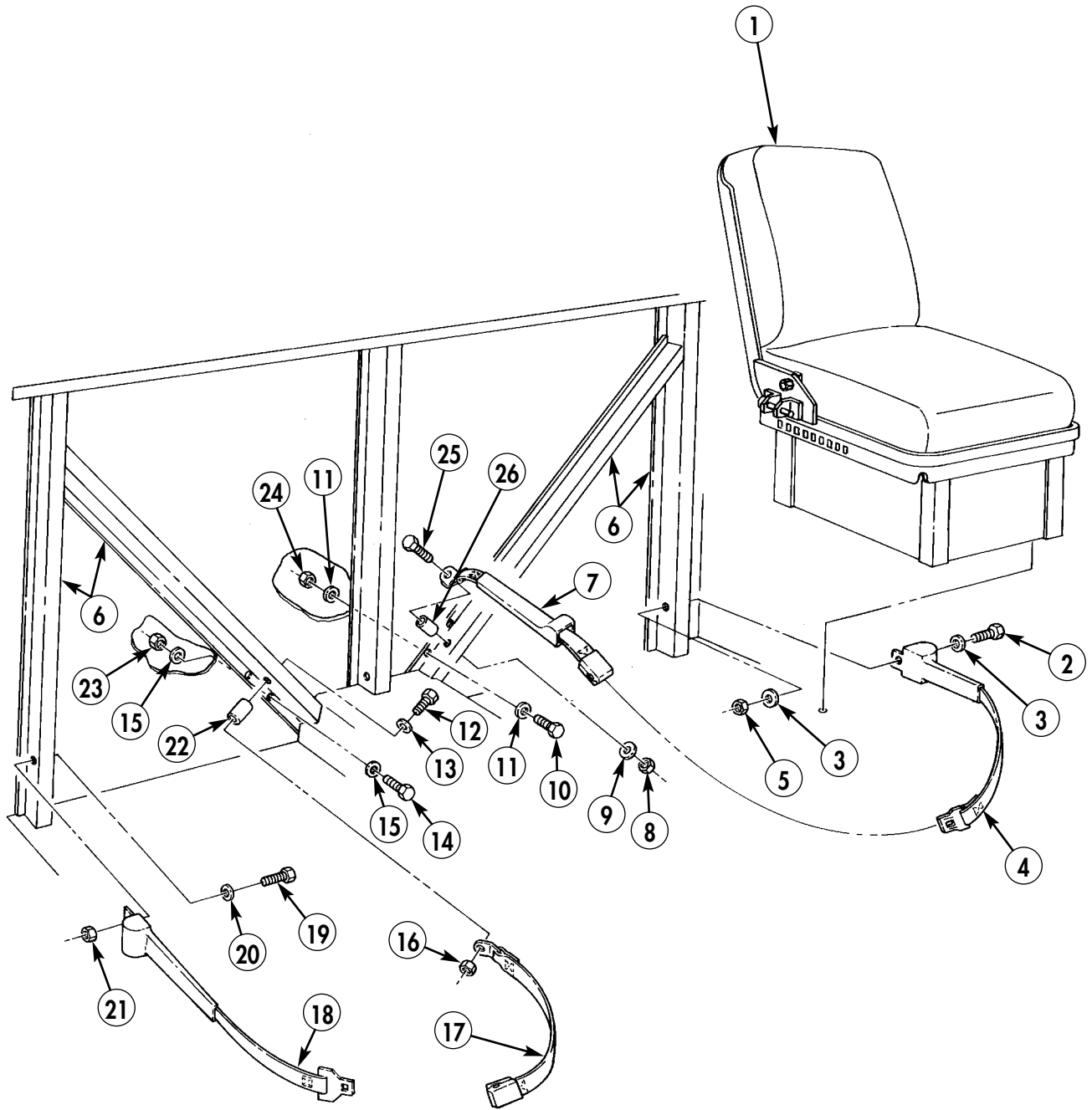

END OF WORK PACKAGE

0396 00-3/4 blank

FIELD MAINTENANCE INSTRUCTIONS FOR SPECIAL PURPOSE KITS

2-1/2 TON, 6X6, M44A2 SERIES TRUCKS (MULTIFUEL)

FLOATING SEATBELT KIT REPLACEMENT

REMOVAL OF DRIVER'S SEATBELTS, INSTALLATION OF DRIVER'S SEATBELTS,
REMOVAL OF COMPANION SEATBELTS, AND INSTALLATION OF COMPANION SEATBELTS

INITIAL SETUP:

Applicable Models

All

Personnel Required

Two

Tools and Special Tools

General mechanic's tool kit
(item 116, WP 0469 00)

Equipment Condition

Parking brake set and wheels chocked
(TM 9-2320-361-10).
Battery ground cable disconnected
(WP 0126 00).
Companion seat removal (WP 0234 00).

Materials/Parts

Four locknuts (item 133, WP 0470 00)
Eight locknuts (item 161, WP 0470 00)

FLOATING SEATBELT KIT REPLACEMENT (Contd)

REMOVAL OF DRIVER'S SEATBELTS

1. Position driver's seat (1) to full forward position.
2. Remove two screws (2), three washers (3), seatbelts (8), and wire ropes (6) and (7) from driver's seat (1).
3. Remove locknut (11), screw (4), two washers (5), and wire rope (6) from back cab panel channel (26). Discard locknut (11).
4. Remove locknut (28), screw (9), two washers (10), spacer (29), and wire rope (7) from back cab panel channel (26). Discard locknut (28).

NOTE

Assistant will help with step 5.

5. Remove four locknuts (27), screws (12), and eight washers (13) from back cab panel channel (26). Discard locknuts (27).

INSTALLATION OF DRIVER'S SEATBELTS

NOTE

Assistant will help with step 1.

1. Install eight washers (13), four screws (12), and new locknuts (27) on back cab panel channel (26).
2. Install wire rope (6) on back cab panel channel (26) with two washers (5), screw (4), and new locknut (11).
3. Install wire rope (7) and spacer (29) on back cab panel channel (26) with two washers (10), screw (9), and new locknut (28).
4. Install two seatbelts (8) and wire ropes (6) and (7) on driver's seat (1) with three washers (3) and screws (2).

REMOVAL OF COMPANION SEATBELTS

1. Remove locknut (18), screw (14), washer (15), seatbelt (19), and spacer (24) from back cab panel channel (26). Discard locknut (18).
2. Remove locknut (23), screw (21), washer (22), and seatbelt (20) from back cab panel channel (26). Discard locknut (23).

NOTE

Assistant will help with step 3.

3. Remove four locknuts (25), screws (16), and eight washers (17) from back cab panel channel (26). Discard locknuts (25).

FLOATING SEATBELT KIT REPLACEMENT (Contd)

INSTALLATION OF COMPANION SEATBELTS

NOTE

Assistant will help with step 1.

1. Install eight washers (17), four screws (16), and new locknuts (25) on back cab panel channel (26).
2. Install seatbelt (20) on back cab panel channel (26) with screw (21), washer (22), and new locknut (23).
3. Install spacer (24) and seatbelt (19) on back cab panel channel (26) with screw (14), washer (15), and new locknut (18).
4. Install companion seat (WP 0234 00).
5. Connect battery ground cable (WP 0126 00).
6. Release parking brake and remove wheel chocks (TM 9-2320-361-10).

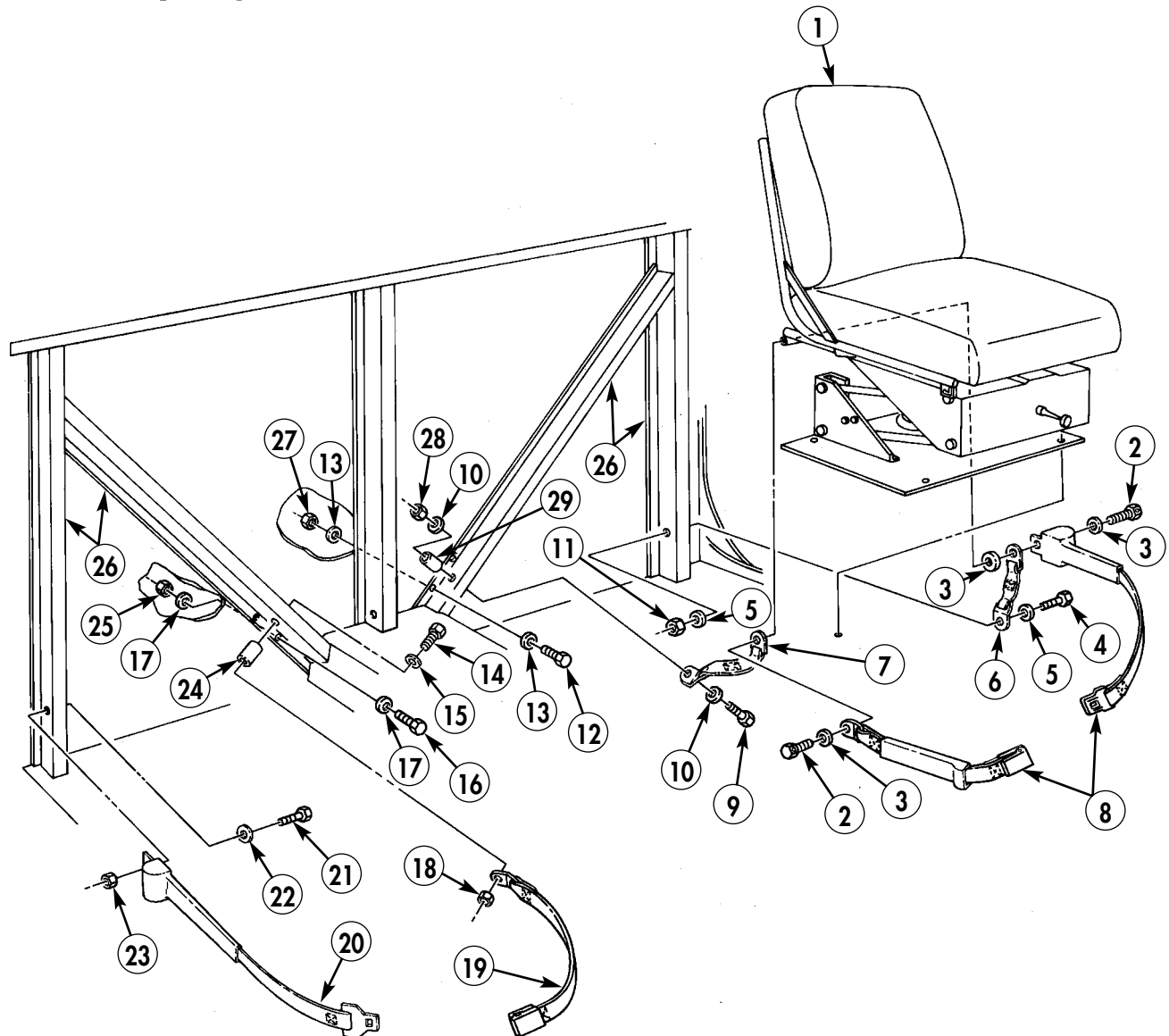

END OF WORK PACKAGE

FIELD MAINTENANCE INSTRUCTIONS FOR SPECIAL PURPOSE KITS

2-1/2 TON, 6X6, M44A2 SERIES TRUCKS (MULTIFUEL)

COMPANION SEAT AND LEG EXTENSION REPLACEMENT REMOVAL AND INSTALLATION

INITIAL SETUP:

Applicable Models

All

Tools and Special Tools

General mechanic's tool kit
(item 116, WP 0469 00)

Materials/Parts

Four lockwashers (item 207, WP 0470 00)
Four locknuts (item 153, WP 0470 00)

Equipment Condition

Parking brake set and wheels chocked
(TM 9-2320-361-10).
Battery ground cable disconnected
(WP 0126 00).

COMPANION SEAT AND LEG EXTENSION REPLACEMENT (Contd)

REMOVAL

1. Remove four screws (9) and companion seat assembly (1) from vehicle floor (4).
2. Remove four locknuts (2), screws (6), and inner support leg (3) from seat frame (5). Discard locknuts (2).
3. Remove four nuts (7), lockwashers (8), screws (11), and two leg extensions (10) from seat frame (5). Discard lockwashers (8).

INSTALLATION

1. Install two leg extensions (10) on seat frame (5) with four screws (11), new lockwashers (8), and nuts (7).
2. Install inner support leg (3) on seat frame (5) with four screws (6) and new locknuts (2).
3. Install companion seat assembly (1) on vehicle floor (4) with four screws (9).
4. Connect battery ground cable (WP 0126 00).
5. Release parking brake and remove wheel chocks (TM 9-2320-361-10).

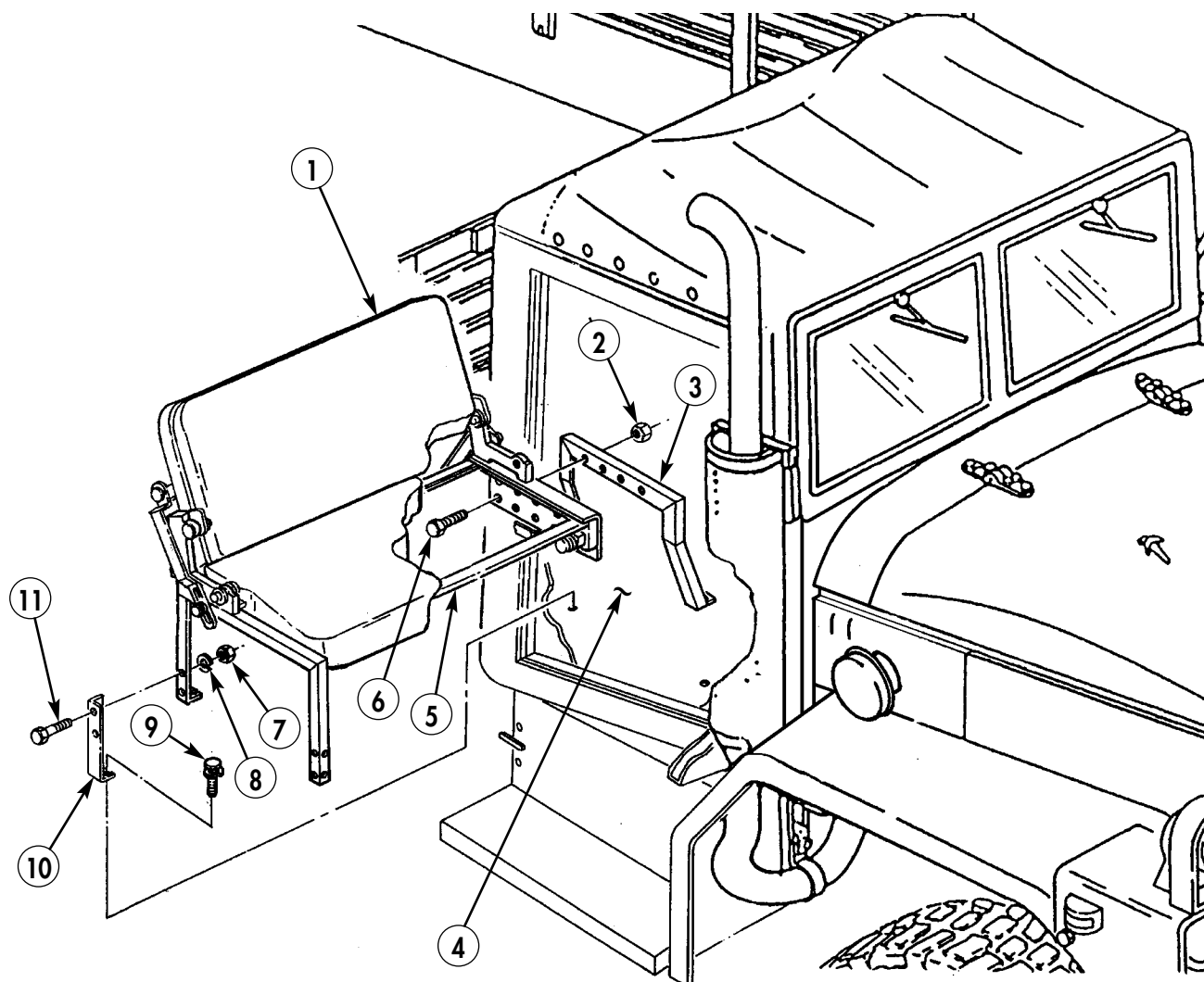

END OF WORK PACKAGE

FIELD MAINTENANCE INSTRUCTIONS FOR SPECIAL PURPOSE KITS

2-1/2 TON, 6X6, M44A2 SERIES TRUCKS (MULTIFUEL)

SWINGFIRE HEATER AND MOUNTING BRACKETS REPLACEMENT REMOVAL AND INSTALLATION

INITIAL SETUP:

Applicable Models

All

Tools and Special Tools

General mechanic's tool kit
(item 116, WP 0469 00)

Materials/Parts

Fourteen lockwashers (item 195, WP 0470 00)
Fourteen locknuts (item 129, WP 0470 00)

Equipment Condition

Parking brake set and wheels chocked
(TM 9-2320-361-10).
Battery ground cable disconnected
(WP 0126 00).
Companion seat removed (WP 0398 00).

SWINGFIRE HEATER AND MOUNTING BRACKETS REPLACEMENT (Contd)

REMOVAL

1. Unlock clamp handle (3) from clip (9) and remove clamp (2) and swingfire heater (1) from stowage brackets (14) and (5).
2. Remove four locknuts (11), lockwashers (10), screws (13), three screws (6), and storage bracket (14) from floor (12). Discard lockwashers (10) and locknuts (11).
3. Remove two locknuts (8), lockwashers (7), screws (4), and stowage bracket (5) from floor (12). Discard locknuts (8) and lockwashers (7).
4. Unlock clips (17) and (20), open clamps (16) and (19), and remove swingfire barrel (15) from stowage brackets (18) and (23).
5. Remove eight locknuts (22), lockwashers (21), screws (24), and stowage brackets (18) and (23) from floor (12). Discard locknuts (22) and lockwashers (21).

INSTALLATION

1. Install stowage brackets (23) and (18) on floor (12) with eight screws (24), new lockwashers (21), and new locknuts (22).
2. Install swingfire barrel (15) on stowage brackets (18) and (23) with clamps (16) and (19) and lock clips (17) and (20).
3. Install stowage bracket (5) on floor (12) with two screws (4), new lockwashers (7), and new locknuts (8).
4. Install stowage bracket (14) on floor (12) with screw (13), three screws (6), four new lockwashers (10), and new locknuts (11).
5. Install swingfire heater (1) on stowage brackets (14) and (5) with clamp (2) and lock clamp handle (3) to clip (9).
6. Install companion seat (WP 0398 00).
7. Connect battery ground cable (WP 0126 00).
8. Release parking brake and remove wheel chocks (TM 9-2320-361-10).

SWINGFIRE HEATER AND MOUNTING BRACKETS REPLACEMENT (Contd)

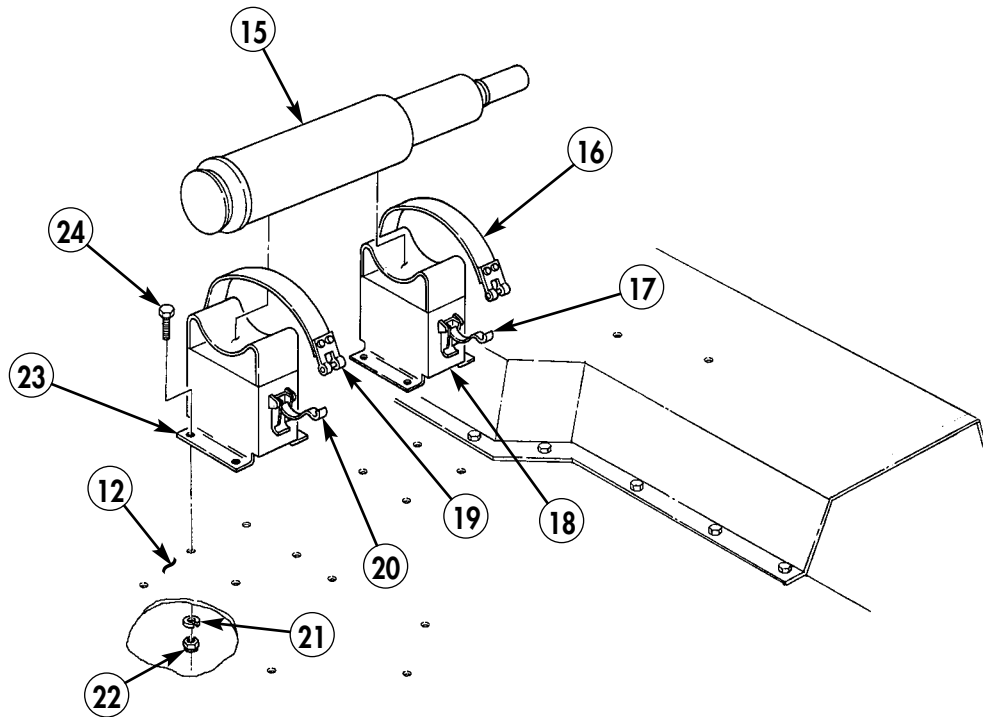
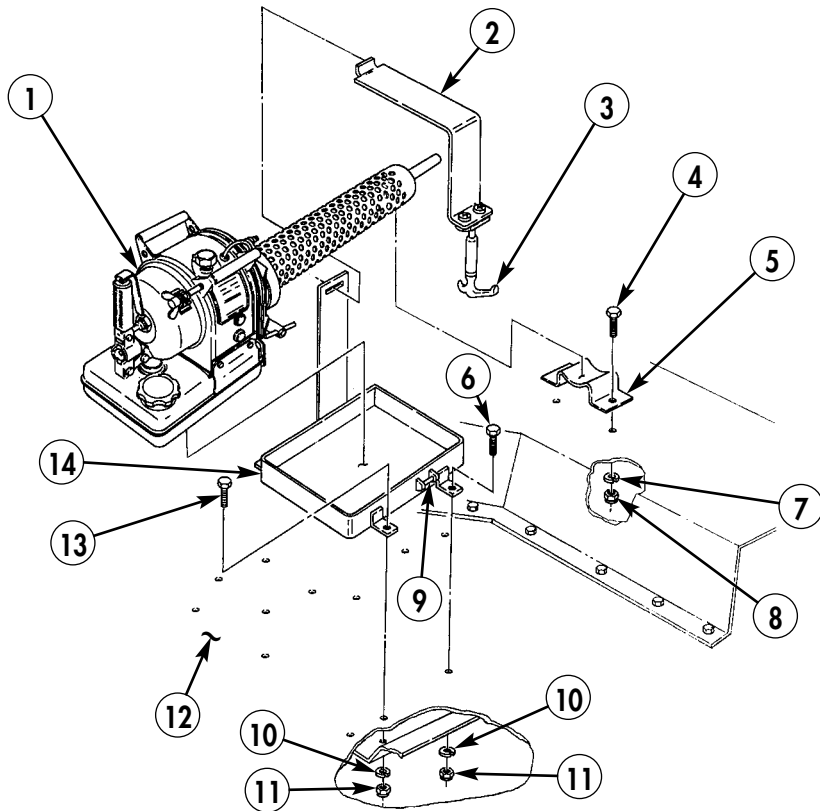

END OF WORK PACKAGE

FIELD MAINTENANCE INSTRUCTIONS FOR SPECIAL PURPOSE KITS

2-1/2 TON, 6X6, M44A2 SERIES TRUCKS (MULTIFUEL)

SWINGFIRE HEATER BATTERY BOX TUBE REPLACEMENT REMOVAL AND INSTALLATION

INITIAL SETUP:

Applicable Models

All

Tools and Special Tools

General mechanic's tool kit
(item 116, WP 0469 00)

Materials/Parts

Six locknuts (item 155, WP 0470 00)
Four locknuts (item 129, WP 0470 00)
Two lockwashers (item 195, WP 0470 00)

Equipment Condition

Parking brake set and wheels chocked
(TM 9-2320-361-10).
Battery box removed (WP 0127 00).

SWINGFIRE HEATER BATTERY BOX TUBE REPLACEMENT (Contd)

REMOVAL

1. Remove two nuts (11), lockwashers (10), screws (7), clamp (9), and exhaust tube (8) from exhaust elbow (16). Discard lockwashers (10).
2. Remove four locknuts (13) and screws (15) from battery support plate (2) and running board supports (6) and (14). Discard locknuts (13).
3. Remove pan assembly (1), insulation (3), and battery support plate (2) from baffle plate (5).
4. Remove six locknuts (12), screws (4), and baffle plate (5) from running board supports (6) and (14). Discard locknuts (12).

INSTALLATION

1. Install baffle plate (5) on running board supports (6) and (14) with six screws (4) and new locknuts (12).
2. Install pan assembly (1), insulation (3), and battery support plate (2) on baffle plate (5).
3. Install battery support plate (2) on running board supports (6) and (14) with four screws (15) and new locknuts (13).
4. Install exhaust tube (8) and clamp (9) on exhaust elbow (16) with two screws (7), new lockwashers (10) and nuts (11).
5. Install battery box (WP 0127 00).
6. Release parking brake and remove wheel chocks (TM 9-2320-361-10).

SWINGFIRE HEATER BATTERY BOX TUBE REPLACEMENT (Contd)

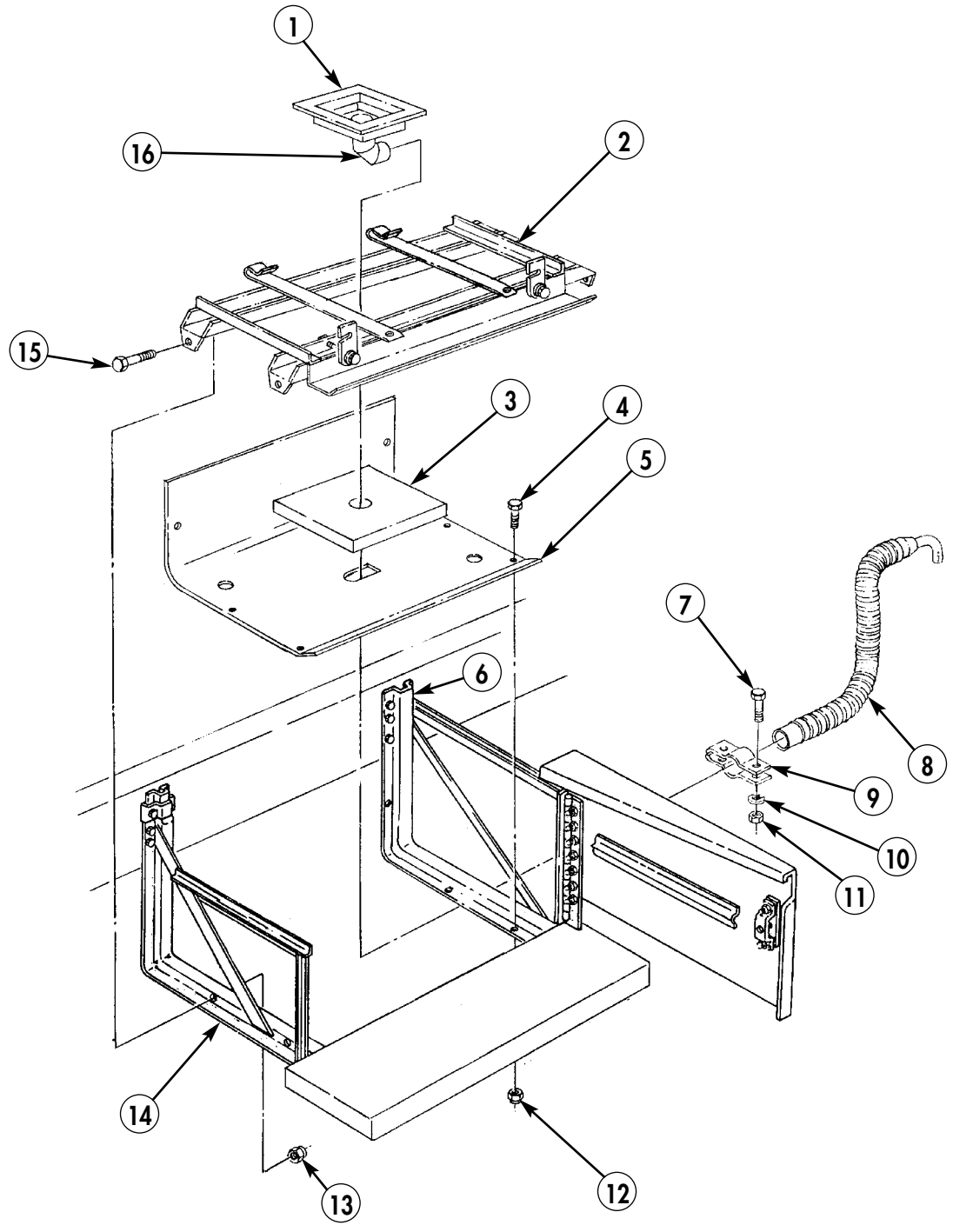

END OF WORK PACKAGE

0400 00-3/4 blank

FIELD MAINTENANCE INSTRUCTIONS FOR SPECIAL PURPOSE KITS

2-1/2 TON, 6X6, M44A2 SERIES TRUCKS (MULTIFUEL)

SWINGFIRE HEATER WATER JACKET REPLACEMENT REMOVAL AND INSTALLATION

INITIAL SETUP:

Applicable Models

All

Tools and Special Tools

General mechanic's tool kit
(item 116, WP 0469 00)

Equipment Condition

Parking brake set and wheels chocked
(TM 9-2320-361-10).

Battery ground cable disconnected
(WP 0126 00).

Cooling system drained (WP 0076 00).

Materials/Parts

Two locknuts (item 129, WP 0470 00)

Two lockwashers (item 195, WP 0470 00)

Sealing compound (item 32, WP 0468 00)

SWINGFIRE HEATER WATER JACKET REPLACEMENT (Contd)

REMOVAL

NOTE

Have drainage container ready to catch coolant.

1. Remove drain plug (5) and drain coolant from water jacket (4).
2. Remove two nuts (14), lockwashers (15), screws (17), clamp (16), and exhaust tube (13) from exhaust port (18). Discard lockwashers (15).
3. Loosen clamps (7) and (12) and remove inlet hose (11) from inlet port (1) and outlet hose (6) from outlet port (3).
4. Remove two locknuts (9), screws (2), and water jacket (4) from brackets (8) and (10). Discard locknuts (9).

INSTALLATION

1. Install water jacket (4) on brackets (8) and (10) with two screws (2) and new locknuts (9).
2. Install inlet hose (11) on inlet port (1) and outlet hose (6) on outlet port (3) and tighten clamps (12) and (7).
3. Install exhaust tube (13) on exhaust port (18) with two screws (17), new lockwashers (15), and nuts (14).
4. Apply sealant to male threads of drain plug (5).
5. Install drain plug (5) on water jacket (4).
6. Fill cooling system to proper level (WP 0076 00).
7. Connect battery ground cable (WP 0126 00).
8. Release parking brake and remove wheel chocks (TM 9-2320-361-10).

SWINGFIRE HEATER WATER JACKET REPLACEMENT (Contd)

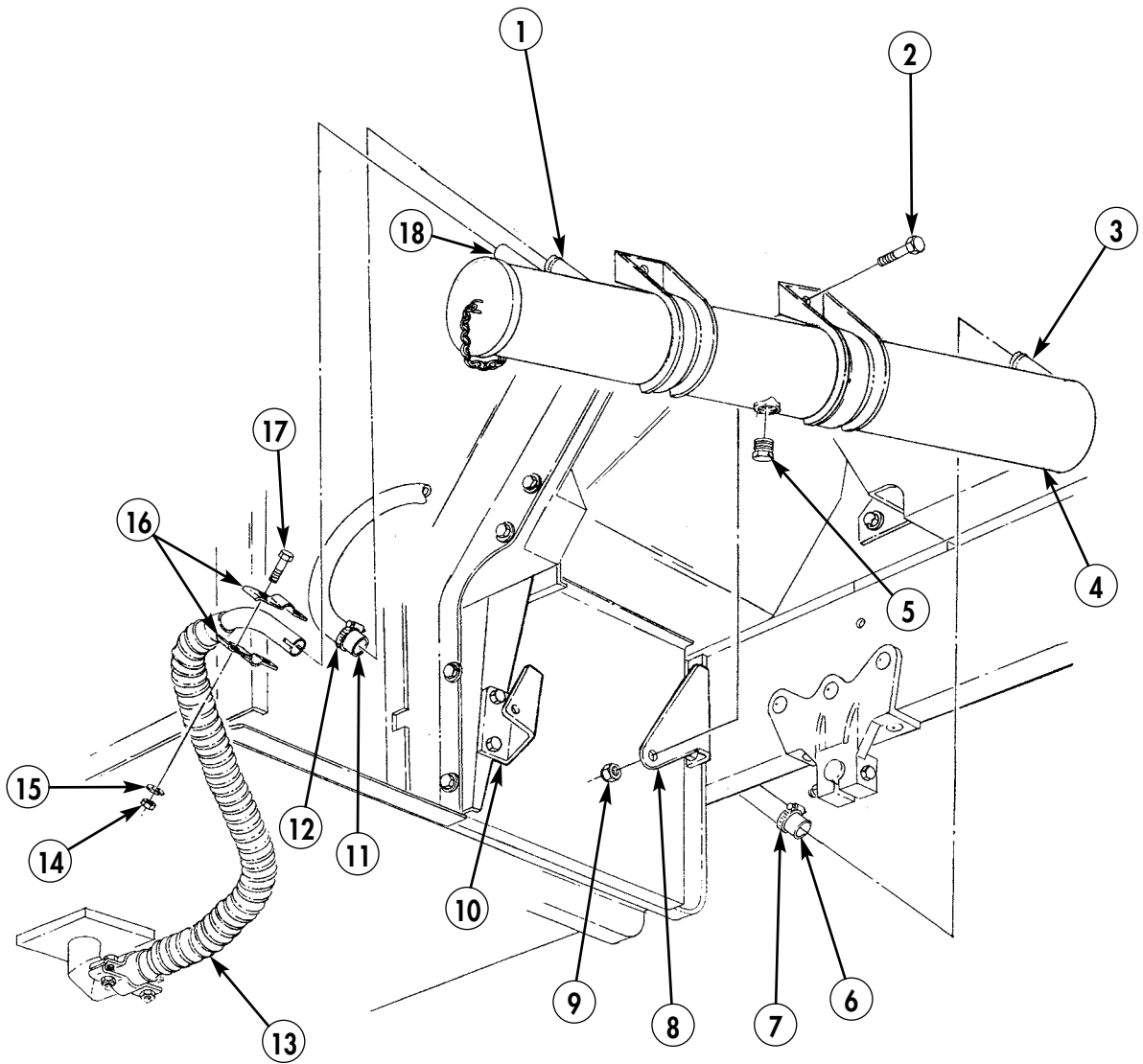

END OF WORK PACKAGE

0401 00-3/4 blank

FIELD MAINTENANCE INSTRUCTIONS FOR SPECIAL PURPOSE KITS

2-1/2 TON, 6X6, M44A2 SERIES TRUCKS (MULTIFUEL)

SWINGFIRE HEATER WATER HOSES REPLACEMENT REMOVAL AND INSTALLATION

INITIAL SETUP:

Applicable Models

All

Tools and Special Tools

General mechanic's tool kit
(item 116, WP 0469 00)

Materials/Parts

Two locknuts (item 129, WP 0470 00)
O-ring (item 281, WP 0470 00)
O-ring (item 282, WP 0470 00)
Sealing compound (item 32, WP 0468 00)

Equipment Condition

Parking brake set and wheels chocked
(TM 9-2320-361-10).
Battery ground cable disconnected
(WP 0126 00).
Hood raised and secured (TM 9-2320-361-10).
Cooling system drained (WP 0076 00).
Swingfire heater water jacket drained
(WP 0401 00).

SWINGFIRE HEATER WATER HOSES REPLACEMENT (Contd)

REMOVAL

1. Remove clamps (3) and (7), outlet hose (2), and inlet hose (1) from outlet port (4) and inlet port (6) on water jacket (5).
2. Remove clamps (19) and outlet hose (1) from adapter (18).
3. Remove two locknuts (21), screws (23), clamps (20), and outlet hose (1) from fender (22). Discard locknuts (21).
4. Remove clamp (8) and inlet hose (2) from adapter (9).
5. Remove adapter (9) from elbow (10).
6. Loosen jamnut (11) and remove elbow (10) and O-ring (12) from engine (13). Discard O-ring (12).
7. Remove adapter (18) from fitting (17).
8. Loosen jamnut (16) and remove fitting (17) and O-ring (15) from water pump housing (14). Discard O-ring (15).

INSTALLATION

1. Apply sealant to male threads of adapters (9) and (18).
2. Install new O-ring (15) and fitting (17) on water pump housing (14) and tighten jamnut (16).
3. Install adapter (18) on fitting (17).
4. Install new O-ring (12) and elbow (10) on engine (13) and tighten jamnuts (11).
5. Install adapter (9) on elbow (10).
6. Install inlet hose (2) on adapter (9) with clamp (8).
7. Install outlet hose (1) on adapter (18) with clamp (19).
8. Install outlet hose (1) and two clamps (20) on fender (22) with two screws (23) and new locknuts (21).
9. Install outlet hose (1) on inlet port (6) on water jacket (5) with clamp (7).
10. Install inlet hose (2) on outlet port (4) on water jacket (5) with clamp (3).
11. Fill swingfire heater water jacket to proper level (WP 0401 00).
12. Fill cooling system to proper level (WP 0076 00).
13. Lower hood and secure (TM 9-2320-361-10).
14. Connect battery ground cable (WP 0126 00).
15. Release parking brake and remove wheel chocks (TM 9-2320-361-10).

SWINGFIRE HEATER WATER HOSES REPLACEMENT (Contd)

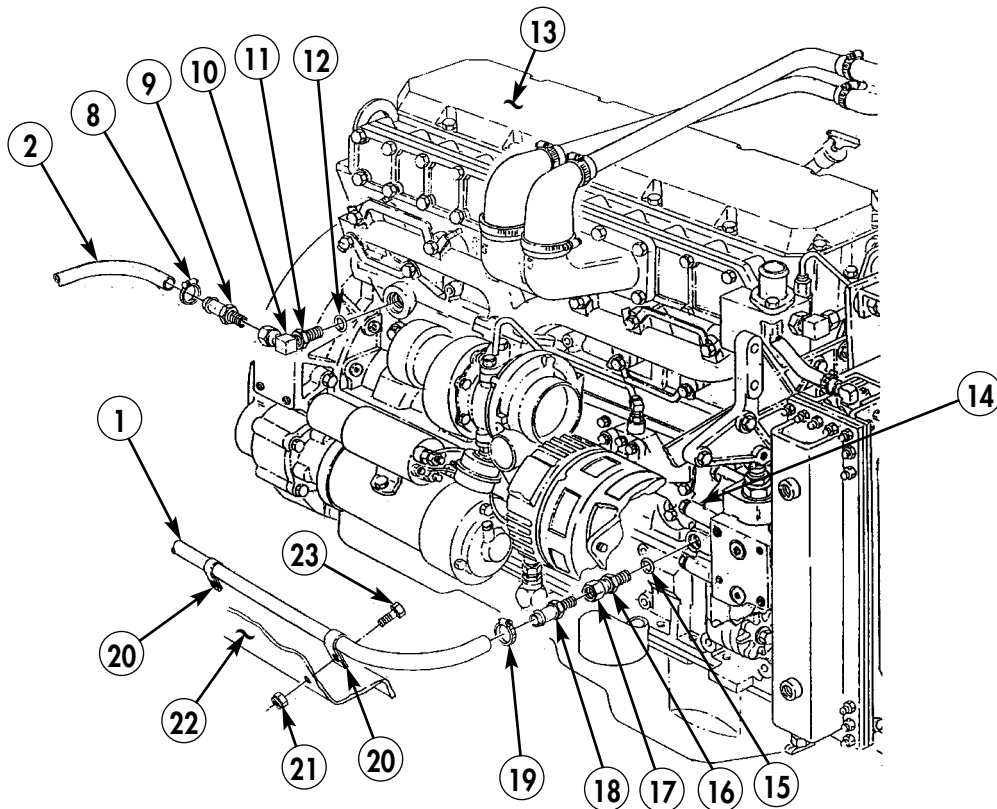
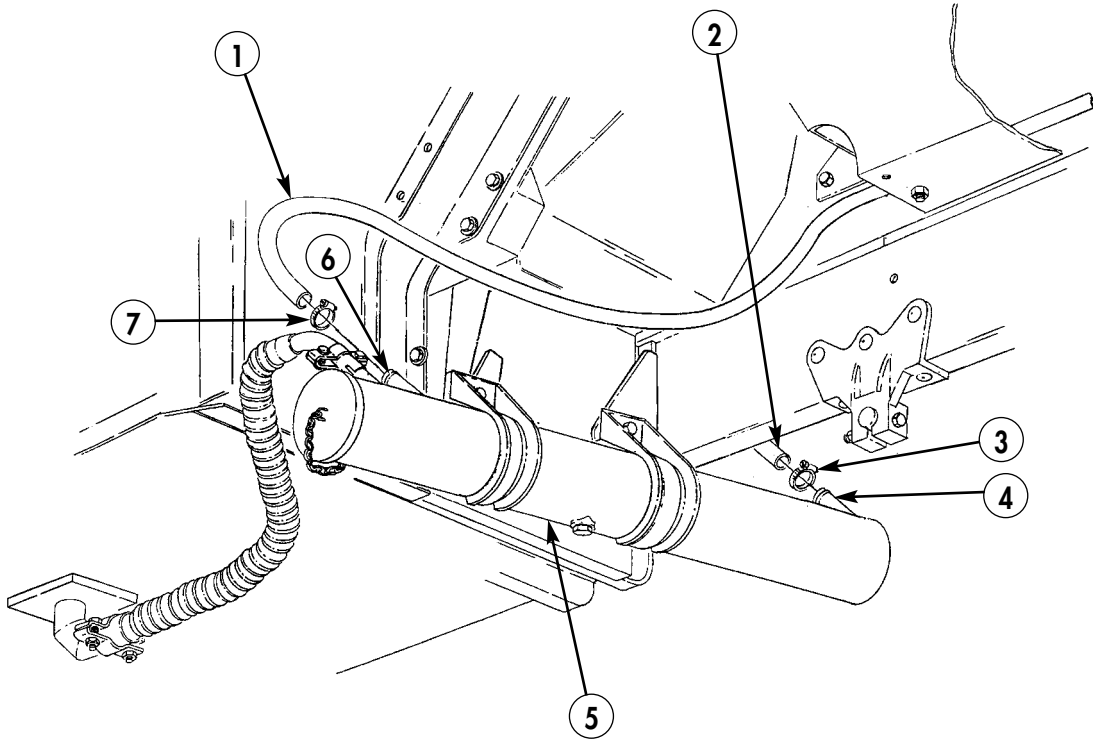

END OF WORK PACKAGE

FIELD MAINTENANCE INSTRUCTIONS FOR SPECIAL PURPOSE KITS

2-1/2 TON, 6X6, M44A2 SERIES TRUCKS (MULTIFUEL)

SWINGFIRE HEATER WATER JACKET BRACKETS REPLACEMENT REMOVAL AND INSTALLATION

INITIAL SETUP:

Applicable Models

All

Tools and Special Tools

General mechanic's tool kit
(item 116, WP 0469 00)

Materials/Parts

Two locknuts (item 129, WP 0470 00)
Two locknuts (item 154, WP 0470 00)

Equipment Condition

Parking brake set and wheels chocked
(TM 9-2320-361-10).
Battery ground cable disconnected
(WP 0126 00).
Swingfire heater water jacket removed
(WP 0401 00).

SWINGFIRE HEATER WATER JACKET BRACKETS REPLACEMENT (Contd)

REMOVAL

1. Remove two locknuts (7), screws (1), and bracket (2) from fender brace (8). Discard locknuts (7).
2. Remove two locknuts (5), screws (3), and bracket (4) from running board support (6). Discard locknuts (5).

INSTALLATION

1. Install bracket (4) on running board support (6) with two screws (3) and new locknuts (5).
2. Install bracket (2) on fender brace (8) with screws (1) and new locknuts (7).
3. Install swingfire heater water jacket (WP 0401 00).
4. Connect battery ground cable (WP 0126 00).
5. Release parking brake and remove wheel chocks (TM 9-2320-361-10).

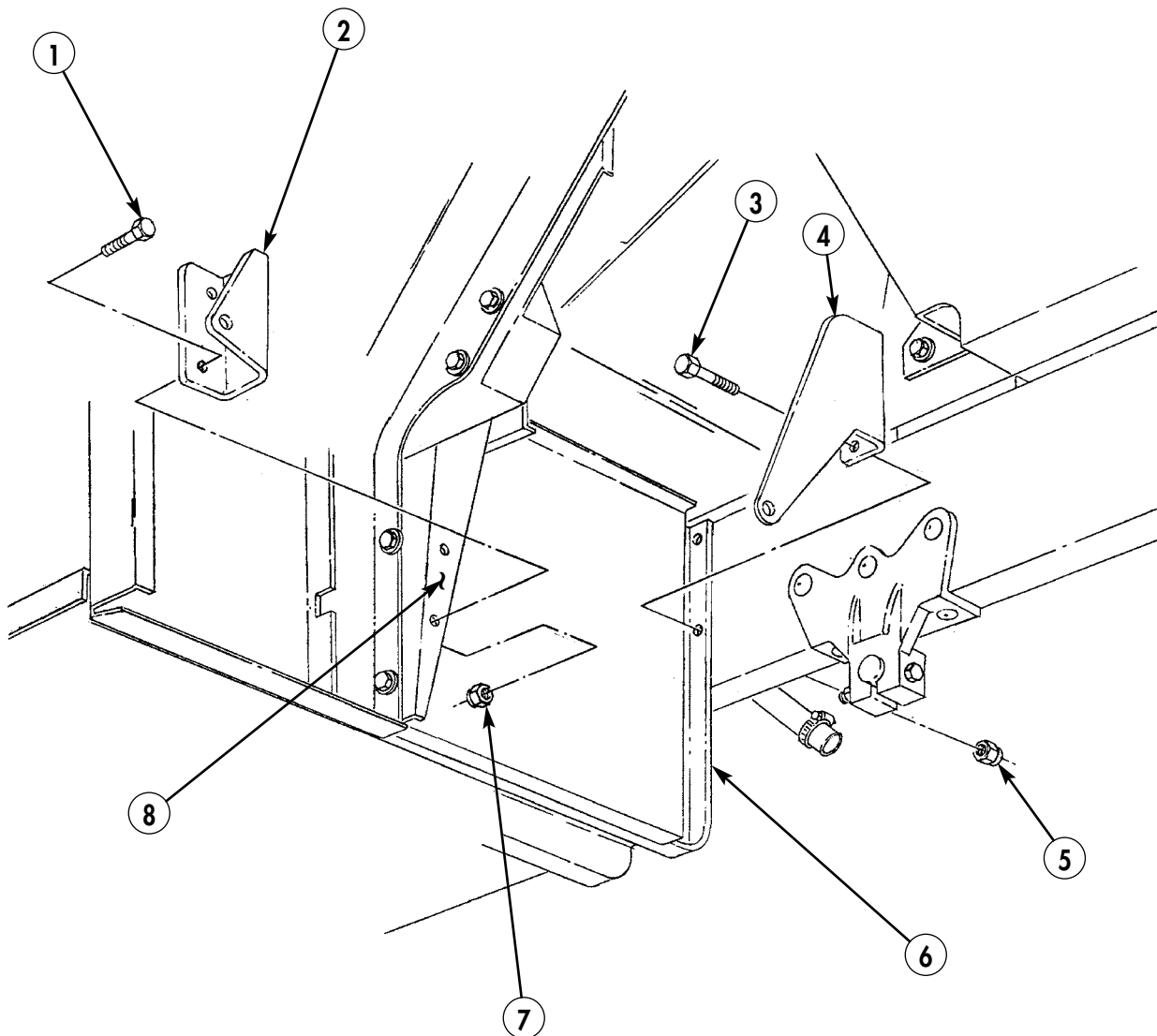

END OF WORK PACKAGE

FIELD MAINTENANCE INSTRUCTIONS FOR SPECIAL PURPOSE KITS

2-1/2 TON, 6X6, M44A2 SERIES TRUCKS (MULTIFUEL)

SWINGFIRE HEATER WIRING HARNESS AND RECEPTACLE REPLACEMENT REMOVAL AND INSTALLATION

INITIAL SETUP:

Applicable Models

All

Materials/Parts

Twenty tiedown straps (item 40, WP 0468 00)

Tools and Special Tools

General mechanic's tool kit
(item 116, WP 0469 00)

Equipment Condition

Parking brake set and wheels chocked
(TM 9-2320-361-10).
Hood raised and secured (TM 9-2320-361-10).
Battery ground cable disconnected
(WP 0126 00).

SWINGFIRE HEATER WIRING HARNESS AND RECEPTACLE REPLACEMENT (Contd)

REMOVAL

1. Loosen screw (7) and remove lead (5) from receptacle (6).
2. Remove nut (3), lockring (4), and receptacle (6) from side panel (8).
3. Remove twenty tiedown straps (17) from lighting harness (10) and lead 10A (9). Discard tiedown straps (17).
4. Disconnect plug (1) from connector (2) and remove lead (5).
5. Disconnect plug (12) from circuit breaker (11).
6. Remove nut (15), screw (13), clamp (14), and lead (9) from lighting harness (10) and support (16).

INSTALLATION

1. Install lead 10A (9) on lighting harness (10) with twenty new tiedown straps (17).
2. Install lighting harness (10), lead 10A (9), and clamp (14) on support (16) with screw (13) and nut (15).
3. Connect plug (12) to circuit breaker (11).
4. Connect plug (1) to connector (2) on lead (5).
5. Install receptacle (6) on side panel (8) with lockring (4) and nut (3).
6. Install lead (5) on receptacle (6) and tighten screws (7).
7. Connect battery ground cable (WP 0126 00).
8. Lower hood and secure (TM 9-2320-361-10).
9. Release parking brake and remove wheel chocks (TM 9-2320-361-10).

SWINGFIRE HEATER WIRING HARNESS AND RECEPTACLE REPLACEMENT (Contd)

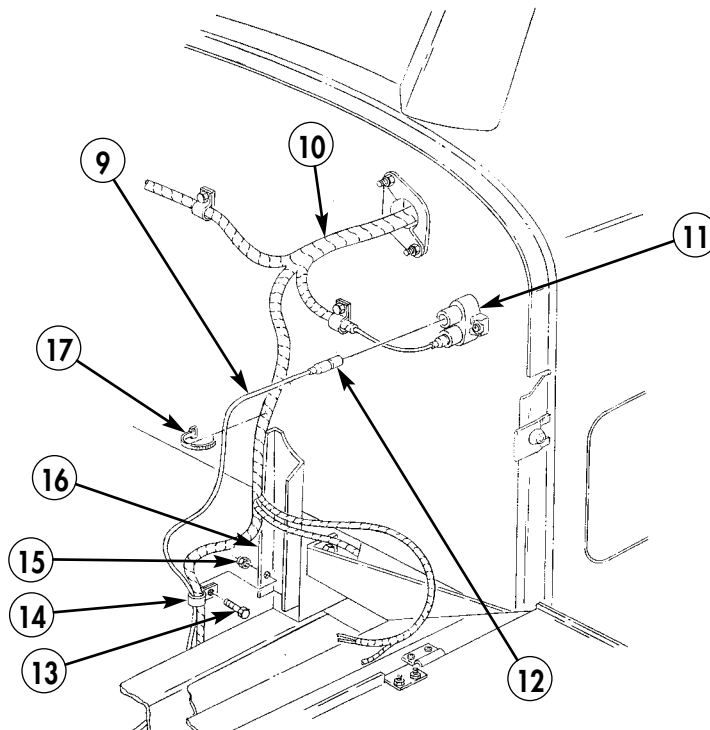
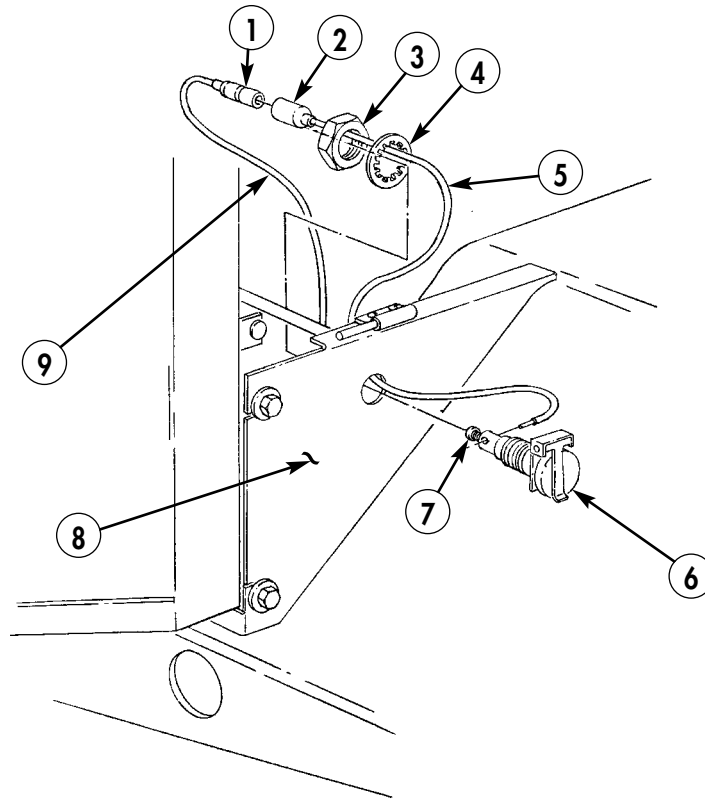

END OF WORK PACKAGE

FIELD MAINTENANCE INSTRUCTIONS FOR SPECIAL PURPOSE KITS

2-1/2 TON, 6X6, M44A2 SERIES TRUCKS (MULTIFUEL)

AIR BRAKE ROTARY VALVE AND AIR LINE REPLACEMENT REMOVAL AND INSTALLATION

INITIAL SETUP:

Applicable Models

All

Tools and Special Tools

General mechanic's tool kit
(item 116, WP 0469 00)

Materials/Parts

Tiedown strap (item 39 WP 0468 00)
Adhesive (item 4, WP 0468 00)
Cap and plug set (item 10, WP 0468 00)
Two lockwashers (item 207, WP 0470 00)

Equipment Condition

Parking brake set and wheels chocked
(TM 9-2320-361-10).
Battery ground cable disconnected
(WP 0126 00).
Raise and support hood (TM 9-2320-361-10).

AIR BRAKE ROTARY VALVE AND AIR LINE REPLACEMENT (Contd)

REMOVAL

WARNING

- Do not disconnect air lines before draining air reservoirs. Small parts under pressure may shoot out with high velocity, causing injury to personnel.
- Eyeshields must be worn when releasing compressed air. Failure to do so may result in injury to personnel.

CAUTION

When disconnecting air lines and hoses, plug all openings to prevent dirt from entering and causing damage to internal parts. Remove plugs prior to installation.

1. Remove tiedown strap (36) from air lines (16) and (17). Discard tiedown strap (36).
2. Loosen nuts (5), (15), and (37) and remove air lines (4), (16), and (17), with inserts (6), (7), and (14), from three straight adapters (8).
3. Loosen nuts (3), (18), and (21) and remove other end of air lines (4), (16), and (17), with inserts (2), (19), and (22), from elbows (1), (20), and (23).
4. Remove elbows (20) and (23) from fittings (24).
5. Loosen nuts (34) and (30) and remove air lines (35) and (29), with inserts (33) and (31), from elbow (32) and straight adapter (28).
6. Remove straight adapter (28) and elbow (32) from fitting (24).
7. Remove two nuts (27), lockwashers (26), and fittings (24) from firewall (25).
8. Remove two screws (12), lockwashers (11), clamp (10), and rotary valve (9) from steering column (13). Discard lockwashers (11).
9. Remove three straight adapters (8) from rotary valve (9).

AIR BRAKE ROTARY VALVE AND AIR LINE REPLACEMENT (Contd)

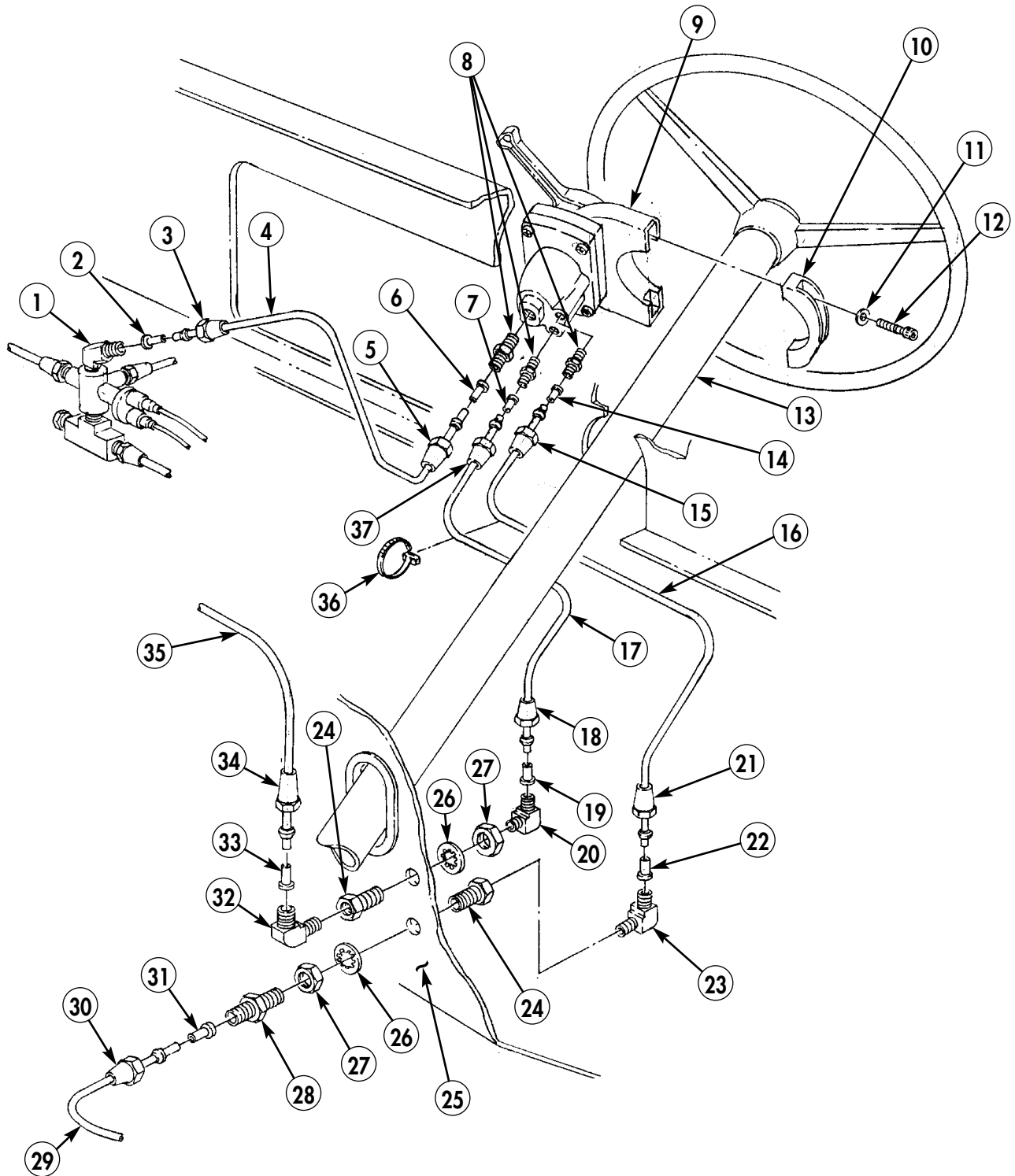

AIR BRAKE ROTARY VALVE AND AIR LINE REPLACEMENT (Contd)

INSTALLATION

1. Apply adhesive to male threads of elbows (1), (20), (23), and (32), three straight adapters (8), and straight adapter (28).
2. Install three straight adapters (8) on rotary valve (9).
3. Install rotary valve (9) and clamp (10) on steering column (13) with two new lockwashers (11) and screws (12).
4. Install two fittings (24), lockwashers (26), and nuts (27) on firewall (25).
5. Install elbow (32) and straight adapter (28) on fittings (24).
6. Install air lines (35) and (29), with inserts (33) and (31), on elbow (32) and straight adapter (28). Tighten nuts (34) and (30).
7. Install elbows (20) and (23) on fittings (24).
8. Install air lines (4), (16), and (17), with inserts (2), (19), and (22), on elbows (1), (20), and (23). Tighten nuts (3), (18), and (21).
9. Install other end of air lines (4), (16), and (17) with inserts (6), (7), and (14), on straight adapters (8). Tighten nuts (5), (15), and (37).
10. Install new tiedown strap (36) on air lines (16) and (17).
11. Start engine (TM 9-2320-361-10) and check for leaks.
12. Fill air reservoir (TM 9-2320-361-10) and check for proper operation.
13. Lower hood and secure (TM 9-2320-361-10).
14. Connect battery ground cable (WP 0126 00).
15. Release parking brake and remove wheel chocks (TM 9-2320-361-10).

AIR BRAKE ROTARY VALVE AND AIR LINE REPLACEMENT (Contd)

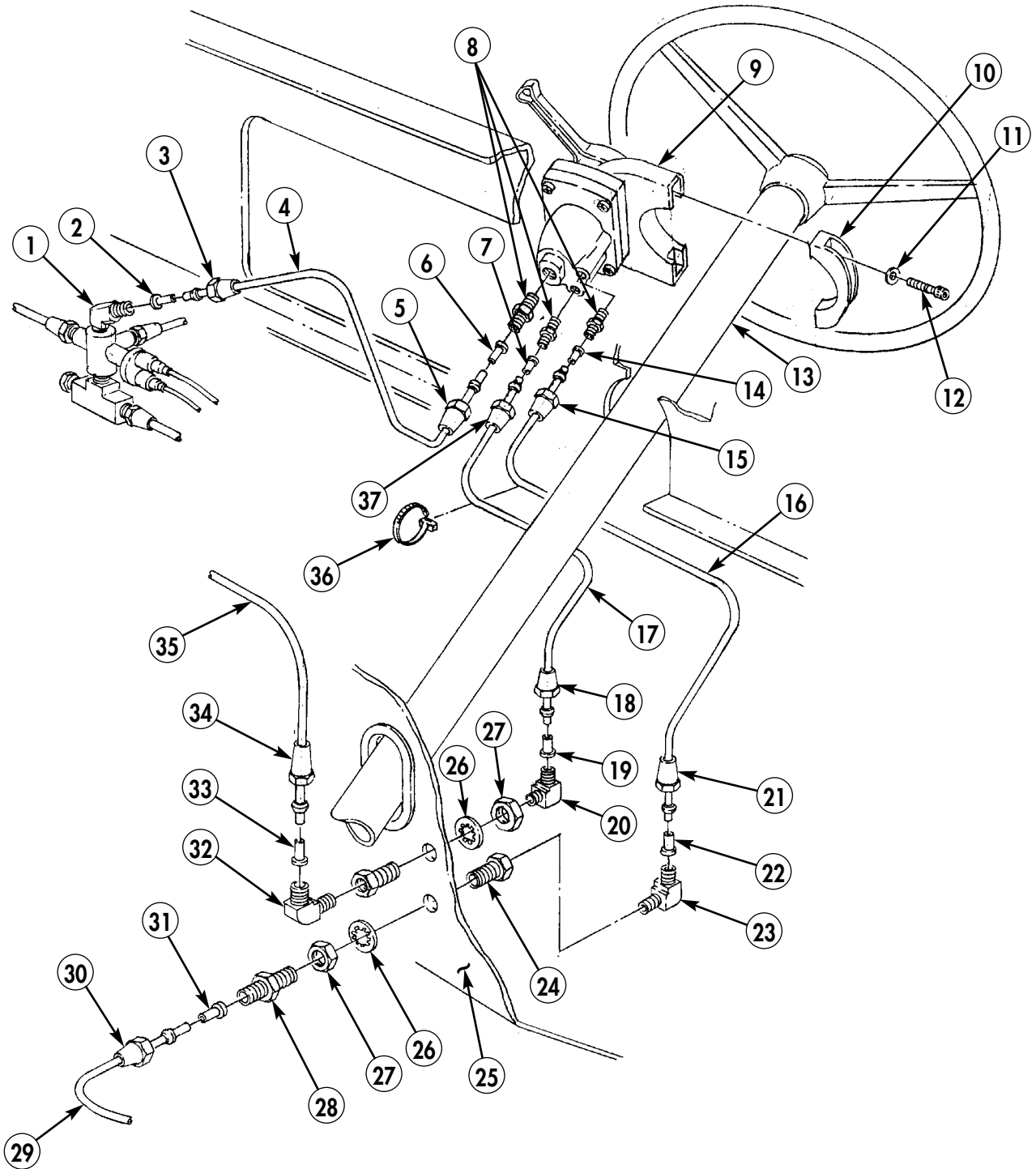

END OF WORK PACKAGE

FIELD MAINTENANCE INSTRUCTIONS FOR SPECIAL PURPOSE KITS

2-1/2 TON, 6X6, M44A2 SERIES TRUCKS (MULTIFUEL)

AIR BRAKE HARNESS REPLACEMENT REMOVAL AND INSTALLATION

INITIAL SETUP:

Applicable Models

All

Materials/Parts

Three tiedown straps (item 40, WP 0468 00)

Tools and Special Tools

General mechanic's tool kit
(item 116, WP 0469 00)

Equipment Condition

Parking brake set and wheels chocked
(TM 9-2320-361-10).
Battery ground cable disconnected
(WP 0126 00).

AIR BRAKE HARNESS REPLACEMENT (Contd)

REMOVAL

1. Remove three tiedown straps (6) from air brake electrical harness (2) and main harness (7). Discard tiedown straps (6).

NOTE

Prior to removal, tag all lead wires for installation.

2. Disconnect two leads 75 (5) from pressure switch (4) on crossmember (3).
3. Disconnect two leads 75 (11) from booster stoplight switch (12).
4. Disconnect two leads 75 (10) from terminal plugs (9) on main harness (7).
5. Remove air brake electrical harness (2) from frame rail (1) and crossmember (8).

INSTALLATION

1. Install air brake electrical harness (2) on main harness (7) on frame rail (1) and crossmember (8) with three new tiedown straps (6).
2. Connect two leads 75 (10) to terminal plugs (9) on main harness (7).
3. Connect two leads 75 (11) to booster stoplight switch (12).
4. Connect two leads 75 (5) to pressure switch (4) on crossmember (3).
5. Connect battery ground cable (WP 0126 00).
6. Release parking brake and remove wheel chocks (TM 9-2320-361-10).

AIR BRAKE HARNESS REPLACEMENT (Contd)

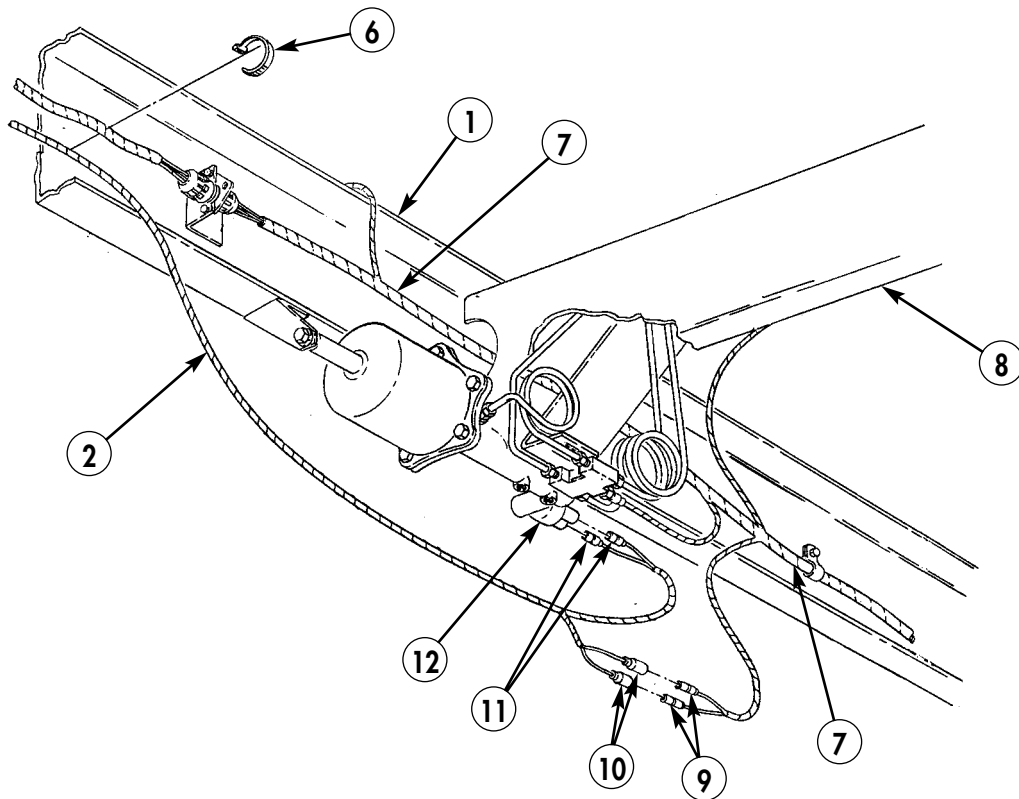
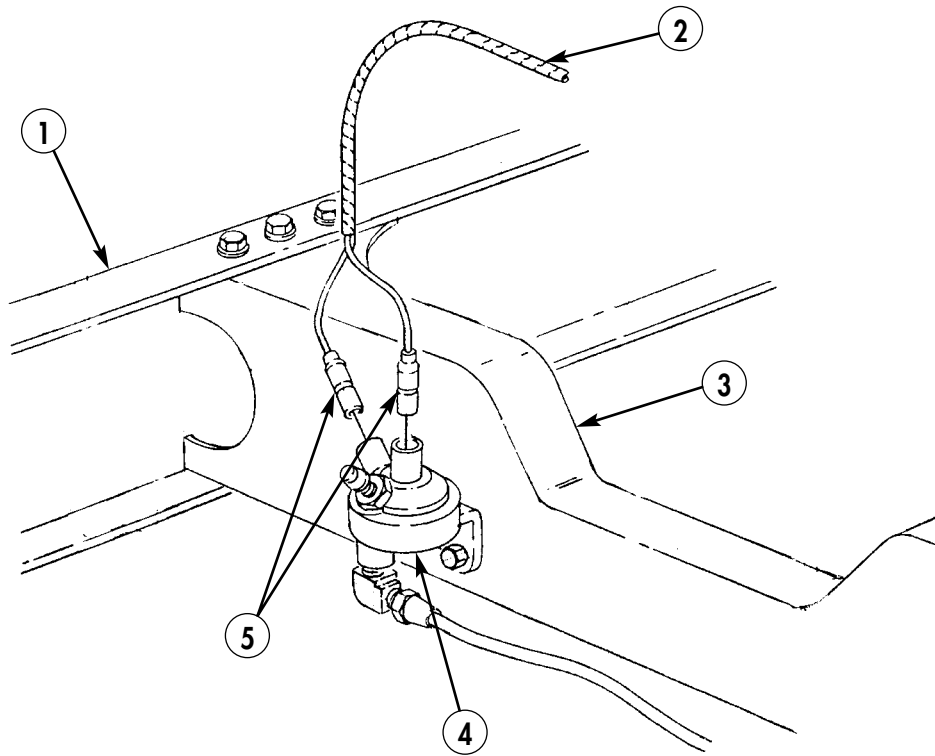

END OF WORK PACKAGE

FIELD MAINTENANCE INSTRUCTIONS FOR SPECIAL PURPOSE KITS

2-1/2 TON, 6X6, M44A2 SERIES TRUCKS (MULTIFUEL)

AIR BRAKE CHECK VALVE, PRESSURE SWITCH, AND AIR LINE REPLACEMENT REMOVAL AND INSTALLATION

INITIAL SETUP:

Applicable Models

All

Tools and Special Tools

General mechanic's tool kit
(item 116, WP 0468 00)

Materials/Parts

Two locknuts (item 145, WP 0470 00)
Locknut (item 155, WP 0470 00)

Materials/Parts (Contd)

Four tiedown straps (item 40, WP 0468 00)
Cap and plug set (item 10, WP 0468 00)
Adhesive (item 4, WP 0468 00)

Equipment Condition

Parking brake set and wheels chocked
(TM 9-2320-361-10).
Battery ground cable disconnected
(WP 0126 00).
Hood raised and secured (TM 9-2320-361-10).
Air reservoir drained (TM 9-2320-361-10).

AIR BRAKE CHECK VALVE, PRESSURE SWITCH, AND AIR LINE REPLACEMENT (Contd)

REMOVAL

WARNING

- Do not disconnect air lines before draining air reservoirs. Small parts under pressure may shoot out with high velocity, causing injury to personnel.
- Eyeshields must be worn when releasing compressed air. Failure to do so may result in injury to personnel.

CAUTION

When disconnecting air lines and hoses, plug all openings to prevent dirt from entering and causing damage to internal parts. Remove plugs prior to installation.

NOTE

Prior to removal, tag air lines for installation.

1. Disconnect two leads 75 (46) of air brake electrical harness (1) from pressure switch (45).
2. Remove four tiedown straps (21) from air lines (2), (7), (9), (20), and (30). Discard tiedown straps (21).
3. Loosen nuts (3), (8), (29), and (37) and remove air lines (2), (7), (9), and (30) with inserts (44), (40), (36), and (28), from elbows (43) and (38) and tee (35).
4. Loosen nut (31) and remove air line (30), with inserts (32), from elbow (33).
5. Remove locknut (39), screw (41), and check valve (42) from crossmember (4). Discard locknut (39).
6. Remove elbows (38) and (43) from check valve (42).
7. Remove tee (35) from check valve (42).
8. Remove two locknuts (6), washers (5), screws (34), and pressure switch (45) from crossmember (4). Discard locknuts (6).
9. Remove elbow (33) from pressure switch (45).
10. Loosen nut (19) and remove air line (20), with insert (18), from elbow (16).
11. Remove elbow (16) from check valve (17).
12. Loosen nuts (10) and (14) and remove air lines (9) and (15), with inserts (11) and (13), from union (12).
13. Loosen nuts (22) and (26) and remove air lines (7) and (27), with inserts (23) and (25), from union (24).

INSTALLATION

1. Apply adhesive to male threads of elbows (16), (33), (38), and (43), unions (12) and (24), and tee (35).
2. Install air lines (7) and (27), with inserts (23) and (25), on union (24) and tighten nuts (22) and (26).
3. Install air lines (9) and (15) with inserts (11) and (13) on union (12) and tighten nuts (10) and (14).
4. Install elbow (16) on check valve (17).
5. Install air line (20), with insert (18), on elbow (16) and tighten nut (19).
6. Install elbow (33) on pressure switch (45).

AIR BRAKE CHECK VALVE, PRESSURE SWITCH, AND AIR LINE REPLACEMENT (Contd)**INSTALLATION (Contd)**

7. Install pressure switch (45) on crossmember (4) with two screws (34), washers (5) and new locknuts (6).
8. Install tee (35) on check valve (42).
9. Install elbows (38) and (43) on check valve (42).
10. Install check valve (42) on crossmember (4) with screw (41) and new locknut (39).
11. Install air line (30), with insert (32), on elbow (33) and tighten nut (31).
12. Install air lines (9), (30), (7), and (2), with inserts (36), (28), (40), and (44), on tee (35) and elbows (38) and (43). Tighten nuts (37), (29), (8), and (3).
13. Install four new tiedown straps (21) on air lines (30), (20), (9), (7), and (2).
14. Connect two leads 75 (46) of air brake electrical harness (1) to pressure switch (45).
15. Fill air reservoir and check for leaks (TM 9-2320-361-10).
16. Lower hood and secure (TM 9-2320-361-10).
17. Connect battery ground cable (WP 0126 00).
18. Release parking brake and remove wheel chocks (TM 9-2320-361-10).

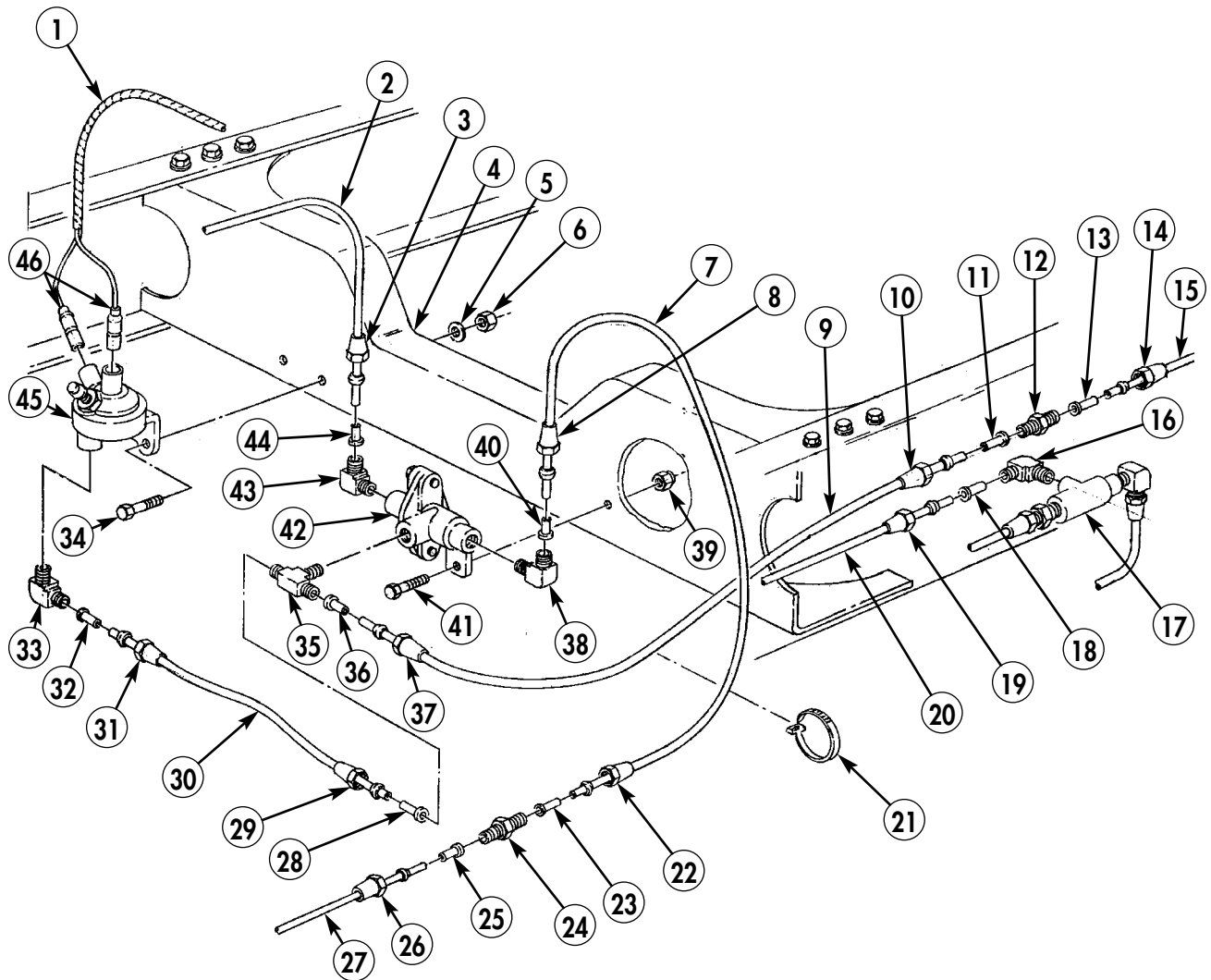

END OF WORK PACKAGE

0407 00-3/4 blank

FIELD MAINTENANCE INSTRUCTIONS FOR SPECIAL PURPOSE KITS

2-1/2 TON, 6X6, M44A2 SERIES TRUCKS (MULTIFUEL)

STEERING ASSIST CYLINDER MAINTENANCE REMOVAL, INSTALLATION, AND ADJUSTMENT

INITIAL SETUP:

Applicable Models

M35A2, M35A2C, M36A2

Tools and Special Tools

General mechanic's tool kit
(item 116, WP 0469 00)

Materials/Parts

Locknut (item 432, WP 0468 00)
Tiedown straps (item 41, WP 0468 00)
Cap and plug set (item 10, WP 0468 00)

Materials/Parts (Contd)

Antiseize compound (item 8, WP 0468 00)
Teflon pipe sealant (item 28, WP 0468 00)

Personnel Required

Two

Equipment Condition

Parking brake set and wheels chocked
(TM 9-2320-361-10).
Air reservoir drained (TM 9-2320-361-10).
Front wheels centered (TM 9-2320-361-10).

STEERING ASSIST CYLINDER MAINTENANCE (Contd)

REMOVAL

WARNING

Do not disconnect air lines before draining air reservoirs. Small parts under pressure may shoot out with high velocity, causing injury to personnel.

CAUTION

When disconnecting air lines and hoses, plug all openings to prevent dirt from entering and causing damage to internal parts.

NOTE

Prior to removal, tag all air lines and hoses for installation.

1. Battery ground cable disconnected (WP 0126 00).
2. Raise vehicle (TM 9-2320-361-10) and place jack stands under front axle. Lower vehicle onto jack stands.
3. Remove tiedown straps (1) along air hoses (20) and (2) as required. Discard tiedown straps (1).
4. Remove air hose (20) from elbow (19).
5. Remove air hose (2) from adapter (3).
6. Remove elbow (19) and adapter (3) from steering assist cylinder (12).
7. Remove six jamnuts (13) from screws (17)

NOTE

Support steering assist cylinder during removal.

8. Remove six nuts (14), tie rod top bracket (15), six screws (17), and tie rod bottom bracket (16) from tie rod (18).

NOTE

Assistant will help with step 8.

9. Remove locknut (10), washer (9), screw (4), washer (5), support bracket (6) with air hose (2), and steering assist cylinder (12) from axle bracket (8). Discard locknut (10).
10. Remove two spacers (7) and pull steering assist cylinder (12) with rubber bearing shields (11) from axle bracket (8).

STEERING ASSIST CYLINDER MAINTENANCE (Contd)

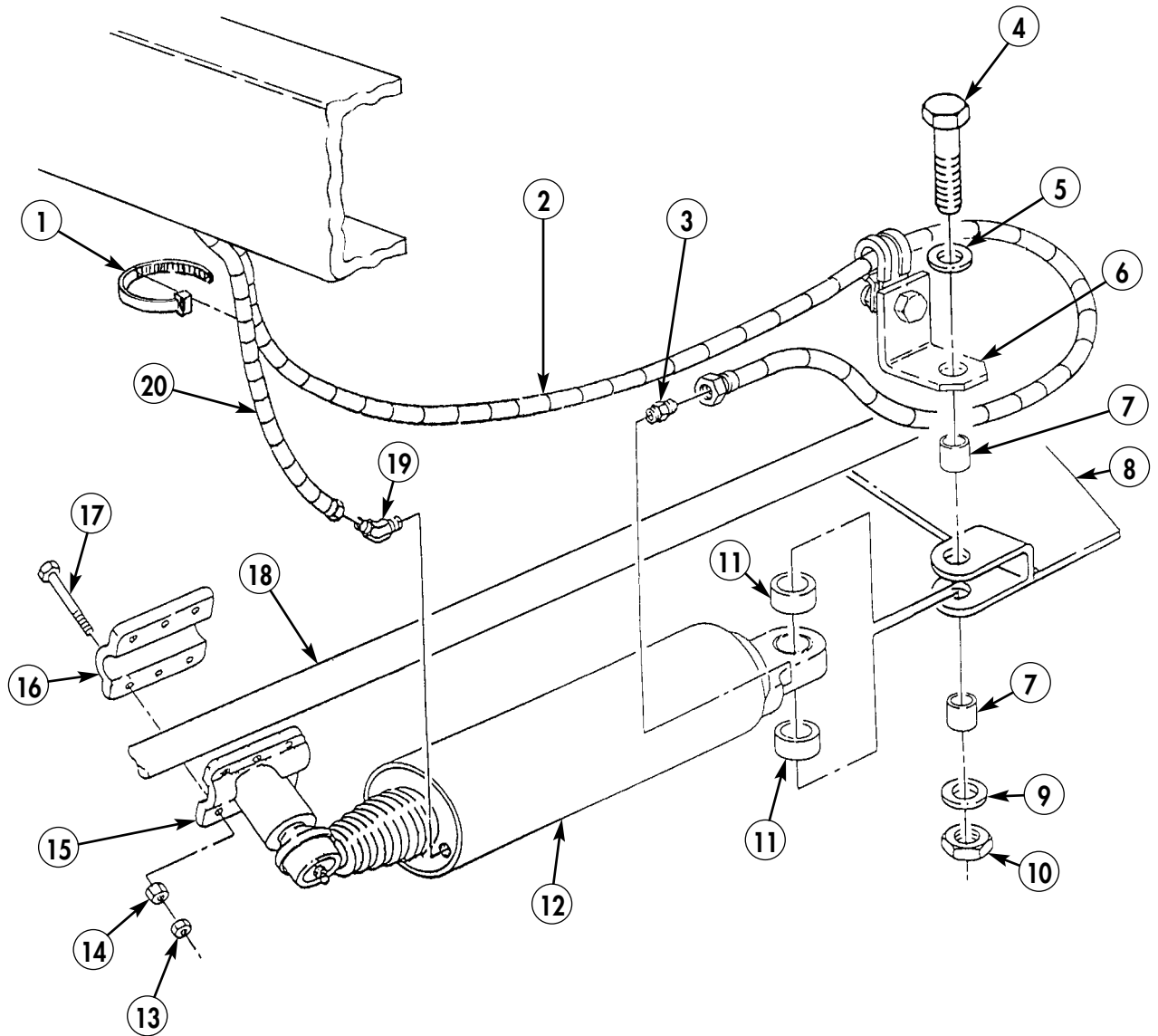

STEERING ASSIST CYLINDER MAINTENANCE (Contd)

INSTALLATION

NOTE

Remove all plugs prior to installation of air lines and hoses.

1. Apply sealant to male threads of adapter (3) and elbow (22).
2. Apply antiseize compound to spherical bearing (20), screw (4), and spacers (7) and (9).

NOTE

- Support steering assist cylinder for installation.
- Assistant will help with steps 3 through 9.

3. Install steering assist cylinder (13) on tie rod (19) with tie rod bottom bracket (17), six screws (18), tie rod top bracket (16), and six nuts (15). Tighten nuts (15) to support one end of steering assist cylinder (13).
4. Position rubber bearing shield (21) on top of spherical bearing (20) and insert end of steering assist cylinder (13) into end of axle bracket (8).
5. Insert spacer (7) through top hole of axle bracket (8) and align spacer (7) in center of rubber bearing shield (21).
6. Position support bracket (6) and washer (5) on axle bracket (8) and insert screw (4) through washer (5), support bracket (6), axle bracket (8), spacer (7), rubber bearing shield (21), and into spherical bearing (20).
7. Place a floor jack under lip end of steering assist cylinder (13) and lift up on steering assist cylinder (13) until rubber bearing shield (12) can be installed between spherical bearing (20) and axle bracket (8).
8. Lower floor jack and insert spacer (9) through bottom hole of axle bracket (8) and align with rubber bearing shield (12).
9. Push screw (4) through spacer (9), rubber bearing shield (12), and out of axle bracket (8).
10. Install washer (10) and new locknut (11) on screw (4). Tighten locknut (11) until locknut (11) connects axle bracket (8).
11. Install six jamnuts (14) on screws (18). Do not tighten jamnuts (14) until adjustment task.
12. Install adapter (3) and elbow (22) on steering assist cylinder (13).
13. Perform adjustment task. Refer to Adjustment in this Work Package (WP).
14. Install air hose (23) on elbow (22).
15. Install air hose (2) on adapter (3).
16. Install new tiedown straps (1), as required.
17. Raise vehicle (TM 9-2320-361-10), remove jack stands from front axle, and lower vehicle to ground.
18. Connect battery ground cable (WP 0126 00).

STEERING ASSIST CYLINDER MAINTENANCE (Contd)

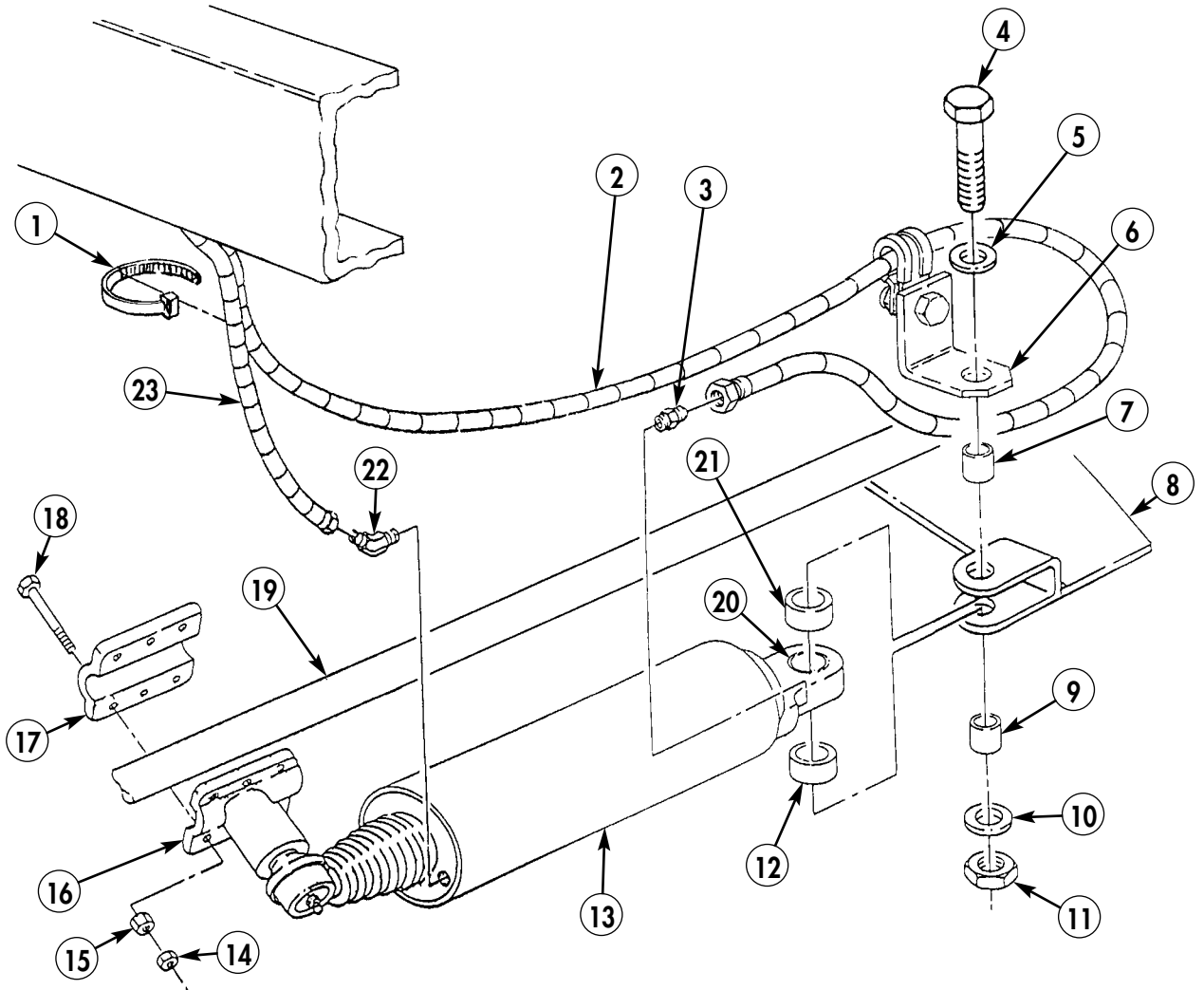

STEERING ASSIST CYLINDER MAINTENANCE (Contd)

ADJUSTMENT

NOTE

- Perform steps 1 and 2 if steering assist cylinder was not removed.
- When power is applied to the steering assist cylinder on a tie rod installation, the tie rod may have a tendency to crank. To limit this condition, perform steps 1 through 10.

1. Remove six jamnuts (6) from screws (4).
2. Loosen six nuts (9) on screws (4).
3. Turn wheels in full right hand turn.
4. Loosen one of the tie rod ends (1), and turn the socket shell (2) in opposite directions.
5. Tighten tie rod ends (1) and turn socket shells (2) in opposite directions.
6. Turn wheels in full left hand turn to ensure tie rod (3) does not bind.
7. Position steering assist cylinder rod (8) approximately 1/2 in. (13 mm) from being fully retracted.
8. Position wheels in a full left hand turn.
9. Tighten center screws (4) and nuts (9) at top and bottom center of tie rod bracket assembly (5).

NOTE

Power assist cylinder must be parallel to the tie rod for proper operation.

10. Turn wheels in full right and left hand turns, checking maximum and minimum strokes of steering assist cylinder (7). Adjust, as required, position of the rod bracket assembly (5) so steering assist cylinder (7) operates as close to minimum dimension as possible, and is parallel to tie rod (3) when wheels are in straight ahead position.
11. Tighten six nuts (9) 30–35 lb-ft (41–47 N•m) at tie rod bracket assembly (5).
12. Install six jamnuts (6) on screws (4) and tighten jamnuts (6) 15–19 lb-ft (20–26 N•m) against nuts (9).
13. Start engine (TM 9-2320-361-10) and allow air reservoir to fill. Check for leaks.
14. Release parking brake and remove wheel chocks (TM 9-2320-361-10).
15. Road test vehicle. Adjust, if necessary.

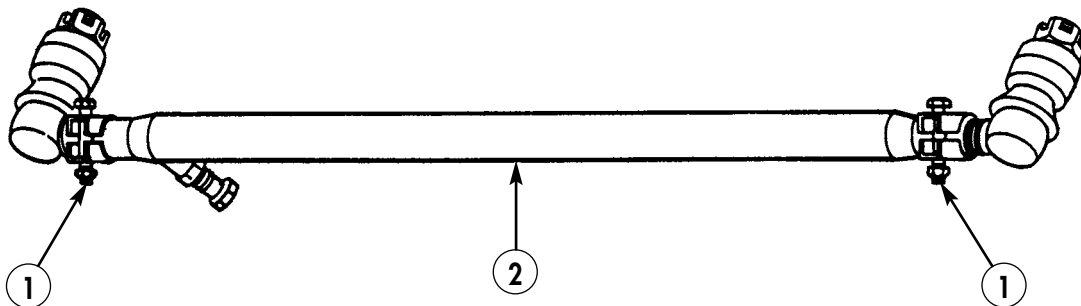

STEERING ASSIST CYLINDER MAINTENANCE (Contd)

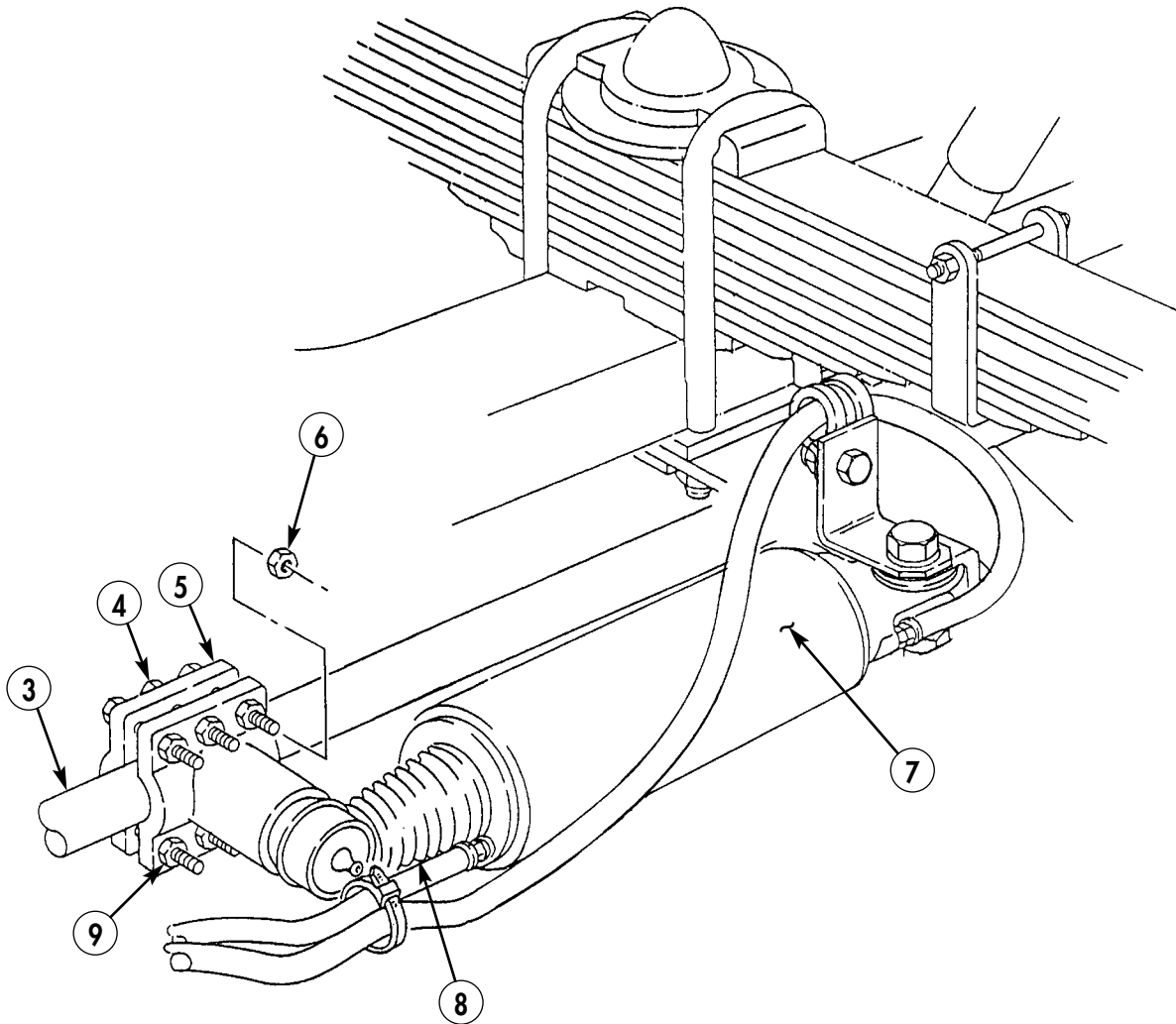

END OF WORK PACKAGE

0408 00-7/8 blank

FIELD MAINTENANCE INSTRUCTIONS FOR SPECIAL PURPOSE KITS

2-1/2 TON, 6X6, M44A2 SERIES TRUCKS (MULTIFUEL)

STEERING ASSIST REGULATOR REPLACEMENT REMOVAL AND INSTALLATION

INITIAL SETUP:

Applicable Models

M35A2, M35A2C, M36A2

Reference

WP 0408 00

Tools and Special Tools

General mechanic's tool kit
(item 116, WP 0469 00)

Equipment Condition

Parking brake set and wheels chocked
(TM 9-2320-361-10).

Battery ground cable disconnected
(WP 0126 00).

Air reservoir drained (TM 9-2320-361-10).

Materials/Parts

Lockwasher (item 213, WP 0470 00)
Cap and plug set (item 10, WP 0468 00)
Sealant (item 28, WP 0468 00)

STEERING ASSIST REGULATOR REPLACEMENT (Contd)

REMOVAL

WARNING

Do not disconnect air lines before draining air reservoirs. Small parts under pressure may shoot out with high velocity, causing injury to personnel.

CAUTION

When disconnecting air lines and hoses, plug all openings to prevent dirt from entering and causing damage to internal parts.

1. Remove tube (9) from fitting (10).
2. Remove fitting (10) from elbow (11).
3. Remove elbow (11) from hollow stud (7).
4. Remove tube (1) from adapter (2).
5. Remove nut (12) and lockwasher (13) from hollow stud (7) and regulator (3) from rail (8). Discard lockwasher (13).
6. Remove hollow stud (7) from fitting (6).
7. Remove fitting (6) from elbow (5).
8. Remove elbow (5) from fitting (4).
9. Remove fittings (2) and (4) from regulator (3).

INSTALLATION

NOTE

Remove all plugs prior to installation of air lines.

1. Apply sealant to male threads of fittings (2), (4), (6), and (10), elbows (5) and (11), and hollow stud (7).
2. Install fittings (2) and (4) on regulator (3).
3. Install elbow (5) on fitting (4).
4. Install fitting (6) on elbow (5).
5. Install hollow stud (7) on fitting (6).
6. Position regulator (3) on rail (8) with new lockwashers (13) and nut (12).
7. Install tube (1) on adapter (2).
8. Install elbow (11) on hollow stud (7).
9. Install fitting (10) on elbow (11).
10. Install tube (9) on fitting (10).
11. Start engine (TM 9-2320-361-10) and allow air pressure to build up to normal operating pressure. Check for leaks.
12. Connect battery ground cable (WP 0126 00).
13. Release parking brake and remove wheel chocks (TM 9-2320-361-10).
14. Road test vehicle. Readjust if necessary (WP 0408 00).

STEERING ASSIST REGULATOR REPLACEMENT (Contd)

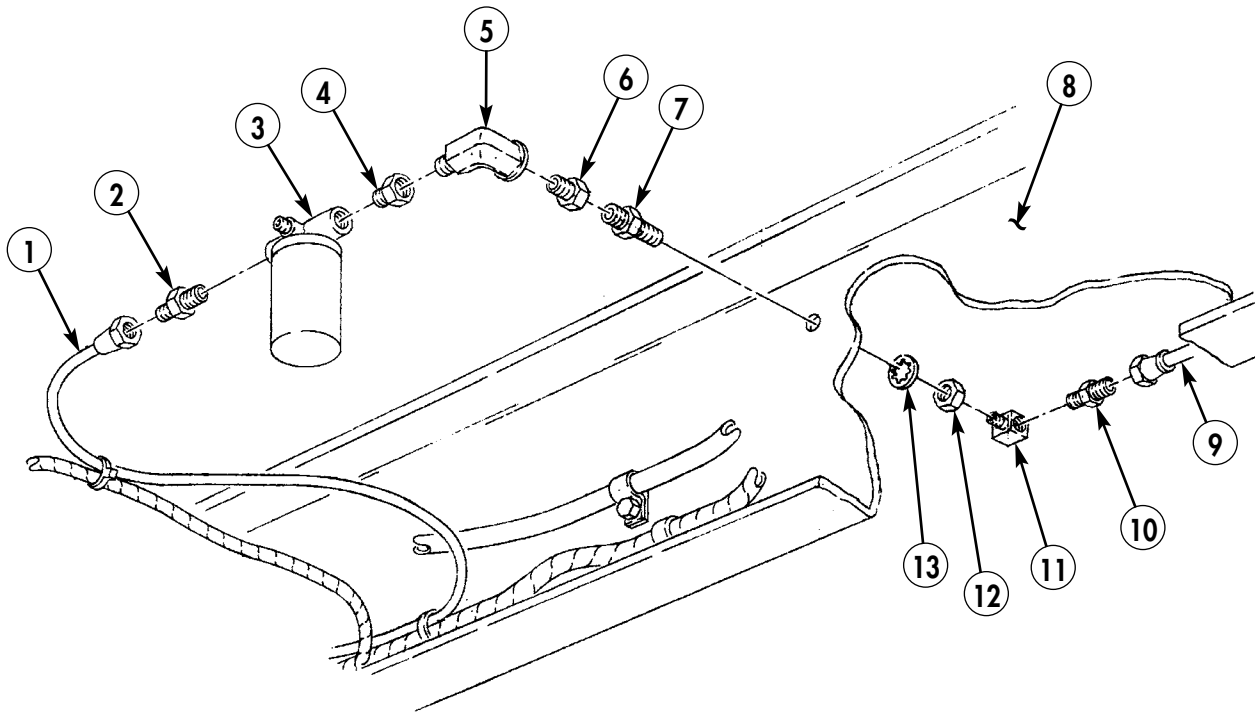

END OF WORK PACKAGE

0409 00-3/4 blank

FIELD MAINTENANCE INSTRUCTIONS FOR SPECIAL PURPOSE KITS

2-1/2 TON, 6X6, M44A2 SERIES TRUCKS (MULTIFUEL)

ARCTIC CARGO BODY ENCLOSURE REPLACEMENT REMOVAL AND INSTALLATION

INITIAL SETUP:

Applicable Models

M35A2

Materials/Parts

Two locknuts (item 166, WP 0470 00)
Eight cotter pins (item 28, WP 0470 00)

Personnel Required

Three

Equipment Condition

Parking brake set and wheels chocked
(TM 9-2320-361-10).
Battery ground cable disconnected
(WP 0126 00).
Reflectors removed (WP 0252 00).
Cargo body personnel heater removed
(WP 0366 00–WP 0372 00).
Troop seats removed (WP 0253 00).
Fire extinguisher removed (WP 0393 00).
Speaking tube removed (WP 0411 00).

ARCTIC CARGO BODY ENCLOSURE REPLACEMENT (Contd)

REMOVAL

1. Remove two screws (5) and striker plate (3) from rear closure assembly (1).

NOTE

Prior to removal, tag lead wires for installation.

2. Remove two screws (10) and light switch (11) from rear closure assembly (1).
3. Remove ten screws (9), five cable clamps (2), and lamp cable (4) from rear closure assembly (1).
4. Remove ten screws (6) and floor angle (8) from cargo body floor (7).
5. Remove step assembly (19) from rear closure assembly (1).
6. Remove two locknuts (15), four washers (16), and handle (20) from rear closure assembly (1). Discard locknuts (15).
7. Remove eight screws (21) and two rear angle brackets (18) from rear closure assembly (1).
8. Remove thirty-two screws (17) and clamping strips (12), (13), and (14) from rear closure assembly (1).
9. Remove six screws (28) and two front corner brackets (27) from cargo body (32).
10. Remove twelve screws (25) and two strips (26) from cargo body (32).
11. Remove eight screws (30) and two brackets (31) from cargo body (32).
12. Remove four screws (23), nuts (29), eight washers (24), and support panel (22) from cargo body (32).

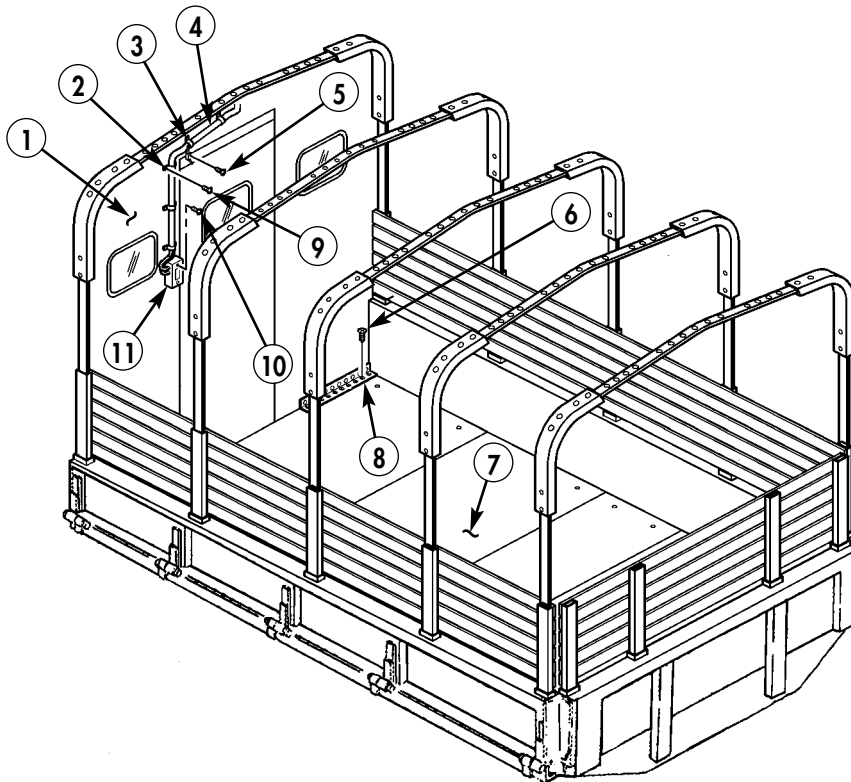

ARCTIC CARGO BODY ENCLOSURE REPLACEMENT (Contd)

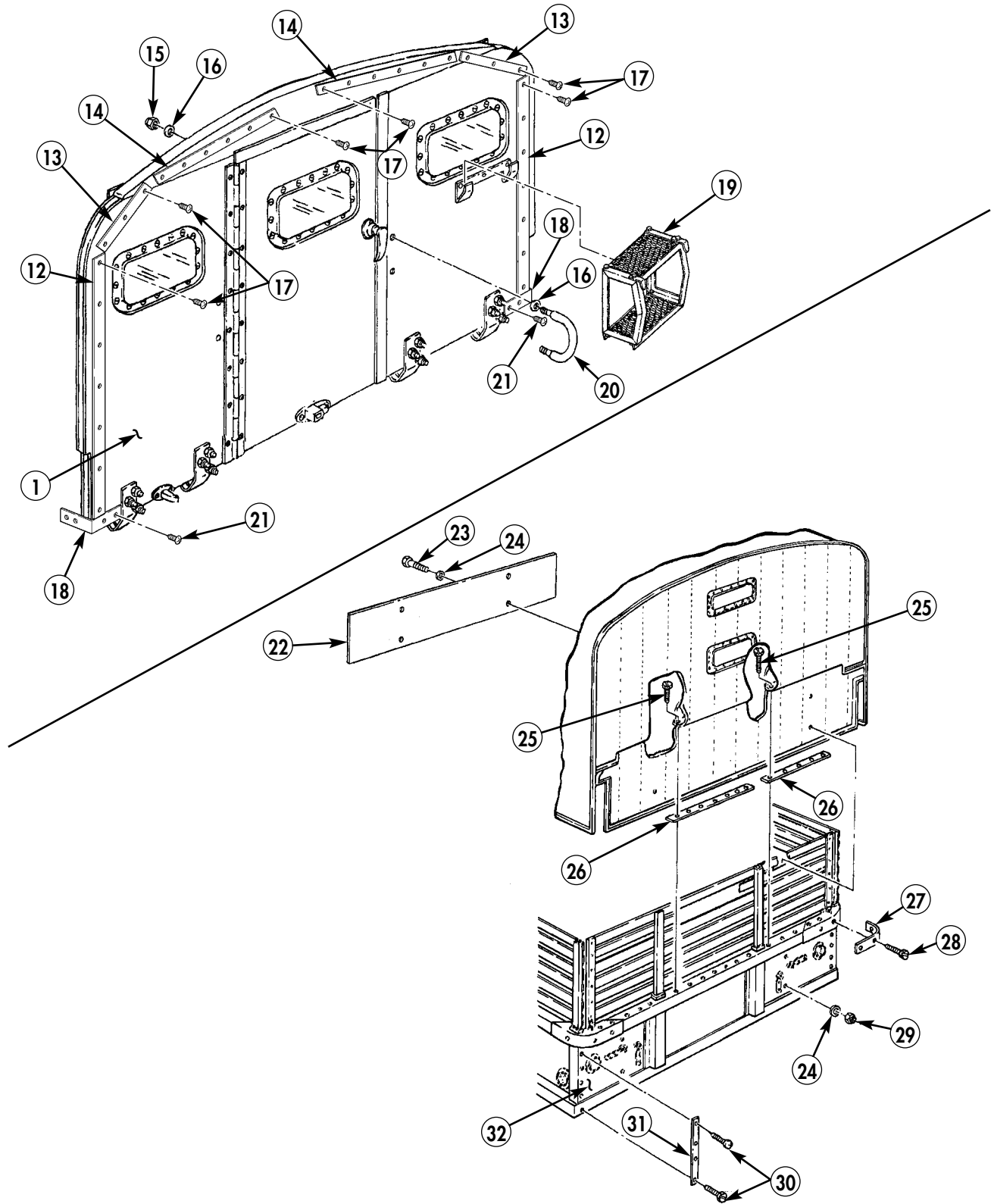

ARCTIC CARGO BODY ENCLOSURE REPLACEMENT (Contd)**REMOVAL (Contd)**

13. Remove fifty screws (4), three strips (3), and strip (5) from cargo body (6)
14. Remove tarpaulin assembly (1) from cargo body (6). Refer to TM 9-2320-361-10.
15. Remove twenty screws (10), ten clamps (9), spacers (8), and two handles (7) from bow assemblies (12).
16. Remove four screws (14) and clamps (13) from conduit (11), front bow assemblies (12), and front rack (2).
17. Remove lamp wire (16) from conduit (11).
18. Remove forty-four screws (14), twenty two clamps (15), and lamp wire (16) from bow assemblies (12).

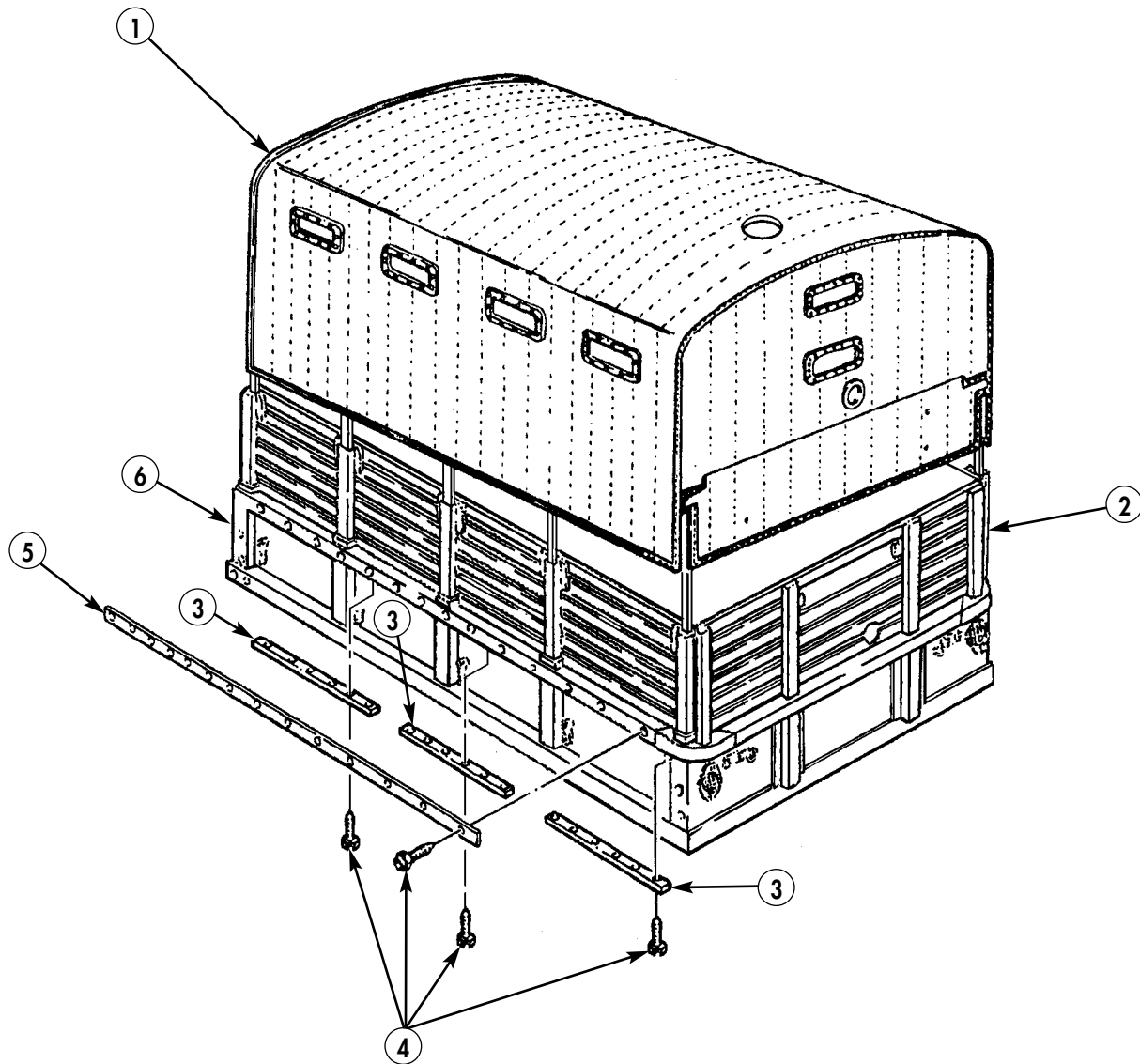

ARCTIC CARGO BODY ENCLOSURE REPLACEMENT (Contd)

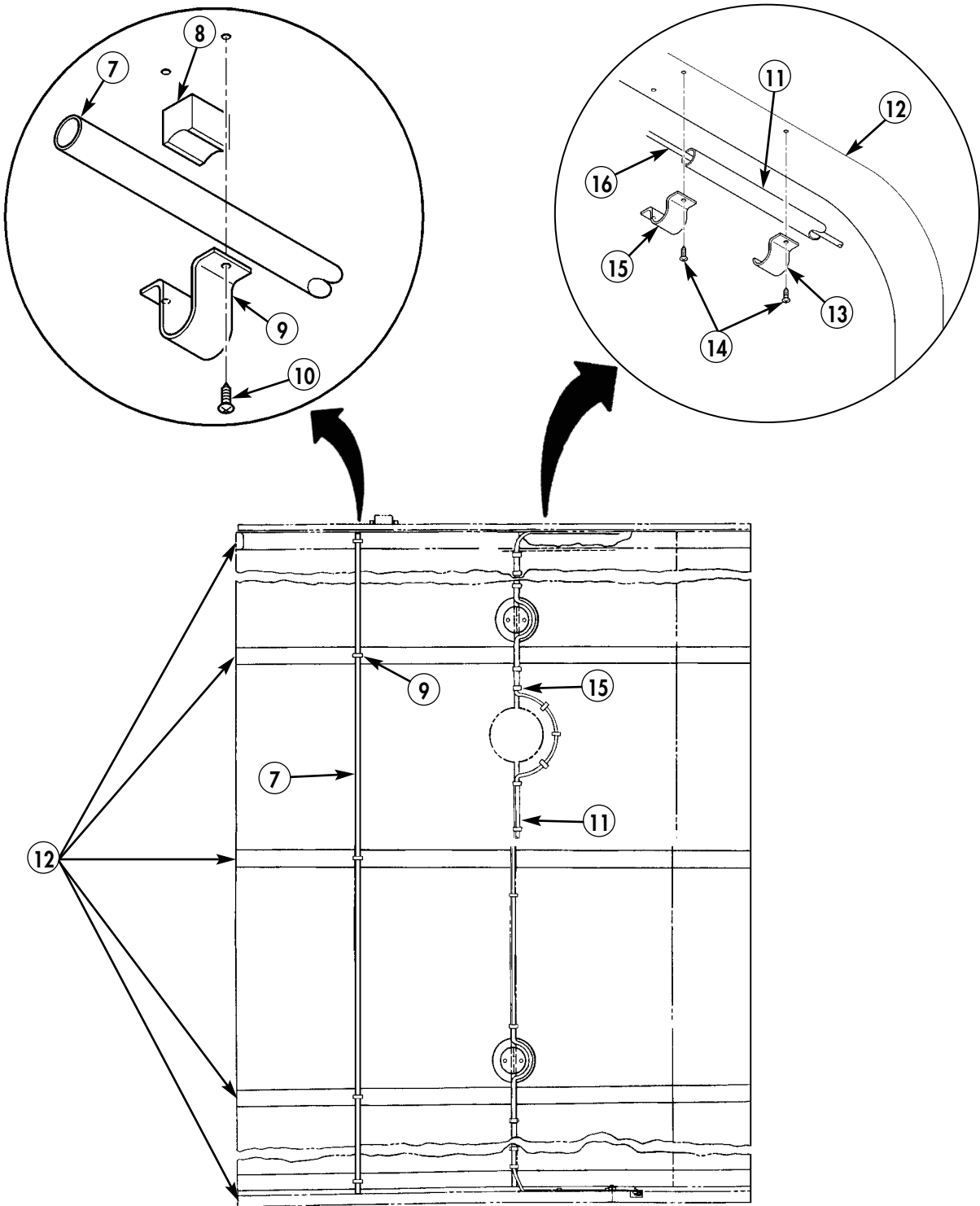

ARCTIC CARGO BODY ENCLOSURE REPLACEMENT (Contd)

REMOVAL (Contd)

19. Remove four screws (8) and two spacers (7) from cargo body (6).
20. Remove twenty-four screws (2) and four corner roof supports (3) from bow assemblies (1).
21. Remove one hundred and twenty screws (2) and roof supports (4) and (5) from bow assemblies (1).

WARNING

Ensure rear closure assembly is supported when removing screws. Failure to do so may allow rear closure assembly to drop unexpectedly causing injury to personnel.

22. Remove fourteen screws (10) from rear closure assembly (9) and bow assembly (1).

NOTE

Assistants will help with steps 23 and 24.

23. Lower rear closure assembly (9) horizontal to cargo body (6).
24. Remove eight cotter pins (13), washers (14), and four pins (15) from rear closure assembly hinges (11). Discard cotter pins (13). Lower rear closure assembly (12) to the ground.

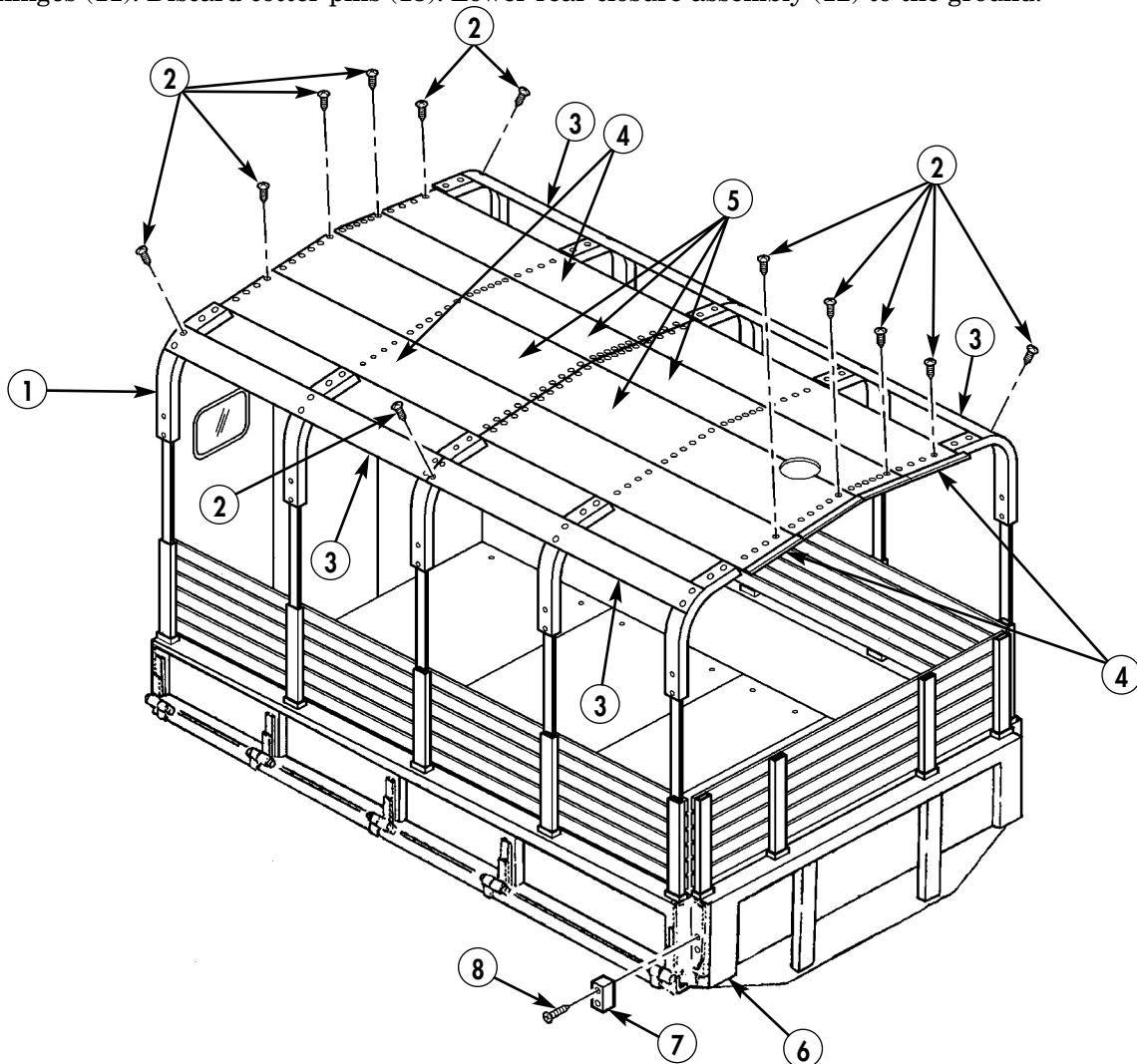

ARCTIC CARGO BODY ENCLOSURE REPLACEMENT (Contd)

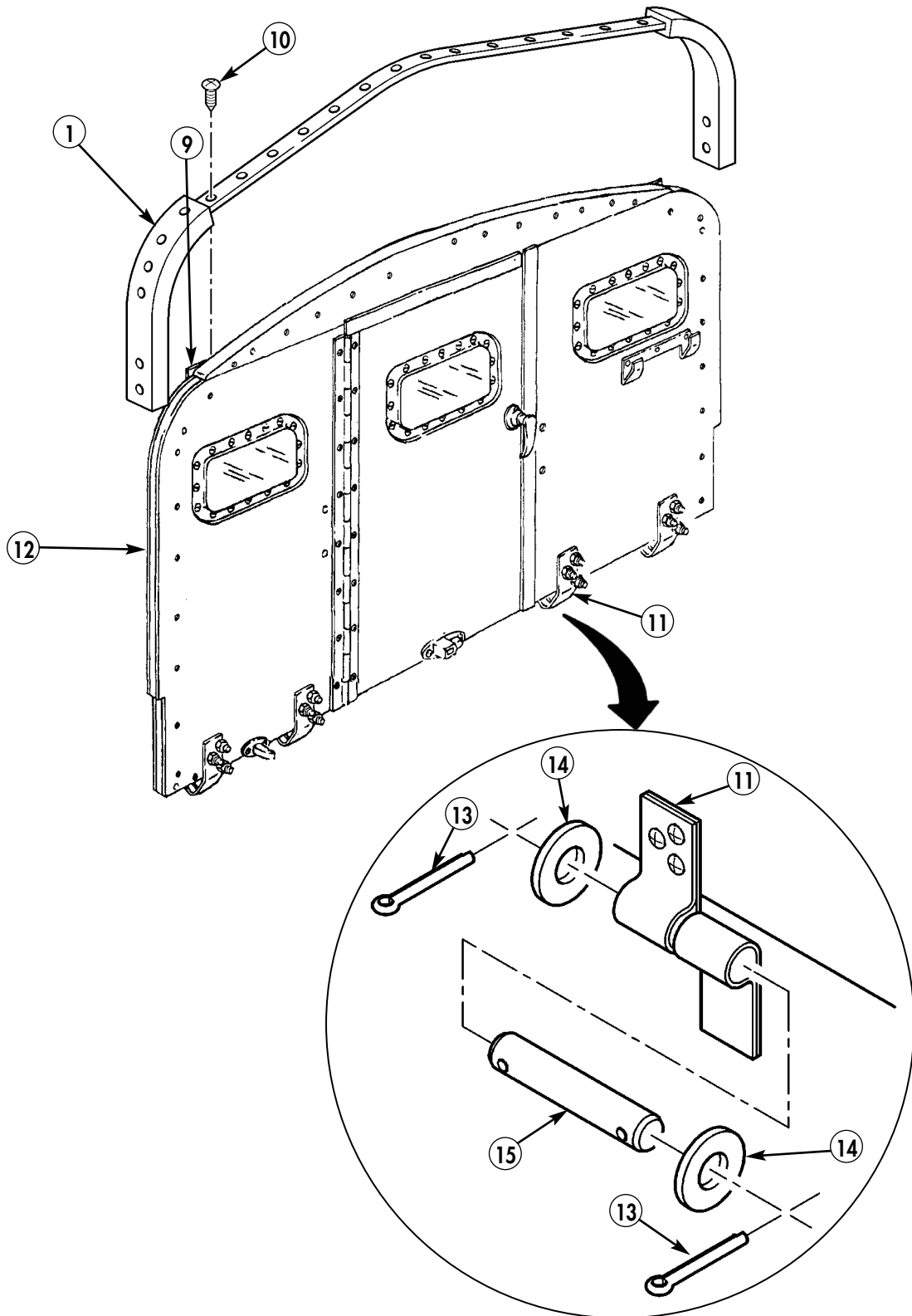

ARCTIC CARGO BODY ENCLOSURE REPLACEMENT (Contd)

REMOVAL (Contd)

25. Remove five bow assemblies (1) from cargo body (2).
26. Remove sixteen screws (6) and floor panels (3), (4), (5), and (7) from cargo body (2).

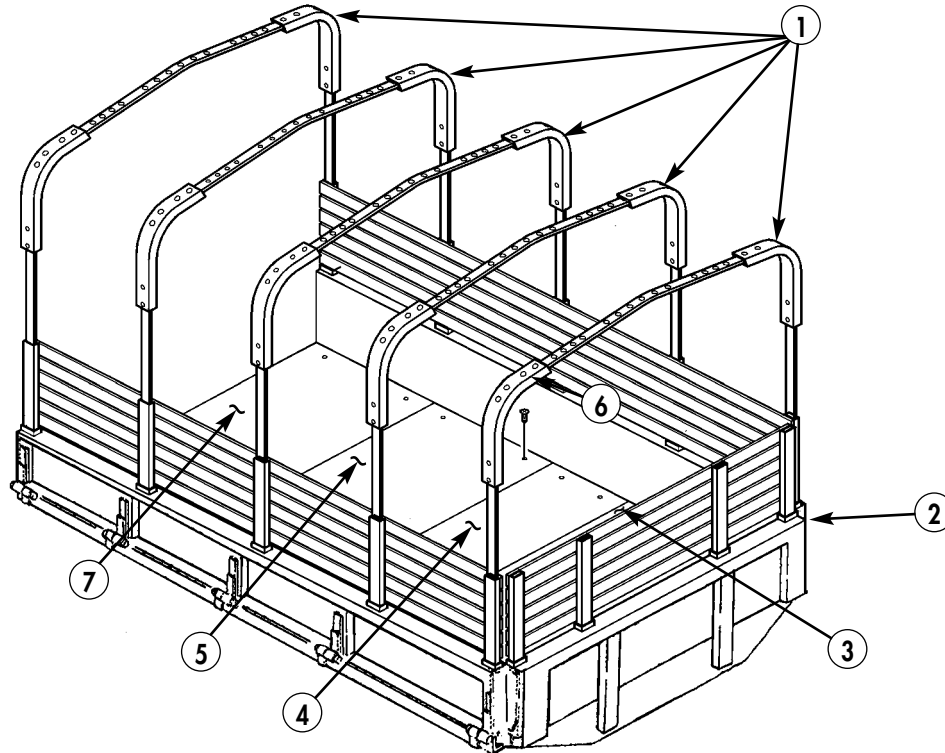

INSTALLATION

1. Install floor panels (3), (4), (5), and (7) to cargo body (2) with sixteen screws (6).
2. Install five bow assemblies (1) to cargo body (2).

NOTE

Assistants will help with step 3 and 4.

3. Raise rear closure assembly (10) horizontal to cargo body (2).
4. Install rear closure assembly hinges (11) with four pins (14), eight washers (13), and new cotter pins (12).
5. Raise rear closure assembly (10) to rear bow assembly (8) and secure with fourteen screws (9).
6. Install conduit (19) to bow assemblies (1) with ten clamps (23) and screws (22).
7. Route lamp wire (24) through conduit (19).
8. Install conduit (19) to bow assembly (1) with four clamps (21) and screws (20).
9. Install two handles (16) to bow assemblies (1) with ten spacers (15), clamps (17), and twenty screws (18).

ARCTIC CARGO BODY ENCLOSURE REPLACEMENT (Contd)

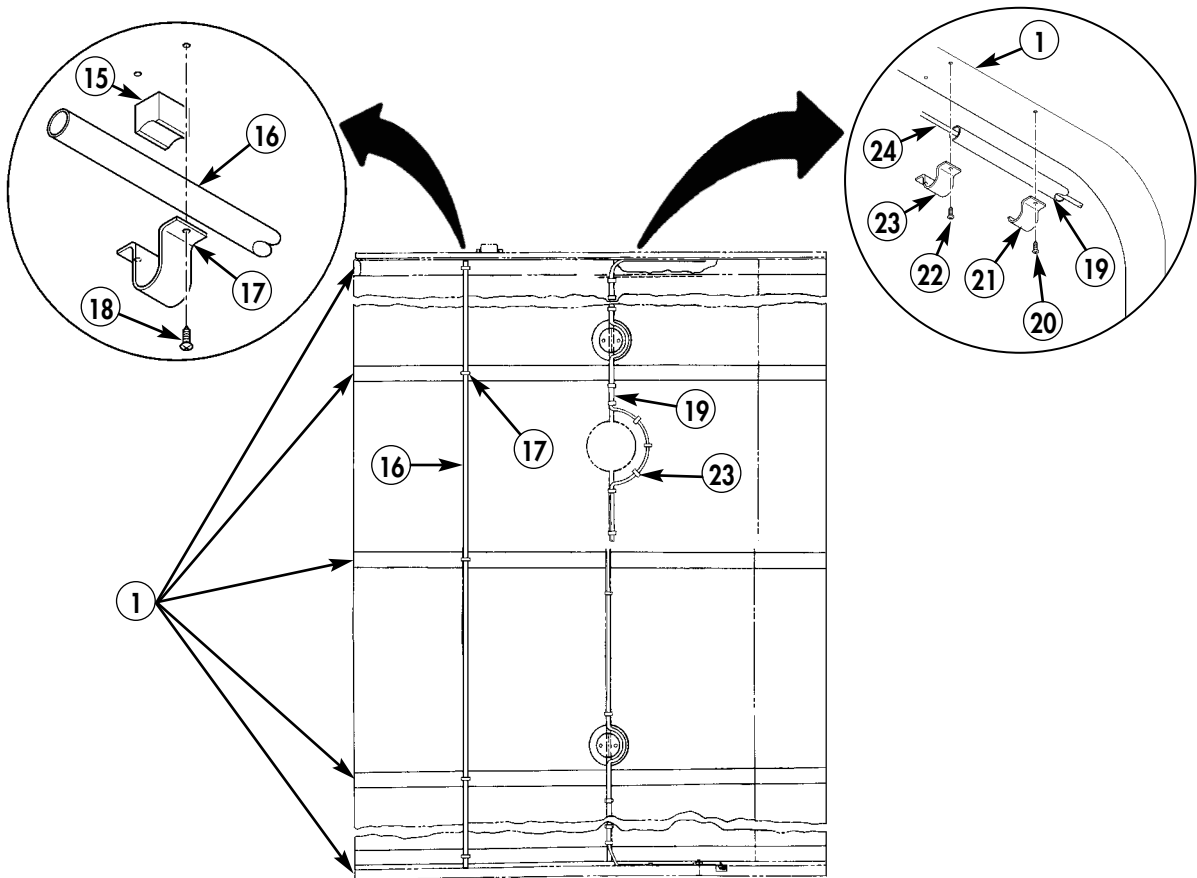
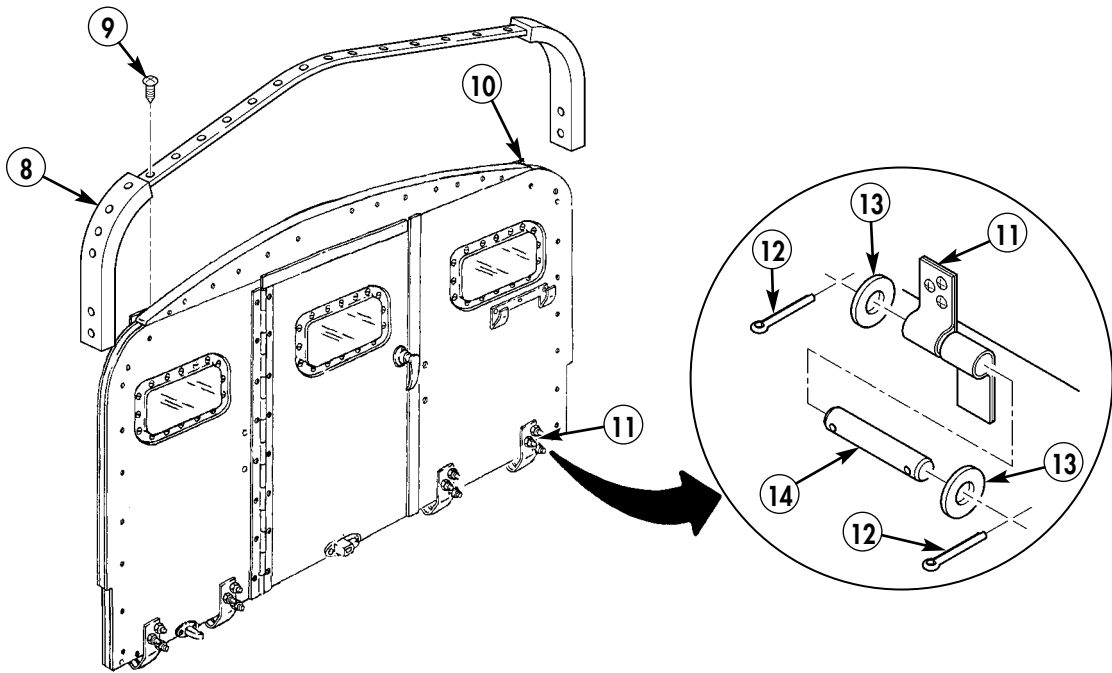

ARCTIC CARGO BODY ENCLOSURE REPLACEMENT (Contd)

INSTALLATION (Contd)

10. Connect rear assembly floor angle (8) to cargo floor (9) with ten screws (7).
11. Install striker plate (4) to rear closure assembly (1) with two screws (6).
12. Connect lamp cable (5) to rear closure assembly (1) with five clamps (3) and ten screws (11).
13. Connect lamp lead wires (5) to light switch (2).
14. Install light switch (2) to rear closure assembly (1) with two screws (10).
15. Install roof supports (14), (15), (16), and (17) to bow assemblies (21) with one hundred twenty screws (13).
16. Install four corner roof supports (12) to bow assemblies (22) with twenty-four screws (13).
17. Install two spacers (19) to cargo body (18) with four screws (20).

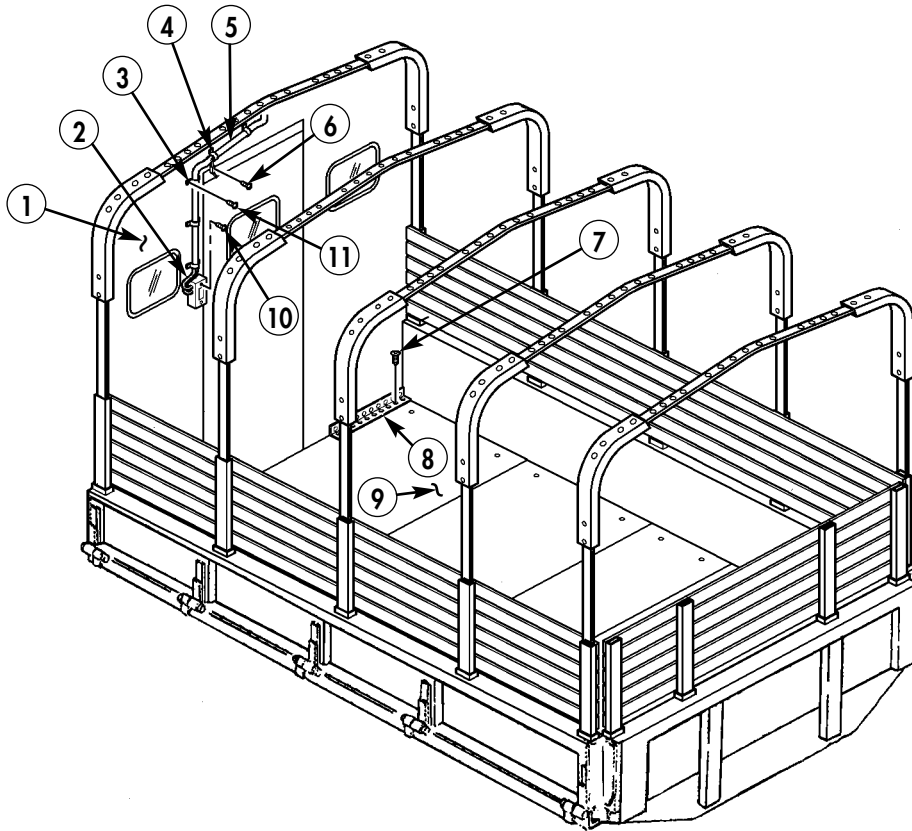

ARCTIC CARGO BODY ENCLOSURE REPLACEMENT (Contd)

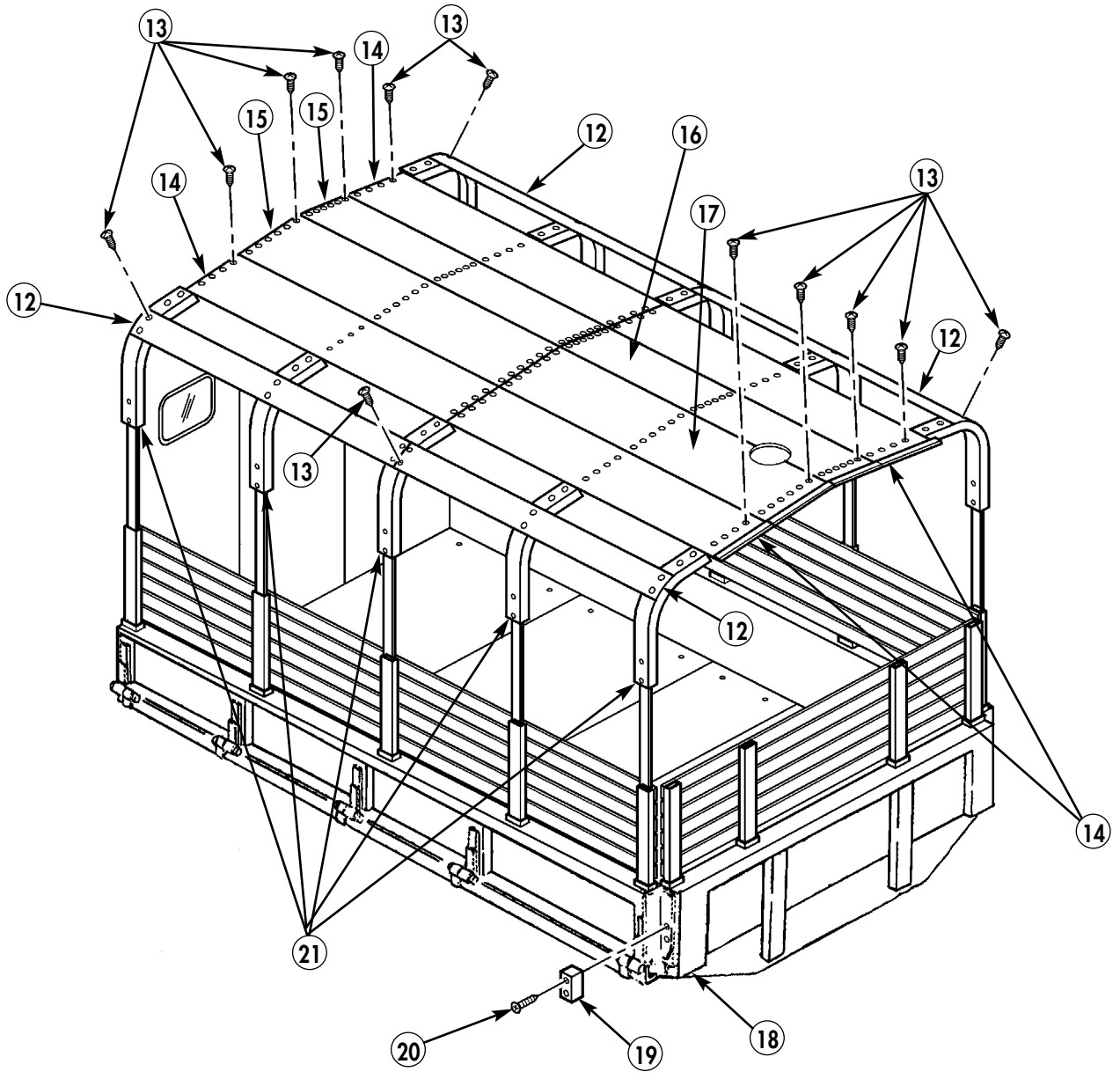

ARCTIC CARGO BODY ENCLOSURE REPLACEMENT (Contd)

INSTALLATION (Contd)

NOTE

Position tarpaulin so both sides hang down evenly.

18. Install tarpaulin (1) onto cargo body (3). Ensure vent hole (2) in tarpaulin assembly (1) lines up with vent hole on roof supports. Refer to TM 9-2320-361-10.
19. Install support panel (7) on tarpaulin (1) and cargo body (3) with four screws (8), eight washers (9), and nuts (14).
20. Install two brackets (16) to front cargo body (3) with eight screws (15).
21. Install two strips (11) on cargo body (3) with twelve screws (10).
22. Install two corner brackets (12) to cargo body (3) with six screws (13).
23. Install three strips (4) and strip (6) to cargo body (3) with fifty screws (5).
24. Install clamping strips (18), (21), and (23) to rear closure assembly (17) with thirty two screws (22).
25. Install two rear corner brackets (25) to rear closure assembly (17) and cargo body (3) with eight screws (27).
26. Install handle (26) to rear enclosure assembly (17) with four washers (20) and two new locknuts (19).
27. Install step assembly (24) to rear closure panel (17).
28. Install speaking tube (WP 0411 00).
29. Install fire extinguisher (WP 0393 00).
30. Install troop seats (WP 0253 00), seat cushions and backrests.
31. Install cargo body personnel heater (WP 0366 00–WP 0372 00).
32. Install reflectors (WP 0252 00).
33. Connect battery ground cable (WP 0126 00).
34. Release parking brake and remove wheel chocks (TM 9-2320-361-10).

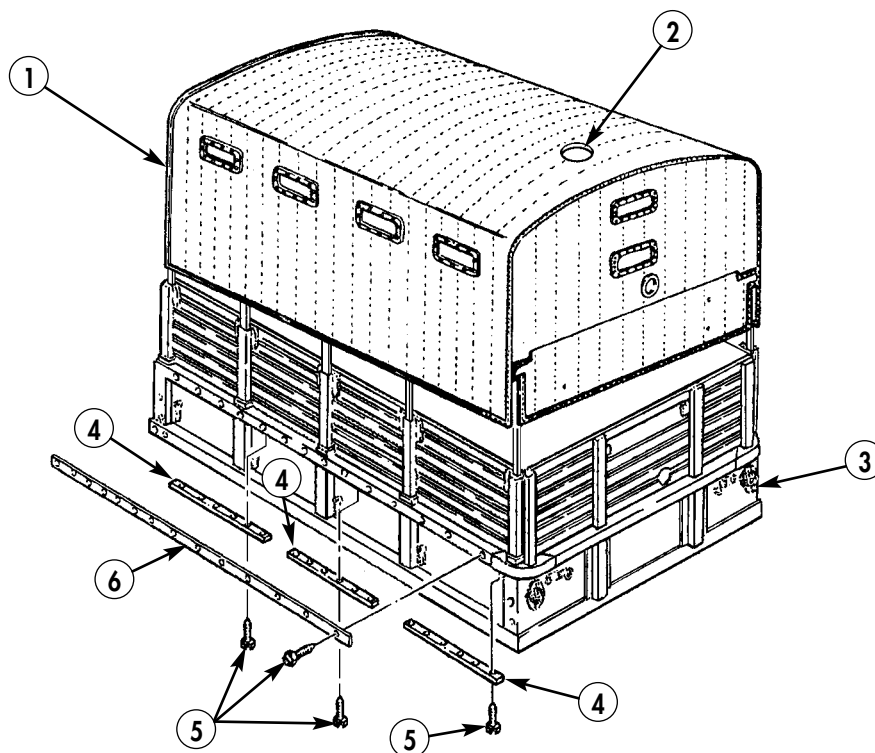

ARCTIC CARGO BODY ENCLOSURE REPLACEMENT (Contd)

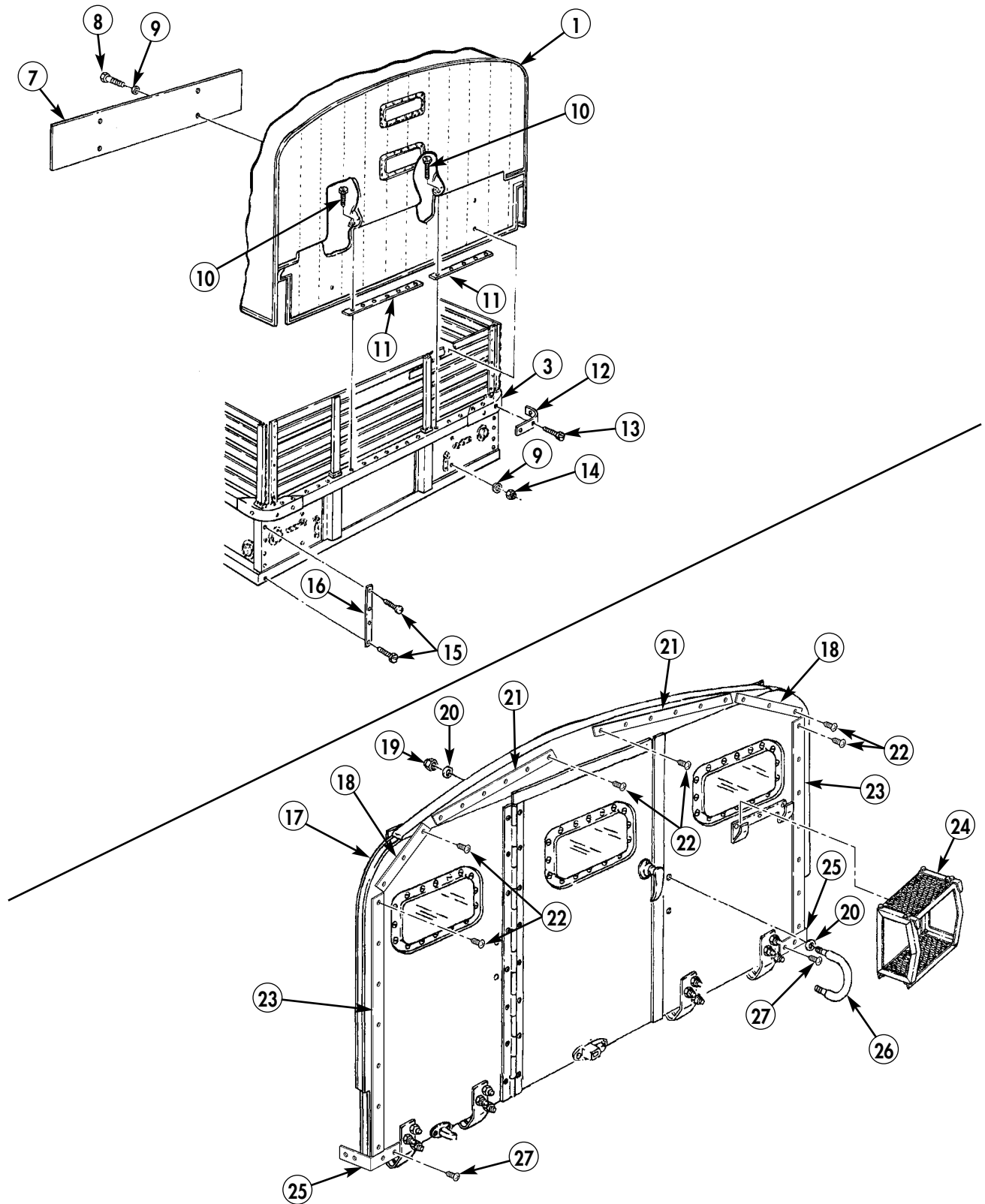

END OF WORK PACKAGE

0410 00-13/14 blank

FIELD MAINTENANCE INSTRUCTIONS FOR SPECIAL PURPOSE KITS

2-1/2 TON, 6X6, M44A2 SERIES TRUCKS (MULTIFUEL)

SPEAKING TUBE REPLACEMENT (M35A2) REMOVAL AND INSTALLATION

INITIAL SETUP:

Applicable Models

M35A2

Personnel Required

Two

Equipment Condition

Parking brake set and wheels chocked
(TM 9-2320-361-10).

Battery ground cable disconnected
(WP 0126 00).

SPEAKING TUBE REPLACEMENT (M35A2) (Contd)

REMOVAL

1. Remove three screws (9) from mouthpiece (8), spacer (7), and cab wall (6).
2. Loosen set screws (10) and remove mouthpiece (8) from speaking tube (16).
3. Remove spacer (7) from speaking tube (16).
4. Remove speaking tube (16) from cab wall (6), ring assembly (1), tarpaulin cone (2), clamp (3), and clip (12).
5. Remove two nuts (11), washers (13), two screws (14), and clip (12) from front cargo rack (15).
6. Remove front cargo rack (15).
7. Remove nut (5), screw (4), clamp (3), and ring assembly (1) from tarpaulin cone (2).

INSTALLATION

1. Install ring assembly (1) in tarpaulin cone (2) with clamp (3), screw (4), and nut (5).
2. Install front cargo rack (15).
3. Install clip (12) to front cargo rack (15) with two screws (14), washers (13), and nuts (11).
4. Install speaking tube (16) to clip (12), through front cargo rack (15), tarpaulin cone (2), ring assembly (1), and cab wall (6).
5. Install spacer (7) on speaking tube (16).
6. Install mouthpiece (8) on speaking tube (16) with set screws (10).

NOTE

Assistant will help with step 7.

7. Secure mouthpiece (8) to spacer (7), cab wall (6), and ring assembly (1) with three screws (9).
8. Connect battery ground cable (WP 0126 00).
9. Release parking brake and remove wheel chocks (TM 9-2320-361-10).

SPEAKING TUBE REPLACEMENT (M35A2) (Contd)

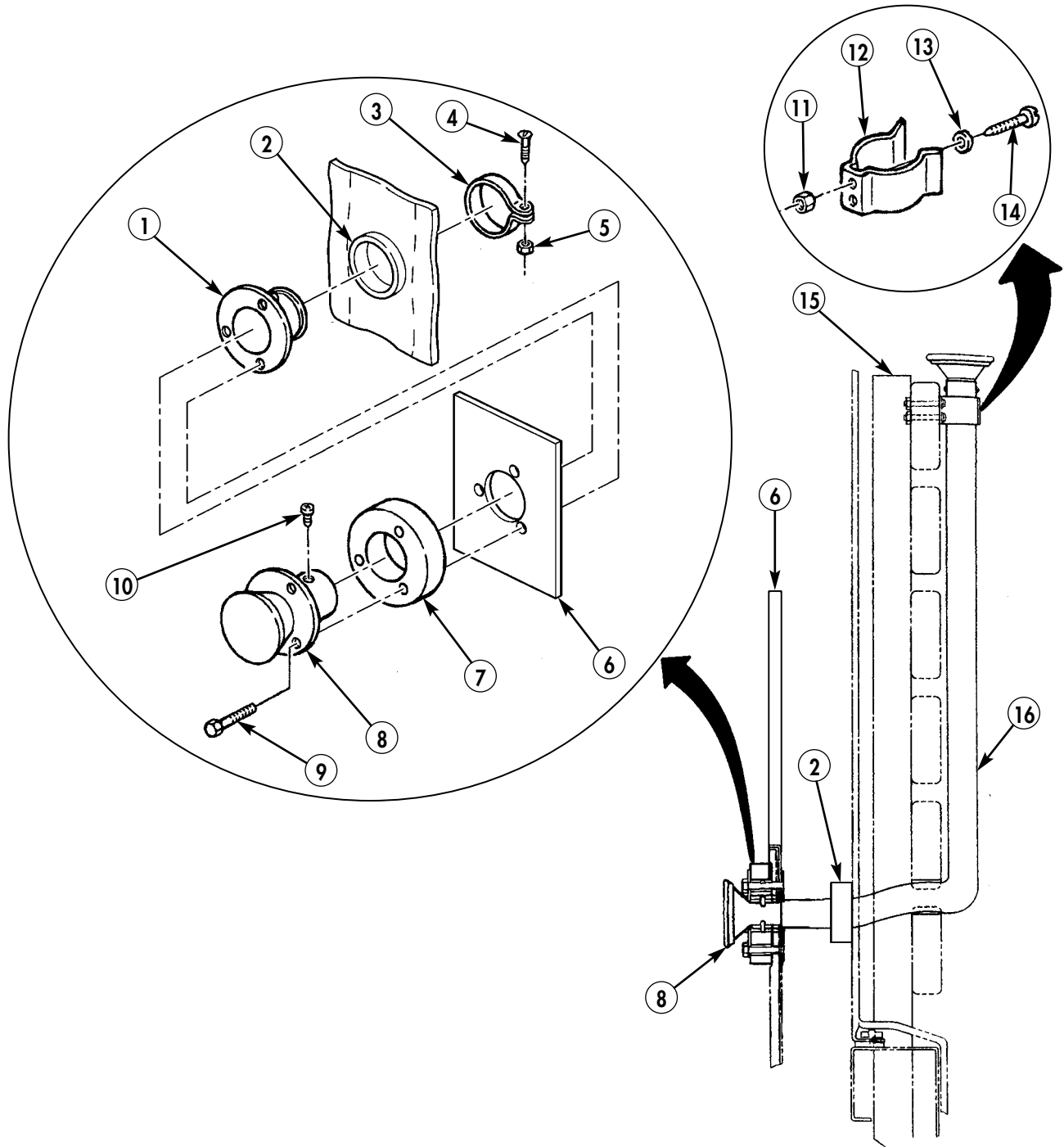

END OF WORK PACKAGE

FIELD MAINTENANCE INSTRUCTIONS FOR SPECIAL PURPOSE KITS

2-1/2 TON, 6X6, M44A2 SERIES TRUCKS (MULTIFUEL)

CARGO BODY TIEDOWN REPLACEMENT REMOVAL AND INSTALLATION

INITIAL SETUP:

Applicable Models

M35A2, M35A2C, M36A2

Tools and Special Tools

General mechanic's tool kit
(item 116, WP 0469 00)

Materials/Parts

Two locknuts (item 153, WP 0470 00)
Sealing compound (item 29, WP 0468 00)

Equipment Condition

Parking brake set and wheels chocked
(TM 9-2320-361-10).

CARGO BODY TIEDOWN REPLACEMENT (Contd)

REMOVAL

Remove locknuts (5), washers (4), tiedown hook (2) and screws (3) from cargo body side (1). Discard locknuts (5).

INSTALLATION

NOTE

Apply sealant to threads of screws prior to installation

1. Install tiedown hook (2) to cargo body side (1) with screws (3), washer (4) and new locknuts (5).
2. Release parking brake and remove wheel chocks (TM 9-2320-361-10).

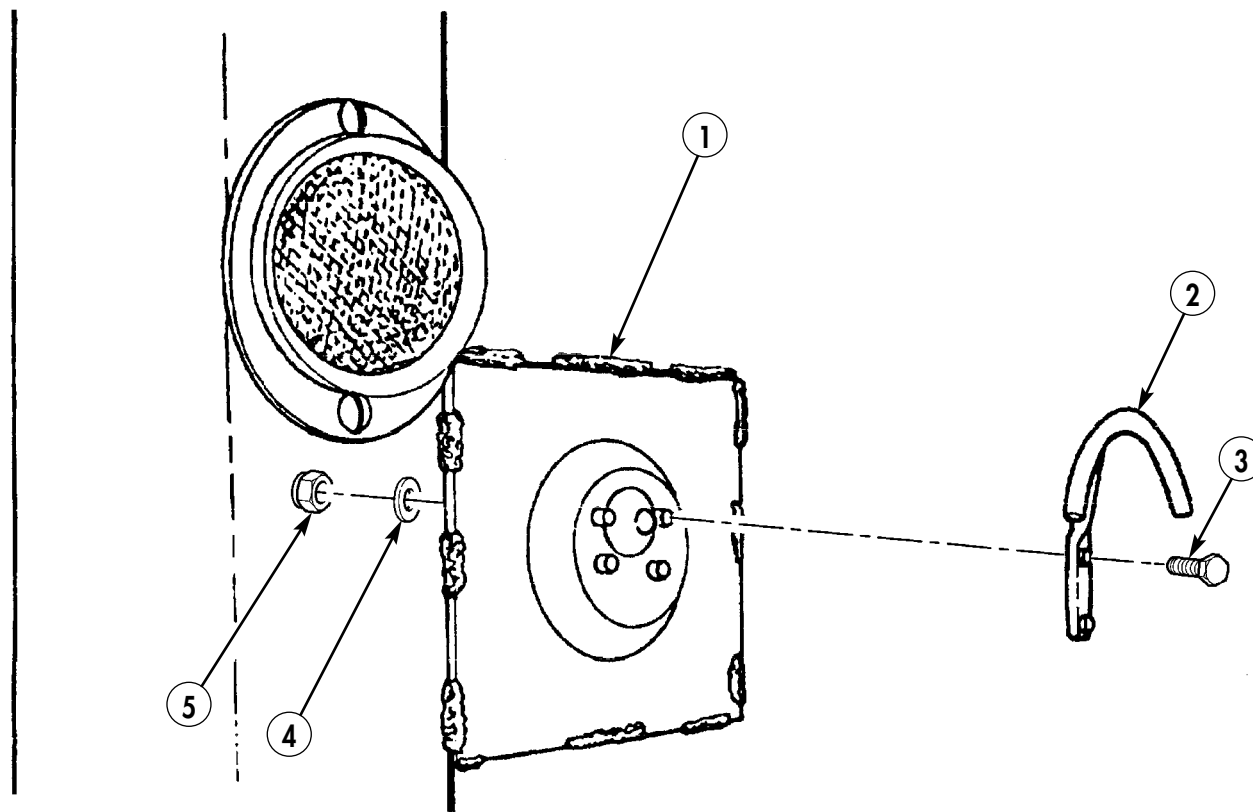

FIELD MAINTENANCE INSTRUCTIONS FOR SPECIAL PURPOSE KITS

2-1/2 TON, 6X6, M44A2 SERIES TRUCKS (MULTIFUEL)

LOW AIR PRESSURE INDICATOR AND LAMP REPLACEMENT REMOVAL AND INSTALLATION

INITIAL SETUP:

Applicable Models

All

Tools and Special Tools

General mechanic's tool kit
(item 116, WP 0469 00)

Materials/Parts

Two lockwashers (item 198, WP 0470 00)

Equipment Condition

Parking brake set and wheels chocked
(TM 9-2320-361-10).

Air reservoir drained (TM 9-2320-361-10).

Battery ground cable disconnected
(WP 0126 00).

LOW AIR PRESSURE INDICATOR AND LAMP REPLACEMENT (Contd)

REMOVAL

1. Turn lens (2) counterclockwise and remove.
2. Push in and turn lamp (3) counterclockwise and remove.
3. Remove two screws (4), lockwashers (5), and low air pressure indicator (6) from instrument cluster (1). Discard lockwasher (5).
4. Disconnect connector (7) from low air pressure indicator (6).

INSTALLATION

1. Connect connector (7) to low air pressure indicator (6).
2. Install low air pressure indicator (6) in instrument cluster (1) with two new lockwashers (5) and screws (4).
3. Install lamp (3) on low air pressure indicator (6).
4. Install lens (2) over lamp (3).
5. Connect battery ground cable (WP 0126 00).
6. Start engine and fill air reservoir (TM 9-2320-361-10).
7. Release parking brake and remove wheel chocks (TM 9-2320-361-10).

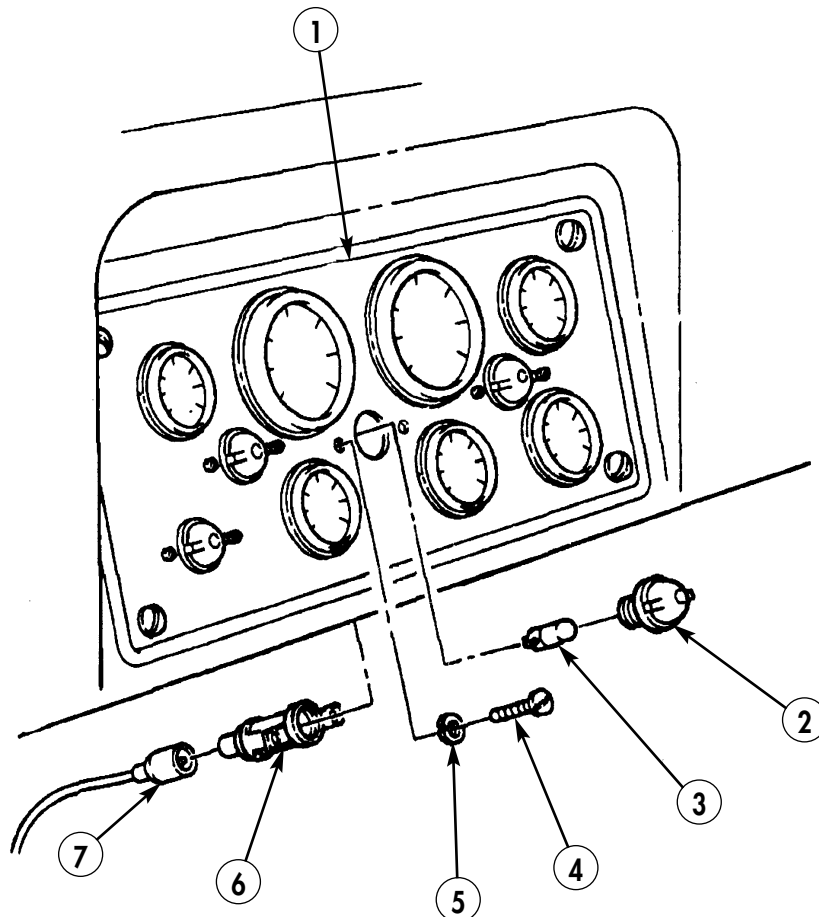

END OF WORK PACKAGE

FIELD MAINTENANCE INSTRUCTIONS FOR SPECIAL PURPOSE KITS

2-1/2 TON, 6X6, M44A2 SERIES TRUCKS (MULTIFUEL)

CAB REINFORCEMENT REPLACEMENT REMOVAL AND INSTALLATION

INITIAL SETUP:

Applicable Models

All except M49A2C

Personnel Required

Two

Tools and Special Tools

General mechanic's tool kit
(item 116, WP 0469 00)

Equipment Condition

Parking brake set and wheels chocked
(TM 9-2320-361-10).

Battery ground cable disconnected
(WP 0126 00).

Materials/Parts

Twelve locknuts (item 145, WP 0470 00)

Lockwasher (item 206, WP 0470 00)

Ninety-three blind rivets

(item 319, WP 0470 00)

Cab top removed (TM 9-2320-361-10).

Driver's and companion's seat removed
(WP 0234 00 and WP 0236 00).

Seatbelts removed

(WP 0396 00 and WP 0397 00).

Cab doors removed (WP 0209 00).

CAB REINFORCEMENT REPLACEMENT (Contd)

REMOVAL

1. Remove twelve screws (1), locknuts (7), seat catch (2), if equipped, and cab reinforcement plate (3) from rear cab wall (8). Discard locknuts (7).
2. Remove seventy-seven blind rivets (5) and cab reinforcement panel (6) from rear cab wall (8). Discard blind rivets (5).

NOTE

Right and left rear pillar gussets are removed the same way.
This procedure covers the left rear pillar gusset.

3. Remove eight blind rivets (5) and rear pillar gusset (4) from rear cab wall (8). Discard blind rivets (5).
4. Remove screw (12), lockwasher (11), and front pillar nut assembly (10) from front door pillar (9). Discard lockwasher (11).

INSTALLATION

1. Install front pillar nut assembly (10) with new lockwasher (11) and screw (12).
2. Install rear pillar gusset (4) to rear cab wall (8) with eight new blind rivets (5).
3. Install cab reinforcement panel (6) to rear cab wall (8) with seventy-seven new blind rivets (6).
4. Install cap reinforcement plate (4) and seat catch (3), if equipped, to rear cab wall (8) with thirteen screws (1) and new locknuts (7).
5. Install seatbelts (WP 0396 00 and WP 0397 00).
6. Install driver's and companion's seat (WP 0234 00 and WP 0236 00).
7. Install cab top (TM 9-2320-361-10).
8. Install cab doors (WP 0209 00).
9. Connect battery ground cable (WP 0126 00).
10. Release parking brake and remove wheel chocks (TM 9-2320-361-10).

CAB REINFORCEMENT REPLACEMENT (Contd)

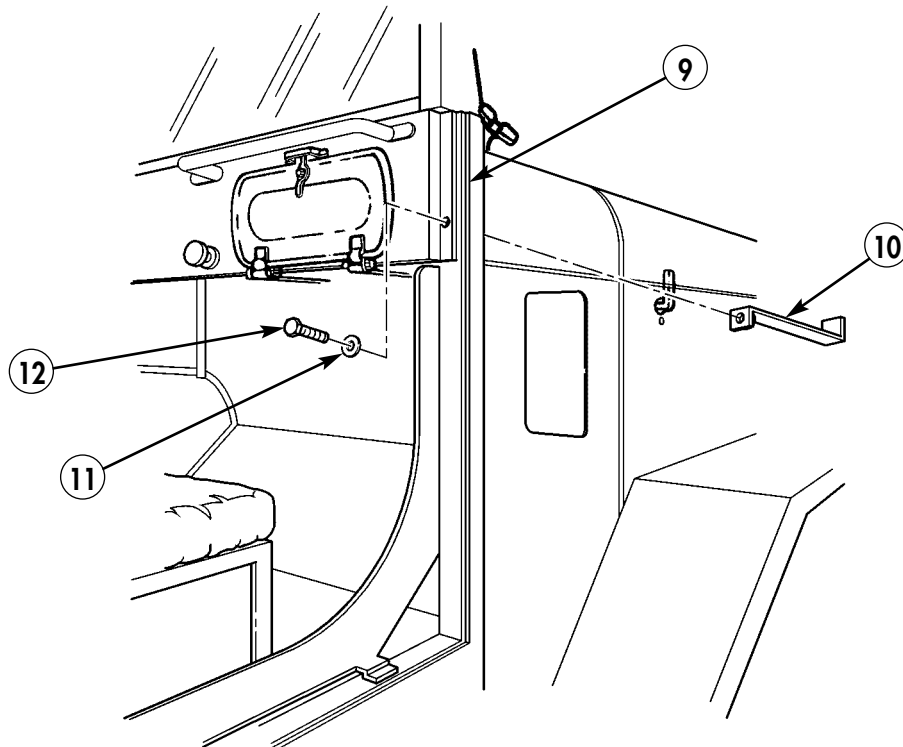
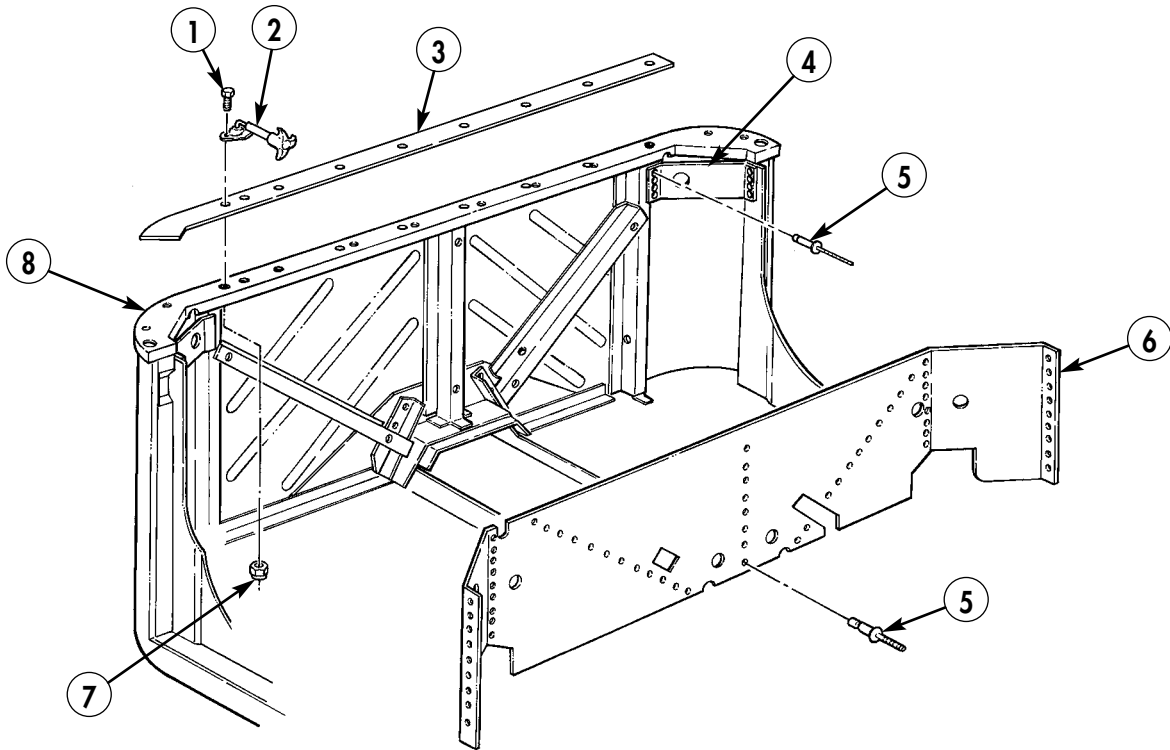

END OF WORK PACKAGE

0414 00-3/4 blank

FIELD MAINTENANCE INSTRUCTIONS FOR SPECIAL PURPOSE KITS

2-1/2 TON, 6X6, M44A2 SERIES TRUCKS (MULTIFUEL)

SUNSHIELD REPLACEMENT (SOFT TOP)

DOOR SUNSHIELD REMOVAL, WINDSHIELD SUNSHIELD REMOVAL,
DOOR SUNSHIELD INSTALLATION, AND WINDSHIELD SUNSHIELD INSTALLATION

INITIAL SETUP:

Applicable Models

All

Tools and Special Tools

General mechanic's tool kit
(item 116, WP 0469 00)

Materials/Parts

Sixteen rivets (item 318, WP 0470 00)

Equipment Condition

Parking brake set and wheels chocked
(TM 9-2320-361-10).

Battery ground cable disconnected
(WP 0126 00).

Cab soft top and bow assemblies removed
(TM 9-2320-361-10).

SUNSHIELD REPLACEMENT (SOFT TOP) (Contd)

NOTE

The left and right side sunshields are installed the same way.
This procedure covers the left side.

DOOR SUNSHIELD REMOVAL

1. Remove four rivets (4) from door frame (1). Discard rivets (4).
2. Remove door sunshield (3) from door frame (1).

WINDSHIELD SUNSHIELD REMOVAL

1. Remove four rivets (4) from windshield frame (5). Discard rivets (4).
2. Remove windshield sunshield (7) from windshield frame (5).

WINDSHIELD SUNSHIELD INSTALLATION

1. Install windshield sunshield (7) to windshield frame (5) with four new rivets (4).

WARNING

All sunshields must be rolled up and properly secured prior to vehicle operation. Failure to do so may result in injury or death to personnel.

2. Roll up windshield sunshield (7) and secure with straps (6).

DOOR SUNSHIELD INSTALLATION

1. Install door sunshield (3) to door frame (1) with four new rivets (4).
2. Roll up door sunshield (3) and secure with straps (2).
3. Install soft top and bow assemblies (TM 9-2320-361-10).
4. Connect battery ground cable (WP 0126 00).
5. Release parking brake and remove wheel chocks (TM 9-2320-361-10).

SUNSHIELD REPLACEMENT (SOFT TOP) (Contd)

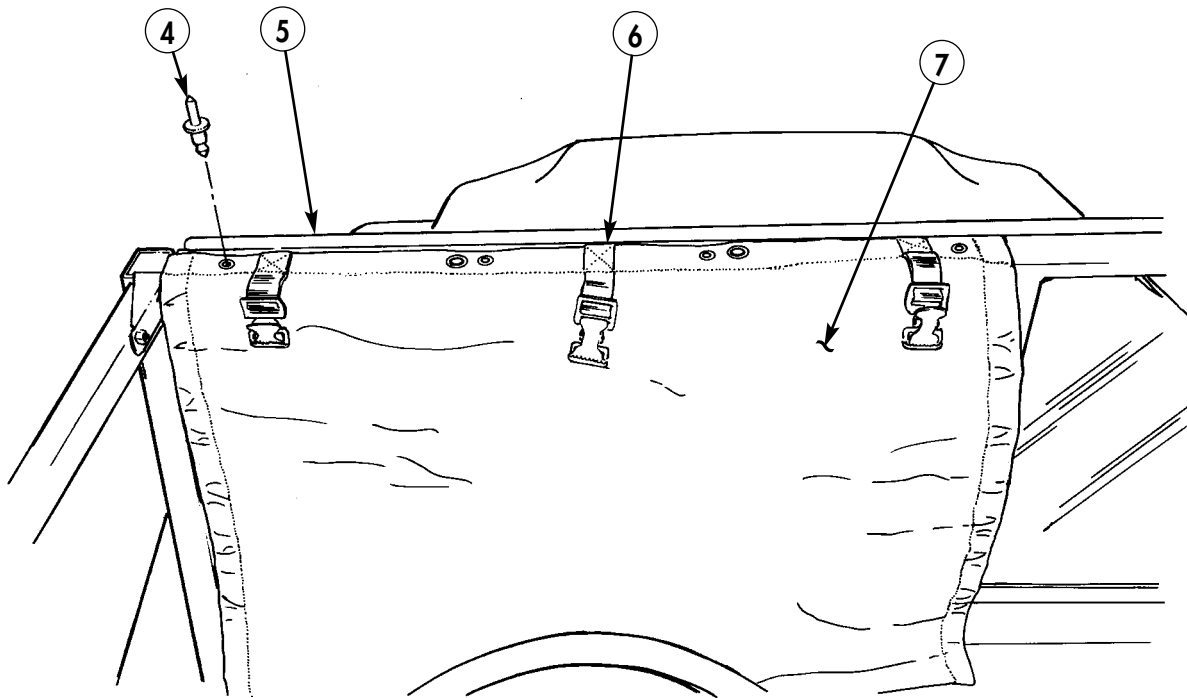
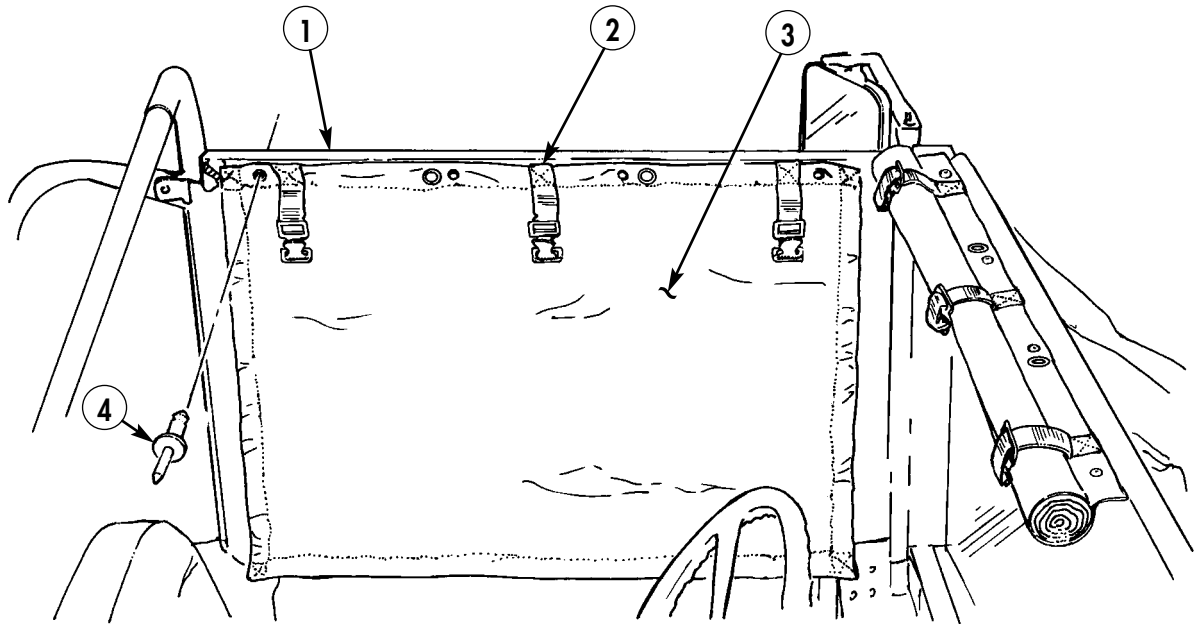

END OF WORK PACKAGE

0415 00-3/4 blank

FIELD MAINTENANCE INSTRUCTIONS FOR SPECIAL PURPOSE KITS

2-1/2 TON, 6X6, M44A2 SERIES TRUCKS (MULTIFUEL)

SUNSHIELD REPLACEMENT (HARD TOP)

DOOR SUNSHIELD REMOVAL, WINDSHIELD SUNSHIELD REMOVAL,
DOOR SUNSHIELD INSTALLATION, AND WINDSHIELD SUNSHIELD INSTALLATION

INITIAL SETUP:

Applicable Models

All

Tools and Special Tools

General mechanic's tool kit
(item 116, WP 0469 00)

Materials/Parts

Sixteen rivets (item 318, WP 0470 00)

Equipment Condition

Parking brake set and wheels chocked
(TM 9-2320-361-10).
Battery ground cable disconnected
(WP 0126 00).

SUNSHIELD REPLACEMENT (HARD TOP) (Contd)

NOTE

The left and right side sunshields are installed the same way.
This procedure covers the left side.

DOOR SUNSHIELD REMOVAL

1. Remove four rivets (5) from door frame assembly (1). Discard rivets (5).
2. Remove door sunshield (2) from door frame assembly (1).

WINDSHIELD SUNSHIELD REMOVAL

1. Remove four rivets (5) from windshield frame assembly (4). Discard rivets (5).
2. Remove windshield sunshield (7) from windshield frame assembly (4).

WINDSHIELD SUNSHIELD INSTALLATION

1. Install windshield sunshield (7) to windshield frame (4) with four new rivets (5).

WARNING

All sunshields must be rolled up and properly secured prior to vehicle operation. Failure to do so may result in injury or death to personnel.

2. Roll up windshield sunshield (7) and secure with straps (6).

DOOR SUNSHIELD INSTALLATION

1. Install door sunshield (2) with four new rivets (5) to door frame assembly (1).
2. Roll up door sunshield (2) and secure with straps (3).
3. Connect battery ground cable (WP 0126 00).
4. Release parking brake and remove wheel chocks (TM 9-2320-361-10).

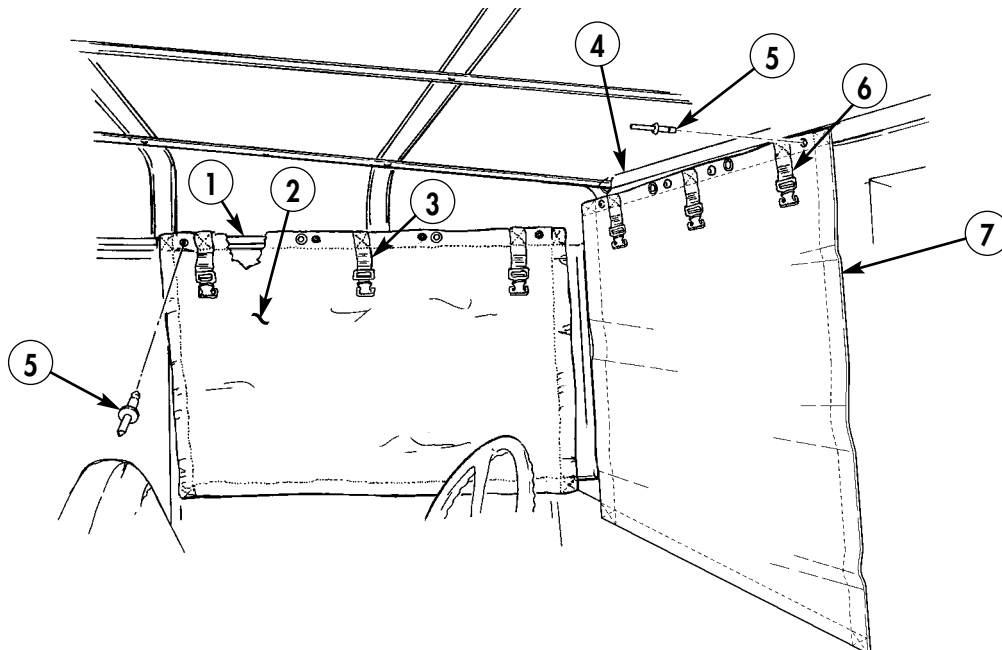

END OF WORK PACKAGE

FIELD MAINTENANCE INSTRUCTIONS FOR SPECIAL PURPOSE KITS

2-1/2 TON, 6X6, M44A2 SERIES TRUCKS (MULTIFUEL)

ENGINE COOLANT HEATER FLAME DETECTOR SWITCH MAINTENANCE

REMOVAL, DISASSEMBLY, INSPECTION, ASSEMBLY, AND INSTALLATION

INITIAL SETUP:

Applicable Models

All

References

WP 0021 00

Tools And Special Tools

General mechanic's tool kit
(item 116, WP 0469 00)
Electrical tool kit (item 114, WP 0469 00)
Multimeter (item 51, WP 0469 00)

Equipment Condition

Parking brake set and wheels chocked
(TM 9-2320-361-10).
Battery ground cable disconnected
(WP 0126 00).
Engine coolant heater removed (WP 0357 00).

Materials/Parts

Five screw-assembled lockwashers
(item 261, WP 0470 00)
Three nut-assembled lockwashers
(item 247, WP 0470 00)
Sleeve (item 433, WP 0470 00)

ENGINE COOLANT HEATER FLAME DETECTOR SWITCH MAINTENANCE (Contd)

NOTE

Prior to removal, tag lead wires for installation.

REMOVAL

1. Remove four screws (6) and guard (7) from heater housing (8).
2. Remove nut-assembled lockwasher (2), ground lead (3), air tube (4), and elbows (1) and (5) from heater housing (8). Discard nut-assembled lockwasher (2).
3. Remove five screw-assembled lockwashers (11) and six leads (12) from flame detector switch (10). Discard screw-assembled lockwashers (11).
4. Loosen nut (9) and remove flame detector switch (10) from heater housing (8).

DISASSEMBLY

1. Remove adjusting screw (15), washer (16), and spring (17) from switch bracket (24) and mount (18).

CAUTION

Ceramic rod is very brittle and is easily broken; handle carefully.

2. Tilt microswitch (13) back on switch bracket (24), invert, and remove ceramic rod (22) from probe (20).
3. Remove two nut-assembled lockwashers (14), screws (23), and microswitch (13) from switch bracket (24). Discard nut-assembled lockwashers (14).
4. Remove split roll pin (21) and switch bracket (24) from mount (18).
5. Remove sleeve (19) and nut (9) from probe (20). Discard sleeve (19).

INSPECTION

1. Inspect flame detector switch (10) for broken ceramic rod (22) or bent probe (20). Replace ceramic rod (22) if broken. Replace flame detector switch (10) if probe (20) is bent.
2. Inspect flame detector switch (10) for carbon buildup and corrosion. Remove carbon buildup or corrosion. Refer to WP 0021 00 for general inspection procedures.

ENGINE COOLANT HEATER FLAME DETECTOR SWITCH MAINTENANCE (Contd)

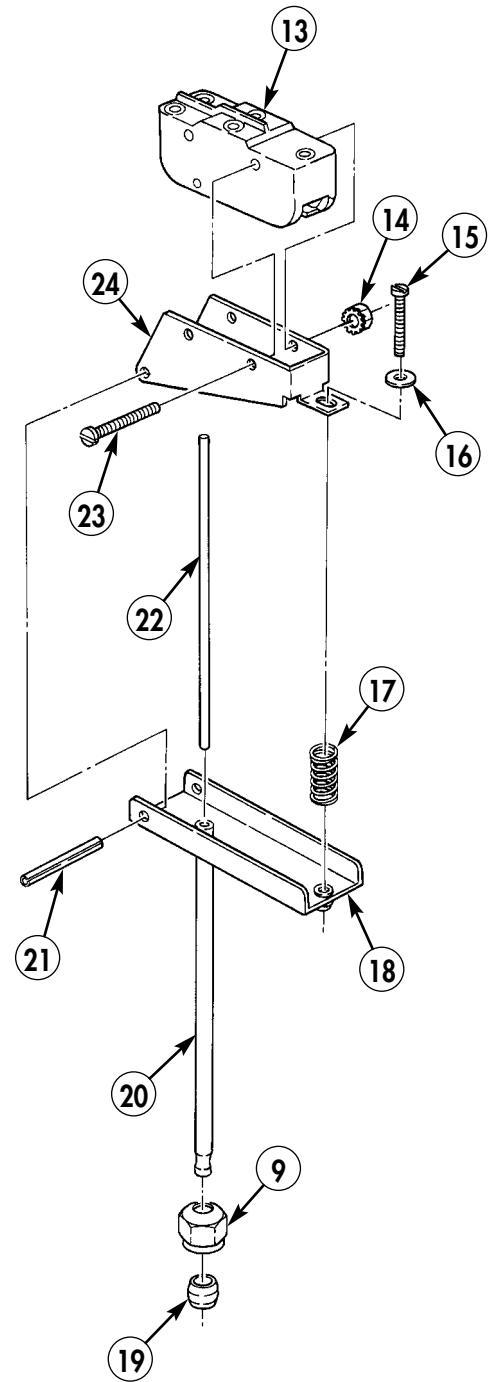
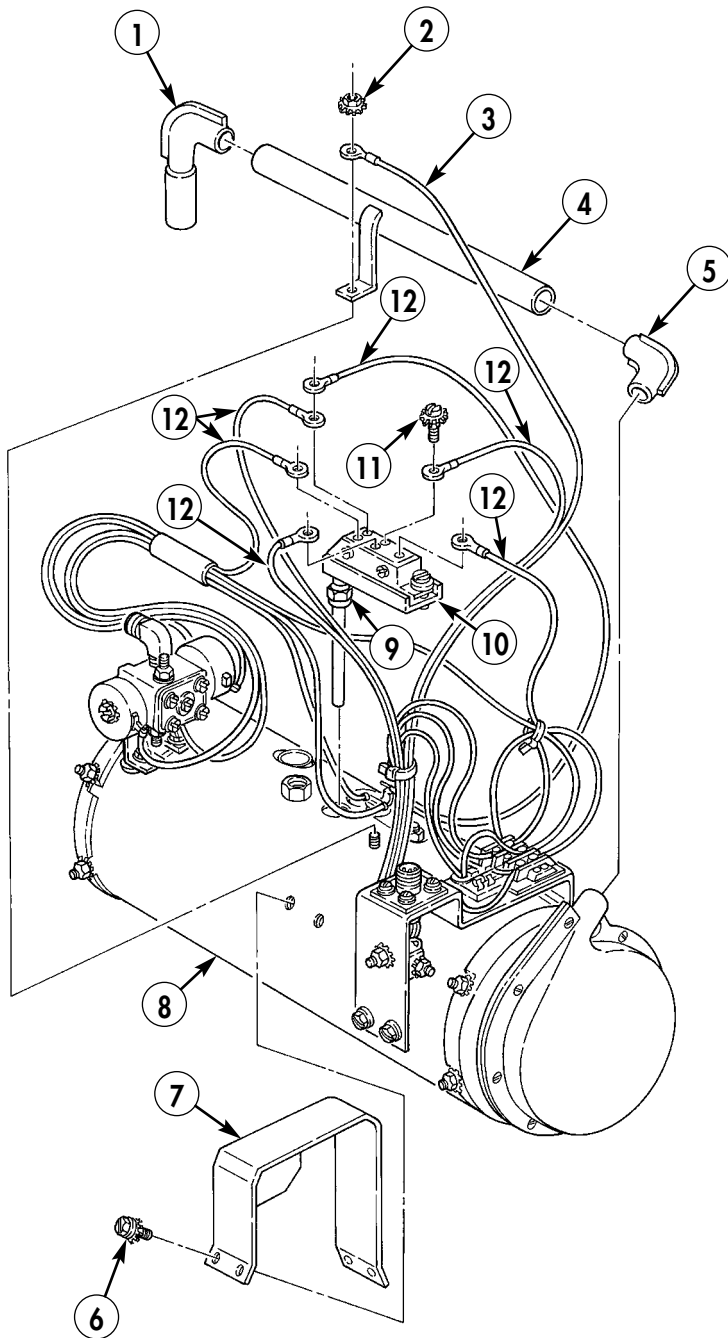

ENGINE COOLANT HEATER FLAME DETECTOR SWITCH MAINTENANCE (Contd)

ASSEMBLY

1. Install nut (7) and new sleeve (8) on probe (9).
2. Install switch bracket (13) on mount (6) with split roll pin (10).
3. Install microswitch (1) on switch bracket (13) with two screws (12) and new nut-assembled lockwashers (2).

CAUTION

Ceramic rod is very brittle and is easily broken; handle carefully.

4. Tilt microswitch (1) and switch bracket (13) back on mount (6) and insert ceramic rod (11) into probe (9).
5. Rotate microswitch (1) back on mount (6) and install spring (5), washer (4), and adjusting screw (3) on switch bracket (13) and mount (6).
6. Tighten adjusting screw (3) until microswitch (1) clicks. Then continue 3/4 turn past click point.

INSTALLATION

1. Install flame detector switch (22) on heater housing (21) and tighten nut (7).
2. Install six leads (24) on flame detector switch (22) with five new screw-assembled lockwashers (23).
3. Install air tube (17), elbows (14) and (18) and ground lead (16) on heater housing (21) with new nut-assembled lockwasher (15).
4. Install guard (20) on heater housing (21) with four screws (19).
5. Test engine coolant heater (WP 0357 00).
6. Connect battery ground cable (WP 0126 00).
7. Release parking brake and remove wheel chocks (TM 9-2320-361-10).

ENGINE COOLANT HEATER FLAME DETECTOR SWITCH MAINTENANCE (Contd)

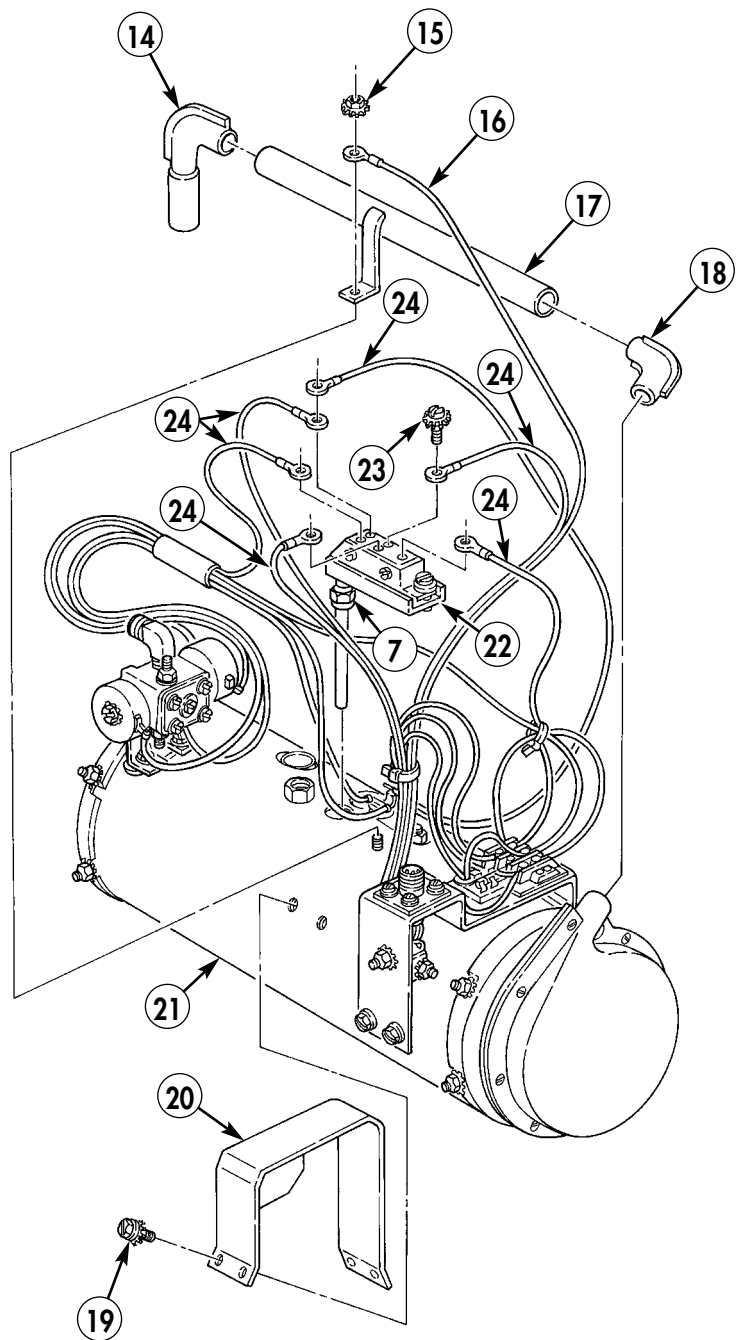
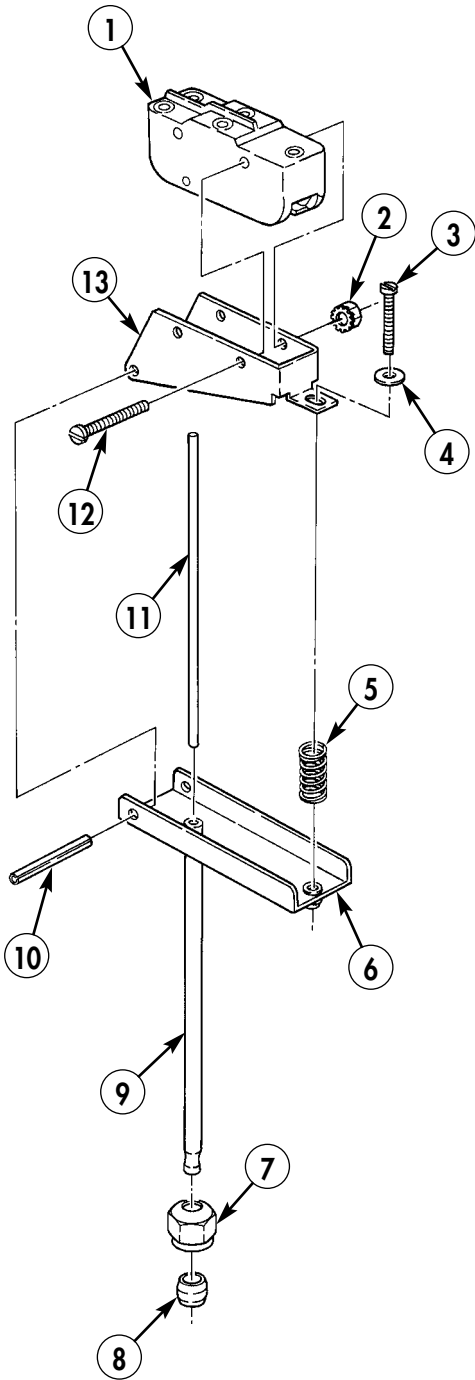

END OF WORK PACKAGE

FIELD MAINTENANCE INSTRUCTIONS FOR SPECIAL PURPOSE KITS

2-1/2 TON, 6X6, M44A2 SERIES TRUCKS (MULTIFUEL)

ENGINE COOLANT HEATER BLOWER MOTOR MAINTENANCE REMOVAL, CLEANING AND INSPECTION, AND INSTALLATION

INITIAL SETUP:

Applicable Models

All

Tools And Special Tools

General mechanic's tool kit
(item 116, WP 0469 00)
Electrical tool kit (item 114, WP 0469 00)
Multimeter (item 51, WP 0469 00)

Materials/Parts

Five nut-assembled lockwasher
(item 247, WP 0470 00)

Materials/Parts (Contd)

Screw-assembled lockwasher
(item 261, WP 0470 00)
Tiedown strap (item 38, WP 0468 00)
Skysol 100 (item 13, WP 0468 00)
Rag (item 27, WP 0468 00)

References

WP 0426 00

Equipment Condition

Parking brake set and wheels chocked
(TM 9-2320-361-10).
Battery ground cable disconnected
(WP 0126 00).
Engine coolant heater removed (WP 0357 00).

ENGINE COOLANT HEATER BLOWER MOTOR MAINTENANCE (Contd)

NOTE

Prior to removal, tag lead wires for installation.

REMOVAL

1. Remove four screws (11) and guard (12) from heater housing (13).
2. Remove tiedown strap (6) from heater wiring. Discard tiedown strap (6).
3. Remove nut-assembled lockwasher (2), ground lead (3), air tube (4), and elbows (1) and (5) from heater housing (13).
4. Remove screw-assembled lockwasher (8) and wire (7) from heater component bracket (14).
5. Remove four nut-assembled lockwashers (10) and blower motor (9) from heater housing (13).

CLEANING AND INSPECTION

1. Inspect blower motor (9) for dirt, grease, and carbon.

WARNING

- Skysol 100 solvent is combustible; DO NOT use or store near heat, sparks, flame, or other ignition sources. Use mechanical ventilation whenever product is used in a confined space, heated above ambient temperatures, or agitated. Keep container sealed when not in use.

Contact with Skysol 100 may cause skin irritation. Use chemical-resistant gloves. In case of skin contact, remove any contaminated clothing and wash skin thoroughly with soap and water. Wash contaminated clothing before reuse. Eye contact may cause irritation, tearing, or blurring of vision. Use face shield or goggles when eye contact may occur. In case of eye contact, flush eyes with large amounts of water for at least 15 minutes or until irritation subsides. Inhalation may cause irritation to upper respiratory passages. DO NOT have food or drink in the vicinity. Failure to comply may result in injury to personnel.

- Compressed air source must not exceed 30 psi (207 kPa). Wear eyeshields when cleaning with compressed air. Failure to wear eyeshields may result in injury to personnel.

2. Clean housing (13) surface with Skysol 100 and dry with clean rag or compressed air. Do not immerse in solvent.

INSTALLATION

1. Install blower motor (9) on heater housing (13) with four new nut-assembled lockwashers (10).
2. Install wire (7) on heater component bracket (14) with new screw-assembled lockwasher (8).
3. Install elbows (1) and (5), air tube (4), and ground lead (3) on heater housing (13) with new nut-assembled lockwasher (2).
4. Place new tiedown strap (6) around heater wiring.
5. Install guard (12) on heater housing (13) with four screws (11).
6. Install engine coolant heater (WP 0076 00).
7. Test engine coolant heater (WP 0426 00).
8. Connect battery ground cable (WP 0126 00).
9. Release parking brake and remove wheel chocks (TM 9-2320-361-10).

ENGINE COOLANT HEATER BLOWER MOTOR MAINTENANCE (Contd)

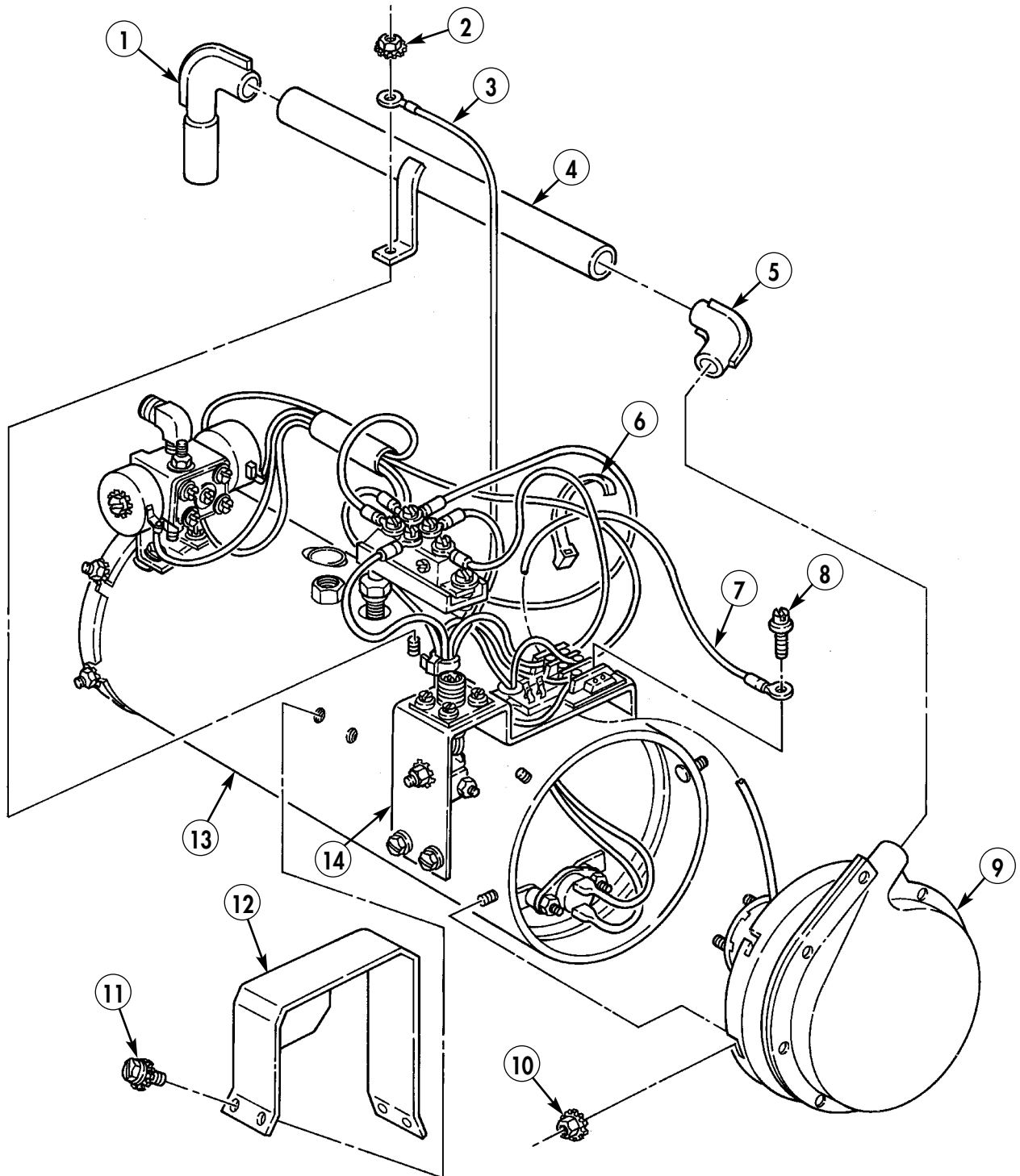

END OF WORK PACKAGE

FIELD MAINTENANCE INSTRUCTIONS FOR SPECIAL PURPOSE KITS

2-1/2 TON, 6X6, M44A2 SERIES TRUCKS (MULTIFUEL)

ENGINE COOLANT HEATER RESTRICTION THERMOSTAT MAINTENANCE REMOVAL, INSPECTION, AND INSTALLATION

INITIAL SETUP:

Applicable Models

All

Tools And Special Tools

General mechanic's tool kit
(item 116, WP 0469 00)
Electrical tool kit (item 114, WP 0469 00)
Multimeter (item 51, WP 0469 00)

Equipment Condition

Parking brake set and wheels chocked
(TM 9-2320-361-10).
Battery ground cable disconnected
(WP 0126 00).
Engine coolant heater blower motor removed
(WP 0418 00).

Materials/Parts

Two nut-assembled lockwashers
(item 247, WP 0470 00)

ENGINE COOLANT HEATER RESTRICTION THERMOSTAT MAINTENANCE (Contd)

REMOVAL

NOTE

Prior to removal, tag lead wires for installation.

1. Disconnect two leads (1) from restriction thermostat (3).
2. Remove two nut-assembled lockwashers (2), restriction thermostat (3), and two spacers (4) from two studs (5). Discard nut-assembled lockwashers (2).

INSPECTION

1. Inspect restriction thermostat (3) for corrosion and bends. Replace if corroded or bent.
2. Check restriction thermostat continuity at room temperature. If continuity exists, replace restriction thermostat (3).

CAUTION

Do not place restriction thermostat in liquid for cooling. Placing restriction thermostat in liquid will cause damage to equipment.

3. Cool restriction thermostat to 20 °F (-6.7 °C). Check restriction thermostat continuity. If continuity does not exist, replace restriction thermostat.

INSTALLATION

1. Install restriction thermostat (3) and two spacers (4) on two studs (5) with two new nut-assembled lockwashers (2).
2. Connect two leads (1) to restriction thermostat (3).
3. Install engine coolant heater blower motor (WP 0418 00).
4. Connect battery ground cable (WP 0126 00).
5. Release parking brake and remove wheel chocks (TM 9-2320-361-10).

ENGINE COOLANT HEATER RESTRICTION THERMOSTAT MAINTENANCE (Contd)

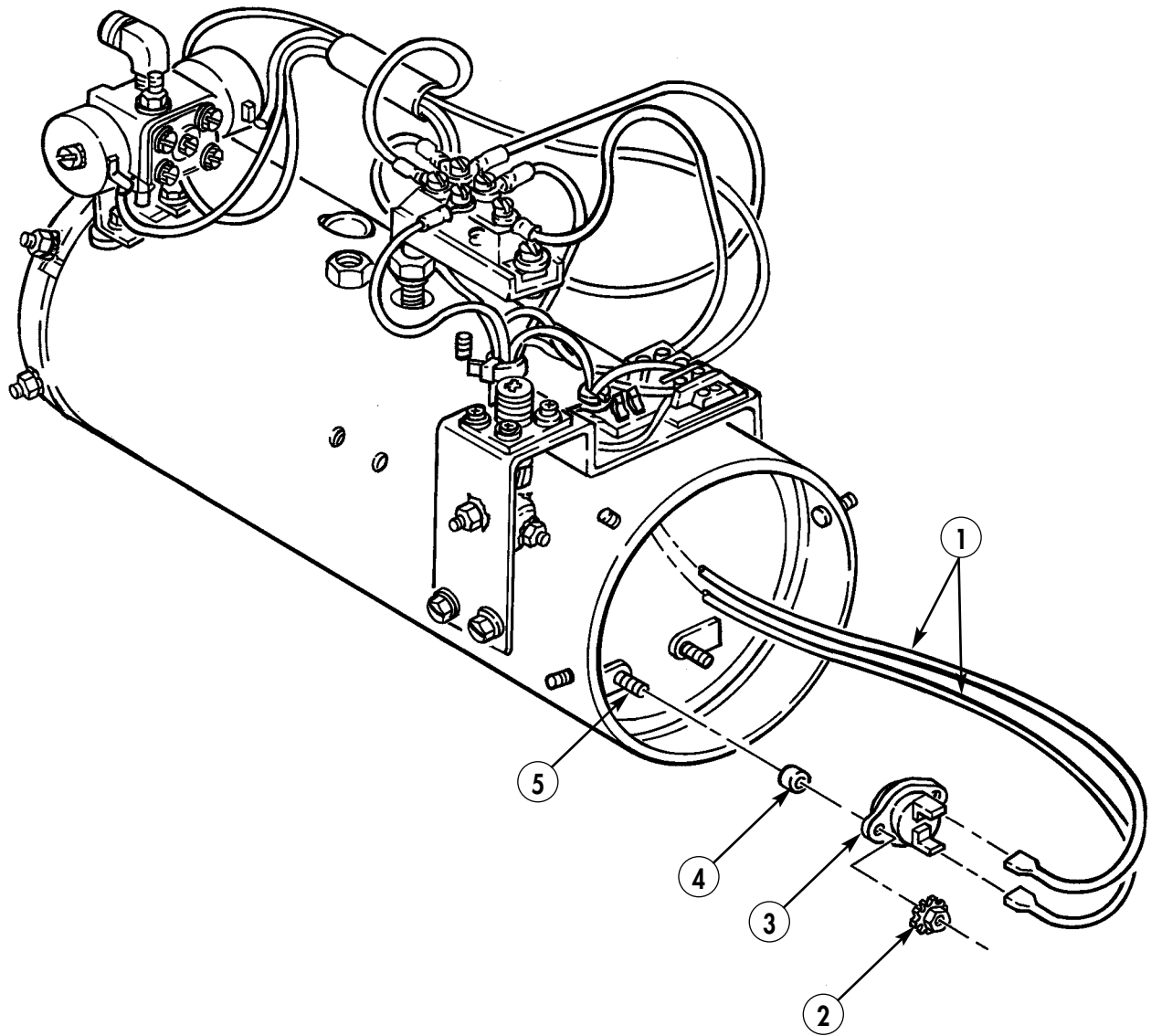

END OF WORK PACKAGE

FIELD MAINTENANCE INSTRUCTIONS FOR SPECIAL PURPOSE KITS

2-1/2 TON, 6X6, M44A2 SERIES TRUCKS (MULTIFUEL)

ENGINE COOLANT HEATER COMPONENT BRACKET MAINTENANCE

REMOVAL, DISASSEMBLY, INSPECTION, ASSEMBLY, AND INSTALLATION

INITIAL SETUP:

Applicable Models

All

Tools And Special Tools

General mechanic's tool kit
(item 116, WP 0469 00)
Electrical tool kit (item 114, WP 0469 00)
Multimeter (item 51, WP 0469 00)

Materials/Parts

Sixteen screw-assembled lockwashers
(item 261, WP 0470 00)
Two nut-assembled lockwashers
(item 247, WP 0470 00)
Tiedown strap (item 38, WP 0468 00)

Equipment Condition

Parking brake set and wheels chocked
(TM 9-2320-361-10).
Battery ground cable disconnected
(WP 0126 00).
Engine coolant heater blower motor removed
(WP 0418 00).

ENGINE COOLANT HEATER COMPONENT BRACKET MAINTENANCE (Contd)

REMOVAL

NOTE

Prior to removal, tag lead wires for installation.

1. Remove tiedown strap (1) from wires. Discard tiedown strap (1).
2. Remove two screw-assembled lockwashers (4), and leads (2), (3), and (5) from heater component bracket (6).
3. Remove leads (3) and (8) from restriction thermostat (9).
4. Remove grommet (11) from leads (3) and (8) and heater housing (10).
5. Remove three screw-assembled lockwashers (16) and leads (13), (14), (15), and (17) from flame detector switch (12). Discard screw-assembled lockwashers (16).
6. Remove four screws (7) and heater component bracket (6) from heater housing (10).

DISASSEMBLY

NOTE

Prior to disassembly, note direction of arrow on diode for installation.

1. Remove diode (23) from diode holder (22).
2. Remove screw-assembled lockwashers (20) and (26), resistor leads (19) and (27), and diode lead (21) from terminal strip (29). Discard screw-assembled lockwashers (20) and (26).
3. Remove screw-assembled lockwasher (25) from diode holder (22) and terminal strip (29). Discard screw-assembled lockwasher (25).
4. Remove screw (24) and diode holder (22) from heater component bracket (31).
5. Remove four screw-assembled lockwashers (28), terminal strip (29), and plate (30) from heater component bracket (31). Discard screw-assembled lockwashers (28).
6. Remove nut-assembled lockwasher (34), screw (37), and resistor (18) from resistor holder (35). Discard nut-assembled lockwasher (34).
7. Remove four screw-assembled lockwashers (36) and receptacle (33) from heater component bracket (31). Discard screw-assembled lockwashers (36).
8. Remove nut-assembled lockwasher (32) and resistor holder (35) from heater component bracket (31). Discard nut-assembled lockwasher (32).

INSPECTION

1. Check diode (23) for continuity. Reverse leads on diode (23) and check for continuity. If circuit is open in both test conditions or closed in both test conditions, replace diode (23).
2. Check resistor (18) for continuity. If continuity does not exist, replace resistor (18).

ENGINE COOLANT HEATER COMPONENT BRACKET MAINTENANCE (Contd)

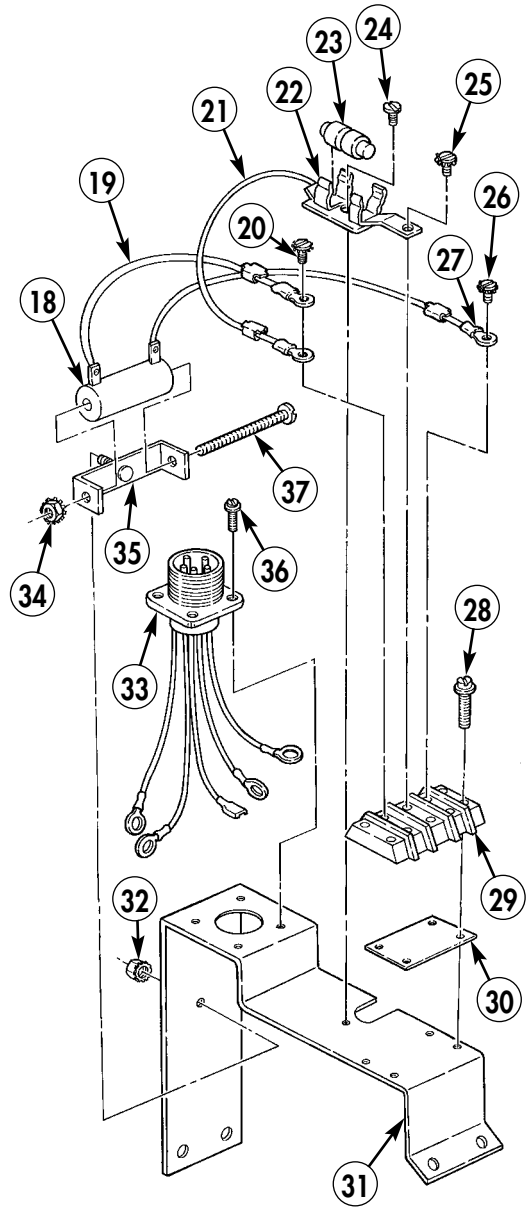
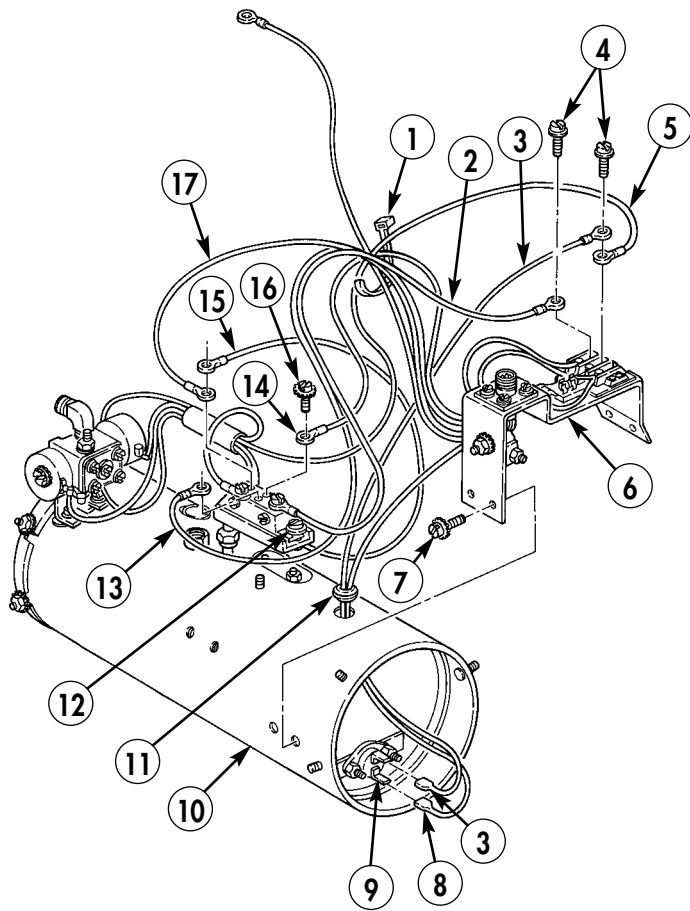

ENGINE COOLANT HEATER COMPONENT BRACKET MAINTENANCE (Contd)

ASSEMBLY

1. Install receptacle (16) on heater component bracket (14) with four new screw-assembled lockwashers (20).
2. Install resistor holder (18) on heater component bracket (14) with new nut-assembled lockwasher (15).
3. Install resistor (1) on resistor holder (18) with screw (19) and new nut-assembled lockwasher (17).
4. Install terminal strip (12) and spacer (13) on heater component bracket (14) with four new screw-assembled lockwashers (11).
5. Install diode holder (5) on heater component bracket (14) with screw (7).
6. Install diode (6) on diode holder (5) with arrow pointed in direction previously noted.
7. Install resistor leads (2) and (9), diode lead (4), and diode holder (5) on terminal strip (12) with screw-assembled lockwashers (3), (8), and (10).

INSTALLATION

1. Install heater component bracket (14) on heater housing (34) with four screws (30).
2. Install leads (26), (27), and (29) on heater component bracket (14) with two new screw-assembled lockwashers (28).
3. Place grommet (33) on leads (27) and (31) and install on heater housing (34).
4. Install leads (21), (22), (24), and (37) on flame detector switch (35) with three new screw-assembled lockwashers (23).
5. Install leads (31) and (27) on restriction thermostat (32).
6. Install new tiedown strap (25) around wires.
7. Install engine coolant heater blower motor (WP 0418 00).
8. Connect battery ground cable (WP 0126 00).
9. Release parking brake and remove wheel chocks (TM 9-2320-361-10).

ENGINE COOLANT HEATER COMPONENT BRACKET MAINTENANCE (Contd)

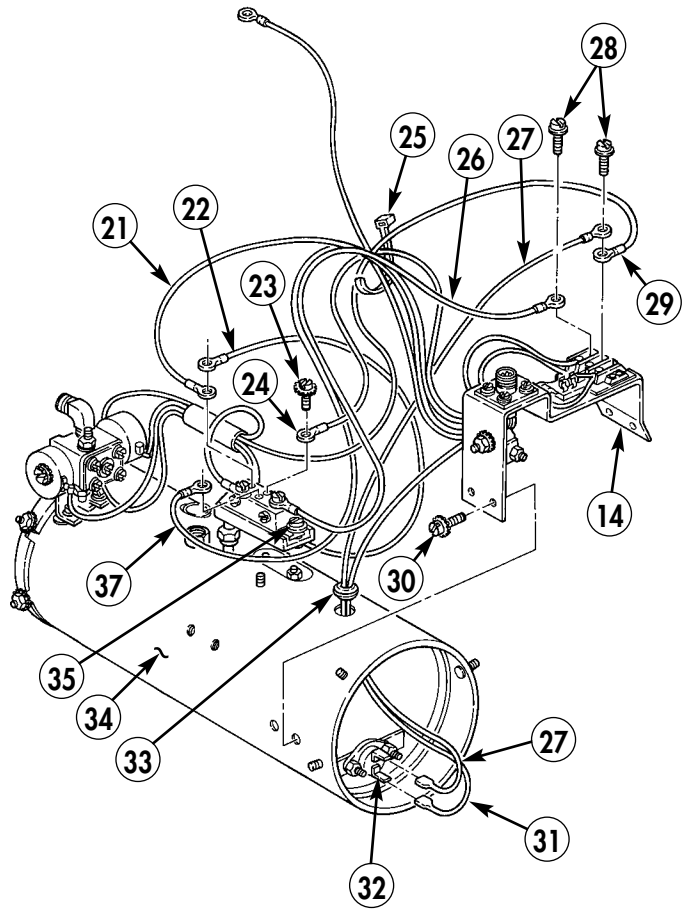
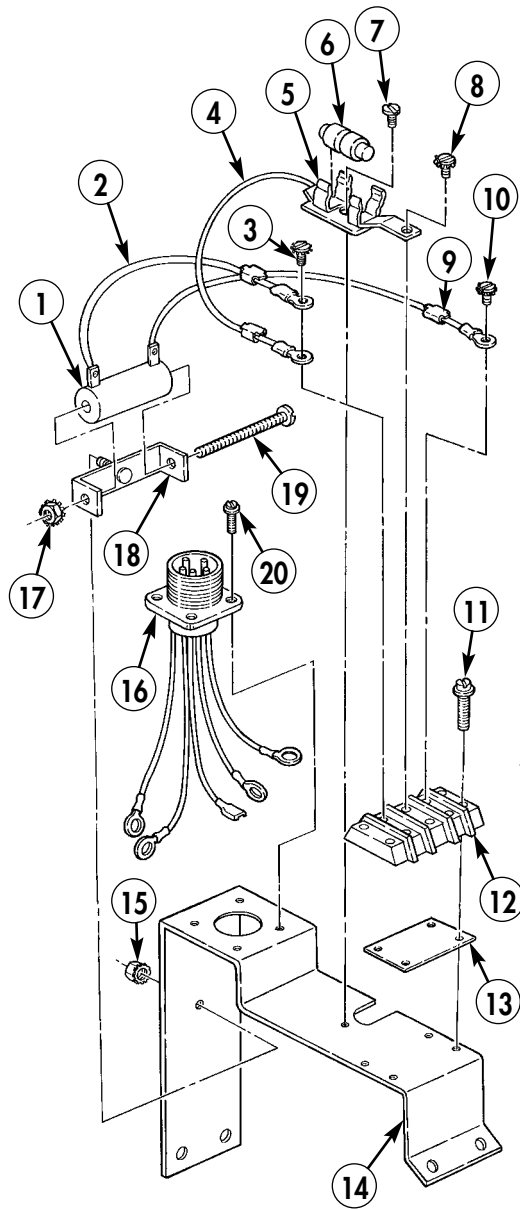

END OF WORK PACKAGE

FIELD MAINTENANCE INSTRUCTIONS FOR SPECIAL PURPOSE KITS

2-1/2 TON, 6X6, M44A2 SERIES TRUCKS (MULTIFUEL)

ENGINE COOLANT HEATER FUEL CONTROL VALVE REPLACEMENT REMOVAL AND INSTALLATION

INITIAL SETUP:

Applicable Models

All

Tools And Special Tools

General mechanic's tool kit
(item 116, WP 0469 00)
Electrical tool kit (item 114, WP 0469 00)
Multimeter (item 51, WP 0469 00)

Materials/Parts

Four screw-assembled lockwashers
(item 261, WP 0470 00)
Nut-assembled lockwasher
(item 247, WP 0470 00)

Equipment Condition

Parking brake set and wheels chocked
(TM 9-2320-361-10).
Battery ground cable disconnected
(WP 0126 00).
Engine coolant heater removed (WP 0357 00).

ENGINE COOLANT HEATER FUEL CONTROL VALVE REPLACEMENT (Contd)

REMOVAL

NOTE

Prior to removal, tag lead wires for installation.

1. Remove four screws (8) and guard (7) from heater housing (6).
2. Remove nut-assembled lockwasher (2), ground lead (3), air tube (4), and elbows (1) and (5) from heater housing (6). Discard nut-assembled lockwasher (2).
3. Disconnect fuel control valve leads (9) and (10) from tab connector (19).
4. Loosen nut (16) and slide down fuel tube (15).
5. Remove screw-assembled lockwasher (22) and lead (21) from heater component bracket (20). Discard screw-assembled lockwasher (22).
6. Remove screw-assembled lockwasher (11) and lead (17) from flame detector switch (18). Discard screw-assembled lockwasher (11).
7. Remove two screw-assembled lockwashers (13) and fuel control valve (12) from bracket (14). Discard screw-assembled lockwashers (13).

INSTALLATION

1. Position fuel control valve (12) on fuel tube (15) and bracket (14).
2. Tighten nut (16) and install fuel control valve (12) on bracket (14) with two new screw-assembled lockwashers (13).
3. Install lead (21) on heater component bracket (20) with new screw-assembled lockwasher (22).
4. Install lead (17) on flame detector switch (18) with new screw-assembled lockwasher (11).
5. Connect fuel control leads (9) and (10) on tab connector (19).
6. Install air tube (4), elbows (1) and (5), and ground lead (3) on heater housing (6) with new nut-assembled lockwasher (2).
7. Install guard (7) on heater housing (6) with four screws (8).
8. Install engine coolant heater (WP 0357 00).
9. Connect battery ground cable (WP 0126 00).
10. Release parking brake and remove wheel chocks (TM 9-2320-361-10).

ENGINE COOLANT HEATER FUEL CONTROL VALVE REPLACEMENT (Contd)

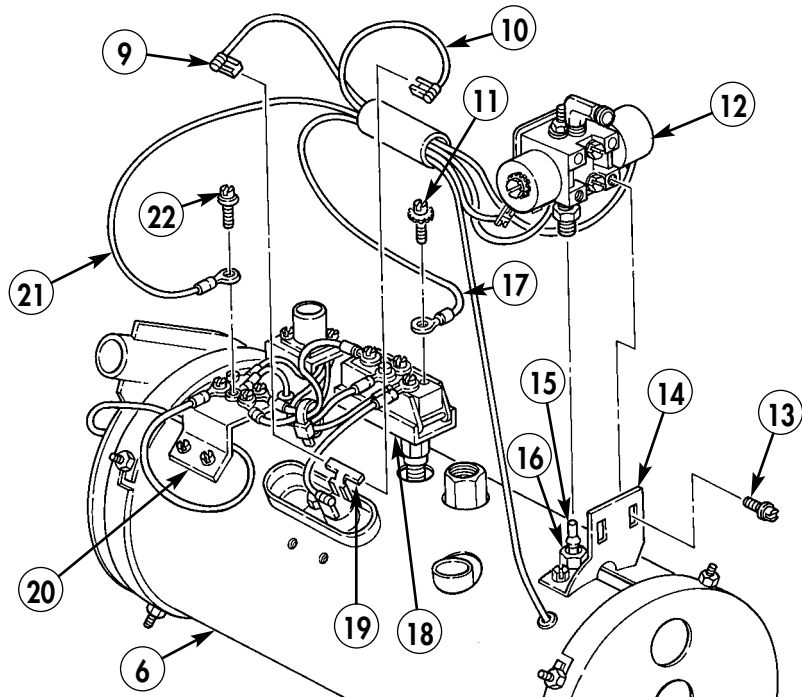
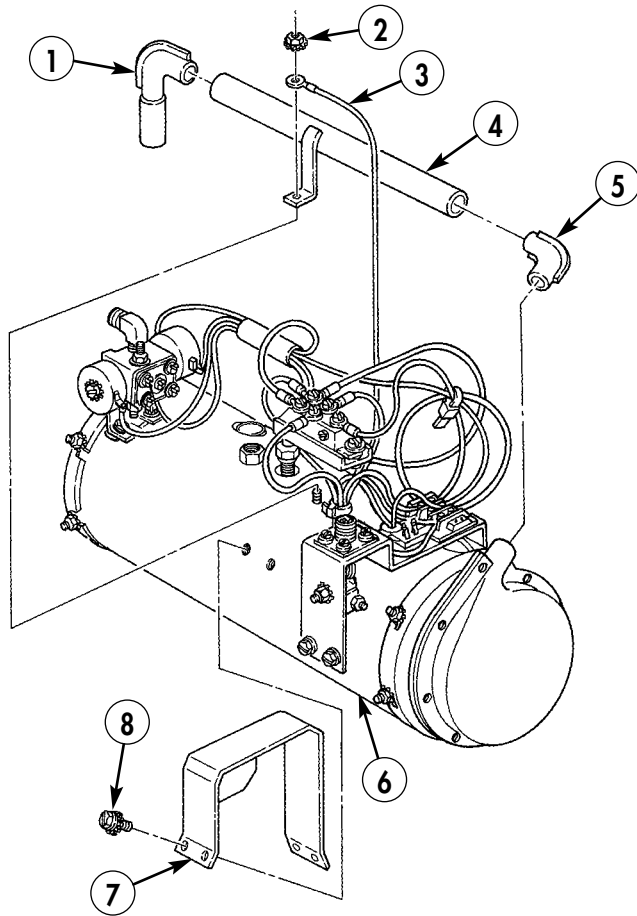

END OF WORK PACKAGE

FIELD MAINTENANCE INSTRUCTIONS FOR SPECIAL PURPOSE KITS

2-1/2 TON, 6X6, M44A2 SERIES TRUCKS (MULTIFUEL)

ENGINE COOLANT HEATER OVERHEAT SWITCH AND IGNITER MAINTENANCE

OVERHEAT SWITCH REMOVAL, IGNITER REMOVAL, INSPECTION,
IGNITER INSTALLATION, AND OVERHEAT SWITCH INSTALLATION

INITIAL SETUP:

Applicable Models

All

Tools And Special Tools

General mechanic's tool kit
(item 116, WP 0469 00)
Electrical tool kit (item 114, WP 0469 00)
Multimeter (item 51, WP 0469 00)

Materials/Parts

Five nut-assembled lockwashers
(item 247, WP 0470 00)
Three lockwashers (item 191, WP 0470 00)
Gasket (item 116, WP 0470 00)

Materials/Parts (Contd)

Igniter (item 124, WP 0470 00)
O-ring (item 285, WP 0470 00)

References

WP 0426 00

Equipment Condition

Parking brake set and wheels chocked
(TM 9-2320-361-10).
Battery ground cable disconnected
(WP 0126 00).
Engine coolant heater removed (WP 0357 00).

ENGINE COOLANT HEATER OVERHEAT SWITCH AND IGNITER MAINTENANCE (Contd)

NOTE

Prior to removal, tag all lead wires for installation.

OVERHEAT SWITCH REMOVAL

1. Remove four screws (6) and guard (7) from heater housing (8).
2. Remove nut-assembled lockwasher (2), ground lead (3), air tube (4), and elbows (1) and (5) from heater housing (8). Discard nut-assembled lockwasher (2).
3. Disconnect lead (9) from overheating switch (13).
4. Disconnect leads (10) and (12) from tab connector (11) and tab connector (11) from overheating switch (13).
5. Remove nut (33), lockwasher (32), retainer (31), overheating switch (13), washer (14), and O-ring (15) from heater housing (8). Discard lockwasher (32) and O-ring (15).

IGNITER REMOVAL

1. Remove four nut-assembled lockwashers (27) and end plate (26) from heater housing (8). Discard lockwasher (27).
2. Remove screw-assembled lockwasher (21), ground strap (22), igniter lead (23), and lockwasher (24) from burner (16). Discard screw-assembled lockwasher (21) and lockwasher (24).
3. Remove nut (28), ground strap (22), and lockwasher (29) from stud (30). Discard lockwasher (29).
4. Remove nuts (19) and (18), preheater resistor strap (17), igniter (20), and gasket (25) from burner (16). Discard igniter (20) and gasket (25).

INSPECTION

Test overheating switch (13) for continuity. If continuity does not exist, replace overheating switch (13).

IGNITER INSTALLATION

CAUTION

Igniter is fragile. Use care when installing igniter. Failure to do so may result in damage to equipment.

1. Install new gasket (25) and new igniter (20) on burner (16).
2. Place preheater resistor strap (17) on igniter (20) and install with two nuts (18) and (19).
3. Install ground strap (22) on stud (30) with nut (28) and new lockwasher (29).
4. Install ground strap (22) and igniter lead (23) on burner (16) with new lockwasher (24) and new screw-assembled lockwasher (21).
5. Install end plate (26) on heater housing (8) with four new nut-assembled lockwashers (27).

OVERHEAT SWITCH INSTALLATION

1. Install new O-ring (15), washer (14), overheating switch (13), and retainer (31) on heater housing (8) with new lockwasher (32) and nut (33).
2. Install leads (10) and (12) on tab connector (11) and install tab connector (11) on overheating switch (13).
3. Install lead (9) on overheating switch (13).
4. Install air tube (4), elbows (1) and (5), and ground lead (3) on heater housing (8) with new nut-assembled lockwasher (2).

ENGINE COOLANT HEATER OVERHEAT SWITCH AND IGNITER MAINTENANCE (Contd)

OVERHEAT SWITCH INSTALLATION (Contd)

5. Install guard (7) on heater housing (8) with four screws (6).
6. Install engine coolant heater (WP 0357 00).
7. Test engine coolant heater (WP 0426 00).
8. Connect battery ground cable (WP 0126 00).
9. Release parking brake and remove wheel chocks (TM 9-2320-361-10).

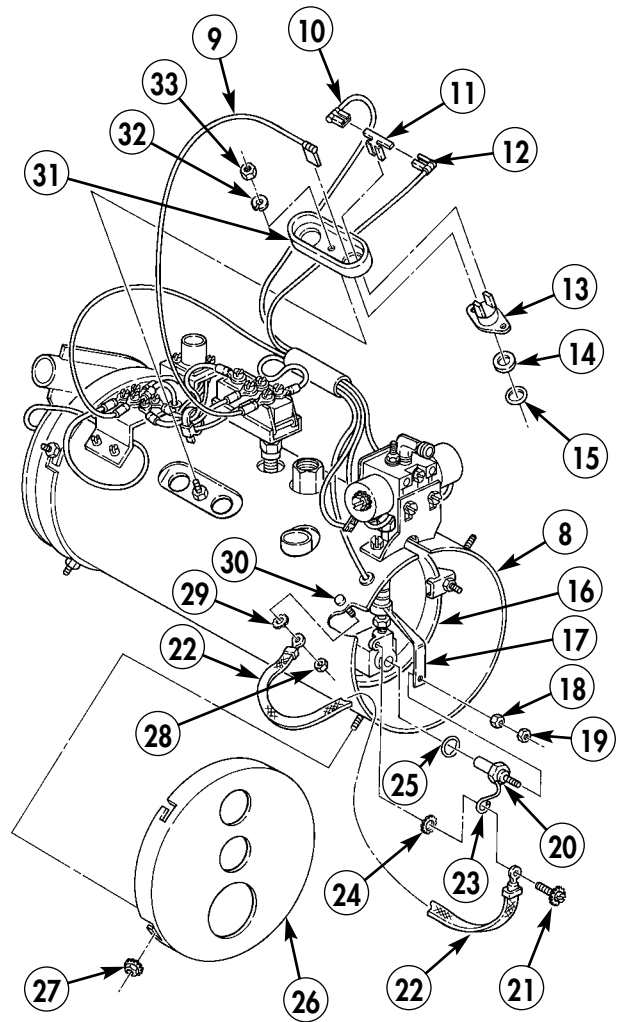
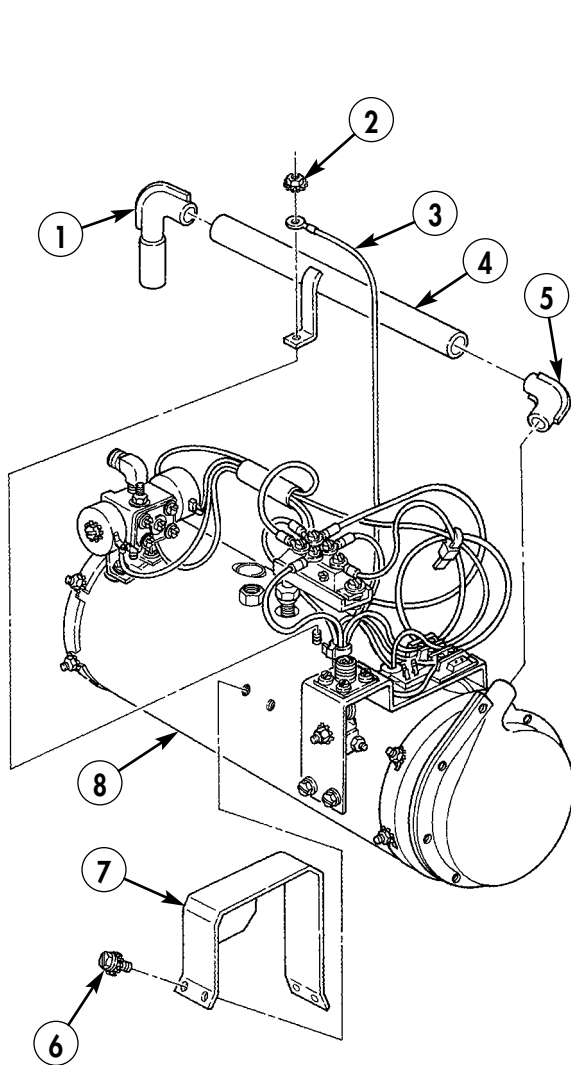

END OF WORK PACKAGE

FIELD MAINTENANCE INSTRUCTIONS FOR SPECIAL PURPOSE KITS

2-1/2 TON, 6X6, M44A2 SERIES TRUCKS (MULTIFUEL)

ENGINE COOLANT HEATER FUEL TUBE AND PREHEATER RESISTOR REPLACEMENT REMOVAL AND INSTALLATION

INITIAL SETUP:

Applicable Models

All

Tools And Special Tools

General mechanic's tool kit
(item 116, WP 0470 00)
Electrical tool kit (item 114, WP 0470 00)
Multimeter (item 51, WP 0470 00)

Materials/Parts

Nut-assembled lockwasher
(item 247, WP 0470 00)
Screw-assembled lockwasher
(item 261, WP 0470 00)
Sleeve (item 433, WP 0470 00)

Equipment Condition

Parking brake set and wheels chocked
(TM 9-2320-361-10).
Battery ground cable disconnected
(WP 0126 00).
Engine coolant heater overheat switch and
igniter removed (WP 0422 00).

ENGINE COOLANT HEATER FUEL TUBE AND PREHEATER RESISTOR REPLACEMENT (Contd)

REMOVAL

NOTE

Prior to removal, tag lead wires for installation.

1. Remove two screws (1), bracket (2), flange (3), and tapping plate (4) from heater housing (15).
2. Remove grommet (14) from hole (13) in heater housing (15) and slide up on lead (10).
3. Remove nut-assembled lockwasher (5), screw-assembled lockwasher (9), and lead (10) from preheater resistor (8). Discard nut-assembled lockwasher (5) and screw-assembled lockwasher (9).
4. Remove fuel tube (11) with preheat resistor (8) from burner (12).
5. Remove sleeve (6), nut (7), and preheat resistor (8) from fuel tube (11). Discard sleeve (6).

INSTALLATION

1. Install preheater resistor (8), nut (7), and new sleeve (6) on fuel tube (11).
2. Install fuel tube (11) with preheater resistor (8) on burner (12).
3. Insert lead (10) through hole (13) in heater housing (15) and install on preheater resistor (8) with new screw-assembled lockwasher (9) and new nut-assembled lockwasher (5).
4. Install grommet (14) in hole (13) on heater housing (15).
5. Position tapping plate (4), flange (3), and bracket (2) on heater housing (15) and install with two screws (1).
6. Install coolant heater overheat switch and igniter (WP 0422 00).
7. Connect battery ground cable (WP 0126 00).
8. Release parking brake and remove wheel chocks (TM 9-2320-361-10).

ENGINE COOLANT HEATER FUEL TUBE AND PREHEATER RESISTOR REPLACEMENT (Contd)

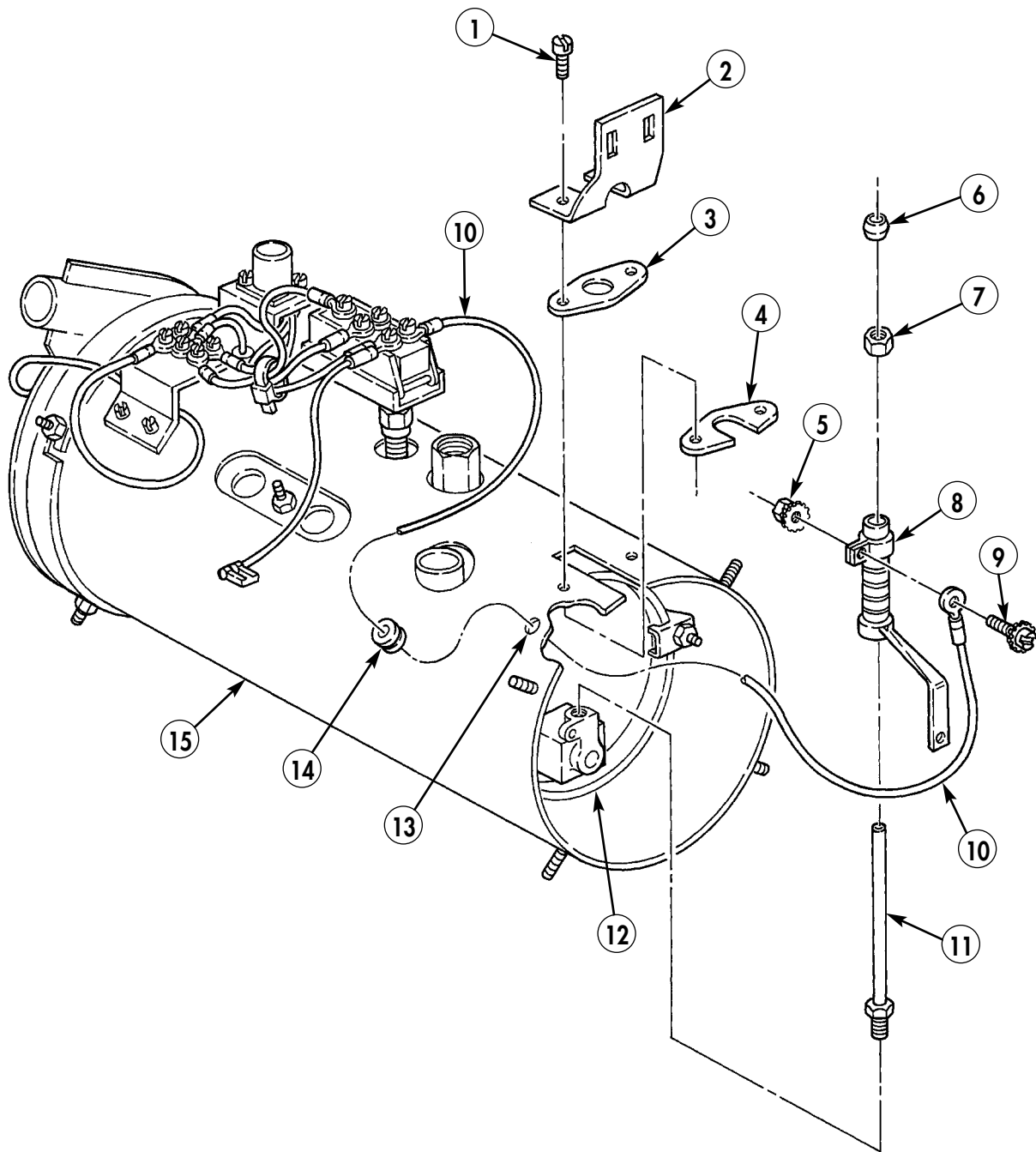

END OF WORK PACKAGE

FIELD MAINTENANCE INSTRUCTIONS FOR SPECIAL PURPOSE KITS

2-1/2 TON, 6X6, M44A2 SERIES TRUCKS (MULTIFUEL)

ENGINE COOLANT HEATER BURNER MAINTENANCE REMOVAL, CLEANING AND INSPECTION, AND INSTALLATION

INITIAL SETUP:

Applicable Models

All

Tools And Special Tools

General mechanic's tool kit
(item 116, WP 0469 00)
Electrical tool kit (item 114, WP 0469 00)
Multimeter (item 51, WP 0469 00)

Materials/Parts

Gasket (item 74, WP 0470 00)
O-ring (item 284, WP 0470 00)
Four nut-assembled lockwashers
(item 247, WP 0470 00)
Skysol 100 (item 13, WP 0468 00)

Equipment Condition

Parking brake set and wheels chocked
(TM 9-2320-361-10).
Battery ground cable disconnected
(WP 0126 00).
Engine coolant heater fuel tube and preheat
resistor removed (WP 0423 00).

ENGINE COOLANT HEATER BURNER MAINTENANCE (Contd)

REMOVAL

Remove four nut-assembled lockwashers (5), clamps (6), hook bolts (7), burner (4), O-ring (3), and gasket (2) from heater exchanger (1). Discard O-ring (3) and gasket (2). Discard nut-assembled lockwashers (5).

CLEANING AND INSPECTION

WARNING

- Skysol 100 solvent is combustible; DO NOT use or store near heat, sparks, flame, or other ignition sources. Use mechanical ventilation whenever product is used in a confined space, heated above ambient temperatures, or agitated. Keep container sealed when not in use.

Contact with Skysol 100 may cause skin irritation. Use chemical-resistant gloves. In case of skin contact, remove any contaminated clothing and wash skin thoroughly with soap and water. Wash contaminated clothing before reuse. Eye contact may cause irritation, tearing, or blurring of vision. Use face shield or goggles when eye contact may occur. In case of eye contact, flush eyes with large amounts of water for at least 15 minutes or until irritation subsides. Inhalation may cause irritation to upper respiratory passages. DO NOT have food or drink in the vicinity. Failure to comply may result in injury to personnel.

- Compressed air source must not exceed 30 psi (207 kPa). When cleaning with compressed air, eyeshields must be worn. Failure to wear eyeshields may result in injury to personnel.

Inspect burner (4) for scorched and charred surfaces. If scorched or charred, clean burner (4) surfaces with wire brush, wipe clean with Skysol 100 solvent, and dry with compressed air. Replace burner (4) if insulating pad is charred or parts are missing.

INSTALLATION

1. Position new gasket (2), new O-ring (3), and burner (4) on heat exchanger (1) and install with four hook bolts (7), clamps (6), and new nut-assembled lockwashers (5).
2. Install engine coolant heater fuel tube and preheater resistor (WP 0423 00).
3. Connect battery ground cable (WP 0126 00).
4. Release parking brake and remove wheel chocks (TM 9-2320-361-10).

ENGINE COOLANT HEATER BURNER MAINTENANCE (Contd)

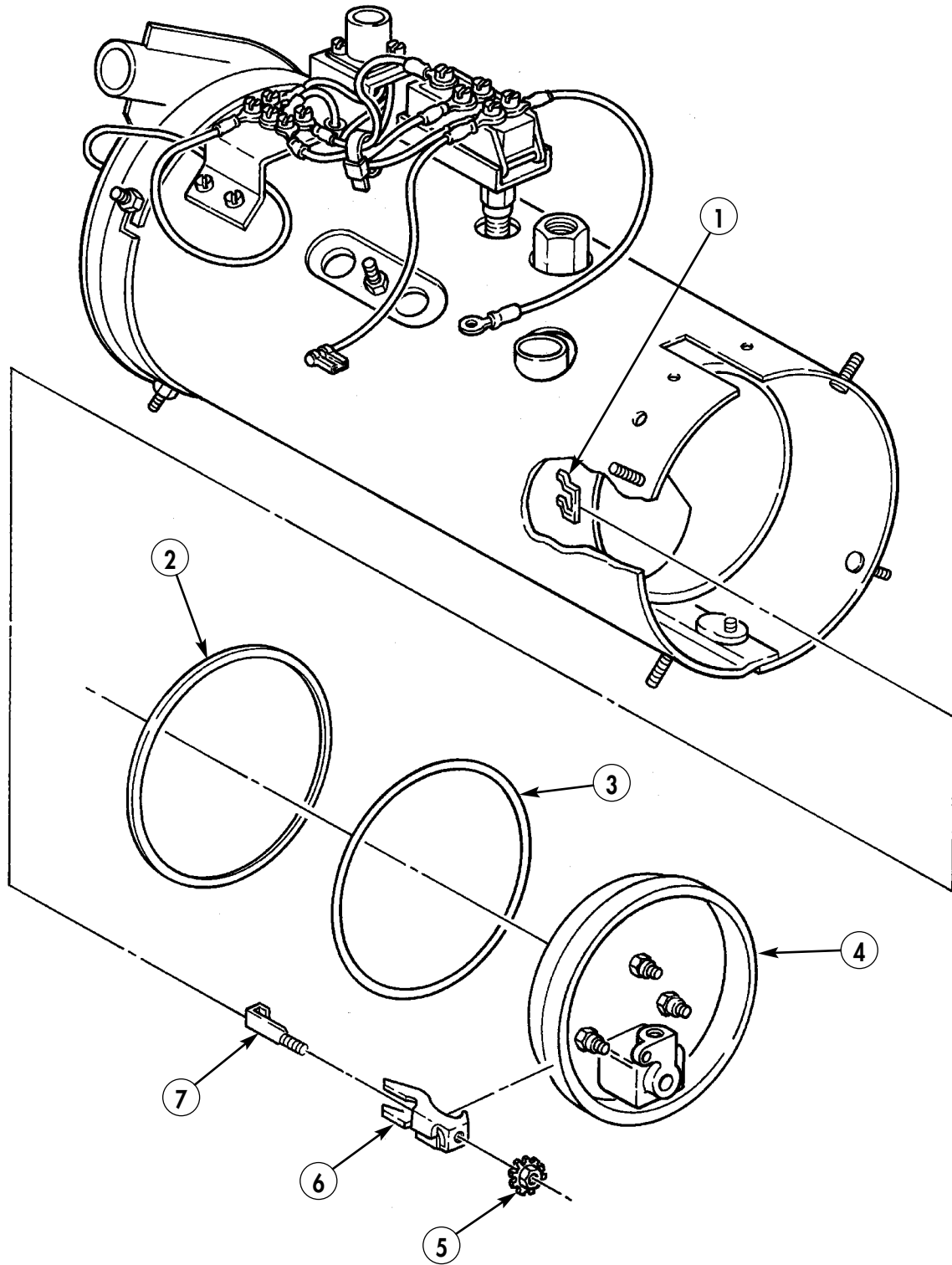

END OF WORK PACKAGE

FIELD MAINTENANCE INSTRUCTIONS FOR SPECIAL PURPOSE KITS

2-1/2 TON, 6X6, M44A2 SERIES TRUCKS (MULTIFUEL)

ENGINE COOLANT HEATER HOUSING REPLACEMENT

REMOVAL AND INSTALLATION

INITIAL SETUP:

Applicable Models

All

Tools And Special Tools

General mechanic's tool kit
(item 116, WP 0469 00)

Materials/Parts

Three screw-assembled lockwashers
(item 261, WP 0470 00)

Equipment Condition

Parking brake set and wheels chocked
(TM 9-2320-361-10).

Battery ground cable disconnected
(WP 0126 00).

Engine coolant heater flame detector switch
removed (WP 0417 00).

Engine coolant heater restriction thermostat
removed (WP 0419 00).

Engine coolant heater burner removed
(WP 0424 00).

ENGINE COOLANT HEATER HOUSING REPLACEMENT (Contd)

REMOVAL

1. Remove three screw-assembled lockwashers (2) from heater housing (1). Discard screw-assembled lockwashers (2).
2. Separate heater housing (1) and remove heat exchanger (5) from heater housing (1).

INSTALLATION

1. Ensure flame detector adapter (3) and exhaust tube (4) are aligned and install heat exchanger (5) in heater housing (1) with three screw-assembled lockwashers (2).
2. Install burner (WP 0424 00).
3. Install restriction thermostat (WP 0419 00).
4. Install flame detector switch (WP 0417 00).
5. Connect battery ground cable (WP 0126 00).
6. Release parking brake and remove wheel chocks (TM 9-2320-361-10).

ENGINE COOLANT HEATER HOUSING REPLACEMENT (Contd)

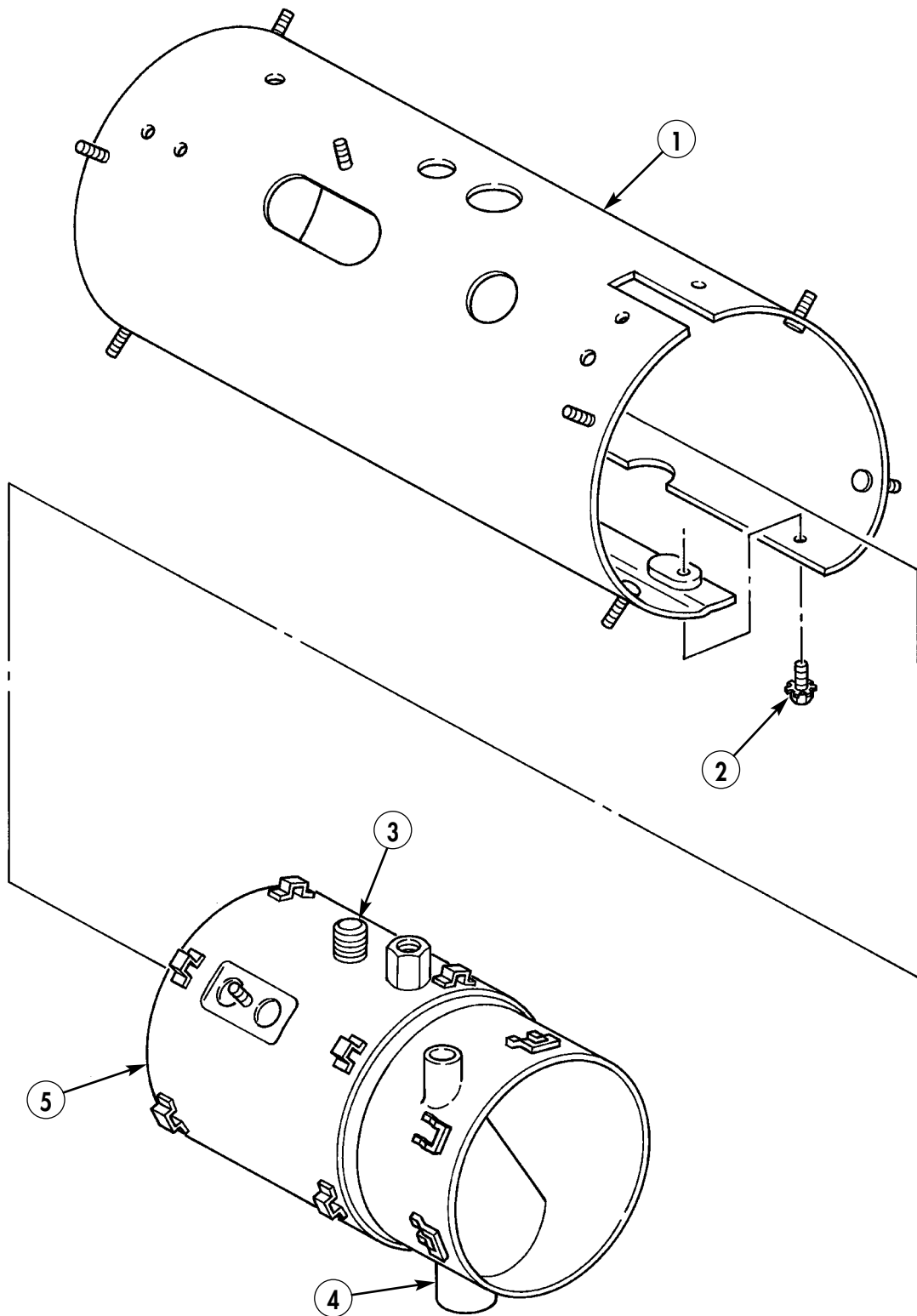

END OF WORK PACKAGE

FIELD MAINTENANCE INSTRUCTIONS FOR SPECIAL PURPOSE KITS

2-1/2 TON, 6X6, M44A2 SERIES TRUCKS (MULTIFUEL)

ENGINE COOLANT HEATER TESTING

PREPARATION, IGNITER TEST, FLAME DETECTOR SWITCH TEST, FUEL CONTROL VALVE TEST, BLOWER MOTOR TEST, RESTRICTION THERMOSTAT TEST, OVERHEAT SWITCH TEST, AND TEST EQUIPMENT REMOVAL

INITIAL SETUP:

Applicable Models

All

Tools and Special Tools

Multimeter (item 51, WP 0469 00)
24-volt DC power source
Coolant container (5 gal.)
Flowmeter
Fuel container
Test stand

References

WP 0417 00–WP 0425 00
WP 0433 00

Equipment Condition

Parking brake set and wheels chocked
(TM 9-2320-361-10).
Battery ground cable disconnected
(WP 0126 00).
Engine coolant heater removed (WP 0357 00).

ENGINE COOLANT HEATER TESTING (Contd)

PREPARATION

WARNING

- Do not perform engine coolant heater testing while smoking or within 50 feet of sparks or open flame. Fuel is flammable and can explode easily, causing injury or death to personnel and damage to equipment.
- Exhaust gases can kill. Do not operate personnel heater in enclosed areas. Ensure work area is well ventilated and exhaust fumes are directed away from test area.

NOTE

- Perform “preparation” subtask before performing any test and perform “test equipment removal” after each test is complete.
- Heater must be tested in same position as mounted on vehicle.
- Use proper coolant required for engines which are being heated.
Water cannot be used because the overheat switch and restriction thermostat are set for temperatures above the boiling point of water.
- Coolant container must be vented and raised above the test apparatus in order for thermosyphon circulation to occur.
- Fuel pump, fuel filter, heater, wiring harness, fuel tubing, control box, and coolant must be the same type used on vehicle.

1. Connect coolant heater (N) to test equipment using schematic on facing page.

ENGINE COOLANT HEATER TESTING (Contd)

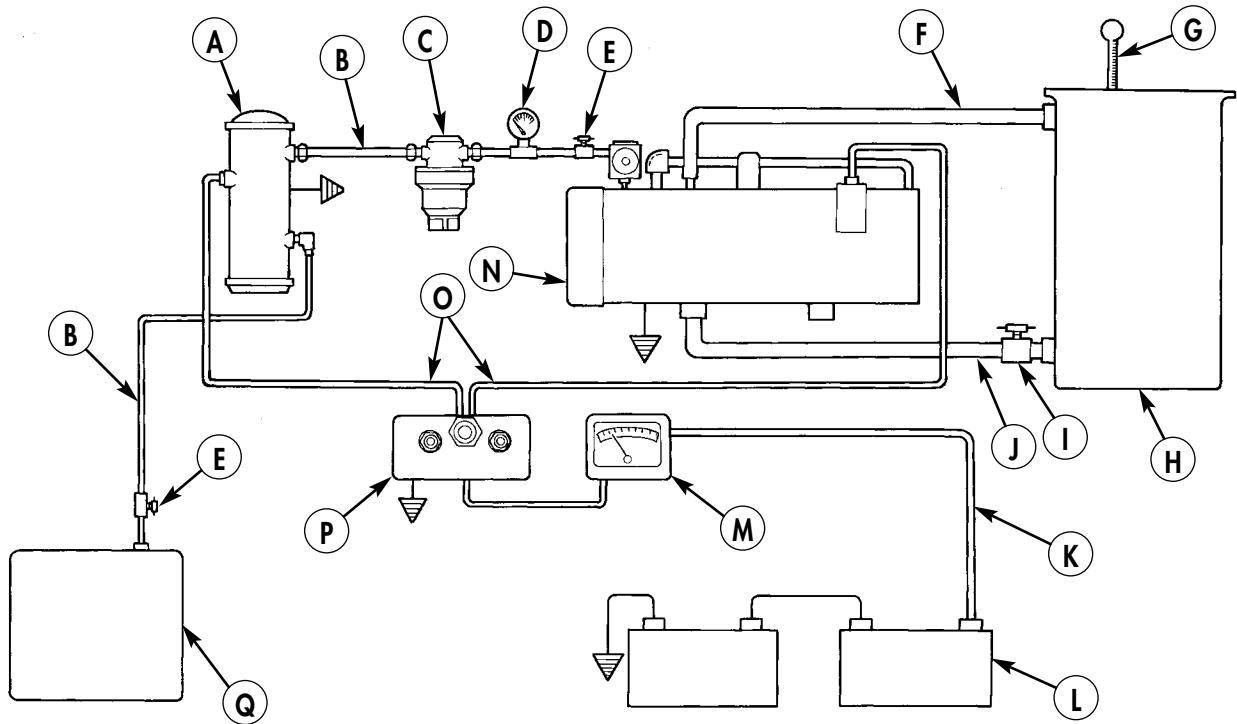

Legend

A.	Electric fuel pump	J.	Coolant inlet hose
B.	Fuel tubing	K.	Power source lead
C.	Fuel filter	L.	24-volt DC power source
D.	Fuel flowmeter	M.	Multimeter
E.	Fuel shutoff valve	N.	Coolant heater assembly
F.	Coolant outlet hose	O.	Wiring harness
G.	Thermometer	P.	Control box
H.	Coolant container	Q.	Fuel tank
I.	Coolant shutoff valve		

ENGINE COOLANT HEATER TESTING (Contd)

PREPARATION (Contd)

2. Remove four screws (2) and guard (1) from heater (9).
3. Disconnect lead (17) from 24-volt power source (18).
4. Remove screw (14), washer (11), and igniter lead (13) from flame detector switch (10).
5. Disconnect fuel control valve leads (6) and (8) from overheating switch (7).
6. Connect hose (4) to bleed screw (14) on fuel control valve (3) and place other end of hose (4) in container (5).
7. Open two fuel shutoff valves (15).

NOTE

Have drainage container ready to catch fuel.

8. Connect lead (17) to power source (18).
9. Ensure switch (22) is in LO position. Place switch (20) in START position and hold. Open bleed screw (14) and let fuel flow until no air bubbles are observed in fuel flowing into container (5).
10. Place switch (20) in OFF position. Close bleed screw (14).
11. Disconnect lead (17) from power source (18).
12. Install igniter lead (13) on flame detector switch (10) with washer (11), and screw (12).
13. Connect fuel control valve leads (6) and (8) on overheating switch (7).
14. Open coolant shutoff valve (16).
15. Check for signs of coolant leaks. Tighten loose connections or replace damaged parts if leaking (WP 0417 00–WP 0425 00) as necessary.
16. Close coolant shutoff valve (16).

IGNITER TEST

NOTE

Ignition time is the interval from activating control box switch to START position until indicator lamp illuminates.

1. Place switch (20) in START position and hold. Record time interval from activating switch (20) until indicator lamp (21) illuminates. During this time interval, record ignition amperage on ammeter (19).
2. If ignition time exceeds three minutes, or if ignition amperage exceeds 15 amperes, check fuel flow components (WP 0417 00–WP 0425 00) as necessary.
3. Place switch (20) in OFF position.

ENGINE COOLANT HEATER TESTING (Contd)

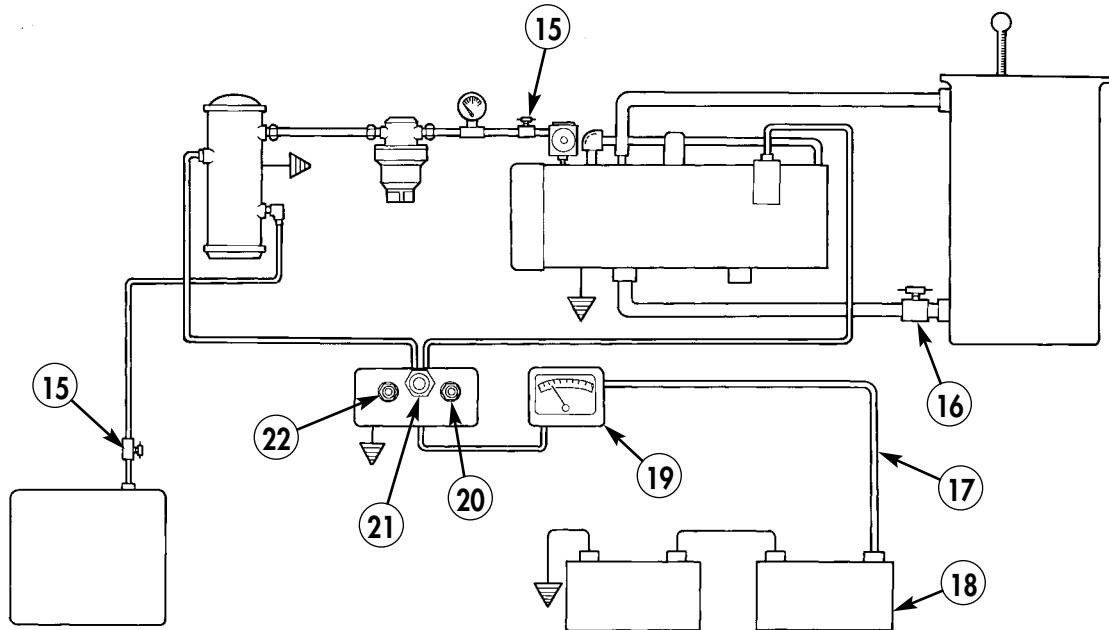
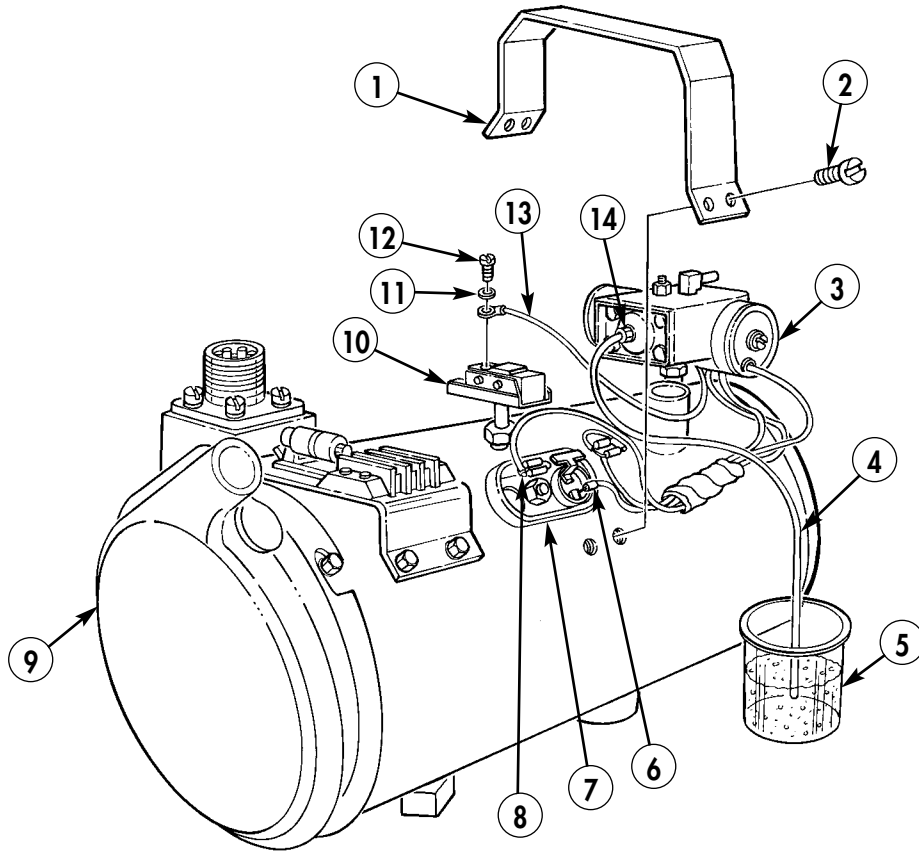

ENGINE COOLANT HEATER TESTING (Contd)

FLAME DETECTOR SWITCH TEST

1. Place switch (3) in START position.
2. When indicator lamp (4) illuminates, place switch (3) in RUN position.
3. If indicator lamp (4) does not light adjustor, replace flame detector switch (6) (WP 0417 00).
4. Place switch (3) in OFF position.

FUEL CONTROL VALVE TEST

1. Place switch (3) in START position.
2. When indicator lamp (4) illuminates, place switch (3) in RUN position.
3. Check fuel consumption at flowmeter (1). Fuel consumption should be 8-11 cc/min at low heat, and 14-19 cc/min at high heat. Replace fuel control valve (7) if fuel consumption rate is not within limits (WP 0421 00).
4. Check operating amperage on ammeter (2). If operating amperage exceeds 4 amperes, check heater wiring. Replace damaged parts (WP 0417 00–WP 0425 00) as necessary.
5. Move switch (5) from LO to HI position. Burning in heater (8) should intensify or decrease. Replace fuel control valve (7) if burning in heater (8) does not intensify or decrease (WP 0421 00).
6. Place switch (5) in LO position.
7. Place switch (3) in OFF position.

BLOWER MOTOR TEST

1. Place switch (3) in START position.
2. When indicator lamp (4) illuminates, place switch (3) in RUN position. Allow heater to run for a few minutes.

NOTE

Purge time is the interval from turning control box to OFF position until the indicator lamp goes out.

3. Place switch (3) in OFF position and record purge time. Burning should stop within thirty seconds; blower motor should continue to run up to three minutes. Replace or adjust flame detector switch (6) (WP 0417 00) if purge time exceeds three minutes.

ENGINE COOLANT HEATER TESTING (Contd)

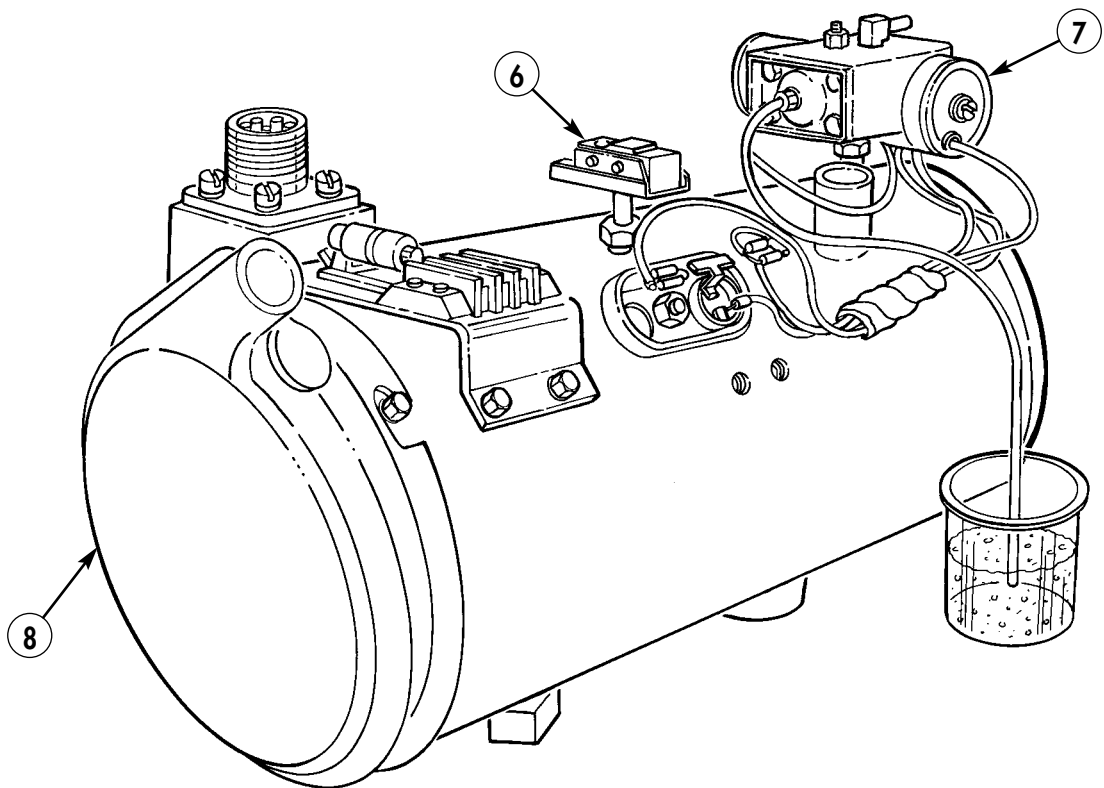
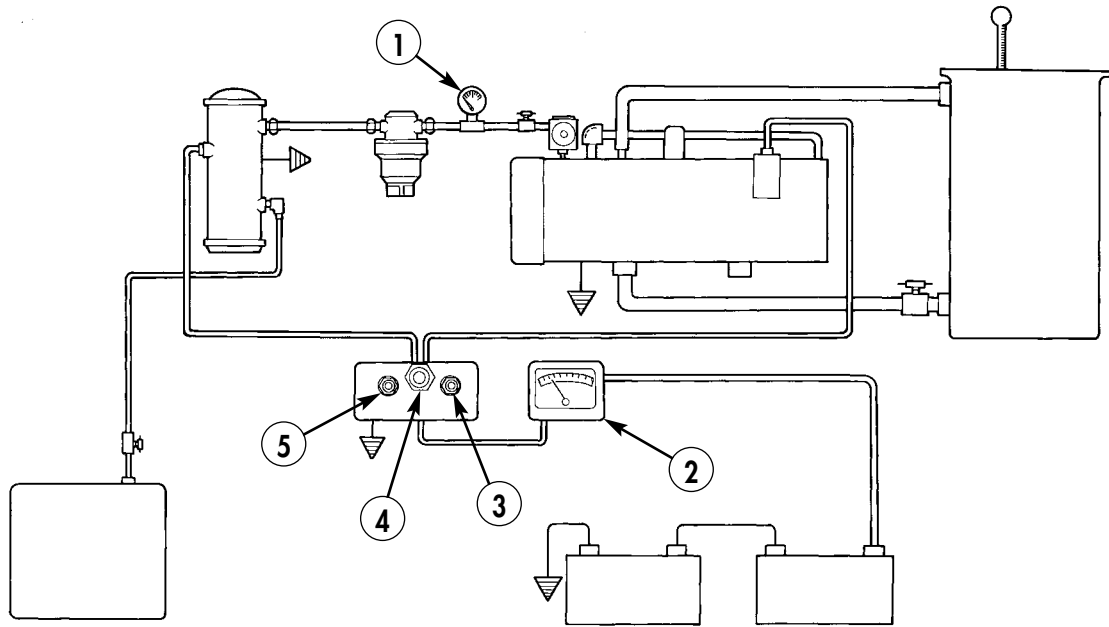

ENGINE COOLANT HEATER TESTING (Contd)

RESTRICTION THERMOSTAT TEST

1. Place switch (4) in START position.
2. When indicator lamp (5) illuminates, place switch (4) in RUN position. Allow heater to run.
3. Check temperature of coolant at thermometer (1). Temperature should be 140–170° F (60.0–76.7° C). Replace restriction thermostat if coolant temperature is not within limits (WP 0421 00).
4. Place switch (4) in OFF position.

OVERHEAT SWITCH TEST

1. Place switch (4) in START position.
2. When indicator lamp (5) illuminates, place switch (4) in RUN position. Allow heater (8) to run.
3. Partially restrict air inlet with a sheet of cardboard or sheet metal. Overheat switch (9) should activate and shut down heater (8) within five minutes. Replace overheat switch (9) if heater (8) does not shut down after five minutes (WP 0433 00).
4. Check temperature of coolant at thermometer (1). Temperature should be 220–250° F (104.4–121.1° C).
5. Replace overheat switch (9) if coolant temperature is not within limits (WP 0433 00).
6. Place switch (4) in OFF position.

TEST EQUIPMENT REMOVAL

WARNING

Allow time for heater to cool before removing from test equipment. Failure to do so may result in injury to personnel or damage to equipment.

1. Disconnect lead (2) from 24-volt power source (3).
2. Install guard (6) on heater (8) with four screws (7).
3. Remove heater (8) from test equipment.
4. Install engine coolant heater (WP 0357 00).
5. Connect battery ground cable (WP 0126 00).
6. Release parking brake and remove wheel chocks (TM 9-2320-361-10).

ENGINE COOLANT HEATER TESTING (Contd)

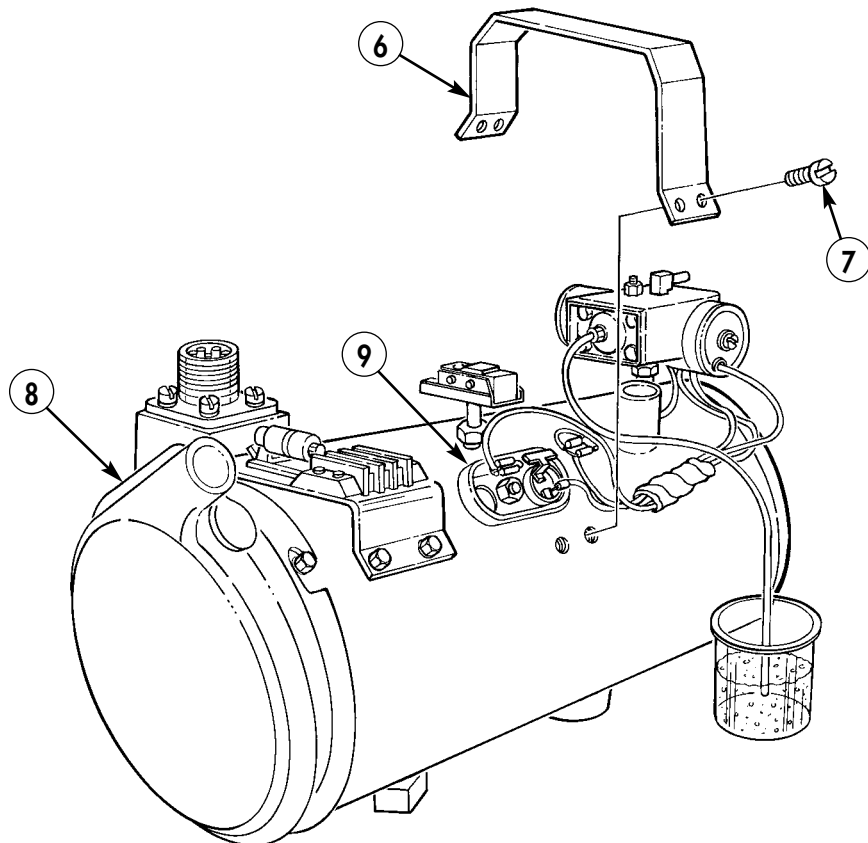
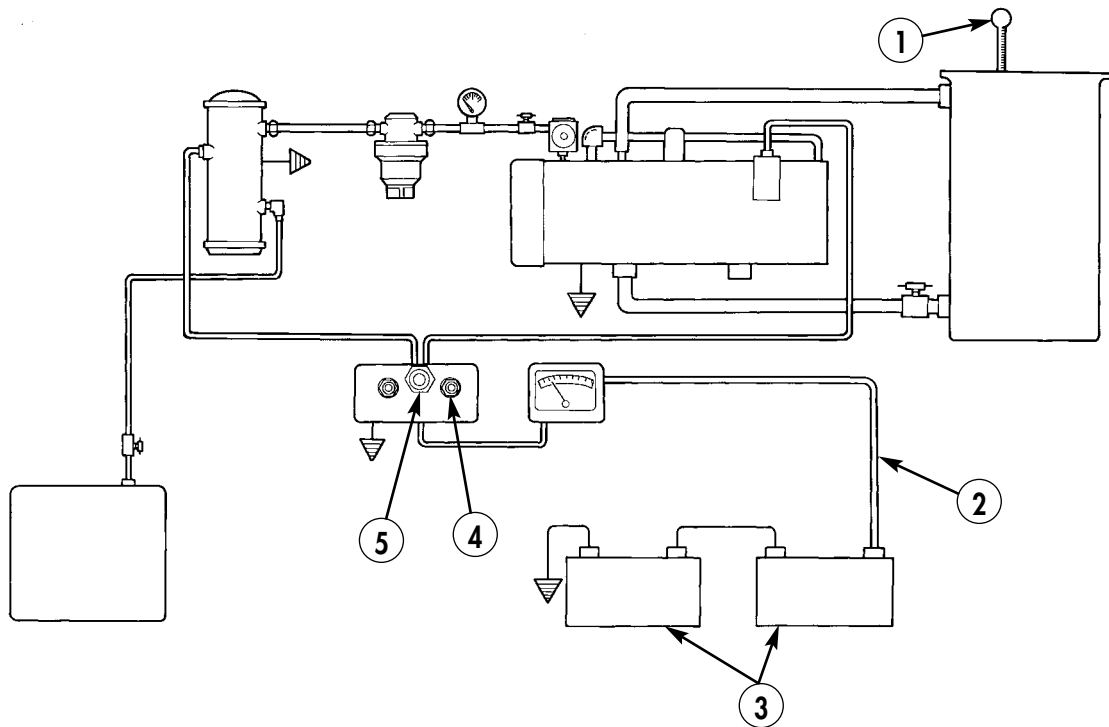

END OF WORK PACKAGE

FIELD MAINTENANCE INSTRUCTIONS FOR SPECIAL PURPOSE KITS

2-1/2 TON, 6X6, M44A2 SERIES TRUCKS (MULTIFUEL)

PERSONNEL HEATER GUARD AND BLOWER MOTOR REPLACEMENT

GUARD REMOVAL, BLOWER MOTOR REMOVAL, BLOWER MOTOR INSTALLATION, AND GUARD INSTALLATION

INITIAL SETUP:

Applicable Models

All

Tools and Special Tools

General mechanic's tool kit
(item 116, WP 0469 00)

Materials/Parts

Nut-assembled lockwasher
(item 247, WP 0470 00)

Materials/Parts (Contd)

Screw-assembled lockwasher
(item 261, WP 0470 00)
Four screw-assembled lockwashers
(item 250, WP 0470 00)

References

WP 0435 00

Equipment Condition

Parking brake set and wheels chocked
(TM 9-2320-361-10).
Battery ground cable disconnected
(WP 0126 00).
Fuel burning personnel heater removed
(WP 0351 00).

PERSONNEL HEATER GUARD AND BLOWER MOTOR REPLACEMENT (Contd)

GUARD REMOVAL

Release two fasteners (10) and remove guard (1) from heater housing (7).

BLOWER MOTOR REMOVAL

NOTE

Prior to removal, tag lead wires for installation.

1. Remove screw-assembled lockwasher (2) and blower motor lead (3) from flame detector switch (4). Discard screw-assembled lockwasher (2).
2. Remove screw (5) and nut-assembled lockwasher (9) from clamp (6) and ignition control unit (8). Discard nut assembled lockwasher (9).
3. Remove grommet (11) from heater housing (7).
4. Loosen four screw-assembled lockwashers (12) and remove blower motor (13) from heater housing (7). Discard screw-assembled lockwashers (12).

BLOWER MOTOR INSTALLATION

1. Install grommet (11) in heater housing (7).
2. Route blower motor lead (3) through grommet (11) in heater housing (7).
3. Install blower motor (13) on heater housing (7) by tightening four new screw-assembled lockwashers (12).
4. Install blower motor lead (3) on flame detector switch (4) with new screw-assembled lockwasher (2).
5. Install clamp (6) on ignition control unit (8) with screw (5) and new nut-assembled lockwasher (9).

GUARD INSTALLATION

1. Position guard (1) on heater housing (7) and hold in place with two fasteners (10).
2. Install fuel burning personnel heater (WP 0351 00).
3. Connect battery ground cable (WP 0126 00).
4. Test fuel burning personnel heater (WP 0435 00).
5. Release parking brake and remove wheel chocks (TM 9-2320-361-10).

PERSONNEL HEATER GUARD AND BLOWER MOTOR REPLACEMENT (Contd)

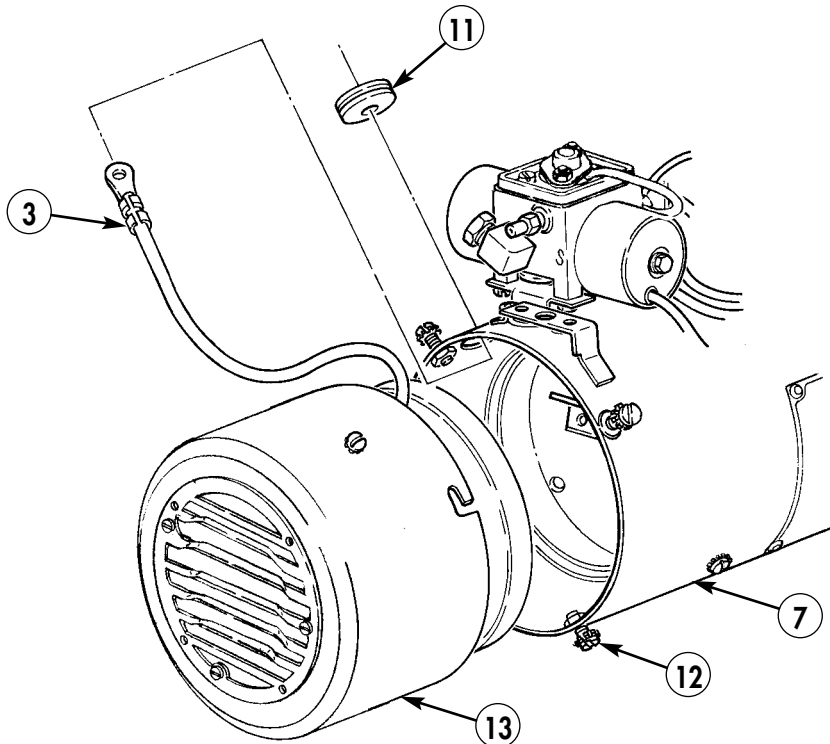
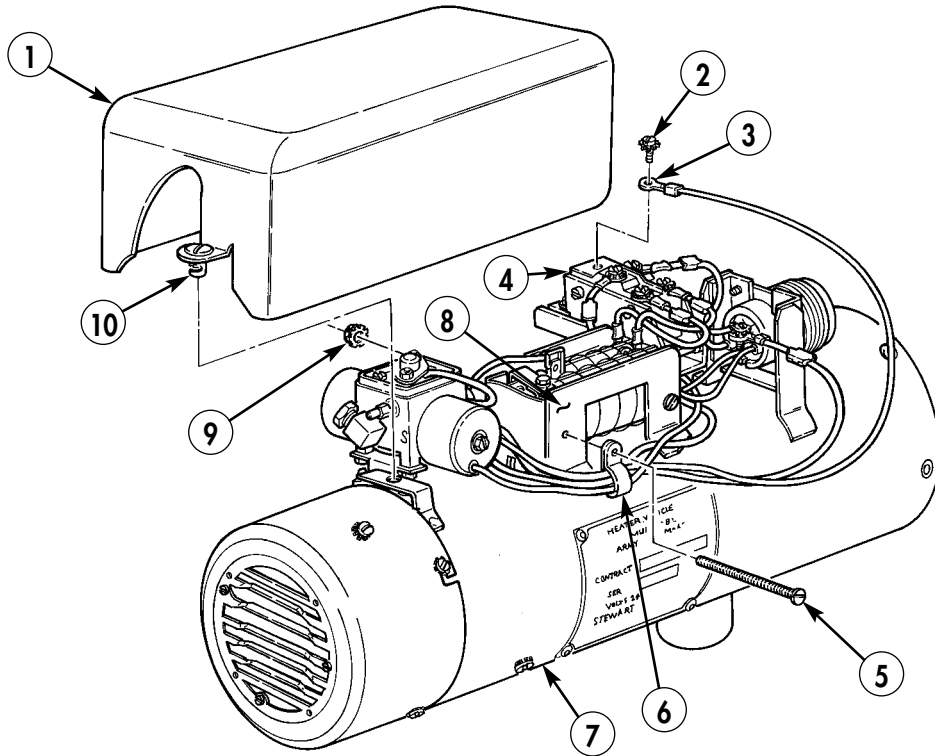

END OF WORK PACKAGE

FIELD MAINTENANCE INSTRUCTIONS FOR SPECIAL PURPOSE KITS

2-1/2 TON, 6X6, M44A2 SERIES TRUCKS (MULTIFUEL)

PERSONNEL HEATER FUEL CONTROL VALVE MAINTENANCE REMOVAL, INSPECTION, AND INSTALLATION

INITIAL SETUP:

Applicable Models

All

Tools and Special Tools

General mechanic's tool kit
(item 116, WP 0469 00)

Materials/Parts

Three nut-assembled lockwashers
(item 247, WP 0470 00)
Screw-assembled lockwasher
(item 261, WP 0470 00)

Equipment Condition

Parking brake set and wheels chocked
(TM 9-2320-361-10).
Battery ground cable disconnected
(WP 0126 00).
Personnel heater guard removed (WP 0427 00).

PERSONNEL HEATER FUEL CONTROL VALVE MAINTENANCE (Contd)

REMOVAL

NOTE

Prior to removal, tag lead wires for installation.

1. Remove nut-assembled lockwasher (8), screw (4), and clamp (5) from ignition control unit (9). Discard nut-assembled lockwasher (8).
2. Remove elbow (12) and nipple (11) from fuel control valve (10).
3. Remove screw-assembled lockwasher (1) and restriction solenoid lead (2) from receptacle (3). Discard screw-assembled lockwasher (1).
4. Remove nut-assembled lockwasher (21) and shutoff valve lead (6) from overheat switch (17). Discard nut-assembled lockwasher (21).
5. Remove nut-assembled lockwasher (20), thermostat lead (19), receptacle lead (7), and ignition control lead (18) from overheat switch (17). Discard nut-assembled lockwasher (20).
6. Remove clamp (5) from wires (6), (2), and (7).
7. Loosen nut (16) and disconnect fuel line (15) from fuel control valve (10).
8. Remove four screws (13) and fuel control valve (10) from heater housing (14).

INSPECTION

Visually inspect fuel control valve (10) for dents or loose wires. Replace fuel control valve (10) if damaged.

INSTALLATION

1. Install fuel control valve (10) on heater housing (14) with four screws (13).
2. Install fuel line (15) on fuel control valve (10). Tighten nut (16).
3. Slide clamp (5) over wires (6), (2), and (7).
4. Install restriction solenoid lead (2) on receptacle (3) with new screw-assembled lockwasher (1).
5. Install ignition control lead (18), receptacle lead (7), and thermostat lead (19) on overheat switch (17) with new nut-assembled lockwasher (20).
6. Install shutoff valve lead (6) on overheat switch (17) with new nut-assembled lockwasher (21).
7. Install clamp (5) on ignition control unit (9) with screw (4) and new nut-assembled lockwasher (8).
8. Install nipple (11) and elbow (12) on fuel control valve (10).
9. Install personnel heater guard (WP 0427 00).
10. Connect battery ground cable (WP 0126 00).
11. Release parking brake and remove wheel chocks (TM 9-2320-361-10).

PERSONNEL HEATER FUEL CONTROL VALVE MAINTENANCE (Contd)

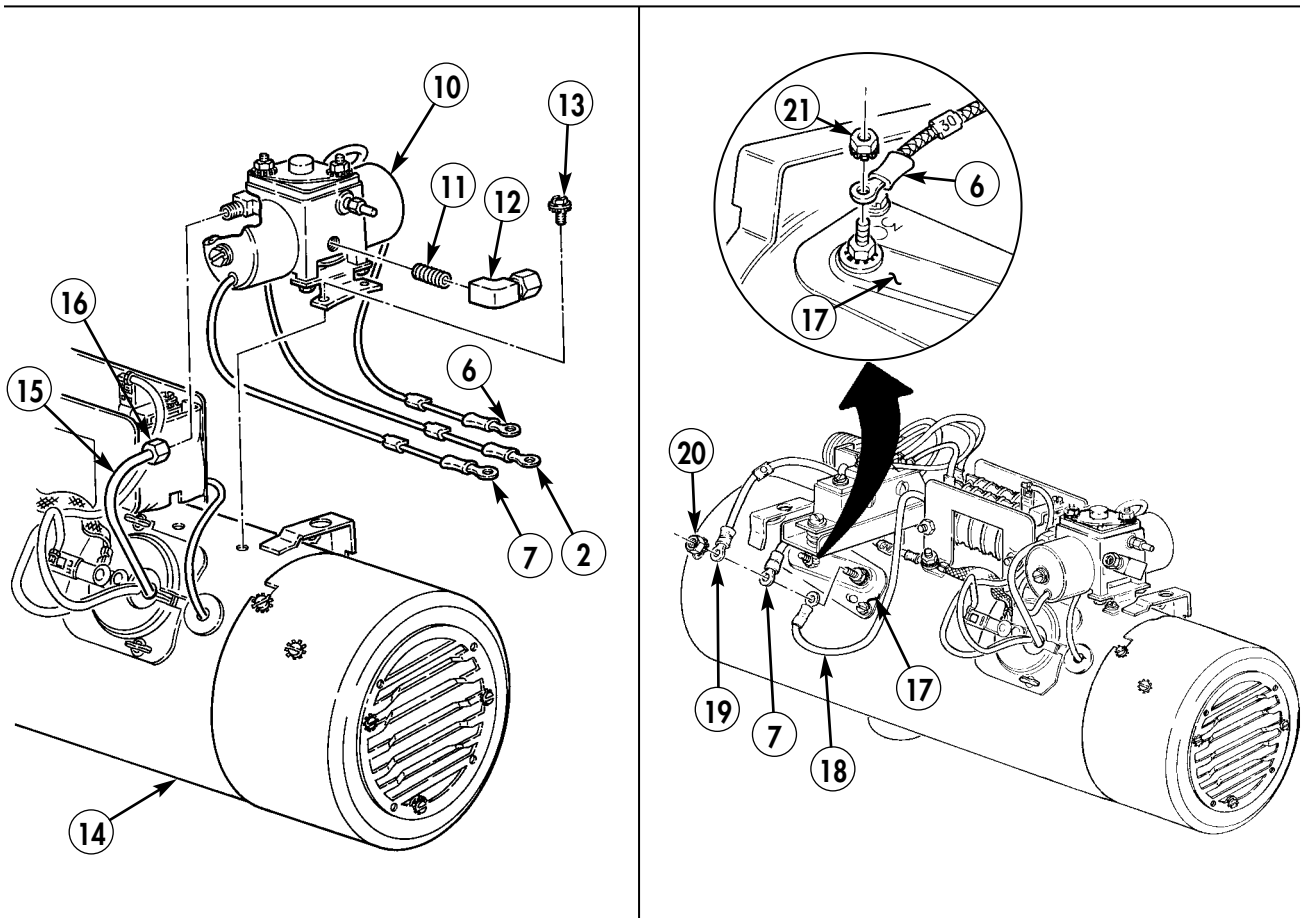
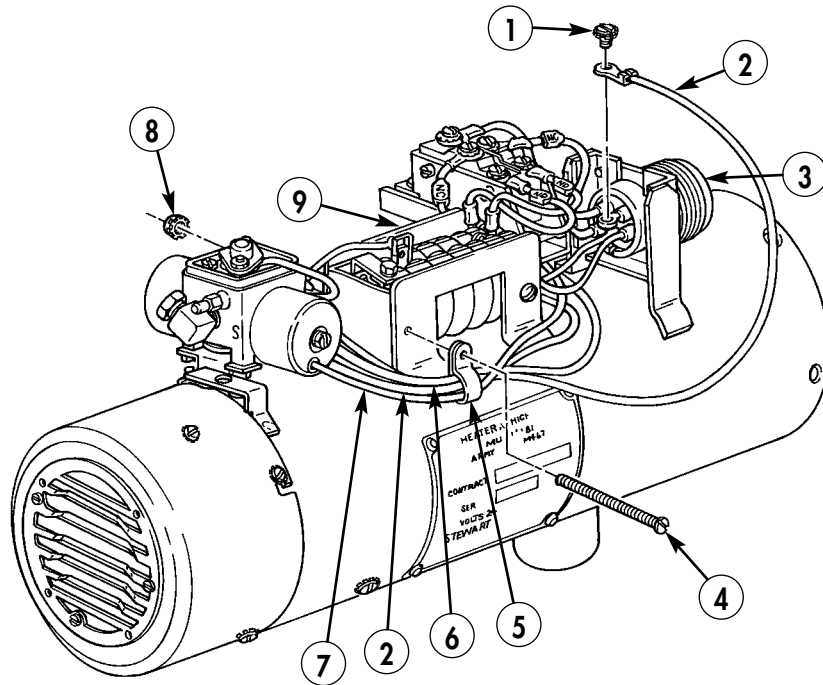

END OF WORK PACKAGE

FIELD MAINTENANCE INSTRUCTIONS FOR SPECIAL PURPOSE KITS

2-1/2 TON, 6X6, M44A2 SERIES TRUCKS (MULTIFUEL)

PERSONNEL HEATER IGNITER AND IGNITION CONTROL UNIT REPLACEMENT IGNITER REMOVAL, IGNITION CONTROL UNIT REMOVAL, IGNITION CONTROL UNIT INSTALLATION, AND IGNITER INSTALLATION

INITIAL SETUP:

Applicable Models

All

Tools and Special Tools

General mechanic's tool kit
(item 116, WP 0469 00)

Materials/Parts

Two lockwashers (item 190, WP 0470 00)
Two screw-assembled lockwashers
(item 261, WP 0470 00)
Igniter (item 123, WP 0470 00)
Nut-assembled lockwasher
(item 247, WP 0470 00)

Equipment Condition

Parking brake set and wheels chocked
(TM 9-2320-361-10).
Battery ground cable disconnected
(WP 0126 00).
Personnel heater guard and blower motor
removed (WP 0427 00).

PERSONNEL HEATER IGNITER AND IGNITION CONTROL UNIT REPLACEMENT (Contd)

NOTE

Prior to removal, tag lead wires for installation.

IGNITER REMOVAL

1. Remove nut (6), receptacle ground lead (13), ground strap (12), and lockwasher (11) from ignition control unit (8). Discard lockwasher (11).
2. Disconnect igniter leads (7) and (10) from ignition control unit (8) and igniter hatch cover (9).
3. Release two fly screws (14) and remove igniter hatch cover (9) from heater housing (15).
4. Press and turn igniter (18) 1/4 turn left and remove from igniter tube (17). Discard igniter (18).
5. Remove screw (16) and igniter tube (17) from heater housing (15).

IGNITION CONTROL UNIT REMOVAL

NOTE

Remove igniter before removing ignition control unit.

1. Remove nut-assembled lockwasher (1), thermostat lead (5), receptacle lead (4), and ignition control lead (3) from overheat switch (2). Discard nut-assembled lockwasher (1).
2. Remove two screw-assembled lockwashers (19) and ignition control leads (20) from flame detector switch (23). Discard screw-assembled lockwashers (19).
3. Remove three screws (21), ignition control unit (8), and lockwasher (22) from heater housing (15). Discard lockwasher (22).

IGNITION CONTROL UNIT INSTALLATION

1. Install new lockwasher (22) and ignition control unit (8) on heater housing (15) with three new screws (21).
2. Install two ignition control leads (20) on flame detector switch (23) with two new screw-assembled lockwashers (19).
3. Install ignition control lead (3), receptacle lead (4), and thermostat lead (5) on overheat switch (2) with new nut-assembled lockwasher (1).

IGNITER INSTALLATION

CAUTION

Igniter is fragile. Use care when installing igniter. Failure to do so may result in damage to equipment.

1. Install new igniter (18) in igniter tube (17). Press and turn igniter (18) 1/4-turn right to hold in place.
2. Install igniter (18) and igniter tube (17) on heater housing (15) and secure with screw (16).
3. Install igniter hatch cover (9) on heater housing (15) and hold in place with two fly screws (14).
4. Connect igniter leads (7) and (10) on ignition control unit (8) and igniter hatch cover (9).
5. Install new lockwasher (11), ground strap (12), and receptacle ground lead (13) on ignition control unit (8) with nut (6).
6. Install personnel heater guard and blower motor (WP 0427 00).
7. Connect battery ground cable (WP 0126 00).
8. Release parking brake and remove wheel chocks (TM 9-2320-361-10).

PERSONNEL HEATER IGNITER AND IGNITION CONTROL UNIT REPLACEMENT (Contd)

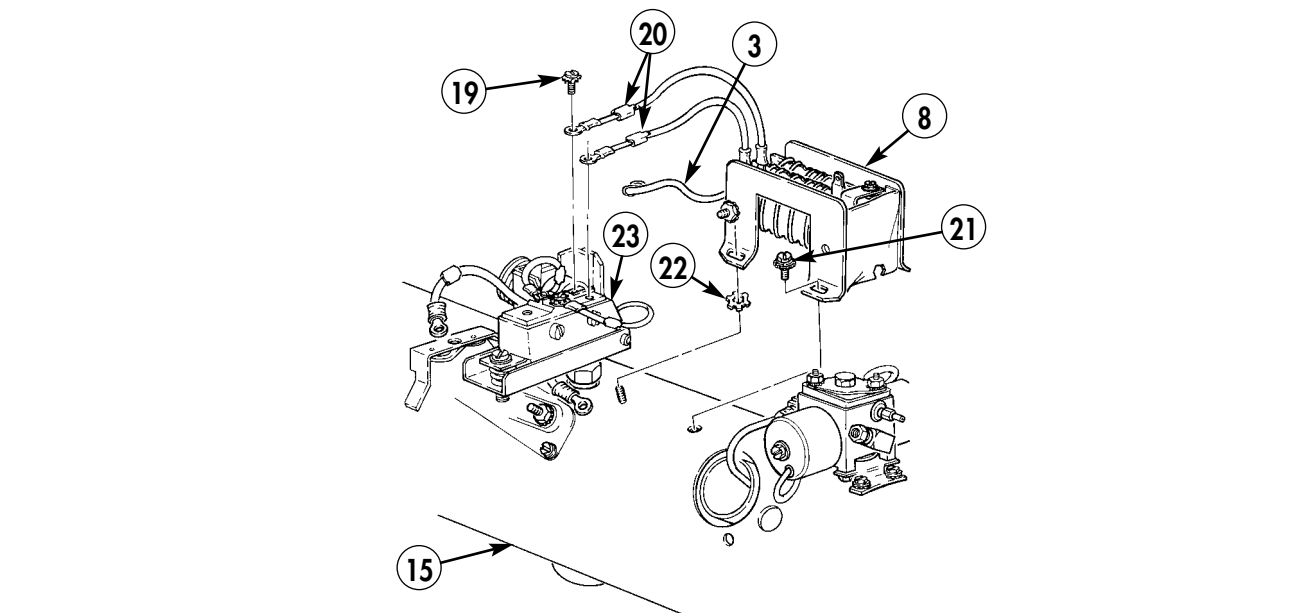
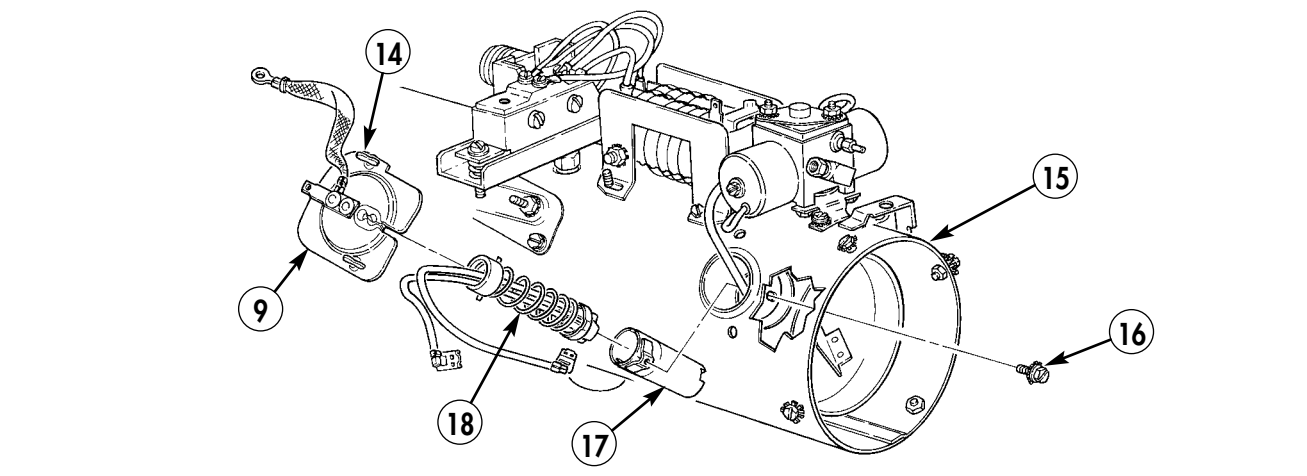
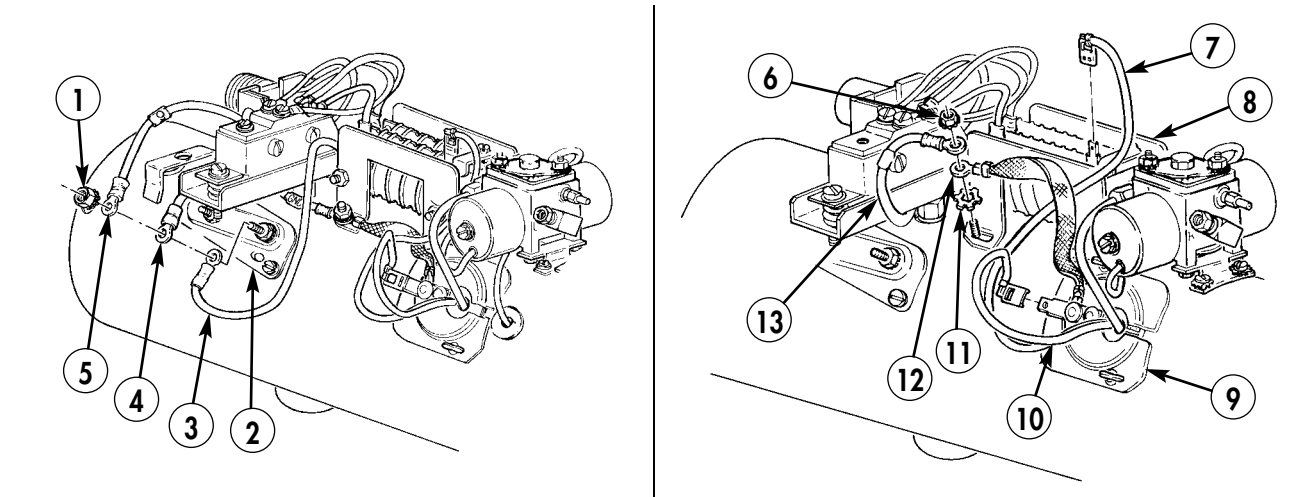

END OF WORK PACKAGE

FIELD MAINTENANCE INSTRUCTIONS FOR SPECIAL PURPOSE KITS

2-1/2 TON, 6X6, M44A2 SERIES TRUCKS (MULTIFUEL)

PERSONNEL HEATER FUEL LINE AND BLOWER HOUSING REPLACEMENT REMOVAL AND INSTALLATION

INITIAL SETUP:

Applicable Models

All

Tools and Special Tools

General mechanic's tool kit
(item 116, WP 0469 00)

Equipment Condition

Parking brake set and wheels chocked
(TM 9-2320-361-10).
Battery ground cable disconnected
(WP 0126 00).
Personnel heater igniter removed
(WP 0429 00).

PERSONNEL HEATER FUEL LINE AND BLOWER HOUSING REPLACEMENT (Contd)**REMOVAL**

1. Loosen nut (3) and remove fuel line (4) from fuel control valve (1).
2. Loosen nut (5) and remove fuel line (4) from burner fuel inlet (6).
3. Remove blower housing (2) from heat exchanger (7) and heater housing (8).

INSTALLATION

1. Place blower housing (2) in heater housing (8).
2. Install fuel line (4) on burner fuel inlet (6) through blower housing (2).
3. Install fuel line (4) on fuel control valve (1).
4. Install personnel heater igniter (WP 0429 00).
5. Connect battery ground cable (WP 0126 00).
6. Release parking brake and remove wheel chocks (TM 9-2320-361-10).

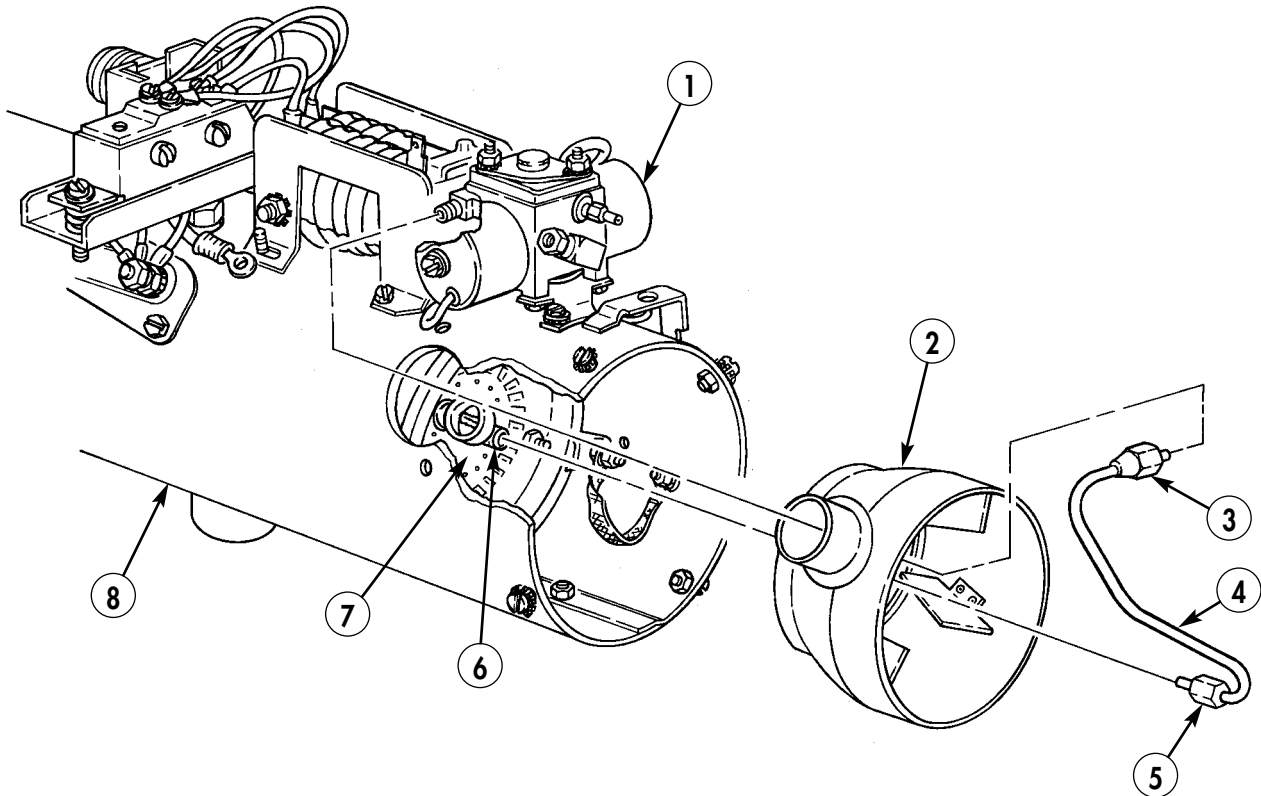
**END OF WORK PACKAGE**

FIELD MAINTENANCE INSTRUCTIONS FOR SPECIAL PURPOSE KITS

2-1/2 TON, 6X6, M44A2 SERIES TRUCKS (MULTIFUEL)

PERSONNEL HEATER FLAME DETECTOR SWITCH MAINTENANCE REMOVAL, DISASSEMBLY, CLEANING AND INSPECTION, ASSEMBLY, AND INSTALLATION

INITIAL SETUP:

Applicable Models

All

Tools and Special Tools

General mechanic's tool kit
(item 116, WP 0469 00)

Materials/Parts

Five screw-assembled lockwashers
(item 261, WP 0470 00)

Equipment Condition

Parking brake set and wheels chocked
(TM 9-2320-361-10).
Battery ground cable disconnected
(WP 0126 00).
Personnel heater guard removed (WP 0427 00).

PERSONNEL HEATER FLAME DETECTOR SWITCH MAINTENANCE (Contd)

REMOVAL

NOTE

Prior to removal, tag lead wires for installation.

1. Remove two screw-assembled lockwashers (8) and ignition control leads (4) from flame detector switch (7). Discard screw-assembled lockwashers (8).
2. Remove screw-assembled lockwasher (1) and blower motor lead (9) from flame detector switch (7). Discard screw-assembled lockwasher (1).
3. Remove two screw-assembled lockwashers (2) and receptacle leads (3) from flame detector switch (7). Discard screw-assembled lockwashers (2).
4. Loosen nut (6) and remove flame detector switch (7) from heater housing (5).

DISASSEMBLY

1. Remove adjusting screw (10), washer (11), and spring (17) from microswitch (12) and mount (13).

CAUTION

Ceramic rod is very brittle and is easily broken; handle carefully. Failure to comply may result in equipment damage.

2. Tilt microswitch (12) back on mount (13).
3. Invert microswitch (12) and remove ceramic rod (18) from probe (14).
4. Remove nut (15) and sleeve (16) from probe (14).

CLEANING AND INSPECTION

Inspect flame detector switch (7) for oxidation and dirt, broken ceramic rod (18), and bent or distorted probe (14). If oxidized or dirty, clean by removing ceramic rod (18) and lightly rapping side of probe (14) to loosen oxides and dirt. Replace flame detector switch (7) if ceramic rod (18) is broken or probe (14) is damaged.

ASSEMBLY

CAUTION

Ceramic rod is very brittle and is easily broken; handle carefully. Failure to comply may result in equipment damage.

1. Tilt microswitch (12) back on mount (13) and insert ceramic rod (18) in probe (14).
2. Position spring (17) in place and tilt microswitch (12) back into position.
3. Install washer (11) and adjusting screw (10) until microswitch (12) clicks, then continue an additional 3/4 turn.
4. Install sleeve (16) and nut (15) on probe (14).

INSTALLATION

1. Install flame detector switch (7) on heater housing (5). Tighten nut (6).
2. Install receptacle leads (3) on flame detector switch (7) with two new screw-assembled lockwashers (2).
3. Install blower motor lead (9) on flame detector switch (7) with new screw-assembled lockwasher (1).
4. Install ignition control leads (4) on flame detector switch (7) with two new screw-assembled lockwashers (8).
5. Install personnel heater guard (WP 0427 00).
6. Connect battery ground cable (WP 0126 00).
7. Release parking brake and remove wheel chocks (TM 9-2320-361-10).

PERSONNEL HEATER FLAME DETECTOR SWITCH MAINTENANCE (Contd)

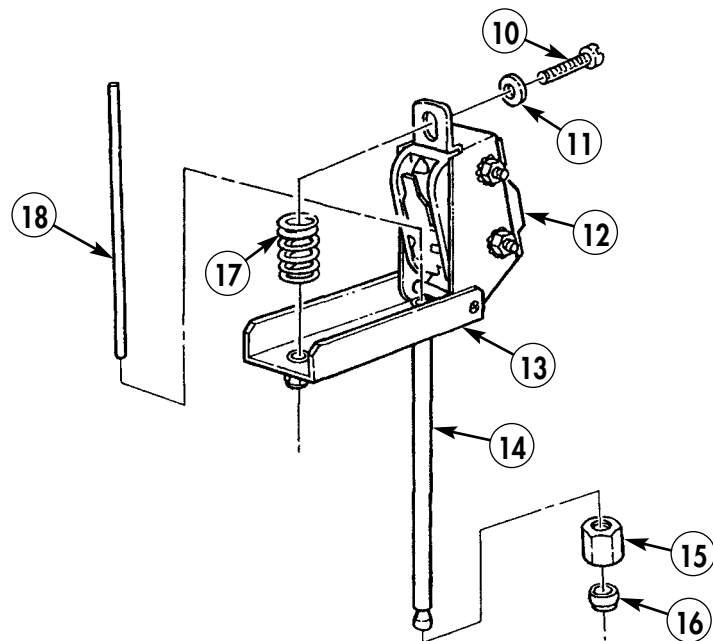
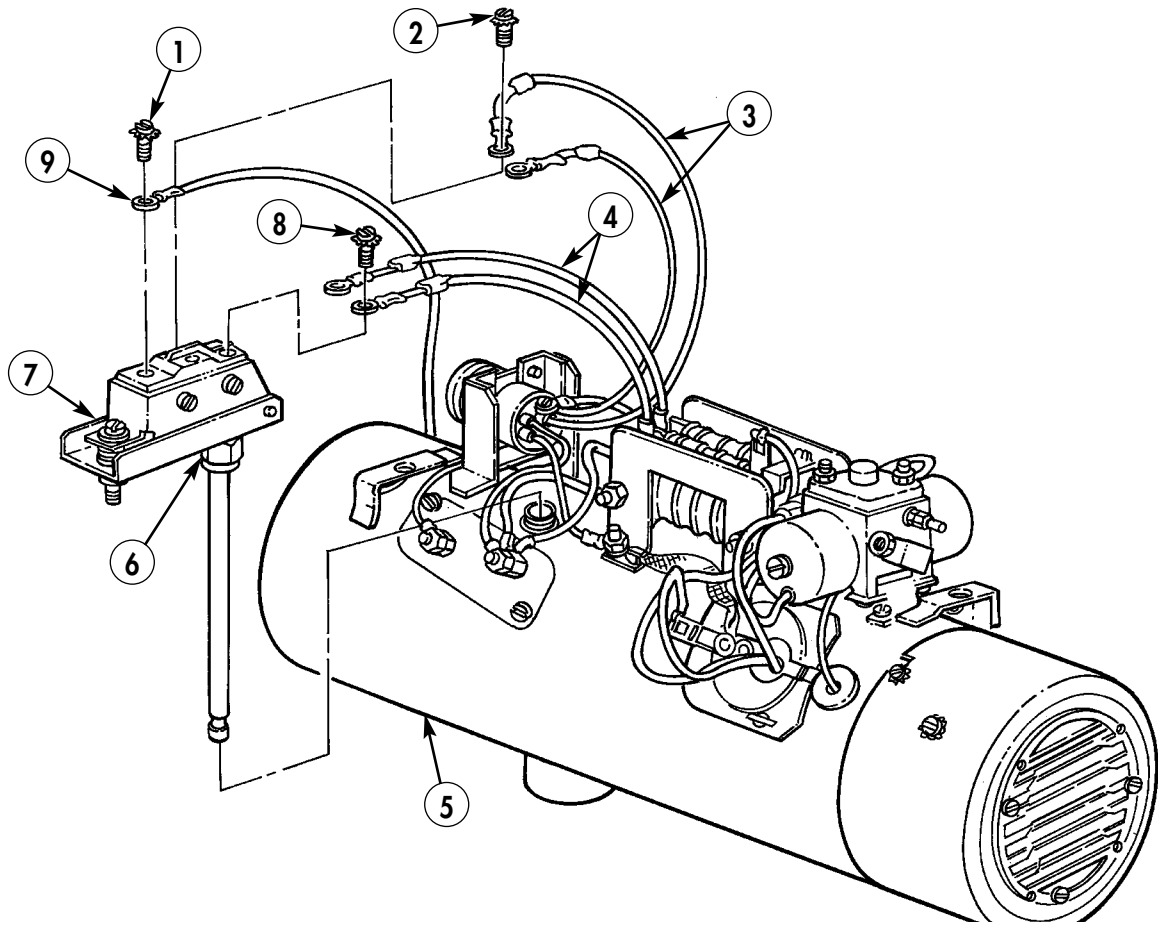

END OF WORK PACKAGE

FIELD MAINTENANCE INSTRUCTIONS FOR SPECIAL PURPOSE KITS

2-1/2 TON, 6X6, M44A2 SERIES TRUCKS (MULTIFUEL)

PERSONNEL HEATER BURNER MAINTENANCE

REMOVAL, DISASSEMBLY, CLEANING AND INSPECTION, ASSEMBLY, AND INSTALLATION

INITIAL SETUP:

Applicable Models

All

Tools and Special Tools

General mechanic's tool kit
(item 116, WP 0469 00)
Electrical tool kit (item 114, WP 0469 00)

Materials/Parts

Six nut-assembled lockwashers
(item 434, WP 0470 00)
Lockwasher (item 190, WP 0470 00)

Materials/Parts (Contd)

Vehicular heater parts kit
(item 304, WP 0470 00)
Rag (item 27, WP 0468 00)
Skysol 100 (item 13, WP 0468 00)

Equipment Condition

Parking brake set and wheels chocked
(TM 9-2320-361-10).
Personnel heater fuel line and blower housing
removed (WP 0430 00).

PERSONNEL HEATER BURNER MAINTENANCE (Contd)

REMOVAL

1. Remove screw (7), nut-assembled lockwasher (4), nut-assembled lockwasher (3), ground strap (5), and lockwasher (6) from heater housing (9) and heat exchanger (10). Discard nut-assembled lockwasher (4), nut-assembled lockwasher (3), and lockwasher (6).
2. Loosen four nut-assembled lockwashers (2) and remove four hook bolts and clamps (1) from burner (8) and heat exchanger (10). Discard nut-assembled lockwashers (2).
3. Remove burner (8) from heat exchanger (10).
4. Remove O-ring (11) and preformed packing (12) from burner (8). Discard preformed packing (12) and O-ring (11).

DISASSEMBLY

1. Remove three nuts (14) and lockwashers (15) and separate burner cup (13) from header (23). Discard lockwashers (15).
2. Remove screw (22), shield (21), washers (20) and (19), vaporizer (18), and fiber washer (17) from burner cup (13). Discard fiber washer (17).
3. Remove wick (16) from burner cup (13). Discard wick (16).

CLEANING AND INSPECTION

WARNING

- Skysol 100 solvent is combustible; DO NOT use or store near heat, sparks, flame, or other ignition sources. Use mechanical ventilation whenever product is used in a confined space, heated above ambient temperatures, or agitated. Keep container sealed when not in use.

Contact with Skysol 100 may cause skin irritation. Use chemical-resistant gloves. In case of skin contact, remove any contaminated clothing and wash skin thoroughly with soap and water. Wash contaminated clothing before reuse. Eye contact may cause irritation, tearing, or blurring of vision. Use face shield or goggles when eye contact may occur. In case of eye contact, flush eyes with large amounts of water for at least 15 minutes or until irritation subsides. Inhalation may cause irritation to upper respiratory passages. DO NOT have food or drink in the vicinity. Failure to comply may result in injury to personnel.

- Eye protection is required when using wire brush for cleaning. Failure to comply may result in injury to personnel.

Inspect burner (8) for scorched and charred surfaces. If scorched or charred, clean surfaces with wire brush and wipe clean with Skysol 100 solvent and clean rag.

ASSEMBLY

1. Insert new wick (16) in burner cup (13). Do not twist wick (16).
2. Lay strands of wick (16) in notches of fiber washer (17).
3. Install new fiber washer (17), vaporizer (18), washers (19) and (20), shield (21), and screw (22) on burner cup (13).
4. Position burner cup (13) on header (23) and secure with three new lockwashers (15) and nuts (14).

PERSONNEL HEATER BURNER MAINTENANCE (Contd)

INSTALLATION

1. Position new preformed packing (12), new O-ring (11), and burner (8) on heat exchanger (10) and install with four clamp and hook bolts (1). Tighten nut-assembled lockwasher (2).
2. Install new lockwasher (6) and ground strap (5) on heater housing (9) and hook bolt (1) with screw (7), new nut-assembled lockwasher (3) and nut-assembled lockwasher (4).
3. Install personnel heater fuel line and blower housing (WP 0430 00).
4. Connect battery ground cable (WP 0126 00).
5. Release parking brake and remove wheel chocks (TM 9-2320-361-10).

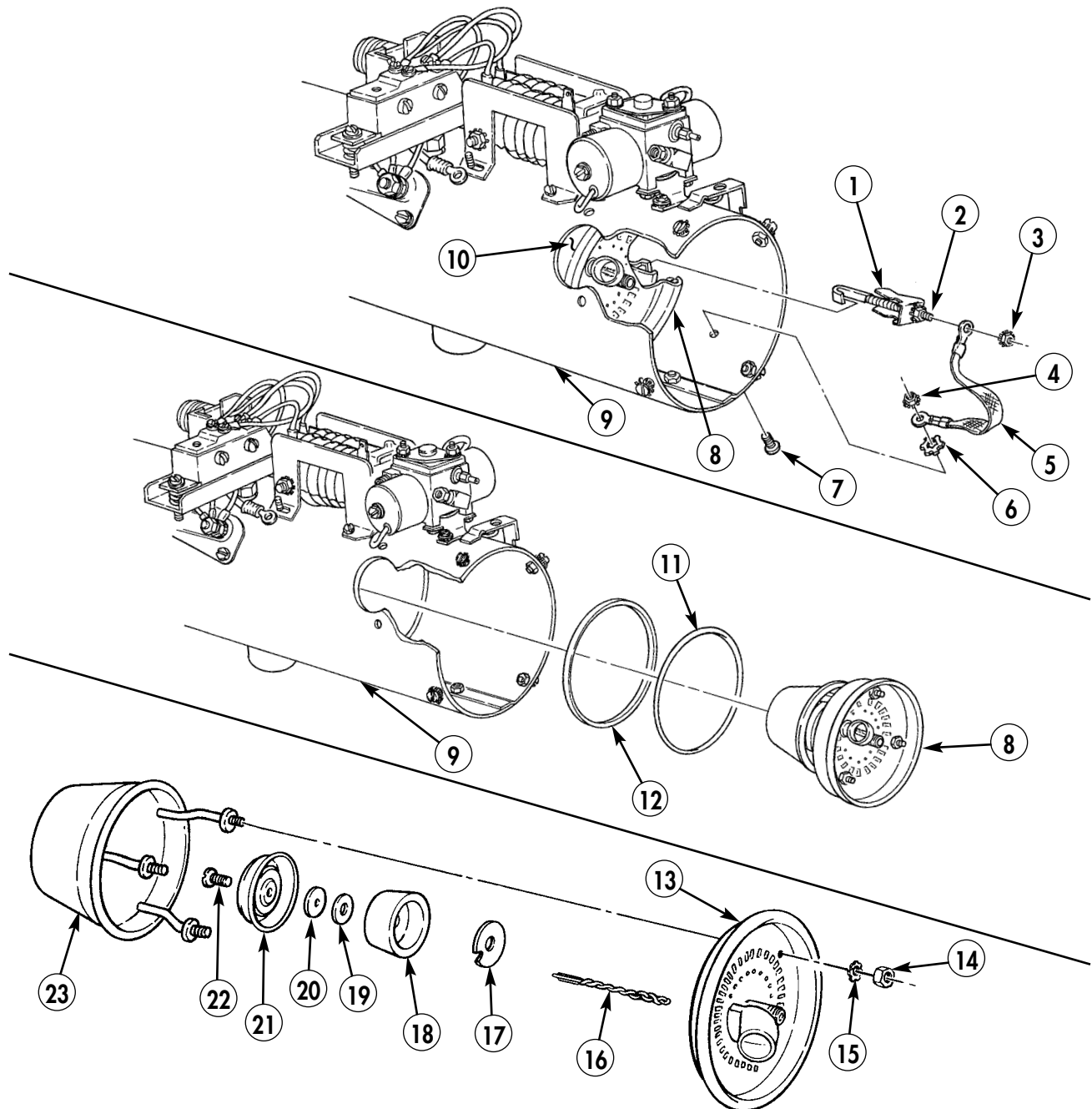

END OF WORK PACKAGE

FIELD MAINTENANCE INSTRUCTIONS FOR SPECIAL PURPOSE KITS

2-1/2 TON, 6X6, M44A2 SERIES TRUCKS (MULTIFUEL)

PERSONNEL HEATER OVERHEAT SWITCH AND RECEPTACLE REPLACEMENT

OVERHEAT SWITCH REMOVAL, RECEPTACLE REMOVAL, RECEPTACLE INSTALLATION,
AND OVERHEAT SWITCH INSTALLATION

INITIAL SETUP:

Applicable Models

All

Tools and Special Tools

General mechanic's tool kit
(item 116, WP 0469 00)
Electrical tool kit (item 114, WP 0469 00)

Materials/Parts

Five screw-assembled lockwashers
(item 261, WP 0470 00)
Four screw-assembled lockwashers
(item 272, WP 0470 00)

Materials/Parts (Contd)

Three nut-assembled lockwashers
(item 247, WP 0470 00)

Equipment Condition

Parking brake set and wheels chocked
(TM 9-2320-361-10).
Battery ground cable disconnected
(WP 0126 00).
Personnel heater guard removed (WP 0427 00).

PERSONNEL HEATER OVERHEAT SWITCH AND RECEPTACLE REPLACEMENT (Contd)

NOTE

Prior to removal, tag lead wires for installation.

OVERHEAT SWITCH REMOVAL

1. Remove nut-assembled lockwasher (1) and shutoff valve lead (2) from overheating switch (5). Discard nut-assembled lockwasher (1).
2. Remove nut-assembled lockwasher (9), receptacle lead (8), thermostat lead (7), and ignition control lead (6) from overheating switch (5). Discard nut-assembled lockwasher (9).
3. Remove two screw-assembled lockwashers (4) and overheating switch (5) from heater housing (3). Discard screw-assembled lockwashers (4).

RECEPTACLE REMOVAL

1. Remove screw-assembled lockwasher (11) and restriction solenoid lead (12) from receptacle (25). Discard screw-assembled lockwasher (11).
2. Remove nut-assembled lockwasher (22) and thermostat lead (21) from overheating switch (20). Discard nut-assembled lockwasher (22).
3. Remove screw-assembled lockwashers (15) and (16) and leads (17) and (13) from flame detector switch (23). Discard screw-assembled lockwashers (15) and (16).
4. Remove nut (14) and receptacle ground lead (24) from stud (19).
5. Remove four screw-assembled lockwashers (10) and receptacle (25) from bracket (18). Discard screw-assembled lockwashers (10).

PERSONNEL HEATER OVERHEAT SWITCH AND RECEPTACLE REPLACEMENT (Contd)

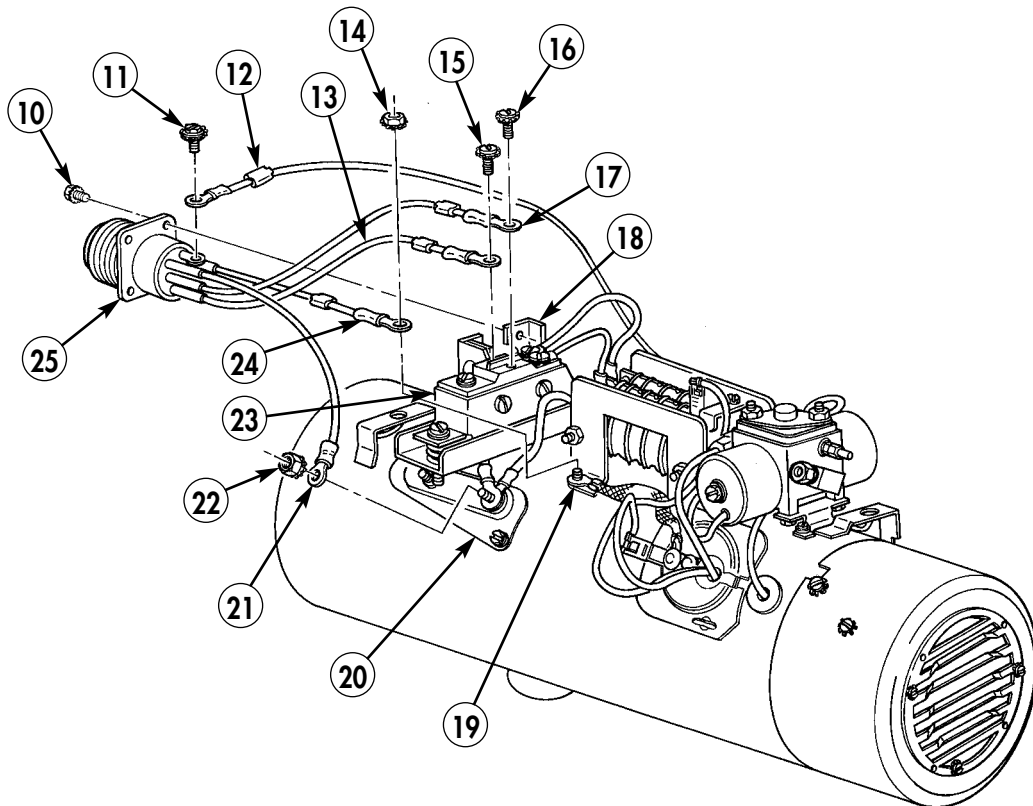
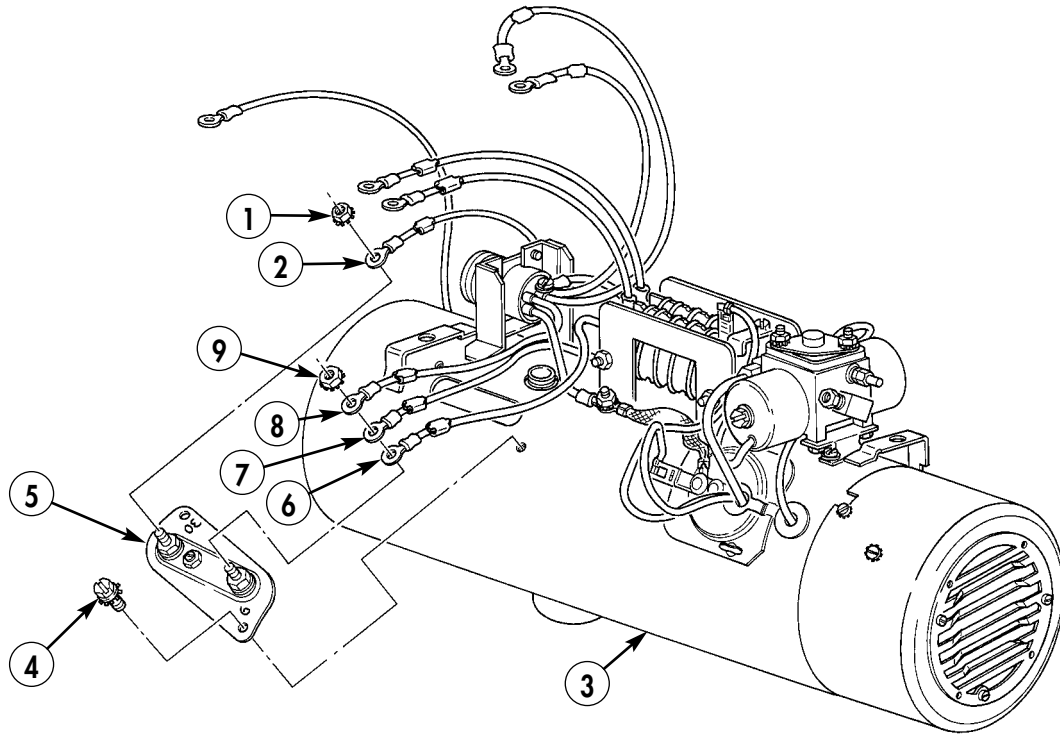

PERSONNEL HEATER OVERHEAT SWITCH AND RECEPTACLE REPLACEMENT (Contd)

RECEPTACLE INSTALLATION

1. Install receptacle (15) on bracket (8) with four new screw-assembled lockwashers (1).
2. Install receptacle ground lead (14) on stud (9) with nut (4).
3. Install leads (16) and (7) on flame detector switch (11) with new screw-assembled lockwashers (5) and (6).
4. Install receptacle lead (12) on overheating switch (10) with new nut-assembled lockwasher (13).
5. Install restriction solenoid lead (3) on receptacle (15) with new screw-assembled lockwasher (2).

OVERHEAT SWITCH INSTALLATION

1. Install overheating switch (21) on heater housing (19) with two screw-assembled lockwashers (20).
2. Install ignition control lead (22), thermostat lead (23), and receptacle lead (24) on overheating switch (21) with new nut-assembled lockwasher (25).
3. Install shutoff valve lead (18) on overheating switch (21) with new nut-assembled lockwasher (17).
4. Install personnel heater guard (WP 0427 00).
5. Connect battery ground cable (WP 0126 00).
6. Release parking brake and remove wheel chocks (TM 9-2320-361-10).

PERSONNEL HEATER OVERHEAT SWITCH AND RECEPTACLE REPLACEMENT (Contd)

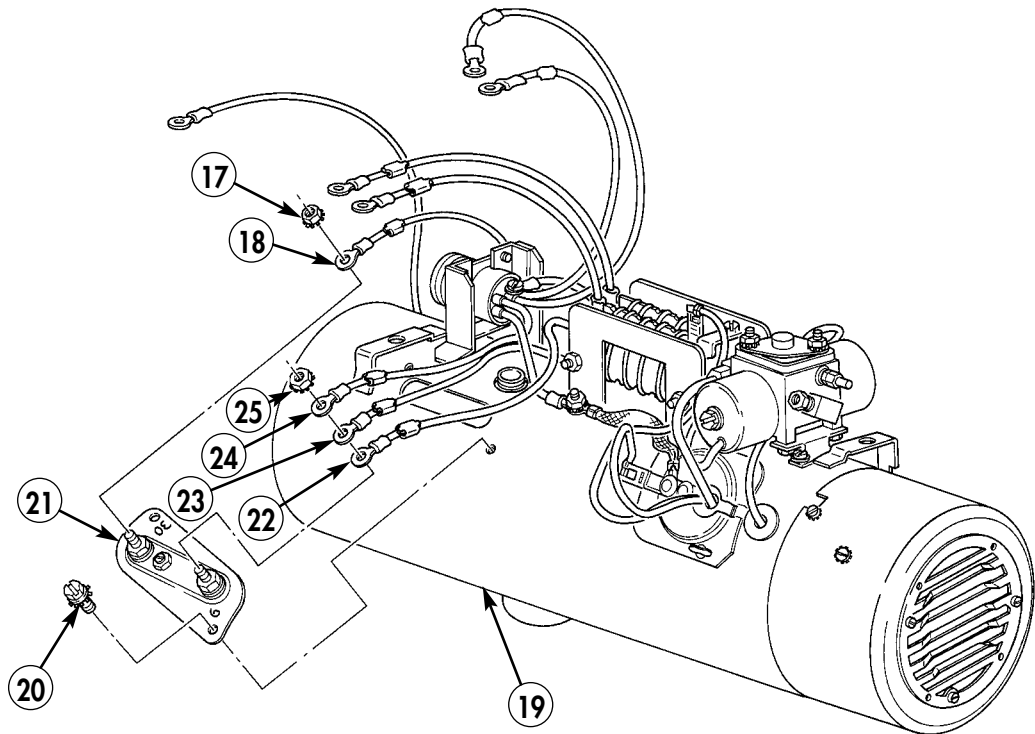
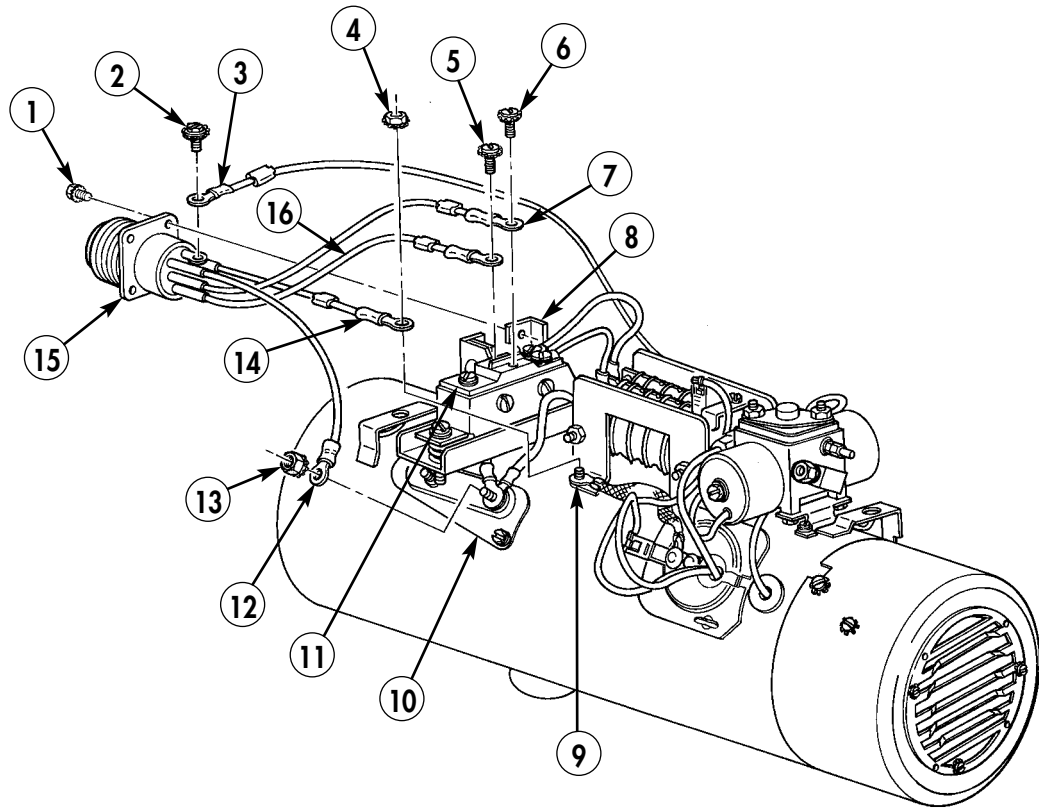

END OF WORK PACKAGE

FIELD MAINTENANCE INSTRUCTIONS FOR SPECIAL PURPOSE KITS

2-1/2 TON, 6X6, M44A2 SERIES TRUCKS (MULTIFUEL)

PERSONNEL HEATER HEAT EXCHANGER MAINTENANCE REMOVAL, CLEANING AND INSPECTION, AND INSTALLATION

INITIAL SETUP:

Applicable Models

All

Tools and Special Tools

General mechanic's tool kit
(item 116, WP 0469 00)
Electrical tool kit (item 114, WP 0469 00)

Equipment Condition

Parking brake set and wheels chocked
(TM 9-2320-361-10).
Battery ground cable disconnected
(WP 0126 00).
Personnel heater blower motor removed
(WP 0427 00).
Personnel heater burner removed
(WP 0432 00).
Personnel heater flame detector switch
removed (WP 0433 00).

PERSONNEL HEATER HEAT EXCHANGER MAINTENANCE (Contd)

REMOVAL

1. Remove three screws (4).
2. Separate heater housing (5).
3. Remove heat exchanger (3) from heater housing (5).

CLEANING AND INSPECTION

WARNING

Compressed air source must not exceed 30 psi (207 kPa). When cleaning with compressed air, eyeshields must be worn. Failure to wear eyeshields may result in injury to personnel.

Inspect heat exchanger (3) for exterior damage, leaks, and corrosion. Replace if damaged, heavily corroded, or leaks are present. To remove carbon from heat exchanger, soak in water for a short time and dry with compressed air.

INSTALLATION

1. Separate heater housing (5) and install heat exchanger (3) in heater housing (5) with three screws (4).
2. Ensure exhaust tube (2) and flame detector adapter (1) extend through holes of heater housing (5).
3. Install personnel heater flame detector switch (WP 0433 00).
4. Install personnel heater burner (WP 0432 00).
5. Install personnel heater blower motor (WP 0427 00).
6. Connect battery ground cable (WP 0126 00).
7. Release parking brake and remove wheel chocks (TM 9-2320-361-10).

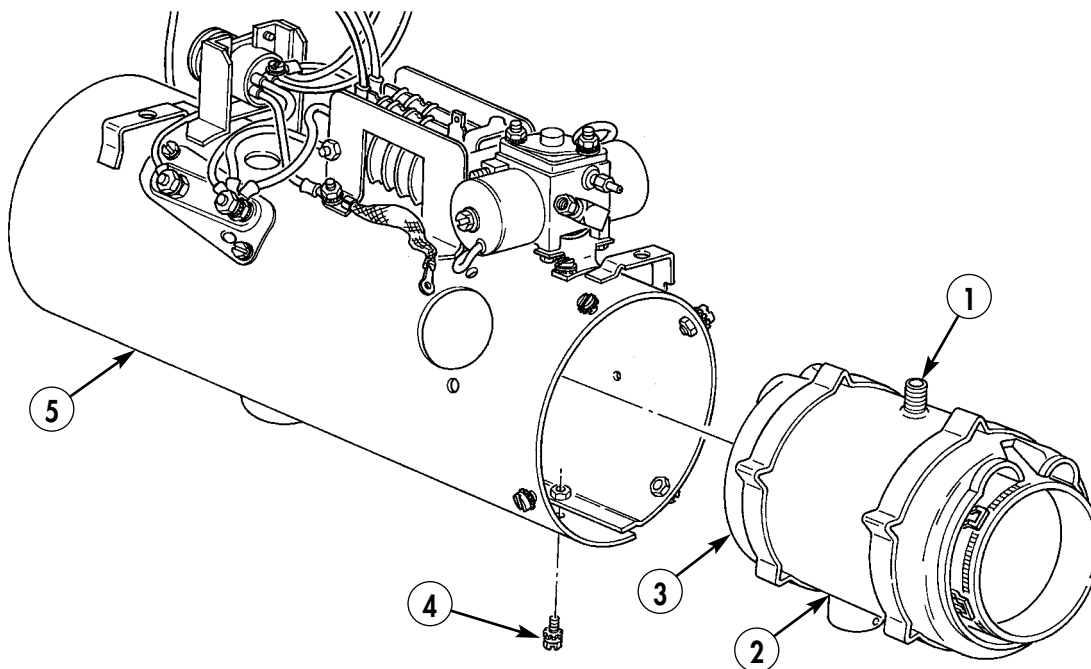

FIELD MAINTENANCE INSTRUCTIONS FOR SPECIAL PURPOSE KITS

2-1/2 TON, 6X6, M44A2 SERIES TRUCKS (MULTIFUEL)

FUEL BURNING PERSONNEL HEATER TESTING

PREPARATION, FLAME DETECTOR SWITCH TEST, FUEL CONTROL VALVE TEST, FLAME DETECTOR SWITCH TEST,
OVERHEAT SWITCH TEST, AND TEST EQUIPMENT REMOVAL

INITIAL SETUP:

Applicable Models

All

References

WP 0426 00–WP 0435 00

Tools and Special Tools

General mechanic's tool kit
(item 116, WP 0469 00)
Multimeter (item 51, WP 0469 00)
Flowmeter
Test stand

Equipment Condition

Parking brake set and wheels chocked
(TM 9-2320-361-10).
Battery ground cable disconnected
(WP 0126 00).
Fuel burning personnel heater removed
(WP 0351 00).

Materials/Parts

Two nut-assembled lockwashers
(item 247, WP 0470 00)

FUEL BURNING PERSONNEL HEATER TESTING (Contd)

PREPARATION

WARNING

- Do not perform this procedure while smoking or within 50 feet of sparks or open flame. Fuel is flammable and can explode, causing injury or death to personnel and damage to equipment.
- Exhaust gases can kill. Do not operate personnel heater in enclosed areas. Ensure work area is well-ventilated and exhaust fumes are directed away from test area.

NOTE

- Fuel pump, fuel filter, heater, wiring harness, fuel tubing, and control box must be the same type installed in vehicle.
- Perform "preparation" subtask before performing any test and perform "test equipment removal" after each test is complete.
- Heater must be tested in same position as mounted on vehicle.
- The cargo body, van primary, and van secondary personnel heaters are tested the same way.

1. Connect heater assembly (F) to test equipment using schematic on next page.

FUEL BURNING PERSONNEL HEATER TESTING (Contd)

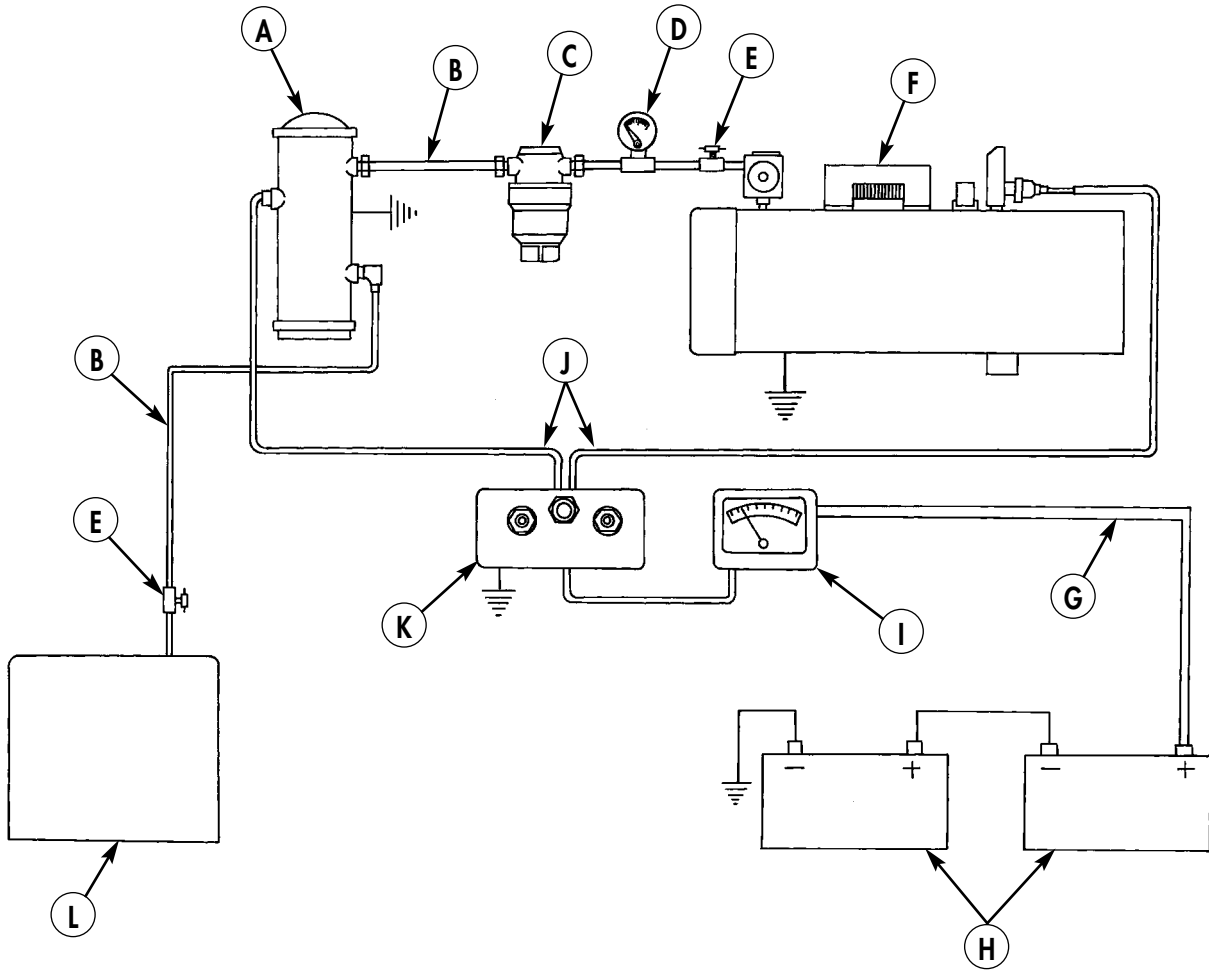

Legend

A.	Electric fuel pump	G.	Power source lead
B.	Fuel tubing	H.	24-volt DC power source
C.	Fuel filter	I.	Multimeter
D.	Fuel flowmeter	J.	Wiring harness
E.	Fuel shutoff valve	K.	Control box
F.	Heater assembly	L.	Fuel tank

FUEL BURNING PERSONNEL HEATER TESTING (Contd)

PREPARATION (Contd)

2. Turn two fasteners (11) and remove guard (5) from heater (13).
3. Disconnect lead (18) from 24-volt power source (20).
4. Disconnect igniter lead (7) from ignition control unit (6).
5. Remove nut-assembled lockwasher (1), shutoff valve lead (2), nut-assembled lockwasher (15) and thermostat lead (14) from overheat switch (3). Discard nut-assembled lockwashers (1) and (15).
6. Connect hose (10) to bleed screw (8) on fuel control valve (9) and place other end of hose (10) in container (12).
7. Connect lead (18) to 24-volt power source (20).
8. Open fuel shutoff valves (17).

NOTE

Have drainage container ready to catch fuel.

9. Place switch (23) in LO position. Place switch (21) in START position and hold. Open bleed screw (8) and let fuel flow from bleed screw (8) until no air bubbles are observed in fuel.
10. Place switch (21) in OFF position. Close bleed screw (8).
11. Install thermostat lead (14) and shutoff valve lead (2) on overheat switch (3) with new nut-assembled lockwasher (15) and (1).
12. Connect igniter lead (7) on ignition control unit (6).

NOTE

Ignition time is the interval from activating control box switch to START position until indicator lamp illuminates.

13. Place switch (21) in START position and hold. Record time interval from activating switch (21) until indicator lamp (22) illuminates. During this time interval, record ignition amperage on meter (19). Place switch (21) in OFF position.
14. If ignition time exceeds three minutes, or if ignition amperage exceeds 15 amperes, check fuel flow and replace damaged parts (WP 0426 00–WP 0435 00), as necessary.

FLAME DETECTOR SWITCH TEST

1. Place switch (21) in START position.
2. When indicator lamp (22) illuminates, place switch (21) in RUN position.
3. If indicator lamp (22) does not light adjustor, replace flame detector switch (4) (WP 0431 00).
4. Place switch (21) in OFF position.

FUEL CONTROL VALVE TESTING

1. Place switch (21) in START position.
2. When indicator lamp (22) illuminates, place switch (21) in RUN position.
3. Check fuel consumption at flowmeter (16). Fuel consumption should be 10-13 cc/min at low heat, and 19-24. cc/min at high heat. If fuel consumption rate is not within limits, replace fuel control valve (9) (WP 0428 00).
4. Check operating amperage at ammeter (19). If operating amperage exceeds 10 amperes, check heater wiring and replace damaged parts (WP 0426 00–WP 0435 00), as necessary.
5. Place switch (21) in OFF position.

FUEL BURNING PERSONNEL HEATER TESTING (Contd)

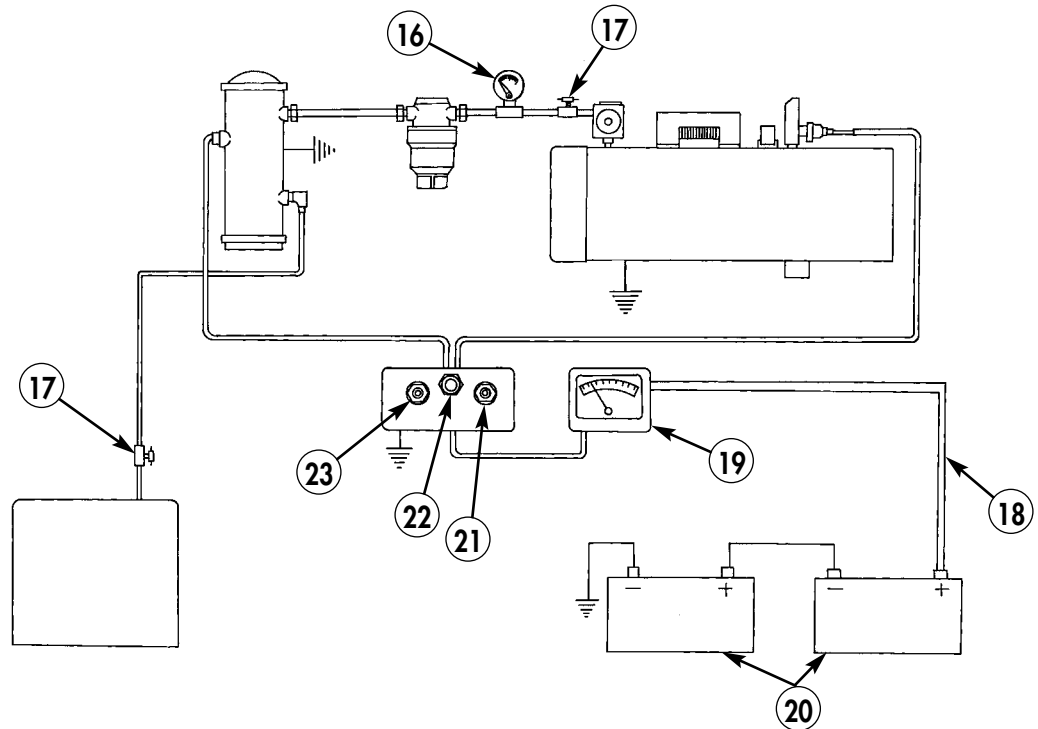
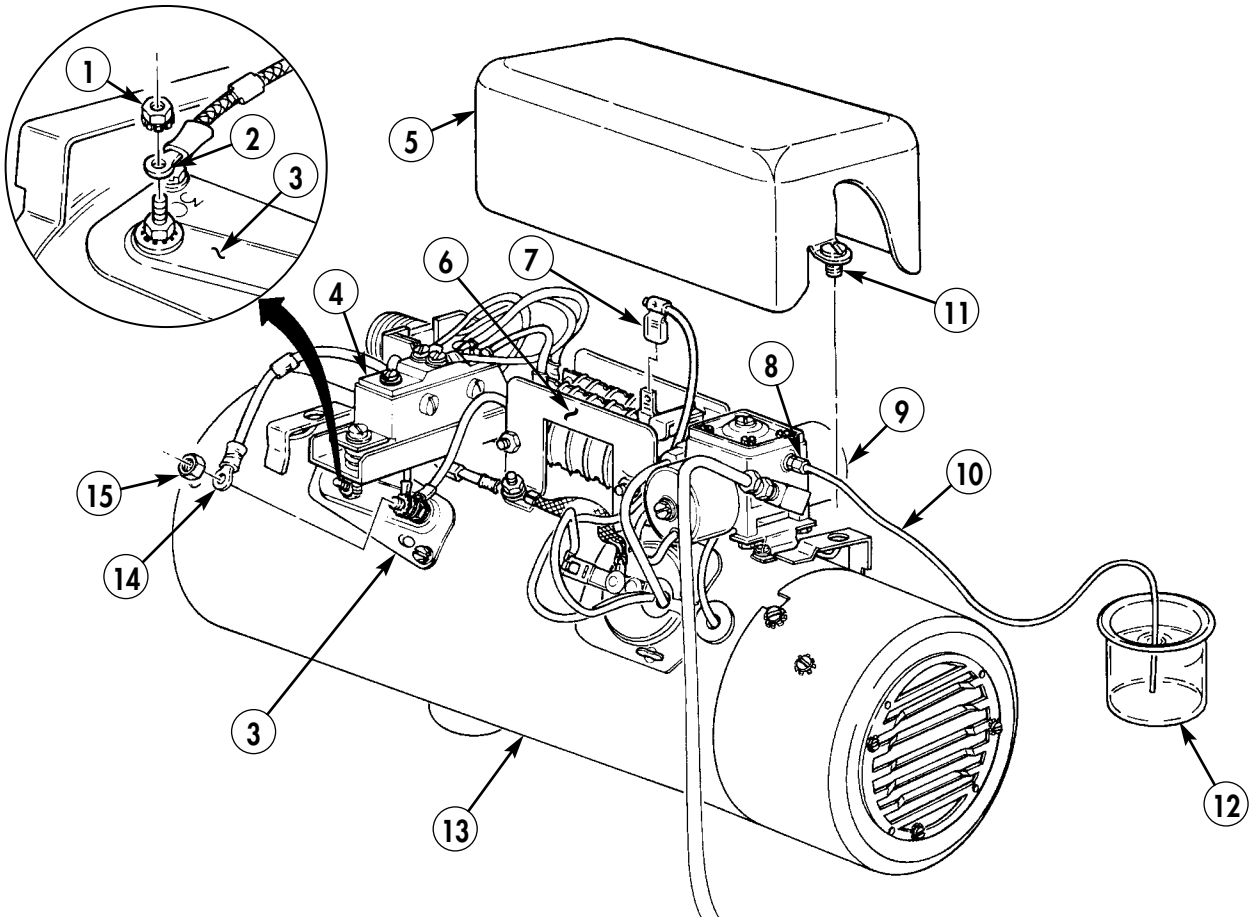

FUEL BURNING PERSONNEL HEATER TESTING (Contd)

FLAME DETECTOR SWITCH TEST

1. Place switch (4) in START position.
2. When indicator lamp (5) illuminates, place switch (4) in RUN position.

NOTE

Purge time is the interval from turning control box switch to OFF position until indicator lamp goes out.

3. Place switch (4) in OFF position and record purge time. Burning should stop within thirty seconds and blower motor (9) should continue to run up to three minutes. If purge time exceeds three minutes, replace or adjust flame detector switch (6) (WP 0431 00).

OVERHEAT SWITCH TEST

1. Place switch (4) in START position.
2. When indicator lamp (5) illuminates, place switch (4) in RUN position and allow heater (10) to operate for one minute.
3. Partially restrict air inlet with a sheet of cardboard or sheet metal. Overheat switch (11) should activate and shut down heater (10) within five minutes.
4. If heater (10) does not shut down after five minutes, replace overheat switch (11) (WP 0433 00).

TEST EQUIPMENT REMOVAL

WARNING

Allow time for heater to cool before removing from test equipment. Failure to do so may result in injury to personnel or damage to equipment.

1. Close fuel shutoff valves (1).
2. Disconnect lead (2) from power source (3).
3. Remove heater (10) from test equipment.
4. Place guard (7) on heater (10) and turn two fasteners (8) to secure.
5. Install fuel burning personnel heater (WP 0351 00).
6. Connect battery ground cable (WP 0126 00).
7. Release parking brake and remove wheel chocks (TM 9-2320-361-10).

FUEL BURNING PERSONNEL HEATER TESTING (Contd)

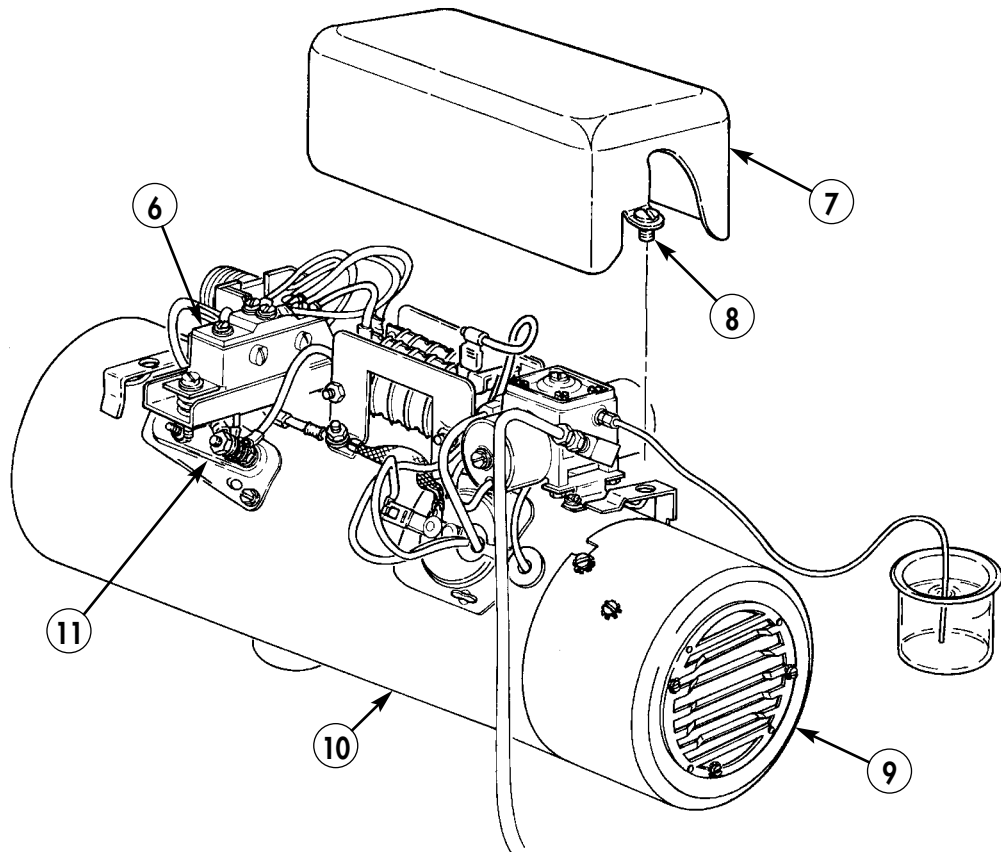
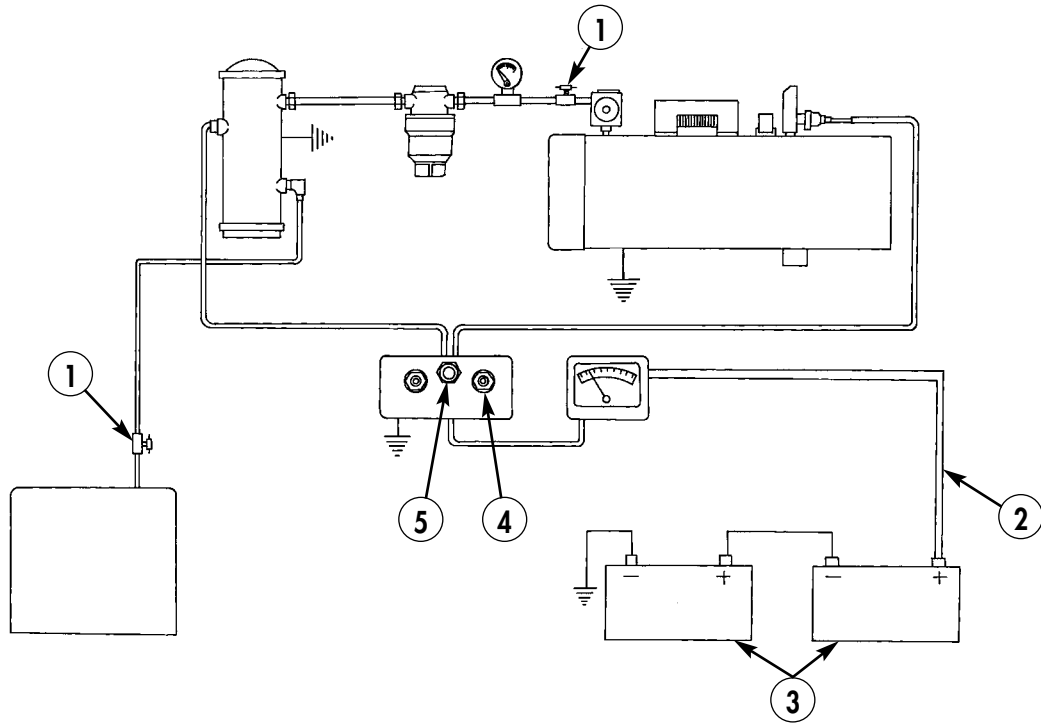

END OF WORK PACKAGE

FIELD MAINTENANCE INSTRUCTIONS FOR SPECIAL PURPOSE KITS

2-1/2 TON, 6X6, M44A2 SERIES TRUCKS (MULTIFUEL)

HARDTOP REAR PANEL WINDOW MAINTENANCE

DISASSEMBLY AND ASSEMBLY

INITIAL SETUP:

Applicable Models

All

Tools and Special Tools

General mechanic's tool kit
(item 116, WP 0469 00)

Equipment Condition

Parking brake set and wheels chocked
(TM 9-2320-361-10).

Battery ground cable disconnected
(WP 0126 00).

Rear panel window removed (WP 0363 00).

HARDTOP REAR PANEL WINDOW MAINTENANCE (Contd)

DISASSEMBLY

1. Remove two screws (8), separate window frame (7), and remove two sashes (6) from window frame (7).
2. Remove two screws (10), sleeves (9), frame rail (5), and glass (3) from sash frame (1).
3. Remove rubber seals (2) and (4) from glass (3) and frame rail (5).

ASSEMBLY

1. Install rubber seal (4) in frame rail (5).
2. Place rubber seal (2) around glass (3).
3. Install glass (3) and frame rail (5) on sash frame (1) with two screws (10) and sleeves (9).
4. Install two sashes (6) in window frame (7) with two screws (8).
5. Install rear panel window (WP 0363 00).
6. Connect battery ground cable (WP 0126 00).
7. Release parking brake and remove wheel chocks (TM 9-2320-361-10).

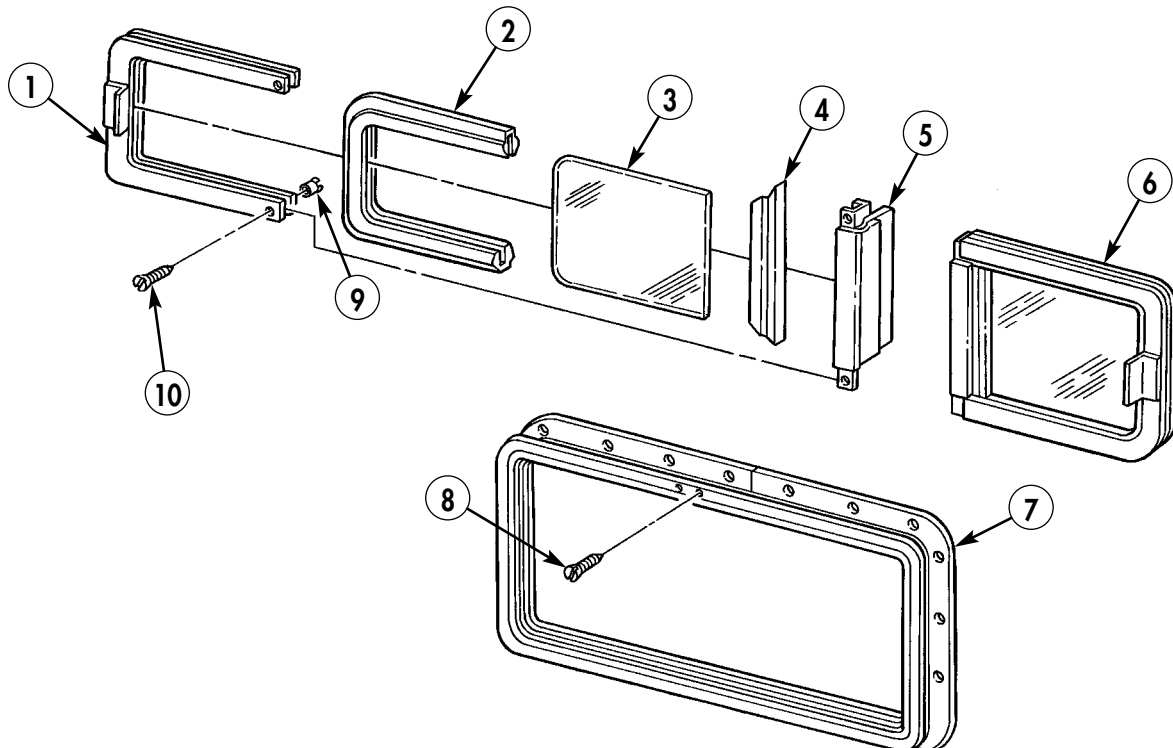

END OF WORK PACKAGE

CHAPTER 5

SUSTAINMENT MAINTENANCE INSTRUCTIONS

2-1/2 TON, 6X6, M44A2 SERIES TRUCKS (MULTIFUEL)

	<u>WP Sequence No.</u>
ENGINE	
Engine Repair	WP 0437 00
Cylinder Head Repair	WP 0438 00
Cylinder Sleeve Replacement	WP 0439 00
Crankshaft Replacement	WP 0440 00
Flywheel Repair	WP 0441 00
Piston and Connecting Rod Replacement	WP 0442 00
Intake and Exhaust Valves, Guides, and Springs Replacement	WP 0443 00
Camshaft and Bearing Replacement	WP 0444 00
Oil Pump Repair	WP 0445 00
FUEL SYSTEM	
Fuel Injector Pump Maintenance	WP 0446 00
COOLING SYSTEM	
Radiator Repair	WP 0447 00
ELECTRICAL SYSTEM	
60-Ampere Alternator Repair	WP 0448 00
Starter Repair	WP 0449 00
TRANSMISSION	
Transmission Repair	WP 0450 00
TRANSFER CASE	
Transfer Case Repair	WP 0451 00
FRONT AND REAR AXLE	
Front Axle Assembly Overhaul	WP 0452 00
Forward-Rear and Rear-Rear Axle Assembly Overhaul	WP 0453 00
Differential Carrier Replacement	WP 0454 00
Differential Carrier Repair	WP 0455 00
BRAKE SYSTEM	
Parking and Service Brakedrum Repair	WP 0456 00
Parking and Service Brakeshoe Repair	WP 0457 00
STEERING GEAR	
Steering Gear Repair	WP 0458 00
CARGO BODIES	
Cargo Bodies Repair	WP 0459 00
TANK BODIES	
Tank Bodies Repair	WP 0460 00
Delivery Pump Repair	WP 0461 00
VAN BODY	
Van Body Maintenance	WP 0462 00

CHAPTER 5

SUSTAINMENT MAINTENANCE INSTRUCTIONS (Contd)

	<u>WP Sequence No.</u>
WINCH	
Front Winch Repair	WP 0463 00
POWER TAKEOFF	
Transmission Power Takeoff (PTO) Repair	WP 0464 00

SUSTAINMENT MAINTENANCE INSTRUCTIONS

2-1/2 TON, 6X6, M44A2 SERIES TRUCKS (MULTIFUEL)

ENGINE REPAIR

For engine repair, refer to TM 9-2815-210-34-2-2.

SUSTAINMENT MAINTENANCE INSTRUCTIONS

2-1/2 TON, 6X6, M44A2 SERIES TRUCKS (MULTIFUEL)

CYLINDER HEAD REPAIR

For cylinder head repair, refer to TM 9-2815-210-34-2-2.

SUSTAINMENT MAINTENANCE INSTRUCTIONS

2-1/2 TON, 6X6, M44A2 SERIES TRUCKS (MULTIFUEL)

CYLINDER SLEEVE REPLACEMENT

For cylinder sleeve replacement, refer to TM 9-2815-210-34-2-2.

SUSTAINMENT MAINTENANCE INSTRUCTIONS

2-1/2 TON, 6X6, M44A2 SERIES TRUCKS (MULTIFUEL)

CRANKSHAFT REPLACEMENT

For crankshaft replacement, refer to TM 9-2815-210-34-2-2.

SUSTAINMENT MAINTENANCE INSTRUCTIONS

2-1/2 TON, 6X6, M44A2 SERIES TRUCKS (MULTIFUEL)

FLYWHEEL REPAIR

For repair of flywheel and components, refer to TM 9-2915-210-34-2-2.

SUSTAINMENT MAINTENANCE INSTRUCTIONS

2-1/2 TON, 6X6, M44A2 SERIES TRUCKS (MULTIFUEL)

PISTON AND CONNECTING ROD REPLACEMENT

For piston and connecting rod replacement, refer to TM 9-2815-210-34-2-2.

SUSTAINMENT MAINTENANCE INSTRUCTIONS

2-1/2 TON, 6X6, M44A2 SERIES TRUCKS (MULTIFUEL)

INTAKE AND EXHAUST VALVES, GUIDES, AND SPRINGS REPLACEMENT

For intake and exhaust valves, guides, and springs replacement, refer to TM 9-2815-210-34-2-2.

SUSTAINMENT MAINTENANCE INSTRUCTIONS

2-1/2 TON, 6X6, M44A2 SERIES TRUCKS (MULTIFUEL)

CAMSHAFT AND BEARING REPLACEMENT

For camshaft and bearing replacement, refer to TM 9-2815-210-34-2-2.

SUSTAINMENT MAINTENANCE INSTRUCTIONS

2-1/2 TON, 6X6, M44A2 SERIES TRUCKS (MULTIFUEL)

OIL PUMP REPAIR

For oil pump repair, refer to TM 9-2815-210-34-2-2.

SUSTAINMENT MAINTENANCE INSTRUCTIONS

2-1/2 TON, 6X6, M44A2 SERIES TRUCKS (MULTIFUEL)

FUEL INJECTOR PUMP MAINTENANCE

For fuel injector pump repair, refer to TM 9-2910-226-34 and/or NMWR 9-2910-305.

SUSTAINMENT MAINTENANCE INSTRUCTIONS

2-1/2 TON, 6X6, M44A2 SERIES TRUCKS (MULTIFUEL)

RADIATOR REPAIR

INSPECTION, TEST, AND REPAIR

INITIAL SETUP:

Applicable Models

All

References

TM 750-254

Tools and Special Tools

General mechanic's tool kit
(item 116, WP 0469 00)
Soldering gun (item 37, WP 0469 00)

Equipment Condition

Radiator and brackets removed (WP 0077 00).

Materials/Parts

Solder (item 37, WP 0468 00)

RADIATOR REPAIR (Contd)

INSPECTION, TEST, AND REPAIR

1. Inspect radiator upper tank (1), lower tank (4), filler neck (2), and overflow pipe (3) for obvious defects. Repair or replace if defective (TM 750-254).
2. Pressure test radiator (5) for leaks (TM 750-254).
3. Repair defective radiator components (TM 750-254).
4. Install radiator and brackets (WP 0077 00).

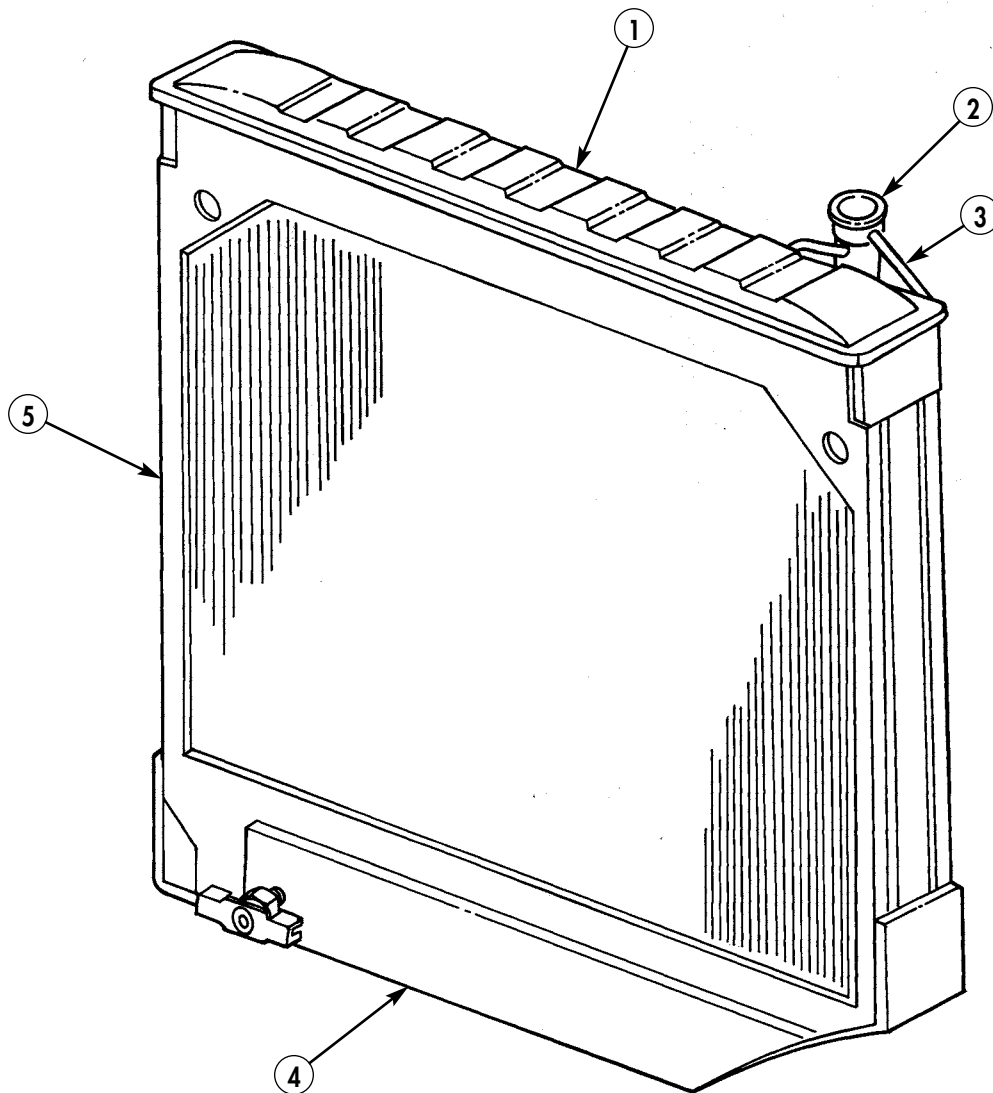

SUSTAINMENT MAINTENANCE INSTRUCTIONS

2-1/2 TON, 6X6, M44A2 SERIES TRUCKS (MULTIFUEL)

60-AMPERE ALTERNATOR REPAIR

DISASSEMBLY, CLEANING AND INSPECTION, AND ASSEMBLY

INITIAL SETUP:

Applicable Models

All

Tools and Special Tools

Arbor press (item 56, WP 0469 00)
General mechanic's tool kit
(item 116, WP 0469 00)
Multimeter (item 51, WP 0469 00)
Soldering gun (item 37, WP 0469 00)
Tool kit, electrical (item 114, WP 0469 00)
Torx socket (item 140, WP 0469 00)
Torque wrench, 3/8-in. drive
(item 138, WP 0469 00)

Materials/Parts

Alternator parts kit (item 296, WP 0470 00)
Alternator parts kit (item 297, WP 0470 00)
Adhesive sealant (item 5, WP 0468 00)
Cleaning compound (item 12, WP 0468 00)
GAA grease (item 17, WP 0468 00)

Materials/Parts (Contd)

Lubricating oil, OE/HDO 30
(item 24, WP 0468 00)
Silicone compound (item 35, WP 0468 00)
Solder (item 37, WP 0468 00)
Tiedown strap (item 40, WP 0468 00)

References

TM 9-214
TC 9-237
WP 0021 00

Equipment Condition

Alternator removed (WP 0085 00).

60-AMPERE ALTERNATOR REPAIR (Contd)

NOTE

Prior to removal, tag lead wires for assembly.

DISASSEMBLY

1. Remove access plug (7) from end housing (4).
2. Remove six screws (1), end cover (2), and O-ring (3) from end housing (4). Discard O-ring (3).

NOTE

Regulator is part of end cover, do not disassemble.

3. Disconnect three leads (10) from three terminals (11) on regulator (12).
4. Remove two screw-assembled lockwashers (6) and output plate cover (5) from end housing (4). Discard screw-assembled lockwashers (6).
5. Remove sealer from three stator leads (8).
6. Unsolder and disconnect three stator leads (8) from three stator lead terminals (9). Refer to TC 9-237.

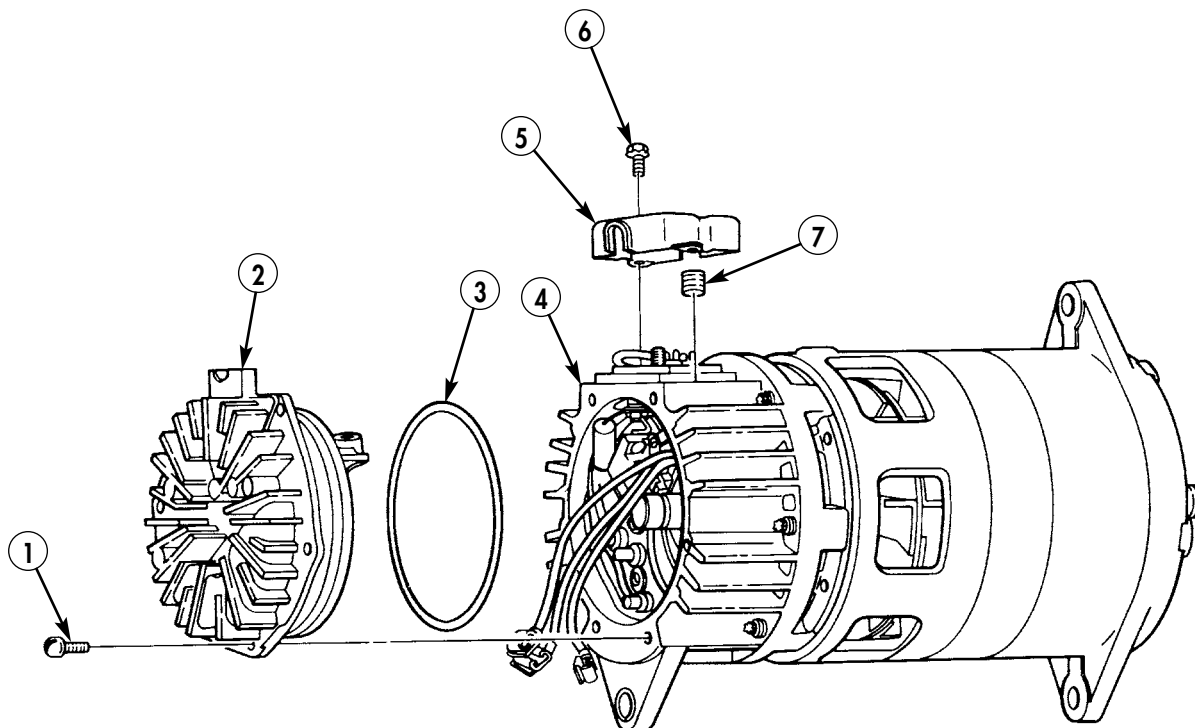

60-AMPERE ALTERNATOR REPAIR (Contd)

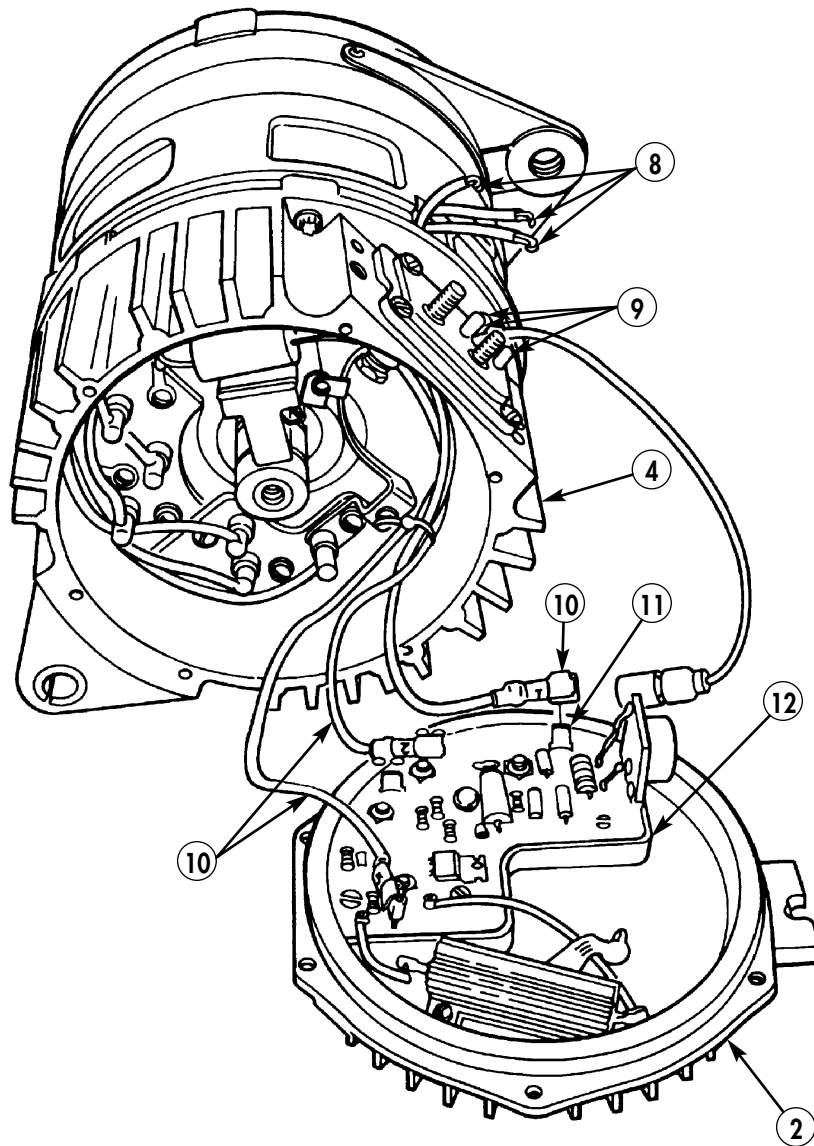

60-AMPERE ALTERNATOR REPAIR (Contd)

DISASSEMBLY (Contd)

7. Scribe a locating mark (5) on end housing (2) and intermediate housing (1).

NOTE

Brush springs will fall free when end housing is removed from intermediate housing.

8. Remove six screws (4), lockwashers (3), and end housing (2) from intermediate housing (1). Discard lockwashers (3).
9. Remove insulating compound from capacitor (6).
10. Remove screw (18), nut (19), lockwasher (20), washer (21), and capacitor (6) from negative rectifier plate (16) and output plate stud (11). Discard lockwasher (20).
11. Remove two screws (12), lockwasher (17), two brush leads (13), and lead (15) from insulator (14) and output strap (7). Discard lockwasher (17).
12. Remove two brushes (24) and springs (23) from brush holder (26).
13. Remove three screws (25), brush holder (26), insulator (14), and shim (22) from end housing (2).
14. Remove screw (8), lockwasher (9), and output strap (7) from positive rectifier plate (10) and output plate stud (11). Discard lockwasher (9).

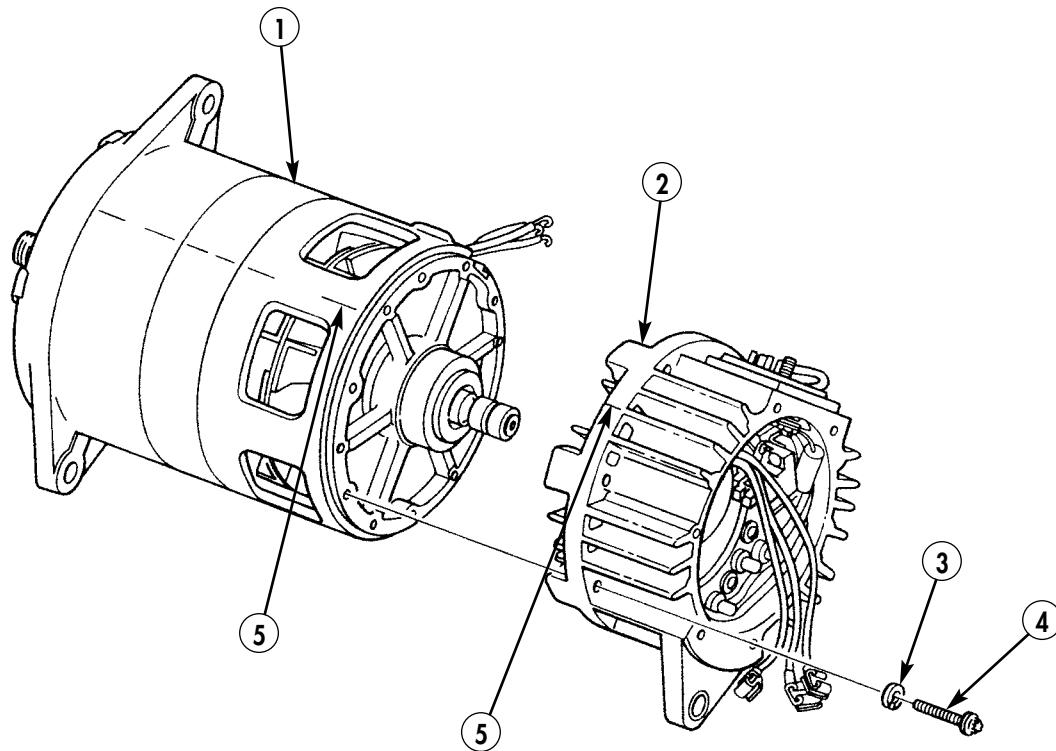

60-AMPERE ALTERNATOR REPAIR (Contd)

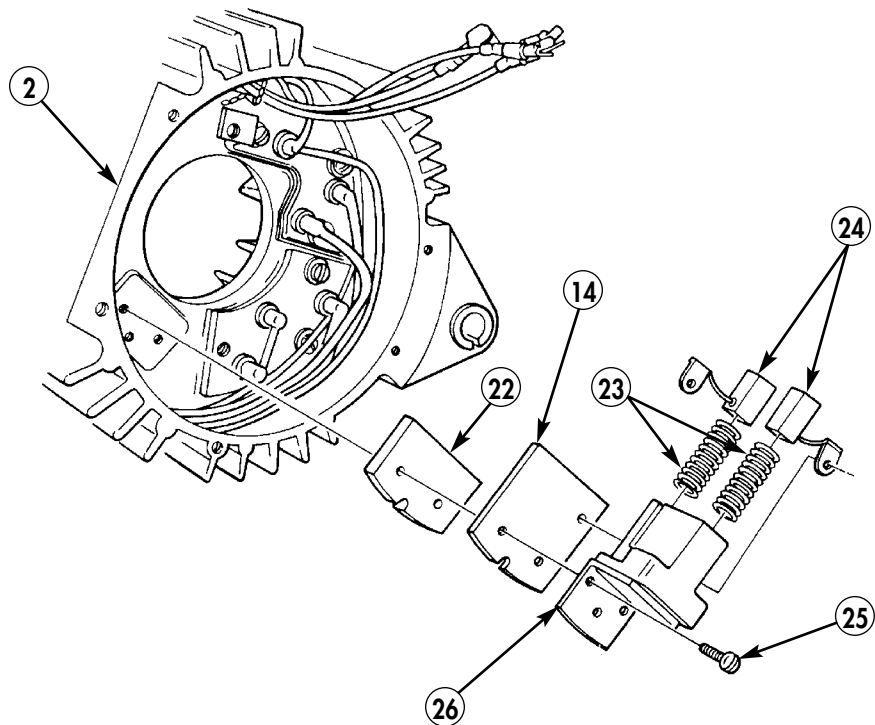
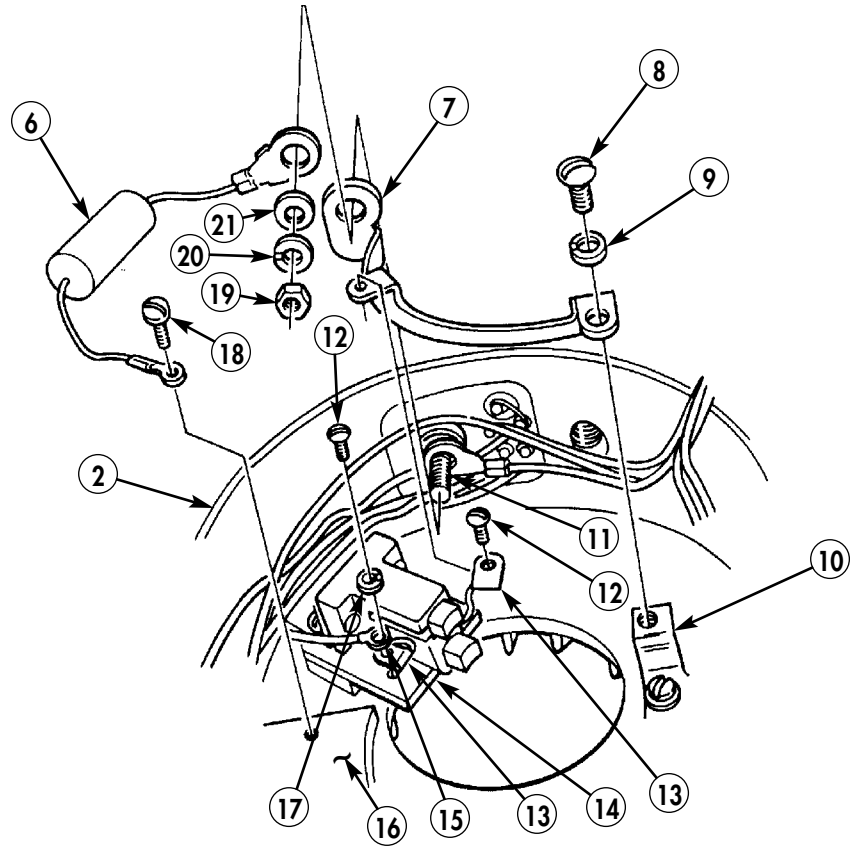

60-AMPERE ALTERNATOR REPAIR (Contd)

DISASSEMBLY (Contd)

15. Remove tiedown strap (1) from three leads (2). Discard tiedown strap (1).
16. Disconnect lead (20) from output plate stud (6).
17. Remove insulating compound from four rectifier terminals (10) and three rectifier terminals (16).
18. Unsolder and disconnect six positive rectifier leads (11) from four positive rectifier terminals (10).
19. Remove three screws (12), washers (13), nylon washers (14), positive rectifier plate (9), and positive rectifier insulator (8) from end housing (3).
20. Unsolder and disconnect three negative rectifier leads (15) from three negative rectifier terminals (16).
21. Remove two screws (17), washers (18), and negative rectifier plate (19) from end housing (3).
22. Remove four screws (4), output plate (5), O-ring (7), six positive rectifier leads (11), three negative rectifier leads (15), and leads (2) from end housing (3). Discard O-ring (7).
23. Scribe locating marks (24) on intermediate housing (23), stator (22), and drive end housing (21).

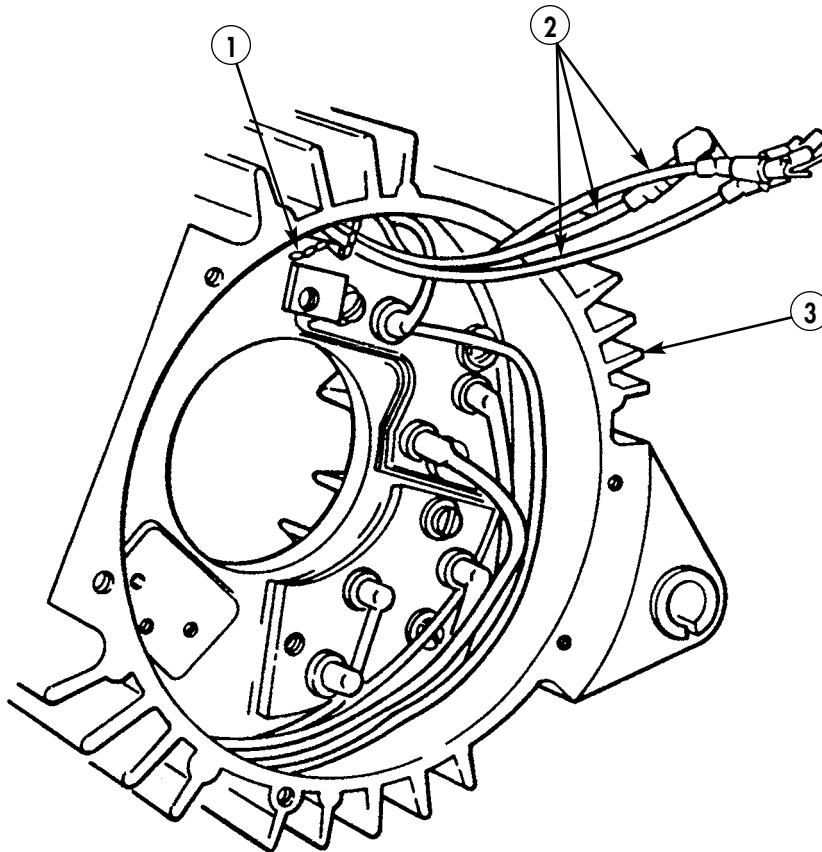

60-AMPERE ALTERNATOR REPAIR (Contd)

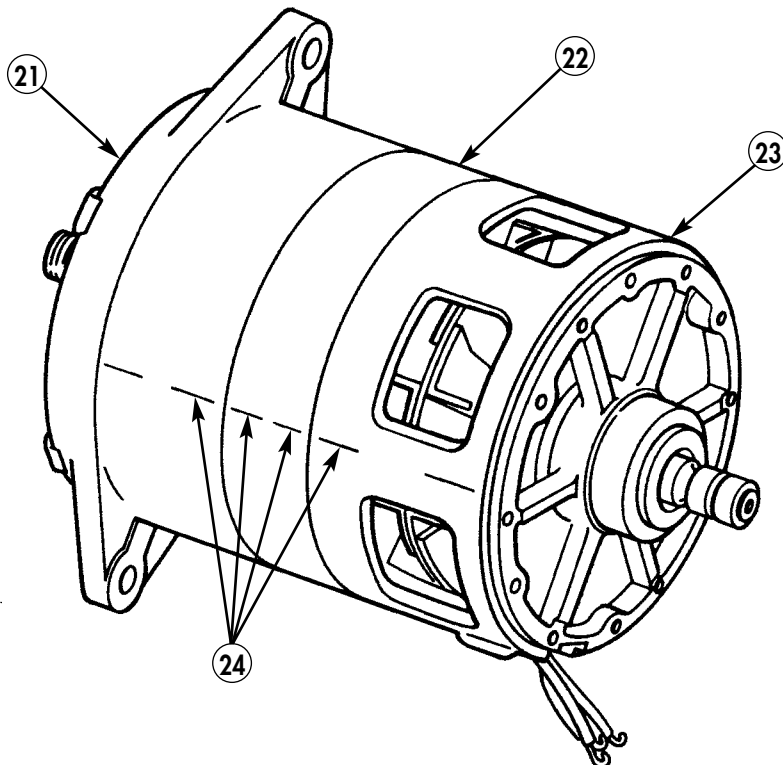
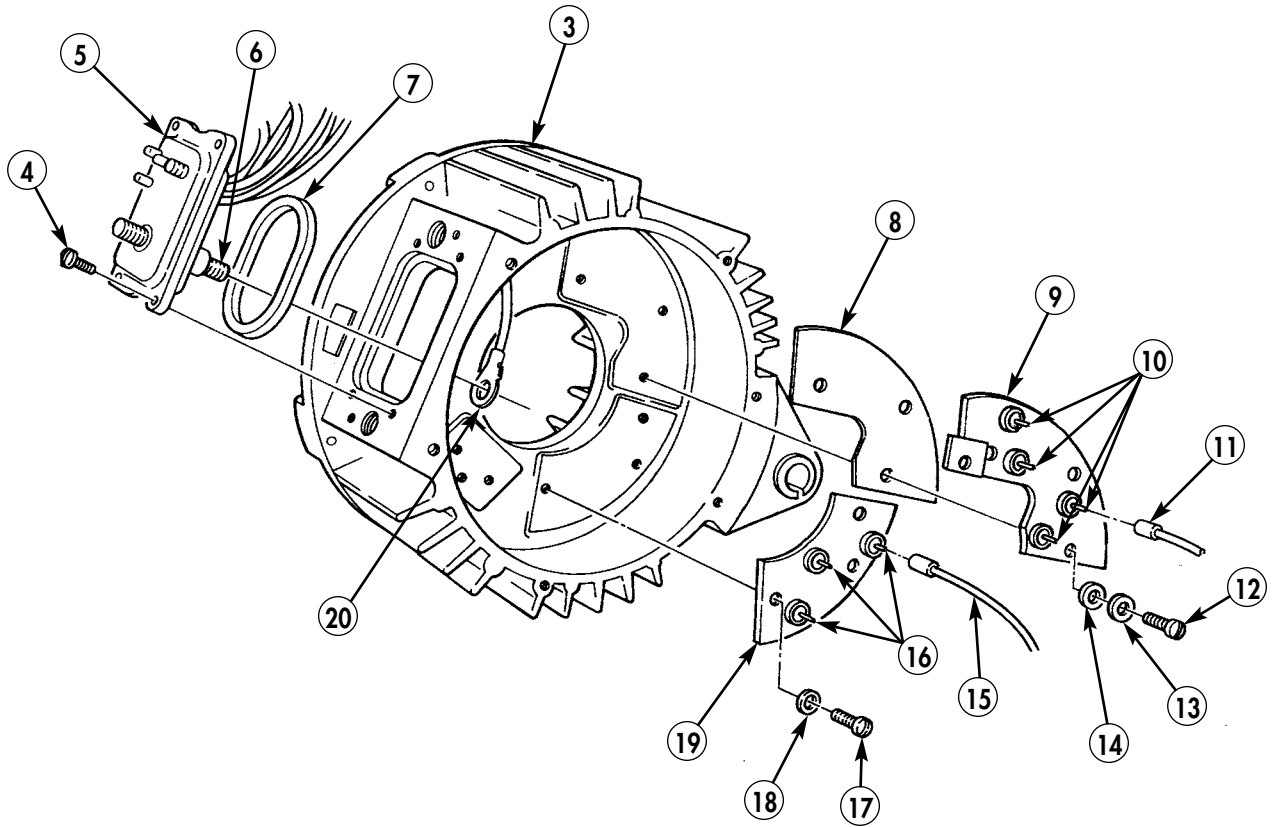

60-AMPERE ALTERNATOR REPAIR (Contd)

DISASSEMBLY (Contd)

24. Remove O-ring (12) from intermediate housing (6). Discard O-ring (12).
25. Remove six screws (2), lockwashers (3), and intermediate housing (6) from stator (4) and drive end housing (1). Discard lockwashers (3).
26. Remove snap ring (11), felt retainer (10), felt seal (9), and felt retainer (8) from intermediate housing (6). Discard snap ring (11), felt retainers (10) and (8), and felt seal (9).
27. Remove seal (5) from intermediate housing (6). Discard seal (5).
28. Press bearing (7) out of intermediate housing (6). Discard bearing (7).
29. Remove six screws (16), bearing retainer (17), and O-ring (18) from drive end housing (1). Discard O-ring (18).
30. Remove sleeve spacer seal (19) from bearing retainer (17). Discard sleeve spacer seal (19).
31. Remove sleeve spacer (20), O-ring (21), and washer (22) from rotor shaft (14). Discard O-ring (21).
32. Position drive end housing (1) in press and press rotor and fan assembly (13) out of drive end housing (1).
33. Remove stator (4) from drive end housing (1).
34. Remove bearing (23) and seal (15) from drive end housing (1). Discard seal (15) and bearing (23).

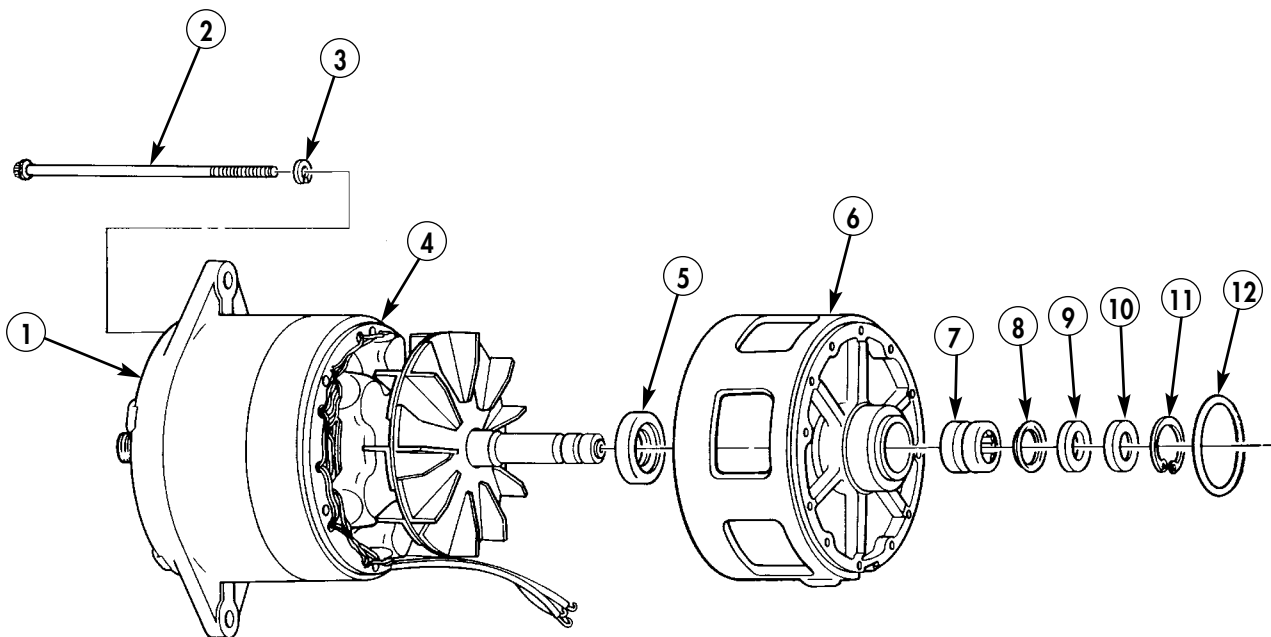

60-AMPERE ALTERNATOR REPAIR (Contd)

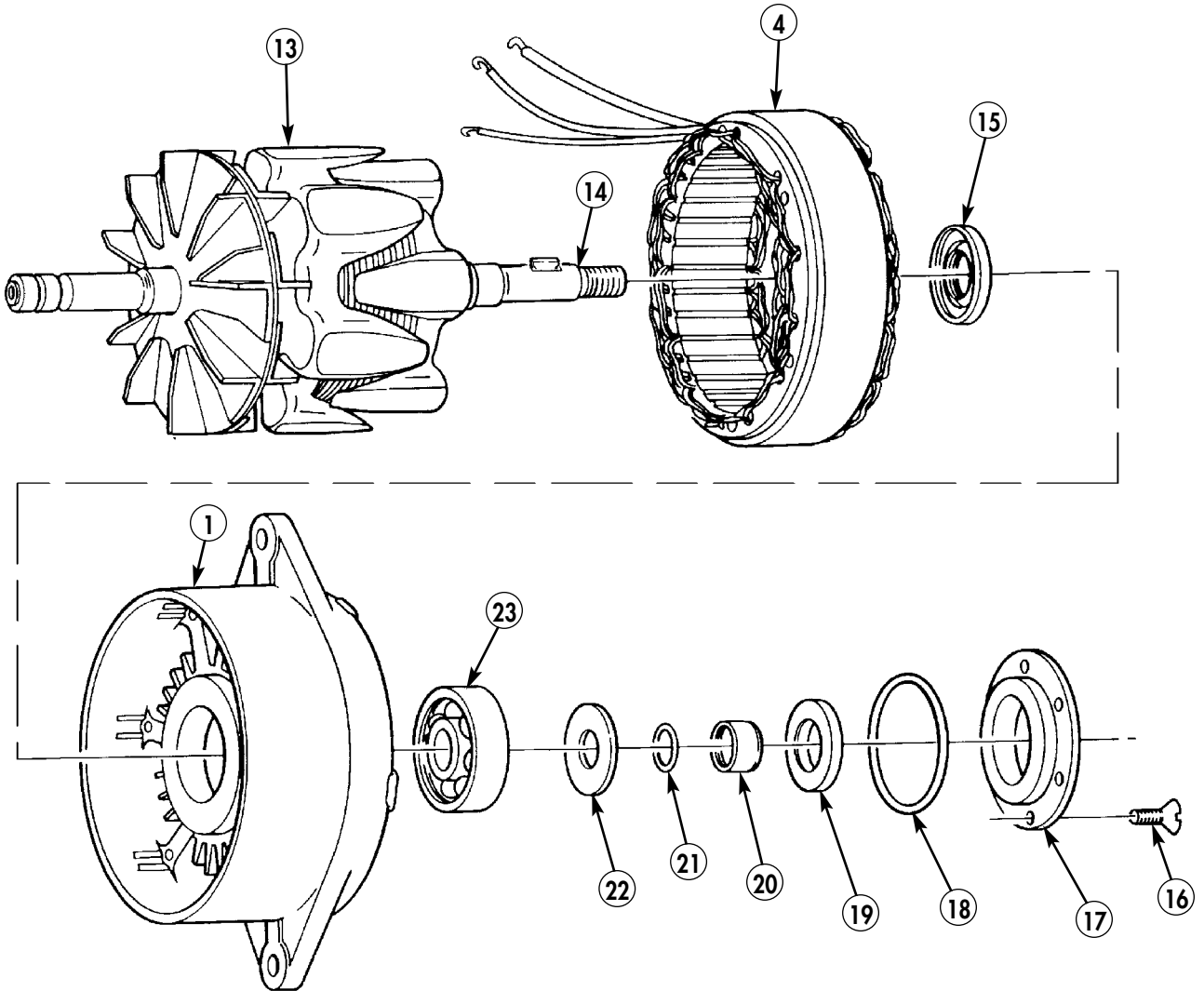

60-AMPERE ALTERNATOR REPAIR (Contd)

CLEANING AND INSPECTION

1. For general cleaning and inspection instructions, refer to WP 0021 00.
2. Inspect end housing (2) for cracks, breaks, and stripped threads. Replace end housing (2) if defective.
3. Check brushes (11) for roughness, galling, and wear. Replace brushes (11) if rough, worn, or brush length is less than 0.250 in. (6.35 mm).
4. Check brush holder (8), brush holder insulator (9), and positive rectifier insulator (3) for cracks and breaks. Replace brush holder (8), brush holder insulator (9), or positive rectifier insulator (3) if cracked or broken.
5. Check brush springs (10) for damage. Replace brush springs (10) if damaged.
6. Check output plate (1) for burned, frayed, or broken wiring. Replace output plate (1) if defective.
7. Check rectifier terminals (4) and (6) in rectifier plates (5) and (7) for continuity in one direction and infinite resistance in opposite direction. Replace rectifier terminals (4) or (6) if defective. Check for shorts from rectifier terminals (4) and (6) to rectifier plates (5) and (7). Replace rectifier plate (5) or (7) if defective.
8. Check stator (18) for grounds. Touch multimeter negative probe to stator (18) and positive probe to the following stator leads: (a) lead (15), (b) lead (16), and (c) lead (17). If continuity is present in any check, stator (18) is grounded; replace alternator.
9. Check stator (18) for open circuits. Touch multimeter probes to the following stator leads: (a) leads (15) and (16), (b) leads (16) and (17), and (c) leads (15) and (17). If continuity is NOT present in any check, replace alternator.
10. Check rotor (14) for grounds. Touch multimeter probe to rotor shaft (13) and other probe to slip ring (12). If ohmmeter does not read over 10,000 ohms, replace alternator.
11. Inspect rotor (14) bearing surfaces (TM 9-214). If bearing is defective, replace.
12. Inspect intermediate housing (20) for cracks, breaks, and stripped threads. Replace alternator if cracked, broken, or threads are stripped.
13. Inspect drive end housing (19) for cracks and breaks. Replace alternator if housing (19) is cracked or broken.
14. Replace end cover (21) if all components pass testing and problem remains.

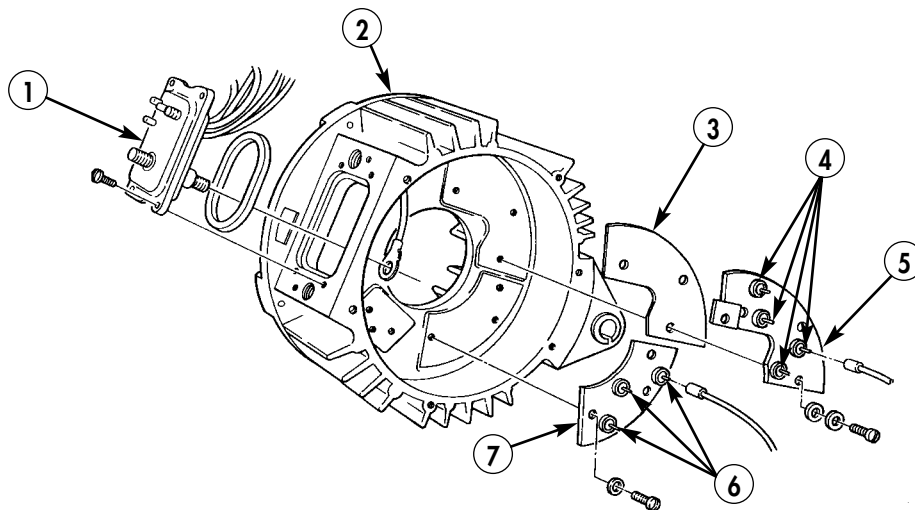

60-AMPERE ALTERNATOR REPAIR (Contd)

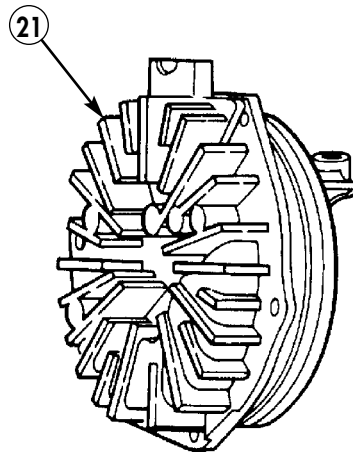
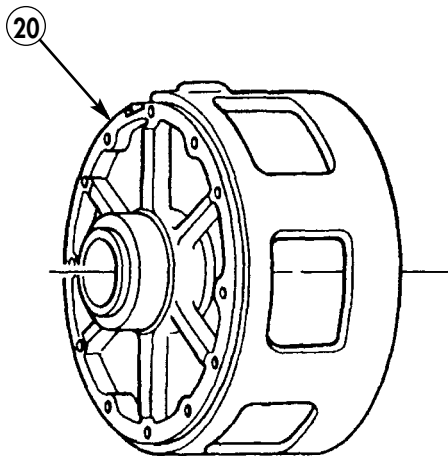
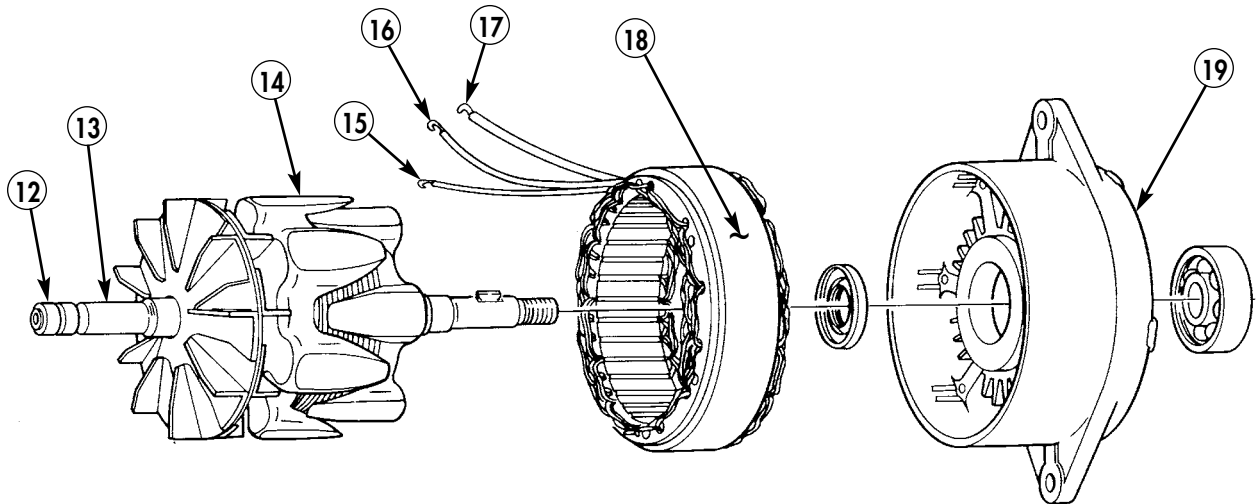
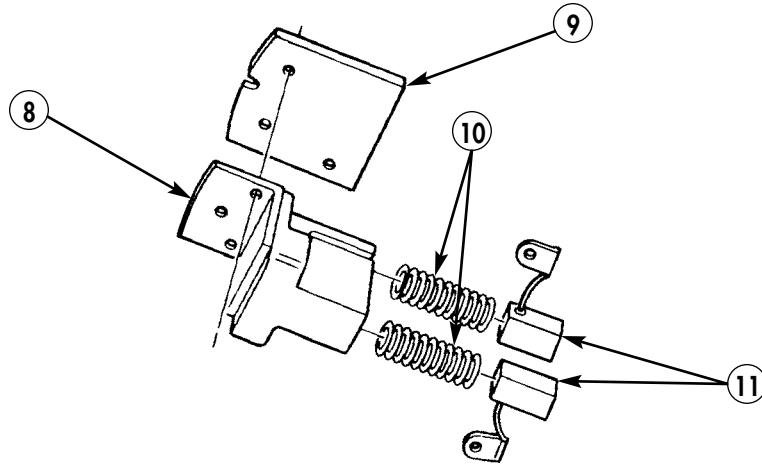

60-AMPERE ALTERNATOR REPAIR (Contd)

ASSEMBLY

CAUTION

- Do not overheat rectifier leads when soldering to rectifier terminals. Damage to rectifier may result.
- Use heat sink when soldering. Failure to do so may result in damage to equipment.

1. Install new bearing (12) and new seal (4) into drive end housing (13). Apply thin film of grease to lip of new seal (4).
2. Align locating scribe marks (25) and install stator (3) into drive end housing (13).
3. Press rotor and fan assembly (1) into new bearing (12) inside of stator (3) and drive end housing (13).
4. Install washer (11), new O-ring (10), and sleeve spacer (9) on rotor shaft (2).
5. Install new sleeve spacer seal (8) and new O-ring (7) on bearing retainer (6). Apply thin film of grease to lip of new spacer seal (8).
6. Install bearing retainer (6) on drive end housing (13) with six screws (5).
7. Press new bearing (18) into intermediate housing (17).
8. Install new seal (16) into intermediate housing (17).
9. Install new felt retainer (19) into intermediate housing (17).
10. Saturate new felt seal (20) with lubricating oil and install into intermediate housing (17).
11. Install new felt retainer (21) into intermediate housing (17) with new snap ring (22).
12. Align locating scribe marks (25) on drive end housing (13), stator (3), and intermediate housing (17).
13. Insert stator (3) wires through holes (24) in intermediate housing (17).
14. Install intermediate housing (17) on stator (3) and drive end housing (13) with six new lockwashers (15) and screws (14).
15. Install new O-ring (23) in intermediate housing (17).

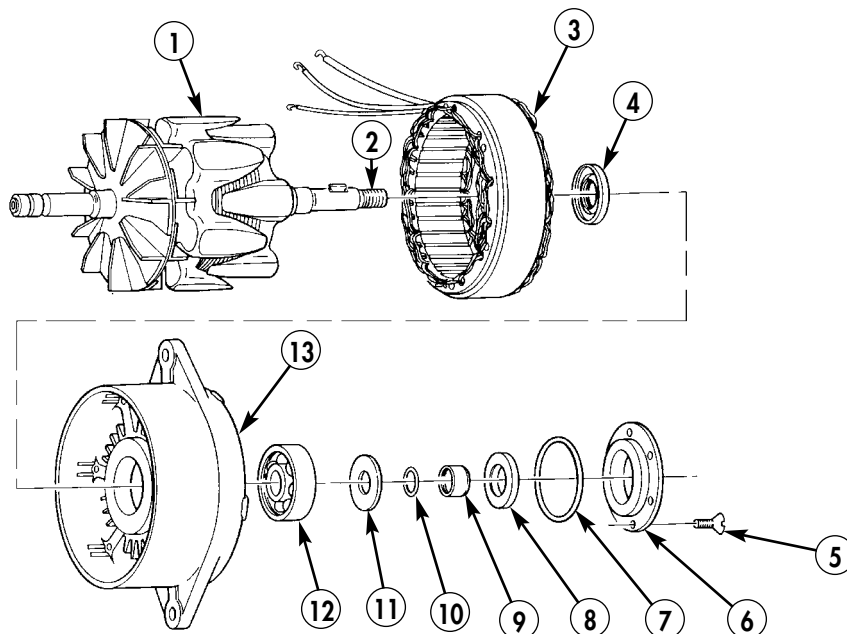

60-AMPERE ALTERNATOR REPAIR (Contd)

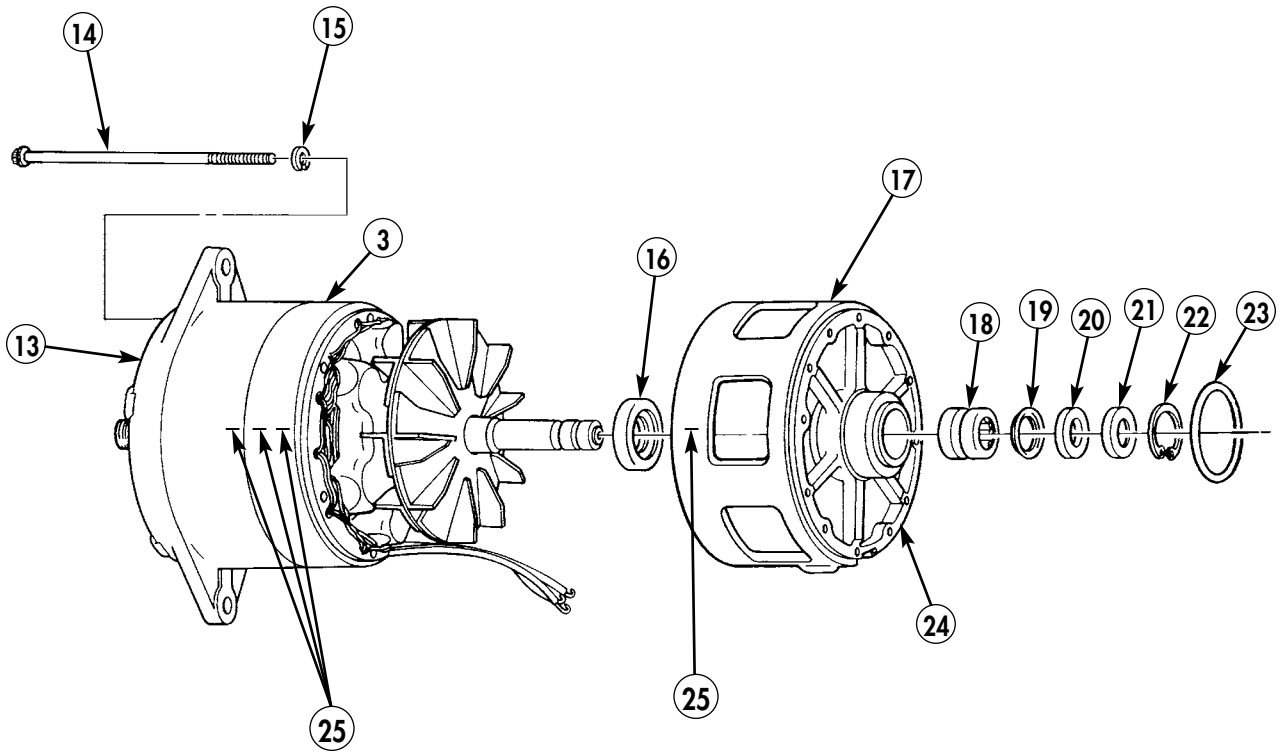

60-AMPERE ALTERNATOR REPAIR (Contd)

ASSEMBLY (Contd)

16. Install new O-ring (4), three negative rectifier leads (13), six positive rectifier leads (9), three leads (20), and output plate (2) into end housing (5) with four screws (1).
17. Apply silicone compound to negative rectifier plate (17).
18. Install negative rectifier plate (17) on end housing (5) with two washers (16) and screws (15).
19. Connect and solder three negative rectifier leads (13) to three negative rectifier terminals (14).
20. Apply silicone compound to insulator (6) and positive rectifier plate (7).
21. Install insulator (6) and positive rectifier plate (7) on end housing (5) with three nylon washers (12), washers (11), and screws (10).
22. Connect and solder six positive rectifier leads (9) to four positive rectifier terminals (8).
23. Apply insulating compound to three rectifier terminals (14) and four rectifier terminals (8).
24. Connect lead (18) to output plate stud (3).
25. Install new tiedown strap (19) to three leads (20).

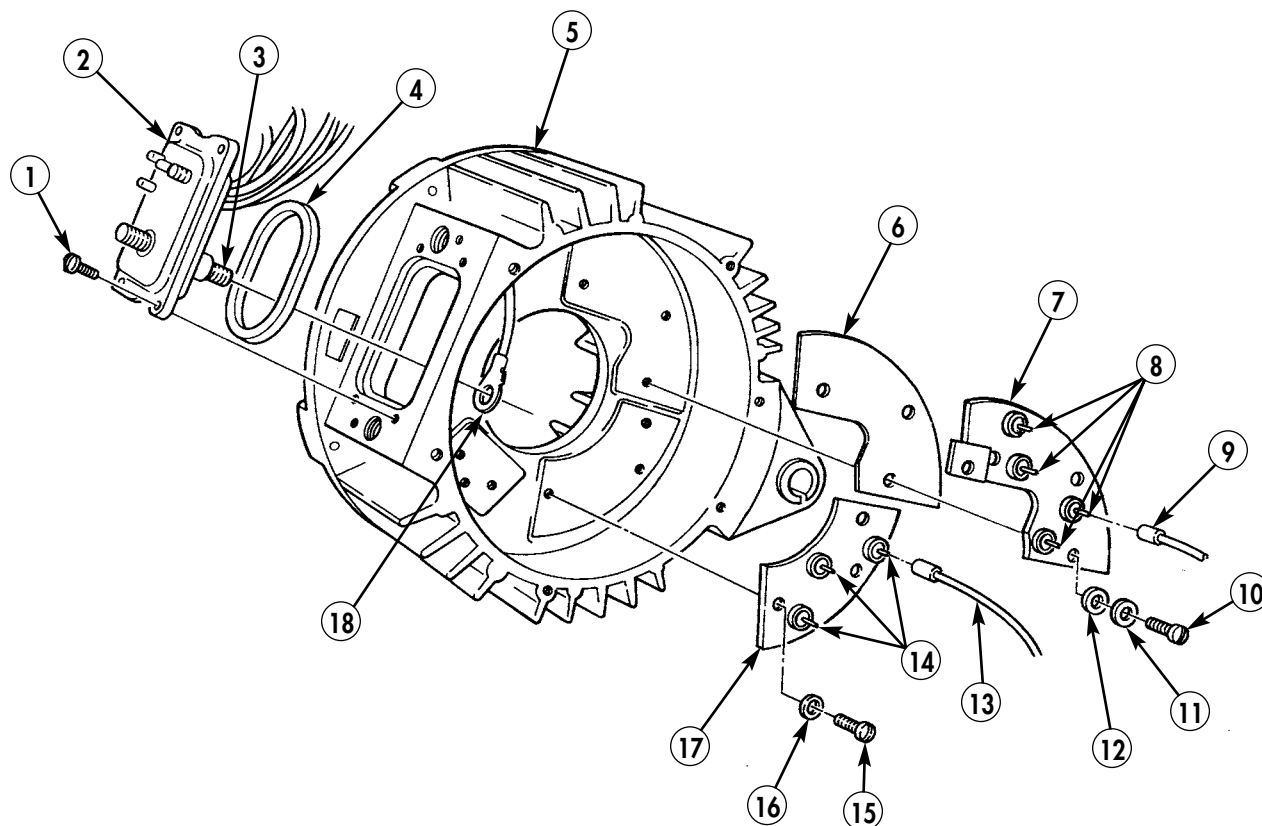

60-AMPERE ALTERNATOR REPAIR (Contd)

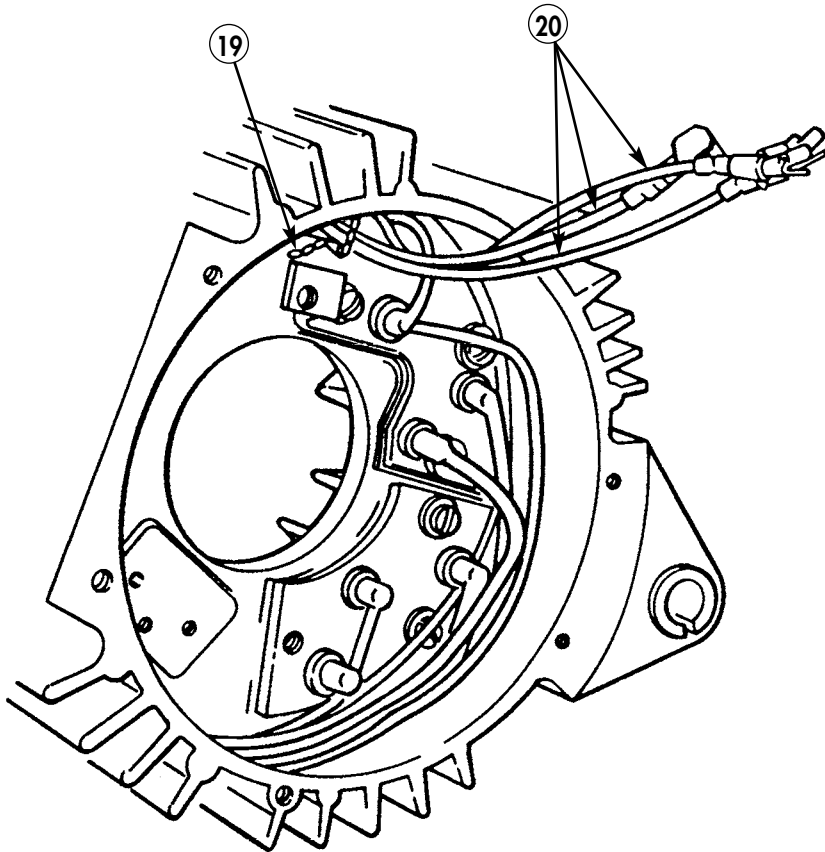

60-AMPERE ALTERNATOR REPAIR (Contd)

ASSEMBLY (Contd)

26. Install shim (2), insulator (3), and brush holder (7) on end housing (1) with three screws (6).
27. Position positive output strap (9) on output plate stud (13) and install on positive rectifier plate (12) with new lockwasher (11) and screw (10).
28. Install two springs (4) into brush holder (7).
29. Install two brush leads (15) and lead (16) on insulator (3) and output strap (9) with new lockwasher (18) and two screws (14).
30. Install capacitor (8) on output plate stud (13) and negative rectifier plate (17) with washer (22), new lockwasher (21), nut (19), and screw (20).
31. Position capacitor (8) on end housing (1) with insulating compound.
32. Install brushes (5) in brush holder (7) against springs (4). Hold in position.
33. Install end housing (1) on intermediate housing (23) with six new lockwashers (24) and screw (25).
34. Align locating scribe marks (26) on intermediate housing (23) and end housing (1).

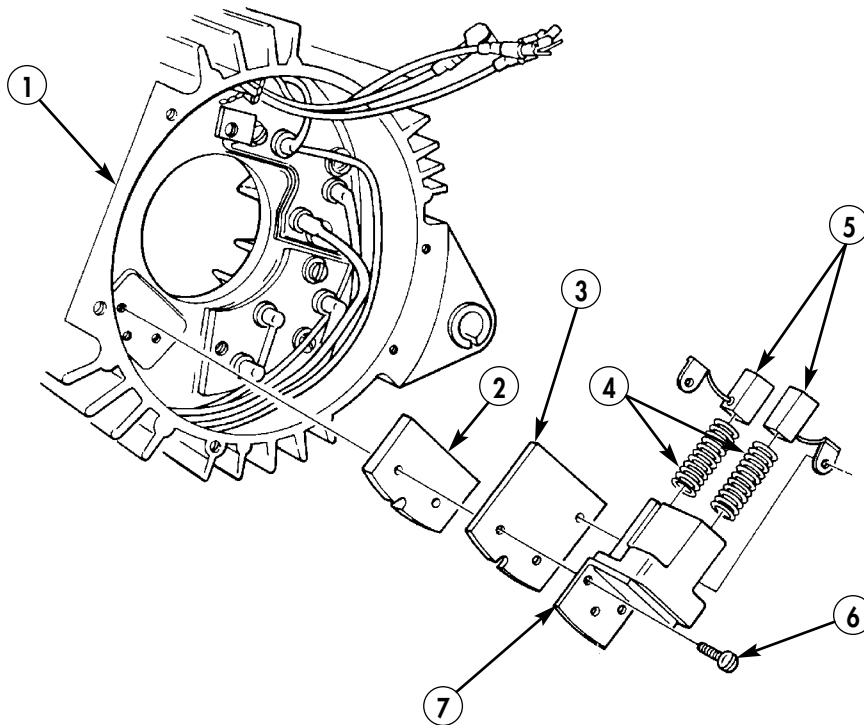

60-AMPERE ALTERNATOR REPAIR (Contd)

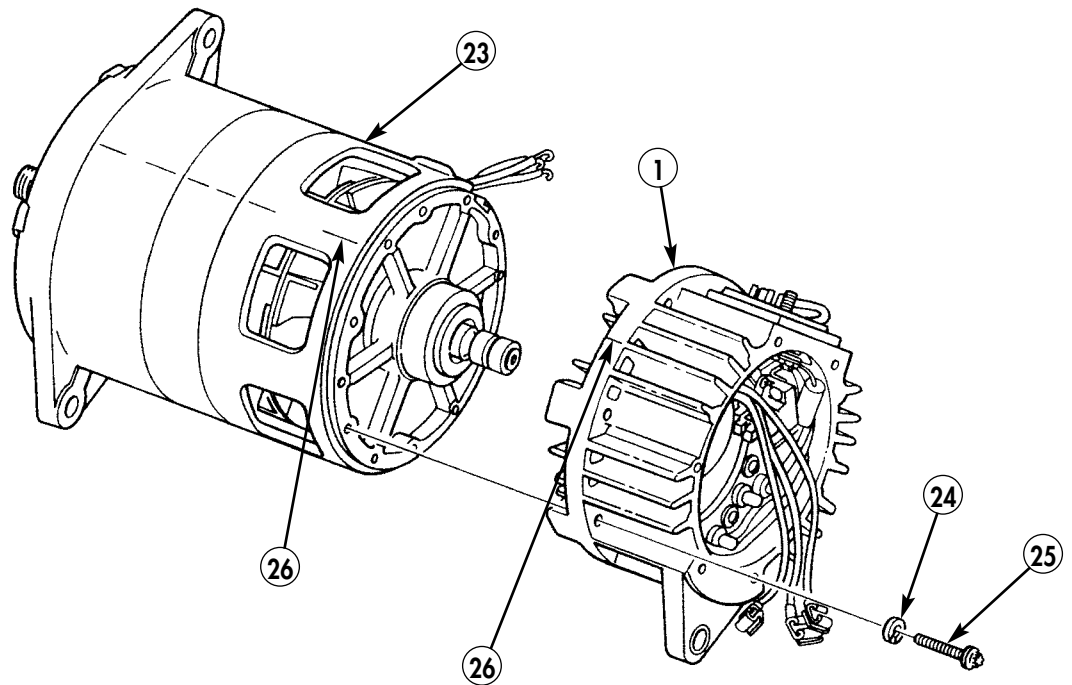
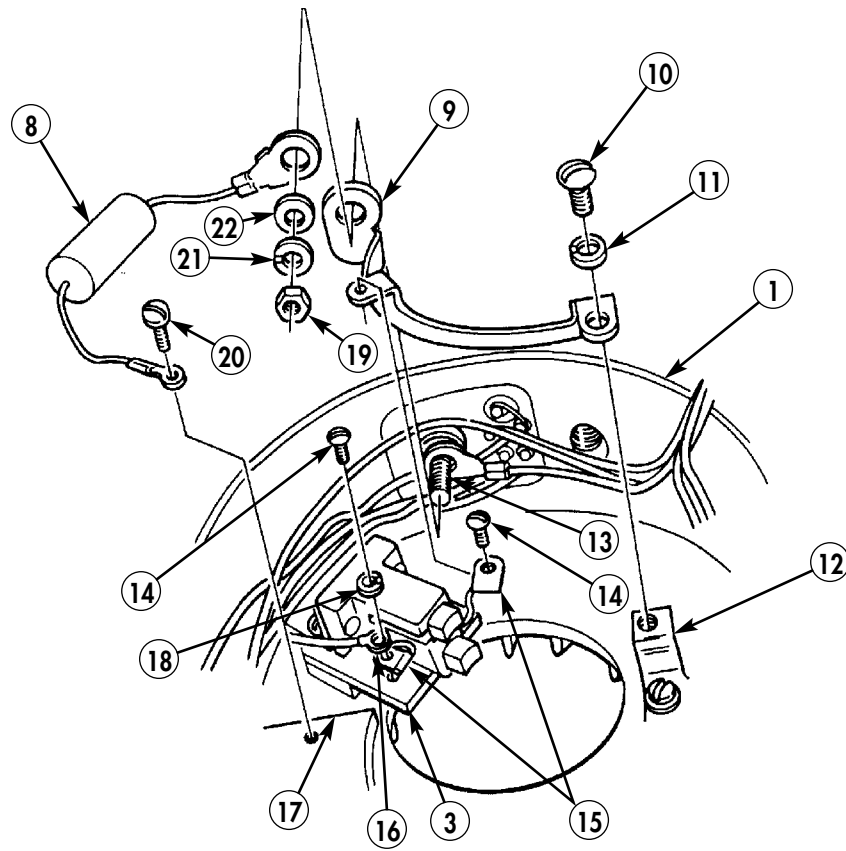

60-AMPERE ALTERNATOR REPAIR (Contd)

ASSEMBLY (Contd)

35. Connect and solder stator leads (1), (2), and (3) to stator terminals (4), (5), and (6).
36. Seal leads (1), (2), and (3) to terminals (4), (5), and (6) with adhesive sealant.
37. Install output plate cover (13) on end housing (12) with two new screw-assembled lockwashers (14).
38. Install new O-ring (11) on end housing (12).
39. Connect three leads (7) to three terminals (8) on regulator (9).
40. Install end cover (10) on end housing (12) with six screws (16).
41. Install access plug (15) on end housing (12). Tighten access plug (15) 24–36 lb-in (3–4 N•m).
42. Install alternator (WP 0085 00).
43. Adjust alternator (WP 0085 00).

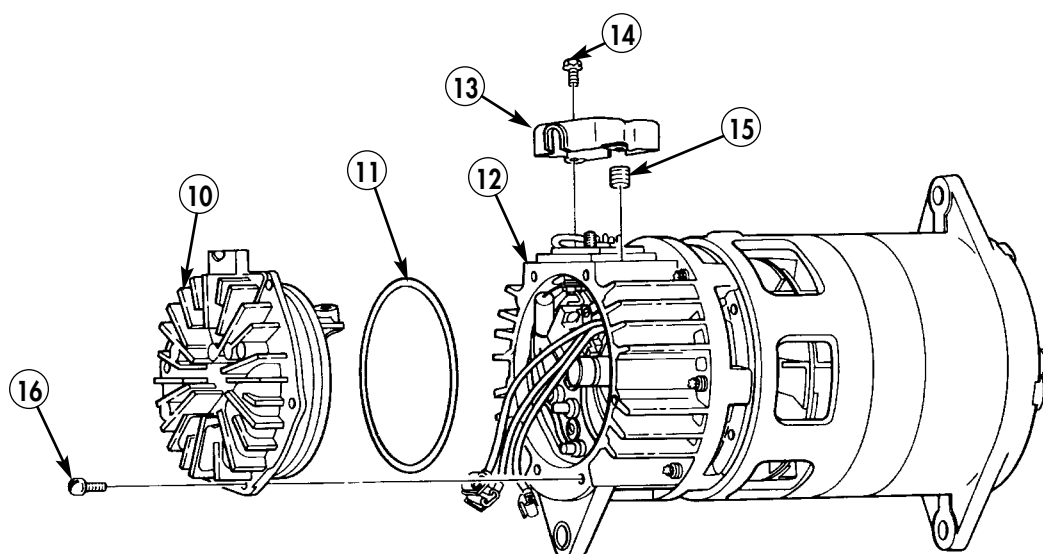
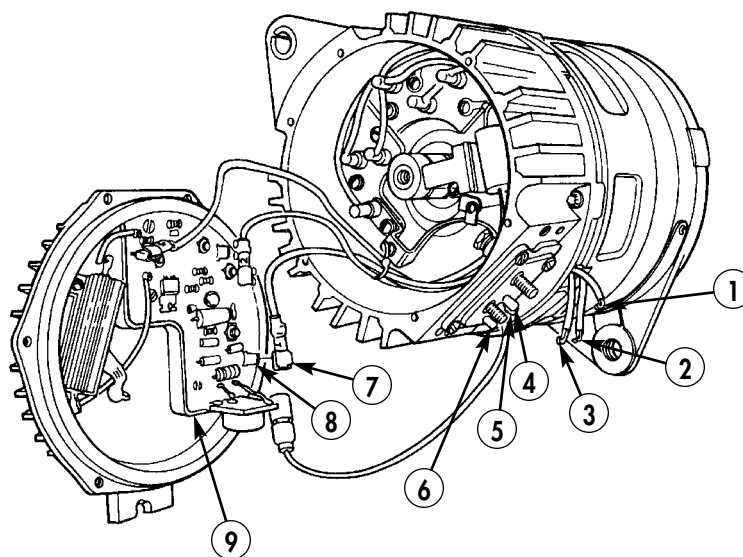

END OF WORK PACKAGE

SUSTAINMENT MAINTENANCE INSTRUCTIONS

2-1/2 TON, 6X6, M44A2 SERIES TRUCKS (MULTIFUEL)

STARTER REPAIR

1. For Delco starter repair, refer to TM 9-2920-242-35.
2. For Prestolite starter repair, refer to TM 9-2920-248-35.

SUSTAINMENT MAINTENANCE INSTRUCTIONS

2-1/2 TON, 6X6, M44A2 SERIES TRUCKS (MULTIFUEL)

TRANSMISSION REPAIR

For transmission repair, refer to TM 9-2520-246-34-1.

SUSTAINMENT MAINTENANCE INSTRUCTIONS

2-1/2 TON, 6X6, M44A2 SERIES TRUCKS (MULTIFUEL)

TRANSFER CASE REPAIR

For transfer case repair, refer to TM 9-2520-246-34-1.

SUSTAINMENT MAINTENANCE INSTRUCTIONS

2-1/2 TON, 6X6, M44A2 SERIES TRUCKS (MULTIFUEL)

FRONT AXLE ASSEMBLY OVERHAUL

For front axle assembly overhaul, refer to NMWR 9-2520-587.

SUSTAINMENT MAINTENANCE INSTRUCTIONS

2-1/2 TON, 6X6, M44A2 SERIES TRUCKS (MULTIFUEL)

FORWARD-REAR AND REAR-REAR AXLE ASSEMBLY OVERHAUL

For forward-rear and rear-rear axle assembly overhaul, refer to NMWR 9-2520-587.

SUSTAINMENT MAINTENANCE INSTRUCTIONS

2-1/2 TON, 6X6, M44A2 SERIES TRUCKS (MULTIFUEL)

DIFFERENTIAL CARRIER REPLACEMENT

REMOVAL AND INSTALLATION

INITIAL SETUP:

Applicable Models

All

Personnel Required

Two

Tools and Special Tools

General mechanic's tool kit
(item 117, WP 0469 00)

Torque wrench, 1/2-in. drive
(item 136, WP 0469 00)

Lifting device (item 48, WP 0469 00)

Utility chains

References

WP 0020 00

Equipment Condition

Axle shafts removed (WP 0147 00).

Axle assembly removed
(WP 0148 00 or WP 0151 00).

Materials/Parts

Gasket (item 115, WP 0470 00)

Lubricating oil, GO 80/90
(item 25, WP 0468 00)

DIFFERENTIAL CARRIER REPLACEMENT (Contd)

WARNING

Accidental or intentional introduction of liquid contaminants into the environment is a violation of state, federal, and military regulations. Refer to Army POL (WP 0001 00) for information concerning storage, use, and disposal of these liquids. Failure to do so may result in damage to environment and health of personnel.

CAUTION

Work area should be clean, well-ventilated, and free from blowing dust and dirt. Damage to equipment could result if area is not clean.

NOTE

Use a drain pan to capture any draining oil. Dispose of fluids in accordance with local policy and ordinances. Ensure all spills are cleaned up.

REMOVAL

1. Remove drain plug (12) from bottom of housing (6) and drain gear oil.
2. Remove eight nuts (1) and washers (2) from eight studs (3).
3. Loosen four remaining nuts (10) on studs (8).
4. Remove screw (5) and washer (4) from carrier (7).
5. Install utility chains on carrier (7) with washer (4) and screw (5). Attach lifting device on utility chains.

WARNING

All personnel must stand clear during lifting operations. A swinging or shifting load may cause injury or death to personnel.

CAUTION

When lifting differential carrier out of axle housing, use care not to damage mounting studs.

NOTE

Assistant will help with steps 6 and 7.

6. Using lifting device, raise carrier (7) 1/2 in. (1.3 cm) out of housing (6) and remove four remaining nuts (10) and washers (9) from studs (8).
7. Remove carrier (7) from housing (6).
8. Remove gasket (11) from housing (6). Discard gasket (11).
9. Lower carrier (7) to workbench and remove lifting device from utility chains.
10. Remove screw (5), washer (4), and chains from carrier (7).

INSTALLATION

1. Install chains on carrier (7) with washer (4) and screw (5).
2. Install new gasket (11) on housing (6).
3. Install lifting device on utility chain.

DIFFERENTIAL CARRIER REPLACEMENT (Contd)

INSTALLATION (Contd)

WARNING

All personnel must stand clear during lifting operations.
A swinging or shifting load may cause injury to personnel.

CAUTION

When lowering differential carrier onto axle housing, use care not to damage mounting studs.

NOTE

Assistant will help with steps 4 and 5.

4. Using lifting device, install carrier (7) on housing (6) leaving 1/2 in. (1.3 cm) gap between carrier (7) and housing (6).
5. Install four washers (9) and nuts (10) on studs (8) and lower carrier (7) onto housing (6).
6. Install eight remaining washers (2) and nuts (1) on eight studs (3).
7. Alternately tighten nuts (10) and (1).
8. Remove lifting device from utility chain.
9. Remove screw (5), washer (4), and utility chain from carrier (7).
10. Install washer (4) and screw (5) on carrier (7). Tighten screw (5) 65–85 lb-ft (88-115 N•m).
11. Install drain plug (12) on bottom of housing (6). Tighten drain plug (12) 35 lb-ft (48 N•m).
12. Install axle assembly (WP 0148 00 or WP 0151 00).
13. Install axle shafts (WP 0147 00).
14. Fill axle housing with GO 80/90 oil (WP 0020 00).

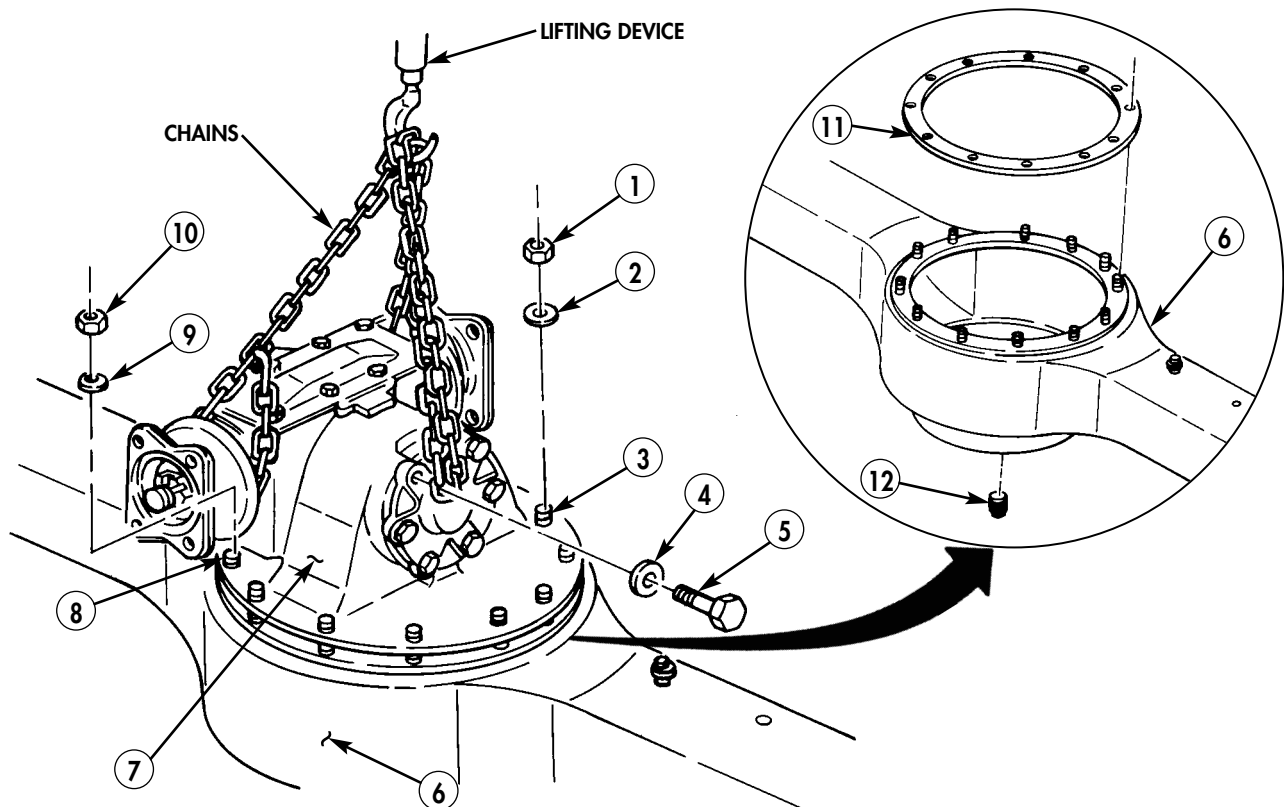

END OF WORK PACKAGE

0454 00-3/4 blank

SUSTAINMENT MAINTENANCE INSTRUCTIONS

2-1/2 TON, 6X6, M44A2 SERIES TRUCKS (MULTIFUEL)

DIFFERENTIAL CARRIER REPAIR

DISASSEMBLY, CLEANING AND INSPECTION, AND ASSEMBLY AND ADJUSTMENT

INITIAL SETUP:

Applicable Models

All

Tools and Special Tools

General mechanic's tool kit
(item 116, WP 0469 00)
Torque wrench, 3/4-in. drive
(item 137, WP 0469 00)
Torque wrench, 1/2-in. drive
(item 136, WP 0469 00)
Inside caliper micrometer
(item 49, WP 0469 00)
Outside caliper micrometer
(item 50, WP 0469 00)
Dial indicator (item 43, WP 0469 00)
Mechanical puller kit (item 64, WP 0469 00)
Handle, remover and replacer
(item 39, WP 0469 00)
Bearing sleeve remover and replacer,
differential carrier bevel gear
(item 69, WP 0469 00)
Oil seal replacer (item 80, WP 0469 00)
Bearing replacer (item 77, WP 0469 00)
Screw, remover and replacer
(item 87, WP 0469 00)
Oil seal remover (item 74, WP 0469 00)
Puller, screw type, differential spider pinion
bushing (item 66, WP 0469 00)
Gauge, force, mechanical, scale
(item 31, WP 0469 00)

Tools and Special Tools (Contd)

Arbor press (item 56, WP 0469 00)
Vise (item 126, WP 0469 00)

Materials/Parts

Eight lockwashers (item 195, WP 0470 00)
Six lockwashers (item 206, WP 0470 00)
Two cotter pins (item 26, WP 0470 00)
Two oil seals (item 356, WP 0470 00)
Gasket and shim set (item 408, WP 0470 00)
Woodruff key (item 386, WP 0470 00)
Blue pigment (item 26, WP 0468 00)
Lubricating oil GO 80/90 (item 25, WP 0468 00)
GAA grease (item 17, WP 0468 00)
Sealing compound (item 30, WP 0468 00)
Safety wire (item 48, WP 0468 00)

Personnel Required

Two

References

TM 9-214
WP 0020 00
WP 0021 00

Equipment Condition

Differential carrier removed (WP 0454 00).

DIFFERENTIAL CARRIER REPAIR (Contd)

DISASSEMBLY

CAUTION

Scribe or center punch alignment marks on each side of carrier for easy identification. Improper installation will result in damage to parts.

1. Scribe or center punch alignment marks on bearing caps (1) and carrier (17).
2. Remove two safety wires (5), two screws (3), and adjusting nut locks (2) from bearing caps (1). Discard safety wires (5).
3. Remove four screws (4), washers (6), and two bearing caps (1) from carrier (17).

CAUTION

Scribe or center punch alignment marks on case halves and helical drive gear. Marks should match those placed on bearing caps. Improper installation will result in damage to equipment.

4. Scribe or center punch alignment marks on case halves (12) and (22) and helical drive gear (19).
5. Remove bearing seats (16) and adjusting nuts (15) from differential gear assembly (18).
6. Secure differential gear assembly (18) in vise.
7. Remove safety wire (20), eight nuts (21), and screws (14) from case halves (12) and (22). Discard safety wire (20).
8. Remove case half (12) from helical drive gear (19).
9. Remove spider (7) with four thrust washers (9), pinion gears (8), two side gears (10), and thrust washers (11) from case half (22).

NOTE

If washers, gears, and spider are not to be replaced, retain them together and proceed to step 11.

10. Remove four thrust washers (9) and pinion gears (8) from spider (7).
11. Remove two side gears (10) and thrust washers (11) from spider (7).
12. Remove helical drive gear (19) from case half (22).

NOTE

Prior to removal, tag bearings for installation.

13. Using mechanical puller, remove two bearings (13) from case halves (12) and (22).

DIFFERENTIAL CARRIER REPAIR (Contd)

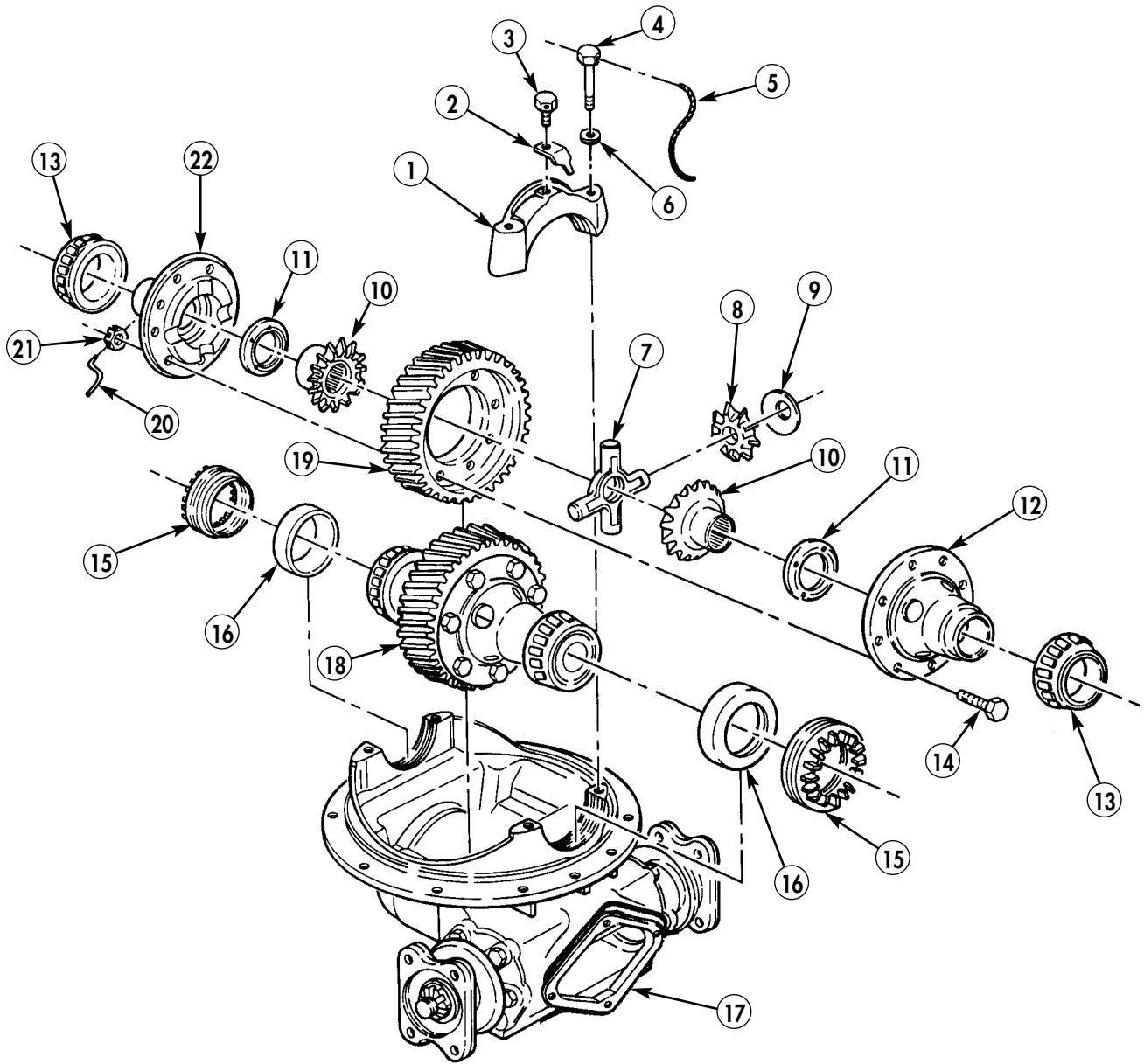

DIFFERENTIAL CARRIER REPAIR (Contd)

DISASSEMBLY (Contd)

14. Remove eight screws (2), lockwashers (1), top cover (3), and gasket (4) from carrier (5). Discard lockwashers (1) and gasket (4).
15. Remove four screws (9), washers (8), inspection cover (7), and gasket (6) from carrier (5). Discard gasket (6).

NOTE

Ensure flanges are secured in vise for easy removal of nuts and washers.

16. Remove two cotter pins (10), nuts (11), and washers (12) from shaft (24). Discard cotter pins (10).
17. Using mechanical puller, remove two flanges (13) with dirt deflectors (14) from shaft (24).

NOTE

Perform step 18 if dirt deflectors are damaged or flanges require replacement.

18. Remove two dirt deflectors (14) from flanges (13).
19. Remove twelve screws (15), washers (16), front retainer (17), rear retainer (19), and shims (18) from carrier (5). Record number/thickness of shims (18) removed from front retainer (17) and rear retainer (19). Tie shims (18) to front retainer (17) and rear retainer (19).
20. Remove spacer (27) from shaft (24).
21. Using oil seal remover, remove two oil seals (20) from retainers (17) and (19). Discard oil seals (20).

CAUTION

Use brass drift to remove shaft and bearing seat. Failure to do so may result in damage to shaft and bearing seat.

22. Remove shaft (24) and bearing seat (21) through rear of carrier (5).
23. Remove bearing seat (26) from front of carrier (5).
24. Remove front bearing (25) and pinion (23) with rear bearing (22) from shaft (24).
25. Remove rear bearing (22) from hub of pinion (23).

DIFFERENTIAL CARRIER REPAIR (Contd)

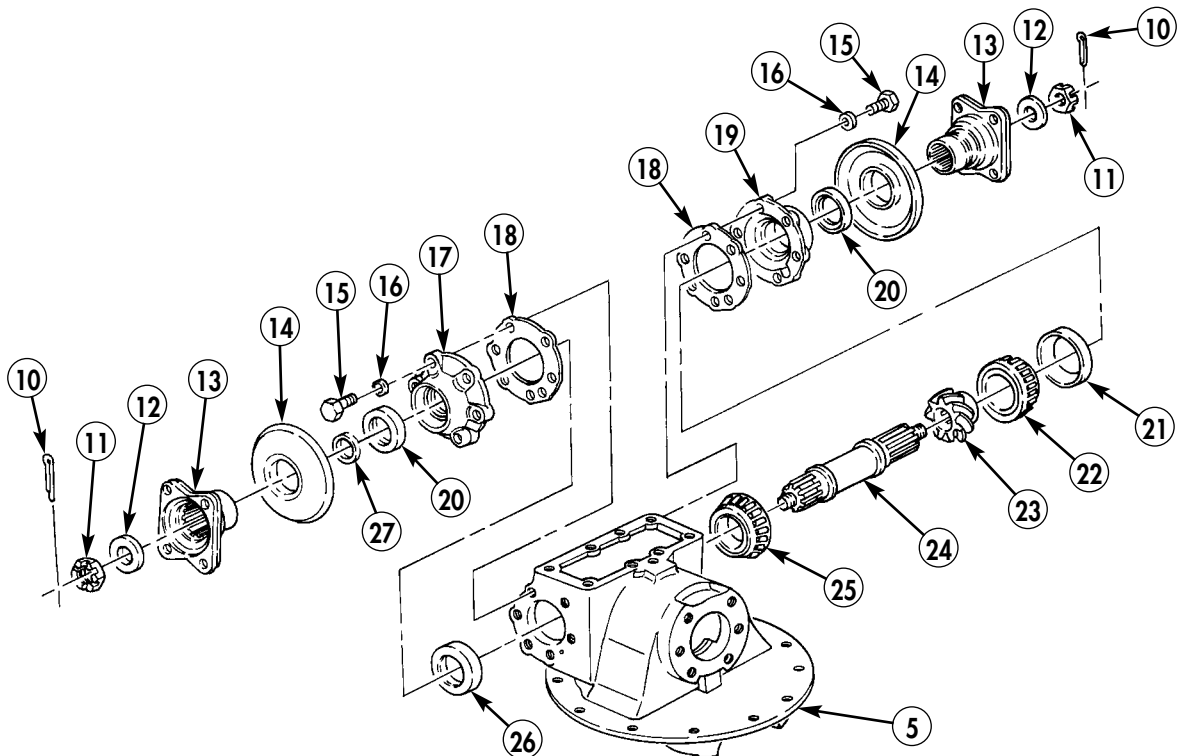
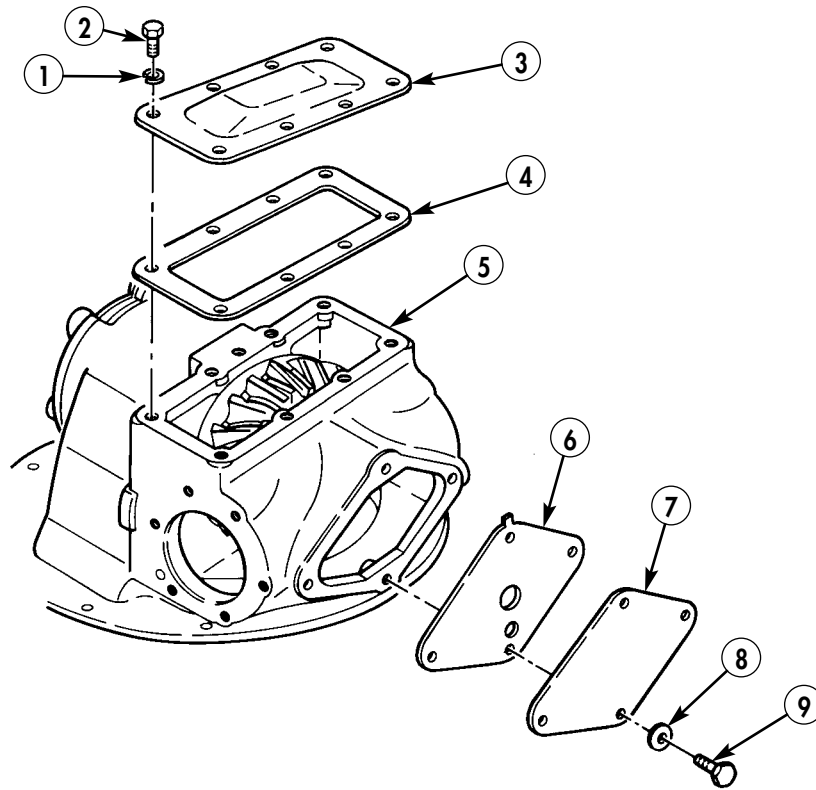

DIFFERENTIAL CARRIER REPAIR (Contd)

DISASSEMBLY (Contd)

26. Remove six screws (5), lockwashers (4), bearing cover (3), and shims (2) from carrier (1). Discard lockwashers (4). Record number/thickness of shims (2) removed. Tie shims (2) to bearing cover (3).

NOTE

Use brass drift to hold bevel gear in place while removing screws.

27. Remove safety wire (8), two screws (7), and plate (6) from helical pinion shaft (11). Discard safety wire (8).

CAUTION

Puller screws must be turned evenly until bearing cage is free from carrier. Failure to remove cage evenly will result in damage to bearing cage, bearings, and carrier.

28. Remove bearing cage (9) and shims (10) from carrier (1) with two puller screws. Record number/thickness of shims (10) removed. Tie shims (10) to bearing cage (9).

CAUTION

Use brass drift to remove bearings and bearing seat from bearing cage. Failure to do so may result in damage to bearings and bearing seat.

29. Remove bearing seat (12), bearings (13) and (14), and bearing seat (15) from bearing cage (9).

CAUTION

- Support beveled gear with soft metal spacers. Failure to do so may result in damage to equipment.
- When removing helical pinion shaft ensure shaft does not become caught on carrier housing. Failure to do so may result in damage to pinion shaft.

30. Press helical pinion shaft (11) from bevel gear (16).

31. Remove woodruff key (17) from helical pinion shaft (11). Discard woodruff key (17).

CAUTION

Use brass drift to remove bevel gear, bearing, and spacer from carrier. Failure to do so may result in damage to gear, bearings, or spacer.

32. Remove bevel gear (16), bearing (21), and spacer (20) from carrier (1).

33. Remove spacer (20) from bearing (21).

DIFFERENTIAL CARRIER REPAIR (Contd)

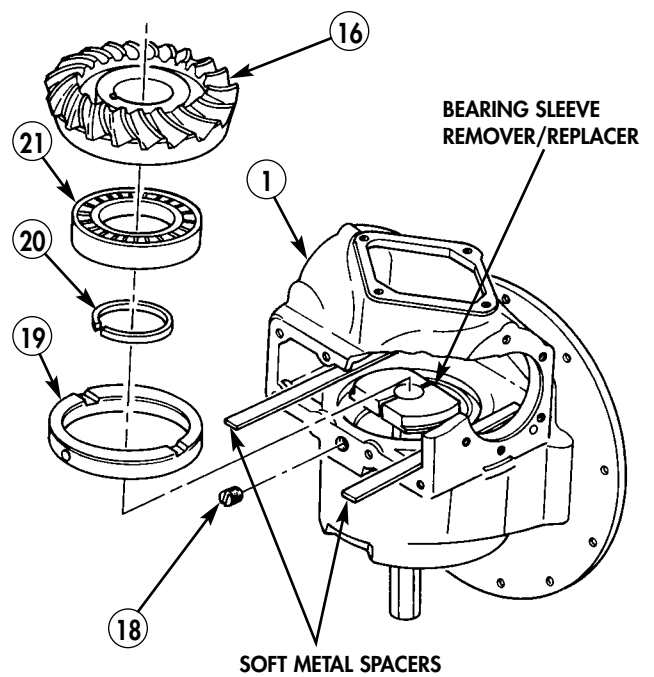
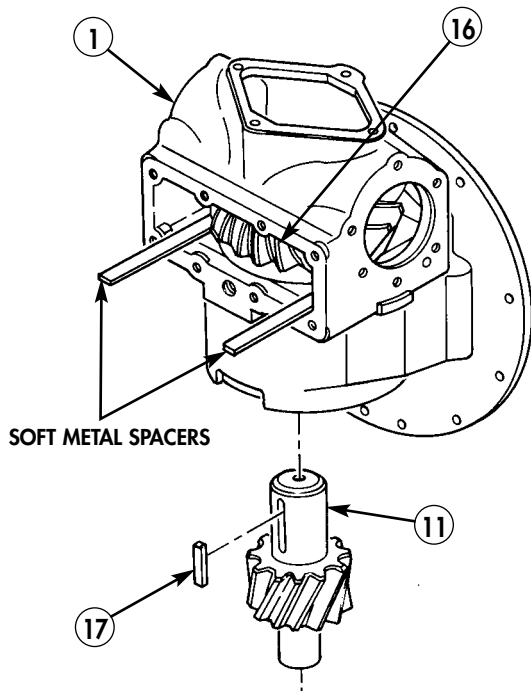
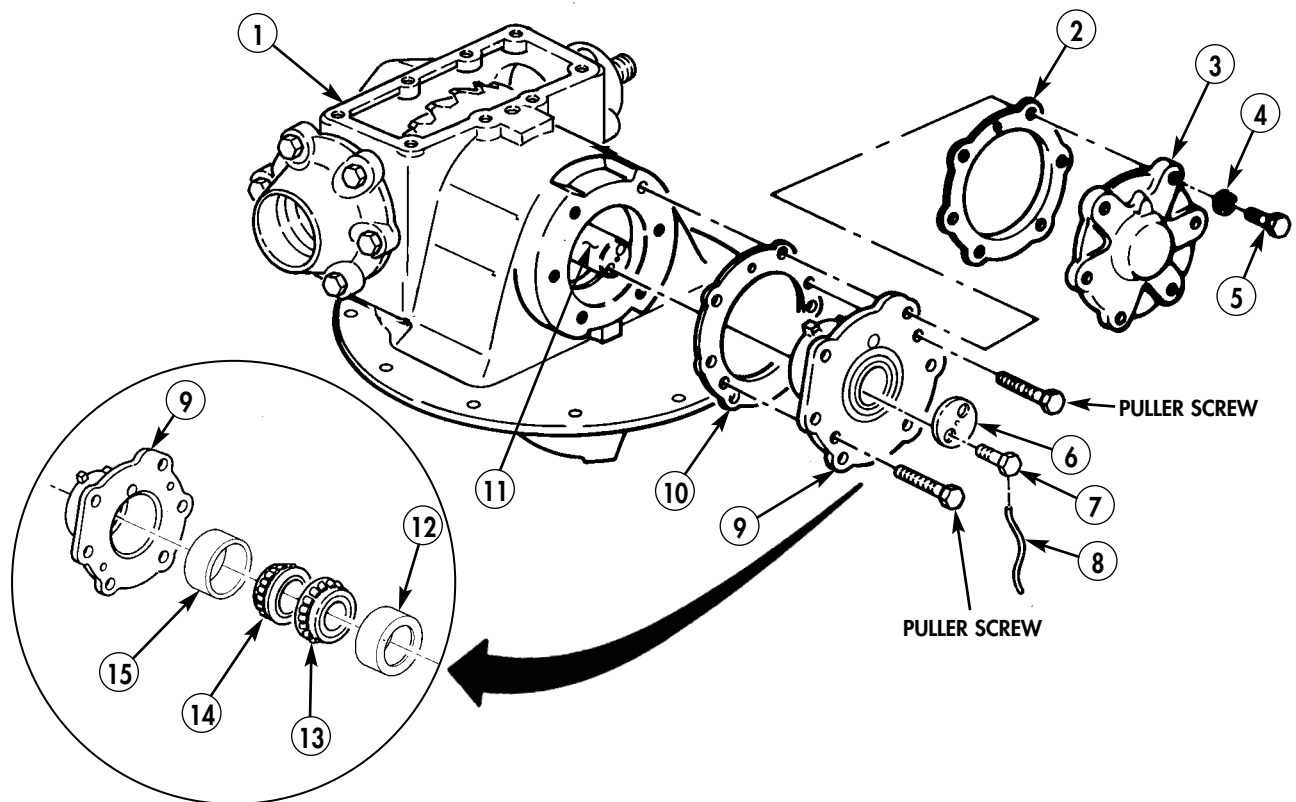

DIFFERENTIAL CARRIER REPAIR (Contd)

DISASSEMBLY (Contd)

34. Remove bearing (21) from bevel gear (16).
35. Remove setscrew (18) from carrier (1).
36. Using bearing sleeve remover/replacer, remove sleeve (19) from carrier (1).

CLEANING AND INSPECTION

1. For general cleaning and inspection instructions, refer to WP 0021 00.
2. Inspect two bearing assemblies (9) and bearing (8) (TM 9-214). Replace bearing assemblies (9) or bearing (8) if damaged.
3. Measure inside diameter of inner race on two bearings (10). Refer to table 1, Wear Limits, for measurements. Replace bearings (10) if not within wear limits.
4. Measure inside diameter of bearing (8). Refer to table 1, Wear Limits, for measurements. Replace bearing (8) if not within wear limits.
5. Measure outside diameter of bearing (8). Refer to table 1, Wear Limits, for measurements. Replace bearing (8) if not within wear limits.
6. Inspect helical pinion gear (4) for chips, breaks, cracks, burrs, or uneven wear. Replace helical pinion gear (4) and helical drive gear (1) if chipped, broken, cracked, burred, or worn unevenly.
7. Measure outside diameter of smaller helical pinion shaft (6). Refer to table 1, Wear Limits, for measurements. Replace helical pinion gear (4) and helical drive gear (1) if not within wear limits.
8. Measure outside diameter of larger helical pinion shaft (5). Refer to table 1, Wear Limits, for measurements. Replace helical pinion gear (4), bevel gear (2), and pinion (3) if not within wear limits.
9. Inspect bevel gear (2) for chips, breaks, cracks, burrs, or uneven wear. Replace bevel gear (2) and pinion (3) if chipped, broken, cracked, burred, or worn unevenly.
10. Inspect sleeve (7) for chips, cracks, or distortion. Replace sleeve (7) if chipped, cracked, or distorted.
11. Measure inside diameter of sleeve (7). Refer to table 1, Wear Limits, for measurements. Replace sleeve (7) if not within wear limits.

Table 1. Wear Limits.

ITEM NO.	ITEM/POINT OF MEASUREMENT	WEAR LIMITS/TOLERANCE	
		INCHES	MILLIMETERS
6	Pinion shaft (outside diameter of large shaft)		
	Used	2.953—2.954	75.006—75.032
	New	2.951—2.952	74.955—74.981
6	Pinion shaft (outside diameter of smaller shaft)	1.625—1.626	41.275—41.300
7	Sleeve (inside diameter)	5.122—5.123	130.099—130.124
8	Bearing		
	Outside diameter	5.117—5.118	129.972—129.997
	Inside diameter	2.952—2.953	74.981—75.006
10	Bearing (inside diameter of inner race)	1.625—1.626	41.275—41.300

DIFFERENTIAL CARRIER REPAIR (Contd)

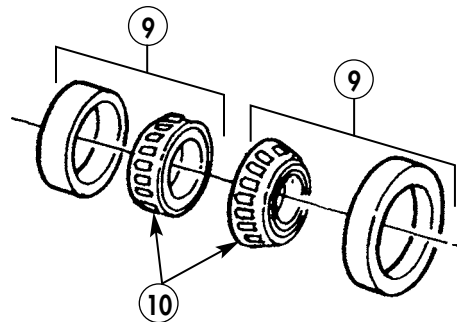
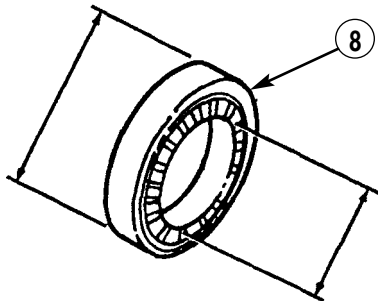
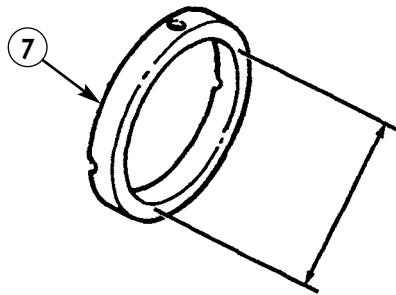
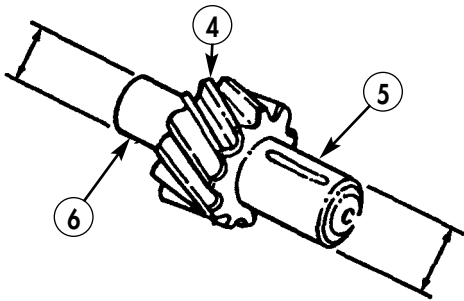
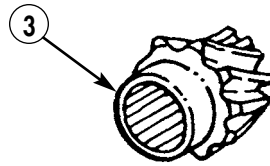
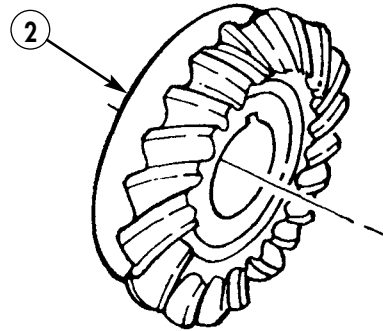
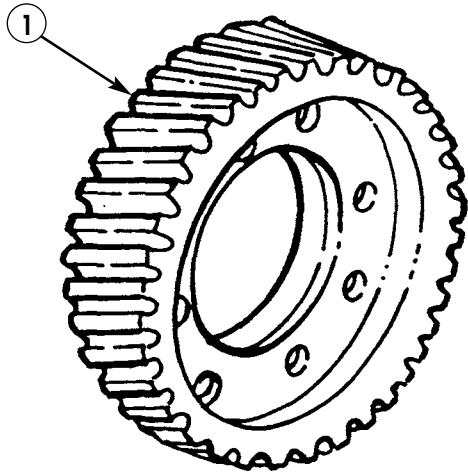

DIFFERENTIAL CARRIER REPAIR (Contd)

CLEANING AND INSPECTION (Contd)

12. Inspect pinion (5) for chips, breaks, cracks, burrs, or uneven wear. Replace pinion (5) and helical drive gear (10) if chipped, broken, cracked, burred, or worn unevenly.
13. Measure outside diameter of hub on pinion (5). Refer to table 2, Wear Limits, for measurements. Replace pinion (5) and helical drive gear (10) if not within wear limits.
14. Inspect rear bearing (6) for chips or distortion. Replace bearing (6) if chipped or distorted.
15. Measure inside diameter of inner race on rear bearing (6). Refer to table 2, Wear Limits, for measurements. Replace rear bearing (6) if not within wear limits.
16. Inspect shaft (4) for chips, breaks, cracks, burrs, or uneven wear. Replace shaft (4) if chipped, broken, cracked, burred, or worn unevenly.
17. Measure outside diameter of shaft (4) at spline (9) where front bearing (3) fits. Refer to table 2, Wear Limits, for measurements. Replace shaft (4) if not within wear limits.
18. Measure outside diameter of shaft (4) at spline (8) where pinion (5) fits. Refer to table 2, Wear Limits, for measurements. Replace shaft (4) if not within wear limits.
19. Inspect bearing (3) for chips or distortion. Replace bearing (3) if chipped or distorted.
20. Measure inside diameter of inner race on front bearing (3). Refer to table 2, Wear Limits, for measurements. Replace bearing (3) if not within wear limits.
21. Measure outside diameter of bearing seat (1). Refer to table 2, Wear Limits, for measurements. Replace bearing (3) and bearing seat (1) if not within wear limits.
22. Measure outside diameter of bearing seat (7). Refer to table 2, Wear Limits, for measurements. Replace rear bearing (6) and bearing seat (7) if not within wear limits.
23. Measure diameter of bearing seats (1) and (7) openings in carrier housing (2). Refer to table 2, Wear Limits, for measurements. Replace housing and cap assembly (2) if not within wear limits.

Table 2. Wear Limits.

ITEM NO.	ITEM/POINT OF MEASUREMENT	WEAR LIMITS/TOLERANCE	
		INCHES	MILLIMETERS
1	Bearing seat (outside diameter)	3.250—3.251	82.550—82.575
2	Carrier housing (inside diameter):		
	Outer race (1) opening	3.250—3.251	82.550—82.575
	Outer race (7) opening	4.331—4.332	110.007—110.033
3	Bearing (inside diameter of inner race)	1.687—1.688	42.850—42.875
4	Shaft:		
	Outside diameter at front bearing (9) end	1.688—1.689	42.875—42.901
	Outside diameter at pinion (8) end	1.626—1.627	41.300—41.326
5	Pinion (outside diameter of hub)	2.500—2.510	63.500—63.754
6	Bearing (inside diameter of inner race)	2.500—2.501	63.500—63.525
7	Bearing seat (outside diameter)	4.331—4.332	110.007—110.033

DIFFERENTIAL CARRIER REPAIR (Contd)

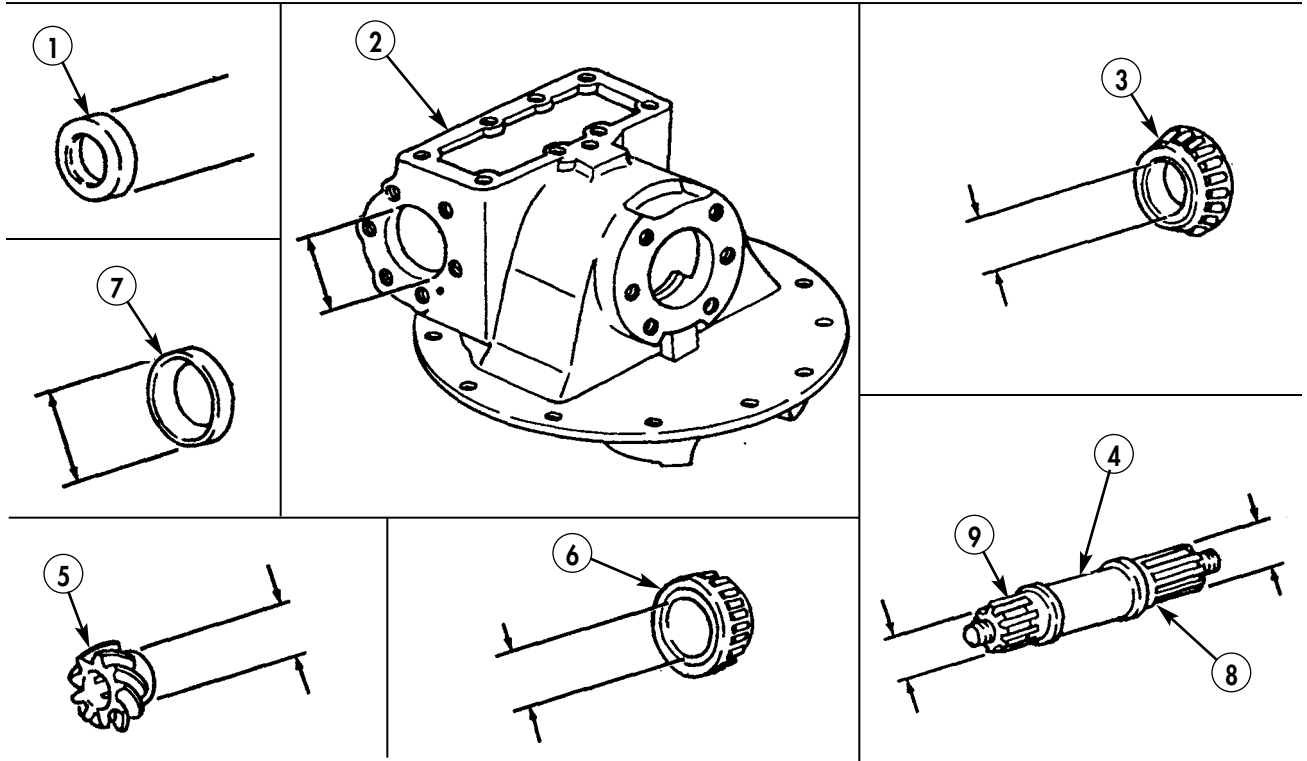
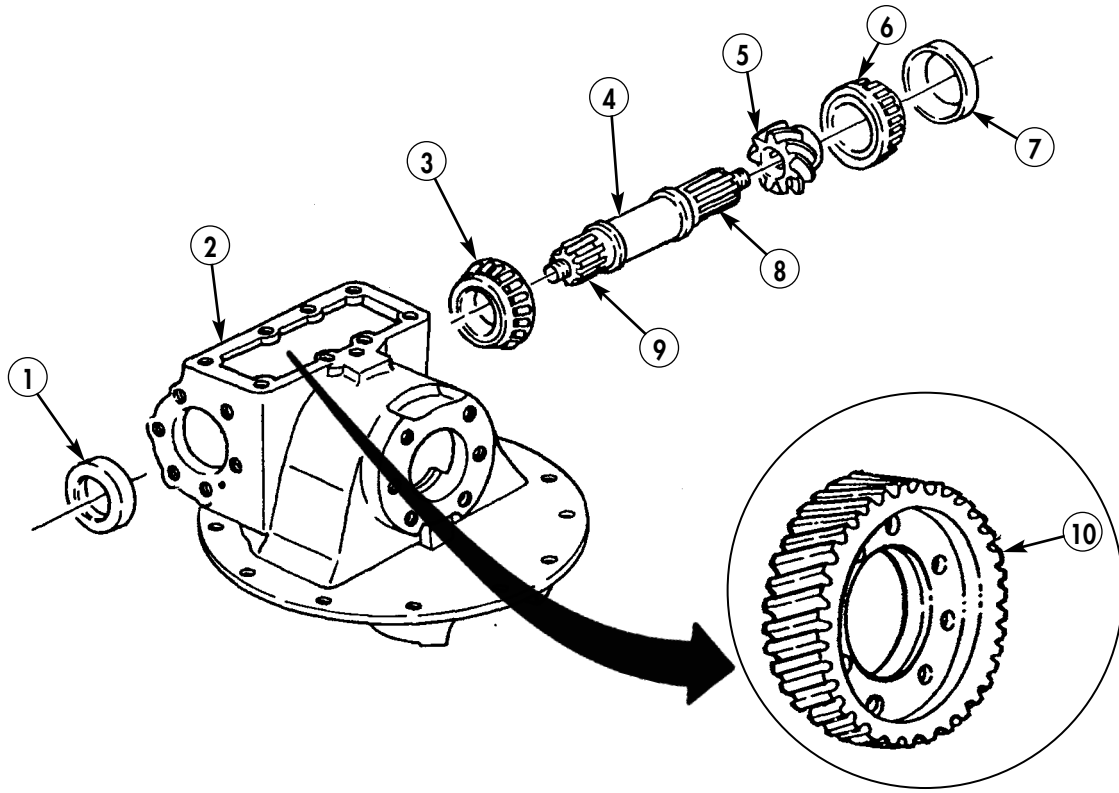

DIFFERENTIAL CARRIER REPAIR (Contd)

CLEANING AND INSPECTION (Contd)

24. Inspect carrier housing (12), two bearing caps (6), and adjusting nuts (10). Replace carrier housing (12) if bearing caps (6) are cracked or distorted. Replace carrier housing (12) or adjusting nuts (10) if cracked, cross-threaded, or stripped.
25. Inspect two bearings (1) and bearing seats (11) and (13) for chips or distortion. Replace bearings (1) or bearing seats (11) and (13) if chipped or distorted.
26. Measure inside diameter of inner race on two bearings (1). Refer to table 3, Wear Limits, for measurements. Replace bearings (1) if not within wear limits.
27. Inspect two case halves (2) for chips, cracks, or distortion. Replace differential assembly (14) if case halves are chipped, cracked, or distorted.
28. Measure outside diameter of case halves (2) at point where bearing (1) inner race fits. Refer to table 3, Wear Limits, for measurements. Replace differential assembly (14) if case halves (2) are not within wear limits.
29. Inspect helical drive gear (5) teeth for chips, breaks, cracks, burrs, or uneven wear. Replace helical drive gear (5) if teeth are chipped, broken, cracked, burred, or worn unevenly.
30. Inspect two thrust washers (3), side gears (4), four thrust washers (9), pinion gears (8), and spider (7) for chips, breaks, cracks, burrs, or uneven wear. Replace two thrust washers (3), side gears (4), four thrust washers (9), pinion gears (8), and spider (7) if any are chipped, broken, cracked, burred, or worn unevenly.
31. Measure inside diameter of four pinion gears (8). Refer to table 3, Wear Limits, for measurements. Replace two thrust washers (3), side gears (4), four thrust washers (9), pinion gears (8), and spider (7) if any pinion gear (8) is not within wear limits.
32. Measure outside diameter of each arm of spider (7). Refer to table 3, Wear Limits, for measurements. Replace two thrust washers (3), side gears (4), four thrust washers (9), pinion gears (8), and spider (7) if any arm of spider (7) is not within wear limits.

Table 3. Wear Limits.

ITEM NO.	ITEM/POINT OF MEASUREMENT	WEAR LIMITS/TOLERANCE	
		INCHES	MILLIMETERS
1	Bearing (inside diameter of inner race)	2.500—2.501	63.500—63.525
2	Case half (outside diameter)	2.504—2.505	63.602—63.627
7	Spider (outside diameter of arms)	0.870—0.880	22.098—22.352
8	Pinion gear (inside diameter)	0.877—0.879	22.276—22.327

DIFFERENTIAL CARRIER REPAIR (Contd)

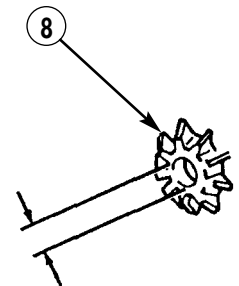
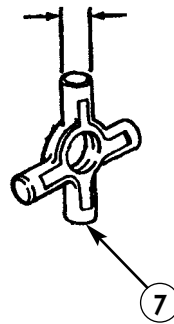
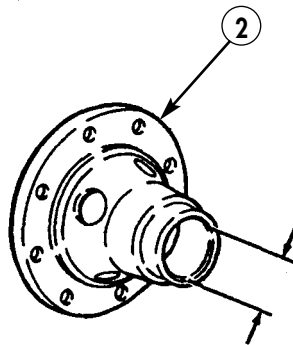
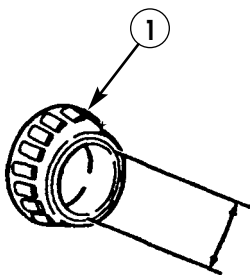
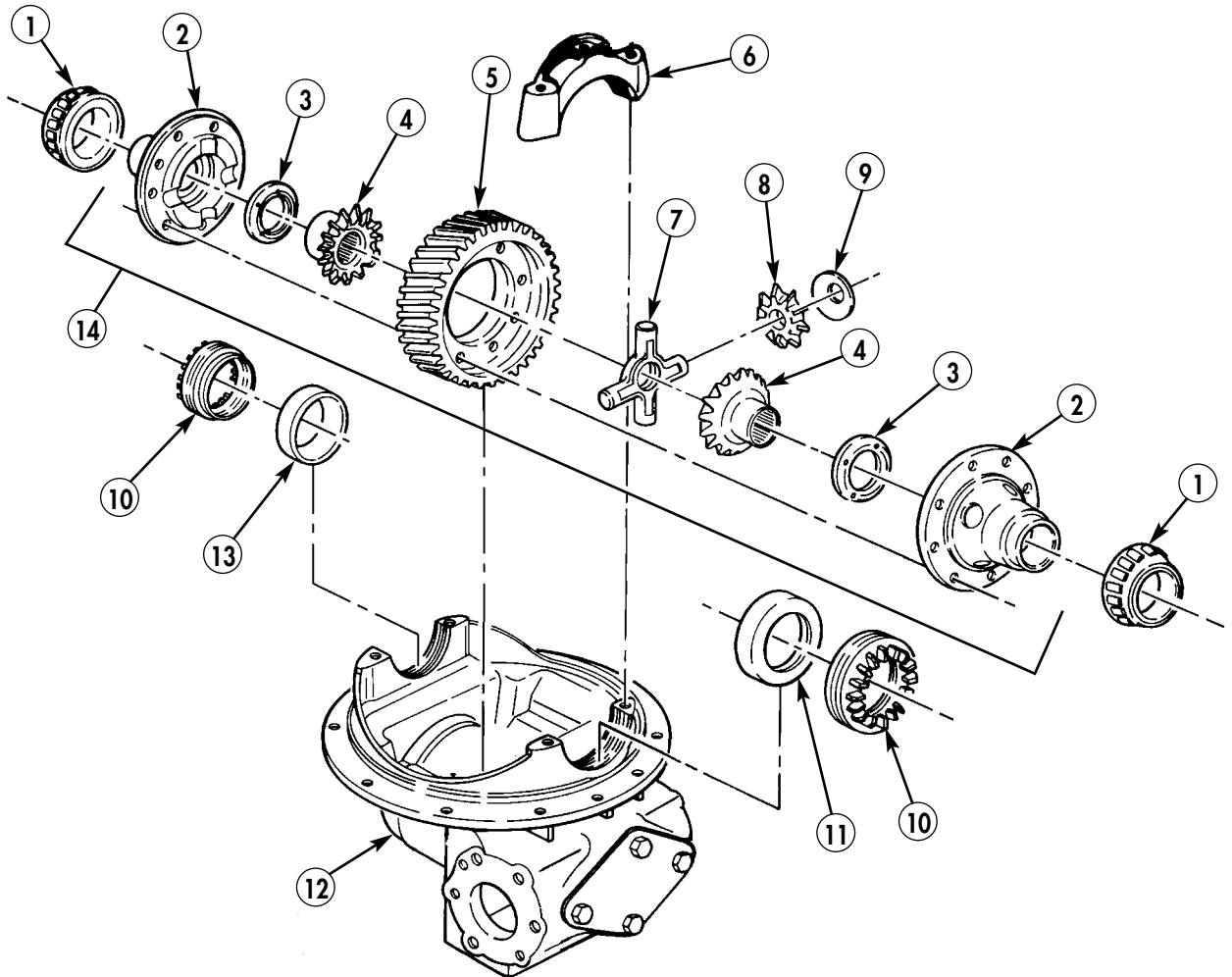

DIFFERENTIAL CARRIER REPAIR (Contd)

ASSEMBLY AND ADJUSTMENT

NOTE

Lubricate all parts before assembly.

1. Press pinion (9) on long end of shaft (10).
2. Press bearing (8) on hub of pinion (9).
3. Press bearing (11) on shaft (10).
4. Install shaft (10) in carrier (12) through opening in rear of carrier (12).

CAUTION

Use brass drift to insert bearing seats in carrier. Failure to do so may result in damage to bearing seats.

5. Install bearing seats (7) and (13) on carrier (12) over bearings (8) and (11).
6. Using oil seal replacer and handle, install new oil seal (6) in front retainer (3) and new oil seal (6) in rear retainer (5).

NOTE

Begin installation of shims with same thickness of shims on front and rear retainer as removed during disassembly.

7. Align holes in shims (4) with holes in retainers (3) and (5) and install shims (4), front retainer (3), shims (4), and rear retainer (5) on carrier (12) with twelve washers (2) and screws (1). Tighten screws (1) 65–85 lb-ft (88–115 N•m).
8. Wrap cable of bearing preload tester around shaft (10) and pull on tester until shaft (10) turns. Proper bearing preload measurement is 7.44–34.04 lb (3.37–15.44 kg).
9. If bearing preload is correct, go to step 14.
10. Remove six screws (1), washers (2), and either retainer (3) or (5) from carrier (12).

NOTE

- If measurement is more than limit, add a shim or use a thicker shim.
- If measurement is less than limit, remove a shim or use a thinner shim.

11. Add or remove shims (4) as necessary.
12. Install retainer (3) or (5) on carrier (12) with six screws (1) and washers (2). Tighten screws (1) 65–85 lb-ft (88–115 N•m).
13. Wrap cable of bearing preload tester around shaft (10) and pull on tester until shaft (10) turns. Proper bearing preload measurement is 7.44–34.04 lb (3.37–15.44 kg).
14. Remove six screws (1), washers (2), rear retainer (5), and shims (4) from carrier (12). Tie shims (4) to retainer (6).

CAUTION

Use brass drift to remove shaft from carrier. Failure to do so may result in damage to shaft.

NOTE

Do not remove bearings or pinion from shaft.

15. Remove bearing seat (7) and shaft (10) through hole in rear of carrier (12).

DIFFERENTIAL CARRIER REPAIR (Contd)

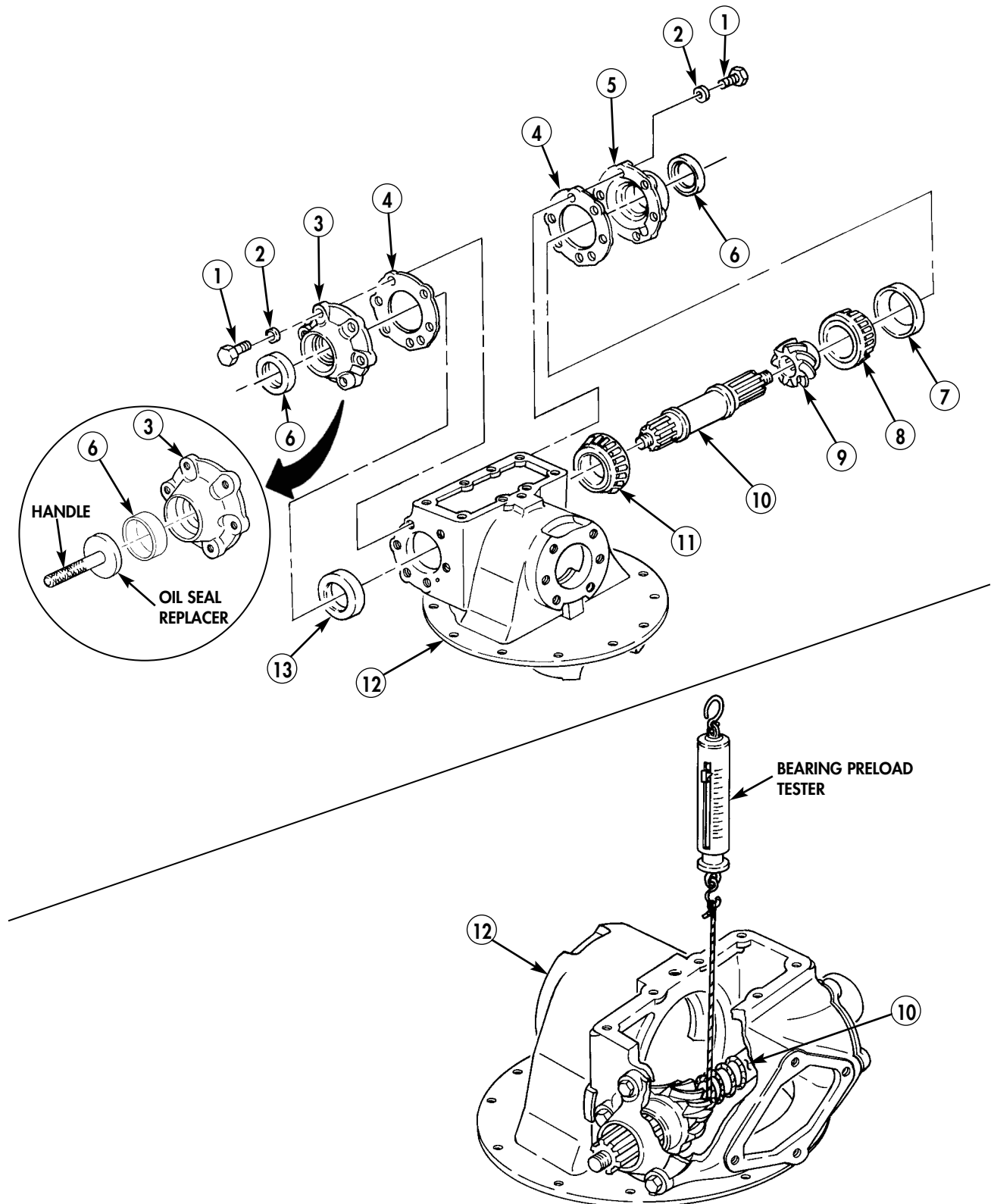

DIFFERENTIAL CARRIER REPAIR (Contd)

ASSEMBLY AND ADJUSTMENT (Contd)

16. Using bearing sleeve remover/replacer and screw, align hole in sleeve (1) with setscrew (7) hole in carrier (2) and install sleeve (1) in carrier (2).
17. Install setscrew (7) in carrier (2) and sleeve (1).

NOTE

Install bearing with beveled side toward gear.

18. Press bearing (4) on bevel gear (3).
19. Install spacer (8) on bevel gear (3) until seated against bearing (4).

CAUTION

Use brass drift to install bevel gear. Failure to do so may result in damage to gear.

20. Install bevel gear (3) in carrier (2) so bevel gear (3) rests in sleeve (1).
21. Install new woodruff key (6) on helical pinion shaft (5).

CAUTION

Use soft metal spacers to securely support bevel gear on sleeve during installation. The bevel gear must not be able to move within the housing. Failure to do so may result in damage to bevel gear and/or housing.

NOTE

Ensure alignment of key in helical pinion shaft with keyway in bevel gear.

22. Press pinion shaft (5) through carrier (2) into bevel gear (3).

DIFFERENTIAL CARRIER REPAIR (Contd)

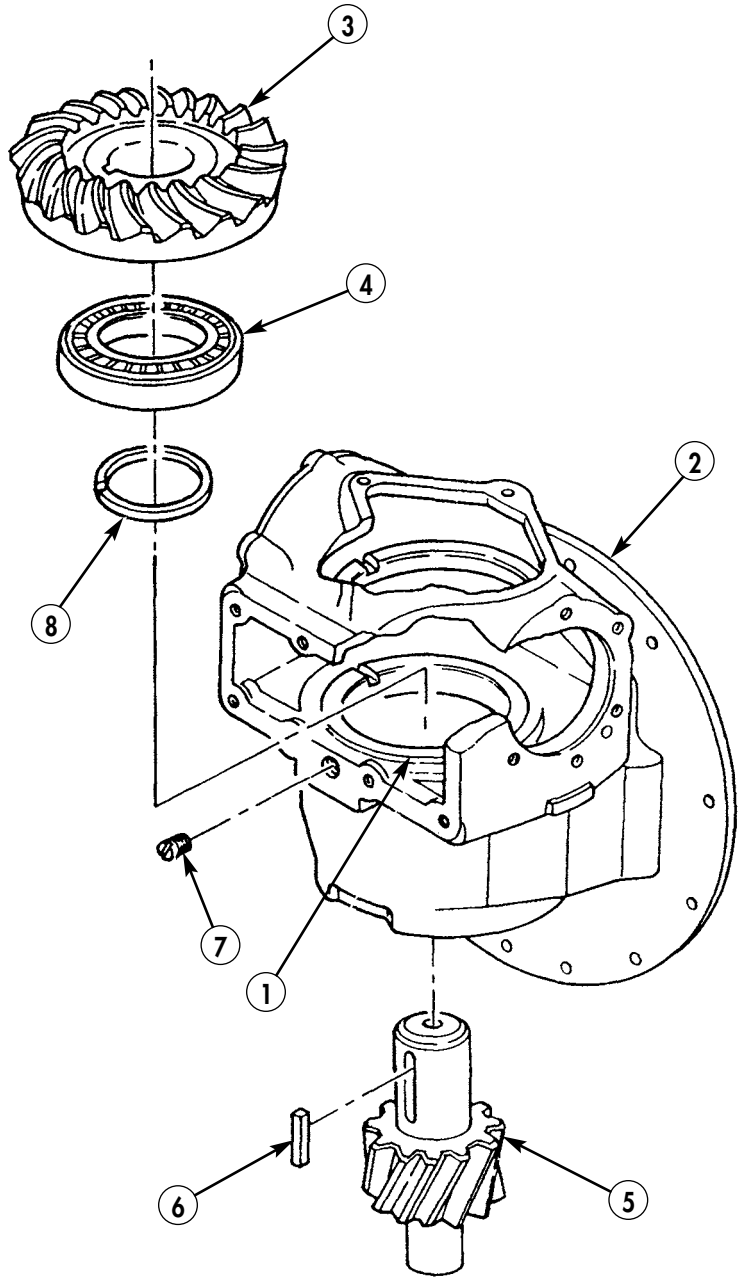
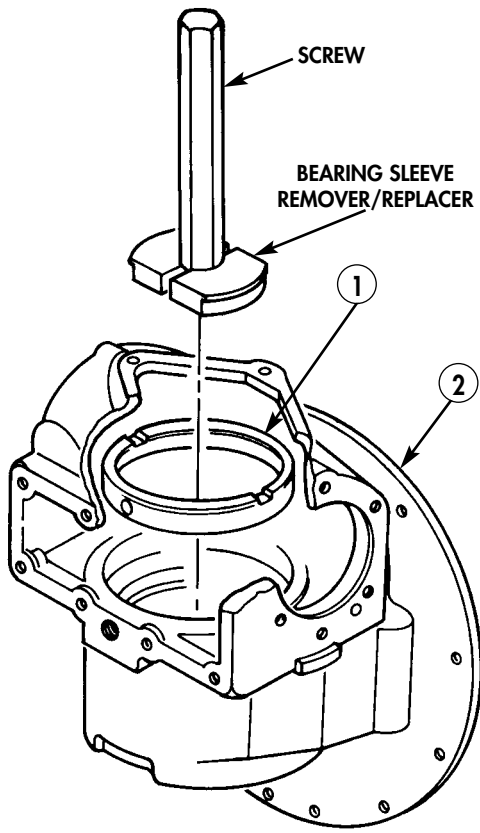

DIFFERENTIAL CARRIER REPAIR (Contd)

ASSEMBLY AND ADJUSTMENT (Contd)

23. Seat bearing seat (17) in bearing cage (13).

NOTE

- Begin installation of shims with same thickness of shims on carrier as removed during disassembly.
- When installing cage, bearings, and races, hold bevel gear in place with soft spacers.

24. Align holes in shims (14) with holes in bearing cage (13) and install shims (14) and bearing cage (13) on carrier (16).

25. Using bearing replacer and arbor press, install bearings (18) and (20) and bearing seats (19) and (17) in bearing cage (13).

NOTE

Secure bevel gear with brass drift to prevent rotation.

26. Install plate (11) on helical pinion shaft (15) with two screws (12). Tighten screws (12) 60–77 lb-ft (81–104 N•m).

27. Inspect carrier (16) for metal shavings. Clean carrier (16) of all shavings.

28. Align holes in shims (8) with holes in bearing cover (9).

NOTE

- Ensure even installation of bearing cage by evenly tightening screws.
- Begin installation with same thickness of shims on cage as removed during disassembly.

29. Install shims (8) and bearing cover (9) on bearing cage (13) and carrier (16) with six screws (10). Tighten screws (10) 65–85 lb-ft (88–115 N•m).

30. Wrap cable of bearing preload tester around bevel gear (1) and pull on tester until helical pinion shaft (15) turns. Record measurement. Proper measurement is 2.4–7.1 lbs (1.1–3.2 kg).

31. If bearing preload is correct, go to step 35.

32. Remove six screws (10) and bearing cover (9) from bearing cage (13) and carrier (16).

NOTE

- If measurement in step 30 is more than limit, add a shim or use a thicker shim.
- If measurement in step 30 is less than limit, remove a shim or use a thinner shim.

33. Add or remove shims (8) as necessary.

34. Repeat steps 29 and 30.

35. Install shaft (2) and bearing seat (3) in carrier (16) through opening in rear of carrier (16).

36. Install shims (4) and retainer (5) on carrier (16) with six washers (6) and screws (7). Tighten screws (7) 65–85 lb-ft (88–115 N•m).

DIFFERENTIAL CARRIER REPAIR (Contd)

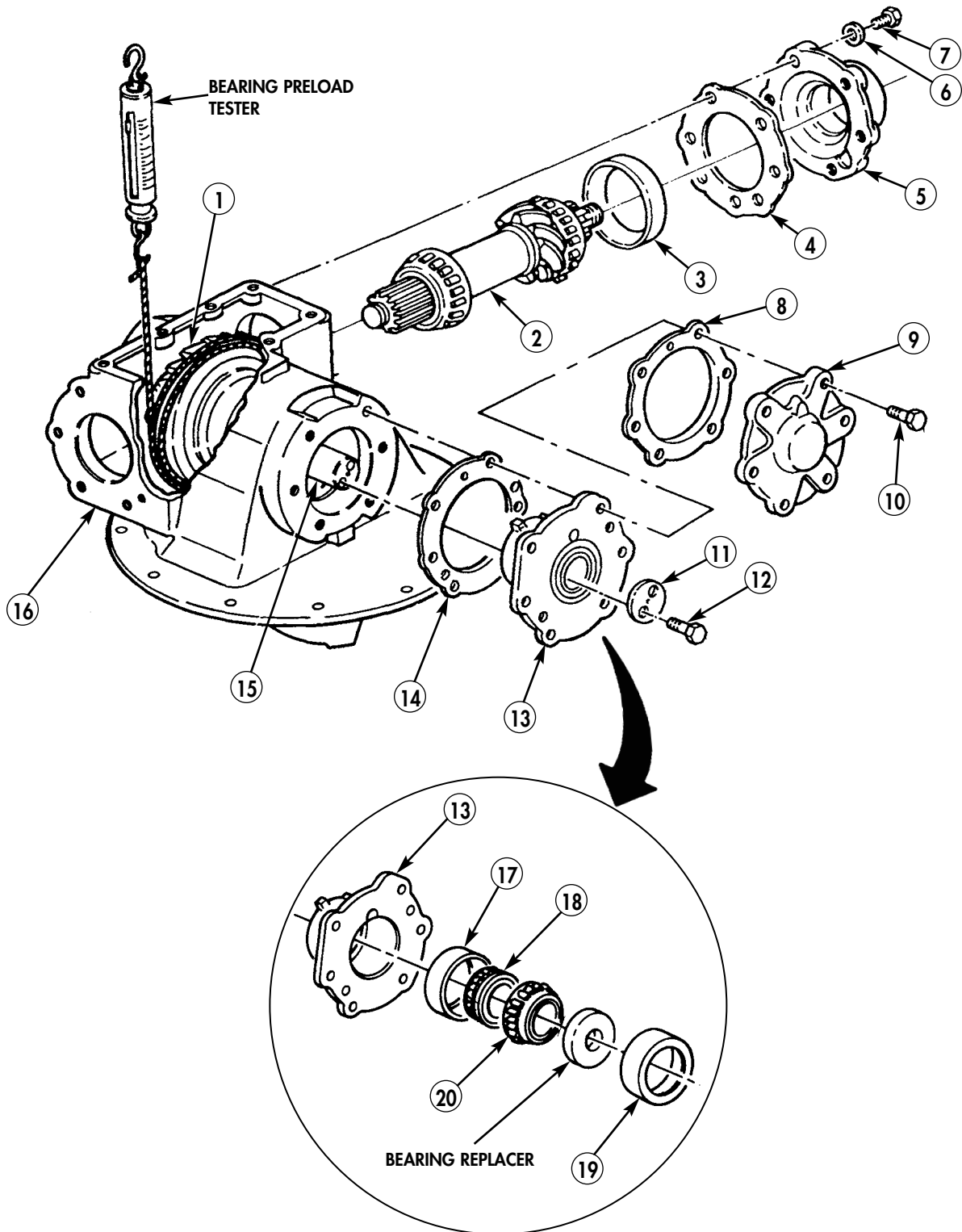

DIFFERENTIAL CARRIER REPAIR (Contd)

ASSEMBLY AND ADJUSTMENT (Contd)

NOTE

Ensure pinion shaft is secured to prevent rotation.

37. Install dial indicator on carrier (1) and position plunger against tooth of bevel gear (2).
38. Measure backlash between bevel gear (2) and helical pinion (3). Proper backlash is 0.005–0.015 in. (0.013–0.038 cm).
39. If backlash is correct, go to step 48.
40. Remove six screws (6), bearing cover (5), and shims (4) from carrier (1). Tie shims (4) to bearing cover (3).

NOTE

Secure bevel gear with brass drift to prevent rotation of bevel gear.

41. Remove two screws (8) and plate (9) from helical pinion shaft (12).
42. Remove bearing cage (10) from carrier (1) with two puller screws.

NOTE

- If backlash is greater than 0.015 in. (0.038 cm), remove a shim or use a thinner shim.
- If backlash is less than 0.005 in. (0.013 cm), add a shim or use a thicker shim.
- Ensure even installation of bearing cage by evenly tightening screws.

43. Add or remove shims (11) as necessary.
44. Align hole in shims (11) with holes in bearing cage (10) and install bearing cage (10) and shim (11) and two puller screws on carrier (1).

NOTE

Secure bevel gear with brass drift to prevent rotation of bevel gear.

45. Install plate (9) on helical pinion shaft (12) with two screws (8). Tighten screws (8) 60–77 lb-ft. (81–104 N•m).
46. Align holes in shims (4) with holes in bearing cover (5), and install shims (4) and bearing cover (5) on carrier (1) with new lockwashers (7) and screws (6). Tighten screws (6) 65–85 lb-ft (88–115 N•m).
47. Repeat steps 37 and 38.
48. Remove dial indicator from carrier (1).

DIFFERENTIAL CARRIER REPAIR (Contd)

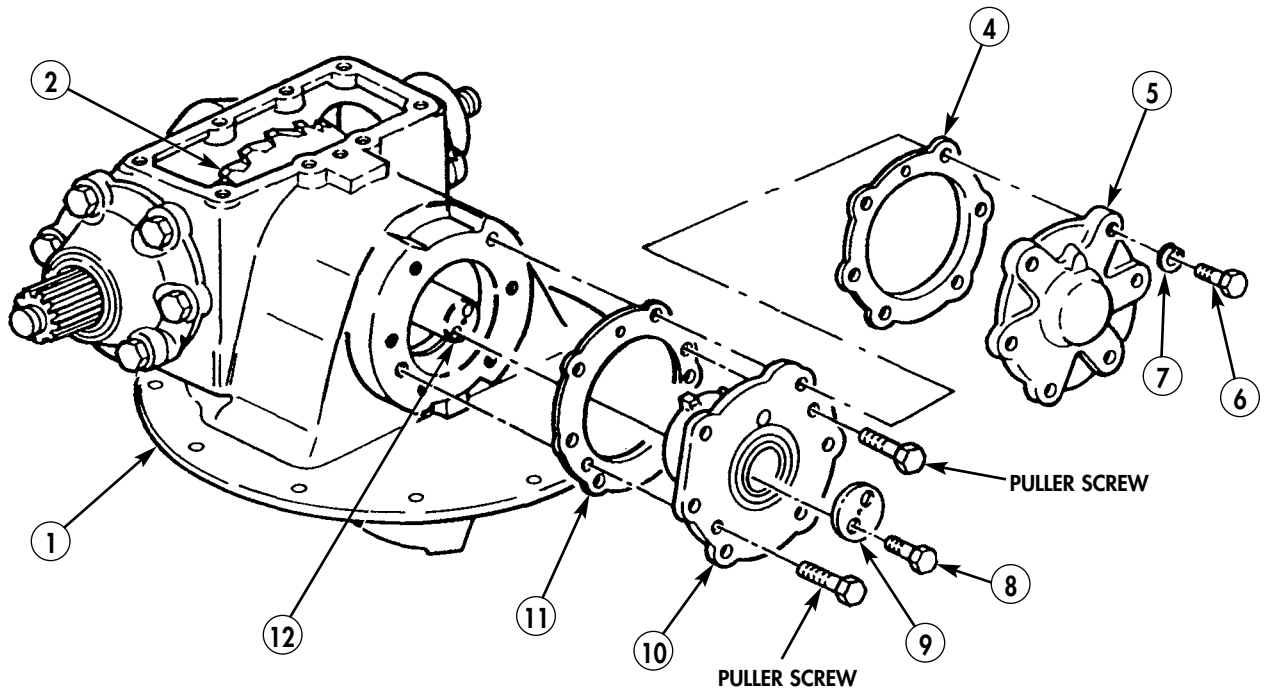
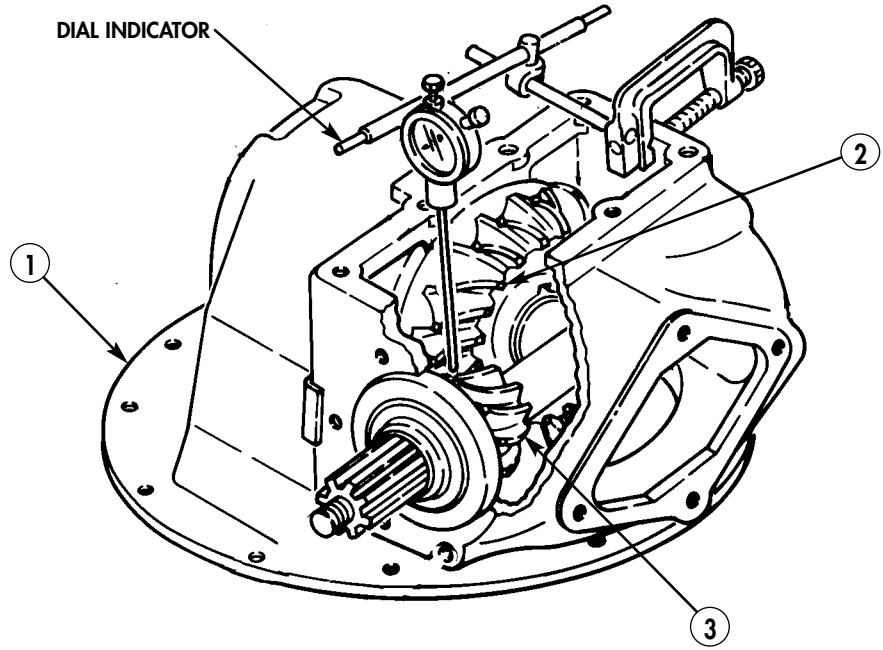

DIFFERENTIAL CARRIER REPAIR (Contd)

ASSEMBLY AND ADJUSTMENT (Contd)

49. Coat teeth of pinion (7) with blue pigment.
50. Install flange (10) on pinion (7) end of shaft (8).
51. Turn flange (10) clockwise one-half to one turn.
52. Inspect teeth of bevel gear (2). Note pattern of contact marks. Pattern "A" shows correct tooth contact.

CAUTION

When correcting tooth contact, always add or remove equal number and thickness of shims for each end of shaft with pinion gear.

Bearing preload will change if shims are interchanged unequally.

53. If tooth contact pattern is correct, clean blue pigment from teeth of pinion (7) and bevel gear (2) and go to step 64.
54. Remove six screws (13), bearing cover (12), and shims (11) from carrier (1). Tie shims (11) to bearing cover (12).

NOTE

Secure bevel gear with brass drift to prevent rotation of bevel gear.

55. Remove two screws (15) and plate (14) from pinion shaft (18).
56. Remove bearing cage (16) from carrier (1) with two puller screws.
57. Remove flange (10), six screws (3), washers (4), rear retainer (9), and shims (6) from carrier (1). Tie shims (6) to rear retainer (9).
58. Remove six screws (3), washers (4), front retainer (5), and shims (6) from carrier (1). Tie shims (6) to front retainer (5).

NOTE

- If tooth contact pattern is "B," remove a shim from rear retainer, and add a shim to front retainer. Add a shim to bearing cage.
- If tooth contact pattern is "C," remove a shim from rear retainer and add a shim to front retainer. Remove a shim from bearing cage.
- If tooth contact pattern is "D," remove a shim from front retainer and add a shim to rear retainer. Add a shim to bearing cage.
- If tooth contact pattern is "E," remove a shim from front retainer and add a shim to rear retainer. Remove a shim from bearing cage.

59. Remove or add shims (6) and/or (17) to front retainer (5), rear retainer (9), and bearing cage (16), as necessary.
60. Align holes in shims (17) and bearing cage (16), and install shims (17), bearing cage (16), shims (11), and bearing cover (12) (steps 24 and 26 through 29) on carrier (1).
61. Align holes in shims (6) with holes in retainers (5) and (9) and install shims (6), front retainer (5), shims (6), and rear retainer (9) on carrier (1) with twelve washers (4) and screws (3).
62. Clean blue pigment from teeth of pinion (7) and bevel gear (2).

DIFFERENTIAL CARRIER REPAIR (Contd)

ASSEMBLY AND ADJUSTMENT (Contd)

- 63. Repeat steps 49 through 52.
- 64. Remove six screws (13), bearing cover (12), and shims (11) from carrier (1).

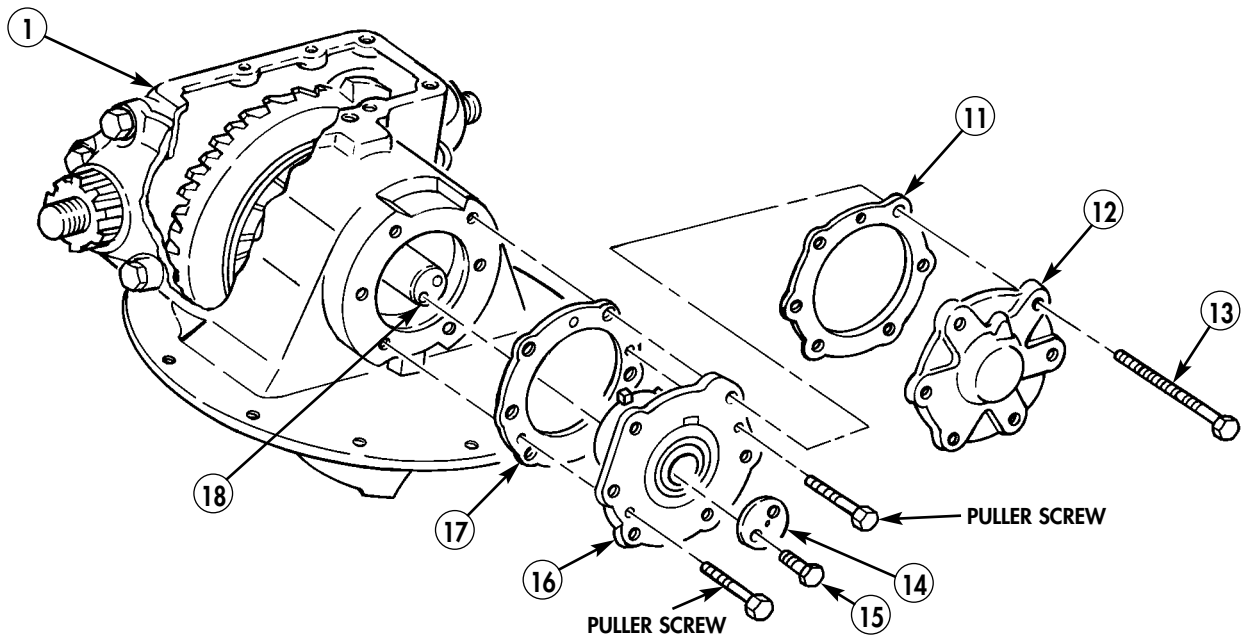
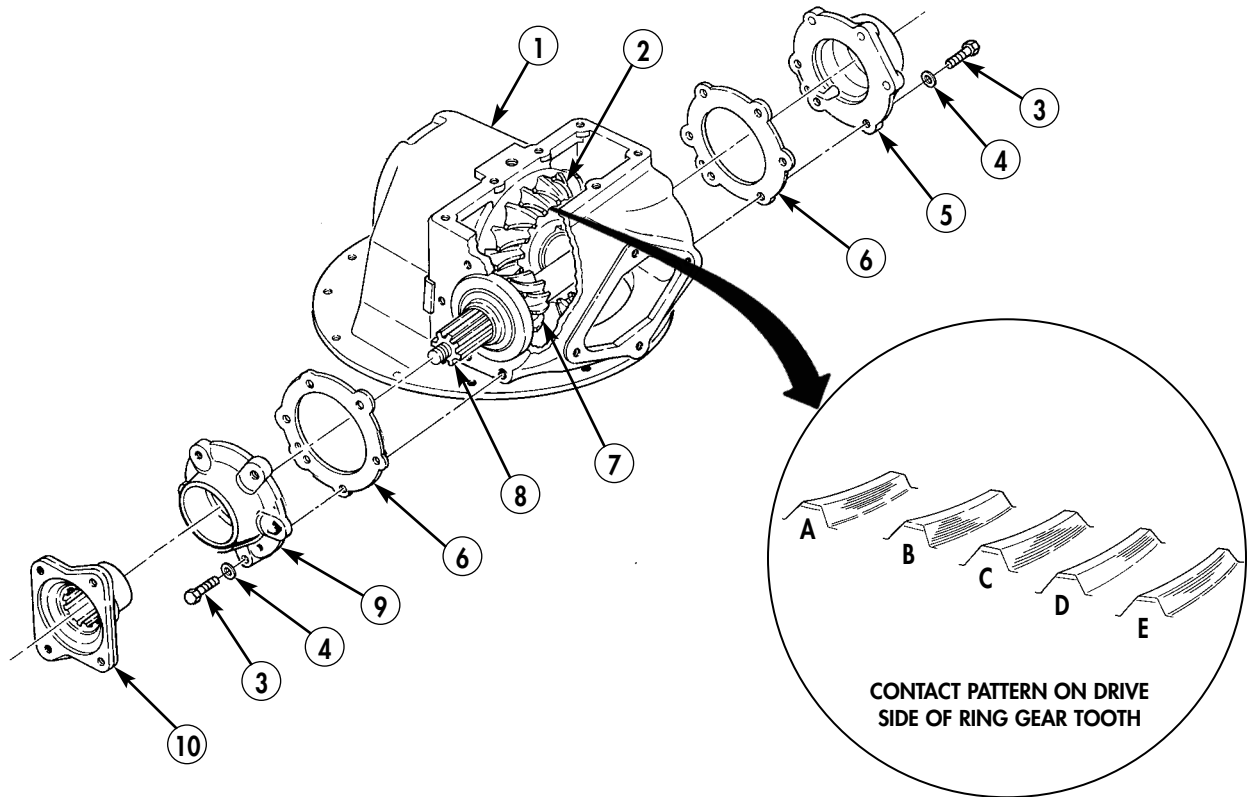

DIFFERENTIAL CARRIER REPAIR (Contd)

ASSEMBLY AND ADJUSTMENT (Contd)

65. Install new safety wire (11) on two screws (10).
66. Install bearing cover (8) and shims (9) on carrier (12) with six new lockwashers (6) and screws (7). Tighten screws (7) 65–85 lb-ft (88–115 N•m).
67. Remove flange (4) from pinion end of shaft (13).
68. Perform step 69 if dirt deflectors (5) were removed.
69. Install two dirt deflectors (5) on two flanges (4).

NOTE

- Apply light coat of GAA grease to splines of flanges before installation.
 - Flanges must be installed with four holes aligned.
 - Before tightening nuts, secure flanges in vise.
 - Ensure cotter pin holes are aligned before removing carrier from vise.
70. Install spacer (14) and two flanges (4) on carrier (12) with two washers (3) and nuts (1). Tighten nuts (1) 300–600 lb-ft (407–814 N•m).
 71. Install two new cotter pins (2) in two nuts (1).

DIFFERENTIAL CARRIER REPAIR (Contd)

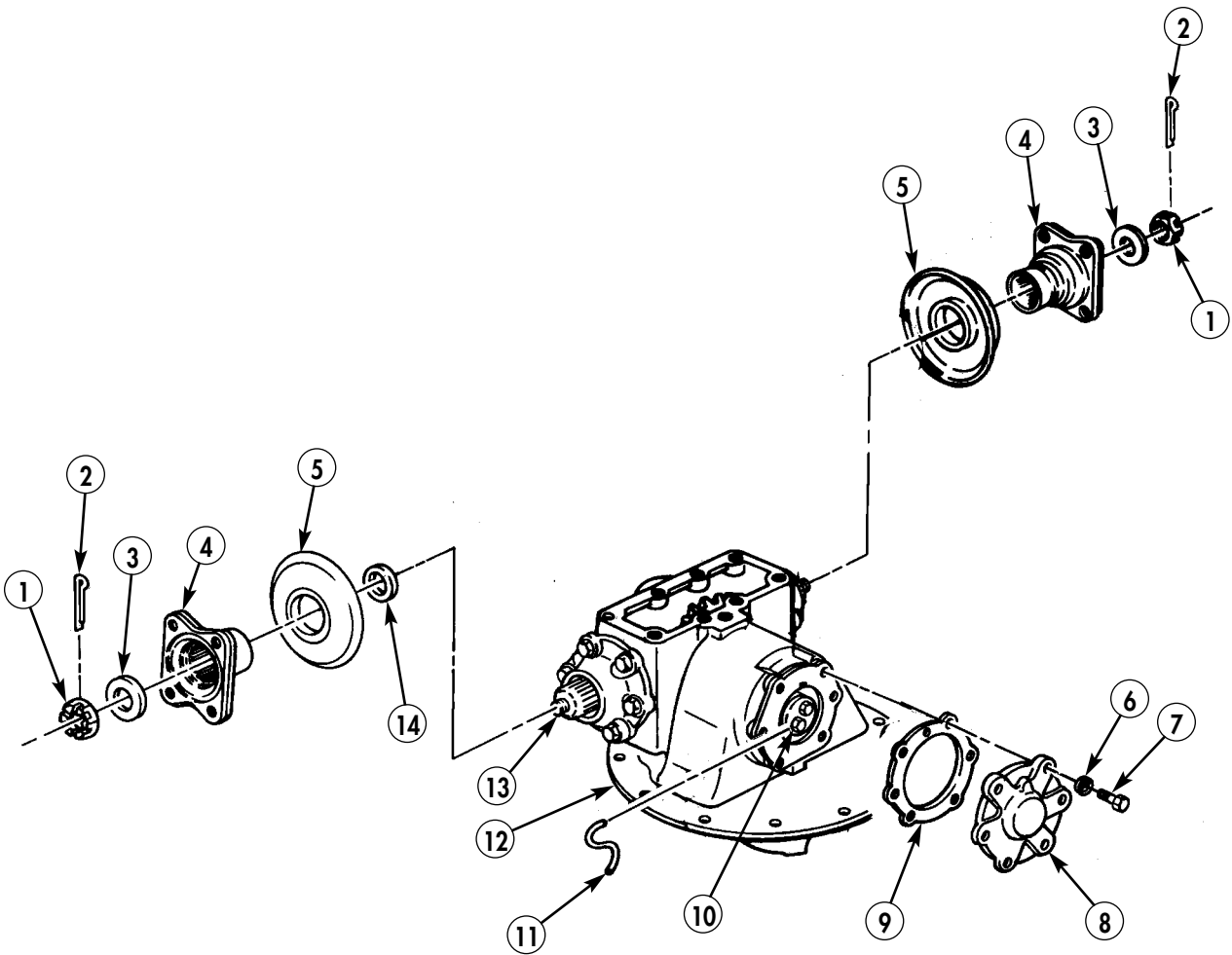

DIFFERENTIAL CARRIER REPAIR (Contd)

ASSEMBLY AND ADJUSTMENT (Contd)

NOTE

Ensure wide end of taper on bearings faces case halves.

72. Press two bearings (1) on case halves (2).
73. If spider (9), thrust washers (11) and (3), pinion gears (10), and side gears (4) were not replaced, proceed in step 77.
74. Install thrust washer (3) and side gear (4) in case half (2).
75. Install four pinion gears (10) and thrust washers (11) on spider (9).
76. Install thrust washer (3) and side gear (4) on spider (9).
77. Install spider (9), four pinion gears (10), side gear (4), four thrust washers (11), and thrust washer (3) in case half (2).

NOTE

Align marks on helical drive gear and case halves.

78. Install helical drive gear (5) on case half (2).

NOTE

Gear assembly should be in vise when tightening nuts.

79. Install other case half (2) on gear assembly with eight screws (12) and nuts (18). Tighten nuts (18) 130–167 lb (176–227 N•m). Align holes in screws and nuts for installation of safety wire (17).
80. Install new safety wire (17) through eight nuts (18).

NOTE

- Differential gear is installed as an assembly with case halves and bearings, thrust washers, side gears, spider, and pinion gears attached to helical drive gear.
- Install bearing seats and adjusting nuts as tagged for installation.

81. Install bearing seats (14) on bearings (1).
82. Install differential gear assembly (16) on carrier (15).
83. Position two adjusting nuts (13) on carrier (15) until seated against bearing seats (14).
84. Install two bearing caps (6) on carrier (15) with four washers (7) and screws (8). Finger-tighten screws (8), and alternately tighten two adjusting nuts (13) to contact bearing seats (14).

DIFFERENTIAL CARRIER REPAIR (Contd)

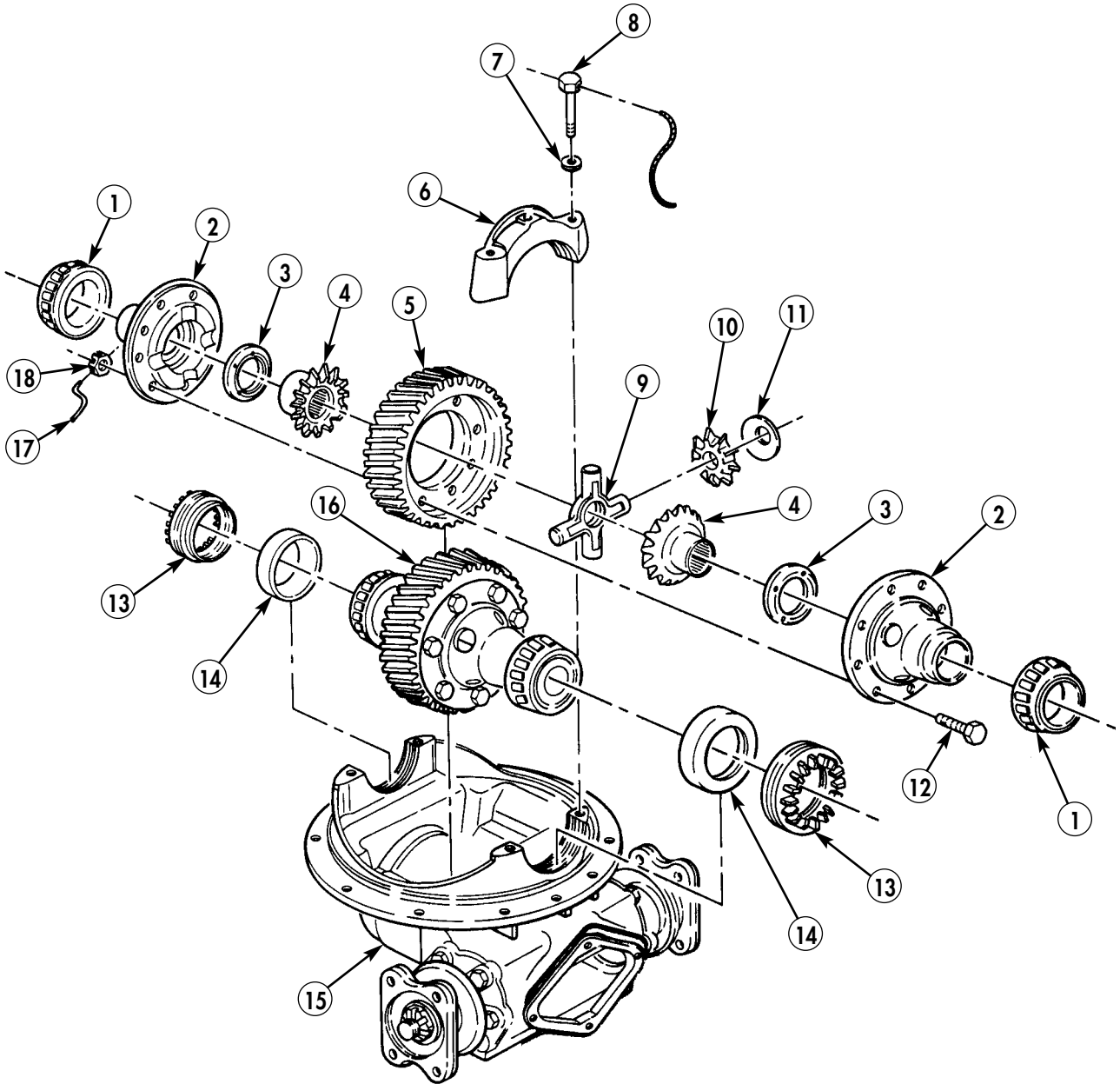

DIFFERENTIAL CARRIER REPAIR (Contd)

ASSEMBLY AND ADJUSTMENT (Contd)

85. Turn helical drive gear (8) several times to seat bearings.
86. Install dial indicator (position A) on carrier (6) so plunger is against side face of helical drive gear (8).
87. Push and pull helical drive gear (8) and check reading on dial indicator (position A).
88. Alternately tighten two adjusting nuts (4) one notch width (5) at a time until dial indicator (position A) reads 0.000 in. (0.00 mm) when helical drive gear (8) is push/pulled.
89. To ensure bearing preload, continue alternately turning adjusting nuts (4) to align notches for lock tabs (3) up to 1.75–7.5 in. (4.45–19.05 cm) notch widths (5) for both sides.
90. Rotate helical drive gear (8) in one direction to check for runout of 0.008 in. (0.203 mm) or less. If runout is more than 0.008 in. (0.203 mm) replace helical drive gear (8) and pinion gear (7).
91. Install dial indicator (position B) on carrier (6) so plunger is on flat side of tooth of helical drive gear (8).

NOTE

Hold pinion shaft or gear to prevent turning.

92. Rotate helical drive gear (8) to set teeth tight on pinion gear teeth (7) and zero dial indicator (position B).
93. Rotate helical drive gear (8) in opposite direction. Gear backlash should be 0.007–0.014 in. (0.178–0.356 mm). If reading is out of range, replace pinion gear (7) and helical drive gear (8).
94. Tighten four screws (10) 116–149 lb-ft (157–202 N•m).
95. Install two lock tabs (3) on bearing caps (9) with two screws (2). Tighten screws (2) 16–20 lb-ft (22–27 N•m).
96. Install new safety wire (1) on four screws (10) and two screws (2). Ensure lock tabs (3) are bent in notches (5).
97. Install new gasket (14) and cover (13) on carrier (6) with eight new lockwashers (11) and screws (12). Tighten screws (12) 20–35 lb-ft (27–47 N•m).

NOTE

Install gasket with tab toward top of carrier.

98. Install new gasket (15) and cover (16) on carrier (6) with four washers (17) and screws (18). Tighten screws (18) 20–35 lb-ft (27–47 N•m).
99. Install differential carrier (WP 0454 00).
100. Fill differential carrier (WP 0020 00).

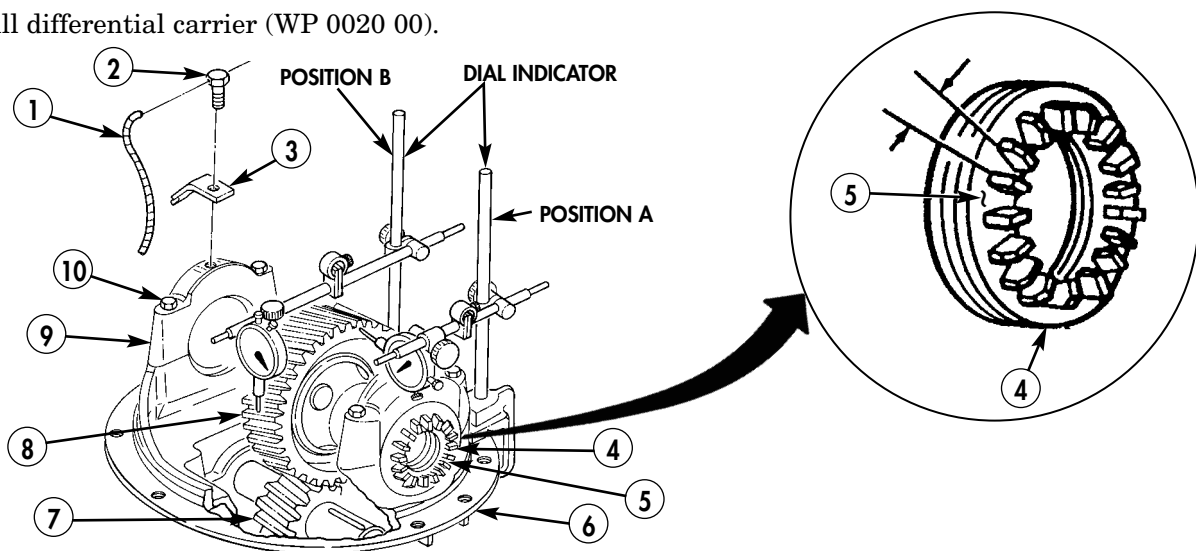

DIFFERENTIAL CARRIER REPAIR (Contd)

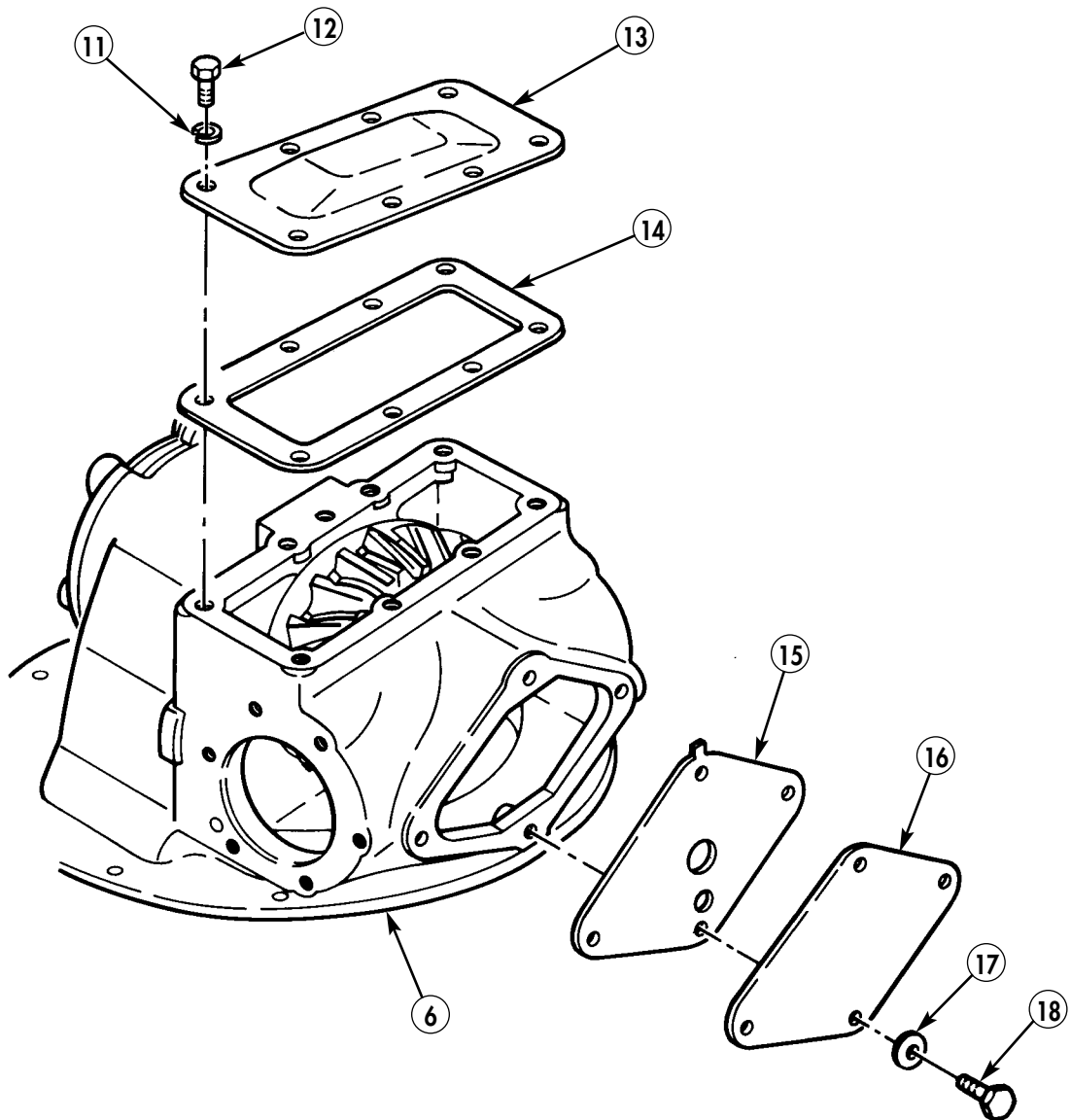

END OF WORK PACKAGE

SUSTAINMENT MAINTENANCE INSTRUCTIONS

2-1/2 TON, 6X6, M44A2 SERIES TRUCKS (MULTIFUEL)

PARKING AND SERVICE BRAKEDRUM REPAIR

CLEANING AND INSPECTION AND REPAIR

INITIAL SETUP:

Applicable Models

All

References

TM 9-4910-482-10

Tools and Special Tools

General mechanic's tool kit
(item 116, WP 0469 00)

Brake and clutch reliner (item 67, WP 0469 00)

Equipment Condition

Parking or service brakedrums removed
(WP 0187 00 or WP 0188 00).

Materials/Parts

Skysol 100 (item 13, WP 0468 00)

PARKING AND SERVICE BRAKEDRUM REPAIR (Contd)

CLEANING AND INSPECTION

WARNING

- Do not use compressed air or dry brush for cleaning when working in areas of vehicle where asbestos brake lining dust may accumulate. Remove asbestos dust and other residue from these areas using a soft bristle brush or cloth soaked with water. Breathing asbestos dust may cause injury to personnel.
- Skysol 100 solvent is combustible; DO NOT use or store near heat, sparks, flame, or other ignition sources. Use mechanical ventilation whenever product is used in a confined space, heated above ambient temperatures, or agitated. Keep container sealed when not in use.

Contact with Skysol 100 may cause skin irritation. Use chemical-resistant gloves. In case of skin contact, remove any contaminated clothing and wash skin thoroughly with soap and water. Wash contaminated clothing before reuse. Eye contact may cause irritation, tearing, or blurring of vision. Use face shield or goggles when eye contact may occur. In case of eye contact, flush eyes with large amounts of water for at least 15 minutes or until irritation subsides. Inhalation may cause irritation to upper respiratory passages. DO NOT have food or drink in the vicinity. Failure to comply may result in injury to personnel.

1. Clean parking or service brakedrums (1) or (2) with Skysol 100 and soft bristle brush. Allow to air dry.
2. Inspect parking or service brakedrums (1) or (2) for warps or cracks. Replace if warped or cracked.
3. Inspect parking or service brakedrums (1) or (2) for scores or pits. If scored or pitted, measure inside diameter.
 - a. Replace parking brakedrum (1) if inside diameter is greater than 13.41 in. (34.06 cm).
 - b. Replace service brakedrum (2) if inside diameter is greater than 15.0 in. (38.1 cm).
4. If inside diameter is less than 13.41 in. (34.06 cm) for parking brakedrum (1) or less than 15.0 in. (38.1 cm) for service brakedrum (2), repair (1) or (2), as necessary.

REPAIR

1. Remove scores or pits from parking brakedrum (1) or service brakedrum (2) by machining (TM 9-4910-482-10).
2. If parking brakedrum (1) or service brakedrum (2) were machined, measure inside diameter. If inside diameter measurement is greater than limits, replace parking brakedrum (1) or service brakedrum (2).
3. Install service or parking brake (WP 0187 00 or WP 0188 00).

PARKING AND SERVICE BRAKEDRUM REPAIR (Contd)

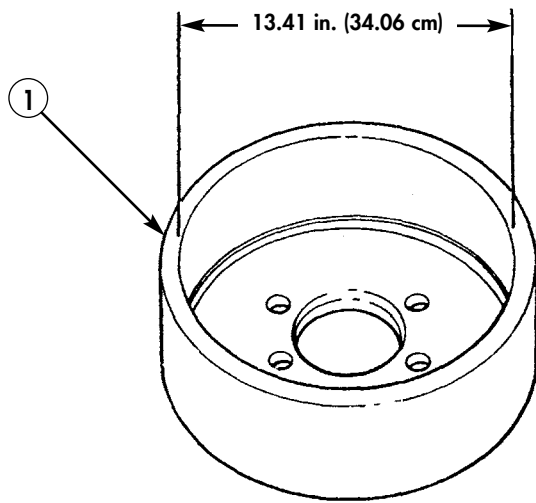

PARKING BRAKEDRUM

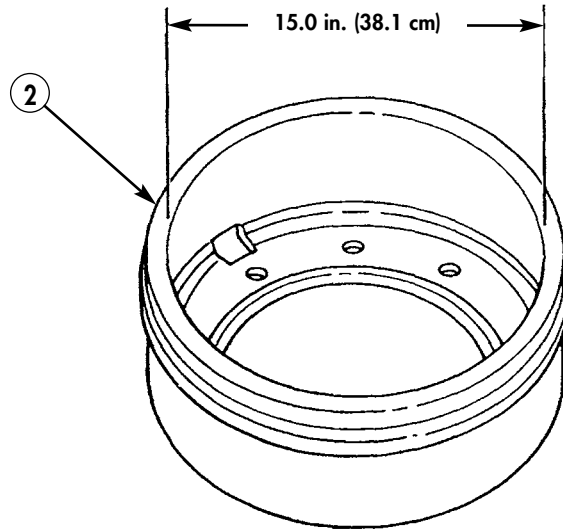

SERVICE BRAKEDRUM

SUSTAINMENT MAINTENANCE INSTRUCTIONS

2-1/2 TON, 6X6, M44A2 SERIES TRUCKS (MULTIFUEL)

PARKING AND SERVICE BRAKESHOE REPAIR

DISASSEMBLY, CLEANING AND INSPECTION, AND ASSEMBLY

INITIAL SETUP:

Applicable Models

All

Tools and Special Tools

General mechanic's tool kit
(item 116, WP 0469 00)

Brake and clutch reliner (item 67, WP 0469 00)

Materials/Parts

Brakeshoe set
(item 299, WP 0470 00)

Materials/Parts (Contd)

Brakeshoe parts kit
(item 300, WP 0470 00)
Skysol 100 (item 13, WP 0468 00)

Equipment Condition

Parking or service brakeshoes removed
(WP 0164 00 or WP 0167 00).

PARKING AND SERVICE BRAKESHOE REPAIR (Contd)

NOTE

- Parking and service brakeshoes are repaired basically the same. This task covers service brakeshoe repair.
- All service and parking brakeshoe linings must be replaced as matched sets.

DISASSEMBLY

Remove fourteen rivets (4) and lining (2) from service brakeshoe (1). Discard rivets (4).

CLEANING AND INSPECTION

WARNING

- Do not use a dry brush or compressed air to clean brakeshoes. There may be asbestos dust on brakeshoes, which can be dangerous to your health if you breathe it. (Brakeshoes must be wet and a soft bristle brush must be used).
- Skysol 100 solvent is combustible; DO NOT use or store near heat, sparks, flame, or other ignition sources. Use mechanical ventilation whenever product is used in a confined space, heated above ambient temperatures, or agitated. Keep container sealed when not in use.

Contact with Skysol 100 may cause skin irritation. Use chemical-resistant gloves. In case of skin contact, remove any contaminated clothing and wash skin thoroughly with soap and water. Wash contaminated clothing before reuse. Eye contact may cause irritation, tearing, or blurring of vision. Use face shield or goggles when eye contact may occur. In case of eye contact, flush eyes with large amounts of water for at least 15 minutes or until irritation subsides. Inhalation may cause irritation to upper respiratory passages. DO NOT have food or drink in the vicinity. Failure to comply may result in injury to personnel.

1. Clean brakeshoe (1) with water and soft bristle brush. Allow to air dry. Clean with Skysol 100.
2. Check brakeshoe (1) for cracks, warps, flat spots on faces, and out-of-round rivet holes (3). Replace if cracked, warped, flat, or holes are out-of-round.

ASSEMBLY

1. Install new lining (2) on service brakeshoe (1) with fourteen new rivets (4).
2. Install parking or service brakeshoes (WP 0164 00 or WP 0167 00).

PARKING AND SERVICE BRAKESHOE REPAIR (Contd)

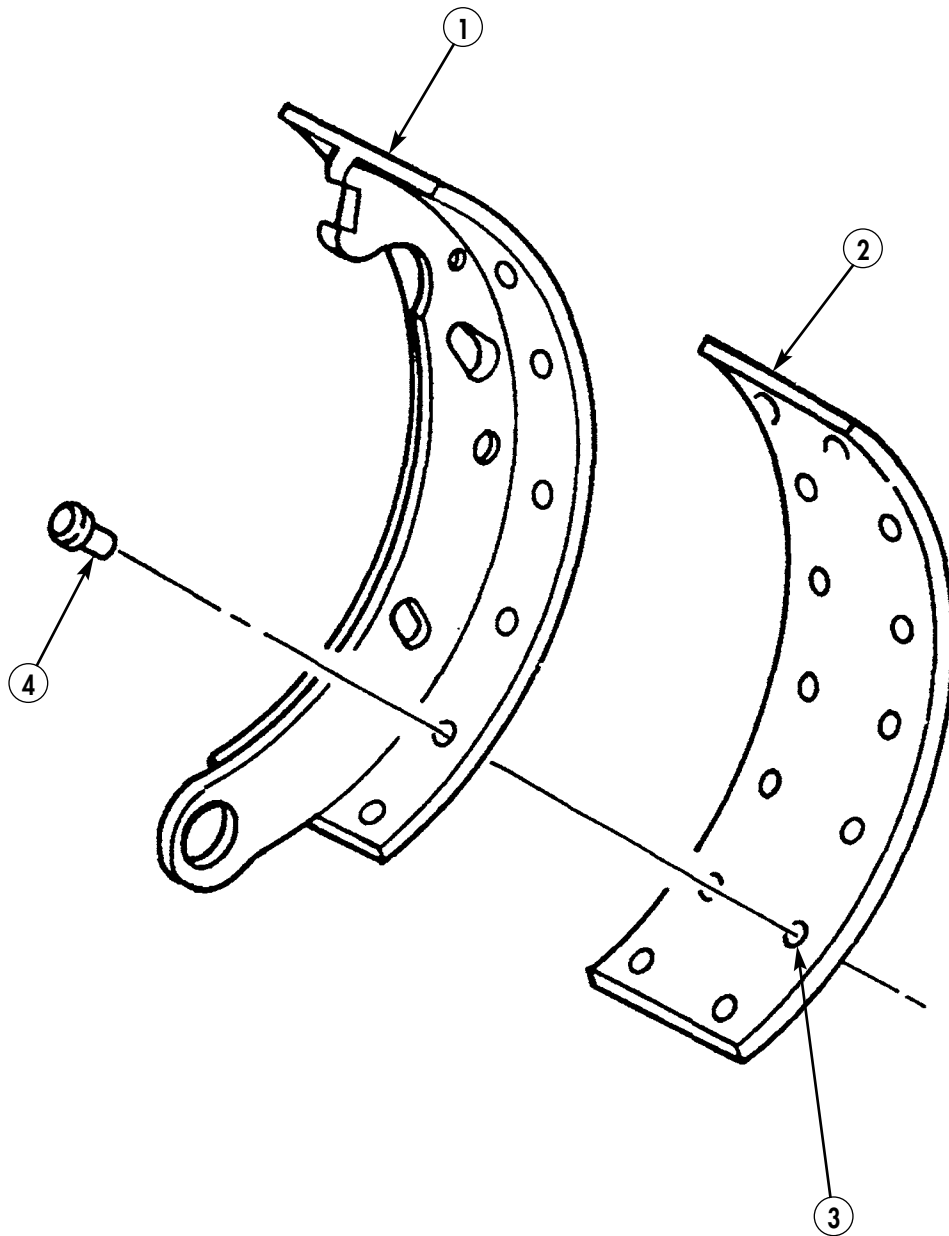

SUSTAINMENT MAINTENANCE INSTRUCTIONS

2-1/2 TON, 6X6, M44A2 SERIES TRUCKS (MULTIFUEL)

STEERING GEAR REPAIR

DISASSEMBLY, CLEANING AND INSPECTION, AND ASSEMBLY

INITIAL SETUP:

Applicable Models

All

Tools and Special Tools

General mechanic's tool kit
(item 116, WP 0469 00)
Torque wrench, 1/2-in. drive
(item 136, WP 0469 00)
Torque wrench, 3/8-in. drive
(item 138, WP 0469 00)
Inside micrometer (item 49, WP 0469 00)
Outside micrometer (item 50, WP 0469 00)
1-1/4-in. socket, 1/2-in. drive
(item 96, WP 0469 00)
Remover and replacer, steering gear housing,
pitman arm shaft bushing
(item 72, WP 0469 00)
Sleeve bearing hand burnisher
(item 14, WP 0469 00)
Remover and replacer, screw
(item 71, WP 0469 00)

Materials/Parts

Two gaskets (item 64, WP 0470 00)
Gasket (item 65, WP 0470 00)
Seal (item 342, WP 0470 00)
Parts kit, steering gear (item 302, WP 0470 00)
Lubricating oil, GO 80/90
(item 25, WP 0468 00)
Sealing compound (item 28, WP 0468 00)

References

TM 9-214
WP 0021 00

Equipment Condition

Steering gear removed (WP 0192 00).

STEERING GEAR REPAIR (Contd)

DISASSEMBLY

1. Remove six screws (11), washers (12), side cover (13), and gasket (7) from gear housing (4). Discard gasket (7).
2. Remove plug (8), nut (10), and preload screw (9) from side cover (13).
3. Clamp gear housing mounting flange (3) in vise with gear tube (14) in up position.

CAUTION

All dirt and grease must be removed from exposed pitman shaft end prior to removal. Failure to clean pitman shaft end may result in scoring of shaft bushings.

4. Remove pitman shaft (6) from gear housing (4).

NOTE

Steering gear may have one or more shims under tube cover. Tag shim(s) in order removed for installation.

5. Remove four screws (15), washers (16), gear tube cover (17), gear tube (14), gasket (18), shim(s) (19), and gasket (18) from cam (22). Discard gaskets (18).

CAUTION

When removing cam from bearing cup bores, do not chip cam grooves, or wedge cam bearings against gear housing. Damage to cam, cam bearings, or gear housing may result.

6. Remove cam (22) from gear housing (4) and end cover tube (25).
7. Remove cam bearing (21) and cup (20) from cam (22).
8. Remove cam bearing (23) and cup (24) from cam (22).

CAUTION

Do not score pitman shaft bushings when removing oil seal from gear housing. Damaged bushings may score pitman shaft.

9. Remove seal (1) from gear housing (4). Discard seal (1).
10. Remove plugs (2) and (5) from gear housing (4).

STEERING GEAR REPAIR (Contd)

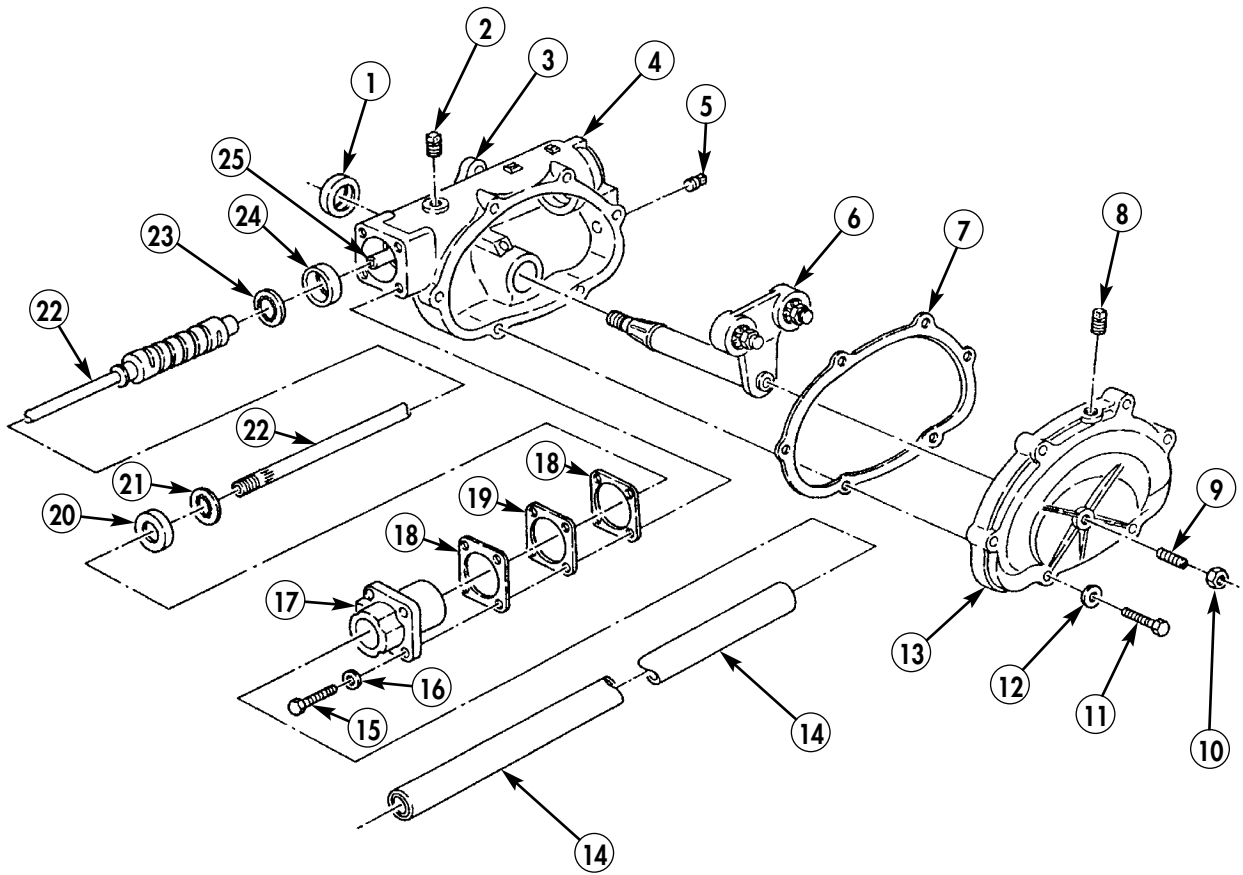

STEERING GEAR REPAIR (Contd)**CLEANING AND INSPECTION****NOTE**

Magnifying glass is recommended for detailed parts inspection.

1. For general cleaning and inspection instructions, refer to WP 0021 00.
2. Inspect plugs (2), (4), and (6). Replace plugs (2), (4), and (6) if defective.
3. Inspect side cover (7) and gasket mating surface for cracks or other damage. Replace side cover (7) if defective.
4. Inspect wear limits on pitman shaft (5). For measurements, refer to table 1, Steering Gear Wear Limits. Replace pitman shaft (5) if worn past limits.
5. Inspect pitman shaft (5) for scoring, bends, and wear. Replace pitman shaft (5) if defective.
6. Inspect gear tube (9) for bends or damage. Replace gear tube (9) if defective.
7. Inspect gear tube cover (8) for cracks or breaks. Replace gear tube cover (8) if defective.
8. Inspect cam (13) for bends or cracks. Replace cam (13) if defective.
9. Inspect cam (13) for chipped, cracked, or scored bearing races and cam grooves. Replace cam (13) if defective.
10. Inspect cam bearings (12) and cups (11) for cracks or scoring. Replace cam bearings (12) and cups (11) if defective.
11. Inspect gear housing (1) and gasket surfaces for cracks or other damage. Replace gear housing (1) if defective.
12. Inspect end cover (3) in gear housing (1) for oil leaks or damage. Replace end cover (3) if defective.
13. Inspect tube bearing (10) for wear (TM 9-214). Replace tube bearing (10) if defective.
14. Inspect pitman shaft taper stud bearings (18) for wear (TM 9-214). Replace pitman shaft taper stud bearings (18) if defective.
15. Bend tang washer tabs (17) down on each bearing (18) and release nut (16). Check each nut (16) for bearing preload. Each bearing preload is 2.5–6.0 lb-in. (0.28–0.68 N•m) with rotating bearing. Replace if bearing(s) (18) will not rotate after correct preload is set.
16. Inspect wear limits on pitman shaft bushings (14) and (15). For measurements, refer to table 1, Steering Gear Wear Limits. Replace bushings (14) and (15) if worn past limits.
17. Inspect pitman shaft bushings (14) and (15) in gear housing (1) for scoring, wear, or other damage. Replace pitman shaft bushings (14) and (15) if defective.

Table 1. Steering Gear Wear Limits.

ITEM NO.	ITEM/POINT OF MEASUREMENT	WEAR LIMITS/TOLERANCE	
		INCHES	MILLIMETERS
5	Pitman shaft (outside diameter)	1.372–1.373	34.849–34.874
14 and 15	Pitman shaft bushings (inner diameter)	1.373–1.375	34.874–34.925

STEERING GEAR REPAIR (Contd)

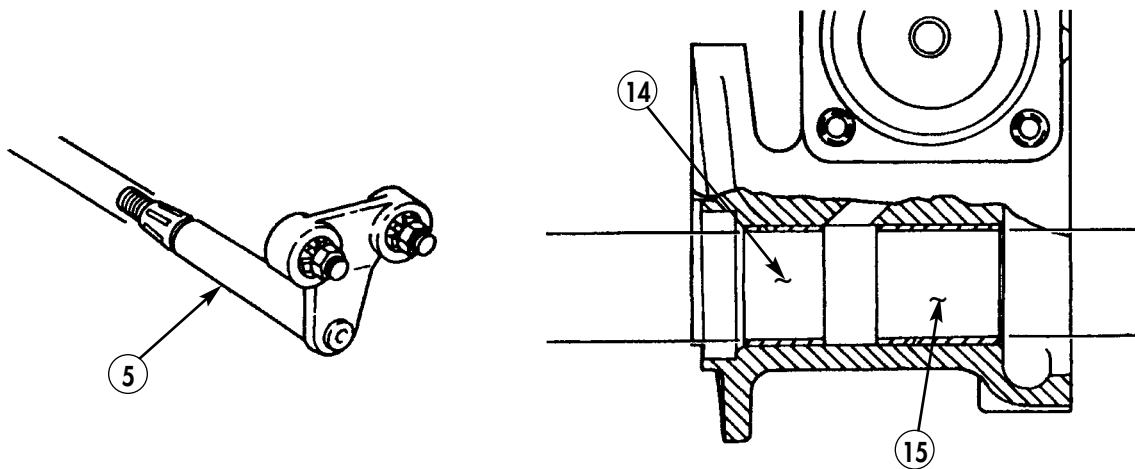
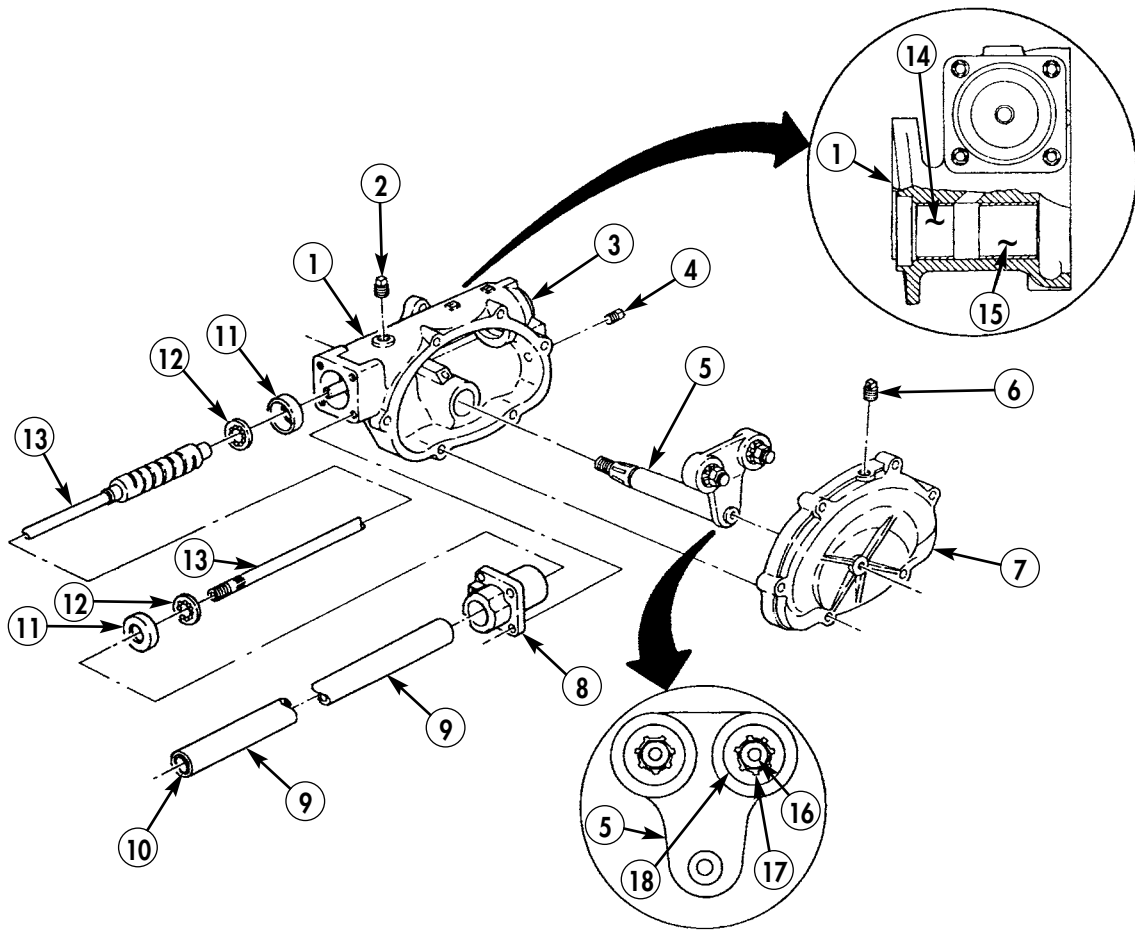

STEERING GEAR REPAIR (Contd)

CLEANING AND INSPECTION (Contd)

NOTE

If pitman shaft bushings in gear housing are defective, perform steps 18 and 19.

18. Remove pitman shaft bushing (2) and (4) from gear housing (3) with bushing remover (1).
19. Install new pitman arm shaft bushings (2) and (4) in gear housing (3) with bushing replacer (1).

NOTE

- Pitman arm shaft to bushing clearance when installed is 0.001–0.003 in. (0.03–0.08 mm). To establish initial clearance, subtract outer diameter of pitman shaft from inner diameter of each bushing in housing. If bushing requires resizing, perform step 20.
 - Inside bushing(s) diameter cannot exceed 1.375 in. (34.925 mm).
20. Ream and burnish new bushings (2) and (4) in gear housing (3) with sleeve bearing hand burnisher.

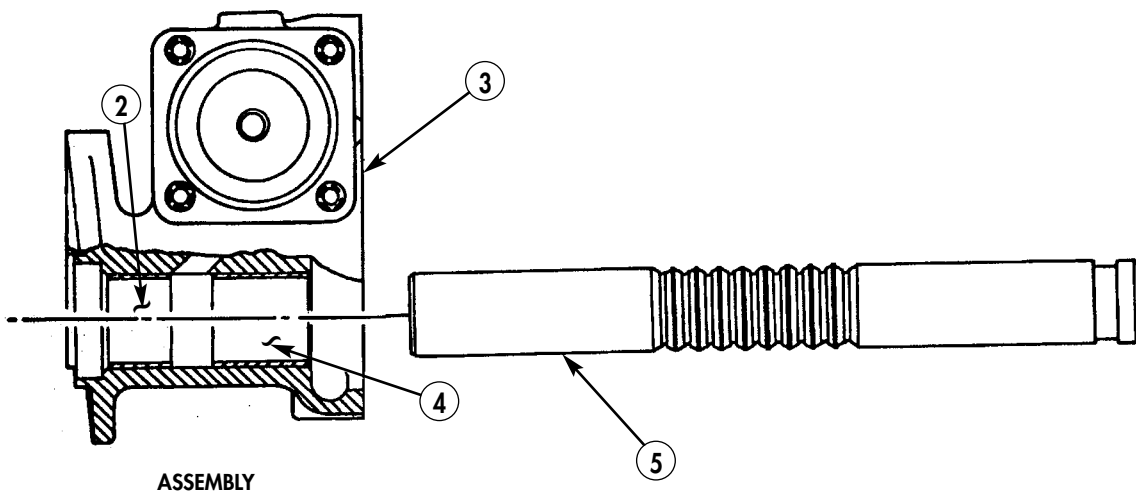
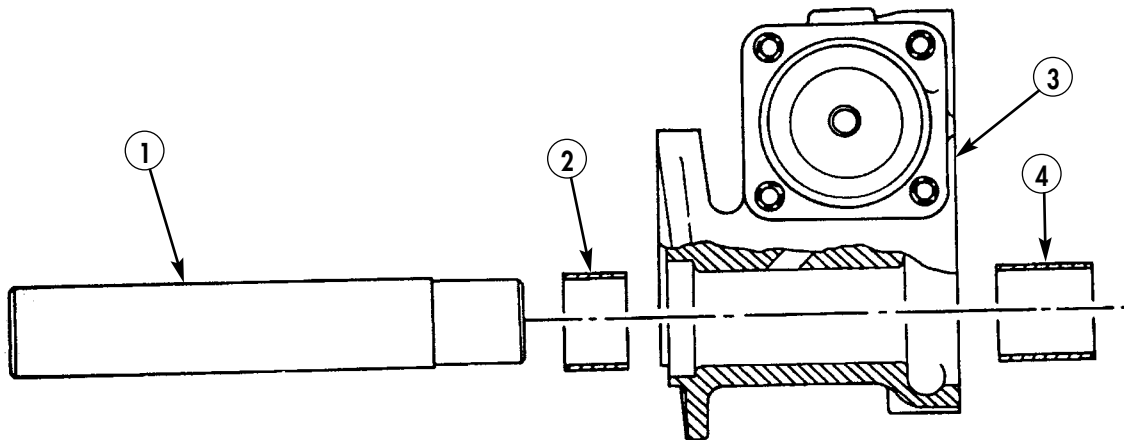

STEERING GEAR REPAIR (Contd)

ASSEMBLY

CAUTION

Assembly area must be free of dirt and grease. Dirt or grease may damage internal steering gear components.

1. Install new seal (9) in gear housing (3).
2. Clamp gear housing mounting flange (11) in vise with cam (5) bore positioned up.
3. Install cup (7) over end cover tube (8) and seat in gear housing (3).
4. Lubricate cam bearings (29) and (6) with oil prior to cam (5) installation.
5. Install cam bearings (29) and (6) and cup (28) on cam (5).
6. Install cam (5) over end cover tube (8) through gear housing (3) and seat bearing (6) on cup (7).

NOTE

Apply sealing compound to all plugs prior to installation.

7. Install plugs (10), (12), and (16) in gear housing (3) and side cover (21).
8. Position new gasket (26), shim(s) (27), new gasket (26), gear tube cover (25), and gear tube (22) over cam (5) on gear housing (3) and install with four washers (23) and new screws (24). Tighten screws (24) 35 lb-ft (47.5 N•m).
9. Using 3/8-in. drive torque wrench, ensure rotational drag on cam end (30) is 3–8 lb-in. (0.3–0.9 N•m).

NOTE

If rotational drag on shaft is not within specifications, add or remove smallest shim for each adjustment until specifications are met.

10. Lubricate pitman shaft bearings (14) with gear oil prior to pitman shaft (13) installation.
11. Install pitman shaft (13) in gear housing (3).
12. Install new gasket (15) and side cover (21) on gear housing (3) with six washers (20) and screws (19).
13. Install preload screw (17) with nut (18) in side cover (21). Do not tighten screw (17) or nut (18).
14. Install steering gear (WP 0192 00).

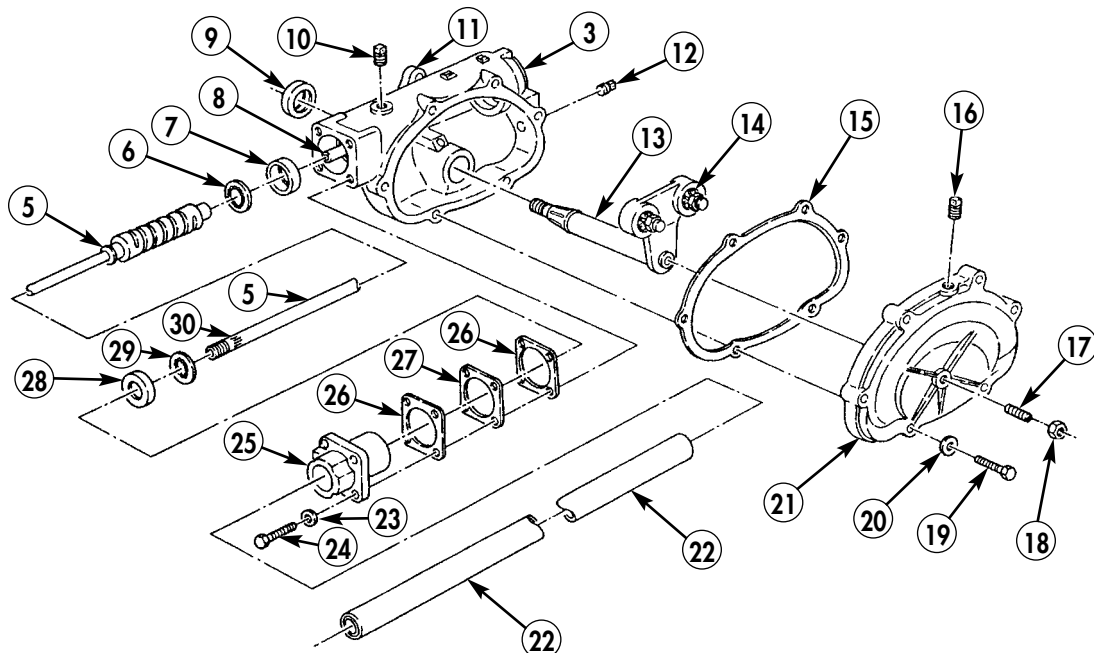

END OF WORK PACKAGE

0458 00-7/8 blank

SUSTAINMENT MAINTENANCE INSTRUCTIONS

2-1/2 TON, 6X6, M44A2 SERIES TRUCKS (MULTIFUEL)

CARGO BODIES REPAIR

1. Remove paint and/or rust from area(s) to be welded or repaired (TC 9-237).
2. Repair cargo body (TC 9-237 and TC 9-510).
3. Paint cargo body as necessary (TM 43-0139 and TB 43-0209).

SUSTAINMENT MAINTENANCE INSTRUCTIONS

2-1/2 TON, 6X6, M44A2 SERIES TRUCKS (MULTIFUEL)

TANK BODIES REPAIR

1. Remove paint and/or rust from area(s) to be welded or repaired (TC 9-237).
2. Repair tank body (TC 9-237 and TC 9-510).
3. Paint tank body as necessary (TM 43-0139 and TB 43-0209).

SUSTAINMENT MAINTENANCE INSTRUCTIONS

2-1/2 TON, 6X6, M44A2 SERIES TRUCKS (MULTIFUEL)

DELIVERY PUMP REPAIR

DISASSEMBLY, CLEANING, INSPECTION, AND ASSEMBLY

INITIAL SETUP:

Applicable Models

M49A2C, M50A3

Tools and Special Tools

General mechanic's tool kit
(item 116, WP 0469 00)
Snapping pliers (item 53, WP 0469 00)

Materials/Parts

Thirty-two lockwashers (item 233, WP 0470 00)
Five seals (item 341, WP 0470 00)
Two gaskets (item 98, WP 0470 00)
Two O-rings (item 287, WP 0470 00)
Two snaprings (item 363, WP 0470 00)
Gasket (item 76, WP 0470 00)
Gasket (item 77, WP 0470 00)

Materials/Parts (Contd)

Gasket (item 97, WP 0470 00)
GAA grease (item 17, WP 0468 00)
Rag (item 27, WP 0468 00)

References

TM 9-214
WP 0020 00
WP 0021 00

Equipment Condition

Delivery pump drain valve removed
(if installed) (WP 0281 00).
Delivery pump removed (WP 0280 00).
Strainer element removed (WP 0284 00).

DELIVERY PUMP REPAIR (Contd)

DISASSEMBLY

1. Remove four screws (3), lockwashers (2), strainer body (1), and gasket (46) from pump body (40). Discard lockwashers (2) and gasket (46).
2. Remove valve cap (7) and gasket (6) from setscrew (5). Discard gasket (6).
3. Place a locator mark on setscrew (5) threads where threads meet cover (4). Remove setscrew (5).
4. Remove four screws (8), lockwashers (9), cover (4), and gasket (10) from pump body (40). Discard lockwashers (9) and gasket (10).
5. Remove spring guide (11), spring (12), and bypass valve (13) from pump body (40).
6. Remove grease fittings (23) and (32) and fittings (25) and (31) from covers (24) and (30).
7. Remove four screws (26), lockwashers (27), cover (24), and gasket (22) from pump head (16). Discard lockwashers (27) and gasket (22).

NOTE

Liner pins may stay with pump heads or liner during removal of pump heads.

8. Remove eight screws (15), lockwashers (14), pump head (16), and O-ring seal (41) from pump body (40). Discard lockwashers (14) and O-ring seal (41).
9. Remove four screws (33), lockwashers (34), cover (30), and gasket (28) from pump head (43). Discard lockwashers (34) and gasket (28).
10. Remove eight screws (44), lockwashers (45), pump head (43), and O-ring seal (42) from pump body (40). Discard lockwashers (45) and O-ring seal (42).
11. Remove seal (29) from cover (30). Discard seal (29).

NOTE

Rotor bearings are snug fit in pump heads. Rotor bearings must be removed to gain access to snaprings in pump heads.

12. Remove rotor bearings (21) and (35) from pump heads (16) and (43).
13. Remove snaprings (20) and (36), seals (19) and (37), washers (18) and (38), and seals (17) and (39) from pump heads (16) and (43). Discard snaprings (20) and (36) and seals (17), (19), (39), and (37).

DELIVERY PUMP REPAIR (Contd)

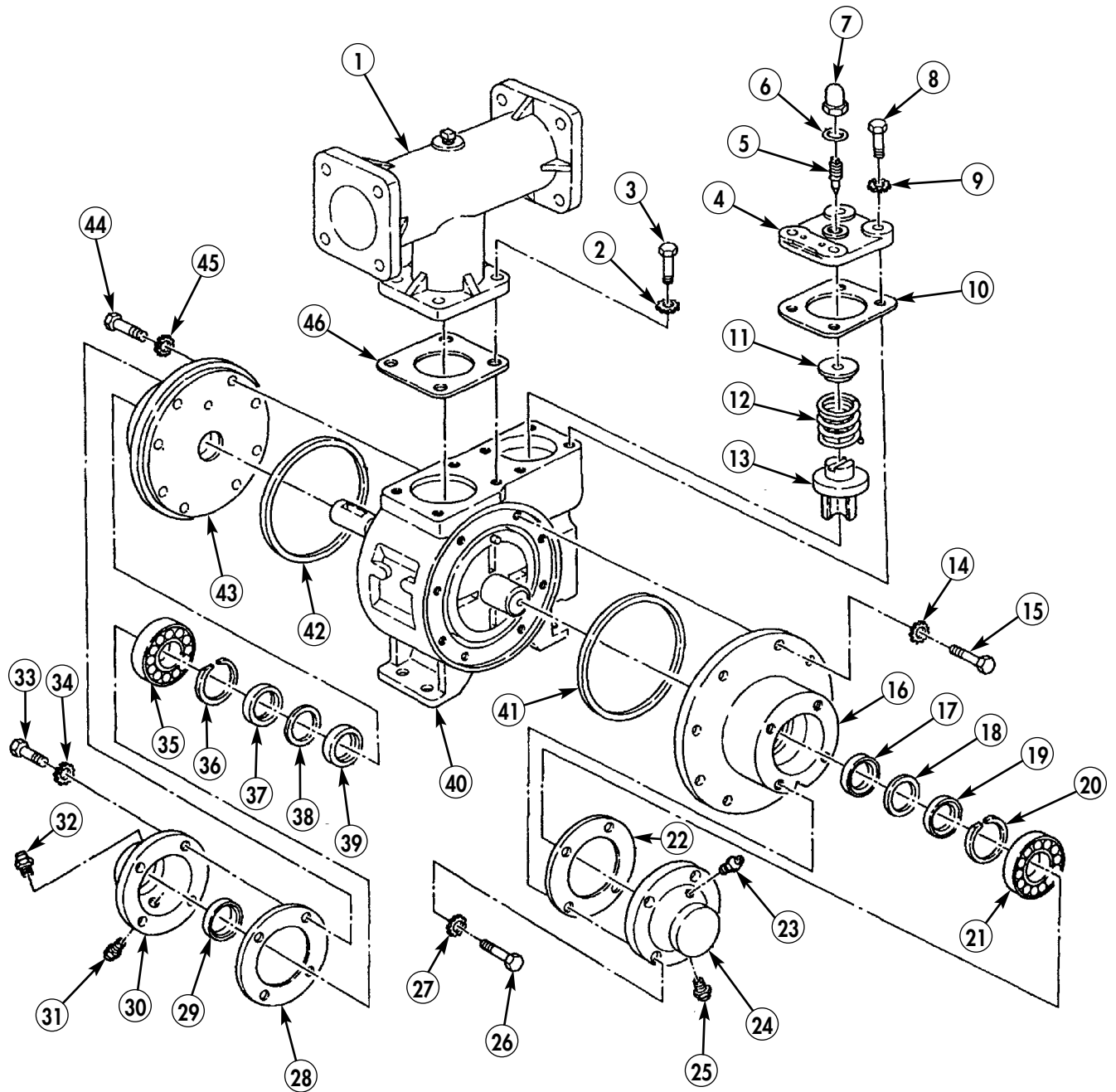

DELIVERY PUMP REPAIR (Contd)

DISASSEMBLY (Contd)

14. Remove rotor (1) from liner (3).
15. Remove four vanes (4) and two rods (5) from rotor (1).
16. Mark liner (3) and pump body (2) for alignment during assembly.
17. Remove liner (3) from pump body (2).

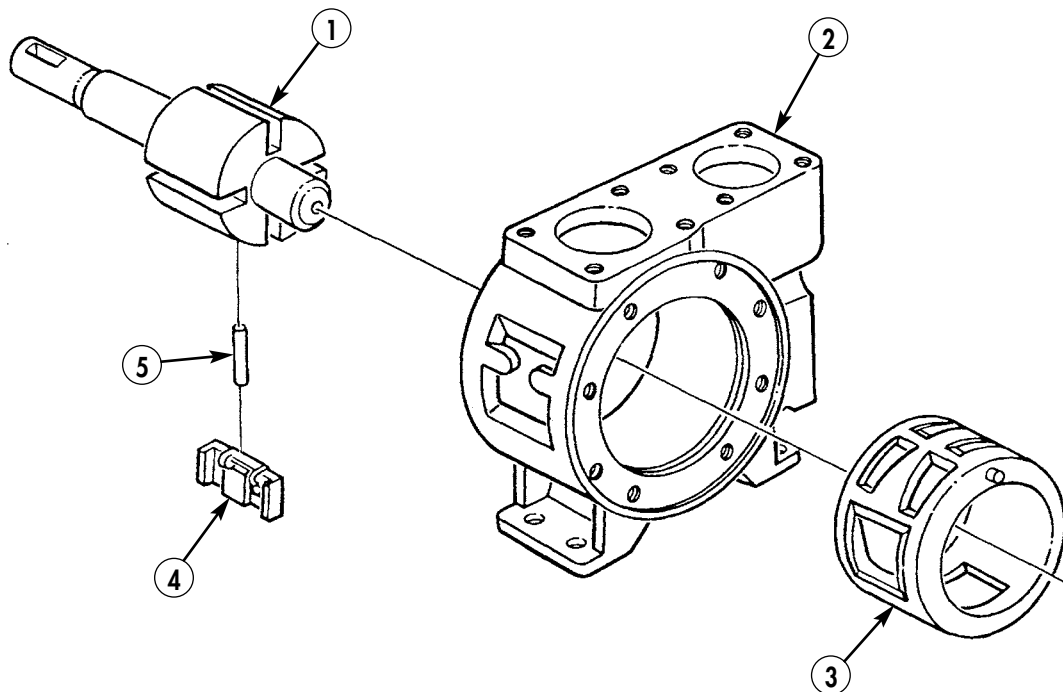

CLEANING

1. For general cleaning instructions, refer to WP 0021 00.
2. Wash delivery pump internal components with soap and hot water. Rinse internal components thoroughly with hot water.
3. Dry internal components using a clean, soft rag.

DELIVERY PUMP REPAIR (Contd)

INSPECTION

- For general inspection instructions, refer to WP 0021 00.

Table 1. Delivery Pump Wear Limits.

ITEM NO.	ITEM/POINT OF MEASUREMENT	WEAR LIMITS/TOLERANCES	
		INCHES	MILLIMETERS
1	Rotor:		
	Shaft diameter at seals	1.18	29.97
	Vane slot width	0.50	12.7
2	Pump body (bore diameter bypass valve)	1.25	31.75
4	Vane:		
	Thickness	0.48–0.49	12.19–12.45
	Width	1.20–1.21	30.48–30.73
	Clearance when installed in rotor	0.01–0.02	0.25–0.51
6	Bypass valve (diameter)	1.24	31.50

- Inspect pump body (2) for cracks, damaged threads, wear, or defects. Refer to table 1, Delivery Pump Wear Limits, for measurements. Replace pump body (2) if damaged or worn past limits.
- Inspect rotor (1) for bent shaft, scoring or wear at shaft, key slot, or vane slot. Refer to table 1, Delivery Pump Wear Limits, for measurements. Replace rotor (1) if damaged or worn past limits.
- Inspect four vanes (4) for bends, cracks, scoring, or wear. Refer to table 1, Delivery Pump Wear Limits, for measurements. Replace vanes (4) if damaged or worn past limits.
- Inspect bypass valve (6) for breakage, scoring, or wear. Refer to table 1, Delivery Pump Wear Limits, for measurements. Replace bypass valve (6) if damaged or worn past limits.

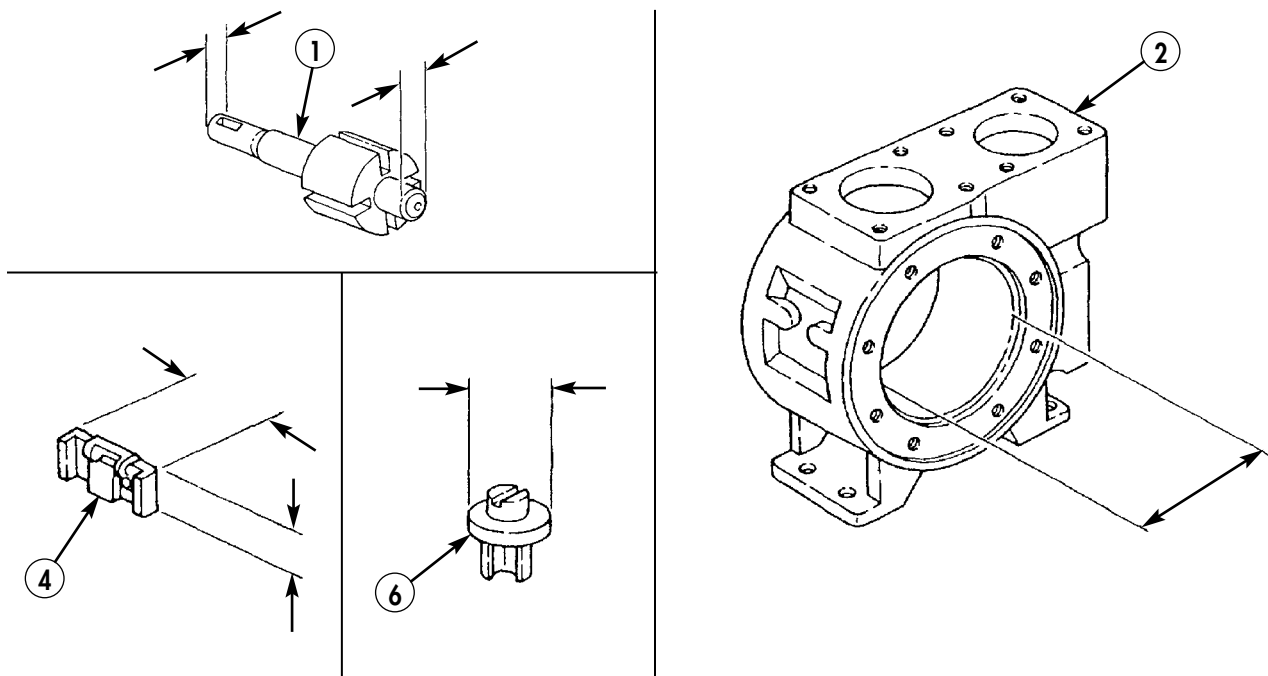

DELIVERY PUMP REPAIR (Contd)

INSPECTION (Contd)

6. Inspect liner (12) for cracks, scoring, or worn chrome plating. Replace liner (12) if damaged or worn.
7. Inspect two rods (18), rotor (19), and four vanes (17) for bends or scoring. Replace two rods (18), rotor (19), and four vanes (17) if damaged.
8. Inspect washers (9) and (14) for grooves and cracks. Replace washers (9) and (14) if damaged.
9. Inspect pump heads (8) and (13) for cracks or thread damage. Replace pump heads (8) and (13) if damaged.
10. Inspect rotor bearings (10) and (15) (TM 9-214). Replace rotor bearings (10) and (15) if damaged.
11. Inspect covers (11) and (16) for cracks or thread damage. Replace covers (11) and (16) if damaged.
12. Inspect spring guide (3) for cracks. Replace spring guide (3) if damaged.
13. Inspect spring (2) for collapsed coils or breakage. Replace spring (2) if damaged.
14. Inspect cover (4) for cracks or thread damage. Replace cover (4) if damaged.
15. Inspect strainer body (1) for cracks or other damage. Replace strainer body (1) if damaged.
16. Inspect valve cap (5) for thread or gasket contact surface damage. Replace valve cap (5) if damaged.
17. Inspect setscrew (6) for threads or tip damage. Replace setscrew (6) if damaged.
18. Inspect two pins (7) in either the liner (12) or heads (8) and (13) for looseness or other damage. Replace two pins (7) if damaged.

DELIVERY PUMP REPAIR (Contd)

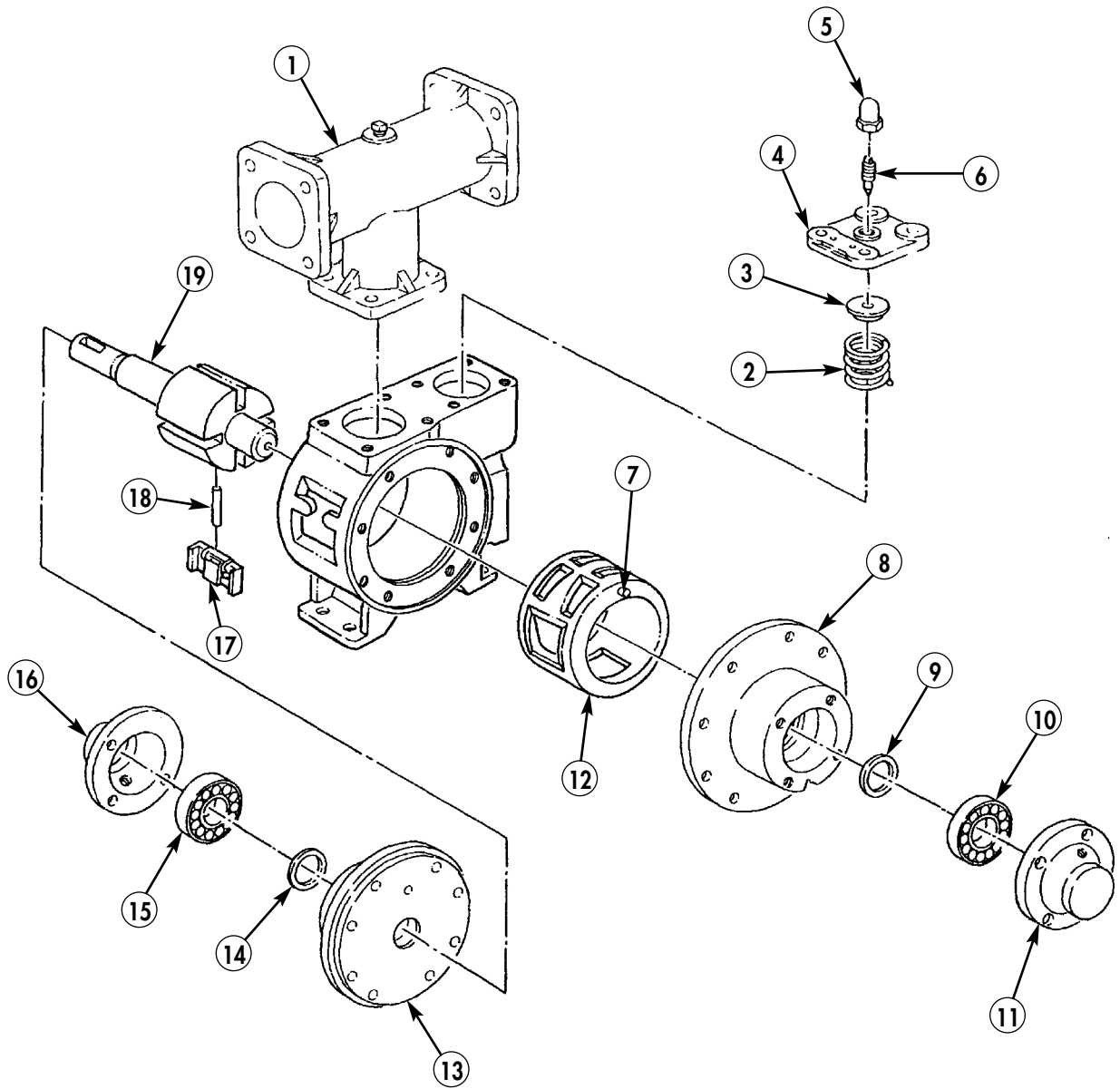

DELIVERY PUMP REPAIR (Contd)

ASSEMBLY

1. Align locator marks and install liner (3) in pump body (2).
2. Install two rods (5) and four vanes (4) in rotor (1).
3. Position rotor (1) in liner (3).
4. Install new O-ring seal (19) and pump head (22) on pump body (2) with eight new lockwashers (20) and screws (21).
5. Install new O-ring seal (46) and pump head (47) on pump body (2) with eight new lockwashers (49) and screws (48).
6. Install new seal (23), washer (24), and new seal (25) in pump head (22) with new snapping (26).
7. Install bearing (27) in pump head (22).
8. Install new gasket (28) and cover (30) on pump head (22) with four new lockwashers (33) and screws (32).
9. Install new seal (45), washer (44), and new seal (43) in pump head (47) with new snapping (42).
10. Install bearing (41) in pump head (47).
11. Install new seal (35) in cover (36).
12. Install new gasket (34) and cover (36) on pump head (47) with four new lockwashers (39) and screws (40).
13. Install grease fittings (29) and (38) and fittings (31) and (37) in covers (30) and (36).
14. Position bypass valve (18), spring (17), and spring guide (16) in pump body (2).
15. Install new gasket (15) and cover (9) over spring guide (16) on pump body (2) with four new lockwashers (14) and screws (13).
16. Install setscrew (10) in cover (9) with locator mark even with cover (9).
17. Install new gasket (11) on setscrew (10) and cover (9) with valve cap (12).
18. Install new gasket (50) and strainer body (6) on pump body (2) with four new lockwashers (7) and screws (8).
19. Install strainer element (WP 0284 00).
20. Install delivery pump (WP 0280 00).
21. Install delivery pump drain valve, if removed (WP 0281 00).
22. Lubricate delivery pump covers (WP 0020 00).

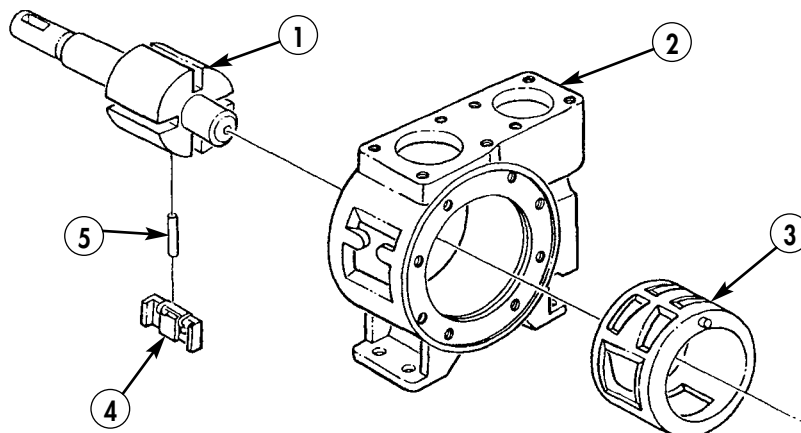

DELIVERY PUMP REPAIR (Contd)

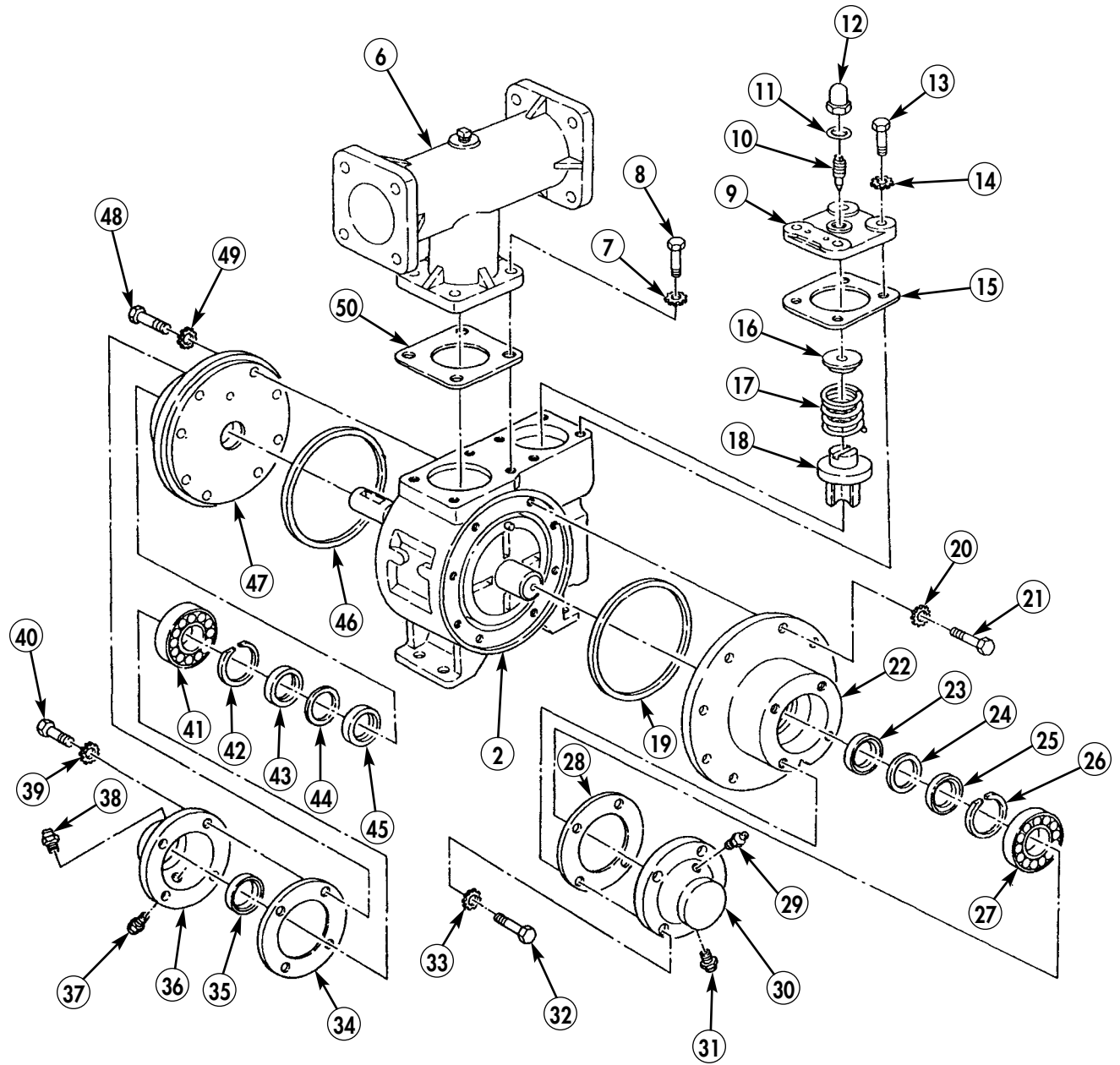

SUSTAINMENT MAINTENANCE INSTRUCTIONS

2-1/2 TON, 6X6, M44A2 SERIES TRUCKS (MULTIFUEL)

VAN BODY MAINTENANCE

REMOVAL, REPAIR, AND INSTALLATION

INITIAL SETUP:

Applicable Models

M185A3, M109A3

Tools and Special Tools

General mechanic's tool kit
(item 116, WP 0469 00)
1-1/8-in. socket, 1/2-in. drive
(item 98, WP 0469 00)
1-1/4-in. socket, 1/2-in. drive
(item 96, WP 0469 00)
Lifting device
Chains

Materials/Parts

Six locknuts (item 167, WP 0470 00)
Four locknuts (item 162, WP 0470 00)

References

TC 9-237
TC 9-510
TM 43-0139
TB 43-0209

Personnel Required

Two

Equipment Condition

Parking brake set and wheels chocked
(TM 9-2320-361-10).
Battery ground cable disconnected
(WP 0126 00).
Front and rear splash guards removed
(WP 0299 00 and WP 0329 00).
Ladders removed (WP 0325 00).

VAN BODY MAINTENANCE (Contd)

REMOVAL

1. Disconnect lead (7) from circuit breaker (2).
2. Remove screw (5) from clamp (6).
3. Remove screw (4) from bond assembly (3).

NOTE

- Perform step 4 if van body is equipped with heater.
- Have drainage container ready to catch fuel.

4. Loosen nut (9) and disconnect fuel line (8) from elbow (1). Allow excess fuel to drain into container.
5. Remove six locknuts (18) and screws (17) from six mounting brackets (16). Discard locknuts (18).

NOTE

Step 6 applies to M109A3 vehicles only.

6. Remove four locknuts (10), screws (15), washers (14), and springs (13) and (12) from two mounting brackets (11). Discard locknuts (10).

NOTE

Step 7 applies to M185A3 vehicles only.

7. Remove four locknuts (19), screws (21), eight spring keepers (20), four springs (22), and springs (23) from two mounting brackets (11). Discard locknuts (19).

VAN BODY MAINTENANCE (Contd)

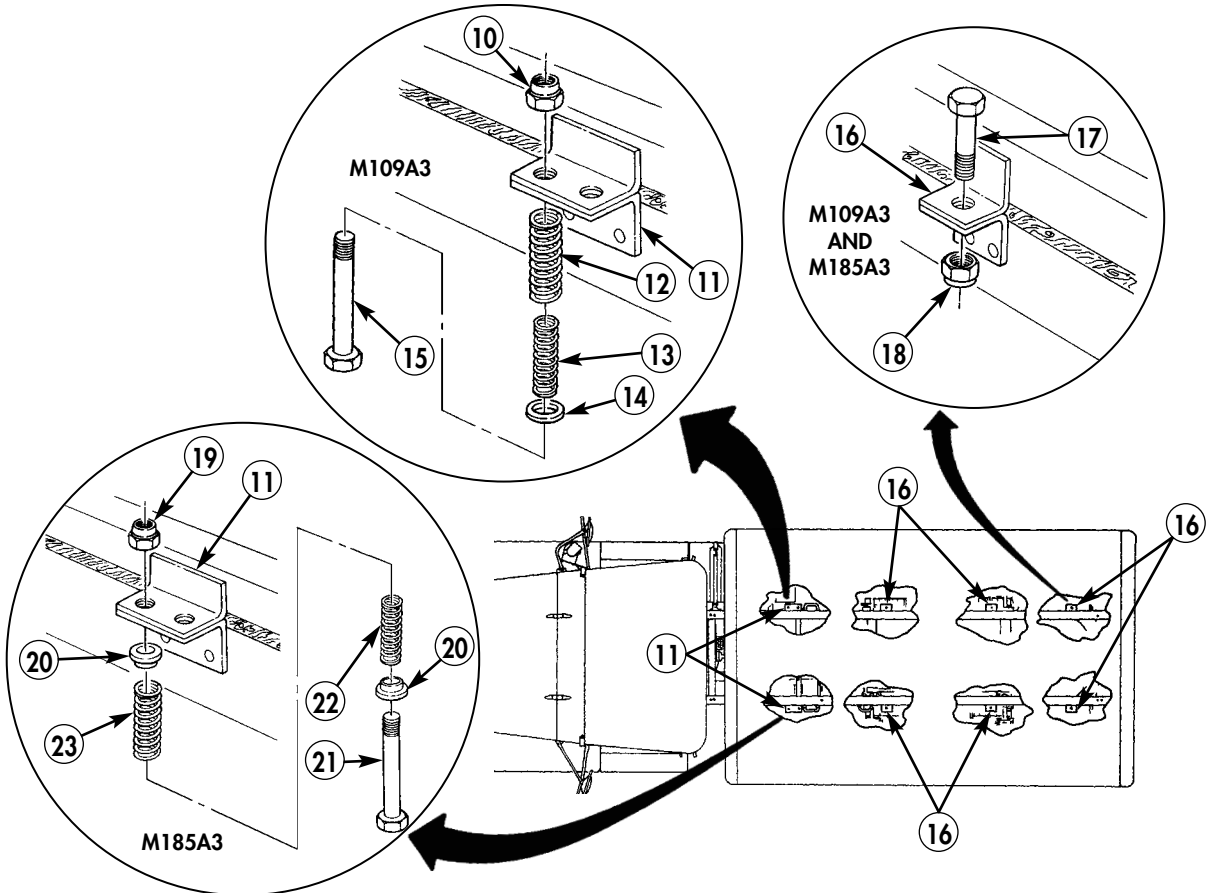
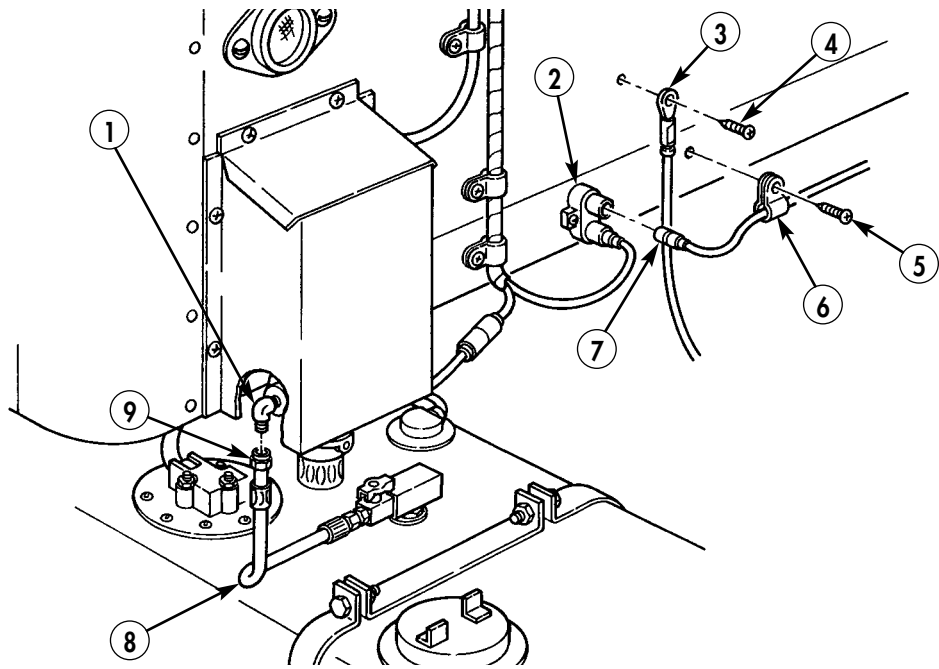

VAN BODY MAINTENANCE (Contd)

REMOVAL (Contd)

WARNING

Ensure lifting capacity is greater than 5,535 lb (2,513kg).
Failure to comply may result in injury to personnel or damage to equipment.

8. Install utility chains on four lifting shackles (1) and lifting device.
9. Attach guide lines to van body (2).

WARNING

- All personnel must stand clear during lifting operations. A swinging or shifting load may cause injury to personnel.
- Support capacity must be greater than weight of van body. Ensure that support capacity is not less than 5,535 lb (2,513 kg). Failure to comply may result in injury to personnel and damage to equipment.

NOTE

Assistant will help with lifting operations.

10. Remove van body (2) and frame sills (4) from chassis (3), and lower van body (2) onto wooden supports.
11. Remove lifting device, utility chains, and guide lines from van body (2).

REPAIR

1. Remove paint and/or rust from area(s) to be welded or repaired (TC 9-237).
2. Repair van body (TC 9-237 and TC 9-510).
3. Paint van body as necessary (TM 43-0139 and TB 43-0209).

INSTALLATION

WARNING

Ensure lifting capacity is greater than 5,535 lb (2,513 kg).
Failure to comply may result in injury to personnel or damage to equipment.

1. Install utility chains on four lifting shackles (1) and lifting device.
2. Attach guide lines to van body (2).

WARNING

All personnel must stand clear during lifting operations.
A swinging or shifting load may cause injury to personnel.

3. Install two frame sills (4) and van body (2) on chassis (3).

NOTE

Step 4 applies to M185A3 vehicles only.

4. Install eight spring keepers (10), four springs (13), springs (12), screws (11), and new locknuts (9) on two mounting brackets (5).

NOTE

Step 5 applies to M109A3 vehicles only.

5. Install four springs (15), springs (16), washers (17), screws (18), and new locknuts (14) on two mounting brackets (5).

VAN BODY MAINTENANCE (Contd)

INSTALLATION (Contd)

6. Install six screws (7) and new locknuts (8) on six mounting brackets (6).
7. Remove lifting device, chains, and guide lines from van body (2).

NOTE

Perform step 8 if van body is equipped with heater.

8. Connect fuel line (26) to elbow (19) by tightening nut (27).
9. Install bond assembly (21) on van body (2) with screw (22).
10. Install clamp (24) on van body (2) with screw (23).
11. Connect lead (25) to circuit breaker (20).
12. Install ladders (WP 0325 00).
13. Install front and rear splash guards (WP 0329 00 and WP 0299 00).
14. Connect battery ground cable (WP 0126 00).
15. Release parking brake and remove wheel chocks (TM 9-2320-361-10).

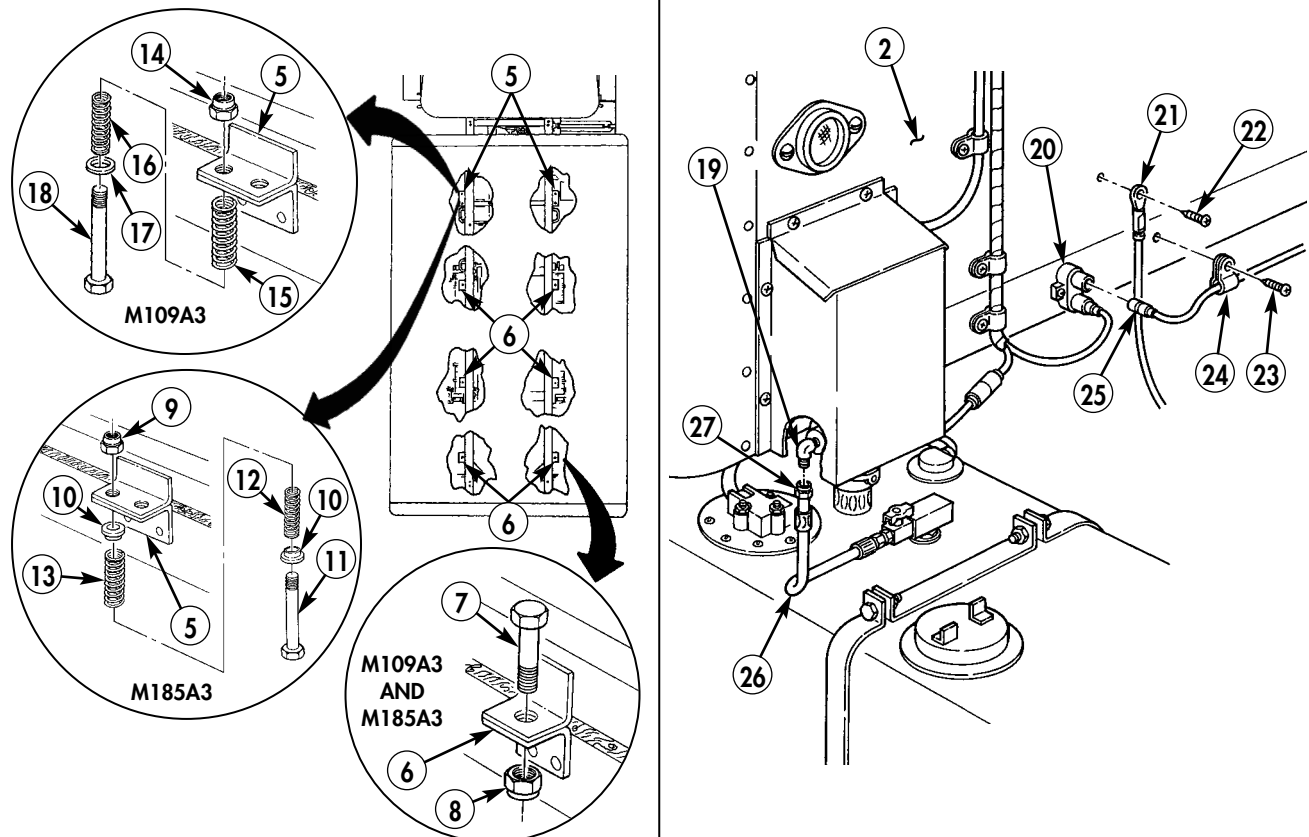
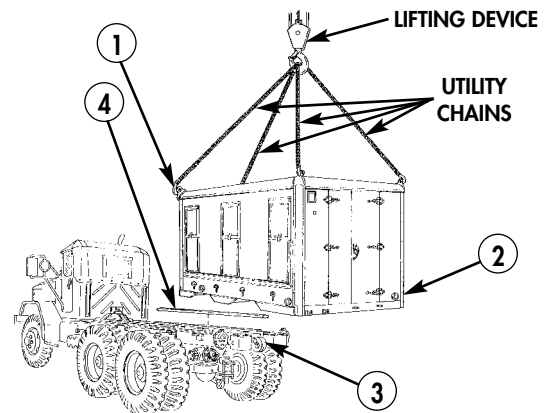

END OF WORK PACKAGE

SUSTAINMENT MAINTENANCE INSTRUCTIONS

2-1/2 TON, 6X6, M44A2 SERIES TRUCKS (MULTIFUEL)

FRONT WINCH REPAIR

WINCH DISASSEMBLY, END FRAME DISASSEMBLY,
GEARCASE DISASSEMBLY, CLEANING AND INSPECTION, GEARCASE ASSEMBLY,
END FRAME ASSEMBLY, AND WINCH ASSEMBLY

INITIAL SETUP:

Applicable Models

All

Tools and Special Tools

General mechanic's tool kit
(item 116, WP 0469 00)
Torque wrench, 1/2-in. dr.
(item 136, WP 0469 00)
Inside micrometer (item 49, WP 0469 00)
Outside micrometer (item 50, WP 0469 00)
Dial indicator (item 43, WP 0469 00)
Mechanical puller kit (item 64, WP 0469 00)
Spring tester (item 110, WP 0469 00)

Materials/Parts

Twelve lockwashers (item 206, WP 0470 00)
Eight lockwashers (item 202, WP 0470 00)
Seven lockwashers (item 200, WP 0470 00)
Six lockwashers (item 229, WP 0470 00)
Six lockwashers (item 230, WP 0470 00)
Six screw-assembled lockwashers
(item 257, WP 0470 00)
Two gaskets (item 105, WP 0470 00)
Two plugs (item 308, WP 0470 00)

Materials/Parts (Contd)

Two woodruff keys (item 382, WP 0470 00)
Two woodruff keys (item 384, WP 0470 00)
Gasket (item 410, WP 0470 00)
Gasket (item 112, WP 0470 00)
Locknut (item 128, WP 0470 00)
O-ring (item 288, WP 0470 00)
Pin (item 305, WP 0470 00)
Plug (item 309, WP 0470 00)
Seal (item 334, WP 0470 00)
Seal (item 335, WP 0470 00)
Seal (item 337, WP 0470 00)
Seal (item 338, WP 0470 00)
Seal (item 340, WP 0470 00)
Woodruff key (item 381, WP 0470 00)
Sealing compound (item 30, WP 0468 00)

References

TM 9-214
WP 0021 00
TM 9-3830-206-34P

Equipment Condition

Front winch removed (WP 0345 00).

FRONT WINCH REPAIR (Contd)

NOTE

For winch repair parts information, refer to TM 9-3830-206-34P.

WINCH DISASSEMBLY

1. Remove four screws (4), lockwashers (5), and channel (3) from gearcase (7) and end frame (12). Discard lockwashers (5).
2. Remove six screws (2), lockwashers (1), and channel (6) from gearcase (7) and end frame (12). Discard lockwashers (1).
3. Remove locknut (13) and end frame (12) from rod (9) and drum shaft (10). Discard locknut (13).
4. Remove plug (11) from end frame (12).
5. Remove plug (8) from gear case (7).

END FRAME DISASSEMBLY

1. Remove six screws (48), lockwashers (47), washers (46), and spacers (45) from end frame (12). Discard lockwashers (47).
2. Remove drum sliding clutch (37), thrust ring (36), and seal (39) from end frame (12). Discard seal (39).
3. Remove adjusting screw (44), spring (42), and drag brakeshoe (41) from end frame (12).
4. Remove plug (34) and setscrew (33) from end frame (12).
5. Remove setscrew (38) from shifter fork (35).
6. Remove shifter fork (35) and woodruff key (24) from shifter shaft (31) while removing shifter shaft (31), ball (29), and spring (28) from end frame (12). Discard woodruff key (24).
7. Remove screw (27), lockwasher (26), lever (25), and woodruff key (30) from shifter shaft (31). Discard lockwasher (26) and woodruff key (30).
8. Remove screw (23), lockwasher (22), plate (21), and seal (32) from end frame (12). Discard lockwasher (22) and seal (32).
9. Remove two nuts (14), poppet latch (15), poppet nut (16), spring (17), and poppet (18) from end frame (12).
10. Remove plug (19), three plugs (20), and pin (43) from end frame (12). Discard pin (43).
11. Remove sleeve (40) from end frame (12).

FRONT WINCH REPAIR (Contd)

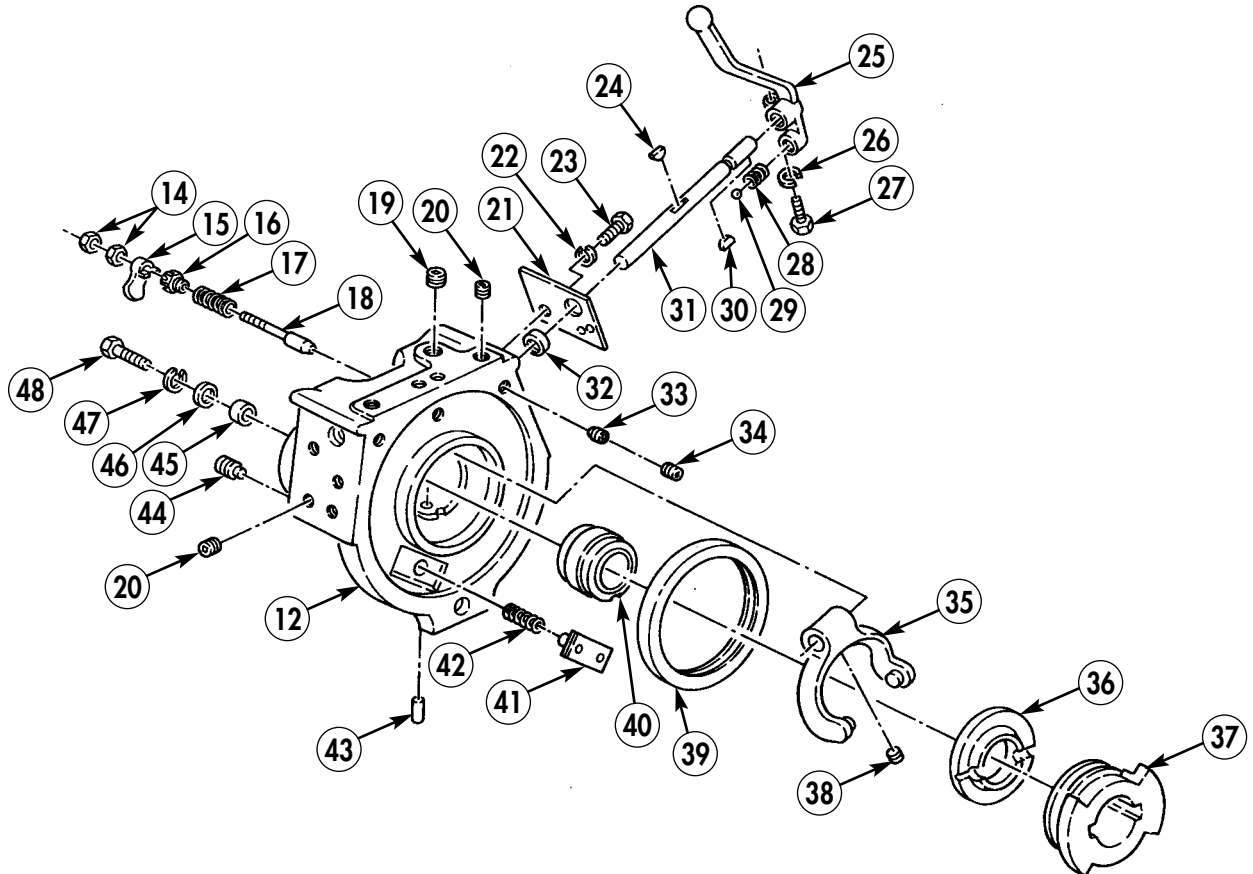
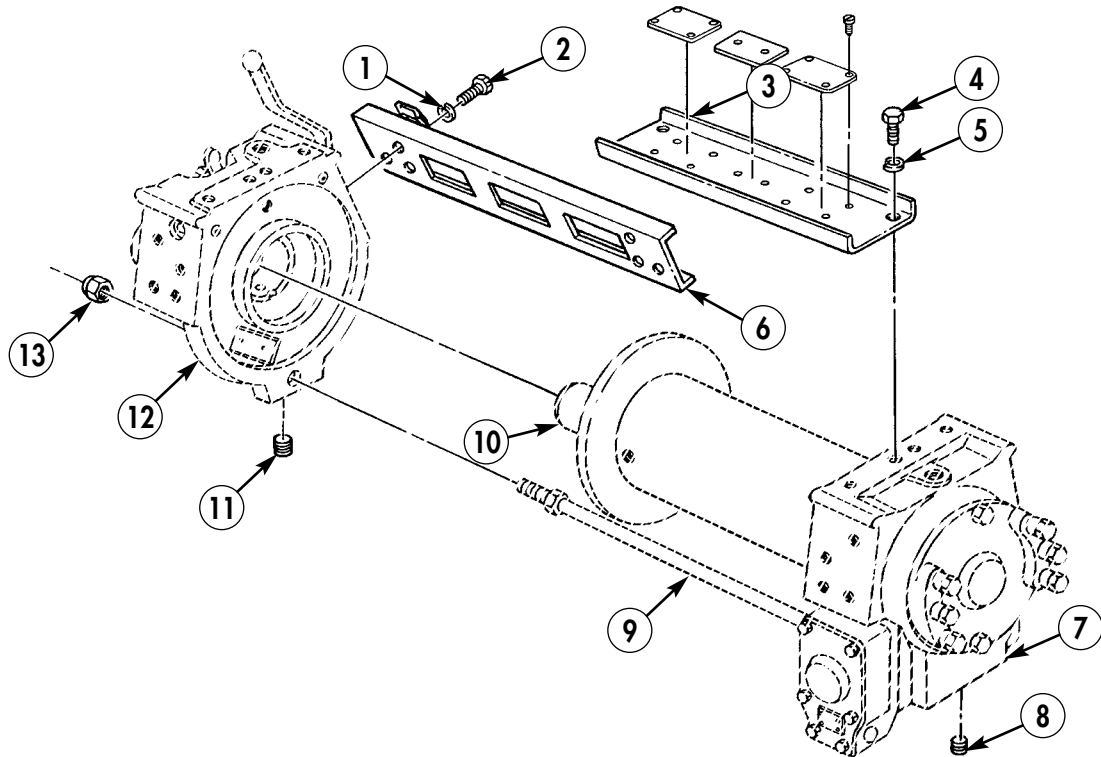

FRONT WINCH REPAIR (Contd)

GEARCASE DISASSEMBLY

1. Remove two woodruff keys (1), drum thrust ring (2), and drum (3) from drum shaft (13). Discard woodruff keys (1).
2. Remove rod (45) from gearcase (5).
3. Remove two jamnuts (44) from rod (45).
4. Remove six screw-assembled lockwashers (33), brake cover (32), and gasket (30) from brakecase (28). Discard screw-assembled lockwashers (33) and gasket (30).
5. Remove screw (39), washer (40), O-ring (41), spring (37), and brakeband (31) from brakecase (28) and brakedrum (38). Discard O-ring (41).
6. Remove screw (34), lockwasher (35), washer (36), brakedrum (38), and woodruff key (24) from worm gear (23). Discard lockwasher (35) and woodruff key (24).
7. Remove four screws (42), lockwashers (43), brakecase (28), and gasket (26) from gearcase (5). Discard lockwashers (43) and gasket (26).
8. Remove seal (27) and plug (29) from brakecase (28). Discard seal (27) and plug (29).
9. Remove eight screws (18), lockwashers (19), six washers (20), spacers (21), cover (17), and gasket (22) from gearcase (5). Discard lockwashers (19) and gasket (22).
10. Remove drum shaft (13) from gearcase (5).
11. Remove spur gear (16) and two woodruff keys (14) from drum shaft (13). Discard woodruff keys (14).
12. Remove four screws (11), lockwashers (12), bearing cap (10), and gasket (8) from gearcase (5). Discard lockwashers (12) and gasket (8).
13. Remove seal (9) from bearing cap (10). Discard seal (9).

CAUTION

Excessive tapping may damage worm gear.

14. Tap worm gear (23) with bearing (7) from gearcase (5).
15. Remove bearing (7) from worm gear shaft (23).
16. Remove bearing (25) from gearcase (5).
17. Remove two setscrews (15) and plug (6) from gearcase (5).
18. Remove seal (4) from gearcase (5). Discard seal (4).

FRONT WINCH REPAIR (Contd)

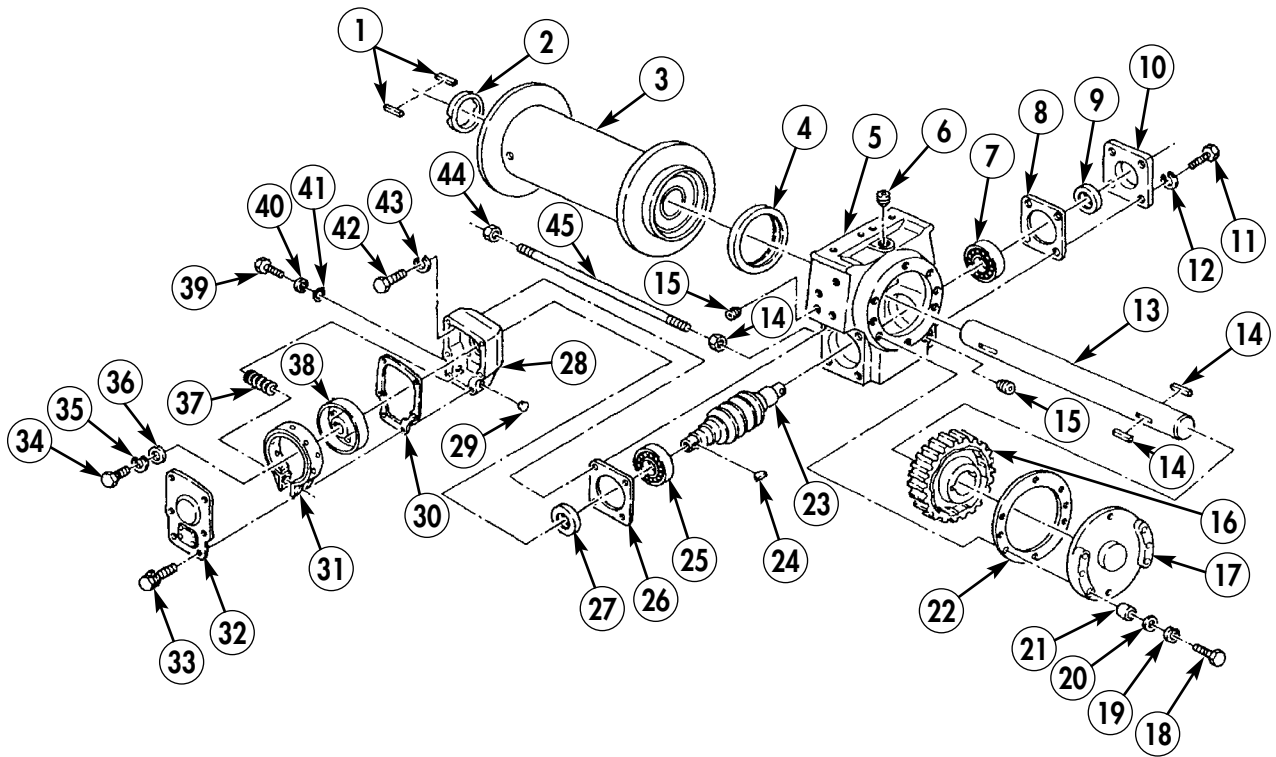

FRONT WINCH REPAIR (Contd)**CLEANING AND INSPECTION**

1. For general cleaning and inspection instructions, refer to WP 0021 00.
2. Inspect two bushings (1) of drum (2) for wear. Refer to table 1, Front Winch Wear Limits, for measurements. Replace if worn past limit.
3. Inspect two gearcase bushings (6) for wear. Refer to table 1, Front Winch Wear Limits, for measurements. Replace if worn past limit.
4. Inspect poppet spring (7), drag brake spring (11), automatic brake spring (3), and shift lever spring (4) for wear. Refer to table 1, Front Winch Wear Limits, for measurements. Replace if worn past limit.
5. Inspect drag brakeshoe (8) lining for wear. Refer to table 1, Front Winch Wear Limits, for measurements. Replace if worn past limit.
6. Inspect automatic brake (12) lining for wear. Refer to table 1, Front Winch Wear Limits, for measurements. Replace if worn past limit.
7. Inspect sliding clutch (13), end frame thrust ring (5), drum thrust ring (9), and sleeve (10) for wear. Refer to table 1, Front Winch Wear Limits, for measurements. Replace if worn past limit.
8. Visually inspect bearings (14) for damage or wear (TM 9-214). Replace bearings if worn or damaged.

Table 1. Front Winch Wear Limits.

ITEM NO.	ITEM/POINT OF MEASUREMENT	WEAR LIMITS/TOLERANCES	
		STANDARD	METRIC
1	Bushings (inner diameter)	1.877–1.880 in.	4.768–4.775 cm
3	Automatic brake spring: Free length Compressed to 1 in. (2.54 cm)	1.5 in. 54 lb-ft	3.81 cm 70.51 N•m
4	Shift lever spring Free length Compressed to 0.625 in. (15.875 mm)	0.6875 in. 1.99 lb-ft	17.4625 mm 27 N•m
5	End frame thrust ring (inner diameter)	1.877–1.889 in.	4.768–4.798 cm
6	Gearcase bushings (inner diameter)	1.877–1.880 in.	4.768–4.775 cm
7	Poppet spring (free length)	1.906 in.	4.841 cm
8	Drag brakeshoe lining (thickness)	0.194–0.25 in.	4.928–6.35 mm
9	Drum thrust ring (inner diameter)	1.887–1.889 in.	4.793–4.798 cm
10	Sleeve (inner diameter)	1.887–1.889 in.	4.793–4.798 cm
11	Drag brake spring Free length Compressed to 1.7 in. (4.3 cm)	2 in. 48 lb-ft	5.08 cm 65 N•m
12	Automatic brake lining (thickness)	0.17–0.19 in.	4.318–4.826 mm
13	Sliding clutch (inner diameter)	1.887–1.889 in.	4.793–4.798 cm

FRONT WINCH REPAIR (Contd)

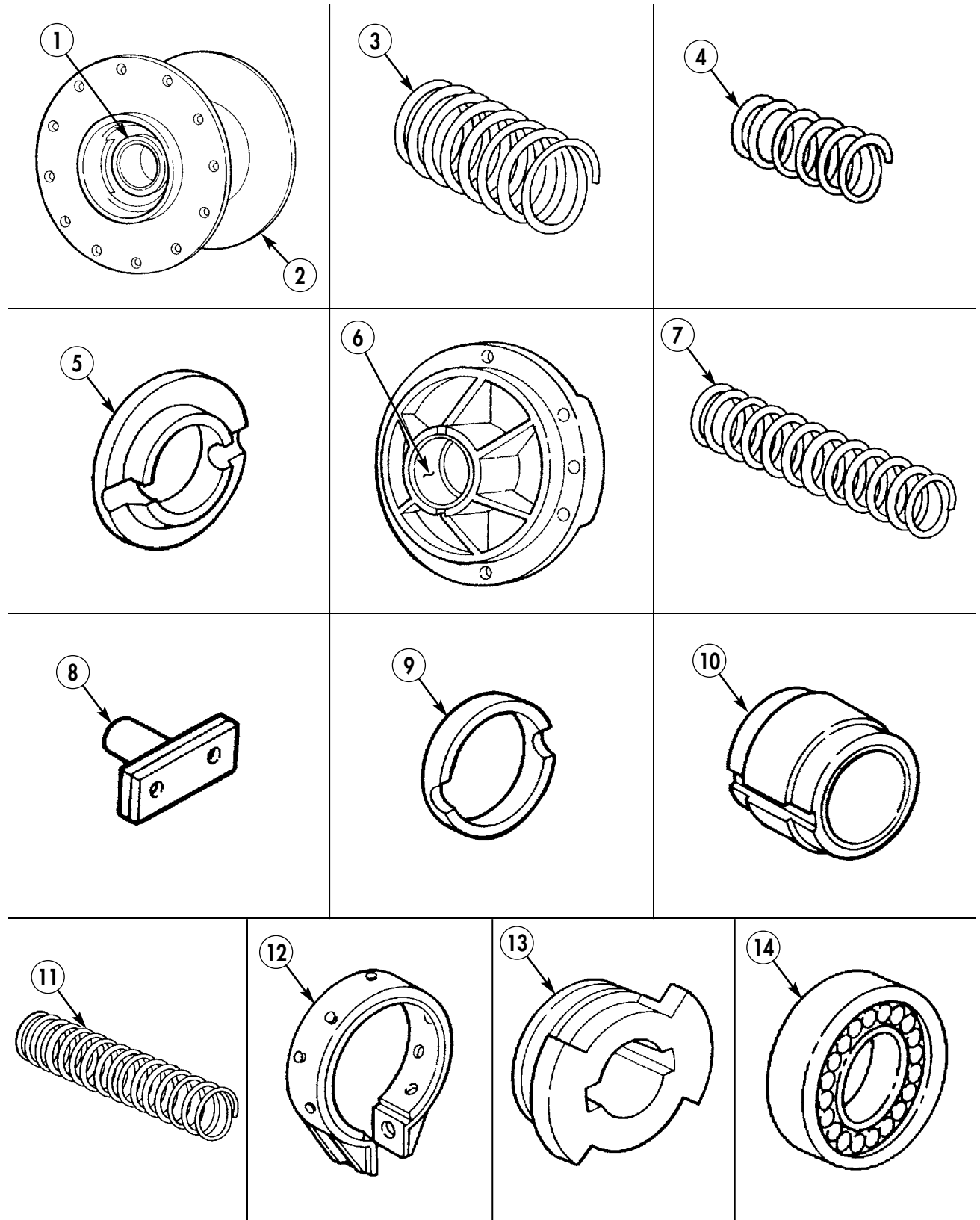

FRONT WINCH REPAIR (Contd)

NOTE

For assembly precautions, refer to WP 0021 00.

GEARCASE ASSEMBLY

1. Install bearing (9) in gearcase (1).
2. Install bearing (2) on worm gear shaft (8).
3. Position worm gear shaft (8) in gearcase (1) and through bearing (9). Tap bearing (2) until seated in gearcase (1).
4. Install new seal (10) in brakecase (11).
5. Apply coat of sealing compound on new gasket (14).
6. Install new gasket (14) and brakecase (11) on gearcase (1) with four new lockwashers (13) and screws (12).
7. Install new seal (3) in bearing cap (4).
8. Apply coat of sealing compound on new gasket (7).
9. Install new gasket (7) and bearing cap (4) on gearcase (1) with four new lockwashers (6) and screws (5).
10. Install dial indicator on gearcase (1) with plunger positioned on the end of worm gear shaft (8).
11. Measure end play of worm gear shaft (8) by moving worm gear shaft (8) back and forth. End play should not be less than 0.005 in. (0.127 mm).
12. Remove dial indicator from gearcase (1).

NOTE

If end play is correct, go to step 14. If end play is incorrect, go to step 13.

13. Remove four screws (5), lockwashers (6), and bearing cap (4) from gearcase (1). Discard lockwashers (6).
14. Perform steps 8 through 12 to install additional gasket (7).

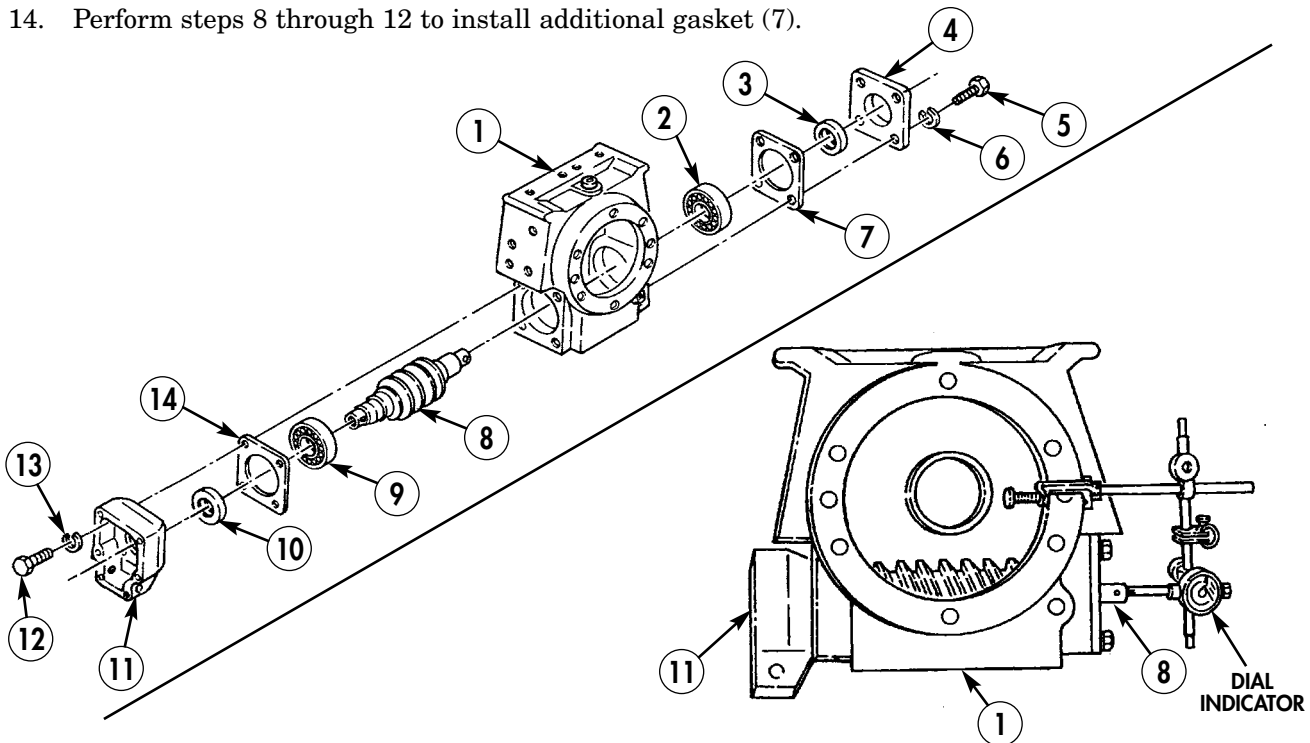

FRONT WINCH REPAIR (Contd)

END FRAME ASSEMBLY (Contd)

1. Install drum shaft (20) in gearcase (1).
2. Install new seal (18) on gearcase (1).
3. Install two setscrews (46) and plugs (19) and (22) in gearcase (1).
4. Install two new woodruff keys (21) and spur gear (29) on drum shaft (20).
5. Install spur gear (29) in gearcase (1) and on worm gear (47).
6. Install new gasket (23) and cover (24) on gearcase (1) with six spacers (25), washers (26), eight new lockwashers (28), and screws (27).
7. Install new woodruff key (30) and brakedrum (40) on worm gear (47) with washer (38), new lockwasher (37), and screw (36).
8. Install new plug (31) in brakecase (11).
9. Install brakeband (33) on brakedrum (40) and brakecase (11) with spring (39), new O-ring (41), washer (42), and screw (43).
10. Install new gasket (32) and cover (35) on brakecase (11) with six new screw-assembled lockwashers (34).
11. Install two jamnuts (44) on rod (45) and install rod (45) on gearcase (1).
12. Install drum (17), thrust ring (16), and two new woodruff keys (15) on drum shaft (20).

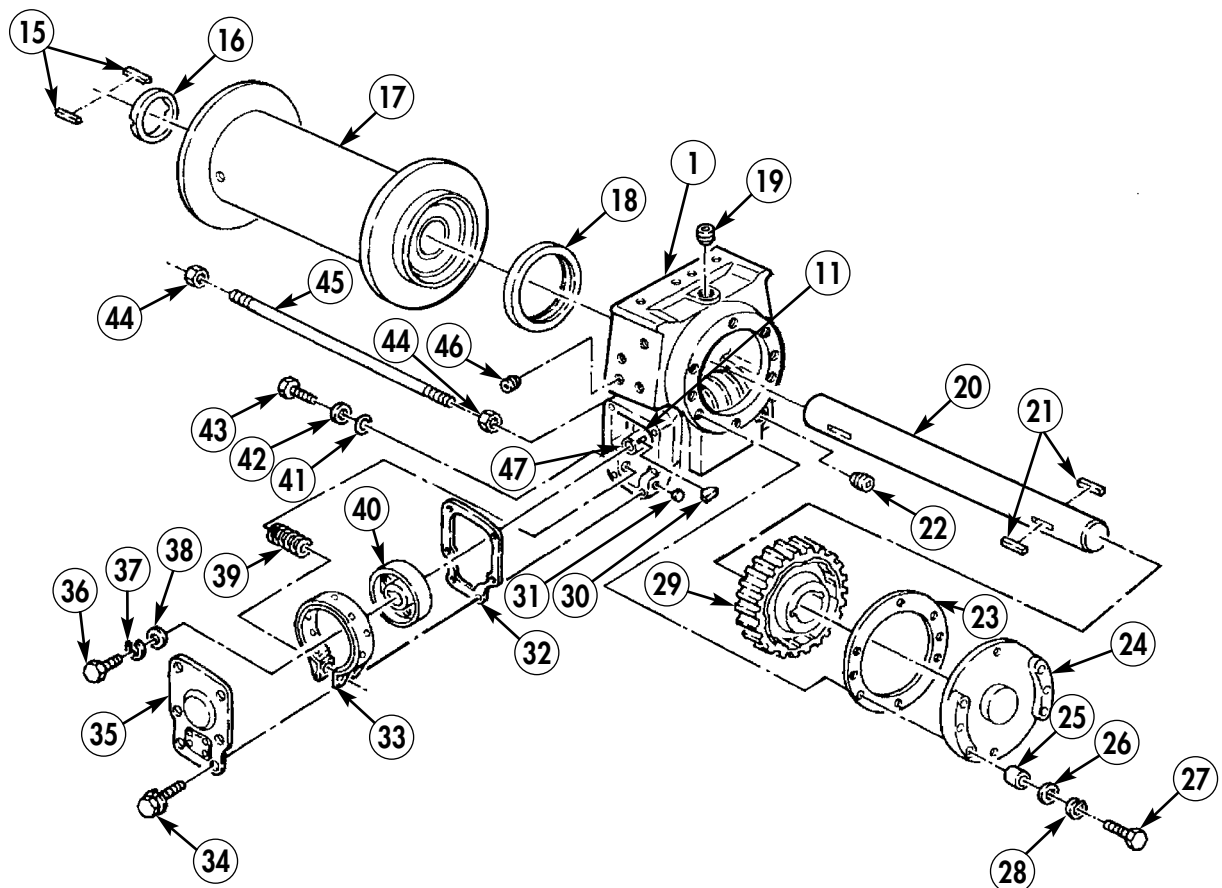

FRONT WINCH REPAIR (Contd)

END FRAME ASSEMBLY (Contd)

13. Install sleeve (27) in end frame (31).
14. Install three plugs (7), plug (6), and new pin (30) in end frame (31).
15. Install poppet (5) and spring (4) in end frame (31) with poppet nut (3).
16. Install poppet latch (2) on poppet nut (3) in lock position with two nuts (1).
17. Install new seal (19) on end frame (31) with plate (8), new lockwasher (9), and screw (10).
18. Install new woodruff key (17) and lever (12) on shifter shaft (18) with new lockwasher (13) and screw (14).
19. Position shifter shaft (18) in end frame (31) and install new woodruff key (11) on shifter shaft (18).
20. Pull shifter shaft (18) partially out of end frame (31) and position spring (15) and ball (16) in lever (12) and install shifter fork (22) on shifter shaft (18) with setscrew (25).
21. Install setscrew (20) and plug (21) in end frame (31).
22. Install drag brake (28) and spring (29) in end frame (31) with adjusting screw (32).
23. Install thrust ring (24), drum sliding clutch (23), and new seal (26) in end frame (31).
24. Install six spacers (33) on end frame (31) with six washers (34), new lockwashers (35), and screws (36).

WINCH ASSEMBLY

NOTE

Ensure sliding clutch and woodruff keys are properly aligned.

1. Install end frame (31) on rod (47) and drum shaft (43).
2. Install channel (37) on gearcase (45) and end frame (31) with six new lockwashers (38) and screws (39).
3. Install channel (40) on gearcase (45) and end frame (31) with four new lockwashers (42) and screws (41).
4. Install new locknut (50) on rod (47) and tighten two jamnuts (48).
5. Install plug (49) in end frame (31).
6. Install plug (46) in gearcase (45).
7. Install front winch (WP 0345 00).

FRONT WINCH REPAIR (Contd)

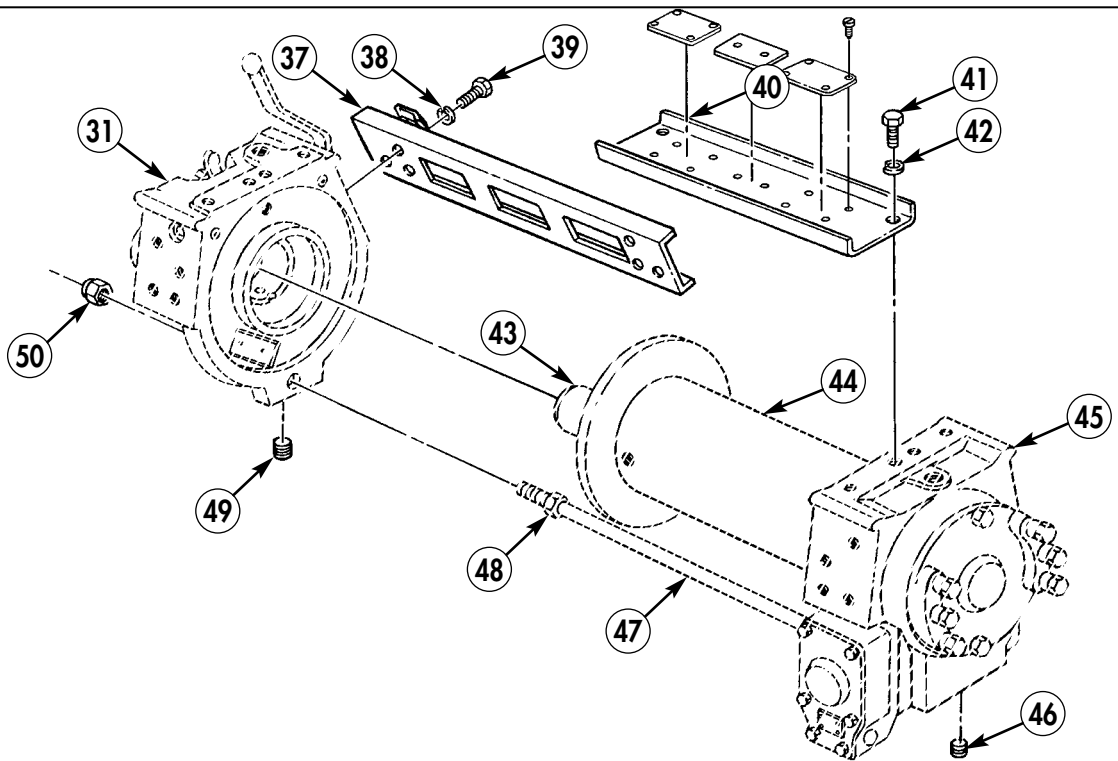
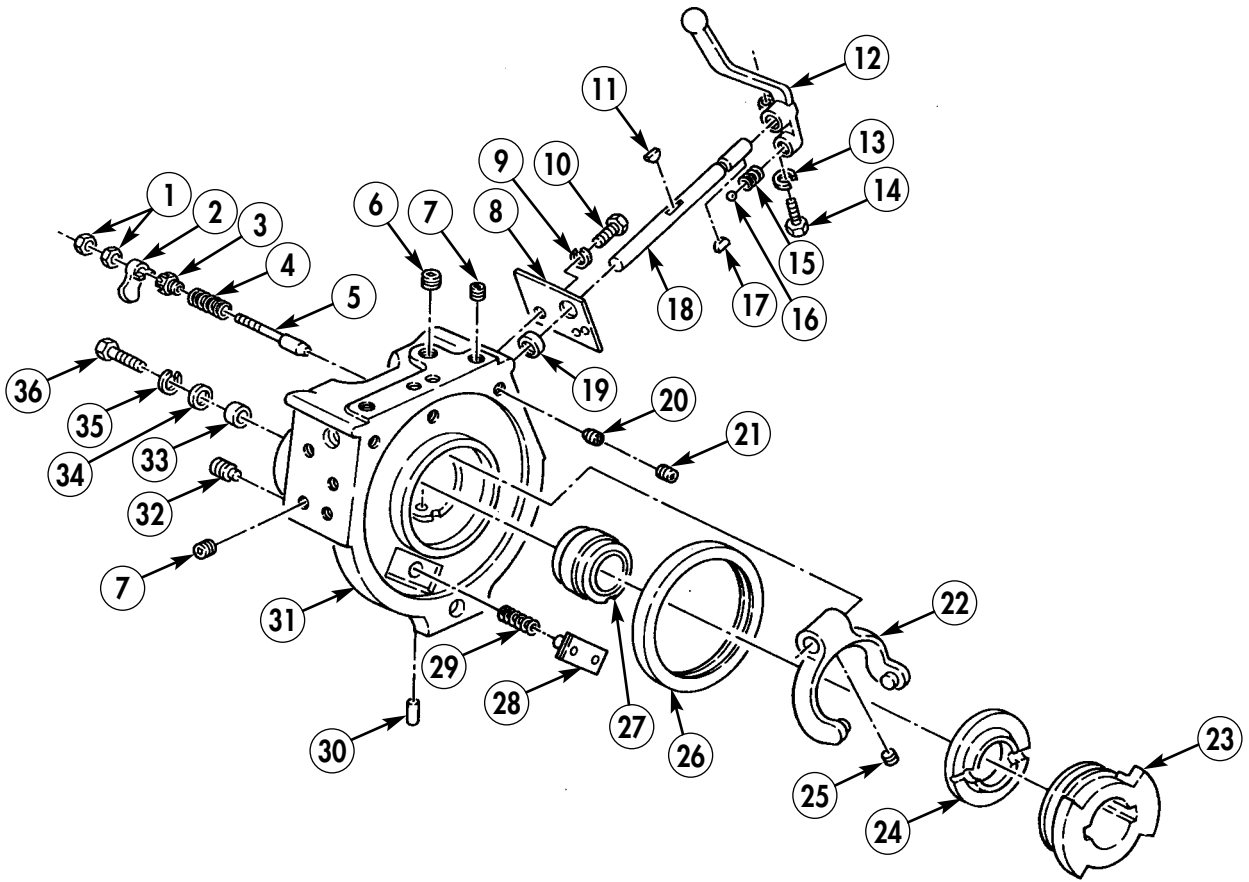

END OF WORK PACKAGE

SUSTAINMENT MAINTENANCE INSTRUCTIONS

2-1/2 TON, 6X6, M44A2 SERIES TRUCKS (MULTIFUEL)

TRANSMISSION POWER TAKEOFF (PTO) REPAIR

For transmission power takeoff (PTO) repair, refer to TM 2520-246-34-1.

CHAPTER 6

SUPPORTING INFORMATION

2-1/2 TON, 6X6, M44A2 SERIES TRUCKS (MULTIFUEL)

	<u>WP Sequence No.</u>
References	WP 0465 00
Maintenance Allocation Chart (MAC) Introduction	WP 0466 00
Maintenance Allocation Chart (MAC)	WP 0467 00
Expendable and Durable Items List	WP 0468 00
Tool Identification List	WP 0469 00
Mandatory Replacement Parts	WP 0470 00
Manufactured Items List	WP 0471 00
Torque Limits	WP 0472 00
Schematics and Wiring Diagrams	WP 0473 00
Index	INDEX-1

SUPPORTING INFORMATION

2-1/2 TON, 6X6, M44A2 SERIES TRUCKS (MULTIFUEL)

REFERENCES

INDEX

The Department of the Army pamphlet (DA PAM 25-30) contains records of current and obsolete publications and blank forms published by the Army, other military services, Department of Defense (DOD) activities, and other government agencies and activities. This pamphlet also provides resources for materials published by other services, but not available through this index, which are used worldwide.

Consolidated Index of Army Publications and Blank FormsDA PAM 25-30

FORMS

Accident Identification CardDD FORM 518
 Oil Analysis LogDA FORM 2408-20
 Equipment Control RecordDA FORM 2408-9
 Equipment Inspection and Maintenance WorksheetDA FORM 2404
 Equipment Log Assembly (Record)DA FORM 2408
 Equipment Maintenance Log (Consolidated)DA FORM 2409
 Equipment Operators Qualification Record (Except Aircraft)DA FORM 348
 Exchange TagDA FORM 2402
 Index of Army Equipment Modification Work OrdersDA PAM 25-33
 Maintenance RequestDA FORM 2407
 Maintenance Request Continuation SheetDA FORM 2407-1
 Maintenance Request RegisterDA FORM 2405
 Material Condition Status ReportDA FORM 2406
 Operator Report Motor Vehicle AccidentsSF 91
 Organizational Control Record for EquipmentDA FORM 2401
 Preventative Maintenance Schedule and RecordDD FORM 314
 Processing and Reprocessing Record for Shipment, Storage, and
 Issue of Vehicle and Spare EnginesDD FORM 1397
 Product Quality Deficiency ReportSF 368
 Report of DiscrepancySF 364
 Recommended Changes to Publications and Blank FormsDA FORM 2028
 Functional Users Manual for The Army Maintenance
 Management System (TAMMS)DA PAM 750-8
 U.S. Army Accident Investigation ReportDA FORM 285
 U.S. Government Motor Vehicle Operations Identification CardOF 346

FIELD MANUALS (FM)

Basic Cold Weather ManualFM 31-70
 Concepts and Equipment of Petroleum OperationsFM 10-67-1
 First AidFM 4-25.11

REFERENCES (Contd)**FIELD MANUALS (FM) (Contd)**

Manual for the Wheeled Driver	FM 21-305
Military Symbols.....	FM 101-5-1
NBC Decontamination.....	FM 3-5
Multiservice Tactics, Techniques, and Procedures for NBC	FM 3-11.4
Northern Operations	FM 31-71
Operation and Maintenance of Army Material in Extreme Cold Weather	FM 9-207
General Fabric Repair	FM 10-16

TECHNICAL MANUALS (TM)

Operators, Unit, Direct Support, and General Support Maintenance Manual for Care, Maintenance Repair, and Inspection of Pneumatic Tires and Inner Tubes	TM 9-2610-200-14
Chemical Agent Alarm Maintenance, Automatic, Portable.....	TM 3-6665-225-12
Cooling Systems, Tactical Vehicles.....	TM 750-254
Decontaminating Apparatus Maintenance, Portable, DS 2	TM 3-4230-204-12&P
General Supply: Deep Water Fording Kits for Ordinance Tank and Automotive Material	SB 9-155
Destruction of Tank-Automotive Equipment to Prevent Enemy Use	TM 750-244-6
Direct and General Support Repair Parts and Special Tools, Lists Truck 2 ½ Ton 6X6, Multifuel, M44A2 Series	TM 9-2320-361-24P
Direct Support, General Support and Depot Maintenance Manual, Starter, (Delco).....	TM 9-2920-242-35
Direct Support, General Support, and Depot Maintenance Manual Starter (Prestolite)	TM 9-2920-248-35
Direct Support and General Support Maintenance Manual for Model 3052 Transmission	TM 9-2520-246-34
Direct Support and General Support Generator Assembly Maintenance.....	TM 9-2920-225-34
General Packing Instructions	TM 746-10
Grinding Machine, Valve Face, Bench Mounting.....	TM 9-4910-484-10
Inspection and Repair of Transfer Case, Transmission, and Power Takeoff.....	TM 9-2520-246-34-1
Inspection, Care, and Maintenance of Antifriction Bearings.....	TM 9-214
Lead Acid Storage Battery Maintenance	TM 9-6140-200-14
Maintenance, Direct Support, and General Support Level Engine Assembly Diesel (Multifuel).....	TM 9-2815-210-34-2-1
Operator's Manual for Brake Drum Lathe	TM 9-4910-482-10
Operator's and Organizational Maintenance Manual, Alarm, Chemical Agent, Automatic Portable Man Pack	TM 3-6665-225-12
Operator's Unit and Direct Support Maintenance Manual with Repair Parts and Special Tools List for Machine Gun Mounts	TM 9-1005-245-13&P
Organizational, Direct Support, and General Support Maintenance for Vehicle Compartment Heaters.....	TM 9-2540-205-24&P

REFERENCES (Contd)**TECHNICAL MANUALS (TM) (Contd)**

Use and Care of Hand Tools and Measuring Tools.....	TM 9-243
Maintenance, Direct Support, and General Support Level Engine Assembly, Diesel (Multifuel) Naturally Aspirated Or Turbocharged, Fuel Injected or Water Cooled	TM 9-2815-210-34-2-2
Materials Used for Cleaning, Preserving, Abrading, and Cementing	TM 9-247
Operator's, Organizational, Direct Support, and General Support Maintenance Manual for Tester, Fuel Injector Pump: Single End Drive 150 to 3600 RPM.....	TM 9-4910-387-14-1
Operator's Manual, Truck 2 ½ Ton, 6X6, Multifuel, M44A2 Series.....	TM 9-2320-361-10
Organizational Maintenance Repair Parts and Special Parts List	TM 9-2320-361-24P
Painting Instructions for Field Use Preservation, Packing of Military Supplies and Equipment	TM 43-0139
Principles of Automotive Vehicles	TM 9-8000
Transportability Guidance Trucks, 2 ½ Ton, 6X6 Truck, Cargo M35.....	TM 55-2320-209-15-1
Simplified Test Equipment for Internal Combustion Engines Reprogrammable	TM 9-4910-571-12&P
Joint Service Manual for Storage and Materials Handling	TM 38-400
Troubleshooting, Direct Support, and General Support Level Engine Assembly Diesel (Multifuel).....	TM 9-2815-210-34-1
Turbocharger Maintenance and Repair	TM 9-2815-210-34-1

TECHNICAL BULLETINS (TB)

Army Oil Analysis Program (AOAP) Guide for Leaders and Users.....	TB 43-0211
Calibration and Repair Requirements for the Maintenance of Army Material	TB 43-180
Color, Marking, and Camouflage Painting of Military Vehicles, Construction Equipment and Materials Handling Equipment.....	TB 43-0209
Functional Grouping Codes.....	TB 750-93-1
Load-Testing Vehicles Used to Handle Missiles and Rockets	TB 9-352
Major Vehicle Mechanical Components Warranty.....	TB 9-2320-209-14
Mandatory Brake Hose Inspection and Replacement	TB 9-2300-405-14
Purging, Cleaning, and Coating Interior Ferrous and Terne Sheet Vehicle Fuel Tanks	TB 43-0212
Equipment Improvement Report and Maintenance Digest for Tank, Automotive and Armament Equipment	TB 43-0001-62
Rustproofing Procedures	TB 43-0213
Safety, Inspection, and Testing of Lifting Devices	TB 43-0142
Security of Tactical Wheeled Vehicles.....	TB 9-2300-422-20
Standard for Overseas Shipment and Domestic Issues of Combat, Tactical and Special Purpose Vehicles	TB 9-2300-281-35
Tactical Wheeled Vehicles: Repair of Frames.....	TB 9-2300-247-40
Use of Antifreeze Solutions and Cleaning Compounds in Engine Cooling Systems	TB 750-651
Warranty Programs for 2 ½ Ton, 6X6, M44A2 Series Trucks.....	TB 9-2320-209-14
Aeronautical Equipment Army Oil Analysis Program	TB 43-0106

REFERENCES (Contd)**TECHNICAL CATALOG (TC)**

Combat Vehicles and Tactical Support Vehicles: Metal Body Repair	TC 9-510
Guide for Basic Military Preservation and Packing.....	TC 38-3
Operator's Manual: Welding Theory and Application.....	TC 9-237

COMMON TABLE OF ALLOWANCES (CTA)

Army Medical Department Expendable/Durable Items.....	CTA 8-100
Expendable/Durable Items (except Medical) Class V, Repair Parts and Heraldic Items	CTA 50-970

ARMY REGULATIONS (AR)

Accident Reporting and Records	AR 385-40
Army Material Maintenance Policy and Retail Maintenance Operations.....	AR 750-1
Catalog of Abbreviations and Brevity Codes	AR 25-52
The Army Publishing Program	AR 25-30
Packaging of Materiel.....	AR 700-15
Prevention of Motor Vehicle Accidents	AR 385-55

OTHER PUBLICATIONS

Antiseize Compound, High Temperature	MIL-A-907E
National Maintenance Work Requirement for Front and Rear Winch Assemblies.....	NMWR 9-3830-501
National Maintenance Work Requirements for Rockwell International Front Axle Assemblies.....	NMWR 9-2520-587
Inspection Equipment, Acquisition, Maintenance, and Disposition	MIL-I-45607C
Inspection Process, Magnetic Particles.....	ASTM E144-01
Methods of Preservation	MIL-STD-2073-1
National Maintenance Work Requirements for Transfer Case Overhaul.....	NMWR 9-2520-588
National Maintenance Work Requirements for Front and Rear Axle Overhaul	NMWR 9-2520-587
National Maintenance Work Requirement for Engine Overhaul	DMWR 5-2815-210

SUPPORTING INFORMATION

2-1/2 TON, 6X6, M44A2 SERIES TRUCKS (MULTIFUEL)

MAINTENANCE ALLOCATION CHART (MAC) INTRODUCTION

THE ARMY MAINTENANCE SYSTEM (AMS)

This Work Package (WP) provides a general explanation of all maintenance and repair functions authorized at two maintenance levels under Two-Level Maintenance System concept.

The Maintenance Allocation Chart (MAC) (WP 0467 00) designates overall authority and responsibility for the performance of maintenance functions on the identified end item or component. The application of maintenance to the end item or component shall be consistent with the capacities and capabilities of the designated maintenance levels, which are shown on the MAC in column (4) as:

Field Level (Tactical)—C (operator/crew), O (unit) maintenance, and F (Direct Support). Field Maintenance is on-system maintenance and is mainly replacement of defective parts and preventative maintenance. Field maintenance returns repaired equipment to operation. It covers crew, unit, and selected DS maintenance tasks. Some “off-system” maintenance can be done at field level, if based on task analysis, it is simple to complete or it is critical to mission readiness.

Sustainment Level (Sustainment)—H (General Support) and D (Depot). Sustainment is off-system maintenance and is mainly repair of defective or worn out equipment/parts. Sustainment maintenance returns repaired equipment/parts to the supply system. It covers selected DS tasks, GS and Depot maintenance.

The tools and test equipment requirements (immediately following the MAC) list the tools and test equipment (both special tools and common tool sets) required for each maintenance function as referenced from the MAC.

The remark (immediately following the tools and test equipment requirements) contains supplemental instructions and explanatory notes for a particular maintenance function.

MAINTENANCE ALLOCATION CHART (MAC) INTRODUCTION (Contd)

MAINTENANCE FUNCTIONS

Maintenance functions are limited to and defined as follows:

1. **Inspect.** To determine the serviceability of an item by comparing its physical, mechanical, and/or electrical characteristics with established standards through examination (e.g., by sight, sound, or feel). This includes scheduled inspection and gauging and evaluation of cannon tubes.
2. **Test.** To verify serviceability by measuring the mechanical, pneumatic, hydraulic, or electrical characteristics of an item and comparing those characteristics with prescribed standards on a scheduled basis, i.e., load testing of lift devices and hydrostatic testing of pressure hoses.
3. **Service.** Operations required periodically to keep an item in proper operating condition; i.e., to clean (includes decontamination, when required), to preserve, to drain, to paint, or to replenish fuel, lubricants, chemical fluids, or gases. This includes scheduled exercising and purging of recoil mechanisms.
4. **Adjust.** To maintain or regulate, within prescribed limits, by bringing into proper position, or by setting the operating characteristics to specified parameters.
5. **Align.** To adjust specified variable elements of an item to bring about optimum or desired performance.
6. **Calibrate.** To determine and cause corrections to be made or to be adjusted on instruments or test, measuring, and diagnostic equipment used in a precision measurement. Consists of comparisons of two instruments, one of which is a certified standard of known accuracy, to detect and adjust any discrepancy in the accuracy of the instrument being compared.
7. **Remove/Install.** To remove and install the same item when required to perform service or other maintenance functions. Install may be the act of emplacing, seating, or fixing into position a spare, repair part, or module component or assembly) in a manner to allow the proper functioning of an equipment or system.
8. **Replace.** To remove an unserviceable item and install a serviceable counterpart in its place. "Replace" is authorized by the MAC and assigned maintenance level is shown as the third position code of the Source, Maintenance and Recoverability (SMR) code.

NOTE

The following definitions are applicable to the repair maintenance functions:

Services – Inspect, test, service, adjust, align, calibrate, and/or replace.

Fault location/troubleshooting – The process of investigating and detecting the cause of equipment malfunctioning; the act of isolating a fault within a system or Unit Under Test (UUT).

Disassembly/assembly – The step-by-step breakdown (taking apart) of a spare/functional group coded item to the level of its least component, that is assigned an SMR code for the level of maintenance under consideration (i.e., identified as maintenance significant).

Actions – Welding, grinding, riveting, straightening, facing, machining, and/or resurfacing.

MAINTENANCE ALLOCATION CHART (MAC) INTRODUCTION (Contd)

MAINTENANCE FUNCTIONS (contd)

9. **Repair.** The application of maintenance services, including fault location/troubleshooting, removal/installation, disassembly/assembly procedures, and maintenance actions to identify troubles and restore serviceability to an item by correcting specific damage, fault, malfunction, or failure in a part, subassembly, module (component or assembly), end item, or system.
10. **Overhaul.** The maintenance effort (service/action) prescribed to restore an item to a completely serviceable/operational condition as required by maintenance standards in appropriate technical publications. Overhaul is normally the highest degree of maintenance performed by the Army. Overhaul does not normally return an item to like-new condition.
11. **Rebuild.** Consists of services/actions necessary for the restoration of unserviceable equipment to a like-new condition in accordance with original manufacturing standards. Rebuild is the highest degree of materiel maintenance applied to Army equipment. The rebuild operation includes the act of returning to zero those age measurements (e.g., hours/miles) considered in classifying Army equipment/components.

EXPLANATION OF COLUMNS IN THE MAC

- Column 1 – Group Number.** Column (1) lists Functional Group Code (FGC) numbers. The purpose of FGC numbers is to identify maintenance significant components, subassemblies, and modules with the Next Higher Assembly (NHA).
- Column 2 – Component/Assembly.** Column (2) contains the item names of components, assemblies, subassemblies, and modules for which maintenance is authorized.
- Column 3 – Maintenance Function.** Column (3) lists the functions to be performed on the item listed in column (2). For a detailed explanation of these functions refer to Maintenance Functions outlined above.
- Column 4 – Maintenance Level.** Column (4) specifies each level of maintenance authorized to perform each function listed in column (3), by indicating work-time required (expressed as man-hours in whole hours or decimals) in the appropriate sub column. This work-time figure represents the active time required to perform that maintenance function at the indicated level of maintenance. If the number or complexity of the tasks within the listed maintenance function varies at different maintenance levels, appropriate work time figures are shown for each level. The work time figure represents the average time required to restore an item to a serviceable condition under typical field operating conditions. This time includes preparation time, including any necessary disassembly/assembly time, troubleshooting/fault location time, and quality assurance time in addition to the time required to perform the specific tasks identified for the maintenance functions authorized in the MAC.
- Column 5 – Tools and Equipment Reference Code.** Column (5) specifies, by code, common tool sets (not individual tools), common Test, Measurement and Diagnostic Equipment (TMDE), and special tools, special TMDE, and special support equipment required to perform the designated function. Codes are keyed to the entries in the tools and test equipment table.
- Column 6 – Remarks Code.** When applicable this column contains a letter code, in alphabetic order, which is keyed to the remarks table entries.

MAINTENANCE ALLOCATION CHART (MAC) INTRODUCTION (Contd)

EXPLANATION OF COLUMNS IN THE TOOLS, SPECIAL TOOLS, AND TEST EQUIPMENT IDENTIFICATION LIST

Column 1 – Tools or Test Equipment Reference Code. The tool and test equipment reference code correlates with a code used in column (5) of the MAC.

Column 2 – Maintenance Level. The lowest level of maintenance authorized to use the tool or test equipment.

Column 3 – Nomenclature. Name or identification of the tool or test equipment.

Column 4 – National Stock Number (NSN). The NSN of the tool or test equipment.

Column 5 – Tool Number. The manufacturer's part number, model number, or type number.

EXPLANATION OF COLUMNS IN THE REMARKS

Column 1 – Remarks Code. The code recorded in column (6) of the MAC.

Column 2 – Remarks. This column lists information pertinent to the maintenance function being performed as indicated in the MAC.

SUPPORTING INFORMATION

2-1/2 TON, 6X6, M44A2 SERIES TRUCKS (MULTIFUEL)

MAINTENANCE ALLOCATION CHART (MAC)

MAINTENANCE ALLOCATION CHART (MAC) (Contd)

Table 1. Maintenance Allocation Chart.

(1) GROUP NO.	(2) COMPONENT/ASSEMBLY	(3) MAINTENANCE FUNCTION	(4) MAINTENANCE LEVEL					(5) TOOLS AND EQUIPMENT REF. CODE	(6) REMARKS
			FIELD		SUSTAINMENT				
			UNIT		DS	GS	DEPOT		
			C	O	F	H	D		
01	ENGINE								
0100	Engine Assembly	Inspect	0.1					A	
		Test		1.5			1		
		Service		2.0			1	A	
		Replace			7.0		1,71,73, 79,94,95,102,110	A	
		Repair				16.0	11,12,21 thru 25,30,31,32	T	
		Overhaul				40.0	16 thru 20	B	
	Pad, Engine Mounting	Inspect		0.2					
		Replace		1.0			1		
0101	Bracket, Front and Rear Engine Mounting	Inspect		0.2					
		Replace			2.0		1,71,94,95,97		
	Head, Cylinder Assembly	Inspect			0.2		1,13,15,72		
		Replace			4.0		1,13,14,23 thru 26,30,42,72		
		Repair				5.0	1,23 thru 26,42,72	T	
	Sleeve, Cylinder	Inspect				0.3			
		Replace				2.0	1,2,15,21,22	T	
0102	Crankshaft	Inspect				1.5			
		Replace				3.0	1,10,27,28,64,65	T	
	Damper, Vibration	Inspect		0.2					
		Replace			2.5		1,71,88,106,107		
0103	Flywheel	Inspect			1.0				
		Replace			4.0		1,72		
		Repair				2.0	1,29,72	T	
0104	Pistons, Connecting Rod	Inspect				0.3			
		Replace				2.0	1,11,12,71,106,107	T	
0105	Guide, Valve	Inspect				0.2			
		Replace				0.5	1,2,24,25,31,32	T	
	Spring, Valve	Inspect				0.3			
		Replace				0.5	1,2,25	T	

MAINTENANCE ALLOCATION CHART (MAC) (Contd)

Table 1. Maintenance Allocation Chart (Contd).

(1) GROUP NO.	(2) COMPONENT/ASSEMBLY	(3) MAINTENANCE FUNCTION	(4) MAINTENANCE LEVEL					(5) TOOLS AND EQUIPMENT REF. CODE	(6) REMARKS
			FIELD			SUSTAINMENT			
			UNIT		DS	GS	DEPOT		
			C	O	F	H	D		
0105 (Contd)	Valves, Intake and Exhaust	Inspect				0.2		1,23,26,30,31	T
		Replace				1.5			
	Arm, Valve Rocker Intake/Exhaust	Inspect			0.2				
		Adjust			0.5		1,71,106,107		
		Replace			1.5		1,31		
		Inspect			0.2				
	Rod, Push Intake Exhaust/Injector	Inspect			0.2				
		Replace			0.5		1,71,106,107		
	Shaft Assembly, Rocker Arm	Inspect			0.3				
		Replace			2.0		1,71,106,107		
	Camshaft and Bearing	Inspect				0.5			
		Replace				4.0	1,2,27,33,39,40,41		
	Timing Gear Cover and Seal	Inspect			0.3				
		Replace			4.0		1		
	Repair			1.0		1,2			
	Inspect			0.3		1			
0106	Pump, Oil	Replace			2.0		1,83,113		
		Repair				4.0	1,83,113		
	Pan, Oil	Inspect		0.1			1		
		Replace			1.0		1,86		
	Engine Oil Cooler and Housing	Replace			0.7		1,108,109		
		Repair			3.0		1,34,35,42,43		
	Oil Filter	Inspect		0.1					
		Replace		0.5			1		
	Breather, Crankcase	Inspect		0.5					
		Replace		1.0			1		
	Manifold, Intake	Inspect			0.5				
		Replace			4.0		1		
	Manifold, Exhaust	Inspect			0.5				
		Replace			0.5		1		
Repair				4.0		1,2			

MAINTENANCE ALLOCATION CHART (MAC) (Contd)

Table 1. Maintenance Allocation Chart (Contd).

(1) GROUP NO.	(2) COMPONENT/ASSEMBLY	(3) MAINTENANCE FUNCTION	(4) MAINTENANCE LEVEL					(5) TOOLS AND EQUIPMENT REF. CODE	(6) REMARKS
			FIELD		SUSTAINMENT				
			UNIT		DS	GS	DEPOT		
			C	O	F	H	D		
02	CLUTCH								
0200	Plate, Pressure	Inspect			0.2				
		Replace			2.0		1,9,69		
	Disk, Clutch	Inspect			0.3				
		Replace					1,69		
0202	Linkage, Clutch Pedal and Control	Inspect		0.2					
		Adjust			0.5		1	T	
		Replace		1.0			1		
03	FUEL SYSTEM								
0301	Injectors, Fuel	Test				0.5	1,36	T	
		Replace			0.5		1,72		
		Calibrate					1,37,38	T	
0302	Pump, Fuel Injector	Inspect			0.5				
		Test				2.0	1,88	T	
		Adjust					1	T	
		Replace			2.0	2.0	1,37		
		Repair				2.0	1,37,38	T	
		Calibrate					1,37,38	T	
	Pump, Fuel, In-Tank	Inspect		0.2		4.0			
		Test		0.5		1.0	1,63,68		
		Replace		1.5			1		
		Repair		1.5			1,3,63,68		
0304	Element, Air Cleaner	Inspect	0.1					A	
		Service	0.5					A	
		Replace		0.5			1		
	Lines and Connections, Vent	Inspect		0.5					
		Replace		1.0			1	D	
	Indicator, Air Cleaner	Inspect	0.1					A	
		Replace		0.2			1		
	Hoses and Clamps	Inspect	0.2					A	
		Replace		0.5			1		

MAINTENANCE ALLOCATION CHART (MAC) (Contd)

Table 1. Maintenance Allocation Chart (Contd).

(1) GROUP NO.	(2) COMPONENT/ASSEMBLY	(3) MAINTENANCE FUNCTION	(4) MAINTENANCE LEVEL					(5) TOOLS AND EQUIPMENT REF. CODE	(6) REMARKS
			FIELD			SUSTAINMENT			
			UNIT	DS	GS	DEPOT			
			C	O	F	H	D		
0305	Turbocharger	Replace		2.0				1	
0306	Tank, Fuel	Replace		1.0				1	
		Repair			1.0			1,2	C
	Lines and Fittings, Fuel	Replace		0.3				1	
		Repair		1.5				1	D
0309	Fuel Filter and Housing	Inspect	0.1						A
		Replace		1.0				1	D
0312	Control, Accelerator, and Throttle Control Linkage	Inspect		0.2					
		Adjust		0.5					
		Replace		1.0				1	
04	EXHAUST SYSTEM								
0401	Exhaust Pipes, Clamps, Shields	Inspect	0.5	0.5					
		Replace		2.0				1	
05	COOLING SYSTEM								
0501	Radiator	Inspect	0.2						A
		Test			0.5	1.0		1	E
		Service		0.3				1	A
		Replace		2.0				1	
		Repair			3.0	3.0		1,13	E
0504	Hoses, Radiator	Inspect	0.2						A
		Replace		0.5				1	
	Water Pump	Inspect		0.5					
		Replace		1.0				1	
0505	Fan Blade	Inspect		0.1					
		Replace		0.5				1	
	Belt, Fan Assembly	Inspect	0.1						
		Adjust		0.3				1	
		Replace		0.5				1	

MAINTENANCE ALLOCATION CHART (MAC) (Contd)

Table 1. Maintenance Allocation Chart (Contd).

(1) GROUP NO.	(2) COMPONENT/ASSEMBLY	(3) MAINTENANCE FUNCTION	(4) MAINTENANCE LEVEL					(5) TOOLS AND EQUIPMENT REF. CODE	(6) REMARKS
			FIELD		SUSTAINMENT				
			UNIT		DS	GS	DEPOT		
			C	O	F	H	D		
06	ELECTRICAL SYSTEM								
0601	Alternator	Inspect		0.1					
		Test		0.5			1,68		
		Adjust		0.6			1		
		Replace		1.0			1,88		
		Repair				2.5	1,3,4,66,67,73,78	F	
0603	Starter Motor	Inspect		0.1					
		Test		0.5			1,68		
		Replace		3.5			1		
		Repair				1.0	1,3,4,67,73,78	G	
0607	Instruments and Gauges	Inspect	0.1	0.2				A	
		Test		0.2			1,60,63,68		
		Replace		1.0			1		
0608	Control, Directional Turn Indicator	Test		0.2			1,68		
		Replace		0.5			1		
0609	Lights	Adjust		0.2			1		
		Replace		0.5			1		
0610	Sending Units and Warning Switches	Inspect	0.1						
		Replace		0.3			1,68		
0611	Horn Assembly	Inspect	0.1					A	
		Replace		0.5			1		
	Switch, Horn	Test		0.1			1,68		
		Replace		0.5			1		
0612	Batteries	Inspect	0.1					A	
		Test		0.5			1,68		
		Service	0.5					A	
		Replace		0.5			1		
	Cables, Battery	Inspect		0.1				A	
		Replace		1.0			1		
		Repair		0.5			1		

MAINTENANCE ALLOCATION CHART (MAC) (Contd)

Table 1. Maintenance Allocation Chart (Contd).

(1) GROUP NO.	(2) COMPONENT/ASSEMBLY	(3) MAINTENANCE FUNCTION	(4) MAINTENANCE LEVEL					(5) TOOLS AND EQUIPMENT REF. CODE	(6) REMARKS
			FIELD		SUSTAINMENT				
			UNIT	DS	GS	DEPOT			
			C	O	F	H	D		
0612 (Contd)	Box, Battery (Contd)	Inspect		0.1					A
		Service		1.5			1		A
		Replace		1.5			1		
	Chassis Wiring Harness	Repair			0.5			1,2	C
		Test		0.5				1,68	
		Replace			4.5			1,67,68,73	
		Repair		1.0				1,3,4,67,68	
07	TRANSMISSION								
0710	Transmission Assembly	Inspect	0.2	0.2					A
		Service	0.5	1.0			1		A
		Replace			4.0			1,72,79,80,86	
		Repair				10.0		1,44,45,72,79,80,86	I
		Overhaul				20.0			I
08	TRANSFER ASSEMBLY								
0801	Transfer Case	Inspect		0.3			1		
		Service		0.5	5.0		1		A
		Replace					1,46 thru 51,72,75,76,102		A
		Repair				4.0			J
		Overhaul				9.5			J
0803	Controls and Linkage, Transfer	Inspect		0.5			1		A
		Adjust		0.3			1		
		Replace		1.5			1		
	Unit, Air Sprag	Test	0.1		1.0				
		Replace			2.1		1		
		Repair					1		
09	PROPELLER AND PROPELLER SHAFTS								
0900	Propeller Shafts	Inspect	0.1						A
		Service		0.5			1		A
		Replace		1.5			1,114		
		Repair		1.0			1,114		
	Bearing, Center	Inspect		0.2					
		Replace		1.5			1,114		

MAINTENANCE ALLOCATION CHART (MAC) (Contd)

Table 1. Maintenance Allocation Chart (Contd).

(1) GROUP NO.	(2) COMPONENT/ASSEMBLY	(3) MAINTENANCE FUNCTION	(4) MAINTENANCE LEVEL					(5) TOOLS AND EQUIPMENT REF. CODE	(6) REMARKS
			FIELD		SUSTAINMENT				
			UNIT		DS	GS	DEPOT		
			C	O	F	H	D		
0900 (Contd)	Joints, Universal	Inspect		0.2					A
		Service		0.3			1		
		Replace		1.5			1,114		
10	FRONT AXLE								
1000	Front Axle Assembly	Inspect	0.1	0.5					A
		Service		1.0			1		
		Replace			5.0		1,70,76		
		Overhaul				14.0	1		K
1002	Carrier Assembly, Differential	Inspect		0.5					
		Service		0.5			1		A
		Replace				7.0	1,102		
		Overhaul				8.0	1,71,72,81,82,87 thru 90,112,121		
	Seal, Pinion	Inspect			0.2				
		Replace			2.0		1,51,57,62		
	Flange, Companion	Inspect			0.3				
		Replace			2.0		1,88		
1004	Steering Mechanism	Inspect		0.5					
		Service		0.2			1		A
		Adjust		1.0			1		
		Replace		3.0			1		
	Knuckle, Steering	Inspect			0.5		1,71,81,82,87,88, 92,93		
		Service		0.2			1		A
		Replace			4.0		1,52,71,92,93		
	Boot, Dust (CV)	Inspect		0.3					A
		Replace		0.7			1		
11	REAR AXLE								
1100	Rear Axle Assembly	Inspect	0.1	0.5					A
		Service		0.5			1		
		Replace			9.0		1,71,86,94,95,96		
		Overhaul				14.0			K

MAINTENANCE ALLOCATION CHART (MAC) (Contd)

Table 1. Maintenance Allocation Chart (Contd).

(1) GROUP NO.	(2) COMPONENT/ASSEMBLY	(3) MAINTENANCE FUNCTION	(4) MAINTENANCE LEVEL					(5) TOOLS AND EQUIPMENT REF. CODE	(6) REMARKS
			FIELD		SUSTAINMENT				
			UNIT	DS	GS	DEPOT			
			C	O	F	H	D		
1102	Carrier Assembly, Differential	Inspect		0.5					
		Service		0.5			1	A	
		Replace				7.0	1,102		
		Repair				6.0	1,55 thru 59,71,72,81,82,87 thru 90,112,121		
		Overhaul				8.0	1,71,72,81,82,87 thru 90,112,121		
	Seal, Pinion	Inspect			0.2				
		Replace			1.0		1,51,57,62		
	Flange, Companion	Inspect			0.3				
		Replace			2.0		1		
	12 BRAKES	1201 Drum, Handbrake	Inspect		1.0				
Replace				1.5			1,86		
Repair						2.5	1,77,81	U	
Linkage, Handbrake			Inspect	0.1					
			Adjust	0.2	0.5			1	
Shoes, Handbrake		Replace		1.0			1		
		Inspect		1.0					
		Adjust		1.0			1		
		Replace		2.5			1,86		
		Repair				4.5	1,77,85,91		
1202 Shoes, Service Brakes	Inspect		0.5						
	Adjust		1.0			1			
	Replace		3.0			1,86			
	Repair				0.5	1,77,85,91			
1204	Master Cylinder	Inspect	0.2						
		Test		1.0			1,60		
		Replace		2.0			1		
	Cylinder, Wheel	Inspect		0.1					
		Replace		2.0			1		
	Cylinder, Air-Hydraulic	Inspect		0.1					
	Replace		1.0			1			

MAINTENANCE ALLOCATION CHART (MAC) (Contd)

Table 1. Maintenance Allocation Chart (Contd).

(1) GROUP NO.	(2) COMPONENT/ASSEMBLY	(3) MAINTENANCE FUNCTION	(4) MAINTENANCE LEVEL					(5) TOOLS AND EQUIPMENT REF. CODE	(6) REMARKS
			FIELD		SUSTAINMENT				
			UNIT		DS	GS	DEPOT		
			C	O	F	H	D		
1204 (Contd)	Lines and Fittings	Inspect		0.1					
		Replace		3.5			1	D,Q	
1206	Brake Pedal	Inspect	0.2					A	
		Adjust		0.5			1		
		Replace		0.2			1		
1208	Air Reservoirs	Inspect		0.2					
		Service	0.2						
		Replace		0.8			1		
	Governor, Air	Adjust		0.3			1		
		Replace		0.5			1		
	Compressor, Air	Inspect	0.1						
Adjust			0.5			1			
Replace			1.5			1,8			
1209	Belt, Drive	Inspect	0.1					A	
		Adjust		0.3			1		
		Replace		0.5			1		
13	WHEELS, HUBS, AND DRUMS								
1311	Bearings, Wheel	Inspect		0.3					
		Service		1.0			1,86		
		Adjust		0.5			1,86		
		Replace		2.5			1,86		
	Drums, Service Brake	Inspect			0.1	0.2		1,86	
		Replace		1.5			1,61,86		
		Repair				2.5	1,61,81	U	
	Hubs, Wheel	Inspect		0.1					
		Replace		1.5			1,86		
	Wheel/Tire Assembly	Inspect	0.1					A	
Service		0.2					A,L		
Replace		2.0					A,L		
1313	Tires	Inspect	0.2					A,L	
		Service	0.2					A	
		Replace		1.0			1,86		
		Repair		1.0			1	L	
		Rebuild					2.0	L	

MAINTENANCE ALLOCATION CHART (MAC) (Contd)

Table 1. Maintenance Allocation Chart (Contd).

(1) GROUP NO.	(2) COMPONENT/ASSEMBLY	(3) MAINTENANCE FUNCTION	(4) MAINTENANCE LEVEL					(5) TOOLS AND EQUIPMENT REF. CODE	(6) REMARKS
			FIELD		SUSTAINMENT				
			UNIT		DS	GS	DEPOT		
			C	O	F	H	D		
1313 (Contd)	Tubes	Inspect		0.2					
		Replace		0.5			1		
		Repair		3.0			1		L
14	STEERING								
1401	Steering Gear	Inspect	0.2						
		Adjust		0.5			1		
		Replace			3.0		1,72		
		Repair				5.5	1,52,54,72,73,81 thru 84		
	Link, Front Drag	Inspect		0.2					
		Replace		1.0			1		
	Rod, Tie Assembly	Inspect		0.2					
		Adjust		0.5			1		
		Replace		1.5			1		
	Arm, Pitman Steering	Inspect		0.1					
		Replace		1.0			1,119		
	Wheel, Steering	Inspect		0.2					
		Replace		1.0			1,88		
15	FRAME AND TOWING ATTACHMENTS								
1501	Frame Assembly	Inspect		0.5	2.0		1,70,86,90,111		
		Repair			4.0		1,70,86,90,111		M
1503	Hook, Pintle	Inspect	0.1						A
		Service		0.1					A
		Replace		0.5			1		
1504	Spare Tire Carrier	Inspect	0.1						A
		Replace		1.0			1		
		Repair		2.0			1		

MAINTENANCE ALLOCATION CHART (MAC) (Contd)

Table 1. Maintenance Allocation Chart (Contd).

(1) GROUP NO.	(2) COMPONENT/ASSEMBLY	(3) MAINTENANCE FUNCTION	(4) MAINTENANCE LEVEL					(5) TOOLS AND EQUIPMENT REF. CODE	(6) REMARKS
			FIELD		SUSTAINMENT				
			UNIT		DS	GS	DEPOT		
			C	O	F	H	D		
16	SPRINGS AND SHOCK ABSORBERS								
1601	Front Springs	Inspect		0.5					
		Replace		3.0			1,86		
		Repair		5.5			1,85,118		
	Shackles and Bolts	Inspect		0.1					
		Replace		1.0			1,86		
	Springs, Rear and Seat	Inspect		0.3					
		Replace		4.0			1,86		
		Repair		6.3			1,86		
1604	Shock Absorber	Inspect		0.1					
		Replace		1.5			1		
1605	Torque Rods	Inspect		0.1					
		Replace		1.5			1,86		
18	BODY, CAB, AND HOOD								
1801	Doors	Inspect	0.1					A	
		Service	0.1	0.1					
		Adjust		0.5				A	
		Replace		1.0				A	
		Repair			2.6		1,2,5,6	N	
	Cab	Inspect	0.2					A	
		Replace				6.0	1	P	
		Repair			6.0		1,2,5,6		
	Hood	Inspect	0.1						
		Adjust		0.5			1		
		Replace		1.0			1		
		Repair			2.0		1,2,6	N	
1802	Fenders	Inspect	0.1						
		Replace		2.0					
		Repair			3.0		1,2,6	N	
	Frame Assembly, Windshield With Glass	Replace		2.0			1		
		Repair			3.5		1,5		

MAINTENANCE ALLOCATION CHART (MAC) (Contd)

Table 1. Maintenance Allocation Chart (Contd).

(1) GROUP NO.	(2) COMPONENT/ASSEMBLY	(3) MAINTENANCE FUNCTION	(4) MAINTENANCE LEVEL					(5) TOOLS AND EQUIPMENT REF. CODE	(6) REMARKS
			FIELD		SUSTAINMENT				
			UNIT		DS	GS	DEPOT		
			C	O	F	H	D		
1806	Seats	Inspect	0.1						
		Replace		0.5				1	
		Repair		1.5				1	U
1810	Body, Cargo	Inspect	0.2						
		Replace			3.0			1,71,94 thru 96,116	
		Repair				4.0		1,2,6	C,N
	Tailgate	Inspect	0.2						
		Replace		1.0				1	
		Repair			2.0			1,2,6	C,N
	Racks	Inspect	0.2						
		Replace		1.0				1	
		Repair		2.0				1	
	Seat, Troop	Inspect	0.2						
		Replace		1.0				1	
		Repair		2.0				1	
1811	Body, Water Tank	Inspect	0.3						
		Replace			4.0			1,71,72,94 thru 97	
		Repair				10.0		1,2,6	C,N
	Covers, Manhole	Inspect	0.1						
		Replace		0.3				1	
		Repair		1.7				1	
	Pump, Delivery	Inspect	0.2						
		Replace		0.5				1	
		Repair				1.5		1,100	
	Control Lever, Cables and Linkage	Inspect	0.3						
		Replace		0.5				1	
		Repair		1.8				1	
Valves, Gate/Discharge	Replace		0.5				1		
	Repair			1.0			1,73,74,82,98,99, 117		
	Service		0.1						
Shaft, Propeller	Replace		0.8				1,114		
	Repair		1.4				1,114		

MAINTENANCE ALLOCATION CHART (MAC) (Contd)

Table 1. Maintenance Allocation Chart (Contd).

(1) GROUP NO.	(2) COMPONENT/ASSEMBLY	(3) MAINTENANCE FUNCTION	(4) MAINTENANCE LEVEL					(5) TOOLS AND EQUIPMENT REF. CODE	(6) REMARKS
			FIELD		SUSTAINMENT				
			UNIT		DS	GS	DEPOT		
			C	O	F	H	D		
1811 (Contd)	Door, Rear Compartment	Replace		0.5				1	
		Repair			1.5			1,72,73,94 thru 97	N
	Body, Fuel Tank	Inspect	0.3						
		Replace			4.0			1,72,73,94 thru 97	
	Pump, Delivery	Repair				10.0		1,2,6	C,N
		Inspect	0.3						A
		Replace		0.5				1	
		Repair				1.5		1,100	
	Control Lever, Cables and Linkage	Inspect	0.3						A
		Replace		0.5				1	
		Repair		1.8				1	
	Valves, Gate/Discharge	Replace		0.5				1	
		Repair			1.0			1,73,74,82,98,99, 117	
	Shaft, Propeller	Service		0.1					
		Replace		0.8				1,114	
		Repair		1.4				1,114	
	Covers, Manhole	Inspect	0.1						A
		Replace		0.2				1	
		Repair		0.7				1	
	Sump Assembly	Inspect	0.3						
Replace				0.5			1		
Repair				1.5			1		
Replace			0.5				1		
Door, Rear Compartment	Repair			1.5			1,72,73,94 thru 97	N	
	Inspect	0.2						A	
1812 Body, Shop Van	Replace				3.5		1,75,84		
	Repair				12.0		1,2,6	N	
Door, Rear Van	Inspect	0.2						A	
	Replace		2.5				1		
Window, Front/Side	Replace			0.6			1		
	Repair			2.0			1,5		

MAINTENANCE ALLOCATION CHART (MAC) (Contd)

Table 1. Maintenance Allocation Chart (Contd).

(1) GROUP NO.	(2) COMPONENT/ASSEMBLY	(3) MAINTENANCE FUNCTION	(4) MAINTENANCE LEVEL					(5) TOOLS AND EQUIPMENT REF. CODE	(6) REMARKS	
			FIELD		SUSTAINMENT					
			UNIT	DS	GS	DEPOT				
			C	O	F	H	D			
1812 (Contd)	Harness, Main Wiring	Replace			5.0			1,67,68		
		Repair		1.0				1,67,68		
20	HOIST, WINCH, POWER CONTROL UNIT, AND POWER TAKEOFF									
2001	Winch, Front	Inspect	0.1							
		Test		0.7				1		
		Service		0.5						
		Adjust		0.5				1	A	
		Replace		3.0				1		
		Repair					4.8		1,71,81,82,87,94 thru 96,116	
		Band, Automatic	Adjust		0.5				1	
			Replace				2.0			
		Cable, Winch	Inspect	0.5						A,R
			Service	0.5						
	Replace			1.0				1		
	Shaft Assembly, Drive	Repair		0.5				1	R	
		Inspect		0.3					A	
		Replace		1.0				1		
	Brakedrum (front only)	Repair		2.0				1		
		Adjust		1.0				1		
	Power Takeoff, Transmission	Replace			2.0					
		Inspect		0.2						
		Adjust		0.2				1		
		Replace			1.0			1,71		
	Controls and Linkage, Power Takeoff	Repair				3.0		1,71,87		
		Adjust		0.3				1		
		Replace			1.0					

MAINTENANCE ALLOCATION CHART (MAC) (Contd)

Table 1. Maintenance Allocation Chart (Contd).

(1) GROUP NO.	(2) COMPONENT/ASSEMBLY	(3) MAINTENANCE FUNCTION	(4) MAINTENANCE LEVEL					(5) TOOLS AND EQUIPMENT REF. CODE	(6) REMARKS
			FIELD		SUSTAINMENT				
			UNIT		DS	GS	DEPOT		
			C	O	F	H	D		
22	BODY, CHASSIS, AND ACCESSORY ITEMS								
2201	Bows	Inspect	0.1					A	
		Replace		1.0			1		
	Cover, Cap Top	Inspect	0.1					A	
		Replace		0.5			1		
		Repair			1.5	1.5	1	S	
2202	Curtains, Body Cover	Inspect	0.1					A	
		Replace		1.0			1		
	Motor, Windshield	Inspect	0.1					A	
		Replace		0.7			1		
	Arm and Blade, Windshield	Inspect	0.1					A	
		Adjust		0.1			1		
		Replace		0.2			1		
	Washer Bottle and Control	Service	0.1					A	
		Replace		0.1			1		
2207	Mirror, Rearview	Inspect	0.5					A	
		Replace		0.5			1		
	Spotlight	Replace		0.5			1		
		Repair		0.5			1		
	Heater, Personnel	Inspect	0.2					A	
		Replace		3.0			1		
33	SPECIAL PURPOSE KITS								
3303	Winterization Kits								
	Kit, Fuel Burning Personnel Heater	Inspect	0.2					A	
		Install			6.0		1,3,4	P	
	Heater, Fuel Burning Personnel	Inspect	0.1					A	
		Replace		0.4			1		
	Kit, Engine Coolant Heater	Inspect	0.2					A	
		Install			10.0		1,3,4	P	

MAINTENANCE ALLOCATION CHART (MAC) (Contd)

Table 1. Maintenance Allocation Chart (Contd).

(1) GROUP NO.	(2) COMPONENT/ASSEMBLY	(3) MAINTENANCE FUNCTION	(4) MAINTENANCE LEVEL					(5) TOOLS AND EQUIPMENT REF. CODE	(6) REMARKS
			FIELD		SUSTAINMENT				
			UNIT		DS	GS	DEPOT		
			C	O	F	H	D		
3303 (Contd)	Heater, Engine Coolant	Inspect	0.1						A
		Replace		0.4				1	
	Kit, Gearshift and Transfer Case Cover	Install			0.5			1	P
	Kit, Radiator Cover	Inspect							A
		Install			1.2			1	P
	Kit, Cargo Body Personnel Heater	Install			6.0			1	P
		Repair			2.0			1	
	Kit, Van Body Primary and Secondary Heater	Install			6.0			1,3,4	P
	Repair			2.0			1,3,4		
3305	Deepwater Fording Kits	Inspect	0.3						A
		Install			12.0			1	P
3307	Special Purpose Kits								
	A-Frame Kit	Inspect	0.2						A
		Install		1.5				1	P
	Kit, Fixed Seatbelt	Install			4.0			1,120	P
	Kit, Floating Seatbelt	Install			4.0			1,120	P
	Kit, Alcohol Evaporator	Install			0.7			1	P
	Hardtop Kit	Inspect	0.1						A
		Install			4.0			1	P
	Slave Receptacle Kit	Install			2.0			1,120	P
	100 Amp Alternator Kit	Install			8.0			1,3,4,120	P
	Machine Gun Mounting Kit	Install		5.0				1	P
	Rifle Mounting Kit	Inspect		0.2					A
		Install			2.0			1,120	P
	Decontamination Mounting Kit	Install		1.0				1,120	P
Chemical Agent Alarm Mounting Kit	Install			4.0			1,120	P	
Fire Extinguisher Mounting Kit	Install		0.5				1,120	P	
Troop Seat Center Mounting Kit	Install		3.5				1,120	P	

MAINTENANCE ALLOCATION CHART (MAC) (Contd)

Table 1. Maintenance Allocation Chart (Contd).

(1) GROUP NO.	(2) COMPONENT/ASSEMBLY	(3) MAINTENANCE FUNCTION	(4) MAINTENANCE LEVEL					(5) TOOLS AND EQUIPMENT REF. CODE	(6) REMARKS
			FIELD		SUSTAINMENT				
			UNIT		DS	GS	DEPOT		
			C	O	F	H	D		
47	GAUGES (NON-ELECTRICAL)								
4701	Speedometer	Inspect	0.1					A	
		Replace		0.4			1		
	Tachometer	Inspect	0.1					A	
		Replace		0.4			1		
4702	Gauge, Air Pressure	Inspect	0.1					A	
		Replace		0.5			1		
4705	Meter, Liquid	Inspect	0.1					A	
		Replace			1.0		1		

MAINTENANCE ALLOCATION CHART (MAC) (Contd)

Table 2. Tool and Test Equipment Requirements

(1) REF. CODE	(2) NOMENCLATURE	(3) NATIONAL STOCK NUMBER	(4) TOOL NUMBER
1	Tool Kit, General Mechanic's	5180-00-177-7033	SC5180-90-CL-N26
2	Shop Equipment, Welding Field Maintenance	3470-00-357-7268	SC4910-95-CL-A08
3	Shop Equipment, Fuel and Electrical	4910-00-754-0714	SC4910-95-CL-A01
4	Tool Kit, Fuel and Electrical	5180-00-754-0655	SC5180-95-CL-B08
5	Tool Kit, Glass Cutting	5180-00-357-7737	SC4990-95-CL-A18
6	Tool Kit, Body and Fender Repair	5180-00-754-0643	SC5180-90-CL-N34
7	Replacer, Oil Seal: Front or Rear Wheel Hub Inner Oil Seal	5120-00-947-2232	10937827
8	Wrench, Pulley Adjusting: Air Compressor Pulley	5120-00-070-7809	10935288
9	Socket, Wrench, Face Spanner: Clutch Release Lever Adjusting Nut	5120-00-034-8443	8390124
10	Replacer, Gear: Crankshaft Gear	5120-00-870-6920	10899179
11	Expander, Piston Ring	5120-00-068-7234	P409S
12	Compressor, Piston Ring: Compressing or Gauging Piston Rings	5120-00-068-7238	10935313
13	Wrench, Box: Cylinder Head Nuts (Long)	5120-00-937-7834	10951484
14	Adapter, Cylinder Compression Tester: Checking Cylinder Compression (Used w/4910-00-870-6283 Gauge Assembly)	4910-00-870-2127	10899183
15	Gauge Assembly: Checking Cylinder Compression (Used w/4910-00-870-2127 Adapter)	4910-00-870-6283	10899180
16	Stand, Maintenance, Automotive Engine: Engine Overhaul (Used w/4910-00-795-0189 Cradle)	4910-00-795-0189	7950189
17	Cradle Assembly: Engine Universal (Used w/4910-00-795-0189 stand)	4910-00-795-0198	7950198
18	Bracket, Angle: Engine Mounting, Right and Left Front (Used w/4910-00-795-0189 Cradle and Stand) (2 Required per Operation)	5340-00-043-5264	10935299
19	Bracket, Double Angle: Engine Mounting Right Rear (Used w/4910-00-795-0198 and 4910-00-795-0189 Cradle and Stand)	5340-00-873-1926	10899188
20	Bracket, Double Angle: Engine Mounting Left Rear (Used w/4910-00-795-0198 and 4910-00-795-0189)	5340-00-873-1925	10912239
21	Ram Kit, Hydraulic: Cylinder Sleeve Removal (Used w/5180-00-071-0736 Remover and Replacer)	4910-00-873-1927	10912249
22	Tool Kit, Cylinder: Remove or Install Cylinder Sleeve (Used w/4910-00-873-1927 Ram Kit)	5180-00-071-0736	10935312
23	Replacing Tool: Intake Valve Seat Insert	5120-00-134-7473	11642007
24	Remover, Valve Guide: Removing or Installing Valve Guides (Used w/5120-00-870-6921 Replacer)	5120-00-871-3513	10899157

MAINTENANCE ALLOCATION CHART (MAC) (Contd)

Table 2. Tool and Test Equipment Requirements (Contd).

(1) REF. CODE	(2) NOMENCLATURE	(3) NATIONAL STOCK NUMBER	(4) TOOL NUMBER
25	Replacer, Valve Guide: Install Valve Guides (Used w/5120-00-8713513 Remover)	5120-00-870-6921	10899158
26	Compressor Assembly, Valve: Compressing Valve Springs or Rotors while Engine is in Vehicle	5120-00-933-6057	10951361
27	Puller Kit, Mechanical: Crankshaft Pulley (Used w/5120-00-870-6914 Adapter: Crankshaft Gear, Camshaft Gear, Compressor, or Water Pump Pulley)	5180-00-338-6721	8708724
28	Plug, Mechanical Puller (Used w/5120-00-338-6721 Puller) (Adapter)	5120-00-870-6914	10899178
29	Extractor, Screw, Threaded Insert: Helical Insert, Flywheel Housing	5120-00-723-6833	1227-6
30	Replacing Tool, Engine: Exhaust Valve Seat Insert	5120-00-134-7480	11642006
31	Reamer, Hand: Intake and Exhaust Valve Guides	5110-01-050-2240	12254220
32	Replacer, Valve Guide (Used w/5120-00-871-3513 Valve Guide Remover)	5120-00-134-7461	11642004
33	Remover and Replacer Kit, Bushing: Camshaft Bearings	5120-00-870-6919	10899154
34	Extractor, Coil Threaded Insert: Helical Threaded Insert, Oil Filter (7/16- to 1-in. Thd Size)	5120-00-251-1527	64595
35	Insert, Screw Threaded Insert: Helical Threaded Insert, Oil Filter (1-14 Thd)	5120-00-204-0881	535-16
36	Tester, Fuel Injector Nozzle	4910-00-255-8641	3YFL
37	Crowfoot Attachment (Used for tightening injector line nuts at injection pump head)	5120-00-134-7459	11642001
38	Stand, Fuel Injector Test	4910-01-194-7667	DFP-156
39	Fixture: Holding Camshaft	3040-00-870-2131	10899172
40	Puller, Mechanical Bearing Plate: Spider Assembly (Used w/5120-00-793-5048 Puller)	5120-00-793-5048	10882818
41	Remover and Replacer Plunger Locks: Removing Camshaft from Housing: Replacing Bearing on Camshaft: Replacing Spider Weight Assembly on Camshaft: Removing Weight Assembly from Camshaft (Used w/5120-00-793-5048 Puller)	5120-00-793-5055	10882856
42	Cap, Valve	4820-00-793-5040	10882854
43	Gauge Set, Pressure Dial Indicating: Fuel Pressure Test	4910-00-319-6195	5704365
44	Adapter, Mechanical Puller: Reverse Idler Gear (Used w/5120-00-313-9496 Puller)	5120-00-708-3254	7083254

MAINTENANCE ALLOCATION CHART (MAC) (Contd)*Table 2. Tool and Test Equipment Requirements (Contd).*

(1) REF. CODE	(2) NOMENCLATURE	(3) NATIONAL STOCK NUMBER	(4) TOOL NUMBER
44	Adapter, Mechanical Puller: Reverse Idler Gear (Used w/5120-00-313-9496 Puller)	5120-00-708-3254	7083254
45	Puller: Reverse Idler Gear (Used w/5120-00-708-3254 Adapter)	5120-00-313-9496	1178
46	Stand, Engine Maintenance	4910-00-246-6138	171ADX
47	Bracket: (Adapting Right Side of Transfer Case to Stand 4910-00-529-8387)	5340-00-610-0920	7010363
48	Bracket: Adapting Left Side of Transfer Case to Stand 4910-00-529-8387)	5340-00-610-0919	7010362
49	Fixture, Transfer Case: Removing and/or Replacing Transfer Case with Lift 4910-00-422-8586	4910-00-694-4777	8708279
50	Remover and Replacer: Transfer Case Idler Shaft Front Bearing Cup (Used w/5340-00-708-3241 Handle)	5120-00-708-3247	7083247
51	Handle, Remover and Replacer (Used w/Removers and Replacers)	5340-00-708-3241	7083241
52	Burnisher: Steering Knuckle Sleeve Bushing	5120-00-708-3237	7083237
53	Screw, Remover and Replacer (Used w/5120-00-473-7372 and 5120-00-708-3246 Remover and Replacer)	5120-00-708-3216	7083216
54	Remover and Replacer: Steering Gear Housing: Pitman Arm Shaft Bushing	5120-00-708-3248	7083248
55	Puller Screw Type: Differential Spider Pinion Bushing	5120-00-836-6689	8366689
56	Burnisher: Differential Spider Pinion Bushing	5120-00-708-3236	7083236
57	Replacer, Oil Seal: Differential Carrier Through Shaft Oil Seals (Used w/5340-00-708-3241 Handle)	5120-00-708-3256	7083256
58	Remover, Oil Seal: Differential Carrier Through Shaft Rear Oil Seal (Used w/5340-00-708-3241 Handle)	5120-00-708-3250	7083250
59	Remover and Replacer, Bearing Sleeve: Differential Carrier Bevel Gear Bearing Sleeve (Used w/5120- 00-708-3241 Handle)	5120-00-708-3246	7083246
60	Gauge Pressure, Dial Indicating (Checking Air Brake Air Pressure)	6685-00-387-9654	216390
61	Wrench, Socket: Wheel Stud Nut	5120-00-293-2452	7083293
62	Remover, Oil Seal: Differential Carrier Through Shaft Front Oil Seal (Used w/5340-00-708-3241 Handle)	5120-00-708-3249	7083249
63	Fuel Pressure Gauge: Fuel Pump (in-tank) Testing	4910-00-255-8673	8673

MAINTENANCE ALLOCATION CHART (MAC) (Contd)

Table 2. Tool and Test Equipment Requirements (Contd).

(1) REF. CODE	(2) NOMENCLATURE	(3) NATIONAL STOCK NUMBER	(4) TOOL NUMBER
64	Crankshaft Driver	5120-00-134-7464	11642010
65	Replacer, Oil Seal: Front Crankshaft Oil Seal	5120-00-134-7481	11642003
66	Torx Socket: 60 amp Alternator	5120-01-227-3159	TLE60
67	Tool Kit, Electrical	5180-00-876-9336	7550526
68	Multimeter	6625-01-265-6000	AN/PSM-45A
69	Clutch Alignment Kit	5180-00-449-3785	A37M
70	Plum Bob	5120-00-238-3299	PBB-8
71	Torque Wrench, 3/4-in. drive	5120-01-118-3679	TESI800A
72	Torque Wrench, 1/2-in. drive	5120-00-640-6364	B107.14M
73	Torque Wrench, 3/8-in. drive	5120-00-230-6380	TQ-12B
74	Caliper, Vernier	5210-01-113-1548	5210-01-113-1548
75	1-1/8-in. Socket, 1/2-in. drive	5120-00-189-7914	1U7111
76	1-1/16-in. Socket, 1/2-in. drive	5120-00-189-7913	B107.1
77	Brake Reliner	4910-00-173-5310	MILR13495
78	Soldering Iron	3439-00-542-0396	8200G3
79	Sling	4910-00-944-4915	1806
80	Bar, Breaker, 1/2-in. drive	5120-00-224-1393	1170500
81	Inside Micrometer	5120-00-221-1921	124BZ
82	Outside Micrometer	5210-00-554-7134	02-0866-9700
83	Adapter, 1/2 in. Male 3/8-in. Female	5130-00-449-7698	SJ409-2/#2DP
84	1-1/4-in. Socket, 1/2-in. drive	5120-00-237-0977	B107.1
85	Riveting Tool	5120-01-289-4310	HP-2
86	Hydraulic Jack	4910-00-289-7233	93660
87	Indicator, Dial	5120-00-277-8840	196A
88	Mechanical Puller Kit	5120-00-423-1596	GGG-P-781
89	Arbor Press	3444-00-449-7295	26A49
90	Tape Measure	5210-00-234-6745	C213
91	Vise	5120-00-293-1439	204
92	1-5/16-in. Socket, 3/4-in. drive	5120-00-232-5681	5120-00-232-5681
93	Wheel Alignment Indicator	4910-00-221-2472	AR40
94	1-1/8-in. Socket, 3/4-in. drive	5120-00-239-0021	9336SPG
95	Bar, Breaker, 3/4-in. drive	5120-00-224-1393	1170500
96	Handle, Socket Wrench, 3/4-in. drive	5120-00-249-1076	1940708
97	1-1/4-in. Socket, 3/4-in. drive	5120-00-235-5871	3105A
98	Spring Tester	6635-00-641-7346	SPT-850285
99	Pipe Wrench	5120-00-277-1486	TKCXIH

MAINTENANCE ALLOCATION CHART (MAC) (Contd)

Table 2. Tool and Test Equipment Requirements (Contd).

(1) REF. CODE	(2) NOMENCLATURE	(3) NATIONAL STOCK NUMBER	(4) TOOL NUMBER
100	Snapping Pliers	5120-00-789-0492	4440R
101	1-1/2-in. Socket, 3/4-in. drive	5120-00-293-0094	9003-12-48
102	Lift, Transmission and Differential	4910-00-585-3622	49
103	1-3/4-in. Socket, 1-in. drive	5120-01-425-8995	8156
104	Handle, Socket Wrench, 1-in. drive	5120-00-221-7968	X-51A
105	11/16-in. Flare Wrench, 12 pt.	5120-00-224-3141	11655785-2
106	1-5/8-in. Socket, 3/4-in. drive	5120-01-399-9692	5552
107	Handle, Socket Wrench, 3/4-in. drive	5120-00-221-7959	H377
108	1/2-in. Allen Wrench	5120-00-198-5391	024-0067-00
109	1-1/4-in. Open-End Wrench	5120-00-187-7134	26-169
110	1-1/4-in. Box Wrench	5120-00-184-8677	B107.100
111	Straightedge	6675-00-224-8807	564000-36
112	Gauge, Force, Mechanical	6670-00-254-4634	A-A-50062-15
113	12-in. Extension, 3/8-in. drive	5120-00-243-1691	35W198
114	Universal Joint, 3/8-in. drive	5120-00-224-9215	1060775
115	2-1/4-in. Socket, 1-in. drive	5120-00-261-2843	5120-00-261-2843
116	1-1/16-in. Socket, 3/4-in. drive	5120-00-189-7928	1817
117	Adjustable Screw	5120-00-264-3793	2117080
118	C-Clamp	5120-00-222-1612	S34250
119	Drill, Electric	4910-00-754-0650	SC-4910-95-CL-A72
120	Remover and Replacer (Used w/5120-00-708-3216 and 5120-00-708-3246)	5120-00-473-7372	7082863

MAINTENANCE ALLOCATION CHART (MAC) (Contd)

Table 3. Remarks.

REFERENCE CODE	REMARKS
A	Perform PMCS as shown in TM 9-2320-361-10.
B	Engine overhaul will be in accordance with DMWR 9-2815-210.
C	Welding will be in accordance with TC 9-237.
D	Repair of lines and fittings will be in accordance with TM 9-243.
E	Test and repair of radiator will be in accordance with TM 750-254.
F	Repair of alternator will be in accordance with TM 9-2920-225-34.
G	Repair of starter will be in accordance with TM 9-2920-243-34.
H	Repair of batteries will be in accordance with TM 9-6140-200-14.
I	Transmission repair and overhaul will be in accordance with TM 9-2520-246-34.
J	Transfer case overhaul will be in accordance with TM 9-2520-246-34-1.
K	Overhaul of front and rear axle will be in accordance with NMWR 9-2520-587.
L	Repair, inspection, and storage of tires/tubes will be in accordance with TM 9-2610-200-14.
M	Repair of frames will be in accordance with TB 9-2300-247-40.
N	Metal body repair will be in accordance with TC 9-510.
O	Overhaul of front winches will be in accordance with NMWR 9-3830-501.
P	Refer to kit installation instructions for kit installation.
Q	Inspection of brake lines will be in accordance with TB 9-2300-405-14.
R	Service/inspection of winch/hoist wire rope/cables will be in accordance with TB 43-0142.
S	Repair of canvas will be in accordance with FM 10-16.
T	Inspection and repair will be in accordance with TM 9-2815-210-34-1.
U	Inspection and repair of brake drums will be in accordance with TM 9-4910-482-10.

SUPPORTING INFORMATION

2-1/2 TON, 6X6, M44A2 SERIES TRUCKS (MULTIFUEL)

EXPENDABLE AND DURABLE ITEMS LIST

This work package (WP) lists expendable and durable items that you will need to operate and maintain the M44A2 vehicle. This list is for information only and is not authority to requisition the listed items. These items are authorized to you by CTA 50-970, Expendable/Durable Items (Except Medical, Class V Repair Parts, and Heraldic Items), or CTA 8-100, Army Medical Department Expendable/Durable Items.

EXPLANATIONS OF COLUMNS IN THE EXPENDABLE/DURABLE ITEMS LIST

Column 1—Item Number. Number assigned for cross-referencing from the Material/Parts list in WP Initial Setups.

Column 2—Level. Lowest level of maintenance that requires the listed item. C = Operator/Crew, O = Unit/AVUM, F = Direct Support/AVIM, H = General Support, D = Depot.

Column 3—National Stock Number (NSN). Number used for requisitioning the item.

Column 4—Item Name, Description, Commercial and Government Entity Code (CAGEC), and Part Number (P/N). Other information needed to identify and requisition the item.

Column 5—Unit of Measure (U/M). Unit of measure or count of the item as issued per the NSN shown in column 3.

EXPENDABLE AND DURABLE ITEMS LIST (Contd)

Table 1. Expendable and Durable Items List.

(1) ITEM NUMBER	(2) LEVEL	(3) NATIONAL STOCK NUMBER	(4) ITEM NAME, DESCRIPTION, CAGEC, PART NUMBER	(5) U/M
1	O	8040-00-262-9026	ADHESIVE: natural rubber, type I (81348) MMM-A-1617 1/2-Pint Can	PT
2	O	8040-00-262-9005	ADHESIVE: natural rubber, type II (81348) MMM-A-1617 1-Gallon Can	GAL.
3	O	8040-00-262-9028	ADHESIVE: reclaimed rubber (81348) MMM-A-1617 1-Pint Can	PT
4	O	8040-00-833-9563	ADHESIVE SEALANT: silicone rubber, Silastic 732 RTV (clear) non-hardening, type I, 5 oz. (94833) 52498 1 Kit	KT
5	O	8040-00-262-9011	ADHESIVE: synthetic rubber, type III (81348) MMM-A-1617 1-Pint Can	PT
6	O	6810-00-822-7637	ALCOHOL (37490) 3032 1-Pint Bottle	PT
7	O	6850-01-464-9125 6850-01-464-9137 6850-01-464-9152 6850-01-464-9096	ANTIFREEZE: permanent, ethylene glycol, (-60°F (-51°C)) inhibited (O-A-548), heavy-duty, green, recycled (58536) A-A-52624 1-Gallon Container 5-Gallon Container 55-Gallon Drum 55-Gallon Drum (Arctic)	GAL. GAL. GAL. GAL.
8	O	8030-00-155-6444	ANTISEIZE COMPOUND (05972) 76759 Tube	OZ
9	C	9150-01-102-9455 9150-01-123-3152 9150-01-072-8379	BRAKE FLUID: automotive, silicone, all-weather, operational and preservative (81349) MIL-B-46176 1-Gallon Container 5-Gallon Container 55-Gallon Drum	GAL. GAL. GAL.
10	O	5340-00-450-5718	CAP AND PLUG SET (19207) 10935405 1 Set	EA
11	O	7510-00-164-8893	CHALK: marking, white (81348) SS-C-266 1 Gross	GR

EXPENDABLE AND DURABLE ITEMS LIST (Contd)

Table 1. Expendable and Durable Items List (Contd).

(1) ITEM NUMBER	(2) LEVEL	(3) NATIONAL STOCK NUMBER	(4) ITEM NAME, DESCRIPTION, CAGEC, PART NUMBER	(5) U/M
12	O	6850-00-598-7328	CLEANING COMPOUND: engine cooling system (oxalic acid/borax inhibitor) (81349) MIL-C-10597 1 Kit	KT
13	C	6850-01-381-4423	CLEANING COMPOUND: solvent, Skysol 100 (0K209) SKYSOL 100 5-Gallon Can	GAL.
14	F	5350-00-221-0872	CLOTH: abrasive (crocus cloth), 9-in. x 11-in. sheets (76381) 051144-02435 50 Sheets/Package	EA
15	O	8030-00-244-1297	CORROSION PREVENTATIVE COMPOUND: grade 2, soft film (81349) MIL-C-16173 1-Gallon Can	GAL.
16	C	7930-00-282-9699	DETERGENT: general purpose, nonsudsing, liquid (80244) MIL-D-16791TY1 1-Gallon Container	GAL.
17	C	9150-01-197-7693 9150-01-197-7690 9150-01-197-7689	GREASE: AUTOMOTIVE AND ARTILLERY (GAA) (81349) M-10924-B, M-10924-C, and M10924-D 14-Ounce Cartridge 1-3/4-Pound Can 6-1/2-Pound Can	OZ LB LB
18	O	9150-01-095-5512	GREASE, BALL AND ROLLER BEARING (73219) L0189.001 Case, 24/14-Ounce Cans	OZ
19	F	9150-00-190-0919	GREASE, GRAPHITE (81348) VV-G-671 6-1/2-Pound Can	LB
20	O	9150-00-190-0918 9150-00-235-5568 9150-00-272-7652	GREASE, GRAPHITE: hard, grade 1 (19207) VV-G-671 1-3/4-Pound Can 6-1/2-Pound Can 35-Pound Can	LB LB LB
21	F	5970-00-186-6529	INSULATING COMPOUND KIT, ELECTRICAL (76381) SCOTCHCAST 10 20 LB 20-Pound Can	LB
22	O	6810-00-264-8983	METHYLETHYLKETONE, TECHNICAL (19207) 7527656 3-Ounce Bottle	OZ

EXPENDABLE AND DURABLE ITEMS LIST (Contd)

Table 1. Expendable and Durable Items List (Contd).

(1) ITEM NUMBER	(2) LEVEL	(3) NATIONAL STOCK NUMBER	(4) ITEM NAME, DESCRIPTION, CAGEC, PART NUMBER	(5) U/M
23	C	9150-00-189-6727 9150-00-186-6668 9150-00-191-2772 9150-00-183-7807	OIL, LUBRICATING, ENGINE, OE/HDO 10 (81349) M2104-1-10-W 1-Quart Can 5-Gallon Drum 55-Gallon Drum Bulk	QT GAL. GAL. GAL.
24	C	9150-00-186-6681 9150-00-188-9858 9150-00-189-6729	OIL, LUBRICATING, ENGINE, OE/HDO 30 (81349) M2104-4-30W 1-Quart Can 5-Gallon Drum 55-Gallon Drum	QT GAL. GAL.
25	C	9150-01-035-5392 9150-01-035-5393 9150-01-035-5394	OIL, LUBRICATING, GEAR, GO 80/90: multipurpose (81349) MIL-PRF-2105, M2105-3-80W90 1-Quart Can 5-Gallon Drum 55-Gallon Drum	QT GAL. GAL.
26	H	8010-00-247-8707	PIGMENT, Paint Products: ultramarine blue (96906) MS35740-1 1/2-Pint Can	PT
27	C	7920-00-205-1711	RAG, WIPING: unbleached cotton and cotton-synthetic, mixed colors (80244) 7920-00-205-1711 50-Pound Bale	EA
28	O	8030-01-218-0321 8030-01-054-0740	SEALANT, PIPE: teflon sealing compound (02570) MS-PTS-50 Tube Box	OZ OZ
29	O	8030-00-148-9833	SEALING COMPOUND: anaerobic, type I, grade K (81349) MIL-S-46163 10-Cubic Centimeter Bottle	CC
30	O	8030-00-252-3391	SEALING COMPOUND: non-hardening, gasket-forming cement, type II (81349) MIL-S-45180 11-Ounce Tube	OZ
31	F	8030-00-247-2525	SEALING COMPOUND: Permatex 1 (62185) Q360 11-Ounce Tube	OZ
32	O	8030-00-965-2438	SEALING COMPOUND: tape form, type III (81349) MIL-S11030 60-Foot Roll	FT
33	F	8030-00-543-4384	SEALING COMPOUND: thread and gasket; fuel, oil, and water resistant (81343) AMS-S-7916 1-Pint Can	PT

EXPENDABLE AND DURABLE ITEMS LIST (Contd)

Table 1. Expendable and Durable Items List (Contd).

(1) ITEM NUMBER	(2) LEVEL	(3) NATIONAL STOCK NUMBER	(4) ITEM NAME, DESCRIPTION, CAGEC, PART NUMBER	(5) U/M
34	F	8030-00-081-2325	SEALING COMPOUND: thread-locking (05972) 07831 50-Cubic Centimeter Bottle	CC
35	F	6850-01-137-8525 6850-00-927-9461	SILICONE COMPOUND (81349) M47113-1A, (19207) 12273204 2-Ounce Package 5-Ounce Tube	OZ OZ
36	H	6850-00-177-5094	SILICONE COMPOUND: with corrosion inhibitor (71984) DC4-20Z 2-Ounce Tube	OZ
37	F	3439-00-224-3567	SOLDER, TIN ALLOY: rosin core (81346) SN60WRAP3 0.094 5 LB 5-Pound Container	LB
38	O	5975-00-899-4606	STRAP, TIEDOWN: electrical components, polyamide nylon, self-locking, black (81343) MS3367-2-0 One Hundred	EA
39	O	5975-00-111-3208	STRAP, TIEDOWN: electrical components, polyamide nylon, self-locking, black (81343) MS3367-5-9 One Hundred	EA
40	O	5975-00-570-9598	STRAP, TIEDOWN: electrical components, nylon, self-locking, type I, 10 in. long (96906) MS3367-7-9 One Hundred	EA
41	O	5975-00-156-3253	STRAP, TIEDOWN, electrical components, plastic, self-locking, type I, class I, natural color (81343) MS3367-2-9 One Hundred	EA
42	O	8030-00-889-3535	TAPE, ANTISEIZE: white, 0.5 in. wide x 260 in. long x 0.0035 in. thick, with snap-on shell (81755) P5025-2R 1 Spool	FT
43	O	5970-00-419-4291	TAPE, INSULATION, ELECTRICAL: black (75037) 17 3-4 in. Black 108-Foot Roll	FT
44	F	7150-00-290-2023	TAPE, PRESSURE-SENSITIVE ADHESIVE: 1/2 in. wide, tan, type 2, flat-back masking tape (0X796) 162K-1/2 60-Yard Roll	YD

EXPENDABLE AND DURABLE ITEMS LIST (Contd)*Table 1. Expendable and Durable Items List (Contd).*

(1) ITEM NUMBER	(2) LEVEL	(3) NATIONAL STOCK NUMBER	(4) ITEM NAME, DESCRIPTION, CAGEC, PART NUMBER	(5) U/M
45	F	7510-00-283-0612	TAPE, PRESSURE-SENSITIVE ADHESIVE: polyester film, opaque, 1 in. wide, 2 millimeters thick (19203) 8790710 60-Yard Roll	YD
46	O	6810-00-678-4418 6810-00-184-4794 6810-00-184-4800	TRICHLOROETHYLENE, TECHNICAL (81346) ASTM D 4080 1-Gallon Container 5-Gallon Container 55-Gallon Drum	GAL. GAL. GAL.
47	F	4020-00-446-1053	TWINE (96599) 4 PLY 40Z12 60-Yard Roll	YD
48	F	9505-00-198-9125	WIRE, NON-ELECTRICAL (80244) 22W1642-125 1-Pound Roll	LB
49	F	9525-00-990-7799	WIRE, NON-ELECTRICAL: safety or lock wire (80205) MS20995NC40 1-Pound Roll	LB
50	O	9505-00-684-4843	WIRE, NON-ELECTRICAL: safety or lock wire (80205) MS20995F41 1-Pound Roll	LB
51	H	9505-00-248-9850	WIRE, NON-ELECTRICAL: zinc coated (galvanized), carbon steel (81346) ASTM A641 1-Pound Roll	LB
52	O	5610-01-027-3980	TAR, PETROLEUM ASPHALT Waterproofing (64247) 558 5 Gallon Container	GAL.

END OF WORK PACKAGE

SUPPORTING INFORMATION

2-1/2 TON, 6X6, M44A2 SERIES TRUCKS (MULTIFUEL)

TOOL IDENTIFICATION LIST

This Work Package (WP) lists all common tools and supplements and special tools/fixtures needed to maintain the M44A2 vehicle.

EXPLANATION OF COLUMNS

- Column (1)—Item Number.** This number is assigned to the entry in the list and is referenced in the initial setup to identify the item (e.g., Clamp, C (item 17, WP 0469 00)).
- Column (2)—Nomenclature.** This column lists the item by noun nomenclature and other descriptive features (e.g., Gauge, belt tension).
- Column (3)—National Stock Number.** This is the National Stock Number (NSN) assigned to the item; use it to requisition the item.
- Column (4)—Part Number.** Indicates the primary number used by the manufacturer (individual, company, firm, corporation, or Government activity) which controls the design and characteristics of the item by means of its engineering drawings, specifications, standards, and inspection requirements to identify an item or range of items.
- Column (5)—Reference.** This column identifies the authorizing supply catalog or RPSTL for items listed in this WP.

TOOL IDENTIFICATION LIST (Contd)

Table 1. Common and Special Tools List.

(1) ITEM NO.	(2) NOMENCLATURE	(3) NATIONAL/NATO STOCK NUMBER	(4) PART NUMBER	(5) REFERENCE
1	Adapter, 1/2-in. Male – 3/8-in. Female	5130-00-449-7698	SJ409-2/#2DP	4910-95-CL-A31
2	Adapter, Cylinder Compression Tester	4910-00-870-2127	10899183	—
3	Adapter, Mechanical Puller, Reverse Idler Gear	5120-00-708-3254	7083254	—
4	Angle Bracket	5340-00-043-5264	10935299	—
5	Automotive Engine Overhaul Maintenance Stand	4910-00-795-0189	7950189	—
6	Bar, Breaker, 1/2-in. drive	5120-00-223-7218	11870	—
7	Bar, Breaker, 3/4-in. drive	5120-00-224-1393	1170500	4910-95-CL-A31
8	Bar, Breaker, 3/4-in. drive	5120-01-335-1515	NPB124A	4910-95CL-A31
9	Bearing Remover/Replacer	5120-00-793-5055	10882856	—
10	Bracket, Angle, (Adapter Left Side of Transfer Case to Stand)	5340-00-610-0919	7010362	—
11	Bracket, Angle, (Adapter Right Side of Transfer Case to Stand)	5340-00-610-0920	7010363	—
12	Burnisher, Steering Knuckle Sleeve Bushing	5120-00-708-3237	7083237	—
13	Burnisher, Differential Spindle Pinion Bushing	5120-00-708-3236	7083236	—
14	Burnisher, Sleeve Bearing Hand	5120-00-708-3238	7083238	Special Tool
15	Caliper, Vernier	5210-01-113-1548	5210-01-113-1548	4910-95-CL-A31
16	Camshaft Bearing and Bushing Remover/Replacer	5120-00-870-6919	10899154	—
17	Clamp, C	5120-00-222-1612	S34250	—
18	Common No. 1 tool kit	4910-00-754-0654	SC4910-95CLA74	—
19	Compressor Assembly, Valve	5120-00-933-6057	10951361	—
20	Compressor, Piston Ring	5120-00-068-7238	10935313	—
21	Cradle Assembly, Engine Universal Stand	4910-00-795-0198	7950198	—
22	Double Angle Engine Mounting Bracket, Left Rear	5340-00-873-1925	10912239	—
23	Double Angle Engine Mounting Bracket, Right Rear	5340-00-873-1926	10899188	—
24	Driver, Crankshaft	5120-00-134-7464	11642010	Special Tool
25	Expander, Piston Ring	5120-00-068-7234	P409S	—

TOOL IDENTIFICATION LIST (Contd)

Table 1. Common and Special Tools List (Contd).

(1) ITEM NO.	(2) NOMENCLATURE	(3) NATIONAL/NATO STOCK NUMBER	(4) PART NUMBER	(5) REFERENCE
26	Extension, 12-in. 3/8-in. drive	5120-00-243-1691	35W198	4910-95-CL-A31
27	Extractor, Coil Threaded Insert, Helical Threaded Insert, Oil Filter	5120-00-251-1527	64595	—
28	Extractor, Screw Thread Insert, Flywheel Housing	5120-00-723-6833	1227-6	—
29	Fixture, Camshaft Control	3040-00-870-2131	10899172	—
30	Fixture, Transfer Case, Remover	4910-00-694-4777	8708279	—
31	Gauge, Force, Mechanical, Scale	6670-00-254-4634	A-A-50062-15	4910-95-CL-A31
32	Gauge, Fuel Pressure, Fuel Pump (in-tank) Testing	4910-00-255-8673	8673	Special Tool
33	Gauge, Pressure, Dial Indicating	4910-00-319-6195	5704365	Special Tool
34	Gauge, Pressure, Dial Indicating, Air Brake Pressure	6685-00-387-9654	1408	Special Tool
35	General Mechanic's Tool Kit, Direct Support	5180-00-762-1740	5704500	—
36	General Mechanic's Tool Kit, General Support (4th Echelon)	5180-00-789-4858	8738098	—
37	Gun, Soldering	3439-00-542-0396	8200G3	4910-95-CL-A31
38	Hand Reamer, Intake and Exhaust Valve Guides	5110-01-050-2240	12254220	
39	Handle, Remover and Replacer	5340-00-708-3241	7083241	Special Tool
40	Handle, Socket Wrench, 1-in. drive	5120-00-221-7968	X-51A	4910-95-CL-A31
41	Handle, Socket Wrench, 3/4-in. drive	5120-00-249-1076	1940708	4910-95CL-A31
42	Handle, Socket Wrench, 3/4-in. drive	5120-00-221-7959	H377	4910-95-CL-A31
43	Indicator, Dial	5120-00-277-8840	196A	4910-95-A63
44	Indicator, Wheel Alignment	4910-00-221-2472	AR40	4910-95CL-A31
45	Insert, Screw Threaded Insert, Helical Threaded Insert, Oil Filter	5120-00-204-0881	535-16	—
46	Installer, Front Seal	5120-01-362-2026	1U7430	—
47	Jack, Hydraulic	4910-00-289-7233	93660	—
48	Lift, Transmission and Differential	4910-00-585-3622	49	—
49	Micrometer, Inside	5210-00-221-1921	124BZ	4910-95-A63
50	Micrometer, Outside	5210-00-554-7134	02-0866-9700	4910-95-CL-A63
51	Multimeter	6625-01-265-6000	AN/PSM-45A	4910-95-CL-A31
52	Parts Kit, Hydraulic Ram	4320-00-873-1927	10912249	—
53	Pliers, Snapping	5120-00-789-0492	4440R	5180-90-CL-N05

TOOL IDENTIFICATION LIST (Contd)

Table 1. Common and Special Tools List (Contd).

(1) ITEM NO.	(2) NOMENCLATURE	(3) NATIONAL/NATO STOCK NUMBER	(4) PART NUMBER	(5) REFERENCE
54	Plug, Mechanical Puller	5120-00-870-6914	10899178	—
55	Plumb Bob	5210-00-238-3299	PBB-8	4910-95-CL-A02
56	Press, Arbor	3444-00-449-7295	26A49	—
57	Puller Kit, Mechanical, Crankshaft Pulley	5180-00-338-6721	8708724	—
58	Puller Kit, Steering Wheel	5180-00-929-1560	CG630B	—
59	Puller Kit, Universal	5180-00-089-3660	A57Q/KRQ104	—
60	Puller Kit, Universal, Reverse Idler Gear	5180-00-313-9496	1178	—
61	Puller, Mechanical	5120-00-449-3769	GGG-P-781TY4SZ2	4910-95-CL-A31
62	Puller, Mechanical	5120-00-310-4669	8708740	Special Tool
63	Puller, Mechanical Bearing Plate, Spider Assembly	5120-00-793-5048	10882818	—
64	Puller, Mechanical Kit	5120-00-423-1596	GGG-P-781	4910-95-CL-A31
65	Puller, Mechanical, Transmission	5120-01-422-7740	RCSK17837	—
66	Puller, Screw Type, Differential Spider Pinion Bushing	5120-00-836-6689	8366689	Special Tool
67	Reliner, Brake and Clutch	4910-00-173-5310	MILR13495	4940-95-B20
68	Remover and Replacer	5120-00-473-7372	7082863	Special Tool
69	Remover and Replacer, Bearing Sleeve, Differential Carrier Bevel Gear	5120-00-708-3246	7083246	Special Tool
70	Remover and Replacer, Oil Seal, Front Crankshaft	5120-00-134-7481	11642003	Special Tool
71	Remover and Replacer, Screw	5120-00-708-3216	7083216	Special Tool
72	Remover and Replacer, Steering Gear Housing, Pitman Arm Shaft Bushing	5120-00-708-3248	7083248	Special Tool
73	Remover and Replacer, Transfer Case Idler Shaft Front Bearing Cup	5120-00-708-3247	7083247	—
74	Remover, Oil Seal	5120-00-708-3250	7083250	Special Tool
75	Remover, Oil Seal, Differential Carrier Through Shaft Front Oil Seal	5120-00-708-3249	7083249	—
76	Remover/Replacer, Valve Guide	5120-00-871-3513	10899157	—
77	Replacer, Bearing	5120-00-708-3252	7083252	Special Tool
78	Replacer, Crankshaft Gear	5120-00-870-6920	10899179	—
79	Replacer, Engine Valve Seat Insert	5120-00-134-7473	11642007	—
80	Replacer, Oil Seal	5120-00-708-3256	7083256	Special Tool

TOOL IDENTIFICATION LIST (Contd)

Table 1. Common and Special Tools List (Contd).

(1) ITEM NO.	(2) NOMENCLATURE	(3) NATIONAL/NATO STOCK NUMBER	(4) PART NUMBER	(5) REFERENCE
81	Replacer, Oil Seal, Front Axle Universal Joint	5120-00-708-3258	7083258	Special Tool
82	Replacer, Oil Seal, Front or Rear Wheel Hub Inner	5120-00-947-2232	10937827	Special Tool
83	Replacer, Valve Guide	5120-00-870-6921	10899158	—
84	Replacer, Valve Guide	5120-00-134-7461	11642004	—
85	Replacer, Valve Guide	5120-00-134-7480	11642006	—
86	Riveter, Blind, Hand	5120-01-289-4310	HP-2	4910-95-A74
87	Screw, Remover and Replacer	5120-00-708-3216	7083216	Special Tool
88	Shop Equipment, Drill, Electric	4910-00-754-0650	SC4910-95CLA72	—
89	Shop Equipment, Fuel and Electrical Maintenance	4910-00-754-0714	SC4910-95CLA01	—
90	Shop Equipment, Welding Field Maintenance	3470-00-357-7268	SC3470-95CLA08	—
91	Sling, Engine and Transmission	4910-01-243-5556	DFP-188	—
92	Socket Wrench, Crowfoot Adapter 5/8-in.	5120-00-134-7459	11642001	Special Tool
93	Socket, 1-1/16-in., 1/2-in. drive	5120-00-189-7913	B107.1	5180-90-CL-N05
94	Socket, 1-1/16-in., 3/4-in. drive	5120-00-189-7928	1817	4910-95-CL-A31
95	Socket, 1-1/2-in., 3/4-in. drive	5120-00-293-0094	9003-12-48	4910-95-CL-A31
96	Socket, 1-1/4-in., 1/2-in. drive	5120-00-237-0977	B107.1	5180-90-CL-N05
97	Socket, 1-1/4-in., 3/4-in. drive	5120-00-235-5871	3105A	4910-95-CL-A31
98	Socket, 1-1/8-in., 1/2-in. drive	5120-00-189-7914	1U7111	5180-90-CL-N05
99	Socket, 1-1/8-in., 3/4-in. drive	5120-00-239-0021	9336SPG	4910-95CL-A31
100	Socket, 1-3/4-in., 1-in. drive	5120-01-425-8995	8156	4910-95-CL-A31
101	Socket, 1-5/16-in., 3/4-in. drive	5120-00-232-5681	5120-00-232-5681	4910-95CL-A31
102	Socket, 1-5/8-in., 3/4-in. drive	5120-01-399-9692	5552	4910-95-CL-A31
103	Socket, 2-1/4-in., 1-in. drive	5120-00-261-2843	5120-00-261-2843	4910-95-CL-A31
104	Stand, Engine Maintenance	4910-00-246-6138	171ADX	—
105	Straight Edge	6675-00-224-8807	564000-36	4910-95-A63
106	Tape, Measuring	5210-00-234-6745	C213	4910-95CL-A31
107	Test Stand, Fuel Injector Pump	4910-01-194-7667	DFP-156	—
108	Tester, Fuel Injector Nozzle	4910-00-255-8641	3YFL	—
109	Tester, Gauge Assembly, Cylinder Compression	4910-00-870-6283	10899180	—

TOOL IDENTIFICATION LIST (Contd)

Table 1. Common and Special Tools List (Contd).

(1) ITEM NO.	(2) NOMENCLATURE	(3) NATIONAL/NATO STOCK NUMBER	(4) PART NUMBER	(5) REFERENCE
110	Tester, Spring Resiliency	6635-00-641-7346	SPT-850285	4910-95-A63
111	Tool Kit, Body and Fender Repair	5180-00-754-0643	SC5180-90-N34	—
112	Tool Kit, Clutch Aligning	5180-00-449-3785	A37M	4910-95-CL-A31
113	Tool Kit, Cylinder	5180-00-071-0736	10935312	—
114	Tool Kit, Electrical	5180-00-876-9336	7550526	—
115	Tool Kit, Fuel and Electrical	5180-00-754-0655	SC5180-95-CL-B08	—
116	Tool Kit, General Mechanic's	5180-00-177-7033	SC5180-90-CL-N26	4910-95-CL-A31
117	Tool Kit, General Mechanic's	5180-00-762-1741	5704501	—
118	Tool Kit, General Mechanic's, Direct Support (3rd Echelon)	5180-00-789-4857	8738097	—
119	Tool Kit, Glass Cutting	5180-00-357-7737	SC4940-95CLA18	—
120	Tool Kit, Organizational Maintenance	5180-00-762-1737	5704499	—
121	Tool Kit, Special Organizational Maintenance (2nd Echelon) Set "A"	5180-00-448-0248	7748886	—
122	Tool Kit, Transmission	5180-01-411-7384	57K3341	—
123	Tool Kit, Vehicle, Special Purpose	5180-01-147-5824	5704171	—
124	Torque Wrench Adapter, Cylinder Head Nuts (Long)	5120-00-937-7834	10951484	—
125	Valve Cap	4820-00-793-5040	10882854	—
126	Vise, Machinist's	5120-00-293-1439	204	—
127	Wrench, 1-1/4-in. Open-End	5120-00-187-7134	26-169	4910-95-CL-A01
128	Wrench, Adjustable, Cylinder	5120-00-264-3793	2117080	4910-95-A74
129	Wrench, Allen 1/2-in.	5120-00-198-5391	024-0067-00	4910-95-CL-A31
130	Wrench, Box 1-1/4-in.	5120-00-184-8677	B107.100	4910-95-A62
131	Wrench, Flare 11/16-in. 12 pt.	5120-00-224-3141	11655785-2	4910-95-CL-N05
132	Wrench, Pipe	5120-00-277-1486	TKCX1H	4910-95-CL-A31
133	Wrench, Socket, Spanner, Clutch Release Lever Adjusting Nut	5120-00-034-8443	8390124	—
134	Wrench, Socket, Wheel Stud Nut	5120-00-293-2452	7083293	—
135	Wrench, Spanner, Air Compressor Pulley	5120-00-070-7809	10935288	Special Tool
136	Wrench, Torque 1/2-in. drive	5120-00-640-6364	B107.14M	4910-95-CL-A31
137	Wrench, Torque 3/4-in. drive	5120-01-118-3679	TESI800A	4910-95-CL-A31
138	Wrench, Torque 3/8-in. drive	5120-00-230-6380	TQ12B	4910-95-CL-A31

TOOL IDENTIFICATION LIST (Contd)

Table 1. Common and Special Tools List (Contd).

(1) ITEM NO.	(2) NOMENCLATURE	(3) NATIONAL/NATO STOCK NUMBER	(4) PART NUMBER	(5) REFERENCE
139	Wrench, Torque Box, Cylinder Head Nuts	5120-00-930-6346	10951485	Special Tool
140	Wrench, Torx Socket 60-amp Alternator	5120-01-452-4396	TLE60	4910-95CL-A31
141	Wrench, Universal Joint, Socket Attachment, 3/8-in. drive	5120-00-224-9215	1060775	4910-95-CL-A31

SUPPORTING INFORMATION

2-1/2 TON, 6X6, M44A2 SERIES TRUCKS (MULTIFUEL)

MANDATORY REPLACEMENT PARTS

INTRODUCTION

This Work Package (WP) lists mandatory replacement parts you will need to maintain M44A2 series vehicles.

This WP includes a list of all mandatory replacement parts referenced in the task initial setups and procedures. These are items that must be replaced during maintenance whether they have failed or not. This includes items based on usage intervals such as miles, time, rounds fired, etc.

EXPLANATION OF COLUMNS

Column (1)—Item Number. Number is assigned to each component/part and is referenced in each WP task initial setups “Materials/Parts” heading.

Column (2)—Nomenclature. Name or identification.

Column (3)—Part Number. The manufacturer’s part number.

Column (4)—National Stock Number. The national stock number of the part.

MANDATORY REPLACEMENT PARTS (Contd)*Table 1. Mandatory Replacement Parts.*

(1) ITEM NO	(2) NOMENCLATURE	(3) PART NUMBER	(4) NATIONAL/NATO STOCK NUMBER
1	Anti-Squeak Material	592V1	2510-00-753-9199
2	Bolt	7521738	5306-00-752-1738
3	Bolt, Assembled Washer	596453	5306-00-317-3096
4	Bolt, Machine	11601337	5306-00-930-5083
5	Bolt, Machine	AN7-5A	5306-00-515-7537
6	Brakeline	7409330	4720-00-203-9515
7	Bushing, Sleeve	10897111	3120-00-184-9515
8	Bushing, Sleeve	11609331	3120-00-105-9923
9	Bushing, Tapered, Piston Pin	2326A2	2805-00-752-1964
10	Capnut	A-A-57174-1	2530-00-693-1029
11	Capnut	A-A-57174-2	2530-00-359-1162
12	Clamp	MS21333-39	5340-00-597-0182
13	Clip	MS16633-1098	5325-00-664-2779
14	Clip	7064468	5310-00-333-7519
15	Cotter Pin	MS24665-172	5315-00-187-9370
16	Cotter Pin	MS24665-210	5315-00-059-0157
17	Cotter Pin	MS24665-363	5315-00-059-0187
18	Cotter Pin	MS24665-465	5315-01-223-4455
19	Cotter Pin	MS24665-490	5315-00-059-0205
20	Cotter Pin	MS24665-423	5315-00-013-7228
21	Cotter Pin	MS24665-357	5315-00-298-1481
22	Cotter Pin	MS24665-361	5315-00-059-0184
23	Cotter Pin	137318	5315-00-846-0126
24	Cotter Pin	MS24665-495	5315-00-234-1664
25	Cotter Pin	MS24665-283	5315-00-842-3044
26	Cotter Pin	MS24665-359	5315-00-013-7214
27	Cotter Pin	MS24665-351	5315-00-839-5821
28	Cotter Pin	MS24665-353	5315-00-839-5822
29	Cotter Pin	MS24665-132	5315-00-839-2325
30	Cotter Pin	MS24665-134	5315-00-839-5820
31	Cotter Pin	MS9245-46	5315-00-939-0832
32	Cotter Pin	MS9245-25	5315-00-619-7158
33	Cotter Pin	MS24665-71	5315-00-829-1326
34	Cotter Pin	MS24665-626	5315-00-013-7303
35	Cotter Pin	MS35677-48	5315-00-866-2673
36	Cotter Pin	11640540	—
37	Disc	8330136	4820-00-321-6425
38	Disk, Filtering	11610365	4330-00-487-2773
39	Fastener	7529309	2540-00-562-0422
40	Filter, Element	14208	4330-00-983-0998

MANDATORY REPLACEMENT PARTS (Contd)

Table 1. Mandatory Replacement Parts (Contd).

(1) ITEM NO	(2) NOMENCLATURE	(3) PART NUMBER	(4) NATIONAL/NATO STOCK NUMBER
41	Filter, Element	GNG-220	4330-00-872-1779
42	Filter, Fuel	6665431	2910-00-884-1211
43	Fuse	F16A250V40A	5920-00-050-0541
44	Gasket	02841	5330-01-399-1923
45	Gasket	02777	5330-01-392-0308
46	Gasket	12356789	5330-01-319-7302
47	Gasket	3025-CB	5330-00-852-5277
48	Gasket	3716-VT	5330-01-246-1043
49	Gasket	HH-G-101TY3STJ	5330-01-444-9183
50	Gasket	2208S305	5330-01-374-9268
51	Gasket	M10387-3-D-07	5330-01-241-6412
52	Gasket	10917063	5330-00-269-3464
53	Gasket	10947445	5330-00-238-5600
54	Gasket	10937348	5330-00-484-3655
55	Gasket	10947432	5330-00-238-5599
56	Gasket	375214C NON-ASBESTOS	5330-01-389-0671
57	Gasket	03110-2	5330-01-378-7401
58	Gasket	11609085	5330-00-567-0141
59	Gasket	10889849	5330-00-851-4653
60	Gasket	10889853	5330-00-851-0483
61	Gasket	MS28775-235	5331-00-582-1560
62	Gasket	10947593	5331-00-903-0523
63	Gasket	11677119	5330-00-106-8555
64	Gasket	033097	5330-00-298-1398
65	Gasket	7521485	5330-00-752-1485
66	Gasket	7521780	5330-01-170-4979
67	Gasket	7521787	5330-00-599-4230
68	Gasket	GA9027	5330-00-871-5425
69	Gasket	7748825 NON-ASBESTOS	5330-01-438-5898
70	Gasket	7748826	5330-00-818-0508
71	Gasket	10899080	5330-00-419-9467
72	Gasket	10894080	5330-00-885-5723
73	Gasket	10899062	5330-00-863-3165
74	Gasket	703349	5330-00-089-0978
75	Gasket	10889926	5330-00-997-1528
76	Gasket	00737 SH41 ST164	5330-00-832-7848
77	Gasket	8327849	5330-01-017-2535
78	Gasket	8327875	5330-00-832-7875
79	Gasket	5156636	5330-00-930-5292
80	Gasket	10889736 NON-ASBESTOS	5330-01-389-2103

MANDATORY REPLACEMENT PARTS (Contd)

Table 1. Mandatory Replacement Parts (Contd).

(1) ITEM NO	(2) NOMENCLATURE	(3) PART NUMBER	(4) NATIONAL/NATO STOCK NUMBER
81	Gasket	10889730 NON-ASBESTOS	5330-01-376-0810
82	Gasket	10889770	5330-00-899-4483
83	Gasket	10889825	5330-00-861-3832
84	Gasket	10889854	5330-00-901-8663
85	Gasket	12380067	5330-01-153-8231
86	Gasket	11642113	5330-00-001-2038
87	Gasket	11642115	5330-00-495-5335
88	Gasket	DC8211	5330-01-037-0663
89	Gasket	DC8226	5330-01-076-6172
90	Gasket	MS35769-18	5330-01-354-0242
91	Gasket	MS35769-26	5330-01-352-3132
92	Gasket	11641987	5330-00-498-2426
93	Gasket	11609088	5330-00-595-5203
94	Gasket	MS35643-1	5330-00-684-7851
95	Gasket	MS28775-110	5331-00-585-6663
96	Gasket	MS35803-210	5330-00-914-4093
97	Gasket	8327846	5330-00-832-7846
98	Gasket	8327847	5330-00-832-7847
99	Gasket	10871869-1	5330-00-930-5953
100	Gasket	10871869-3	5330-01-235-0173
101	Gasket	10937245	5330-00-489-8346
102	Gasket	10937302	5330-00-930-5952
103	Gasket	T75-2	5330-00-978-9575
104	Gasket	40-1098702	5330-01-389-0664
105	Gasket	7538728	5330-00-753-8728
106	Gasket	7539072	5300-00-753-9072
107	Gasket	7412770	5330-00-741-2770
108	Gasket	7401419	5330-00-318-4083
109	Gasket	7951125	5330-01-173-0161
110	Gasket	8327322	5330-01-396-0000
111	Gasket	8327597	5330-00-832-7597
112	Gasket	3001493	5330-00-318-4299
113	Gasket	8344200-1	5330-00-522-8428
114	Gasket	5X495	5330-00-712-1244
115	Gasket	7521782	5330-00-752-1782
116	Gasket	7520358	5330-00-752-0358
117	Gasket	2315T2	5330-00-752-0959
118	Gasket	10897087	5330-00-406-1543
119	Gasket	RCSK15277	5330-01-398-1740
120	Gasket	P413	5330-00-318-4323

MANDATORY REPLACEMENT PARTS (Contd)*Table 1. Mandatory Replacement Parts (Contd).*

(1) ITEM NO	(2) NOMENCLATURE	(3) PART NUMBER	(4) NATIONAL/NATO STOCK NUMBER
121	Gasket, Fill	3249BU	5330-01-131-9380
122	Gasket, O-ring	7700242	5331-00-770-0242
123	Igniter	CS-4520-SV-0705	4520-00-217-5782
124	Igniter	G484055	4520-00-312-2017
125	Key, Machine	MS20066-210	5315-00-780-8475
126	Locknut	MS17829-5C	5310-00-245-3424
127	Locknut	MS51943-39	5310-00-488-3889
128	Locknut	451081	5310-00-045-1081
129	Locknut	M45913/2-6FG5C	5310-00-959-1488
130	Locknut	M45913/3-4FG8C	5310-00-935-9022
131	Locknut	M45913/1-7FG5C	5310-00-057-7080
132	Locknut	M45913/1-10FG5C	5310-00-225-6408
133	Locknut	M45913/3-5FG8C	5310-00-241-6658
134	Locknut	79NM124	5310-00-638-5706
135	Locknut	C-1467	5310-01-445-1488
136	Locknut	M45913/1-10FG5C	5310-00-225-6408
137	Locknut	M45913/1-6CG5C	5310-00-087-4652
138	Lockscrew	10898724	5306-00-850-3884
139	Locknut	MS51943-33	5310-00-814-0673
140	Locknut	11641656	5310-00-791-9525
141	Locknut	11609727-1	5310-00-139-4627
142	Locknut	11609727-2	5310-00-176-6690
143	Locknut	MS21245L10	5310-00-449-2381
144	Locknut	MS21044N3	5310-00-877-5797
145	Locknut	MS21044N4	5310-00-877-5796
146	Locknut	MS21044N5	5310-00-088-0553
147	Locknut	MS21044N8	5310-00-877-5795
148	Locknut	MS21044N08	5310-00-811-3494
149	Locknut	MS122031	5310-00-285-7037
150	Locknut	MS17830-06C	5310-00-176-6341
151	Locknut	MS21045-8	5310-00-062-4954
152	Locknut	MS21045-4	5310-00-061-7325
153	Locknut	MS21045-5	5310-00-982-9812
154	Locknut	MS21045-6	5310-00-982-4908
155	Locknut	M45913/1-5FG5C	5310-00-984-3807
156	Locknut	M45913/1-7FG5C	5310-00-057-7080
157	Locknut	MS 21045-L06	5310-00-857-5560
158	Locknut	MS21042-3	5310-00-807-1467
159	Locknut	MS21042-4	5310-00-807-1468
160	Locknut	MS21083N3	5310-00-902-6676

MANDATORY REPLACEMENT PARTS (Contd)*Table 1. Mandatory Replacement Parts (Contd).*

(1) ITEM NO	(2) NOMENCLATURE	(3) PART NUMBER	(4) NATIONAL/NATO STOCK NUMBER
161	Locknut	MS51943-40	5310-00-935-3750
162	Locknut	M45913/3-10FG8C	5310-00-241-6664
163	Locknut	M45913/1-8CG5C	5310-00-225-6993
164	Locknut	M45913/3-12FG8C	5310-00-935-3569
165	Locknut	M45913/1-4CG5C	5310-00-088-1251
166	Locknut	M45913/1-10FG5C	5310-00-225-6408
167	Locknut	M45913/2-12FG5C	5310-00-832-9719
168	Locknut	MS51922-22	5310-00-067-4903
169	Locknut	MS5913/2-6FG5C	5310-00-959-1488
170	Locknut	M45913/1-5CG5C	5310-00-984-3806
171	Locknut	8327988	5310-00-240-9332
172	Locknut	9419471	5310-01-432-6727
173	Locknut	9416918	5310-01-012-8962
174	Locknut	9419476	5310-00-982-4912
175	Locknut	9419470	5310-01-407-9492
176	Locknut	9422295	5310-01-119-3668
177	Locknut	9422302	5310-01-184-5784
178	Locknut	9419460	5310-01-432-8290
179	Locknut	9442938	5310-01-315-3403
180	Locknut	MS51988-4	5310-01-234-9414
181	Locknut	MS51967-14	5310-00-768-0318
182	Lockscrew	MS35764-1295	5306-01-015-5675
183	Lockscrew	MS35764-1579	5306-01-129-7590
184	Lockscrew	MS35764-1575	5306-00-131-9474
185	Lockscrew	MS35764-852	5306-00-241-6592
186	Lockwasher	11500207	5310-01-206-7306
187	Lockwasher	MS122031	5310-00-285-7037
188	Lockwasher	A20393-302	5310-01-242-3236
189	Lockwasher	C-1707	5310-01-458-4589
190	Lockwasher	MS45904-57	5310-00-061-0004
191	Lockwasher	MS45904-77	5310-00-953-8628
192	Lockwasher	MS35340-46	5310-00-959-4675
193	Lockwasher	MS35340-45	5310-00-959-4679
194	Lockwasher	MS35337-11	5310-00-011-2724
195	Lockwasher	23E06	5310-00-637-9541
196	Lockwasher	MS35334-23	5310-00-685-3194
197	Lockwasher	MS35335-30	5310-00-209-0788
198	Lockwasher	MS35335-31	5310-00-596-7693
199	Lockwasher	21FAF616	5310-00-458-2382
200	Lockwasher	23MS35338-50	5310-00-820-6653

MANDATORY REPLACEMENT PARTS (Contd)

Table 1. Mandatory Replacement Parts (Contd).

(1) ITEM NO	(2) NOMENCLATURE	(3) PART NUMBER	(4) NATIONAL/NATO STOCK NUMBER
201	Lockwasher	MS35340-47	5310-00-655-9370
202	Lockwasher	MS35338-49	5310-00-167-0680
203	Lockwasher	MS35338-43	5310-00-045-3296
204	Lockwasher	MS35333-37	5310-00-579-0079
205	Lockwasher	MS35333-44	5310-00-595-7237
206	Lockwasher	004-003005-057	5310-00-003-4094
207	Lockwasher	MS35338-40	5310-00-582-5965
208	Lockwasher	MS45904-61	5310-00-889-2769
209	Lockwasher	MS45904-70	5310-00-082-0650
210	Lockwasher	MS45904-76	5310-00-061-1258
211	Lockwasher	MS45904-80	5310-00-080-9785
212	Lockwasher	MS45904-68	5310-00-889-2528
213	Lockwasher	MS35338-47	5310-00-209-0965
214	Lockwasher	MS35335-34	5310-00-514-6674
215	Lockwasher	MS35333-38	5310-00-559-0070
216	Lockwasher	MS35333-40	5310-00-550-1130
217	Lockwasher	MS35333-46	5310-00-543-4385
218	Lockwasher	MS35340-40	5310-00-655-9505
219	Lockwasher	MS35338-40	5310-00-543-2410
220	Lockwasher	MS35333-78	5310-00-261-7156
221	Lockwasher	09169665	5310-00-584-5272
222	Lockwasher	201506	5310-01-373-2539
223	Lockwasher	2101048S	5310-00-003-4094
224	Lockwasher	272739	5310-01-317-8164
225	Lockwasher	MS35333-39	5310-00-576-5752
226	Lockwasher	MS35333-41	5310-00-167-0721
227	Lockwasher	MS35338-52	5310-00-754-2005
228	Lockwasher	MS35338-53	5310-00-584-7889
229	Lockwasher	MS35338-45	5310-00-407-9566
230	Lockwasher	MS35339-30	5310-00-013-1139
231	Lockwasher	MS35335-36	5310-00-550-3503
232	Lockwasher	MS35335-37	5310-00-209-5116
233	Lockwasher	MS35335-35	5310-00-627-6128
234	Lockwasher	MS35338-108	5310-00-680-6823
235	Lockwasher	MS35338-138	5310-00-933-8120
236	Lockwasher	MS35338-139	5310-00-933-8121
237	Lockwasher	MS35340-50	5310-00-045-5001
238	Lockwasher	MS35340-51	5310-00-052-6454
239	Lockwasher	MS35335-38	5310-00-616-6354
240	Lockwasher	MS35335-39	5310-00-800-0695

MANDATORY REPLACEMENT PARTS (Contd)*Table 1. Mandatory Replacement Parts (Contd).*

(1) ITEM NO	(2) NOMENCLATURE	(3) PART NUMBER	(4) NATIONAL/NATO STOCK NUMBER
241	Lockwasher	MS35335-32	5310-00-596-7691
242	Lockwasher	MS35335-33	5310-00-209-0786
243	Lockwasher	MS51416-1	5310-01-347-6148
244	Lockwasher	1914107	5310-00-809-3365
245	Lockwasher	MS35338-42	5310-00-045-3299
246	Lockwasher, Bolt Assembled	186493	5306-00-018-6493
247	Lockwasher, Nut Assembled	1540294-3	5310-00-063-7360
248	Lockwasher, Screw Assembled	423569	5305-00-042-3569
249	Lockwasher, Screw Assembled	423571	5305-00-042-3571
250	Lockwasher, Screw Assembled	489142	5305-00-018-8370
251	Lockwasher, Screw Assembled	594001	5306-00-059-4001
252	Lockwasher, Screw Assembled	594119	5305-00-317-3102
253	Lockwasher, Screw Assembled	596455	5305-01-247-5009
254	Lockwasher, Screw Assembled	11668680	5305-01-128-5656
255	Lockwasher, Screw Assembled	11663070	5305-01-104-9018
256	Lockwasher, Screw Assembled	7373279	5305-01-104-9019
257	Lockwasher, Screw Assembled	187527	5305-00-018-7527
258	Lockwasher, Screw Assembled	187995	5305-00-696-5285
259	Lockwasher, Screw Assembled	455174	5305-00-696-5293
260	Lockwasher, Screw Assembled	455176	5305-01-225-2106
261	Lockwasher, Screw Assembled	423531	5305-00-403-5130
262	Lockwasher, Screw Assembled	7529290-7092434	5305-00-508-1954
263	Lockwasher, Screw Assembled	7092443	5305-00-237-6259
264	Lockwasher, Screw Assembled	7092435	5305-00-144-1509
265	Lockwasher, Screw Assembled	7092436	5305-01-163-9566
266	Lockwasher, Screw Assembled	7092437	5305-01-014-5115
267	Lockwasher, Screw Assembled	7092439	5305-01-175-7370
268	Lockwasher, Screw Assembled	7092446	5305-01-268-9486
269	Lockwasher, Screw Assembled	7092445	—
270	Lockwasher, Screw Assembled	7372083	5305-00-569-8909
271	Lockwasher, Screw Assembled	NAS720-6-5	5305-00-820-6356
272	Lockwasher, Screw Assembled	8359533	5305-00-135-3032
273	Lockwasher, Screw Assembled	9409115	5306-00-286-1476
274	Lockwasher, Screw Assembled	170677	5305-00-456-2582
275	Lockwasher, Screw Assembled	191178	5305-00-019-1178
276	Nut	MS35690-625	5310-00-543-5653
277	Nut	MS51967-8	5310-00-732-0558
278	Nut	MS51968-12	5310-00-732-5916
279	O-ring	AS29513-115	5331-00-248-3847
280	O-ring	AS3582-116	5331-00-829-2608

MANDATORY REPLACEMENT PARTS (Contd)

Table 1. Mandatory Replacement Parts (Contd).

(1) ITEM NO	(2) NOMENCLATURE	(3) PART NUMBER	(4) NATIONAL/NATO STOCK NUMBER
281	O-ring	3D2824	5331-00-944-8291
282	O-ring	3K0360	5331-00-948-6482
283	O-ring	MS28775-238	5331-00-579-7545
284	O-ring	718768-22	5331-00-089-0998
285	O-ring	730051-1	5331-01-129-0361
286	O-ring	MS28775-032	5331-01-049-7374
287	O-ring	MS29513-258	5330-00-599-3072
288	O-ring	AN6227B7	5331-00-640-9613
289	O-ring	11639519-1	5331-00-463-0200
290	O-ring	11639519-2	5331-00-462-0907
291	O-ring	8330909	5330-00-318-4326
292	Parts Kit, Air Cylinder	5704159	2520-00-394-9718
293	Parts Kit, Dust Boot	MPS528	2530-00-741-0883
294	Parts Kit, Fuel Filter	5702757	4330-00-808-2407
295	Parts Kit, Fuel Filter	5702776	4330-00-134-7835
296	Parts Kit, Alternator	90-2531	2920-01-168-4129
297	Parts Kit, Alternator	90-2532	2920-01-168-4130
298	Parts Kit, Oil Filter	5702659	4330-00-884-4801
299	Brakeshoe Set	12356756	2530-01-281-5224
300	Parts Kit, Service Brakeshoe	5704531	2530-01-217-8427
301	Parts Kit, Service Brakeshoe	8332057	2530-00-319-6001
302	Parts Kit, Steering Gear	505491	2530-00-752-1486
303	Parts Kit, Vehicular, Heater	5704051	2540-00-201-3474
304	Parts Kit, Vehicular, Heater	5704052	2540-00-200-4249
305	Pin	141240	5315-00-014-1240
306	Pin	MS16562-225	5315-00-841-4443
307	Pin	7064470	5315-00-316-0992
308	Plug	G1251	4730-00-018-9566
309	Plug	MS35648-3	5340-00-050-1589
310	Plug	11608954	5320-01-176-9407
311	Retaining Ring	5226154	5325-00-174-9829
312	Retaining Ring	10896682	5325-01-418-8638
313	Rivet	7B5049	5320-00-262-6492
314	Rivet	8729083	—
315	Rivet	11608955	5320-01-176-9396
316	Rivet	103488	3040-00-091-6849
317	Rivet	MS35743-91	5320-00-735-5198
318	Rivet	M24243/1B604	5320-00-493-4101
319	Rivet, Blind	SSPV-86	5320-01-139-9774
320	Rivet, Split	MS35684-21	5320-00-013-6326

MANDATORY REPLACEMENT PARTS (Contd)*Table 1. Mandatory Replacement Parts (Contd).*

(1) ITEM NO	(2) NOMENCLATURE	(3) PART NUMBER	(4) NATIONAL/NATO STOCK NUMBER
321	Screw	B1821BH038F300N	5305-00-269-3246
322	Screw	7979595	5306-00-752-1739
323	Screw	7521739	5306-01-078-3958
324	Screw	B1821BH025F056N	5305-00-068-0512
325	Screw, Assembled Lockwasher	8757892	5306-00-165-8241
326	Screw, Bolt	10896689	5306-00-177-5278
327	Screw, Drive	MS21318-27	5305-00-253-5618
328	Screw, Machine	MS35206-294	5305-00-984-5674
329	Seal	AN901-10C	5365-00-196-6710
330	Seal	13610A	5330-00-178-4668
331	Seal	10912514	5330-00-081-3416
332	Seal	11677274	2530-01-061-8926
333	Seal	10896684	5330-00-891-7826
334	Seal	500094	5330-00-286-8149
335	Seal	5193274	5330-00-179-0972
336	Seal	7061147	5330-00-558-0210
337	Seal	7538704	5330-00-695-1170
338	Seal	304451	5330-00-696-0279
339	Seal	8741839	9320-00-179-3434
340	Seal	7461	5330-00-291-1554
341	Seal	331918	5330-00-566-0794
342	Seal	032077TYPEA	5330-00-534-2937
343	Seal	7264338	5330-00-181-3673
344	Seal	7264339	5330-00-180-9070
345	Seal	7264436	—
346	Seal	7264437	5330-00-182-6659
347	Seal, Channel Lift	7373301	9390-00-737-3301
348	Seal, Channel Lift Filler	10906350	2510-00-179-5708
349	Seal, Dust, Gasket	10951475	5330-00-930-5961
350	Seal, Frame	P302319	9390-00-737-3300
351	Seal, Lead	F2738-A01-2-4-24	5340-00-902-0426
352	Seal, Packing Preformed	31683	5330-00-297-6330
353	Seal, Packing Preformed	A52484-2	5330-00-090-2128
354	Seal, Plain	A1205Q667	5330-00-706-1238
355	Seal, Plain, Encased	7748859	5330-00-848-9943
356	Seal, Plain, Encased	12470104	5330-00-143-8666
357	Seal, Plain, Encased	10896684	5330-00-891-7826
358	Seal, Rubber	7085399	5330-00-174-8634
359	Seal, Washer	10896710	5310-00-209-1761
360	Seat, Valve	11640548	4820-00-176-4589

MANDATORY REPLACEMENT PARTS (Contd)

Table 1. Mandatory Replacement Parts (Contd).

(1) ITEM NO	(2) NOMENCLATURE	(3) PART NUMBER	(4) NATIONAL/NATO STOCK NUMBER
361	Sleeve	222-652	4730-01-193-7390
362	Sleeve	476624	4730-00-701-7737
363	Snapping, Retaining	7363055	5365-00-698-4346
364	Spring	5167466	5360-00-516-7466
365	Spring Plate	10883281	2530-00-908-8162
366	Spring Washer	7372766	5310-00-264-4085
367	Strip, Filler	7373325	5330-00-737-3325
368	Strip, Filler	7005421	5330-00-700-5421
369	Stud, Bolt	10896719-1	5306-01-104-5885
370	Stud, Bolt	10896719-2	5306-00-170-0141
371	Valve, Drain	MS35782-2	4820-00-720-4488
372	Washer	M2025103	5310-00-167-0821
373	Washer	5214539	5310-00-275-6635
374	Washer	MS15795-814	5310-00-773-7618
375	Washer	1229G969	5310-00-752-1650
376	Washer, Seal	10896710	5310-00-209-1761
377	Wear Pad, Plate	7521639	2510-00-752-1639
378	Weatherstrip	7368623	2510-00-409-3993
379	Weatherstrip	7373337	9390-00-737-3337
380	Woodruff Key	MS35756-14	5315-00-616-5520
381	Woodruff Key	106751	5315-00-616-5522
382	Woodruff Key	8328341	5315-00-281-7651
383	Woodruff Key	MS35756-8	5315-00-616-5526
384	Woodruff Key	MS35756-11	5315-00-616-5523
385	Woodruff Key	8744221	5315-00-501-9454
386	Woodruff Key	7521791	5315-00-696-0271
387	Woodruff Key	MS20066-231	5315-00-957-7544
388	Woodruff Key	MS35756-16	5315-00-616-5529
389	Retainer	MS16626-1100	5325-00-281-9885
390	Lockscrew	10912494	5306-00-081-9812
391	Cotter Pin	MS24665-304	5315-00-241-7330
392	Gasket	10935201	5330-00-078-8998
393	Gasket	10935199	5330-00-075-1768
394	Gasket	10935197	5330-00-078-8997
395	Lockscrew	MS35764-248	5306-01-118-3134
396	Lockwasher	MS35340-44	5310-00-682-5930
397	Gasket	11609963	5330-00-930-9229
398	O-ring	AS3582-212	5331-00-829-2607

MANDATORY REPLACEMENT PARTS (Contd)*Table 1. Mandatory Replacement Parts (Contd).*

(1) ITEM NO	(2) NOMENCLATURE	(3) PART NUMBER	(4) NATIONAL/NATO STOCK NUMBER
399	Gasket	10889857	5330-00-860-9140
400	Gasket	10889862	5330-00-860-9141
401	Gasket	10889858	5330-01-018-7153
402	Hose	MS521301A2 17R-3	4720-01-270-0426
403	Gasket	10889933	5330-00-860-0574
404	Gasket	10935625	5330-00-908-6340
405	Seal, Ring	10889757	5330-00-899-6726
406	Locknut	400D612	5310-00-998-7385
407	Lockplate	11610207	5340-00-101-5600
408	Gasket and Shim Set	7521764NON-ASBESTOS	5330-01-384-4617
409	Gasket	30-155-13	5330-00-752-1061
410	Gasket	7538737	5330-00-753-8737
411	Lockwasher	MS35340-48	5310-00-834-7606
412	Lockwasher	MS35340-44	5310-00-682-5930
413	Tiedown Strap	MS3367-1-9	5975-00-074-2072
414	Lockwasher, Screw Assembled	88066	5305-00-591-3388
415	Seal	7061146	5330-00-558-0213
416	Seal, Plain, Encased	8738032	5330-00-075-1764
417	Bushing	7521694	5365-00-752-1694
418	Nut	MS51968-8	5310-00-732-0559
419	Seal	213630	5330-00-090-2128
420	Seal	A1205Q667	5330-00-706-1238
421	Cotter Pin	MS24665-360	5315-00-298-1499
422	Locknut	MS51943-40	5310-00-488-3888
423	Filler Strip	7005421	5330-00-700-5421
424	Lockwasher, Screw Assembled	425859	5306-00-042-5859
425	Lockwasher	120380	5310-00-543-2705
426	Lockwasher	MS35489-40	5325-00-185-0004
427	Locknut	190254	5310-01-269-9245
428	Lockwasher	MS35333-36	5310-00-193-7577
429	Locknut	MS21083N4	5310-00-903-8282
430	Gasket	11609133	5330-00-571-7055
431	Woodruff Key	MS35756-18	5315-00-616-5527

MANDATORY REPLACEMENT PARTS (Contd)*Table 1. Mandatory Replacement Parts (Contd).*

(1) ITEM NO	(2) NOMENCLATURE	(3) PART NUMBER	(4) NATIONAL/NATO STOCK NUMBER
432	Locknut	272739	5310-01-317-8164
433	Sleeve	4060115	4730-01-193-7390
434	Locknut	706131	5310-01-287-6543
435	Rivet	MS16535-300	5320-00-242-1545
436	Locknut	M45913/1-5FS3	5310-00-927-3877
437	Rivet, Solid	426614	5320-01-244-4034
438	Locknut	M45913/3-4CG8C	5310-00-061-4650
439	Gasket	7521787	5330-00-599-4230

END OF WORK PACKAGE

0470 00-13/14 blank

SUPPORTING INFORMATION

2-1/2 TON, 6X6, M44A2 SERIES TRUCKS (MULTIFUEL)

MANUFACTURED ITEMS LIST

This Work Package (WP) includes complete instructions for making items authorized to be manufactured at field and sustainment maintenance levels.

FUEL INJECTION PUMP GEAR HUB WRENCH

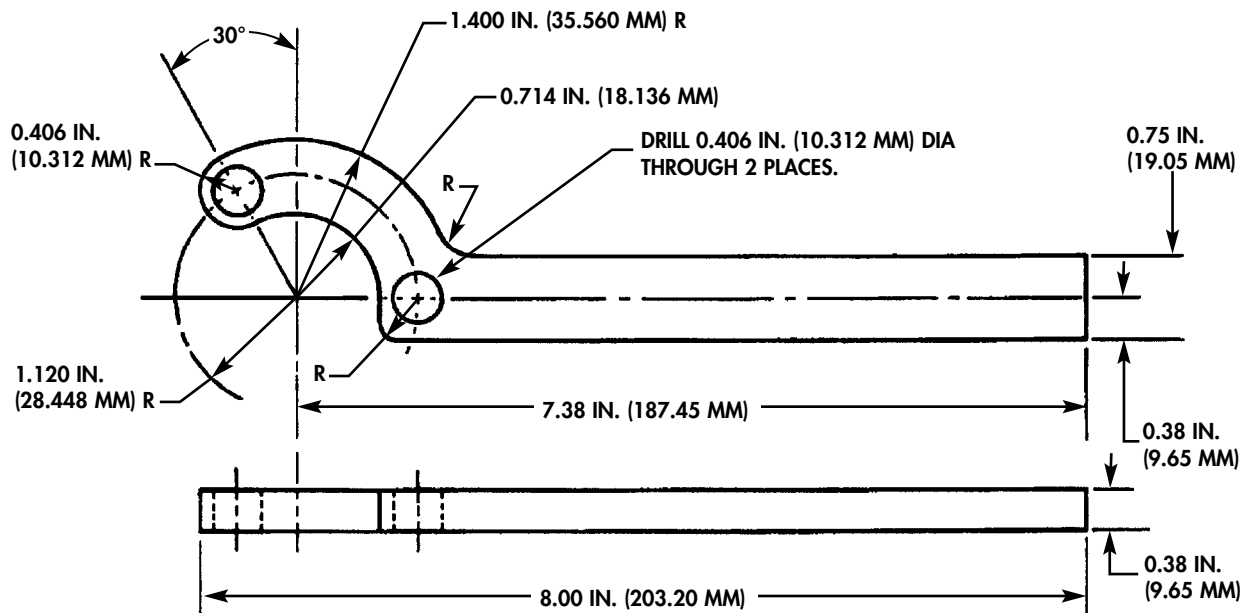

1. Fabricate from NSN 9510-00-596-2063, MS 500106-015, carbon steel bar, 8 in. (203.20 mm) X 2 in. (50.8 mm) X 0.38 in. (9.65 mm).
2. The tolerance on all three decimal dimensions is + 0.005 in. (0.127 mm) and the tolerance on all two place decimal dimensions is + 0.03 in. (0.76 mm).
3. Trim steel to specifications in diagram above.
4. Drill two holes to specifications in diagram above.
5. Tool is used for removal of hub on fuel injection pump.

MANUFACTURED ITEMS LISTS (Contd)

FUEL LINE DUST CAP ASSEMBLY TOOL

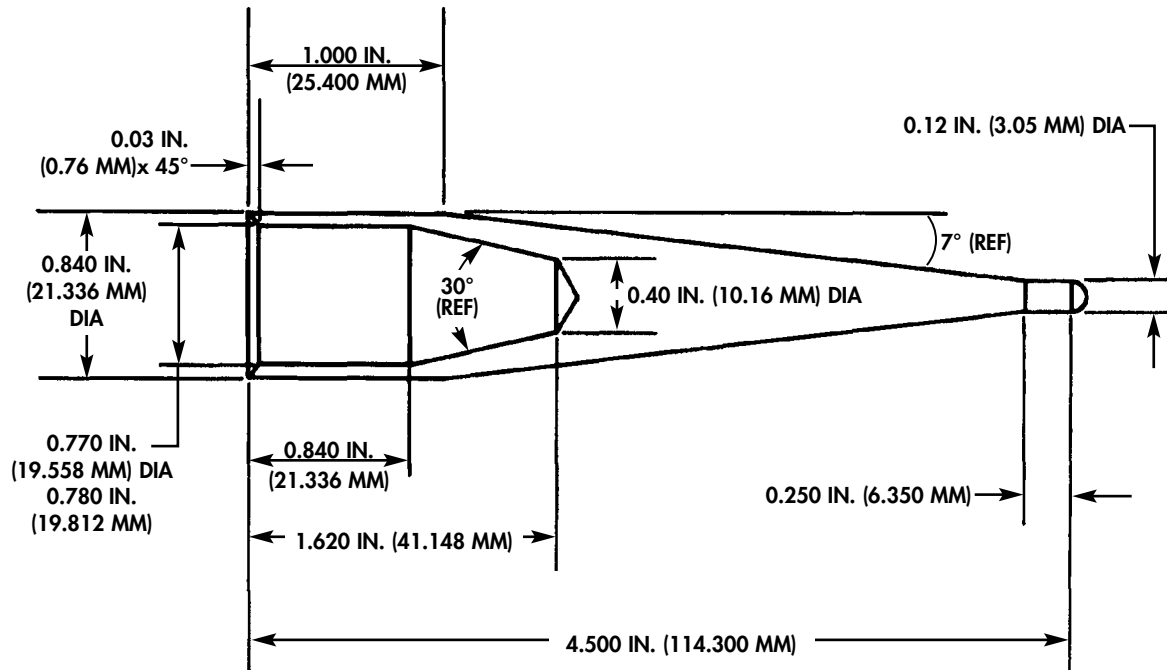

1. Fabricate from NSN 9510-00-224-1691, QQS634, carbon steel cylinder, 5.000 in. (127.000 mm) in length and 0.90 in. (22.86) in diameter.
2. The tolerance on all three decimal dimensions is + 0.005 in. (0.127 mm) and the tolerance on all two place decimal dimensions is + 0.03 in. (0.76 mm).
3. Trim steel to dimensions in diagram above.
4. Drill one hole to dimensions in diagram above.
5. Tool is used for installation of dust caps on fuel injector tubes.

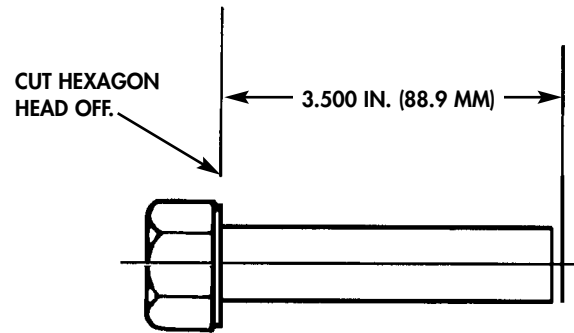
MANUFACTURED ITEMS LISTS (Contd)**FLYWHEEL GUIDE SCREW**

1. Fabricate from NSN 5305-00-716-8179, MS 90726-121, 1/2 - 20 UNF 2A x 3.500 in. (88.9 mm) screw.
2. The tolerance on all three decimal dimensions is + 0.005 in. (0.127 mm).
3. Cut off hexagon head of screw as shown in diagram above.
4. Grind sharp edges from cut end.
5. Tool is used for removal and installation of flywheel.

SUPPORTING INFORMATION

2-1/2 TON, 6X6, M44A2 SERIES TRUCKS (MULTIFUEL)

TORQUE LIMITS

This Work Package (WP) provides general torque limits for screws used on the M44A2 series vehicle. Special torque limits are indicated in the maintenance procedures for applicable components. The general torque limits in this WP shall be used when specific torque limits are not indicated in the maintenance procedure. These general torque limits cannot be applied to screws that retain rubber components. The rubber components will be damaged before the correct torque limit is reached. If a special torque limit is not given in the maintenance instructions, tighten the screw or nut until it touches the metal bracket, then tighten it one more time.

TORQUE TABLES

Table 1 lists dry torque limits. Dry torque limits are used on screws that do not have lubricants applied to the threads. Table 2 lists wet torque limits. Wet torque limits are used on screws that have high pressure lubricants applied to the threads. For metric fasteners, refer to table 3 for torque limit requirements.

HOW TO USE TORQUE LIMITS

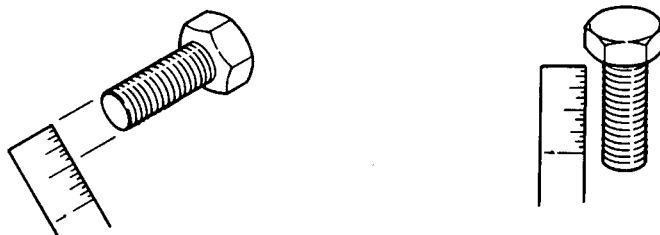

1. Measure the diameter of the screw you are installing.
2. Count the number of threads per inch.
3. Under the heading **SIZE**, look down the left hand column until you find the diameter of the screw you are installing. (There will usually be two lines beginning with the same size).
4. In the second column under **SIZE**, find the number of threads per inch that matches the number of threads you counted in step 2. (Not required for metric screws).

CAPSCREW HEAD MARKINGS

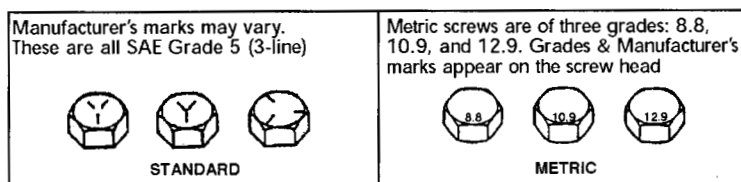

5. To find the grade screw you are installing, match the markings on the head to the correct picture of Capscrew Head Markings in the illustration preceding the torque table.
6. Look down the column under the picture you found in step 5, until you find the torque limit (in., lb-ft or N•m) for the diameter and threads per inch of the screw.

TORQUE LIMITS (Contd)

Table 1. Torque Limits for Dry Fasteners.

SIZE			TORQUE							
			SAE GRADE NO.1 OR 2		SAE GRADE NO.5		SAE GRADE NO. 6 OR 7		SAE GRADE NO. 8	
DIA. INCHES	THREADS PER INCH	DIA. MILLIMETERS	POUND FEET	NEWTON METERS	POUND FEET	NEWTON METERS	POUND FEET	NEWTON METERS	POUND FEET	NEWTON METERS
1/4	20	6.35	5	7	8	11	10	14	10	16
1/4	28	6.35	6	8	10	14	12	16	12	16
5/16	18	7.94	11	15	17	23	21	28	24	33
5/16	24	7.94	12	16	19	26	24	33	27	37
3/8	16	9.53	20	27	30	41	40	54	45	61
3/8	24	9.53	23	31	35	47	45	61	50	68
7/16	14	11.11	30	41	50	68	60	81	70	95
7/16	20		35	47	55	75	70	95	80	108
1/2	13	12.70	50	68	75	102	95	129	110	149
1/2	20		55	75	90	122	100	136	120	163
9/16	12	14.29	65	88	110	149	135	183	150	203
9/16	18		75	102	120	163	150	203	170	230
5/8	11	15.88	90	122	150	203	190	258	220	298
5/8	18		100	136	180	244	210	285	240	325
3/4	10	19.05	160	217	260	353	320	434	380	515
3/4	16		180	244	300	407	360	488	420	596
7/8	9	22.23	140	190	400	542	520	705	600	813
7/8	14		155	210	440	597	580	786	660	895
1	8	25.40	220	298	580	786	800	1085	900	1220
1	12		240	325	640	868	860	1166	1000	1356
1-1/8	7	25.58	300	407	800	1085	1120	1519	1280	1735
1-1/8	12		340	461	880	1193	1260	1708	1440	1952
1-1/4	7	31.75	420	569	1120	1519	1580	2142	1820	2468
1-1/4	12		460	624	1240	1681	1760	2386	2000	2712
1-3/8	6	34.93	560	759	1460	1979	2080	2820	2380	3227
1-3/8	12		640	868	1690	2291	2380	3227	2720	3688
1-1/2	6	38.10	740	1003	1940	2630	2780	3769	3160	4284
1-1/2	12		840	1139	2200	2983	3100	4203	3560	4827

CAPSCREW HEAD MARKINGS



Manufacturer's marks may vary.
These are all SAE Grade 5 (3-line).

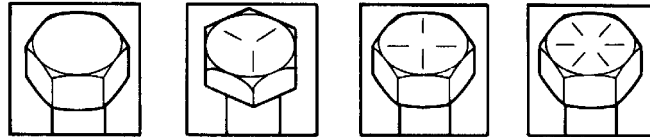

TORQUE LIMITS (Contd)

Table 2. Torque Limits for Wet Fasteners.

SIZE			TORQUE							
			SAE GRADE NO.1 OR 2		SAE GRADE NO.5		SAE GRADE NO. 6 OR 7		SAE GRADE NO. 8	
DIA. INCHES	THREADS PER INCH	DIA. MILLIMETERS	POUND FEET	NEWTON METERS	POUND FEET	NEWTON METERS	POUND FEET	NEWTON METERS	POUND FEET	NEWTON METERS
1/4	20	6.35	4	5	6	8	8	11	9	12
1/4	28	6.35	5	7	7	9	9	12	10	14
5/16	18	7.94	8	11	13	18	16	22	18	24
5/16	24	7.94	9	12	14	19	18	24	20	27
3/8	16	9.53	15	20	23	31	30	41	40	54
3/8	24	9.53	17	23	25	34	30	41	44	60
7/16	14	11.11	24	33	35	47	45	61	55	75
7/16	20		25	34	40	54	50	68	60	81
1/2	13	12.70	35	47	55	75	70	95	80	108
1/2	20		40	54	65	88	80	108	90	122
9/16	12	14.29	50	68	80	108	100	136	110	149
9/16	18		55	75	90	122	110	149	130	176
5/8	11	15.88	70	95	110	149	140	190	170	239
5/8	18		80	108	130	176	160	217	180	244
3/4	10	19.05	120	163	200	271	240	325	280	380
3/4	16		140	190	220	298	280	380	320	434
7/8	9	22.23	110	149	300	407	400	542	460	624
7/8	14		120	163	320	434	440	597	500	678
1	8	25.40	160	217	440	597	600	813	680	922
1	12		170	230	480	651	660	895	740	1003
1-1/8	7	25.58	220	298	600	813	840	1139	960	1302
1-1/8	12		260	353	660	895	940	1274	1080	1464
1-1/4	7	31.75	320	434	840	1139	1100	1491	1360	1844
1-1/4	12		360	488	920	1247	1320	1790	1500	2034
1-3/8	6	34.93	420	569	1100	1491	1560	2115	1780	2413
1-3/8	12		460	624	1260	1708	1780	2413	2040	2766
1-1/2	6	38.10	560	759	1460	1979	2080	2820	2360	3200
1-1/2	12		620	841	1640	2224	2320	3145	2660	3606

CAPSCREW HEAD MARKINGS



Manufacturer's marks may vary.
These are all SAE Grade 5 (3-line).

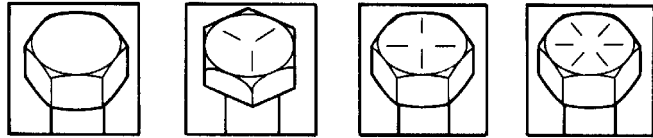

TORQUE LIMITS (Contd)

Table 3. Torque Limits for Metric Fasteners.

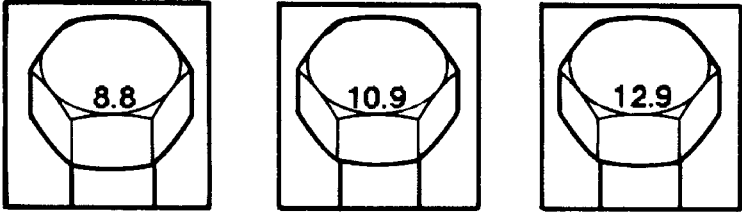
CAPSCREW HEAD MARKINGS							
							
SIZE		TORQUE					
		METRIC GRADE 8.8		METRIC GRADE 10.9		METRIC GRADE 12.9	
DIA. INCHES	THREADS PER INCH	POUND FEET	NEWTON METERS	POUND FEET	NEWTON METERS	POUND FEET	NEWTON METERS
.157	4	2	3	3	4	4	5
.197	5	4	5	6	8	7	9
.237	6	7	9	10	14	11	15
.276	7	11	15	16	22	20	27
.315	8	18	24	25	34	29	39
.394	10	32	43	47	64	58	79
.473	12	58	79	83	113	100	136
.552	14	94	127	133	180	159	216
.630	16	144	195	196	266	235	319
.709	18	190	258	269	365	323	438
.788	20	260	353	366	496	440	597
.867	22	368	499	520	705	678	919
.946	24	470	637	664	900	794	1077
1.064	27	707	959	996	1350	1235	1674
1.182	30	967	1311	1357	1840	1630	2210

TORQUE LIMITS (Contd)

TUBING APPLICATION TIGHTENING ASSEMBLY INSTRUCTIONS

MINI BARB

Slide tubing over barbed insert until it bottoms on fitting.

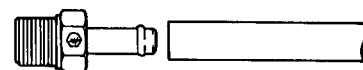

1. Slide nut and then sleeve on tubing.
2. Slide Inner Diameter (I.D.) of tubing onto fitting insert until it bottoms.
3. Assemble nut to fitting body.
4. Tighten assembly finger tight to cover body threads.

KNURL-ON

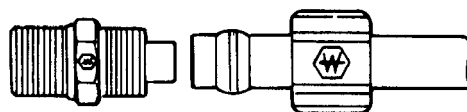

1. Slide nut and then sleeve on tubing.
2. Slide I.D. of tubing onto fitting insert until it bottoms.
3. Assemble nut to fitting body.
4. Finger tighten nut. From that point, tighten with a wrench two complete turns.

SELF-ALIGN-PTF

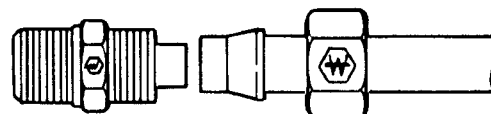

1. Cut tubing to desired length. Ensure ends are currently reasonably square.
2. Slide tubing into preassembled fitting and push until tube bottoms.
3. Tighten nut as indicated in chart. Another check on proper assembly is dimension A , when nut is fully tightened.

NYLON TUBING FOR AIR BRAKE

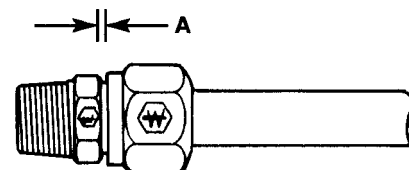

DISASSEMBLY—Remove nut and pull tubing out of fitting body. Insert will remain on tubing.

ASSEMBLY—Push tubing and insert into fitting body until it bottoms. Thread nut onto fitting body and tighten as in step 3.

TUBE O.D.	TIGHTEN NUT TO	A
1/4	85–115 lb-in.(9.6–13.0 N•m)	.085–.105
3/8	12–17 lb-ft (16.3–23.0 N•m)	.125–.145
1/2	25–33 lb-ft (33.9–44.7 N•m)	.100–.120
5/8	26–35 lb-ft (35.3–47.5 N•m)	.115–.135
3/4	38–50 lb-ft (51.5–67.8 N•m)	.180–.200

TORQUE LIMITS (Contd)

TUBING APPLICATION TIGHTENING ASSEMBLY INSTRUCTIONS (Contd)

1. Slide nut and then sleeve on tubing. Threaded end of nut B must face out.
2. Insert tubing into fitting. Ensure tubing is bottomed on fitting shoulder.
3. Thread nut onto fitting body until it is hand tight.
4. From that point, tighten with a wrench the number of turns indicated at right.

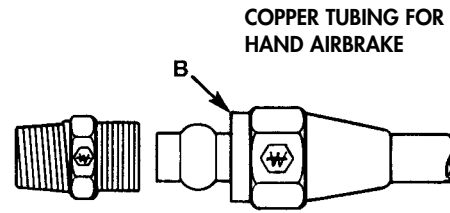

TUBE SIZE	ADDITIONAL NUMBER OF TURNS FROM HAND TIGHT
1/4, 3/8	1-3/4
1/2, 5/8, 3/4	3-1/4

TORQUE WRENCH ADAPTERS

Some tasks require the use of a torque wrench adapter when the nut or screw cannot be reached with a regular socket on the end of the torque wrench. These adapters add to the overall length of the torque wrench and make the dial or scale reading less than actual torque applied to the nut or screw. To prevent over torquing and damage to equipment, calculate correct dial or scale reading using the conversion formula on the following page.

TORQUE LIMITS (Contd)

CONVERSION FORMULA

Correct dial or scale readings are determined by the use of the following formula:

$$\text{Correct Reading} = \text{Required torque value} \div \frac{\text{Length of torque wrench} + \text{Length of adapter}}{\text{Length of torque wrench}}$$

NOTE

The length of the torque wrench is measured from the center of the handle to the center of the drive. The length of the adapter is measured from the center of the drive to the center of the wrench

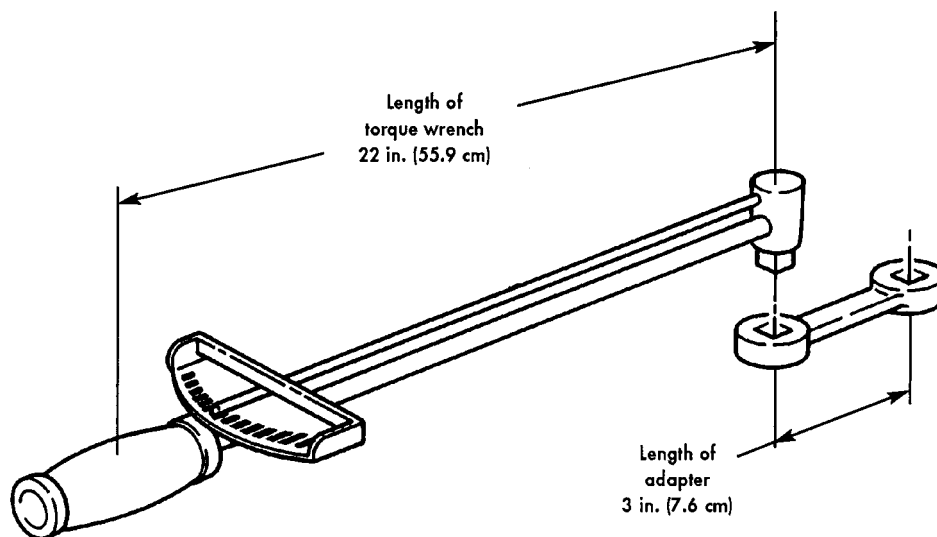

In this example, the torque wrench measures 22 in. (55.9 cm) and the adapter is 3 in. (7.6 cm). The required torque is 19 lb-ft (25.8 N•m).

$$\begin{aligned} \text{Correct Reading} &= 19 \text{ lb-ft (25.8 N}\cdot\text{m)} \div \frac{22 \text{ in. (55.9 cm)} + 3 \text{ in.}}{22 \text{ in. (55.9 cm)}} \\ \text{Correct Reading} &= 19 \text{ lb-ft (25.8 N}\cdot\text{m)} \div \frac{25 \text{ in. (63.5 cm)}}{22 \text{ in. (55.9 cm)}} \\ \text{Correct Reading} &= 19 \text{ lb-ft (25.8 N}\cdot\text{m)} \div 1.14 \\ \text{Correct Reading} &= 17 \text{ lb-ft (23.0 N}\cdot\text{m)} \end{aligned}$$

INDEX

WP Sequence No.

A

AC Receptacle Replacement (115-Volt)	WP 0309 00
Accelerator Pedal, Brackets, and Rod Maintenance	WP 0070 00
Access Door Molding and Access Plate Replacement	WP 0333 00
Accessory Power Switch Replacement	WP 0104 00
A-Frame Kit Maintenance	WP 0388 00
Air Brake Check Valve, Pressure Switch, and Air Line Replacement	WP 0407 00
Air Brake Harness Replacement	WP 0406 00
Air Brake Rotary Valve and Air Line Replacement	WP 0405 00
Air Cleaner Cap and Filter Element Replacement	WP 0052 00
Air Cleaner Assembly Maintenance	WP 0053 00
Air Cleaner Indicator and Tube Maintenance	WP 0054 00
Air Compressor and Pulley Maintenance	WP 0180 00
Air Compressor Drivebelt Maintenance	WP 0182 00
Air Compressor Governor Maintenance	WP 0183 00
Air Compressor Maintenance	WP 0181 00
Air Compressor Support and Gasket Replacement	WP 0040 00
Air Horn, Solenoid, and Bracket Replacement	WP 0114 00
Air Intake Tube and Cap Replacement	WP 0051 00
Air Pressure Gauge Replacement	WP 0094 00
Air Reservoirs Replacement	WP 0179 00
Air System Safety Valve Replacement	WP 0177 00
Airbrake Cutoff Valves and Couplings Replacement	WP 0185 00
Airbrake Hand Control Valve Replacement	WP 0178 00
Air-Hydraulic Cylinder Replacement	WP 0171 00
Alcohol Evaporator Maintenance	WP 0364 00
Alternator (60 Ampere) and Mounting Bracket Maintenance	WP 0085 00
Alternator Belts Maintenance	WP 0084 00
Alternator Pulley Replacement	WP 0086 00
Alternator Repair (60 Ampere)	WP 0448 00
Arctic Cargo Body Enclosure Replacement	WP 0410 00
Automatic Brake Test and Adjustment	WP 0344 00
Automatic Dump Valve and Sump Assembly Maintenance (M49A2C)	WP 0267 00

B

Battery and Battery Box Replacement and Servicing	WP 0127 00
Battery and Charging System Troubleshooting	WP 0012 00
Battery Box and Heater Pad Replacement	WP 0360 00
Battery Cables and Clamps Maintenance	WP 0126 00
Blackout Drive Lamp and Housing Replacement	WP 0123 00
Blackout Master Switch Replacement (M109A3)	WP 0316 00
Blackout Switch Replacement	WP 0339 00
Blower Motor Receptacle Replacement	WP 0338 00
Brake Pedal Adjustment	WP 0174 00
Brake Pedal Lever Replacement	WP 0173 00
Brush Guard, Stone Shield, and Headlight Guard Replacement	WP 0203 00
Bumper Step Kit Replacement	WP 0394 00

INDEX (Contd)

WP Sequence No.

C

Cab Cowl Vent Replacement	WP 0224 00
Cab Door and Hinges Replacement	WP 0209 00
Cab Door Catch Replacement.	WP 0216 00
Cab Door Check Rod Replacement.	WP 0215 00
Cab Door Dovetail Wedge Replacement	WP 0208 00
Cab Door Glass Assembly and Weatherseal Replacement.	WP 0210 00
Cab Door Inspection Hole Cover Replacement	WP 0207 00
Cab Door Weatherseals Replacement	WP 0217 00
Cab Door Window Regulator and Handle Replacement.	WP 0213 00
Cab Handle Replacement	WP 0223 00
Cab Reinforcement Replacement	WP 0414 00
Cab Soft Top Turnbuttons and Lashing Hooks Replacement	WP 0233 00
Cab Tunnel, Rear Tunnel, and Toeboard Replacement	WP 0230 00
Cable Retractor Replacement (M49A2C).	WP 0274 00
Camshaft and Bearing Replacement	WP 0444 00
Cargo Bodies Maintenance.	WP 0262 00
Cargo Bodies Tailgate Maintenance	WP 0261 00
Cargo Body Dropside Replacement (M35A2C)	WP 0259 00
Cargo Body Front Rack Maintenance (M35A2C)	WP 0258 00
Cargo Body Front Rack Maintenance (M36A2)	WP 0260 00
Cargo Body Personnel Heater Control Box Replacement	WP 0370 00
Cargo Body Personnel Heater Diverter and Duct Replacement	WP 0372 00
Cargo Body Personnel Heater Fuel Filter Replacement	WP 0369 00
Cargo Body Personnel Heater Fuel Line Replacement	WP 0371 00
Cargo Body Personnel Heater Fuel Pump Replacement	WP 0368 00
Cargo Body Personnel Heater Mounting Bracket Maintenance	WP 0367 00
Cargo Body Personnel Heater Replacement	WP 0366 00
Cargo Body Rack and Troop Seat Maintenance	WP 0253 00
Cargo Bodies Repair	WP 0459 00
Cargo Body Tailgate Replacement (M35A2C).	WP 0255 00
Cargo Body Tiedown Replacement.	WP 0412 00
Cargo Body Upper and Lower Rear Splash Guard Replacement	WP 0256 00
Cargo Body Tailgate Replacement	WP 0254 00
Chemical Agent Alarm Mounting Kit Replacement	WP 0392 00
Circuit Breaker Harness Replacement	WP 0319 00
Circuit Breaker Replacement.	WP 0115 00
Circuit Breaker Replacement (24-Volt)	WP 0324 00
Clutch Control Linkage Maintenance	WP 0047 00
Clutch Maintenance	WP 0050 00
Clutch Release Bearing, Shaft, and Fork Maintenance	WP 0049 00
Companion Seat and Leg Extension Replacement	WP 0398 00
Companion Seat Maintenance	WP 0234 00
Compressed Air and Brake System Troubleshooting	WP 0010 00
Compressed Air and Brake System Troubleshooting Index.	WP 0009 00
Converter Receptacle Replacement	WP 0331 00
Converter Replacement	WP 0328 00
Converter Selector Switch Replacement	WP 0326 00
Cooling System Servicing	WP 0076 00

INDEX (Contd)

WP Sequence No.

C (Contd)

Crankcase Breather Tube Adapter Replacement	WP 0045 00
Crankcase Breather Tube Maintenance	WP 0043 00
Crankshaft Replacement	WP 0440 00
Cylinder Head Maintenance.	WP 0027 00
Cylinder Head Repair	WP 0438 00
Cylinder Sleeve Replacement.	WP 0439 00

D

Data Plate Replacement	WP 0245 00
DC Receptacle Replacement (24-Volt) (M185A3)	WP 0310 00
Decontamination Mounting Kit Replacement.	WP 0391 00
Deep Water Fording Kit Air Intake Tubes Replacement	WP 0385 00
Deep Water Fording Kit Control Valve Replacement	WP 0386 00
Deep Water Fording Kit Regulator Valve Replacement	WP 0387 00
Delivery Pump Drain Valve Replacement.	WP 0281 00
Delivery Pump Front Propeller Shaft Maintenance	WP 0292 00
Delivery Pump Inlet Tube Replacement (M49A2C)	WP 0278 00
Delivery Pump Outlet Tube Replacement (M49A2C).	WP 0277 00
Delivery Pump Rear Propeller Shaft Maintenance	WP 0293 00
Delivery Pump Repair	WP 0461 00
Delivery Pump Replacement	WP 0280 00
Delivery Pump Strainer Replacement.	WP 0284 00
Differential Carrier Repair.	WP 0455 00
Differential Carrier Replacement	WP 0454 00
Discharge Valve Control Levers Maintenance (M49A2C)	WP 0264 00
Discharge Valve Repair.	WP 0265 00
Discharge Valve Replacement (M49A2C)	WP 0263 00
Dome Lamp and Housing Replacement	WP 0302 00
Door Check Replacement	WP 0336 00
Door Glass Channel Replacement	WP 0212 00
Door Glass Replacement.	WP 0211 00
Door Holder Assembly and Bracket Replacement	WP 0335 00
Drag Link Replacement	WP 0195 00
Driver's Seat Base Maintenance	WP 0235 00
Driver's Seat Cushion, Backrest, Frame, and Seat Adjuster Replacement.	WP 0237 00
Driver's Seat Replacement	WP 0236 00

E

Electrical System Troubleshooting Index	WP 0011 00
Engine Coolant Heater Blower Motor Maintenance.	WP 0418 00
Engine Coolant Heater Burner Maintenance	WP 0424 00
Engine Coolant Heater Component Bracket Maintenance	WP 0420 00
Engine Coolant Heater Flame Detector Switch Maintenance.	WP 0417 00
Engine Coolant Heater Fuel Control Valve Replacement	WP 0421 00
Engine Coolant Heater Fuel Tube and Preheater Resistor Replacement.	WP 0423 00
Engine Coolant Heater Harness Replacement	WP 0358 00
Engine Coolant Heater Housing Replacement	WP 0425 00

INDEX (Contd)

WP Sequence No.

E (Contd)

Engine Coolant Heater Overheat Switch and Igniter Maintenance	WP 0422 00
Engine Coolant Heater Replacement.	WP 0357 00
Engine Coolant Heater Restriction Thermostat Maintenance.	WP 0419 00
Engine Coolant Heater Testing	WP 0426 00
Engine Front and Rear Mounting Brackets Replacement.	WP 0026 00
Engine Front Mount Pad Replacement	WP 0024 00
Engine Oil Filter Housing Maintenance	WP 0039 00
Engine Oil Cooler Replacement	WP 0038 00
Engine Oil Filter and Body Maintenance	WP 0044 00
Engine Rear Mount Pad Replacement.	WP 0025 00
Engine Repair	WP 0437 00
Engine Replacement	WP 0046 00
Engine Stop Control Cable Maintenance	WP 0071 00
Engine Temperature Sending Unit Replacement	WP 0107 00
Equipment Description and Data	WP 0002 00
Exhaust Blower Duct Assembly Replacement	WP 0337 00
Exhaust Blower Motor and Bracket Replacement	WP 0301 00
Exhaust Blower Switch Replacement	WP 0327 00
Exhaust System Replacement (All Except M50A3)	WP 0073 00
Exhaust System Replacement (M50A3)	WP 0074 00
Exhaust Tube Replacement	WP 0355 00
Expendable and Durable Items List	WP 0468 00

F

Fan Replacement.	WP 0075 00
Filter Separator Maintenance (M49A2C)	WP 0286 00
Filter Separator-to-Sump Pipe Replacement (M49A2C)	WP 0273 00
Fire Extinguisher and Mounting Kit Replacement	WP 0393 00
Fixed Seatbelt Kit Replacement.	WP 0396 00
Flexible Hydraulic Brake Line Modification.	WP 0176 00
Floating Seatbelt Kit Replacement	WP 0397 00
Floodlight Bracket Replacement	WP 0332 00
Flywheel and Transmission Adapter Plate Maintenance.	WP 0029 00
Flywheel Repair	WP 0441 00
Forward-Rear and Rear-Rear Axle Assembly Overhaul.	WP 0453 00
Forward-Rear and Rear-Rear Axle Assembly Replacement.	WP 0151 00
Frame Alignment Inspection	WP 0206 00
Front and Rear Axle Breather Maintenance.	WP 0144 00
Front and Rear Differential Oil Seal Replacement	WP 0149 00
Front and Rear Fuel Tank Discharge Tubes Replacement (M49A2C)	WP 0266 00
Front Axle Assembly Overhaul	WP 0452 00
Front Axle Engagement Air Cylinder Maintenance	WP 0136 00
Front Axle Oil Seal Assembly Replacement	WP 0143 00
Front Axle Replacement	WP 0148 00
Front Axle Shaft and Universal Joint Maintenance.	WP 0142 00
Front Axle Shaft Flange Maintenance.	WP 0146 00
Front Bumper Replacement.	WP 0204 00
Front Composite Lamps, Housing, and Bracket Replacement.	WP 0122 00

INDEX (Contd)

WP Sequence No.

F (Contd)

Front Fenders Maintenance	WP 0238 00
Front Hub and Drum Maintenance	WP 0187 00
Front Shackle (W/ Winch) Replacement	WP 0198 00
Front Shackle (W/O Winch) Replacement	WP 0197 00
Front Splash Guard Replacement	WP 0257 00
Front Spring Bumper Replacement	WP 0155 00
Front Spring Maintenance	WP 0156 00
Front Spring Replacement	WP 0153 00
Front Spring Shackle Replacement	WP 0154 00
Front Wheel Drive Lock-In Switch Indicator and Air Pressure Switch Replacement . .	WP 0118 00
Front Wheel Drive Lock-In Switch Maintenance	WP 0135 00
Front Winch Cable Replacement	WP 0343 00
Front Winch Drag Brake Test and Adjustment	WP 0342 00
Front Winch Extension Replacement	WP 0205 00
Front Winch Propeller Shaft Replacement	WP 0346 00
Front Winch Replacement	WP 0345 00
Front Window Sash Maintenance	WP 0320 00
Front Wiring Harness Replacement	WP 0091 00
Fuel and Water Tank Bodies Maintenance	WP 0298 00
Fuel and Water Tank Nozzle Holder Replacement	WP 0270 00
Fuel Burning Personnel Heater Replacement	WP 0351 00
Fuel Burning Personnel Heater Testing	WP 0435 00
Fuel Hose and Nozzle Replacement (M49A2C)	WP 0269 00
Fuel Injection Pump Replacement	WP 0069 00
Fuel Injector Nozzle and Holder Maintenance	WP 0067 00
Fuel Injector Pump Maintenance	WP 0446 00
Fuel Injector Tubes Maintenance	WP 0068 00
Fuel Level Sending Unit Replacement	WP 0109 00
Fuel Line Adapter Replacement	WP 0340 00
Fuel Pump (In-Tank) Fuse Replacement	WP 0059 00
Fuel Pump (In-Tank) Maintenance	WP 0061 00
Fuel Return Tees and Tubes Replacement	WP 0062 00
Fuel Tank Filler Cap and Sleeve Replacement	WP 0058 00
Fuel Tank Manhole Cover Maintenance (M49A2C)	WP 0268 00
Fuel Tank Replacement	WP 0060 00

G

Gallon Meter Replacement (M49A2C)	WP 0276 00
Gate Valve Replacement	WP 0283 00
General Information	WP 0001 00
General Maintenance Procedures	WP 0021 00
Globe Valve Replacement (M49A2C)	WP 0272 00
Glove Compartment Replacement	WP 0225 00

INDEX (Contd)

WP Sequence No.

H

Hand Throttle Control Cable Maintenance.....	WP 0072 00
Hardtop Maintenance.....	WP 0363 00
Hardtop Rear Panel Window Maintenance.....	WP 0436 00
Headlight Beam Selection Switch Replacement.....	WP 0111 00
Headlight Bracket and Rubber Radiator Shield Replacement.....	WP 0219 00
Headlight High Beam Indicator and Lamp Replacement.....	WP 0100 00
Heating Systems Troubleshooting.....	WP 0015 00
Hood and Radiator Cover Replacement.....	WP 0362 00
Hood Fasteners Replacement.....	WP 0220 00
Hood Hinges Replacement.....	WP 0222 00
Hood Maintenance.....	WP 0221 00
Horn Button Replacement.....	WP 0113 00
Hot Water Personnel Heater Blower Motor Resistor Replacement.....	WP 0117 00
Hot Water Personnel Heater Control Switch Replacement.....	WP 0116 00
Hydraulic Brake Line Replacement.....	WP 0175 00
Hydraulic Master Cylinder Maintenance.....	WP 0170 00
Hydraulic Wheel Cylinder Replacement.....	WP 0169 00

I

Indicators, Gauges, and Warning System Troubleshooting.....	WP 0014 00
Instrument Cluster Replacement.....	WP 0093 00
Intake and Exhaust Manifolds Maintenance.....	WP 0041 00
Intake and Exhaust Valves, Guides, and Springs Replacement.....	WP 0443 00
Intermediate Propeller Shaft Maintenance (M36A2).....	WP 0140 00
Intermediate Turn Signal Replacement.....	WP 0121 00
Introduction to STE/ICE Troubleshooting.....	WP 0016 00
Introduction to Troubleshooting.....	WP 0004 00

L

Left and Right Conlinks Maintenance.....	WP 0241 00
Light Switch Replacement.....	WP 0101 00
Lighting and Wiper System Troubleshooting.....	WP 0013 00
Low Air Buzzer Replacement.....	WP 0110 00
Low Air Pressure Indicator and Lamp Replacement.....	WP 0413 00
Low Air Pressure Switch Replacement.....	WP 0108 00
Lubrication Instructions.....	WP 0020 00

M

Machine Gun Mount Kit Replacement.....	WP 0389 00
Magnetic Starter Relay and Mounting Bracket Replacement.....	WP 0087 00
Maintenance Allocation Chart (MAC).....	WP 0467 00
Maintenance Allocation Chart (MAC) Introduction.....	WP 0466 00
Mandatory Replacement Parts.....	WP 0470 00
Manifold Heater (Covered) Replacement.....	WP 0065 00
Manifold Heater (Uncovered) Replacement.....	WP 0066 00
Manifold Heater Switch Replacement.....	WP 0105 00
Manufactured Items List.....	WP 0471 00
Mechanical Systems Troubleshooting - Unit.....	WP 0006 00
Mechanical Systems Troubleshooting Index - Unit.....	WP 0005 00
Mechanical Systems Troubleshooting - Direct Support.....	WP 0008 00

INDEX (Contd)

WP Sequence No.

M (Contd)

Mechanical Troubleshooting Index - Direct Support	WP 0007 00
Meter Outlet Tube Replacement (M49A2C)	WP 0282 00
Meter-to-Filter Tube Replacement (M49A2C).	WP 0275 00
Mirror and Brackets Replacement.	WP 0244 00
Multibreaker Box Replacement	WP 0317 00

O

Oil Cooler Tube and Hoses Replacement.	WP 0083 00
Oil Dipstick Tube Replacement	WP 0042 00
Oil Pan Replacement.	WP 0035 00
Oil Pan Shroud and Exhaust Tube Replacement	WP 0356 00
Oil Pressure Gauge, Battery and Alternator Gauge, Fuel Gauge, and Engine Temperature Gauge Replacement.	WP 0095 00
Oil Pressure Regulator Housing Maintenance	WP 0037 00
Oil Pressure Sending Unit Replacement.	WP 0106 00
Oil Pump Maintenance.	WP 0036 00
Oil Pump Repair	WP 0445 00
Outside Door Handle, Inside Door Handle, and Cab Door Lock Replacement.	WP 0214 00
Overturn Tubes Replacement (M49A2C).	WP 0271 00

P

Parking and Service Brakedrum Repair	WP 0456 00
Parking and Service Brakeshoe Repair	WP 0457 00
Parking Brake Cable Replacement	WP 0165 00
Parking Brake Lever Replacement	WP 0166 00
Parking Brakedrum Replacement	WP 0163 00
Parking Brakeshoe Maintenance	WP 0164 00
Pedal Shaft Support Replacement	WP 0048 00
Personnel Heater Air Vent Replacement.	WP 0248 00
Personnel Heater Burner Maintenance.	WP 0432 00
Personnel Heater Control Box Replacement.	WP 0352 00
Personnel Heater Control Cables Maintenance	WP 0249 00
Personnel Heater Defroster Hoses Replacement	WP 0251 00
Personnel Heater Diverter Replacement.	WP 0247 00
Personnel Heater Flame Detector Switch Maintenance	WP 0431 00
Personnel Heater Fuel Control Valve Maintenance	WP 0428 00
Personnel Heater Fuel Filter Replacement.	WP 0354 00
Personnel Heater Fuel Line and Blower Housing Replacement	WP 0430 00
Personnel Heater Fuel Pump Replacement	WP 0353 00
Personnel Heater Guard and Blower Motor Replacement.	WP 0427 00
Personnel Heater Heat Exchanger Maintenance	WP 0434 00
Personnel Heater Igniter and Ignition Control Unit Replacement	WP 0429 00
Personnel Heater Inlet and Outlet Hose Replacement	WP 0079 00
Personnel Heater Overheat Switch and Receptacle Replacement.	WP 0433 00
Personnel Heater Supply Hose Replacement	WP 0246 00
Personnel Hot Water Heater Replacement	WP 0250 00
Pintle Hook Maintenance.	WP 0199 00
Pioneer Tool Bracket Replacement	WP 0350 00
Piston and Connecting Rod Replacement	WP 0442 00

INDEX (Contd)

WP Sequence No.

P (Contd)

Pitman Arm Replacement	WP 0191 00
Power Switch Maintenance	WP 0334 00
Preventive Maintenance Checks and Services (PMCS)	WP 0023 00
Preventive Maintenance Checks and Services (PMCS) Introduction	WP 0022 00
Primary and Secondary Heater Exhaust Tube Replacement	WP 0378 00
Primary and Secondary Heater Switches Replacement	WP 0381 00
Primary Fuel Filter Maintenance	WP 0063 00
Primary Heater Air Inlet Duct Replacement	WP 0379 00
Primary Heater and Duct Replacement	WP 0380 00
Primary Heater Auxiliary Duct Replacement	WP 0382 00
Primary Heater Fuel Filter Replacement	WP 0375 00
Primary Heater Fuel Lines Replacement	WP 0376 00
Primary Heater Fuel Pump Cover Replacement	WP 0374 00
Primary Heater Fuel Pump Replacement	WP 0373 00
Primary Heater Fuel Shutoff and Coupling Replacement	WP 0377 00
Propeller Shaft Maintenance	WP 0139 00

Q

Quick-Disconnect Coupling Half Maintenance	WP 0184 00
--	------------

R

Radiator and Brackets Maintenance	WP 0077 00
Radiator Repair	WP 0447 00
Rear Axle Shaft Maintenance	WP 0147 00
Rear Bumperette Replacement	WP 0201 00
Rear Cab Mount and Bracket Replacement	WP 0231 00
Rear Compartment Door Maintenance	WP 0288 00
Rear Composite Lamps and Housing Replacement	WP 0125 00
Rear Hub and Drum Maintenance	WP 0188 00
Rear Shackle Replacement	WP 0200 00
Rear Splash Guard Replacement	WP 0299 00
Rear Spring Maintenance	WP 0158 00
Rear Spring Replacement	WP 0157 00
Rear Spring Seat Replacement	WP 0159 00
Rear Spring Wear Pad Replacement	WP 0161 00
Rear Wiring Harness Replacement	WP 0092 00
Receptacle Replacement (115-Volt)	WP 0311 00
Receptacle Strip Replacement (115-Volt)	WP 0312 00
References	WP 0465 00
Reflector Replacement	WP 0252 00
Rifle Mounting Kit Replacement	WP 0390 00
Rocker Arm Covers Replacement	WP 0030 00
Rocker Arms and Pushrods Maintenance	WP 0031 00

INDEX (Contd)

WP Sequence No.

S

Safety Switch Box Replacement.	WP 0318 00
Safety Switch Fuse Replacement.	WP 0300 00
Schematics and Wiring Diagrams	WP 0473 00
Sealed Beam and Headlamp Housing Adjustment.	WP 0120 00
Sealed Beam and Headlamp Housing Replacement.	WP 0119 00
Secondary and Final Fuel Filters Testing and Maintenance.	WP 0064 00
Secondary Heater and Duct Replacement.	WP 0384 00
Secondary Heater Fuel Lines Replacement	WP 0383 00
Separator Element Test, Gauge, and Lines Maintenance (M49A2C)	WP 0285 00
Service Brake Adjustment	WP 0168 00
Service Brake Bleeding.	WP 0172 00
Service Brakeshoes Maintenance.	WP 0167 00
Service Upon Receipt	WP 0019 00
Shock Absorber Replacement.	WP 0160 00
Side Marker and Clearance Lamps Replacement.	WP 0124 00
Side Panel Replacement	WP 0218 00
Side Rail Maintenance	WP 0341 00
Side Window Sash Maintenance	WP 0321 00
Slave Receptacle Replacement.	WP 0365 00
Spare Tire Carrier Maintenance	WP 0202 00
Speaking Tube Replacement (M35A2).	WP 0411 00
Speed Control Cable Maintenance.	WP 0294 00
Speedometer and Tachometer Replacement	WP 0096 00
Speedometer Driveshaft and Adapter Replacement.	WP 0099 00
Starter Repair	WP 0449 00
Starter Motor Replacement	WP 0088 00
Starter Switch Replacement.	WP 0089 00
STE/ICE-R Go Chain Troubleshooting	WP 0017 00
STE/ICE-R No-Go Chain Troubleshooting	WP 0018 00
Steering Assist Cylinder Maintenance	WP 0408 00
Steering Assist Regulator Replacement	WP 0409 00
Steering Gear Adjustment	WP 0193 00
Steering Gear Repair	WP 0458 00
Steering Gear Replacement	WP 0192 00
Steering Knuckle and Steering Arm Maintenance.	WP 0150 00
Steering Knuckle Boot Replacement	WP 0145 00
Steering Wheel Replacement	WP 0196 00
Stoplight Switch Replacement	WP 0112 00
Sunshield Replacement (Hard Top)	WP 0416 00
Sunshield Replacement (Soft Top)	WP 0415 00
Swingfire Heater and Mounting Brackets Replacement	WP 0399 00
Swingfire Heater Battery Box Tube Replacement	WP 0400 00
Swingfire Heater Water Hoses Replacement	WP 0402 00
Swingfire Heater Water Jacket Brackets Replacement	WP 0403 00
Swingfire Heater Water Jacket Replacement	WP 0401 00
Swingfire Heater Wiring Harness and Receptacle Replacement.	WP 0404 00

INDEX (Contd)

WP Sequence No.

T

Tachometer Adapter Replacement	WP 0098 00
Tachometer Drive Shaft and Drive Core Maintenance	WP 0097 00
Tandem Axle Replacement	WP 0152 00
Tank Bodies Frame Sill Maintenance	WP 0297 00
Tank Bodies Front Splash Guard Replacement	WP 0295 00
Tank Bodies Repair	WP 0460 00
Tank Bodies Upper and Lower Rear Splash Guard Replacement	WP 0296 00
Tappet Chamber Cover and Gasket Replacement	WP 0033 00
Theory of Operation	WP 0003 00
Thermal Barrier Insulation Replacement	WP 0359 00
Thermostat, Housing, and Hose Replacement	WP 0081 00
Tie Rod and Tie Rod End Replacement	WP 0194 00
Timing Gears Cover and Gasket Replacement	WP 0032 00
Toe-In Check and Adjustment	WP 0190 00
Tool Identification List	WP 0469 00
Toolbox (Under Cab) Replacement	WP 0226 00
Torque Limits	WP 0472 00
Torque Rods Replacement	WP 0162 00
Transfer Case Breather Maintenance	WP 0137 00
Transfer Case Controls and Linkage Maintenance (W/ PTO)	WP 0133 00
Transfer Case Controls and Linkage Maintenance (W/O PTO)	WP 0134 00
Transfer Case Replacement	WP 0138 00
Transfer Case Power Takeoff (PTO) Maintenance	WP 0348 00
Transfer Case Repair	WP 0451 00
Transmission Breather Maintenance	WP 0128 00
Transmission Gearshift and Transfer Case Lever Cover Replacement	WP 0361 00
Transmission Gearshift Lever Knob and Boot Replacement	WP 0129 00
Transmission Gearshift Lever Replacement	WP 0130 00
Transmission Installation	WP 0132 00
Transmission Power Takeoff (PTO) Repair	WP 0464 00
Transmission Power Takeoff (PTO) Shift Linkage Maintenance	WP 0347 00
Transmission Power Takeoff (PTO), Cover, and Gasket Maintenance	WP 0349 00
Transmission Removal	WP 0131 00
Transmission Repair	WP 0450 00
Troop Seat Center Mounted Kit Replacement	WP 0395 00
Turbocharger Oil Drain Tube, Hose, and Adapter Replacement	WP 0056 00
Turbocharger Oil Inlet Tube and Adapter Replacement	WP 0055 00
Turbocharger Replacement	WP 0057 00
Turn Signal Control and Indicator Lamp Replacement	WP 0102 00
Turn Signal Flasher Replacement	WP 0103 00

U

Universal Joint Maintenance	WP 0141 00
Upper and Lower Radiator Hose Replacement	WP 0078 00

INDEX (Contd)

WP Sequence No.

V

Valve Tappets Maintenance	WP 0034 00
Van Bodies Front Splash Guard Replacement	WP 0329 00
Van Body Access Door Replacement	WP 0322 00
Van Body Access Plate, Access Cover, and Retainer Assembly Replacement	WP 0323 00
Van Body Cabinet and Work Bench Table Replacement	WP 0306 00
Van Body Ceiling Panel Replacement	WP 0307 00
Van Body Maintenance	WP 0462 00
Van Body Side Panel Replacement	WP 0308 00
Van Body Tool Replacement (M185A3)	WP 0330 00
Van Door Maintenance	WP 0305 00
Van Door Replacement	WP 0303 00
Van Door Seals Replacement	WP 0304 00
Vehicle Boarding Ladder Replacement	WP 0325 00
Vibration Damper and Seal Replacement	WP 0028 00

W

Water Can Bracket and Running Board Replacement	WP 0232 00
Water Manifold and Hose Replacement	WP 0080 00
Water Pump Housing and Water Pump Replacement	WP 0082 00
Water Pump Manifold Replacement (M50A3)	WP 0279 00
Water Tank Discharge Tube, Cover, and Valve Replacement (M50A3)	WP 0289 00
Water Tank Discharge Valve Control Levers Maintenance (M50A3)	WP 0290 00
Water Tank Filler Cover Replacement (M50A3)	WP 0287 00
Water Tank Manhole Cover Replacement (M50A3)	WP 0291 00
Wheel Bearing Adjustment	WP 0189 00
Wheel, Tire, and Tube Maintenance	WP 0186 00
Winch Repair (Front)	WP 0463 00
Windshield Arm, Glass Assembly, and Handle Replacement	WP 0229 00
Windshield Assembly Maintenance	WP 0228 00
Windshield Glass Replacement	WP 0227 00
Windshield Washer Reservoir, Tubing, Jet, and Pump Replacement	WP 0239 00
Windshield Wiper Blade and Arm Replacement	WP 0243 00
Windshield Wiper Idler Shaft and Housing Replacement	WP 0242 00
Windshield Wiper Switch, Motor, and Conlink Covers Replacement	WP 0240 00
Wire Plug Wiring Harness Replacement	WP 0314 00
Wiring Harness Connector Repair	WP 0090 00
Wiring Harness Replacement (115- and 24-Volt)	WP 0315 00
Wiring Harness Replacement (115-Volt)	WP 0313 00

By Order of the Secretary of the Army:

Official:

A handwritten signature in black ink that reads "Joyce E. Morrow". The signature is written in a cursive style with a large, stylized initial "J".

JOYCE E. MORROW
*Administrative Assistant to the
Secretary of the Army*

0617813

PETER J. SCHOOMAKER
*General, United States Army
Chief of Staff*

Distribution:

To be distributed in accordance with the initial distribution number (IDN) 380417,
requirements for TM 9-2320-361-24-2.

SUPPORTING INFORMATION

2-1/2 TON, 6X6, M44A2 SERIES TRUCKS (MULTIFUEL)

SCHEMATICS AND WIRING DIAGRAMS

TITLE	PAGE NO.
Foldout 1. Electrical Wiring Diagram	0473 00-1
Foldout 2. Van Body Electrical System Wiring Diagram	0473 00-3
Foldout 3. Hydraulic Brake System Diagram	0473 00-5
Foldout 4. Compressed Air System	0473 00-7

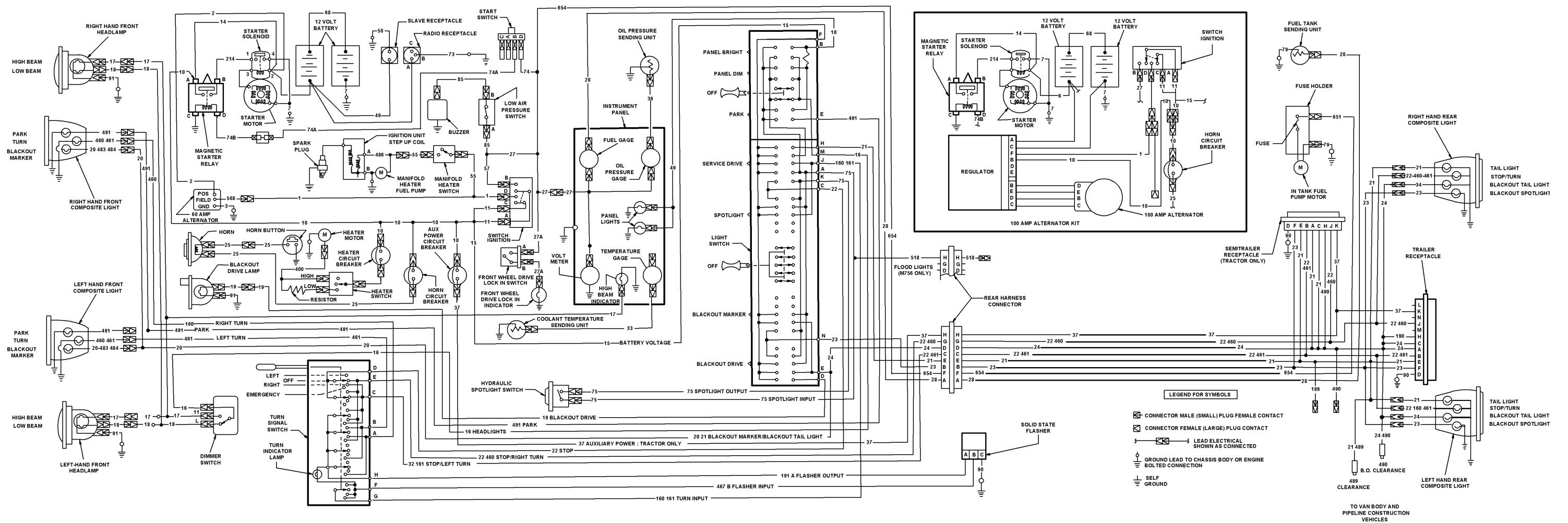

Foldout 1. Electrical Wiring Diagram.

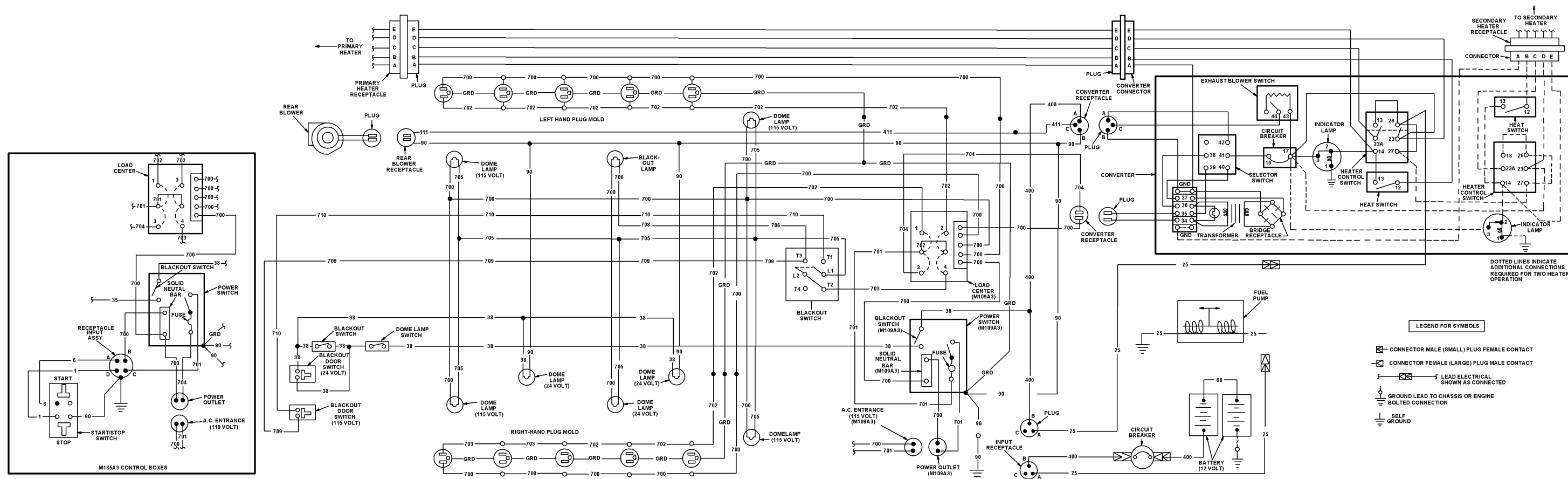

Foldout 2. Van Body Electrical System Wiring Diagram.

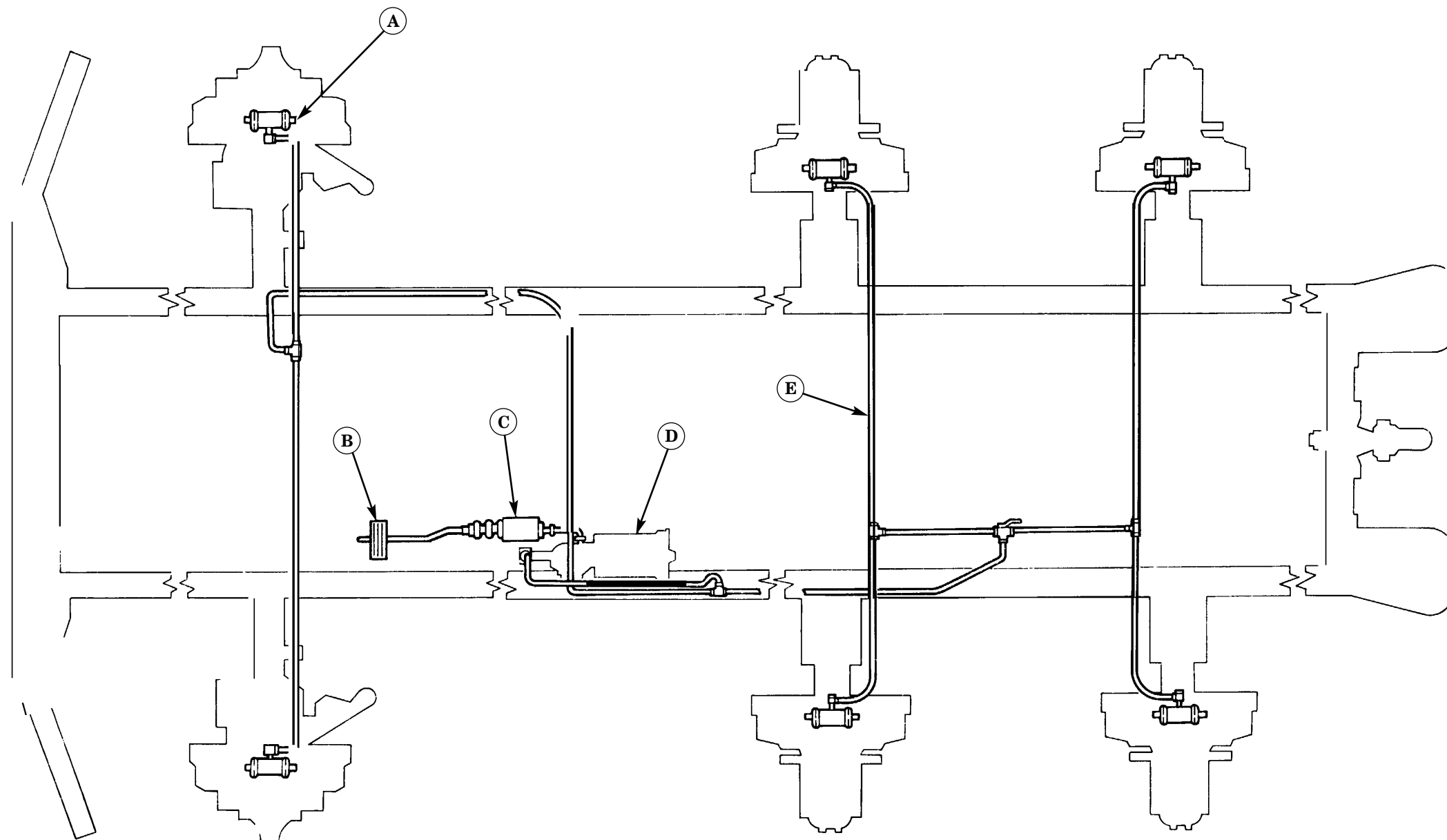

- Ⓐ WHEEL CYLINDER
- Ⓑ BRAKE PEDAL
- Ⓒ MASTER CYLINDER
- Ⓓ AIR HYDRAULIC CYLINDER
- Ⓔ BRAKE LINE

Foldout 3. Hydraulic Brake System Diagram.

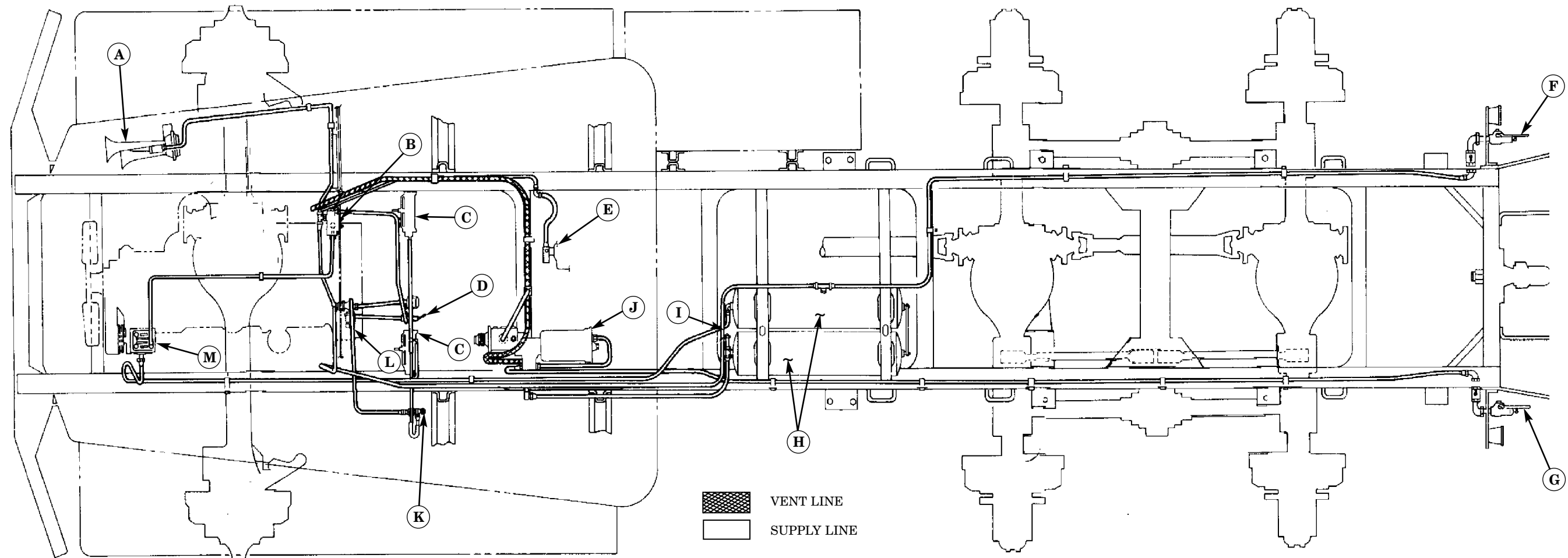

- | | | | |
|----------------------------------|--|----------------------------|-------------------------------------|
| (A) AIR HORN | (E) FRONT AXLE ENGAGEMENT AIR CYLINDER | (H) AIR RESERVOIRS | (K) WINDSHIELD WIPER SWITCH |
| (B) GOVERNOR | (F) REAR EMERGENCY AIR COUPLING | (I) SAFETY VALVE | (L) LOW AIR PRESSURE WARNING SWITCH |
| (C) WINDSHIELD WIPER MOTORS | (G) REAR SERVICE AIR COUPLING | (J) AIR HYDRAULIC CYLINDER | (M) AIR COMPRESSOR |
| (D) FRONT AXLE ENGAGEMENT SWITCH | | | |

Foldout 4. Compressed Air System.

RECOMMENDED CHANGES TO PUBLICATIONS AND BLANK FORMS For use of this form, see AR 25-30; the proponent agency is ODISC4.	Use Part II (reverse) for Repair Parts and Special Tools Lists (RPSTL) and Supply Catalogs/Supply Manuals (SC/SM).	DATE: <p style="text-align: center;">28 October 2006</p>
---	--	--

TO: (Forward to proponent of publication or form) (include ZIP code) AMSTA-LC-LPIT Tech Pubs, TACOM-RI 1 Rock Island Arsenal Rock Island, IL 61299-7630	FROM: (Activity and location) (include ZIP code) <p style="text-align: center;">Co. B, 1st BN, 2nd Brigade Ft. Hood, TX 76445</p>
---	---

PART I - ALL PUBLICATIONS (EXCEPT RPSTL AND SC/SM) AND BLANK FORMS

PUBLICATION/FORM NUMBER <p style="text-align: center;">TM 9-2320-361-24-2</p>	DATE <p style="text-align: center;">18 August 2006</p>	TITLE <p style="text-align: center;">TECHNICAL MANUAL, VOLUME 1 OF 2, FIELD AND SUSTAINMENT MAINTENANCE MANUAL</p>
--	---	---

ITEM NO.	PAGE NO.	PARA-GRAPH	LINE NO.*	FIGURE NO.	TABLE NO.	RECOMMENDED CHANGES AND REASON (Provide exact wording of recommended changes, if possible).
	0346 00-2					<p>Removal, Step 2, reference to cotter pins (6) is wrong reference. Reference should be changed to (9).</p>
<h1 style="font-size: 4em; margin: 0;">SAMPLE</h1>						

*Reference to line numbers within the paragraph or subparagraph.

TYPED NAME, GRADE, OR TITLE <p style="text-align: center;">Pat Smith</p>	TELEPHONE EXCHANGE/AUTOVON, PLUS EXTENSION <p style="text-align: center;">AV272-4162</p>	SIGNATURE <p style="text-align: center;"><i>Pat Smith</i></p>
--	---	--

<i>TO: (Forward direct to addressee listed in publication)</i> AMSTA-LC-LPIT Tech Pubs, TACOM-RI 1 Rock Island Arsenal Rock Island, IL 61299-7630	<i>FROM: (Activity and location)</i> <i>(include ZIP code)</i>	<i>DATE:</i>
---	---	--------------

PART II - REPAIR PARTS AND SPECIAL TOOLS LISTS AND SUPPLY CATALOGS/SUPPLY MANUALS

<i>PUBLICATION/FORM NUMBER</i> TM 9-2320-361-24-2	<i>DATE</i> 18 August 2006	<i>TITLE</i> TECHNICAL MANUAL, VOLUME 1 OF 2, FIELD AND SUSTAINMENT MAINTENANCE MANUAL
--	-------------------------------	---

<i>PAGE NO.</i>	<i>COLM NO.</i>	<i>LINE NO.</i>	<i>NATIONAL STOCK NUMBER</i>	<i>REFERENCE NO.</i>	<i>FIGURE NO.</i>	<i>ITEM NO.</i>	<i>TOTAL NO. OF MAJOR ITEMS SUPPORTED</i>	<i>RECOMMENDED ACTION</i>
SAMPLE								

PART III - REMARKS (Any general remarks or recommendations, or suggestions for improvement of publications and blank forms. Additional blank sheets may be used if more space is needed.)

<i>TYPED NAME, GRADE, OR TITLE</i>	<i>TELEPHONE EXCHANGE/AUTOVON, PLUS EXTENSION</i>	<i>SIGNATURE</i>
------------------------------------	---	------------------

RECOMMENDED CHANGES TO PUBLICATIONS AND BLANK FORMS						Use Part II (<i>reverse</i>) for Repair Parts and Special Tool Lists (RPSTL) and Supply Catalogs/Supply Manuals (SC/SM).	DATE
For use of this form, see AR 25-30; the proponent agency is ODISC4.							
TO: (<i>Forward to proponent of publication or form</i>) (<i>Include ZIP Code</i>) AMSTA-LC-LPIT / TECH PUBS, TACOM-RI 1 Rock Island Arsenal Rock Island, IL 61299-7630						FROM: (<i>Activity and location</i>) (<i>Include ZIP Code</i>)	
PART I - ALL PUBLICATIONS (EXCEPT RPSTL AND SC/SM) AND BLANK FORMS							
PUBLICATION/FORM NUMBER TM 9-2320-361-24-2						DATE 18 August 2006	TITLE 2-1/2 TON, 6X6, M44A2 SERIES TRUCKS (MULTIFUEL)
ITEM NO.	PAGE NO.	PARA-GRAPH	LINE NO. *	FIGURE NO.	TABLE NO.	RECOMMENDED CHANGES AND REASON (<i>Provide exact wording of recommended changes, if possible.</i>)	
<i>*Reference to line numbers within the paragraph or subparagraph.</i>							
TYPED NAME, GRADE OR TITLE					TELEPHONE EXCHANGE/AUTOVON, PLUS EXTENSION		SIGNATURE

TO: <i>(Forward direct to addressee listed in publication)</i> AMSTA-LC-LPIT / TECH PUBS, TACOM-RI 1 Rock Island Arsenal Rock Island, IL 61299-7630	FROM: <i>(Activity and location) (Include ZIP Code)</i>	DATE
--	---	------

PART II – REPAIR PARTS AND SPECIAL TOOL LISTS AND SUPPLY CATALOGS/SUPPLY MANUALS

PUBLICATION NUMBER TM 9-2320-361-24-2	DATE 18 August 2006	TITLE 2-1/2 TON, 6X6, M44A2 SERIES TRUCKS (MULTIFUEL)
--	------------------------	--

PAGE NO.	COLM NO.	LINE NO.	NATIONAL STOCK NUMBER	REFERENCE NO.	FIGURE NO.	ITEM NO.	TOTAL NO. OF MAJOR ITEMS SUPPORTED	RECOMMENDED ACTION

PART III – REMARKS *(Any general remarks or recommendations, or suggestions for improvement of publications and blank forms. Additional blank sheets may be used if more space is needed.)*

TYPED NAME, GRADE OR TITLE	TELEPHONE EXCHANGE/AUTOVON, PLUS EXTENSION	SIGNATURE
----------------------------	--	-----------

RECOMMENDED CHANGES TO PUBLICATIONS AND BLANK FORMS						Use Part II (<i>reverse</i>) for Repair Parts and Special Tool Lists (RPSTL) and Supply Catalogs/Supply Manuals (SC/SM).	DATE
For use of this form, see AR 25-30; the proponent agency is ODISC4.							
TO: (<i>Forward to proponent of publication or form</i>) (<i>Include ZIP Code</i>) AMSTA-LC-LPIT / TECH PUBS, TACOM-RI 1 Rock Island Arsenal Rock Island, IL 61299-7630						FROM: (<i>Activity and location</i>) (<i>Include ZIP Code</i>)	
PART I - ALL PUBLICATIONS (EXCEPT RPSTL AND SC/SM) AND BLANK FORMS							
PUBLICATION/FORM NUMBER TM 9-2320-361-24-2						DATE 18 August 2006	TITLE 2-1/2 TON, 6X6, M44A2 SERIES TRUCKS (MULTIFUEL)
ITEM NO.	PAGE NO.	PARA-GRAPH	LINE NO. *	FIGURE NO.	TABLE NO.	RECOMMENDED CHANGES AND REASON (<i>Provide exact wording of recommended changes, if possible.</i>)	
<i>*Reference to line numbers within the paragraph or subparagraph.</i>							
TYPED NAME, GRADE OR TITLE				TELEPHONE EXCHANGE/AUTOVON, PLUS EXTENSION		SIGNATURE	

TO: <i>(Forward direct to addressee listed in publication)</i> AMSTA-LC-LPIT / TECH PUBS, TACOM-RI 1 Rock Island Arsenal Rock Island, IL 61299-7630	FROM: <i>(Activity and location) (Include ZIP Code)</i>	DATE
--	---	------

PART II - REPAIR PARTS AND SPECIAL TOOL LISTS AND SUPPLY CATALOGS/SUPPLY MANUALS

PUBLICATION NUMBER TM 9-2320-361-24-2	DATE 18 August 2006	TITLE 2-1/2 TON, 6X6, M44A2 SERIES TRUCKS (MULTIFUEL)
--	------------------------	--

PAGE NO.	COLM NO.	LINE NO.	NATIONAL STOCK NUMBER	REFERENCE NO.	FIGURE NO.	ITEM NO.	TOTAL NO. OF MAJOR ITEMS SUPPORTED	RECOMMENDED ACTION

PART III - REMARKS *(Any general remarks or recommendations, or suggestions for improvement of publications and blank forms. Additional blank sheets may be used if more space is needed.)*

TYPED NAME, GRADE OR TITLE	TELEPHONE EXCHANGE/AUTOVON, PLUS EXTENSION	SIGNATURE
----------------------------	--	-----------

THE METRIC SYSTEM AND EQUIVALENTS

LINEAR MEASURE

- 1 Centimeter = 10 Millimeters = 0.01 Meters = 0.3937 Inches
- 1 Meter = 100 Centimeters = 1,000 Millimeters = 39.37 Inches
- 1 Kilometer = 1,000 Meters = 0.621 Miles

SQUARE MEASURE

- 1 Sq Centimeter = 100 Sq Millimeters = 0.155 Sq Inches
- 1 Sq Meter = 10,000 Sq Centimeters = 10.76 Sq Feet
- 1 Sq Kilometer = 1,000,000 Sq Meters = 0.386 Sq Miles

CUBIC MEASURE

- 1 Cu Centimeter = 1,000 Cu Millimeters = 0.06 Cu Inches
- 1 Cu Meter = 1,000,000 Cu Centimeters = 35.31 Cu Feet

LIQUID MEASURE

- 1 Milliliter = 0.001 Liters = 0.0338 Fluid Ounces
- 1 Liter = 1,000 Milliliters = 33.82 Fluid Ounces

TEMPERATURE

- Degrees Fahrenheit (F) = $^{\circ}\text{C} \cdot 9 \div 5 + 32$
- Degrees Celsius (C) = $\text{F}^{\circ} - 32 \cdot 5 \div 9$
- 212° Fahrenheit is equivalent to 100° Celsius
- 90° Fahrenheit is equivalent to 32.2° Celsius
- 32° Fahrenheit is equivalent to 0° Celsius

WEIGHTS

- 1 Gram = 0.001 Kilograms = 1,000 Milligrams = 0.035 Ounces
- 1 Kilogram = 1,000 Grams = 2.2 Lb
- 1 Metric Ton = 1,000 Kilograms = 1 Megagram = 1.1 Short Tons

APPROXIMATE CONVERSION FACTORS

TO CHANGE	TO	MULTIPLY BY
Inches	Millimeters	25.4
Inches	Centimeters	2.540
Feet	Meters	0.305
Yards	Meters	0.914
Miles	Kilometers	1.609
Square Inches	Square Centimeters	6.451
Square Feet	Square Meters	0.093
Square Yards	Square Meters	0.836
Square Miles	Square Kilometers	2.590
Acres	Square Hectometers	0.405
Cubic Feet	Cubic Meters	0.028
Cubic Yards	Cubic Meters	0.765
Fluid Ounces	Milliliters	29.573
Pints	Liters	0.473
Quarts	Liters	0.946
Gallons	Liters	3.785
Ounces	Grams	28.349
Pounds	Kilograms	0.4536
Short Tons	Metric Tons	0.907
Pound-Feet	Newton-Meters	1.356
Pounds Per Square Inch	Kilopascals	6.895
Miles Per Gallon	Kilometers Per Liter	0.425
Miles Per Hour	Kilometers Per Hour	1.609
TO CHANGE	TO	MULTIPLY BY
Millimeters	Inches	0.03937
Centimeters	Inches	0.3937
Meters	Feet	3.280
Meters	Yards	1.094
Kilometers	Miles	0.621
Square Centimeters	Square Inches	0.155
Square Meters	Square Feet	10.764
Square Meters	Square Yards	1.196
Square Kilometers	Square Miles	0.386
Square Hectometers	Acres	2.471
Cubic Meters	Cubic Feet	35.315
Cubic Meters	Cubic Yards	1.308
Milliliters	Fluid Ounces	0.034
Liters	Pints	2.113
Liters	Quarts	1.057
Liters	Gallons	0.264
Grams	Ounces	0.035
Kilograms	Pounds	2.2046
Metric Tons	Short Tons	1.102
Newton-Meters	Pound-Feet	0.738
Kilopascals	Pounds Per Square Inch	0.145
Kilometers Per Liter	Miles Per Gallon	2.354
Kilometers Per Hour	Miles Per Hour	0.621

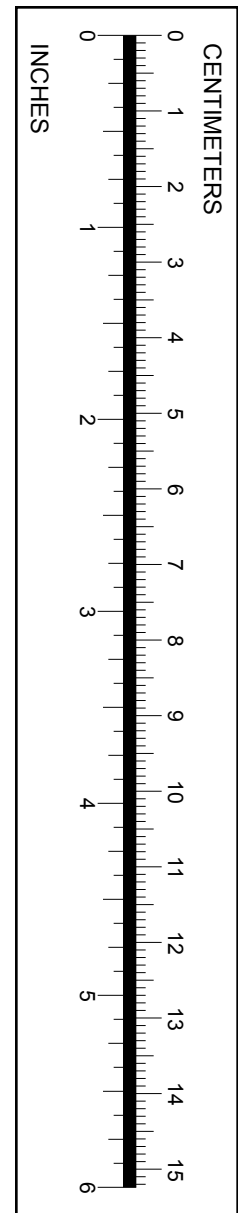

PIN: 083364-000□□