

**TECHNICAL MANUAL  
ORGANIZATIONAL MAINTENANCE MANUAL  
FOR**

TRUCK, CHASSIS: 5-TON, 6X6  
M39, M39A2, M40, M40A1, M40A2, M40A1C, M40A2C,  
M61, M61A1, M61A2, M63, M63A1,  
M63A2, M63C, M63A1C, M63A2C, M63A1D, M63A2D,  
M139A1, M139A2, M139C, M139A2C, M139D,  
M139A2D, M139F, M139A1F,  
M139A2F; TRUCK, CARGO: M41, M41A2, M54, M54A1,  
M54A2, M54A1C, M54A2C, M55, M55A1, M55A2;  
TRUCK, DUMP: M51, M51A1, M51A2;  
TRUCK, TRACTOR: M52, M52A1, M52A2, ;  
TRUCK, TRACTOR, WRECKER: M246, M246A1,  
M246A2; TRUCK, VAN, EXPANSIBLE:  
M291A1, M291A2, M291A1C, M291A2C, M291A1D,  
M291A2D; TRUCK, WRECKER, MEDIUM:  
M62, M543, M543A1, M543A2; TRUCK, BRIDGING,  
M139, M328A1, M328A2; TRUCK, LOGGING,  
M748A1, M748A2.

---

**HEADQUARTERS, DEPARTMENT OF THE ARMY**

This copy is a reprint which includes current  
pages from Changes 1 through 3.

JUNE 1973



CHANGE

NO. 3

TM 9-2320-211-20  
C 3  
HEADQUARTERS  
DEPARTMENT OF THE ARMY  
WASHINGTON, DC, 28 April 1982

ORGANIZATIONAL MAINTENANCE MANUAL  
FOR

TRUCK, CHASSIS; 5TON, 6X6, M39, M39A2, M40, M40A1, M40A2, M40A1C, M40A2C, M61, M61A1, M61A2, M63, M63A1, M63A2, M63C, M63A1C, M63A2C, M63A1D, M63A2D, M139A1, M139A2, M139C, M139A2C, M139D, M139A2D, M139F, M139A1F, M139A2F; TRUCK, CARGO; M41, M41A2, M54, M54A1, M54A2, M54A1C, M54A2C, M55, M55A1, M55A2; TRUCK, DUMP; M51, M51A1, M51A2; TRUCK, TRACTOR; M52, M52A1, M52A2; TRUCK, TRACTOR, WRECKER; M246, M246A1, M246A2; TRUCK, VAN EXPANSIBLE; M291A1, M291A2, M291A1C, M291A2C, M291A1D, M291A2D; TRUCK WRECKER, MEDIUM; M62, M543, M543A1, M543A2; TRUCK, BRIDGING; M139, M328A1, M328A2; TRUCK, LOGGING; M748A1, M748A2.

TM 9-2320-211-20, June 1973, is changed as follows:

1. Remove old pages and insert new pages as indicated below. New or changed material is indicated by a vertical bar in the margin of the page. Added or revised illustrations are indicated by a vertical bar adjacent to the illustration identification number.

**Remove Pages**

**Insert Pages**

**Remove Pages**

**Insert Pages**

iii through viii  
2-3 through 2-10  
N o n e  
2-47 through 2-50  
2-77 through 2-80  
2-97 and 2-98  
2-151 and 2-152  
2-157 through 2-166  
2-169 through 2-172  
N o n e  
2-173 and 2-174  
2-177 and 2-178

iii through viii  
2-3 through 2-10  
2-10.1 through 2-10.22  
2-47 through 2-50  
2-77 through 2-80  
2-97 and 2-98  
2-151 and 2-152  
2-157 through 2-166  
2-169 through 2-172  
2-172.1 and 2-172.2  
2-173 and 2-174  
2-177 and 2-178

2-183 and 2-184  
2-187 through 2-188.2  
2-217 and 2-218  
2-223 and 2-224  
2-231 and 2-232  
B-1 through B-22  
N o n e  
Index 1 through Index 13  
N o n e  
N o n e

2-183 and 2-184  
2-187 through 2-188.2  
2-217 and 2-218  
2-223 and 2-224  
2-231 and 2-232  
B-1 through B-22  
B-23 through B-30  
Index 1 through Index 13  
I n d e x 1 4  
Form 2028-2 (sample)  
Form 2028-2 (3 sets)

2. File this change sheet in front of the publication for reference purposes.

**By Order of the Secretary of the Army:**

**E. C. MEYER**  
*General, United States Army*  
*Chief of Staff*

**Official:**

**ROBERT M. JOYCE**  
*Brigadier General, United States Army*  
*The Adjutant General*

**DISTRIBUTION:**

To be distributed in accordance with DA Form 12-38, Organizational requirements for 5-Ton Truck, M39 Series.



CHANGE

HEADQUARTERS  
DEPARTMENT OF THE ARMY

WASHINGTON, DC 20 May 1978

NO. 2

ORGANIZATIONAL MAINTENANCE MANUAL  
FOR

TRUCK, CHASSIS: 5-TON, 6X6, M39, M39A2, M40, M40A1, M40A2, M40A1C, M40A2C, M61, M61A1, M61A2, M63, M63A1, M63A2, M63C, M63A1C, M63A2C, M63A1D, M63A2D, M139A1, M139A2, M139C, M139A2C, M139D, M139A2D, M139F, M139A1F, M139A2F; TRUCK, CARGO: M41, M41A2, M54, M54A1, M54A2, M54A1C, M54A2C, M55, M55A1, M55A2; TRUCK, DUMP: M51, M51A1, M51A2; TRUCK, TRACTOR: M52, M52A1, M52A2; TRUCK, TRACTOR, WRECKER: M246, M246A1, M246A2; TRUCK, VAN EXPANSIBLE: M291A1, M291A2, M291A1C, M291A2C, M292A1D, M291A2D; TRUCK, WRECKER, MEDIUM: M62, M543, M543A1, M543A2; TRUCK, BRIDGING, M139, M328A1, M328A2; TRUCK, LOGGING, M748A1, M748A2.

TM 9-2320-211-20, 1 June 1973, is changed as follows:

1. Remove old pages and insert new pages as indicated below. New or changed material is indicated by a vertical line in the margin of the page. Added or revised illustrations are indicated by vertical bar adjacent to the identification number.

Remove Pages	Insert Pages
2-41 and 2-42	2-41 and 2-42
2-131 and 2-132	2-131 and 2-132
2-151 and 2-152	2-151 and 2-152
None	2-152.1 and 2-152.2
2-173 and 2-174	2-173 and 2-174
2-177 and 2-178	2-177 and 2-178
2-187 and 2-188	2-187 and 2-188
None	2-188.1 and 2-188.2
2-217 and 2-218	2-217 and 2-218
None	2-218.1 and 2-218.2
2-223 and 2-224	2-223 and 2-224
None	2-224.1 and 2-224.2
2-225 and 2-226	2-225 and 2-226
3-5 and 3-6	3-5 and 3-6
B-3 and B-4	B-3 and B-4
B-7 and B-8	B-7 and B-8
2-43 and 2-44	2-43 and 2-44

File this change sheet in front of the publication for reference purposes.

By Order of the Secretary of the Army:

BERNARD W. ROGERS  
*General, United States Army*  
*Chief of Staff*

Official:

J. C. PENNINGTON  
*Brigadier General, United States Army*  
*The Adjutant General*

**DISTRIBUTION:**

To be distributed in accordance with DA Form 12-38, organizational maintenance requirements for Truck, Chassis, Cargo, Dump, Tractor, Van Expansibile, and Bridge Transport Stake.

CHANGE

No. 1

HEADQUARTERS  
DEPARTMENT OF THE ARMY  
WASHINGTON, DC, 4 June 1976

**Organizational Maintenance Manual  
for  
TRUCK, CHASSIS: 5-Ton, 6x6,  
M39, M39A2, M40, M40A1, M40A2, M40A1C, M40A2C,  
M61, M61A1, M61A2, M63, M63A1,  
M63A2, M63C, M63A1C, M63A2C, M63A1D, M63A2D,  
M139A1, M139A2, M139C, M139A2C, M139D,  
M139A2D, M139F, M139A1F,  
M139A2F; TRUCK, CARGO: M41, M41A2, M54, M54A1,  
M54A2, M54A1C, M54A2C, M55, M55A1, M55A2;  
TRUCK, DUMP: M51, M51A1, M51A2;  
TRUCK, TRACTOR: M52, M52A1, M52A2;  
TRUCK, TRACTOR, WRECKER: M246, M246A1,  
M246A2; TRUCK, VAN EXPANSIBLE:  
M291A1, M291A2, M291A1C, M291A2C, M291A1D,  
M291A2D; TRUCK, WRECKER, MEDIUM:  
M62, M543, M543A1, M543A2; TRUCK, BRIDGING,  
M139, M328A1, M328A2; TRUCK, LOGGING,  
M748A1, M748A2.**

TM 9-2320-211-20, 1 June 1973, is changed as follows:

1. Remove old pages and insert new pages as indicated below. New or changed material is indicated by a vertical line in the margin of the page. Added or revised illustrations are indicated by vertical bar adjacent to the identification number.

<i>Remove pages</i>	<i>Insert pages</i>
2-1 through 2-8	2-1 through 2-8
2-97 and 2-98	2-97 and 2-98
2-131 and 2-132	2-131 and 2-132
2-159 and 2-160	2-159 and 2-160
2-169 and 2-170	2-169 and 2-170
2-187 through 2-190	2-187 through 2-190
2-217 and 2-218	2-217 and 2-218
2-233 and 2-234	2-233 and 2-234
None	2-234.1 and 2-234.2
B-1 through B-6	B-1 through B-22

2. File this change sheet in front of the publication for reference purposes.

By Order of the Secretary of the Army:

FRED C. WEYAND  
*General, United States Army*  
*Chief of Staff*

Official:

PAUL T. SMITH  
*Major General, United States Army*  
*The Adjutant General*

Distribution:

To be distributed in accordance with DA Form 12-38, Organizational maintenance requirements for Truck, 5-Ton, M39 Series, 6x6.

## WARNING

### CARBON MONOXIDE POISONING CAN BE DEADLY

*Carbon monoxide is a colorless, odorless, deadly poisonous gas, which, when breathed, deprives the body of oxygen and causes suffocation. Exposure to air contaminated with carbon monoxide produces symptoms of headache, dizziness, loss of muscular control, apparent drowsiness, and coma. Permanent brain damage or death can result from severe exposure. It occurs in the exhaust fumes of fuel-burning heaters and internal-combustion engines and becomes dangerously concentrated under conditions of inadequate ventilation. The following precautions must be observed to insure the safety of personnel whenever the personnel heater, main, or auxiliary engine of any vehicle is operated for maintenance purposes or tactical use.*

Do *not* operate heater or engine of vehicle in an enclosed area unless it is adequately ventilated.

Do *not* idle engine for long periods without maintaining adequate ventilation in personnel compartments.

Do not drive any vehicle with inspection plates, cover plates or engine compartment doors removed unless necessary for maintenance purposes.

*Be alert* at all times during vehicle operation for exhaust odors and exposure symptoms. If either is present, immediately ventilate personnel compartments. If symptoms persist, remove affected personnel from vehicle and treat as follows: Expose to fresh air; keep warm; do not permit physical exercise, and if necessary, administer artificial respiration.

*The best defense against carbon monoxide poisoning is adequate ventilation.*

Prior to placing the adapter in the generating system, the vehicle ground cable (battery negative cable) must be disconnected.

Hold the insulated portion of the cable. Do not touch the terminal contact portion of the cable when performing tests.

When removing the battery cables, disconnect the ground cable first. When installing the battery cables, connect the ground cable last. When two ground cables are used, both cables must be disconnected prior to working on equipment where shorting of cables can occur. Incorrect cable replacement sequence is extremely dangerous. Accidental contact of the cable replacing tool with the vehicle causes a direct short resulting in arcing and instant heating of the tool to red heat. This can cause painful burns on hands and serious damage to the tools, vehicle, and battery. Moreover, the shorted battery may explode, spraying hot acid over the surrounding area.

The M52 and M246 vehicles should have a flame and spark arrestor muffler installed to prevent fire when hauling flammable or explosive cargo. The muffler can be identified by a cleanout plug located in the front lower portion of the muffler housing. Any vehicle that does not have a flame and spark arrestor muffler should be tagged **DO NOT USE FOR TRANSPORTING OF FLAMMABLE OR EXPLOSIVE CARGO.**

When using the M51 or M51A2 dump truck models as personnel carriers, the dump control lever in the cab must be secured in a locked position.

Do not permit smoking, sparks, or open flame within 60 ft of the vehicle during any operation involving removal or draining of the fuel-carrying components.

Always wear gloves when handling wire cable. Never let cable run through the hands. Broken wires can cause painful injuries.

When inflating a tire, turn the side ring away from any person nearby to prevent injury if the ring should fly off.

Exhaust gases are dangerous. Troubleshoot exhaust systems in a well ventilated area to preclude injury to personnel.

## **WARNING**

Remove rings, watches; etc., prior to performing any electrical troubleshooting to prevent accidental short circuits and /or electric shock.

Do not permit a hot wire to touch metal parts of the vehicle at any time. Testing by striking a hot wire against a ground (flash testing) will create an arc that can cause personal injury and destroy the connector on the lead.

Explosive fumes. When draining tanks, attach a ground wire from the vehicle fuel tank to the fuel receptacle to carry off static electricity.

Before checking or draining the radiator, turn the filler cap to the left until its stop is reached. The cap is then in its vented position. This allows pressure to escape. Noncompliance could result in serious burns.

TECHNICAL MANUAL }  
 No. 9-2320-211-20 }

HEADQUARTERS,  
 DEPARTMENT OF THE ARMY  
 WASHINGTON, D.C., 1 June 1973

ORGANIZATIONAL MAINTENANCE MANUAL

FOR

TRUCK, CHASSIS: 5-TON, 6x6, M39, M39A2, M40, M40A1, M40A2t  
 M40A1C, M40A2C, M61, M61A1, M61A2, M63, M63A1, M63A2, M63C,  
 M63A1C, M63A2C, M63A1D, M63A2D, M139A1, M139A2, M139C,  
 M139A2C, M139D, M139A2D, M139F, M139A1F, M139A2F; TRUCK,  
 CARGO: M41, M41A2, M54, M54A1, M54A2, M54A1C, M54A2C, M55,  
 M55A1, M55A2; TRUCK, DUMP: M51, M51A1, M51A2; TRUCK,  
 TRACTOR: M52, M52A1, M52A2; TRUCK, TRACTOR,  
 WRECKER: M246, M246A1, M246A2; TRUCK, VAN, EX-  
 PANSIBLE: M291A1, M291A2, M291A1C, M2P1A2C, M291A1D,  
 M291A2D; TRUCK, WRECKER, MEDIUM: M62, M543, M543A1,  
 M543A2; TRUCK, BRIDGING: M139, M328A1, M328A2; TRUCK,  
 LOGGING, M748A1, M748A2.

		Paragraph	Page
<b>CHAPTER</b>	1. INTRODUCTION		
<b>Section</b>	I. General . . . . .	1-1	1-1
	II. Description and data . . . . .	1-6	1-1
<b>CHAPTER</b>	2. ORGANIZATIONAL MAINTENANCE INSTRUCTIONS.		
<b>Section</b>	I. Service upon receipt of materiel . . . . .	2-1	2-1
	II. Repair parts, special tools, and equipment . . . . .	2-4	2-3
	III. Lubrication instructions . . . . .	2-6	2-6
	IV. Preventive maintenance checks and services . . . . .	2-8	2-6
	V. Troubleshooting the vehicle.. . . .	2-13	2-9
	VI. Troubleshooting the electrical system . . . . .	2-15	2-20
	VII. Radio interference suppression. . . . .	2-36	2-71
	VIII. Field expedient repairs.. . . .	2-40	2-72
	IX. Engine maintenance in vehicle-gasoline . . . . .	2-42	2-73
	X. Engine maintenance in vehicle-diesel . . . . .	2-50	2-81
	XI. Engine maintenance in vehicle-multifuel . . . . .	2-56	2-83
	XII. Maintenance of fuel system-gasoline . . . . .	2-62	2-85
	XIII. Maintenance of fuel system-diesel and multifuel . . . . .	2-76	2-94
	XIV. Maintenance of exhaust system-gasoline engine . . . . .	2-99	2-111
	XV. Maintenance of exhaust system-diesel and multifuel . . . . .	2-103	2-112
	XVI. Maintenance of cooling system . . . . .	2-108	2-116
	XVII. Ignition system-gasoline engine . . . . .	2-119	2-123
	XVIII. Maintenance of starting system-gasoline . . . . .	2-123	2-128
	XIX. Maintenance of starting system—diesel and multifuel . . . . .	2-127	2-129
	XX. Generator system . . . . .	2-130	2-130
	XXI. Batteries and lighting system . . . . .	2-133	2-131
	XXII. Wiring circuits and harnesses.. . . .	2-140	2-136

\* This manual supersedes TM 9-2320-211-20, 29 March 1963, including all changes.

XXIII. Instrument cluster, switches, circuit breakers, sending units, horn, and directional signal controls, . . . . .	2-142	2-137
XXIV. Maintenance of transmission . . . . .	2-172	2-146
XXV. Maintenance of transfer . . . . .	2-174	2-146
XXVI. Maintenance of propeller shafts, universal joints, and center bearing . . . . .	2-178	2-147
XXVII. Maintenance of front axle . . . . .	2-182	2-150
XXVIII. Maintenance of rear axle . . . . .	2-184	2-151
XXIX. Maintenance of brake system.. . . .	2-188	2-152
XXX. Maintenance of compressed air system . . . . .	2-198	2-161
XXXI. Maintenance of wheels, hubs, and drums . . . . .	2-206	2-168
XXXII. Maintenance of steering system. . . . .	2-213	2-172
XXXIII. Maintenance of frame, towing attachments, and brackets . . . . .	2-223	2-178
XXXIV. Maintenance of springs and shock absorbers, . . . . .	2-230	2-181
XXXV. Maintenance of body, cab, and hood . . . . .	2-235	2-185
XXXVI. Maintenance of dump body-M51, M51A1 and M51A2 . . . . .	2-241	2-187
XXXVII. Maintenance of expansible van body— M291A1, M291A1C, M291A1D, M291A2, M291A2C, M291A2D . . . . .	2-246	2-195
XXXVIII. Maintenance of wrecker crane-M62, M246, M246A1, M246A2 . . . . .	2-279	2-212
XXXIX. Maintenance of wrecker M543, M543A1, M543A2 . . . . .	2-292	2-217
XL. Maintenance of front winch assembly . . . . .	2-314	2-225
XLI. Maintenance of rear winch assembly-M62, M543, M543A1 and M543A2 . . . . .	2-319	2-228
XLII. Maintenance of body, chassis, and accessory items . . . . .	2-329	2-233
XLIII. Maintenance of nonelectrical gages and measuring devices . . . . .	2-332	2-233
<b>CHAPTER</b> 3. MAINTENANCE OF MATERIEL USED IN CONJUNCTION WITH MAJOR ITEM.		
Section I. Hot water personnel heater kit.. . . .	3-1	3-1
II. Gasoline personnel heater kit.... . . . .	3-5	3-2
III. Fuel burning personnel heater kit-multifuel models . . . . .	3-10	3-3
IV. Powerplant heaterkit—multifuel models . . . . .	3-13	3-4
V. Primer pump . . . . .	3-17	3-4
<b>APPENDIX</b> A. REFERENCES . . . . .		A-1
B. MAINTENANCE ALLOCATION CHART . . . . .		B-1
<b>INDEX</b> . . . . .		Index-1



## LIST OF ILLUSTRATIONS

Figure	Title	Page
1 - 1	Typical 5-ton truck, cargo . . . . .	1 - 2
1 - 2	Typical 5-ton truck, tractor . . . . .	1 - 2
1 - 3	Typical 5-ton truck, tractor, wrecker . . . . .	1 - 3
1 - 4	Typical 5-ton truck, medium wrecker . . . . .	1 - 3
1 - 5	Typical 5-ton truck, expansible van with rear lift platform . . . . .	1 - 4
2 - 1	Deleted . . . . .	2 - 1
2 - 2	Deleted . . . . .	2 - 1
2-2.1	Deleted . . . . .	2 - 2
2 - 3	Deleted . . . . .	2 - 2
2 - 4	Special tools and equipment . . . . .	2 - 4
2 - 5	Low-voltage circuit testers . . . . .	2-24
2 - 6	Leads for electrical test equipment . . . . .	2-24
2 - 7	Electrical test equipment adapter sets . . . . .	2-25
2-7.1	Multimeter . . . . .	2-26
2 - 8	Schematic layout of low-voltage circuit . . . . .	2-27
2-8.1	DC voltage test with multimeter . . . . .	2-29
2-8.2	AC voltage test with multimeter . . . . .	2-30
2-8.3	Resistance test with multimeter . . . . .	2-31
2-8.4	Continuity test with multimeter . . . . .	2-31
2 - 9	General location of electrical components . . . . .	2-33
2-10	Battery system . . . . .	2-34
2 - 11	Battery voltage test . . . . .	2-34
2 - 12	Load bank voltage test . . . . .	2-34
2 - 13	Combined battery voltage check . . . . .	2-35
2 - 14	Battery indicator . . . . .	2-35
2 - 15	Battery indicator circuit . . . . .	2-36
2 - 16	Generator adapter in place with connecting points shown . . . . .	2-36
2 - 17	Regulator adapter in place with connecting points shown . . . . .	2-36
2 - 18	Generating system wiring . . . . .	2-37
2 - 19	Generator output test hook-up . . . . .	2-37
2-20	Regulator voltage control test hookup . . . . .	2-38
2-21	Regulator amperage control test hookup . . . . .	2-39
2-22	Generator regulator line switch cut out test hookup . . . . .	2-39
2-23	Starter circuit . . . . .	2-40
2-24	Starter draw check at battery . . . . .	2-41
2-25	Solenoid test hookup . . . . .	2-41
2-26	Starter amperage draw test . . . . .	2-42
2-27	Starter solenoid — diesel and multifuel . . . . .	2-43
2-28	Starter switch test . . . . .	2-44
2-29	Frame-to-battery cable ground loss test . . . . .	2-44
2-30	Battery connector cable test . . . . .	2-45
2-31	Battery-to-solenoid cable test . . . . .	2-45
2-32	Starter solenoid-to-starter connector test . . . . .	2-46
2-33	Instrument cluster—rear view . . . . .	2-46
2-34	Electrical testing diagram . . . . .	2-47
2-35	Ignition circuit test . . . . .	2-49
2-36	Ignition circuit diagram . . . . .	2-50
2-37	Distributor with cover removed . . . . .	2-51
2-38	Lighting circuit diagram . . . . .	2-53
2-39	Supplementary turn signal wiring diagram . . . . .	2-54
2-39.1	Directional signal system solid state wiring diagram . . . . .	2-55
2-40	Light switch positions . . . . .	2-56
2-40.1	Directional signal system, tests 1 and 2 . . . . .	2-57
2-40.2	Directional signal system, tests 3,4, and 5 . . . . .	2-59
2-40.3	Directional signal system, tests 6 and 7 . . . . .	2-60
2-40.4	Directional signal system, test 8 . . . . .	2 - 61
2-41	Expansible van wiring diagram . . . . .	2 - 62
2-41.1	Van body 24-volt dc system wiring diagram . . . . .	2 - 63
2-41.2	Van body 24-volt dc system, tests 1, 2, and 3 . . . . .	2 - 64
2-41.3	Van body 120/208-volt ac system wiring diagram . . . . .	2 - 65
2-41.4	Van body 120-volt lighting circuit, tests 1 and 2 . . . . .	2 - 66

## LIST OF ILLUSTRATIONS—(Continued)

Figure	Title	Page
2-41.5	Van body 120/208-volt ac system, tests 1 and 2 . . . . .	2-67
2-41.6	Van body 120/208-volt ac system, test 3 . . . . .	2-68
2-41.7	Van body blackout relay system wiring diagram . . . . .	2-69
2-41.8	Van body blackout relay system tests . . . . .	2-70
2-42	Starter with cover removed . . . . .	2-71
2-43	Carburetor and manifolds installed to right of engine . . . . .	2-74
2-44	Top right view of installed engine . . . . .	2-75
2-45	Adjusting valve clearance . . . . .	2-77
2-46	Removing oil filter element . . . . .	2-77
2-47	Removing filter housing . . . . .	2-78
2-48	Removing filter base plate gasket . . . . .	2-78
2-49	Removing crankcase breather cap and filter . . . . .	2-78
2-50	Removing crankcase breather cup . . . . .	2-78
2-51	Removing crankcase breather bracket and tube assembly . . . . .	2-79
2-52	Lines and fittings . . . . .	2-79
2-53	Diagram of clutch and control linkage . . . . .	2-80
2-54	Adjusting rotochamber . . . . .	2-81
2-55	Diesel engine oil filters . . . . .	2-81
2-56	Filter housing base . . . . .	2-82
2-57	Disconnecting lubrication line at turbocharger — diesel . . . . .	2-82
2-58	Disconnecting lubrication line bracket at manifold heater housing — diesel . . . . .	2-82
2-59	Disconnecting lubrication line at oil filter base — diesel . . . . .	2-82
2-60	Crankcase breather assembly — exploded view . . . . .	2-83
2-61	Multifuel engine oil filters . . . . .	2-83
2-62	Replacing oil filter element . . . . .	2-84
2-63	Disconnecting lubrication lines at turbocharger — multifuel models . . . . .	2-84
2-64	Removing crankcase breather tube — multifuel models . . . . .	2-85
2-65	Idle and throttle adjusting screws . . . . .	2-86
2-66	Choke linkage . . . . .	2-87
2-67	Top right section of cab cowl . . . . .	2-89
2-68	Antidiesel control — carburetor with integral antidiesel valve . . . . .	2-90
2-69	Antidiesel valve and controls — intake manifold modified degasser models . . . . .	2-90
2-70	Fuel filter installed under left front fender . . . . .	2-92
2-71	Lower right rear corner of cab . . . . .	2-93
2-72	Air cleaner . . . . .	2-94
2-73	Removing air cleaner locking mechanism . . . . .	2-94
2-74	Pulling air cleaner element from housing . . . . .	2-94
2-75	Removing rubber connectors and air cleaner tube . . . . .	2-95
2-76	Removing air cleaner . . . . .	2-95
2-77	Disconnecting rubber connector from air tube . . . . .	2-95
2-78	Removing air tube . . . . .	2-96
2-79	Disconnecting fuel shutoff control wire — diesel only . . . . .	2-96
2-80	Removing fuel shutoff control from instrument panel . . . . .	2-96
2-81	Removing shutoff valve — diesel only . . . . .	2-97
2-82	Removing emergency fuel shutoff control wire — diesel only . . . . .	2-97
2-83	Removing emergency fuel shutoff control from instrument panel — diesel only . . . . .	2-97
2-84	Removing fuel shutoff control — multifuel only . . . . .	2-97
2-85	Primary and secondary fuel filters — multifuel engine LDS465- 1 . . . . .	2-98
2-86	Fuel filter - exploded view - multifuel engine LDS 465-1 . . . . .	2-99
2-87	Accelerator and throttle linkage — diesel and multifuel . . . . .	2-100
2-88	Fuel tank . . . . .	2-101
2-89	Main tank on M51A2 model . . . . .	2-101
2-90	Auxiliary tank . . . . .	2-101
2-91	Braced fuel tank . . . . .	2-101
2-92	Fuel transfer pump . . . . .	2-102
2-93	Manifold heater supply and fuel return valves — multifuel engine LDS 465- 1 . . . . .	2-102
2-94	Fuel solenoid valves — multifuel engine LDS 465-1 . . . . .	2-103
2-95	Fuel filter - diesel models . . . . .	2-103
2-96	Fuel filter exploded view . . . . .	2-103
2-97	Secondary fuel filter - diesel models . . . . .	2-104
2-98	Removing or installing element from fuel filter housing — diesel models . . . . .	2-104

## LIST OF ILLUSTRATIONS—(Contklued)

Figure	Title	Page
2-99	Spark plug . . . . .	2-104
2-100	Injector nozzle . . . . .	2-104
2-101	Removing spark plug housing. . . . .	2-105
2-102	Intake manifold, heater system components —multifuel models . . . . .	2-105
2-103	Removing manifold heater wiring harness — multifuel models . . . . .	2-107
2-104	Disconnecting electrical lead from manifold heater fuel pump diesel models . . . . .	2-108
2-105	Disconnecting fuel lines at pump.. . . . .	2-108
2-106	Removing manifold heater fuel pump . . . . .	2-108
2-107	Removing ignition unit . . . . .	2-109
2-108	Disconnecting electrical leads from coil . . . . .	2-109
2-109	Removing coil from mounting plate . . . . .	2-109
2-110	Disconnecting manifold heater fuel filter lines . . . . .	2-109
2-111	Removing manifold heater fuel filter — multifuel models . . . . .	2-110
2-112	Disconnecting electrical leads and fuel lines at two solenoids — diesel models . . . . .	2-110
2-113	Removing two-valve solenoid assembly — diesel models . . . . .	2-110
2-114	separating two solenoids from backing plate — diesel models . . . . .	2-110
2-115	Muffler support and tailpipe . . . . .	2-111
2-116	Removing front exhaust elbow clamp — diesel models . . . . .	2-112
2-117	Removing front exhaust pipe — multifuel models . . . . .	2-112
2-118	Removing exhaust pipe bracket. . . . .	2-112
2-119	Removing front exhaust pipe... . . . .	2-112
2-120	Removing center exhaust pipe front bracket . . . . .	2-113
2-121	Removing center exhaust pipe rear bracket . . . . .	2-113
2-122	Vertical exhaust stack - multifuel models — exploded view . . . . .	2-114
2-122.1	Vertical exhaust stack - diesel models . . . . .	2-115
2-123	Upper section of radiator - left rear view . . . . .	2-116
2-124	Upper section of radiator - multifuel models . . . . .	2-116
2-125	Radiator mounting . . . . .	2-117
2-126	Removing radiator assembly . . . . .	2-117
2-127	Drive belt adjustment . . . . .	2-117
2-128	Adjusting drive belts . . . . .	2-118
2-129	Drive belt deflection and adjustment . . . . .	2-118
2-130	Removing fan and generator drive belts . . . . .	2-119
2-131	Brush guard mountings . . . . .	2-119
2-132	Removing fan . . . . .	2-119
2-133	Removing fan pulley . . . . .	2-119
2-134	Removing radiator stay rod from thermostat housing — gasoline models . . . . .	2-120
2-135	Removing thermostats — gasoline models . . . . .	2-120
2-136	Thermostat housing -multifuel models . . . . .	2-120
2-137	Removing thermostat housing and thermostat — multifuel models . . . . .	2-121
2-138	Removing thermostat and seal — multifuel models . . . . .	2-121
2-139	Disconnecting thermostat housing-to-coolant pump hose and oil cooler inlet tube -multifue] models . . . . .	2-121
2-140	Water pump – diesel engine... . . . .	2-122
2-141	Water pump –multifuel engine. . . . .	2-122
2-142	Timing light connected to adapters . . . . .	2-123
2-143	Ignition timing indicator... . . . .	2-123
2-144	Ignition system — gasoline engine. . . . .	2-125
2-145	Positioning distributor breaker cam for distributor installation . . . . .	2-125
2-146	Distributor assembly with cover attached . . . . .	2-126
2-147	Checking distributor breaker lever spring tension . . . . .	2-126
2-148	Checking and setting distributor contact point gap . . . . .	2-126
2-149	Distributor with cover removed. . . . .	2-127
2-150	Starter and fuel pump installed on left rear side of engine . . . . .	2-128
2-151	Starter and solenoid — diesel and multifuel models . . . . .	2-130
2-152	Generator . . . . .	2-131
2-153	Battery installation . . . . .	2-132
2-154	Removing headlight rim.... . . . .	2-132
2-155	Removing headlight retaining ring and sealed-beam lamp unit . . . . .	2-133
2-156	Adjusting headlight . . . . .	2-134
2-157	Headlight aiming diagram . . . . .	2-134

## LIST OF ILLUSTRATIONS—(Continued)

Figure	Title	Page
2-158	Removing parking and blackout marker lamp . . . . .	2-135
2-159	Removing blackout driving light . . . . .	2-135
2-160	Removing blackout driving light sealed-beam lamp unit . . . . .	2-136
2-161	Locations of instruments and controls . . . . .	2-138
2-162	Horn installed on vehicle (solenoid with mounting brackets) . . . . .	2-139
2-163	Removing tachometer drive adapter . . . . .	2-143
2-164	Horn installed in vehicle (solenoid without mounting brackets) . . . . .	2-144
2-165	Directional signal control, removal and installation . . . . .	2-145
2-166	Directional signal flasher unit — removal and installation . . . . .	2-145
2-167	Directional signal control indicator — removal and installation . . . . .	2-145
2-167.1	Removing transmission breather vent . . . . .	2-146
2-168	Removing airshift lines and connectors . . . . .	2-146
2-169	Diagram of axle driving propeller shafts . . . . .	2-147
2-170	Yoke-mounted universal joint... . . . .	2-148
2-171	Propeller shaft assembly . . . . .	2-148
2-172	Disassembly of universal joint... . . . .	2-149
2-173	Flange-mounted universal joint... . . . .	2-150
2-173.1	Steering knuckle boot removal and installation — outer retaining plate . . . . .	2-151
2-173.2	Steering knuckle boot removal and installation — inner retaining clamp . . . . .	2-151
2-174	Rear suspension system . . . . .	2-152
2-175	Removing rear axle shaft . . . . .	2-152.1
2-176	Handbrake mounted to rear of transfer . . . . .	2-152.1
2-177	Brake pedal linkage with master cylinder attached . . . . .	2-153
2-178	Turning brakeshoe adjusting cam. . . . .	2-153
2-179	Inspection cover attached to hub and drum assembly . . . . .	2-153
2-180	Checking clearance between brakeshoe . . . . .	2-154
2-181	Back side of backing plate assembly. . . . .	2-154
2-182	Brake and clutch pedal assembly mounted to vehicle . . . . .	2-154
2-183	Brake master cylinder with pedal and linkage attached . . . . .	2-156
2-184	Air hydraulic cylinder . . . . .	2-157
2-185	Removing brakeshoe return spring. . . . .	2-158
2-186	Removing brakeshoes and anchor pins assembly . . . . .	2-158
2-187	Removing handbrake shoe and lever assembly . . . . .	2-160
2-188	Compressed air system piping diagram . . . . .	2-161
2-189	Trailer brake coupling installed at front of vehicle . . . . .	2-162
2-190	Checking and adjusting air compressor unloader . . . . .	2-162
2-191	Air compressor air strainer (7539372) — exploded view . . . . .	2-163
2-191.1	Air compressor air strainer (MS53005-1) . . . . .	2-163
2-192	Air compressor (air cooled) -gasoline models . . . . .	2-164
2-193	Loosening or tightening puller adjusting flange screws . . . . .	2-164
2-194	Loosening or tightening air compressor pulley adjusting flange . . . . .	2-164
2-195	Air compressor — multifuel models. . . . .	2-165
2-196	Air compressor governor (8330262) with air strainer disassembled . . . . .	2-166
2-196.1	Air compressor governor (MS53006-1) . . . . .	2-166
2-197	Air reservoirs installed to frame left side rail . . . . .	2-167
2-198	Wheel and tire assembly with bolted-on type side ring (14.00x20 tires) . . . . .	2-168
2-199	Wheel and tire assembly with snap-on type side ring (11.00x20 tires) . . . . .	2-169
2-200	Hub assembly—cutaway view. . . . .	2-169
2-201	Removing hub and drum assembly. . . . .	2-169
2-202	Removing outer bearing adjusting nut . . . . .	2-171
2-202.1	Steering piping installation, modification kit, P/N 11680896 . . . . .	2-172.2
2-203	Front wheel alignment . . . . .	2-173
2-204	Front axle assembly with wheel and tire assembly removed . . . . .	2-174
2-205	Steering gear unit . . . . .	2-175
2-206	Removing steering wheel . . . . .	2-175
2-207	Steering linkage under left fender. . . . .	2-175
2-208	Draglink assembly — exploded view . . . . .	2-176
2-209	Removing hydraulic oil reservoir - gasoline and diesel models . . . . .	2-177
2-210	Removing hydraulic oil reservoir — multifuel models . . . . .	2-178
2-211	Pintle hook and safety chain shackle mounted to rear of vehicle . . . . .	2-179

## LIST OF ILLUSTRATIONS-(Continued)

Figure	Title	Page
2-212	Lifting shackle assembly . . . . .	2-179
2-213	Fifth wheel - M52, M52A1, and M52A2 . . . . .	2-180
2-214	Approach plate - M52, M52A1, and M52A2 . . . . .	2-180
2-215	Center deckplate - M52, M52A1, and M52A2 . . . . .	2-180
2-216	Left front spring and shock absorber . . . . .	2-182
2-217	Spring seat bearing adjustment. . . . .	2-183
2-218	Removing brush guard . . . . .	2-185
2-219	Cab with tarpaulin removed . . . . .	2-186
2-219.1	Driver's seat removal . . . . .	2-187
2-219.2	Driver's seat cushion disconnect points . . . . .	2-187
2-219.3	Driver's seat removal and installation . . . . .	2-187
2-219.4	Driver's seat cushion removal and installation . . . . .	2-187
2-219.5	Driver's seat backrest cushion removal and installation . . . . .	2-188
2-219.6	Companion seat removal . . . . .	2-188
2-220	Dump body troop seat accessory kit - M51, M51A2, and M51A2 . . . . .	2-188.2
2-221	Right front view of hydraulic pump mounting . . . . .	2-188.2
2-222	Bottom view of control valve assembly with pump and adapter removed . . . . .	2-189
2-223	Removing control valve assembly. . . . .	2-189
2-224	Hoist assembly flexible lines.... . . . .	2-189
2-225	Installing seat hooks in slots... . . . .	2-190
2-226	Installing seat . . . . .	2-191
2-227	Stowing seats . . . . .	2-192
2-228	Seats, rack, bows, and safety strap.. . . .	2-193
2-229	Bow stowage racks . . . . .	2-194
2-230	Van in operating position - rearview . . . . .	2-196
2-231	Van body in retracted position - front interior view . . . . .	2-197
2-232	Van electrical controls . . . . .	2-198
2-233	Hinged roof-operated blackout switch . . . . .	2-199
2-234	Ceiling fixtures and lights . . . . .	2-200
2-235	Side panel counterbalance cables - disassembled view . . . . .	2-201
2-236	Side panel locks . . . . .	2-202
2-237	Sidepanel lock mechanism . . . . .	2-202
2-238	Doorlocks and windows . . . . .	2-204
2-239	Heater fuel pump - lines and connections . . . . .	2-206
2-240	Bonnet door right-hand controls and linkage . . . . .	2-206
2-241	Bonnet front door in opened position . . . . .	2-207
2-242	Removing emergency and blackout lamp . . . . .	2-209
2-243	Removing emergency and blackout light fixture . . . . .	2-209
2-244	Fluorescent ceiling light fixture. . . . .	2-210
2-245	110-volt receptacle and blackout switch . . . . .	2-212
2-246	Floodlight mounted on left side of shipper support . . . . .	2-213
2-247	Floodlight - lamp and switch replacement . . . . .	2-213
2-248	Removing or installing wiring harness - wrecker models . . . . .	2-215
2-249	Electric brake lock mounted on frame left side rail . . . . .	2-215
2-250	Hydraulic oil motor lines and restrictor valve . . . . .	2-216
2-251	Hydraulic cylinder packing adjustment . . . . .	2-217
2-252	Relief valve adjustment . . . . .	2-218
2-252.1	Hydraulic system filter - partially exploded view . . . . .	2-218.1
2-253	Governor override solenoid replacement . . . . .	2-219
2-254	Removing or installing override switch . . . . .	2-219
2-255	Removing or installing slipping brushes . . . . .	2-220
2-256	Automatic brake band adjustment. . . . .	2-220
2-257	Hoist cable replacement . . . . .	2-221
2-258	Boom foot end cable sheaves replacement . . . . .	2-221
2-259	Attaching hoist cable connectors. . . . .	2-222
2-260	Patch plate over power divider assembly . . . . .	2-223
2-261	Propeller shaft assembly replacement . . . . .	2-223
2-261.1	Two-section shaft replacement . . . . .	2-224
2-262	Adjusting boom roller assembly . . . . .	2-224.1
2-263	Boom roller assembly replacement . . . . .	2-225
2-264	Front winch - left rear view . . . . .	2-225

## LIST OF ILLUSTRATIONS—(Continued)

Figure	Title	Page
2-265	Front winch and propeller shaft — bottom view . . . . .	2-226
2-266	Front winch and level wind installed to vehicle — right side view . . . . .	2-226
2-267	Front winch and level wind — installed to vehicle . . . . .	2-227
2-268	Rear winch — left rear view . . . . .	2-228
2-269	Rear winch — top view of right end . . . . .	2-229
2-270	Power divider installed to underside of M62 wrecker . . . . .	2-229
2-271	Using crane to remove rear winch assembly . . . . .	2-230
2-272	Rear end of M62 with floor plate raised — left side view . . . . .	2-231
2-273	Underside of crane base plate (removed from M62) . . . . .	2-231
2-274	Separating rear winch drive chain — M62, M543, M543A1, and M543A2 . . . . .	2-232
2-275	Cable guide rollers . . . . .	2-233
2-275.1	Rear view mirror removal and installation . . . . .	2-234
2-276	Tachograph chart divisions . . . . .	2-237
2-277	Diagram scales . . . . .	2-238
2-278	Speed recordings . . . . .	2-239
2-279	Traveling and stationary times . . . . .	2-239
2-280	Distances traveled . . . . .	2-239
2-281	Engine rpm recording . . . . .	2-240
2-282	Good driving . . . . .	2-241
2-283	Bad driving . . . . .	2-241
2-284	Speed and rpm diagram . . . . .	2-242
2-285	Gear disengaged . . . . .	2-242
2-286	Gradient driving (incorrect) . . . . .	2-242
2-287	Gradient driving (correct) . . . . .	2-242
2-288	Wrong gear . . . . .	2-243
2-289	High rpm . . . . .	2-243
2-290	Engine idling . . . . .	2-243
2-291	Cold starting . . . . .	2-243
2-292	Idling time . . . . .	2-243
2-293	Lowered speed . . . . .	2-244
2-294	No speed recorded . . . . .	2-244
2-295	Interrupted recordings . . . . .	2-245
2-296	Coinciding figures . . . . .	2-245
2-297	Superimposed distance recordings . . . . .	2-245
2-298	Constant speeds . . . . .	2-245
2-299	Speed recordings . . . . .	2-246
2-300	Vertical readings . . . . .	2-246
3 - 1	Personnel heater kit — hot water . . . . .	3 - 1
3 - 2	Heater unit — sideview . . . . .	3 - 2
3 - 3	Removing lines and fittings - gasoline heater . . . . .	3 - 3
3 - 4	Fuel filter . . . . .	3 - 3
3 - 5	Removing primer pump . . . . .	3 - 5
3 - 6	Decontamination apparatus location . . . . .	3 - 5

## CHAPTER 1

## INTRODUCTION

## Section I. GENERAL

**1-1. Scope**

These instructions are for use by organizational level personnel. They apply to the following vehicles:

Truck, Cargo	5-Ton, 6x6, M41, M54, M54A1, M54A2, M55, M55A1, and M55A2.
Truck, Cargo, Dropside	5-Ton, 6x6, M54A1C, and M54A2C.
Truck, Dump	5-Ton, 6x6, M51, M51A1, and M51A2.
Truck, Tractor	5-Ton, 6x6, M52, M52A1, and M52A2.
Truck, Tractor, Wrecker	5-Ton, 6x6, M246, M246A1, and M246A2.
Truck, Van, Expansibile	5-Ton, 6x6, M291A1, M291A2, M291A1C, M291A2C, M291A1D, and M291A2D.
Truck, Stake, Bridge Transporting.	5-Ton, 6x6, M139, M328A1, and M328A2.
Truck, Wrecker, Medium	5-Ton, 6x6, M62, M543, M543A1, and M543A2.
Truck, Bolster	5-Ton, 6x6, M748A1, and M748A2.

**1-2. Maintenance Forms and Records**

Maintenance forms, records, and reports which are to be used by personnel at all maintenance levels are listed in and prescribed by TM 38-750.

**1-3. Reporting of Equipment Publication Improvements**

The reporting of errors, omissions, and recommendations for improving this publication by the individual user is encouraged. Reports should be submitted on DA Form 2028 (Recommended Changes to Publications) and forwarded direct to: Commander, US Army Tank-Automotive Command, ATTN: AMST-MAP, 28251 Van Dyke, Warren, MI 48090.

**1-4. Administrative Storage.**

Refer to TM 740-90-1 for vehicle storage procedures.

**1-5. Destruction of Army Materiel to Prevent Enemy Use.**

Refer to TM 750-244-6 for procedures concerning destruction of materiel to prevent enemy use.

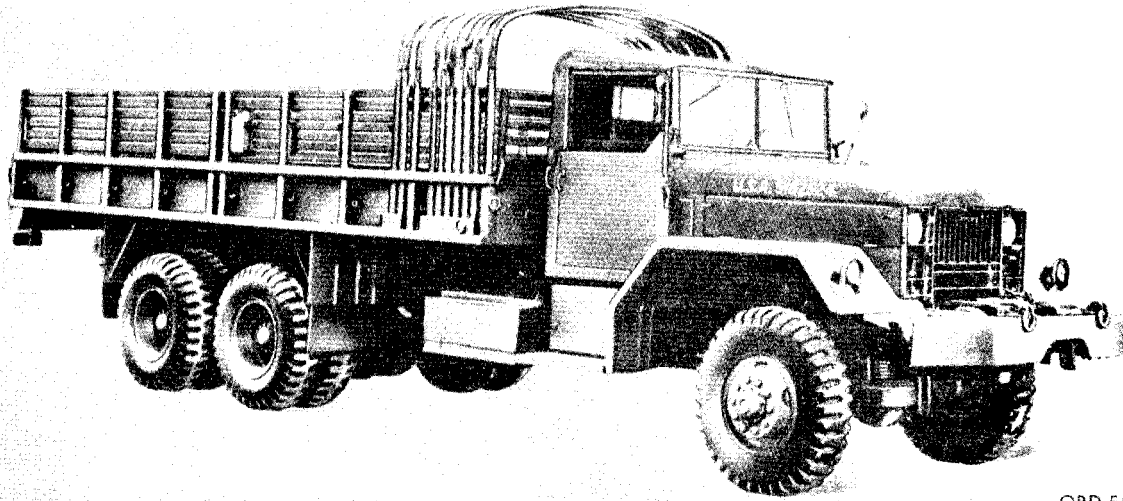
## Section II. DESCRIPTION AND DATA

**1-6. Description.**

The 5-ton, 6x6, trucks (fig. 1-1 through 1-5) covered in this manual are described in detail in TM 9-2320-211-10. Additional descriptive information and data is covered in applicable sections of this manual.

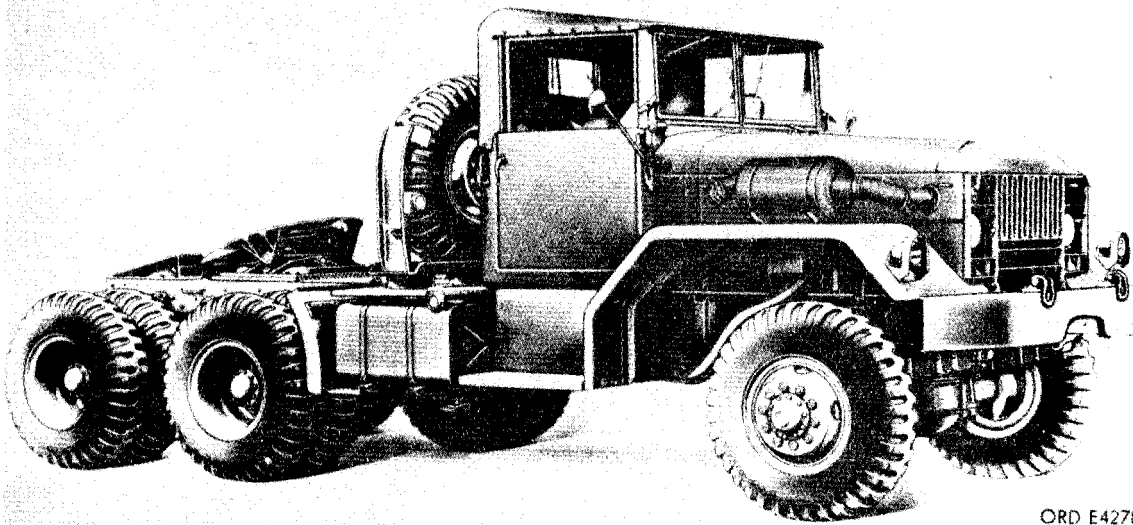
**1-7. Identification and Tabulated Data.**

*a. Identification.* Refer to operator's manual (TM 9-2320-211-10) for identification plates and additional data.



ORD E42775

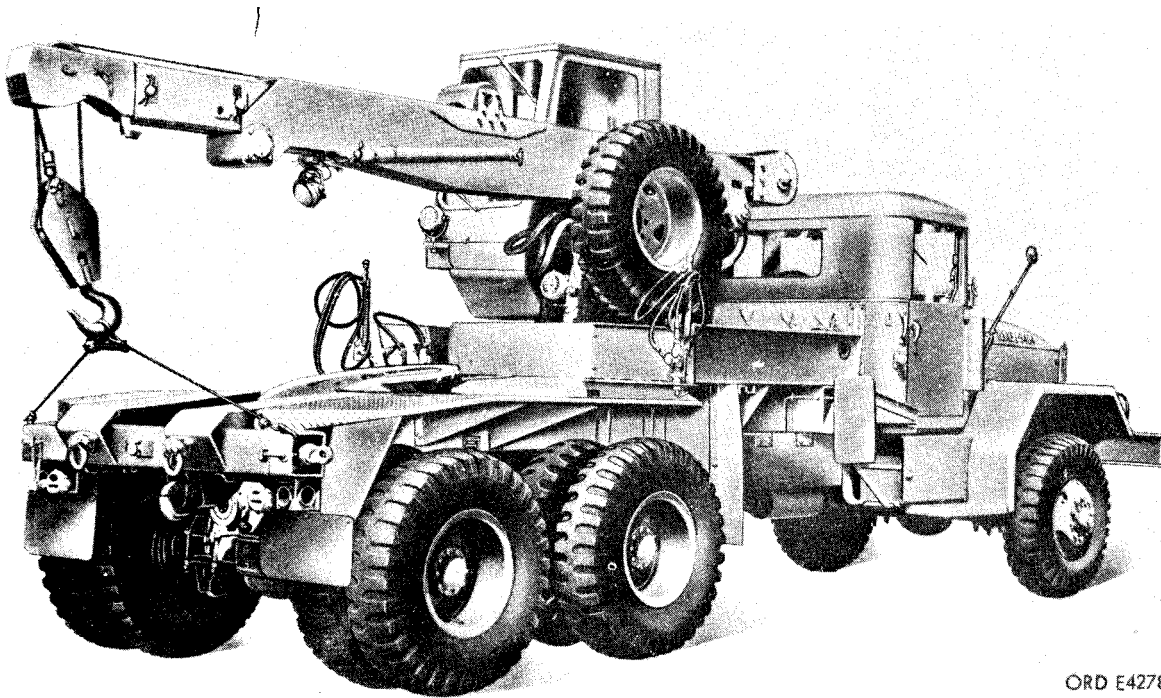
*Figure 1-1. Typical 5-ton truck, cargo.*



ORD E42780

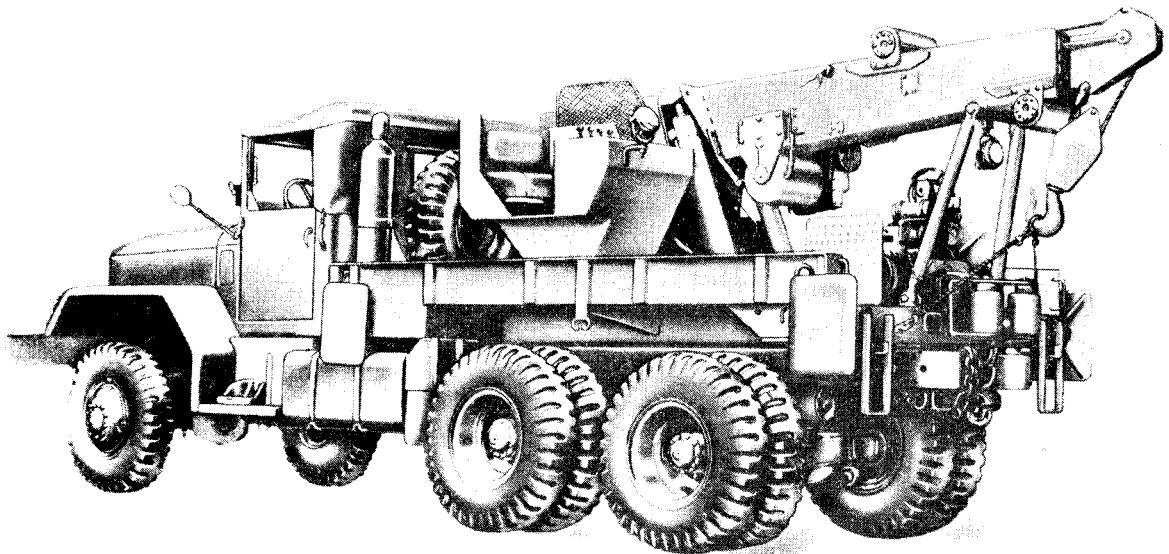
*Figure 1-2. Typical 5-ton truck, tractor.*





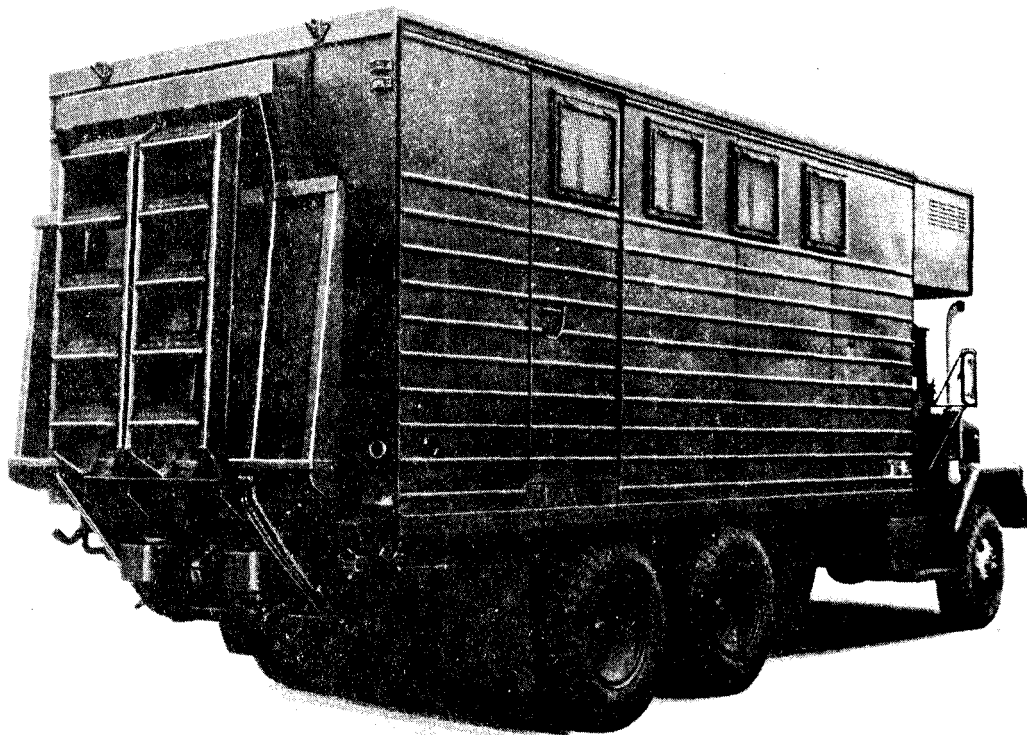
ORD E42782

*Figure 1-3. Typical 5-ton truck, tractor wrecker.*



ORD E42786

*Figure 1-4. Typical 5-ton truck, medium wrecker.*



AT 27141

Figure 1-5. Typical 5-ton truck, expansible van with rear lift platform.

**b. Tabulated Data.**

**(1) Engine.**

Make:

Models M40A1, M40A1C, M51A1, M52A1, M54A1, M54A1C, M55A1, M61A1, M63A1, M63A1C, M139A1, M139A1F, M246A1, M291A1, M291A1C, M291A1D, M328A1, M543A1, and M748A1 ..... Mack ENDT-673  
 Models M39, M40, M40C, M41, M51, M54, M55, M61, M62, M63, M63C, M139, M139C, M139D, M139F, M246, and M543 Continental R6602  
 Models M40A2C, M51A2, M52A2, M54A2, M54A2C, M55A2, M61A2, M63A2, M139A2F, M246A2, M291A2, M291A2C, M291A2D, M328A2, M543A2, and M748A2 Continental LDS 465-1/LDS 465-1A.

Type:

Mack ENDT-673 Diesel, turbocharged, watercooled.  
 Continental R6602 Gasoline, watercooled  
 Continental LDS 465-1 and 1A ..... Multifuel turbocharged, water cooled, compression-ignition.

Valves ..... valve-in-head  
 Cylinders ..... 6 (in-line)  
 Firing order ..... 1-5-3-6-2-4

Brake hp:

Mack ENDT-673 205 @ 2,100 rpm  
 Continental R6602 224 @ 2,800 rpm  
 Continental LDS 465-1 and 1A ..... 175-180 @ 2,600 rpm

Compression ratio:

Mack ENDT-673 16.50:1  
 Continental R6602 6.4:1  
 Continental LDS465-1 and 1A ..... 2 2 : 0 1

Compression pressure:

Mack ENDT-673 575 psi @ 1,000 rpm

Maximum torque:

Mack ENDT-673:  
 Gross . . . . . 5 6 0 ft.-lb. @ 1,400-1,600 rpm.  
 Net ..... 5 2 9 ft.-lb. @ 1,400-1,600 rpm.

Continental LDS 465-1 and 1A:  
 Gross ..... 425 ft.-lb @ 2,000 rpm

Governed speed:

Mack ENDT-673:  
 No load ..... 2,100-2,200 rpm  
 Continental R6602:  
 No load . . . . . 2,750-2,800 rpm  
 Continental LDS 465-1 and 1A  
 No load . . . . . 2,850-2,900 rpm

Idle speed:

Mack	ENDT	T-673	550-600	rpm
Continental	R6602		400-450	rpm
Continental	LDS 465-1			
and	1A	650-700		rpm

Specific fuel consumption (approx.):

Diesel and multifuel	5 miles per gallon
Gasoline	4 miles per gallon

(2) Fuel System.

Models M40A1, M40A1C, M51A1, M52A1, M54A1, M54A1C, M55A1, M61A1, M63A1, M36A1C, M139A1, M139A1F, M246A1, M291A1, M291A1C, M291A1D, M32A1, M543A1, and M748A1:

Fuel filter:

Make	Purolator
Model:	
Primary	OB-9M-41
Secondary	DSK-607

Type of fuel:

Diesel	Per	Federal specification VV-F800, fuel oil, diesel grade:
		DFA — All temperatures
		DF1 — Do not use below -10° F.
		DF2 — Do not use below +32° F.

**NOTE**

During emergency combat conditions where no other fuel is available, JP-5 aircraft turbine engine fuel is authorized in diesel or multifuel vehicles.

Models M39, M40, M40C, M41, M51, M52, M54, M55, M61, M62, M63, M63C, M139, M139C, M139D, M139F, M246, and M543:

Carburetor w/ governor:

Make	Holley
Model	885 -JJS

Air cleaner:

Make	Donaldson
Type	Oil bath
Oil capacity	5-pt

Fuel pump mechanical:

Make	AC Spark Plug
Model	Series BF
Type	Diaphragm
Normal pressure	4 to 5 psi
Location	Mtd to crankcase

Type of fuel Gasoline

Models M40A2C, M51A2, M52A2, M54A2, M54A2C, M55A2, M61A2, M63A2, M63A2C, M139A2F, M246A2, M291A2, M291A2C, M291A2D, M328A2, M543A2, and M748A2:

Fuel pump electrical:

Model	10947358-3
Type	Electrical
Location	Inside fuel tank

Fuel transfer pump:

Model	7748814
Type	Electric
Fuel delivery	Approx. 30 gal/hr

Fuel filter—primary:

Models	8395476 (LDS 465-A1) and 5638455 (LDS 465-1)
--------	--

Types. Fluid Pressure (LDS 465-1) and Scraper (LDS 465-1, LDS 465-1A converted).

Elements 6280916 (LDS 465-1, 1A converted) and 8729068 (LDS 465-1, production)

Location Left side frame

Fuel filters—(secondary and final):

Models	10935475 (LDS 465-1A) and 8712440 (LDS 465-1)
--------	---

Type Replaceable element  
Elements kit 5702776 (LDS 465-1A) and 8712439 (LDS 465-1).

Location (1) Left side frame; (1) Left side engine (LDS 465-1); (2) Left side engine (LDS 465-1A).

Fuel injection system:

Make	American-Bosch
Model	PSB6A
Type	Single plunger distributor type design with mechanical governor and fuel supply pump.

Injection nozzles (6):

Make	American Bosch
Model	ADB
Types	Multihole (LDS 465-1) and single hole (LDS 465-1A)

Type of fuel:

<i>Fuel Requirements</i>	<i>Temperature Limits</i>
Grade DF2 fuel (of spec VV-F-800).	Do not use below +32° F
Grade DF1 fuel (of spec VV-F-800).	Do not use below -10° F.
Grade DFA fuel (of spec VV-F-800).	All temperatures
Gasoline (MIL-G-3056)	All temperatures (emergency use only)

Air induction system (multi fuel and diesel):

Air cleaner:	
Model	7737120
Type	Dry
Location	Right fender
Cartridge	7737491
Servicing indicator	On rh instrument panel
Turbocharger:	
optional make	(Aireserch Industrial Division)
Model	T1204 (Mack ENDT-673)

Make . . . . . Schwitzer Corp. 4LE-354.  
 Model . . . . . 4-456 and 4D554 (Mack  
 ENDT-6731).  
 Type . . . . . Oil-cooled, exhaust-driven,  
 blower compressor.

(3) *Cooling system.*

Thermostat:

Models M40A1, M40A1C,  
 M51A1, M52A1, M54A1,  
 M54A1C, M55A1, M61A1,  
 M63A1, M63A1C, M139A1,  
 M139A1F, M246A1,  
 M291A1, M291A1C,  
 M291A1D, M328A1,  
 M543A1 and M748A1:

Starts to open 170° F.  
 Fully opened 200° F.

Models M40A2C, M51A2, M52A2,  
 M54A2, M54A2C, M55A2, M61A2,  
 M63A2, M63A2C, M139A2F,  
 M246A2, M291A2, M291A2C,  
 M291A2D, M328A2, M543A2, and  
 M748A2:  
 Opens at . . . . . 180° F.

Water pump:

Models M40A1, M40A1C, M51A1,  
 M52A1, M54A1, M54A1C, M55A1,  
 M61A1, M63A1, M63A1C, M139A1,  
 M139A1F, M246A1, M291A1,  
 M291A1C, M291A1D, M328A1,  
 M543A1 and M748A1:

Make . . . . . Mack  
 Model . . . . . 316 GCA-1108B  
 Type . . . . . Centrifugal impeller

Models M39, M40, M40C, M41,  
 M51, M52, M54, M55, M61, M62,  
 M63, M63C, M139, M139C, M139D,  
 M139F, M246, and M543:  
 Type . . . . . Centrifugal impeller

Models M40A2C, M51A2, M52A2,  
 M54A2, M54A2C, M55A2, M61A2,  
 M63A2, M63A2C, M139A2F,  
 M246A2, M291A2, M291A2C,  
 M291A2D, M328A2, M543A2, and  
 M748A2:  
 Model . . . . . 10889962  
 Type J . . . . . Centrifugal impeller

Radiator:

Models M40A1, M40A1C, M51A1,  
 M52A1, M54A1, M54A1C, M55A1,  
 M61A1, M63A1, M63A1C, M139A1,  
 M139A1F, M246A1, M291A1,  
 M291A1C, M291A1D, M328A1,  
 M543A1 and M748A1:

Pressure cap . . . . . 7 psi

Models M39, M40, M40C, M41, M51,  
 M52, M54, M55, M61, M62, M63,  
 M63C, M139, M139C, M139D,  
 M139F, M246, and M543:  
 Make . . . . . Modine  
 Type . . . . . Fin and tube  
 Pressure cap . . . . . 4 psi

Models M40A2C, M51A2, M52A2,  
 M54A2, M54A2C, M55A2, M61A2,  
 M63A2, M63A2C, M139A2F,  
 M246A2, M291A2, M291A2C,  
 M291A2D, M328A2, M543A2,  
 and M748A2:

Make . . . . . 11640319  
 Type . . . . . Fin and tube  
 Pressure cap . . . . . 7 psi

Generator:

Model . . . . . 1117495  
 Voltage (rated) . . . . . 24 volts

Generator regulator:

Model . . . . . 1118606  
 Type . . . . . Vibrating  
 voltage (rated) . . . . . 24 volts  
 Ground polarity Negative

Voltage regulator:

Operating range (hot) 27-29 volts at 120° F.

Starter:

Make . . . . . Delco-Remy  
 Voltage . . . . . 24 volts

(5) *Transmission.*

Manufacturer . . . . . Spicer  
 Models M40A1, M40A1C, M51A1,  
 M52A1, M54A1, M54A1C, M55A1,  
 M61A1, M63A1, M63A1C, M139A1,  
 M139A1F, M246A1, M291A1,  
 M291A1C, M291A1D, M328A1,  
 M543A1 and M748A1 6453  
 All other models 6352  
 Type . . . . . Synchromesh  
 Speeds forward . . . . . 5  
 Speeds reverse . . . . . 1  
 Gear ratios:

Models M40A1, M40A1C, M51A1,  
 M52A1, M54A1, M54A1C,  
 M55A1, M61A1, M63A1, M63A1C,  
 M139A1, M139A1F, M246A1,  
 M291A1, M291A1C, M291A1D,  
 M328A1, M543A1 and M748A1:  
 1st . . . . . 6.07  
 2nd . . . . . 3.40  
 3rd . . . . . 1.79  
 4th . . . . . 1.00  
 5th . . . . . .78  
 Reverse . . . . . 6.09

All other models:

1st . . . . . 7.31  
 2nd . . . . . 4.08  
 3rd . . . . . 2.41  
 4th . . . . . 1.43  
 5th . . . . . 1.00  
 Reverse . . . . . 7.33

(6) *Transfer case.*

Manufacturer . . . . . Rockwell Standard  
 Model . . . . . T-138

Ratios:

Rear output shaft:  
 Low range . . . . . 2.024: 1.00  
 High range . . . . . 1.00: 1.00

Front output shaft:  
 Low range . . . . . 2.163:1.00  
 High range . . . . . 1.068:1.00

(7) *Axles.*

Front:

Make . . . . . Rockwell Standard  
 Model . . . . . FM240HX1  
 Gear ratio (all models  
 except M139C) . . . . . 6.443:1.00  
 Model M139C . . . . . 10.26:1.00  
 Lubricant capacity . . . . . 12-qt

Rear:

Make . . . . . Rockwell Standard  
 Model . . . . . M204H  
 Gear ratio (all models  
 except M139C) . . . . . 6.443:1.00  
 Model M139C . . . . . 10.26:1.00  
 Lubricant capacity . . . . . 12-qt

(8) *Brakes.*

Service:

Type . . . . . Air-assisted hydraulic

Air compressor:

Make . . . . . Midland-Ross; Bendix-  
 Westinghouse.  
 Type . . . . . 2-UE-7-1/4 V.W.

Air reservoirs:

Make . . . . . Bendix-Westinghouse  
 Size . . . . . 7-inch diameter

Trailer . . . . . Full air

(9) *Wheels and Tires.*

Tire size:

M40 . . . . . 11:00x20  
 M61 . . . . . 11:00x20  
 M139 . . . . . 14:00x20  
 M139C . . . . . 14:00x20  
 M41 . . . . . 14:00x20  
 M54 . . . . . 11:00x20  
 M51 . . . . . 11:00x20  
 M52 . . . . . 11:00x20  
 M246 . . . . . 12:00x20  
 M62 . . . . . 11:00x20

Wheels . . . . . Offset, disk-type

(10) *Steering.*

Steering gear:

Make . . . . . Ross Gear and Tool Co.  
 Model . . . . . HP-70  
 Type . . . . . Hydraulic

Ratios:

Extreme left . . . . . 19:1  
 Center . . . . . 22:1  
 Extreme right . . . . . 19:1

Hydraulic oil reservoir:

Make . . . . . International Harvester Co.  
 Model . . . . . IHC-101012R11  
 Capacity . . . . . 8½ qt

Relief valve:

Make . . . . . Pesco  
 Model . . . . . PS-05-2223-020-1

Hydraulic pump:

Models M40A1, M40A1C,  
 M51A1, M52A1, M54A1, M54A1C,  
 M55A1, M61A1, M63A1, M63A1C,  
 M139A1, M139A1F, M246A1,  
 M291A1, M291A1C, M291A1D,  
 M328A1, M543A1 and M748A1:  
 Make . . . . . Vickers Inc.

Model . . . . . VTM 27  
 Manufacturer's number . . . . . 38QC417  
 Type . . . . . Vane, rotary  
 Models M39, M40, M40C, M41,  
 M51, M52, M54, M55, M61, M62,  
 M63, M63C, M139, M139C,  
 M139D, M139F, M246, and M543:

Earlier models:

Make . . . . . Pesco  
 Model . . . . . PS-052057-50-01  
 Type . . . . . Gear  
 Reference number . . . . . 7369967

Late models:

Make . . . . . Pesco  
 Model . . . . . PS-052017-010-01  
 Type . . . . . Gear  
 Reference number . . . . . 7971028

Models M40A2C, M51A2,  
 M52A2, M54A2, M54A2C,  
 M55A2, M61A2, M63A2, M63A2C,  
 M139A2F, M246A2, M291A2,  
 M291A2C, M291A2D, M328A2,  
 M543A2, and M748A2:

Make . . . . . Vickers Inc.  
 Model . . . . . VTM  
 Type . . . . . Vane

(11) *Frame.*

Type . . . . . Side rail  
 Channel dimensions (in.) . . . . . 8x3x5/ 16

(12) *Springs and shock absorbers.*

Front springs (All Models

Except M63, M139):

Make . . . . . Standard Steel Spring Co.  
 Manufacturer's number . . . . . SSS-9112A  
 Number of leaves . . . . . 10 and 12 (M63, M139  
 models).  
 Length (under load) . . . . . 50 in.  
 Width of leaves . . . . . 3 in.

Rear springs:

Make . . . . . Standard Steel Spring Co.  
 Manufacturer's number . . . . . SSS-9113  
 Number of leaves . . . . . 13  
 Length . . . . . 59¼ in.  
 Width of leaves . . . . . 4 in.

Shock absorbers:

Make . . . . . Deko Products Div.  
 Model . . . . . 750-T  
 Manufacturer's number . . . . . DP-5516454  
 Type . . . . . Nonadjustable,  
 doubleacting.  
 Location . . . . . Front only

(13) *Cab.*

Capacity . . . . . three-man  
 Top . . . . . tarpaulin  
 Windshield . . . . . two-piece

(14) *Heater data (van models).*

Manufacturer . . . . . Hunter  
 Model no . . . . . UH-68  
 Power requirements . . . . . Single-phase, 120 volts, ac,  
 60-cycle.  
 Output . . . . . 60,000 Btu-hr  
 Lowest starting temperature . . . . . -65° F.  
 Power consumption:  
 Starting . . . . . 400 w  
 Running . . . . . 800w  
 Air output . . . . . 425 cfm



## CHAPTER 2

## ORGANIZATIONAL MAINTENANCE INSTRUCTIONS

## Section I. SERVICE UPON RECEIPT OF MATERIEL

**2-1. General**

Refer to TM 9-2320-211-10 for operating instructions, break-in operating precautions, and break-in speeds. Whenever practical, the vehicle operator will assist organizational maintenance personnel when performing these services.

**2-2. Inspecting and Servicing the Equipment**

a. If any exterior surfaces are coated with rust-preventive compound, remove it with drycleaning solvent or mineral spirits paint thinner.

b. Read DD Form 1397 (Processing and Deprocessing Record for Shipment, Storage, and Issue of Vehicles and Spare Engines), and follow all precautions checked thereon. This tag should be attached to the steering wheel, shifting levers, or ignition switch.

c. On processed materiel, when the engine has been stored for over 30 days, service the engine as outlined in TB ORD 392 by doing the following:

- (1) Remove spark plugs from each cylinder.
- (2) Atomize spray 2 ounces of lubricating oil, (Military symbol PL Special) into each cylinder through the spark plug opening.
- (3) After an interval of 15 minutes, rotate the engine by hand or starter for about 30 seconds and reinstall the spark plugs.

Figure 2-1. Deleted.

Figure 2-2. Deleted.

## Section II. REPAIR PARTS, SPECIAL TOOLS, AND EQUIPMENT

**2-4. Tools and Equipment**

a. Standard and commonly used tools and equipment having general application to this materiel are authorized for issue by tables of allowances (TA) and tables of organization and equipment (TOE).

**NOTE**

If the vehicle has been driven to the using organization, most or all of the above procedures should have been performed.

d Follow the general procedures given in TM 9-2320-211-10.

e. Perform the S (6-month or 6,000 mile) preventive-maintenance service (see instructions for specific procedures, para 2-12).

f. Lubricate those points illustrated in the lubrication order regardless of interval, excluding gear cases and engine. Check processing tag for gear case and engine oil. If the tag states that the oil is suitable for 500 miles of operation and is of the proper viscosity for local climatic operation, check the level but do not change the oil.

g. Schedule an S service on DD Form 314 (Preventive-Maintenance Schedule and Record (card)) and arrange for an oil change at 500 miles.

h. If the vehicle is delivered with a dry-charged battery, activate the battery in accordance with TM 9-6140-200-15.

**2-3. Correction of Deficiencies**

Deficiencies involving unsatisfactory design and / or materiel are to be reported as explained in TM 38-750.

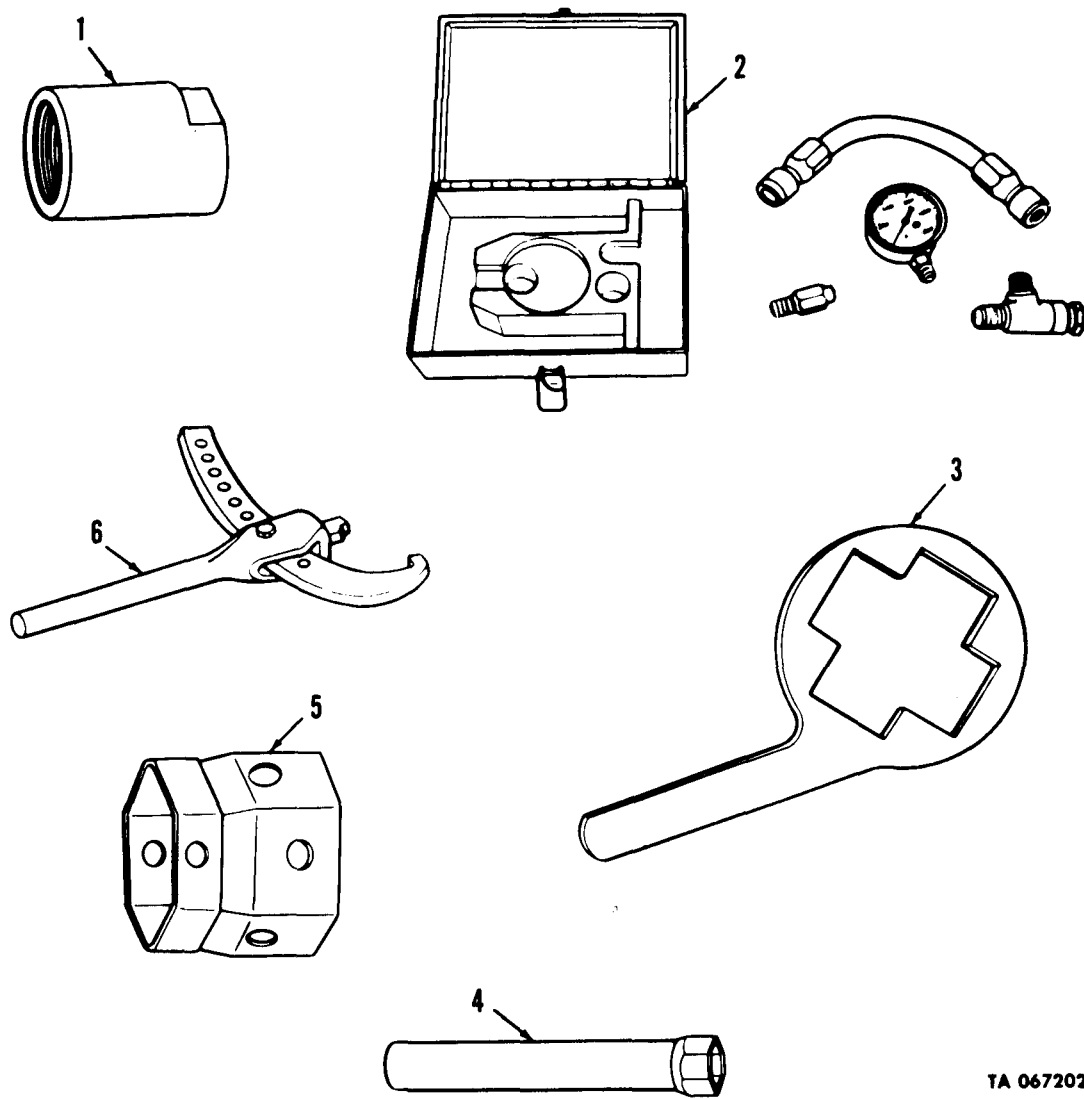
b. Special tools and equipment (fig. 2-4) specially designed for use by organizational level maintenance personnel are listed in table 2-1. A complete list of organizational maintenance tools are listed in TM 9-2320-211-20P, which is the authority for requesting replacements.

Figure 2-2.1. Deleted.

Figure 2-3. Deleted.



THIS **PAGE LEFT BLANK INTENTIONALLY**



TA 067202

Figure 2-4. Special tools and equipment.

**2-5. Maintenance Repair Parts. Repair parts** listed in TM 9-2320-211-20P which is the authority for supplied for material covered in this technical manual are requisitioning replacements.

Table 2-1, Special Tools, Test and Support Equipment

Item	NSN or Reference No.	Reference		Use	Fig. No.	Item No.
		Fig. No.	Para No.			
PRESSURE CHECKING KIT: Hydraulic system, steering.	4910-00-627-7043		2-213.1	To pressure check hydraulic system.	2-4	2
WRENCH	5120-00-070-7809	2-194	2-199d	Loosening or tightening air compressor pulley adjusting flange.	2-4	3
WRENCH, SPANNER	5120-00-293-0316	2-251	2-294	For adjusting packing gland in hoist cylinders— M543, M543A 1 and M543A2 wreckers.	2-4	6
ADAPTER, PULLER: Steering wheel.	5120-00-303-1195	2-206	2-216	With puller 5120-00-449-377 1 for removing and replacing steering wheel.	2-4	1
WRENCH, SOCKET	5120-00-378-3139	2-202	2-210a	For wheel bearing nut.	2-4	5
WRENCH, SOCKET	5120-00-437-7741	2-47	2-46b	Engine oil filter seal plate bolt.	2-4	4

### Section III. LUBRICATION INSTRUCTIONS

2-6. General. Paragraph 2-7 contains lubrication instructions to supplement lubrication order LO 9-2320-211-12.

2-7. Detailed Instructions.

*a. General.* Keep all lubricants in closed containers and store in a cool, dry place. Prevent foreign

material from contaminating the lubricants. Drain lubricants into suitable containers.

*b. Cleaning.* Keep lubrication points clean. Clean up spills immediately.

*c. Points of Lubrication.* Service the points of lubrication at the required intervals. Refer to the lubrication order LO 9-2320-211-12.

### Section IV. PREVENTIVE MAINTENANCE CHECKS AND SERVICES

2-8. General. The best way to maintain vehicles covered by this manual is to inspect them on a regular basis so minor faults can be discovered and corrected before they result in serious damage, failure, or injury. This section contains systematic instructions for inspection, adjustment, and correction of vehicle components to avoid costly repairs or major breakdowns. This is preventive maintenance checks and services (PMCS).

2-9. Intervals. Organizational maintenance, assisted by operator/crew will perform the checks and services contained in table 2-2 at the following intervals:

*a. Semiannually (S).* Every 6 months or 6,000 miles (9,656 km.), whichever comes first.

*b. Annua/v (A).* Every 12 months or 12,000 miles (19,311 km.), whichever comes first.

*c. Biennially (B).* Every 24 months or 24,000 miles (38,622 km.), whichever comes first.

2-10. Reporting Repairs. All vehicle shortcomings will be reported on DA 2404 (TM 38-750), Equipment Inspection and Maintenance Worksheet, immediately after the PMCS and before taking corrective action. They will also be reported in the equipment log.

2-11. General Service and **Inspection Procedures.**

*a.* While performing specific PMCS procedures make sure items are correctly assembled, secure, not unserviceable, not worn, not leaking, and adequately lubricated as defined below:

(1) An item is **CORRECTLY ASSEMBLED** when it is in proper position and all parts are present.

(2) When wires, nuts, washers, hoses, or attaching hardware to an item cannot be moved by hand, wrench, or pry-bar, it is **SECURE**.

(3) An item is **UNSERVICEABLE** if it is worn beyond repair and is likely to fail before the next scheduled inspection.

(4) An item is **WORN** if there is too much play between joining parts or marking data, warning, and caution plates are not readable.

(5) An item **LEAKS** if:

(a) There is fluid seepage as indicated by wetness, discoloration, or smell; or

(b) There is air seepage as indicated by a hissing sound or the formation of bubbles exist after water has been applied directly over the area in question.

(6) If an item meets the requirements specified by the lubrication order. LO 9-2320-211-12, then it is **ADEQUATELY LUBRICATED**.

*b.* Where the instruction “tighten” appears in a procedure, you must tighten with a wrench to the given torque value even when the item appears to be secure.

#### WARNING

Dry cleaning solvent used to clean parts can be harmful to personnel and property. Do not use near open flame or excessive heat. Flash point of solvent is 132° F (59°C).

*c.* Where the instruction “clean” appears in a procedure, you must use dry cleaning solvent (SD-2), specification P-D 680 to clean grease or oil from metal parts. After the item is cleaned, rinsed, and dried, apply a light grade of oil to unprotected surfaces to prevent rusting. On rubber and plastic materials use soap and water.

## 2-12. Specific PMCS Procedures.

*a.* The preventive maintenance for which you are responsible is provided below in table 2-2. The checks and services listed are arranged in logical order requiring minimal time and effort on your part.

*b.* The following columns read across on the PMCS schedule:

(1) **Item Number.** Provides logical order for PMCS performance and is used as a source number for SF-368, on which your PMCS results will be recorded.

(2) **Intervals.** Shows a bullet (•) opposite each item number to indicate when that check is to be performed. The bullet will be repeated when consecutive item numbers are to be inspected during the same interval. Interval columns include:

(a) Semiannual (six month) checks;

(b) Annual (yearly) checks; and

(c) Biennially (every two years) checks.

(3) **Item To Be Inspected.** Lists the system, common name, or location of the item to be inspected.

(4) **Procedures.** Provides instructions for servicing, inspection, replacement, or adjustment, and in some cases, having item repaired at a higher level.

## NOTE

Always do your preventive maintenance checks and services in the order it has been prepared. Once it gets to be a habit, you'll be able to spot anything wrong in a hurry.

Table 2-2. Organizational Preventive Maintenance Checks and Services.

Item No.	S-Semiannually			Item To Be Inspected	A-Annually	B-Biennially	Procedures
	S	A	B				
							<p>PRIOR TO ROAD TEST:</p> <p>Perform all before operation checks listed in TM 9-2320-211-10, "Preventive Maintenance Checks and Services".</p> <p>NOTE</p> <p>Road test must be performed regardless of interval.</p> <p>ROAD TEST</p> <p>NOTE</p> <p>The following inspections will be performed during starting and warm-up, just prior to actual road test.</p>
1				Starter			While starting vehicle, listen for unusual noises and difficult cranking at starter.
2				Engine and engine compartment			<p>a. Listen for unusual noises, hesitations, and varying idle speed. Observe response to accelerator feed.</p> <p>b. Be alert for excessive vibration and the smell of fuel, oil, or exhaust.</p>
3				Dials and indicators			<p>Observe the following dials and indicators for proper operation:</p> <p>a. <i>Low Air Pressure Warning Buzzer.</i> Should sound off when air pressure is below 60 psi. (413 kPa).</p> <p>b. <i>Primary and Secondary Air Pressure Gages.</i> Should reach operating pressure (90-120 psi. - 826 kPa) within two minutes of starting.</p> <p>c. <i>Battery-Generator Indicator.</i> Needle will point to green area when batteries are holding a full charge.</p> <p>d. <i>Tachometer.</i> Should read 650-700 rpm. with engine idling.</p> <p>e. <i>Engine Oil Pressure Gage.</i> Will read between 10-30 psi. (69-206 kPa) at idle.</p> <p>f. <i>Engine Coolant Temperature Gage.</i> Should read 165-195° F (73-90°C) at normal operating temperature.</p> <p>g. <i>Parking Brake Warning Light.</i> Will be lit when parking brake is engaged.</p>

**Table 2-2. Organizational Preventive Maintenance Checks and Services (continued).**

Item No.	Interval			Item To Be Inspected	Procedures
	S	A	B		
4				Cab safety devices	<p><i>h. Air Filter Indicator.</i> Shows red flag when there are restrictions in the air intake system.</p> <p>Observe the following items and their controls for security, ease of movement, and proper operation:</p> <ul style="list-style-type: none"> <li><i>a. Horn</i></li> <li><i>b. Windshield Wipers and Washers</i></li> <li><i>c. Seat Belts and Fasteners</i></li> <li><i>d. Turn Signals</i></li> <li><i>e. Panel Lights</i></li> <li><i>f. Headlights</i></li> <li><i>g. Stoplights</i></li> <li><i>h. Blackout Lights</i></li> <li><i>i. Parking Lights</i></li> <li><i>j. Hazard Warning Lights</i></li> </ul> <p style="text-align: center;"><b>NOTE</b></p> <p>Now begin the actual road test. The vehicle will be driven at least five miles over varied terrain. This will provide ample time for detection of malfunctions.</p>
5				Accelerator	<p>Test for engine response to accelerator feed. Observe sticking or binding of accelerator pedal.</p>
6				Brakes	<ul style="list-style-type: none"> <li><i>a.</i> Test braking response to brake pedal. Vehicle should slow down immediately.</li> <li><i>b.</i> Reach a desired speed and lightly apply brake pedal with steady force. Vehicle should stop smoothly without noticeable side-pull or chatter.</li> <li><i>c.</i> After stopping vehicle and with transmission in neutral, release brake pedal. The wheel brakes should release immediately and without difficulty.</li> </ul>

Table 2-2. Organizational Preventive Maintenance Checks and Services (continued).

S-Semiannually

A-Annually

B-Biennially

Item No.	Interval			Item To Be Inspected	Procedures
	S	A	B		
7				Steering	<p><i>d.</i> With vehicle on incline and transmission in neutral, engage parking brake. Vehicle should not move.</p> <p><i>a.</i> Check vehicle response to steering wheel action. Vehicle should respond instantly. Check steering wheel free play. With vehicle moving forward, free play should not exceed more than 1 inch (2.54 cm.) in either direction.</p> <p><i>b.</i> Turn steering wheel to extreme left, then right, to detect hard steering, steering backlash, or shimmy.</p> <p><i>c.</i> With vehicle on straight, level terrain, lightly hold steering wheel to detect pull or wander.</p>
8				Engine	<p><i>a.</i> Check engine operation at all speeds. Be sure that engine does not exceed governed speed (2100 rpm).</p> <p><i>b.</i> Observe engine instruments to detect malfunctions.</p> <p><i>c.</i> Be alert for unusual noises or smells.</p>
9				Transmission	<p><i>a.</i> Check for response to shifting and smoothness of operation in all speed ranges.</p> <p><i>b.</i> Be alert for unusual noises and difficulty in shifting in any speed range.</p>
10				Transfer	Engage transfer to insure proper operation. Observe smoothness of engagement.
11				Suspension	Observe how vehicle responds to road shocks. Shifts or constant bouncing indicates malfunction.
12				Emergency fuel cut-off control	Pull out to stop engine. When engine has stopped, push in to original position.
13	●			Clutch	<p style="text-align: center;">AFTER ROAD TEST:</p> <p>Check clutch free travel. Free travel must be from 2 to 2½ inches. (5.08 to 6.35 cm.). Determine if the action of the pedal return spring is satisfactory. With the transmission in neutral, depress the clutch pedal and listen for unusual noise which may indicate a defective release bearing. Note if the clutch disengages completely or if it has a tendency to drag. Note if the clutch chatters, grabs, or slips. Repair as necessary.</p>
14	●			Hubs and drums	<p><i>a.</i> Beginning at rear of vehicle, cautiously feel each wheel hub and brake drum for overheating which can indicate a defective wheel bearing or dragging brake.</p> <p><i>b.</i> Brake drums cool to the touch usually indicate improper adjustment, defective or inoperative brake.</p>





Table 2-2. Organizational Preventive Maintenance Checks and Services (continued).

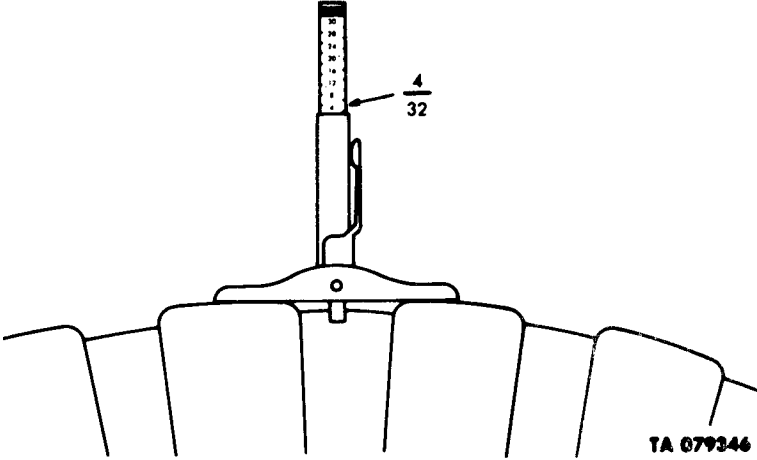
Item No.	S-Semiannually			Item To Be Inspected	Procedures
	A	B	B		
18		●			<p>c. Check each tire for wear using tire tread depth gage as shown below. Tread depth should not be less than 1/8".</p>  <p>d. Make sure all wheel lug nuts are present and tight on each wheel. Torque 450-500 lb-ft (610-678 N.m).</p> <p>e. Inspect wheel side rings for dents, bends, or breaks that could cause them to pop off when tires are being inflated.</p>
		●			
		●			
			●	Frame and crossmembers	<p>a. Inspect frame side rails for cracks, breaks, bends, wear, and deterioration.</p> <p>b. Inspect crossmembers for missing rivets, bolts, obstructions to other components, breaks, and wear.</p>
			●		
19			●	Rear axles, differentials	<p>a. Inspect rear axle housings for dents, and cracks that could cause leaks.</p> <p>b. Insure axle housing grease fittings, plugs, and fittings are present and secure.</p> <p>c. Inspect differentials for dents and cracks that could cause leaks.</p> <p>d. Insure that differential fill plug (2) and drain plug (3) are not leaking and are secure.</p>
		●			
		●			

Table 2-2. Organizational Preventive Maintenance Checks and Services (continued).

S-Semiannually

A-Annually

B-Biennially

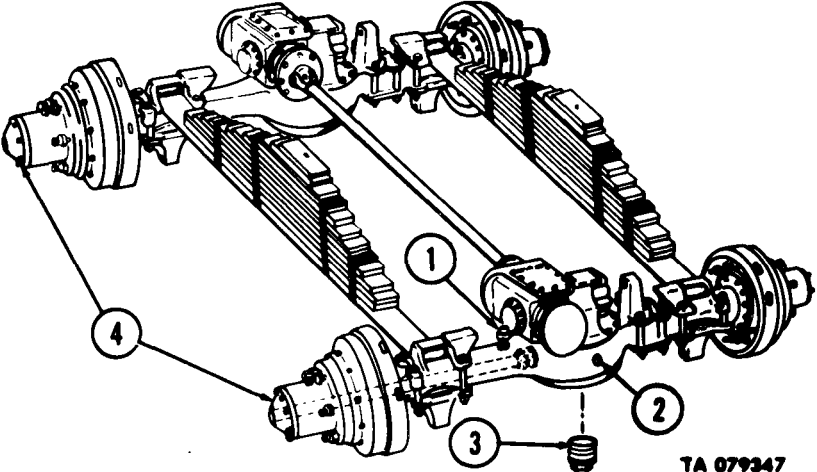
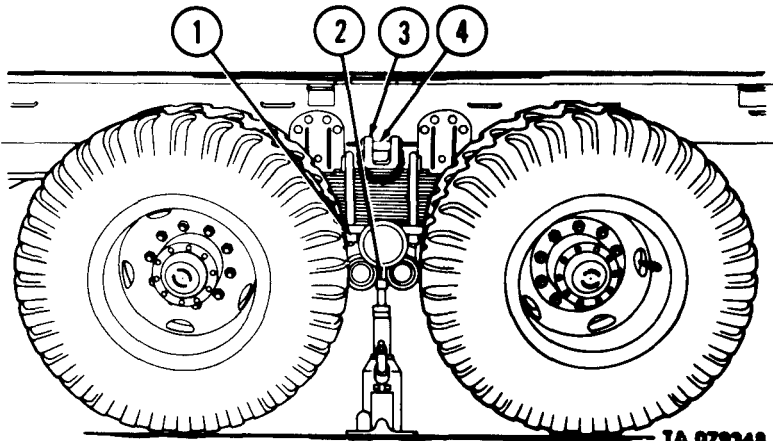
Item No.	Interval			Item To Be Inspected	Procedures
	S	A	B		
20		•		Rear suspension	<p>e. Tighten all rear axle drive flange bolts (4). Torque 81-104 lb-ft (110-141 N.m).</p> <p>f. Remove breather valves (1) and clean with compressed air, regulated at 35 psi maximum.</p>  <p style="text-align: right;">TA 079347</p>
	•	•	•		<p>a. Inspect spring leaves, retaining clips, and center bolts for deterioration, wear, breaks, and looseness.</p> <p>b. Tighten spring U-bolts (1). Torque 350-400 lb-ft (475-542 N.m).</p> <p>c. Test spring seat bearing free play by placing jack under spring seat bracket (2), jack the vehicle up so the spring moves freely up and down in the guide brackets. This removes all the applied weight from the spring seat. Put prybar between U-bolt saddle (3) and lifting pin (4). Pull up on prybar. A little free play should be detected. If there is too much free play, adjust spring seat bearing.</p> <p>d. Remove, clean, and repack trunnion bearing (para 2-185).</p>  <p style="text-align: right;">TA 079348</p>

Table 2-2. Organizational Preventive Maintenance Checks and Services (continued).

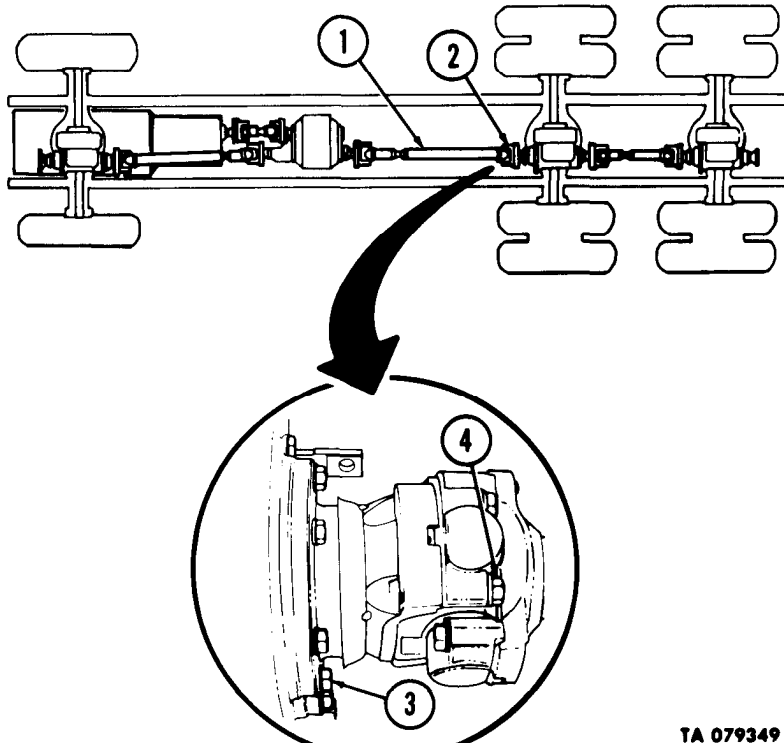
Item No.	S-Semiannually			Item To Be Inspected	Procedures
	Interval	A	B		
21	•			Propeller shafts and universal joints	<p>a. Inspect all propeller shafts (1) for bends, cracks, wear, and deterioration.</p> <p>b. Inspect U-joints (2) for wear and play, broken or missing lubrication fittings. There should be no play at U-joints.</p> <p>c. Make sure all companion flange mounting screws (3) and U-joint mounting screws (4) are tight. Torque both 32-40 lb-ft (43-54 N.m).</p>  <p style="text-align: right;">TA 079349</p>
	•				
		•			
22	•			Transfer	<p>a. Inspect transfer case for oil leaks, dents, cracks, and loose bolts that could cause leaks.</p> <p>b. Inspect security of transfer case mounting bolts and mounting brackets. Look for evidence of bracket wear and deterioration.</p> <p>c. Inspect shift linkage for cracks, bends, wear and play.</p>
	•				
		•			

Table 2-2. Organizational Preventive Maintenance Checks and Services (continued).

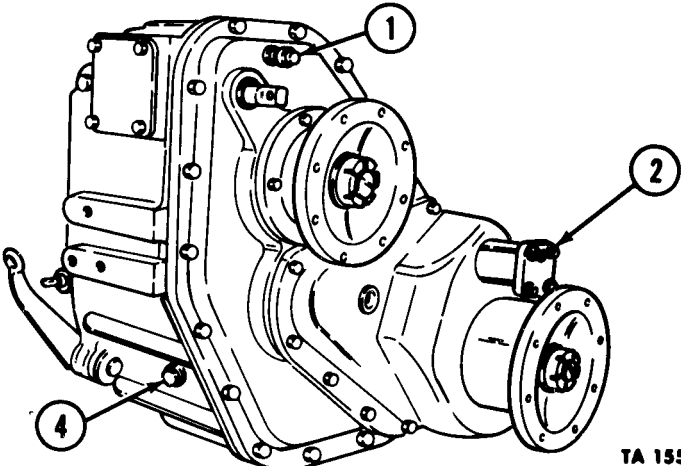
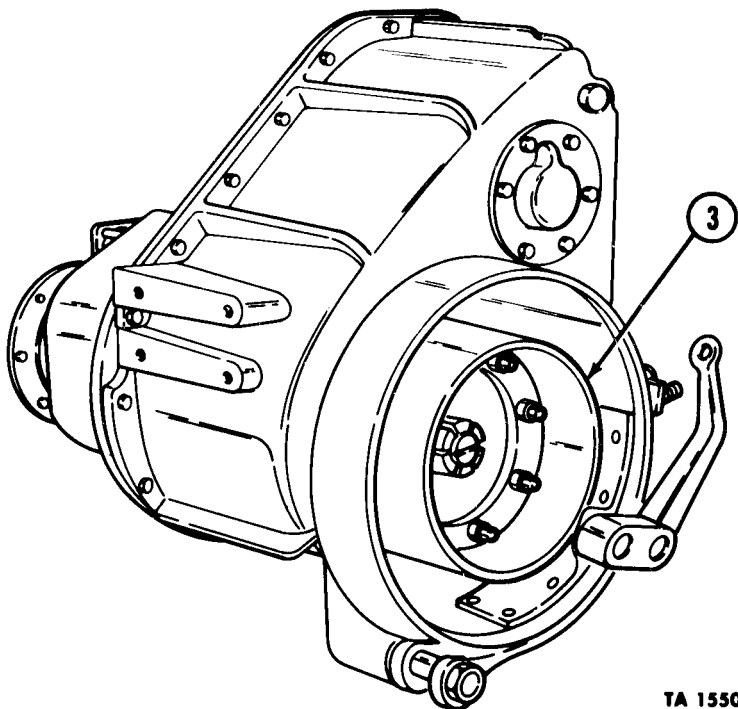
Item No.	S-Semiannually			A-Annually	B-BIENNIALY	Procedures
	S	A	B			
	•					<p>d. Inspect air vent valve (1), air shift cylinder (2) and attaching lines, hoses, tubes and connectors for cracks, breaks, leaks, and wear.</p> <p>e. Inspect hand brake components (3) for damage, excessive wear, and malfunction.</p>  <p style="text-align: right;">TA 155041</p> <p>f. Inspect magnetic drain plug for evidence of metal particles. If evidence of metal particles are seen, notify DS Maintenance. Insure drain plug (4) is secure.</p>  <p style="text-align: right;">TA 155042</p>
	•					
	•					

Table 2-2. Organizational Preventive Maintenance Checks and Services (continued).

Item No.	Interval			Item To Be Inspected	Procedures
	S	A	B		
23	g			Transmission	<p><i>a.</i> Inspect transmission case for damage and indication of oil leaks. Inspect transmission linkage for damage and excessive wear or play. Check oil level. Operate engine and shift transmission through all speed ranges; check operation and be alert for unusual noises. Inspect and clean air breather valve. Visually check oil for contamination (metal particles, dirt, sand).</p> <p><i>b.</i> Inspect transmission shift linkage for bends, excessive play, cracks, and wear that could cause failure.</p>
24	e			Engine underside	<p><i>a.</i> Inspect underside of engine for fuel, water, and oil leaks.</p> <p><i>b.</i> Inspect oil pan and pan drain plug for leaks, and security. Tighten oil pan mounting screws. Torque 28-40 lb-ft (38-54 N.m).</p> <p><i>c.</i> Inspect attaching components for security, leaks, breaks, dents, and completeness of assembly.</p> <p><i>d.</i> Inspect under vehicle for any indication of oil, water, fuel, or hydraulic fluid leaks.</p> <p><i>e.</i> Inspect and service crankcase breather.</p> <p style="text-align: center;"><b>ENGINE COMPARTMENT:</b></p> <p style="text-align: center;"><b>NOTE</b></p> <p>Open engine hood and secure with retaining bar. Also, remove both splash shields. Disengage emergency fuel cutoff control linkage.</p>
25				Air intake system	<p><i>a.</i> Inspect air cleaner, hoses, and tubing for proper installation, cracks, breaks, and loose connections that could permit unfiltered air to enter the engine.</p> <p><i>b.</i> Inspect filter element for bends, tears, or the presence of dirt and oil. Clean or replace as necessary.</p>
26				Starter and starter wiring	<p><i>a.</i> Inspect starter mounting bolts for presence and security. Tighten mounting bolts 80-100 lb-ft (108-136 N.m).</p> <p><i>b.</i> Inspect starter wiring for frays, splits, wear, loose terminals, and missing insulation.</p>

Table 2-2. Organizational Preventive Maintenance Checks and Services (continued).

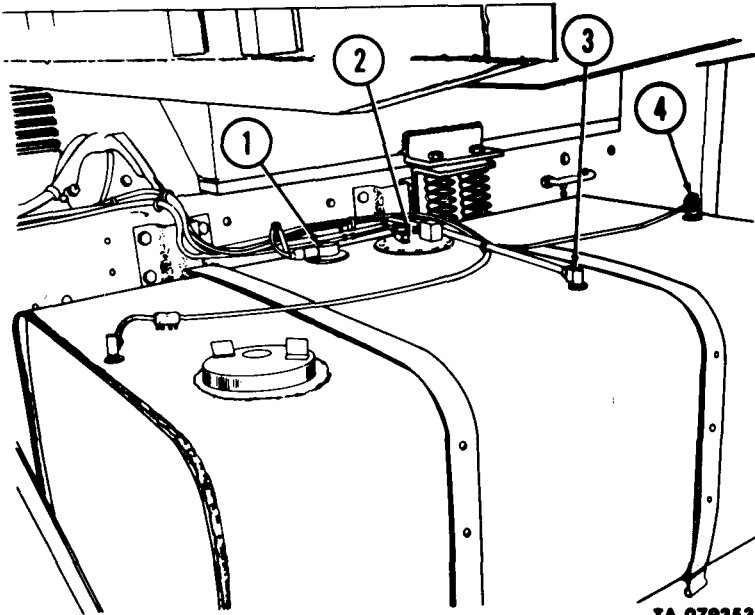
Item No.	Interval			Item To Be Inspected	Procedures
	S	A	B		
27	●			Electrical wiring	Inspect all engine compartment wiring for frays, splits, missing insulation or poor connections. Replace any worn wiring.
28	●			Batteries	Check specific gravity of each cell and record specific gravity. Check electrolyte level. Inspect battery cables for tightness and condition. Clean top of batteries, coat terminals lightly with grease. Reference TM 9-6140-200-14 and DA Pamphlet 750-34.
29	●			Fuel system	<p><b>NOTE</b></p> <p>The fuel, steering and air systems will not follow the PMCS flow diagram preceding this table. Return to where you left off after completing the checks and services for these systems.</p> <p>a. Inspect fuel tank(s) for dents, cracks, and broken welds that could cause leaks.</p> <p>b. Inspect all fuel lines for loose connections, splits, cracks, and bends that could cause leaks.</p> <p>c. Inspect fuel sending unit (1) and its wiring for loose connections, frays, splits, and missing insulation.</p> <p>d. Inspect fuel inlet tube (2), fuel outlet tube (3) and vent hoses (4) at fuel tank for loose connections, cracks, splits, wear, and security.</p>
	●				
	●				
	●				
	●				
	●				 <p>TA 079353</p> <p>e. Inspect fuel filter housing for security, dents, and cracks that could cause leaks. Drain water from filter and inspect filter element for dirt, damage, and unserviceability. Replace any unserviceable fuel filter.</p>





Table 2-2. Organizational Preventive Maintenance Checks and Services (continued).

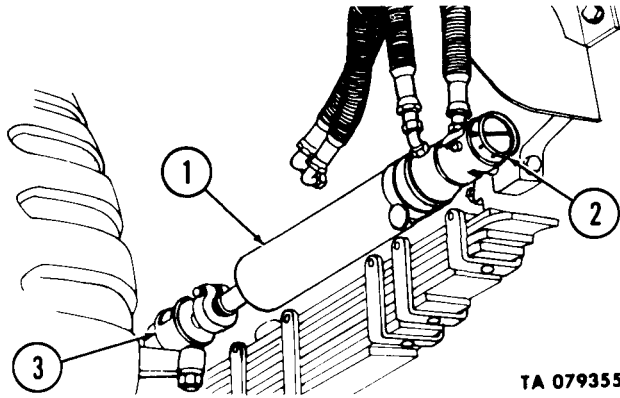
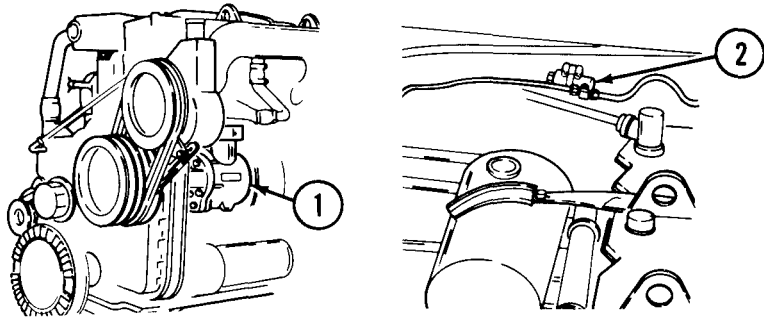
Item No.	S-Semiannually			Item To Be Inspected	Procedures
	S	A	B		
31		•			<p>e. Inspect power steering assist cylinder (1) for security and proper travel adjustment (25.5 in. - 65.0 cm.). Travel adjustment distance is measured between center lines of spring shackle bolt ball stud (2) and steering knuckle arm ball stud (3).</p>  <p style="text-align: right;">TA 079355</p>
		•			<p>f. Inspect steering stops for presence and security.</p> <p style="text-align: center;"><b>NOTE</b></p> <p>Anytime leakage is suspected in the compressed air system, use the soapsuds method of detection. If a leak exists, bubbles will form around the area in question. If leakage exists, tighten connection or replace component.</p>
		•		Compressed air and brake system	<p>a. Drain water from air reservoirs and observe water for milky, blue, or green coloring. Any of these conditions indicate internal engine malfunctions. Notify DS maintenance.</p> <p>b. Inspect four air reservoirs, their attaching valves, lines and connections for mounting security, bends, dents, and cracks that could cause leaks.</p> <p>c. Inspect air compressor (1) and air governor (2) for mounting security and leaks.</p>
		•			 <p style="text-align: right;">TA 155045</p>
		•			<p>d. Inspect trailer brake hoses and couplings for security and leaks.</p>

Table 2-2. Organizational Preventive Maintenance Checks and Services (continued).

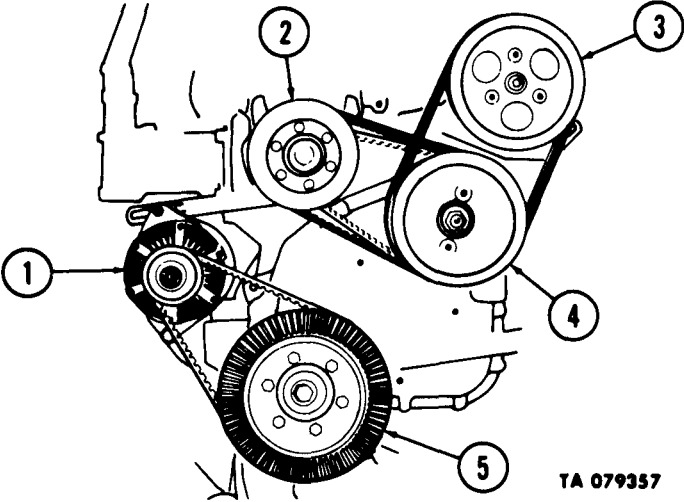
Item No.	Interval			Item To Be Inspected	Procedures
	S	A	B		
32	•			Drive pulleys and belts	<p>a. Inspect alternator (1), fan hub (2), power steering pump (3), accessory drive (4), and vibration dampener (5), drive belts for splits, cracks, breaks, and wear.</p>  <p style="text-align: right;">TA 079357</p>
	•				<p>b. With the aid of a ruler, check the tension of all drive belts. Belts will not give more than 3/4 inch (1.9 cm.) or less than 1/2 inch (1.27 cm.) at belt center point when properly adjusted.</p>
33	•			Engine lubrication and oil lines	<p>a. Check oil level at dipstick and observe evidence of metal particles at end of dipstick. Notify DS maintenance if metal particles are present.</p>
	•				<p>b. Inspect all oil lines and hoses for cracks, frays, and wear that could cause leaks.</p>
	•				<p>c. Inspect oil filter housing for security. Make sure filter center bolt is tight. Torque 25-35 lb-ft (34-47 N.m).</p>
34	•			Cooling system	<p>d. Inspect rocker housing covers for evidence of leaks. Notify DS maintenance if leaks exist.</p>
	•				<p>a. Inspect coolant level at surge tank. Surge tank should be at least 3/4 full.</p> <p>b. Inspect all hoses for security, splits, wear, and cracks that could cause leaks. Inspect hose clamps for wear and serviceability.</p>

Table 2-2. Organizational Preventive Maintenance Checks and Services (continued).

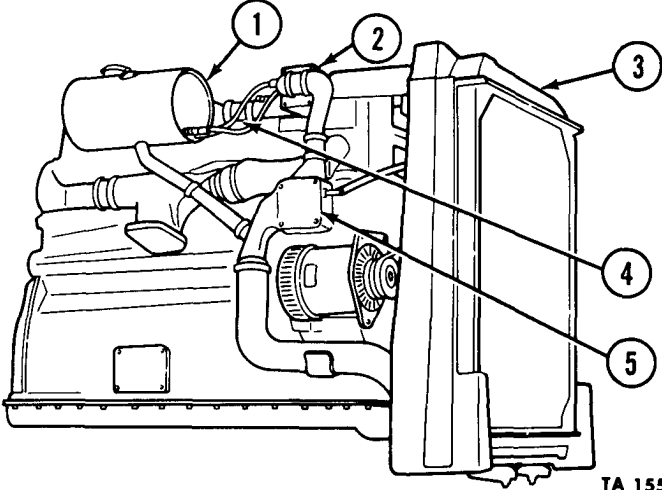
Item No.	S-Semiannually			Item To Be Inspected	Procedures
	S	A	B		
	•				<p>c. Inspect surge tank (1), thermostat housing (2), radiator (3), water manifold (4), engine oil cooler (5) for leaks, looseness, wear, and serviceability.</p>  <p style="text-align: right;">TA 155046</p>
	•				<p>d. Inspect radiator core for clogged or bent fins, leaks, and protruding objects. Clean clogged core and remove protruding objects.</p>
	•				<p>e. Inspect fan blades for security, breaks, missing or loose bolts.</p>
	•				<p>f. Inspect temperature sending unit for presence and security. Inspect sending unit wiring for frays, splits, breaks, and missing insulation.</p>
35	•			Alternator and alternator wiring	<p>a. Inspect alternator for secure mounting.</p> <p>b. Inspect alternator mounting bracket and attaching hardware for cracks, bends, and secure mounting.</p> <p>c. Inspect alternator wiring for security, frays, bare wires, and loose terminal connections. Make sure quick-disconnect is secure.</p>
36	•			Front suspension	<p>a. Inspect springs and shackles for cracks, breaks, and security. Tighten spring U-bolts. Torque 350-400 lb-ft (475-542 N.m.).</p> <p>b. Inspect shock absorbers and mounting brackets for looseness, wear, cracks, serviceability and leaks. Replace leaking shock absorbers.</p>
37		•		Front wheel alinement	<p>Check front end alinement. Correct toe-in is <math>1/8 \pm 1/16</math> inch (3.175 cm. <math>\pm</math> 1.59 cm.).</p>
38		•		Engine and cab mounts	<p>a. Inspect front and rear engine and cab mounting brackets for looseness, wear, cracks, splits, broken welds, worn bushings, and missing bolts.</p>

Table 2-2. Organizational Preventive Maintenance Checks and Services (continued).

Item No.	S-Semiannually			Item To Be Inspected	Procedures
	S	A	B		
		•			<p>b. Tighten front engine trunion bolts. Torque 150 lb-ft (203 N.m). Tighten engine flywheel housing-to-frame mounting bolts. Torque 75-83 lb-ft (102-113 N.m).</p> <p>c. Tighten front and rear cab mounting bolts. Torque 50 lb-ft (68 N.m).</p>
		•			<b>VEHICLE REAR:</b>
39		•		Spare tire carrier	Inspect spare tire carrier for security, completeness of assembly and proper operation.
40		•		Rear wiring	Inspect rear wiring at tail lights for frays, splits, loose terminals, and missing insulation.
41		•		Towing pintle	Check operation of pintle hook. Inspect pintle and bracket for cracks, breaks, wear and mounting security.
42		•		Lifting shackles and brackets	Inspect all lifting shackles and brackets for damage and completeness of assembly.
43		•		Front winch	<p>a. Inspect winch power takeoff for operation and malfunction. Inspect condition of winch shearpin.</p> <p>b. Check winch for operation, malfunction and damage. Check gear case oil level. Test drag brake and automatic brake. Inspect winch cable for excessive wear, damage, kinks, frayed strands, and for proper lubrication.</p> <p>c. Inspect front winch for mounting security and broken and missing parts.</p> <p>d. Test drag brake for proper operation. Pay off about four or five feet of cable, then stop. Drum must stop turning as soon as pulling has stopped. If winch continues to turn, adjust drag brake adjusting screw (1) and test again.</p> <p>e. Test automatic brake by parking your vehicle on a decline. Winch another vehicle up the decline and then shift winch control lever into neutral. Winched vehicle must not roll backward. If it does, adjust automatic brake adjusting screw (2) and test again.</p>
	•				
	•				

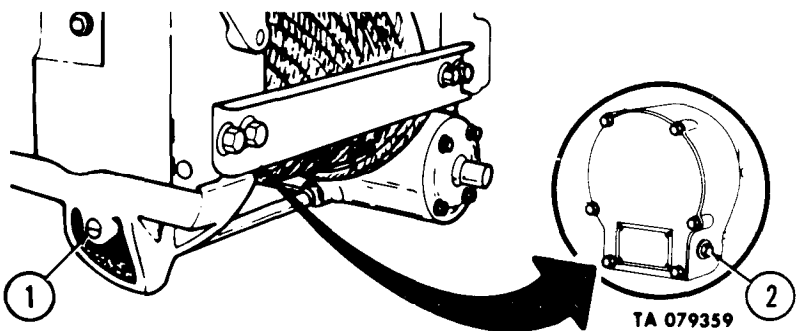




Table 2-2. Organizational Preventive Maintenance Checks and Services.

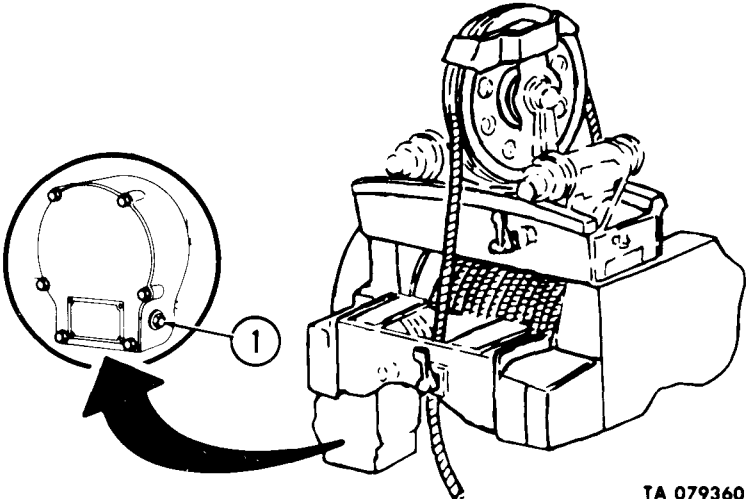
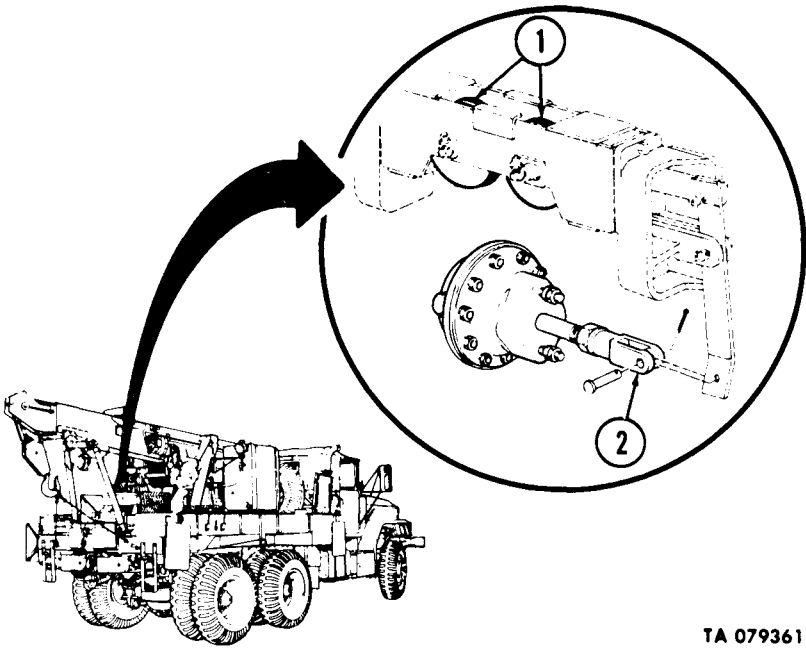
Item No.	S-Semiannually			Item To Be Inspected	Procedures
	S	A	B		
					 <p style="text-align: right;">TA 079360</p> <p><i>h.</i> Check cable tensioner sheaves for proper adjustment. A 5/8 inch diameter rod should fit snugly between tension sheaves (1). If rod cannot be inserted or fits loosely between sheaves, adjust cable tensioner.</p> <p style="text-align: center;"><b>NOTE</b></p> <p>Turning air chamber push rod yoke (2) to right increases distance between sheaves (when cable tensioner control valve lever is in the ON position). Turn yoke left to decrease distance between sheaves.</p>  <p style="text-align: right;">TA 079361</p>

Table 2-2. Organizational Preventive Maintenance Checks and Services (continued).

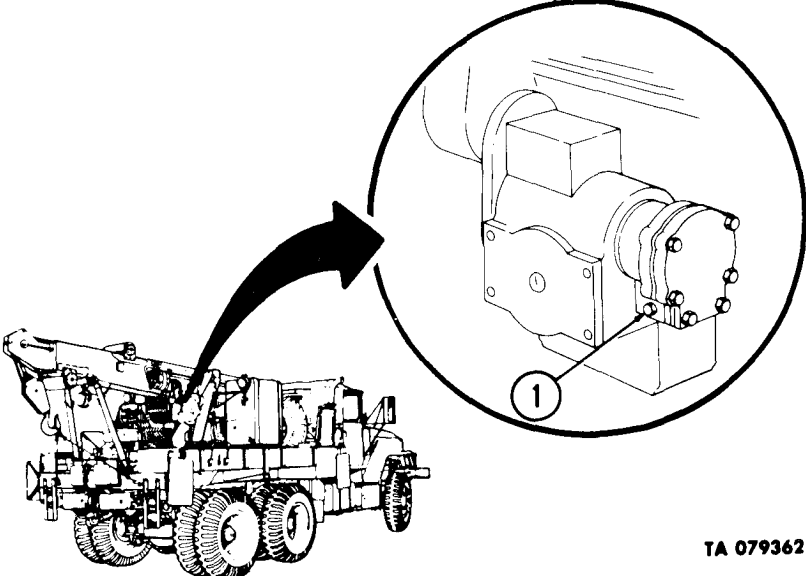
Item No.	Interval			Item To Be Inspected	Procedures
	S	A	B		
45		•		Hydraulic crane and wrecker (M62, M246, M543)	<p>a. Inspect all hydraulic lines, hoses, valves, and their connections for looseness, wear, and leaks. Observe hoses that are split, cracked, or worn.</p> <p>b. Operate crane through full range of movement. Observe smooth operation of pump control linkage and control levers. There should not be any binding or sticking.</p> <p>c. Test automatic hoist drum brake for proper operation. Lift a load off ground and then place hoist control lever in neutral. The automatic brake should sustain the weight of the load. If load begins to lower, tighten automatic brake adjusting screw (1) and test again.</p> <div style="text-align: center;">  <p style="text-align: right;"><b>TA 079362</b></p> </div> <p>d. With boom raised, inspect crane cylinder piston rods for bends and scoring.</p> <p>e. While operating crane, observe that the fuel pump governor is maintaining <math>1250 \pm 50</math> rpm during hoisting operation. Notify DS maintenance if engine rpm is surging erratically.</p> <p>f. Extend crane cable completely and look for frays, broken strands and wear.</p> <p>g. Inspect and clean hydraulic tank swing motor and hoist crane motor breather caps.</p>
		•			
		•			
		•			
		•			
		•			
		•			
		•			
		•			
		•			
46		•		Dump body and hoist (M51)	<p>a. Inspect dump body for completeness of assembly. Make sure dump body is alined with frame.</p> <p>b. Inspect dump hydraulic lines, hoses, and their fittings for leaks, splits, and wear that could cause leaks.</p>
		•			

Table 2-2. Organizational Preventive Maintenance Checks and Services (continued).

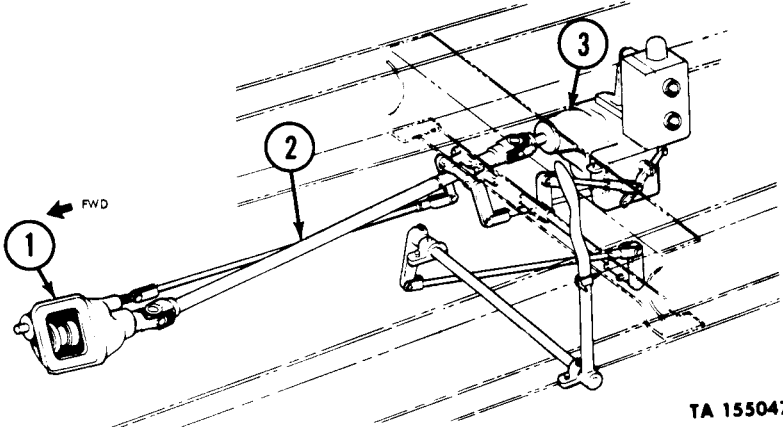
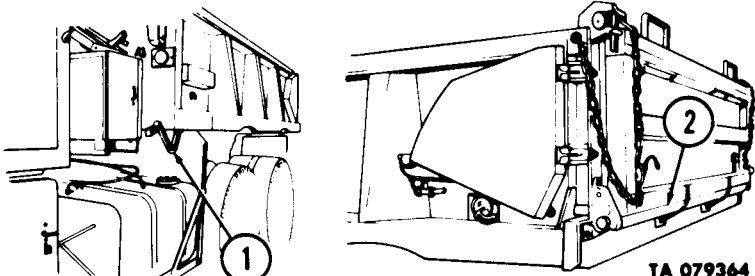
Item No.	Interval			Item To Be Inspected	Procedures
	S	A	B		
		•			<p>c. Inspect transmission power take-off (1), hydraulic pump drive shaft (2) and hydraulic pump (3) for mounting security and leaks.</p>  <p style="text-align: right;">TA 155047</p>
		•			<p>d. Make sure tailgate control rod hand lever (1) locks and unlocks tailgate lower latch (2). Inspect control linkage for play, wear, and serviceability.</p>  <p style="text-align: right;">TA 079364</p>
		•			<p>e. Operate dump body and observe smooth raising and lowering of body.</p>
			•		<p>f. With dump body raised, inspect cylinder piston rods for scoring and wear.</p>
			•		<p>g. Tighten all loose dump body mounting bolts. Torque 240 lb-ft (325 N.m).</p>
47	•			Expansible van body (M291)	<p>a. Make a general inspection of the van body. Inspect and operate heater, air conditioner, ventilators, dome lights and switches to insure proper operation.</p> <p>b. Inspect electrical wiring for frays, splits, loose terminals and wear.</p> <p>c. Expand and retract van body. Notice binding, sticking, or bends, wear, and improper lubrication of expanding or retracting mechanisms.</p>



Table 2-2. Organizational Preventive Maintenance Checks and Services (continued).

Item No.	S-Semiannually			A-Annually	B-Biennially	Procedures
	S	A	B	Item To Be Inspected		
48		●		Expansive van with liftgate (M291A1D)		<p><i>a.</i> Inspect all hydraulic lines, hoses, and their fittings for cuts, splits, wear, and leaks.</p> <p><i>b.</i> Operate lift gate through full range of operation. Observe sticking, binding, hesitation, and control lever response.</p> <p><i>c.</i> With lift gate extended, inspect lift arms and support assemblies for security of mounting, completeness of assembly, and wear.</p>
49			●	Fifth wheel, tractor truck & tractor wrecker truck (M52, M246)		Inspect fifth wheel for completeness of assembly. Make sure mounting screws are tight. Torque 100-130 lb-ft (136-176 N.m).
50		●		Cargo body		Inspect cargo body and related components for damage, completeness, secureness of assembly, operation, proper stowage, and excessive part wear.
51		●		Bridge transporting truck (M328A1)		Inspect body of bridge transporting truck for damage and completeness of assembly. Inspect rear and side tiedown winches for damage, completeness of assembly, operation, and excessive part wear. Inspect tail-board roller assembly, and lead guide roller for damage, operation and completeness of assembly. Inspect floodlight assembly for damage, completeness, and secureness of assembly, and operation.
52		●		Intervehicular electrical cables, receptacles, and air hose lines and fittings		Inspect intervehicular electrical cable receptacle and air hose lines and fittings for damage, completeness of assembly, operation, and excessive wear.
53		●		Lights and accessories		<p>Check operation of lights, (driving, blackout, turn signal, and warning lights). Check operation of horn (if tactical situation permits.).</p> <p style="text-align: center;"><b>FINAL ROAD TEST:</b></p> <p>After all services and inspections have been completed, take vehicle on a short road test to make sure all corrections have been accomplished. Correct any defects or malfunctions that are observed during this test.</p>

Table 2-2. Organizational Preventive Maintenance Checks and Services (continues~).

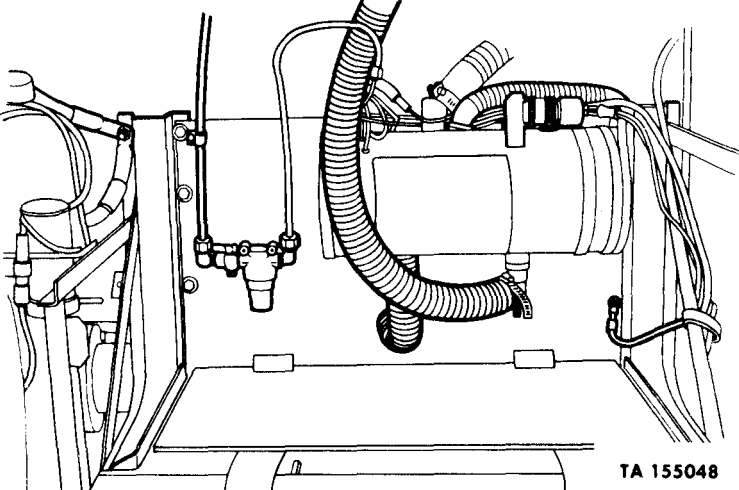
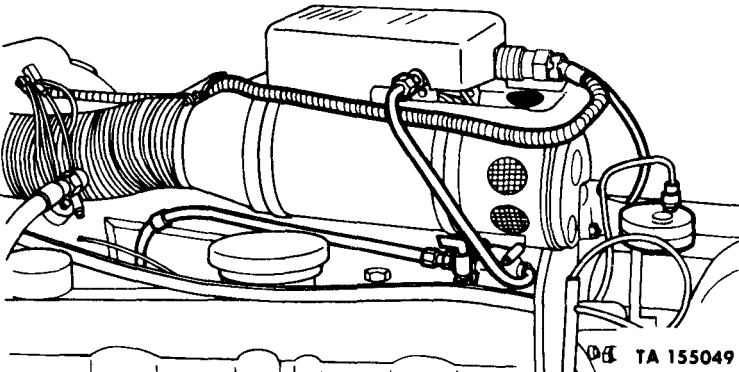
Item No.	Interval			Item To Be Inspected	Procedures
	S	A	B		
<b>ITEMS SPECIAL TO WINTERIZATION KIT AND PERSONNEL HEATER</b>					
54		•		Fuel pump and fuel lines	Remove the lower cover, and clean and inspect the fuel strainer screen. Replace the screen, if it is distorted or collapsed. Inspect all fuel lines for leaks. Make repairs as necessary.
55		•		Fuel filters	Remove and clean fuel sediment bowls and filter elements. Inspect elements and gaskets and replace them if they are damaged.
56		•		Powerplant heater	Check all attaching components for looseness, dents, and other damage. Remove any accumulated dirt from the area, and be sure heater mountings are secure.
 <p style="text-align: right;">TA 155048</p>					
57		•		Powerplant heater electrical wiring	Inspect complete wiring for frayed, cracked, or worn insulation; broken strands; and loose or dirty connections.
58		•		Personnel heater	Check all attaching components for looseness, dents, and other damage. Repair or replace damaged parts as necessary. Remove any accumulated dirt from the area, and be sure heater mountings are secure.
 <p style="text-align: right;">TA 155049</p>					

Table 2-2. Organizational Preventive Maintenance Checks and Services (continued),

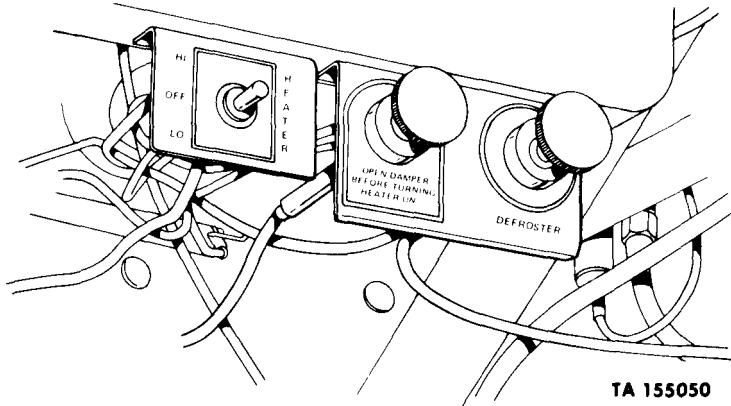
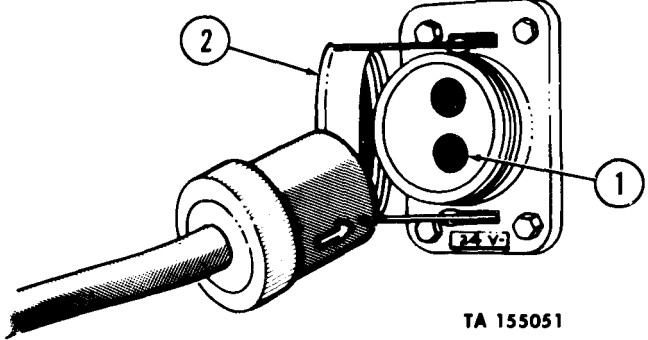
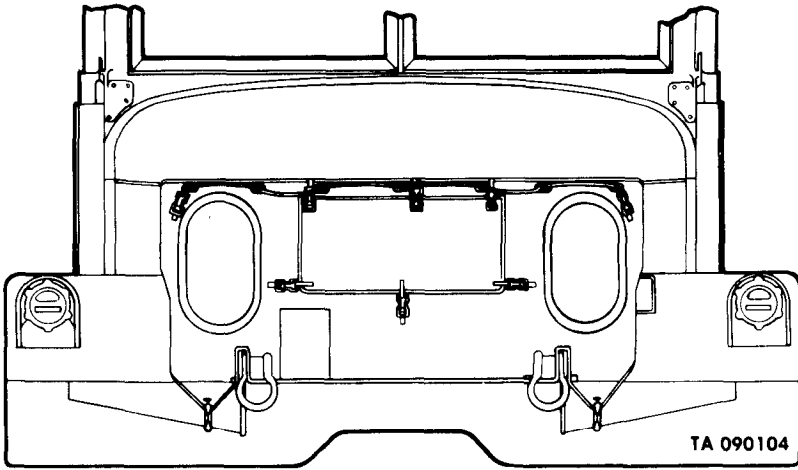
Item No.	S-Semiannually			A-Annually	B-Biennially	Procedures
	Interval	S	A	B	Item To Be Inspected	
59			●		Personnel heater electrical wiring	[inspect the complete wiring harness for frayed, cracked, or worn broken strands; and loose or dirty connections.
60			●		Exhaust tubes	Examine personnel and power plant heater exhaust tubes for breaks, restrictions, leaks and loose connections.
61		●			Engine coolant connections	Check for evidence of coolant leaks and damaged hoses.
62			●		Personnel heater and defroster controls	Check handles for operation and cables for proper attachments.  TA 155050
63			●		Defroster	Check duct clamps for tightness and ducting for damage.
64			●		Battery box heater	Remove batteries and check heating pad for signs of leaks and damage. Check coolant hose connections for tightness and hoses for damage.
65			●		Hardtop closure	Check the closure for damage and proper attachment, and weatherseals for signs of air leaks. If damage is detected, notify direct support maintenance.
66			●		Closure windows	Check operation and clean if necessary.
67			●		Slave receptacle	Check for dirt in the connectors (1) and the cap (2) for tightness.  TA 155051

Table 2-2. Organizational Preventive Maintenance Checks and Services (continued).

Item No.	S-Semiannually			Item To Be Inspected	Procedures
	S	A	B		
68		•		Hood, side, and radiator cover	<p>Check for tears, rips, and other damage. Be sure all straps and fasteners are in place.</p> 
69	•			Alcohol evaporator	<p>Check secureness of mounting. Refill alcohol container as necessary (alcohol grade 3).</p>

## Section V. TROUBLESHOOTING THE VEHICLE

**2-13. General.** Paragraphs 2-13 and 2-14 contain troubleshooting information useful in locating and correcting some of the troubles which may develop in the vehicle. Refer to table 2-3. Each symptom of a trouble given for an individual unit or system is followed by a list of probable causes of the trouble and suggested procedures to be followed to remedy the malfunction.

**2-14. Procedures.** This manual cannot cover all possible troubles and deficiencies that may occur under the many conditions of operation. If a specific trouble, test, and remedy are not covered herein, proceed to isolate the system in which the trouble occurs, and then locate the defective component. Do not neglect the use of

any test instruments such as the voltmeter, ammeter, test lamp, hydrometer, and pressure and vacuum gages that are available. Standard automotive theories and principles of operation apply in troubleshooting the vehicle. Question the vehicle operator to obtain the maximum number of observed symptoms. The greater the number of symptoms of a trouble that can be evaluated, the easier will be the isolation of the defect.

### NOTE

Electrical leads on the vehicle are marked with a circuit-number metal band attached to the junction or terminal end of each lead.

THIS PAGE LEFT BLANK INTENTIONALLY

Table 2-3. Troubleshooting—Vehicle

Item No.	Malfunction	Probable Cause	Corrective Action
1	Engine will not crank.	<p>GASOLINE ENGINE</p> <p>a. Defective batteries, wiring connections, or starting system.</p> <p>b. Starter or solenoid defective.</p>	<p>Check electrolyte specific gravity. Replace defective batteries (para 2-22). Replace starter or solenoid (para 2-124 and 2-126).</p>
2	Engine cranks but fails to start.	<p>a. Fuel tanks empty.</p> <p>b. Engine flooded.</p> <p>c. Insufficient cranking speed.</p> <p>d. No spark.</p> <p>e. Carburetor choke inoperative.</p> <p>f. Clogged fuel tank ventline, fuel line, or fuel filters.</p> <p>g. Fuel pump inoperative.</p>	<p>Fill tanks.</p> <p>Push choke in, open throttle and crank engine to remove excessive fuel.</p> <p>Recharge batteries.</p> <p>Refer to para 2-119.</p> <p>Inspect choke valve for proper operation and adjust choke controls (para 2-66).</p> <p>Clean lines and / or filters.</p>
3	Engine does not attain maximum revolutions per minute.	<p>a. Faulty ignition system.</p> <p>b. Insufficient or improper grade of oil.</p> <p>c. Engine overheats.</p> <p>d. Improper valve adjustment.</p> <p>e. Sticking valves.</p> <p>f. Faulty compression.</p> <p>g. Increased back pressure due to clogged or collapsed muffler or tailpipe.</p> <p>h. Clogged fuel filters.</p> <p>i. Faulty fuel pump.</p> <p>j. Accelerator linkage improperly adjusted.</p> <p>k. Clogged air cleaners.</p>	<p>Test pump; replace if defective (para 2-72).</p> <p>Refer to para 2-32.</p> <p>Drain crankcase and refill to correct level with proper grade of oil (LO 9-2320-211-12).</p> <p>Refer to item below.</p> <p>Check valve clearance and if necessary, adjust (para 2-45).</p> <p>Remove cylinder head cover (para 2-45), and apply penetrating oil to valve stems. If valves still are not free, notify supporting maintenance personnel.</p> <p>Test compression (para 2-43).</p> <p>Clean or replace muffler (para 2-101) or tailpipe (para 2-100).</p> <p>Clean filters (para 2-73).</p> <p>Refer to item 2g.</p> <p>Check linkage and adjust as necessary (para 2-67).</p> <p>Remove and service air cleaners (para 2-63).</p> <p>Adjust timing (para 2-120).</p>
4	Engine misfires at idle speed.	<p>l. Distributor out of time.</p> <p>a. Carburetor idle setting incorrect.</p> <p>b. Choke improperly positioned.</p> <p>c. Spark plug gaps improperly set.</p> <p>d. Faulty distributor operation.</p> <p>e. Vacuum leak.</p> <p>f. Improper valve clearance.</p> <p>g. Leaky cylinder head gasket.</p> <p>h. Defective or sticky valves.</p>	<p>Adjust idle setting and throttle linkage (para 2-65 and 2-68).</p> <p>Adjust choke control and linkage (para 2-66).</p> <p>Adjust spark plug gap (para 2-121).</p> <p>Refer to Table 2-4: IGNITION SYSTEM.</p> <p>Use engine oil to check for leaks at throttle shaft, carburetor flange and inlet manifolds.</p> <p>Adjust valve clearance (para 2-45).</p> <p>Notify supporting maintenance personnel.</p> <p>Check engine vacuum (para 2-44). Erratic vacuum gage readings at constant engine speed, indicate defective valve operation. Notify supporting maintenance personnel if gage reading is erratic.</p>

\*Refer to footnote at end of table.

Table 2-3. Troubleshooting—Vehicle—Continued

Item No.	Malfunction	Probable Cause	Corrective Action
GASOLINE ENGINE—Continued			
5	Engine misfires at high speeds.	a. Faulty ignition system b. Improper valve adjustment. c. Restricted fuel lines or fuel filter. d. Defective fuel pump	Refer to table 2-4, IGNITION SYSTEM. Check and adjust valve clearances (para 2-45). Refer to item 2f Refer to item 2g
6	Engine idles too fast.	e. Spark plug gap improperly set. a. Improper carburetor idle adjustment. b. Improper accelerator linkage adjustment. c. Intake manifold gaskets leaking.	Adjust gap (para 2-121) Adjust carburetor idle mixture (para 2-65), and adjust throttle adjusting screws (para 2-68). Adjust linkage (para 2-67)
7	Engine overheats	a. Low coolant in system b. Lean air-fuel mixture c. Late ignition timing	Inspect gaskets for leakage. Replace if necessary (para 2-44). Refill cooling system (para 2-108). Adjust carburetor (para 2-65). Inspect engine for leaks at manifold and carburetor gaskets. Check ignition timing and adjust as necessary (para 2-120).
8	Engine falters	Clogged or worn carburetor parts.	Replace carburetor (para 2-65). Notify supporting maintenance personnel if engine still falters.
9	Engine backfires	a. Crossed spark plug cables. b. Cracked coil or distributor cap. c. Out of time	Check cables for proper firing order sequence (1-5-3-6-2-4). Inspect distributor cap and coil for tracks or carbonized spots, indicating current leakage. Inspect all carbon tips in cap. Replace cap or coil if any cracks or carbonization is noted (para 2-119). Check ignition system timing (para 2-120).
10	Excessive oil consumption.	a. Oil leaks b. Engine overheating c. Clogged cylinder block ventilation breather and strainer. d. Poor compression e. Excessive low-speed driving in too-high gear range.	Inspect engine, engine components, and ground under engine for oil leaks. Tighten leaking connections and repair or replace broken lines. Refer to item 20. Check ventilation breather and strainer. Service as indicated in para 2-47. Test compression on all cylinders (para 2-43). If difference of 10 psi between cylinders is noted, notify supporting maintenance personnel. Vehicle must be operated in proper gear ratio for desired speed according to road conditions.
11	Engine oil pressure low as indicated by oil pressure gage.	a. Inadequate engine oil supply; low oil level. b. Defective oil pressure gage. c. Defective oil pressure sending unit. d. Improper oil viscosity	Check engine oil for proper level and proper viscosity; replenish oil (LO 9-2320-211-12). * Replace gage (para 2-148). * Replace sending unit (para 2-163). Drain and refill with oil of proper viscosity.
12	Excessive noise on increased acceleration.	Insufficient lubrication.	Check for low oil pressure and high oil consumption. Add oil if required. Notify supporting maintenance if these conditions are not normal.
13	Excessive noise with engine idling.	Insufficient lubrication	Refer to item 12

\* Refer to footnote at end of table.

Table 2-3. *Troubleshooting—Vehicle—Continued*

Item No.	Malfunction	Probable Cause	Corrective Action
<b>DIESEL AND MULTIFUEL ENGINE</b>			
14	Engine will not crank.	<ul style="list-style-type: none"> <li>a. Defective starter switch.</li> <li>b. Defective master switch.</li> <li>c. Battery cables loose or dirty.</li> <li>d. Defective battery</li> <li>e. Defective starter or starter solenoid.</li> <li>f. Hydrostatic lock or mechanical seizure within engine.</li> </ul>	Replace starter switch (para 2-128). Replace master switch (para 2-154). Clean and tighten cables. Replace batteries (para 2-22). Replace starter and starter solenoid (para 2-128, 2-129). Notify supporting maintenance.
15	Engine cranks but fails to start (adequate fuel in tank).	<ul style="list-style-type: none"> <li>a. Dirty or defective fuel filter(s).</li> <li>b. Clogged or defective fuel supply pump.</li> <li>c. Engine starter cranking speed to low.</li> </ul>	Service filters as necessary (para 2-82, 2-88). Notify supporting maintenance.  Defective battery or starting system.
16	Engine starting motor operates but does not engage flywheel ring gear.	Damaged starter pinion or drive assembly.	Replace starter and starter solenoid (para 2-128 and 2-129).
17	Engine manifold heater fails to operate properly (cold weather starting).	<ul style="list-style-type: none"> <li>a. Defective heater switch</li> <li>b. Defective ignition unit lead or spark plug.</li> <li>c. Defective manifold heater fuel pump.</li> </ul>	Replace heater switch (para 2-142). Test and replace as necessary (para 2-33). Replace manifold heater fuel pump (para w-93 and 2-94). Replace thermostat(s) (para 2-115).
18	Engine starts, but misfires or does not run smoothly; exhaust may contain considerable amount of bluish-white smoke.	<ul style="list-style-type: none"> <li>a. Engine temperature below normal.</li> <li>b. Water or dirt in fuel</li> <li>c. Partially restricted air cleaner or air duct.</li> </ul>	Service fuel filters and drain fuel tank. Service air cleaner (para 2-77).
19	Engine low on power	<ul style="list-style-type: none"> <li>a. Improper fuel being used.</li> <li>b. Clogged fuel filter</li> <li>c. Air cleaner restricted; note air filter indicator.</li> <li>d. Leaking exhaust system causing reduced pressure to turbocharger.</li> </ul>	Drain tanks; refill with proper fuel. Replace filter element (para 2-82 and 2-88). Service air cleaner (para 2-77).  Repair exhaust system leaks.
20	Engine overheats as indicated by coolant temperature gage.	<ul style="list-style-type: none"> <li>a. Fan belts loose, worn, or broken.</li> <li>b. Defective coolant temperature gage.</li> <li>c. Defective coolant temperature sending unit.</li> <li>d. Defective or sticking thermostat.</li> <li>e. Restricted air flow through radiator assembly.</li> <li>f. Defective cooling system</li> <li>g. Inadequate engine lubrication.</li> </ul>	Check fan belts tension; replace belts or adjust as required (para 2-111, 2-112). Replace gage (para 2-153).  Replace sending unit (para 2-167).  Replace thermostat (para 2-114). Remove restriction. Clean radiator fins. Refer to Para 2-109 Check engine oil for proper level and proper viscosity. Replace fuel filter element
21	Engine oil pressure low as indicated by oil pressure gage.	<ul style="list-style-type: none"> <li>h. Insufficient fuel pressure</li> <li>a. Inadequate engine oil supply; low oil level.</li> <li>b. Defective oil pressure gage.</li> <li>c. Defective oil pressure sending unit.</li> <li>d. Improper oil viscosity</li> </ul>	Check engine oil for proper level and proper viscosity; replenish oil. Replace gage (para 2-148). Replace sending unit (para 2-163). Drain and refill with oil of proper viscosity (LO 9-2320-211-12).
22	Engine oil consumption excessive.	<ul style="list-style-type: none"> <li>a. Restricted crankcase breather.</li> <li>b. Improper oil viscosity</li> </ul>	Service as necessary Drain and refill with oil of proper viscosity.
23	Defective air intake system.	<ul style="list-style-type: none"> <li>a. Air cleaner restricted; note air filter indicator.</li> <li>b. Restricted air-inlet ducts.</li> </ul>	Service air cleaner (para 2-77).  Remove restriction

\*Refer to footnote at end of table.



Item No.	Malfunction	Probable Cause	Corrective Action
		<b>CLUTCH</b>	
24	Clutch slips or drags.	Insufficient free-pedal travel (less than one inch).	Adjust pedal linkage (para 2-55, 2-61).
25	Clutch chatters	Loose, broken, or defective clutch mounting bolts, insulators, or brackets.	Inspect transmission attaching bolt, propeller shafts, universal joints and bearings for improper or loose connections. Tighten as required.
		<b>EXHAUST SYSTEM</b>	
26	Defective exhaust system.	a. Defective or restricted muffler or exhaust pipe. b. Loose or defective manifold and exhaust pipe flange clamps.	Clean or replace muffler or exhaust pipe (para 2-103). Tighten or replace flange clamps as required.
		<b>COOLING SYSTEM</b>	
27	Engine overheats; temperature rises over 200° F.	a. Lack of coolant b. Coolant leaks c. Faulty water pump d. Leaky radiator core e. Loose fan belt f. Defective thermostat g. Clogged radiator h. Defective or improper radiator pressure caps. h. Obstruction preventing free air flow through radiator. i. Inlet or outlet hose collapsed. j. Sludge in cylinder block. k. Plugged water jacket l. Scale in cylinder block.	Replenish water in radiator. Add antifreeze if necessary. Inspect cooling system for leaks. Tighten or replace hose as necessary. Replace pump (para 2-118 and 2-118I). Replace radiator (para 2-110). Adjust belts (para 2-111 and 2-112). Remove and test thermostat (para 2-114 and 2-115); replace if necessary. Clean and flush radiator (para 2-110). Check caps and replace if necessary. Remove bugs, leaves, and accumulated dirt from radiator, using high-pressure air or water. Check condition of hoses and replace if necessary. Drain, flush, and refill cylinder block. Drain system (para 2-108 and 2-109). Disconnect radiator hose and reverse-flush the radiator. Refer to TM 750-254. Clean and neutralize system. Refer to TM 750-254.
28	Overcooling (inability to attain engine operating temperature after suitable warmup).	a. Defective thermostat b. Inaccurate temperature gage.	Refer to item 27f Replace gage (para 2-153).
		<b>TRANSMISSION TRANSFER</b>	
29	Excessive noise	a. Insufficient lubrication. b. Propeller shaft misaligned or out of balance.	Check level and if required, add lubricant according to lubrication order (LO 9-2320-211-12). Check universal joints for worn needle bearings (para 2-178). Replace if necessary. Check propeller shaft for alinement and check flanges for loose mounting bolts.
30	Loss of lubricant	a. Loose drain plugs b. Damaged gaskets, seals, or housings. c. Inoperative ventilating valves.	Tighten drain plugs Notify supporting maintenance personnel. Clean ventilating valves (para 2-173).
31	Excessive lubricant	Overfilled	Check lubricant level and drain to level of filler plug.
		<b>PROPELLER SHAFTS</b>	
32	Excessive noise or vibration.	a. Lack of lubrication b. Worn universal joint parts.	Lubricate according to lubrication order (LO 9-2320-211-12). Replace worn parts (para 2-178).

\* Refer to footnote at end of table.

Table 2-3. Troubleshooting—Vehicle—Continued

No.	Malfunction	Probable Cause	Corrective Action
32	Continued	<p>PROPELLER SHAFTS—Continued</p> <p>c. Worn slip joints</p> <p>d. Loose drive flange bolts.</p> <p>e. Shaft sprung from contact with obstruction.</p>	<p>Remove propeller shaft (para 2-179 and 2-180). Check condition of slip-joint splines and replace slip joint if necessary.</p> <p>Tighten flange bolts attaching drive flange to propeller shaft and transmission.</p> <p>Replace propeller shaft (para 2-179 and 2-180).</p>
33	Difficult to turn steering wheel.	<p>FRONT AND REAR AXLES</p> <p>a. Hydraulic power unit inoperative.</p> <p>b. Tires underinflated</p> <p>c. Lack of Lubricant</p> <p>d. Bind in steering knuckles.</p>	<p>Check oil level in steering system (LO 9-2320-211-12). Notify support maintenance personnel.</p> <p>Check tire pressure and inflate as specified on servicing data plate affixed to instrument panel.</p> <p>Lubricate steering knuckle, tie rods, and drag link ends according to LO 9-2320-211-12.</p> <p>Jack up the front axle to clear wheels of the ground. Disconnect the drag link at the steering lever left end assembly (para 2-213). Turn wheels from side to side. If binding, disconnect one end of the tie rod from the steering lever. If binding persists and lubrication does not free the knuckle, notify supporting maintenance personnel for replacement of the front axle assembly.</p>
34	Hard steering; wandering.	<p>a. Axle shifted</p> <p>b. Power steering system inoperative.</p> <p>c. Tires unequally inflated.</p> <p>d. Front wheel bearings out of adjustment.</p> <p>e. Insufficient toe-in</p>	<p>Measure from the front spring rear eye to a fixed point on the axle. Compare with a like measurement on the opposite side. If they do not agree, inspect for a broken front spring main leaf and center bolt. Check for loose or broken U bolts (para 2-182) or springs. Replace defective parts (para 2-182).</p> <p>Check oil level in power steering oil system and add oil if necessary.</p> <p>Check tire inflation and inflate properly. See servicing data (para 2-213).</p> <p>Adjust wheel bearings (para 2-211).</p>
35	Continuous axle noise.	<p>a. Wheel bearings in need of lubrication.</p> <p>b. Front or rear wheel out of adjustment.</p> <p>c. Tires improperly inflated or damaged. (If noise is caused by tires, noise will disappear when vehicle is driven over soft terrain.)</p> <p>d. Loss of lubricant</p>	<p>Check toe-in (para 2-214).</p> <p>Lubricate bearings according to lubrication order (LO 9-2320-211-12).</p> <p>Check bearings for wear and adjustment.</p> <p>Inflate tires properly (TM 9-2320-211-10).</p>
36	Excessive backlash in rear axle drive flange.	<p>a. Axle flange nuts loose</p> <p>b. Ring gear and pinion out of adjustment or worn excessively.</p>	<p>Clean breather vent</p> <p>Tighten nuts to a torque of 160 ft.-lb.</p> <p>Replace axle assembly. Notify supporting maintenance.</p>

\*Refer to footnote at end of table.

Table 2-3. Troubleshooting—Vehicle—Continued

Item No	Malfunction	Probable Cause	Corrective Action
37	Excessive or uneven tire wear.	<ul style="list-style-type: none"> <li>a. Improve wheel alinement.</li> </ul>	Adjust toe-in (para 2-214). If this does not correct the deficiency, notify supporting maintenance personnel.
38	Binding in front axle shafts.	<ul style="list-style-type: none"> <li>b. Improper braking.</li> <li>c. Improper tire inflation</li> <li>a. Excessively worn universal joints.</li> <li>b. Spacer washer not installed in the axle shaft.</li> </ul>	Adjust brakes (para 2-188). Inflate tires evenly (para 2-213). Replace worn parts (para 2-182). Check the end plug of the shaft by moving the shaft in and out of the housing. Install a spacer if movement is over 1 / 16 inches.
<b>BRAKE SYSTEM- HANDBRAKES</b>			
39	Does not hold parked vehicle.	<ul style="list-style-type: none"> <li>a. Loose brake linkage</li> <li>b. Brake lining worn</li> <li>c. Grease on lining</li> </ul>	Adjust linkage (para 2-195). Replace brakeshoes (para 2-197). Replace brakeshoes and correct the grease leak (para 2-197).
40	Brake drags and overheats.	<ul style="list-style-type: none"> <li>a. Vehicle operated with brake partially applied.</li> <li>b. Handbrake improperly adjusted.</li> <li>c. Brake drum out-of-round</li> <li>d. Weak brakeshoe retractor spring.</li> </ul>	Check the hand brake lever for a full-release position. Adjust turn cap on top of brake lever (para 2-196). Replace drum (para 2-195). Replace spring (para 2-197).
<b>SERVICE BRAKES</b>			
41	Insufficient brakes	<ul style="list-style-type: none"> <li>a. Brake linings worn</li> <li>b. Low air pressure (below 80 psi) due to leaks in system.</li> <li>c. Air in hydraulic brake system (spongy brake pedal).</li> <li>d. Defective brake air-over hydraulic cylinder.</li> </ul>	Adjust brakes (para 2-189) and / or replace brakeshoe assembly (para 2-193). Repair or replace leaking fittings or lines. Bleed hydraulic system (para 2-190, 2-191, and 2-192). Replace brake air hydraulic cylinder (para 2-191).
42	Dragging brakes	<ul style="list-style-type: none"> <li>a. Restricted brake lines</li> <li>b. Brakeshoe sticking to anchor pin.</li> <li>c. Shoes adjusted too close to drum.</li> <li>d. Sticking wheel cylinder piston or master cylinder.</li> <li>e. Defective brake air hydraulic cylinder.</li> <li>f. Insufficient pedal free travel.</li> </ul>	Remove and clean brake lines (para 2-194). Lubricate anchor pin Adjust brakeshoes (para 2-189). Replace wheel cylinder as required (para 2-192). Replace brake air hydraulic cylinder (para 2-191). Adjust brake travel to ¼"-½" (para 2-189).
43	Brakes do not apply	<ul style="list-style-type: none"> <li>a. No air pressure in brake system.</li> <li>b. Restricted or broken tubing or brake line.</li> </ul>	Build up air pressure above 80 psi by operating engine at fast idle. Inspect brake lines; tighten all connections or replace lines as necessary (para 2-194).
44	Brakes grab	<ul style="list-style-type: none"> <li>a. Grease or grit on brake lining.</li> <li>b. Brake linkage binding</li> <li>c. Spring U bolts loose or broken.</li> <li>d. Brake drum out-of-round scored, or cracked.</li> <li>e. Loose lining on brakeshoe.</li> </ul>	Replace brakeshoe assembly (para 2-193). Lubricate anchor pins Tighten or replace U bolts (para 2-193) Replace drum (para 2-189). Replace brakeshoe assembly (para 2-193).
45	One brake grabs	<ul style="list-style-type: none"> <li>a. Improper brake adjustment.</li> <li>b. Weak or broken brakeshoe retractor spring.</li> <li>c. Brakeshoe binding on anchor pin.</li> <li>d. Wheel bearings (front) defective or out of adjustment.</li> </ul>	Adjust brakes (para 2-189). Replace the spring (para 2-193). Lubricate the anchor pin Adjust or replace (para 2-211).

\*Refer to footnote at end of table

Item No.	Malfunction	Probable Cause	Corrective Action
<b>SERVICE BRAKES-Continued</b>			
45	Continued	<p>e. Rear wheel bearings defective or out of adjustment.</p> <p>f. Restricted brake line</p>	<p>Inspect bearings; adjust and lubricate or replace if necessary (para 2-211).</p> <p>Locate and replace the line (para 2-194).</p>
46	Nosiy brakes	<p>a. Defective brakeshoe assembly.</p> <p>b. Scored or damaged brakedrum.</p> <p>c. Bent brakeshoes, anchor pins, or plates.</p>	<p>Replace the brakeshoe assembly (para 2-193).</p> <p>Replace the drum (para 2-193).</p> <p>Replace parts as required (para 2-193).</p>
47	Uneven braking.	<p>a. Improper brake adjustment.</p> <p>b. Worn brake lining</p> <p>c. Grease on lining</p> <p>d. Brakeshoe retractor spring weak or broken.</p>	<p>Adjust brakes (para 2-189).</p> <p>Replace the brakeshoe assembly (para 2-193).</p> <p>Replace the brakeshoe assembly (para 2-193).</p> <p>Replace the spring (para 2-193).</p>
48	Trailer brakes inoperative.	<p>e. Brake drum out-of-round.</p> <p>a. Hand control valve faulty.</p> <p>b. Hose connections leaking or disconnected.</p>	<p>Replace the drum (para 2-193).</p> <p>Check the valve for proper operation and replace if necessary (para 2-202).</p> <p>Check the hose connections (para 2-199).</p>
49	Air pressure will not rise to normal, or rises too slowly.	<p>a. Leak in air lines or fittings.</p> <p>b. Clogged compressor discharge line.</p> <p>c. Loose compressor drive belt (gasoline or multifuel engine).</p> <p>d. Defective compressor</p>	<p>Locate the leak and tighten fittings or replace lines as necessary (para 2-205).</p> <p>Replace line (para 2-205) and notify supporting maintenance personnel. Adjust belt (para 2-112).</p> <p>Replace compressor (gasoline or multifuel only)</p>
<b>WHEELS AND TIRES</b>			
50	Excessive or uneven tire wear.	<p>a. Unequal tire pressure</p> <p>b. Tires of unequal rolling radii used on dual wheels.</p> <p>c. Uneven vehicle load distribution.</p> <p>d. Front wheels misaligned</p> <p>e. Front wheel bearings damaged or worn.</p> <p>f. Wheel and tire assembly out of balance.</p>	<p>Inflate tires properly. Refer to TM 9-2320-211-10.</p> <p>Match tires</p> <p>Redistribute load properly</p> <p>Check wheel alinement (para 2-214).</p> <p>Adjust or replace bearings (para 2-211).</p> <p>Rotate wheels and tires (para 2-206).</p>
51	Wheel pounding	<p>a. Front hub bearings damaged.</p> <p>b. Rear hub bearings damaged.</p> <p>c. Wheel and tire out of balance.</p> <p>d. Wheel bent</p>	<p>Replace bearings (para 2-211).</p> <p>Replace bearings (para 2-211).</p> <p>Rotate wheels and tires (para 2-206).</p> <p>Replace wheel (para 2-207) .</p>
52	Shimmy	<p>a. Tires on front wheels improperly inflated.</p> <p>b. Bent wheel or rim</p> <p>c. Worn, loose, or damaged front wheel bearings.</p> <p>d. Worn tie rod ends</p> <p>e. Tire and wheel assembly out of balance.</p>	<p>Inflate tires properly. See servicing data plate on instrument panel.</p> <p>Replace wheel (para 2-207).</p> <p>Replace bearings (para 2-211).</p> <p>Replace (para 2-215)</p> <p>Rotate wheels and tires (para 2-206).</p>
<b>STEERING SYSTEM</b>			
53	Steering wheel difficult to turn	<p>a. Power steering system inoperative.</p>	<p>Check the oil level in the power steering oil system, and add oil if necessary.</p>

\* Refer to footnote at end of table.

Table 2-3. Troubleshooting—Vehicle—Continued

Item No.	Malfunction	Probable Cause	Corrective Action
<b>STEERING SYSTEM—Continued</b>			
53	Continued	b. Bind in steering knuckle.	Jack up the front axle to clear wheels of ground. Disconnect the drag link at the front axle (para 2-218, 2-219). Turn the wheels from side to side. If there is binding, disconnect one end of the tie rod from the knuckle. If binding persists and lubrication does not free knuckles, notify supporting maintenance personnel.
54	Inability to maintain straight course; wandering or weaving.	Steering gear drag link ends loose, or improperly adjusted.	Inspect and adjust the drag link end (para 2-218, and 2-219).
55	Power steering system oil leaks.	Broken or loose oil lines.	Replace defective lines and fittings.
56	Steering operation spongy or sloppy.	Air in hydraulic lines	Turn the steering wheel from full left turn to full right turn to purge lines.
57	Insufficient flexibility	a. Insufficient spring shackle pin lubrication. b. Frozen spring shackles	Lubricate the spring shackle (LO 9-2320-211-12). Free-up and lubricate shackles (para 2-230).
58	Excessive flexibility	Shock absorbers inoperative.	Disconnect shock absorber links and test action. If little or no resistance is felt, replace shock absorbers (para 2-234).
59	Excessive NOISE	a. Worn spring pins or shackle bolts. b. Worn or broken shock absorber links. c. Spring leaf failure at spring eye. d. Spring leaf failure at center section of spring.	Use a pry bar to test the wear of pins and bolts. Replace if necessary (para 2-230). Inspect links for wear, damage, or looseness. Replace shock absorber bushings if necessary (para 2-234). Replace spring (para 2-230). Replace spring. Tighten U bolts to torque recommended.
<b>FRAME</b>			
60	Pintle loose in housing.	a. Loose slotted nut b. Worn washer	Remove cotter pin and tighten nut (para 2-224). Readjust pintle hook assembly as in a above or replace washer (para 2-223).
61	Pintle stuck in housing.	a. Bent pintle shank b. Dry, needs lubrication	Replace hook assembly (para 2-224). Free pintle and lubricate in accordance with LO 9-2320-211-12.
<b>WINCH</b>			
62	Winch does not operate.	a. Power takeoff not engaged. b. Shearpin failure c. Drum clutch not engaged	Engage power takeoff. If power takeoff does not engage, notify supporting maintenance personnel. Replace shearpin (para 2-315 and 2-320). Engage drum clutch. If clutch does not engage, notify supporting maintenance personnel.
63	Winch does not hold	Brake slipping	Adjust brake (para 2-315).
64	Excessive heat at winch brake case.	Brake incorrectly adjusted	Adjust brake (para 2-315).
65	Noisy operation	a. Lack of lubrication b. Worn or damaged internal parts.	Lubricate winch (LO 9-2320-211-12). Replace winch (para 2-315 and 2-320).

\* Refer to footnote at end of table.

Table 2-3. Troubleshooting—Vehicle—Continued

Item No.	Malfunction	Probable Cause	Corrective Action
66	Excessive noise	<p><b>POWER TAKEOFF</b></p> <p><i>a.</i> Noise from transmission may be transmitted to power takeoff.</p> <p><i>b.</i> Noise from transfer power takeoff may reflect through transfer.</p>	<p>Check for loose power takeoff mounting screws, and tighten if necessary. Continued noise indicates worn gears or bearings in transmission or PTO (notify supporting maintenance personnel).</p> <p>Check for loose mounting screws and tighten them as necessary. Check the oil pump to see that it is operating properly. Continued noise indicates worn gears or bearings (notify supporting maintenance personnel).</p>
67	Lack of power	<p><b>HYDRAULIC CRANE ASSEMBLY</b></p> <p><i>a.</i> Oil level low in hydraulic oil reservoir.</p> <p><i>b.</i> Incorrect governor setting.</p> <p><i>c.</i> Leaks in the hydraulic system.</p>	<p>Check hydraulic oil level and add oil if necessary.</p> <p>Notify supporting maintenance personnel.</p> <p>Inspect the entire hydraulic system for leaks. Tighten all connections where leaks are evident. If any lines or fittings need replacing, notify ordnance maintenance personnel.</p>
68	Crane does not lift smoothly.	<p><i>a.</i> Oil level low in hydraulic oil reservoir.</p> <p><i>b.</i> Air in hydraulic system</p> <p><i>c.</i> Defective relief valve</p>	<p>Replenish oil (see LO 9-2320-211-12).</p> <p>Operate the crane through its full range of movements several times to expel any air in the hydraulic system.</p> <p>Notify supporting maintenance personnel.</p>
69	Swinger motor does not rotate crane smoothly.	<p><i>a.</i> Defective valve at control bank.</p> <p><i>b.</i> Hydraulic motor and drive assembly inoperative.</p>	<p>Operate the control valve lever. Any evidence of sticking or erratic operation requires replacement of the control valve bank.</p> <p>Notify supporting maintenance personnel.</p>
70	Noisy hydraulic pump.	<p><i>a.</i> Oil level low in hydraulic oil reservoir.</p>	<p>If the oil level is low, check the complete hydraulic system for leaks. Fill the reservoir to the proper level.</p>
71	Defective control valve bank assembly.	<p>Failure of levers of the control valve bank assembly to return to NEUTRAL after operation.</p>	<p>Notify supporting maintenance personnel.</p>
72	Leaks at hydraulic connections.	<p>Loose or damaged fittings.</p>	<p>Refer to the item above</p>
73	Ceiling lights and service receptacles do not deenergize when doors are opened under blackout conditions.	<p><b>EXPANSIBLE VAN ILLUMINATION, SERVICE AND BLACKOUT CIRCUITS</b></p> <p><i>a.</i> Short circuit at hinged section blackout circuit plungers.</p> <p><i>b.</i> Short circuit at the contact plate on the side panel.</p>	<p>Remove the plunger. Wrap the metal housing of the plungers with insulator tape. Wrap the wire leading to the terminals with insulator tape. Install the plungers.</p> <p>Remove the contact plate. Tape exposed parts of the cable. Install the contact plate.</p>
74	Ceiling lights and service receptacle fails to energize when doors are closed under blackout conditions.	<p><i>a.</i> Plunger not making contact with the contact plate.</p> <p><i>b.</i> Loose connection to the plunger or contact plate.</p>	<p>Screw toggle clamp eyebolt inward to shorten clamp. If a malfunction persists, align the hinged section-operated plungers with the surface of the contact plate.</p> <p>Remove the plungers and contact plates. Repair the connections at the terminals.</p>

\* Refer to footnote at end of table.

Item No.	Malfunction	Probable Cause	Corrective Action
		<b>EXPANSIBLE VAN ILLUMINATION SERVICE AND BLACKOUT CIRCUITS—Continued</b>	
75	Ceiling fluorescent tube fails to light.	a. Fluorescent tube terminals not making proper contact.	Press the end terminals of the ceiling fixture together to improve contact with fluorescent tubes.
76	Emergency light, blackout light, and ceiling light fail to light.	b. Burned out starter c. Burned out fluorescent tube. Burned out lamp	Replace the starter Replace the fluorescent tube. Replace the lamp
		<b>EXPANSIBLE FAN VEHICLE CLEARANCE LIGHTS</b>	
77	Clearance lights fail to light.	a. Burned out lamps. b. Damaged tee connectors.	Replace the lamp Check the tee connectors. Replace if necessary.
		<b>VAN BODY</b>	
78	Difficulty in expanding and retracting side panels.	Foreign matter in rollers or sprockets.	Remove the roller and sprocket covers. Remove foreign matter.
79	Side panel cannot be locked in retracted position.	a. Front edge of side panel not fully retracted.  b. Top of side panel too far out to engage edge of roof.	Place a heavy wood block against the rub rail at the front of the panel. Strike the block with a heavy hammer.  Place a heavy wood block against the flat surface of the seal retainer opposite the locking bar at the top of the side panel. Strike the block with a heavy hammer.
80	Van body not waterproof or light-tight.	a. Lower part of side panel not tight against van body.  b. Toggle clamp not drawing top of side panel sufficiently tight.  c. Sagging end panel door  d. Lip of block seal at inner rear corner of hinged roof forced out of position.  e. Loss or wear of seal at top of two rear doors.	Place a heavy wood block against the rub rail at the end of the side panel where the leak is apparent. Strike the block with heavy hammer. Loosen the jam nut on the toggle clamp eyebolt. Screw the eyebolt inward to shorten it. Add shims of rubber seal material to the seal on the outer edge of the hinged roof until the seal meets the top of the end panel door. Move the side panel out to disengage the corner block seal. Push the seal lip up into the correct position so the end panel door properly engages the seal when the side panel is retracted. Re-cover the area with improvised sealing material.
81	Right rear and side door locks will not operate.	a. One or more lock bolts jammed.  b. Lock bolt fails to engage striker plate.	Locate the jammed lock by removing the vertical bars and testing each lock. Replace the lock or locks. Place shims under the lock until the bolt properly engages the striker plate.
		<b>HEATING SYSTEM</b>	
82	Heater will not ignite	a. Burned out fuel pump b. Shutoff valve closed on gas tank.	Replace the fuel pump Open the shutoff valve
83	Heater stops operating	c. Restriction in fuel line a. Burned out fuel pump b. Restriction in fuel lines c. Restriction in check valve. d. Clogged fuel filter screen.	Check and clear all fuel lines. Replace the fuel pump Check and clear all fuel lines. Check and clear the check valve. Clean or replace the filter screen.
		<b>EXPANSIBLE VAN AIR CONDITIONING SYSTEM</b>	
84	Air conditioner fails to maintain proper temperature.	Dirty or clogged air filters.	Remove and clean filters.
85	Air conditioner compressor fails to start.	Bonnet front door is closed.	Open bonnet front door

\* Refer to troubleshooting the electrical system, paragraphs 2-15 through 2-35.

**Section VI. TROUBLESHOOTING THE ELECTRICAL SYSTEM**

**2-15. General**

Paragraphs 2-15 through 2-35 information to locate and correct problems in the electrical system, and includes a troubleshooting chart (Table 2-4), a diagram showing the location of the various electrical components (fig. 2-9), the use and function of authorized test equipment, and specific information on testing the various circuits.

**2-16. Electrical System Circuits**

Electrical circuits for this vehicle will be covered

under seven major categories as listed below (see figure 2-9 for general locations):

Circuit	Paragraphs
Batteries	2-22
Generator system	2-23, 2-24, 2-25
Starter circuit	2-26 through 2-29
Monitoring circuit	2-30
Ignition circuits	2-32, 2-33
Light circuits	2-34
Directional signal (solid state)	2-34

Table 2-4. Troubleshooting—Electrical System

Item No.	Malfunction	Probable Cause	Corrective Action
<b>IGNITION SYSTEM— GASOLINE ENGINE</b>			
1	No spark (battery-generator indicator pointer shows low or <i>no</i> reading).	<ul style="list-style-type: none"> <li>a. Ignition switch off</li> <li>b. Defective ignition switch</li> <li>c. Defective ignition coil or distributor.</li> <li>d. Distributor breaker points not opening or faulty.</li> <li>e. Defective distributor capacitor.                             <ul style="list-style-type: none"> <li>a. Defective distributor rotor.</li> <li>b. Loose electrical connections.</li> </ul> </li> <li>c. Defective spark plug cables.</li> </ul>	<p>Turn ignition switch on</p> <p>Replace the switch if required (para 2-154).</p> <p>Check the continuity of circuit No. 12 from the ignition switch to the coil, and from the coil to the distributor. If current shows from the switch to the coil, but not from the coil to the distributor, replace the coil (para 2-122); otherwise replace the distributor (para 2-122).</p> <p>Inspect the breaker points. If they are burned or pitted, replace them (para 2-122). Adjust the point opening (para 2-122).</p> <p>Replace the capacitor (para 2-122). Replace the rotor (para 2-122).</p> <p>Clean and tighten all electrical connections from the starter to the distributor.</p> <p style="text-align: center;"><b>WARNING</b></p> <p>In the following procedure hold the insulated portion of the cable. Do not touch the terminal contact portion of the cable while performing the test.</p> <p>Test each cable by disconnecting it from the spark plug and holding it 3/8 inch from the cylinder head while cranking the engine. Replace any cable not producing good spark (para 2-119).</p> <p>Adjust the spark plug gap (para 2-122).</p> <p>Check the breaker point opening and adjust it if necessary (para 2-122). Inspect cables and connections. Test the coil and replace it if necessary. Check spark plug and <i>coil</i> cables for continuity. Replace them if necessary (para 2-119 and 2-122).</p>
2	No spark (battery-generator indicator reads normal).		
3	Engine misfires at high speeds.	<ul style="list-style-type: none"> <li>a. Spark plugs improperly set.</li> <li>b. Distributor breaker opening improperly set.</li> <li>c. Defective ignition coil</li> <li>d. Defective ignition wiring</li> </ul>	



**Table 2-4. Troubleshooting—Electrical System—Continued**

Item No.	Malfunction	Probable Cause	Corrective Action
4	Engine does not attain maximum rpm.	<p align="center"><b>IGNITION SYSTEM— GASOLINE ENGINE—Continued</b></p> <p>Pre-ignition due to defective or improper spark plugs.</p>	<p>With engine temperature at normal operating range (160° F. to 180° F.), accelerate the vehicle in high gear. If pre-ignition or spark knock is present, a pinging sound will be heard. After checking the ignition system thoroughly, replace spark plugs; if this does not correct the condition, notify direct support maintenance personnel.</p>
5	Starter inoperative	<p align="center"><b>STARTING SYSTEM</b></p> <p>a. Batteries discharged.</p> <p>b. Loose, corroded, or broken cables.</p> <p>c. Defective solenoid</p> <p>d. Defective starter switch</p>	<p>Check electrolyte level and specific gravity (para 2-22). Replace defective batteries.</p> <p>Clean and tighten all electrical connections at battery, ground, and starter. Replace cable if they are broken, or if a terminal clamp is excessively corroded.</p> <p>Replace the solenoid (para 2-126). Check the linkage from the starter pedal to the upper clevis of the starter (gasoline engine). Energize the starter switch for testing purpose. Test the defective switch. Replace the defective starter if required (para 2-124).</p>
6	Noisy starter	<p>a. Loose starter mounting</p> <p>b. Defective drive assembly</p> <p>c. Worn commutator or bushings.</p> <p>d. Defective bearing due to lack of lubrication.</p>	<p>Tighten starter mounting screws. Replace the starter (para 2-124). Replace the starter (para 2-124). Replace the starter (para 2-124).</p>
7	Starter sluggish; will not attain full cranking speed.	<p>a. Discharged or defective batteries.</p> <p>b. Dirty or loose terminals</p> <p>c. Sticking brushes; commutator or armature rubbing field coils.</p>	<p>Check electrolyte level and specific gravity (para 2-22). Recharge or replace batteries as necessary (para 2-134).</p> <p>Clean and tighten terminal connections. Replace starter (para 2-124).</p>
8	Battery-generator indicator shows low charge.	<p align="center"><b>GENERATOR SYSTEM</b></p> <p>a. Faulty batteries</p> <p>b. Electrolyte level low in batteries.</p> <p>c. Loose connection in generator-regulator or battery circuit.</p> <p>d. Generator-regulator out of adjustment.</p>	<p>Refer to item 5a above</p> <p>Add water to correct level. Check the battery-generator indicator for a high reading.</p> <p>Clean and tighten the battery terminal connections, and check all connections in the circuit (fig. 2-134).</p> <p>Replace the generator-regulator if required (para 2-132). Polarize the generator (para 2-131). Notify direct support maintenance personnel.</p>
9	Noisy generator	<p>a. Loose generator mounting</p> <p>b. Generator drive pulley loose on shaft.</p> <p>c. Worn commutator, sticky brushes, or armature rubbing on field coils.</p>	<p>Tighten the generator mounting bolts and adjust the drive belts (para 2-131).</p> <p>Tighten the pulley</p> <p>Replace the generator (para 2-131). Polarize the generator (para 2-131).</p>

Item No.	Malfunction	Probable Cause	Corrective Action
<b>GENERATOR SYSTEM—Continued</b>			
10	Generator does not charge.	<p>a. Broken or loose drive belts. b. Faulty voltage regulator</p> <p>c. Faulty generator</p>	<p>Replace or adjust the drive belts. Replace the generator-regulator if required. Polarize the generator (para 2-131). Replace the generator if required (para 2-131). Polarize the generator (para 2-131). Replace the generator-regulator if required (para 2-131). Polarize the generator.</p>
11	Generator output excessive (battery-generator indicator almost on extreme right of meter scale).	<p>a. Faulty voltage regulator</p> <p>b. Faulty generator</p>	<p>Replace the generator (para 2-131). Polarize the generator (para 2-131). Replace the generator (para 2-131). Polarize the generator (para 2-131).</p>
12	Generator output low or unsteady (battery-generator indicator fluctuates between low and medium charge with engine operating).	<p>a. Loose drive belt b. Loose connections in battery-to-generator or voltage regulator circuit. c. Faulty voltage regulator</p> <p>d. Sticky brushes or rough commutator</p>	<p>Tighten the drive belt (para 2-131). Check circuits No. 8 and 4 for continuity and tightness. Replace the generator-regulator if required (para 2-131). Polarize the generator (para 2-131). Replace the generator (para 2-131). Polarize the generator (para 2-131).</p>
<b>LIGHTING SYSTEM</b>			
13	Headlights do not light.	<p>a. Broken or burned out lamp. b. Defective light switch</p> <p>c. Broken light cable</p>	<p>Replace the lamp (para 2-155). Use a jumper wire across the switch contacts. If the lamp lights, replace the switch (para 2-155). Refer to the lighting circuit diagram. Locate the break and repair the cable as necessary. Replace the regulator (para 2-132).</p>
14	Frequent lamp failures. High battery-generator indicator reading.	<p>a. Generator-regulator out of adjustment. b. Poor battery ground connection.</p>	<p>Clean and tighten the battery and lamp ground connections.</p>
15	Insufficient light. Low battery-generator indicator reading.	<p>a. Poor lamp or battery ground connections. b. Loose lamp terminals connections. c. Discharged batteries</p>	<p>Clean and tighten the battery and lamp ground connections. Locate and tighten the loose terminal connections. Check the electrolyte level and specific gravity (para 2-22). Charge or replace the batteries (para 2-134).</p>
16	Turn signals do not blink (on vehicle outside).	<p>a. Bulb (front or rear) burned out. b. Flasher defective</p>	<p>Replace bulb Replace flasher</p>
17	Turn signals totally inoperative.	<p>Flasher defective</p>	<p>Replace flasher</p>
18	Turn signal indicator (in cab) does not blink.	<p>a. Lamp defective b. Flasher defective</p>	<p>Replace lamp Replace flasher</p>
19	Floodlights do not respond to light switch.	<p>a. Lamps burned out; faulty switch. b. Faulty circuit, or wiring, or defective light assembly defective. c. Brush slipping assembly defective.</p>	<p>Replace lamps (para 2-133) or switch (para 2-155). Notify supporting maintenance personnel. Notify supporting maintenance personnel.</p>
<b>INSTRUMENTS, GAGES AND SENDING UNITS</b>			
20	Speedometer or tachometer noisy or fluctuating.	<p>Binding or kinked flexible shaft.</p>	<p>Replace flexible shaft (para 2-150, 2-151).</p>
21	Water temperature gage inoperative.	<p>a. Temperature sending unit faulty. b. Gage faulty</p>	<p>Replace sending unit (para 2-167). Replace gage (para 2-153)</p>
22	Fuel level gage inoperative.	<p>a. Fuel tank sending unit faulty. b. Gage faulty</p>	<p>Replace the sending unit (para 2-162). Replace the gage (para 2-146)</p>

Table 2-4. Troubleshooting-Electrical System—Continued

Item No.	Malfunction	Probable Cause	Corrective Action
<b>INSTRUMENTS, GAGES AND SENDING UNITS—Continued</b>			
23	Air pressure gage inoperative.	a. Compressed air reservoir supply low.	Run the engine to build up pressure to 100 psi. If the gage does not register immediate buildup, replace the gage (para 2-144).
24	Oil pressure gage inoperative.	b. Air reservoir drain petcocks open. a. Sending unit faulty	Shut the petcocks Replace the sending unit (para 2-163).
25	Horn inoperative	b. Gage faulty a. Low or no air pressure  b. Electrical circuit broken. horn system.  c. Defective solenoid	Replace the gage (para 2-148) Check the air pressure gage. Refer to item 22 above. Check circuit No. 25 for continuity to the horn button. Replace the horn switch if necessary (para 2-156). Replace the solenoid (para 2-169).
<b>RADIO INTERFERENCE SUPPRESSION</b>			
26	Interference while vehicle is in motion with engine not operating.	Loose cables, bonding, or connections; frayed insulation in vehicle wiring.	Inspect all wiring and replace it if it is defective. Clean and tighten all connections.
27	Interference only when engine is running.	Generator system	Accelerate the engine, and turn the ignition switch off with engine at a high speed. If the noise continues after the switch is shut off, the cause is in the generator system.
28	Variable pitch whining noise which varies with engine rpm.	a. Loose or dirty regulator connections.  b. Defective generator-regulator capacitor. c. Loose or frayed fan and drive belts.	Check the regulator ground cable and its mounting bolts to determine if the connections are free from dirt, paint, or other foreign material that could impair conductivity. Check for tightness. Check generator system. Tighten or replace belts as necessary (para 2-111).
29	Variable clicking noise which varies with engine rpm.	d. Defective generator bearings. a. Ignition system  b. Improper spark plug gap c. Improper breaker points d. Defective spark plug cables. e. Defective spark plugs  f. Fuel pump	Replace the generator (para 2-131). Accelerate the engine and turn the ignition switch off with the engine at a high speed. If the noise stops immediately, the cause is in the ignition system. Adjust the gap (para 2-121) Adjust the points (para 2-122). Replace the cables With the engine running, disconnect the cables from the plugs one at a time. If the noise is reduced or eliminated, the cause is the spark plug. Replace the plug (para 2-12). Check the fuel pump and electrical connections.

**2-17. Test Equipment**

Test procedures covered in this section are based on the use of the low-voltage circuit tester, wheeled vehicle adapter set, adapter set. Test procedures used may also be made on the vehicle using any suitable voltmeter, ammeter, or ohmmeter having the required electrical range.

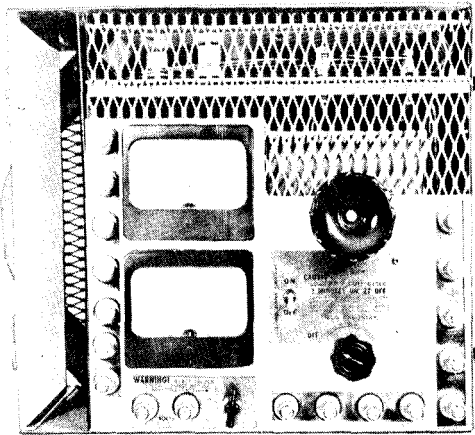
**2-18. Low-Voltage Circuit Tester**

Figure 2-5 illustrates the two types of low-voltage circuit testers (LVCT) in general use. The LVCT consists of a voltmeter, an ammeter, a fixed resistance, load bank, and field rheostat unit. They are mounted in a metal case, which also provides stowage space for the meter leads and accessories

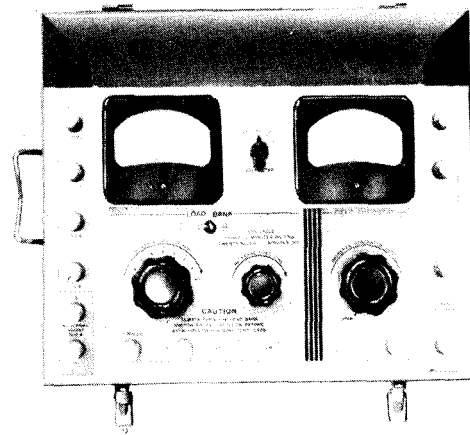
(fig. 2-6) with which all the necessary tests can be made. Other test sets consist of these elements (voltmeter, ammeter; etc.) as separate units; the tests described can be performed equally well using meters and load banks separately.

**NOTE**

Two models of the Low Voltage Circuit Tester are shown in figure 2-5. Throughout this section one meter is designated meter A and other meter B.

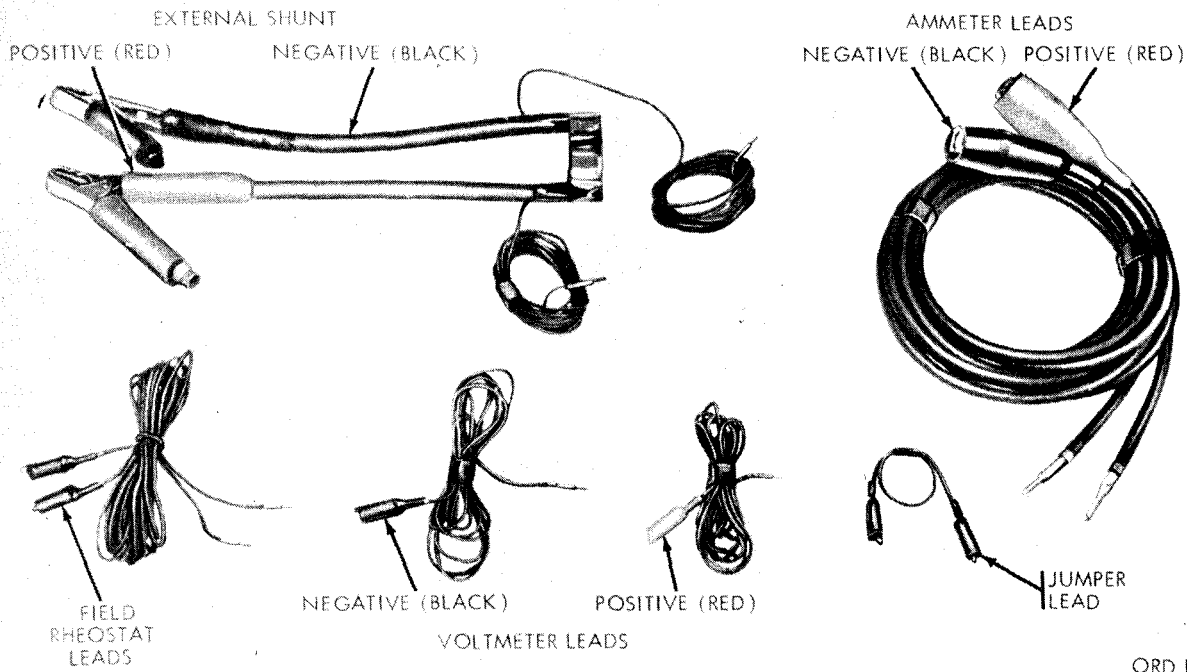


METER A



METER B ORD E42930

Figure 2-5 Low voltage circuit testers.



ORD E42931

Figure 2-6 Leads for electrical test equipment.

**2-19. Adapter Sets**

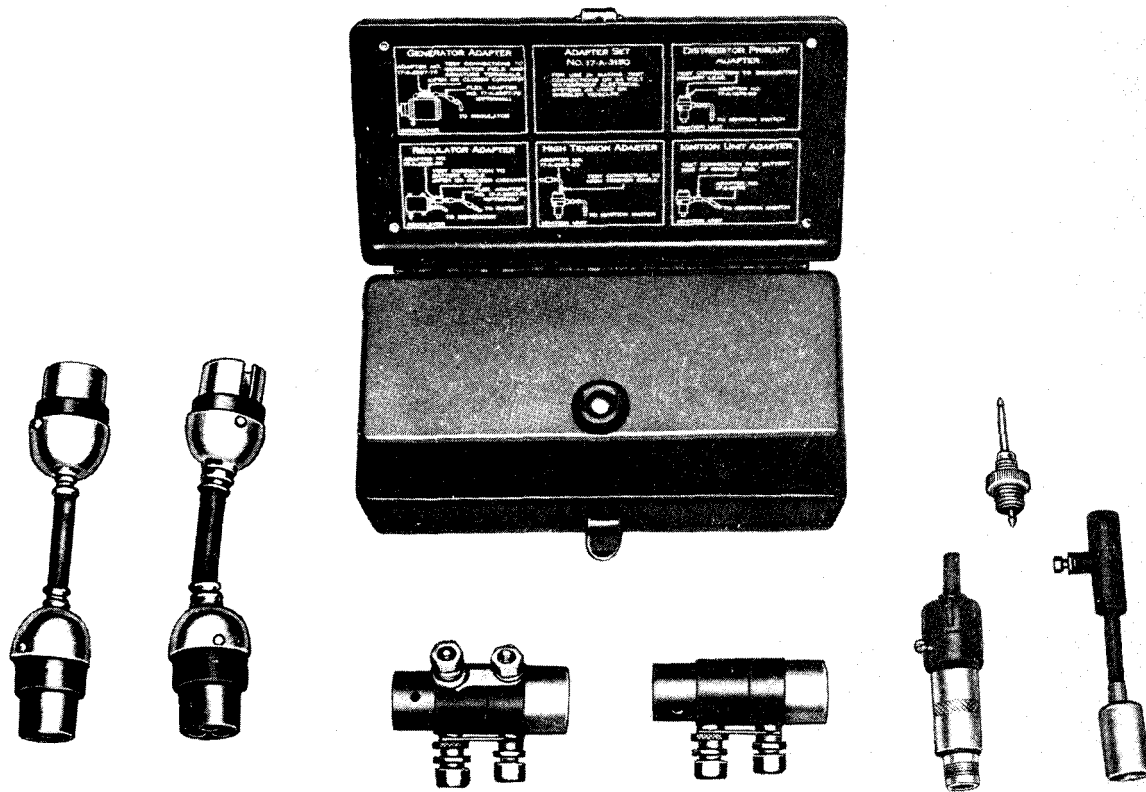
a. Two adapter sets are shown in figure 2-7. They are interchangeable, differing only in design. Both adapter sets are used for external connections of the waterproof electrical system in use on military vehicles. One set consists of seven pieces—

three for the ignition system and four for the charging system. The other set consists of five pieces—three for the ignition system and two for the charging system (fig. 207).

b. The multimeter (fig. 2-7-1) is a lightweight portable instrument for use in making voltage tests

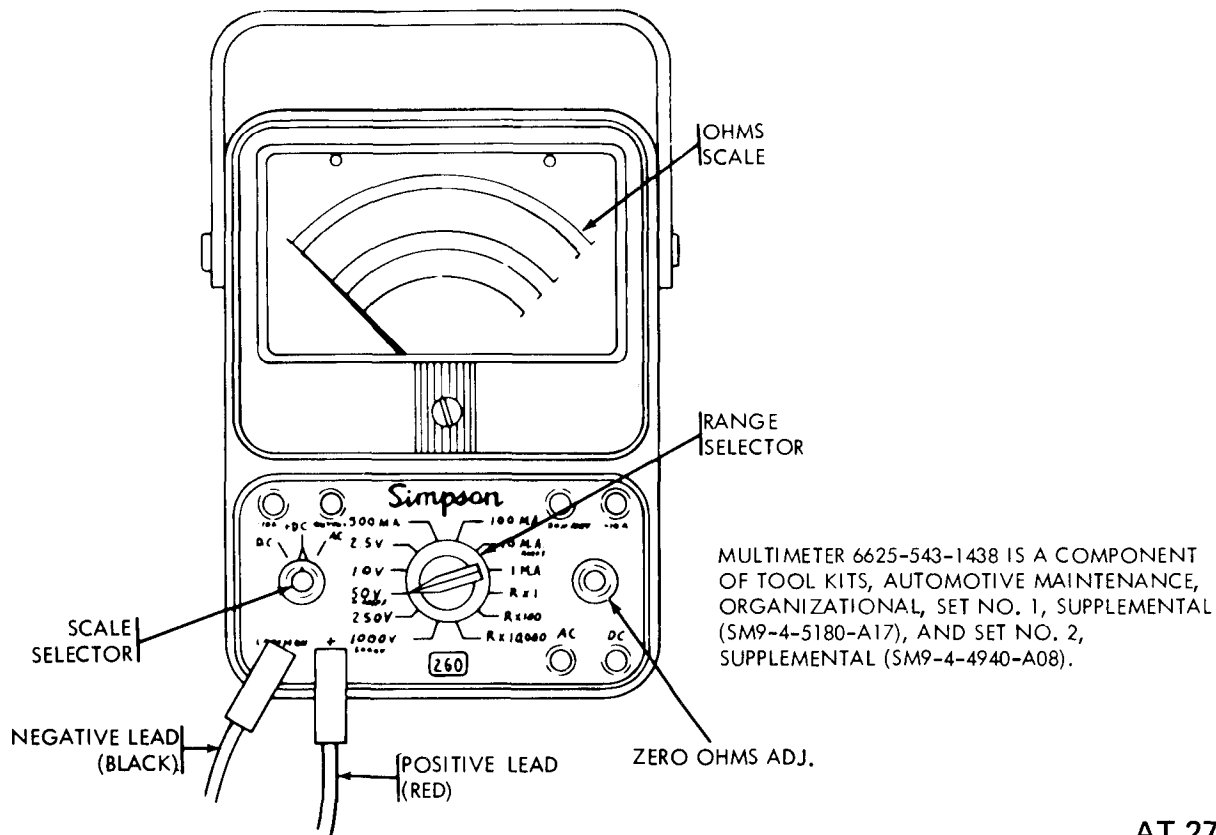
where load banks or ammeter ranges are not required. The multimeter is also useful in making resistance or continuity tests of components

suspected of being open, intermittent, or short circuited.



ORD E42932

Figure 2-7 Electrical test equipment adapter sets.



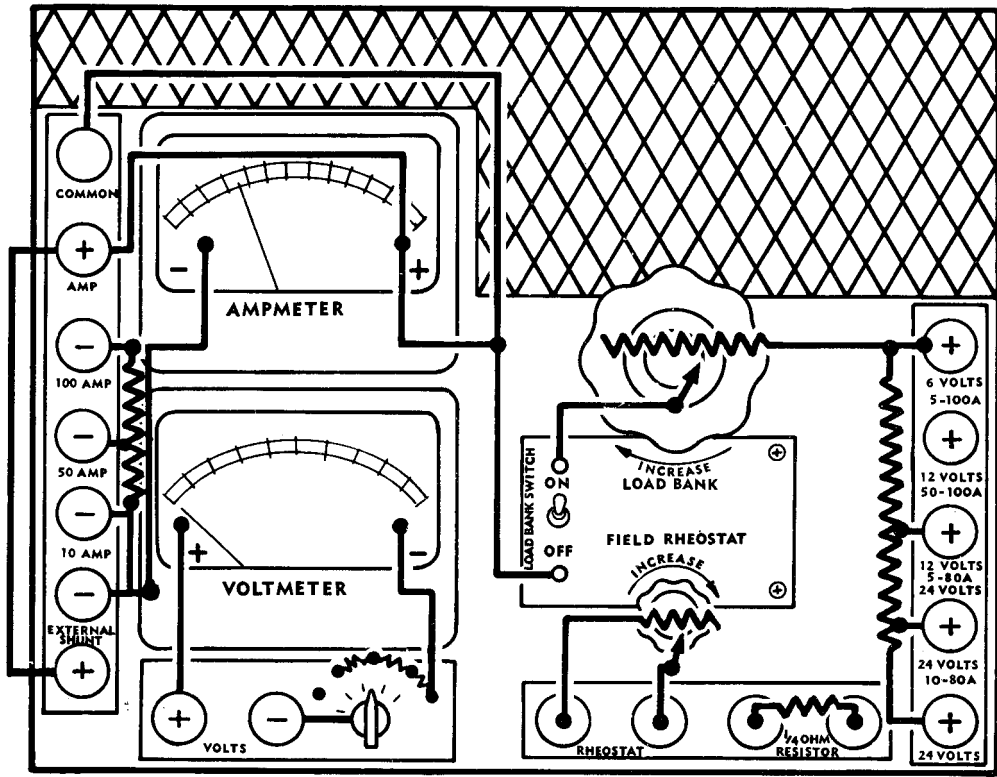
AT 27530

Figure 2-7.1 Multimeter.

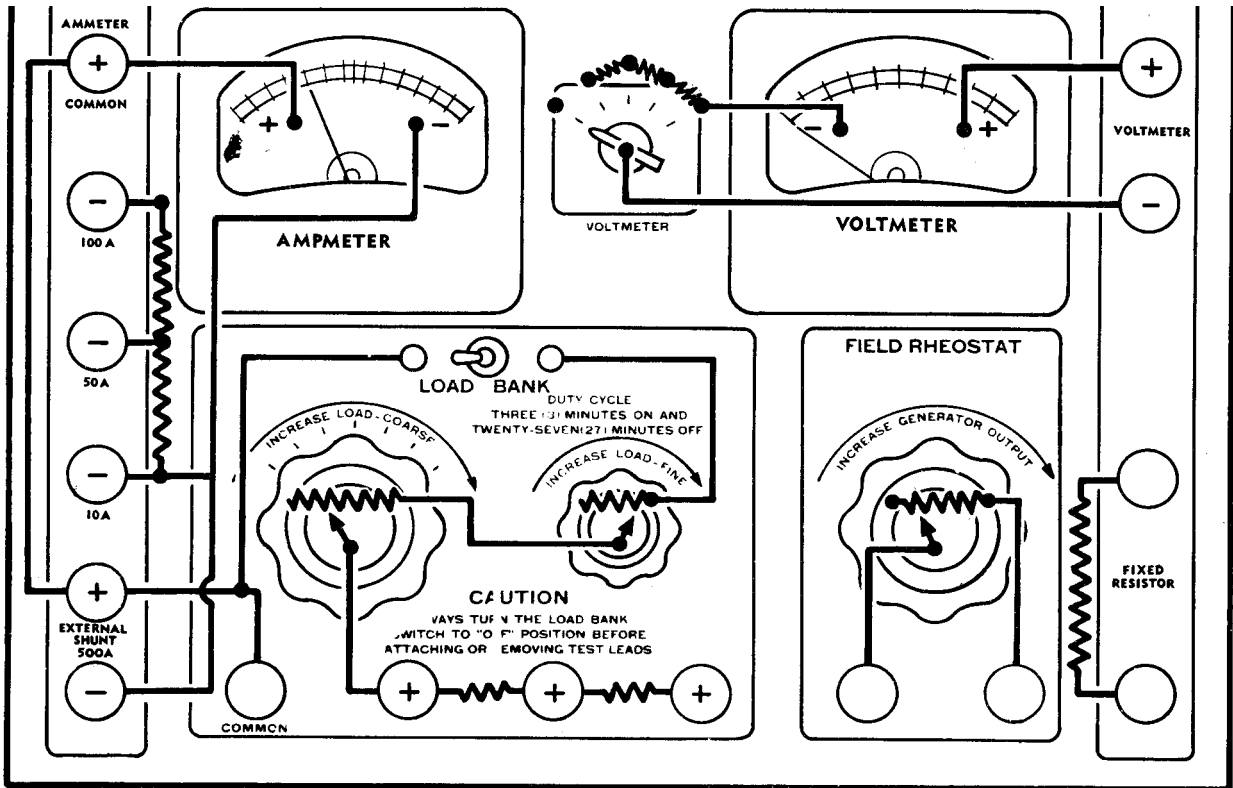
**2-20. Tester Functions and Use**

a. *Voltmeter.* The two voltmeter terminals are mounted below (meter A) or beside (meter B) the voltmeter (fig. 2-5). One terminal is marked positive (+) and the other is marked negative (-).

The proper meter range is selected by placing the selector switch in the proper voltage range. For example, if the highest reading were expected to be less than 1 volt, the 1-volt range would be used. To read the battery voltage of a 12-volt battery, use the 20-volt range; etc.



METER A



METER B

ORD E42933

Figure 2-8 Schematic layout of low voltage circuit testers.

### CAUTION

Do not test for over 100 amperes without using a shunt, since the meter could be damaged. The large leads on the shunt are connected to the component being tested. The small leads are connected to the meter. The meter is then connected in series with the circuit being tested. Note that the terminals are marked external shunt.

b. *Ammeter.* The ammeter is mounted on the upper left-hand side of the case (fig. 2-8) and like the voltmeter, has terminals for connecting the leads. There is a common or positive (+) terminal and three negative (—) terminals, which are marked 10, 50, and 100 amperes, respectively. In addition, an external shunt may be used on this meter to read ampere values up to 500 amperes by using the terminals provided for the small leads on the shunt. Note that the meter's zero is one-third of the way up the scale. This permits reading current flow in either direction in a circuit without changing meter leads.

c. *Resistance Unit.* The two terminals marked  $\frac{1}{4}$ -ohm resistor or fixed resistor on the instrument panel provide fixed resistance for testing units in the charging circuit. The resistance unit is designed for either 6— or 12—volt system. Connecting test leads between the two terminals provides  $\frac{1}{4}$ -ohm resistance. The ammeter test leads are used when utilizing this resistance unit; but this unit is not in any way connected to either the voltmeter or ammeter.

d. *Field Rheostat Unit.* The two field rheostat terminals on the instrument panel provide a connection for a rheostat (or variable resistance) located under the instrument panel. This unit is used to assist in charging system checks.

e. *Load Bank.* Meter A has six binding posts to provide the proper load resistance for testing

various battery, generator, and alternator voltages. The common binding post is connected internally to the ammeter positive (+) binding post, eliminating the need for a jumper lead when making a load test. The load resistance may be changed by the load bank control knob or removed from the circuit by the load bank switch. Meter B has four binding posts with the common lead on the left. Amperage is controlled by adjusting the coarse and fine control knobs.

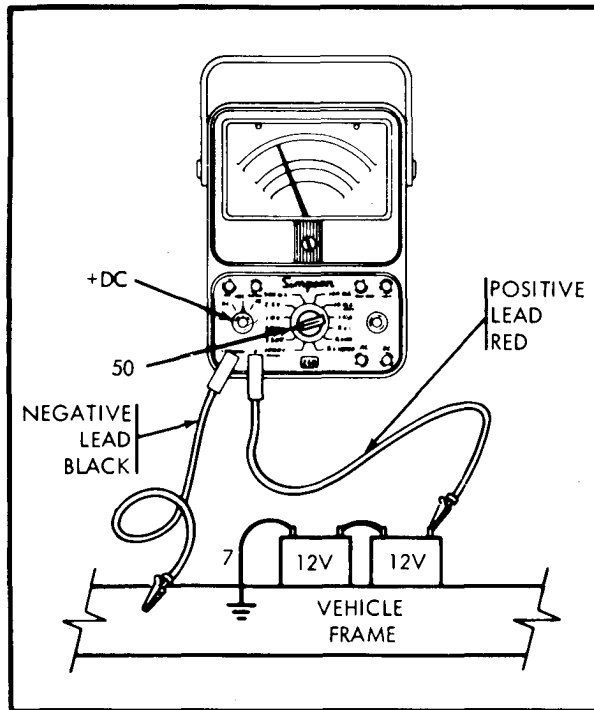
#### f. *Multimeter Functions and Use.*

(1) *Voltmeter.* The voltmeter (fig. 2-8.1) is similar to the voltmeter portion of the LVCT. Three meter ranges (2.5, 10, and 50 volts) are available for use in automotive testing. Two additional ranges (250) and 1,000 volts) are useful in testing electronic equipment. Ranges are selected by the range selector switch.

(2) *AC voltmeter.* The AC voltmeter (fig. 2-8.2) is used for making tests of the lighting and power systems in the van body. Although several ranges are provided on the meter, only the 250-volt range is used for troubleshooting on the van lighting and power systems.

(3) *Ohmmeter.* The ohmmeter (figures 2-8.3 and 2-8.4) is used for making resistance and continuity tests. The ohmmeter is basically a voltmeter and internal battery connected in series, so that when the two test leads are connected together, the voltmeter reads the battery voltage. When a conductive circuit is connected between the test leads, the voltmeter will indicate how much voltage is being lost (voltage drop) in the circuit. In the case of a length of wire, there will be little or no voltage drop for a small coil or a resistor, there may be a considerable voltage drop. The amount of voltage drop is directly related to the resistance (in ohms) of the component being tested.





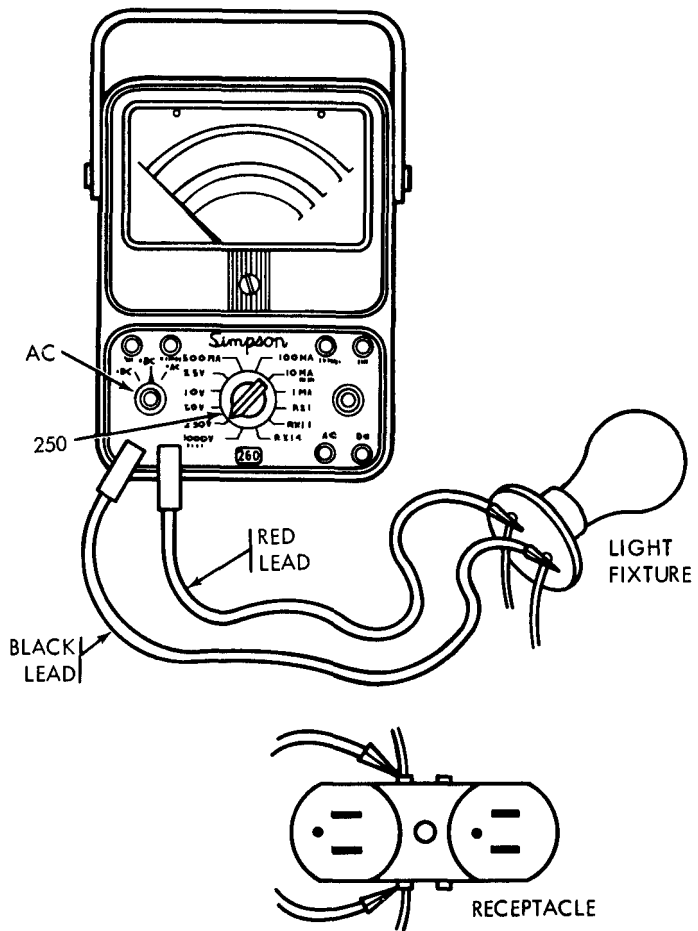
## DC VOLTAGE TEST

(USED TO MEASURE BATTERY VOLTAGE, VOLTAGE DROPS, OR DC VOLTAGE AT TEST POINTS.)

1. SET SCALE SELECTOR ON +Dc.
2. SET RANGE SELECTOR ON 50V,
3. CONNECT NEGATIVE LEAD (BLACK) TO VEHICLE FRAME, ENGINE, OR OTHER NEGATIVE TEST POINT STATED IN TEST PROCEDURE.
4. TOUCH POSITIVE LEAD (RED) TO TEST POINT STATED IN TEST PROCEDURE. NEEDLE SHOULD MOVE TOWARD CENTER OF SCALE TO INDICATE VOLTAGE.

AT 27531

Figure 2-8.1 DC voltage test with multimeter.



AC VOLTAGE TEST

(USED TO MEASURE AC VOLTAGE AT VARIOUS POINTS IN THE VAN BODY).

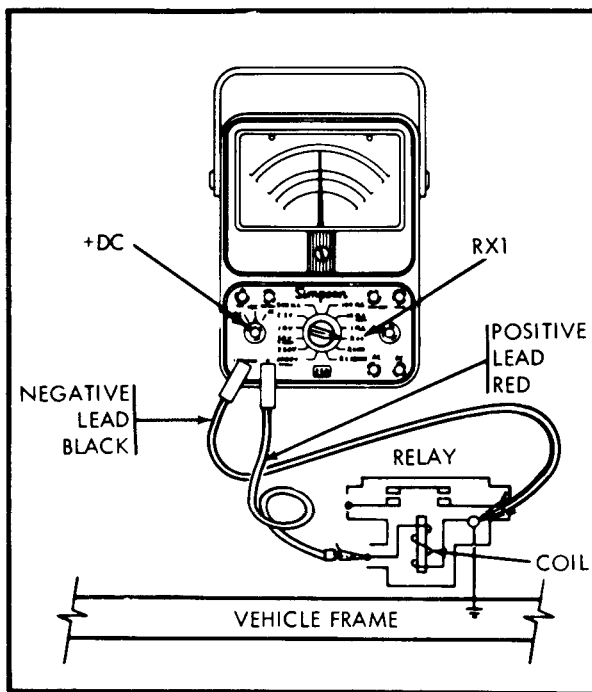
1. SET SCALE SELECTOR TO AC.
2. SET RANGE SELECTOR TO 250V,
3. WITH POWER TURNED OFF, CONNECT TEST CLIPS TO TERMINALS OF UNIT TO BE TESTED. EITHER COLOR TO EITHER TERMINAL.
4. TURN ON POWER. NEEDLE SHOULD MOVE TOWARD CENTER OF SCALE TO INDICATE VOLTAGE.
5. TURN OFF POWER BEFORE TOUCHING OR REMOVING CLIPS TO AVOID ELECTRICAL SHOCK.

**AT 27532**

*Figure 2-8.2. AC voltage test with multimeter.*

RESISTANCE TEST

(USED TO MEASURE RESISTANCE OF COILS OR RESISTORS, AND TO LOCATE SHORT CIRCUITS)



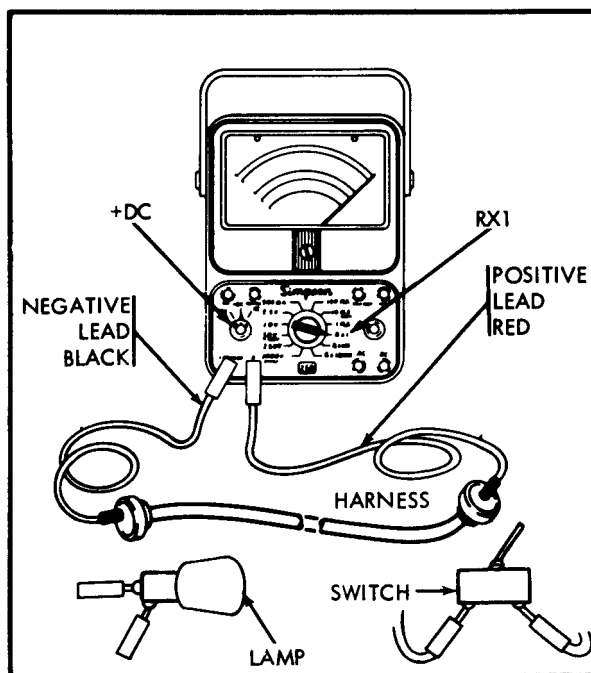
1. SET SCALE SELECTOR SWITCH ON + DC.
2. SET RANGE SELECTOR SWITCH ON RX1.
3. TOUCH METER LEADS TOGETHER AND TURN ZERO OHMS ADJUST UNTIL NEEDLE IS ON "0" OHMS.
4. MAKE SURE THERE IS NO BATTERY VOLTAGE CONNECTED TO CIRCUIT TO BE TESTED.
5. ATTACH NEGATIVE LEAD (BLACK) TO COMPONENT FRAME OR NEGATIVE TERMINAL.
6. TOUCH POSITIVE LEAD (RED) TO OTHER TERMINAL OF COMPONENT BEING TESTED.
7. READ RESISTANCE ON METER SCALE.
8. IF METER NEEDLE DOES NOT MOVE, CIRCUIT IS OPEN.
9. IF METER NEEDLE MOVES COMPLETELY ACROSS SCALE TO "0" A SHORT CIRCUIT EXISTS, OR A HEAVY-DUTY COMPONENT WITH VERY LOW RESISTANCE.

**AT 27533**

Figure 2-8.3. Resistance test with multimeter.

CONTINUITY TEST

(USED TO TEST FOR CABLE BREAKS, LOOSE WIRES, BURNT OUT LAMPS OR OTHER ITEMS)



1. SET SCALE SELECTOR ON +DC.
2. SET RANGE SELECTOR SWITCH ON RX1.
3. BE SURE THERE IS NO BATTERY VOLTAGE CONNECTED TO CIRCUIT TO BE TESTED.
4. ATTACH NEGATIVE LEAD (BLACK) TO ONE END OF CIRCUIT.
5. TOUCH POSITIVE LEAD (RED) TO OTHER END OF CIRCUIT. NEEDLE SHOULD MOVE TO RIGHT HAND END OF SCALE.
6. IF NEEDLE DOESN'T MOVE, CIRCUIT IS OPEN, OR LAMP IS BURNT OUT, OR COMPONENT OPEN.
7. IF NEEDLE FLICKERS, OR JUMPS BACK AND FORTH, LOOSE CONNECTIONS ARE INDICATED.

**AT 27534**

Figure 2-8.4. Continuity test with multimeter.

**2-21. General Instructions**

a. Prior to performing any test with meters, observe the following instructions:

(1) Be sure of the test being made. To insure correct testing, the sequence listed for individual tests must be followed.

(2) Always select a meter range higher than the expected reading.

(3) Ammeters are always inserted in the current carrying line in series. Breaking ammeter connections opens the line.

(4) Voltmeters are always inserted across a

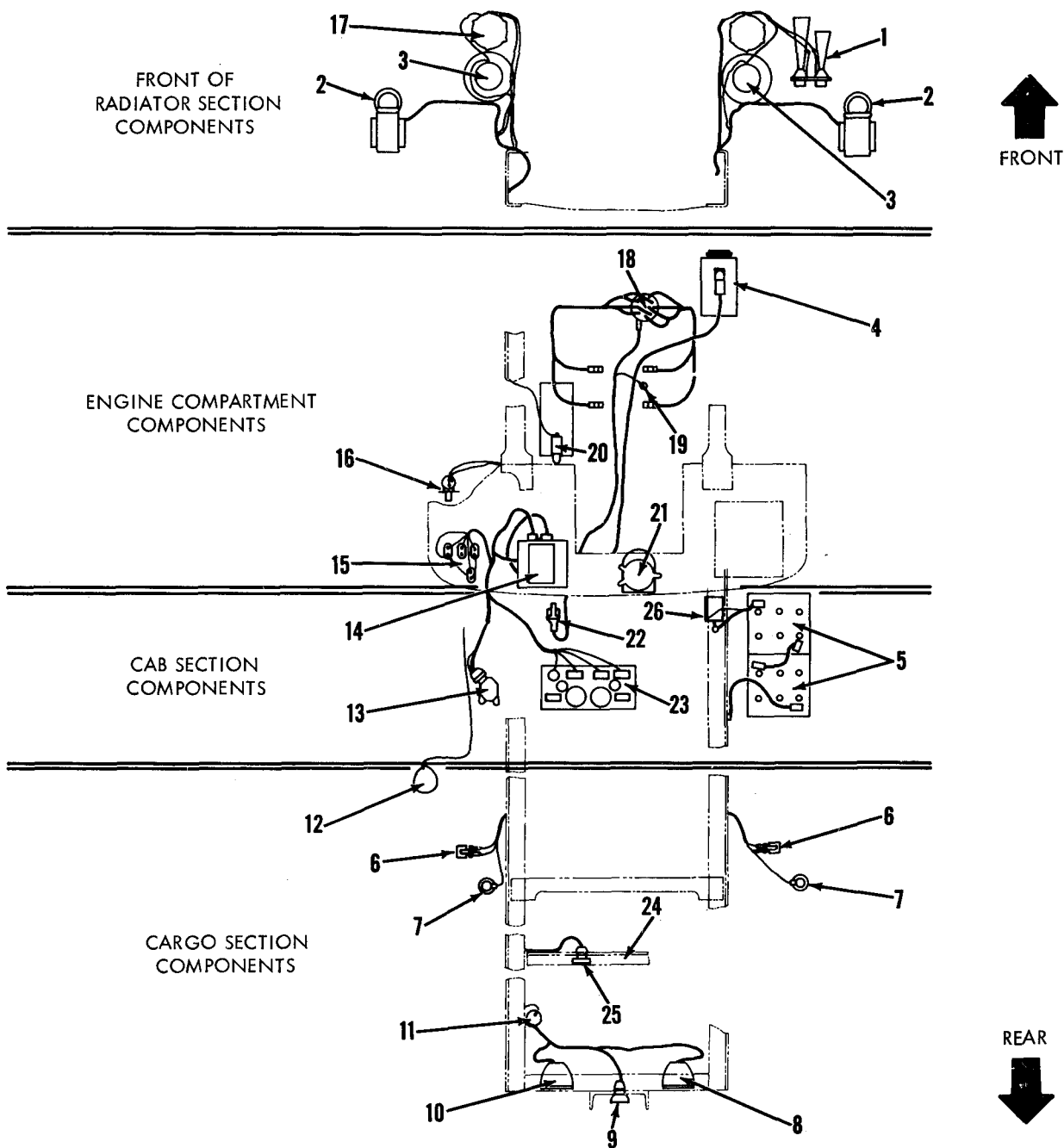
load, in parallel. Breaking voltmeter connections disconnects the voltmeter.

(5) Always connect the negative leads marked (—) first.

(6) Always barely touch positive lead to its post to see if meter movement is in right direction before firmly attaching to post,

*b.* The proper hook-up of the LVCT is very important in order to afford protection to the meters as well as to obtain accurate readings.

*c.* For general location of electrical components, refer to fig. 2-9.



FRONT OF  
RADIATOR SECTION  
COMPONENTS

ENGINE COMPARTMENT  
COMPONENTS

CAB SECTION  
COMPONENTS

CARGO SECTION  
COMPONENTS

FRONT  
↑

REAR  
↓

- |                                    |                                   |
|------------------------------------|-----------------------------------|
| 1 Horn assembly                    | 14 Current and voltage regulator  |
| 2 Blackout marker lights           | 15 Circuit breakers               |
| 3 Headlight                        | 16 Headlight dimmer switch        |
| 4 Generator                        | 17 Blackout driving light         |
| 5 Battery                          | 18 Distributor                    |
| 6 Fuel pump                        | 19 Water temperature sending unit |
| 7 Fuel gage sending unit           | 20 Starter                        |
| 8 Blackout taillight and stoplight | 21 Low air buzzer                 |
| 9 Trailer receptacle               | 22 Low air pressure switch        |
| 10 Service stoplight and taillight | 23 Instrument cluster             |
| 11 Stoplight switch                | 24 Winch mounting platform *      |
| 12 Floodlight *                    | 25 Semitrailer receptacle *       |
| 13 Light switch                    | 26 Magnetic switch                |

\* M543 Models install only.

AT 34814

Figure 2-9. General location of electrical components.

2-22. Batteries

**CAUTION**

Certain precautions must be observed before beginning any tests on the 24-volt system. Do not permit a hot wire to touch metal parts of the vehicle at any time. Flash testing by striking a hot wire against a ground will cause an arc that will completely destroy the connector on the lead. This is caused by 24 volts in the system. Personnel who have been accustomed to using this type of test on 6- or 12-volt systems must be very careful not to forget that they are working with higher voltage.

a. *Battery Indicator.* Vehicle batteries should be tested prior to performing any electrical checks in the vehicle. This vehicle has two 12-volt batteries connected in series furnishing 24 volts to the electrical system in accordance with figure 2-10. This vehicle has a 24-volt electrical system that uses a negative (—) ground and a positive (+) power feed to the electrical components. Turn on the ignition switch and observe the battery indicator in accordance with figure 2-10.

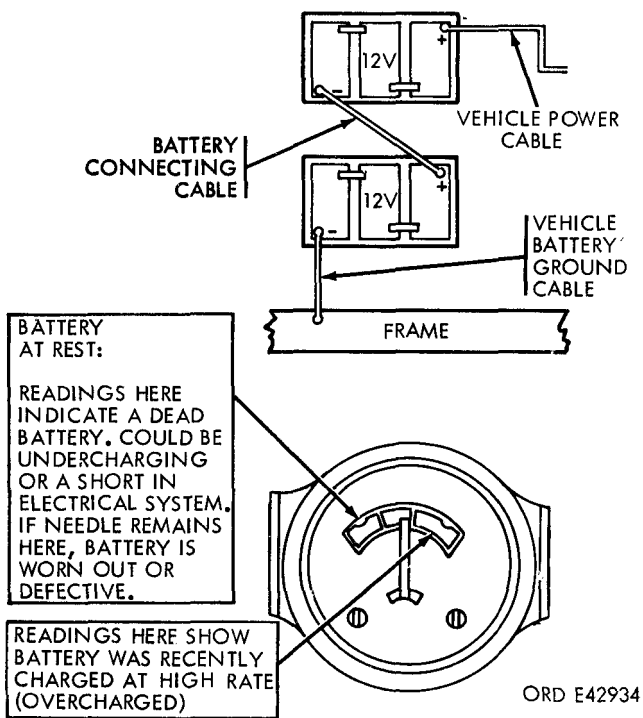


Figure 2-10. Battery system.

b. *Battery Test.*

(1) *Specific gravity.* Use a battery hydrometer and check each battery cell. Water should not be added prior to this test. Battery specific gravity readings should be at least 1.225 in each cell. Variation of more than .025 gravity points per cell (temperature corrected) indicates a battery fault. If

this occurs, replace the battery. Check the batteries for damaged case, terminals, or cell cover plates.

(2) *Battery voltage test (fig. 2-11).* Using a voltmeter, select the 50-volt scale and check the voltage charge status. Individual battery voltage must not be less than 11 volts or more than 13 volts.

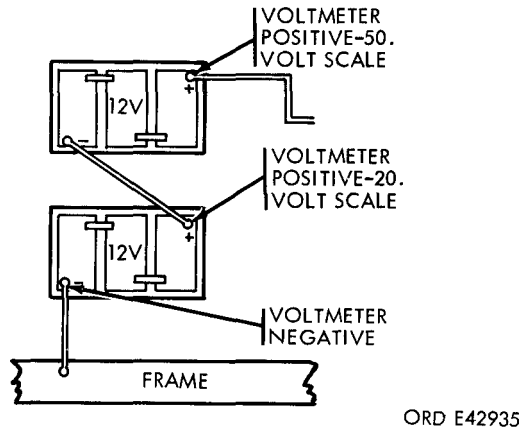


Figure 2-11. Battery voltage test.

c. *Individual Battery Check Using Load Bank (Fig. 2-12).*

(1) Connect one end of the positive ammeter lead to the 12 volts, 50-50-100A load bank terminal of the tester (fig. 2-8), and the other end to the positive (+) terminal of one of the batteries.

(2) Connect one end of the negative ammeter lead to the 100 AMP ammeter terminal of the tester (fig. 2-8), and the other end to the negative (—) terminal of the same battery to which the positive lead is connected.

(3) Connect one end of the voltmeter positive lead to the voltmeter positive terminal of the tester (fig. 2-8), and the other end to the same positive (+) terminal of the battery to which the positive ammeter lead is connected.

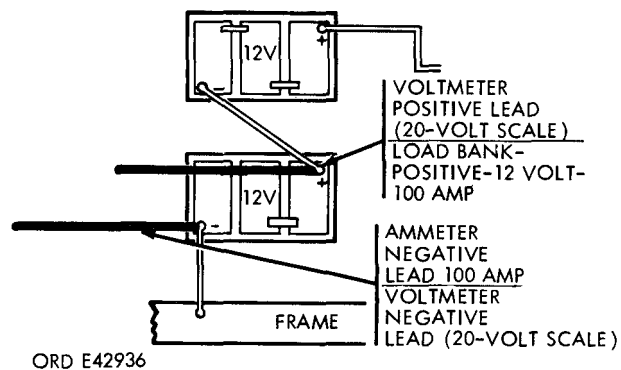


Figure 2-12. Load bank voltage test.

(4) Connect one end of the negative voltmeter lead to the negative terminal of the tester (fig. 2-8). and the other end to the same negative (-) terminal of the battery to which the negative ammeter lead is connected.

(5) Turn the voltage selector switch to the 20-volt scale.

(6) Turn on load bank switch and install a load of 80 to 90 amperes by turning the load bank knob clockwise. Read the voltmeter.

(7) Battery voltage under load should not drop below nine volts.

(8) Turn the load bank knob counterclockwise to the stop position. Turn off the load switch and the voltmeter selector switch. Disconnect all leads from the battery and then disconnect all leads from the tester.

d. *Combined Battery Voltage Check.* To check combined voltage, connect the voltmeter in accordance with figure 2-13. and take the readings shown.

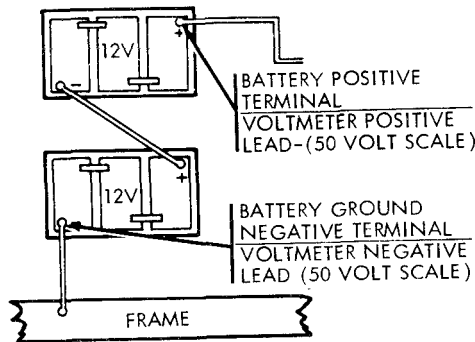
**CAUTION**

Do not crank over 30 seconds. Battery voltage must not be less than 18 volts to properly fire ignition.

(1) Open circuit voltage should be 24 to 26 volts.

(2) Leave the ignition off. Leave the test lead on. Crank the engine with the vehicle starter.

(3) If the batteries will not meet the above criteria, replace or charge the batteries.



ORD E42937

Figure 2-13. Combined battery voltage check.

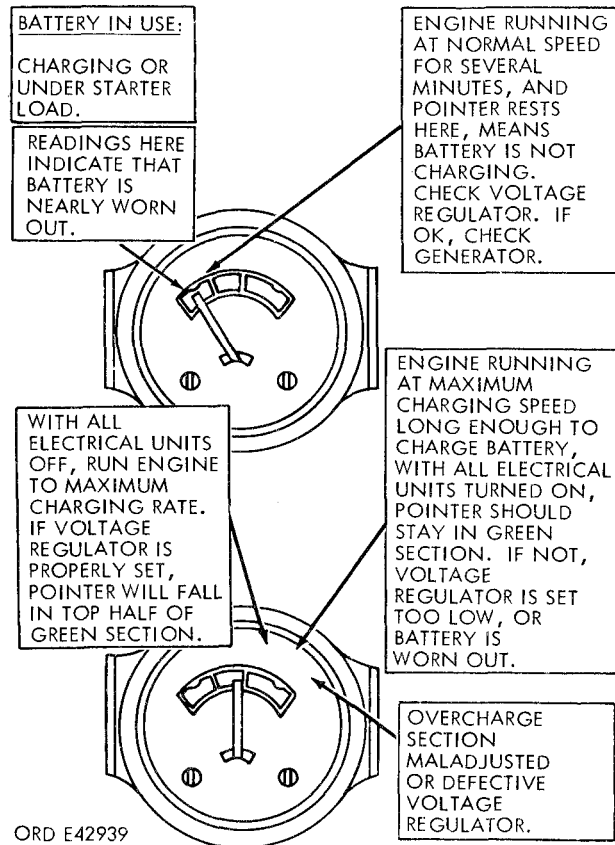
**2-23. Generator System**

**NOTE**

Troubleshooting of the generating system includes checking of the generator, generator regulator, and cables. To test the generator circuit, four components on the vehicle must be checked in the following sequence to insure trouble-free operation and a minimum of meter connections.

a. Prior to starting engine, check the generator fan belts for proper adjustment. Generator belts must be adjusted in accordance with paragraph 2-113 to insure maximum output of the generator. Loose belts can give low voltage readings, low amperage readings, and can cause belt squeal.

b. Turn the ignition switch to ON, and observe the battery generator indicator (fig. 2-14); the indicator pointer should be on the yellow scale or on the edge of the green scale. The indicator pointer should never be on the red scale when the ignition switch is in the ON position.



ORD E42939

Figure 2-14. Battery indicator.

c. Start the engine and observe the action of the battery indicator. When the engine is operated at approximately 1000 to 1200 rpm, the meter indicator pointer should move toward the green scale or to the right side of the meter (fig. 2-14).

d. If the meter does not operate as prescribed, the following troubleshooting procedure should be taken.

(1) Turn the ignition switch to OFF.

(2) Disconnect the wire at the battery indicator and connect it to the positive lead of a voltmeter (fig. 2-15). With the negative lead of the voltmeter grounded, and the ignition switch ON, the voltmeter should indicate battery voltage.

(3) Start and run the engine at 1,000 to 1,200 rpm; the voltmeter should indicate a generator voltage of 27.5 to 28.5 volts.

(4) If the voltmeter does not indicate generator voltage charge as specified, check the generating system and adjust, replace, or repair components as necessary. The battery indicator wiring is shown in figure 2-15.

(5) If the voltmeter indicates a generator voltage charge as specified, and the battery indicator does not conform to the test in *b* and *c* above, replace the battery indicator (para 2-22 b).

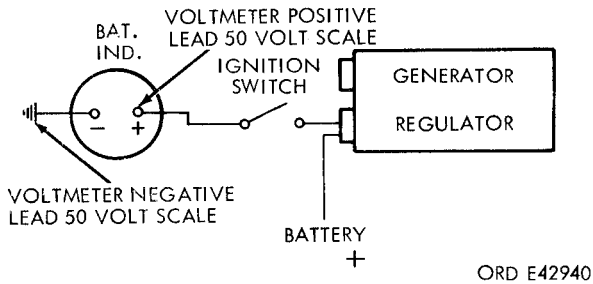


Figure 2-15. Battery indicator circuit.

## 2-24. Generator Testing

### WARNING

Prior to placing the adapter in the generating system, the vehicle ground cable (battery negative cable) must be disconnected.

### CAUTION

Do not exceed 30 volts and 30 amps since damage to the generator could result.

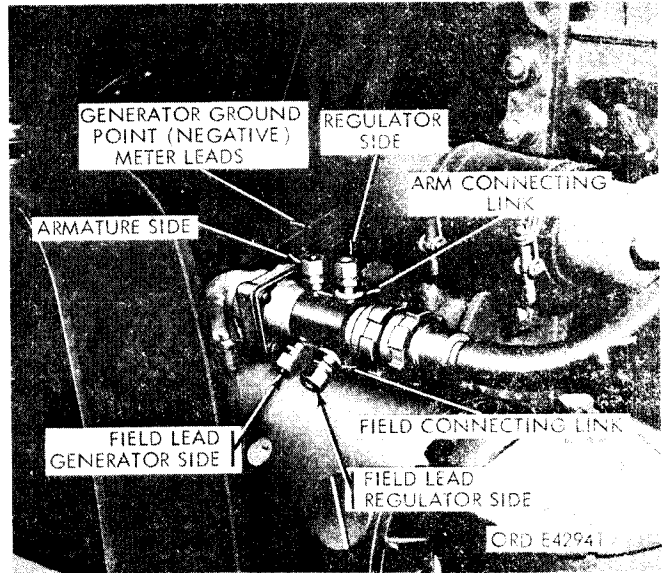


Figure 2-16 Generator adapter in place with connecting points shown.

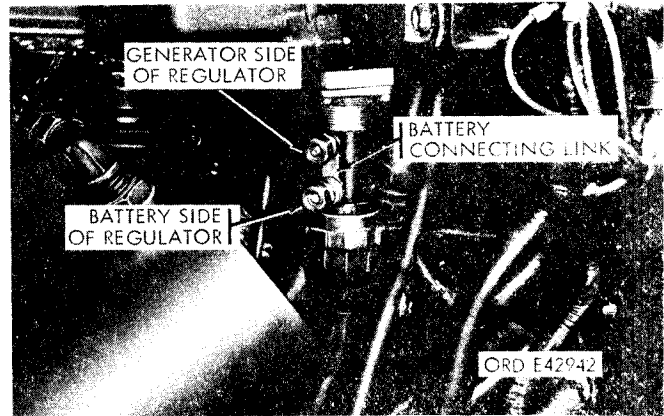
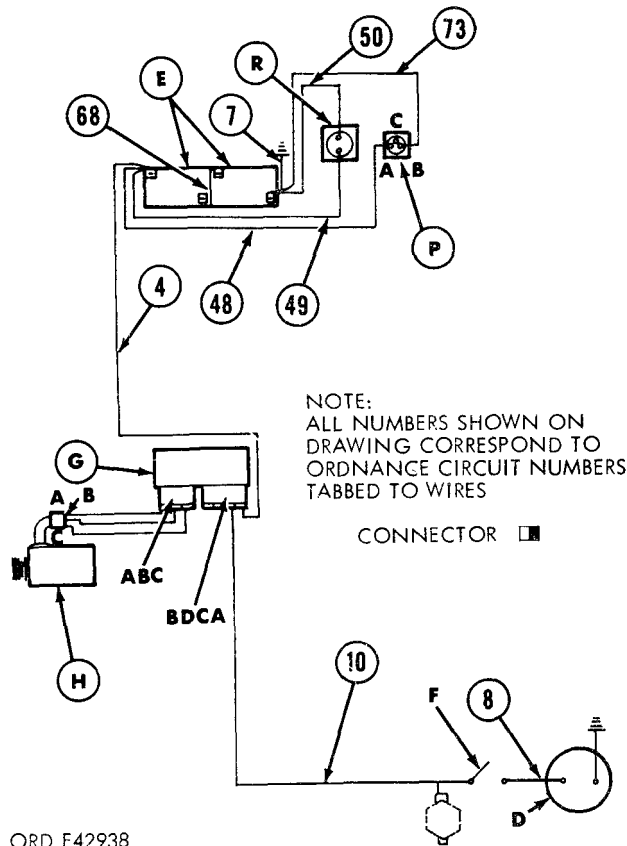


Figure 2-17 Regulator adapter in place with connecting points shown.





ORD E42938

- D Battery-generator indicator
- E Batteries
- F Ignition switch
- G Generator-regulator
- H Generator
- R Slave receptacle
- P Radio receptacle

Circuit No.	Cable gage	Circuit description
4	8	Battery to regulator A terminal
7	0	Battery ground
8	14	Ignition switch to battery indicator
10	12	Regulator (shunt) to circuit breakers
48	8	Battery to radio receptacle (feed)
49	0	Battery to slave receptacle ( + )
50	0	Slave receptacle to battery ( - )
68	0	Battery interconnecting cable
73	8	Radio receptacle to battery (ground)

Figure 2-18. Generating system wiring.

a. Disconnect the generator-to-regulator cable at the generator and insert the adapter as shown in figure 2-16. Refer to figure 2-18 for the generator system wiring layout.

b. Disconnect the battery-to-regulator cable at the vehicle regulator and insert the adapter as shown in figure 2-17.

c. Check all connecting links to make sure they are closed and not touching any metal on the vehicle.

d. Check all connecting cables for proper connections and insure that they are clear of metal objects on the vehicle.

e. Connect the battery ground cable.

f. Open both links on the generator-mounted adapter and, with the lead connected to 24-volt positive (+) source, just touch the field lead of the generator. This will insure that the generator has the correct polarity.

g. Connect the ammeter positive (+) lead to the load bank side of the ammeter, 24-VOLTS, 10-80A, and connect the other end to the armature lead of the generator as shown in figure 2-19.

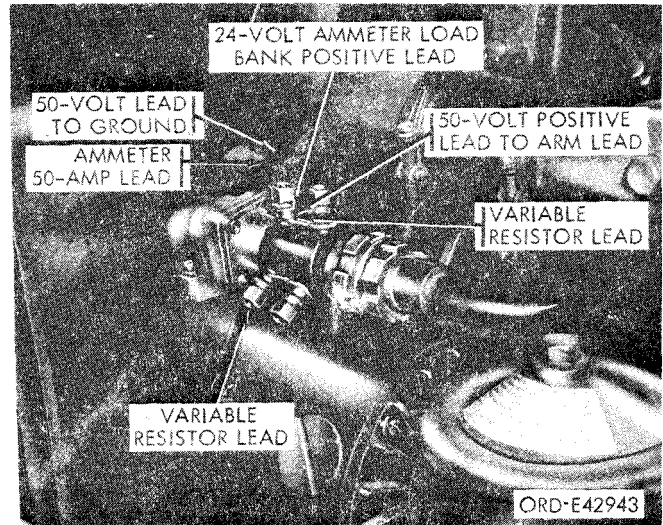


Figure 2-19. Generator output test hookup.

h. Connect the ammeter negative (—) lead to the meter side (fig. 2-8), 50 AMP. and connect the other end to the vehicle generator ground or battery ground (fig. 2-19).

i. Connect the positive (+) lead of the voltmeter (fig. 2-8) to the positive (+) side of the meter connection and other end to the armature side of the generator (fig. 2-19).

j. Connect the negative (—) lead to the negative (—) side of the meter (fig. 2-8), and the other end to the vehicle frame or battery ground.

k. Select the 50-volt scale (fig. 2-8).

1. Connect one lead of the variable resistance to the generator armature, and the other lead to the generator field (fig. 2-16 and 2-19).

m. With the meters connected as in figure 2-19, and the variable resistor and LOAD BANK SWITCH in the OFF position, start the engine and set it to run at a high idle (1000 to 1200 rpm).

n. With the LOAD BANK SWITCH in the OFF position, move the variable field rheostat and observe the voltmeter. When 30-volts is shown on meter, stop turning the field rheostat.

o. If no voltage is registered, check to see that

connections are correct. If correct, replace the generator.

p. With the load bank knob in the fully CCW position, turn on the load bank switch. Observe the ammeter and slowly apply about a 5-amp load by turning the load knob clockwise. As the load is increased, the voltage will drop.

q. With engine running at 1000 to 1200 rpm, turn the field control knob, and maintain the 30-volt output. Then turn the load control knob. The amperage load should not exceed 30 amps. As the amperage increases in this test, the voltage will drop. The field control knob must be turned to maintain proper voltage. Then turn the load control knob to increase the amperage.

r. If 30 volts and 30 amps cannot be maintained, check the belts for proper adjustment (para 2-113). (Loose belts can slip when a load is applied, giving low readings.)

s. If all checks are made and the generator

output requirements of 30 volts and 30 amps at 1200 engine rpm cannot be reached, replace the generator.

## 2-25. Regulator Testing

### NOTE

Prior to making the following regulator tests, the generator must be completely tested as in paragraph 2-24. The same adapters used in generator testing are required to test the regulator. The radio ground strap must be connected to insure the grounding of the regulator (fig. 2-20).

a. *Voltage Control Test (Fig. 2-20).*

(1) Select the 50-volt scale and turn the LOAD BANK SWITCH to OFF. The load bank control knob must be in the fully counterclockwise position.

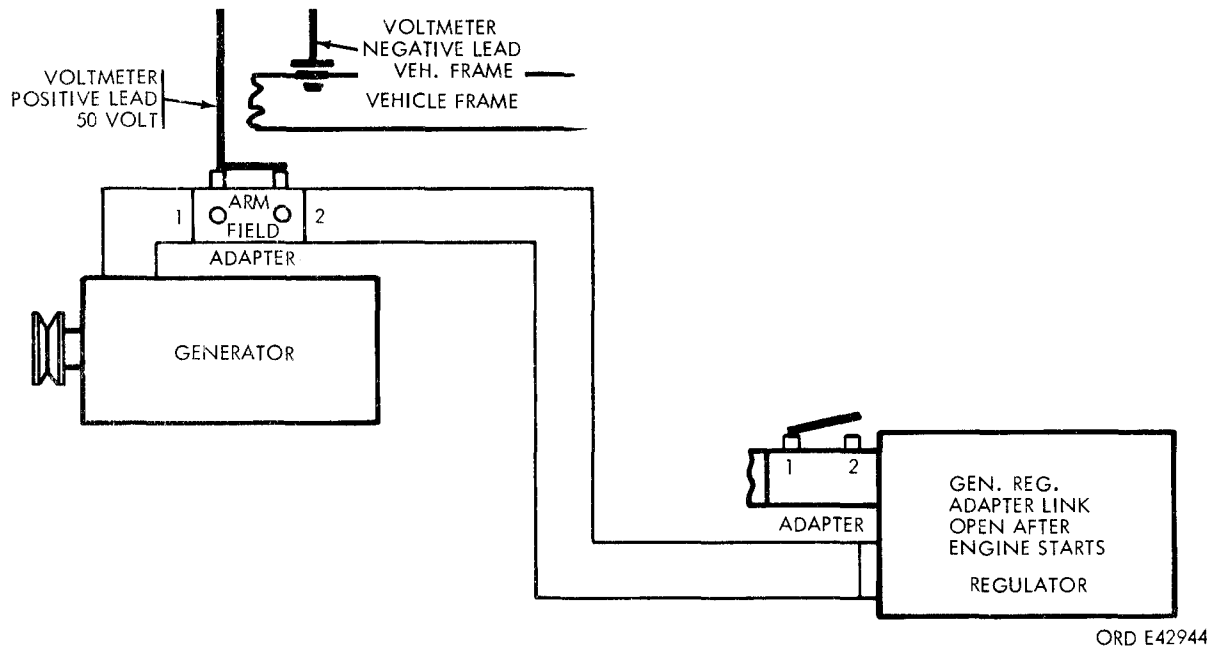


Figure 2-20. Regulator voltage control test hookup.

(2) With the engine stopped, connect the meter to the adapters as shown in figure 2-18. Check to insure that cables are properly connected and not touching vehicle metal (fig. 2-20).

(3) With all adapter links closed, start the engine and observe the voltmeter reading. This should be 27.5 to 29 volts with the engine running at 1000 to 1200 rpm.

(4) Open the adapter link on the regulator and check the voltage on open circuit. With the engine at 1000 to 1200 rpm, the voltage should be 27.5 to 29 volts (fig. 2-20).

(5) If the voltmeter shows less than 27.5 volts, check the wiring between the generator and the

regulator for defective wire (fig. 2-19). Repair as required.

(6) If the wiring is not defective and the regulator voltage is under 27.5 or exceeds 29 volts, replace the regulator (para 2-132).

b. *Amperage Control Test.*

### CAUTION

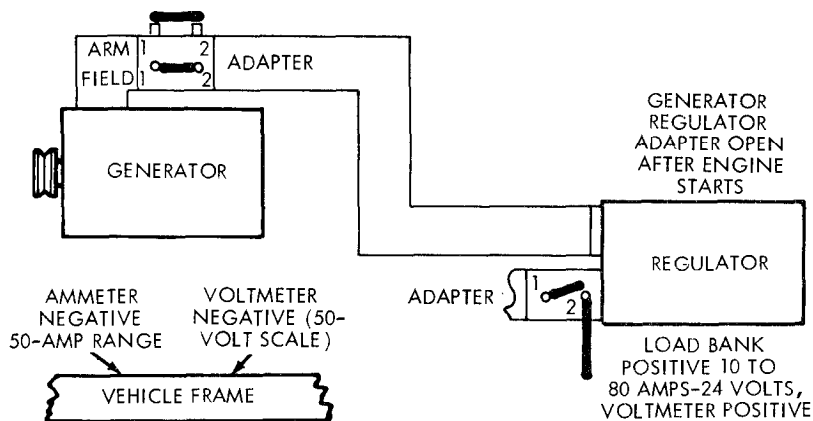
The adapter link must be open for the following test.

### CAUTION

Do not allow the voltmeter to go below 22 volts while making this test.

(1) If the regulated voltage is 27.5 to 29 volts as in the voltage control test; then, with the engine

idling, connect the ammeter and voltmeter as shown in figure 2-21.



ORD E42945

Figure 2-21. Regulator amperage control test hookup.

(2) Turn on the load switch; watch the ammeter and voltmeter. If the voltage drops and the amperage shows on meter, turn the control knob until the voltage reads at least 23 volts and the low amperage is shown on the meter.

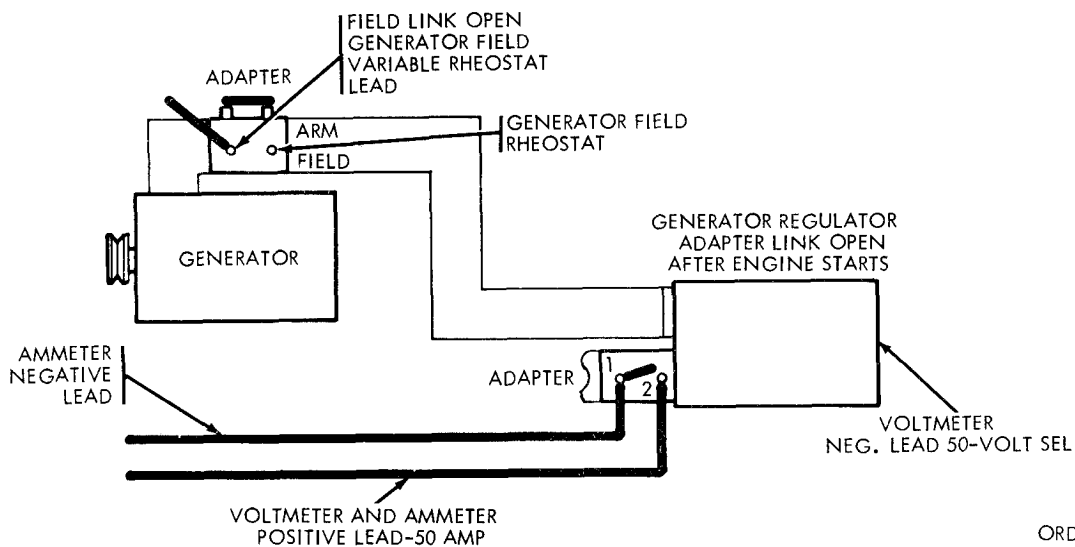
(3) Run the engine at 1000 to 1200 rpm. Turn the control knob until the ammeter reads 24 to 27 amps. The voltmeter should start dropping at that point, and the ammeter should remain at 24 to 27 amps.

(4) If the ammeter exceeds 27 amps or reads below 23 amps, replace the regulator (para 2-132).

(5) If the regulator meets the requirements in the voltage control and amperage control tests—27.5 to 29 volts and 23 to 27 amps—it is regulating correctly. The cutout switch must still be checked.

*c. Line Switch Cutout.*

(1) Connect the voltmeter, ammeter, and variable rheostat as shown in figure 2-22. Turn the field rheostat fully counterclockwise, or to its off position.



ORD E42946

Figure 2-22. Generator regulator line switch cutout test hookup.

(2) With the field link on the generator adapter open and the link on the regulator open, bring the engine to 1000 to 1200 rpm, and observe

the ammeter and voltmeter. The reading should be below 10 volts and no amperage reading.

(3) Turn the field rheostat clockwise until the

ammeter shows a low charge rate of 1 to 5 amps. This indicates the line switch is closed. Observe the voltmeter. This should be reading 22 to 25 volts. The line switch must close below the regulated voltage (27.5 to 29 volts).

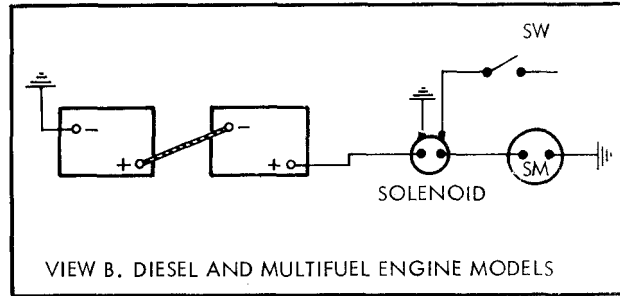
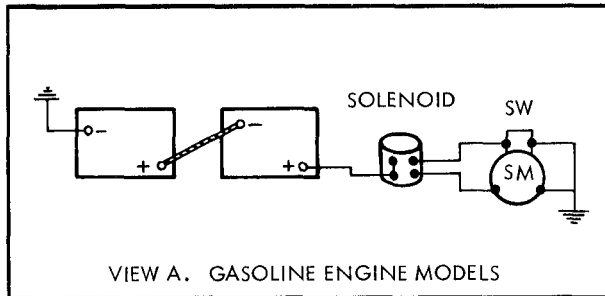
(4) With the engine still at 1000 to 1200 rpm, turn the field rheostat counterclockwise and observe the ammeter. The meter should move to the discharge side for about 10 to 12 amps, then to zero. This indicates that the line switch is open.

(5) If the regulator will not meet the above test specifications, replace the regulator (para 2-132).

**2-26. Starter Circuit Testing—Gasoline Engine**

**CAUTION**

Prior to checking the starter cables for tight



AI 34815

Figure 2-23. Starter circuit.

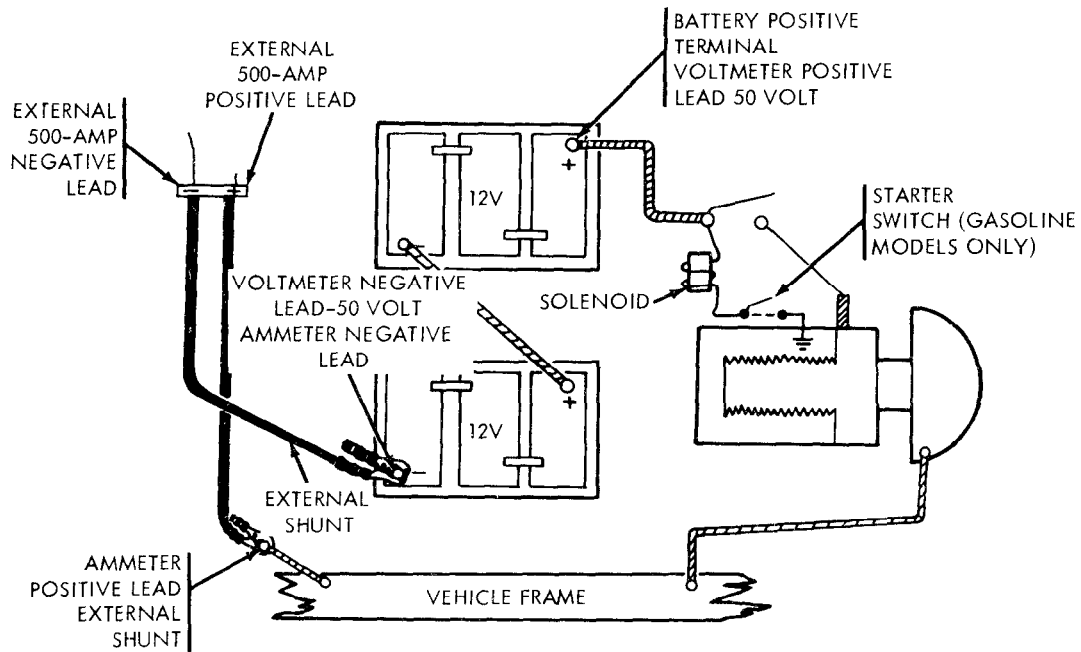
*b. Starter Draw Check at Battery.*

(1) Disconnect the ground cable from the battery post of the grounded battery.

(2) Connect the light positive external shunt lead to the positive external shunt terminal of the

tester, and connect the light negative external shunt lead to the negative external shunt terminal of the tester.

(3) Connect the heavy positive external shunt lead to the ground cable as shown in figure 2-24.



AT 34816

Figure 2-24 Starter draw check at battery.

(4) Connect the heavy negative external shunt to the negative post of the grounded battery and the negative lead of the voltmeter with the selector on the 50-volt scale.

(5) Connect positive (+) voltmeter lead to the battery plug terminal.

(6) Close the starter motor switch (with the ignition switch in the OFF position) and read the ammeter.

(7) Starter motor amperage should not exceed 300 amperes, maximum.

(8) Voltage should read not less than 18 volts.

(9) If the starter circuit conforms to the above tests, remove the test leads and connect the ground cable to the negative post of the grounded battery.

(10) If the starter circuit does not meet the above requirements, check the circuit using the sequence in c and d below.

c. Testing Starter Solenoid (Gasoline Model).

(1) Set the voltmeter on the 50-amp scale. Connect the negative (black) lead (fig. 2-25) to the vehicle battery ground or frame. Connect the positive (red) lead to the battery side of the solenoid. The meter should read a battery voltage of 23 to 26 volts.

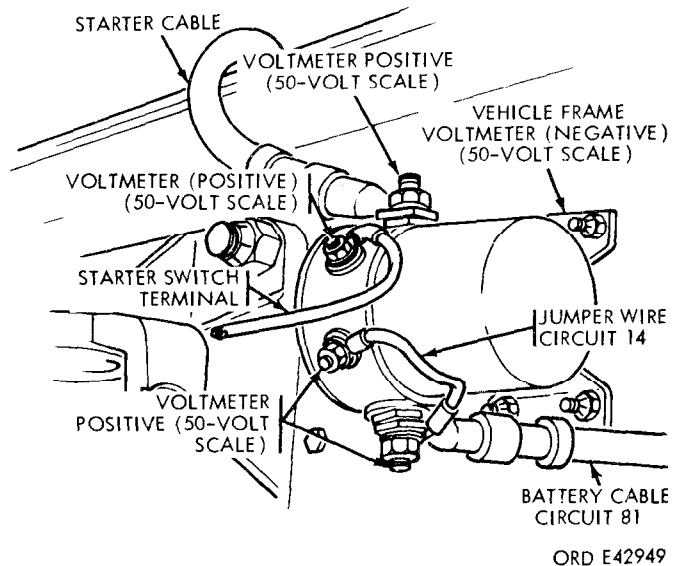


Figure 2-25. Solenoid test hookup.

(2) Move the voltmeter positive (+) red lead to the small contact connected by circuit jumper wire number 14. The meter should read battery voltage.

(3) Move the positive (+) red lead of the voltmeter to the small terminal on the starter side of the solenoid (fig. 2-25). The meter should read battery voltage.

(4) If battery voltage is not obtained at this point, disconnect the wire, running to the starter switch, from the solenoid; the meter should read battery voltage. If no voltage is obtained, replace the starter solenoid (para 2-126). This test indicates that the coil is defective.

(5) If the battery voltage reading is present move the red positive (+) lead to the large terminal of the solenoid on the starter side (fig. 2-25). Depress the starter switch lever. The starter solenoid should close and the meter should read battery voltage.

(6) If solenoid does not close, use a jumper wire and ground the small starter switch terminal to the frame. The switch should close and the meter should indicate battery voltage. If the solenoid closes with this check, the starter switch circuit is defective.

(7) If the solenoid relay will not close during this check, replace the solenoid (para 2-126).

*d. Starter Amperage Draw Test.*

**NOTE**

Starter amperage draw test is made at the starter to insure that the required voltage and amperage are reaching the starter and are not lost through the connecting components.

(1) Connect the voltmeter leads and 500-amp shunt leads to the tester.

(2) Place voltage selector in the 50-volt position and connect the negative lead of the voltmeter to the battery or frame ground as shown in figure 2-26.

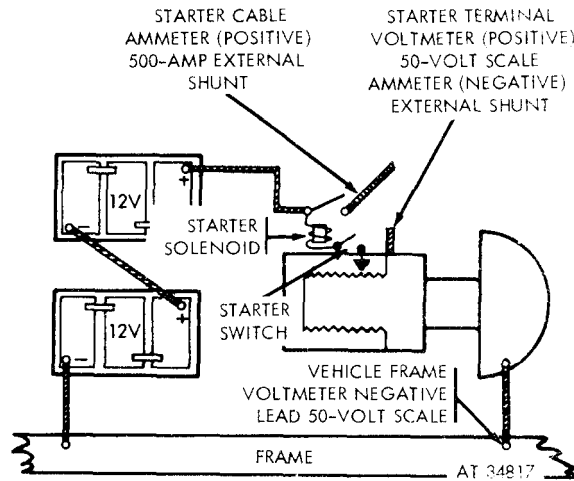


Figure 2-26. Starter amperage draw test.

(3) Disconnect the starter cable at the starter and connect the large positive external shunt lead to cable. Refer to figure 2-26.

(4) Connect the large negative external shunt lead and the voltmeter plus lead to the starter cable post on the starter. Refer to figure 2-26.

(5) Close the starter switch and observe the readings, voltage 18 to 24 and amperage 150 to 200 amps.

(6) If the starter circuit closes and the voltage and amperage are correct, the starter circuit and connections are functioning correctly.

(7) If the starter voltage is present but the starter will not crank, check the cables for line drop.

(8) If the amperage draw is too high, replace the starter (para 2-124). The same is true if the voltage is present, but no amperage is shown on meter.

## 2-27. Starter Circuit Testing—Diesel and Multifuel

### CAUTION

Prior to checking the starter cables for tight connections, the ground strap must be removed from the vehicle batteries. This is required to eliminate shorting of tools on the vehicle frame, which may cause damage and endanger personnel.

### NOTE

Prior to making electrical checks on the starter, the condition of the batteries and the electrical connections must be checked to insure that the proper voltage and amperage are available.

*a. Description.* The starter circuit tested in this paragraph includes a starter switch, a starter solenoid relay, and a starter motor as shown in figure 2-23. To test the complete starter circuit for amperage draw and functioning of components, the following checks should be made at the battery.

*b. Starter Draw Check at Battery.* Refer to paragraph 2-26b and figure 2-24.

*c. Starter Amperage Draw Test.*

### NOTE

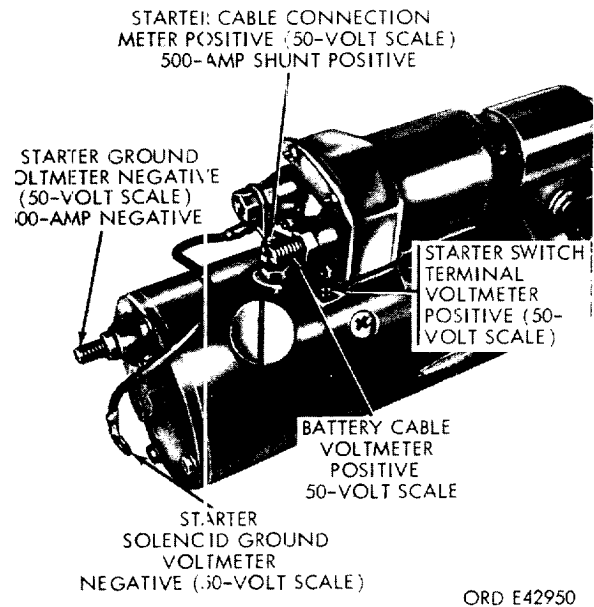
The starter amperage draw test is made at the starter to insure that the required voltage and amperage are reaching the starter and are not lost through the connecting points.

(1) Connect voltmeter leads and 500-amp shunt leads to the tester.

(2) Place the voltage selector in the 50-volt position, and connect the voltmeter negative lead to the battery or frame ground as illustrated in figure 2-26.

(3) Disconnect the starter cable at the starter and connect the large positive external shunt lead to the cable. Refer to figure 2-27.

(4) Connect the large negative external shunt lead and the voltmeter positive (+) lead to the starter cable post on the starter. Refer to figure 2-27.



ORD E42950

Figure 2-27. Starter solenoid—diesel and multifuel models.

(5) Close the starter switch and observe the readings, voltage 18 to 24 volts, and amperage 250 to 300 amps.

(6) If voltage and amperage are correct when the starter circuit is closed, the starter circuits and the connections are functioning properly.

(7) If voltage is present but the starter will not crank, inspect the cable connections for a voltage drop.

(8) If the amperage is too high, replace the starter (refer to para 2-128). Do the same if the voltage is present, but no amperage shows on the meter.

## 2-28. Electrical Power Loss Test—Gasoline Engine

These tests are made to insure that the required voltage and amperage are reaching the components and are not lost through connecting cables and switches.

*a. Starter Switch Test (Gasoline Model) (Fig. 2-28).*

(1) The starter switch is located on top of the starter and is used to ground the starter solenoid and complete the starter circuit.

(2) To check the starter switch, connect the negative (—) lead to vehicle ground, and put the selector on the 50-volt scale.

(3) Connect the positive (+) lead of the voltmeter to the magnetic side of the starter switch. The meter should read battery voltage. If the meter reads battery voltage, the circuit to the switch is complete.

(4) Remove the positive (+) lead and connect it to the other side of the starter switch. The meter should read no voltage.

(5) Connect the positive (+) lead to the relay side of the starter switch and the negative (—) lead to the ground side of the switch. The meter should read battery voltage.

(6) Close the starter switch with the ignition switch set to OFF. The meter should read zero volts.

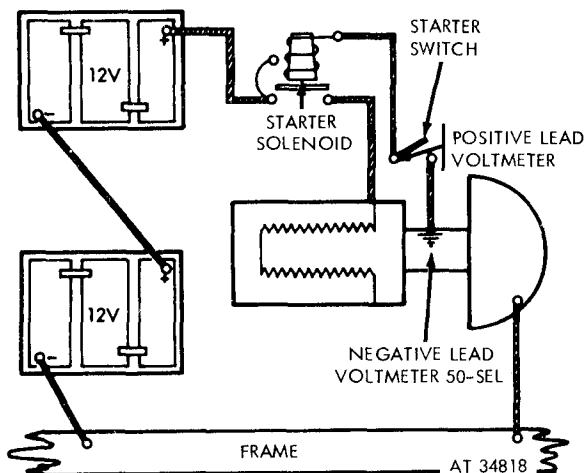


Figure 2-28. Starter switch test.

*b. Frame-to-Battery Cable Ground Loss Test.*

(1) Connect the voltmeter leads to the tester. Select the 50-volt scale.

(2) Connect the positive voltmeter lead to the vehicle frame (fig. 2-29).

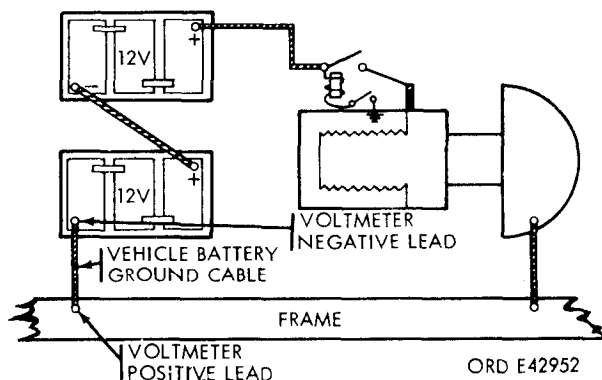


Figure 2-29. Frame-to-battery cable ground loss test.

(3) Connect the negative voltmeter lead to the negative post of the grounded battery.

(4) Close the starter motor switch with the ignition switch in the OFF position and read the voltmeter.

(5) If the voltage reading is below 20 volts, change the selector switch to the 20-volt position and repeat (4) above.

(6) If the voltage reading is below 10 volts, change the selector switch to the 10-volt position and repeat (4) above.

(7) If the voltage reading is below 1 volt, change the selector switch to the 1-volt position and repeat (4) above.

(8) The maximum allowable voltage loss is 0.1 volt.

(9) Place the voltmeter selector switch in the OFF position, and remove the voltmeter tester leads from the frame and battery post.

*c. Battery Connector Cable Test (Fig. 2-30).*

(1) Move the selector switch to the 50-volt position on the tester.

(2) Connect one end of the positive (+) voltmeter lead to the positive (+) terminal of the tester, and the other end to the positive (+) post of the grounded battery.

(3) Connect one end of the negative (—) voltmeter lead to the negative terminal of the tester, and the other end to the ungrounded battery negative post.

(4) Close the starter switch with the ignition switch in the OFF position. Read the voltmeter.



(5) If voltage is less than 20 volts, place the selector switch in the 20-volt position and repeat (4) above.

(6) If voltage reading is less than 10 volts, place selector switch in the 10-volt position. Repeat (4) above.

(7) If reading is less than 1 volt, place selector switch in the 1-volt position and repeat (4) above.

(8) The maximum allowable voltage loss is 0.2 volt.

(9) Turn the voltage selector switch to the OFF position after the check is completed, and remove all test leads from the battery cable.

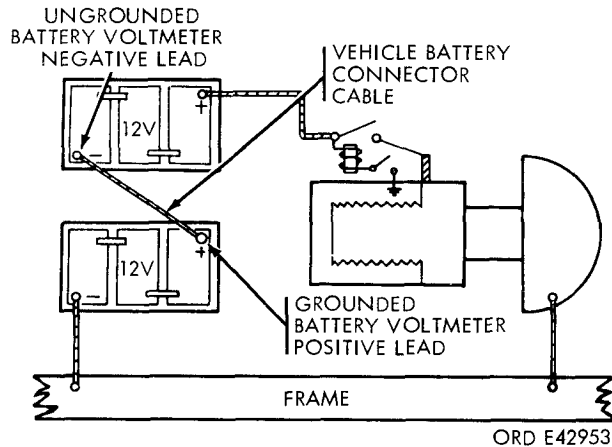


Figure 2-30. Battery connector cable test.

d. Battery-to-Solenoid Cable Test (Fig. 2-31).

(1) Leave the voltmeter leads connected to the tester.

(2) Connect the positive (+) voltmeter lead to the positive post of the ungrounded battery.

(3) Connect the negative (-) voltmeter lead to the starter solenoid relay terminal.

(4) Place the voltage selector switch in the 50-volt position, close the starter switch with the ignition switch in the OFF position and read the voltmeter.

(5) If the voltage reading is less than 20 volts, change the selector switch to the 20-volt position and repeat (4) above.

(6) If the reading is less than 10 volts, change the selector switch to the 10-volt position and repeat (4) above.

(7) If the reading is less than 1 volt, change the selector switch to the 1-volt position. Repeat the procedure and read the voltmeter.

(8) The maximum allowable voltage loss is 0.2 volt.

(9) After the check is completed, turn the voltage selector switch to the OFF position, and remove the voltmeter leads from the battery to the solenoid cable.

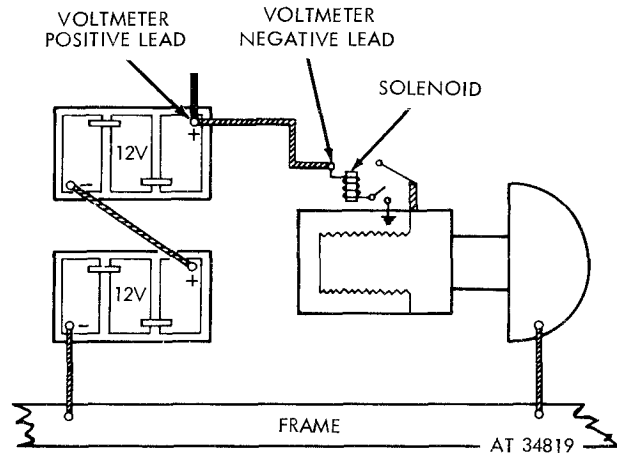


Figure 2-31. Battery-to-solenoid cable test.

e. Starter Solenoid-to-Starter Connector Test (Fig. 2-32).

(1) Leave the voltmeter leads connected to the tester.

(2) Connect the positive (+) voltmeter lead to the terminal at the solenoid relay starter connector side.

(3) Connect the negative (-) voltmeter lead to the terminal of the connector on the starter motor housing.

(4) Place the voltage selector switch in the 50-volt position, close the starter switch with the ignition switch in the OFF position, and read the voltmeter.

(5) If the voltage reading is less than 20 volts, change the selector switch to the 20-volt position and repeat (4) above.

(6) If the reading is less than 10 volts, change the selector switch to the 10-volt position and repeat (4) above.

(7) If the reading is less than 1 volt, change the selector switch to the 1-volt position and repeat (4) above.

(8) The maximum allowable voltage loss is 0.2 volt.

**2-29. Electrical Power Loss Tests—Diesel and Multifuel**

Refer to paragraph 2-28 for applicable tests..

**2-30. Monitoring Circuits (Fuel, Oil, and Temperature Gage Testing)**

a. Check the vehicle battery voltage. Charge or replace the battery if the voltage is not as prescribed in paragraph 2-22.

b. Check the battery cables and terminals for good condition. Repair or replace battery cables and terminals as required. Be sure that they are properly secured.

c. With the ignition switch turned to OFF, disconnect the No. 27 lead from the back of the gage (fig. 2-33).

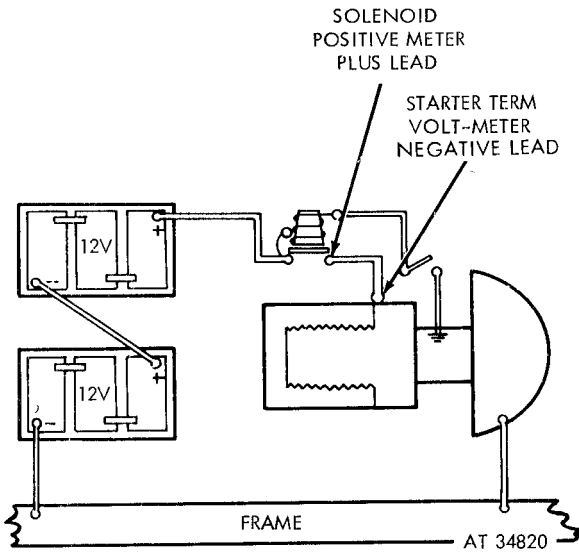


Figure 2-32. Starter solenoid-to-starter connector test.

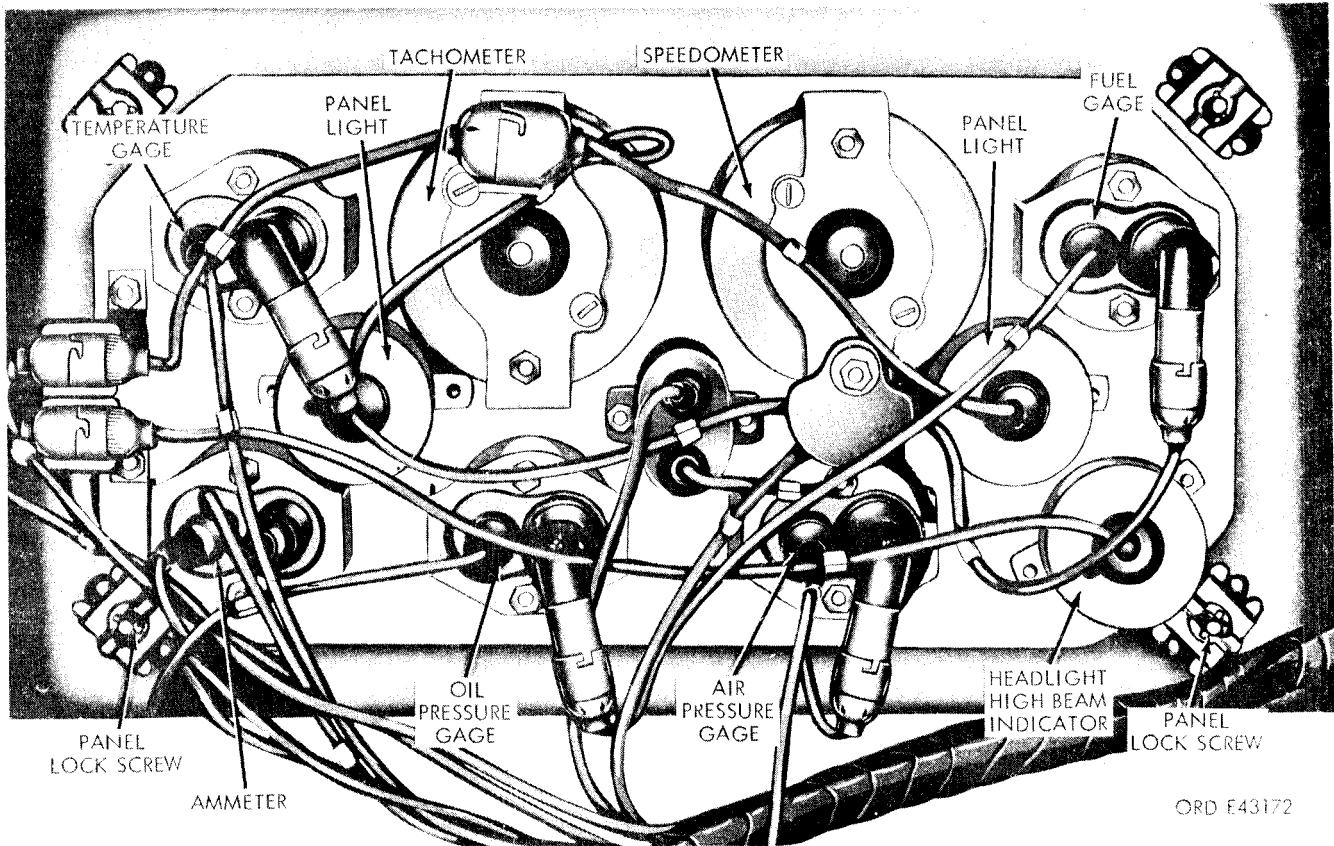


Figure 2-33. Instrument cluster—rear view.

d. With the voltage selector on the 50-volt scale, connect the negative (—) lead of the voltmeter to vehicle ground and the positive (+) lead to wire No. 27 from the ignition switch.

e. With the ignition switch turned to ON (fig. 2-34), the voltmeter should indicate battery voltage.

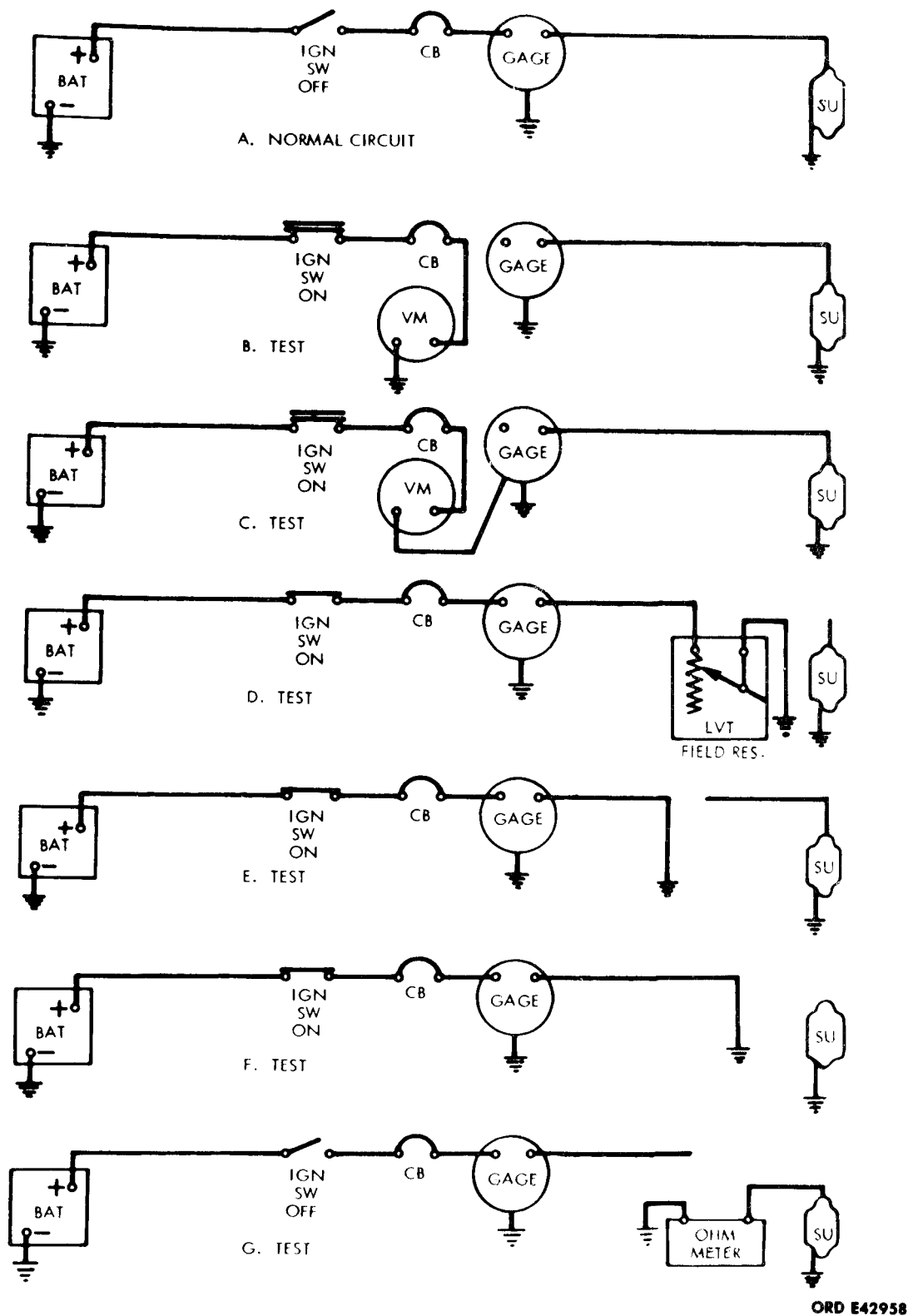


Figure 2-34. Electrical testing diagram.

**NOTE**

If a lower than battery voltage, or a zero voltage reading is indicated, check the circuit for loose or broken connections. Repair as required.

f. Remove voltmeter's negative (-) lead from vehicle ground and contact case of gage (fig. 2-34). Voltmeter should indicate battery voltage.

**NOTE**

This check (*f* above) is important. If case of gage is not properly grounded, gage will not operate.

g. Turn ignition switch to OFF.

h. Disconnect voltmeter positive (+) lead from ignition switch-to-gage wire and connect wire to gage.

i. Disconnect wire from gage to sending unit at the gage.

j. Connect a suitable jumper wire to sending unit side of gage.

k. Connect one lead of field rheostat to jumper wire from gage, and the other field rheostat wire to vehicle ground (fig. 2-34).

l. Turn ignition switch ON.

m. Turn field control knob and watch gage. The oil pressure and fuel gage should go from zero to full scale if operating correctly. Using a 13- to 15-ohm resistance, gage should read  $\frac{1}{2}$  scale.

**NOTE**

This check (*m* above) will not check the temperature gage, since it is a high resistance gage.

n. To check temperature gage, ground one end of jumper wire from gage to vehicle ground. The temperature gage should read high temperature when grounded, and zero temperature when jumper is not grounded (fig. 2-34).

o. Turn ignition switch to OFF.

p. Remove jumper wire from gage and connect wire from sending unit to the gage.

q. Disconnect wire from sending unit to gage at the sending unit (fig. 2-34).

r. Turn ignition switch to ON.

s. Make the same checks as in *e* and *n* above. If gage does not conform to the readings outlined, repair or replace wire from gage to sending unit.

r. Turn ignition switch to OFF. Connect wire from gage to sending unit.

**NOTE**

Electrical gages indicate an approximate reading; for accurate readings, use master gages connected to the circuit being tested.

**2-31. Sending Units.**

a. To test functioning of the sending units, an ohmmeter with a 0- to 7,000-ohm range is recommended. The following procedure applies to any sending unit being tested.

b. Disconnect wire from gage-to-sending unit at the sending unit.

**CAUTION**

Do not connect the ohmmeter to the ignition circuit and turn the ignition switch to ON since ohmmeter will be damaged.

c. Connect positive (+) lead of ohmmeter to the sending unit and negative (-) lead of ohmmeter to vehicle ground (fig. 2-34).

(1) *Temperature gage sending unit.*

(a) If ohmmeter indicates a zero reading when engine is cold, replace sending unit. The sending unit should indicate a high resistance.

(b) Start engine. The ohmmeter will indicate a lower reading as engine is warming up.

(c) Stop engine. The ohmmeter will indicate a high reading as engine is cooling.

(d) Replace sending unit if readings are not as indicated in (*b*) and (*c*) above.

(2) *Oil pressure gage sending unit.*

(a) The ohmmeter should indicate a 0- to 1-ohm reading with engine stopped; if ohmmeter does not indicate this reading, or exceeds 1 ohm, replace sending unit.

(b) Start engine. The ohmmeter should indicate a higher reading (10 to 40 ohms); if a higher reading is not indicated, replace sending unit.

(3) *Fuel gage sending unit.*

(a) Check for ground between fuel tank and vehicle with ohmmeter. A zero reading should be obtained. If fuel tank is not grounded to vehicle, the sending unit will not operate.

(b) The ohmmeter should indicate a reading between 0 and 40 ohms, depending on the amount of fuel in the tank. If ohmmeter indicates a reading higher than 40 ohms, replace sending unit.

(c) The ohmmeter should indicate a higher reading as fuel tank is filled and a lower reading as fuel is withdrawn. If sending unit does not conform to this test, replace sending unit.

(d) To test inaccessible sending units and the electrical wire from gage to sending unit, omit procedure in (*b*) and (*c*) above, and proceed as follows:

1. Disconnect wire from gage to sending unit at the gage.

2. Connect positive (+) lead of ohmmeter to wire from sending unit and the ohmmeter negative (-) lead to vehicle ground.

3. Follow procedures outlined in (3)(a) through (3)(c) above for sending unit being tested.

(e) Defective sending units will be replaced as prescribed in pertinent technical manuals.

**2-32. Ignition Circuit Test — Gasoline.**

**NOTE**

Prior to making ignition circuit checks, a voltage check must be made on the starter

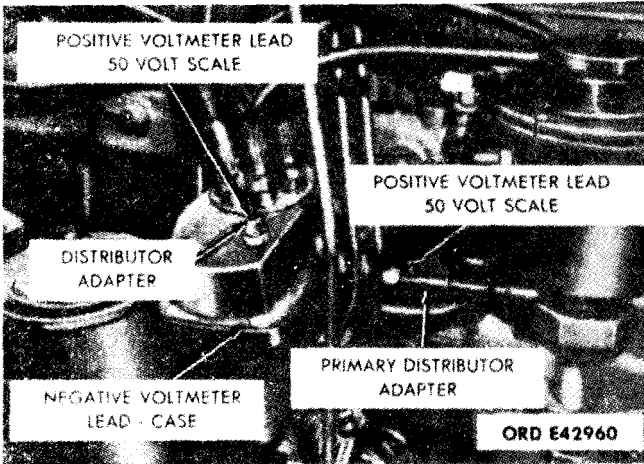


Figure 2-35. Ignition circuit test

circuit to determine if 18 volts are present when cranking the engine.

*a. Primary Circuit Test.*

(1) Disconnect the primary wire at the distributor and insert the primary ignition adapter. Unscrew the plug from the top of the distributor and insert the distributor adapter (fig. 2-35).

(2) Place the voltage selector in the 50-volt position and ground the negative (-) lead.

(3) Connect the positive (+) lead to the primary adapter; turn on the ignition switch. The meter should read battery voltage. (If voltage is present, skip the ignition switch checks, since this indicates that the ignition switch is functioning.)

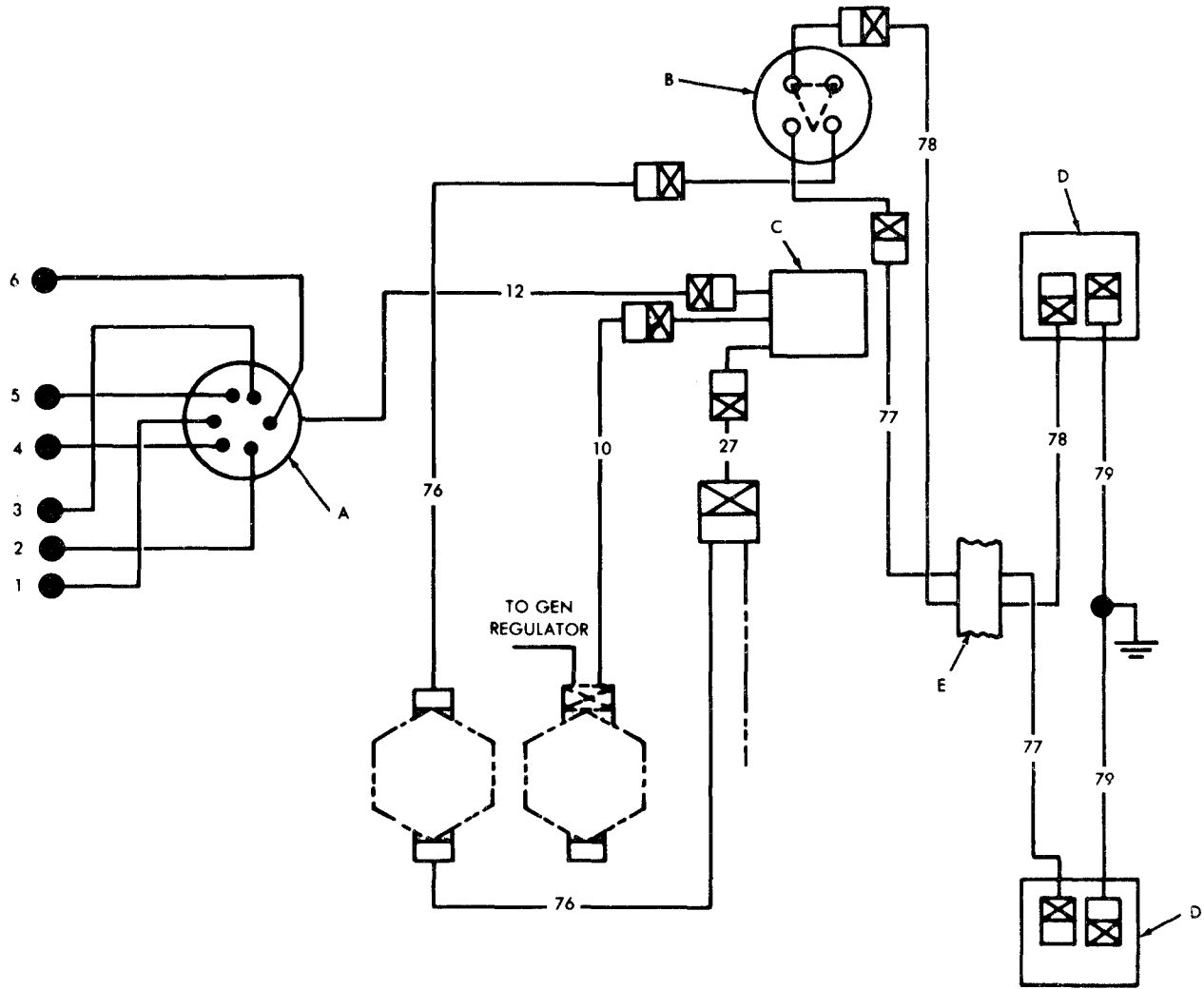
(4) If no voltage is present with the ignition switch on, check the generator regulator to see that it is properly connected. If the regulator is unplugged at the battery side, no voltage will be present at the distributor.

(5) If the voltage regulator is plugged in, remove the meter leads and check the power to the ignition switch.

*b. Ignition Switch Test.*

(1) Remove battery ground cable.

(2) Disconnect the ignition switch feed wire (no. 10). Connect the positive (+) voltmeter lead to the wire from the battery to the switch (fig. 2-36.)



- A Coil and distributor
- B Fuel pump selector switch
- C Ignition switch
- D Electric fuel pump
- E Dash receptacle terminals J and H

TA 067251

Circuit No.	Cable Gage	Circuit Description
12	14	Ignition switch to ignition coil
10	12	Circuit breaker to ignition switch (feed)
27	14	Ignition switch to circuit breaker
76	14	Fuel pump control feed
77	14	Fuel pump switch to fuel pump left
78	14	Fuel pump switch to fuel pump right
79	14	Fuel tank ground

Figure 2-36. Ignition circuit diagram.

(3) Place the voltage selector in the 50-volt position and ground the negative (—) lead.

(4) Replace the ground cable on the battery. The meter should read battery voltage.

(5) If voltage is present, remove the ground cable and connect the No. 10 wire to the switch.

(6) If no voltage is present, go to the generator regulator and disconnect the battery side of the regulator.

(7) Connect the voltmeter lead to the A pin of the disconnected plug on the harness.

(8) With the battery ground strap connected and the negative (—) lead of the meter connected to ground, the battery voltage should show on the meter.

(9) If voltage is present, take a small jumper lead and connect it from pin A on the harness to pin C. (Make checks a, b, c, and d above and below.) If voltage is now present, replace the regulator (para 2-132). If no voltage is present, check the wiring for breaks or shorts and repair as required (para 2-26).

*c. Distributor Tests, Cap On (Fig. 2-35).*

(1) With the voltage selector on the 50-volt scale, ground the meter to the side of distributor.

(2) Connect the positive (+) lead to the distributor adapter (fig. 2-35).

(3) Turn on ignition switch.

(4) Observe the voltmeter. The voltmeter should read low voltage or battery voltage, depending on the distributor point position.

(5) If the points are open the voltmeter should read battery voltage.

(6) If the points are closed, the voltmeter should be on zero or have a maximum voltage of three-tenths of a volt.

(7) If the voltmeter reads battery voltage, but will not drop when the points close, the points are defective. Remove and replace the points or the distributor.

(8) If the voltmeter will not read battery voltage when the points are open, distributor components are defective. Remove and replace the distributor or check it in accordance with the following procedure.

*d. Distributor Test, Cap Removed (fig. 2-37).*

(1) Remove the distributor cap with the ignition switch off.

(2) Ground the negative (—) lead of the meter to the case selector in the 50-volt position.

(3) Use a short jumper lead, and connect it across the points.

(4) Turn on the ignition switch.

(5) Connect the positive (+) lead of the meter to the top of the resistor. The voltage reading should be 24 volts. If not the primary circuit or feed-through capacitor is defective.

(6) Connect the positive (+) lead of the meter

to the resistor side of the coil. The voltage should be 5 to 8 volts. If not the resistor is defective or the jumper on the points is not grounded.

(7) Remove the jumper from the points and insert insulating material between the points, or insure that they are fully open.

(8) Connect the positive (+) lead of the meter to the point side of the coil. The voltage should read battery voltage. If no voltage is shown, the coil or the condenser is defective or the points are grounded.

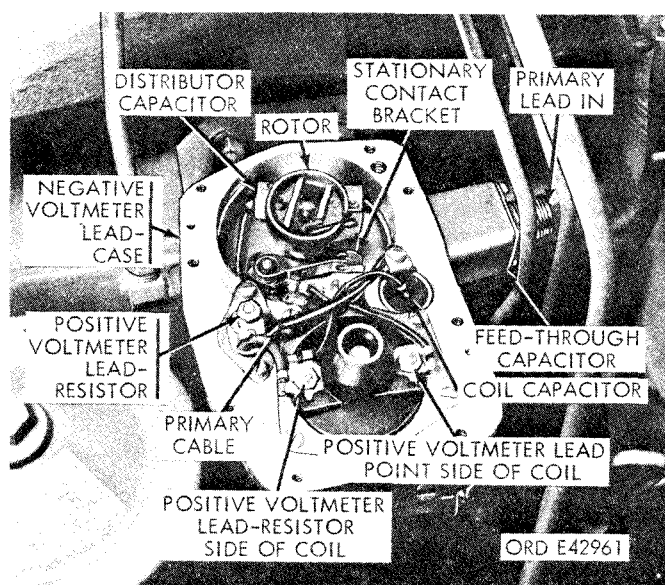


Figure 2-37. Distributor with cover removed.

### 2-33. Ignition Unit and Spark Plug Test— Diesel and Multifuel CAUTION

Do not attempt to test the ignition unit by jumping the spark from the end of the lead to ground. High voltage will destroy the contact spring in the terminal end.

Connect the spark plug and the spark plug lead to the ignition unit. Ground the spark plug shell to provide a complete electrical circuit. Apply 14.30 volts dc to the ignition A pin. The B pin is grounded. If the ignition unit is in good working order, and the spark plug does not fire correctly, replace the spark plug and repeat the test. If it still does not fire correctly, replace the spark plug and repeat the test. If it still does not fire correctly, replace the ignition lead and repeat the test procedure. If it still does not fire properly, replace the ignition unit.

### 2-34. Lighting Circuit Testing

#### NOTE

In addition to general test procedures given here, see table 2-4 for lighting system troubleshooting, including turn signals (fig. 2-39 and fig. 2-39.1).

a. *General Description.* The electrical wiring of this vehicle is of waterproof construction. Where multiple connectors are necessary, they are the screw type, sealed by preformed packing on a sealed composition connector. The electrical circuits are numbered in accordance with the ordinance system and can be identified from the diagram shown in figure 2-38. To establish continuity of any circuit, check with suitable test equipment, using the technique described in this guide.

b. *Directional Signal System.*

(1) The directional signal system circuit (fig. 2-39.1) uses a solid state (transistorized) flasher unit. The basic components consist of a directional signal control assembly (mounted on the steering column), a flasher unit, connecting cables, and four lamps. The individual front lamps are contained in the park, turn, and blackout light assemblies mounted at the front of the vehicle. The rear lamps are combined with the service stoplights and are contained in stoplight part and blackout marker light assemblies at the rear of the vehicle.

(2) The system is energized by setting the light switch to the stoplight position, which supplies 24 volts from terminal J via wire 460-461 to terminal G of the directional signal control unit. Moving the control unit lever to indicate a turn connects terminal G to terminal F and supplies 24 volts to the flasher unit. The flasher unit contains electronic circuitry which interrupts this 24-volt current at a regular rate of 1/2- to one-second intervals. This interrupted voltage appears at ter-

minal A. An indicator lamp in the end of the control lever is connected to terminal H and flashes on and off with the interrupted voltage.

(3) When the control lever is moved to indicate a left turn, the flasher unit is energized as described (2) above. At the same time terminal H is connected to terminal C which connects to the left turn signal lamp via wire 22-461 and terminal B which connects to the left front turn signal lamp via wire 461. The spotlight switch circuit (terminal D) is disconnected from the left stoplight circuit (terminal C), and is connected only to the right stoplight circuit (terminal E) so the right stoplight will function normally when the service brakes are applied.

(4) When the control lever is moved to indicate a right turn, the same action occurs except that terminal E is connected to the right rear stoplight via wire 22-460, and terminal A is connected to the right front turn signal lamp via wire 460. The stoplight switch circuit [terminal D) is disconnected from the right stoplight circuit (terminal E) and connected only to the left stoplight circuit (terminal C) so the left stoplight will function normally when the service brakes are applied.

(5) When the control lever is moved to the hazard warning position, all four lights (terminals A, B, C, and E) are connected to terminal H so that all turn indicator lights on the vehicle (and trailer) will flash simultaneously. In this position, the stoplight (terminal D) is disconnected completely, since the vehicle is normally not driven with the hazard warning lights in operation.

Key to figure 2-38:

A	B. O. marker and parking light	H	Dimmer switch
B	Horn	J	Headlights
C	Panel lights	K	B. O. driving lights
D	High beam indicator light	L	Circuit breakers
E	Light switch	M	Horn button
F	Taillight and stoplight	N	Stoplight switch
G	Trailer connector receptacle	P	Dash receptacle

Circuit No.	Cable gage	Circuit description
10	12	Regulator (shunt) to circuit breaker
15	14	Circuit breaker to light switch (feed)
16	14	Light switch to dimmer switch
17	14	Dimmer switch to headlights high beam and indicator.
18	14	Dimmer switch to headlights lower beam
19	14	Light switch to B.O. driving light
20	14	Light switch to B. O. marker lights
21	14	Light switch to service taillight and trailer receptacle.
22	14	Light switch to service stoplight and trailer receptacle.
23	14	Light switch to B. O. stoplight and trailer receptacle.
24	14	Light switch to B. O. taillight and trailer receptacle.
25	14	Circuit breaker to horn to horn button
37	14	Circuit breaker to trailer receptacle (aux. power).
40	14	Light switch to instrument lights
75	14	Light switch to stoplight switch
90	14	Trailer receptacle to ground
91	14	Headlight ground
4 9 0	14	Blackout clearance light
4 9 1	14	Light switch to parking lights



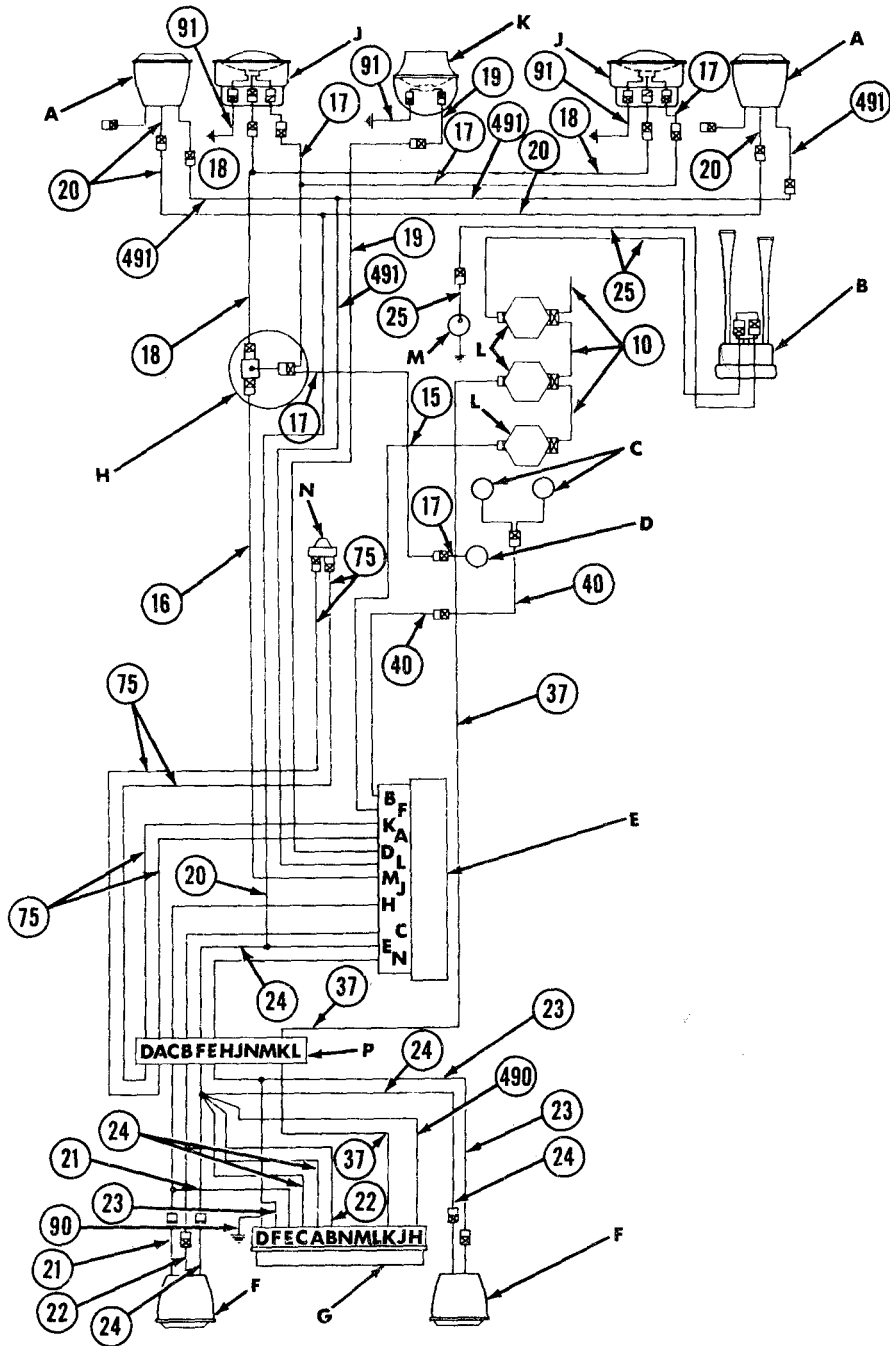
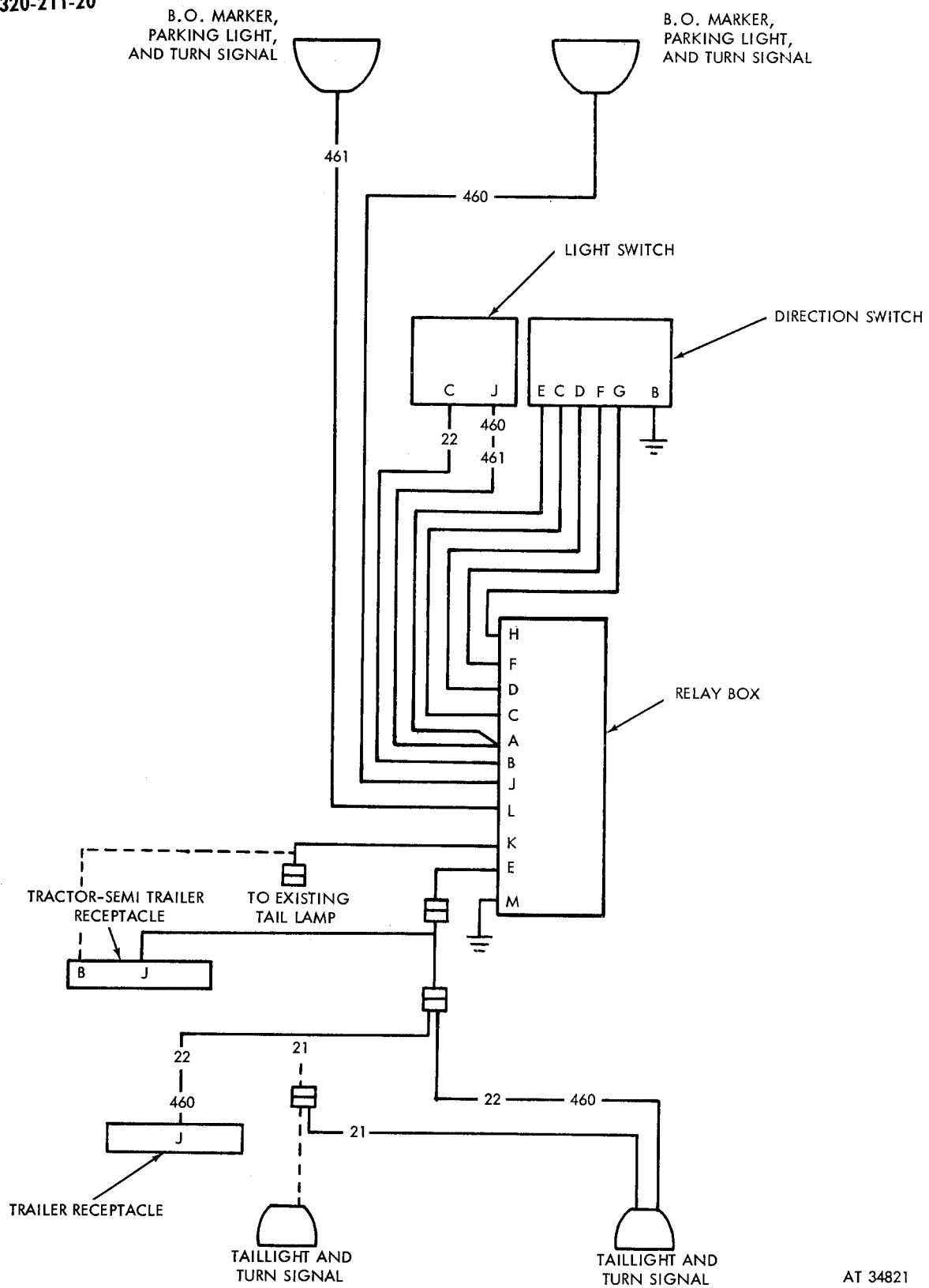


Figure 2-38. Lighting circuit diagram.

ORD E42962



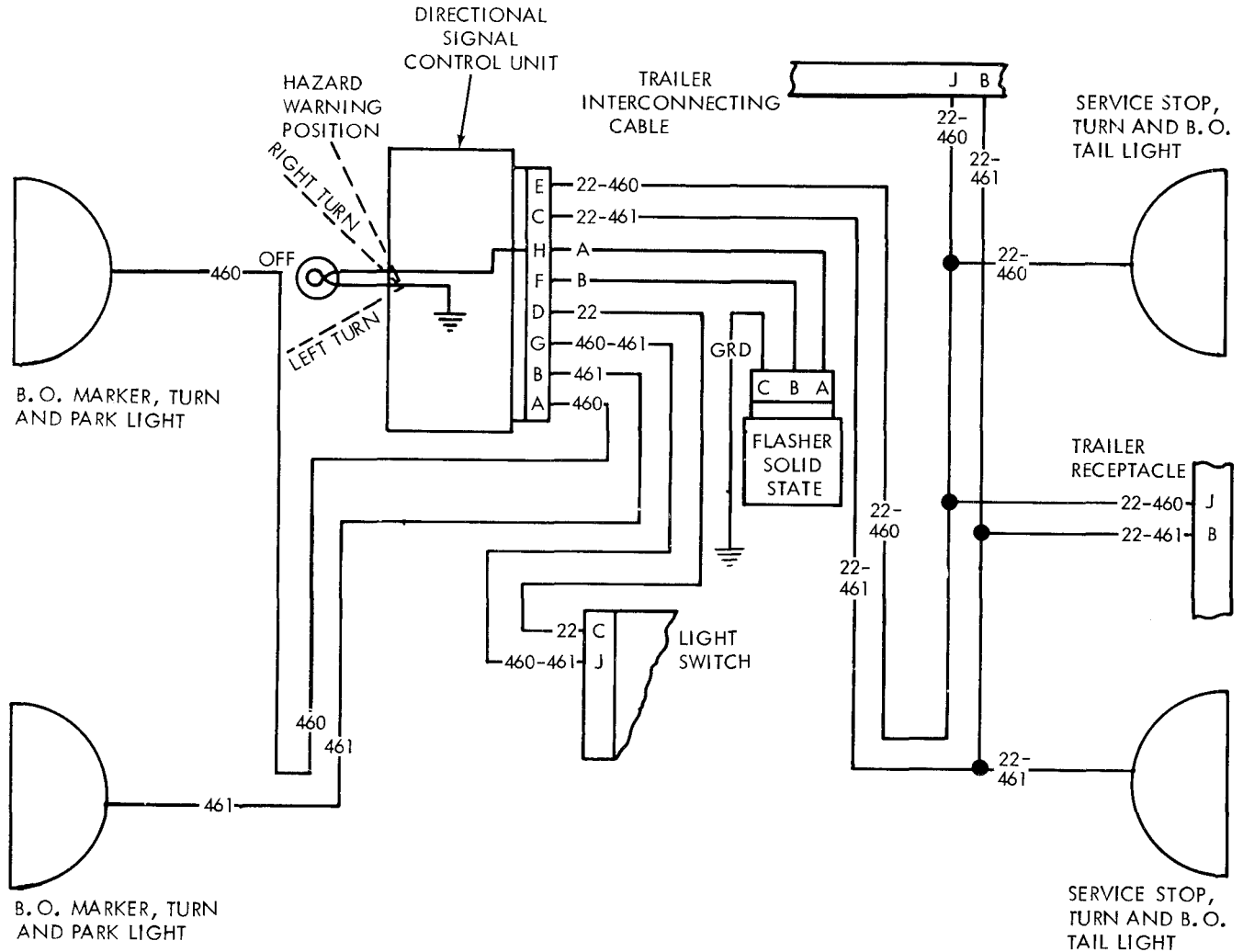
AT 34821

Figure 2-39. Supplementary turn signal wiring diagram.

Circuit No.	Cable gage
21	14
22	14
460	14
461	14

*Circuit description*

Light switch to service taillight and trailer receptacle.  
 Light switch to service spotlight and trailer receptacle.  
 B. O. marker, parking light, and turn signals.  
 B. O. marker, parking light, and turn signals.



TA010793

Figure 2-39.1. Directional signal system solid state wiring diagram.

c. *General Test Procedures.* All lights described in this section are 24-volt operated and have a 24-volt negative (—) ground, so the meter negative (—) lead will be connected to common ground for most tests unless otherwise the procedure specifies a

specific ground wire. The following procedure should be used to test the light circuits.

- (1) Place the headlight switch (fig. 2-40) in the desired position for the lights to be checked.

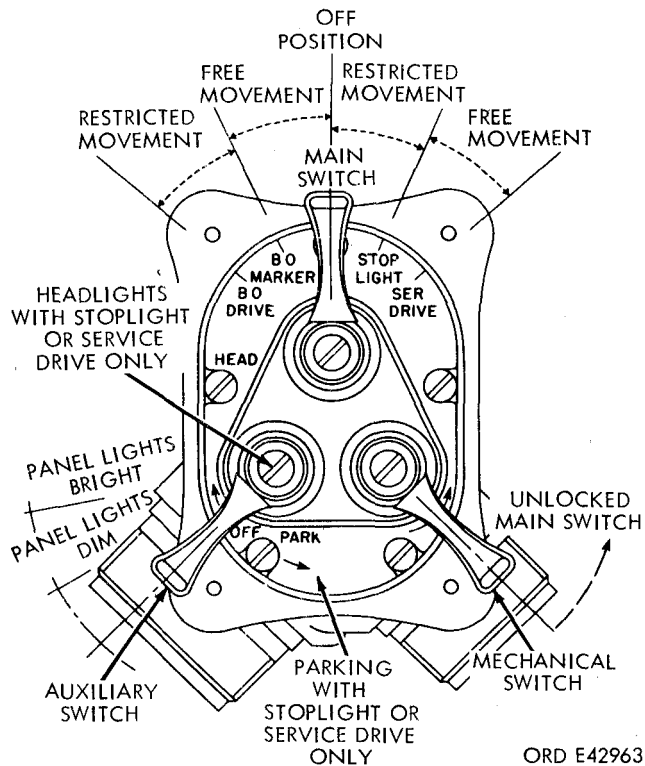


Figure 2-40. Light switch positions.

(2) Visually check the lights for proper operation.

(3) Actuate the dimmer switch for headlight operation and again visually check for proper operation.

(4) If one headlight will not operate but the other units will, the problem is not in the light switch or circuit breakers. Replace the lamp unit or check for a loose ground connection and tighten if necessary. Check and replace wiring harness as required.

(5) If all of the light units are inoperative, the problem could be in the circuit breakers or the light switch. Also, check to see that the battery cables are

tightened securely. Replace the circuit breakers or light switch and tighten the battery cables as required.

d. Directional Signal System Circuit (figure 2-40.1) (Tests 1 and 2).

**NOTE**

Before starting tests, make a thorough visual inspection for loose connection, poor ground or frayed cables. Make all necessary repairs before proceeding.

(1) *Test 1.* Perform the lamp continuity test. Set the main light switch to the STOPLIGHT position. Try all positions of the directional signal control lever, and observe which lights do not light in any position of the lever. Have an assistant depress the brake pedal and observe the stoplights. If the stoplights light, the rear lamps are operational. If the stoplights do not light, or if the front turn indicators do not light in any position of the control lever, turn the light switch to the OFF position and disconnect connector 460, 461, 22-460, or 22-461, corresponding to the defective light (fig. 2-40.1). Set up the multimeter for a continuity test. Clip the black test lead to the vehicle frame. Touch the red test lead to the connector on the light as shown in figure 2-40.1, test 1. If the meter needle deflects to approximately 5 ohms, the lamp is normal and the trouble is elsewhere. If the meter does not deflect at all (infinity reading), replace the lamp and re-test. If the meter still shows infinity or considerably more than 5 ohms, touch the red test lead to the frame ground making sure to scrape through the paint to the bare metal. If the meter does not deflect completely to zero ohms, inspect the ground connection by removing the wire and scraping all metal surfaces bright, and reconnecting. When the light has been restored to 5 ohms, reconnect the connector and test the directional system again. If the trouble still exists, perform the wire harness tests.

(2) Test 2. Perform the wiring harness voltage test. Set up the multimeter for dc voltage tests. Disconnect connectors 460, 461, 22-460, or 22-461, corresponding to defective light (fig. 2-40.1). Set the main light switch to the STOPLIGHT position and the directional signal control lever to the HAZARD WARNING position. Connect the multimeter as shown in fig. 2-40.1, test 2. Clip the

black test lead to the vehicle frame. Touch the red test lead to the center contact of the cable connector on the wiring harness. The voltmeter needle should deflect at a rate of 1 to 2 times per second. If meter needle does not deflect, leave the connector disconnected from the light and perform the wiring harness continuity test.

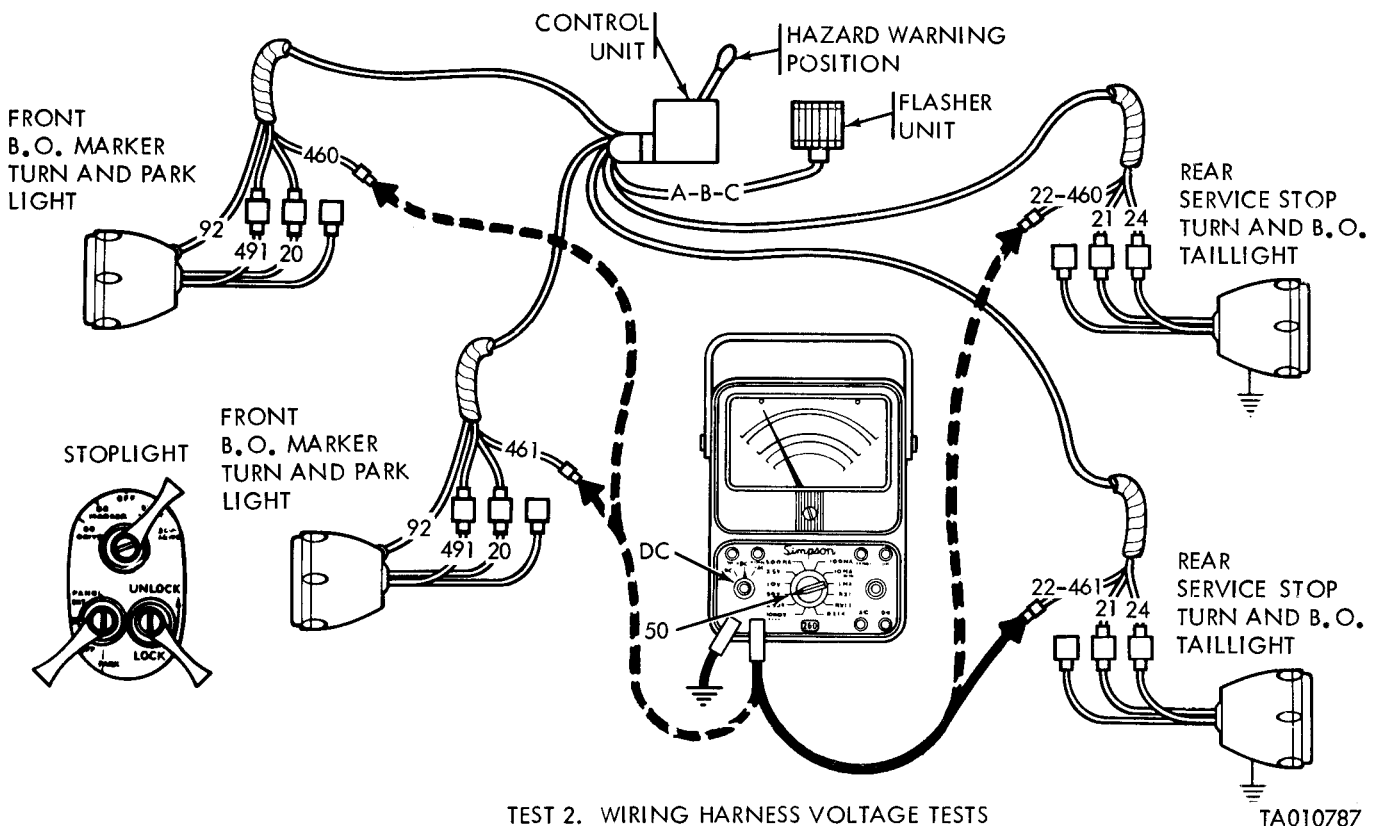
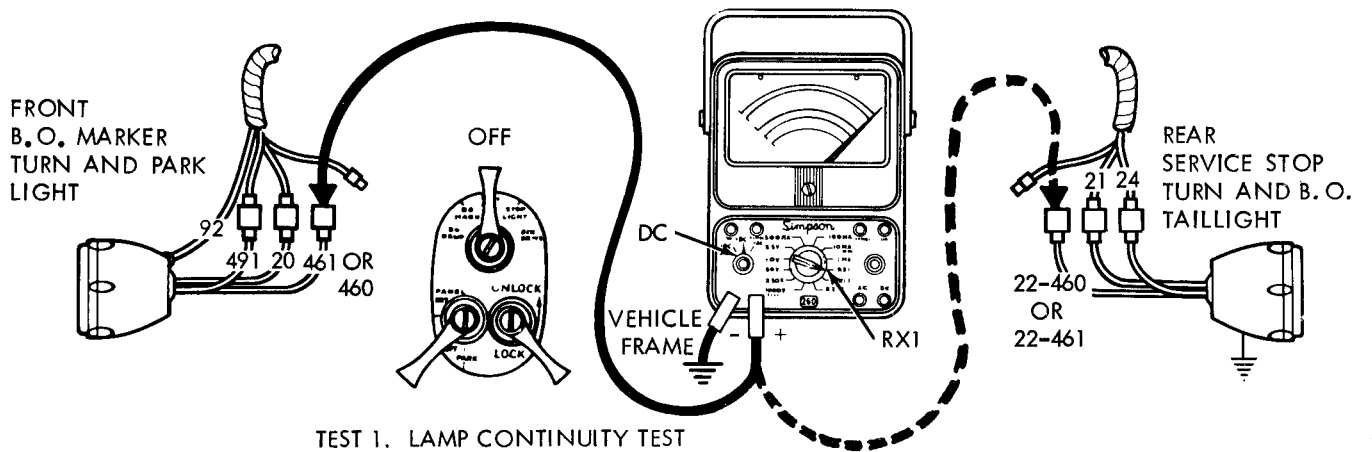


Figure 2-40.1. Directional signal system tests, 1 and 2.

e. Directional Signal System Circuit (figure 2-40.2) (Tests 3, 4 and 5).

Malfunction: Individual lamps do not light with directional signal control lever in any position. Circuit: 460, 461, 22-460, and 22-461.

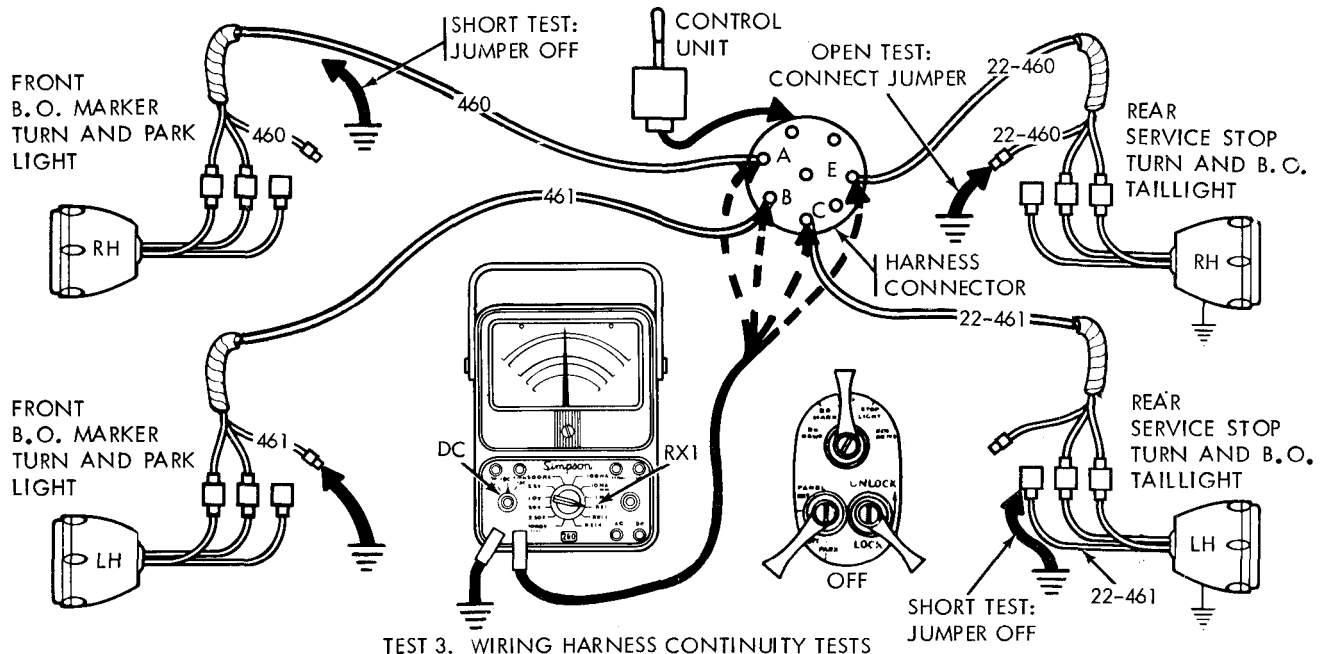
(1) Test 3. Perform the wiring harness continuity test. Set up the multimeter for a continuity test (see fig. 2-8.4). Set the main light switch to OFF. Connect the black test lead to the vehicle frame near the control unit. Remove the cable

connector from the control unit. Touch the red test lead to a socket in the cable connector to correspond with the defective circuit. The meter needle should not deflect (infinite reading). If there is any deflection, the wiring harness has a short circuit, or a high-resistance leakage. Inspect the harness for frayed or pinched cables, and make repairs. If infinity is indicated on the meter, connect a jumper wire from the vehicle frame to the cable connector at the lights as shown in figure 2-40.2, test three (3). Touch the red test lead to the appropriate socket terminal in the cable connector at the control unit. The meter needle should deflect fully showing zero ohms. If the needle deflects less than full deflection, inspect the wiring harness for breaks, frayed wires, corroded connections; etc., and make necessary repairs. When all lamp and wiring harnesses have continuity restored, and the system still does not operate, perform the flasher and control unit tests.

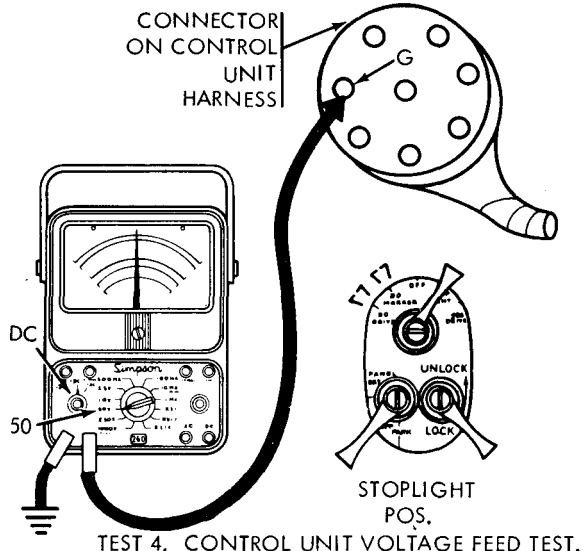
Malfunction: No lights operate with directional signal control lever in any position. Circuit: 460, 461.

(2) *Test 4.* Perform the directional signal control unit voltage feed test. Set up the multimeter for dc voltage testing (see fig. 2-8.1). Remove the cable connector from the directional signal control unit. Set the main light switch to the STOPLIGHT position. Measure the voltage from the vehicle frame to terminal G of the cable connector on the wiring harness, figure 2-40.2, test 4. The meter needle should indicate 24 volts. If the reading is less or none, remove the cable connector from the light switch and perform the continuity test. If continuity is satisfactory, the light switch is defective (fig. 2-40.3). When 24 volts has been restored to contact G of the directional control unit cable connector and the system still does not operate, perform the flasher continuity test.

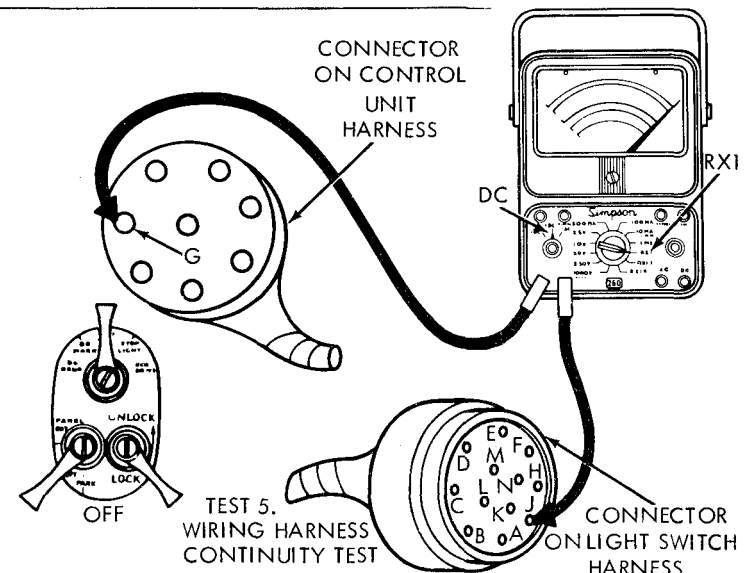
(3) *Test 5.* Perform the wiring harness continuity test. Set up the multimeter for continuity testing (fig. 2-8.4). Connect the test leads between contact G on the control unit end, and contact J at the light switch end (fig. 2-40.2).



TEST 3. WIRING HARNESS CONTINUITY TESTS



TEST 4. CONTROL UNIT VOLTAGE FEED TEST.



TEST 5. WIRING HARNESS CONTINUITY TEST

TA010788

Figure 2-40.2. Directional signal system tests 3, 4 and 5.

*f*, Directional Signal System Circuit (fig. 2-40.3) Tests 6 and 7).

Circuit: A, B, C.

(1) **Test 6.** Perform the flasher unit continuity test. Set up the multimeter for continuity testing (fig. 2-8.4). Remove the cable connector from the flasher unit. Remove the cable connector from the control unit. Measure continuity between the cable wires (fig. 2-40.3, test 6). If any wire does not have continuity, inspect it and make necessary repairs. If all three wires show continuity perform the flasher operational test.

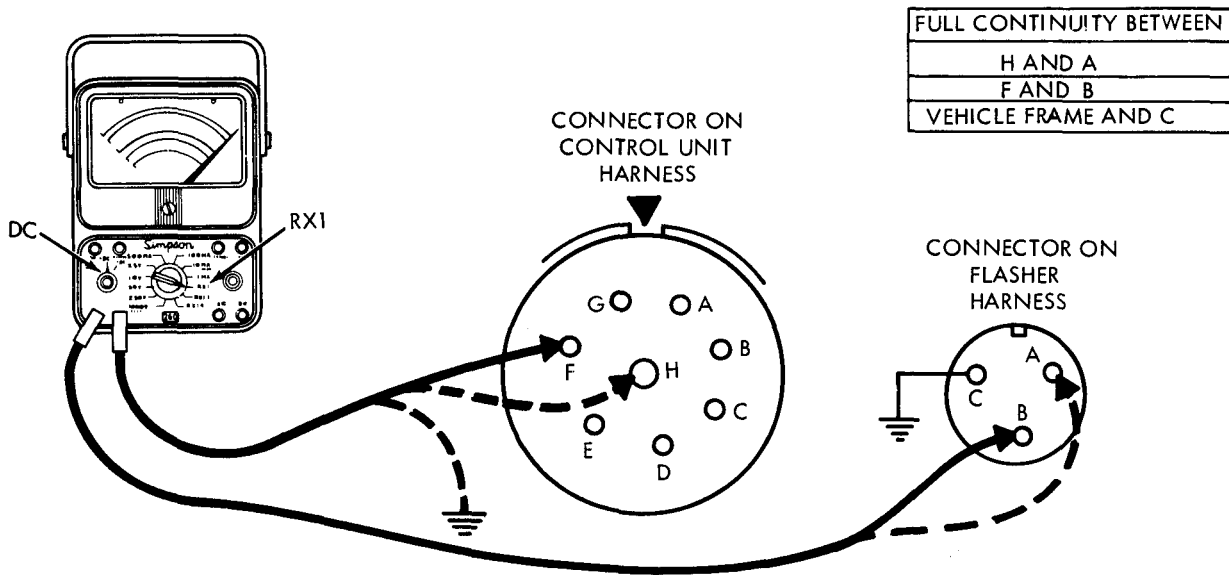
**NOTE**

It may be necessary to remove the flasher from the vehicle to make test 7 and 8.

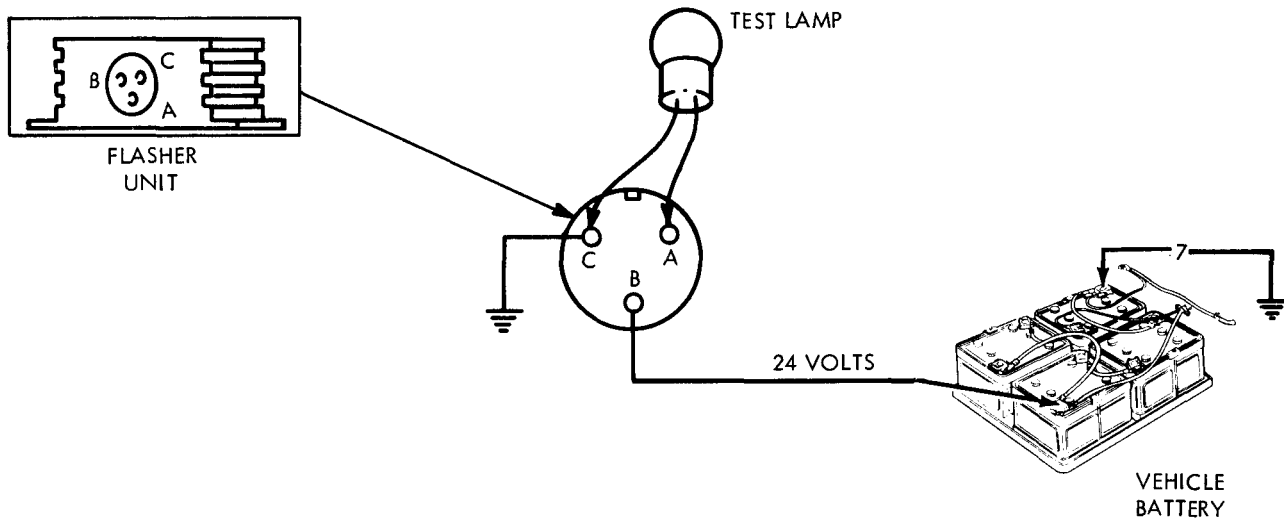
Malfunction: Flashes erratically, no flash, or very slow flash. Circuit: A, B, C.

(2) **Test 7.** Perform the flasher operational test. Disconnect the cable connector from the flasher. Connect a source of positive 24 volts to terminal B of the flasher socket. (If voltage is inadvertently reversed to the flasher, it will not operate. However, the flasher will not be harmed, due to a built-in reversal protection.) Connect an MS35478-1683 lamp between contact A and C. Connect contact C to negative 24 volts, (fig. 2-40.3, test 7). The flasher should flash at the rate of 60 to 120 flashes per minute at a regular rate without skipping. If it does not flash, or flashes irregularly,

replace the flasher unit. If the flasher test is satisfactory, perform the control unit bench test.



TEST 6. FLASHER UNIT CABLE CONTINUITY TEST.



TEST 7. FLASHER OPERATIONAL TEST

TA010789

Figure 2-40.3. Directional signal system tests, 6 and 7.

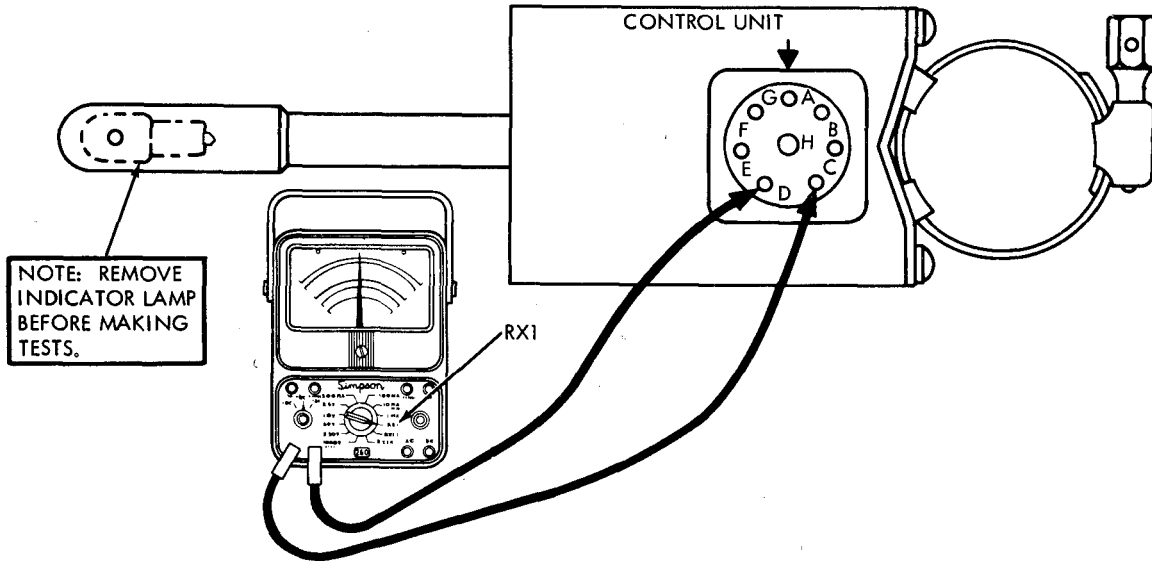
g. *Directional Signal System Circuit* (fig. 2-40.4) (Test 8).

Malfunction: System operates incorrectly in one or more positions of the directional signal control lever (all lights and wiring harness test satisfactory). Circuit: 22, 22-260, 22-261, 460, and 461.

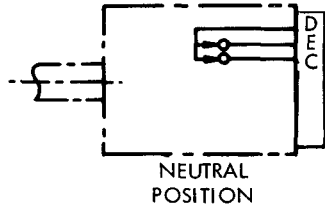
Perform the directional signal control unit continuity test. Set up the multimeter for continuity

testing (fig. 2-8.4). Remove the cable connector from the control unit, and if necessary, remove the control unit from the vehicle. Remove the indicator lamp from the control arm. Set the control lever in each of the four operating positions and perform tests (fig. 2-40.4). If any circuit does not test as shown, replace the control unit.



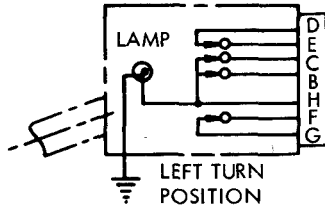


**SCHMATIC DIAGRAM**



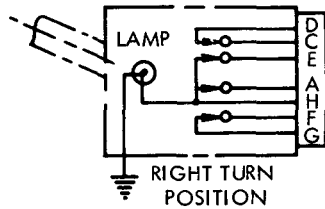
FROM PIN:	TO PIN:	INDICATION
H	A	OPEN
H	B	OPEN
H	C	OPEN
H	E	OPEN
D	C	SHORTED
D	E	SHORTED
F	G	OPEN

**A. DIRECTIONAL SIGNAL CONTROL LEVER IN "NEUTRAL" POSITION**



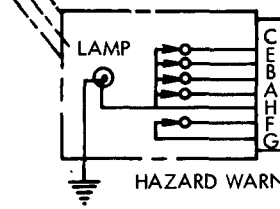
H	B	SHORTED
H	C	SHORTED
H	A	OPEN
H	E	OPEN
F	G	SHORTED
D	E	SHORTED
D	C	OPEN

**B. DIRECTIONAL SIGNAL CONTROL LEVER IN "LEFT TURN" POSITION**



F	G	SHORTED
H	A	SHORTED
H	E	SHORTED
H	B	OPEN
H	C	OPEN
D	C	SHORTED
D	E	OPEN

**C. DIRECTIONAL SIGNAL CONTROL LEVER IN "RIGHT TURN" POSITION**



H	A	SHORTED
H	B	SHORTED
H	C	SHORTED
H	E	SHORTED
D	E	OPEN
D	C	OPEN
F	G	SHORTED

**D. DIRECTIONAL SIGNAL CONTROL LEVER IN "HAZARD WARNING" POSITION**

TEST 8. DIRECTIONAL SIGNAL CONTROL UNIT CONTINUITY TESTS.

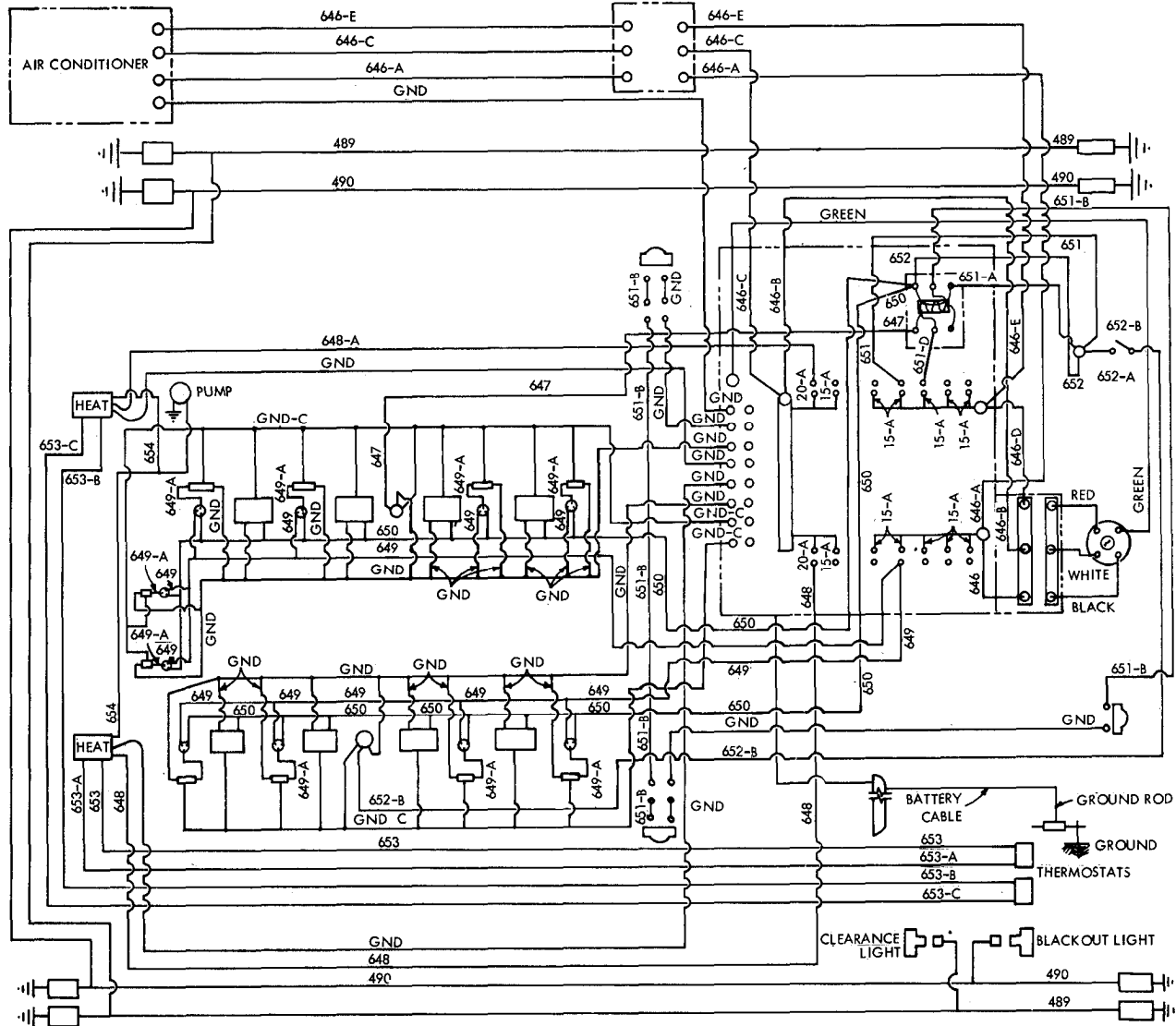
TA010790

Figure 2-40.4. Directional signal system test 8.

**2-35. Electrical System for Expansible Van body**

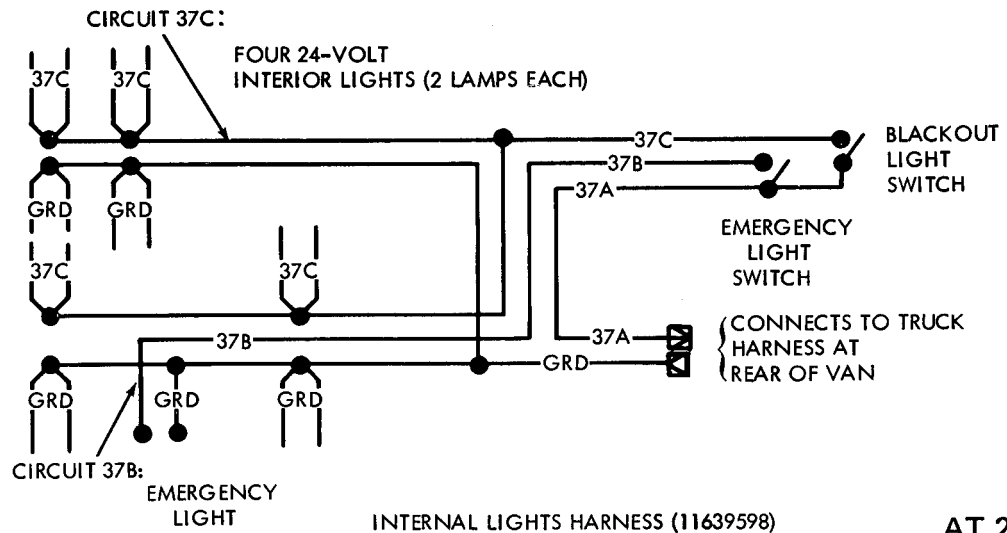
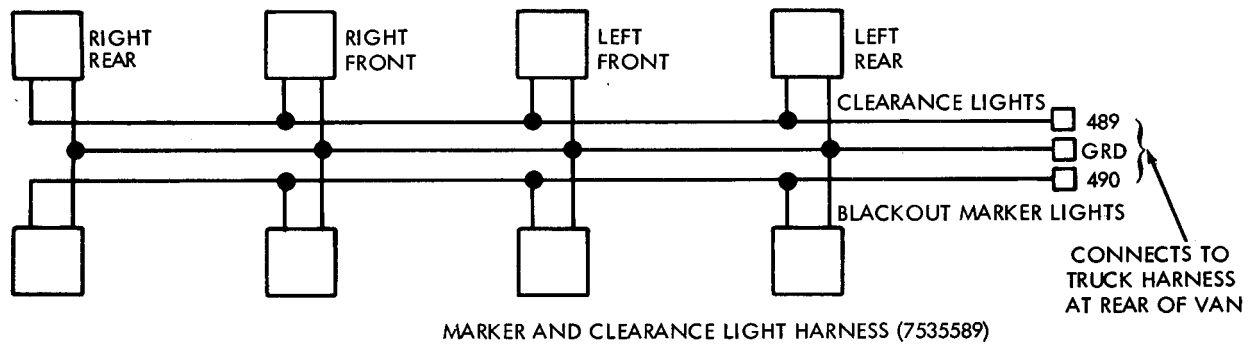
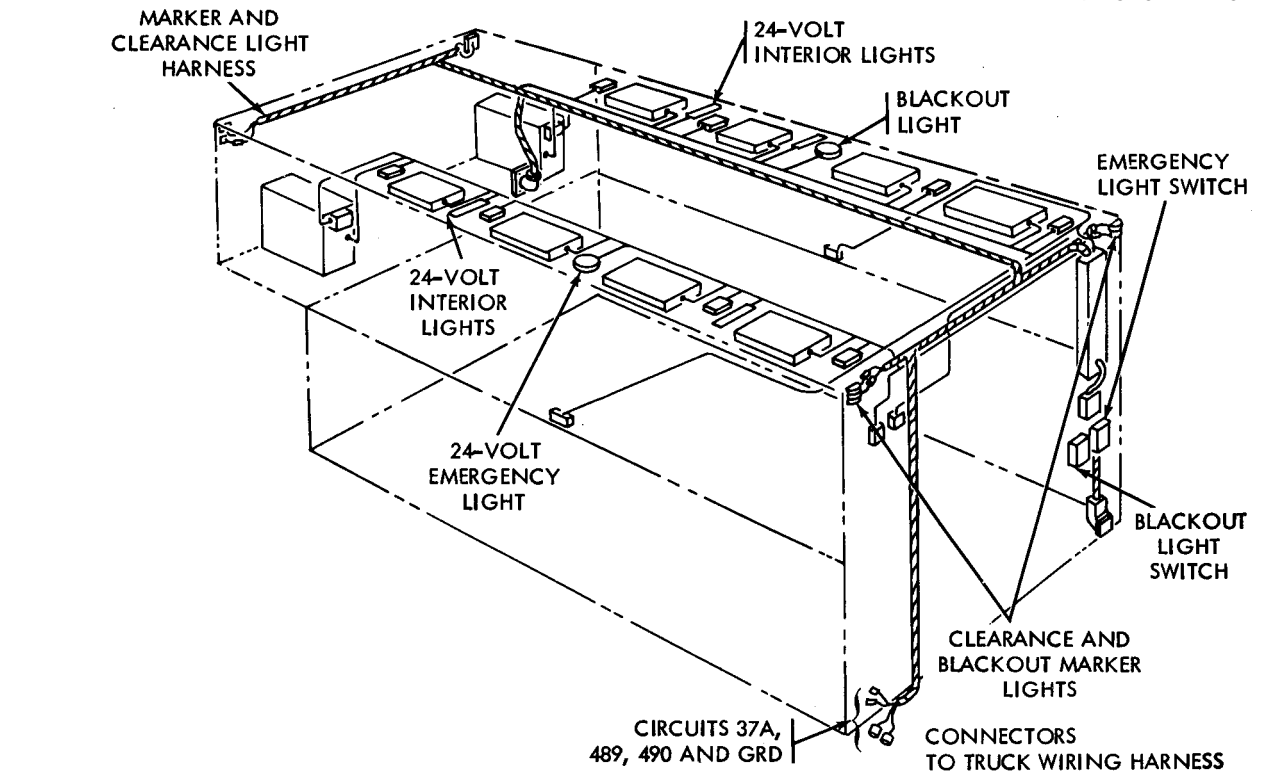
The van body electrical systems (fig. 2-41) are divided into ac and dc systems. The 24-volt dc system obtains its power from the truck electrical system and supplies power for clearance lights, blackout marker lights, interior emergency light,

and interior blackout lights. The 100 / 208 volt ac system obtains its power from an external power source and supplies power to the blackout and fluorescent lights, heaters, air condition, and power receptacles. These circuits, along with overload protective devices and control instruments are described in paragraph 2-246.



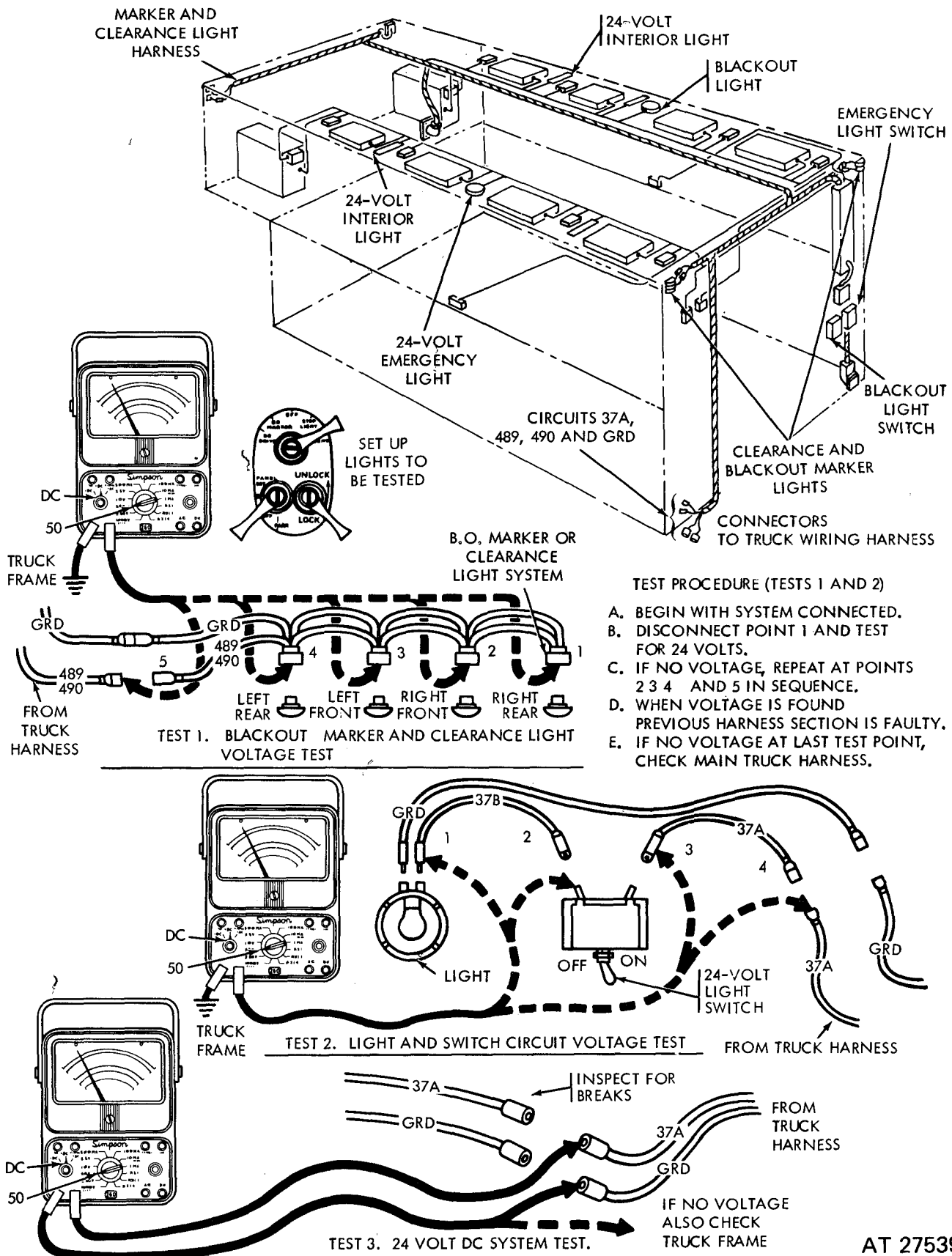
ORD E78492

Figure 2-41. Expansible van wiring diagram.



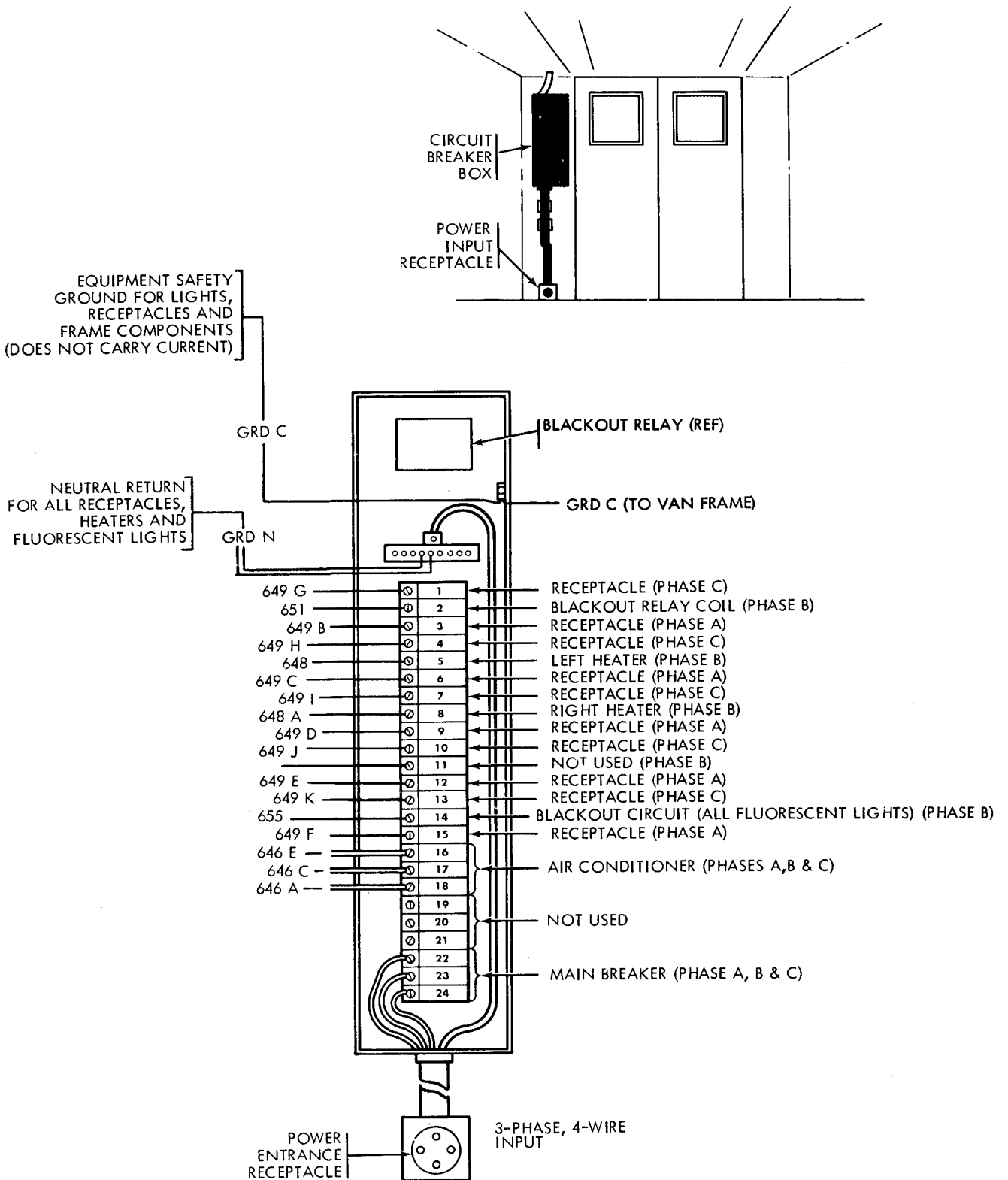
AT 27538

Figure 2-41.1. Van body 24-volt dc system wiring diagram.



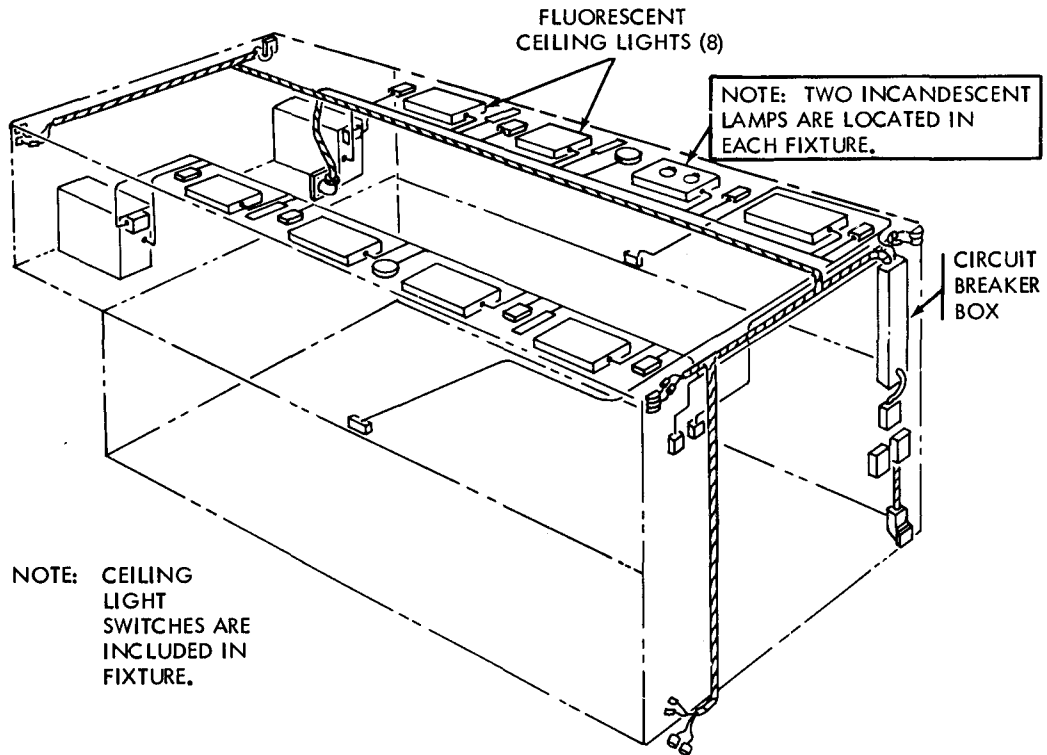
AT 27539

Figure 2-41.2. Van body 24-volt dc system tests 1, 2, and 3.



AT 27540

Figure 2-41.3. Van body 120 / 208-volt ac system wiring diagram.



OBSERVED SYMPTOM	PROBABLE CAUSE	REMEDY
DELAYED OR SLOW START	LOW CIRCUIT VOLTAGE OR INCORRECT FREQUENCY LOW SURROUNDING TEMPERATURE END OF LAMP LIFE	ADJUST VOLTAGE TO 115 VOLTS, 60 CYCLES RAISE ABOVE 65°F. REPLACE LAMP
BLINKS, BUT WON'T START	LOOSE SOCKET CONTACTS LOW CIRCUIT VOLTAGE LOW TEMPERATURE END OF LAMP LIFE	REPAIR SOCKET ADJUST TO 116 VOLTS RAISE TO 65°F. REPLACE LAMP
GLOWS DIMLY, BUT DOES NOT BLINK OR START	DEFECTIVE STARTER DEFECTIVE BALLAST	REPLACE FIXTURE REPLACE FIXTURE
STARTS, BUT IS DIM AND HAS DARK AREAS	TEMPERATURE BELOW 50°F. TEMPORARY LAMP DEFECT	RAISE ABOVE 65°F. ALLOW WARM-UP TIME
BOTH ENDS BLACKENED AND LAMP FLICKERS	END OF LAMP LIFE	REPLACE LAMP

TEST 1. FLUORESCENT LIGHT OBSERVATION TEST

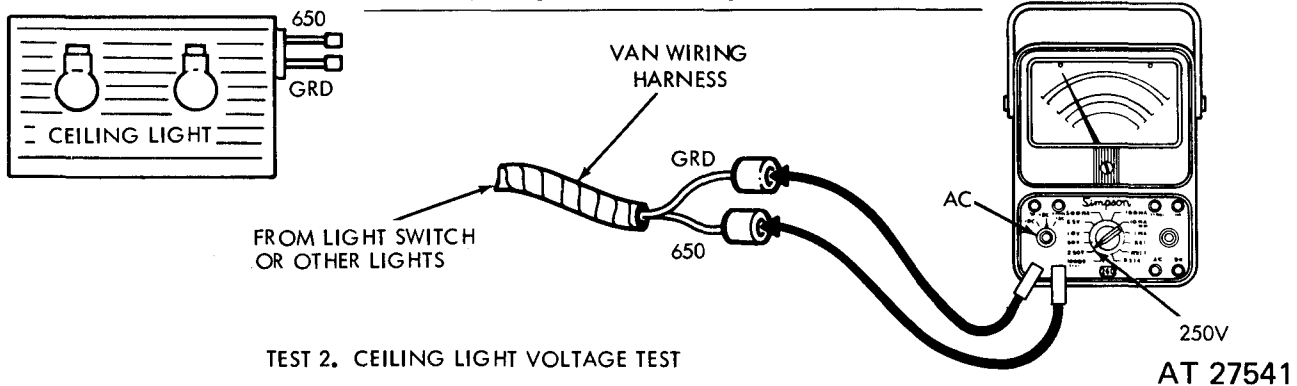
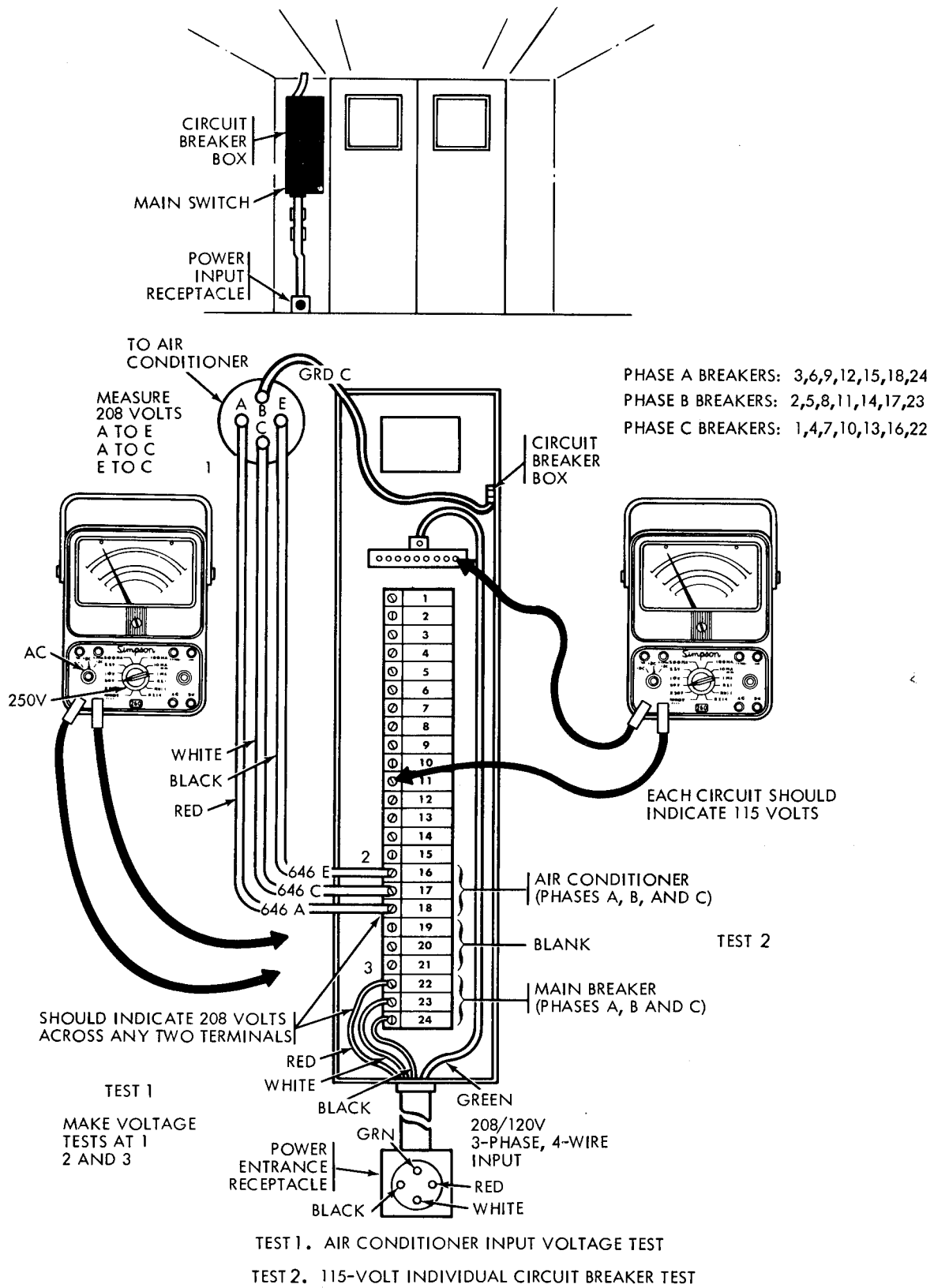
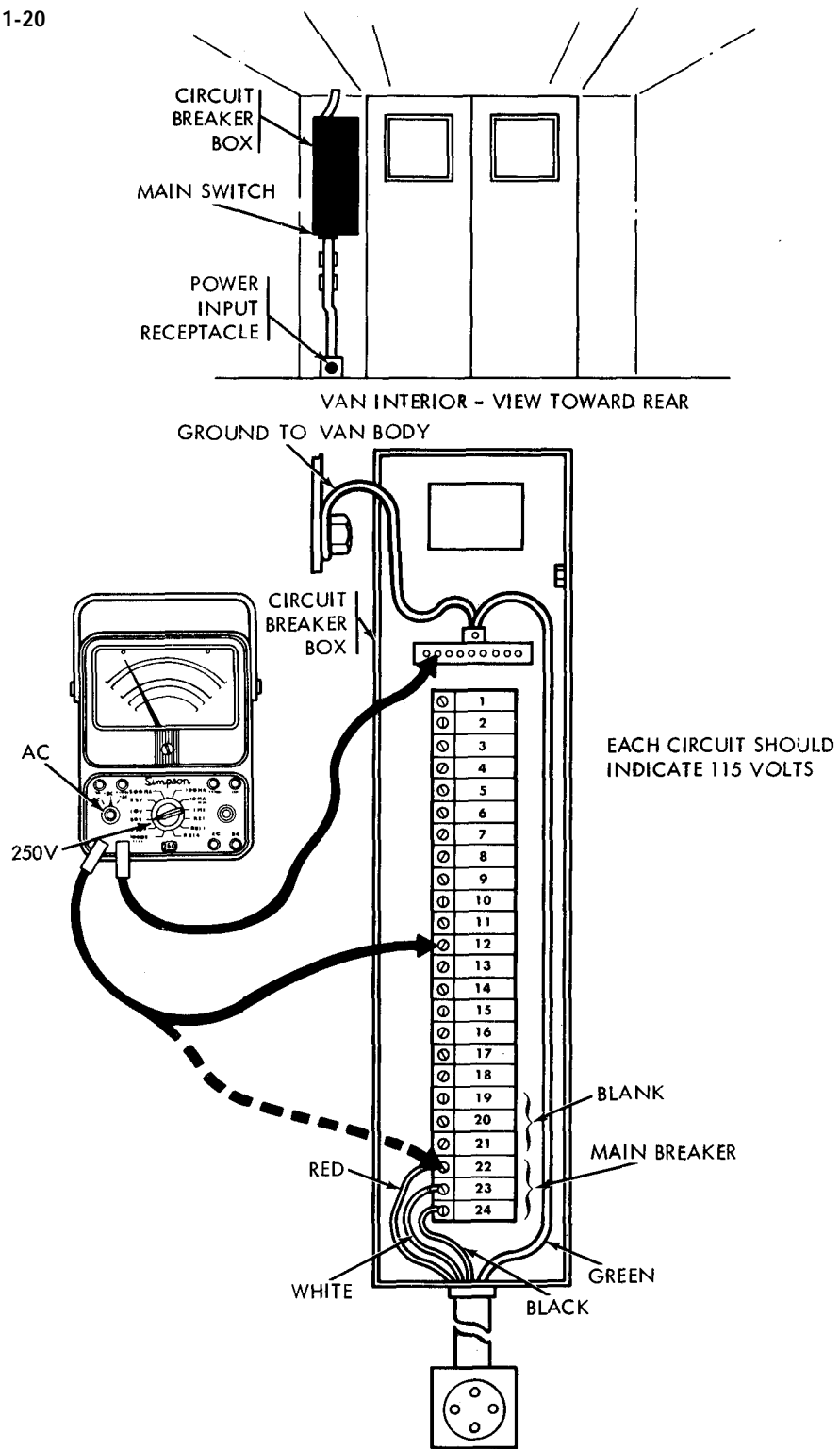


Figure 2-41.4. Van body 120-volt lighting circuit tests 1 and 2.



AT 27542

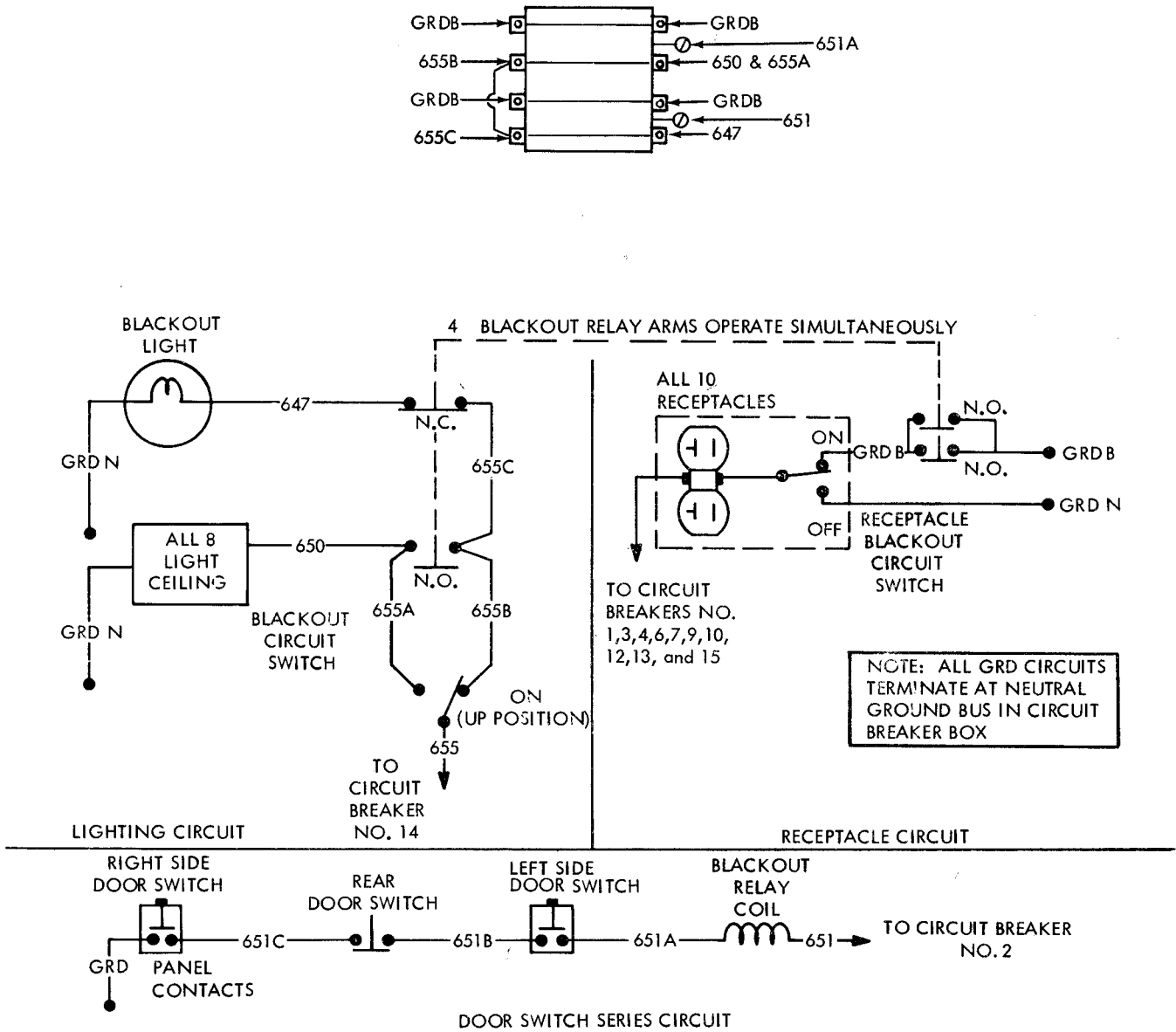
Figure 2-41.5. Van body 120 / 208-volt ac system tests 1 and 2.



AT 2754

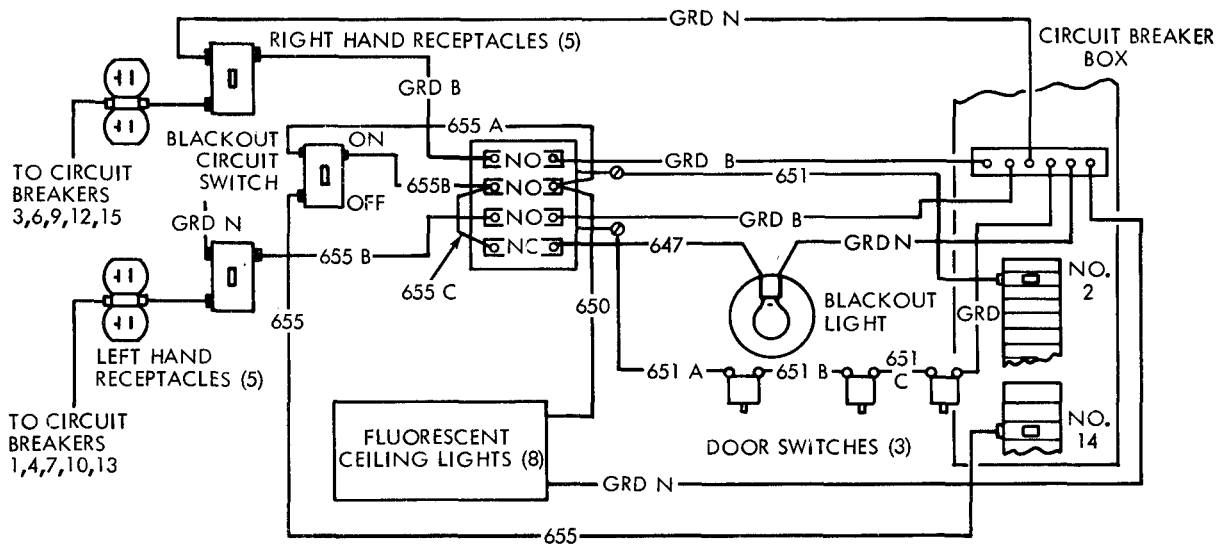
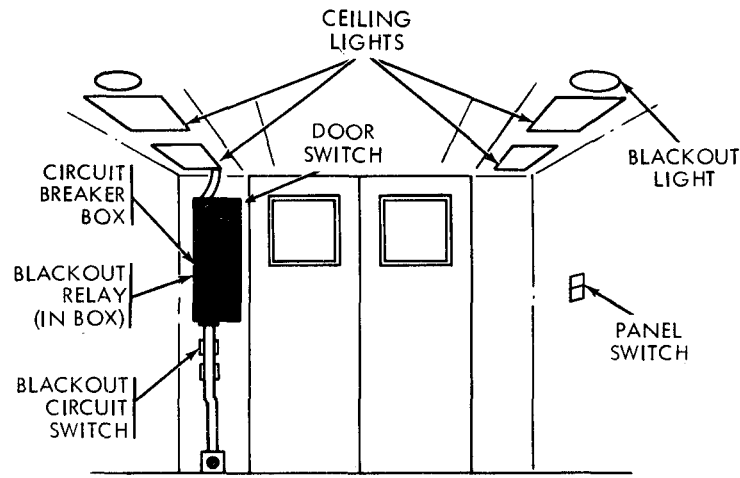
Figure 2-41.6. Van body 120 / 208-volt ac system test 3.





AT 27544

Figure 2-41.7. Van body blackout relay system wiring diagram..



TEST NO.	TEST CONDITIONS			LIGHTING		115.V SHOULD BE BETWEEN	MEASURED AT	FAULTY PART IF NO VOLTAGE
	CIRCUIT BREAKER NO. 2	B.O. SWITCH	DOOR POSITION	B.O. LIGHT	CEILING LIGHT			
A	ON	ON	OPEN	OUT	OUT	655 & GRD	CIRCUIT BREAKER NO. 14	CIRCUIT BREAKER NO. 14
B	ON	ON	OPEN	OUT	OUT	655B & GRD	RELAY	B.O. SWITCH
C	ON	ON	OPEN	OUT	OUT	647 & GRD	RELAY	RELAY
D	ON	ON	CLOSED	LIT	OUT	651 & GRD	RELAY	DOOR SWITCH
E	ON	ON	CLOSED	LIT	OUT	651A & GRD	RELAY	RELAY
F	OFF	ON	CLOSED	LIT	LIT	-	-	RELAY
G	OFF	ON	OPEN	OUT	LIT	-	-	RELAY
H	OFF	ON	CLOSED	OUT	OUT	647 & GRD	RELAY	RELAY
I	ANY	OFF	ANY	OUT	OUT	655 & GRD	CIRCUIT BREAKER NO. 14	CIRCUIT BREAKER NO. 14
J	ANY	OFF	ANY	OUT	OUT	655A & GRD	B.O. SWITCH	B.O. SWITCH
K	ANY	OFF	ANY	OUT	OUT	650 & GRD	CEILING LIGHT	VAN HARNESS

AT 27545

Figure 2-41.8. Van body blackout relay system tests.

### 2-36. General Methods Used to Attain Proper Suppression

Essentially, suppression is attained by providing a low resistance patch to ground for the stray currents. The methods used included shielding the ignition and high-frequency wires, grounding the frame with bonding straps, and using capacitors and resistors.

### 2-37. Interference Suppression Components

Radio interference suppression is accomplished in the electrical subassemblies of this vehicle by use of shielding, feed-through type capacitors, teeth type lockwashers, suppressed spark plugs, and braided bond straps.

### 2-38. Replacement of Suppression Components

#### a. Ignition and Starting System Radio Interference Suppression.

(1) *General.* The high tension harness assemblies and the cable to each spark plug are individually shielded utilizing molded rubber-covered, woven, metallic hose shielding terminated at all joints with appropriate threaded fittings. Each spark plug is integrally shielded and suppressed with a 10,000 ohm built-in resistor-suppressor. The ignition coil is likewise integrally shielded and suppressed. The primary connection at the distributor terminal is equipped with a feed-through capacitor (condenser).

#### (2) Maintenance.

(a) *Distributor capacitor (condenser)* (fig. 2-37). To replace the distributor capacitor, disconnect the primary cable at the distributor. Remove eight screws and lockwashers from the distributor cover and remove the cover and gasket. Discard the gasket. Remove four screws and lockwashers holding the primary lead in the receptacle to the side of the distributor and remove the receptacle and gasket. Discard the gasket. Disconnect the capacitor cable or primary cable from the resistor terminal, and pull out the capacitor.

(b) *Spark plug cables.* Replace spark plug cables if the rubber or metallic shielding is damaged in any way (para 2-119).

(c) *Starter capacitor.* Remove the commutator end cover from the starter (fig. 2-42) by raising clips from the groove in the starter housing and slide off the cover. Disconnect the capacitor cable from the terminal on the brush holder, remove the capacitor-mounting screw, and remove the capacitor. Position a new capacitor, and install the mounting screw. Connect the cable to the brush holder terminal through the groove in the starter frame. Install the commutator end cover.

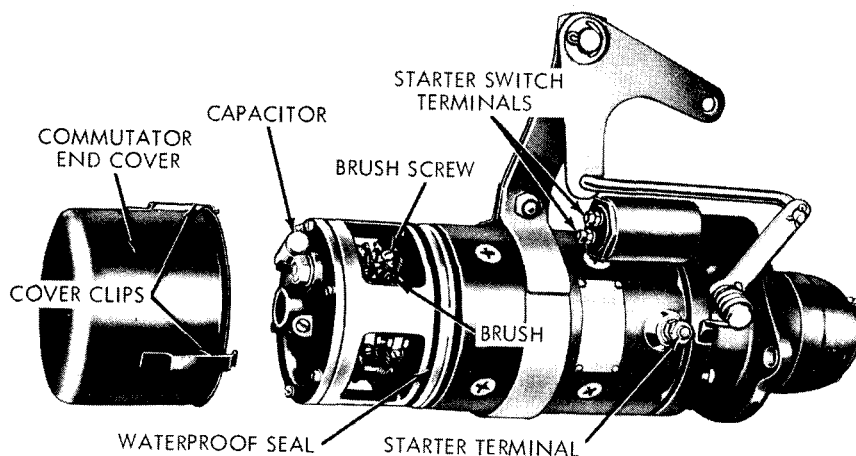


Figure 2-42. Starter with cover removed.

ORD E43176

*b. Generator System Radio Interference Suppression.*

(1) *General.* The generator mounting bracket is bonded to the engine with plated, toothed lockwashers. The generator itself is bonded to its mounting bracket in similar manner, and is integrally shielded and suppressed. The armature and field lead from the generator to the regulator is inclosed in rubber-covered flexible metallic hose and terminated at each end, utilizing appropriate threaded fittings. The generator regulator is integrally shielded and suppressed, and its mounting is bonded to the firewall of the vehicle with plated, teeth type lockwashers.

(2) *Maintenance.*

(a) *Generator capacitor.* Since generator capacitor replacement requires generator disassembly, the capacitor will not be removed while the generator is mounted on the vehicle. Notify supporting maintenance personnel.

(b) *Generator-regulator capacitor.* Generator-regulator capacitor replacement requires regulator disassembly; therefore, the capacitor will not be removed while the regulator is mounted on the vehicle. Notify supporting maintenance personnel.

*c. Radio Interference Suppression Bonding.*

(1) *General.* Bond straps are used to unite all parts and thereby form a shield about the entire powerplant.

(2) *Description and data.* The following is a list of locations of the bonding straps surrounding the powerplant.

(a) *The* upper brush guard support brackets bonded to each fender by a tinned copper braid bond strap and plated, teeth type lockwashers.

(b) *The* radiator bonded to the engine

support brackets on each side by a tinned copper braid bond strap and plated, teeth type lockwashers.

(c) *The* engine cylinder head bonded to the firewall in a similar manner.

(d) *The* transmission bonded to the frame sidemember by a tinned copper braid bond strap and plated, teeth type lockwashers.

**2-39. Test for Radio Interference**

The overall efficiency of the radio interference suppression system may be tested as follows:

a. Position a radio-equipped vehicle within 25 feet of the truck to be tested. Shut off its engine and turn on its radio equipment for maximum sensitivity.

b. Turn on the radio equipment in the test truck, if so equipped.

c. Start the truck engine and turn on all auxiliary equipment. No increase in background noise in either the truck equipment or the nearby vehicle should be heard.

d. If noise is heard in either radio equipment, turn off or disconnect the electrical generating or operating components one at a time until the noise stops.

e. When a component is found which causes interference, check it carefully for loose connections, secure mountings, missing tooth washers, or damaged or broken metal housing.

f. If the interference cannot be eliminated with thorough cleaning and minor repairs, replace the component.

g. If radio interference still is present, repeat operation d above. More than one component may be causing interference.

**Section VIII. FIELD EXPEDIENT REPAIRS**

**2-40. General**

Organizational maintenance troubles may occur while the vehicle is operating in the field where supplies and repair parts are not available for normal corrective action. The following expedient repairs may be made in emergencies, but vehicles

must be removed from operation as soon as possible for proper repairs. Additional field repairs are noted in TM 9-2320-211-10.

**2-41. Procedures**

Once the trouble is isolated, refer to Table 2-5 to find a possible expedient repair.

Table 2-5. Field Expedient Repairs

Trouble	Expedient remedy
1. Front differential noisy	Remove front propeller shaft and axles, and operate the vehicle without front-wheel drive.
2. Defective differential	Remove intermediate-to-rear axle propeller shaft and rear axle shafts. When axle shafts are removed, the openings in the ends must be covered securely to keep out dirt and foreign matter.
3. Noisy intermediate or rear axle wheel bearings.	
a. Burned-out wheel bearings (intermediate axle).	Move the disabled wheel onto a rock, log, or similar object to raise the wheel as high as possible if a jack is not available. While the wheel is raised, tie the axle as tight as possible to the frame with a chain. Caution should be exercised to prevent the chain from causing damage to the brake lines. Remove the axle shaft from the axle housing and cover the opening to keep out foreign matter. Repeat the operation on the opposite side of the vehicle.
b. Burned-out wheel bearings (rear axle).	Repeat the operation described above for intermediate-to-rear axle propeller shaft instead of axle shafts.
4. Intermediate differential noisy. Defective differential.	Remove transfer-to-intermediate and intermediate-to-rear axle propeller shafts. Remove axle shafts from axles with defective differentials. The vehicle will operate on power supplied by the front axle.

**NOTE**

When wheels are tied up, the vehicle should not be loaded too heavily.

**NOTE**

When power is supplied by the front axle only, the vehicle should not be loaded too heavily.

## Section IX. ENGINE MAINTENANCE IN VEHICLE—GASOLINE

### 2-42. General

The gasoline engine is a 4-cycle, 6-cylinder, in-line, valve-in-head, liquid-cooled, electrically-ignited Continental R6602 model. Left and right are the left and right sides respectively of the engine as viewed from the operator's seat. Front is the fan and drive belt end of the engine, while rear is the flywheel end.

### 2-43. Compression Test

**NOTE**

Battery voltage should be normal (para 2-22) before proceeding with the following steps.

a. Remove all spark plugs (para 2-121) from the left side of the engine.

b. Pull out the throttle control knob (fig. 2-163) as far as it will go and leave it in the locked-out position.

**CAUTION**

Do not crank the engine more than is necessary to obtain a maximum reading.

c. Insert a compression gage in the No. 1 spark plug hole, depress the starter button to crank the engine, and note the maximum compression indicated by the gage.

d. If the pressure in the cylinder is appreciably below normal (110 to 130 psi), pour one teaspoonful of engine oil through the spark plug hole on top of the piston to prevent loss of compression temporarily and repeat *c* above.

**NOTE**

Low compression brought up to normal by oil sealing indicates piston, piston ring, or cylinder sleeve wear or damage. Low compression not brought up to normal by this method indicates valve or cylinder head gasket leakage. In either case, notify direct support maintenance personnel.

e. Repeat *c* above for each remaining cylinder, and if necessary, repeat *d* above.

f. When the compression test is completed, install the spark plugs (para 2-121).

g. Release the throttle control (para 2-68).

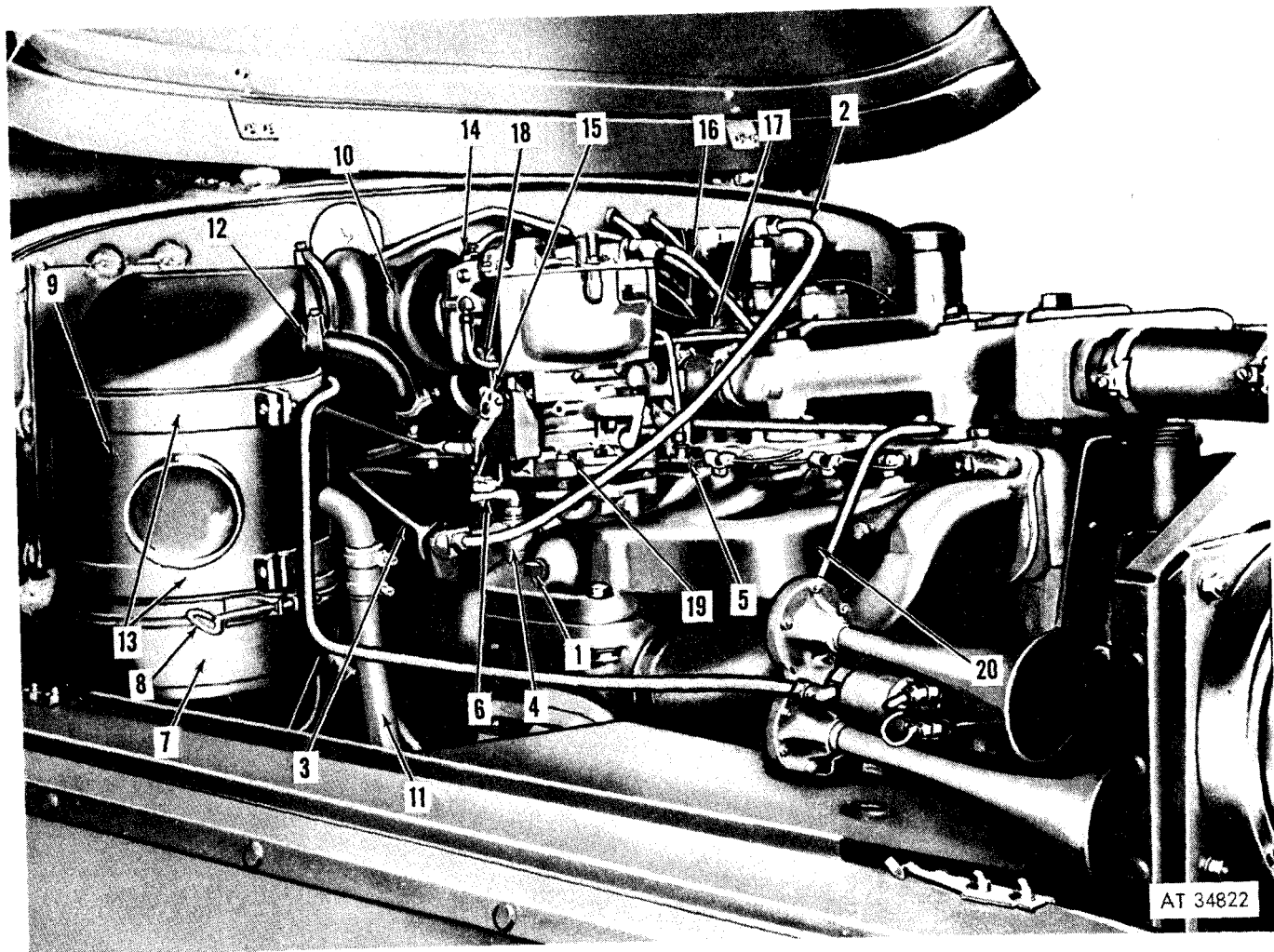
### 2-44. Intake and Exhaust Manifolds

a. *Manifold Vacuum Test.*

**NOTE**

The key numbers in parentheses are for figure 2-43 unless otherwise indicated.

(1) Remove pipe plug (1), and install gage in plug hole.



- 1 Pipe plug
- 2 Vacuum line
- 3 Distributor vent line
- 4 Crankcase ventilating shutoff valve
- 5 Cylinder head priming tee
- 6 Shutoff valve lever
- 7 Oil cup
- 8 Thumb screw
- 9 Air cleaner body
- 10 Air cleaner-to-carburetor inlet hose
- 11 Air cleaner-to-air compressor intake line
- 12 Air cleaner outlet hose
- 13 Mounting bands
- 14 Hose clamp
- 15 Throttle valve plate lever
- 16 Fuel pump-to-carburetor line
- 17 Governor valve-to-governor line
- 18 Carburetor-to-governor valve line
- 19 Safety nut
- 20 Intake manifold

Figure 2-43. Carburetor and manifolds installed to right side of engine.

(2) With the engine running at normal idling speed, observe the manifold vacuum indicated by the gage.

(3) A steady gage reading of 18-21 inches of mercury indicates normal manifold vacuum. A

gage reading which fluctuates between 10 and 15 inches of mercury indicates valve or cylinder head gasket leakage. A steady low gage reading indicates carburetor spacer or gasket leakage.

(4) Accelerate and decelerate the engine

quickly, observing the minimum and maximum gage readings.

(5) Failure of the manifold vacuum to drop to approximately two inches and to rise to at least 24 inches, as engine speed decreases and increases, indicates diluted engine oil, faulty piston rings, or abnormal restriction of the carburetor, air cleaner, or exhaust system.

#### NOTE

The vacuum gage readings in (2) above apply to sea level. These readings will be reduced by approximately one inch of mercury for each 1,000 feet of altitude above sea level.

(6) Stop the engine. Remove the vacuum gage. Install and tighten the plug (1) in the hole.

b. Removal.

#### NOTE

The key numbers in parentheses are for figure 2-43, unless otherwise indicated.

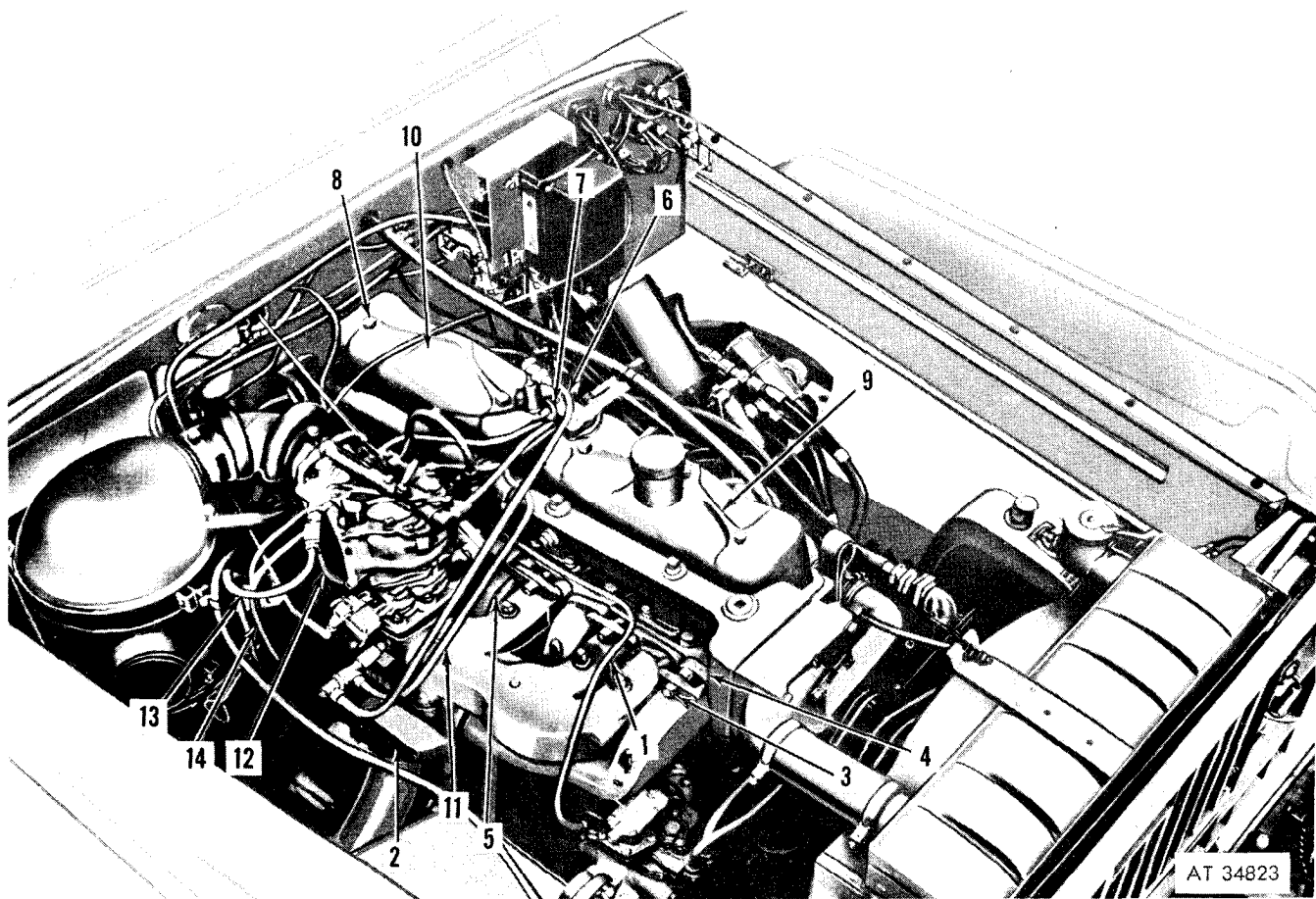
(1) Disconnect the vacuum line (2) and distributor ventilation line (3) at the intake manifold.

(2) Disconnect the crankcase ventilation shutoff valve control (4) on those vehicles equipped with a manually controlled crankcase ventilation system.

(3) Remove the carburetor (para 2-65).

(4) On vehicles equipped with a primer pump unscrew the connector at the priming tee (5), and disconnect the tube from tee.

(5) Disconnect both ends of the air compressor-to-governor line (1, fig. 2-44).



- |  |  |
|--|--|
| 1 Air compressor-to-governor line      | 8 Cap screw                                      |
| 2 Exhaust pipe mounting flange         | 9 Front rocker arm cover                         |
| 3 Hexagon nut                          | 10 Rear rocker arm cover                         |
| 4 Manifold clamp                       | 11 Distributor vent line                         |
| 5 Heat shield                          | 12 Carburetor-to-governor valve line             |
| 6 Vacuum line                          | 13 Carburetor-to-governor valve line             |
| 7 Crankcase ventilating line connector | 14 Governor valve control valve-to-governor line |

Figure 2-44. Top right view of installed engine.

(6) Loosen the four nuts securing the exhaust pipe to the mounting flange (2, fig. 2-44). Turn the mounting flange of the exhaust pipe counterclockwise (as viewed from the top) until the large holes in the flange are alined with the washers under the mounting nuts. The exhaust flange will slip over the mounting nuts separating the exhaust pipe from its manifold.

(7) Remove the 13 nuts (3, fig. 2-44), six on the upper side and seven on the lower side of the intake and exhaust manifold assembly, from the manifold studs on the right side of the front and rear cylinder head assemblies. Remove the manifold clamps (4, fig. 2-44) and heat shield (5, 2-44).

(8) Remove the remaining two nuts from the upper front and rear manifold studs, and remove the manifold assembly. Remove and discard the manifold gaskets.

(9) Remove the three cap screws and washers from the lower side of the exhaust manifold center section, separate the intake and exhaust manifolds, and remove the steel spacer at the center of the intake manifold.

(10) Remove the exhaust manifold end sections and packing rings (three rings on each end section) from the center section.

*c. Installation.*

**NOTE**

The key numbers in parentheses are in figure 2-43 unless otherwise indicated.

(1) Thoroughly clean gasket surfaces on the manifolds and the front and rear cylinder heads, and install new gaskets on the manifold studs.

(2) With three packing rings in place on inner end of each exhaust manifold end section, insert the end sections in the front and rear ports of the center section.

(3) Install the steel spacer between the assembly flanges of the intake and exhaust manifolds, and install three cap screws with washers in the flanges from the lower side of the exhaust manifold center section. Do not tighten the cap screws ((6) below).

(4) Using a straightedge, twist the exhaust manifold end sections until the mounting flanges are alined (flat in same plane) with the intake manifold mounting flanges.

(5) Position the manifold assembly on the manifold studs on the right side of the front and rear cylinder head assemblies, and secure it with two hexagon nuts (3, fig. 2-44), one each on the upper front and rear manifold studs.

(6) Position the heat shield (5, fig. 2-44) and manifold clamps on the upper and lower manifold studs and install the remaining 13 mounting nuts. Tighten the nuts to 80 to 90 ft-lb. torque. Tighten

the cap screws securing the exhaust manifold to the intake manifold to 50 to 60 ft.-lb. torque.

(7) Install a new exhaust-pipe-to-manifold sealing ring at the upper end of the exhaust pipe. Slip the exhaust pipe mounting flange (2, fig. 2-44) over the nuts and washers on the exhaust pipe mounting studs, and rotate the flange clockwise (viewed from top) so that the small holes in the flange are alined with the washers under the mounting nuts. Tighten the nuts.

(8) Install the air-compressor-to-governor line (1, fig. 2-44).

(9) Connect the primer pump tube to the priming tee (5). Tighten the connector (on vehicles equipped with primer pump).

(10) Install the carburetor (para 2-65).

(11) Connect the distributor ventilation line (3) and vacuum line (2) at the intake manifold.

(12) Connect the crankcase ventilation shutoff valve control, and adjust the shutoff valves (para 2-45d.).

(13) Start the engine and run it until normal operating temperature is reached. Check the tightness of all mounting nuts, bolts, and connections.

**2-45. Valve Clearance Adjustment**

*a. Preliminary.* Start the engine and run it until normal operating temperature (160° to 170° F.) is reached.

*b. Valve Rocker Cover Removal.*

(1) Disconnect the vacuum line (6, 2-44) at the crankcase metering valve.

(2) Remove the four nuts and lockwashers securing the crankcase ventilating line connector (7, fig. 2-44) to the front and rear cylinder head covers. Remove the connector and discard the two connector gaskets.

(3) Remove the three cap screw (8, fig. 2-44) and washers securing the front or rear cover (9 and 10, fig. 2-44) to the cylinder head, and remove the cover.

(4) Remove and discard the cylinder head cover gasket.

(5) If the engine has a crankcase ventilating shutoff valve (4, fig. 2-43), pull out the shutoff valve control handle.

**NOTE**

Step (5) will prevent excessive air leakage through the vacuum line into the intake manifold which could cause improper engine idling.

(6) If the engine has no shutoff valve, proceed with steps (a), (b), and (c).

(a) Disconnect the vacuum line (6, fig. 2-44) from the intake manifold elbow.

(b) Disconnect the distributor ventilation line (11, fig. 2-44) from the intake manifold tee.



(c) Tape the elbow and tee intake manifold openings to prevent excessive air leakage which would cause improper engine idle.

*c. Valve Clearance Adjustment.*

(1) Start the engine and check the temperature gage to be sure that the engine coolant is still at normal operating temperature.

(2) With the engine idling, insert the feeler gage between the valve stem cap (fig. 2-45) and the valve actuating ball socket at each valve to check for proper clearance. Clearance should be .018 inches for intake and .024 for exhaust.

(3) If the clearance is incorrect, using a wrench and screwdriver, loosen the valve-adjusting screw jamnut (fig. 2-45), and turn the adjusting screw (clockwise to decrease, counterclockwise to increase) until proper clearance is obtained.

(4) Hold the screw in the adjusting position, tighten the jamnut, and again check the clearance.

(5) Repeat (2), (3), and (4) above until all valves are adjusted to the recommended clearance.

(6) Stop the engine.

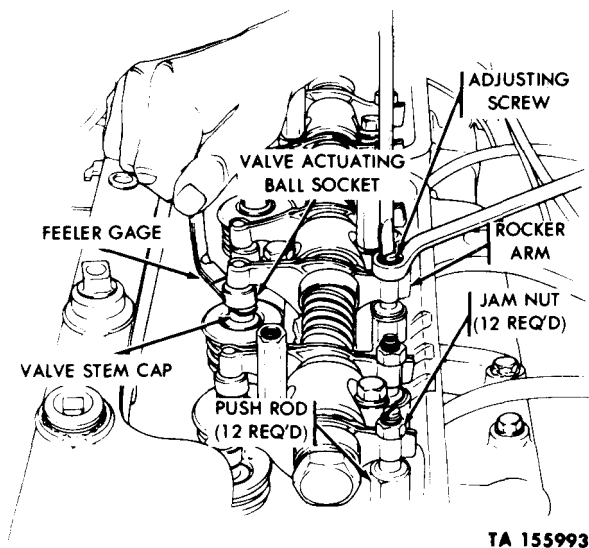


Figure 2-45. Adjusting valve clearance.

*d. Valve Rocker Cover Installation.*

(1) Position a new cover gasket and secure the cover to the cylinder head with three capscrews (8, fig. 2-44) and washers.

(2) If both covers were removed, repeat step (1) above to install the other cover.

(3) Position two new crankcase ventilation line connector gaskets, and secure the connector to the studs with four lockwashers and nuts. Tighten the nuts.

(4) If the engine has a crankcase ventilating shutoff valve (4, fig. 2-43), push the fording valve control handle in.

(5) If the engine has no ventilating shutoff valve, proceed as indicated in steps (a), (b), and (c) below.

(a) Remove the tape from the elbow and tee openings of the intake manifold.

(b) Connect the distributor ventilation line (11, fig. 2-44) to the tee.

(c) Connect the vacuum line to the elbow.

(6) Connect the vacuum line (2, fig. 2-43) to the crankcase ventilating shutoff valve (4, fig. 2-43).

(7) Start the engine, and check the cylinder head cover area for oil leaks.

**2-46. Oil Filters.**

*a. Filter Elements.*

*(1) Removal.*

(a) Remove the plugs (fig. 2-46) and let the oil drain into a suitable container.

(b) Unscrew the nuts (fig. 2-46) retaining the covers to the filter housings. Remove the covers and springs.

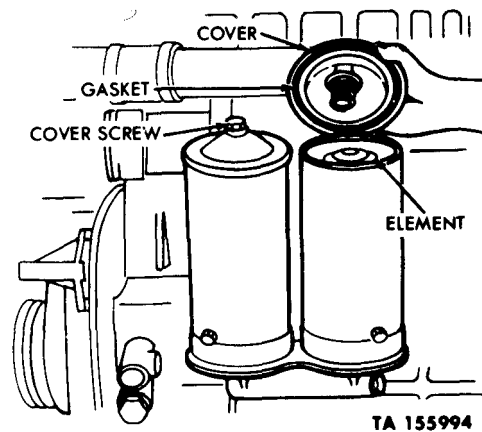


Figure 2-46. Removing oil filter element.

(c) Pull the elements out of the housings (fig. 2-46). Discard the elements and cover gaskets.

*(2) Installation.*

(a) Use a drycleaning solvent or spirits paint thinner to clean out the inside of the filter housings and covers.

(b) Install the drain plugs.

(c) Place the new elements (fig. 2-46) inside the filter housings.

(d) Add oil to the filters and the engine (LO 9-2320-211-12).

(e) Position the filter cover springs on top of the elements.

(f) Position the filter covers with new gaskets on top of the housings, and secure the covers with nuts (fig. 2-46).

(g) Run the engine until operating temperature is reached, and check the filters for leaks.

*b. Filter Housings.*

*(1) Removal.*

(a) Follow the procedures described in a(1) above for removal of the filter elements.

(b) Unscrew the bolts securing the housings to filter base plate (fig. 2-47) using special wrench (4, fig. 2-4). Remove housings from base plate.

(c) Lift gaskets off base plate (fig. 2-48) and discard them.

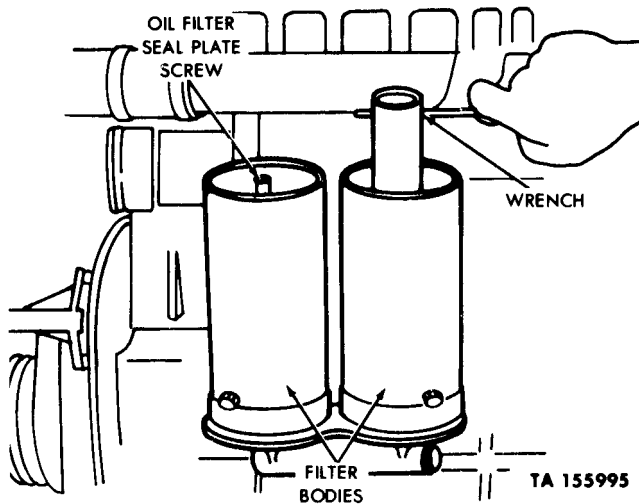


Figure 2-47. Removing filter housing.

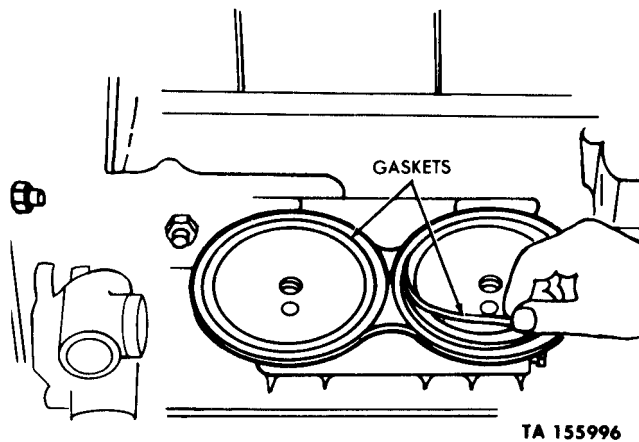


Figure 2-48. Removing filter base plate gasket.

(2) *Installation.*

(a) Position new gaskets on base plate as shown in figure 2-48.

(b) Secure housings to base plate with bolts (fig. 2-47). Use special wrench (4, fig. 2-4) to tighten bolts.

(c) Follow procedures described in a(2) above to install filter element.

**2-47. Crankcase Breather.**

*a. Maintenance.*

(1) Remove filter assembly as described in b(1) and (2) below.

(2) Pour old oil from cup. Clean inside of cup.

(3) Fill oil cup to correct level with new oil.

(4) Dip filter mesh in a drycleaning solvent or mineral spirits paint thinner, and rapidly move filter up and down several times.

(5) Dry out filter.

(6) Check entire crankcase breather assembly for cracks and damaged threads. Also inspect gasket surfaces for nicks and burs, and wipe these surfaces clean.

(7) Install oil cup and filter as described in c(3) and (4) below.

*b. Removal.*

(1) Remove cap (fig. 2-49) from filter. Unscrew four screws securing filter to breather cup and remove filter. Slip rubber gasket off filter.

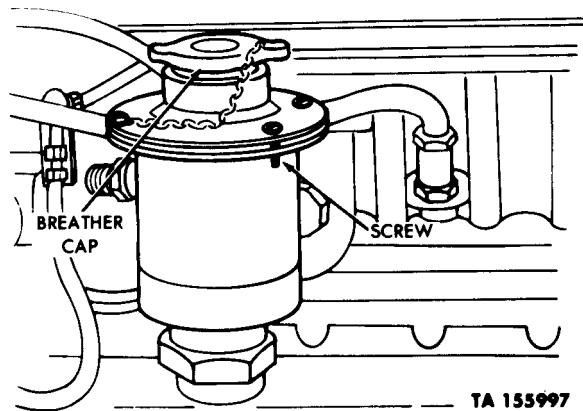


Figure 2-49. Removing crankcase breather cap and filter.

(2) Unscrew bolt (fig. 2-50) securing cup to bracket and remove cup. Pry gasket off bottom of cup.

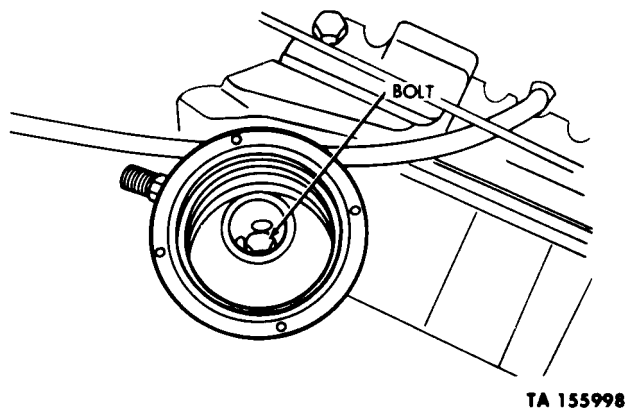


Figure 2-50. Removing crankcase breather cup.

(3) Remove two nuts and lockwashers securing crankcase tube bracket to oil cooler studs (fig. 2-51).

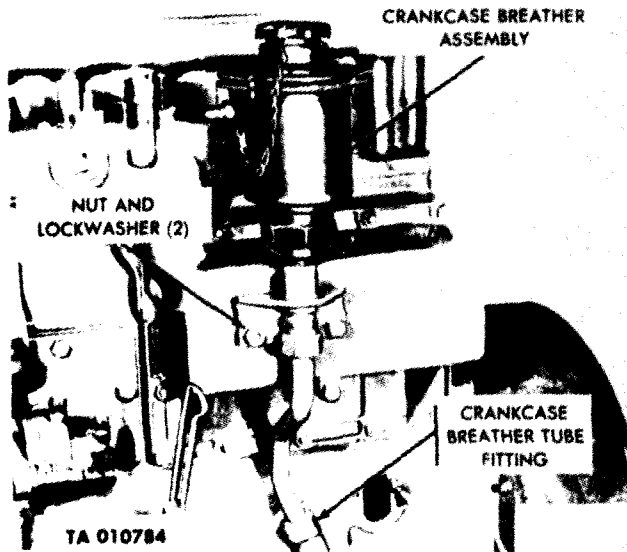


Figure 2-51. Removing crankcase breather bracket and tube assembly.

(4) Unscrew the fitting (fig. 2-51). Remove the breather bracket and tube assembly.

*c. Installation.*

(1) Secure the breather bracket and tube assembly at the fitting (fig. 2-51).

(2) Mount the tube bracket on the oil cooler studs. Retain the bracket with two lockwashers and nuts (fig. 2-51). Tighten the nuts.

(3) Position the gasket to the bottom of the cup, and secure the cup with the bolt (fig. 2-50). Tighten the bolt.

(4) Position the rubber gasket to the filter, and place the filter in the cup. Secure the filter to the cup with four screws (fig. 2-49). Tighten the screws and install the cap.

**2-48. Lines and Fittings.**

*a. Removal.*

**NOTE**

Before removing a line, mark or tag the line to insure proper installation.

(1) Hold the connector with a wrench, and use another wrench to unscrew the nut.

(2) Use the same method described in (1) above to disconnect the line at both ends.

**CAUTION**

Avoid bending or kinking of lines.

(3) Cover any line port opening to prevent entrance of foreign material.

(4) Remove the line clips and line.

*b. Inspection.*

(1) Check the lines for any kinks, fractures, tube wall separation, and damaged ends.

(2) Check fittings, nuts, and sleeves for damaged threads or fractures.

(3) Replace any damaged, worn, or otherwise unserviceable parts.

*c. Fabrication.*

(1) *Lines.*

(a) Cut sized tubing to required length.

**NOTE**

Make sure ends of tubing are square.

(b) Remove burrs from inside and outside of the tubing wall.

(c) Bend the tubing to conform to the shape of the defective line.

(2) *Fittings-compression type.*

(a) Position the nut of the tubing with the threaded end toward the tube end (fig. 2-52).

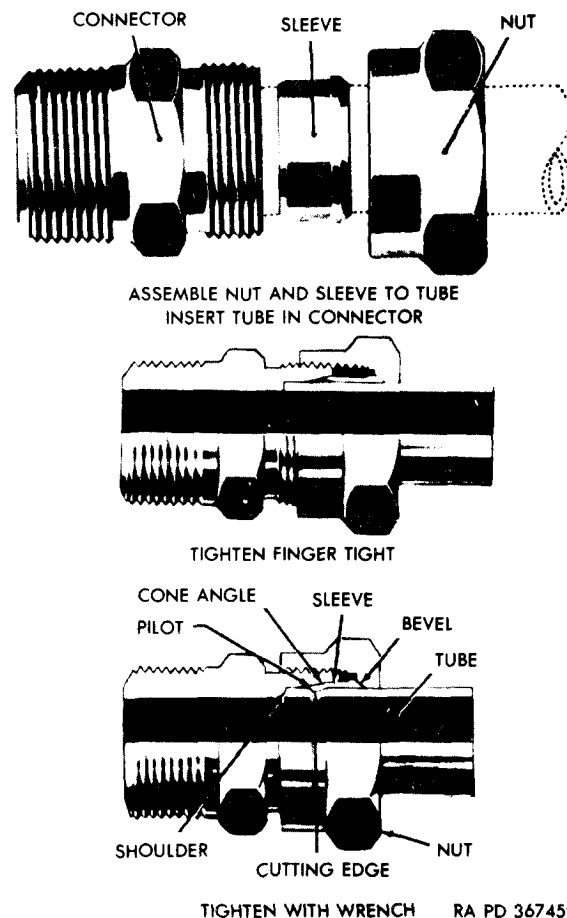


Figure 2-52. Lines and Fittings.

(b) Position a tight fitting sleeve on the tubing with the head toward the nut (fig. 2-52).

(c) Install the tube in the connector.

(d) Align the tubing to the bottom on the connector shoulder and turn the nut finger tight.

(e) Place the connector in a vise and turn the nut slowly with a wrench while turning the tube by hand until the sleeve grips the tube and the tube can no longer be revolved by hand.

(f) Turn the nut one and one-half additional turns to secure the grip of the sleeve on the tube.

(3) *Fittings-flare type.*

(a) Install the nut on the tubing with the threaded end toward the tube end.

(b) Flare the tubing end with a flaring tool.

**NOTE**

Make sure flare is even all around.

(c) Insert the flared end into the recessed part of the nut for good seating.

d. *Installation.*

**CAUTION**

Do not over tighten nuts. This will damage fittings.

(1) Remove the protective cover from the line port opening.

(2) Clean the line thoroughly using a drycleaning solvent or mineral spirits.

(3) Dry with compressed air.

**NOTE**

If dry compressed air is not available, place the line on a clean surface and allow the line to dry out for at least five minutes.

(4) Remove the cover from any connectors. Wipe connectors with a clean, lint-free cloth that has been dampened with a solvent or mineral spirits.

(5) Lubricate threads with hydraulic fluid.

(6) Aline tube ends in connectors. Turn the nuts finger tight.

(7) Hold the connector with a wrench while tightening the tube nut with another wrench.

**2-49 Clutch Controls and Linkage.**

a. *General.* The clutch pedal must have a movement of at least 2 to 2½ inches before the clutch begins to disengage. This movement is called free travel. Whenever natural wear on the clutch facing causes the free travel to be less than 2 to 2½ inches, the clutch must be adjusted (b below). A properly adjusted clutch will take hold (engage) gradually, not slip, and will release instantly when the clutch pedal is depressed.

**NOTE**

On M62, M543, and M543A2 models, prior to making the pedal linkage adjustment described in b below, turn the rotochamber linkage adjustment screw in to prevent contact with the inner lever

b. *Adjustment (fig. 2-53).*

(1) Loosen the locknut on the control rod.

(2) Pull outward on the adjusting yoke pin at the lower end of the control rod, and separate the adjusting yoke from the throw out release lever.

**NOTE**

Pin does not completely come out of yoke.

(3) Turn the adjusting yoke on the control rod as necessary to obtain the correct pedal free travel. To increase free travel, turn the yoke counterclockwise. To decrease free travel, turn the yoke clockwise.

(4) Position the yoke on the clutch release lever, and install the yoke pin.

(5) Unhook the lower end of the clutch pedal return spring from the bracket on the outside of the frame left side rail.

(6) Depress the clutch pedal and judge pedal free travel as described in a above.

**NOTE**

If 2 to 2½ inches of clutch pedal free travel cannot be obtained, measure from the center of the clevis pin hole to the end of the clutch control rod which screws into the adjusting yoke. If the length of rod is shorter than 7.125 to 7.375 inches, replace the rod with one of the correct length.

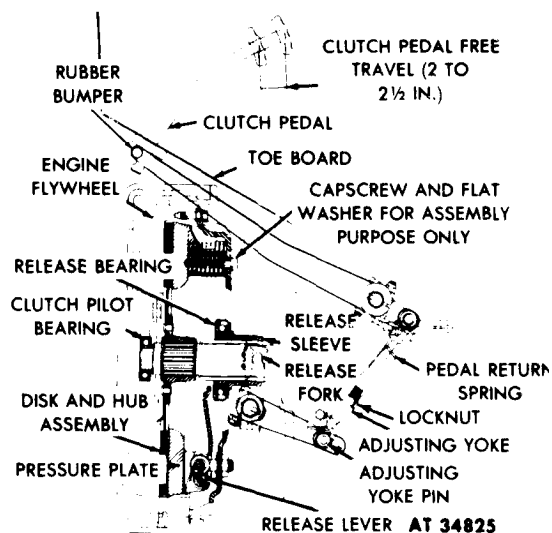


Figure 2-53. Diagram of clutch and control linkage.

(7) If free travel is still incorrect, repeat (2), (3), (4), and (5) above until the correct free travel is obtained.

(8) Tighten the locknut on the control rod.

(9) Hook the lower end of the clutch pedal return spring to the bracket on the outside of the frame left side rail.

(10) Adjust the rotochamber as follows:

(a) Loosen the locknut on the adjusting

screw installed in the clutch release outer lever (fig. 2-54).

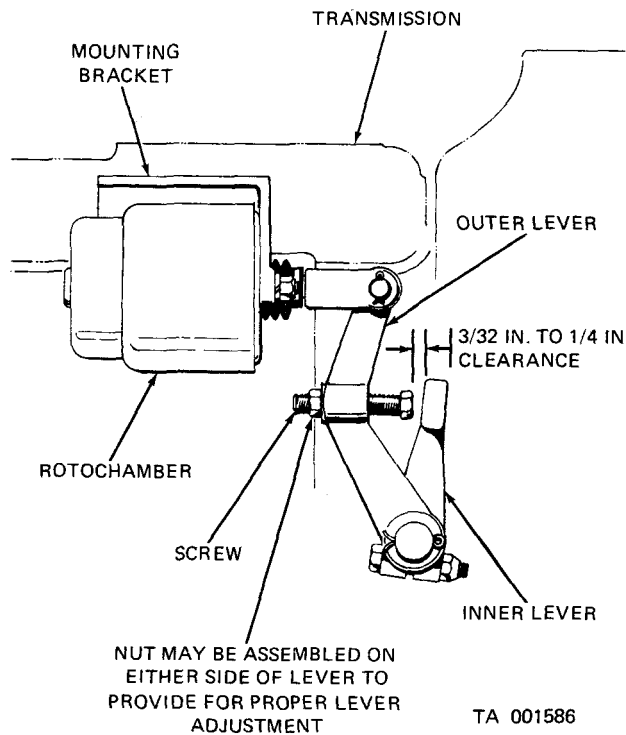


Figure 2-54. Adjusting rotochamber.

(b) Turn the adjusting screw until the clearance between the adjusting screw head and the upper end of the inner lever is between  $3/32$  and  $1/4$  inch (fig. 2-54).

(c) Hold the adjusting screws to prevent it from turning while tightening the locknut (fig. 2-54).

*c. Removal.*

(1) Detach the control rod yoke from the release lever by pulling the pin outward (fig. 2-53).

**NOTE**

Pin does not come completely out of yoke.

(2) Remove the nut and screw securing the control rod lever to the shaft (fig. 2-53). Remove the control rod and lever assembly from the shaft.

(3) Unhook the upper end of the clutch return spring from clip, and remove the spring at the lower end (from the bracket on the frame rail).

(4) Remove the nut and screw securing the clutch pedal assembly to the lever shaft. Force the pedal assembly off the end of the shaft. Remove the key.

*d. Repair.* Weld, straighten, or replace any broken or damaged clutch linkage parts as necessary.

*e. Installation.*

(1) Position the control rod and lever assembly on the end of the shaft as shown in figure 2-53. Secure the lever to the shaft with a screw and nut.

(2) Secure that control rod yoke to the release lever by pushing the pin (fig. 2-53) inward.

(3) Place the slotted key in position and install the clutch pedal assembly onto the shaft. Install the screw and tighten the nut securing the pedal assembly to the lever shaft.

(4) Hook the upper and lower end of the clutch return spring in place.

## Section X. ENGINE MAINTENANCE IN VEHICLE—DIESEL

### 2-50. General

The diesel engine is a 4-cycle, 6-cylinder, in-line, valve-in-head, liquid-cooled, turbocharged, compression-ignited Mack ENDT-673 model. Left and right are the left and right sides respectively of the engine as viewed from the operator's seat. Front is the fan and drive belt end of the engine, while rear is the flywheel end.

### 2-51. Oil Filter Element Replacement

*a. Preliminary.* Remove the two drain plugs (fig. 2-55) and allow the oil to drain into a suitable container.

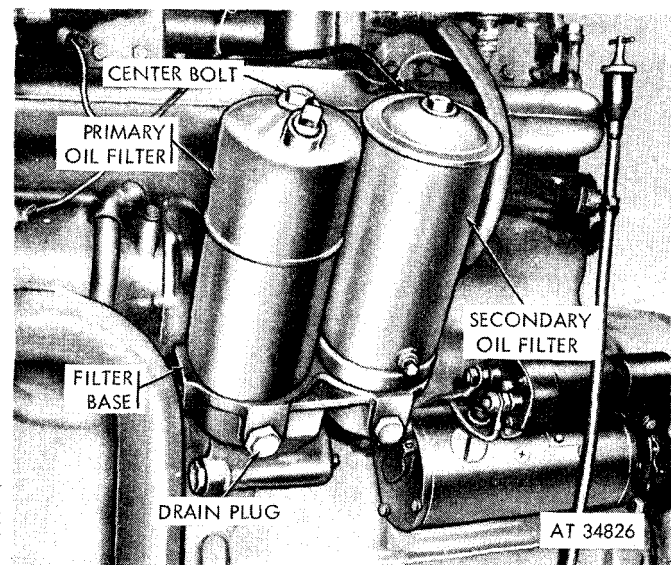


Figure 2-55. Diesel engine oil filters.

*b. Full flow type filter.*

(1) Unscrew the center bolt securing the filter housing to the base. (The bolt and housing are removed as an assembly.)

(2) Remove and discard the filter element, housing gasket, and bolt gaskets (2).

(3) Clean the filter housing, center bolt, and seal seat using drycleaning solvent or mineral spirits paint thinner.

(4) Position a new gasket on the base (fig. 2-56).

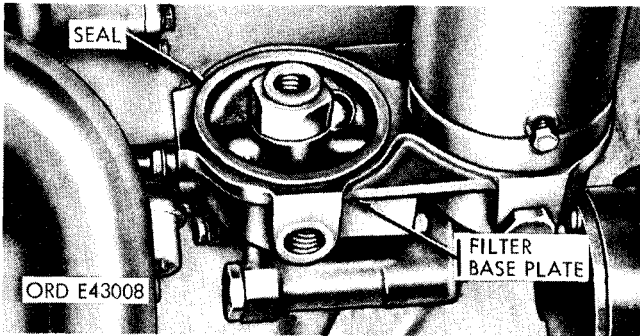


Figure 2-56. Filter housing base.

(5) Assemble the gasket on the center bolt and install it on the housing. Install the retaining spring, flat washer, spacer washer, and gasket on the bolt.

(6) Insert a new element in the housing and attach the housing to the base with the center bolt.

*c. Bypass type filter.* Since the diesel engine has the same type secondary filter as the gasoline engine, refer to paragraph 2-47 for element replacement.

**2-52. Turbocharger Oil Lines and Fittings**

*a. Removal.*

(1) Disconnect lubrication line (fig. 2-57) from turbocharger.

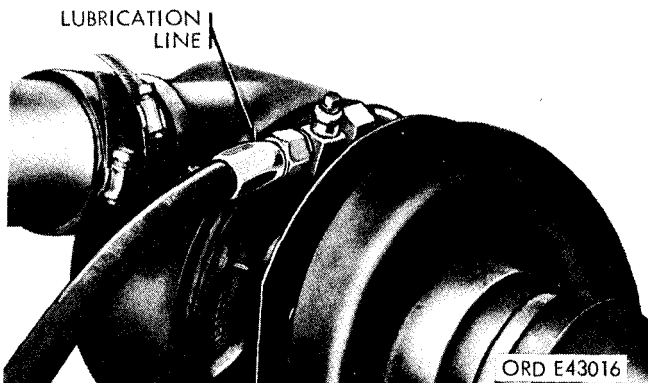


Figure 2-57. Disconnecting lubrication line at turbocharger —diesel.

(2) Remove the bolt (fig. 2-58) securing the lubrication line bracket to the manifold heater housing.

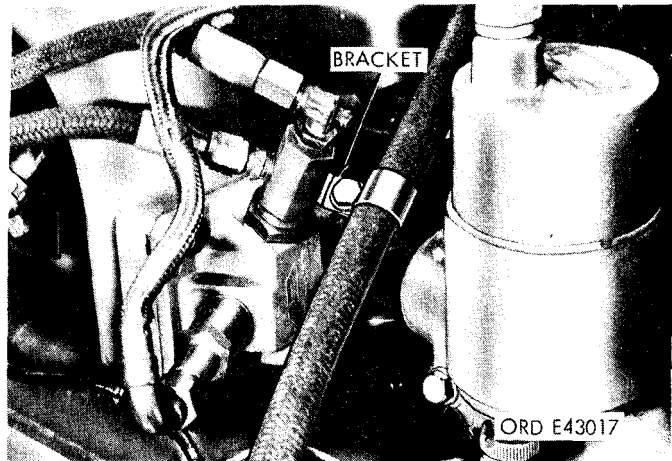


Figure 2-58. Disconnecting lubrication line bracket at manifold heater housing—diesel.

(3) Disconnect the lubrication line (fig. 2-59) from the elbow connection at the oil filter base plate and remove the line.

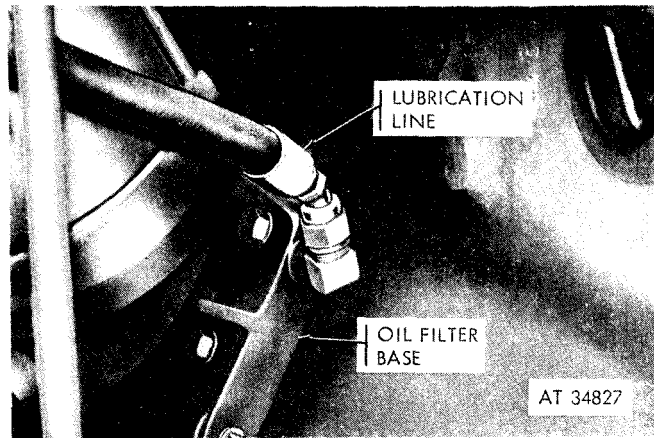


Figure 2-59. Disconnecting lubrication line at oil filter base —diesel.

*b. Installation.*

(1) Connect the line (fig. 2-59) to the elbow connector at the filter base plate.

(2) Use the bracket and bolt (fig. 2-58) to secure the line at the manifold heater housing.

(3) Connect the lubrication line (fig. 2-58) to the turbocharger.

**2-53. Lines and Fittings**

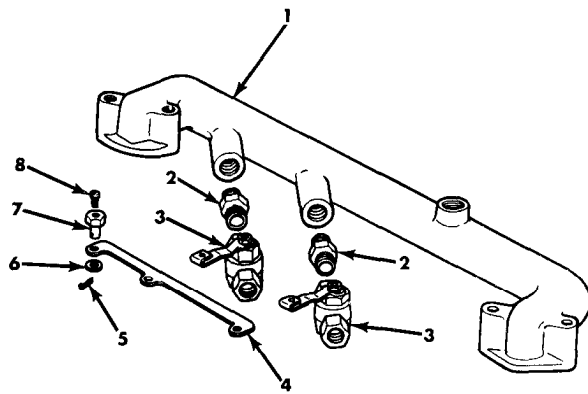
Refer to paragraph 2-48 for instructions on fabrication of new tube assemblies.

**2-54. Crankcase Breather Valves**

*a. Removal.*

(1) Remove cotter pins, flat washer, swivels, and screws attaching the link to the two shutoff valves (fig. 2-60).

- (2) Remove the two breather tubes attached to the valves.
- (3) Remove the valves.



AT 8484

- |                             |                |
|-----------------------------|----------------|
| 1 Breather pipe             | 5 Pin, cotter  |
| 2 Nipple, ventilation valve | 6 Washer, flat |
| 3 Valve, shutoff            | 7 Swivel       |
| 4 Link, ventilation valve   | 8 Swivel screw |

Figure 2-60. Crankcase breather assembly—exploded view.

*b. Installation.*

- (1) Install breather valves.
- (2) Install breather tubes to valves.
- (3) Install link swivels, screws, flat washers, and cotter pins.

**2-55. Clutch Controls and Linkage**

Refer to paragraph 2-49 for adjustment, removal, repair, and installation procedures.

**Section XI. ENGINE MAINTENANCE IN VEHICLE—MULTIFUEL**

**2-56. General**

The multifuel engine is a 6-cylinder, in-line, liquid-cooled, 4-cycle, compression-ignited engine designed to operate on a variety of fuels, including diesel fuel, compression ignition fuel, low grade gasoline, and regular grade gasoline without modification or adjustment. Mixing of fuels is permissible in this engine.

**2-57. Oil Filter Element Replacement**

**NOTE**

The two oil filter elements are identical and are replaced in the same manner; in the following procedure, only the rear filter element is replaced.

*a. Removal.*

- (1) Remove the pipe plug and drain the oil into a suitable container (fig. 2-61).

**NOTE**

If the vehicle has not been running for 15 minutes, it is not necessary to drain the filter.

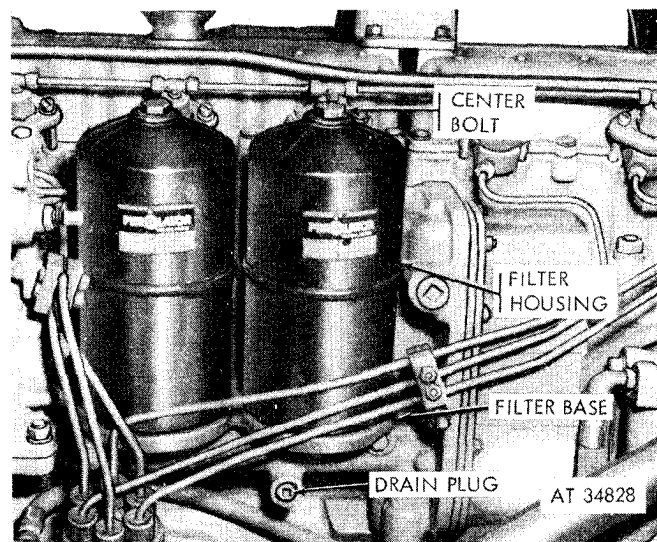


Figure 2-61. Multifuel engine oil filters.

(2) Unscrew the center bolt securing the rear oil filter housing to the filter base (fig. 2-62).

**NOTE**

The bolt and housing are removed as an assembly.

(3) Remove and discard the filter element, housing seal, and bolt gasket (fig. 2-62).

(4) Clean the filter housing, center bolt and seal seat, using drycleaning solvent or mineral spirits paint thinner.

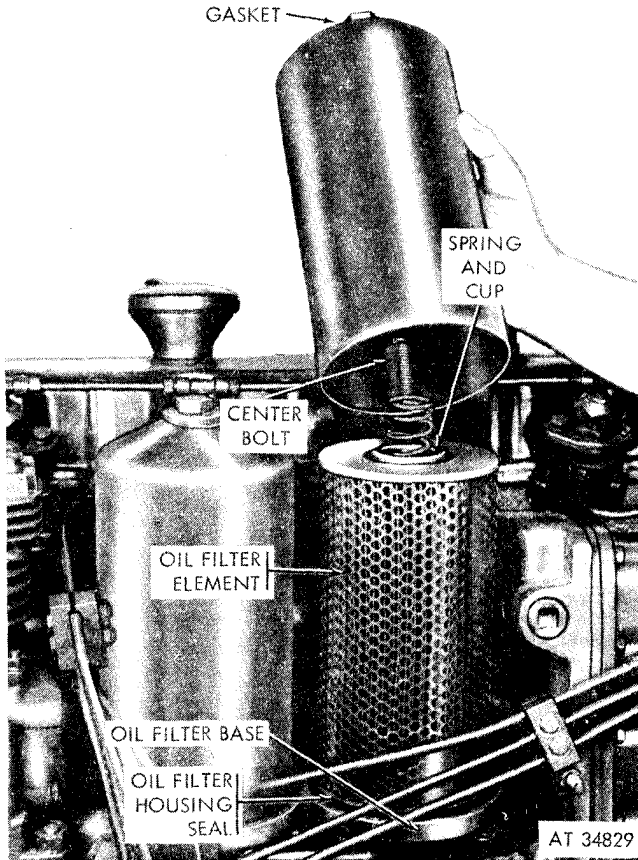


Figure 2-62. Replacing oil filter element.

**b. Installation.**

- (1) Position a new seal and filter element on the base plate.
- (2) Assemble the center bolt on the filter housing with a new gasket.
- (3) Position the spring and cup on top of the element.
- (4) Attach the housing to the base with the center bolt.
- (5) Install the drain plug.
- (6) Add oil (LO 9-2320-211-12).
- (7) Start the engine and check for gasket leaks.

**2-58. Turbocharger Oil Lines and Connections**

(Fig. 2-63.)

**a. Removal.**

(1) Disconnect the turbocharger lubrication line at the connection located on the upper section of the unit.

(2) Remove the bolt from the bracket securing the turbocharger lubrication line to the manifold heater housing.

(3) Remove the lubrication line (drain) from the pipe-to-tube adapter at the block.

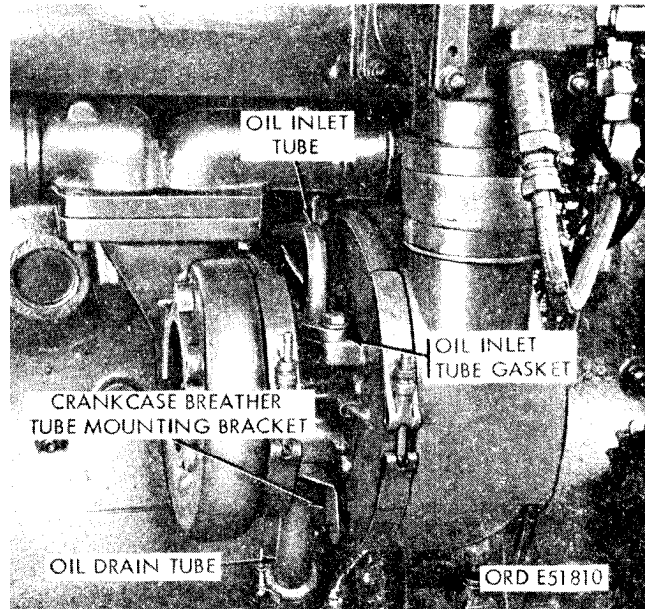


Figure 2-63. Disconnecting lubrication lines at turbocharger —multifuel models.

**b. Installation.**

(1) Install the lubrication line to the pipe-to-tube adapter at the block.

(2) Secure the line to the manifold heater housing with the bracket and bolt.

(3) Connect the line to the upper section of the unit.

**2-59. Lines and Fittings**

Refer to paragraph 2-48 for instructions on fabrication of new tube assemblies.

**2-60. Crankcase Breather Tube**

**a. Removal.**

(1) Loosen the clamp that secures the hose to the breather tube (fig. 2-64).



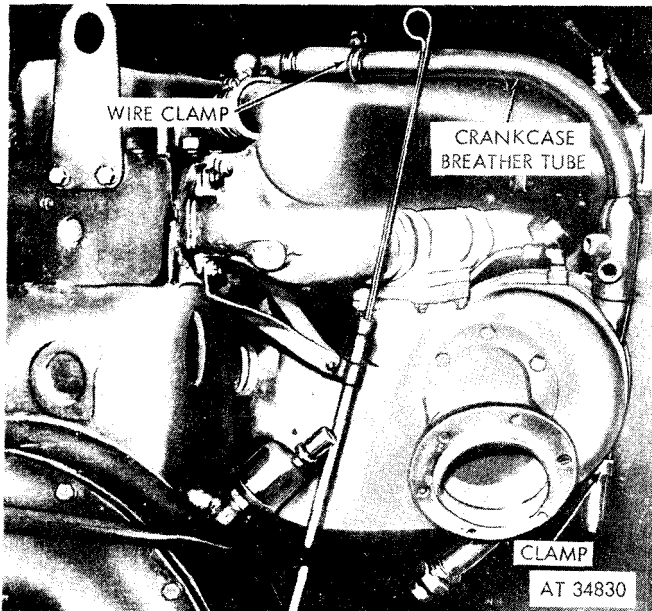


Figure 2-64. Removing crankcase breather tube—multifuel models.

(2) Remove the nut, lockwasher, flat washer, and capscrew securing the tube clamp to the bracket (fig. 2-64).

(3) Pull the breather tube and clamp assembly from the engine.

*b. Installation.*

(1) Position the breather tube and clamp assembly. Tighten the tube-to-hose clamp.

(2) Secure the tube clamp to the bracket with the capscrew, flat washer, lockwasher, and nut.

## 2-61. Clutch Controls and Linkage

Refer to paragraph 2-49 for adjustment, removal, repair, and installation procedures.

## Section XII. MAINTENANCE OF FUEL SYSTEM—GASOLINE

### 2-62. General

Fuel system components discussed in this section include an oil-bath type air cleaner, a down draft type dual concentric carburetor (with an integral engine speed governor), an element type fuel filter, a fuel tank (some models have a dual tank arrangement) with connecting lines and fittings, and a governor valve. In addition, an anti-dieseling valve (or degasser) is controlled from the instrument panel. This valve is mounted either on the intake manifold (early models) or carburetor (late models.).

### 2-63. Air Cleaner

#### NOTE

The key numbers in parentheses are for figure 2-43, unless otherwise indicated.

#### *a. Maintenance.*

(1) Support the oil cup (7) and loosen the thumb screw (8) to remove the oil cup from the retaining clamp.

(2) Pour the old oil from the cup, and clean the cup.

(3) Fill the oil cup with clean oil to correct level.

(4) Remove the air cleaner body (9) from the cab cowl. Refer to step *b* below for the removal procedure.

(5) Submerge the air cleaner body in the dry cleaning solvent, and rapidly move the cleaner body up and down in solvent to clean the filter mesh inside the cleaner body.

(6) Remove the air cleaner body from the dry cleaning solvent and let it drip dry.

(7) Install the air cleaner body (9). Refer to step *c* below for installation procedure.

(8) Position the oil cup and retaining clamp on the air cleaner body and tighten the clamp thumb screw (8).

#### *b. Removal.*

(1) Loosen the retaining clamp thumbscrew (8) and remove the oil cup (7).

(2) Loosen the hose clamp securing the air cleaner-to-carburetor inlet hose (10) to the air cleaner outlet sleeve, and remove the hose.

(3) Loosen the hose clamp at the upper end of the air cleaner-to-air compressor intake line (11), and remove the line from the air cleaner outlet tube (vehicles equipped with air cleaner-to-air compressor intake line hose only).

(4) Loosen the hose clamp at the upper end of the air cleaner outlet hose, and remove it from the air cleaner outlet tube.

(5) Unscrew three connectors from the coupling and elbow assembly at the left side of the air cleaner body, and disconnect the three vent lines.

(6) Remove the two screws and nuts; one each from the upper and lower air cleaner mounting bands (13). Spread the bands to permit removal of the cleaner body (9), and remove the cleaner body from the cab cowl.

*c. Installation.*

(1) Position the air cleaner body (q) on the right frontside of the cab cowl, draw the ends of the upper mounting band together, install a screw in holes in the ends of the band, install the horn line retaining clip on the screw, and install the nut and tighten it.

(2) Position the three vent lines at the coupling and elbow assembly at the left side of the air cleaner body, and tighten the connectors.

(3) Slide the upper end of the air cleaner outlet hose (12) on the outlet tube at the left side of the air cleaner, and tighten the hose clamp.

(4) Slide the air cleaner-to-air compressor intake line (11) on the outlet tube at the front of the air cleaner, and tighten the hose clamp (vehicles equipped with air cleaner-to-air compressor intake line hose only).

(5) Slide the air cleaner-to-carburetor inlet hose (10) on the outlet sleeve at the left side of the air cleaner, and tighten the hose clamp.

(6) Install the oil cup (a (8) above).

**2-64. Ventilation Lines and Fittings**

Refer to paragraph 2-48 for removal and installation of ventilation lines and fittings.

**2-65. Carburetor**

*a. Adjustment.*

**NOTE**

Make sure engine is sufficiently warmed up before adjusting the carburetor.

(1) *Throttle adjustment.* The throttle adjusting screw (fig. 2-65) controls the degree of throttle valve plate opening when the throttle valve lever is in the idling position and is adjusted as indicated below.

(a) Start the engine.

(b) Check the accelerator to make sure it is completely released, and that the throttle and choke control are pushed completely in against the instrument panel.

(c) Turn the throttle adjusting screw clockwise to increase, or counterclockwise to decrease the engine idle speed. The tachometer should read 400-450 rpm.

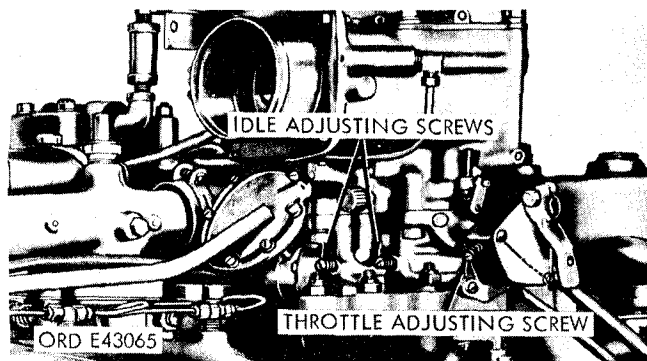


Figure 2-65. Idle and throttle adjusting screws.

(2) *Idle adjustment (with vacuum gage).*

**CAUTION**

Do not turn the idle adjusting screw in far enough to jam the needle valve on the end of the screw against the valve seat. If this occurs, the needle valve will be damaged and will require replacement of the idle adjusting screw before a satisfactory engine idle adjustment can be made.

**NOTE**

Both idle adjusting screws must be turned out the same number of turns (to provide equal clearance between the valve seats and adjusting screw needle valves) to provide a maximum performance in the engine speed range just above idling speed.

(a) Remove the pipe plug (1, fig. 2-43) at the right side of the intake manifold, and install the vacuum gage in the pipe plug hole.

(b) Adjust the throttle as in (1) above.

(c) Turn the idle adjusting screws (fig. 2-65), one at a time, until the vacuum gage indicates the highest steady manifold vacuum. Turning the idle adjusting screws in (clockwise) provides a leaner idle mixture, and turning the idle adjusting screw out (counterclockwise) provides a richer idle mixture.

(d) Check the idle adjusting screw settings.

1. Turn one idle adjusting screw in (clockwise), counting the number of turns, until the needle valve on the end of the screw just touches the valve seat; then turn the adjusting screw out (counterclockwise) the same number of turns.

2. Repeat the operation for other idle adjusting screw.

(e) If the idle mixture adjustment results in an increase in idling speed great enough to require resetting the throttle adjusting screw, the idle adjusting screws must also be re-set.

(f) When engine idle adjustment is satisfactory, stop the engine.

(g) Remove the vacuum gage and install the pipe plug in the threaded hole, and tighten it securely.

(3) *Idle adjustment (without vacuum gage).*

(a) Adjust the throttle adjusting screw.

(b) Turn one idle adjusting screw (fig. 2-65) in (clockwise) until the engine speed begins to drop; then turn the adjusting screw out (counterclockwise), counting the number of turns, until the engine speed again begins to drop.

(c) Set the idle adjusting screw halfway between the two points determined in (b) above.

(d) Repeat the procedures (b) and (c) above for the other idle adjusting screw, being sure that it is set equally with the first screw.

(e) If the idle mixture adjustment results in an increase in idling speed great enough to require re-setting the throttle adjusting screw, the idle adjusting screws must be re-set.

*b. Removal.*

(1) Loosen the hose clamp (14, fig. 2-43) securing the air cleaner-to-carburetor inlet hose (10) to the air inlet sleeve on the carburetor, and remove the hose from the sleeve.

(2) Remove the nut from the ball stud at the back side of the throttle valve plate lever (15) and remove the throttle cross-shaft-to-carburetor rod lever. Replace the nut on the ball stud to prevent its loss.

(3) Unscrew the connector securing the fuel pump-to-carburetor line (16) to the elbow at the front of the carburetor, and remove the line.

(4) Unscrew the connector securing the governor valve-to-governor line (17) to the governor air inlet at the left side of the carburetor, and remove the line (all models except M62, M246, and M543).

(5) Unscrew the connector securing the governor valve control valve-to-governor line (14, fig. 2-44) to the governor air inlet at the left side of the carburetor, and remove the line (M62, M246, and M543).

(6) Unscrew the connector securing the carburetor-to-governor valve line (18 fig. 2-43) to the elbow at the right rear of the carburetor, and remove the line (all models except M62, M246, and M543).

(7) Unscrew the connector securing the carburetor-to-governor valve line (12, fig. 2-44) to the tee at the right of the carburetor, and remove the line (M62, M246, and M543).

(8) Unscrew the connector securing the carburetor-to-governor valve line (13, fig. 2-44) tee at the right rear of the carburetor, and remove the line (M62, M246, and M543 only).

(9) Loosen the choke lever swivel screw (fig. 2-66) securing the choke control wire to the choke valve plate lever at the left side of the carburetor. Loosen the choke lever bracket clamp screw, and remove the choke control from the lever and bracket.

(10) Remove the six safety nuts (19, fig. 2-43) from the carburetor mounting studs at the carburetor base, and remove the carburetor from the intake manifold (20). Remove and discard the carburetor-to-manifold gasket.

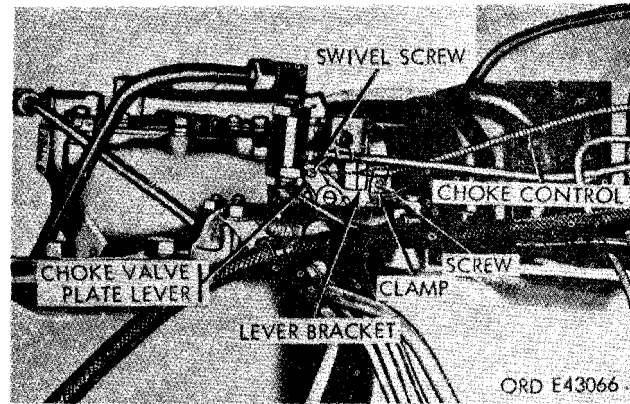


Figure 2-66. Choke linkage.

*c. Installation.*

**NOTE**

When installing a new or rebuilt carburetor on the M62, M246, or M543, coordinate the operation with supporting maintenance personnel.

(1) Install a new carburetor carburetor-to-manifold gasket on the carburetor mounting studs.

(2) Position the carburetor on the mounting studs on the top of the intake manifold, (20) install six safety nuts (19) on the studs, and tighten, the nuts to 25-30 ft.-lb. torque.

(3) Insert the choke control wire in the hole in the end of the choke lever swivel; but do not tighten the swivel screw. Position the choke control (fig. 2-66) under the choke lever bracket clamp and tighten the clamp screw.

(4) Position the carburetor-to-governor valve line (18, fig. 2-43) at the elbow on the right rear of the carburetor, and tighten the connector (all models except M62, M246, and M543).

(5) Position the carburetor-to-governor valve line (12, fig. 2-44) at the tee at the right rear of the carburetor, and tighten the connector (M62, M246, and M543 only).

(6) Position the carburetor-to-governor valve line (13) at the tee at the right rear of the carburetor, and tighten the connector (M62, M246, and M543 only).

(7) Position the governor valve control valve-to-governor line (14) at the governor air inlet on the left side of the carburetor, and tighten the connector (M62, M246, and M543 only).

(8) Position the governor valve-to-governor

line (17, fig. 2-43) at the governor air inlet on the left side of the carburetor, and tighten the connector (all models except M62, M246, and M543).

(9) Position the fuel pump-to-carburetor line (16) at the elbow at the front of the carburetor, and tighten the connector.

(10) Remove the nut from the ball stud at the end of the throttle cross-shaft-to-carburetor rod, insert the ball stud in hole at the end of throttle valve lever (15), and install the nut on the stud.

(11) Slide the air cleaner-to-carburetor inlet hose (10) over the air inlet sleeve at the rear of the carburetor, and tighten it with the hose clamp.

(12) Adjust the choke control (para 2-66a).

(13) Adjust the throttle control (para 2-68a).

(14) Adjust the carburetor (*a*, above).

## 2-66. Choke Control

### NOTE

Choke control is properly adjusted when the choke control valve plate inside the carburetor air horn is in its wide-open position, and the choke control knob is all the way in against the instrument panel.

### NOTE

A marking line on the left end of the choke valve plate shaft indicates the position of the valve plate.

#### *a. Adjustment.*

(1) Loosen the swivel screw (fig. 2-66) securing the choke control wire to the choke lever.

(2) Push the choke control in against the instrument panel as far as it will go.

(3) Move the upper end of the choke valve plate lever (fig. 2-66) forward as far as it will go and tighten the swivel screw.

#### *b. Removal.*

(1) Loosen the swivel screw (fig. 2-66) securing the choke control wire to the choke valve plate lever.

(2) Loosen the choke lever bracket clamp screw (fig. 2-66), and remove the choke control from the choke valve plate lever and lever bracket.

(3) Remove the nut and lockwasher from the choke control at the back side of the instrument panel, and pull the choke control assembly from the cab cowl and the front of the instrument panel.

#### *c. Installation.*

(1) Insert the choke control in the hole of the instrument panel, and install the lockwasher and retaining nut on the choke control at the back side of the instrument panel.

(2) Position the choke control knob so that the lettering on the face of the knob is in the horizontal position and tighten the retaining nut.

(3) Push the free end of the control wire conduit through the hole in the rubber grommet in the cab cowl.

(4) Pull the free end of the choke control (from the front side of the cab cowl) until the choke control wire reaches the choke valve plate lever.

(5) Position the control under the lever bracket clamp, and insert the end of the control wire in the hole in the choke valve plate lever swivel.

(6) With the choke control in against the instrument panel as far as it will go, move the upper end of the choke valve plate lever forward as far as it will go, and tighten the swivel screw and lever bracket clamp screw.

## 2-67. Accelerator Linkage Adjustment

### CAUTION

Do not move the lower end of the throttle valve plate lever toward the rear of the truck in order to insert the ball stud.

### NOTE

The throttle control linkage is properly adjusted when the full range movement of the throttle valve lever matches the full range movement of the accelerator pedal.

*a.* Adjust the throttle as described in paragraph 2-65 *a.*

*b.* Remove the nut from the ball stud at the back side of the throttle valve plate lever (15, fig. 2-43).

*c.* Remove the throttle cross-shaft-to-carburetor rod from the throttle valve plate lever.

### NOTE

When the throttle cross-shaft-to-carburetor rod is removed from the throttle valve plate lever, the lever will be moved automatically to the wide-open throttle position, due to the action of the governor spring inside the engine speed governor mounted on the left side of the carburetor.

*d.* Depress the accelerator pedal until the underside of the pedal contacts the head of the pedal stop screw. Hold the pedal in its completely depressed position.

*e.* Raise the front end of the throttle cross-shaft-to-carburetor rod. Check to see whether the ball stud can be inserted in the hole at the lower end of the throttle valve plate lever without changing the length of the rod.

*f.* If necessary, adjust the length of the throttle cross-shaft-to-carburetor rod.

(1) Loosen the jamnut at the rear of the ball joint on the forward end of the throttle cross-shaft-to-carburetor rod, and turn the ball joint (clockwise to shorten, or counterclockwise to lengthen rod) until the ball stud can be connected to the throttle valve plate lever, without moving either the rod or lever.

(2) Tighten the jamnut at the rear of the ball joint. Release the accelerator pedal.

*g.* Insert the ball stud on the front end of the throttle cross-shaft-to-carburetor rod in the hole at the lower end of the throttle valve plate lever. Install the nut on the stud at the back side of the lever, and tighten the nut.

## 2-68. Throttle Control

### NOTE

The throttle control is in proper adjustment when the accelerator linkage is properly adjusted and the throttle control can be pulled out approximately one-eighth inch before starting to actuate the throttle valve plate lever.

#### *a.* Adjustment.

- (1) Adjust the accelerator linkage (para 2-67).
- (2) Loosen the screw securing the collar (fig. 2-67) to the throttle control wire.
- (3) Position the collar on the throttle control wire. Maintain a clearance of approximately one-eighth inch between the top surface of the collar and the underside of the cross-shaft link clip when the throttle valve plate lever is in the idling position, and the throttle control knob is in against the instrument panel as far as it will go.
- (4) Tighten the throttle control wire collar screw.

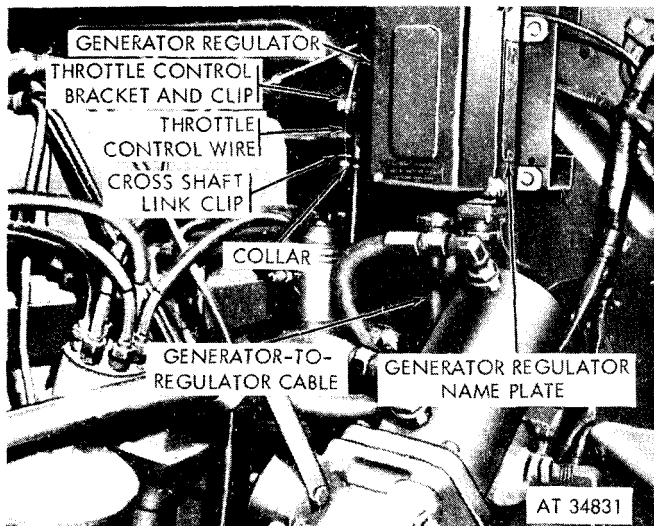


Figure 2-67. Top right section of cab cowl.

#### *b.* Removal.

(1) Loosen the screw securing the collar (fig. 2-67) to the throttle control wire and remove the collar.

(2) Loosen the nut and bolt securing the throttle control supporting the bracket clip to the supporting bracket, and remove the control from the clip.

(3) Pull the free end of the throttle through the rubber bushing in the cab cowl and into the cab.

(4) Remove the jamnut and lockwasher from the throttle control at the back side of instrument panel, and pull the throttle control from the front of the instrument panel.

#### *c.* Installation.

(1) Insert the throttle control in the hole in the instrument panel and install the lockwasher and jamnut on the throttle control at the back side of the instrument panel. Position the throttle control knob so that the lettering on the face of the knob is in a vertical position, and tighten the jamnut.

(2) Push the free end of the throttle control through the bushing in the cab cowl.

(3) Position the control under the throttle control-supporting bracket clip, push the control wire through the hole in the forward end of the cross-shaft link clip, and tighten the nut and bolt securing the clip to the supporting bracket (fig. 2-67).

(4) Install the collar (fig. 2-67) on the control wire, and adjust the throttle control (a above).

## 2-69. Anti-diesel Control-Valve Integral with Carburetor

(fig. 2-68.)

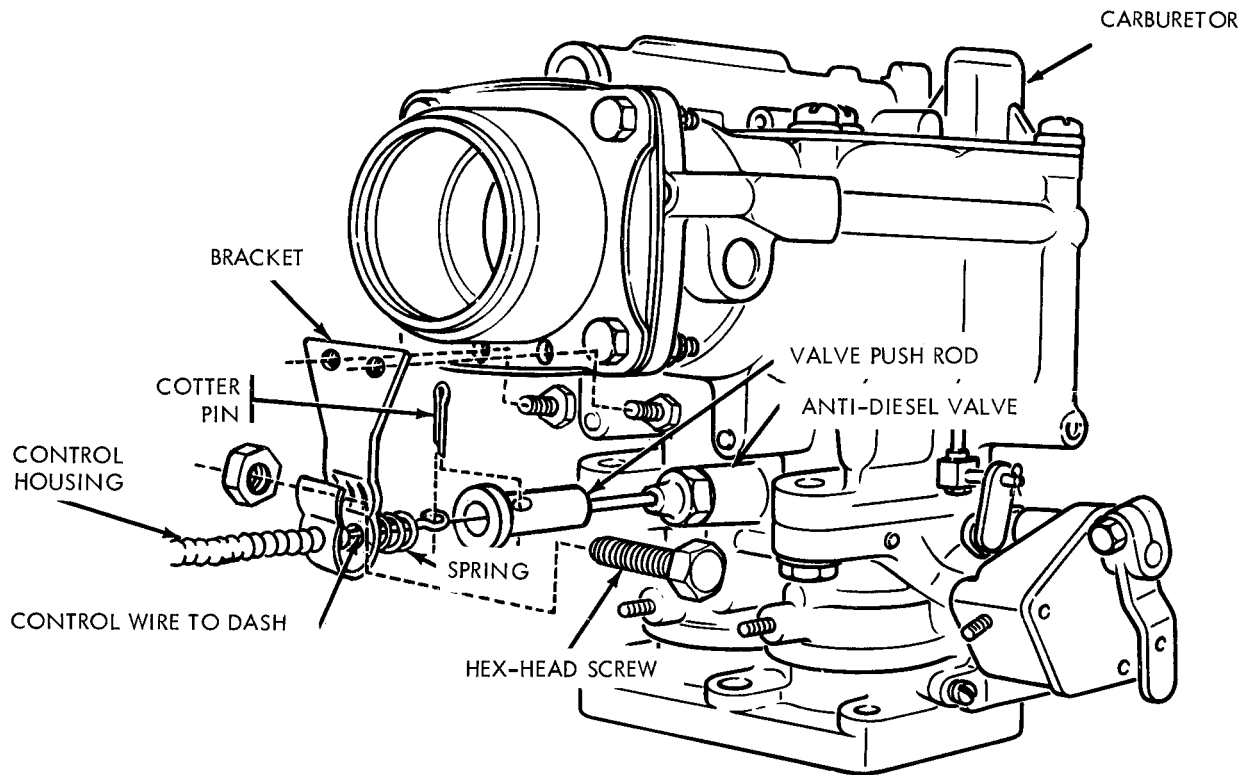
#### *a.* Removal.

(1) Pull the cotter pin from the antidiesel valve push rod.

(2) Pull the control wire out of the push rod while holding and catching the spring.

(3) Remove the hexagon head screw from the bracket to free the control wire sheath.

(4) Release the knob on the dash by removing the nut and washer attaching the knob and control wire to the dash. Pull the control wire and knob assembly out through the instrument panel in the cab.



AT 34832

Figure 2-68. Antidiesel control—carburetor with integral antidiesel valve.

*b. Installation.*

- (1) Position the control knob and control wire through the instrument panel.
- (2) Secure the knob to the instrument panel with the washer and nut.
- (3) Secure the control wire housing to the bracket with the hexagon head screw.
- (4) Position the eye end of the control wire into the push rod, and secure the control wire to the push rod with a cotter pin.

**2-70. Antidiesel Control Valve Mounted to Intake Manifold**

(Fig. 2-69).

*a. Removal.*

- (1) Remove the control wire from the valve handle.
- (2) Remove the nut, screw, and washer securing the control wire housing to the fabricated bracket.
- (3) Remove the nut and washer behind the instrument panel securing the control knob, and slide the knob off.
- (4) Pull the knob, housing, and control wire out through the instrument panel in cab.

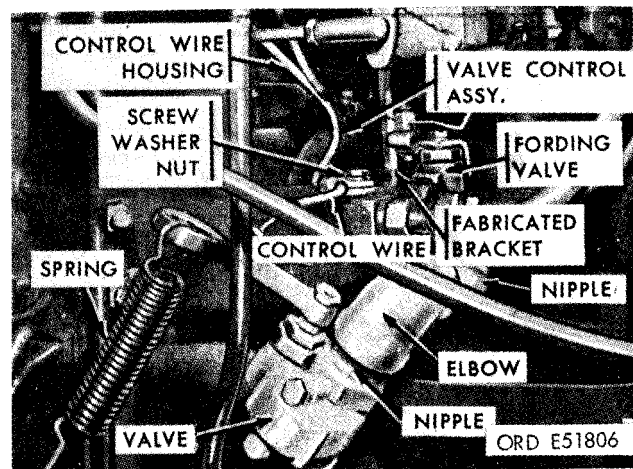


Figure 2-69. Antidiesel valve and controls—intake manifold modified degasser models.

*b. Installation.*

- (1) Position the housing and control wire through the instrument panel.
- (2) Secure the control knob to the instrument panel with the washer and nut.

(3) Install the control wire housing on the fabricated bracket and secure it with washer, screw, and nut.

(4) Connect the control wire to the valve handle.

### 2-71. Antidiesel Valve (degasser)

(Fig. 2-69.)

#### NOTE

This paragraph covers removal and installation of the antidiesel (degassing) valve (intake manifold type) installed on some models by rescinded MWO ORD-W23. Later model vehicles have this device incorporated in the carburetor.

#### a. Removal.

(1) Lift the spring off of the valve handle and remove it from the hole in the body.

(2) Remove the control wire from the valve handle.

(3) Unscrew the valve from the threaded plug hole in the intake manifold.

#### NOTE

If the valve is not to be replaced; e.g., when a later model carburetor-with-valve is being installed; be sure to replace the pipe plug.

#### b. Installation.

(1) Screw the valve into threaded plug hole intake manifold.

(2) Install the control wire on the valve handle.

(3) Place the spring on the valve handle and insert it into the hole in the body.

### 2-72. Fuel Pump

a. *Testing.* The condition of the fuel pump can be determined by two tests, both of which are performed while the unit is installed on the engine ((1) and (2) below).

#### (1) Pressure test.

(a) Unscrew the connector at the lower end of the fuel-pump-to-carburetor line (16, fig. 2-43), and remove the line from the outlet side of the fuel pump (1, fig. 2-150).

(b) Install the pressure gage at the outlet side of the fuel pump.

(c) Start the engine and set the throttle at 900 rpm. Observe the fuel pump pressure indicated by the gage. If the pressure indicated by the gage is within specified limits (4 to 5 psi), proceed as in (e) and (f) below; otherwise, replace the fuel pump.

(d) Stop the engine.

(e) Remove the pressure gage from the outlet side of the fuel pump, position the fuel pump-to-carburetor line at the pump outlet, and tighten the connector.

(f) perform the capacity test ( (2) below).

#### (2) Capacity test.

(a) Unscrew the connector at the upper end

of the fuel pump-to-carburetor line (16, fig. 2-43) from the elbow at the front of the carburetor, and remove the line.

(b) Attach a bleeder hose to the upper end of the fuel pump-to-carburetor line, and support the outlet of the bleeder hose at, or slightly higher than, carburetor level.

(c) While holding a container under the bleeder hose outlet, start the engine. Operate the engine for 45 seconds after the fuel starts to flow into the container, then stop the engine.

(d) Measure the quantity of fuel pumped into the container during the test period.

(e) If the fuel capacity is satisfactory (at least 1 pint in 45 seconds of operation), proceed as in (f) below; otherwise replace the fuel pump.

(f) Remove the bleeder hose from the upper end of the fuel pump-to-carburetor line, position the line at the elbow at the front of the carburetor, and tighten the connector.

#### b. Removal

(1) Unscrew the connector at the lower end of the fuel pump-to-carburetor line, and remove the line from the outlet side of the fuel pump.

(2) Unscrew the nut at the junction of the fuel pump-to-fuel filter flexible line (3, fig. 2-150) and the fuel pump-to-fuel filter rigid line (2, fig. 2-150), and disconnect the lines.

(3) Unscrew the connector on the front end of the fuel pump-to-flywheel housing vent line from the elbow at the lower left side of the fuel pump, and remove the line.

(4) Support the fuel pump and remove the sockethead screw and hexhead nut securing the fuel pump to the crankcase.

(5) Remove the fuel pump from the mounting stud, and remove and discard the mounting gasket.

(6) Unscrew the fuel pump-to-fuel filter flexible line from the elbow at the inlet side (rear) of the fuel pump.

#### c. Installation.

(1) Screw the threaded end of the fuel pump-to-fuel filter flexible line in the elbow at the inlet side (rear) of the fuel pump.

(2) Place a new fuel pump mounting gasket on the stud at the rear lower left side of the crankcase, position the fuel pump on the stud, and install the socket-head screw in front of the fuel pump mounting hole. Install the hexagon-head nut on the fuel pump mounting stud, and tighten the nut and socket-head screw.

(3) Position the front end of the fuel pump-to-flywheel housing vent line at the elbow on the lower left side of the fuel pump, and tighten the connector.

(4) Connect the fuel pump-to-fuel filter flexible line to the fuel pump-to-fuel filter rigid line, and tighten the connector.

(5) Position the lower end of the fuel pump-to-carburetor line at the outlet on the front of the fuel pump, and tighten the connector.

**2-73. Fuel Filter**

(Fig. 2-70.)

*a. Maintenance.*

(1) *Draining filter bowl.* Remove the drain plug from the bottom of the filter bowl, and allow the bowl to drain. Install the drain plug at the bottom of the bowl.

(2) *Cleaning strainer element.*

(a) Support the filter bowl. Remove the cap screw from the top of the filter cover. Remove the bowl and gasket from the cover. Pour the contents from the bowl.

(b) Pull the strainer element assembly from the filter bowl mounting tube.

(c) Clean the strainer element assembly and inside of the filter bowl with drycleaning solvent or mineral spirits paint thinner.

(d) Install the strainer element assembly on the filter bowl mounting tube.

(e) Position the filter bowl and gasket at the underside of the filter cover. Install the bowl retaining cap screw, and tighten it.

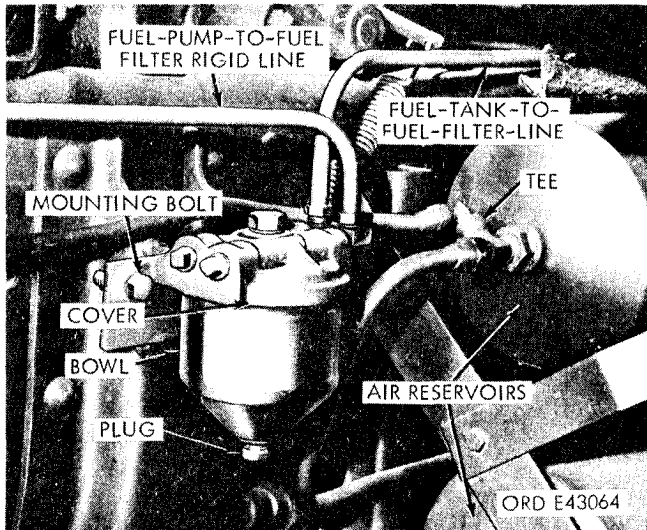


Figure 2-70. Fuel filter installed under left front fender.

*b. Removal.*

(1) Unscrew the connector at the lower end of the fuel pump-to-fuel filter rigid line from the elbow at the rear of the fuel filter. Remove the line.

(2) Unscrew the connector at the front end of the fuel tank-to-fuel filter line from the elbow at the rear of the fuel filter. Remove the line.

(3) Unscrew the connector at the lower end of the fuel filter-to-primer pump line from the elbow at the front of the fuel filter. Remove the line (vehicles equipped with a primer pump only).

(4) Remove the two mounting bolts, nuts, and lockwashers securing the fuel filter to the mounting bracket attached to the frame crossmember. Remove the fuel filter assembly.

*c. Installation.*

(1) Position the fuel filter assembly at the mounting bracket attached to the frame crossmember. Install two mounting bolts, lockwashers, and nuts.

(2) Position the front end of the fuel tank-to-fuel filter line at the elbow at the rear of the fuel filter, and tighten the connector.

(3) Position the lower end of the fuel pump-to-fuel filter rigid line at the elbow at the rear of the fuel filter. Tighten the connector.

(4) Position the lower end of the fuel filter-to-primer pump line at the elbow at the front of the fuel filter. Tighten the connector (vehicles equipped with a primer pump only).

**2-74. Fuel Tank**

(Fig. 2-71.)

*a. Maintenance.*

(1) *Filling.* Refer to TM 9-2320-211-10.

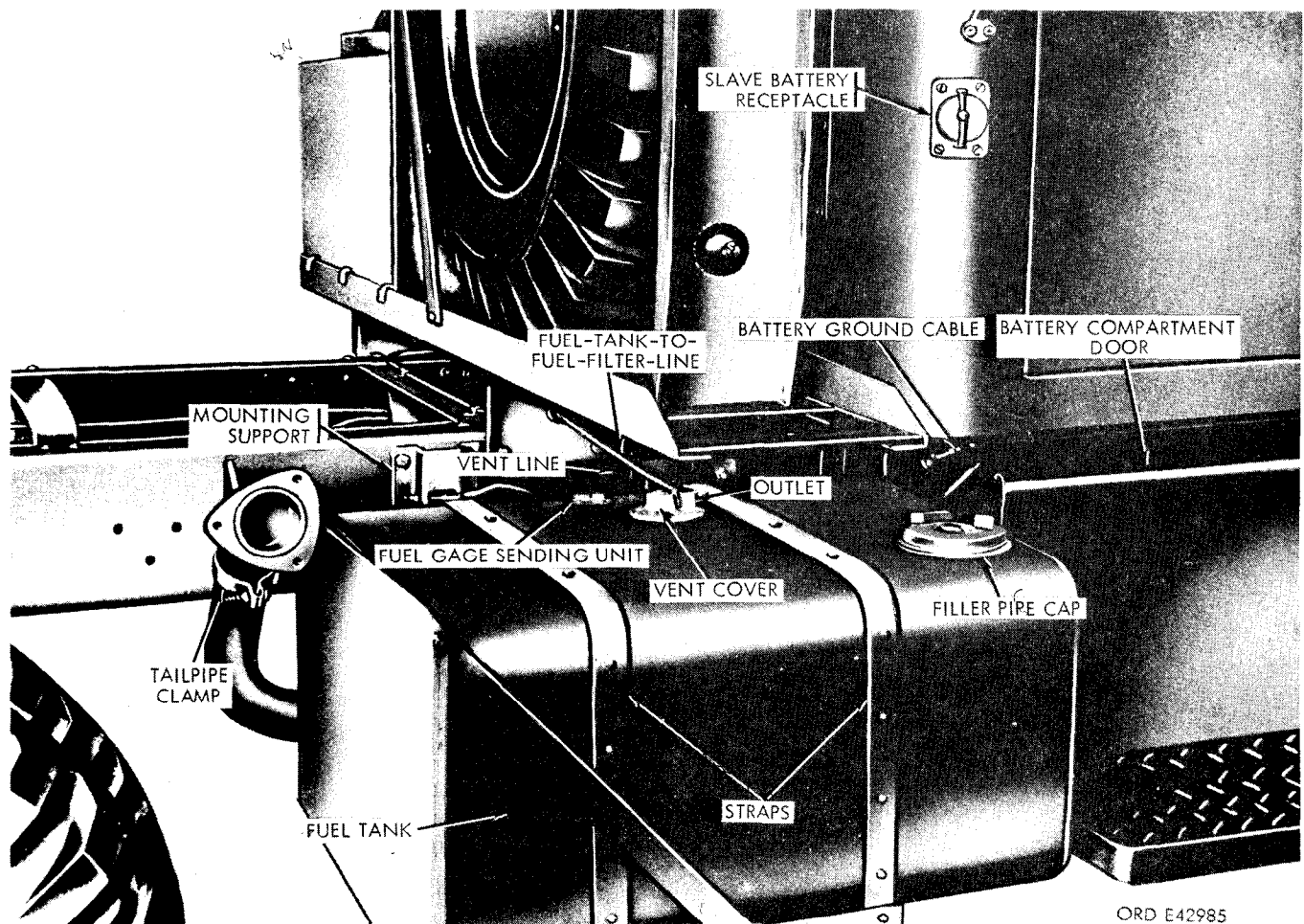
(2) *Draining.*

(a) Place a clean container, with a capacity equal to that of the fuel tank, under the drain opening in the bottom of the fuel tank.

(b) Remove the drain plug from the bottom of the fuel tank and allow the contents of the tank to drain into the container.

(c) Install the drain plug at the bottom of the fuel tank.





ORD E42985

Figure 2-71. Lower right rear corner of cab.

*b. Removal.*

- (1) Drain the fuel tank ( a (2) above)
- (2) Rotate the bayonet type connector at the fuel gage sending unit counterclockwise. Remove the fuel gage cable from the sending unit.
- (3) Unscrew the connector at the tank end of the fuel tank-to-fuel filter line from the outlet at the top of the fuel tank. Remove the line.
- (4) Unscrew the connector at the tank end of the fuel tank-vent line from the vent cover at the top of the fuel tank. Remove the line.
- (5) Remove the two nuts and lockwashers; one each from the bottom end of the front and rear fuel tank straps. Pull the T bolt, secured to the bottom end of each strap, free of the holes in the mounting supports.
- (6) Remove the fuel tank.

*c. Installation.*

- (1) Position the fuel tank on the two mounting supports bolted to the left and / or right from the side rail.
- (2) Position the front and rear fuel tank straps on the tank. Insert the T bolt at the lower end of

each strap in the hole in the outer end of each (front and rear) mounting support. Install a lockwasher and nut on each T bolt. Tighten the nuts.

(3) Position the fuel tank ventilation line at the ventilation cover on top of the fuel tank. Tighten the connector.

(4) Position the fuel tank-to-fuel filter line at the outlet on top of the fuel tank. Tighten the connector.

(5) Insert the bayonet type connector on the end of the fuel gage cable in the terminal socket on the fuel gage sending unit. Rotate the connector clockwise to lock the pins on the connector in the socket slots.

(6) Fill the fuel tank (TM 9-2320-211-10). Look under the tank for any indication of fuel leakage.

### 2-75. Lines and Fittings

When replacing any of the fuel lines or fittings, coat all threaded connections with a liquid type gasket cement before installation, and tighten all con-

nections. Be sure that the mounting clips are installed where necessary and that the lines are

securely mounted. In addition, refer to paragraph 2-48 for removal and installation procedures.

### Section XIII. MAINTENANCE OF FUEL SYSTEM—DIESEL AND MULTIFUEL

#### 2-76. General

The fuel system components discussed in this section include a dry type air cleaner, a shut off control and valves, primary, secondary, and final fuel filters, a fuel tank or dual fuel tank system with various lines and fittings, and a manifold heater system. The manifold heating system consists of an electric fuel pump, two solenoid shutoff valves, fuel nozzle, ignition unit (coil), spark plug, and wiring harness.

#### 2-77. Air Cleaner

##### NOTE

Differences between diesel and multifuel engine air cleaners involve only the number of clamps on, and the configuration of some air tubes.

a. *Servicing the Element.* Every 1,000 miles, semiannually, and / or when the air restriction indicator on the instrument panel shows the air cleaner needs servicing, proceed as follows:

(1) *Removal.*

(a) Release the three latches securing the cover to the air cleaner housing (fig. 2-72), and remove the cover.

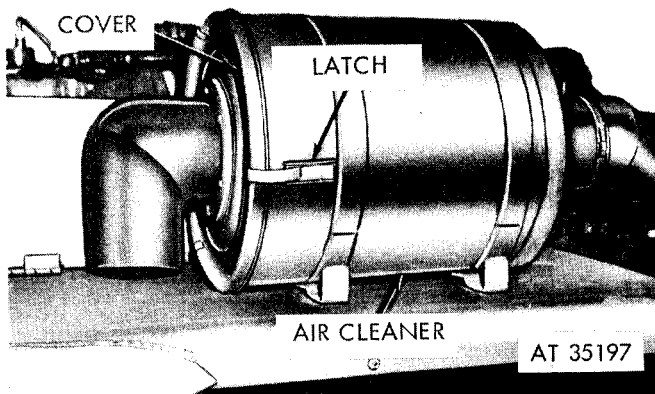


Figure 2-72. Air cleaner.

(b) Turn the locking mechanism counterclockwise until the mechanism disengages from the clamps. Pull the locking mechanism out (fig. 2-73).

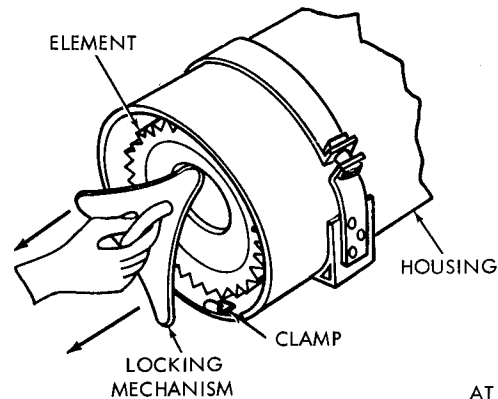


Figure 2-73. Removing air cleaner locking mechanism.

(c) Pull the air cleaner element from the housing (fig. 2-74).

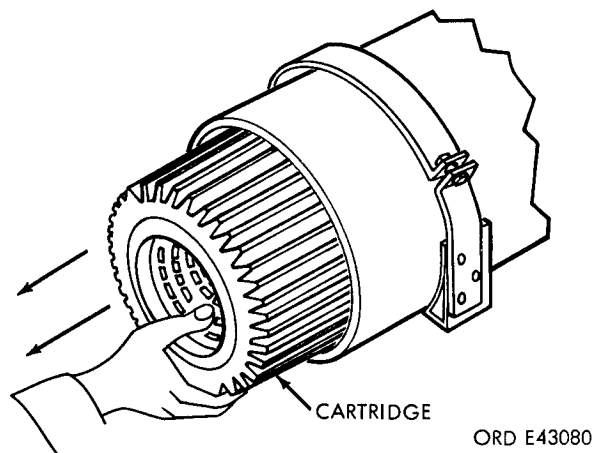


Figure 2-74. Pulling air cleaner element from housing.

(2) *Cleaning.*

(a) Inspect the removed element for evidence of damage.

(b) If no damage is found, wash it with detergent in cool or lukewarm water. Do not use gasoline or other solvents. Soak the element approximately 5 to 10 minutes, slush it, and let it dry.

(c) After the washing, carefully inspect it

for evidence of holes, tears, or seal damage. If the element is serviceable return it to stock.

**NOTE**

The air restriction indicator will show some red when the element is partially restricted as an advance indication of the need for servicing. When an extended period of operation is planned and the indicator shows a state of dust plugging (partial red indication) too great for mission completion, the air cleaner must be serviced.

(3) *Installation.*

(a) Install the element into the air cleaner housing.

(b) Press the locking mechanism into the air cleaner housing, and turn it clockwise until it is locked in the clamps.

(c) Install the cover onto the air cleaner housing lock latches.

*b. Removal.*

(1) Loosen the two clamps securing the two rubber connectors and the air tube assembly (fig. 2-75). Remove the connectors and tube assembly from the vehicle. If necessary, loosen the two clamps to separate the air tube from the connectors.

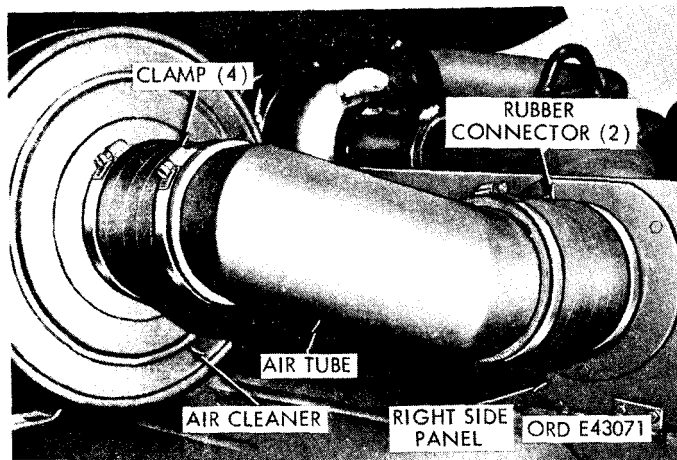


Figure 2-75. Removing rubber connectors and air cleaner tube.

(2) Remove the six nuts, bolts, and washers securing the air cleaner. Lift the air cleaner off of the fender (fig. 2-76).

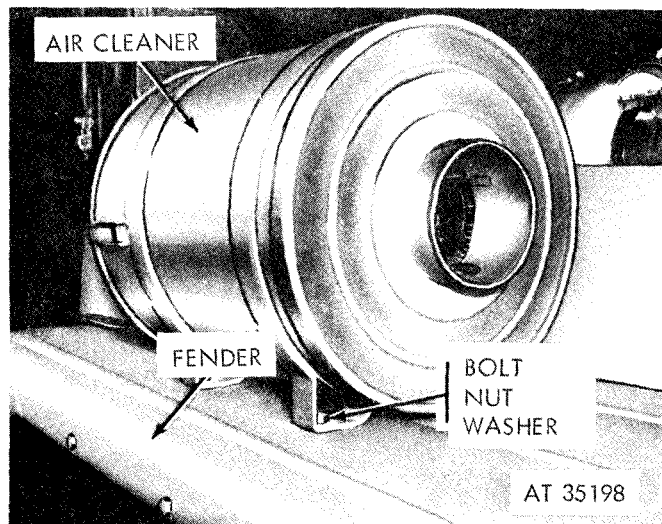


Figure 2-76. Removing air cleaner.

(3) Loosen the clamp securing the rubber connector to the air tube, Separate the connector from the air tube (fig. 2-77).

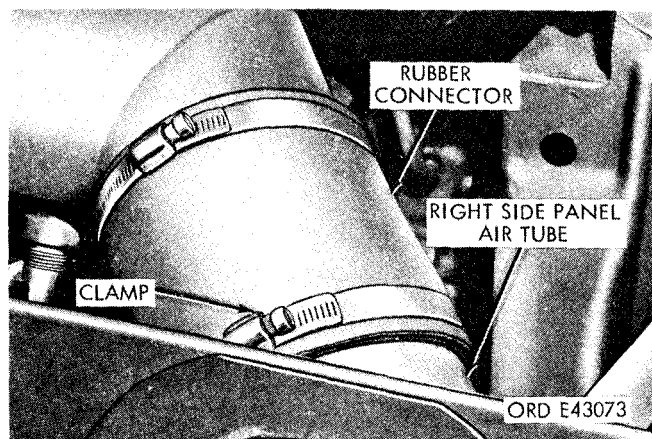


Figure 2-77. Disconnecting rubber connector from air tube.

(4) Disconnect the ventilation line from the air tube, and remove the three nuts and bolts securing the air tube to the right side panel. Remove the air tube (fig. 2-78).

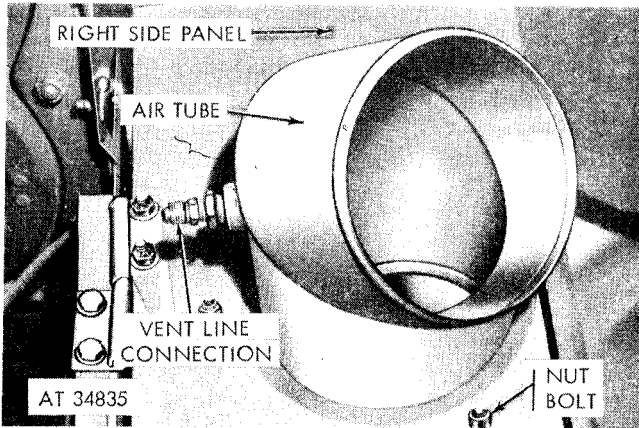


Figure 2-78. Removing air tube.

c. Installation.

(1) Use the three bolts and nuts to secure the air tube to the right side panel (fig. 2-78). Connect the ventilation line to the tube.

(2) Slip the rubber connector over the right panel air tube end, and tighten the clamp (fig. 2-77) securing the connector to the tube.

(3) Position the air cleaner on the fender (fig. 2-76), and secure the cleaner unit to the fender with four bolts, lockwashers, and nuts.

(4) Install two rubber connectors onto the air tube, and secure the connectors to the tube by tightening the two clamps.

(5) Position the two connectors and the air tube assembly, and secure them with clamps (fig. 2-75).

(6) Push the air cleaner element into the housing. Position and turn the locking mechanism clockwise until the mechanism is secured in place by the clamps (fig. 2-73).

(7) Secure the cover to the air cleaner with the three latches.

**2-78. Low Pressure Lines—Diesel and Multifuel**

a. General. Only the removal of the low pressure fuel lines not adversely affected by minor contamination is allocated to organizational maintenance. On multifuel engines these lines include all but the final fuel filter-to-injection pump and its bypass line.

b. Removal. Refer to paragraph 2-48a.

c. Installation. Refer to paragraph 2-48 d.

**2-79. Fuel Shutoff Control and Valve—Diesel Models.**

a. Removal.

(1) Loosen the setscrew securing the control wire to the fuel rack lever (fig. 2-79).

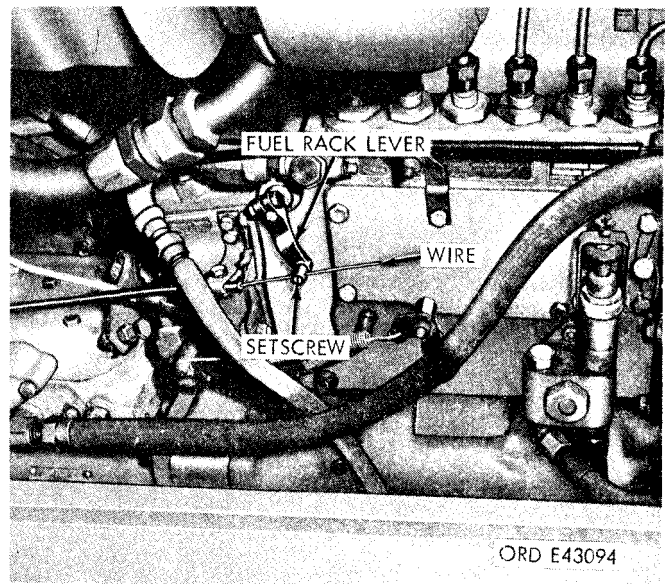


Figure 2-79. Disconnecting fuel shutoff control wire-diesel only.

(2) Remove the nut and lockwasher securing the shutoff control to the instrument panel. Pull the control from the panel (fig. 2-80).

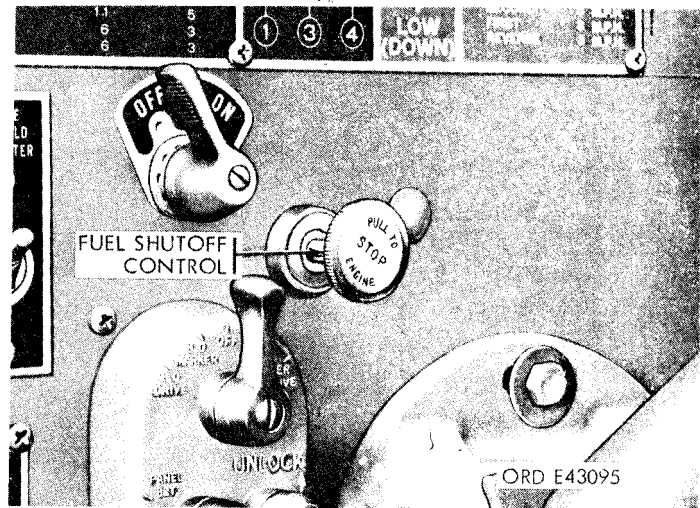


Figure 2-80. Removing fuel shutoff control from instrument panel.

(3) Remove the fuel shutoff valve (fig. 2-181).

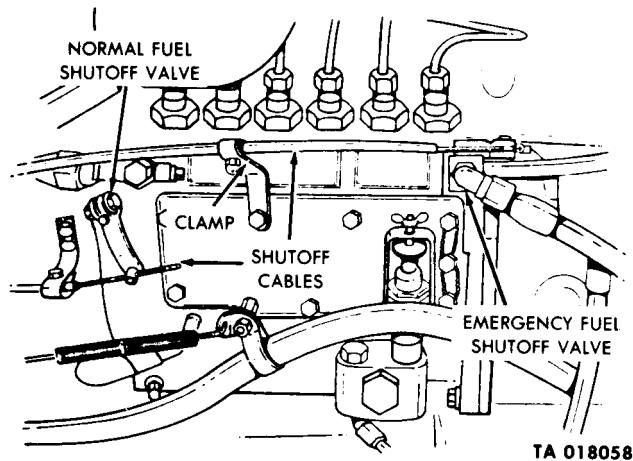


Figure 2-81. Removing shutoff valve—diesel only

*b. Installation.*

- (1) Install the fuel shutoff valve (fig. 2-81).
- (2) Position the control on the instrument panel, and secure it to the panel with a lockwasher and nut (fig. 2-80).
- (3) String the control cable wire through the cowl opening to the fuel rack lever. Secure the wire to the lever by tightening the setscrew (fig. 2-79).

**2-80. Emergency Fuel Shutoff Control-Diesel Models.**

*a. Removal.*

- (1) Loosen the setscrew securing the control wire to the collar. Remove the collar (fig. 2-82).

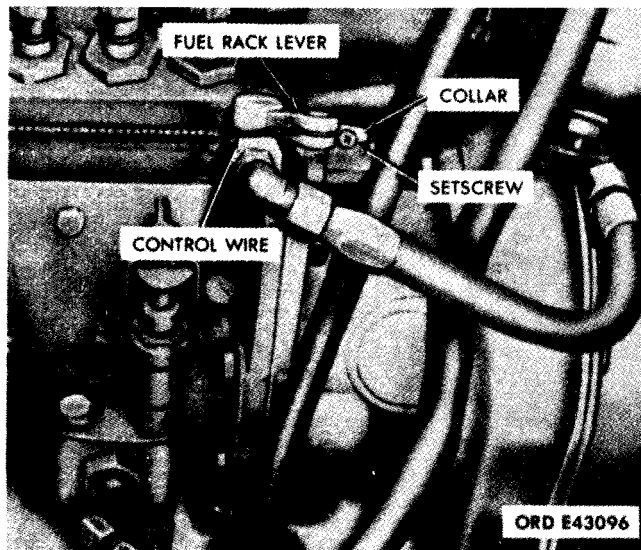


Figure 2-82. Removing emergency fuel shutoff control wire—diesel only.

- (2) Unscrew the nut and remove the bolt securing the emergency control cable to the clamp. Pull the cable from the clamp (fig. 2-81).

- (3) Remove the nut and lockwasher securing the emergency shutoff control to the instrument panel. Pull the control away from the panel (fig. 2-83).

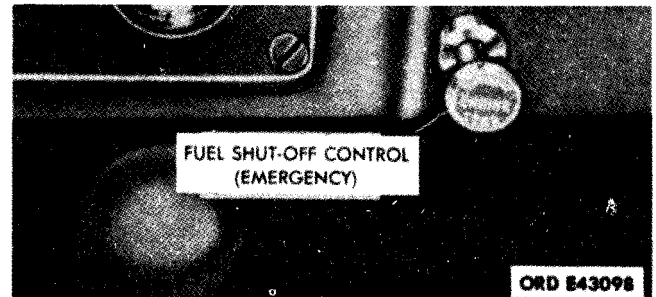


Figure 2-83. Removing emergency fuel shutoff control from instrument panel—diesel only.

*b. Installation.*

- (1) Position the emergency shutoff control on the instrument panel. Secure the control to the panel with a lockwasher and nut.
- (2) String the control cable through the cowl opening, and secure it to the clamp with a bolt and nut.
- (3) Position the collar and control cable wire end to the fuel rack lever. Tighten the setscrew securing the wire to the collar.

**2-81. Fuel Shutoff Control-Multifuel Models (Fig. 2-84).**

*a. Removal*

- (1) Remove the retaining nut and lockwasher securing the shutoff control to the instrument panel.
- (2) Remove the cotter pin from the pin securing the fuel shutoff control to the fuel shutoff valve. Remove the castellated nut, washer, and screw, and remove the control wire.

*b. Installation.*

- (1) Position the control to the instrument panel, and secure it with a lockwasher and nut.
- (2) Secure the control wire with a washer, screw, and nut. Install the shutoff control to the shutoff valve with the pin and cotter pin.

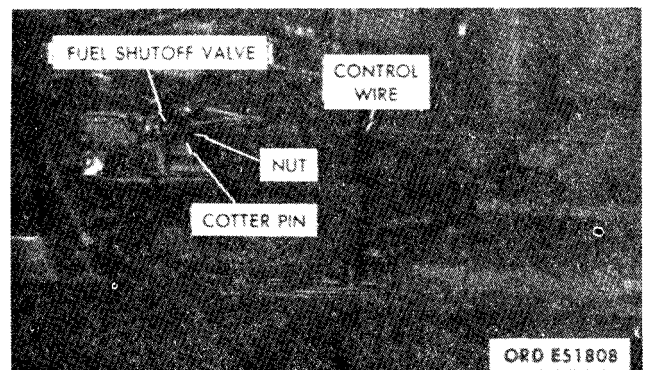


Figure 2-84. Removing fuel shutoff control—multifuel only.

## 2-82. Fuel Filters—Multifuel Models.

- a. *Maintenance.* Refer to TM 9-2320-211-10.
- b. *Removal.*

### NOTE

The primary, secondary, and final filter element replacement procedures are similar. The primary and secondary fuel filters will be changed at 6,000 miles or semiannually, whichever occurs first. The final fuel filter will be changed only during engine overhaul/rebuild or during troubleshooting procedures. Use the following procedures to replace any one of the filters.

### CAUTION

Disconnect battery ground cable before removing secondary and final fuel filters on multifuel engine LDS465-1A.

(1) Open the filter drain plug (fig. 2-85), and drain the fuel into a suitable container.

(2) Remove the bolt and washer securing the filter housing. Remove the housing, and discard the gasket.

(3) Remove the element and gasket. Discard the secondary and final elements and gaskets (do not discard the primary element).

c. *Cleaning.*

(1) Thoroughly clean the primary element in a

drycleaning fluid or mineral spirits paint thinner.

(2) Clean the secondary and / or final housing with drycleaning fluid or mineral spirits paint thinner.

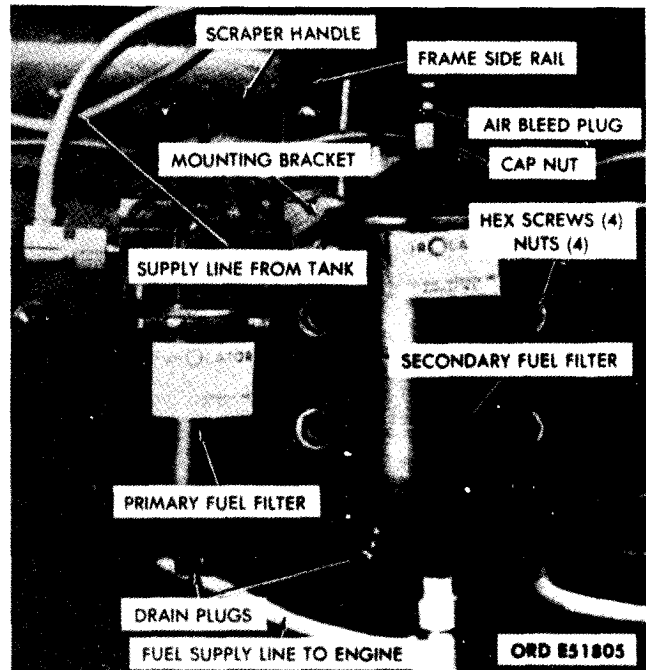


Figure 2-85. Primary and secondary fuel filters—multifuel engine LDS465-1.

**CAUTION**

Cover all items until they are installed to prevent contamination by dust or dirt.

*d. Installation.*

(1) Position a new secondary or final element (fig. 2-86) in the housing. Use new gaskets.

(2) Use new gaskets when installing the primary element and housing assembly.

(3) Install the filter drainplugs. Start the engine and allow it time to warm up. Check all filters for leaks. Tighten where necessary.

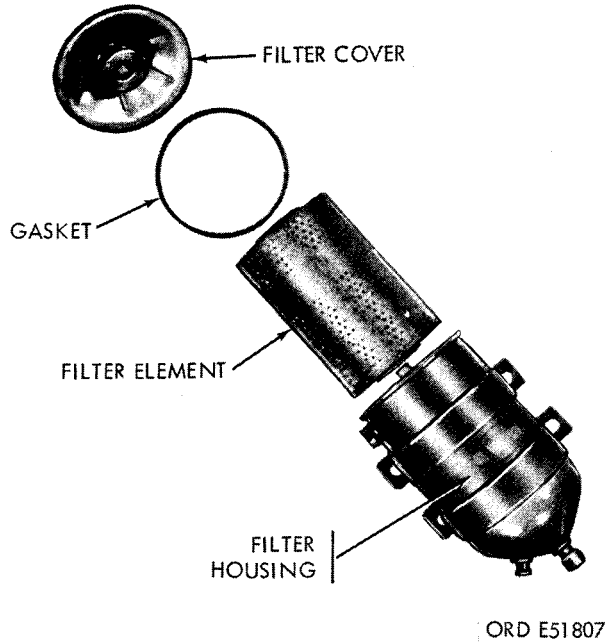


Figure 2-86. Fuel filter—exploded view—multifuel engine LDS 465-1.

**2-83. Throttle Linkage—Diesel and Multifuel Models**

(fig. 2-87.)

*a. Removal.*

(1) Remove the screw from the connector attaching the throttle control wire to the throttle rod assembly.

(2) Loosen the clamp holding the control wire housing to the firewall.

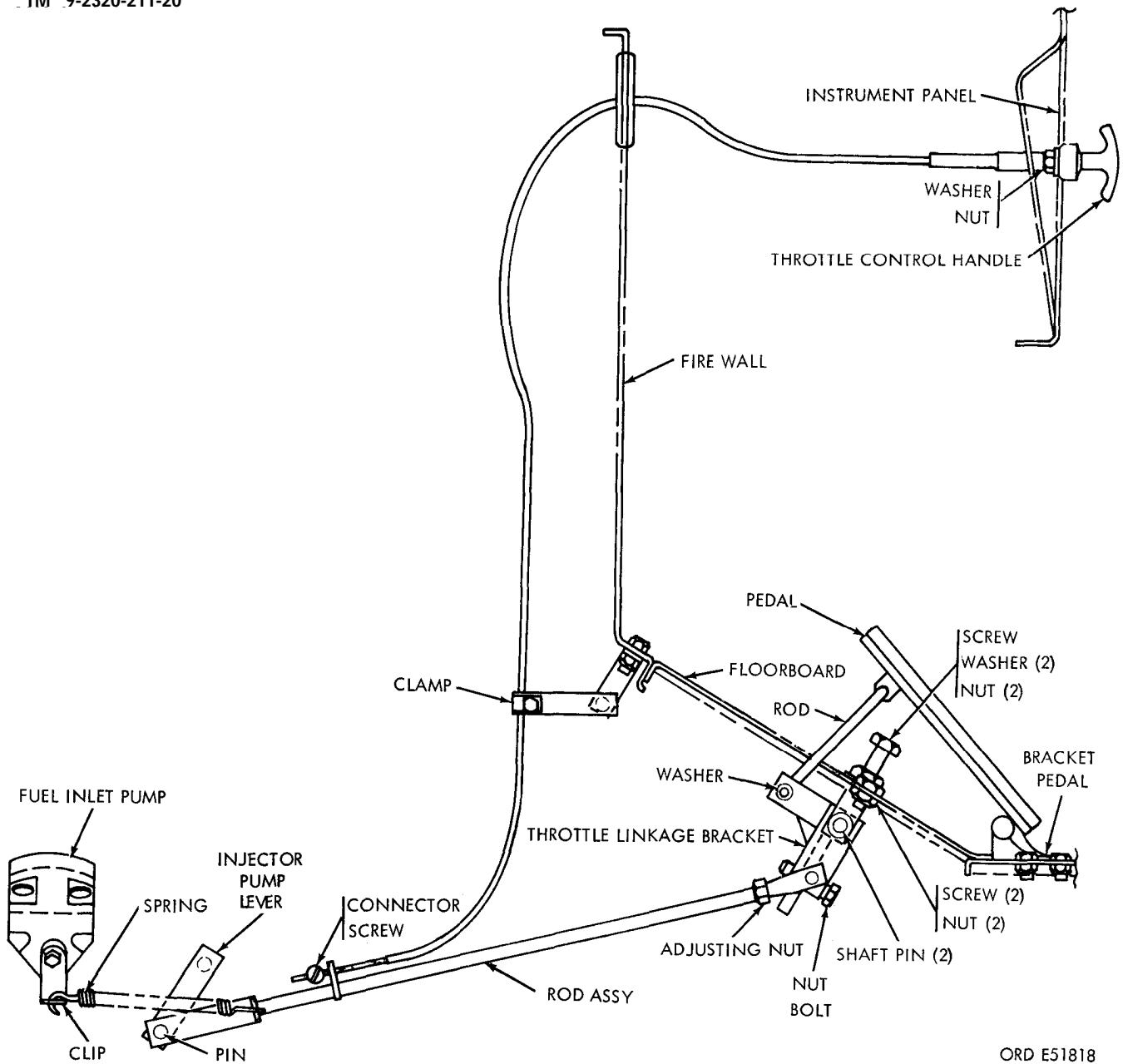
(3) Remove the screw and washer attaching the throttle control handle to the instrument panel, and pull the throttle control assembly through the instrument panel into the cab.

*b. Installation.*

(1) String the throttle control assembly through the instrument panel, and secure the control handle to the panel with a washer and screw.

(2) Secure the control wire to the firewall with the clamp.

(3) Attach the control wire to the throttle rod with a screw.



ORD E51818

Figure 2-87. Accelerator and throttle linkage—diesel and multifuel.

**2-84. Accelerator Linkage—Diesel and Multifuel**

*a. Removal.*

- (1) Remove the hand throttle as described in paragraph 2-83 a.
- (2) Remove the spring from the throttle rod assembly.
- (3) Remove the pin and cotter key attaching the linkage to the fuel rack lever.
- (4) Remove the nut and bolt securing the rod assembly to the bracket.

**NOTE**

- Do not remove the rod assembly at the adjusting nut since this will change the fuel injector setting.
- (5) Remove the washer securing the pedal rod to the linkage bracket. Remove the rod.
  - (6) Remove the two nuts and screws securing the throttle linkage bracket to the floorboard.
  - (7) Remove the two nuts and screws securing the pedal and pedal bracket to the floorboard, and remove the pedal.



*b. Installation.*

- (1) Secure the pedal and bracket assembly to the floorboard with two screws and nuts.
- (2) Secure the linkage bracket to the floorboard with two screws and nuts.
- (3) Connect the pedal rod and washer to the linkage bracket.
- (4) Secure the rod assembly to the bracket with a bolt and nut.
- (5) Attach the linkage to the fuel rack with the pin and cotter key.
- (6) Attach the spring to the rod, and install the throttle assembly.

**2-85. Fuel Tank**

*a. Removal.*

- (1) Remove the drain plug and drain the fuel tank (fig. 2-88).
- (2) Disconnect the engine feed line, engine return line, vent line, electrical lead and, on dual tank models, the fuel transfer line (fig. 2-89).

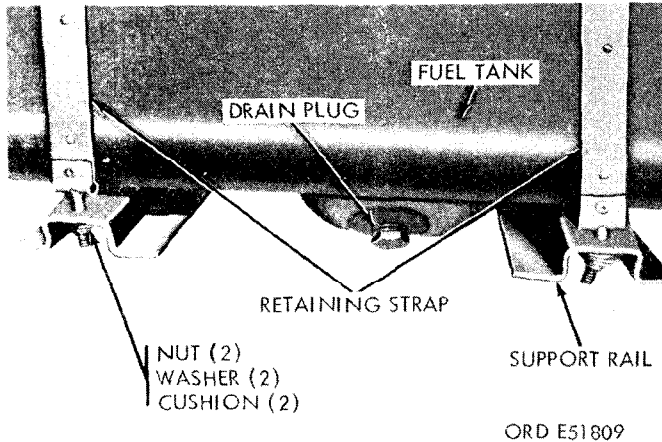


Figure 2-88. Fuel tank.

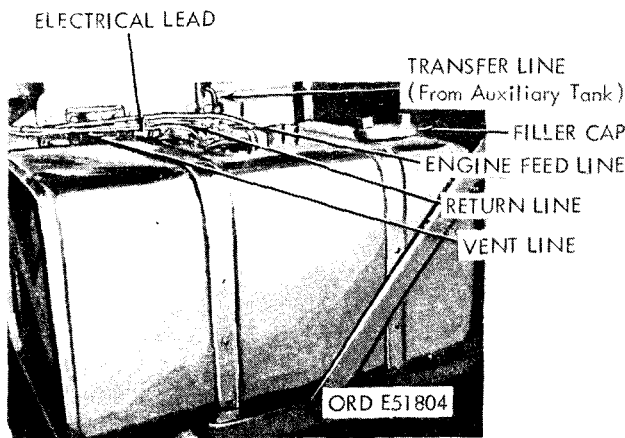


Figure 2-89. Main tank on M51A2 model.

- (3) On dual tank models, disconnect the auxiliary tank lines as follows (fig. 2-90): Disconnect transfer pump feed line, vent line, electrical lead, and fuel feed line to main tank.

**NOTE**

On vehicles with a braced fuel tank (fig. 2-91), it is necessary to remove the reinforcing brace before the fuel tank can be removed. Remove the two bolts, nuts, and washers that retain the brace.

- (4) On vehicles without braced support rails (fig. 2-91), remove the tank as follows: Remove the nut, washer, and cushion attaching the retaining strap to the support rails. Remove the fuel tank.

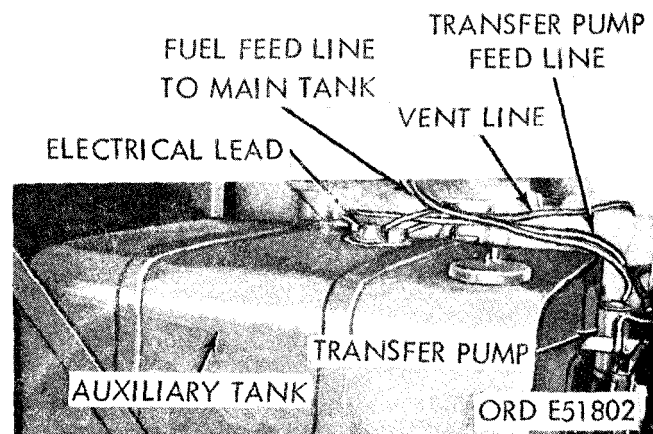


Figure 2-90. Auxiliary tank.

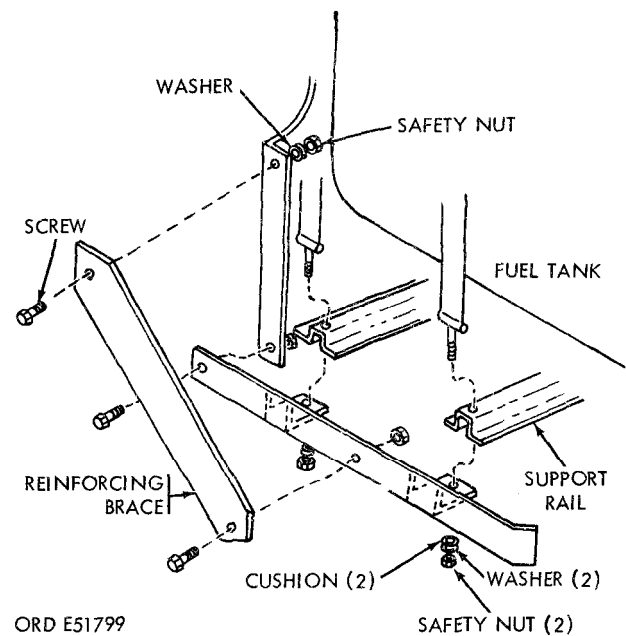


Figure 2-91. Braced fuel tank.

*b. Installation.*

(1) Position the tank and retain it with the strap, cushion, washer, and nut (fig. 2-91).

**NOTE**

On those vehicles with a braced tank (fig. 2-91), secure the brace with two washers, bolts, and nuts.

(2) Connect all auxiliary tank lines. This includes the fuel feed line, transfer pump feed line, vent line, and electrical lead (fig. 2-90).

(3) Connect the main tank lines as follows: Feed line, return line, vent line, and electrical lead (fig. 2-89).

(4) Install the drain plug, and fill the tank with fuel. Run the engine and check the tank and line connections for leaks. If necessary, re-tighten the connections.

**2-86. Fuel Transfer Pump—Multifuel**

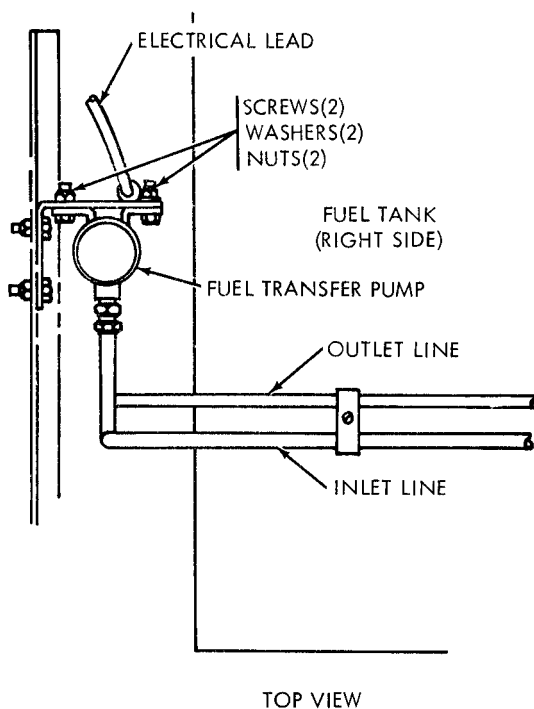
(Fig. 2-92.)

*a. Removal.*

(1) Disconnect the electrical lead.

(2) Disconnect the inlet and outlet line.

(3) Remove the two screws, nuts and washers attaching the pump to the bracket, and remove the pump.



ORD E51821

Figure 2-92. Fuel transfer pump.

*b. Installation.*

(1) Secure the pump to the bracket with two washers, screws, and nuts.

(2) Connect the inlet and outlet line.

(3) Connect the electrical lead.

**2-87. Manifold Heater Supply Valve and Fuel Return Valve—Multifuel Models**

*a. Removal.*

(1) Disconnect the electrical lead and inlet and outlet lines from heater fuel supply valve and / or fuel return valve (fig. 2-93).

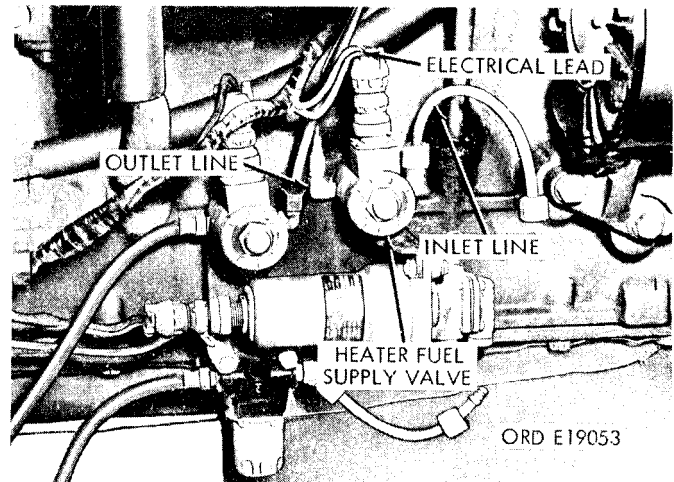


Figure 2-93. Manifold heater supply and fuel return valves-- multifuel engine LDS 465-1.

(2) Remove the three capscrews and lock-washers securing the flame heater fuel pump and fuel filter bracket to the crankcase, and remove the bracket with the solenoid valves (fig. 2-94).

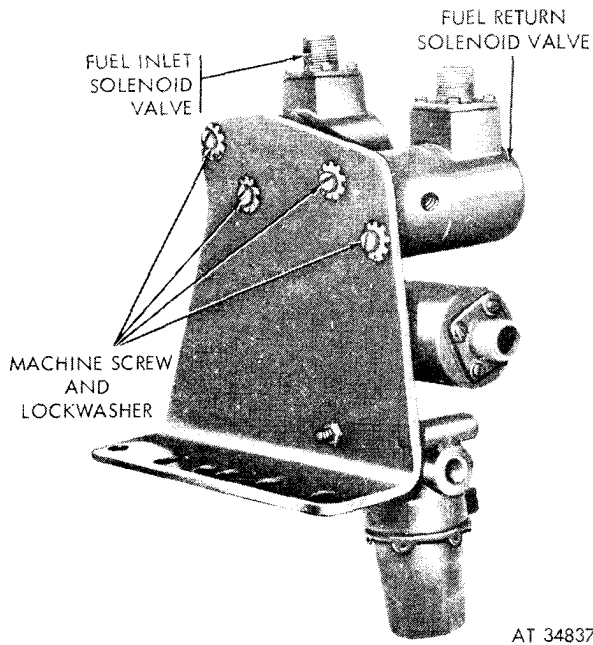


Figure 2-94. Fuel solenoid valves—multifuel engine LDS 465-1.

**b. Installation.**

- (1) Secure the supply and / or return valves to the bracket (fig. 2-93).
- (2) Secure the fuel pump and filter bracket to the crankcase with the three lockwashers and cap screws.
- (3) Connect the electrical lead and fuel inlet and outlet lines to the supply valve and / or return valve (fig. 2-93).

**2-88. Fuel Filters—Diesel Models**

*a. Maintenance.* Refer to TM 9-2320-211-10.

**b. Primary Filter.**

- (1) *Removal.* Remove the bolt and lockwasher securing the filter to mounting bracket (fig. 2-95). Remove the filter assembly, and pull the two gaskets, element, and spring out of the housing (fig. 2-96). Discard the gaskets.

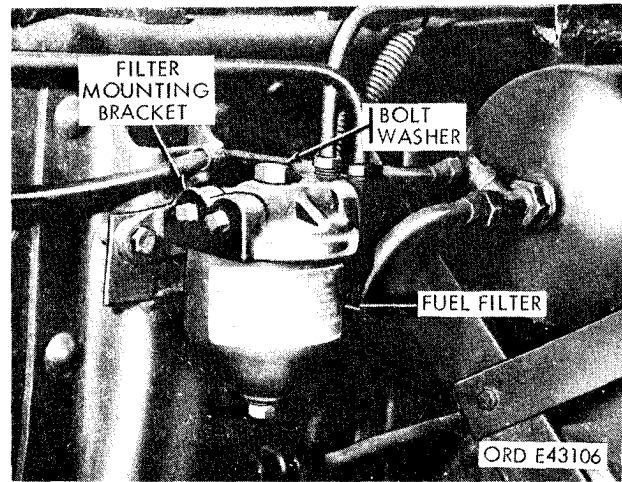


Figure 2-95. Fuel filter—diesel models.

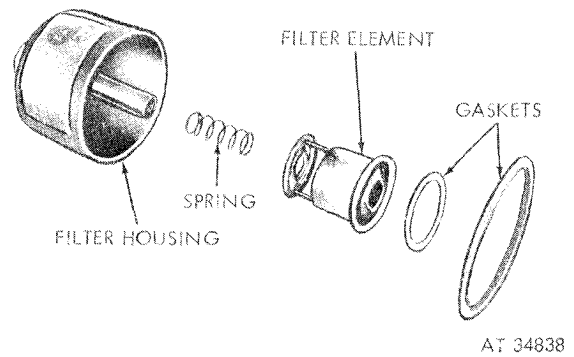


Figure 2-96. Fuel filter—exploded view.

- (2) *Installation.* Position the spring, element, and smaller element gasket in the housing (fig. 2-96). Place the larger housing-to-bracket gasket into position, and secure the filter assembly to the mounting bracket with the washer and bolt (fig. 2-95).

**c. Secondary Filter.**

**(1) Removal.**

- (a) Open the pet cock and drain the fuel into a suitable container (fig. 2-97).
- (b) Disconnect the fuel line at the cover elbow (fig. 2-97).

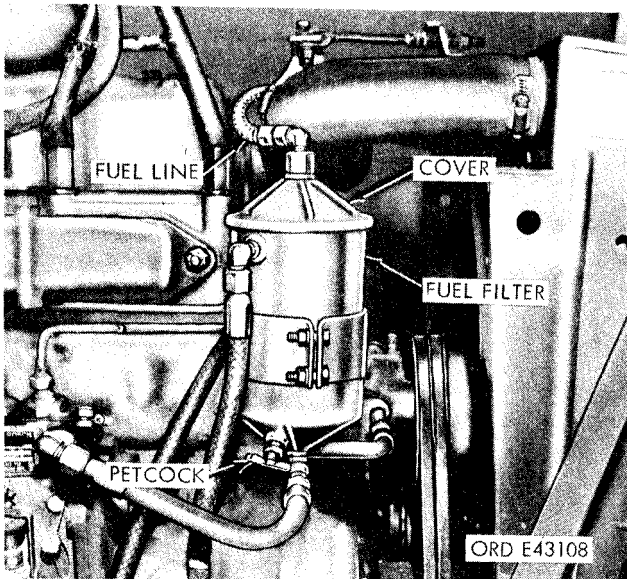


Figure 2-97. Secondary fuel filter—diesel models.

(c) Remove the cover from the housing; discard the cover gasket.

(d) Lift the element out of the housing. Discard the element (fig. 2-98).

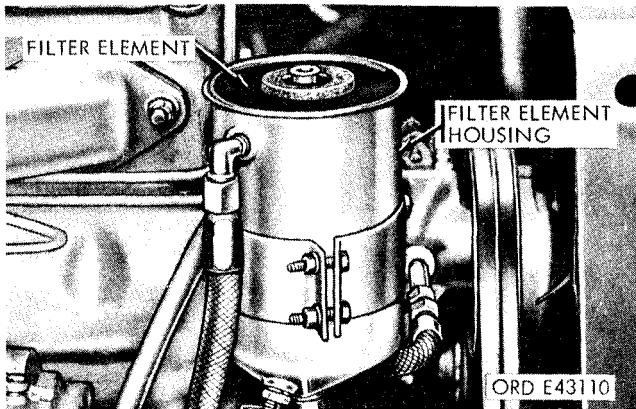


Figure 2-98. Removing or installing element from fuel filter housing—diesel models.

(2) Installation.

(a) Place a new element into the housing (fig. 2-98).

(b) Position a new gasket and the cover on the housing (fig. 2-97).

(c) Connect the fuel line to the elbow on the cover (fig. 2-97), and close the drain cock.

**2-89. Manifold Heater Injector Nozzle, Spark Plug, and Spark Plug Housing—Diesel Models**

a. Removal.

(1) Disconnect the igniter wire from the spark plug, and remove the plug with the gasket from the housing (fig. 2-99).

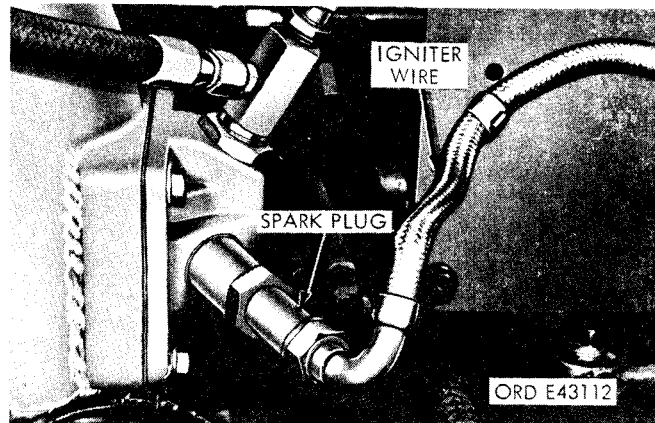


Figure 2-99. Spark plug.

(2) Disconnect the two fuel lines from the injector nozzle. Remove the injector nozzle from the housing (fig. 2-100).

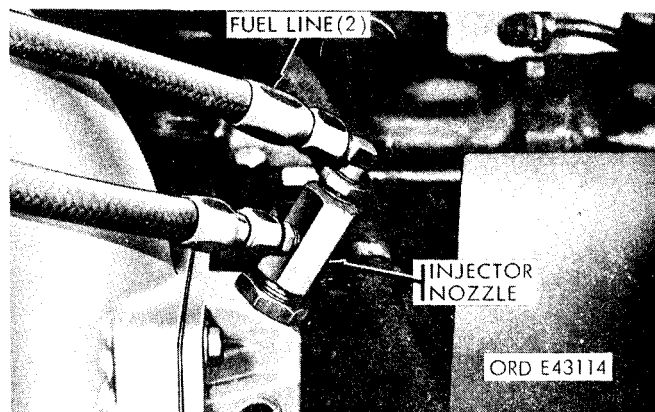


Figure 2-100. Injector nozzle.

(3) Remove the four bolts and lockwashers securing the housing to the intake elbow. Separate the oil line and clamp from the housing. Remove the housing and gasket (fig. 2-101).

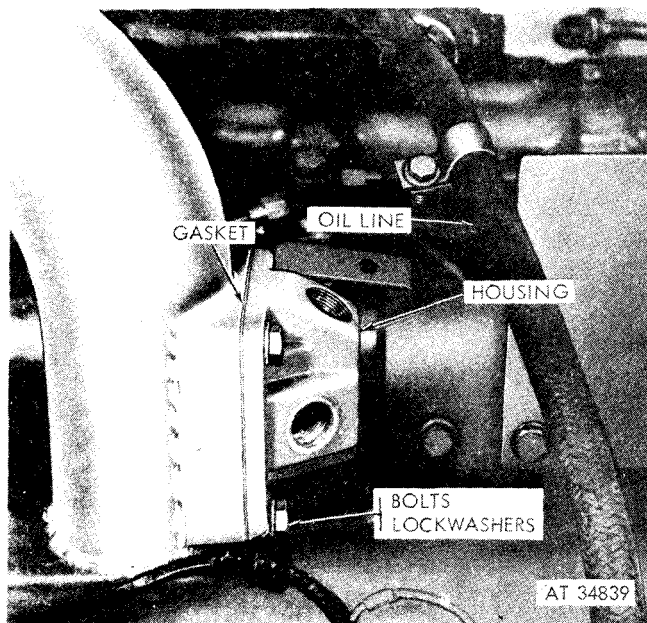


Figure 2-101. Removing spark plug housing.

*b. Installation.*

(1) Mount the housing with a gasket on the intake elbow. Secure the housing (as well as the oil line and clamp assembly) with four lockwashers and bolts (fig. 2-101).

(2) Install the injector nozzle to the housing, and connect the fuel lines to the nozzle (fig. 2-100).

(3) Install the spark plug with the gasket (use a new gasket if the plug is a new one) in the housing (fig. 2-100). Connect the igniter wire to the plug.

**2-90. Manifold Heater Injector Nozzle, Spark Plug, and Spark Plug Housing—Multi-fuel Models**

(fig. 2-102)

*a. Removal.*

(1) Disconnect the ignition lead from the spark plug.

(2) Remove the spark plug from the spark plug housing.

(3) Unscrew the spark plug housing from the flame heater body.

(4) Remove the fuel lines from the injector nozzle.

(5) Unscrew the injector nozzle from the flame heater body.

(6) Remove the bolts and lockwashers securing the flame heater housing to the intake manifold, and remove the housing. Leave the harness retaining clip on the harness for future installation.

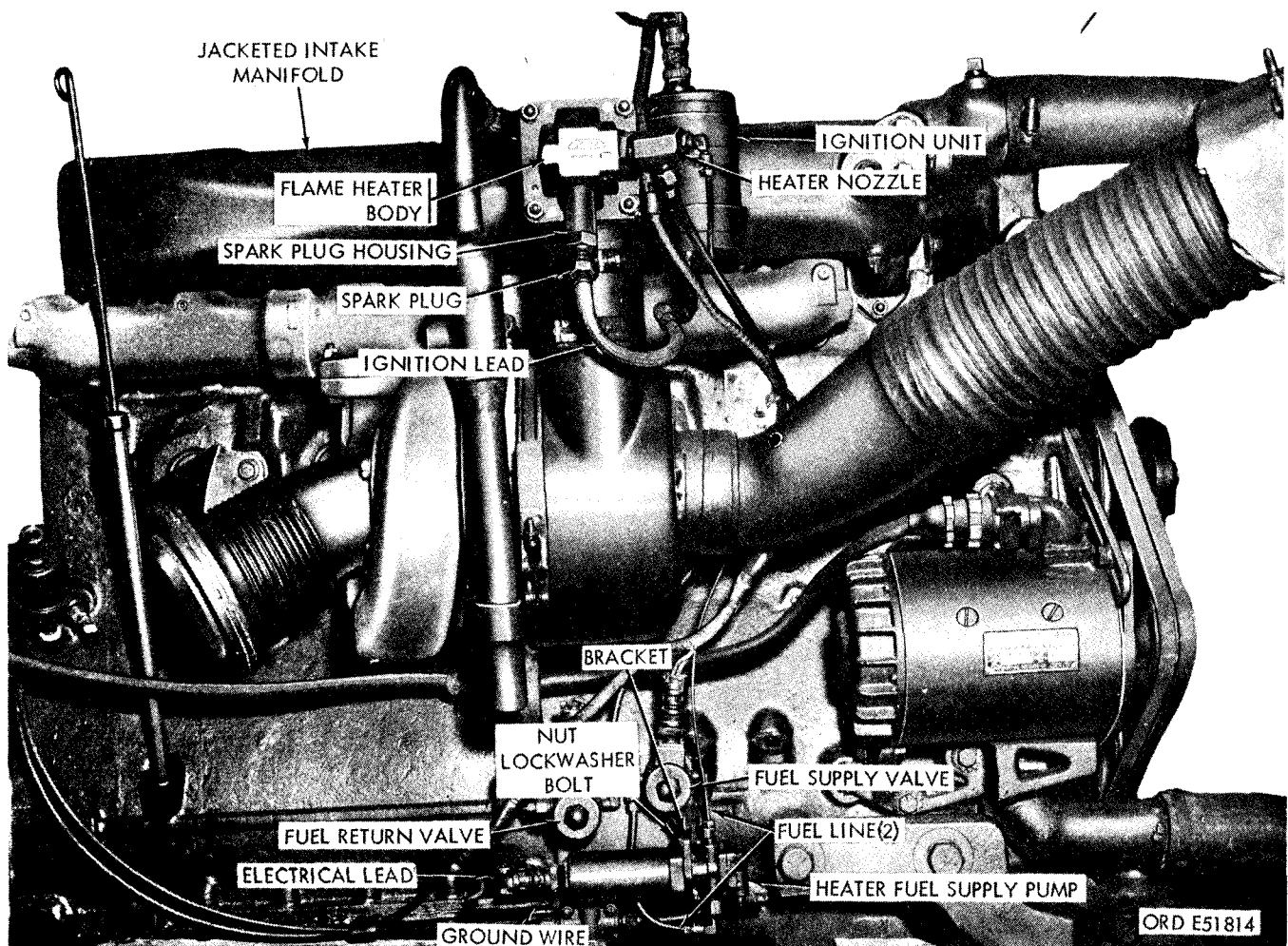


Figure 2-102. Intake manifold heater system components—multi fuel models.

*b. Installation.*

(1) Secure the flame heater housing intake manifold with lockwashers and bolts.

(2) Screw the injector nozzle into the flame heater body, and connect the fuel lines to the nozzle.

(3) Install the spark plug housing to the flame heater body.

(4) Screw the spark plug into the housing, and connect the ignition lead to the plug.

**2-91. Manifold Heater Wiring Harness—Diesel Models**

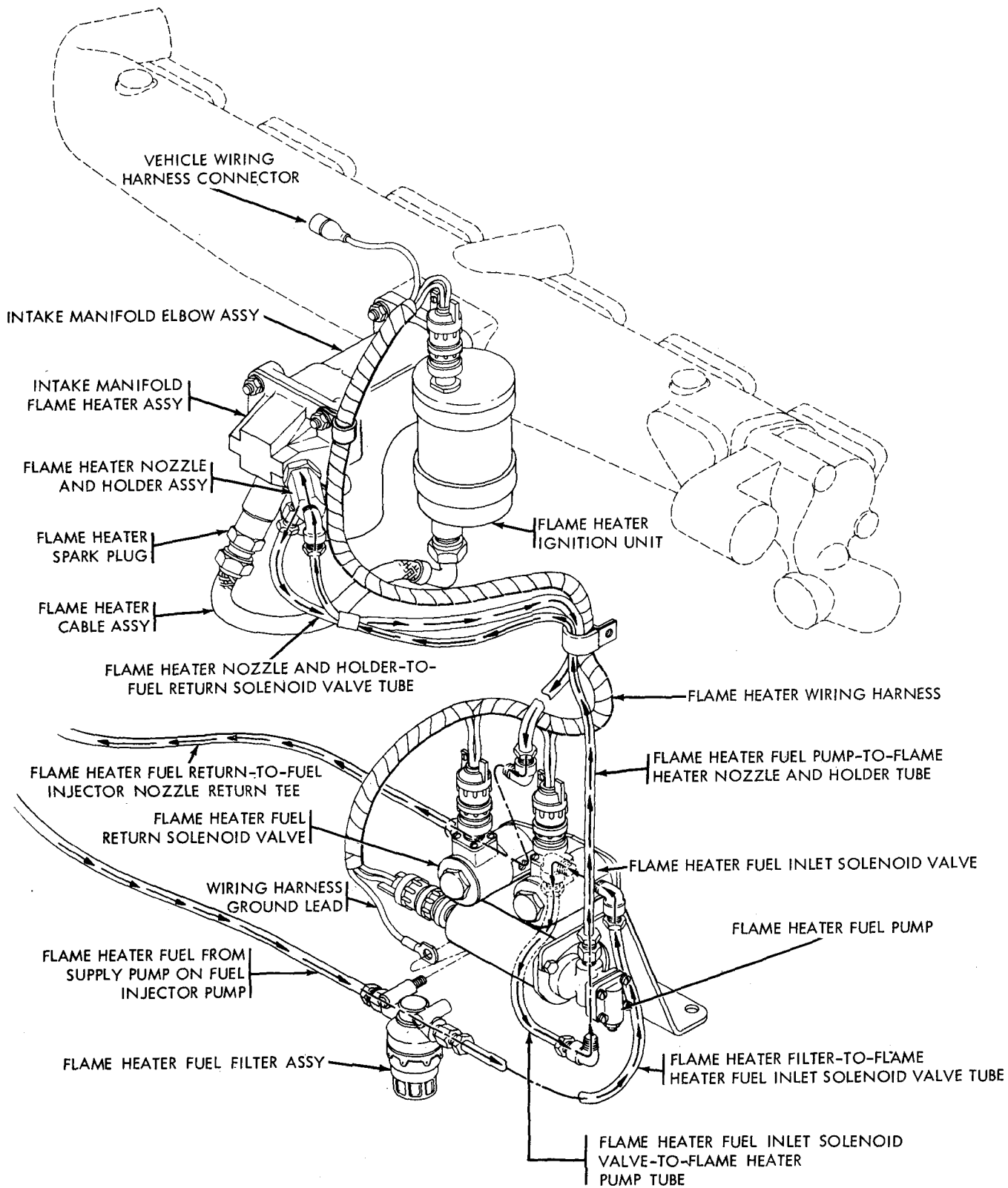
*a. Removal.* Disconnect the branched wiring

harness for intake manifold heater components at the ground lead terminal and five connecting points.

*b. Installation.* Connect the branched wiring harness for the intake manifold heater components at the five connecting points and the ground lead terminal.

**2-92. Manifold Heater Wiring Harness—Multifuel Models**

(Fig. 103.)



ORD E56716

Figure 2-103. Removing manifold heater wiring harness—multifuel models.

*a. Removal.*

(1) Disconnect the electrical connectors at the fuel pump (lead and ground wire).

(2) Disconnect the electrical leads at the fuel return valve and fuel supply valve.

(3) Disconnect the electrical leads at the ignition unit and main harness (near ignition unit).

*b. Installation.*

(1) Connect the electrical lead and ground wire at the fuel pump.

(2) Connect the electrical leads to the fuel return and fuel supply valves.

(3) Connect the electrical leads to the ignition unit and main harness.

**2-93. Electric Fuel Supply Pump for Manifold Heater—Diesel Models**

*a. Removal.*

(1) Disconnect the electrical lead from the fuel pump (fig. 2-104).

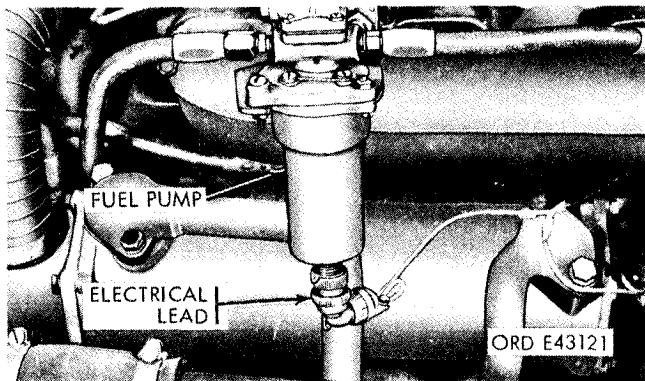


Figure 2-104. Disconnecting electrical lead from manifold heater fuel pump—diesel models.

(2) Disconnect the two fuel lines (fig. 2-105) from the pump.

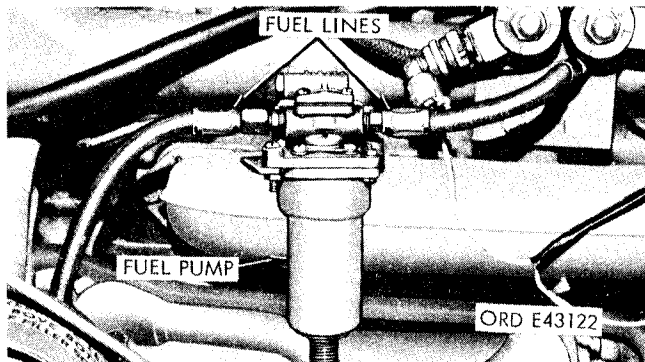


Figure 2-105. Disconnecting fuel lines at pump.

(3) Remove the two nuts and lockwashers (fig. 2-106) securing the pump assembly to the mounting studs. Remove pump.

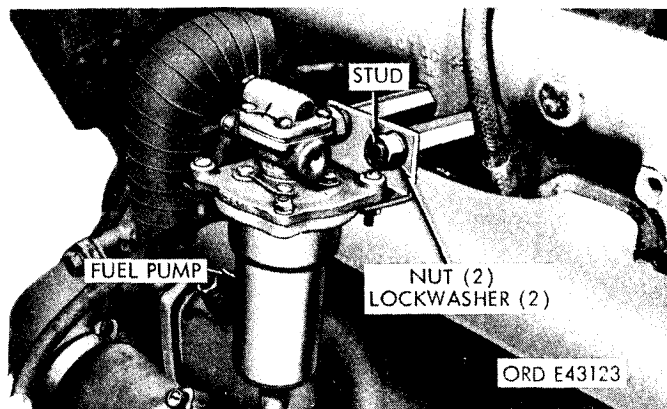


Figure 2-106. Removing manifold heater fuel pump.

*b. Installation.*

(1) Mount the pump on studs, and secure it with two lockwashers and nuts (fig. 2-106).

(2) Connect the two fuel lines to the pump (fig. 2-105).

(3) Connect the lead to the pump (fig. 2-104).

**2-94. Electric Fuel Supply Pump for Manifold Heater—Multifuel Models**

(Fig. 2-103.)

*a. Removal.*

(1) Disconnect the fuel supply lines and electrical lead from the fuel supply pump.

(2) Remove the nuts, lockwashers, and bolts securing the supply pump to the bracket, and remove the supply pump.

*b. Installation.*

(1) Secure the heater fuel supply pump to the bracket with the required number of lockwashers, bolts, and nuts.

(2) Connect the fuel lines and electrical lead to the supply pump.

**2-95. Manifold Heater Ignition Unit (Coil)—Multifuel Models**

(Fig. 2-107.)

*a. Removal.*

(1) Disconnect the power supply lead and ignition lead from the ignition unit (fig. 2-107).

(2) Remove the two nuts and lockwashers securing the ignition unit to the ignition unit bracket, and remove the ignition unit (fig. 2-107).

*b. Installation.*

(1) Mount the ignition unit to its bracket, and secure the unit with two lockwashers and nuts.

(2) Connect both leads to the ignition unit.



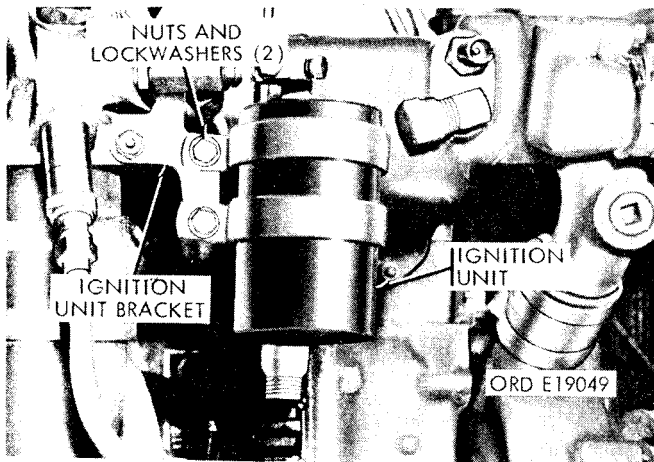


Figure 2-107. Removing ignition unit.

**2-96. Manifold Heater Ignition Unit (Coil)—Diesel Models**

*a. Removal.*

(1) Disconnect the electrical leads from the top and bottom of the coil unit (fig. 2-108).

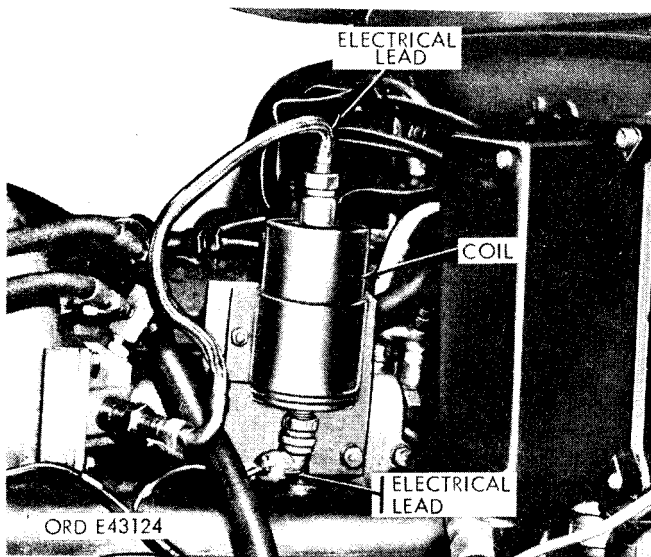


Figure 2-108. Disconnecting electrical leads from coil.

(2) Remove the two bolts and lockwashers securing the coil unit to the mounting plate (fig. 2-109). Remove coil.

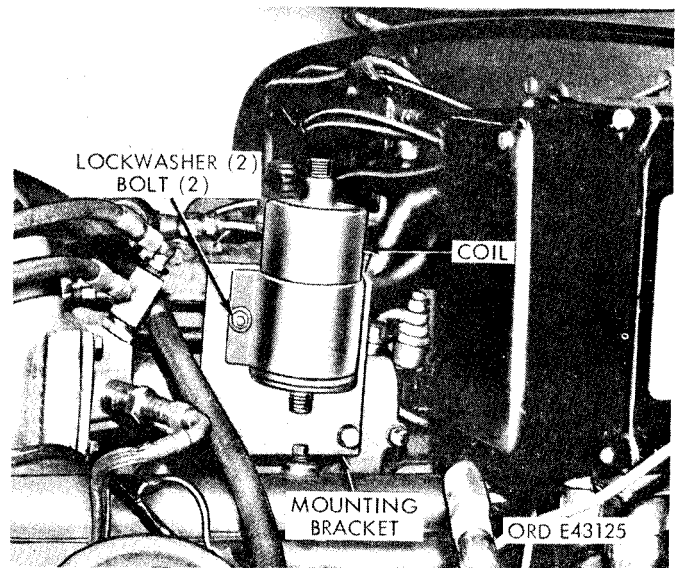


Figure 2-109. Removing coil from mounting plate.

*b. Installation.*

(1) Secure the coil to the mounting plate with two lockwashers and bolts (fig. 2-109).

(2) Connect the electrical leads at the top and bottom of the coil unit (fig. 2-108).

**2-97. Manifold Heater Fuel—Multifuel Models**

*a. Removal.*

(1) Disconnect the heater fuel filter inlet and outlet lines (fig. 2-110).

(2) Remove the screws and lockwashers securing the filter to the bracket (fig. 2-111).

(3) Remove the ground wire and fuel filter.

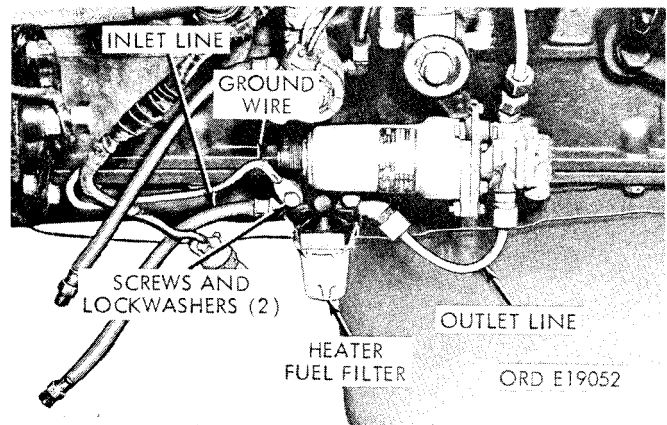


Figure 2-110. Disconnecting manifold heater fuel filter lines.

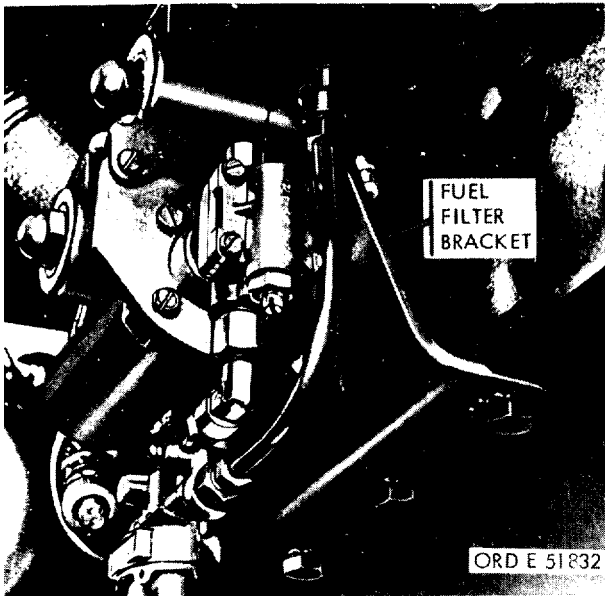


Figure 2-111. Removing manifold heater fuel filter—multifuel models.

**b. Installation.**

(1) Secure the ground wire and filter to the bracket with lockwashers and screws (fig. 2-111).

(2) Connect the filter inlet and outlet lines to the filter (fig. 2-110).

**2-98. Manifold Heater Supply Valve and Fuel Return Valve—Diesel Models**

**a. Removal.**

(1) Disconnect the two electrical leads (one from each solenoid) as shown in figure 2-112.

(2) Disconnect the four fuel lines from the two solenoids (fig. 2-112).

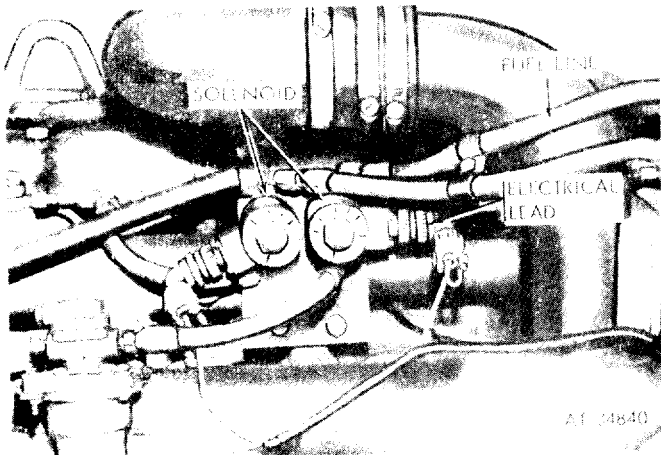


Figure 2-112. Disconnecting electrical leads and fuel lines at two solenoids—diesel models.

(3) Remove the screw securing the tachometer cable clamp to the solenoid backing plate (fig. 2-113). Separate the cable from the solenoid assembly.

(4) Unscrew the two bolts mounting the solenoid assembly to the engine, and remove the assembly (fig. 2-113).

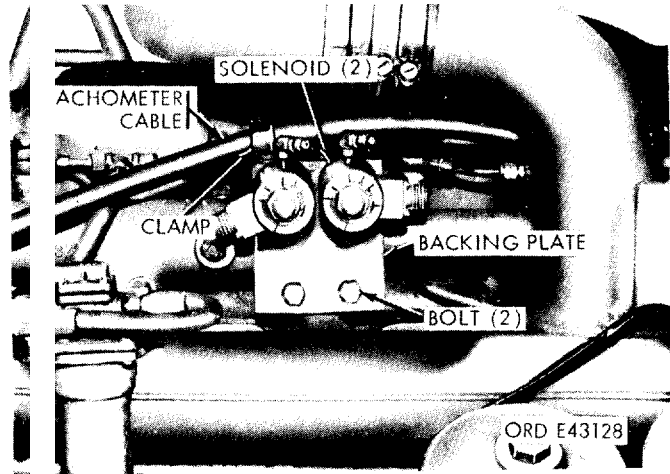


Figure 2-113. Removing two-valve solenoid assembly—diesel models.

(5) Remove the remaining three screws securing the two solenoids to the backing plate (fig. 2-114).

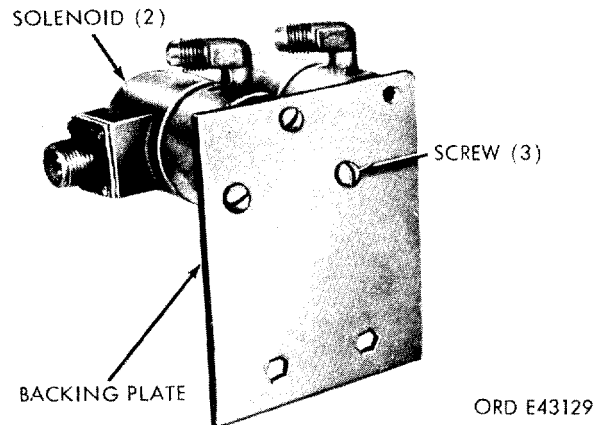


Figure 2-114. Separating two solenoids from backing plate—diesel models.

**b. Installation.**

(1) Secure the two solenoids to the backing plate with the three screws (fig. 2-144).

(2) Mount the solenoid assembly to the engine with two bolts (fig. 2-113).

(3) Use the fourth screw to mount the tachometer cable and clamp assembly to the backing plate (fig. 2-113).

(4) Connect the fuel lines (fig. 2-112) to the solenoids.

(5) Connect the two electrical leads to the solenoids (fig. 2-112).

## Section XIV. MAINTENANCE OF EXHAUST SYSTEM—GASOLINE ENGINE

**WARNING**

The M52 and M246 vehicles should have a flame and spark arrestor muffler installed to prevent fire when hauling flammable or explosive cargo. The muffler can be identified by a cleanout plug located in the front lower portion of the muffler housing. Any vehicle that does not have a flame and spark arrestor muffler should be tagged **DO NOT USE FOR TRANSPORTING OF FLAMMABLE OR EXPLOSIVE CARGO.**

**2-99. General**

The exhaust system consists of an exhaust pipe, muffler, and tail pipe extension assembly. A sealing ring is installed between the exhaust pipe and the manifold to prevent gas leakage. The entire exhaust system is supported by clamps and brackets attached to the frame right side rail.

**2-100. Tailpipe and Extension**

(Fig. 2-115.)

*a. Removal.*

(1) Separate the tailpipe extension from the tailpipe by removing the three nuts and bolts from the mating flanges. Remove the extension. Discard the extension-to-tailpipe gasket.

(2) Remove the three nuts and bolts securing the tailpipe to the muffler.

(3) Remove the nut and bolt from the tailpipe clamp, spread the clamp, and remove the tailpipe from the vehicle.

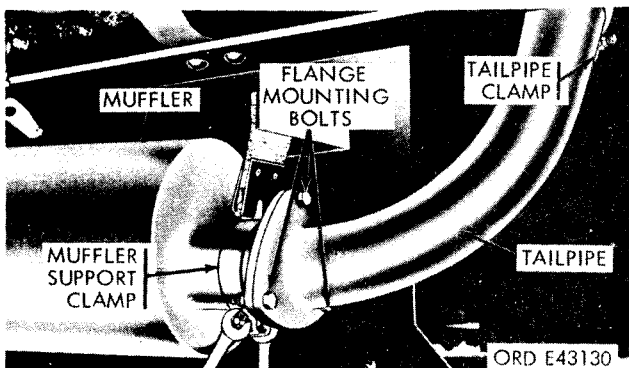


Figure 2-115. Muffler support and tailpipe.

*b. Installation.*

(1) Position the tailpipe to the vehicle, install the tailpipe clamp, and secure it with a nut and bolt.

(2) Place a new gasket between the tailpipe

and the muffler mating flanges, and secure the tailpipe with three bolts and nuts.

(3) Using a new extension-to-tailpipe gasket, secure the extension flanged end to the tailpipe with three bolts and nuts.

**2-101. Muffler***a. Removal.*

(1) Remove the four nuts and bolts securing the muffler front flanged end to the exhaust pipe.

(2) Remove the three nuts and bolts securing the muffler to the tailpipe (fig. 2-115).

(3) Unscrew the two nuts and bolts securing the muffler support clamp (fig. 2-115) around the muffler. Spread the clamps apart and remove the muffler.

*b. Installation.*

(1) Place a new gasket on the exhaust pipe flange. Position the muffler front flange end to the exhaust pipe with four bolts and nuts.

(2) Using a new gasket, secure the muffler to the tailpipe with three bolts and nuts (fig. 2-115).

(3) Spread the muffler support clamp apart, and slip it around the muffler, securing it with two bolts and nuts (fig. 2-115).

**2-102. Exhaust Pipe***a. Removal.*

(1) Remove the four nuts and bolts securing the exhaust pipe to the muffler. Discard the gasket.

(2) Remove the two nuts and bolts securing the exhaust pipe clamp to the exhaust pipe. Discard the gasket.

(3) Loosen the four nuts on the mounting studs at the exhaust manifold. Turn the pipe mounting flange until the larger holes align with the washers under the mounting nuts.

(4) Slide the exhaust pipe flange over the mounting nuts and washers, and remove the exhaust pipe. Discard the sealing ring.

*b. Installation.*

(1) Place a new sealing ring into position on the exhaust pipe front flanged end.

(2) Slip the exhaust pipe front end over the four nuts and washers onto the mounting studs. Rotate the exhaust pipe flange until the smaller holes align with washers. Tighten the nuts securing the pipe to the manifold.

(3) Using a new gasket, position the exhaust pipe to the muffler and secure it with four bolts and nuts.

(4) Position the exhaust pipe clamp to the exhaust pipe, and secure it with two nuts and bolts.

**Section XV. MAINTENANCE OF EXHAUST SYSTEM—DIESEL AND MULTIFUEL**

**2-103. General**

The exhaust system consists of a three-piece (front, center, and rear) pipe assembly connected together. This exhaust pipe assembly is secured to the vehicle frame by brackets at three locations. Vertical exhaust stack kits are installed on multifuel models.

**2-104. Front Exhaust Pipe**

*a. Removal.*

(1) On diesel models remove the nut and bolt securing the clamp around the flange of the front exhaust pipe and exhaust elbow (fig. 2-116). (On multifuel models, remove the three safety nuts, lockwashers, and screws securing the exhaust pipe flange to the exhaust elbow and bracket (fig. 2-117).

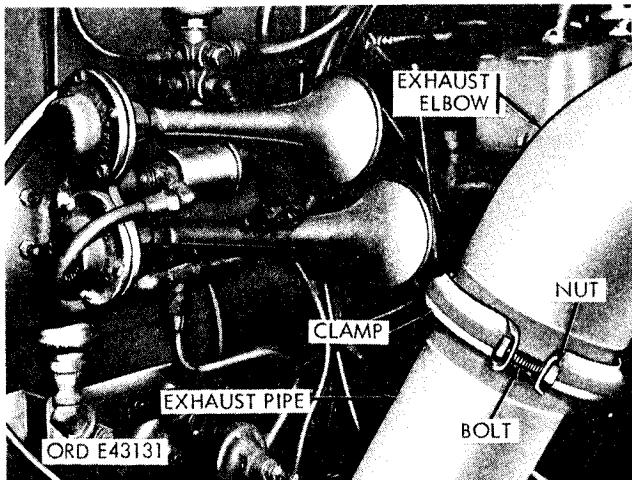


Figure 2-116. Removing front exhaust elbow clamp—diesel models.

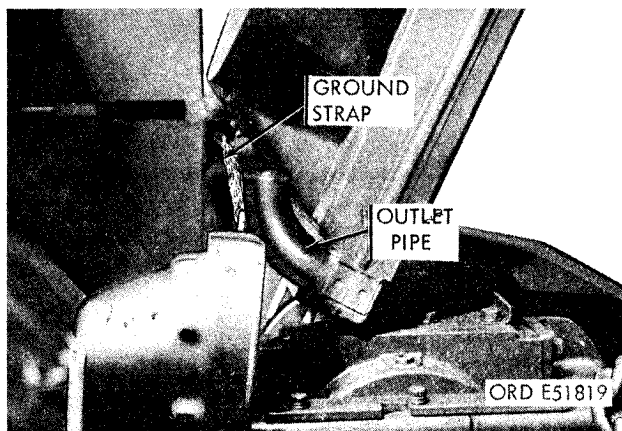


Figure 2-117. Removing front exhaust pipe-multifuel models.

(2) Remove the two nuts and bolts securing the bracket to the exhaust pipe, and remove the bracket (fig. 2-118).

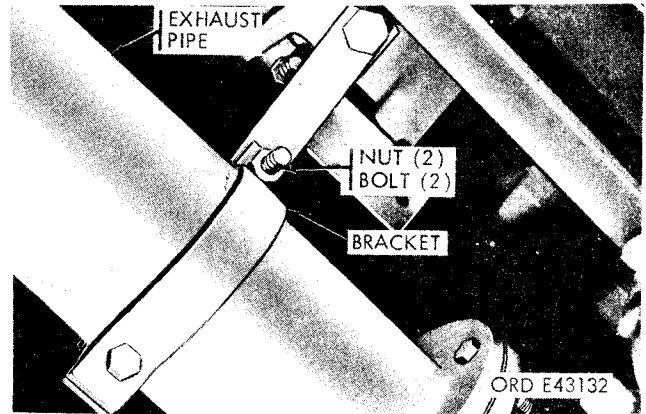


Figure 2-118. Removing exhaust pipe bracket.

(3) Remove the four safety nuts and bolts securing the flange of the front exhaust pipe to the flange of the center exhaust pipe, and remove the front exhaust pipe and gasket (fig. 2-119).

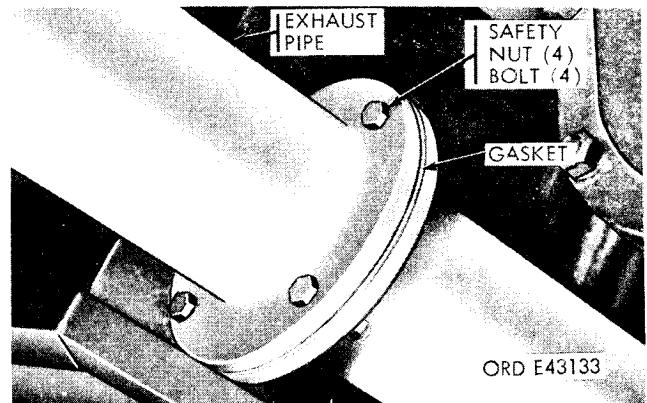


Figure 2-119. Removing front exhaust pipe.

*b. Installation.*

(1) Using a new gasket, position the front exhaust pipe to the center exhaust pipe, and secure it with four nuts and bolts.

(2) Position the bracket to the exhaust pipe, and secure it with two nuts and bolts.

(3) Secure the front exhaust pipe to the exhaust elbow. On diesel models install the clamp, and secure it with a nut and bolt. On multifuel models secure it with three safety nuts and lockwashers.

### 2-105. Rear Exhaust Pipe

*a. Removal.* Unscrew the three nuts. Remove the three bolts and lockwashers securing the rear pipe to the center pipe. Remove the rear pipe.

*b. Installation.* Secure the rear pipe to the center pipe with three bolts, lockwashers, and nuts.

### 2-106. Center Exhaust Pipe

*a. Removal.*

(1) Refer to paragraph 2-104 *a* (3), and follow same procedure.

(2) Refer to paragraph 2-105 *a*, and follow same procedure.

(3) Remove the two nuts and bolts securing the front bracket (fig. 2-120).

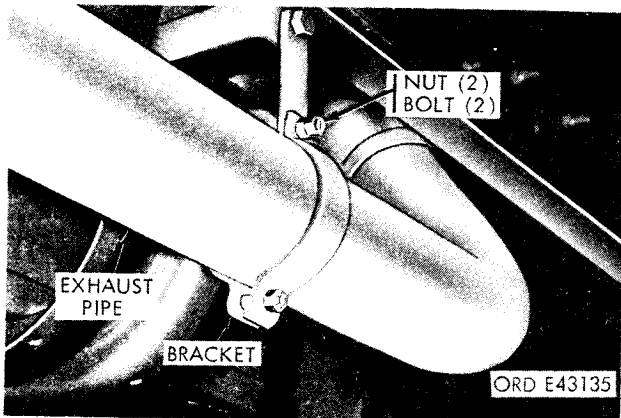


Figure 2-120. Removing center exhaust pipe front bracket.

(4) Remove the two nuts and bolts securing the rear center pipe bracket. Remove the center pipe (fig. 2-121).

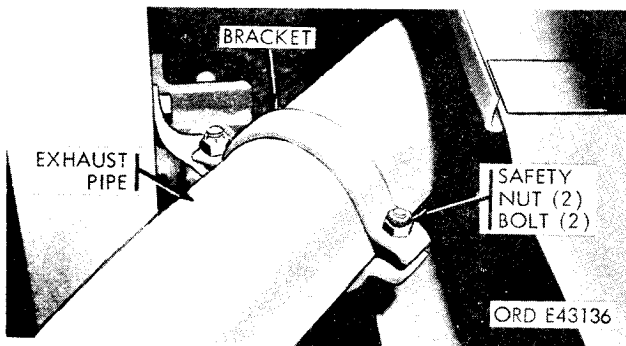


Figure 2-121. Removing center exhaust pipe rear bracket.

*b. Installation.*

(1) Secure the center pipe to the frame with the front and rear bracket (fig. 2-120). Tighten the nuts securing the brackets.

(2) Refer to paragraph 2-104 *b* (3), and follow a similar procedure.

(3) Refer to paragraph 2-105 *b*, and follow a similar procedure to complete the installation of the center pipe.

### 2-107. Vertical Exhaust Stack—Multifuel Models

#### NOTE

The key numbers noted in parenthesis are for figure 2-122, unless otherwise indicated.

*a. Removal (fig. 2-122).*

(1) Loosen the coupling (11) securing the exhaust pipe. Remove the adapter (12), and the adapter gasket (13).

(2) Remove the four nuts (16) securing the two saddles (10), two U bolts (8), and screen shield (9). Remove the saddles, U bolts, and shield.

(3) Remove the two nuts (18) securing the saddle (5) and U bolt (7). Remove the saddle, U bolt, and exhaust pipe assembly. If necessary, separate the pipe extension (6) from the pipe (14).

(4) If necessary, remove the nuts (15) and screws (19) securing the mounting support bracket assembly. Remove the assembly.

(5) If required, remove the nut (2), spring (3), and screw (1) to separate the exhaust mounting bracket (4) from the support bracket (17).

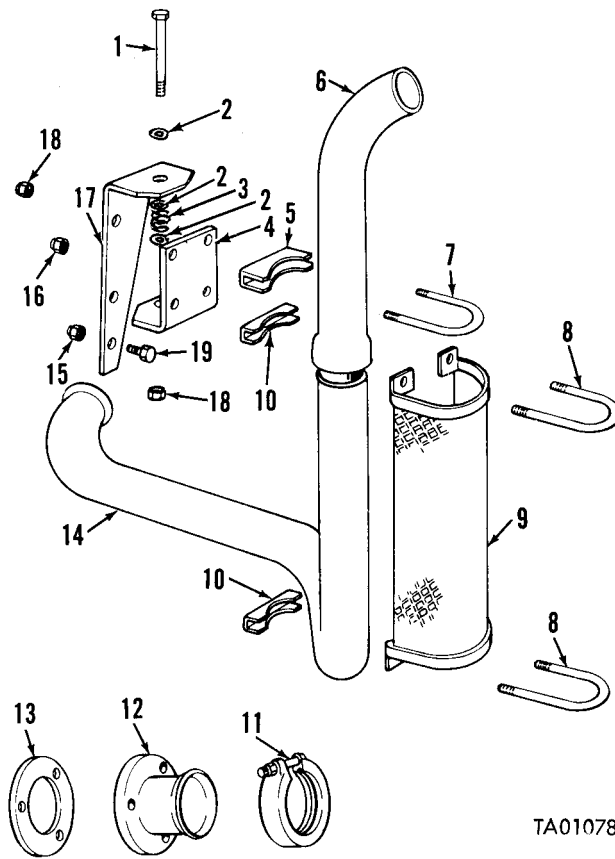
*b. Installation.*

(1) Reverse steps (5) and (4) above to install the support mounting bracket assembly.

(2) Secure the exhaust pipe and its gasket (13) to the adapter (12) with the coupling (11).

(3) Secure the exhaust pipe with the shield (9), two U bolts (8), two saddles (10), and four nuts (16). Tighten the nuts.

(4) Secure the upper pipe extension (6) with an additional U bolt (7) and saddle (5). Secure the U bolt and saddle with two nuts (18). Tighten the nuts.



TA010782

- |                    |                                   |
|--------------------|-----------------------------------|
| 1 Screw            | 11 Coupling (for LDS 465-1 only). |
| 2 Washer           | 12 Adapter                        |
| 3 Spring           | 13 Adapter gasket                 |
| 4 Mounting bracket | 14 Exhaust pipe                   |
| 5 Saddle           | 15 Nut                            |
| 6 Pipe extension   | 16 Nut                            |
| 7 U bolt           | 17 Support bracket                |
| 8 U bolt           | 18 Nut                            |
| 9 Shield           | 19 Screw                          |
| 10 Saddle          |                                   |

Figure 2-122. Vertical exhaust stack—multifuel models—exploded view.

**2-107.1 Vertical Exhaust Stack Diesel Models**

*a. Removal (fig. 2-122.1).* Refer to paragraph 2-107 a for a similar procedure.

*b. Installation.* Refer to paragraph 2-107 b for a similar procedure.

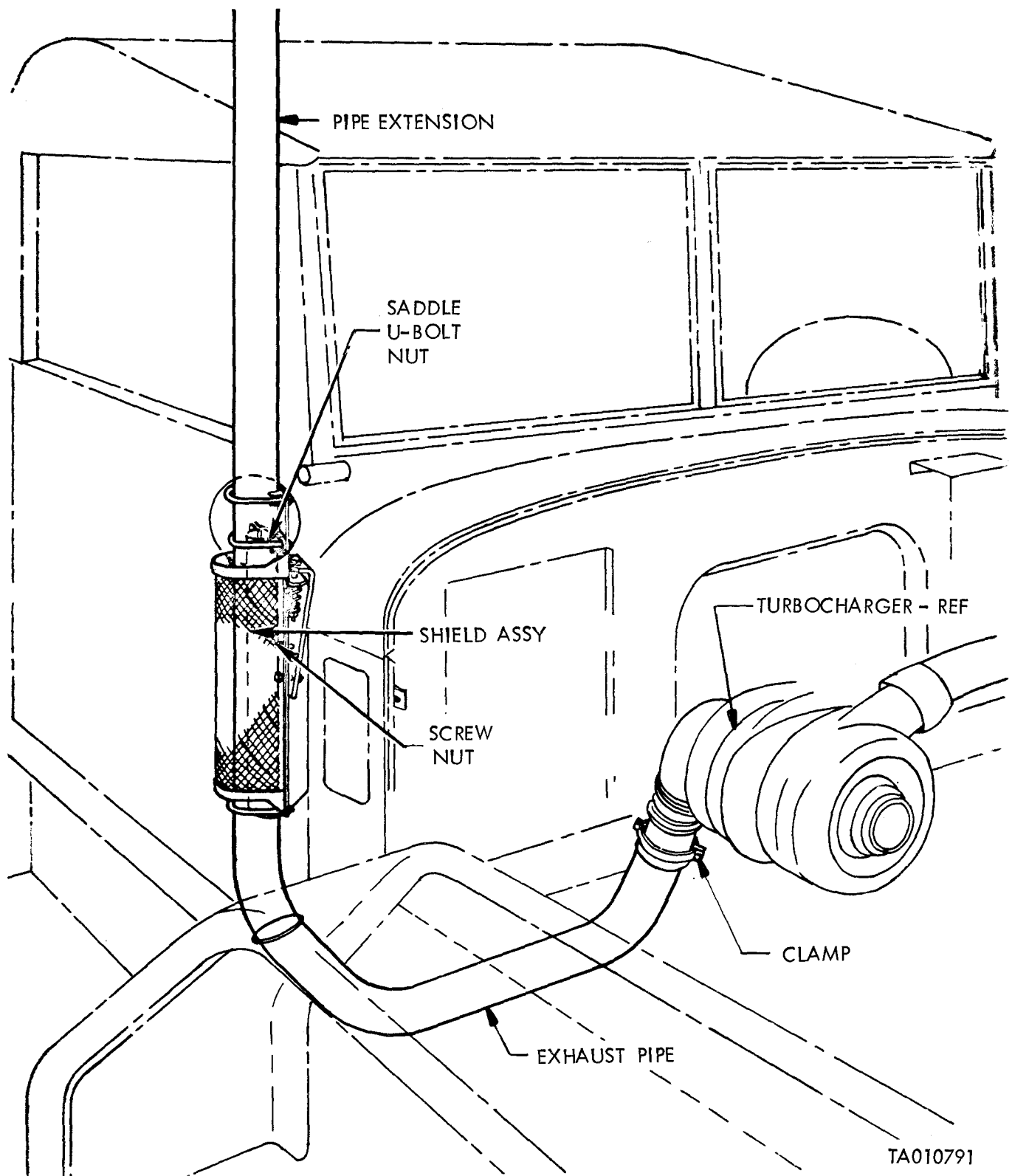


Figure 2-122.1. Vertical Exhaust Stack—Diesel Models.

Section XVI. MAINTENANCE OF COOLING SYSTEM

2-108. General

Cooling system components include a fin and tube type core radiator, a six-bladed fan with pulley and drive belts, two metal bellows type thermostats, and hoses, lines, and fittings required to connect the cooling system components to the engine and air compressor. The multifuel models have a single thermostat mounted inside their housing, and the various hose lines, tubes, and fittings (including an oil cooler water inlet tube) to circulate coolant throughout the cooling system.

2-109. Maintenance

Refer to TM 9-2320-211-10 for draining, cleaning, neutralizing, and flushing the cooling system.

2-110. Radiator

a. Removal.

- (1) Drain the cooling system. Refer to TM 9-2320-211-10.
- (2) Remove the brush guard (para 2-236).
- (3) Loosen the nut at the front end of the stay rod (fig. 2-123). Pull the stay rod front end upward, and remove the rod from the bracket. On multifuel models, remove the nuts and washers at the front of the stay brace (fig. 2-124).

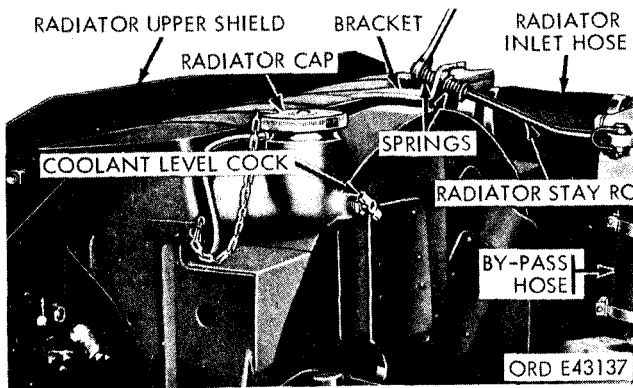


Figure 2-123. Upper section of radiator—left rear view.

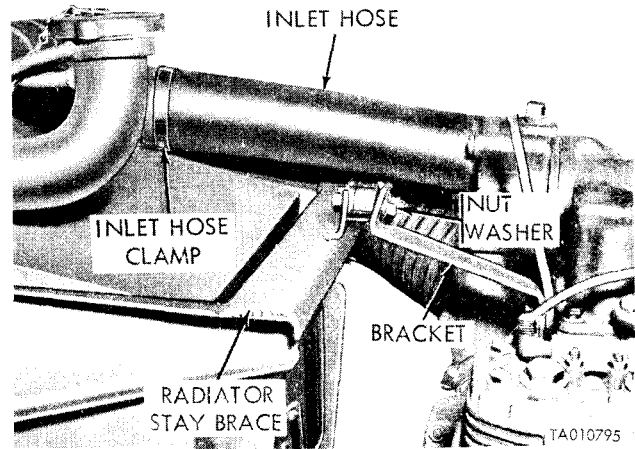


Figure 2-124. Upper section of radiator—multifuel models.

- (4) Loosen the front clamp on the inlet hose (fig. 2-123).
- (5) Loosen the front clamp on the outlet hose on the lower right side.

NOTE

Access to the outlet hose is available through the door in the fender panel on multifuel models.

- (6) Loosen the two nuts and bolts securing the radiator upper shield. Pull the upper shield (fig. 2-123) forward, and remove it from the brackets.
- (7) Loosen the bolt at the top left side of the frame strap from the crossmember. On multifuel models, remove the ground strap from the radiator shroud.
- (8) Remove the two mounting nuts (fig. 2-125), washers, and springs (rubber mounts take the place of springs on multifuel models) from the underside of the engine front mounting support.



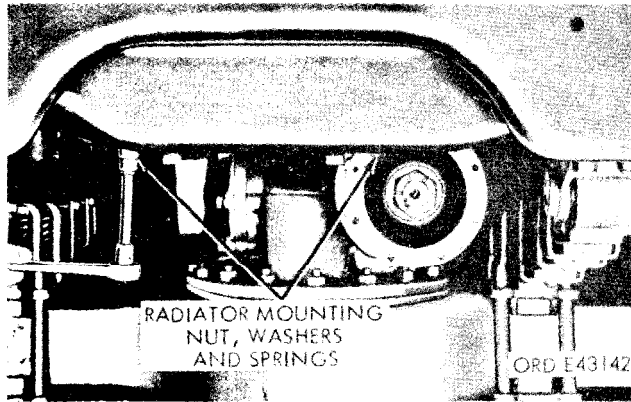


Figure 2-125. Radiator mounting.

(9) Lift the radiator (fig. 2-126) away from the mounting place.

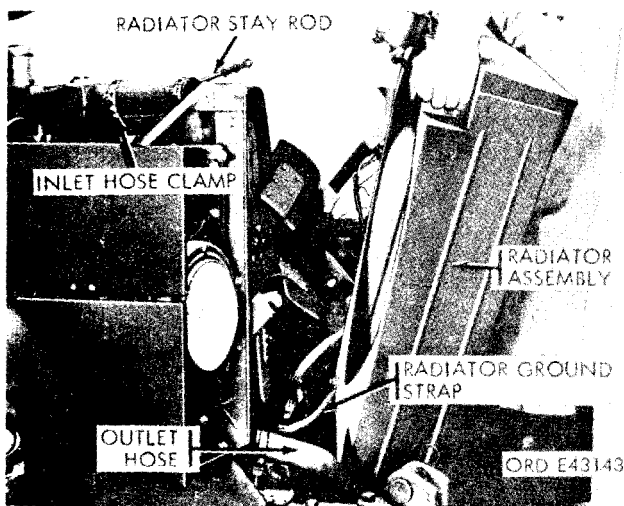


Figure 2-126. Removing radiator assembly.

*b. Installation.*

(1) Be sure that the two radiator support spacers are installed on the left and right mounting studs on the bottom of the radiator; then insert the radiator mounting studs in the holes in the engine front mounting support.

(2) Install the springs (rubber mounts on multifuel models), washers, and nuts on the radiator mounting studs from the underside of the engine front mounting support. Tighten the nuts evenly. Do not completely compress the springs.

(3) Slide the radiator ground strap terminal under the head of the ground strap retaining bolt and tooth type lockwasher at the top left side of the frame front crossmember, and tighten bolt. On multifuel models, connect the ground strap to the shroud.

(4) Tighten the clamp to secure the outlet hose at the lower right side.

(5) Tighten the front clamp on the inlet hose (fig. 2-123).

(6) Place the front end of the stay rod (fig. 2-123) in the bracket, and tighten the nut. On multifuel models, install the washers and nuts to secure the stay brace at the front. Do not completely compress the springs.

(7) Slide the slotted ends of the radiator upper shield (fig. 2-125) under the head of the bolt and lockwasher on the left and right headlight support brackets, and tighten the nuts and bolts.

(8) Slide the front end of the radiator inlet hose (fig. 2-126) on the radiator inlet, and tighten the hose clamp.

(9) Install the brush guard (para 2-236).

(10) Fill the cooling system. Refer to TM 9-2320-211-10.

**2-111. Drive Belts—Gasoline and Diesel Models**

*a. Adjustment.* Drive belt adjustment should be made on new engines after the vehicle has traveled 100 miles. Check the drive belt tension by applying a slight pressure individually to each belt at a point midway between fan and generator pulleys. Belt deflection at this point should be between ¼ and ½ inch as indicated in figure 2-127. If belt deflection is less than ¼ inch or more than ½ inch, adjust as follows:

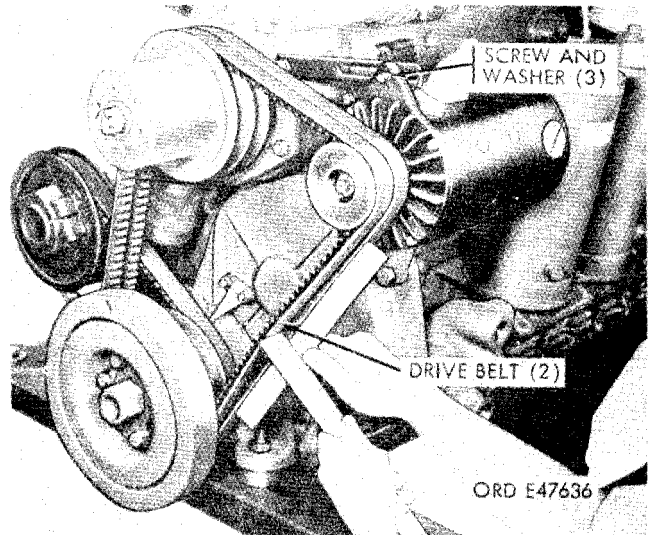


Figure 2-127. Drive belt adjustment.

(1) Loosen the **generator-to-adjusting** arm screw (fig. 2-127).

(2) Insert the end of the rim tool-and-wheel nut wrench handle (fig. 2-128), or a 30-inch bar between the crankcase and the generator.

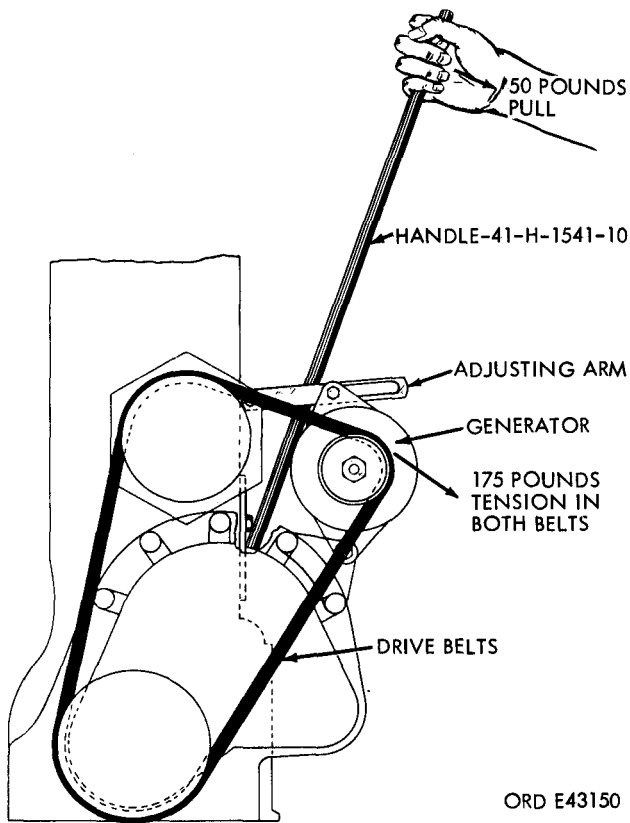


Figure 2-128. Adjusting drive belts.

**NOTE**

Make sure that the lower end of the handle will bear against the crankcase at a point directly below the front cap screw on the valve tappet chamber front cover.

(3) Pull the upper end of the handle away from the engine with a pull of 50 pounds (fig. 2-128), and keeping the handle in this position, tighten the generator-to-adjusting arm screw (fig. 2-127).

*b. Removal.*

(1) Loosen the generator-to-adjusting arm screw (fig. 2-127), and move the generator as far as it will go toward the engine.

(2) Remove the front belt from the generator, fan, and crankshaft pulleys, and lift the belt over the fan.

(3) Remove the rear belt as described in (2) above.

*c. Installation.*

(1) Place the rear drive belt (fig. 2-127) over the fan, and then over the crankshaft, fan, and generator pulleys.

(2) Install the front drive belt as described in (1) above.

(3) Adjust the drive belts as described in *a* above.

**2-112. Drive Belts—Multifuel**

*a. Adjustment.* Drive belt adjustment should be made on new engines after the vehicle has traveled 100 miles. Check the drive belt tension by applying a slight pressure individually to each belt at a point midway between the fan and generator pulleys. Belt deflection at this point should be three-quarters of an inch (fig. 2-129). If the belt deflection is found to be otherwise, adjust the belt tension as follows:

(1) Loosen the generator-to-adjusting-arm capscrew (fig. 2-127).

(2) Insert the end of the rim tool-and-wheel nut wrench handle or a 30-inch bar, between the crankcase and the generator. Make sure that the lower end of the handle will bear against the crankcase at a point directly below the front capscrew on the valve tappet chamber front cover.

(3) Pull the upper end of the handle with a pull of 50 pounds and, keeping the handle in this position, tighten the generator-to-adjusting arm cap screw. This procedure should place both belts under the proper tension, and allow the belt deflection specified above.



Figure 2-129. Drive belt deflection and adjustment.

*b. Removal.*

(1) Remove the capscrews, lockwasher, and special flanged washer securing the generator adjusting arm to the generator assembly.

(2) Push the generator assembly toward the engine, and remove the engine fan and generator belts from the generator pulley and coolant pump pulley.

**NOTE**

Belts must always be replaced in pairs.

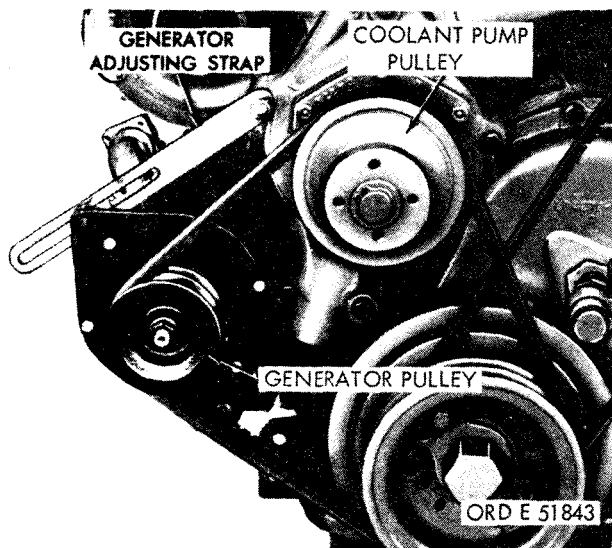


Figure 2-130. Removing fan and generator drive belts.

*c. Installation (fig. 2-130).*

- (1) Position the belts over the fan, crankshaft, and generator pulleys.
- (2) Adjust the belts as described in *a* above.

**2-113. Fan and Fan Pulley**

*a. Removal.*

- (1) Drain the cooling system. Refer to TM 9-2320-21-10.
- (2) Loosen the nut and bolt (fig. 2-131) at the left and right frame brackets and at the left and right brush guard braces, and tilt the upper end of the brush guard forward.
- (3) Remove the radiator upper shield (para 2-110).
- (4) Remove the radiator stay rod from the radiator (para 2-110).
- (5) Loosen the front hose clamp on the radiator inlet hose (fig. 2-110), and tilt the upper end of the radiator forward.
- (6) Remove the capscrews (fig. 2-132) and lockwashers securing the fan to the fan pulley hub, and remove the fan.

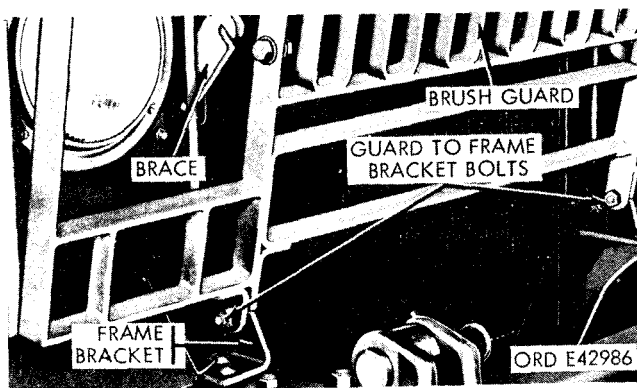


Figure 2-131. Brush guard mountings.

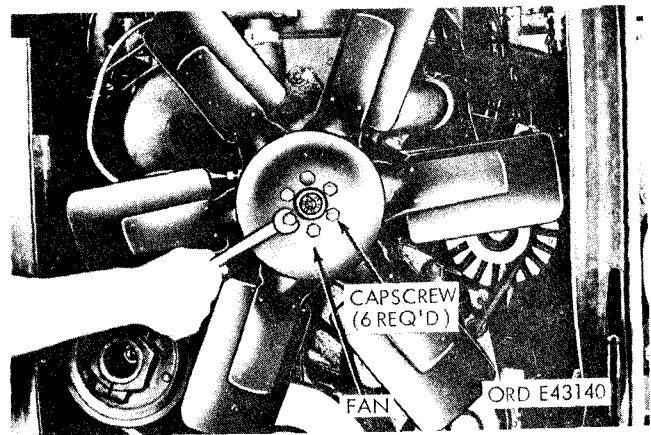


Figure 2-132. Removing fan.

- (7) Remove the drive belts (para 2-111 *b*).
- (8) Remove the cotter pin, slotted nut, lockwasher, and washer (fig. 2-133) from the water pump drive shaft. Pull the fan pulley from the shaft.

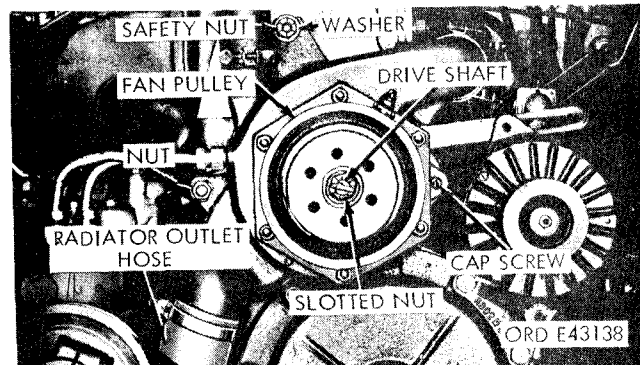


Figure 2-133. Removing fan pulley.

*b. Installation.*

- (1) Slide the fan pulley (fig. 2-133) on the water pump drive shaft, and secure the pulley with the washer, lockwasher, slotted nut, and cotter pin.
- (2) Position the fan (fig. 2-132) at the front of the fan pulley hub, and install six capscrews and lockwashers, and tighten the screws.
- (3) Push the upper end of the radiator toward the rear of the vehicle, and install the radiator stay rod (para 2-110).
- (4) Slide the front end of the radiator inlet hose (fig. 2-110) on the radiator inlet, and tighten the hose clamp.
- (5) Install the radiator upper shield (para 2-110).
- (6) Push the top of the brush guard toward the rear of the vehicle, and engage the slots in the left and right braces (fig. 2-236) with the bolts in the brush guard. Tighten the guard-to-frame bracket nuts and bolts and the guard-to-brace nuts and bolts.
- (7) Fill the cooling system. Refer to TM 9-2320-211-10.

**2-114. Thermostats**

*a. Removal.*

- (1) Drain the cooling system. Refer to TM 9-2320-211-10.
- (2) Loosen the rear clamp on the radiator inlet hose (fig. 2-134).
- (3) Loosen the upper clamp on the bypass hose (fig. 2-134).
- (4) Remove the cotter pin and radiator stay rod pin (fig. 2-134) securing the stay rod to the thermostat housing, and remove the stay rod.
- (5) Remove the six capscrews (fig. 2-135) and lockwashers at the front of the thermostat housing, and remove the housing from the bypass hose and from the radiator inlet hose. Remove and discard the thermostat housing-to-water outlet header gasket.
- (6) Pull the thermostats (fig. 2-135) from the housing.

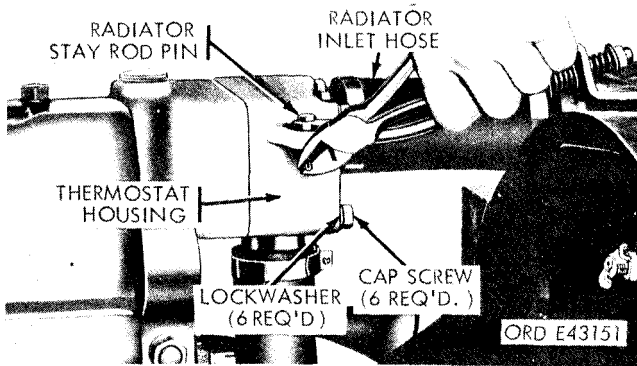


Figure 2-134. Removing radiator stay rod from thermostat housing—gasoline models.

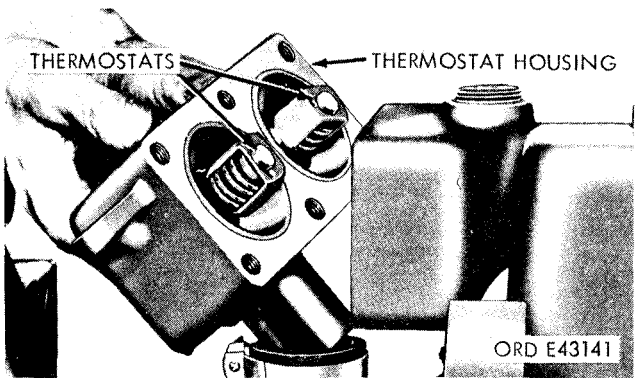


Figure 2-135. Removing thermostats—gasoline models.

*b. Installation.*

- (1) Clean gasket surfaces on the thermostat housing (fig. 2-135) and water outlet header, and install a new gasket on the front of the header using a liquid type gasket cement.
- (2) Make sure that the rubber seals are in place on the two thermostats, and place the thermostats in the housing.
- (3) Slide the outlet on the front of the thermostat housing (fig. 2-135) into the radiator inlet hose. Slide the outlet on the bottom of the thermostat housing into the bypass hose. Position the thermostat housing at the front of the water outlet header, and install the six capscrews and lockwashers. Tighten the capscrews.
- (4) Position the rear end of the radiator stay rod at the bracket on the left side of the thermostat housing (fig. 2-134), and install the radiator-stay-rod pin and cotter pin.
- (5) Tighten the rear clamp on the radiator inlet hose (fig. 2-134) and the upper clamp on the bypass hose.
- (6) Fill the cooling system. Refer to TM 9-2320-211-10.

mostat housing (fig. 2-135) into the radiator inlet hose. Slide the outlet on the bottom of the thermostat housing into the bypass hose. Position the thermostat housing at the front of the water outlet header, and install the six capscrews and lockwashers. Tighten the capscrews.

(4) Position the rear end of the radiator stay rod at the bracket on the left side of the thermostat housing (fig. 2-134), and install the radiator-stay-rod pin and cotter pin.

(5) Tighten the rear clamp on the radiator inlet hose (fig. 2-134) and the upper clamp on the bypass hose.

(6) Fill the cooling system. Refer to TM 9-2320-211-10.

**2-115. Thermostat and Seal—Multifuel Models**

*a. Removal.*

- (1) Drain the cooling system. Refer to TM 9-2320-211-10.
- (2) Loosen the rear clamp on the radiator inlet hose.
- (3) Remove the two capscrews and plain washers securing the thermostat housing assembly to the intake manifold (fig. 2-136).
- (4) Loosen the two clamps securing the thermostat housing-to-water pump hose (fig. 2-137).
- (5) Remove the thermostat housing assembly with the thermostat installed.
- (6) Remove and discard the intake manifold-to-thermostat housing gasket.
- (7) Remove the thermostat from the thermostat housing assembly (fig. 2-137).
- (8) Inspect the thermostat seal. When defects are noted, replace the seal (fig. 2-138).

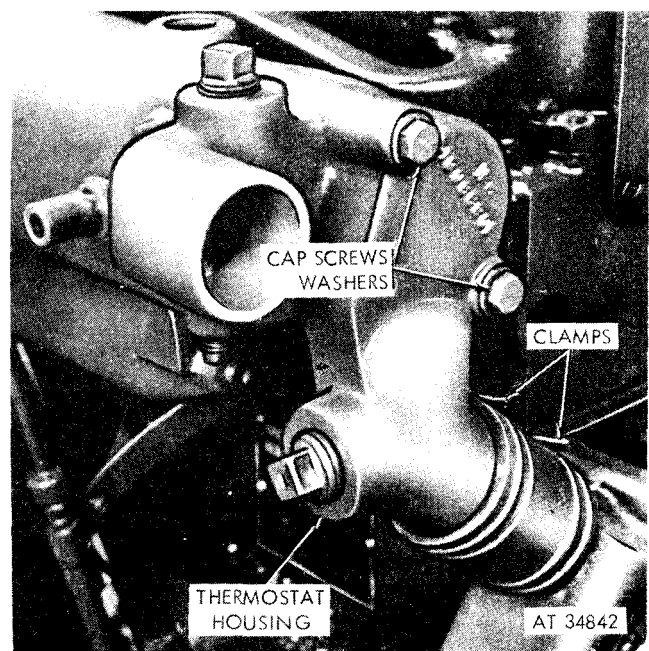


Figure 2-136. Thermostat housing—multifuel models.

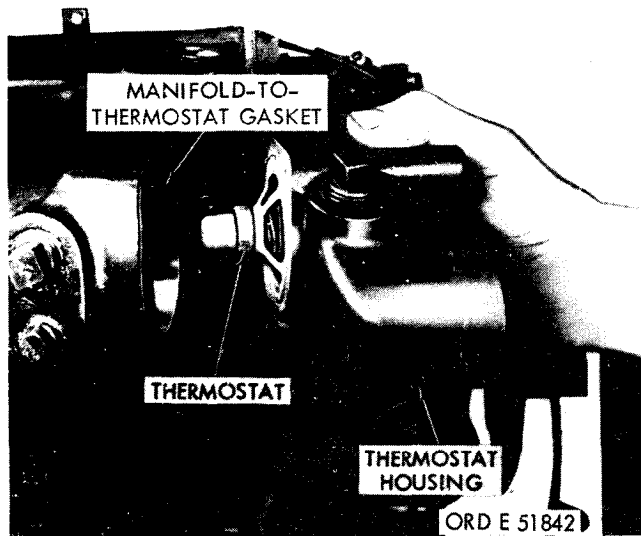


Figure 2-137. Removing thermostat housing and thermostat—multifuel models.

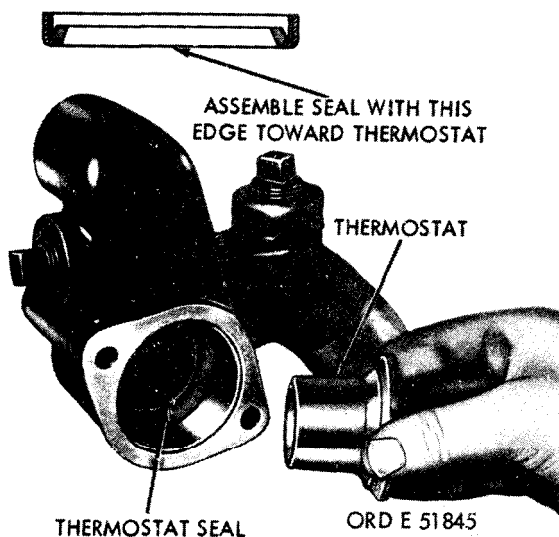


Figure 2-138. Removing thermostat and seal—multifuel models.

**b. Installation.**

- (1) Check to see if the seal is in position (fig. 2-138) before installing the thermostat in the housing.
- (2) Position the new intake manifold-to-thermostat housing gasket, and secure the thermostat and its housing to the intake manifold with two washers and capscrews (fig. 2-136).
- (3) Tighten the clamps to secure the thermostat housing-to-water pump hose (fig. 2-137).

**2-116. Hose, Lines, Tubes, and Fittings**

**a. Water Hoses and Lines.** Generally, water hoses and lines will be removed when adjacent components are removed: i.e., the radiator inlet

hose will normally be removed along with the radiator.

**b. Oil Cooler Water Inlet Tube.**

**(1) Removal.**

(a) Remove the hose and two hose clamps from the oil cooler water inlet tube.

(b) Remove the four nuts and lockwashers securing the oil cooler inlet tube to the coolant pump (fig. 2-139).

(2) **Installation.** Install the oil cooler water inlet tube in the reverse order of (1) above.

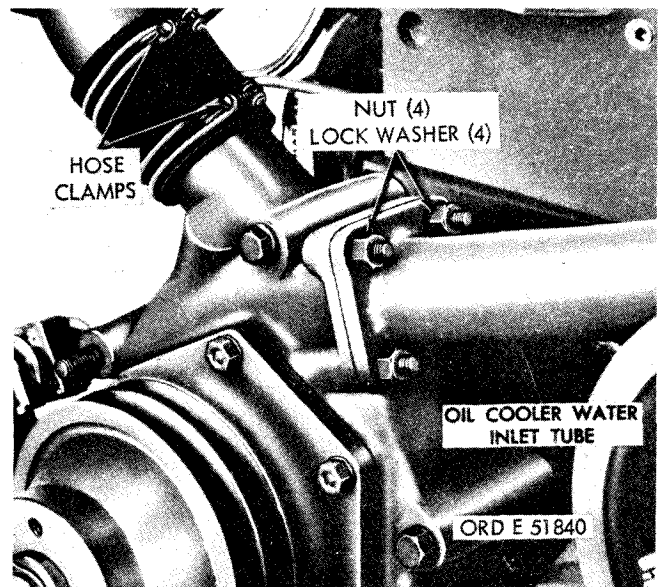


Figure 2-139. Disconnecting thermostat housing-to-coolant pump hose and oil cooler inlet tube—multifuel models.

**2-117. Water Pump—Gasoline Engine**

**a. Removal.**

- (1) Remove the fan (para 2-113).
- (2) Loosen the front hose clamp on the water inlet hose.
- (3) Loosen the upper hose clamp on the radiator outlet hose.
- (4) Unscrew the connectors at the right side of the water pump housing, and remove the air compressor water inlet and outlet lines from the water pump housing.
- (5) Remove the nut and lockwasher securing the water pump to the stud at the right front end of the crankcase, and remove the capscrew securing the water pump to the bracket at the front left end of the crankcase.
- (6) Support the water pump and remove the safety nut and washer from the stud at the front end of the front cylinder head. Remove the pump from the water inlet and outlet hoses and the front of the engine.

**b. Installation.**

- (1) Position the water pump on the studs on the right front end of the crankcase and the front

end of the front cylinder head. Replace the nut and lockwasher on the crankcase stud; and replace the self-locking nut and washer on the cylinder head stud.

(2) Install the capscrew to secure the pump to the left front end of the crankcase.

(3) Position the air-compressor water inlet and outlet lines at the right side of the water pump housing, and tighten the connectors.

(4) Slide the upper end of the radiator outlet hose on the water pump inlet, and tighten the hose clamp.

(5) Slide the front end of the water inlet hose on the water pump outlet, and tighten the hose clamp.

(6) Install the fan (para 2-113).

### 2-118. Water Pump-Diesel Engine

#### a. Removal.

(1) Remove the radiator (para 2-110).

(2) Remove the fan and drive belts (para 2-111).

(3) Remove the fan pulley and disconnect the water pump lines.

(4) Remove the two bolts securing the water pump to the water manifold (fig. 2-139).

(5) Remove the two bolts securing the filter.

(6) Remove the bolt securing the belt tension bracket.

(7) Remove the two bolts securing the water pump housing to the engine, and remove the water pump (fig. 2-140).

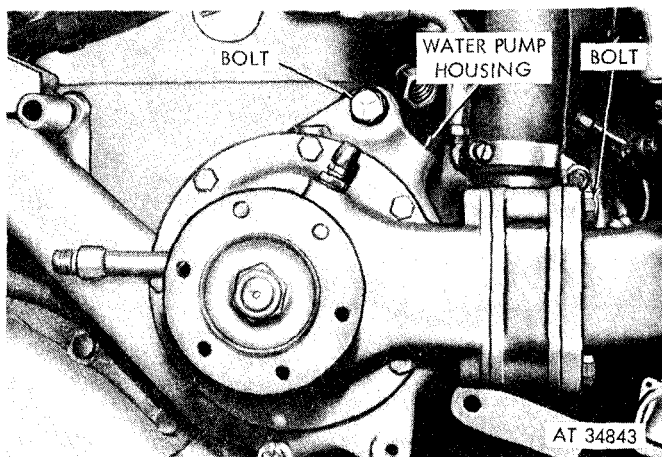


Figure 2-140. Water pump—diesel engine.

#### b. Installation.

(1) Position the water pump housing to the engine, and secure it with two bolts (fig. 2-140).

(2) Position the belt tension bracket, and install the bolt.

(3) Install the fuel filter, and secure it with two bolts.

(4) Secure the water pump to the water manifold with two bolts.

(5) Connect the water pump lines, and install the fan pulley.

(6) Install the fan and drive belts (para 2-111).

(7) Install the radiator (para 2-110).

### 2-118.1. Water Pump—Multifuel Engine

#### a. Removal.

(1) Remove the fan and drive belts (para 2-112).

(2) Loosen the two hose clamps securing the bypass hose between the water pump and thermostat, and slide the hose up on the thermostat housing until the hose is free from the water pump (fig. 2-141).

(3) Remove the four plain nuts and lockwashers securing the oil cooler water inlet tube to the water pump assembly. Separate the flange of the inlet tube from the pump (fig. 2-140).

(4) Remove the three capscrews and lockwashers securing the water pump. Remove the water pump from the engine (fig. 2-141).

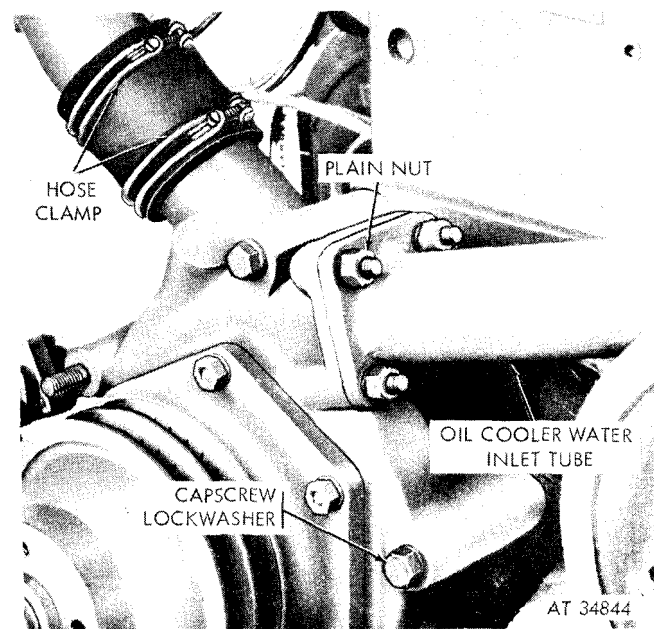


Figure 2-141. Water pump—multifuel engine.

#### b. Installation.

(1) Install the water pump on the engine, and secure it with three capscrews and lockwashers (fig. 2-141).

(2) Position the oil cooler water inlet tube to the water pump, and secure it with four plain nuts and lockwashers (fig. 2-141).

(3) Position the bypass hose between the water pump and the thermostat, and secure it by tightening the two hose clamps.

(4) Install the fan and drive belts (para 2-112).

## Section XVI. IGNITION SYSTEM—GASOLINE ENGINE

**2-119. General**

The ignition system is composed of an ignition switch, coil, distributor assembly, spark plugs, spark plug wires, and primary wire. The ignition system produces and delivers high voltage current to the spark plugs.

**2-120. Ignition Timing**

**a. General.** The procedure for checking and correcting ignition timing for engines with a sealed ignition system requires special adapters (fig. 2-142) which are part of the electrical connector tool kit.

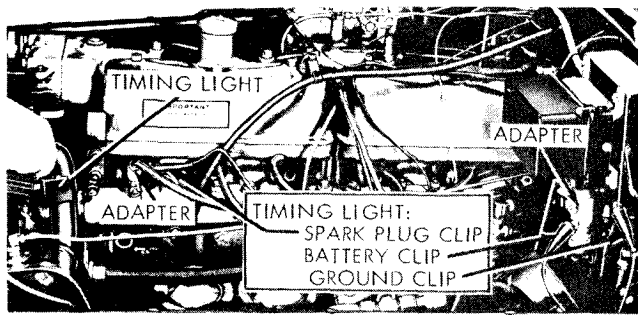


Figure 2-142. Timing light connected to adapters.

**b. Checking and Correcting Timing.**

- (1) Clean, adjust, or replace the distributor points as necessary (para 2-122d).
- (2) Remove the spark plug cable from the No. 1 spark plug; unscrew the coupling nut and screw on the spark plug testing adapter.
- (3) Place the spark plug cable on top of the spark plug testing adapter.
- (4) Fasten the clip of the red lead from the timing light to the terminal on the side of the spark plug adapter.
- (5) Disconnect the battery harness at the generator regulator, and install the regulator testing adapter.
- (6) Connect the harness to the adapter. Turn the voltage selector switch of the timing light to 24 volts.
- (7) Connect the red gloved lead to either terminal on the adapter and the black gloved lead to a suitable ground.
- (8) Apply chalk to the 5-degree BTC mark (fig. 2-143) on the crankshaft pulley to permit easy observation.
- (9) With the engine running at idling speed (450 rpm), direct the beam of light down at the timing pointer on the timing gear cover. If the timing mark is aligned with the pointer when viewed with the timing light, the timing is correct.

screws (1, fig. 2-144) holding the distributor to the top of the distributor drive housing, until the pointer and the five-degree notch coincide.

**NOTE**

Turning the distributor body clockwise will advance the spark, and counterclockwise will retard the spark.

**NOTE**

It is not necessary to disconnect the distributor vent line, since the line will flex sufficiently to allow close adjustment.

(11) Tighten the distributor clamp screws when the timing is adjusted properly.

(12) Disconnect the timing light and remove the timing testing adapters from the spark plug and the regulator.

(13) Connect the No. 1 spark plug cable. Connect the battery harness to the generator regulator.

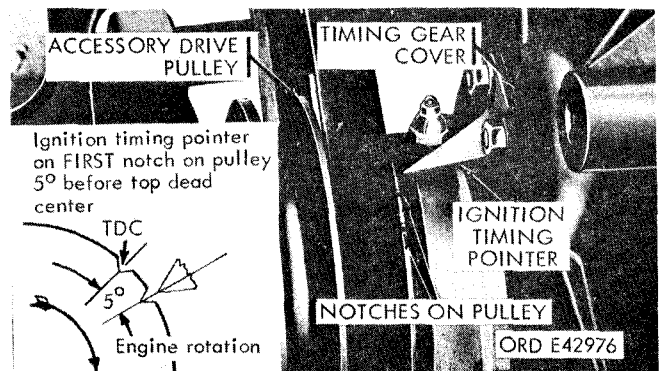


Figure 2-143. Ignition timing indicator.

**2-121. Spark Plugs****a. Removal.**

- (1) Loosen the nut securing the spark plug cable to the plug. Disconnect the cable from the plug.
- (2) Unscrew and remove the plug from the recess in the cylinder head. Discard the spark plug gasket.
- (3) Repeat Steps (1) and (2) above for the remaining spark plugs to be removed.

**b. Cleaning and Inspection.**

- (1) Clean the spark plugs with standard plug cleaning equipment.
- (2) If the electrodes are excessively burned or worn, replace the plug or plugs as required.

**c. Adjustment.**

- (1) Use a round feeler gage to check the gap between electrodes. The gap should be 0.030 inch.
- (2) If necessary, adjust the gap by bending the side electrode.

*d. Installation.*

- (1) Place a new gasket on the plug.
- (2) Install the plug and torque it to 25 to 30 ft.-lb.
- (3) Aline the cable with the spark plug, and carefully push the connector into the spark plug shielding well.
- (4) Tighten the adapter nut fingertight; then, tighten an additional half turn with the proper wrench.
- (5) Repeat the above steps for the remaining plugs.

**2-122. Distributor Assembly**

**NOTE**

The key numbers in parentheses are for figure 2-144 unless otherwise indicated.

*a. Removal.*

- (1) Unscrew the connectors on the lower ends of the spark cables, and remove the cables from the distributor cover.
- (2) Unscrew the connector (2) from the primary lead-in at the rear of the distributor (4), and remove the primary wire (3).

(3) Unscrew the nut (5) from the elbow at the front of the distributor, and remove the distributor vent line (6).

(4) Remove the two screws (1), lockwashers (7), and distributor mounting clamps (8), from the top of the distributor drive housing (9), and lift the distributor from the housing. Remove and discard the distributor mounting gasket.

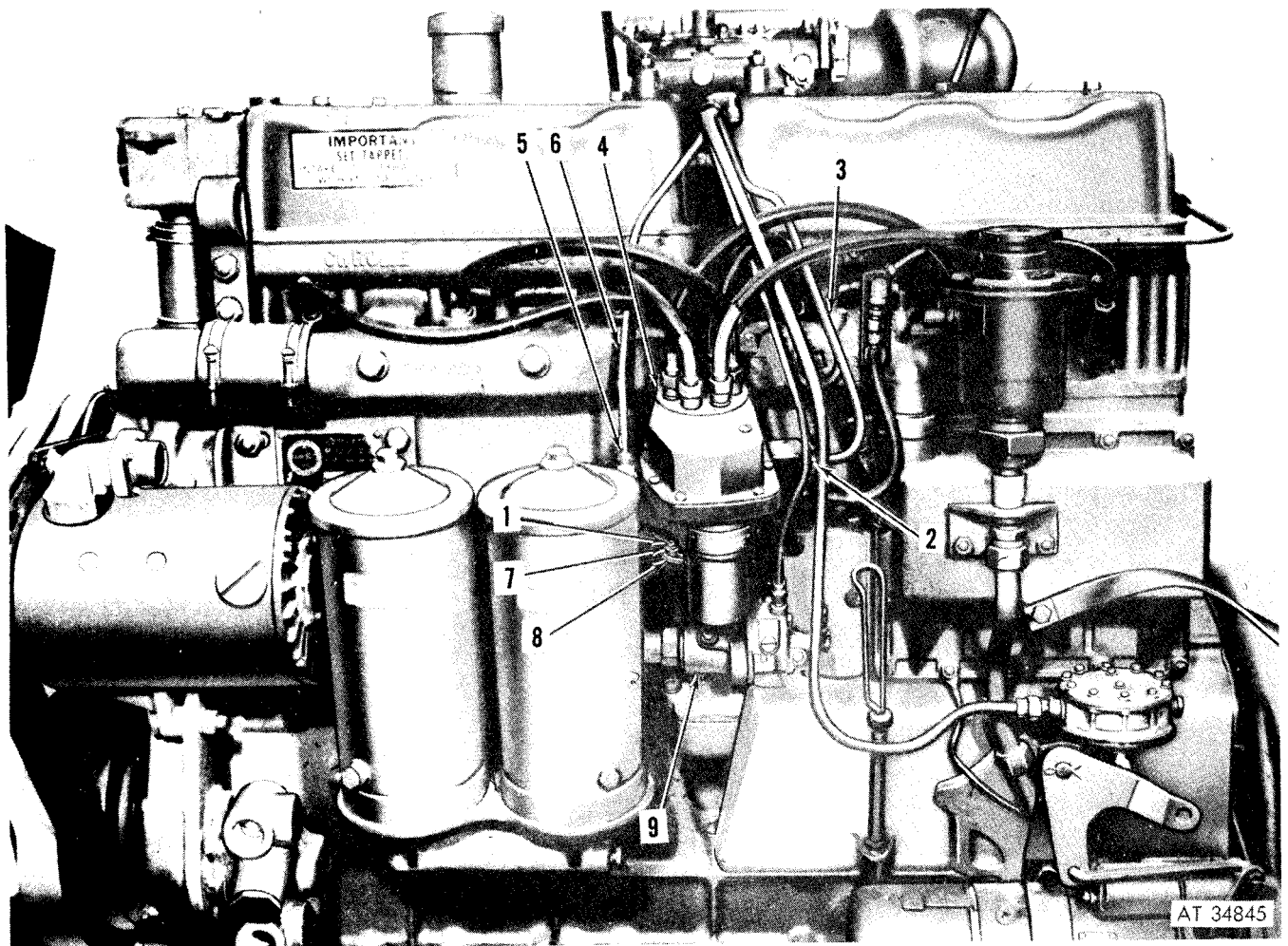
*b. Installation.*

(1) Turn the engine in small increments, using the starter (by momentarily depressing the starter button with the ignition switch in the OFF position), until the crankshaft pulley stops so that the top dead center (TDC) timing mark (fig. 2-143) is in line with the ignition timing pointer.

(2) Remove eight screws and lockwashers, and remove the cover and rotor.

(3) Turn the distributor shaft until the lobe of the cam trailing flat on the cam assembly, opens the breaker points. Place a straightedge (fig. 2-145) against this flat, and turn the shaft until the straightedge crosses the edge of the distributor housing between the scribed marks.





- |                                 |                                |
|---------------------------------|--------------------------------|
| 1 Mounting clamp screw          | 6 Distributor ventilation line |
| 2 Primary wire connector        | 7 Mounting clamp lockwasher    |
| 3 Distributor primary cable     | 8 Mounting clamp               |
| 4 Distributor and coil assembly | 9 Distributor drive housing    |
| 5 Ventilation line nut          |                                |

Figure 2-144. Ignition system—gasoline engine.

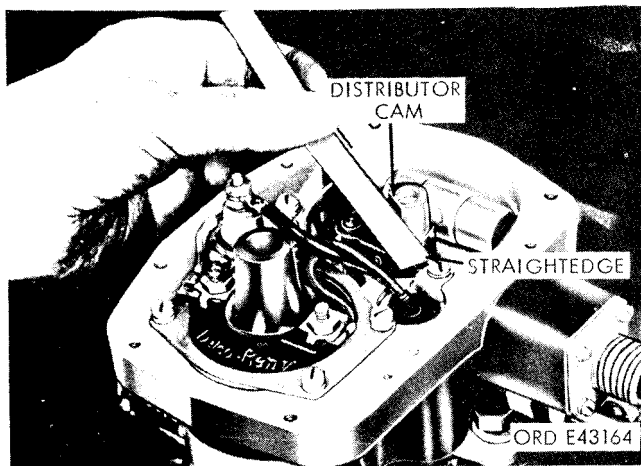


Figure 2-145. Positioning distributor breaker cam for distributor installation.

(4) Install a new mounting gasket on top of the distributor drive housing (9), and position the distributor and coil assembly (4) on the housing, engaging the coupling at the lower end of the distributor shaft with the coupling on the upper end of the drive shaft inside the housing.

(5) Position the two distributor mounting clamps (8) on top of the drive housing, and secure them with the two capscrews (1) and lockwashers.

(6) Adjust the breaker point gap ( $d$ ) (1) below).

(7) Install the rotor on the breaker cam, position the distributor cover on the housing being sure that the cover gasket is in place, and secure the assembly with eight screws and lockwashers (fig. 2-146).

(8) Position the distributor primary wire (3) at

the primary lead-in on the rear of the distributor, and tighten the connector (2).

(9) Position the distributor vent line (6) at the elbow on the front of the distributor, and tighten the nut (5).

(10) Insert the ends of the spark plug cables in the cable sockets (corresponding to spark plug numbers in the distributor cover) (fig. 2-146), and tighten the connectors.

(11) Check the ignition timing, and correct it if necessary (para 2-120).

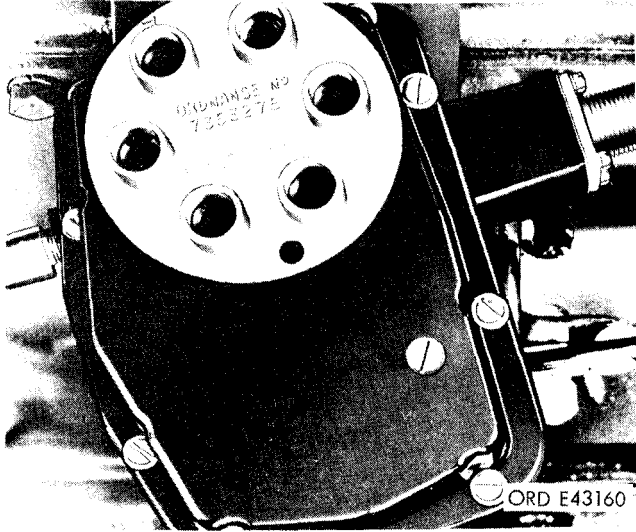


Figure 2-146. Distributor assembly with cover attached.

*c. Distributor cap.*

(1) Removal.

(a) Remove the distributor cover (b(2) above).

(b) Remove the five screws holding the distributor cap in the cover, and lift out the cap.

(2) Installation.

(a) Position the distributor cap in the distributor cover, and fasten it with five screws.

(b) Install the distributor cover, and fasten it with eight screws and lockwashers.

*d. Distributor Contact Points and Capacitor.*

(1) Inspection and Adjustment.

**CAUTION**

Do not use emery cloth to dress points.

(a) Examine the points for pitting or wear.

(b) If the points are slightly pitted or burned, dress them with a point file or with grade 2 / 20 flint paper, and remove the filings with (compressed air).

(c) If the points are badly pitted or worn, replace the points. Also replace the capacitor (condenser) since it is probably the cause of the pitting.

(d) If the contact points are in satisfactory condition, proceed as in (e) below.

(e) Test the breaker lever spring tension by hooking a spring scale (fig. 2-147) at the end of the breaker lever as close as possible to the contact point. Pull the breaker lever away from the cam, noting the pull on the scale to separate the points. (The reading on the scale should be between 17 and 21 ounces.)

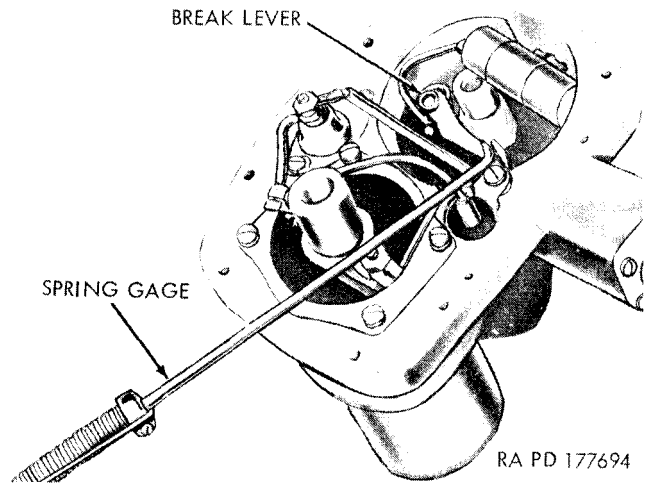


Figure 2-147. Checking distributor breaker lever spring tension.

(f) If necessary, adjust the breaker spring tension by loosening the screw securing the spring to the stationary bracket, shifting the spring, and retightening the screw.

(g) If unable to adjust the spring tension, replace the point set.

(h) To adjust the breaker points turn the engine in small increments. Momentarily depress the starter button with the ignition switch in the OFF position until the high point of the cam assembly holds the breaker lever at the maximum gap between the contact points.

(i) Using a feeler gage (fig. 2-148), check the maximum gap between the contact points.

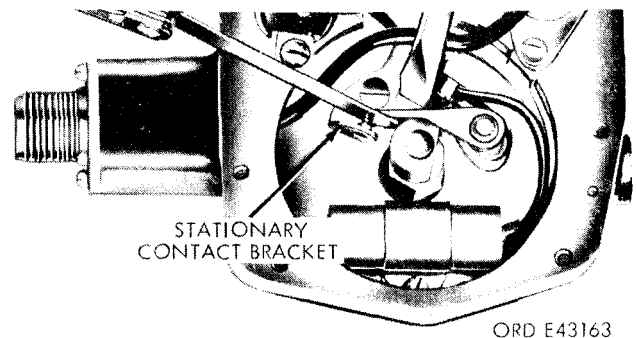


Figure 2-148. Checking and setting distributor contact point gap.

**NOTE**

It is important that the gap between the points is 0.022 inch. If the gap requires adjustment, loosen the stationary bracket screw, and turn the adjusting screw until the correct gap is obtained. Tighten the stationary bracket screw.

(2) *Removal (fig. 2-149).*

(a) Remove the nut and screw securing the two leads at the stationary contact bracket terminal.

(b) Lift the moveable contact point breaker lever off the pivot pin.

(c) Remove the screw securing the stationary contact point bracket. Pull the bracket off the pivot pin.

(d) Remove the mounting screw securing the capacitor (condenser). Remove the capacitor.

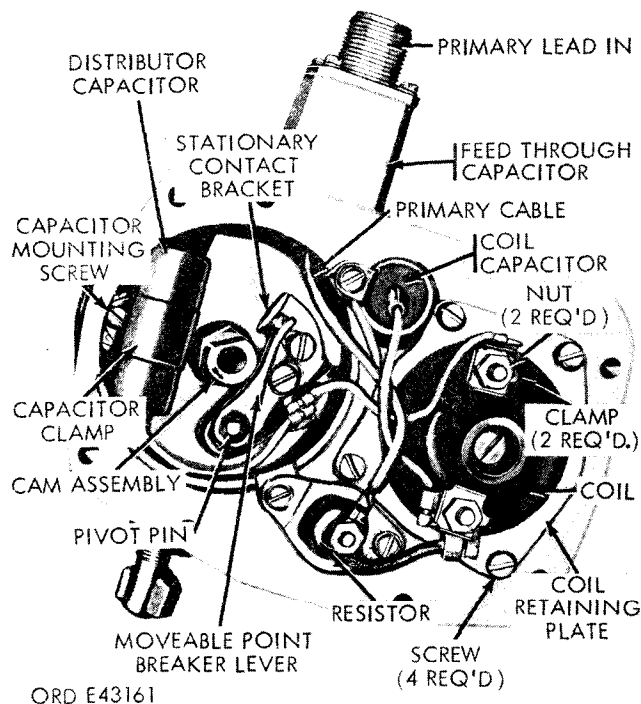


Figure 2-149. Distributor with cover removed.

(3) *Installation (fig. 2-149).*

**CAUTION**

Do not overlubricate. Lubricant must not get on contact points.

(a) Position a new stationary contact bracket on the pivot pin, and secure the bracket with a screw. Do not completely tighten the screw.

(b) Place a drop of engine oil on the pivot pin. Position the moveable point breaker lever spring on the stationary bracket lug side toward the cam assembly.

(c) Secure the capacitor (condenser) with a mounting screw.

(d) Position the coil lead and capacitor lead at the stationary contact bracket terminal. Secure these two wires with a screw and nut while holding the breaker lever spring down so that the spring notch makes a good contact with the terminal screw.

(e) After the points have been adjusted, tighten the stationary contact bracket screw.

(f) Place a couple of drops of engine oil on the felt wick at the center of the cam assembly.

(g) Place just a trace of general purpose grease on the cam lobe.

*e. Ignition Coil (fig. 2-149).*

(1) *Removal.*

(a) Disconnect the three leads from the ignition coil.

(b) Remove the four screws securing the coil retaining plate to the housing, and lift out the plate.

(c) Lift out the ignition coil, and discard the nonmetallic washer.

(2) *Installation.*

(a) Place a new washer in the recess in the distributor housing, and install the coil in housing.

**NOTE**

The coil must be positioned so that the (+) terminal is near the resistor.

(b) Install the holddown bracket, and secure it with four screws.

(c) Connect the resistor lead and the coil capacitor lead to the positive (+) terminal on the ignition coil.

(d) Connect the lead from the contact support to the ignition coil negative (−) terminal.

*f. Resistor (fig. 2-149).*

(1) *Removal.*

(a) Disconnect the primary lead to the resistor and the resistor lead to the positive (+) terminal on the ignition coil.

(b) Remove the two screws and lockwashers securing the resistor to the housing, and lift it out.

(2) *Installation.*

(a) Position the resistor, and secure it with screws and lockwashers.

(b) Connect the resistor lead positive (+) terminal on the ignition coil.

(c) Connect the primary lead to the resistor.

*g. Coil Capacitor (fig. 2-149).*

(1) *Removal.*

(a) Disconnect the coil capacitor lead from the positive (+) terminal on the ignition coil.

(b) Remove the coil capacitor clamp screw and lockwasher and lift out the coil capacitor.

(2) *Installation.*

(a) Position the coil capacitor housing and

its holddown clamp, and secure it with a screw and lockwasher.

(b) Connect the coil capacitor lead to the positive (+) terminal on the ignition coil.

## Section XVIII. MAINTENANCE OF STARTING SYSTEM—GASOLINE

### 2-123. General.

Starting system components discussed in this section include the starter, starter linkage, solenoid, manual starter switch, and starter cables.

### 2-124. Starter

#### NOTE

The key numbers in parentheses are for figure 2-150 unless otherwise indicated.

#### a. Removal.

- (1) Disconnect the battery ground cable.
- (2) Remove the two terminal stud nuts at the front of the manual starter switch (4) on top of the starter, and remove the two cables, one from each terminal.
- (3) Remove the nut and lockwasher securing the starter cable to the starter, and remove the starter cable.
- (4) Remove the cotter pin and yoke pin securing the control rod (5) to the bellcrank (11), and remove the control rod yoke from the bellcrank.
- (5) Remove the three screws (6) and lockwashers securing the starter to the front of the flywheel housing, pull the starter forward, and remove it from the engine. Remove and discard the starter mounting gasket.
- (6) Remove the cotter pin securing the starter control link (7) to the lever (8), and remove the link from the lever.

(7) Remove the screw (9) and safety nut clamping the bracket (10). Spread the bracket, and slide the bracket with the bellcrank and starter control link over the end of the starter.

#### b. Installation.

(1) Slide the bracket (10) with the bellcrank (11) and starter control link (7) on the starter, and loosely clamp the bracket to the starter with the capscrew (9) and safety nut.

(2) Insert the rear end of the starter control link in the hole in the upper end of the lever (8), and secure it with a cotter pin.

(3) Position the starter and a new mounting gasket on the front of the flywheel housing, and install three screws (6) and lockwashers. Using a torque wrench, tighten the screws to 145 to 155 ft.-lb. torque.

(4) While sliding the bracket (10) on the starter, align the bellcrank and yoke at the lower end of the control rod (5), and tighten the screw and nut clamping the bracket to the starter.

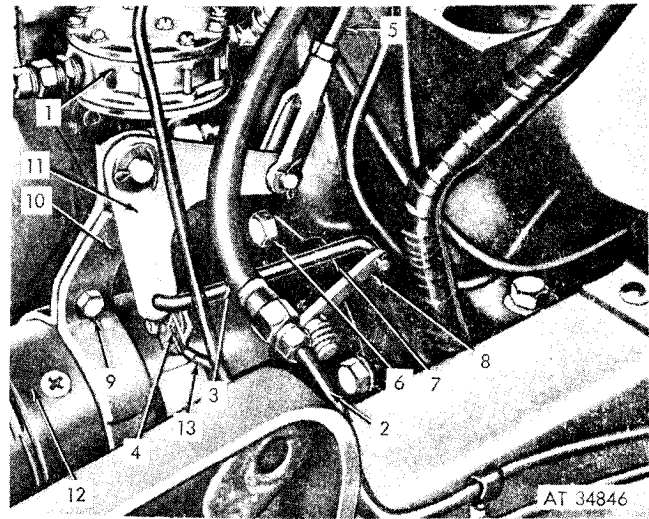
2-128

(5) Position the control rod yoke on the bellcrank, and secure it with a yoke pin and cotter pin.

(6) Install the starter cable on the terminal stud at the left side of the starter, install a nut on the stud, and tighten it.

(7) Install two cable terminals on the terminal studs at the front of the manual starter switch (4); install two nuts, one on each stud, and tighten them.

(8) Connect the battery ground cable.



- 1 Fuel pump
- 2 Fuel pump-to-fuel filter rigid line
- 3 Fuel pump-to-fuel filter flexible line
- 4 Manual starter switch
- 5 Control rod
- 6 Starter mounting screw
- 7 Control link
- 8 Lever
- 9 Capscrew
- 10 Bracket
- 11 Bellcrank
- 12 Starter
- 13 Starter switch primary wire

Figure 2-150. Starter and fuel pump installed on left rear side of engine.

### 2-125. Starter Linkage

#### a. Removal.

(1) Remove the cotter pin and yoke pin securing the control rod (5) to the bellcrank (11). Remove the rod from the bell crank.

(2) Remove the cotter pin securing the control link (7) to the lever (8), and remove the link from the lever.

(3) Remove the capscrew (9) and safety nut clamping the bracket (10) to the starter (12). Spread the bracket, and slide the bracket with the bellcrank and control link over the end of the starter.

(4) Remove the cotter pin securing the front end of the control link to the bellcrank, and remove the line from the bellcrank.

(5) Remove the cotter pin and washer securing the bellcrank to the bracket (10), and remove the bellcrank from the bracket.

(6) Remove the two screws and nuts securing the control rod mounting plate to the underside of the toeboard. Remove the mounting plate and control rod (5) from the toeboard.

*b. Installation.*

(1) Position the control rod mounting plate and control rod (5) on the underside of the toeboard, and secure them with two screws and nuts.

(2) Position the bellcrank (11) on the pin at the upper end of the bracket (10), and secure it with a washer and cotter pin.

(3) Insert one end of the control link (7) in the hole in the lower end of the bellcrank, and secure it with a cotter pin.

(4) Slide the bracket (10), bellcrank, and control link on the starter (12), and loosely clamp the bracket to the starter with a screw (9) and nut.

(5) While sliding the bracket on the starter, align the bellcrank and yoke at the lower end of the control rod (5), and tighten the screw and nut to clamp the bracket to the starter.

(6) Position the control rod yoke on the bellcrank, and secure it with the yoke pin and a cotter pin.

(7) Insert the rear end of the starter control link in the hole in the upper end of the lever (8), and secure it with a cotter pin.

## **2-126. Solenoid and Manual Starter Switch**

*a. Removal of Solenoid (fig. 2-25).*

(1) Remove the nut and washer securing the

starter cable to the terminal stud on top of the solenoid, and remove the cable from the terminal stud.

(2) Remove the nut and washer securing the starter primary cable to the upper terminal stud on the left side of the solenoid, and remove the wire from the terminal stud.

(3) Remove the nut and washer securing the battery cable to the terminal stud on the bottom of the solenoid, and remove the cable from the terminal stud.

(4) Remove the four capscrews and safety nuts securing the solenoid to the inside of the frame right side rail, and remove the solenoid from the side rail.

*b. Installation of Solenoid (fig. 2-25).*

(1) Position the starter solenoid on the inside of the frame right side rail, and secure it with four capscrews and safety nuts.

(2) Install the battery cable on the terminal stud at the bottom of the solenoid, and secure it with a washer and nut.

(3) Install the primary cable on the upper terminal stud at the left side of the solenoid, and secure it with a washer and nut.

(4) Install the starter cable on the terminal stud at the top of the solenoid, and secure it with a washer and nut.

*c. Removal of Manual Starter Switch (fig. 2-150).*

(1) Remove the two electrical leads from the starter switch mounted on the starter.

(2) Remove the set screw.

(3) Unscrew the starter switch (4) from the starter.

*d. Installation of Manual Starter Switch (fig. 2-150).* Install the starter switch in the reverse order of removal.

## **Section XIX. MAINTENANCE OF STARTING SYSTEM— DIESEL AND MULTIFUEL**

### **2-127. General**

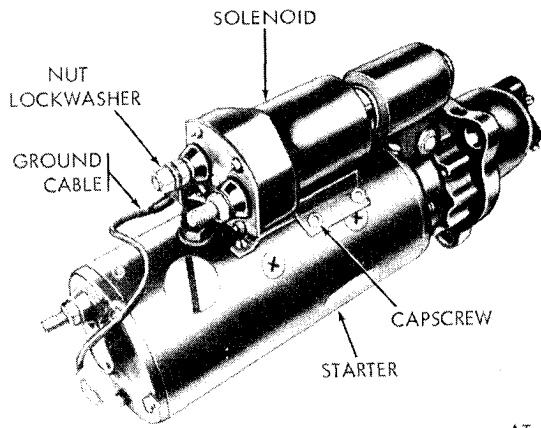
The starting system components discussed in this section are the starter and solenoid.

### **2-128. Starter**

(Fig. 2-151.)

*a. Removal.*

(1) Remove the nuts and lockwashers securing the three cables to the starter and starter solenoid.



AT 34847

Figure 2-151. Starter and solenoid—diesel and multifuel models.

(2) Remove the three screws securing the starter to the flywheel housing. Remove the starter.

*b. Installation.*

(1) Secure the starter to the flywheel with the three screws.

(2) Connect the three cables to the starter and starter solenoid with lockwashers and nuts.

2-129. **Solenoid**

(Fig. 2-151.)

*a. Removal.*

(1) Remove the two nuts and lockwashers securing the ground connection between the solenoid and starter. Remove the ground cable.

(2) Remove the four screws securing the solenoid mounting bracket to the starter housing. Remove the solenoid from the starter.

*b. Installation.*

(1) Secure the solenoid and its bracket to the starter with four screws.

(2) Connect the ground cable to the starter ground terminal and the solenoid terminal with two lockwashers and nuts.

**Section XX. GENERATING SYSTEM**

2-130. **General**

The generating system consists of the generator, the generator regulator, and the battery-generator indicator.

**2-131. Generator and Generator Pulley**

(Fig. 2-152.)

*a. Removal.*

(1) *Generator.*

(a) Remove the connector nut on the generator-to-regulator harness at the generator output elbow, and slide the nut back on the harness.

(b) Carefully remove the cables from the generator, and remove the gasket.

(c) Loosen the two generator mounting bolts and nuts.

(d) Remove the generator adjusting arm screw, and pivot the generator toward the engine as far as possible.

(e) Remove the drive belts from the generator pulley.

(f) Remove the generator mounting nuts, lockwashers, and bolts, and lift the generator from the engine.

(2) *Generator pulley.*

(a) Remove the self-locking nut and washer from the tapered drive shaft.

(b) install a standard 3-legged puller over the pulley body. Tighten the puller to the shaft end, and rap the puller sharply to disengage the pulley from the shaft.

(c) Remove and lift the key from the keyway on shaft.

*b. Installation.*

(1) *Generator pulley.*

(a) Position the key in the keyway on the shaft.

(b) Aline the pulley keyway with the key, and slip the pulley over the shaft and key.

(c) Tap the pulley into position, and secure it with the self-locking nut and washer.

(2) *Generator.*

(a) Mount the generator on the mounting brackets and install the bolt, two spacers, and the self-locking nut in the mounting hole at each end of the generator.

**NOTE**

Do not tighten nuts.

(b) Position the drive belts over the generator pulley.

(c) Install the generator adjusting arm on the generator, and secure it with the adjusting screw and lockwasher.

(d) Adjust the drive belts (para 2-111 or 112).

(e) Tighten the mounting nuts and bolts.

(f) Polarize the generator if a new or rebuilt generator is being installed (*c below*).

(g) Install a gasket and connect the generator-to-generator harness to the generator output elbow. Tighten the connector nut.

*c. Polarization.***CAUTION**

Do not start the engine until the generator has been polarized.

(1) Disconnect the wiring harness from the connector at the generator.

(2) Using a jumper wire with suitable prods, momentarily connect the field terminal at the generator receptacle to the positive (+) terminal on the battery.

**NOTE**

This connection allows a momentary surge of battery current to flow through the generator field windings which automatically gives the generator the correct polarity with respect to the batteries.

(3) Connect the wiring harness at the generator, and tighten the connector nut.

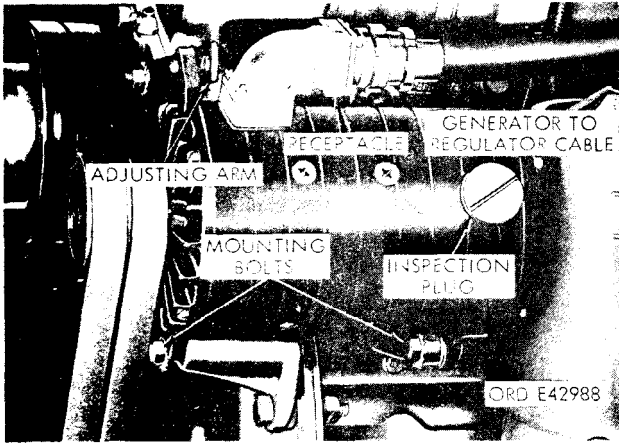


Figure 2-152. Generator

**2-132. Generator Regulator**

(Fig. 2-67.)

*a. Removal.*

(1) Disconnect the battery ground cable at the battery.

(2) Remove the connector nut of the generator-to-regulator harness, and carefully pull the harness from the regulator.

(3) Disconnect the battery harness in a like manner at the regulator.

(4) Remove the four bolts, nuts, and lock-washers securing the regulator to the mounting bracket. Remove the regulator.

*b. Installation.***CAUTION**

Do not start the engine until the generator has been polarized.

(1) Position the generator on the mounting bracket so that the harness connectors are facing down. Secure it to the bracket with four bolts, lock-washers, and nuts.

(2) Connect the battery harness to the four-contact connector of the regulator by tightening the connector nut.

(3) Connect the generator-to-regulator harness to the three-contact connector in a like manner.

(4) Connect the battery ground cable to the negative (−) post of the battery.

(5) Polarize the generator (para 2-131 c).

**Section XXI. BATTERIES AND LIGHTING SYSTEM****2-133. General**

*a. Batteries.* Two 12-volt, lead-acid type batteries are connected in series to supply the 24 volts required to start and operate the engine and lights when current requirements exceed the generator output.

*b. Lights.* All service lights are waterproofed, and include headlights, parking lights, stoplights, and taillights. Also included with the service lights is a blackout lighting system consisting of a seal beamed driving light unit, marker lights contained within the regular parking light units, a stoplight

unit, and blackout taillights. On some vehicles directional signal lamps are installed in the parking and taillight assemblies.

**2-134. Batteries and Cables****WARNING**

When removing the battery cables, disconnect the ground cable first. When installing the battery cables, connect the ground cable last. When two ground cables are used, both cables must be disconnected prior to working on the equipment where

shorting of cables can occur. An incorrect cable replacement sequence is extremely dangerous. Accidental contact of the cable replacing tool with the vehicle caused a direct short, resulting in arcing and instant heating of the tool to red heat. This can cause painful burns on hands and serious damage to tools, vehicle, and battery. Moreover, the shorted battery may explode, spraying hot acid over the surrounding area.

*a. Cleaning.* The top of the battery must be kept clean. Tighten the plugs and clean the battery with a brush dipped in an alkaline solution, such as ammonia or a solution of bicarbonate of soda and water. After the foaming stops, flush the top of the battery with clean water. If the terminals and cable clamps are corroded, disconnect the cable and clean them as described above for the top of the battery. Connect the cables and waterproof the battery terminals by packing them with GAA grease.

*b. Removal.*

- (1) Open the battery compartment door.
- (2) Loosen the wingnuts on both battery box clamps (fig. 2-153), and unhook the clamps from the box.

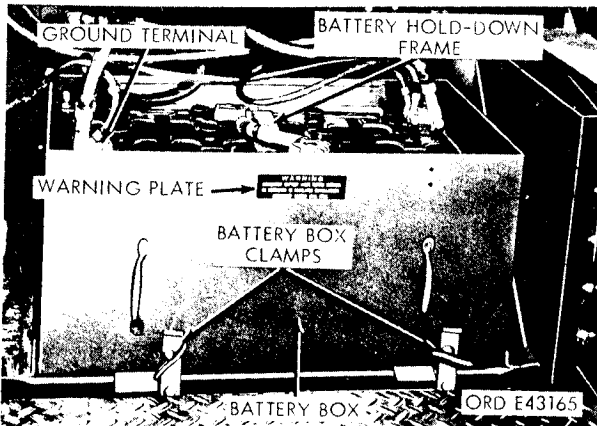


Figure 2-153. Battery installation.

(3) Pull the battery box assembly out onto the step, and disconnect the cable from the negative (—) terminal post to ground (fig. 2-153).

(4) Disconnect all cables at the positive (+) and negative terminal posts on both batteries.

(5) Remove the battery holddown frame. Lift both batteries out of the box (fig. 2-153).

*c. Installation.*

(1) Position the batteries in the box with the positive (+) posts toward the front of the vehicle, and secure the batteries with the holddown frame (fig. 2-153).

(2) Connect interconnecting cable from the negative (—) post of the front battery to the positive (+) post of the rear battery.

(3) Connect the batter-to-solenoid cable to the positive (+) post of the front battery.

(4) Connect the ground cable from the frame to the negative (—) post of the rear battery.

(5) Pack GAA grease around all terminal post connections.

(6) Slide the box assembly into the battery compartment, tighten the clamps with two wing nuts, and close the compartment door (fig. 2-153).

## 2-135. Headlights

*a. Removing Sealed-Beam Lamp Unit.*

(1) Remove the three mounting screws from the headlight rim (fig. 2-154), and remove the rim.

(2) Remove the three screws attaching the retaining ring (fig. 2-155) to the headlight body, and remove the ring.

(3) Pull the sealed-beam lamp unit from headlight body, and disconnect the cables at the waterproof connectors (fig. 2-155).

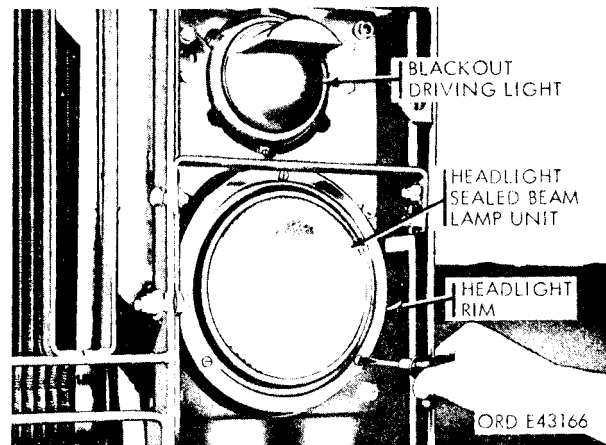


Figure 2-154. Removing headlight rim



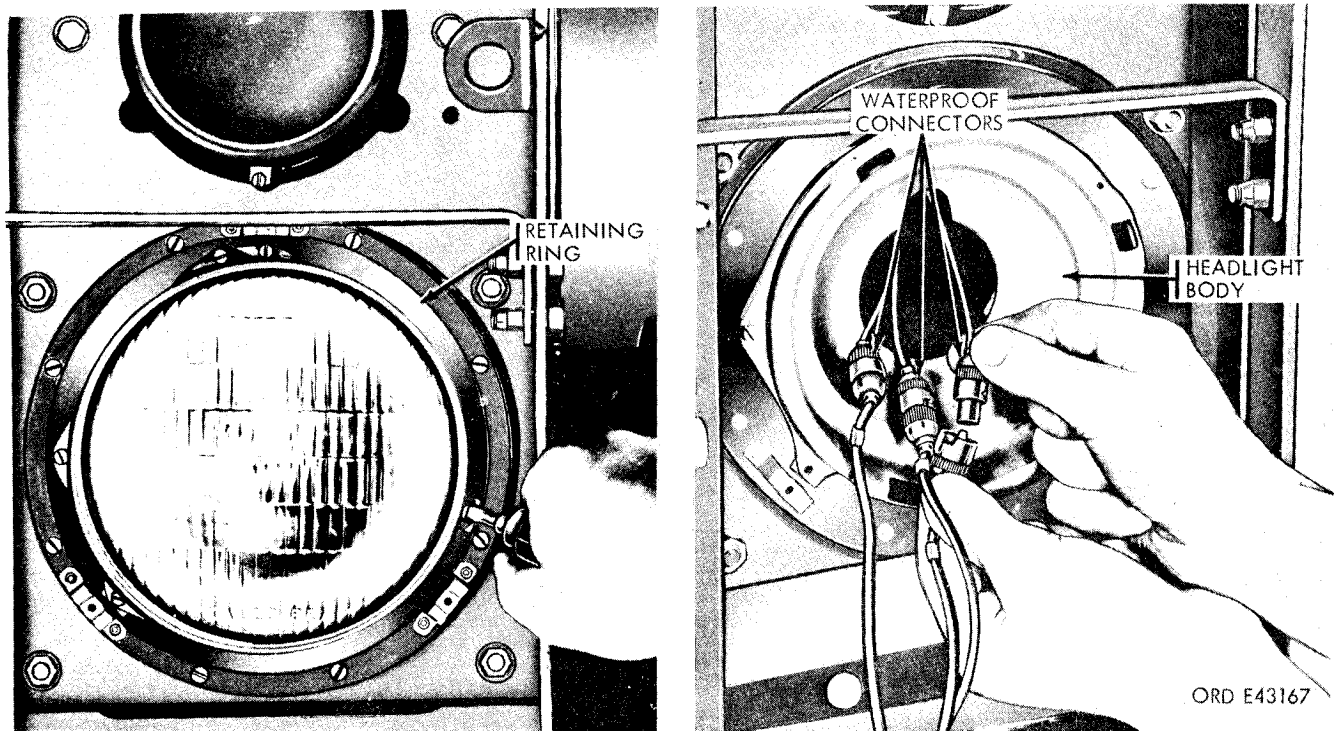


Figure 2-155. Removing headlight retaining ring and sealed-beam lamp unit.

#### **b. Installing Sealed-beam Lamp Unit.**

(1) Connect the three cables at the waterproof connectors (fig. 2-155), and position the lamp unit in the headlight body.

(2) Position the retaining ring (fig. 2-155), and secure it with three screws.

(3) Position the headlight rim (fig. 2-154), and secure it with three screws.

#### **c. Adjusting Headlights.**

(1) Headlight beam direction is changed by two lamp-unit adjusting screws located behind the holes in the rim; one at the top and one on the side (fig. 2-156). Turn the top adjusting screw to change the direction of the beam vertically, and turn the side adjusting screw to change the direction horizontally. Adjust the lights as detailed below.

(2) Place the unloaded vehicle on a smooth level surface so that the headlights are 25 feet away from a vertical wall or other vertical surface. The centerline of the vehicle must be at right angles to the vertical surface. Use the headlight aiming

diagram (fig. 2-157) for aid in laying out the adjustment lines.

(3) Measure the height of the headlight center from the floor, and mark a horizontal line (X-X) at this height on the vertical surface.

(4) Mark a line (A-A) one-twelfth of the distance between line X-X and the floor below line X-X.

(5) Draw vertical lines (B-B and C-C) directly in front of each headlight.

(6) Turn on the headlights at the light switch, and select the high beam with the headlight beam selector switch.

(7) Cover one headlight while adjusting the other. Aim the headlight so that the center of the hot (brightest) spot registers with the intersecting lines (A-A and B-B, or A-A and C-C respectively).

(8) After each light is aimed separately, check both lights simultaneously for conformity to line A-A.

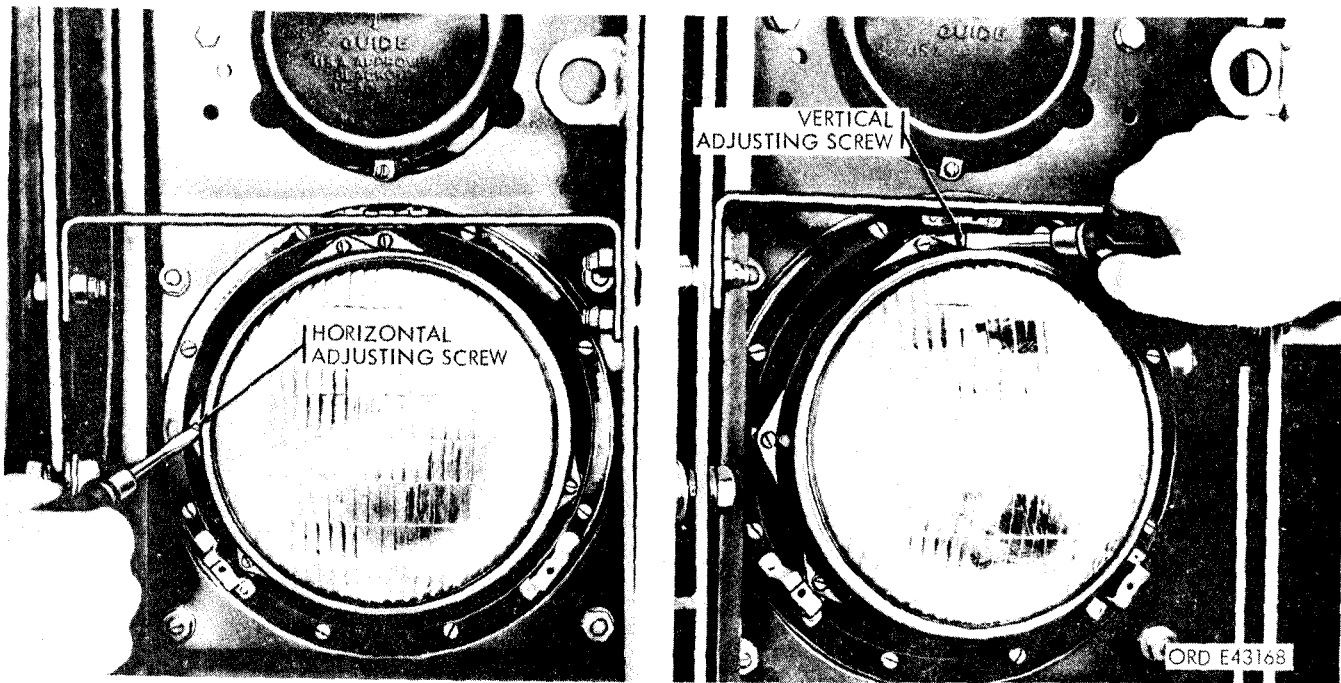


Figure 2-156. Adjusting headlight.

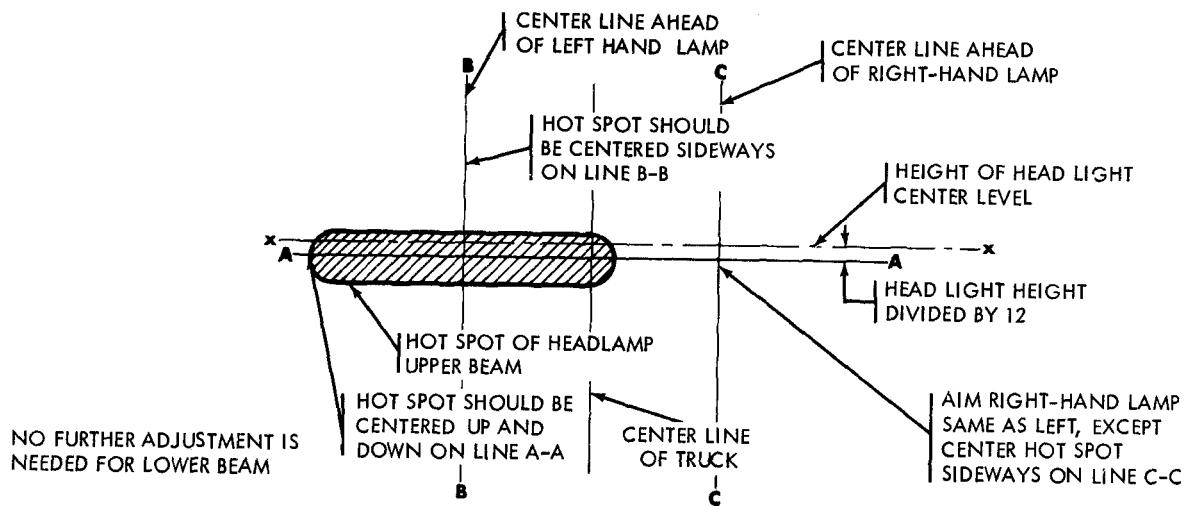


Figure 2-157. Headlight aiming diagram.

**2-136. Parking lights**

*a. Removal (fig. 2-158).*

- (1) Remove six screws securing the parking light door to the light body.
- (2) Remove the parking light door and the preformed door seal.
- (3) Push the lamp in and turn it counterclockwise to remove the defective lamp from the socket.

**NOTE**

Three lamps are installed inside each

parking light assembly. The third lamp is for use as a directional lamp on some models.

*b. Installation (fig. 2-158).*

- (1) Insert the base of the lamp in the socket and turn the lamp clockwise to lock it in the socket.
- (2) operate the light switch to test the lights.
- (3) Install the preformed packing in the groove in the parking light door; position the door and secure it with six screws.

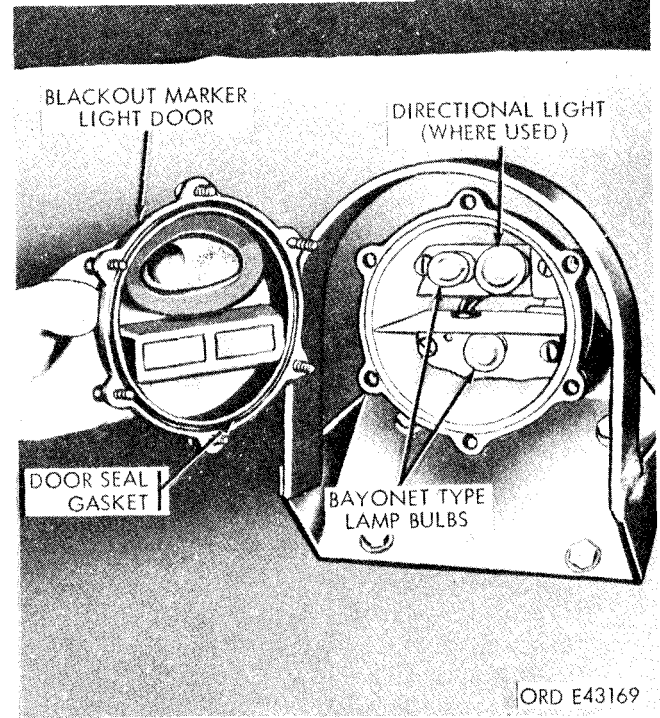
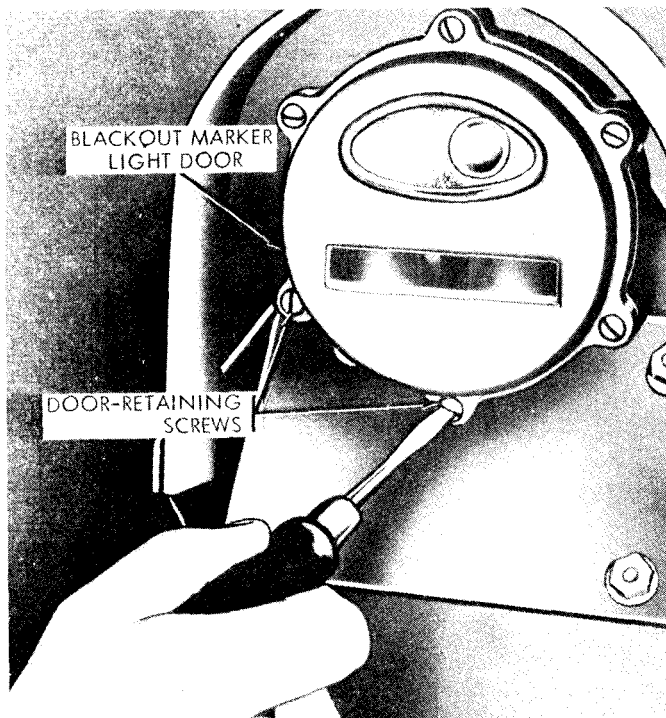


Figure 2-158. Removing parking and blackout marker lamp.

**2-137. Blackout Driving Light**

*a. Removal.*

- (1) Remove the three door retaining screws (fig. 2-159) from the blackout driving light door.
- (2) Pull the door and sealed-beam lamp unit assembly forward, and remove the waterproof connectors from the connector clips (fig. 2-159).

- (3) Disconnect the waterproof connectors (fig. 2-160).

- (4) Remove the three lamp unit retaining springs (fig. 2-160), and remove the lamp unit from the door.

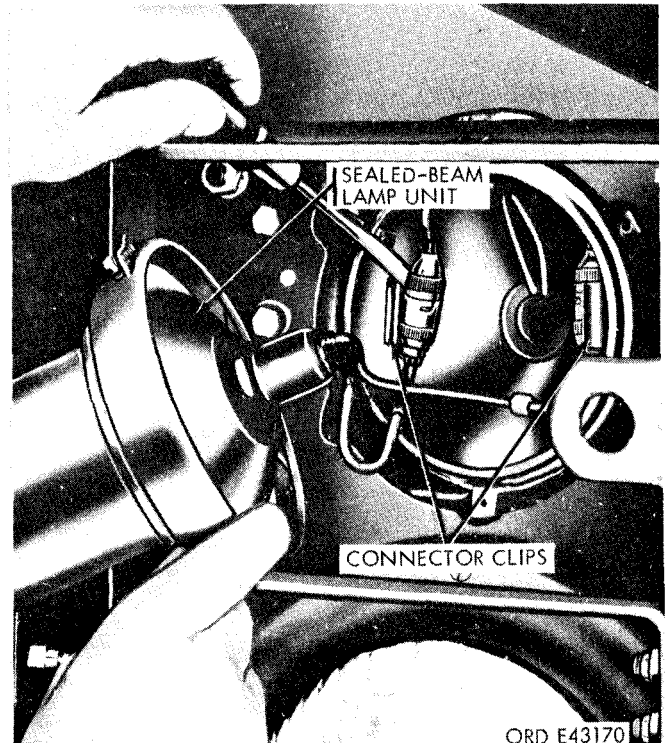
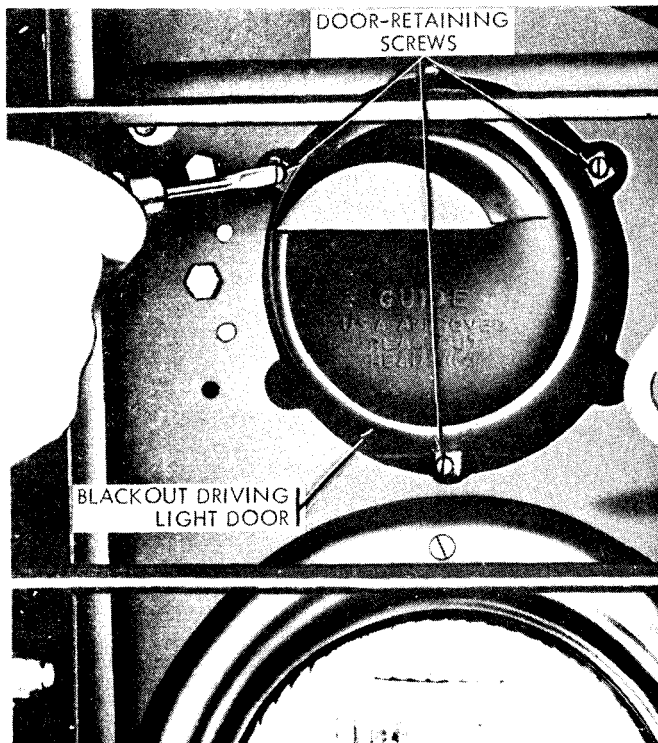


Figure 2-159. Removing blackout driving light.

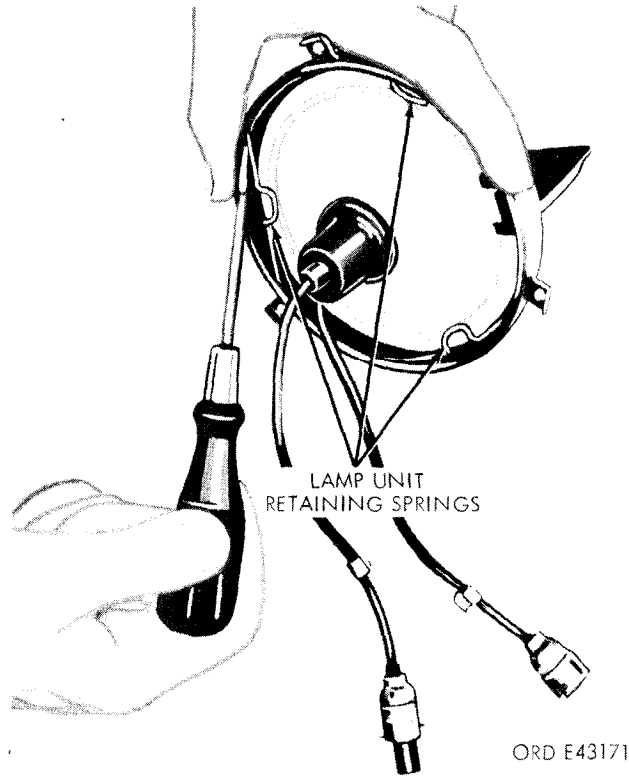


Figure 2-160. Removing blackout driving light sealed-beam lamp unit.

**b. Installation.**

(1) Position the sealed-beam lamp units in the blackout driving light door (cover), and secure them with the three retaining springs (fig. 2-160).

(2) Connect the lamp unit cables to the wiring harness cables (fig. 2-160), and fasten the cable connectors in the connector clips (fig. 2-159).

(3) Position the door (fig. 2-159) and lamp unit assembly on the front of the light body, and install the three door retaining screws. Tighten the screws.

(4) Operate the light switch to test the blackout driving light.

**2-138. Stoplight and Taillight (Including Directional Lights)**

**a. Removal.** The procedures for removing the service stoplight and taillight (including directional

lights) are the same as those for removing the parking and directional lights (para 2-136 a).

**b. Installation.** The procedures for installing the service stoplight and taillight (including directional lights) are the same as those for installing parking and directional lights (para. 2-136 b).

**2-139. Blackout-Marker Lights, Blackout Stoplight, and Blackout Taillights**

**a. Removal.** The procedure for removing blackout-marker lights, blackout stoplight, and blackout taillights are the same as those for removing parking lights (para 2-136 a).

**b. Installation.** The procedures for installing blackout-marker lights, blackout stoplight, and blackout taillights are the same as those for installing parking lights (para 2-136 b).

**Section XXII. WIRING CIRCUITS AND HARNESSSES**

**2-140. General**

**NOTE**

Repair of harness cables and wires should be limited to splicing broken wires and replacing terminals and / or end connectors.

**a. Wiring.** Cable ends are always soldered to their connecting plug socket or terminal using rosin flux solder (never acid flux). Two types of cable

connectors are used on these vehicles. One is a plug-and-receptacle type with the receptacle encased in a metal sleeve. The plug is secured to the receptacle by a retaining nut screwed onto the sleeve to form a watertight housing. The other type of cable connector is the bayonet type with two interlocking bells enclosing an insulated connector, and with two rubber bushings forming a watertight joint.

**NOTE**

A circuit number tag is placed at both ends of the cable.

*b. Harness.* When a group of cables go from one general location to another, the cables are bound together to form a harness. Three main harnesses are used on these vehicles. One harness extends from the generator regulator to the circuit breakers, ammeter, and batteries. Another harness extends from the light switch to the instrument cluster, circuit breaker, and all lights. The remaining harness extends from the light switch to the trailer coupling receptacle.

**2-141. Receptacles***a. Slave Battery Receptacle.*

(1) *Removal.* Remove the four screws securing the slave battery receptacle (fig. 2-71) to the right rear corner of cab. Pull the receptacle away from the cab, and disconnect the two cables at the connectors.

(2) *Installation.* Connect the two receptacle cables to the two cables inside the cab. Position the receptacle (fig. 2-71) on the side of the cab, and install the four screws. Tighten the screws.

*b. Radio Receptacle.*

(1) *Removal.* Remove the four nuts, lock-washers, and bolts securing the radio receptacle to the bracket. Remove the receptacle from the bracket, and disconnect the two cables at the connectors.

(2) *Installation.* Connect the two receptacle cables to the cables in the cab. Position the receptacle on the bracket, and install four bolts, lockwashers, and nuts. Tighten the nuts.

*c. Trailer Coupling Receptacle.*

(1) *Removal.* Remove the four nuts, lock-washers, and bolts securing the trailer coupling receptacle to the mounting. Disconnect the cables at the connectors behind the receptacle. Push the receptacle to the rear, and remove it from the vehicle.

(2) *Installation.* Connect the cables at the connectors behind the trailer coupling receptacle. Position the receptacle on the mounting, and install the four bolts, lockwashers, and nuts. Tighten the nuts.

## Section XXIII. INSTRUMENT CLUSTER, SWITCHES, CIRCUIT BREAKERS, SENDING UNITS, HORN AND DIRECTIONAL SIGNAL CONTROLS

**2-142. General**

*a. Instrument Cluster.* Instrument cluster components (fig. 2-33) include the air pressure gage, ammeter, fuel gage, headlight high-beam indicator light, oil pressure gage, panel lights, speedometer, tachometer, tachograph (M52A1 and M52A2 models only), and the temperature gage. The speedometer, tachometer, and tachograph are mechanically operated units connected by flexible shafts to their respective sending units. The tachograph takes the place of both the speedometer and tachometer on some M52A1 and M52A2 models. All other instrument cluster gages are electrically operated.

*b. Sending Units.* There are individual sending units for the air pressure gage, fuel gage, oil pressure gage, speedometer, tachometer, tachograph, temperature gage, and low air pressure warning buzzer. Both the air pressure gage sending

unit and the low air pressure buzzer sending units are connected into the air reservoir-to-air governor line.

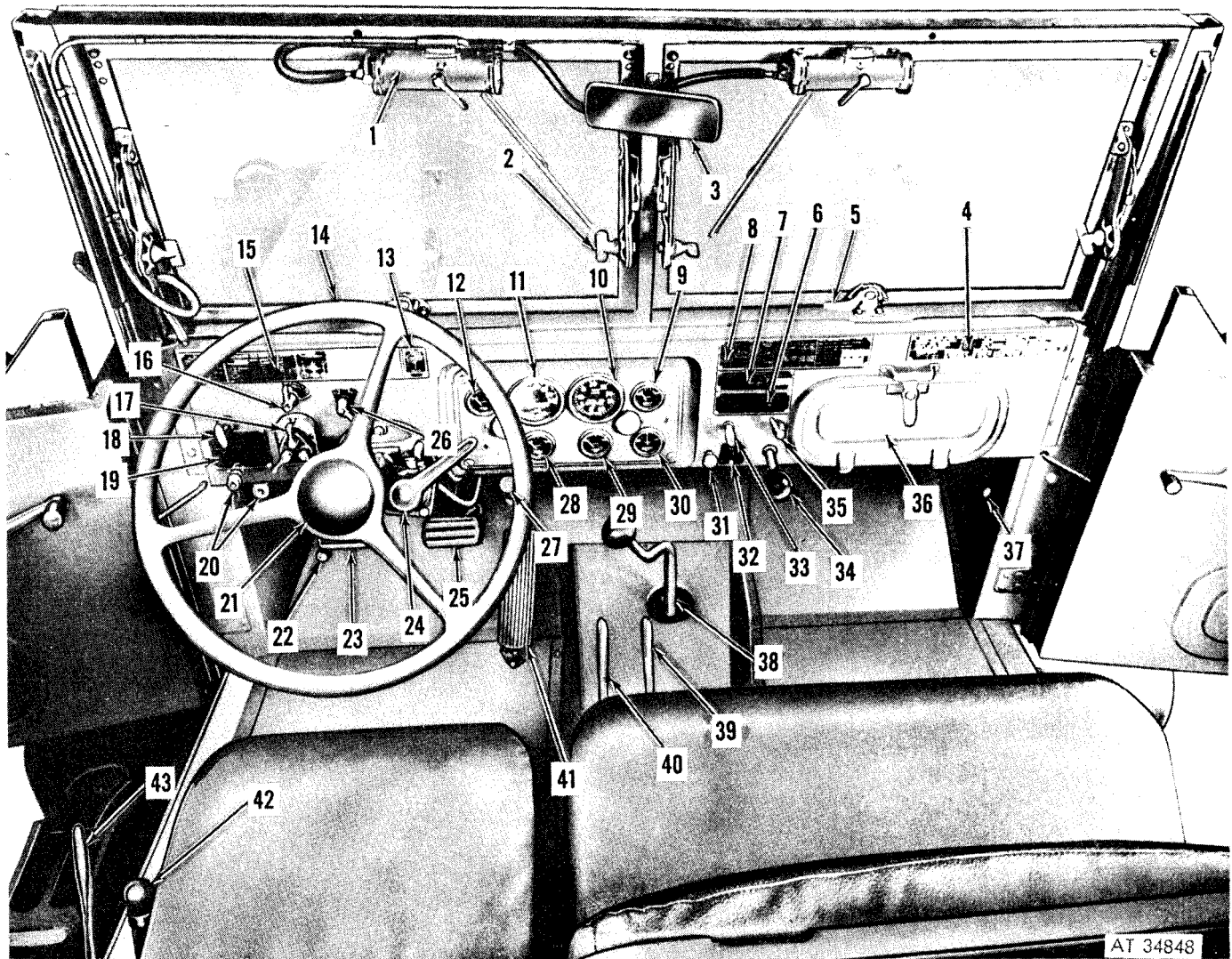
*c. Switches and Circuit Breakers.***NOTE**

The key numbers noted in parentheses are for figure 2-161, unless otherwise indicated.

(1) *Manually operated switches (fig. 2-161).* These switches include the ignition (16), light (17), electric brake lock (32), horn (21), dimmer (22), warning light (26), and floodlight (35).

(2) *Stoplight switch (fig. 2-188).* This air-operated switch (21) is connected into the compressed air system, and it is located just in front of the transfer case.

(3) *Circuit breakers (fig. 2-44).* These four automatic reset type circuit breakers protect the various electrical circuits.



AT 34848

- |  |  |
|--|--|
| 1 Windshield wiper motor   | 24 Handbrake valve (trailer brakes)  |
| 2 Windshield adjusting arm clamping screw  | 25 Brake pedal   |
| 3 Rear view mirror   | 26 Warning light switch  |
| 4 Servicing and publication data plate   | 27 Starter button  |
| 5 Windshield lock handle   | 28 Air pressure gage   |
| 6 Crankcase ventilating shutoff valve data plate                                 | 29 Oil pressure gage   |
| 7 Responsible agency data plate  | 30 Ammeter   |
| 8 Truck nameplate  | 31 Choke control   |
| 9 Temperature gage   | 32 Electric brake lock switch button and data plate  |
| 10 Tachometer  | 33 Crankcase ventilating shutoff valves control  |
| 11 Speedometer   | 34 Primer pump (early production vehicle only)   |
| 12 Fuel gage   | 35 Floodlight switch   |
| 13 Dump body control data plate (M51) or power divider control data plate (M62). | 36 Map compartment   |
| 14 Steering wheel  | 37 Cowl ventilator   |
| 15 Instruction plate   | 38 Transmission gearshift lever  |
| 16 Ignition switch   | 39 Transfer shift lever (early production vehicles) or winch control lever (late production vehicles). |
| 17 Light switch  | 40 Winch control lever (early production vehicles) or transfer shift lever (late production vehicles). |
| 18 Throttle control  | 41 Accelerator pedal   |
| 19 Low air pressure warning and winch control data plate                         | 42 Handbrake lever   |
| 20 Trouble light outlet  | 43 Dump body control lever (M51) or power divider control lever (M62)                                  |
| 21 Horn button   |  |
| 22 Dimmer switch   |  |
| 23 Clutch pedal  |  |

Figure 2-161. Locations of instruments and controls.

d. *Horn.* The waterproof horn assembly (fig. 2-162) is an electrically controlled air-operated unit. Depressing the horn button (21, fig. 2-161) completes the circuit to the horn solenoid.

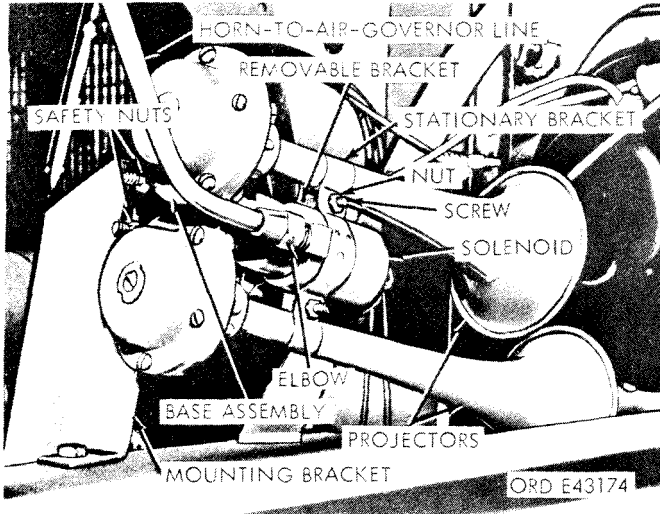


Figure 2-162. Horn installed on vehicle (solenoid with mounting brackets).

## 2-143. Instrument Cluster

### a. Removal (fig. 2-33).

(1) Remove the four panel lockscrews securing the panel, and pull the cluster away from the panel.

(2) Disconnect the bayonet type connectors securing the gage-to-circuit breaker cable to the gages and lights at the back of the instrument cluster.

(3) Unscrew the nut securing the speedometer flexible shaft to the speedometer, and pull the shaft end from the speedometer.

(4) Support the instrument cluster, and unscrew the nut securing the tachometer flexible shaft to the tachometer. Pull the shaft end from the tachometer, and remove the instrument cluster from the vehicles.

### b. Installation (fig. 2-33).

(1) Position the instrument cluster at the opening in the instrument panel, insert the end of the tachometer flexible shaft in the tachometer, and tighten the connector nut.

(2) Insert the end of the speedometer flexible shaft in the speedometer, and tighten the connector nut.

(3) Connect the bayonet type connectors on the gage and light cables to gages and lights at the back of the instrument cluster.

(4) Position the instrument cluster on the front of the instrument panel, and install the four panel lockscrews, one at each corner of the instrument mounting plates.

## 2-144. Air Pressure Gage

### a. Removal (fig. 2-33).

(1) Remove the four panel lockscrews securing the instrument cluster to the instrument panel, and pull the cluster away from the panel.

(2) Disconnect the two bayonet type electrical connectors, and remove the cables from the back of the air pressure gage.

(3) Remove the two nuts and lockwashers from the gage mounting studs. Remove the mounting bracket from the studs, and remove the air pressure gage from the front of the instrument cluster.

### b. Installation (fig. 2-33).

(1) Insert the air pressure gage in the opening in front of the instrument cluster. Install the mounting bracket on the gage studs at the back of the instrument cluster. Install the two lockwashers and nuts on the studs. Tighten the nuts.

(2) Connect the bayonet type connectors on the two gage cables to the back of the gage.

(3) Position the instrument cluster on the front of the instrument panel, and install the four panel lockscrews, one at each corner of the instrument mounting plate.

## 2-145. Ammeter or Charge Indicator

a. *Removal.* Procedure for removing the ammeter is the same as for the air pressure gage. Refer to paragraph 2-144 a.

### NOTE

If the vehicle is equipped with a charge indicator instead of an ammeter, the indicator will only have one electrical connection.

b. *Installation.* The procedure for installing the ammeter is the same as for the air pressure gage. Refer to paragraph 2-144 b.

## 2-146. Fuel Gage

a. *Removal.* The procedure for removing the fuel gage is the same as for the air pressure gage. Refer to paragraph 2-144 a.

b. *Installation.* The procedure for installing the fuel gage is the same as for the air pressure gage. Refer to paragraph 2-144 b.

## 2-147. Headlight High-Beam Indicator Light

### a. Removal (fig. 2-33).

(1) Remove the four panel lockscrews securing the instrument cluster to the instrument panel, and pull the cluster away from the panel.

(2) Disconnect the bayonet type connector at the clip on the left (viewing back side of cluster) side of the instrument mounting plate.

(3) Remove the two screws and lockwashers from the front side of the instrument cluster. Remove the indicator light from the back side of the cluster.



*b. Installation* (fig. 2-33).

(1) Position the headlight high-beam indicator light on the back side of the instrument cluster, and install the two screws and lockwashers at the front side of the cluster.

(2) Connect the bayonet type connector on the light cable to the connector at the clip on the left (viewing back side of cluster) side of the instrument mounting plate.

(3) Position the instrument cluster on the front of the instrument panel, and install the four panel lockscrews; one at each corner of the instrument mounting plate.

*c. Lamp Replacement.*

(1) Remove the headlight high-beam indicator light ( *a* above).

(2) Press the body and cover assembly together, turn the body counterclockwise, and separate the body and the cover.

(3) Remove the bayonet-base lamp from the socket. Discard the lamp.

(4) Install the new bayonet-base lamp in the socket.

(5) Install the light body in the cover, press the body and the cover together, and turn the body clockwise to engage the body retaining pins in the cover slots.

(6) Install the headlight high-beam indicator light ( *b* above).

**2-148. Oil Pressure Gage**

*a. Removal.* The procedure for removing the oil pressure gage is the same as for the air pressure gage. Refer to paragraph 2-144 *a*.

*b. Installation.* The procedure for installing the oil pressure gage is the same as for the air pressure gage. Refer to paragraph 2-144 *b*.

**2-149. Panel Lights**

*a. Removal* (fig. 2-33).

(1) Remove the four panel lockscrews securing the instrument cluster to the instrument panel, and pull the cluster away from the panel.

(2) Disconnect the bayonet type connector at the clip secured to the tachometer mounting stud.

(3) Remove the four screws and lockwashers from the front side of the instrument cluster, and remove the left and right panel lights from the back side of the instrument cluster.

*b. Installation* (fig. 2-33).

(1) Position one panel light on the back of the instrument cluster, and install two screws and lockwashers at the front side of the cluster.

(2) Repeat (1) above for the other panel light.

(3) Connect the bayonet type connector on the light cables to the connector at the clip secured to the tachometer mounting stud.

(4) Position the instrument cluster on the front of the instrument panel, and install the four panel lockscrews; one at each corner of the instrument mounting plate.

*c. Lamp Replacement.* The procedure for replacing the panel light lamp is same as for the headlight beam indicator light lamp. Refer to paragraph 2-147 *c*.

**2-150. Speedometer and Flexible Shaft**

Refer to paragraphs 2-333 and 2-334 for removal and installation procedures.

**2-151. Tachometer and Flexible Shaft**

Refer to paragraphs 2-335 and 2-336 for removal and installation procedures.

**2-152. Tachograph—M52A1 and M52A2**

Refer to paragraphs 2-337 and 2-338 for removal and installation procedures.

**2-153. Temperature Gage**

*a. Removal.* The procedure for removing the temperature gage is the same as for removing the air pressure gage. Refer to paragraph 2-114 *a*.

*b. Installation.* The procedure for installing the temperature gage is the same as the air pressure gage. Refer to paragraph 2-144 *b*.

**2-154. Ignition Switch.**

*a. Removal.*

(1) Disconnect the battery ground cable (para 2-134).

(2) Remove the screw from the front of the ignition switch lever (16, fig. 2-161), and pull the lever from the switch shaft.

(3) Remove the hexagon nut and tooth type lockwasher from the switch body at the front of the instrument panel, and remove the switch from the back of the panel.

(4) Disconnect the bayonet type connectors on the switch cables, and remove the switch from the vehicle.

*b. Installation.*

(1) Connect the bayonet type connectors on the switch cables to the battery, gage, and coil cable, and to the circuit breaker connectors. Note that the three terminal cables from the switch are numbered with circuit marker sleeves, and make connections as shown below:

<i>Terminal No.</i>	<i>Circuit</i>	<i>Circuit terminal mark</i>
1	Battery	A
2	Temperature gage	A
	Oil Pressure gage	B
	Fuel Gage	A
3	Ignition coil	B



(2) Position the switch on the back side of the instrument panel with the switch body extending through the hole in the panel, and install the tooth type lockwasher and hexagon nut on the switch body. Tighten the nut.

(3) Install the switch lever (16, fig. 2-161) on the switch shaft, and secure it with the screw.

(4) Connect the battery ground cable (para 2-134).

*c. Testing.* Disconnect all terminals. Connect one terminal of the test light or the buzzer to the battery cable and test for continuity of all terminals.

## 2-155. Light Switch

### *a. Removal.*

(1) Unscrew the nuts securing the two wiring harness plugs to the receptacles on the bottom of the light switch, at the back side of the instrument panel, and pull both harness plugs from the receptacles.

(2) Remove the four screws from the front of the instrument panel, and remove the switch (17, fig. 2-161) from the back of the panel.

### *b. Installation.*

(1) Position the light switch on the back side of the instrument panel with the electrical receptacles pointing down, and the switch housing extending through the opening in the instrument panel. Install the four screws, and tighten them.

(2) Insert the two wiring harness plugs in the receptacles on the bottom of the light switch (17, fig. 2-161), and tighten both plug retaining nuts.

## 2-156. Horn Button (switch)

### *a. Removal.*

(1) While holding the steering wheel stationary, press down on the horn button (21, fig. 2-161). Turn the button in either direction, and release it. Lift the button from the steering wheel hub.

(2) Remove the contact button cup, spring, and cap from the center of the steering wheel.

(3) Remove the three screws securing the horn button plate to the hub. Leave the horn wire in position, and remove the plate from the hub.

### *b. Installation.*

(1) Position the horn button plate in the center of the steering wheel hub, and secure it with three screws.

(2) Install the contact button cap, spring, and cup on the horn button plate.

(3) Position the horn button (21, fig. 2-161) in the center of the steering wheel hub, press down the button, and turn it in either direction until the button flange is locked in the rubber retainers on the horn button plate. Release the horn button.

## 2-157. Dimmer Switch

### *a. Removal.*

(1) From inside the cab, remove the two screws securing the dimmer switch (22, fig. 2-163) to the underside of the toeboard.

(2) Disconnect the three bayonet type connectors on the switch cables, and remove the switch from the vehicle.

### *b. Installation.*

(1) Position the dimmer switch (22, fig. 2-161) on the under side of the toeboard, and secure it with two screws from inside the cab.

(2) Connect the three bayonet type connectors on the switch cables.

## 2-158. Stoplight Switch.

### *a. Removal.*

(1) Disconnect the two bayonet type connectors at the top of the stoplight switch.

(2) Unscrew the sleeve nut on the brake hydraulic line from the elbow at the bottom of the switch.

(3) Remove the two screws and nuts securing the switch to the inside of the frame left side rail, and remove the switch from the vehicle.

### *b. Installation.*

(1) Position the stoplight switch on the inside of the frame left side rail, and secure it with two screws and nuts.

(2) Position the brake hydraulic line at the elbow on the bottom of the switch, and tighten the sleeve nut on the elbow.

(3) Connect the two bayonet type connectors on the harness cables to the terminal connectors on top of the switch.

(4) Bleed the brakes (para 2-190) if necessary.

## 2-159. Low Air Pressure Warning Buzzer

### *a. Removal.*

(1) Disconnect the terminal connections at the buzzer.

(2) Remove the three screws, lockwashers, and nuts securing the buzzer to the back side of the instrument panel, and remove the buzzer.

### *b. Installation.*

(1) Position the low air pressure warning buzzer on the back side of the instrument panel, and secure it with three screws, lockwashers, and nuts.

(2) Connect the low air pressure sending unit cable to the buzzer terminal.

## 2-160. Circuit Breakers

### *a. Removal.*

(1) Disconnect the two bayonet type connectors on the harness cable from the circuit-breaker terminal connectors.

(2) Remove the two screws, lockwashers, and nuts securing the breaker to the left front side of the cab cowl, and remove the breaker from the cowl.

*b. Installation.*

(1) Position the circuit breaker on the left front side of the cab cowl, and secure it with two screws, lockwashers, and nuts.

(2) Connect the two harness cable connectors to the circuit breaker terminal connectors.

**2-161. Air Pressure Gage Sending Unit**

*a. Removal (fig. 2-188).*

(1) Disconnect the bayonet type connector on the air pressure gage-to-sending unit cable from the terminal connector at the sending unit.

(2) Unscrew the sending unit from the air manifold installed in the air reservoir-to-air governor line on the back of the cab cowl behind the instrument panel, and remove the sending unit from the vehicle.

*b. Installation (fig. 2-188).*

(1) Screw the threaded end of the air pressure gage sending unit into the threaded hole in the air manifold at the back side of the cab cowl behind the instrument panel.

(2) Connect the bayonet type connector on the air pressure gage-to-sending unit cable to the terminal connector at the sending unit.

**2-162. Fuel Gage Sending Unit**

*a. Removal (fig. 2-71).*

(1) Disconnect the bayonet type connector on the fuel gage-to-fuel gage sending unit cable from the terminal connector at the sending unit.

(2) Remove the five screws and washers securing the sending unit to the top of the fuel tank, and remove the sending unit from the tank. Remove and discard the fuel tank sending unit gasket.

*b. Installation (fig. 2-71).*

(1) Install a new fuel tank sending unit gasket at the opening in the top of the fuel tank.

(2) Insert the fuel gage sending unit in the tank opening, and secure it with five screws and washers.

(3) Connect the bayonet type connector on the fuel gage-to-fuel gage sending unit cable to the terminal connector on the sending unit.

**2-163. Oil Pressure Gage Sending Unit**

*a. Removal.* The procedure for removing the oil pressure gage sending unit is the same as for the air pressure gage sending unit. Refer to paragraph 2-144.

*b. Installation.* The procedure for installing the oil pressure gage sending unit is the same as for the air pressure gage sending unit. Refer to paragraph 2-144.

**2-164. Speedometer Sending Unit**

*a. Removal (fig. 2-168).*

(1) Unscrew the nut securing the flexible shaft to the speedometer sending unit on the front of the transfer case, and pull the shaft end from the sending unit.

(2) Unscrew the coupling nut securing the sending unit to the transfer case, and remove the unit from transfer case.

*b. Installation (fig. 2-168).*

(1) Insert the speedometer sending unit drive shaft in the opening at the front of the transfer case, and tighten the coupling nut.

(2) Insert the end of the speedometer flexible shaft in the sending unit and tighten the connector nut.

**2-165. Tachometer Sending Unit**

*a. Removal.*

(1) *Gasoline engine.*

(a) Unscrew the nut securing the tachometer flexible shaft to the sending unit at the drive housing, and pull the shaft end from the sending unit.

(b) Unscrew the nut (bearing retainer) securing the sending unit to the distributor drive housing, and remove it from the housing.

(2) *Diesel engine.*

(a) Unscrew the nut securing the tachometer flexible shaft to the sending unit (drive assembly) and pull the shaft end from the sending unit.

(b) Remove the two screws and lockwashers securing the sending unit on the engine auxiliary drive housing. Remove the gasket.

*b. Installation.*

(1) *Gasoline engine.*

(a) Insert the tachometer sending unit in the opening at the front distributor drive housing, so that the drive shaft engages the slot in the end of the governor control valve shaft. Tighten the nut (bearing retainer).

(b) Aline the key on the end of the tachometer flexible shaft with the keyway in the drive shaft, insert the end of the flexible shaft in the sending unit, and tighten the connector nut.

(2) *Diesel engine.*

(a) Install the gasket and sending unit on the auxiliary drive housing, and attach it with two screws and washers.

(b) Aline the key on the end of the tachometer flexible shaft with the keyway in the sending unit, insert it in the sending unit, and tighten the connector nut.

**2-166. Tachometer Sending Unit (Drive Adapter)—Multifuel Models**

**NOTE**

The tachometer, which is mounted on the instrument panel, is driven by an adapter. The drive adapter, which is mounted on the timing cover, is driven by the camshaft.

*a. Removal (fig. 2-163)*

- (1) Remove the tachometer drive adapter and drive shaft from the tachometer takeoff adapter.
- (2) Remove the tachometer takeoff adapter and the adapter gasket.

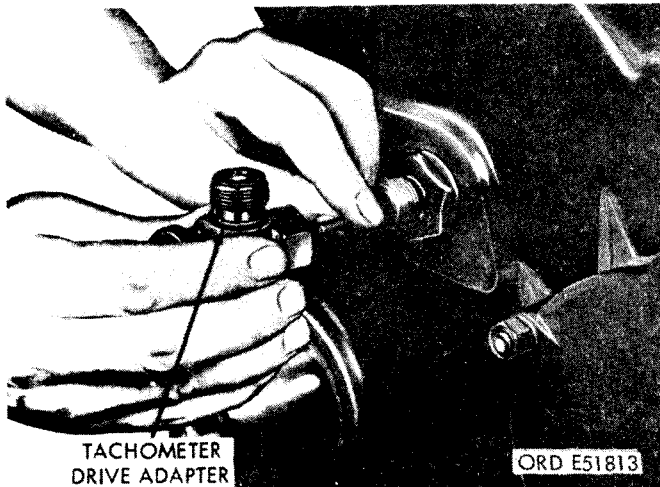


Figure 2-163. Removing tachometer drive adapter.

*b. Installation (fig. 2-163).*

- (1) Position the gasket and install the takeoff adapter in place.
- (2) Install the drive adapter and shaft to the takeoff adapter.

**2-167. Temperature Gage Sending Unit**

*a. Removal.* The procedure for removing the temperature gage sending unit is the same as for the air pressure gage sending unit. Refer to paragraph 2-144 *a.*

*b. Installation.* The procedure for installing the temperature gage sending unit is the same as for the air pressure gage sending unit. Refer to paragraph 2-144 *b.*

**2-168. Low Air Pressure Sending Unit**

*a. Removal.*

(1) Disconnect the bayonet type connector on the low air pressure sending unit-to-air pressure warning buzzer cable, at the terminal connector on top of the sending unit, mounted on the back side of the cab cowl behind the instrument panel.

(2) Disconnect the bayonet type connector on the ignition switch-to-low air pressure sending unit cable at the terminal connector on the bottom of the sending unit.

(3) Unscrew the nut securing the air line from the air manifold to the right side of the sending unit, and remove the line from the unit. Unscrew the nut securing the air line from the air manifold to the rear of the sending unit, and remove the line from the unit.

(4) Remove the two screws and washers securing the sending unit to the back side of the cab cowl, and remove the sending unit from the vehicle.

*b. Installation.*

(1) Position the low air pressure sending unit on the back side of the cab cowl behind the instrument panel, and secure it with the two screws and lockwashers.

(2) Position the line from the air manifold at the threaded opening in the right side of the sending unit, and tighten the connector nut. Position the line from the air manifold at the threaded opening in the rear of the sending unit, and tighten the connector nut.

(3) Connect the bayonet type connector on the ignition switch-to-low air pressure sending unit cable to the terminal connector on the bottom of the sending unit.

(4) Connect the bayonet type connector on the low air pressure sending unit-to-air pressure warning buzzer cable, to the terminal connector on the top of the sending unit.

**2-169. Horn Assembly**

**NOTE**

Multifuel models have the horn and solenoid assembly mounted on the right side of the firewall.

*a. Solenoid (with Mounting Brackets).*

*(1) Removal (fig. 2-162).*

*(a)* Remove the two bayonet-type connectors from the clips on the left side of the solenoid, and disconnect both connectors.

*(b)* Unscrew the connector securing the horn-to-air governor line to the elbow at the base of the solenoid, and remove the line from the elbow.

*(c)* Unscrew the elbow from the base of the solenoid.

*(d)* Loosen the two nuts and screws clamping the solenoid mounting brackets to the projectors, and unscrew both projectors from the horn base assembly.

*(e)* Unscrew the solenoid from the horn base assembly.

*(2) Installation (fig. 2-162).*

*(a)* Screw the threaded end of the solenoid into the threaded hole in the horn base assembly, and aline the solenoid mounting brackets with the projector holes in the base assembly.

*(b)* Position both projectors between the ends of the solenoid mounting brackets, and screw both projectors into the horn base assembly.

Tighten the two screws and nuts clamping the brackets to the projectors.

(c) Install the elbow in the base of the solenoid.

(d) Position the horn-to-air governor line at the elbow, and tighten the connector.

(e) Connect the bayonet-type connectors on the two solenoid cables to the wiring harness connectors, and secure the connectors in the clips on the left side of the solenoid.

*b. Solenoid (Without Mounting Brackets).*

(1) *Removal (fig. 2-164).*

(a) Remove the two bayonet-type connectors from the clips on the front of the solenoid, and disconnect both connectors.

(b) Unscrew the connector securing the horn-to-air governor line to the elbow at the base of the solenoid, and remove the line from the elbow.

(c) Unscrew the elbow from the base of the solenoid.

(d) Loosen the locknut on the threaded section of the solenoid base, and unscrew the solenoid from the horn base assembly.

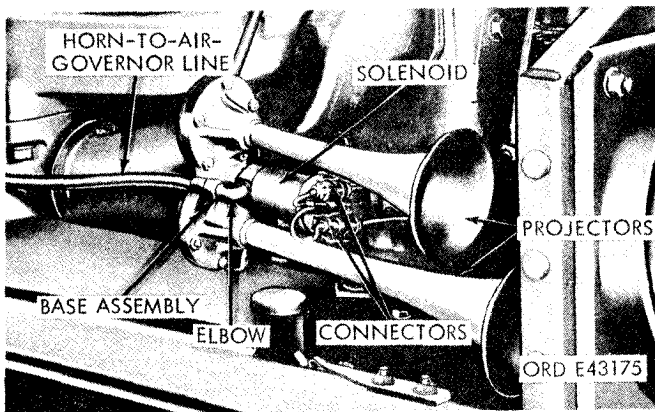


Figure 2-164. Horn installed in vehicle (solenoid without mounting brackets).

(2) *Installation (fig. 2-164).*

(a) Screw the threaded end of the solenoid into the threaded hole in the horn base assembly, and tighten the locknut.

(b) Install the elbow in the base of the solenoid.

(c) Position the horn-to-air governor line at the elbow, and tighten the connector.

(d) Connect the bayonet type connectors on the two solenoid cables to the wiring harness connectors, and secure the connectors in the clips on the front of the solenoid.

*c. Horn (fig. 2-162 and 2-164).*

(1) *Removal.*

(a) Remove the two bayonet type connectors from the clips on the solenoids, and disconnect both connectors.

(b) Unscrew the connector securing the horn-to-air governor line to the elbow at the base of the solenoid, and remove the line from the elbow.

(c) Remove the two safety nuts and screws securing the horn base assembly to the mounting bracket, and remove the horn from the vehicle.

(2) *Installation.*

(a) Position the horn base assembly on the mounting bracket at the right front fender, and secure it with the two screws and safety nuts.

(b) Position the horn-to-air governor line at the elbow, and tighten the connector.

(c) Connect the bayonet type connectors on the two solenoid cables to the wiring harness connectors, and secure the connectors in the clips on the solenoid.

**2-170. Turn Signal Switch**

*a. Removal.*

(1) Disconnect the wires on the turn signal switch mounted on the steering column.

(2) Unscrew the clamp securing the turn signal switch to the steering column. Remove the switch.

*b. Installation.*

(1) Position the switch to the steering column, and screw the clamp to secure the switch in place.

(2) Connect the wires to the turn signal switch.

**2-170.1 Directional Signal Control**

(Fig. 2-165.)

*a. Removal.*

(1) Disconnect the electrical cable connector underneath the directional control.

(2) Unscrew and disconnect the clamp securing the signal control to the steering column, and remove the directional signal control.

*b. Installation.* Refer to the removal procedure, and reverse the sequence.

**2-170.3 Directional Signal Control Indicator Lamp**

(Fig. 2-167.)

*a. Removal.*

(1) Unscrew and remove the lamp cover (lens).

(2) Remove the indicator lamp by pushing it in and turning it counterclockwise.

*b. Installation.* Refer to the removal procedure, and reverse the sequence.

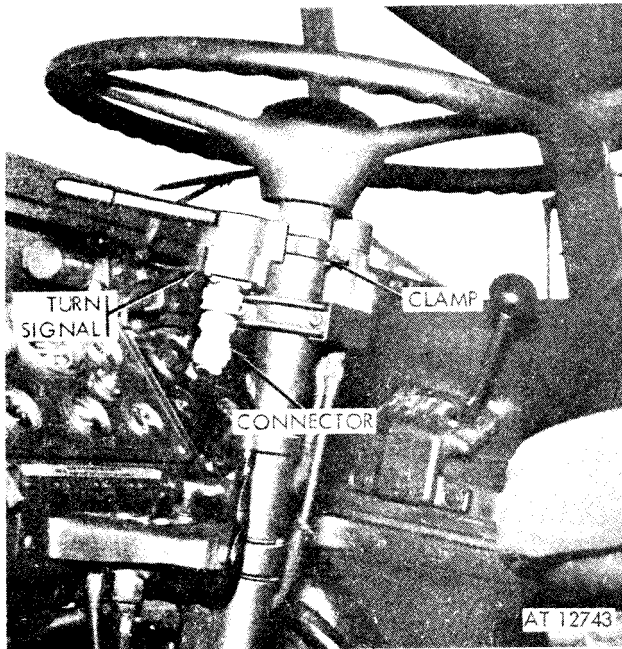


Figure 2-165. Directional signal control—removal and installation.

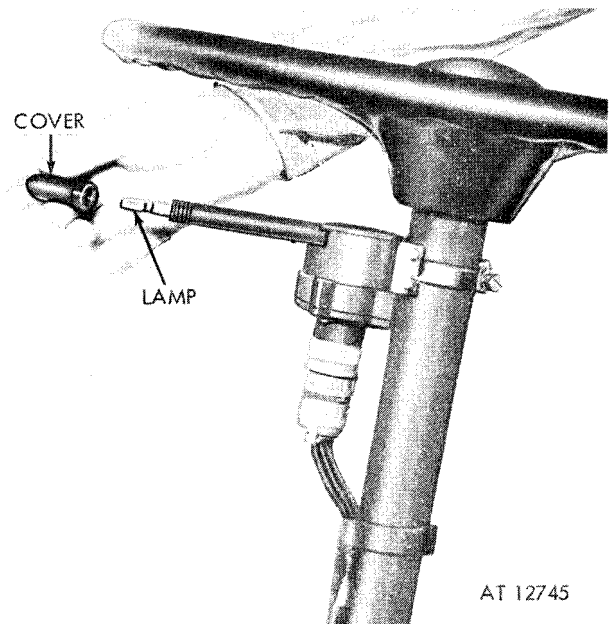


Figure 2-167. Directional signal control indicator—removal and installation.

**2-170.2 Directional Signal Flasher Unit**

(Fig. 2-166.)

*a. Removal.*

(1) Disconnect the electrical cable connector from the side of the flasher unit.

(2) Remove the two screws and lockwashers securing the flasher unit to the cab forward bulkhead, and remove the directional signal flasher unit.

*b. Installation.* Refer to the removal procedure, and reverse the sequence.

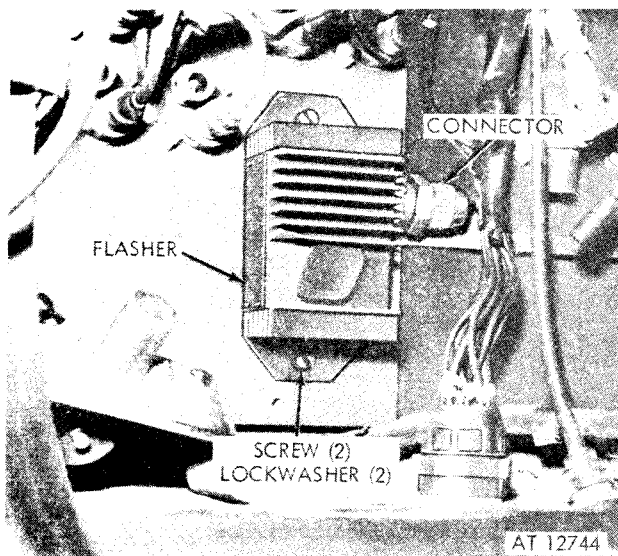


Figure 2-166. Directional signal flasher unit—removal and installation.

**2-171. Air Restriction Indicator—Diesel and Multifuel**

*a. Removal.*

(1) Disconnect the air line at the rear of the indicator.

(2) Remove the two nuts, screws, and washers securing the indicator to the instrument panel. Remove the indicator.

*b. Installation.*

(1) Secure the restriction indicator to the instrument panel with two screws, washers, and nuts. Tighten the nuts.

(2) Connect the air line at the rear of the indicator.

Section XXIV. MAINTENANCE OF TRANSMISSION

**2-172. Service**

Check the lubrication level when changing the engine oil or troubleshooting the transmission. If necessary, add lubricant according to the lubrication order (LO 9-2320-211-12).

**2-173. Breather Vent**

(Fig. 2-167.1.)

*a. Removal.*

(1) Remove the screws securing the tunnel. Pull the tunnel off the cab floor.

(2) Remove the breather vent by rotating it counterclockwise.

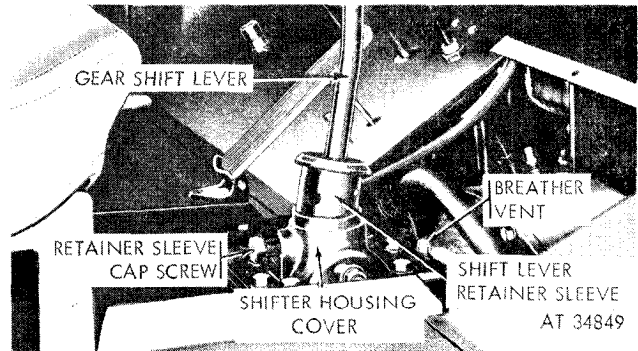


Figure 2-167.1. Removing transmission breather vent.

*b. Installation.*

(1) Screw the breather vent clockwise into position.

(2) Secure the tunnel to the cab floor with screws.

Section XXV. MAINTENANCE OF TRANSFER

**2-174. Service**

Check the lubrication level when changing engine oil or troubleshooting the transfer. If necessary, add lubricant according to the lubrication order (LO 9-2320-211-12).

**2-175. Breather Vent**

*a. Removal.* Remove the breather vent by rotating it counterclockwise.

*b. Installation.* Secure the breather vent in place with clockwise rotation.

**2-176. Controls and Linkage Repair**

Weld, straighten, or replace any broken, bent, or damaged controls or linkage parts as necessary.

**2-177. Air Shift Lines and Connectors**

*a. Removal.* From underneath the vehicle, unscrew the air shift line connectors (fig. 2-168) at the junction of the rigid and flexible lines.

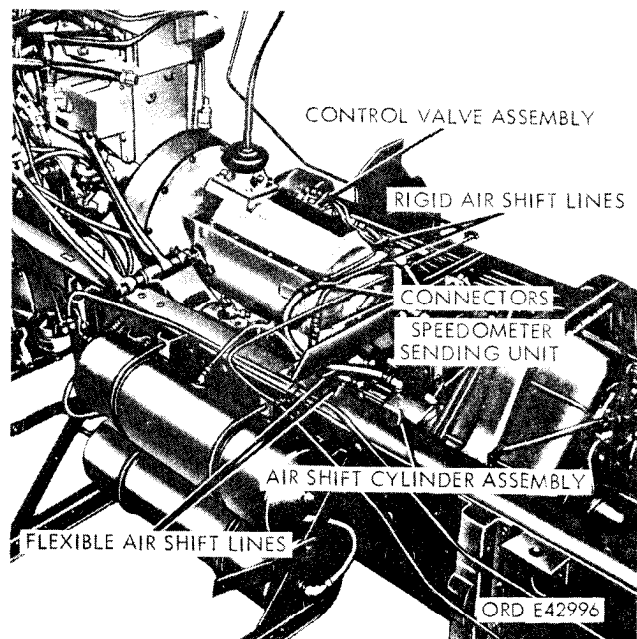


Figure 2-168. Removing air shift lines and connectors.

**NOTE**

Place identification tags on the air shift lines to facilitate installation.

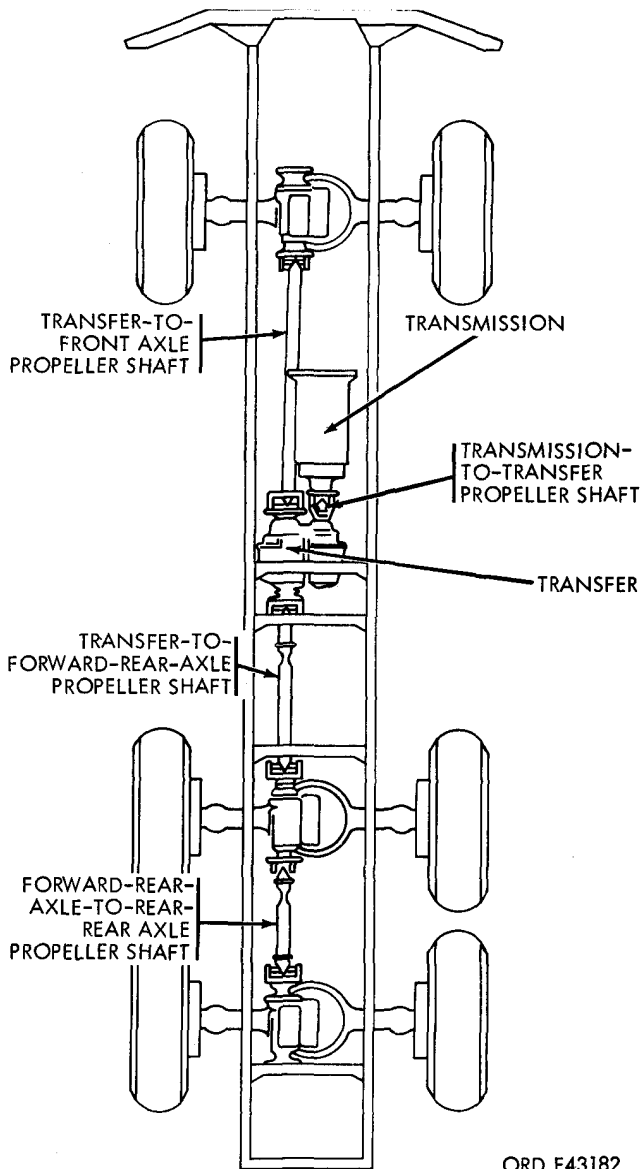
*b. Inspect and Repair.* Inspect the lines and connectors for damage. Replace any damaged lines or connectors.

*c. Installation.* Connect the flexible lines at the left front of the transfer to the rigid lines at the top rear of the transmission. Tighten the connectors (fig. 2-168).

**Section XXVI. MAINTENANCE OF PROPELLER SHAFTS, UNIVERSAL JOINTS, AND CENTER BEARING**

**2-178. General**

Four propeller shafts with universal joint assemblies (fig. 2-169) at both ends; the transmission-to-transfer, transfer-to-front axle, transfer-to-forward-rear axle, and the forward-rear-axle-to-rear axle shafts; transmit power from the transmission to the transfer and the front and rear axles. In addition, propeller shafts are used to transmit power from the power takeoff to the front winch (on those vehicles equipped with a front winch), from the power takeoff to the hydraulic hoist pump (on M51 and M(51A2 models), from the power takeoff to the power divider (on M62 models only), and from the power takeoff to the crane hydraulic pump (on M246 model only).



ORD E43182

Figure 2-169. Diagram of axle driving propeller shafts.

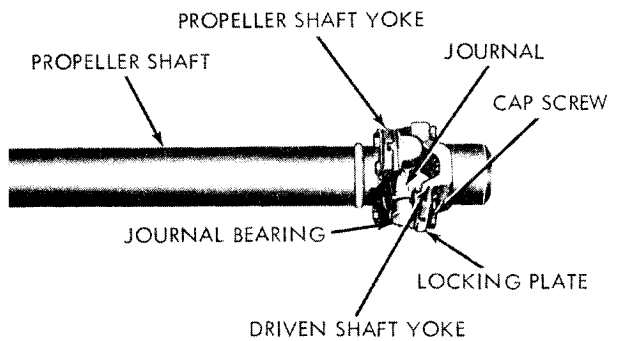
**2-179. Propeller Shaft (with Yoke-Mounted Universal Joints)**

*a. Removal.*

(1) Bend the two locking plates down, and remove the four capscrews (two screws to each plate) securing the universal joints to the driven yoke (fig. 2-170).

(2) Remove the locking plates, and separate the propeller shaft assembly (including universal joint journal) from the driven yoke (fig. 2-170).

(3) Repeat steps (1) and (2) above at the other end of the propeller shaft assembly, and remove the shaft assembly from the vehicle.



ORD E43183

Figure 2-170. Yoke-mounted universal joint.

*b. Disassembly.*

(1) Position the propeller shaft assembly in a vise.

(2) Remove the universal joint assembly (one from each end of shaft) by bending the locking plates (7, fig. 2-172) down and removing the four screws (6) securing the two locking plates.

(3) With the propeller shaft assembly (fig. 2-171) still secured in the vise, remove the dust cap from the yoke, and slip the cap onto the propeller shaft splines.

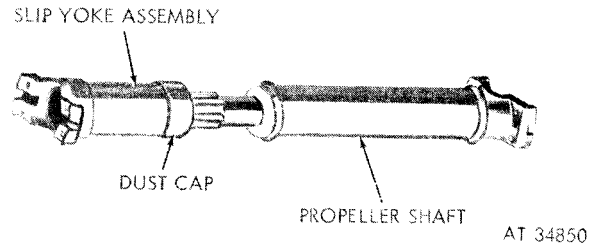


Figure 2-171. Propeller shaft assembly.

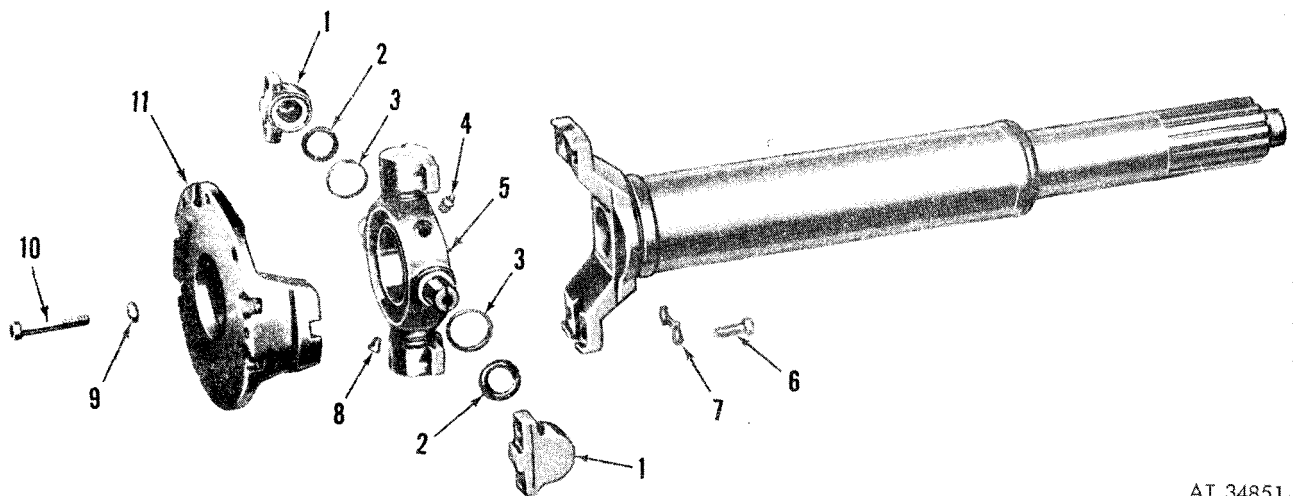
(4) Remove the slip yoke from the propeller shaft splined end (fig. 2-171).

(5) Slide dust cap off propeller shaft, and remove three washers.

(6) To disassemble universal joints, remove four bearings (1, fig. 2-172) cork washers, (2) and dust shields (3) from cross journal shafts (5).

(7) If necessary remove lubrication fitting (4) from cross journal.





AT 34851

1 Bearing  
2 Washer  
3 Shield  
4 Fitting  
5 Journal  
6 Screw

7 Plate  
8 Valve  
9 Washer  
10 Bolt  
11 Yoke

Figure 2-172. Disassembly of universal joint.

*c. Repair.*

(1) Inspect the cross journal bearing surfaces for nicks, burs, and scratches. Also inspect all four shafts and bearing caps for signs of excessive wear. In addition, dust shields should be checked for a bent condition.

(2) If any indication of damage in (1) above is apparent, replace the entire universal joint assembly. This includes cork washers, dust shields, bearing caps, locking plates, screws, and the cross journal. Always replace cork washers.

(3) Clean all parts in a drycleaning solvent or mineral spirits paint thinner. Allow the parts to soak in solvent for a short time if possible. Use a small, stiff-bristle brush to remove any remaining dirt.

(4) Rinse the parts in a clean solvent and dry them with compressed air. Always protect the parts from any wind-blown dust or falling dirt until the parts are assembled.

(5) Inspect the propeller shaft and slip yoke splines and all threaded areas of the various parts.

(6) Inspect the slip yoke and propeller shaft for cracks, excessive wear, and bent condition. Also check the yoke journal opening for possible distortion.

(7) If the yoke or propeller shaft is damaged, replace the damaged part. If necessary, replace the entire slip yoke and propeller shaft assembly.

(8) If necessary, replace the split washer and / or cork washer for the slip yoke.

(9) Inspect all lubrication fittings for clear passageways and signs of other damage. If necessary, replace fittings.

*d. Assembly.*

(1) Secure the propeller shaft in a suitable vise.

(2) Slide the dust cap (with washers positioned under cap) onto the splined end of the propeller shaft (fig. 2-171).

(3) Position the slip yoke onto the propeller shaft splined end, and screw the dust cap assembly into place on the slip yoke (fig. 2-171).

(4) If necessary, assemble the universal joints by positioning the four dust shields (3, fig. 2-172), cork washers (2), and bearings (1) onto the cross journal shafts (5). If removed, install the lubrication fitting (4) on the cross journal.

(5) Position the flanges of the bearing journals to the yoke ends (fig. 2-170). Secure the universal joint assembly (one at each end of the shaft assembly) to the propeller shaft yoke with two locking plates (7, fig. 2-172 and four capscrews (6)

*e. Installation.*

**NOTE**

Always install propeller shafts so the slip joint is at the power input end of the shaft assembly.

## TM 9-2320-211-20

(1) Secure the propeller shaft and universal joint assembly to the driven yoke (fig. 2-170) with two locking plates (7, fig. 2-172) and four screws (6) (two screws to each plate). Bend the plates into place.

(2) Perform step (1) above to install the other end of the shaft and the joint assembly to the other driven yoke. Tighten the screws at both end to completely secure the propeller shaft and joint assembly to the vehicle.

(3) Lubricate the shaft and joint assembly in accordance with LO 9-2320-211-12.

### 2-180. Propeller Shaft (with Flange-Mounted Universal Joints)

#### a. Removal.

(1) Remove the eight nuts and bolts securing the propeller shaft adapter flange to the driven shaft companion flange (fig. 2-173).

(2) Repeat step (1) above at the other end of the propeller shaft assembly, and remove the shaft assembly from the vehicle.

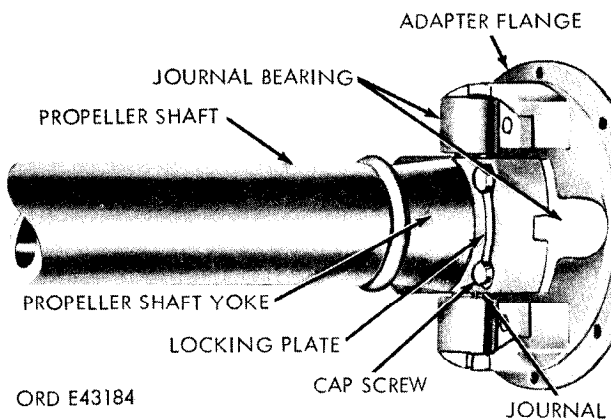


Figure 2-173. Flange-mounted universal joint.

#### b. Disassembly.

(1) Remove the four bolts and lockwashers securing the two locking plates (fig. 2-173). Remove the plates and the adapter flange.

(2) Repeat step (1) above to remove the adapter flange at the other end of the propeller

shaft and universal joint assembly,

(3) Refer to paragraph 2-179 *b* and follow similar procedures to complete disassembly of the propeller shaft and universal joint assembly.

#### c. Repair.

(1) Refer to paragraph 2-179 *c* and follow similar procedures.

(2) Inspect the adapter flanges for stripped threads, cracks, and a bent condition. If damaged in any way, replace the adapter.

#### d. Assembly.

(1) Refer to paragraph 2-179 *d*, and follow similar procedures to complete the assembly of the universal joints and the propeller shaft.

(2) Secure the adapter flange to the propeller shaft and universal joint assembly with two locking plates and four screws and lockwashers. Bend the locking plates over the screws (fig. 2-173).

(3) Repeat step (2) above at the other end of the propeller shaft and universal joint assembly.

#### e. Installation.

### NOTE

Always install propeller shafts so that the slip is at the power input end of the shaft assembly.

(1) Secure the propeller shaft adapter flange (fig. 2-173) to the companion flange on the driven shaft.

(2) Repeat step (1) above at the other end of the propeller shaft assembly. Tighten the nuts at both flange ends of the shaft.

(3) Lubricate the shaft and joint assembly in accordance with LO 9-2320-211-12.

### 2-181. Propeller Shaft Center Bearing

#### a. Removal.

(1) Remove the propeller shaft assembly from the vehicle as described in paragraph 2-179 *a*.

(2) Remove the four nuts and bolts securing the center bearing to the frame cross member.

(3) Remove the center bearing from the vehicle.

#### b. Installation.

(1) Position the center bearing to the frame cross member with four bolts and nuts.

## Section XXVII. MAINTENANCE OF FRONT AXLE

### 2-182. General

The front axle assembly is a hypoid, double-reduction, single-speed type. It is secured to the underside of the front springs.

### 2-183. Breather Vent

#### CAUTION

Insure that the area surrounding the

breathervale has been thoroughly cleaned so that foreign matter will not enter the axle assembly when removing the ventilation valves.

a. *Removal.* Remove the air breather valve by turning it counterclockwise.

b. *Cleaning.*

(1) Soak the ventilation valves in a drycleaning solvent or in mineral spirits paint thinner.

(2) Thoroughly brush the valves with a stiff bristle brush. Insure that passages are clean, and that the valve caps move freely.

(3) If necessary, use a soft metal rod to remove obstructions.

(4) Use compressed air to dry out the valves.

(5) Lubricate the valves sparingly with clean engine oil (OE).

c. *Instullation.* Secure the breather valve by turning it clockwise and tightening it in place.

### 2-183.1. Steering Knuckle Boot.

#### a. Removal.

(1) Remove four screws and washers securing boot guard to steering knuckle.

(2) Remove locking wire from 12 screws securing boot retaining plate to steering knuckle and slide plate back on axle housing (fig. 2-173.1).

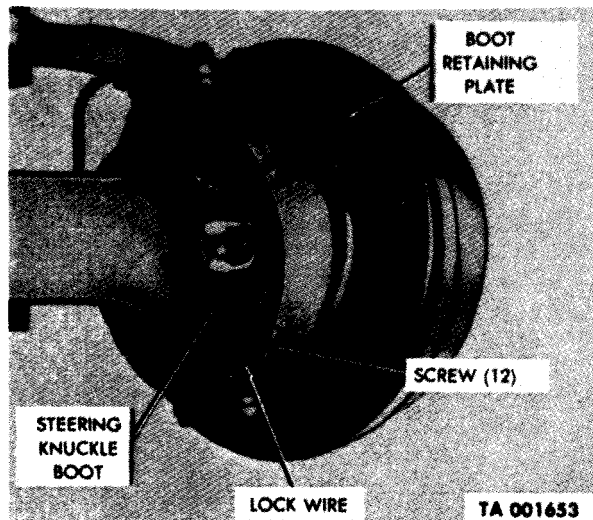


Figure 2-173.1. Steering knuckle boot removal and installation—outer retaining plate.

(3) Pull boot away from steering knuckle to expose inner clamp screw. Remove and discard inner clamp screw. Remove clamp and boot from axle (fig. 2-173.2).

b. *Installation.* When installing inner clamp, use new screw. Bend screw to prevent loosening.

(1) Place boot on axle housing with fabric side of zipper facing steering knuckle. Be sure TOP on boot is in

line with top of steering knuckle. Close zipper and apply a liberal amount of sealer cement to zipper locks and fabric. Allow cement to set for 3 to 5 minutes.

(2) Force inner clamp lip of boot into groove on axle housing. Install inner clamp with screw and nut positioning 1 or 2 inches from zipper. Tighten clamp and make sure lip on boot is well seated in axle groove (fig. 2-173.2).

(3) Lace zipper locks with fine wire (3 laces) near edge of boot and cut off excess zipper at least 1/4 inch from zipper lockwire. Apply sealer cement over exposed zipper and fabric.

(4) Position outer edge of boot on steering knuckle. Install boot retaining plate and secure with 12 screws. Install locking wire (fig. 2-173.1).

(5) Install boot guard and secure with four lockwashers and screws. Torque lower screws to 130-170 lb-ft.

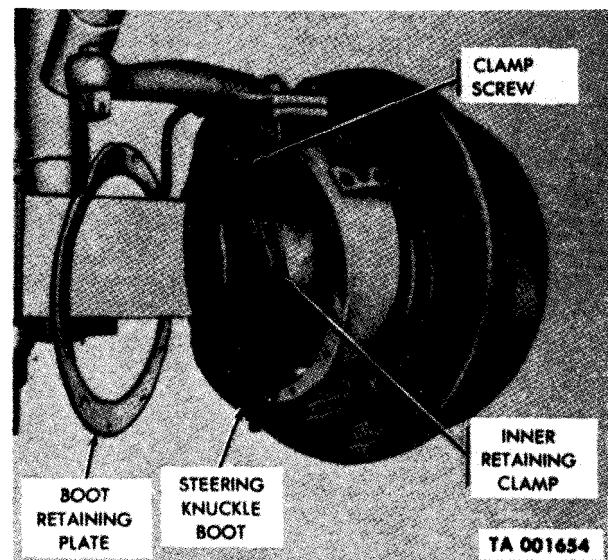


Figure 2-173.2. Steering knuckle boot removal and installation—inner retaining clamp.

**2-183.2. Repair of Steering Knuckle Boot.** Torn or punctured boots may be repaired by application of a cold patch. If, after inspection determines that punctured or slightly torn boot is otherwise in good condition, unclamp and clean thoroughly. Rough up with sandpaper and apply cement. Proceed as with a tube patch. Information on patching rubber may be found in TM 9-2610-200-20.

## Section XXVIII. MAINTENANCE OF REAR AXLE

**2-184. General.** Two identical rear axle assemblies, mounted in tandem, are included in the rear suspension system (fig. 2-174). The rear axle assembly is a hypoid, double-reduction, single-speed type. Three identical torque rod assemblies, two at the right end of the axle and one at the left end of the axle, connect each rear axle assembly to the rear suspension brackets. These torque rods not only maintain the correct relative positions of the rear axle assemblies.

but also transmit driving and braking forces from the axles to the frame. A differential and carrier assembly, mounted at the top center of the axle housing transmits power from the transfer-to-forward-rear-axle and forward-rear-axle-to-rear-axle propeller shafts (fig. 2-174) to the left and right drive shafts inside the axle housing.

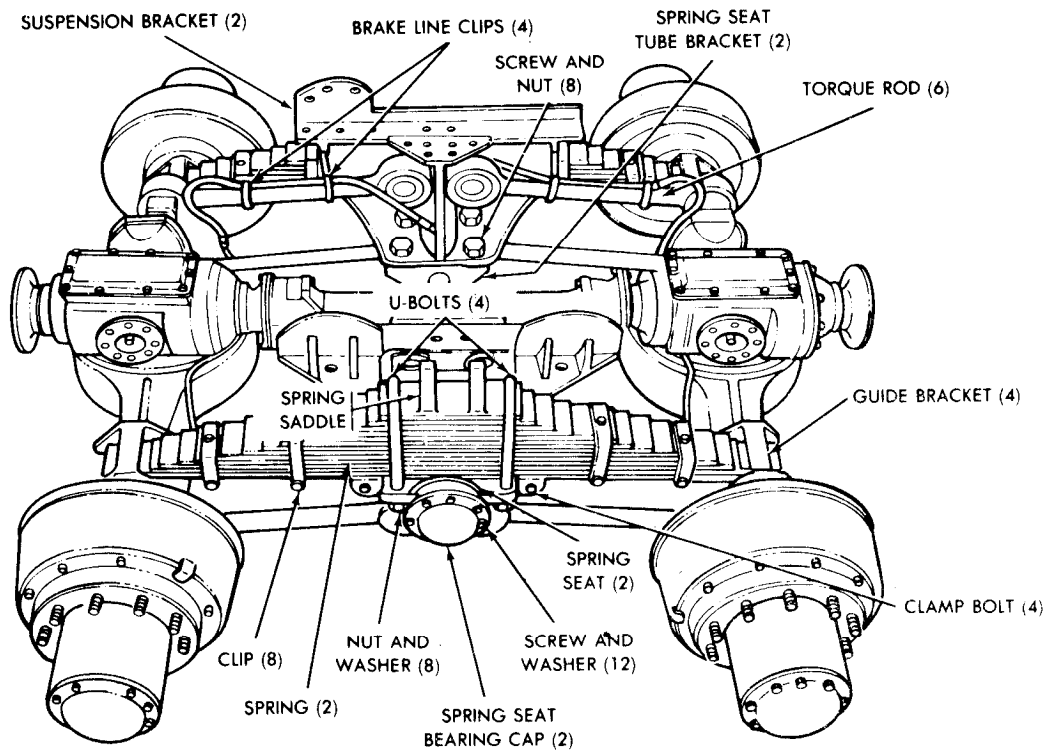


Figure 2-174. Rear Suspension System.

TA 001692

### 2-185. Maintenance.

#### a. Rear Spring Seats — Removal.

(1) Remove wheels from both rear axles to provide access to spring seats to be removed. Support axles with blocks or jack stands.

(2) Place jack under cross tube connecting left and right spring seats. Raise jack sufficient to remove load from springs.

(3) Remove clamp bolts from front and rear ends of spring seats (fig. 2-174).

(4) Remove four nuts and washers from U-bolts and remove U-bolts.

(5) Remove six screws and washers, securing spring seat bearing cap and remove cap and gasket (fig. 2-174).

(6) Remove outer bearing adjusting nut, washer and inner 0-bearing, adjusting nut from cross tube.

(7) Pull spring seat and bearings from cross tube.

(8) Remove dust seal washer, two dust seals, wiper retainer, wiper; grease seal and two bearings and caps from spring seat.

(9) Clean all parts in dry cleaning solvent. Type II (SD2) Fed. Spec. PP-680. Wire brush or buff if required.

(10) Inspect bearing and cups for pitting and wear. (Place special emphasis on inner bearing and cup.) Replace, if required.

b. *Lubrication.* Lubricate bearing, using lubricator, bearing NSN 4930-00-704-1852, with grease artillery and automotive (GAA) MIL-G-10924.

c. *Installation.* Adjust bearings using scale dial indicating NSN 6670-00-254-4634 with 24 to 32 lbs. Pull to rotate spring seat and complete installation (one through eight above).

**2-186. Axle Shaft.***a. Removal*

(1) Remove the 10 screws and lockwashers securing the axle drive flange (fig. 2-175) to the hub and drum assembly.

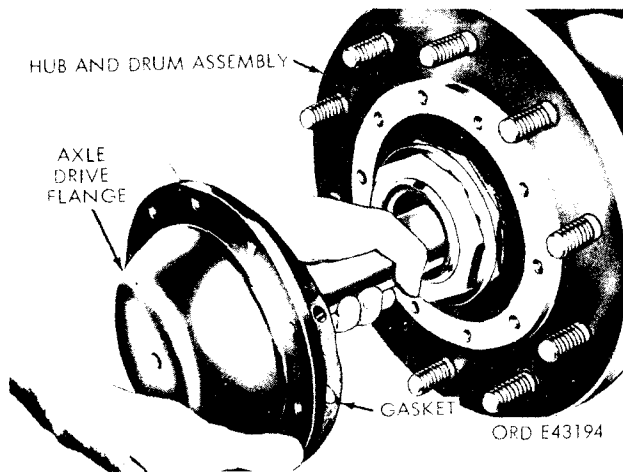


Figure 2-175. Removing rear axle shaft.

(2) Remove the axle shaft by pulling on the axle drive flange (fig. 2-175). Remove and discard the flange gasket.

*b. Installation.*

(1) Slide a new gasket (fig. 2-175) over the splined shaft end and hold the gasket in position on the flange.

(2) Insert the splined end of the shaft in the hub. Push the axle drive flange inward toward the center of the truck. Carefully guide the shaft splined end into the splined differential side gear.

(3) Align the ten drive flange holes with the ten matching holes in the drum. Install 10 screws and lockwashers. Tighten the screws to 70-80 ft.-lb. torque.

**2-187. Breather Vent**

Refer to paragraph 2-183.

**Section XXIX. MAINTENANCE OF BRAKE SYSTEM****2-188. General**

*a. Service Brake System.* Service brake components include the pedal and linkage, master cylinder, air hydraulic cylinder, wheel cylinders, connecting lines and fittings for the hydraulic fluid, and the brake.

*b. Hand Brake.* Handbrake components include a brake drum (fig. 2-176) and a pair of brake shoes mounted at the rear of the transfer. In addition, a cable is connected to the handbrake lever in the cab. The drum is bolted to the transfer rear output shaft. The two brakeshoes are pinned together and then bolted to a bracket extending from the transfer rear output shaft bearing cover.

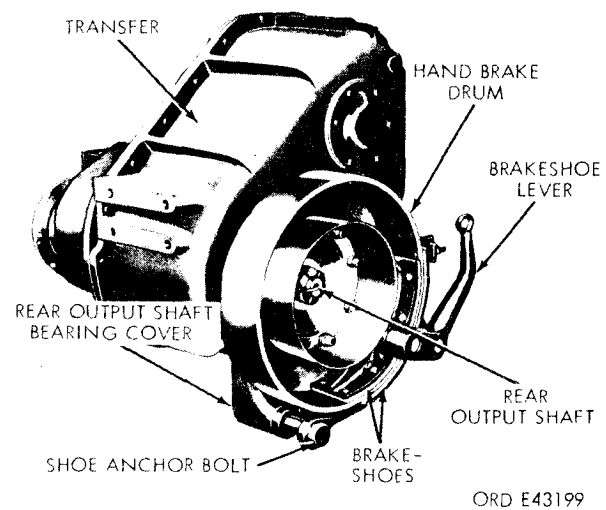


Figure 2-176. Handbrake mounted to rear of transfer.

This page intentionally left blank.

**2-189. Service Brake Pedal and Linkage***a. Adjustments.***NOTE**

Brake Pedal free travel must be between  $\frac{1}{4}$  and  $\frac{1}{2}$  inch. Excessive free travel reduces the master cylinder piston stroke. If free travel is too short, the brakes will drag after several applications.

*(1) Free travel adjustment.*

*(a)* Remove the pin (fig. 2-177) securing the push rod yoke to the pedal lever.

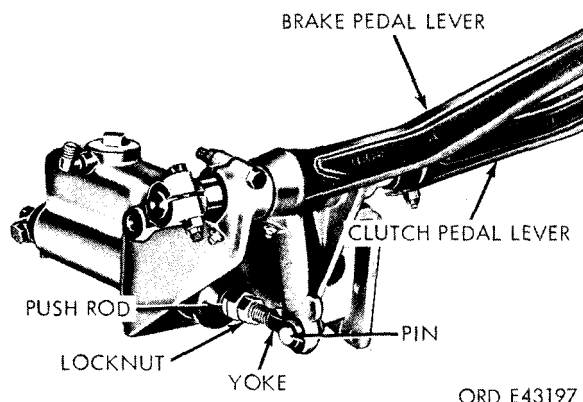


Figure 2-177. Brake pedal linkage with master cylinder attached.

*(b)* Hold the push rod to prevent it from turning, and loosen the locknut on the yoke (fig. 2-177).

*(c)* Holding the push rod, turn the yoke until the desired brake pedal free travel is obtained (fig. 2-177).

**NOTE**

To increase free travel, turn the yoke clockwise. To decrease free travel, turn the yoke counterclockwise.

*(d)* Position the push rod yoke on the pedal lever and install the yoke pin (fig. 2-177).

*(e)* Check the brake pedal free travel. If necessary, repeat *(a)*, *(b)*, *(c)* and *(d)* above until the correct free travel is obtained.

*(f)* Tighten the locknut on the push rod yoke, holding the push rod to prevent it from turning (fig. 2-177).

*(2) Minor adjustment.*

*(a)* To compensate for normal lining wear, adjust the service brakes when the brake pedal pad travel is within 2 inches of the cab floor board with the brake pedal in the applied position.

**NOTE**

The master cylinder must be full to within one-half inch of the top and the air pressure above 65 PSI.

*(b)* Adjust the wheel bearings (para 2-211) at one wheel.

*(c)* Turn the rear shoe adjusting cam (fig. 2-178) on the back side of the backing plate counterclockwise until, the brake drags slightly when the wheel is turned by hand.

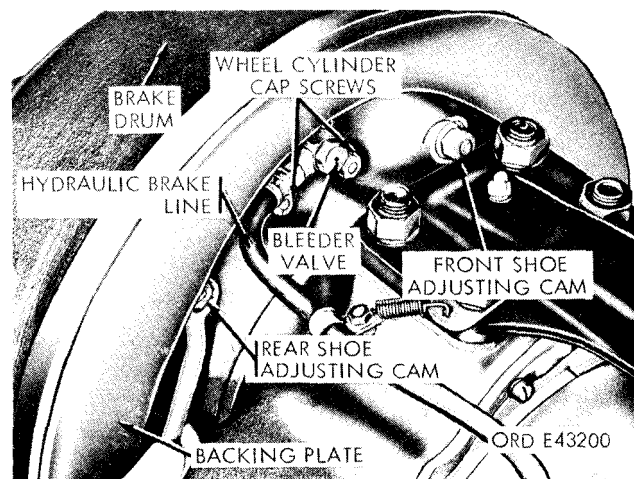


Figure 2-178. Turning brakeshoe adjusting cam.

*(d)* Turn the adjusting cam clockwise just enough to allow the wheel to rotate freely.

*(e)* Turn the front shoe adjusting cam (fig. 2-178) clockwise until the brake drags slightly when the wheel is turned by hand.

*(f)* Turn the adjusting cam counterclockwise just enough to allow the wheel to rotate freely. Make the adjustment of both cams as uniform as possible.

*(g)* Lower the wheel, and repeat the above procedures at each remaining wheel.

*(3) Major Adjustment.*

*(a)* With the wheel and tire assembly removed, remove the nut and lockwasher from the stud securing the inspection cover (fig. 2-179) to the brake drum. Remove the cover.

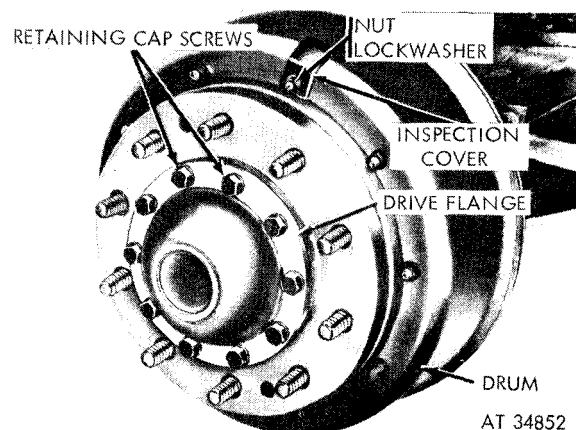


Figure 2-179. Inspection cover attached to hub and drum assembly.

(b) Rotate the brake drum until inspection hole is 1½ inches above the lower end of the rear brake shoe.

(c) Insert the feeler gage in the inspection hole (fig. 2-180) to determine the clearance between the brakeshoe and the drum. Clearance should be 0.010 inch at this point.

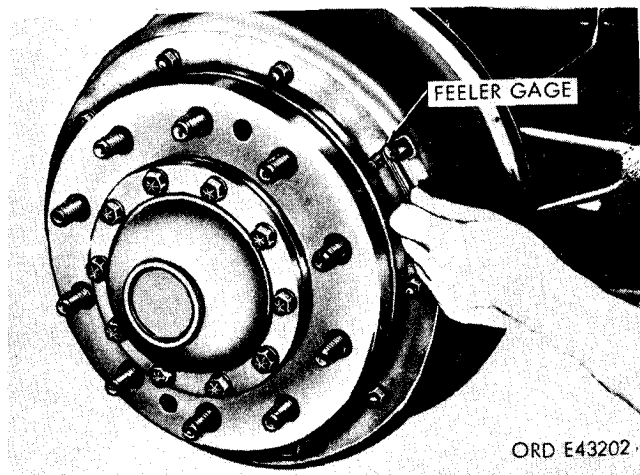


Figure 2-180. Checking clearance between brakeshoe and drum.

(d) If the clearance between the shoe and the drum is incorrect, adjust the clearance as described in (e) and (f) below.

(e) Loosen the rear anchor pin locknut (fig. 2-181) at the back side of the backing plate.

(f) While the locknut, turn the anchor pin until a 0.010-inch clearance between the shoe and the drum is obtained. To reduced the clearance, turn the anchor pin clockwise. To increase the clearance, turn the anchor pin counterclockwise.

(g) Rotate the brake drum until the inspection hole is 1½ inches below the upper end of the rear brakeshoe. Insert the feeler gage in the inspection hole to determine the clearance between the brakeshoe and the drum. Clearance should be 0.020 inch at this point.

(h) If the clearance between the shoe and the drum is incorrect adjust the clearance as described in (i) and (j) below.

(i) Turn the rear shoe adjusting cam (fig. 2-178) until the clearance between the shoe and the drum, measured by feeler gage, is 0.020 inch. To reduce the clearance, turn the cam counterclockwise. To increase the clearance, turn the cam clockwise.

(j) Recheck to be sure that a 0.010 inch clearance is maintained at the lower end of the rear shoe.

(k) Adjust the clearance between the lower and the upper ends of the front brakeshoe and the drum ( (b) through (i) above).

**NOTE**

Clearance between the lower end of the front shoe and the drum is decreased by turning the front anchor pin counterclockwise, and increased by turning the pin clockwise. Clearance between the upper end of the front shoe is increased by turning the front shoe adjusting cam counterclockwise, and is decreased by turning the cam clockwise.

(l) While holding anchor pins (fig. 2-181) to prevent them from turning, tighten both anchor pin locknuts and check the brakeshoe clearance again.

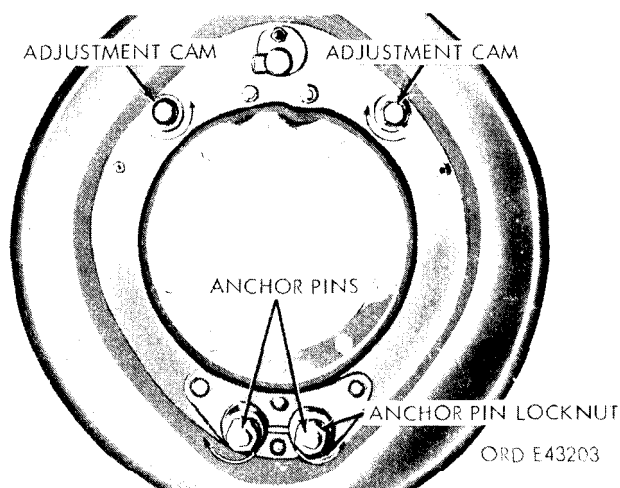


Figure 2-181. Back side of backing plate assembly.

(m) Position the inspection cover (fig. 2-179), on the brake drum stud, install a lockwasher and nut on the stud, and tighten the nut.

**b. Removal.**

(1) Remove the capscrew securing the clutch pedal lever to the lever shaft (fig. 2-182). Remove the pedal assembly from the shaft.

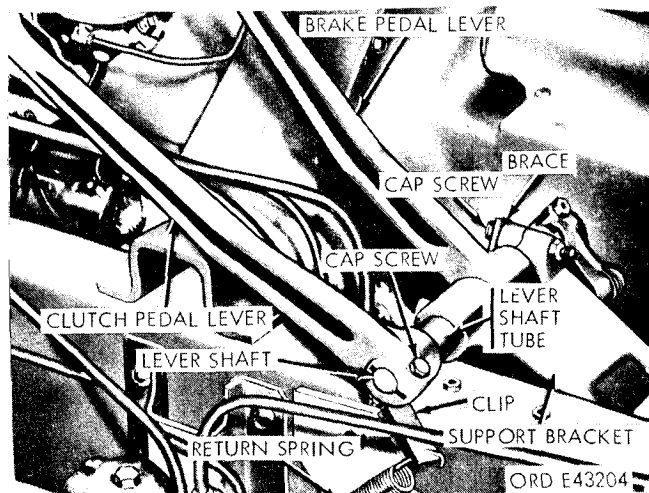


Figure 2-182. Brake and clutch pedal assembly mounted to vehicle.



(2) Unhook the upper end of the clutch pedal return spring (fig. 2-182) from the clip bolted to the lower end of the clutch pedal lever.

(3) Remove the nut and screw (fig. 2-182) from the lower end of the clutch pedal lever, and remove the lever clip and key from the lever shaft.

(4) Remove the other cotter pin from the end of the yoke pin, remove the yoke pin (fig. 2-53), and remove the control rod from the control rod lever.

(3) Remove the nut and screw from the upper end of the brake pedal lever (fig. 2-182), and remove the brake pedal stem from the lever.

(6) Remove the rubber bumper from the stem, and remove the brake pedal from the top side of the floor board.

(7) Remove the nut and screw from the control rod lever, and remove the lever and key from the lever shaft.

(8) Remove the cotter pin from the end of the yoke pin (fig. 2-177), remove the yoke pin, and remove the push rod yoke from the lower end of the brake pedal lever.

(9) Unhook the upper end of the brake pedal return spring from the lower end of the brake pedal lever.

(10) Remove the nut and capscrew (fig. 2-182) from the upper right side of the support bracket, and remove the lever shaft tube with the shaft and bushings from the brake pedal lever and support bracket.

#### *c. Installation.*

(1) Position the brake pedal lever (fig. 2-182) at the support bracket, and install the lever shaft tube with the shaft and bushings in the bore of the bracket and lever.

#### **NOTE**

Make sure that the groove in the lever shaft tube is aligned with the screw hole in the upper right side of the support bracket to permit insertion of the capscrew.

(2) Aline the hole in the upper end of the support bracket brace (fig. 2-182) with the screw hole in the upper right side of the support bracket, and install the screw in the holes in the brace and bracket. Install the nut on the screw, and tighten it.

(3) Install the clutch control rod lever and key on the shaft, and secure it with the capscrew and nut.

(4) Position the control rod on the lower end of the control rod lever, install the yoke pin, and install the cotter pin in the end of the yoke pin.

(3) Install the clutch pedal lever (fig. 2-182) and key on the shaft. Position the return spring bracket clip at the lower end of the lever, install the capscrew in the holes in the lever and clip, and install the nut on the capscrew. Tighten the nut on the capscrew.

(6) Hook the upper end of the clutch pedal return spring to the clip at the lower end of the clutch pedal lever.

(7) Hook the upper end of the brake pedal return spring to the lower end of the brake pedal lever.

(8) Position the yoke (fig. 2-177) on the front of the master cylinder push rod at the lower end of the brake pedal lever, install the yoke pin, and install the cotter pin to the end of the yoke pin.

(9) Insert the brake pedal stem in the hole in the top side of the floor board, install the rubber bumper on the stem, and insert the stem in the hole at the upper end of the brake pedal lever.

(10) Install the capscrew and nut at the upper end of the pedal lever, and tighten it.

(11) Lubricate the brake pedal lever and lever shaft.

(12) Check the brake pedal free travel and adjust it if necessary (para 2-189 *a*).

(13) Check the clutch pedal free travel and adjust it if necessary (para 2-49).

## **2-190. Master Cylinder**

### *a. Maintenance.*

#### **NOTE**

All lines and cylinders involved in the hydraulic fluid system must be filled solidly for 100 percent efficiency. Air sometimes does get into the system due to loose connections, faulty seals, or replacement of one of the components. When this occurs, bleeding is required.

#### (1) *Bleeding.*

#### **CAUTION**

Use nonpetroleum base hydraulic brake fluid. The use of petroleum base oil renders the brakes inoperative.

(a) To bleed the master cylinder, clean the bleeder valve and place the bleeder tube over the end of the valve.

(b) Place the other end of the tube in a glass jar or bottle so that the end is submerged in the hydraulic brake fluid.

(c) Unscrew the bleeder valve three-fourths of a turn and depress the brake pedal slowly, checking the fluid flowing from the end of the bleeder tube for air bubbles. Hold the pedal in the depressed position.

(d) Tighten the bleeder valve, and slowly release the brake pedal.

#### **NOTE**

Make sure that the master cylinder is kept filled with brake fluid during the bleeding operation. Do not use fluid removed during the bleeding operation to fill the master cylinder.

(e) Repeat (c) and (d) above until all air

bubbles cease to appear or when fluid flows from the bleeder tube in a solid stream.

(f) Remove the bleeder tube from the bleeder valve, and check the valve again to be sure that it is closed tightly. Perform the bleeding operation at the air hydraulic cylinder as described in paragraph 2-191 a.

(2) *Filling.*

**CAUTION**

Use nonpetroleum base hydraulic brake fluid. The use of petroleum base oil renders the brakes inoperative. Use care during filling to prevent dirt and other foreign matter from entering the reservoir.

(a) Remove the filler cap. Fill the reservoir with new brake fluid (LO 9-2320-211-12) until the fluid level is ½ inch below the filler cap opening.

(b) Check the filler cap gasket to be sure that it will seat properly. Install the cap and tighten it.

*b. Removal.*

(1) Remove the cotter pin from the end of the yoke pin, remove the yoke pin, and remove the master cylinder push rod yoke from the lower end of the brake pedal lever (fig. 2-177).

(2) Unscrew the connector securing the ventilation line to the elbow, and remove the line from the elbow (fig. 2-183).

(3) Unscrew the connector securing the hydraulic fluid line to the outlet fitting, and remove the line from the fitting (fig. 2-183).

(4) Remove the four nuts and bolts from the mounting flange on the front of the master cylinder, and remove the master cylinder from the support bracket (fig. 2-183).

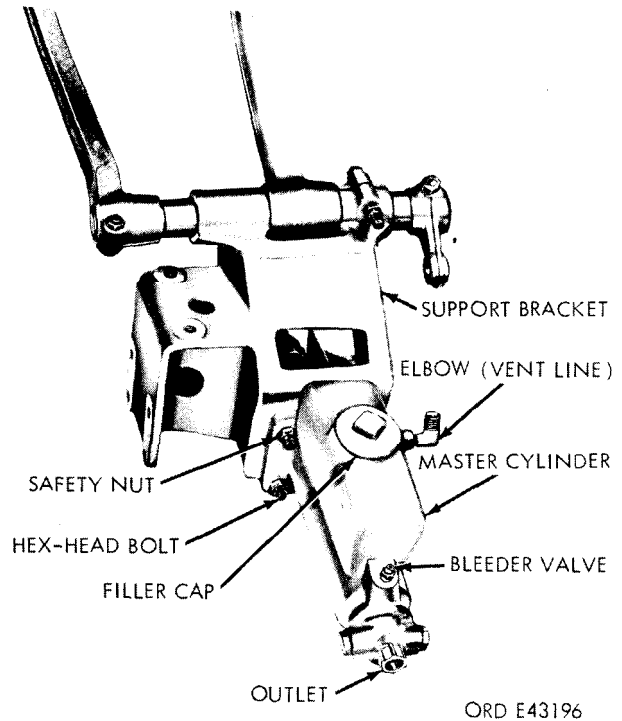


Figure 2-183. Brake master cylinder with pedal and linkage attached.

*c. Installation.*

(1) Position the master cylinder at the rear of the support bracket, install the four bolts in the holes in the master cylinder mounting flange and bracket, and install the four nuts on the bolts (fig. 2-183).

(2) Position the hydraulic line at the outlet fitting, and tighten the connector (fig. 2-183).

(3) Position the ventilation line at the elbow and tighten the connector (fig. 2-183).

(4) Position the yoke at the front end of the master cylinder push rod on the lower end of the brake pedal lever, install the yoke pin, and install the cotter pin in the end of the yoke pin (fig. 2-177).

(5) Fill the master cylinder (a(2) above).

(6) Bleed the brakes (a(1) above).

## 2-191. Air Hydraulic Cylinder (Power Brake Unit).

### a. Maintenance.

#### (1) Air leakage test.

(a) Operate the engine at a fast idle to build the air pressure in the system up to normal operating pressure (105-120 psi) as registered on the air pressure gage.

(b) When the air pressure reading on the gage is up to normal (105-120 psi), shut off engine.

(c) If the air pressure drops appreciably, check the lines and fittings for leaks (para 2-205).

(d) Tighten the connections and / or replace the lines and fittings in the area where a leak is discovered.

(e) Repeat (a), (b), and (c) above again. If the leakage malfunction has not been corrected by tightening and / or replacement in (d) above, disconnect the air exhaust line from the air hydraulic cylinder exhaust port.

(f) Connect a flexible hose or bent tube to the exhaust port (hose or tube must be long enough so that the end can be immersed in a jar of water), and immerse the free end in a jar of water.

(g) If bubbles appear in the water, a leaking control valve is indicated, and the air hydraulic cylinder must be replaced.

(h) With the compressed air system fully charged, apply the brakes and hold the pressure on the brake pedal while observing the air pressure gage reading.

(i) A loss of air pressure indicates a leaking control valve or leakage past the air hydraulic cylinder air piston. In this case, the air hydraulic cylinder must be replaced.

#### (2) Hydraulic Leakage Test.

(a) With the compressed air system fully charged, apply the brakes. Hold the pressure on the brake pedal while observing the air pressure gage reading.

(b) If the pedal gradually falls away under pressure, there is leakage in the hydraulic lines, wheel cylinders, master cylinder, or air hydraulic cylinder. Tighten the connections and / or replace the defective parts as required.

(c) Disconnect the outlet line from the master cylinder and close the opening. Depress the brake pedal and hold pressure on the pedal.

(d) If the pedal gradually falls away under pressure, leakage past the master cylinder piston is indicated. In this case, replace the master cylinder.

(3) *Bleeding Air Hydraulic Cylinder.* Perform the bleeding operations as in paragraph 2-190a. Bleed the upper bleeder valve first and the lower bleeder valve last.

### b. Removal.

(1) Remove the four nuts from bolts securing metal shield to underside of air hydraulic cylinder, and remove bolts and shield from cylinder (fig. 2-184).

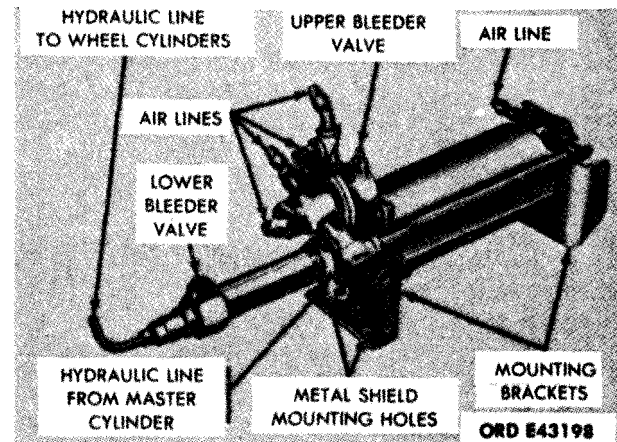


Figure 2-184. Air hydraulic cylinder.

(2) Unscrew the connector securing the hydraulic line (fig. 2-184) to the front of the air hydraulic cylinder, and remove the line from the cylinder.

(3) Unscrew the connectors securing the four air lines to the top of the air hydraulic cylinder (fig. 2-184), and unscrew the connector securing one air line to the rear of the cylinder, and remove the five lines from the cylinder.

### NOTE

Place identification tags on all lines to facilitate installation of the air hydraulic cylinder.

(4) Unscrew the connector securing the hydraulic line from the master cylinder to the bottom center of the air hydraulic cylinder (fig. 2-184), and remove the line from cylinder.

(5) Support the air hydraulic cylinder, remove the two mounting bolts each from the front and rear mounting brackets (fig. 2-184) on the cylinder, and remove the cylinder from the vehicle.

### c. Installation.

(f) Position the air hydraulic cylinder under the frame left side rail, and install the two mounting bolts at the front and rear mounting brackets (fig. 2-184) on the cylinder.

(2) Position the hydraulic line from the master cylinder at the fitting at the bottom center of the hydraulic cylinder (fig. 2-184) and tighten the connector.

(3) Position the four air lines at the fittings and the top of the air hydraulic cylinder (fig. 2-184), and tighten the connectors. Position the air line at the fitting at the rear of the cylinder, and tighten the connector.

(4) Position the hydraulic line (fig. 2-184) at the outlet at the front end of the air hydraulic cylinder, and tighten the connector.

(5) Position the metal shield at the bottom of the air hydraulic cylinder mounting brackets (fig. 2-184), install four bolts and nuts, and tighten the nuts.

(6) Bleed the air hydraulic cylinder and wheel cylinders (para 2-190a).

**2-192. Brake Wheel Cylinders.**

*a. Maintenance.* Bleed each wheel cylinder as described in paragraph 2-190a.

*b. Removal.*

(1) Remove the wheel and tire assembly (para 2-207).

(2) Remove the hub and drum assembly (para 2-210).

(3) Unscrew the connector securing the hydraulic brake line (fig. 2-178) to the wheel cylinder at the back side of the backing plate assembly and remove the line from the cylinder.

(4) Unhook the return spring (fig. 2-185) from one of the brakeshoes.

(5) Remove the two wheel cylinder capscrews (fig. 2-178) and lockwashers from the back side of the backing plate assembly, and remove the wheel cylinder (fig. 2-185) with its cover from the front side of the backing plate.

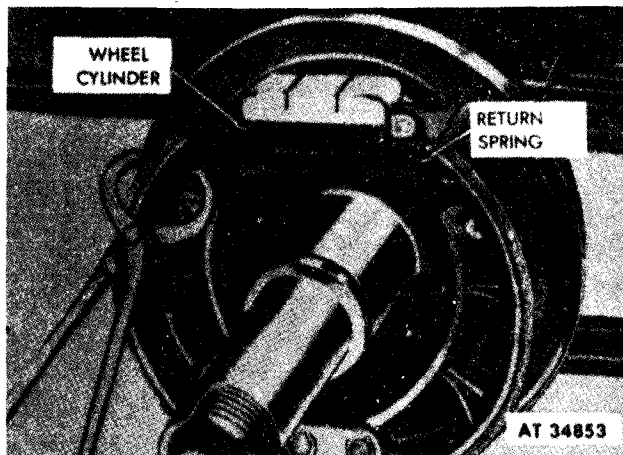


Figure 2-185. Removing brakeshoe return spring.

*c. Installation.*

(1) Position the wheel cylinder (fig. 2-185) with its cover on the front side of the backing plate assembly, install the two wheel cylinder capscrews (fig. 2-178) with lockwashers in the holes at the back side of the backing plate, and tighten the capscrews.

(2) Install the return spring (fig. 2-185) between the brakeshoes.

(3) Position the hydraulic brake line (fig. 2-178) at the wheel cylinder inlet on the rear backing plate assembly and tighten the connector.

(4) Install the hub and drum assembly (para 2-210).

(5) Install the wheel and tire assembly (para 2-207).

(6) Bleed the wheel cylinder (para 2-190a).

(7) Adjust the brakes, using the minor adjustment procedures (para 2-188a(2)).

**2-193. Service Brakeshoes.**

*a. Removal.*

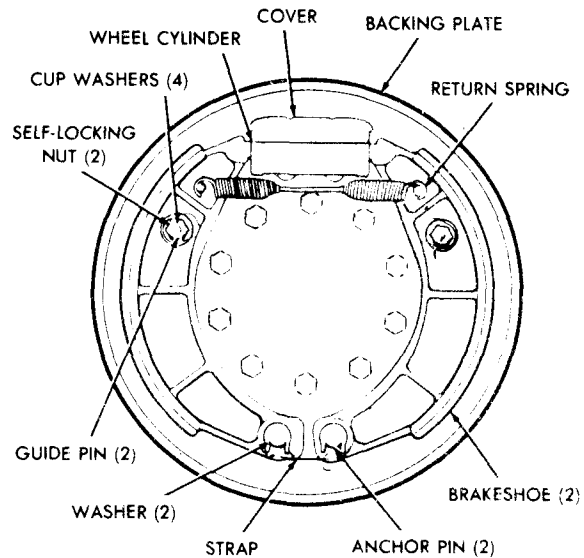
(1) Remove the wheel and tire assembly (para 2-207).

(2) Remove the hub and drum assembly (para 2-210).

(3) Install the clamp over the ends of the wheel cylinder to hold the wheel cylinder pistons in position.

(4) Unhook the return spring (fig.2-185) from both brakeshoes.

(5) Remove two retaining nuts, four cup washers, and two outer springs securing brakeshoes to guide pins (fig. 2-186).



TA 018048

Figure 2-186. Removing brakeshoes and anchor pins assembly.

(6) Remove the anchor pin locknuts (fig. 2-186) and anchor pins from the front side of the backing plate

(7) Pull the anchor pins from the bore at the lower end of the brakeshoes (fig. 2-186).

(8) Remove the two cup washers, two innersprings, guide pin retaining star washer and nut. Drive out old guide pins.

*b. Installation.*

(1) Install large end of redesigned guide pin into its hole in backing plate and fasten with star washer and locknut.

(2) Hold pin with a 3/8 inch open end wrench and tighten nut until shoulder of pin bottoms against the backing plate.

(3) Install anchor pins (fig. 2-186) with the anchor pin plate in the bore at the lower end of the brakeshoes. Turn the anchor pins to position the punchmarks (which indicate the high side of the anchor pin cams) toward each other.

(4) Install two inner springs, one long; one short, and two cup washers on the new guide pins. Anchor pins are to be inserted in the holes at the bottom of the backing plate. Insure that the wheel cylinder push rods engage the slots in the upper end of the brakeshoes. Install cup washers, outer springs, and retaining nut on new guide pins (fig. 2-186).

(5) Install anchor pin locknuts (fig. 2-181) at the back side of the backing plate assembly.

(6) Install the return spring (fig. 2-185) between the brakeshoes, and remove the clamp from the ends of the wheel cylinder.

(7) Install the hub and drum assembly (para 2-210).

(8) Bleed the wheel cylinder (para 2-190a).

(9) Adjust the brakes, using major adjustment procedures (para 2-189a(3)).

(10) Install wheel and tire assembly (para 2-207).

## 2-194. Hydraulic Lines and Brake Hoses.

### NOTE

The hydraulic lines between the master cylinder, air hydraulic cylinder and axles are rigid type lines of seamless metal tubing. Flexible type lines are used to connect the axle lines to the wheel cylinders.

*a. Maintenance.* Check flexible brake hoses for seepage at any point. Inspect for pinching of hose; evidence of rub wear due to interference with vehicle structure; and hose stress caused by improper installation. Take corrective action to reinstall and/or replace defective parts as needed.

### NOTE

When brake hoses are worn, chafed, cracked, crimped or abraded, resulting in damage to hose through outer casing to the first ply of fabric, it is mandatory that the hose assembly be replaced.

*b. Removal.*

(f) To remove the line, disconnect both ends of the line.

(2) Remove the retaining clips from the line. Remove the line from the vehicle.

*c. Installation.*

### CAUTION

Do not kink or twist the hose when tightening the end fittings.

(1) To install the line, position the line between the hydraulic system components to be connected.

### CAUTION

Use cushioned retaining clamps (NSN 5340-00-854-6729) when installing flexible brake lines.

(2) Secure the line with retaining clips, and connect the lines at both ends.

(3) Tighten all connections, and bleed the brake hydraulic system (para 2-190).

## 2-195. Handbrakes.

*a. General.* The handbrake is properly adjusted when it will hold the vehicle on an incline with at least one-third of the handbrake lever travel in reserve, or if the application of the brake at a speed of 10 mph stops the vehicle.

*b. Adjustment.*

### NOTE

Adjust the brakeshoe stop screw to obtain approximately 0.015 inch clearance between the outer shoe and the brakedrum before adjusting the cable at the brakeshoe lever.

(1) To increase the braking action of the handbrake, turn the adjusting cap at the end of the brake lever clockwise. To decrease the action (to prevent dragging of brakeshoes), turn the adjusting cap counterclockwise.

(2) If the braking action cannot be increased sufficiently by turning the adjusting cap clockwise, turn the adjusting cap counterclockwise, adjust the cable tension at the brakeshoe lever, and then turn the adjusting cap clockwise until the correct brake adjustment is obtained.

(3) To adjust the cable at the brakeshoe lever, hold the adjusting nut on the transfer end of the cable, loosen the locknut, turn the adjusting nut clockwise on the cable, and tighten the locknut.

## 2-196. Handbrake Lever and Cable.

*a. Removal.*

(1) Remove the cotter pin from the clevis pin securing the cable clevis to the lower end of the hand brake lever, and remove the clevis pin. Remove the cable assembly from the handbrake lever.

(2) Remove the two nuts securing the handbrake lever assembly to the left end of the operator's seat.

(3) Remove the five nuts and screws securing the handbrake lever assembly to the top side and the cable clamp bracket to the underside of the cab floor. Remove the brake lever assembly and the cable clamp bracket from the cab floor.

(4) Remove the nut and screw securing the closed clip and the handbrake cable to the clip extension at the left end of the rear cab crossmember. Remove the clip from the cable.

(5) Remove the locknut and adjusting nut from the end of the handbrake cable at the brakeshoe lever. Remove the cable from the lever.

(6) Remove the two screws and nuts securing the cable anchor clamp and the cable to the cable clamp bracket bolted to the rear of the transfer case. Remove the clamp and cable from the bracket.

- (7) Remove the cable assembly from the truck.  
*b. Installation.*

**NOTE**

When replacing the handbrake cable at the cab, the clamp must be installed in the first groove from the end of the cable conduit. When installing the cable at the transfer end, the cable must be positioned in the second groove from the end of the cable conduit. When installing the cable on M52, M52A1, and M52A2 models, the following items are not required: Two clamps, plate, and attaching plate parts.

- (1) Position the handbrake lever assembly on the top and the cable clamp bracket (with cable clamped in place) on the underside of the cab floor. Install five screws and nuts through the lever assembly and cab floor, clamp the bracket, and tighten it.
- (2) Install the two nuts and studs at the left end of the operator's seat to secure the hand brake lever assembly to the seat, and tighten the nuts.
- (3) Position the cable clevis on the lower end of the handbrake lever link, insert the clevis pin in the holes in the clevis and link, and install a cotter pin in the clevis pin.
- (4) Insert the free end of the cable in the hole at the upper end of the brakeshoe lever, and install the adjusting nut and locknut on the end of the cable.
- (5) Position the cable on the cable clamp bracket at the rear of the transfer case.

**NOTE**

Make sure that the cable clamp spacer is in place on the bracket under the cable.

- (6) Position the cable anchor clamp over the cable, insert the two capscrews and tighten them.
- (7) Place the closed clip on the cable, and position the clip and cable on the clip extension at the left end of the rear cab cross tension at the end of the rear cab crossmember.
- (8) Insert the capscrew in the holes in the clip and extension, install the safety nut on the capscrew, and tighten it.
- (9) Adjust the handbrake (para 2-195b).

**2-197. Handbrake Shoes.**

*a. Removal.*

- (1) Block the wheels to prevent the vehicle from moving.
- (2) Unhook the brakeshoe retracting spring from the outer end of the shoe stop screw.
- (3) Unhook the brakeshoe lever retracting spring from the upper end of the brakeshoe lever, and remove the cable from the lever.
- (4) Remove the locknut and adjusting nut from the end of the cable at the brakeshoe lever, and remove the

- cable from the lever.
- (5) Remove the locknut from the front end of the shoe anchor bolt (fig. 2-176) and unscrew the bolt from the bracket integral with the transfer rear output shaft bearing cover.
- (6) Remove the shoe anchor bolt from the bore at the lower end of the outer shoe.
- (7) Spread the inner and outer shoes (fig. 2-187), and remove the shoe and lever assembly from the brakedrum.
- (8) Remove the C washer from the front end of the two brakeshoe lever pins (fig. 2-187). Remove the inner and outer shoes from the pins.

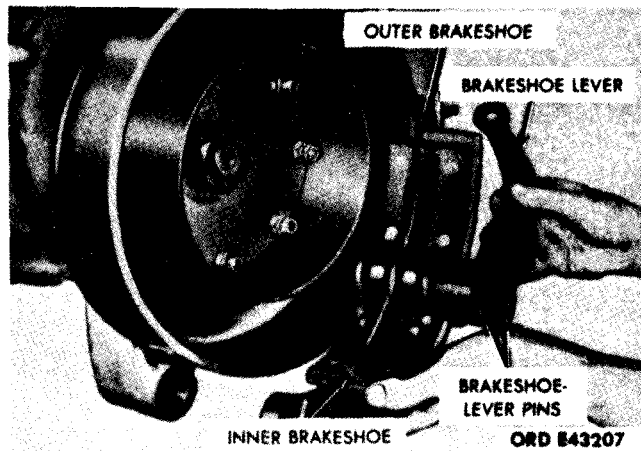


Figure 2-187. Removing handbrake shoe and lever assembly.

*b. Installation.*

- (1) Position the inner and outer brakeshoes (fig. 2-187) on the brakeshoe lever pins, and install the C washer at the front end of both pins.
- (2) Position the shoe and lever assembly on the brakedrum (fig. 2-187).
- (3) Insert the shoe anchor bolt (fig. 2-176) in the bore at the lower end of the outer shoe, screw the bolt through the bracket integral with the transfer rear output shaft bearing cover, and loosely install the locknut on the anchor bolt.
- (4) Screw the anchor bolt into the bracket until a slight bind is felt when operating the brakeshoe lever, then back off the bolt one-half turn, and tighten the locknut.
- (5) Insert the end of the handbrake cable in the hole in the upper end of the brakeshoe lever, and install the adjusting nut and locknut on the end of the cable.
- (6) Hook the end of the brakeshoe retracting spring over the outer end of the shoe stop screw.
- (7) Hook the end of the brakeshoe lever retracting spring in the eye at the upper end of the brakeshoe lever.
- (8) Adjust the handbrake (para 2-195).
- (9) Remove the wheel blocks.

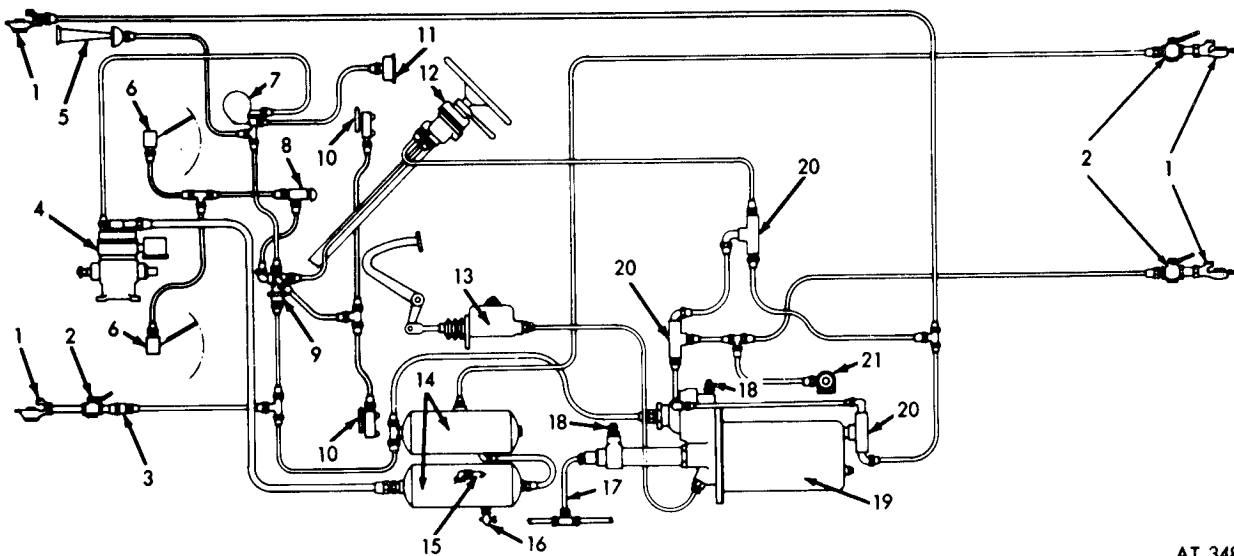
## Section XXX. MAINTENANCE OF COMPRESSED AIR SYSTEM

**2-198. General.**

a. *Components.* Air system components consist of two air reservoirs, a hand-control valve, an air compressor, an air governor, trailer broke couplings, two air supply valves, and air lines and fittings. One of the cylindrically-shaped air reservoirs, the lower one, has a safety valve which automatically opens when air pressure reaches 150 psi. This lower reservoir also contains a cock for draining condensation that accumulates in the reservoirs.

b. *Operation.* Compressed air from one vehicle's system is transferred into another vehicle's air system (or into the trailer airbrake system) through trailer brake

couplings (fig. 2-189) mounted to the front and rear of the vehicle (1, fig. 2-188). The steering column mounted hand-controlled valve (12, fig. 2-188) is used to control the braking of a towed vehicle. Dummy couplings and manually-operated cutout cocks (fig. 2-189) block air flow when the system is not connected to another vehicle and / or air system. The compressed air flows from one component to another through copper tubing lines. Each line has threaded fittings at both ends. One check valve (3, fig. 2-188) and three double check valves (20, fig. 2-188) automatically regulate air flow throughout the system. Two supply valves (10, fig. 2-188) are in the line from the upper reservoir to an air governor (7, fig. 2-188).



AT 34854

Legend for fig. 2-188:

KEY	ITEM	KEY	ITEM
1	Trailer coupling	12	Hand-control valve
2	Trailer coupling cutout cocks	13	Master cylinder
3	Single check valve	14	Air reservoir
4	Air compressor	15	Air reservoir safety valve
5	Horn	16	Air reservoir drain cock
6	Windshield wiper	17	Hydraulic line to wheel
7	Air governor	18	Hydraulic bleeder valve
8	Windshield wiper control valve	19	Air hydraulic brake cylinder
9	Junction block	20	Double check valve
10	Air supply valve	21	Stoplight switch
11	Air pressure gage sending unit		

Figure 2-188. Compressed air system piping diagram.

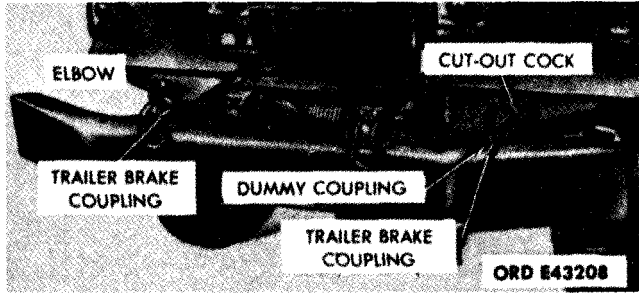


Figure 2-189. Trailer brake coupling installed at front of vehicle.

2-199. Air Compressor.

*a. Air Leakage Tests.* Excessive leakage at components or at connections in the compressed air system can be detected by the soapsuds method. With compressed air system fully charged, coat outside of components and connections with soapsuds to check for leakage. A 3-inch bubble formed in three seconds is the maximum leakage permissible. If excessive leakage is found, tighten the connection or replace the component.

*b. Adjust (all models).*

*(1) Unloader Valve Clearance Adjustment.*

*(a)* Remove unloader-valve cover (fig. 2-190) from compressor cylinder head. Remove cover gasket from cylinder head and discard it.

*(b)* Using feeler gage (fig. 2-190), check clearance of unloader valves; it should be 0.010 to 0.015-inch. If clearance is not within these limits, adjust valves as described in *(c)* below. If clearance is correct, proceed as in *(d)* below.

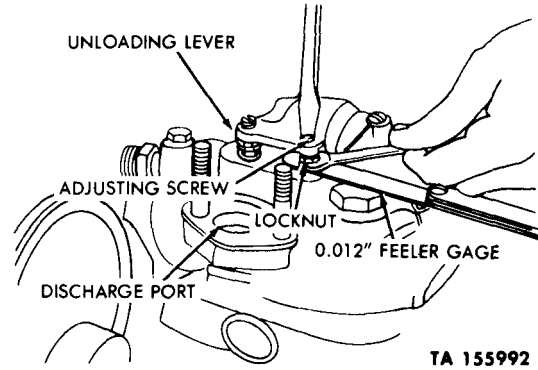


Figure 2-190. Checking and adjusting air compressor unloader.

*(c)* Loosen locknut (fig. 2-190) on both adjusting screws, turn screws until a 0.12-inch clearance is obtained, and tighten locknuts.

*(d)* Position new gasket on compressor cylinder head, and install unloader-valve cover.



(2) *Drive belt tension adjustment — gasoline engine.*

(a) Check compressor drive belt tension by applying pressure to belt at a point midway between the compressor pulley and the crankshaft pulley. Belt deflection at this point should be one-half inch. If belt deflection is found to be more or less than one-half inch, adjust belt tension as described in (b) below.

(b) Loosen two screws on front flange of compressor drive pulley. Using a wrench, turn flange in or out on threaded hub until correct belt tension described in (a) above is obtained. Tighten two screws on front flange of compressor drive pulley.

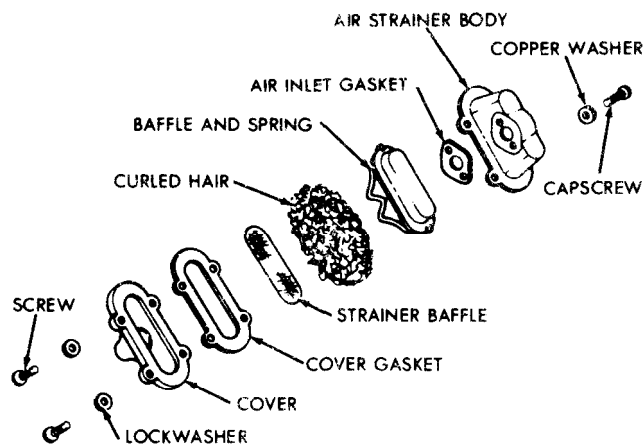
c. *Servicing (all models).*

NOTE

Servicing the air compressor consists of cleaning and oiling the curled hair pad inside air strainer 7539372 (fig. 2-191). Air compressor air strainer MS53005-1 (fig. 2-191.1) is not serviceable and must be replaced as a unit.

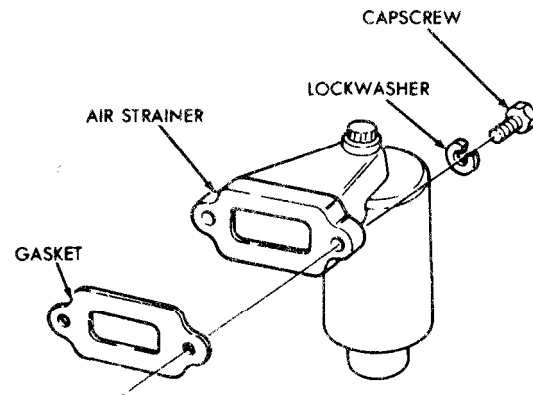
(1) Loosen clamp screw at underside of air strainer, and remove hose from strainer intake (fig. 2-191).

(2) Remove two capscrews and washers securing strainer (fig. 2-191) to right side of air compressor, and remove strainer from compressor. Remove and discard air inlet gasket (fig. 2-191).



TA 155988

Figure 2-191. Air compressor air strainer 7539372.



TA 155962

Figure 2-191.1. Air compressor air strainer MS53005-1.

(3) Remove four screws (fig. 2-191) and lockwashers securing cover to air strainer body, and remove cover from the body. Remove and discard cover gasket.

(4) Remove strainer baffle (fig. 2-191) and curled hair from air strainer body. Wash curled hair thoroughly in drycleaning solvent or mineral spirits paint thinner.

(5) Saturate curled hair with engine oil, squeeze out excess oil, and place hair in the strainer body.

(6) Install strainer-baffle in strainer body with screen side of baffle next to curled hair.

(7) Position new cover gasket and cover on bottom of air strainer body, and install four screws and lockwashers in holes in cover and body. Tighten screws.

(8) Position air strainer (fig. 2-191) and new inlet gasket (fig. 2-191) on right side of air compressor. Install two screws, washers, and gaskets in holes of air strainer body and air compressor block. Tighten screws.

(9) Slide hose onto intake sleeve at underside of air strainer, and tighten clamp screw.

d. *Removal.*

(1) *Air compressor (air cooled) — gasoline engine.*

(a) Unscrew connector securing air compressor-to-air reservoir line (fig. 2-192) to top rear of air compressor cylinder head, and remove line from head.

(b) Unscrew connector securing air-compressor-to-governor lines (fig. 2-192) to top front of air compressor cylinder head, and remove line from head.

(c) Remove four hexagon nuts and lockwashers (fig. 2-192) from studs securing air compressor to compressor mounting bracket at lower right side of engine crankcase, and remove compressor drive belt from the pulley.

(d) Lift compressor from mounting bracket. Remove and discard compressor-to-mounting bracket gasket.

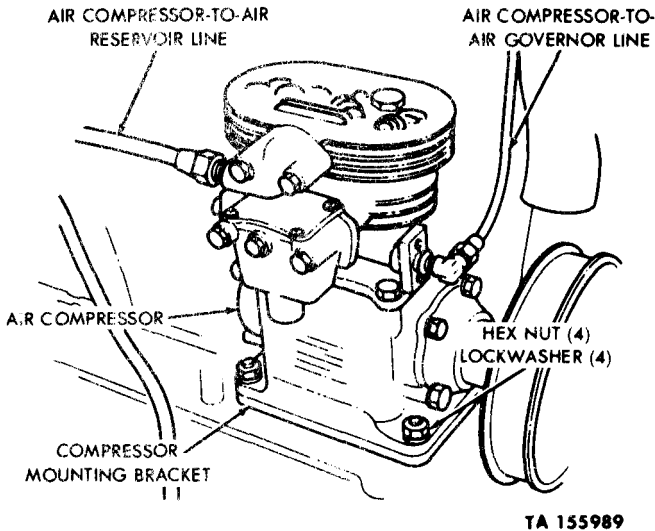


Figure 2-192. Air compressor (air cooled)—gasoline models.

(2) Air compressor (liquid cooled — gasoline engine).

(a) On vellicies equipped with an aircleaner-to-air compressor intake hose, loosen clamp screw at underside of air strainer, and remove hose from strainer intake.

(b) Unscrew connectors securing water inlet and outlet lines to fittings at front of air compressor cylinder head, and remove lines from fittings.

(c) Unscrew connector securing air compressor-to-air reservoir line to top rear of air compressor cylinder head, and remove line from head.

(d) Unscrew connector securing air compressor-to-governor line to top rear of air compressor cylinder head, and remove line from head.

(e) Remove four hexagon nuts and lockwashers from studs securing air compressor mounting bracket at lower right side of engine crankcase, and remove compressor drive belt from pulley. Lift compressor, and discard compressor-to-mounting bracket gasket.

(3) Air compressor — multifuel engine.

(a) Loosen the two air compressor pulley adjusting flange capscrews (fig. 2-193).

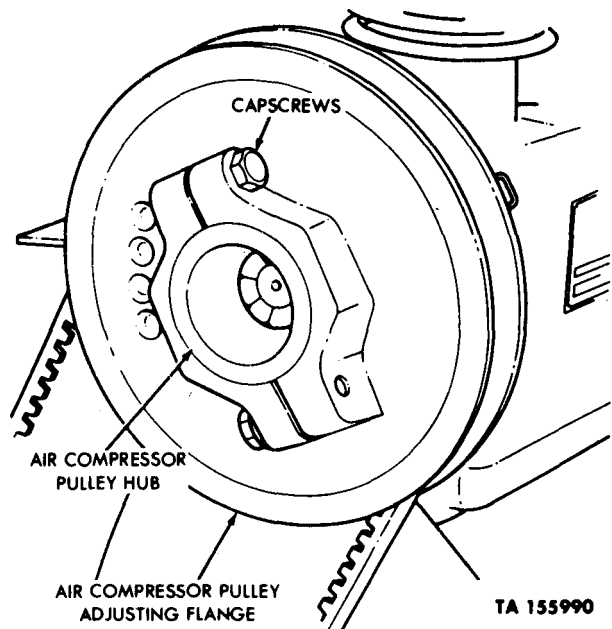


Figure 2-193. Loosening or tightening pulley adjusting flange screws.

(b) Using a wrench (3, fig. 2-4), turn compressor pulley adjusting flange counterclockwise until air compressor drive belt can be removed (fig. 2-194).

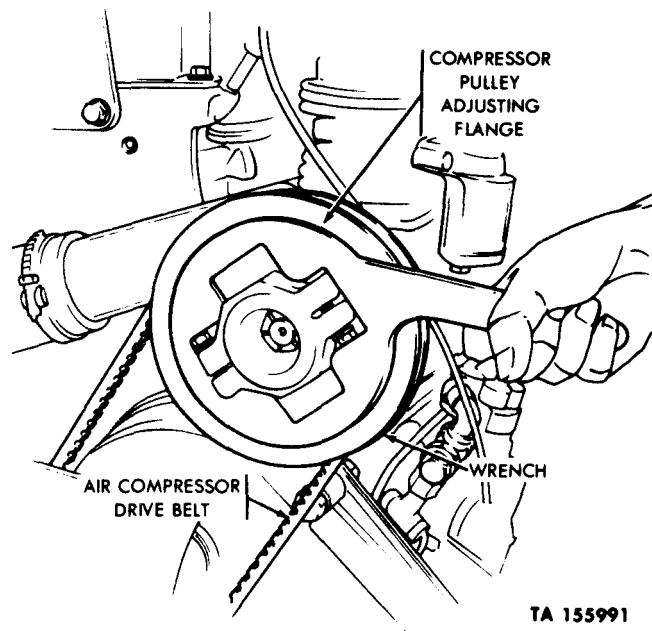


Figure 2-194. Loosening or tightening air compressor pulley adjusting flange.

- (c) Remove air compressor drive belt.
- (d) Remove capscrew and clip holding the fuel return-to-fuel injector pump overflow valve tube to air compressor. Install capscrew on air compressor tube inlet (fig. 2-195).
- (e) Remove four plain nuts and lockwashers securing air compressor assembly to the air compressor support assembly (fig. 2-195).
- (f) Remove air compressor assembly, and discard the air compressor-to-support gasket (fig. 2-195).

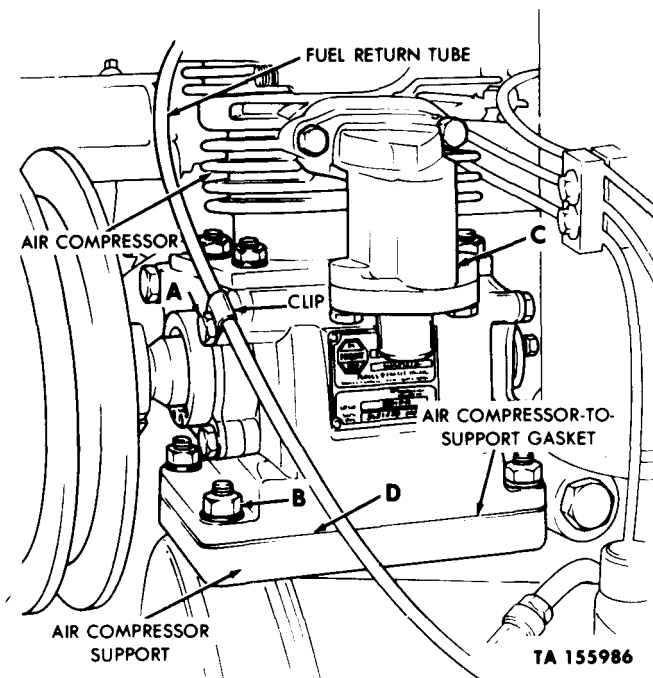


Figure 2-195. Air compressor—multifuel models.

*e. Installation.*

(1) *Air compressor (air cooled) — gasoline engine.*

- (a) Clean gasket surfaces on compressor mounting bracket (fig. 2-192) and air compressor crankcase, and install new gasket on mounting bracket.
- (b) Position air compressor on mounting bracket, and loosely install four lockwashers and nuts (fig. 2-192) on the mounting bracket studs.
- (c) Place compressor drive belt on pulley. Tighten mounting nuts on studs.
- (d) Position air compressor-to-air reservoir and the air compressor-to-governor lines at the cylinder head, and tighten connections (fig. 2-192).

(2) *Air compressor (liquid cooled) — gasoline engine.*

(a) Clean gasket surfaces on compressor mounting bracket and air compressor crankcase, and install new gasket on mounting bracket.

(b) Position air compressor on mounting bracket, and loosely install four lockwashers and nuts on mounting bracket studs. Place compressor drive belt on pulley.

(c) Position air compressor-to-governor line at inlet at top rear of air compressor cylinder head, and tighten connection.

(d) Position air compressor-to-air reservoir line at outlet at top rear air compressor cylinder head, and tighten connector.

(e) Position water inlet and outlet lines at the fittings on front of air compressor cylinder head, and tighten connectors.

(f) On vehicles equipped with an air cleaner-to-air compressor intake hose, slide hose on intake sleeve at underside of air strainer, and tighten clamp screw.

(3) *Air compressor — multifuel engine.*

(a) Using a new gasket, position air compressor to the support assembly, and secure it with four nuts and lockwashers (fig. 2-195).

(b) Remove capscrew from air compressor tube inlet. Position the fuel return-to-fuel injector pump overflow valve tube to the air compressor, and secure it with the capscrew and clip (fig. 2-195).

(c) Install air compressor drive belt.

(d) Using wrench (3, fig. 2-4), turn compressor pulley adjusting flange clockwise until drive belt is tight (fig. 2-194).

(e) Tighten the two air compressor pulley adjusting flange capscrews (fig. 2-193).

**2-200. Air Governor (8330262 and MS53006-1)**

*a. Servicing Air Governor 8330262.*

NOTE

Servicing the air governor consists of cleaning and oiling the lamb's wool (or nylon) pad inside the governor air strainer.

(1) Remove cap nut (fig. 2-196) from governor strainer body, and pull the cup strainer, cylinder strainer, and lamb's wool (or nylon) from the strainer body.

(2) Wash cup, strainer, cylinder strainer, and lamb's wool in drycleaning solvent or mineral spirits paint thinner.

NOTE

On models with a nylon pad air strainer, clean pad with soap and water.

(3) Saturate the lamb's wool (or nylon) pad with engine oil, squeeze out excess oil, and place pad in the cylinder strainer.

(4) Insert cylinder strainer and cup strainer in strainer body, and install capnut.

*b. Removal.*

(1) Unscrew connector securing air reservoir-to-governor line and governor-to-horn line to the lower fitting at left side of air governor, and remove lines.

(2) Unscrew connector securing line from air compressor to air governor.

(3) Remove T fitting (governor MS53006-1).

(4) Unscrew two screws, and remove air governor.

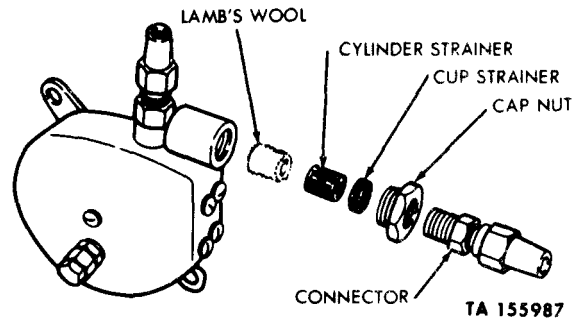
*c. Installation.*

(1) Position air governor on right side of cowl, install two screws, and tighten.

(2) Install T fitting (governor MS53006-1) (fig. 2-196.1).

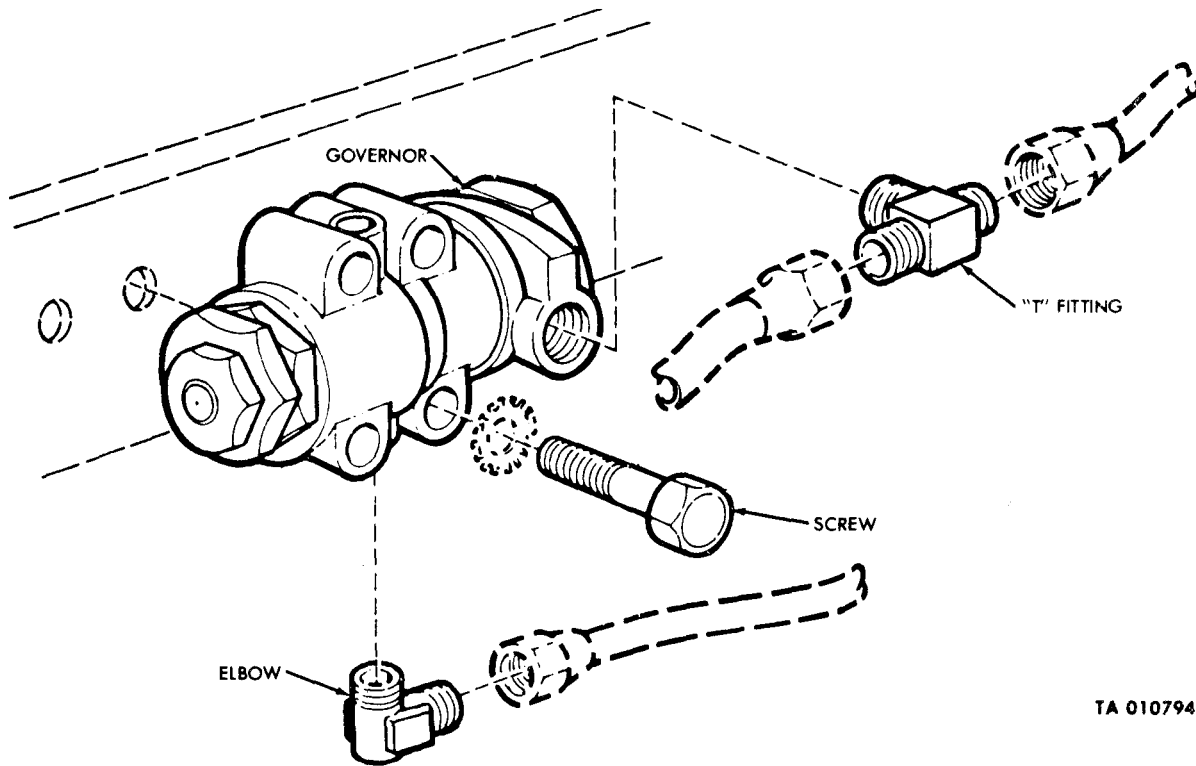
(3) Connect air compressor line to the air governor.

(4) Connect air reservoir-to-governor line and governor-to-horn line to the air governor.



AIR COMPRESSOR GOVERNOR

Figure 2-196. Air compressor governor (8330262) with air strainer disassembled.



TA 010794

Figure 2-196.1. Air compressor governor MS53006-1. ■

## 2-201. Air Reservoirs

### a. Removal.

(1) Open the drain cock on the underside of the lower air reservoir (fig. 2-197) to relieve the pressure in the compressed air system.

(2) After the compressed air has been exhausted from the system, unscrew the connector securing the air compressor-to-air reservoir line (fig. 2-170) to the front end of the lower reservoir, and remove the line from the reservoir.

(3) Unscrew the connector securing the air line tee (fig. 2-197) to the front end of the upper reservoir, and remove the tee from the reservoir.

(4) Unscrew the connector securing the upper-to-lower reservoir line (fig. 2-197) to the rear end of the lower reservoir, and remove the line from the reservoir.

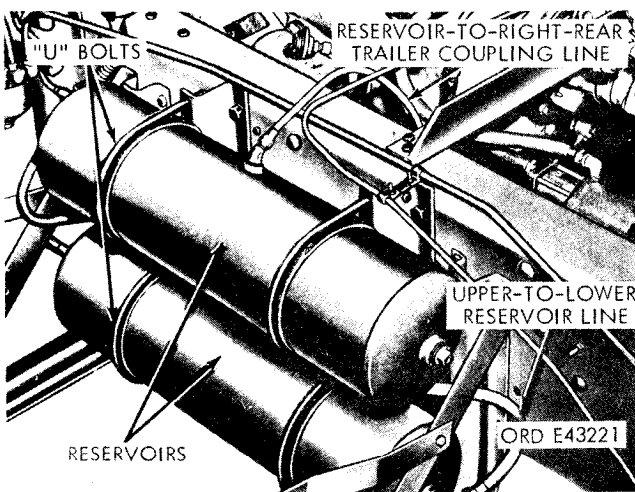


Figure 2-197. Air reservoirs installed to frame left side rail.

(5) Unscrew the connector securing the upper-to-lower reservoir line to the underside of the upper reservoir, and remove the line from the reservoir.

(6) Unscrew the connector securing the reservoir-to-right-rear trailer coupling line (fig. 2-197) to the top of the upper reservoir, and remove the line from the reservoir.

(7) Support the lower reservoir, remove the two nuts from the front and rear U-bolts (fig. 2-197), remove the U-bolts from the reservoir mounting brackets, and remove the lower reservoir from the vehicle.

(8) Support the upper reservoir, remove the two nuts from the front and rear U-bolts (fig. 2-197), remove the U-bolts from the reservoir mounting brackets, and remove the reservoir from the vehicle.

### b. Installation.

(1) Position the upper reservoir (fig. 2-197) on the mounting bracket bolted to outside of the frame left side rail.

(2) Install the front and rear U-bolts over the reservoir with the ends inserted in the holes in the bracket, and install the two nuts on each U-bolt. Tighten the nuts.

(3) Install the lower reservoir (fig. 2-197), using same procedures as in (1) and (2).

(4) Position the reservoir-to-right-rear trailer coupling line (fig. 2-197) at the outlet on the top or upper reservoir, and tighten the connector.

(5) Position the upper-to-lower-reservoir line (fig. 2-197) at the inlet on the underside of the upper reservoir, and tighten the connector.

(6) Position the upper-to-lower-reserve line at the outlet on the rear end of the lower reservoir, and tighten the connector.

(7) Position the air line tee (fig. 2-70) at the outlet on the front end of the upper reservoir, and tighten the connector.

(8) Position the air compressor-to-air reservoir line (fig. 2-70) at the inlet on the front end of the lower reservoir, and tighten the connector.

(9) Close the drain cock on the underside of the lower air reservoir.

## 2-202. Hand Control Valve

### a. Removal.

(1) Open the drain cock on the underside of the lower air reservoir (16, fig. 2-188) to relieve the pressure in the compressed air system.

(2) Unscrew the connector securing the air supply line to the hand control valve (1.2, fig. 2-188), and remove the line from the valve.

(3) Unscrew the connector securing the trailer coupling line to the hand control valve (12, fig. 2-188), and remove the line from the valve.

(4) Remove the two nuts, lockwashers, and clamp from the screws securing the hand control valve to the steering gear jacket, and remove the valve from the jacket.

(5) Remove the two screws from the hand control valve mounting flange.

### b. Installation.

(1) Insert the two screws in the holes in the hand control valve mounting flange.

(2) Position the hand control valve on the right side of the steering gear jacket and install the clamp, two lockwashers, and nuts on the screws in the hand control valve mounting flange. Tighten the screw and nuts.

(3) Position the trailer coupling line at the outlet on the underside of the hand control valve (12, fig. 2-188), and tighten the connector.

(4) Position the air supply line at the inlet on the underside of the hand control valve (1.2, fig. 2-188), and tighten the connector securely.

(5) Close the drain cock on the underside of the lower air reservoir.

**2-203. Trailer Brake Couplings**

*a. Removal.*

- (1) If necessary, close the cutout cock (fig. 2-189) at the coupling or couplings to be removed.
- (2) Remove the dummy coupling from the trailer brake coupling (fig. 2-189).
- (3) Unscrew the trailer brake coupling from the cutout cock or elbow, and remove the coupling (fig. 2-189).

**NOTE**

The cutout cock is open when the handle is at a 90° angle with the body of the cock. Stops are provided to prevent the handle from being turned beyond its normal open and closed positions.

*b. Installation.*

- (1) Turn the coupling onto the cutout cock or elbow at the threaded end (fig. 2-189).
- (2) Connect the dummy coupling to the trailer brake coupling to prevent dirt or foreign matter from entering the compressed air system lines.

**2-204. Air Supply Valves**

*a. Removal.*

- (1) Open the drain cock on the underside of the lower air reservoir (16, fig. 2-188) to relieve the pressure in the compressed air system.
- (2) Unscrew the connector securing the air supply line to the air supply valve (10, fig. 2-188).
- (3) Unscrew the cap from the air supply valve.
- (4) Remove the two safety nuts and capscrews securing the air supply valve to the cab cowl, and remove the valve.

*b. Installation.*

- (1) Position the air supply valve on the cab cow, and secure it with two capscrews and safety nuts.
- (2) Position the air supply line at the inlet part of the air supply valve (10, fig. 2-188) and tighten the connector.
- (3) Screw the cap on the air supply valve outlet.
- (4) Close the drain cock on the underside of the lower air reservoir (16, fig. 2-188).

**2-205. Air Lines and Fittings**

*a. Removal.*

- (1) Open the drain cock on the underside of the lower air reservoir.
- (2) Unscrew the connectors at both ends of the line.
- (3) Where necessary, remove the nut and screw securing the air line clip to the vehicle. Remove the line.
- (4) Where necessary, remove the fittings (tees, check valves, junction block; etc.) from the vehicle.

*b. Installation.*

- (1) Where necessary, install the fittings on the vehicle, and tighten them in place.
- (2) Where necessary, position the line and clip on the vehicle, and secure the clip with a screw and nut.
- (3) Screw the connectors at both ends of the line into place. Tighten the connectors.
- (4) Close the drain cock at the underside of the lower air reservoir.

**Section XXXI. MAINTENANCE OF WHEELS, HUBS, AND DRUMS**

**2-206. General**

*a. Wheels.* The wheels (fig. 2-198 and 2-199) are of the offset-disk type, and are interchangeable between the front and rear axles and on opposite sides of the vehicle. Two types of tire mountings are used. Some of the wheels are equipped with snap-on type side rings. The wheels are secured by capnuts installed on the mounting studs at the hub flanges. The capnuts are interchangeable between hubs on the same side, but not between hubs on the opposite sides of the vehicle.

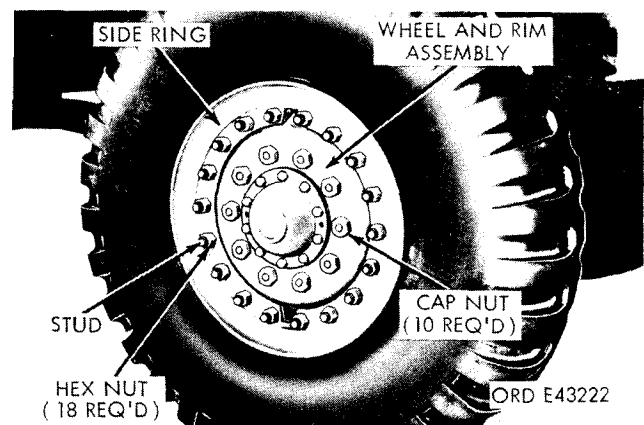
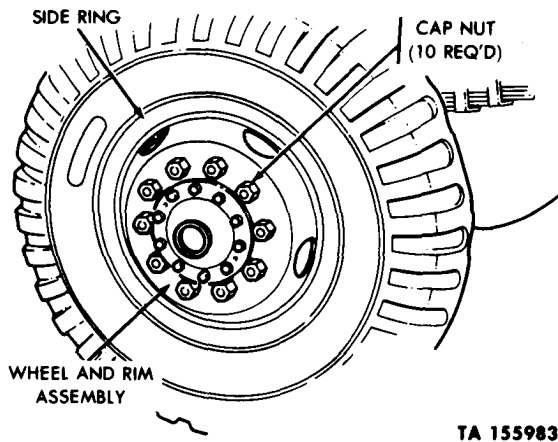


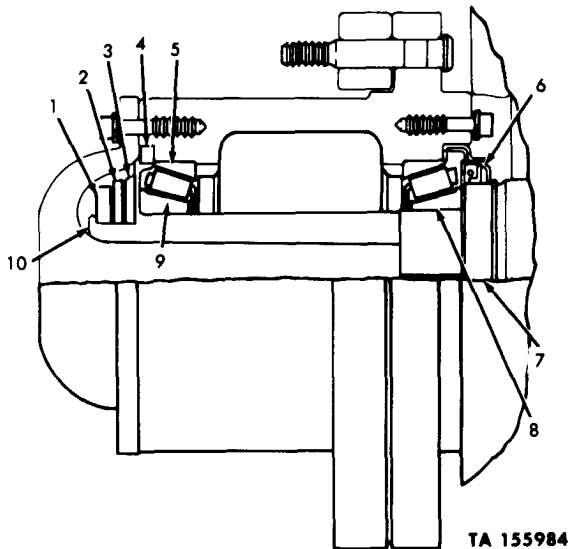
Figure 2-198. Wheel and tire assembly with bolted-on type side ring (14.00x20 tires).



TA 155983

Figure 2-199. Wheel and tire assembly with snap-on type side ring (11:00x20 tires).

*b. Hubs.* All hubs (fig. 2-200) are mounted on opposed tapered roller bearings. Each hub is secured to its axle with an inner bearing adjusting nut, bearing nut washer, and outer bearing adjusting nut. All hubs are equipped with inner oil seals, but only the rear hubs have outer oil seals.

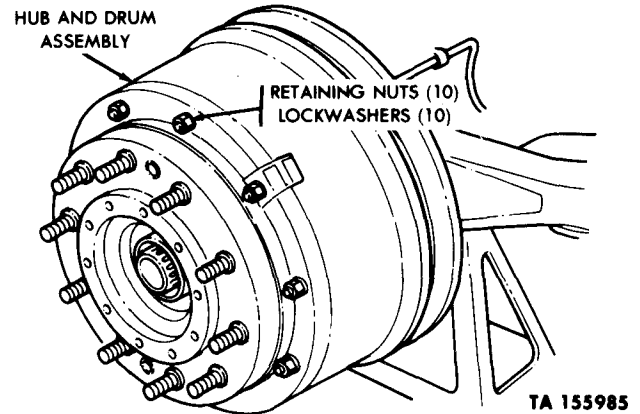


TA 155984

- 1 Outer bearing adjusting nut
- 2 Adjusting nut washer
- 3 Inner bearing adjusting nut
- 4 Outer oil seal (rear only)
- 5 Tapered roller bearing cup
- 6 Inner bearing oil seal
- 7 Oil seal wiper (rear only)
- 8 Inner tapered roller bearing cone
- 9 Outer tapered roller bearing cone
- 10 Axle spindle

Figure 2-200. Hub assembly—cutaway view.

*c. Drums.* All drums (fig. 2-201) are secured to the hubs by retaining nuts and lockwashers installed on the mounting studs at the hub flanges. All drums are interchangeable between front and rear axles and opposite sides of the vehicle.



TA 155985

Figure 2-201. Removing hub and drum assembly.

## 2-207. Wheel and Tire Assembly

### a. Maintenance.

(1) *Matching Tires.* Replacement tires should be of the same design and tread as the other tires on the vehicle. Differences in design and tread in some instances result in unequal rolling radii. If tires do not have the same outside diameter within one-half inch, excessive tread scuffing will result. When selecting a replacement tire, select one having an outside diameter that matches within one-half inch the outside diameter of the other tires on the vehicle, particularly on the same axle. Measure the outside diameter of the tires with a conventional tire measuring gage.

(2) *Periodic Tire Rotation.* Tires should be inspected for evenness of wear and be measured, as described in (1) above, after every 2,000 miles of vehicle operation. At this time, based on the results of inspection and measurements, if uneven wear is indicated, proceed to rotate the tires around.

### NOTE

Refer to TM 9-2610-200-20 for proper tire rotation procedures.

### b. Removal (figs. 2-198 and 2-199).

#### CAUTION

On wheel and tire assemblies with bolted-on type side rings (fig. 2-198), do not loosen the side ring retaining nuts.

(1) Loosen the 10 capnuts securing the wheel and tire assembly to the hub.

(2) Raise the wheel off the ground until the tire clears the ground.

(3) Remove the 10 capnuts, and pull the wheel and tire assembly off the hub studs.

### c. Installation (figs. 2-198 and 2-199).

(1) Position the tire and wheel assembly onto the hub studs.

(2) Install 10 capnuts on studs, securing wheel and tire assembly to hub. Alternately tighten nuts.

(3) Lower wheel to the ground, and again tighten all 10 nuts.

**2-208.** Tire (with Bolted-on Side Ring) and Tube Assembly

*a. Removal (fig. 2-198).*

(1) Remove wheel and tire assembly as described in paragraph 2-207.

**CAUTION**

Do not attempt to remove side ring until inner tube is completely deflated.

(2) Remove valve core from inner tube stem, and allow tube to become completely deflated.

(3) Remove 18 side ring retaining nuts, and remove side ring from wheel.

(4) Using tire irons to dislodge bead of tire from rim, remove tire, tube, and bead lock from rim.

(5) Install valve core in inner tube stem, and inflate tube sufficiently to spread tire beads.

(6) Pry upon bead lock at a point about eight inches from the hinges. Collapse bead lock and turn it 90° to remove it from tire.

(7) Deflate inner tube, and remove it from tire.

*b. Repair Of Tube.* Refer to TM 9-2610-200-20.

*c. Installation.*

**CAUTION**

The side ring retaining nuts must be tightened before inflating tire.

(1) Install tube in tire and inflate it sufficiently to hold it in place.

(2) With bead lock collapsed, insert inner tube valve stem through hole in bead lock.

(3) Install bead lock in side of casing, press it part way through tire, and inflate tube sufficiently to spread tire beads.

(4) Turn bead lock, and work it into position between the tire beads. Deflate inner tube completely.

(5) While holding one end of bead lock with a foot, pull other end of bead lockup with both hands until hinge snaps into place.

(6) Center bead lock so edges are below beads of the tire at all points.

(7) Install tire and bead lock assembly on wheel rim with valve stem pointing outward.

**NOTE**

Make sure bead lock lug engages valve stem slot in rim.

(8) Install side ring, and secure it with 18 side ring retaining nuts. Tighten nuts alternately.

(9) Inflate tire.

(10) Install wheel and tire assembly as described in paragraph 2-207c.

**2-209.** Tire (with Snap-on Side Ring) and Tube Assembly

*a. Removal (fig. 2-199).*

(1) Remove wheel and tire assembly as described in paragraph 2-207b.

(2) Remove valve core from inner tube stem, and allow tube to become completely deflated.

(3) With wheel and tire assembly laying flat and with side ring facing upward, insert a tire iron into notch in side ring.

(4) Working a tire iron between side ring and disk, pry side ring off of the wheel.

(5) Turn wheel and tire over, and dislodge tire from taper on wheel rim.

(6) Remove wheel from tire.

*b. Repair Of Tube.* Refer to TM 9-2610-200-20.

*c. Installation.*

**WARNING**

To prevent injury, place tire and wheel in safety cage. If safety cage is not available, install two safety chains around the tire and through the wheel approximately 180 degrees apart before inflating,

(1) Place inner tube inside tire, install tire flap, and inflate inner tube sufficiently to prevent tube from being pinched during tire mounting.

(2) Place wheel flat on ground, and place tire over wheel. Insert valve stem through hole in wheel rim so stem points toward wheel disk.

(3) Position side ring (fig. 2-199) on wheel with flange down, and start inner flange of ring under wheel flange opposite notch in side ring.

(4) Using a woodblock and hammer, force side ring into position on wheel rim.

(5) Make certain side ring is seated properly against rim of wheel through its entire circumference, then inflate tire.

(6) Install wheel and tire assembly as described in paragraph 2-207c.

**2-210.** Hub and Drum Assembly.

*a. Removal.*

(1) Remove wheel and tire assembly as described in paragraph 2-207b.

(2) Remove 10 drive flange retaining capscrews, and remove flange from hub.

(3) Using special wheel nut wrench (5, fig. 2-4) as shown in figure 2-202, remove outer bearing adjusting nut, bearing nut washer, and inner bearing adjusting nut from the spindle.



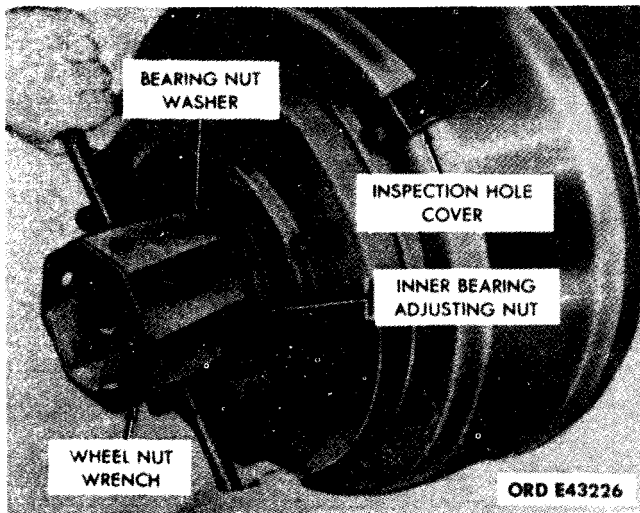


Figure 2-202. Removing outer bearing adjusting nut.

(4) Remove the outer-bearing oil seal (4, fig. 2-200) from the hub outer bore (rear axles only).

(5) Remove the outer tapered roller bearing cone (9, fig. 2-200).

(6) Remove the hub and drum assembly (fig. 2-201) from the axle spindle (10, fig. 2-200).

(7) Remove the 10 nuts (fig. 2-201) and lockwashers securing the brake drum to the hub, pry the drum from the hub.

*b. Installation.*

(1) Position the brake drum on the studs at the hub outer flange, and install 10 lockwashers (fig. 2-29) and nuts on the studs. Tighten the nuts.

(2) Install the hub and drum assembly (fig. 2-201) on the axle spindle so that the inner tapered roller bearing cone and inner-bearing oil seal enter the hub inner bore.

(3) Install the outer tapered roller bearing cone (9, fig. 2-200) in the hub outer bore against the outer tapered roller bearing cup.

(4) Install the outer bearing oil seal (4, fig. 2-200) on the spindle against the cone (rear axles only).

(5) Using a wheel nut wrench (5, fig. 2-4), install the inner bearing adjustment nut on the spindle.

(6) Install the wheel and tire assembly (para 2-207c).

(7) Adjust the wheel bearings (para 2-211a).

## 2-211. Wheel Bearings.

*a. Adjustment.*

### NOTE

Before adjusting the wheel bearings (front and or rear), make the inspection as described in (1) through (4) below.

(1) Raise the wheel until it clears the ground.

(2) Grasp the top of the tire, and alternately push and pull on the tire. Observe the amount of wheel wobble

or play.

(3) If the wheels are correctly adjusted, play or wobble will be barely perceptible, and the wheel and / or wheels will turn easily.

(4) If the adjustment is correct, lower the wheel to the ground. If the adjustment is necessary, follow the procedures in steps (5) through (10) below.

(5) With the wheel raised, remove the 10 drive-flange retaining screws (fig. 2-198), and remove the flange from the hub.

### NOTE

The rear axle shaft is also removed when removing the drive flange from the rear hub.

(6) Using the wheel nut wrench (5, fig. 2-4), as shown in figure 2-202, remove the outer bearing adjusting nut washer.

(7) While turning the wheel, tighten the inner bearing adjusting nut (3, fig. 2-200, using large end of the wrench. Torque to 50 lb-ft to correctly position bearings; then back off nut approximately 1/16 to 1/4 turn, Recheck the wheel bearing adjustment as described in (1) through (3) above.

(8) Use the wheel nut wrench to install the adjusting nut washer (2, fig. 2-200) and outer bearing adjusting nut. Torque to  $325 \pm 75$  lb-ft.

(9) Check the adjustment. Position the drive flange (fig. 2-175) on the hub, and install the 10 retaining screws.

### NOTE

When installing the drive flange at the rear hubs, the rear axle shaft must be installed also.

(10) Lower the wheel and remove the jack.

*b. Removal.*

(1) Remove the hub and drum assembly as described in paragraph 2-210a.

(2) Remove the inner bearing oil seal (6, fig. 2-200) and the inner tapered roller bearing cone (8, fig. 2-200) from the hub.

*c. Cleaning and Inspection.*

(1) Clean both the inner and outer tapered roller bearing cones.

(2) Inspect the cones for excessive wear and other defects which would prevent smooth operation and replace the cones if necessary.

(3) Inspect the bearing cups in the hub bores for wear, scoring, or distortion. If necessary, replace the cups as described in paragraph 2-212.

*d. Installation.*

(1) Lubricate the inner and outer tapered roller bearing cones (para 2-212).

(2) Install the inner bearing oil seal (6, fig. 2-200) and inner tapered roller bearing cone (8, fig. 2-200) on the spindle.

(3) Install the hub and drum assembly as described in paragraph 2-210.

## 2-212. Wheel Bearing Cups.

*a. Removal.*

(1) Remove the hub and drum assembly as described in paragraph 2-210a.

(2) Using a puller, remove the outer bearing cup (5, fig. 2-200) from the hub.

(3) Turn the hub and drum assembly over, and remove the inner bearing cup from the hub.

*b. Installation.*

(1) Lay the hub and drum assembly flat with the outer end facing up, position the outer tapered roller bearing cup (5, fig. 2-200) in the hub bore, and press the cup into place against the shoulder in the bore.

(2) Turn the hub and drum assembly over, position the inner bearing cup in the hub bore, and press the cup into place against the shoulder in the bore.

(3) Install the hub and drum assembly as described in paragraph 2-210b.

## Section XXXII. MAINTENANCE OF STEERING SYSTEM

2-213. General. The steering system components consist of the three-spoke steering wheel, the hydraulic oil reservoir, the pressure relief valve for the hydraulic system, and the steering linkage. The steering linkage consists of a pitman arm, upper and lower drag links, and a tie rod assembly.

## 2-213.1. Hydraulic Pressure Test.

*a.* Connect the hydraulic pressure gage (test set power steering, NSN 4910-00-627-7043, P/N 7010267) in the hydraulic system. Disconnect the hydraulic hose at the control valve oil inlet elbow; to this elbow, connect the hose supplied in the test kit. Connect a tee between this hose and the original hose removed from the control valve. At the top of the tee, connect the pressure gage using the adapter provided in the test kit.

## NOTE

Perform air bleed procedures as indicated in para *d.*

*b.* Start the engine and warm it up to operating temperature. Watch for rapid pressure build up on the pressure gage. (If this happens, shut the engine off immediately since the pressure may increase to where the hydraulic hoses are ruptured or the gage ruined.) Turn the steering wheel in a full right or left turn and increase engine speed up 1,000 rpm. Continue turning the steering wheel until the turn stop on the front axle is reached. Hold the wheel tight in this position for only a few seconds. The gage pressure should read between 750 psi and 1,100 psi maximum.

## NOTE

If the pressure drops off sharply when a full left turn is reached, the left turn test should be repeated, but with an assistant holding a ¼-inch thick piece of metal between the front axle left turn stop. The loss of pressure in a left turn is due to the power cylinder piston traveling far enough forward to allow the hydraulic pressure to escape past the piston ring into the front cylinder port to the oil reservoir. Restricting the turn radius of the front wheels restricts the piston travel so that a proper test can be made. If system pressure is in excess of 1,100 psi, an external relief valve modification kit must be installed. Use modification kit, NSN 2530-00-173-6938, P / N 11680896, to alter the system.

*c. Alteration Procedure.*

(1) Remove existing pressure hose from the steering pump to inlet port on steering control valve.

(2) Remove existing return hose from outlet port on steering control valve to reservoir.

(3) Install bracket support assembly (I) (fig. 2-202.1) Install bottom bolt first.

(4) Assemble tee (F) and tee (G) to relief valve (H) (fig. 2-202.1).

(5) Install relief valve (H) on mounting bracket support (I) (fig. 2-202.1).

(6) Install hoses (C) (D) (J) (K) in locations indicated (fig. 2-202.1). Prior to installing hose (K) to inlet port or steering control valve, connect the hydraulic pressure gage (Test Set Power Steering NSN 4910-00-627-7043) in series. Leave the pressure gage line fitting to control valve loose for system bleeding.

(7) Fill reservoir (A) with OE / HDO-10 oil (MIL-L 2104B) so that oil covers the bottom of the filler screen. Replace reservoir cap to prevent any dirt entering the system.

*d. Power Steering System Bleeding procedure.*

(1) With engine shutoff control in the "OUT" (fuel off) position, manifold heater switch in "OFF" position, engage starter and crank engine for five (5) seconds. Repeat until solid oil comes out of loose fitting at control valve (para 2-213.1c(6)).

(2) Exercise the power steering system with the steering wheel, do not go to the full right or full left rotation. Continue this procedure until the pump noise from air has diminished.

(3) Perform power steering pump tests and adjustments as outlined in para 2.213.1, page 2-172. (Operating pressure in this system is limited to 1,100 psi by the relief valve (H) preset at factory.)

(4) After tests and adjustments are completed, shut down engine, remove pressure gage and connect the hose (K) to the control valve.

(5) Restart engine, exercise steering system and check all fittings for leaks.

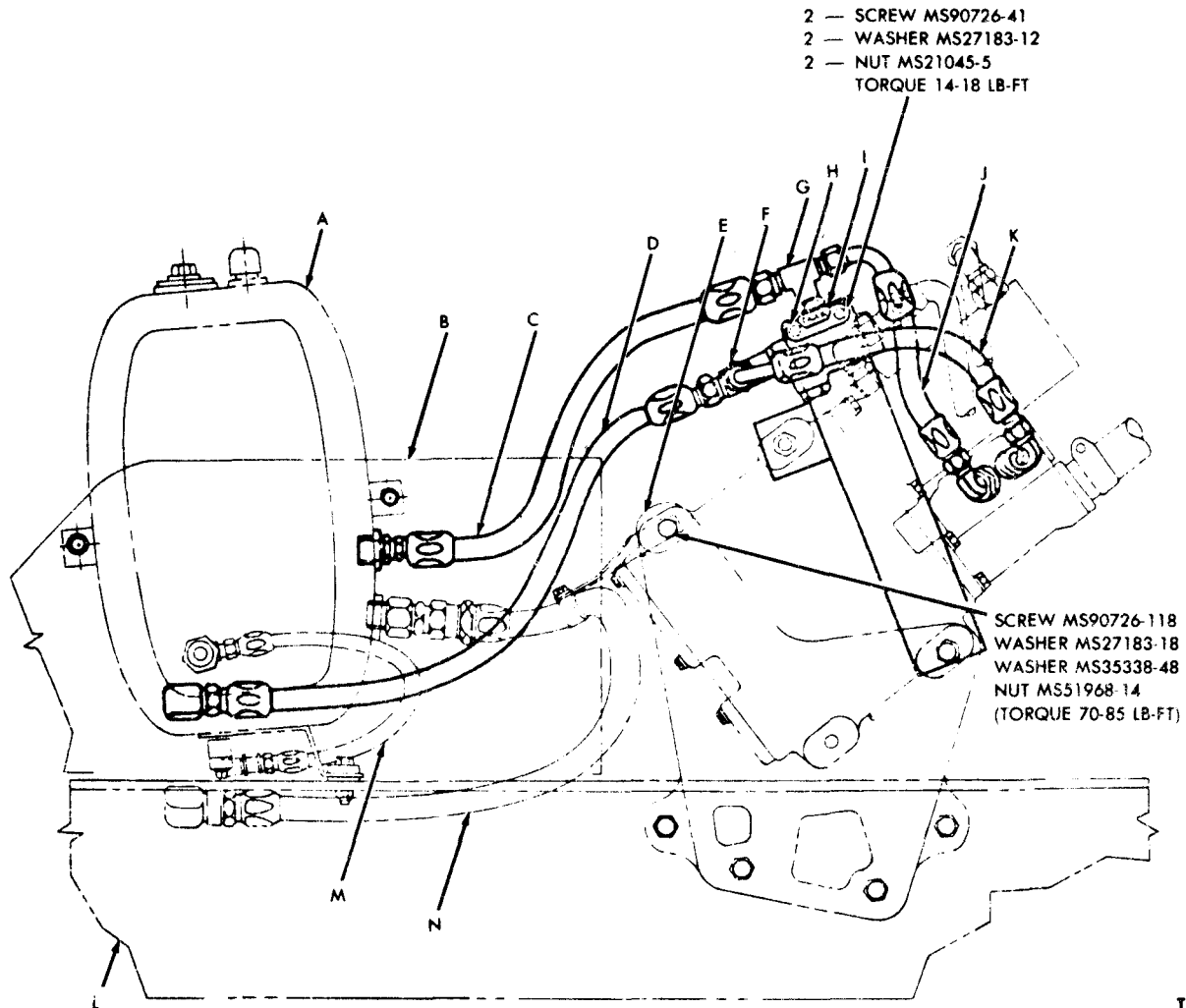
**2-213.2.** Hydraulic Pump Assembly. The hydraulic pump assembly is checked in the same manner as in paragraph 2-21.3. *1a.* No external leakage is allowed during the test. Check all joints and hydraulic lines. The pump should maintain pressures indicated in paragraph 2-213.1*b* above in the system during operation of the steering gear.

**NOTE**

To determine whether the hydraulic pump relief valve is at fault in the early production models, it is necessary to bypass the separate relief valve.

**2-214. Front Wheel Alinement**

*a. Caster (fig. 2-203).* Front caster is the inclination of the center line through the upper and lower steering knuckle trunnions toward the rear of the truck. Caster is established by the design and can be changed only by the shifting of the front axle on the springs, or by distortion of the chassis frame or springs. There is no adjustment for caster.



TA 018014

- |                              |                              |
|------------------------------|------------------------------|
| A — RESERVOIR ASSEMBLY       | H — VALVE                    |
| B — SPLASH PANEL             | I — BRACKET SUPPORT          |
| C — HOSE ASSEMBLY (RETURN)   | J — HOSE ASSEMBLY (RETURN)   |
| D — HOSE ASSEMBLY (PRESSURE) | K — HOSE ASSEMBLY (PRESSURE) |
| E — STEERING BRACKET         | L — FRAME                    |
| F — TEE                      | M — HOSE ASSEMBLY (BY-PASS)  |
| G — TEE                      | N — HOSE ASSEMBLY (SUPPLY)   |

Figure 2-202.1. Steering Piping Installation, Modification Kit, P / N 11680896.

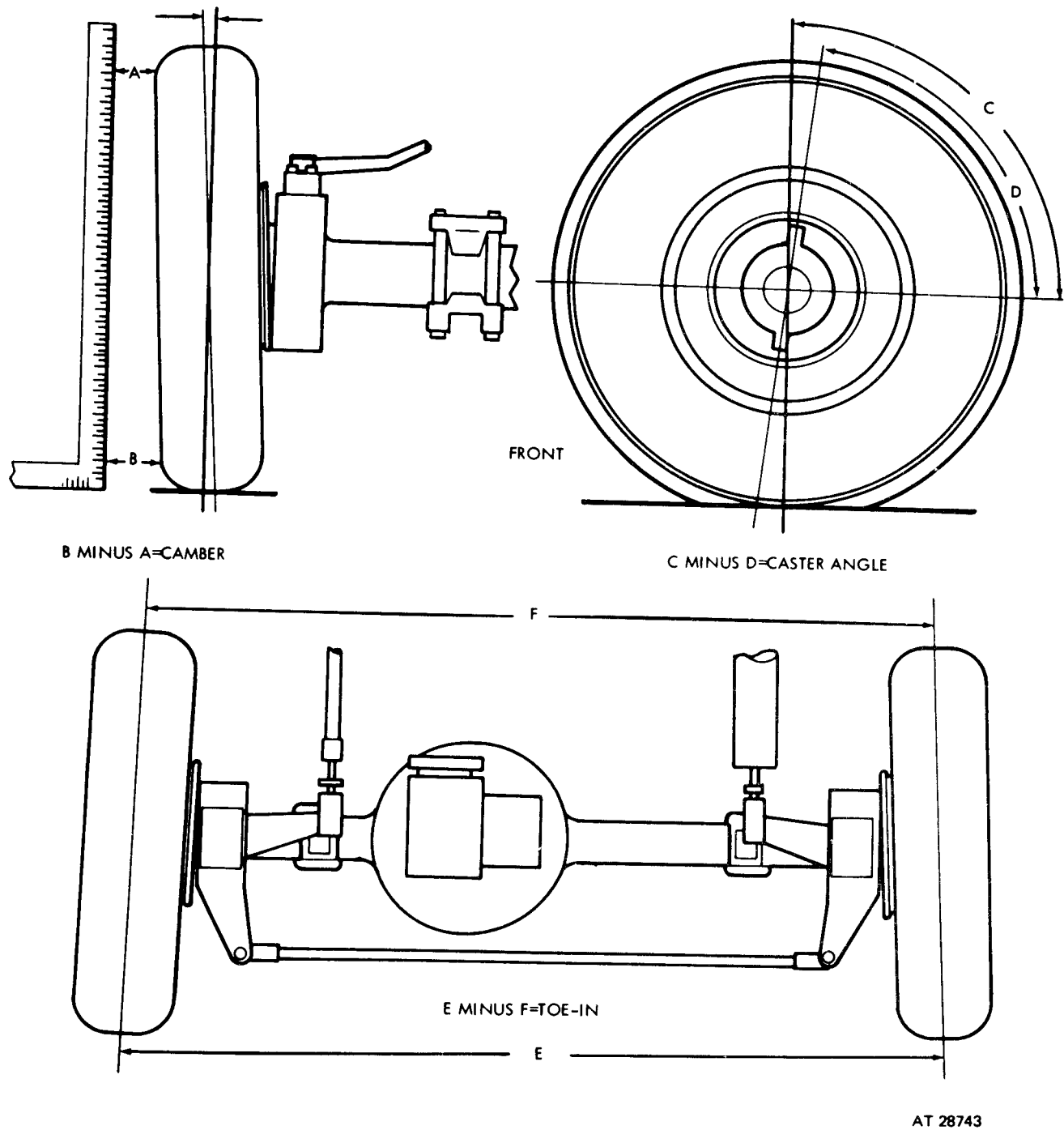


Figure 2-203. Front wheel alignment.

*b. Camber* (fig. 2-203). Camber is the inclination of the vertical center line through the wheel and tire assembly away from the vertical center line of the truck. There is no adjustment for camber; however, loose wheel bearings, loose knuckle trunion bearings, a bent steering knuckle, or a bent axle housing will affect

camber.

*c. Turning Angle.* The front wheel turning angle is the maximum angle through which the wheels may be turned from the straightahead position. This angle is limited by the turning stops that are welded after the adjustment.

*d. Toe-in Check* (fig. 2-203).

**NOTE**

Toe-in is the amount by which the wheels are closer together at the front than at the rear when the wheels are in the straightahead position. Camber causes both wheels to have a tendency to run outward from the truck. Toe-in counteracts this tendency and causes the wheels to roll straightahead with no scuffing action.

(1) Inflate the tires to the correct pressure, and place the truck on a smooth, level surface with the wheels in a straightahead position.

(2) Place the gage between the wheels ahead of the axle, with the ends of the gage bearing against the tire side walls and with both pendant chains just touching the ground.

(3) Set the gage so the pointer registers zero. Remove the gage and place it at the same relative position at the rear of the axle with the ends of gage bearing against the tire side walls and with both pendant chains just touching the ground.

(4) The pointer will indicate the amount of toe-out. Correct toe-in is  $1/8 \pm 1/16$  inch.

*e. Toe-in Adjustment.*

(1) Remove the tack weld from the tie rod ends if the weld is evident.

(2) Loosen the two locking bolts on each tie rod end.

(3) Shorten or lengthen the tie rod by turning the tie rod with a pipe wrench.

(4) After adjusting, again check the toe-in.

(5) When the adjustment is correct, tighten the locking bolts.

**NOTE**

Do not tack weld the ends of the tie rod.

**2-215. Tie Rod.**

*a. Removal (fig. 2-204).*

**NOTE**

Loose wheel bearings, damaged wheels, a bent steering knuckle, a bent axle housing, or a bent tie rod will affect toe-in.

(1) With the vehicle on a level surface, apply the handbrake.

(2) Raise the front axle enough to take the weight of the vehicle off the front wheel.

(3) Remove the cotter pin and nut from the stud at each end of the tie rod.

(4) Remove the tie rod end studs from the left and right steering knuckle arms. Remove the tie rod assembly.

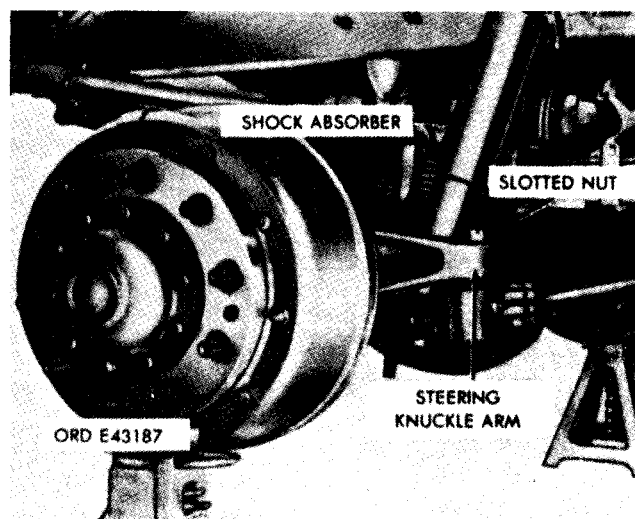


Figure 2-204. Front axle assembly with wheel and tire assembly removed.

*b. Installation (fig. 2-204).*

(1) Insert the tie rod end studs in the steering knuckle arm holes.

(2) Install two slotted nuts, one on each stud, and torque nuts 140 to 180 lb-ft for all models with exception of M39, M39A2 chassis, M41 and M41A2 cargo trucks.

(3) Install cotter pins to the slotted end nuts. Lower the wheels, and adjust the toe-in (para 2-214e).

(4) Lubricate the rod in accordance with L0 9-2320-211-12.

**2-216. Steering Wheel.**

*a. Removal.*

(1) Remove the horn button assembly (para 2-156).

(2) Remove the hexagon nut (fig. 2-205) securing the steering wheel to the upper end of the steering shaft.

(3) Install the horn bottom assembly (para 2-156).

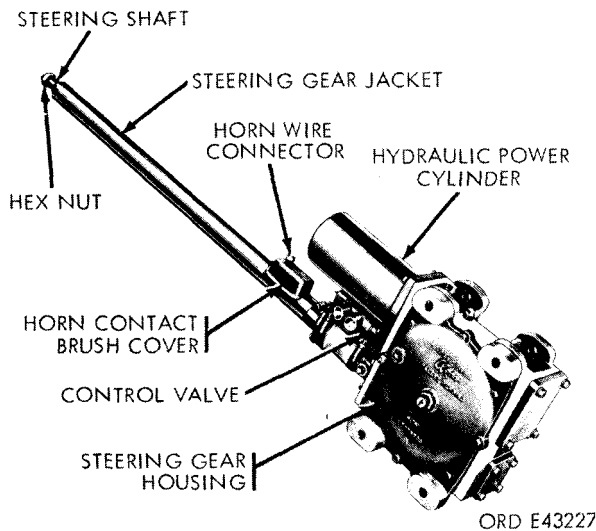


Figure 2-205. Steering gear unit.

(3) Using a puller (fig. 2-206), remove the steering wheel from the steering shaft.

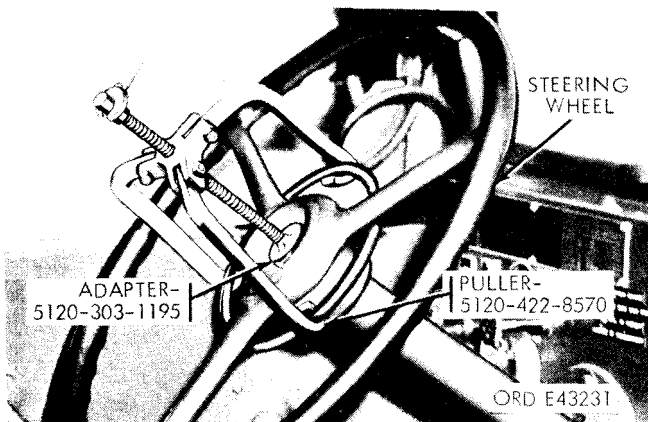


Figure 2-206. Removing steering wheel.

**b. Installation.**

(1) Position the steering wheel on the upper end of the steering shaft (fig. 2-200) with the splines on the end of the shaft engaging the splines in the bore of the steering wheel hub.

**NOTE**

The steering wheel should be installed so that the spokes form a Y when viewed from the operator's seat with the front wheels in a straightahead position.

(2) Install the hexagon nut (fig. 2-20.5) on the steering shaft and tighten it.

**2-217. Pitman Arm**

**a. Removal (fig. 2-207).**

(1) Remove the nut and lockwasher securing the pitman arm to the left end of the pitman arm shaft.

(2) Pull the pitman arm from the shaft.

(3) Disconnect the rear end of the upper drag link from the pitman arm ball stud (para 2-218).

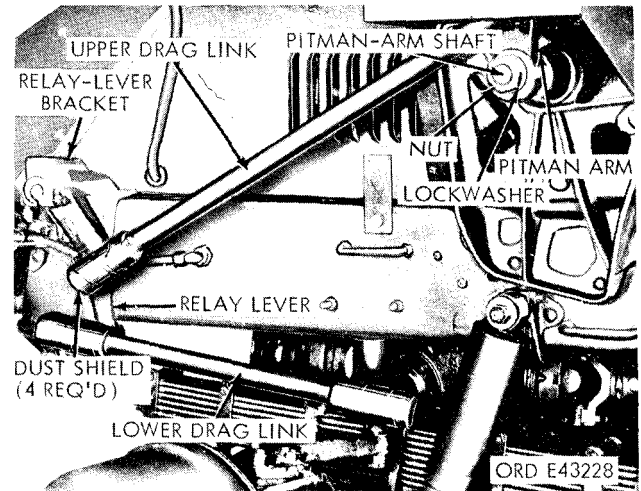


Figure 2-207. Steering linkage under left fender.

**b. Installation (fig. 2-207).**

(1) Connect the rear of the upper drag link to the pitman arm ball stud (para 2-218).

(2) Set the front wheels in a straightahead position, and set the steering wheel in the mid-position.

(3) Position the pit man arm on the splined shaft with the arm pointing upward.

(4) Push the pitman arm onto the shaft until the nut can be installed on the threaded end of the shaft.

(3) Install the lockwasher and nut on the shaft and tighten it.

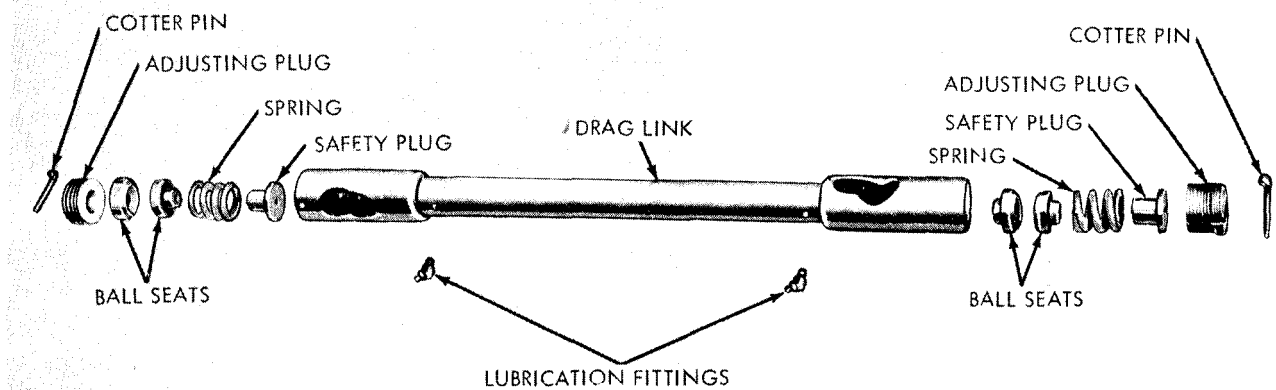
**2-218. Upper Drag Link**

**a. Removal.**

(1) Remove the dust shield (fig. 2-207) from the pitman arm end of the upper drag link.

(2) Remove the cotter pin (fig. 2-208) from the drag link.

(3) Unscrew the adjusting plug (fig. 2-208) as far as possible without removing it from the end of the drag link.



ORD E43232

Figure 2-208. Drag link assembly—exploded view.

(4) Repeat (1), (2), and (3) above at the relay lever end of the drag link.

(5) Turn the steering wheel in both directions to loosen the drag link ends, pull the front end of the drag link from the ball stud at the relay lever, pull the rear end of the drag link from the ball stud at the pitman arm, and remove the drag link from the vehicle.

*b. Installation.*

(1) Place the rear end of the upper drag link (fig. 207) on the pitman arm ball stud, and screw the adjusting plug (fig. 208) into the end of the drag link, but do not tighten it.

**NOTE**

The distance between the ball stud opening and the drag link end is greater at one end of the drag link assembly than at the other (fig. 2-208). Install the upper drag link so that the end with the greater distance between the ball stud opening and the drag link end is at the pitman arm.

(2) Place the front end of the upper drag link on the upper ball stud on the relay lever (fig. 2-207). Screw the adjusting plug into the end of the drag link, but do not tighten it.

(3) Install the dust shield (fig. 2-207) at both ends of the drag link, and lubricate the drag link.

(4) Turn the adjusting plug into the rear end of the drag link until the ball seats (fig. 2-208) and clamp the pitman arm ball stud firmly; then back out the adjusting plug until the slot in the plug is aligned with the first cotter pin hole. Install a new cotter pin.

(5) Repeat (4) above at the front end of the upper drag link.

(6) Lubricate the upper drag link in accordance with LO 9-2320-211-12.

**2-219. Lower Drag Link**

*a. Removal.* Remove the lower drag link (fig. 2-207) from the ball studs at the relay lever and steering arm as described in paragraph 2-218a.

*b. Installation.*

**NOTE**

Install the lower drag link so that the end with greater distance between the ball stud opening and the drag link end is at the relay lever.

(1) Install the lower drag link as described in paragraph 2-218b.

(2) Lubricate the link in accordance with LO 9-2320-211-12.

**2-220. Relay lever**

*a. Removal.*

(1) Remove the front end of the upper drag link from the upper ball stud at the relay lever.

(2) Remove the front end of the lower drag link from the lower ball stud at the relay lever.

(3) Remove the safety nut and screw at the left side of the relay lever bracket.

(4) Remove the lubrication fitting from the outer end of the relay lever pin, and install the screw in the lubrication fitting hole.

(5) Pulling on the screw, pull the relay lever pin from the bracket, and remove the lever from the bracket.

*b. Installation.*

(1) Position the relay lever in the bracket on the frame left side rail, and install the relay lever pin in the bore of the bracket and lever.

**NOTE**

The groove in the pin must be at the bottom of the bracket bore.

(2) Install the screw and safety nut in the left side of the bracket to clamp the pin in the bracket. Tighten the screw and nut.





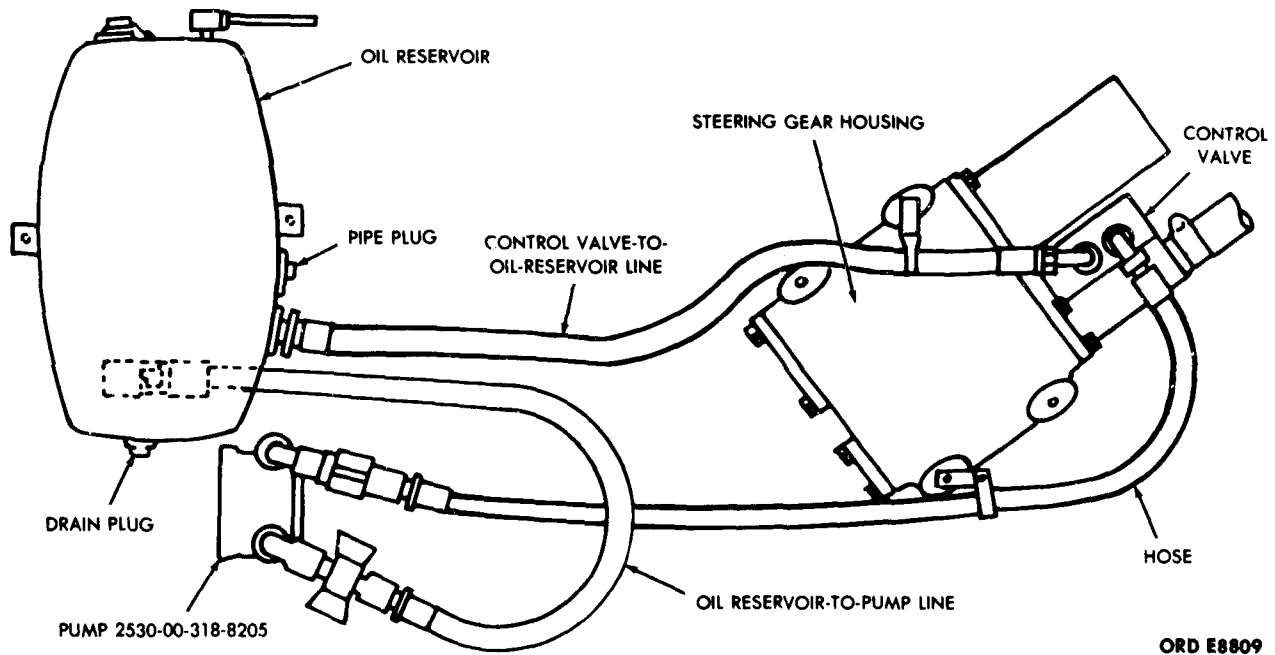


Figure 2-210. Removing hydraulic oil reservoir—multifuel models.

c. Installation fig. 2-209, 2-210).

(1) Support the reservoir in position, and secure the reservoir to the left front fender splash shield with four washers, two screws, and two safety nuts. Tighten the nuts.

(2) Install a spacer, washer, and one cushion to the screw, and place the screw into the bracket hold at the bottom of the reservoir.

(3) Secure the reservoir bracket to the frame left side rail with the other cushion and safety nut on the screw. Tighten the nut.

(4) Connect the outlet line, two inlet lines, and the

ventilation line to the reservoir and tighten all connectors.

(5) Install and tighten the drain plug.

(6) Fill the reservoir in accordance with LO 9-2320-211-12. Check for possible leaks.

**2-222.1. Steering Conversion Kit.** For installation instructions refer to drawing 11672548 (8 sheets); for illustration to drawing 11672547 (4 sheets) and 11677197 (5 sheets) and to 11672552(1 sheet) for template used in installation. Refer to TM 9-2320-260-20 for maintenance of steering conversion kit.

### Section XXXIII. MAINTENANCE OF FRAME, TOWING ATTACHMENTS, AND BRACKETS

**2-223. General.** The frame attachments and brackets discussed in this section include the towing pintle, the lifting shackle assembly, the safety chain shackle assembly, and the fifth wheel assembly. The pintle hook mounting bracket and safety chain shackle bracket are bolted to the frame bumper (which is bolted to the frame).

**2-224. Pintle Assembly.**

a. Hook.

(1) *Service.* Periodically lubricate the pintle assembly in accordance with LO 9-2320-211-12.

(2) *Removal.* Remove the cotter pin, slotted nut, and washer (from behind rear crossmember) securing the hook to the mounting bracket. Pull the hook from the bracket (fig. 2-11).

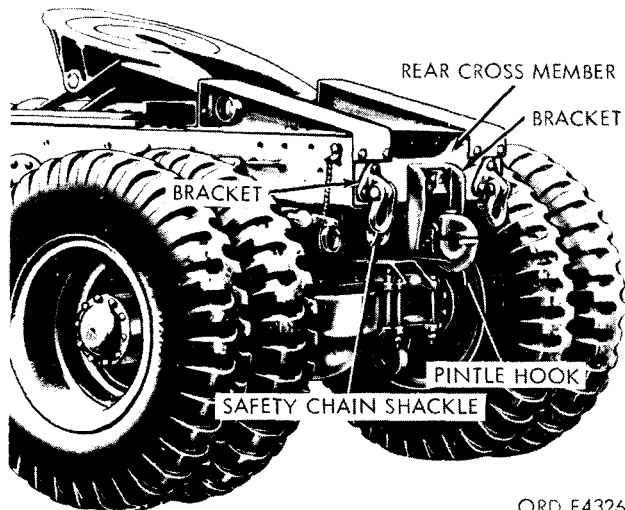


Figure 2-211. Pintle hook and safety chain shackle mounted to rear of vehicle.

(3) *Repair.*

(a) Clean the hook in a drycleaning solvent or mineral spirits paint thinner. If necessary, use a stiff-bristle brush to clean off the dirt that still clings to the hook.

(b) Inspect the hook shaft and the threaded end of the shaft for signs of excessive wear and / or damage. Also inspect the hook, lock, and latch for damage. Check the lubrication fittings.

(c) Use a fine stone, if necessary, to remove any raised metal or scores; replace the latch chain if it is missing, broken, or damaged in any way.

(4) *Installation.* Insert the threaded end of the hook in the hole in the mounting bracket (fig. 2-212). Secure the hook to the bracket with a plain washer, slotted nut, and cotter pin. Adjust the pintle hook to 0.003 / 0.017 inch between the plain washer and the mounting bracket, to permit free rotation of the pintle.

b. *Bracket.*

(1) *Removal.* Remove the hook as described in a(2) above. Unscrew the eight nuts, and remove the eight screws securing the bracket to the rear crossmember. Remove the bracket (fig. 2-211).

(2) *Installation.* Secure the bracket to the rear crossmember with eight screws and nuts (fig. 2-211). Tighten the nuts. Install the hook as described in a(4) above. Lubricate the pintle assembly in accordance with LO 9-2320-211-12.

a. *Shackle.*

(1) *Removal.* Remove the clip securing the clevis pin. Pull the pin out, and remove the shackle (fig. 2-212).

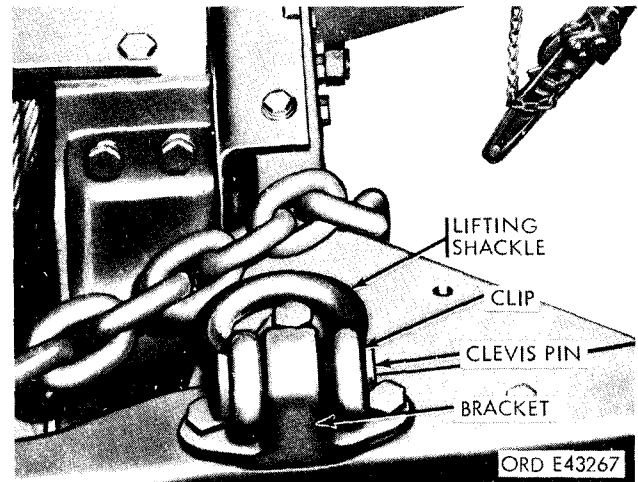


Figure 2-212. Lifting shackle assembly.

(2) *Installation.* Position the shackle to the bracket. Insert the clevis pin through the shackle and bracket (fig. 2-212). Secure the pin with the clip.

b. *Bracket.*

(1) *Removal.*

(a) Remove the lifting shackle as described in a(1) above.

(b) Remove the two capscrews and safety nuts securing the front end of the bracket to the top of the front bumper.

(c) Remove the safety nut, short spacer, cap screw, and long spacer securing the rear end of the bracket to the top of the front bumper. Remove the bracket from the bumper.

(2) *Installation.*

(a) Position the lifting shackle bracket on top of the front bumper. Secure the front end of the shackle to the bumper with two capscrews and safety nuts.

(b) Position the long spacer between the bumper flanges under the bracket rear mounting hole. Insert the capscrew through the hole and spacer. Install the short spacer and safety nut on the capscrew at the underside of the bottom bumper flange, and tighten the nut.

(c) Install the lifting shackle as described in a(2) above.

## 2-226. Safety Chain Shackle Assembly

a. *Shackle.*

(1) *Removal.* Refer to paragraph 2-225a (1), and follow similar procedures.

(2) *Installation.* Refer to paragraph 2-225a (2), and follow similar procedures.

b. *Bracket.*

(1) *Removal.* Refer to paragraph 2-225a (1), and follow similar procedures to remove the

shackle. Remove the three safety nuts and screws securing the bracket to the rear crossmember, and remove the bracket.

(2) *Installation.* Secure the bracket to the rear crossmember with three screws and nuts. Tighten the nuts. Refer to paragraph 2-225a (2), and follow similar procedures to install the shackle.

**2-227. Spare Wheel Carrier**

*a. Removal.*

(1) Remove the four safety nuts and screws securing the spare wheel carrier mounting brackets to the frame.

(2) Remove the carrier and tool box assembly from the vehicle.

*b. Installation.*

(1) Position the carrier assembly to the frame.

(2) Secure the carrier mounting brackets to the frame with four screws and safety nuts. Tighten the nuts.

**2-228. Fifth Wheel Assembly—M52, M52A1, and M52A2 Models**

*a. General.* The fifth wheel assembly on the above models includes the fifth wheel, the approach plate, and the center deck plate. The fifth wheel (fig. 2-213) is bolted to the inside of the side rails. The approach plate (fig. 2-214) and center deck plate (fig. 2-215) are bolted directly to the frame left and right side rails.

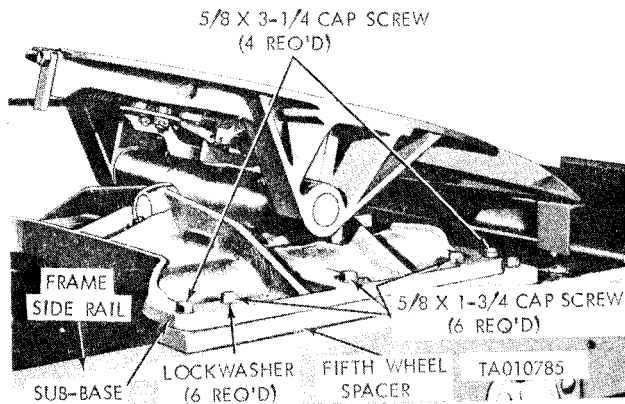


Figure 2-213. Fifth wheel—M52, M52A1, and M52A2.

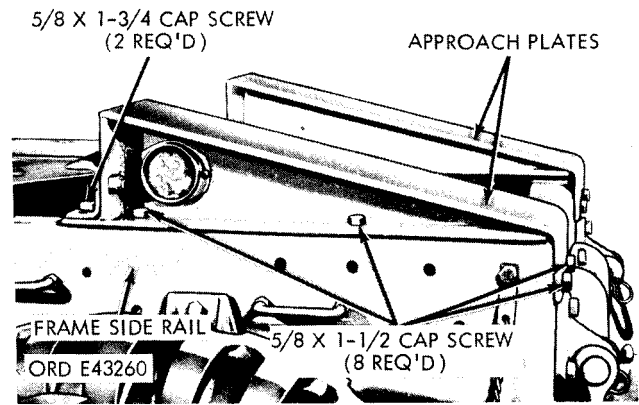


Figure 2-214. Approach plate—M52, M52A1, and M52A2.

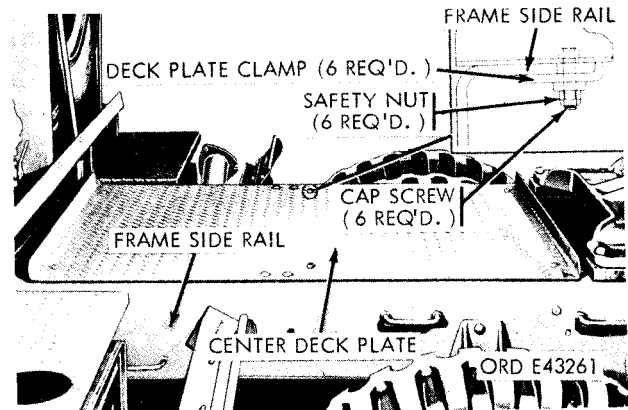


Figure 2-215. Center deck plate—M52, M52A1, and M52A2.

*b. Fifth Wheel (fig. 2-213).*

(1) *Adjustment.* The fifth wheel is equipped with two adjusting wedges that control its lateral movement. The adjusting wedges are used in the full-locked position when the vehicle is operated on the highway. For off-highway use, the wedges should be in the fully withdrawn position. No other adjustment is required.

(2) *Removal.*

(a) Remove the six screws and lockwashers and the four screws and safety nuts (located on inside of frame side rails) securing the fifth wheel subbase to the fifth wheel spacers and frame side rails.

(b) Using overhead hoisting equipment, remove the fifth wheel from the vehicle.

(3) *Installation.*

(a) Lift the fifth wheel into position on the spacers bolted to the frame side rails, and align the mounting screw holes in the subbase and spacers.

(b) Install the six screws and lockwashers in the holes in the subbase and spacers, and tighten them. Insert the four screws through the holes in the subbase and spacer, install the four safety nuts on the screws, and tighten them.

(c) Lubricate the fifth wheel in accordance with LO 9-2320-211-12.

c. *Approach Plate (fig. 2-214).*

(1) *Removal.*

(a) Remove the eight screws and safety nuts, and the two screws and safety nuts securing the approach plate assembly to the frame side rails.

(b) Lift the approach plate assembly from the vehicle.

(2) *Installation.*

(a) Lift the approach plate assembly into position on the frame side rails, and align the mounting screw holes in the approach plates and side rails.

(b) Install the two screws and eight screws in the holes in the approach plates and side rails. Install the 10 safety nuts on the screws, and tighten them.

d. *Center Deck Plate (fig. 2-215).*

(1) *Removal.*

(a) Remove the six screws, safety nuts, and desk plate clamps securing the center deck plate to the frame side rails.

(b) Lift the center deck plate from the vehicle.

(2) *Installation.*

(a) Lift the center deck plate into position

on the frame side rails, and align the mounting screw holes in the plate and side rails.

(b) Insert the six screws in the holes in the plate and side rails, and install the six safety nuts and deck plate clamps on the screws. Tighten the screws and nuts.

**2-229. Fifth wheel assembly—M246 Model**

a. *General.* Fifth wheel components on the tractor-wrecker (M246 model) include a fifth wheel and approach plates which are part of the crane body. The fifth wheel is bolted to both the crane body side rails and the frame side rails.

b. *Fifth Wheel.*

(1) *Adjustment.* Refer to paragraph 2-228 b (1), and follow similar procedures.

(2) *Removal.*

(a) Remove the safety nuts (located on the inside of the truck frame side rails) from the eight screws, four on each side of the fifth wheel subbase, securing the fifth wheel to the crane body side rails and the truck frame side rails. Remove the screws.

(b) Remove the two screws and lockwashers, one on each side of subbase, securing the fifth wheel to the crane body side rails.

(c) Using overhead hoisting equipment, remove the fifth wheel from the vehicle.

(3) *Installation.*

(a) Lift the fifth wheel into position on the crane body side rails, and align the mounting screw hole in the subbase and side rails.

(b) Install the capscrew and lockwasher in the center hole on each side of the subbase (into the tapped hole in the side rail), and tighten it.

(c) Insert the eight screws in the holes in the subbase, the crane body side rails, and the truck frame side rails. Install eight safety nuts on the screws, and tighten them.

(d) Lubricate the fifth wheel in accordance with LO 9-2320-211-12.

## Section XXXIV. MAINTENANCE OF SPRINGS AND SHOCK ABSORBERS

### 2-230. General

a. *Front Spring.* Semielliptic, leaf type spring assemblies (fig. 2-216) are mounted to both sides of vehicle. Two U bolts and clamp plates secure the front springs to axle. The spring assemblies are mounted to a pivoting shackle at the rear spring

end and to a hanger at the front end. The pivoting shackle is secured to a hanger mounted to the vehicle side rail. The front hanger is secured to the same side rail. Spring leaves are held together by a bolt extending through the center of each leaf. Six clips hold the leaves in constant alinement.

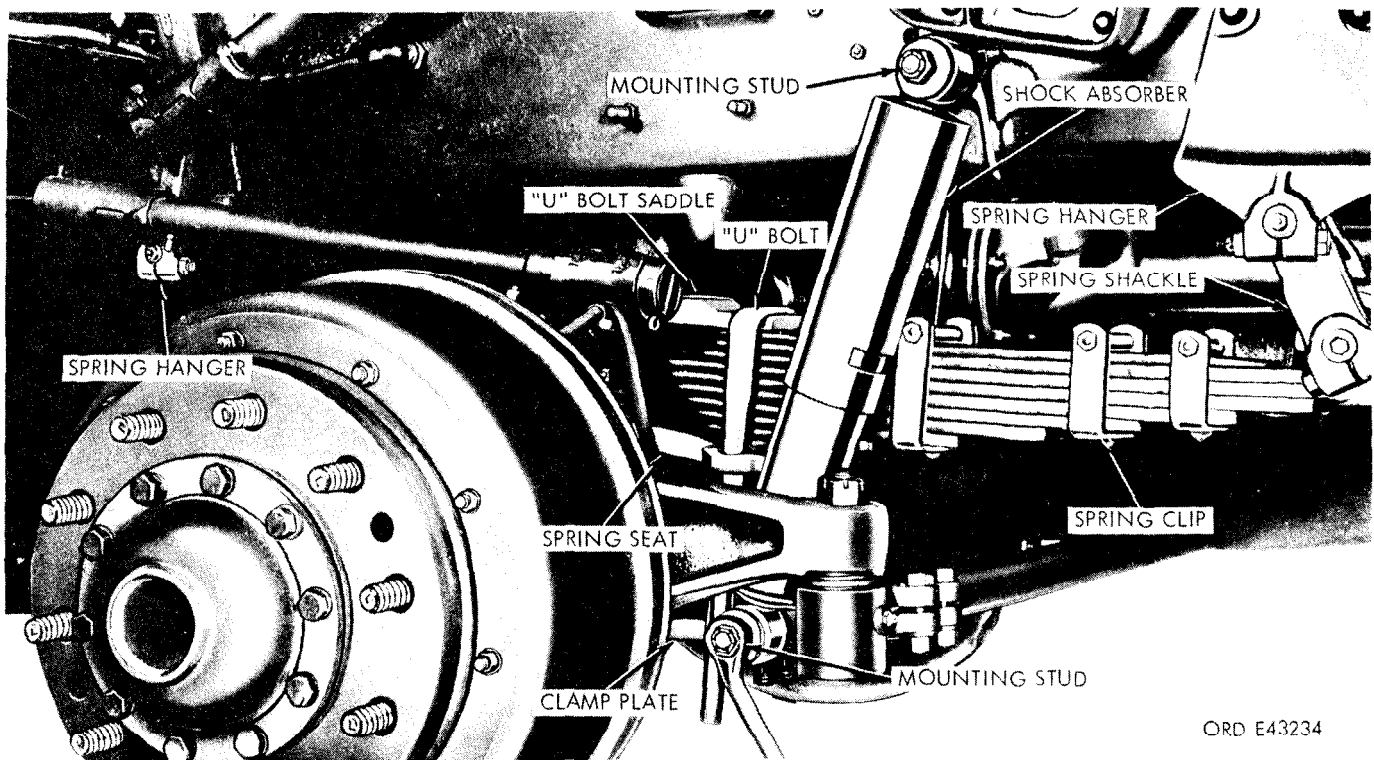


Figure 2-216. Left front spring and shock absorber.

*b. Rear Springs.* Semielliptic, leaf type assemblies (fig. 2-174) are mounted to both sides of the vehicle. Two U bolts secure the spring assembly to the spring seat. Both ends of each spring assembly slide freely in guide brackets bolted to the two rear axles. Spring leaves are held together by a bolt through the center of each leaf. Four clips hold the leaves in constant alinement.

*c. Shock Absorbers.* Two nonadjustable, double-acting shock absorbers (fig. 2-216) are mounted to the front of the vehicle. The upper end is secured to the frame side rail by a mounting bracket. The lower end is secured to the spring clamp plate. Four rubber bushings (two to each eye) are installed in the upper and lower ends of the shock absorber.

### 2-231. Front Springs

#### *a. Removal.*

(1) Remove the front wheel (para 2-207) and raise the frame to remove the load from the springs.

(2) Loosen the safety nut on the capscrew at the bottom of the front spring hanger. Drive the pin from the hanger and the front spring eye. Remove the spring from the front hanger.

(3) Loosen the safety nut on the capscrew at the bottom of the spring shackle. Drive the pin from the shackle and rear spring eye. Remove the spring from the shackle.

(4) Remove the safety nut securing the lower shock absorber mounting eye to the stud at the clamp plate. Remove the washer, two rubber bushings, and the mounting eye from the stud.

(5) Remove the four nuts and lockwashers from the two U bolts at the underside of the clamp plate, and remove the clamp plate, two U bolts, and the U bolt saddle.

(6) Lift the spring off the spring seat and remove it from the vehicle. Remove the spring seat from the axle.

(7) If necessary, loosen the safety nut on the capscrew at the bottom of the front rear hanger.

(8) Drive the pin out of the top of the shackle, and remove the shackle. If necessary, remove the bushing from the shackle eye.

#### *b. Installation.*

(1) If removed, replace the bushing in the shackle eye.

(2) Position the shackle to the hanger, and drive the pin through the shackle and hanger. Tighten the safety nut on the capscrew securing the shackle to the hanger.

(3) Place the spring seat on top of the front axle. Position the front spring on top of the seat so that the lower end of the spring center bolt enters the hole in the center of the seat.

(4) Position the U-bolt saddle on top of the spring. Place the U-bolts over the saddle with their ends through the holes in spring seat.

(5) Position the clamp plate on the underside of the axle with the U-bolts extending through the holes in the clamp plate. Install the four lockwashers and nuts in the two U-bolts. Tighten the nuts on the U-bolts to 300-400 lb-ft torque.

#### NOTE

Be sure that the clamp plate is installed so that the shock absorber mounting stud is at the rear of the axle.

(6) Install the lower shock absorber mounting eye, with a rubber bushing inserted in each end of the eye, on the mounting stud at the rear left side of the clamp. Install the washer and safety nut on the stud and tighten the nut.

(7) Position the rear spring eye at the spring shackle. Install the pin through the shackle and spring eye. Tighten the safety nut on the capscrew at the bottom of the shackle to clamp the pin in place.

(8) Position the front spring eye at the spring hanger. Install the pin through the hanger and spring eye. Tighten the safety nut on the capscrew at the bottom of the hanger to clamp pin in place.

(9) Lower the frame to place a load on the spring, and lubricate the spring shackle and hanger pins in accordance with LO 9-2320-211-12.

## 2-232. Rear Springs.

### a. Removal.

(1) Remove the rear wheels (para 2-207).

(2) Raise the frame to remove the load from the springs.

(3) Place a jack under the spring seat. Support the seat to prevent the seat and torque rod assembly from dropping when the U-bolts are removed.

(4) Remove the clamp bolts and nuts securing the front and rear ends of the spring seat tube bracket to the underside of the suspension bracket.

(5) Remove the four nuts and lockwashers from the two U-bolts. Lower the spring seat on the jack until the ends of the U-bolt are free of the seat.

(6) Remove the U-bolts from the spring saddle, and remove the saddle from the spring.

#### NOTE

On wrecker models M62 and M543, and tractor-wrecker, model M246, remove the U-bolts and the stabilizer beam from the rear spring.

(7) Slide one end of the spring through the guide bracket on either axle until the opposite end of the spring is free of its guide bracket.

(8) Then slide the other end of the spring from its guide bracket, and remove the spring from the vehicle.

### b. Installation (fig. 2-174).

(1) Slide one end of the spring through the guide bracket on either axle.

(2) Slide the other end of the spring into its guide bracket, and position the spring so that the lower end of the spring center bolt is directly over the hole in the center of the spring seat.

(3) Position the spring saddle on top of the spring. Place the two U-bolts over the saddle and spring.

#### NOTE

On the M62, M543, and M246, place the stabilizer beam over the spring and secure it with U-bolts.

(4) Raise the spring seat and insert the ends of the U-bolts in the holes in the seat.

(5) Raise the seat against the spring, being sure that the lower end of the spring center bolt enters the hole in the center of the seat.

(6) Install the four lockwashers and nuts on the U-bolts, and tighten the nuts to 350-450 lb-ft torque.

(7) Install the clamp bolts through the front and rear ends of the spring seat tube bracket and suspension bracket. Remove the jack from under the seat.

(8) Lower the frame to place a load on the spring.

## 2-233. Spring Seats.

### a. Bearing Adjustment.

(1) Remove the wheels from both rear axles (para 2-207) to provide access to the spring seat to be adjusted.

(2) Place the jack under the cross tube connecting the left and right spring seats (fig. 2-217). Raise the jack sufficiently to hold the tube in position.

(3) Remove the four nuts and lockwashers from the two U-bolts (fig. 2-216). Remove the U-bolts from the spring seat and spring saddle.

(4) Remove the clamp bolts (fig. 2-174) from the front and rear ends of the spring seat.

(5) Place two jacks under the spring, one on each side of spring seat. Raise the spring clear of the seat sufficiently to permit some rotation of the spring seat around the end of the cross tube (fig. 2-217).

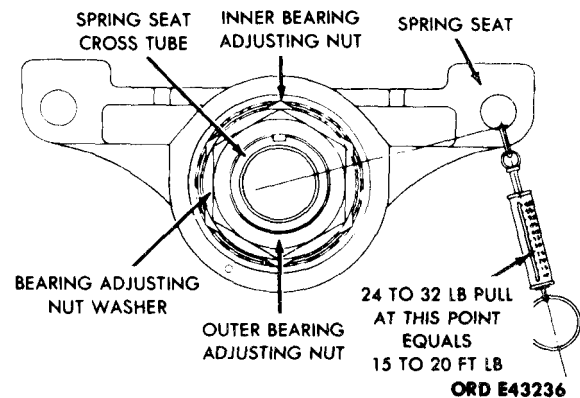


Figure 2-217. Spring seat bearing adjustment.

(6) Hook the end of a tester scale in the clamp bolt hole (fig. 2-217), and pull downward on the scale, noting the pull required to rotate the spring seat on the cross tube.

(7) When the bearings are correctly adjusted, the pull on the scale required to rotate the spring seat is 24 to 32 pounds. This is equal to 15 to 20 lb-ft preload on the bearings.

**NOTE**

If the spring seat bearing adjustment is required, proceed as described in (8) through (12) below. Otherwise proceed as in (13) through (18) below.

(8) Remove the six capscrews and lockwashers from the spring seat cap. Remove the cap from the spring seat assembly. Remove and discard the cap gasket.

(9) Remove the outer bearing adjusting nut (fig. 2-217) and the bearing adjusting nut washer from the cross tube.

(10) Turn the inner bearing adjusting nut (fig. 2-217) until a pull of 24 to 32 pounds on the scale is required to rotate the spring seat.

(11) Install the bearing adjusting nut washer and outer bearing adjusting nut on the cross tube. Tighten the nut. Check the bearing adjustment as described in (6) above.

(12) Position a new cap gasket and spring seat cap on the spring seat (fig. 2-174). Install the six capscrews and lockwashers.

(13) Lower the spring on the spring seat, and remove the jacks from under the spring.

(14) With the spring saddle (fig. 2-174) in position on top of the spring, place two U-bolts over the saddle and spring, inserting the ends of the U-bolts in the holes in spring seat.

(15) Install four lockwashers and nuts on the two U-bolts. Tighten the nuts.

(16) Install the clamp bolts in the front and rear ends of spring seat. Tighten the bolts.

(17) Remove the jack from under the cross tube

connecting the left and right spring seats.

(18) Install the wheels on both rear axles (para 2-207).

*b. Removal.*

(1) Disconnect the spring seat from spring as described in (1) through (5) above.

(2) Remove the six capscrews and lockwashers from the spring seat cap. Remove the cap from the spring seat assembly. Remove and discard the cap gasket.

(3) Remove the outer bearing adjusting nut (fig. 2-217), bearing adjusting nut washer and the inner bearing adjusting nut from the cross tube.

(4) Pull the spring seat with the outer tapered roller bearing cone from the spring seat.

(5) Remove dust seal washer, two dust seals, wiper retainer, wiper, grease seal and two bearings and cups from spring seat.

*c. Installation.*

(1) With the inner tapered roller bearing cone in position on the cross tube (fig. 2-217), install the spring seat assembly on the cross tube so that the cone enters the bearing cup in the outer bore of the seat.

(3) Install the inner bearing adjusting nut on the end of the cross tube, and adjust the bearings as described in paragraph *a* above.

**2-234. Shock Absorbers.**

*a. Removal (fig. 2-216).*

(1) Raise the vehicle to remove the load from the shock absorber.

(2) Refer to paragraph 2-23 *1a(4)* for procedures to disconnect the lower shock absorber mounting eye.

(3) Remove the safety nut securing the upper shock absorber mounting eye. Remove the washer, two rubber bushings, and the shock absorber from vehicle. Discard the bushings.

*b. Installation (fig. 2-216).*

(1) Position the shock absorber on the studs with new bushings installed to the upper and lower ends.

(2) Install a washer and safety nuts on the upper and lower end.

(3) Lower the vehicle to the ground.



## Section XXXV. MAINTENANCE OF BODY, CAB, AND HOOD

### 2-235. General

Components discussed in this section include the brush guard, the cab top frame, the windshield assembly, the cab seat cushions, and the cargo body. The cargo body is an open top metal unit mounted behind the cab on the frame. Removable front and side cargo racks include sockets for six top bows which support a tarpaulin cover for the cargo area. Also incorporated in the cargo racks are troop seats that can be lowered. These are supported by hinged legs. The spare tire is mounted on a bracket at the forward end of the cargo body.

### 2-236. Brush guard

#### a. Removal (fig. 2-218).

- (1) Unscrew the two brace nuts. Remove the nuts and bolts.
- (2) Remove the two mounting bolts. Pull the brush guard forward, and remove it from the vehicle.

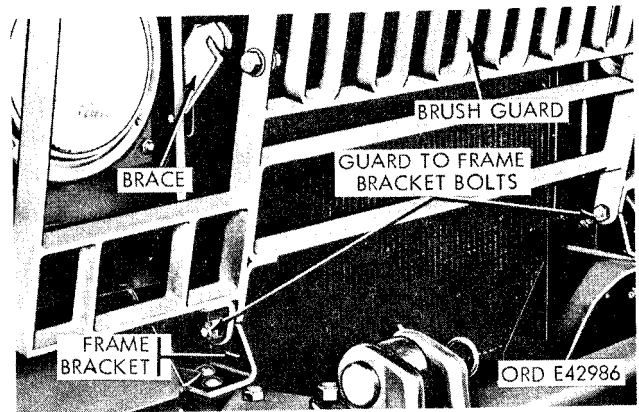


Figure 2-218. Removing brush guard.

#### b. Installation (fig. 2-218).

- (1) Position the brush guard and secure it with two mounting bolts.
- (2) Secure the guard to braces with two bolts and nuts. Tighten all bolts and nuts securing the guard to the vehicle.

### 2-237. Cab Top Frame

#### a. Removal (fig. 2-219).

- (1) Remove the cab top tarpaulin as described in TM 9-2320-211-10.
- (2) Disengage both cab roof rails from the windshield frame.
- (3) Turn the rails in and then down on the hinge at the lock pillar post.
- (4) Loosen the thumb screw at both pillar posts. Lift the pillar posts and bow assembly from sockets.
- (5) Remove the crossbars from the bows.

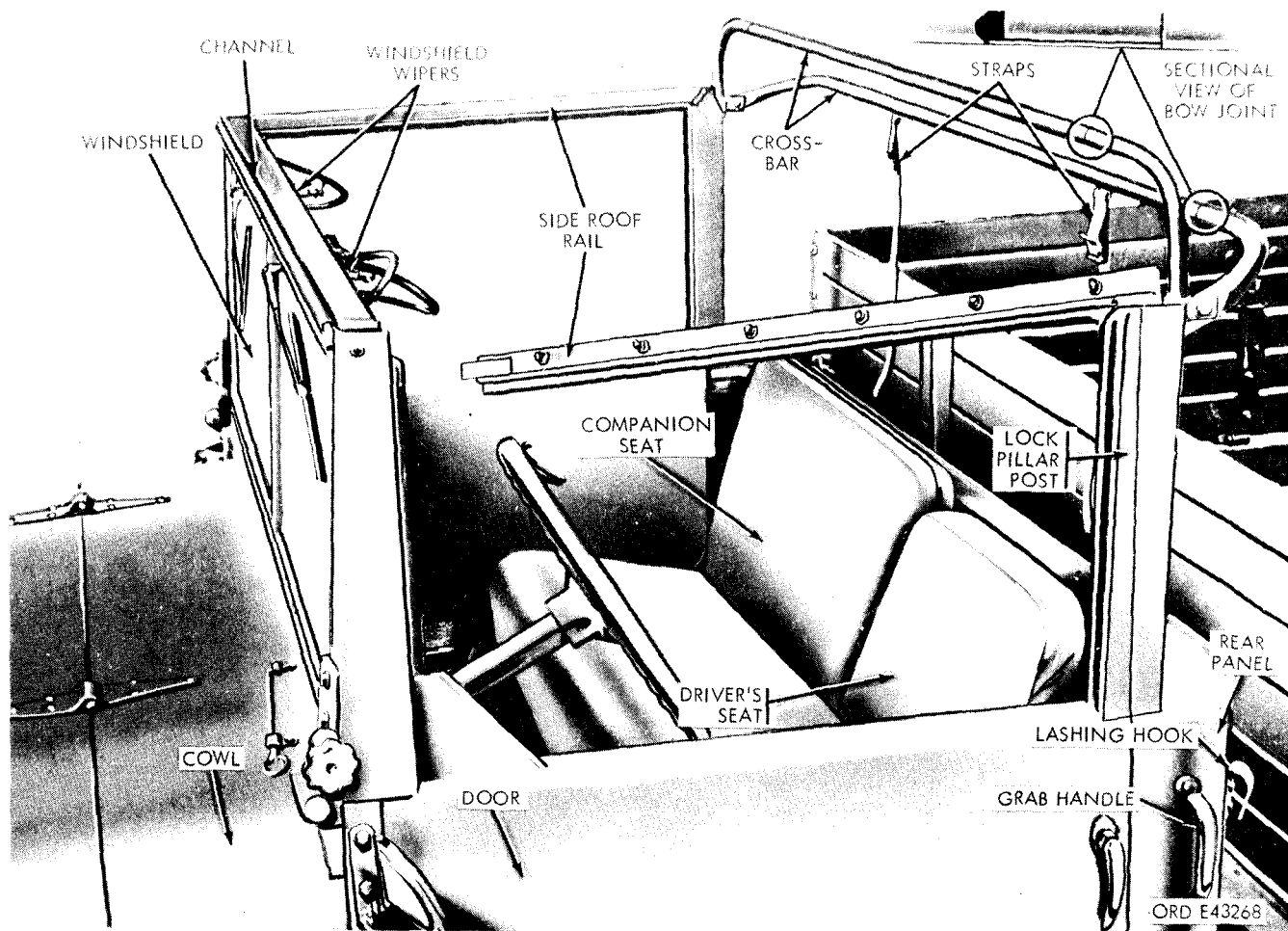


Figure 2-219. Cab with tarpaulin removed.

*b. Stowage.*

- (1) Strap the crossbars and pillar posts together with straps on the rear crossbar.
- (2) Stow the assembly in (1) above behind the cab seats.

*c. Installation (fig. 2-219).*

- (1) Insert the crossbars in bows so that the crossbar with straps is to the rear bow.
- (2) Position the pillar post assembly into sockets. Tighten the thumb screws on both sides.
- (3) Raise the cab roof rails and swing them around into position.
- (4) Engage the rail front ends into the upper corner slots of the windshield frame.

**2-238. Windshield Assembly**

*a. Removal (fig. 2-219).*

- (1) Disconnect the windshield wiper hose at the lower end of the wiper motor tubing.
- (2) Remove the eight nuts and bolts securing the windshield hinges to the cab.
- (3) Remove the windshield assembly from the vehicle.

*b. Installation (fig. 2-219).*

- (1) Position the windshield assembly to the vehicle, and secure the windshield hinge to the cab with eight bolts and nuts.
- (2) Connect the wiper hose to the wiper motor tubing.

**2-239. Cab Seat Cushions**

*a. Removal.*

- (1) Remove the cotter pin from the straight pin securing the link to the frame. Remove the companion seat cushion.
- (2) Remove the two cotter pins from the pins securing the seat back cushion to the frame. Remove the companion seat back cushion from the vehicle.
- (3) Remove the two nuts and bolts securing the operator's seat cushion to the frame. Remove the seat cushion.
- (4) Pull the operator's seat back cushion up and off the frame.

*b. Installation.*

(1) Place the operator's seat back cushion on the frame, and slide it down into position.

(2) Position the operator's seat and secure it to the frame with two bolts and nuts.

(3) Position the companion seat back cushion, and secure it to the frame with two pins. Secure the pins with two cotter pins.

(4) Position the companion seat cushion, and secure it with the straight pin to the link and frame. Secure the pin with a cotter pin.

**2-239.1. Driver's Seat Replacement (Bench Type).**

*a. Removal.* Lift up the driver's seat cushion, and remove the four safety nuts and eight washers holding the driver's seat frame to the seat frame base (fig. 219.). Release the seat adjuster locking handle and remove the seat.

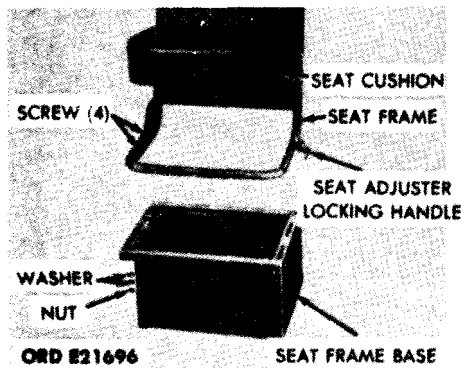


Figure 2-219.1. Driver's seat—removal.

*b. Installation.* Position the driver's seat on the base and engage the adjuster locking handle. Lift up the seat cushion and fasten the seat frame to the base with the two plain washers and safety nut on each of the four studs.

**2-239.2. Driver's Seat and Backrest Cushion Replacement (Bench Type).**

*a. Removal.* Slide the backrest cushion up and off the frame. Remove the two nuts and bolts holding the seat cushion hinges to the seat frame hinges (fig. 2-219.2), and remove the cushion.

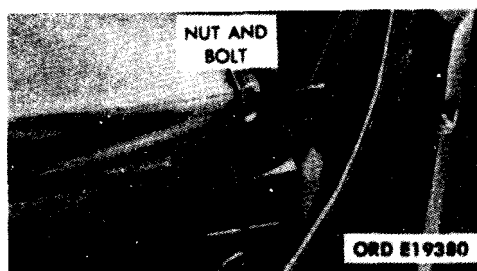


Figure 2-219.2. Driver's seat cushion disconnect points.

*b. Installation.* Position the seat cushion on the seat frame and fasten the hinges with the two bolts and safety nuts. Slide the backrest cushion over the back frame so the frame enters the upper portion of the cushion cover.

**2-239.3. Driver's Seat Replacement (Floating Type).**

*a. Removal (fig. 2-219.3).* Remove four screws securing seat base to cab floor and remove seat assembly from cab.

*b. Installation (fig. 2-219.3).* Position seat assembly in cab. Holes in seat base must be alined with holes in cab floor. Secure seat to cab floor with four screws and washers.

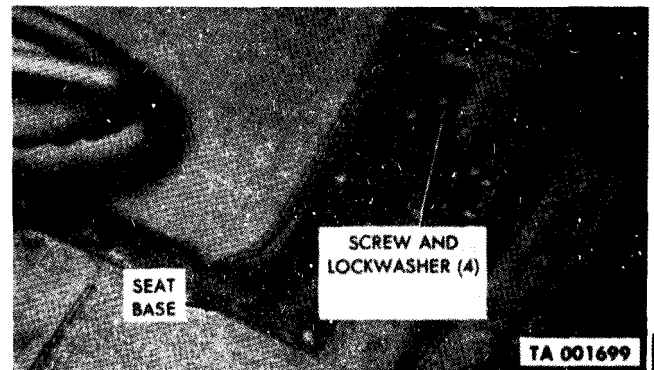


Figure 2-219.3. Driver's seat removal and installation.

**2-239.4. Seat Cushion Replacement (Floating Type).**

*a. Removal (fig. 2-219.4).* Remove four screws and washers securing cushion mounting brackets to underside of seat cushion. Remove seat cushion from seat frame.

*b. Installation (fig. 2-219.4).* Position cushion on seat frame. Position cushion mounting brackets on seat frame pins and secure brackets to seat cushion with four screws and washers.

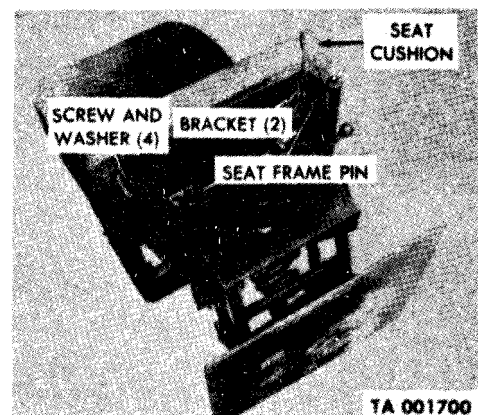


Figure 2-219.4. Driver's seat cushion removal and installation.

**2-239.5. Backrest Cushion Replacement (Floating Type).**

a. *Removal (fig. 2-219.5).* Remove seat assembly from cab (2-239.1a above). Remove four screws securing backrest cushion to adjuster rod brackets and remove wear plate. Remove four screws securing upper mounting brackets to backrest cushion and remove cushion from seat frame.

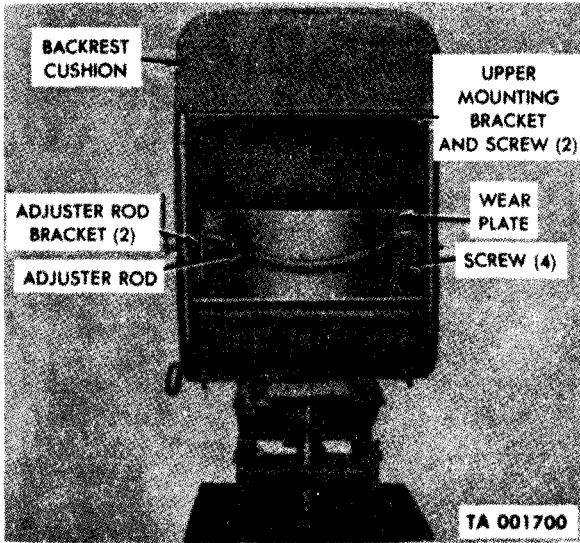


Figure 2-219.5. Driver's seat backrest cushion removal and installation

b. *Installation (fig. 2-219.5).* Position cushion on seat frame and secure to frame with two upper mounting brackets and two screws. Position wear plate between cushion and adjuster rod brackets. Secure adjuster rod brackets and wear plate to cushion with four screws. Install seat in cab (2-239.1b above).

**2-239.6. Companion Seat Replacement.**

a. *Removal (fig. 2-219.6).* Lift up the companion seat cushion. Remove the two screws securing the companion seat frame legs to the floor, remove the four safety nuts and screws securing the seat frame to the driver's seat base, and remove the seat.

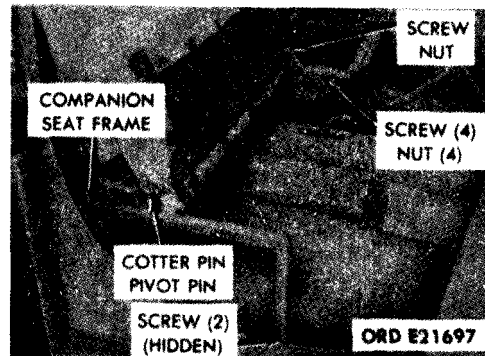


Figure 2-219.6. Companion seat removal.

b. *Installation (fig. 2-219.6).* Place the companion seat on the floor. Secure the seat frame to the driver's seat base with four hex-head screws and safety nuts. Secure the seat frame legs to the floor with two hex-head split lockwasher screws.

**2-239.7. Companion Seat and Backrest Cushion Replacement.**

a. *Removal (fig. 2-219.6).* Remove the two cotter pins and the pivot pins of the two safety nuts and screws holding the seat cushion hinges to the seat frame. Lift up the seat cushion. Remove the safety nut and screw holding the cushion to the seat cushion link, and remove the seat cushion. Pull up and pull out the bottom rear edge of the backrest cushion, and pull the cushion from the backrest frame.

b. *Installation (fig. 2-219.6).* Seat the top rear edge of the backrest cushion under hooks on the top edge of the backrest frame. While pulling up on the cushion, press the cushion back to seat the lower edge in the frame. Install the two pivot and cotter pins or two hex-head screws and safety nuts through the seat and frame hinge to secure the seat. Lift up the seat and secure the cushion to the seat cushion link with a hex-head screw and safety nut.

**2-240. Cargo Body-M41, M54, M54A1, M54A1C, M54A2. M55, M55A1, and M55A2.**

*a. Troop Seats.*

*(1) Removal.*

**NOTE**

Seats are removed with or without side cargo racks.

*(a)* To remove the seats with side cargo racks, lift them straight up to free the stake ends from the sockets at the side of the body.

*(b)* To remove troop seats only, remove the cotter pins and hinge pins from the six hinges securing each seat to the rack stakes. Release the seat latches, disengage the hinges, and remove the seats.

*(2) Installation.*

**NOTE**

Seats are installed with or without side cargo racks.

*(a)* If the seats were removed with the side cargo racks, position the stakes into the sockets and push the rack down.

*(b)* To install the seats only, position the seats on the side rack hinge pin and the cotter pin to the six hinges on each seat. Fold the seat up against the rack, and fasten it in place with the seat latches.

*b. Body Cover.* Refer to paragraph 2-245 for removal and installation procedures.

*c. Body Curtains.* Refer to paragraph 2-245e for removal and installation procedures.

*d. Body Bows.* Refer to paragraph 2-245c for removal and installation procedures.

## Section XXXVI. MAINTENANCE OF DUMP BODY - M51, M51A1, M51A2

**2-241. General.** Dump body and hoist assembly components consist of the all-steel welded dump body and subframe, the gear type hydraulic pump which is bolted to the control valve assembly, the control linkage for the power takeoff and control valve, and hydraulic lines and fittings for the system. In addition, troop seat accessory kits designed to permit dump trucks to transport personnel are available. These kits consist of seats and backs (called racks) with a tarpaulin covering held up by the necessary bows (fig. 2-220).

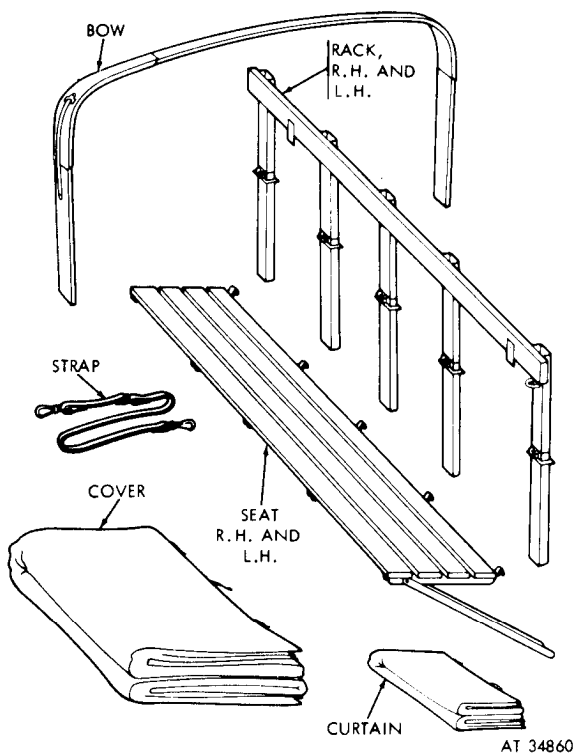


Figure 2-220. Dump body troop seat accessory kit—  
M51, M51A1 and M51A2

### 2-242. Hydraulic Pump.

#### a. Removal (fig. 2-216).

(1) Remove the drain plug. Drain the fluid from the reservoir and hydraulic system.

### NOTE

To completely drain the hydraulic system the hoist cylinder pistons must be completely extended or in the raised position.

(2) Remove the power takeoff-to-pump propeller shaft from the pump shaft.

(3) Remove the six capscrews and lockwashers securing the pump to the bottom flange of the control valve adapter. Remove the pump from the adapter.

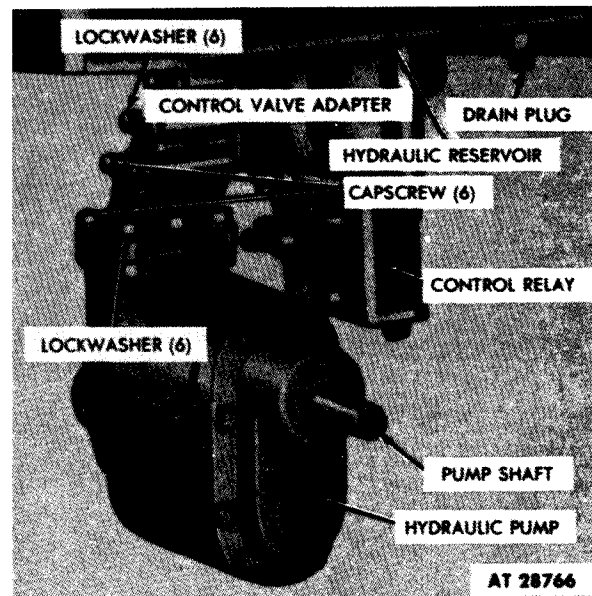


Figure 2-221. Right front view of hydraulic pump mounting.

#### b. Installation (fig. 2-221).

(1) Position the hydraulic pump on the bottom flange of the control valve adapter, and secure the pump to the flange with the six capscrews and lockwashers. Tighten the capscrews.

(2) Install the power takeoff-to-pump propeller shaft on the pump shaft.

(3) Replace the drain plug, and fill the hydraulic system.

### 2-243. Control Valve Assembly.

#### a. Removal.

(1) Remove the hydraulic pump (para 2-242).

(2) Remove the six capscrews (fig. 2-221) and

lockwashers securing the control valve adapter to the control valve. Remove the adapter from the valve.

(3) Remove the control valve levers (fig. 2-222) from the trunnion.

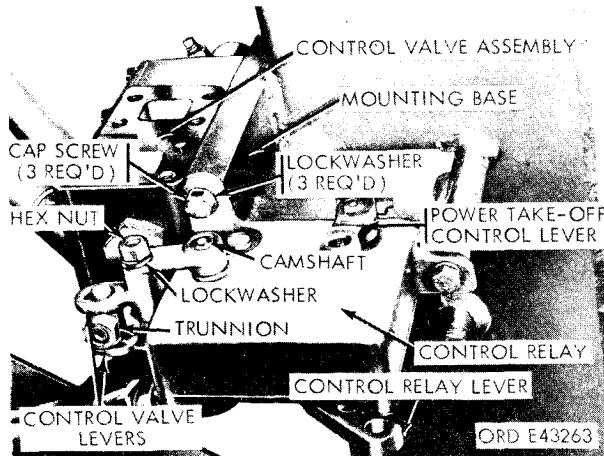


Figure 2-222. Bottom view of control valve assembly with pump and adapter removed.

(4) Disconnect the four hydraulic flexible lines from the manifolds (fig. 2-223) installed in the control valve outlet ports.

(5) Remove the eight cap screws (fig. 2-223) and lockwashers securing the control valve assembly to the mounting base. Remove the valve from the base.

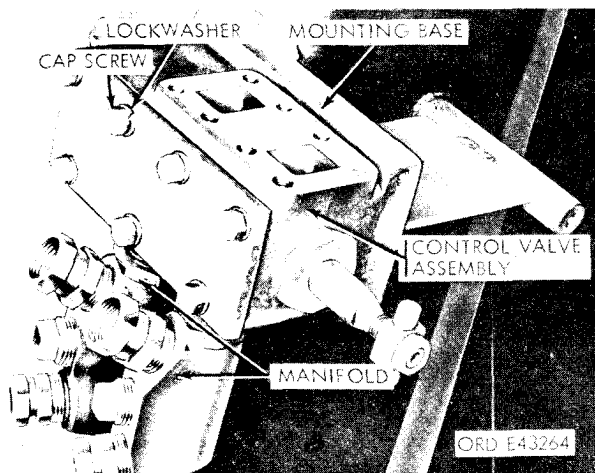


Figure 2-223. Removing control valve assembly.

#### b. Installation.

(1) Position the control valve assembly (fig. 2-223) on the mounting base at the rear of the reservoir, and secure it with eight cap screws and lockwashers.

(2) Connect the four hydraulic flexible lines to the manifolds (fig. 2-223) installed in the control valve ports. Refer to figure 2-224 when connecting the lines.

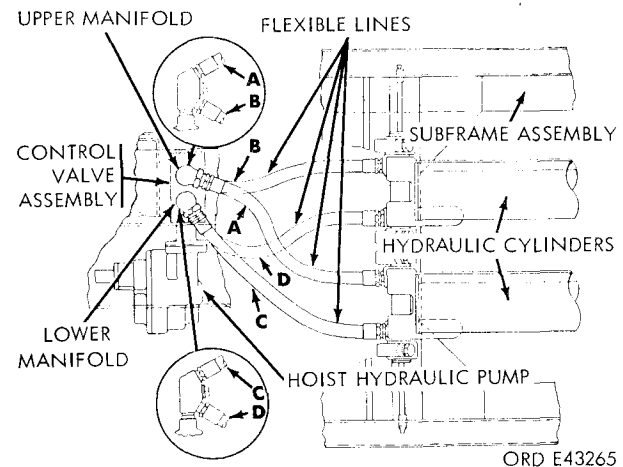


Figure 2-224. Hoist assembly flexible lines.

(3) Install the control valve levers (fig. 2-222) on the trunnion.

(4) Position the control valve adapter (fig. 2-221) on the control valve assembly, and secure it with six capscrews and lockwashers.

(5) Install the hydraulic pump (para 2-242).

#### 2-244. Hydraulic Lines and Fittings

##### CAUTION

Before disconnecting any hydraulic line, place an identification tag on the line and its corresponding part to prevent incorrect installation of the hydraulic line.

##### a. Removal (fig. 2-224).

(1) Unscrew the sleeve nut and both ends of the line being removed.

(2) Remove the line from the vehicle.

##### b. Installation (fig. 2-224).

(1) Position the flexible line on the proper hydraulic cylinder.

(2) Connect the line to the ports at the base of the cylinder and manifold fitting.

**NOTE**

When installing new lines or fittings, never tighten over two turns after the sleeve has shouldered in the body of the fitting.

(3) Tighten all flexible-line sleeve nuts.

**2-245. Troop Seat Accessory Kit**

**WARNING**

When using the M51 dump truck model or the M51A2 dump truck model as a personnel carrier, the dump control lever in

the cab must be secured in its locked position.

**a. Installing Seats.**

(1) Fold out the legs of the right troop seat assembly flat on the floor of the body.

(2) Raise the hook end of the seat assembly, and engage the hooks in the slots in the side of the body as shown in figure 2-225.

(3) Raise the seat, using hook ends as pivots and fold the legs under the seat as shown in figure 2-226.

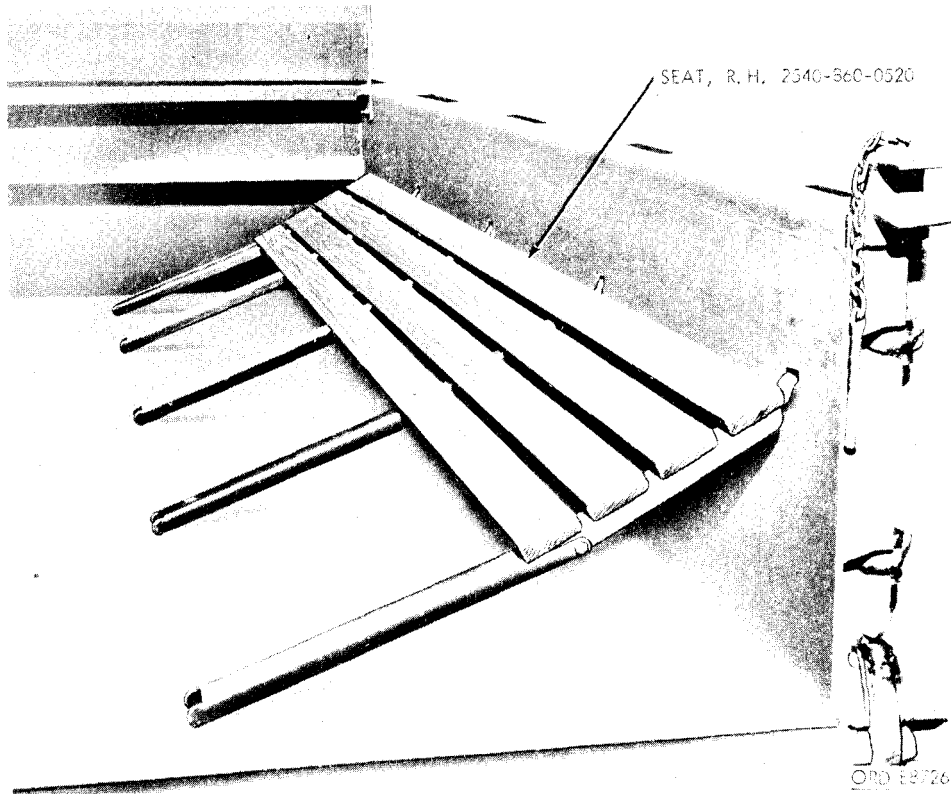


Figure 2-225. Installing seat hooks in slots.



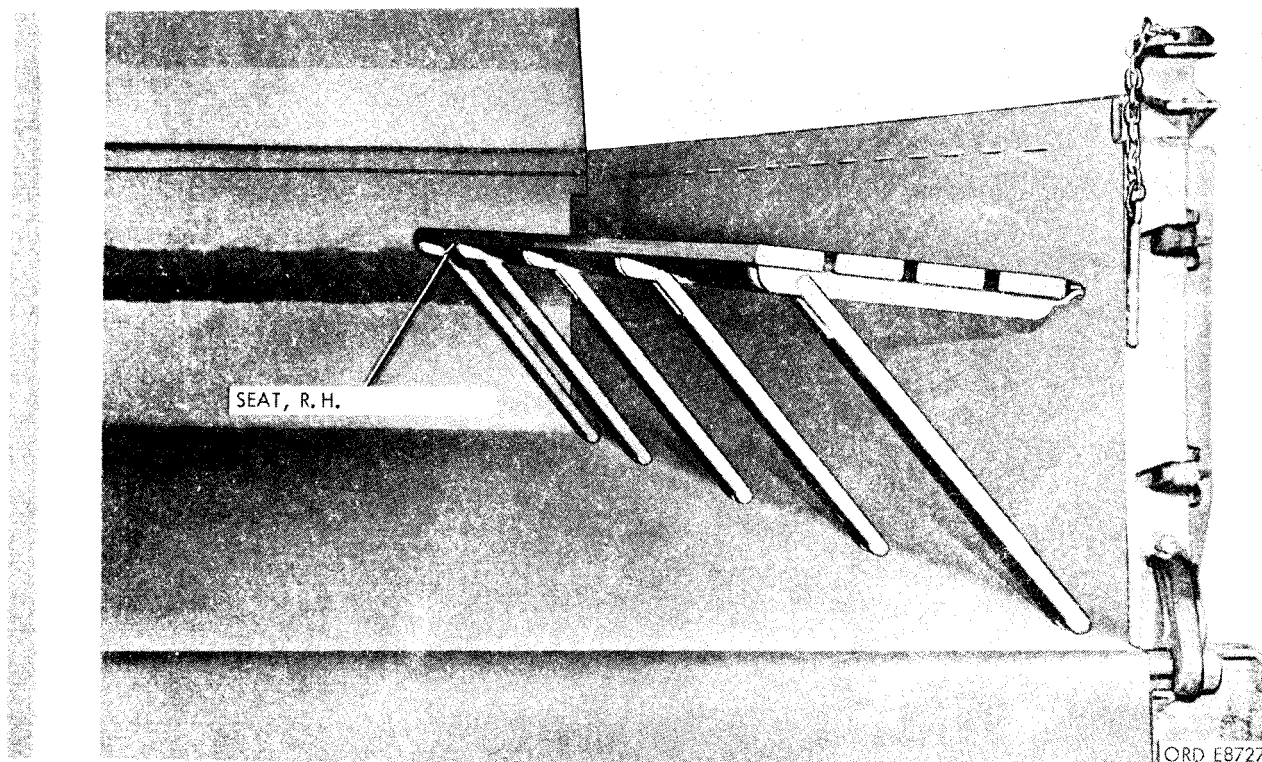


Figure 2-226. Installing seal.

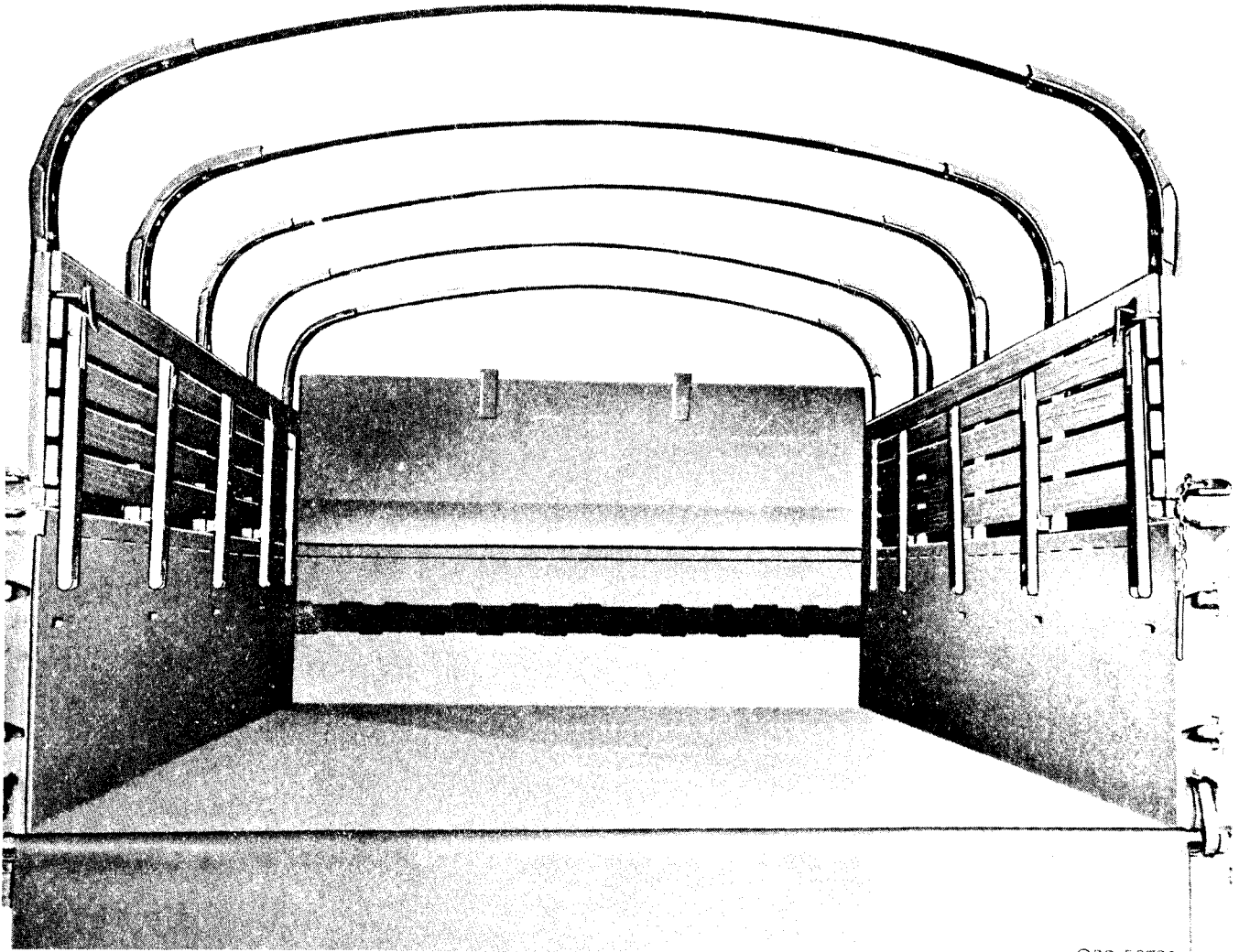
(4) Install the seat assembly by following the procedures similar to (1), (2), and (3) above.

*b. Remove Seats.*

(1) Raise the seats, fold out the legs, and lower the seat as shown in figure 2-227.

(2) Disengage the hook ends from the slots in the side of the body.

(3) Lift the hook end of the seat to engage the hinge pins in the rack, pivot the seat into the stored position, lock it with the latch provided, and fold down the legs as shown in figure 2-227.



ORD E8730

*Figure 2-227. Stowing seats.*

*c. Side Racks and Bows.*

(1) Position the right side rack over the stake pockets on the right side of the dump body and drop it in place as indicated in figure 2-228.

(2) Install the left side rack in the same manner.

(3) Position the bows over the rack pockets and drop them in place as indicated in figure 2-228.

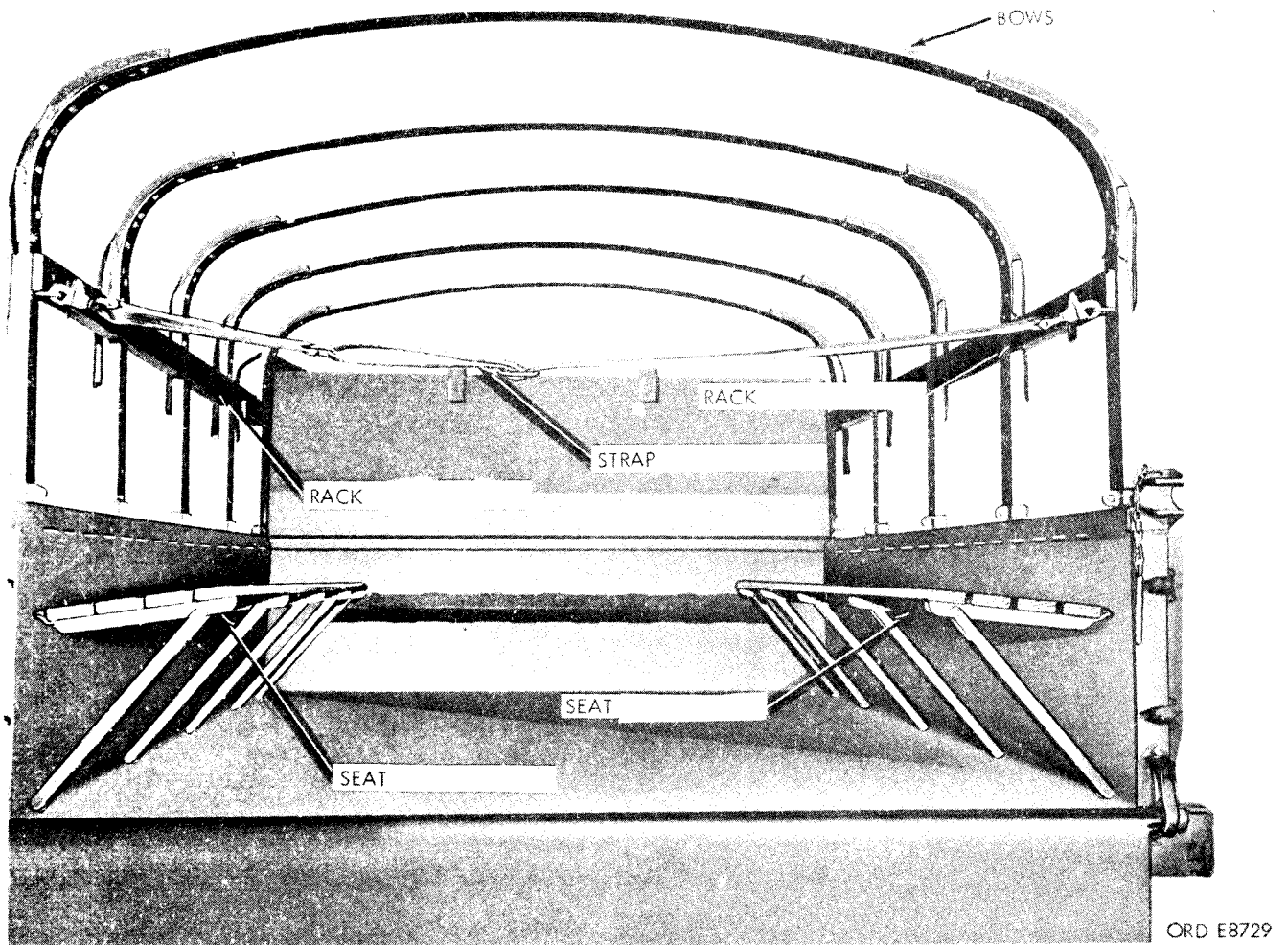
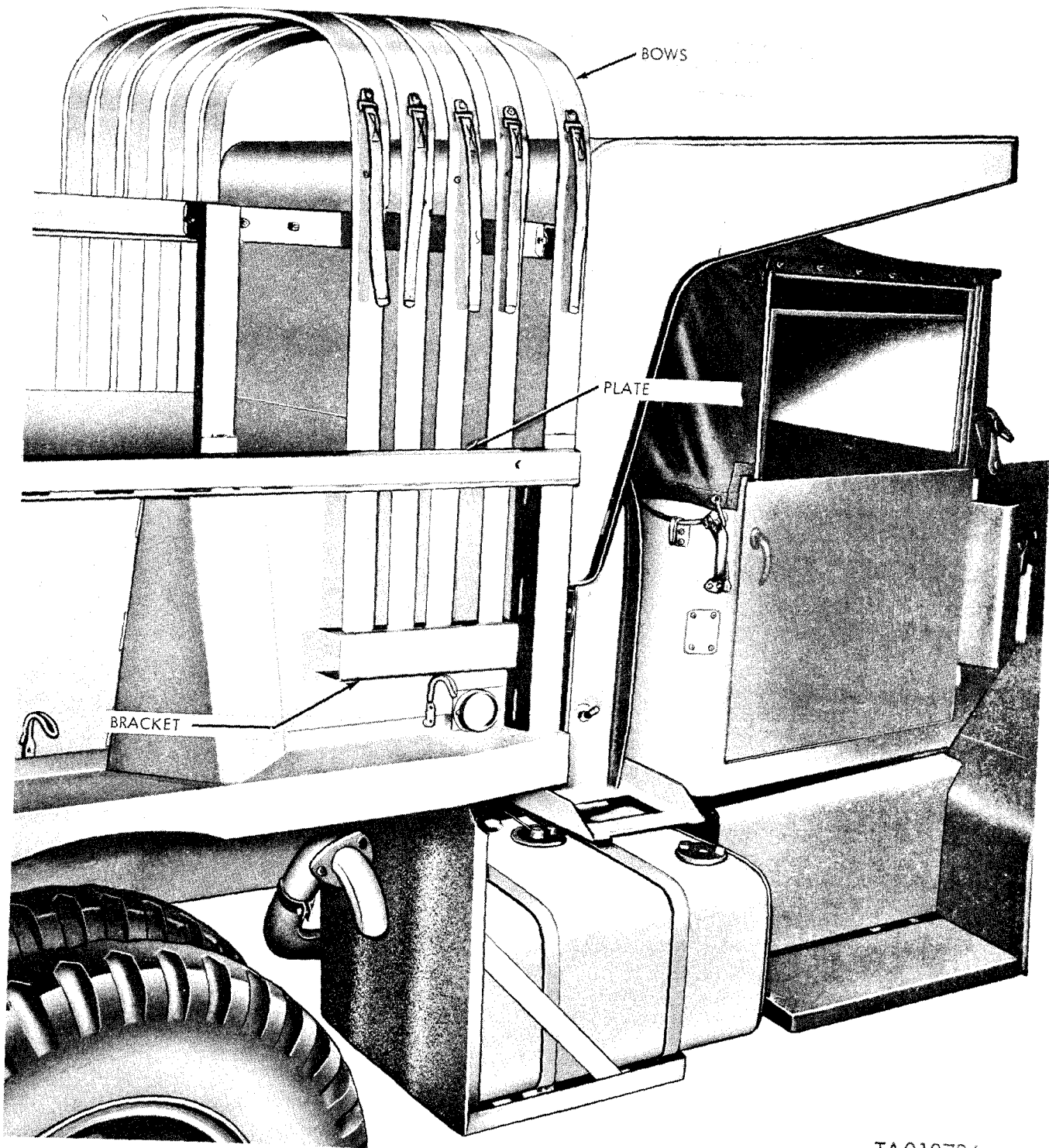


Figure 2-228. Seats, rack, bows, and safety strap.

*d. Bow Stowage.* To store the bows temporarily, lift the bows out of the side racks, and place them in the bow storage brackets as shown in figure 2-229.



TA010786

Figure 2-229. Bow stowage racks.

*e. Tarpaulin Cover, Curtain, and Safety Strap.*

(1) Lay the cover folded lengthwise over the top of the bows, and unfold it toward the sides.

(2) Lash the sides of the cover down to the appropriate lashing hooks.

(3) Pull the drawstrings of the cover bonnet

over the cab shield and tie them down to the appropriate hooks.

(4) Fasten the end curtain to the rear of the cover.

(5) Hook the safety strap to the rear of the rack assemblies as shown in figure 2-228.

**NOTE**

When using the M51 dump truck model or the M51A2 dump truck model as a dump truck, racks, seats, bows, and covers must be removed and stored off the vehicle.

**Section XXXVII. MAINTENANCE OF EXPANSIBLE  
VAN BODY—M291A1, M291A1C, M291A1D  
M291A2, M291A2C AND M291A2D**

**2-246. General**

*a. Van Body.* Expansible van trucks M291A2 and M291A2C have a 17-foot van body mounted on an M63A2D chassis with auxiliary sills to raise the floor above the wheels. When fully expanded, a weathertight enclosure 7 feet high, and 16X17 feet in area is formed. Leveling jacks are provided at each corner to stabilize and level the expanded body. The van is sealed to prevent the entrance of water and the escape of light in both the expanded and retracted positions. The M291A1D and M291A2D trucks have a tailgate which can be operated by an electric motor or vehicle driven hydraulic system. All facilities including lighting, heating, air conditioning, and blackout protection may be used in both the expanded and retracted positions. The M291A1C and M291A2C differ from the M291A1, M291A1D, M291A2 and M291A2D, in that they have no windows. In the M291A1, M291A2, and M291A1D, and M291A2D four windows with brush guards, insect screens, and sliding blackout panels are located in each side panel to admit daylight to the van interior when it is in the expanded position. Two entrance doors, set into the side panels, toward the rear, permit access to the van when it is in the expanded position. Two entrance doors in the van rear panel permit access to the van when it is in both the expanded and retracted positions. Two stationary windows are located in the rear doors. Two lightweight aluminum ladders, stowed on the rear doors, facilitate access to the van floor level. A

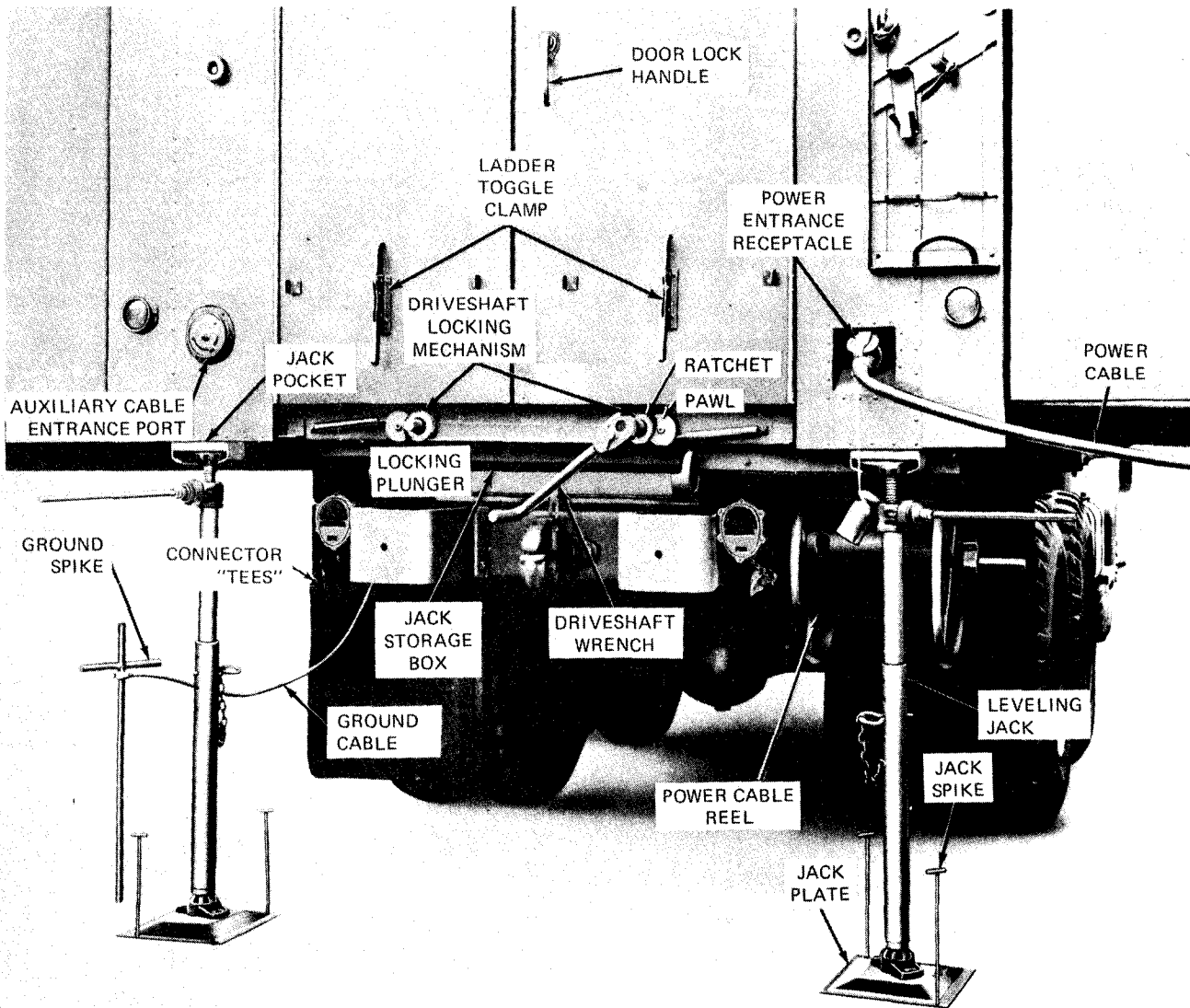
telephone entrance jack and auxiliary power cable entrance port are located on the left rear panel near the bottom. The pioneer tool bracket and power cable entrance receptacle are located on the right rear panel. A bonnet, extending from the front panel of the van, houses two heating units and the air conditioning unit. The electrical system, includes a 24-volt dc circuit for vehicular light operation and 100-volt and 208-volt, 3-phase circuits for auxiliary equipment operation. Vehicular clearance and blackout lights are located on the bonnet face and the van rear panel.

*b. Expanding Mechanisms.* Refer to TM 9-2320-211-10 for a description of the expanding mechanism.

*c. Electrical Systems.*

(1) *General.* The van electrical system includes three basic electrical circuits for the operation of its auxiliary equipment and vehicle lights. All circuits incorporate appropriately designed overload protection and control facilities. These are described under specific headings in this paragraph. The circuits include:

*(a) The 24-volt dc system, powered by the vehicle batteries.* This system is used only for the operation of the van body clearance and blackout lights. The lights are mounted on the four top outside corners of the van body. Connection to the vehicle electrical system is made by means of tee connectors inserted into the vehicle rear light circuit at the lower left-hand corner of the van body (fig. 2-230).



AT 26979

Figure 2-230. Van in operating position—rear view.

(b) The 110-208-volt, 3-phase, 60-cycle system, powered from an external source. This system is used to furnish power directly to the 208-volt air conditioner unit, and is split into three single phases to furnish power to the 110-volt circuit breaker box. Connection to the van body is by means of a 4-wire cable and connector plugged into the power cable entrance receptacle at the rear of the van body (fig. 2-230)

(c) The 110-volt, single phase, 60-cycle system, derived from the 208-volt, 3-phase, 60-cycle system. The 208-volt, 3-phase, power circuit is separated into three groups of four circuits each in the 110-volt circuit breaker box. Each group of circuit breakers is used to supply power to various items of auxiliary equipment mounted permanently in the van body, as well as additional equipment installed for tactical purposes.

(2) Power entrance receptacle. The power entrance (fig. 2-230) is located on the lower right corner of the van rear panel. A spring-loaded, hinged cap locks the cable in the receptacle and prevents the entrance of foreign matter when the cable is removed.

(3) 100-foot power cable and reel. The 100-foot power cable consists of a 4-wire rubber-insulated cable equipped at one end with a female receptacle to accommodate the 4-prong entrance receptacle, and at the opposite end with a male receptacle designed to fit the female receptacle of the outside power source. The cable is stowed on the power cable reel mounted on the right rear corner of the chassis frame (fig. 2-230) when the van is in its traveling position. A canvas boot is provided to protect the cable while it is in the stowed position.

(4) *36-inch auxiliary power cable.* The 36-inch auxiliary power cable (fig. 2-231) is similar in construction to that of the 100-foot power cable except that only one end is fitted with a receptacle to accommodate the van power entrance receptacle. The opposite end is separated into four individual wires which are used to make connections to an outside power source whose output connector

differs from the one on the far end of the 100-foot power cable ((3) above). When in use, the auxiliary power cable is plugged into the far end of the 100-foot power cable and the four wires on the auxiliary cable are used to make appropriate connections to the outside power source. The auxiliary power cable is stowed on the left equipment anchor rail attached to the ceiling of the van body.

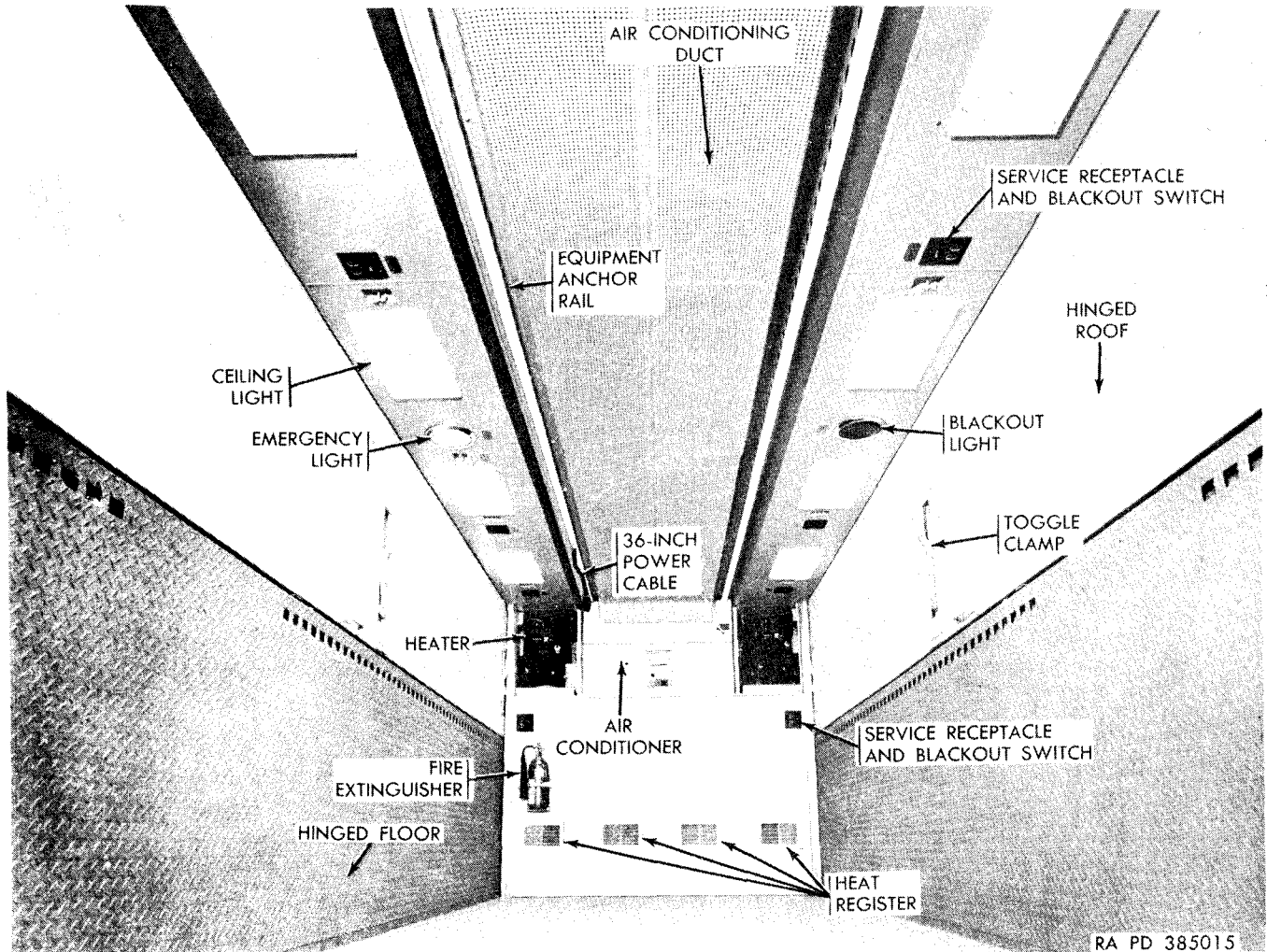


Figure 2-231. Van in body in retracted position—front interior view.

(5) *Main power switch.* The main power switch (fig. 2-232) is provided to cut off all external power to the van body electrical system. It contains

no fuses or circuit breakers, and is used when electrical repairs are made to the van wiring system, or as an emergency switch.



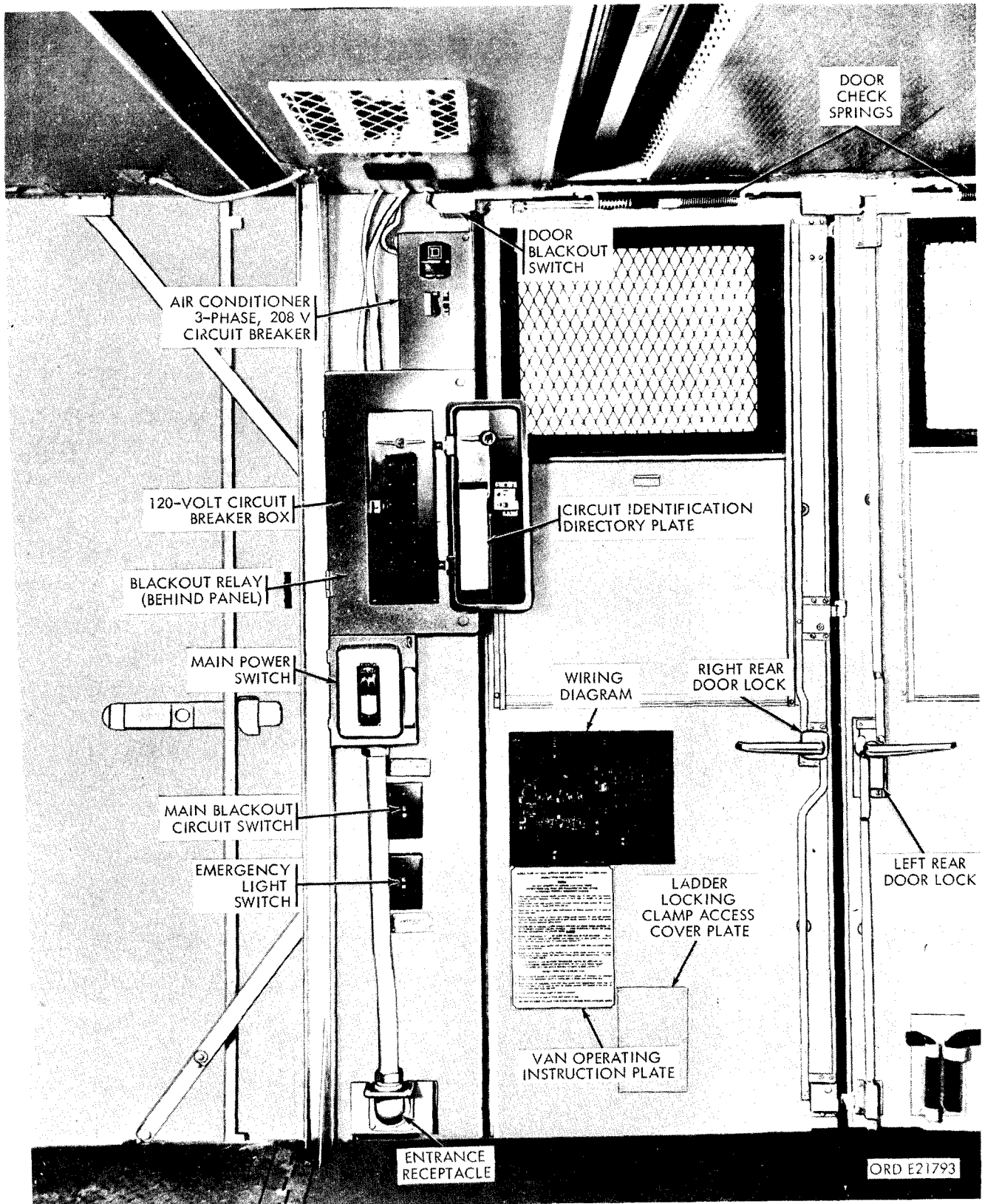


Figure 2-232. Van electrical controls.



(6) *110-volt circuit breaker box.* The 110-volt circuit breaker box (fig. 2-232) provides a distribution and control station for all equipment requiring 110-volt ac power. It contains 12 push type circuit breaker switches, electrically connected in three groups of four each. Each group is connected to one leg of the 3-phase power system, thus providing three individual 110-volt branch circuits. Six of the circuit breaker switches are used in the van body electrical system. The remaining six are available for use with tactical materiel installed in the van body, as required. The circuit breakers function as primary control switches for all 110-volt equipment, and also provide protection for overloaded circuits. The circuit breaker box is covered by a large door which provides access to the interior wiring compartment for maintenance. A smaller door, equipped with a lock and key, permits access to the circuit breaker switches. A circuit identification directory plate is attached to the inner side of the smaller door.

(7) *Blackout relay.* The blackout relay is located inside the circuit breaker box (fig. 2-232). It is a single-pole, double-throw, magnetic type rated at 60 amperes at 110 volts. The relay automatically interrupts the van lighting and receptacle circuits whenever the doors are opened, provided the main blackout circuit switch is in the ON position. However, the individual receptacle blackout switches can override the relay when the operating equipment must be in continuous operation or is not a blackout hazard.

(8) *Main blackout circuit switch.* The main blackout circuit switch (fig. 2-232) controls the blackout circuit. In the ON position, the switch includes the blackout relay in the lighting and receptacle circuits so that these circuits are interrupted by the door-operated switches. In the OFF position, the switch bypasses the blackout relay, eliminating the function of the door-operated switches.

(9) *Door-operated blackout switches.* Three 6-ampere, 110-volt, pushbutton type door-operated blackout switches (fig. 2-232) are located in the van wall near the top of the hinged sides of the two side

doors and right rear door. Each switch is actuated by an adjustable plunger operated by a striker plate attached to the top of the door. Thus, when the door is opened, the plunger actuates the switch which in turn trips the blackout relay and interrupts the lighting and receptacle circuits.

(10) *Hinged roof-operated plungers and plates.* Blackout circuit contact plungers (fig. 2-233) are located in the edges of the hinged roof sections so as to align with striker plates in the mating edges of the hinged floor sections and side panels. The plungers and mating plates maintain continuity of the blackout circuits when the van is in both the expanded and retracted positions.

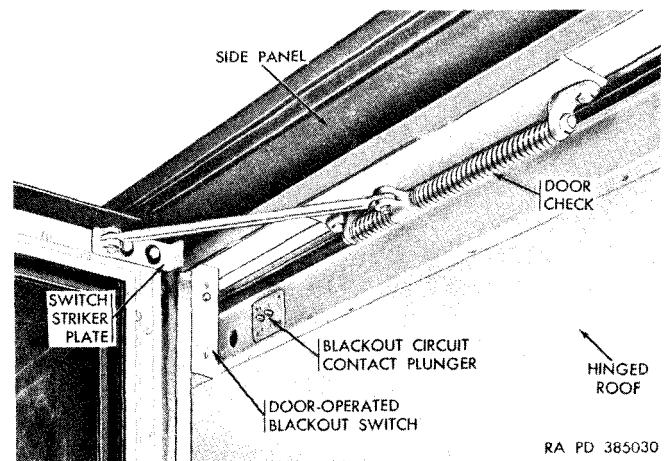


Figure 2-233. Hinged roof-operated blackout switch.

(11) *Receptacle and blackout switches.* Ten combined receptacles and blackout switches located in the van ceiling and front wall (fig. 2-231 and 2-234) provide power outlets for operation of the 110-volt equipment housed in the van. The integral blackout switches are used to bypass the blackout feature when equipment must remain in continuous operation, or does not involve a blackout hazard. Cord holder hooks (fig. 2-234) are placed adjacent to the ceiling receptacles to prevent accidental disconnection of the power cords.

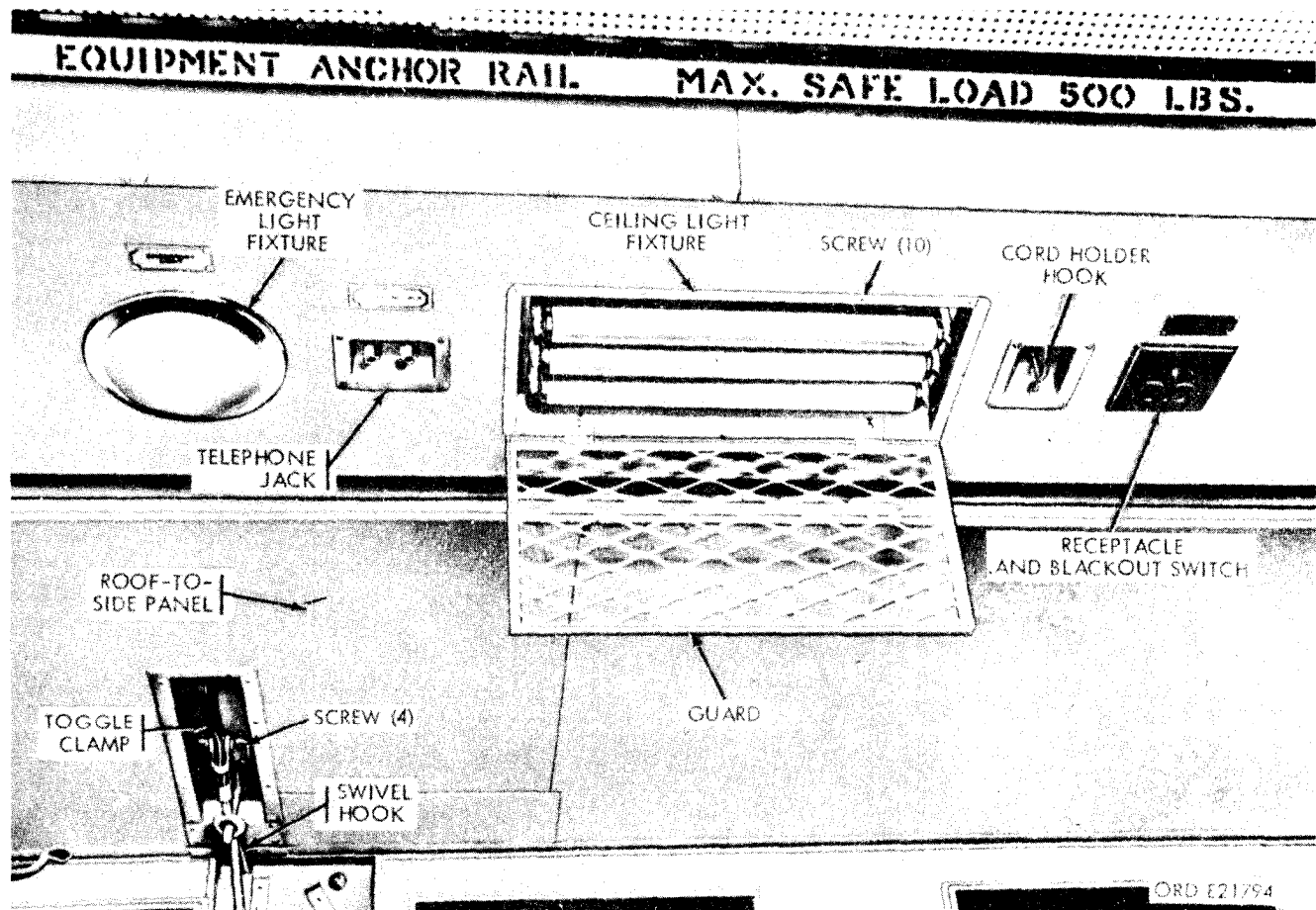


Figure 2-234. Ceiling fixtures and lights.

(12) *Emergency light.* The emergency light (fig. 2-231 and 2-234) is located approximately in the center of the van ceiling at the left of the air conditioning duct. It consists of a fixture containing a standard 60-watt lamp covered by a white frosted lens. The light is controlled by a separate emergency light switch and operates independently of the main blackout circuit switch and door-operated switches.

(13) *Blackout light.* The blackout light (fig. 2-231) is located approximately in the center of the van ceiling at the right of the air conditioning duct. It is similar to the emergency light, except that it is equipped with a 25-watt blue lamp and blue lens. The light operates in conjunction with the blackout relay and blackout door-operated switches, and is automatically turned on when the doors are opened, and off when they are closed, when the main blackout switch is in the ON position.

(14) *Ceiling fixtures and lights.* Eight rectangular ceiling light fixtures (figs. 2-231 and 2-234) are located in the van ceiling on either side of the air conditioning duct. Each contains three 20-watt fluorescent tubes, two 60-watt lamps, and

light switches. The tubes and lamps are protected by a hinged wire-mesh guard.

(15) *3-phase air condition circuit breaker.* The 3-phase air conditioner circuit breaker (fig. 2-232) is a 3-pole, 20-amp, 250-volt magnetic thermal type used to protect the air conditioner circuit and to shut off power to the air conditioner system during maintenance. It may also be utilized as a emergency switch for the air conditioner when necessary.

(16) 24-volt vehicle clearance and blackout lights are located on the upper front face of the bonnet and on the upper corners of the van rear panel. The clearance lights are placed above the blackout lights and are identical except that the front lights are equipped with amber lenses and the rear lights with red lenses. The clearance and blackout lights are controlled from the vehicle light switch in conjunction with the vehicle lighting system.

(17) *Ground spike.* The van electrical system ground spike (fig. 2-230) consists of a pointed steel spike to which the ground cable is attached. The other end of the cable is fitted with a terminal for

attachment to the ground spike connector at the rear of the van body. Handles are provided on the ground spike so it may easily be pushed into the earth. The spike is stowed in the jack storage box (fig. 2-230) at the rear end of the van when not in use.

*d. Heating System.* The van heating system incorporates two fuel-burning, 60,000 B.t.u noncontaminating, hot air heaters operating on 110-volt ac, 60-cycle, single-phase power. The heaters are located in the van bonnet on either side of the air conditioner (fig. 2-231). Control facilities permit circulation of both heated and unheated fresh air drawn from outside the van, mixed with heated and unheated air drawn from inside the van. The proportion of outside and inside air may be varied. Hot air ducts in the van front wall conduct heated air from the heaters into the van interior through four heat registers (fig. 2-231) in the van front panel when the registers are open. When the registers are closed, the heated air is conducted through corrugated ducts beneath the aluminum floor tread plate, which functions as a radiator. This function extends to the hinged floor sections so that the heat-radiating surface of the floor is available when the van is in both its expanded and its retracted positions.

*e. Air Conditioning System.* The van air conditioning system is located in the van bonnet. Control facilities permit circulation of both cooled

and uncooled air drawn from outside the van, and cooled and uncooled air drawn from inside the van. The proportion of outside and inside air may be varied. A perforated air conditioning duct (fig. 2-231), located on the van ceiling, conducts cooled or uncooled air to the van interior.

### 2-247. Side Panel Counterbalance Cables

(Fig. 2-235.)

#### a. Removal.

(1) Place the van side panel in its fully expanded position (TM 9-2320-211-10).

(2) Secure the end panel doors in their open position.

(3) Support the hinged roof with swivel hooks (fig. 2-234). Place a 1-inch wood block between the end swivel hook and the hinged roof to release the tension on the counterbalance cable.

(4) Remove the cotter pin, clevis pin, and clevis which attaches the cable to the vertical drop arm, and remove the clevis from the arm.

(5) Remove the cotter pins and roller pins which attach the upper and lower rollers to the corner post, and remove the upper and lower rollers. Removal of the lower roller will release the lower folding arm.

(6) Unscrew the lower cable end from the turn buckle, then unscrew the turnbuckle from the turn buckle eye.

(7) Withdraw the cable upward through the guides, and remove the cable.

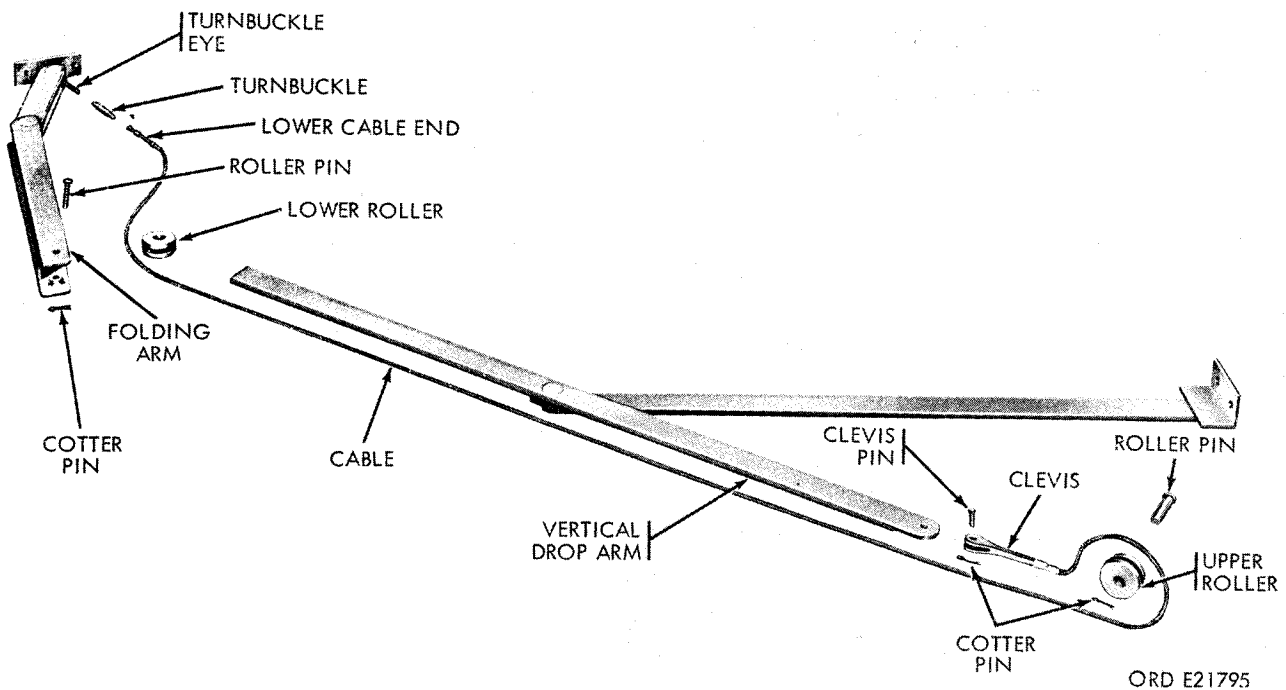


Figure 2-235. Side panel counterbalance cables—disassembled view.

*b. Installation.*

- (1) Remove the turnbuckle and turnbuckle eye from the replacement cable.
- (2) Thread the turnbuckle end of the cable downward through the guides.
- (3) Screw the turnbuckle onto the turnbuckle eye remaining in the floor bracket, and screw the turnbuckle end of the cable into the turnbuckle.
- (4) Align the holes in the end of the folding arm with the holes in the corner post. Place the roller in the channel of the folding arm with the cable behind the roller. Insert the roller pin through the arm and roller. Secure the roller pin with a cotter pin.
- (5) Position the upper roller in the roller mounting plate on the corner post with the cable in the roller groove. Insert the roller pin through the roller and corner post, and secure the pin with a cotter pin.
- (6) Pull the cable clevis down over the end of the vertical drop arm, and align the holes in the clevis and arm. Insert the pin through the holes, and secure the pin with a cotter pin.
- (7) Tighten the turnbuckle until the cable is taut.

**2-248. Ladder Locking Clamp**

(Fig. 2-230.)

*a. Removal.* Working inside the van (fig. 2-232) remove the six screws attaching the cover plate to the rear door, and remove the cover plate. Working outside the van, remove the four nuts and lockwashers attaching the locking clamp to the rear door, and remove the locking clamp.

*b. Installation.* Position the locking clamp on the outside of the rear door, and insert four roundhead screws through the holes in the clamp yoke and door. Attach the clamp to the door with four lockwashers and four hexagon nuts. Install the cover plate with four panhead screws.

**2-249. Roof-to-Side Panel Toggle Clamps**

**NOTE**

The roof-to-side panel toggle clamps can be replaced only when the van is in the retracted position.

*a. Removal.* Release the clamp. Remove the four screws which attach the yoke base to the niche in the hinged roof section, and remove the clamp.

*b. Installation.* Position the yoke base in the niche with the eyebolt toward the anchor post, and attach the base to the niche with four self-tapping screws. Engage the hook eye with the anchor post, and close the clamp.

**2-250. Side Panel Rear Locks**

(Fig. 2-236 and 2-237.)

*a. Removal.*

- (1) Remove the eight screws attaching the

lock cover plate to the panel, and remove the cover plate. Remove the insulating material.

(2) Remove the two screws attaching the lock bolt retainer to the edge of the door frame.

(3) Remove the cotter pins from the clevis pins, remove the clevis pins, and separate the clevises from the lock.

(4) Remove the self-locking nut and washer securing the lock handle shank in the lock.

(5) Remove the four nuts and lockwashers which attach the lock to the van body, and remove the lock.

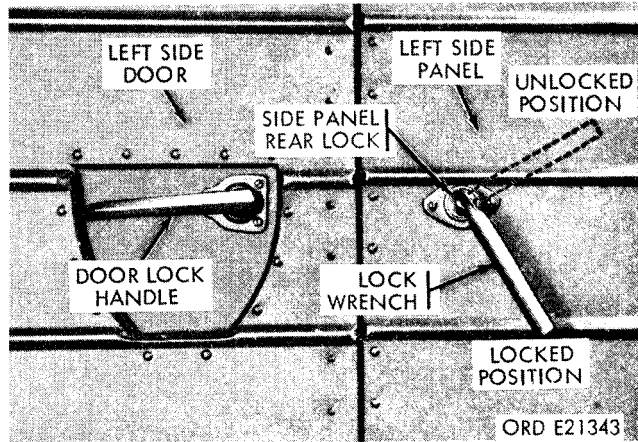


Figure 2-236. Side panel locks.

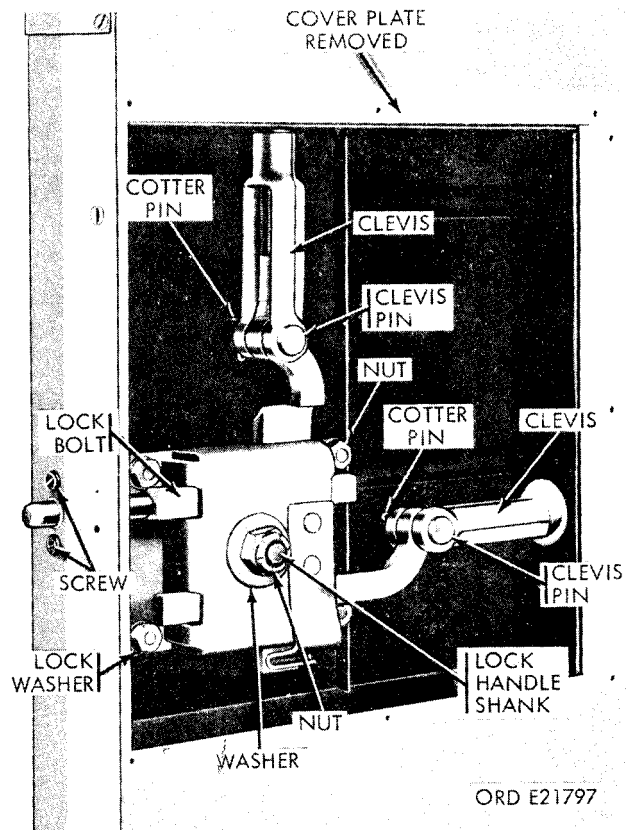


Figure 2-237. Side panel lock mechanism

*b. Installation.*

(1) Slide the lock bolt retainer onto the lock bolt with the plate toward the end of the bolt.

(2) Position the lock on the lock handle shank and four corner studs.

(3) Slide the lock bolt retainer into position against the inside of the door frame, and attach it with two panhead tapping screws inserted from the outer edge of the door frame.

(4) Attach the lock to the van body with four lockwashers and four self-locking nuts.

(5) Secure the lock handle shank to the lock with a washer and a self-locking nut.

(6) Aline the holes in the clevises with the holes in the lock arms, and insert the clevis pins. Secure the clevis pins with cotter pins. Replace the insulating material previously removed.

(7) Attach the lock cover plate to the panel with eight panhead screws.

### **2-251. Side Panel Front Locks and Hinged Locks**

(Fig. 2-236. )

*a. Removal.*

(1) Remove the eight screws attaching the lock cover plate to the panel, and remove the cover plate. Remove the insulating material from the lock recess.

(2) Remove the cotter pins from the clevis pins, remove the clevis pins, and separate the clevis from the lock.

(3) Remove the self-locking nut securing lock handle shank in the lock.

(4) Remove the four nuts and lockwasher attaching the lock to the van body, and remove the lock.

*b. Installation.*

(1) Position the lock on the lock handle shank and four corner studs, and attach it to the van body with four lockwashers and four self-locking nuts.

(2) Secure the lock handle shank to the lock with a washer and a self-locking nut.

(3) Aline the holes in the clevises with the holes in the lock arms, and insert the clevis pins. Secure the clevis pins with cotter pins. Replace the insulating material previously removed.

(4) Attach the lock cover plate to the panel with eight panhead screws.

### **2-252. Door Locks and Latches**

(Fig. 2-232 and 2-238).

*a. Right Rear and Side Door Locks.**(1) Removal.*

*(a)* Remove the cotter pin holding the vertical bar to the lockpin.

*(b)* Remove the four attaching screws which attach the lock to the door, and remove the lock.

*(2) Installation.*

*(a)* Aline the holes in the lock and door. Attach the lock with four panhead tapping screws.

*(b)* Place the hole in the vertical bar over the lockpin. Secure it with a cotter pin.

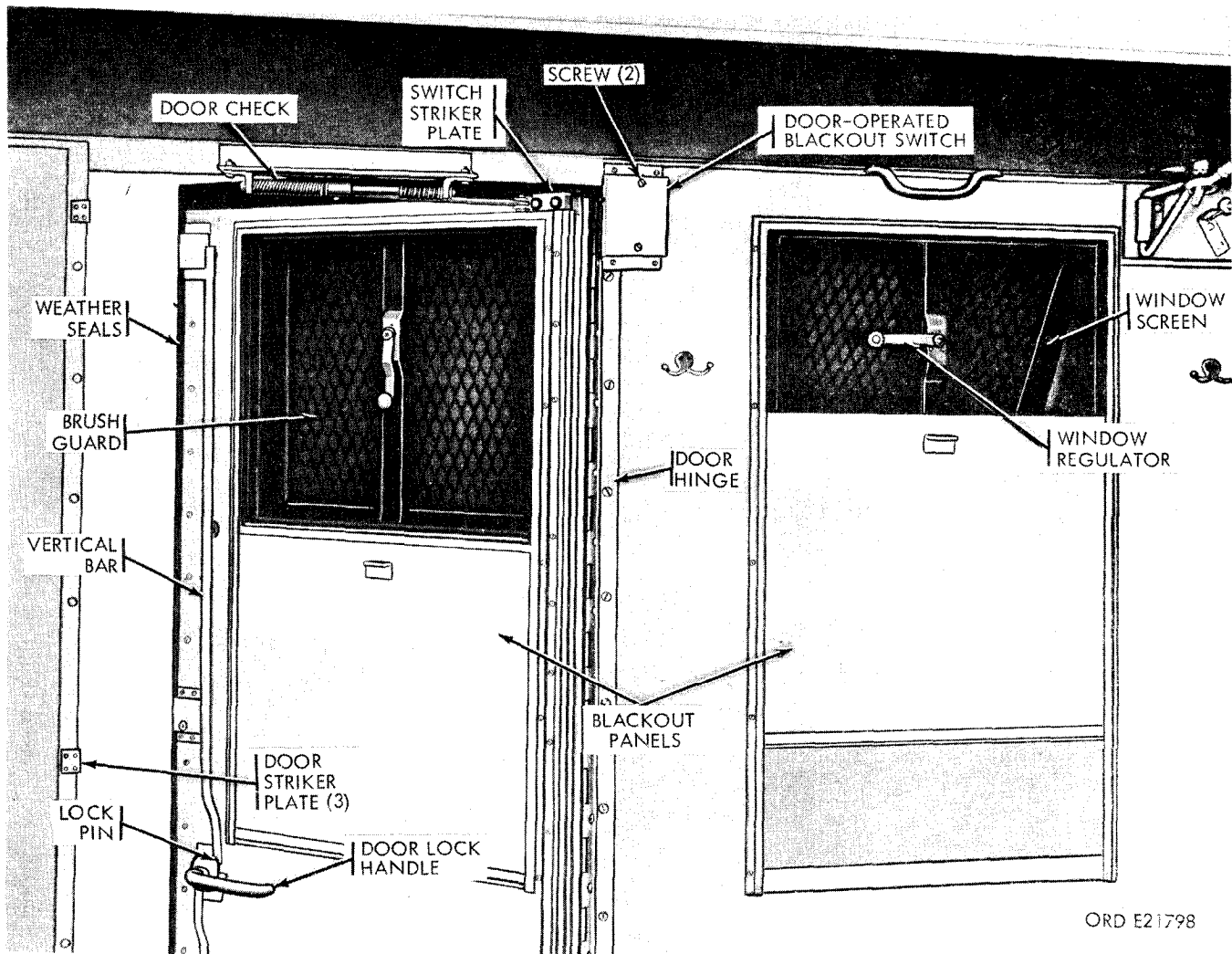


Figure 2-238. Door locks and windows.

*b. Left Rear Door Lock.*

(1) *Removal.*

(a) Drive out the pin which attaches the lock handle to the lock mechanism, and remove the lock handle.

(b) Remove the cotter pins which attach the vertical bars to the lock mechanism.

(c) Remove the four screws which attach the lock mechanism to the door, and remove the mechanism.

(2) *Installation*

(a) Align the holes in the lock mechanism and door, and attach the mechanism with four panhead tapping screws.

(b) Secure the vertical bars to the lock mechanism with cotter pins.

(c) Insert the shank of the lock handle into the hole in the lock mechanism with the pin holes aligned.

(d) Secure the handle in the lock mechanism with a dowel pin.

**2-253. Door Strike Plates**

(Fig. 2-238).

*a. Removal.* Remove the three screws holding the striker plate to the door or body, and remove the striker plate.

*b. Installation.* Attach the striker plate to the door or body with two panhead screws through the flange and one flathead tapping screw through the striker plate. Grind the flathead screw flush with the striker plate.

**2-254. Door Check Spring**

(Fig. 2-232 and 2-238. )

*a. Removal.*

(1) Remove the bolt, lockwasher, and nut attaching the shaft bracket to the mounting angle. Remove the locknut from the spring shaft, and remove the shaft bracket and short spring.

(2) Swing the door back until the slider separates from the spring shaft. Remove the long spring.

*b. Installation.*

(1) Place the long spring on the spring shaft, and replace the slider on the spring shaft.

(2) Place the short spring on the spring shaft. Place the shaft bracket on the spring shaft, and secure the bracket with a self-locking nut.

(3) Attach the shaft bracket to the mounting angle with a bolt, lockwasher, and nut.

**2-255. Door Hinge**

(Fig. 2-238. )

*a. Removal.*

(1) Open the door, remove the two screws attaching the door check arm bracket to the door, and remove the bracket.

(2) Remove the screws attaching the door hinge to the van body, and remove the door.

(3) Lift the rubber door seal to reveal the screws attaching the hinge to the door. Remove the screws, take off the hinge seal and seal retainers.

*b. Installation.*

(1) Position the flat rubber seal against the back of the hinge, and place the hinge against the door with the edge of the hinge leaf flush with the edge of the seal.

(2) Position the hinge and seal on the door.

(3) Position the half-round rubber seal along the front of the hinge, and place the aluminum retainer over the flap of the half-round seal.

(4) Aline the holes in the retainer, hinge leaf, and door; and attach the retainer and the hinge to the door with panhead sheet metal screws.

(5) Position the door and hinge against the door post with the flap-rubber seal flush with the edge of the hinge leaf.

(6) Aline the holes in the hinge leaf with the holes in the door post, and secure the retainer, seals, and hinge with panhead sheet metal screws.

**2-256. Panel Weather Seals**

(Fig. 2-238.)

*a. Removal.* Remove the nuts and bolts securing the seal retainer to the panel, and remove the retainer and seal.

*b. Installation.* Position the retainer over the seal flap. Aline the holes in the retainer with the holes in the panel. Attach the retainer and seal with bolts and hexagon nuts.

**2-257. Window Screens**

(Fig. 2-238. )

*a. Removal.* Remove the plastic cord retainer from the edge of the screen and remove the screen.

*b. Installation.* Position the screen in the frame, and force the plastic cord retainer into the space between the screen and the frame.

**2-258. Window Brush Guards**

(Fig. 2-238. )

*a. Removal.* Release the latches at the bottom of

the brush guard. Drive out the hinge pins, and remove the brush guards.

*b. Installation.* Position the brush guards, and aline the hinges. Insert the hinge pins, and engage the latches to secure the brush guards.

**2-259. Window Regulators**

(Fig. 2-238. )

*a. Removal.* Remove the cross-point head screw, and remove the regulator.

*b. Installation.* Install the regulator so that the handle is in a downward vertical position when the window is closed. Secure one cross-point oval-head machine screw.

**2-260. Window Glass and Seal**

(Fig. 2-238.)

*a. Removal.* Remove 18 screws, and remove the window glass seal retainer. Remove the window glass and seal. Separate the seal from the window glass.

*b. Installation.* Install the seal around the window glass, and position the glass and seal in the window frame. Position the seal retainer, and secure it with 18 roundhead tapping screws.

**2-261. Window Blackout Panel**

(Fig. 2-238. )

*a. Removal.* Remove 18 screws around the blackout panel guide frame, and remove the blackout panel.

*b. Installation.* Aline the holes in the blackout panel side frame and van body side panel. Attach the guide frame with 18 panhead tapping screws.

**2-262. Van Operating and Locking Devices***a. Drive Shaft Locking Ratchets (Fig. 2-230).*(1) *Removal.*

(a) Drive out the taper pin which attaches the ratchet to the drive shaft.

(b) Tap the ratchet free from the shaft, and remove the ratchet.

(2) *Installation.*

(a) Position the ratchet on the drive shaft with teeth facing toward the pawl and with the taper pin holes alined.

(b) Secure the ratchet to the drive shaft with the taper pin.

*b. Drive Shaft Locking Pawls (Fig. 2-230).*(1) *Removal.*

(a) Remove the special shoulder screw attaching the locking pawl to the underframe rear crossmember.

(b) Disengage the locking plunger from the pawl, and remove the pawl.

(2) *Installation.*

(a) Engage the slot in the pawl with the locking plunger. Aline the screw holes.

(b) Secure the pawl to the crossmember with the special shoulder screw.

**TM 9-2320-211-20**

*c. Drive Shaft Locking Plungers (Fig. 2-230).*

(1) *Removal.*

(a) Remove the self-locking nut attaching the locking plunger housing to the stud on the rear crossmember.

(b) Disengage the plunger from the slot in the pawl, and remove the plunger housing from the stud.

(2) *Installation.*

(a) Engage the plunger in the slot in the pawl, then depress the plunger until it is possible to attach the plunger housing to the stud of the rear crossmember.

(b) Secure the housing to the stud with a self-locking nut.

**2-263. Heater Fuel Pump**

(Fig. 2-239.)

**WARNING**

Do not permit smoking, sparks, or open flame within 60 feet of the vehicle during any operation involving removal or draining of the fuel-carrying components.

*a. Plunger Spring and Filter Element Servicing.*

(1) Remove the bottom cap from the fuel pump.

(2) Wash the filter element, spacer, spring, and cover in mineral spirits paint thinner. Inspect the filter element for cracks and other damage; replace it if necessary. Test the action of the spring. Replace a weak, bent, or broken spring.

(3) Install the parts in reverse order of removal, using a new gasket in the pump cap.

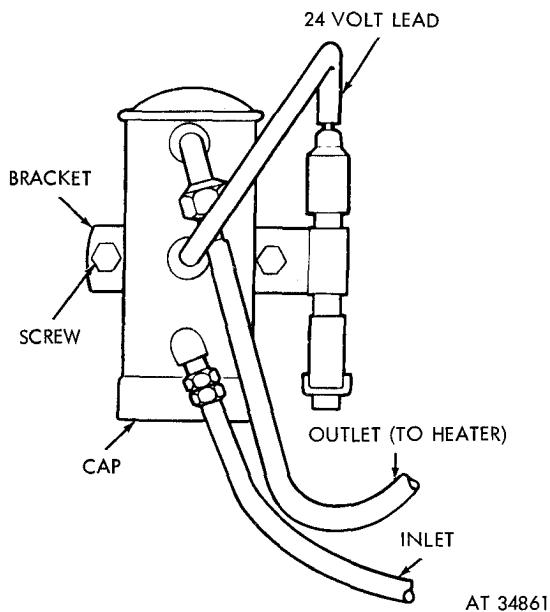


Figure 2-239. Heater fuel pump, lines, and connections.

*b. Removal.*

(1) Close the heater shutoff valve.

(2) Disconnect the electrical lead.

(3) Disconnect the fuel lines from the fuel pump inlet and outlet.

(4) Remove the two screws holding the fuel pump integral bracket to the van body, and remove the fuel pump.

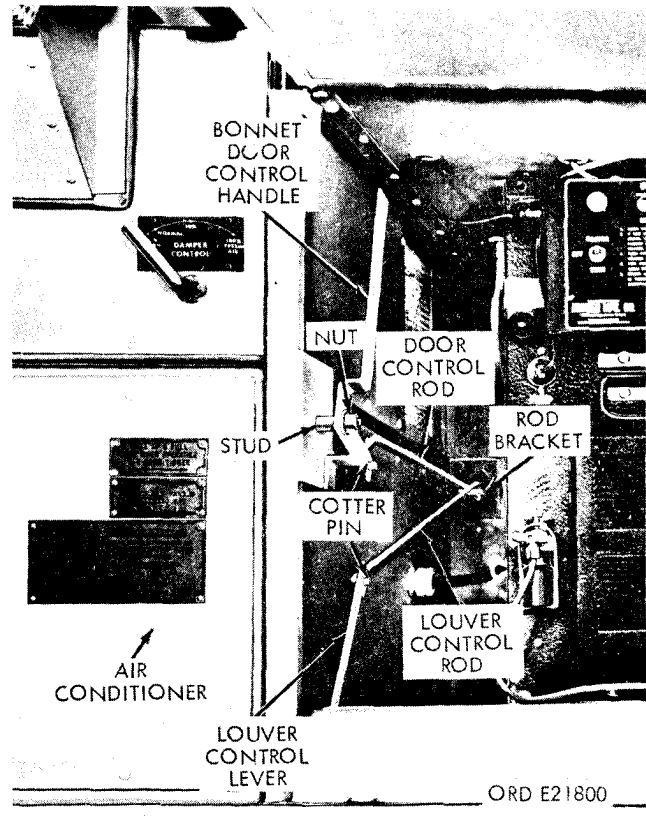


Figure 2-240. Bonnet door right-hand controls and linkage.

*c. Installation.*

(1) Secure the fuel pump with its integral bracket to the van body with two hexagon-head screws.

(2) Connect the fuel lines to the fuel pump inlet and outlet.

(3) Connect the electrical lead.

(4) Open the heater shutoff valve. (fig. 2-240).

**2-264. Heater Fuel Filter**

*a. Removal.*

(1) Close the heater shutoff valve.

(2) Place a suitable container under the filter bowl to catch escaping fuel.

(3) Loosen the clamp screw holding the filter bowl, and remove the clamp and bowl.

(4) Unscrew the filter from the filter head.

*b. Installation.*

(1) Screw the filter into the filter head.



(2) Install the filter bowl, attach the clamp, and secure the bowl with the clamp screw.

(3) Open the heater shutoff valve.

2-265. Fuel and Overflow Lines

a. Removal.

(1) Disconnect the fuel line union connectors at the heater.

(2) Remove the screws which attach the clips to the van front panels, and remove the clips.

(3) Pull the lines down through the holes in the floor of the bonnet.

CAUTION

Do not make sharp bends in the lines.

b. Installation.

(1) Push the lines up through the holes in the floor of the bonnet.

(2) Secure the union connectors and heater, and bend the lines to fit if necessary.

(3) Attach the clips holding the lines to the van front panel with panhead screws.

2-266. Heater Shutoff Valves

a. Removal.

(1) Disconnect the fuel line at the heater shutoff valve.

(2) Unscrew the valve from the filter head.

b. Installation.

(1) Screw the shutoff valve into the filter head.

(2) Connect the fuel line to the valve.

2-267. Fuel Line Fittings and Fuel Tank Shutoff Valves

a. Removal. Loosen the nuts on each side of the valve or fitting and remove the valve or fitting from the line.

b. Installation. Install the valve or fitting between the ends of the line, and tighten the nuts.

2-268. Bonnet Handles and Control Rods

a. Removal.

(1) Working inside van, open the bonnet front door with the bonnet front door control handles.

(2) Working outside van, remove the hooked end of the control rod from the control rod clip on the door (fig. 2-241).

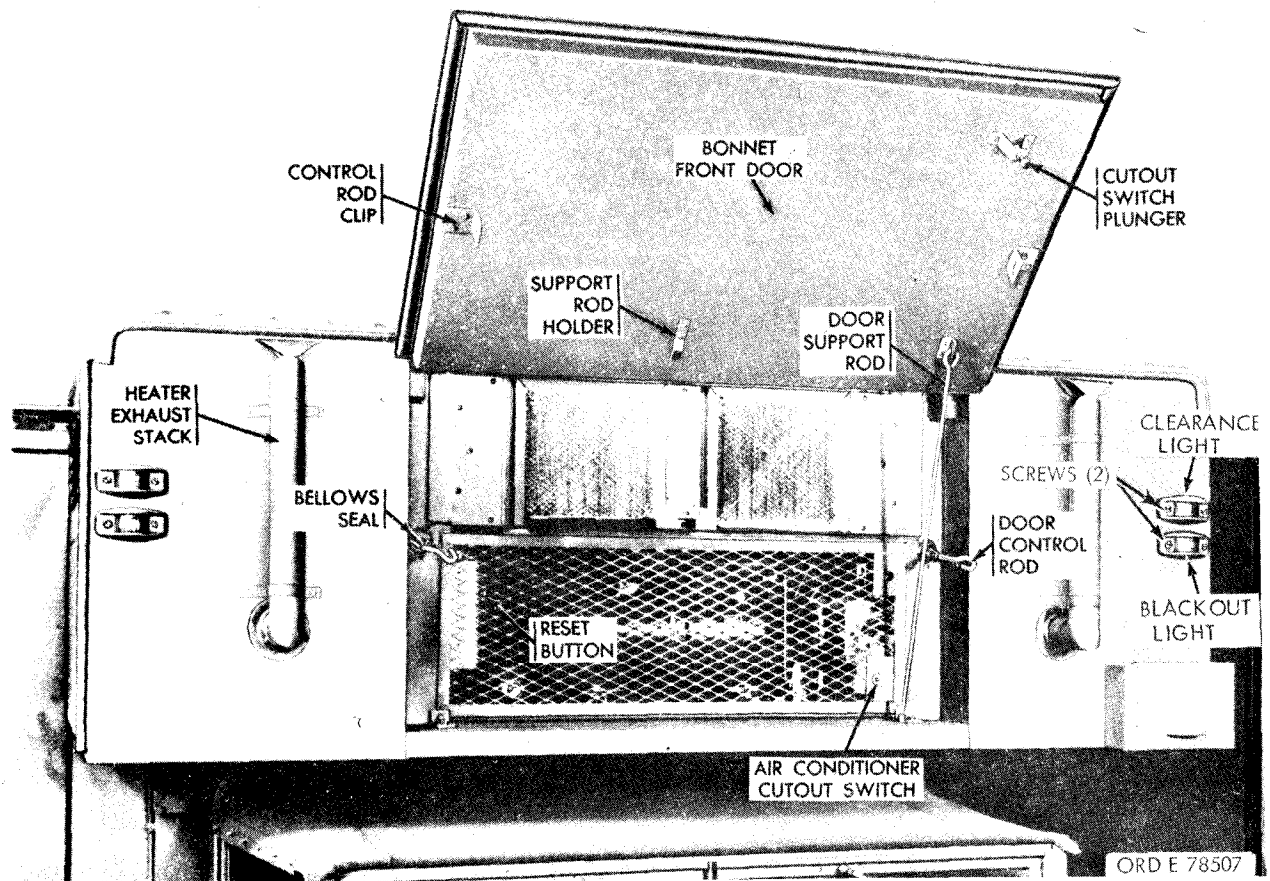


Figure 2-241. Bonnet front door in opened position.

(3) Working inside the van, remove the cotter pin from the rearward end of the rod, and separate the rod from the handle.

(4) For the right-hand control rod only, remove the cotter pin from the forward end of the louver control rod. Separate the louver control rod from the bracket on the door control rod.

(5) Pull the rod rearward through the rubber bellows seal. Exercise caution to prevent tearing the seal.

*b. Installation.*

(1) Working inside the van, push the hooked end of the control rod through the rubber bellows seal.

(2) Insert the rearward end of the rod into the hole in the handle, and secure it with a cotter pin.

(3) For the right-hand control rod only, insert the forward end of the louver control rod in the bracket on the door control rod. Secure it with a cotter pin.

(4) Working outside the van, insert the hooked end of the door control into the control rod clip on the door.

**NOTE**

When necessary to replace both rods at the same time, unhook the rods from the rod clips and prop the front door open with the door support rod attached to the inner side of the door.

**2-269. Van Body Clearance and Blackout Lamps**

(Fig. 2-241.)

*a. Removal.*

(1) Remove the two screws attaching the lens housing to the base, and remove the housing.

(2) Press the lamp inward, turn it one-quarter turn counterclockwise, and remove the lamp.

*b. Installation.*

(1) Press the lamp inward, turn it one-quarter turn clockwise.

(2) Attach the lens housing to the base with two ovalhead machine screws.

**2-270. Van Body Clearance and Blackout Lights**

(Fig. 2-241. )

*a. Removal.*

(1) Remove the two screws attaching the lens housing to the base, and remove the housing.

(2) Remove the four screws attaching the light base to the body, and separate the base from the body.

(3) Disconnect the bayonet type connectors joining the base to the lighting harness cable, and remove the base. Mark the leads.

*b. Installation.*

(1) Connect the bayonet type connector in the base to the lighting harness cable marked in a (3) above.

(2) Attach the base to the body with four panhead tapping screws.

(3) Attach the lens housing to the base with the two ovalhead machine screws.

**2-271. Outside Power Connector Cable**

(Fig. 2-230. )

*a. Removal.*

(1) Remove the cable reel canvas boot.

(2) Remove the cotter pin from the reel outer bearing support.

(3) Unbuckle the strap holding the end of cable to the reel.

(4) Unreel the cable, and detach it from the reel barrel.

*b. Installation.*

(1) Place the end of the cable into the hole in the reel barrel, reel the cable onto the barrel, and secure the free end with a strap.

(2) Lock the reel by inserting a cotter pin through the hole in the outer bearing support and the reel shaft.

(3) Cover the reel with the canvas boot.

**2-272. Power Cable Reel**

(Fig. 2-230.)

*a. Removal.* Remove the cotter pin from the outer reel bearing housing. Support the reel, remove the nut, lockwashers, and bolts attaching the bearing housings to the angle bars. Lower the reel to the ground.

*b. Installation.* Position the reel on the angle bars with the bearing housing bolt holes alined with the holes in the angle bars. Attach the bearing housings to the angle bars with four hexagon-head bolts, lockwashers, and a hexagon nut.

**2-273. Inside Telephone Jack Posts**

(Fig. 2-234. )

*a. Removal.*

**NOTE**

Inside jack posts are located on the van ceiling panel at the left of the air conditioning duct and on the van left rear panel immediately below the fire extinguisher.

(1) Remove the four screws attaching the jack-post box to the ceiling (or rear panel), and separate the box from the panel.

(2) Remove the two screws attaching the connecting wires to the jack posts, and disconnect the wires.

(3) Remove the two nuts holding the jack posts in the box, and remove the posts from the box

*b. Installation.*

**CAUTION**

Be careful that the bare wires do not touch each other or any metallic van body components.

- (1) Insert the jack posts through the rubber grommets in the box, and secure each with one hexagon nut.
- (2) Connect the wires to the jack posts with two roundhead screws.
- (3) Position the box in the panel (or ceiling), and secure it with four panhead tapping screws.

**2-274. Outside Telephone Jack Posts**

(Fig. 2-230.)

*a. Removal.*

**NOTE**

The outside jack posts are located on the outside left rear panel, in line with the rear inside jack posts. Most of the outside jack post replacement procedure is performed through the rear inside jack post box.

- (1) Working inside the van body, remove the four screws attaching the rear inside jack post box to the panel, and remove the box.
- (2) Remove the screws attaching the connecting wires to the outside jack posts, and disconnect the wires.
- (3) Remove the nuts holding the outside jack posts in the box.
- (4) Working outside the van body, open the spring-hinged cover on the left rear panel, and withdraw the outside jack posts.

*b. Installation.*

**CAUTION**

Be careful that the bare wires do not touch each other or any other metallic van body components.

- (1) Working outside the van body, open the spring-hinged cover on the left rear panel, and insert the jack posts through the rubber grommets in the box.
- (2) Working inside the van body, secure the outside jack posts in the box with hexagon nuts.
- (3) Connect the wires to the outside jack posts with roundhead screws.
- (4) Position the rear inside box on the panel, and secure it with four panhead tapping screws.

**2-275. Emergency Light and Blackout Light Fixtures**

**NOTE**

Replacement procedures for the emergency light and blackout light fixtures are identical.

*a. Lenses and Lamps (Fig. 2-242).*

- (a) Loosen the ring door locking screw and open the ring door.
- (b) Pull the lens retaining clip from the ring door, and remove the lens.
- (c) Position the white lens in the emergency light ring door, or blue lens in the blackout light ring door, and secure it with the lens retaining clip.

- (d) Close the ring door, and tighten the ring door locking screw.
- (2) *Replacement of lamps.*
- (a) Loosen the ring door locking screw. Then, open the ring door, and remove the lamp.
  - (b) Install a 60-watt white frosted lamp in the emergency light fixture or a 25-watt blue lamp in the blackout light fixture.
  - (c) Close and secure the ring door.

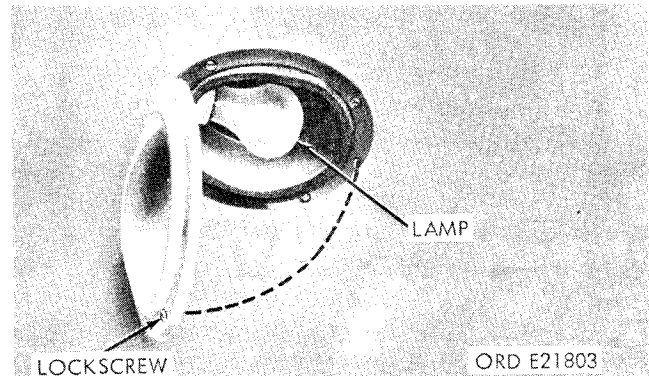


Figure 2-242. Removing emergency and blackout lamp.

*b. Light fixtures (Fig. 2-243).*

(1) *Removal.*

- (a) See that the main power switch is in the OFF position. Loosen the ring door locking screw, and open the ring door.
- (b) Remove the four screws in the reflector flange attaching the fixture to the ceiling, and separate the fixture from the ceiling.
- (c) Disconnect the electrical wires from the socket terminals. Note the location of the connections for later installation.

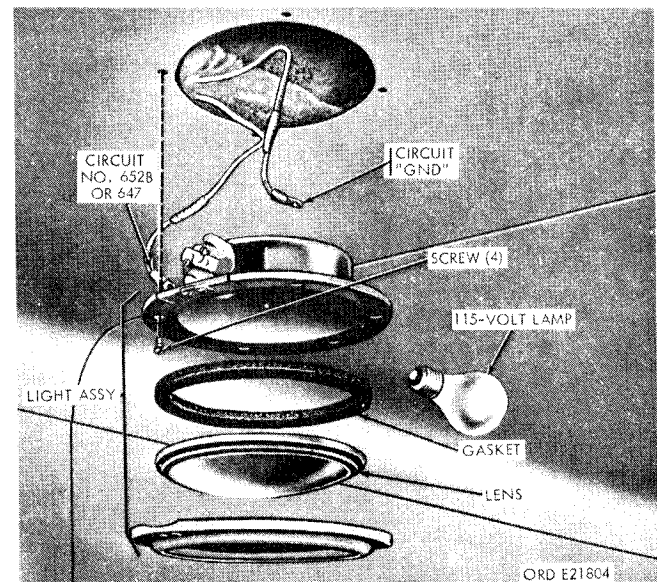


Figure 2-243. Removing emergency and blackout light fixture.

(2) *Installation.*

(a) Connect the wires and ground to the socket terminals from which they were removed.

(b) Attach the fixture to the ceiling with four panhead tapping screws.

(c) Close the ring door, and tighten the ring door locking screw.

2-276. Fluorescent Ceiling Light Fixture

(Fig. 2-244. )

a. *Removal.*

(1) See that the main power switch is in the OFF position.

(2) Remove the 10 screws attaching the light fixture to the ceiling, and separate the fixture from the ceiling.

(3) Loosen the wire nuts, and disconnect the two electrical wires from the light fixture wires. Note the location and circuit number of the connections for later installation.

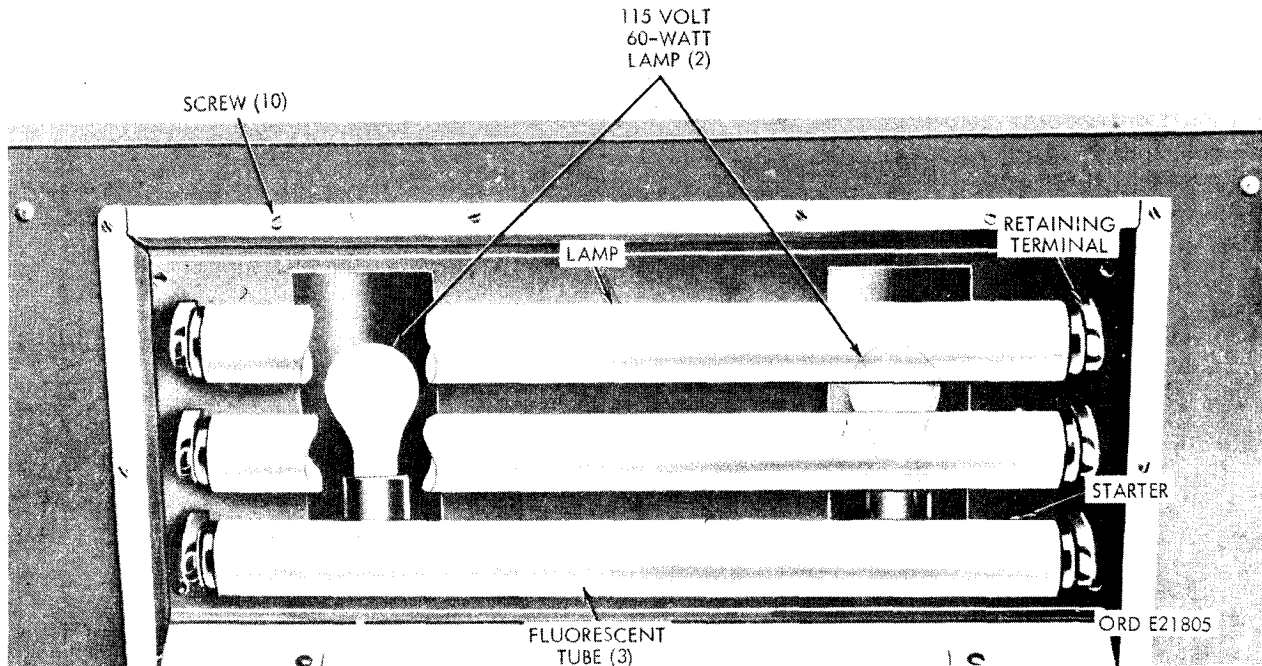


Figure 2-244. Fluorescent ceiling light fixture.

b. *Installation.*

(1) Connect the two electrical wires and ground, noted in a(3) above to the light fixture wires with the two wire nuts.

(2) Attach the fixture to the ceiling with the ten pan bead tapping screws.

c. *Fluorescent Tubes.*

(1) *Removal.*

(a) Loosen the two screws, and open the hinged mesh guard.

(b) Spread the retaining terminals, and remove the tube.

(2) *Installation.*

(a) Install the replacement 15-watt fluorescent tube by snapping it into the retaining terminals.

(b) Press the terminals together.

(c) Close the mesh guard, and secure it with the two panhead tapping screws.

d. *Starters.*

(1) *Removal.*

(a) Loosen the two screws, and open the hinged mesh guard.

(b) Remove the fluorescent tube (c above).

(c) Turn the starter one-quarter turn counterclockwise, and remove the starter from the fixture.

(2) *Installation.*

(a) Position a new starter in the fixture, and turn the starter one-quarter turn clockwise.

(b) Install the fluorescent tube (c above).

(c) Close the mesh guard, and secure it with the two panhead tapping screws.

e. *Lamps.*

(1) *Removal.*

(a) Loosen the two screws, and open the hinged mesh guard.

(b) Remove the fluorescent tubes (cabove).

(c) Remove all defective 115-volt lamps.

(2) *Installation.*

(a) Install 115-volt, 60-watt white frosted lamps.

(b) Install the fluorescent tubes ( c above).

(c) Close and secure the mesh guard with the panhead tapping screws.

**2-277. Blackout Switches**

*a. Main Blackout Circuit Switch (Fig. 2-232).*

(1) *Removal.*

(a) See that the main power switch is in the OFF position.

(b) Remove the two screws attaching the cover plate to the switch, and remove the cover plate.

(c) Remove the two screws attaching the switch box, and separate the switch from the box.

(d) Disconnect the three electrical wires from the switch terminals. Note the location of the connections for later installation.

(2) *Installation.*

(a) Connect the electrical wires to the switch terminals from which they were removed. (See (1) (d) above).

(b) Attach the switch to the switch box with the two panhead tapping screws.

(c) Attach the cover plate to the switch with the two ovalhead machine screws.

*b. Door-operated Blackout Switches (Fig. 2-232 and 2-238).*

(1) *Removal.*

(a) See that the main power switch is in the OFF position.

(b) Remove the two screws attaching the cover plate to the switch box, and remove the cover plate.

(c) Disconnect the electrical wires from the switch terminals. Note the location of the connections and mark them for later installation.

(d) Remove the two screws attaching the switch to the switch box, and remove the switch from the box.

(2) *Installation.*

(a) Thread the electrical wires through the

holes in the switch box to bring the wires adjacent to the terminals.

(b) Install the switch in the switch box with two flathead machine screws. Connect the wires, marked in (1) (c) above, and ground to the switch terminals from which they were removed.

(c) Attach the cover plate to the switch box with two flathead machine screws.

*c. Hinged Roof-operated Blackout Circuit Plungers (Fig. 2-233).*

(1) *Removal.*

(a) Place the van side panel in its fully expanded position, and support the hinged roof with swivel hooks (TM 9-2320-211-10).

(b) See that the main power switch is in the OFF position.

(c) Remove the four screws attaching the plunger plate to the edge of the hinged roof, and remove the plunger plate.

(d) Disconnect the two electrical wires from the plunger terminals. Note the location of the connections, and mark them for later installation.

(2) *Installation.*

(a) Connect the electrical wires, marked in (1) (d) above, and ground to the plunger terminals from which they were removed with two roundhead screws.

(b) Attach the plunger plate to the hinged roof edge with four roundhead screws.

(c) Retract the van side panel to its fully retracted position. (TM 9-2320-211-10).

*d. 110-Volt Receptacle and Blackout Switch (Fig. 2-245).*

(1) *Removal.*

(a) See that the main power switch is in the OFF position.

(b) Remove the three screws attaching the cover plate to the switch, and remove the cover plate.

(c) Remove the two screws attaching the switch to the switch box, and separate the switch box.

(d) Disconnect the three electrical wires from the switch terminals. Note the location of the connections, and mark them for later installation,

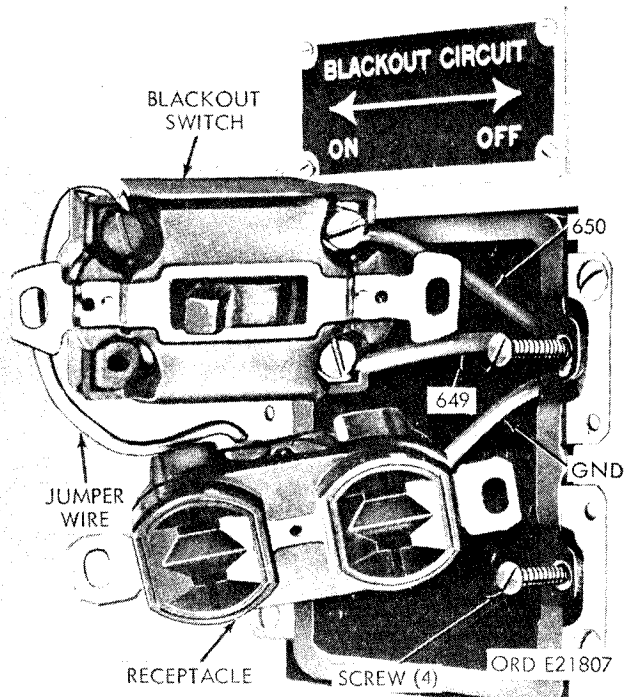


Figure 2-245. 110-volt receptacle and blackout switch.

(2) *Installation.*

(a) Connect the electrical wires, marked in

(1) (d) above, and the jumper wire to the switch terminals from which they were removed.

(b) Attach the switch to the switch box with the two panhead tapping screws.

(c) Attach the cover plate to the switch with the three ovalhead machine screws.

**2-278. Emergency Light Switch**

(Fig. 2-232. )

*a. Removal.*

(1) See that the main power switch is in the OFF position.

(2) Remove the two screws attaching the cover plate to the switch, and remove the cover plate.

(3) Remove the two screws attaching the switch to the switch box, and separate the switch from the box.

(4) Disconnect the two electrical wires from the switch terminals. Note the location of the connections, and mark them for later installation.

*b. Installation.*

(1) Connect the electrical wires, marked in a (4) above, to the switch terminals from which they were removed.

(2) Attach the switch to the switch box with two panhead tapping screws.

(3) Attach the cover plate to the switch with two ovalhead machine screws.

**Section XXXVIII. MAINTENANCE OF WRECKER CRANE—**

**M62, M246, M246A1, AND M246A2**

**2-279. General**

a. The M62 and M246 wrecker crane models are hydraulically-operated units powered by the vehicle's engine. An extendable boom on both models is capable of 360° rotation and approximately 45° elevation.

b. Each of the crane's functions is dependent upon hydraulic components. Control of the crane is accomplished by a control valve bank consisting of four, two-way hydraulic valves bolted together to form a single unit. Each valve controls one of the crane's four functions, such as lifting or lowering the boom, winding or unwinding the hoist drum, extending or retracting the boom, and swinging the boom left or right.

**NOTE**

The M62 crane operational controls are cab enclosed, whereas the M246 crane has an open-top cab.

**2-280. Hydraulic Lines and Fittings**

*a. Removal.*

**CAUTION**

Before disconnecting any hydraulic line, place an identification tag on the line and its corresponding part to prevent incorrect installation of the line and corresponding part.

(1) Unscrew the sleeve nut at both ends of the flexible line or tube.

(2) Remove the clamps or brackets securing the line (or tube) to the crane (where used).

(3) Remove the line (or tube) from the vehicle.

*b. Installation.*

**CAUTION**

When installing new tubes and fittings, never tighten them over two turns after the sleeve has shouldered in the body of the fitting.

- (1) Position the flexible line (or tube) on the crane.
- (2) Secure the line with clamps or brackets, where clamps and brackets are provided.
- (3) Tighten all flexible line sleeve nuts.
- (4) Pull the tube-fitting sleeve nuts up finger-tight, then give the nut a one-eighth turn with a wrench.

- (2) Position the door and lamp unit assembly in the front of the flood-light body, and insert the cable terminals under the lamp unit terminal screw heads. Tighten the terminal screws.
- (3) Insert the lamp unit in the floodlight body, align the door-mounting screw holes, and secure the door to the body with the three screws.

**2-281. Floodlight Lamp Unit**

(Fig. 2-246. )

*a. Removal.*

- (1) Remove the three screws securing the door to the floodlight body, and pull the door and lamp unit assembly from the body.
- (2) Loosen the two terminal screws on the back of the lamp unit, remove the two cables from the terminals, and remove the door and lamp unit assembly from the floodlight.
- (3) Remove the four springs securing the lamp unit to the door, and remove the lamp unit from the door. Discard the lamp unit.

*b. Installation.*

- (1) Insert the new lamp unit in the door, and secure it with four retaining springs.

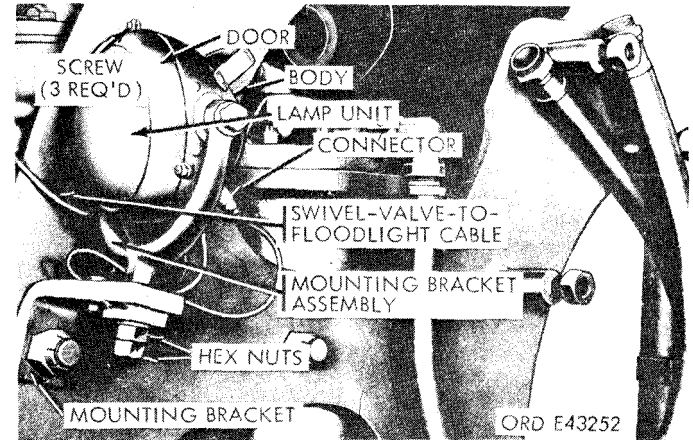


Figure 2-246. Floodlight mounted on left side of shipper support.

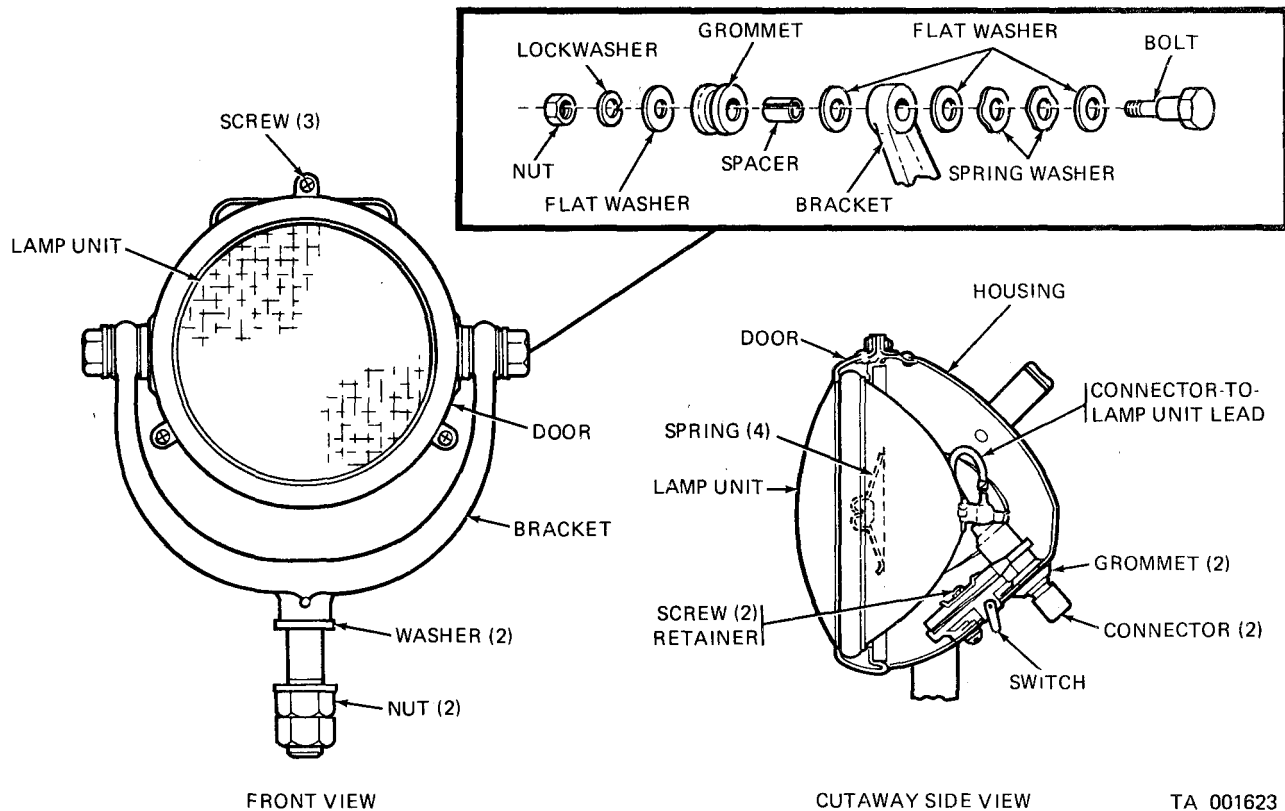


Figure 2-247. Floodlight lamp and switch replacement.

**2-282. Floodlight Switch**

*a. Removal.*

(1) Remove the floodlight lamp unit (para 2-281).

(2) Disconnect the two bayonet type connectors securing the flood light cables to the rear of the floodlight.

(3) Remove the two screws securing the contact bracket and switch assembly to the inside of the floodlight body. Remove the bracket and switch assembly (with cables) from the body.

(4) Pull the switch cable plug type terminal from the contact bracket socket.

(5) Disconnect the switch cable bayonet type connector from the lamp unit cable connector.

(6) Remove the two screws and lockwashers securing the switch assembly to the contact bracket, and remove the switch assembly from the bracket.

*b. Installation.*

(1) Position the floodlight switch assembly on the contact bracket, and secure it with two screws and lockwashers.

(2) Insert the switch cable plug type terminal in the contact bracket socket.

(3) Connect the switch cable bayonet type connector to the lamp unit cable connector.

(4) Position the contact bracket and switch assembly in the floodlight body, and secure the bracket to the body with two screws.

(5) Connect the two floodlight cable bayonet type connectors to the connector at the rear of the floodlight.

(6) Install the floodlight lamp unit (para 2-281).

**2-283. Floodlight**

(Fig. 2-246. )

*a. Removal.*

(1) Disconnect the two bayonet type connectors securing the floodlight cables to the rear of the floodlight.

(2) Remove two hexagon nuts and plain washers securing floodlight mounting bracket

assembly to mounting bracket bolted to shipper support.

(3) Remove floodlight assembly from mounting bracket.

*b. Installation.*

(1) Insert floodlight mounting bracket stud through hole in mounting bracket bolted to shipper support.

(2) Install a plain washer and two hexagon nuts on the stud.

(3) Connect the two floodlight cable bayonet type connectors to the connectors at rear of floodlight.

**2-284. Floodlight cables**

(Fig. 2-248. )

*a. Plug and Receptacle Type Connectors.*

(1) *Removal.* Unscrew the connector retaining nut, and pull the plug from the receptacle. Disconnect the cable at both ends, remove the cable from the clamps (or clamp) securing it to the vehicle, and remove the cable.

(2) *Installation.* Position the cable (or harness), and secure it to the vehicle with clamps (or clamp). Install the plugs in the receptacle, and tighten the connector retaining nuts.

**NOTE**

Before installing the connector plugs, insure that the rubber sealing gaskets and / or rings are in place. Also insure that the locating key and keyway are alined before attempting to insert the plug. Do not force the plug. If the key and keyway are properly alined, the plug pins will enter the receptacle sockets without having to be forced. Do not twist or knik the cable.

*b. Bayonet Type Connectors.*

(1) *Removal.* Rotate one of the connector halves counterclockwise. Pull the connector apart.

(2) *Installation.* Refer to note in *a (2)* above. Position the cable and secure it to the vehicle with clamps (or clamp). Insert the small bell in the end of the large bell. Rotate one of the bells clockwise to lock the bells together.



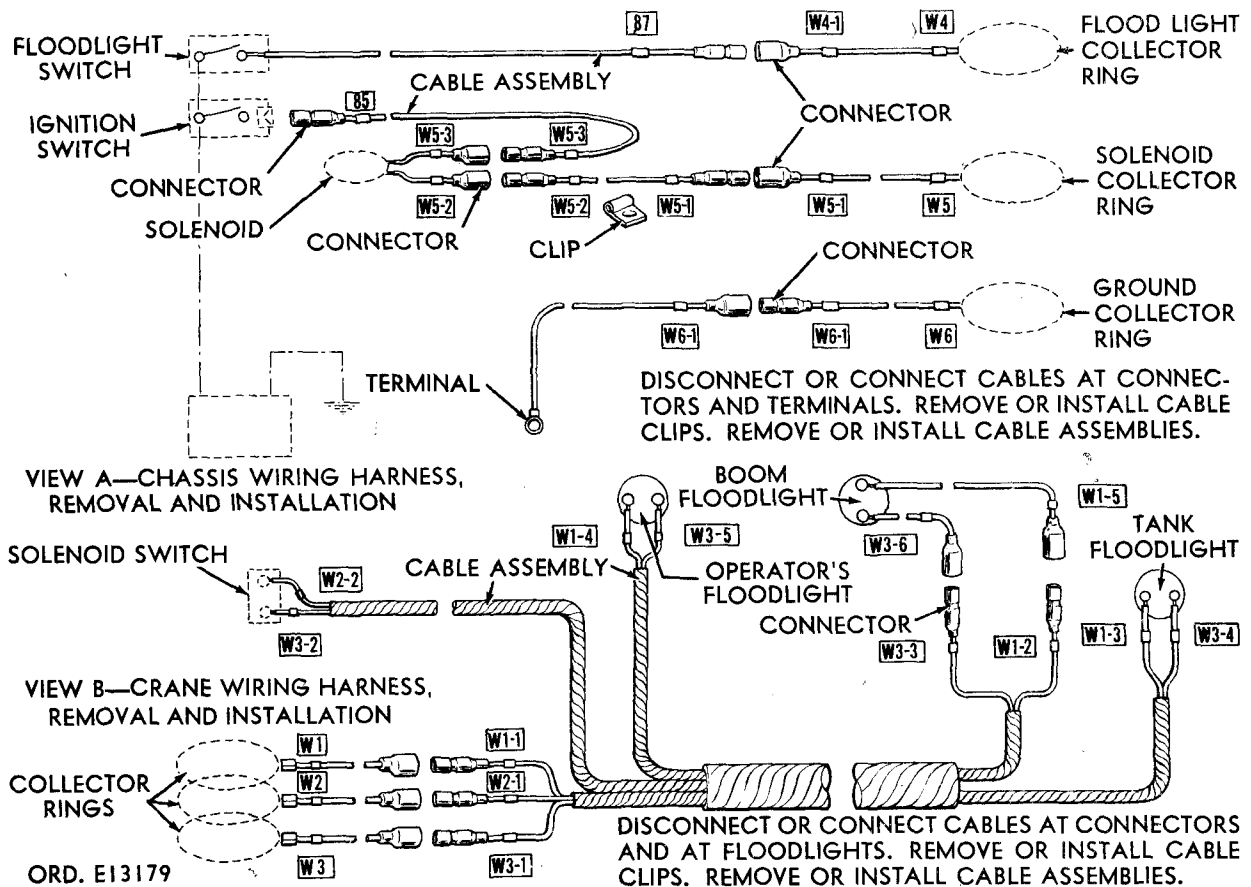


Figure 2-248. Removing or installing wiring harness—wrecker models.

**2-285. Electric Brake Lock**

(Fig. 2-249.)

*a. Removal.*

(1) Disconnect the bayonet type connector securing the brake lock cable to the harness. Separate the cable and harness.

(2) Unscrew the two sleeve nuts securing the brake hydraulic lines to the front and rear of the brake lock. Remove the lines from the lock.

(3) Remove the safety nut and capscrew securing the brake lock to the inside of the frame left side rail, and remove the lock from the vehicle.

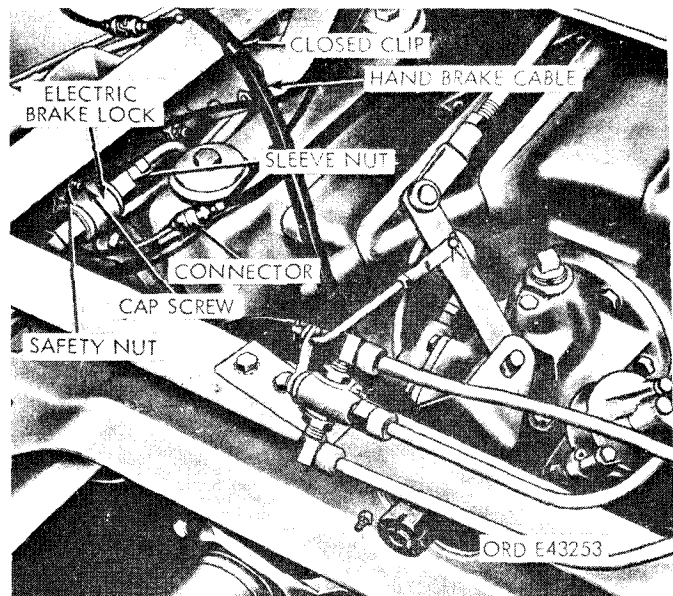


Figure 2-249. Electric brake lock mounted on frame left side rail.

*b. Installation.*

(1) Position the electric brake lock on the inside of the frame left side rail, and secure it with the capscrew and safety nut.

(2) Position the brake hydraulic lines at the front and rear of the brake lock, and tighten the two sleeve nuts.

(3) Connect the bayonet type connector on the brake lock cable to the brake lock switch-to-brake lock harness connector.

(4) Bleed the brakes (para 2-189) if necessary.

**2-286. Electric Brake Lock Switch**

*a. Removal.*

(1) Remove the two screws from the front of the instrument panel, and remove the electric brake lock switch (32, fig. 2-163) from the back of the panel.

(2) Disconnect the two bayonet type connectors securing the harness cables to the back of the switch. Remove the switch.

*b. Installation.*

(1) Connect the two bayonet type connectors on the harness cables to the connectors on the back of the electric brake lock switch button ( 32, fig. 2-163) and data plate.

(2) Position the switch on the back of the instrument panel with the switch button extending through the hole in the panel. Secure it with two screws.

**2-287. Warning Light Switch**

*a. Removal.*

(1) Remove the screw from the front of the warning light switch lever (26, fig.2-163), and pull the lever from the switch shaft.

(2) Remove the hexagon nut, the tooth type lockwasher, and the indicating plate from the switch body at the front of the instrument panel. Remove the switch from the back of the panel.

(3) Disconnect the two switch-cable bayonet type connectors from the harness cable connectors. Remove the switch from the vehicle.

*b. Installation.*

(1) Position the warning light switch (26, fig. 2-163) on the back side of the instrument panel with the switch body extending through the hole in the panel.

(2) Install the indicating plate, lockwasher, and hexagon nut on the switch body, and tighten the nut.

(3) Connect the two switch cable connectors to the harness cable connectors.

(4) Install the switch lever (fig. 2-163) on the switch shaft, and secure it with a screw.

**2-288. Floodlight Switch (Inside Cab)**

*a. Removal.* The procedure for removing the

floodlight switch (35, fig. 2-163) is the same as for the warning light switch. Refer to paragraph 2-287 *a.*

*b. Installation.* The procedure for installing the floodlight switch is the same as for the warning light switch. Refer to paragraph 2-287 *b.*

**2-289. Control Lever Knob**

*a. Removal.* Unscrew the control lever knob from the control lever.

*b. Installation.* Position and screw the control lever knob on the control lever.

**2-290. Restrictor Valve**

(Fig. 2-250. )

*a. Removal.*

(1) Unscrew the sleeve nut at the restrictor valve end of the hydraulic oil motor line.

(2) Unscrew the restrictor valve from the elbow, and remove the valve.

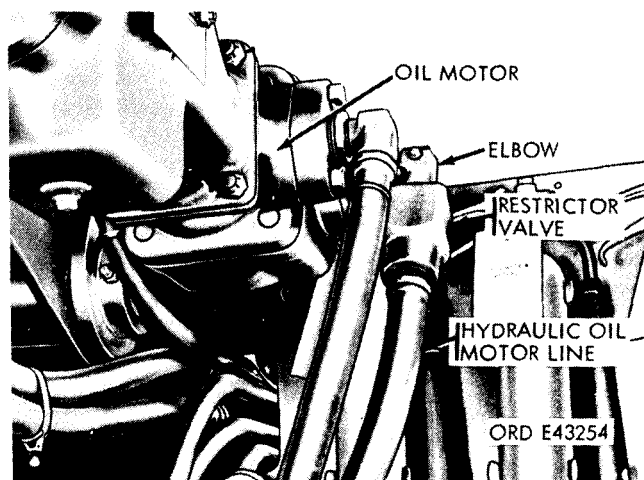


Figure 2-250. Hydraulic oil motor lines and restrictor valve.

*b. Installation.*

(1) Screw the restrictor valve to the elbow.

(2) Screw the sleeve nut on the hydraulic oil motor line at the restrictor valve.

**2-291. Hoist Cables**

*a. Removal.*

(1) Unwind the cable from the drum. Refer to TM 9-2320-211-10.

(2) Drive the cable wedge from the drum and remove the cable from the hole in the drum. Remove the cable from the boom and boom sheaves.

*b. Installation.*

(1) Thread the hoist cable around the boom sheaves. Position the cable on top of the boom and shipper assembly, and insert the end of the cable in the hole in the drum. Secure the cable to the drum with the cable wedge.

(2) Wind up the cable on the drum. Refer to TM 9-2320-211-10.

## Section XXXIX. MAINTENANCE OF WRECKER CRANE— M543 AND M543A1

### 2-292. General.

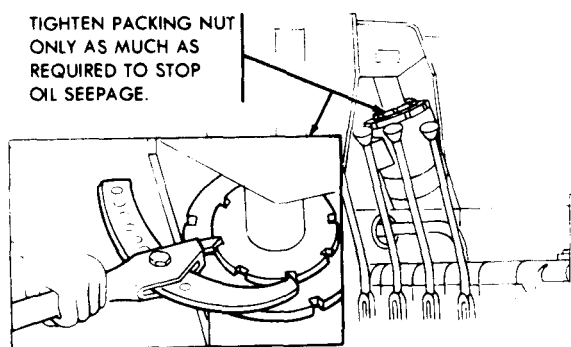
*a.* The M543 and M543A1 wrecker crane models are hydraulically operated units powered by the vehicle's engine. An extendable boom on both models is capable of 360° rotation (270° with stops) and approximately 45° elevation. These models include a hydraulic crane, winch assembly, and power train assembly.

*b.* Each of the crane's functions is dependent upon hydraulic pressure supplied by a valve type hydraulic pump. This pump forces pressurized fluid through a swivel valve to each of the crane's hydraulic components. Control of the crane is accomplished by a single unit control valve bank assembly. The valve assembly controls all of the crane's functions, such as lifting or lowering the boom, winding or unwinding the hoist drum, extending or retracting the boom, and swinging the boom left or right. On later vehicles the hydraulic system is equipped with a filter. An indicator on the outside of the filter indicates the filter element condition and determines the necessity of cleaning.

**2-293. Hydraulic Lines and Fittings.** Refer to paragraph 2-280 and follow similar procedures for removal and installation.

### 2-294. Hydraulic Cylinders.

*a. General.* The two boom elevating cylinders and the boom crowd cylinder have an adjustable packing gland nut (fig. 2-251) to correct oil leakage at the packing around the piston rod. Adjustment is the same for all three cylinders.



TA 155981

Figure 2-251. Hydraulic cylinder packing adjustment.

### *b. Adjustment.*

(1) Using a spanner wrench (6, fig. 2-4) as shown in figure 2-251, tighten the packing nut only as much as required to stop oil seepage. When the adjustment has been used up, a new packing must be installed.

(2) When adjusting the packing nut on a boom cylinder, remove the block (fig. 2-257), and extend the boom slowly until the adjustment opening in the inner boom at the cylinder packing nut is alined with the stop block opening in the outer boom.

(3) Adjust the packing nut using a punch, or bar, to tighten it. Tighten it only as much as is required to stop the oil seepage.

### 2-295. Hydraulic System Pressure.

*a. General.* The hydraulic system operates at approximately 1,200 psi. An adjustable relief valve in the control valve bank governs this pressure and protects the hydraulic system from going beyond 1,210 to 1,215 psi.

#### *b. Relief Valve Test.*

(1) Remove pipe plug from the control valve bank, and install hydraulic pressure gage (2, fig. 2-4) as shown in figure 2-252.

(2) Lower hoist cable to the ground to prevent fouling of the hoist cable block with the boom sheaves while testing the relief valve setting.

(3) With boom fully extended, move control lever to the extended position, and hold it there.

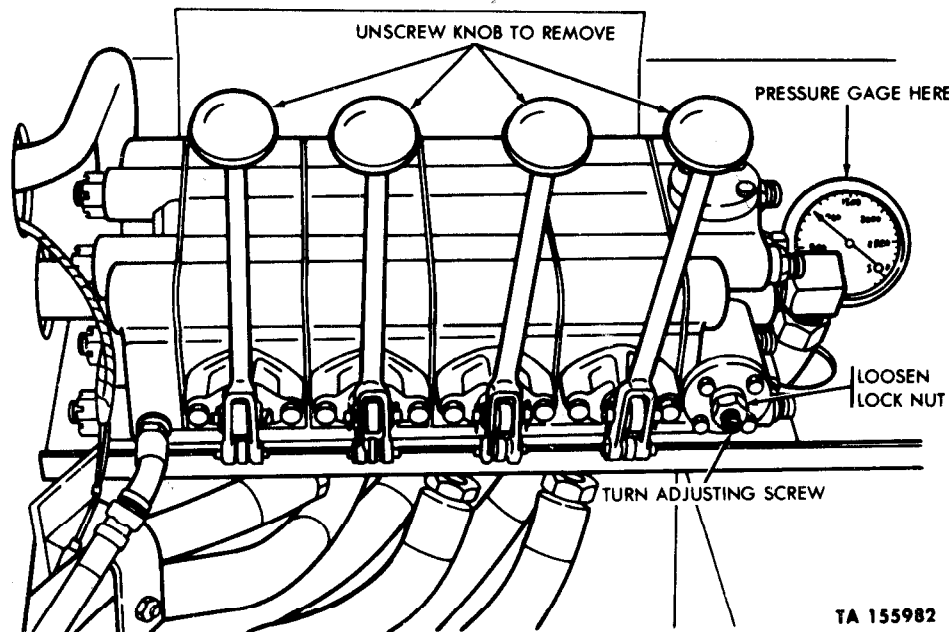
(4) While holding control lever in the extended position, observe pressure indicated on hydraulic pressure gage.

(5) The pressure indicated on gage is pressure at which the relief valve is opening. If gage indicates an incorrect relief valve setting (more or less than 1,210 to 1,215 psi) adjust relief valve as described in *c* below.

*c. Relief Valve Adjustment.* Gar Wood Valve Bank Assembly, 10876206.

(1) Loosen locknut on adjusting screw (figure 2-252).

(2) Turn adjusting screw as required to obtain correct relief valve setting of 1,210 to 1,215 psi.



TA 155982

Figure 2-252. Relief valve adjustment.

**NOTE**

Turning the adjusting screw clockwise increases the pressure required to open the relief valve. Turning the adjusting screw counterclockwise decreases the relief valve opening pressure.

(3) After the correct relief valve setting is obtained, hold the adjusting screw and tighten the locknut.

(4) Remove the pressure gage from the control valve bank, and install the pipe plug.

*d. Relief Valve Adjustment.* (Parker Hannifin Valve Bank Assembly, 11621117).

(1) Remove capnut from relief valve adjusting screw and loosen jamnut.

(2) Turn adjusting screw as necessary to obtain correct relief setting of 1,210 and 1,215 psi.

(3) After correct relief valve setting is obtained, hold adjusting screw and tighten jamnut. Install capnut.

(4) Disengage hydraulic pump, remove gage from valve bank, and install plug.

(5) Position valve bank cover on gondola and secure with five screws.

**NOTE**

If correct pressure reading cannot be obtained by adjusting relief valve, notify direct support maintenance.

**2-296. Hydraulic System Filter.***a. Removal.*

(1) Place a suitable container under filter to catch spilled oil. A built in shutoff valve will prevent hydraulic oil reservoir from draining when filter element is removed. However, approximately one to three gallons of oil will spill from filter when removing and installing filter element.

(2) Remove four screws securing rear cover to filter housing.

(3) Quickly pull rear cover and filter element from housing.

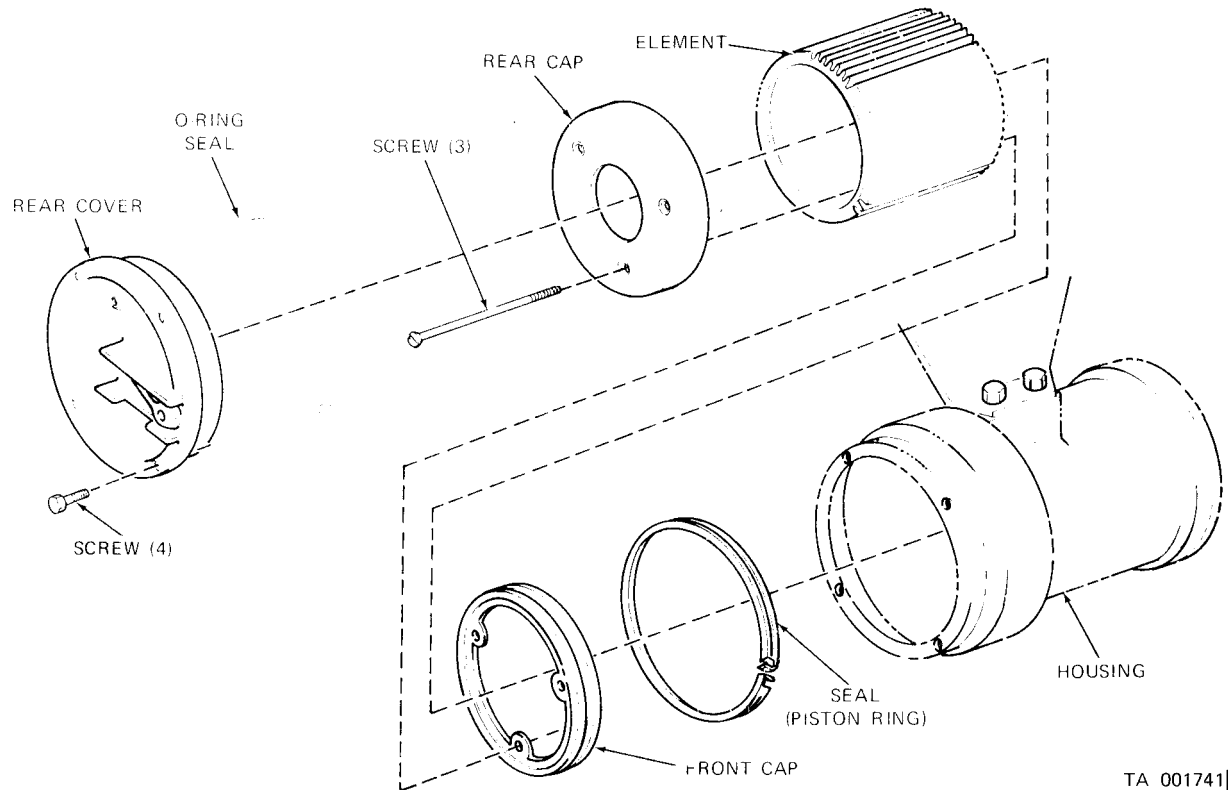
**NOTE**

Do not hesitate when pulling cover and filter element from housing. The shutoff valve will not shut off oil flow from reservoir until cover and filter element are removed from housing.

(4) Remove three screws securing rear filter element cap to front filter element cap. Separate caps from filter element.

(5) Remove seal ring from front filter element cap.

(6) Remove O-ring seal from rear cover.



TA 001741

Figure 252.1. Hydraulic system filter—partially exploded view.

*b. Cleaning.*

- (1) Wash all parts in cleaning solvent.
- (2) Using compressed air, direct air stream from inside filter element toward outside.
- (3) Blow off outside of filter element, and again direct air stream from inside of element toward outside.
- (4) Using compressed air, air dry all other parts.

*c. Installation.*

**NOTE**

Check all parts for excessive wear or damage and replace as required.

- (1) Position front and rear filter element caps on filter element and secure with three screws.

- (2) Install seal ring on front filter element cap.

(3) Aline slot in rear filter element cap with indicator arm shaft in rear cover and install filter element in cover.

- (4) Install O-ring seal on rear cover.

(5) Position filter element and rear cover in filter housing with indicator toward boom. Quickly push filter element and rear cover fully into housing. Hold rear cover and filter element in housing until retaining screws are installed.

- (6) Secure rear cover to housing with four screws.

(7) Check oil level in reservoir and add oil if required.

This page intentionally left blank.

*d. Installation.*

(1) Make sure the element is free to move in the bore and does not hang up.

(2) Install a new preformed packing and cover plate, making sure that the indicator spiral blade enters the slot in the element cover.

**NOTE**

The cover plate can be installed in any of four positions.

(3) Install the cover plate so the indicator can easily be read.

**2-297. Floodlight Lamp Unit**

Refer to paragraph 2-281.

**2-298. Floodlight Switch**

Refer to paragraph 2-282.

**2-299. Floodlight**

Refer to paragraph 2-283.

**2-300. Floodlight Cables**

Refer to paragraph 2-284.

**2-301. Electric Brake Lock**

Refer to paragraph 2-285.

**2-302. Warning Light Switch.**

Refer to paragraph 2-287.

**2-303. Floodlight Switch (Inside Cab)**

Refer to paragraph 2-288.

**2-304. Control Lever Knob**

Refer to paragraph 2-289.

**2-305. Restrictor Valve**

The restrictor valve, located in the oil motor and ram cylinder hydraulic lines, will be inspected during the removal and installation of the hydraulic lines and fittings. Refer to paragraph 2-280.

**2-306. Governor Override Solenoid**

(Fig. 2-253.)

*a. Removal.*

(1) Disconnect the solenoid electrical leads at the connectors as shown.

(2) Remove the screw from the clip securing the electrical leads to the bracket.

(3) Remove the two nuts securing the solenoid to the bracket, and remove the solenoid.

*b. Installation.*

(1) Secure the solenoid to the bracket with the two nuts.

(2) Position and secure the electrical leads with the clip and screw.

(3) Connect the solenoid electrical leads at the connectors.

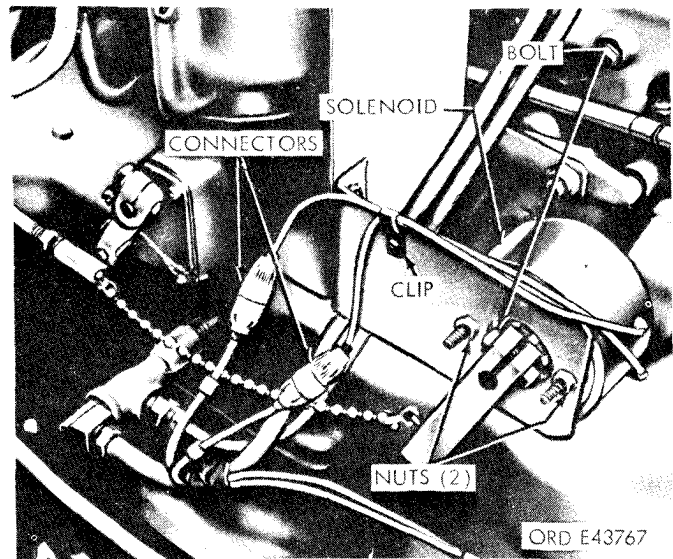


Figure 2-253. Governor override solenoid replacement.

**2-307. Override Switch**

(Fig. 2-254.)

*a. Removal.*

(1) Disconnect the two electrical leads from the override switch at the connectors as shown.

(2) Remove the two screws securing the override switch to the panel. Remove the switch.

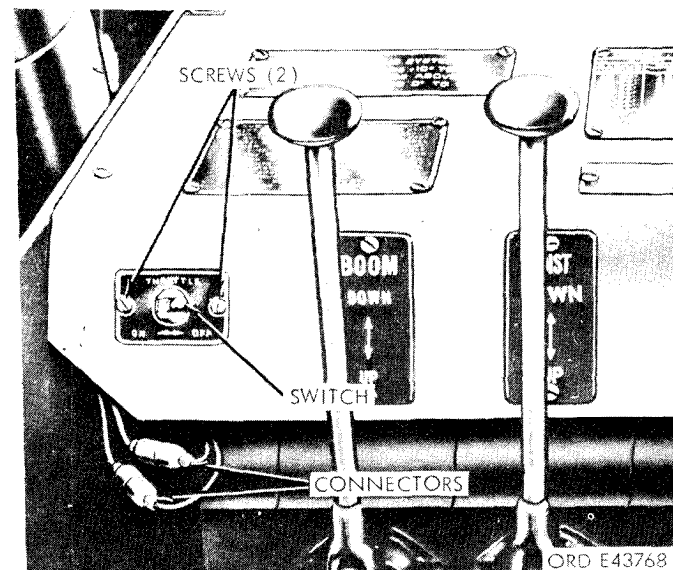


Figure 2-254. Removing or installing override switch.

*b. Installation.*

(1) Position the switch and secure it with two screws.

(2) Connect the two electrical leads.

**2-308. Slipping Brush**

(Fig. 2-255)

*a. Removal.*

(1) Remove the caps from the brush holder and brush assemblies. Remove the brushes.

(2) Remove the four capscrews and lockwashers securing the brush holder support plate to the pump support. If necessary, remove the plate and gasket. Discard the gasket.

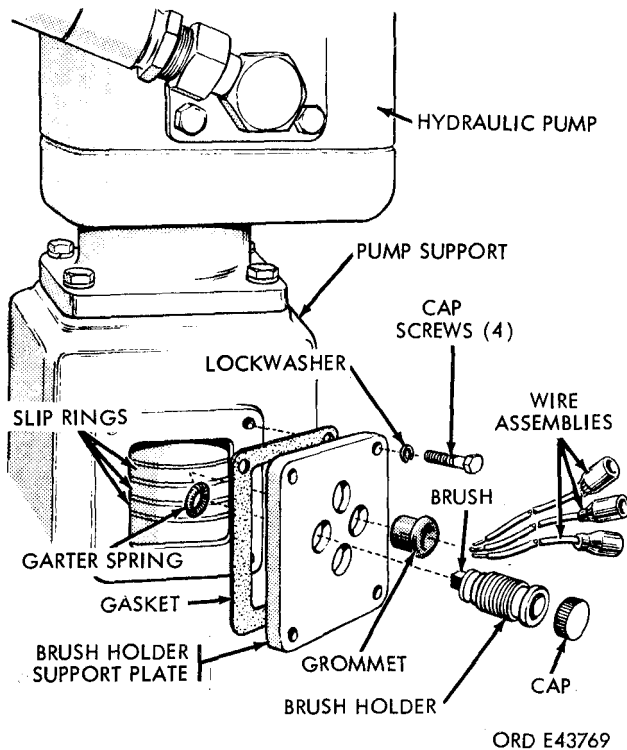


Figure 2-255. Removing or installing slipping brushes.

*b. Installation.*

(1) If necessary, replace the sliprings.

(2) Assemble the grommet and wiring assemblies through the brush plate holder.

(3) Connect the wiring. Secure the brush holder support plate and gasket to the pump support.

(4) Position the brush and brush holder assemblies through the support plate. Install the caps.

**2-309. Automatic Hoist Brake Band**

(Fig. 2-256)

*a. General.* The automatic hoist brake is attached to the drive (worm gear) shaft of the hoist winch gear box and sustains the winch load whenever the delivery of power to the drive shaft is

interrupted; e.g., shifting the control lever to neutral.

*b. Adjustment.* Tighten the brake adjusting screw to obtain a spring compression of  $1 - 7 / 32 \pm 1 / 32$  inch. Do not exceed this adjustment or the brake band will run hot.

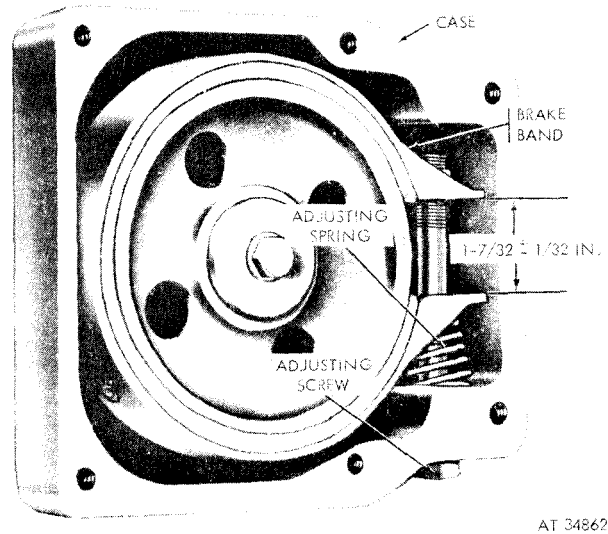


Figure 2-256. Automatic brake band adjustment.

*c. Removal.*

(1) Remove the six capscrews and lockwashers holding the automatic brake casecover. Remove the cover.

(2) Remove the brake adjusting screw from the brake case. Separate the plain washer and preformed packing from the adjusting screw. Discard the packing.

(3) Remove the adjusting screw spring, and pull the brake band assembly from the brake case.

*d. Installation.*

(1) Position the brake band assembly and adjusting screw spring in the case.

(2) Assemble the washer and a new preformed packing to the adjusting screw.

(3) Tighten the adjusting screw into place, and adjust the screw as described in *b* above.

(4) Secure the cover to the case with six lockwashers and capscrews.

**2-310. Hoist Cable**

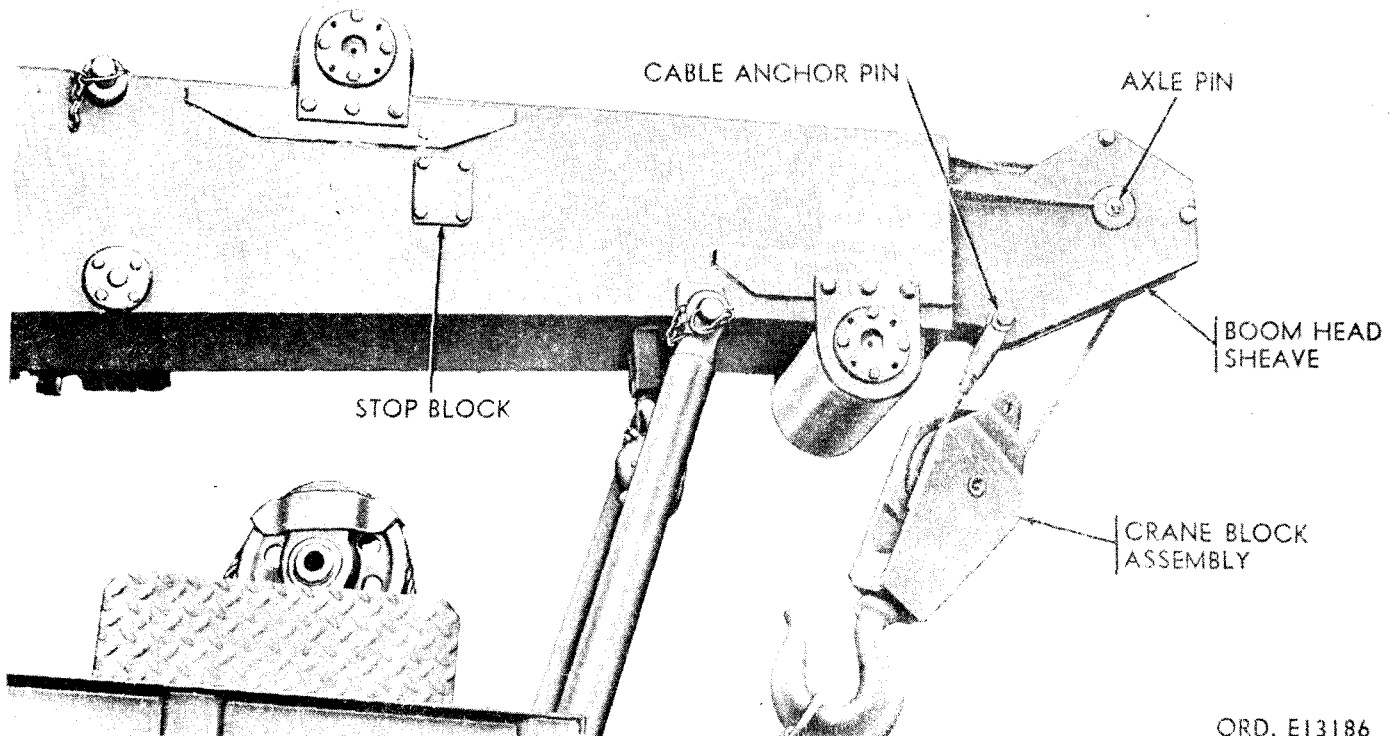
**WARNING**

Always wear gloves when handling wire cable. Never let the cable run through bare hands. Broken wires can cause painful injuries.

*a. Removal.*

(1) Remove the cable anchor pin from the boom head, and remove the crane block assembly (fig. 2-257).

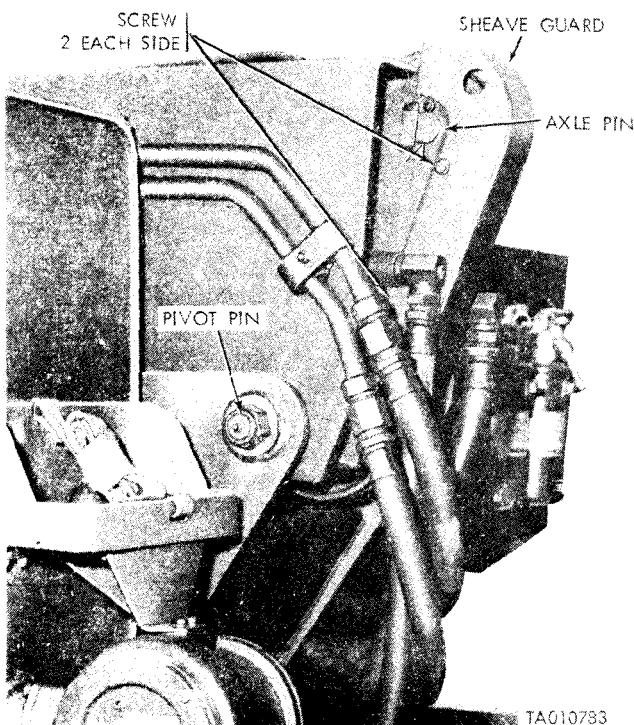




ORD. E13186

Figure 2-257. Hoist cable replacement.

(2) Remove the capscrews from the sheave guard, and remove the guard (fig. 2-258).



TA010783

Figure 2-258. Boom foot end cable sheaves replacement.

(3) Unwind the cable from the hoist drum by moving the hoist control lever to the DOWN position, and pull the cable out as it unwinds from the drum.

**NOTE**

Failure to maintain tension on the cable while the drum is turning will cause the cable to become snarled on the drum and the boom structure.

(4) Completely unwind the cable from the drum. Remove the hexagon-socket setscrew from the winch drum, and pull the end of the cable from the hole in the drum and out through the sheaves and boom.

(5) Unscrew the connector sleeve, pull the cable from the connector, and remove the fluted plug and sleeve from the cable (fig. 2-259).

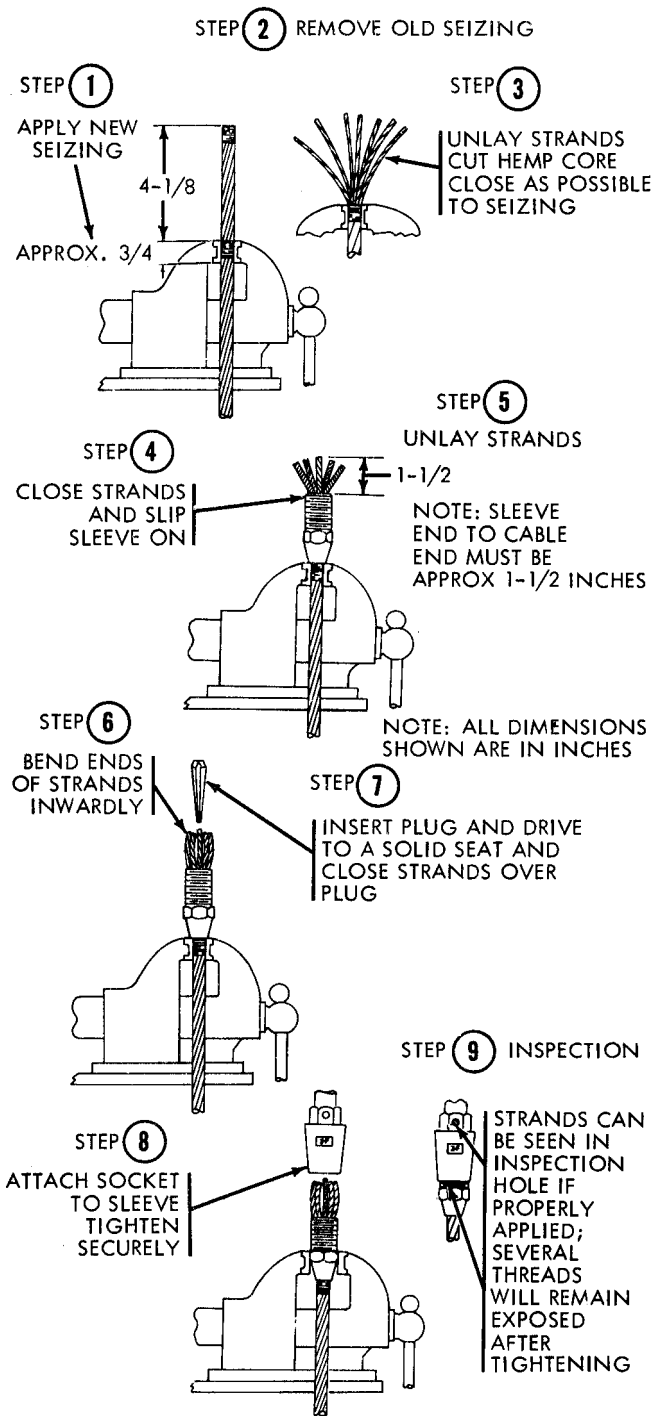


Figure 2-259. Attaching hoist cable connectors.

b. Installation.

**CAUTION**

The cable must be fully seated in the socket and visible through the inspection hole.

(2) Install the hoist cable connector as indicated in figure 2-259.

(2) Thread the cable through the boom head

sheave and down through the boom, around the rear sheaves (fig. 2-258).

(3) Insert the end of the cable in the hole in the drum and tighten the hexagon-socket setscrew to secure the cable to the drum.

(4) Wind the cable on the drum by moving the hoist control lever to the UP position. Place a light load on the cable while winding to insure a tight and neat wind.

(5) Install the sheave guard (fig. 2-258).

**2-311. Hoist Cable Sheaves and Guard**

a. *General.* The boom head cable sheave (fig. 2-257), and upper boom foot sheave have an axle pin (fig. 2-250) held in place by a cotter pin. The lower boom foot sheave is fixed on the pivot pin (fig. 2-258) of the boom foot end.

b. *Boom Head Sheave and Upper Boom Foot Sheave.*

(1) *Removal.*

(a) Remove the four capscrews that attach the sheave guard (fig. 2-258).

(b) Slack off the hoist cable, and remove the cotter pin keeper from the upper sheave axle pin, and remove the pin and sheave.

(c) The boom head sheave (fig. 2-257) is removed in the same manner.

(2) *Installation.*

(a) Install the boom head sheave (fig. 2-257).

(b) Position the upper sheave, and install the axle pin. Secure the axle pin with a cotter pin (fig. 2-257). Position the cable in the upper sheave groove.

(c) Secure the sheave guard with four capscrews.

c. *Lower Boom Foot Sheaves.*

(1) *Removal.*

(a) Remove the sheave guard as in b (1) (a) above. Slack off the cable tension.

(b) Secure the boom assembly with a suitable overhead hoisting device to hold it while the pivot pin (fig. 2-258) is removed.

(c) Remove the pivot pin keeper nuts and drive out the pivot pin to remove the lower boom foot sheave.

(2) *Repair.*

(a) Inspect the sheave guard for damage.

(b) If the sheave guard is twisted, dented, or broken, straighten or weld it as required.

(3) *Installation.*

(a) Position the lower boom foot sheave, and secure it with the pivot pin and nuts.

(b) Remove the overhead hoisting device securing the boom assembly.

(c) Install the sheave guard as in b (2) (c) above.

**2-312. Propeller Shaft.**

*a. General.* The propeller shaft for the hoisting system transmits power from the power divider to the bevel gear box.

*b. One Section Shaft Removal.*

(1) Disconnect the power takeoff-to-power divider propeller shaft from the drive shaft yoke at the front of the power divider.

(2) Disconnect the rear winch front propeller shaft from the winch output shaft yoke at the rear of the power divider.

(3) Disconnect the power divider controls.

(4) Remove the patch plate above the power divider assembly (fig. 2-260), and secure the power divider assembly with a suitable lifting device as shown in figure 2-261.

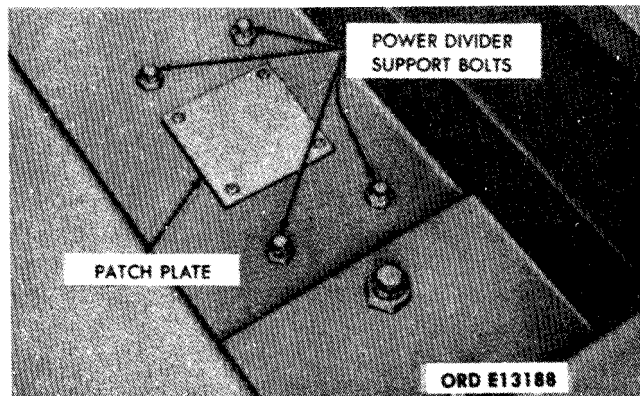


Figure 2-260. Patch over power divider assembly.

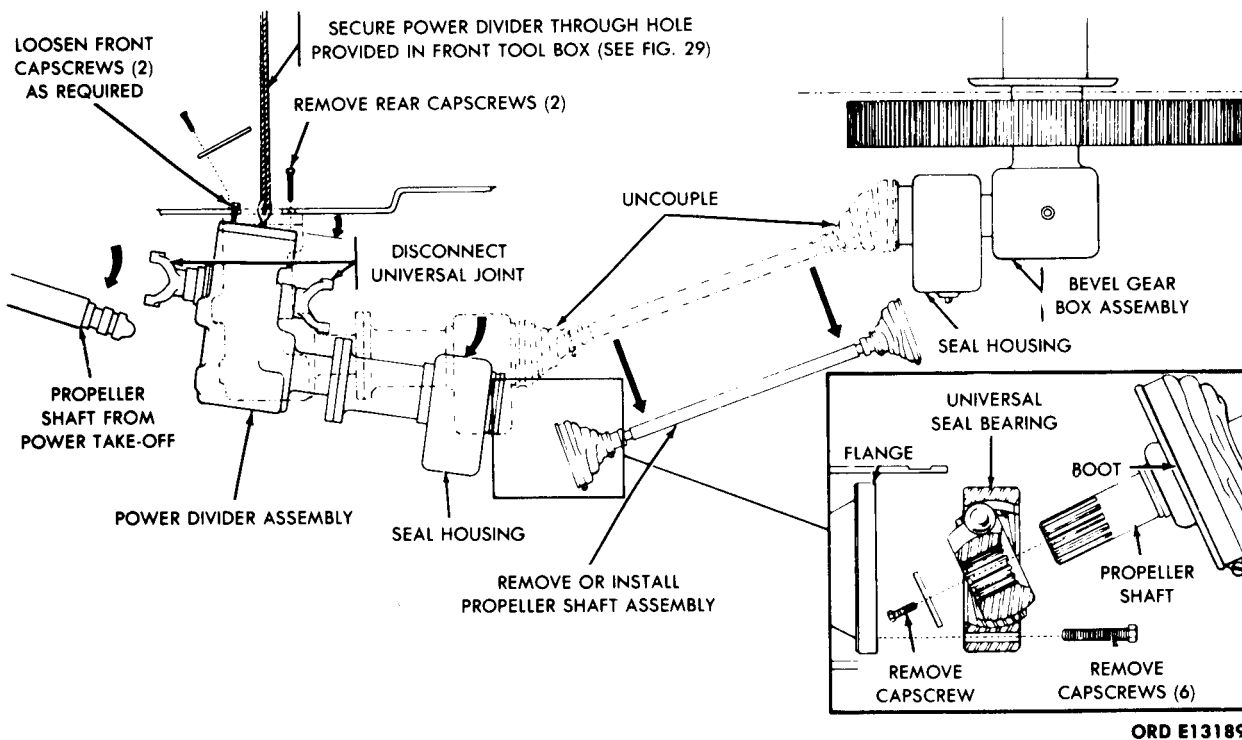


Figure 2-261. Propeller shaft assembly replacement.

(5) Remove the clamps and slide back the composition dust seal attached to the seal housings at each end of the propeller shaft (fig. 2-261).

(6) Remove the capscrews from the flange couplings at each end of the propeller shaft.

(7) Loosen the power divider support bolts. Lower the power divider slightly to provide clearance and permit removal of the propeller shaft from the seal housings as shown in figure 2-261.

*c. One Section Shaft Installation.*

(1) Install the propeller shafts in position in the seal housings (fig. 2-261).

(2) Raise the power divider up into position, tighten the support bolts securely, remove the lifting device, and replace the patch plate above the power divider assembly (fig. 2-260).

(3) Install the capscrews in the flange couplings at each end of the propeller shaft (fig. 2-261). Position the composition dust seal housings, and secure them with clamps.

(4) Connect the power divider controls.

(5) Connect the rear winch front propeller shaft

from the winch output shaft yoke at the rear of the power divider.

(6) Connect the power takeoff-to-power divider propeller shaft from the drive shaft yoke at the front of the power divider.

*d. Two Section Shaft Removal (fig. 2-261.1).*

(1) Remove four bolts from flanged disconnect of propeller shaft. Allow each half of shaft to swing down for removal clearance.

(2) Remove universal bearing dust seal from housing.

(3) Remove six screws securing universal bearing to flange at each end of the propeller shaft.

*e. Two Section Shaft Installation (fig. 2-261.1).*

(1) Position propeller shaft halves into seal housings.

(2) Install six screws securing universal bearing to flange at each end of the propeller shaft.

(3) Position universal bearing dust seal on seal housing and secure with clamps.

(4) Join propeller shaft halves at flanged disconnect and tighten four bolts.

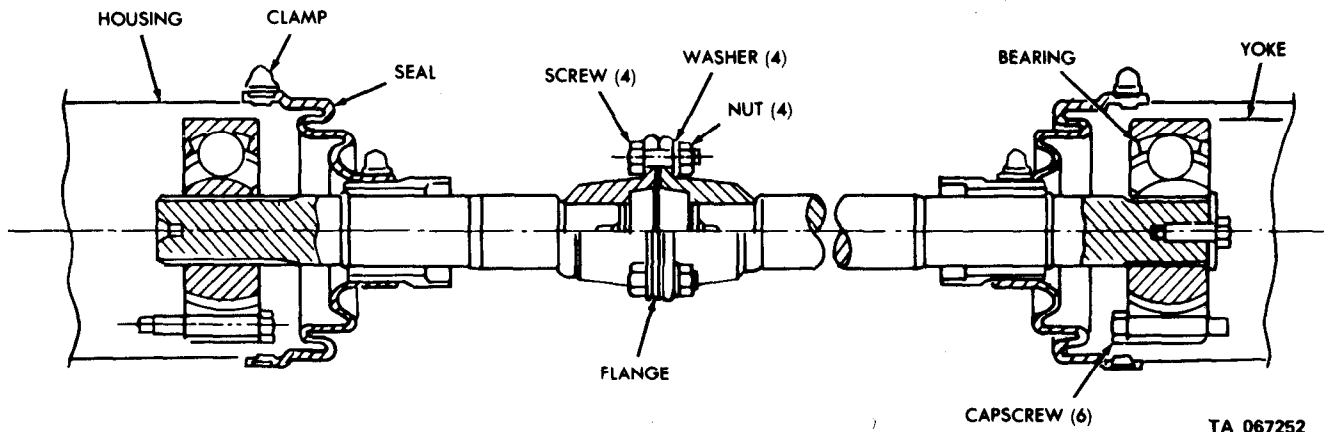


Figure 2-261.1. Two-section shaft replacement.

**2-313. Boom and Shipper Cable Roller***a. Adjustment (Fig. 2-262).**(1) Vertical.*

*(a)* Remove the four capscrews and lock-washers securing the flange-mounted cap.

*(b)* Turn the mounting cap to the next set of holes.

**NOTE**

The procedure in (b) above moves the shaft and flanged roller assemblies closer to the inner boom, taking up excess play caused by wear.

*(c)* Replace the capscrews, and repeat the

procedure at the opposite end of the roller assembly.

*(2) Lateral.*

*(a)* Remove the four capscrews and lock-washers securing the flange-mounted cap.

*(b)* Remove the shim from under the flange of the mounting cap.

*(c)* Replace the capscrews, and repeat the procedure at the opposite end of the roller assembly.

*b. Removal.* Remove the six capscrews securing the roller frame to the boom assembly, and remove the roller assembly (fig. 2-263).

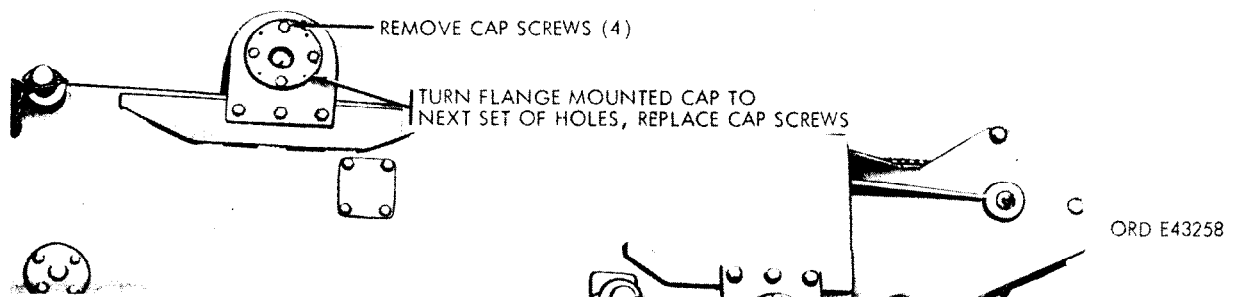
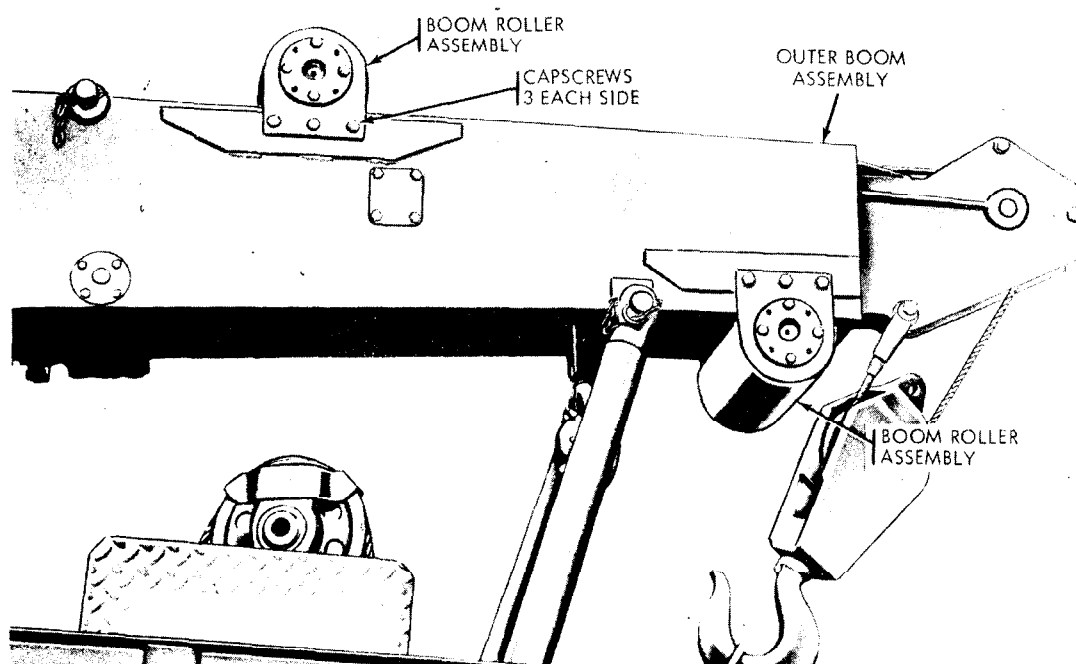


Figure 2-262. Adjusting boom roller assembly.

This page intentionally left blank.



ORD E43257

Figure 2-263. Boom roller assembly replacement.

*c. Installation.* Position the roller assembly on the boom assembly, and secure it with the cap-screws (fig. 2-263).

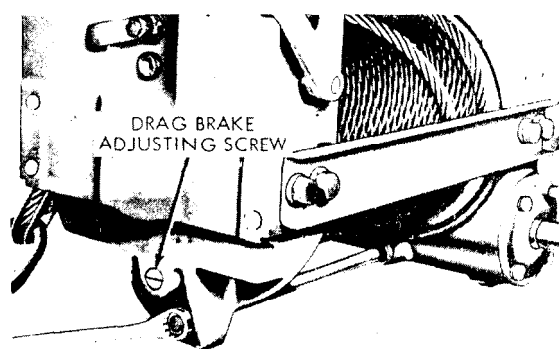
**Section XL. MAINTENANCE OF FRONT WINCH ASSEMBLY**

**2-314. General**

*a.* Front winch components include the winch assembly, the level wind and the winch drive. The front winch assembly is a worm-gear, jaw-clutch, horizontal-drum type with an internal automatic brake and drum drag brake. The automatic brake is secured to the front end of the drive (worm gear) shaft. The internally mounted drag brake is in constant contact with the left end of the winch drum.

*b.* Some front winches have a level winding device and a manually-operated cable tensioner mounted on the front of the winch. The level wind controls the cable so it winds around the drum in tight, even layers. Power for operating the winch (winch drive) comes from the vehicle's engine through the power takeoff which is connected to the winch by a propeller shaft. This shaft is secured to the winch drive shaft by a shearpin.

action of the drag brake, turn the adjusting screw (fig. 2-264) clockwise. Test the adjustment as described in *b* (1) below.



CRD E43240

Figure 2-264. Front winch—left rear view.

**2-315. Front Winch**

*a. Adjustment.*

(1) *Drag brake.* To increase the braking

(2) *Automatic brake.* To increase braking action of the automatic brake, turn the adjusting bolt ( 1, fig. 2-268) clockwise one-half turn, and test the brake adjustment as described in *b* (2) Below.

**NOTE**

Do not tighten the screw more than one-half turn before testing as described in *b* (2) below.

**NOTE**

When correctly adjusted, the brake will become warm but should not be too hot to allow the hand to be held on the brake cover.

*b. Test.*

(1) *Drag brake.*

(a) To check the drag brake adjustment, disengage the winch drum clutch and pull the cable.

(b) Stop pulling the cable. Observe whether the winch drum stops turning as soon as the pulling is stopped.

(c) If the drum continues turning without any pull on the cable, adjust the drag brake as described in *a* (1) above.

(2) *Automatic brake.*

(a) To check the automatic brake adjustment, park the vehicle at the top of a 30° to 45° slope with vehicle facing downhill.

(b) Attach the cable to another vehicle at the bottom of the hill and, using the front winch only, start pulling the other vehicle up the hill.

(c) When the vehicle being pulled is part of the way up the hill, shift the front winch control lever into neutral.

(d) If the vehicle being pulled up the hill rolls backward, adjust the automatic brake as described in *a* (2) above.

*c. Removal.*

(1) Attach the hoisting equipment to the winch and hoist until the slack is just removed from the chain or cable.

(2) Separate the propeller shaft front universal joint from the yoke (fig. 2-265) on the winch drive shaft.

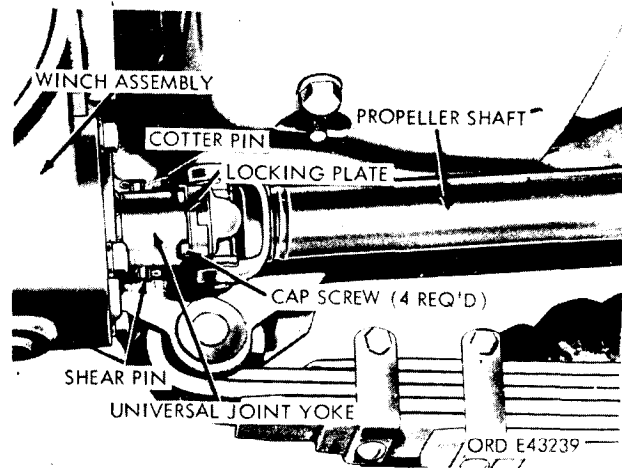


Figure 2-265. Front winch and propeller shaft—bottom view

(3) Remove the three hexagon-head bolts, safety nuts, and lock washers (fig. 2-266) from the mounting bracket at each end of the winch.

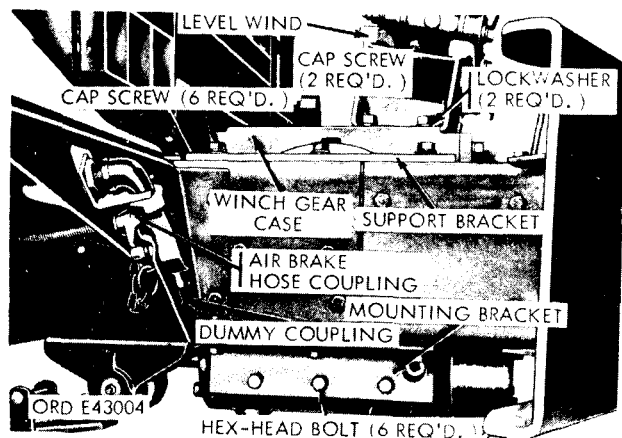


Figure 2-266. Front winch and level wind installed to vehicle—right side view.



(4) Remove the three capscrews (fig. 2-266) and lockwashers from the support bracket at each end of the winch.

(5) Hoist the winch high enough to clear the front bumper, and remove the winch from the vehicle.

*d. Installation.*

(1) Attach the hoisting equipment to the winch, and hoist the winch high enough to clear the front bumper.

(2) Lower the winch between the frame side rail extensions, and aline the winch mounting holes.

(3) Install the three capscrews (fig. 2-266) and lockwashers in the holes in the support bracket and side rail extension at each end of the winch, and tighten the capscrews.

(4) Install the three hexagon-head bolts, lockwashers, and safety nuts in the mounting bracket holes at each end of the winch (fig. 2-266).

(5) Connect the propeller shaft front universal joint to the yoke (fig. 2-265) on the winch drive shaft.

(6) Remove the hoisting equipment from the winch.

### 2-316. Propeller Shaft Assembly

*a. Removal.* Refer to paragraph 2-312.

*b. Installation.* Refer to paragraph 2-312.

*c. Shearpin Replacement (fig. 2-265).*

#### CAUTION

Never substitute rivets, pins, or bolts in place of the shearpin.

(1) Turn the universal joint yoke on the winch drive shaft, and aline the shearpin holes in the yoke with the hole through the shaft.

(2) Drive the broken part of the shearpin from the drive shaft.

(3) Insert a new aluminum alloy shearpin into the alined holes of the yoke and drive shaft. Install two cotter pins (one at each end of the shearpin).

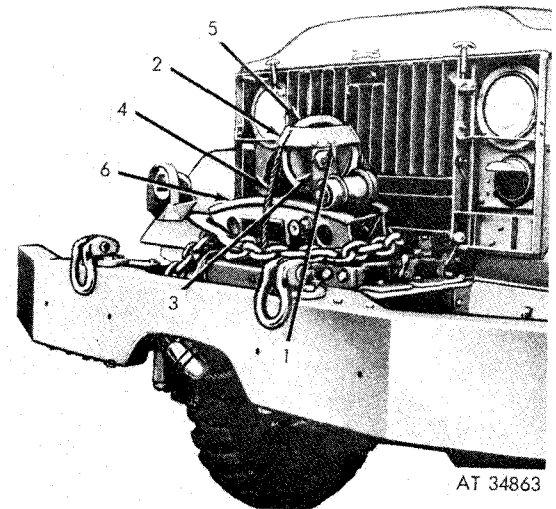
### 2-317. Level Wind

(Fig. 2.267.)

*a. Removal.*

(1) Remove the four capscrews (1) and lockwashers securing the level wind cable guard (2) to the swivel sheave frame (3). Remove the cable guard.

(2) Remove the winch cable (4) from the swivel sheave (5), and place the cable around one end of the trolley track (6). Install the cable guard, four lockwashers and capscrews to prevent their loss.



- |                       |                 |
|-----------------------|-----------------|
| 1 Capscrew            | 4 Winch cable   |
| 2 Cable guard         | 5 Swivel sheave |
| 3 Swivel sheave frame | 6 Trolley track |

Figure 2-267. Front winch and level wind—installed to vehicle.

(3) Remove the two capscrews (fig. 2-266) and washers securing the right end of the level wind to the gear case.

(4) Remove the two capscrews and washers securing the left end of the level wind to the end frame.

(5) Lift the level wind assembly off of the winch and remove the level wind from the vehicle.

*b. Installation.*

(1) Position the level wind (fig. 2-266) on top of the winch, and aline the level wind mounting holes.

(2) Install the two washers and capscrews in the holes in the right end of the level wind and the gearcase.

(3) Install the two washers and capscrews in the holes in the left end of the level wind and the end frame.

(4) Place the cable in the swivel sheave groove. Position the cable guard on the swivel sheave frame and install the four lockwashers and capscrews in the guard and frame holes.

### 2-318. Winch Cable

*a. Removal.*

(1) Completely unwind the cable from the drum.

(2) Remove the hexagon-socket setscrew from

## TM 9-2320-211-20

the winch drum, and pull the end of the cable from the hole in the drum.

(3) Pull the cable from the level wind swivel sheave and tensioner sheaves.

### b. Installation.

(1) Thread the winch cable between the tensioner sheaves and over the level wind swivel sheave.

(2) Insert the end of the cable in the hole in the drum, and tighten the hexagon-socket setscrew to secure the cable to the drum.

(3) Wind the cable on the drum. Refer to TM 9-2320-211-10.

## Section XLI. MAINTENANCE OF REAR WINCH ASSEMBLY

### 2-319. General

a. Rear winch components include the winch assembly, the level wind, the winch drive, and the control linkage. The rear winch assembly is a worm-gearred, horizontal-drum type with an internal, automatic brake. The automatic brake is secured to the rear end of the drive (worm gear) shaft.

b. All rear winches have a level wind and manually-controlled, pneumatically-operated cable tensioner mounted on the rear of the winch. The level wind and cable tensioner control the cable so it winds around the drum in tight, even layers. Power for operating the winch (winch drive) comes from the vehicle's engine through the power takeoff which is connected by a propeller shaft to the power divider. A forward and a rear propeller shaft are connected by a universal joint which is supported by a pillow block extending from the power divider to the bearing assembly. A sprocket and driver chain assembly is secured to the winch shaft by a shearpin. The rear winch control linkage consists of the winch shift lever rear control rod relay levers and the front control rod.

### 2-320. Rear Winch

#### a. Adjustment.

(1) *Automatic brake.* Refer to paragraph 2-315. (The automatic brake adjustment procedure is the same for front and rear winch.)

#### (2) Cable Tensioner.

(a) Before adjusting the cable tensioner, perform the following preliminary procedures in (b) through (f) below.

(b) Remove the chain and hook assembly from the winch cable, and pull the cable from between the tension sheaves (2, fig. 2-268).

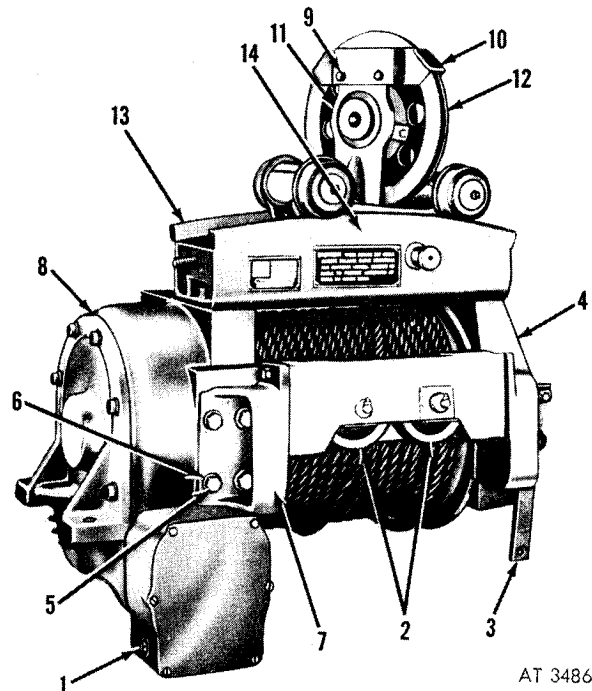
(c) Start engine to build up normal operating pressure (105 to 120 psi) in compressed air system.

(d) Move cable tensioner control valve lever to ON position (3, fig. 2-268).

(e) Check opening between sheaves with a 5/8-inch diameter rod. If rod cannot be inserted between sheaves, or if rod fits loosely between

sheaves, adjust cable tensioner as described in (g) through (i) below.

(f) If opening between sheaves is correct (sheaves just closed on rod), proceed as described in (m) through (o) below.



1 Adjusting screw	8 Gearcase
2 Tension sheave	9 Capscrew
3 Adjusting frame lever	10 Cable guard
4 End frame	11 Swivel sheave frame
5 Capscrew	12 Swivel sheave
6 Lockwasher	13 Trolley track
7 Frame bracket	14 Level wind

Figure 2-268. Rear winch—left rear view.

(g) Remove cotter pin and yoke pin securing air chamber push rod yoke to lower end of tension sheave adjusting-frame lever, and remove yoke from lever (fig. 2-269).

(h) Loosen locknut on air chamber push rod, and turn yoke on push rod as necessary to obtain correct gap between sheaves.

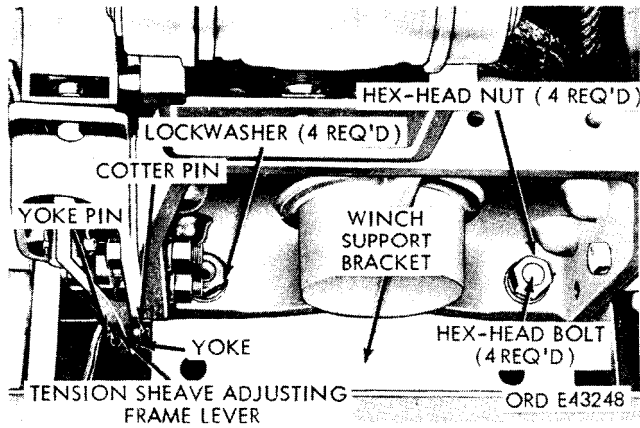


Figure 2-269. Rear winch—top view of right end.

**NOTE**

Turning the yoke clockwise on the push rod increases the distance between the sheaves (when the cable tensioner control valve lever is in the ON position). Turning the yoke counterclockwise on the push rod decreases the distance between the sheaves.

(i) Position the push rod yoke on the lower end of the tension sheave adjusting-frame lever, and install the yoke pin through the yoke and lever. Install the cotter pin in the end of the yoke pin.

(j) Insert the 5/8-inch diameter rod between the sheaves, and move the control valve lever to the ON position.

(k) The sheaves should just close on the rod. If necessary, repeat (a) through (e) above until the correct adjustment is obtained.

(1) Move the control valve lever to the OFF position, and measure the maximum opening between the sheaves. The opening should be at least 13 / 16-inch, to permit the 3/4-inch cable to pass freely between the sheaves when unwinding the cable.

(m) Stop the engine.

(n) Pass the cable between the tension sheaves (1, fig. 268) and between the upper and lower guide rollers.

(o) Install the chain and hook assembly on the winch cable.

(3) *Control linkage.*

(a) Move the rear winch shift lever to the NEUTRAL position. Lock the lever in this position by means of the lock hinge attached to the floor plate.

(b) Remove the cotter pin and yoke pin securing the front control rod yoke to the winch output shifter shaft arm, and remove the control rod yoke from the arm (fig. 2-271).

(c) Pushing on the shifter shaft arm, push the shifter shaft into the power divider as far as it will go.

(d) Pull the shifter shaft out of the power

divider to the NEUTRAL position. This can be felt due to a poppet ball inside the power divider falling into the first groove on the shifter shaft. This movement of the shifter shaft from the UNWIND to the NEUTRAL position is approximately 1 3/8 inches.

**NOTE**

If the linkage is so far out of adjustment that the correct adjustment cannot be obtained by following the procedures, (a) through (d) above, make an additional adjustment at the yoke connecting the rear control rod to the lower end of the winch shift lever.

(e) Loosen the locknut on the forward control rod, and turn the yoke on the control rod as necessary until the yoke can be connected to the shifter shaft arm without movement of the shifter shaft.

(f) Tighten the locknut on the forward control rod.

(g) Position the control rod yoke over the shifter shaft arm, install the yoke pin through the yoke and arm, and install a cotter pin in the end of the yoke pin.

**NOTE**

When proper adjustments have been made, movement of the rear winch shift lever from NEUTRAL to UNWIND is three-quarters of an inch. Movement of the lever from NEUTRAL to WIND is 1 3/8 inches.

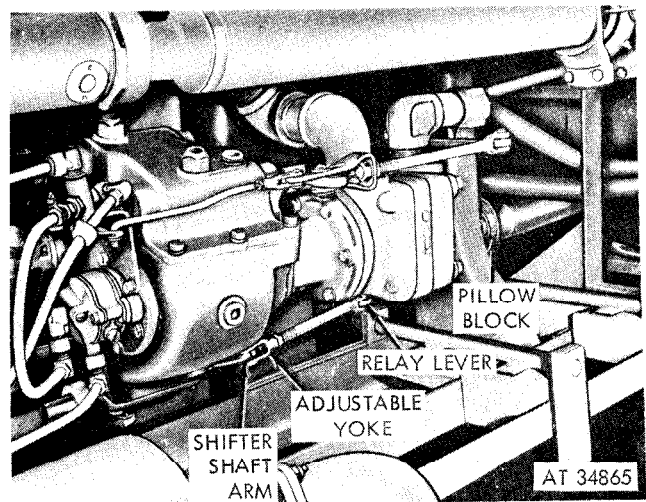


Figure 2-270. Power divider installed to underside of M62 wrecker.

b. *Removal.*

(1) Remove the cotter pin (fig. 2-269) and the yoke pin securing the air chamber push rod yoke to the lower end of the tension sheave adjusting-frame lever. Remove the yoke from the lever.

(2) Remove the two capscrews and safety nuts

**TM 9-2320-211-20**

securing the floor plate (fig. 2-269) to the support bracket bolted to the rear of the winch.

(3) Remove the drive chain (para 2-325).

(4) Remove the four hexagon-head bolts (fig. 2-269), nuts, and lockwashers securing the winch to the left and right support brackets.

(5) Remove the chain and hook assembly from the winch cable.

(6) Using the wrecker crane (fig. 2-271) or other overhead hoisting equipment, remove the rear winch from the vehicle.

*c. Installation.*

(1) Lift the rear winch into position on the rear of the wrecker body. Align the winch mounting holes with the holes in the left and right support brackets.

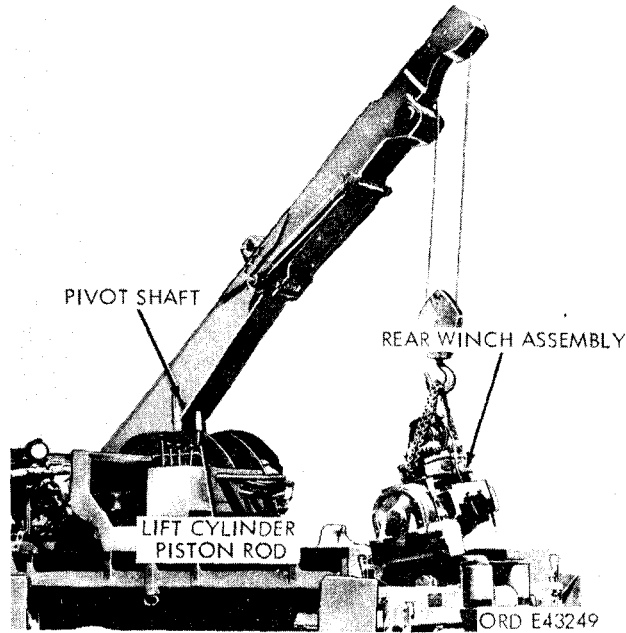
(2) Secure the winch to the support brackets with four hexagon-head bolts (fig. 2-269), lockwashers, and nuts.

(3) Pass the cable between the tension sheaves (2, fig. 2-268) and between the upper and lower guide rollers. Install the chain and hook assembly on the cable.

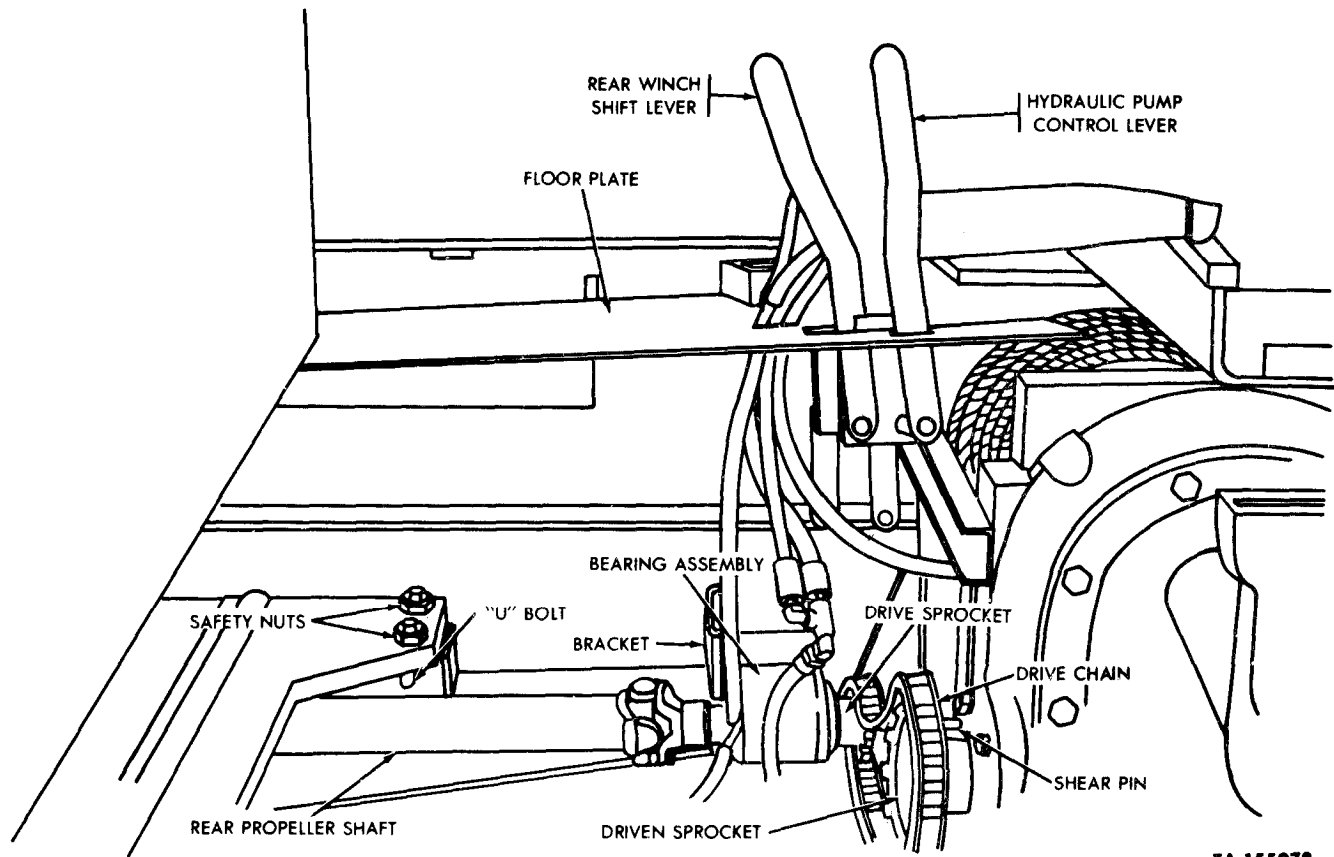
(4) Install the drive chain (para 2-325 *b*).

(5) Install the two capscrews in the holes in the floor plate (fig. 2-272) and support bracket bolted to the rear of the winch. Install the safety nuts on the screws, and tighten them.

(6) Position the air chamber push rod yoke on the lower end of the tension sheave adjusting-frame lever (fig. 2-269), and secure it with the yoke pin and cotter pin.



*Figure 2-271. Using crane to remove rear winch assembly.*



TA 155978

Figure 2-272. Rear end of M62 with floor plate raised—left side view.

**2-321. Cable Tensioner.****a. Removal.**

(1) Remove rear winch as described in paragraph 2-320b.

(2) Remove four capscrews and lockwashers securing cable tensioner to gearcase (8, fig. 2-268).

(3) Remove four capscrews, four lockwashers, and two hexagon nuts securing cable tensioner to end frame (4, fig. 2-268) and remove tensioner from winch.

**b. Installation.**

(1) Position cable tensioner on rear of winch, and align holes in right tension sheave frame bracket and end frame (4, fig. 2-268).

(2) Install four capscrews, four lockwashers, and two nuts in holes in bracket and end frame.

(3) Install four capscrews (5) and lockwashers (6) in holes in left tension sheave frame bracket (7) and gearcase (8, fig. 2-268).

(4) Install winch as described in paragraph 2-320c.

**2-322. Front Propeller Shaft.****a. Removal.**

(1) Disconnect front propeller shaft and front universal joint from yoke on power divider winch output shaft (para 2-179).

(2) Pull propeller shaft toward front of vehicle, and remove rear universal joint with slip yoke assembly, from front (splined) end of rear propeller shaft (fig. 2-273).

(3) Disconnect front propeller shaft rear universal joint from rear propeller shaft slip yoke (para 2-179).

(4) Remove universal joint at each end of front propeller shaft (para 2-179).

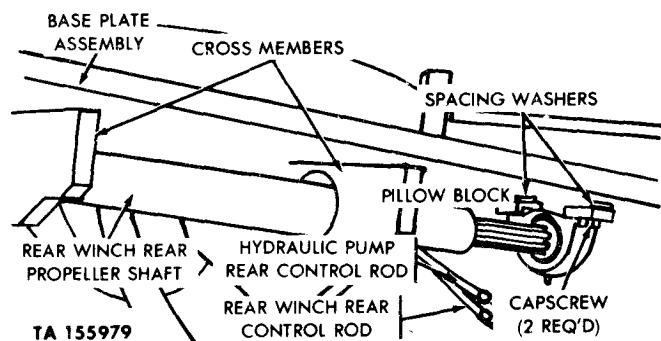


Figure 2-273. Underside of crane base plate (removed from M62).

**b. Installation.**

(1) Install universal joint at each end of front propeller shaft (para 2-179).

(2) Attach rear propeller shaft slip yoke to front propeller shaft rear universal joint (para 2-179).

(3) Slide rear propeller shaft slip yoke, with front propeller shaft attached, on front (splined) end of rear propeller shaft (para 2-179).

(4) Connect front propeller shaft front universal joint to yoke on power divider winch output shaft (para 2-179).

**2-323. Rear Propeller Shaft.**

*a. Removal.*

(1) Remove crane base plate from vehicle.

(2) Refer to paragraph 2-322a and follow similar procedures to remove rear propeller shaft.

*b. Installation.*

(1) Refer to paragraph 2-322b and follow similar procedures to install rear propeller shaft.

(2) Install crane base plate to vehicle.

**2-324. Pillow Block.**

*a. Removal.*

(1) Disconnect front propeller shaft rear universal joint from slip yoke on front (splined) end of rear propeller shaft (para 2-179).

(2) Slide slip yoke from front end of rear propeller shaft (fig. 2-273).

(3) Remove two capscrews (fig. 2-273), securing pillow block to underside of base plate, and remove spacing washers from between base plate and pillow block.

(4) Loosen setscrew securing pillow block bearing inner race to rear propeller shaft, slide pillow block forward, and remove it from shaft.

*b. Installation.*

(1) Slide pillow block (fig. 2-273) on front (splined) end of rear propeller shaft, and aline mounting holes with holes in underside of base plate.

(2) Place spacing washers between pillow block and base plate, and secure pillow block to underside of base plate with two capscrews.

(3) Tighten setscrew in pillow block bearing inner race securing race to the shaft.

(4) Slide slip yoke onto front end of rear propeller shaft. Connect front propeller shaft rear universal joint to slip yoke (para 2-179).

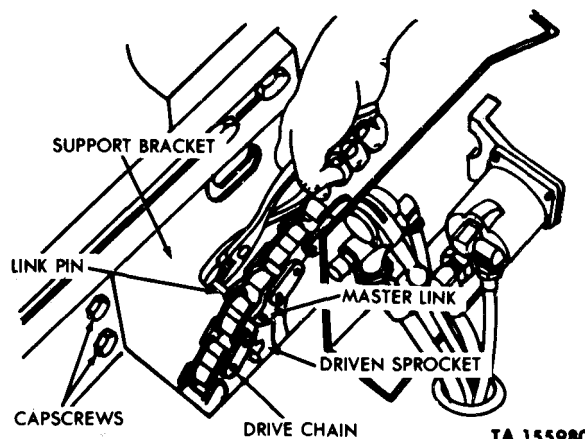
**2-325. Drive Chain (Fig. 2-274).**

*a. Removal.*

(1) Remove two nuts, lockwashers, and capscrews securing chain guard to floor plate.

(2) Operate winch, turning the drum in small increments, until master link in chain is visible.

(3) Remove cotter pin and link pin from master link, and separate ends of chain. Remove chain from sprockets.



TA 155980

Figure 2-274. Separating rear winch drive chain—M62, M543, M543A1, and M543A2.

*b. Installation.*

(1) Loosen nuts securing bearing assembly (fig. 2-272) to mounting bracket.

(2) Place drive chain (fig. 2-272) around sprockets, pull ends of chain together, and install link pin. Install a cotter pin in end of the link pin.

(3) Tighten nuts on bearing assembly mounting studs and bolts to 50-60 lb-ft torque.

(4) Check drive chain for proper tension (1/2-inch deflection at midpoint between drive sprocket and driven sprocket).

(5) If necessary, remove bearing assembly, and add or remove spacing shims until proper chain tension is obtained.

(6) Position chain guard on floor plate, and secure it with two capscrews, lockwashers, and nuts.

**2-326. Shearpin (Fig. 2-272).**

*a. Removal.*

(1) Turn driven sprocket on winch drive shaft.

(2) Aline shearpin holes in sprocket hub and shaft, and drive broken part of shearpin out of drive shaft.

**CAUTION**

Never substitute rivets, pins, or bolts in place of the proper shearpin.

*b. Installation.*

(1) Insert a new shearpin through alined sprocket hub and drive shaft holes.

(2) Install a cotter pin in end of shearpin.

**2-327. Level Wind**

(Fig. 2-268.)

*a. Removal.*

(1) Remove the four capscrews (9) and lockwashers (two from each side) securing the cable guard (10) to the swivel sheave frame.

(2) Remove the winch cable from the swivel sheave (12), and place the cable around one end of the trolley track (13).

(3) Replace the cable guard, four lockwashers, and four capscrews to prevent their loss.

(4) Remove the two capscrews and lockwashers securing the left end of the level wind to the end frame (4).

(5) Remove the two cap screws and lockwashers securing the right end of the level wind to the gearcase (8).

(6) Lift the level wind (14) off of the winch, and remove it from the vehicle.

*b. Installation.*

(1) Position the level wind (14) on top of the winch, and aline the level wind mounting holes.

(2) Install the two capscrews and lockwashers in the holes in the right end of the level wind and gearcase (8). Install the two capscrews and lockwashers in the holes in the left end of the level wind and end frame (4). Tighten the cap screws to 80-100 ft.-lb. torque.

(3) Remove the four cap screws and lockwashers, securing the cable guard (10) to the swivel sheave frames (11), and remove the cable guard.

(4) Place the winch cable in the swivel sheave groove, position the cable guard on the swivel sheave frame, and install the four capscrews and lockwashers in the holes in the guard and frame. Tighten the capscrews to 20-25 ft.-lb. torque.

**2-328. Winch Cable***a. Removal.*

(1) Completely unwind the cable from the winch drum. Refer to TM 9-2320-211-10.

(2) Remove the hexagon-head setscrew from the winch drum, and pull the end of the cable from the hole in the drum.

(3) Remove the cable from the level wind sheave (12, fig. 2-268) and guide rollers (fig. 2-275).

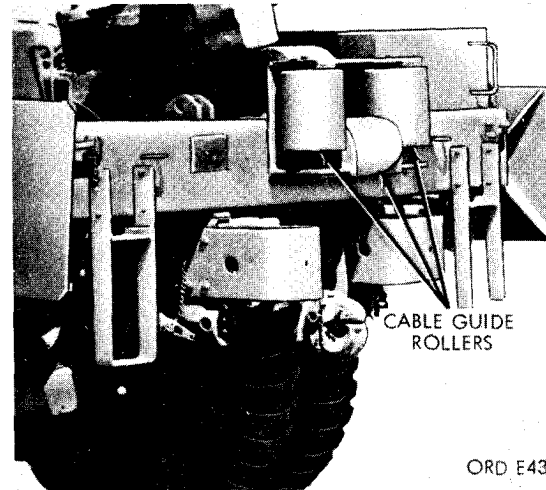


Figure 2-275. Cable guide rollers.

*b. Installation.*

(1) Pass the cable between the upper and lower guide rollers (fig. 2-275), and over the level wind swivel sheave (12, fig. 2-268).

(2) Insert the end of cable in hole in the winch drum. Install the hexagon-head setscrew in the hole in the drum, and tighten the setscrew to secure the cable to the drum.

(3) Wind the cable on the drum. Refer to TM 9-2320-211-10.

**Section XLII. MAINTENANCE OF BODY ACCESSORY ITEMS****2-329. General.**

Miscellaneous body accessory items covered in paragraphs 2-330 and 2-331 are the windshield wiper and motor (mounted at top of the windshield frame), and the rear view mirror (mounted to the windshield center post).

**2-330. Windshield Wiper and Motor**

(Fig. 2-219.)

*a. Removal.*

(1) Unscrew the nut securing the arm and blade assembly to the wiper motor shaft. Remove the wiper arm from the shaft.

(2) Pull the air hose from the wiper motor intake connection.

(3) Remove the four screws and lockwashers securing the wiper motor to the top of the windshield frame. Remove the motor.

*b. Installation.*

(1) Position the wiper motor at the top inside of the windshield frame, and secure the motor to the frame with four lockwashers and screws.

(2) Install the air hose to the motor intake connecting point.

(3) Position the arm and blade assembly on

the front end of the motor shaft. Secure the arm and blade assembly shaft, and tighten the nut.

**2-331. Rear View Mirror.**

**a. Mirror Removal (fig. 2-275.1).**

(1) Remove nut and lockwasher securing mirror to lower mounting bracket.

(2) Loosen nut securing mirror to upper mounting bracket.

(3) Slide top of mirror out of slot in upper mounting bracket. Lift mirror to remove from lower mounting bracket.

**b. Mirror Installation (fig. 2-275.1).**

(1) Position mirror lower mounting stud into hole in lower mounting bracket. Slide mirror upper mounting stud

into slot in upper mounting bracket.

(2) Install nut and lockwasher on upper and lower mounting stud. Adjust mirror and tighten nuts.

**c. Mirror Arm Removal (fig. 2-275.1).**

(1) Remove one screw securing mirror arm to bracket on cab cowl.

(2) Remove cab door upper hinge pivot bolt and remove mirror upper arm from hinge. Reinstall upper hinge pivot bolt. Repeat same procedure for mirror lower arm.

**d. Mirror Arm Installation (fig. 2-275.1).**

(1) Remove cab door upper hinge pivot bolt and reinstall with pivot bolt through mirror upper arm. Repeat same procedure for mirror lower arm.

(2) Position forward mirror arm on bracket attached to cab cowl and secure with screw and nut.

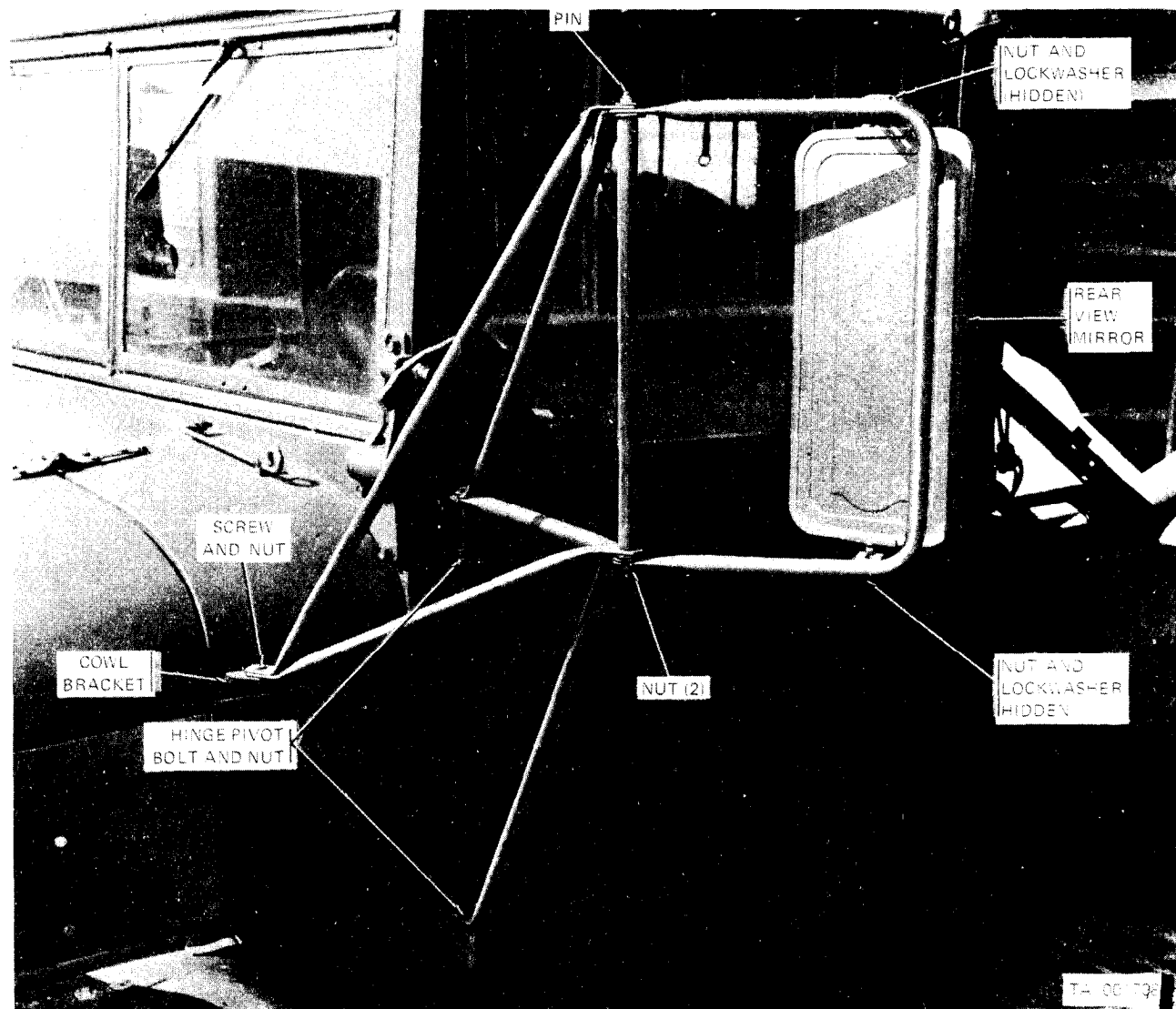


Figure 2-275. 1. Rear view mirror removal and installation.



## Section XLIII. MAINTENANCE OF NONELECTRICAL GAGES AND MEASURING DEVICES

### 2-332. General

*a. Speedometer and Tachometer.* The speedometer and tachometer are mechanically operated units which are connected by flexible shaft assemblies to their respective sending units.

*b. Tachograph.* Late production 5-ton, M52A1 and M52A2 tractors may have a tachograph assembly installed in the instrument panel of the vehicle cab which replaces the tachometer and speedometer. The face of the tachograph indicates vehicle speed, engine rpm and time. The time is recorded by a 24-hour clock in the unit which requires winding before each trip. The tachograph contains a paper chart which records vehicle speed, engine rpm, and stop-and-go periods on a 24-hour basis. The tachograph face is equipped with a red warning light which indicates overspeeding of the engine, and is set to flash at 3,000 engine rpm on the M52A2 and at 2,300 engine rpm on the M52A1. The two drive cables which operate the speedometer and engine rpm tachograph are the same as those used on the original speedometer and tachometer.

### 2-333. Speedometer

(Fig. 2-163.)

#### *a. Removal.*

- (1) Remove the instrument cluster [para 2-143]
- (2) Unscrew the nut securing the flexible shaft to the speedometer. Pull the shaft away from the speedometer.
- (3) Remove the nut and washer securing the instrument cluster wiring harness to the stud on the speedometer. Pull the harness off of the stud.
- (4) Remove the wiring harness stud and the lockwasher from the lower mounting stud.
- (5) Remove the nut and lockwasher from the upper mounting stud.
- (6) Remove the mounting bracket from the studs, and pull the speedometer unit out of the front of the instrument cluster.

#### *b. Installation.*

- (1) Insert the speedometer unit into the

proper opening of the instrument cluster from the front.

- (2) Install the speedometer mounting bracket on the studs at the back of the instrument cluster.

- (3) Install the lockwasher and nut on the upper stud, and tighten the nut.

- (4) Assemble the lockwasher and wiring harness stud on the lower mounting stud, and tighten the stud.

- (5) Position the wiring harness on the stud and secure the harness to the stud with a washer and nut. Tighten the nut.

- (6) Insert the end of the flexible shaft in the speedometer, and tighten the connector nut.

- (7) Secure the instrument cluster to the panel (para 2-143).

### 2-334. Speedometer Flexible Shaft

#### *a. Removal.*

- (1) Unscrew the nut securing the flexible shaft to the speedometer (fig. 2-33), and pull the shaft end from the speedometer.

- (2) Unscrew the nut securing the flexible shaft to the speedometer sending unit on front of the transfer case. Pull the shaft end from the sending unit.

- (3) Disconnect the four clips securing the shaft to the vehicle. Remove the shaft and clips, and remove the clips from the flexible shaft.

#### *b. Installation.*

- (1) Place the four clips on the flexible shaft and secure the flexible shaft to the vehicle with the clips.

#### NOTE

When positioning the flexible shaft in the vehicle, be sure that the end with the driving key is at the sending unit on the transfer case.

- (2) Insert the end of the flexible shaft in the sending unit on the front of the transfer case, and tighten the connector nut.

- (3) Insert the square end of the flexible shaft in the speedometer, and tighten the connector nut.

**THIS PAGE LEFT BLANK INTENTIONALLY**

**2-335. Tachometer**

(Fig. 2-163.)

*a. Removal.*

(1) Remove the instrument cluster (para 2-143).

(2) Unscrew the nut securing the tachometer flexible shaft to the tachometer. Pull the shaft away from the tachometer.

(3) Remove the bayonet type electrical connector from the clip secured to the upper tachometer mounting stud.

(4) Remove the nut, lockwasher, and connector clip from the upper stud.

(5) Remove the nut and lockwasher from the lower tachometer mounting stud, and remove the mounting bracket from the studs.

(6) Remove the tachometer from the front of the instrument cluster.

*b. Installation.*

(1) Insert the tachometer unit into the proper opening of the instrument cluster from the front.

(2) Install the tachometer mounting bracket on the studs at the back of the instrument cluster.

(3) Install the lockwasher and nut on the lower stud, and tighten the nut.

(4) Assemble the connector clip, lockwasher, and nut on the upper mounting stud, and tighten the nut.

(5) Insert the panel light cable bayonet type connector into the clip.

(6) Insert the end of the flexible shaft in the tachometer, and tighten the connector nut.

(7) Secure the instrument cluster to the panel (para 2-143).

**2-336. Tachometer Flexible Shaft***a. Removal.*

(1) Unscrew the nut securing the tachometer flexible shaft to the tachometer (fig. 2-33), and pull the shaft from the tachometer.

**NOTE**

The sending unit is located on the distributor drive housing on the gasoline engine, on the right side of the engine block on the diesel engine, and on the timing chain cover on the multifuel engine.

(2) Unscrew the nut securing the flexible shaft to the tachometer sending unit, and pull the shaft end from the sending unit.

(3) Remove the capscrew and nut securing the closed clip to the mounting bracket bolted to the engine.

(4) Pull the flexible shaft from the rubber grommet in the cab cowl, and remove the shaft from the vehicle. Remove the closed clip from the flexible shaft.

*b. Installation.*

(1) Install the closed clip on the tachometer

flexible shaft, and insert the end of the shaft through the grommet in the cab cowl. Position the closed clip on the mounting bracket attached to the engine, and secure it with the capscrew and nut.

**NOTE**

When positioning the flexible shaft in the vehicle, be sure that the end with the driving key is at the sending unit.

(2) Aline the key on the end of the flexible shaft with the keyway in the sending unit, insert the end of the shaft in the unit, and tighten the connector nut.

(3) Insert the square end of the flexible shaft in the tachometer (fig. 2-33), and tighten the connector nut.

**2-337. Tachograph***a. Removal.*

(1) Remove the instrument cluster (para 2-143).

(2) Disconnect the flexible shafts (two) and wiring on the rear of tachograph.

(3) Remove the two retaining wing nuts and then remove the tachograph assembly through the front of the instrument cluster panel.

*b. Installation.*

(1) Insert the tachograph unit into the proper instrument cluster opening, and secure it with two wing nuts.

(2) Connect the flexible shafts and wiring to the rear of the tachograph unit.

(3) Secure the instrument cluster to the panel (para 2-143).

**2-338. Tachograph Flexible Shafts**

The tachograph flexible shafts are the same as those used for the speedometer and tachometer. Refer to paragraphs 2-334 and 2-336 for removal and installation procedures.

**2-339. Tachograph Light Bulb Replacement****NOTE**

Do not try to remove the front instrument glass to change the light bulbs.

*a.* Open the front of the tachograph unit with the locking key.

*b.* Remove the paper chart to expose the three light receptacles (the base of the bulbs will show).

*c.* Lift the edge of the strap (this strap is hinged on one side), and lift the bulb out of the receptacle.

**2-340. Using the Tachograph***a. Placing in Operation.***CAUTION**

Do not operate the tachograph without a chart.

(1) Fill in the new chart with the name of the operator and assistant operator, the registration number of the vehicle, the date, and the readings of the total mileage counter and the engine revolution counter.

(2) Open the instrument by turning the key to the left; use the key as a handle. Insert a new chart into the instrument, and close the instrument by turning the key to the right. Remove the key during the trip.

(3) Lift the clamping lever of the time positioning device to insert or remove chart. When inserting a new chart, note the following:

(a) The green printed side faces toward the inside of the instrument, or toward the person inserting the chart. The blue printed side faces the cover.

(b) Place the edge of the chart under the rpm coupling. Close the clamping lever.

(c) Insert a new chart every day before starting the engine. Charts left in an instrument for several days make it impossible to analyze the recordings, since—in the case of the 24-hour chart—tracings are superimposed on one another after 24 hours.

(4) When new charts are not available, insert a used chart and operate the vehicle in this manner until new charts are available. This will protect the stylus or fingers of the instrument from damaging the assembly.

(5) Insert only charts with a speed range corresponding to that of instrument in use. If diagram charts with the wrong speed range are used, a false reading will result and the charts will be useless as records.

(6) Handle and store diagram charts carefully. Do not fold or scratch them. Do not write in the recording fields. Handle accident charts with special care, since testimony may depend on them.

(7) Wind the clock by pulling out the lever and moving it to and fro until it strikes the stop. Push back the lever into its former position. The clock can also be wound when the diagram chart is inserted.

(8) Set the clock by turning the diagram chart support to the left (rough setting). The final setting is done by the lateral hand setting wheel. Use figures on the support as help.

(9) Adjust the clock movement if it is fast or slow by moving the adjusting lever to plus (if the clock is slow) or to minus (if the clock is fast).

(10) Adjust the vibration stylus in the following manner:

(a) Adjust the screw: Turn right; the stylus lifts; turn left, the stylus sinks.

(b) Revolution warning contact: Turn right; the warning is a higher rpm ; turn left; the warning is at a lower rpm.

(11) Transpose data generated from the charts onto DA Form 2408-1. Charts which contain unusual data must be retained at the unit to support actions in connection with equipment improvement recommendations, warranty claims, accidents, operator discipline; etc. Other charts may be destroyed after the data has been recorded.

*b. Tachograph Charts.*

(1) General. The chart of the tachograph aids in efficient organization, and provides statistical data on the economical use of vehicles and on the manner of driving.

**NOTE**

The stylus referred to in these instructions is any of the various needles that mark the chart during vehicle operation.

(2) *Tachograph diagram charts.* The chart consists of a strong, red backing paper, 123-mm in diameter, which is covered with a very thin recording layer. Each sapphire tipped stylus of the tachograph cuts precise lines in this recording layer to reveal the red backing.

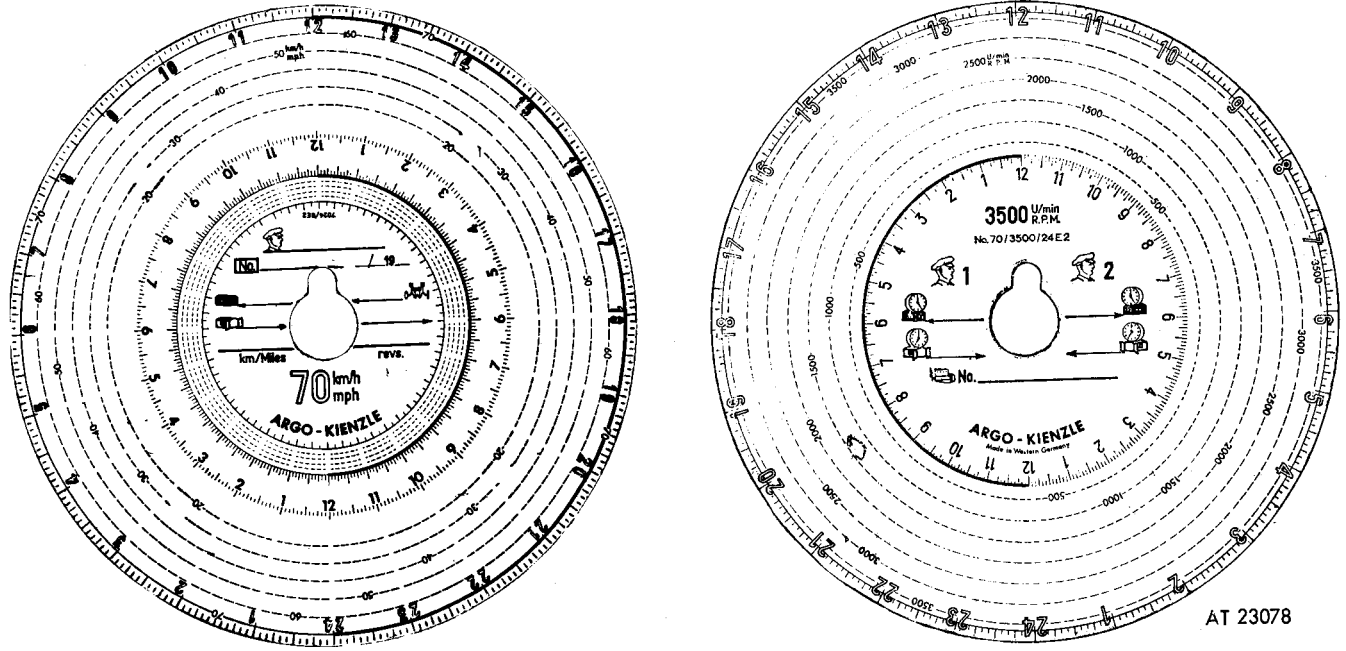
(3) *Recording.* The recording fields are divided up by green markings, which enable numerical values to be read off. It is not possible to alter or remove recorded markings without damaging the wax surface of the chart. The clock mechanism rotates the chart forward at a uniform rate so that the recordings are related to time. In the case of the one-day chart (24 hours), the recording field covers the whole paper (360° ).

**NOTE**

The charts must be changed just before or immediately after they have completed one rotation; otherwise new recordings will be superimposed on old recordings.

*c. Tachograph Chart Divisions (fig. 2-276).*

(1) *On the chart.* Three independent values are recorded: vehicle speed, driving and stopped time, and distance traveled. Once the chart has been inserted and the cover of the instrument closed, the three styluses begin to record. The time scale is printed on the outer edge of the chart. Further time scales in the individual recording fields make it possible to read off these values against their respective recordings. The time scale has five-minute graduations (fig. 2-277).



AT 23078

Figure 2-276. Tachograph chart divisions.

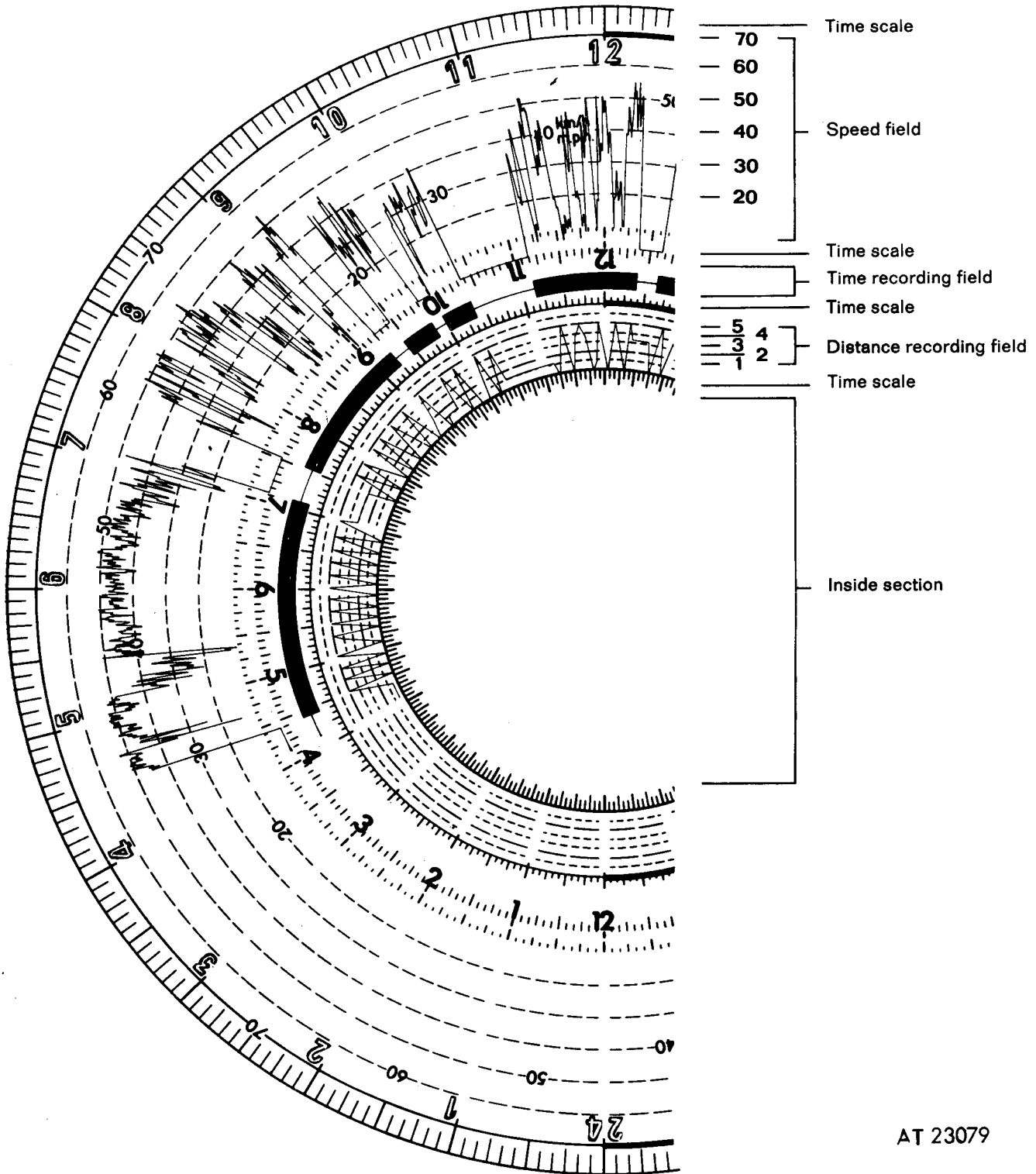
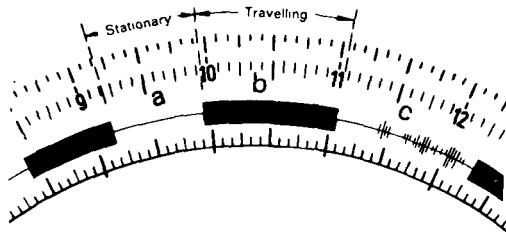


Figure 2-277. Diagram scales.

(2) *Inner field.* Whenever a chart is changed, mark the inside section of the new chart with the name of the operator and the date of the first trip. Enter the figure shown on the mileage counter when the chart is inserted and removed. Careful entry of all these items will save unnecessary inquiries when the charts are evaluated.

(3) *Speed recordings.* The speed field of the chart disc is divided up by concentric circles which show how fast the vehicle was driven. When accelerating, the speed recording stylus moves upward in a straight line and when braking it moves

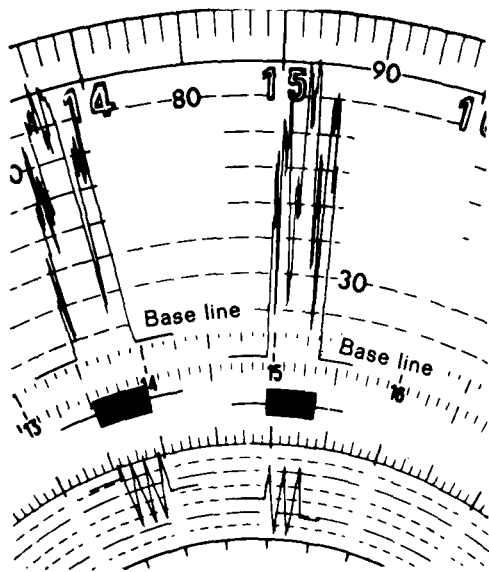
downwards. When the vehicle is stationary a concentric base line is recorded. The base line must run at a given radius; otherwise the recording will not correspond to the actual speed of the vehicle. Figure 2-278 shows the precise position of the base lines. If the base line does not fall within this range, but lies below it, it is possible that the stylus was bent down to indicate that the vehicle was driven more slowly than it really was.



AT 23080

Figure 2-278. Speed recordings.

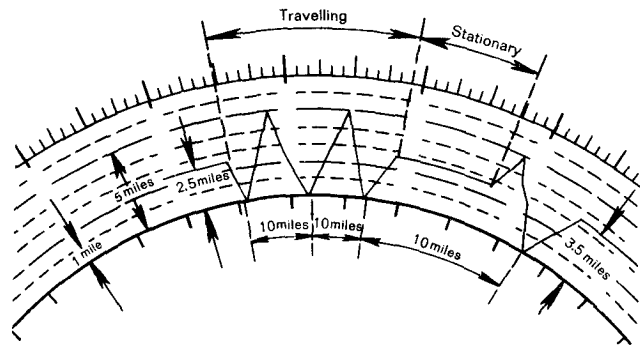
(4) *Traveling and stationary times.* The time (vibration) stylus marks the vehicle traveling and stationary times. The recording mechanism consists of a simple oscillating pendulum kept in balance by a spring. When the vehicle is in motion, the vibrations of the pendulum are transmitted to a stylus. The stylus is deflected through a given width and in the case of an extended journey the recording takes the shape of a broad, red band. The vibrating pendulum is in fact a simple form of seismograph which records all vibrations of the vehicle independently of the tachograph drive mechanism. This recording will remain unaffected by a faulty drive mechanism or a broken or disconnected cable (fig. 2-279).



AT 23081

Figure 2-279. Traveling and stationary times.

(5) *Record of distances traveled.* The distance stylus registers the distances covered, and also distance with respect to time. Complete upward and downward arcs correspond to 10 miles or kilometers. Pauses between distance are registered as concentric lines. To enable accurate readings to be made, the recording field itself is divided up by concentric circular lines (fig. 2-280); the distance between each 2 lines corresponds to exactly one mile traveled. At the same time the speed stylus also marks the outer time graduation or the graduation below this line as indicated in (3) above.



AT 23082

Figure 2-280. Distances traveled.

(6) *Engine rpm.* In addition to speed and traveling and stationary periods, engine rpm is also recorded. It is recorded simultaneously on the reverse side of this chart. The recording field for engine rpm is also divided up by concentric circles. This enables the viewer to read off accurately the rpm reached at a given time. Various rpm ranges are available. The recording is not made in a straight line, but in an arc. The time graduation is related to the base line and the maximum rpm measuring range. Unlike the speed diagram, the base line is recorded immediately after inserting the disc and not only when cover is closed (fig. 2-281).

**NOTE**

Insure that these vehicles are not used without permission after duty hours.

(4) *Traveling time.* Traveling time is seen from the broad band of the time recordings and corresponds to time spent at the wheel. Total time traveled can be added up with the analyzer. It is important in calculating the average speed and determining the driving manner.

(5) *Stationary times.* The thin concentric line denotes a stationary vehicle. The stationary time can be determined precisely by using the chart analyzer. This is done in a single operation which also determines traveling time. In the case of primary local use, there may be considerable stationary time. Some reasons for long stationary periods are:

- (a) Loading and unloading.
- (b) Waiting at loading bay.
- (c) Repairs, servicing, and refueling.
- (d) Pauses in work.

(6) *Degree of utilization.* The degree of utilization is the ratio of traveling time to total operating time.

$$\text{Degree of utilization} = \frac{\text{Traveling time} \times 100\%}{\text{Total time}}$$

Vehicle load should also be taken into account when computing degree of utilization.

(7) *Average speed.* The average speed is calculated from data taken from the chart.

$$\text{Average for journey (mph)} = \frac{\text{Miles traveled} \times 60}{\text{Total time (min)}}$$

$$\text{Average driving mph} = \frac{\text{Miles traveled} \times 60}{\text{Actual driving time (min)}}$$

The closer the ratio approaches 100%, the more economical is the manner of driving. As a general guide, the minimum value for local transport should be 50-60 percent while the percentage should be higher for long distance work.

(8) *Applicable speed limits.* Maximum speeds are prescribed by law. Check the chart from time to time to see that these limits are actually being observed.

(9) *Distance traveled in miles and kilometers.* Distance covered is found from the visible distance counter or from chart notations. The mileage counter section of the distance recorder counts all miles traveled even when the tachograph is open. The day's journey or any partial journey can be determined from the chart. At the start and end of the journey the distance recorder figures must be entered in the inner field of the chart. The difference between the two values must coincide with

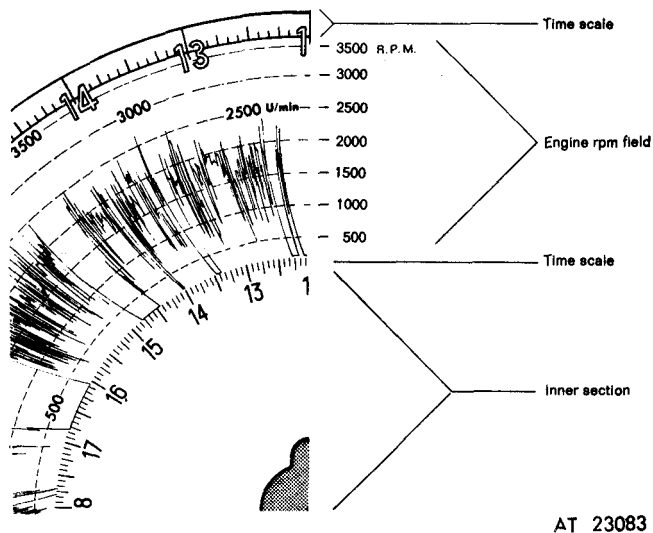


Figure 2-281. Engine rpm recording.

d. Chart as Data Source.

(1) *General.* The chart disc provides valuable statistical information on driving, from which all essential data for testimonies can be obtained. The results of evaluation give clear answers to all questions relating to vehicle use. For example:

- (a) Time percentage of vehicle utilization.
- (b) Number of stops and length of stops.
- (c) Excessive speed.
- (d) Excessive engine idling.
- (e) Correct warm up, correct shut down.
- (f) Driving in proper rpm range.
- (g) Overrevving.
- (h) Lugging.
- (i) Total engine rpm compared to total miles.

The tachograph automatically provides information on all these factors on the chart. The recordings have only to be correctly evaluated.

(2) *Time range for evaluation.* The extent and time required for evaluation depends on the data to be processed. A detailed operational analysis need not be carried out over a whole year. For example, evaluation can be made over an uninterrupted period of about one month, then extrapolated over the year to figure the degree of utilization of a vehicle. For a thoroughly detailed analysis using auxiliary devices, a time of one to two minutes per chart is required.

(3) *Working times.* The chart is inserted at the start of duty hours and removed at the end of duty hours. The beginning and end of the recordings must correspond with those hours. By adding up the partial times marked by the red band of the time during duty hours can be determined. The thin line recordings indicate pauses or breaks.



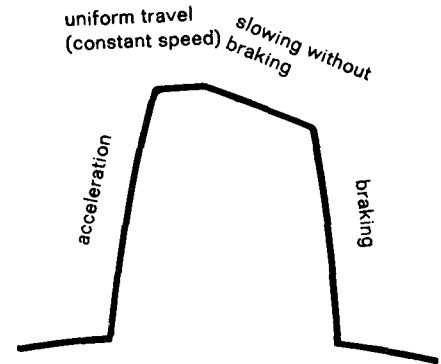
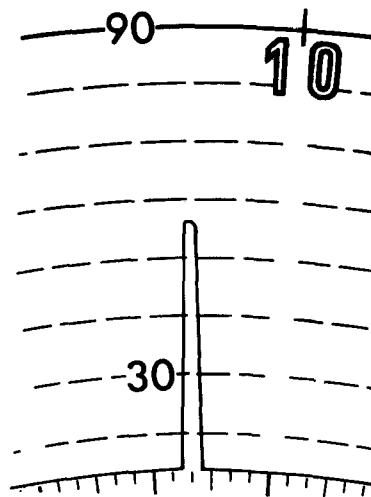
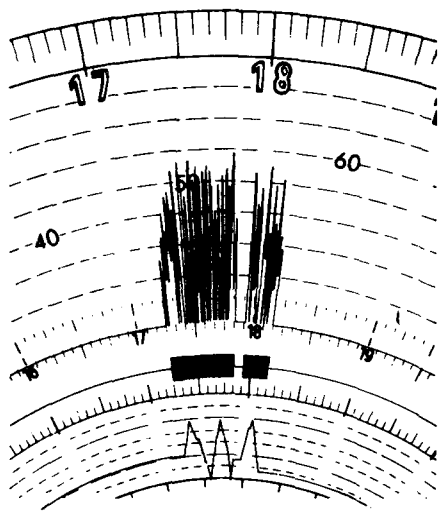
the distance recorded on the chart. Otherwise either the entries have been falsified or the instrument has been left open.

*e. Data on Economy and Manner of Driving.*

(1) *General.* Practical experience and experiments prove that a vehicle operator has considerable influence on economical operation of his vehicle. The diagram chart clearly shows when the manner of driving is good or when it is poor and requires improvement. The diagrams are evaluated without any special aids simply by examining the speed recordings or engine rpm recordings. Evaluation requires very little time and should take place daily. Put to one side any charts which are not immediately clear and examine them later. The quality of driving is determined on one hand by

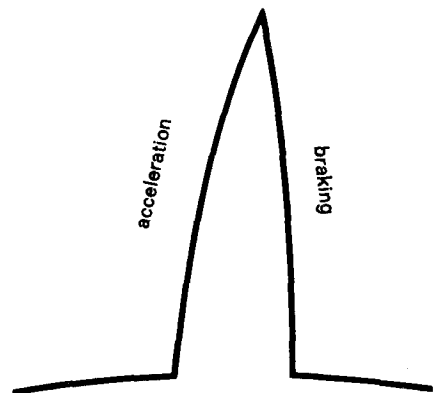
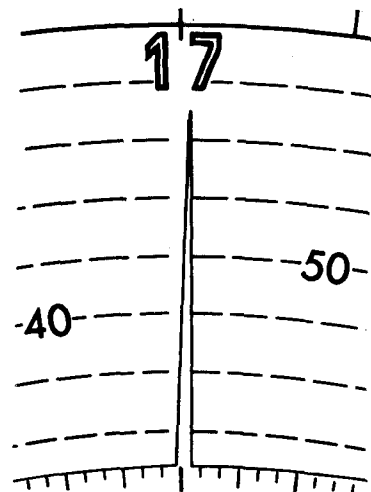
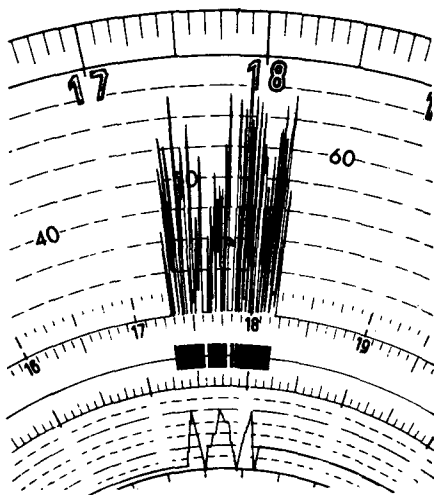
even, uniform progress and on the other hand by speed of travel. The closer the maximum speed is to average speed, the more uniform and economical is the manner of driving. High, needle-shaped speed peaks should be avoided as far as possible. They prove that the vehicle has been accelerated unnecessarily only to be braked again almost at once. This is proof of bad driving and often the reason why the vehicle has a shorter useful life. When evaluating the charts, the type of use, road and traffic conditions, and vehicle size must be taken into account.

(2) *Economy and driving manner expressed in speed chart.* Figures 2-282 and 2-283 demonstrate good and bad driving charts, respectively.



AT 23085

Figure 2-282. Good driving.



AT 23084

Figure 2-283. Bad driving.

(3) *Manner of driving expressed in speed and rpm diagram.* For vehicles used over short distances, determination of speed of travel on its own is not sufficient. Because of the speed limits and because of traffic control, there are certain conditions with which an operator must comply. But the operator still has a considerable influence on the economic running of his vehicle even though the speed recordings may appear to show only slight differences. Figure 2-284 shows the importance of these remarks. These charts show in each case two trips on a normal scheduled route with economical driving and two trips with uneconomical driving. To the inexperienced eye there is hardly any difference between the speed recordings. On the other hand the rpm recordings show the characteristic features of both types of driving. While in one case rpm has been used only within an economic range, in the other case the engine has run at maximum rpm in the individual gears. There is a difference of 40 percent in fuel consumption compared to an increase in journey time of only 2 percent.

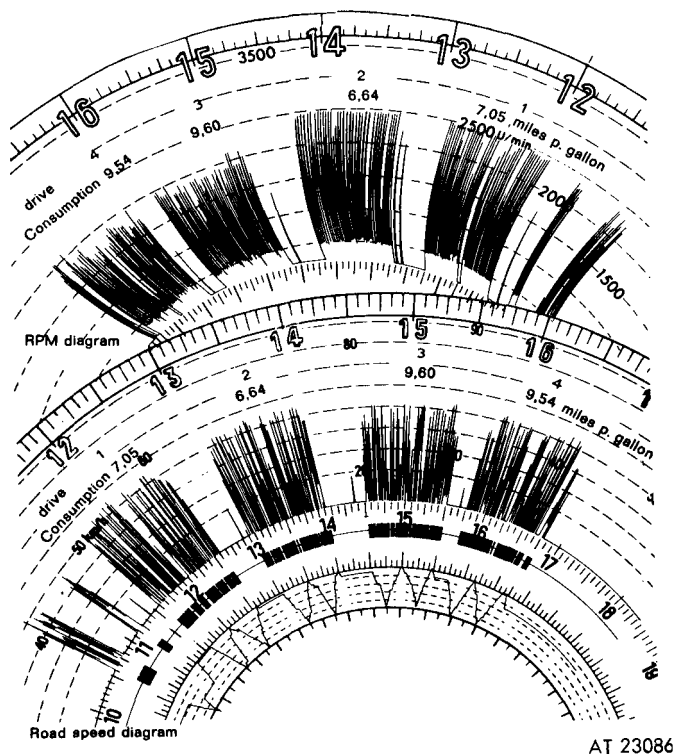
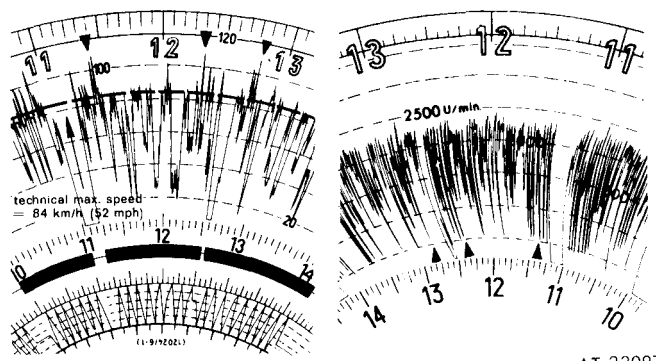


Figure 2-284. Speed and rpm diagram.

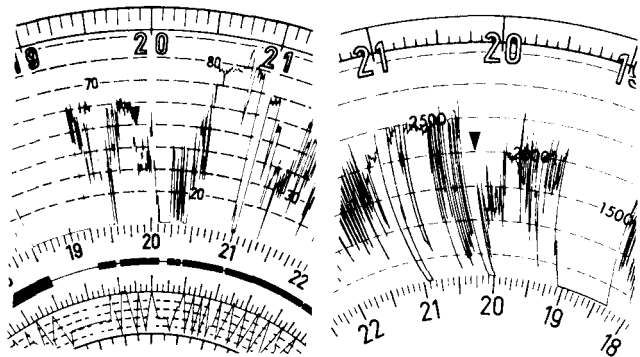
(4) *Driving without gear engaged.* This can be recognized from the fact that individual speed peaks extend above the maximum speed specified in operating instructions for the vehicle. At the same time the rpm diagram shows engine idling. If the engine were coupled to the wheels, rpm would increase with speed of travel (fig. 2-285).



AT 23087

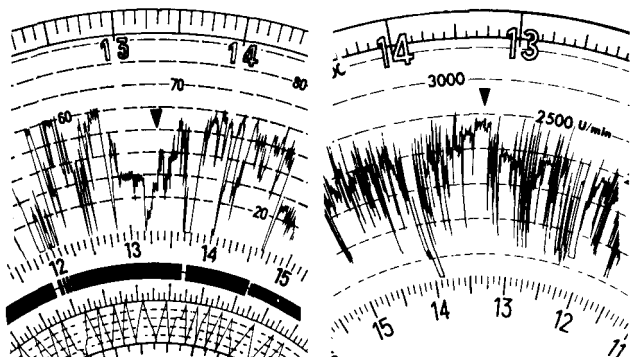
Figure 2-285. Gear disengaged.

(5) *Driving up and down gradients (fig. 2-286 and 2-287).* The speed chart on its own (fig. 2-286) does not lead to any conclusion as to which gear was engaged. The rpm chart shows that the engine was overloaded at low rpm. Damage to the engine is often the result of such handling.



AT 23089

Figure 2-286. Gradient driving (incorrect).

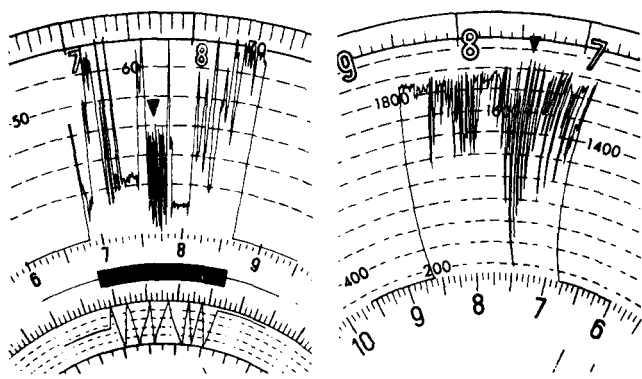


AT 23090

Figure 2-287. Gradient driving (correct).

(6) *Traveling downhill in wrong gear.* The speed of travel varies constantly as a result of acceleration caused by vehicle weight. When the foot brake is applied, heavy stress on the foot brake

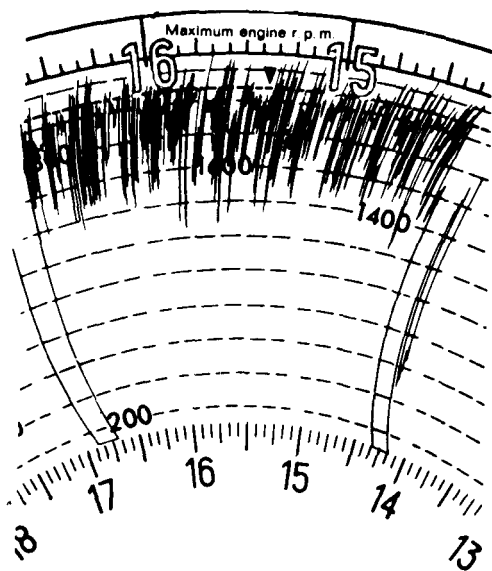
and transmission components results. The rpm chart also reveals constant alternation between high and low rpm. The engine can easily be run at excessively high rpm (fig. 2-288).



AT 23091

Figure 2-288. Wrong gear.

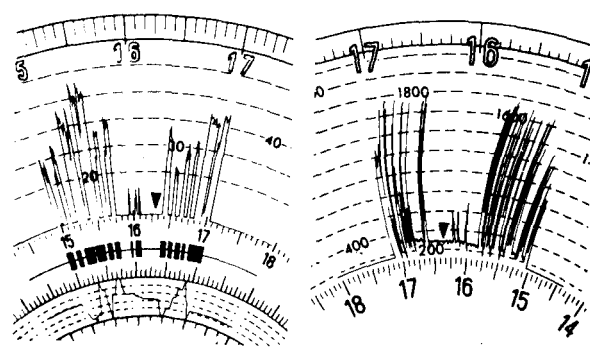
(7) Engine run at excessively high rpms. The speed chart does not reveal this fault in driving. On the other hand it can be seen clearly from the rpm chart that the permissible maximum rpm is constantly being exceeded (fig. 2-289).



AT 23092

Figure 2-289. High rpms.

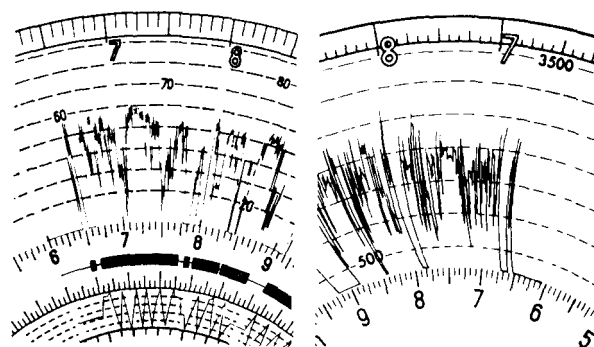
(8) Engine idling. In the case of older vehicles engine idling can be recognized only as a narrow, jagged band on the time stylus recording (fig. 2-290). On the other hand, the rpm chart clearly reveals unnecessary running of the engine for a period of several hours.



AT 23093

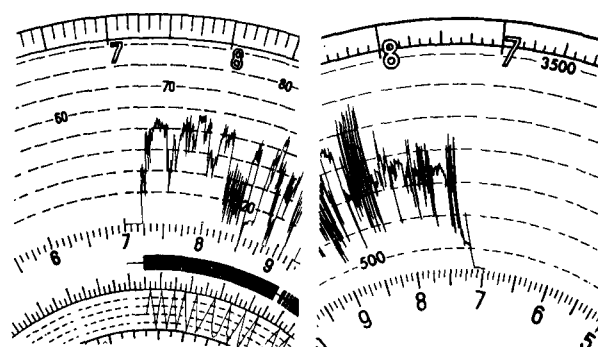
Figure 2-290. Engine idling.

(9) Cold starting and warming up the engine. In figure 2-291, the chart shows that the engine was accelerated to maximum rpm when cold; this can cause damage to the pistons and other parts of the engine. Recording of idling for several minutes during duty hours points to the fact that the engine has been warmed up (fig. 2-292). Speed recording does not begin until after this.



AT 23094

Figure 2-291. Cold starting.



AT 23095

Figure 2-292. Idling time.

(10) *Falsifications and irregularities.* Certain recordings may seem impossible to explain from the information given up to now. The cause may be an unintentional or intentional interference by the driver or a defective instrument. The special design of the tachograph with its various mechanisms offers a wide range of possibilities for checking through which any irregularity can be ascertained. In practice, falsification hardly ever occurs. However, the following are descriptions of possible falsification methods.

(11) *Lowered speed.*

(a) *Identifying feature.* The speed stylus records below the prescribed base line.

(b) *Cause.* The speed stylus is bent in order to simulate lower speeds. To find the actual speed, add the difference to the recorded speed. The instrument must be readjusted (fig. 2-293).

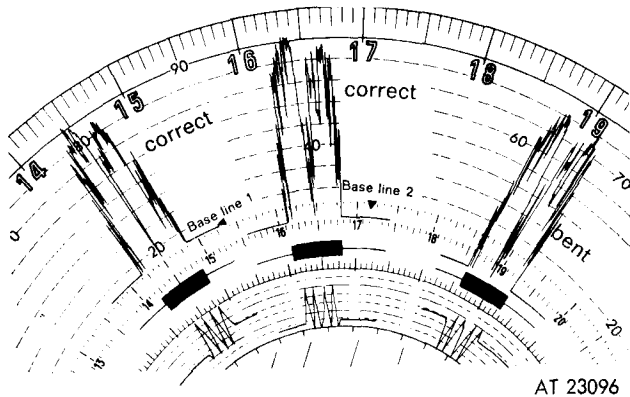
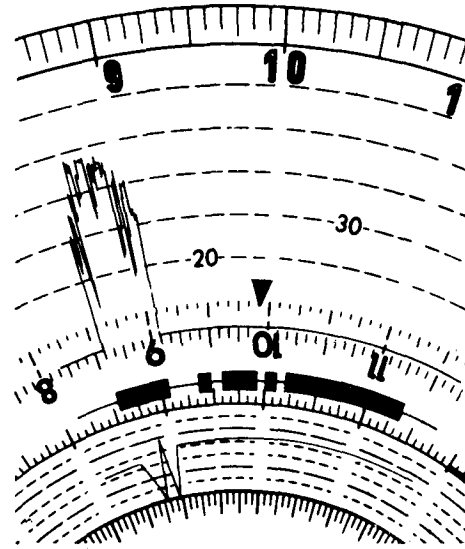


Figure 2-293. Lowered speed.

(12) *No speed or distance recordings.*

(a) *Identifying feature.* The time stylus records only traveling and stationary times; speed and distance recordings are not made.

(b) *Cause.* The drive shaft is defective or has been intentionally unscrewed to conceal unauthorized trips. However, the driving of a trip can still be determined (fig. 2-294).



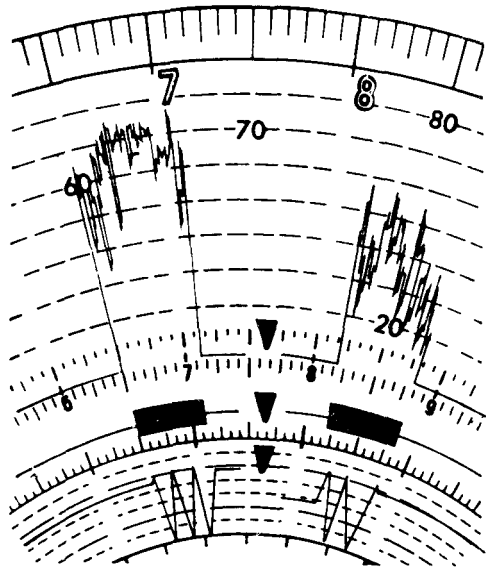
AT 23097

Figure 2-294. No speed recorded.

(13) *Interrupted recordings.*

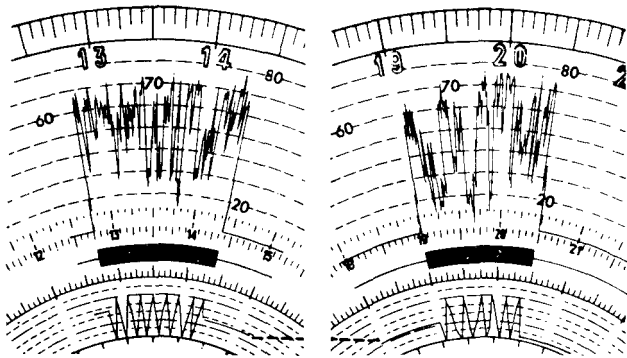
(a) *Identifying feature.* All recordings are interrupted.

(b) *Cause.* The instrument cover has been opened. If the distance recordings do not coincide the vehicle has been used in the meantime. The length of the journeys can be ascertained from the difference between the recorded distance and the distance counter figure shown in the inner field of the chart (fig. 2-295). Also check whether the final recorder figures coincide with the initial figures of the next chart (fig. 2-296). If the values do not coincide, trips have been made between removal of one chart and insertion of the next one. Also note the time of removal and insertion of the chart which is clearly marked. Normally a new chart should be inserted at once. If the distances do coincide, the chart may have been turned backwards to simulate different working times.



AT 23098

Figure 2-295. Interrupted recordings.



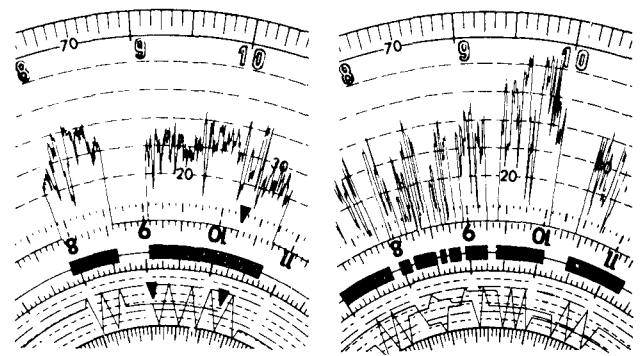
AT 23099

Figure 2-296. Coinciding figures.

(14) Distance recordings superimposed.

(a) Identifying feature. Distance recordings are superimposed. Speed and distance recordings appear to indicate simultaneous standstill and travel.

(b) Cause. Either the instrument was opened and the chart turned back (fig. 2-297) in order to conceal unusually long breaks, or the chart was in the instrument for more than 24 hours (fig. 2-297), and the recordings have consequently been superimposed. Check the time of insertion and removal. Care should be taken to prevent such superimposition of recordings.



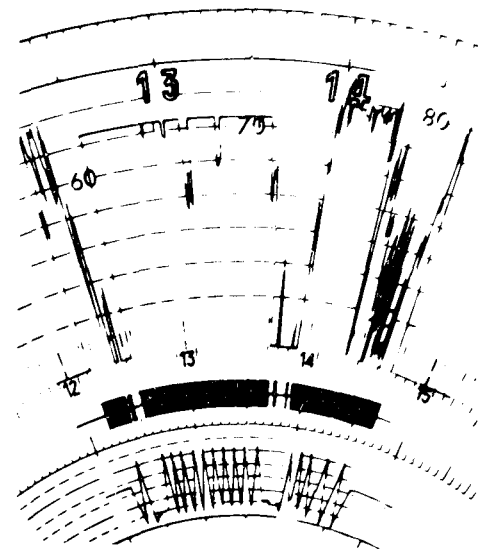
AT 23100

Figure 2-297. Superimposed distance recordings.

(15) Long periods of constant speed.

(a) Identifying feature. The speed recording runs for an unusually long time at a uniform level; constant speeds of this kind are never obtained in practice.

(b) Cause. The speed stylus is prevented from moving upwards by foreign objects inserted in the instrument to indicate that lower speeds have been maintained than is actually the case. Demonstration of the interference is possible by calculating the average speed for the period of time in question (fig. 2-298). It will usually be found that this appears to be higher than the maximum speed of the vehicle. In the case of the tachographs with additional rpm recording, the rpm chart should also show similar uniform rpm.



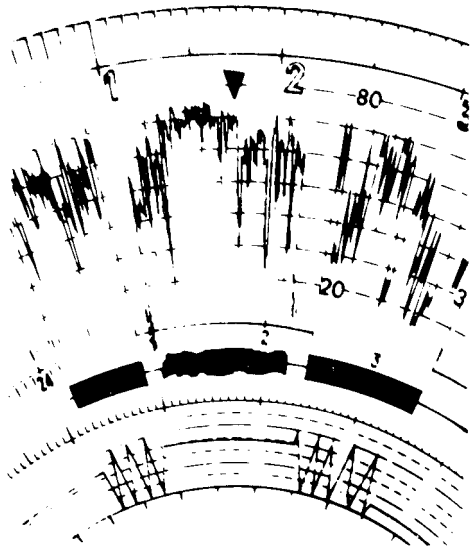
AT 23101

Figure 2-298. Constant speeds.

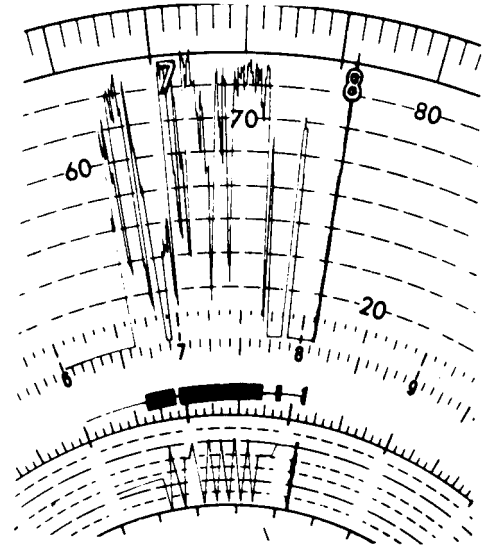
(16) Difference between speed recordings. Cause: Recording have been filled in by hand (fig. 2-299). These differ from those of the

instrument. Usually the distance recordings will show the vehicle to be stationary while only the speed line is recorded.

wound and remained stationary or else the clock mechanism was intentionally blocked. The chart no longer moves and the styluses record in the same position (fig. 2-300).



AT 23102



AT 23103

Figure 2-299. Speed recordings.

(17) All three styluses give vertical readings. Cause: The clock mechanism was not

Figure 2-300. Vertical readings.

## CHAPTER 3

**MATERIEL USED IN CONJUNCTION  
WITH MAJOR ITEM**

**Section I. HOT WATER PERSONNEL HEATER KIT**

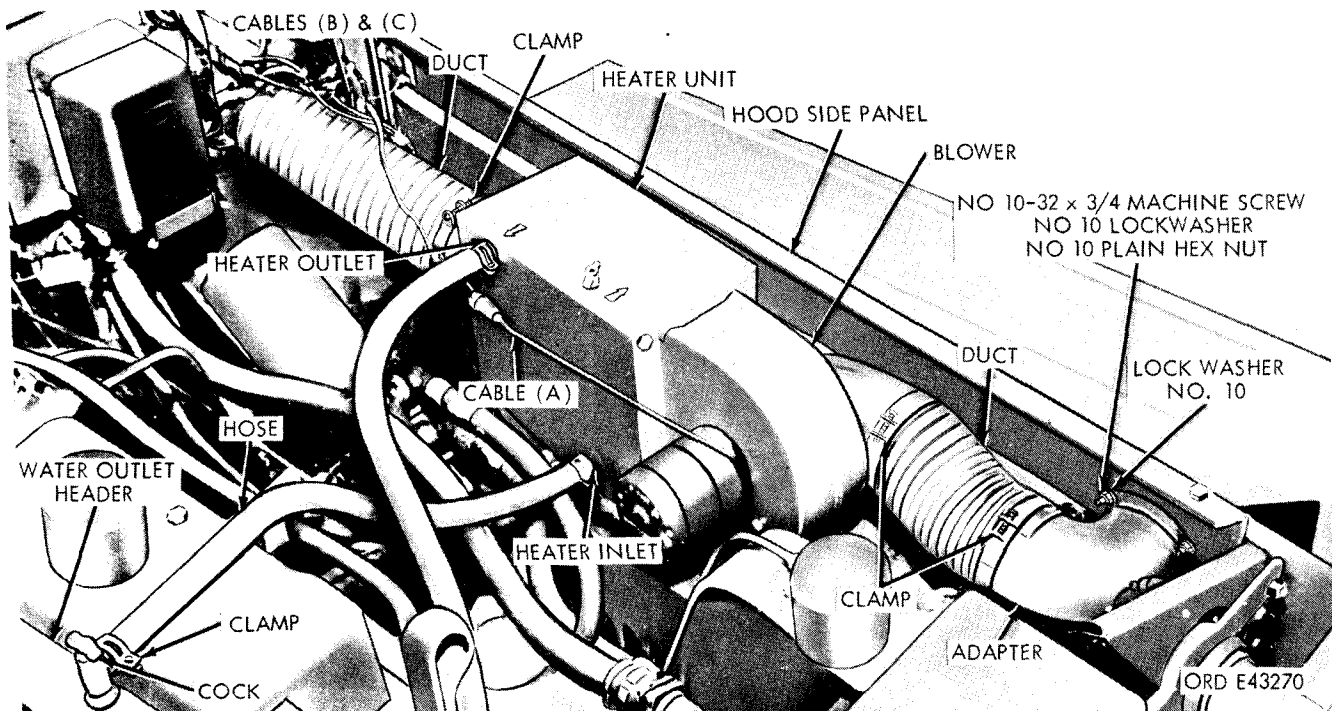
**3-1. General**

The personnel heater, which is bolted to the top of the left fender splash shield in the engine compartment, distributes heated air to the cab and / or windshield defroster through a blower and heat diverter. The heat flow is controlled by AIR and DEFROSTER knobs on the instrument panel. These knobs operate butterfly or damper valves in

the heater outlet, adapter elbow, and heat diverter assembly.

**3-2. Heater Unit***a. Removal.*

(1) Disconnect the cable (A, fig. 3-1) from the socket on the heater unit.



*Figure 3-1. Personnel heater kit—hot water.*

(2) Disconnect the cables (B and C, fig. 3-1) from the double connector.

(3) Loosen the two clamps (one clamp at either end of the heater unit). Disconnect both the outlet and inlet ducts from the heater unit (fig. 3-1). Disconnect the two hoses.

(4) Remove the screws and lockwashers securing the adapter to the rear of the heater unit (fig. 3-2). Remove the adapter.

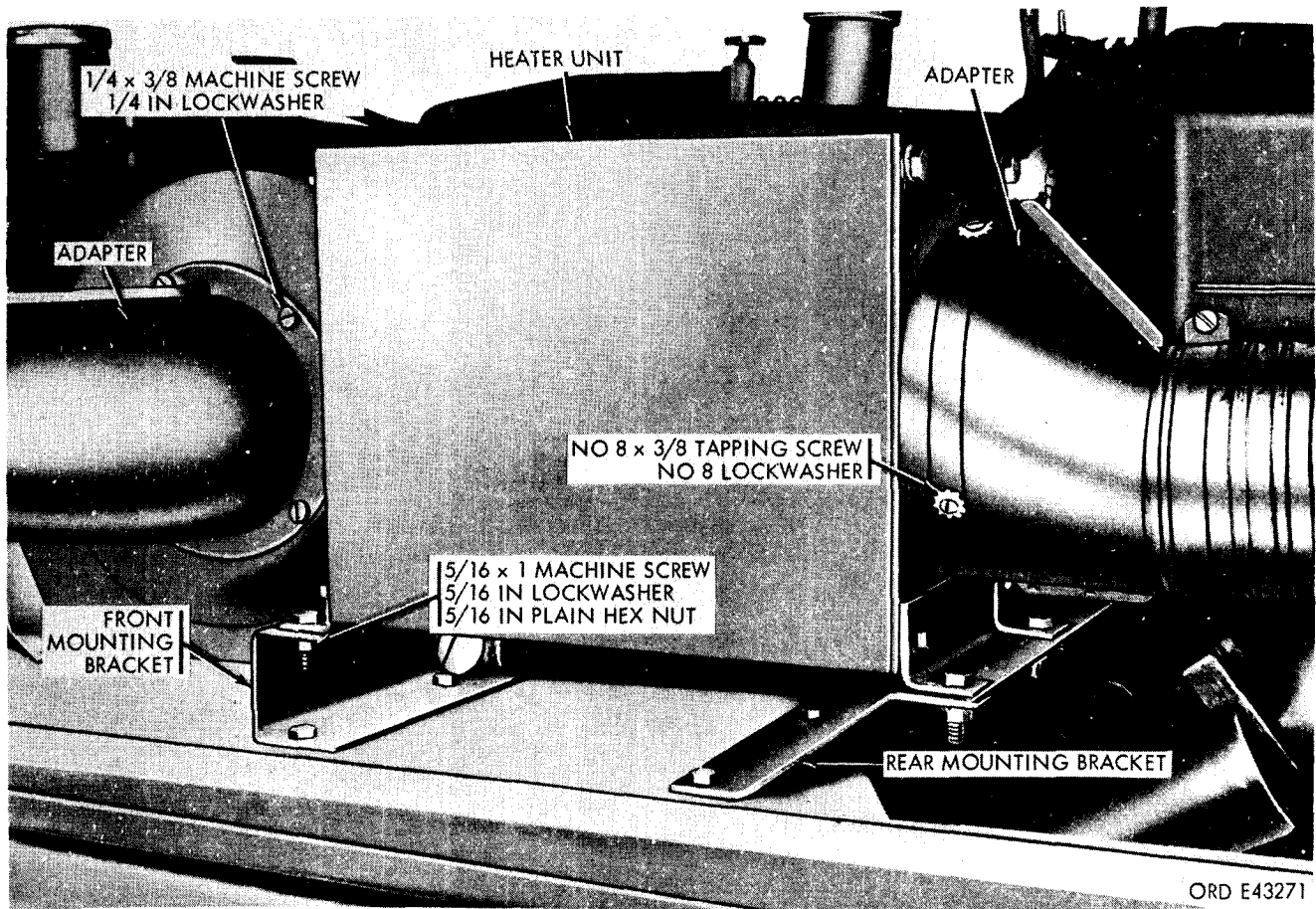


Figure 3-2. Heater unit--side view.

(5) Remove the screws and lockwashers securing the adapter to the blower end of the heater unit (fig. 3-2). Remove the adapter.

(6) Unscrew the nuts and remove the screws and lockwashers securing the heater unit to the front end and rear mounting brackets (fig. 3-2).

*b. Installation.*

(1) Secure the heater unit to the front and rear mounting brackets with the lockwashers, screws, and nuts (fig. 3-2).

(2) Secure the adapter to the rear of the heating unit with the lockwashers and screws (fig. 3-2).

(3) Assemble the front adapter to the blower with the lockwashers and screws (fig. 3-2).

(4) Slide the inlet and outlet ducts onto their

respective heater openings. Secure both ducts to the heater unit with two clamps (one to each duct) as shown in figure 3-1. Connect the two hoses.

(5) Connect the cables (B and C). Connect the cable (A) as shown in figure 3-1.

3-3. Thermostats

*a. Removal.* Refer to paragraph 2-114.

*b. Installation.* Refer to paragraph 2-114.

3-4. Heater Hoses

(Fig. 3-1)

*a. Removal.* Remove the clamps securing the heater unit hoses at both ends. Remove the hoses from the vehicle (fig. 3-1).

*b. Installation.* Position the hoses and secure them at both ends with the clamps.

**Section II. GASOLINE PERSONNEL HEATER KIT**

**3-5. General**

The blower type gasoline personnel heater, which is bolted to the top of the left fender inside the engine compartment, distributes heated air to the cab and / or windshield defroster by a blower and heat

diverter. The amount of heat flow is controlled by means of a fuel-metering device. The fuel control (metering device) fluctuates according to setting of the heat control thermostat (gasoline heater only) located in cab.



### 3-6. Lines and Fittings

(Fig. 3-3.)

*a. Removal.* Disconnect the fuel line from the fittings at the carburetor and fuel filter. Remove the fuel line.

*b. Installation.* Connect the fuel line to the fittings at the carburetor and fuel filter.

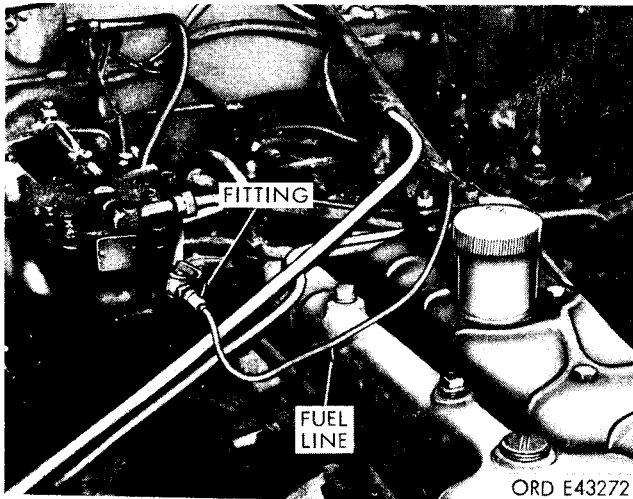


Figure 3-3. Removing lines and fittings—gasoline heater.

### 3-7. Electric Fuel Pump

*a. Maintenance.*

(1) Turn the electric fuel pump lower cover clockwise, and remove the cover, fuel strainer screen, and lower cover gasket.

(2) Wash the screen in a drycleaning solvent or mineral spirits paint thinner.

(3) Install a new gasket, screen, and cover and lock them in place by turning the cover counterclockwise.

*b. Removal.*

(1) Disconnect the shield cable.

(2) Remove the two screws securing the pump assembly, and remove the pump.

*c. Installation.*

(1) Secure the pump assembly with two screws.

(2) Connect the shield cable.

### 3-8. Fuel Filter

(Fig. 3-4.)

*a. Removal.* Unscrew the sediment bowl from the filter body, and remove the filter element and gasket. Discard the gasket.

*b. Installation.* Use a new gasket when screwing the sediment bowl onto the filter body. Install the bowl.

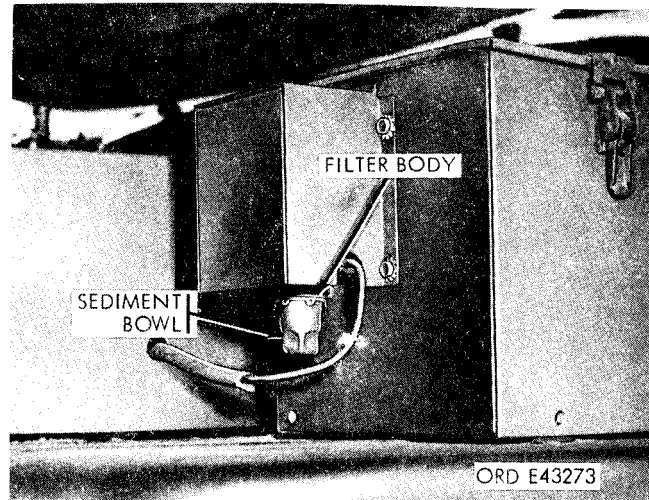


Figure 3-4. Fuel filter.

### 3-9. Heater Control Thermostat

*a. Removal.* Remove the two screws securing the thermostat control. Disconnect the two wires, and remove the control.

*b. Installation.* Position the control unit, and secure it with the two screws. Connect the two wires.

## Section III. FUEL BURNING PERSONNEL HEATER KIT— MULTIFUEL MODELS

### 3-10. General

Personnel heater kits installed on multifuel models are blower type, fuel burning heaters. These heater units are bolted to the top of the left fender on the inside of the engine compartment. Two heater settings are provided (high and low). The heat flow is controlled by means of a fuel metering device which is part of the heater unit. Heat settings are controlled by switches at the control box. An electric fuel pump allows heater operation without the engine running.

### 3-11. Heater Control Box Assembly

*a. Indicator Lamp.*

(1) *Removal.* Unscrew the lamp cover. Push the lamp in, and turn it clockwise to remove it.

(2) *Installation.* Push the lamp in, and turn it counterclockwise to install it. Screw the lamp cover in place.

*b. Heater Control Box.*

(1) *Removal.*

(a) Disconnect the heater-to-control box harness at the receptacle.

## TM 9-2320-211-20

(b) Disconnect the heater power lead.

(c) Remove the two screws and nuts attaching the control box and plate to the instrument panel.

### NOTE

The powerplant heater control box is attached to a panel bracket.

(d) Remove the control box and plate as an assembly.

(2) *Installation.*

(a) Position the plate and control box as an assembly to the instrument panel, and secure it to the panel with the two screws and nuts.

(b) Connect the power lead.

(c) Also connect the heater-to-control box harness at the receptacle.

c. *Heater Control Box Switch.*

(1) *Removal.*

(a) Remove the two screws holding the front panel to the housing.

(b) Tag the switch leads before disconnecting them.

(c) Unscrew the switch retaining nut (at the toggle). Remove the switch.

(2) *Installation.*

(a) Secure the switch mechanism with the retaining nut. Tighten the nut.

(b) Connect the leads to the correct connecting points.

(c) Secure the switch front panel to the housing with the two screws. Tighten the screws.

## 3-12. Electric Fuel Pump—Multifuel Models

a. *Maintenance.* Turn the electric fuel pump lower cover clockwise and remove it, the fuel strainer screen, and the lower cover gasket. Wash the screen in drycleaning solvent or mineral spirits paint thinner. Replace the cover, using a new gasket and the old screen. Lock the cover in place by turning it counterclockwise.

b. *Removal.*

(1) Remove the four screws and nuts which fasten the pump shield to the tool compartment inner wall (mounted on left running board).

(2) Twist and connect the shielded cable; remove the two screws and nuts attaching the pump to the compartment wall.

c. *Installation.*

(1) Secure the pump to the compartment wall with the two nuts and screws. Connect the shielded cable.

(2) Secure the pump shield to the tool compartment inner wall with the four screws and nuts.

## Section IV. POWER PLANT HEATER KIT—MULTIFUEL MODELS

### 3-13. General

The powerplant heater is a fuel burning unit with a maximum heat output of 24,000 B.t.u. / hr. The heater exhaust accounts for 8,000 B.t.u. / hr of heater output. The heater is mounted on the side of the vehicle in the battery box compartment. The batteries and battery box are relocated to the crew compartment. The batteries and battery box are relocated to the crew compartment under the companion seat. The heater heats the coolant in the engine to the operating temperature during standby periods. Exhaust gases from the heater burner pass through tubing to an oil pan shroud and escape between the edges of the shroud and the oil pan,

thus heating the crankcase lubricant. The powerplant heater is designed for overnight and standby heating, as well as prestart heating.

### 3-14. Fuel Lines

Refer to paragraph 2-75 and follow similar procedures when removing and installing the personnel heater kit.

### 3-15. Fuel Filter

Refer to paragraph 3-8.

### 3-16. Heater Control Box Assembly

Refer to paragraph 3-11 and follow similar removal and installation procedures.

## Section V. PRIMER PUMP

### 3-17. General

The primer pump, which is mounted on the lower right side of the instrument panel, boosts the fuel supply to the intake manifold when starting the engine during cold weather.

### 3-18. Primer Pump

a. *Removal.*

(1) Disconnect the fuel lines from the primer pump.

(2) Unscrew the outer locknut, and remove the primer pump (fig. 3-5).

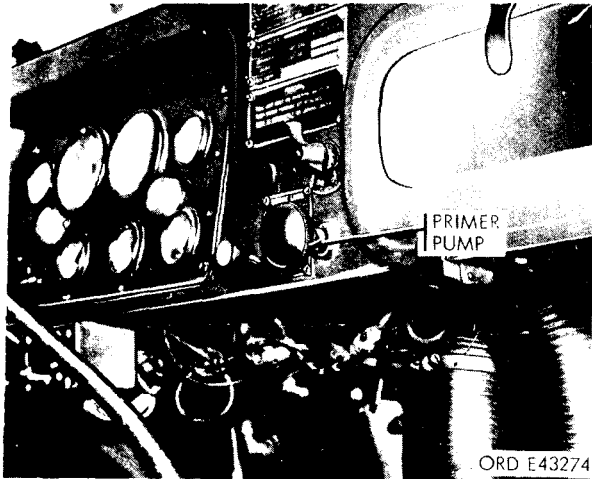


Figure 3-5. Removing primer pump.

- b. Installation.
- (1) Secure the primer pump to the instrument panel with the locknut (fig. 3-5).
  - (2) Connect the fuel lines to the primer pump.

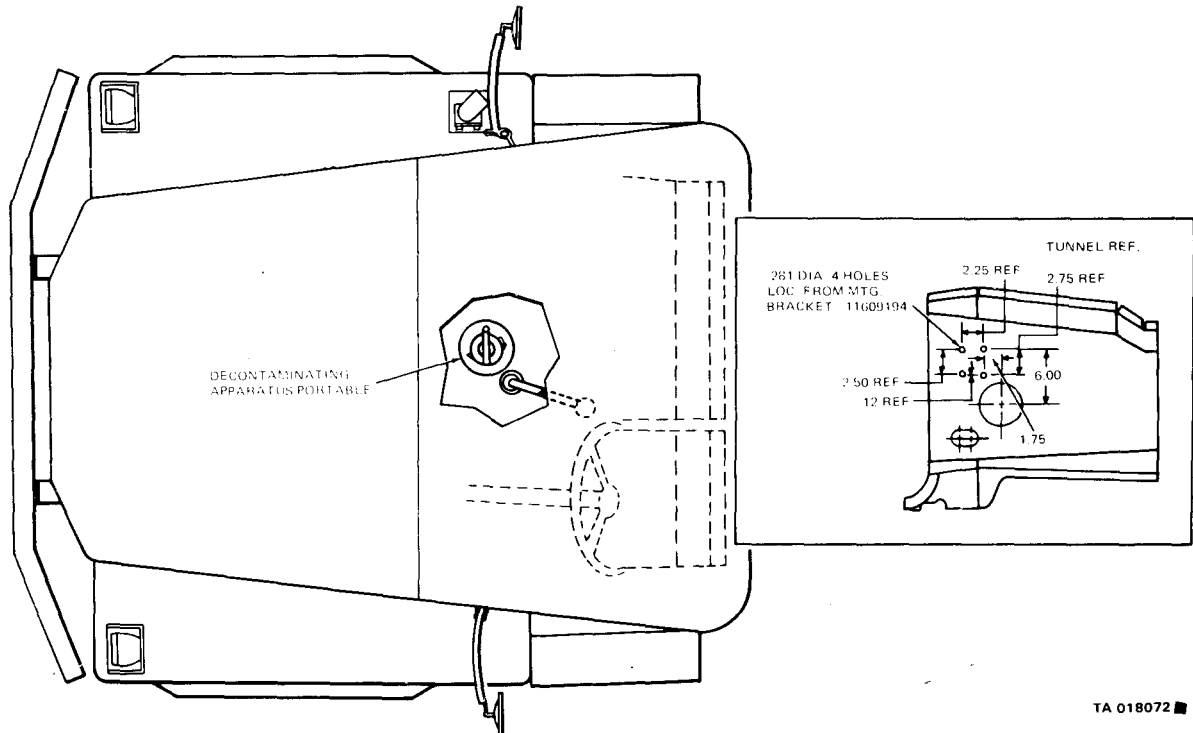
## Section VI. DECONTAMINATION APPARATUS

### 3-19. Location.

The stowage location of the M11 decontamination apparatus for the M39 series of 5-ton, 6x6 trucks is on top of the top of the transmission terminal cover (figure 3-6). A mounting bracket is fastened forward of the gear shift lever and on the right hand side.

### NOTE

Be sure to remove all sharp corners of bracket, if any.



TA 018072 ■

Figure 3-6. Decontamination apparatus location.

This page intentionally left blank.

APPENDIX A

REFERENCES

**A-1. Indexes**

The following indexes should be consulted frequently for the latest changes to or revisions of references given in this appendix and for new publications or instructions relating to materiel covered in this manual.

Index of Motion Pictures and Related Audio-Visual Aids, Transparencies, GTA Charts and Recordings	DA Pam 108-1
Index of Administrative Publications	DA Pam 310-1
Index of Blank Forms	DA Pam 310-2
Index of Technical Manuals, Technical Bulletins, Supply Manuals (Types 7, 8, and 9), Supply Bulletins, and Lubrication Orders	DA Pam 310-4
Index of Doctrinal, Training, and Organizational Publications	DA Pam 310-3

**A-2. Forms**

The following forms pertain to this material. (Refer to DA Phamplet 310-2 for the index to TM 38-750 for an explanation of their use).

- DA Form 2028: Recommended Changes to Publications
- DA Form 2407: Maintenance Request
- DA Form 2408: Equipment LOG Assembly (Records.)
- DD Form 1397: Processing and Deprocessing Record for Shipment, Storage and Issue of Vehicles and Spare Engines.

**A-3. Other Publications**

The following publications contain information pertinent to major item materiel and associated equipment:

<i>a. Demolition</i>	
Procedures for Destruction of Tank-Automotive Equipment to Prevent Enemy Use (US Army Tank-Automotive Command)	TM 750-244-6
<i>b. Vehicle.</i>	
Truck, 5-Ton, 6X6, M39, M40, M41, M52, M54, M61, M63, M139, M246, M291, M328, M543, and M748 Series	LO 9-2320-211-12
Operator's Manual: Truck, 5-Ton, 6X6, M39, M40, M41, M52, M54, M61, M63, M139, M246, M291, M328, M543, and M748 Series	TM 9-2320-211-10
Organizational Maintenance Repair Parts and Special Tools Lists: Truck, 5-Ton, 6X6, M39, M40, M41, M52, M54, M61, M63, M139, M246, M291, M328, M543, and M748 Series	TM 9-2320-211-20P
Equipment Serviceability Criteria for Truck, 5-Ton, 6X6, M39, M40, M41, M52, M54, M61, M63, M139, M246, M291, M328, M543, and M748 Series	TM 9-2320-211-ESC
<i>c. Camouflage</i>	
	FM 5-20
<i>d. Decontamination.</i>	
Chemical, Biological, and Radiological (CBR) Decontamination	TM 3-220
Chemical, Biological, Radiological, and Nuclear Defense	FM 21-40
<i>e. General.</i>	
Accident Reporting and Records	AR 385-40
Basic Cold Weather Manual	FM 31-70
Cooling Systems: Tactical Vehicles	TM 750-254
Manual for the Wheeled Vehicle Driver	TM 21-305
Driver Selection and Training (Wheeled Vehicles)	TM 21-300
Deep-Water Fording of Ordnance Materiel	TM 9-238
Fording Kits for Combat and Transport Vehicles	MIL-F-3201
Maintenance Assistance and Instruction Team (MAIT) Program	AR 750-51
Army Motor Transport Operations	FM 55-30
Mountain Operations	FM 31-72
Northern Operations	FM 31-71
Operation and Maintenance of Army Materiel in Cold Weather (0° F. to—65° F.)	TM 9-207
Petroleum Handling Equipment and Operation	TM 10-1101

**TM 9-2320-211-20**

Preservation, Methods of . . . . . MIL-P-116  
Principles of Automotive Vehicles . . . . . TM 9-8000  
Prevention of Motor Vehicle Accidents . . . . . AR 385-55  
Organizational Maintenance: Spark Plugs Used on Ordnance Materiel. . . . . TM 9-8638  
Functional Grouping Codes—Combat, Tactical, and Support Vehicles and Special Purpose Equipment. . . . . TM 750-93-1

*f. Maintenance and Repair.*

Organizational Care, Maintenance and Repair Pneumatic Tires and Inner Tubes. . . . . TM 9-2610-200-20  
Combat Vehicles and Tactical Transport Vehicles: Procedure for Starting Engines with Slave Cable. . . . . TB ORD 537  
Description, Use, Bonding Techniques, and Properties of Adhesives. . . . . TB ORD 1032  
General Supply: Winterization Kits for Army Tank-Automotive Materiel . . . . . SB 9-16  
Inspection, Care and Maintenance of Antifriction Bearings . . . . . TM 9-214  
Operator's, Organizational, Direct Support and General Support Maintenance Manual: Storage  
Batteries: Lead-Acid Type . . . . . TM 9-6140-200-14  
Army Material Maintenance Concepts and Policies. . . . . AR 750-1  
Operator's Manual: Welding Theory and Application . . . . . TM 9-237

*g. Shipment and Limited Storage.*

Color Marking and Preparation of Equipment for Shipment . . . . . AR 746-1  
Preservation, Packaging, and Packing of Military Supplies and Equipment (Volumns I and II) TM 38-230-1 and  
TM 38-230-2.  
Preservation, Packaging, Packing and Marking Materials, Supplies, and Equipment Used by the Army SB 38-100  
The Army Maintenance Management System (TAMMS) . . . . . TM 38-750  
Shipment and Limited Storage . . . . . MIL-V-62038

## APPENDIX B MAINTENANCE ALLOCATION CHART

### Section I. INTRODUCTION

#### B-1. General.

*a.* This section provides a general explanation of all maintenance and repair functions authorized at various maintenance levels.

*b.* The Maintenance Allocation Chart (MAC) in section II designates overall responsibility for the performance of maintenance functions on the identified end item or component. The implementation of the maintenance functions upon the end item or component will be consistent with the assigned maintenance functions.

#### B-2. Maintenance Functions.

*a. Inspect.* To determine the serviceability of an item by comparing its physical, mechanical, and/or electrical characteristics with established standards through examination.

*b. Test.* To verify serviceability and detect incipient failure by measuring the mechanical or electrical characteristics of an item and comparing those characteristics with prescribed standards.

*c. Service.* Operations required periodically to keep an item in proper operating condition, i.e., to clean (decontaminate), to preserve, to drain, to paint, or to replenish fuel, lubricants, hydraulic fluids, or compressed air supplies.

*d. Adjust.* To maintain, within prescribed limits, by bringing into proper or exact position, or by setting the operating characteristics to specified parameters.

*e. Aline.* To adjust specified variable elements of an item to bring about optimum or desired performance.

*f. Calibrate.* To determine and cause corrections to be made or to be adjusted on instruments or test measuring and diagnostic equipments used in precision measurement. Consists of comparisons of two instruments, one of which is a certified standard of known accuracy, to detect and adjust any discrepancy in the accuracy of the instrument being compared.

*g. Install.* The act of emplacing, seating, or fixing into position an item, part, or module (component or assembly) in a manner to allow the proper functioning of an equipment or system.

*h. Replace.* The act of substituting a serviceable like type part, subassembly, or module (component or assembly) for an unserviceable counterpart.

*i. Repair.* The application of maintenance services<sup>1</sup> or other maintenance actions<sup>2</sup> to restore serviceability to an item by correcting specific damage, fault, malfunction, or failure in a part, subassembly, module (component or assembly), end item, or system.

*j. Overhaul.* That maintenance effort (services / actions) necessary to restore an item to a completely serviceable/operational condition as prescribed by maintenance standards (i.e., DMWR) in appropriate technical publications. Overhaul is normally the highest degree of maintenance performed by the Army. Overhaul does not normally return an item to like new condition.

*k. Rebuild.* Consists of those services/actions necessary for the restoration of unserviceable equipment to a like new condition in accordance with original manufacturing standards. Rebuild is the highest degree of material maintenance applied to Army equipment. The rebuild operation includes the act of returning to zero those age measurements (hours/miles, etc.) considered in classifying Army equipments/components.

#### B-3. Column Entries Use in the MAC.

*a. Column 1, Group Number.* Column 1 lists group numbers, the purpose of which is to identify components, assemblies, subassemblies, and modules with the next higher assembly.

*b. Column 2, Component/Assembl.v.* Column 2 contains the names of components, assemblies, subassemblies, and modules for which maintenance is authorized.

*c. Column 3, Maintenance Functions.* Column 3 lists the functions to be performed on the item listed in column 2. (For detailed explanation of these functions, see para B-2.)

*d. Column 4, Maintenance Level.* Column 4 specifies, by the listing of a "work time" figure in the appropriate subcolumn(s), the lowest level of maintenance authorized to perform the function listed in column 3. This figure represents the active time required to perform the maintenance function at the indicated level of maintenance. If the number or complexity of the tasks

<sup>1</sup>Services—inspect, test, service, adjust, aline, calibrate, or replace.

<sup>2</sup>Action—welding, grinding, riveting, straightening, facing, remachining, or resurfacing.

within the listed maintenance function vary at different maintenance levels, appropriate "work time" figures will be shown for each level. The number of manhours specified by the "work time" figure represents the average time required to restore an item (assembly, subassembly, component, module, end item, or system) to a serviceable condition under typical field operating conditions. This time includes preparation time, troubleshooting time, and quality assurance / quality control time in addition to the time required to perform the specific tasks identified for the maintenance functions authorized in the maintenance allocation chart. The symbol designations for the various maintenance levels are as follows:

- C ..... Operator or crew
- O ..... Organization maintenance
- F ..... Direct support maintenance
- H..... General support maintenance
- D ..... Depot maintenance

*e. Column 5, Tools and Equipment.* Column 5 specified, by code, those common tool sets (not

individual tools) and special tools, test, and support equipment required to perform the designated function.

**B-4. Column Entries Used in Tool and Test Equipment Requirements.**

*a. Column 1, Tool or Test Equipment Reference Code.* The tool and test equipment reference code correlates with a maintenance function on the identified end item or component.

*b. Column 2, Maintenance Level.* The lowest level of maintenance authorized to use the tool or test equipment.

*c. Column 3, Nomenclature.* Name or identification of the tool or test equipment.

*d. Column 4, National/NATO Stock Number.* The National or NATO stock number of the tool or test equipment.

*e. Column 5, Tool Number.* The manufacturer's part number.

*f. Column 6, Remarks.* This column lists information pertinent to the maintenance functions being performed as indicated on the MAC, section II.



## Section II. MAINTENANCE ALLOCATION CHART

(1) Group Number	(2) Component/Assembly	(3) Maintenance Function	(4) Maintenance Category					(5) Tools and Equipment	(6) Remarks
			C	O	F	H	D		
<b>01</b>	<b>ENGINE</b>								
0100	Engine Assembly (Diesel)	Service Replace Repair		2.0	9.0 14.0				59,60,61,62, 63,64
		Overhaul					40.0		30,52-66
0101	Cylinder Head Assembly	Replace Repair			4.0	5.0			66,173 57,58,60,66
0102	Crankshaft	Replace Repair				4.0 4.5			
0103	Flywheel	Replace Repair				2.5		2.0	
0104	Connecting Rods and Pistons	Replace Repair				9.4 2.			
0105	Valves: Intake and Exhaust	Adjust Replace			1.5 15.0				
0106	Oil Pump	Replace Repair			3.0		2.0		
0108	Manifolds: Intake and Exhaust	Replace			3.0				
<b>01</b>	<b>ENGINE</b>								
0100	Engine Assembly (Multifuel)	Service Replace Repair		2.0	9.0 14.0				6,7,15,16, 17,32,33,34, 35
		Overhaul					40.0		1-17, 20, 106-135
0101	Cylinder Head Assembly	Replace Repair			4.0	5.0			5,7,9,66
0102	Crankshaft	Replace Repair				3.0		4.0	6,8
0103	Flywheel	Replace Repair				2.5		2.0	
0104	Connecting	Replace Repair				2.0 1.0			
	Piston and Sleeve Assembly	Replace				6.0			
0105	Valves: Intake and Exhaust	Adjust Replace			1.5 15.0				

Section II. MAINTENANCE ALLOCATION CHART (Continued)

(1) Group Number	(2) Component/Assembly	(3) Maintenance Function	(4) Maintenance Category					(5) Tools and Equipment	(6) Remarks
			C	O	F	H	D		
0106	Oil Pump	Replace Repair			3.0	2.0			
0108	Manifolds: Intake and Exhaust	Replace			2.5				
<b>01</b>	<b>ENGINE (GASOLINE)</b>								
0100	Engine Assembly	Service Replace Repair Overhaul		2.0	11.0 12.0		40.0	73,79,80,81, 87,90,91 73-9	
0101	Head: Cylinder	Replace Repair			3.5	4.0		7,48	
0102	Crankshaft	Replace Repair				3.0	4.0	79	
0103	Flywheel	Replace Repair				12.0	14.0		
0104	Connecting Rods and Pistons	Replace Repair				9.4 2.0			
0105	Valves: Intake and Exhaust	Adjust Replace			1.5 15.0				
0106	Oil Pump	Replace Repair			1.5	3.0			
	Lines and Fittings	Inspect Replace	0.1	1.0					
	Filter, Oil	Service Replace		1.0 0.6					
	Breather, Crankcase	Service Replace		0.2 0.3					
	Screen, Crankcase Breather Valve	Service Replace		0.2 0.5					
0108	Manifolds: Intake and Exhaust	Replace			3.0				
<b>02</b>	<b>CLUTCH</b>								
0200	Clutch, Assembly	Replace Repair			4.2 1.0				
0202	Clutch, Release Mechanism Pedal Linkage	Adjust Replace Repair		1.0 2.0 2.0					

## Section II. MAINTENANCE ALLOCATION CHART (Continued)

(1) Group Num- ber	(2) Component/Assembly	(3) Main- ten- ance Function	(4) Maintenance Category					(5) Tools and Equipment	(6) Remarks
			C	O	F	H	D		
<b>03</b>	<b>FUEL SYSTEM</b>								
0301	Fuel Injector (Diesel)	Calibrate Replace Repair			2.0 2.0 4.0	2.0		89-97	
	Fuel Injector (Multifuel)	Replace Repair			2.0 4.0			12,73,75-79 12,73,75-79	
	Carburetor (Gasoline)	Service Adjust Replace Repair		0.2 0.2 0.6	2.2			100,	
0302	Fuel Supply Pump (Diesel, Multifuel)	Calibrate Replace Repair Overhaul			2.0 2.0	2.0 4.0 7.0			
	Fuel Supply Pump (Gasoline)	Replace Repair		1.0	1.5				
0304	Cleaner: Air (Gas)	Service Replace		0.5 0.5					
	Cleaner: Air (Diesel and Multi)	Service Replace		0.5 0.5					
	Element and Body: (Gasoline)	Service Replace		1.0 0.5					
	Element: (Diesel and Multifuel)	Service Replace		0.5 0.5					
	Precleaner: (Diesel and Multi)	Inspect Replace		0.5					
	Indicator: Air Cleaner	Inspect Replace	0.1	0.5					
0305	Turbocharger (Diesel)	Replace Repair			0.7	1.5		67-72	
	Turbocharger (Multifuel)	Replace Repair			0.7	1.5		67-72	
0306	Fuel Tank	Replace Repair		1.0	1.0				
0308	Governor, Engine Valve (Gasoline)	Adjust Replace Repair			0.2 0.5 0.8				

Section II. MAINTENANCE ALLOCATION CHART (Continued)

(1) Group Number	(2) Component/Assembly	(3) Maintenance Function	(4) Maintenance Category					(5) Tools and Equipment	(6) Remarks
			C	O	F	H	D		
	Control Valve: M246,M246A	Adjust Replace Repair			0.2 0.5 0.5				
0309	Fuel Filter	Service Replace	0.3	0.5					
0311	Harness, Manifold Heater	Replace Repair		1.0	1.0				
0312	Controls and Linkage Accelerator	Adjust Replace Repair		0.5 1.0 1.0					
<b>04</b>	<b>EXHAUST SYSTEM</b>								
0401	Mufflers and Pipes	Inspect Replace		0.2 3.0					
<b>05</b>	<b>COOLING SYSTEM</b>								
0501	Radiator	Inspect Service Replace Repair	0.3 0.5	1.5	1.5				
0503	Thermostat	Replace		0.5					
0504	Water Pump	Replace Repair		1.0	0.8				
	Belt, Water Pump	Inspect Adjust Replace	0.1	0.5 0.5					
0505	Belt, Fan Assembly	Adjust Replace		0.2 1.0					
	Belt	Inspect Adjust Replace	0.	0.2 0.5					
<b>06</b>	<b>ELECTRICAL SYSTEM</b>								
060	Generator	Test Replace Repair		0.2 0.8		2.0		D	
0602	Regulator (Diesel, Gasoline and Multifuel)	Test Replace		0.2 0.5					
0603	Starter	Replace Repair		0.8	2.8				

## Section II. MAINTENANCE ALL CHART (Continued)

(1) Group Number	(2) Component/Assembly	(3) Maintenance Function	(4) Maintenance Category					(5) Tools and Equipment	(6) Remarks
			C	O	F	H	D		
0605	Distributor (Gasoline)	Adjust Replace Repair		0.5	1.0 2.0				
0606	Engine Safety Controls	Replace		0.4					
0607	Instrument or Engine Control Panel	Replace		0.5					
	Switches and Circuit Breakers	Test Replace		0.5 1.0					
	Instruments and Gages	Adjust Replace		0.3 1.0					
	Lamps	Replace		0.					
	Switch, Ignition and Starter	Test Replace		0.2 0.5					
0608	Control, Directional Turn Indicator	Test Replace		0.2 0.5					
	Flasher	Replace		0.5					
0609	Lights	Inspect Adjust Replace	0.	0.2 0.5					
	Harness, Flood Light: M52	Repair		0.5					
	Light Flood: M52, M543	Replace Repair		0.5	1.0				
0610	Sending, Units and Warning Switches	Test Replace		0.2 0.5					
	Unit, Sending	Test Replace		0.2 0.5					
	Switch, Stoplight	Test Replace		0.2 0.5					
	Buzzer, Warning	Test Replace		0.1 0.5					
0611	Horn	Replace		0.5					
	Switch, Horn	Test Replace		0.2 0.5					
0612	Battery	Inspect Service Replace Repair	0.	0.5 0.5			4.0		A
	Support	Replace		1.0					

Section II. MAINTENANCE ALLOCATION CHART (Continued)

(1) Group Number	(2) Component/Assembly	(3) Maintenance Function	(4) Maintenance Category					(5) Tools and Equipment	(6) Remarks
			C	O	F	H	D		
0613	Cables, Battery	Replace Repair		0.8 0.5					
	Box, Battery	Replace Repair		1.8 1.5					
	Slave Receptacle	Replace Repair		0.7 0.5					
	Hull or Chassis Wiring Harness	Test Replace Repair		0.5 1.0	4.5				
	Receptacle, Trailer Coupling	Replace Repair		0.2 0.5					
	Harness: Trailer Connector (M246 and M543)	Replace Repair		2.0	1.0				
<b>07</b>	<b>TRANSMISSION</b>								
0701	Transmission Assembly	Service Replace Repair Overhaul		0.2	4.2 6.2	10.5		17,20,22 17,20,22	
0704	Housing: Shifter Assembly	Replace Repair			1.0 1.8			19 18,19,20,22	
<b>08</b>	<b>TRANSFER AND FINAL DRIVE ASSEMBLIES</b>								
080	Power Transfer Assembly	Service Replace Repair Overhaul		0.5	4.6	4.0 9.5			
0803	Controls and Linkage, Transfer	Adjust Replace Repair			0.3 1.5 1.0				
	Cylinder Air Shift Lines and Connections Air Shift	Replace Replace Repair			2.0 1.0 1.0				
	Valve, Breather	Service Replace		0.2 0.5					
<b>09</b>	<b>PROPELLER AND PROPELLER SHAFTS</b>								
0900	Shafts, Propeller	Service Replace		0.5 1.5					

## Section II. MAINTENANCE ALLOCATION CHART (Continued)

(1) Group Num- ber	(2) Component/Assembly	(3) Main- tenance Function	(4) Maintenance Category					(5) Tools and Equipment	(6) Remarks
			C	O	F	H	D		
10 1000	Joint, Universal	Service Replace Repair		0.3 1.5 1.0					
	Bearing, Center	Replace		1.5					
	<b>FRONT AXLE</b>								
	Front Axle Assembly	Service Replace Repair Overhaul		1.0	5.0 5.0		10.0	25,26,34,35 36	
1002	Valve, Breather	Service Replace		0.2 0.5					
	Carrier, Assembly Differential	Service Replace Repair		0.5		7.0	4.0	21,23,27-33, 38	
1	Gears, Differential	Replace					2.0		
	Bearings	Replace					2.0		
	Seal Pinion	Replace			2.0				
	Flange, Drive	Replace			2.0				
1	Arms and Flanges	Replace			2.5				
	Shaft, Front Axle	Replace			4.0				
	Bearings and Seals	Replace			2.0				
	Boot, Flange	Replace		0.7					
11 1100	Knuckle	Service Replace Repair		0.2		2.5 2.0			
	Sleeve, Bearing	Replace			1.5				
	<b>REAR AXLE</b>								
	Rear Axle Assembly	Service Replace Repair Overhaul		0.5	4.0 4.0		14.0	32 32	
1	Valve, Breather	Service Replace		0.2 0.5					
	Shaft, Rear Axle	Replace Repair			1.5 2.0				

Section II. MAINTENANCE ALLOCATION CHART (Continued)

(1) Group Number	(2) Component/Assembly	(3) Maintenance Function	(4) Maintenance Category					(5) Tools and Equipment	(6) Remarks
			C	O	F	H	D		
	Carrier, Differential	Service Replace Repair		0.5	7.5		4.0	21,23,27, 28-33,38	
	Gears	Replace				2.0			
	Bearings	Replace				2.0			
	Seal, Pinion	Replace			2.0				
	Flange, Drive	Replace			2.0				
<b>12</b>	<b>BRAKES</b>								
1201	Drum, Hand Brake	Adjust Replace Repair		0.5	1.5				
	Shoes, Hand Brake	Adjust Replace Repair		0.5 2.0	1.5				
	Linkage, Hand Brake	Adjust Replace		0.5 1.0					
1	Shoes, Service Brake	Adjust Replace Repair		1.0 3.0	2.0				
1204	Hydraulic Brake System								
	Master Cylinder	Service Replace	0.	2.0					
	Cylinder, Wheel	Replace		2.0					
	Cylinder, Air//Hydraulic	Service Replace Repair		0.3 0.9	1.5			49	
	Lines and Fittings	Replace		3.5					B
1206	Brake Pedal Pad	Replace		1.7					
	Brake Pedal	Replace		0.2					
1208	Lines and Fittings, Air System	Inspect Replace Repair		0.5 0.5 0.6					B



## Section II. MAINTENANCE ALLOCATION CHART (Continued)

(1) Group Num- ber	(2) Component/Assembly	(3) Main- tenance Function	(4) Maintenance Category					(5) Tools and Equipment	(6) Remarks
			C	O	F	H	D		
1209	Valves and Fittings, Air System	Replace		0.1					
	Reservoir, Air//Secondary	Service Replace	0.2	0.8					
	Valve, Safety	Replace		0.5					
	Valve, Hand Control	Replace Repair		1.0 1.0					
	Hose, Trailer Brake	Replace Repair		0.3 0.4					
	Governor, Air	Adjust Replace		0.4 0.3					
	Compressor, Air (Gas and Multifuel)	Replace		3.0					
	Valve, Unloader	Replace			0.2				
	Lines and Fittings	Replace Repair		0.5 0.6					
	Compressor, Air (Diesel)	Replace Repair			0.5 4.0				
1211	Trailer Brake Connections and Fittings	Replace Repair		0.4 1.2					
	Hose: Trailer Brake —M246	Replace Repair		0.4 1.0					
	Coupling, Trailer Brake	Replace Repair		0.4 1.0					
<b>13</b>	<b>WHEELS, HUBS AND DRUMS</b>								
1311	Bearings: Wheel	Service Adjust Replace		2.0 0.5 1.5					
	Drum, Service Brake	Replace Repair		1.5	2.0				
	Hub, Wheel Studs	Replace		1.5					
	Wheel/Tire Assembly	Replace		1.0					
	Ring, Retaining, Tire	Replace		0.1					
	Seals, Hub	Replace		2.5					

Section II. MAINTENANCE ALLOCATION CHART (Continued)

(1) Group Number	(2) Component/Assembly	(3) Maintenance Function	(4) Maintenance Category					(5) Tools and Equipment	(6) Remarks
			C	O	F	H	D		
1313	Tires	Inspect Service Replace Repair	0.2 0.1	1.8		1.0			E
	Tubes	Replace Repair		0.5 1.0					E
<b>14</b>	<b>STEERING</b>								
1401	Link, Front Drag	Service Replace Repair		0.2 1.0 1.0					
	Rod, Tie Assembly	Service Replace Repair		0.2 1.5 1.5					
	Arm, Pitman Steering	Replace		1.0					
	Column, Steering	Replace Repair			2.5 2.0				
	Wheel, Steering	Replace		1.0					
1	Gear, Steering Assembly	Service Adjust Replace Repair		0.5	0.5 3.0 2.5		103 37,39,40 37,39,40,41		
1410	Pump, Hydraulic and Reservoir	Service Test Replace Repair	0.	0.7	1.5 1.0		43		
1411	Lines and Fittings, Power Steering	Replace		0.5					
1412	Cylinder, Power and Control Valve Assembly	Adjust Replace Repair		0.5	1.5 2.0				
<b>15</b>	<b>FRAME, TOWING ATTACHMENTS AND DRAWBARS</b>								
1501	Frame	Inspect Repair	0.2			2.5			F
	Bumper, Front	Replace		2.0					
	Brackets, Frame	Replace		1.0					
1503	Pintle	Service Replace		0.1 0.5					
1504	Carrier, Spare Wheel	Replace Repair		1.0 1.0					

## Section II. MAINTENANCE ALLOCATION CHART (Continued)

(1) Group Number	(2) Component/Assembly	(3) Maintenance Function	(4) Maintenance Category					(5) Tools and Equipment	(6) Remarks
			C	O	F	H	D		
1 5 0 6	Wheel, Fifth	Service Replace Repair		0.5 2.5	4.0				
1 6	<b>SPRINGS AND SHOCK ABSORBERS</b>								
1 6 0 1	Front Spring	Replace Repair		3.0	2.0				
	Shackle and Bolts	Replace		1.0					
	Spring, Rear and Seat	Replace Repair		4.0	2.0				
1 6 0 4	Absorber, Front Shock	Replace		0.5					
1 6 0 5	Rod, Rear Torque	Replace			1.5				
1 8	<b>BODY, HOOD CAB</b>								
1 8 0 1	Door	Service Adjust Replace Repair		0. 0.5	1.0 1.0				
	Cab	Replace			6.0				
1 8 0 1	Hood	Adjust Replace Repair		0.5	2.0 1.0				
	Guard, Radiator	Replace Repair		0.5 1.0					
1 8 0 2	Fenders	Replace Repair			2.0 1.0				
	Windshield, Assembly	Inspect Replace Repair	0.1	2.0	1.5				
	Washer, W/S	Service Replace	0.1	0.5					
	Running Board	Replace Repair			2.0 3.0				
1 8 0 6	Seat, Cushion	Replace Repair		1.0	1				
1 8 0 8	Straps, Brackets	Replace Repair		1.0 1.0					

Section II. MAINTENANCE ALLOCATION CHART (Continued)

(1) Group Number	(2) Component/Assembly	(3) Maintenance Function	(4) Maintenance Category					(5) Tools and Equipment	(6) Remarks
			C	O	F	H	D		
1810	Boxes	Replace			1			F	
	Body	Repair			10.0				
	Gate, Tail	Replace			1.0				
		Repair			2.0				
	Racks	Replace		1.0					
		Repair			2.0				
	Seat, Troop	Replace		1.0					
		Repair		1.0					
	Hoist, Cylinders and Power Controls Hoist Cylinder	Replace			8.0		6.0		
		Repair							
Pump, Hydraulic: M291A1D,M291A2D	Service		0.2						
	Replace			2.5					
	Repair			7.0					
Valve Control: M291A1D,M291A2D	Service			1.0					
	Replace			2.0					
	Repair			4.0					
1812	Doors	Replace			2.5		5.0		
1812	Roof, Ceiling, Sides, Floor, Underframe	Replace				8.0			
		Repair				16.0			
	Counterbalance	Service		1.0					
		Replace				8.0			
		Repair				6.0			
	Lift Gate Controls	Replace			2.0		3.0		
	Repair								
	Lift Gate Hydraulic Lines	Replace			1.0				
	Lift Gate Cylinders and Pump	Replace			3.0		6.0		
	Repair								
	Electrical Wiring	Replace			4.0		4.0		
	Repair								
	Hydraulic Tailgate: M291A1D,M291A2D	Service		0.3					
		Adjust			0.5				
		Aline			0.5				
		Replace			4.0				
	Repair			6.0					
	Cylinder, Elevating: M291A1D,M291A2D	Replace			2.0				
		Repair			4.0				

## Section II. MAINTENANCE ALLOCATION CHART (Continued)

(1) Group Number	(2) Component/Assembly	(3) Maintenance Function	(4) Maintenance Category					(5) Tools and Equipment	(6) Remarks
			C	O	F	H	D		
1812	Cylinder, Closing: M291A1D,M291A2D	Replace Repair			2.0 4.0				
	Lock Hook Assembly, Elevating: M291A1D,M291A2D	Adjust Replace Repair			1.0 1.0 2.0				
	Power Take Off: M291A1D,M291A2D	Service Replace Repair		0.3	2.0 6.0				
	Drive Shaft, Universal Joints: M291A1D,M291A2D	Service Replace Repair		0.2 2.0 2.0					
	Levers, Operating: M291A1D,M291A2D	Adjust Replace Repair			1.0 2.0 4.0				
	Pivot Arms: M291A1D,M291A2D	Service Replace		0.3	2.0				
	Mounting Brackets and Supports: M291A1D,M291A2D	Replace Repair			2.0 2.0				
	Electric Power Unit: M291A1D,M291A2D	Inspect Service Replace Repair		0.2 0.2	3.0 5.0				
	Hand Controls, Air Condition: M291	Repair		1.0					
	Lines and Fittings, fuel Tank to Heater: M29	Replace Repair		4.0 3.0					
20	Air Conditioner	Replace Repair			4.0 6.0				
	<b>HOIST, WINCH, CAPSTAN, WINDLASS, POWER CON- TROL UNIT, AND POWER TAKE OFF</b>								
2001	Winch, Front	Inspect Service Adjust Replace Repair Overhaul	0.1	0.5 0.5 3.0	4.0	6.0			
	Shear Pin	Replace	0.5						
	Band, Automatic	Adjust Replace		0.5	2.0				

Section II. MAINTENANCE ALLOCATION CHART (Continued)

(1) Group Number	(2) Component/Assembly	(3) Maintenance Function	(4) Maintenance Category					(5) Tools and Equipment	(6) Remarks
			C	O	F	H	D		
	Cable, Winch	Inspect Service Replace Repair	0.5 0.5	1. 0.5					
	Disk, Brake	Inspect Adjust Replace		02.	1.0 2.0				
	Pump, Hydraulic Winch	Replace Repair			2.0	4.0			
	Shaft, Hydraulic Pump	Inspect Replace Repair		0.3	1.0 2.0				
	Lines and Fittings, Hydraulic	Inspect Replace		0.2	0.5				
	Boom, Assembly	Inspect Test Service Replace Repair		0.2 0.3	0.5 15.0 8.0				
	Joint: Universal	Service Replace		0.2 1.0					
	Base Plate: M543	Replace				2.0			
	Boom and Shipper: M62,M246,M246A M543,M543A M543A2	Replace Repair				10.4 4.0			
	Boom	Repair				4.0			
	Shipper	Repair				4.0			
	Cylinders (Boom and Hoist)	Replace Repair			1.8 1.0				
	Hydraulic Motor (Swing and and Hoist)	Replace Repair			1.5	1.0			
	Drive Angle (Bevel Gear)	Replace Repair				1.0 1.5			
	Automatic Brake Band (Hoist)	Adjust Replace		0.2	0.3				
	Operator's Cab	Replace				6.0			
	Hydraulic Pump	Replace Repair			0.5	1.0			

## Section II. MAINTENANCE ALLOCATION CHART (Continued)

(1) Group Number	(2) Component/Assembly	(3) Maintenance Function	(4) Maintenance Category					(5) Tools and Equipment	(6) Remarks
			C	O	F	H	D		
200	Winch Hoist	Replace Repair			4.3	5.6			
	Hydraulic Oil Reservoir	Replace Repair			1.6 2.0				
	Boom and Shipper Rollers	Adjust Replace Repair		0.2	1.5 1.0				
	Gear, Case and Hoist (Speed Reduction)	Replace Repair			1.5	1.0			
	Ring, Gear and Bearing (Turntable), M543	Replace				2.0			
	Case Hoist (Speed Reduction), M62, M246, M246A M543, M543A2, M543A2	Replace Repair				1.5 1.0			
	Swing Drive Gear Box	Replace Repair				3.2 2.0			
	Cylinder and Hoist: M51, M52A1, M52A2	Replace Repair			8.0 4.5				
	Hoist Pump: M51, M51A, M52A2	Repair Replace		2.0	4.5				
	Side Winches and Components, M328A1	Replace Repair		2.8 2.0					
2004	Rear Winch Assembly and Components: M748A	Replace Repair		2.0 6.0					
	Power Take Off	Adjust Replace Repair Overhaul		0.2	1.0 2.5	3.5			
	Power Take Off Controls and Linkage	Adjust Replace Repair		0.2	0.5 1.0				
22	<b>MISCELLANEOUS BODY AND ACCESSORY ITEMS</b>								
220	Cover, Cab	Replace Repair		0.2	1.5				
	Bows	Inspect Replace Repair	0.1	0.1 0.					

Section II. MAINTENANCE ALLOCATION CHART

(1) Group Number	(2) Component/Assembly	(3) Maintenance Function	(4) Maintenance Category					(5) Tools and Equipment	(6) Remarks
			C	O	F	H	D		
2202	Cover, Body	Inspect Replace Repair	0.4	0.6	1.5				
	Curtains, Body	Replace Repair		0.2	1.0				
	Accessory Items								
	Motor, Windshield Wiper Blade	Adjust Replace		0.3 0.4					
	Mirror Assembly, Rear View	Replace		0.2					
	Valve, Control, Windshield Wiper	Replace		0.2					
2210	Plate, Vehicle Data	Replace		0.2					
<b>33</b>	<b>GROUP — SPECIAL PURPOSE KITS</b>								
3303	Winterization Kits								
	Kit, Heater Personnel	Replace Repair Overhaul			6.0 8.0 16.0				
	Kit, Personnel Hot Water Heater	Replace Repair Overhaul		4.0	3.0 8.0				
	Kit, Heater Power Plant	Replace Repair Overhaul			3.0 4.0	8.0			
	Kit, Closure Hard Top	Replace Repair Overhaul			4.0 2.0 4.0				
	Kit, Thermal Barrier	Replace Repair Overhaul			1.5 1.0 2.0				
	Kit, Deep Water Fording	Replace Repair Overhaul			8.0 4.0 6.0				
	Kit, Electric Brakes	Replace Repair Overhaul			4.0 2.0 4.0				
	Kit, Troop Seat, Accessory	Replace Repair Overhaul			6.0 2.0 4.0				



## Section II. MAINTENANCE ALLOCATION CHART (Continued)

(1) Group Number	(2) Component/Assembly	(3) Maintenance Function	(4) Maintenance Category					(5) Tools and Equipment	(6) Remarks
			C	O	F	H	D		
	Kit, Tie Down	Replace Repair Overhaul			1.5 2.0 4.0				
	Kit, A-Frame	Replace Repair Overhaul			1.0 1 2.0				
	Kit, Air Brake	Replace Repair Overhaul		2.0 2.0	4.0				
<b>47</b>	<b>GAGES AND MEASURING DEVICES</b>								
470	Adapter, Speedometer and Tachograph Drive	Replace		0.6					
	Shaft, Flexible, Speedometer and Tachograph	Replace		1.0					
	Core, Flexible Shaft, Speedometer and Tachograph	Replace		0.5					
	Tachograph: Lamps and Charts	Adjust Replace		0.5 1.0					
	Tachograph	Replace		1.0					
	Speedometer	Replace		1.0					
4702	Gage, Air Pressure	Inspect Replace	0.	0.6					
	<b>NOTE:</b> Tachograph is used on truck, tractor, M52A and M (Late Production)								

**THIS PAGE LEFT BLANK INTENTIONALLY**

## Section III. TOOL AND TEST EQUIPMENT REQUIREMENTS

(1) Reference Code	(2) Maintenance Level	(3) Nomenclature	(4) National/NATO Stock Number	(5) Tool Number
1	H,D	Replacing Tool Engine: Exhaust Valve Seat Insert	5120-00-134-7480	11642006
2	H,D	Replacing Tool: Intake Valve Seat Insert	5	11642007
3	F,H,D	Wrench Spanner: Engine Baring (Authorized for Battalion Only)	5120-00-133-9863	11600900
4	F,H,D	Adapter, Mechanical, Steering Wheel	5120-00-303-1195	8708638
5	F,H,D	Adapter, Cylinder Compression Tester: Checking Cylinder Compression (Used W/Gage Assembly 4910-00-870-6283)	4910-00-870-2127	10899183
6	F,H,D	Replacer Gear: Crankshaft Gear	5120-00-870-6920	10899179
7	F,H,D	Wrench, Box: Cylinder Head	5120-00-930-6346	10951485
8	F,H,D	Puller Kit Mechanical: Crankshaft Pulley, Crankshaft Gear and Camshaft Gear (Used W/ Plug 5)	5120-00-338-672	8708724
9	F,H,D	Gage Assembly: Checking Cylinder Compression (Used W/ Adapter - 4910-00-870-2)	4910-00-870-6283	10899180
10	F,H,D	Ram Kit, Hydraulic: Cylinder Sleeve Removal (Used W/ Tool / Tool Kit - 5180-00-07 5180-00-071-0736)	4910-00-873-1927	10912249
11	H,D	Tool Kit, Cylinder: Remove or Install Cylinder Sleeve (Used W/ Ram Kit - 4190-00-873-	5180-00-07	10935312
12	H,D	Cradle Assembly: Engine Universal (Used W/ Stand / Stand 4910-00-795-0)	4910-00-795-0198	7950198
13	H,D	Bracket Angle: Engine Mounting Right and Left Front (Used W/ Cradle / Cradle - 4910-00-795-0)	5340-00-043-5264	10935299
14	H,D	Bracket Double Angle: Engine Mounting Right Rear (Used W/ Cradle / Cradle - 4910-00-795-0)	5340-00-267-9988	10935298
15	H,D	Bracket Double Angle: Engine Mounting Left Rear (Used W/ Cradle / Cradle - 4910-00-795-0)	5340-00-226-6547	10935297
16	F,H,D	Stand, Maintenance, Automotive Engine: Engine Overhaul (Used W/ Cradle / Cradle 4910-00-795-0)	4910-00-795-0189	7950189

## Section III. TOOL AND TEST EQUIPMENT REQUIREMENTS (Continued)

(1) Reference Code	(2) Maintenance Level	(3) Nomenclature	(4) National/NATO Stock Number	(5) Tool Number
17	F,H	Hoisting Unit, Automotive Maintenance: (Removing and Replacing Transmission)	4910-00-448-0254	8387771
18	F,H	Bracket: (Adapting Right Side of Transfer Case to Stand- 4910-00-449-41 4910-00-449-4196)	4910-00-610-0920	7010363
19	F,H	Fixture, Transfer Case: (Removing and/or or Replacing Transfer Case)	5120-00-341-4974	8708898
20	O,	Puller, Mechanical (Water Pump Pulley and Fan Hub)	5120-00-708-3210	7083210
21	F,	Puller Screw Type: (Differential Helical Pinion Cage)	5120-00-836-6689	8366689
22	F,H	Replacer: (Transmission or Transfer Case Companion Flanges)	5120-00-795-0147	7950147
23	F,H	Scale: Differential Pinion Bearing Pre-Load	6670-00-347-5922	7950157
24	F,	Bracket	5340-00-610-0919	7010362
25	F,	Reamer: (Front Axle Spindle Bushing Used W/ Bar / Bar 41-B-155)	5110-00-795-0124	7950124
26	F,	Remover: Front Axle Spindle Inner Bushing	5120-00-378-4301	7950127
27	F,H	Remover and Replacer: (Differential Spider Pinion Bushing)	5120-00-795-0089	7950089
28	F,H	Burnisher: Differential Spider Pinion Bushing	5120-00-795-0088	7950088
29	F,H	Adapter: (Differential Carrier Bearing)	5120-00-795-0112	79501
30	F,H	Remover and Replacer: (Differential Forward Bearing Cage Bearing Cup)	5120-00-795-0159	7950159
31	F,	Remover and replacer: (Differential Rear Bearing Cups)	5120-00-795-0079	7950079
32	F,	Replacer: (Rear Axle Oil Seal Wiper)	5120-00-795-0136	7950136
33	F,	Replacer: (Differential Carrier Spur Pinion Cage Bearing Cup)	5120-00-795-0082	7950082
34	F,H	Burnisher: (Steering Knuckle Sleeve Bushing)	5	7950134
35	F,H	Replacer: (Front Axle Inner Spindle Bushing or Pitman Arm Shaft Oil Seal)	5120-00-795-0129	7950129
36	F,H,D	Remover and Replacer: (Steering Knuckle Bushings or Piston Pin Bushing)	5120-00-795-0130	7950

## Section III. TOOL AND TEST EQUIPMENT REQUIREMENTS (Continued)

(1) Reference Code	(2) Maintenance Level	(3) Nomenclature	(4) National/NATO Stock Number	(5) Tool Number
37	F,H,D	Adapter: (Steering Relay Pin)	5120-00-707-9783	7079783
38	F,H	Replacer: (Differential Case Companion Flanges)	5120-00-795-0155	7950155
39	F,H	Burnisher: (Steering Gear Housing Bushing)	5120-00-795-0139	7950
40	F,H	Remover and Replacer: (Steering Gear Housing Bushing)	5120-00-795-0137	7950137
41	F,H	Reamer: (Steering Gear Housing Bushing)	5110-00-795-0248	7950248
42	F,H	Replacer: (Transfer Case, Front Driver Gear Oil Seal)	5120-00-795-0152	7950152
43	O,	Kit: (Checking Oil Pressure in Steering)	4910-00-627-7043	7010267
44	F,H	Remover and Replacer: (Torque Rod Ball Assembly)	5120-00-048-7370	8708220
45	H	Reamer, Hand, Carbon Removing, Nozzle	5	17-T-11
46	H	Tester, Fuel Injector Pump	4910-00-817-743	1
47	H	Tool Compressing Injection Pump Tappet	5120-00-862-9371	1
48	H	Wrench, Box Cylinder Head	5120-00-473-65	7078072
49	F,H	Replacer: (Air Hydraulic Cylinder Push Rod Oil Seal)	5120-00-6	8742053
50	H,D	Adapter, Stand Engine, Overhaul Stand, Front	4910-00-996-7256	10938060
51	H,D	Adapter, Stand Engine, Overhaul Stand, Front	4910-00-996-7257	1093806
52	H,D	Adapter, Cylinder, Compression Tester	4910-00-997-7402	17-T-11176
53	H,D	Adapter, Tension Wrench, Connecting Rod Cap Screw Wrench	4910-00-997-7417	17-T-1560
54	H,D	Brush, Nozzle tip, Carbon Removing	4910-00-977-7405	17-T-112
55	H,D	Cap, Valve, Protection, Fuel Inlet, 6 Required	49	17-T-
56	H,D	Gage, Rotor Setting, Water Pump Rotor	4910-00-977-8967	17-T-11310
57	H,D	Reamer, Hand, Carbon Removing Nozzle	5	17-T-1
58	H,D	Vise, Needle	4910-00-977-7416	17-T-11100

## Section III. TOOL AND TEST EQUIPMENT REQUIREMENTS (Continued)

(1) Reference Code	(2) Maintenance Level	(3) Nomenclature	(4) National/NATO Stock Number	(5) Tool Number
59	F,H,D	Installer, Drive Nozzle Sleeve	5	17-T-
60	H,D	Reamer, Valve Guide 1 / 2" Diameter	5110-00-255-6541	17-T-
61	F,H,D	Sleeve, Centering Injection Nozzle Reassembling	5120-00-156-8621	705660
62	H,D	Wrench, Pronged, Injection Pump Bottom Plug	5120-00-793-5045	10882851
63	F,H,D	Replacer, Oil Seal, Water Pump Bearing and Seals	5120-00-134-0160	11644677
64	F,H,D	Installer, Kit, Crankshaft Rear Seal	5180-00-134-0159	1
65	H,D	Remover and Replacer Kit, Camshaft Auxiliary Shaft Bearings	4910-00-756-2720	11644695
66	H,D	Wrench, Cylinder Head, Cylinder Head Nut	5120-00-937-7834	10951484
67	H,D	Support Block, Assemble Thrust Collar and Compressor Wheel	4910-00-870-3759	10899151
68	H,D	Compressor, Wheel (Comp. Wheel)	4910-00-977-7414	17-T-
69	H,D	Sleeve, Installing, Installing Rings on Shaft	4910-00-870-2122	10899149
70	H,D	Sleeve, Installer, Thrust Collar Rings	4910-00-885-3465	10899148
71	H,D	Support, Disassembly Comp. Wheel	4910-00-870-2124	10899152
72	H,D	Spacer, Clearance Checking, Checking Compressor Wheel Back Clearance	4910-00-870-2123	10899150
73	F,H,D	Arbor (Clutch Plate Alining)	5120-00-795-013	7950131
74	H,D	Broach and Burnisher (Piston Pin Bushing)	3443-00-795-0860	7950860
75	H,D	Kit, Bracket (Stand Cradle Adapter)	4910-00-795-0630	7950630
76	H,D	Pan (Oil Drip; Used W/49 / 4910-00-795-0189 Stand)	4930-00-545-8639	8708359
77	H,D	Plate, Support (Piston Pin Bushing)	3443-00-795-0663	7950663
78	F,H,D	Puller, Kit, Mechanical (Timing Gears)	5120-00-338-672	8708724
79	F,H,D	Refacer, (Water Pump Housing Bushing)	5110-00-795-0165	7950165
80	F,H,D	Remover (Tachometer Drive Housing Oil Seal Bearing)	5120-00-795-008	795008
81	H,D	Remover and Replacer (Valve Guide)	5120-00-795-0105	7950105

## Section III. TOOL AND TEST EQUIPMENT REQUIREMENTS

(1) Reference Code	(2) Maintenance Level	(3) Nomenclature	(4) National/NATO Stock Number	(5) Tool Number
82	H,D	Remover and Replacer (Piston Pin)	5120-00-795-0142	7950142
83	H,D	Remover and Replacer, Draw Bar Type: (Camshaft Bushing)	5120-00-878-8541	7950163
84	H,D	Remover and Replacer (Piston Rings)	5120-00-494-1846	7950177
85	F,H,D	Replacer (Tachometer Driver Oil Seal and Bearing)	5120-00-795-0108	7950108
86	H,D	Replacer (Valve Seat Insert)	5120-00-795-0132	7950132
87	O,	Wrench (Oil Filter; Seal Plate)	5120-00-473-7741	7076229
88	O,	Wrench (Cylinder Head Bolt)	5120-00-473-6511	7078072
89	H,D	Coupling Drive, Injection Pump	4910-00-981-2770	17-T-11412
90	H,D	Pin, Tappet Retaining	4910-00-977-7408	17-T-
91	H,D	Plug, Machine Thread, Fuel Line Protection Injector Pump	5365-00-981-2767	49A
92	H,D	Ring, Flange Adapter	4910-00-981-277	17-T-11411
93	H,D	Reamer, Hand, Governor Operating Lever	5	17-T-
94	H,D	Tool, Plunger Spring, Compression, Plunger Spring	4910-00-977-7419	17-T-
95	H,D	Tool, Valve Seat, Seat Reconditioning	4910-00-977-7418	17-T-1933
96	H,D	Tube, Nozzle Fuel Inlet, Test Fuel Injector Pump	4910-00-981-2768	203-GCA
97	H,D	Wrench, Control Rack, Control Rack Outer Bushing	49	17-T-1973
98	F,H,D	Bit, Screwdriver	5120-00-222-1452	7080544
99	F,H,D	Fixture (Holding Governor Diaphragm)	5120-00-592-3680	7380071
100	F,H,D	Gage, Depth (Measuring Float Assembly)	5120-00-708-0755	7080755
101	F,H,D	Wrench (Power Valve)	5120-00-378-4388	7083390
1	F,H,D	Wrench (Economizer Piston Assembly)	5120-00-708-3395	7083395
103	H,D	Bracket, Double Angle: Engine Mounting RightRear(Used W/Cradle/Cradle 4910-00-795-0	4910-00-873-1926	10899188

## Section III. TOOL AND TEST EQUIPMENT REQUIREMENTS (Continued)

(1) Reference Code	(2) Maintenance Level	(3) Nomenclature	(4) National/NATO Stock Number	(5) Tool Number
104	H,D	Bracket, Double Angle: Engine Mounting Left Rear (Used W/ Cradle 4910-00-795-0198)	4910-00-873-1925	10912239
105	O,	Wrench, Pulley Adjusting: Air Compressor Pulley	5120-00-070-7809	10935288
106	F,H,D	Socket, Wrench, Face Spanner: (Clutch Release Lever Adjusting Nut)	5120-00-034-8443	8390134
107	H,D	Remover and Replacer Kit, Bushing: Camshaft Bearings	5120-00-870-6919	10899154
108	H,D	Remover, Valve Guide: Removing or Installing Valve Guides (Used W/ Replacer / Replacer 5120-00-870-6921)	5120-00-87 3	10999157
1	H,D	Replacer, Valve Guide: Install Valve Guides (Used W/ Remover 5120-00-871-35)	5120-00-870-6921	10899158
110	F,H,D	Compressor Assembly, Valve: Compressing Valve Springs or Rotors While Engine is in Vehicle	5120-00-933-6057	10951361
111	F,H,D	Plug, Mechanical Puller: (Used W/ Puller / Puller 5120-00-338-6721 (Adapter))	5120-00-870-6914	10899178
112	F,H,D	Expander Piston Ring	5120-00-068-7234	10935314
113	F,H,D	Compressor, Piston Ring: Compressing or Gaging Piston Rings	5120-00-068-7238	10935313
114	F,H,D	Extractor, Coil Thread Insert: Helical Threaded Insert, Oil Filter (7/ 16 to 1" Thd. Size)	5120-00-251-1527	7751056
115	F,H,D	Insert, Screw Thread Insert: Helical Threaded Insert, Oil Filter (1-14 Thd.)	5120-00-204-0881	10912379
116	H,D	Wrench, Spanner: (Bearing Lock Nut)	5120-00-870-6926	10899169
117	H,D	Fixture: (Holding Camshaft)	4910-00-870-213	10899172
118	H,D	Fixture: (Holding Pump)	4910-00-870-2128	10899198
119	H,D	Compressor, Spring: (Outer Plunger Tappet Spring)	5120-00-870-6925	10899170
120	H,D	Puller, Mechanical Bearing Plate: Spider Assembly (Used W/ 5 / 5120-00-793-5055 Remover and Replacer)	5120-00-793-5048	10882818



## Section III. TOOL AND TEST EQUIPMENT REQUIREMENTS (Continued)

(1) Reference Code	(2) Maintenance Level	(3) Nomenclature	(4) National/NATO Stock Number	(5) Tool Number
121	H,D	Remover and Replacer Plunger Locks: Removing Camshaft from Housing: Replacing Bearing on Camshaft: Replacing Spider Weight Assembly on Camshaft: Removing Weight Assembly from Camshaft: (Used W/5/ 5120-00-793-5048 Puller)	5120-00-793-5055	10882856
122	H,D	Gage: (Spring Gap)	491	10882854
123	H,D	Wrench, Spanner: (Spider Clutch Spring Adjusting Nut)	5120-00-793-5046	10882889
124	F	Tester, Nozzle	4910-00-255-8641	1
125	H,D	Adapter, Mechanical Puller (Engine Cylinder Liners)	5120-00-708-3234	7083234
126	F,H,D	Kit Bracket (Engine Stand, Used on 4910-00-795-0)	4910-00-795-03	7950319
127	F,H,D	Puller Mechanical (Used W/5 Pulley and Vibration Damper)	5120-00-708-3305	7083305
128	F,H,D	Replacer Oil Seal (Timing Gear Cover)	5120-00-708-3256	7083256
129	F,H,D	Replacer, Gear Pulley (Crankshaft Timing Gear)	5120-00-708-3253	7083253
1	H,D	Remover and Replacer (Camshaft Bushing)	5180-00-708-3245	7083245
131	H,D	Remover and Replacer (Engine Valve Guide)	5120-00-708-3240	7083240
132	H,D	Kit, Camshaft Bearing (Remover and and Installer)		17-T-11110
133	H,D	Lever, Torque Adapter (Injection Pump Governor Drive Slip Clutch)	5120-00-321-6582	79-TSE-7947
134	O,	Puller, Plunger (Injection Pump)	5120-00-422-8967	70-TSE-7667
135	F,H,D	Scraper, Injection Nozzle Body Pressure Chamber		1
136	F,H,D	Tool, Alinement (Timing Gear Cover, 4" Bearing Crankshaft)	5	17-T-1
137	H,D	Wrench, Pronged (Injector Pump Governor Drive Gear)	5120-00-321-6517	79-TSE-7920
138	H,D	Fuel Injection Pump Extractor	5120-00-977-7404	17-T-1
139	H,D	Lifter, Pump Tappet	5120-00-977-7406	1

## Section III. TOOL AND TEST EQUIPMENT REQUIREMENTS (Continued)

(1) Reference Code	(2) Maintenance Level	(3) Nomenclature	(4) National/NATO Stock Number	(5) Tool Number
140	H,D	Needles, Orifice Cleaning (Injector Nozzle)	4910-00-977-7407	17-T-
141	H,D	Puller, Mechanical (Governor Drive Gear)	5120-00-977-7409	17-T-
142	H,D	Rod, Drive (Control Rack Outer Bushing)	4910-00-977-74	17-T-
143	F,H,D	Extractor, Coil Thread Insert (Flywheel #10 to 3/8 Helical Threaded Insert)	5120-00-723-6833	MI 1309A
144	F,H,D	Insertor, Screw Thread (Flywheel Housing #10 to 3/8 Helical Threaded Insert)	5120-00-797-2402	MI
145	H,D	Remover and Replacer (Camshaft Bushings)	5120-00-870-6919	10899154
146	O,	Adjuster, Shaft (Star Starter Solenoid)	4910-00-792-8626	10935617
147	F,H,D	Tube, Attaching, Nozzle (Connecting Injector Nozzle to 4910-00-255-8641 Tester)	4910-00-795-7953	10882963
148	H,D	Gage, Spacing: Nozzle Vane Space (.230), Nozzle Ring 138714	4910-00-758-2373	10951060
I	H,D	Replacer, Thrust Collar or Compressor Wheel Shaft (Used W/B-10899 Support)	5120-00-870-6924	10899147
150	H,D	Socket Wrench: Compressor Housing	5120-00-654-3629	8755594
151	H,D	Compressor, Piston Ring: (Air Compressor, Piston Ring)	5120-00-322-6223	8708744
152	H,D	Bit, Valve Grinding: Grinding Compressor Unloader Valves (Used W/B-8683496 Handle)	4910-00-473-6960	5411962
153	D	Gage, Pinion Setting: (Differential Pinion)	4910-00-795-0104	7950104
154	F,D	Puller, Mechanical: (Transmission Reverse Idler Shaft)	5120-00-092-9074	8708669
155	F,H,D	Refacer: Water Pump Housing Bushing	5110-00-795-0165	7950165
156	F,	Remover and Replacer: (Transfer Case Front Intermediate Shaft Bearing Cup)	5120-00-795-0091	795009
157	H,D	Remover and Replacer: (Piston Rings)	5120-00-494-1846	7950177
158	C,	Wrench, Air Compressor: (Belt Tension Adjusting)	5120-00-390-7779	8390170
159	F,H,D	Screwdriver: (Air Hydraulic Cylinder Cylinder Relay Piston Sleeve)	5120-00-555-9126	8742054

## Section III. TOOL AND TEST EQUIPMENT REQUIREMENTS (Continued)

(1) Reference Code	(2) Maintenance Level	(3) Nomenclature	(4) National/NATO Stock Number	(5) Tool Number	
160	H,D	Reamer, Hand: (Type U Compressor Head; Facing Discharge Valve Seats)	5110-00-473-7274	6248607	
161	H,D	Reamer, Hand: (Type U — 7-1/4 Cu. Ft. Compressor; Reaming Unloader Valve Seat)	5110-00-473-7294	6248606	
162	H,D	Tool Lapping (Type U — 7-1/4 Cu. Ft. Compressor; Lapping Discharge Valve Seat)	5120-00-473-7612	5411954	
163	H,D	Reamer, Hand: (Type U — 7-1/4 Cu. Ft. Compressor Unloader Valve Seat and 1/4 Diameter Guide)	5110-00-690-8573	7065758	
164	H,D	Handle, Grinding Bit: (Used W/5345-00-541- Disc, 4910-00-473-6960 Bit)	4910-00-775-3758	8683496	
165	D	Burnisher, Sleeve: (Front Axle Spindle Bushing)	5120-00-795-0133	7950133	
1	F,H,D	Replacer Gear: (Crankshaft Timing Gear)	5120-00-707-6220	7076220	
167	H,D	Replacer, Snap Ring: (Air Hydraulic Cylinder Check Valve Snap Ring)	5120-00-610-6720	8742059	
1	D	Wrench: (Wheeler Bearing Nut)	5120-00-378-3139	7076968	
169	D	Gear, Pressure: Dial Indicating (Air Brake; Checking Air Pressure)	6685-00-387-9654	7541305	
1	H,D	Adapter, Puller (Transfer Case Front Rear Bearing Cone: Used W/5	5120-00-795-0090	7950090	
	O,	No. 1 Common Organizational Maintenance Tool Kit	4910-00-754-0654	SC49 A74	
	O,	No. 2 Common Organizational Maintenance Tool Kit	4910-00-754-0650	SC 4910-95-C- A72	
	O,	No. 1 Supplemental Organizational Maintenance Tool Kit	4910-00-754-0653	SC A73	49
	O,	No. 2 Supplemental Organizational Maintenance Tool Kit	4910-00-754-0743	SC A18	49



## INDEX

	Paragraph	Page		Paragraph	Page
Accelerator linkage—gasoline:			Air pressure gage:		
Adjustment . . . . .	2-67	2-88	Installation . . . . .	2-144b	2-139
Accelerator linkage—diesel and multifuel:			Removal . . . . .	2-144a	2-139
Installation . . . . .	2-84b	2-101	Air pressure gage sending unit:		
Removal . . . . .	2-84a	2-100	Installation . . . . .	2-161b	2-142
Adapter sets . . . . .	2-29	2-24	Removal . . . . .	2-161a	2-142
Adjustments:			Air reservoirs:		
Accelerator linkage—gasoline . . . . .	2-67a	2-88	Installation . . . . .	2-201b	2-167
Air compressor . . . . .	2-199b	2-162	Removal . . . . .	2-201a	2-167
Boom and shipper cable rollers—			Air restriction indicator—diesel		
M543 and M543A1 wrecker crane . . . . .	2-313a	2-224.1	and multifuel:		
Carburetor—gasoline . . . . .	2-65a	2-86	Installation . . . . .	2-171b	2-145
Choke control—gasoline . . . . .	2-66a	2-88	Removal . . . . .	2-171a	2-145
Clutch controls and linkage . . . . .	2-49b	2-80	Air shift lines and connectors, transfer:		
Drive belts, cooling system—			Inspection . . . . .	2-177b	2-147
gasoline and diesel . . . . .	2-111a	2-117	Installation . . . . .	2-177c	2-147
Drive belts, cooling system—			Removal . . . . .	2-177a	2-146
multifuel . . . . .	2-112a	2-118	Repair . . . . .	2-177b	2-147
Front winch . . . . .	2-315a	2-225	Air supply valves:		
Handbrake . . . . .	2-195b	2-159	Installation . . . . .	2-204b	2-168
Hoist brake band, M543 . . . . .	2-309	2-220	Removal . . . . .	2-204a	2-168
Hydraulic cylinders—M543 and			Ammeter or charge indicator:		
M543A1 wrecker crane . . . . .	2-294b	2-217	Installation . . . . .	2-145b	2-139
Hydraulic system pressure relief valve—			Removal . . . . .	2-145a	2-139
M543 and M543A1 wrecker crane . . . . .	2-295c	2-217	Antidiesel control valve integral with		
Rear winch . . . . .	2-320a	2-228	carburetor—gasoline engine:		
Service brake pedal and linkage . . . . .	2-189a	2-153	Installation . . . . .	2-69b	2-90
Spark plugs . . . . .	2-121c	2-123	Removal . . . . .	2-69a	2-89
Spring seat bearing . . . . .	2-233a	2-183	Antidiesel control valve mounted to		
Steering knuckle arm . . . . .	2-221a	2-177	intake manifold—gasoline engine:		
Throttle control—gasoline . . . . .	2-68a	2-89	Installation . . . . .	2-70b	2-90
Valve clearance—gasoline . . . . .	2-45c	2-77	Removal . . . . .	2-70a	2-90
Wheel bearings . . . . .	2-211a	2-171	Antidiesel valve (degasser):		
Administrative storage . . . . .	1-4	1-1	Installation . . . . .	2-71b	2-91
Air cleaner—diesel and multifuel:			Removal . . . . .	2-71a	2-91
Installation . . . . .	2-77c	2-96	Assembly (see specific item)		
Removal . . . . .	2-77b	2-95	Automatic hoist brake band—		
Servicing the element . . . . .	2-77a	2-94	wrecker crane—M543 and M543A1:		
Air cleaner—gasoline engine:			Adjustment . . . . .	2-309b	2-220
Installation . . . . .	2-63c	2-86	General . . . . .	2-309a	2-220
Maintenance . . . . .	2-63a	2-85	Installation . . . . .	2-309d	2-220
Removal . . . . .	2-63b	2-85	Removal . . . . .	2-309c	2-220
Air compressor:			Axle, front (see front axle)		
Adjustment . . . . .	2-199b	2-162	Axle, rear (see rear axle)		
Air leakage . . . . .	2-199a	2-162	Axle, shaft, rear:		
Installation . . . . .	2-199e	2-165	Installation . . . . .	2-186b	2-152.1
Removal . . . . .	2-199d	2-163	Removal . . . . .	2-186a	2-152.1
Servicing . . . . .	2-199c	2-163	Batteries and box:		
Air conditioning system—expansible van . . . . .	2-246e	2-201	Cleaning . . . . .	2-134a	2-132
Air governor . . . . .	2-200	2-165	Installation . . . . .	2-134c	2-132
Air hydraulic cylinder (power brake unit):			Removal . . . . .	2-134b	2-132
Installation . . . . .	2-191c	2-158	Batteries and lighting system:		
Maintenance . . . . .	2-191a	2-157	Batteries and cables . . . . .	2-134	2-131
Removal . . . . .	2-191b	2-157	Blackout driving light . . . . .	2-137	2-135
Air lines and fittings:			Blackout--marker lights . . . . .	2-139	2-136
Installation . . . . .	2-205b	2-168	Blackout stoplights . . . . .	2-139	2-136
Removal . . . . .	2-205a	2-168	Blackout taillights . . . . .	2-139	2-136
			Directional lights . . . . .	2-138	2-136

	Paragraph	Page		Paragraph	Page
General	2-133	2-131	Hydraulic lines and brake hoses	2-194	2-159
Headlights	2-135	2-132	Master cylinder	2-190	2-155
Parking lights	2-136	2-134	Service brake pedal and linkage	2-189	2-153
Stoplight	2-138	2-136	Service brake shoes	2-193	2-159
Taillight	2-138	2-136	Brake wheel cylinder:		
Battery test:			Installation	2-192c	2-158
Combined battery check	2-22d	2-35	Maintenance	2-192a	2-158
Individual battery check	2-22c	2-34	Removal	2-192b	2-158
Specific gravity	2-22b	2-34	Breather vent, front axle:		
Voltage test	2-22b	2-34	Cleaning	2-183b	2-150
Bearings, wheel (see wheel bearings)			Installation	2-183c	2-151
Blackout driving light:			Removal	2-183a	2-150
Installation	2-137b	2-136	Breather vent, rear axle:	2-187	2-152
Removal	2-137a	2-135	Breather vent, transfer:		
Blackout marker lights:			Installation	2-175b	2-146
Installation	2-139b	2-136	Removal	2-175a	2-146
Removal	2-139a	2-136	Breather vent, transmission:		
Blackout stoplight:			Installation	2-173b	2-146
Installation	2-139b	2-136	Removal	2-173b	2-146
Removal	2-139a	2-136	Brush guard:		
Blackout switches—expansible van:			Installation	2-236b	2-185
Door-operated	2-277b	2-211	Removal	2-236a	2-185
Hinged roof-operated circuit plungers	2-277c	2-211	Cab seat cushions:		
Main circuit	2-277a	2-211	Installation	2-239b	2-186
110-volt receptacle	2-277d	2-211	Removal	2-239a	2-186
Blackout taillights:			Cab top frame and cover:		
Installation	2-139b	2-136	Installation	2-237c	2-186
Removal	2-139a	2-136	Removal	2-237a	2-185
Body accessory items:			Stowage	2-237b	2-186
General	2-329	2-233	Carburetor—gasoline:		
Rear view mirror:			Adjustment	2-65a	2-86
Installation	2-331b	2-234	Installation	2-65c	2-87
Removal	2-331a	2-234	Removal	2-65b	2-87
Windshield wiper and motor:			Cargo body-M41, M54, M54A1, M54A1C, M54A2, M55, M55A1, and M55A2:		
Installation	2-330b	2-233	Body bows	2-245c	2-192
Removal	2-330a	2-233	Body cover	2-245e	2-194
Body, cab, and hood:			Body curtains	2-245e	2-194
Bows	2-245c	2-192	Troop seats	2-240a	2-188
Brush guard	2-236	2-185	Center exhaust pipe-diesel and multifuel engine:		
Cab seat cushions	2-239	2-186	Installation	2-106b	2-113
Cab top frame and cover	2-237	2-185	Removal	2-106a	2-113
Cargo body-M41, M54, M54A1, M54A1C, M54A2, M55, M55A1, and M55A2	2-240	2-187	Choke control—gasoline:		
Curtains	2-245e	2-194	Adjustment	2-66a	2-88
General	2-235	2-185	Installation	2-66c	2-88
Windshield assembly	2-238	2-186	Removal	2-66b	2-88
Bonnet handles—expansible van:			Circuit breakers:		
Installation	2-268b	2-208	Installation	2-160b	2-142
Removal	2-268a	2-207	Removal	2-160a	2-141
Boom and shipper cable roller— wrecker crane M543, M543A1, and M543A2	2-313a	2-224.1	Clutch controls and linkage—diesel	2-55	2-83
Adjustment	2-313c	2-225	Clutch controls and linkage—gasoline engine:		
Installation	2-313c	2-225	Adjustment	2-49b	2-80
Removal	2-313b	2-224.1	General	2-49a	2-80
Brake system:			Installation	2-49e	2-81
Air hydraulic cylinder (power brake unit)	2-191	2-157	Removal	2-49c	2-81
Brake wheel cylinders	2-192	2-158	Repair	2-49d	2-81
General	2-188	2-152	Clutch controls and linkage—multifuel	2-61	2-85
Hand brake shoes	2-197	2-160	Compressed air system:		
Hand brake lever and cable	2-196	2-160	Compressor	2-199	2-162
Handbrake	2-195	2-159	General	2-198	2-161

	Paragraph	Page		Paragraph	Page
Governor . . . . .	2-200	2-165	Door check spring-expansive van:		
Hand control valve . . . . .	2-202	2-167	Installation . . . . .	2-254b	2-204
Lines and fittings . . . . .	2-205	2-168	Removal . . . . .	2-254a	2-204
Reservoirs . . . . .	2-201	2-167	Door hinge—expansive van:		
Supply valves . . . . .	2-204	2-168	Installation . . . . .	2-255b	2-205
Trailer brake couplings . . . . .	2-203	2-168	Removal . . . . .	2-255a	2-205
Compression test, gasoline engine . . . . .	2-43	2-73	Door locks and latches—expansive		
Control rods—expansive van:			van:		
Installation . . . . .	2-268b	2-208	Left rear . . . . .	2-252b	2-204
Removal . . . . .	2-268a	2-207	Side . . . . .	2-252a	2-203
Control valve assembly—dump body			Right rear . . . . .	2-252a	2-203
M51, M51A1, and M51A2:			Door striker plates—expansive van:		
Installation . . . . .	2-243b	2-188.2	Installation . . . . .	2-253b	2-204
Removal . . . . .	2-243a	2-188.2	Removal . . . . .	2-253a	2-204
Controls and linkage, transfer:			Drag link (see steering system)		
Repair . . . . .	2-176	2-146	Drive belts, cooling system—		
Cooling system:			gasoline and diesel models:		
Drive belts- gasoline and diesel . . . . .	2-111	2-117	Adjustment . . . . .	2-111a	2-117
Drive belts-multifuel . . . . .	2-112	2-118	Installation . . . . .	2-111c	2-118
Fan and fan pulley . . . . .	2-113	2-119	Removal . . . . .	2-111b	2-118
General . . . . .	2-108	2-116	Drive belts, cooling system—multifuel:		
Hose and lines . . . . .	2-116	2-121	Adjustment . . . . .	2-112a	2-118
Maintenance . . . . .	2-109	2-116	Installation . . . . .	2-112c	2-118
Oil cooler water inlet tube . . . . .	2-116b	2-121	Removal . . . . .	2-112b	2-118
Radiator . . . . .	2-110	2-116	Drums, wheel: General . . . . .	2-206	2-168
Thermostats . . . . .	2-114	2-120	Dump body—M51, M51A, and M51A2:		
Thermostat and seal-multifuel			Control valve assembly . . . . .	2-243	2-188.2
models . . . . .	2-115	2-120	General . . . . .	2-241	2-188.2
Tubes and fittings . . . . .	2-116	2-121	Hydraulic lines and fittings . . . . .	2-244	2-189
Water pumps:			Hydraulic pump . . . . .	2-242	2-188.2
Diesel engine . . . . .	2-118	2-122	Troop seat accessory kit . . . . .	2-245	2-190
Gasoline engine . . . . .	2-117	2-121	Electric brake lock:		
Multifuel engine . . . . .	2-118.1	2-122	Installation . . . . .	2-285b	2-216
Couplings (set trailer brake couplings)			Removal . . . . .	2-285a	2-215
Cover, cab tarpaulin . . . . .	2-237	2-185	Electric brake lock switch:		
Cover, body tarpaulin . . . . .	2-245e	2-194	Installation . . . . .	2-286b	2-216
Crankcase breather-gasoline engine:			Removal . . . . .	2-286a	2-216
Installation . . . . .	2-47c	2-79	Electric fuel supply pump for		
Maintenance . . . . .	2-47a	2-78	manifold heater—diesel models:		
Removal . . . . .	2-47b	2-78	Installation . . . . .	2-93b	2-108
Crankcase breather tube-multifuel:			Removal . . . . .	2-93a	2-108
Installation . . . . .	2-60b	2-84	Electric fuel supply pump for		
Removal . . . . .	2-60a	2-84	manifold heater—multifuel models:		
Crankcase breather valves-diesel:			Installation . . . . .	2-94b	2-108
Installation . . . . .	2-54b	2-83	Removal . . . . .	2-94a	2-108
Removal . . . . .	2-54a	2-82	Electric power loss test—diesel		
Destruction of Army materiel to			and multifuel (see electrical power		
prevent enemy use . . . . .	1-5	1-1	loss tests—gasoline engine)		
Dimmer switch:			Electrical power loss tests—gasoline		
Installation . . . . .	2-157b	2-141	engine:		
Removal . . . . .	2-157a	2-141	Battery connector cable test . . . . .	2-28c	2-44
Disassembly (see specific item)			Battery-to-solenoid cable test . . . . .	2-28d	2-45
coil capacitor . . . . .	2-122g	2-127	Frame-to-battery cable ground		
Distributor cap . . . . .	2-122c	2-126	loss test . . . . .	2-28b	2-44
Distributor contact points and			Starter solenoid-to-starter		
capacitor . . . . .	2-122d	2-126	connector test . . . . .	2-28e	2-45
Ignition coil . . . . .	2-122e	2-127	Starter switch test . . . . .	2-28a	2-44
Installation . . . . .	2-122b	2-124	Electrical system circuits:		
Removal . . . . .	2-122a	2-124	Batteries . . . . .	2-22	2-34
Resistor . . . . .	2-122f	2-127	Generator system . . . . .	2-23	2-35
Distributor tests:			Ignition . . . . .	2-32	2-49
Cap on . . . . .	2-32c	2-51	Lights . . . . .	2-34	2-51
Cap removed . . . . .	2-32d	2-51			

	Paragraph	Page		Paragraph	Page
Monitoring	2-30	2-46	Door hinge	2-255	2-205
Starter	2-26	2-40	Door latches	2-252	2-203
	and	and	Door locks	2-252	2-203
	2-27	2-43	Door striker plates	2-253	2-204
Electrical system troubleshooting (see troubleshooting the electrical system)			Electrical systems	2-246c	2-195
Electrical system—expansible van	2-246c	2-195	Electrical system	2-35	2-62
Electrical test equipment:			Emergency light fixtures	2-275	2-209
Adapter sets	2-19	2-24	Emergency light switch	2-278	2-212
Ammeter	2-20b	2-28	Expanding mechanisms	2-246b	2-195
Field rheostat unit	2-20d	2-28	Flourescent ceiling light fixture	2-276	2-210
General instructions	2-21	2-32	Fuel and overflow lines	2-265	2-207
Load bank	2-20e	2-28	Fuel line fittings	2-267	2-207
Low voltage circuit test	2-18	2-23	Fuel tank shutoff valves	2-267	2-207
Resistance unit	2-20c	2-28	General	2-246	2-195
Tester functions and use	2-20	2-26	Heater fuel filter	2-264	2-206
Voltmeter	2-20a	2-26	Heater fuel pump	2-263	2-206
Emergency fuel shutoff control—diesel models:			Heating	2-246d	2-201
Installation	2-80b	2-97	Inside telephone jack posts	2-273	2-208
Removal	2-80a	2-97	Ladder locking clamps	2-248	2-202
Emergency light and blackout light fixture—expansible van:			Operating and locking devices	2-262	2-205
Lenses and lamps	2-275a	2-209	Outside power connector cable	2-271	2-208
Light fixtures	2-275b	2-209	Outside telephone jack posts	2-274	2-209
Emergency light switch—expansible van:			Panel weather seals	2-256	2-205
Installation	2-278b	2-212	Power cable reel	2-272	2-208
Removal	2-278a	2-212	Roof-to-side panel toggle clamps	2-249	2-202
Engine maintenance in vehicle:			Side panel counterbalance cables	2-247	2-201
Diesel—general	2-50	2-81	Side panel front locks and hinged locks	2-251	2-203
Gasoline—general	2-42	2-73	Side panel rear locks	2-250	2-202
Multifuel—general	2-56	2-83	Window blackout panel	2-261	2-205
Errors, equipment publications, reporting of	1-3	1-1	Window brush guards	2-258	2-205
Exhaust pipe—gasoline engine:			Window glass and seal	2-260	2-205
Installation	2-102b	2-111	Window regulators	2-259	2-205
Removal	2-102a	2-111	Window screens	2-257	2-205
Exhaust system—diesel and multifuel:			Fan and fan pulley, cooling system:		
Center exhaust pipe	2-106	2-113	Installation	2-113b	2-119
Front exhaust pipe	2-104	2-112	Removal	2-2-113a	2-119
General	2-103	2-112	Field expedient repairs:		
Rear exhaust pie	2-105	2-113	General	2-40	2-72
Vertical exhaust stack—multifuel models	2-107	2-113	Procedures	2-41	2-72
Exhaust system—gasoline engine:			Fifth wheel—M246 model:		
Exhaust pipe	2-102	2-111	Fifth wheel	2-229b	2-181
General	2-99	2-111	General	2-229a	2-181
Muffler	2-101	2-111	Fifth wheel assembly—M52, M52A21, and M52A2 models:		
Tailpipe and extension	2-100	2-111	Approach plate	2-228c	2-181
Exhaust system maintenance:			Center deck plate	2-228d	2-181
Diesel and multifuel—general	2-103	2-112	Fifth wheel	2-228b	2-180
Gasoline—general	2-99	2-111	General	2-228a	2-180
Expanding mechanisms—expansible van	2-246b	2-195	Flasher (see turn signal switch)		
Expansible van body—M291A1, M291A1C, M291A1D, M291A2, M291A2C, and M291A2D:			Floodlight:		
Air conditioning system	2-246e	2-201	Installation	2-283b	2-214
Blackout light fixtures	2-275	2-209	Removal	2-283a	2-214
Blackout switches	2-227	2-211	Floodlight cables:		
Body	2-246a	2-195	Installation	2-284a	2-214
Bonnet handles	2-268	2-207	Removal	2-284a	2-214
Clearance and blackout lamps	2-269	2-208	Floodlight lamp unit:		
Clearance and blackout lights	2-270	2-208	Installation	2-281b	2-213
Control rods	2-268	2-207	Removal	2-281a	2-213
Door check spring	2-254	2-204	Floodlight switch:		
			Installation	2-282b	2-214
			Removal	2-282a	2-214



	Paragraph	Page		Paragraph	Page
Floodlight switch (inside cab) M62, M246, M246A1, and M246A2:			Heater control box:		
Installation . . . . .	2-288b	2-216	Installation . . . . .	3-11b	3-4
Removal . . . . .	2-288a	2-216	Removal . . . . .	3-11b	3-3
Fluorescent ceiling light fixture— expansible van:			Heater control box switch:		
Flourescent tubes . . . . .	2-276c	2-210	Installation . . . . .	3-11c	3-4
Installation . . . . .	2-276b	2-210	Removal . . . . .	3-11c	3-4
Lamps . . . . .	2-276e	2-210	Indicator lamp:		
Removal . . . . .	2-276a	2-210	Installation . . . . .	3-11a	3-3
Starters . . . . .	2-276d	2-210	Removal . . . . .	3-11a	3-3
Frame, towing attachments, and brackets:			Fuel filters-diesel models:		
Fifth wheel assembly—M246, M246A1, and M246A2 models . . . . .	2-229	2-181	Maintenance . . . . .	2-88a	2-103
Fifth wheel assembly—M52, M52A1, and M52A2 models . . . . .	2-228	2-180	Primary filter . . . . .	2-88b	2-103
General . . . . .	2-223	2-178	Secondary filter . . . . .	2-88c	2-103
Lifting shackle assembly . . . . .	2-225	2-179	Fuel filter-gasoline engine:		
Pintle hook . . . . .	2-224	2-178	Installation . . . . .	2-7c	2-92
Safety chain shackle assembly . . . . .	2-226	2-179	Maintenance . . . . .	2-73a	2-92
Spare wheel carrier . . . . .	2-227	2-180	Removal . . . . .	2-73b	2-92
Front axle:			Fuel filters-multifuel models:		
Breather vent . . . . .	2-183	2-150	Cleaning . . . . .	2-82c	2-98
General . . . . .	2-182	2-150	Installation . . . . .	2-82d	2-98
Front exhaust pipe—diesel and multifuel:			Maintenance . . . . .	2-82a	2-98
Installation . . . . .	2-104b	2-112	Removal . . . . .	2-82b	2-98
Removal . . . . .	2-104a	2-112	Fuel gage:		
Front springs:			Installation . . . . .	2-146b	2-139
Description . . . . .	2-230a	2-181	Removal . . . . .	2-146a	2-139
Installation . . . . .	2-231b	2-182	Fuel gage sending unit:		
Removal . . . . .	2-231a	2-182	Installation . . . . .	2-162 b	2-142
Front wheel alinement:			Removal . . . . .	2-162 a	2-142
Camber . . . . .	2-214b	2-173	Fuel line fittings-expansible van:		
Caster . . . . .	2-214a	2-172	Installation . . . . .	2-267 b	2-207
Toe-in adjustment . . . . .	2-214e	2-174	Removal . . . . .	2-267 a	2-207
Toe-in check . . . . .	2-214d	2-174	Fuel pump—gasoline engine:		
Turning angle . . . . .	2-214c	2-174	Installation . . . . .	2-72c	2-91
Front winch assembly:			Removal . . . . .	2-72b	2-91
Front winch:			Testings . . . . .	2-72a	2-91
Adjustment . . . . .	2-315a	2-225	Fuel shutoff control—multifuel models:		
Installation . . . . .	2-315d	2-227	Installation . . . . .	2-81b	2-97
Removal . . . . .	2-315c	2-226	Removal . . . . .	2-81a	2-97
Test . . . . .	2-315b	2-226	Fuel shutoff control and valve-diesel models:		
General . . . . .	2-314	2-225	Installation . . . . .	2-79b	2-96
Level wind:			Removal . . . . .	2-79a	2-96
Installation . . . . .	2-317b	2-227	Fuel system—diesel and multifuel:		
Removal . . . . .	2-317a	2-227	Accelerator linkage . . . . .	2-84	2-100
Propeller shaft assembly:			Air cleaner . . . . .	2-77	2-94
Installation . . . . .	2-316b	2-227	Electric fuel supply pump for manifold heater—diesel models . . . . .	2-93	2-108
Removal . . . . .	2-316a	2-227	Electric fuel supply pump for manifold heater—multifuel models . . . . .	2-94	2-108
Shearpin replacement . . . . .	2-316c	2-227	Emergency fuel shutoff control— diesel models . . . . .	2-80	2-97
Winch cable:			Fuel filters-diesel models . . . . .	2-88	2-103
Installation . . . . .	2-318b	2-227	Fuel filters—multifuel models . . . . .	2-82	2-98
Removal . . . . .	2-318a	2-227	Fuel shutoff control—multifuel models . . . . .	2-81	2-97
Fuel and overflow lines—Expansible van:			Fuel shutoff control and valve— diesel models . . . . .	2-79	2-96
Installation . . . . .	2-265b	2-207	Fuel tank . . . . .	2-85	2-101
Removal . . . . .	2-265a	2-207	General . . . . .	2-76	2-94
Fuel burning gasoline heater kit— multifuel models:			Low pressure lines . . . . .	2-78	2-96
Electric fuel pump:			Manifold heater fuel filter— multifuel models . . . . .	2-97	2-109
Installation . . . . .	3-12c	3-4	Manifold heater ignition unit (coil)-diesel models . . . . .	2-96	2-109
Maintenance . . . . .	3-12a	3-4			
Removal . . . . .	3-12b	3-4			

	Paragraph	Page		Paragraph	Page
Manifold heater ignition unit (coil)—multifuel models . . . . .	2-95	2-108	Installation . . . . .	3-9b	3-3
Manifold heater injector nozzle, spark plug, and spark plug housing—diesel models . . . . .	2-89	2-104	Removal . . . . .	3-9a	3-3
Manifold heater injector nozzle, spark plug, and spark plug housing—multifuel models . . . . .	2-90	2-105	Lines and fittings: Installation . . . . .	3-6b	3-3
Manifold heater supply valve and fuel return valve—diesel models . . . . .	2-98	2-110	Removal . . . . .	3-6a	3-3
Manifold heater supply valve and fuel return valve—multifuel models . . . . .	2-87	2-102	Generating system: General . . . . .	2-130	2-130
Manifold heater wiring harness—diesel models . . . . .	2-91	2-106	Generator and generator pulley . . . . .	2-131	2-130
Manifold heater wiring harness—multifuel models . . . . .	2-92	2-106	Generator regulator . . . . .	2-132	2-131
Throttle linkage . . . . .	2-83	2-99	Generator and generator pulley: Installation . . . . .	2-131b	2-130
Transfer pump—multifuel . . . . .	2-86	2-102	Polarization . . . . .	2-131c	2-131
Fuel system—gasoline: Accelerator linkage . . . . .	2-67	2-88	Removal . . . . .	2-131a	2-130
Air cleaner . . . . .	2-63	2-85	Generator regulator: Installation . . . . .	2-132b	2-131
Antidiesel control . . . . .	2-69,	2-89,	Removal . . . . .	2-132a	2-131
	2-70,	2-90,	Generator system: Troubleshooting . . . . .	2-23	2-35
	and	and	Generator system radio interference suppression: Replacement of components . . . . .	2-38b	2-72
	2-71	2-91	Generator testing . . . . .	2-24	2-36
Carburetor . . . . .	2-65	2-86	Governor override solenoid—wrecker crane M543 and M543A1: Installation . . . . .	2-3066	2-219
Choke control . . . . .	2-66	2-88	Removal . . . . .	2-306a	2-219
Fuel filter . . . . .	2-73	2-92	Handbrake: Adjustment . . . . .	2-195b	2-159
Fuel pump . . . . .	2-72	2-91	General . . . . .	2-195a	2-159
Fuel tank . . . . .	2-74	2-92	Handbrake lever and cable: Installation . . . . .	2-196b	2-159
General . . . . .	2-62	2-85	Removal . . . . .	2-196a	2-159
Lines and fittings . . . . .	2-75	2-93	Handbrake shoes: installation . . . . .	2-197b	2-160
Throttle control . . . . .	2-68	2-89	Removal . . . . .	2-197a	2-160
Ventilation lines and fittings . . . . .	2-64	2-86	Hand control valve, compressed air system: Installation . . . . .	2-202b	2-167
Fuel tank—diesel and multifuel: Installation . . . . .	2-85b	2-102	Removal . . . . .	2-202a	2-167
Removal . . . . .	2-85a	2-101	Harness, wiring . . . . .	2-140b	2-137
Fuel tank—gasoline engine: Installation . . . . .	2-74c	2-93	Harness, manifold, heater (see manifold heater)		
Maintenance . . . . .	2-74a	2-92	Headlight, high-beam indicator light: Installation . . . . .	2-147b	2-140
Removal . . . . .	2-74b	2-93	Lamp replacement . . . . .	2-147c	2-140
Fuel tank shutoff valves—expansible van: Installation . . . . .	2-267b	2-207	Removal . . . . .	2-147a	2-139
Removal . . . . .	2-267a	2-207	Headlights, sealed-beam lamp unit: Adjusting . . . . .	2-135c	2-133
Fuel transfer pump—multifuel: Installation . . . . .	2-86b	2-102	Installing . . . . .	2-135b	2-133
Removal . . . . .	2-86a	2-102	Removing . . . . .	2-135a	2-132
Gages, electrical (see instrument cluster 0)			Heater fuel filter—expansible van: Installation . . . . .	2-264b	2-206
Gages, nonelectrical (see nonelectrical gages and measuring devices)			Removal . . . . .	2-264a	2-206
Gasoline personnel heater kit: Electric fuel pump: Installation . . . . .	3-7c	3-3	Heater fuel pump—expansible van: Installation . . . . .	2-263c	2-206
Maintenance . . . . .	3-7a	3-3	Plunger spring and filter element servicing . . . . .	2-263a	2-206
Removal . . . . .	3-7b	3-3	Removal . . . . .	2-263b	2-206
Fuel filter Installation . . . . .	3-8b	3-3	Heater kits, personnel (see material used in conjunction with major item)		
Removal . . . . .	3-8a	3-3	Heater shutoff valves—expansible van: Installation . . . . .	2-266b	2-207
General . . . . .	3-5	3-2	Removal . . . . .	2-266a	2-207
Heater control thermostat:			Heating system—expansible van . . . . .	2-246d	2-201
			Hoist brake band . . . . .	2-309	2-220

	paragraph	Page		Paragraph	Page
Hoist cable-wrecker crane			M51, M51A1, and M51A2:		
M543 and M543A1:			Installation . . . . .	2-242b	2-188.2
Installation . . . . .	2-310b	2-222	Removal . . . . .	2-242a	2-188.2
Removal . . . . .	2-310a	2-220	Hydraulic system filter--wrecker		
Hoist cables--wrecker crane			crane M543, M543A1, and M543A2:		
M62 and M246:			Cleaning . . . . .	2-296b	2-218.1
Installation . . . . .	2-291b	2-216	Installation . . . . .	2-296c	2-218.1
Removal . . . . .	2-291a	2-216	Removal . . . . .	2-296a	2-218
Hoist cable sheaves and guard-			Hydraulic system pressure--wrecker		
wrecker crane M543, M543A1,			crane M543, M543A1, and M543A2:		
and M543A2:			General . . . . .	2-295a	2-217
Boom head sheave and			Relief valve adjustment . . . . .	2-295c	2-217
upper boom foot sheave . . . . .	2-311b	2-222	Relief valve test . . . . .	2-295b	2-217
General . . . . .	2-311a	2-222	Identification and tabulated data . . . . .	1-7	1-1
lower boom foot sheaves . . . . .	2-311c	2-222	Ignition and starting system radio		
Horn assembly:			interference suppression: Replacement		
Horn . . . . .	2-169c	2-144	of components . . . . .	2-38a	2-71
Solenoid (with mounting brackets) . . . . .	2-169a	2-143	Ignition circuit test--gasoline:		
Solenoid (without mounting brackets) . . . . .	2-169b	2-144	Distributor tests, cap on . . . . .	2-32c	2-51
Horn button (switch):			Distributor tests, cap removed . . . . .	2-32d	2-51
Installation . . . . .	2-156b	2-141	Ignition switch test . . . . .	2-32b	2-49
Removal . . . . .	2-156a	2-141	Primary circuit test . . . . .	2-32a	2-49
Hose lines, cooling system:			Ignition switch:		
Installation . . . . .	2-116a	2-121	Installation . . . . .	2-154b	2-140
Removal . . . . .	2-116a	2-121	Removal . . . . .	2-154a	2-140
Hot water personnel heater kit:			Testing . . . . .	2-154c	2-141
General . . . . .	3-1	3-1	Ignition system- gasoline engine:		
Heater hoses:			Distributor assembly . . . . .	2-122	2-124
Installation . . . . .	3-4b	3-2	General . . . . .	2-119	2-123
Removal . . . . .	3-4a	3-2	Ignition timing . . . . .	2-120	2-123
Heater unit:			Sparkplugs . . . . .	2-121	2-123
Installation . . . . .	3-2b	3-2	Ignition timing:		
Removal . . . . .	3-2a	3-1	Checking and correcting timing . . . . .	2-120b	2-123
Thermostats:			General . . . . .	2-120a	2-123
Installation . . . . .	3-3b	3-2	Ignition unit and spark plug test--		
Removal . . . . .	3-3a	3-2	diesel and multifuel: . . . . .	2-33	2-51
Hub and drum assembly:			Inside telephone jack jack posts--		
Installation . . . . .	2-210b	2-171	expandable van:		
Removal . . . . .	2-210a	2-170	Installation . . . . .	2-273b	2-208
Hubs, wheel: General . . . . .	2-206	2-168	Removal . . . . .	2-273a	2-208
Hydraulic cylinder--wrecker crane			Installation (see specific item)		
M543, M543A1, and M543A2:			Instrument cluster: . . . . .	2-142a	2-137
Adjustment . . . . .	2-294b	2-217	Buzzers: Low air pressure		
General . . . . .	2-294a	2-217	warning . . . . .	2-159	2-141
Hydraulic lines and brake hoses.			Circuit breakers . . . . .	2-160	2-141
(see lines and hoses. hydraulic			Gages:		
brake system)			Air pressure . . . . .	2-144	2-139
Hydraulic lines and fittings--dump			Fuel . . . . .	2-146	2-139
body M51, M51A1, and M51A2:			Oil pressure . . . . .	2-148	2-140
Installation . . . . .	2-244b	2-189	Temperature . . . . .	2-153	2-140
Removal . . . . .	2-244a	2-189	General . . . . .	2-142	2-137
Hydraulic lines and fittings--			Horn assembly . . . . .	2-169	2-143
wrecker crane M543, M543A1,			Indicators:		
and M543A2 . . . . .	2-293	2-217	Air restriction diesel		
Hydraulic lines and fittings--			and multifuel . . . . .	2-171	2-145
wrecker crane M62, M246,			Ammeter . . . . .	2-145	2-139
M246A1, and M246A2:			Headlight high beam . . . . .	2-147	2-139
Installation . . . . .	2-280b	2-212	Speedometer . . . . .	2-150	2-140
Removal . . . . .	2-280a	2-212	Tachograph . . . . .	2-152	2-140
Hydraulic oil reservoir, steering system:			Tachometer . . . . .	2-151	2-140
Installation . . . . .	2-222c	2-178	Installation . . . . .	2-143b	2-139
Maintenance . . . . .	2-222a	2-177	Removal . . . . .	2-143a	2-139
Removal . . . . .	2-222b	2-177	Sending units:		
Hydraulic pump--dump body			Air pressure gage . . . . .	2-161	2-142

	Paragraph	Page		Paragraph	Page
Fuel gage . . . . .	.2-162	2-142	Low voltage circuit tester . . . . .	.2-18	2 - 2 3
Low air pressure . . . . .	.2-168	2-143	Lower drag link:		
Oil pressure . . . . .	.2-163	2-142	Installation . . . . .	.2-219b	2-176
Speedometer . . . . .	.2-164	2-142	Removal . . . . .	.2-219a	2-176
Tachometer . . . . .	.2-165	2-142	Lubrication:		
Tachometer-multifuel . . . . .	.2-166	2-143	Cleaning . . . . .	.2-6b	2-6
Temperature gage . . . . .	.2-167	2-143	Detailed instructions, general . . . . .	.2-7a	2-6
Switches:			General . . . . .	.2-6	2-6
Dimmer . . . . .	.2-157	2-141	Points of lubrication . . . . .	.2-7c	2-6
Horn . . . . .	.2-156	2-141	Maintenance forms and records . . . . .	.1-2	1-1
Ignition . . . . .	.2-154	2-140	Maintenance repair parts . . . . .	.2-5	2-4
Light . . . . .	.2-155	2-141	Manifold heater fuel filter—		
Panel light . . . . .	.2-149	2-140	multifuel models:		
Stoplight . . . . .	.2-158	2-141	Installation . . . . .	.2-97b	2-110
Turn signal . . . . .	.2-170	2-144	Removal . . . . .	.2-97a	2-109
intake and exhaust manifolds—			Manifold heater ignition unit (coil)—		
gasoline engine:			diesel models:		
Installation . . . . .	.2-44c	2-76	Installation . . . . .	.2-96b	2-109
Manifold vacuum test . . . . .	.2-44a	2-73	Removal . . . . .	.2-96a	2-109
Removal . . . . .	.2-44b	2-75	Manifold heater ignition unit (coil)-		
Kits, personnel heater (see			multifuel models:		
materiel used in conjunction			Installation . . . . .	.2-95b	2-108
with major item)			Removal . . . . .	.2-95a	2-108
Ladder locking clamp—expansible van:			Manifold heater injector nozzle, spark		
Installation . . . . .	.2-248b	2-202	plug, and spark plug housing—		
Removal . . . . .	.2-248a	2-202	diesel models:		
Lifting shackle assembly:			Installation . . . . .	.2-89b	2-105
Bracket . . . . .	.2-225b	2-179	Removal . . . . .	.2-89a	2-104
Shackle . . . . .	.2-225a	2-179	Manifold heater injector nozzle, spark		
Light switch:			plug, and spark plug housing—		
Installation . . . . .	.2-155b	2-141	multifuel models:		
Removal . . . . .	.2-155a	2-141	Installation . . . . .	.2-90b	2-106
Lighting circuit testing:			Removal . . . . .	.2-90a	2-105
Description . . . . .	.2-34a	2-5 2	Manifold heater supply valve and		
Directional signal system . . . . .	.2-34b	2-5 2	fuel return valve—diesel models:		
Lights, general . . . . .	.2-133b	2-131	Installation . . . . .	.2-98b	2-110
Lines and fittings—diesel . . . . .	.2-53	2-8 2	Removal . . . . .	.2-98a	2-110
Lines and fittings—gasoline engine:			Manifold heater supply valve and		
Fabrication . . . . .	.2-48c	2-79	fuel return valve—multifuel models:		
Fuel system . . . . .	.2-75	2-93	Installation . . . . .	.2-87b	2-103
Inspection . . . . .	.2-48b	2-79	Removal . . . . .	.2-87a	2-102
Installation . . . . .	.2-48d	2-80	Manifold heater wiring harness—		
Removal . . . . .	.2-48a	2-79	diesel models:		
Lines and fittings—multifuel . . . . .	.2-59	2-84	Installation . . . . .	.2-91b	2-106
Lines and hoses, hydraulic brakes:			Removal . . . . .	.2-91a	2-106
Installation . . . . .	.2-194c	2-159	Manifold heater wiring harness—		
Maintenance . . . . .	.2-194a	2-159	multifuel models:		
Removal . . . . .	.2-194b	2-159	Installation . . . . .	.2-92b	2-108
Lines, tubes, and fittings—cooling system:			Removal . . . . .	.2-92a	2-108
Oil cooler water inlet tube . . . . .	.2-116b	2-121	Manual starter switch—gasoline engine:		
Water hoses and lines . . . . .	.2-116a	2-121	Installation . . . . .	.2-126d	2-129
Low air pressure sending unit:			Removal . . . . .	.2-126c	2-129
Installation . . . . .	.2-168b	2-143	Master cylinder, brake system:		
Removal . . . . .	.2-168a	2-143	Installation . . . . .	.2-190c	2-156
Low air pressure warning buzzer:			Maintenance . . . . .	.2-190a	2-155
Installation . . . . .	.2-159b	2-141	Removal . . . . .	.2-190b	2-156
Removal . . . . .	.2-159a	2-141	Materiel used in conjunction		
Low pressure lines—diesel			with major items:		
and multifuel:			Fuel burning personnel heater		
General . . . . .	.2-78a	2-96	kit—multifuel models . . . . .	.3-10	3-3
Installation . . . . .	.2-78c	2-96	Gasoline personnel heater kit . . . . .	.3-5	3-2
Removal . . . . .	.2-78b	2-96	Hot water personnel heater kit . . . . .	.3-1	3-1
			Powerplant heater kit—multifuel		

	Paragraph	Page		Paragraph	Page
models	3-13	3-4	Panel lights, instrument:		
Primer pump	3-17	3-4	Installation	2-149b	2-140
Modification work order application	2-11e	2-6	Removal	2-149a	2-140
Monitoring circuits (fuel, oil, and temperature gage): Troubleshooting	2-30	2-46	Replacement	2-149c	2-140
Muffler-gasoline engine:			Panel weather seals—expansible van:		
Installation	2-101b	2-11	Installation	2-256b	2-205
Removal	2-101a	2-111	Removal	2-256a	2-205
Nonelectrical gages and measuring devices:			Parking lights:		
General	2-332	2-234. 1	Installation	2-136b	2-134
Speedometer:			Removal	2-136a	2-134
Installation	2-333b	2-234.1	Personnel heater kits (see materiel used in conjunction with major items)		
Removal	2-2-333a	2-234.1	Pintle assembly:		
Speedometer flexible shaft:			Bracket	2-224b	2-179
Installation	2-334b	2-234.1	Hook	2-224a	2-178
Removal	2-334a	2-234. 1	Pitman arm:		
Tachograph:			Installation	2-217b	2-175
installation	2-337b	2-235	Removal	2-217a	2-175
Removal	2-337a	2-235	Power cable reel—expansible van:		
Using the	2-340	2-235	Installation	2-272b	2-208
Tachograph flexible shaft:			Removal	2-272a	2-208
Installation	2-338	2-235	Powerplant heater kit (see materiel used in conjunction with major item)		
Removal	2-338	2-235	Powerplant heater kit-multifuel models:		
Tachograph light bulb: Replacement	2-339	2-235	General	3-13	3-4
Tachometer:			Fuel filter:		
Installation	2-335b	2-235	Installation	2-8b	3-3
Removal	2-335a	2-235	Removal	2-8a	3-3
Tachometer flexible shaft:			Fuel lines:		
Installation	2-336b	2-235	Installation	3-14	3-4
Removal	2-336a	2-235	Removal	3-14	3-4
Oil cooler water inlet tube	2-116b	2-121	Heater control box assembly:		
Oil filters-gasoline engine:			Installation	3-11b	3-3
Elements	2-46a	2-77	Removal	3-11a	3-3
Housings	2-46b	2-77	Preventive maintenance checks and services:		
Oil filter elements- diesel:			General	2-8	2-6
Preliminary	2-51a	2-81	General procedures	2-11	2-6
Primary filter	2-51b	2-82	Intervals	2-9	2-6
Secondary filter	2-51c	2-82	Reporting repair	2-10	2-6
Oil filter elements—multifuel:			Specific procedures	2-12	2-7
Installation	2-57b	2-84	Primer pump:		
Removal	2-57a	2-83	General	3-17	3-4
Oil pressure gage:			Installation	3-18b	3-5
Installation	2-148b	2-140	Removal	3-18a	3-4
Removal	2-148a	2-140	Propeller shaft-wreck crane		
Oil pressure gage sending unit:			M543, M543A1, and M543A2:		
Installation	2-163b	2-142	General	2-312a	2-223
Removal	2-163a	2-142	Installation	2-312c	2-224
Outside power connector cable-expansible van:			Removal	2-312b	2-223
Installation	2-271b	2-208	Propeller shaft:		
Removal	2-271a	2-208	Center bearing:		
Outside telephone jack posts—expansible van:			Installation	2-181b	2-150
installation	2-274b	2-209	Removal	2-181a	2-150
Removal	2-274a	2-209	General	2-178	2-147
Overrides switch-wrecker crane M543, M543A1, and M543A2:			With flange-mounted universal joints:		
Installation	2-307b	2-220	Assembly	2-180d	2-150
Removal	2-307a	2-219	Disassembly	2-180b	2-150
Packing ram (see hydraulic cylinder adjustment—wrecker)			installation	2-180e	2-150
			Removal	2-180a	2-150
			Repair	2-180c	2-150
			With yoke-mounted universal joints:		
			Assembly	2-179d	2-149
			Disassembly	2-179b	2-148

	Paragraph	Page		Paragraph	Page
Installation	.2-179e	2-149	Winch cable:		
Removal	.2-179a	2-148	Installation	.2-328b	2-233
Repair	.2-179c	2-149	Removal	.2-328a	2-233
Propeller shaft, front winch	.2-316	2-227	Receptacles, electrical:		
Propeller shafts, rear winch:			Radio	.2-141b	2-137
Front	.2-322	2-231	Slave battery	.2-141a	2-137
Rear	.2-323	2-232	Trailer coupling	.2-141c	2-137
Pump, hoist (see dump body M51)			Regulator testing:		
Racks, cargo	.2-240	2-188	Amperage control test	.2-25b	2-38
Radiator, cooling system:			Line switch cutout	.2-25c	2-39
Installation	.2-110b	2-117	Voltage control test	.2-25a	2-38
Removal	.2-110a	2-116	Relay lever:		
Radiator guard (see brush guard)			Installation	.2-220b	2-176
Radio interference suppression:			Removal	.2-220a	2-176
General methods used to attain	.2-36	2-71	Removal (see specific item)		
Interference suppression components	.2-37	2-71	Repair (see specific item)		
Replacement of suppression components	.2-38	2-71	Repair parts, special tools and equipment	.24	2-1
Radio interference suppression bonding:			Repairs, field expedient	.2-40	2-72
Replacement of components	.2-38c	2-72	Replacement (see specific item)		
Radio interference: Test	.2-39	2-72	Reporting of equipment publication improvements	.1-3	1-1
Rear axle:			Restrictor valve:		
Axle shaft	.2-186	2-152.1	Installation	.2-290b	2-216
Breather vent	.2-187	2-152.1	Removal	.2-290a	2-216
General	.2-184	2-151	Roof-to-side panel toggle clamp—expansible van:		
Maintenance	.2-185	2-151	Installation	.2-249b	2-202
Rear exhaust pipe—diesel and multifuel models:			Removal	.2-249a	2-202
Installation	.2-105b	2-113	Safety chain shackle assembly:		
Removal	.2-105b	2-113	Bracket	.2-226b	2-179
Rear springs:			Shackle	.2-226a	2-179
Description	.2-230b	2-182	Seat cushions (see body, cab and hood)		
Installation	.2-232b	2-183	Seats, cargo body troop	.2-240	2-188
Removal	.2-232a	2-183	Seats, dump body troop	.2-245	2-190
Rear view mirror (see body accessory items)			Sending units (see instrument cluster)		
Rear winch assembly:			Service brake pedal and linkage:		
Cable tensioner:			Adjustments	.2-189a	2-153
Installation	.2-2-321b	2-231	Installation	.2-189c	2-155
Removal	.2-321a	2-231	Removal	.2-189b	2-154
Drive chain:			Service brakeshoes:		
Installation	.2-325b	2-232	Installation	.2-193b	2-159
Removal	.2-325a	2-232	Removal	.2-193a	2-159
Front propeller shafts:			Service brake system	.2-188a	2-152.1
Installation	.2-322b	2-231	Service upon receipt of materiel:		
Removal	.2-322a	2-231	Correcting of deficiencies	.2-3	2-1
General	.2-319	2-228	General	.2-1	2-1
Level wind:			Inspecting and servicing the equipment	.2-2	2-1
Installation	.2-327b	2-233	Shock absorbers:		
Removal	.2-327a	2-233	Description	.2-230c	2-182
Pillow block:			Installation	.2-234b	2-184
Installation	.2-324b	2-232	Removal	.2-234a	2-184
Removal	.2-324a	2-232	Side panel counterbalance cables—expansible van:		
Rear propeller shaft:			Installation	.2-247b	2-202
Installation	.2-323b	2-232	Removal	.2-247a	2-201
Removal	.2-323a	2-232	Side panel front locks and hinged locks—expansible van:		
Rear winch:			Installation	.2-251b	2-203
Adjustment	.2-320a	2-228	Removal	.2-251a	2-203
Installation	.2-320c	2-230	Side panel rear locks—expansible van:		
Removal	.2-320b	2-229			
Shearpin:					
Installation	.2-326b	2-232			
Removal	.2-326a	2-232			

	Paragraph	Page		Paragraph	Page
Installation . . . . .	.2-250b	2-203	Solenoid and manual starter switch . . . . .	.2-126	2-129
Removal . . . . .	.2-250a	2-202	Starter . . . . .	.2-124	2-128
Slipping brush-wrecker crane			Starter linkage . . . . .	.2-125	2-128
M543, M543A1, and M543A2:			Steering knuckle arm:		
Installation . . . . .	.2-308b	2-220	Adjustment . . . . .	.2-221a	2-177
Removal . . . . .	.2-308a	2-220	Inspection . . . . .	.2-221b	2-177
Solenoid, starter-diesel and multifuel:			Steering system:		
Installation . . . . .	.2-129b	2-130	Conversion kit . . . . .	.2-222.1	2-178
Removal . . . . .	.2-129a	2-130	Front wheel alinement . . . . .	.2-214	2-172.1
Solenoid, starter-gasoline engine			General . . . . .	.2-213	2-172
Installation . . . . .	.2-126b	2-129	Hydraulic oil reservoir . . . . .	.2-222	2-177
Removal . . . . .	.2-126a	2-129	Lower drag link . . . . .	.2-219	2-176
Spare wheel carrier:			Pitman arm . . . . .	.2-217	2-175
Installation . . . . .	.2-227b	2-180	Relay lever . . . . .	.2-220	2-176
Removal . . . . .	.2-227a	2-180	Steering gear . . . . .	.2-213	2-172
Spark plugs:			Steering knuckle arm . . . . .	.2-221	2-177
Adjustment . . . . .	.2-121c	2-123	Steering wheel . . . . .	.2-216	2-174
Cleaning and inspection . . . . .	.2-121b	2-123	Tie rod . . . . .	.2-215	2-174
Installation . . . . .	.2-121d	2-124	Upper drag link . . . . .	.2-218	2-175
Removal . . . . .	.2-121a	2-123	Steering wheel:		
Special tools and equipment . . . . .	.2-4	2-1	Installation . . . . .	.2-216b	2-175
Speedometer and flexible shaft . . . . .	.2-150	2-140	Removal . . . . .	.2-216a	2-174
Speedometer sending unit:			Stoplight and taillight (including		
Installation . . . . .	.2-164b	2-142	directional light):		
Removal . . . . .	.2-164a	2-142	Installation . . . . .	.2-138b	2-136
Springs:			Removal . . . . .	.2-138a	2-136
Front . . . . .	.2-231	2-182	Stoplight switch:		
Rear . . . . .	.2-232	2-183	Installation . . . . .	.2-158b	2-141
Spring seats:			Removal . . . . .	.2-158a	2-141
Bearing adjustment . . . . .	.2-233a	2-183	Storage, administrative . . . . .	.1-4	1-1
Installation . . . . .	.2-233c	2-184	Switches (see instrument cluster)		
Installation . . . . .	.2-233b	2-184	Tabulated data and identification . . . . .	.1-7	
Springs and shock absorbers:			Tachograph kit . . . . .	.2-152	2-140
Front springs . . . . .	.2-231	2-182	Tachometer and flexible shaft . . . . .	.2-151	2-140
General . . . . .	.2-230	2-181	Tachometer sending unit:		
Rear springs . . . . .	.2-232	2-183	Installation . . . . .	.2-165b	2-142
Shock absorbers . . . . .	.2-234	2-184	Removal . . . . .	.2-165a	2-142
Spring seats . . . . .	.2-233	2-183	Tachometer sending unit—multifuel models:		
Starter circuit testing—diesel			installation . . . . .	.2-166b	2-143
and multifuel:			Removal . . . . .	.2-166a	2-143
Description . . . . .	.2-27a	2-43	Tailpipe and extension—gasoline engine:		
Starter amperage draw test . . . . .	.2-27c	2-43	Installation . . . . .	.2-100b	2-111
Starter draw check at battery . . . . .	.2-27b	2-43	Removal . . . . .	.2-100a	2-111
Starter:			Temperature gage:		
Diesel and multifuel models:			Installation . . . . .	.2-153b	2-140
Installation . . . . .	.2-128b	2-130	Removal . . . . .	.2-153a	2-140
Removal . . . . .	.2-128a	2-129	Temperature gage sending unit:		
Gasoline models:			Installation . . . . .	.2-167b	2-143
Installation . . . . .	.2-124b	2-128	Removal . . . . .	.2-167a	2-143
Removal . . . . .	.2-124a	2-128	Test equipment, electrical (see		
Linkage:			electrical test equipment)		
Installation . . . . .	.2-125b	2-129	Thermostats and seal, cooling system—		
Removal . . . . .	.2-125a	2-128	multifuel models:		
Starter circuit testing—gasoline engine:			Installation . . . . .	.2-115b	2-121
Description . . . . .	.2-26a	2-40	Removal . . . . .	.2-115a	2-120
Starter amperage draw test . . . . .	.2-26d	2-42	Thermostats, cooling system:		
Starter draw check at battery . . . . .	.2-26b	2-40	Installation . . . . .	.2-114b	2-120
Testing starter solenoid . . . . .	.2-26c	2-41	Removal . . . . .	.2-114a	2-120
Starting system—diesel multifuel:			Throttle control—gasoline:		
General . . . . .	.2-127	2-129	Adjustment . . . . .	.2-68a	2-89
Solenoid . . . . .	.2-129	2-130	Installation . . . . .	.2-68c	2-89
Starter . . . . .	.2-128	2-129	Removal . . . . .	.2-68b	2-89
Starting system—gasoline engine:			Throttle linkage—diesel and		
General . . . . .	.2-123	2-128			

	Paragraph	Page		Paragraph	Page
multifuel models:			Removal . . . . .	2-52a	2-82
Installation . . . . .	2-83b	2-99	Turbocharger oil lines and connections—multifuel:		
Removal . . . . .	2-83a	2-99	Installation . . . . .	2-58b	2-84
Tie rod:			Removal . . . . .	2-58a	2-84
Installation . . . . .	2-215b	2-174	Turn signal switch:		
Removal . . . . .	2-215a	2-174	Installation . . . . .	2-170b	2-144
Tire (with bolted-on side ring) and tube assembly:			Removal . . . . .	2-170a	2-144
Installation . . . . .	2-208c	2-170	Universal joints (see propeller shaft)		
Removal . . . . .	2-208a	2-170	Upper drag link:		
Repair of tube . . . . .	2-208b	2-170	Installation . . . . .	2-218b	2-176
Tire (with snap-on side ring) and tube assembly:			Removal . . . . .	2-218a	2-175
installation . . . . .	2-209c	2-170	Valve clearance adjustment—gasoline engine:		
Repair of tube . . . . .	2-209b	2-170	Adjustment . . . . .	2-45c	2-77
Removal . . . . .	2-209a	2-170	Preliminary . . . . .	2-45a	2-76
Trailer brake couplings:			Valve rocker cover—gasoline engine:		
Installation . . . . .	2-203b	2-168	Removal . . . . .	2-45e	2-76
Removal . . . . .	2-203a	2-168	Replacement . . . . .	2-45d	2-77
Transfer case:			Van body clearance and blackout lamps—expansible van:		
Air shift lines and connectors . . . . .	2-177	2-146	Installation . . . . .	2-269b	2-208
Breather vent . . . . .	2-175	2-146	Removal . . . . .	2-269a	2-208
Controls and linkage repair . . . . .	2-176	2-146	Van body clearance and blackout lights—expansible van:		
Service . . . . .	2-174	2-146	Installation . . . . .	2-270b	2-208
Transmission: Servicing . . . . .	2-172	2-146	Removal . . . . .	2-270a	2-208
Transmission breather vent:			Van operating and locking devices—expansible van:		
Installation . . . . .	2-173b	2-146	Drive shaft locking pawls:		
Removal . . . . .	2-173a	2-146	Installation . . . . .	2-262b	2-205
Troop seat, cargo . . . . .	2-240	2-188	Removal . . . . .	2-262b	2-205
Troop seat accessory kit—dump body M51 and M51A2 . . . . .	2-245	2-190	Drive shaft locking plungers:		
Bow storage . . . . .	2-245d	2-193	Installation . . . . .	2-262c	2-206
Installation . . . . .	2-245a	2-190	Removal . . . . .	2-262c	2-206
Removal . . . . .	2-245b	2-191	Drive shaft locking ratchets:		
Side racks and bows . . . . .	2-245c	2-192	Installation . . . . .	2-262a	2-205
Tarpaulin, cover, and safety strap . . . . .	2-245e	2-194	Removal . . . . .	2-262a	2-205
Troubleshooting the electrical system:			Vehicle troubleshooting (see troubleshooting the vehicle)		
Batteries . . . . .	2-22	2-34	Ventilation lines and fittings—gasoline (see lines and fittings—gasoline)		
Expansible van body . . . . .	2-35	2-62	Vertical exhaust stack—multifuel models:		
Fuel gage circuit . . . . .	2-30	2-46	Installation . . . . .	2-107b	2-113
General . . . . .	2-15	2-20	Removal . . . . .	2-107a	2-113
Generator system . . . . .	2-23	2-35	Warning buzzer (see instrument cluster)		
Generator testing . . . . .	2-24	2-36	Warning light switch:		
Ignition circuits . . . . .	2-32	2-49	Installation . . . . .	2-287b	2-216
Ignition unit . . . . .	2-33	2-51	Removal . . . . .	2-287a	2-216
Light circuit . . . . .	2-34	2-51	Water hoses and lines, cooling system . . . . .	2-116a	2-121
Monitoring circuit . . . . .	2-30	2-46	Water pump, cooling system:		
Oil gage circuit . . . . .	2-30	2-46	Diesel engine:		
Power loss . . . . .	2-28/ 2-29	2-43/ 2-46	Installation . . . . .	2-118b	2-122
Regulator . . . . .	2-25	2-38	Removal . . . . .	2-118a	2-122
Sending units . . . . .	2-31	2-48	Gasoline engine:		
Spark plugs . . . . .	2-33	2-51	Installation . . . . .	2-117b	2-121
Starter circuit . . . . .	2-26/ 2-27	2-40/ 2-43	Removal . . . . .	2-117a	2-121
System circuits . . . . .	2-16	2-20	Multifuel engine:		
Temperature gage circuit . . . . .	2-30	2-46	Installation . . . . .	2-118.1b	2-122
Test equipment . . . . .	2-17	2-23	Removal . . . . .	2-118.1a	2-122
Troubleshooting the vehicle:			Wheel and tire assembly:		
General . . . . .	2-13	2-10.20			
Procedures . . . . .	2-14	2-10.20			
Turbocharger oil lines and fittings—diesel:					
Installation . . . . .	2-52b	2-82			



	Paragraph	Page		Paragraph	Page
Installation	2-207c	2-169	Wrecker crane—M543, M543A1,		
Maintenance	2-207a	2-169	and M543A2—Continued		
Removal	2-207b	2-169	Electric brake lock	2-301	2-219
Wheel bearings:			Floodlight	2-299	2-219
Adjustment	2-211a	2-171	Floodlight cables	2-300	2-219
Cleaning and inspection	2-211c	2-171	Floodlight lamp unit	2-297	2-219
Installation	2-211d	2-171	Floodlight switch	2-298	2-219
Removal	2-211b	2-171	Floodlight switch (inside cab)	2-303	2-219
Wheel bearing cups:			General	2-292	2-217
installation	2-212b	2-172	Governor override solenoid	2-306	2-219
Removal	2-212a	2-172	Hoist cable	2-310	2-220
Wheels, general	2-206a	2-168	Hoist cable sheaves and		
Winch (see front winch and			guard	2-311	2-222
rear winch)			Hydraulic cylinders	2-294	2-217
Window blackout panel—expansible van:			Hydraulic lines and fittings	2-293	2-217
Installation	2-261b	2-205	Hydraulic system filter	2-296	2-218
Removal	2-261a	2-205	Hydraulic system pressure	2-295	2-217
Window brush guards—expansible van:			Override switch	2-307	2-219
Installation	2-258b	2-205	Propeller shaft	2-312	2-223
Removal	2-258a	2-205	Restrictor valve	2-305	2-219
Window glass and seal—expansible van:			Slipring brush	2-308	2-220
Installation	2-260b	2-205	Warning light switch	2-302	2-219
Removal	2-260a	2-205	Wrecker crane—M62, M246,		
Window regulators—expansible van:			M246A1, and M246A2:		
Installation	2-259b	2-205	Control lever knob	2-289	2-216
Removal	2-259a	2-205	Electric brake lock	2-285	2-215
Window screens—expansible van:			Electric brake lock switch	2-286	2-216
Installation	2-257b	2-205	Floodlight	2-283	2-214
Removal	2-257a	2-205	Floodlight lamp unit	2-281	2-213
Windshield assembly:			Floodlight switch	2-282	2-214
Installation	2-238b	2-186	Floodlight switch (inside cab)	2-288	2-216
Removal	2-238a	2-186	General	2-279	2-212
windshield wiper (see body			Hoist cables	2-291	2-216
accessory items)			Hydraulic lines and fittings	2-280	2-212
Windshield wiper motor (see			Restrictor valve	2-290	2-216
body accessory items)			Warning light switch	2-287	2-216
Wiring	2-140a	2-136			
Wiring circuits and harnesses:					
General	2-140	2-136			
Receptacles	2-141	2-137			
Wrecker crane—M543, M543A1,					
and M543A2:					
Automatic hoist brake band	2-309	2-220			
Boom and shipper cable rollers	2-313	2-224.1			
Control lever knob	2-304	2-219			

THIS PAGE LEFT BLANK INTENTIONALLY

By Order of the Secretary of the Army:

**CREIGHTON W. ABRAMS**  
*General, United States Army*  
*Chief of Staff*

Official:

**VERNE L. BOWERS**  
*Major General, United States Army*  
*The Adjutant General*

Distribution:

To be distributed in accordance with DA Form 12-38, Organizational Maintenance Requirements for 5-Ton Trucks Cargo, M41, M54, M55, Truck Dump, M51, Truck Tractor, M52, M246, Truck Van Expansibile, M291A2, M291A2C, M291A2D; M291A2, M291A2C, and Truck Wreckers, Medium M62 and M543.





# SOMETHING WRONG WITH THIS PUBLICATION?

THEN... JOT DOWN THE DOPE ABOUT IT ON THIS FORM, CAREFULLY TEAR IT OUT, FOLD IT AND DROP IT IN THE MAIL!

FROM: (PRINT YOUR UNIT'S COMPLETE ADDRESS)  
 CDR 1st Bn 65th ADA  
 Attn: SP4 Jane Idone  
 Key West FL 33040

DATE SENT  
 Date sent in

PUBLICATION NUMBER  
 C3, TM 9-2320-211-20

PUBLICATION DATE  
 28 Apr 82

PUBLICATION TITLE  
 ORGANIZATIONAL MAINTENANCE MANUAL

BE EXACT... PIN-POINT WHERE IT IS

IN THIS SPACE TELL WHAT IS WRONG AND WHAT SHOULD BE DONE ABOUT IT:

PAGE NO.	PARA-GRAPH	FIGURE NO.	TABLE NO.
2-48	2-307		
2-171	2-210 b.(5)		
2-80		2-53	

CHANGE TO READ AS FOLLOWS: TO CHECK TEMPERATURE GAGE, GROUND ONE END OF JUMPER WIRE FROM THE GAGE TO VEHICLE GROUND. THE TEMPERATURE GAGE SHOULD READ HIGH TEMPERATURE WHEN GROUNDED, AND ZERO TEMPERATURE WHEN JUMPER IS NOT GROUNDED.

CHANGE TO READ AS FOLLOWS: USING A WHEEL NUT WRENCH (5, Fig. 2-4), INSTALL THE INNER BEARING ADJUSTMENT NUT ON THE SPINDLE.

CLUTCH PEDAL FREE TRAVEL SHOULD BE (2 TO 2 1/2 IN.) ALSO, CHANGE NOTE ABOVE FIGURE 2-53 TO READ 2 TO 2 1/2 INCHES.

# SAMPLE

TA 126410

PRINTED NAME, GRADE OR TITLE, AND TELEPHONE NUMBERS  
 SP4 Jane Idone AutoVan 222-2224

SIGN HERE:  
*Jane Idone*

FILL IN YOUR  
UNIT'S ADDRESS



FOLD BACK

DEPARTMENT OF THE ARMY

POSTAGE AND FEES PAID  
DEPARTMENT OF THE ARMY  
DOD 314



TEAR ALONG PERFORATED LINE

OFFICIAL BUSINESS  
PENALTY FOR PRIVATE USE \$300

COMMANDER  
U.S. ARMY TANK-AUTOMOTIVE COMMAND  
ATTN: DRSTA-MBA  
WARREN, MI 48090

SAMPLE



FILL IN YOUR  
UNIT'S ADDRESS



FOLD BACK

DEPARTMENT OF THE ARMY

POSTAGE AND FEES PAID  
DEPARTMENT OF THE ARMY  
DOD 314



TEAR ALONG PERFORATED LINE

OFFICIAL BUSINESS  
PENALTY FOR PRIVATE USE \$300

COMMANDER  
U.S. ARMY TANK-AUTOMOTIVE COMMAND  
ATTN: DRSTA-MBA  
WARREN, MI 48090





FILL IN YOUR  
UNIT'S ADDRESS



FOLD BACK

DEPARTMENT OF THE ARMY

---

---

OFFICIAL BUSINESS  
PENALTY FOR PRIVATE USE \$300

POSTAGE AND FEES PAID  
DEPARTMENT OF THE ARMY  
DOD 314



TEAR ALONG PERFORATED LINE

COMMANDER  
U.S. ARMY TANK-AUTOMOTIVE COMMAND  
ATTN: DRSTA-MBA  
WARREN, MI 48090



FILL IN YOUR  
UNIT'S ADDRESS



FOLD BACK

DEPARTMENT OF THE ARMY

---

---

OFFICIAL BUSINESS  
PENALTY FOR PRIVATE USE \$300

POSTAGE AND FEES PAID  
DEPARTMENT OF THE ARMY  
DOD 314



TEAR ALONG PERFORATED LINE

COMMANDER  
U.S. ARMY TANK-AUTOMOTIVE COMMAND  
ATTN: DRSTA-MBA  
WARREN, MI 48090



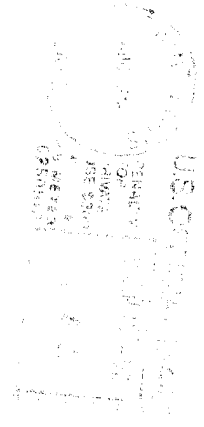
DEPARTMENT OF THE ARMY  
 US ARMY PUBLICATIONS CENTER  
 1655 WOODSON ROAD  
 ST. LOUIS, MISSOURI 63114-6181

SPECIAL FOURTH  
 CLASS RATE BOOKS

OFFICIAL BUSINESS  
 PENALTY FOR PRIVATE USE, \$300

COMMANDER  
 USAMC MAT RDMS SPT ACTV  
 ATTN AMXMD-PC (LIBRARY)  
 LEXINGTON KY 40511-5101

NO499



DA PUBLICATION/FORM NUMBER			CHG OR DATE	
TM 9-2320-211-20				
LOCATION	QUANTITY	UNIT OF ISSUE	ACTION	ROM DATE
LCISE	2	EA		7212
PKG SIZE	ITEM NO.	BULK/RCPY DATE	SLAGPC CONTROL NO.	
	364753	PLK7216	7217	13660

APC FORM 4-26S (10 Sep 86)

PREVIOUS EDITION MAY BE USED IF EXHAUSTED

ZEAE 4