

**TECHNICAL MANUAL**  
**VOLUME 1 OF 3**  
**SCHEDULED MAINTENANCE**  
**ORGANIZATIONAL LEVEL**  
**5-TON, 6X6, M39 SERIES TRUCKS**  
**(MULTIFUEL)**

**TRUCK, CHASSIS: M40A2C,**  
**M61A2, M63A2; TRUCK, CARGO:**  
**M54A2, M54A2C, M55A2; TRUCK,**  
**DUMP: M51A2; TRUCK, TRACTOR:**  
**M52A2; TRUCK, WRECKER, MEDIUM: M543A2**

Chapter 1  
Preventive  
Maintenance

Chapter 2  
Checkout ,  
Alinement, and  
Adjustment

Chapter 3  
Lubrication

Chapter 4  
Scheduled  
Maintenance of  
Material Used  
in Conjunction  
with Major  
Items

Appendix A  
References

Appendix B  
Maintenance  
Allocation Chart

**NOTE:**  
THE STYLE OF THIS TM IS  
EXPERIMENTAL. IT IS BEING TRIED  
BY THE ARMY ONLY ON  
A LIMITED BASIS

---

**WARNING**

---

**EXHAUST GASES CAN BE DEADLY**

Exposure to exhaust gases produces symptoms of headache, dizziness, loss of muscular control, apparent drowsiness, and coma. Permanent brain damage or death can result from severe exposure.

Carbon monoxide occurs in the exhaust fumes of fuel burning heaters and internal combustion engines, and becomes dangerously concentrated under conditions of inadequate ventilation. The following precautions must be observed to insure the safety of personnel whenever fuel burning heater(s) or engine of any vehicle is operated for maintenance purposes or tactical use.

Do not operate heater or engine of vehicle in an enclosed area unless it is adequately ventilated.

Do not idle engine for long periods without maintaining adequate ventilation in personnel compartments.

Do not drive any vehicle with inspection plates or cover plates removed unless necessary for maintenance purposes.

Be alert at all times during vehicle operation for exhaust odors and exposure symptoms. If either are present, immediately ventilate personnel compartments. If symptoms persist, remove affected personnel from vehicle and treat as follows: expose to fresh air; keep warm; do not permit physical exercise; if necessary, administer artificial respiration.

If exposed, seek prompt medical attention for possible delayed onset of acute lung congestion. Administer oxygen if available.

The best defense against exhaust gas poisoning is adequate ventilation.

---

**WARNING**

---

Serious or fatal injury to personnel may result if the following instructions are not complied with.

Use extreme care when removing radiator cap, especially when temperature gage shows above 180°F.

Always wear leather gloves when handling winch cable. Never allow cable to slip through hands. Do not operate winch with less than four turns of cable on drum.

Do not drive truck until the low air pressure warning buzzer is silent and the air pressure gage shows at least 65 PSI. This is the minimum pressure required for safe braking action.

Do not use hand throttle to drive the vehicle.

Do not park truck with front transmission gearshift lever in gear.

If your vehicle class number is greater than the bridge class number, do not cross.

CHANGE

NO. 1

HEADQUARTERS  
DEPARTMENT OF THE ARMY  
Washington D.C., 30 November 1990

TECHNICAL MANUAL  
VOLUME 1 OF 3  
**SCHEDULED MAINTENANCE**  
ORGANIZATIONAL LEVEL  
**5-TON, 6X6 M39 SERIES TRUCKS**  
**(MULTIFUEL)**  
  
**TRUCK, CHASSIS: M40A2C,**  
**M61A2, M63A2, TRUCK, CARGO:**  
**M54A2, M54A2C, M55A2; TRUCK,**  
**DUMP: M51A2; TRUCK, TRACTOR:**  
**M52A2; TRUCK, WRECKER, MEDIUM: M543A2**

TM 9-2320-211-20-1, dated 10 December 1980 is changed as follows:

1. Remove old pages and insert new pages as indicated below.
2. New or changed material is indicated by a vertical bar in the margin of the page.

Remove Pages	Insert Pages
1-9 and 1-10	1-9 and 1-10

File this change sheet in front of the publication for reference purposes.

By Order of the Secretary of the Army

CARL E. VUONO  
*General, United States Army*  
*Chief of Staff*

THOMAS F. SIKORA  
*Brigadier General, United States Army*  
*The Adjutant General*

Distribution:

To be distributed in accordance with DA Form 12-38-E. Block 0515, Unit maintenance requirements for TM 9-2320-211-20-1.

**Approved for Public release; distribution Is unlimited.**



TECHNICAL MANUAL  
NO.9-2320-211-20-1  
TECHNICAL ORDER  
NO.36A12-1C-422-1-1

DEPARTMENTS OF THE ARMY  
AND  
THE AIR FORCE  
WASHINGTON, DC, 10 December 1980

**TECHNICAL MANUAL**  
**VOLUME 1 OF 3**  
**SCHEDULED MAINTENANCE**  
**ORGANIZATIONAL LEVEL**  
**5-TON, 6X6, M39 SERIES TRUCKS**  
**(MULTIFUEL)**

Model		NSN without Winch	NSN with Winch
Chassis	M40A2C	2320-00-969-4114	
	M61A2	2320-00-055-9264	2320-00-965-0321
	M63A2	2320-00-226-6251	2320-00-285-3757
Truck, Cargo	M54A2	2320-00-055-9266	2320-00-055-9265
	M54A2C	2320-00-926-0874	2320-00-926-0874
	M55A2C	2320-00-073-8476	2320-00-055-9259
Truck, Dump	M51A2	2320-00-055-9262	2320-00-055-9263
Truck, Tractor	M52A2	2320-00-055-9260	2320-00-055-9261
Truck, Wrecker, Medium	M543A2		2320-00-055-9258

\*This manual together with TM 9-2320-211-20-2-1, 10 December 1980; TM 9-2320-211-20-2-2, 10 December 1980; TM 9-2320-20-3-1, 10 December 1980 and TM 9-2320-211-20-3-2, 10 December 1980 supersedes so much of TM 9-2320-211-20, 1 June 1973 as pertains to multi fuel vehicles.

**REPORTING OF ERRORS AND RECOMMENDING IMPROVEMENTS**

You can help improve this manual. If you find any mistakes or if you know of a way to improve the procedure, please let us know. Mail your letter, DA Form 2028 (Recommended Changes to Publication and Blank Forms), or DA Form 2028-2 located in the back of this manual direct to: Commander, U.S. Army Tank Automotive Materiel Readiness Command, ATTN: DRSTA-MB, Warren, Michigan 48090. A reply will be furnished to you.

VOLUME 1 OF 3

	Paragraph	Page
CHAPTER 1. PREVENTIVE MAINTENANCE		
General . . . . .	1-1	1-1
Intervals . . . . .	1-2	1-1
Reporting Repairs . . . . .	1-3	1-1
General Service and Inspection Procedures . . . . .	1-4	1-1
Specific PMCS Procedures . . . . .	1-5	1-2
Preventive Maintenance Locators. . . . .	1-6	1-2
2. CHECKOUT, ALINEMENT, AND ADJUSTMENT		
General . . . . .	2-1	2-1
3. LUBRICATION		
General . . . . .	3-1	3-1
Special Instructions. . . . .	3-2	3-1
4. SCHEDULED MAINTENANCE OF MATERIAL USED IN CONJUNCTION WITH MAJOR ITEMS		
General . . . . .	4-1	4-1
PMCS Procedures. . . . .	4-2	4-1
APPENDIX A. REFERENCES . . . . .		A-1
B. MAINTENANCE ALLOCATION CHART . . . . .		B-1

VOLUME 2 OF 3

Part 1 of 2

CHAPTER 1. GENERAL INFORMATION . . . . .	1-1
2. TROUBLESHOOTING APPROACH . . . . .	2-1
3. TROUBLESHOOTING INDEX. . . . .	3-1
4. TEST EQUIPMENT PROCEDURES INDEX . . . . .	4-1
5. TROUBLESHOOTING ROADMAPS. . . . .	5-1
6. FAULT SYMPTOM INDEXES . . . . .	6-1
7. SAMPLE TROUBLESHOOTING PROCEDURES . . . . .	7-1
8. ENGINE SYSTEM TROUBLESHOOTING. . . . .	8-1
9. ENGINE SYSTEM TROUBLESHOOTING SUMMARY . . . . .	9-1
10. ENGINE DRIVELINE SUBSYSTEM TROUBLESHOOTING . . . . .	10-1
11. CLUTCH SYSTEM TROUBLESHOOTING . . . . .	11-1
12. CLUTCH SYSTEM TROUBLESHOOTING SUMMARY . . . . .	12-1
13. CLUTCH SYSTEM CHECKOUT PROCEDURES . . . . .	13-1
14. FUEL SYSTEM TROUBLESHOOTING. . . . .	14-1

	Page
CHAPTER 15. FUEL SYSTEM TROUBLESHOOTING	
SUMMARY.....	15-1
16. FUEL SYSTEM SUPPORT DIAGRAMS . . . . .	16-1
17. FUEL SYSTEM TEST PROCEDURES . . . . .	17-1
18. FUEL SYSTEM CHECKOUT PROCEDURES . . . . .	18-1
19. EXHAUST SYSTEM TROUBLESHOOTING. . . . .	19-1
20. EXHAUST SYSTEM TROUBLESHOOTING	
SUMMARY.....	20-1
21. EXHAUST SYSTEM SUPPORT DIAGRAMS . . . . .	21-1
22. COOLING SYSTEM TROUBLESHOOTING . . . . .	22-1
23. COOLING SYSTEM TROUBLESHOOTING	
SUMMARY.....	23-1
24. COOLING SYSTEM TEST PROCEDURES. . . . .	24-1
25. COOLING SYSTEM CHECKOUT	
PROCEDURES.....	25-1
26. ELECTRICAL SYSTEM TROUBLESHOOTING. . . . .	26-1

Part 2 of 2

27. ELECTRICAL SYSTEM TROUBLESHOOTING	
SUMMARY.....	27-1
28. ELECTRICAL SYSTEM SUPPORT DIAGRAMS . . . . .	28-1
29. ELECTRICAL SYSTEM TEST EQUIPMENT	
PROCEDURES.....	29-1
30. ELECTRICAL SYSTEM OPERATING AND	
PRELIMINARY PROCEDURES . . . . .	30-1
31. ELECTRICAL SYSTEM CHECKOUT	
PROCEDURES.....	31-1
32. TRANSMISSION SYSTEM TROUBLESHOOTING . . . . .	32-1
33. TRANSFER SYSTEM TROUBLESHOOTING. . . . .	33-1
34. TRANSFER SYSTEM TROUBLESHOOTING SUMMARY	34-1
35. TRANSFER SYSTEM SUPPORT DIAGRAMS . . . . .	35-1
36. TRANSFER SYSTEM CHECKOUT	
PROCEDURES.....	36-1
37. PROPELLER SHAFT SYSTEM TROUBLE-	
SHOOTING.....	37-1
38. PROPELLER SHAFT SYSTEM TROUBLE-	
SHOOTING SUMMARY.....	38-1
39. PROPELLER SHAFT SYSTEM SUPPORT	
DIAGRAMS.....	39-1
40. FRONT AXLE SYSTEM TROUBLESHOOTING.....	40-1
41. FRONT AXLE SYSTEM TROUBLESHOOTING	
SUMMARY.....	41-1
42. FRONT AXLE SYSTEM CHECKOUT	
PROCEDURES.....	42-1
43. REAR AXLE SYSTEM TROUBLESHOOTING. . . . .	43-1
44. REAR AXLE SYSTEM TROUBLESHOOTING	
SUMMARY. . . . .	44-1

	<b>Page</b>
CHAPTER 45. REAR AXLE SYSTEM CHECKOUT PROCEDURES. . . . .	45-1
46. BRAKE SYSTEM TROUBLESHOOTING . . . . .	46-1
47. BRAKE SYSTEM TROUBLESHOOTING SUMMARY. . . . .	47-1
48. BRAKE SYSTEM SUPPORT DIAGRAMS . . . . .	48-1
49. BRAKE SYSTEM TEST PROCEDURES . . . . .	49-1
50. BRAKE SYSTEM CHECKOUT PROCEDURES . . . . .	50-1
51. WHEEL SYSTEM TROUBLESHOOTING . . . . .	51-1
52. WHEEL SYSTEM TROUBLESHOOTING SUMMARY. . . . .	52-1
53. WHEEL SYSTEM CHECKOUT PROCEDURES. . . . .	53-1
54. STEERING SYSTEM TROUBLESHOOTING . . . . .	54-1
55. STEERING SYSTEM TROUBLESHOOTING SUMMARY. . . . .	55-1
56. STEERING SYSTEM SUPPORT DIAGRAMS . . . . .	56-1
57. STEERING SYSTEM CHECKOUT PROCEDURES . . . . .	57-1
58. SPRING AND SHOCK ABSORBER SYSTEM TROUBLESHOOTING. . . . .	58-1
59. SPRING AND SHOCK ABSORBER SYSTEM TROUBLESHOOTING SUMMARY. . . . .	59-1
60. FRONT WINCH TROUBLESHOOTING . . . . .	60-1
61. FRONT WINCH TROUBLESHOOTING SUMMARY . . . . .	61-1
62. FRONT WINCH CHECKOUT PROCEDURES . . . . .	62-1
63. DUMP BODY AND HOIST SYSTEM TROUBLESHOOTING. . . . .	63-1
64. DUMP BODY AND HOIST SYSTEM TROUBLESHOOTING SUMMARY. . . . .	64-1
65. DUMP BODY AND HOIST SYSTEM SUPPORT DIAGRAMS. . . . .	65-1
66. DUMP BODY AND HOIST SYSTEM TEST PROCEDURES. . . . .	66-1
67. DUMP BODY AND HOIST SYSTEM CHECKOUT PROCEDURES. . . . .	67-1
68. REAR WINCH TROUBLESHOOTING. . . . .	68-1
69. REAR WINCH TROUBLESHOOTING SUMMARY . . . . .	69-1
70. REAR WINCH SUPPORT DIAGRAMS. . . . .	70-1
71. REAR WINCH CHECKOUT PROCEDURES . . . . .	71-1
72. WRECKER SYSTEM TROUBLESHOOTING . . . . .	72-1
73. WRECKER SYSTEM TROUBLESHOOTING SUMMARY. . . . .	73-1
74. WRECKER SYSTEM SUPPORT DIAGRAMS . . . . .	74-1
75. WRECKER SYSTEM TEST PROCEDURES. . . . .	75-1
76. WRECKER SYSTEM CHECKOUT PROCEDURES . . . . .	76-1
77. ENGINE COOLANT HEATER TROUBLESHOOTING. . . . .	77-1
78. ENGINE COOLANT HEATER TROUBLESHOOTING SUMMARY. . . . .	78-1



	Page
CHAPTER 79. ENGINE COOLANT HEATER TEST PROCEDURES . . . . .	79-1
80. ENGINE COOLANT HEATER CHECKOUT PROCEDURES. . . . .	80-1
81. FUEL BURNING HEATER SYSTEM TROUBLESHOOTING. . . . .	81-1
82. FUEL BURNING HEATER SYSTEM TROUBLESHOOTING SUMMARY. . . . .	82-1
83. FUEL BURNING HEATER SYSTEM CHECKOUT PROCEDURES . . . . .	83-1
84. HOT WATER HEATER SYSTEM TROUBLESHOOTING. . . . .	84-1
85. HOT WATER HEATER SYSTEM TROUBLESHOOTING SUMMARY. . . . .	85-1
86. HOT WATER HEATER SYSTEM CHECKOUT PROCEDURES . . . . .	86-1
87. NONELECTRICAL GAGES TROUBLESHOOTING. . . . .	87-1
88. NONELECTRICAL GAGES TROUBLESHOOTING SUMMARY. . . . .	88-1
89. NONELECTRICAL GAGES SUPPORT DIAGRAMS. . . . .	89-1
90. NONELECTRICAL GAGES CHECKOUT PROCEDURES. . . . .	90-1

VOLUME 3 OF 3

Part 1 of 2

CHAPTER 1. GENERAL MAINTENANCE INFORMATION . . . . .	1-1
2. ENGINE SYSTEM GROUP MAINTENANCE	
Section I. Scope. . . . .	2-1
II. Valve Covers and Gaskets . . . . .	2-1
III. Engine Lubrication System. . . . .	2-13
3. CLUTCH SYSTEM GROUP MAINTENANCE	
I. Scope. . . . .	3-1
II. Clutch Release Mechanism . . . . .	3-1
4. FUEL SYSTEM GROUP MAINTENANCE	
I. Scope. . . . .	4-1
II. Fuel Pumps. . . . .	4-1
III. Air Cleaner. . . . .	4-10
IV. Turbocharger. . . . .	4-22
v. Fuel Tanks and Fuel Lines. . . . .	4-26
VI. Fuel Filters. . . . .	4-59
VII. Engine Starting Aids. . . . .	4-85
VIII. Accelerator and Throttle Control . . . . .	4-160
5. EXHAUST SYSTEM GROUP MAINTENANCE	
I. Scope. . . . .	5-1
II. Exhaust Pipes and Mufflers. . . . .	5-1

CHAPTER 6.	COOLING SYSTEM GROUP MAINTENANCE	
Section I.	Scope. . . . .	6-1
II.	Radiator Assembly. . . . .	6-1
III.	Thermostat. . . . .	6-30
IV.	Water Pump. . . . .	6-36
V.	Fan Assembly and Related Parts . . . . .	6-48
VI .	Cooling System. . . . .	6-59
7.	ELECTRICAL SYSTEM GROUP MAINTENANCE	
I.	Scope. . . . .	7-1
II.	Charging System. . . . .	7-1
III.	Starting System. . . . .	7-24
IV.	Engine Safety Controls. . . . .	7-37
V.	Instrument Panel Components. . . . .	7-41
VI.	Lighting System. . . . .	7-131
VII.	Gage Sending Units and Warning Switches . . . . .	7-195
VIII.	Horn Assembly. . . . .	7-205
IX.	Battery System. . . . .	7-214
X.	Chassis Harnesses. . . . .	7-237
XI.	Miscellaneous Items. . . . .	7-249
8.	TRANSMISSION SYSTEM GROUP MAINTENANCE	
I.	Scope. . . . .	8-1
II.	Transmission Breather. . . . .	8-1
9.	TRANSMISSION TRANSFER SYSTEM GROUP MAINTENANCE	
I.	Scope. . . . .	9-1
II.	Transmission Transfer Air System . . . . .	9-1
10.	PROPELLER SHAFTS GROUP MAINTENANCE	
I.	Scope. . . . .	10-1
II.	Propeller Shaft Assemblies . . . . .	10-1
11.	FRONT AND REAR AXLES GROUP MAINTENANCE	
I.	Scope. . . . .	11-1
II.	Front and Rear Axle Housings. . . . .	11-1
III.	Steering Mechanism. . . . .	11-5
IV.	Rear Axle. . . . .	11-12
12.	BRAKE SYSTEM GROUP MAINTENANCE	
I.	Scope. . . . .	12-1
II.	Handbrake Assembly and Related Parts . . . . .	12-1
III.	Service Brankes. . . . .	12-28
IV.	Hydraulic Brake System. . . . .	12-50
V.	Mechanical Branke System. . . . .	12-111
VI.	Air Brake Sytem. . . . .	12-117
VII.	Compressed Air System. . . . .	12-158
VIII.	Trailer Brake Connections.. . . .	12-178
Part 2 of 2		
13.	WHEEL SYSTEM GROUP MAINTENANCE	
I.	Scope. . . . .	13-1
II.	Front Wheel Assembly. . . . .	13-1

	Page
III. Rear Wheel Assembly. . . . .	13-45
IV. Tires. . . . .	13-73
CHAPTER 14. STEERING SYSTEM GROUP MAINTENANCE	
Section I. Scope. . . . .	14-1
II. Mechanical Steering Gear Assembly . . . . .	14-1
III. Steering Hoses, Lines, and Fittings . . . . .	14-41
IV. Steering Reservoir. . . . .	14-47
15. FRAME AND TOWING ATTACHMENTS GROUP MAINTENANCE	
I. Scope. . . . .	15-1
II. Frame Components . . . . .	15-1
III. Pintles and Towing Attachments . . . . .	15-9
IV. Spare Wheel Carrier. . . . .	15-29
V. Fifth Wheel Assembly. . . . .	15-54
16. SPRINGS AND SHOCK ABSORBERS GROUP MAINTENANCE	
I. Scope. . . . .	16-1
II. Springs. . . . .	16-1
III. Shock Absorbers. . . . .	16-32
17. BODY , CAB , HOOD, AND HULL GROUP MAINTENANCE	
I. Scope. . . . .	17-1
II. Body and Cab Components . . . . .	17-1
III. Windshield. . . . .	17-12
IV. Seats. . . . .	17-14
V. Stowage and Tool boxes . . . . .	17-24
VI. Cargo Body Components . . . . .	17-39
18. WINCH , HOIST, AND CRANE ASSEMBLIES GROUP MAINTENANCE	
I. Scope. . . . .	18-1
II. Winch, Hoist, and Crane Assemblies . . . . .	18-1
19. BODY ACCESSORY ITEMS GROUP MAINTENANCE	
I. Scope. . . . .	19-1
II. Canvas Items and Related Part. . . . .	19-1
III. Sccessory Items. . . . .	19-21
IV. Data Plates. . . . .	19-46
20. NONELECTRICAL GAGES GROUP MAINTENANCE	
I. Scope. . . . .	20-1
II. Nonelectrical Gage. . . . .	20-1
21. MAINTENANCE OF MATERIAL USED IN CONJUNCTION WITH MAJOR ITEMS	
I. Scope. . . . .	21-1
II. Winterization Kits. . . . .	21-1
APPENDIX A. REFERENCES . . . . .	A-1
INDEX . . . . .	Index 1



## CHAPTER 1

### PREVENTIVE MAINTENANCE



**1-1. General.** The best way to maintain vehicles covered by this manual is to inspect them on a regular basis so minor faults can be discovered and corrected before they result in serious damage, failure, or injury. This section contains systematic instructions for inspection, adjustment, and correction of vehicle components to avoid costly repairs or major breakdowns. This is preventive maintenance checks and services (PMCS).

**1-2. Intervals.** Organizational maintenance, assisted by operator crew, will perform the checks and services contained in table 1-1 at the following intervals:

a. *Semiannually (S).* Every 6 months or 6,000 miles (9,654 km.), whichever comes first.

b. *Annually (A).* Every 12 months or 12,000 miles (19,308 km.), whichever comes first.

c. *Biennially (B).* Every 24 months or 24,000 miles (38,616 km.), whichever comes first.

**1-3. Reporting Repairs.** All vehicle shortcomings will be reported on DA 2404 (TM 38-750), Equipment Inspection and Maintenance Worksheet, immediately after the PMCS and before taking corrective action. They will also be reported in the equipment log.

#### 1-4. General Service and Inspection Procedures,

a. While performing specific PMCS procedures, make sure items are correctly assembled, secure, not unserviceable, not worn, not leaking, and adequately lubricated as defined below:

(1) An item is **CORRECTLY ASSEMBLED** when it is in proper position and all parts are present.

(2) When wires, nuts, washers, hoses, or attaching hardware to an item cannot be moved by hand, wrench, or pry-bar, it is **SECURE**.

(3) An item is **UNSERVICEABLE** if it is worn beyond repair and is likely to fail before the next scheduled inspection.

(4) An item is **WORN** if there is too much play between joining parts or marking data, warning, and caution plates are not readable.

(5) An item **LEAKS** if:

(a) There is fluid seepage as indicated by wetness, discoloration, or smell; or

(b) There is air seepage as indicated by a hissing sound or the formation of bubbles exist after water has been applied directly over the area in question.

(6) If an item meets the requirements specified by the lubrication order, LO-9-2320-211-12, then it is **ADEQUATELY LUBRICATED**.

b. Where the instruction "tighten" appears in a procedure, you must tighten with a wrench to the given torque value even when the item appears to be secure.

#### WARNING

Dry cleaning solvent used to clean parts can be harmful to personnel and property. Do not use near open flame or excessive heat. Flash point of solvent is 100° F (44.2° C).

c. Where the instruction "clean" appears in a procedure, you must use dry, cleaning solvent (SD-2), specification P-D 680 to clean grease or oil from metal parts. After the item is cleaned, rinsed, and dried, apply a light grade of oil to unprotected surfaces to prevent rusting. On rubber and plastic materials use soap and water.

#### NOTE

**All references to TM9-2320-211-10 apply to the 10 Series only.**

**1-5. Specific PMCS Procedures.**

a. The preventive maintenance for which you are responsible is provided below in table 1-1. The checks and services listed are arranged in logical order requiring minimal time and effort on your part.

b. The following columns read across on the PMCS schedule:

(1) *Item Number.* Provides logical order for PMCS performance and is used as a source number for SF-368. on which your PMCS results will be recorded.

(2) *Intervals.* Shows a bullet (0) opposite each item number to indicate when that check is to be performed. The bullet will be repeated when consecutive item numbers are to be inspected during the same interval. Interval columns include:

- (a) Semiannual (six month) checks;
- (b) Annual (yearly) checks; and
- (c) Biennially (every two years) checks.

(3) *Item To Be Inspected.* Lists the system, common name, or location of the item to be inspected.

(4) *Procedures.* Provides instructions for servicing, inspection, replacement, or adjustment, and in some cases, having item repaired at a higher level.

**1-6. Preventive Maintenance Locators.**

Figures 1-1 through 1-5 show general locations for PMCS.

**NOTE**

Always do your preventive maintenance checks and services in the order it has been prepared. Once it gets to be a habit, you'll be able to spot anything wrong in a hurry.

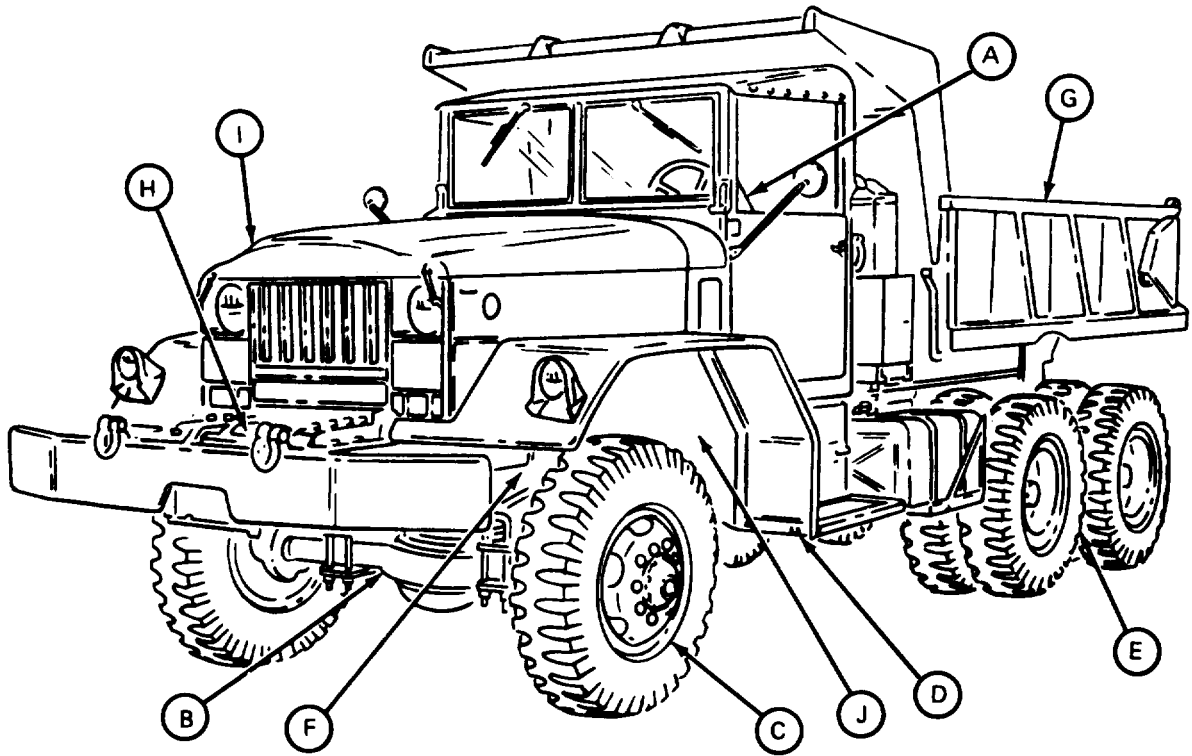

TA 048589

- |                                   |                                |
|-----------------------------------|--------------------------------|
| A. Controls                       | E. Rear axles                  |
| B. Front axle                     | Rear differentials             |
| Front differential                | Rear springs                   |
| Front springs and shock absorbers | F. Steering system             |
| C. Wheel hubs                     | G. Body and frame              |
| Brake drums                       | H. Front winch                 |
| Wheels and tires                  | I. Air cleaner                 |
| D. Transmission                   | Engine crankcase breather      |
| Transfer case                     | Oil filters                    |
| Propeller shafts                  | Manifold preheater             |
| Air reservoirs                    | J. Fuel filters and fuel lines |
| Air-hydraulic cylinder            |                                |

*Figure 1-1. Preventive Maintenance Locators.*

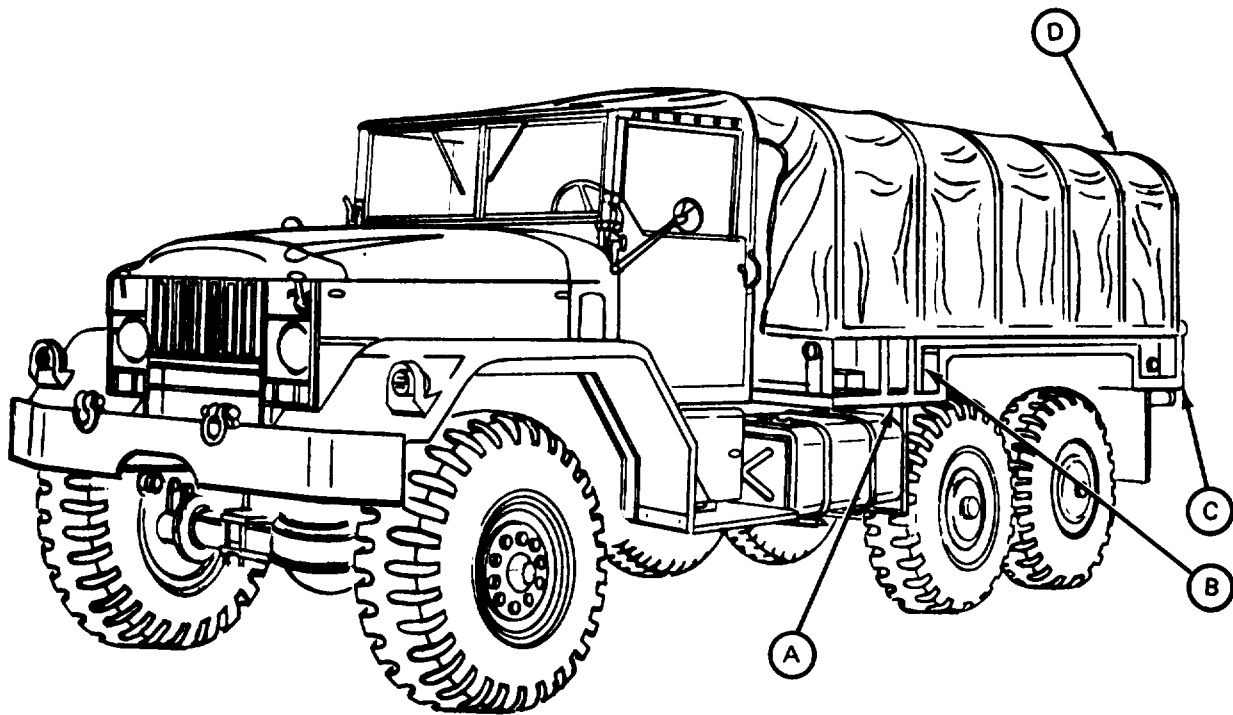

TA 048590

- A. Bedplate
- B. Side panels
- C. Tailgate

D. Tarpaulin

*Figure 1-2. M54A2, M54A2C, and M55A2C, Cargo Trucks, Preventive Maintenance Locators*



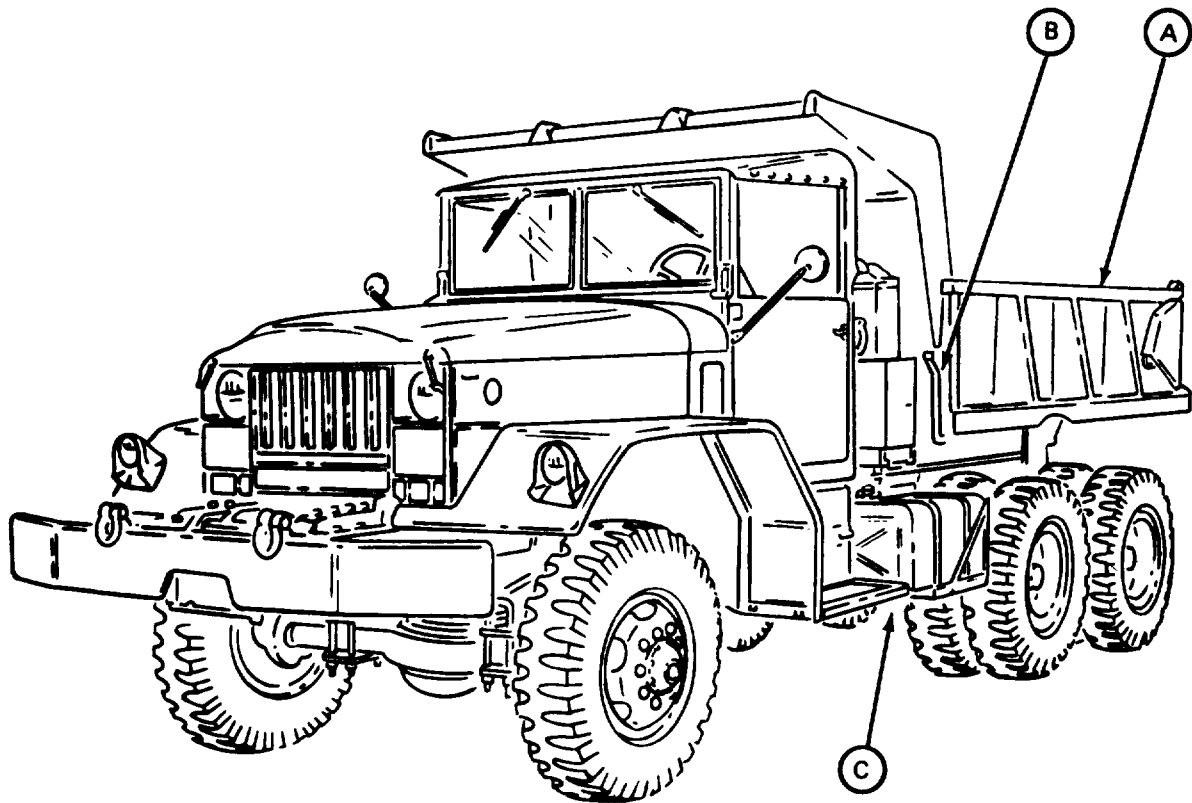

TA 048591

A. Dump body

B. Tailgate control rod hand

C. Hydraulic hoist system

**Figure 1-3. M51A2 Dump Truck, Preventive Maintenance Locators.**

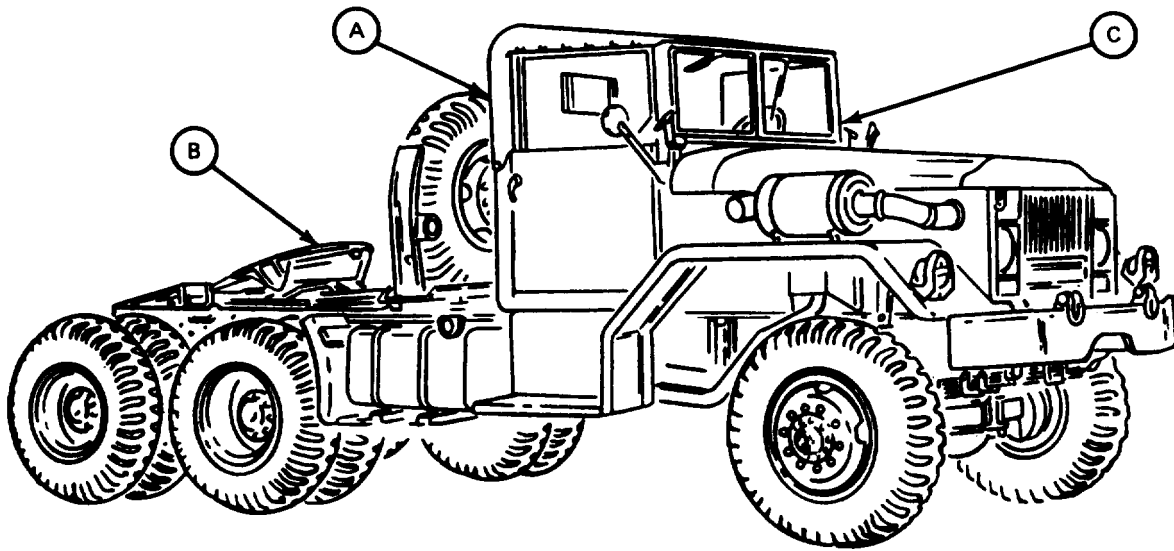

TA 048592

A. Airbrake hoses  
Electrical cable

B. Fifth wheel  
C. Airbrake hand control valve

*Figure 1-4. M52A2 Tractor Truck, Preventive Maintenance Locators.*

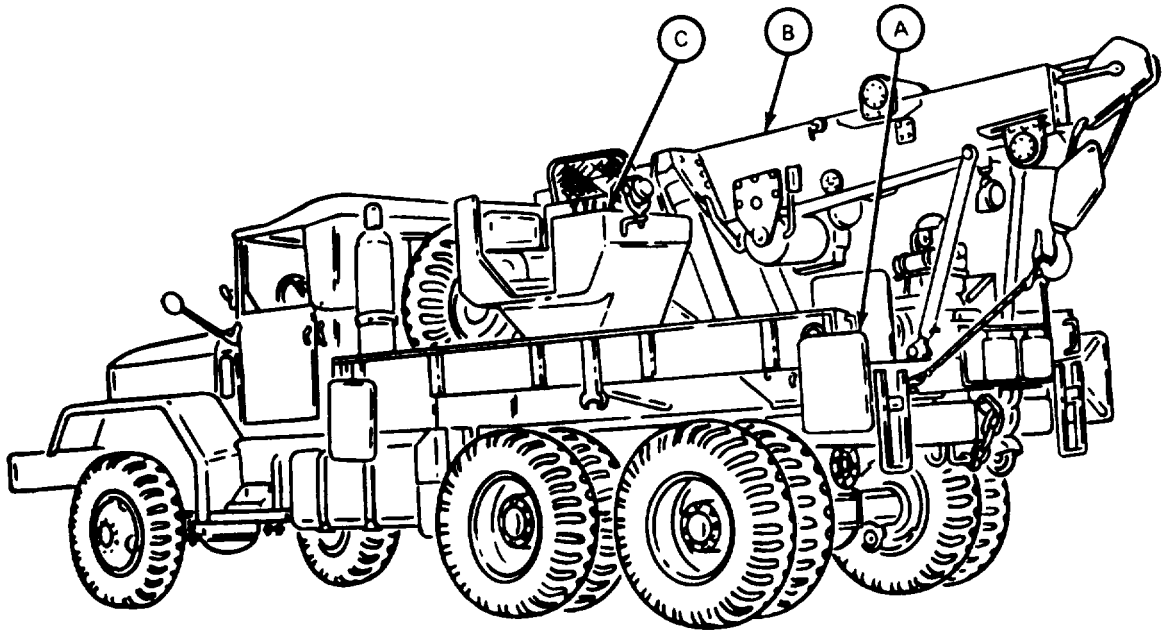

TA 048593

- A. Rear winch
  - Boom controls
- B. Boom assembly
  - Floodlight

- C. Boom Controls
  - Pressure relief valve
  - Floodlights

**Figure 1-5. M543A2 Medium Wrecker Truck, Preventive Maintenance Locators.**

**Table 1-1. Organizational Preventive Maintenance Checks and services.**

Item No.	S-Seniannually			Item To Be Inspected	Procedures
	Internal	A	B		
					<p align="center"><b>PRIOR TO ROAD TEST:</b></p> <p>Perform all before operation checks listed in TM 9-2320-211-10. "Preventive Maintenance Checks and Services".</p> <p align="center"><b>NOTE</b></p> <p>Road test must be performed regardless of interval.</p> <p align="center"><b>ROAD TEST</b></p> <p align="center"><b>NOTE</b></p> <p>The following inspections will be performed during starting and warm-up. just prior to actual road test.</p>
1				Starter	While starting vehicle, listen for unusual noises and difficult cranking at starter.
2				Engine and engine compartment	<p>a. Listen for unusual noises. hesitations. and varying idle speed. Observe response to accelerator feed.</p> <p>b. Be alert for excessive vibration and the smell of fuel. oil. or exhaust,</p>
3				Dials and indicators	<p>Observe the following dials and indicators for proper operation:</p> <p>a. <i>Low Air Pressure Warning Buzzer.</i> Should sound off when air pressure is below 60 psi. (413 kpls.).</p> <p>h. <i>Primary and Secondary Air Pressure Gages.</i> Should reach operating pressure (90-120 psi, - 826 kpls.) within two minutes of starling.</p> <p>c. <i>Vo/tometer (Batteries).</i> Needle will point to green area when batteries are holding a full charge.</p> <p>d. <i>Tachometer.</i> Should read 550-600 rpm. with engine idling.</p> <p>e. <i>Engine Oil Pressure Gage.</i> Will read between 10-30 psi. (69-206 kpls. ) at idle.</p> <p>f. <i>Engine Coolant Temperature Gage.</i> Should read 165-195° F (73-90°C) at normal operating temperature.</p> <p>g. <i>Parking Brake Warning Light.</i> Will be lit when parking brake is engaged.</p>

**Table 1-1. Organizational Preventive Maintenance Checks and Services**

S-Semiannually

A-Annually

B-Biennially

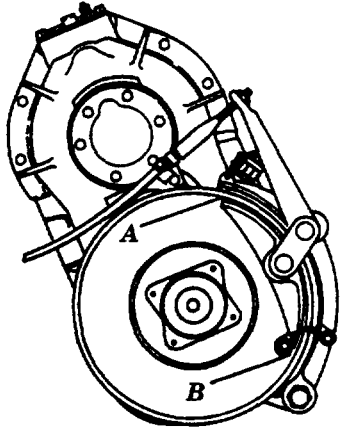
Item No.	Interval			Item To Be Inspected	Procedures
	S	A	B		
4				Cab safety devices	<p>h. <i>Air filter Indicator</i>. Shows red flag when there are restrictions in the air intake system.</p> <p>Observe the following items and their controls for security, ease of movement, and proper operation.</p> <ul style="list-style-type: none"> <li>a. <i>Horn</i></li> <li>b. <i>Windshied Wipers and Washers</i></li> <li>c. <i>Seat Belts and Fasteners</i></li> <li>d. <i>Turn Signals</i></li> <li>e. <i>Panel Lights</i></li> <li>f. <i>Headlights</i></li> <li>g. <i>Stoptlights</i></li> <li>h. <i>Blackout Lights</i></li> <li>i. <i>Parking Lights</i></li> <li>j. <i>Hazard Warning Lights</i></li> </ul> <div style="text-align: right;">  <p><b>Parking Brake Drum</b></p> </div> <p style="text-align: center;"><b>NOTE</b></p> <p>Now begin the actual road test. The vehicle will be driven at least five miles over varied terrain. This will provide ample time for detection of malfunctions.</p>
5				Accelerator	Test for engine response to accelerator feed. Observe sticking or binding of accelerator pedal
6				Brakes	<ul style="list-style-type: none"> <li>a. Test braking response to brake pedal. Vehicle should slow down immediately.</li> <li>b. Reach a desired speed and lightly apply brake pedal with steady force. Vehicle must stop smoothly without noticeable side-pull or chatter.</li> <li>c. After stopping vehicle and with transmission in neutral, release brake pedal. The wheel brakes must release immediately and without difficulty.</li> <li>d. Inspect parking brakeshoes for wear. Replace both brakeshoes if lining thickness is 3/16 in. (4.76 mm) or less.</li> <li>e. Inspect parking brake cable, lever, and brakeshoe assembly for binding and loose or missing components. Tighten components if loose or replace if missing or damaged.</li> <li>f. Check parking brake shoe clearance between inner and outer parking brake shoe linings and parking brake drum at both ends (A and B) at the same time, as shown in the figure above. If parking brake shoe clearance is not 0.015 in. (0.397 mm), adjust parking brake, as necessary.</li> </ul>

**Table 1-1. Organizational Preventive Maintenance Checks and Services**  
**S-Semiannually                      A-Annually                      B-Biennially**

Item No.	Interval			Item To Be Inspected	Procedures
	S	A	B		
7				Steering	<p>g. With vehicle on incline and transmission in neutral, engage parking brake. Vehicle must not move.</p> <p>a. Check vehicle response to steering wheel action. Vehicle must respond instantly. Check steering wheel free play. With Vehicle moving forward, free play must not exceed 1 inch (2.54 cm) in either direction.</p> <p>b. Turn steering wheel to extreme left, then right, to detect hard steering, steering backlash, or shimmy.</p> <p>c. With vehicle on straight, level terrain, slightly hold steering wheel to detect pull or wander.</p>
8				Engine	<p>a. Check engine operation at all speeds. Be sure that engine does not exceed governed speed (2850 -2900 rpm).</p> <p>b. Observe engine instruments to detect malfunctions.</p> <p>c. Be alert for unusual noises or smells.</p>
9				Transmission	<p>a. Check for response to shifting and smoothness of operation in all speed ranges.</p> <p>b. Be alert for unusual noises and difficulty in shifting in any speed range.</p>
10				Transfer	Engage transfer to insure proper operation. Observe smoothness of engagement.
11				Suspension	Observe how vehicle responds to road shocks. Shifts or constant bouncing indicates malfunction.
12				Emergency fuel cut-off control	Deleted
13				Clutch	<p align="center"><b>NOTE</b></p> <p>Check clutch free travel. Free travel must be from 2to 21/2 inches. Determine if the action of the pedal return spring is satisfactory. With the transmission in neutral, depress the clutch pedal and listen for unusual noise which may indicate a defective release bearing. Note if the clutch disengages completely or if it has a tendency to drag. Note if the clutch chatters, grabs or slips. Repair as necessary.</p>
14				Hubs and drums	<p>a. Beginning at rear of vehicle, cautiously feel each wheel hub and brake drum for overheating which can indicate a defective wheel bearing or dragging brake.</p> <p>b. Brake drums cool to the touch usually indicate improper adjustment, defective or inoperative brake.</p> <p>c. Check that master cylinder is not loose, damaged, or leaking.</p>

**Table 1-1. Organizational Preventive Maintenance Checks and (continued).**

**S - Semiannually                      A - Annually                      B - Biennially**

Item No.	Interval			Item To Be Inspected	Procedures																																											
	S	A	B																																													
15	●			Axles, transmission, transfer, and differentials	Cautiously feel each for overheating which can indicate low lubrication levels.																																											
16			●	Vehicle exterior	<p style="text-align: center;"><b>NOTE</b></p> <p>Items 16 and 17 will be inspected as you get to them during the after road test procedures.</p> <p>Inspect the following items for completeness, security, operation, and readability, as in the case of data plates:</p> <ul style="list-style-type: none"> <li>a. Glass</li> <li>h. Fasteners</li> <li>c. Hinges</li> <li>d. Panels</li> <li>e. Storage Boxes</li> <li>f. Tarpaulin</li> <li>g. Data, Caution, and Warning Plates</li> <li>h. Safety Equipment. Inspect rear view mirrors and safety straps for serviceability. Inspect fire extinguisher for charge.</li> <li>i. Exhaust System. Operate engine and inspect engine manifold, muffler, and exhaust pipe for leaks. Inspect for damaged pipes, loose clamps, and blown gaskets or seals. Inspect all mounting clamps for tightness</li> </ul>																																											
17			●	Tires	<ul style="list-style-type: none"> <li>a. Inspect each tire for nicks, cuts, gouges, protruding objects, and wear on tread and sidewalls.</li> <li>b.. Insure that each tire is properly inflated (see table below).</li> </ul>																																											
					<table border="1" style="width: 100%; border-collapse: collapse;"> <thead> <tr> <th rowspan="3">Vehicle Type (Tire Size)</th> <th colspan="4">Pressure (psi)</th> </tr> <tr> <th colspan="2">Front</th> <th colspan="2">Rear</th> </tr> <tr> <th>H</th> <th>C-C</th> <th>H</th> <th>C-C</th> </tr> </thead> <tbody> <tr> <td>M812A1 (14:00x20)</td> <td>50</td> <td>25</td> <td>30</td> <td>25</td> </tr> <tr> <td>M813,M813A1, M814,M815, M817, M818, M820, M820A1, M820A2 (11:00x20)</td> <td>80</td> <td>60</td> <td>50</td> <td>30</td> </tr> <tr> <td>M816(11:00x20)</td> <td>70</td> <td>60</td> <td>70</td> <td>60</td> </tr> <tr> <td>M819 ( 12: 00x20)</td> <td>90</td> <td>70</td> <td>50</td> <td>30</td> </tr> <tr> <td>M821 ( 14: 00x20)</td> <td>50</td> <td>40</td> <td>30</td> <td>25</td> </tr> <tr> <td>All models: Mud, sand and snow</td> <td>25</td> <td>25</td> <td>25</td> <td>25</td> </tr> </tbody> </table>	Vehicle Type (Tire Size)	Pressure (psi)				Front		Rear		H	C-C	H	C-C	M812A1 (14:00x20)	50	25	30	25	M813,M813A1, M814,M815, M817, M818, M820, M820A1, M820A2 (11:00x20)	80	60	50	30	M816(11:00x20)	70	60	70	60	M819 ( 12: 00x20)	90	70	50	30	M821 ( 14: 00x20)	50	40	30	25	All models: Mud, sand and snow	25	25	25	25
Vehicle Type (Tire Size)	Pressure (psi)																																															
	Front		Rear																																													
	H	C-C	H	C-C																																												
M812A1 (14:00x20)	50	25	30	25																																												
M813,M813A1, M814,M815, M817, M818, M820, M820A1, M820A2 (11:00x20)	80	60	50	30																																												
M816(11:00x20)	70	60	70	60																																												
M819 ( 12: 00x20)	90	70	50	30																																												
M821 ( 14: 00x20)	50	40	30	25																																												
All models: Mud, sand and snow	25	25	25	25																																												
					H: Highway                      C-C: Cross-country																																											

**Table 1-1. organizational Preventive , Maintenance Checks and Services (continued).**

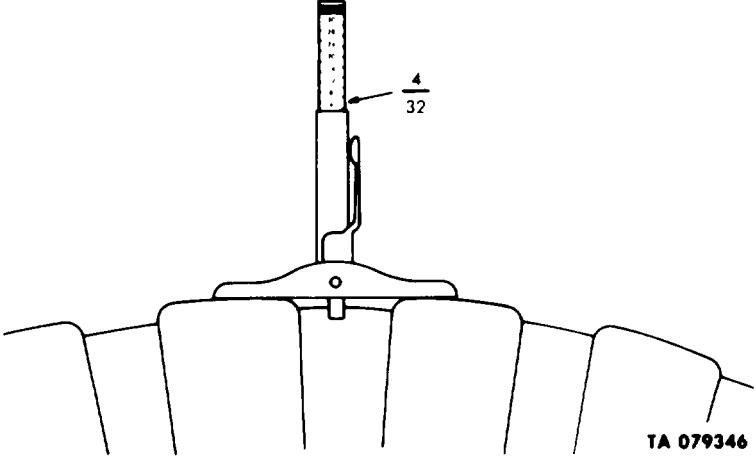
Item No.	S-Semiannually			A-Annually	B-Biennially
	S	A	B	Item To Be Inspected	
18		•		<p>Procedures</p> <p>c. Check each tire for wear using tire tread depth gage as shown below. Tread depth should not be less than 1 8".</p>  <p>d. Make sure all wheel lug nuts are present and tight on each wheel torque 450-500 lb-ft (610-678 N.m).</p> <p>e. Inspect wheel side rings for dents, bends, or breaks that could cause them to pop off when tires are being inflated.</p> <p style="text-align: center;"><b>VEHICLE UNDERSIDE:</b></p> <p>u. Inspect frame side rails for cracks, breaks, bends, wear, and deterioration.</p> <p>b. Inspect crossmembers for missing rivets, bolts, obstructions to other components, breaks, and wear,</p> <p>a. Inspect rear axle housings for dents, and cracks that could cause leaks.</p> <p>b. Insure axle housing grease fittings, plugs, and fittings are present and secure.</p> <p>c. Inspect differentials for dents and cracks that could cause leaks</p> <p>d. Insure that differential fill plug (2) and drain plug (3) are not leaking and are secure,</p>	
		•			
		•			
			•		
		•			
			•		
			•		
			•		
			•		
			•		
19			•	<p>Rear axles, differentials</p>	
		•			
			•		
		•			



**Table 1-1. Organizational Preventive Maintenance Checks and Services (continued).**  
**S - Semiannually      A - Annually      B - Biennially**

Item No.	Interval			Item To Be Inspected	Procedures
	S	A	B		
20		•		Rear suspension	<p>e. Tighten all rear axle drive flange bolts (4). Torque 81-104 lb-ft (110-141 N.m).</p> <p>f. Remove breather valves (1) and clean with compressed air, regulated at 35 psi maximum.</p>  <p style="text-align: right;">TA 079347</p>
		•			<p>a. Inspect spring leaves, retaining clips, and center bolts for deterioration, wear, breaks, and looseness.</p> <p>b. Tighten spring U-bolts (1). Torque 350-400 lb-ft (475-542 N.M.).</p> <p>c. Test spring seat bearing free play by placing jack under spring seat bracket (2), jack the vehicle up so the spring moves freely up and down in the guide brackets. This removes all the applied weight from the spring seat. Put prybar between U-bolt saddle (3) and lifting pin (4). Pull up on prybar. A little free play should be detected. If there is too much free play, adjust spring seat bearing.</p> <p>d. Remove, clean, and repack trunion bearing (para 2-185).</p>  <p style="text-align: right;">TA 079348</p>
		•			
			•		

Table 1-1. Organizational Preventive Maintenance Checks and Services (continued).

Item No.	Interval			Item To Be Inspected	Procedures
	S	A	B		
21	•			Propeller shafts and universal joints	<p>a. Inspect all propeller shafts (1) for bends, cracks, wear, and deterioration.</p> <p>b. Inspect U-joints (2) for wear and play, broken or missing lubrication fittings. There should be no play at U-joints.</p> <p>c. Make sure all companion flange mounting screws (3) and U-joint mounting screws (4) are tight. Torque both 32-40 lb-ft.</p>  <p style="text-align: right;">TA 079349</p>
22	•			Transfer	<p>a. Inspect transfer case for oil leaks, dents, cracks, and loose bolts that could cause leaks.</p> <p>b. Inspect security of transfer case mounting bolts and mounting brackets. Look for evidence of bracket wear and deterioration.</p> <p>c. Inspect shift linkage for cracks, bends, wear and play.</p>

Table I-1. Organizational Preventive Maintenance Checks and Services (continued).

Item No.	Interval			Item To Be Inspected	Procedures
	S	A	B		
	•				<p>d. Inspect air vent valve (1), air shift cylinder (2) and attaching lines, hoses, tubes and connectors for cracks, breaks, leaks, and wear.</p> <p>e. Inspect hand brake components (3) for damage, excessive wear, and malfunction.</p>  <p style="text-align: right;">TA 155041</p> <p>f. Inspect magnetic drain plug for evidence of metal particles. If evidence of metal particles are seen, notify DS Maintenance. Insure drain plug (4) is secure.</p>  <p style="text-align: right;">TA 155042</p>
	•				
	•				

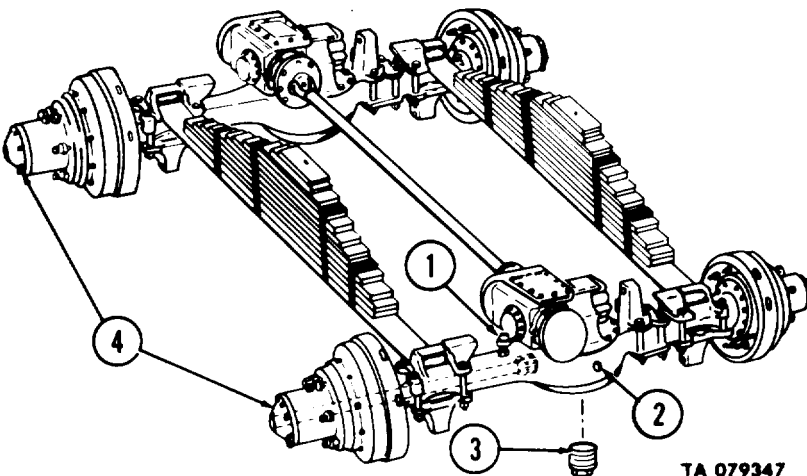
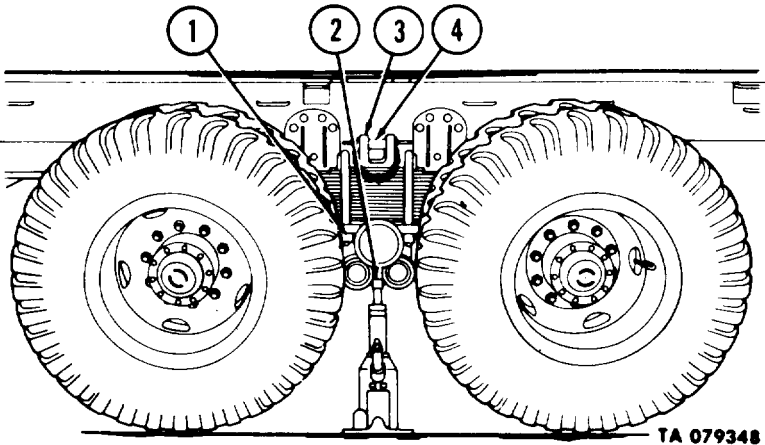
**Table 1-1. Organizational Preventive Maintenance Checks and Services (continued).**

Item No.	Interval			Item To Be Inspected	Procedures
	S	A	B		
23	●			Transmission	<p><i>a.</i> Inspect transmission case for damage and indication of oil leaks. Inspect transmission linkage for damage and excessive wear or play. Check oil level. Operate engine and shift transmission through all speed ranges; check operation and be alert for unusual noises, Inspect and clean air breather valve. Visually check oil for contamination (metal particles, dirt, sand).</p> <p><i>b.</i> Inspect transmission shift linkage for bends, excessive play, cracks, and wear that could cause failure.</p>
24	●			Engine underside	<p><i>a.</i> Inspect underside of engine for fuel, water, and oil leaks.</p> <p><i>b.</i> Inspect oil pan and pan drain plug for leaks, and security. Tighten oil pan mounting screws. Torque 28-40 lb-ft (38-54 N.m).</p> <p><i>c.</i> Inspect attaching components for security, leaks, breaks, dents, and completeness of assembly.</p> <p><i>d.</i> Inspect under vehicle for any indication of oil, water, fuel, or hydraulic fluid leaks.</p> <p><i>e.</i> Inspect and service crankcase breather.</p> <p style="text-align: center;"><b>ENGINE COMPARTMENT:</b></p> <p style="text-align: center;"><b>NOTE</b></p> <p>Open engine hood and secure with retaining bar. Also, remove both splash shields. Disengage emergency fuel cutoff control linkage.</p>
25	●			Air intake system	<p><i>a.</i> Inspect air cleaner, hoses, and tubing for proper installation, cracks, breaks, and loose connections that could permit unfiltered air to enter the engine.</p> <p><i>b.</i> Inspect filter element for bends, tears, or the presence of dirt and oil. Clean or replace as necessary.</p>
26		●		Starter and starter wiring	<p><i>a.</i> Inspect starter mounting bolts for presence and security. Tighten mounting bolts 80-100 lb-ft (108-136 N.m).</p> <p><i>b.</i> Inspect starter wiring for frays, splits, wear, loose terminals, and missing insulation.</p>

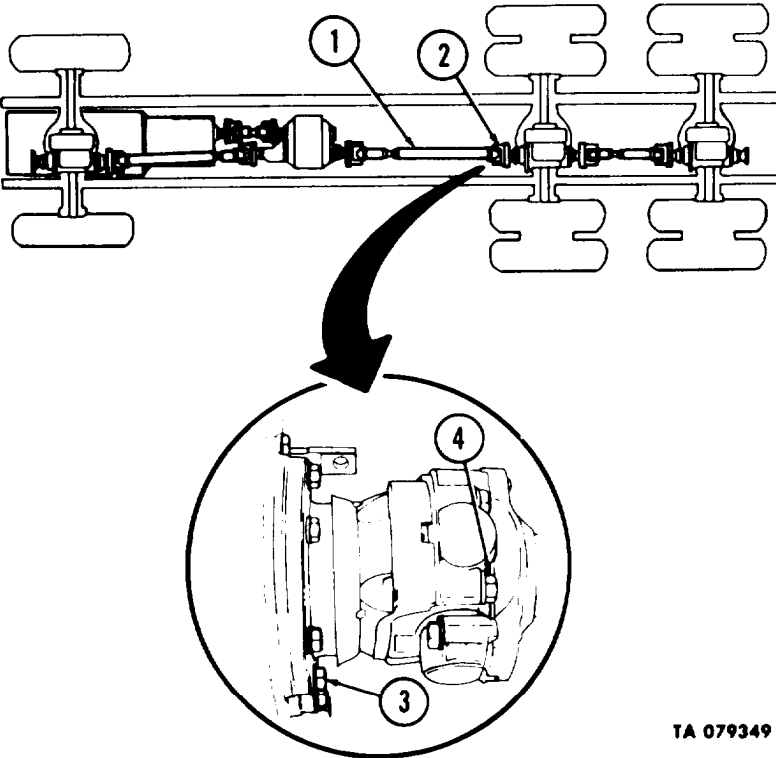
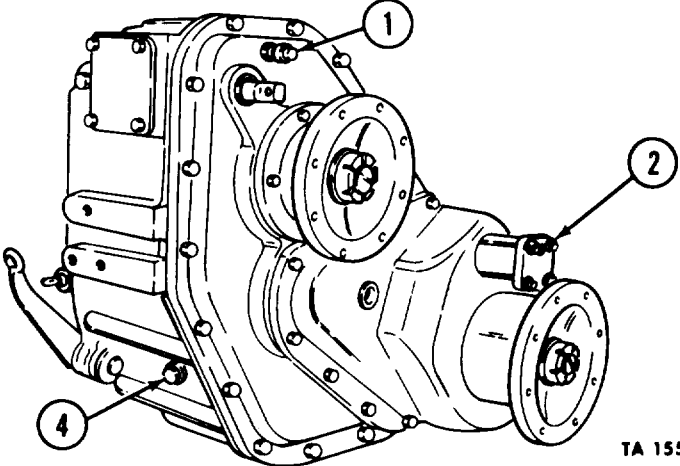
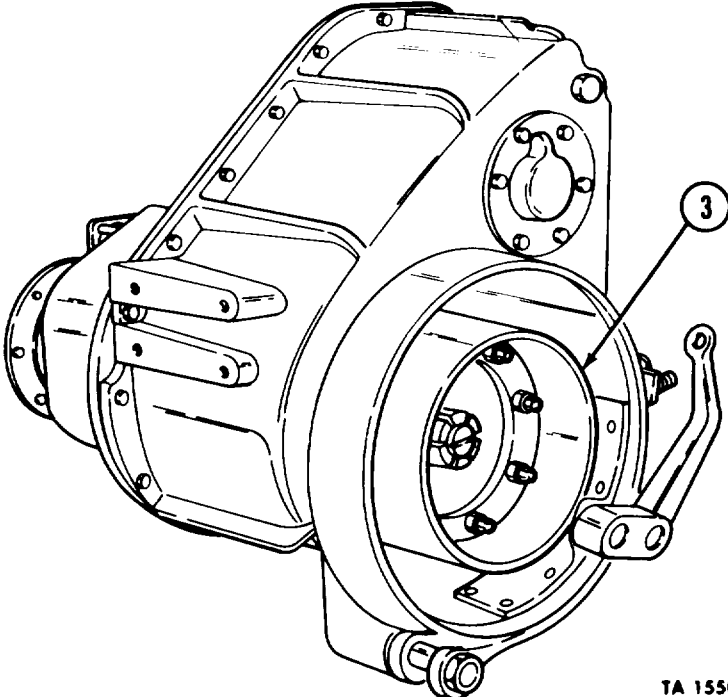
Table 1-1. Organizational Preventive Maintenance Checks and Services (continued).

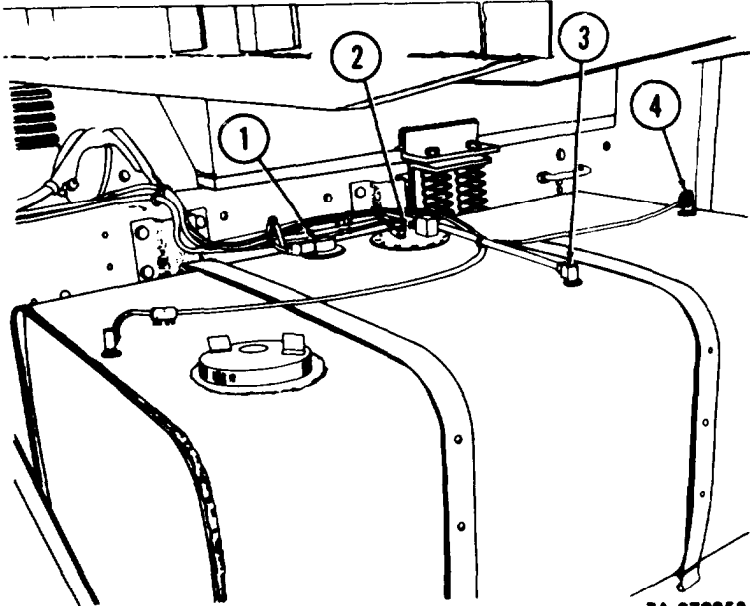
Item No.	S. Semiannually			A. Annually	B-Biennially	Procedures	
	S	A	B				
27	•					Electrical wiring	Inspect all engine compartment wiring for frays, splits, missing insulation or poor connections. Replace any worn wiring.
28	•					Vehicle batteries	Check specific gravity of each cell and record specific gravity. Check electrolyte level. Inspect battery cables for tightness and condition. Clean top of batteries, coat terminals lightly with grease. Reference TM 9-6140-200-14 and DA Pamphlet 750-34.
29	•					Fuel system	<p><b>NOTE</b></p> <p>The fuel, steering and air systems will not follow the PMCS flow diagram preceding this table. Return to where you left off after completing the checks and services for these systems.</p> <p>a. Inspect fuel tank(s) for dents, cracks, and broken welds that could cause leaks.</p> <p>b. Inspect all fuel lines for loose connections, splits, cracks, and bends that could cause leaks.</p> <p>c. Inspect fuel sending unit (1) and its wiring for loose connections, frays, splits, and missing insulation.</p> <p>d. Inspect fuel inlet tube (2), fuel outlet tube (3) and vent hoses (4) at fuel tank for loose connections, cracks, splits, wear, and security.</p>  <p>TA 079353</p> <p>e. Inspect fuel filter housing for security, dents, and cracks that could cause leaks. Drain water from filter and inspect filter element for dirt, damage, and unserviceability. Replace any unserviceable fuel filter.</p>
	•						
	•						
	•						
	•						

**Table 1-1. Organizational Preventive Maintenance Checks and Services (continued).**

Item No.	Interval			Item To Be Inspected	Procedures
	S	A	B		
30	•			Steering system	<p><i>f.</i> Observe fittings to fuel pump and fuel pump body for leaks. Notify DS maintenance if leaks exist.</p> <p><i>a.</i> Inspect power steering pump for cracks or dents that could cause leaks.</p> <p><i>b.</i> Follow routing of all hydraulic steering lines, hoses, and tubes to inspect for loose fittings, cracks, bends, breaks, and leaks.</p> <p><i>c.</i> Inspect steering column U-joints (1), steering knuckles (2), tie rod assembly (3), steering arm (4), drag link (5), and pitman arm (6), for breaks, cracks, rust, wear, and unserviceability.</p>  <p style="text-align: right;">TA 155044</p> <p><i>d.</i> Tighten steering gear mounting bolts. Torque 260-280 lb-ft (353-380 N.m). Inspect gear for leaks. Notify DS maintenance if leaks exist.</p>

Table 1-1. Organizational Preventive Maintenance Checks and Services (continued).

Item No.	Interval			Item To Be Inspected	Procedures
	S	A	B		
31		•			<p>e. Inspect power steering assist cylinder (1) for security and proper travel adjustment (25.5 in. - 65.0 cm.). Travel adjustment distance is measured between center lines of spring shackle bolt ball stud (2) and steering knuckle arm ball stud (3).</p>  <p style="text-align: right;">TA 079355</p>
		•			<p>f. Inspect steering stops for presence and security.</p> <p style="text-align: center;"><b>NOTE</b></p> <p>Anytime leakage is suspected in the compressed air system, use the soapsuds method of detection. If a leak exists, bubbles will form around the area in question. If leakage exists, tighten connection or replace component.</p>
		•		Compressed air and brake system	<p>a. Drain water from air reservoirs and observe water for milky, blue, or green coloring. Any of these conditions indicate internal engine malfunctions. Notify DS maintenance.</p> <p>b. Inspect four air reservoirs, their attaching valves, lines and connections for mounting security, bends, dents, and cracks that could cause leaks.</p> <p>c. Inspect air compressor (1) and air governor (2) for mounting security and leaks.</p>
		•			<p style="text-align: center;"><b>NOTE</b></p> <p>Engine views do not necessarily show the multifuel engine.</p>  <p style="text-align: right;">TA 155045</p>
		•			<p>d. Inspect trailer brake hoses and couplings for security and leaks.</p>

Table 1-1. organizational Preventive Maintenance Checks and Services (continued).

Item No.	S-Semiannually			Item To Be Inspected	Procedures
	Interval	A	B		
32	•			Drive pulleys and belts	<p>a. Inspect alternator (1), fan hub (2), power steering pump (3), accessory drive (4), and vibration dampener (5), drive belts for splits, cracks, breaks, and wear.</p>  <p style="text-align: right;">TA 079357</p>
	•				<p>b. With the aid of a ruler, check the tension of all drive belts. Belts will not give more than 3/4 inch (1.9 cm.) or less than 1/2 inch (1.27 cm.) at belt center point when properly adjusted.</p>
33	•			Engine lubrication and oil lines	<p>a. Check oil level at dipstick and observe evidence of metal particles at end of dipstick. Notify DS maintenance if metal particles are present.</p>
	•				<p>b. Inspect all oil lines and hoses for cracks, frays, and wear that could cause leaks.</p>
	•				<p>c. Inspect oil filter housing for security. Make sure filter center bolt is tight. Torque 25-35 lb-ft (34-47 N.m).</p>
	•				<p>d. Inspect rocker housing covers for evidence of leaks. Notify DS maintenance if leaks exist.</p>
34	•			Cooling system	<p>a. Inspect coolant level at surge tank. Surge tank should be at least 3/4 full.</p>
	•				<p>b. Inspect all hoses for security, splits, wear, and cracks that could cause leaks. Inspect hose clamps for wear and serviceability.</p>

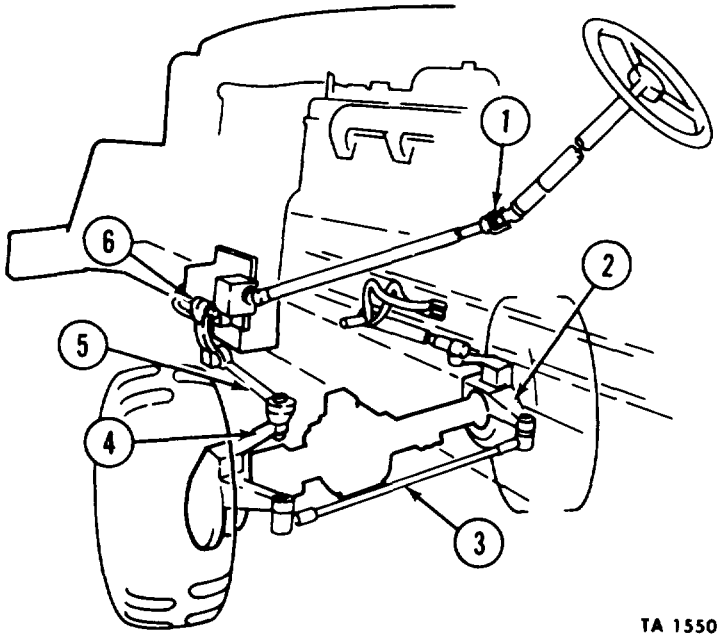

Table 1-1. Organizational Preventive Maintenance Checks and Services (continued).

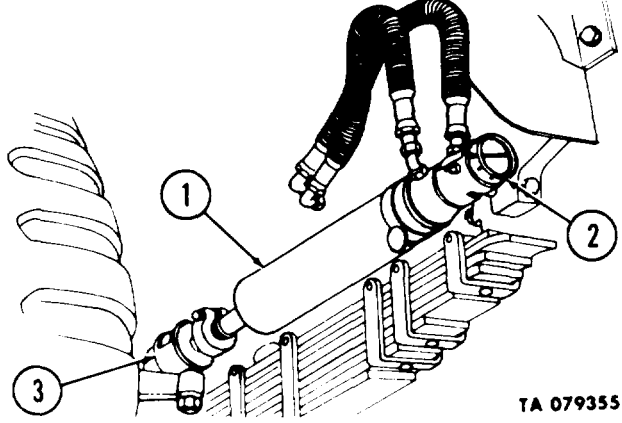
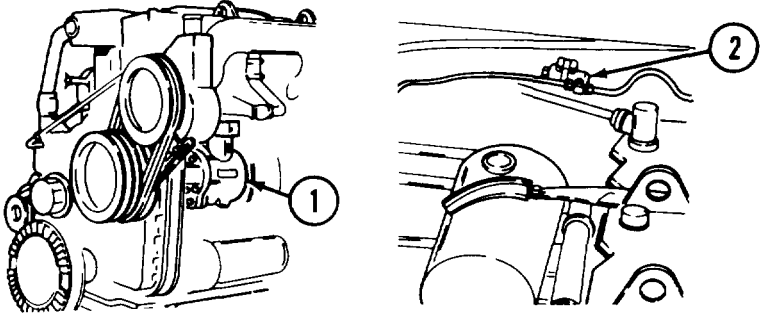
S - Semiannually A - Annually

B-Biennially

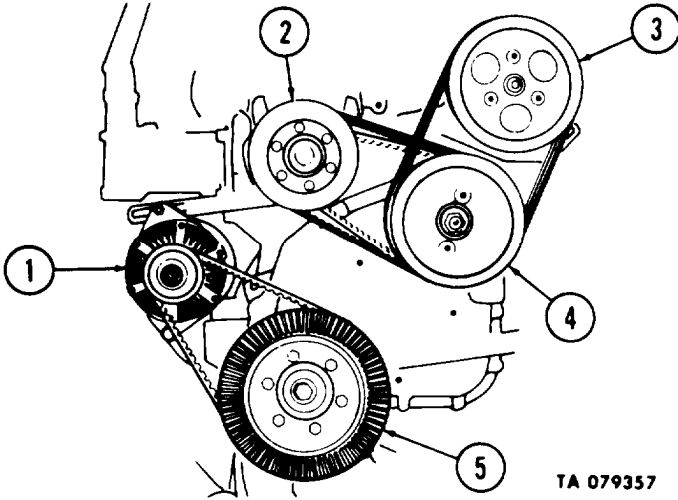
Item No.	Interval			Item To Be Inspected	Procedures
	S	A	B		
	•				<p>c. Inspect surge tank (1), thermostat housing (2), radiator (3), water manifold (4), engine oil cooler (5) for leaks, looseness, wear, and serviceability.</p>  <p style="text-align: right;">TA 155046</p>
	•				<p>d. Inspect radiator core for clogged or bent fins, leaks, and protruding objects. Clean clogged core and remove protruding objects.</p>
	•				<p>e. Inspect fan blades for security, breaks, missing or loose bolts.</p>
	•				<p>f. Inspect temperature sending unit for presence and security. Inspect sending unit wiring for frays, splits, breaks, and missing insulation.</p>
35	•			Alternator and alternator wiring	<p>a. Inspect alternator for secure mounting.</p> <p>b. Inspect alternator mounting bracket and attaching hardware for cracks, bends, and secure mounting.</p> <p>c. Inspect alternator wiring for security, frays, bare wires, and loose terminal connections. Make sure quick-disconnect is secure.</p>
36	•			Front suspension	<p>a. Inspect springs and shackles for cracks, breaks, and security. Tighten spring U-bolts. Torque 350-400 lb-ft (475-542 N.m.).</p> <p>b. Inspect shock absorbers and mounting brackets for looseness, wear, cracks, serviceability and leaks. Replace leaking shock absorbers.</p>
37		•		Front wheel alinement	<p>Check front end alinement. Correct toe-in is 1/8 +/- 1/16 inch (3.175 cm. +/- 1.59 cm.).</p>
38		•		Engine and cab mounts	<p>a. Inspect front and rear engine and cab mounting brackets for looseness, wear, cracks, splits, broken welds, worn bushings, and missing bolts.</p>

Table 1-1. Organizational Preventive Maintenance Checks and Services (continued).

Item No.	S-Semiannually			Item To Be Inspected	Procedures
	S	A	B		
		•			<p>b. Tighten front engine trunnion bolts. Torque 150 lb-ft (203 N.m). Tighten engine flywheel housing-to-frame mounting bolts. Torque 75-83 lb-ft (102-113 N.m).</p> <p>c. Tighten front and rear cab mounting bolts. Torque 50 lb-ft (68 N.m).</p> <p style="text-align: center;"><b>VEHICLE REAR:</b></p>
39		•		Spare tire carrier	Inspect spare tire carrier for security, completeness of assembly and proper operation.
40		•		Rear wiring	Inspect rear wiring at tail lights for frays, splits, loose terminals, and missing insulation.
41		•		Towing pintle	Check operation of pintle hook. Inspect pintle and bracket for cracks, breaks, wear and mounting security.
42		•		Lifting shackles and brackets	Inspect all lifting shackles and brackets for damage and completeness of assembly.
43		•		Front winch	<p>a. Inspect winch power takeoff for operation and malfunction. Inspect condition of winch shearpin.</p> <p>b. Check winch for operation, malfunction and damage. Check gear case oil level. Test drag brake and automatic brake. Inspect winch cable for excessive wear, damage, kinks, frayed strands, and for proper lubrication.</p> <p>c. Inspect front winch for mounting security and broken and missing parts.</p> <p>d. Test drag brake for proper operation. Pay off about four or five feet of cable, then stop. Drum must stop turning as soon as pulling has stopped. If winch continues to turn, adjust drag brake adjusting screw (1) and test again.</p> <p>e. Test automatic brake by parking your vehicle on a decline. Winch another vehicle up the decline and then shift winch control lever into neutral. Winched vehicle must not roll backward. If it does, adjust automatic brake adjusting screw (2) and test again.</p>
	•				
	•				

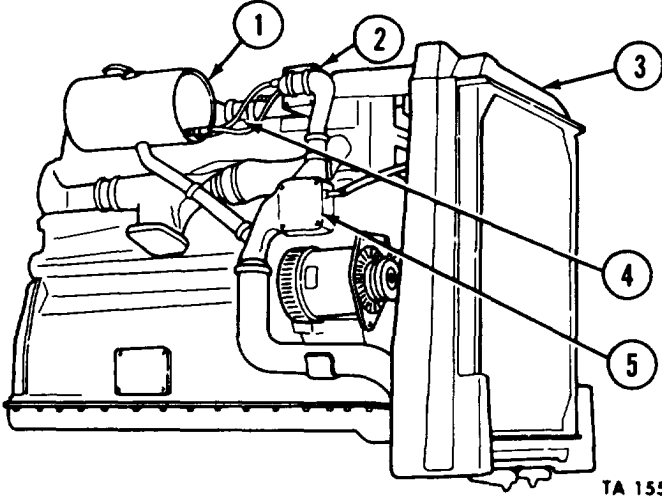
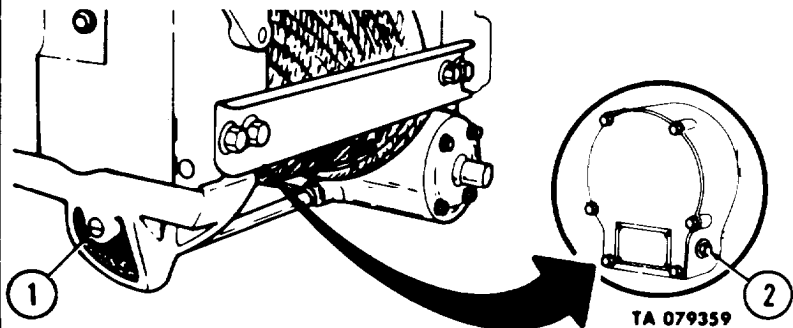

**Table 1-1. Organizational Preventive Maintenance Checks and Services (continued).**

Item No.	S-Semiannually			A-Annually	B-Biennially	Procedures
	S	A	B			
44		●				<p style="text-align: center;"><b>NOTE</b></p> <p>Place hand on brake cover after adjustment. If cover is hot to the touch, loosen adjusting screw one half turn.</p> <p><i>f.</i> Unwind winch cable completely and inspect for kinks, frays, and wear.</p> <p><i>a.</i> Inspect rear winch and winch controls for mounting security.</p> <p><i>b.</i> Check winch for operation, malfunction, and damage. Check gear case oil level. Test automatic brake. Inspect winch cable for excessive wear, damage, kinks, frayed strands, and for lubrication. Test for proper cable tension.</p> <p><i>c.</i> Inspect rear winch control linkage for operation, malfunction, and proper adjustment.</p> <p><i>d.</i> Inspect drive chain for damage and proper tension. Inspect winch shearpin.</p> <p><i>e.</i> Test automatic brake by parking vehicle on incline. Winch another vehicle up the incline and then shift winch control lever into neutral. If winched vehicle rolls backward, adjust automatic brake adjusting screws (1) and test again.</p> <p><i>f.</i> Inspect winch for operation, malfunction, and damage. Check gear case oil level. Test drag brake and automatic brake. Check winch cable for excessive wear, damage, kinks, frayed strands, and proper lubrication.</p> <p><i>g.</i> Inspect drive chain for damage and proper tension. Inspect winch shearpin.</p> <p style="text-align: center;"><b>NOTE</b></p> <p>Place hand on brake cover after testing. If cover is hot to the touch, loosen adjusting screw 1/2 turn.</p>

Table 1-1. Organizational Preventive Maintenance Checks and Services.

Item No.	S-Semiannually			Item To Be Inspected	Procedures
	S	A	B		
					 <p style="text-align: right;">TA 079360</p> <p><i>h.</i> Check cable tensioner sheaves for proper adjustment. A 5/8 inch diameter rod should fit snugly between tension sheaves (1). If rod cannot be inserted or fits loosely between sheaves, adjust cable tensioner.</p> <p style="text-align: center;"><b>NOTE</b></p> <p>Turning air chamber push rod yoke (2) to right increases distance between sheaves (when cable tensioner control valve lever is in the ON position). Turn yoke left to decrease distance between sheaves.</p>  <p style="text-align: right;">TA 079361</p>

Table 1-1. Organizational Preventive Maintenance Checks and Services (continued).

S - Semiannually

A - Annually

B-Biennially

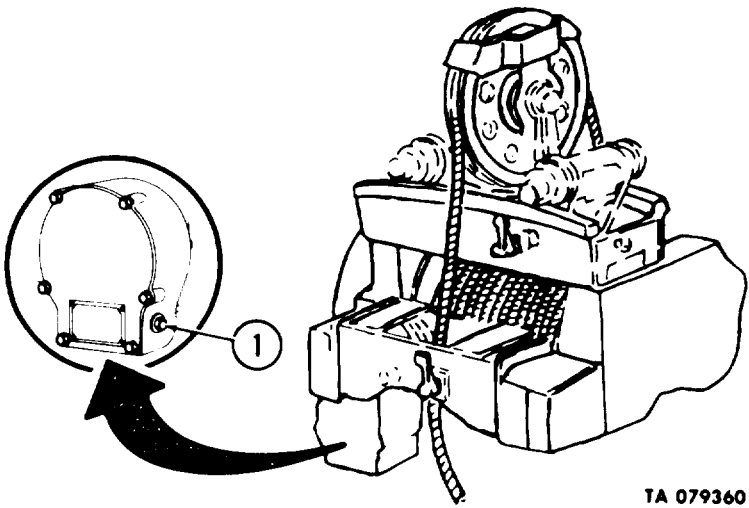
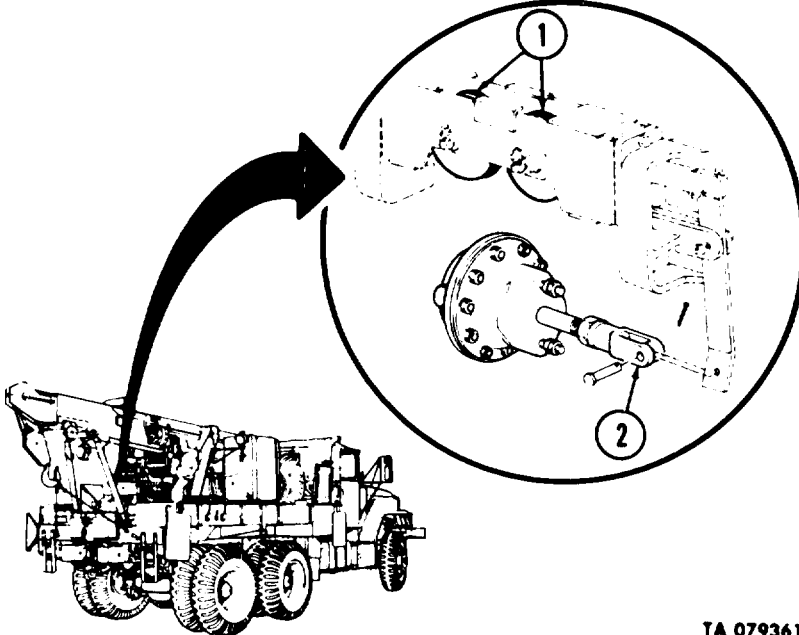
Item No.	Interval			Item To Be Inspected	Procedures
	S	A	B		
45		•		Hydraulic crane and wrecker (M291A2D)	<p>a. Inspect all hydraulic lines, hoses, valves, and their connections for looseness, wear, and leaks. Observe hoses that are split, cracked, or worn.</p> <p>b. Operate crane through full range of movement. Observe smooth operation of pump control linkage and control levers. There should not be any binding or sticking.</p> <p>c. Test automatic hoist drum brake for proper operation. Lift a load off ground and then place hoist control lever in neutral. The automatic brake should sustain the weight of the load. If load begins to lower, tighten automatic brake adjusting screw (1) and test again.</p> <div style="text-align: center;">  <p style="text-align: right;">TA 079362</p> </div> <p>d. With boom raised, inspect crane cylinder piston rods for bends and scoring.</p> <p>e. While operating crane, observe that the fuel pump governor is maintaining 1250 + 50 rpm during hoisting operation. Notify DS maintenance if engine rpm is surging erratically.</p> <p>f. Extend crane cable completely and look for frays, broken strands and wear.</p> <p>g. Inspect and clean hydraulic tank swing motor and hoist crane motor breather caps.</p>
		•			
		•			
		•			
		•			
		•			
		•			
		•			
		•			
		•			
46		•		Dump body and hoist (M151A2)	<p>a. Inspect dump body for completeness of assembly. Make sure dump body is alined with frame.</p> <p>b. Inspect dump hydraulic lines, hoses, and their fittings for leaks, splits, and wear that could cause leaks.</p>
		•			

Table 1-1. Organizational Preventive Maintenance Checks and Services (continued).

Item No.	S-Semiannually			Item To Be Inspected	Procedures
	S	A	B		
47		•		Expansible van body	<p>c. Inspect transmission power take-off (1), hydraulic pump drive shaft (2) and hydraulic pump (3) for mounting security and leaks.</p>  <p style="text-align: right;">TA 155047</p>
		•			<p>d. Make sure tailgate control rod hand lever (1) locks and unlocks tailgate lower latch (2). Inspect control linkage for play, wear, and serviceability.</p>   <p style="text-align: right;">TA 079364</p>
		•			<p>e. Operate dump body and observe smooth raising and lowering of body.</p>
		•			<p>f. With dump body raised, inspect cylinder piston rods for scoring and wear.</p>
		•			<p>g. Tighten all loose dump body mounting bolts. Torque 240 lb-ft (325 N.m).</p>
	•			<p>a. Make a general inspection of the van body. Inspect and operate heater, air conditioner, ventilators, dome lights and switches to insure proper operation.</p>	
	•			<p>b. Inspect electrical wiring for frays, splits, loose terminals and wear.</p>	
	•			<p>c. Expand and retract van body. Notice binding, sticking, or bends, wear, and improper lubrication of expanding or retracting mechanisms.</p>	

Table 1-1. Organizational Preventive Maintenance Checks and Services (continued).

Item No.	S-Semiannually			Item To Be Inspected	A-Annually	B-Biennially	Procedures			
	S	A	B							
48		●		Expansible van with liftgate			<p>a. Inspect all hydraulic lines, hoses, and their fittings for cuts, splits, wear, and leaks.</p> <p>b. Operate lift gate through full range of operation. Observe sticking, binding, hesitation, and control lever response.</p> <p>c. With lift gate extended, inspect lift arms and support assemblies for security of mounting, completeness of assembly, and wear.</p>			
49			●					Fifth wheel, tractor truck & tractor wrecker truck		Inspect fifth wheel for completeness of assembly. Make sure mounting screws are tight. Torque 100-130 lb-ft (136-176 N.m).
50		●						Cargo body		Inspect cargo body and related components for damage, completeness, secureness of assembly, operation, proper stowage, and excessive part wear.
51		●		Bridge transporting truck			Inspect body of bridge transporting truck for damage and completeness of assembly. Inspect rear and side tiedown winches for damage, completeness of assembly, operation, and excessive part wear. Inspect tail-board roller assembly, and lead guide roller for damage, operation and completeness of assembly. Inspect floodlight assembly for damage, completeness, and secureness of assembly, and operation.			
52		●		Intervehicular electrical cables, receptacles, and air hose lines and fittings			Inspect intervehicular electrical cable receptacle and air hose lines and fittings for damage, completeness of assembly, operation, and excessive wear.			
53		●		Lights and accessories			Check operation of lights, (driving, blackout, turn signal, and warning lights). Check operation of horn (if tactical situation permits.).			
<b>FINAL ROAD TEST:</b>										
After all services and inspections have been completed, take vehicle on a short road test to make sure all corrections have been accomplished. Correct any defects or malfunctions that are observed during this test.										

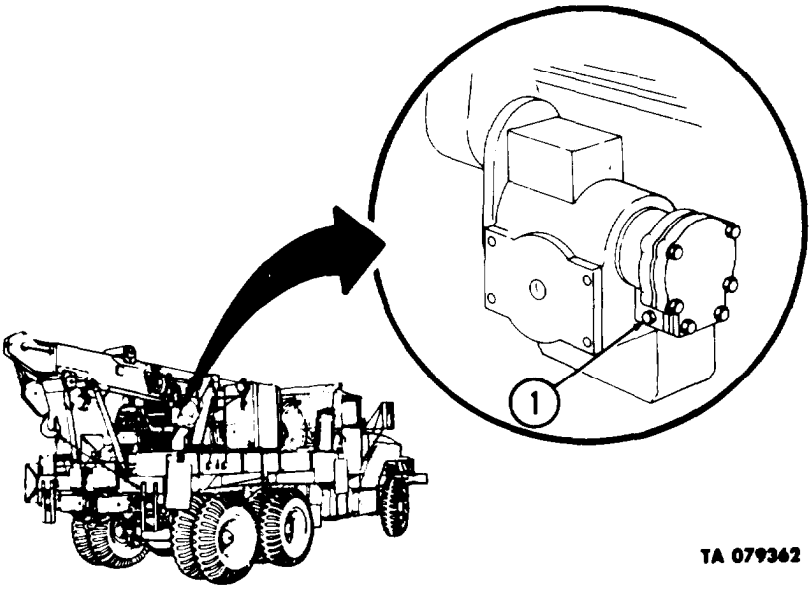
Table 1-1. Organizational Preventive Maintenance Checks and Services (continued).

Item No.	Interval			Item To Be Inspected	Procedures
	S	A	B		
					<b>ITEMS SPECIAL TO WINTERIZATION KIT AND PERSONNEL HEATER</b>
54		●		Fuel pump and fuel lines	Remove the lower cover, and clean and inspect the fuel strainer screen. Replace the screen, if it is distorted or collapsed. Inspect all fuel lines for leaks. Make repairs as necessary.
55		●		Fuel filters	Remove and clean fuel sediment bowls and filter elements. Inspect elements and gaskets and replace them if they are damaged.
56		●		Powerplant heater	Check all attaching components for looseness, dents, and other damage. Remove any accumulated dirt from the area, and be sure heater mountings are secure.
					 <small>TA 155048</small>
57		●		Powerplant heater electrical wiring	Inspect complete wiring for frayed, cracked, or worn insulation; broken strands; and loose or dirty connections.
58		●		Personnel heater	Check all attaching components for looseness, dents, and other damage. Repair or replace damaged parts as necessary. Remove any accumulated dirt from the area, and be sure heater mountings are secure.
					 <small>TA 155049</small>

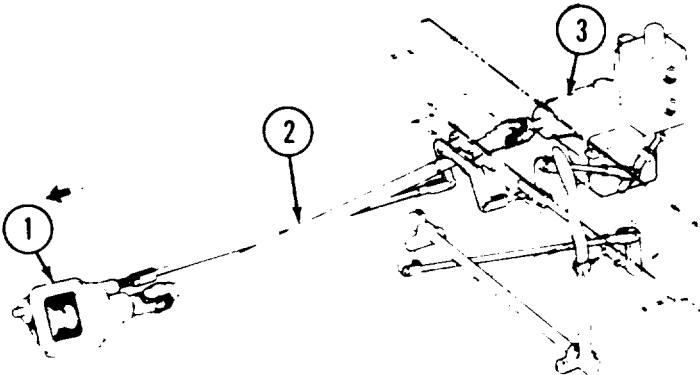
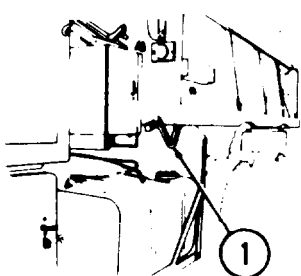
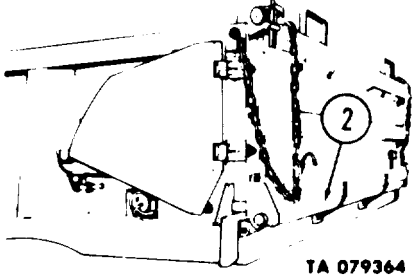

Table 1-1. Organizational Retentive Maintenance Checks and Services (continued).

S - Semiannually A - Annually B - Biennially

Item No.	Interval			Item To Be Inspected	Procedures
	S	A	B		
59		●		Personnel heater electrical wiring	Inspect the complete wiring harness for frayed, cracked, or worn broken strands; and loose or dirty connections.
60		●		Exhaust tubes	Examine personnel and power plant heater exhaust tubes for breaks, restrictions, leaks and loose connections.
61	●			Engine coolant connections	Check for evidence of coolant leaks and damaged hoses.
62		●		Personnel heater and defroster controls	Check handles for operation and cables for proper attachments.  TA 155050
63		●		Defroster	Check duct clamps for tightness and ducting for damage.
64		●		Battery box heater	Remove batteries and check heating pad for signs of leaks and damage. Check coolant hose connections for tightness and hoses for damage.
65		●		Hardtop closure	Check the closure for damage and proper attachment, and weatherseals for signs of air leaks. If damage is detected, notify direct support maintenance.
66		●		Closure windows	Check operation and clean if necessary.
67		●		Slave receptacle	Check for dirt in the connectors (1) and the cap (2) for tightness.  TA 155051

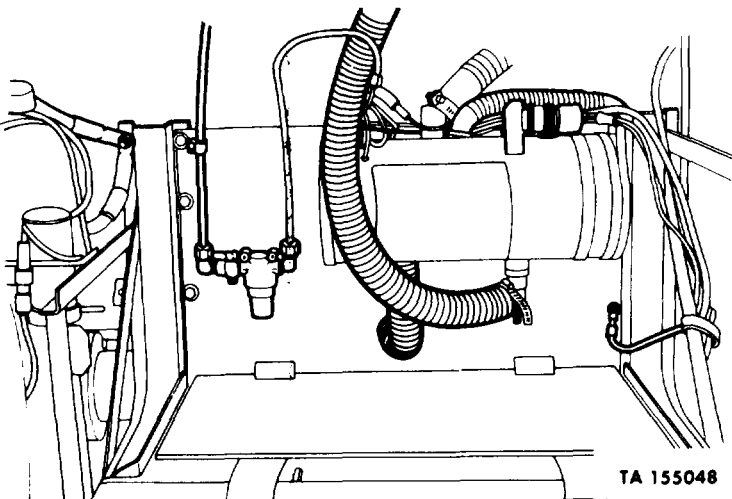
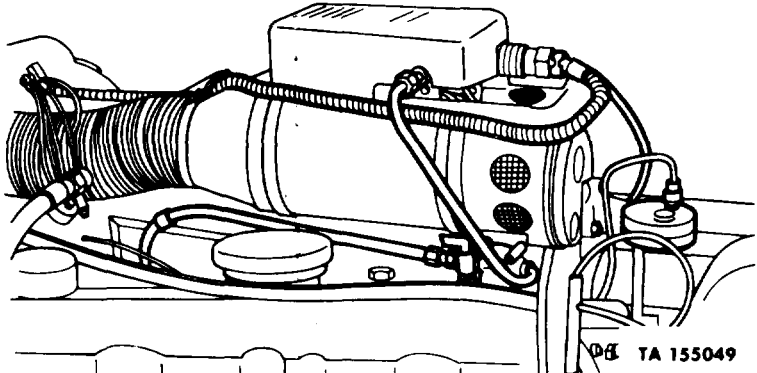
Table 1-1. Organizational Preventive Maintenance Checks and Services (continued).

S - Semiannually A - Annually B - Biennially

Item No.	Interval			Item To Be Inspected	Procedures
	S	A	B		
68		•		Hood, side and radiator cover	<p>Check for tears, rips, and other damage. Be sure all straps and fasteners are in place.</p> 
69	•			Alcohol evaporator	<p>Check secureness of mounting. Refill alcohol containers as necessary (alcohol grade 3).</p>

## CHAPTER 2

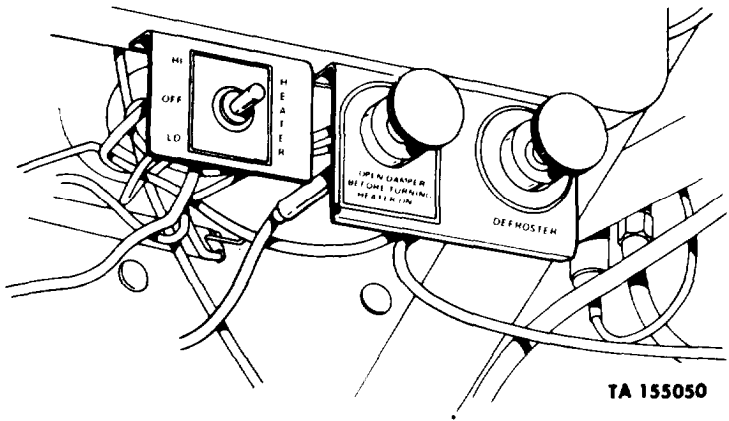
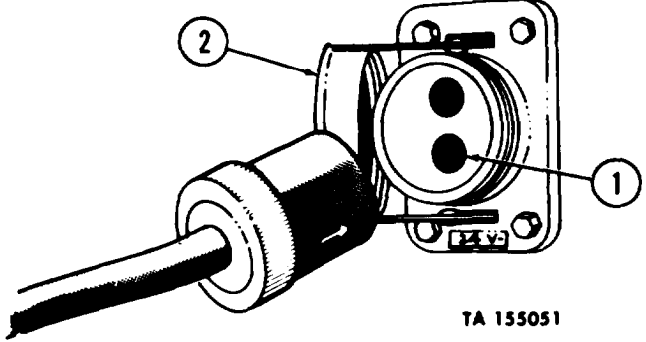
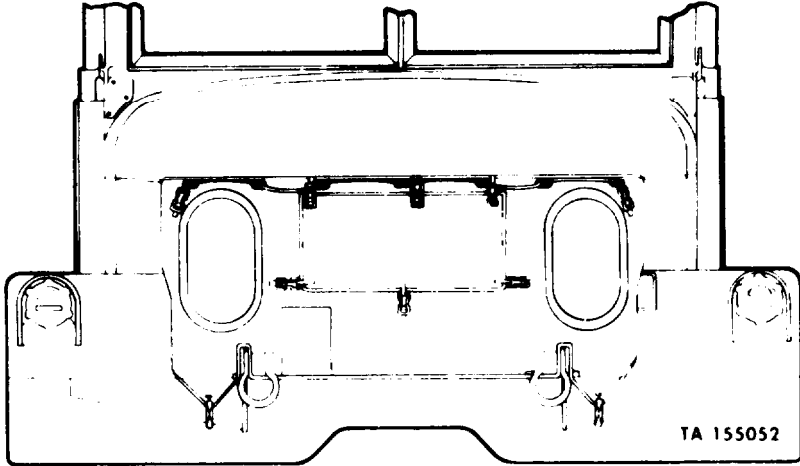
### CHECKOUT, ALINEMENT, AND ADJUSTMENT

---

2-1. GENERAL. There are no scheduled checkout, alinement, or adjustment procedures to be done at organizational level of maintenance other than those in PMCS tables.

## CHAPTER 3

### LUBRICATION

---

3-1. GENERAL. Refer to LO 9-2320-211-12 for lubrication of the truck.

3-2. SPECIAL INSTRUCTIONS. There are no special lubrication instructions for trucks operating under unusual conditions other than those given in LO 9-2320-211-12.

## CHAPTER 4

### SCHEDULED MAINTENANCE OF MATERIAL USED IN CONJUNCTION WITH MAJOR ITEMS

---

4-1. GENERAL. These preventive maintenance checks and services (PMCS) cover the special purpose kits supplied as part of the truck. The special purpose kits include the hot water heater kit, arctic winterization kits, deep water fording kit, electric brake kit, and A-frame kit.

4-2. PMCS PROCEDURES. Refer to TM 9-2320-211-10 for preventive maintenance checks and services for the special purpose kits.



**APPENDIX A**

**REFERENCES**

**A-1. PUBLICATION INDEXES AND GENERAL REFERENCE.**

Indexes should be checked often for the latest changes, or revisions of references given in this appendix and for new publications on materiel covered in this technical manual.

a. Military Publications Indexes.

- Index of Army Motion Pictures  
and Related Audio-Visual Aids . . . . . DA Pam 108-1
- Index of Administrative Publications . . . . . DA Pam 310-1
- Index of Blank Forms.... . . . . DA Pam 310-2
- Index of Doctrinal Training and  
Organizational Publications . . . . . DA Pam 310-3

Military Publications:

- Index of Technical Manuals, Technical  
Bulletins, Supply Bulletins, and  
Lubrifications Orders . . . . . DA Pam 310-4
- Index of Supply Catalogs and  
Supply Manuals (excluding types  
7,8, and 9) . . . . . DA Pam 310-6
- Index of Modification Work Orders . . . . . DA Pam 310-7
- Common Tools and Equipment . . . . .  
Supply Manuals . . . . . DA Supply Manuals  
SC-4910-95-CL-A01, A02,  
A50, A63, A67, A68, A72,  
A73, and A74.  
SC-4910-95-CL-A31.

b. General Reference.

- Authorization Abbreviations and Brevity  
Codes . . . . . AR310-50
- Dictionary of United States Army Terms . . . . . AR 310-25

**A-2. FORMS.**

The following forms are for this materiel (refer to DA pamphlet 310-2 for index of blank forms and to TM 38-750 for explanation of their use).

- Recommended Changes to Publications . . . . . DA Form 2028
- Maintenance Request - Continuation Sheet . . . . . DA Form 2407-1
- Equipment Log Assembly (Records) . . . . . DA Form 2408
- Processing and Reprocessing Records for  
Shipment, Storage, and Issue of  
Vehicles and Spare Engines . . . . . DD Form 1397

**A-3. OTHER PUBLICATIONS.**

**A. Vehicle.**

- Lubrication Order . . . . . LO 9-2320-211-12
- Operator's Manual . . . . . TM 9-2320-211-10
- Direct Support and General Support  
Maintenance Manual . . . . . TM 9-2320-211-34
- Organizational Maintenance Repair Parts  
and Special Tool List . . . . . TM 9-2320-211-20P
- Direct Support and General Support  
Maintenance Repair Parts and  
Special Tool List. . . . . TM 9-2320-211-34P

**b. General.**

- Rustproofing for Tactical Vehicles . . . . . TB 43-0213
- Chemical, Biological, and Radiological  
(CBR) Decontamination . . . . . TM 3-220
- Chemical, Biological, Radiological, and  
Nuclear Defense . . . . . FM 21-40
- Rigging . . . . . TM 5-725
- Accident Reporting and Records . . . . . AR 385-40
- Basic Cold Weather Manual . . . . . FM 31-70
- Cooling Systems: Tactical Vehicles. . . . . TM 750-254
- Manual for the Wheeled Vehicle Driver . . . . . FM 21-305
- Army Motor Transport Units  
and Operations . . . . . FM 55-30
- Color, Marking and Comouflage Painting of  
Military Vehicles, Construction Equipment,  
and Material Handling Equipment . . . . . TB 43-0209

## APPENDIX B

### MAINTENANCE ALLOCATION CHART

---

#### Section I. INTRODUCTION

##### **B-1. GENERAL.**

a. This section provides a general explanation of all maintenance and repair functions authorized at various maintenance levels.

b. The Maintenance Allocation Chart (MAC ) in section II designates overall responsibility for the performance of maintenance functions on the identified end item or component. The implementation of the maintenance functions upon the end item or component will be consistent with the assigned maintenance functions.

c. Section III lists the special tools and test equipment required for each maintenance function as referenced from section II.

d. Section IV contains supplemental instructions on explanatory notes for a particular maintenance function.

##### **B-2. MAINTENANCE FUNCTIONS.**

a. Inspect. To determine the serviceability of an item by comparing its physical, mechanical and/or electrical characteristics with established standards through examination.

b. Test. To verify serviceability and detect incipient failure by measuring the mechanical or electrical characteristics of an item and comparing those characteristics with prescribed standards.

c. Service. Operations required periodically to keep an item in proper operating condition, i.e. to clean (decontaminate), to preserve, to drain, to paint, or to replenish fuel, lubricants, hydraulic fluids, or compressed air supplies.

d. Adjust. To maintain, within prescribed limits, by bringing into proper or exact position, or by setting the operating characteristics to specified parameters.

e. Align. To adjust specified variable elements of an item to bring about optimum or desired performance.

f. Calibrate. To determine and cause corrections to be made or to be adjusted on instruments or test measuring and diagnostic equipments used in precision measurement. Consists of comparisons of two instruments, one of which is a certified standard of known accuracy, to detect and adjust any discrepancy in the accuracy of the instrument being compared.

g. Install. The act of emplacing, seating, or fixing into position an item, part, or module (component or assembly) in a manner to allow the proper functioning of an equipment or system.

h. Replace. The act of substituting a serviceable like type part, subassembly, or module (component or assembly) for an unserviceable counterpart.

i. Repair. The application of maintenance services or other maintenance actions<sup>2</sup> to restore serviceability to an item by correcting specific damage, fault, malfunction, or failure in a part, subassembly, module (component or assembly), end item, or system.

j. Overhaul. That maintenance effort (services/actions) necessary to restore an item to a completely serviceable/operational condition as prescribed by maintenance standards (i.e., DMWR) in appropriate technical publications. Overhaul is normally the highest degree of maintenance performed by the Army. Overhaul does not normally return an item to like new condition.

k. Rebuild. Consists of those services/actions necessary for the restoration of unserviceable equipment to a like new condition in accordance with original manufacturing standards. Rebuild is the highest degree of materiel maintenance applied to Army equipment. The rebuild operation includes the act of returning to zero those age measurements (hours/miles), etc.) considered in classifying Army equipments/components.

**B-3. COLUMN ENTRIES USED IN THE MAC.**

a. Column 1, Group Number. Column 1 lists group numbers, the purpose of which is to identify components, assemblies, subassemblies, and modules with the next higher assembly.

b. Column 2, Component/Assembly. Column 2 contains the names of components, assemblies, subassemblies, and modules for which maintenance is authorized.

c. Column 3, Maintenance Functions. Column 3 lists the functions to be performed on the item listed in column 2. (For detailed explanation of these functions, see para B-2.)

d. Column 4, Maintenance Level. Column 4 specifies, by the listing of a "work time" figure in the appropriate subcolumn(s), the lowest level of maintenance authorized to perform the function listed in column 3. This figure represents the active time required to perform the maintenance function at the indicated level of maintenance. If the number or complexity of the tasks within the listed maintenance function vary at different maintenance levels, appropriate "work time" figures will be shown for each level. The number of manhours specified by the "work time" figure represents the average time required to restore an item (assembly, subassembly, component, module, end item, or system) to a serviceable condition under typical field operating conditions. This time includes preparation time, troubleshooting time, and quality assurance/quality control time in addition to the time required to perform the specific tasks identified for the maintenance functions authorized in the maintenance allocation chart. The symbol designations for the various maintenance levels are as follows:

- C. . . . . Operator or crew
- D. . . . . Organization maintenance
- F. . . . . Direct support maintenance
- H. . . . . General support maintenance
- D. . . . . Depot maintenance

e. Column 5, Tools and Equipment. Column 5 specifies, by code, those common tools sets (not individual tools) and special tools, test, and support equipment required to perform the designated function.

f. Column 6, Remarks. This column contains a letter code in alphabetic order which is keyed to the remarks contained in section IV.

<sup>1</sup>  
Services-inspect, test, service, adjust, align, calibrate, or replace.

<sup>2</sup>Action-welding, grinding, riveting, straightening, facing, remachining, or resurfacing.



**B-4. COLUMN ENTRIES USED IN TOOL AND TEST EQUIPMENT REQUIREMENTS.**

a. Column 1, Tool or Test Equipment Reference Code. The tool and test equipment reference code correlates with a maintenance function on the identified end item or component.

b. Column 2, Maintenance Level. The lowest level of maintenance authorized to use the tool or test equipment.

c. Column 3, Nomenclature. Name or identification of the tool or test equipment.

d. Column 4, National/NATO Stock Number. The National or NATO stock number of the tool or test equipment.

e. Column 5, Tool Number. The manufacturer's part number.

**B-5. EXPLANATION OF COLUMNS IN SECTION IV.**

a. Reference Code. The code scheme recorded in column 6, section II.

b. Remarks. This column lists information pertinent to the maintenance function being performed as indicated on the MAC in section II.

Section II. MAINTENANCE ALLOCATION CHART

(1) Group Number	(2) Component/Assembly	(3) Maintenance Function	(4) Maintenance Level					(5) Tools and Equipment	(6) Remarks
			C	O	F	H	D		
01	ENGINE							79,80,81	
0100	Engine Assembly (Multifuel)	Service Replace Repair	2.0		8.0 13.7	21.0		2-12,47-56, 65,68	
	Overhaul					38.5		2-12,47-56, 65-68	
	Pad, Engine Mounting	Replace			1.0				
0101	Crankcase, Block and Cylinder Head								
	Head, Cylinder Assembly	Replace Repair			2.0	10.4		4,78	
0102	Crankshaft	Replace Repair				3.0	2.5	3	
0103	Flywheel Assembly	Replace Repair			3.5	2.0		65.66	
0104	Pistons, Connecting Rods								
	Connecting Rod	Replace Repair				2.0 1.0			
	Piston & Cylinder Sleeve Assembly	Replace				5.9		6,7,53,54	
0105	Valves, Camshaft and Timing System								
	Valves, Intake and Exhaust	Adjust Replace			1.5 15.1			49,50,51	
	Camshaft and Bearings	Replace				12.0		48	
	Gears, Timing	Replace			2.0			45	
0106	Engine Lubrication System								
	Oil Pump	Replace Repair			3.0	1.0			
	Filter, Oil	Service Replace Repair		1.0 1.2	1.0			55,56	

Section II. MAINTENANCE ALLOCATION CHART - Cont

(1) Group Number	(2) Component/Assembly	(3) Maintenance Function	(4) Maintenance Level					(5) Tools and Equipment	(6) Remarks
			C	O	F	H	D		
01	ENGINE – cont								
	Pan, Oil	Replace Repair			3.0 2.0				
0108	Manifolds	Replace			2.0				
02	CLUTCH							79,80,81	
0200	Clutch Assembly								
	Plate, Pressure, Friction	Replace Repair			4.4 1.0				
	Disk, Clutch	Replace			4.4				
0202	Clutch Release Mechanism								
	Bearings, Clutch Release	Replace			4.2				
	Controls & Linkage Clutch	Service Adjust Replace	0.2						
				0.3 0.4					
03	FUEL SYSTEM								79,80,81
0301	Carburetor, Fuel Injector								
	Nozzle and Holder, Fuel Injector	Replace Repair			2.0 4.0				
0302	Fuel Pump	Test Service Calibrate Replace Repair Overhaul				1.5 1.0 2.0 1.5 2.5 20.1			57-64,68 57-64,68
0304	Air Cleaner	Inspect Service Replace Repair	0.1 0.3	0.5 0.8 0.5					
0305	Turbocharger	Replace Repair			0.7	1.5			40-44,69-71

Section II. MAINTENANCE ALLOCATION CHART -Cont

(1) Group Number	(2) Component/Assembly	(3) Maintenance Function	(4) Maintenance Level					(5) Tools and Equipment	(6) Remarks
			C	O	F	H	D		
03	FUEL SYSTEM – cont								
0306	Tanks, Lines, Fittings, Headers								
	Tank, Fuel	Service Replace Repair	0.2	0.5 0.5	1.0				
	Lines, Connections and Fittings	Replace Repair		0.5 0.5					
0309	Fuel Filter	Service Replace Repair	0.1	0.3 1.0					
0311	Engine Starting Aids								
	Manifold Heater	Replace Repair		0.5 0.8					
0312	Accelerator, Throttle or Choke Controls								
	Controls and Linkage, Accelerator	Adjust Replace Repair		0.3 0.9 0.5					
	Throttle Controls and Engine Stop	Replace Repair		0.5 0.5					
04	EXHAUST PIPES						79,80,81		
0401	Muffler and Pipes	Inspect Replace		0.2 1.5					
05	COOLING SYSTEM						79,80,81		
0501	Radiator	Test Service Replace Repair	1.5	1.9	0.1 1.5				
	Cap, Radiator	Inspect Replace		0.1 0.1					
0502	Shroud, Radiator Fan	Replace		0.3					

Section II. MAINTENANCE ALLOCATION CHART - Cont

(1) Group Number	(2) Component/Assembly	(3) Maintenance Function	(4) Maintenance Level					(5) Tools and Equipment	(6) Remarks
			C	O	F	H	D		
05	COOLING SYSTEM - cont								
0503	Water Manifold, Hieaders, Thermo- stats and Housing Gasket								
	Hose. Lines and Fittings	Replace Repair		0.4 0.3					
	Manifold, Water (Multifuel)	Replace			0.8				
	Thermostat	Test Replace		0.5 0.5					
0504	Water Pump	Replace		0.8					
0505	Fan Assembly								
	Belt. Fan	Inspect Adjust Replace		0.1 0.2 1.0					
	Fan	Replace		0.2					
06	ELECTRICAL SYSTEM						79,80,81		
0601	Generator. Alternator	Test Replace Repair		0.2 0.5	2.0				
0602	Regulator	Test Replace		0.2 0.4					
0603	Starting Motor	Test Replace Repair		0.2 0.8	2.0		67		
0607	instrument or Engine Control Panel								
	Instruments	Replace		0.2					
0608	Miscellaneous Items								
	Switches. Light	Replace		0.2					
	Flasher, Solid State	Replace		0.3					
0609	Lights	Aline Replace Repair		0.3 0.5 0.7					

Section II. MAINTENANCE ALLOCATION CHART - Cont

(1) Group Number	(2) Component/Assembly	(3) Maintenance Function	(4) Maintenance Level					(5) Tools and Equipment	(6) Remarks
			C	O	F	H	D		
06	ELECTRICAL SYSTEM – cont								
0610	Sending Units and Warning Switches	Test Replace		0.1 0.2					
0611	Horn	Adjust Replace Repair		0.1 0.2 0.5					
0612	Batteries, Storage	Inspect Test Service Replace Repair	0.1	0.2 0.1 0.4		4.0		A	
	Battery Box	Inspect Service Replace Repair	0.1	1.5 1.8 1.5					
0613	Hull or Chassis Wiring Harness	Test Replace Repair		0.2 2.2	4.0				
07	TRANSMISSION						79,80,81		
0700	Transmission Assembly	Service Replace Repair Overhaul	0.1	0.3	4.0 1.0	4.0	8.0	16	
0701	Transmission Shafts	Replace				2.6			
C704	Transmission Top Cover Assembly	Replace Repair			0.5 0.9				
08	TRANSFER AND FINAL DRIVE ASSEMBLIES						79,80,81		
0801	Power Transfer	Service Replace Repair	0.1	0.3	4.6 1.0	6.0		13,14,17 16,36,77	
		Overhaul					11.2	16,36,77	
	Air Transfer Cylinder	Repair			1.0				
	Lines and Fittings	Replace Repair		1.0 1.0					

Section II. MAINTENANCE ALLOCATION CHART - Cont

(1) Group Number	(2) Component/Assembly	(3) Maintenance Function	(4) Maintenance Level					(5) Tools and Equipment	(6) Remarks
			C	O	F	H	D		
08	TRANSFER AND FINAL DRIVE ASSEMBLIES - cent								
0803	Gear Shift. Vacuum Booster and Controls								
	Controls and Linkage	Adjust Replace Repair		0.3 1.0 0.5					
09	PROPELLER SHAFTS							79,80,81	
0900	Shaft Propeller, Assembly	Replace Repair		0.8 1.4					
	Joint, Universal	Service Replace Repair		0.1 0.7 1.5					
10	FRONT AXLE							79,80,81	
1000	Front Axle Assembly	Service Replace Repair		0.2 3.2	4.5 5.1				19,20,28-31, 73
		Overhaul					20.5		19,20,28-31, 73
1002	Carrier. Differential	Replace Repair			7.5				14,17,21-27 32,72
		Overhaul				7.0	19.5		14,17,21-27, 32,72
1004	Steering Mechanism	Service Replace Repair		0.1 1.5 0.5	2.2				
11	REAR AXLE							79,80,81	
1100	Rear Axle Assembly	Service Replace Repair Overhaul		0.3 2.0	6.0 4.0				
							38.9		
1102	Carrier, Differential	Replace Repair			7.5				14,17,21-27, 32,72
		Overhaul				7.0	19.5		14,17,21-27, 32,72

Section II. MAINTENANCE ALLOCATION CHART - Cont

(1) Group Number	(2) Component/Assembly	(3) Maintenance Function	(4) Maintenance Level					(5) Tools and Equipment	(6) Remarks
			C	O	F	H	D		
12	BRAKES							79,80,81	
1201	Hand Brakes								
	Drum, Hand Brake	Replace Repair		1.2	2.0				
	Shoe, Hand Brake	Replace Repair		0.5	0.8				
	Linkage, Parking	Service Adjust Replace	0.1 0.1	0.3 0.5					
1202	Service Brakes								
	Shoe, Brake Service	Adjust Replace		0.1 1.4					
1204	Hydraulic Brake System								
	Cylinder, Master	Service Replace		0.1 2.0					
	Cylinder, Air Hydraulic	Replace Repair Overhaul		0.9	1.5			39,74 39,74	
1206	Mechanical Brake System								
	Brake Pedal	Adjust Replace		0.2 0.2					
[1208	Air Brake System								
	Lines and Fittings	Replace		0.1					B
	Reservoir, Air	Service Replace	0.1	1.6					
1209	Air Compressor Assembly								
	Belt, Drive	Service Replace Repair		0.1 1.6	2.0			76	
	Governor, Air	Inspect Adjust Replace	0.1	0.1 0.2 1.1				47	



Section II. MAINTENANCE ALLOCATION CHART - Cont

(1) Group Number	(2) Component/Assembly	(3) Maintenance Function	(4) Maintenance Level					(5) Tools and Equipment	(6) Remarks
			C	O	F	H	D		
12	BRAKES - cont								
1211	Trailer Brake Connections and Controls								
	Coupling, Trailer Brake	Replace Repair		0.4 0.2					
13	WHEELS						79,80,81		
1311	Wheel Assembly								
	Hub Assembly	Service Replace Repair		0.1 1.3 1.8			75		
	Drum, Service Brake	Replace Repair		1.2	1.5				
1313	Tires	Inspect Service Replace Repair	0.1 0.1	0.1 1.2		0.8		C	
14	STEERING								
1401	Mechanical Steering Gear Assembly								
	Drag Link Assembly	Adjust Replace Repair		0.1 0.3 0.5					
	Tie Rod Assembly	Replace Repair		1.2 1.5					
1407	Power Steering Gear Assembly	Service Adjust Replace Repair		0.1	0.3 4.5 3.1				
	Arm: Pitman	Replace		0.7					
1410	Hydraulic Pump								
	Pump, Hydraulic Steering	Replace Repair			0.5 1.0				
1411	Hoses, Lines, Fittings	Replace		0.4					

Section II. MAINTENANCE ALLOCATION CHART - Cont

(1) Group Number	(2) Component/Assembly	(3) Maintenance Function	(4) Maintenance Level					(5) Tools and Equipment	(6) Remarks
			C	O	F	H	D		
14	STEERING – cont								
1412	Hydraulic Cylinder	Replace Repair			0.8 1.0				
1413	Tanks, Reservoirs	Service Replace			0.2 1.0				
1414	Steering System Valves								
	Control Steering Valve	Replace Repair			0.5 0.8				
15	FRAME TOWING ATTACH- MENTS AND DRAWBARS						79,80,81		
1501	Frame Assembly	Repair		1.0		20.0		D	
1503	Pintles and Towing Attachments	Service Replace Repair		0.1 0.2 0.7					
1504	Spare Wheel Carrier and Tire Lock	Replace Repair		0.8 1.2					
1506	Fifth Wheel	Service Adjust Replace Repair		0.1 0.5 1.7	2.0				
16	SPRINGS AND SHOCK ABSORBERS						79,80,81		
1601	Springs								
	Springs, Front	Replace Repair		1.6 2.4					
	Springs, Rear	Replace Repair		1.0 1.8					
	Rear Spring Seat	Repair		1.0			38		
1604	Shock Absorber Equipment	Replace		0.3					
1605	Torque, Radius and Stabilizer Rods	Replace			0.4				

Section II. MAINTENANCE ALLOCATION CHART - Cont

(1) Group number	(2) Component/Assembly	(3) Maintenance Function	(4) Maintenance Level					(5) Tools and Equipment	(6) Remarks
			C	O	F	H	D		
18	BODY, CAB, HOOD AND HULL							79,80,81	
1801	Body, Cab, Hood and Hull Assemblies								
	Cab	Repair			12.0				
	Door	Replace Repair		0.4 0.2	0.5				
	Hood	Replace Repair			0.2 0.7				
	Guard, Radiator	Replace		0.3					
1802	Fenders, Running Boards with Mounting and Attaching Parts, Outriggers, Windshield, Glass, etc.								
	Fenders	Replace Repair			2.7 0.5				
	Windshield	Replace Repair		0.4 0.2	0.8				
	Running Boards	Replace Repair			0.3 0.2				
1806	Upholstery, Seats and Carpets	Replace Repair		0.6 0.2	0.3				
1808	Stowage Racks, Boxes, Straps Carrying Cases, Cable Reels, Hose Reels, etc.	Replace Repair			0.2 0.2				
1810	Cargo Body	Replace Repair			3.0 3.0	3.0 3.0			
	Rack and Seat Assembly	Replace Repair		0.4 0.6					
	Tailgate	Service Replace Repair	0.1	0.6	0.3				

Section II. MAINTENANCE ALLOCATION CHART - Cont

(1) Group Number	(2) Component/Assembly	(3) Maintenance Function	(4) Maintenance Level					(5) Tools and Equipment	(6) Remarks
			C	O	F	H	D		
20	HOIST, WINCH, CAPSTAN, WINDLASS, POWER CONTROL UNIT AND POWER TAKEOFF							79,80,81	
2001	Hoist, Capstan, Windlass, Crane or Winch Assembly								
	Winch	Service Adjust Replace Repair Overhaul	0.3	0.3 0.3 1.6 1.0	1.6	3.0	5.6		
	Band, Automatic Brake	Adjust Replace Repair		0.2 0.3	1.0				
	Cable, Winch	Service Inspect Replace Repair	0.4 0.2	0.8 1.0					E
	Shaft Assembly, Drive	Service Replace	0.1	0.8					
	Shear Pin	Replace	0.2						
004	Power Takeoff Assembly	Replace Repair			1.0	2.4			
	Controls and Linkage	Service Adjust Replace Repair		0.1 0.3	0.3 0.4				
2	BODY, CHASSIS AND ACCESSORY ITEMS							79,80,81	
201	Canvas, Rubber or Plastic Items								
	Bows	Install Replace Repair	0.3	0.3 0.2					
	Cover, Body	Install Replace Repair	0.3	0.3	0.5				

Section II. MAINTENANCE ALLOCATION CHART - Cont

(1) Group number	(2) Component/Assembly	(3) Maintenance Function	(4) Maintenance Level					(5) Tools and Equipment	(6) Remarks
			C	O	F	H	D		
22	BODY, CHASSIS AND ACCESSORY ITEMS - cont								
2202	Accessory Items								
	Motor, Windshield Wiper	Replace		0.2					
	Mirror Assembly	Replace Repair		0.2 0.2					
2210	Data Plates and Instruction Holders	Replace		0.1					
47	GAGES (NON-ELECTRICAL)							79,80,81	
4701	Instruments (Speed and Distance)								
	Speedometer	Replace		0.4					
	Shaft Assembly, Flexible	Replace		0.4					
	Tachometer	Replace		0.4					
	Shaft Assembly, Flexible	Replace		0.4					
	Joint, Angle Drive	Replace Repair		0.6 0.6				46	
	SUPPLEMENT NUMBER 1								
	TRUCK, WRECKER, 5 TON, 6x6 M543A2								
	NOTE: This Supplement pertains to maintenance operations peculiar to the truck, wrecker, M543A2 and must be used in conjunction with the basic allocation chart								
03	FUEL SYSTEM							79,80,81	
0302	Fuel Pumps								
	Valve, Governor mvs Manual Variable Speed	Adjust Replace			0.3 0.8				
06	ELECTRICAL SYSTEM							79,80,81	

Section II. MAINTENANCE ALLOCATION CHART - Cont

(1) Group Number	(2) Component/Assembly	(3) Maintenance Function	(4) Maintenance Level					(5) Tools and Equipment	(6) Remarks
			C	O	F	H	D		
06	ELECTRICAL SYSTEM - cent								
0608	Miscellaneous Items								
	Switch, Floodlight Control	Replace		0.5					
0609	Lights								
	Light, Flood	Replace Repair		0.3 0.7					
0613	Hull or Chassis Wiring Harness								
	Harness, Wiring	Replace Repair		3.0 2.2					
18	BODY								
1812	Special Purpose Bodies						79,80,81		
	Outriggers and Jacks	Service Replace Repair	0.1	0.4	0.8				
	Wrecker Body	Repair			1.0				
20	WINCH, POWER TAKEOFF and HOIST						79,80,81		
2001	Crane or Winch Assembly								
	Plate, Base	Repair				5.8			
	Boom, Inner and Outer	Service Replace Repair	0.1			1.6 3.0			
	Cylinder, Boom Crowd	Replace Repair			1.6 4.0				
	Cylinder, Boom Elevating	Replace Repair			1.6 4.0				
	Slipring	Replace				7.2			
	Brush, Slipring	Replace			0.5				
	Block, Load	Service Replace Repair	0.1	1.5	4.0				

Section II. MAINTENANCE ALLOCATION CHART - Cont

(1) Group Number	(2) Component/Assembly	(3) Maintenance Function	(4) Maintenance Level					(5) Tools and Equipment	(6) Remarks
			C	O	F	H	D		
2001	Crane or Winch Assembly – cont								
	Packing, Boom Elevating Cylinder	Adjust Replace		0.2		1.8			
	Motor, Hydraulic (Swing and Hoist)	Replace Repair			1.5	4.7			
	Drive, Angle (Bevel Gear)	Replace Repair				1.0 1.5			
	Band, Automatic Brake (Hoist)	Adjust Replace		0.8	2.0				
	Cab, Operator's	Repair			6.0				
	Cable, Hoist	Inspect Service Replace Repair	0.1 2.0		1.5				E
	Coupling, Hoist Motor	Replace			1.2				
	Pump, Hydraulic	Replace Repair			0.5	1.0			
	Winch, Boom Hoist	Service Replace Repair	0.1		3.0	5.6			
	Lines and Fittings	Replace		2.0					
	Disk, Hoist Brake	Replace			1.0				
	Reservoir, Hydraulic Oil	Service Replace Repair	0.1		1.6 2.0				
	Guard and Bracket	Replace		0.1					
	Rollers, Boom and Shipper	Service Adjust Replace Repair	0.1		0.2	1.5 1.0			
	Shaft, Propeller, Angle Drive	Service Replace Repair	0.1		0.8 1.4				

Section II. MAINTENANCE ALLOCATION CHART -- Cont

(1) Group Number	(2) Component/Assembly	(3) Maintenance Function	(4) Maintenance Level					(5) Tools and Equipment	(6) Remarks
			C	O	F	H	D		
2001	Crane or Winch Assembly - cent								
	Case, Gear. Hoist (Speed Reduction)	Service Replace Repair	0.1		1.5		1.0		
	Gear, Ring and Bearing (Turntable)	Replace					1.8		
	Gearbox, Swing Drive	Replace Repair					3-2 2-0		
	Valve Assembly, Control Bank	Adjust Replace Repair		0.2			2-1 3.2		
	Relief Valve	Adjust Replace					0.1 0.5		
	Line, Vent	Replace		2.0					
	Valve, Restrictor	Replace		1.2					
	Knob, Control Lever	Replace		0.3					
	Power Divider	Replace Repair			1.0		4.5		
	Winch, Rear	Service Replace Repair Overhaul	0.1	0.1 2.0					6.0
	Winch Cable Tensioner and Brake Chamber Assy	Repair				1-0			
22	BODY AND ACCESSORY ITEMS							79,80,81	
2201	Canvas, Rubber or Plastic Items								
	Seat, Operator	Replace Repair		0.5		0.5			



Section II. MAINTENANCE ALLOCATION CHART - Cont

(1) Group Number	(2) Component/Assembly	(3) Maintenance Function	(4) Maintenance Level					(5) Tools and Equipment	(6) Remarks
			C	O	F	H	D		
18	SUPPLEMENT NUMBER 2								
	TRUCK, DUMP, 5 TON. 6x6, M51A2								
	NOTE: This supplement pertains to maintenance operations peculiar to the truck, dump, M51A2 and must be used in conjunction with the basic allocation chart								
1812	BODY						79,80,81		
	Special Purpose Bodies								
	Gate, Tail w/Linkage	Service Adjust Replace Repair	0.1	0.1	0.5 0.8				
	Body, Dump	Repair			3.0				
20	HOIST, WINCH AND POWER TAKEOFF						79,80,81		
2001	Hoist								
	Cylinder, Hoist	Service Replace Repair		0.2	2.0 3.0				
	Pump, Hoist	Replace Repair		0.5	2.0				
	Lines and Fittings	Replace		2.0					
	Joint, Universal	Service Replace		0.2 0.5					
	Controls	Replace Repair		0.3 0.4					
	Valve, Control	Replace Repair			2.0 2.7				
	Bearings, Lifting Arm	Replace			0.3				

Section II. MAINTENANCE ALLOCATION CHART - Cont

(1) Group Number	(2) Component/Assembly	(3) Maintenance Function	(4) Maintenance Level					(5) Tools and Equipment	(6) Remarks
			C	O	F	H	D		
	SUPPLEMENT NUMBER 3  TRUCK, TRACTOR, 5 TON, 6x6, M52A2  NOTE: This supplement pertains to maintenance operations peculiar to the truck, tractor, M52A2 and must be used in conjunction with the basic allocation chart								
06	ELECTRICAL SYSTEM							79,80,81	
0613	Hull or Chassis Wiring Harness  Harness, Trailer Connector Cable	Replace Repair		0.3	0.5				
12	Brakes							79,80,81	
1211	Trailer Brake Connections and Controls  Cock, Cutout  Coupling  Hose, Trailer Brake	Replace Repair  Replace Repair		0.5 0.2 0.3 0.3 0.3					
15	FRAME							79,80,81	
1506	Fifth Wheel	Service Adjust Replace Repair	0.1 0.5	1.0	2.0				
47	GAGES (NON-ELECTRICAL)							79,80,81	
4701	Instruments (Speed and Distance)  Tachograph	Service Replace		0.1 1.0					

Section II. MAINTENANCE ALLOCATION CHART - Cont

(1) Group Number	(2) Component/Assembly	(3) Maintenance Function	(4) Maintenance Level					(5) Tools and Equipment	(6) Remarks
			C	O	F	H	D		
	SUPPLEMENT NUMBER FOUR								
	SPECIAL PURPOSE KITS								
	NOTE: This supplement pertains to maintenance operations for kits used in conjunction with the M51/M54A2 series trucks								
33	SPECIAL PURPOSE KITS						79,80,81		
3301	Reusable Shipping Container	Replace Repair			0.1	1.0			
3303	Winterization Kits								
	Kit, Engine Coolant -65°F	Install			12.0				
	Hoses and Tubes	Replace			0.5				
	Heater Assy -65°F	Test Replace Repair		0.5	0.5 1.5 1.0				
	Tube, Exhaust	Replace			0.5				
	Shroud Assembly, Oil Pan	Replace Repair			0.5 0.7				
	Cover Assembly, Hood	Replace Repair		0.5	0.7				
	Cover Assembly, Radiator	Replace Repair		0.4	0.5				
	Cable, Control	Replace		0.5					
	Pump, Fuel	Replace Test Service		0.5 0.3 0.2					
	Insulation, Battery Box	Replace			0.7				
	Kit, Personnel Hot Water Heater (-25°F)	Install			12.0				
	Diverter	Replace			0.7				
	Ducting	Replace			0.7				

Section II. MAINTENANCE ALLOCATION CHART-Cont

(1) Group Number	(2) Component/Assembly	(3) Maintenance Function	(4) Maintenance Level					(5) Tools and Equipment	(6) Remarks
			C	O	F	H	D		
3303	Winterization Kits – cont								
	Cable, Control	Replace		0.5					
	Heater, Assy	Test		0.5					
		Replace			1.5				
		Repair			1.0				
	Hoses	Replace		0.5					
	Leads, Electrical	Inspect		0.2					
		Replace			0.4				
		Repair			0.5				
	Breaker, Circuit	Test		0.3					
		Replace		0.5					
	Box Assembly, Control	Test		0.3					
		Replace		0.5					
		Repair			0.6				
	Harness, Electrical	Replace			1.0				
		Repair			1.0				
	Kit, Fuel Burning Personnel Heater (-65°F)	Install			12.0				
	Boot, Transmission Shift Lever	Replace		0.5					
	Cover, Transfer and Winch Shift Levers	Replace		0.5					
	Evaporator	Inspect		0.2					
		Replace		0.5					
		Repair		0.7					
	Tube, Evaporator	Replace		0.3					
	Line, Fuel	Replace		0.3					
		Repair		0.5					
	Resistor	Test		0.2					
		Replace		0.3					
	Switch, Blower Motor	Test		0.2					
		Replace		0.3					
	Diverter	Replace			0.5				
	Ducting	Replace			0.5				

Section II. MAINTENANCE ALLOCATION CHART - Cont

(1) Group Number	(2) Component/Assembly	(3) Maintenance Function	(4) Maintenance Level					(5) Tools and Equipment	(6) Remarks
			C	O	F	H	D		
3303	Winterization Kits - cont								
	Kit, Thermal Barrier (-65°F)	Install			12.0				
	Panels	Replace Repair			1.0 0.8				
	Floormats	Replace Repair			1.0 0.8				
	Covers	Replace Repair			0.8 0.8				
	Kit, Slave Receptacle	Install			1.5				
	Receptacle Assy	Test Replace Repair		0.3 0.8 0.5					
	Kit, Hardtop Cab	Install			3.5				
	Panel, Rear	Replace Repair			2.2 1.5				
	Run, Side Window	Adjust Replace			0.3 1.0				
	Retainer, Window Run	Replace			0.5				
	Insulation	Replace			0.5				
	Window Assy, Rear	Replace Repair			1.2 0.7				
	Glass, Rear Window	Replace			1.0				
	Seals	Replace			1.0				
	Top Assembly	Replace Repair			2.0 1.5				
	3305	Deep Water Fording Kits							
Kit, Deep Water Fording		Install			2.0				
Cable. Control		Replace			0.7				
Valve, Control		Replace			1.5				

Section II. MAINTENANCE ALLOCATION CHART - Cont

(1) Group Number	(2) Component/Assembly	(3) Maintenance Function	(4) Maintenance Level					(5) Tools and Equipment	(6) Remarks
			C	O	F	H	D		
3305	Deep Water Fording Kits – cont								
	Hoses and Tubes	Replace			0.9				
	Snorkel	Replace			0.5				
	Valve, Relief	Replace			0.6				
	Valve, Regulator	Replace			0.9				
3307	Special Purpose Kits								
	Controller Assembly	Test			0.2				
		Service			0.2				
		Adjust			0.3				
		Replace			1.0				
	Harness, Electrical	Test			0.3				
		Replace			1.0				
		Repair			0.8				
	Rheostat Assembly	Test			0.3				
		Replace			0.9				
	Kit, A-Frame	Install			2.0				
	Screw, Adjusting	Adjust			0.2				
		Replace			0.3				
	Pins and Chains	Replace			0.5				
Tube, Spreader	Replace			0.6					
Tube, Spacer	Replace			0.6					
Cable	Replace			1.0					

**Section III. TOOL AND TEST EQUIPMENT REQUIREMENTS**

(1) Reference Code	(2) Maintenance Level	(3) Nomenclature	(4) National/NATO Stock Number	(5) Tool Number
1	O, F, H, D	Adapter, Mechanical, Steering Wheel	5120-00-303-1195	8708638
2	F, H, D	Adapter, Cylinder Compression Tester: Checking Cylinder Compression (Used w/Gage Assy. 4910-00-870-6283)	4910-00-870-2127	10899183
3	F, H, D	Replacer Gear: Crankshaft Gear	5120-00-870-6920	10899179
4	F, H, D	Wrench, Box: Cylinder Head	5120-00-930-6346	10951485
5	F, H, D	Gage Assembly: Checking Cylinder Compression (Used w/Adapter - 4910-00-870-2127)	4910-00-870-6283	10899180
6	H, D	Ram Kit, Hydraulic: Cylinder Sleeve Removal (Used w/Tool Kit - 5180-00-071-0736)	4910-00-873-1927	10912249
7	H, D	Tool Kit, Cylinder: Remove or Install Cylinder Sleeve (Used with Ram Kit - 4190-00-873-1927)	5180-00-071-0736	10935312
8	H, D	Cradle Assembly: Engine Universal (Used w/Stand 4910-00-795-0189)	4910-00-795-0198	7950198
9	H, D	Bracket Angle: Engine Mounting Right and Left Front (Used w/Cradle - 4910-00-795-0198)	5340-00-043-5264	10935299
10	H, D	Bracket Double Angle: Engine Mounting Right Rear (Used w/Cradle - 4910-00-795-0198)	5340-00-267-9988	10935298
11	H, D	Bracket, Double Angle: Engine Mounting Left Rear (Used w/Cradle - 4910-00-795-0198)	5340-00-226-6547	10935297
12	H, D	Stand, Maintenance, Automotive Engine: Engine Overhaul (Used with Cradle - 4910-00-795-0198)	4910-00-795-0189	7950189
13	H, D	Bracket: (Adapting Right Side of Transfer Case To Stand - 4910-00-449-4196)	4910-00-610-0920	7010363
14	F, H, D	Fixture, Transfer Case: (Removing and/or Replacing Transfer Case)	5120-00-341-4974	8708898

Section III. TOOL AND TEST EQUIPMENT REQUIREMENTS -Cont

(1) Reference Code	(2) Maintenance Level	(3) Nomenclature	(4) National/NATO Stock Number	(5) Tool Number
15	H, D	Puller Screw Type: (Differential Helical Pinion Cage)	5120-00-836-6689	8366689
16	F, H, D	Replacer: (Transmission or Transfer Case Companion Flanges)	5120-00-795-0147	7950147
17	H, D	Scale: Differential Pinion Bearing Pre-Load	6670-00-347-5922	7950157
18	H, D	Bracket: (Adapting Left Side of Transfer Case to 4910-00-449-4196 Stand)	5340-00-610-0919	7010362
19	H, D	Reamer: (Front Axle Spindle Bushing Used with Bar -41-B-155)	5110-00-795-0124	7950124
20	H, D	Remover: Front Axle Spindle Inner Bushing	5120-00-378-4301	7950127
21	D	Remover and Replacer: (Differential Spider Pinion Bushing)	5120-00-795-0089	7950089
22	D	Burnisher: Differential Spider Pinion Bushing	5120-00-795-0088	7950088
23	H, D	Adapter: (Differential Carrier Bearing)	5120-00-795-0112	7950112
24	F, H, D	Remover and Replacer (Differential Forward Bearing Cage Bearing Cup)	5120-00-795-0159	7950159
25	H, D	Remover and Replacer: (Differential Rear Bearing Cup)	5120-00-795-0079	7950079
26	H, D	Replacer: (Rear Axle Oil Seal Wiper)	5120-00-795-0136	7950136
27	H, D	Replacer: (Differential Carrier Spur Pinion Cage Bearing Cup)	5120-00-795-0082	7950082
28	H, D	Burnisher: (Steering Knuckle Sleeve Bushing)	5120-00-795-0134	7950134
29	H, D	Replacer: (Front Axle Inner Spindle Bushing or Pitman Arm Shaft Oil Seal)	5120-00-795-0129	7950129
30	H, D	Remover and Replacer: (Steering Knuckle Bushing or Piston Pin Bushing)	5120-00-795-0130	7950130
31	F, H, D	Adapter: (Steering Relay Pin)	5120-00-707-9783	7079783



## Section III. TOOL AND TEST EQUIPMENT REQUIREMENTS - Cont

(1) Reference Code	(2) Maintenance Level	(3) Nomenclature	(4) National/NATO Stock Number	(5) Tool Number
32	F, H, D	Replacer: (Differential Case Companion Flanges)	5120-00-795-0155	7950155
33	H, D	Burnisher: (Steering Gear Housing Bushing)	5120-00-795-0139	7950139
34	H, D	Remover and Replacer: (Steering Gear Housing Bushing)	5120-00-795-0137	7950137
35	H, D	Reamer: (Steering Gear Housing Bushing)	5110-00-795-0248	7950248
36	F, H, D	Replacer: (Transfer Case, Front Driver Gear Oil Seal)	5120-00-795-0152	7950152
37	O, F, H, D	Test Set: (Checking Oil Pressure in Steering)	4910-00-627-7043	7010267
38	H, D	Remover and Replacer: (Torque Rod Ball Assembly)	5120-00-048-7370	8708220
39	F, H, D	Replacer: (Air Hydraulic Cylinder Push Rod Oil Seal)	5120-00-610-6719	8742053
40	H, D	Support Block, Assemble Thrust Collar and Compressor Wheel (Used w/5120-00-870-6924 Replacer)	4910-00-870-3759	10899151
41	H, D	Sleeve, Thrust Collar Ring Expander	4910-00-870-2122	10899149
42	H, D	Sleeve, Installer, Thrust Collar or Rings	4910-00-885-3465	B-10899148
43	H, D	Support, Disassembly Compressor Wheel	4910-00-870-2124	10899152
44	H, D	Spacer, Clearance Checking, Checking Compressor Wheel Back Clearance	4910-00-870-2123	10899150
45	F, H, D	Puller, Kit, Mechanical (Timing Gears or Companion Flanges)	5120-00-338-6721	8708724
46	F, H, D	Replacer (Tachometer Driver Oil Seal and Bearing)	5120-00-795-0108	7950108
47	O, F, H, D	Wrench, Pulley Adjusting: Air Compressor Pulley	5120-00-070-7809	10935288
48	H, D	Remover and Replacer Kit, Bushing: Camshaft Bearings	5120-00-870-6919	10899154

Section III. TOOL AND TEST EQUIPMENT REQUIREMENTS - Cont

(1) Reference Code	(2) Maintenance Level	(3) Nomenclature	(4) National/NATO Stock Number	(5) Tool Number
49	H, D	Remover, Valve Guide: Removing or Installing Valve Guides (Used w/Replacer 5120-00-870-6921)	5120-00-871-3513	B-10999157
50	H, D	Replacer, Valve Guide: Install Valve Guides (Used w/Remover 5120-00-871-3513)	5120-00-870-6921	10899158
51	F, H, D	Compressor Assembly, Valve: Compressing Valve Springs or Rotors While Engine is in Vehicle	5120-00-933-6057	10951361
52	F, H, D	Plug, Mechanical Puller: Used with Puller 5120-00-338-6721 (Adapter)	5120-00-870-6914	10899178
53	F, H, D	Expander Piston Ring	5120-00-068-7234	10935314
54	F, H, D	Compressor, Piston Ring: Compressing or Gaging Piston Rings	5120-00-068-7238	10935313
55	F, H, D	Extractor, Coil Thread Insert: Helical Threaded Insert, Oil Filter (7/16 to 1" Thd. Size)	5120-00-251-1527	7751056
56	F, H, D	Inserter, Screw Thread Insert: Helical Threaded Insert, Oil Filter (1-14 Thd.)	5120-00-204-0881	10912379
57	H, D	Wrench, Spanner: (Bearing Lock Nut)	5120-00-870-6926	10899169
58	H, D	Fixture: (Holding Camshaft)	4910-00-870-2131	10899172
59	H, D	Fixture: (Holding Pump)	4910-00-870-2128	10899198
60	H, D	Compressor, Spring: (Outer Plunger Tappet Spring)	5120-00-870-6925	10899170
61	H, D	Puller, Mechanical Bearing Plate: Spider Assembly: Used w/5120-00-793-5055 Remover and Replacer	5120-00-793-5048	10882818
62	H, D	Remover and Replacer Plunger Locks: Removing Camshaft from Housing: Replacing Bearing on Camshaft: Replacing Spider Weight Assy on Camshaft: Removing Weight Assy from Camshaft: Used w/5120-00-793-5048 Puller	5120-00-793-5055	10882856

## Section III. TOOL AND TEST EQUIPMENT REQUIREMENTS - Cont

(1) Reference Code	(2) Maintenance Level	(3) Nomenclature	(4) National/NATO Stock Number	(5) Tool Number
63	H, D	Gage: (Spring Gap) (Governor)	4910-00-793-5040	10882854
64	H, D	Wrench, Socket: (Spider Clutch Spring Tension Adjusting Nut)	5120-00-793-5046	10882889
65	F, H, D	Extractor, Coil Thread Insert (Flywheel Housing #10 to 3/8 Helical Threading Insert)	5120-00-723-6833	MIL-T-1309A
66	F, H, D	Insertor, Screw Thread (Flywheel Housing, #10 to 3/8 Helical Threaded Insert)	5120-00-797-2402	MIL-T-00Z1 21309A, TYPE III, CLASS I, STYLE A
67	O, F, H, D	Adjuster, Shaft (Star, Starter Solenoid)	4910-00-792-8626	10935617
68	F, H, D	Tube, Attaching, Nozzle (Connecting Injector Nozzle to 4910-00-225-8641 Tester)	4910-00-795-7953	10882963
69	H, D	Gage, Spacing: Nozzle Vane Space (.230) Nozzle ring 138714)	4910-00-758-2373	10951060
70	H, D	Replacer, Thrust Collar or Compressor Wheel Shaft (Used w/4910-00-870-3759 Support)	5120-00-870-6924	10899147
71	H, D	Socket Wrench, Compressor Housing	5120-00-654-3629	8755594
72	H, D	Gage, Pinion Setting (Differential Pinion)	4910-00-795-0104	7950104
73	H, D	Burnisher, Sleeve (Front Axle Spindle Bushing)	5120-00-795-0133	7950133
74	F, H, D	Replacer, Snap Ring (Air Hydraulic Cylinder Check Valve Snap Ring)	5120-00-610-6720	8742059
75	O, F, H, D	Wrench (Wheel Bearing Nut)	5120-00-378-3139	7076869
76	H, D	Gage, Pressure, Dial Indicating (Checking Air Brake Pressure)	6685-00-387-9654	7541305
77	H, D	Adapter, Puller (Transfer Case Front/Rear Bearing Cone) (Used w/5120-00-356-4544)	5120-00-795-0090	7950090

Section III. TOOL AND TEST EQUIPMENT REQUIREMENTS - Cont

(1) Reference Code	(2) Maintenance Level	(3) Nomenclature	(4) National/NATO Stock Number	(5) Tool Number
78	F, H, D	Wrench, Box (Torquing Cylinder Head Nuts Index, Fuel Injectors)	5120-00-937-7834	10951484
79	O, F, H, D	No. 1 Common Organizational Maintenance Tool Kit	4910-00-754-0654	SC 4910-95-CL-A74
80	O, F, H, D	No. 1 Supplemental Organizational Maintenance Tool Kit	4910-00-754-0653	SC 4910-95-CL-A73
81	O, F, H, D	No. 2 Common Organizational Maintenance Tool Kit	4910-00-754-0650	SC 4910-95-CL-A72
<b>SPECIAL TOOL KITS</b>				
(The below listed kits contain the special tools listed above, at the maintenance levels indicated)				
	O	TOOL KIT, TRUCK: Organizational Maintenance (2nd Echelon), Set A	4910-00-071-0739	8738100
	O	TOOL KIT, TRUCK: Organizational Maintenance (2nd Echelon), Set B	5180-00-071-0740	8738101
	F	TOOL KIT, TRUCK: Direct Support Maintenance (3rd Echelon)	5110-00-071-0741	8738102
	H	TOOL KIT, TRUCK: General Support Maintenance (4th Echelon)	5180-00-071-0742	8738103
	D	TOOL KIT, TRUCK: Depot Maintenance (5th Echelon)	5180-00-071-0743	8738104

**Section IV. REMARKS**

REFERENCE CODE	REMARKS									
A	Repair of batteries will be in accordance with TM-6140-200-14 and DA Pamphlet 750-34.									
B	Inspection of brake lines will be in accordance with TB9-2300-405-14.									
C	<table border="0" style="width: 100%;"> <tr> <td style="width: 15%;">Tires/Tubes:</td> <td style="width: 40%;">Repair</td> <td style="width: 45%;">TM9-2610-200-20</td> </tr> <tr> <td></td> <td>Inspection</td> <td>TM9-2610-201-14</td> </tr> <tr> <td></td> <td>Storage</td> <td>TM743-200-1</td> </tr> </table>	Tires/Tubes:	Repair	TM9-2610-200-20		Inspection	TM9-2610-201-14		Storage	TM743-200-1
Tires/Tubes:	Repair	TM9-2610-200-20								
	Inspection	TM9-2610-201-14								
	Storage	TM743-200-1								
D	Repair of frames in accordance with TB9-2300-247-40									
E	Service/inspection of winch/hoist wire rope/cables will be in accordance with TB43-0142.									



By Order of the Secretaries of the Army and the Air Force:

E. C. MEYER  
*General, United States Army*  
*Chief of Staff*

Official:

J. C. PENNINGTON  
Major General, *United States Army*  
*The Adjutant General*

LEW ALLEN, JR., *General, USAF*  
*Chief of Staff*

Official:

VAN L. CRAWFORD, JR., *Colonel, USAF*  
*Director of Administration*

Distribution:

To be distributed in accordance with DA Form 12-38, Organizational Maintenance requirements for 5-Ton Truck Chassis, etc.





RECOMMENDED CHANGES TO EQUIPMENT TECHNICAL PUBLICATIONS



THEN... JOT DOWN THE DOPE ABOUT IT ON THIS FORM, CAREFULLY TEAR IT OUT, FOLD IT AND DROP IT IN THE MAIL!

**SOMETHING WRONG WITH THIS PUBLICATION?**

FROM: (PRINT YOUR UNIT'S COMPLETE ADDRESS)

OPERATIONS SECTION  
375th ASA Co.  
FORT HOOD, TX 76544

DATE SENT

PUBLICATION NUMBER

TM 32-5895-215-ESC

PUBLICATION DATE

OCT 71

PUBLICATION TITLE

AN/MLQ-24

BE EXACT... PIN-POINT WHERE IT IS

PAGE NO	PARA-GRAPH	FIGURE NO	TABLE NO
6	2H		
6	2I		

IN THIS SPACE TELL WHAT IS WRONG AND WHAT SHOULD BE DONE ABOUT IT:

THE RATING FOR THIS STEP DOES NOT ACCOUNT FOR THE OPERATIONAL CONDITION OF THE COUNTER ON THE IP-81A.

RECOMMEND THIS STEP RATE THE SYSTEM RED WHEN THE COUNTER IS INOPERATIVE SINCE THE EQUIPMENT CANNOT ACCOMPLISH ITS PRIMARY MISSION.

CHANGE INSTRUCTIONS TO READ "REPEAT STEP H FOR REMAINING TUNERS OF SYSTEM."

SAMPLE

PRINTED NAME, GRADE OR TITLE, AND TELEPHONE NUMBER

BILL N. ERNEST SP/4

SIGN HERE:

Bill N. Ernest

DA FORM 2028-2 JUL 79

PREVIOUS EDITIONS ARE OBSOLETE.

P.S.-IF YOUR OUTFIT WANTS TO KNOW ABOUT YOUR RECOMMENDATION MAKE A CARBON COPY OF THIS AND GIVE IT TO YOUR HEADQUARTERS.

TEAR ALONG PERFORATED LINE

FILL IN YOUR  
UNIT'S ADDRESS



FOLD BACK

DEPARTMENT OF THE ARMY

\_\_\_\_\_  
\_\_\_\_\_

OFFICIAL BUSINESS

Commander  
US Army Tank-Automotive  
Materiel Readiness Command  
ATTN: DRSTA-MB  
Warren, MI 48090

TEAR ALONG PERFORATED LINE

RECOMMENDED CHANGES TO EQUIPMENT TECHNICAL PUBLICATIONS



THEN... JOT DOWN THE DOPE ABOUT IT ON THIS FORM, CAREFULLY TEAR IT OUT, FOLD IT AND DROP IT IN THE MAIL!

**SOMETHING WRONG WITH THIS PUBLICATION?**

FROM: (PRINT YOUR UNIT'S COMPLETE ADDRESS)

DATE SENT

PUBLICATION NUMBER

TM 9-2320-211-20-1

PUBLICATION DATE

10 Dec 80

PUBLICATION TITLE 5-Ton, 6X6, M39

Series Trucks (Multifuel)

BE EXACT... PIN-POINT WHERE IT IS

PAGE NO	PARA-GRAPH	FIGURE NO	TABLE NO
---------	------------	-----------	----------

IN THIS SPACE TELL WHAT IS WRONG AND WHAT SHOULD BE DONE ABOUT IT:

TEAR ALONG PERFORATED LINE

PRINTED NAME, GRADE OR TITLE, AND TELEPHONE NUMBER

SIGN HERE:

DA FORM 2028-2  
1 JUL 79

PREVIOUS EDITIONS ARE OBSOLETE.

P.S.—IF YOUR OUTFIT WANTS TO KNOW ABOUT YOUR RECOMMENDATION MAKE A CARBON COPY OF THIS AND GIVE IT TO YOUR HEADQUARTERS.

FILL IN YOUR  
UNIT'S ADDRESS



FOLD BACK

DEPARTMENT OF THE ARMY

\_\_\_\_\_  
\_\_\_\_\_

OFFICIAL BUSINESS

Commander  
US Army Tank-Automotive  
Materiel Readiness Command  
ATTN: DRSTA-MB  
Warren, MI 48090

TEAR ALONG PERFORATED LINE

RECOMMENDED CHANGES TO EQUIPMENT TECHNICAL PUBLICATIONS



**SOMETHING WRONG** WITH THIS PUBLICATION?

THEN... JOT DOWN THE DOPE ABOUT IT ON THIS FORM, CAREFULLY TEAR IT OUT, FOLD IT AND DROP IT IN THE MAIL!

FROM: (PRINT YOUR UNIT'S COMPLETE ADDRESS)

DATE SENT

PUBLICATION NUMBER

TM 9-2320-211-20-1

PUBLICATION DATE

10 Dec 80

PUBLICATION TITLE 5-Ton, 6X6, M39

Series Trucks (Multifuel)

BE EXACT... PIN-POINT WHERE IT IS

PAGE NO.	PARA-GRAPH	FIGURE NO.	TABLE NO.

IN THIS SPACE TELL WHAT IS WRONG AND WHAT SHOULD BE DONE ABOUT IT:

TEAR PERFORATED LINE

PRINTED NAME, GRADE OR TITLE AND TELEPHONE NUMBER

SIGN HERE:

DA FORM 2028-2  
1 JUL 79

PREVIOUS EDITIONS ARE OBSOLETE.

P.S.—IF YOUR OUTFIT WANTS TO KNOW ABOUT YOUR RECOMMENDATION MAKE A CARBON COPY OF THIS AND GIVE IT TO YOUR HEADQUARTERS.

FILL IN YOUR  
UNIT'S ADDRESS

FOLD BACK

DEPARTMENT OF THE ARMY

OFFICIAL BUSINESS

Commander  
US Army Tank-Automotive  
Materiel Readiness Command  
ATTN: DRSTA-MB  
Warren, MI 48090

TEAR ALONG PERFORATED LINE

RECOMMENDED CHANGES TO EQUIPMENT TECHNICAL PUBLICATIONS



# SOMETHING WRONG WITH THIS PUBLICATION?

THEN... JOT DOWN THE DOPE ABOUT IT ON THIS FORM, CAREFULLY TEAR IT OUT, FOLD IT AND DROP IT IN THE MAIL!

FROM: (PRINT YOUR UNIT'S COMPLETE ADDRESS)

DATE SENT

PUBLICATION NUMBER

TM 9-2320-211-20-1

PUBLICATION DATE

10 Dec 80

PUBLICATION TITLE 5-Ton, 6X6, M39

Series Trucks (Multifuel)

BE EXACT... PIN-POINT WHERE IT IS

PAGE NO

PARA-GRAPH

FIGURE NO

TABLE NO

IN THIS SPACE TELL WHAT IS WRONG AND WHAT SHOULD BE DONE ABOUT IT:

TEAR ALONG PERFORATED LINE

PRINTED NAME, GRADE OR TITLE, AND TELEPHONE NUMBER

SIGN HERE:

DA FORM 1 JUL 79 2028-2

PREVIOUS EDITIONS ARE OBSOLETE.

P.S.—IF YOUR OUTFIT WANTS TO KNOW ABOUT YOUR RECOMMENDATION MAKE A CARBON COPY OF THIS AND GIVE IT TO YOUR HEADQUARTERS.

FILL IN YOUR  
UNIT'S ADDRESS

FOLD BACK

DEPARTMENT OF THE ARMY

\_\_\_\_\_  
\_\_\_\_\_

OFFICIAL BUSINESS

Commander  
US Army Tank-Automotive  
Materiel Readiness Command  
ATTN: DRSTA-MB  
Warren, MI 48090

TEAR ALONG PERFORATED LINE



# THE METRIC SYSTEM AND EQUIVALENTS

## LINEAR MEASURE

1 Centimeter = 10 Millimeters = 0.01 Meters = 0.3937 Inches  
 1 Meter = 100 Centimeters = 1,000 Millimeters = 39.37 Inches  
 1 Kilo Meter = 1,000 Meters = 0.621 Miles

## WEIGHTS

1 Gram = 0.001 Kilograms = 1,000 Milligrams = 0.035 Ounces  
 1 Kilogram = 1,000 Grams = 2.2 Lb  
 1 Metric Ton = 1,000 Kilograms = 1 Megagram = 1.1 Short Tons

## LIQUID MEASURE

1 Milliliter = 0.001 Liters = 0.0338 Fluid Ounces  
 1 Liter = 1,000 Milliliters = 33.82 Fluid Ounces

## SQUARE MEASURE

1 Sq Centimeter = 100 Sq Millimeters = 0.155 Sq Inches  
 1 Sq Meter = 10,000 Sq Centimeters = 10.76 Sq Feet  
 1 Sq Kilometer = 1,000,000 Sq Meters = 0.386 Sq Miles

## CUBIC MEASURE

1 Cu Centimeter = 1,000 Cu Millimeters = 0.06 Cu Inches  
 1 Cu Meter = 1,000,000 Cu Centimeters = 35.31 Cu Feet

## TEMPERATURE

$5/9 (^{\circ}\text{F} - 32) = ^{\circ}\text{C}$   
 212° Fahrenheit is equivalent to 100° Celsius  
 90° Fahrenheit is equivalent to 32.2° Celsius  
 32° Fahrenheit is equivalent to 0° Celsius  
 $9/5 \text{ C}^{\circ} + 32 = \text{F}^{\circ}$

## APPROXIMATE CONVERSION FACTORS

TO CHANGE	TO	MULTIPLY BY
Inches . . . . .	Centimeters . . . . .	2.540
Feet . . . . .	Meters . . . . .	0.305
Yards . . . . .	Meters . . . . .	0.914
Miles . . . . .	Kilometers . . . . .	1.609
Square Inches . . . . .	Square Centimeters . . . . .	6.451
Square Feet . . . . .	Square Meters . . . . .	0.093
Square Yards . . . . .	Square Meters . . . . .	0.836
Square Miles . . . . .	Square Kilometers . . . . .	2.590
Acres . . . . .	Square Hectometers . . . . .	0.405
Cubic Feet . . . . .	Cubic Meters . . . . .	0.028
Cubic Yards . . . . .	Cubic Meters . . . . .	0.765
Fluid Ounces . . . . .	Milliliters . . . . .	29.573
Pints . . . . .	Liters . . . . .	0.473
Quarts . . . . .	Liters . . . . .	0.946
Gallons . . . . .	Liters . . . . .	3.785
Ounces . . . . .	Grams . . . . .	28.349
Pounds . . . . .	Kilograms . . . . .	0.454
Short Tons . . . . .	Metric Tons . . . . .	0.907
Pound-Feet . . . . .	Newton-Meters . . . . .	1.356
Pounds Per Square Inch . . . . .	Kilopascals . . . . .	6.895
Miles Per Gallon . . . . .	Kilometers Per Liter . . . . .	0.425
Miles Per Hour . . . . .	Kilometers Per Hour . . . . .	1.609
TO CHANGE	TO	MULTIPLY BY
Centimeters . . . . .	Inches . . . . .	0.394
Meters . . . . .	Feet . . . . .	3.280
Meters . . . . .	Yards . . . . .	1.094
Kilometers . . . . .	Miles . . . . .	0.621
Square Centimeters . . . . .	Square Inches . . . . .	0.155
Square Meters . . . . .	Square Feet . . . . .	10.764
Square Meters . . . . .	Square Yards . . . . .	1.196
Square Kilometers . . . . .	Square Miles . . . . .	0.386
Square Hectometers . . . . .	Acres . . . . .	2.471
Cubic Meters . . . . .	Cubic Feet . . . . .	35.315
Cubic Meters . . . . .	Cubic Yards . . . . .	1.308
Millimeters . . . . .	Fluid Ounces . . . . .	0.034
Liters . . . . .	Pints . . . . .	2.113
Liters . . . . .	Quarts . . . . .	1.057
Liters . . . . .	Gallons . . . . .	0.264
Grams . . . . .	Ounces . . . . .	0.035
Kilograms . . . . .	Pounds . . . . .	2.205
Metric Tons . . . . .	Short Tons . . . . .	1.102
Newton-Meters . . . . .	Pound-Feet . . . . .	0.738
Kilopascals . . . . .	Pounds Per Square Inch . . . . .	0.145
Kilometers Per Liter . . . . .	Miles Per Gallon . . . . .	2.354
Kilometers Per Hour . . . . .	Miles Per Hour . . . . .	0.621

