

ARMY TECHNICAL MANUAL
NAVY PUBLICATION
AIR FORCE TECHNICAL ORDER
MARINE CORPS TECHNICAL MANUAL

TM 5-6115-584-12
NAVFAC P-8-622-12
TO 35C2-3-456-1
TM 05682C-12

TECHINICAL MANUAL

OPERATOR AND ORGANIZATIONAL
MAINTENANCE MANUAL

GENERATOR SET, DIESEL ENGINE DRIVEN, TACTICAL SKID MTD 5KW, 1 PHASE
- 2 WIRE, 1 PHASE - 3 WIRE, 3 PHASE - 4 WIRE, 120, 120/240 AND 120/208 VOLTS

<u>DOD MODEL</u>	<u>CLASS</u>	<u>HERTZ</u>	<u>NSN</u>
MEP-002A	UTILITY	60	6115-00-465-1044

This copy is a reprint which includes current
pages from Change 1 through 11.

PUBLISHED UNDER THE AUTHORITY OF THE DEPARTMENTS OF THE ARMY, AIR FORCE, NAVY
AND HEADQUARTERS U.S. MARINE CORPS

JULY 1977

CHANGE

HEADQUARTERS
DEPARTMENTS OF THE ARMY, NAVY AND AIR FORCE
AND HEADQUARTERS U.S. MARINE CORPS

NO. 11

WASHINGTON, D.C., 27 APRIL 1992

Operator and Organizational Maintenance Manual

**GENERATOR SET, DIESEL ENGINE DRIVEN, TACTICAL SKID MTD, 5KW
1 PHASE-2 WIRE, 1 PHASE-3 WIRE, 3 PHASE-4 WIRE
120, 120/240 AND 120/208 VOLTS**

Approved for public release; Distribution is unlimited

TM 5-6115-584-12, NAVFAC P-8-622-12, TO 35C2-3-456-1, TM 05682C-12, 22 July 1977 is changed as follows:

1. The banner page for Change 9 to this manual is numbered incorrectly on the left hand side of the page. The number is changed from 10 to 9.

2. Remove and insert pages as indicated below. New or changed text material is indicated by a vertical bar in the margin. An illustration change is indicated by a miniature pointing hand.

Remove pages

Insert pages

D-17 and D-18

D-17 and D-18

3. Retain this sheet in front of manual for reference purposes.

ARMY TM 5-6115-584-12
NAVFAC P-8-622-12
AIR FORCE TO-35C2-3-456-1
MARINE CORPS TM-05682C-12
C I I

By Order of the Secretaries of the Army, Air Force, and Navy (Including the Marine Corps):

Official:



MILTON H. HAMILTON
*Administrative Assistant to the
Secretary of the Army*

01056

GORDON R. SULLIVAN
*General, United States Army
Chief of Staff*

Official:

CHARLES C. McDONALD
*General, USAF
Commander Air Force Logistics Command*

MERRILL A. McPEAK
*General, USAF
Chief of Staff*

DAVID E. BOTTORFF
*Rear Admiral, CEC, US Navy
Commander
Navy Facilities Engineering Command*

H. E. REESE
*Deputy for Support
Marine Corps Research, Development and
Acquisition Command*

DISTRIBUTION:

To be distributed in accordance with DA Form 12-25E, (qty rqr block no. 0856).

CHANGE

HEADQUARTERS,
DEPARTMENTS OF THE ARMY, NAVY AND AIR FORCE
AND HEADQUARTERS U.S. MARINE CORPS
WASHINGTON, D.C., 24 May 1991

NO. 10

Operator and Organizational Maintenance Manual

**GENERATOR SET, DIESEL ENGINE DRIVEN, TACTICAL SKID MTD, 5KW,
1 PHASE 2 WIRE, 1 PHASE-3 WIRE, 3 PHASE-4 WIRE
120, 120/240 AND 120/208 VOLTS**

DOD MODEL
MEP-002A

CLASS
UTILITY

HERTZ
60

NSN
6115-00-465-1044

Approved for public release; distribution is unlimited

TM 5-6115-584-12, NAVFAC P-8-622-12, TO 35C2-3-456-1, 22 July 1977, is changed as follows:

1. The U.S. Marine Corp TM-05682C-12 is being deleted from this manual. All future change pages and revisions will reflect this.
2. Remove and insert pages as indicated below. New or changed text material is indicated by a vertical bar in the margin. An illustration change is indicated by a miniature pointing hand.

Remove pages

vii and viii
4-1 and 4-2
4-23 through 4-28
- - -
4-29 and 4-30

Insert pages

vii and viii
4-1 and 4-2
4-23 through 4-28
4-28.1 through 4-28.4
4-29 and 4-30

3. Retain this sheet in front of manual for reference purposes.

ARMY TM 5-6115-584-12
NAVFAC P-8-622-12
AIR FORCE TO-35C2-3-456-1
C 10

By Order of the Secretaries of the Army , Air Force, and Navy :

CARL E. VUONO
General, United States Army
Chief of Staff

Official:

PATRICIA P. HICKERSON
Colonel, United States Army
The Adjutant General

MERRILL A. McPEAK
General USAF
Chief of Staff

Official:

CHARLES C. McDONALD
General, USAF
Commander, Air Force Logistics Command

DAVID E. BOTTORFF
Rear Admiral, CEC, US Navy
Commander
Navy Facilities Engineering Command

DISTRIBUTION:

To be distributed in accordance with DA Form 12-25E, (qty rqr block no. 0856)

CHANGE

HEADQUARTERS,
DEPARTMENTS OF THE ARMY, NAVY AND AIR FORCE
AND HEADQUARTERS U.S. MARINE CORPS
WASHINGTON, D.C., 17 MAY 1991

NO. 9

Operator and Organizational Maintenance Manual

**GENERATOR SET, DIESEL ENGINE DRIVEN, TACTICAL SKID MTD, 5KW,
1 PHASE 2 WIRE, 1 PHASE-3 WIRE, 3 PHASE-4 WIRE
120, 120/240 AND 120/208 VOLTS**

Approved for public release; distribution is unlimited

TM 5-6115-584-12, NAVFAC P-8-622-12, TO 35C2-3-456-1, TM 05682C-12, 22 July 1977, is changed as follows:

1. Remove and insert pages as indicated below. New or changed text material is indicated by a vertical bar in the margin. An illustration change is indicated by a miniature pointing hand.

Remove pages

1-5 and 1-6
1-11/(1-12 blank)
2-1 and 2-2
2-2.1/(2-2.2 blank)
3-5 and 3-6
4-1 and 4-2
4-6.1/(4-6.2 blank)

4-25 and 4-26
4-41 and 4-42
4-49 and 4-50
D-13 thru D-16
D-17 and D-18

Insert pages

1-5 and 1-6
1-11/(1-12 blank)
2-1 and 2-2
2-2.1/(2-2.2 blank)
3-5 and 3-6
4-1 and 4-2
4-6.1/(4-6.2 blank)
4-6.3/(4-6.4 blank)
4-25 and 4-26
4-41 and 4-42
4-49 and 4-50
D-13 thru D-16
D-17 and D-18

2. Retain this sheet in front of manual for reference purposes.

ARMY TM 5-6115-584-12
NAVFAC P-8-622-12
AIR FORCE TO-35C2-3-456-1
MARINE CORPS TM-05682C-12
C 9

By Order of the Secretaries of the Army , Air Force, and Navy (Including the Marine Corps):

CARL E. VUONO
General, United States Army
Chief of Staff

Official:

PATRICIA P. HICKERSON
Colonel, United States Army
The Adjutant General

MERRILL A. McPEAK
General USAF
Chief of Staff

Official:

CHARLES C. McDONALD
General, USAF
Commander, Air Force Logistics Command

DAVID E. BOTTORFF
Rear Admiral, CEC, US Navy
Commander
Navy Facilities Engineering Command

H.E. REESE
Deputy for Support
Marine Corps Research, Development and
Acquisition Command

DISTRIBUTION:

To be distributed in accordance with DA Form 12-25E, (qty rqr block no. 0856)

ARMY TM 5-6115-584-12
NAVFAC P-8-622-12
AIR FORCE TO 35C2-3-456-1
MARINE CORPS TM-05682C-12
C 8

CHANGE

HEADQUARTERS,
DEPARTMENTS OF THE ARMY, NAVY AND AIR FORCE
AND HEADQUARTERS U.S. MARINE CORPS
WASHINGTON, D.C., 10 October 1990

NO. 8

**OPERATOR AND ORGANIZATIONAL
MAINTENANCE MANUAL
GENERATOR SET, DIESEL ENGINE DRIVEN, TACTICAL SKID MTD, 5KW, 1 PHASE
2 WIRE, 1 PHASE - 3 WIRE, 3 PHASE - 4 WIRE, 120, 120/240 AND 120/ 208 VOLTS**

DOD MODEL	CLASS	HERTZ	NSN
MEP-002A	UTILITY	60	6115-00-465-1044

Approved for public release; distribution is unlimited

TM 5-6115-584-12, NAVFAC P-8-622-12, TO 35C2-3-456-1, TM 05682C-12, 22 July 1977 is changed as follows:

1. Remove and insert pages as indicated below. New or changed text material is indicated by a vertical bar in the margin. An illustration change is indicated by a miniature pointing hand.

Remove pages

Insert pages

3-9 and 3-10

3-9 and 3-10

2. Retain this sheet in front of manual for reference purposes.

ARMY TM 5-6115-584-12
NAVFAC P-8-622-12
AIR FORCE TO 35C2-3-456-1
MARINE CORPS TM 05682C-12
C 8

By Order of the Secretaries of the Army , Air Force, and Navy (Including the Marine Corps):

CARL E. VUONO
General, United States Army
Chief of Staff

Official:

THOMAS F. SIKORA
Brigadier General, United States Army
The Adjutant General

MICHAEL J. DUGAN
General USAF
Chief of Staff

Official:

CHARLES C. MCDONALD
General, USAF
Commander, Air Force Logistics Command

B.F. MONTOYA
Rear Admiral, CEC, US Navy
Commander
Navy Facilities Engineering Command

H.E. REESE
Executive Director
Marine Corps Research, Development and
Acquisition Command

DISTRIBUTION:

To be distributed in accordance with DA Form 12-25E, (qty rqr block no. 0656).

CHANGE

HEADQUARTERS,
DEPARTMENTS OF THE ARMY, NAVY AND AIR FORCE
AND HEADQUARTERS U.S. MARINE CORPS
WASHINGTON, D.C., 11 June 1990

NO. 7

Operator and Organizational Maintenance Manual

GENERATOR SET, DIESEL ENGINE DRIVEN,
TACTICAL SKID MTD, 5 KW,
1-PHASE-2 WIRE, 1-PHASE-3 WIRE, 3-PHASE-4 WIRE,
120, 120/240 AND 120/208 VOLTS

<u>DOD MODEL</u>	<u>CLASS</u>	<u>HERTZ</u>	<u>NSN</u>
MEP-002A	UTILITY	60	6115-00-465-1044

Approved for public release; distribution is unlimited

TM 5-6115-584-12, NAVFAC P-8-622-12, TO 35C2-3-456-1, TM 05682C-12, 22 July 1977, is changed as follows:

1. Remove and insert pages as indicated below. New or changed text material is indicated by a vertical bar in the margin. An illustration change is indicated by a miniature pointing hand.

Remove pages	Insert pages
iii and iv	iii and iv
---	iv.1 and iv.2
v through viii/viii	v through viii
1-2.1/1-2.2	1-2.1/1-2.2
---	1-4.1 /1-4.2
1-5 and 1-6	1-5 and 1-6
---	1-6.1/1-6.2
2-1 and 2-2	2-1 and 2-2
3-5 through 3-10	3-5 through 3-10
3-13 and 3-14	3-13 and 3-14
3-19 through 3-24	3-19 through 3-24
3-27/3-28	3-27/3-28
4-1 through 4-6	4-1 through 4-6
4-11 and 4-12	4-11 and 4-12
4-15 and 4-18	4-15 and 4-18
4-21 and 4-26	4-21 and 4-26
4-29 through 4-38	4-29 through 4-38
4-41 through 4-42.2	4-41 through 4-42.2
4-45 through 4-50	4-45 through 4-50
4-53 and 4-54	4-53 and 4-54
4-57 through 4-60	4-57 through 4-60
---	5-1 through 5-30
C-1/C-2	C-1/C-2
---	D-16.1 /D-16.2

TM 5-6115-584-12
NAVFAC P-8-622-12
TO-35C2-3-456-1
TM-05682C-12
C 7

D-17 and D-18
Index 1 and Index 2

D-17 and D-18
Index 1 and Index 2

2. Retain this sheet in front of manual for reference purposes.

By Order of the Secretaries of the Army , Air Force, and Navy (Including the Marine Corps):

CARL E. VUONO
General, United States Army
Chief of Staff

Official:

THOMAS F. SIKORA
Brigadier General, United States Army
The Adjutant General

LARRY D. WELCH, General USAF
Chief of Staff

Official:

ALFRED G. HANSEN
General, USAF, Commander, Air Force
Logistics Command

B.F. MONTOYA
Rear Admiral, CEC, US Navy
Commander
Navy Facilities Engineering Command

H.E. REESE
Executive Director
Marine Corps Research, Development and
Acquisition Command

DISTRIBUTION:

To be distributed in accordance with DA Form 12-25E, (qty rqr block no. 0856).

ARMY
NAVY
AIR FORCE
MARINE CORPS

TM 5-6115-584-12
NAVFAC P-8-622-12
TO-35C2-3-456-1
TM-05682C-12
C 6

CHANGE

No. 6

HEADQUARTERS
DEPARTMENTS OF THE ARMY, AIR FORCE, NAVY
AND HEADQUARTERS, U. S. MARINE CORPS
WASHINGTON, D. C. , 26 March 1990

Operator and Organizational
Maintenance Manual

GENERATOR SET, DIESEL ENGINE DRIVEN, TACTICAL SKID
MTD 5 KU, 1 PHASE-2 WIRE, 1 PHASE-3 WIRE
3 PHASE-4 WIRE, 120, 120/240 AND 120/208 VOLTS

DOD MODEL
MEP-002A

CLASS
UTILITY

HERTZ
60

NSN
6115-00-465-1044

Approved for public release; distribution is unlimited.

TM 5-6115-584-12, NAVFAC P-8-622-12, TO 35C2-3-456-1, TM 05682C-12, 22 July 1977, is changed as follows:

1. Remove and insert pages as indicated below. New or changed text material is indicated by a vertical bar in the margin. An illustration change is indicated by a miniature pointing hand.

Remove pages

1-1 and 1-2

1-5 and 1-6
1-11/1-12
2-3 through 2-6
3-1 and 3-2
3-3 and 3-4
3-5 and 3-6
3-9 and 3-10
4-5 and 4-6
4-37 and 4-38
4-41 and 4-42
A-1/A-2
D-9 through D-14
D-17 and D-18

Insert pages

1-1 and 1-2
1-2.1/1-2.2
1-5 and 1-6
1-11/1-12
2-3 through 2-6
3-1
3-4
3-5 and 3-6
3-9 and 3-10
4-5 and 4-6
4-37 and 4-38
4-41 and 4-42
A-1/A-2
D-9 through D-14
D-17 and D-18

2. Retain this sheet in front of manual for reference purposes.

TM 5-6115-584-12
NAVFAC P-8-622-12
TO 35C2-3-456-1
TM 05682C-12
C 6

By Order of the Secretaries of the Army, Air Force and Navy (Including the Marine Corps):

CARL E. VUONO
General, United States Army
Chief of Staff

Official:

WILLIAM J. MEEHAN, II
Brigadier General, United States Army
The Adjutant General

LARRY D. WELCH, General USAF
Chief of Staff

Official:

ALFRED G. HANSEN
General, USAF, Commander, Air Force
Logistics Command

B. F. MONTROYA
Rear Admiral, CEC, US Navy
Commander
Navy Facilities Engineering Command

H.E. REESE
Executive Director
Marine Corps Research, Development and
Acquisition Command

DISTRIBUTION:

To be distributed in accordance with DA Form 12-25A, Operator and Unit Maintenance requirements for Generator Set, Diesel Driven, Tactical, Skid Mounted, 120V, 120/240V, 120/208V, 5KW, 60HZ, 1PH/2 Wire, 1PH/3 Wire, 3PH/4 Wire (MEP-002A) (TM 5-6115-584 Series).

TM 5-6115-584-12
NAVFAC P-8-622-12
TO 35C2-3-456-1
TM 05682C-12
C 5

CHANGE }
NO. 5 }

HEADQUARTERS, DEPARTMENTS
OF THE ARMY, NAVY AND AIR FORCE
HEADQUARTERS U.S. MARINE CORPS, WASHINGTON D.C. 17 June 1988

Operator and Organizational
Maintenance Manual

GENERATOR SET, DIESEL ENGINE DRIVEN, TACTICAL SKID
MTD 5 KW, 1 PHASE-2 WIRE, 1 PHASE-3 WIRE
3 PHASE-4 WIRE, 120, 120/240 AND 120/208 VOLTS

DOD MODEL	CLASS	HERTZ	NSN
MEP-002A	UTILITY	60	6115-00-465-1044

TM 5-6115-584-12, NAVFAC P-8-622-12, TO 35C2-3-456-1, TM 05682C-12, 22 July 1977, is changed as follows:

1. Remove and insert pages as indicated below. New or changed text material is indicated by a vertical bar in the margin. An illustration change is indicated by a miniature pointing hand.

Remove pages

i through vii/viii
1-5 and 1-6
1-9 through 1-11/1-12
1-13 through 1-15/1-16
2-1 and 2-2

3-3 through 3-6

3-7 through 3-10
3-19 and 3-20
4-5 and 4-6

4-39 through 4-42.1/4-42.2
4-57 and 4-58
B-1 and B-2
C-1/C-2

Insert pages

i through vii/viii
1-5 and 1-6
1-9 through 1-11/1-12
1-13 through 1-15/1-16
2-1 and 2-2
2-2.1/2-2.2
2-6.1/2-6.2
3-3 through 3-6
3-6.1/3-6.2
3-7 through 3-10
3-19 and 3-20
4-5 and 4-6
4-6.1/4-6.2
4-39 through 4-42.2
4-57 and 4-58
B-1 and B-2
C-1/C-2

2. Retain this sheet in front of manual for reference purposes.

TM 5-6115-584-12
NAVFAC P-8-622-12
TO 35C2-3-456-1
TM 05682C-12
C 5

By Order of the Secretaries of the Army, the Navy, and the Air Force (Including the Marine Corps)

Official:

R. L. DILWORTH
Brigadier General, United States Army
The Adjutant General

CARL E. VUONO
General, United States Army
Chief of Staff

J. P. JONES, JR.
Rear Admiral, CEC, US Navy
Commander
Naval Facilities Engineering Command

Official:

ALFRED G. HANSEN
General, USAF, Commander, Air Force
Logistics Command

LARRY D. WELSH, General USAF
Chief of Staff

J. J. WENT
Lieutenant General, USMC
Deputy Chief of Staff for Installations and Logistics

DISTRIBUTION:

To be distributed in accordance with DA Form 12-25A, Operator and Unit Maintenance requirements for Generator Set, Diesel Driven, Tactical, Skid Mounted, 120V, 120/240V, 120/208V, 5KW, 60HZ, 1PH/2 Wire, 1PH/3 Wire, 3PH/4 Wire (MEP-002A) (TM 5-6115-584 Series)

Army Technical Manual
Navy Publication
Air Force Technical Order
Marine Corps Technical Manual

TM 5-6115-584-12
NAVFAC P-8-622-12
TO 35C2-3-456-1
TM 05682C-12
C 4

CHANGE }
NO. 4 }

HEADQUARTERS
DEPARTMENTS OF THE ARMY, NAVY and AIR FORCE
WASHINGTON, D.C., 14 April 1986

Operator and Organizational
Maintenance Manual

GENERATOR SET, DIESEL ENGINE DRIVEN, TACTICAL SKID
MTD 5 KW, 1 PHASE-2 WIRE, 1 PHASE-3 WIRE
3 PHASE-4WIRE, 120, 120/240 AND 120/208 VOLTS

DOD MODEL
MEP-002A

CLASS
UTILITY

HERTZ
60

NSN
6115-00-465-1044

TM 5-6115-584-12, NAVFAC P-8-622-12, TO 35C2-3-456-1, TM 05682C-12, 22 July 1977, is changed as follows:

1. Remove and insert pages as indicated below. New or changed text material is indicated by a vertical bar in the margin. An illustration change is indicated by a miniature pointing hand.

Remove pages

1-1 and 1-2
1-11/1-12
2-1 and 2-2
3-3 through 3-10
3-25 and 3-26
4-5 and 4-6
4-23 and 4-24
A-1/A-2
B-1 and B-2
C-1/C-2
D-13 and D-14
D-17 and D-18

Insert pages

1-1 and 1-2
1-11/1-12
2-1 and 2-2
3-3 through 3-10
3-25 and 3-26
4-5 and 4-6
4-23 and 4-24
A-1/A-2
B-1 and B-2
C-1/C-2
D-13 and D-14
D-17 and D-18

2. Retain this sheet in front of manual for reference purposes.

TM 5-6115-584-12
NAVFAC P-8-622-12
TO 35C2-3-456-1
TM 05682C-12
C 4

By Order of the Secretaries of the Army, the Navy, and the Air Force:

JOHN A. WICKHAM, JR.
General, United States Army
Chief of Staff

Official:

R. L. DILWORTH
Brigadier General, United States Army
The Adjutant General

J. P. JONES, JR.
Rear Admiral, CEC, US Navy
Commander
Naval Facilities Engineering Command

Official:

CHARLES A. GABRIEL, General USAF
Chief of Staff

EARL T. O'LOUGHLIN
General, USAF, Commander, Air Force
Logistics Command

GEORGE B. CRIST
Lieutenant General, USMC
Deputy Chief of Staff for Installations and Logistics

DISTRIBUTION:

To be distributed in accordance with DA For 12-25A, Operator and Organizational Maintenance requirements for Generator Set, Diesel Driven, Tactical, Skid Mounted, 120V, 120/240V, 120/208V, 5KW, 60HZ, 1PH/2 Wire, 1PH/3 Wire, 3PH/4 Wire (MEP-002A).

CHANGE }
NO. 3 }

DEPARTMENTS OF THE ARMY, NAVY,
AIR FORCE AND MARINE CORPS
WASHINGTON, D.C., 8 October 1982

Operator and Organizational
Maintenance Manual

GENERATOR SET, DIESEL ENGINE DRIVEN, TACTICAL SKID
MTD 5 KW, 1 PHASE-2 WIRE, 1 PHASE-3 WIRE,
3 PHASE-4 WIRE, 120, 120/240 AND 120/208 VOLTS

DOD MODEL	CLASS	HERTZ	NSN
MEP-002A	UTILITY	60	6115-00-465-1044

TM 5-6115-584-12/NAVFAC P-8-622-12/TO 35C2-3-456-1/TM 05682C-12, 22 July 1977,
is changed as follows:

1. Remove and insert pages as indicated below.

	Remove Pages	Insert Pages
Chapter 1	1-13 and 1-14	1-13 and 1-14
Chapter 2	2-1 and 2-2	2-1 and 2-2
Chapter 3	3-5 and 3-6 3-9 and 3-10 3-17 and 3-18 3-27/3-28	3-5 and 3-6 3-9 and 3-10 3-17 and 3-18 3-27/3-28
Chapter 4	4-3 thru 4-6 4-11 and 4-12 4-15 and 4-16 4-23 thru 4-32 4-37 thru 4-42 4-43 and 4-44	4-3 thru 4-6 4-11 and 4-12 4-15 and 4-16 4-23 thru 4-32 4-37 thru 4-42.1/4-42.2 4-43 and 4-44
Appendix B	B-1 and B-2	B-1 and B-2
Appendix C	C-1/C-2	C-1/C-2
Appendix D	D-5 and D-6 D-11 thru D-14	D-5 and D-6 D-11 thru D-14
INDEX	Index 1 thru Index 6	Index 1 thru Index 6

2. New or changed text material is indicated by a vertical bar in the margin. An illustration change is indicated by a miniature pointing hand.

3. Retain this sheet in front of manual for reference purposes.

TM 5-6115-584-12
NAVFAC P-8-622-12
TO 35C2-3-456-1
TM 05682C-12
C 3

By Order of the Secretaries of the Army, the Navy, and the Air Force:

E. C. MEYER
General, United States Army
Chief of Staff

Official:

ROBERT M. JOYCE
Major General, United States Army
The Adjutant General

W. M. ZOBEL
Rear Admiral, CEC, US Navy
Commander
Naval Facilities Engineering Command

Official:

CHARLES A. GABRIEL, General, USAF
Chief of Staff

JAMES P. MULLINS
General, USAF, Commander, Air Force
Logistics Command

H. A. HATCH
Lieutenant General, USMC
Deputy Chief of Staff for Installations and Logistics

DISTRIBUTION:

To be distributed in accordance with DA Form 12-25D, Operator Maintenance requirements for Generator Sets, Engine Driven: 5 KW, 60 HZ

Marine Corps:
MARCORPS CODE: AGB

DEPARTMENT OF THE ARMY TECHNICAL MANUAL
DEPARTMENT OF THE NAVY PUBLICATION
DEPARTMENT OF THE AIR FORCE TECHNICAL ORDER
MARINE CORPS TECHNICAL MANUAL

TM 5-6115-584-12
NAVFAC P-8-622-12
TO 35C2-3-456-1
TM 05682C-12
C 2

CHANGE }
NO. 2 }

DEPARTMENTS OF THE ARMY, NAVY,
AIR FORCE AND MARINE CORPS
Washington, DC, 30 March 1979

Operator and Organizational
Maintenance Manual

GENERATOR SET, DIESEL ENGINE DRIVEN, TACTICAL SKID
MTD 5 KW, 1 PHASE-2 WIRE, 1 PHASE-3 WIRE,
3 PHASE-4 WIRE, 120, 120/240 AND 120/208 VOLTS

DOD MODEL	CLASS	HERTZ	NSN
MEP-002A	UTILITY	60	6115-00-465-1044

TM 5-6115-584-12/NAVFAC P-8-622-12/TO 35C2-3-456-1/TM 05682C-12, 22 July 1977,
is changed as follows:

1. Remove old pages and insert new pages as indicated below.

Remove Pages	Insert Pages
iii and iv	iii and iv
1-1 and 1-2	1-1 and 1-2
1-7 and 1-8	1-7 and 1-8
1-11/(1-12 blank)	1-11/(1-12 blank)
1-13 and 1-14	1-13 and 1-14
1-15/(1-16 blank)	1-15/(1-16 blank)
3-1 and 3-2	3-1 and 3-2
4-13 and 4-14	4-13 and 4-14
4-15 and 4-16	4-15 and 4-16
4-33 and 4-34	4-33 and 4-34
4-35 and 4-36	4-35 and 4-36
B-1/(B-2 blank)	B-1 and B-2
C-1 thru C-19/(C-20 blank)	C-1/(C-2 blank)
	D-1 thru D-19/(D-20 blank)

2. New or changed material is indicated by a vertical bar in the margin of the page.

3. File this change sheet in front of the publication for reference purposes.

By Order of the Secretaries of the Army, the Navy, and the Air Force:

Official:

BERNARD W. ROGERS
General, United States Army
Chief of Staff

J. C. PENNINGTON
Major General, United States Army
The Adjutant General

D. G. ISELIN
Rear Admiral, CEC, U. S. Navy
Commander, Naval Facilities
Engineering Command

Official:

LEW ALLEN, JR., General, USAF
Chief of Staff

VAN L. CRAWFORD, JR., Colonel, USAF
Director of Administration

H. A. HATCH
Major General, U. S. Marine Corps
Deputy Chief of Staff for Installations and Logistics

Distribution:

Active Army:

To be distributed in accordance with DA Form 12-25D, Operator maintenance requirements for Generator Sets, Engine Driven, 5 KW, 60 HZ.

Marine Corps:

MARCORPS CODE: AGB

TM 5-6115-584-12
NAVFAC P-8-622-12
TO 35C2-3-456-1
TM 05682C-12
C 1

CHANGE }
No. 1 }

DEPARTMENTS OF THE ARMY, NAVY,
AIR FORCE AND MARINE CORPS
WASHINGTON, DC, 15 March 1978

**Operator and Organizational
Maintenance Manual**

**GENERATOR SET, DIESEL ENGINE DRIVEN, TACTICAL SKID
MTD 5 KW, 1 PHASE-2 WIRE, 1 PHASE-3 WIRE,
3 PHASE-4 WIRE, 120, 120/240 AND 120/208 VOLTS**

**DOD MODEL
MEP-002A**

**CLASS
UTILITY**

**HERTZ
60**

**NSN
6115-00-465-1044**

TM 5-6115-584-12/NAVFAC P-8-622-12/TO 35C2-3-456-1/TM 05682C-12, 22 July 1977, is changed as follows:
On front cover and throughout manual, Navy publication NAVFAC P-8-262-11 should read, "NAVFAC
P-8-622-12".

By Order of the Secretaries of the Army, the Navy, and the Air Force:

BERNARD W. ROGERS
General, United States Army
Chief of Staff

Official:

J. C. PENNINGTON
Brigadier General, United States Army
The Adjutant General

D. G. ISELIN
Rear Admiral, CEC, U. S. Navy
Commander,
Naval Facilities Engineering Command

Official:

DAVID C. JONES, General USAF
Chief of Staff

JAMES J. SHEPARD, Colonel, USAF
Director of Administration

H. A. HATCH
Major General, US Marine Corps
Deputy Chief of Staff for Installations and Logistics

Distribution:

To be distributed in accordance with DA Form 12-25D, Operator Maintenance requirements for
Generator Sets, Engine Driven: 5 KW, 60 HZ.

**HEADQUARTERS
DEPARTMENTS OF THE ARMY, NAVY, AIR FORCE, & USMC
WASHINGTON, D.C. 22 July 1977**

**OPERATOR AND ORGANIZATIONAL
MAINTENANCE MANUAL**

GENERATOR SET, DIESEL ENGINE DRIVEN, TACTICAL SKID MTD 5KW, 1 PHASE
2 WIRE, 1 PHASE-3 WIRE, 3 PHASE-4 WIRE, 120, 120/240 AND 120/208 VOLTS

<u>DOD MODEL</u> MEP-002A	<u>CLASS</u> UTILITY	<u>HERTZ</u> 60	<u>NSN</u> 6115-00-465-1044
------------------------------	-------------------------	--------------------	--------------------------------

TABLE OF CONTENTS

		Page
	LIST OF EFFECTIVE PAGES	v
	LIST OF ILLUSTRATIONS	vi
	LIST OF TABLES	vii
CHAPTER 1.	INTRODUCTION	1-1
Section I.	GENERAL	1-1
	1-1. Scope	1-1
	1-2. Limited Applicability	1-1
	1-3. Maintenance Forms and Records	1-1
	1-4. Reporting of Errors	1-1
	1-5. Levels of Maintenance Accomplishment	1-1
	1-6. (A, MC) Destruction of Material to Prevent Enemy Use	1-1
	1-7. (A, F, MC) Administrative Storage	1-1
	1-8. Preparation for Shipment and Storage	1-1
Section II.	DESCRIPTION AND DATA	1-2
	1-9. Description of Generator Set.	1-2
	1-10. Tabulated Data	1-5
CHAPTER 2.	OPERATING INSTRUCTIONS.	2-1
Section I.	OPERATING PROCEDURE	2-1
	2-1. General	2-1
	2-2. Power Connections	2-1
	2-3. Equipment Reconnection	2-1
	2-4. Starting Generator Set	2-1
	2-5. Operating in Alternate Modes.	2-6
	2-6. Shutting Down Unit	2-6

TABLE OF CONTENTS (CONT)

			Page
Section	II.	OPERATING UNDER UNUSUAL CONDITIONS	2-6
		2-7. Operation in Extreme Heat	2-6
		2-8. Operation in Extreme Cold (-25 °F, -32°C)	2-6
		2-9. Operation in Dusty or Sandy Areas	2-6
		2-10. Operation in Wet or Humid Areas	2-6
Section	III.	OPERATION USING NATO SLAVE CABLE	2-6.1
CHAPTER	3.	OPERATOR MAINTENANCE INSTRUCTIONS	3-1
Section	I.	CONSUMABLE OPERATING AND MAINTENANCE SUPPLIES	3-1
		3-1. Consumable Supplies	3-1
Section	II.	LUBRICATION INSTRUCTIONS	3-1
		3-2. General	3-1
		3-3. Lubrication Order	3-1
Section	III.	PREVENTIVE MAINTENANCE CHECKS AND SERVICES (PMCS)	3-4
		3-4. General	3-4
		3-5. Correcting and Reporting Deficiencies	3-4
		3-6. Determining PMCS Intervals	3-4
		3-7. PMCS for Units in Continuous Operation	3-4
		3-8. Preventive Maintenance Checks and Services	3-4
Section	IV.	TROUBLESHOOTING	3-5
		3-9. General	3-6
		3-10. Malfunctions Not Corrected By Use of the Troubleshooting Table	3-6
Section	V.	OPERATOR MAINTENANCE PROCEDURES	3-8
		3-11. Battery Assembly	3-8
		3-12. Ground Rod and Fuel Drum Adapter Hold-Down Assembly	3-9
		3-13. Fuel Tank Assembly	3-10
		3-14. Shutter Box Assembly	3-10
		3-15. Exhaust Muffler Assembly	3-13
		3-16. Engine Starter Assembly	3-13
		3-17. AC Output Control Box Assembly	3-14
		3-18. Air Cleaner Assembly	3-14
		3-19. Control Cubicle Assembly	3-17
		3-20. Fuel System (Less Tank)	3-19
		3-21. Control Cubicle Support Assembly, Speed Control and Engine Control Wiring Harness	3-20
		3-22. Engine Cooling System	3-21
		3-23. Generator Assembly	3-23
		3-24. Engine Assembly	3-23
		3-25. Skid-Base Assembly	3-27
CHAPTER	4.	ORGANIZATIONAL MAINTENANCE	4-1
Section	I.	SERVICE UPON RECEIPT OF MATERIAL	4-1
		4-1. Inspecting and Servicing Generator Set	4-1
		4-2. Installing Generator Set	4-2
Section	II.	MOVEMENT TO A NEW WORKSITE	4-4
		4-3. Dismantling Generator Set for Movement	4-4
		4-4. Reinstalling Generator Set After Movement	4-4

TABLE OF CONTENTS (CONT)

		Page
Section	III. REPAIR PARTS; SPECIAL TOOLS; SPECIAL TEST, MEASUREMENT AND DIAGNOSTIC EQUIPMENT AND SPECIAL SUPPORT EQUIPMENT	4-4
	4-5. Special Tools and Equipment	4-4
	4-6. Maintenance Repair Parts	4-4
Section	IV. LUBRICATION INSTRUCTIONS.	4-4
	4-7. Lubrication	4-4
Section	V. PREVENTIVE MAINTENANCE CHECKS AND SERVICES (PMCS).	4-5
	4-8. PMCS, General	4-5
Section	VI. TROUBLESHOOTING	4-6
	4-12. Troubleshooting, General	4-6
	4-13. Malfunctions Not Corrected By Use of the Troubleshooting Table	4-6
Section	VII. RADIO INTERFERENCE SUPPRESSION	4-10
	4-14. General Methods for Proper Suppression	4-10
	4-15. Radio Interference Suppression Components	4-10
Section	VIII. MAINTENANCE OF ENGINE COOLING SYSTEM	4-12
	4-16. Description and Function	4-12
	4-17. Engine Cooling Assembly	4-12
Section	IX. MAINTENANCE OF FUEL SYSTEM	4-16
	4-18. Description and Function	4-16
	4-19. Fuel Tank Assembly	4-16
	4-20. Fuel Filter Assemblies and Strainer Assembly	4-17
	4-21. Electric Fuel Pumps, Fuel Hoses and Auxiliary Solenoid Valve	4-21
	4-22. Auxiliary Fuel Solenoid Valve.	4-21
	4-23. Fuel Shut-Off Solenoid Valve	4-21
Section	X. MAINTENANCE OF ENGINE ELECTRICAL SYSTEM	4-24
	4-24. Description and Function	4-24
	4-25. Battery Assembly	4-24
	4-26. Engine Starter Assembly	4-26
	4-27. Battery Charging Alternator.	4-29
	4-28. Starter Lockout Switch and Gear	4-31
Section	XI. MAINTENANCE OF OIL SYSTEM	4-33
	4-29. Function and Description	4-33
	4-30. Oil Cooler	4-33
	4-31. Low Oil Pressure Switch	4-34
	4-32. Oil Filter	4-36
	4-33. Oil Pressure Gauge	4-37
Section	XII. MAINTENANCE OF CONTROL SYSTEM	4-38
	4-34. Description and Function	4-38
	4-35. DC Control System	4-38

TABLE OF CONTENTS (CONT)

		Page
Section	XII. MAINTENANCE OF CONTROL SYSTEM (CONT):	
	4-36. AC Instrumentation System	4-38
	4-37. Load Terminal Board Assembly	4-41
	4-38. Control Cubicle Assembly	4-41
Section	XIII. MAINTENANCE OF ENGINE	4-45
	4-39. Description and Function	4-45
	4-40. Exhaust Muffler Assemblies	4-45
	4-41. Air Cleaner Assembly	4-47
	4-42. Engine Assembly	4-47
	4-43. Intake Manifold Assembly	4-49
	4-44. Rocker Arm Covers	4-50
	4-46. Breather	4-50
	4-46. Valve Rocker Area	4-51
	4-47. Injector Nozzle Assembly and Fuel Lines	4-52
	4-48. Glow Plug Assemblies	4-52
	4-49. Oil Drain Hose and Valve	4-54
	4-50. Oil Pan-Base	4-54
	4-51. Oil Fill Tube	4-54
	4-52. Engine Mounting Assembly	4-54
Section	XIV. MAINTENANCE OF GENERATOR ASSEMBLY	4-56
	4-53. Description and Function	4-56
	4-54. (Generator/Exciter Assembly	4-57
	4-55. Screen-Guard	4-57
Section	XV. MAINTENANCE OF SKID-BASE	4-57
	4-56. Description and Function	4-57
	4-57. Skid-Base	4-57
CHAPTER 5	MATERIAL USED IN CONJUNCTION WITH DOD STANDARD 5KW DIESEL ENGINE DRIVEN, MODEL MEP-002A	5-1
Section	I. AUXILIARY EQUIPMENT	5-1
	5-1. General	5-1
Section	II. ACOUSTIC SUPPRESSION KIT....	5-2
	5-2. Acoustic Suppression Kit	5-2
	5-3. Cover Assembly	5-2
	5-4. Top Panel Assembly	5-8
	5-5. Left Panel Assembly	5-10
	5-6. Right Panel Assembly	5-12
	5-7. Rear Panel Assembly	5-14
	5-8. Exhaust Plenum Assembly	5-16
	5-9. Left Support Assembly	5-16
	5-10. Right Support Assembly	5-18
	5-11. Front Panel Assembly	5-18
	5-12. Side Closure Assembly	5-21
	5-13. Rear Closure Assembly	5-21
	5-14. Rear Flap Assembly	5-24

TABLE OF CONTENTS (CONT)

		Page
Section	III. ACOUSTIC SUPPRESSION KIT REPAIR	5-26
	5-15. General	5-26
	5-16. Panel Replacement	5-26
	5-17. Latch Replacement	5-28
	5-18. Catch Replacement	5-28
	5-19. Rubber Flap Replacement	5-28
	5-20. Hinges	5-30
	5-21. Captive Nuts	5-30
	5-21. Front Panel Silencer	5-30
APPENDIX A.	REFERENCES	A-1
APPENDIX B.	COMPONENTS OF END ITEM LIST	
Section	I. INTRODUCTION	
	II. INTEGRAL COMPONENTS OF END ITEM	B-1
	III. BASIC ISSUE ITEMS	B-2
APPENDIX C.	ADDITIONAL AUTHORIZATION LIST	
Section	I. INTRODUCTION	C-1
	II. ADDITIONAL AUTHORIZATION SHEET	C-1
APPENDIX D.	MAINTENANCE ALLOCATION CHART	
Section	I. INTRODUCTION	D-1
	II. MAINTENANCE ALLOCATION CHART	D - 3
	III. TOOLS, TEST AND SUPPORT EQUIPMENT REQUIREMENTS	D-18
	IV. EXPLANATION OF REFERENCE CODES	D-19
INDEX		INDEX 1

Reproduction for non-military use of the information or illustrations contained in this publication is not permitted. The policy for military use reproduction is established for the Army in AR 380-5, for the Navy and Marine Corps in OPNAVINST 5510.1B, and for the Air Force in Air Force Regulation 205-1.

LIST OF EFFECTIVE PAGES

Insert latest changed pages; dispose of superseded pages in accordance with applicable regulations.

NOTE: On a changed page, the portion of the text affected by the latest change is indicated by a vertical line, or other change symbol, in the outer margin of the page. Changes to illustrations are indicated by miniature pointing hands. Changes to wiring diagrams are indicated by shaded areas.

Total number of pages in this manual is 150 consisting of the following:

Page No.	#Change No.
Warning0
Blank0
i - vii0
viii Blank	0
1-1 - 1-110
1-12 Blank0
1-13 - 1-150
1-16 Blank	0
2-1 - 2-60
3-1 - 3-270
3-28 Blank	0
4-1 - 4-590
4-60 Blank	0
A-1	0
A-2 Blank	0
B-1	0
B-2 Blank	0
C-1 - C-19	0
C-20 Blank	0
Index 1 - Index 6	0

Zero in this column indicates an original page.

LIST OF ILLUSTRATIONS

Figure	Title	Page
1-1.	Engine Generator Set, Right-Rear, Three-Quarter View	1-3
1-2.	Engine Generator Set, Left-Front, Three-Quarter View	1-4
1-2.1	Engine Generator Set with Acoustic Suppression Kit...	1-4.1
1-3.	Tie Down, Lifting, and Towing Provisions Crated Set	1-8
1-4.	Installation Plans	1-9
1-5.	Fuel System Schematic	1-9
1-6.	Electrical Cable Schematic..	1-10
1-7.	Generator Set Electrical Schematic	1-11
1-8.	Generator Set Wiring Harness..	1-13
1-9.	AC Output Control Box Wiring Harness	1-14
1-10.	Control Cubicle Wiring Harness	1-15
2-1.	Load Terminals	2-3
2-2.	Reconnection Switch	2-3
2-3.	Starting Procedure	2-4
2-4.	Load Terminal and Reconnection Configuration	2-5
3-1.	Lubrication Order	3-2
3-2.	Battery Assembly	3-9
3-3.	Ground Rod and Fuel Drum Adapter Hold-Down	3-10
3-4.	Fuel Tank	3-11
3-5.	Shutter and Thermo Power Element Assembly	3-12
3-6.	Exhaust Muffler Assembly	3-13
3-7.	Electric Starter	3-14
3-8.	AC Output Control Box Assembly	3-14
3-9.	Air Cleaner and Shroud Assembly	3-15
3-10.	Air Cleaner Assembly	3-16
3-11.	Cleaning Air Filter Element	3-17
3-12.	Control Cubicle	3-18
3-13.	Fuel Filters and Fuel Strainer Assembly	3-19
3-14.	Fuel Pump Assembly	3-20
3-15.	Control Cubicle Support Assembly	3-20
3-16.	Speed Control Assembly	3-21
3-17.	Engine Cooling Assembly	3-22
3-18.	Generator Assembly	3-23
3-19.	Intake Manifold Assembly	3-24
3-20.	Oil Drain Hose	3-25
3-21.	Oil Filter and Oil Pressure Switch	3-25
3-22.	Engine Stop Solenoid	3-25
3-23.	Battery and Frame	3-26
3-24.	Ground Stud	3-27
4-1.	Uncrating Generator Set	4-2
4-2.	Grounding Generator Set	4-3
4-3.	Primary Radio Interference Suppression Components	4-11
4-4.	Shutter Assembly	4-14
4-5.	Adjusting Shutters	4-15
4-6.	Adjusting Thermo Unit	4-15
4-7.	Fuel Tank Assembly	4-17
4-8.	Testing Float Switch	4-18
4-9.	Fuel Filter	4-19
4-10.	Fuel Strainer Element,	4-19
4-11.	Fuel Filters and Fuel Strainer Assembly	4-20

LIST OF ILLUSTRATIONS

Figure	Title	Page
4-12.	Fuel Pump, Fuel Hoses and Solenoid	4-22
4-13.	Fuel Pump	4-23
4-14.	Adjusting Fuel Shut-Off Solenoid	4-23
4-15.	Fuel Solenoid Test Set-Up	4-24
4-16.	Installing Battery Cables	4-25
4-17.	Testing Batteries	4-26
4-18.	Engine Starter installation	4-27
4-19.	Testing Engine Starter	4-28. 1
4-20.	Testing Field Coil, Style II Starter	4-28. 2
4-21.	Inspecting Engine Starter Brushes, Style I Starter	4-28. 2
4-21A.	Inspecting Engine Starter Brushes, Style II Starter	4-28. 3
4-22.	Engine Starter Assembly, Style I Starter	4-28. 4
4-22A.	Engine Starter Assembly, Style II Starter	4-28. 4
4-23.	Battery Charging Alternator	4-29
4-24.	Testing Battery Charging Regulator/Rectifier Assembly	4-31
4-25.	Lockout Switch and Gear	4-32
4-26.	Adjusting Starter Lockout Switch	4-33
4-27.	Pressure Oil System	4-34
4-28.	Oil Cooler Assembly	4-34
4-29.	Replacing Oil Cooler Hoses	4-36
4-30.	Oil Filter Assembly	4-36. 1
4-31.	Replacing Oil Pressure Gauge	4-37
4-32.	Load Terminal Board Assembly	4-39
4-32. 1	Terminal Clip Replacement	4-40
4-33.	Control Cubicle Assembly	4-41
4-33. 1	Relay K1	4-43
4-34.	Removing Control Cubicle Support Assembly	4-43. 1
4-36.	Control Cubicle Test Set-Up	4-44
4-36.	Engine Assembly	4-46
4-37.	Exhaust Muffler and Air Cleaner Assemblies	4-48
4-38.	Rocker Arm Covers	4-49
4-39.	Cleaning Rocker Arm Cover Oil Line	4-50
4-40.	Breather Assembly	4-51
4-41.	Checking and Adjusting Rocker Arm to Valve Clearance	4-52
4-42.	Cylinder Head Assembly	4-53
4-43.	Oil Fill Tube	4-54
4-44.	Engine Mounting Assembly	4-55
4-45.	Generator Screen-Guard	4-56
4-46.	Skid-Base Assembly	4-58
5-1.	Instruction and Rating Plates	5-3
5-2.	Cover Assembly, Removal and installation	5-7
5-3.	Top Panel Assembly and Exhaust Plenum, Removal and installation	5-9
5-4.	Left Panel Assembly, Removal and Installation	5-11
5-5.	Right Panel Assembly, Removal and Installation	5-13
5-6.	Rear Panel Assembly, Removal and Installation	5-15
5-7.	Left Support Assembly, Removal and Installation	5-17
5-8.	Right Support Assembly, Removal and installation	5-19
5-9.	Front Panel Assembly, Removal and Installation	5-20
5-10.	Side Closure Assembly, Removal and Installation	5-22
5-11.	Rear Closure Assembly, Removal and installation	5-23
5-12.	Rear Flap Assembly, Removal and Installation	5-25
5-13.	Replacement of ASK Hardware Items	5-29

LIST OF TABLES

Table	Title	Page
2-1	Generator Set Controls and Instruments	2-2
2-2.	Reconnection Switch Positions	2-4
3-1.	Consumable Operating and Maintenance Supplies	3-1
3-2.	Preventive Maintenance Checks and Services	3-4
3-3.	Troubleshooting	3-6
4-1.	Preventive Maintenance Check and Services	4-5
4-2.	Troubleshooting	4-7
4-3.	Master switch Continuity Check	4-41
4-4.	Voltmeter-Ammeter Range Selector Switch Conttnuity Check	4-42

CHAPTER 1 INTRODUCTION

Section I. GENERAL

1-1. SCOPE.

This manual is for your use in operating and maintaining the DOD Standard Generator Set, 5KW Diesel Engine Driven, Model MEP-002A. It contains sections for operating procedures for operation under both normal and unusual conditions; a section for lubrication instructions, including a Lubrication Order; a section for preventive maintenance; a section for troubleshooting; and sections for both operator maintenance procedures and organizational maintenance procedures. Thoroughly familiarize yourself with the unit before operating or servicing.

1-2. LIMITED APPLICABILITY.

Some portions of this publication are not applicable to all services. These portions are prefixed to indicate the services to which they pertain: (A) for Army, (F) for Air Force, (N) for Navy, and (MC) for Marine Corps. Portions not prefixed are applicable to all services.

1-3. MAINTENANCE FORMS AND RECORDS.

a. (A) Maintenance forms and records used by Army personnel are prescribed in DA PAM 738-750.

b. (F) Maintenance forms and records used by Air Force personnel are prescribed in AFM-66-1 and the applicable 00-20 Series Technical Orders.

c. (N) Navy users should refer to their service peculiar directives to determine applicable maintenance forms and records to be used.

d. (MC) Maintenance forms and records used by Marine Corps personnel are prescribed in TM 4700-15/1.

1-3.1. (A) HAND RECEIPT.

Hand Receipts covering the End Item/Components of End Item (COEI), Basic Issue (BII) and Additional Authorization List (AAL) items are published in an Army Hand Receipt Manual. The Hand Receipt Manual numerical designation is the same as the related Army Technical Manual with the letters HR added to the number. These manuals

are published to aid in property accountability and are available through: Commander, US Army Adjutant General Publication Center, ATTN: AGDLD, 1655 Woodson Road, St. Louis, MO 63120.

1-4. REPORTING OF ERRORS.

Report of errors, omissions, and recommendations for improvement of this publication by the individual user is encouraged. Reports should be submitted as follows:

a. (A) Army - DA Form 2028 directly to: Commander, US Army Troop Support Command, ATTN: AMSTR-MCTS, 4300 Goodfellow Boulevard, St. Louis, MO 63120-1798.

b. (F) Air Force - AFTO Form 22 directly to: Commander, Sacramento Air Logistics Center, ATTN: SM-ALC-MMEDTA, McClellan Air Force Base, CA 95652-5609 in accordance with TO-00-1-1.

c. (N) Navy - by letter directly to: Commanding Officer, Naval Construction Battalion Center, ATTN: Code 15741, Bldg. 43, Port Hueneme, CA 93043-5000.

d. (MC) Marine Corps - by NAVMC Form 10772 directly to: Commanding General, Marine Corps Logistics Base, (Code 850), Albany, GA 31704-5000.

1-5. LEVELS OF MAINTENANCE ACCOMPLISHMENT.

a. (A, MC) Army and Marine Corps users shall refer to the Maintenance Allocation Chart (MAC) for tasks and levels of maintenance to be performed.

b. (F) Air Force users shall accomplish maintenance at the user level consistent with their capability in accordance with policies established in AFM 66-1.

c. (N) Navy users shall determine their maintenance levels in accordance with their service directives.

1-6. (A, MC) DESTRUCTION OF MATERIAL TO PREVENT ENEMY USE.

Army and Marine Corps personnel shall refer to TM 750-244-3 as a source for procedures for the destruction of material to prevent enemy use.

1-7. (A, F, MC) ADMINISTRATIVE STORAGE.

Air Force personnel shall refer to TO 35-1-4, Processing and Inspection of Aerospace Ground Equipment, for storage and shipment of this equipment. Marine Corps personnel shall refer to MCO P4450.7. For the Army:

a. Placement of equipment in administrative storage should be for short periods of time when a shortage of maintenance effort exists. Items should be in mission readiness within 24 hours or within the time factors as determined by the directing authority. During the storage period appropriate maintenance records will be kept.

b. Before placing equipment in administrative storage, current maintenance services and equip-

ment serviceable criteria (ESC) evaluations should be completed, shortcomings and deficiencies should be corrected, and all modification work orders (MWO'S) should be applied.

c. Storage site selection. Inside storage is preferred for items selected for administrative storage. If inside storage is not available, trucks, vans, conex containers and other containers may be used.

1-8. PREPARATION FOR SHIPMENT AND STORAGE.

a. (A) Army - Refer to TB 740-97-2.

b. (F) Air Force - Refer to TO 35-1-4 for end item Generator Sets and to TO 38-1-5 for installed engine.

c. (N, MC) Navy and Marine Corps refer to individual service directives for requirements.

Section II. DESCRIPTION AND DATA

1-9 DESCRIPTION OF GENERATOR SET.

This unit is a 5 kilowatt, 60 Hertz Generator Set. It consists of a revolving field alternator powered by an air cooled diesel engine. See figures 1-1 and 1-2 for the location of major components and figure 1-2.1 for generator with acoustic suppression kit (ASK) installed.

a. Engine.

(1) The engine powering this Generator Set is a 2 cylinder, 4 cycle air cooled engine, with a 70 cubic tncb (cu. in) displacement. A mechanical governor keeps engine speed at 1800 revolutions per minute (RPM) under rated load conditions.

(2) Fuel is supplied either from this unit's self-contained fuel tank or, by using an adapter, directly from a 55 gallon drum or other source. The fuel is filtered by two cartridge type fuel filters and a single fuel strainer. Two electric, self-priming fuel pumps pump fuel to the fuel injection pump which delivers the fuel at high pressure to fuel injection nozzles in the cylinder head. When auxiliary source of fuel is used, three electric fuel pumps are Used.

(3) Two 12 volt "wet cell" batteries in series supply power for a 24 volt electric starter and for glow plugs, located in the cylinder head, and two air heaters located in the intake manifold, used for cold weather starting. An alternator located beneath the blower wheel and completely separate from the main alternator automatically recharges these batteries when the engine is operating.

b. Generator.

The generator on this set is a four pole, revolving field type. Alternating current, supplied by the exciter assembly, is rectified and used to create the four pole, revolving field. A "solid-state" voltage regulator assembly automatically adjusts this current to obtain a constant ($\pm 3\%$) voltage in the main stator (output) windings.

c. Controls.

All operator controls and indicator gauges necessary for running the engine Generator Set are located on the control panel. On ASK equipped generators, an oil pressure gauge is located on the engine under air intake door and a fuel level gauge is located on the fuel tank. The speed control is located behind a small flap on the rear panel assembly below the control panel.

Controls for selecting output voltage are located on the output control box

d. Generator Set Electrical System (see schematic figure 1-7).

(1) General. The generator set's electrical system consists of two distinct systems (1) the dc system used primarily for operating control and excitation and (2) the ac output system to supply power to the load.

The dc source consists of a 24 volt battery set (BT1 and BT2) that is kept charged by a battery charging alternator (G2) and voltage regulator rectifier assembly (A5). Fuse (F1) protects the alternator from overload. Circuit breaker (CB2) protects the battery charging system from overload. Slave receptacle (J15) permits an alternate external supply to be connected to the battery circuit.

(2) Operation. Placing MASTER SWITCH (S1) into the PREHEAT position, the preheat relay R2 is activated to energize the heater elements (ER1 and ER2) and the engine glow plugs (HR3 and HR4).

Placing the MASTER SWITCH in the PRIME-RUN-AUXILIARY position activates the fuel pumps E2 and E3 as well as the auxiliary fuel pump E1. If the fuel level is down, the fuel level switch S3 will be closed and the auxiliary fuel solenoid will actuate permitting fuel to be pumped into the tank.

Placing the MASTER SWITCH (S1) into the PRIME-RUN position maintains power to the main fuel pumps but deactivates the auxiliary fuel pump.

(a) Start. Placing the MASTER SWITCH (S1) into the start position maintains the fuel pump circuits and the preheat circuits to the glow plugs (HR3 and HR4) as well as to energize the governor solenoid (K5) and start relay (K1). The crank relay (K3) is energized, in turn energizing the start solenoid (K6) and activating the starter (B1). The governor brings the engine to speed, building up oil pressure and closing oil pressure switch (S5). The exciter field is flashed during this starting procedure.

(b) Run. Placing the MASTER SWITCH (S1) in the PRIME-RUN position keeps the governor solenoid (K5) energized thru the now closed oil pressure switch (S5) and fuel will be supplied to the engine as long as the oil pressure is normal and the align temperature switch (S4) is not activated by high temperature.

(c) Stop. Placing the MASTER SWITCH (S1) in the OFF position de-energizes the governor solenoid (K5) shutting off fuel to stop the engine. High temperature or low oil pressure will also shut the engine down.

(3) AC Circuitry. The main alternator (G1) is wound with six pairs of coils that may be connected by the AC Reconnect switch (S6) into various combinations, the output of which is available at the load terminal board (TB1). Circuit breaker (CB1) protects the alternator from overloads. The volt/ampere select switch (S8) permits switching voltmeter (M5) and ammeter (M4) to read the load current and voltage for the various arrangement of outputs.

Voltage regulator (A2) and current voltage transformer CVT1 monitors the alternator output voltage

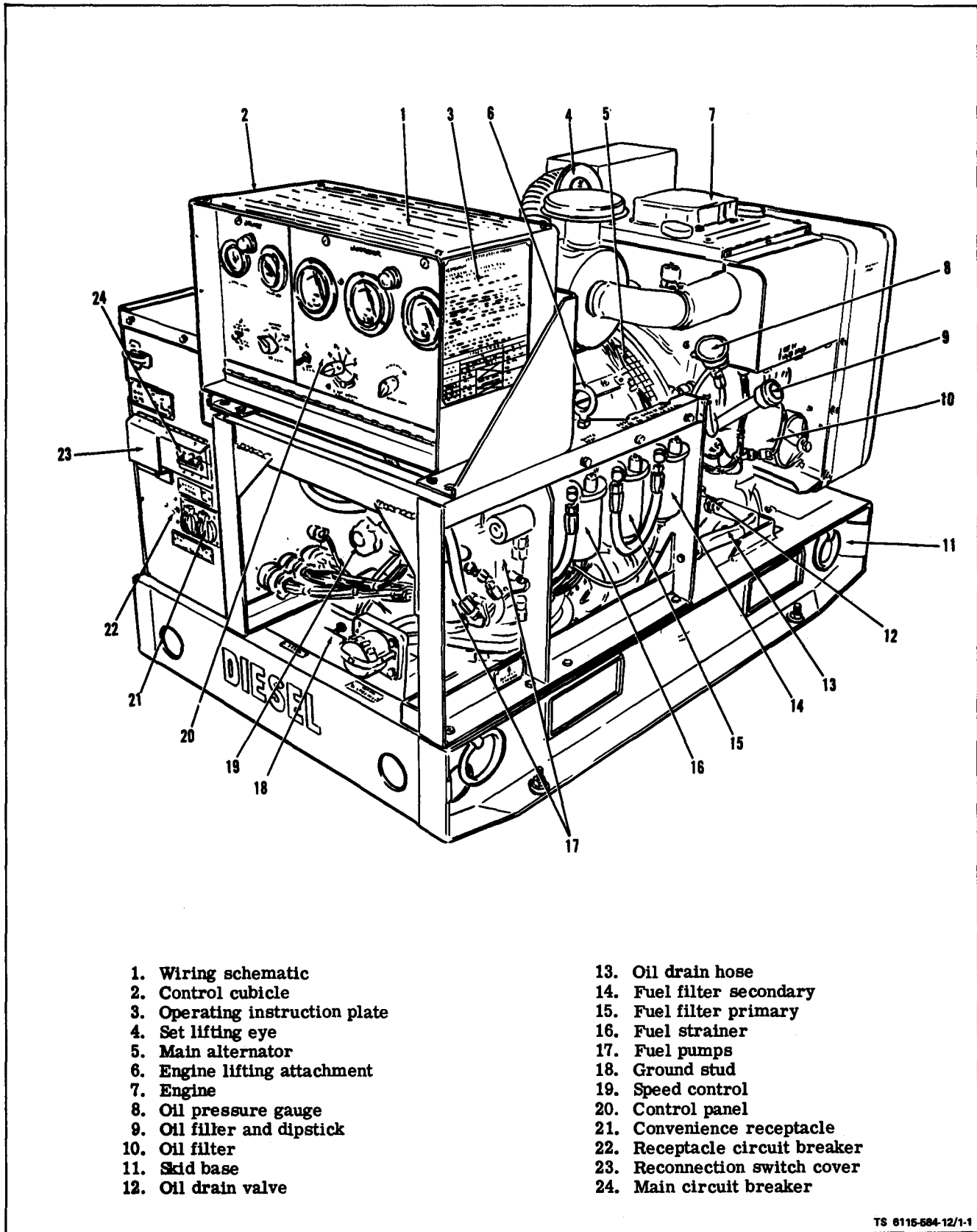

- | | |
|--------------------------------|--------------------------------|
| 1. Wiring schematic | 13. Oil drain hose |
| 2. Control cubicle | 14. Fuel filter secondary |
| 3. Operating instruction plate | 15. Fuel filter primary |
| 4. Set lifting eye | 16. Fuel strainer |
| 5. Main alternator | 17. Fuel pumps |
| 6. Engine lifting attachment | 18. Ground stud |
| 7. Engine | 19. Speed control |
| 8. Oil pressure gauge | 20. Control panel |
| 9. Oil filler and dipstick | 21. Convenience receptacle |
| 10. Oil filter | 22. Receptacle circuit breaker |
| 11. Skid base | 23. Reconnection switch cover |
| 12. Oil drain valve | 24. Main circuit breaker |

TS 6115-584-12/1-1

Figure 1-1. Engine Generator Set, Right-Rear, Three-Quarter View

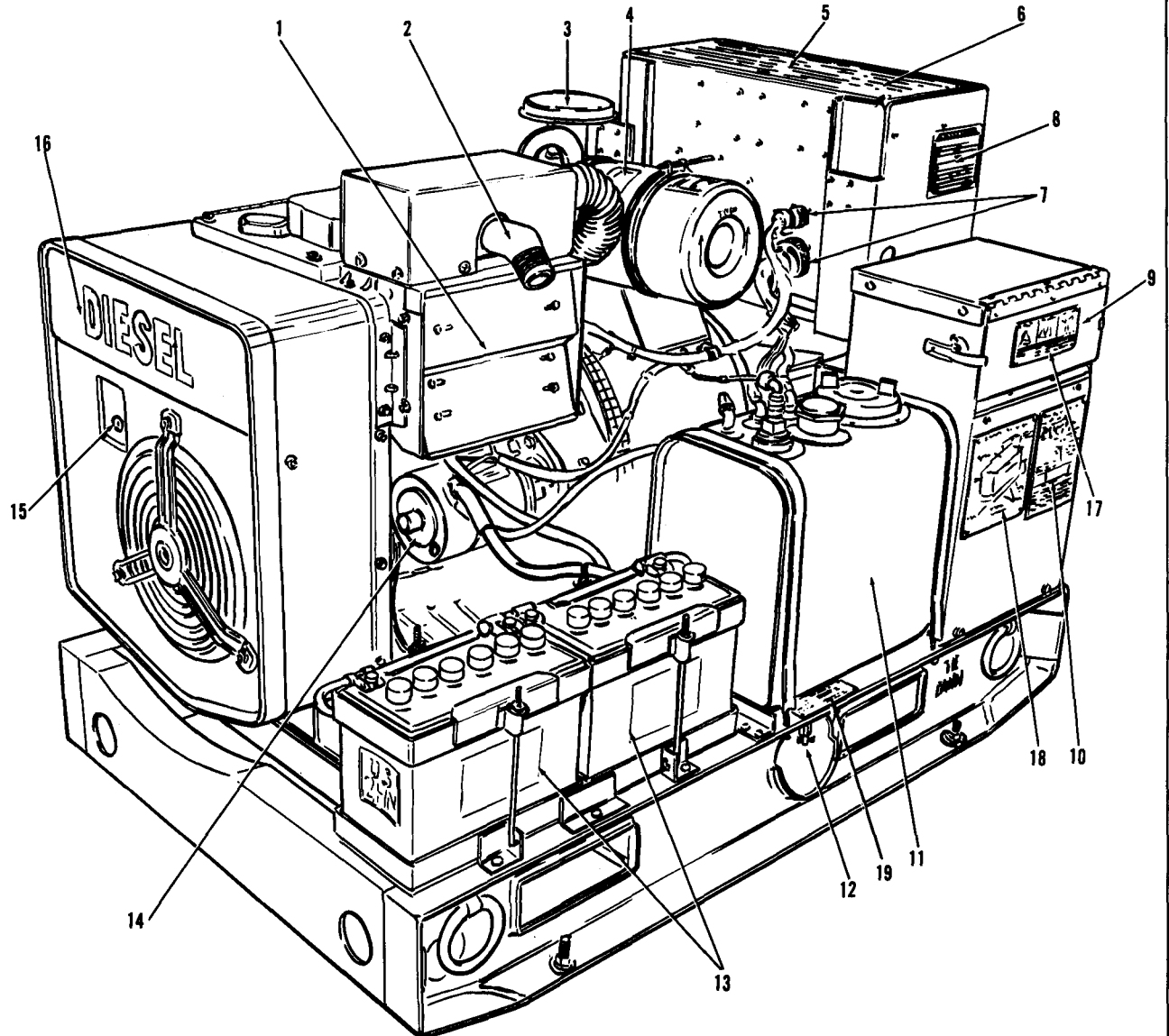

- | | |
|------------------------------|---------------------------------------|
| 1. Air shutter assembly | 10. AC output control box assembly |
| 2. Exhaust muffler assembly | 11. Fuel tank |
| 3. Engine air intake | 12. Fuel tank drain |
| 4. Air cleaner assembly | 13. Batteries |
| 5. Control cubicle | 14. Starter |
| 6. Wiring schematic | 15. Governor adjustment screw |
| 7. Connectors | 16. Blower housing |
| 8. Identification plate | 17. Load terminal reconnections |
| 9. Load terminal board cover | 18. Tie down and lifting instructions |
| | 19. Battery connection plate |

TS 6115-584-12/1-2

Figure 1-2. Engine Generator Set, Left-Front, Three-Quarter View

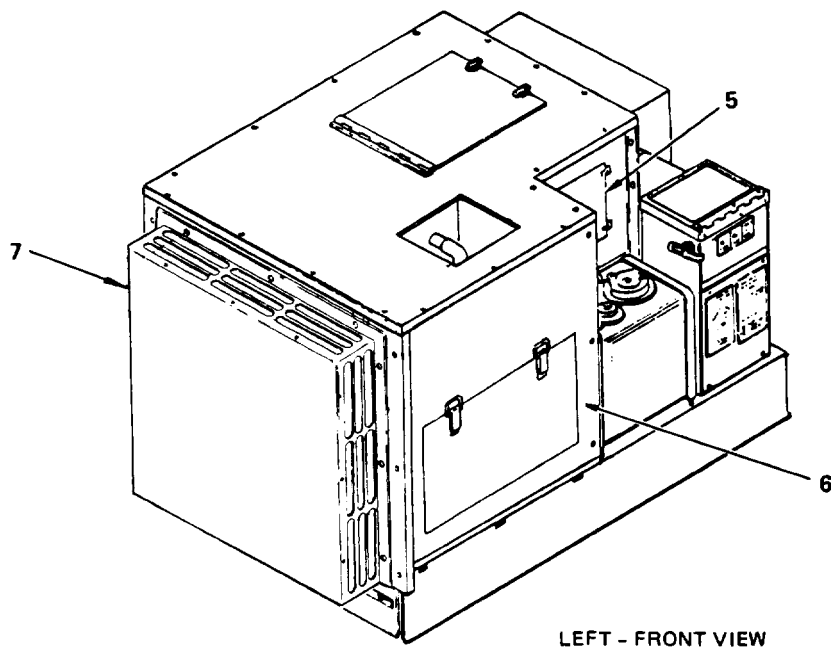
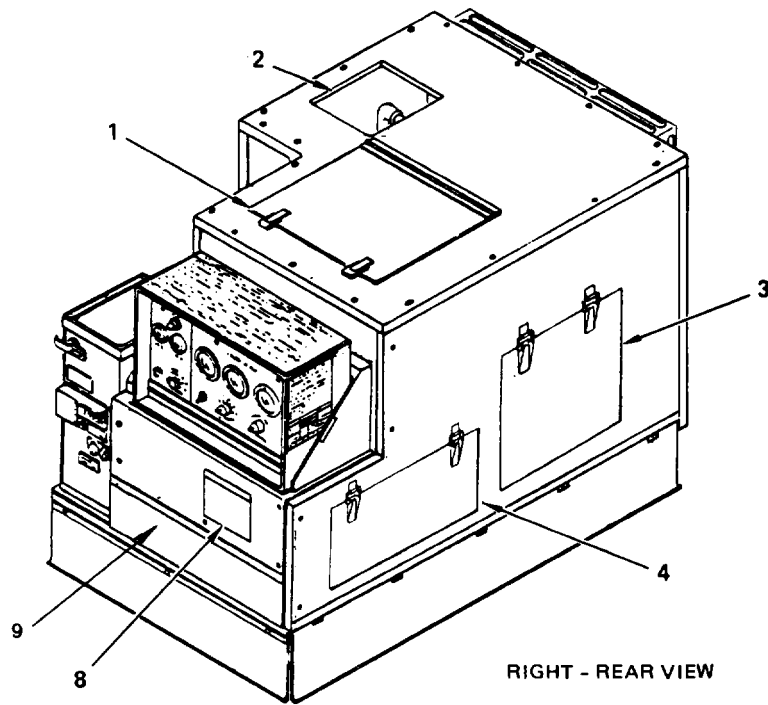

- | | |
|-------------------|-----------------------|
| 1. AIR INTAKE | 5. AIR CLEANER |
| 2. EXHAUST PLENUM | 6. BATTERIES |
| 3. OIL | 7. COOLING AIR INTAKE |
| 4. FUEL FILTERS | 8. SPEED CONTROL FLAP |
| | 9. REAR PANEL FLAP |

Figure 1-2.1. Engine Generator Set with Acoustic Suppression Kit

and current under load and varies the exciter field either up or down to keep the generator field at such a value as to maintain constant alternator output voltage. The regulated voltage setting can be varied using the voltage adjust rheostat (R1).

An ac receptacle (J14) is connected through a protective circuit breaker (CB3) to provide 120 VAC.

Outputs from the voltage regulator (A2) transformed by transforms (T1 and T2) to a value suitable for input to frequency transducer (A3) which energizes frequency meter (M3).

1-10. TABULATED DATA.

Identification and Instruction Plates (see figures 1-1 and 1-2).

(1) Identification Plate.

(a) Location. This plate is located on the side of the control cubicle.

(b) Content.

US DEPARTMENT OF DEFENSE

GENERATOR SET DIESEL ENGINE 5KW 60 Hz

MODEL: MEP 002A

SER NO.:

NSN: 6115-00-465-1044

REG NO.:

TM 5-6115-584-12

TO-35C2-3-456-1

NAVFAC P-8-622-12

TM-05682C-12

VOLTS: 120V 1 PH.
120/240V 1 PH.
120/208V 3PH.

PF: 0.8

AMPS: 52,26,17.3

LG: 51 IN

W: 32 IN

HGT: 37 IN

DATE MFG:

CONTR NO:

WARRANTY:

DATE INSP:

MFD BY:

INSP STAMP:

(2) Operating Instruction Plate.

(a) Location. This plate is located on the side of the control cubicle.

(b) Content.

OPERATING INSTRUCTIONS



Hot refueling of generators while they are operating poses a safety hazard and should not be attempted. Hot engine surfaces and sparks produced from the engine and generator circuitry are possible sources of ignition. Severe injury or death to personnel and damage to the equipment may result.

Ground set to avoid shock hazard.

BEFORE STARTING SET

NOTE: Push in DC CONTROL CIRCUIT BREAKER. Pull manual governor control throttle all the way out and then push back in approximately halfway.

1. Fill crankcase (do not overfill) and fuel tank. Ensure that vent cap on underside of the fuel filler cap is open before starting generator.
2. Set batteries are negative ground.

STARTING SET

1. Move "MASTER SWITCH" to "PRIME & RUN" position to allow fuel to prime set.
2. Move "MASTER SWITCH" "PREHEAT" position and hold for (1) minute.

NOTE: Preheat is not required when engine is hot.

3. Move "MASTER SWITCH" to "START" position and hold until engine fires continuously. If engine does not start within 15 seconds repeat steps 1 and 2.
4. "MASTER SWITCH" will return to "PRIME & RUN" position when released. If running from auxiliary fuel source, move "MASTER SWITCH" to "PRIME & RUN AUX FUEL" position.
5. After warm up. Check frequency and voltage and adjust if necessary.
6. Move "AC CIRCUIT BREAKER" to "ON" position.

STOPPING SET

1. Move "AC CIRCUIT BREAKER" to "OFF" position.
2. Move "MASTER SWITCH" to "OFF" position.
3. For emergency stop pull "DC CONTROL CIRCUIT BREAKER."

TM 5-6115-584-12
 NAVFAC P-8-622-12
 TO-35C2-3-456-1
 TM-05682C-12

SERVICE INSTRUCTIONS

Ambient Temperature	Fuels		Lubricating Oil Capacity (Less Filter) 3.0QT
	Primary-Diesel	Capacity-6.75 GAL Emergency-JP4	
-65° to -25°F -54° to -12°C	VV-F-800Grade DFA		MIL-L-10295
-25° to -10°F -32° to -23°C	VV-F-800 Grade DF1		MIL-L-10295
-10° to +30°F -23° to -1°C	VV-F-800 Grade DF1	For JP4 operation, see Instruction Manual	MIL-L-2104 Grade 10
+30° to +100°F -1° to +38°C	VV-F-800 Grade DF2		MIL-L-2104 Grade 30
+100° to +125°F +38° to +52°C	VV-F-800 Grade DF2		MIL-L-2104 Grade 30

b. Tabulated Data for Generator Set.

(1) Generator Set.

Manufacturer:	Onan Division of Onan Corp.
Model:	MEP 002A
Mode:	60 Hz
Operating temperature range:	
without external heat	-25° to +125°F, -32 to +52°C
with external heat	-65° to -25°F, -54° to -32°C
Maximum Rated Output	5KW (0.8 power factor) (0-5000 ft above sea level)
Voltage:	120V. (single phase, 2 wire) 120/240V. (single phase, 3 wire) 120/208V. (3-phase, 4 wire)
Fuel capacity:	6.75 gallons (25.5 liters)
Dimensions and weights:	
overall length	51 in. (129.5 cm.)
overall width	32in. (81.3 cm)
overall height	37in. (94 cm.)
net weight empty	960 lbs. (435.5 kg.)
net weight filled	1040 lbs. (471.7 kg.)
Shipping weight	1010 lbs. (458.1 kg.)
cubage.	35 cu. ft. (.99 cubic meters)
Dimensions and weights with ASK installed:	
overall length	58 in. (147.4 cm)
overall width.	36 in. (91.4 cm)
overall height	39 in. (99 cm)
net weight empty	1084 lb (492.2kg)
net weight filled	1164 lb (528.5kg)
shipping weight	1084 lb (492.2 kg)
cubage	46 cu ft (1.3 cubic meters)

Displacement: 70cu. in. (1147 cc.)
Compression ratio: 19:1
Horsepower: 8.9 @ 1800 RPM (0-5000 ft above sea level)
Lubricating oil capacity: 3 qts, 4 qts if filter is changed (2.8 liters, 3.7 liters if filter is changed)
Governor: internal flyball, external adjustment
Maximum battery charge rate not less than 6.5 ampere
Starting motor voltage: 24 VDC
Oil filter element part no.: MS35802-2

(3) Batteries.

Type: 2HN (per MS 35000-1)
Voltage: 12 VDC
Amp-Hrs: 45

(4) Fuel pumps.

Manufacturer: Bendix Corp.
Model: Part No. 480517
Ground Polarity: Negative

(5) Fuel filters.

Manufacturer: Fram Corp.
Model: 244350
Fuel filter element: Part No. C-1125PL

(6) Fuel strainer.

Manufacturer: Fram Corp.
Model: Part No. 244344
Fuel strainer element: Part No. C1824

(7) Air cleaner.

Manufacturer: Donaldson Co., Inc.
Model: Part No. KAX 00-3851
Air cleaner element: Part No. P101222

(8) Engine oil filter.

Manufacturer: Fram Corp.
Model: Part No. 170429
oil filter element: Part No. MS35802-2

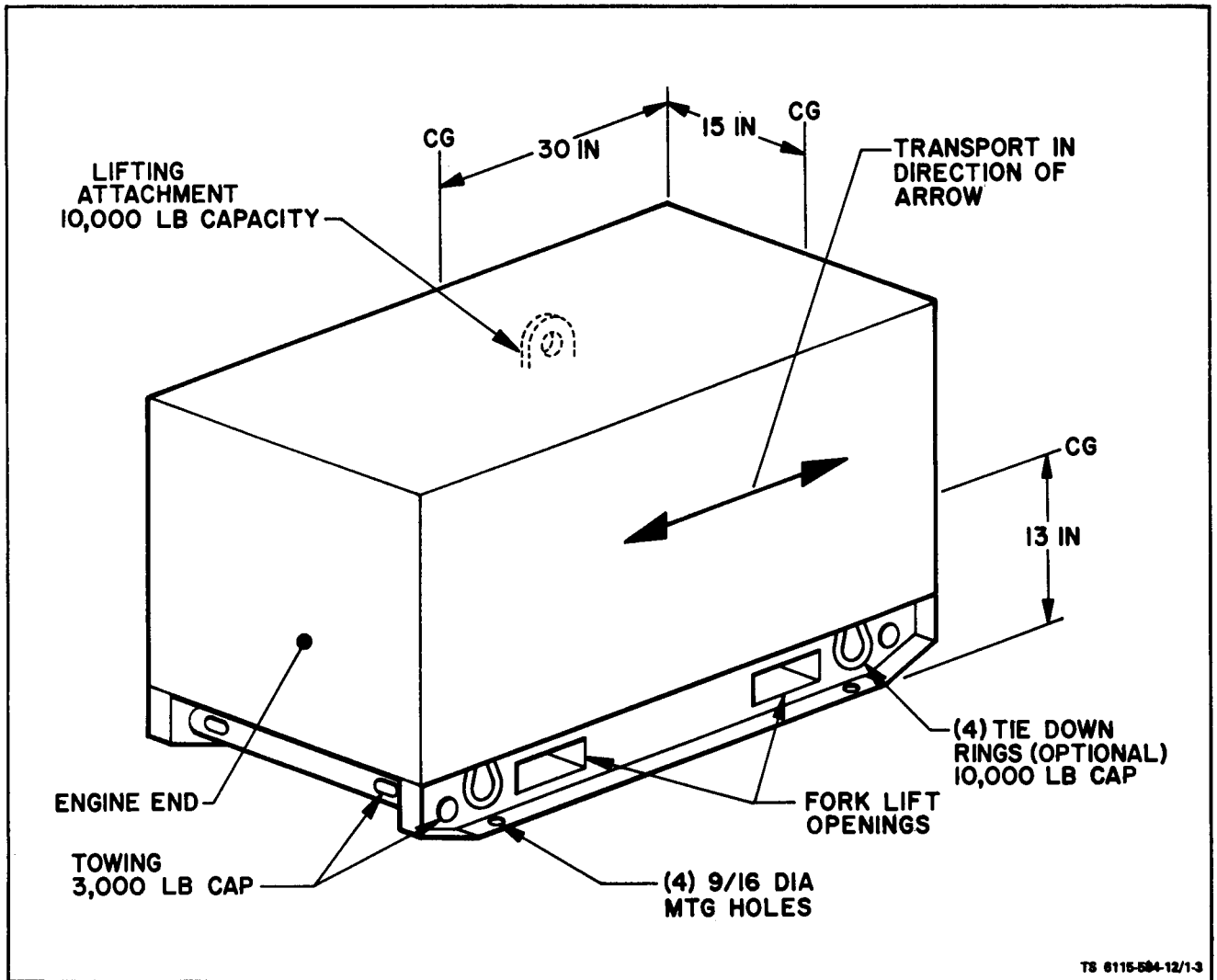

Figure 1-3. Tie Down, Lifting, and Towing Provisions Crated Set

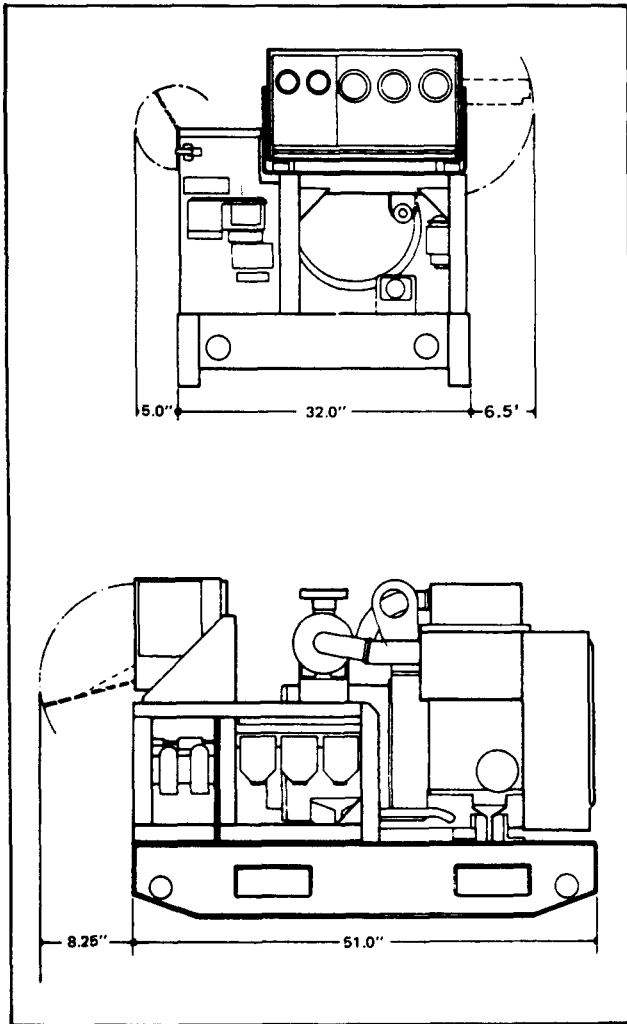

Figure 1-4. Installation Plans

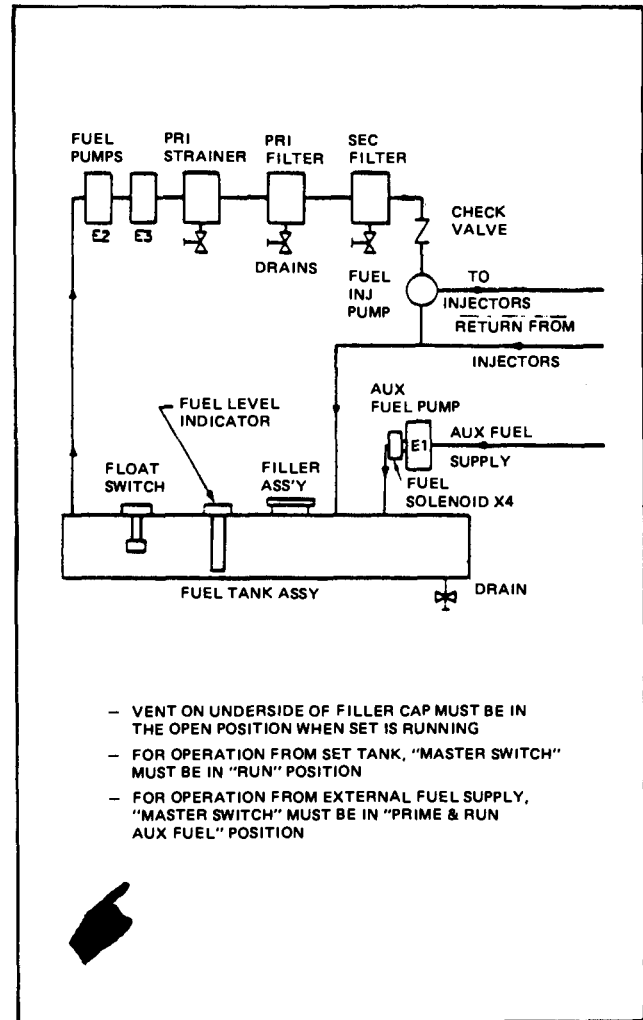
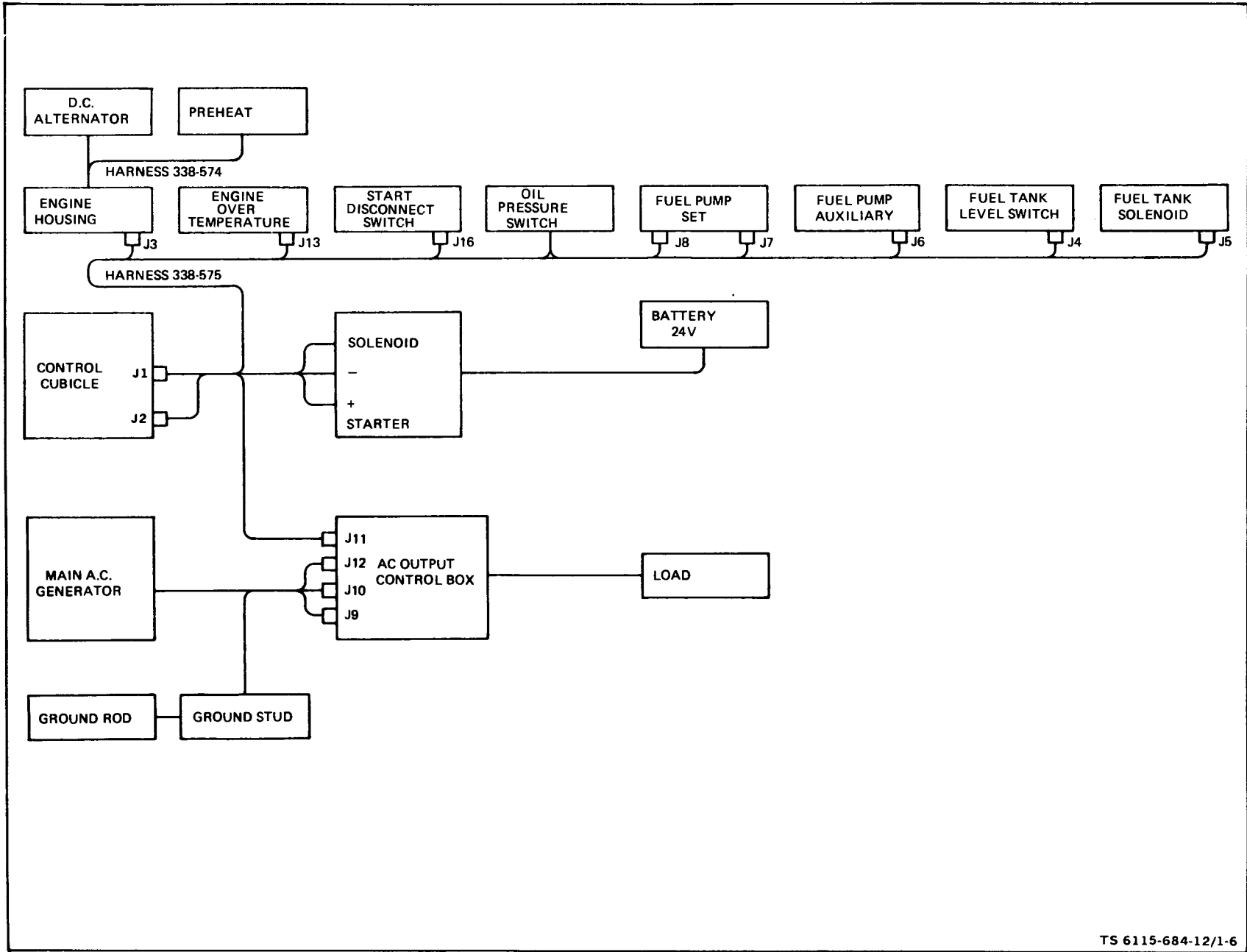

Figure 1-5. Fuel System Schematic



TM 5-6115-584-12
NAVFAC P-8-622-12
TO-35C2-3-456-1
TM-05682C-12

Figure 1-6. Electrical Cable Schematic

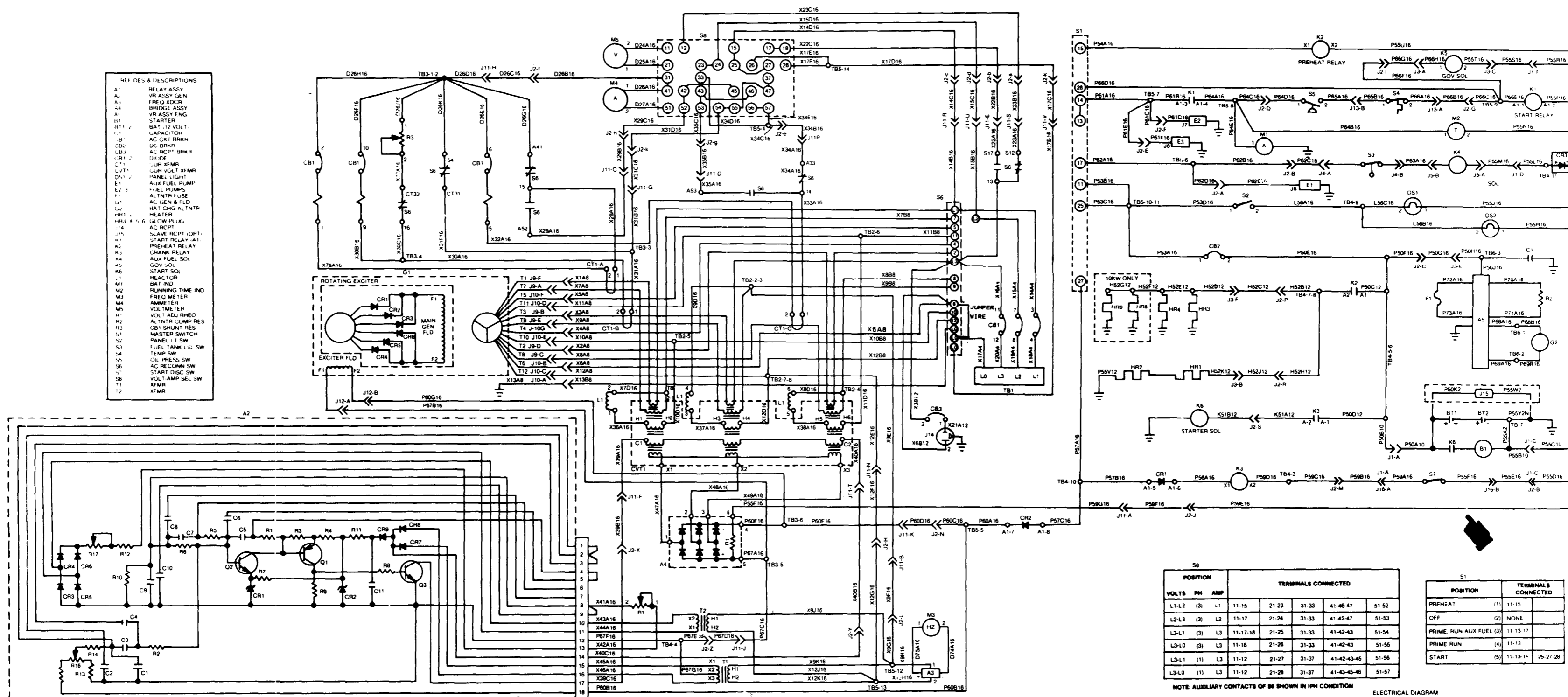
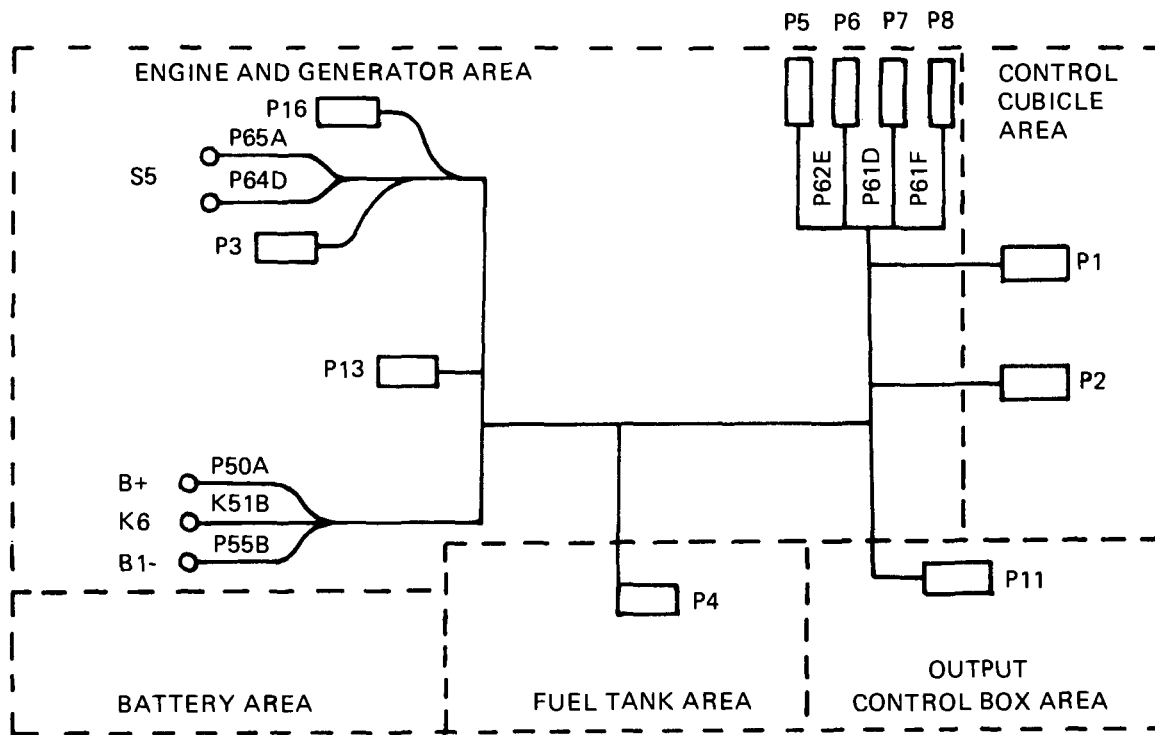

Figure 1-7. Generator Set Electrical Schematic.

WIRE NO.	FROM	TO	WIRE NO.	FROM	TO
D26C16	P2-f	P11-H	P66B16	P2-G	P13-A
H52C12	P2-P	P3-F	P66G16	P2-1	P3-A
G52J12	P2-R	P3-B	P67D16	P2-Z	P11-J
K51B12	P2-S	K6-1	X9F16	P2-L	P11-B
P50A10	P1-A	B1+(K6)	X12F16	P2-H	P11-N
P50G16	P2-C	P3-E	X14C16	P2-c	P11-R
P55B10	P1-C	B1-(K6)	X15C16	P2-d	P11-U
P55E16	P2-J	P11-A	X17C16	P2-K	P11-V
P55M16	P1-D	P5-A	X22B16	P2-b	P11-E
P55S16	P1-F	P3-C	X23B16	P2-a	P11-S
P58B16	P2-M	P16-A	X29B16	P2-b	P11-C
P59B16	P2-W	P16-B	X31C16	P2-k	P11-G
P60D16	P2-N	P11-K	X34B16	P2-e	P11-P
P61D16	P2-F	P7	X35B16	P2-g	P11-D
P61F16	P2-E	P8	X39B16	P2-X	P11-F
P62G16	P2-B	P4-A	X40B16	P2-Y	P11-T
P62E16	P2-A	P6			
P63A16	P5-B	P4-B			
P64D16	P2-D	S5-1			
P65A16	P13-B	S5r2			



NOTE

LAST TWO DIGITS IN "WIRE NO." INDICATES WIRE SIZE.
 THUS D26C16 IS A 16 GAUGE WIRE THE LETTER P INDICATES PLUG.
 THE LAST DIGIT INDICATES PIN NUMBER. THUS WIRE D26C16 GOES FROM PLUG 2, PIN 1 TO PLUG 11, PIN RF.

Figure 1-8. Generator Set Wiring Harness

TM 5-6115-584-12
 NAVFAC P-8-622-12
 TO-35C2-3-456-1
 TM-05682C-12

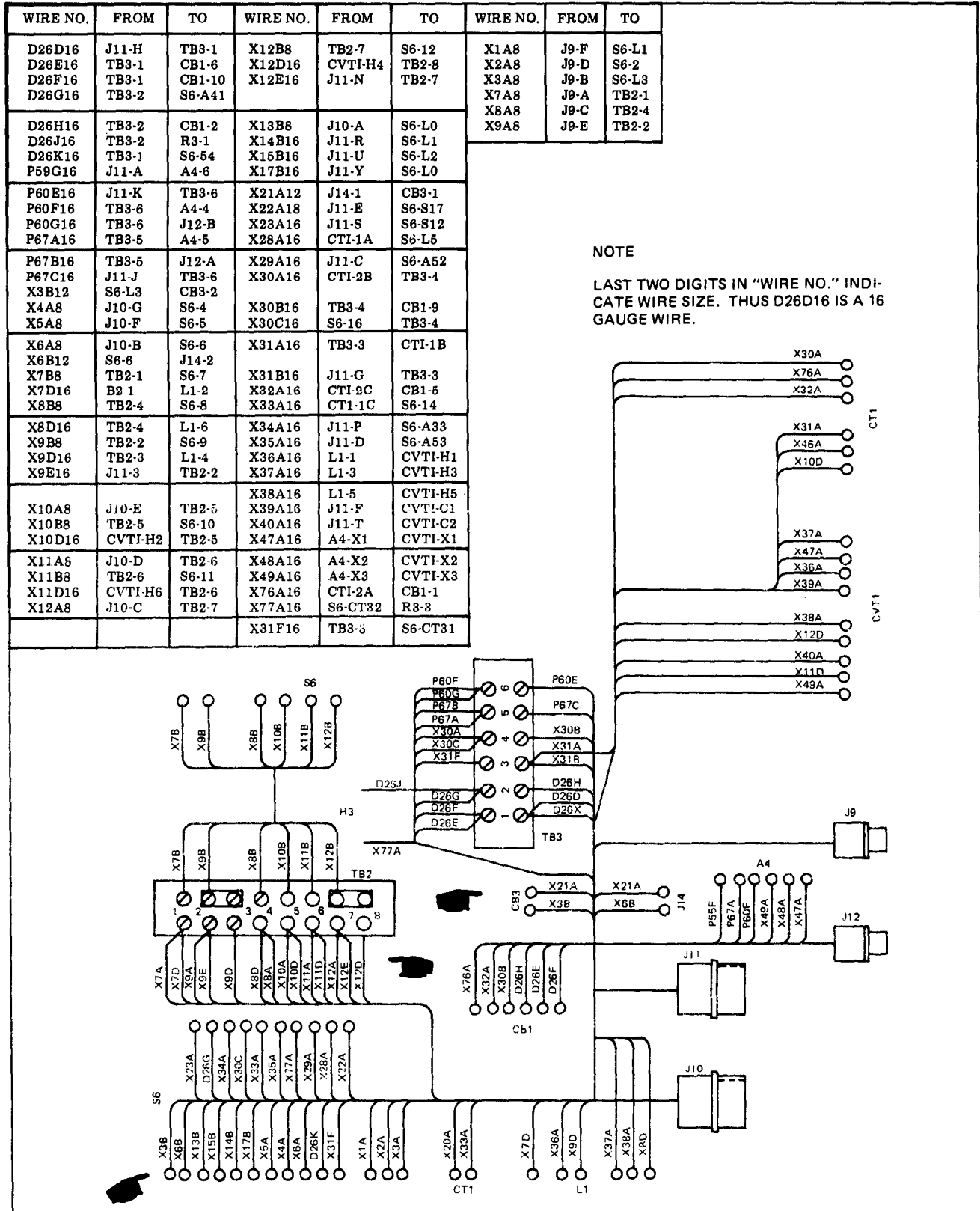
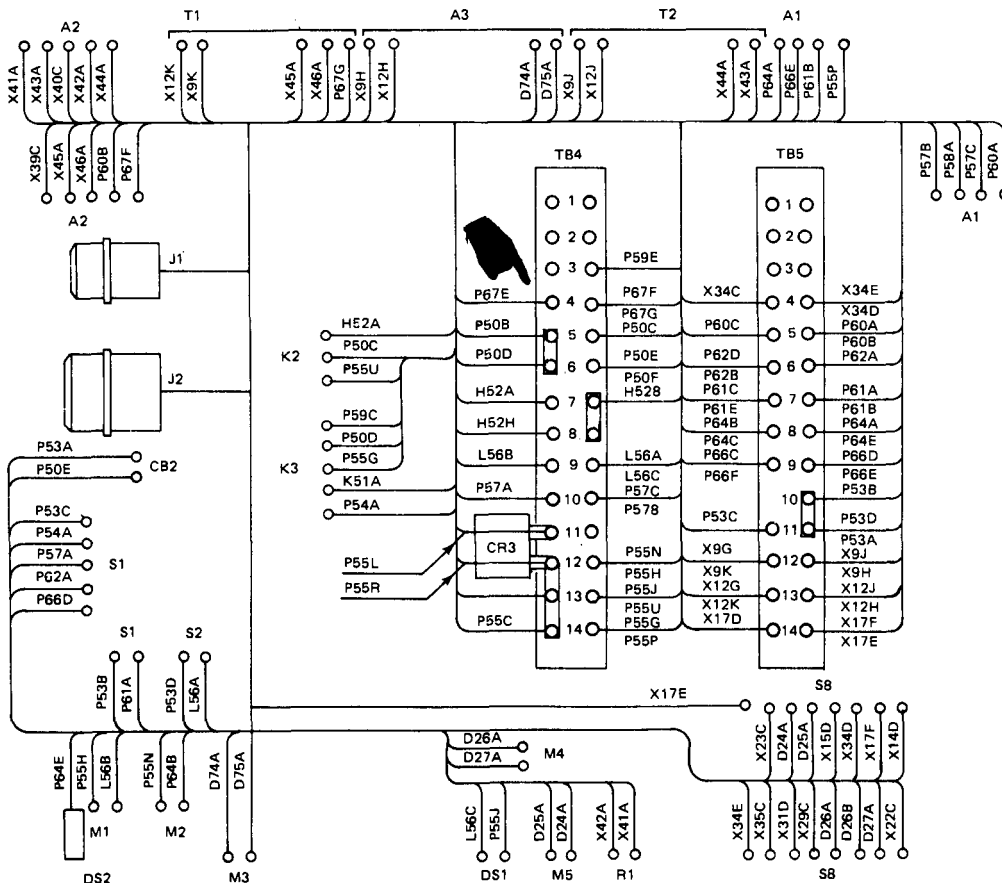

Figure 1-9. AC Output Control Box Wiring Harness

WIRE NO.	FROM	TO	WIRE NO.	FROM	TO	WIRE NO.	FROM	TO	WIRE NO.	FROM	TO
D24A16	M5-2	S8-11	P55C10	J1-C	TB4-14	P62D16	J2-A	TB5-6	X17F16	S8-28	TB5-14
D25A16	M5-1	S8-21	P55D16	J2-W	TB4-13	P64A16	A1-4	TB5-8	X22C16	J2-b	S8-18
D26A16	M4-1	S8-41				P64B16	M2-1	TB5-8	X23C16	J2-a	S8-12
D26B16	J2-F	S8-31	P55H16	DS2-1	TB4-12	P64C16	J2-D	TB5-8	X29C16	J2-b	S8-52
D27A16	M4-2	S8-61	P55J16	DS1-1	TB4-13	P64E16	M1-1	TB5-8	X31D16	J2-k	S8-54
D74A16	M3-2	A3-	P55L16	J1-D	TB4-12	P66C16	J2-G	TB5-9	X34C16	J2-e	TB5-4
D75A16	M3-1	A3+	P55N16	M2-2	TB4-12	P66D16	S1-28	TB5-9	X34D16	S8-33	TB5-4
H52A12	K2-A2	TB4-7	P55P16	A1-2	TB4-14	P66E16	A1-1	TB5-9	X34E16	S8-57	TB5-4
H52B12	J2-P	TB4-7	P55R16	J1-F	TB4-11	P66F16	J2-1	TB5-9	X35C16	J2-g	S8-63
H52H12	J2-R	TB4-8	P55U16	K2-X2	TB4-13	P67E16	J2-Z	TB4-4	X39C16	J2-X	A2-17
K51A12	J2-S	K3-A2	P57A16	S1-27	TB4-10	P67F16	A2-12	TB4-4	X40C16	J2-Y	A2-14
L58A16	S2-2	TB4-9	P57B16	A1-5	TB4-10	P67G16	T1-X2	TB4-4	X41A16	R1-2	A2-8
L56B16	DS2-2	TB4-9	P57C16	A1-8	TB4-10	X9G16	J2-L	TB5-12	X42A16	R1-1	A2-13
L56C16	DS1-2	TB4-9	P58A16	K3-X1	A1-6	X9H16	A3-1	TB5-12	X43A16	T2-X2	A2-10
P50B10	J1-A	TB4-5	P59C16	J2-M	TB4-3	X9J16	T2-H1	TB5-12	X44A16	T2-X1	A2-11
P50C12	K2-A1	TB4-5	P60A16	A1-7	TB5-5	X9K16	T1-H1	TB5-12	X45A16	T1-X1	A2-15
P50D12	K3-A1	TB4-6	P60B16	A2-18	TB5-5	X12G16	J2-H	TB5-13	X46A16	T1-X3	A2-16
P50E16	CB2-2	TB4-6	P60C16	J2-N	TB5-5	X12H16	A3-2	TB5-13	P59D16	K3-X2	TB4-3
P50F16	J2-C	TB4-6	P61A16	S1-14	TB5-7	X12J16	T2-H2	TB5-13	P59E16	J2-J	TB4-3
P53A16	CB2-1	TB5-11	P61B16	A1-3	TB5-7	X12K16	T1-H2	TB5-13			
P53B16	S1-11	TB5-10	P61C16	J2-F	TB5-7	X14D17	J2-c	S8-L5			
P53C16	S1-25	TB5-11	P61E16	J2-E	TB5-7	X15D16	J2-d	S8-24			
P53D16	S2-1	TB5-11	P62A16	S1-17	TB5-6	X17D16	J2-k	TB5-14			
P54A16	S1-15	K2-X1	P62B16	J2-B	TB5-6	X17E16	S8-26	TB5-14			



NOTE

LAST TWO DIGITS IN "WIRE NO." INDICATE WIRE SIZE. THUS D24A16 IS A 16 GAUGE WIRE.

Figure 1-10. Control Cubicle Wiring Harness

CHAPTER 2
OPERATING INSTRUCTIONS

Section I. OPERATING PROCEDURE

2-1. GENERAL.

a. This chapter contains instructions for operation, power and control connections. Location and function of controls and indicators, and safety precautions are also provided.

b. Refer to table 3-2 and perform "Before Operation" Preventive Maintenance Checks and Services before operating the Generator Set.

CAUTION

If set will be idle for some time, disconnect the negative battery lead. Be sure to reconnect when load is placed on set.

c. Table 2-1 describes the Generator Set controls and instruments (see figure 2-3).

WARNING

All personnel involved in the operation or maintenance of the Generator Set should become thoroughly familiar with the safety precautions prior to performing operation or maintenance procedures.

Prior to connection of load cables, make sure all switches are in OFF or OPEN position, the Generator Set is not operating.

Inspect the Generator Set ground connection prior to starting the unit. Electrical defects in load lines or load equipment can cause death by electrocution when contact is made with an ungrounded system.

Do not smoke or carry an open flame when servicing the batteries or fuel tank. Exercise extreme care to prevent electrical arcing in the area of the batteries.

Battery electrolyte contains sulfuric acid and can cause severe burns. Handle it with care. If the electrolyte comes in contact with the body, eyes, or clothing, rinse immediately with clean water. Avoid spilling electrolyte on painted surfaces. Do not work alone or smoke when servicing batteries.

Do not operate Generator Set in an enclosed area unless the exhaust gases are piped to the outside. Continued breathing of exhaust fumes is dangerous.

Stay clear of all exposed electrical terminals when Generator Set is operating.

Remove all rings, watches and other jewelry when performing maintenance on this equipment. Loose fitting clothing should be secured to prevent it from catching in moving parts.

2-2. POWER CONNECTIONS.

WARNING

BEFORE ATTEMPTING TO CONNECT LOAD CABLES, MAKE SURE THE GENERATOR SET IS NOT OPERATING. ALL SWITCHES ARE IN THE OFF OR OPEN POSITION.

To connect load cables to Generator Set, attach load leads to terminals located in output control box, as required. See figures 2-1 and 2-3.

NOTE

For 120V, 1 PH operation connect safety ground (generally green) and neutral (white) to L-1. Connect the hot wire (black) to L-3.

2-3. EQUIPMENT RECONNECTION.

Before operating unit, be certain voltage and frequency rating of the load matches that of the Generator Set. If the output voltage of the Generator Set must be changed to match a particular load, rotate reconnection switch located on Reconnection Panel to desired output connections. See figure 2-2.

2-4. STARTING GENERATOR SET (SEE FIGURE 2-3).

CAUTION

Do not idle engine.

Operate generator set only at rated RPM.

Do not use either to aid starting generator set.

Do not operate in excess of 200 hours continuous with JP-4, MIL-J-5624 bulk fuel.

a. When starting a set with a dry fuel system or after a filter drain or change:

(1) Push in the DC circuit breaker.

- (2) Ensure vent on underside of fuel filler cap is open.
- (3) Open air intake access door on Acoustic Suppression Kit (ASK) (4, figure 1-2.1).
- (4) Prime fuel lines by slightly opening plug (1, figure 4-9) on head (8, figure 4-9). Do this on Filter Assembly nearest check valve (6, figure 4-11).
- (5) Move master switch to PRIME& RUN.
- (6) When pump slows down and no further air bubbles appear around plug, tighten plug (1, fig. 4-9).

NOTE

Preheat is not required when engine is warm.

- b. Move master switch to PREHEAT position and hold for one minute.

Table 2-1. Generator Set Controls and Instruments

CONTROL	DESCRIPTION	FUNCTION
BATTERY INDICATOR	Green - fully charged; Yellow - charging; Red - under or over charging	Indicates the degree of charge of the batteries. Needle in the green area indicates fully charged between 26 and 30 volts. Needle in yellow area indicates charging condition between 20 and 26 volts. Needle in red area indicates an under charge or an over charge condition.
Panel Light	Shielded, bulb type, two used	Illuminates control panel.
RUNNING TIME meter	Hourmeter; 0 to 9,999.9 hours	Indicates total operating time of Generator Set.
Frequency Meter	Range 55 to 65 Hz; 0.1 Hz scale divisions; red mark at 60 Hz	Indicates frequency of Generator output.
% RATED CURRENT METER	0 to 133 percent range; red line at 100 percent, green line at 80 percent.	Indicates percent of rated output current.
Voltmeter, AC	0 to 300 volt scale; suppressed from 0 to 100 volts and linear from 100 to 300 volts. Red marks at 120, 208, and 240 volt points.	Indicates Generator Set output voltage.
VOLTAGE ADJUST RHEOSTAT	Rheostat	Adjusts Generator Set output voltage. Clockwise to increase and counterclockwise to decrease.
AMMETER-VOLTMETER TRANSFER SWITCH	Rotary switch	Used to select phase, voltage and current combination for reading on ammeter and voltmeter.
PANEL LIGHT SWITCH MASTER SWITCH	Toggle switch; ON-OFF Rotary switch, 5 positions, PREHEAT, OFF, PRIME & RUN AUX. FUEL, PRIME & RUN, AND START	Controls panel lights. When placed in PREHEAT position, electrical power is applied to glow plugs and preheaters on the engine to aid in cold engine starting. In OFF position, all dc circuits are deenergized except panel lights, and battery charging system. This position is used to stop the unit under normal operation. The PRIME & RUN AUX. FUEL position, is used when set is running and auxiliary fuel system is being used and also to prime entire fuel system before starting if required. The PRIME & RUN position is used when set is running and auxiliary fuel system is not used and also to prime engine fuel system only before starting if required. When placed in START position, energizes engine cranking system for engine starting, activates glow plugs and air heaters, and by-passes protective devices.
DC CONTROL CIRCUIT BREAKER	7.5 AMP breaker	Use for protecting dc circuit in case of short and also for emergency stopping; pull out to activate.

Table 2-1. Generator Set Controls and Instruments (Cont)

Control	Description	Function
OIL PRESSURE GAUGE	Located on oil fill side of engine. 0-50 pounds per square inch (psi)	Indicates engine oil pressure.
RECONNECTION SWITCH	Located on output control box. Three position rotary switch.	Used to select 120V, 1 phase; 120/240V, 1 phase; or 120/208V, 3 phase output for Generator Set.

c. Place master switch in START position and hold until engine comes to operating speed. If engine does not start within 15 seconds repeat steps b and c.

d. Master switch will return to PRIME & RUN position when released. If running from auxiliary fuel source, move master switch to PRIME & RUN AUX. FUEL position.

NOTE

If engine does not come to operating speed within 15 seconds, a minimum of 30 seconds cooling period must be observed before attempting another start.

e. Check oil pressure on engine mounted gauge. Oil pressure should be at least 20 psi minimum. Check frequency on frequency meter on control panel and adjust governor if necessary, using speed control. Frequency meter should read 61.5 with no load. Pulling speed control knob out will increase frequency,

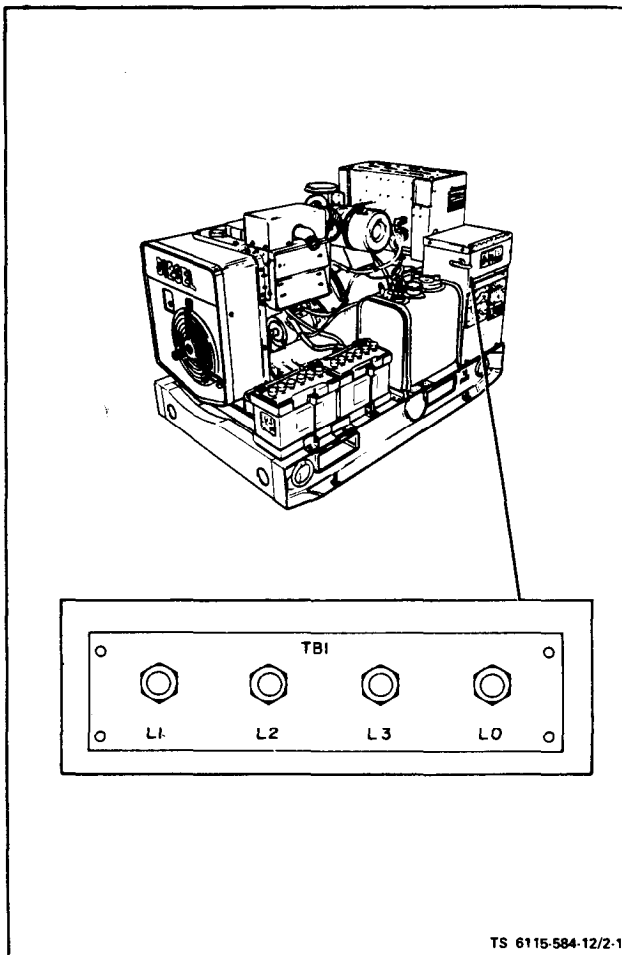

Figure 2-1. Load Terminals

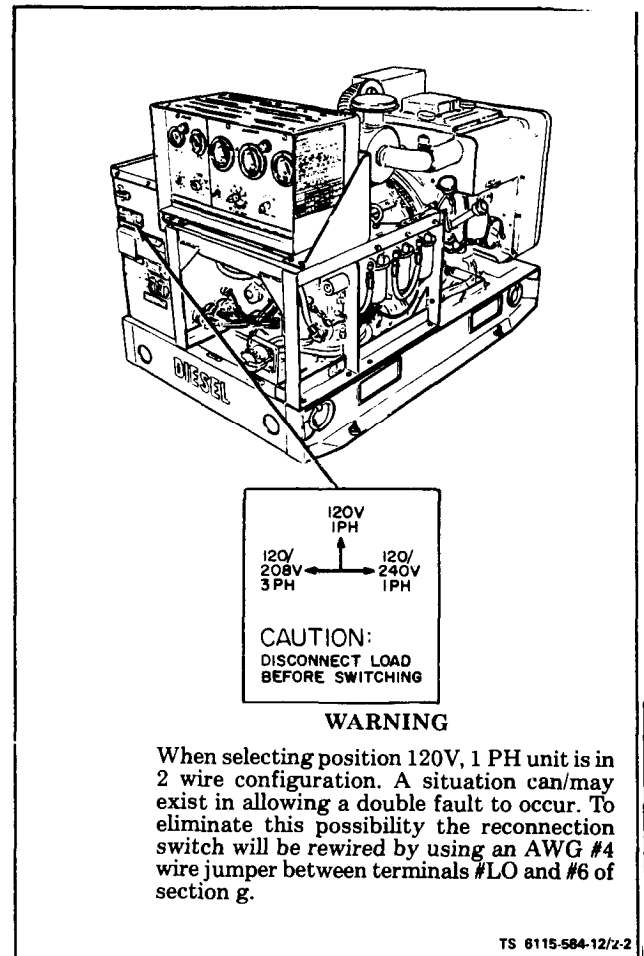

Figure 2-2. Reconnection Switch

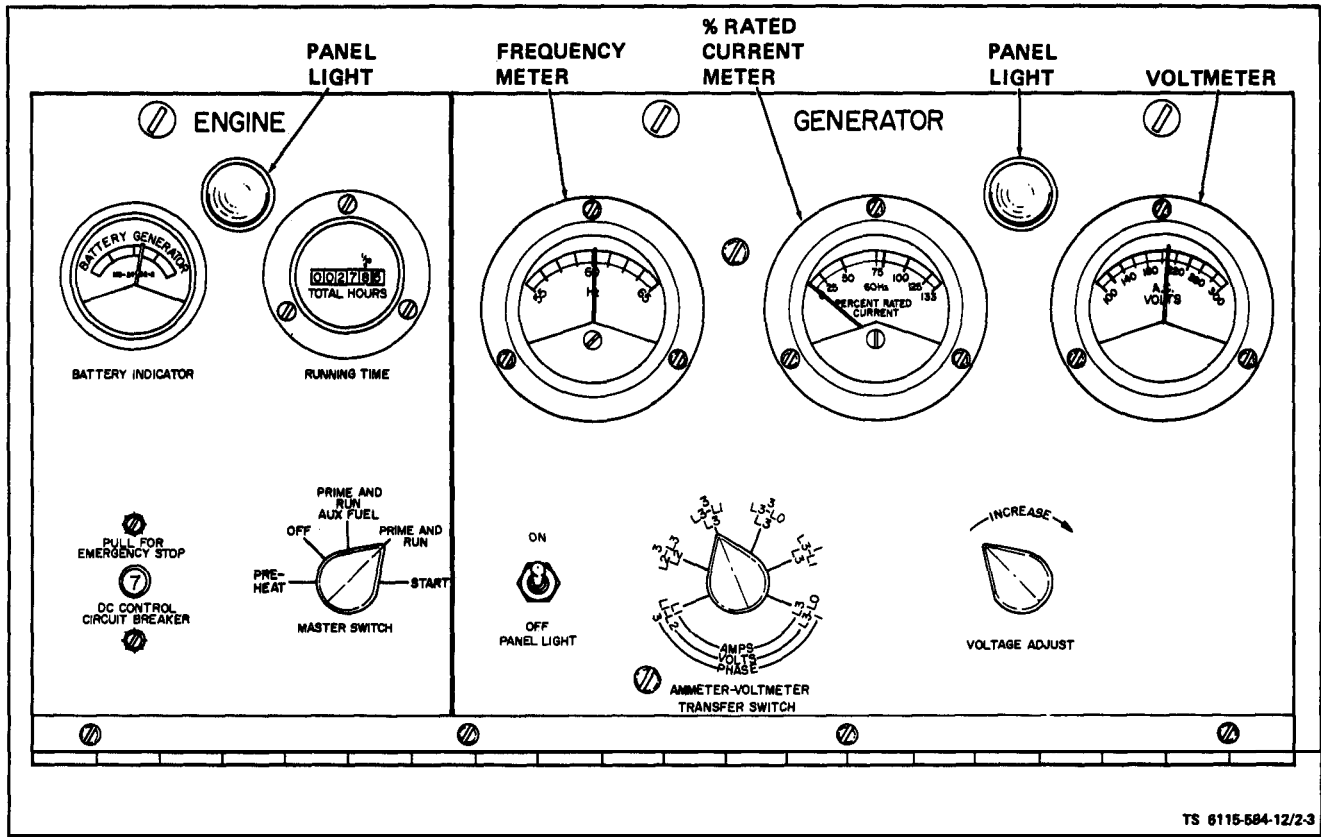

Figure 2-3. Starting Procedure

pushing speed control knob in will decrease frequency. Text For fine-control turn knob CW to increase and CCW to decrease.

f. Place ammeter-voltmeter transfer switch in position corresponding to the position of the reconnection switch. Adjust voltage adjust rheostat to desired voltage as read on voltmeter. Turn rheostat clockwise to increase voltage or counterclockwise to decrease voltage.

g. Place AC circuit breaker in ON position. Adjust speed control to obtain 60 Hz.

h. Place ammeter-voltmeter transfer switch in position to check percent rated current for either 1-phase 120 V. output, 1-phase 120/240V. output, or 3-phase 120/208 V. output. See table 2-1 and figure 2-3.

NOTE

For 3-phase output each of the four positions indicated in table 2-2 must be checked.

Observe percent rated current meter. Do not exceed 5% load difference between phases. A 0.8 power factor

Table 2-2. Reconnection Switch Positions

Load Voltage and Phase	Switch Position Amps - Volts - Phase	Measurement Across Terminals
120V 1 phase	L3 L3-L1 1	L3-L1
120/240V 1 phase	L3 L3-L0 1	L3-L0
120/206V 3 phase	L1 L1-L2 3	L1-L2
	L2 L2-L3 3	L2-L3
	L3 L3-L1 3	L3-L1
	L3 L3-L0 3	L3-L0

load equals a 100% meter reading for maximum rated load. A 1.0 power factor load equals a 80% meter reading for maximum rated load.

i. During operating of the Generator Set observe the following.

- (1) Check % rated current meter.
- (2) Check fuel level gauge periodically.
- (3) Oil pressure gauge located on engine should indicate 20 psi minimum.
- (4) Check running time meter periodically in order to perform preventive maintenance check and services at proper intervals.

(5) Battery indicator should indicate yellow while battery is charging, green when battery is fully charged.

(6) AC voltmeter should indicate 120V., 208V. or 240V. depending on load connection.

(7) Frequency meter should indicate 60 Hz (at full rated load).

j. During operation, inspect for leaks, paying particular attention to engine fuel and oil lines and connections.

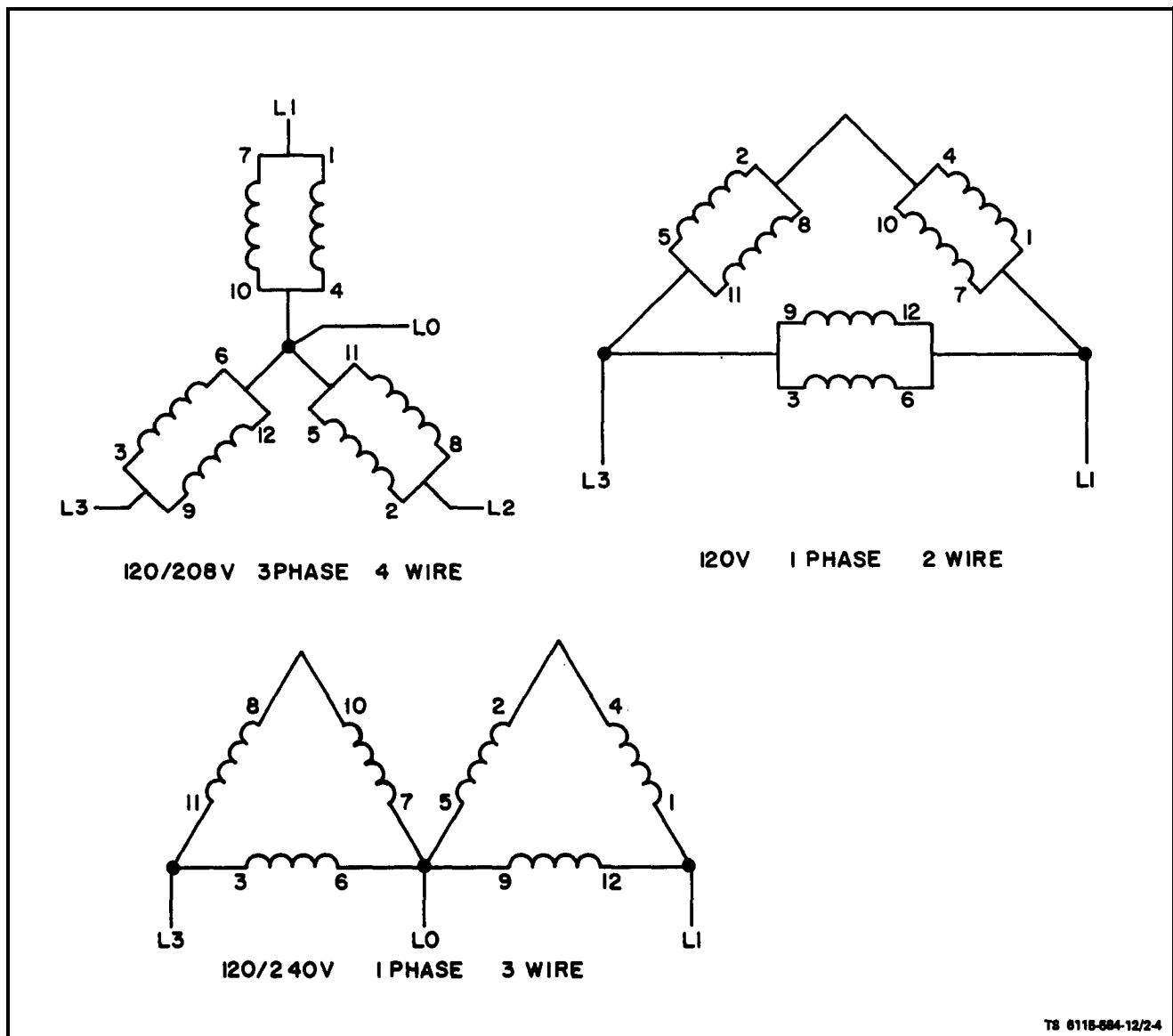

Figure 2-4. Load Terminal and Reconnection Configuration

k. During operation, listen for unusual noises which may indicate a pending malfunction.

2-5. OPERATING IN ALTERNATE MODES.

WARNING

When selecting position 120V, 1 PH unit is in 2 wire configuration. A situation can/may exist in allowing a double fault to occur. To eliminate this possibility the reconnection switch will be rewired by using an AWG #4 wire jumper between terminals #LO and #6 of section g.

CAUTION

Disconnect load before switching.

This unit can be set for 120 volt-1-phase, 120/240 volt-1-phase, or 120-208 volt-3-phase output. Rotate reconnection switch to desired output connection. Refer to figure 2-2.

Section II. OPERATION UNDER UNUSUAL CONDITIONS

2-7. OPERATION IN EXTREME HEAT.

To ensure satisfactory operation under conditions of extreme heat, accomplish the following:

- a. Be sure that nothing obstructs air flow to and from the unit.
- b. Keep cooling fins clean.
- c. Inspect battery electrolyte level daily. Add distilled water if necessary.
- d. Keep generator free of dirt and grime. Be sure ventilating screens are free of obstructions.

2-8. OPERATION IN EXTREME COLD (-25°F, -32°C).

To ensure satisfactory operation under conditions of extreme cold accomplish the following:

- a. Use correct lubricating oil in engine crankcase for temperature conditions. (Refer to figure 3-1). Change oil only when engine is warm.
- b. Use Arctic Grade diesel fuel.
- c. Keep batteries in a well charged condition.
- d. Be certain air cleaner intake control is in cold weather position.
- e. Shutter blades should be fully closed for cold engine open only partially under light load, open more as load increases.

2-6. SHUTTING DOWN UNIT.

- a. Place AC circuit breaker in the OFF position.
- b. To stop the Generator Set, place the master switch in the OFF position.
- c. After operation of the Generator Set, perform the inspection and service requirements as outlined in preventive maintenance checks and services under Operator Maintenance Instructions, Chapter 3.
- d. Emergency Stop. To stop Generator Set in an emergency, pull out DC control circuit breaker (see figure 2-3).
- e. If Generator Set is not going to be operated for two weeks or more, disconnect the negative cable from the battery. The generator set will be ready to go upon reconnection of the negative cable.

- f. Hold master switch in START position for 2 minutes after engine comes to operating speed.

2-9. OPERATION IN DUSTY OR SANDY AREAS.

To ensure that the Generator Set will operate satisfactorily in dusty or sandy areas, accomplish the following

- a. Clean Generator Set frequently.
- b. Service air cleaner frequently. Check air restriction indicator daily. If red signal is visible, service the air cleaner. Be certain that all air cleaner and intake manifold connections do not leak. Be certain oil filler cap fits snugly.
- c. Change crankcase oil and oil filter frequently.
- d. Store oil and fuel in dust-free containers.
- e. Make sure that Generator Set ground connection is free of dust and sand and connections are tight before starting the unit.

2-10. OPERATION IN WET OR HUMID AREAS.

To ensure that the Generator Set will operate satisfactorily in wet or humid areas, accomplish the following

- a. Keep fuel tank full to protect against moisture condensation and accumulation.
- b. Check wiring connectors for corrosion and wire insulation for signs of deterioration.

CHAPTER 3
OPERATOR MAINTENANCE INSTRUCTIONS

Section I. CONSUMABLE OPERATING AND MAINTENANCE SUPPLIES

3-1. CONSUMABLE SUPPLIES.

Table 3-1 contains all consumable supplies and the required quantities necessary for operating and maintaining this Generator Set.

Table 3-1. Consumable Operating and Maintenance Supplies

(1) Component Application	(2) National Stock Number	(3) Description	(4) Qty Required for Initial Operation	(5) Qty Required for 8 Hours Operation	(6) Notes
Tank, Fuel	9130-00-256-8613	JP-4, MIL-J-5624, Bulk	6.75 Gal.	6.75 Gal.	Emergency only
	9140-00-286-5294	FUEL OIL, DIESEL as follows: Regular Grade, DF2	6.75 Gal.	6.75 Gal.	
	9140-00-286-5286	Winter Grade, DF1	6.75 Gal.	6.75 Gal.	
	9140-00-286-5283	Artic Grade, DFA	6.75 Gal.	6.75 Gal.	
Crankcase		OIL, LUBRICATING five gallon pail as follows:			
	9150-00-265-9435	Grade OE 30, MIL-L-2104	4.0 Qt.		
	9150-00-265-9435	Grade OE 10, MIL-L-2104	4.0 Qt.		
	9150-00-242-7603	Grade OES Grade OE/HDO 15-40	4.0 Qt. 4.0 Qt.		
Batteries	6810-00-249-9354	Electrolyte	1.4 Gal.		

Section II. LUBRICATION INSTRUCTIONS

3-2. GENERAL.

To prevent excessive wear and insure continued operation, lubrication of certain moving parts on this unit is required. The Lubrication Order reproduced in this section shows the areas of this unit which require lubrication and also the

proper lubricant to be used.

3-3. LUBRICATION ORDER.

Refer to Lubrication Order LO 5-6115-584-12 for lubrication instructions.

Pages 3-2 and 3-3 including figure 3-1 deleted.

Section III. PREVENTIVE MAINTENANCE CHECKS AND SERVICES (PMCS)

3-4. GENERAL.

To ensure that the Generator Set is ready for operation at all times it must be inspected systematically, so that defects may be discovered and corrected before they result in serious damage or failure. The necessary preventive maintenance checks and services that are to be performed by the Operator personnel are listed and described in paragraph 3-8.

3-5. CORRECTING AND REPORTING DEFICIENCIES.

Defects discovered during operation will be noted for future correction. Stop operation immediately if a deficiency is noted which would damage the equipment or is a safety hazard. All deficiencies and short comings will be recorded together with the corrective actions taken on the applicable form. Marine Corps users should refer to current issue of TM 4700-15/1.

3-6. DETERMINING PMCS INTERVALS.

Certain Operator PMCS on this unit should be performed on a - per hours of operation - basis. The running time meter on the control panel should be used to determine the Generator Set operating time.

3-7. PMCS FOR UNITS IN CONTINUOUS OPERATION.

For PMCS performed on an operating time basis, perform PMCS as close as possible to the time intervals indicated. For units in continuous operation, perform PMCS before starting operation if continuous operation will extend service interval past that which is shown.

3-8. PREVENTIVE MAINTENANCE CHECKS AND SERVICES.

Table 3-2 contains a tabulated listing of PMCS which shall be performed by the Operator personnel. The item numbers are listed consecutively and indicate the sequence of minimum requirements.

NOTE

Leakage definitions for operator/crew PMCS shall be classified as follows:

- Class I Seepage of fluid (as indicated by wetness or discoloration) not great enough to form drops.
- Class II Leakage of fluid great enough to form drops but not enough to cause drops to drip from item being checked/inspected.
- Class III Leakage of fluid great enough to form drops that fall from the item-being checked/inspected.



Equipment operation is allowable with minor leakages (Class I or II). Of course, you must consider the fluid capacity in the item/system being checked/inspected. When in doubt, notify your supervisor.

When operating with Class I or Class II leaks, continue to check fluid levels as required.

Table 3-2. Operator/Crew Preventive Maintenance Checks and Services

NOTE

Within designated interval, these checks are to be performed in the order listed.

Item No.	Interval					Item To Be Inspected	Procedures Check for and have repaired or adjusted as necessary	Equipment is Not Ready/ Available if:
	B	D	A	W	M			
1	•					Generator Set	<p>NOTE</p> <p>Perform lubrication prior to or in conjunction with before PMCS. Refer to LO 5-6115-584-12. Keep your unit clean by wiping of dirt and oil as you do PMCS.</p> <p>Make the following walk around checks:</p> <p>a. Check for fuel and oil leaks on, around, or under unit. Check for missing, cracked, broken, loose, or damaged parts.</p> <p>b. Check oil level (oil fill dipstick). Add oil as required, refer to LO 5-6115-584-12.</p>	Class III oil leak or any fuel leakage is found.

Table 3-2. Operator/Crew Preventive Maintenance Checks and Services (Cont.)

NOTE

Within designated interval, these checks are to be performed in the order listed.

B-Before D-During A-After W-Weekly M-Monthly

Item No.	Interval					Item To Be Inspected	Procedures Check for and have repaired or adjusted as necessary	Equipment is Not Ready/ Available if:
	B	D	A	W	M			
1	•					Generator set (cont.)	<p>c. Check that grounding cable is installed and tight (para 4-2e, fig. 4-2).</p> <p>d. Check restriction indicator; if RED, clean or replace air filter element. (para 3-18)</p> <p style="text-align: center;">NOTE</p> <p>During starting and operation, check restriction indicator. Check for leaks, loose or cracked parts, unusual noise, rough-running, excessive vibration, lack of power, incorrect instrument readings, or any indication of a failing or defective component. If suspected, notify organizational maintenance.</p>	<p>Cable is improperly installed or missing.</p> <p>Air cleaner is missing or unserviceable. Indicator indicates red.</p>
2		•				Controls and a. Battery indicator b. Frequency meter c. Percent rated current meter d. Voltmeter e. Oil pressure gage f. Fuel gage	<p>Instruments will indicate within specified limits.</p> <p>Normal indication: yellow while charging, green when fully charged.</p> <p>Normal indication: 60 Hz (red line) with load on generator.</p> <p>Normal indication: Percent of load (output) on each phase. Not to exceed 100% load or 5% difference between phases.</p> <p>Normal indication: 120, 208 or 240 volts depending on AMP Volt transfer switch position.</p> <p>Normal indication: 20 to 45 psig at rated RPM.</p> <p>Normal indication: Full</p>	<p>Indicating in the Red.</p> <p>Proper frequency cannot be maintained.</p> <p>Desired voltage cannot be obtained.</p> <p>Oil pressure drops below 15 psig.</p>
3			•			Fuel tank	<p>Fill tank upon completion of operation.</p> <div style="text-align: center; border: 2px dashed black; padding: 5px; width: fit-content; margin: 10px auto;"> CAUTION </div> <p>Dangerous gases. Do not smoke or use open flame while servicing battery, due to possible presence of hydrogen, a highly explosive gas.</p>	

Table 3-2. Operator/Crew Preventive Maintenance Checks and Services (Cont.)

NOTE

Within designated interval, these checks are to be performed in the order listed.

Item No.	Interval				Item To Be Inspected	Procedures Check for and have repaired or adjusted as necessary	Equipment is Not Ready/ Available if:
	B-Before	D-During	A-After	W-Weekly			
4			●		Batteries	<p>NOTE</p> <p>If the Generator Set is not going to be operated for two weeks or more, disconnect the negative cable from the battery. The Generator Set will be ready to go upon reconnection of the negative cable.</p> <p>Even if the Generator Set is operated every day, the battery may still run down. A run down battery does not have time to be recharged. Run the Generator Set for at least 30 minutes at rated speed. Allow extra running time if the preheater was used, or if starting took several tries.</p> <p>Check battery electrolyte levels. Proper level is 3/8 inch above plates. Use clean water (distilled if available).</p>	
5	●		●		Fuel strainer and filters	<p>NOTE</p> <p>Fuel system temperature must be above freezing when draining water and sediment.</p> <p>Drain water and sediment from strainer, primary and secondary filters. Allow to drain until fuel runs clean (para 3-20).</p>	
6				●	Fuel tank	Drain water and sediment. Allow to drain until fuel runs clean (para 3-13).	
7		●	●		Acoustical Suppression Kit (ASK)	Make a visual inspection of the ASK for loose or missing hardware, and for any bent, cracked or broken parts. Tighten all loose hardware.	
					Front Panel Assembly	Ensure that front panel assembly is free from obstructions or accumulation of dirt, leaves, debris which would hinder air flow.	
8	●		●		Day Tank	Drain water and sediment.	
						<p>NOTE</p> <p>In freezing weather drain shortly after operation. Allow to drain until fuel runs clear.</p>	

Section IV. TROUBLESHOOTING

3-9. GENERAL

This section contains troubleshooting information for locating and correcting operating troubles which may develop in the Generator Set. Each malfunction for an individual component, unit, or system is followed by a list of tests or inspections which will help you to determine probable causes and corrective actions to take. You should perform the test/inspections and corrective actions in the order listed.

3-10. MALFUNCTIONS NOT CORRECTED BY USE OF THE TROUBLESHOOTING TABLE.

This manual cannot list all malfunctions that may occur nor all test or inspections and corrective actions. If a malfunction is not listed or cannot be corrected by listed corrective actions, notify your supervisor.

Table 3-3. Troubleshooting (Cont)

MALFUNCTION	TEST OR INSPECTION	CORRECTIVE ACTION
4. ENGINE STARTS AND RUNS NORMALLY BUT SUDDENLY "STOPS."		
	Step 1. Check fuel level indicated by gauge on fuel tank (paragraph 3-13).	Add fuel if necessary.
	Step 2. Check to see that shutters on shutter box have fully opened (paragraph 3-14).	Refer to next higher level of maintenance.
	Step 3. Check to see that blower housing grille and engine cooling fins are clean (paragraph 3-22).	Refer to next higher level of maintenance.
	Step 4. Low oil pressure will cause engine to shut down. Check oil level (paragraph 3-24).	Add correct weight oil, if necessary.
	Step 5. Check that vent on under side of fuel filler cap is open (paragraph 3-13).	Clear vent hole.
5. ENGINE RUNS BUT EMITS BLACK SMOKE IN EXHAUST.		
	Step 1. Check air cleaner assembly to see that inlet shutter assembly is in proper position for either COLD WEATHER or NORMAL WEATHER operation (paragraph 3-18).	Push knob and slide assembly into proper position.
	Step 2. Check for restricted air intake, Red signal on air flow indicator should be visible (paragraph 3-18).	Remove any restriction from intake port. Check and if necessary clean or replace air cleaner filter
	Step 3. Check load on Generator by checking % rated current meter on control panel (paragraph 3-19).	Notify immediate supervisor.
6. ENGINE RUNS WITH EXCESSIVE OIL CONSUMPTION,		
	Step 1. Inspect for oil leaks especially at front and rear oil seals, at oil pan gasket and dipstick cap (paragraph 3-24).	Notify higher level of maintenance.
	Step 2. Check for red warning signal on air flow indicator indicating a dirty air cleaner filter (paragraph 3-18).	Clean or replace filter. Reset air flow indicator by pushing reset button.
	Step 3. Check for air leaks to crankcase (loose oil filler cap, leaks at gaskets, etc) (paragraph 3-24).	Tighten oil filler cap or notify higher level of maintenance.

Table 3-3. Troubleshooting (Cont)

MALFUNCTION	TEST OR INSPECTION	CORRECTIVE ACTION
7. GENERATOR SUPPLIES NO VOLTAGE TO LOAD.		
	Step 1. Check main circuit breaker for ON position on ac output control box.	Place circuit breaker in ON position. If breaker will not stay on, perform the following actions: Make certain load leads are attached to the correct load terminals. Make certain connections are clean and tight. Verify load is not excessive to generator capability and does not have an internal short. Notify higher level maintenance.
8. GENERATOR SUPPLIES IMPROPER (UNDER OR OVER) VOLTAGE FREQUENCY TO LOAD.		
	Step 1. Check reconnection switch on ac output control box.	Make certain switch position matches load.
		CAUTION
		Disconnect load before switching.
	Step 2. Check load terminal board (paragraph 3-17).	Make certain load leads are attached to the correct load terminals. Make certain connections are clean and tight.
	Step 3. Check engine speed.	Adjust engine speed by turning speed control assembly until frequency meter on control panel indicates 60 Hz with load on Generator Set. If engine speed cannot be brought up so that Generator operates at 60 Hz, check external governor linkage for binding and check steps under ENGINE STARTS BUT DOES NOT RUN SMOOTHLY. If engine speed cannot be brought down so that Generator operates at 60 Hz, check external governor linkage for binding or notify higher level maintenance (paragraph 3-21).

Section V. OPERATOR MAINTENANCE PROCEDURES

3-11. **BATTERY ASSEMBLY.**

a. Inspect (see figure 3-2). On generators equipped with acoustic suppression kit (ASK), remove batteries access door for inspection.

(1) Inspect battery cable terminal connectors (2), (10) and (11) for corrosion, deterioration, or physical damage. Inspect battery terminal covers (16) for proper installation and physical condition. Replace if cracked, split or torn.

(2) Inspect cables (1), (3), and (4) for breaks, damage and deteriorated insulation.

(3) Inspect battery top frames (5), bottom frame (12), and tray (13) for corrosion or physical damage. Check to see that frame is held securely in place and that all attaching hardware, nut (7), washer, (8), screw (14), washer (15), and bolt (9), is securely in place. Check that frame is free of electrolyte.

(4) Inspect battery (6) for leaks or cracks. Check top of battery and battery caps for cleanliness. Check battery electrolyte (liquid) level. Level should be

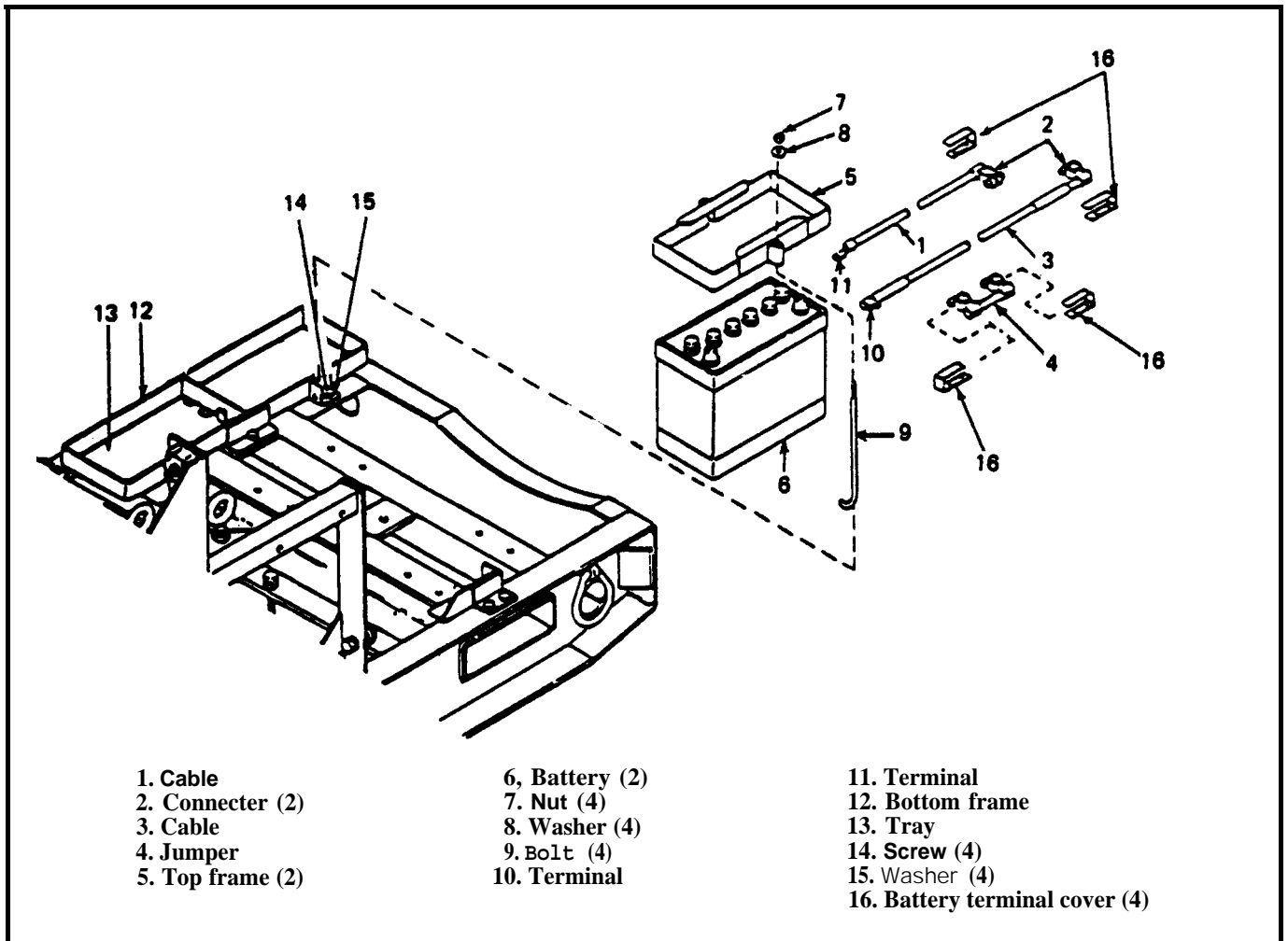

Figure 3-2. Battery Assembly

3/8 inch above top of plates. Check that battery caps are not loose.

b. Clean.

(1) Clean terminal connectors, (2), (4), (10) and (11), batteries (6) and frame using a low sodium solution and wipe dry with a clean cloth. Notify higher level of maintenance if terminals, cables, batteries or frame is damaged.

c. Service.

NOTE

The 6TN and 6TL batteries can be mixed or matched. However, maintenance-free batteries cannot be mixed or matched with military batteries. The 6TN and 6TL batteries will perform properly in hot weather as long as electrolyte levels are carefully monitored. If the electrolyte expands and causes the level to rise, some fluid must be removed. If the level becomes too low due to evaporation, distilled water may be used to obtain the proper level. A good grade of drinking water (excluding mineral water) may be used if distilled water is not available.

Electrolyte (NSNs 6810-00-249-9354 and 6810-00-843-1640) have a specific gravity of 1.280 and should be used in these batteries. Do NOT adjust the electrolyte in wet batteries to a lower specific gravity.

(1) Fill batteries (6) with clean distilled water to a level of 3/8 inch above top of plates. In freezing weather, run engine a minimum of one hour after adding water.

3-12. GROUND ROD AND FUEL DRUM ADAPTER HOLD-DOWN ASSEMBLY.

a. Removal (see figure 3-9). On ASK equipped generators, remove oil access door and fuel filter access door and perform the following procedures.

(1) Ground Rod and Fuel Drum Adapter. Loosen screws (1) and lockwashers (2). Slide three piece ground rod (3) out of hold-down assembly (4), then slide out fuel drum adapter (5).

(2) Hold-down adapter. Grasp hold-down assembly (4) and remove screw (1) and lockwasher (2). Remove hold-down assembly.

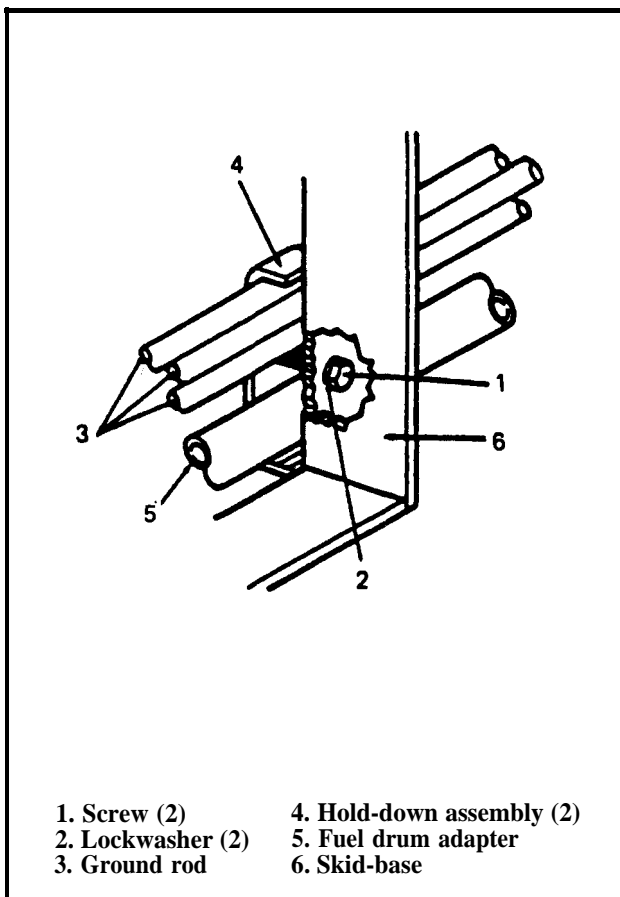

Figure 3-3. Ground Rod and Fuel Drum Adapter Hold-Down

b. Cleaning and Inspection.

(1) Ground Rod. Inspect ground rod for damage and corrosion. Pay particular attention to the threaded portions of each piece, making certain the three pieces can be properly assembled.

(2) Fuel Drum Adapter. Inspect adapter (5) for cleanliness and condition of threaded portions. Clean adapter with cleaning solvent and dry.

(3) Hold. down. Check hold-down assembly (4) for physical damage and check condition of hardware (1 and 2).

c. Installation.

(1) Hold-down. Position lockwashers (2) on screws (1) and insert into holes in skid-base (6). Position hold-down assemblies (4) against skid-base (6), then start screw (1).

CAUTION

Do not over-tighten screws as damage to hold-down assemblies may occur.

(2) Ground Rods and Fuel Drum Adapter. Slide fuel drum adapter (5) and three piece ground rod assembly (3) between hold-down assemblies (4) and skid base (6). Tighten screws (1).

3-13. FUEL TANK ASSEMBLY.

a. Cleaning and Inspection (see figure 3-4).

(1) Fuel Tank Strap Assemblies. Inspect both straps (1) for damage that would prevent them from securely holding fuel tank (4) to skid-base (10). Check that both straps are tight. Tighten straps by tightening nuts (2) and washers (3) securing each strap to skid-base.

(2) Fuel Tank. Visually check fuel tank (4) for dents or leaks. Check that filler cap (8) fits securely onto tank and that filler cap and surrounding area is clean. Clean using solvent and clean cloth.

(3) Fuel Level Gauge. Check fuel level gauge (6) for physical damage. Check that gauge shows FULL when tank is full, and EMPTY when tank is empty. Notify higher level of maintenance for replacement of fuel level gauge.

(4) Float Switch. Inspect float switch (7) for physical damage. Check that float switch is properly attached to tank.

(5) Fittings. Inspect three fittings (5) for physical damage. Check that fittings are secured to fuel tank. Notify higher level of maintenance of leaky or damaged fittings.

(6) Fuel Drain Valve. Inspect drain valve (9) for physical damage. Check that valve operates properly. If not, notify higher level of maintenance.

(7) Filler Cap Assembly. Inspect filler cap (8) for physical damage. Check that vent on underside of cap opens and closes easily. Ensure that vent on underside of filler cap is open before starting generator.

3-14. SHUTTER BOX ASSEMBLY.

a. Inspect (see figure.3-5).

CAUTION

Do not operate unit if shutter assembly is not operating properly.

(1) Shutter Assembly. Check shutter assembly with unit running under normal operating conditions. When engine is cold, shutter assembly should be fully closed. When engine warms up, shutter assembly should be fully open at 140°F (60°C) or above at full rated load. Make certain shutter assembly is free of dirt and oil which could cause shutters to stick.

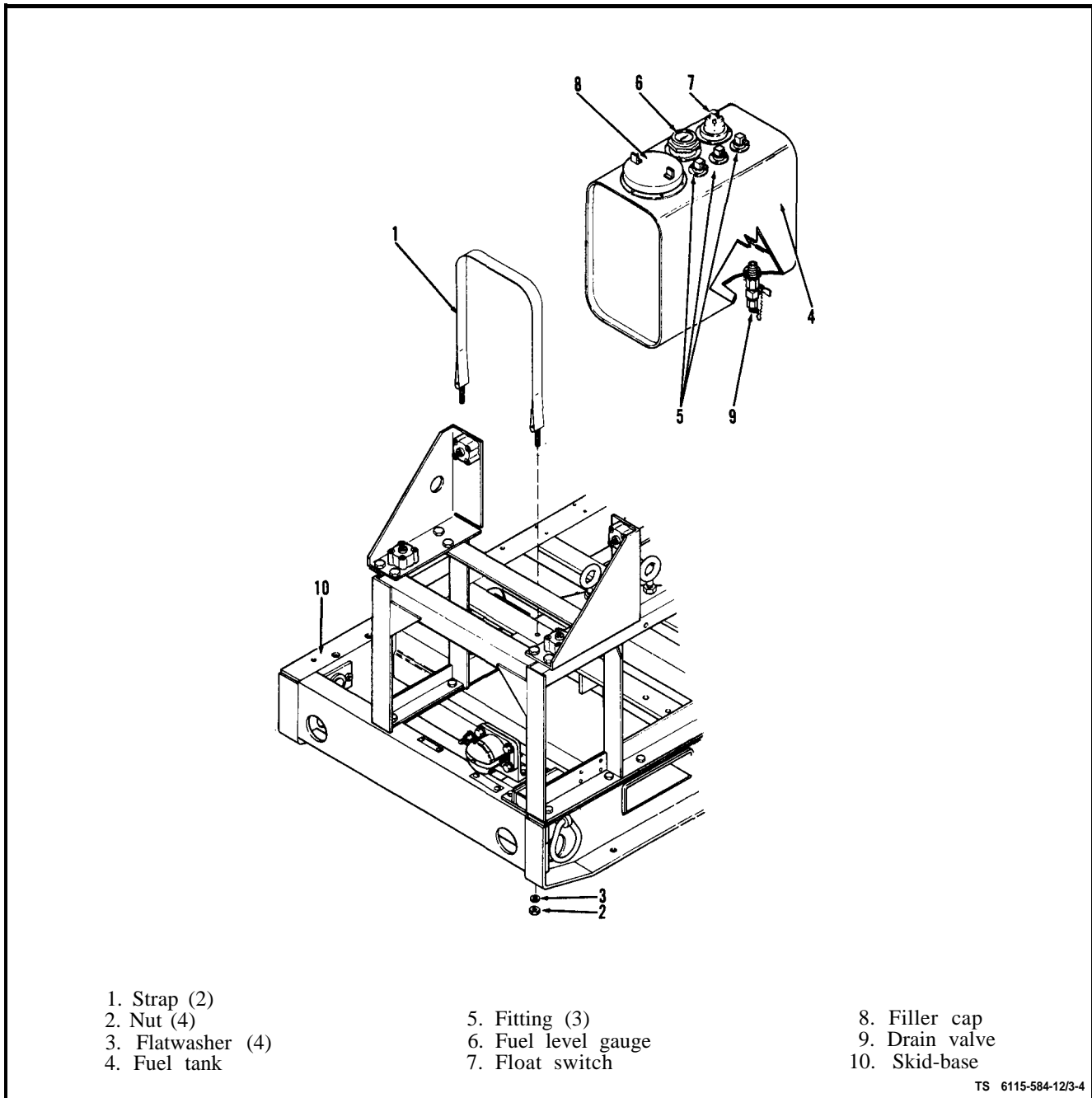

Figure 3-4. Fuel Tank

(2) Bracket Assembly. Check bracket assembly (1) for secure mounting to shutter (4) and shutter box (10). Brackets (11) should turn freely on bearings (12) without excessive play.

(3) Shutters. Check shutters (4) to see that they are free of dirt or grease. Check to see shutters are

flat and straight. Check to see that shutters close securely and that they can be easily opened by hand.

(4) Thermo Power Unit. Check thermo power unit (7) located on inside of shutter assembly to see that it is free of dirt, grease, or physical damage. Notify higher level of maintenance for replacement of thermo power unit.

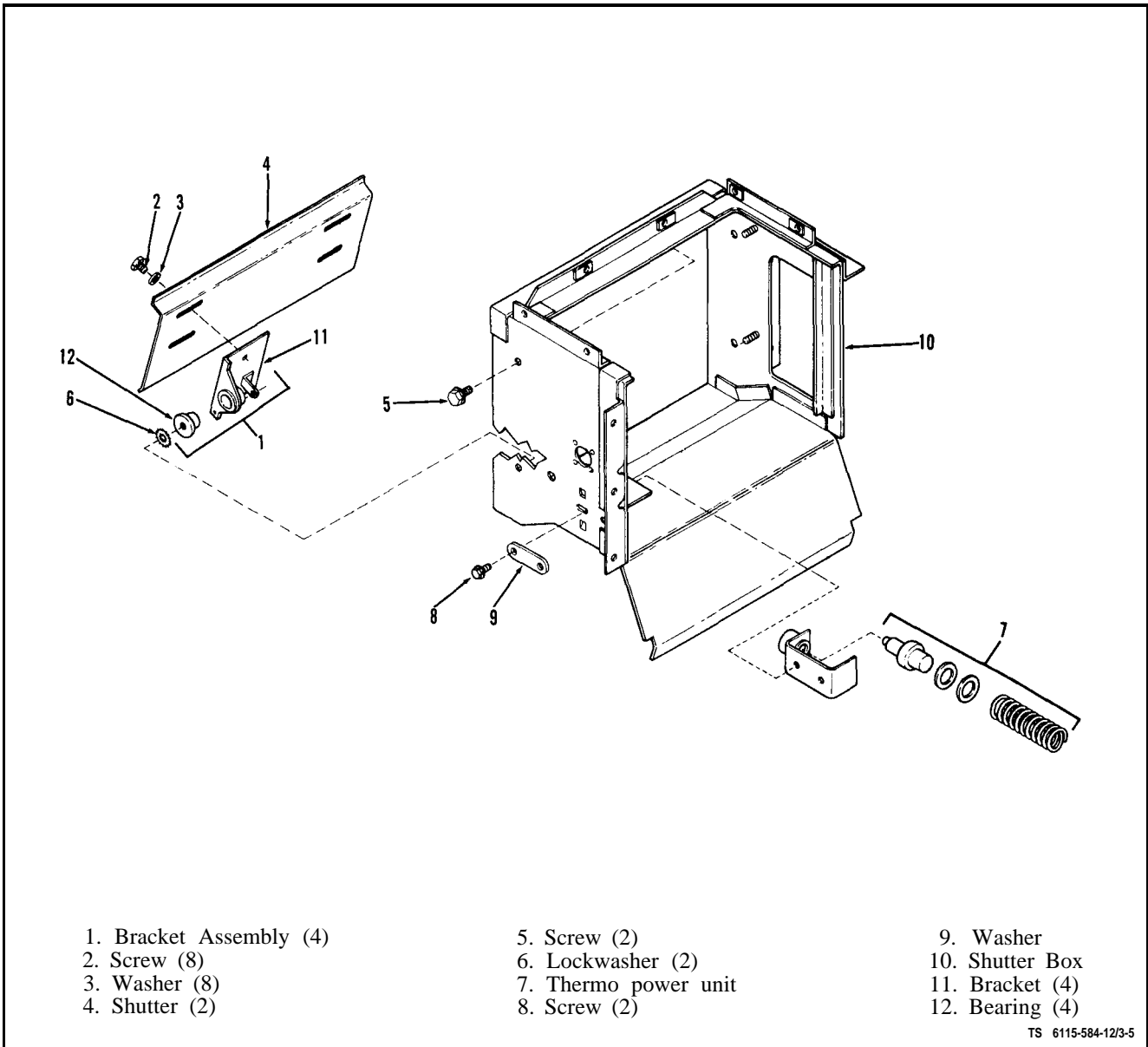

Figure 3-5. Shutter and Thermo Power Element Assembly

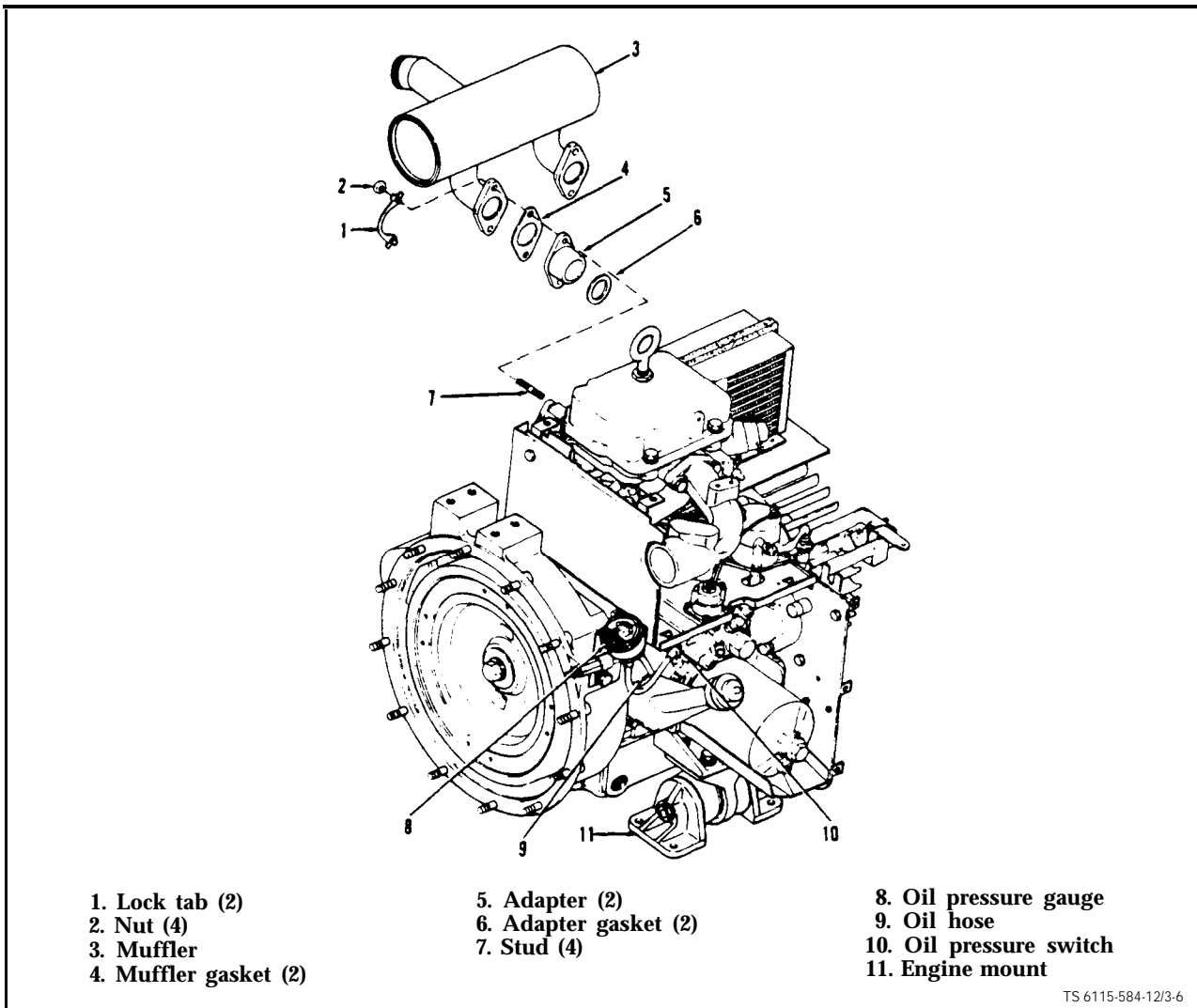

Figure 3-6. Exhaust Muffler Assembly

3-15. EXHAUST MUFFLER ASSEMBLY

WARNING

Do not touch muffler assembly while unit is running or immediately after shutdown, as severe burns may result.

a. Inspect (see figure 3-6). Manually open shutter assembly and check that muffler assembly (3) is securely fastened to unit. Check that nuts (2) and lock tabs (1) attaching muffler to unit are in place.

Check to see that exhaust is not obstructed and there is no evidence of leaks.

3-16. ENGINE STARTER ASSEMBLY

a. Cleaning and Inspection (see figure 3-7). On ASK equipped generators, remove BATTERIES access door. Clean engine starter (1) by removing loose dirt with a stiff nonmetallic brush. Clean off remaining dirt and oil with dry cleaning solvent (Fed. Spec. P-D-680). Inspect starter to see that electrical connections (4) are clean and tight. Check to see that mounting bolts (2) are tight. Check starter (1) for physical damage.

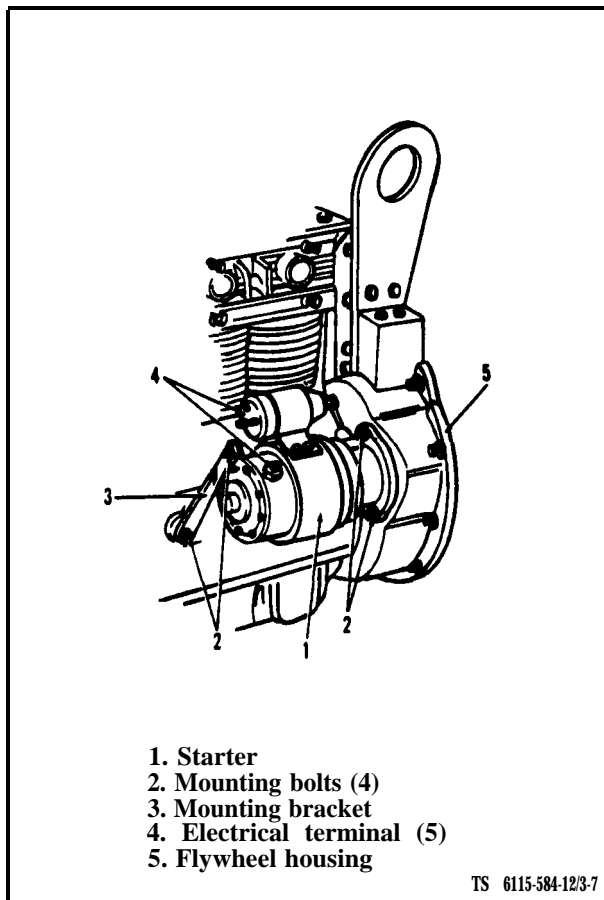

Figure 3-7. Electric Starter

3-17. AC OUTPUT CONTROL BOX ASSEMBLY.

a. Inspect (see figure 3-8).

(1) Control Box Assembly. Check box assembly for cracks, dents, or other physical damage. Inspect to see that covers (1) for both 120 volt ac outlets operate properly. Check latches (2) securing load terminal board cover (3). Check to see that cover (3) for load terminal board opens and closes properly. Check to see that electrical connectors (4) are clean and securely mounted.

(2) Load Terminal Board Assembly. Check condition of load terminal board (5) and load terminals (6) for cleanliness and tightness. Make certain that the load leads are secured to terminals.

3-18. AIR CLEANER ASSEMBLY.

a. Inspect on Equipment (see figure 3-9). On ASK equipped generators, open AIR INTAKE and AIR CLEANER access doors.

(1) Housing. Inspect housing (8) for dirt, grease, dents or other physical damage. Check to see that housing is securely attached to bracket assembly (1).

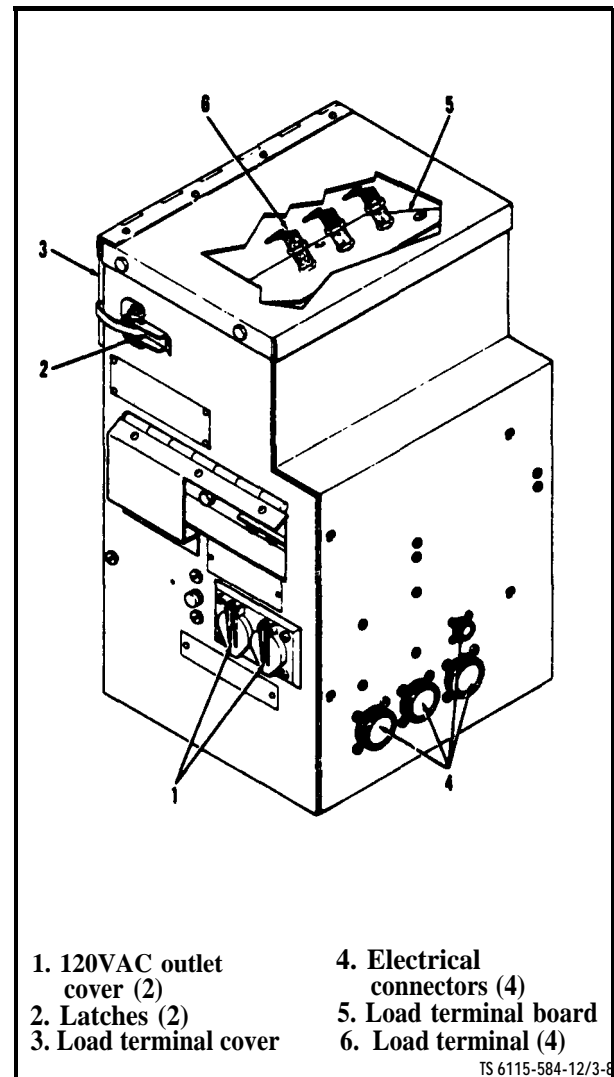

Figure 3-8. AC Output Control Box Assembly

check that clamp (17) attaching dust cap (18) to housing is secure and arrows on dust cap are pointing up. check that two clamps (7) holding cold weather operation intake hose (19) are secure.

(2) Bracket Assembly. Inspect bracket assembly (1) to see that it is securely fastened to generator housing (2). check that capscrews (3) and lockwashers (4) which attach bracket to generator housing, and three spacers (5) are in place.

(3) Inlet Shutter (see figure 3-10). Check inlet shutter (6) to see that it slides easily from COLD WEATHER to NORMAL WEATHER position and back.

(4) Air Flow Indicator (see figure 3-10). Check air flow indicator (7) for dirt, grease, or physical damage.

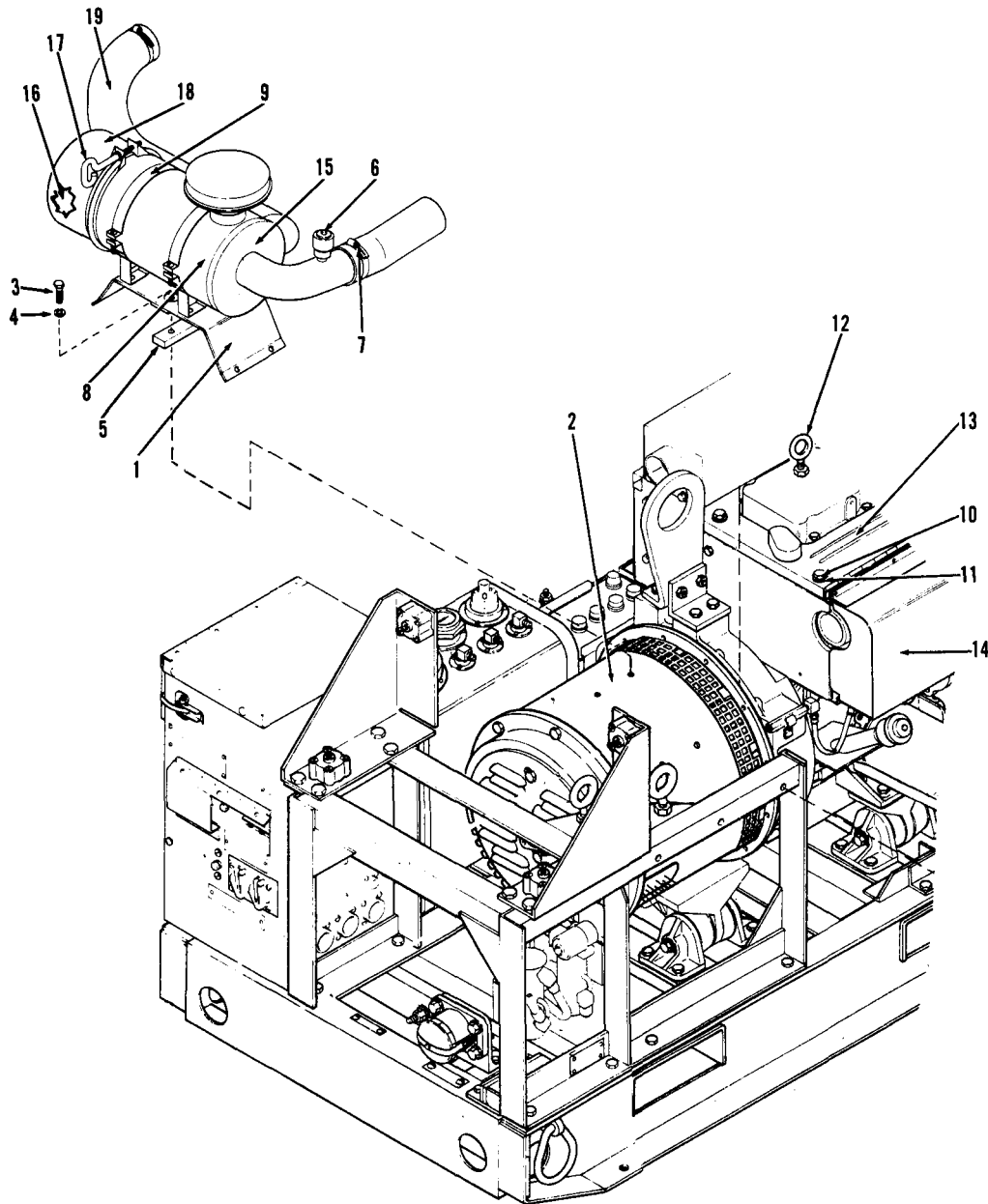

- | | | |
|-----------------------|-------------------------------|--------------------------|
| 1. Bracket assembly | 7. Hose clamp | 14. Panel |
| 2. Generator housing | 8. Air cleaner housing | 15. Air cleaner assembly |
| 3. Capscrews (6) | 9. Clamp | 16. Seal |
| 4. Lockwashers (6) | 10. Screw (4) | 17. Clamp |
| 5. Spacers (3) | 11. Washer (4) | 18. Dust cap |
| 6. Air flow indicator | 12. Engine lifting attachment | 19. Hose |
| | 13. Shroud | |

TS 6115-584-12/3-9

Figure 3-9. Air Cleaner and Shroud Assembly

b. Removal and Service.

(1) Dust Cap (see figure 3-10). Every 100 operating hours (more frequently in dusty areas) service dust cap (1) by removing cap from air cleaner housing (5), removing rubber seal (9), and cleaning out any dirt or debris. The clamp (10) is loosened to remove dust cap and seal.

CAUTION

Do not use compressed air of more than 100 psi on the air cleaner element.

(2) Air Cleaner Element (see figure 3-10). Every 1000 operating hours, or more frequently as conditions dictate, or when red warning on air flow indicator becomes visible, clean or replace air cleaner element (4). To remove the element remove dust cap (1) and seal (9). Remove wing nut (2), seal (3) and remove element (4). To clean element, direct dry clean air up and down pleats on the inside of the element. (See figure 3-11.) If element is very dirty, wash it by soaking in mild detergent and water. Soak for fifteen minutes or more. Rinse element thoroughly with clean water from hose (maximum pressure 40 psi). Air dry completely a minimum of 24 hours before re-using. Do not dry with compressed air or heat over 150° F (66° C).

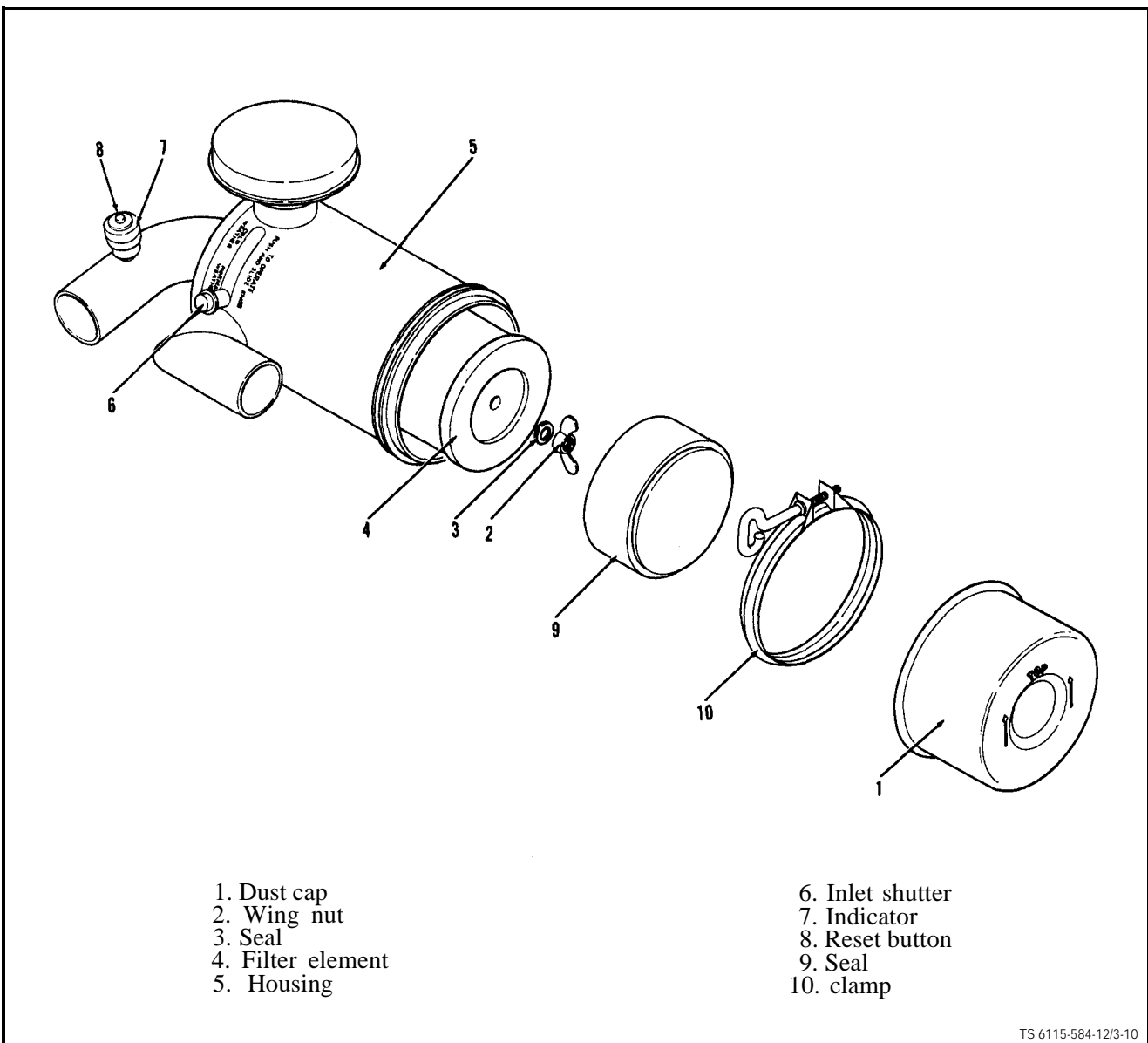

Figure 3-10. Air Cleaner Assembly

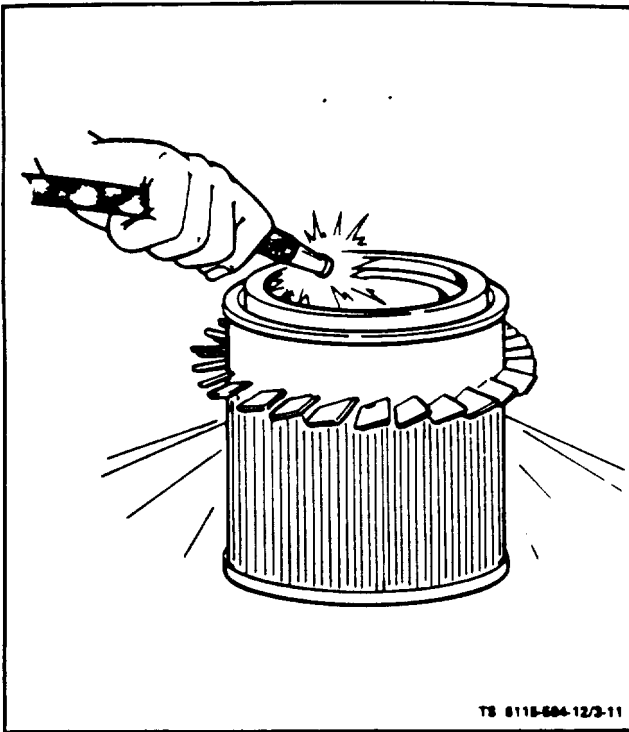

Figure 3-11. Cleaning Air Filter Element

CAUTION

Do not re-use element more than twice. Do not re-use element if it has even the slightest rupture.

c. Installation.

(1) Air Cleaner Element. Slide element (4, figure 3-10) over stud in housing (5), install seal (3) on wing nut (2) and secure element with wing nut (2). Hand tighten wing nut. Install seal (9) and dust cap (1). Be certain "Top" on dust cap faces up. Retighten clamp (10) to secure dust cap.

3-19. CONTROL CUBICLE Assembly.

a. Inspect (see figure 3-12).

(1) Control Cubicle Assembly. Inspect cubicle for dirt, grease or physical damage which might affect operation of the unit. Loosen three fasteners holding control panel to permit access to the inside of the cubicle. Check to see that all parts mounted to the cubicle are secure and all hardware is in place. Check that all instruments and controls operate normally when unit in running. Check for broken or badly insulated harness wires and, if necessary, refer to higher level of maintenance.

(2) Panel Light Assemblies (DS1 and DS2). Inspect panel light assemblies (1) for cracked or miss-

ing lamp covers. Check that electrical connections are clean and tight.

(3) panel Light Switch. Operate lamp switch (2) to check that lamps are operable.

(4) Meters. Battery Indicator (M1), Hourmeter (M2), Frequency Meter (M3), Percent Current Meter (M4) and AC Voltmeter (M5). Inspect meter glass to see that it is not cracked. Check to see the meter face is clean and readable. Check to see that pointer is not bent. Check to see that electrical connection are clean and tight.

(5) DC Control Circuit Breaker (CB2). Inspect circuit breaker for physical damage. Inspect electrical connections to see that they are clean and tight. Check to see that when button on breaker is pushed in or pulled out, it will remain in that position.

(6) Master Rotary Switch (S1). Inspect switch for physical damage. Inspect electrical connections to see that they are clean and tight. Check to see that when placed in the OFF, PRIME & RUN AUX FUEL, or PRIME & RUN positions the switch will remain in position. Check to see that when placed in the PRE-HEAT position and released, switch returns to OFF position. With DC Control Circuit Breaker (CB2) pulled out (unit will not crank), check to see that when released from START position the switch will automatically return to PRIME & RUN position.

(7) Panel Light Switch (S2). Inspect switch for physical damage. Inspect for clean and tight electrical connections. Check to see that switch will remain in both ON and OFF positions.

(8) Ammeter - Voltmeter Transfer Switch. Inspect switch for physical damage. Inspect for clean and tight electrical connection. Check to see that switch will remain in both ON and OFF positions.

(9) Voltage Adjust Rheostat (R1). Inspect rheostat for physical damage. Inspect for clean and tight electrical connections. Note rheostat position and check that rheostat moves smoothly thru its range. Return rheostat to previously noted position.

(10) AC Voltage Regulator (A2). Visually inspect board and components for signs of overheating, cleanliness and physical damage. Inspect for clean and tight connections to the board and that board is securely mounted.

(11) Transformers (T1 and T2). Inspect transformers for physical damage, cleanliness and that electrical connections are clean and tight.

(12) Wiring Harness. Inspect wiring harness for physical damage such as broken or frayed wires or damaged insulation.

(13) Control Cubicle Box. Inspect box for physical damage.

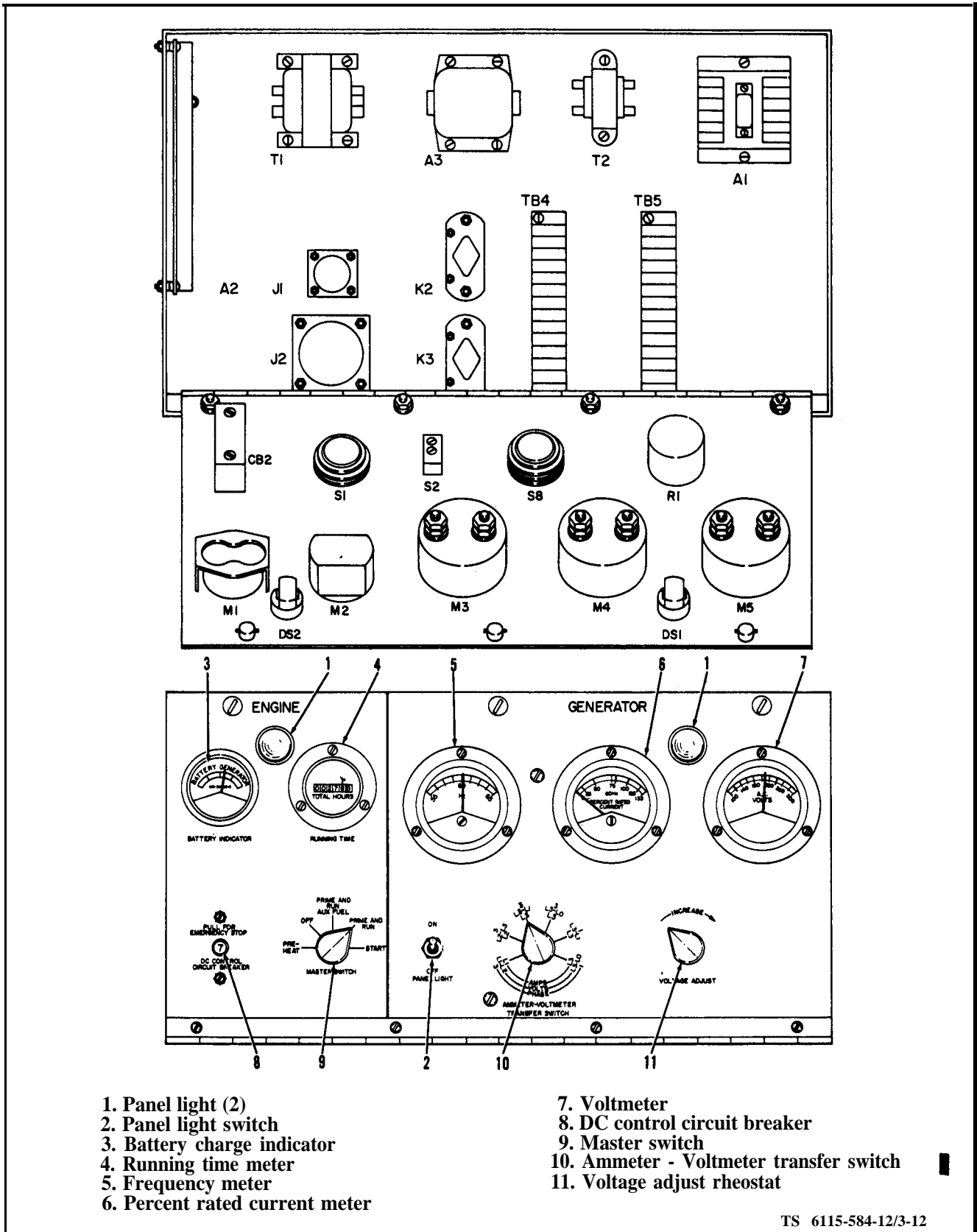

Figure 3-12. Control Cubicle

b. Service

(1) Panel Light. Panel lamp cover can be removed for cleaning by turning them counterclockwise when viewed from front.

(2) Panel Lamps. Panel lamps are screw in base types and are replaceable.

3-20. FUEL SYSTEM (LESS TANK).

a. Inspect (see Figure 1-2.1). On ASK equipped generators, remove FUEL FILTERS access door.

(1) Fuel Filter Assemblies (see figure 3-13). Inspect iwo fuel filter assemblies (10) for dents or other

physical damage. Check for leaks especially around fuel line fittings (12), drains (1), and where bowl joins the head. Check that fuel filter assemblies are securely attached to mounting bracket (16) and that bracket is securely attached to bracket support on skid-bass.

(2) Fuel Strainer Assembly (see figure 3-13). Inspect strainer assembly (11) for dents or other physical damage. Check for leaks especially around fuel line fittings (12), drain (1), or where the bowl joins the head. Check that strainer assembly (11) is securely attached to mounting bracket (16).

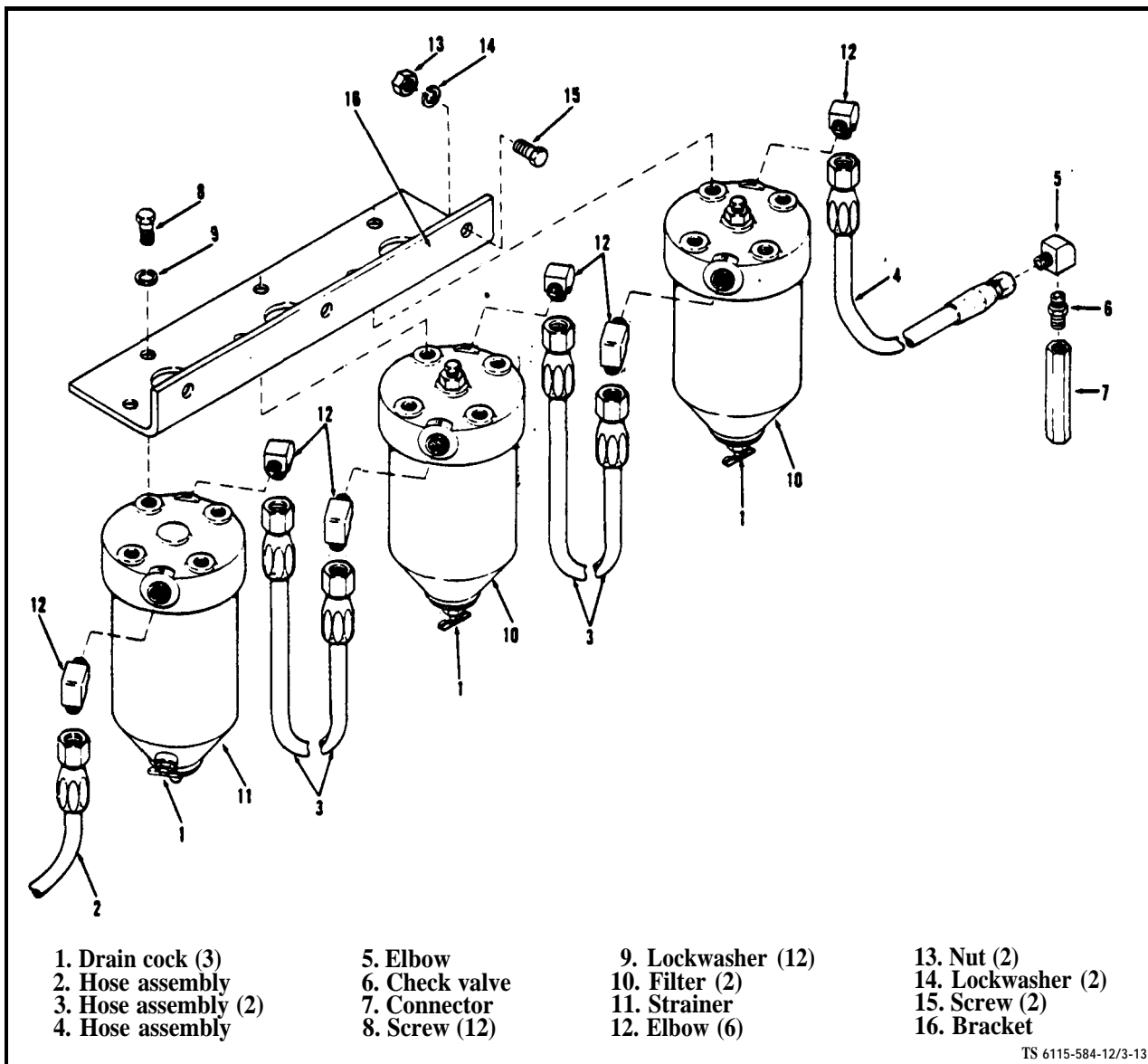

Figure 3-13. Fuel Filters and Fuel Strainer Assembly

(3) Fuel Pump Assemblies (Three) (see figure 3-14). Inspect fuel pumps (1) for dents or other physical damage. Check for leaks especially around hose assembly fittings (2). Check that fuel pumps are securely attached to mounting bracket (3) and that mounting bracket is securely attached to bracket support on skid-base. Inspect electrical leads to fuel pumps to see that wires and connectors are not broken, frayed, or damaged. Check that connectors are tightly connected. Check that cap (4) on auxiliary fuel pump inlet is securely in place when unit is not being run from auxiliary fuel supply,

(4) Fuel Hoses. Inspect fuel hoses (2, 3 and 4, figure 3-13) for leaks or physical damage. Check to see that fuel hose fittings are securely tightened in place.

b. Service. On ASK equipped generators, remove fuel filters access door.

(1) Fuel Filter Assemblies (see figure 3-13). Daily before operation, open drain valves (1) and drain water and sediment from filter assemblies.

(2) Fuel Strainer Assembly. Daily, before and after operation, open drain valves (1) and drain water and sediment from strainer assembly (11).

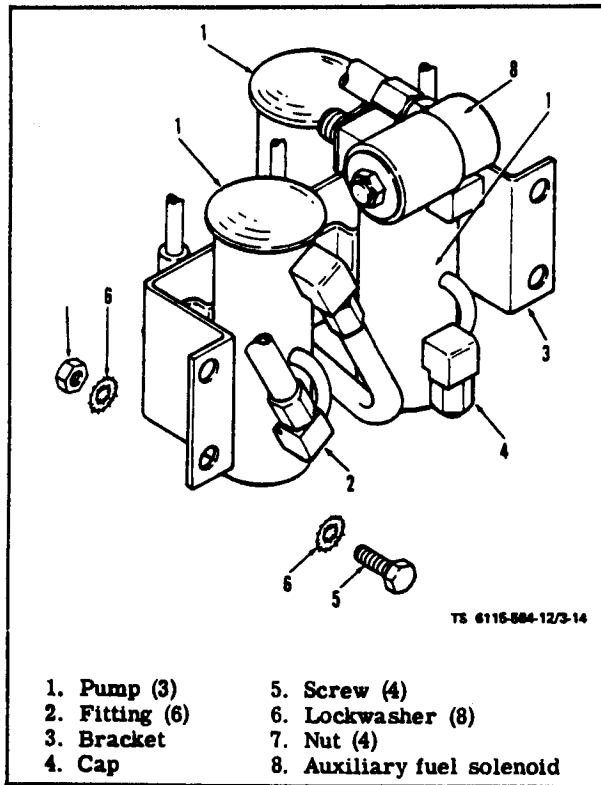

Figure 3-14. Fuel Pump Assembly

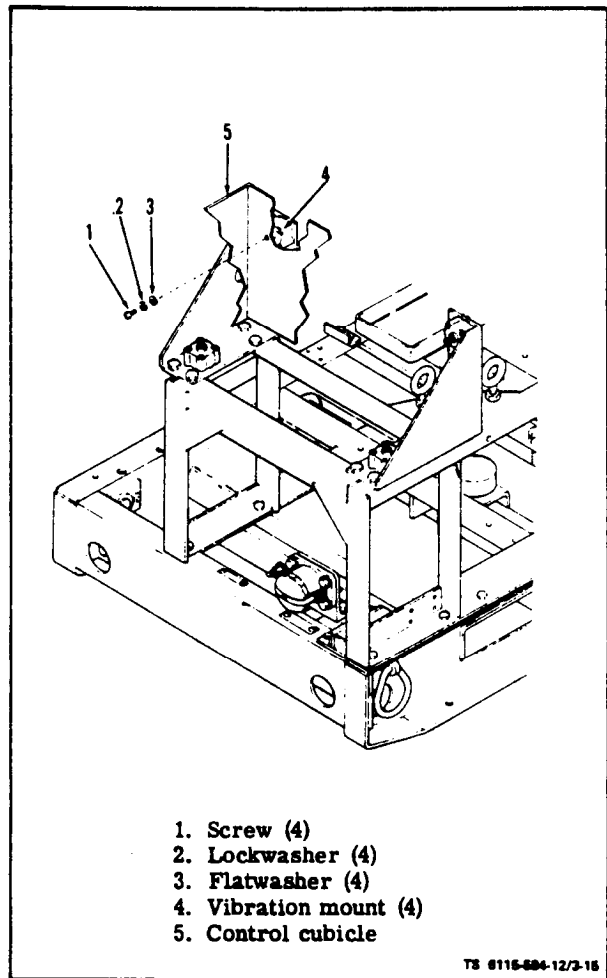

Figure 3-15. Control Cubicle Support Assembly

3-21. CONTROL CUBICLE SUPPORT ASSEMBLY, SPEED CONTROL AND ENGINE CONTROL WIRING HARNESS.

a. Inspect.

(1) Vibration Mounts (Four) (see figure 3-15). Inspect vibration mounts for deterioration or physical damage. Inspect mounts to see that they are free of dirt, fuel, or oil. Check to see that mounts are securely attached to control cubicle support on skid-base. If mounts are faulty, refer to higher level of maintenance.

(2) Engine Control Wiring Harness Assembly. On ASK equipped generator, open or remove all access doors. Inspect wiring harness for broken or frayed wires. Check for wires with damaged or deteriorated insulation. Check that all connectors and terminals are clean and tight.

(3) Speed Control Assembly (see figure 3-16). On ASK equipped generators lift motor speed control flap. Inspect to see that speed control is firmly attached to unit. Check that speed control moves in and out freely. If speed control is loose, refer to higher level maintenance.

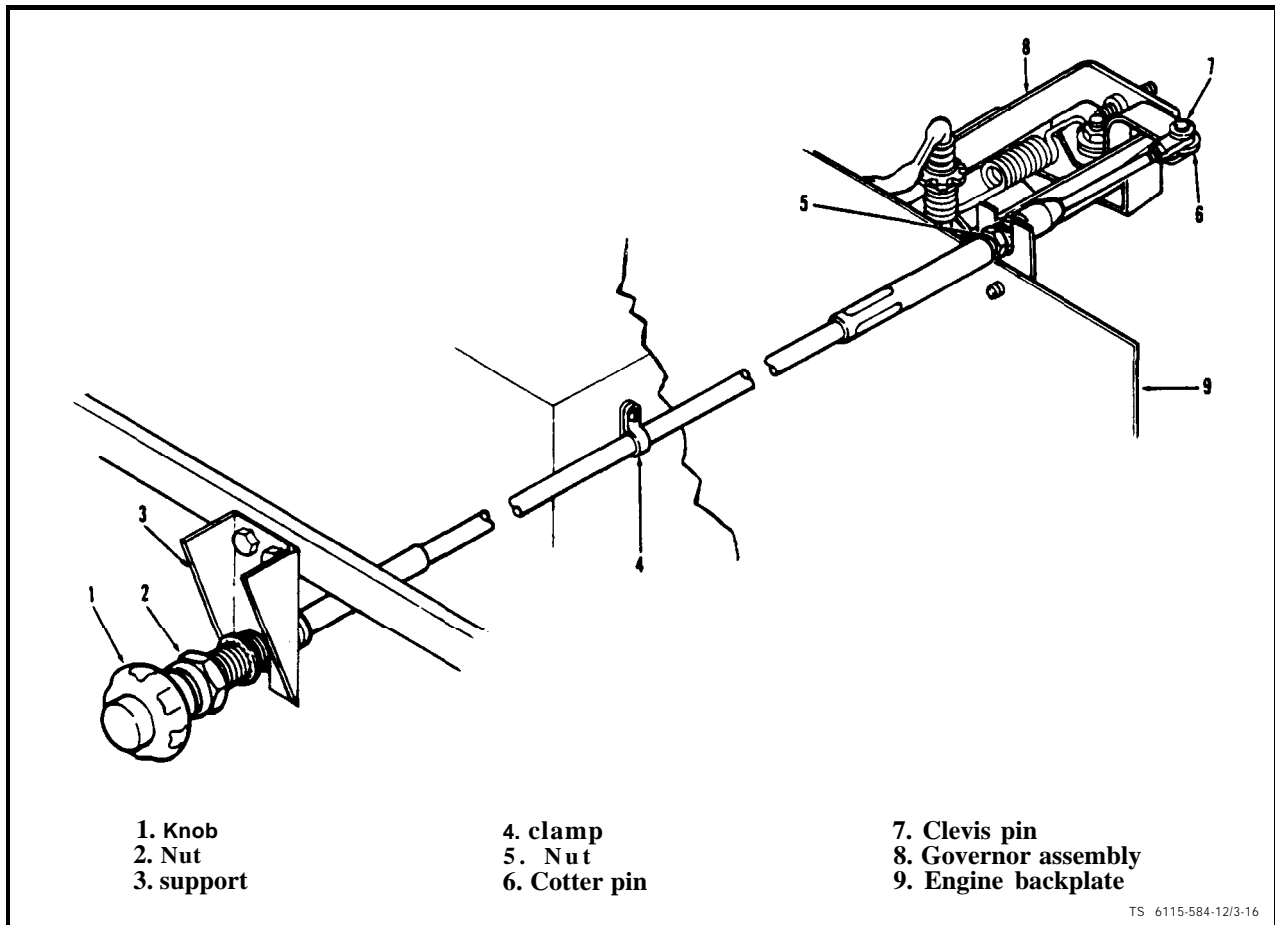

Figure 3-16. Speed Control Assembly

3-22. ENGINE COOLING SYSTEM.

a. Inspect (see figure 3-17). On ASK equipped generators, inspection is limited to parts of shroud assembly visible through access doors.

(1) **Shroud Assembly.** Inspect shroud assembly (11) and door panel (12) for dents or other physical damage. Inspect hinge attaching air housing panel (12) to see that it swings freely. Check to see that shroud assembly and door panel are properly secured to engine.

(2) **Blower Housing Assembly.** Inspect blower housing assembly (32) for dents or other physical

damage. Check that blower housing assembly is properly secured to engine. With engine running check for noise which would indicate blower wheel is rubbing against blower housing assembly or blower grille. (For units without ASK.)

(3) **Blower Housing Grille Assembly.** Inspect grille (29) for dents or other physical damage and that grille is properly secured to engine. (For units without ASK.)

TM 5-6115-584-12
NAVFAC P-8-622-12
TO-35C2-3-456-1
TM-05682C-12

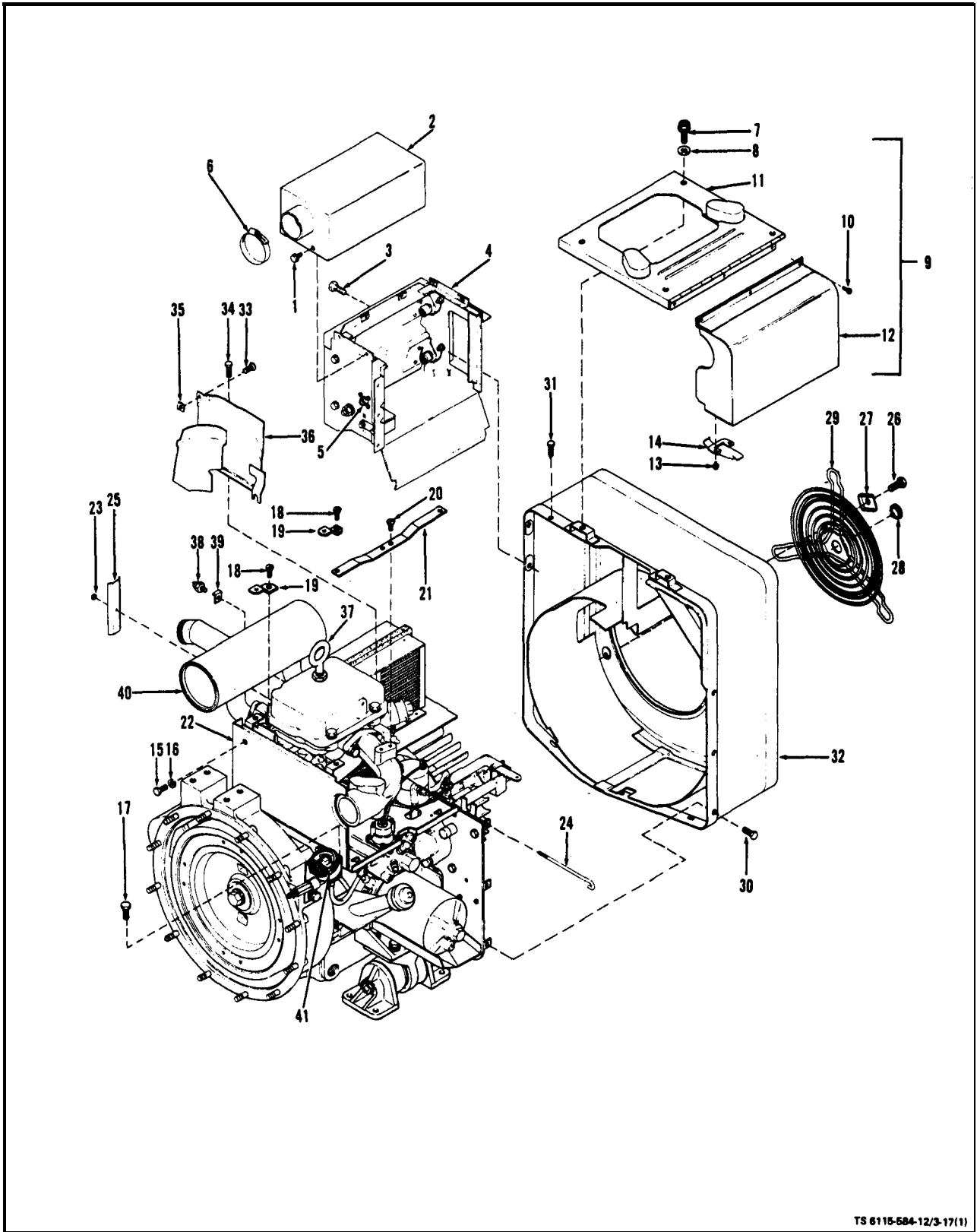

TS 6115-584-12/3-17(1)

Figure 3-17. Engine Cooling Assembly (Sheet 1 of 2)

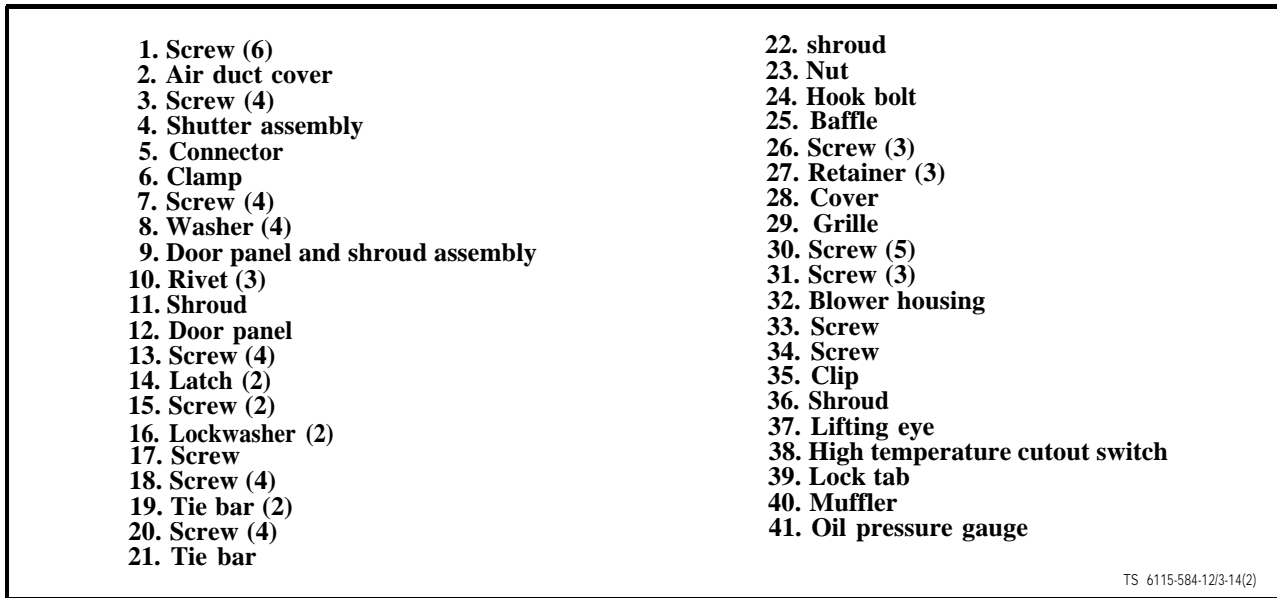
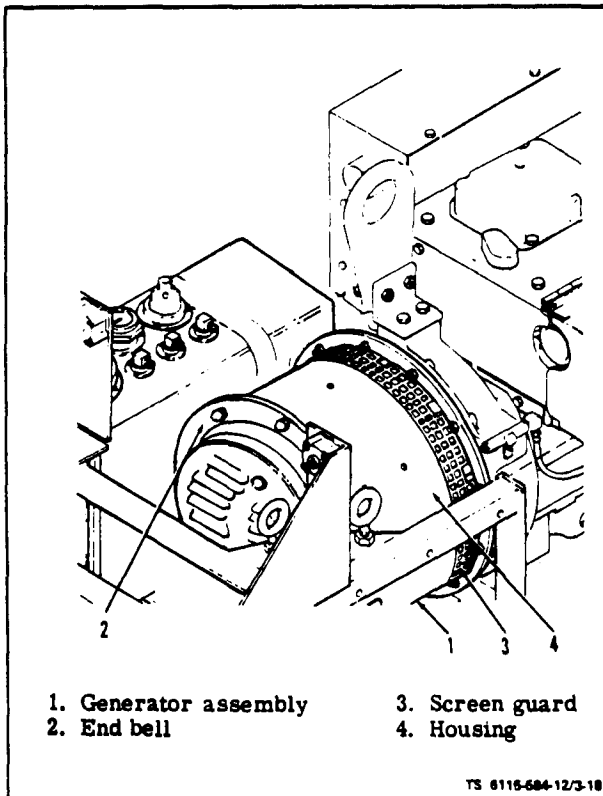

Figure 3-17. Engine Cooling Assembly (Sheet 2 of 2)

3-23. GENERATOR ASSEMBLY.

On ASK equipped generators, inspection is limited to screenguard areas visible through access doors. Inspect screenguard (3, figure 3-18) to see that is clean and free of

debris and free of dents or cracks. Check that screen-guard is securely fastened in place over opening in generator housing-stator assembly. Inspect end-bell (2) to see that it is clean and free of cracks or other physical damage. Check that openings in end-bell and end-bell cover are free of debris. Check that end-bell is securely attached to generator housing.



- | | |
|--|---|
| <ol style="list-style-type: none"> 1. Generator assembly 2. End bell | <ol style="list-style-type: none"> 3. Screen guard 4. Housing |
|--|---|

Figure 3-18. Generator Assembly

3-24. ENGINE ASSEMBLY.

a. Lifting attachment (see figure 3-17). On ASK equipped generators, open air intake door, Inspect for cracks or other physical damage. Check that lifting eye (37) is securely mounted.

b. Intake Manifold Assembly (see figure 3-19). On ASK equipped generators, if intake manifold is suspected of possible problems, refer to higher level of maintenance. Inspect intake manifold (1) for cracks or physical damage. Check that manifold is properly secured to cylinder head and mounting screws (5) and lock tabs (3) are in place.

c. Oil Drain Hose (see figure 3-20). On ASK equipped generators, remove oil access door and inspect oil drain hose for physical damage. Check that drain valve operates properly and does not leak when closed. Check that oil drain hose is properly stored when not in use.

d. Engine Mounting Assemblies (see figure 3-19). On ASK equipped generators, remove oil access door and batteries access door. Inspect engine mounts (13) for deterioration or physical damage. Check for accumulations of dirt, fuel, or oil. Check that mounts are securely attached to engine and to skid-base with all mounting hardware in place.

TM 5-6115-584-12
NAVFAC P-8-622-12
TO-35C2-3-456-1
TM-05682C-12

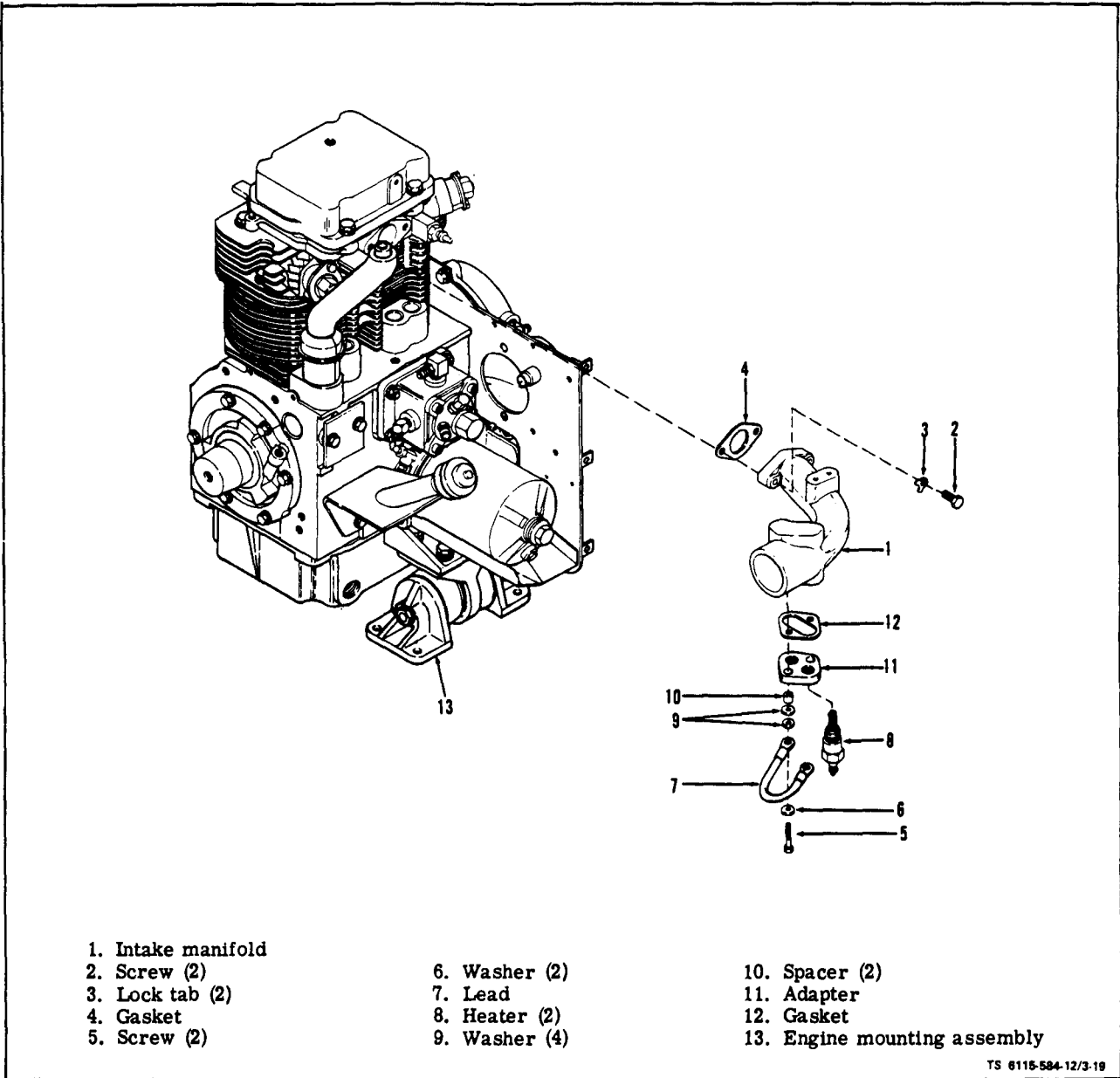

Figure 3-19. Intake Manifold Assembly

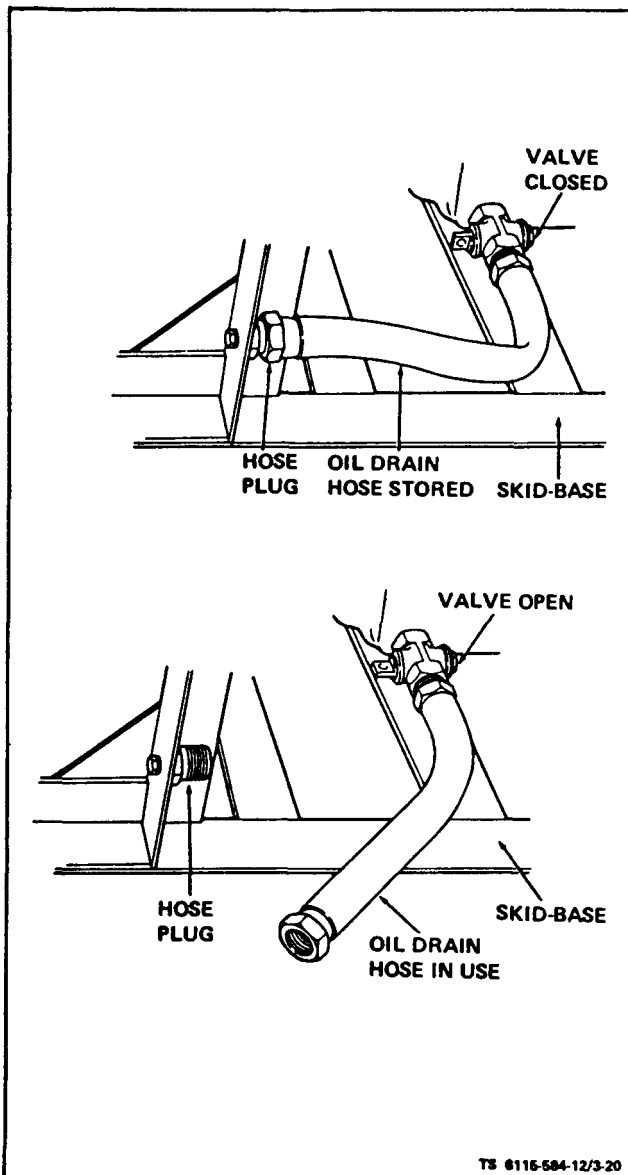

Figure 3-20. Oil Drain Hose

e. Oil Filter Assembly (see figure 1-1). Inspect oil filter assembly for dents or other physical damage. Check for leaks especially at gasket (1, figure 3-21) between body (3) and adapter (5) and between bolt (2) and body (3). Check to see that drain plug (4) is securely in place and does not leak.

f. Oil Pressure Switch (see figure 3-21). Inspect oil pressure switch (6) for dents or other physical damage. Check that switch is securely mounted to oil filter adapter (5). Check for leaks where switch (6) attaches to adapter(5). Check that both electrical connections (7) to switch (6) are tight and free of corrosion.

g. Oil Pressure Gauge Assembly (see 41, figure 3-17). Inspect glass lens to see that it is not cracked.

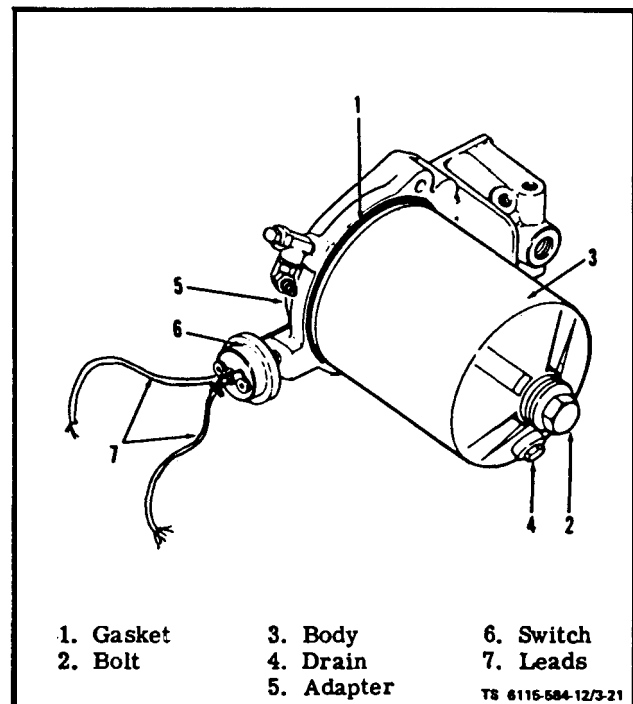

Figure 3-21. Oil filter and Oil Pressure Switch

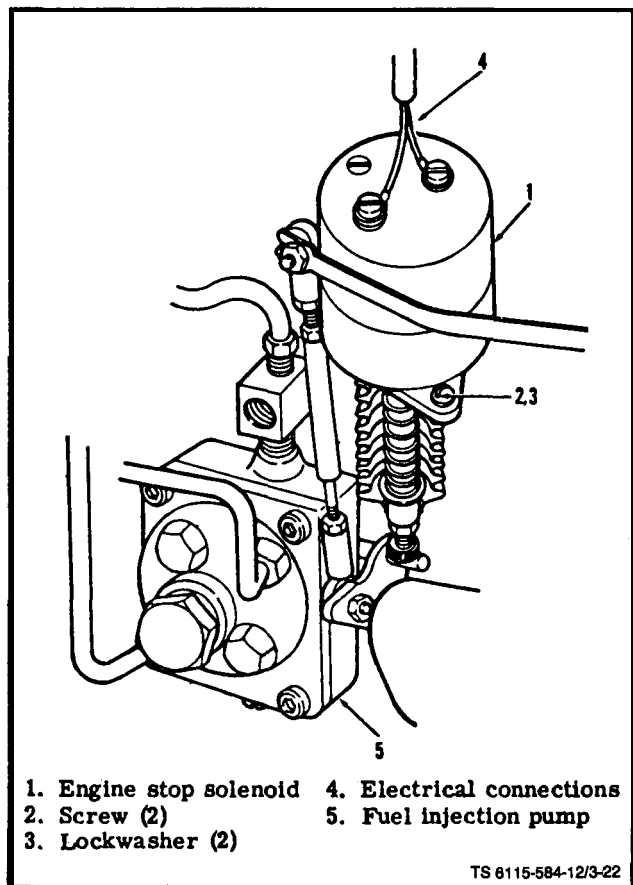

Figure 3-22. Engine Stop Solenoid

TM 5-6115-584-12
NAVFAC P-8-622-12
TO-35C2-3-456-1
TM-05682C-12

Inspect to see that there is no dirt or oil underneath lens indicating that gauge is no longer properly sealed. Check to see that pointer is not bent or damaged. Check that markings on gauge are readable. Check to see that meter is fastened securely to engine.

h. Flexible Oil Lines (see figure 1-1). Inspect flexible oil lines to the oil pressure gauge and the oil cooler for physical damage. Check for leaks especially around fittings.

i. Engine Stop Solenoid (see figure 3-22). Inspect stop solenoid (1) for dents or other physical damage. Check that solenoid is securely attached to cylinder shroud bottom pan with two screws (2) and lockwashers (3). Check that electrical connections (4) to solenoid are clean and tight.

j. Oil Dip-Stick and Housing (see figure 1-1). Inspect oil dip-stick and housing (9) for physical damage. Check for leaks especially at gasket between

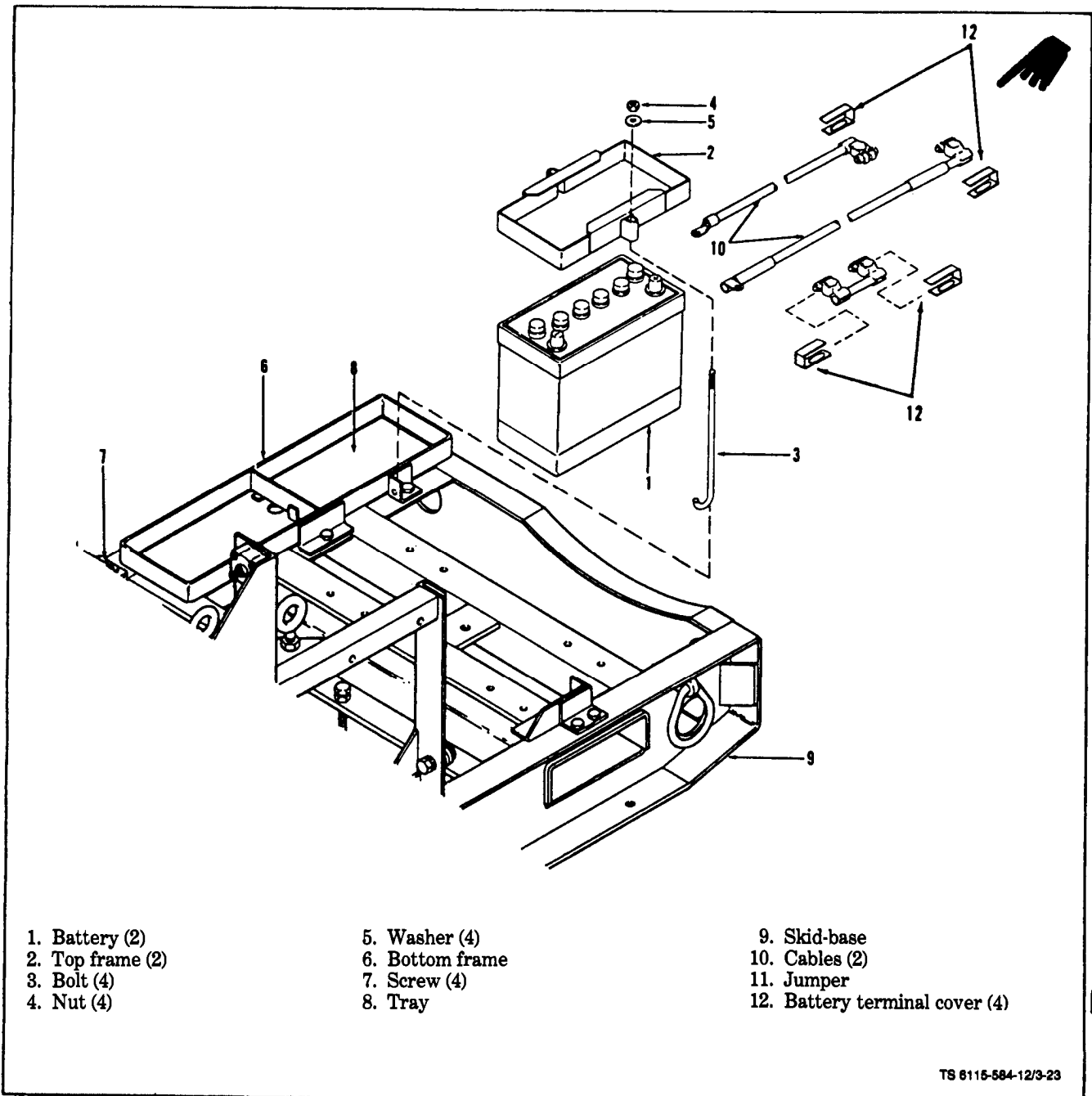

Figure 3-23. Battery and Frame

housing and engine block. Check that dip-stick fits securely into housing with no leaks.

3-25. SKID-BASE ASSEMBLY.

WARNING

Battery electrolyte can cause severe burns to the skin. Always flush exposed parts of the skin with water as quickly as possible.

a. Inspect (see figure 3-23).

(1) Battery Frame Bottom. On ASK equipped generators, remove BATTERIES access door. Inspect battery frame bottom (6) for dents, cracks, corrosion, or other physical damage. Check to see that battery frame bottom is free of corrosion.

(2) Battery Frame Top. Inspect battery frame top (2) for dents, cracks, corrosion, or other physical damage. Check to see that battery tray (8) is free of corrosion. Check that battery tray is securely attached to skid-base (9) with screw (7). Check that battery frame top (2) is securely attached to battery frame bottom (6) with hook bolts (3), nuts (4) washer (5).

(3) Inspecting Ground Stud (see figure 3-24). On ASK equipped generators, lift rear panel flap and inspect ground stud for deformed threads, corrosion, or other physical damage. Check that ground stud is securely attached to skid-base. Check that connections to stud are clean and tight.

(4) Inspect ground wire and ground rod for physical damage and check that connections are tight.

b. Cleaning. Remove corrosion with a suitable neutralizing agent. Wipe dry with a clean cloth.

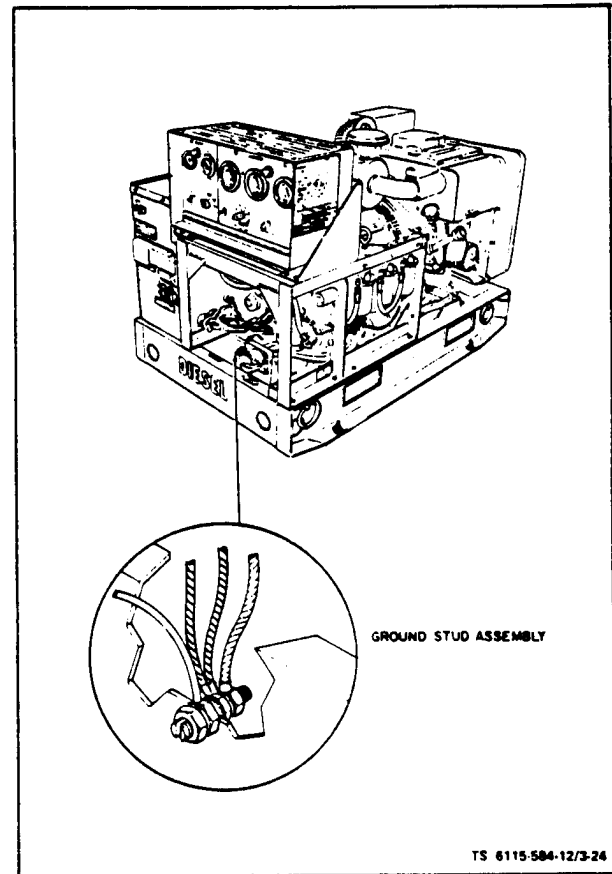

Figure 3-24. Ground Stud

CHAPTER 4

ORGANIZATIONAL MAINTENANCE

Section I. SERVICE UPON RECEIPT OF MATERIAL

4-1. INSPECTING AND SERVICING GENERATOR SET.

a. Unloading Equipment.

(1) The dry weight of the engine Generator Set is 960 pounds. A crane, fork lift, or similar lifting device or fabricated skids must be used to unload the equipment. The equipment must be kept in the UP position while unloading.

WARNING

Do not use a lifting device with a capacity of less than 1500 pounds. Do not allow the crated Generator Set to swing while it is suspended. Failure to observe this warning may result in serious injury or death to personnel.

b. Unpacking.

(1) Before unpacking, move the engine Generator Set as near as possible to the location where it will be operated.

CAUTION

Exercise care in the use of bars, hammers, and similar tools while uncrating the unit to avoid damaging the equipment.

(2) Remove the top and then the sides of the crate (figure 4-1).

(3) Remove barrier bag, dessicant bags, and shipping material from engine Generator Set.

(4) Disconnect engine Generator Set from crate skid by removing carriage bolts, nuts, washers, and lift engine Generator Set off skid.

c. Service and Inspection.

(1) Prepare the engine Generator Set for inspection and servicing as outlined in the following paragraphs. For Army users, refer to D Form 2258.

(2) Make a thorough visual inspection of the entire Generator Set for loose or missing hardware or damaged or missing parts. Report all damaged or missing parts on DD Form 6.

(3) Inspect all air cleaner connections for tightness and damage.

(3.1) On ASK equipped generators, inspect ASK for damage. Check that exhaust plenum is clear of debris.

(4) Check engine intake and exhaust systems (figure 1-2) to make certain they are unobstructed by foreign material.

(5) Check that main fuel tank drain cock (figure 1-2) is closed.

(6) Remove all preservative material except for preservatives crankcase oil.

WARNING

Do not smoke or use an open flame in the vicinity when filling fuel tank.

Hot refueling of generators while they are operating poses a safety hazard and should not be attempted. Hot engine surfaces and sparks produced from the engine and generator circuitry are possible sources of ignition. Severe injury or death to personnel and damage to the equipment may result.

NOTE

On generators equipped with acoustic suppression kit (ASK), route auxiliary fuel line under rear flap on skid to auxiliary fuel pump.

(7) Fill fuel tank with appropriate fuel and set MASTER SWITCH (figure 2-3) to RUN position to connect main fuel tank to electrical fuel pumps. If an auxiliary source of fuel is to be used in operating the engine Generator Set, connect fuel hose to AUXILIARY FUEL CONNECTION and set MASTER SWITCH to RUN AUX FUEL position.

(8) Batteries are shipped in a dry state. If batteries are hermetically sealed, destroy sealing device inside each cell by tapping with a blunt instrument. Remove all sealing particles. Battery electrolyte must be requisitioned separately. To activate the battery, remove all caps and fill battery cells with electrolyte. Electrolyte level should be 3/8 inch above top of plates for each cell. Make sure vent holes in caps are open, and replace caps. Connect batteries as shown in figure 4-16.

NOTE

The electrolyte level must be rechecked approximately 30 minutes after initial filling as the plates and separators will absorb the solution, thus resulting in a low level. If the battery is not to be used within 12 hours after initial filling, it should be put on a charger and brought up, to the correct specific gravity. Test batteries as described in paragraph 4-25c, for the ambient temperature in effect.

WARNING

Do not smoke or use an open flame in the vicinity when servicing batteries. Batteries generate hydrogen, a highly explosive gas. Electrolyte contains sulphuric acid and can cause severe burns. Handle it with care. If the solution comes in contact with the body, eyes or clothing, rinse immediately with clean water. Avoid spilling electrolyte on ainted surfaces.

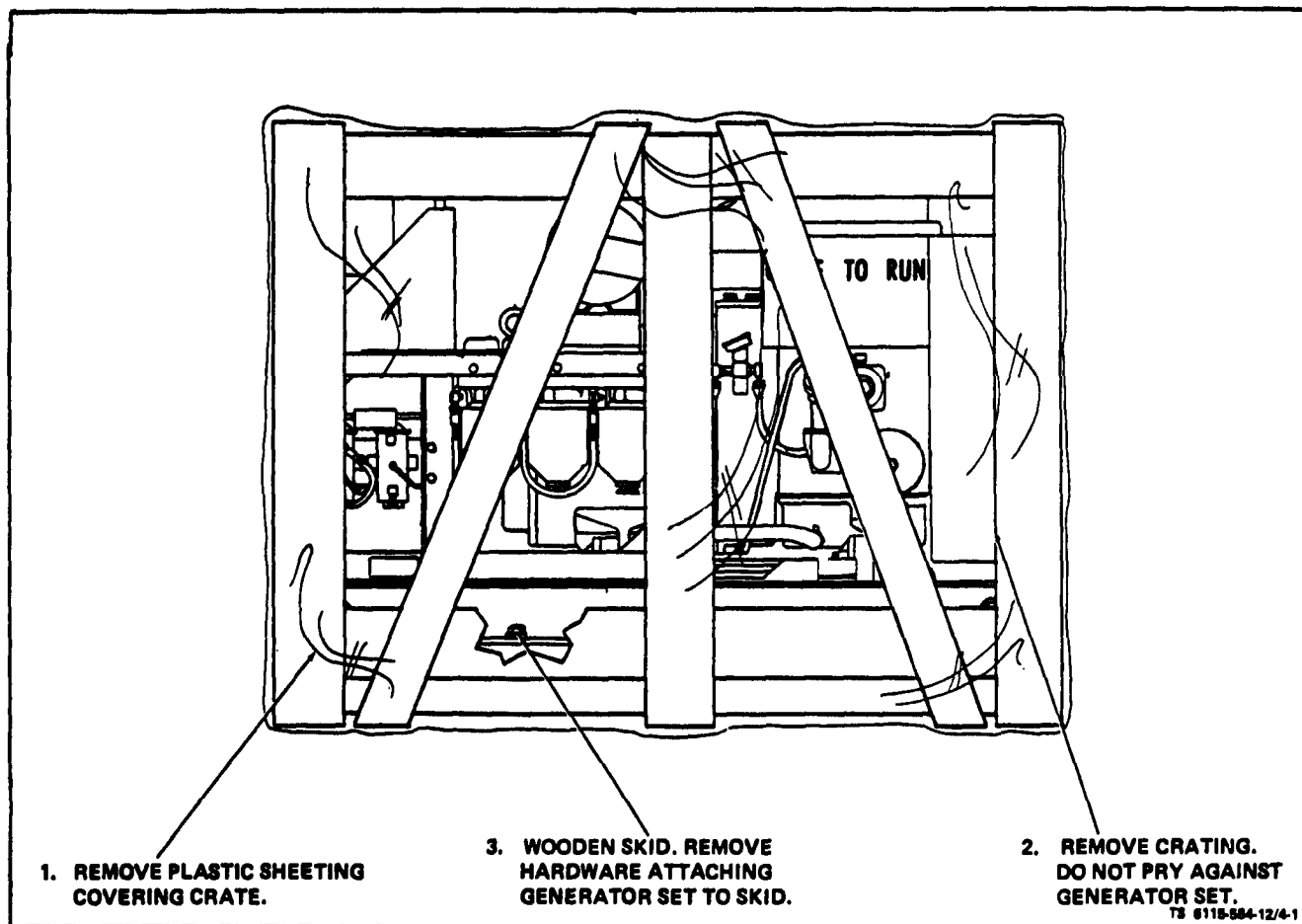

Figure 4-1. Uncrating Generator Set

(9) Check crankcase oil level (paragraph 3-2) and add oil as necessary (paragraph 3-3) in accordance with the lubrication order (figure 3-1).

4-2. INSTALLING GENERATOR SET

a. General. The engine Generator Set should be installed on a site clear of obstacles, with ample ventilation and level within ± 15 degrees maximum.

b. Outdoor Installation. When preparing for a permanent installation, be sure the base is solid enough to support the weight of the unit. See figure 1-4 for dimensions of the base. Select a location where there will be sufficient space on all sides for servicing and operation of the engine Generator Set. When preparing a temporary installation, move the engine Generator Set as close to the worksite as practical. Use suitable planks, logs, or other material for a base in an area where the ground is soft.

c. Indoor Installation. Keep the area well ventilated at all times, so that the engine Generator Set will receive a maximum supply of air. If a free supply of fresh air is not available, provide duct work which will assure at least 1350 cubic feet of air per minute.

If louvers are used at the air entrance, increase the duct work size by 25 to 50 percent. Install a gas-tight metal pipe exhaust from the exhaust outlets to the outside of the installation. The termination of the exhaust pipe shall be such that hot gases or sparks will be discharged harmlessly and will not be directed against combustible material or into an area containing flammable gases or vapors. Use as few bends in the pipe and as short a pipe as possible. The exhaust pipe should include a low point with suitable means for draining of condensate. Provide metal shields, 12 inches larger in diameter than the exhaust pipe where the line passes through flammable walls. Line the exhaust pipe with fiberglass if there is any danger of anyone touching it.

WARNING

Do not operate the engine Generator Set in an enclosed area unless the exhaust gases are piped to the outside. Inhalation of exhaust fumes will result in serious illness or death.

d. Leveling. The Generator Set is a portable unit and is designed to operate satisfactorily up to 15°

out-of-level. Set up the unit as level as possible and keep it as level as possible during operation.

e. Grounding. The Generator Set must be grounded prior to operation. The ground can be, in order of preference: (1) an underground metallic water piping system, (2) a driven metal rod, or (3) a buried metal plate (figure 4-2). If the effectively grounded portion of the buried metallic water pipe is less than 10 feet due to insulated sections or joints, this preferred

grounding method must be supplemented by an additional driven metal rod ground or a buried metal plate ground. A driven metal ground rod must have a minimum diameter of 5/8 inch if solid or 3/4 if pipe, and driven to a minimum depth of 8 feet. A buried metal ground plate must have a minimum area of 9 square feet, minimum thickness of 1/4 inch, and be buried at a minimum depth of 4 feet. The ground lead must be at least No. 6 AWG (American Wire Gauge) copper wire. Ground rods are available as optional equipment.

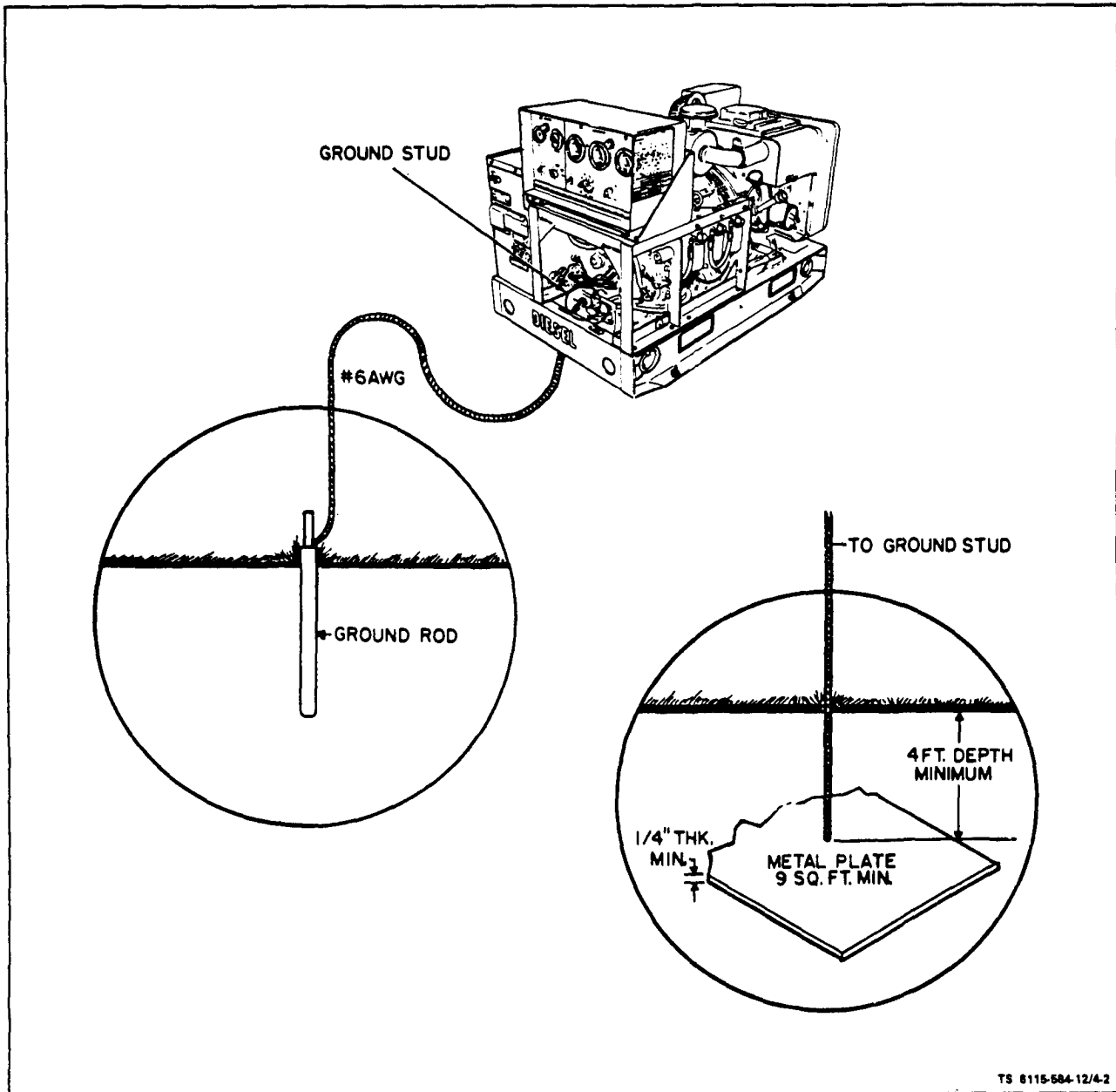

Figure 4-2. Grounding Generator Set

Section II. MOVEMENT TO A NEW WORKSITE

4.3 DISMANTLING GENERATOR SET FOR MOVEMENT.

a. Preparation for Movement.

- (1) Disconnect the load cables.
- (2) Remove exhaust pipe extension if used.
- (3) Make certain vent on underside of fuel filler cap is closed.
- (4) Refer to the Items Troop Installed or Authorized List (Appendix B and make sure all items are on the equipment.
- (5) Disconnect the ground lead from the ground stud.

(6) On ASK equipped generators, remove batteries access door. Disconnect negative battery cable from battery.

(7) Disconnect any other hoses, lines or cables, if used.

(8) Close and secure all doors and panels.

b. Movement. Preferred means of movement is to transport. Towing for short distance is permissible if terrain is suitable.

4-4. REINSTALLING GENERATOR SET AFTER MOVEMENT.

Refer to paragraph 4-2 for installation after movement to a new worksite.

Section III. REPAIR PARTS; SPECIAL TOOLS; SPECIAL TEST, MEASUREMENT AND DIAGNOSTIC EQUIPMENT AND SPECIAL SUPPORT EQUIPMENT

4-5. SPECIAL TOOLS AND EQUIPMENT.

Special tools are listed in Appendix D, Section III.

4-6. MAINTENANCE REPAIR PARTS.

Repair parts and equipment are listed and illustrated in the repair parts and special tools list manual covering organizational maintenance for this Generator Set.

Section IV. LUBRICATION INSTRUCTIONS

4-7. LUBRICATION.

a. Lubrication Order. Lubrication instructions for the Generator Set are contained in L05-6115-564-12.

(F) Air Force lubrication instructions appear in the applicable work card set in the TO 35C2-3-1-428 series.

NOTE

Insure that crankcase is hot before draining oil.

(b) **Oil Change (see figure 3-20). On ASK equipped generators, remove oil access door.**

(1) With drain valve closed, disconnect oil drain hose from the plug on the skid-base.

(2) Open drain valve and drain oil into a container having at least a 7 quart capacity.

(3) Close drain valve.

(4) Connect oil drain hose to plug on skid-base.

(5) Open drain plug (1, figure 4-30) and drain oil filter oil into a container having at least a 1 quart capacity.

(6) Remove through bolt (2) and Pull oil filter body (3) loose from oil filter adapter (5).

(7) Discard gasket (4) and oil filter element (6).

(8) Wipe inside of oil filter body (3) clean with a rag.

(9) Wipe inside of adapter (6) clean with a rag. Insure the gasket groove is free of foreign material. Inspect gaskets (7) and (10) to be sure they are not torn or frayed. Check that retainer (8), and spring (9) are not deformed. Replace damaged components.

(10) Apply a thin coat of clean engine oil, MIL-L-2104 to a new gasket (4). Install new gasket (4) in groove of adapter (5).

(11) Assemble components on through belt (2) in the order shown in figure 4-30. Position body (3) with drain plug (1) down on adapter (5). Tighten through bolt (2) to 13±2 ft-lb.

(12) Pour 4 quarts of engine oil (see lubrication order for proper grade of oil) into oil fill tube (9, figure 1-1).

(13) Check oil level with dip-stick.

(14) After 5 minutes of engine operation, check crankcase oil level and bring oil level to full mark.

Section V. PREVENTIVE MAINTENANCE CHECKS AND SERVICES (PMCS)

4-8. PMCS, GENERAL.

To ensure that the Generator Set is ready for operation at all times, it must be inspected systematically so defects may be discovered and corrected before they result in serious damage, failure or safety hazard. The necessary preventive maintenance checks and services that are to be performed by Organizational personnel are listed and described in the following paragraphs. Defects discovered during operation will be noted for future correction. Stop operation immediately if a deficiency is noted which would damage the equipment or present a safety hazard. All faults will be recorded together with the corrective actions taken on the applicable form. Air Force users shall refer to the applicable inspection manuals and work card sets in the TO 35C2-3-1-426 series for periodic requirements. Marine Corps users should refer to current issue of TM 4700-15/1. On ASK equipped generators, full or partial removal of ASK may be necessary to perform PMCS.

4-9. Determining PMCS Intervals. Organizational PMCS on this unit should be performed on a - per hours of operation - basis. The running time meter on the control panel should be used to determine the Generator Set operating time.

4-10. PMCS for Units in Continuous Operation. For PMCS performed on an operating time basis, perform PMCS as close as possible to the time intervals indicated. For units in continuous operation, perform PMCS before starting operation if continuous operation will extend service interval past that which is shown.

4-11. (A, N, MC) Preventive Maintenance Checks and Services. Table 4-1 contains a tabulated listing of PMCS which shall be performed by Organizational personnel. The item numbers are listed consecutively and indicate the sequence of minimum requirements.

Table 4-1. ORGANIZATIONAL PREVENTIVE MAINTENANCE CHECKS AND SERVICES

ITEM NO.	INTERVAL			ITEM TO BE INSPECTED	PROCEDURES Check for and have repaired or adjusted as necessary	EQUIPMENT IS Not Ready/ Available if:
	W	M	H			
1		●		Generator Set	Inspect the generator set for loose or missing components and hardware, and unusual wear or deterioration. Clean generator set.	
2				Fuel Strainer and Filter Drains	Note Fuel system must be above freezing temperatures when draining water and sediment from the strainer, filters, and tank.	

TABLE 4-1. ORGANIZATIONAL PREVENTIVE MAINTENANCE CHECKS AND SERVICES--continued

ITEM NO.	INTERVAL			ITEM TO BE INSPECTED	PROCEDURES Check for and have repaired or adjusted as necessary	EQUIPMENT IS Not Ready/ Available if:
	W	M	H			
	●				Open drains on fuel strainer, and primary and secondary filters. Drain water and sediment (para 3-20). Allow to drain until fuel runs clean.	
3		●		Fuel Tank	Open drain on fuel tank and drain water and sediment (para 3-13). Allow to drain until fuel runs clean.	
4			100	Lubricating Oil and Filter	Change lubricating oil and filter every 100 hours of operation (L.O., fig. 3-1).	
5			300	Fuel Strainer	Clean fuel strainer every 300 hours of operation (para 4-20).	
6			500	Primary Fuel Filter	Service primary filter every 500 hours of operation (para 4-20).	
7			1000	Secondary Fuel Filter	Service secondary filter every 1000 hours (para 4-20).	
8			300	Batteries	Perform a hydrometer test on batteries every 300 hours, or quarterly. Refer to para 4-25c for test procedures.	
9			500	Crankcase Breather	Inspect breather tube every 500 hours, clean as necessary (para 4-45).	
10			100	Dust caps on air cleaner	Clean out dust caps on air cleaner assembly (every 100 operating hours or more frequently under unusual conditions.)	
11			1000	Air cleaner	Clean every 1000 operating hours or as conditions dictate. Replace air cleaner every 2000 operating hours.	

TABLE 4-1. ORGANIZATIONAL PREVENTIVE MAINTENANCE CHECKS AND SERVICES--continued

ITEM NO.	INTERVAL			ITEM TO BE INSPECTED	PROCEDURES Check for and have repaired or adjusted as necessary	EQUIPMENT IS Not Ready/ Available if:
	W	M	H			
12			500	Bonding Strap (Engine to skid base)	Remove bolts from both ends of bonding strap (see item 1, Fig 4-3) and inspect for corrosion on the bonding strap or mating surfaces of the engine and skid base. Clean surfaces and replace strap.	
13			500	Rocker Arm Covers	Service rocker arm covers every 500 operating hours (para 4-44).	
14			500	Valve Rocker Arms	Adjust the rocker arm to proper valve clearance every 500 operating hours (para 4-46).	

Section VI. TROUBLESHOOTING

4-12. TROUBLESHOOTING, GENERAL.

This section contains troubleshooting information for locating and correcting operating troubles which may develop in the Generator Set. Each malfunction for an individual component, unit or system is followed by a list of tests or inspections which will help you to determine probable causes and corrective actions to take. You should perform the tests/inspections and corrective actions in the order listed.

4-13. MALFUNCTIONS NOT CORRECTED BY USE OF THE TROUBLESHOOTING TABLE.

This manual cannot list all malfunctions that may occur, nor all tests or inspections and corrective actions. If a malfunction is not listed or cannot be corrected by listed corrective actions, notify your supervisor.

Table 4.2. Troubleshooting

MALFUNCTION	TEST OR INSPECTION	CORRECTIVE ACTION
1. ENGINE FAILS TO CRANK WHEN MASTER SWITCH IS HELD IN THE START POSITION.		
	Step 1. Test batteries (paragraph 4-25).	Replace defective batteries. Check battery alternator fuse and replace if necessary.
	Step 2. Inspect battery and starter cables for corrosion and loose connections.	Clean or tighten cables.
	Step 3. Test "START" position of master switch (paragraph 4-38).	Replace defective master switch.
	Step 4. Inspect and test for open starter solenoid switch or for short to ground (paragraph 4-26).	Replace defective solenoid.
	Step 5. Inspect and test starter lockout switch (paragraph 4-28).	Adjust switch points if they are not closing or replace defective switch.
2. STARTER TURNS BUT WILL NOT ENGAGE ENGINE.		
	Step 1. Inspect starter drive assembly (paragraph 4-26).	Clean drive assembly if it is sticking.
	Step 2. Inspect starter drive gear assembly for worn or broken teeth (paragraph 4-26).	Replace starter.
9. ENGINE CRANKS NORMALLY BUT FAILS TO START.		
	Step 1. Test stop solenoid for correct operation (Paragraph 4-23).	Replace bad solenoid.
	Step 2. Inspect fuel pumps for clogged strainers (paragraph 4-21).	Replace strainer element.
	Step 3. Inspect for clogged fuel strainer element or fuel filter elements (paragraph 4-20).	Clean strainer element; replace fuel filter elements.
	Step 4. Check for clogged fuel lines to injector pump.	Clean or replace clogged fuel lines.
	Step 5. Test for worn or damaged fuel pumps (paragraph 4-21).	Replace bad pumps.
	Step 6. Inspect and test intake manifold heaters (paragraph 4-43).	Replace bad heaters.

Table 4-2. Troubleshooting (Cont)

MALFUNCTION	TEST OR INSPECTION	CORRECTIVE ACTION
3. ENGINE CRANKS NORMALLY BUT FAILS TO START (Cont).		
	Step 7. Inspect and test glow plug assemblies (paragraph 4-48).	Replace bad glow plugs.
4. ENGINE STARTS BUT DOES NOT RUN SMOOTHLY (MISFIRES, KNOCKS, OR MAKES UNUSUAL NOISES).		
	Step 1. Check steps 1, 2, 3, 4 and 5 under ENGINE CRANKS NORMALLY BUT FAILS TO START above.	Perform corrective action as necessary.
	Step 2. Check valve to rocker arm clearance (paragraph 4-46).	Adjust clearance if necessary.
5. LOW ENGINE POWER ESPECIALLY UNDER HEAVY LOAD.		
	Step 1. Check steps 1, 2, 3, 4 and 5 under ENGINE CRANKS NORMALLY BUT FAILS TO START above.	Perform corrective actions as necessary.
	Step 2. Check air cleaner assembly for obstructions (paragraph 4-41).	Remove obstructions.
6. ENGINE HAS EXCESSIVE OIL CONSUMPTION.		
	Step 1. Check air cleaner element.	Clean or replace element if necessary.
	Step 2. Check breather pipe (paragraph 4-45).	Clean or replace breather pipe.
7. LOW OIL PRESSURE.		
	Step 1. Check oil level (paragraph 4-51).	Add oil if required,
	Step 2. Check oil pressure gauge (paragraph 4-33).	Replace a bad gauge.
8. HIGH OIL PRESSURE.		
	Step 1. Check oil.	Add proper grade of oil.
	Step 2. Check oil pressure gauge (paragraph 4-33).	Replace gauge if necessary.

Table 4-2. Troubleshooting (Cont)

MALFUNCTION	TEST OR INSPECTION	CORRECTIVE ACTION
9. ENGINE SHUTS DOWN.		
	Step 1. Check oil level (paragraph 4-51).	Add proper grade of oil.
	Step 2. Check for restricted air cooling system (paragraph 4-41).	Clean restrictions from system.
	Step 3. Check for overload on generator.	Keep generator load within set capability.
	Step 4. Check low oil pressure switch (paragraph 4-31).	Replace a bad switch.
	Step 5. Check thermo over heat switch (paragraph 4-17c).	Replace a bad switch.
10. ENGINE VIBRATES.		
	Step 1. Engine mounts loose or bad (paragraph 4-52).	Tighten mounting or replace as necessary.
	Step 2. Check for loose blower wheel.	Tighten blower wheel.
	Step 3. Check valve clearance (paragraph 4-46).	Reset valve clearance.
11. LOW GENERATOR OUTPUT VOLTAGE (NO LOAD).		
	Step 1. Low engine speed.	Set engine speed to achieve 60 Hz at frequency meter (paragraph 2-4).
	Step 2. Check voltage adjust rheostat (R1) setting (paragraph 4-38).	Set rheostat (R1) for proper output voltage.
12. HIGH GENERATOR OUTPUT VOLTAGE (NO LOAD).		
	Step 1. Check voltage adjust rheostat (R1) setting (paragraph 4-38).	Set rheostat (R1) for proper output voltage.
13. AC CIRCUIT BREAKER (CB1) WILL NOT CLOSE.		
	Step 1. Check for short circuit load.	Remove short circuit.

Table 4-2. Troubleshooting (Cont)

MALFUNCTION
TEST OR INSPECTION
CORRECTIVE ACTION
<p>14. BATTERIES DO NOT RETAIN CHARGE.</p> <p style="padding-left: 40px;">Step 1. Check for blown alternator protection fuse (F1) (paragraph 4-27).</p> <p style="padding-left: 80px;">Replace fuse.</p> <p style="padding-left: 40px;">Step 2. Check for bad battery or batteries (paragraph 4-25).</p> <p style="padding-left: 80px;">Replace defective battery.</p>

Section VII. RADIO INTERFERENCE SUPPRESSION

4-14. GENERAL METHODS FOR PROPER SUPPRESSION.

Essentially, suppression is attained by providing a low resistance path to ground for stray currents. The methods used include shielding the ignition and high-frequency wires, grounding the frame with bonding straps, and using filtering systems.

4-15. RADIO INTERFERENCE SUPPRESSION COMPONENTS.

a. Primary Suppression Components. The primary suppression components are those whose primary

function it is to suppress radio interference. The primary suppression components are shown in figure 4-3.

b. Secondary Suppression Components. These components have radio interference suppression functions which are incidental or secondary to their primary function. They are the internal-external tooth lock-washers on the fuel pumps and battery charging regulator-rectifier.

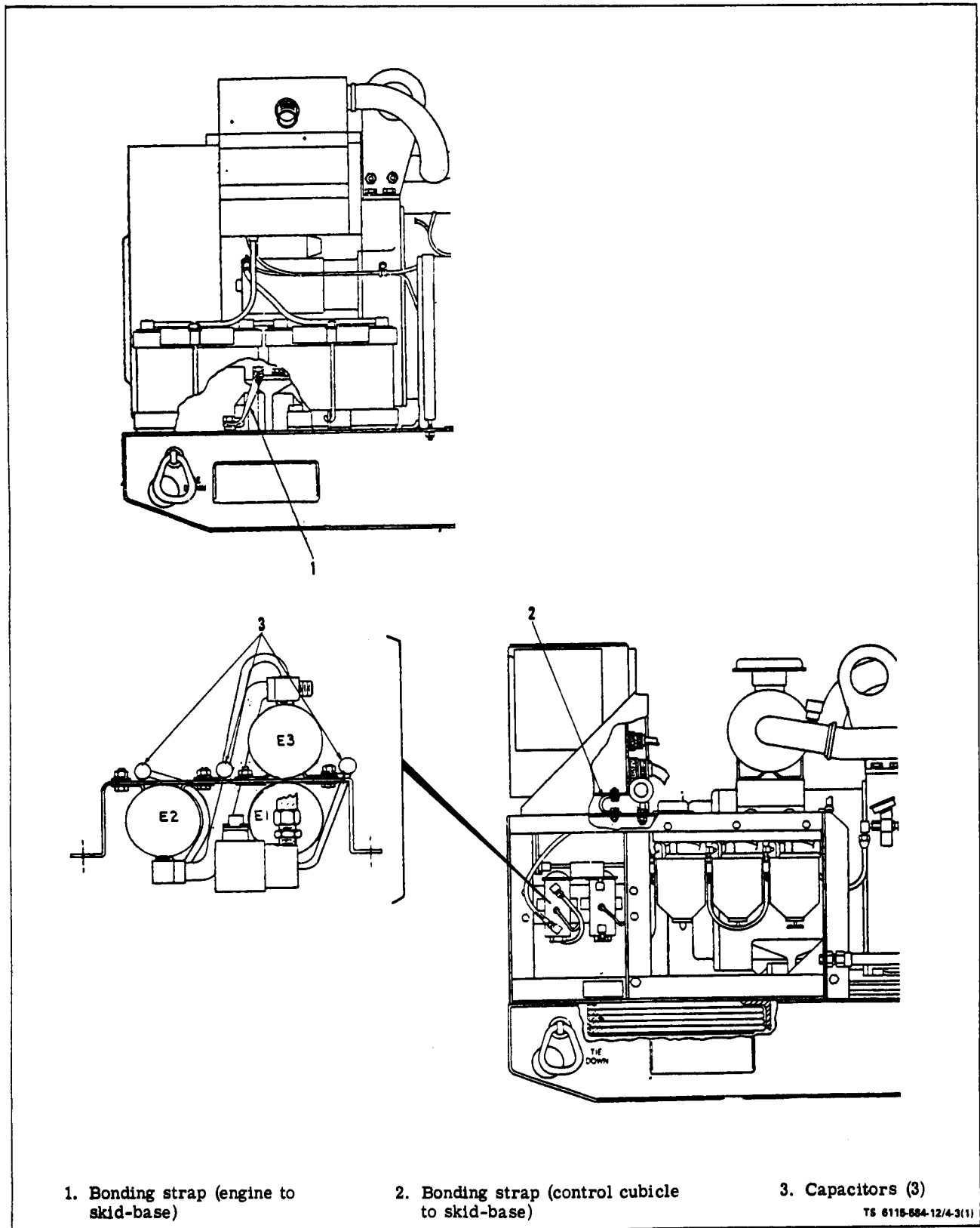

Figure 4-3. Primary Radio Interference Suppression Components (Sheet 1 of 2)

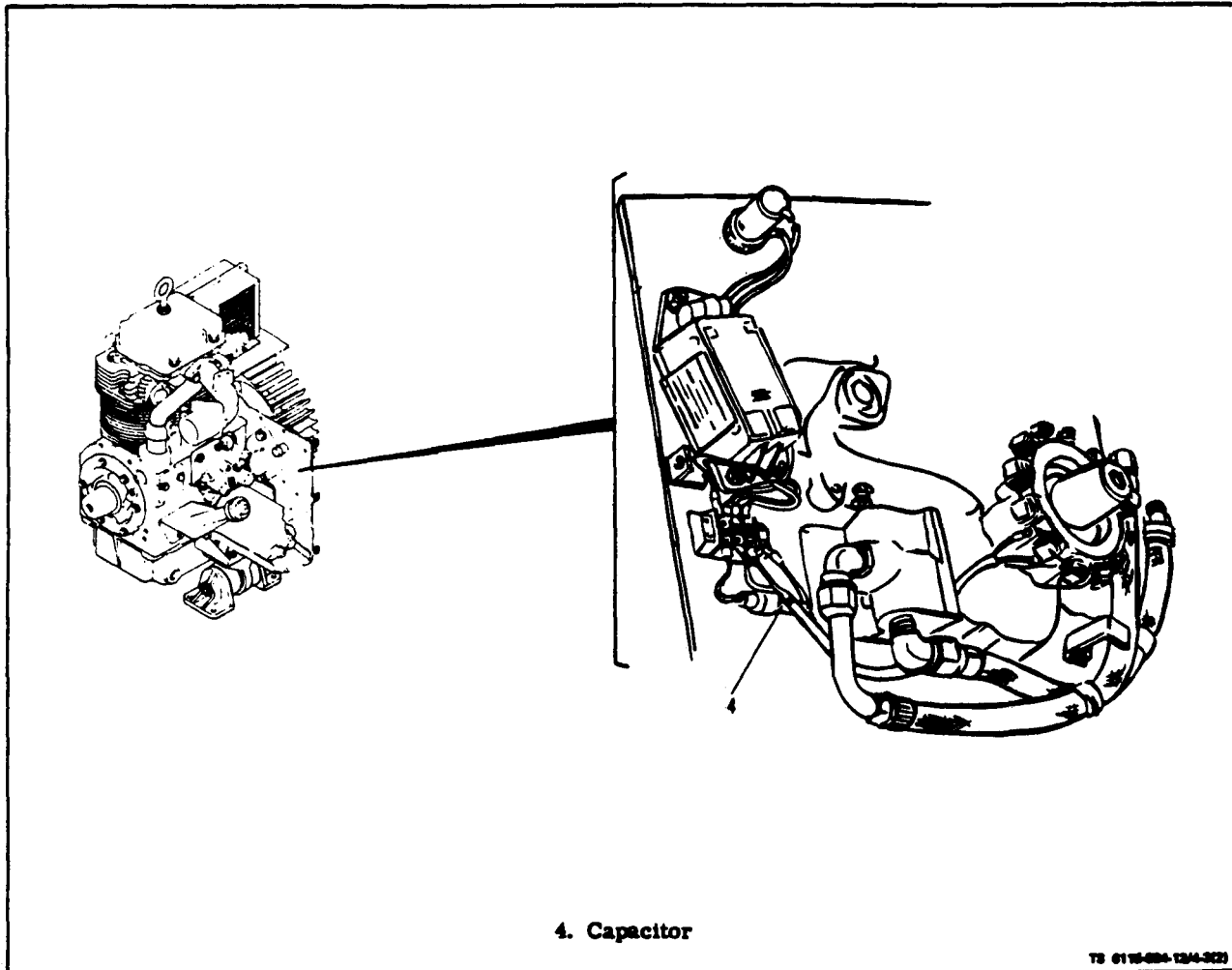

Figure 4-3. Primary Radio Suppression Components (Sheet 2 of 2)

Section VIII. MAINTENANCE OF ENGINE COOLING SYSTEM

4-16. DESCRIPTION AND FUNCTION.

The engine has a pressure air cooling system. Fins on the engine blower draw air into the front of the engine housing and force it past the cylinders and out the right side of the engine. The engine air outlet uses a shutter assembly to control engine temperature. Part of the air is directed thru the air cleaner at cold temperatures. A thermo power unit controls shutter opening which limits air flow when the engine is cold. When the engine air temperature reaches approximately 120° F (49° C), the shutters begin to open. The shutters are completely open at 140° F (60° C). The cooling system contains a high temperature cut-out switch that shuts down the engine in can the engine temperature reaches 394°F (201°C).

4-12 Change 7

4-17. ENGINE COOLING ASSEMBLY.

Inspection (see figure 3-14). On ASK equipped generators, refer to para. 5-3 and 5-8 and remove ASK cover and exhaust plenum assemblies. Check that ASK front panel assembly is clear of debris.

(1) Check shutters on shutter assembly (4) for cleanliness and obstructions. Check blower housing (32) externally and internally at engine blower for cleanliness and obstructions.

(2) Open panel (12) by opening latches (14) and check that panel hinge works properly. With panel open, check engine fins for cleanliness and obstructions to airflow.

b. Removal.

(1) Disconnect negative lead from batteries.

(2) Air Housing Duct Cover. Loosen hose clamp (6) and remove air housing duct cover (2) by removing screws (1).

(3) Shutter Assembly. Disconnect wiring to thermal switch at connector plug (5) on outside of shutter assembly. Remove capscrews (3) attaching shutter assembly to engine and blower housing (33). Carefully pull shutter assembly (4) away from muffler (40) until lead from connector (5) to high temperature cutout switch (38) becomes accessible. Disconnect leads from high temperature cutout switch (38) and remove shutter assembly (4).

(4) Remove screws (33 and 34) and remove front shroud (36).

(5) Shroud Assembly. Open latches (14), remove screws (7), and washers (8), lift panel (9) and shroud (11) as an assembly from the engine and blower housing (33).

(6) Baffles and Shrouds. Remove rear shroud (22) by removing screw (17), screw (15), washer (16), screws (20 and 18) and tie bars (19 and 21). Remove baffle (25) by removing nuts (23) and J bolt (24).

(7) Blower Grille Assembly. Remove screws (26) and retainers (27) and remove grille (29).

(8) Blower Housing. Remove screws (30) attaching housing (32) to engine and remove screw (31) attaching housing to oil cooler support bracket. Remove housing (32).

(9) Refer to paragraph 4-30 and remove oil cooler and base. Remove screw (33), clip (35), and remove shroud (36).

c. Cleaning and Testing.

(1) Inspect the engine fins and the housing assemblies for debris and remove as necessary. Clean using detergent, clean cloth and brush.

(2) Disconnect leads and remove high temperature cutout switch from cylinder head. Check continuity between two terminals while heating switch with its mounting stud submerged in oil. When the temperature of the oil reaches $394 \pm 10^\circ \text{F}$ ($201 \pm 5^\circ \text{C}$) the switch should open. Switch should close when temperature drops below $394 \pm 10^\circ \text{F}$ ($201 \pm 5^\circ \text{C}$). If switch does not perform as indicated, replace.

d. Disassembly of Shutter Assembly (see figure 4-4).

(1) Shutter Thermo Power Unit Assembly. Remove electrical connector (3) by removing screws

(1) and nuts (2). Remove screws (4) and special washer (5) attaching thermo unit assembly (6) to shutter assembly and remove thermo power unit assembly. Be careful plunger does not fall out of thermo unit assembly.

(2) Shutters. Remove eight screws (7) and washers (8) attaching shutters (9 and 10) to bracket assemblies (11, 12 and 13). Remove shutters. Remove nuts (14) washer (15) and shutter torsion springs (6). Brackets (12) can now be removed. Remove bracket bearings (17). Remove screws (19) and remove bearing (17) and washer (18), brackets (11 and 13).

(3) Brackets.

(a) Remove clips (20) that retain lower rod (21) in bracket (11) and pivot arm (22). Remove lower rod and bracket (9). Remove bracket bearing, screw (19) and remove bearing (17) and washer (18).

(b) Remove nut (23), clip (24) and ball arm assembly (25). Remove bracket (12) and associated bearing (17), washer (18) and screw (19) using procedure as in paragraph (a) above.

(c) Remove pivot arm (22) by removing nut (26), lockwasher (27), flatwasher (28), washer (29), bearings (30) and bolt (31).

e. Test.

(1) Thermo Power Unit Assembly. Immerse the thermo unit into a container of oil while monitoring the oil temperature. Plunger of thermo unit should start to extend when temperature reaches 120°F (49°C). Total extension at 140°F (60°C) should be at least $13/64$ inch. Replace thermo unit if it does not operate properly.

f. Reassembly of Shutter Assembly.

(1) Brackets.

(a) Reassemble pivot arm (22) using bolt (31), bearings (30), washer (29), flatwasher (28), lockwasher (27) and nut (26).

(b) Mount bracket (13) to box (32) using bearings (17), lockwasher (18), and screw (19). Be careful not to confuse bracket (13) with bracket (12). Connect ball arm assembly (25) to bracket (13) and pivot arm (22) using clip (24) and nut (23).

(c) Mount bracket (11) along with bearing (17), lockwasher (18) and screw (19). Ensure that bracket is mounted so that shutter divider acts as inside stop. Mount lower rod (21) to bracket (11) and pivot arm (22) using clips (21).

(d) Install brackets (12), bearings (17) and lockwasher (18). Ensure that lower bracket is mounted so that shutter divider acts as inside stop.

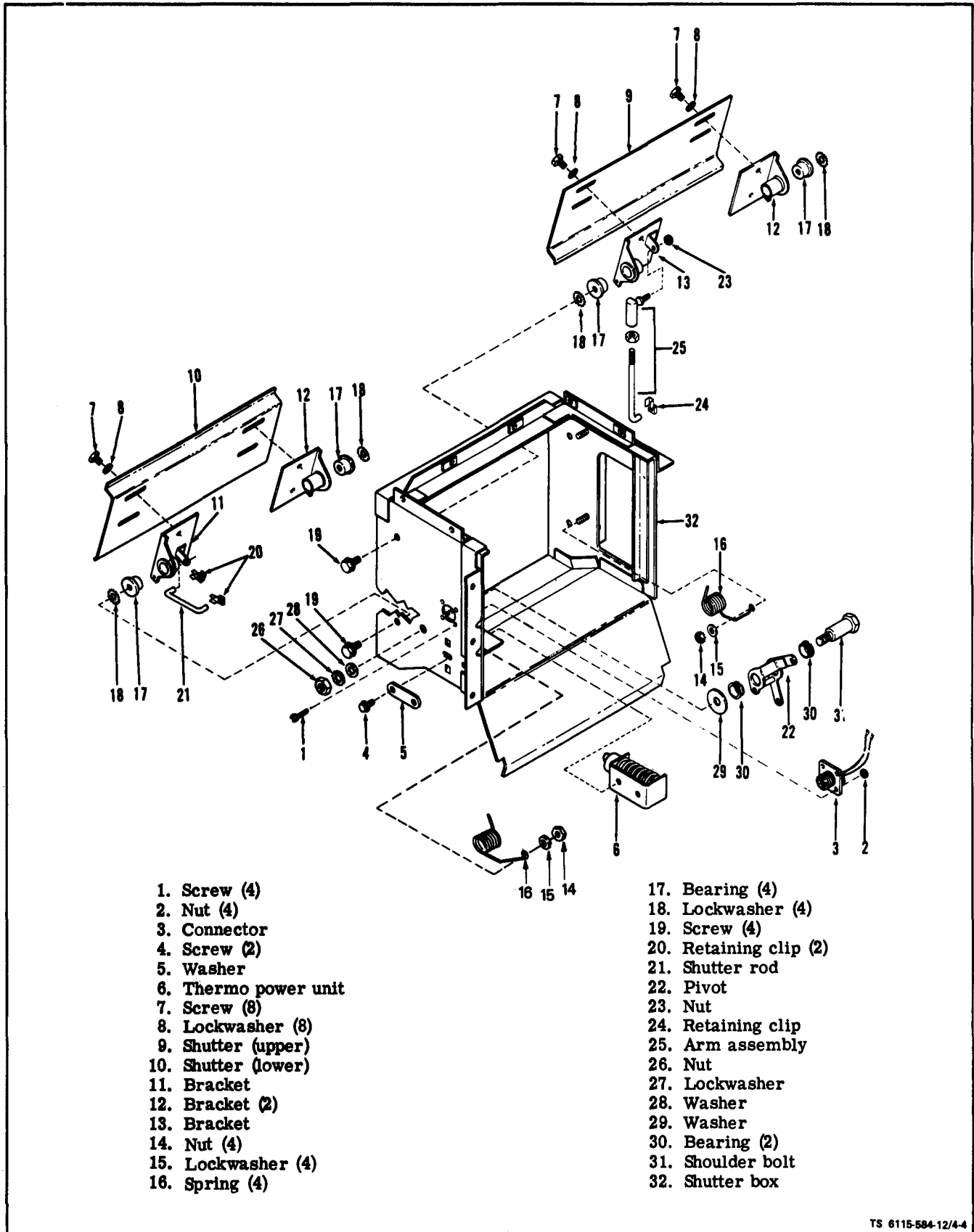

- 1. Screw (4)
- 2. Nut (4)
- 3. Connector
- 4. Screw (2)
- 5. Washer
- 6. Thermo power unit
- 7. Screw (8)
- 8. Lockwasher (8)
- 9. Shutter (upper)
- 10. Shutter (lower)
- 11. Bracket
- 12. Bracket (2)
- 13. Bracket
- 14. Nut (4)
- 15. Lockwasher (4)
- 16. Spring (4)

- 17. Bearing (4)
- 18. Lockwasher (4)
- 19. Screw (4)
- 20. Retaining clip (2)
- 21. Shutter rod
- 22. Pivot
- 23. Nut
- 24. Retaining clip
- 25. Arm assembly
- 26. Nut
- 27. Lockwasher
- 28. Washer
- 29. Washer
- 30. Bearing (2)
- 31. Shoulder bolt
- 32. Shutter box

TS 6115-584-12/4-4

Figure 4-4. Shutter Assembly

(2) Install power unit assembly (6) into shutter assembly box (32) using screws (4) and special washer (5). Mount connector (3) using screws (1) and nuts (2).

(3) Shutters. Mount torsion spring (16) using nut (14) and washer (15). Mount shutters using screws (7) and washers (8). Ensure that adequate clearance between shutter and shutter box sides is maintained and that brackets (12) are seated against shoulder of bearing (17) prior to tightening Screws (7). Check shutter to ensure they will fully open and close without binding.

g. Adjustments.

(1) Shutters (see figure 4-5). Disconnect ball joint from upper shutter. Adjust ball joint until upper shutter closes tightly on lower shutter when lower shutter is held closed. Re-attach ball joint to upper shutter.

(2) Thermo Unit (see figure 4-6). With Generator Set at 70° F, (21°C) loosen thermo unit guide mounting screws, the mounting holes in the shutter box are slotted. Slide the assembly to a position where the thermo unit plunger rests on roll pins with shutters closed. Tighten mounting screws.

h. Installation (see figure 3-17).

(1) Install oil cooler and base as described in paragraph 4-28. Install shroud (36), clip (35) and screw (33).

(2) Blower Housing. Install blower housing (32) on engine using screws (30 and 31).

(3) Blower Grille Assembly. Install grille (29) on blower housing (32) using screws (26) and retainers (27). (For units without ASK.)

(4) Baffles and Shrouds. Install shroud (22) using screws (15 and 17) and washer (16). Install rear shroud (36) using screw (33), clip (35) and screw (34). Install baffle (25) with hook bolt (24) and nut (23).

(5) Shroud Assembly. Install door panel (12) and shroud (11) as an assembly to the engine and blower housing (32) using screws (7) and washers (8). Close latches (14).

(6) Shutter Assembly. Install shutter assembly (4) on engine and blower housing (32) using capscrews (3). Connect connector plug to thermo unit connector receptacle (5).

(7) Air Housing Duct Cover. Mount air housing duct cover (2) to shutter assembly (4) using screws (1). Connect air intake hose to duct cover using hose clamp (6).

(8) On ASK equipped generators, refer to para 5-3 and 5-8 and replace ASK cover assembly and exhaust plenum.

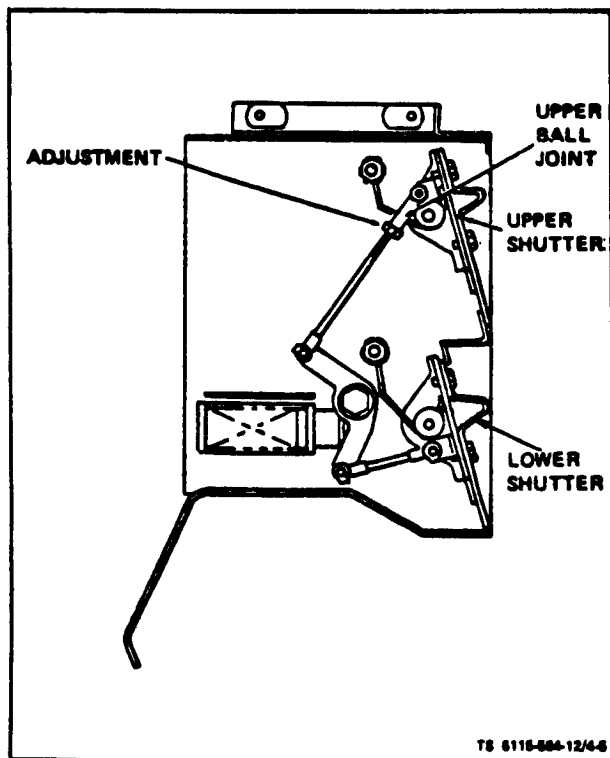

Figure 4-5. Adjusting Shutters

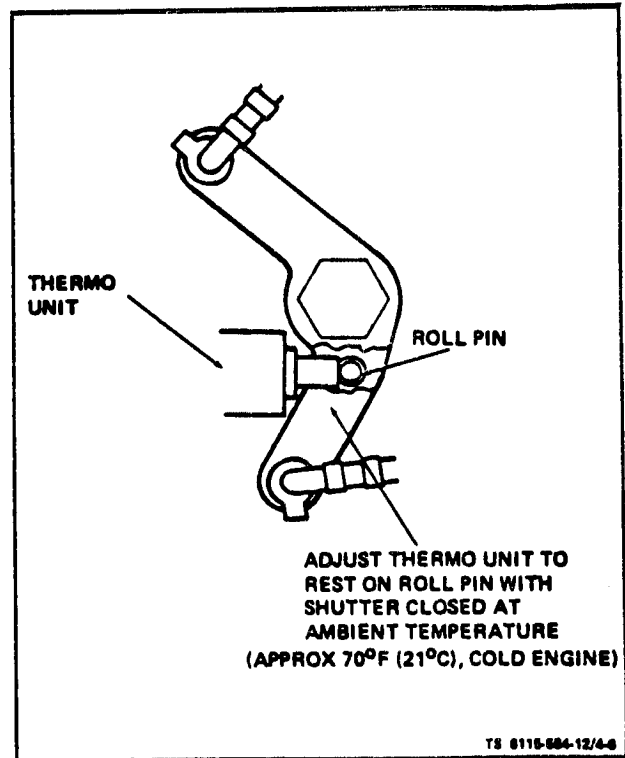

Figure 4-6. Adjusting Thermo Unit

Section IX. MAINTENANCE OF FUEL SYSTEM

4-18. DESCRIPTION AND FUNCTION.

a. Low Pressure System (see Schematic figure 1-5).

(1) Fuel pump may draw fuel from an external source to fill set tank or set tank may be filled manually. If an external fuel source is selected, a float valve assembly in the set tank maintains the fuel level in the tank. Two other fuel pumps (in series) draw fuel from the set tank and force the fuel through a primary strainer, two filters, and a check valve assembly, to the injection pump.

b. High Pressure System.

(1) Fuel injection pump forces the fuel, under high pressure, to the fuel injection nozzles. The injection nozzles provide fuel to each combustion chamber of the engine. Unused fuel is returned from the injectors to the fuel tank. A cam and gear on the camshaft drives the fuel injection pump. The gear drives the pump face gear, providing fuel distribution to each cylinder in the proper order. The cam operates the pump plunger, pressurizing fuel to the nozzles. A control sleeve meters fuel by controlling the length of time the plunger spill port is closed, maintaining pressure, and therefore, the amount of fuel delivered in each stroke. The pintle type injection nozzles are conventional inward opening with adjustable opening pressure. They are factory adjusted to open at 1900 to 1950 psi.

4-19. FUEL TANK ASSEMBLY.

a. Inspection on Equipment. Refer to paragraph 3-13a.

b. Removal (see figure 4-7). Drain fuel into suitable container by opening drain valve. Tag and disconnect fuel hoses from fuel tank fittings. Disconnect electrical lead from electrical connector (10). Remove nut (1) and flatwasher (2) from straps (3) on outside of fuel tank. Remove tank from skid-base. On ASK equipped generators, remove top panel, left side panel and side closure (Refer to paragraphs 5-4, 5-5, and 5-12).

c. Disassembly.

(1) Fuel Level Gauge. Unscrew and remove fuel level gauge (5) using tools only on the hex portion of the gauge.

(2) Float Switch. Unscrew collar and disconnect electrical connector (10) if not previously disconnected. Unscrew and remove float switch (6) using tools only on the square portions of the switch.

(3) Unscrew and remove fittings (7).

(4) Holding pipe adapter (11) with a wrench, unscrew and remove drain valve (8).

(5) Loosen filler cap and remove filler cap (4) and strainer (5).

d. Cleaning and Inspection.

(1) Tank. Clean tank exterior using suitable solvent and clean cloth and brush. Inspect tank for signs of physical damage. If damaged refer to higher level of maintenance.

(2) Fuel Level Gauge. Check that fuel level gauge face is clean and readable. Check that as cork float is moved up and down, the meter movement rotates.

(3) Float Switch. Inspect terminal connector for damage to threads. Check to see that float slides on shaft without binding. Clean with suitable solvent if required.

(4) Fittings. Inspect fittings for good leak-free seating on tank and check threads for physical damage.

(5) Fuel Drain Valve Assembly. Check that drain valve does not leak and threads for physical damage.

e. Test.

(1) Float Switch. Remove float switch (6) from tank (9). Using an ohmmeter, check for continuity between terminals A and B of Switch (see figure 4-8). Switch should show no continuity when float is up. Switch should close when float drops to 2-7/8 ±3/16 inch from threaded collar of float switch. Replace switch if it does not operate properly.

(2) Tank. If tank shows signs of physical damage or leaks refer to higher level of maintenance.

f. Reassembly (see figure 4-7).

(1) Fuel Drain Valve. Engage threads of fuel drain valve assembly (8) 1/2 turn into fuel tank adapter (11). Coat threads with sealing compound MIL-S-22473. Tighten valve assembly into adapter (11).

(2) Fittings. Engage threads of fitting (7) 1/2 turn into fuel tank (9). Coat threads with sealing compound MIL-S-22473. Tighten fittings into tank. Fittings should face Generator Set for proper connection of fuel lines. Attach fuel lines to fittings.

(3) Float Switch. Engage threads of float switch (6) 1/2 turn into tank (9). Coat threads with sealing compound MIL-S-22473. Tighten float switch (6) into tank using tools only on square portion of switch. Attach electrical lead to connector (10) on top of float switch and tighten.

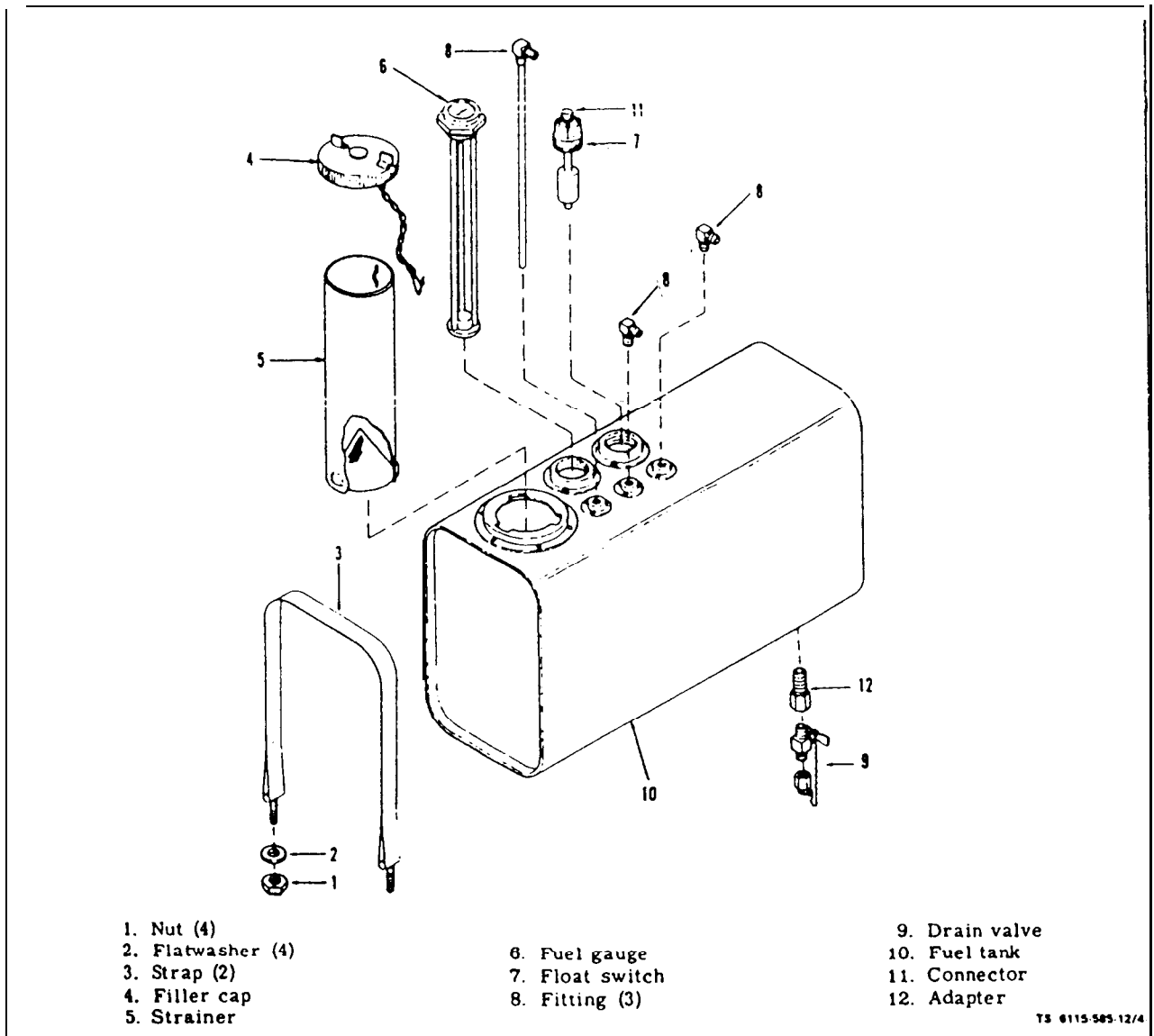

Figure 4-7. Fuel Tank Assembly

(4) Fuel Level Gauge. Engage threads of fuel level gauge (5) 1/2 turn into tank (9). Coat threads with sealing compound MIL-S-22473. Tighten float level gauge into tank using tools only on hex portion of gauge. Install filler cap (4) and strainer (5) into tank (9).

g. Installation.

(1) Install straps (3) onto the skip-base and secure with nut (1) and flatwasher (2) on inside of skid-base only.

(2) Position fuel tank assembly onto skid-base, position straps over tank assembly and secure with nut (1) and flatwasher (2). *On ASK equipped generators, install side closure, left side panel, and top panel (refer to paragraphs 5-12, 5-5 and 5-4).

(3) Check that drain valve is closed before filling tank with proper grade of fuel.

NOTE

After each time fuel filters or strainer is drained or elements replaced, purge air from fuel system by moving master switch on control panel to PRIME & RUN position. This should activate the fuel transfer pump and force trapped air back to the vented fuel tank.

4-20. **FUEL FILTER ASSEMBLIES AND STRAINER ASSEMBLY.**

There are two identical fuel filter assemblies (see figure 3- 13), one which acts as the primary and the

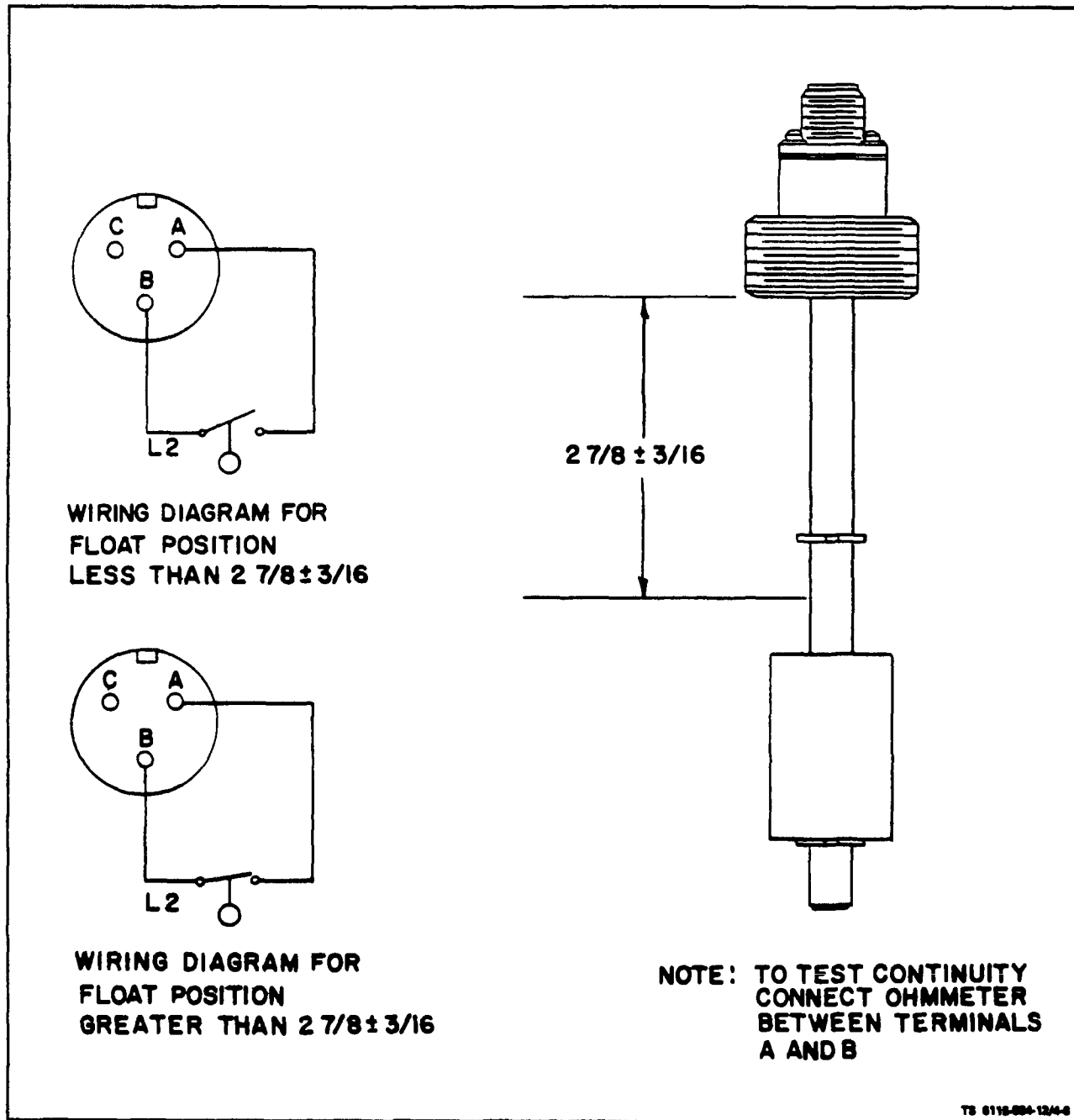

Figure • 4-8. Testing Float Switch

other as secondary, plus there is one fuel strainer. If these filters or strainer are plugged, fuel flow will be restricted and the engine may not run properly. Periodic maintenance is required for this assembly.

a. Inspection (on Equipment). On ASK equipped generators, remove FUEL FILTERS access door,

(1) Fuel Filter Assemblies and Strainer Assembly. Inspect the assembly for secure mounting, loose or leaking fittings and hoses, leaking valves and leaking at bowl and head interface.

or leaking fittings and hoses, leaking valves and leaking at bowl and head interface.

b. Service.

(1) Fuel Filters (see figure 4-9). On ASK equipped generators, remove tight panel assembly (para 6-6). Remove plug (1), open drain cock (2) and drain fuel into suitable container. Remove bolt assembly (3), gasket (4) and filter body (5). Remove filter element (6) and gasket (7). Inspect element for ruptures, clogs or other

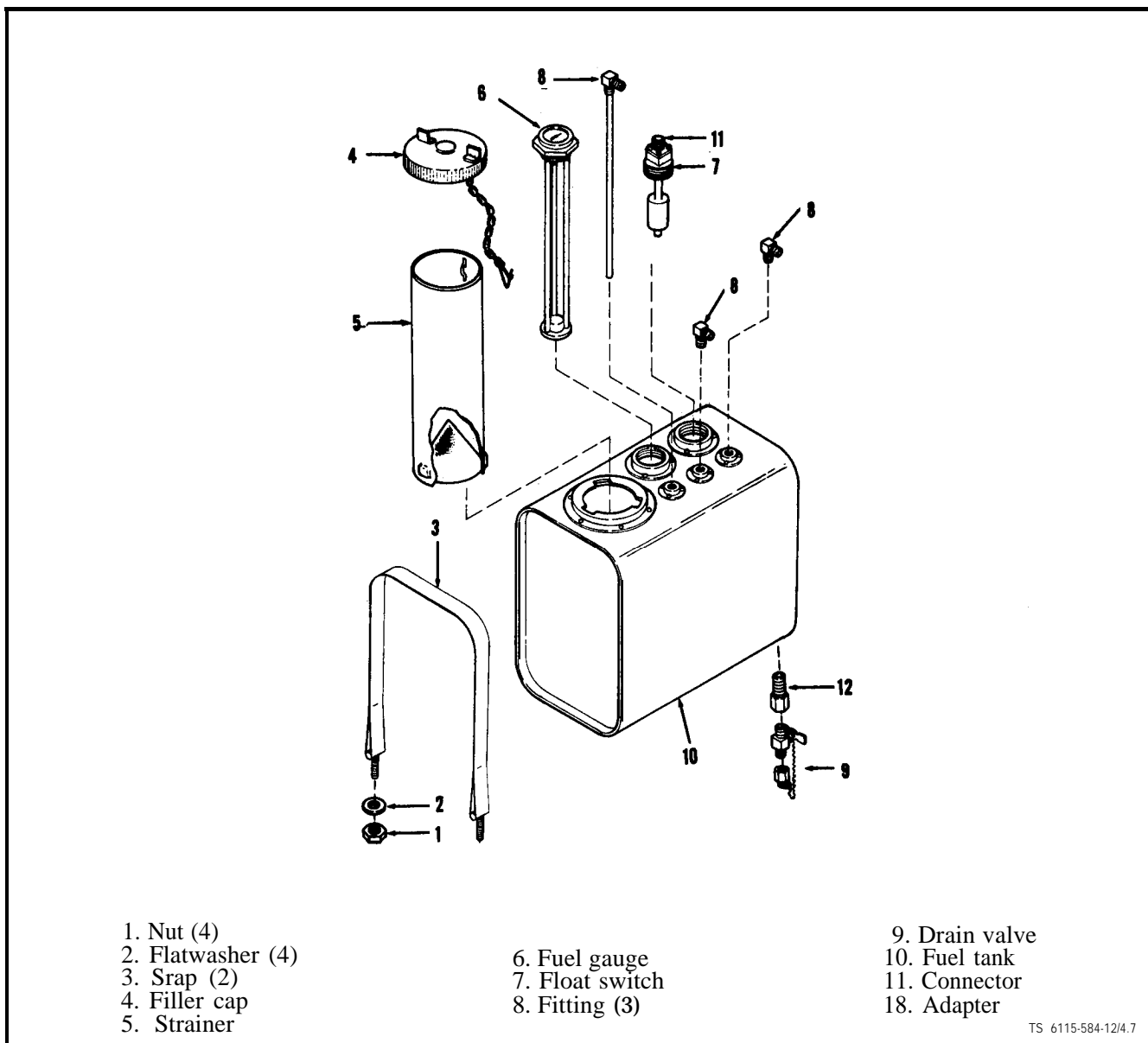

Figure 4-7. Fuel Tank Assembly

(4) Fuel Level Gauge. Engage threads of fuel level gauge (5) 1/2 turn into tank (9). Coat threads with sealing compound MIL-S-22473. Tighten float level gauge into tank using tools only on hex portion of gauge. Install filler cap (4) and strainer (5) into tank (9).

g. Installation.

(1) Install straps (3) onto the skid-base and secure with nut (1) and flatwasher (2) on inside of skid-base only.

(2) Position fuel tank assembly onto skid-base. position straps over tank assembly and secure with nut (1) and flatwasher (2).

(3) Check that drain valve is closed before filling tank with proper grade of fuel.

NOTE

After each time fuel filters or strainer is drained or elements replaced, purge air from fuel system by moving master switch on control panel to PRIME & RUN position. This should activate the fuel transfer pump and force trapped air back to the vented fuel tank.

4-20. FUEL FILTER ASSEMBLIES AND STRAINER ASSEMBLY

There are two identical fuel filter assemblies (see figure 3-13), one which acts as the primary and the

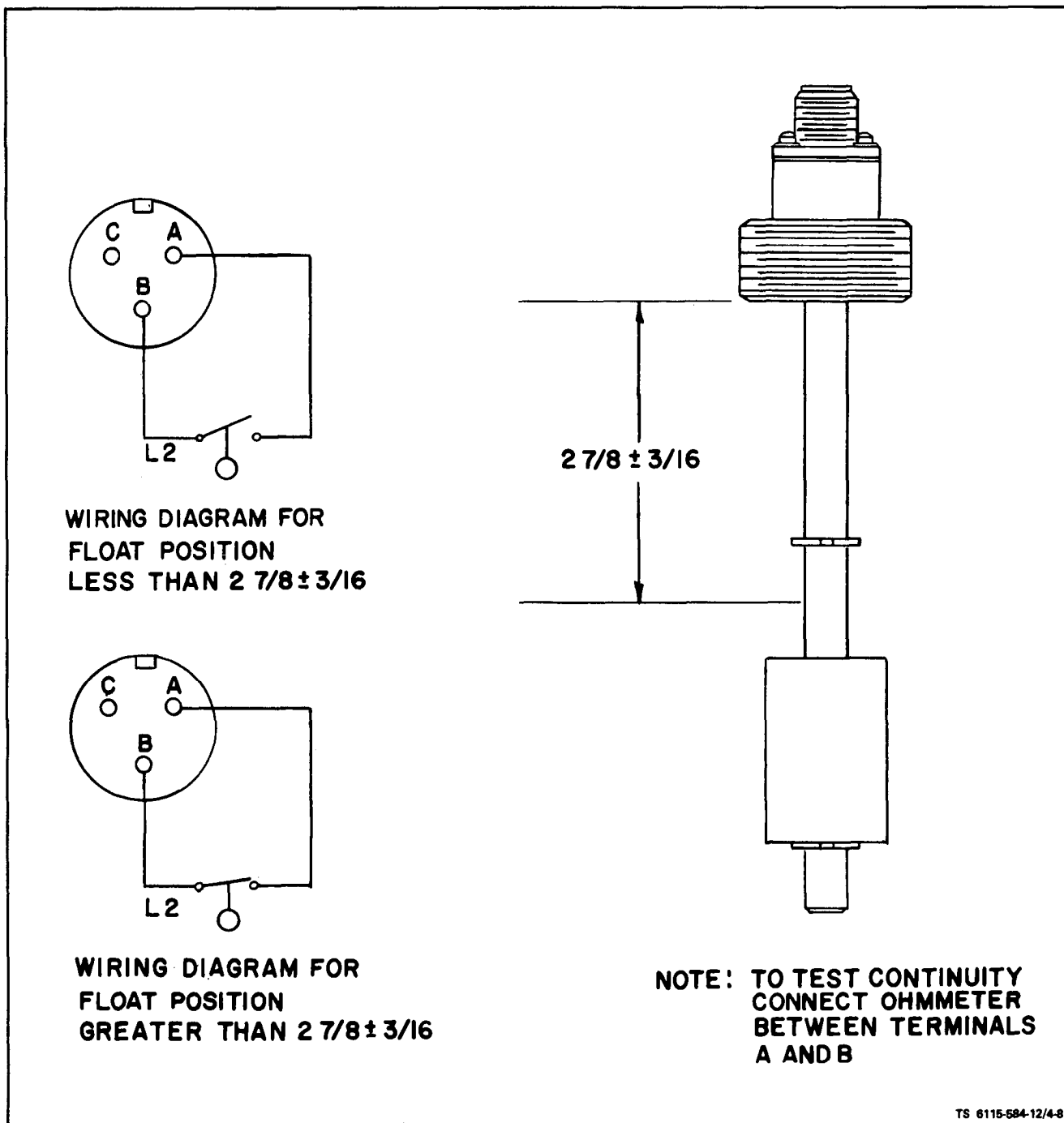

Figure • 4-8. Testing Float Switch

other plus there is one fuel strainer. If these filters or strainer are plugged, fuel flow will be restricted and the engine may not run properly. Periodic maintenance is required for this assembly.

a. Inspection (on Equipment).

(1) Fuel Filter Assemblies and Strainer Assembly. Inspect the assembly for secure mounting, loose

or leaking valves and leaking at bowl and head interface.

b. Service.

(1) Fuel Filters (see figure 4-9). Remove plug (1), open drain cock (2) and drain fuel into suitable container. Remove bolt assembly (3), gasket (4) and filter body (5). Remove filter element (6) and gasket (7). Inspect element for ruptures, clogs or other

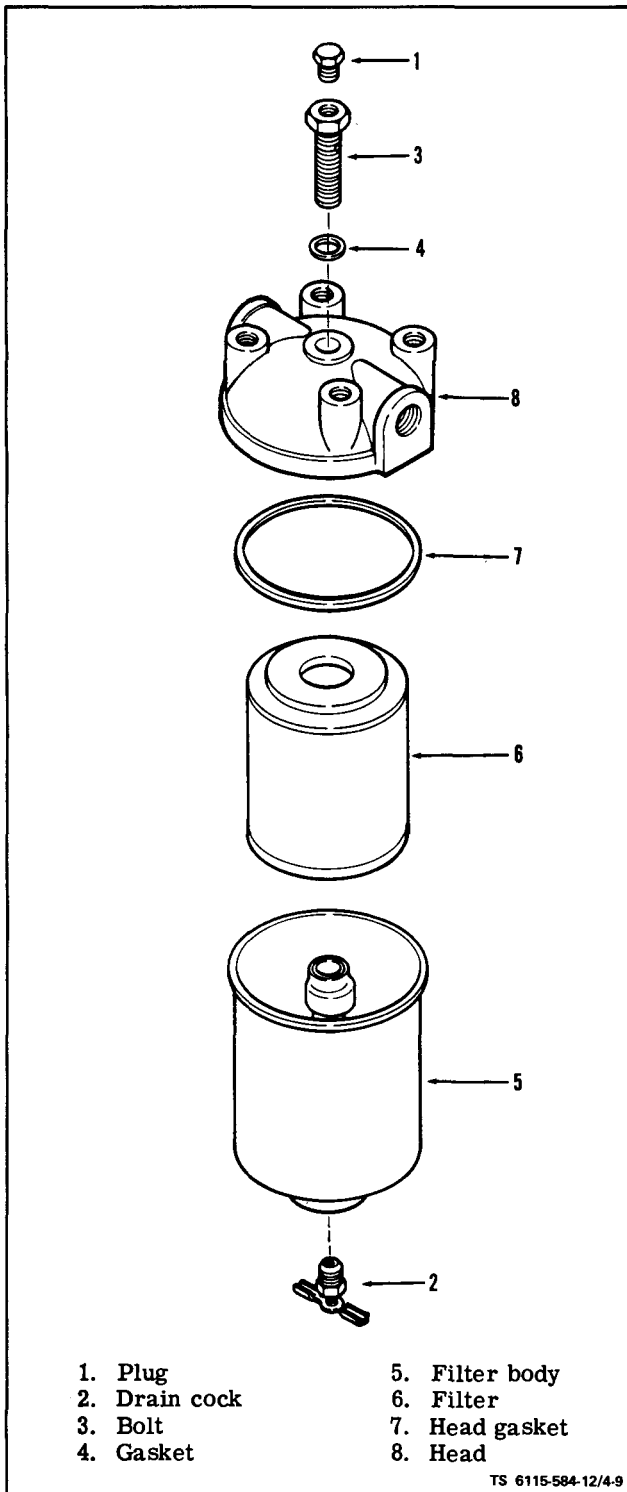

Figure 4-9. Fuel Filter

physical damage. Replace element if necessary. Change primary element every 500 operating hours, and secondary filter elements every 1000 operating hours. Replace filter element (6), gasket (7), filter body (5), gasket (4), and bolt assembly (3). Close drain cock (2) and install plug (1).

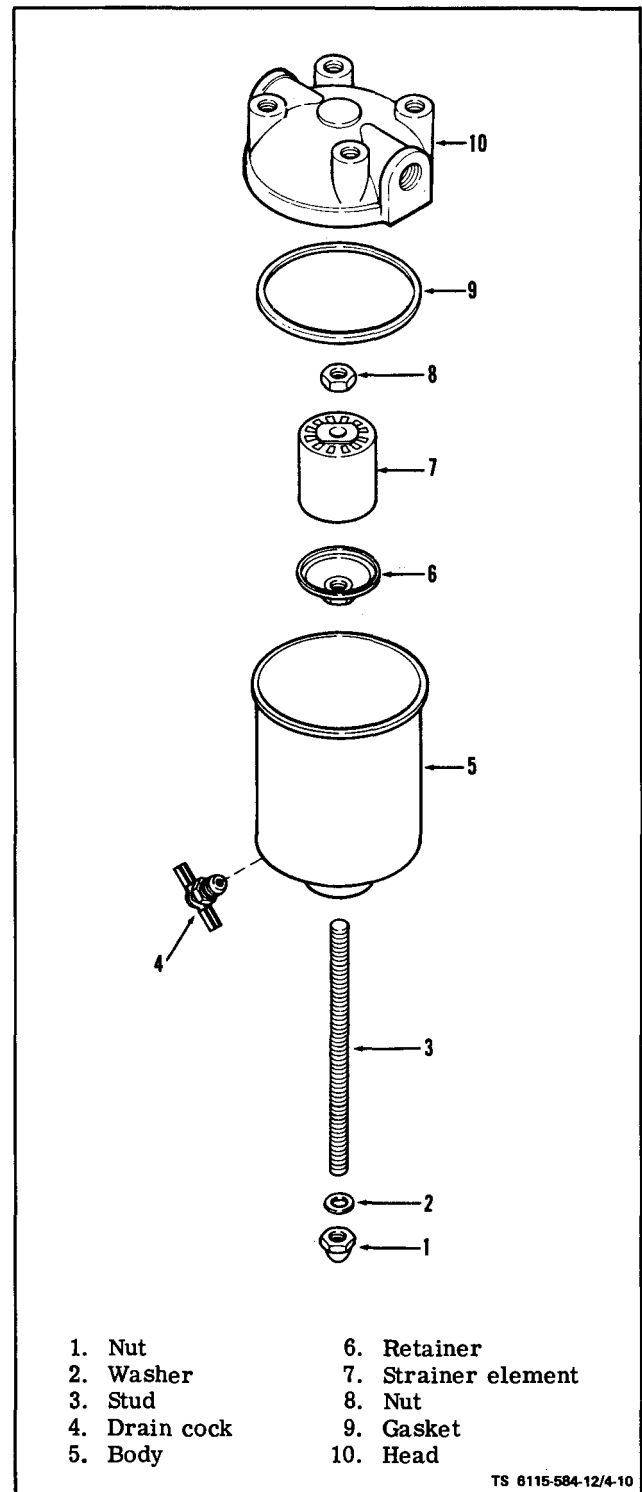

Figure 4-10. Fuel Strainer Element

(2) Fuel Strainer Element (see figure 4-10). Open drain valve (4) and drain fuel into suitable container. Remove nut (1) and washer (2) attaching body (5) to head (10) and remove body and gasket (9). Remove retainer (6) and remove strainer element (7). Inspect element for physical damage or clogging.

WARNING

Clean parts in a well-ventilated area. Avoid inhalation of solvent fumes and prolonged exposure of skin to cleaning solvent. Wash exposed skin thoroughly. Dry cleaning solvent (Fed. Spec P-D-680) used to clean parts is potentially dangerous to personnel and property. Do not use near open flame or excessive

heat. Flash point of solvent is 100° F to 138°F (38°C to 59°C).

Every 300 operating hours, clean strainer element (7) by soaking in dry cleaning solvent (Fed. Spec P-D-680) and dry thoroughly using a clean dry cloth. Replace strainer element (7) on stud (3) and secure with retainer (6). Position gasket (9) and body (5) on head (10) and secure with washer (2) and nut(1). Close drain cock (4).

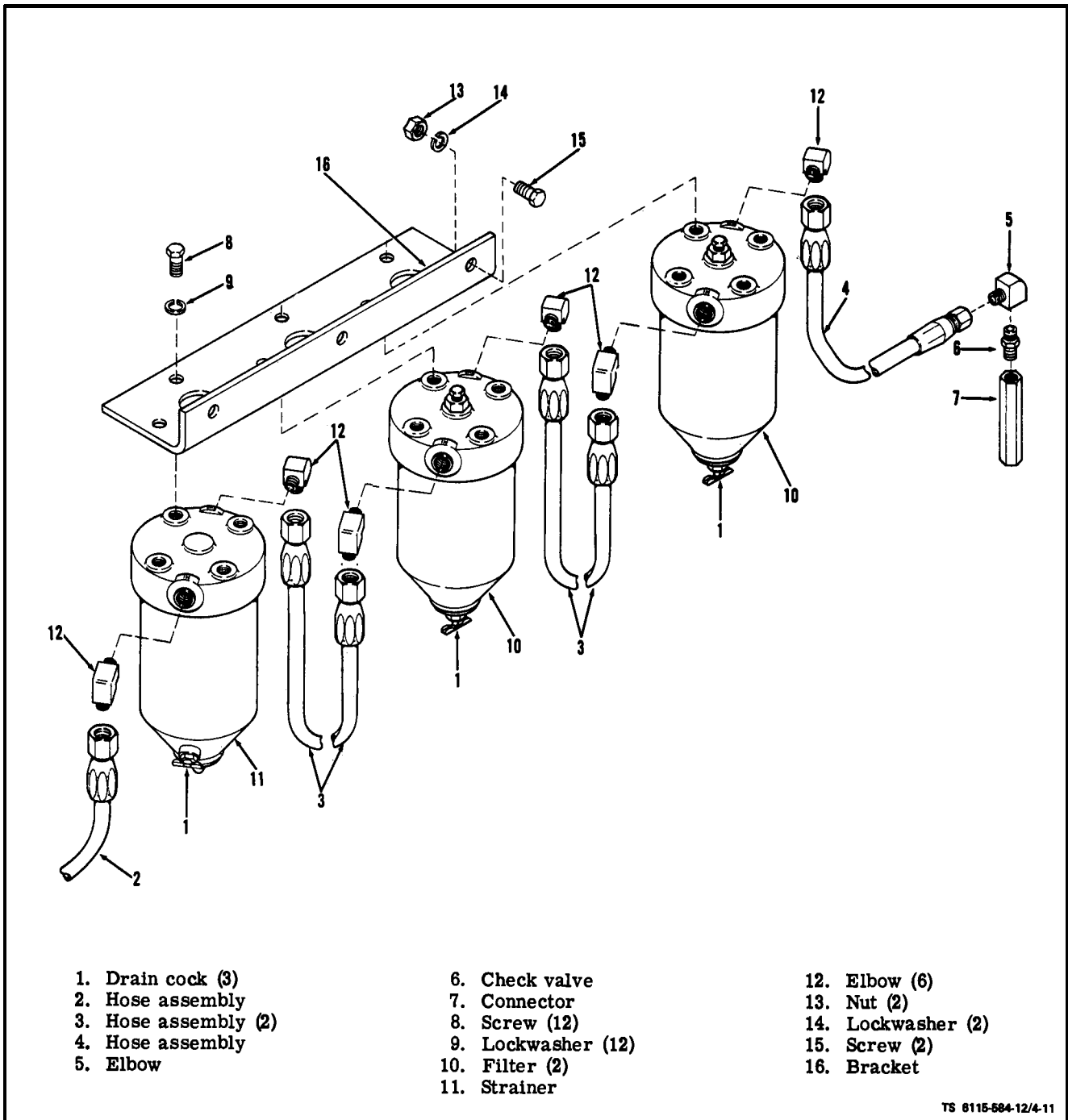

TS 6115-584-12/4-11

Figure 4-11. Fuel Filters and Fuel Strainer Assembly

c. Removal.

(1) Fuel Filter Assembly (see figure 4-11). Drain fuel into a suitable container by opening drain valve (1). Disconnect fuel lines (2, 3 and 4) and drain fuel lines. Remove elbow (5), check valve (6) and coupling (7). Plug fuel lines to prevent accumulation of foreign material.

(2) Remove screws (8) and lockwasher (9) attaching each filter assembly (10) and strainer assembly (11) to mounting bracket and remove filter or strainer assembly. Remove inlet and outlet fittings (12). Be careful when removing fittings not to damage housing.

(3) Remove nuts (13), lockwashers (14), screws (15) and remove bracket (16).

(4) Inspect check valve (6) for cleanliness. Using a clean punch depress check valve from seat (opposite end of arrow) and check for free movement and reseating upon release. Replace check valve if it does not move freely.

d. Installation.

(1) Position bracket (16) on frame and secure with screws (15), lockwashers (14) and nuts (13).

(2) Position fuel filter assembly (10) or fuel strainer (11) on bracket (16) and secure with lockwashers (9) and screws (8).

(3) Install coupling (7), check valve (6) and elbow (5) on fuel line (4). Make sure arrow on check valve points toward coupling (7).

(4) Connect fuel lines (4, 3 and 2). Tighten drain valve (1) in each filter assembly and strainer assembly.

(5) On ASK equipped generators, install right panel assembly (para. 5-6).

4-21. ELECTRIC FUEL PUMPS. FUEL AND AUXILIARY SOLENOID VALVE.

a. Testing on Equipment. Perform operational test for each pump individually. Each pump should pump at 6 to 7 psi as registered on an accurate fuel pressure gauge. Connect fuel pressure gauge to output port of pump. Turn master switch to **PRIME AND RUN** position. pressure gauge should register 6 to 7 psi. Replace defective pumps.

b. Service (see figure 4-13). On ASK equipped generators, remove fuel access door. Remove cover (1), gasket (2) and strainer (3). Be careful not to lose magnet (4). Every 500 operating hours replace gasket (2) and strainer (3) in both main pumps and auxiliary pump. Ensure that chamfered surface of magnet (4) is up prior to installation of new strainer and gasket.

c. Removal (see figure 4-12).

(1) Fuel Lines. Tag and remove fuel hoses (1, 2, 3 and 4) by unscrewing at fittings (5, 15 and 16). Keep

hoses clean and plug to prevent contamination. Disconnect electrical connector (22) at solenoid valve (6).

(2) Fuel Pumps. Tag and disconnect electrical lead from each fuel pump at connector on wiring harness. Remove nuts (7), lockwashers (8 and 11) and screws (9) attaching each pump (12 and 13) and pump lead (10) to bracket (21) and remove pumps.

(3) Remove solenoid valve (6) from fittings (16 and 17) and remove fitting (5) from solenoid valve.

(4) Remove fittings (14, 15, 16 and 17) from fuel pumps. Remove nuts (18), lockwasher (19), screw (20) and remove bracket (21).

d. Installation.

(1) Position bracket (21) on frame and secure with screws (20), lockwashers (19) and nuts (18).

(2) Install fuel fittings (17, 16, 15, 14 and 5) in fuel pumps (12 and 13).

(3) Turn solenoid valve (6) onto fuel pump outlet fittings (16 and 17) and position on fuel pump as shown in figure 4-12.

(4) Install fuel pumps (12 and 13) on bracket (21) and secure with screws (9), washers (8 and 11) and nuts (7). Reconnect electrical leads to wiring harness and fuel solenoid valve.

(5) Install and tighten fuel hoses (4, 3, 2 and 1).

4-22. AUXILIARY FUEL SOLENOID VALVE.

a. Test on Equipment. On ASK equipped generators, remove fuel access door and perform the following procedures:

(1) Ensure output pressure of auxiliary fuel pump is 6 to 7 psi and fuel level in set tank is below 1/2 full. Disconnect harness at solenoid valve connector. Place master switch in PRIME RUN and AUX position. Ensure voltage between points A and B on harness connector is 24 VDC. Reconnect harness to solenoid valve. Test output pressure at output side of solenoid valve. Pressure should be same as output pressure of auxiliary fuel pump, if not replace solenoid valve.

(2) With 24 volts dc applied across solenoid terminals A and B, the solenoid should draw approximately 1/2 ampere, if not replace solenoid valve.

4-23. FUEL SHUT-OFF SOLENOID

a. Inspect (on Equipment) (see figure 4-14). On ASK equipped generators, remove right panel assembly (para 5-6). Check that electrical connections (1) are secure and clean. Check that rubber boot (11) is clean and not broken. Check that governor and pump linkage moves freely and is clean.

b. Test (on Equipment) (see figure 4-15).

(1) Tag and remove the solenoid harness leads (1). Figure 4-14.

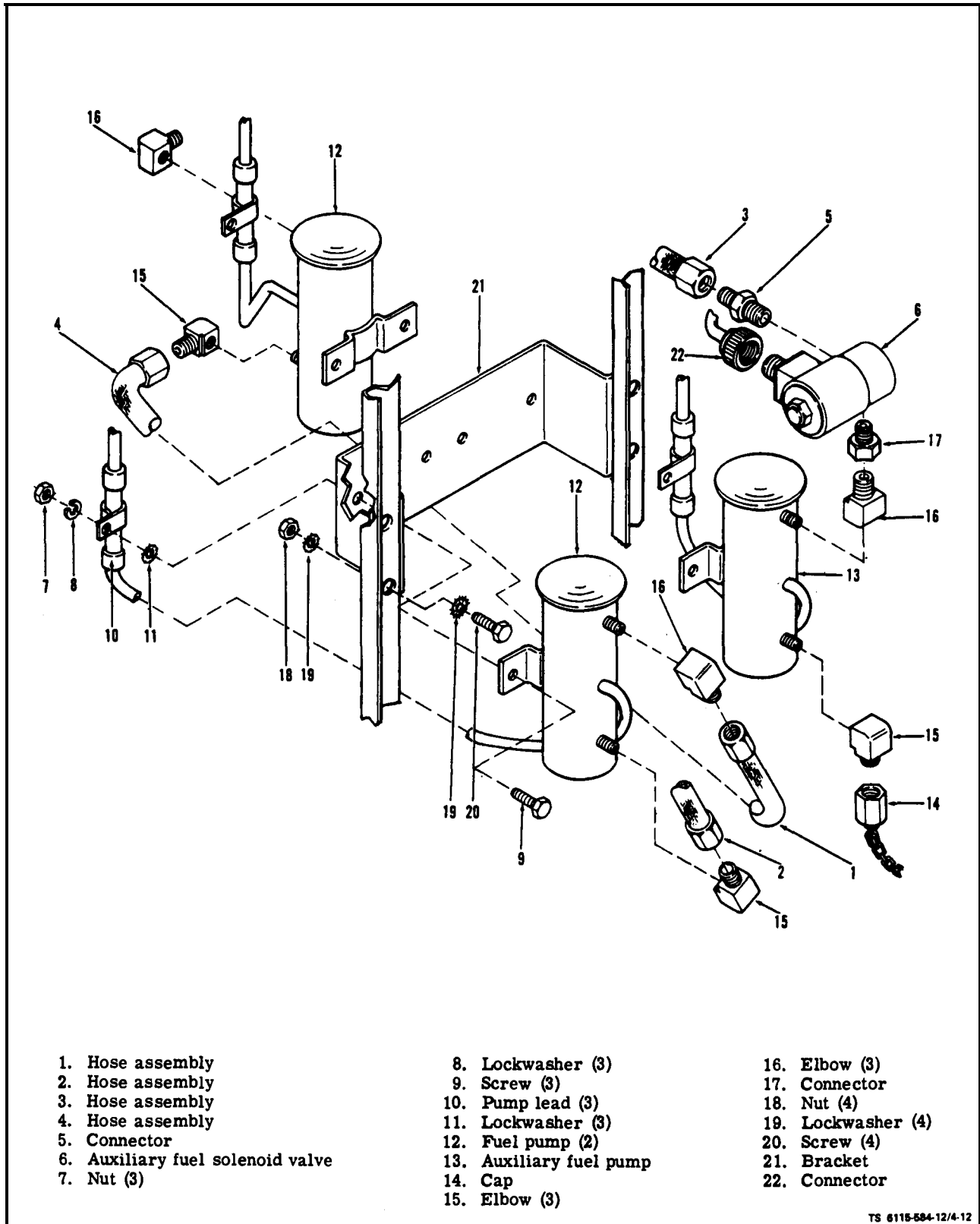

TS 6115-584-12/4-12

Figure 4-12. Fuel Pump, Fuel Hoses and Solenoid

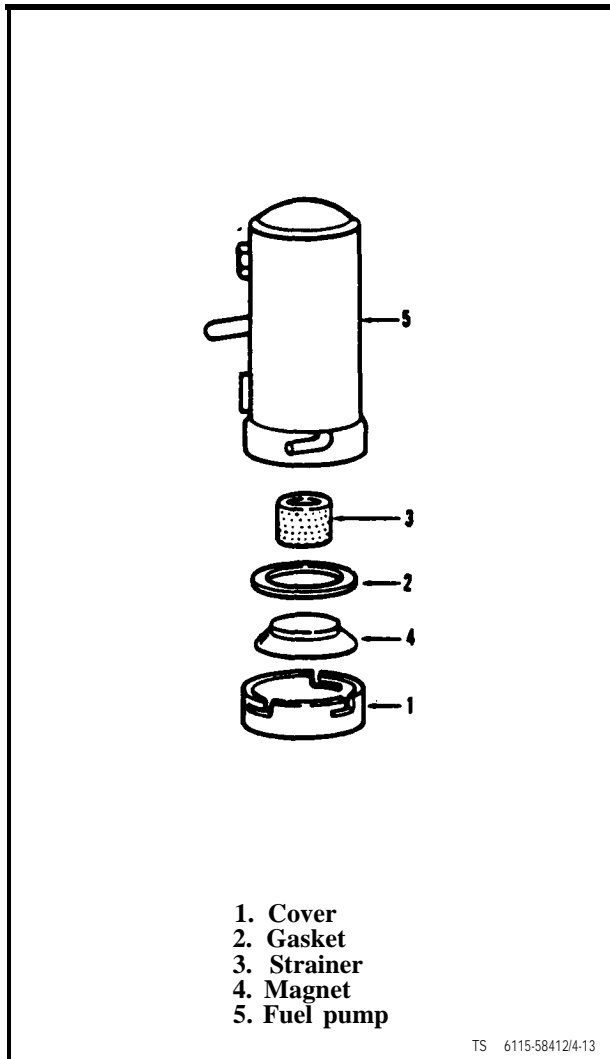

Figure 4-13. Fuel Pump

(2) Check for continuity between terminals of the fuel shut-off solenoid. If continuity is not obtained, the unit is unserviceable.

(3) Check for ground between fuel shut-off solenoid terminals and ground. If terminals are grounded, the unit is unserviceable.

(4) Connect the solenoid into test set-up (fig 4-15).

(5) With switch (S1) closed, the plunger should actuate and the current draw should be 0.25 ampere dc.

(6) If plunger does not actuate or, if meter reads above 0.35 ampere, replace solenoid.

c. Remove (see figure 4-14). Tag and disconnect harness leads (1). Remove the shut-off solenoid by removing screws (9) and lockwashers (10).

d. Installation. Mount shut-off solenoid using screws (9) and lockwashers (10). Reconnect previously tagged and removed harness wires (1).

e. Adjust. The solenoid plunger (3) should be adjusted so it fully stops injection when in the de-energized position. With engine running at full rated load, clearance between plunger (3) and control arm (4) should be at least 1/8 inch. To adjust the plunger length, turn the knurled head screw (5) and jam nut (6) on bottom of plunger. On ASK equipped Generator Sets, install right panel assembly (para. 5-6).

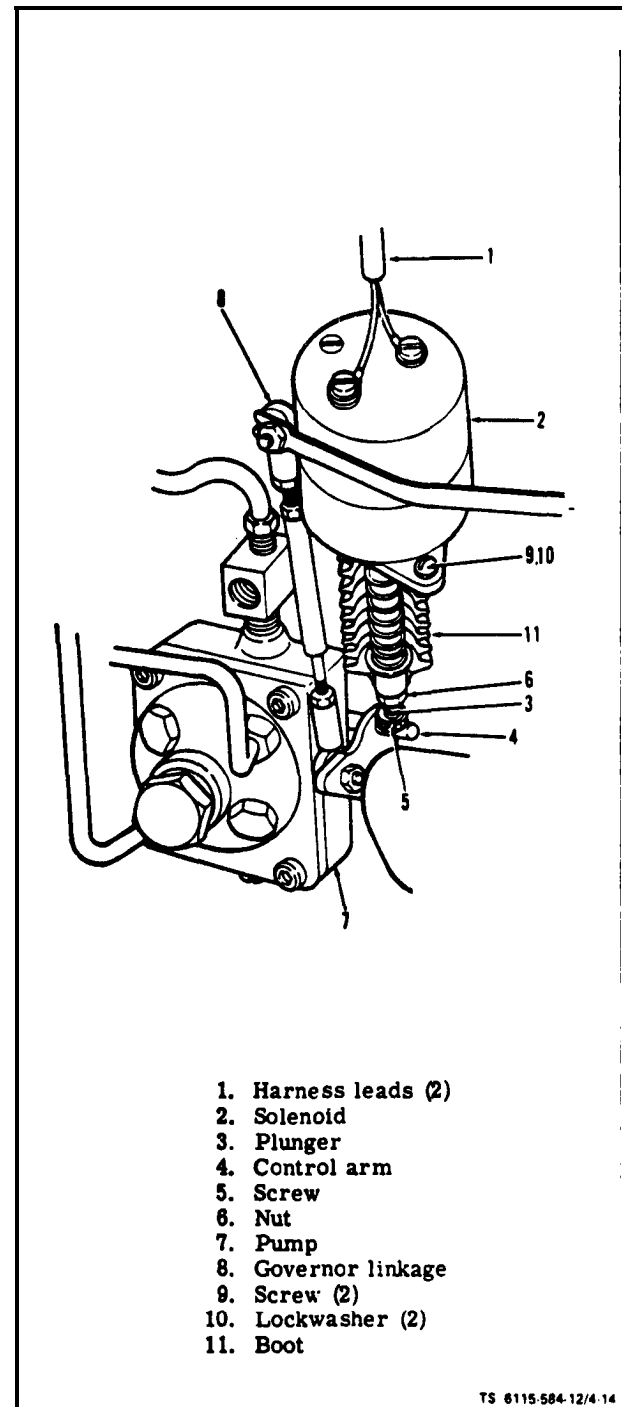

Figure 4-14. Adjusting Fuel Shut-Off Solenoid

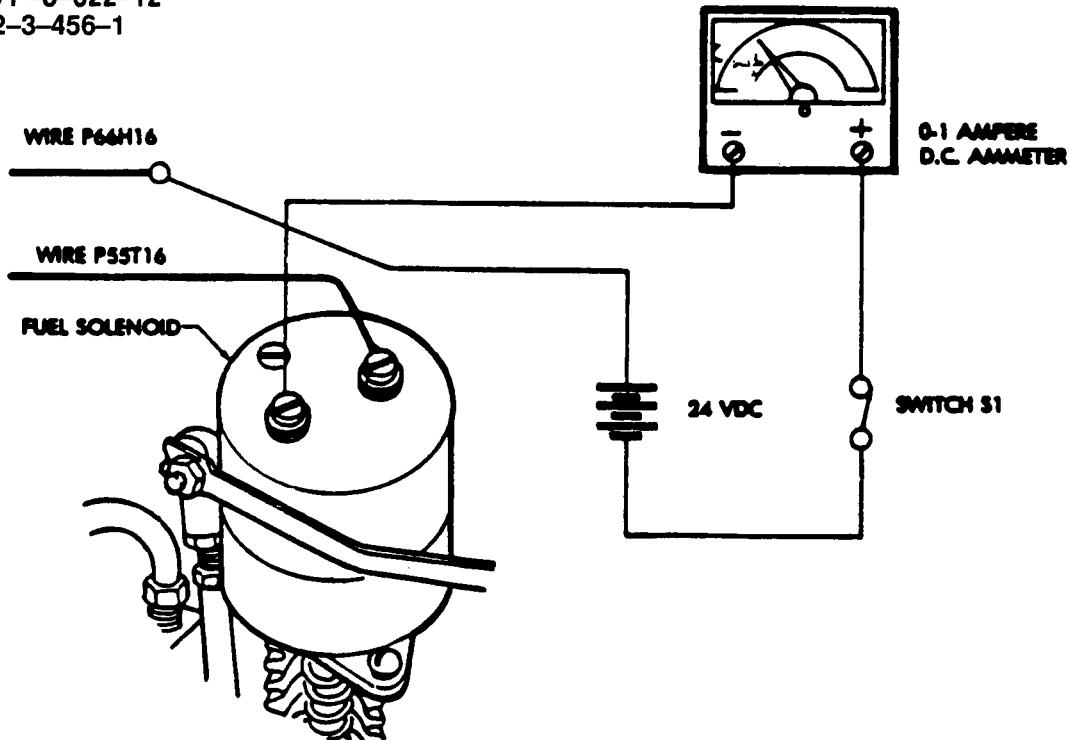

Figure 4-15. Fuel Solenoid Test Set-Up.

Section X. MAINTENANCE OF ENGINE ELECTRICAL SYSTEM

4-24. DESCRIPTION AND FUNCTION

a. The engine is cranked by a 24 volt electric starting motor (see figure 1-7). When starting motor solenoid is energized, the solenoid core pulls in, shifting the pinion gear into engagement with the engine flywheel ring gear. At the same time, contacts in the solenoid close to provide a circuit for the starter. The starting motor is protected from overspeeding by an overrunning clutch. Two 12 volt batteries in series are used. The starting switch for this starting circuit is located in the control cubicle. A blower wheel alternator is utilized to maintain the battery charge. The stator is mounted on the engine block and the permanent magnet rotor is mounted into the air cooling system blower. Solid state diode rectifiers convert the alternating current generated in the stator to direct current for battery charging.

b. Anew (Style II) gear-reduction electric starter will be installed on engines manufactured during 1990; and will be available as a replacement when the original starter, (Style 1) is no longer available. The Style II starters are interchangeable with the Style I starter.

4-25. BATTERY ASSEMBLY.

CAUTION

Metal objects making contact between the positive and negative

battery terminals, or between the positive battery terminal and the generator frame can cause **FIRE** or **EXPLOSION**. Always keep the battery terminal covers on the battery terminals. See Figure 3-23.

a. Battery Cables (Including Jumper Cable) (see figure 4-16). On ASK equipped generators, remove BATTERIES access door.

(1) Test. Test battery cable for continuity. Replace any cable that does not show continuity.

(2) Remove. Remove negative battery cable from negative (-) battery terminal. Remove positive (+) battery cable from positive battery terminal.

Tag and disconnect cables from starter case and starter solenoid. Remove jumper between batteries. Clean battery, starter, and starter solenoid terminals thoroughly and install new cables as given below.

(3) Replace. Attach jumper cable between negative (-) terminal of one battery and positive (+) terminal of the other battery. Attach positive battery cable to the "B" Terminal stud on starter solenoid. Attach negative battery cable (-) to the ground terminal "G" of the starter. See figure 4-16. Attach positive cable (+) to positive terminal on one battery and negative cable (-) to negative terminal on the other battery. Tighten all terminal connectors securely.

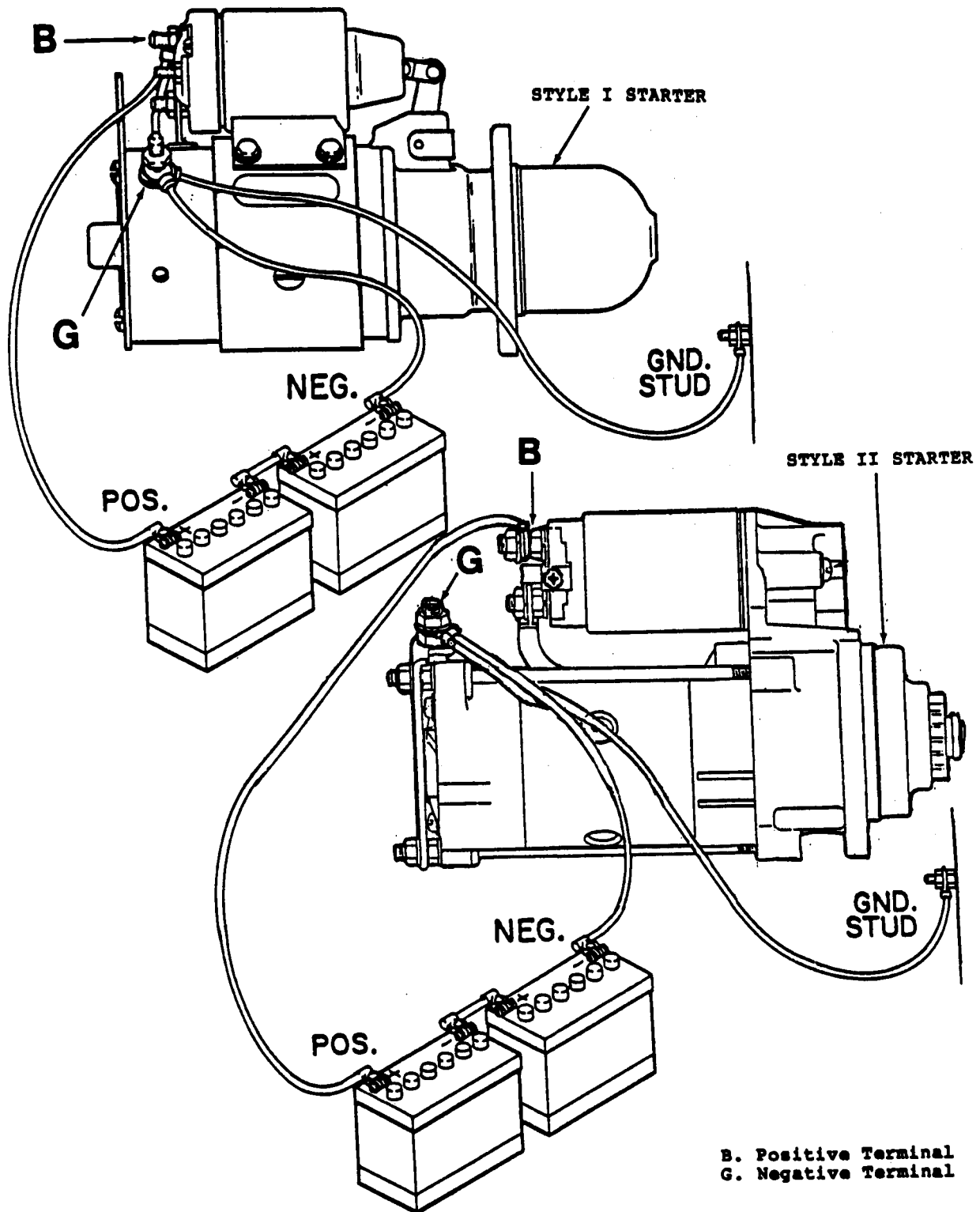

Figure 4-16. Installing Battery Cables.

NOTE

Always detach negative (-) cable first and reattach it last.

b. Battery Top (Hold-down) Frame (see figure 3-23).

(1) Remove. Tag and disconnect battery cables (10) and jumper cable (11) from batteries (1). Remove six nuts (4) and flatwashers (5) holding top frame (2) in place, and remove top frame. If hook bolts (3) do not need replacing, they need not be removed from frame (6).

(2) Replace. Hook six bolts (3) onto bottom frame (6). Place top frame (2) over batteries (1) making certain hook bolts slide through the top frame. Secure top frame in place with six flatwashers (5) and nuts (4). Reattach battery cables (10) and jumper cable (11).

(3) Repair. Straighten battery top frames making certain they fit securely over batteries and hold batteries in place.

c. Storage Batteries.

WARNING

Battery electrolyte can cause severe burns to the skin. Always flush exposed parts of the skin with water as quickly as possible.

(1) Test. Charge battery for a sufficient time for battery to be fully charged (1 to 2 hours). Test each cell of battery separately using a hydrometer. Remove cap from one cell and draw fluid from that cell into hydrometer. Hydrometer must register a specific gravity of 1.260 to 1.280. If specific gravity is below 1.260, charge battery. See figure 4-17. Replace fluid into cell and replace cap. Check each battery cell using this procedure. If one or more cells in a battery will not take a charge, replace battery.

(2) Remove. Remove battery cables and top frames, a and b above. Remove batteries from battery frame.

(3) Replace. Place batteries in battery frame with negative (-) terminals toward control panel end of generator and positive (+) terminals toward blower housing end of generator. Install battery top frame and battery cables as outlined above.

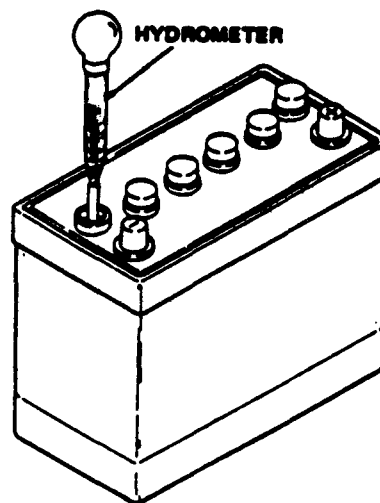

Figure 4-17. Testing Batteries

4-26. ENGINE STARTER ASSEMBLY

a. Test. On equipment (see figure 4-1 9). On ASK equipped generators, remove BATTERIES access door.

(1) Make sure batteries are fully charged and that all battery and starter cables are serviceable and properly installed. Disconnect all starter to solenoid connection.

(2) Connect voltmeter as shown in figure 4-19, Test a. If voltage is indicated, solenoid is defective. Proceed to step (4).

(3) Reconnect all starter to solenoid connections. Connect voltmeter as shown in figure 4-19, Test a. If battery voltage (24 volts) is not indicated, the starter (B1) may be defective. Proceed to step (4).

(4) Momentarily connect a jumper as shown in figure 4-19, Test b. Voltmeter reading should drop to zero and starter should crank engine. If voltmeter reading does not drop to zero, solenoid is defective. If voltmeter readings drop to zero but starter fails to crank engine, starter is defective.

b. Removal (see figure 4-18). On ASK generators remove batteries access door. Tag and disconnect leads (1) thru (6). On Style I Starters, remove nut (7), lockwasher (8), screw (9). Loosen but do not remove screw (10), lockwasher (11) and swing

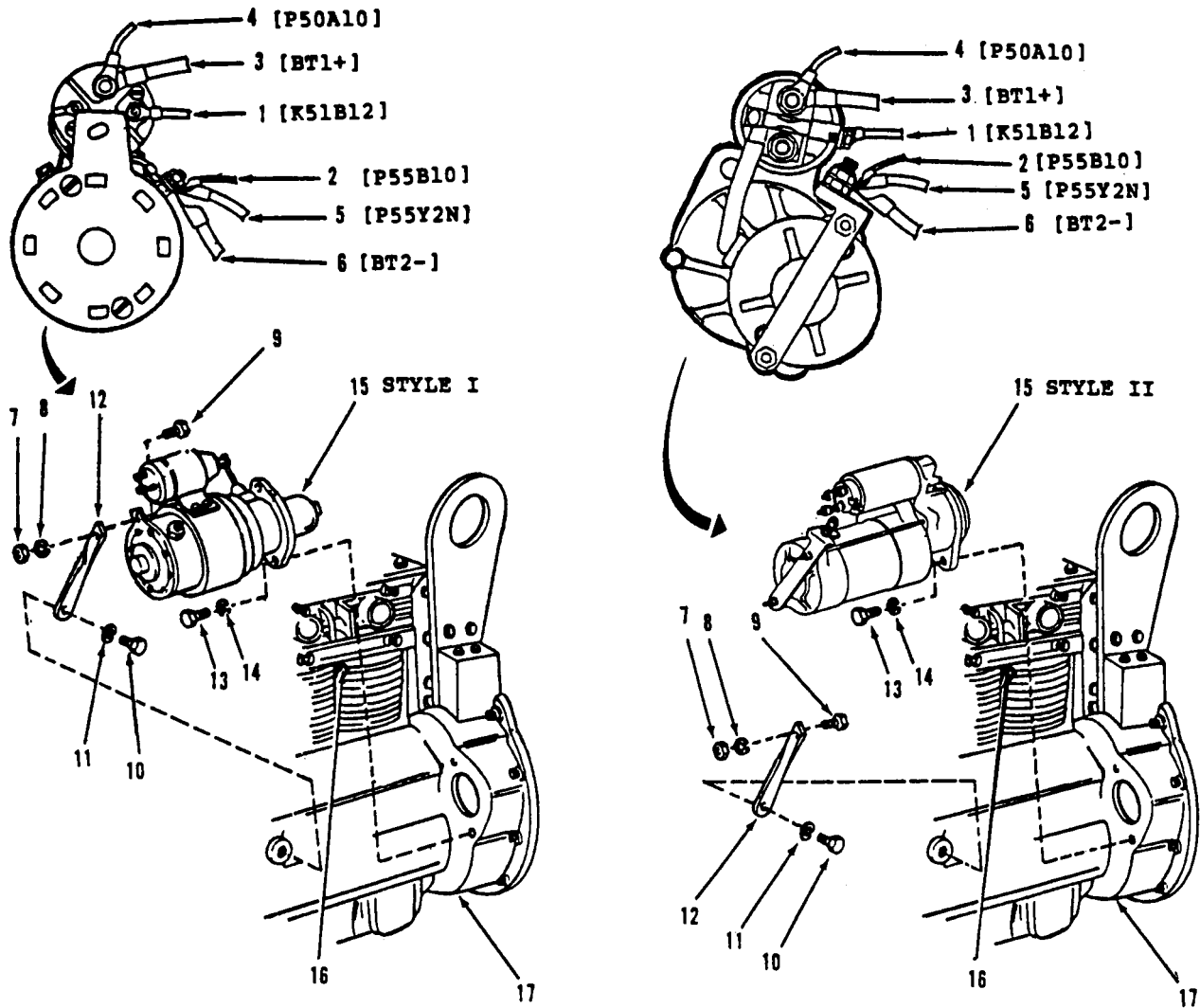

- | | | |
|------------------|---------------------|------------------------------------|
| 1. Lead [K51B12] | 7. Nut | 13. Screw (2) |
| 2. Lead [P55B10] | 8. Lockwasher | 14. Lockwasher (2) |
| 3. Lead [BT1+] | 9. Screw | 15. Starter |
| 4. Lead [P50A10] | 10. Screw | 16. High temperature cutout switch |
| 5. Lead [P55Y2N] | 11. Lockwasher | 17. Flywheel housing |
| 6. Lead [BT2-] | 12. Support bracket | |

Figure 4-18. Engine Starter Installation

support bracket (12) down and away from starter. On Style II Starter, support bracket is not fastened to the starter, loosen screw (10), lockwasher (11) and swing support bracket down and away.

NOTE

Support bracket and associated hardware must remain with engine at all times! It provides support for Style I Starters that may be used to replace Style II Starters during Operator and Organizational maintenance. The support bracket and associated hardware is supplied on all engines manufactured with either the Style I or Style II Starters.

Support starter (15) and remove screws (13), lock washers (14) attaching starter to flywheel housing (17). Slide starter out of housing.

c. Cleaning and Inspection of Starter Brushes Solenoid and Drive.

(1) Cleaning Starter. Refer to paragraph 3-16a.

(2) Inspecting Solenoid Switch.

(a) Style I Starter. Refer to figure 4-22. Inspect solenoid switch (1) for cracks, dents, or other physical damage. Check to see that the electrical terminals are clean and free of corrosion. Check that the rubber boot (2) on plunger (3), cotter pin (4), clevis pin (5), and yoke (6) are in good condition. Check that plunger (3) and yoke (6) operate freely. Check that solenoid switch (1) is securely fastened to the starter motor (8), with screws (14).

(b) Style II Starter. Refer to figure 4-22A. Inspect solenoid switch (3) for cracks, dents, or other physical damage. Check to see that the electrical terminals are clean and free of corrosion. Check that solenoid switch (3) is securely fastened to the starter motor (4), with screws (1).

(3) Inspecting Drive Assembly. Refer to figure 4-22 for Style I Starter and figure 4-22A for Style II Starter. Inspect drive gear for cracks or chipped teeth. Check that gear and spring of drive moves freely, and returns to rear position when released.

(4) Inspecting Brushes.

(a) Style I Starter. Refer to figure 4-21. Remove two through bolts (1) and lift end plate (2) away from frame. Lift brush tension springs (3) and lift each brush (4) from holder for inspection. Check brush face for deep surface pits, cracks, or excessive chipping. Measure brush length. See figure 4-21. When brush is worn to length less than 1/4 inch, notify higher level maintenance for replacement of brushes (4). Clean area around brushes and commutator and dry with low pressure compressed air. Lift brush springs (3) and insert brushes (4) in brush holder. Reposition end plate (2) on frame and insert and tighten through bolts (1) securely.

d. Bench Test.

(1) Starter Assembly. Refer to paragraph 4-26a.

(2) Field Coil. Connect continuity tester as shown in figure 4-19, Test c. An open circuit indicates a defective field coil.

Test for continuity between field coil lead and field frame as shown in figure 4-19, Test d. Continuity indicates that the field coil is shorted to the field frame.

(3) Field Coil. Style II Starter.

(a) Connect tester for continuity between the field coil brushes as shown in figure 4-20, Test C. An open circuit indicates a defective field coil.

(b) Connect tester for continuity between a field brush and stator frame as shown in figure 4-20, Test D. Continuity indicates that the field coil is shorted to the frame.

e. Repair. Style I Starter.

(1) Remove Solenoid. If solenoid is defective, remove as follows: Refer to figure 4-22. Remove nut and lockwasher holding lead (12) on small solenoid switch terminal. Remove nut and lockwasher from negative terminal (9) freeing lead (12). Remove nut and lockwasher from solenoid field terminal (11). Remove cotter pin (4) and clevis pin (5) from plunger (3) and yoke (6). Remove screws (14) and lift solenoid switch (1) from frame (8). Retain hardware from terminals for solenoid installation.

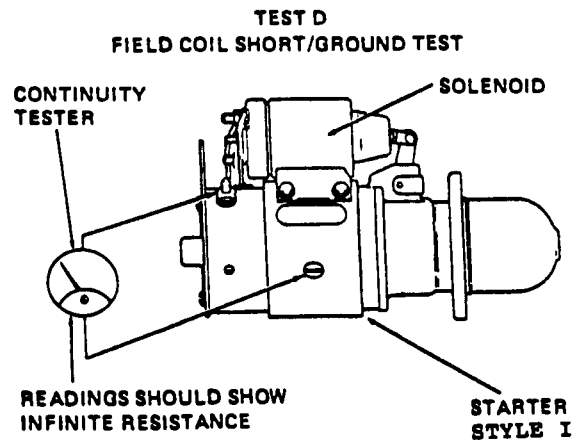
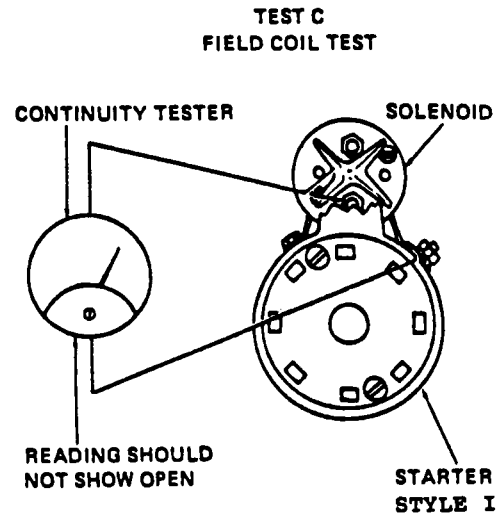
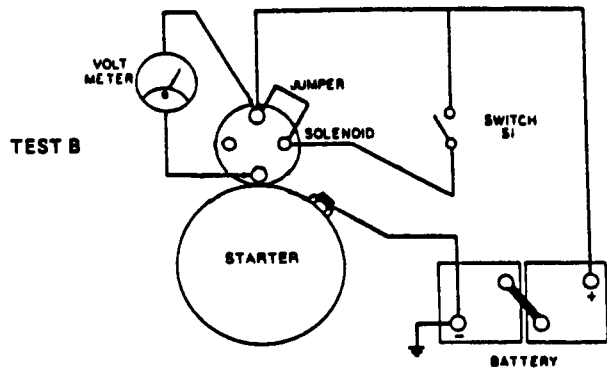
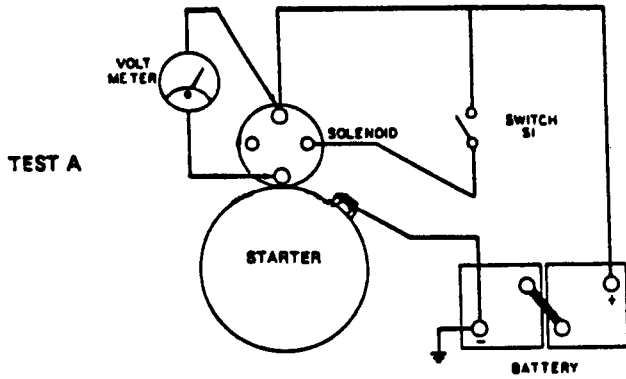

Figure 4-19. Testing Engine Starter

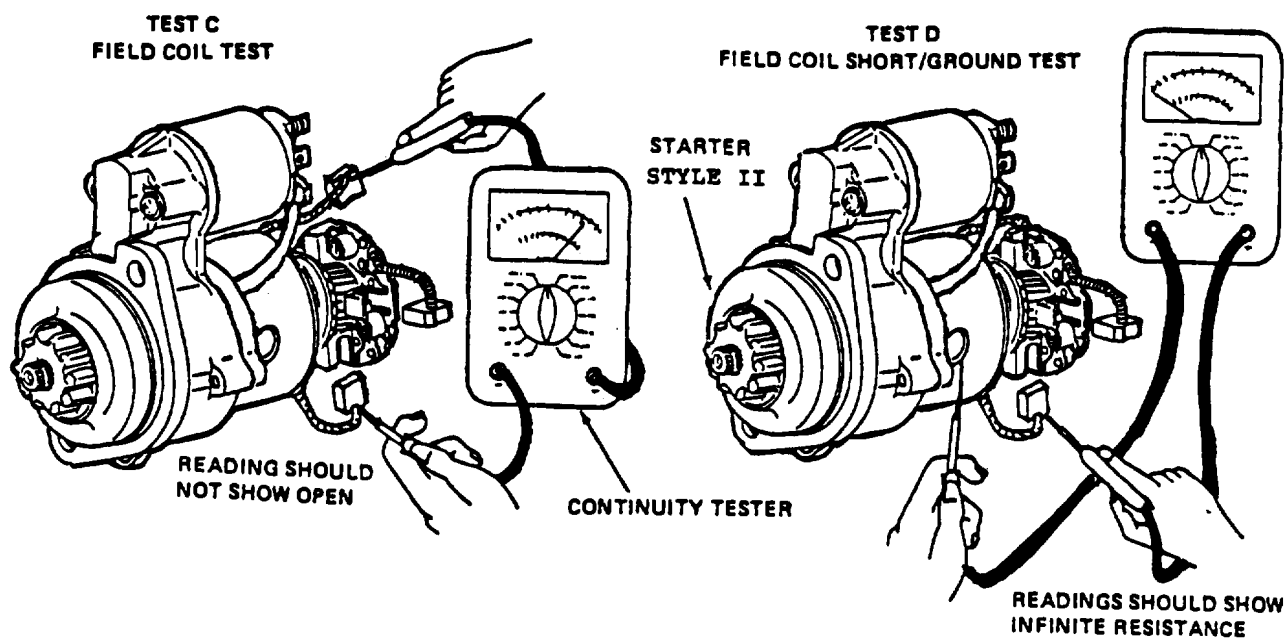

Figure 4-20. Testing Field Coil, Style II Starter

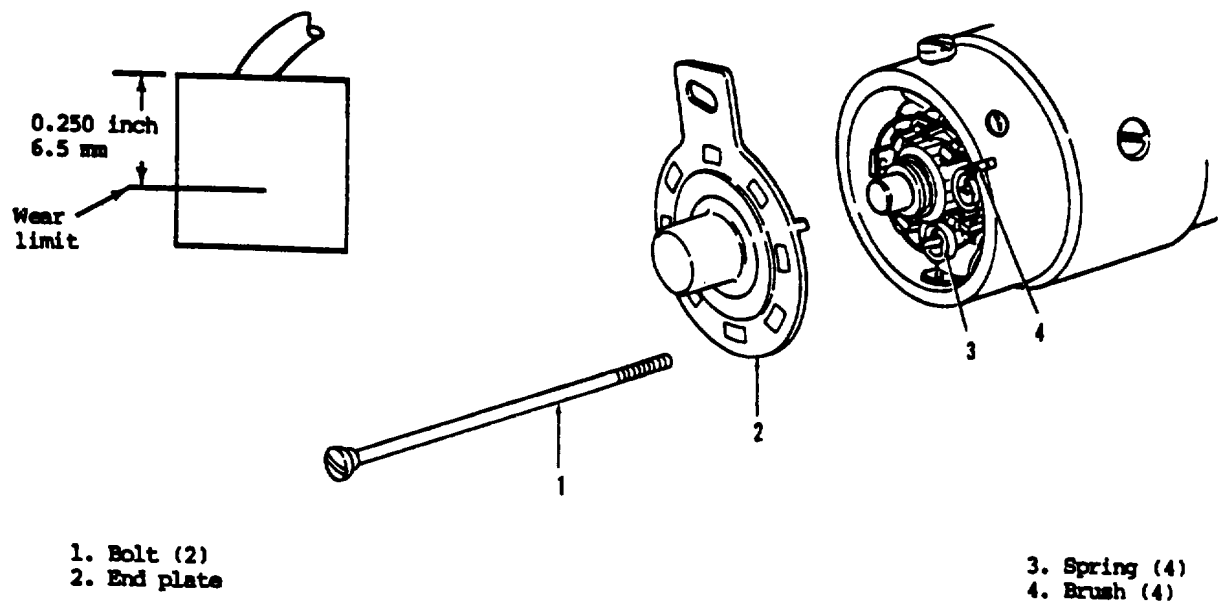
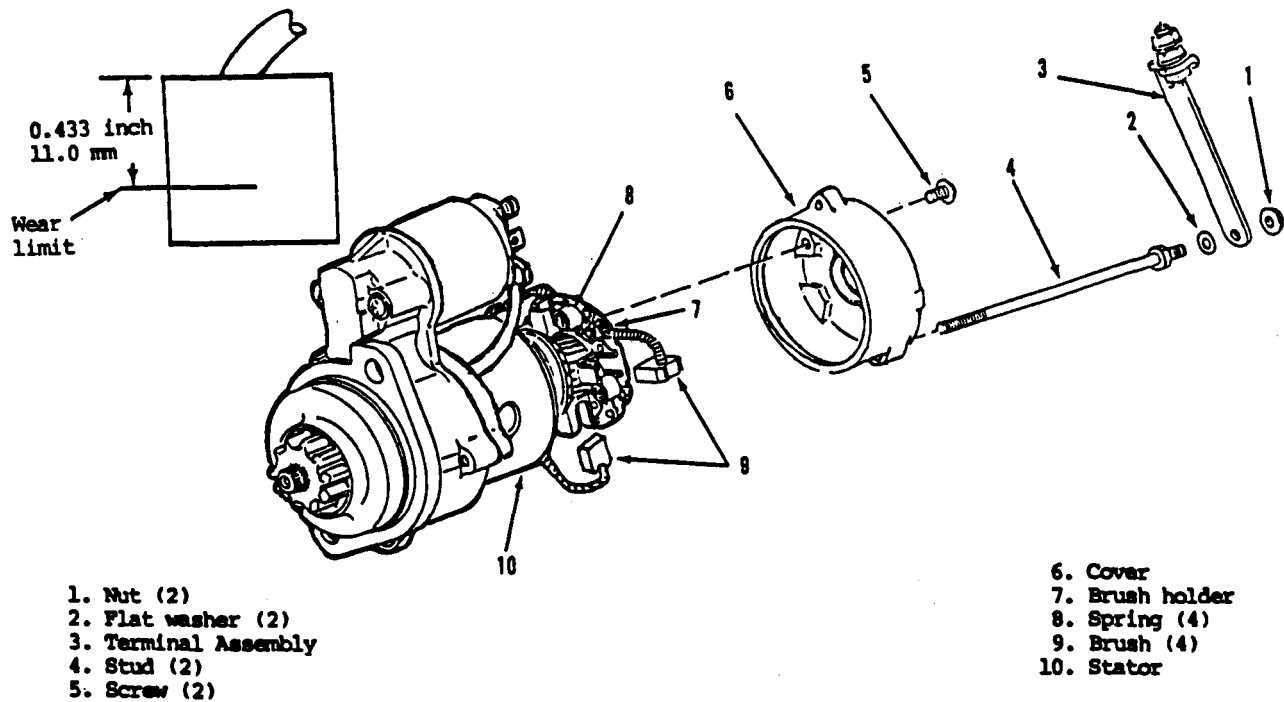

Figure 4-21. Inspecting Starter Brushes, Style I Starter



- 1. Nut (2)
- 2. Flat washer (2)
- 3. Terminal Assembly
- 4. Stud (2)
- 5. Screw (2)

- 6. Cover
- 7. Brush holder
- 8. Spring (4)
- 9. Brush (4)
- 10. Stator

Figure 4-21 A. Inspecting Starter Brushes, Style II Starter

(2) Install Solenoid. Refer to figure 4-22. Place solenoid (1) on frame (8) and move to rear until field terminal (11) enters field coil lead strap. Install nut and lockwasher, do not tighten. Install screws (14), do not tighten. Align the plunger (3) on yoke (6) and insert clevis pin (5) and secure with cotter pin (4). Install lead (12) on small solenoid terminal and on negative terminal (9) Secure with nuts and lockwashers. Tighten nut and lockwasher on field terminal (11), and screws (14)

f. Repair. Style II Starter.

(1) Remove Solenoid. If solenoid is defective, remove as follows: Refer to figure 4-22A. Remove nut and lockwasher on terminal (M) freeing lead (L). Remove screws (1), solenoid switch (3) and spacers (2). Retain hardware from terminal (M).

NOTE

Solenoid mounting screw removal may require the use of an impact type driver.

(2) Install Solenoid. Refer to figure 4-22A. Support new solenoid (3) and original spacer(s), engage solenoid plunger on lever(yoke), secure using new screws (1).

g. Install Starter. Refer to figure 4-18. Slide starter into opening in flywheel housing (17). Make certain starter lies flat against housing, Attach starter to housing with screws (13) and lockwashers (14). For Style I Starter, swing support bracket (12) into position at back of the starter, and attach with screw (9), nut (7) and lockwasher (8). Tighten screw (10) and lock washer (11) securing support bracket (12) to engine block. Replace tagged leads per diagram, figure 4-18. Remove tags.

4-27. BATTERY CHARGING ALTERNATOR.

a. Battery Alternator Stator (see figure 4-23). On ASK equipped generators; remove ASK cover assembly (para 5-3).

(1) Remove blower housing (see paragraph 4-17).

(2) Inspect. The presence of the blower wheel limits inspection of the battery alternator to inspecting that two leads (1) from stator (2) are free of damage and are not rubbing against blower wheel and are securely connected to terminal block (3) located on engine back plate (4).

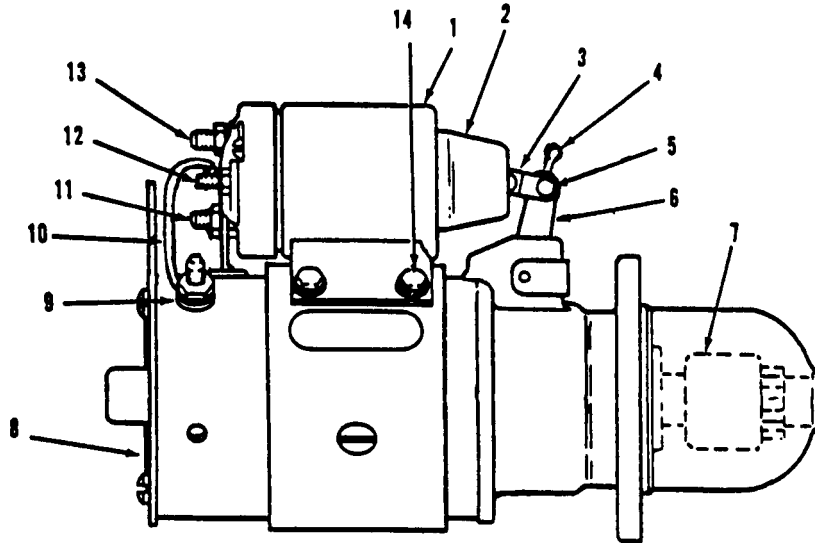

- | | | |
|--------------------|------------------------------|---------------------------------|
| 1. Solenoid switch | 6. Yoke | 11. Terminal Field |
| 2. Boot | 7. Drive assembly | 12. Terminal switch |
| 3. Plunger | 8. Starter | 13. Terminal battery (Positive) |
| 4. Cotter pin | 9. Terminal Field (Negative) | 14. Screw (4) |
| 5. Clevis pin | 10. Lead | |

Figure 4-22. Engine Starter Assembly, Style I Starter

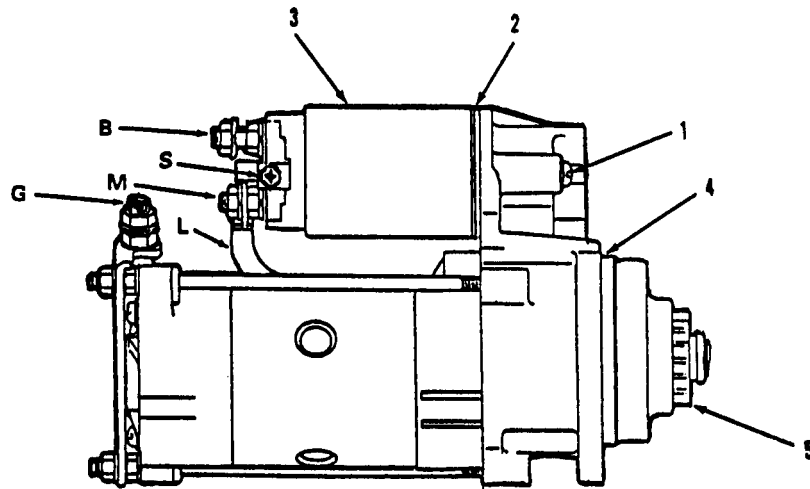

- | | |
|--------------------------------|--------------------|
| B. Terminal battery (Positive) | 1. Screw (2) |
| G. Terminal ground (Negative) | 2. Spacer(s) |
| L. Lead stator to solenoid | 3. Solenoid switch |
| M. Terminal motor | 4. Starter |
| S. Terminal switch | 5. Drive assembly |

Figure 4-22A. Engine Starter Assembly, Style II Starter

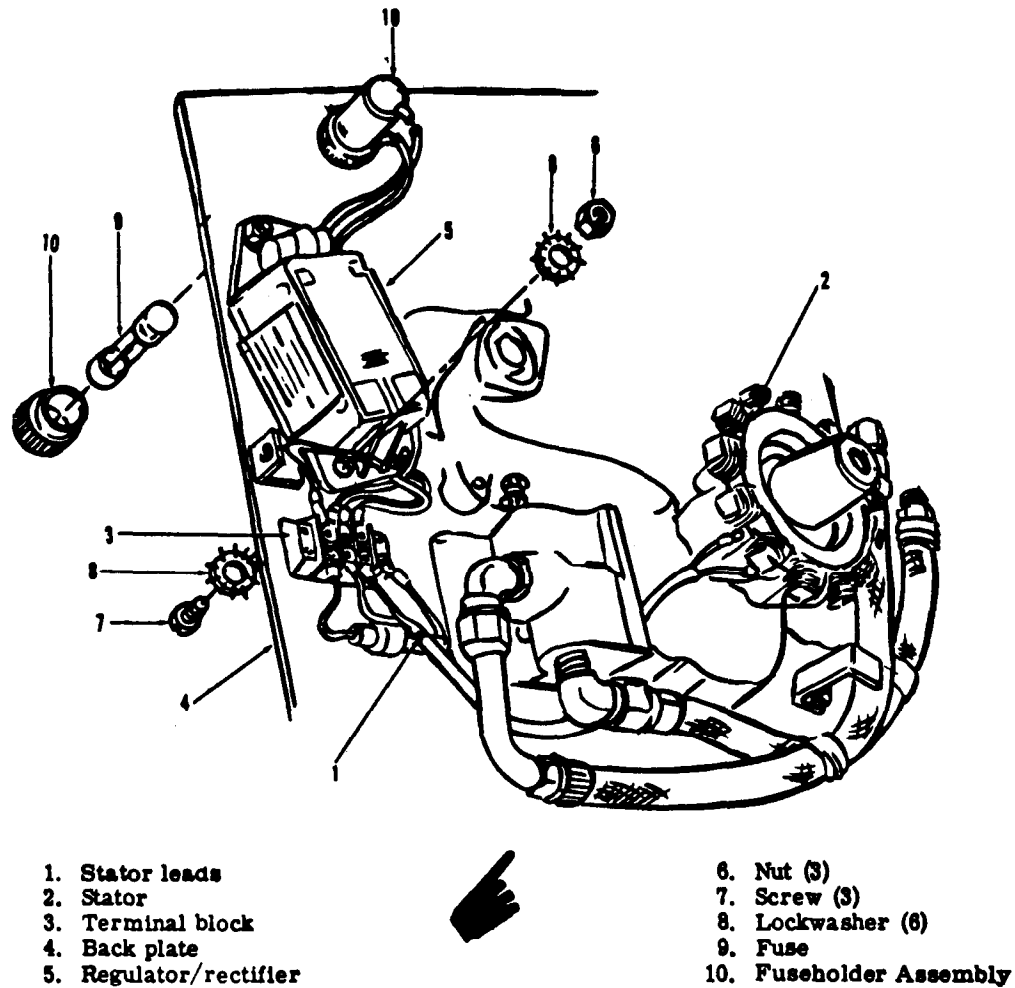

Figure 4-23. Battery Charging Alternator

WARNING

Avoid contact with blower wheel while testing battery alternator voltage.

(3) Test.

CAUTION

Do not operate unit more than 3 minutes with blower housing removed.

(a) Tag and disconnect stator lead (1) from stator at terminal block (3) Check between two stator leads for approximately 0.6 ohms continuity. If open or shorted, notify higher level of maintenance. Check for continuity between each lead and ground. If continuity is found, notify higher level of maintenance.

(b) With the stator leads (1) disconnected, check voltage across two leads (1) from stator. Voltage should be in a range of 30-35 volts AC with the engine operating normally at 1800 RPM. If voltage is less than 30 volts AC, stator on magnets in rotor maybe defective. Refer to higher level of maintenance for replacement of stator or rotor. Reconnect stator leads (1).

CAUTION

Avoid operation of Generator Set for more than 3 minutes with engine blower housing removed, as engine will overheat.

b. Battery Charging Regulator/Rectifier Assembly (see figure 4-23).

(1) Inspect. Inspect regulator/rectifier assembly (5) for physical damage. Check that leads from assembly to terminal block (3) are not damaged or frayed. Check that assembly is securely mounted to engine back plate (4).

(2) Test.

(a) Test stator as given in paragraph 4-27a above to see that it is operating correctly.

(b) Remove fuse (9, figure 4-23) and connect a 10 amp ammeter across the fuse holder terminals as shown in figure 4-24. With engine operating normally at 1800 RPM, charge rate should be no less than 6.5 amps when loaded by a discharged battery. Charge rate should taper-off as battery becomes charged.

NOTE

Observe proper polarity when making current test.

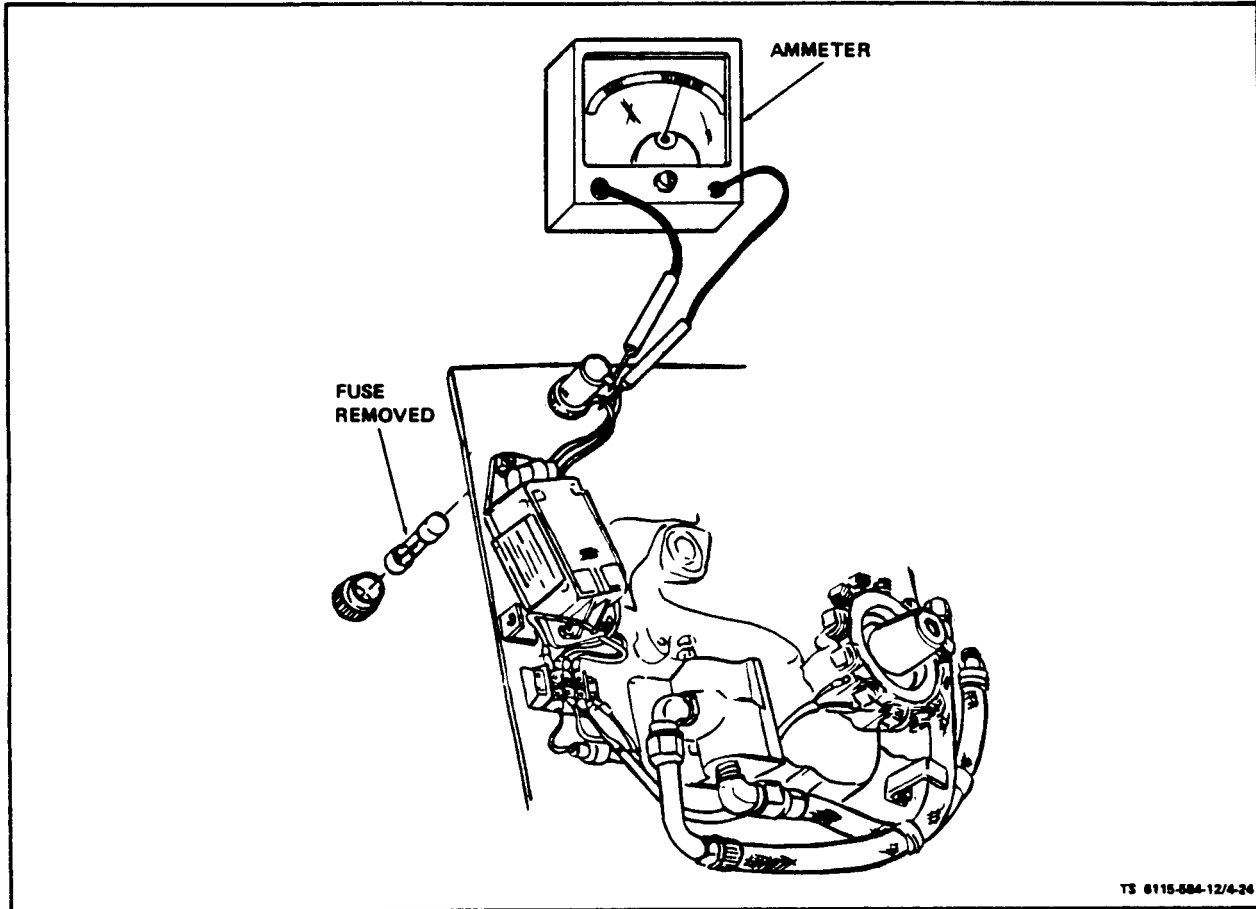

Figure 4-24. Testing Battery Charging Regulator/Rectifier Assembly

(3) Remove (see figure 4-23). Disconnect and tag leads on regulator/rectifier assembly. Remove screws (7), washers (8) and nuts (6) attaching assembly to engine back plate and remove assembly.

(4) Replace. Attach assembly to engine back plate with three screws (7), six lockwashers (8), and three nuts (6). Attach tagged leads from assembly.

c. Battery Charger Circuit Fuse (see figure 4-23).

(1) Inspect. Inspect fuse (9) for physical damage. Check that end caps on fuse are free of corrosion. Check that fuse is properly mounted in fuse holder.

(2) Test. Test fuse (9) for continuity using an ohmmeter. Replace fuse that does not show continuity.

(3) Replace. Remove fuse holder cap and remove fuse. Install new fuse in fuse holder body and attach fuse holder cap.

d. Terminal Block (see figure 4-23).

(1) Inspect. Inspect terminal block (3) for physical damage. Check that electrical connections to block are clean and tight. Check that block is securely fastened to engine back plate (4).

(2) Test. Tag and disconnect leads to terminal block. Check to see that there is no continuity between terminals on terminal block and ground.

(3) Replace. Tag and disconnect leads at terminal block. Remove two screws and nuts attaching block to engine plate and remove block. Attach new terminal block to engine back plate with two screws and nuts. Connect previously tagged leads to terminal block. Remove tags. On ASK equipped generators, install ASK cover assembly (para 5-3).

4-28. STARTER LOCKOUT SWITCH AND GEAR ASSEMBLY.

On ASK equipped generators, remove oil access door.

a. Inspect (see figure 4-25). Disconnect negative battery cable. Remove wing nut (1) and cover (3) and inspect switch contact points between contact spring (15) and adjusting screw (14) for physical damage.

b. Test. With engine off, disconnect switch at connector (8). Using an ohmmeter, test that there is

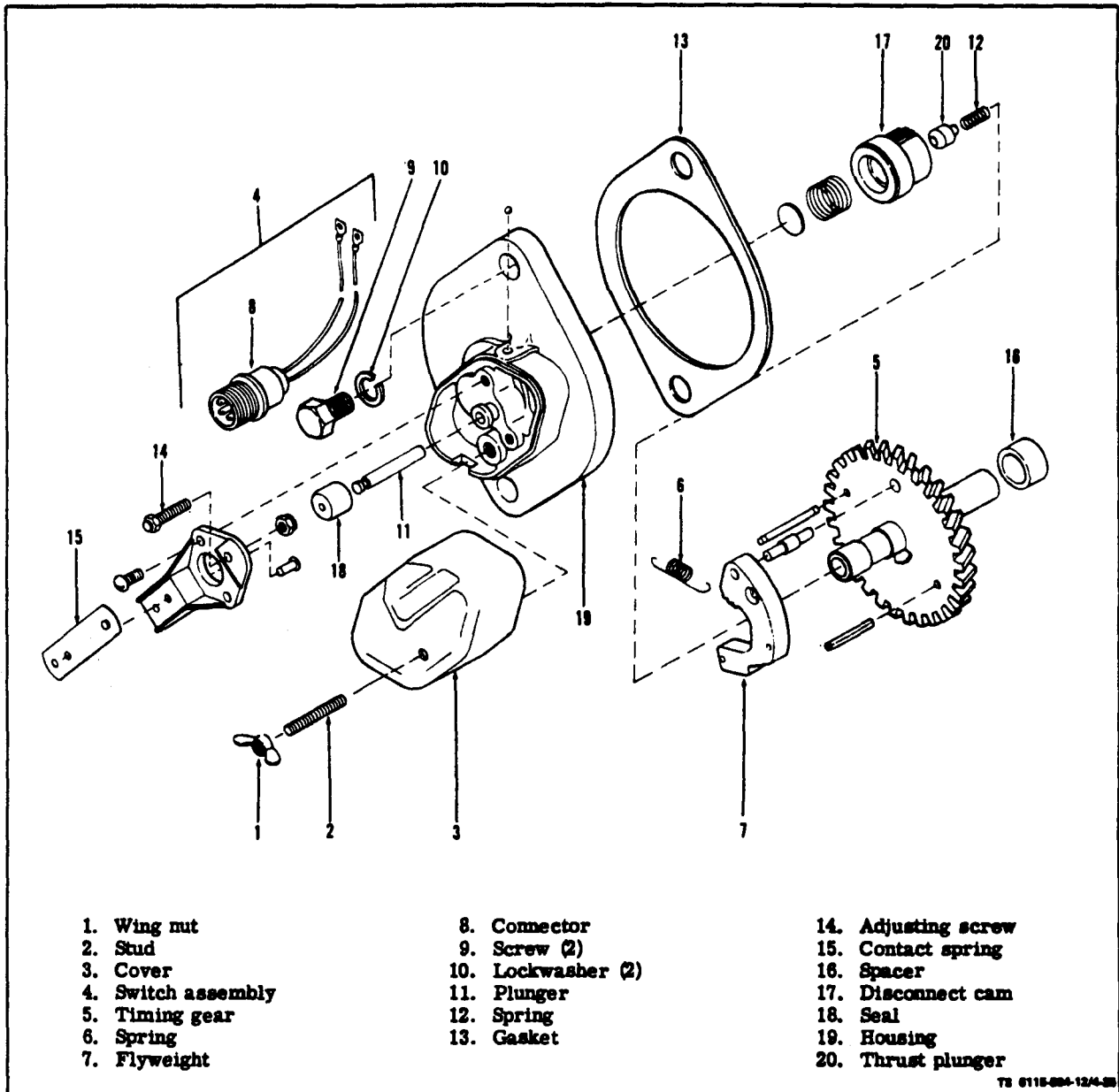

Figure 4-25. Starter Lockout Switch and Gear Assembly

continuity between connector (8) pins A and B on lead from switch. Reconnect switch, operate engine at operating speed disconnect connector (8) and between pins A and B On switch, check that switch is open (no continuity).

c. Remove. Disconnect switch lead from connector (8). Remove two screw (9) and lockwashers (10) attaching switch to engine back plate. Carefully remove switch taking care not to lose thrust plunger

(20) and spring (12). Slide gear (5) out through opening in engine back plate. Clean any gasket (13) material from switch and back plate.

d. Repair. Repair starter lockout switch by replacing parts found to be defective under inspection

e. Replace. Make certain spacer (16) is on shaft and slip timing gear (5) through opening in engine back plate. Make certain that shaft seats properly in gear cover and that gear teeth are properly meshed. Place thrust plunger (20) and spring (12) in gear shaft. Slide switch and gasket (13) over shaft and attach to engine back plate with two screws (9) and lockwashers (10). Use a new gasket (13) between switch and engine back plate. Reconnect electrical connector (8).

f. Adjust. With engine stopped, remove cover retaining wing nut (1) and remove cover (3). Turn adjusting screw (14) clockwise until points open. Turn adjusting screw counterclockwise until points just close (see figure 4-26). Start engine and disconnect switch from wiring harness at connector (8, figure 4-25). Adjust adjusting screw for a 0.040 point gap. Replace cover (3) and wing nut (1). Reconnect connector (8).

CAUTION

Be sure two wires are recessed in slot of housing before tightening cover down.

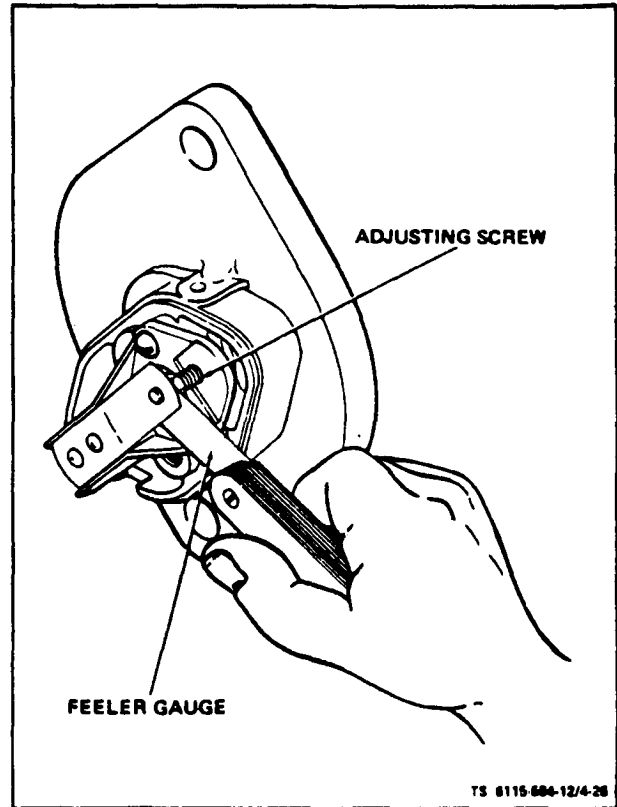

Figure 4-26. Adjusting Starter Lockout Switch

Section XI. MAINTENANCE OF OIL SYSTEM

4-29. FUNCTION AND DESCRIPTION

The diesel engine has pressure lubrication to all working parts (see figure 4-27). The oil system includes oil intake cup, gear type oil pump, bypass valve, oil pressure gauge, low oil pressure shutoff, full-flow oil filter, oil cooler, and passages to deliver oil throughout the engine. Oil is held in the oil base, and forced through the oil filter and oil cooler by the pump. Lines leading to the rocker housing, passages through the block to crankshaft and front camshaft bearing, crankshaft passages to connecting rod bearings and connecting rod passages to piston pin bushings complete the oil system network. The bypass valve controls oil pressure by allowing excess oil to flow directly back to the crankcase.

4-30. OIL COOLER

a. Inspect (see figure 4-28). On ASK equipped generators, remove ASK cover assembly (para 5-3). Inspect oil cooler (1) for physical damage. Visually check for leaks where oil cooler is connected to oil hoses (figure 4-29). Check that cooler is securely fastened to mounting plate (2, figure 4-28) and that plate is securely fastened to engine. Inspect all hoses for

leaks and physical damage. Inspect seal (1A, figure 4-28) and replace if damaged. Blower housing must be removed to inspect cooler and hoses.

b. Service. Every 500 operating hours clean oil cooler fins with air gun (50 psi) held 12 inches away from the fins. Every 2500 operating hours remove oil cooler and flush in both directions using solvent at 25 psi.

c. Remove. Remove blower housing. Disconnect oil cooler hoses at valve of oil filter adapter (see figure 4-29), Drain cooler into suitable container. Remove four machine screws (3, figure 4-26) and special U-shaped washers (4) attaching oil cooler (1) and oil cooler seal (1A) to mounting plate (2) and remove cooler (1). Remove and check hoses. Plug hose if not used immediately.

d. Replace. Install oil cooler (1) and oil cooler seal (1A) on mounting plate (2) and secure with screws (3) and special U-shaped washers (4). Attach oil hoses to cooler as shown in figure 4-29. Replace blower housing shown in figure 4-29. Replace blower housing, Replace any oil lost. On ASK equipped generators, replace ASK cover assembly (para 5-3).

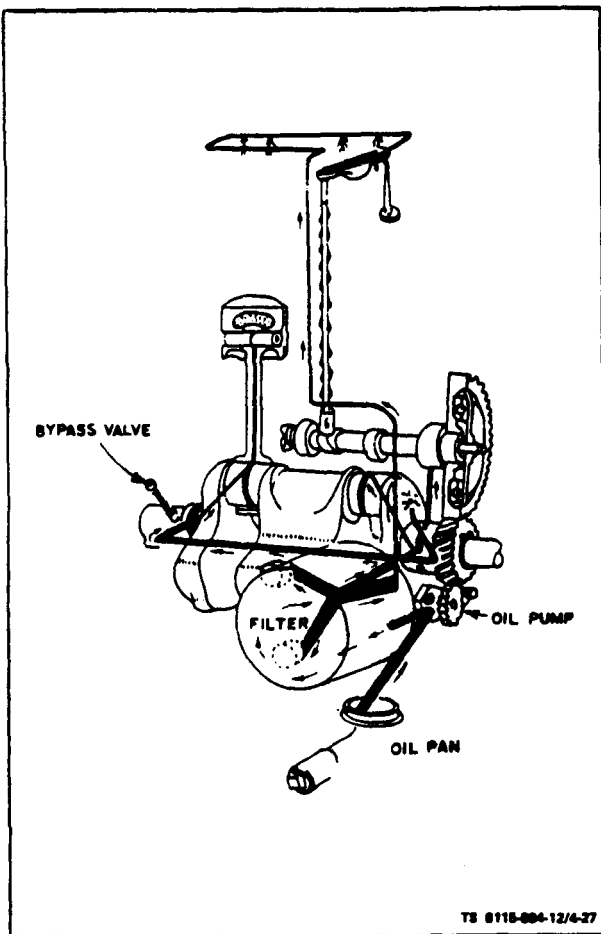

Figure 4-27. Pressure Oil System

4-31. LOW OIL PRESSURE SWITCH.

On ASK equipped generators, remove oil access door.

a. Test on Equipment (see figure 4-30). Disconnect leads from terminals 1 and 2. With master switch in off position, use ohmmeter to check for continuity between terminals 1 and 2 of switch. If continuity is indicated, replace switch. Connect leads to switch terminals 1 and 2.

b. Removal. Disconnect leads from terminals 1 and 2. Use wrench on square portion at base of switch (11) and remove from adapter (5).

c. Bench Test. Connect switch to a controllable supply of dry compressed air. Connect ohmmeter across terminals 1 and 2 and slowly apply compressed air. Switch should close (continuity) when 14 ± 2 psi of compressed air is applied.

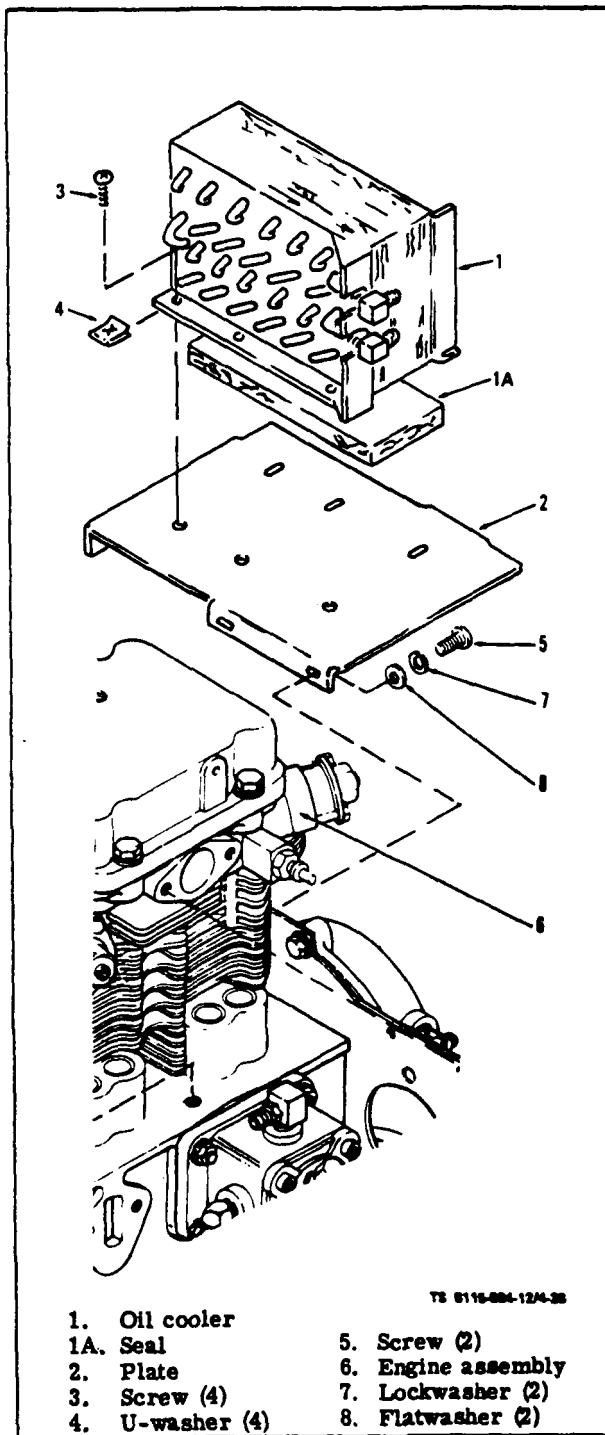

Figure 4-28. Oil Cooler Assembly

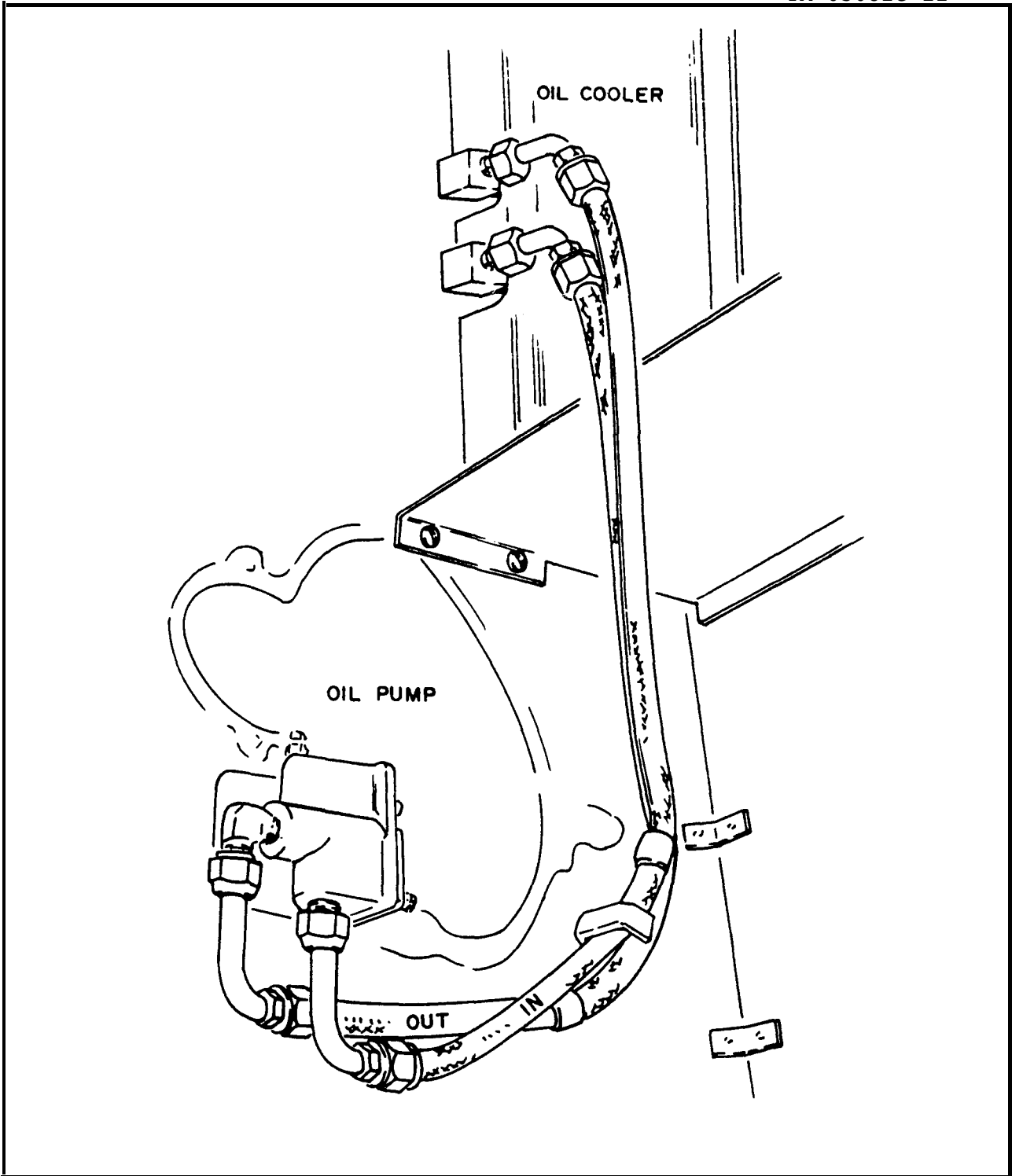

Figure 4-29. Replacing Oil Cooler Hoses

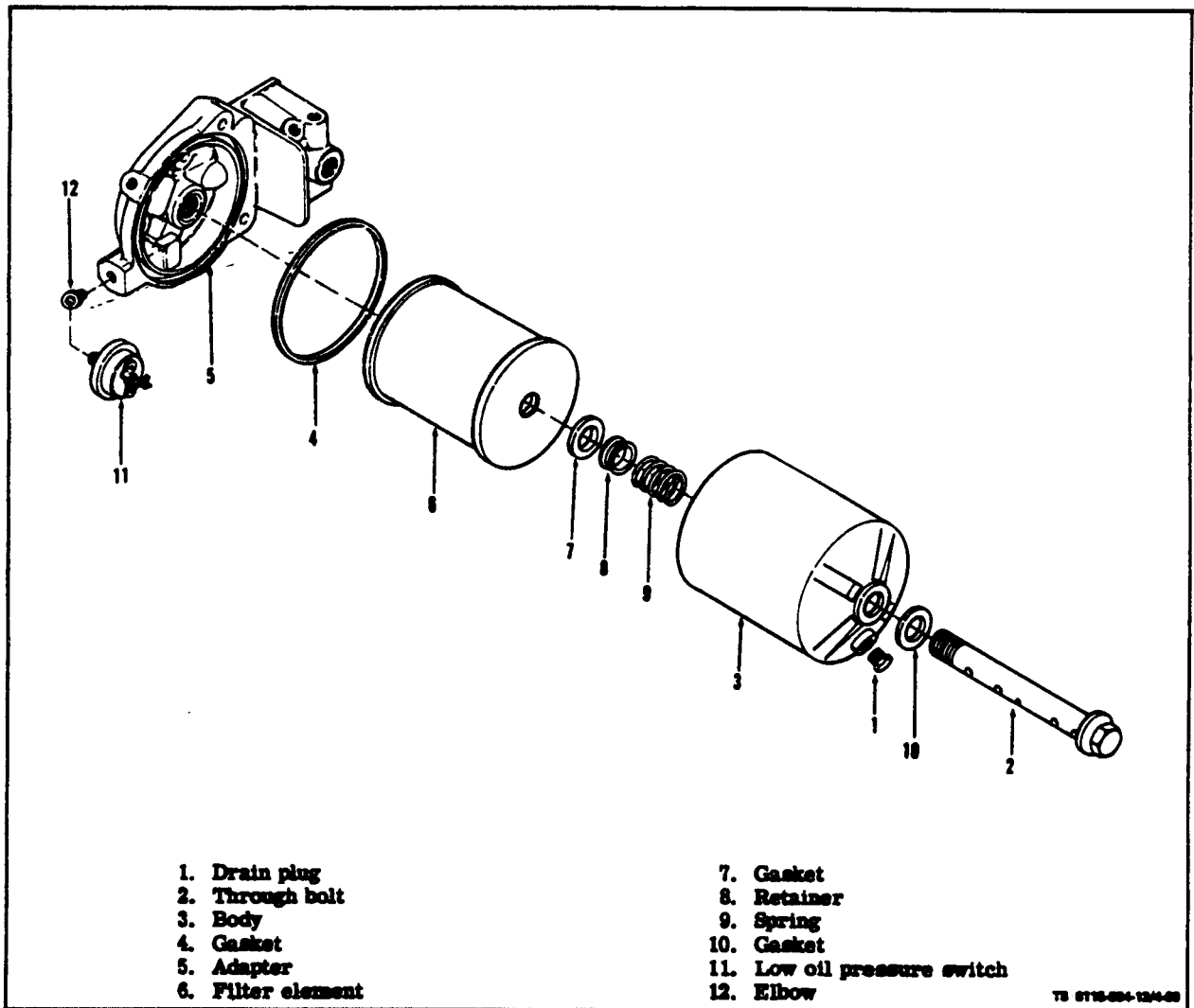

Figure 4-30. Oil Filter Assembly

d. Install. Install switch (11) in adapter (5) and tighten. Use wrench on square portion of switch base. Connect leads at terminals 1 and 2.

b. Remove. Drain oil filter into suitable container by removing drain plug (1). Loosen through bolt (2) and remove body (3). Remove and discard filter (6) and gasket (4).

4-32. OIL FILTER.

On ASK equipped generators, remove oil access door.

a. Service (see figure 4-30). Every 100 operating hours replace oil filter element. Clean inside of bowl while filter is removed. Replace defective hoses.

c. Replace. Clean filter mounting area in adapter (5) and inside of body (3). Install new element (6) in body (3). Install new gasket (4) in groove of adapter (5). Position body (3) (drain down) with element installed on adapter (6) and secure with through bolt (2). Tighten through bolt 10 to 15 ft-lb.

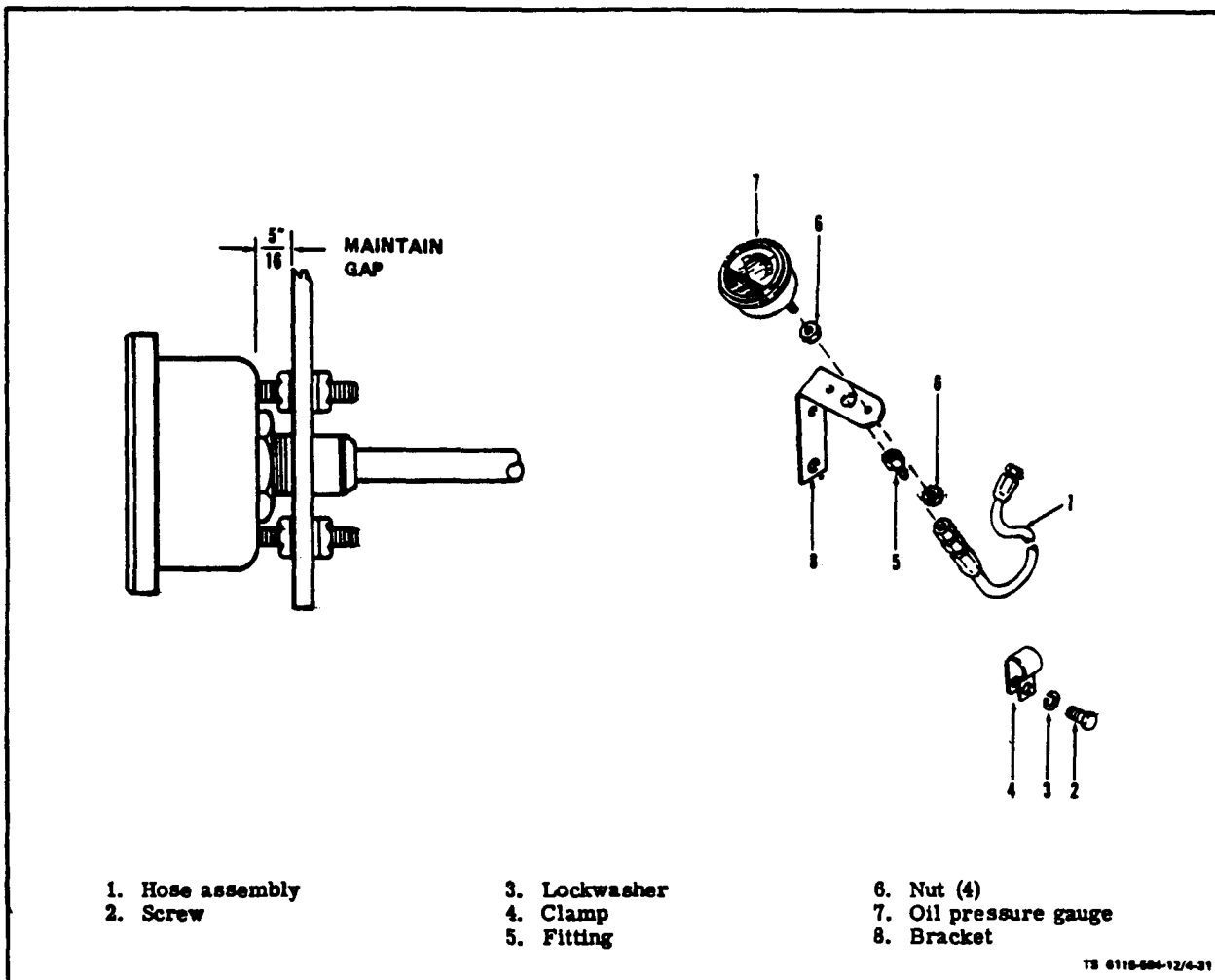

Figure 4-31. Replacing Oil Pressure Gauge

4-33. OIL PRESSURE GAUGE.

On ASK equipped generators, remove oil access door.

a. Test. Attach a pressure gauge of known accuracy between flexible oil line and unit pressure gauge. Operate unit for 1/2 hour and check that both gauges read the same. At rated RPM the normal oil pressure is 20 to 45 PSI which is dependent on air and engine temperature, grade of oil, and wear tolerance of engine. If the unit pressure gauge is in error by more than 5 lbs, replace.

b. Remove (see figure 4-31). Disconnect and drain oil line (1) top oil pressure gauge (7), Remove screw (2),

lockwasher (9), clamp (4) and remove oil Pressure gauge and bracket. Remove fitting (5) and nuts (6) attaching gauge (7) to mounting bracket (8) and remove gauge (7).

c. Replace. Install oil pressure gauge (7) on mounting bracket (8) with nuts (6) two on each side of bracket (8). Maintain gap between gauge and bracket as indicated on figure 4-31. Position oil pressure gauge and bracket on engine and install clamp (4), lockwasher (3) and screw (2). Connect and tighten oil line (1).

Section XII. MAINTENANCE OF CONTROL SYSTEM

4-34. DESCRIPTION AND FUNCTION.

NOTE

All symbols (CB2, S1, etc.) are the same as used on the wiring diagram, figure 1-7, and elsewhere throughout the manual.

4-35. DC CONTROL SYSTEM.

Operation of the dc control system is as follows. Operator controlled dc functions are all contained in three items mounted on the control panel. These are the dc circuit breaker (CB2), the master switch (S1), and the panel light switch (S2) (see figure 4-33).

a. The dc circuit breaker (CB2) controls all dc power to the unit. When it is de-energized (pulled out), all dc control circuits are de-energized, except the battery charging system which is self protected by fuse (F1). This breaker can be used for emergency stopping of the unit.

b. The master switch (S1) controls all starting and operating of the set under normal conditions. It is a five position rotary switch with the extreme position in either direction being a momentary position. The five positions control set operates as follows. When the master switch is placed in position 1, marked PREHEAT on control panel, a circuit is completed between terminals 11 and 15 of the master switch, this applies power to the coil of the preheat relay (K2). When the preheat relay contacts close, power is then applied to the glow plugs and preheater on the engine. This position of the switch should be used for starting any time the engine is cold, or has not been run for sometime. The normal period for preheating is 1 minute, but can be as long as 1 minute 30 seconds as conditions dictate. This switch position is momentary so that the preheat circuit remains activated only as long as the operator holds the switch in PREHEAT or START position. When the master switch is placed in position 2, marked OFF on control panel, all dc circuits are de-energized except the panel lights, battery indicator, and the battery charging system. This position is used to stop the set under normal operation. When the master switch is placed in position 3, marked PRIME & RUN AUX. FUEL on control panel, circuits are completed between terminals 11-13, 11-14, 11-17 of the master switch. This applies power to the engine fuel pumps, and the auxiliary fuel system and also to one side of an open contact of relay (K1). This position is used when the set is running and the auxiliary fuel system is being used, and also to prime the entire fuel system before starting. Position 4 of the master switch, marked PRIME & RUN on the control panel, is the same as position 3 except that the circuit between terminals 11-17, of the master switch is not made. This position is used when the set is running and the auxiliary fuel system is not being used, and also to prime the engine fuel system only before starting.

When the master switch is placed in position 5, marked START on the control panel, circuits are completed between terminals 11-13, 11-14, 11-15, 25-27, 25-28. The circuits between 11-13, 11-14, 11-15 activate the engine fuel pumps, apply power to one side of an open contact of relay K1 and activate the pre-heat circuit as described in previous positions of the switch. The circuit between 25-28 of the master switch bypasses the safety devices which are capable of stopping the engine. Bypassing the low oil pressure safety device (S5) is essential until the engine has sufficient oil pressure to close its contacts. Bypassing the safety device completes a circuit to the engine fuel solenoid and relay coil (K1). Energizing the start relay (K1) completes a circuit through the contacts of (K1) to the running time meter, and to one side of the low oil pressure switch. The circuit between 25-27 of the master switch applies battery voltage to the field flash resistor through diode (CR2). This action applies field flashing current to the exciter field. It sled applies power through diode (CR1), which prevents starting set when the battery polarity is reversed, and the closed contacts of the start disconnect switch (S7) to the crank relay coil (K3). When the crank, relay contacts close, a circuit is completed to the starter solenoid (K6), which closes and starts the cranking motor. With the engine fuel solenoid energized and the starting motor cranking the engine, the engine should start and accelerate toward the speed setting of the governor. When engine speed passes approximately 1000 RPM the start disconnect switch contact opens de-energizing the crank relay (K3) and in turn the start solenoid and starting motor. With the engine accelerating and ac voltage building up, the governor will take control of the engine and the voltage regulator will bring voltage to the value set by voltage adjust rheostat. By the time the Generator Set is under control of the regulator and governor, the engine oil pressure will be sufficient to permit returning master switch (S1) to the PRIME & RUN or PRIME & RUN AUX. FUEL position depending on desired set operation. The set will now be operating under control of the voltage regulator and governor but without any load. As stated above, the set is now ready to accept a load. Placing the ac circuit breaker in the ON position connects the selected generator output to the set load terminals. The breaker can be opened manually or by automatic action of the internal relay trip device in the case of an overload or a short circuit. The panel light switch activates the panel lights when placed in the ON position.

4-36. AC INSTRUMENTATION SYSTEM.

Operation of the ac instrumentation system which consists primarily of ammeter voltmeter and ammeter-voltmeter transfer switch is as follows. The function of the ammeter-voltmeter transfer switch (S8) and the meter switching section of the re-connection switch (S6) is to provide the connections

for correct readings of voltmeter and ammeter in all voltage connections and to ensure that the secondaries of the current transformers are never open circuited. This combination also ensures that when the Generator Set is connected for 3 phase operation that no

meter indications will be obtained with the ammeter. voltmeter transfer switch (S8) in positions 5 or 6, which are single phase positions. It also ensures the reverse of this condition for positions 1, 2, 3, and 4 of switch (S8).

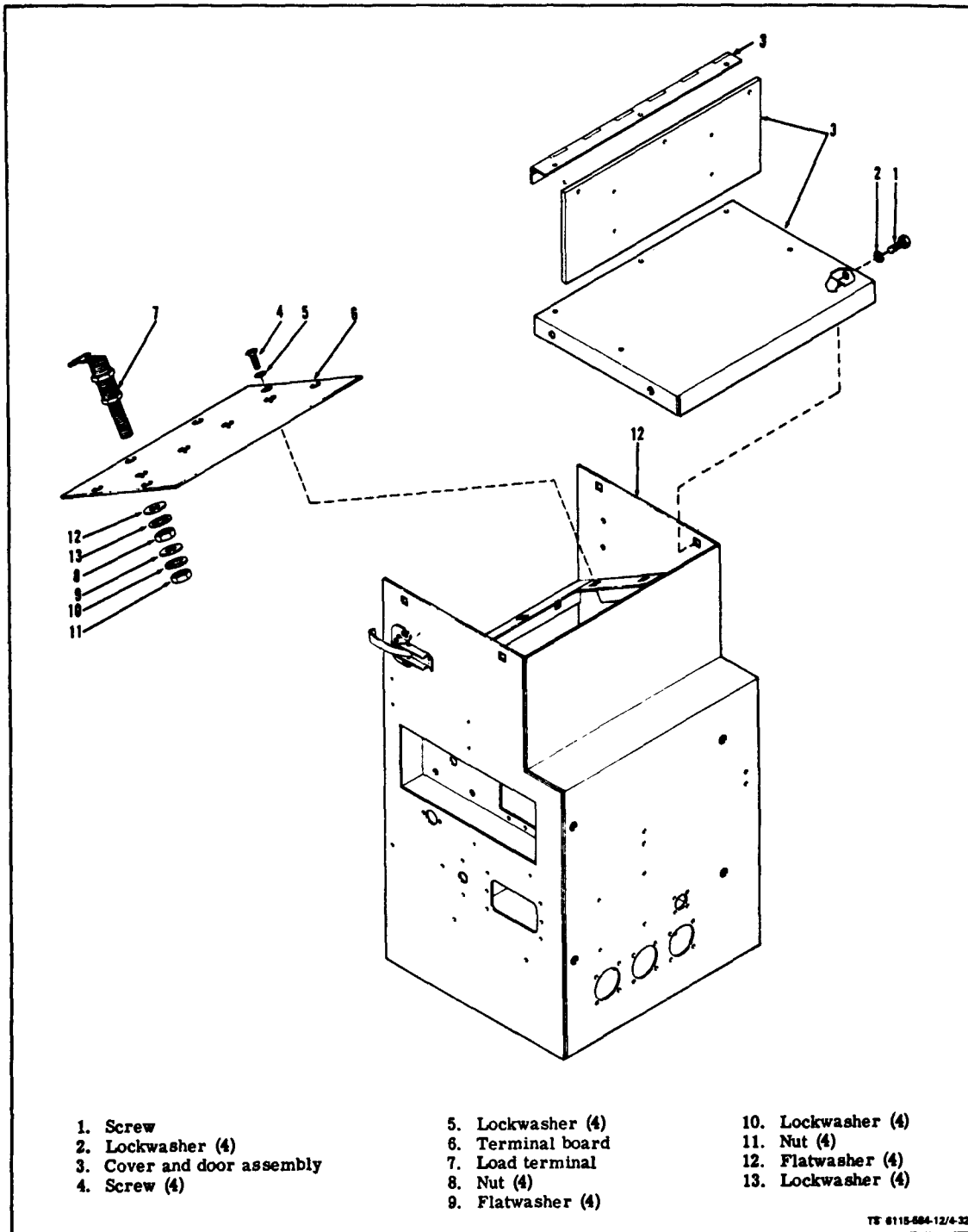

Figure 4-32. Load Terminal Board Assembly

4-37. LOAD TERMINAL BOARD ASSEMBLY.

a. Load Terminal Removal (see figure 4-32).

- (1) Unlatch door (3).
- (2) Remove screws (1), lockwasher (2), and cover and door assembly (3).
- (3) Remove screws (4) and lockwashers (5).
- (4) Carefully lift terminal board (6) and tag and disconnect leads from load terminals (7) by removing nut (11), lockwasher (10) and flatwasher (9).
- (5) Remove load terminal (7) from terminal board (6) by removing nut (8), flatwasher (12) and lockwasher (13).

b. Load Terminal Installation (see figure 4-32).

- (1) Install load terminal (7) to terminal board (6) by installing lockwasher (13), flatwasher (12) and nut (8).
- (2) Connect leads to terminals (7) by installing flatwashers (9), lockwashers (10) and nut (11).
- (3) Install lockwashers (5) and screws (4).
- (4) Install door assembly (3), lockwashers (2) and screws (1).

(5) Latch door.

c. Replacement of Lost or Broken Terminal Clip (Retainer Safety Clip), The terminal clip is a component of both the load terminal and the ground terminal. If the terminal clip is lost or broken, fabricate as follows:

(1) Requisition bulk wire NSN 9505-00-804-3814 (0.042 inch diameter) for the ground terminal (ground stud). Requisition bulk wire NSN 9505-01-049-0144 (0.050 inch diameter) for the load terminal.

(2) Cut off about 3 inches of the wire, short enough to keep the clips from touching another terminal or the generator frame in the open or closed position,

(3) Slip the wire through the hole in the terminal.

(4) Hold the terminal as shown (Detail A, figure 4-32.1) and bend both ends of the wire straight up keeping the wire in as straight a line as you can with terminal body.

(5) Bend the wire into back-to-back 90° angles (Detail B, figure 4-32.1) so that the legs of both angles are about one-half inch long.

(6) Bend the ends of each 90° angle down and around into a U-shape (Detail C, figure 4-32.1) so that if done properly, the clip will hold the nut when it is unscrewed to install the cable (Detail D, figure 4-32.1).

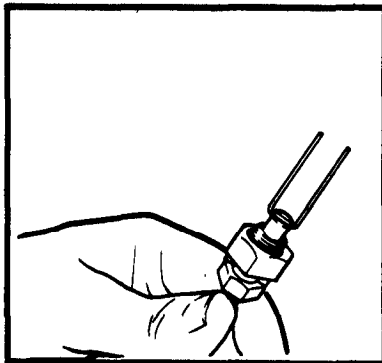

DETAIL A

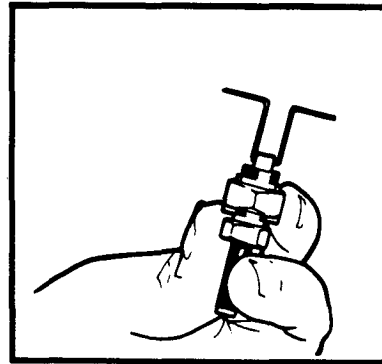

DETAIL B

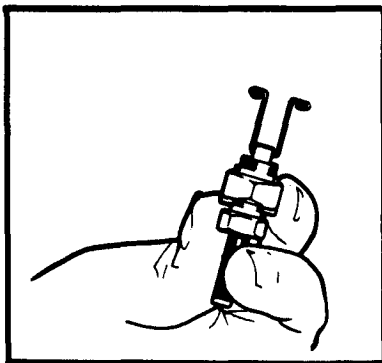

DETAIL C

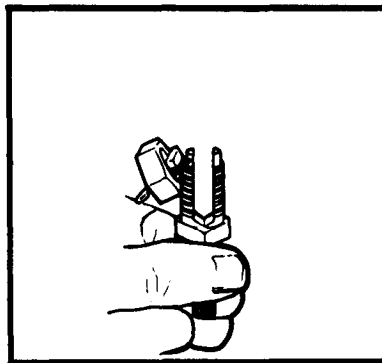

DETAIL D

Figure 4-32.1. Terminal Clip Replacement

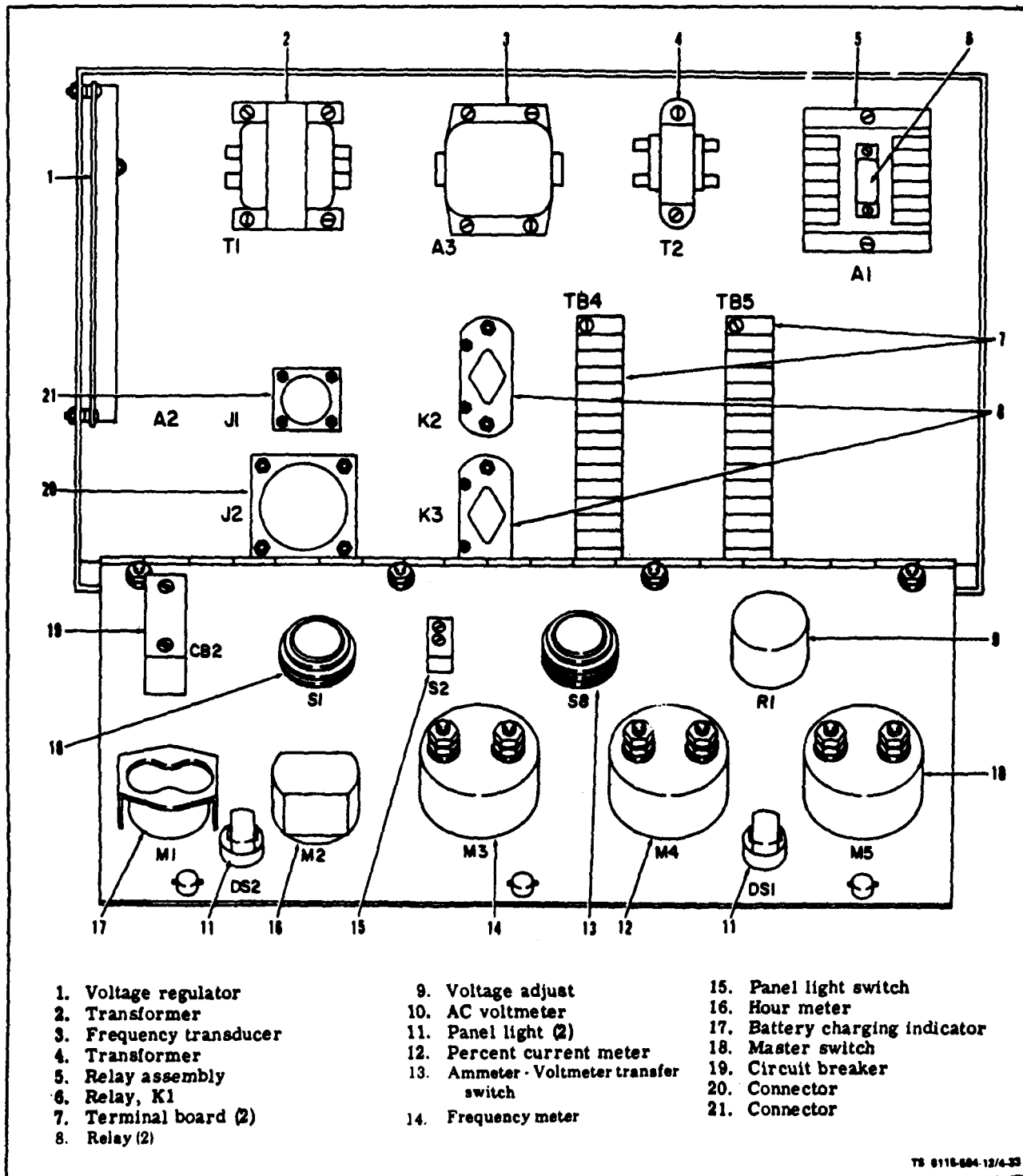

Figure 4-33. Control Cubicle Assembly

4-38. CONTROL CUBICLE ASSEMBLY.

a. Test, On Equipment (see figure 4-33).

NOTE

When disconnecting leads from terminals, tape leads to prevent electrical shorts.

(1) Control Cubical. Perform operational test on control cubicle, checking for proper operation in each of the Generator Set's three modes using a voltmeter of known accuracy. Check that ac output voltage indicated on control panel matches output voltage at terminal board. Check that Generator Set does come to an EMERGENCY STOP when dc control circuit breaker (figure 2-3) is pulled. Test individual components of the control cubicle as given below. See figure 4-33 for location of components.

(2) With the generator operating at rated speed or 60 Hz, flash the generator field by placing the master switch on the control cubicle in the start position. If the generator voltage fails to build up after flashing, the control cubicle may be defective.

(3) Voltage Adjust Rheostat (R1). Turn the Ammeter Voltmeter transfer switch to its various positions. For each position of the switch, turn voltage adjust rheostat to its extreme positions, Voltage readings should be as follows. Voltage adjust range shall be between 205 and 220V for the 120/208V, 3 phase, 4 wire connection. Between 114 and 126V for the 120V, 1 phase, 2 wire connection. Between 228 and 252V for the 120/240V, 1 phase, 3 wire connection.

(4) Panel Light Assemblies (DS1) and (DS2). With a good incandescent lamp in place and 24 vdc present at terminals of panel light (panel light switch ON) check that lamps do not light.

NOTE

Be certain panel light switch is OFF before installing or replacing panel light assembly.

(5) Hour Meter (M2). Operate Generator Set. Check hour meter against a known accurate time source. Replace meter if necessary.

(6) Battery Charging Indicator (MI), Connect meter capable of reading at least 35 volts DC from terminal on battery charging indicator to ground. Operate Generator Set. With the needle in the yellow area, the meter should read between 18 and 27.5 volts. With the needle in the green area, the meter should read between 24.5 and 31.5 volts. NOTE: The apparent overlap in voltage between the yellow high and green low is the result of a plus or minus 1.5 voltmeter tolerance.

(7) DC Control Circuit Breaker (CB2). Operate Generator Set. Pull circuit breaker (CB2). If generator does not come to an emergency stop, stop the unit using master switch and replace breaker.

CAUTION

Disconnect battery cable before making checks, unless otherwise noted.

(8) Master Switch (S1). Disconnect battery. Tag and disconnect seven leads to master switch. Using an ohmmeter, check for continuity between terminals for each of the five switch positions as given in table 4-3. If continuity is not found for each set of terminals listed, replace master switch.

(9) Panel Light Switch (S2). Tag and disconnect two leads to panel light switch. Using an ohmmeter, test for continuity between terminals on switch. With the switch in the OFF position, there should be no

Table 4-3 Master Switch Continuity Check

Switch Position	Check for Continuity Between Terminals
PREHEAT	11-15
OFF	NONE
RUN AUX FUEL	11-13-17
RUN	11-13
START	11-13-15 25-27-38

Table 4-4. Voltmeter-Ammeter Range Selector Switch Continuity Check

Switch Position			Check for Continuity Between Terminals				
volts	Phase	Amps					
L1-L2	3	L1	11-15	21-23	31-33	41-46-47	51-52
L2-L3	3	L2	11-17	21-24	31-33	41-42-47	51-53
L3-L1	3	L3	11-17-18*	21-25	31-33	41-42-43	51-54
L3-L0	3	L3	11-18	21-26	31-33	41-42-43	51-55
L3-L1	1	L3	11-12	21-27	31-37	41-42-43-45	51-56
L3-L0	1	L3	11-12	21-28	31-37	41-43-45-46	51-57

* Terminal 17 is jumped to terminal 18.

continuity. With the switch in the ON position, there should be continuity. Replace switch if necessary.

(10) Ammeter . Voltmeter Transfer Switch (S8). Tag and disconnect sixteen leads to range selector switch. Check for continuity between terminals for each of the six switch positions as given in table 4-4. If continuity is not found for each set of terminals listed, replace switch.

(11) Relays (K1), (K2), (K3), Assembly A-1, CR-1, and CR-2. Open circuit breaker (CB2). On ASK equipped generators, remove batteries access door. Disconnect battery cable. Tag, disconnect and tape terminals lugs of the following: A1 and A2 on crank relay (K3), A1 and A2 on preheat relay (K2), and A1-4 and A1-3 on relay assembly A1, Tag and disconnect terminals A1-5, A1-6, A1-7, and A1-8 on relay assembly A1. Test for shorted or open diodes CR-1 and CR-2 by using an ohmmeter. Connect positive lead of the ohmmeter to A1-5 and negative lead to A1-6, ohmmeter should indicate high resistance, then reverse the leads and ohmmeter should indicate low resistance. Connect positive lead of the ohmmeter to A1-7 and negative lead to A1-8, ohmmeter should read high resistance, then reverse leads and ohmmeter should read low resistance. Replace defective diodes that fail the above test. Reconnect wire to A1-5, A1-6, A1-7, and A1-8 to A1 relay assembly. Reconnect battery cable, close circuit breaker (CB2). Hold master switch in START position and using an ohmmeter check for continuity between terminals A1 and A2 on crank relay K3 and A1-3 and A1-4 on A1 relay assembly. Continuity should end when master switch is released. Repeat test for preheat relay K2 holding master switch in PREHEAT position. Replace defective relays. Reconnect wires to relay K2, K3, and A1 relay assembly.

(12) Terminal Board Assemblies (TB4) and (TB5). Tag and disconnect leads to terminal boards. Test from each terminal to ground for shorts. Replace board if any terminal shows continuity to ground.

NOTE

On ASK equipped generators, access to J1 and J2 is through air intake door.

(13) Wiring Harness. Test wiring harness by using an ohmmeter checking continuity of each wire. Perform point to point checks between points indicated on figure 1-10. Wiring harness need not be totally disconnected for checking continuity.

(14) Transformer (T1) (see figure 4-33). Tag and disconnect five leads to transformer T1. Using an ohmmeter check primary winding by measuring resistance from terminal H1 to H2. Resistance should be 18.6 ohms \pm 1.86 ohms. Check secondary winding by measuring resistance from terminal X1 to X3. Resistance should be 1.6 ohms \pm .16 ohms. If either of the windings do not show the proper resistance, replace transformer.

(15) Transformer (T2) (see figure 4-33). Tag and disconnect four leads to transformer T2. Check primary winding by measuring resistance from terminal H1 to H2. Resistance should be 155 ohms \pm 15.5 ohms. Check secondary winding by measuring resistance from terminal X1 to X2. Resistance should be 18.8 ohms \pm 1.88 ohms. If either of the windings do not show the proper resistance, replace transformer.

b. Remove.

(1) Control Cubicle. On ASK equipped generators, remove rear panel assembly (para. 5-7). Open air intake door. Tag and detach two connectors for wiring harness from control cubicle (see figure 1-2). Remove screw (6, figure 4-34) and nut (8) attaching ground strap to cubicle support frame. Remove four screws (2), lockwashers (3) and flatwashers (4) attaching control cubicle to vibration mounts (5) and remove cubicle (1).

c. Inspect.

(1) Inspect the control cubicle assembly per paragraph 3-19.

(2) Frequency Transducer (A3) (see figure 4-33). Inspect transducer for physical damage. Check to see that the electrical connections to transducer are clean and tight. Check to see that transducer is securely attached to the control cubicle.

TM 5-6115-584-12
NAVFAC P-8-622-12
TO-35C2-3-456-1
TM-05682C-12

(3) Relay Assembly (A1). Inspect relay assembly (5) for physical damage. Check that electrical connections to assembly are clean and tight. Check that assembly is securely attached to control cubicle.

(4) Relay (K1). Inspect relay (6) for physical damage and continuity (see figure 4-33.1). Remove relay from socket and inspect for bent or missing pins. Check that relay is secured to socket with two screws.

d. Disassembly.

(1) Panel Light Assemblies (DS1) and (DS2) (see figure 4-33). Tag and detach two leads to each panel light assembly (DS1) and (DS2). Remove nut and lock-washer securing light assembly to control panel and remove light assembly.

(2) Hour Meter (M2). Tag and disconnect two leads to hour meter. Remove three screws, lock-washers, and nuts attaching hour meter to control panel and remove meter.

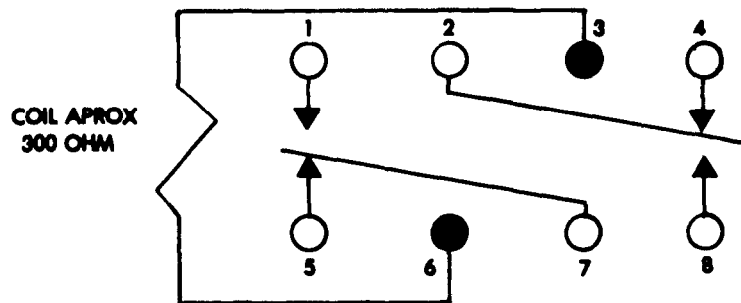

Figure 4-33.1. Relay K1.

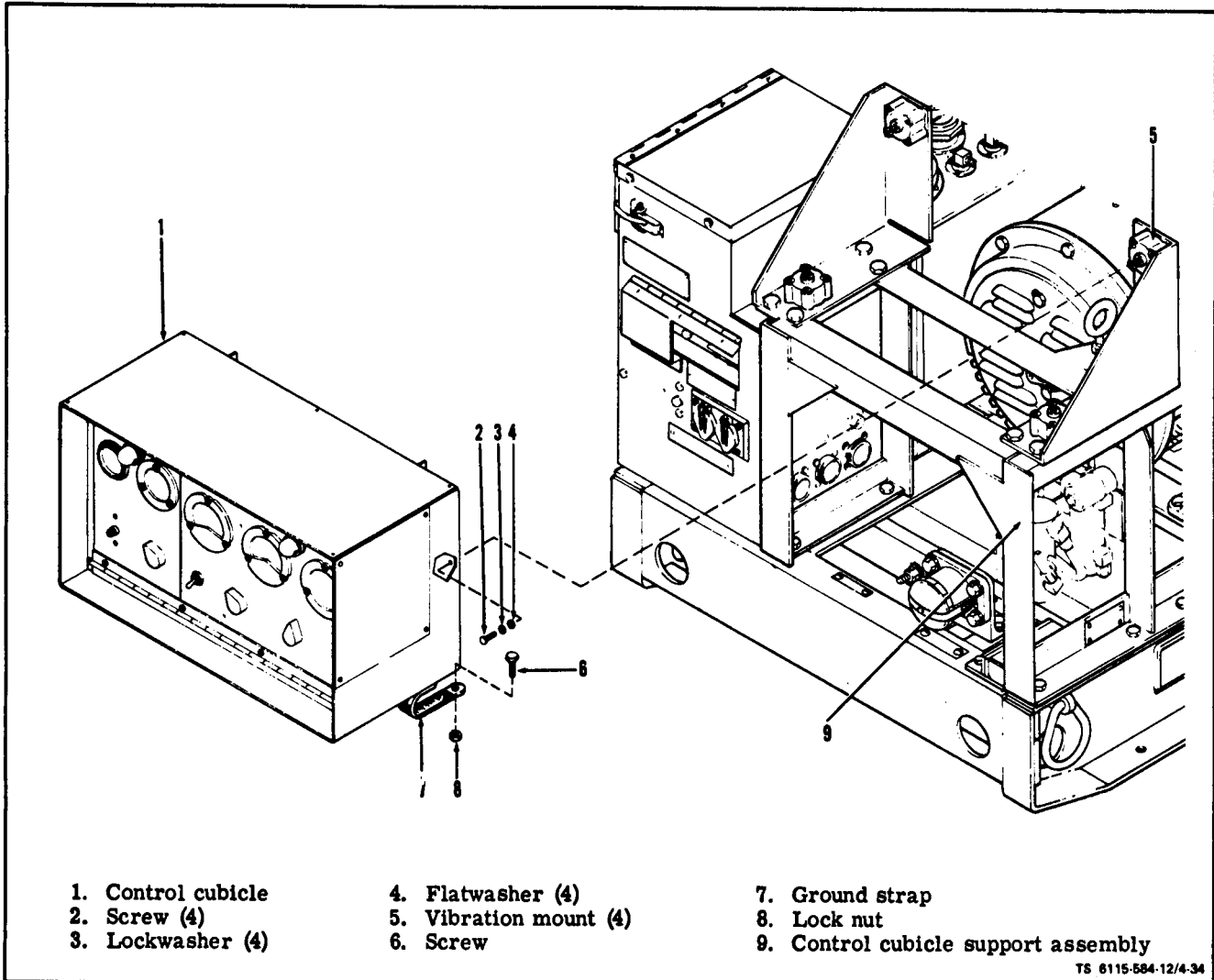

Figure 4-34. Removing Control Cubicle Support Assembly

(3) Battery Charging Indicator (M1). Tag and disconnect lead to indicator. Remove two lockwashers and nuts and retainer holding meter in place and remove indicator.

(4) DC Control Circuit Breaker (CB2). Disconnect two leads to breaker. Remove two screws attaching breaker to control panel and remove breaker.

(5) Master Switch (S1). Disconnect battery. Tag and disconnect seven leads to master switch. Remove switch knob by loosening two setscrews. Remove nut attaching switch to control panel and remove switch.

(6) Panel Light Switch (S2). Tag and disconnect two leads to switch. Remove nut attaching switch to control panel and remove switch.

(7) Ammeter - Voltmeter Transfer Switch (S8). Tag and disconnect sixteen leads to range selector switch.

Remove switch knob by loosening two setscrews. Remove nut attaching switch to control panel and remove switch. Install new switch as given above.

(8) Voltage Adjust Rheostat (R1). Tag and disconnect two leads to rheostat. Remove rheostat knob by loosening two allen setscrews. Remove nut and washer attaching rheostat to panel and remove rheostat (9).

(9) Transformer (T1). Tag and disconnect five leads to transformer. Remove four screws and lockwashers attaching transformer to control cubicle and remove transformer.

(10) Transformer (T2). Tag and disconnect four leads to transformer. Remove two screws and lockwashers attaching transformer to cubicle and remove transformer.

TM 5-6115-584-12
NAVFAC P-8-622-12
TO-35C2-3-456-1
TM-05682C-12

(11) Relay (K2-K3). Disconnect battery. Tag and disconnect four leads to relay. Remove two screws and nuts attaching relay to control cubicle.

(12) Terminal Board Assemblies (TB4 and TB5). Tag and disconnect leads to terminal boards. Remove two screws and nuts attaching board to control cubicle and remove board.

NOTE

TB4 has 27 leads and TB5 has 36 leads.

e. Assembly.

(1) Panel Light Assemblies (DS1 and DS2). Attach new light assembly to control panel with the nut and lockwasher supplied with each assembly. Attach two tagged leads to each panel light (if necessary refer to wiring diagram, figure 1-7).

(2) Hour Meter (M2). Attach hour meter to control panel with three screws, lockwashers, and nuts provided with meter. Attach two tagged leads to meter (if necessary, refer to wiring diagram, figure 1-7).

(3) Battery Charging Indicator (M1). Slide battery charging indicator into opening in control panel. Place retainer over back of indicator and secure with two lockwashers and nuts. Attach lead to indicator (if necessary, refer to wiring diagram, figure 1-7).

(4) DC Control Circuit Breaker (CB2). Attach circuit breaker to control panel with the two screws. Reconnect tagged leads to breaker (if necessary, refer to wiring diagram, figure 1-7).

(5) Master Switch (S1). Attach master switch to control panel with nut and key ring provided with switch. Make certain key on key ring aligns with slot in control panel. Push switch knob onto shaft and attach with two allen screws. Attach seven tagged leads to switch (if necessary, refer to wiring diagram, figure 1-7).

(6) Panel Light Switch (S2). Attach panel light switch to control panel with nut and key ring. Make certain key on key ring aligns with slot in control panel. Attach two tagged leads to switch (if necessary, refer to wiring diagram, figure 1-7).

(7) Ammeter . Voltmeter Transfer Switch (S8). Attach range selector switch to control panel with nut and key ring. Make certain key on key ring aligns with slot in control panel. Push switch knob onto shaft and attach with two allen screws. Attach sixteen tagged leads to switch (if necessary, refer to wiring diagram, figure 1-7).

(8) Relay (K1). Plug new relay into socket on relay assembly A1 and secure with two screws.

(9) Relay (K2 and K3). Attach relay to control cubicle with two screws and nuts. Reconnect four tagged leads per wiring diagram, figure 1-7.

(10) Terminal Board Assemblies (TB4) and (TB5). Attach board to control cubicle with two screws and nuts. Attach tagged leads to board (if necessary, refer to schematic, figure 1-10).

(11) Voltage Adjust Rheostat (R1). Attach rheostat (9) to control panel with nut and lockwasher provided with rheostat. Make certain that rheostat aligns with slot on panel. Push rheostat knob onto shaft and attach using two allen screws. Attach two tagged leads to rheostat per wiring diagram, figure 1-7.

(12) Transformer (T1). Attach transformer to control cubicle with four screws and nuts. Connect five tagged leads to (T1) per wiring diagram, figure 1-7.

(13) Transformer (T2). Attach transformer to control cubicle with four screws and nuts. Connect four tagged leads to (T2) per wiring diagram, figure 1-7.

f. Bench Test. Connect the control cubicle as shown in figure 4-35 and proceed as follows.

(1) Position switches as follows:

- (a) Master switch-stop
- (b) Panel light switch-off
- (c) S1-closed
- (d) S2-open

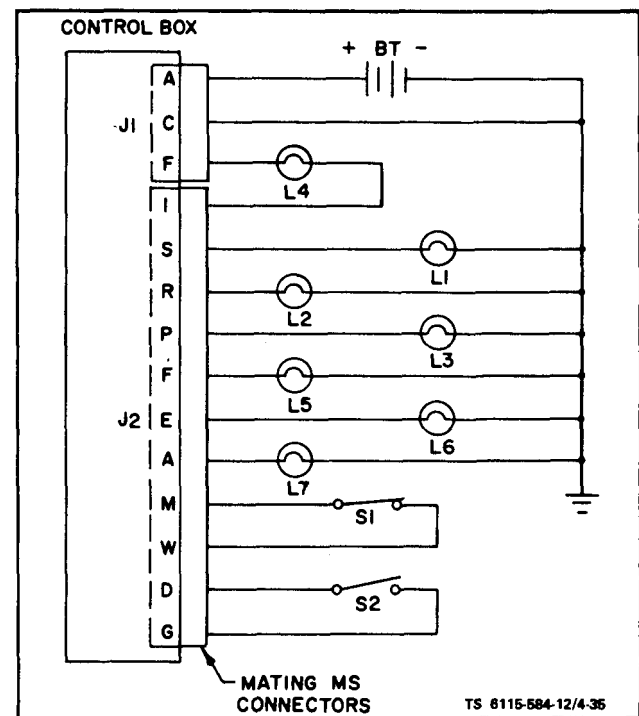

Figure 4-35. Control Cubicle Test Set-Up

(2) Place master switch in preheat position. Lamps L2 and L3 shall light indicating that the preheat circuitry is correct.

(3) Place master switch in start position. Lamps L1, L2, L3, L4, L5 and L6 shall light indicating that all circuits for starting are correct.

(4) With the master switch in the start position, open switch S1. Lamp L1 shall extinguish indicating that the start disconnect circuitry is correct.

(5) With the master switch in the start position. Close switch S2 and then, place the master switch in the prime and run position. Lamps L2 and L3 shall extinguish. Lamps L4, L5 and L6 shall remain lit indicating that the prime and run circuitry are correct.

(6) With the master switch in the prime and run position and lamps L4, L5 and L6 lit open switch S2. Lamp L4 shall extinguish indicating that the engine protective devices circuit and the prime circuit is correct.

(7) Repeat the procedure of step 5, except that the master switch shall be placed in the prime and run aux fuel position after closing switch S2. Lamps L4, L5, L6 and L7 shall remain lit indicating that the prime and run aux fuel circuitry is correct.

(8) With the master switch in the prime and run aux fuel position and lamps L4, L5, L6 and L7 lit open switch S2. Lamp L4 shall extinguish indicating that the engine protective devices circuit and the prime circuit is correct.

(9) Place master switch in the stop position. All lamps shall be out indicating that all stop circuits are correct.

(10) Place panel light switch in the on position. Panel lights shall be on indicating that the panel light circuit is correct.

(11) Reposition all switches as in step 1 and disconnect test setup.

(12) Test CR1 and CR2 as follows:

(a) Remove wires from terminals 6 and 7 of A1.

(b) Measure forward and backward resistance of CR1 between terminals 5 and 6 of A1. Resistance should read high in one direction and low in the other. If not, CR1 is bad.

(c) Measure forward and backward resistance of CR2 between terminals 7 and 8 of A1. Resistance should read high in one direction and low in the other. If not, CR2 is bad.

g. Install.

(1) Control Cubicle. Attach control cubicle (1, figure 4-34) to four vibration mounts (5) with four screws (2), lockwashers (3), and flatwashers (4). Attach ground strap (7) to cubicle support frame with screw (6) and nut (8). Attach two connectors from wiring harness to connectors on back of control cubicle. On ASK equipped generators, install rear panel assembly (para. 5-7).

Section XIII. MAINTENANCE OF ENGINE

4-39. DESCRIPTION AND FUNCTION.

(See figure 4-36.) The engine assembly is a two cylinder, air cooled, overhead valve, fuel injected diesel equipped with; a blower housing (1) and a shutter assembly (2) used to direct and control cooling air, an oil cooler (3) and gear type oil pump used to cool and circulate lubricating oil in the engine, a replaceable cartridge type oil filter (4) to remove contaminants from the lubricating oil, fuel injection pump (5) to supply metered fuel to the engine combustion cylinders through fuel injectors located in the cylinder heads, air intake manifold (16) and heaters (18) that receive combustion air from the external air cleaner (9) and heat the combustion air if required, starter motor (6) coupled to the engine drive gear for cranking the engine for starting, a corrosion resistant exhaust muffler (7) to reduce engine exhaust noise, and a mechanical governor used to maintain engine speed at 1800 RPM under varying load.

4-40. EXHAUST MUFFLER ASSEMBLY

a. Inspect (see figure 4-37). If engine exhaust is noisy or if exhaust gases are detected from shutter assembly, indications are that muffler (3) or gaskets (4) and (6) may be defective.

b. Remove. Remove shutter assembly as outlined in paragraph 4-17. Bend lock tabs (2) down and remove four nuts (1) holding muffler (3) in place. Remove lock tabs (2), mufflers (3), muffler gaskets (4), adapters (5) and adapter gaskets (6) from each cylinder head.

c. Replace. Place gaskets (6), adapters (5) in place on each cylinder head. Slide new muffler gaskets (4), muffler (3), and lock tabs (2) over studs (7) in cylinder head and secure to cylinder head with nuts (1).

TM 5-6115-584-12
NAVFAC P-8-622-12
TO-35C2-3-456-1
TM-05682C-12

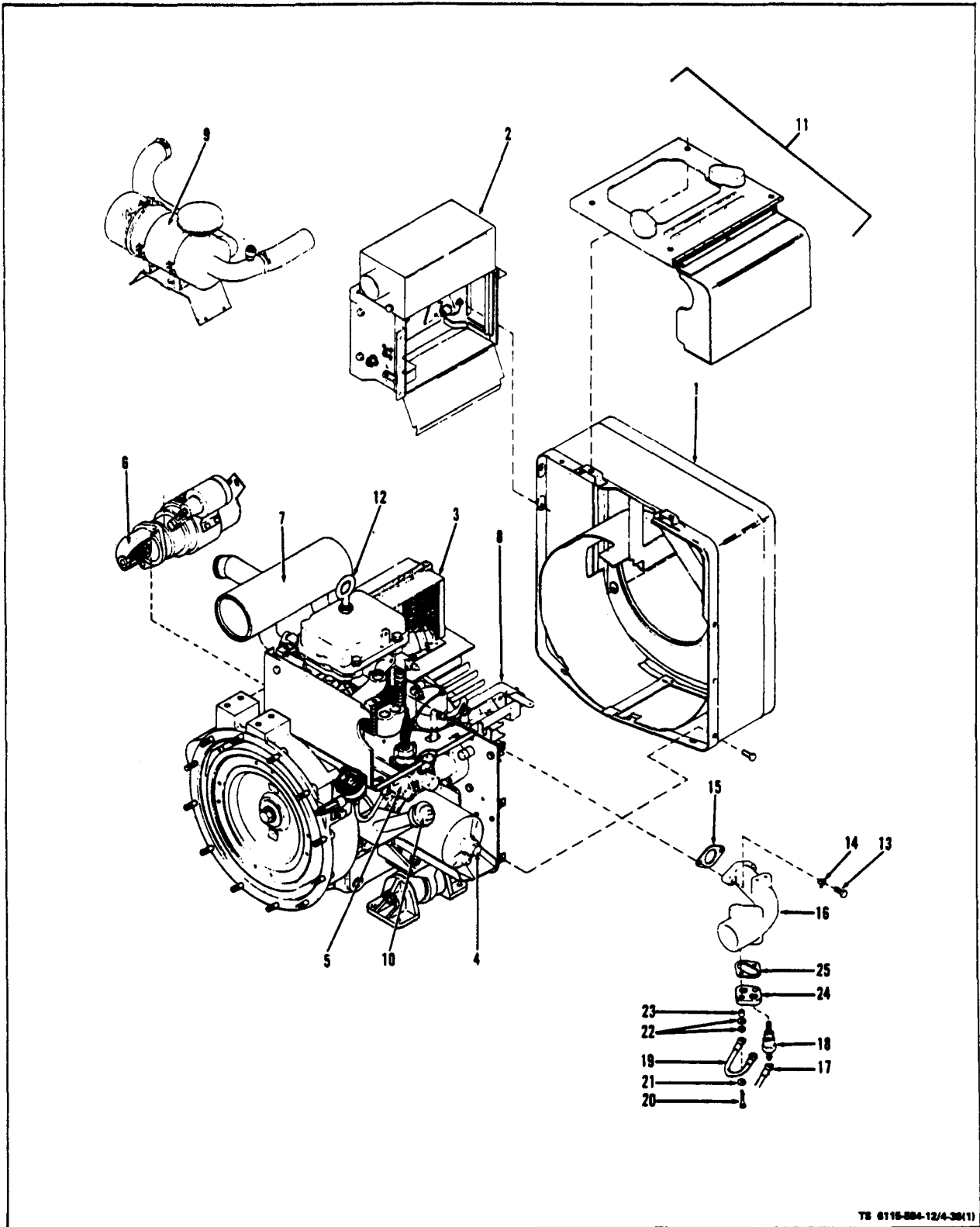

Figure 4-36. Engine Assembly (Sheet 1 of 2)

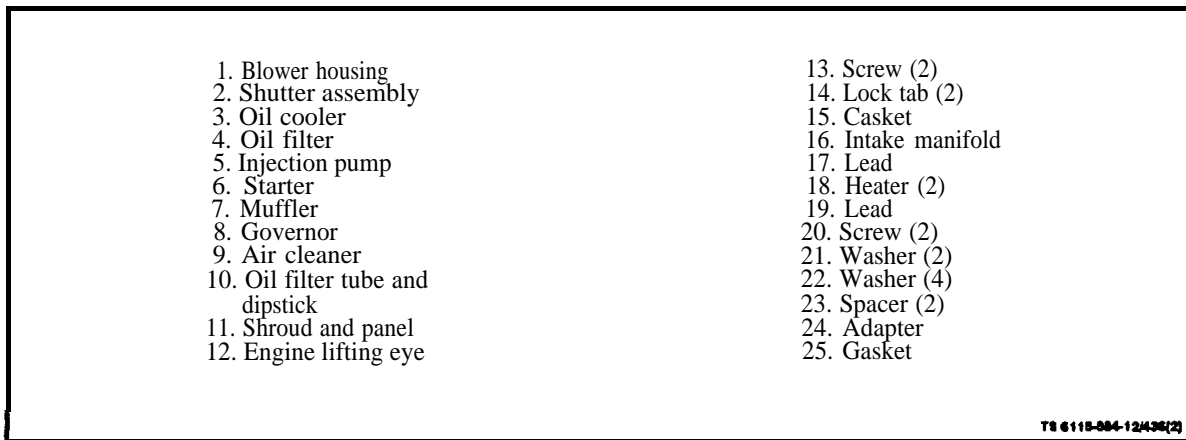

Figure 4-36. Engines Assembly (Sheet 2 of 2)

NOTE

Upper and lower nut must be tightened evenly in small increments so that muffler will lay flat against adapters.

Bend lock tabs (2) up to secure nuts (1).

4-41. AIR CLEANER ASSEMBLY.

a. Inspect (see figure 4-37). On ASK equipped generators, open air intake door and air cleaner door.

(1) Air Cleaner Assembly. Check air cleaner assembly for corrosion, broken or dented components or split hoses.

b. Remove.

(1) Air Cleaner Assembly. Loosen hose clamps (9 and 11) attaching two air intake hoses (10 and 12) to housing and detach hoses. Remove screws (13), lockwashers (14) and remove air cleaner and bracket and spacers (15). Remove air flow indicator (16) by turning Counterclockwise.

(2) Remove nut (17), lockwashers (18), screw (19) and separate air cleaner (20) and bracket (21).

c. Repair.

(1) Air Cleaner Assembly. Weld and straighten air cleaner housing as necessary.

(2) Mounting Bracket (see figure 4-37). If bracket (21) is split or bent, weld and straighten bracket as necessary. After completing repairs, check that bracket securely attaches air cleaner to set.

d. Install.

(1) Air Cleaner Assembly (see figure 4-37). Install air cleaner (20) on bracket (21) and secure with screws (19), lockwashers (18) and nuts (17). Install airflow indicator (16) on air cleaner.

(2) Install air cleaner, bracket and spacers (15) on generator housing and secure with lockwashers (14) and screws (13). Install hoses (10 and 12) and secure with clamps (9) and (11).

4-42. ENGINE ASSEMBLY.

a. Inspect (see figure 1-1). Inspect engine for loose connections, leaks in oil and fuel systems, and free action of all moving parts. Check that engine is securely mounted to skid-base. On ASK equipped generators, inspections of the engine assembly are limited to components accessible through the access doors.

b. Test. Operate engine with no load on Generator Set, until it warms up to normal operating temperature indicated by shutters being in an intermediate position between open and closed. Check oil pressure. Oil pressure should be 20-45 psi. Check frequency on frequency meter. Frequency should be approximately 60 Hz indicating that engine speed is about 1800 RPM. Apply full rated load to engine. Check that governor adjusts engine quickly, smoothly, and without excessive hunting. Check that exhaust is normal under load. Check that engine runs without excessive fuel or oil consumption. Check that no unusual noise is heard. Inability of engine to meet these tests may indicate engine malfunctioning. See Troubleshooting, Section VI.

c. Service. Service engine according to the schedule given in table 4-1, Preventive Maintenance Checks and Services.

d. Adjust. The only engine adjustments applicable to this level of maintenance are to the valve rocker arms, stop solenoid, and starter lockout switch.

NOTE

Engine lifting attachment is for lifting engine alone. Do not use this attachment for lifting engine if generator is still attached. Use the set lifting eye for this purpose (see figure 1-1).

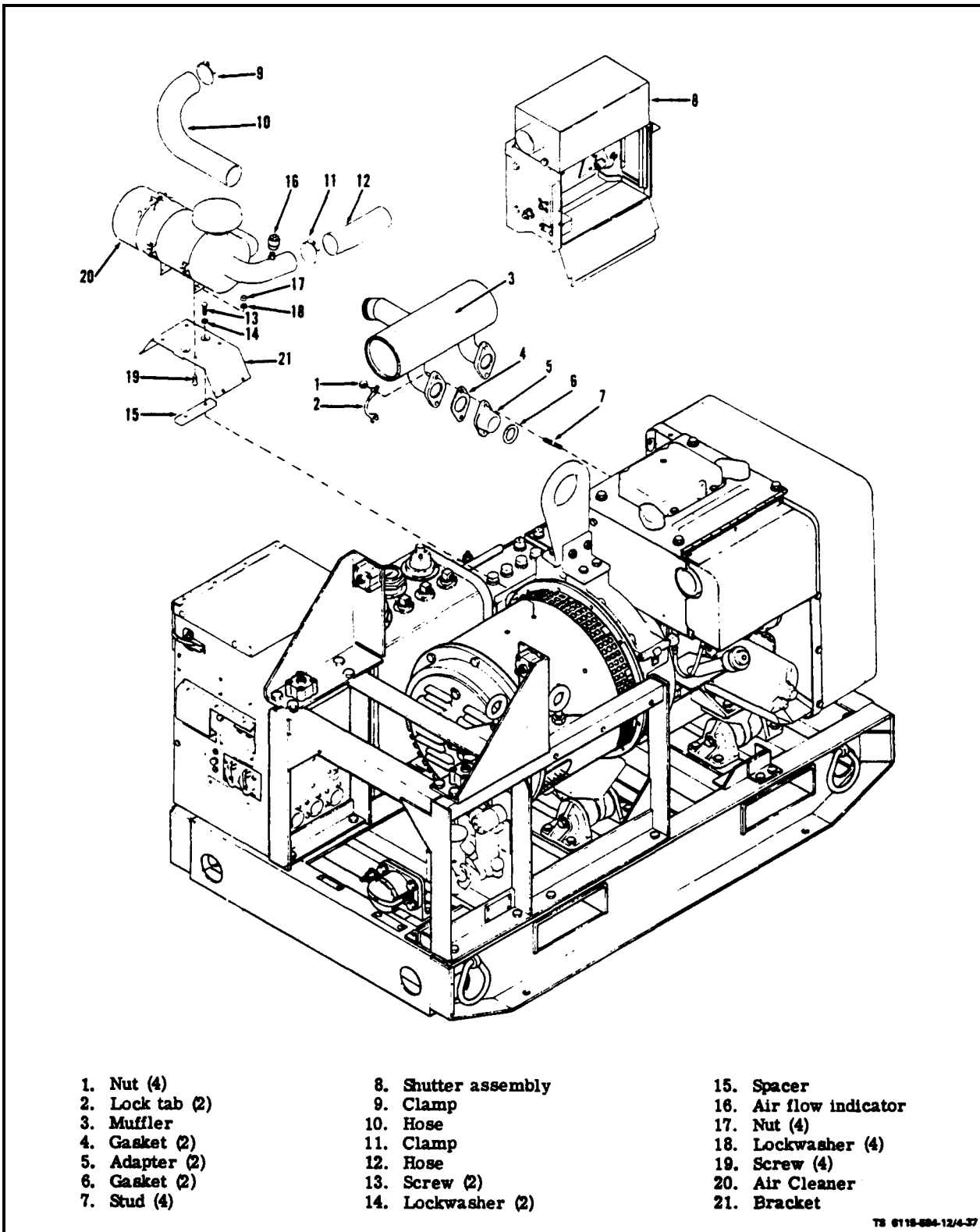

Figure 4-37. Exhaust Muffler and Air Cleaner Assemblies

4-43. INTAKE MANIFOLD A S S E M B L Y.

a. Test On Equipment (see figure 4-36). On ASK equipped generators, remove right panel assembly (para. 5-6). Remove hose between intake manifold and air cleaner to permit visual inspection of heater coils (18). Place master switch (see figure 2-3) in the PREHEAT position. Good coils should start to heat within one minute. Release switch as soon as coil begins to heat. Replace a bed heater.

b. Inspect. Inspect heater for physical damage. Check that electrical connections to heater are clean

and tight. While engine is operating, check for leaks especially at the gasket (15; figure 4-36) between manifold and cylinder head and the gasket (25) between the manifold heater adapter (24) and the manifold. Drop oil from an oil can or hold piece of thin paper on point suspected of leaking. If leak exists, oil will be sucked in or paper will be sucked against leaking area.

c. Remove. Tag and disconnect leads (17 and 19) from heaters (18) and remove heaters (18). Remove lead (19) by removing screw (20), washers (21 and 22) and spacer (23). Remove adapter (24) and gasket

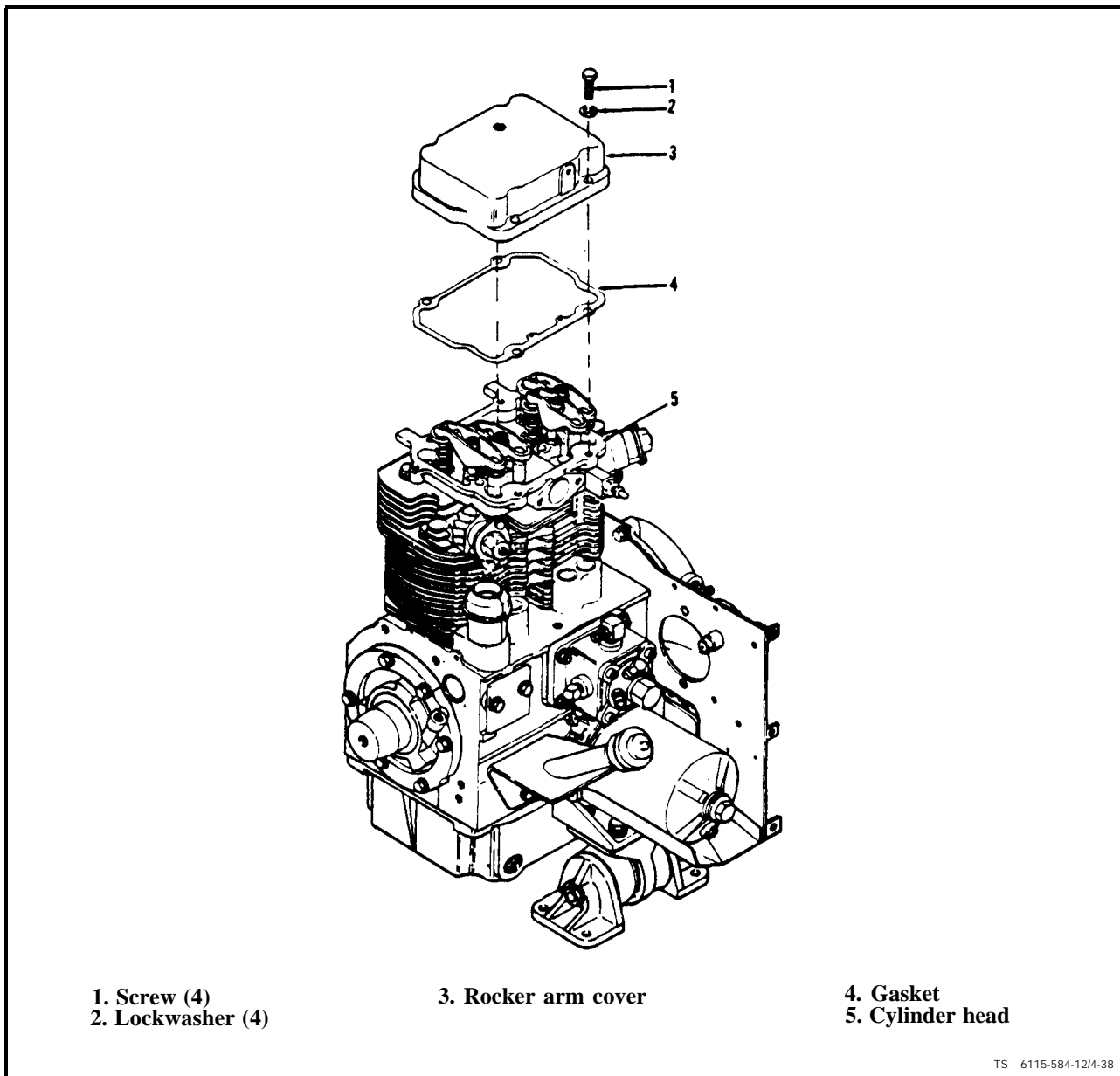

Figure 4-38. Rocker Arm Covers

c. Bend lock tabs (14) down and remove four screws (13) attaching manifold to cylinder heads and remove manifold (16). Clean away any gasket material (15) stuck to cylinder heads or manifold.

d. Repair. Remove manifold as given above and replace gasket if leaks occur.

e. Install. Install intake manifold (16) and new gasket (15) to cylinder head and secure with two screws (13) and lock tabs (14). Torque screws 13 to 15 ft-lbs. Bend lock tabs (14) up to prevent screws (13) from loosening. Install good heater elements (18) into heater adapter (24). If heater adapter threads are damaged, replace adapters. Install heater adapter (24), gasket (25) and lead (19) on intake manifold and secure with spacer (33), washers (21 and 22) and screw (20). Reconnect lead (17) to heater.

NOTE

If heater adapter is removed, make certain new gaskets and spacer are used for reassembly.

4.44. ROCKER ARM COVERS.

a. Inspect (see figure 4-38). Inspect rocker arm cover (3) for dents or other physical damage. Check for leaks especially at the gasket (4) between cover and cylinder head (5). Check that cover (3) is securely attached to cylinder head with screws (1), and lockwashers (2).

b. Remove. Remove shroud (13, figure 3-9) per paragraph 4-17b. Remove four screws (1, figure 4-38) and lockwashers (2) attaching each rocker arm cover (3) to cylinder head (5) and remove cover carefully. Clean gasket (4) from both cover and cylinder head.

c. Service. Every 500 operating hours, remove rocker arm covers and clean oil lines. Flush oil lines with clean diesel fuel and clean small holes with a fine wire. See figure 4-39.

NOTE

Adjust valve rocker arms and clean breather while cover is off.

d. Replace. Place gasket (4, figure 4-38) in position on each cylinder head. Install each rocker arm cover (3) to cylinder head and secure with four screws (1) and lockwashers (2). Tighten screws 7 to 8 ft-lb.

NOTE

Always use a new gasket when installing rocker arm covers.

4-45. BREATHER.

a. Inspect (see figure 4-40). Inspect exterior of breather for damage. Inspect that tube (2) is securely attached to breather valve (6). Inspect that tube (12) is securely seated in engine (13),

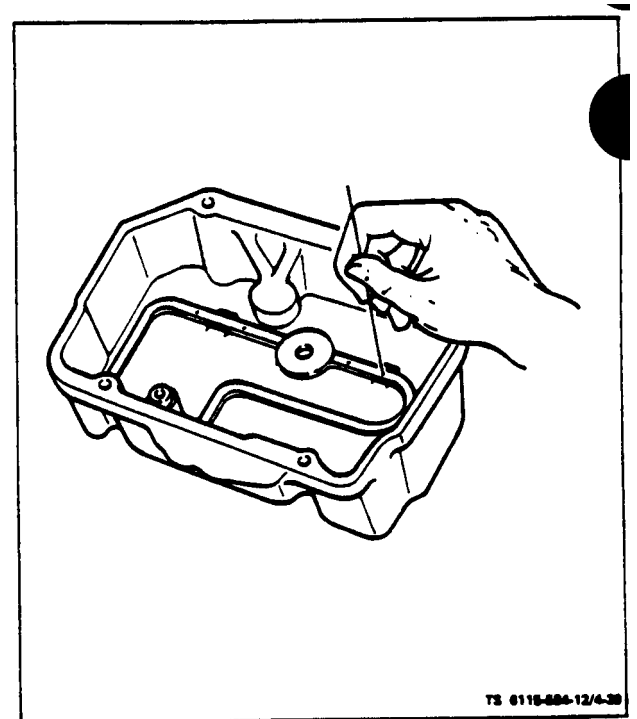

Figure 4-39. Cleaning Rocker Arm Cover Oil Line

b. Service.

(1) Remove tube (2) from breather valve (6).

(2) Loosen screw (3) and remove clamp (4).

(3) Remove insulators (5) and pull off valve (6), screen (8) and filter (10).

(4) Wipe parts with clean cloth. Wash filter mesh (10) and valve (6) in dry cleaning solvent Fed. Spec. PD 680.

c. Remove,

(1) Loosen clamp (1) and remove tube (2) from valve (6).

(2) Remove clamp (4) by loosening screw (3).

(3) Remove valve (6), screen (7), retainer (8) and packing (9),

(4) Remove filter (10) and cup (11) from tube (12).

(5) Remove tube (12) from engine (13).

d. Install.

(1) Assemble filter (10) and cup (11) in breather tube (12).

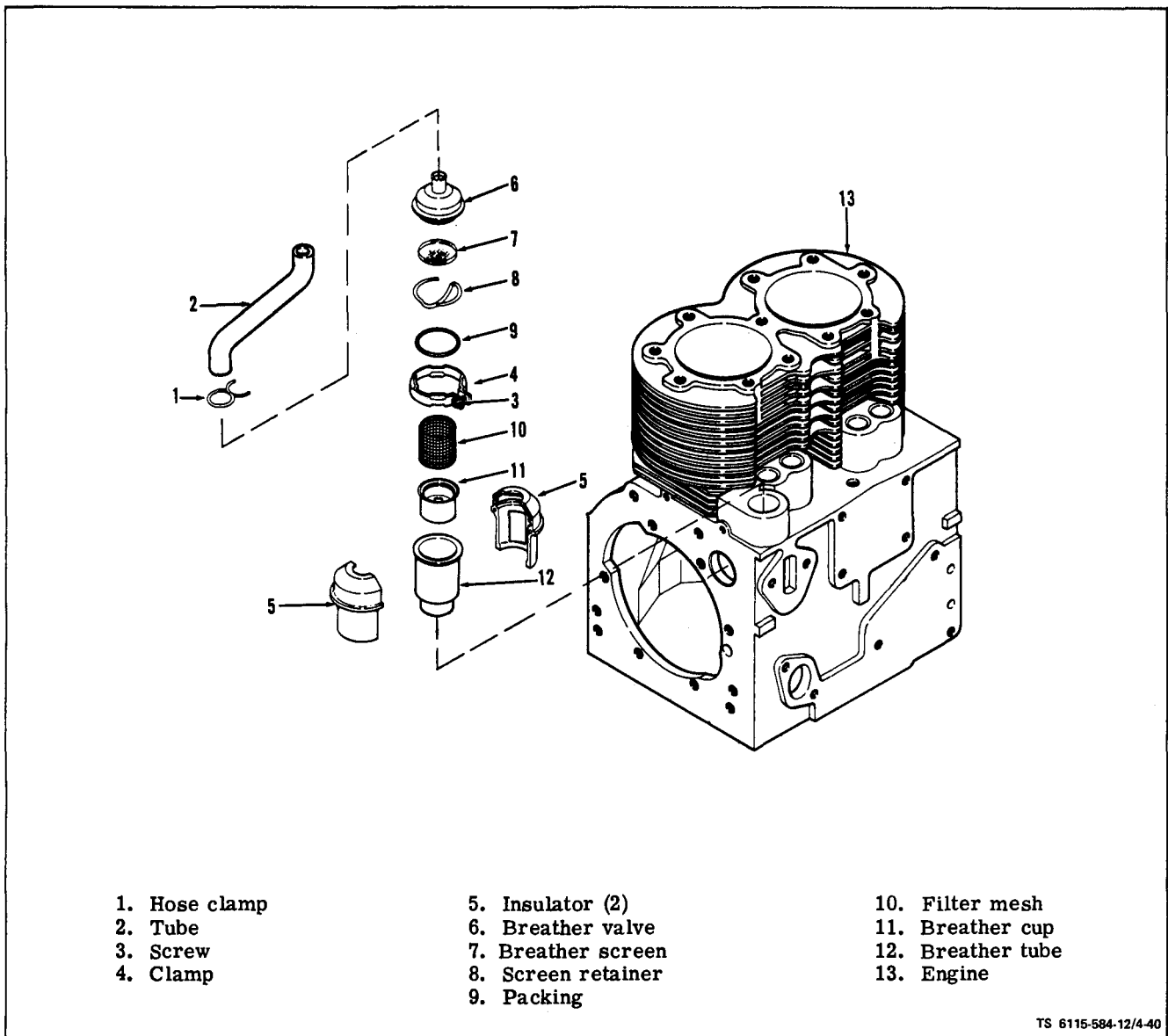

Figure 4-40. Breather Assembly

(2) Place screen (7) in valve (6) and install retainer (8).

(3) Assemble valve (6) on breather tube (12) with packing (9) between them.

(4) Install insulators (5) on breather assembly and install clamp (4) over insulators (5).

(5) Tighten screw (3).

(6) Install breather and insulator assembly on engine (13).

(7) Connect tube (2) and clamp (1) to breather valve (6).

4-46. VALVE ROCKER ARMS.

a. Inspect (see figure 4-41). Inspect rocker arms for physical damage or excessive wear.

b. Adjust. Check and adjust the rocker arm to proper valve clearance every 500 operating hours. Correct valve clearance is .010 inch for intake valve and .007 inch for exhaust valve.

NOTE

Readjust rocker arm to valve clearance after the first 50 hours of operation on a new or rebuilt engine.

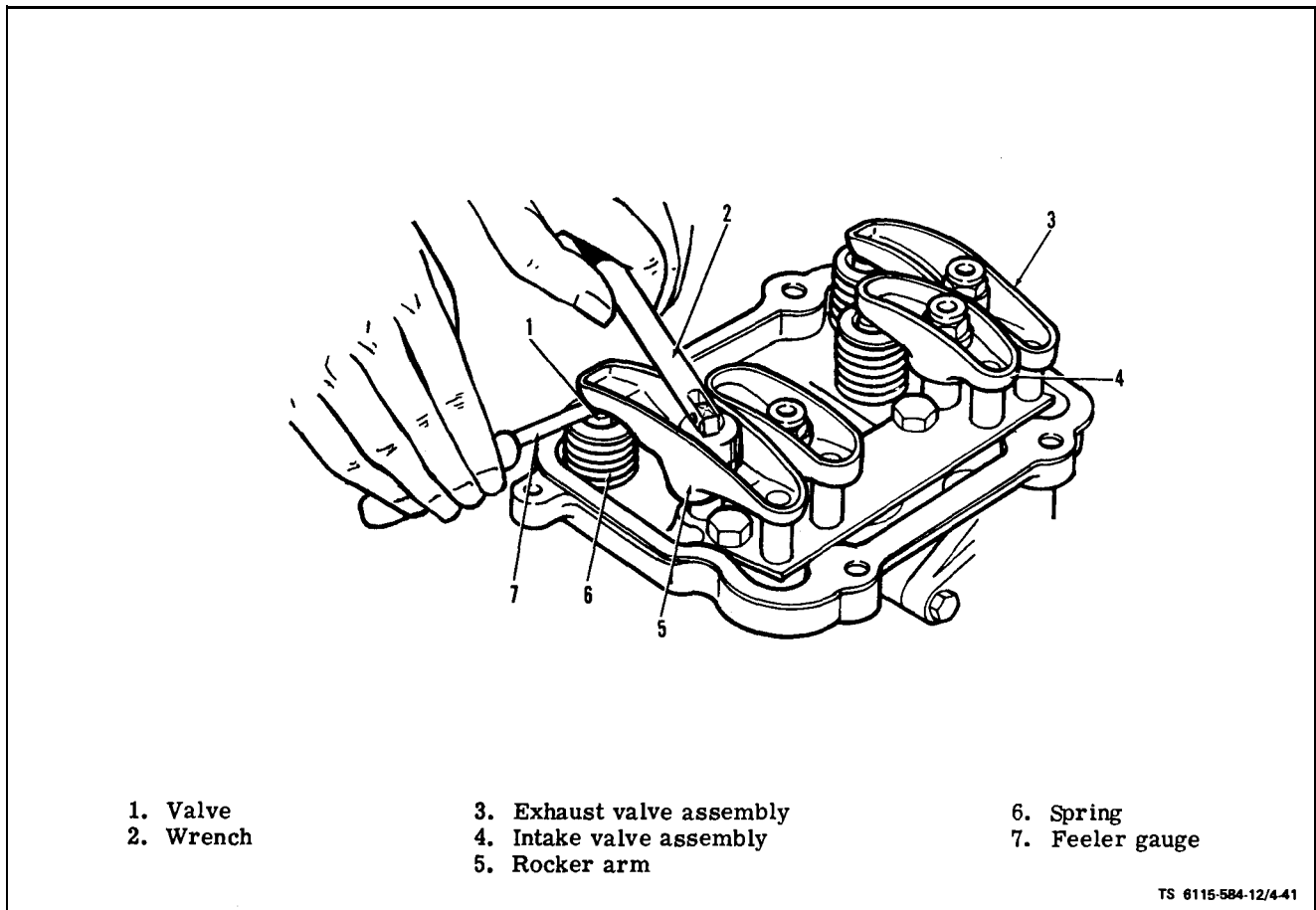

Figure 4-41. Checking and Adjusting Rocker Arm to Valve Clearance

Always check and adjust the valve tappet clearance when the engine is at an ambient of approximately 70°F (18°C). Remove rocker cover and proceed as follows :

CAUTION

Turn blower wheel clockwise only.

(1) Using 5/8" socket wrench and extension, turn the blower wheel clockwise until No. 1 cylinder is on its compression stroke, which follows the closing of its intake valve. See figure 4-41 for identification of intake valve assembly.

(2) Continue clockwise rotation until the letter "A" appears in the timing port on the side of the generator adapter. This puts No. 1 cylinder in the power stroke with both valves closed.

(3) By using a feeler gauge, check the clearance between the rocker arm and the valve stem cap. See figure 4-41. Increase or reduce the clearance until the proper gap is established, adjusting with the locknut which secures the rocker arm to the cylinder

head. Correct valve clearance is 0.010 for intake valve, 0.007 for exhaust valve.

(4) To adjust the valve clearance for No. 2 cylinder, turn the blower wheel clockwise 180° until the letter "B" appears in the timing port and adjust valves as given in step 3.

(5) Install rocker cover and tighten screws 7 to 8 ft-lb.

4-47. INJECTOR NOZZLE ASSEMBLY AND FUEL LINES.

a. Inspect.

(1) Injector Nozzle Assembly (see figure 4-42). Inspect for leaking fuel. Inspect fuel fittings for tightness.

(2) Fuel Lines. Inspect fuel lines for leaks and damage to fittings.

4-48. GLOW PLUG ASSEMBLIES.

a. Inspect (see figure 4-42). Inspect glow plugs for physical damage. Check that electrical lead to glow

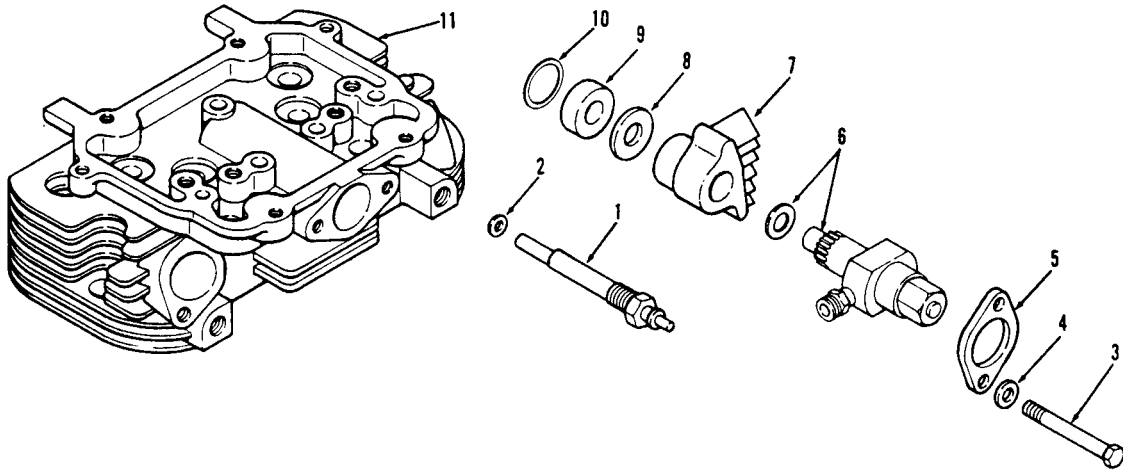

- 1. Glow plug (2)
- 2. Gasket (2)
- 3. Bolt (4)
- 4. Washer (4)

- 5. Retaining flange (2)
- 6. Injector nozzle (2)
- 7. Adapter (2)

- 8. Gasket (2)
- 9. Heat shield (2)
- 10. Gasket (2)
- 11. Cylinder head

TS 6115-584-12/4-42

Figure 4-42. Cylinder Head Assembly

TM 5-6115-584-12
NAVFAC P-8-622-12
TO-35C2-3-456-1
TM-05682C-12

plug is clean and tight. Check for leakage where the glow plug enters cylinder head.

b. Test. Remove electrical lead to glow plug. Use ohmmeter to test for continuity. from terminal of glow plug and ground, Open circuit indicates bad glow plug.

CAUTION

With master switch in the PREHEAT position, 24 volts dc is applied to the glow plug body. Do not handle plug with the master switch in the PREHEAT position.

c. Remove. Disconnect lead to glow plug. Unscrew glow plug and remove it from cylinder head. If glow plug was leaking where it entered cylinder head, remove gasket with a hooked wire and replace.

d. Install. If gasket (2, figure 4-42) has been removed, place new gasket over glow plug. Coat plug threads with anti-seize compound and screw glow plug into cylinder head. Tighten glow plug 10 to 15 ft-lb dry. Attach electrical lead to plug. On ASK equipped generators, install top panel assembly (para. 5-4).

4-49. OIL DRAIN HOSE VALVE.

a. Replace (see figure 3-20). On ASK equipped generators, remove oil access door, Drain engine 011 Into a suitable container. Disconnect oil drain hose from valve. Remove valve. Attach serviceable hose to valve. Use pipe thread sealant on all pipe threads, Always store hose against frame when not in use.

4-50. OIL BASE.

a. Inspect. Inspect oil base for dents, cracks, or other physical damage. Check for leaks, especially at the gasket between oil base and cylinder block.

4-51. OIL FILL TUBE.

a. Remove (see figure 4-43). On ASK equipped generators, remove oil access door. Remove oil level indicator (1). Remove screw (2), and lockwasher (3). Remove oil fill tube (4) and scrape gasket (5) from mating surface on cylinder block (6) and oil fill tube (4).

b. Installation. Install gasket (5) between oil fill tube (4) and cylinder block (6). Attach oil fill tube (4) with screw (2) and lockwasher (3). Install oil level indicator (1) in oil fill tube (4).

4-52. ENGINE MOUNTING ASSEMBLY.

a. Inspect (see figure 4-44). On ASK equipped generators, remove cover assembly. (para 5-3). Check to see that mounting nuts and bolts are tight. Check rubber mounts (14) for cracks and breaks.

b. Remove. Use engine lifting assembly to remove weight off of mounting assembly and remove screws

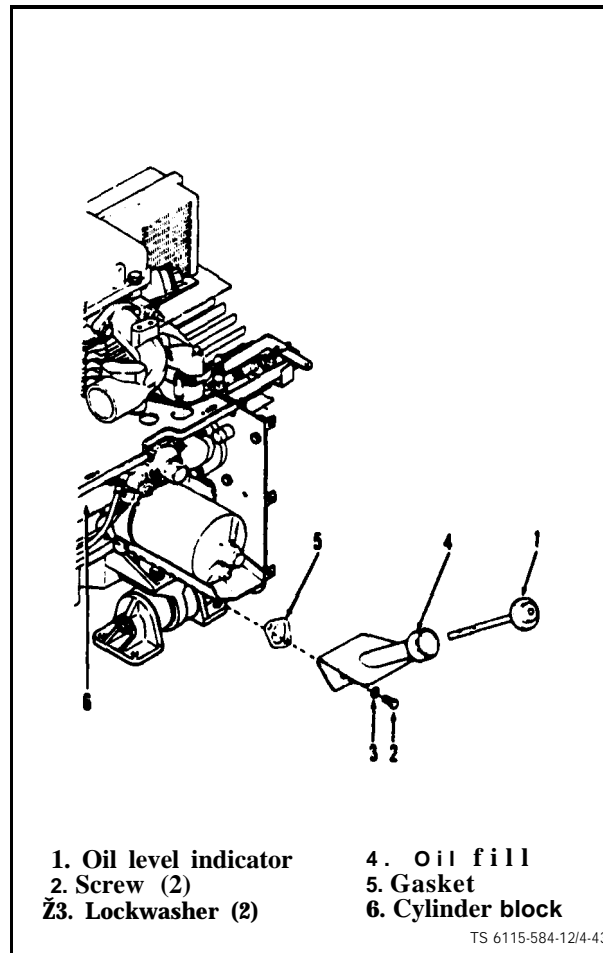

Figure 4-43. Oil Fill Tube

(1), lockwasher(3), flatwasher (2) and nuts (4) that secure each mounting assembly to skid-base (5). Remove screws (6), lockwashers (7) and flatwashers (8) and remove mounts.

c. Disassembly. Remove screw (9), nut (10), lockwasher (11) and flatwasher (12). Remove brackets (13). Remove resilient mounts (14) and spacer (16) from bracket (17). Do not remove alignment pin (15), unless it is damaged.

d. Reassembly. Install mounts (14) and spacer (16) into bracket (17). Using screw (9), flatwasher (12), lockwasher (11) and nut (10), assemble brackets (13) to the mount.

e. Installation. Install mounts on engine and secure with screw (6), lockwasher (7) and flatwasher (8). Lower engine and mounts to skid-base and secure mounts to base with screws (1), washers (2), lockwashers (3) and nuts (4). On ASK equipped generators, install ASK cover assembly (para 5-3).

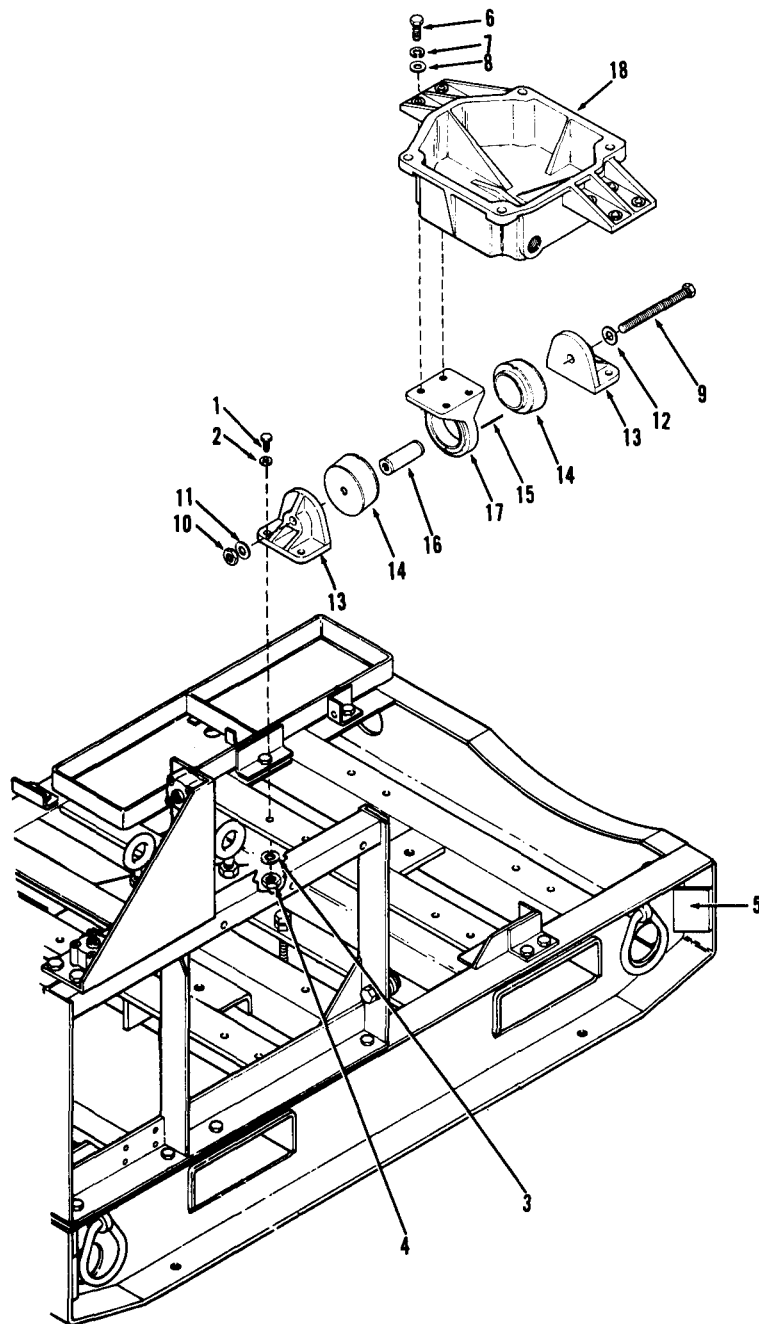

- | | | |
|-------------------|-------------------|---------------------|
| 1. Screw (8) | 7. Lockwasher (4) | 13. Bracket (2) |
| 2. Flatwasher (8) | 8. Flatwasher (4) | 14. Mount (2) |
| 3. Lockwasher (8) | 9. Screw | 15. Roll-pin |
| 4. Nut (8) | 10. Nut | 16. Spacer |
| 5. Skid-base | 11. Lockwasher | 17. Support bracket |
| 6. Screw (4) | 12. Flatwasher | 18. Oil base |

TS 6115-584-12/4-44

Figure 4-44. Engine Mounting Assembly

Section XIV. MAINTENANCE OF GENERATOR ASSEMBLY

4-53. DESCRIPTION AND FUNCTION.

The generator (main alternator) (see figure 1-1) is a single bearing, splashproof, self-ventilated unit, with a flange to attach to the engine flywheel housing. Major generator components are stator, rotor, and brushless exciter. The stator is composed of a compressed stack of one piece laminations held in position by stator bars welded axially on the outside diameter of the laminations. A steel wrapper welded to these bars provides the generator frame. The generator windings each occupy two groups of slots 180 mechanical degrees apart. The generator rotor is composed of one piece rotor laminations, stacked, compressed, and held in position by copper damper bars welded to the copper end laminations. Rotor windings are made of Type L2 Class 155 copper wire insulated from ground with MIL-I-22834A synthetic bonded paper. The rotor is press fitted and keyed to the rotor shaft, and balanced. The brushless rotating exciter with rotating rectifier unit is used for providing excitation current to the rotating field of the generator. The complete excitation unit consists of four basic component assemblies: a three-phase rotating armature, alternating current generator; a three-phase full-wave bridge rectifier composed of six

semi-conductor "diodes mounted on two heat sinks, a voltage regulator and current-voltage transformers. The exciter armature and the bridge rectifier assembly are mounted on the rotor shaft of the synchronous generator and are connected to the generator field windings. The stator of the brushless exciter consists of field coils wound on the poles and attached to the generator endbell. During operation of the generator, the three-phase power generated in the rotating exciter armature is applied directly to the rotating rectifier assembly. The six diodes, mounted on rotating heat sinks, are connected to form a three-phase, full-wave bridge. The direct current output of the bridge rectifier is applied to the rotating field of the generator. Thus, the two assemblies; exciter armature and synchronous field form a single rotating assembly, enabling electrical connections to be made without the use of brushes, collector rings or commutator. Excitation current for the stationary field coils of the excitation unit is supplied by the synchronous generator, and controlled through the static type automatic voltage regulator. The voltage regulator continuously compares the output voltage of the synchronous generator with a stable reference voltage. The difference between the two voltages constitutes an error signal which indicates an output

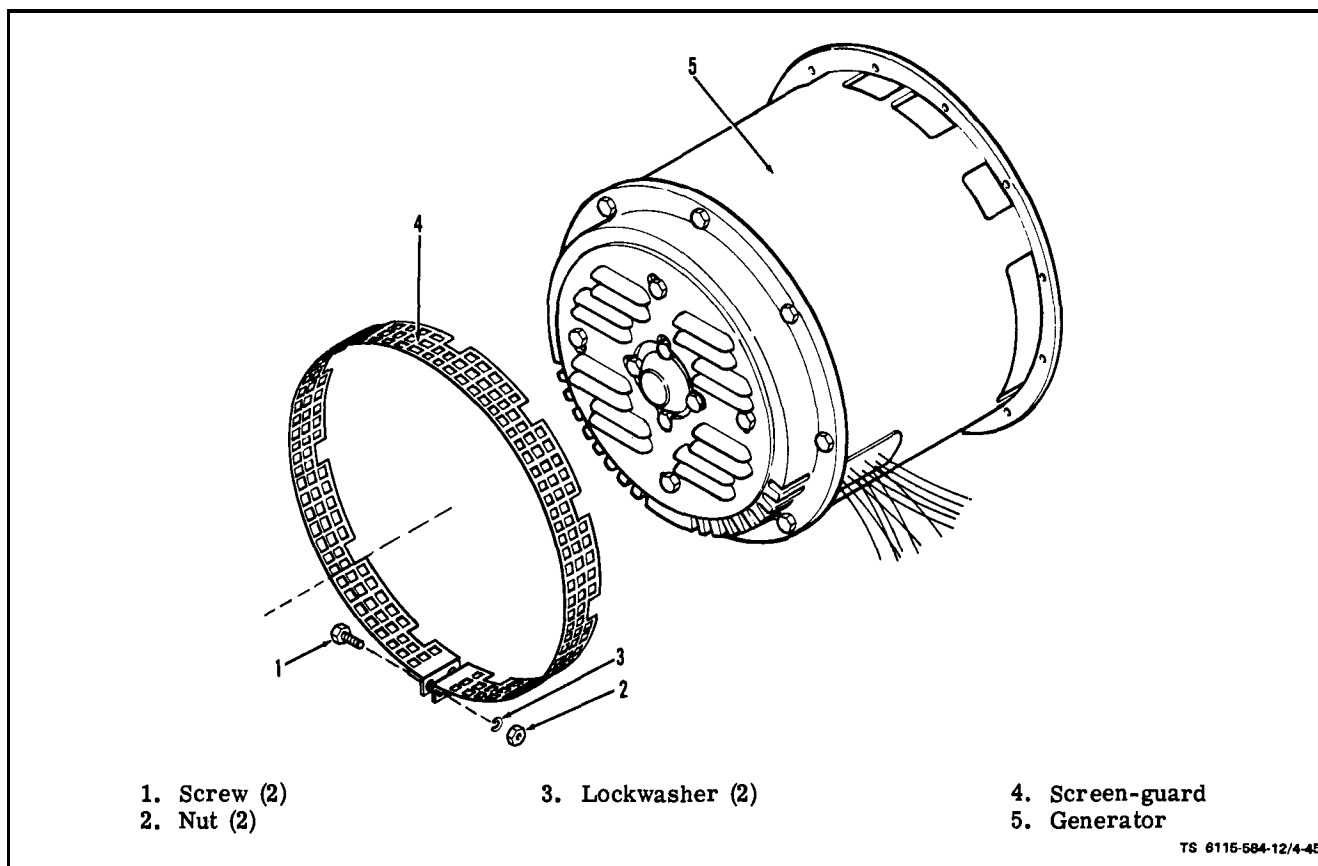

Figure 4-45. Generator Screen-Guard

voltage, that is higher or lower than the Generator Set point. This error signal is amplified and used to control the direct current output of the voltage regulator which is applied to the control windings of the current-voltage transformers.

4-54. GENERATOR/EXCITER ASSEMBLY.

a. Inspect (see figure 1-1). On ASK equipped generator, remove ASK cover assembly (para 5-3). Inspect the generator/exciter assembly for physical damage. Check that assembly is clean and free of dirt, or oil. Check that electrical leads from generator/exciter are free of damage. Check that assembly is securely mounted to engine and to the skid-base.

4-55. SCREEN-GUARD.

a. Inspect. Inspect screen-guard for cleanliness and physical damage.

b. Remove (see figure 4-45), Remove two screws (1), lockwashers (3), and nuts (2) holding screen-guard (4) in place and remove screen-guard.

c. Repair. Weld and straighten screen-guard as necessary. After repairs are completed, check that screen-guard attaches properly to generator and does not touch any moving part.

d. Install. Place serviceable screen-guard in position over openings in generator stator-housing assembly (5). Tighten screen-guard (4) in position with two screws (1), lockwashers (3) and nuts (2). On ASK equipped generators, install ASK cover assembly (para 5-3).

Section XV. MAINTENANCE OF SKID-BASE

4-56. DESCRIPTION AND FUNCTION,

(See figure 1-1.) The skid-base serve. as a base for mounting all major components of the Generator Set. Revisions for towing or lifting with a forklift are built into the skid-base. Tie down rings are also provided.

4-57. SKID-BASE.

a. Inspect (see figure 4-46). On ASK equipped generators, refer to Chapter 5 for removal procedures for the entire ASK.

(1) Vibration Mounts, Inspect vibration mounts (3) for cracked rubber and loose or missing hardware.

(2) Battery Frame Bottom. Inspect battery frame (11) for corrosion, bends, dents or broken welds.

(3) Battery Tray, Inspect battery tray (12) for corrosion, or physical damage.

(4) Ground Stud. Inspect ground stud (16) for physical damage to threads, nuts and washers.

(6) Tie Down Ring. Inspect tie down rings (25) for physical damage. Check that they are securely mounted to skid-base.

(6) Skid-Base. Inspect skid-base (24) for physical damage. Check that skid-base is not bent or bowed,

b. Remove (see figure 4-46).

(1) Vibration Mounts.

(a) Refer to paragraph 4-38 and remove control cubicle.

(b) Remove four screws (1, figure 4-46) and nuts (2) attaching each mount in place and remove mounts (3).

(2) Battery Frame and Tray Removal.

(a) See paragraph 4-25 and remove battery hold-downs and batteries,

(b) Remove screws (4 and 8, figure 4-46), bevel washers (7), lockwashers (6 and 10), and nuts (5 and 9). Remove frame (11) and tray (12).

(3) Ground Stud. Remove nut (13) and lockwasher (14) attaching wound leads (15) from starter to ground stud (16). Remove nut (13) and lockwasher (14) attaching ground stud to skid-base (24). Remove stud.

(4) Slave Receptacle. Tag and remove leads (17) from slave receptacle (21). Remove receptacle (21) by removing screws (18), nuts (19) and lockwashers (20). Remove mounting bracket (23) by removing screws (22).

c. Repair.

(1) Battery Frame Bottom. Clean, weld and straighten battery frame as required.

(2) Battery Tray, Clean and straighten battery tray as necessary.

(3) Broken or Loot Terminal Clip (Retainer, Safety Clip). For fabrication procedure, see Chapter 4, Section XII Maintenance of Control System, paragraph 4-37.

d. Install (see figure 4-46).

(1) Vibration Mounts.

(a) Position mounts (3) and install screws (1) and nuts (2).

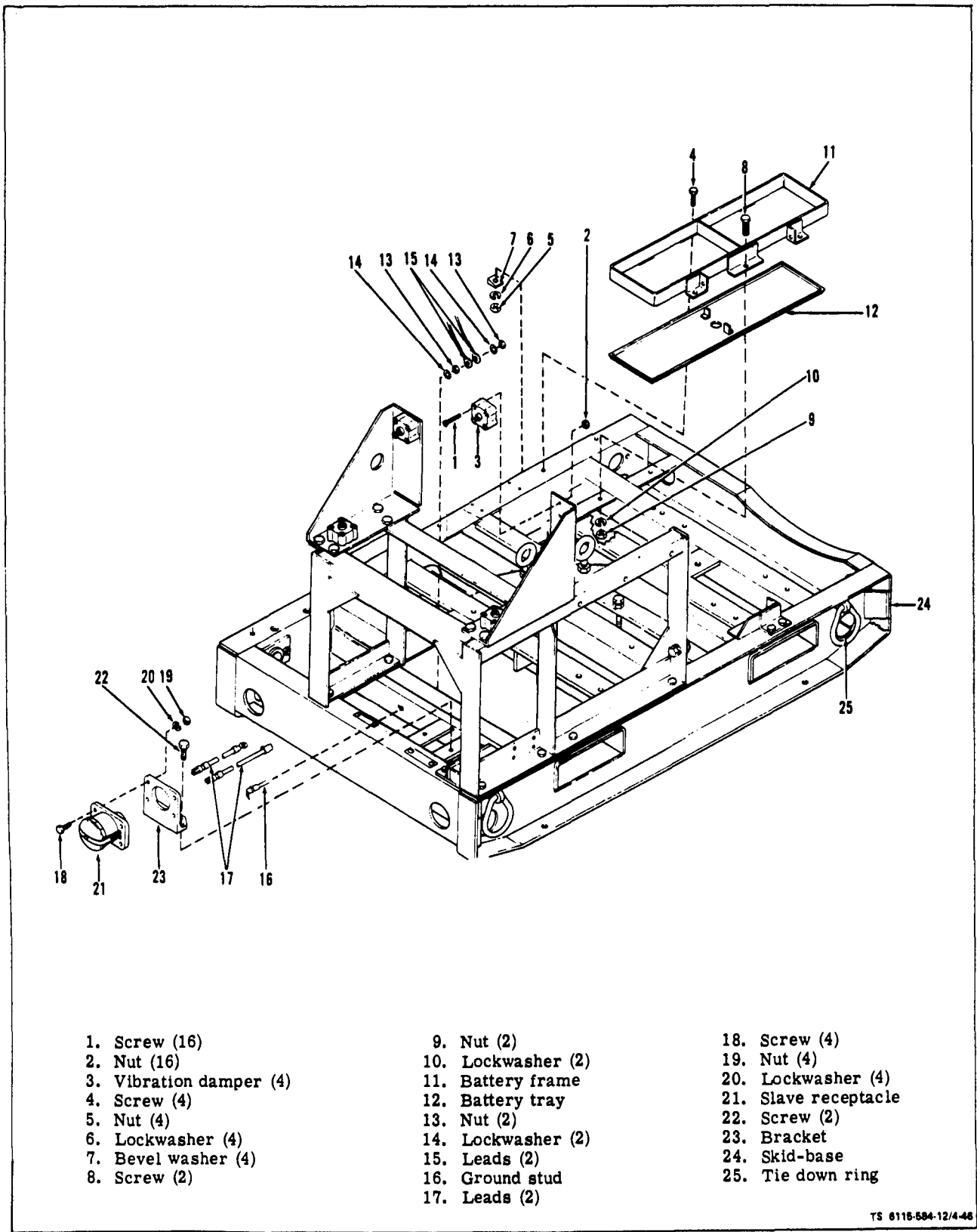

Figure 4-46. Skid-Base Assembly

(b) Refer to paragraph 4-38 and install control cubicle.

(2) Battery Frame Bottom and Tray.

(a) Position battery tray (12) and bottomframe (11) on skid-base (24). Attach by installing nuts (5 and 9), lockwashers (6 and 10), bevel washers (7) and screws (4 and 8).

NOTE

Bevel washers are only on the four bolts at the outside of the skid-base.

(b) See paragraph 4-25 and install batteries and battery hold-downs.

(3) Slave Receptacle. Install bracket (23) with screws (22). Install slave receptacle (21) on bracket with screws (18), lockwashers (20) and nuts (19). Install leads (17) on slave receptacle as tagged. Remove tags.

(4) Ground Stud. Install ground stud (16) on skid-base (24) with lockwasher (14) and nut (13). Install leads (15 and 17) on ground stud (16) with lockwasher (14) and nut (13). On ASK equipped generators, install entire ASK (refer to chapter 5).

CHAPTER 5

MATERIEL USED IN CONJUNCTION WITH DOD STANDARD GENERATOR
SET, 5KW DIESEL ENGINE DRIVEN, MODEL MEP-002A

Section I. AUXILIARY EQUIPMENT

5-1. GENERAL.

This chapter describes all Organizational Level Maintenance procedures for auxiliary equipment (kits) which are used in conjunction with the generator set. Any effects of the auxiliary equipment on the operation or maintenance procedures for the generator set are identified in the procedures where they occur.

Section II. ACOUSTIC SUPPRESSION KIT

5-2. ACOUSTIC SUPPRESSION KIT.

The acoustic suppression kit (ASK) is an add-on enclosure that reduces the noise level from the DOD Standard Generator Set, 5KW Diesel Engine Driven, Model MEP-002A. The control cubicle and ac output control box assembly are not covered and the fuel tank is only partially covered. Other controls or areas requiring frequent service can be reached through top, right and left panel access doors. All ASK information plates are shown in figure 5-1.

5-3. COVER ASSEMBLY.

a. Removal. See figure 5-2. Remove cover assembly consisting of top panel, left and right panels, and front panel assemblies as follows:

(1) Remove three screws (1) and washers (2) securing left panel assembly (3) to left support assembly (4).

(2) Remove three screws (5) and locknuts (6), and six washers (7 and 8) securing left panel assembly (3) to side closure assembly (9).

(3) Remove five screws (10) and washers (11) securing right panel assembly (12) to right support assembly (13).

(4) Remove two screws (14) and washers (15) securing right panel assembly (12) to rear panel assembly (16) and remove two screws (17) and locknuts (18), and four washers (19 and 20) securing right panel assembly (12) to rear closure assembly (21).

(5) Remove seven screws (22) and locknuts (23), and 14 washers (24 and 25) securing top panel assembly (26) to rear closure (21) and side closure assembly (9).

WARNING

The ASK Cover assembly is heavy. Four (4) people are required to lift cover. Failure to follow safety rules could result in personal injury.

(6) Lift and remove cover assembly from generator set.

OPERATING INSTRUCTIONS

BEFORE STARTING SET

1. INSURE MAIN CIRCUIT BREAKER IS OFF.
2. REMOVE ASK DOOR LABELED "OIL-FILL, DRAIN, FILTER". FILL CRANKCASE (DO NOT OVERFILL). FILL FUEL TANK. ENSURE THAT VENT ON UNDERSIDE OF FUEL FILLER CAP IS OPEN BEFORE STARTING GENERATOR SET.
3. 'WARNING' - GROUND SET TO AVOID SHOCK HAZARD. LIFT FLAP ON ASK REAR PANEL ASSEMBLY TO CHECK THAT GENERATOR SET IS PROPERLY GROUNDED.
4. SET BATTERIES ARE NEGATIVE GROUND.
5. INSURE ALL DOORS ARE IN PLACE, CLOSED AND LATCHED FOR OPERATION.

STARTING SET

1. MOVE "MASTER SWITCH" TO "PRIME & RUN" POSITION TO ALLOW FUEL TO PRIME SET.
2. MOVE "MASTER SWITCH" TO "PREHEAT" POSITION AND HOLD FOR (1) MINUTE.
NOTE: PREHEAT IS NOT REQUIRED WHEN ENGINE IS HOT.
3. MOVE "MASTER SWITCH" TO "START" POSITION AND HOLD UNTIL ENGINE FIRES CONTINUOUSLY. IF ENGINE DOES NOT START WITHIN 15 SECONDS, REPEAT STEPS 1 AND 2.
4. "MASTER SWITCH" WILL RETURN TO "PRIME & RUN" POSITION WHEN RELEASED. IF RUNNING FROM AUXILIARY FUEL SOURCE, MOVE 'MASTER SWITCH" TO "PRIME & RUN AUX FUEL" POSITION.
5. AFTER WARM UP, CHECK FREQUENCY AND VOLTAGE AND ADJUST IF NECESSARY. LIFT FLAP LABELED 'SPEED CONTROL" FOR SET FREQUENCY ADJUSTMENT.
6. MOVE "AC CIRCUIT BREAKER" TO "ON" POSITION.

STOPPING SET

1. MOVE "AC CIRCUIT BREAKER" TO "OFF" POSITION.
2. MOVE "MASTER SWITCH" TO 'OFF" POSITION.
3. FOR EMERGENCY STOP, PULL "DC CONTROL CIRCUIT BREAKER".

SERVICE INSTRUCTIONS

AMBIENT TEMPERATURE	FUELS		LUBRICATING OIL
	CAPACITY: 5KW-7 GAL 10KW-12.5 GAL		CAPACITY (LESS FILTER) 5KW-3 QT 10KW-5.5 QT
	PRIMARY-DIESEL	EMERGENCY-JP4	
-65° TO -25° F -54° TO -32° C	VV-F-800 GRADE DFA	FOR JP4 OPERATION SEE INSTRUCTION MANUAL	MIL-L-10295
-25" TO -10" F -32° TO -23" C	VV-F-800 GRADE DF1		
-10° TO +30° F -23° TO -1° C			MIL-L-2104 GRADE 10
+30° TO +100° F -1° TO +38° C	VV-F-800 GRADE DF2		
+100° TO +107° F +38° TO +42° C			MIL-L-2104 GRADE 30

Figure 5-1. Instruction and Rating Plates (Sheet 1 of 4)

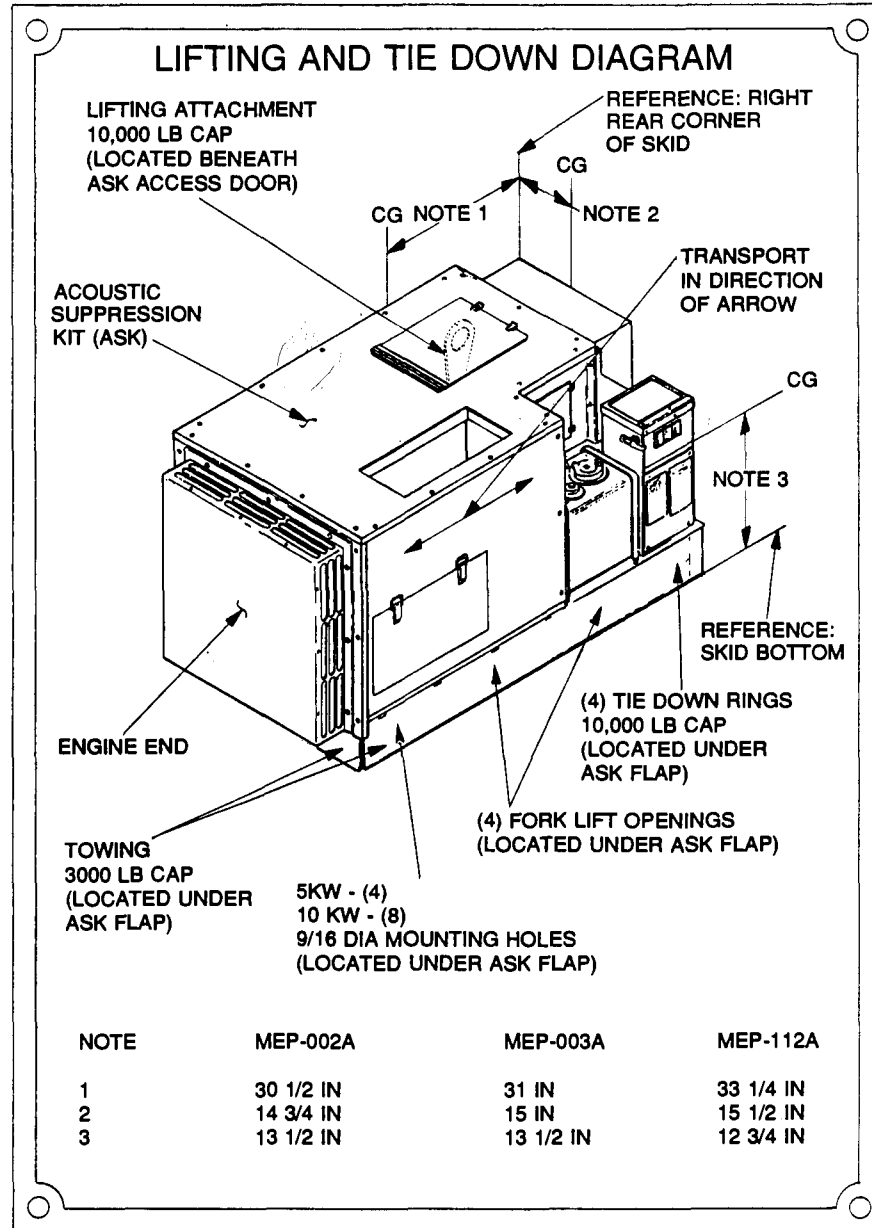

Figure 5-1. Instruction and Rating Plates (Sheet 2)

WARNING

**-INSTALL/CLOSE TO RUN-
WHEN UNIT OPERATING WITH ACCESS
DOOR REMOVED/OPEN, HEARING
PROTECTION REQUIRED WITHIN
SEVEN (7) FEET**

ALTITUDE	TEMP
SEA LEVEL (760mmHg)	107°F(41.7°C)
3000 FEET (632mmHg)	103°F(39.5°C)

Figure 5-1. Instruction and Rating Plates (Sheet 3)

TM 5-6115-584-12
NAVFAC P-8-622-12
TO 35C2-3-456-1
TM-05682C-12

US DEPARTMENT OF DEFENSE			
ACOUSTIC SUPPRESSION KIT (ASK), 5 KW			
MODEL	MEP-002AAS	NSN	6115-01-273-7377
SER NO	ASK-5-	REG NO	
KIT WT	126 LB	LG	57.63 IN
		W	35.75 IN
		HGT	31.25 IN
DATE MFD		CONTR NO	DAAK01-88-D-D083
WARRANTY	MO	DATE INSR	
MFD BY	INDUSTRIAL ACOUSTICS COMPANY, INC.		INSP STAMP
GENERATOR SET, DIESEL ENGINE, 5 KW W/ASK			
GROS WT	1084 LB		
LG	57.63 IN	W	35.75 IN
		HGT	38.25 IN

Figure 5-1. Instruction and Rating Plates (Sheet 4)

b. Installation. See figure 5-2. Replace cover assembly consisting of top panel assembly, left and right panel assemblies and front panel assembly on generator as follows:

WARNING

The ASK Cover assembly is heavy. Four (4) people are required to lift cover. Failure to follow safety rules could result in personal injury.

- (1) Position cover assembly on generator set.
- (2) Install seven screws (22) and locknuts (23), and 14 washers (24 and 25) securing top panel assembly (26) to rear closure assembly (21) and side closure assembly (9).
- (3) Torque screws (22) to 16 \pm 2 ft-lbs dry.
- (4) Install two screws (17) and locknuts (18), and four washers (19 and 20) securing right panel assembly (12) to rear closure assembly (21) and install two screws (14) and washers (15) securing right panel assembly (12) to rear panel assembly (16).
- (5) Torque screws (17) to 16 \pm 2 ft-lbs dry.
- (6) Torque screws (14) to 18 \pm 2 in.-lbs dry.
- (7) Install five screws (10) and washers (11) securing right panel assembly (12) to right support assembly (13).
- (8) Torque screws (10) to 18 \pm 2 in.-lbs dry.
- (9) Install three screws (5) and locknuts (6), and six washers (7 and 8) securing left panel assembly (3) to side closure assembly (9)
- (10) Torque screws (5) to 16 \pm 2 ft-lbs dry.
- (11) Install three screws (1) and washers (2) securing left panel assembly (3) to left support assembly (4).
- (12) Torque screws (1) to 18 \pm 2 in.-lbs dry.

5-4. TOP PANEL ASSEMBLY.

a. Removal. See figure 5-3. Remove top panel assembly from left, right and front panel assemblies and side and rear closure assemblies as follows:

- (1) Remove 11 screws (1) and washers (2) securing top panel assembly (3) to left panel assembly (4), right panel assembly (5) and front panel assembly (6).

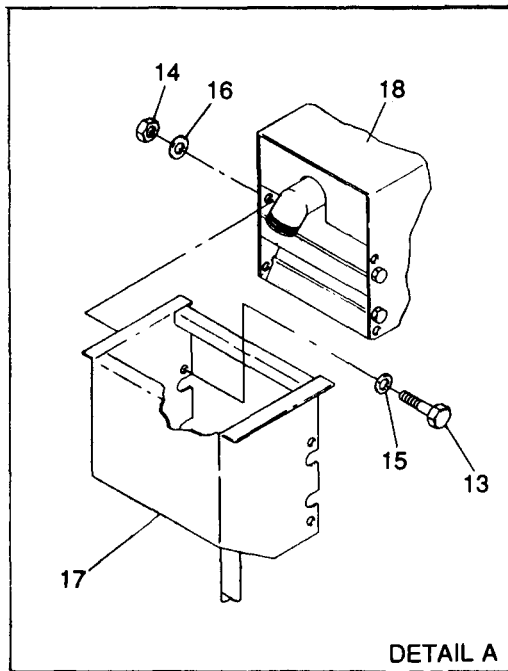
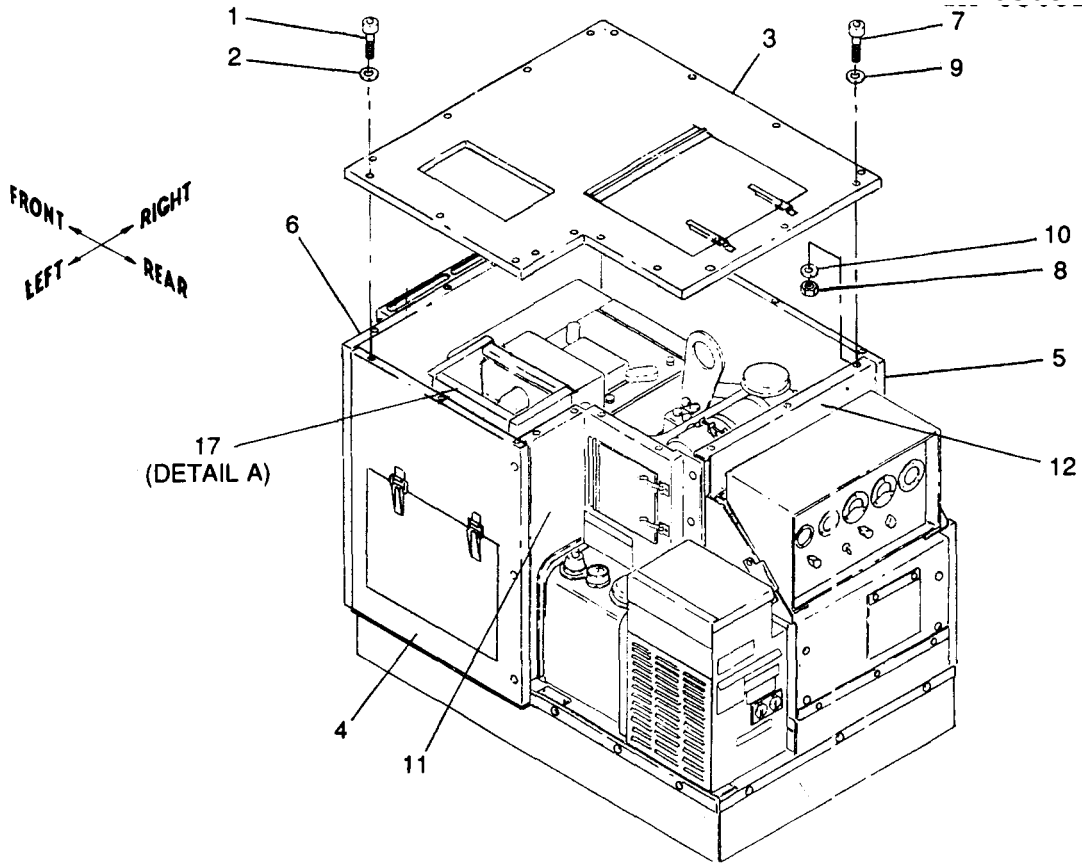

Figure 5-3. Top Panel Assembly and Exhaust Plenum, Removal and Installation

(2) Remove seven screws (7) and locknuts (8), and 14 washers (9 and 10) securing top panel assembly (3) to side closure assembly (11) and rear closure assembly (12).

(3) Lift off top panel assembly (3).

b. Installation. See figure 5-3. Install top panel assembly to left, right and front panel assemblies and to side and rear closure assemblies as follows:

(1) Position top panel assembly (3) on left panel assembly (4) right panel assembly (5), front panel assembly (6), side closure assembly (11), and rear closure assembly (12).

(2) Install seven screws (7) and locknuts (8), and 14 washers (9 and 10) securing top panel assembly (3) to side closure assembly (11) and rear closure assembly (12).

(3) Install 11 screws (1) and washers (2) securing top panel assembly (3) to left panel assembly (4), right panel assembly (5) and front panel assembly (6).

(4) Torque screws (7) to 16 \pm 2 ft-lbs dry.

(5) Torque screws (1) to 18 \pm 2 in.-lbs dry.

5-5. LEFT PANEL ASSEMBLY.

a. Removal. See figure 5-4. Remove left panel assembly from left support assembly, side closure assembly, and front and top panel assemblies as follows:

(1) Remove three screws (1) and washers (2) securing left panel assembly (3) to left support assembly (4).

(2) Remove three screws (5) and washers (6) securing left panel assembly (3) to front panel assembly (7).

(3) Remove three screws (8) and washers (9) securing left panel assembly (3) to top panel assembly (10).

(4) Remove three screws (11) and locknuts (12), and six washers (13 and 14) securing left panel assembly (3), to side closure assembly (15) and lift off left panel assembly (3).

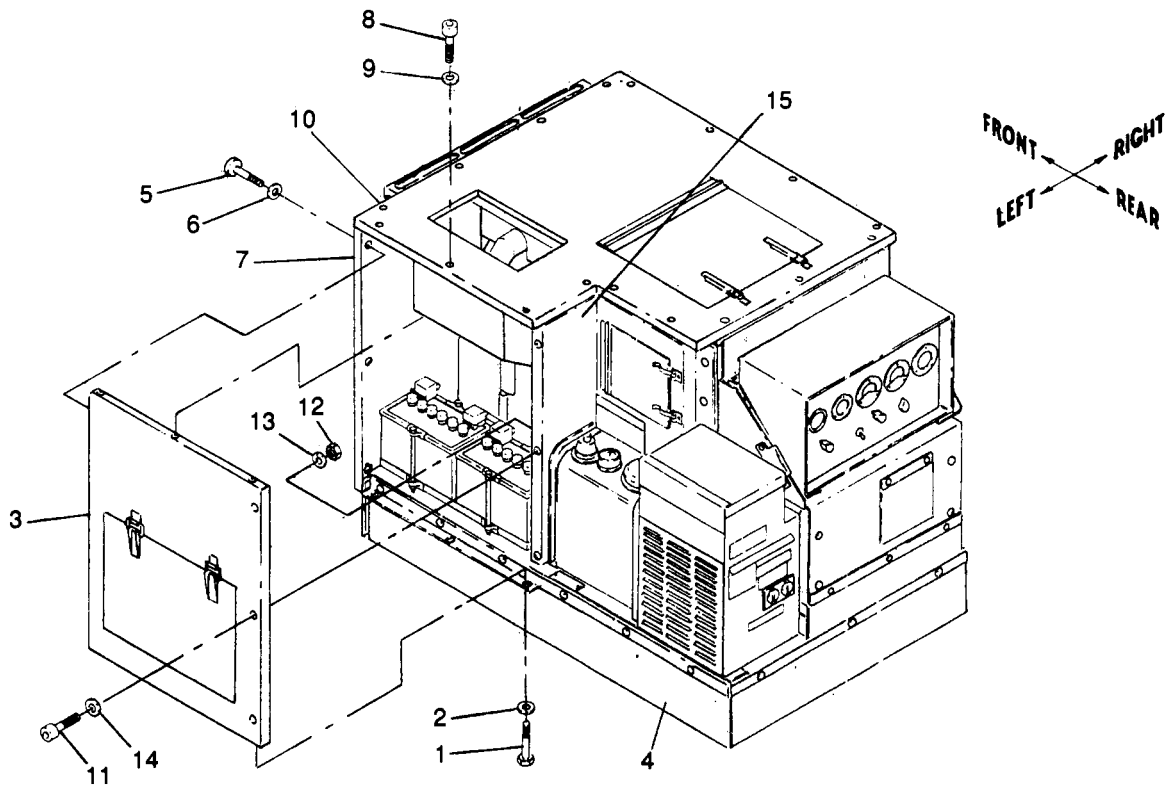

Figure 5-4. Left Panel Assembly, Removal and Installation

TM 5-6115-584-12
NAVFAC P-8-622-12
TO 35C2-3-456-1
TM-05682C-12

b. Installation. See figure 5-4. Install left panel assembly to left support assembly, side closure assembly and front and top panel assemblies as follows:

(1) Position left panel assembly (3) on left support assembly (4) and install three screws (11) and locknuts (12), and six washers (13 and 14) securing left panel assembly (3) to side closure assembly (15) .

(2) Torque screws (11) to 16 ±2 ft-lbs dry.

(3) Install three screws (8) and washers (9) securing left side panel assembly (3) to top panel assembly (10).

(4) Torque screws (8) to 18 ±2 in.-lbs dry,

(5) Install three screws (5) and washers (6) securing left panel assembly (3) to front panel assembly (7).

(6) Torque screws (5) to 18 ±2 in.-lbs dry.

(7) Install three screws (1) and washers (2) securing left panel assembly (3) to left support assembly (4).

(8) Torque screws (1) to 18 ±2 in.-lbs dry.

5-6. RIGHT PANEL ASSEMBLY.

a. Removal. See figure 5-5. Remove right panel assembly from right support assembly, rear closure assembly and rear, top and front panel assemblies as follows:

(1) Remove five screws (1) and washers (2) securing right panel assembly (3) to right support assembly (4).

(2) Remove three screws (5) and washers (6) securing right panel assembly (3) to front panel assembly (7).

(3) Remove four screws (8) and washers (9) securing right panel assembly (3) to top panel assembly (10).

(4) Remove two screws (11) and locknuts (12), and four washers (13 and 14) securing right panel assembly (3) to rear closure assembly (15) and remove two screws (16) and washers (17) securing right panel assembly (3) to rear panel assembly (18) and lift off right panel assembly (3).

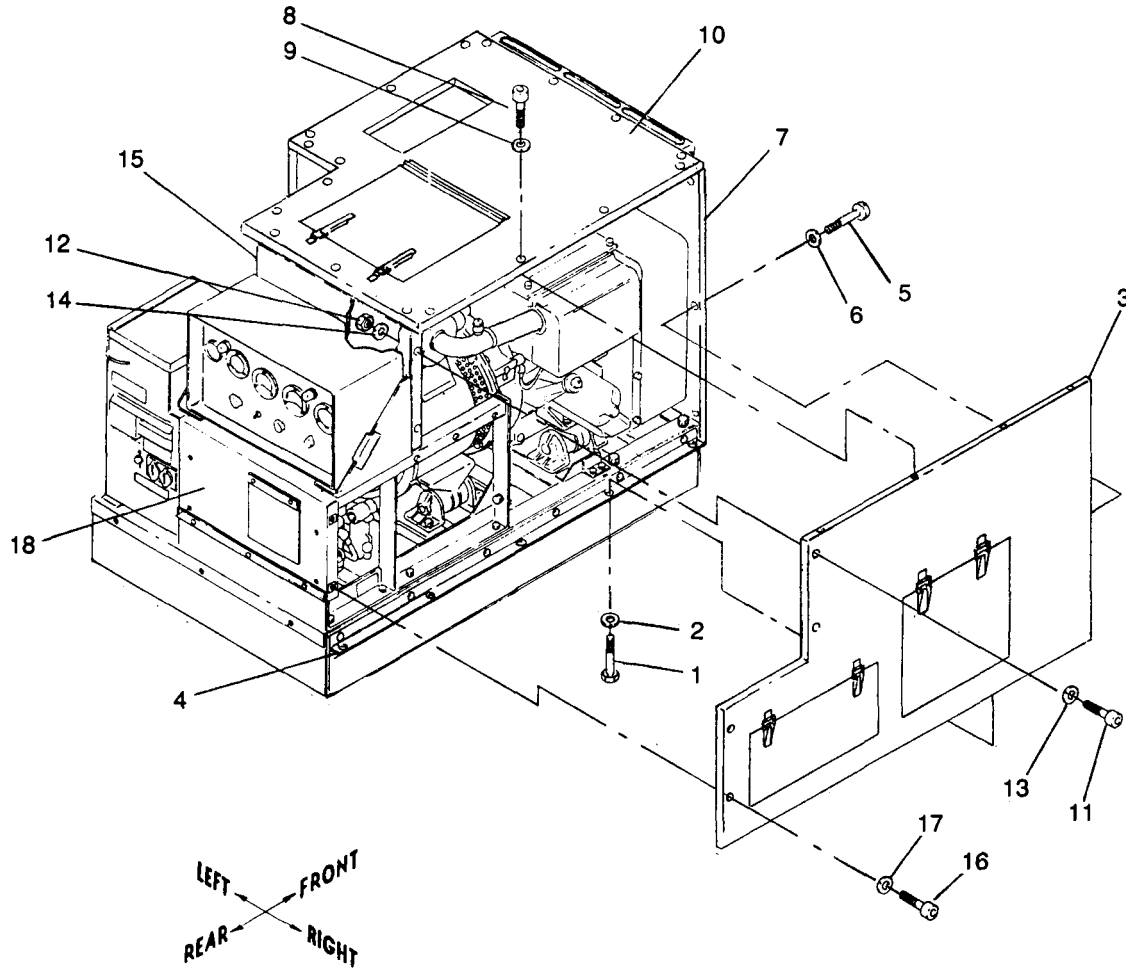

Figure 5-5. Right Panel Assembly, Removal and Installation

b. Installation. See figure 5-5. Install right panel assembly to right support assembly, rear closure assembly and front, top and rear panel assemblies as follows:

(1) Position right panel assembly (3) on right support assembly (4) and install two screws (16) and washers (17) securing right panel assembly (3) to rear panel assembly (18), and install two screws (11) and locknuts (12), and four washers (13 and 14) securing right panel assembly (3) to rear closure assembly (15).

(2) Torque screws (16) to 18 \pm 2 ft-lbs dry.

(3) Torque screws (11) to 16 \pm 2 in.-lbs dry.

(4) Install four screws (8) and washers (9) securing right panel assembly (3) to top panel assembly (10).

(5) Torque screws (8) to 18 \pm 2 in.-lbs dry.

(6) Install three screws (5) and washers (6) securing right panel assembly (3) to front panel assembly (7).

(7) Torque screws (5) to 18 \pm 2 in.-lbs dry.

(8) Install five screws (1) and washers (2) securing right panel assembly (3) to right support assembly (4).

(9) Torque screws (1) to 18 \pm 2 in.-lbs dry.

5-7. REAR PANEL ASSEMBLY.

a. Removal. See figure 5-6. Remove rear panel assembly from control cubicle support frame and right panel assembly as follows:

(1) Remove two screws (1) and washers (2) securing right panel assembly (3) to rear panel assembly (4).

(2) Remove four screws (5) and locknuts (6) and eight washers (7 and 8) securing rear panel assembly (4) to control cubicle support frame (9), and remove rear panel assembly (4).

b. Installation. See figure 5-6. Install rear panel assembly to control cubicle support frame and right panel assembly as follows:

(1) Position rear panel assembly (4) on control cubicle support frame (9) and install four screws (5) and locknuts (6), and eight washers (7 and 8) securing rear panel assembly (4) to control cubicle support frame (9).

(2) Torque screws (5) to 16 \pm 2 ft-lbs dry.

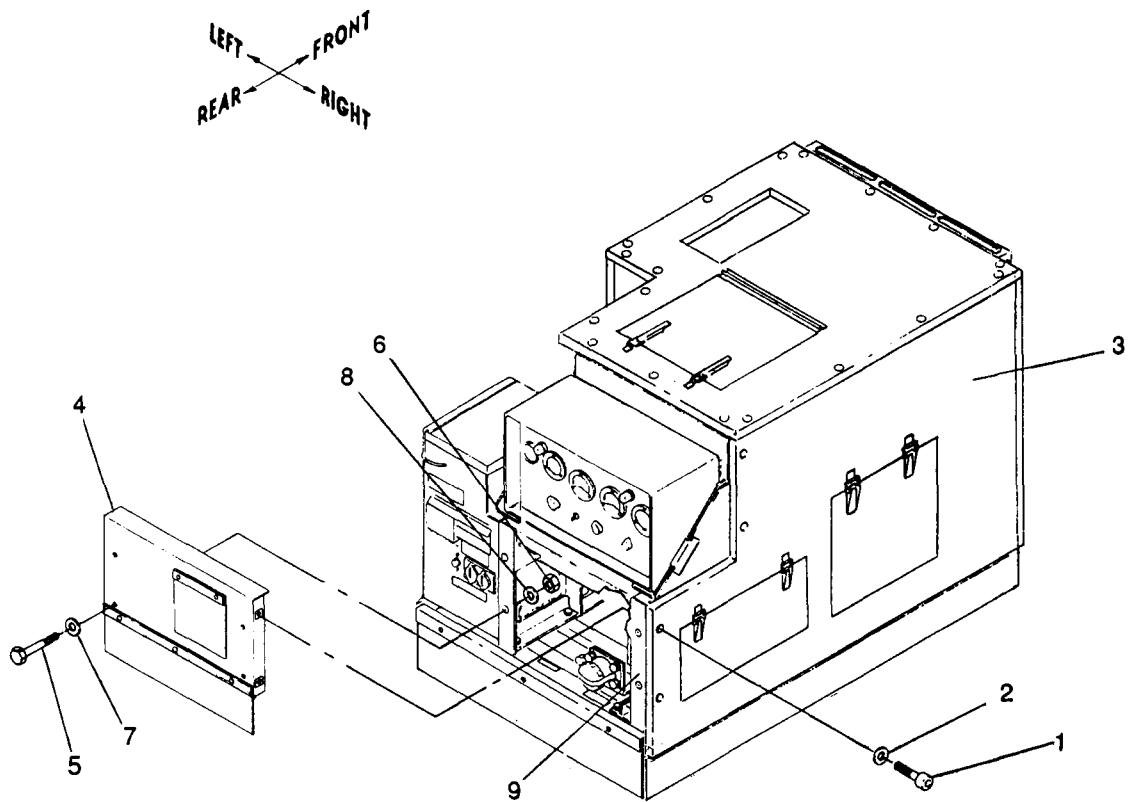

Figure 5-6. Rear Panel Assembly, Removal and Installation

(3) Install two screws (1) and washers (2) securing right panel assembly (3) to rear panel assembly (4).

(4) Torque screws (1) to 18 \pm 2 in.-lbs dry.

5-8. EXHAUST PLENUM ASSEMBLY.

a. Removal. See figure 5-3. Remove exhaust plenum assembly from shutter assembly as follows:

(1) Remove top panel assembly (3) as described in paragraph 5-4.

(2) Remove four screws (13) and locknuts (14), and eight washers (15 and 16) securing exhaust plenum assembly (17) to shutter assembly (18) and lift off exhaust plenum assembly (17).

b. Installation. See figure 5-3. Install exhaust plenum assembly on shutter assembly as follows:

(1) Position exhaust plenum assembly (17) on shutter assembly (18) and install four screws (13) and locknuts (14), and eight washers (15 and 16) securing exhaust plenum assembly (17) to shutter assembly (18).

(2) Torque screws (13) to 16 \pm 2 ft-lbs dry.

(3) Install top panel assembly (3) as described in paragraph 5-4.

5-9. LEFT SUPPORT ASSEMBLY.

a. Removal. See figure 5-7. Remove left support assembly from skid and left panel assembly as follows:

(1) Remove four screws (1) and washers (2) securing access plate (3) to AC output control box (4).

(2) Remove left panel assembly (5), as described in paragraph 5-5.

(3) Loosen six screws (6) and slide out left support assembly (7) from under skid (8).

b. Installation. See figure 5-7. Install left support assembly to skid and left panel assembly as follows:

(1) With six screws (6) loosened, slide left support assembly (7) between skid (8) and bevel washers (9).

(2) Torque screws (6) to 26 \pm 2 ft-lbs dry.

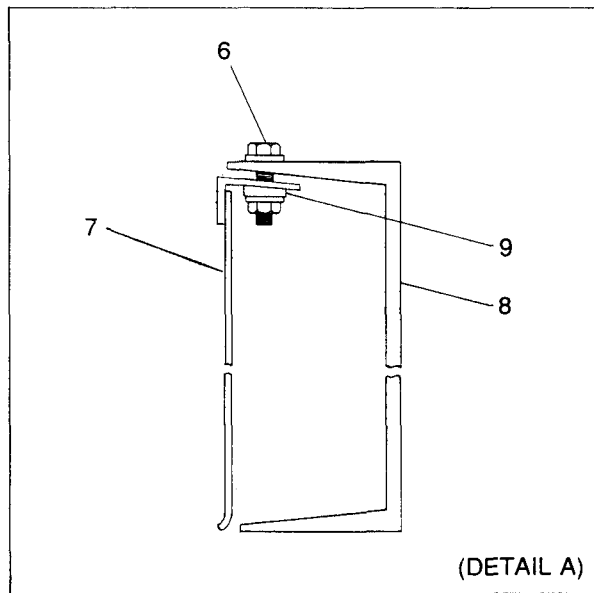
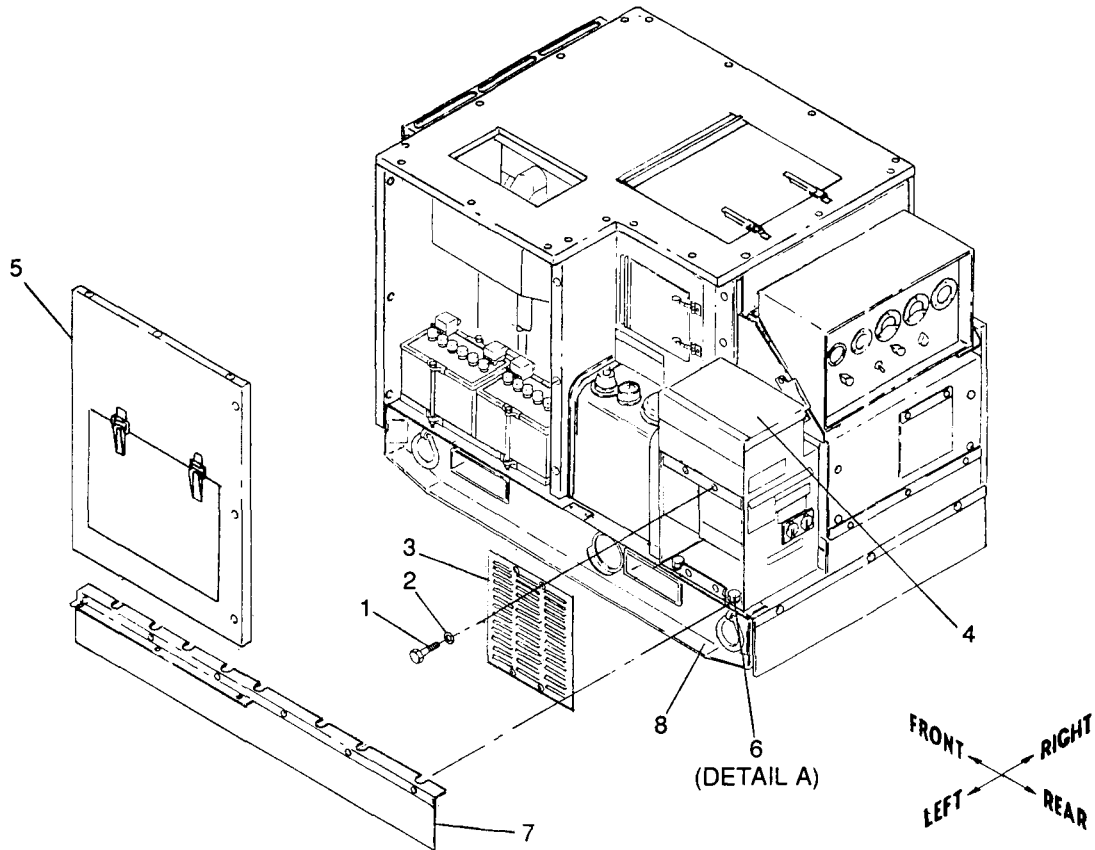

Figure 5-7. Left Support Assembly, Removal and Installation

(3) Install left panel assembly (5) as described in paragraph 5-5.

(4) Install access plate (3) to AC output control box (4) with four screws (1) and washers (2).

5-10. RIGHT SUPPORT ASSEMBLY.

a. Removal. See Figure 5-8. Remove right support assembly from skid and right panel assembly as follows:

(1) Remove right panel assembly (1) as described in paragraph 5-6.

(2) Loosen six screws (2) securing right support assembly (3) to skid (4) and slide out right support assembly (3) from under skid (4).

b. Installation. See figure 5-8. Install right support assembly to skid and right panel assembly as follows:

(1) With six screws (2) loosened, slide right support assembly (3) between skid (4) and bevel washers (5).

(2) Torque screws (2) to 26 \pm 2 ft-lbs dry.

(3) Replace right side panel (1) as described in paragraph 5-6.

5-11. FRONT PANEL ASSEMBLY.

a. Removal. See figure 5-9. Remove front panel assembly from top, right and left panel assemblies as follows:

(1) Remove four screws (1) and washers (2) securing the front panel assembly (3) to top panel assembly (4).

(2) Remove six screws (5) and washers (6) securing front panel assembly (3) to left panel assembly (7) and right panel assembly (8).

(3) Remove front panel assembly (3).

b. Installation. See figure 5-9. Install front panel assembly to top, right and left panel assemblies as follows:

(1) Position front panel assembly (3) against left panel assembly (7) and right panel assembly (8) and secure with six screws (5) and washers (6).

(2) Install four screws (1) and washers (2) securing front panel assembly (3) to top panel assembly (4).

(3) Torque screws (5 and 1) to 18 \pm 2 in.-lbs dry.

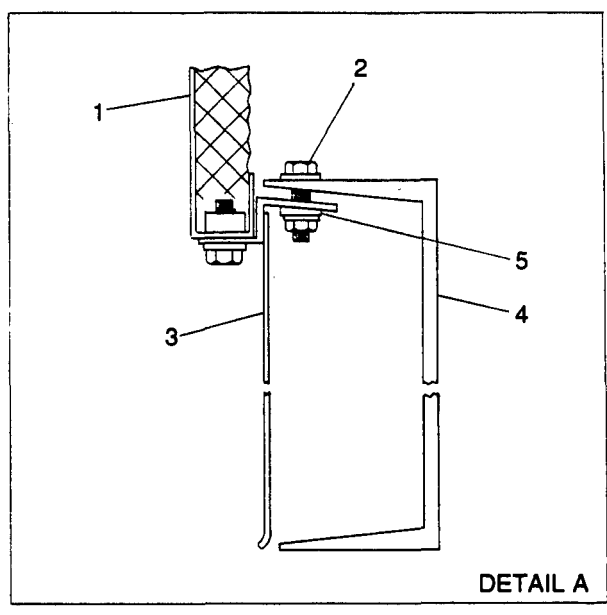
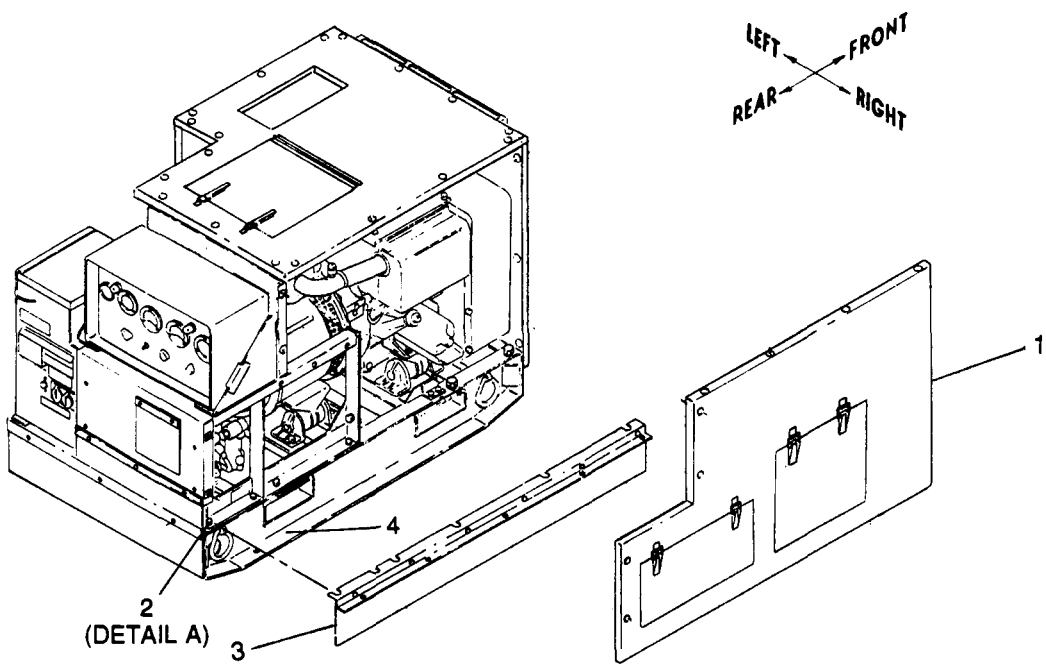

Figure 5-8. Right Support Assembly, Removal and Installation

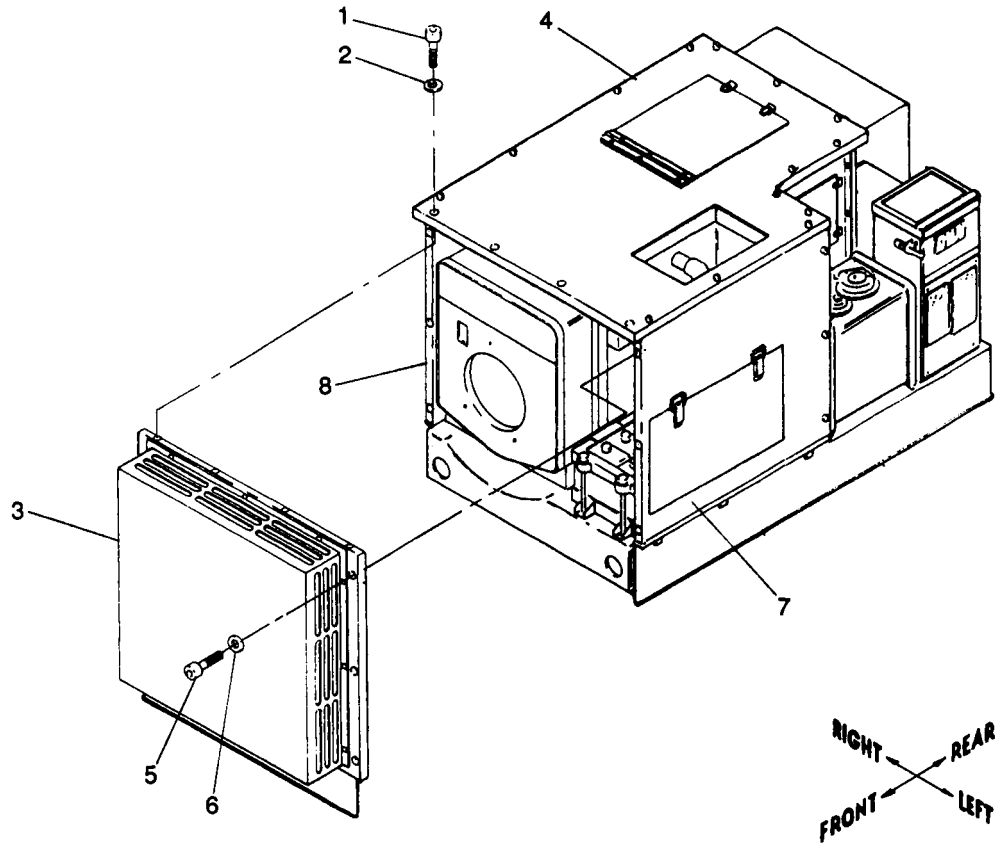

Figure 5-9. Front Panel Assembly, Removal and Installation

5-12. SIDE CLOSURE ASSEMBLY.

a. Removal. See figure 5-10. Remove side closure assembly from rear closure assembly, top and left panel assemblies as follows:

(1) Remove top panel assembly (1) as described in paragraph 5-4.

(2) Remove three screws (2) and locknuts (3) and six washers (4 and 5) securing side closure assembly (6) to left panel assembly (7).

(3) Remove two screws (8) and locknuts (9), and four washers (10 and 11) securing side closure assembly (6) to rear closure assembly (12) and remove side closure assembly (6).

b. Installation. See figure 5-10. Install side closure assembly to rear closure assembly, top & left panel assemblies as follows:

(1) Position side closure assembly (6) against rear closure assembly (12).

(2) Install side closure assembly (6) to rear closure assembly (12) using two screws (8) and locknuts (9), and four washers (10 and 11).

(3) Torque screws (8) to 16 ±2 ft-lbs dry.

(4) Install three screws (2) and locknuts (3) and six washers (4 and 5).

(5) Torque screws (2) to 16 ±2 ft-lbs dry.

(6) Install top panel assembly (1) as described in paragraph 5-4.

5-13. REAR CLOSURE ASSEMBLY.

a. Removal. See figure 5-11. Remove rear closure assembly from control box support, side closure assembly and right and top panel assemblies as follows:

(1) Remove top panel assembly (1) as described in paragraph 5-4.

(2) Remove two screws (2) and locknuts (3), and four washers (4 and 5) securing rear closure assembly (6) to right panel assembly (7).

(3) Remove two screws (8) and locknuts (9), and four washers (10 and 11) securing side closure assembly (12) to rear closure assembly (6).

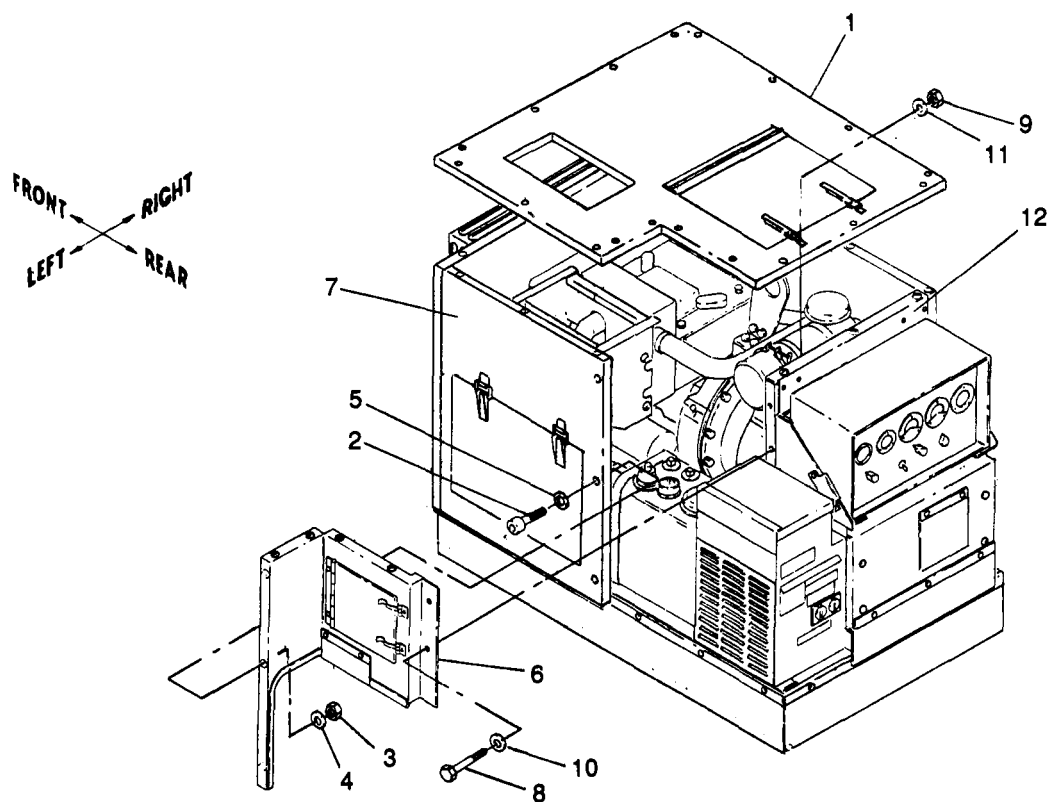

Figure 5-10. Side Closure Assembly, Removal and Installation

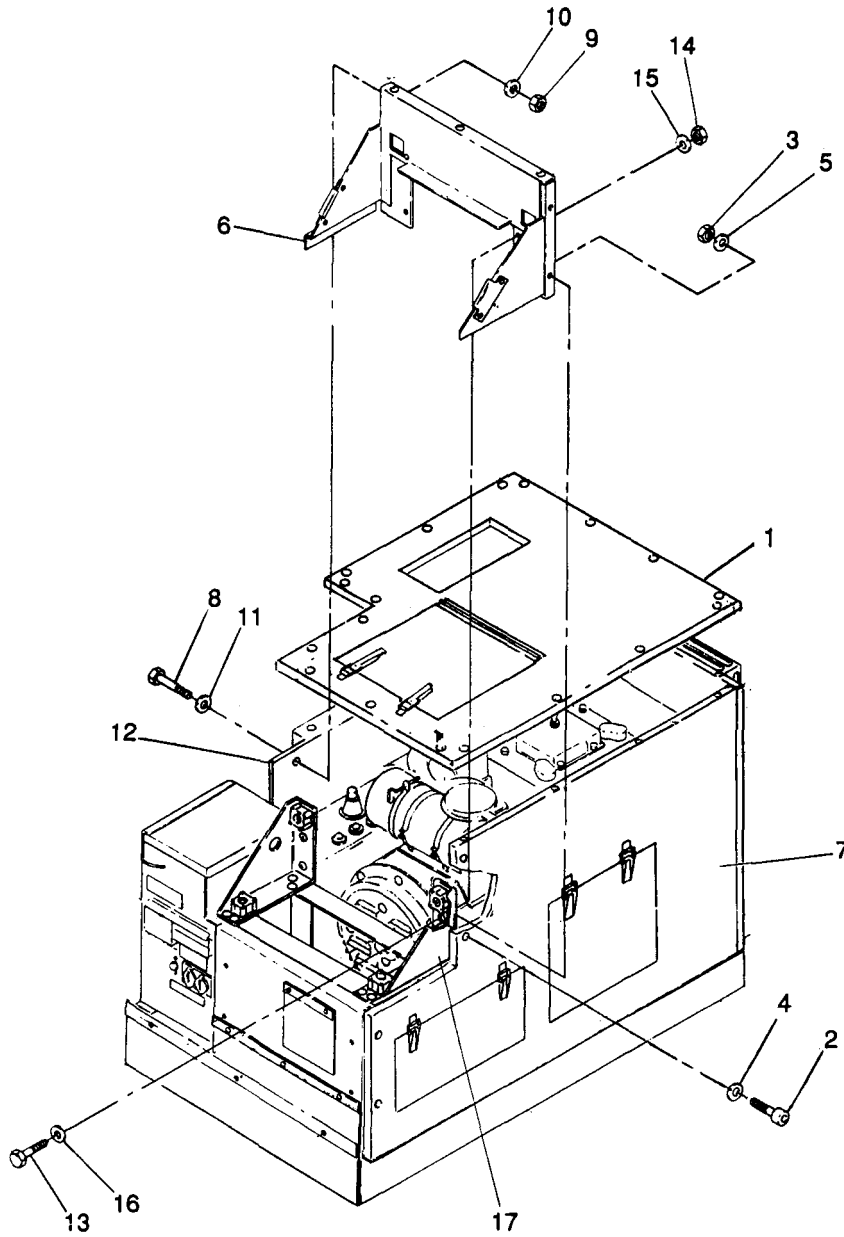

Figure 5-11. Rear Closure Assembly, Removal and Installation

(4) Remove four screws (13) and locknuts (14), and eight washers (15 and 16) securing rear closure assembly (6) to mounting brackets (17) and remove rear closure assembly (6).

b. Installation. See figure 5-11. Install rear closure assembly to control box support, side closure assembly, right and top panel assemblies as follows:

(1) Install four screws (13) and locknuts (14), and eight washers (15 and 16) securing rear closure assembly (6) to mounting brackets (17).

(2.) Tighten screws (13) to 16 \pm 2 ft-lbs dry.

(3) Install two screws (8) and locknuts (9), and four washers (10 and 11) securing side closure assembly (12) to rear closure assembly (6).

(4) Torque screws (8) to 16 \pm 2 ft-lbs dry.

(5) Install two screws (2) and locknuts (3) and four washers (4 and 5) securing rear closure assembly (6) to right panel assembly (7).

(6) Torque screws (2) to 16 \pm 2 ft-lbs dry.

(7) Install top panel assembly (1) as described in paragraph 5-4.

5-14. REAR FLAP ASSEMBLY.

a. Removal. See figure 5-12. Remove rear flap assembly from skid as follows:

(1) Remove three screws (1) and locknuts (2), and six washers (3 and 4) securing rear flap assembly (5) to skid (6).

(2) Remove rear flap assembly (5).

b. Installation. See figure 5-12. Install rear flap assembly to skid as follows:

(1) Position rear flap assembly (5) on skid (6) and install three screws (1) and locknuts (2), and six washers (3 and 4).

(2) Torque screws (1) to 16 \pm 2 ft-lbs dry.

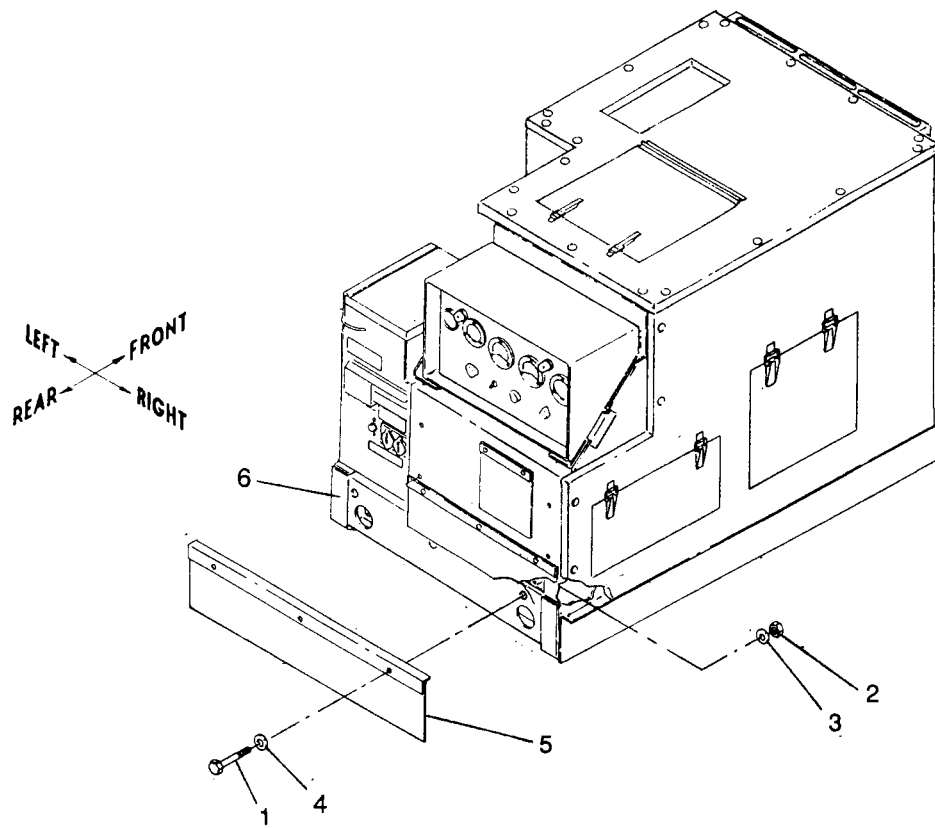

Figure 5-12. Rear Flap Assembly, Removal and Installation

SECTION III. ACOUSTIC SUPPRESSION KIT REPAIR

5-15. GENERAL.

WARNING

The local safety office and Preventative Medicine Support Activity must be consulted prior to initial CARC painting.

This section provides repair procedures for the acoustic suppression kit (ASK). Repair of the ASK at all levels of Maintenance is limited to replacement of panel assemblies and replacement of hinges, latches, catches, captive nuts, rubber flaps and the front panel silencer assembly. After repair is accomplished, paint needed areas in accordance with MIL-T-704 using paint colors green 383, brown 383, and black as required by FED-STD-595.

5-16. REPLACEMENT OF ASK COMPONENTS.

a. Refer to Table 3-2 for inspection of ASK components for damage and to determine if replacement is necessary.

b. Remove the ASK component to be replaced by following the applicable removal procedures outlined in Section II.

c. Prior to replacement of the rear panel, left support, right support, side closure and rear closure assemblies; adhesive backed teflon tape must be applied to the new assemblies as follows:

(1) Rear Panel Assembly (refer to figure 5-6, item 4).

(a) Wipe surface clean.

(b) Cut a 11 3/4 in. length of adhesive backed teflon tape from supplied bulk material.

(c) Apply adhesive backed teflon tape to the right edge of rear panel assembly (edge with captive nuts). Use hand pressure to remove air bubbles.

(d) Clear tape from captive nut openings.

(2) Left Support Assembly (refer to figure 5-7, item 7).

(a) Wipe surface clean.

(b) Cut a 50 in. length of adhesive backed teflon tape from supplied bulk material.

(c) Apply adhesive backed teflon tape to left support assembly top surface (slotted surface which mounts against underside of skid) . Use hand pressure to remove air bubbles.

(d) Clear tape from slotted openings.

(3) Right Support Assembly (refer to figure 5-8, item 3).

(a) Wipe surface clean.

(b) Cut a 50 in. length of adhesive backed teflon tape from supplied bulk material.

(c) Apply adhesive backed teflon tape to right support assembly top surface (slotted surface which mounts against underside of skid). Use hand pressure to remove air bubbles.

(d) Clear tape from slotted openings.

(4) Side Closure Assembly (refer to figure 5-10, item 6).

(a) Wipe surface clean.

(b) Cut a 20 1/2 in. length and a 29 1/4 in. length of adhesive backed teflon tape from supplied bulk material.

(c) Apply adhesive backed teflon tape to top edges (edges with four holes) and left edge (edge with three holes). Use hand pressure to remove air bubbles.

(d) Clear tape from holes.

(5) Rear Closure Assembly (refer to figure 5-11, item 6).

(a) Wipe surface clean.

(b) Cut a 23 in. length and a 14 in. length of adhesive backed teflon tape from supplied bulk material.

(c) Apply adhesive backed teflon tape to top edge (edge with three holes) and right edge (edge with two holes which will contact right panel assembly). Use hand pressure to remove air bubbles.

(d) Clear tape from holes.

d. Install ASK replacement components by following the applicable installation procedures outlined in Section II.

5-17. LATCH REPLACEMENT.

The following procedures are for replacement of side closure door latch assemblies. Figure 5-13 (Illustration A) shows a typical latch assembly replacement.

- a. Remove damaged latch assembly (1) by drilling out rivet (2) using a No. 11 drill bit (0.191 dia.).
- b. Install new latch assembly (1) with a 3/16 inch dia. rivet (2) using hand riveter.

5-18. CATCH REPLACEMENT.

The following procedures are typical for replacement of all access door catch assemblies. Figure 5-13 (Illustration B) shows a typical catch assembly replacement using the left panel as an example.

- a. Remove damaged catch assembly (1) by drilling out rivets (2) using a No. 11 drill bit (0.191 dia.).
- b. Install new catch assembly (1) with four 3/16 inch dia. rivets (2) using hand riveter.

5-19. RUBBER FLAP REPLACEMENT.

The following procedures are typical for replacement of all rubber flaps. Figure 5-13 (Illustration C) shows a rubber flap replacement using the rear flap assembly as an example.

- a. Remove rubber flap (1) (and retainer(s) if provided) from panel, support, or angle (2) by removing screws (3), washers (4) and nuts (5) (or by drilling out rivets using a No. 11 drill bit). Save retainer(s) (if provided) for reuse.
- b. Use old rubber flap as a pattern to cut a new flap from bulk material and to mark new holes in flap for rivets or screws.
- c. Drill out holes for rivets or screws in new rubber flap. Use No. 11 (0.191 dia.) drill bit for rivet holes.
- d. Install new rubber flap (1) (with old retainer(s) if provided) on panel, support, or angle (2) with same number of screws (3), washers (4) and nuts (5) (or 3/16 inch dia. rivets using hand riveter).

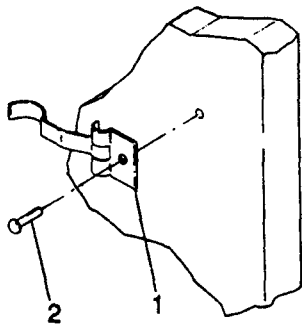

A. LATCH

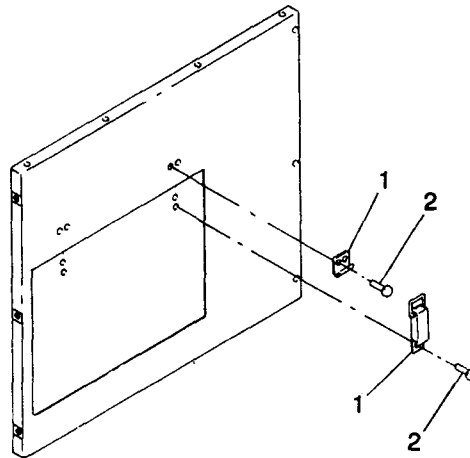

B. CATCH

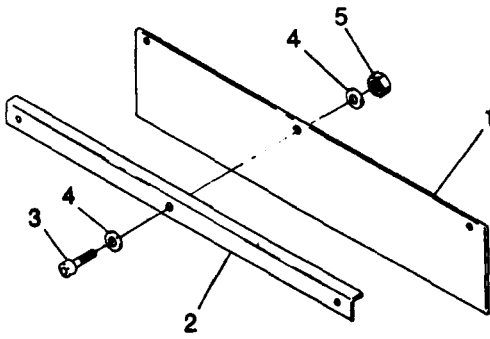

C. RUBBER FLAP

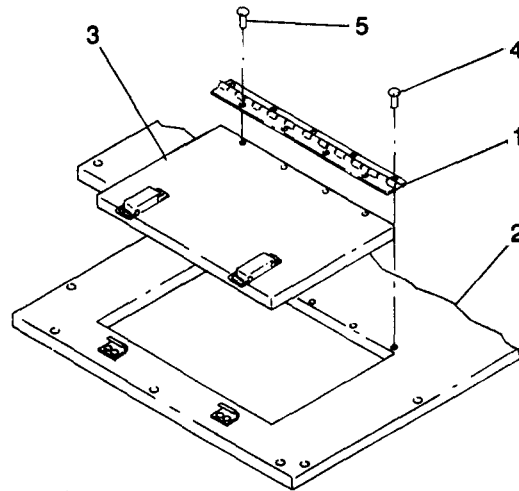

D. HINGE

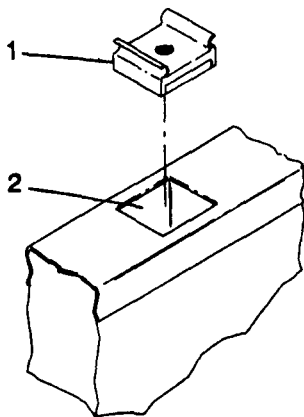

E. CAPTIVE NUT

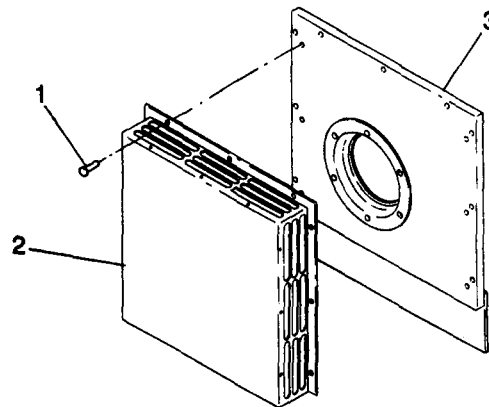

F. FRONT PANEL SILENCER

Figure 5-13. Replacement of ASK Hardware Items

TM 5-6115-584-12
NAVFAC P-8-622-12
TO 35C2-3-456-1
TM-05682C-12

5-20. HINGES.

The following procedures are for hinge replacement on the top panel assembly access door. See figure 5-13. (Illustration D).

a. Remove hinge (1) from panel assembly (2) and access door (3) by drilling out rivets (4 and 5) using a No. 11 drill bit (0.191 dia.).

b. Install hinge (1) to access door (3) and panel assembly (2) with same number of 3/16 inch dia. rivets (4 and 5) using hand riveter.

5-21. CAPTIVE NUTS.

The following procedures are typical for replacement of captive nuts installed in the left and right panel assemblies, rear panel assembly, and front panel assembly. See figure 5-13 (Illustration E) showing an example for replacement of captive nuts.

a. Remove captive nut (1) from panel (2) by squeezing sides of cage with pliers. Pull out until nut is freed.

b. Install new captive nut (1) by squeezing sides of cage with pliers until nut can be inserted into square opening in panel.

5-22. FRONT PANEL SILENCER.

The following procedures are to be followed for replacement of the silencer attached to the front panel. See figure 5-13 (Illustration F).

a. Remove nine rivets (1) securing silencer (2) to front panel (3) by drilling out rivets using a No. 11 drill bit (0.191 dia.).

b. Apply adhesive backed teflon tape to all four inside edges of new silencer. Clear tape from rivet hoses. Locate silencer on front panel by aligning rivet holes.

c. Install new silencer (2) to front panel (3) with nine 3/16 inch dia. rivets (1) using hand riveter.

APPENDIX A

REFERENCES

1. PAINTING:
 - T.O. 35-1-3 Painting and marking of USAF aerospace Ground Equipment.
 - TM 43-0139 Painting and marking of USAF aerospace Ground Equipment.
 - Painting Instructions for Field Use.
2. RADIO SUPPRESSION:
 - MIL-STD-461 Radio Interference Suppression.
3. MAINTENANCE
 - T.O. 1-1-1 Cleaning of Aerospace Equipment.
 - T.O. 1-1-2 Corrosion Control and Treatment for Aerospace Equipment.
 - T.O. 35-1-11 Organization, Intermediate and Depot Level Maintenance for FSC 6115 Equipment.
 - T.O. 35-1-12 Components and Procedures for Cleaning Aerospace Ground Equipment.
 - T.O. 35-1-26 Repair/Replacement Criteria for FSC 6115 Aerospace Ground Equipment.
 - T.O. 35-1-524 USAF Equipment Registration Number System Applicable to FSC 6115 Equipment.
 - TM5-764 Electric Motor and Generator Repair.
 - TM5-766 Electric Power Generation in the Field.
 - DA PAM 738-750 The Army Maintenance Management System.
 - TM 5-6115-584-24P Organizational, Intermediate (field) Direct Support and General Support and
 - NAVFAC P-8-622-24P Depot Maintenance Repair Parts List.
 - TO 35C2-3-456-4
 - SL-4-05682C
4. SHIPMENT AND STORAGE:
 - T.O. 35-1-4 Processing and Inspection of Aerospace Ground Equipment for Storage and Shipment.
 - T.O. 38-1-5 Processing and Inspection of Non-Mounted, Non-Aircraft Gasoline and Diesel Engines for Storage and Shipment.
5. DESTRUCTION OF MATERIAL:
 - TM 750-244-3 Procedures for Destruction of Equipment to Prevent Enemy Use.

APPENDIX B
COMPONENTS OF END ITEMS LIST

Section I. INTRODUCTION

B-1. SCOPE.

This appendix lists Integral Components of and Basic Issue Items (BII) for the 5KW Generator Set to help you inventory items required for safe and efficient operation.

B-2. GENERAL.

The components of end item list are divided into the following sections:

a. Section II. Integral Components of the End Item.

These Items, when assembled, comprise the 5KW Generator Set and must accompany it whenever it is transferred or turned in.

b. Section III. Basic Issue Items.

These are minimum essential items required to place the 5KW Generator Set in operation, to operate it and to perform emergency repairs. Although shipped separately packed, they must accompany the Generator Set during operation and whenever it is transferred between accountable officers. The illustrations will assist you with hard-to-identify items. This manual is your authority to requisition replacement BII based on Table(s) of Organization and Equipment (TOE) /Modification Table of Organization and Equipment (MTOE) authorization of the end item.

B-3. EXPLANATION OF COLUMNS.

a. Illustration: This column is divided as follows:

(1) Figure Number. Indicates the figure number of the illustration on which the item is shown (if applicable).

(2) Item Number. The number used to identify item called out in the illustration.

b. National Stock Number (NSN); Indicates the national stock number assigned to the end item which will be used for requisitioning.

c. Part Number (P/N): Indicates the primary number used by the manufacturer which controls the design and characteristics of the item by means of its engineering drawings, specifications, standards and inspection requirements to identify an item or range of items.

d. Description: Indicates the federal item name and if required, a minimum description to identify the item.

e. Location. The physical location of each item listed is given in this column. The lists are designed to inventory all items in one area of the major item before moving on to an adjacent area.

f. Quantity Required (Qty Reqd): This column lists the quantity of each item required for a complete major item.

g. Quantity: This column is left blank for use during inventory. Under the received column, list the quantity you actually receive on your major item. The date columns are for use when you inventory the major item at a later date, such as for shipment to another site.

Section II. INTEGRAL COMPONENTS OF END ITEM

(1) Illustration (a) (b) Figure Item No. No.	(2) National Stock Number	(3) Part No. & FSCM	(4) Description	(5) Location	(6) Usable On Code	(7) Qty Reqd
NONE						

Section III. ITEMS TROOP INSTALLED OR AUTHORIZED LIST

(1) SMR Code	(2) Federal Stock Number	(3) Description	(4) Unit of Mess	(5) Qty Auth
PAC	7520-00-559-9618	Case, Maintenance and Operational Manual	EA	1
PAC	5975-00-878-3791	Rod, Ground w/attachments and wire	EA	1
PAC	6145-00-960-6278	6 AWG Copper Wire	FT	5
PAC	5935-00-322-8959	Adapter Connector	EA	1
PAC	5120-01-013-1676	Slide Hammer, Ground Rod	EA	1
PAC	4210-00-566-8837	Extinguisher, Fire, Monobromotrifluoromethane w/mounting bracket (charged replacement cylinder only NSN 4210-00-708-0031). Operating temperature range -50° F (-10°C) to +120° F (+49° C). Note: When inspection, maintenance or replacement of cylinder on Walter Kidde Co. extinguisher is necessary, the proper torque for swivel nut is not to exceed 160 inch pounds maximum,	EA	1
PAC	6140-00-179-8418	Boot, Battery Terminal	EA	4

APPENDIX C
 ADDITIONAL AUTHORIZATION LIST

Section I. INTRODUCTION

C-1. SCOPE.

This appendix lists additional items you are authorized for the support of the 5KW Generator Set

in with it. These items are authorized to you by CTA, MTOE, TDA or JTA.

C-2. GENERAL.

This list identifies items that do not have to accompany the 5KW Generator Set and that do not have to be turned

C-3. EXPLANATION OF LISTING,

National stock number, descriptions and quantities are provided to help you identify and request the additional items you require to support this equipment.

Section II. ADDITIONAL AUTHORIZATION LIST

(1) NATIONAL STOCK NUMBER	(2) DESCRIPTION	(3) U/M	(4) QTY AUTH
6115-01-273-7377	Acoustic Suppression Kit	KT	1

APPENDIX D

MAINTENANCE ALLOCATION CHART

Section I. INTRODUCTION

D-1. GENERAL.

a. This section provides a general explanation of all maintenance and repair functions authorized at various maintenance levels.

b. Section II designates overall responsibility for the performance of maintenance functions on the identified end item or component. The implementation of the maintenance functions upon the identified end item or component will be consistent with the assigned maintenance functions.

c. Section III lists the tools and test equipment required for each maintenance function as referenced from Section II.

d. Section IV contains supplemental instructions or explanatory notes required for a particular maintenance function.

D-2. EXPLANATIONS OF COLUMNS IN SECTION II.

a. Group Number. Column 1. The assembly group number is a numerical group assigned to each assembly. The assembly groups are listed on the MAC in disassembly sequence beginning with the first assembly removed in a top down disassembly sequence.

b. Assembly Group. Column 2. This column contains a brief description of the components of each assembly group.

c. Maintenance Functions. Column 3. This column lists the various maintenance functions (A through K). The upper case letter placed in the appropriate column indicates the lowest maintenance level authorized to perform these functions. The active repair time required to perform the maintenance function is included directly below the symbol identifying the category of maintenance. The symbol designations for the various maintenance levels are as follows:

- C - Operator or Crew
- O - Organizational Maintenance
- F - Direct Support Maintenance
- H - General Support Maintenance
- D - Depot Maintenance

The maintenance functions are defined as follows:

A - INSPECT. To determine serviceability of an item by comparing its physical, mechanical and electrical characteristics with established standards.

B - TEST. To verify serviceability and to detect electrical or mechanical failure by use of test equipment.

C - SERVICE. To clean, to preserve, to charge and to add fuel, lubricants, cooling agents and air. (If it is desired that elements, such as painting and lubricating, be defined separately, they may be so listed.)

D - ADJUST. To rectify to the extent necessary to bring into proper operating range.

E - ALIGN. To adjust specified variable elements of an item to bring to optimum performance.

F - CALIBRATE. To determine the corrections to be made in the readings of instruments or test equipment used in precise measurement. Consists of the comparison of two instruments, one of which is a certified standard of known accuracy, to detect and adjust any discrepancy in the accuracy of the instrument being compared with the certified standard.

G - INSTALL. To set-up for use in an operational environment such as an emplacement, site or vehicle.

H - REPLACE. To replace unserviceable items with serviceable like items.

I - REPAIR. Those maintenance operations necessary to restore an item to serviceable condition through correction of material damage or a specific failure. Repair may be accomplished at each level of maintenance.

J - OVERHAUL. Normally, the highest degree of maintenance performed by the Army in order to minimize time work is in process consistent with quality and economy of operation. It consists of that maintenance necessary to restore an item to completely serviceable condition as prescribed by maintenance standards in technical publications for each item of equipment. Overhaul normally does not return an item to like new, zero mileage or zero hour condition.

K - REBUILD. The highest degree of material maintenance. It consists of restoring equipment as nearly as possible to new condition in accordance with

original manufacturing standards. Rebuild is performed only when required by operational considerations or other paramount factors and then only at the depot maintenance level. Rebuild reduces to zero the hours of miles the equipment, or component thereof, has been in use.

d. Tools and Equipment. Column 4. This column is provided for referencing by code the tools and test equipment (Section III), required to perform the maintenance functions (Section II).

e. Remarks. Column 5. This column is provided for referencing by code the remarks (Section IV) pertinent to the maintenance functions.

D-3. EXPLANATION OF COLUMNS IN SECTION III.

a. Reference Code. This column consists of a number and a letter separated by a dash. The number references the T&TE requirements listed in Section II. The letter represents the specific maintenance function the item is to be used with in Columns (A through K) of Section II.

b. Maintenance Level. This column shows the lowest level of maintenance authorized to use the tool or test equipment.

c. Nomenclature. This column lists the name or identification of the tool or test equipment.

d. Tool Number. This column lists the manufacturer's code and part number or federal stock number of tool or test equipment.

D-4. EXPLANATION OF COLUMNS IN SECTION IV.

a. Reference Code. This column consists of two letters separated by a dash (entered from Column 5 of Section II). The first letter references Alpha sequence in Column 5 and the second letter references a maintenance function, Column 3 (A through K).

b. Remarks. This column lists information pertinent to the maintenance function to be performed (as indicated in Section II).

Section II. MAINTENANCE ALLOCATION CHART

(1) GROUP NO.	(2) ASSEMBLY GROUP	(3) MAINTENANCE FUNCTIONS											(4) TOOLS AND EQUIPMENT	(5) REMARKS	
		A	B	C	D	E	F	G	H	I	J	K			
		INSPECT	TEST	SERVICE	ADJUST	ALIGN	CALIBRATE	INSTALL	REPLACE	REPAIR	OVERHAUL	REBUILD			
01	BATTERY ASSEMBLY														
	Cables, Battery	C 0.1	O 0.1	O 0.1					O 0.2						
	Frame, Top (Hold-down)	C 0.1		O 0.2					O 0.2	O 0.3					
	Battery, Storage (2)	C 0.1	O 0.2	O 0.2					O 0.2				1-B		A-A, B-B
02	ROD ASSEMBLY, GROUND														
	Hold-down Assembly	C 0.1							C 0.1						
	Rod Assembly	C 0.1		C 0.1					C 0.1						
03	TANK ASSEMBLY, FUEL														
	Strap Assembly, Fuel Tank (2)	C 0.1							O 0.2						
	Tank, Fuel	C 0.1	F 0.6	C 0.2					O 0.7	F 1.0			2-I		A-A, D-I
	Gauge, Fuel Level	C 0.1							O 0.2						
	Switch, Float	C 0.1	O 0.3						O 0.2				3-B		A-A, L-B
	Fittings (3)	C							O 0.2						A-A

Change 2 D-3

TMS-6115-584-12
 NAVFAC P-8-622-12
 TO-35C2-3-456-1
 TM-05682C-12

Section II. MAINTENANCE ALLOCATION CHART (CONT)

(1) GROUP NO.	(2) ASSEMBLY GROUP	(3) MAINTENANCE FUNCTIONS											(4) TOOLS AND EQUIPMENT	(5) REMARKS	
		A	B	C	D	E	F	G	H	I	J	K			
		INSPECT	TEST	SERVICE	ADJUST	ALIGN	CALIBRATE	INSTALL	REPLACE	REPAIR	OVERHAUL	REBUILD			
03	Cont'd														
	Valve, Fuel Drain	C 0.1							O 0.2						A-A
	Filler Cap Assembly	C 0.1							C 0.1						A-A
04	CONTROL CUBICLE ASSEMBLY														
	Control Cubicle	C 0.3	O 0.2		O 0.2				O 8.0	F 4.0	H 6.0	D 6.0	3-B	A-A, C-B, K-D	
	Voltmeter, DC	C 0.1	O 0.1						O 0.2					A-A, L-B	
	Lamp, Incandescent	C 0.1		C 0.1					C 0.1					A-A	
	Light Assembly, Panel	C 0.1	O 0.2	C 0.1					O 0.2				3-B	A-A, I-B	
	Hour Meter	C 0.1	O 0.1						O 0.2					A-A, C-B	
	Meter, Frequency	C 0.1	F 0.1		F 0.1				F 0.2				3-B	A-A, C-B	
	Ammeter, AC	C 0.1	F 0.1		F 0.1				F 0.2					A-A, C-B, M-D	
	Voltmeter, AC	C 0.1	F 0.1						F 0.2					A-A, C-B, M-D	

Section II. MAINTENANCE ALLOCATION CHART (CONT)

(1) GROUP NO.	(2) ASSEMBLY GROUP	(3) MAINTENANCE FUNCTIONS											(4) TOOLS AND EQUIPMENT	(5) REMARKS
		A	B	C	D	E	F	G	H	I	J	K		
		INSPECT	TEST	SERVICE	ADJUST	ALIGN	CALIBRATE	INSTALL	REPLACE	REPAIR	OVERHAUL	REBUILD		
04	Cont'd													
	Rheostat, Voltage Adj.	C 0.1	O 0.1						O 0.2				3-B	A-A, L-B
	Switch, Amp-Volt Transfer	C 0.1	O 0.2						O 0.3				3-B	A-A, L-B
	Switch, Panel Light	C 0.1	O 0.1						O 0.1				3-B	A-A, L-B
	Switch, Rotary, Master	C 0.1	O 0.2						O 0.3				3-B	A-A, L-B
	Circuit Breaker, DC Control	C 0.1	O 0.1						O 0.1				3-B	A-A, L-B
	Transformers, T-1 & T-2	C 0.1	O 0.2						O 0.4				3-B	A-A, I-B
	Regulator, Voltage, AC	F 0.2	F 0.4		F 0.4				F 0.3	H 1.2			3-B	A-A, L-B, F-I
	Relay K2 and K3	O 0.1	O 0.1						O 0.2				3-B	A-A, L-B
	Transducer, Frequency	O 0.1	F 0.2						F 0.3				3-B	A-A, L-B
	Relay Assembly, A-1	O 0.1	O 0.2						O 0.2				3-B	A-A, L-B

Change 3 D-5

TM 5-6115-584-12
 NAVFAC P-8-622-12
 TO-35C2-3-456-1
 TM-05682C-12

Section II. MAINTENANCE ALLOCATION CHART (CONT)

TM 5-6115-584-12
 NAVFAC P-8-622-12
 TO-35C2-3-456-1
 TM-05682C-12

(1) GROUP NO.	(2) ASSEMBLY GROUP	(3) MAINTENANCE FUNCTIONS											(4) TOOLS AND EQUIPMENT	(5) REMARKS	
		A	B	C	D	E	F	G	H	I	J	K			
		INSPECT	TEST	SERVICE	ADJUST	ALIGN	CALIBRATE	INSTALL	REPLACE	REPAIR	OVERHAUL	REBUILD			
04	Cont'd														
	Relay, K1	O 0.1	O 0.2						O 0.7					3-B	A-A, L-B
	Terminal Board Assembly	O 0.2	O 0.3						O 1.2						A-A
	Wiring Harness Assembly Control Cubicle	C 0.4	O 2.0						F 4.5	F 2.0				6-I	A-A, J-I
	Box, Control Cubicle	C 0.3							F 5.4	F 3.0				2-I	A-A
05	CONTROL ASSEMBLY														
	Wiring Harness Assembly Engine Control	C 0.1	F 0.2						F 0.4	F 0.5				6-I	L-B, J-I
	Control Assembly, Speed	C 0.1							O 0.3						A-A
06	CONTROL BOX ASSEMBLY AC OUTPUT														
	Box Assembly, Control	C 0.2	F 0.6						F 0.6	H 1.2	H 0.8	D 0.8			I-B
	Connector Assembly (4)	F 0.1	F 0.2						F 0.6	F 0.4					A-A, L-B
	Board Assembly, Load Terminal	C 0.1							O 0.4						A-A

Section II. MAINTENANCE ALLOCATION CHART (CONT)

(1) GROUP NO.	(2) ASSEMBLY GROUP	(3) MAINTENANCE FUNCTIONS											(4) TOOLS AND EQUIPMENT	(5) REMARKS		
		A	B	C	D	E	F	G	H	I	J	K				
		INSPECT	TEST	SERVICE	ADJUST	ALIGN	CALIBRATE	INSTALL	REPLACE	REPAIR	OVERHAUL	REBUILD				
06	Cont'd															
	Bridge Assembly, Printed Circuit Board	F 0.1	F 0.3						F 0.4	F 0.5					3-B, 6-I	A-A, L-B
	Reactor, Linear	F 0.2	F 0.2						F 0.4						3-B	A-A, L-B
	Transformer Assembly, CT1 & CVT1	F 0.2	F 0.5						F 2.8						3-B	A-A, I-B
	Wiring Harness Assembly	F 0.4	F 0.5						F 3.2	F 0.8					6-I	A-A, J-I
	Switch, Rotary Connection	F 0.3	F 0.3						F 0.8						3-B	A-A, L-B
	Circuit Breaker, 15A	F 0.1	F 0.2						F 0.3						3-B	A-A, L-B
	Receptacle, Conv	F 0.1	F 0.1						F 0.3						3-B	A-A, L-B
	Circuit Breaker, Main	F 0.1	F 0.3						F 0.8						3-B	A-A, L-B
	Control Box	F 0.2							F 1.4	F 1.5					2-I	A-A, D-I
07	FUEL SYSTEM (Less Tank)															
	Filter Assembly, Fuel (2)	C 0.1		C 0.1					O 0.2							A-A, O-C

Change 2 D-7

TM5-6115-584-12
NAVFAC P-8-622-12
FO-35C2-3-456-1
TM-05682C-12

Section II. MAINTENANCE ALLOCATION CHART (CONT)

(1) GROUP NO.	(2) ASSEMBLY GROUP	(3) MAINTENANCE FUNCTIONS										(4) TOOLS AND EQUIPMENT	(5) REMARKS		
		A	B	C	D	E	F	G	H	I	J			K	
		INSPECT	TEST	SERVICE	ADJUST	ALIGN	CALIBRATE	INSTALL	REPLACE	REPAIR	OVERHAUL			REBUILD	
07	Cont'd														
	Element, Fuel Filter	O 0.1							O 0.1						N-C
	Strainer Assembly, Fuel (Primary)	C 0.1		C 0.1					O 0.1						O-C
	Strainer Element, Fuel	O 0.1		O 0.2					O 0.1						A-A, O-C
	Pump Assembly, Fuel (Electric)	C 0.1	O 0.3	O 0.2					O 0.2						C-B, N-C
	Lines, Fuel (Flexible)	C 0.1							O 0.3						A-A
08	AIR CLEANER ASSEMBLY														
	Housing, Air Cleaner	C 0.1		C 0.2					O 0.3	O 0.5					A-A, D-I
	Cap Assembly, Dust	C 0.1		C 0.2											A-A, D-I
	Filter Air Cleaner	C 0.1		C 0.2					C 0.1						A-A, N-C
	Bracket Assembly	C 0.1							O 0.3	O 0.5					A-A, D-I
	Shutter Assembly, Inlet	C 0.1											2-I		A-A

Section II. MAINTENANCE ALLOCATION CHART (CONT)

(1) GROUP NO.	(2) ASSEMBLY GROUP	(3) MAINTENANCE FUNCTIONS											(4) TOOLS AND EQUIPMENT	(5) REMARKS		
		A	B	C	D	E	F	G	H	I	J	K				
		INSPECT	TEST	SERVICE	ADJUST	ALIGN	CALIBRATE	INSTALL	REPLACE	REPAIR	OVERHAUL	REBUILD				
08	Cont'd Indicator, Air Flow	C 0.1							O 0.1							A-A
09	GENERATOR ASSEMBLY															
	Generator/Exciter Assembly	O 0.5	F 1.5						F 2.5	F 4.0	H 10.0	D 18.0	7, 8, 9-H 10-1-J		C-B	
	Screen-Guard Assembly Generator	C 0.1							O 0.1	O 0.5					D-1	
	End-Bell, Generator	C 0.1							F 0.8						F-B	
	Exciter Field, Generator	F 0.2	F 0.3						F 0.8	F	H	D	3-B		P-B	
	Housing-Stator Assembly Generator	F 0.8	F 2.5						F 1.8	F	H	D	3-B		P-B	
	Rotor Assembly, Generator	F 0.8	F 2.5						F 1.8	F	H	D	3-B		P-B	
	Rotor Assembly, Exciter	F 0.6	F 1.0						F 1.2	H	H	D	3-B		P-B	
	Bearing, Rotor Shaft	F 0.2							F 0.5				11-H		R-A	
	Rectifier Assembly, Exciter	F 0.2	F 0.3						F 1.5	F 0.5			3-B, 12-I		L-B, F-B	

Change 6

D-9

TM 5-6115-584-12
NAVFAC P-8-622-12
T035C2-3-456-1
TM-05682C-12

Section II. MAINTENANCE ALLOCATION CHART (CONT)

(1) GROUP NO.	(2) ASSEMBLY GROUP	(3) MAINTENANCE FUNCTIONS											(4) TOOLS AND EQUIPMENT	(5) REMARKS	
		A	B	C	D	E	F	G	H	I	J	K			
		INSPECT	TEST	SERVICE	ADJUST	ALIGN	CALIBRATE	INSTALL	REPLACE	REPAIR	OVERHAUL	REBUILD			
09	Cont'd														
	Disc, Coupling	F 0.1							F 2.0						A-A
	Fan Generator	F 0.1							F 2.0						A-A
10	SHUTTER ASSEMBLY														
	Shutter Assembly	C 0.1							O 0.6	F 0.5			2-I	A-A, D-I	
	Bracket Assembly, Shutter	C 0.1							O 0.6	F 0.5				D-I	
	Shutters	C 0.1			O				O 0.8	F				D-I	
	Thermo Unit	C 0.1	O 0.4		O				O 0.6				4-B	E-B, F-B	
11	EXHAUST MUFFLER ASSEMBLY														
	Muffler	C 0.1							O 0.5					A-A	
12	COOLING SYSTEM, ENGINE														
	Panel, Air Housing	C 0.1							O 0.2	F 0.8			2-I	A-A, D-I	
	Shroud Assembly	C 0.1							O 0.3	F 0.6			2-O	A-A, D-I	

Section II. MAINTENANCE ALLOCATION CHART (CONT)

(1) GROUP NO.	(2) ASSEMBLY GROUP	(3) MAINTENANCE FUNCTIONS											(4) TOOLS AND EQUIPMENT	(5) REMARKS			
		A	B	C	D	E	F	G	H	I	J	K					
		INSPECT	TEST	SERVICE	ADJUST	ALIGN	CALIBRATE	INSTALL	REPLACE	REPAIR	OVERHAUL	REBUILD					
12	Cont'd																
	Grille Assembly, Blower Housing	C 0.1							O 0.1	F 0.3						2-I	A-A, D-I
	Housing Assembly, Blower	C 0.1							O 0.5	F 1.5						2-I	A-A, D-I
13	ELECTRIC STARTER ASSEMBLY																
	Starter Assembly	C 0.1	O 0.1						O 0.2	F 0.8	F 1.5					3-B	A-A, C-B
	Switch Solenoid	O 0.1	O 0.2						O 0.3							3-B	C-B
	Brush Assembly	O 0.2							F 0.5								G-A, L-B
	Drive Assembly	O 0.2						F 0.2	F 0.3								A-A
	Armature		F 0.3						F 0.3	F 0.5						5-B	H-B
14	ENGINE ASSEMBLY, EXTERNAL																
	Engine, Generator Set	O 1.0	O 1.0	C 1.0	O 0.5				F 2.8	F 4.0	H 10.0	D 10.0				7-H, 8-H	A-A, C-B F-C, S-D
	Flywheel & Ring Gear Assembly	F 0.1							F 1.8							2-I	A-A, D-I

Change 6 D-11

TM 5-6115-584-12
 NAVFAC P-8-622-12
 TO-35G2-3-456-1
 TM-05682C-12

Section II. MAINTENANCE ALLOCATION CHART (CONT)

TM 5-6115-584-12
 NAVFAC P-8-622-12
 TO-35C2-3-456-1
 TM-05682C-12

1) ● GROUP NO	2) ASSEMBLY GROUP	3) MAINTENANCE FUNCTIONS										4) TOOLS AND EQUIPMENT	5) REMARKS		
		A	B	C	D	E	F	G	H	I	J			K	
		INSPECT	TEST	SERVICE	ADJUST	ALIGN	CALIBRATE	INSTALL	REPLACE	REPAIR	OVERHAUL			REBUILD	
14	Cont'd														
	Housing, Flywheel	F 0.1							F 2.0						
	Heater, Manifold	O 0.1	O 0.1						O 0.3						A-A, L-B
	Manifold Assembly, Intake	C 0.1							O 0.2	O 0.2					A-A
	Wheel Assembly, Blower	F 0.1							F 0.5	F 0.8					A-A
	Lines, Oil, Flexible, Oil Cooler to Oil Pump	O 0.1							O 0.3						A-A
	Cooler Assembly, Oil	O 0.1	F 0.4	O 0.1					O 0.3						A-A, U-B
	Gauge Assembly, Oil Pressure	C 0.1	O 0.1						O 0.2						
	Hoses, Oil	C 0.1							O 0.2						A-A
	Governor Assembly	O 0.1	O 0.2		F				F 0.3	F 0.8					F-B
	Lines, Fuel, Pump to Injector	O 0.1							F 0.3						A-A
	Starter Lockout Switch and Gear Assembly	O 0.1	O 0.2		O 0.2				O 0.3	O				3-B	K-D, L-B

Section II. MAINTENANCE ALLOCATION CHART (CONT)

(1) GROUP NO.	(2) ASSEMBLY GROUP	(3) MAINTENANCE FUNCTIONS											(4) TOOLS AND EQUIPMENT	(5) REMARKS	
		A	B	C	D	E	F	G	H	I	J	K			
		INSPECT	TEST	SERVICE	ADJUST	ALIGN	CALIBRATE	INSTALL	REPLACE	REPAIR	OVERHAUL	REBUILD			
14	Cont'd														
	Solenoid, Fuel Stop	C 0.1	O 0.2	O 0.2	O 0.2				O 0.2					3-B	L-B
	Rotor, Battery Alternator	F 0.1	F 0.2						F 0.3						
	Stator, Battery Alternator	O 1.0	O 1.0						F 1.0					3-B	L-B
	Regulator/Rectifier Assembly, Battery Charging	O 0.1	F 0.2						F 0.3					3-B	A-A, L-B
	Fuse, Battery Charger Circuit	O 0.1	O 0.1						O 0.1					3-B	A-A
	Terminal Block	O 0.1	O 0.2						O 0.1					3-B	A-A, I-B
15	ENGINE ASSEMBLY, INTERNAL														
	Cover Assembly, Rocker Arm	O 0.1		O 0.3					O 0.1						A-A
	Rocker Arm	O 0.1			O 0.5				F 0.8						F-D
	Cylinder Head Assembly	F 0.5							F 2.5	F 2.0	H 3.0	D 4.0		13-H	A-A, V-I
	Locks & Retainers, Valve Springs	F 0.1							F 0.5					14-H	A-A

Change 3 D-13

TM 5-6115-584-13
NAVFAC P-8-622-12
TO-35C2-3-456-1
TM-05682C-12

Section II. MAINTENANCE ALLOCATION CHART (CONT)

TM 5-6115-584-12
 NAVFAC P-8-622-12
 TO-35C2-3-456-1
 TM-05682C-12

(1) GROUP NO.	(2) ASSEMBLY GROUP	(3) MAINTENANCE FUNCTIONS											(4) TOOLS AND EQUIPMENT	(5) REMARKS	
		A	B	C	D	E	F	G	H	I	J	K			
		INSPECT	TEST	SERVICE	ADJUST	ALIGN	CALIBRATE	INSTALL	REPLACE	REPAIR	OVERHAUL	REBUILD			
15	Cont'd														
	Spring Valve	F 0.2	F 0.5						F 1.0					15-B	W-B
	Valves, Intake & Exhaust	F 0.4							F 1.0					16-H	A-A
	Nozzle & Holder Assembly, Fuel Injector	O 0.2	F 0.8	F	F				F 1.5	H 0.8	H 0.8			20-B,H	F-B
	Plug Assembly, Glow	O 0.1	O 0.1						O 0.3						
	Guide, Valve Stem	F 0.4							H 2.0					17-H	
	Seat, Intake & Exhaust Valves	F 0.4							D 4.0	F 1.0				18-H, 19-H	A-A, F-I
	Head, Cylinder	F 0.5							F 2.5	F 2.0	H 3.0	D 4.0		13-H	F-J
	Push Rod, Valve	F 0.3							F 0.5						A-A
	Tube, Oil Fill	C 0.1							O 0.2						A-A
	Pump Assembly, Fuel Injection	F 0.1	F 0.5		F 0.5				H 1.0	H 0.8	D 1.0	D 1.0		20-BH, 27-BH	F-B, D-I T-D, S-D
	Filter Assembly, Oil	C 0.1		O 0.2					O 0.2						

Section II. MAINTENANCE ALLOCATION CHART (CONT)

(1) GROUP NO.	(2) ASSEMBLY GROUP	(3) MAINTENANCE FUNCTIONS											(4) TOOLS AND EQUIPMENT	(5) REMARKS	
		A INSPECT	B TEST	C SERVICE	D ADJUST	E ALIGN	F CALIBRATE	G INSTALL	H REPLACE	I REPAIR	J OVERHAUL	K REBUILD			
15	Cont'd														
	Element, Oil Filter	O 0.1							O 0.2						N-C
	Switch, Pressure, Oil	C 0.1	O 0.2						O 0.1						A-A, C-B
	Adapter Assembly, Oil Filter	F 0.1							F 1.0						
	Hose, Oil Drain	C 0.1							O 0.3						
	Pan-Base, Oil	O 0.1							F 1.8						
	Cup Assembly, Governor	F 0.1							F 1.0						
	Pump Assembly, Oil	F 0.2	F 0.3						F 2.5						C-B
	Piston & Connecting Rod Piston Assembly	F 0.2							F 1.8	F 2.5				21-H	F-I
	Pin, Piston	F 0.2							F 0.6					22-H	
	Rings, Piston	F 0.4							F 1.2					23-H, 24-H	
	Connecting Rod Assembly	F 0.2							F 1.8	F 2.5				21-H, 13-H	

Change 2 D-15

TMS-6115-584-12
NAVFAC P-8-622-12
TO-35C2-3-456-1
TM-05682C-12

Section II. MAINTENANCE ALLOCATION CHART (CONT)

(1) GROUP NO.	(2) ASSEMBLY GROUP	(3) MAINTENANCE FUNCTIONS											(4) TOOLS AND EQUIPMENT	(5) REMARKS			
		A	B	C	D	E	F	G	H	I	J	K					
		INSPECT	TEST	SERVICE	ADJUST	ALIGN	CALIBRATE	INSTALL	REPLACE	REPAIR	OVERHAUL	REBUILD					
15	Cont'd																
	Bearings, Rod	F 0.4							F 1.8					25-H			
	Cover Assembly, Gear	F 0.1							F 1.4		F 0.8						
	Camshaft Assembly	F 0.3							F 3.5	F 2.0	H 2.0	H 2.0		A-A, D-I			
	Valve Assembly, Oil By-pass	F 0.2	F 0.3						F 1.3								
	Crankshaft & Main Block Bearings	F 0.8							F 2.0					25-H, 13-H		F-H	
	Crankshaft	F 0.8							F 5.5				D 5.0				
	Oil Breather	O 0.1		O 0.2					O 0.2							A-A	
	Block, Cylinder	F 0.2							F 3.5		H 0.8		D 10.0	27-B,H		A-A, F-J	
	Mounting Assembly, Engine	C 0.1							O 0.6	O 0.8							
16	SKID-BASE ASSEMBLY																
	Frame Bottom, Battery	C 0.1							O 0.2	O 0.3						A-A, D-I	

Section II. MA NTENANCE ALLOCATION CHART (CONT)

(1) GROUP NO.	(2) ASSEMBLY GROUP	(3) MAINTENANCE FUNCTIONS											(4) TOOLS AND EQUIPMENT	(5) REMARKS	
		A	B	C	D	E	F	G	H	I	J	K			
		INSPECT	TEST	SERVICE	ADJUST	ALIGN	CALIBRATE	INSTALL	REPLACE	REPAIR	OVERHAUL	REBUILD			
16	Cont'd														
	Tray, Battery	C 0.1							0 0.2	0 0.3					A-A, D-I
	Stud, Ground	C 0.1							0 0.1						A-A
	Ring, Tie Down	0 0.2							F 0.6						A-A
	Skid-base	0 0.3							F 6.0	F 8.0					A-A, D-I
	Control Panel Vibration Mounts	C 0.1							0 0.2						A-A
	Lifting Attachment	C 0.1							0 0.1						A-A
17	ACOUSTIC SUPPRESSION KIT	C 0.2						F 4.0	0 3.0						A-A, F-H
	Top Panel Assy	C 0.1							0 0.3	0 0.8			28-I		A-A, F-H, F-I
	Left Panel Assy	C 0.1							0 0.3	0 0.5			28-I		A-A, F-H, F-I
	Right Panel Assy	C 0.1							0 0.3	0 0.7			28-I		A-A, F-H, F-I

Change 7 D-16:1/(D-16:2 blank)

TM 5-6115-584-12
NAVFAC P-8-622-12
TO-35C2-3-456-1
TM-05682C-12

Section II. MAINTENANCE ALLOCATION CHART (CONT)

(1) GROUP NO.	(2) ASSEMBLY GROUP	(3) MAINTENANCE FUNCTIONS											(4) TOOLS AND EQUIPMENT	(5) REMARKS
		A	B	C	D	E	F	G	H	I	J	K		
		INSPECT	TEST	SERVICE	ADJUST	ALIGN	CALIBRATE	INSTALL	REPLACE	REPAIR	OVERHAUL	REBUILD		
17	Rear Panel Assy	C 0.1							0 0.3	0 0.7			28-I	A-A, F-H, F-I
	Exhaust Plenum Assy	C 0.1							0 0.6					A-A, F-H
	Left Support Assy	C 0.1							0 0.6	0 0.9			28-I	A-A, F-H, F-I
	Right Support Assy	C 0.1							0 0.6	0 0.9			28-I	A-A, F-H, F-I
	Front Panel Assy	C 0.1							0 0.3	0 1.0			28-I	A-A, F-H, F-I
	Side Closure Assy	C 0.1							0 0.6	0 0.9			28-I	A-A, F-H, F-I
	Rear Closure Assy	C 0.1							0 0.6					A-A, F-H
	Rear Flap Assy	C 0.1							0 0.3	0 0.6			28-I	A-A, F-H, F-I

Change 7 D-17

TM 5-6115-584-12
NAVFAC P-8-622-12
FO-35C2-3-456-1
TM-05682C-12

Section III. TOOLS, TEST AND SUPPORT EQUIPMENT REQUIREMENTS

Reference Code	Maintenance Category	Nomenclature	Tool Number
1-B	O	Tester, Battery Electrolyte Solution	6630-171-5126 or Equal
2-I	F	Torch Outfit, Cutting and Welding Tool Set L/I W67706	3433-357-6311 or Equal
3-B	O	Multimeter	6625-581-2036 or Equal
4-B	O	Thermometer, Self Indicating 50-400 Degrees F Range	6685-527-7867 or Equal
5-B	F	Test Set Armature	6625-233-1459 or Equal
6-I	F	Tool Kit, Electrical Connector Repair	5180-876-9366 or Equal
7-H	F	Hoist, Chain, 3 Ton	3950-292-9879 or Equal
8-H	F	Trestle, Hoist, Portable 5 Ton	3950-449-7005 or Equal
9-H	F	Multimeter, Split Core	6625-892-1497 or Equal
10-I-J	F	Ohmmeter	6625-581-2466 or Equal
11-H	F	Puller Attachment Component of Puller Kit 5180-701-8046	5180-711-6753 or Equal
12-I	F	Soldering Outfit, Electric	3439-853-8760 or Equal
13-H	F	Wrench, Torque 1/2" Drive	5120-640-6364 or Equal
14-H	F	Lifter, Valve Spring	5120-239-8686 or Equal
15-B	F	Tester, Spring Resiliency	5120-449-8028 or Equal
16-H	F	Grinding Machine, Valve Face	4910-540-4679 or Equal
17-H	H	Remover & Replacer, Valve Guide	5120-219-8404 or Equal
18-H	H	Remover & Replacer, Insert Valve Seat	5120-473-7393 or Equal
19-H	H	Grinding Set, Valve Seat	4910-473-6437 or Equal
20-B-H	F	Tool Kit, Diesel Injector Repair	4910-317-8265 or Equal
21-H	H	Indicator, Connecting Rod Alignment	4910-733-2487 or Equal
22-H	H	Caliper Micrometer, Outside 0" thru 1"	5120-540-2978 or Equal
23-H	H	Compressor, Piston Ring	5120-250-6055 or Equal
24-H	H	Expander, Piston Ring	5120-894-0758 or Equal
25-H	H	Caliper, Micrometer, Outside 2" thru 3"	5210-221-1745 or Equal
26-F-B	H	Compressor Tester Gage	4910-00-870-6283 or Equal
27-B-H	F	Gage, Depth, Micrometer	5210-00-542-4602 or Equal
27-F-B	H	Adapter	4910-00-870-2127 or Equal

ALPHABETICAL INDEX

Subject	Paragraph Figure, Table, Number
A	
AC Instrumentation System	4-36
Acoustic Suppression Kit	5 - 2
Instruction and Rating Plates	5-3 thru 5-14,
Removal and Installation Procedures	F5-2 thru F5-12
Repair and Replacement of Hardware items	6-16 thru 5-22, F5-13
AC Output Control Box Assembly	F3-8
Inspection	3-17
AC Output Control Box Wiring Harness	F1-9
Administrative Storage	1-7
Air Cleaner Assembly	F3-10
Impaction	3-18,4-41
Installation	3-18,4-41
Removal and Service	3-18,4-41
Repair	4-41
Air Cleaner and Shroud Assembly	F3-9
Air Filter Element, cleaning	F3-11
Auxiliary Fuel Solenoid Valve	4-22
Test, On Equipment	4-22
Auxiliary Equipment	5-1
B	
Batteries, Testing	F4-17
Battery Assembly	F3-2
Cleaning	3-11
Inspection	3-11
Removal	4-25
Repair	4-25
Replacement	4-25
Test	4-25
Battery Cables, Installing	F4-16
Battery Charging Alternator	F4-23, 4-27
Inspection	4-27
Removal	4-27
Replacement	4-27
Test	4-27
Battery Charging Regulator/Rectifier Assembly,	F4-24
Battery and frame	F3-23
Breather	F4-40, 4-45
C	
Consumable Operating and Maintenance Supplies	T3-1, 3-1
Control Cubicle Assembly	F3-12, F4-33
Assembly	4-38
Disassembly	4-38
Inspection	3-19
Installation	4-38
Removal	4-38
Service	3-19
Test Bench	4-36
Test, On Equipment	4-38
Control Cubicle Support Assembly	F3-15
Inspection	3-21
Removing	F4-34
Control Cubicle Test Set-Up	F4-35
Control Cubicle Wiring Harness	F1-10
Control System, Description and Function	4-34
Cylinder Head Assembly	F4-42

ALPHABETICAL INDEX (CONT)

Subject	Paragraph, Figure, Table, Number
D	
DC Control System	4-35
Destruction of Material to Prevent Enemy Use	1-6
E	
Electric Starter	F3-7
Electrical Cable Schematic.	F1-6
Engine Assembly	F4-36
Adjustment	4-42
Description and Function	4-39
Inspection	3-24, 4-42
Service	4-42
Test	4-42
Engine Cooling System..	F3-17
Adjustment	4-17
Cleaning	4-17
Description and Function..	4-16
Disassembly	4-17
Inspection	3-22, 4-17
Installation	4-17
Reassembly	4-17
Removal	4-17
Test	4-17
Engine Electrical System, Description and Function.	4-24
Engine Generator Set	
Engine Generator Set with Suppression Kit	F1-2.1
Left-Front, Three-Quarter View	F1-2
Right-Rear, Three-QuarterView	F1-1
Engine Mounting Assembly	F4-44
Disassembly	4-52
Inspection	4-52
Installation	4-52
Reassembly	4-52
Removal	4-52
Engine Starter Assembly	F4-18, F4-22
Cleaning and Inspection	3-16, 4-26
Installation	4-26
Removal	4-26
Repair	4-26
Test, Bench	4-26
Test, Equipment	4-26
Engine Starter Brushes, Inspecting	F4-21
Engine Starter, Testing	F4-19
Engine Starter Wiring Diagram.	F4-20
Engine Stop Solenoid	F3-22
Engine Wiring Harness, Inspection	3-21
Exhaust Muffler and Air Cleaner Assemblies	F4-37
Exhaust Muffler Assemblies	F3-6
Inspection	3-15, 4-40
Removal	4-40
Replacement	4-40
F	
Float Switch, Testing	F4-8
Fuel Filter	F4-9

Section II. MAINTENANCE ALLOCATION CHART (CONT)

(1) GROUP NO.	(2) ASSEMBLY GROUP	(3) MAINTENANCE FUNCTIONS											(4) TOOLS AND EQUIPMENT	(5) REMARKS
		A	B	C	D	E	F	G	H	I	J	K		
		INSPECT	TEST	SERVICE	ADJUST	ALIGN	CALIBRATE	INSTALL	REPLACE	REPAIR	OVERHAUL	REBUILD		
17	Rear Panel Assy	C 0.1							0 0.3	0 0.7			28-I	A-A, F-H, F-I
	Exhaust Plenum Assy	C 0.1							0 0.6					A-A, F-H
	Left Support Assy	C 0.1							0 0.6	0 0.9			28-I	A-A, F-H, F-I
	Right Support Assy	C 0.1							0 0.6	0 0.9			28-I	A-A, F-H, F-I
	Front Panel Assy	C 0.1							0 0.3	0 1.0			28-I	A-A, F-H, F-I
	Side Closure Assy	C 0.1							0 0.6	0 0.9			28-I	A-A, F-H, F-I
	Rear Closure Assy	C 0.1							0 0.6					A-A, F-H
	Rear Flap Assy	C 0.1							0 0.3	0 0.6			28-I	A-A, F-H, F-I

Section III. TOOLS, TEST AND SUPPORT EQUIPMENT REQUIREMENTS

REFERENCE CODE	MAINTENANCE CATEGORY	NOMENCLATURE	TOOL NUMBER
1-B	O	Tester, Battery Electrolyte Solution	
2-I	F	Torch Outfit, Cutting and Welding Tool Set LI W67706	6630-171-5126 or Equal
3-B	O	Multimeter	3433-357-6311 or Equal
4-B	O	Thermometer, Self Indicating 50-400 Degrees F Range	6685-527-7867 or Equal
5-B	F	Test Set Armature	6625-233-1459 or Equal
6-I	F	Tool Kit, Electrical Connector Repair	5180-876-9366 or Equal
7-H	F	Hoist, Chain, 3 Ton	3950-292-9879 or Equal
8-H	F	Trestle, Hoist, Portable 5 Ton	3950-449-7005 or Equal
9-H	F	Multimeter, Split Core	6625-892-1497 or Equal
10-I-J	F	Ohmmeter	6625-581-2466 or Equal
11-H	F	Puller Attachment Component of Puller Kit 5180-701-8046	5180-711-6753 or Equal
12-I	F	Soldering Outfit, Electric	3439-853-8760 or Equal
13-H	F	Wrench, Torque 1/2" Drive	5120-640-6364 or Equal
14-H	F	Lifter, Valve Spring	5120-239-8686 or Equal
15-B	F	Tester, Spring Resiliency	5120-449-8028 or Equal
16-H	H	Grinding Machine, Valve Face	4910-540-4679 or Equal
17-H	H	Remover & Replacer, Valve Guide	5120-219-8404 or Equal
18-H	H	Remover & Replacer, Insert Valve Seat	5120-473-7393 or Equal
19-H	H	Grinding Set, Valve Seat	4910-473-6437 or Equal
20-B-H	F	Tool Kit, Diesel Injector Repair	4910-317-8265 or Equal
21-H	F	Indicator, Connecting Rod Alignment	4910-733-2487 or Equal
22-H	H	Caliper, Micrometer, Outside 0" thru 1"	5120-540-2978 or Equal
23-H	F	Compressor, Piston Ring	5120-250-6055 or Equal
24-H	F	Expander, Piston Ring	5120-894-0758 or Equal
25-H	H	Caliper, Micrometer, Outside 2" thru 3"	5210-221-1745 or Equal
26-F-B	H	Compressor Tester Gage	4910-00-870-6283 or Equal
27-B-H	F	Gage, Depth, Micrometer	5210-00-542-4602 or Equal
27-F-B	H	Adapter	4910-00-870-2127 or Equal

Section IV. EXPIANATION OF REFERENCE CODES

REFERENCE CODE	REMARKS
A - A	Visual Inspection
B-B	Hydrometer Test
C-B	Operational Test
D-I	Weld and Straighten
E-B	Thermometer Test
F-B, C-D, H, I-J	In accordance with Procedure in Applicable TM
G-A	Inspect for Minimum Length
H-B	Growler Test
I-B	Test for known Voltage
J-I	Fabricate New Harness
K-D	Adjust after Repair or Replacement
L-B	Continuity Test
M-D	Zero Adjustment
N-C	Replace Element
O-C	Drain Condensation
P-B	Insulation Breakdown and Continuity Tests
Q-K	Rewind
R-A	Visual Audible and Physical Heat Detection
S-D	Adjust to Specification in Applicable TM
T-D	Adjust Injector Pressure Setting
U-B	Pressure Test
V-I	Includes Replacing Valves and Springs
W-B	Spring Tension and Length

ALPHABETICAL INDEX

Subject	Paragraph, Figure, Table, Number
A	
AC Instrumentation System...	4-36
AC Output Control Box Assembly.	F3-8
Inspection	3-17
AC Output Control Box Wiring Harness	F1-9
Administrative Storage	1-7
Air Cleaner Assembly	F3-10
Inspection	3-18, 4-41
Installation	3-18, 4-41
Removal and Service	3-18, 4-41
Repair	4-41
Air Cleaner and Shroud Assembly..	F3-9
Air Filter Element, Cleaning.	F3-11
Ammeter - Voltmeter Transfer Switch Continuity Check	T4-4
Auxiliary Fuel Solenoid Valve.	4-22
Test, On Equipment	4-22
B	
Batteries, Testing	F4-17
Battery Assembly	F3-2
Cleaning	3-11
Inspection	3-11
Removal	4-25
Repair	4-25
Replacement	4-25
Test	4-25
Battery Cables, Installing	F4-16
Battery Charging Alternator	F4-23, 4-27
Inspection	4-27
Removal	4-27
Replacement	4-27
Test	4-27
Battery Charging Regulator/Rectifier Assembly, Testing	F4-24
Battery and Frame	F3-23
Breather	F4-40, 4-45
C	
Consumable Operating and Maintenance Supplies	T3-1, 3-1
Control Cubicle Assembly	F3-12, F4-33
Assembly	4-38
Disassembly	4-38
Inspection	3-19
Installation	4-38
Removal	4-38
Service	3-19
Test, Bench	4-38
Test, On Equipment	4-38
Control Cubicle Support Assembly	F3-15
Inspection	3-21
Removing,	F4-34
Control Cubicle Test Set-Up	F4-35
Control Cubicle Wiring Harness	F1-10
Control System, Description and Function	4-34
Cylinder Head Assembly	F4-42

ALPHABETICAL INDEX (CONT)

Subject	Paragraph, Figure, Table, Number
D	
DC Control System	4-35
Destruction of Material to Prevent Enemy Use	1-6
E	
Electric Starter	F3-7
Electrical Cable Schematic..	F1-6
Engine Assembly	F4-36
Adjustment	4-42
Description and Function	4-39
Inspection	3-24, 4-42
Service	4-42
Test	4-42
Engine Cooling System.	F3-17
Adjustment	4-17
Cleaning	4-17
Description and Function	4-16
Disassembly	4-17
Inspection	3-22, 4-17
Installation	4-17
Reassembly	4-17
Removal	4-17
Test	4-17
Engine Electrical System, Description and Function	4-24
Engine Generator Set	
Left-Front, Three-Quarter View	F1-2
Right-Rear, Three-Quarter View	F1-1
Engine Mounting Assembly	F4-44
Disassembly	4-52
Inspection	4-52
Installation	4-52
Reassembly	4-52
Removal	4-52
Engine Starter Assembly	F4-18, F4-22
Cleaning and Inspection	3-16, 4-26
Installation	4-26
Removal	4-26
Repair	4-26
Test, Bench	4-26
Test, On Equipment	4-26
Engine Starter Brushes, Inspecting	F4-21
Engine Starter, Testing	F4-19
Engine Starter Wiring Diagram	F4-20
Engine Stop Solenoid	F3-22
Engine Wiring Harness, Inspection	3-21
Exhaust Muffler and Air Cleaner Assemblies	F4-37
Exhaust Muffler Assemblies	F3-6
Inspection	3-15, 4-40
Removal	4-40
Replacement	4-40
F	
Float Switch, Testing	F4- 8
Fuel Filter	F4- 9

ALPHABETICAL INDEX (CONT)

Subject	Paragraph, Figure, Table, Number
F (CONT)	
Fuel Filter and Strainer Assembly	F3-13, F4-11
Inspection	4-20
Installation	4-20
Removal	4-20
Service	4-20
Fuel Pump	F3-14, F4-13
Fuel Pump, Fuel Hoses and Solenoid	F4-12
Fuel Pumps and Hoses	
Installation.	4-21
Removal.	4-21
Service	4-21
Test, On Equipment	4-21
Fuel Shut-Off Solenoid, Adjusting	F4-14
Fuel Shut-Off Solenoid	
Adjustment.	4-23
Inspection.	4-23
Installation.	4-23
Removal	4-23
Test, On Equipment	4-23
Fuel Solenoid Test Set-Up	F4-15
Fuel Strainer Element	F4-10
Fuel System, Description and Function	4-18
Fuel System (Less Tank), Inspection	3-20
Fuel System Schematic	F1-5
Fuel Tank Assembly	F3-4, F4-7
Cleaning.	3-13, 4-19
Disassembly	4-19
Inspection.	3-13, 4-19
Installation	4-19
Reassembly	4-19
Test.	4-19
G	
Generator Assembly	F3-18
Description and Function.	4-53
Inspection	3-23
Inspection	4-54
Generator/Exciter Assembly, Inspection	F4-45
Generator Screen-Guard	F4-45
Generator Set	
Controls and Instruments	T2-1
Description.	1-9
Dismantling for Movement.	4-3
Electrical Schematic	F1-7
Grounding	F4-2
Inspection and Servicing on Receipt	4-1
Installation.	4-2
Installation Plans	F1-4
Re-installing after Movement	4-4
Tabulated Data	1-10
Urcrating	F4-1
Wiring Harness	F1-8
Glow Plug Assemblies	
Inspection	4-48
Installation.	4-48
Removal	4-48
Test.	4-48

ALPHABETICAL INDEX(CONT)

Subject	Paragraph, Figure, Table, Number
G (CONT)	
Ground Rod and Fuel Drum Adapter Hold-Down Assembly	F3-3
Cleaning and Inspection	3-12
Installation	3-12
Removal	3-12
Ground Stud.	F3-24
I	
Injector Nozzle Assembly and Fuel Lines, Inspection	4-47
Intake Manifold Assembly	F3-19
Inspection	4-43
Installation	4-43
Removal	4-43
Repair	4-43
Test, On Equipment	4-43
L	
Levels of Maintenance Accomplishment	1-5
Load Terminal Board Assembly.	F4-32
Installation	4-37
Removal	4-37
Load Terminal and Reconnection Configuration	F2-4
Load Terminals	F2-1
Lockout Switch and Gear	F4-25
Low Oil Pressure Switch	
Installation	4-31
Removal	4-31
Test, Bench	4-31
Test, On Equipment	4-31
Lubrication Instructions	
Operator/Crew	3-2
Organizational	4-7
Lubrication Order	F3-1, 3-3
M	
Maintenance Forms and Records	1-3
Maintenance Repair Parts	4-6
Manual	
Applicability	1-2
Scope	1-1
Master Switch Continuity Check	T4-3
O	
Oil Cooler	F4-28
Inspection	4-30
Removal	4-30
Replacement	4-30
Service	4-30
Oil Cooler Hoses, Replacing	F4-29
Oil Drain Hose	F3-20
Oil Drain Hose and Valve, Replacement	4-49
Oil Fill Tube	F4-43
Installation	4-51
Removal	4-51

ALPHABETICAL INDEX (CONT)

Subject	Paragraph, Figure, Table, Number
O (CONT)	
Oil Filter	F4-30
Removal	4-32
Replacement	4-32
Service	4-32
Oil Filter and Oil Pressure Switch.	F3-21
Oil Pan-Base, Inspection	4-50
Oil Pressure Gauge	
Removal	4-33
Replacement	F4-31, 4-33
Test	4-33
Oil, System, Description and Function	4-29
Operating Procedures	
Equipment Reconnection	2-3
General	2-1
Operating in Alternate Modes	2-5
Operating in Dusty or Sandy Areas.	2-9
Operation in Extreme Cold	2-8
Operation in Extreme Heat	2-10
Operation in Wet or Humid Areas.	2-2
Power Connections	2-6
Shutting Down Unit	2-4
Starting Generator Set	2-4
P	
Preparation for Shipment or Storage	1-8
Pressure Oil System	F4-27
Preventive Maintenance Checks and Services	T3-2, T4-1
Operator/Crew	
Correcting and Reporting Deficiencies	3-5
Determining Intervals	3-6
General	3-4
Units in Continuous Operation	3-7
Organizational	
Determining Intervals	4-9
General	4-8
Units in Continuous Operation	4-10
Primary Radio Interference Suppression Components	F4-3
R	
Radio Interference Suppression Components	4-15
General Methods	4-14
Reconnection Switch	F2-2
Reconnection Switch Positions	T2-2
Reporting Of Errors	1-4
Rocker Arm Cover Oil Line, Cleaning	F4-39
Rocker Arm Covers	F4-38
Inspection	4-44
Removal	4-44
Replacement	4-44
Service	4-44
Rocker Arm to Valve Clearance, Checking and Adjusting	F4-41

ALPHABETICAL INDEX (CONT)

Subject	Paragraph, Figure, Table, Number
S	
Screen-Guard	
Inspection	4-55
Installation	4-55
Removal	4-55
Repair	4-55
Shutter Assembly	F4-4
Shutter Box Assembly, Inspection	3-14
Shutter and Thermo Power Element Assembly	F3-5
Shutters, Adjusting	F4-5
Skid-Base	F4-46
Cleaning	3-25
Description and Function	4-56
Inspection	3-25, 4-57
Installation	4-57
Removal	4-57
Repair	4-57
Special Tools	4-5
Speed Control	F3-16
Inspection	3-21
Starter Lockout Switch Adjusting	F4-26
Starter Lockout Switch and Gear	
Adjustment	4-28
Inspection	4-28
Removal	4-28
Repair	4-28
Replacement	4-28
Test	4-28
Starting Procedure	F2-3
T	
Thermo Unit, Adjusting	F4-6
Tie Down, Lifting, and Towing Provisions Crated Set	F1-3
Troubleshooting	T3-3, T4-2
Operator General	3-9
Organizational, General	4-12
V	
Valve Rocker Arms	
Adjustment	4-46
Inspection	4-46

By Order of the Secretaries of the Army, the Navy, and the Air Force:

BERNARD W. ROGERS
General, United States Army
Chief of Staff

Official:

PAUL T. SMITH
Major General, United States Army
The Adjutant General

D. G. ISELIN
Rear Admiral, CEC, U. S. Navy
Commander,
Naval Facilities Engineering Command

Official:

DAVID C. JONES, General, USAF
Chief of Staff

JAMES J. SHEPARD, Colonel, USAF
Director of Administration

W. R. JOHNSON
Brigadier General, U. S. Marine Corps
Acting Deputy Chief of Staff for Installation and Logistics

Distribution:

To be distributed in accordance with DA Form 12-25D, Operator maintenance requirements for Generator Sets, Engine Driven: 5 KW, 60 HZ.

