

**LUBRICATION ORDER**

3 December 1991

**LO 9-2320-363-12**

**TRUCK, TRACTOR, LINE HAUL  
52,000 GVWR, 6X4, M915A2  
(NSN 2320-01-272-5029)**

**AND**

**TRUCK, TRACTOR, LIGHT EQUIPMENT TRANSPORTER (LET)  
68,000 GVWR, 6X6, W/WINCH, M916A1  
(NSN 2320-01-272-5028)**

Reference: TM 9-2320-363-20 and Federal Supply Catalog C9100-IL

**REPORTING ERRORS AND RECOMMENDING IMPROVEMENTS**

You can help improve this manual. If you find any mistakes or if you know of a way to improve the procedures, please let us know. Mail your letter or DA Form 2028 (Recommended Changes to Publications and Blank Forms) direct to: Commander, U.S. Army Tank-Automotive Command, ATTN: AMSTA-MB, Warren, MI 48397-5000. A reply will be furnished to you.

Intervals (on-condition or hard time) and the related man-hour times are based on normal operation. The man-hour time specified is the time you need to do all the services prescribed for a particular interval. On-condition (OC) oil sample intervals shall be applied unless changed by the Army Oil Analysis Program (AOAP) laboratory. Change the hard time interval if your lubricants are contaminated or if you are operating the equipment under adverse operating conditions, including longer-than-usual operating hours. The hard time interval may be extended during periods of low activity. If extended, adequate preservation precautions must be taken. Hard time intervals will be applied in the event AOAP laboratory support is not available.

Intervals shown in this Lubrication Order are based on calendar and mileage. An example of a mileage and calendar interval is 10/A, in which 10 stands for 10,000 miles and A stands for annually. This lubrication is to be performed at whatever interval

occurs first for the vehicle. Special lubrication intervals and services are shown by use of an asterisk (\*).

Clean parts and fittings with drycleaning solvent, Type II (SD-2) (P-D-680); solvent (biodegradable), (MIL-C-87936); or equivalent. Dry before lubricating. Dotted arrow points indicate lubrication on both sides of the equipment.

The lowest level of maintenance authorized to lubricate a point is indicated by one of the following symbols, as appropriate: Operator/Crew (C); Unit Maintenance (O). Operator/Crew may lubricate points listed for Unit Maintenance (O) when authorized by Unit Maintenance.

On the lubrication chart there are references to notes and/or views. The views are shown on cards 10 through 18; the notes on cards 19 through 24.

Approved for public release; distribution is unlimited

**KEY**

<b>Lubricants (See Note 19)</b>	<b>Refill Capacity (Approximate)</b>	<b>Expected Temperatures</b>	<b>Intervals</b>
OE/HDO Lubricating Oil I.C.E. Tactical (MIL-L-2104)  OEA Lubricating Oil I.C.E. Arctic (MIL-L-46167)  Engine w/3 Filters  Transmission  Transfer Case (M916A1 only)  Power Steering  Winch Reservoir (M916A1 only)  Oil Can Points	   41 Quarts (38.78 Liters)  33 Quarts (31.2 Liters)  5 Quarts (4.7 Liters)  2 Quarts (1.9 Liters)  42 Gallons (159 Liters)  As Required	   See Chart A  See Chart B  See Chart D  See Chart A  See Chart C  See Chart A	D - Daily  W - Weekly  S - Semiannually  A - Annually  5 - 5,000 Miles  10 - 10,000 Miles  20 - 20,000 Miles  75 - 75,000 Miles  OC - On-Condition
GO Lubricating Oil, Gear, Multipurpose (MIL-L-2105)  M915A2 Front Axle (Hub)  M915A2 Differentials Forward-Rear Rear-Rear  M916A1 Differentials Forward-Rear Rear-Rear  M916A1 Differential (Front Drive Axle)  Winch Drum (M916A1 only)	  As Required  13 Quarts (12.3 Liters) 14.5 Quarts (13.7 Liters)  22 Quarts (20.8 Liters) 23 Quarts (21.8 Liters)  13.5 Quarts (12.8 Liters)  5 Quarts (4.7 Liters)	  See Chart E  See Chart E See Chart E  See Chart E See Chart E  See Chart E  See Chart E	
GAA Grease, Automotive and Artillery (MIL-L-10924)  Front Wheel Knuckle (M915A2 only)  Front Axle Spring	  As Required  As Required	  All Temperatures  All Temperatures	

**KEY**

<b>Lubricants (See Note 19)</b>	<b>Refill Capacity (Approximate)</b>	<b>Expected Temperatures</b>	<b>Intervals</b>
Rear Axle Spring	As Required	All Temperatures	D - Daily
Equalizing Beam	As Required	All Temperatures	W - Weekly
Fifth Wheel	As Required	All Temperatures	S - Semiannually
Steering Gear and Shaft Universals	As Required	All Temperatures	A - Annually
Camshaft Slack Adjusters	As Required	All Temperatures	5 - 5,000 Miles
Camshaft Bushings	As Required	All Temperatures	10- 10,000 Miles
Pintle Hook	As Required	All Temperatures	20 - 20,000 Miles
Tach Drive	As Required	All Temperatures	75- 75,000 Miles
Wheel Bearings	As Required	All Temperatures	OC - On-Condition
Tie Rod	As Required	All Temperatures	
Fan Hub	As Required	All Temperatures	
Driveline Universal Joints, Slip Yokes, and Splines	As Required	All Temperatures	
Trunnion Universal Joint (M916A1 only)	As Required	All Temperatures	
Speedometer (M916A1 only)	As Required	All Temperatures	
Tail Roller (M916A1 only)	As Required	All Temperatures	
Winch Cable (M916A1 only)	As Required	All Temperatures	
Taillights	As Required	All Temperatures	
Antifreeze, Ethylene Glycol, Inhibited, Heavy Duty (MIL-A-46153)	Total Capacity 65 Quarts (61.5 Liters)	See Chart F	
Antifreeze, Arctic Type (MIL-A-11755)			
Drycleaning Solvent, Type II (SD-2) (P-D-680)	As Required	All Temperatures	
Solvent (biodegradable) (MIL-C-87936)		All Temperatures	

**CHART A (TO BE USED FOR SPECIFYING LUBRICANTS  
FOR ENGINE, POWER STEERING, AND OIL CAN APPLICATIONS)**

LUBRICANT	EXPECTED TEMPERATURES																			
	°F	-70	-60	-50	-40	-30	-20	-10	0	+10	+20	+30	+40	+50	+60	+70	+80	+90	+100	+120
	°C	-57	-51	-46	-40	-34	-29	-23	-18	-12	-7	-1	+4	+10	+16	+21	+27	+32	+38	+49
OE/HDO (MIL-L-2104) Lubricating Oil, ICE, Tactical																				
OEA (MIL-L-46167) Lubricating Oil, ICE, Arctic																				
OE/HDO - 15/40 (0 - 1236)																				
OE/HDO - 10 * (0 - 237)																				
OE/HDO - 30 (0 - 238)																				
OE/HDO - 40 (N/A)																				
OEA * (0 - 183)																				

\* If OEA lubricant is required to meet the low expected-temperature range, OEA lubricant is to be used in lieu of OE/HDO - 10 lubricant for all expected temperatures where OE/HDO - 10 is specified.

**CHART B (TO BE USED FOR SPECIFYING LUBRICANTS FOR TRANSMISSION APPLICATIONS)**

LUBRICANT	EXPECTED TEMPERATURES																			
	°F	-70	-60	-50	-40	-30	-20	-10	0	+10	+20	+30	+40	+50	+60	+70	+80	+90	+100	+120
	°C	-57	-51	-46	-40	-34	-29	-23	-18	-12	-7	-1	+4	+10	+16	+21	+27	+32	+38	+49
OE/HDO (MIL-L-2104) Lubricating Oil, ICE, Tactical																				
OEA (MIL-L-46167) Lubricating Oil, ICE, Arctic																				
OE/HDO - 15/40 (0 - 1236)																				
OE/HDO - 10 * (0 - 237)																				
OEA * (0 - 183)																				

\* If OEA lubricant is required to meet the low expected-temperature range, OEA lubricant is to be used in lieu of OE/HDO - 15/40 lubricant for all expected temperatures where OE/HDO - 10 and OE/HDO - 15/40 is specified.

**CHART C (TO BE USED FOR SPECIFYING OE/HDO FOR HYDRAULIC APPLICATIONS)**

LUBRICANT	EXPECTED TEMPERATURES																			
	°F	-70	-60	-50	-40	-30	-20	-10	0	+10	+20	+30	+40	+50	+60	+70	+80	+90	+100	+120
	°C	-57	-51	-46	-40	-34	-29	-23	-18	-12	-7	-1	+4	+10	+16	+21	+27	+32	+38	+49
OE/HDO (MIL-L-2104) Lubricating Oil, ICE, Tactical																				
OEA (MIL-L-46167) Lubricating Oil, ICE, Arctic																				
OE/HDO - 10 * (0 - 237)																				
OEA * (0 - 183)																				

\* If OEA lubricant is required to meet the low expected-temperature range, OEA lubricant is to be used in lieu of OE/HDO - 10 lubricant for all expected temperatures where OE/HDO - 10 is specified.

**CHART D (TO BE USED FOR SPECIFYING LUBRICANTS FOR TRANSFER CASE)**

LUBRICANT	EXPECTED TEMPERATURES																			
	°F	-70	-60	-50	-40	-30	-20	-10	0	+10	+20	+30	+40	+50	+60	+70	+80	+90	+100	+120
	°C	-57	-51	-46	-40	-34	-29	-23	-18	-12	-7	-1	+4	+10	+16	+21	+27	+32	+38	+49
OE/HDO (MIL-L-2104) Lubricating Oil, ICE, Tactical																				
OEA (MIL-L-46167) Lubricating Oil, ICE, Arctic																				
OE/HDO - 40 (N/A)																				
OEA * (0-183)																				

\* If OEA lubricant is required to meet the low expected-temperature range, OEA lubricant is to be used in lieu of OE/HDO - 10 lubricant for all expected temperatures where OE/HDO - 10 is specified.

### CHART E (TO BE USED FOR SPECIFYING LUBRICANTS FOR AXLES/WINCH APPLICATIONS)

LUBRICANT	EXPECTED TEMPERATURES																						
	°F	-70	-60	-50	-40	-30	-20	-10	0	+10	+20	+30	+40	+50	+60	+70	+80	+90	+100	+120			
	°C	-57	-51	-46	-40	-34	-29	-23	-18	-12	-7	-1	+4	+10	+16	+21	+27	+32	+38	+49			
GO (MIL-L-2105) Lubricating Oil, Gear, Multipurpose																							
GO - 75 (0 - 186)		—————																					
GO - 80/90 (0 - 226)																							
GO - 85/140 (0 - 228)																							

### CHART F (TO BE USED FOR SPECIFYING ANTIFREEZE)

LUBRICANT	EXPECTED TEMPERATURES																				
	°F	-90	-80	-70	-60	-50	-40	-30	-20	-10	0	+10	+20	+30	+40	+50	+60	+70	+80	+90	
	°C	-68	-62	-57	-51	-46	-40	-34	-29	-23	-18	-12	-7	-1	+4	+10	+16	+21	+27	+32	
(MIL-A-46153) Antifreeze, Ethylene Glycol Inhibited, Heavy Duty (MIL-A-11755) Antifreeze, Arctic Type																					
MIL-A-46153																					
MIL-A-11755																					

## MODEL M915A2/M916A1 LUBRICATION REQUIREMENTS

Item - Lubricant (Number of Fittings) - Interval

Interval - Lubricant (Number of Fittings) - Item

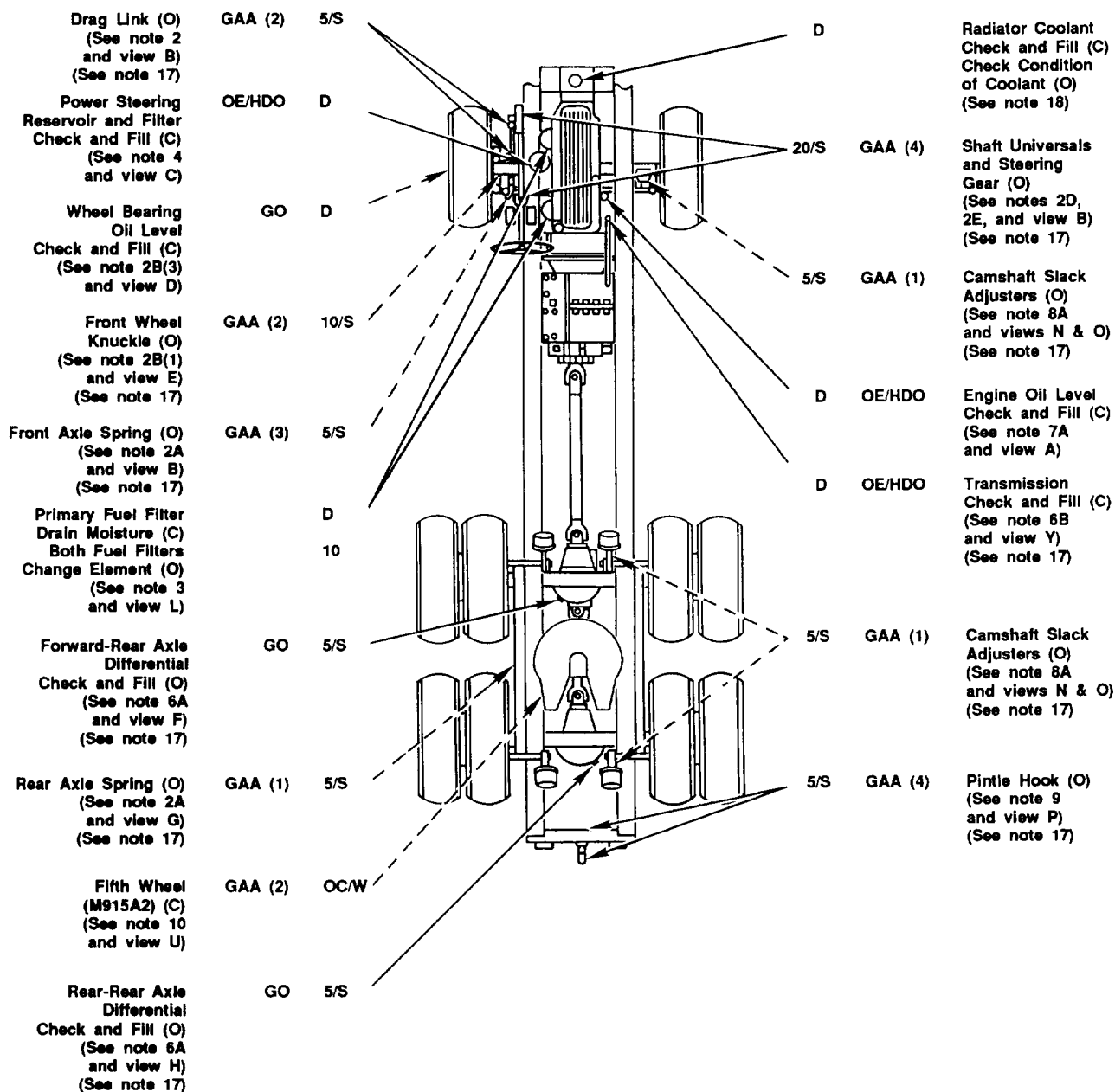

NOTE: Dotted arrow points indicate lubrication on both sides of vehicle.

### INTERVALS

D - DAILY (OPERATOR)	10 - 10,000 MILES
W - WEEKLY	20 - 20,000 MILES
S - SEMIANNUALLY	75 - 75,000 MILES
A - ANNUALLY	OC - ON-CONDITION
5 - 5,000 MILES	

# MODEL M915A2/M916A1 LUBRICATION REQUIREMENTS

Item - Lubricant (Number of Fittings) - Interval

Interval - Lubricant (Number of Fittings) - Item

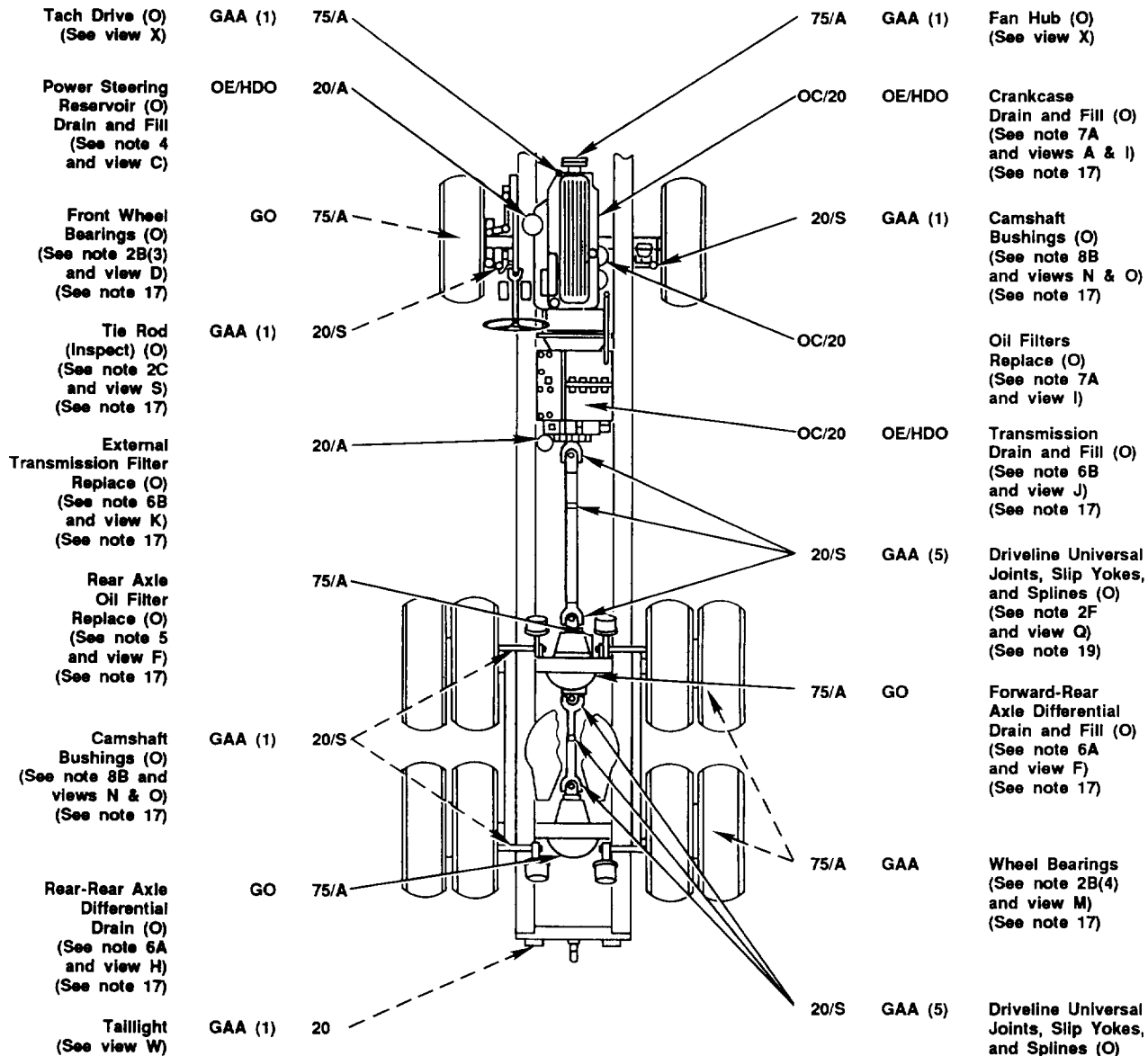

NOTE: Dotted arrow points indicate lubrication on both sides of vehicle.

### INTERVALS

D - DAILY (OPERATOR)	10 - 10,000 MILES
W - WEEKLY	20 - 20,000 MILES
S - SEMIANNUALLY	75 - 75,000 MILES
A - ANNUALLY	OC - ON-CONDITION
5 - 5,000 MILES	



# MODEL M916A1 LUBRICATION REQUIREMENTS

Item - Lubricant (Number of Fittings) - Interval

Interval - Lubricant (Number of Fittings) - Item

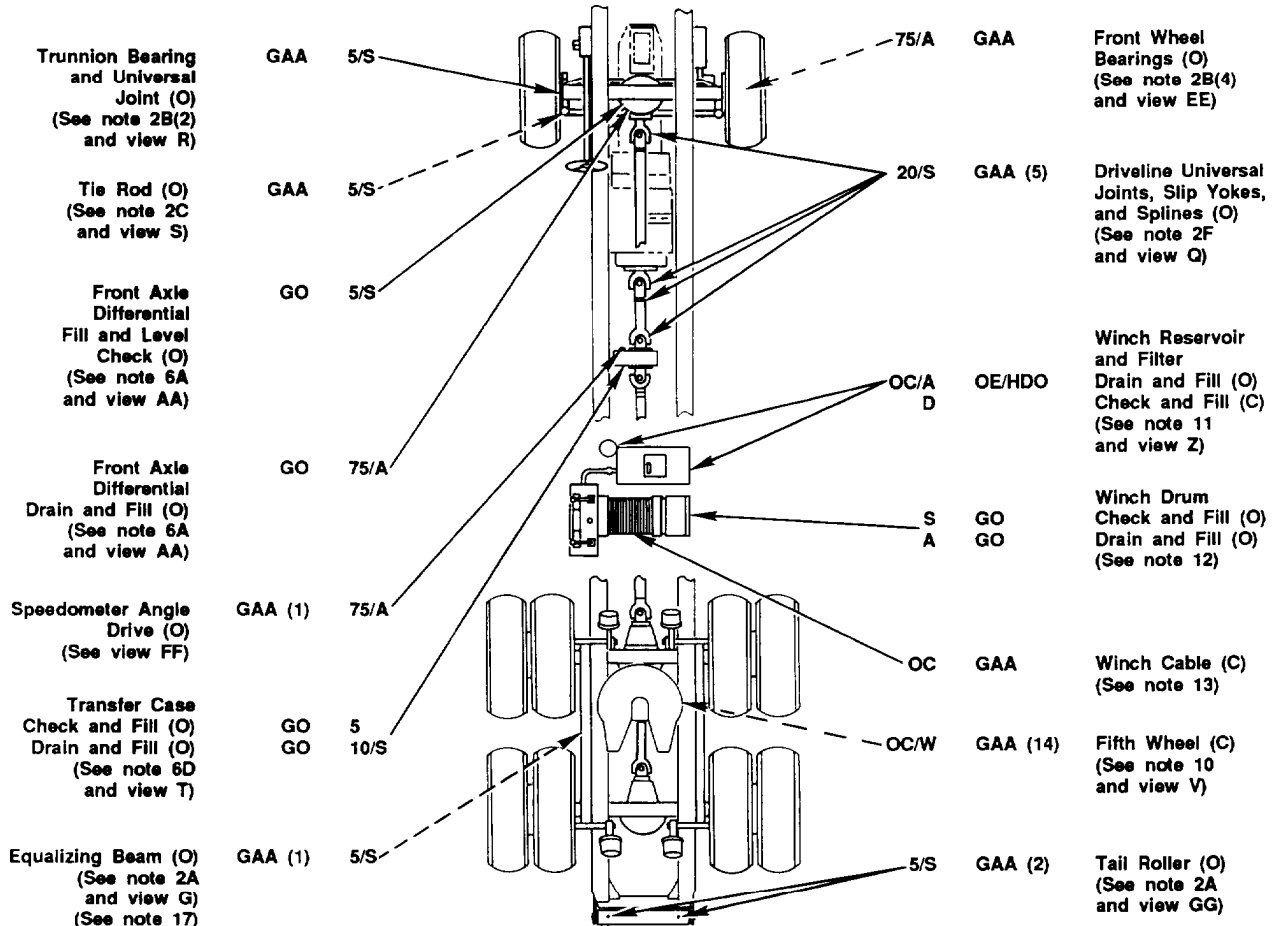

NOTE: Dotted arrow points indicate lubrication on both sides of vehicle.

## INTERVALS

D - DAILY (OPERATOR) 10 - 10,000 MILES  
 W - WEEKLY 20 - 20,000 MILES  
 S - SEMIANNUALLY 75 - 75,000 MILES  
 A - ANNUALLY OC - ON-CONDITION  
 5 - 5,000 MILES

TOTAL MAN-HOURS								
	D	W	S	A	5,000	10,000	20,000	75,000
M915A2	.6	.2	2.9	8.1	2.6	.6	3	7
M916A1	.6	.2	4.6	8.9	5.4	.6	3.3	7.3

NOTE: The above man-hours have been established on an individual basis and, hence, are not applicable at maintenance facilities where production line methods are employed.

**A** ENGINE

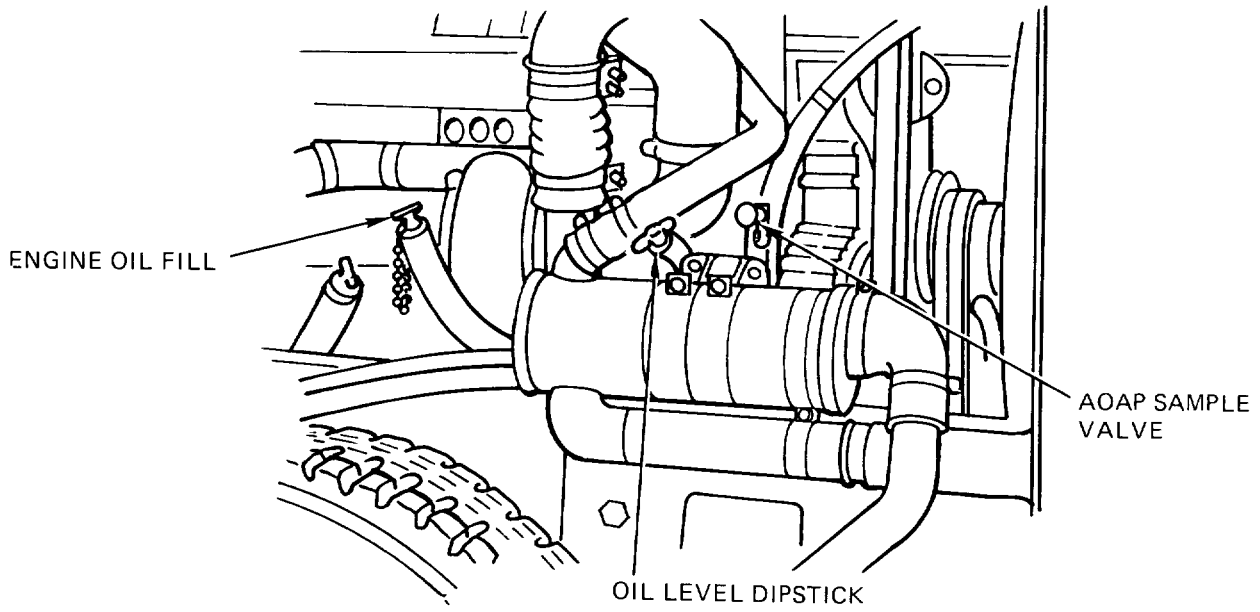

**B** DRAG LINK, FRONT AXLE SPRING, STEERING SHAFT UNIVERSALS, AND STEERING GEAR

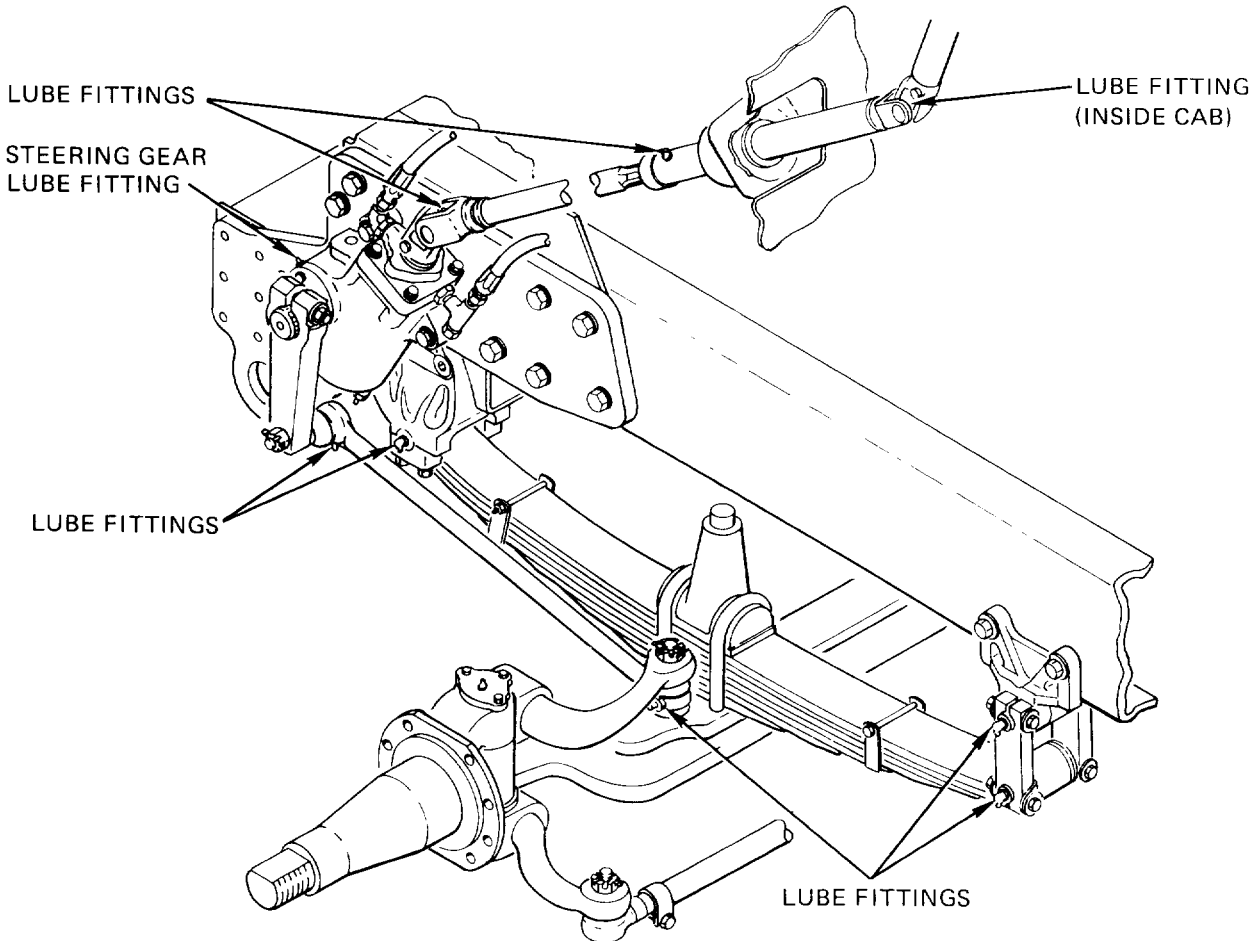

**C POWER STEERING RESERVOIR**

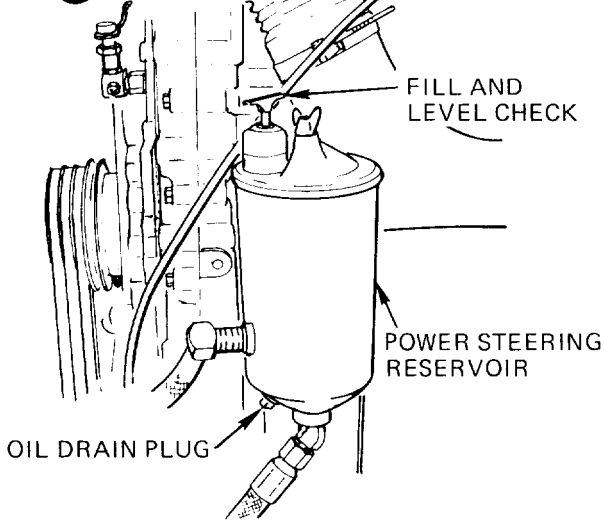

**D M915A2 NON-DRIVE AXLE HUB ASSEMBLY**

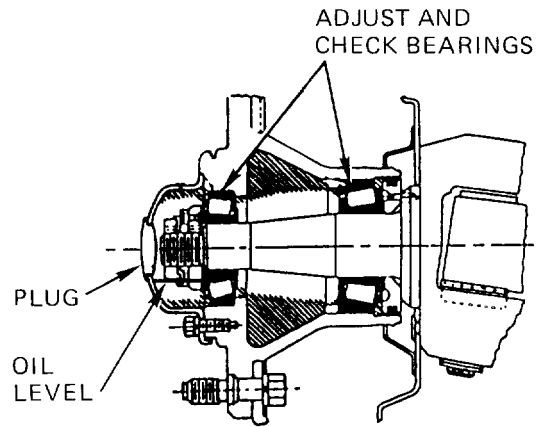

**E M915A2 FRONT WHEEL KNUCKLE**

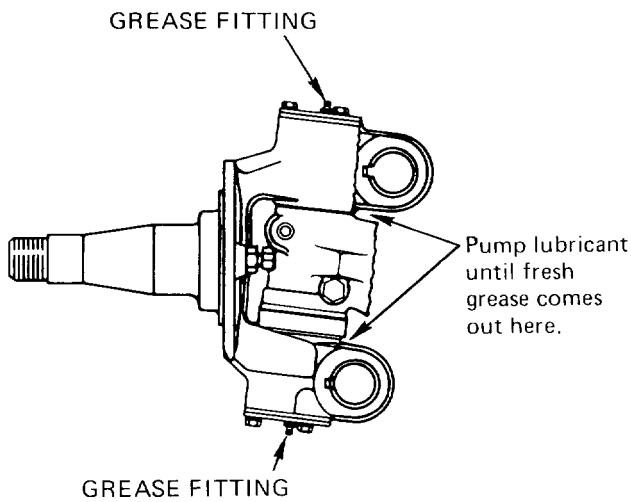

**F FORWARD-REAR AXLE**

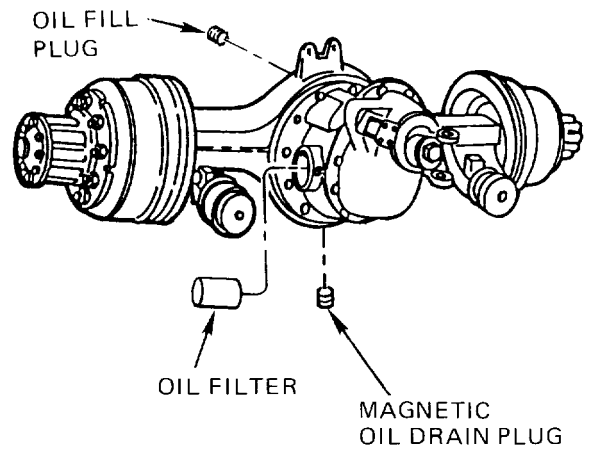

**G REAR AXLE SPRING AND EQUALIZING BEAM**

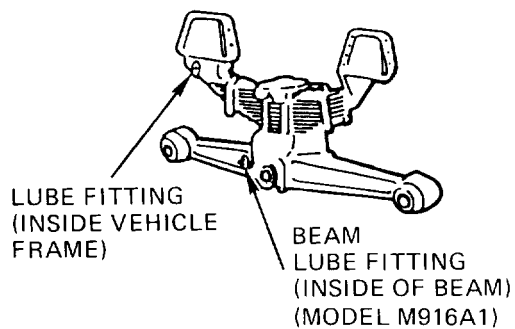

**H REAR-REAR AXLE**

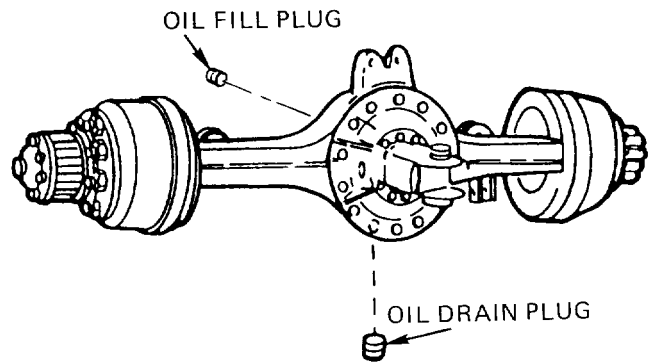

**I** ENGINE OIL DRAIN PLUG AND OIL FILTERS

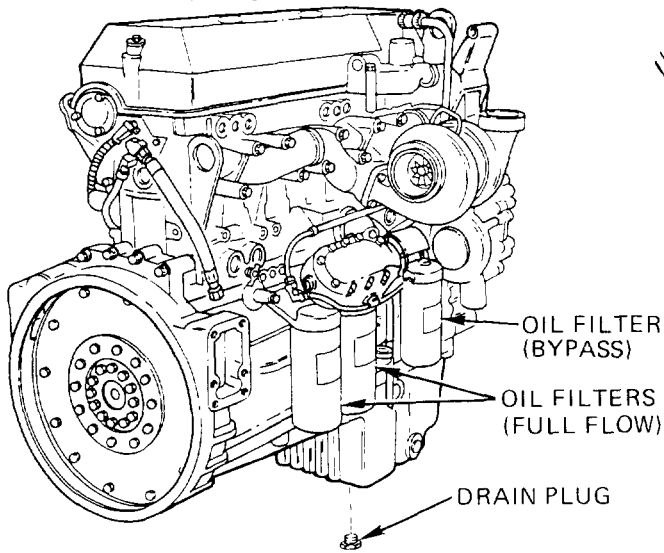

**J** TRANSMISSION OIL DRAIN PLUG

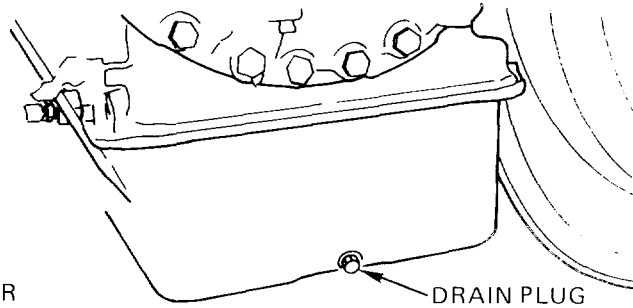

**K** TRANSMISSION OIL FILTER

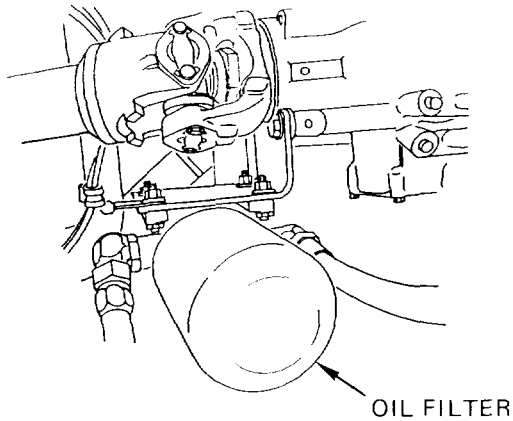

**L** FUEL FILTERS

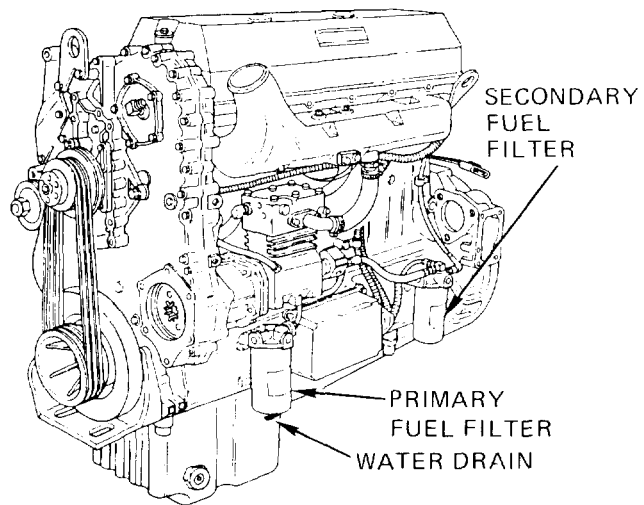

**M** DRIVE AXLE HUB ASSEMBLY

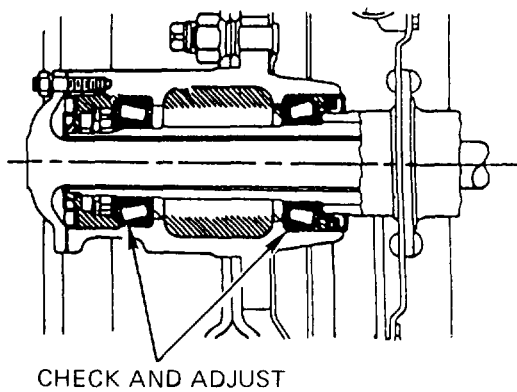

**N** BRAKE CAMSHAFT BRACKET BUSHING LUBRICATION

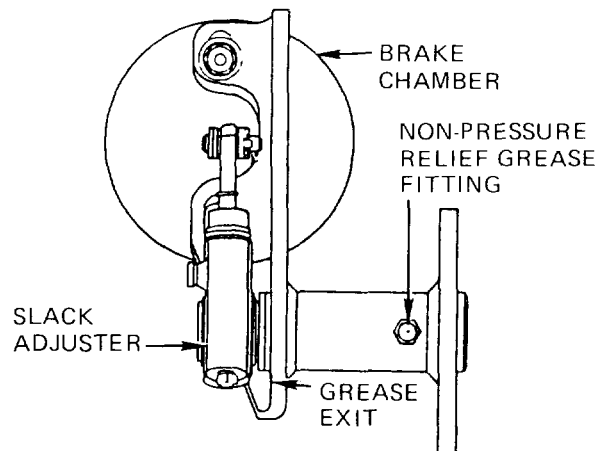

**O BRAKE AUTOMATIC SLACK ADJUSTERS**

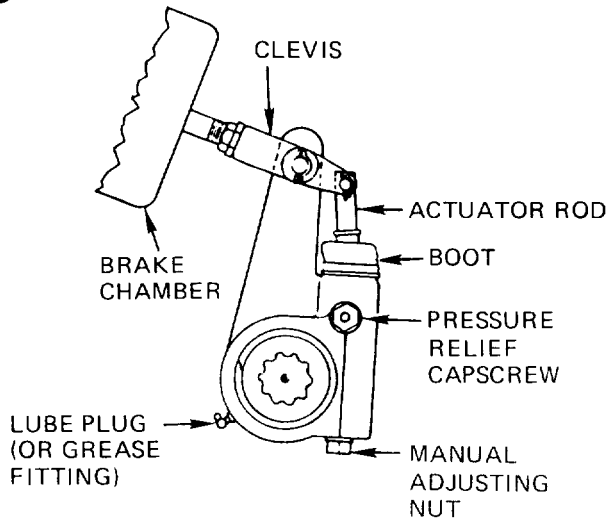

**P PINTLE HOOK**

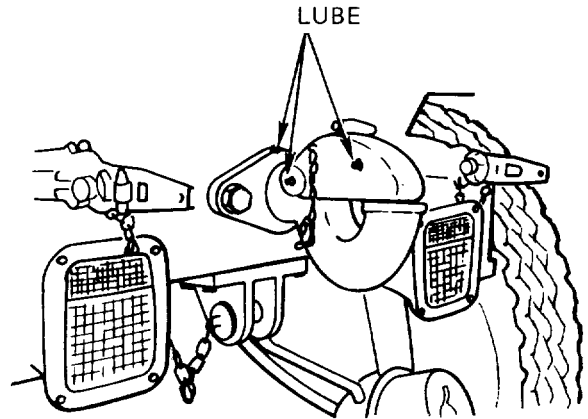

**Q DRIVELINE UNIVERSAL JOINTS, SLIP YOKES, AND SPLINES**

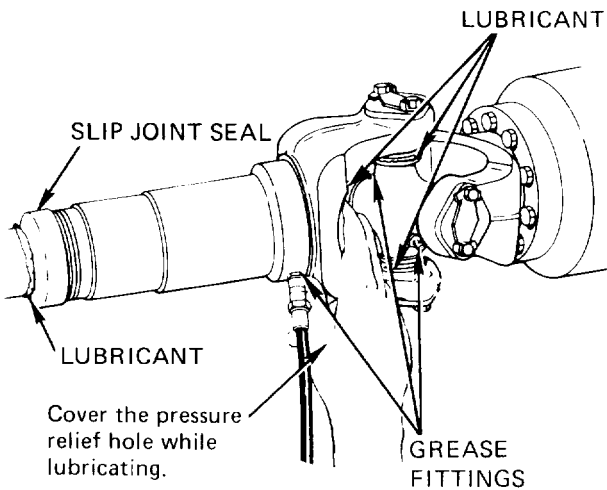

**R M916A1 TRUNNION UNIVERSAL JOINT FRONT AXLE**

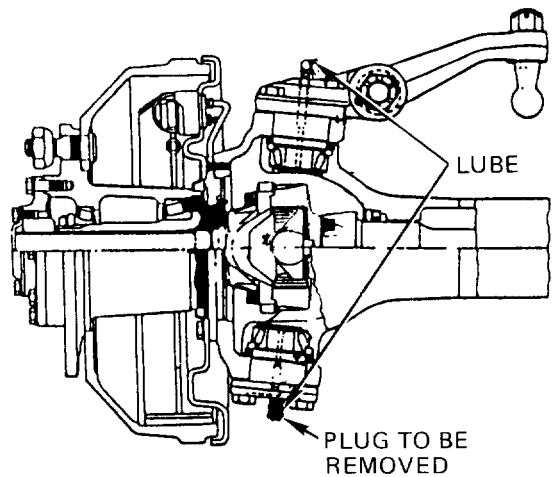

**S TIE ROD**

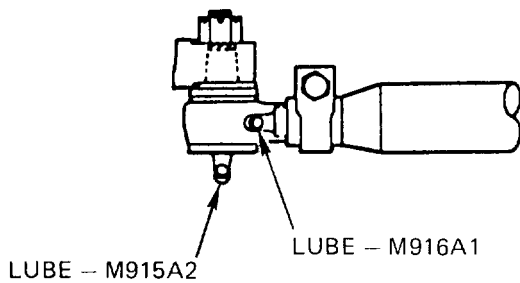

**T TRANSFER CASE - M916A1 ONLY**

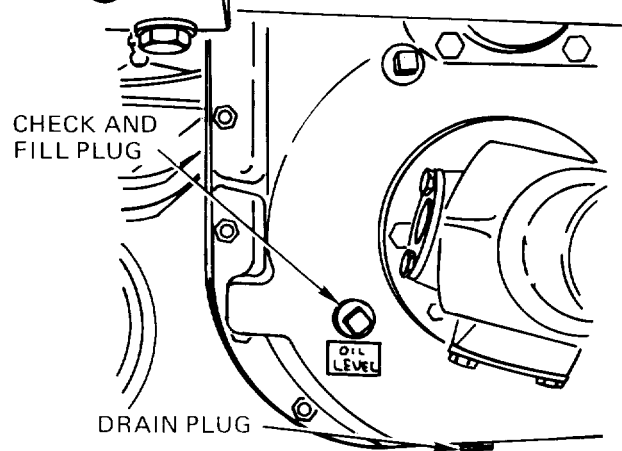

(Under vehicle, looking forward)

**U** FIFTH WHEEL - M915A2

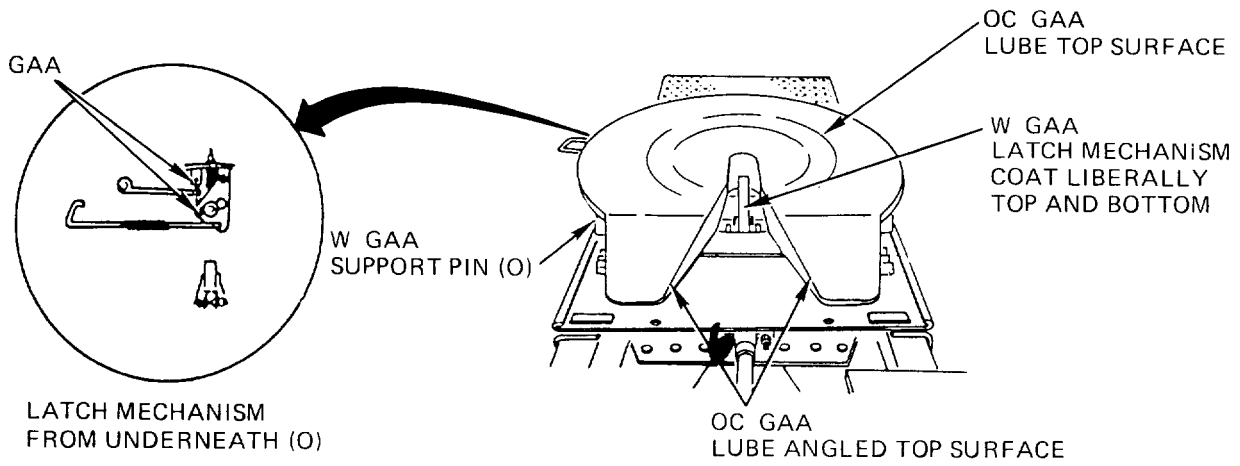
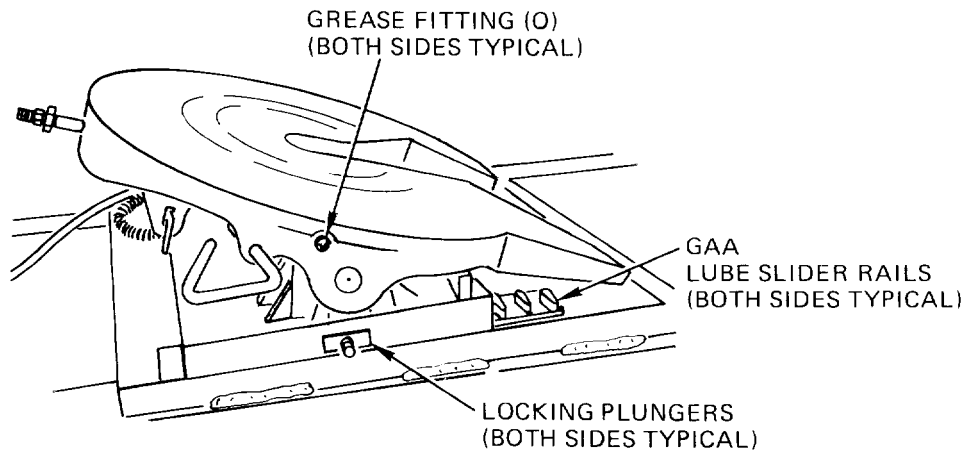

**V FIFTH WHEEL - M916A1**

LUBE SLIDER RAILS AND  
LOCKING PLUNGERS  
(BOTH SIDES TYPICAL)

GREASE FITTINGS (O)  
(BOTH SIDES TYPICAL)

GREASE FITTINGS (O)  
(BOTH SIDES TYPICAL)

GREASE FITTING (O)

LOCK PLUNGER  
SHAFT  
W GAA  
LUBE TOP  
SURFACE

JAWS (CLEAN AND  
COAT LIGHTLY)

JAW PINS

ROCKER  
SHAFT (O)

LATERAL SHAFT

W GAA  
BASE  
(CLEAN AND COAT  
LIGHTLY)

GAA

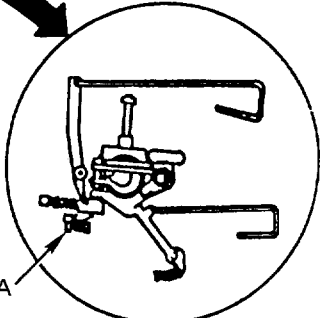

LATCH MECHANISM  
FROM UNDERNEATH (O)

**W TAILLIGHT**

GREASE  
FITTING  
GAA

**X TACH DRIVE/FAN HUB**

GREASE  
FITTINGS

**Y TRANSMISSION**

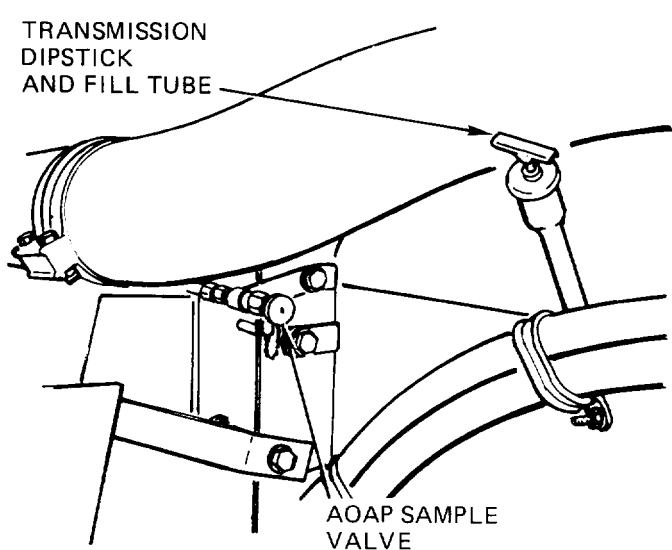

**Z WINCH RESERVOIR - M916A1**

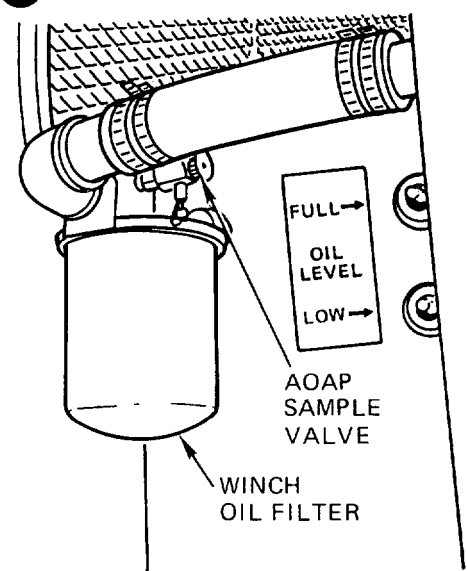

**AA M916A1 FRONT AXLE LUBRICATION DIFFERENTIAL OIL LEVEL LOCATION**

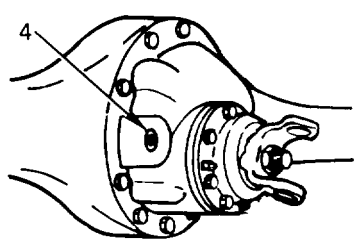
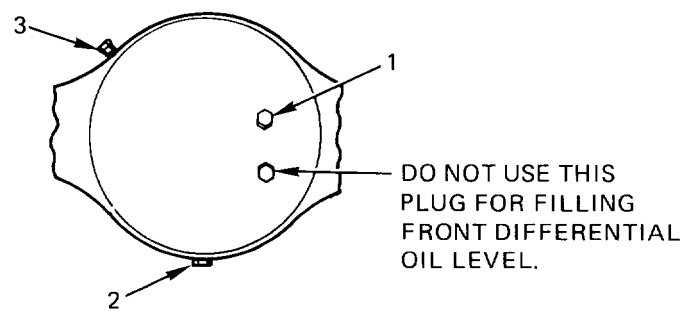

- LEGEND:
- 1. FILLER PLUG
  - 2. DRAIN PLUG
  - 3. VENT PLUG
  - 4. OIL LEVEL PLUG

**BB CAB DOOR**

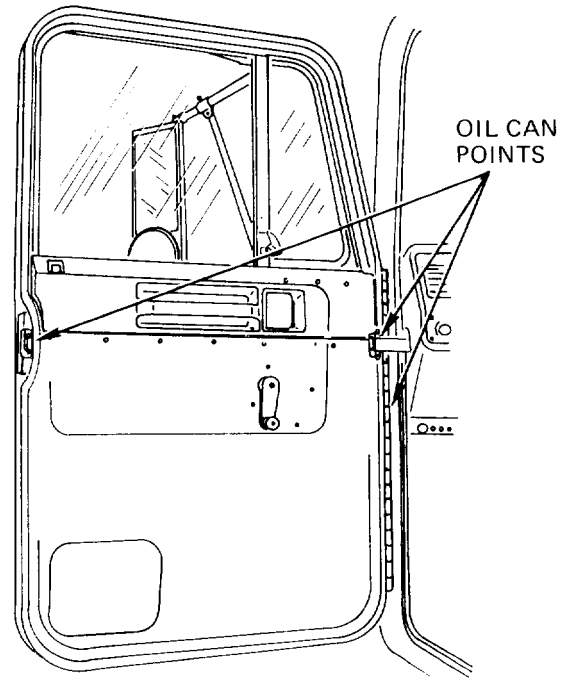



**CC SEATS**

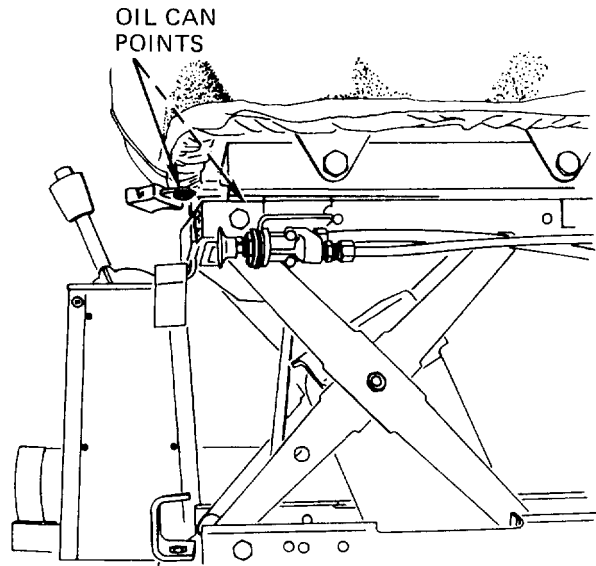

**DD SPARE TIRE CARRIER**

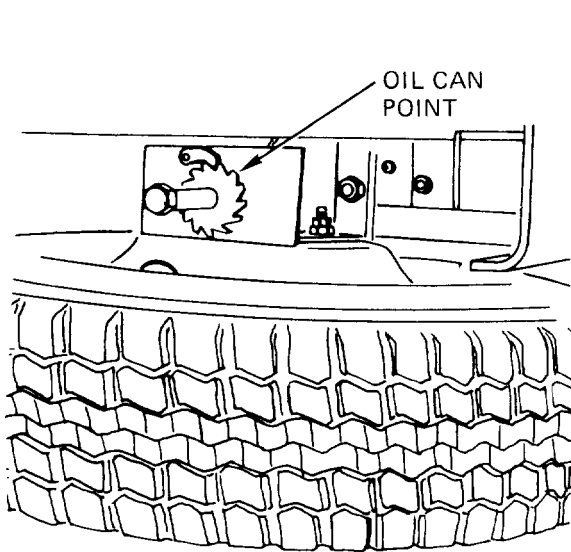

M915A2

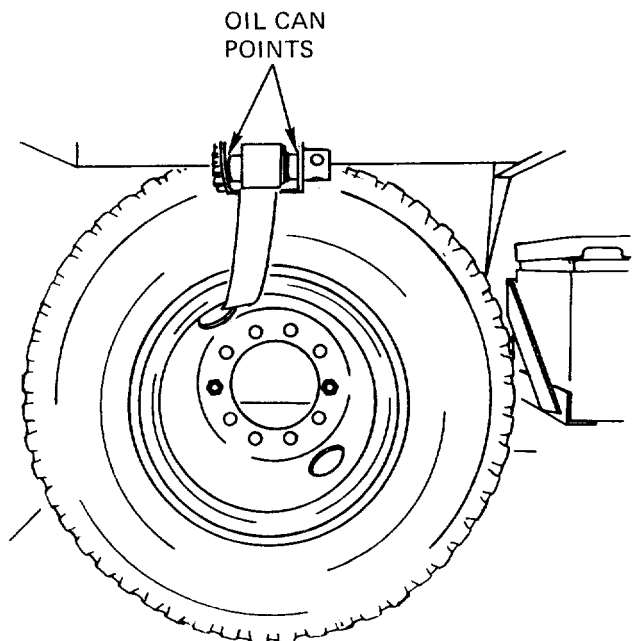

M916A1

**EE** WHEEL BEARINGS

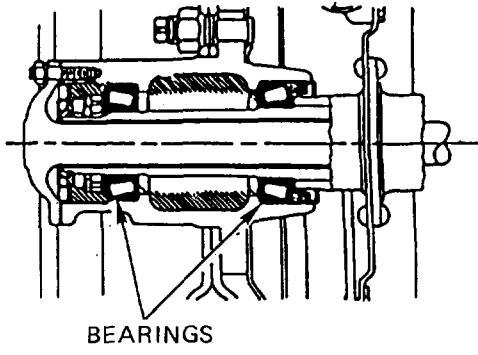

**FF** SPEEDOMETER ANGLE DRIVE

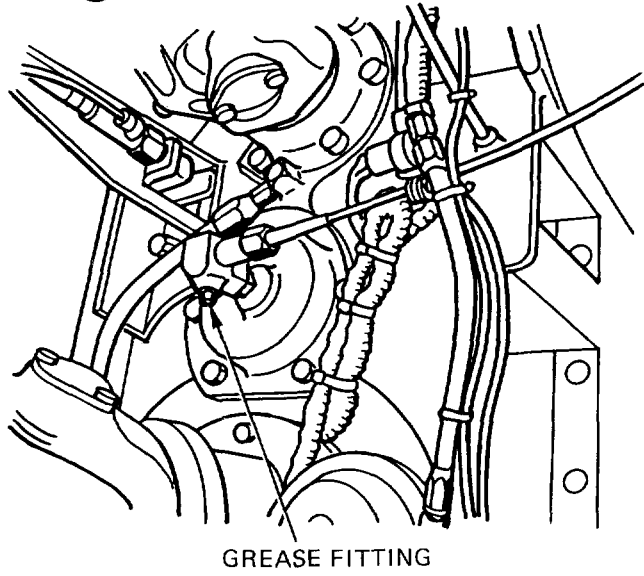

**GG** TAIL ROLLER

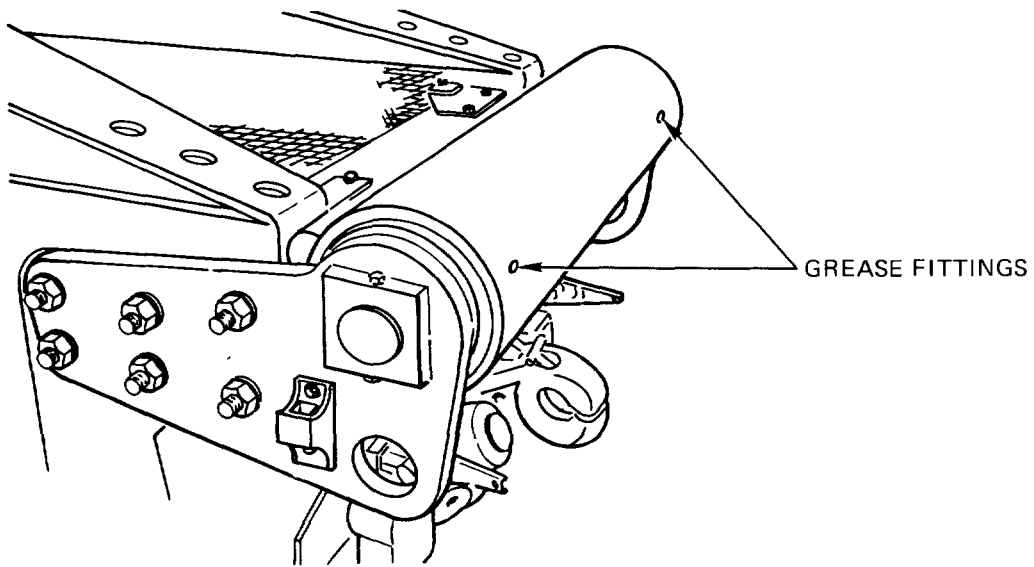

## NOTES

### 1. INTERVALS

This instruction applies only to vehicles in normal operation. Lubricate more frequently to compensate for unusual/adverse conditions, such as high or low temperatures, fording in water over 20 inches deep, or exposure to sand or dust. Intervals for change of filters (fuel, oil, air, etc.) are unchanged. Lubricants that have become contaminated will be changed regardless of scheduled intervals. Intervals for items under warranty will not be changed from those recommended by the manufacturer until after the warranty has expired. When practicable, lubrication services will be made to coincide with the vehicle Unit PMCS.

The calendar intervals may be extended during periods of low activity. If extended, adequate preservation precautions must be taken.

To validate the warranty on the M915A2 and the M916A1, an initial (annual) service must be completed at 5,000 miles. All other services will be scheduled from the initial 5,000-mile service.

### 2. GREASE POINTS

a. Hold pressure gun on fittings until new grease appears. This will ensure that all the old contaminated grease has been forced out. Take weight off suspension equalizing beam during lubrication to ensure uniform application of grease into the trunnion bushing. When lubricating front and rear suspension, raise vehicle to take weight off the suspension to permit the lubrication to reach all bearing surfaces. During lubrication, rotate tail roller.

b. Front Wheel Knuckle Joint (M915A2), Trunnion Bearing and Trunnion Joint (M916A1)

(1) M915A2 Knuckle Pins - Initially grease at 5,000 miles; thereafter every 10,000 miles or semiannually. Apply grease to knuckle grease fittings.

(2) M916A1 Trunnion Bearing - To lubricate, remove bottom plug and grease top fitting until new grease comes out of the bottom. When new grease comes out, wipe clean and reinstall plug. Lubricate every 5,000 miles or semiannually.

(3) M915A2 Front Axle, Wheel Bearings - Check daily. Remove rubber plug and add oil until visible in sight glass.

(4) M915A2 and M916A1 Inner and Outer Bearings - Inspect and adjust inner and outer bearings on both sides of axles every 75,000 miles or annually. Before installing wheel bearings onto spindle, coat bearing journals with a film of grease to defer fretting corrosion.

(5) M916A1 Front Axle Only - Remove, clean, repack, and adjust wheel bearings every 75,000 miles or annually.

c. Tie Rod

(1) M915A2 - Every 20,000 miles or semiannually wipe fittings clean, then pump new grease into tie rod ends until fresh grease is seen at the ball stud neck.

(2) M916A1 - Every 5,000 miles wipe fittings clean, then pump new grease into tie rod ends until fresh grease is seen at the ball stud neck.

#### d. Shaft Universals

Lubricate every 5,000 miles or semiannually in the following manner:

- (1) Check for looseness.
- (2) Apply grease.
- (3) Observe lube purging from all seals until new grease comes out.
- (4) If grease does not purge, manipulate the universal joint until purging occurs.
- (5) If the above is not successful, remove cup or joint and check old grease. If rusty, gritty, or burnt, replace the universal joint.

#### e. Steering Gear

Lubricate every 5,000 miles or semiannually in the following manner:

- (1) Locate grease fitting on trunion side of the steering gear, near the output shaft.

CAUTION: Do not use an automatic or power grease gun on this fitting, because the rate of flow is too high. This high-flow rate could force grease inside the high-pressure seal, which could contaminate the hydraulic system and also promote seal leakage.

- (2) Use a hand-type grease gun to force grease through the fitting until you can see it past the external dirt and water seal.

#### f. Driveline Universal Joints, Slip Yokes, and Splines

Lubricate every 20,000 miles or semiannually as follows:

- (1) Check for looseness or sideplay.
- (2) Apply grease until purging takes place at the air hole in the end of the slip yoke.

### 3. FUEL FILTER

Install new fuel filters every 10,000 miles. Fill the new filters with clean fuel; install the filters, turning them until they fully contact the gasket, then turn an additional 1/2 turn by hand.

### 4. POWER STEERING FLUID AND FILTER

Check daily with the fluid at operating temperature and engine running. Change filter and oil initially after 5,000 miles and then every 20,000 miles or annually.

### 5. FORWARD-REAR AXLE OIL FILTER

- a. Initially, the filter should be changed at the same time as the oil (5,000 miles). After that, change the filter at 75,000-mile intervals or annually.

NOTE: There may be approximately 1 pint of lubricant remaining in the filter. Be careful not to spill it when removing the filter.

- b. To change the filter, use a suitable filter strap wrench.

CAUTION: If filter is tightened more than 3/4 turn after contacting gasket, damage to the filter might result.

- c. To install the filter, coat face of gasket on new oil filter with specified drive unit lubricant. Install oil filter over the adapter and tighten 3/4 turn after gasket contacts base. Do not overtighten. It may be necessary to use a filter strap wrench.

## 6. GEAR CASES

### a. Axle Differentials

- (1) Initial Operation - After the initial 5,000 miles of operation, drain the differentials while the assembly is still warm from operation. Inspect the magnetic drain plug for signs of excessive metal particle buildup and notify Direct Support Maintenance if this condition exists. Clean plugs and replace when lubricant has stopped draining. Axles must not be flushed with a solvent. Thereafter change oil every 75,000 miles or annually.
- (2) Checking Level - Check at 5,000-mile intervals and maintain level at the bottom of fill plug opening when housing is cold.

NOTE: When a safe level of lubricant in a gear housing is indicated at the time of scheduled lubrication, the lubricant retaining seal is considered functional, even though the seal may indicate questionable leakage. Frequent observation of seal as a potential problem area is recommended. When seepage or leakage of lubricant adversely affects the proper function of parts within the area (e.g., brakes), the retaining seal must be replaced.

- (3) The following capacities should be used as a guide only. Do not overfill:

M915A2 Rear Tandem

Fill forward-rear with 13 quarts; rear-rear with 14.5 quarts. Change filter at each oil change.

M916A1 Rear Tandem

Fill forward-rear with 22 quarts; rear-rear with 23 quarts.

M916A1 Front Driving

Fill with 13.5 quarts.

- (4) Drain and Fill Plug Installation - Tighten plug until one thread is visible at housing surface. If less than one thread is visible, replace plug.

### b. Transmission

The oil should be warm when draining. Remove the drain plug and allow the oil to drain completely. If AOAP support is not available, change oil every 20,000 miles.

- (1) Cold Oil Check (COLD RUN band) - Run the engine for 1 minute at 1000 rpm to charge the system. Idle the engine until the temperature reaches 60°-120°F (16°-49°C). With the engine idling and the transmission in neutral, remove the dipstick from the oil filler tube and check the oil level. Oil registering in the COLD RUN band indicates a sufficient quantity of oil to safely operate the transmission until the temperature reaches 160°-200° F (71°-93°C). When the temperature is 160°-200° F (71°-93°C), a hot oil check must be made.

(2) Hot Oil Check (HOT RUN band) - Be sure the temperature has reached 160°-200 F (71°-93°C). With the engine idling and the transmission in neutral, remove the dipstick from the oil filler tube and check the oil level. If the oil level registers in the HOT RUN band, the quantity of oil in the transmission is safe for operating the vehicle. If it registers on or below the bottom line of the HOT RUN band, add the required amount of oil necessary to bring the oil level to the middle of the HOT RUN band. Approximately 1 quart (0.95 liter) of oil is required to move the oil level from the bottom line of the HOT RUN band to the middle of the HOT RUN band.

(3) Transmission oil must be sampled every 90 days as prescribed by DA Pam 738-750.

Check breather weekly and clean every 20,000 miles. Fill through dipstick tube, with 33 quarts of oil. (Refer to TM 9-2320-363-20 for procedure). Maintain oil level between ADD and FULL marks on dipstick with engine at idle and transmission in neutral. Do not overfill.

c. External filter should be changed when:

- (1) The vehicle has accumulated its first 5,000 miles, and
- (2) The filter is known to be contaminated or clogged, or
- (3) Service is recommended by AOAP laboratory analysis, or
- (4) At 20,000-mile/annual intervals.

d. Transfer Case (M916A1)

Drain oil at operating temperature every 10,000 miles. Maintain oil level to bottom edge of fill port. Do not overfill. Capacity is 5 quarts (4.7 liters).

## 7. CRANKCASE

- a. Check oil level daily. To check engine oil level, wait at least 10 minutes after stopping to allow oil to drain into crankcase. Safe operating level is between ADD and FULL marks on dipstick. Engine capacity is 41 quarts with all filters.
- b. Engine oil must be sampled every 90 days as prescribed by DA Pam 738-750.
- c. Oil filters shall be changed when:
  - (1) They are known to be contaminated, or
  - (2) Service is recommended by the AOAP laboratory.
- d. If AOAP lab support is not available, change engine oil every 20,000 miles/annually, whichever comes first.

## 8. BRAKES

a. Front and Rear Slack Adjusters

M915A2 and M916A1 - Every 5,000 miles or semiannually wipe fittings clean and pump grease into fittings until new grease is seen flowing from pressure relief valve in the pawl capscrew.

b. Front and Rear Axle Camshaft Bushings

M915A2 and M916A1 - Lubricate fittings every 20,000 miles or semiannually.

9. PINTLE HOOK (M915A2/M916A1)

Lubricate all fittings every 5,000 miles or semiannually with GAA. Clean and lube other parts with an authorized solvent and OE/H DO.

10. FIFTH WHEEL (M915A2/M916A1)

Every 5,000 miles or weekly apply GAA to top plate and latch and all lubrication fittings. Clean and lube moving parts on underside with authorized solvent and OE/HDO and grease top plate and latch as required.

11. WINCH (M916A1)

a. Hydraulic Reservoir - Check level prior to operating winch. Change oil any time the oil becomes contaminated with water (milky appearance) or metallic particles due to circuit component failure. Remove and clean or replace inlet strainer and replace return filter element in conjunction with fluid change. If oil is found not contaminated during required interval inspection because winch was not used, retain oil but replace filter.

b. Hydraulic oil must be sampled every 90 days as prescribed by DA Pam 738-750.

12. WINCH DRUM (M916A1)

Check and fill semiannually. After initial 5,000 miles of vehicle operation, drain and fill winch drum; thereafter drain and fill annually.

13. WINCH CABLE (M916A1)

Unwind entire cable, clean and oil every 5,000 miles or semiannually. Using a brush, soak cable with clean OE/HDO. Wipe off excess and coat with GAA before rewinding cable on drum. Examine cable after each use. Clean and lubricate as necessary.

14. ARMY OIL ANALYSIS PROGRAM (AOAP) SAMPLING PROCEDURES

The engine oil sampling valve is located on the transmission oil cooler bracket, beside the engine oil dipstick (view A). The transmission oil sampling valve is next to the transmission oil dipstick, just under the exhaust pipe (view Y). The hydraulic winch oil sampling valve is located on the winch filter housing (view Z).

a. Ensure that the oil to be sampled is at its normal operating temperature (TM 9-2320-363-10).

b. Open valve, pump approximately 2 ounces (60 ml) into a suitable container, and discard. This will remove waste impurities.

c. Place sample bottle (TB 43-0210) under valve and fill sample bottle to approximately 1/2 inch (1.3 cm) below neck of bottle. Close valve and check for leaks.

d. Send oil sample to AOAP laboratory. If AOAP laboratory is not available, use hard time intervals.

15. OIL CAN POINTS

Every 5,000 miles lubricate these points using OE/HDO sparingly:

a. Door hinges and latches (view BB).

b. Driver and passenger seat adjusters and sliding tracks (view CC).

c. Spare tire carrier (M915A2 and M916A1) ratchet gear shaft (view DD).

16. DO NOT LUBRICATE

Spring leaves, alternator, starter wiring.

17. FORDING AND HIGH-PRESSURE WASHING

- a. Lubrication after fording. After fordings, lubricate all fittings below fording depth and check submerged gearboxes for presence of water.
- b. Lubrication after high-pressure washing. After a thorough washing, lubricate all grease fittings and oil can points outside and underneath vehicle.

18. COOLANT LEVEL

Check coolant level daily. Coolant must be within 2-1/2 inches below filler neck. Refer to TB 750-651 for testing. Use MIL-A-46153 for temperatures consistently above -40° F (-40°C). Use MIL-A-11755 for temperatures consistently below -40° F (-40°C).

19. MILITARY SYMBOLS FOR LUBRICANTS

The following references are lubrication symbols used within this Lubrication Order to the appropriate specification:

- OE/HDO     Lubricating Oil, internal Combustion Engine Tactical Service, MIL-L-2104
- OEA         Lubricating Oil, Internal Combustion Engine (Arctic), MIL-L-46167
- GO          Lubricating Oil, Gear, Multipurpose, MIL-L-2105
- GAA         Grease, Automotive and Artillery, MIL-G-10924

By Order of the Secretary of the Army:

Official:

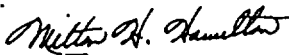

MILTON H. HAMILTON  
*Administrative Assistant to the  
Secretary of the Army*  
00198

GORDON R. SULLIVAN  
*General, United States Army  
Chief of Staff*

Distribution:

To be distributed in accordance with DA Form 12-38-E, (Block 0854), Operator Maintenance Requirements for LO9-2320-363-12.