

# ARMY TB 9-2320-302-13&P-2 AIR FORCE T.O. 36A12-1C-1600-11-2

---

## TECHNICAL BULLETIN

OPERATOR'S, UNIT AND DIRECT SUPPORT  
MAINTENANCE MANUAL, INSTALLATION INSTRUCTIONS, AND  
REPAIR PARTS AND SPECIAL TOOLS LISTS (RPSTL)

FOR

CREW PROTECTION KIT

FOR

TRUCK, TRACTOR, LINE-HAUL:

52,000 GVWR, 6 X 4, M915A3P1

NSN: 2320-01-523-2486

TRUCK, TRACTOR, LINE-HAUL:

52,000 GVWR, 6 X 4, M915A2P1

NSN: 2320-01-523-2482

TRUCK, TRACTOR, LIGHT EQUIPMENT TRANSPORTER (LET):

68,000 GVWR, 6 X 6, W/WINCH, M916A3P1

NSN: 2320-01-531-2636

TRUCK, DUMP, HEAVY, CHASSIS:

68,000 GVWR, 6 X 6, 14 CU YD, ON-OFF HIGHWAY, M917A2P1

NSN: 2320-01-531-2637

TRUCK, TRACTOR, LINE-HAUL:

52,000 GVWR, 6 X 4, M915A4P1

NSN: 2320-01-523-2632

TRUCK, DUMP, HEAVY, CHASSIS:

68,000 GVWR, 6 X 6, 14 CU YD, ON-OFF HIGHWAY, M917A1P1

NSN: 2320-01-531-2632

TRUCK, TRACTOR, LIGHT EQUIPMENT TRANSPORTER (LET):

68,000 GVWR, 6 X 6, W/WINCH, M916A1P1

NSN: 2320-01-531-2629

TRUCK, TRACTOR, LIGHT EQUIPMENT TRANSPORTER (LET):

68,000 GVWR, 6 X 6, W/WINCH, M916A2P1

NSN: 2320-01-531-2634

DISTRIBUTION STATEMENT A - Approved for public release; distribution is unlimited

---

HEADQUARTERS, DEPARTMENTS OF THE ARMY AND AIR FORCE

29 JUNE 2007



## WARNING SUMMARY

This warning summary contains general safety warnings and hazardous materials warnings that must be understood and applied during operation and maintenance of this equipment. Failure to observe these precautions may cause serious injury or death to personnel. Also included are explanations of safety and hazardous materials icons used within this technical bulletin.



CHEMICAL - Drop of liquid on hand shows that the material will cause burns or irritation to human skin or tissue.



EYE PROTECTION - Person with goggles shows that the material will injure the eyes.



FIRE - Flame shows that a material may ignite and cause burns.



FLYING PARTICLES - Arrows bouncing off face with face shield shows that particles flying through the air will harm face.



HEAVY PARTS - Hand with heavy object on top shows that heavy parts can crush and harm.



HEAVY PARTS - Heavy object on human figure shows that heavy parts present a danger to life or limb.



VAPOR - Human figure in a cloud shows that material vapors present a danger to life or health.

NOTE

For information on first aid, refer to FM 4-25.11.

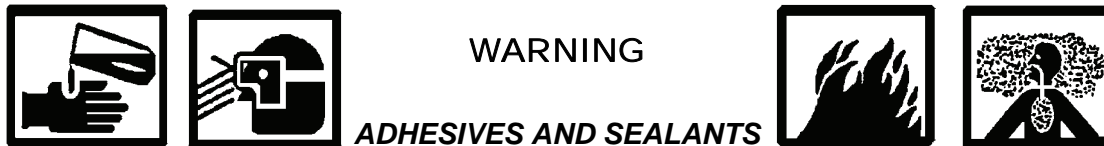

WARNING

**ADHESIVES AND SEALANTS**

Use caution when using adhesives and sealants. Prolonged inhalation of vapors can cause lung irritation. Contact with skin can cause dermatitis. Wear gloves and safety goggles and use product in a well-ventilated area away from open flame. If ingested, keep individual calm and seek medical attention. DO NOT induce vomiting. If contact with skin or eyes is made, flush thoroughly with water. Dispose of cleanup rags IAW local policy and ordinances. Failure to follow this warning may cause injury to personnel.



WARNING

**COMPRESSED AIR**

Particles blown by compressed air are hazardous. DO NOT exceed 15 psi (103 kPa) nozzle pressure when drying parts with compressed air. Use a maximum of 30 psi (207 kPa) when cleaning components. DO NOT direct compressed air against human skin. Make sure air stream is directed away from user and other personnel in the area. To prevent injury, user must wear protective goggles or face shield. Failure to follow this warning may result in injury or death.



WARNING

**DRILLING AND RIVETING**

Eye protection is required when drilling and when using riveter to install rivets. Failure to follow this warning may cause injury to personnel.



WARNING

**HAZARDOUS WASTE**

When servicing this vehicle, performing maintenance or disposing of materials such as engine coolant, hydraulic fluid, lubricants, battery acids or batteries, and CARC paint, consult your unit/local hazardous waste disposal center or safety office for local regulatory guidance. If further information is needed, please contact The Army Environmental Hotline at 1-800-872-3845.



WARNING

**HEAVY COMPONENTS**





## TB 9-2320-302-13&P-2

- Use extreme caution when handling heavy parts. Provide adequate support and use assistance during procedure. Ensure that any lifting device used is in good condition and of suitable load capacity. Keep clear of heavy parts supported only by lifting device. Failure to follow this warning may cause injury or death to personnel.
- Use extreme caution when handling heavy parts. Provide adequate support and use assistance during procedure. Failure to follow this warning may cause injury or death to personnel.
- Cab assembly with armor kit installed weighs 3,520 lb (1598 kg). Use hoist with lifting capacity of 4,000 lb (1816 kg) to support cab assembly. Failure to follow this warning may cause injury or death to personnel.



**WARNING**

**SHARP EDGES**

- Use caution when handling window glass. Glass can break unexpectedly during removal/installation procedure. Wear face shield, apron, and gloves. Failure to follow this warning may cause injury to personnel.
- Edges of metal armor panels may be sharp. Wear protective gloves when handling armor panels. Failure to follow this warning may cause injury to personnel.



**WARNING**

**SOLVENT CLEANING COMPOUND**

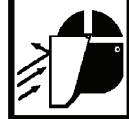

- Solvent cleaning compound MIL-PRF-680 Type III is an environmentally compliant and low toxic material. However, it may be irritating to the eyes and skin. Use protective gloves and goggles. Use in well-ventilated areas. Keep away from open flames and other sources of ignition. Failure to follow this warning may cause injury to personnel.
- Improper cleaning methods and use of unauthorized cleaning solvents may injure personnel and damage equipment. Refer to TM 9-247, *Materials Used for Cleaning, Preserving, Abrading, and Cementing Ordnance Materiels and Related Materiels Including Chemicals*, for correct information.
- Fire extinguishers should be placed nearby when using solvent cleaning compound.
- Cloths or rags saturated with solvent cleaning compound must be disposed of IAW authorized facilities' procedures.
- Eye shields must be worn when cleaning with a wire brush. Flying rust and metal particles may cause injury.

**WARNING**

### **THREAT PROTECTION**

For proper threat protection, ballistic glass must be correctly installed onto ballistic glass frame. During installation, ensure that decal "INSTALL THIS SURFACE TOWARDS THREAT" is located on outside of cab. Improperly installed ballistic glass will not protect occupants. Failure to follow this warning may cause injury or death to personnel.

**WARNING**

***VEHICLE OPERATION***

Due to increased weight with armor kit installed, operator should be aware of differences in vehicle's driving characteristics and adjust driving accordingly. Failure to do so may cause injury or death to personnel.

**WARNING**

***WELDING NOT AUTHORIZED***

To ensure survivability of personnel, welding repairs on armor kit are NOT authorized. If armor plates are damaged, they must be replaced. Failure to follow this warning may cause failure of armor, resulting in injury or death to personnel.

**WARNING**

- The center of gravity is higher on a vehicle with a Crew Protection Kit installed.
- Always use slower speed when operating vehicle.
- DO NOT operate vehicle on steep hills or inclines.
- Failure to follow these warnings may cause injury or death to personnel.

**WARNING**

Visibility is reduced on a vehicle with a armor kit installed. Always use ground guides when maneuvering vehicle near obstacles. Failure to follow this warning may cause injury to personnel or damage to equipment.

**WARNING**

Vehicles with a Crew Protection Kit installed have different door handles and latching hardware. DO NOT allow clothing or equipment to catch on door hardware. Failure to follow this warning may cause injury to personnel.

**WARNING**

DO NOT park vehicle on a hill or incline. The parking brake has a reduced capacity due to the increased weight of vehicle with armor kit installed. Failure to follow this warning may cause injury or death to personnel.

**WARNING**

For proper threat protection, armor must be installed correctly into the armor frame. During installation, ensure that the surface marked "STRIKE FACE" is facing outward towards the threat. Exposing the passive side of the ballistic panel outward makes the armor less effective. Failure to follow this warning may cause injury or death to personnel.

TB 9-2320-302-13&P-2  
T.O. 36A12-1C-1600-11-2

---

Change  
No. 1

HEADQUARTERS  
DEPARTMENTS OF THE ARMY AND AIR FORCE  
WASHINGTON, D.C., 30 NOVEMBER 2007

TECHNICAL BULLETIN

OPERATOR'S, UNIT AND DIRECT SUPPORT  
MAINTENANCE MANUAL, INSTALLATION INSTRUCTIONS, AND  
REPAIR PARTS AND SPECIAL TOOLS LISTS (RPSTL)  
FOR

CREW PROTECTION KIT  
FOR

TRUCK, TRACTOR, LINE-HAUL:

52,000 GVWR, 6 X 4, M915A3P1

NSN: 2320-01-523-2486

TRUCK, TRACTOR, LINE-HAUL:

52,000 GVWR, 6 X 4, M915A2P1

NSN: 2320-01-523-2482

TRUCK, TRACTOR, LIGHT EQUIPMENT TRANSPORTER (LET):

68,000 GVWR, 6 X 6, W/WINCH, M916A3P1

NSN: 2320-01-531-2636

TRUCK, DUMP, HEAVY, CHASSIS:

68,000 GVWR, 6 X 6, 14 CU YD, ON-OFF HIGHWAY, M917A2P1

NSN: 2320-01-531-2637

TRUCK, TRACTOR, LINE-HAUL:

52,000 GVWR, 6 X 4, M915A4P1

NSN: 2320-01-523-2484

TRUCK, DUMP, HEAVY, CHASSIS:

68,000 GVWR, 6 X 6, 14 CU YD, ON-OFF HIGHWAY, M917A1P1

NSN: 2320-01-531-2632

TRUCK, TRACTOR, LIGHT EQUIPMENT TRANSPORTER (LET):

68,000 GVWR, 6 X 6, W/WINCH, M916A1P1

NSN: 2320-01-531-2629

TRUCK, TRACTOR, LIGHT EQUIPMENT TRANSPORTER (LET):

68,000 GVWR, 6 X 6, W/WINCH, M916A2P1

NSN: 2320-01-531-2634

**DISTRIBUTION STATEMENT A** - Approved for public release; distribution is unlimited.

TB 9-2320-302-13&P-2, 29 June 2007, is updated as follows:

1. File this sheet in front of manual for reference.
2. This change is a result of expanding technical bulletin to joint service use.
3. New or updated text is indicated by a vertical bar in outer margin of the page.
4. Remove old pages and insert new pages as indicated below:

**Remove Pages**

A/B Blank

i-vi

----

----

Cover

**Insert Pages**

A/B Blank

i-vi

DA Form 2028 sample

DA Form 2028 (2 copies)

Cover

**ARMY TB 9-2320-302-13&P-2**  
**AIR FORCE T.O. 36A12-1C-1600-11-2**  
**C1**

By Order of the Secretary of the Army:

GEORGE W. CASEY, JR.  
*General, United States Army*  
*Chief of Staff*

Official:



JOYCE E. MORROW  
*Administrative Assistant to the*  
*Secretary of the Army*  
0731102

JOHN P. JUMPER  
*General, United States Air Force*  
*Chief of Staff*

Official:

GREGORY S. MARTIN  
*General, United States Air Force*  
*Commander, Air Force Materiel Command*

Distribution:

To be distributed in accordance with the initial distribution number (IDN) 344848,  
requirements for TB 9-2320-302-13&P-2

## LIST OF EFFECTIVE PAGES/WORK PACKAGES

Date of issue for original Technical Bulletin is:

Original . . . . . 29 June 2007

Change No. 1 . . .30 November 2007

Total number of pages for front and rear matter is **26** and total number of work packages is 42 consisting of the following:

<b>Page/WP No.</b>	<b>*Change No.</b>	<b>Page/WP No.</b>	<b>*Change No.</b>
Front Cover	1	WP 0027 00 (4 pp.)	0
a—d	0	WP 0028 00 (6 pp.)	0
A/(B Blank)	1	WP 0029 00 (6 pp.)	0
i—vi	1	WP 0030 00 (10 pp.)	0
Ch. 1 title page	0	WP 0031 00 (8 pp.)	0
WP 0001 00 (4 pp.)	0	WP 0032 00 (4 pp.)	0
WP 0002 00 (2 pp.)	0	Ch. 5 title page	0
WP 0003 00 (4 pp.)	0	WP 0033 00 (2 pp.)	0
Ch. 2 title page	0	WP 0034 00 (4 pp.)	0
WP 0004 00 (2 pp.)	0	WP 0035 00 (4 pp.)	0
WP 0005 00 (2 pp.)	0	WP 0036 00 (4 pp.)	0
WP 0006 00 (4 pp.)	0	WP 0037 00 (4 pp.)	0
WP 0007 00 (2 pp.)	0	WP 0038 00 (80 pp.)	0
Ch. 3 title page	0	WP 0039 00 (20 pp.)	0
WP 0008 00 (4 pp.)	0	WP 0040 00 (14 pp.)	0
WP 0009 00 (14 pp.)	0	WP 0041 00 (7 pp.)	0
WP 0010 00 (2 pp.)	0	WP 0042 00(15 pp.)	0
Ch. 4 title page	0	Index 1—Index 4	0
WP 0011 00 (6 pp.)	0	Back Cover	0
WP 0012 00 (6 pp.)	0		
WP 0013 00 (4 pp.)	0		
WP 0014 00 (2 pp.)	0		
WP 0015 00 (2 pp.)	0		
WP 0016 00 (4 pp.)	0		
WP 0017 00 (18 pp.)	0		
WP 0018 00 (6 pp.)	0		
WP 0019 00 (4 pp.)	0		
WP 0020 00 (2 pp.)	0		
WP 0021 00 (2 pp.)	0		
WP 0022 00 (6 pp.)	0		
WP 0023 00 (8 pp.)	0		
WP 0024 00 (4 pp.)	0		
WP 0025 00 (8 pp.)	0		
WP 0026 00 (8 pp.)	0		



TECHNICAL BULLETIN  
TB 9-2320-302-13&P-2

HEADQUARTERS  
DEPARTMENTS OF THE ARMY AND AIR FORCE  
WASHINGTON, D.C.  
29 June 2007

**TECHNICAL BULLETIN**

**OPERATOR'S, UNIT AND DIRECT SUPPORT  
MAINTENANCE MANUAL, INSTALLATION INSTRUCTIONS, AND  
REPAIR PARTS AND SPECIAL TOOLS LISTS (RPSTL)  
FOR  
CREW PROTECTION KIT**

**FOR**

**TRUCK, TRACTOR, LINE-HAUL:**

**52,000 GVWR, 6 X 4, M915A3P1**

**NSN: 2320-01-523-2486**

**TRUCK, TRACTOR, LINE-HAUL:**

**52,000 GVWR, 6 X 4, M915A2P1**

**NSN: 2320-01-523-2482**

**TRUCK, TRACTOR, LIGHT EQUIPMENT TRANSPORTER (LET):**

**68,000 GVWR, 6 X 6, W/WINCH, M916A3P1**

**NSN: 2320-01-531-2636**

**TRUCK, DUMP, HEAVY, CHASSIS:**

**68,000 GVWR, 6 X 6, 14 CU YD, ON-OFF HIGHWAY, M917A2P1**

**NSN: 2320-01-531-2637**

**TRUCK, TRACTOR, LINE-HAUL:**

**52,000 GVWR, 6 X 4, M915A4P1**

**NSN: 2320-01-523-2484**

**TRUCK, DUMP, HEAVY, CHASSIS:**

**68,000 GVWR, 6 X 6, 14 CU YD, ON-OFF HIGHWAY, M917A1P1**

**NSN: 2320-01-531-2632**

**TRUCK, TRACTOR, LIGHT EQUIPMENT TRANSPORTER (LET):**

**68,000 GVWR, 6 X 6, W/WINCH, M916A1P1**

**NSN: 2320-01-531-2629**

**TRUCK, TRACTOR, LIGHT EQUIPMENT TRANSPORTER (LET):**

**68,000 GVWR, 6 X 6, W/WINCH, M916A2P1**

**NSN: 2320-01-531-2634**

**REPORTING ERRORS AND RECOMMENDING IMPROVEMENTS**

You can help improve this publication. If you find any mistakes or if you know of a way to improve the procedures, please let us know. Submit your DA Form 2028 (*Recommended Changes to Equipment Technical Publications*), through the Internet, on the Army Electronic Product Support (AEPS) website. The Internet address is <https://aeps.ria.army.mil/>. The DA Form 2028 is located under the Public Applications section in the AEPS Public Home Page. Fill out the form and click on SUBMIT. Using this form on the AEPS will enable us to respond quicker to your comments and better manage the DA Form 2028 program. You may also mail, fax or e-mail your letter or DA Form 2028 directly to: AMSTA-LC-LMPP/TECH PUBS, TACOM-RI, 1 Rock Island Arsenal, Rock Island, IL 61299-7630. The e-mail address is: ROCK-TACOM-TECH-PUBS@conus.army.mil. The fax number is DSN 793-0726 or Commercial (309) 782-0726.

**DISTRIBUTION STATEMENT A** - Approved for public release; distribution is unlimited.

# Table of Contents

	<b>Page Number</b>
<b>CHAPTER 1 GENERAL INFORMATION, EQUIPMENT DESCRIPTION AND DATA, AND THEORY OF OPERATION</b>	
WP 0001 00 General Information . . . . .	0001 00-1
WP 0002 00 Equipment Description and Data. . . . .	0002 00-1
WP 0003 00 Theory of Operation . . . . .	0003 00-1
<b>CHAPTER 2 OPERATOR INSTRUCTIONS</b>	
WP 0004 00 Description and Use of Operator Controls . . . . .	0004 00-1
WP 0005 00 Operation Under Usual Conditions . . . . .	0005 00-1
WP 0006 00 Operation Under Unusual Conditions . . . . .	0006 00-1
WP 0007 00 Stowage and Decal/Data Plate Guide . . . . .	0007 00-1
<b>CHAPTER 3 OPERATOR MAINTENANCE INSTRUCTIONS</b>	
WP 0008 00 Operator Preventive Maintenance Checks and Services (PMCS) Introduction .	0008 00-1
WP 0009 00 Operator Preventive Maintenance Checks and Services (PMCS). . . . .	0009 00-1
WP 0010 00 Cleaning Ballistic Glass . . . . .	0010 00-1
<b>CHAPTER 4 UNIT MAINTENANCE INSTRUCTIONS</b>	
WP 0011 00 General Maintenance Instructions. . . . .	0011 00-1
WP 0012 00 Door and Frame Assembly Replacement . . . . .	0012 00-1
WP 0013 00 Door Handle Replacement . . . . .	0013 00-1
WP 0014 00 Door Cam Latch Replacement . . . . .	0014 00-1
WP 0015 00 Door Cam Latch Adjustment. . . . .	0015 00-1
WP 0016 00 Door Ballistic Glass and Frame Assembly Replacement . . . . .	0016 00-1
WP 0017 00 Underbody Mine Blast Panel Replacement. . . . .	0017 00-1
WP 0018 00 Rear Cab Armor Replacement. . . . .	0018 00-1
WP 0019 00 Emergency Egress Replacement . . . . .	0019 00-1
WP 0020 00 Plexiglass window replacement . . . . .	0020 00-1
WP 0021 00 Stowage Box Adapter Frame Replacement. . . . .	0021 00-1
WP 0022 00 Left B-Pillar Armor Replacement. . . . .	0022 00-1
WP 0023 00 Right B-Pillar Armor Replacement. . . . .	0023 00-1
WP 0024 00 A-Pillar Armor Replacement. . . . .	0024 00-1
WP 0025 00 Left Wheel Well Blast Deflector Replacement. . . . .	0025 00-1
WP 0026 00 Right Wheel Well Blast Deflector Replacement. . . . .	0026 00-1
WP 0027 00 Left Firewall Armor Replacement. . . . .	0027 00-1
WP 0028 00 Right Firewall Armor Replacement . . . . .	0028 00-1
WP 0029 00 Center Firewall Armor Replacement. . . . .	0029 00-1
WP 0030 00 Windshield Ballistic Glass Replacement. . . . .	0030 00-1
WP 0031 00 Roof Armor Replacement . . . . .	0031 00-1
WP 0032 00 Cowl Armor Replacement. . . . .	0032 00-1
<b>CHAPTER 5 SUPPORTING INFORMATION</b>	
WP 0033 00 References . . . . .	0033 00-1
WP 0034 00 Maintenance Allocation Chart (MAC) Introduction . . . . .	0034 00-1
WP 0035 00 Maintenance Allocation Chart (MAC) . . . . .	0035 00-1
WP 0036 00 Expendable and Durable Items List . . . . .	0036 00-1
WP 0037 00 Torque Limits . . . . .	0037 00-1
WP 0038 00 Crew Protection Kit Installation Instructions . . . . .	0038 00-1



## Table of Contents - Continued

	<b>Page Number</b>
WP 0039 00 M915 Upgrade Armor Kit Installation Instructions .....	0039 00-1
WP 0040 00 Emergency Egress Installation Instructions V2.0 .....	0040 00-1
WP 0041 00 Repair Parts and Special Tools Lists (RPSTL) Introduction. ....	0041 00-1
WP 0042 00 Repair Parts and Special Tools Lists (RPSTL) .....	0042 00-1
<b>GROUP 33 SPECIAL PURPOSE KITS</b>	
3307 - SPECIAL PURPOSE KITS .....	1-1
DOOR SUPPORT FRAMES.....	1 1-1
UNDERBODY MINEBLAST PANELS .....	2 2-1
ARMORED DOORS AND DOOR CAM LATCH.....	3 3-1
REAR CAB ARMOR AND WINDOW .....	4 4-1
B-PILLAR ARMOR.....	5 5-1
LOWER A-PILLAR ARMOR .....	6 6-1
FIREWALL ARMOR.....	7 7-1
BALLISTIC WINDSHIELD AND SURROUNDING ARMOR.....	8 8-1
ROOF ARMOR .....	9 9-1
FRONT COWL ARMOR .....	10 10-1
WHEEL WELL BLAST DEFLECTORS AND HOOD SUPPORT BRACKETS.....	11 11-1
REAR STOWAGE BOX ADAPTER FRAME.....	12 12-1
HOOD LATCH STRAP MOUNTING .....	13 13-1
EXHAUST STACK BRACKETS AND MOUNTING .....	14 14-1
 NATIONAL STOCK NUMBER INDEX .....	 I-1
PART NUMBER INDEX.....	I-3
 Index .....	 Index-1

# HOW TO USE THIS TECHNICAL BULLETIN

## NOTE

If at any time you are unsure how to use this bulletin or you cannot locate the information you need, notify your supervisor.

### INTRODUCTION

1. This bulletin is designed to help you operate and maintain the M915A3P1, M916A2P1, M916A3P1, M917A2P1, M915A4P1, M917A1P1, M916A1P1, and M916A2P1 Crew Protection Kit. It also provides installation instructions for the Crew Protection Kit and the Repair Parts and Special Tools Lists (RPSTL).
2. This bulletin is written in work package format:
  - a. Chapters divide the bulletin into major categories of information (e.g., *General Information, Equipment Description and Data, and Theory of Operation; Operator Instructions; Operator Maintenance Instructions; Unit Maintenance Instructions; and Supporting Information*).
  - b. Each Chapter is divided into work packages, which are identified by a 6-digit number (e.g., 0001 00, 0002 00) located on the upper right-hand corner of each page. The work package page number (e.g., 0001 00-1, 0001 00-2) is located centered at the bottom of each page.
  - c. If a Change Package is issued to this bulletin, added work packages use the 5<sup>th</sup> and 6<sup>th</sup> digits of their number to indicate new material. For instance, work packages inserted between WP 0001 00 and WP 0002 00 are numbered WP 0001 01, WP 0001 02, etc.
3. Read through this bulletin to become familiar with its organization and contents before attempting to operate or maintain the armor kit.

### CONTENTS OF THIS BULLETIN

1. A *Warning Summary* is located at the beginning of this bulletin. Become familiar with these warnings before operating or performing maintenance on the armor kit.
2. A *Table of Contents*, located in the front of the bulletin, lists all chapters and work packages in the publication.
  - a. The Table of Contents also provides *Reporting Errors and Recommending Improvements* information and DA Form 2028 addresses, for the submittal of corrections to this bulletin.
  - b. If you cannot find what you are looking for in the Table of Contents, refer to the alphabetical *Index* at the back of the bulletin.
3. Chapter 1, *General Information, Equipment Description and Data, and Theory of Operation*, provides general information on the bulletin and the armor kit.
4. Chapter 2, *Operator Instructions*, explains and illustrates all operator procedures for the armor kit: *Operation Under Usual Conditions* and *Operation Under Unusual Conditions*.
5. Chapter 3 deals with *Operator Maintenance Instructions*. This chapter includes *Operator Preventive Maintenance Checks and Services (PMCS) Introduction* and *Operator Preventive Maintenance Checks and Services (PMCS)*.
6. Chapter 4 includes all maintenance tasks related to *Unit Maintenance Instructions*.
7. Chapter 5 includes *Supporting Information: References; Maintenance Allocation Chart (MAC) Introduction; Maintenance Allocation Chart (MAC); Expendable and Durable Items List; Tool Identification List; Torque Limits; Crew Protection Kit Installation Instructions; Repair Parts and Special Tools Lists (RPSTL) Introduction; and Repair Parts and Special Tools Lists (RPSTL)*.

### **FEATURES OF THIS BULLETIN**

1. WARNINGS, CAUTIONS, NOTES, subject headings, and other important information are highlighted in **BOLD** print as a visual aid.

### **WARNING**

A WARNING indicates a hazard which may cause injury or death to personnel.

### **CAUTION**

A CAUTION is a reminder of safety practices or directs attention to usage practices that may cause damage to equipment.

### **NOTE**

A NOTE is a statement containing information that will make the procedures easier to perform.

2. Statements and words of particular interest may be printed in CAPITAL LETTERS to create emphasis.
3. Within a procedural step, reference may be made to another work package in this bulletin or to another bulletin. These references indicate where you should look for more complete information.
  - a. If you are told: "Refer to *Crew Protection Kit Installation Instructions* (WP 0038 00)", go to WP 0038 00 in this bulletin for instructions on this procedure.
  - b. If you are told: "For complete information on M915A3 Operator PMCS, refer to TM 9-2320-302-10, go to *References* in WP 0033 00 for complete information on the cited reference.
4. Illustrations are placed after, and as close to, the procedural steps to which they apply. Callouts placed on the art are text or numbers.
5. Numbers located at lower right corner of art (e.g., 440-001; 440-002) are art control numbers and are used for tracking purposes only.
6. Technical instructions include metric units as well as standard units. For your reference, a *Metric Conversion Chart* is located on the inside back cover of the bulletin.



**CHAPTER 1**  
**GENERAL INFORMATION, EQUIPMENT**  
**DESCRIPTION AND DATA, AND THEORY OF OPERATION**



**SCOPE**

This technical bulletin is for your use in operating and performing Operator, Unit, and Direct Support Maintenance on the Crew Protection Kit installed on:

Truck, Tractor, M915A3P1, Line-Haul

Truck, Tractor, M915A2P1, Line-Haul

Truck, Tractor, M916A3P1, Light Equipment Transporter (LET)

Truck, Dump, M917A2P1, Heavy, Chassis

Truck, Tractor, M915A4P1, Line-Haul

Truck, Dump, M917A1P1, Heavy, Chassis

Truck, Tractor, M916A1P1, Light Equipment Transporter (LET)

Truck, Tractor, M916A2P1, and Light Equipment Transporter (LET)

This technical bulletin also covers armor kit installation instructions and the Repair Parts and Special Tools Lists (RPSTL) for the armor kit.

**MAINTENANCE FORMS, RECORDS, AND REPORTS**

Department of the Army forms and procedures used for the equipment will be those prescribed by DA PAM 750-8, *Functional Users Manual for The Army Maintenance Management System (TAMMS)*, as contained in the Maintenance Management Update.

**REPORTING EQUIPMENT IMPROVEMENT RECOMMENDATIONS (EIR)**

If your armor kit needs improvement, let us know. Send us an EIR. You, the user, are the only one who can tell us what you don't like about your equipment. Let us know why you don't like the design or performance. If you have Internet access, the easiest and fastest way to report problems or suggestions is to go to <https://aeps.ria.army.mil/aepspublic.cfm> (scroll down and choose the "Submit Quality Deficiency Report" bar). The Internet form lets you choose to submit an Equipment Improvement Recommendation (EIR), or a Product Quality Deficiency Report (PQDR). You may also submit your information using an SF Form 368 (*Product Quality Deficiency Report*). You can send your SF Form 368 via e-mail, regular mail, or facsimile using the addresses/facsimile numbers specified in DA PAM 750-8, *Functional Users Manual for The Army Maintenance Management System (TAMMS)*. We will send you a reply.

**CORROSION PREVENTION AND CONTROL (CPC)**

1. Corrosion Prevention and Control (CPC) of Army materiel is a continuing concern. It is important that any corrosion problems with this item be reported so that the problem can be corrected and improvements can be made to prevent the problem in future items.
2. While corrosion is typically associated with rusting of metals, it can also include deterioration of other materials, such as rubber and plastic. Unusual cracking, softening, swelling, or breaking of these materials may be a corrosion problem. If a corrosion problem is identified, it can be reported using SF Form 368 (*Product Quality Deficiency Report*). Use of key words such as "corrosion," "rust," "deterioration," or "cracking" will ensure that the information is identified as a CPC problem. The form should be submitted to the address specified in DA PAM 750-8.

**DESTRUCTION OF ARMY MATERIEL TO PREVENT ENEMY USE**

For destruction of Army material to prevent enemy use, refer to TM 750-244-6.

**PREPARATION FOR STORAGE OR SHIPMENT**

**Refer to TM 9-2320-302-20-1 for the Following Vehicles:**

- Truck, Tractor, M915A3P1, Line-Haul
- Truck, Tractor, M916A3P1, Light Equipment Transporter (LET)
- Truck, Dump, M917A2P1, Heavy, Chassis

**Refer to TM 9-2320-303-24-1 for the Following Vehicles:**

- Truck, Tractor, M915A4P1, Line-Haul

**Refer to TM 9-2320-363-20-1 for the Following Vehicles:**

- Truck, Tractor, M915A2P1, Line-Haul
- Truck, Tractor, M916A1P1, Light Equipment Transporter (LET)
- Truck, Tractor, M916A2P1, and Light Equipment Transporter (LET)
- Truck, Dump, M917A1P1, Heavy, Chassis

**LIST OF ABBREVIATIONS/ACRONYMS**

**NOTE**

Refer to ASME Y14.38-1999 for standard abbreviations.

<b>ABBREVIATION/ACRONYMS</b>	<b>DEFINITION</b>
cm	Centimeter
CAGEC	Commercial and Government Entity Code
CPK	Crew Protection Kit
CU YD.	Cubic Yard
EMP.	Electromagnetic Pulse
ft	Feet
gal.	Gallon
HCI	Hardness Critical Item
IAW	In Accordance With
in.	Inch
kg	Kilogram
kPa.	Kilopascals
L	Liter
LET	Light Equipment Transporter
lb	Pound
lb-ft	Pound Foot
lb-in.	Pound Inch
MAC	Maintenance Allocation Chart
mm.	Millimeter
MWO.	Modification Work Order



**LIST OF ABBREVIATIONS/ACRONYMS - CONTINUED**

<b>ABBREVIATION/ACRONYMS</b>	<b>DEFINITION</b>
NHA	Next Higher Assembly
NIIN	National Item Identification Number
Nm	Newton Meter
NSN	National Stock Number
PMCS	Preventive Maintenance Checks and Services
psi	Pounds Per Square Inch
P/N	Part Number
RPSTL	Repair Parts and Special Tools List
SMR	Source, Maintenance, and Recoverability
SRA	Specialized Repair Activity
TAMMS	Functional Users Manual for the Army Maintenance Management System
TB	Technical Bulletin
TMDE	Test, Measurement, and Diagnostic Equipment
U/M	Unit of Measure
UOC	Usable On Code
UUT	Unit Under Test

**QUALITY OF MATERIAL**

Material used for replacement, repair or modification of the Crew Protection Kit must meet the requirements of this technical bulletin. If quality of material requirements are not stated in this technical bulletin, the material must meet the requirements of the drawings, standards, specifications, or approved engineering change proposals applicable to the Crew Protection Kit.

**SAFETY, CARE, AND HANDLING**

Follow procedures, warnings, and cautions as written in this technical bulletin.

**END OF WORK PACKAGE**



***EQUIPMENT CHARACTERISTICS, CAPABILITIES, AND FEATURES***

1. The Crew Protection Kit provides improved protection for the following vehicles:
  - a. Truck, Tractor, M915A3P1, Line-Haul;
  - b. Truck, Tractor, M915A2P1, Line-Haul;
  - c. Truck, Tractor, M916A3P1, Light Equipment Transporter (LET);
  - d. Truck, Dump, M917A2P1, Heavy, Chassis;
  - e. Truck, Tractor, M915A4P1, Line-Haul;
  - f. Truck, Dump, M917A1P1, Heavy, Chassis;
  - g. Truck, Tractor, M916A1P1, Light Equipment Transporter (LET); and
  - h. Truck, Tractor, M916A2P1, Light Equipment Transporter (LET).
2. The Crew Protection Kit consists of the following:
  - a. Underbody mine blast, firewall, and wheel well blast deflector armor;
  - b. Front cowl, rear cab, emergency egress, right and left A-pillar, right and left B-pillar, and roof armor panels;
  - c. Door armor assemblies; and
  - d. Ballistic glass for windshield.

**LOCATION AND DESCRIPTION OF MAJOR COMPONENTS**

The illustration below shows major armor kit components and their location in relation to the cab.

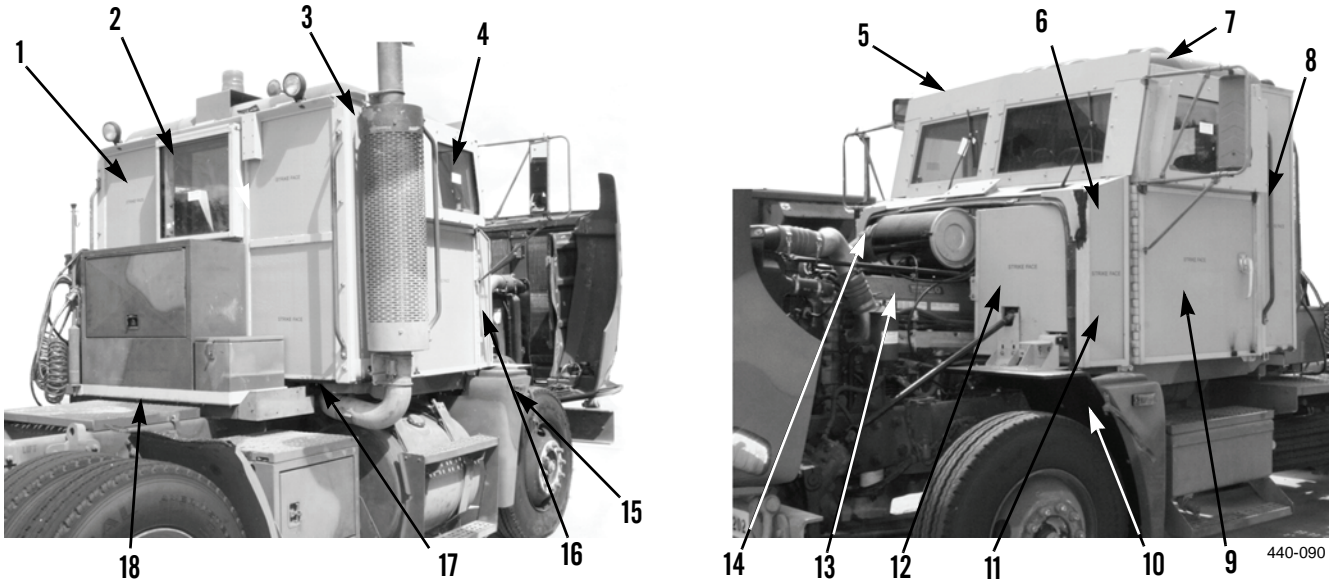

KEY	COMPONENT
1	Rear Cab Armor
2	Emergency Egress
3	Right B-Pillar Armor
4	Right Door Armor and Frame Assembly
5	Windshield Frame and Windshield Ballistic Glass
6	Front Cowl Armor
7	Roof Armor
8	Left B-Pillar Armor
9	Left Door Armor and Frame Assembly
10	Left Wheel Well Blast Deflector
11	Left A-Pillar Armor
12	Left Firewall Armor
13	Center Firewall Armor
14	Right Firewall Armor
15	Right Wheel Well Blast Deflector
16	Right A-Pillar Armor
17	Underbody Mine Blast Panels
18	Rear Stowage Box Adapter Frame

END OF WORK PACKAGE

**GENERAL**

The Crew Protection Kit consists of two armored doors, roof armor, windshield ballistic glass, underbody mine blast armor, firewall armor, front cowl armor, rear cab armor panels, emergency egress, two A-pillar armor panels, two B-pillar armor panels, and two wheel well blast deflectors.

Side armor assembly consists of two door frames and doors, A-pillar armor, and B-pillar armor. Door frames are mounted to existing door frame and bolted in place. Armored door assembly (which incorporates ballistic glass) is hung using a hinge pin to hold it to frame assembly. Remaining components of the side armor consists of the lower A-pillar armor in the front and B-pillar armor in the rear. The A- and B-pillar armor are bolted to the door frame.

There are three underbody mine blast panels that are attached to each other using two stud plates. The underbody mine blast panels are attached under the cab with six mounting brackets. Mounting brackets are mounted under the cab and attached to the floor using grade 8 bolts.

Rear armor frame is bolted at top and bottom to rear of truck cab. Studs on rear of B-pillar armor support the sides of rear armor frame. Five rear armor plates and emergency egress frame are inserted into the rear armor frame. Emergency egress can be operated from inside or outside the vehicle to provide emergency escape.

The roof armor is located inside the vehicle cab. Roof armor is supported by the roof armor frame which is attached to brackets at the door frames and upper bolts of the rear armor. The three main roof armor panels are supported by two dividers.

Front armor consists of the windshield ballistic glass and front cowl armor. Remaining armor panels are fastened to the vehicle using attachment brackets and grade 8 fasteners.

## THEORY OF OPERATION - CONTINUED

0003 00

**GENERAL - CONTINUED**

The M915A2, M915A3, and M915A4 with an armor kit installed has an upgraded suspension. The following tables list the parts replaced with the upgrade. Use original Technical Manuals when servicing the suspension on these vehicles. Refer to Table 1 for M915A2 part information, refer to Table 2 for M915A3 part information, and refer to Table 3 for M915A4 part information.

**Table 1. M915A2 Front Suspension Kit (Part Number: 57K4954)**  
**TM Reference - TM 9-2320-363-20.**

QTY	PART NUMBER	NSN	PART DESCRIPTION
2	A16-11814-001	2510-01-537-5820	14,000 lb Flat Leaf Suspension Spring, 4 in.
4	11-09624-095	5306-01-327-6409	U Bolt-Suspension, 7/8-14 x 9.5 in. long
8	16-09040-002	2510-01-326-9147	Wear Plate-Spring Pin, Shackle
2	16-11905-xxx		Spacer, Axle Stop to Spring, 1.25 x 4.0 x 6.0 in.
6	16-12373-000	3040-01-327-0143	Pin-Spring
8	23-00461-007	5310-01-343-1030	Nut-Hex, 7/8-14 in.
24	23-09114-003	5310-00-767-9425	Washer-Hardened, 1/2 in. nominal ID
8	23-09114-005	5310-00-584-7796	Washer-Hardened, 7/8 in. nominal ID
8	23-09114-009	5310-01-329-7043	Washer-Hardened, 1 1/8 in. nominal ID, 1.25 in.
8	23-09440-250	5305-00-616-6375	Screw-Cap, Hex, 1/2-13 x 2.5 in. long, Grade 8
8	23-09440-325	5305-01-139-7071	Screw-Cap, Hex, 1/2-13 x 3.25 in. long, Grade 8
16	23-09860-012		Washer-Flat, 1.25 x 1.88 x 0.031 in.
8	23-13175-108		Nut-Hex, 1/2-13 in.
6	23-13275-000		Fitting, Lubrication, 90 degree Elbow
2	16-13363-011	5365-01-356-8951	Shim-Axle, 3.0 degree, 4.0 in.
2	23-09271-138	5315-01-327-5977	Pin-Dowel, .75 in. OD x 1.38 in. long
1	1-4854		Data Plate
1	M915A2		14K Suspension Installation Instructions

## GENERAL - CONTINUED

**Table 2. M915A3 Front Suspension Kit (Part Number: 57K4955)**  
**TM Reference - TM 9-2320-302-20.**

QTY	PART NUMBER	NSN	PART DESCRIPTION
NA	620-C03409		GVG-FR 14.6K SUSP
2	A16-12614-001	2510-01-533-2169	Spring-14.6K TPR,4,USF,GBRZ
REF	D16-16555-001		Instruction-Suspension, 14.6K, FRT, M915 LHS
2	11-09624-100	5306-01-327-5536	U Bolt-Suspension, 7/8-14 in., 494, 10.00 in.
2	11-09624-095	5306-01-327-6409	U Bolt-Suspension, 7/8-14 in., 494, 9.50 in.
1	16-10386-003	5365-01-329-1141	Spacer-Axle,1.00 in., 575 x 400, 766OD
1	16-10386-004		Spacer-Axle,1.25 in., 575 x 400, 766OD
1	23-09271-238	5315-01-502-8292	Pin-Dowel,.75 in. OD x 2.38 in. long
1	23-09271-262	3120-01-481-3166	Pin-Dowel,.75 in. OD x 2.62 in. long
8	23-09440-325	5305-01-139-7071	Screw-Cap, Hex 1/2-13 x 3.25 in. Grade 8PO
8	23-09114-005	5310-00-584-7796	Washer-Hardened, 7/8 in. nominal ID
8	23-00461-007	5310-01-343-1030	Nut-Hex, 7/8-14 in.
24	23-09114-003	5310-00-767-9425	Washer-Hardened, 1/2 in. nominal ID
12	23-13175-108		Nut-Hex, 1/2-13 in.
16	23-09860-012		Washer-Flat, 1.25 x 1.88 x 0.031 in.
8	16-09040-002	2510-01-326-9147	Wear Plate-Spring Pin, Shackle
6	16-12373-000	3040-01-327-0143	Pin-Spring
6	23-13275-000		Fitting, Lubrication, 90 degree Elbow
2	16-13363-011	5365-01-356-8951	Shim-Axle, 3.0 degree, 4.0 in.
8	23-09114-009	5310-01-329-7043	Washer-Hardened,1 1/8 in. nominal ID, 1.25 in. actual ID
4	23-09440-400		Screw-Cap, Hex, 1/2-13 x 4.0 in. long, Grade 8
1	1-4855		Data Plate
1	M915A3		14K Suspension Installation Instructions

## GENERAL - CONTINUED

**Table 3. M915A4 Front Suspension Kit (Part Number: 57K4956)**  
**TM Reference -TM 9-2320-303-24.**

QTY	PART NUMBER	NSN	PART DESCRIPTION
2	A16-11814-001	2510-01-537-5820	14,000 lb Flat Leaf Suspension Spring, 4 in.
4	11-09624-120	5306-01-528-2142	U Bolt-Suspension, 7/8-14 x 12.0 in. long
8	16-09040-002	2510-01-326-9147	Wear Plate-Spring Pin, Shackle
2	16-10386-013	5365-01-531-2112	Spacer, Axle Stop to Spring
6	16-12373-000	3040-01-327-0143	Pin-Spring
8	23-00461-007	5310-01-343-1030	Nut-Hex, 7/8-14
24	23-09114-003	5310-00-767-9425	Washer-Hardened, 1/2 in. nominal ID
8	23-09114-005	5310-00-584-7796	Washer-Hardened, 7/8 in. nominal ID
8	23-09114-009	5310-01-329-7043	Washer-Hardened, 1 1/8 in. nominal ID, 1.25 in.
8	23-09440-250	5305-00-616-6375	Screw-Cap, Hex, 1/2-13 x 2.5 in. long, Grade 8
8	23-09440-325	5305-01-139-7071	Screw-Cap, Hex, 1/2-13 x 3.25 in. long, Grade 8
16	23-09860-012		Washer-Flat, 1.25 x 1.88 x 0.031 in.
8	23-13175-108		Nut-Hex, 1/2-13 in.
6	23-13275-000		Fitting, Lubrication, 90 degree Elbow
2	16-13363-011	5365-01-356-8951	Shim-Axle, 3.0 degree, 4.0 in.
2	23-09271-338	5315-01-527-9244	Pin-Dowel, .75 in. OD x 3.88 in. long
1	1-4856		Data Plate
1	M915A4		14K Suspension Installation Instructions

END OF WORK PACKAGE



**CHAPTER 2**  
**OPERATOR INSTRUCTIONS**



**DESCRIPTION AND USE OF OPERATOR CONTROLS**

**0004 00**

**GENERAL**

1. This work package describes all operator controls for the Crew Protection Kit.
2. Do not attempt to operate the vehicle with armor kit installed until becoming familiar with the location and function of all armor kit controls.

**OPERATOR CONTROLS**



KEY	CONTROL OR INDICATOR	FUNCTION
1	Exterior Grab Handle	Provides hand hold on outside of door.
2	Exterior Door Handle	Allows driver or passenger side door to be opened from outside cab.
3	Window Latch	Allows driver or passenger side window to be opened from inside cab.
4	Interior Grab Handle	Provides hand hold on inside of door.
5	Interior Door Handle	Allows driver or passenger side door to be opened from inside cab.

OPERATOR CONTROLS - CONTINUED

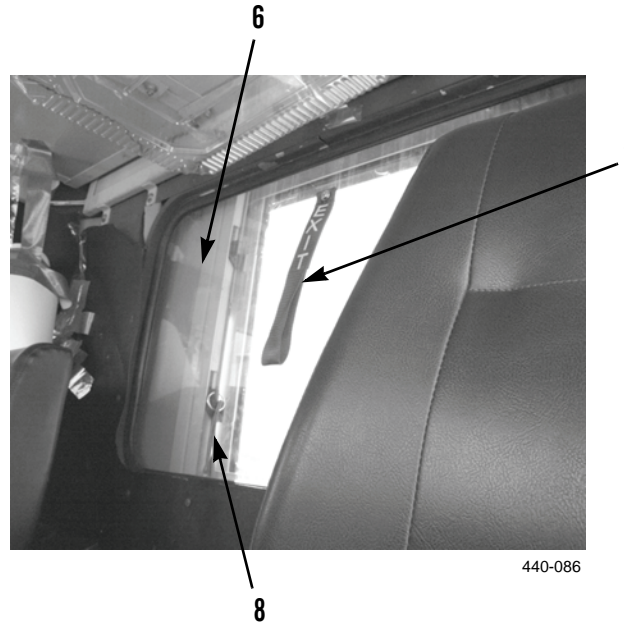

KEY	CONTROL OR INDICATOR	FUNCTION
6	Emergency Egress	Provide an alternate exit from cab. Refer to WP 0006 00.
7	Red Exit Strap	Presents a method for removal of plexiglass window panel. Refer to WP 0006 00.
8	Release Strap	Secures escape hatch in closed position. Pull strap to release emergency egress and push emergency egress open. Refer to WP 0006 00.

END OF WORK PACKAGE

**GENERAL**

1. This work package contains instructions for safely operating the following vehicles with armor kit installed:  
Truck, Tractor, M915A3P1, Line-Haul;  
Truck, Tractor, M915A2P1, Line-Haul;  
Truck, Tractor, M916A3P1, Light Equipment Transporter (LET);  
Truck, Dump, M917A2P1, Heavy, Chassis;  
Truck, Tractor, M915A4P1, Line-Haul;  
Truck, Dump, M917A1P1, Heavy, Chassis;  
Truck, Tractor, M916A1P1, Light Equipment Transporter (LET); and  
Truck, Tractor, M916A2P1, and Light Equipment Transporter (LET).
2. Before operating vehicle with armor kit read and follow the procedures in *Operation Under Usual Conditions* in Operator's Manual for specific vehicle. Refer to *References* in 0033 00 for more information on cited reference.

**INITIAL ADJUSTMENTS AND DAILY CHECKS****NOTE**

Refer to 0004 00 for the location and operation of operator controls.

Perform *Preventive Maintenance Checks and Services (PMCS)* before operation (WP 0008 00 and WP 0009 00).

**OPERATING VEHICLE****WARNING**

Due to increased weight with armor kit installed, operator should be aware of differences in vehicle's driving characteristics and adjust driving accordingly. Failure to do so may cause injury or death to personnel.

1. With armor kit installed, vehicle is heavier than usual. Due to this increased weight, adjust driving to allow for greater stopping distance.
2. Vehicle may steer differently with armor kit installed. Adjust vehicle speed accordingly and exercise caution.

**WARNING**

- The center of gravity is higher on a vehicle with an armor kit installed.
  - Always use slower speed when operating vehicle.
  - DO NOT operate vehicle on steep hills or inclines.
  - Failure to follow these warnings may cause injury or death to personnel.
3. The center of gravity is higher with a Crew Protection Kit installed. Use slower speeds when making turns or changing lanes. The higher center of gravity increases the chance of rollover.

**WARNING**

Visibility is reduced on a vehicle with armor kit installed. Always use ground guides when maneuvering vehicle near obstacles. Failure to follow this warning may cause injury to personnel or damage to equipment.

4. Visibility is reduced with a armor kit installed. Operate vehicle with caution and use ground guides.

**OPERATING VEHICLE - CONTINUED****WARNING**

Vehicles with an armor kit installed have different door handles and latching hardware. DO NOT allow clothing or equipment to catch on door hardware. Failure to follow this warning may cause injury to personnel.

5. When entering or exiting the vehicle, use three-point contact procedure at all times. Keep clothing and equipment away from door hardware.

**WARNING**

DO NOT park vehicle on a hill or incline. The parking brake has a reduced capacity due to the increased weight of vehicle with armor kit installed. Failure to follow this warning may cause injury or death to personnel.

6. Park vehicle on level surface.
7. Operate heater/air conditioning system as needed to ensure proper cab ventilation as in Operator's Manual for specific vehicle. Refer to *References* in 0033 00 for more information on cited reference.
8. Maintain good visibility for operating personnel. Keep all ballistic glass clean. Follow cleaning instructions in *Cleaning Ballistic Glass* (WP 0010 00).

**END OF WORK PACKAGE**

Before operating vehicle with Crew Protection Kit read and follow the procedures in *Operation Under Unusual Conditions* in Operator's Manual for specific vehicle. Refer to *References* in 0033 00 for more information on cited reference.

**EMERGENCY EGRESS OPERATION (FROM INSIDE CAB)**

1. Use red exit strap (2) to remove glass (1) in rear window.
2. Pull release strap (4) and push emergency egress (3) to open.

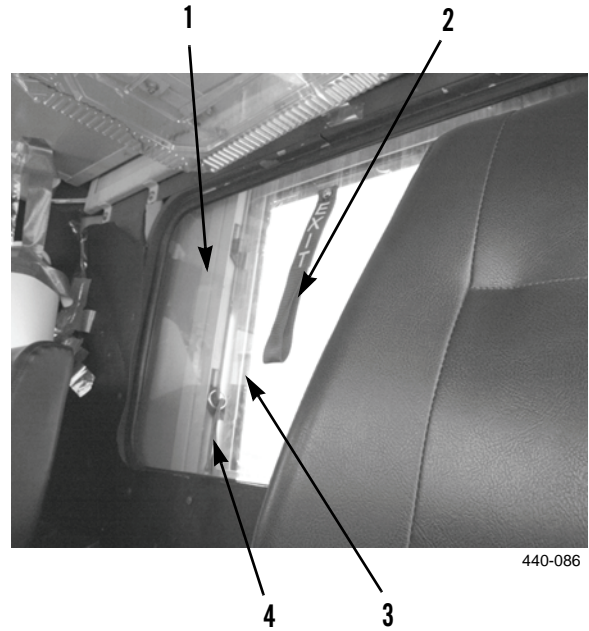

3. Exit vehicle through rear window.

**EMERGENCY EGRESS OPERATION (FROM OUTSIDE CAB)**

1. Pull red exit strap up (5) and pull emergency egress (3) to open.
2. Force window (1) inward and enter cab.

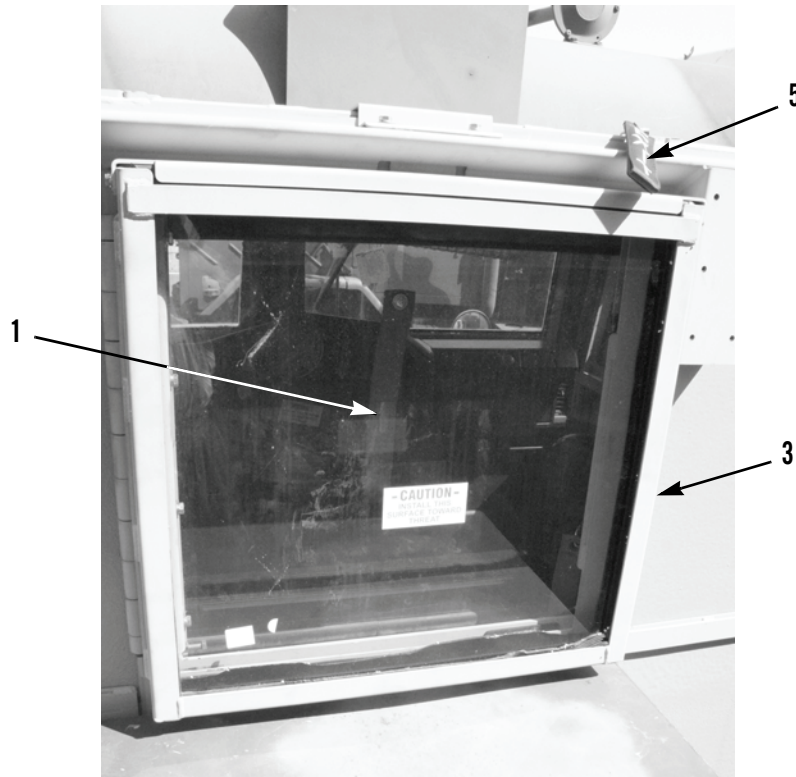

440-088

**OPERATION IN EXTREME TEMPERATURES**

Operation in extreme temperatures with an armor kit installed requires altering operating procedures.

**Extreme Cold****CAUTION**

Never use scraper to remove frost or ice from ballistic glass. Failure to follow this caution will damage outer layer of ballistic glass.

**NOTE**

Clearing frost from ballistic glass requires more time than standard glass.

Extend vehicle warm-up time and operate heater and defroster to clear frost from ballistic glass as in Operator's Manual for specific vehicle. Refer to *References* in 0033 00 for more information on cited reference.



---

**OPERATION UNDER UNUSUAL CONDITIONS - CONTINUED**

---

**0006 00**

***OPERATION IN EXTREME TEMPERATURES - CONTINUED***

**Extreme Heat**

**NOTE**

The armor kit absorbs and retains more heat than a standard cab.

1. Park vehicle away from direct sunlight whenever possible.
2. Operate air conditioner to cool down interior of cab as in Operator's Manual for specific vehicle. Refer to *References* in 0033 00 for more information on cited reference.

**END OF WORK PACKAGE**



**GENERAL**

1. There is no stowage guide related to the Crew Protection Kit. Refer to Operator's Manual for specific vehicle. Refer to *References* in WP 0033 00 for more information on cited reference.
2. For information on decals and data plates refer to Operator's Manual for specific vehicle. Refer to *References* in WP 0033 00 for more information on cited reference.

**END OF WORK PACKAGE**



**CHAPTER 3**  
**OPERATOR MAINTENANCE INSTRUCTIONS**



**GENERAL****NOTE**

- Information in this PMCS Introduction applies only to preventive maintenance checks and services for the Crew Protection Kit.
  - For vehicle-specific information, refer to the PMCS introduction in Operator's Manual for specific vehicle. Refer to *References* in WP 0033 00 for more information on sited reference.
1. To ensure that the Crew Protection Kit is ready for operation at all times, it must be inspected on a regular basis so that defects may be found and corrected before they result in injury or death due to equipment failure.
  2. The PMCS Table in WP 0009 00 contains systematic instructions on inspections and services to be performed by the operator to keep your equipment in good operating condition and ready for its primary mission.

**EXPLANATION OF TABLE ENTRIES**

1. **Item Number (Item No.) Column.** Numbers in this column are for reference. When completing DA Form 2404 or DA Form 5988-E (*Equipment Inspection and Maintenance Worksheet*), include the item number for the check/service indicating a fault. Item numbers also appear in the order that you must perform checks and services for the interval listed.
2. **Interval Column.** This column tells you when you must perform the procedure in the procedure column.
  - a. *Before* procedures must be done immediately before you operate vehicle with Crew Protection Kit installed.
  - b. *After* procedures must be done immediately after operating vehicle with Crew Protection Kit installed.
  - c. *Weekly* procedures must be done once each week.
3. **Location, Item to Check/Service Column.** This column provides the location and item to be checked or serviced.

**NOTE**

The WARNINGS and CAUTIONS appearing in your PMCS table should always be observed. WARNINGS and CAUTIONS appear before applicable procedures. You must observe these WARNINGS to prevent injury or death to personnel, and CAUTIONS to prevent your equipment from being damaged.

4. **Procedure Column.** This column gives the procedure you must perform to check or service the item listed in the Item to Check/Service column, to know if the equipment is ready or available for its intended mission. You must perform the procedure at the time stated in the interval column.
5. **Not Fully Mission Capable If: Column.** Information in this column tells you what faults will keep your equipment from being capable of performing its primary mission. If you perform check/service procedures that show faults listed in this column, the equipment is not mission-capable. Follow standard operating procedures for maintaining the equipment or reporting equipment failure.

**GENERAL PMCS PROCEDURES**

1. Always perform PMCS in the same order so it gets to be a habit. Once you've had some practice, you'll spot anything wrong in a hurry.
2. If anything looks wrong and you can't fix it, write it on your DA Form 2404 or DA Form 5988-E. If you find something seriously wrong, IMMEDIATELY report it to your supervisor.
3. Before performing preventive maintenance, read all the checks required for the applicable interval and prepare all that is needed to make all the checks. You'll always need a Rag, Wiping (Item 9, WP 0036 00) or two.

---

**OPERATOR PREVENTIVE MAINTENANCE CHECKS AND SERVICES (PMCS)  
INTRODUCTION - CONTINUED**

---

0008 00

**GENERAL PMCS PROCEDURES - CONTINUED****WARNING**

Solvent cleaning compound MIL-PRF-680 Type III is an environmentally compliant and low toxic material. However, it may be irritating to the eyes and skin. Use protective gloves and goggles. Use in well-ventilated areas. Keep away from open flames and other sources of ignition. Failure to follow this warning may cause injury to personnel.

- a. **Keep It Clean.** Dirt, grease, oil, and debris get in the way and may cover up a serious problem. Clean as you work and as needed. Use Cleaning Compound, Solvent, Type III (Item 4, WP 0036 00) on all metal surfaces. Use Detergent, General Purpose, Liquid (Item 7, WP 0036 00) and water when you clean rubber, plastic, and painted surfaces.

**WARNING**

When servicing this vehicle, performing maintenance or disposing of materials such as engine coolant, hydraulic fluid, lubricants, battery acids or batteries, and CARC paint, consult your unit/local hazardous waste disposal center or safety office for local regulatory guidance. If further information is needed, please contact The Army Environmental Hotline at 1-800-872-3845.

- b. **Hazardous Waste Disposal.** Ensure all spills are cleaned up and disposed of IAW local policy and ordinances.
- c. **Rust and Corrosion.** Check metal parts for rust and corrosion. If any bare metal or corrosion exists, clean and apply a light coat of Oil, Lubricating, OE/HDO-10 (Item 8, WP 0036 00). Report it to your supervisor.
- d. **Bolts, Nuts, and Screws.** Check bolts, nuts, and screws for obvious looseness, missing, bent, or broken condition. If you find one is loose, notify your supervisor.
- e. **Electric Wires and Connectors.** Look for cracked or broken insulation, bare wires, and loose or broken connectors. Reconnect loose connectors. Ensure that wires are in good condition.

**CAUTION**

- Remove rings or other hard objects from hands before cleaning ballistic glass. **DO NOT** use hard, dirty or gritty cloths on ballistic glass. **DO NOT** apply water or detergent unless ballistic glass is cool and is protected from heating effects of sunlight. Failure to follow these instructions will damage ballistic glass.
  - **DO NOT** use bug spray or other aerosol sprays on or near ballistic glass. Failure to follow these instructions will damage ballistic glass.
- f. **Ballistic Glass.** Keep ballistic glass clean (WP 0010 00).



---

**OPERATOR PREVENTIVE MAINTENANCE CHECKS AND SERVICES (PMCS)  
INTRODUCTION - CONTINUED - CONTINUED**

---

0008 00

**GENERAL PMCS PROCEDURES - CONTINUED****4. Inspection Procedures and Replacement Criteria for Armor and Ballistic Glass.**

- a. **Metallic Armor.** Inspect for and replace the armor if any of the following conditions exist:
  - (1) Stage 3 rust spots are areas of corrosion which may indicate a rusted through condition; (i.e., metal in corroded area is unsound and small pin holes are present).
  - (2) Stage 4 rust is a rust through condition.
  - (3) User modifications that have not been authorized by the Vehicle PM.
  - (4) Examine areas around bolts and bolt holes for cracks or elongation of the holes. Cracks that are 1 in. or longer, or 2 consecutive bolt holes elongated are cause to replace the armor panel.
  - (5) Look for signs that the armor has been deformed or damaged, including:
    - (a) Armor that is dented or bent out of shape.
    - (b) Bent door frames and door support posts which won't allow the doors to close properly.
    - (c) Bent, warped, or misaligned body panels that cause gaps between adjacent armor panels.
    - (d) Any complete penetration of the armor (a hole in the armor) or multiple gouges 1/4 in. or deeper within 3 in. of each other.
- b. **Ceramic/Composite Armor.** Inspect for and replace if there is any visible damage.
- c. **Transparent Armor (Ballistic Glass).** Inspect transparent armor for damage and replace if any of the following conditions exist:
  - (1) Cloudiness in the glass which interferes with the driver's vision.
  - (2) Rock chips, cracks with spider webbing, decals, or stickers that impair vision.
  - (3) Any damage that exposes the glass below the first layer.

**END OF WORK PACKAGE**



Table 1. Preventive Maintenance Checks and Services (PMCS).

Item No.	Interval	Location	Procedure	Not Fully Mission Capable If:
		Item To Check/Service		
			<p><b>NOTE</b></p> <ul style="list-style-type: none"> <li>• Perform PMCS in Operator Technical Manual for specific vehicle BEFORE performing PMCS for the Crew Protection Kit. Refer to <i>References</i> in WP 0033 00 for more information on cited reference.</li> <li>• Review all WARNINGS, CAUTIONS, and NOTES before performing PMCS and operating vehicle.</li> <li>• Perform all PMCS checks if:                             <ul style="list-style-type: none"> <li>a. You are the assigned operator but have not operated the vehicle with armor kit since the last weekly checks.</li> <li>b. You are operating the vehicle with armor kit for the first time.</li> </ul> </li> <li>• Perform PMCS with vehicle parked on level ground, parking brake applied, transmission in N (Neutral), wheels blocked, and engine shut down.</li> </ul>	

Table 1. Preventive Maintenance Checks and Services (PMCS) - Continued.

Item No.	Interval	Location	Procedure	Not Fully Mission Capable If:
		Item To Check/ Service		
1	Before	FRONT AND LEFT SIDE		
		Front Armor	<p>a. Inspect center firewall armor and cowl armor panels for damage, loose, or missing mounting hardware.</p> <p>b. Inspect center firewall armor and cowl armor panels for areas of rust or corrosion.</p> <p>c. Inspect center firewall armor and cowl armor panels for nearby cracks or elongation of bolt holes.</p> <p>d. Inspect center firewall armor and cowl armor panels for any holes or gouges.</p> <p>e. Inspect left firewall armor panel for damage, loose, or missing mounting hardware.</p> <p>f. Inspect left firewall armor frames for areas of rust or corrosion.</p> <p>g. Inspect windshield ballistic glass mounting hardware for damage, loose, or missing mounting hardware.</p> <p>h. Inspect exterior surface of windshield ballistic glass for rock chips, cracks, scratches, pitting, any damage that expose glass below the first layer, cloudiness, or any stickers that impair vision.</p> <p>i. If dirty, clean windshield ballistic glass (WP 0010 00).</p>	<p>Any panel or armor plate is damaged, bent out of shape, misaligned, loose, missing, or mounting bolts are loose or missing.</p> <p>Any corrosion where area is unsound and small pin holes are present, or a rusted through condition is present.</p> <p>Any cracks that are longer than 1 in. or two consecutive bolt holes that are elongated.</p> <p>Any complete penetration of the armor (hole in the armor) or multiple gouges 1/4 in. or deeper within 3 in. of each other.</p> <p>Any armor panel assembly is damaged or mounting hardware is loose or missing.</p> <p>Any corrosion where area is unsound and small pin holes are present, or a rusted through condition is present.</p> <p>Any ballistic glass mounting hardware is damaged, loose, or missing, or mounting bolts are loose or missing.</p> <p>Rock chips, cracks with spider webbing, scratches, pitting, or damage in the exterior layer of ballistic glass that expose glass below the first layer, cloudiness that impairs vision.</p>

Table 1. Preventive Maintenance Checks and Services (PMCS) - Continued.

Item No.	Interval	Location	Procedure	Not Fully Mission Capable If:
		Item To Check/Service		
1 (Con't)	Before	Front Armor		

Table 1. Preventive Maintenance Checks and Services (PMCS) - Continued.

Item No.	Interval	Location	Procedure	Not Fully Mission Capable If:
		Item To Check/Service		
2	Before	Side Armor (Left Side)	<p>a. Inspect wheel well blast deflector for damage, loose, or missing mounting hardware.</p> <p>b. Inspect wheel well blast deflector frame for areas of rust or corrosion.</p> <p>c. Inspect A-pillar and B-pillar armor panels and door assembly for damage, loose, or missing mounting hardware.</p> <p>d. Inspect A-pillar and B-pillar frames and door assembly frames for damage, loose, or missing mounting hardware.</p> <p>e. Inspect door ballistic glass mounting hardware for damage, loose, or missing mounting hardware.</p> <p>f. Inspect exterior surface of door ballistic glass for rock chips, cracks, scratches, pitting, any damage that expose glass below the first layer, cloudiness, or any stickers that impair vision.</p>	<p>Any wheel well blast deflector is damaged or mounting hardware is loose or missing.</p> <p>Any corrosion where area is unsound and small pin holes are present, or a rusted through condition is present.</p> <p>Any side A-pillar and B-pillar armor or door assembly is damaged or mounting hardware is loose or missing.</p> <p>Any corrosion where area is unsound and small pin holes are present, or a rusted through condition is present.</p> <p>Any ballistic glass mounting hardware is damaged, loose, missing, or mounting bolts are loose or missing.</p> <p>Rock chips, cracks with spider webbing, scratches, pitting, or damage in the exterior layer of ballistic glass that expose glass below the first layer, cloudiness that impairs vision.</p>

Table 1. Preventive Maintenance Checks and Services (PMCS) - Continued.

Item No.	Interval	Location	Procedure	Not Fully Mission Capable If:
		Item To Check/Service		
2 (Con't)	Before	Side Armor (Left Side)		

Table 1. Preventive Maintenance Checks and Services (PMCS) - Continued.

Item No.	Interval	Location	Procedure	Not Fully Mission Capable If:
		Item To Check/Service		
3	Before	Underbody Mine Blast Panel (Left Side)	Inspect left underbody mine blast panel under vehicle for damage, loose, or missing mounting hardware.	Any mine blast panel is damaged or mounting hardware is loose or missing.
 <p style="text-align: center;">LEFT UNDERBODY MINE BLAST PANEL</p> <p style="text-align: right;">440-082</p>				
4	Before	<div style="border: 1px solid black; padding: 2px; text-align: center;">ROOF</div> Roof Armor	a. Open door and enter cab. Close door using grab handle. Make sure door closes without binding (WP 0004 00). b. Make sure door ballistic glass can open, close, and securely lock. c. Inspect interior surface of door ballistic glass and windshield ballistic glass for cracks, scratches, or pitting. d. If dirty, clean ballistic glass (WP 0010 00).	Door binds.  Door ballistic glass will not close or lock.  Cracks, scratches, or pitting on the interior surface of the door ballistic glass or windshield ballistic glass.



Table 1. Preventive Maintenance Checks and Services (PMCS) - Continued.

Item No.	Interval	Location	Procedure	Not Fully Mission Capable If:
		Item To Check/Service		
4 (Con't)	Before	Roof Armor	<p>e. Inspect left and center roof armor panels for damage, loose, or missing mounting hardware.</p> <p>f. Inspect left and center roof armor panel frames for areas of rust or corrosion.</p>	<p>Any armor panel is damaged or mounting hardware is loose or missing.</p> <p>Any corrosion where area is unsound and small pin holes are present, or a rusted through condition is present.</p>

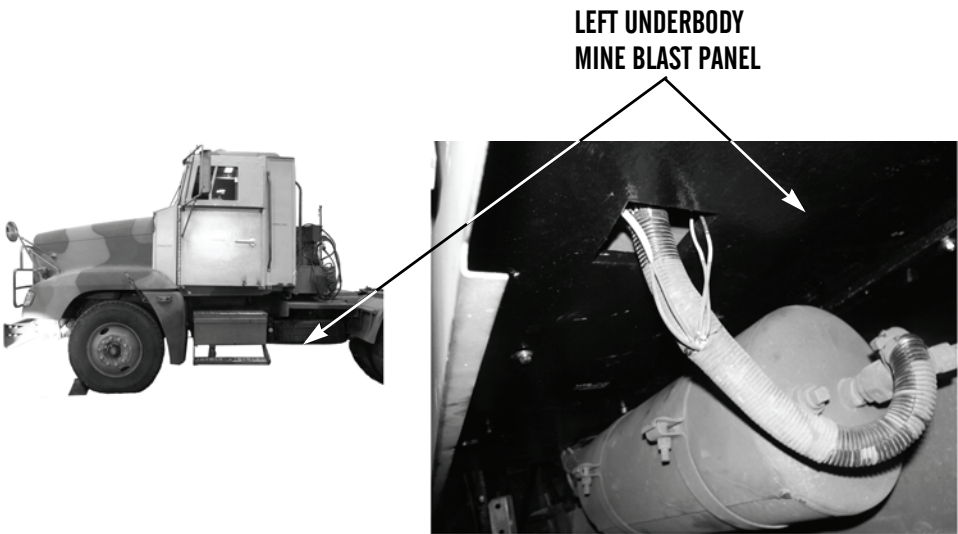

440-007

Table 1. Preventive Maintenance Checks and Services (PMCS) - Continued.

Item No.	Interval	Location	Procedure	Not Fully Mission Capable If:
		Item To Check/Service		
5	Before	REAR ROOF AND RIGHT SIDE		
		Rear Cab Armor	<p>a. Inspect rear cab armor for damage, loose, or missing mounting hardware.</p> <p>b. Inspect rear cab armor frames for areas of rust or corrosion.</p> <p>c. Inspect emergency egress for damage.</p> <p>d. Inspect emergency egress ballistic glass mounting hardware for damage, loose, or missing mounting hardware.</p> <p>e. Inspect exterior surface of emergency egress ballistic glass for rock chips, cracks, scratches, pitting, any damage that expose glass below the first layer, cloudiness, or any stickers that impair vision.</p>	<p>Rear cab armor is damaged, loose, missing, or mounting bolts are loose or missing.</p> <p>Any corrosion where area is unsound and small pin holes are present, or a rusted through condition is present.</p> <p>Emergency egress is missing or damaged.</p> <p>Any ballistic glass mounting hardware is damaged, loose, or missing, or mounting bolts are loose or missing.</p> <p>Rock chips, cracks with spider webbing, scratches, pitting, or damage in the exterior layer of ballistic glass that expose glass below the first layer, or cloudiness that impairs vision.</p>



Table 1. Preventive Maintenance Checks and Services (PMCS) - Continued.

Item No.	Interval	Location	Procedure	Not Fully Mission Capable If:
		Item To Check/Service		
6	Before	Door and Windshield Ballistic Glass	a. Open door and enter cab. Close door using grab handle. Make sure door closes without binding (WP 0004 00).  b. Make sure door ballistic glass can open, close, and securely lock.  c. Inspect interior surface of door ballistic glass and windshield ballistic glass for cracks, scratches, or pitting.  d. If dirty, clean ballistic glass (WP 0010 00).	Door binds.  Door ballistic glass will not close or lock.  Cracks, scratches, or pitting on the interior surface of the door ballistic glass or windshield ballistic glass.

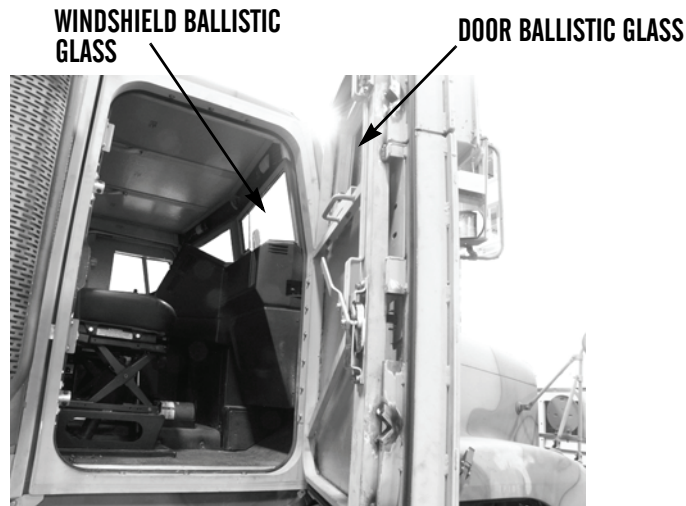

440-083

Table 1. Preventive Maintenance Checks and Services (PMCS) - Continued.

Item No.	Interval	Location	Procedure	Not Fully Mission Capable If:
		Item To Check/Service		
7	Before	Roof Armor (Right Side)	a. Inspect right roof armor panel for damage, loose, or missing mounting hardware.  b. Inspect right roof armor panel frames for areas of rust or corrosion.	Any armor panel is damaged or mounting hardware is loose or missing.  Any corrosion where area is unsound and small pin holes are present, or a rusted through condition is present.
				
440-010				

Table 1. Preventive Maintenance Checks and Services (PMCS) - Continued.

Item No.	Interval	Location	Procedure	Not Fully Mission Capable If:
		Item To Check/Service		
8	Before	<b>Underbody Mine Blast Panel (Right Side)</b>	Inspect right and center underbody mine blast panels under cab for damage, loose, or missing mounting hardware.	Any mine blast panel is damaged or mounting hardware is loose or missing.
9	Before	<b>Side Armor (Right Side)</b>	<p>a. Inspect A-pillar and B-pillar armor panels and door assembly for damage, loose, or missing mounting hardware.</p> <p>b. Inspect A-pillar and B-pillar frames and door assembly frames for areas of rust or corrosion.</p> <p>c. Inspect door ballistic glass mounting hardware for damage, loose, or missing mounting hardware.</p> <p>d. Inspect exterior surface of door ballistic glass for rock chips, cracks, scratches, pitting, any damage that expose glass below the first layer, cloudiness, or any stickers that impair vision.</p>	<p>Any side A-pillar or B-pillar armor or door assembly is damaged or mounting hardware is loose or missing.</p> <p>Any corrosion where area is unsound and small pin holes are present, or a rusted through condition is present.</p> <p>Any ballistic glass mounting hardware is damaged, loose, missing, or mounting bolts are loose or missing.</p> <p>Rock chips, cracks with spider webbing, scratches, pitting, or damage in the exterior layer of ballistic glass that expose glass below the first layer, or cloudiness that impairs vision.</p>

Table 1. Preventive Maintenance Checks and Services (PMCS) - Continued.

Item No.	Interval	Location	Procedure	Not Fully Mission Capable If:
		Item To Check/Service		
9 (Con't)	Before	Side Armor (Right Side)	<p>e. Inspect wheel well blast deflector for damage, loose, or missing mounting hardware.</p> <p>f. Inspect wheel well blast deflector frame for areas of rust or corrosion.</p> <p>g. Inspect right firewall armor panel for damage, loose, or missing mounting hardware.</p> <p>h. Inspect right firewall armor frames for areas of rust or corrosion.</p>	<p>Any wheel well blast deflector is damaged or mounting hardware is loose or missing.</p> <p>Any corrosion where area is unsound and small pin holes are present, or a rusted through condition is present.</p> <p>Any armor panel assembly is damaged or mounting hardware is loose or missing.</p> <p>Any corrosion where area is unsound and small pin holes are present, or a rusted through condition is present.</p>

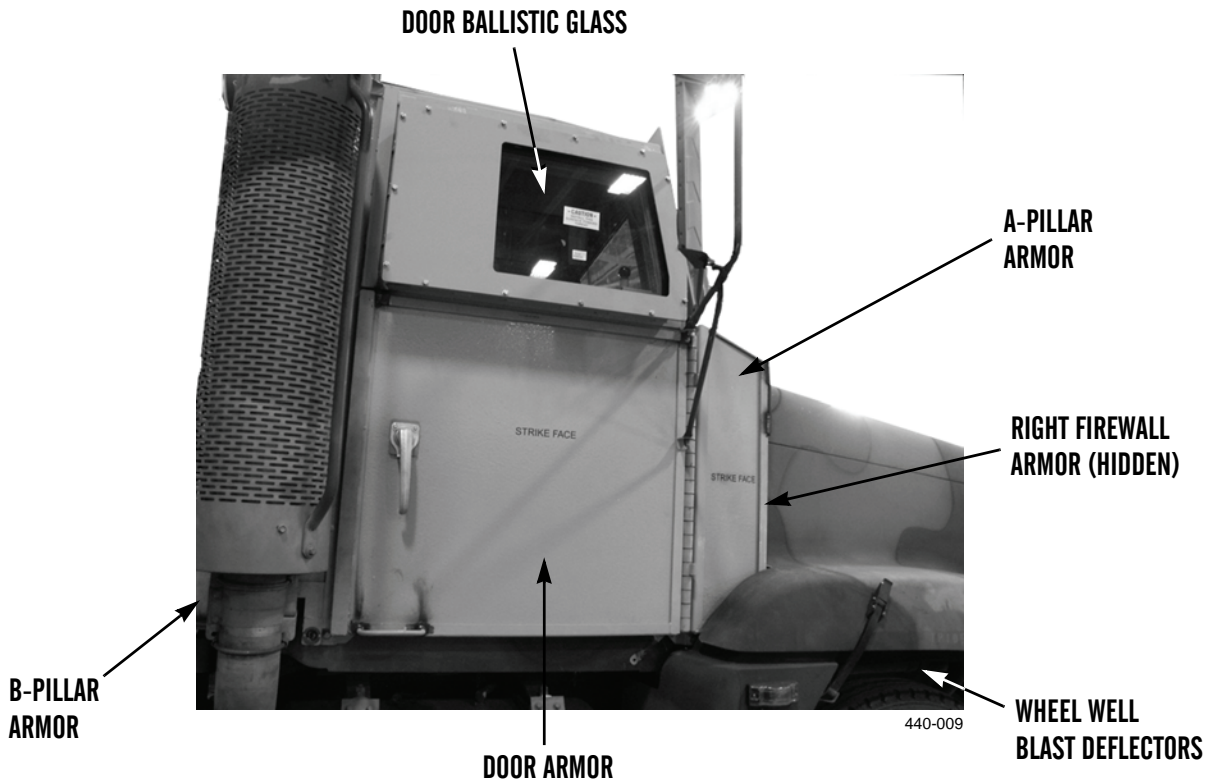

Table 1. Preventive Maintenance Checks and Services (PMCS) - Continued.

Item No.	Interval	Location	Procedure	Not Fully Mission Capable If:
		Item To Check/Service		
10	Weekly	Front Suspension	Inspect front suspension springs and mounting hardware for cracks, breaks, loose, or missing hardware and/or shackles. Notify your supervisor of any damage found.	Any cracks, breaks, loose hardware, or damage to suspension springs is noted.
11	Weekly	Cab Mounts	Inspect cab mounts for evidence of deterioration, over-compression, or loose mounting hardware. Notify your supervisor of any damage or looseness found.	
12	Weekly	Wheels and Wheel Rims	Inspect wheel lug nuts and wheel rim bolts/nuts for looseness (e.g., polished surface, rust, or minor cracks around bolt and wheel mating surfaces). Notify your supervisor of any looseness found.	Two or more studs or nuts are missing from the same wheel.
13	Weekly	Crew Protection Kit Mounting Hardware	Check all armor kit mounting hardware for loose or missing hardware. Notify your supervisor of any loose or missing mounting hardware found.	
14	Weekly	Escape Hatch	a. Ensure there is no damage to straps and mounting hardware. b. Inspect for damage to escape hatch seal. Notify your supervisor of any damage found.	Escape hatch door will not latch closed securely.
15	Weekly	Door Assemblies	Check both door assembly seals, hardware, and door stops for damaged or loose components. Notify your supervisor of any damage found.	Door assembly is damaged, loose, missing, or mounting bolts are loose or missing.

END OF WORK PACKAGE





---

**CLEANING BALLISTIC GLASS**

**0010 00**

---

**THIS WORK PACKAGE COVERS**

Cleaning

---

**INITIAL SETUP**

**Maintenance Level**

Operator

**Materials/Parts**

Detergent, General Purpose, Liquid (Item 7, WP 0036 00)

Rag, Wiping (Item 9, WP 0036 00)

**Equipment Conditions**

**(M915A3P1, M916A3P1, and M917A2P1)**

Vehicle parked on level ground (TM 9-2320-302-10)

Parking/Emergency Brake applied (TM 9-2320-302-10)

Engine OFF (TM 9-2320-302-10)

Battery Disconnect Switch in OFF position (TM 9-2320-302-10)

**Equipment Conditions - Continued**

**(M915A4P1)**

Vehicle parked on level ground (TM 9-2320-303-10)

Parking/Emergency Brake applied (TM 9-2320-303-10)

Engine OFF (TM 9-2320-303-10)

Battery Disconnect Switch in OFF position (TM 9-2320-303-10)

**(M915A2P1, M916A1P1, M916A2P1, and M917A1P1)**

Vehicle parked on level ground (TM 9-2320-363-10)

Parking/Emergency Brake applied (TM 9-2320-363-10)

Engine OFF (TM 9-2320-363-10)

If equipped, Battery Disconnect Switch in OFF position (TM 9-2320-363-10) otherwise disconnect Battery Cables (TM 9-2320-363-20-2)

---

**CLEANING**

**CAUTION**

- Remove rings or other hard objects from hands before cleaning ballistic glass. DO NOT use hard, dirty, or gritty cloths on ballistic glass. DO NOT apply water or detergent unless ballistic glass is cool and is protected from heating effects of sunlight. Failure to follow these instructions will damage ballistic glass.
- DO NOT use bug spray or other aerosol sprays on or near ballistic glass. Failure to follow these instructions will damage ballistic glass.

**NOTE**

Follow this procedure to clean inner plastic laminate surfaces of ballistic glass. Clean outside surfaces of ballistic glass as you would clean plain glass as directed by manufacturer.

1. Add Detergent, General Purpose, Liquid (Item 7, WP 0036 00) to 1 gal. (3.8 L) of water as directed by manufacturer.
2. Saturate a soft, clean cloth with cleaning solution and lightly rub plastic surfaces.
3. Flush off cleaning solution with water and dry with a soft, clean cloth.

**END OF WORK PACKAGE**



**CHAPTER 4**  
**UNIT MAINTENANCE INSTRUCTIONS**



---

**GENERAL MAINTENANCE INSTRUCTIONS**

**0011 00**

---

**THIS WORK PACKAGE COVERS**

Scope	Standard Tool Requirements
Work Safety	Use of Thread Adhesive
General Information	Use of Sealant
Cleaning Instructions	Applying Torque
Inspection Instructions	Tagging Instructions
Painting Instructions	

---

**INITIAL SETUP**

**Maintenance Level**

Unit

**Tools and Special Tools**

Tool Kit, General Mechanic's (Item 9, WP 0035 00)  
 Shop Equipment, Common No. 1 (Item 6, WP 0035 00)

**Materials/Parts**

Adhesive, Thread (Item 1, WP 0036 00)  
 Cleaning Compound, Solvent, Type III (Item 4, WP 0036 00)  
 Cloth, Abrasive (Item 5, WP 0036 00)  
 Detergent, General Purpose, Liquid (Item 7, WP 0036 00)

**Materials/Parts - Continued**

Oil, Lubricating, OE/HDO-10 (Item 8, WP 0036 00)  
 Rag, Wiping (Item 9, WP 0036 00)  
 Tag, Marker (Item 12, WP 0036 00)

**References**

WP 0033 00  
 WP 0037 00  
 TB 43-0209  
 TB 43-0242  
 TM 9-247

---

**SCOPE**

1. These general maintenance instructions contain general shop practices and specific methods you must be familiar with to properly install and maintain the armor kit.
2. Read and understand these practices and methods before starting maintenance tasks on the armor kit.

**WORK SAFETY****WARNING**

- Use caution when handling window glass. Glass can break unexpectedly during removal/installation procedure. Wear face shield, apron, and gloves. Failure to follow this warning may cause injury to personnel.
  - Edges of metal armor panels may be sharp. Wear protective gloves when handling armor panels. Failure to follow this warning may cause injury to personnel.
1. Before starting a task, think about the risks and hazards to your safety as well as others. Wear protective gear such as safety goggles or lenses, face shield, safety shoes, and gloves. Protect yourself against injury.
  2. Observe all WARNINGS and CAUTIONS.
  3. When lifting heavy parts, have someone help you. Make sure that lifting equipment is working properly, that it is suitable for the task assigned, of sufficient load capacity, and is secured against slipping.
  4. Always use power tools carefully.
  5. Before beginning a procedure, ensure that the following conditions have been observed, unless otherwise specified:
    - a. Vehicle must be parked on level ground with parking/emergency brake applied.
    - b. Transmission must be in N (Neutral).
    - c. Engine must be OFF.
    - d. Battery disconnect switch must be in OFF position.

These procedures are located in Operator's Manual for specific vehicle. Refer to *References* in WP 0033 00.

**GENERAL INFORMATION**

1. Before beginning a task, find out how much teardown is needed to fix the equipment as described in this bulletin. Sometimes complete teardown is not necessary. Remove components only as far as necessary to replace damaged or broken parts.
2. All tags and forms attached to the equipment must be checked to learn the reason for removal from service. Check all Modification Work Orders (MWOs) and Technical Bulletins (TBs) for equipment changes and updates.
3. Replace all locknuts and lockwashers if removed during procedure.
4. Inspect seals for damage. Replace seals if damaged.

**CLEANING INSTRUCTIONS**

1. **General.**
  - a. The importance of cleaning must be thoroughly understood by maintenance personnel. Great care and effort are required in cleaning. Dirt and foreign material are a constant threat to satisfactory maintenance.
  - b. The following should apply to all cleaning operations:
    - (1) Keep all related parts and components together. DO NOT mix parts.
    - (2) Clean all parts before inspection and before installation.
    - (3) To prevent contamination, hands should be kept free of accumulation of grease, which can collect dust, dirt, or grit.

**CLEANING INSTRUCTIONS - CONTINUED**2. Cleaning Instructions.**WARNING**

- Solvent cleaning compound MIL-PRF-680 Type III is an environmentally compliant and low toxic material. However, it may be irritating to the eyes and skin. Use protective gloves and goggles. Use in well-ventilated areas. Keep away from open flames and other sources of ignition. Failure to follow this warning may result in injury to personnel.
  - Improper cleaning methods and use of unauthorized cleaning solvents may injure personnel and damage equipment. Refer to TM 9-247, *Materials Used for Cleaning, Preserving, Abrading, and Cementing Ordnance Materiels and Related Materiels Including Chemicals*, for correct information.
  - Fire extinguishers should be placed nearby when using solvent cleaning compound.
  - Cloths or rags saturated with solvent cleaning compound must be disposed of IAW authorized facilities' procedures.
  - Eye shields must be worn when cleaning with a wire brush. Flying rust and metal particles may cause injury.
- a. Use solvent cleaning compound to clean any surface coated with grease or oil.

**WARNING**

Particles blown by compressed air are hazardous. DO NOT exceed 15 psi (103 kPa) nozzle pressure when drying parts with compressed air. Use a maximum of 30 psi (207 kPa) when cleaning components. DO NOT direct compressed air against human skin. Failure to follow this warning may result in injury or death to personnel. Make sure air stream is directed away from user and other personnel in the area. To prevent injury, user must wear protective goggles or face shield.

- b. Clear out all drilled or tapped (threaded) holes with compressed air to remove dirt and solvent cleaning compound.
- c. Wash externally exposed parts, not subject to grease and oil, with detergent and water. Rinse thoroughly and air dry.
- d. Remove old sealing compound using a wire brush and solvent cleaning compound.
- e. Clean all rusted surfaces using a wire brush and abrasive cloth.
- f. After cleaning, cover or wrap all parts to protect them from dust and dirt. Any part that is subject to rust should be lightly coated with Oil, Lubricating, OE/HDO-10 (Item 8, WP 0036 00).

**INSPECTION INSTRUCTIONS**

1. **General.** All components and parts must be carefully inspected to determine if they are serviceable for reuse or if they must be replaced.
2. **Drilled and Tapped (Threaded) Holes.**
  - a. Inspect for wear, distortion (stretching), cracks, or any other damage in or around holes.
  - b. Inspect threaded areas for wear, distortion, or evidence of cross-threading.
  - c. If damage is noted, entire part should be replaced.
3. **Armor Plates.**
  - a. Inspect for breaks, cracks, dents, and rust damage.
  - b. Particularly check areas around studs, screw openings, and sharp corners.

**WARNING**

To ensure survivability of personnel, welding repairs on armor kit are NOT authorized. If armor plates are damaged, they must be replaced. Failure to follow this warning may cause failure of armor, resulting in injury or death to personnel.

- c. Replace any damaged armor plate. DO NOT repair by welding.
4. **Bolts and Screws.** Replace if threads are damaged, bent, loose, or stretched.
5. **Studs.** If studs are damaged, repair or replace as necessary.
6. **Rubber Seals.** Replace seal if damaged, cracked, or shows signs of excessive wear.

**PAINTING INSTRUCTIONS****CAUTION**

Whenever paint is applied, care must be taken to prevent covering up installation aid markings (**THIS SIDE UP**, up arrows ↑, etc.). These installation aid markings must be protected during paint application by using masking tape, paper, etc.

Parts must be painted in accordance with TB 43-0209, *Color, Marking, and Camouflage Painting of Military Vehicles, Construction Equipment, and Materials Handling Equipment*, and TB 43-0242, *CARC Spot Painting*.

**STANDARD TOOL REQUIREMENTS**

1. The following are general practices regarding the use of tools:
  - a. Always use the proper tool kit and tools for the procedure being performed.
  - b. Ensure that tools are clean and lubricated to reduce wear and to prevent rust.
  - c. Keep track of tools. DO NOT be careless with them.
  - d. Return tools to toolbox when finished with repair or maintenance.
  - e. Return toolboxes and tools to tool storage when not in use.
  - f. Inventory tools before and after each use.
2. Some maintenance tasks may require special or fabricated tools. The “Initial Setup” of the procedure will specify any special or fabricated tools needed to perform that procedure. Use these special tools only for the maintenance procedures for which they are designed or called out. If you are unfamiliar with a required tool, see your supervisor.



**USE OF THREAD ADHESIVE****WARNING**

Use caution when using adhesives and sealants. Prolonged inhalation of vapors can cause lung irritation. Contact with skin can cause dermatitis. Wear gloves and safety goggles and use product in a well-ventilated area away from open flame. If ingested, keep individual calm and seek medical attention. **DO NOT** induce vomiting. If contact with skin or eyes is made, flush thoroughly with water. Dispose of cleanup rags IAW local policy and ordinances. Failure to follow this warning may cause injury to personnel.

Selected bolts and screws require use of Adhesive, Thread (Item 1, WP 0036 00) during installation of the armor kit, or when replacing armor kit components. Generally, if no locking fastener (i.e., locknut or lockwasher) is used, thread adhesive is required.

**USE OF SEALANT**

1. When applying sealant, follow manufacturer's instructions on label of container.
2. Sealant should be applied with an even and continuous 1/4 in. bead along mating surfaces.

**APPLYING TORQUE**

1. When tightening fasteners, use torque value as specified in *Torque Limits* (WP 0037 00).
2. If a unique torque value is required, it will be provided in the procedural step of the task.

**TAGGING INSTRUCTIONS**

1. Use Tag, Marker (Item 12, WP 0036 00) to identify all electrical wires and any other parts which may be hard to identify or replace later. Fasten tags to parts during removal by wrapping wire fasteners around or through parts and twisting ends together. Position tags to be out of the way during cleaning, inspection, and repair. Mark tags with a pencil, pen, or marker.
2. Whenever possible, identify electrical wires with the number of the terminal or wire to which it connects. If no markings can be found, tag both wires or wire and terminal, and use the same identifying mark for both. If you cannot tag a wire because it must fit through a small hole or you cannot reach it, write down the description of the wire and the point to which it connects or draw a simple diagram on paper. Be sure to write down enough information so you will be able to properly connect the wires during assembly. If you need to identify a loose wire, look for identifying number near end of the wire, stamped on a permanent metal tag. Compare the number to wire numbers on the appropriate electrical schematic.
3. Identify and tag other parts as required by name and installed location.

**END OF WORK PACKAGE**



**DOOR AND FRAME ASSEMBLY REPLACEMENT**

**0012 00**

**THIS WORK PACKAGE COVERS**

Removal, Cleaning and Inspection, Installation

**INITIAL SETUP**

**Maintenance Level**

Unit

**Tools and Special Tools**

- Tool Kit, General Mechanic's (Item 9, WP 0035 00)
- Shop Equipment, Common No. 1 (Item 6, WP 0035 00)
- Link, Bearing (Lifting) (Item 5, WP 0035 00)
- Sling, Nylon (Item 8, WP 0035 00)
- Lifting Device (500-lb Minimum Capacity)

**Materials/Parts**

- Rag, Wiping (Item 9, WP 0036 00)
- Locknut (20)
- Lockwasher (6)

**Personnel Required**

Two

**References**

WP 0011 00

**Equipment Conditions**

**(M915A3P1, M916A3P1, and M917A2P1)**

- Vehicle parked on level ground (TM 9-2320-302-10)
- Parking/Emergency Brake applied (TM 9-2320-302-10)
- Engine off (TM 9-2320-302-10)

**Equipment Conditions - Continued**

**(M915A3P1, M916A3P1, and M917A2P1) - Continued**

- Battery Disconnect Switch in OFF position (TM 9-2320-302-10)
- Outside Door Mirror removed (TM 9-2320-302-20-2)

**(M915A4P1)**

- Vehicle parked on level ground (TM 9-2320-303-10)
- Parking/Emergency Brake applied (TM 9-2320-303-10)
- Engine OFF (TM 9-2320-303-10)
- Battery Disconnect Switch in OFF position (TM 9-2320-303-10)
- Outside Door Mirror removed (TM 9-2320-303-24-1)

**(M915A2P1, M916A1P1, M916A2P1, and M917A1P1)**

- Vehicle parked on level ground (TM 9-2320-363-10)
- Parking/Emergency Brake applied (TM 9-2320-363-10)
- Engine OFF (TM 9-2320-363-10)
- If equipped, Battery Disconnect Switch in OFF position (TM 9-2320-363-10), otherwise, disconnect Battery Cables (TM 9-2320-363-20-2)
- Outside Door Mirror removed (TM 9-2320-363-20-2)

**NOTE**

The following procedure is for right door assembly. Use same procedure for left door assembly.

**REMOVAL****WARNING**

Use extreme caution when handling heavy parts. Provide adequate support and use assistance during procedure. Ensure that any lifting device used is in good condition and of suitable load capacity. Keep clear of heavy parts supported only by lifting device. Failure to follow this warning may cause injury or death to personnel.

1. Attach a sling to armored door (10).
2. Attach lifting device to sling on armored door (10).
3. Using lifting device, hold armored door suspended and remove hinge pin (11) and armored door (10) from door frame assembly (5).
4. Remove lifting device from sling on door assembly (10).
5. Remove sling from door assembly (10).
6. Remove two locknuts (1), washers (2), bolts (4), and washers (3) from door frame assembly (5). Discard locknuts.
7. Remove six bolts (12), washers (13), and lockwashers (14) from door frame assembly (5). Discard lockwashers.
8. Remove six locknuts (6), washers (7), bolts (9), and washers (8) from door frame assembly (5). Discard locknuts.

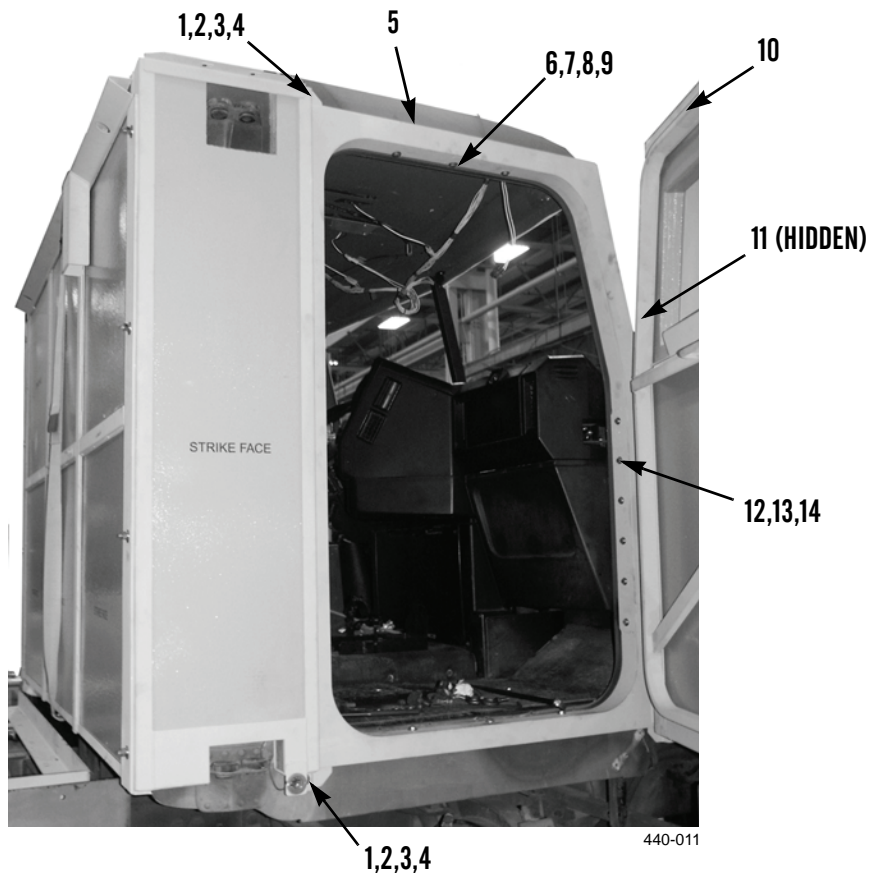

**DOOR AND FRAME ASSEMBLY REPLACEMENT - CONTINUED**

0012 00

**REMOVAL - CONTINUED**

9. Remove four locknuts (15), washers (16), bolts (18), washers (17), and two cam engagement angles (19) from door frame assembly (5). Discard locknuts.
10. Remove four locknuts (20), washers (21), bolts (23), washers (22), and two angle alignment guides (24) from door frame assembly (5). Discard locknuts.

**WARNING**

Use extreme caution when handling heavy parts. Provide adequate support and use assistance during procedure. Failure to follow this warning may cause injury or death to personnel.

11. With assistance, remove four locknuts (25), washers (26), bolts (28), washers (27), and door frame assembly (5) from vehicle. Discard locknuts.

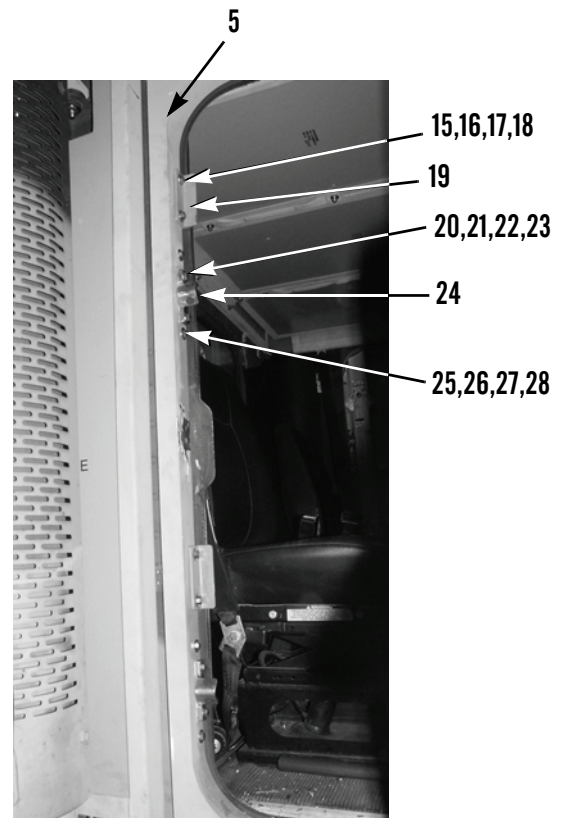

440-013

**CLEANING AND INSPECTION**

Clean and inspect all parts IAW *General Maintenance Instructions* (WP 0011 00).

**INSTALLATION****WARNING**

Use extreme caution when handling heavy parts. Provide adequate support and use assistance during procedure. Failure to follow this warning may cause injury or death to personnel.

1. Install door frame assembly (5) to vehicle door frame with four washers (27), bolts (28), washers (26), and new locknuts (25).
2. Install two angle alignment guides (24), four washers (22), bolts (23), washers (21), and new locknuts (20) on door frame assembly (5).
3. Install two cam engagement angles (19), four washers (17), bolts (18), washers (16), and new locknuts (15) on door frame assembly (5).

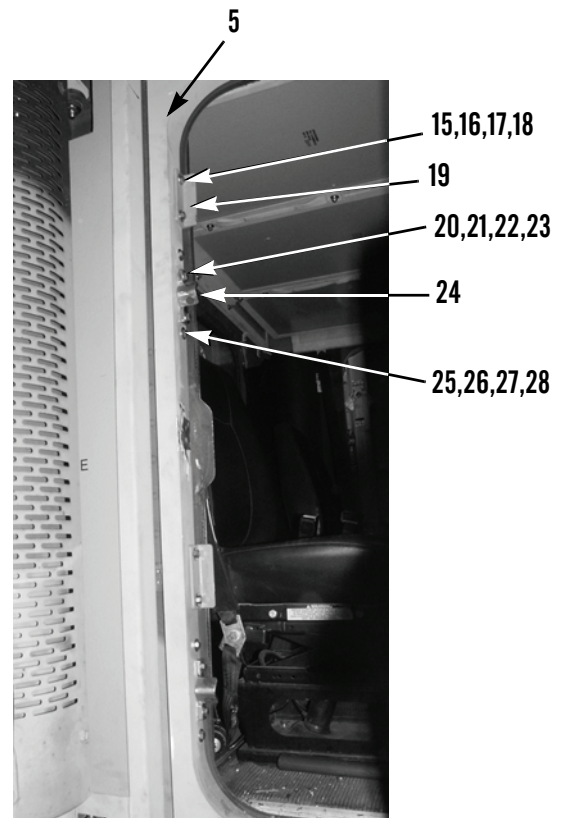

440-013

4. Install six washers (8), bolts (9), washers (7), and new locknuts (6) on door frame assembly (5).
5. Install six new lockwashers (14), washers (13), and bolts (12) on door frame assembly (5).
6. Install two washers (3), bolts (4), washers (2), and new locknuts (1) on door frame assembly (5).



---

**DOOR AND FRAME ASSEMBLY REPLACEMENT - CONTINUED**

---

**0012 00**

***INSTALLATION - CONTINUED***

12. Verify correct operation of door assembly (WP 0004 00).
13. If removed, install outside mirror on door assembly. For the M915A3P1, M916A3P1, and M917A2P1, refer to TM 9-2320-302-20-2. For the M915A4P1, refer to TM 9-2320-303-24-1. For the M915A2P1, M916A1P1, M916A2P1, and M917A1P1, refer to TM 9-2320-363-20-2.

**END OF WORK PACKAGE**



---

**DOOR HANDLE REPLACEMENT**

**0013 00**

---

**THIS WORK PACKAGE COVERS**

Removal, Cleaning and Inspection, Installation

---

**INITIAL SETUP**

**Maintenance Level**

Unit

**Tools and Special Tools**

Tool Kit, General Mechanic's (Item 9, WP 0035 00)

**Materials/Parts**

Rag, Wiping (Item 9, WP 0036 00)

Cotter Pin (2)

Lockwasher (3)

**References**

WP 0011 00

WP 0015 00

**Equipment Conditions**

**(M915A3P1, M916A3P1, and M917A2P1)**

Vehicle parked on level ground (TM 9-2320-302-10)

Parking/Emergency Brake applied (TM 9-2320-302-10)

Engine OFF (TM 9-2320-302-10)

Battery Disconnect Switch in OFF position (TM 9-2320-302-10)

**Equipment Conditions - Continued**

**(M915A4P1)**

Vehicle parked on level ground (TM 9-2320-303-10)

Parking/Emergency Brake applied (TM 9-2320-303-10)

Engine OFF (TM 9-2320-303-10)

Battery Disconnect Switch in OFF position (TM 9-2320-303-10)

**(M915A2P1, M916A1P1, M916A2P1, and M917A1P1)**

Vehicle parked on level ground (TM 9-2320-363-10)

Parking/Emergency Brake applied (TM 9-2320-363-10)

Engine OFF (TM 9-2320-363-10)

If equipped, Battery Disconnect Switch in OFF position (TM 9-2320-363-10), otherwise, disconnect Battery Cables (TM 9-2320-363-20-2)

---

**NOTE**

The following procedure is for right door handles. Use same procedure for left door handles.

**DOOR HANDLE REPLACEMENT - CONTINUED**

**0013 00**

**REMOVAL**

1. Remove three bolts (1), washers (3), lockwashers (2), and external door handle (4) from external mounting plate (5). Discard lockwashers.

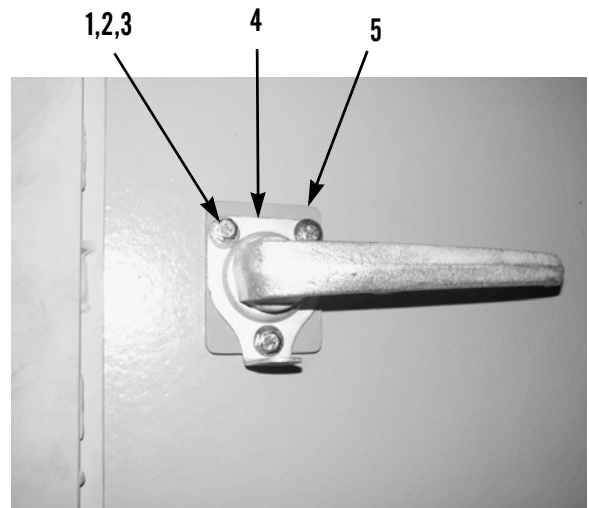

440-004

2. Remove two bolts (6), external mounting plate (5), and internal mounting plate (10) from door assembly (7).
3. Remove two cotter pins (8) and internal door handle (9) from door assembly (7). Discard cotter pins.

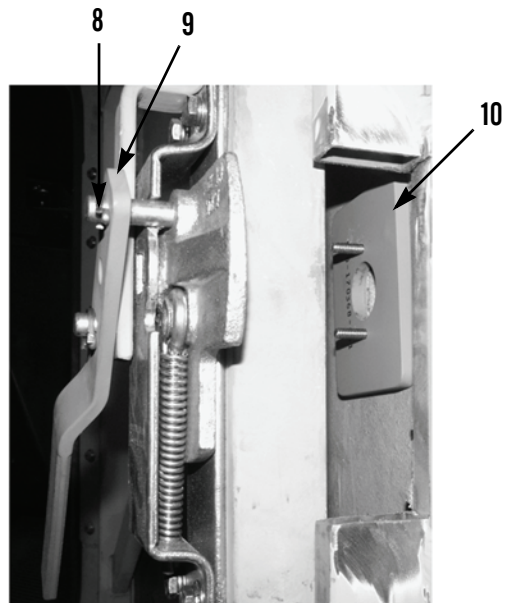
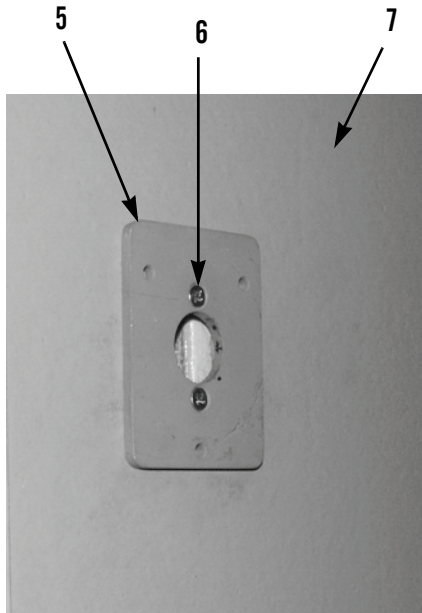

440-012

***CLEANING AND INSPECTION***

Clean and inspect all parts IAW *General Maintenance Instructions* (WP 0011 00).

***INSTALLATION***

1. Install internal door handle (9) and two new cotter pins (8) on door assembly (7).
2. Install internal mounting plate (10), external mounting plate (5), and two bolts on door assembly (7). Center plate hole on internal bolt hole before tightening bolts.
3. Install external door handle (4), three new lockwashers (2), washers (3), and bolts (1) on external mounting plate (5).
4. Check alignment of door latch (WP 0015 00).

**END OF WORK PACKAGE**



---

**DOOR CAM LATCH REPLACEMENT**

---

0014 00

**THIS WORK PACKAGE COVERS**Removal, Cleaning and Inspection, Installation

---

**INITIAL SETUP****Maintenance Level**

Unit

**Tools and Special Tools**

Tool Kit, General Mechanic's (Item 9, WP 0035 00)

**Materials/Parts**

Rag, Wiping (Item 9, WP 0036 00)

Cotter Pin (3)

Lockwasher (8)

**References**

WP 0004 00

WP 0011 00

**Equipment Conditions****(M915A3P1, M916A3P1, and M917A2P1)**

Vehicle parked on level ground (TM 9-2320-302-10)

Parking/Emergency Brake applied (TM 9-2320-302-10)

Engine OFF (TM 9-2320-302-10)

Battery Disconnect Switch in OFF position (TM 9-2320-302-10)

**Equipment Conditions - Continued****(M915A4P1)**

Vehicle parked on level ground (TM 9-2320-303-10)

Parking/Emergency Brake applied (TM 9-2320-303-10)

Engine OFF (TM 9-2320-303-10)

Battery Disconnect Switch in OFF position (TM 9-2320-303-10)

**(M915A2P1, M916A1P1, M916A2P1, and M917A1P1)**

Vehicle parked on level ground (TM 9-2320-363-10)

Parking/Emergency Brake applied (TM 9-2320-363-10)

Engine OFF (TM 9-2320-363-10)

If equipped, Battery Disconnect Switch in OFF position (TM 9-2320-363-10), otherwise, disconnect Battery Cables (TM 9-2320-363-20-2)

---

**NOTE**

The following procedure is for right side latch. Use same procedure for left side latch.

**DOOR CAM LATCH REPLACEMENT - CONTINUED**

0014 00

**REMOVAL**

1. Remove two cotter pins (10) and interior door handle (9) from door latch (6). Discard cotter pins.
2. Remove cotter pin (1), four washers (2), and cam connecting bar (7) from door latch (6). Discard cotter pin.
3. Remove eight bolts (3), washers (5), lockwashers (4), and two door latches (6) from door assembly (8). Discard lockwashers.

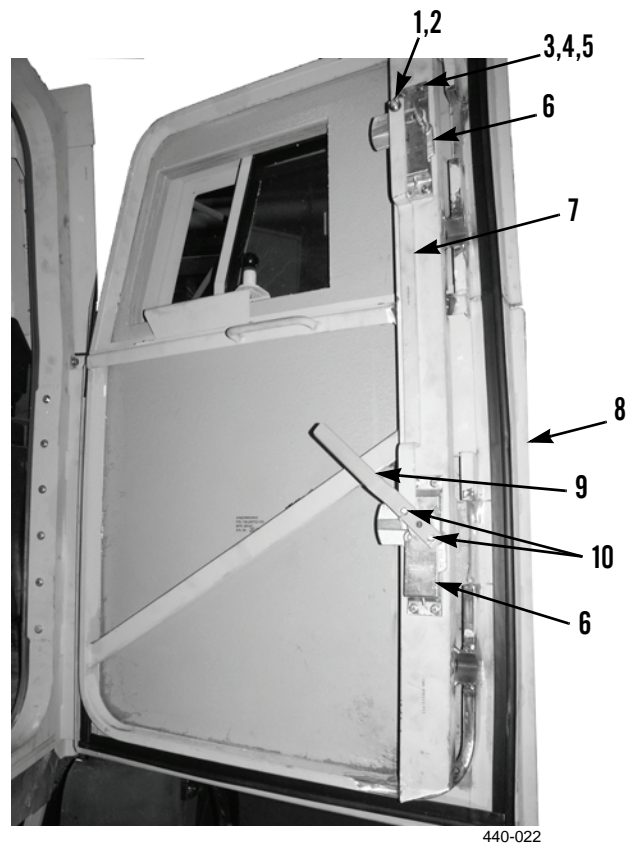
**CLEANING AND INSPECTION**

Clean and inspect all parts IAW *General Maintenance Instructions* (WP 0011 00).

**INSTALLATION**

1. Install two door latches (6), eight new lockwashers (4), washers (5), and bolts (3) on door assembly (8).
2. Install cam connecting bar (7), four washers (2), and new cotter pin (1) on door latch (6).
3. Install door handle (9) and two new cotter pins (10) on door latch (6).
4. Verify correct operation of door assembly (WP 0004 00).

**END OF WORK PACKAGE**

---

**DOOR CAM LATCH ADJUSTMENT**

**0015 00**

---

**THIS WORK PACKAGE COVERS**

Adjustment

---

**INITIAL SETUP**

**Maintenance Level**

Unit

**Tools and Special Tools**

Tool Kit, General Mechanic's (Item 9, WP 0035 00)

**Materials/Parts**

Rag, Wiping (Item 9, WP 0036 00)

**Equipment Conditions**

**(M915A3P1, M916A3P1, and M917A2P1)**

Vehicle parked on level ground (TM 9-2320-302-10)

Parking/Emergency Brake applied (TM 9-2320-302-10)

Engine OFF (TM 9-2320-302-10)

Battery Disconnect Switch in OFF position (TM 9-2320-302-10)

**Equipment Conditions - Continued**

**(M915A4P1)**

Vehicle parked on level ground (TM 9-2320-303-10)

Parking/Emergency Brake applied (TM 9-2320-303-10)

Engine OFF (TM 9-2320-303-10)

Battery Disconnect Switch in OFF position (TM 9-2320-303-10)

**(M915A2P1, M916A1P1, M916A2P1, and M917A1P1)**

Vehicle parked on level ground (TM 9-2320-363-10)

Parking/Emergency Brake applied (TM 9-2320-363-10)

Engine OFF (TM 9-2320-363-10)

If equipped, Battery Disconnect Switch in OFF position (TM 9-2320-363-10), otherwise, disconnect Battery Cables (TM 9-2320-363-20-2)

---

**ADJUSTMENT****NOTE**

The contact point for the cam latch can be adjusted by loosening two bolts (1) for the upper cam and two bolts (3) for the lower cam.

1. Loosen two bolts (1) and adjust upper cam engagement angle (2) until upper cam pulls door closed without binding.
2. Loosen two bolts (3) and adjust lower cam engagement angle (4) until lower cam pulls door closed without binding.
3. Repeat steps 1 and 2 as required to ensure correct operation of cam latching mechanism.

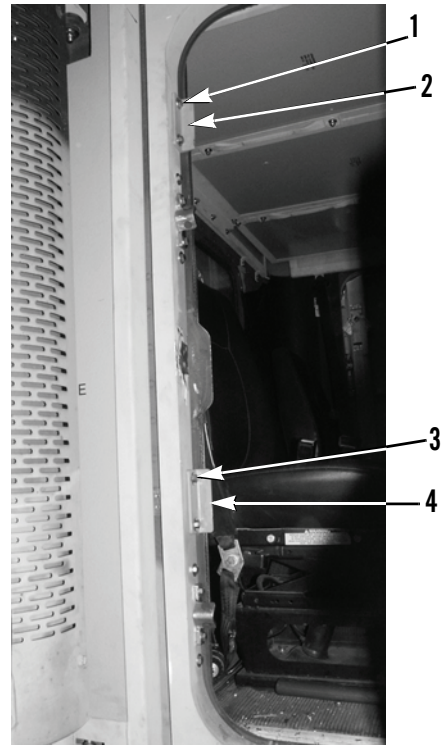

440-013

**END OF WORK PACKAGE**



---

**DOOR BALLISTIC GLASS AND FRAME ASSEMBLY REPLACEMENT**

---

**0016 00**

**THIS WORK PACKAGE COVERS**

Removal, Cleaning and Inspection, Installation

---

**INITIAL SETUP**

**Maintenance Level**

Unit

**Tools and Special Tools**

Tool Kit, General Mechanic's (Item 9, WP 0035 00)

**Materials/Parts**

Rag, Wiping (Item 9, WP 0036 00)

Lockwasher (14)

**Personnel Required**

Two

**References**

WP 0011 00

**Equipment Conditions**

**(M915A3P1, M916A3P1, and M917A2P1)**

Vehicle parked on level ground (TM 9-2320-302-10)

Parking/Emergency Brake applied (TM 9-2320-302-10)

Engine OFF (TM 9-2320-302-10)

Battery Disconnect Switch in OFF position (TM 9-2320-302-10)

**Equipment Conditions - Continued**

**(M915A4P1)**

Vehicle parked on level ground (TM 9-2320-303-10)

Parking/Emergency Brake applied (TM 9-2320-303-10)

Engine OFF (TM 9-2320-303-10)

Battery Disconnect Switch in OFF position (TM 9-2320-303-10)

**(M915A2P1, M916A1P1, M916A2P1, and M917A1P1)**

Vehicle parked on level ground (TM 9-2320-363-10)

Parking/Emergency Brake applied (TM 9-2320-363-10)

Engine OFF (TM 9-2320-363-10)

If equipped, Battery Disconnect Switch in OFF position (TM 9-2320-363-10), otherwise, disconnect Battery Cables (TM 9-2320-363-20-2)

---

**NOTE**

The following procedure is for right side door ballistic glass and frame. Use same procedure for left side door ballistic glass and frame.

**REMOVAL****WARNING**

- Use extreme caution when handling heavy parts. Provide adequate support and use assistance during procedure. Failure to follow this warning may cause injury or death to personnel.
  - Use caution when handling window glass. Glass can break unexpectedly during removal/installation procedure. Wear face shield, apron, and gloves. Failure to follow this warning may cause injury to personnel.
1. With assistance, remove 14 bolts (1), washers (3), lockwashers (2), and door ballistic glass frame (4) while maintaining support for door ballistic glass (6). Discard lockwashers.
  2. With assistance, carefully remove door ballistic glass (6) from outside of door (5).

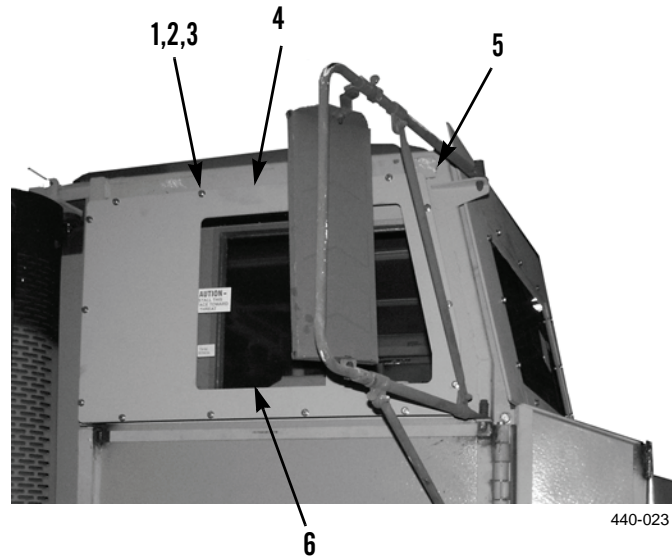
**CLEANING AND INSPECTION**

Clean and inspect all parts IAW *General Maintenance Instructions* (WP 0011 00).

**INSTALLATION****WARNING**

- Use extreme caution when handling heavy parts. Provide adequate support and use assistance during procedure. Failure to follow this warning may cause injury or death to personnel.
  - Use caution when handling window glass. Glass can break unexpectedly during removal/installation procedure. Wear face shield, apron, and gloves. Failure to follow this warning may cause injury to personnel.
  - For proper threat protection, ballistic glass must be correctly installed onto ballistic glass frame. During installation, ensure that decal “INSTALL THIS SURFACE TOWARDS THREAT” is located on outside of cab. Improperly installed ballistic glass will not protect occupants. Failure to follow this warning may cause injury or death to personnel.
1. With assistance, carefully install ballistic glass (6) from outside of door (5).
  2. With assistance, install door ballistic glass frame (4), 14 new lockwashers (2), washers (3), and bolts (1) while maintaining support for ballistic glass (6).

**END OF WORK PACKAGE**



**THIS WORK PACKAGE COVERS**

Removal, Cleaning and Inspection, Installation

**INITIAL SETUP**

**Maintenance Level**

Unit

**Tools and Special Tools**

Tool Kit, General Mechanic's (Item 9, WP 0035 00)

Sling, Beam Type (Item 7, WP 0035 00)

**Materials/Parts**

Rag, Wiping (Item 9, WP 0036 00)

Two each Block, Wood 6 ft x 2 in. x 4 in.

One each Block, Wood 12 in. x 4 in. x 4 in.

Locknut (2)

Lockwasher (40)

**Personnel Required**

Two

**References**

WP 0011 00

**Equipment Conditions**

**(M915A3P1, M916A3P1, and M917A2P1)**

Vehicle parked on level ground (TM 9-2320-302-10)

Parking/Emergency Brake applied (TM 9-2320-302-10)

Engine OFF (TM 9-2320-302-10)

Battery Disconnect Switch in OFF position (TM 9-2320-302-10)

Right and Left Seats removed (TM 9-2320-302-20-2)

Transmission Shift Tower removed (TM 9-2320-302-20-2)

Air Cleaner and Intake Duct Hosing removed (TM 9-2320-302-20-2)

**Equipment Conditions - Continued**

**(M915A4P1)**

Vehicle parked on level ground (TM 9-2320-303-10)

Parking/Emergency Brake applied (TM 9-2320-303-10)

Engine OFF (TM 9-2320-303-10)

Battery Disconnect Switch in OFF position (TM 9-2320-303-10)

Right and Left Seats removed (TM 9-2320-303-24-1)

Transmission Shift Tower removed (TM 9-2320-303-24-1)

Air Cleaner and Intake Duct Hosing removed (TM 9-2320-303-24-1)

**(M915A2P1, M916A1P1, M916A2P1, and M917A1P1)**

Vehicle parked on level ground (TM 9-2320-363-10)

Parking/Emergency Brake applied (TM 9-2320-363-10)

Engine OFF (TM 9-2320-363-10)

If equipped, Battery Disconnect Switch in OFF position (TM 9-2320-363-10), otherwise, disconnect Battery Cables (TM 9-2320-363-20-2)

Right and Left Seats removed (TM 9-2320-363-20-2)

Transmission Shift Tower removed (TM 9-2320-363-20-2)

Air Cleaner and Intake Duct Hosing removed (TM 9-2320-363-20-2)

**REMOVAL**

1. Remove two locknuts (3) and washers (2) from rear cab mounts (1). Discard locknuts.

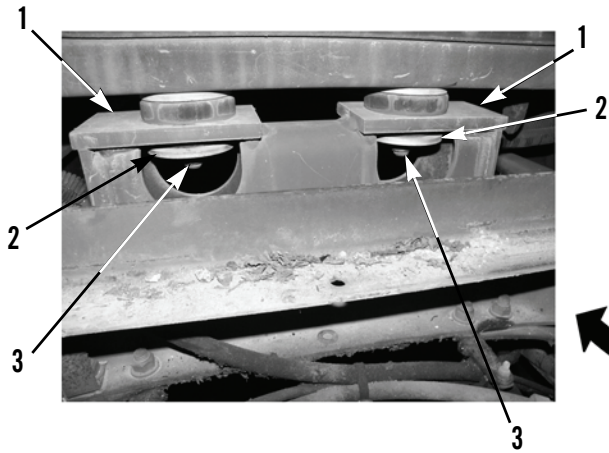

440-091

**REMOVAL - CONTINUED****WARNING**

- Use extreme caution when handling heavy parts. Provide adequate support and use assistance during procedure. Ensure that any lifting device used is in good condition and of suitable load capacity. Keep clear of heavy parts supported only by lifting device. Failure to follow this warning may cause injury or death to personnel.
  - Cab assembly with armor kit installed weighs 3,520 lb (1598 kg). Use hoist with lifting capacity of 4,000 lb (1816 kg) to support cab assembly. Failure to follow this warning may cause injury or death to personnel.
2. Lift cab assembly (4) using lifting device attached to sling. Insert a 12 in. x 4 in. x 4 in. block of wood as shown (5).

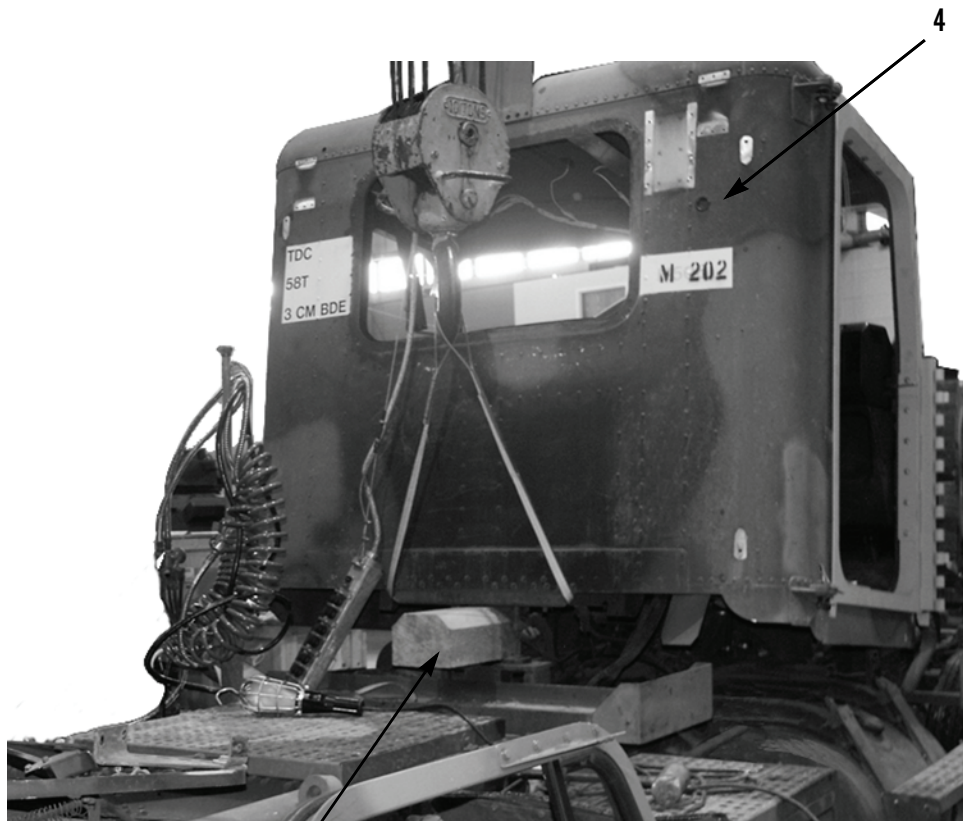

440-015

5

**REMOVAL - CONTINUED**

3. Pull shift cable (10) through center underbody mine blast panel (9).
4. Place two 6 ft long 2 in. x 4 in. supports across truck frame (11), under cab.

**WARNING**

Use extreme caution when handling heavy parts. Provide adequate support and use assistance during procedure. Failure to follow this warning may cause injury or death to personnel.

5. With assistance, remove eight nuts (6), lockwashers (7), washers (8) and center underbody mine blast panel (9), using 2 in. x 4 in. supports as a guide. Discard lockwashers.
6. Remove two 6 ft long 2 in. x 4 in. supports.

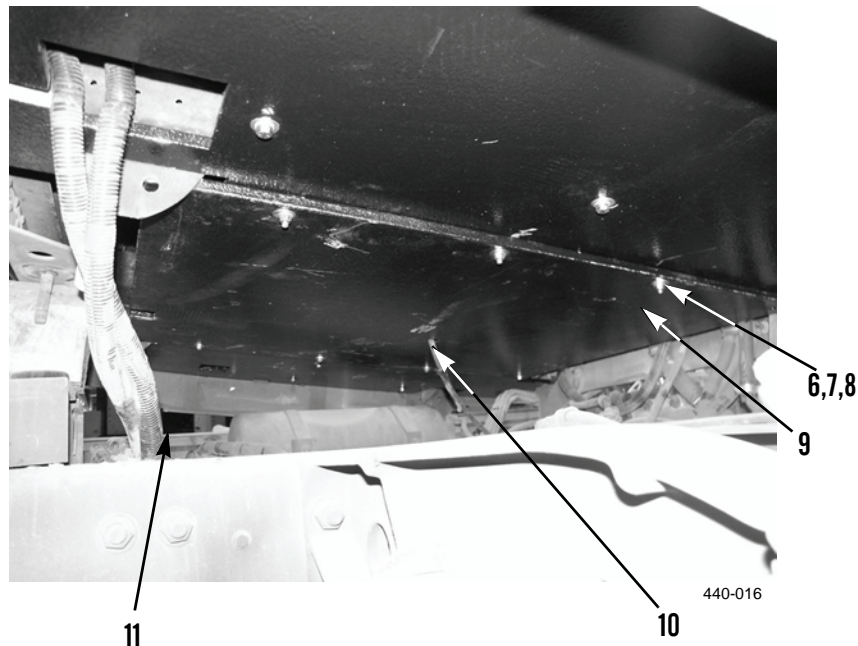



**REMOVAL - CONTINUED****WARNING**

Use extreme caution when handling heavy parts. Provide adequate support and use assistance during procedure. Failure to follow this warning may cause injury or death to personnel.

7. With assistance, remove eight bolts (13), washers (14), lockwashers (15), and right underbody mine blast panel (12) from underside of cab assembly (4). Discard lockwashers.
8. Remove stud plate (16) from right underbody mine blast panel (12).

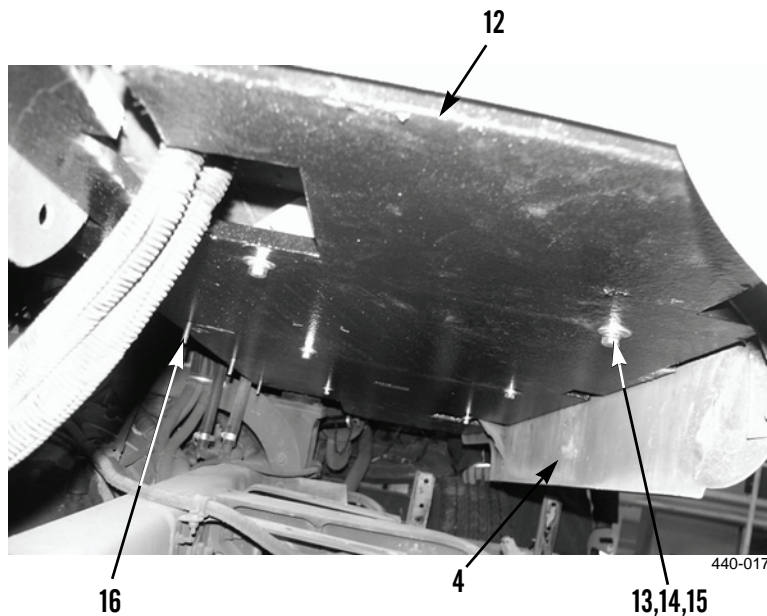

**REMOVAL - CONTINUED****NOTE**

Assistance is required to remove mine blast mounting brackets from underneath cab as mounting hardware is removed.

9. With assistance, remove six bolts (17), washers (18), lockwashers (19), and three right-hand mine blast mounting brackets (20) from underside of cab assembly (4). Discard lockwashers.

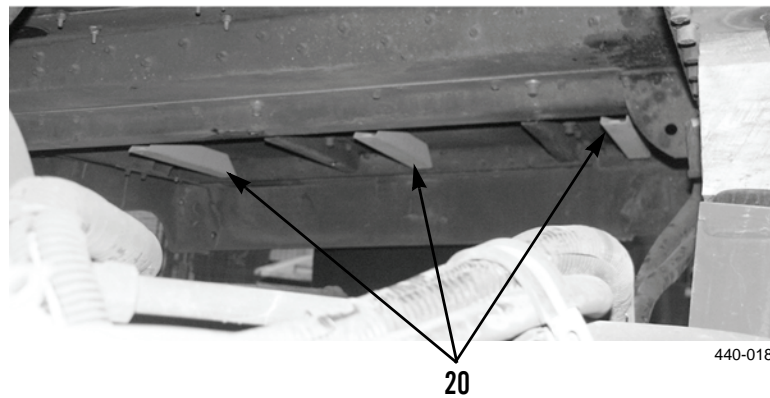
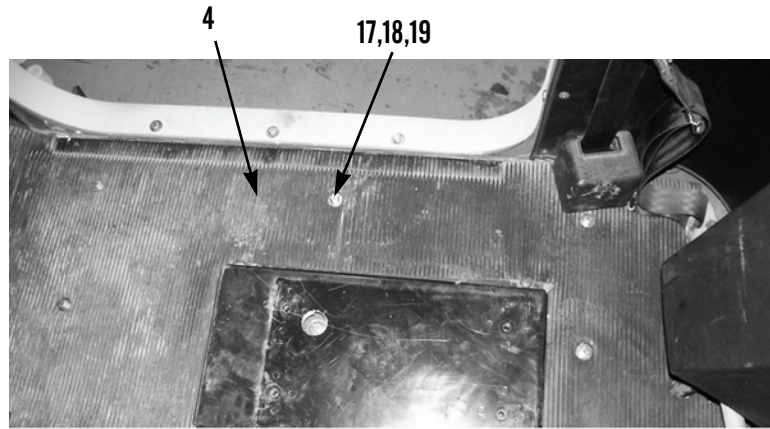

**UNDERBODY MINE BLAST PANEL REPLACEMENT - CONTINUED**

**0017 00**

**REMOVAL - CONTINUED**

10. Remove four bolts (21), washers (22), lockwashers (23), and ground wires (27) from transmission wiring harness plug mounting plate (24) located on left inside of cab assembly (4). Discard lockwashers.
11. Pull transmission wiring harness (25) through left underbody mine blast panel (26).

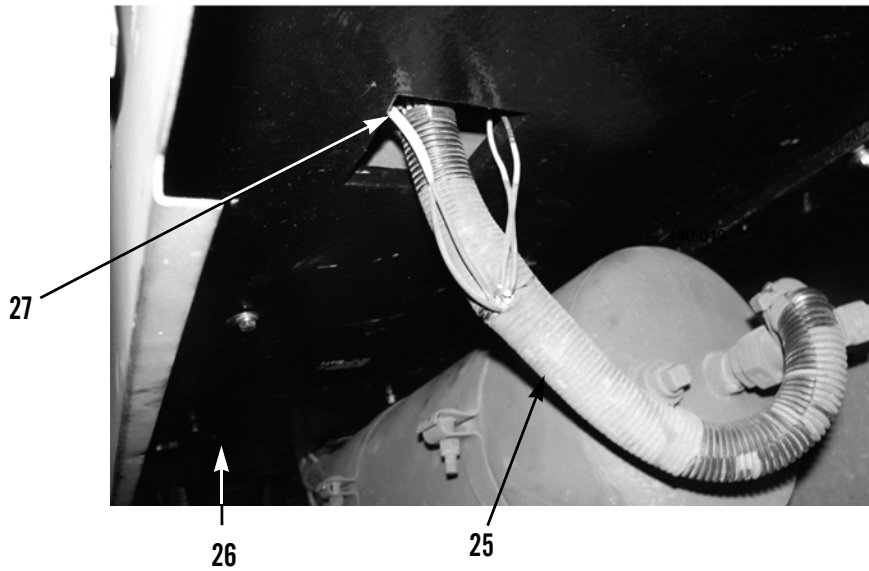
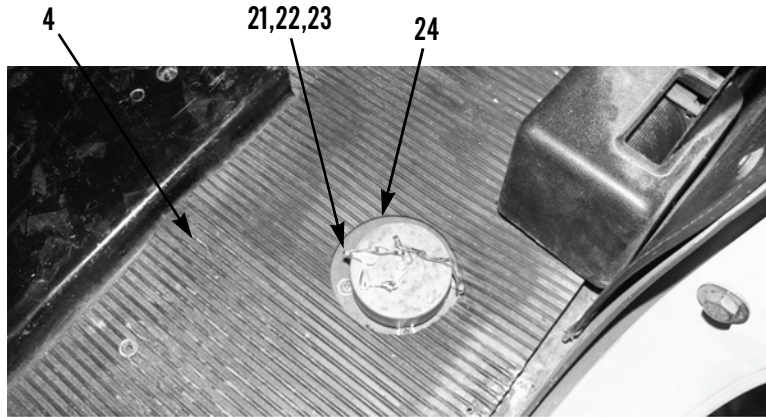

**REMOVAL - CONTINUED****WARNING**

Use extreme caution when handling heavy parts. Provide adequate support and use assistance during procedure. Failure to follow this warning may cause injury or death to personnel.

12. With assistance, remove eight bolts (28), washers (29), lockwashers (30), and left underbody mine blast panel (26) from underside of cab assembly (4). Discard lockwashers.
13. Remove stud plate (31) from left underbody mine blast panel (26).

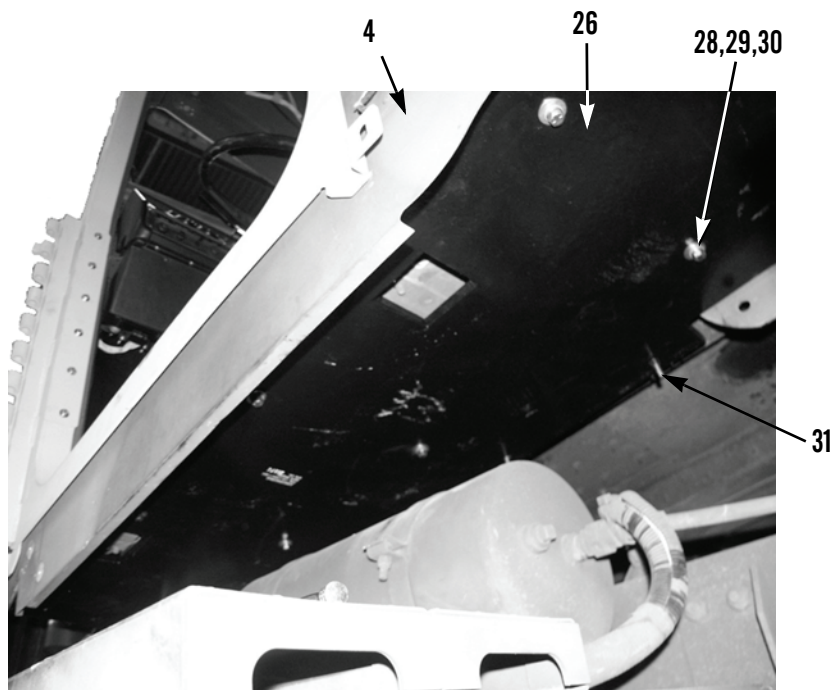

440-020

**REMOVAL - CONTINUED**

**NOTE**

Assistance is required to remove mine blast mounting brackets from underneath cab as mounting hardware is removed.

14. With assistance, remove six bolts (32), washers (33), lockwashers (34), and three left-hand mine blast mounting brackets (35) under cab assembly (4). Discard lockwashers.

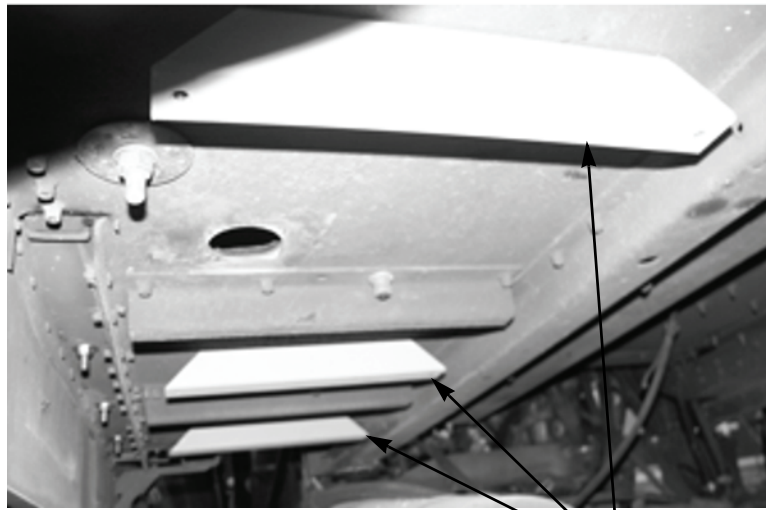
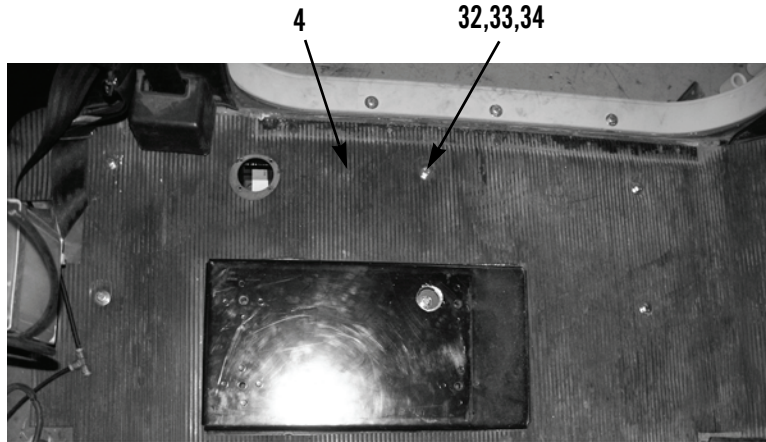

440-021

35

**CLEANING AND INSPECTION**

Clean and inspect all parts IAW *General Maintenance Instructions* (WP 0011 00).



**INSTALLATION**

**NOTE**

Assistance is required to hold up mine blast mounting brackets underneath cab as mounting hardware is installed.

1. With assistance, install three left-hand mine blast mounting brackets (35) with six new lockwashers (34), washers (33), and bolts (32) under cab assembly (4).

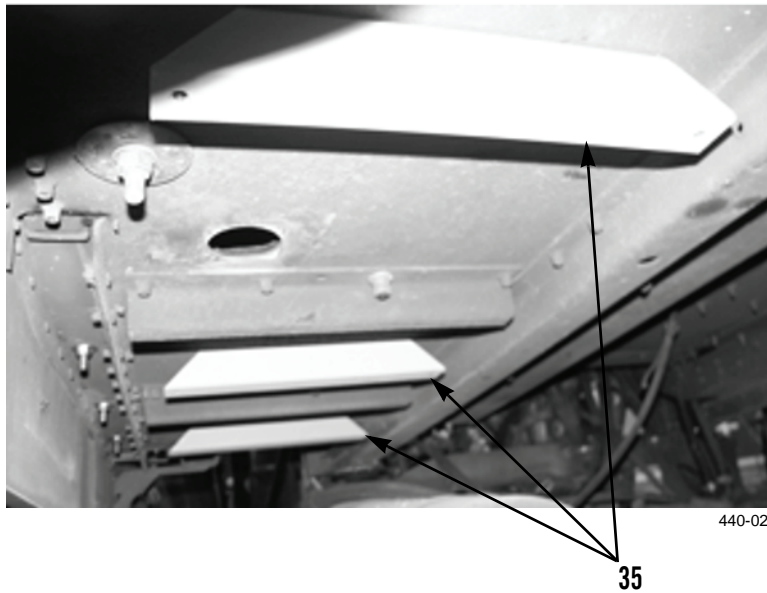
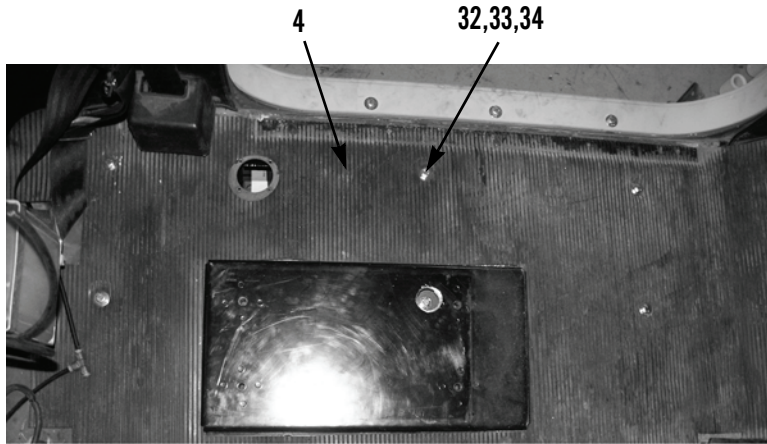

440-021

**INSTALLATION - CONTINUED**

2. Install stud plate (31) on left underbody mine blast panel (26).

**WARNING**

Use extreme caution when handling heavy parts. Provide adequate support and use assistance during procedure. Failure to follow this warning may cause injury or death to personnel.

3. With assistance, install left underbody mine blast panel (26), eight new lockwashers (30), washers (29), and bolts (28) on underside of cab assembly (4).

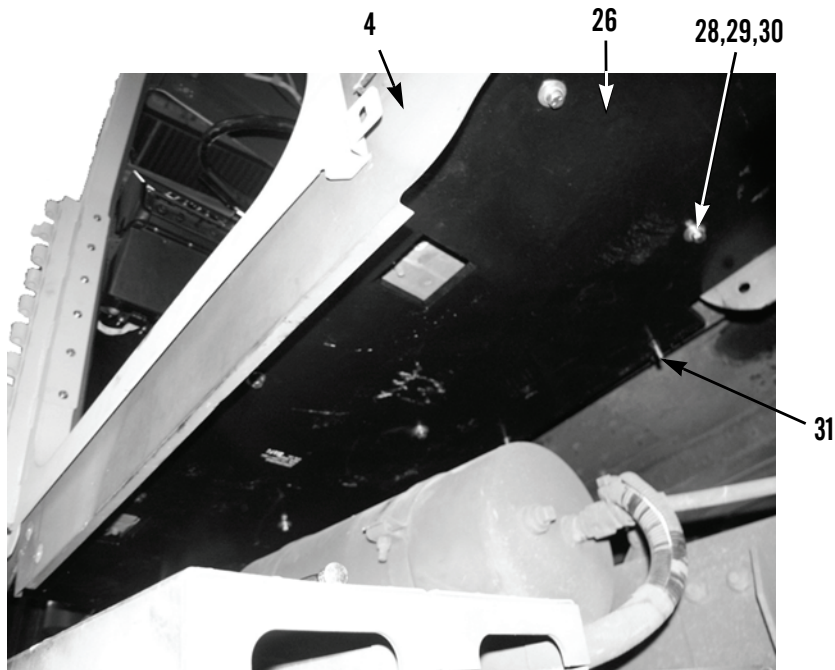

440-020

**INSTALLATION - CONTINUED**

4. Push cable (25) through left underbody mine blast panel (26).
5. Install cable plug mounting plate (24) located on left inside of cab assembly (4) with four ground wires (27), new lock-washers (23), washers (22), and bolts (21).

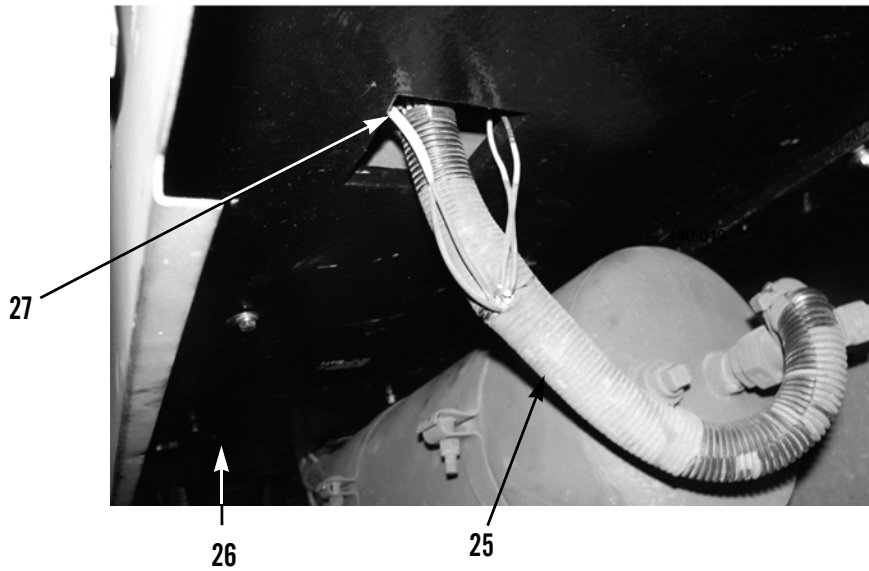
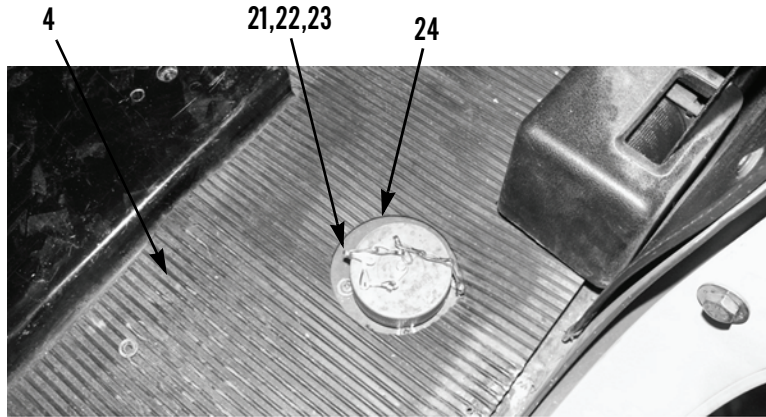



**INSTALLATION - CONTINUED**

**NOTE**

Assistance is required to hold up mine blast mounting brackets underneath cab as mounting hardware is installed.

6. With assistance, install three right-hand mine blast mounting brackets (20), six new lockwashers (19), washers (18), and bolts (17) on underside of cab assembly (4).

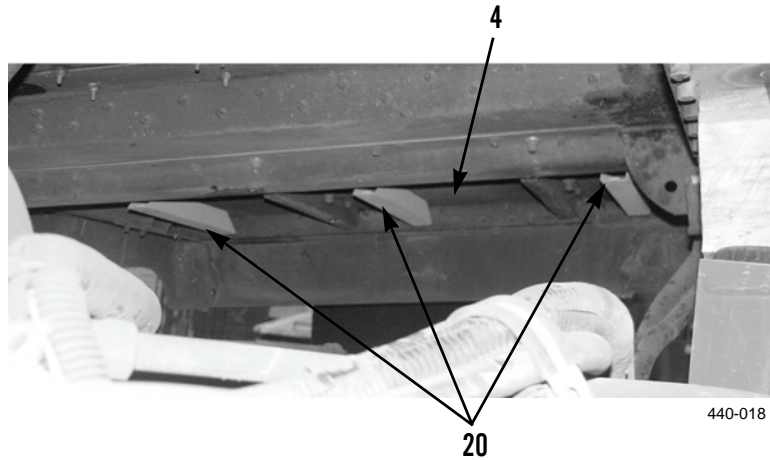

**INSTALLATION - CONTINUED**

7. Install stud plate (16) on right underbody mine blast panel (12).

**WARNING**

Use extreme caution when handling heavy parts. Provide adequate support and use assistance during procedure. Failure to follow this warning may cause injury or death to personnel.

8. With assistance, install right underbody mine blast panel (12), eight new lockwashers (15), washers (14), and bolts (13) on underside of cab assembly (4).

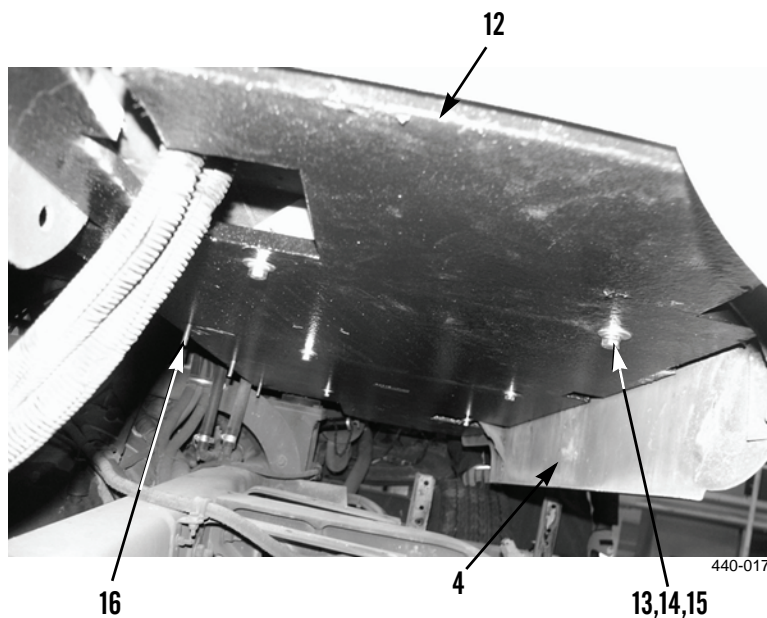

**INSTALLATION - CONTINUED**

9. Place two 6 ft long 2 in. x 4 in. supports across truck frame (11), under cab.

**WARNING**

Use extreme caution when handling heavy parts. Provide adequate support and use assistance during procedure. Failure to follow this warning may cause injury or death to personnel.

10. With assistance, install center underbody mine blast panel (9), eight washers (8), new lockwashers (7), and nuts (6).
11. Remove two 6 ft long 2 in. x 4 in. supports.
12. Push shift cable (10) through center underbody mine blast panel (9) and through hole to inside of cab.

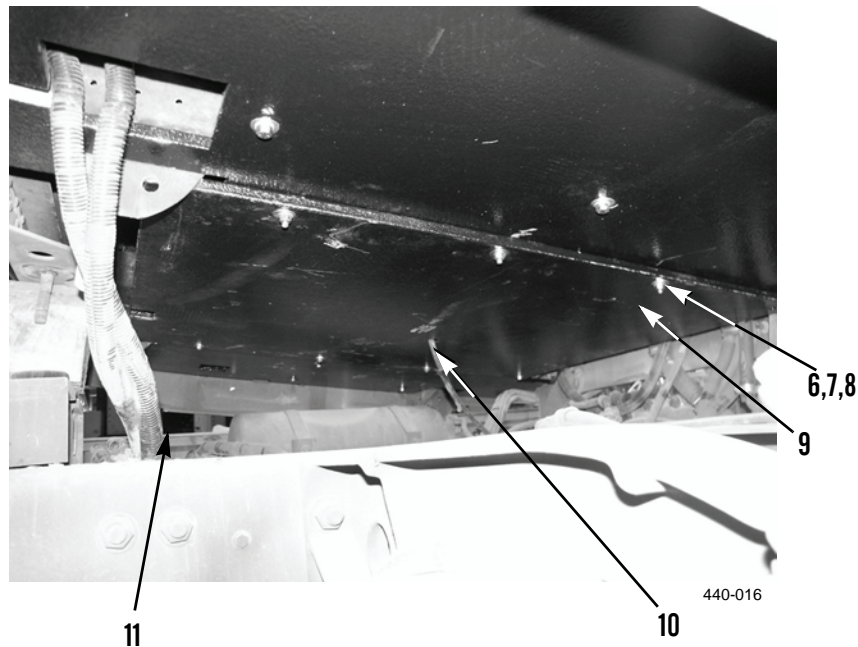

**INSTALLATION - CONTINUED****WARNING**

- Use extreme caution when handling heavy parts. Provide adequate support and use assistance during procedure. Ensure that any lifting device used is in good condition and of suitable load capacity. Keep clear of heavy parts supported only by lifting device. Failure to follow this warning may cause injury or death to personnel.
  - Cab assembly with armor kit installed weighs 3,520 lb (1598 kg). Use hoist with lifting capacity of 4,000 lb to support cab assembly. Failure to follow this warning may cause injury or death to personnel.
13. Lift cab assembly (4), using lifting device attached to sling. Remove 12 in. x 4 in. x 4 in. block of wood (5), then lower cab.

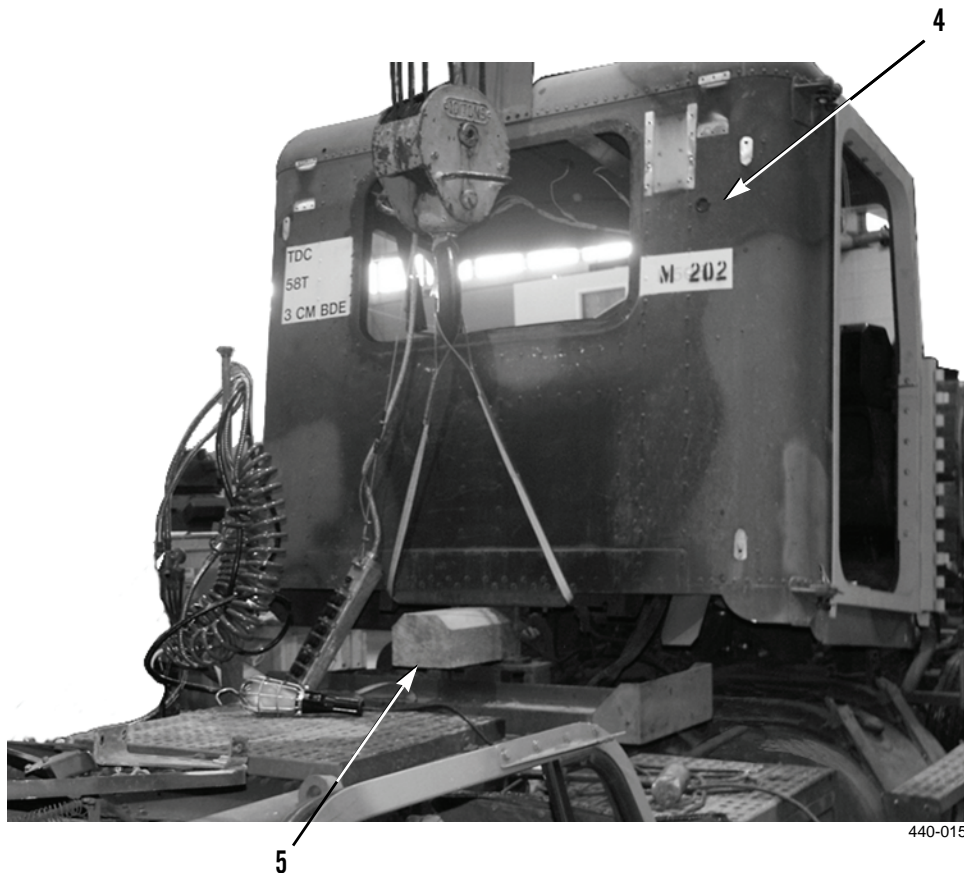

**INSTALLATION - CONTINUED**

14. Install two washers (2) and new locknuts (3) on rear cab mounts (1).

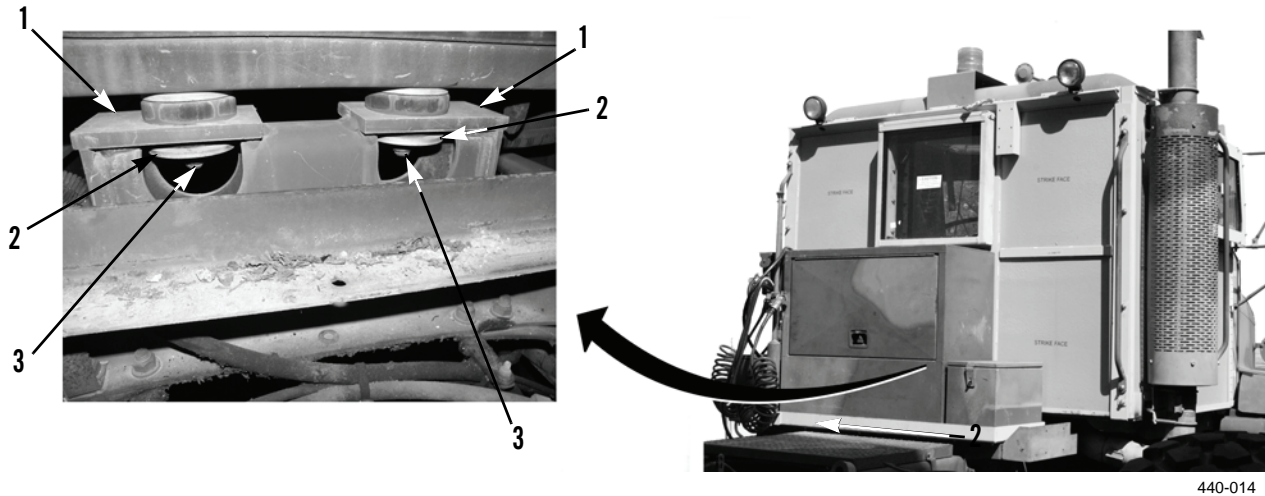

15. Install air cleaner and intake duct hosing. For the M915A3P1, M916A3P1, and M917A2P1, refer to TM 9-2320-302-20-2. For the M915A4P1, refer to TM 9-2320-303-24-1. For the M915A2P1, M916A1P1, M916A2P1, and M917A1P1, refer to TM 9-2320-363-20-2.
16. Install transmission shift tower. For the M915A3P1, M916A3P1, and M917A2P1, refer to TM 9-2320-302-20-2. For the M915A4P1, refer to TM 9-2320-303-24-1. For the M915A2P1, M916A1P1, M916A2P1, and M917A1P1, refer to TM 9-2320-363-20-2.
17. Install right and left seats. For the M915A3P1, M916A3P1, and M917A2P1, refer to TM 9-2320-302-20-2. For the M915A4P1, refer to TM 9-2320-303-24-1. For the M915A2P1, M916A1P1, M916A2P1, and M917A1P1, refer to TM 9-2320-363-20-2.

**END OF WORK PACKAGE**



---

**REAR CAB ARMOR REPLACEMENT**

---

0018 00

**THIS WORK PACKAGE COVERS**Removal, Cleaning and Inspection, Installation

---

**INITIAL SETUP****Maintenance Level**

Unit

**Tools and Special Tools**

Tool Kit, General Mechanic's (Item 9, WP 0035 00)

**Materials/Parts**

Rag, Wiping (Item 9, WP 0036 00)

Locknut (13)

Lockwasher (14)

**Personnel Required**

Two

**References**

WP 0011 00

WP 0019 00

**Equipment Conditions****(M915A3P1, M916A3P1, and M917A2P1)**

Vehicle parked on level ground (TM 9-2320-302-10)

Parking/Emergency Brake applied (TM 9-2320-302-10)

Engine OFF (TM 9-2320-302-10)

Battery Disconnect Switch in OFF position (TM 9-2320-302-10)

Personal Gear Storage Box removed (TM 9-2320-302-20-2)

**Equipment Conditions - Continued****(M915A4P1)**

Vehicle parked on level ground (TM 9-2320-303-10)

Parking/Emergency Brake applied (TM 9-2320-303-10)

Engine OFF (TM 9-2320-303-10)

Battery Disconnect Switch in OFF position (TM 9-2320-303-10)

Personal Gear Storage Box removed (TM 9-2320-303-24-1)

**(M915A2P1, M916A1P1, M916A2P1, and M917A1P1)**

Vehicle parked on level ground (TM 9-2320-363-10)

Parking/Emergency Brake applied (TM 9-2320-363-10)

Engine OFF (TM 9-2320-363-10)

If equipped, Battery Disconnect Switch in OFF position (TM 9-2320-363-10), otherwise, disconnect Battery Cables (TM 9-2320-363-20-2)

Personal Gear Storage Boxes removed (TM 9-2320-363-20-2)

---



**REAR CAB ARMOR REPLACEMENT - CONTINUED****0018 00****REMOVAL**

1. Remove two nuts (6), lockwashers (8), washers (7), and set aside two rear cab lights (1) from rear cab armor frame (11). Discard lockwashers.
2. Remove four bolts (2), lockwashers (3), washers (4), and two brackets (5) from rear cab armor frame (11). Discard lockwashers.

**WARNING**

Use extreme caution when handling heavy parts. Provide adequate support and use assistance during procedure. Failure to follow this warning may cause injury or death to personnel.

3. With assistance, remove two top rear cab armor panels (9) from rear cab armor frame (11).
4. Remove emergency egress panel (10) (WP 0019 00).
5. Remove three center support dividers (12) from rear cab armor frame (11).
6. With assistance, remove three bottom rear cab armor panels (13) from rear cab armor frame (11).
7. Remove eight nuts (14), lockwashers (15), washers (16), and two rear cab grab handles with adapter plates (17) from rear cab armor frame (11). Discard lockwashers.

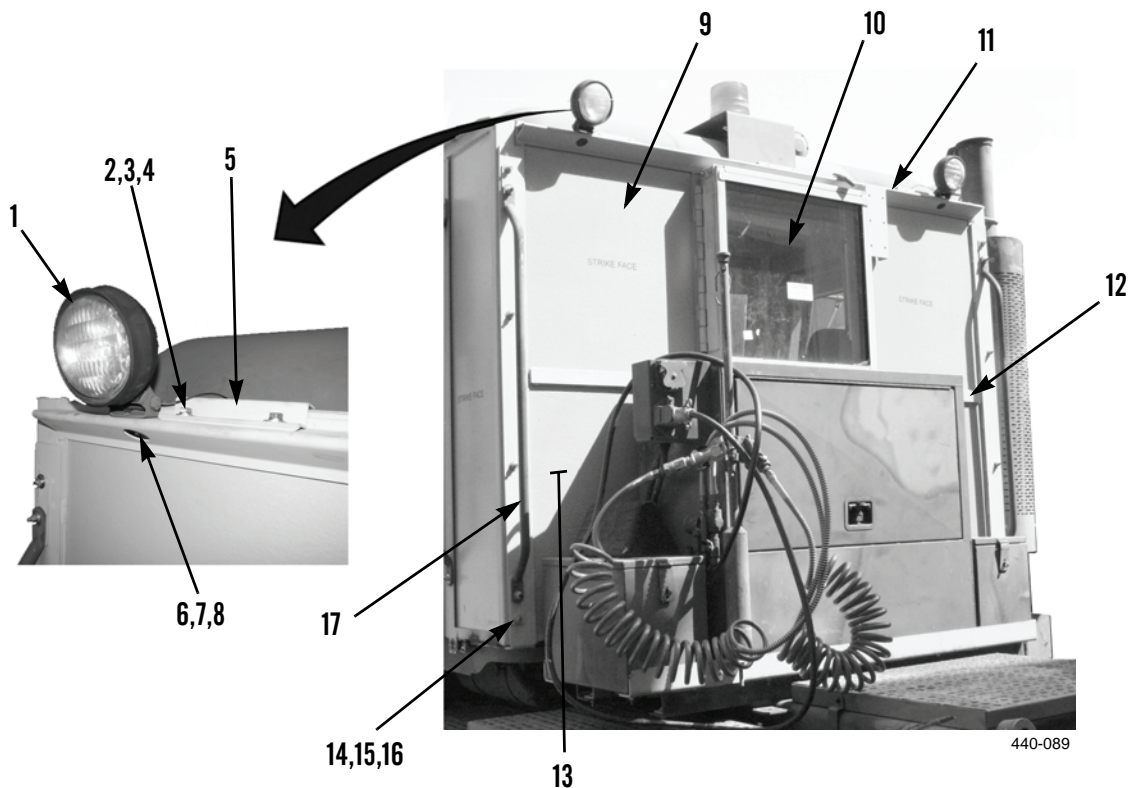



**REAR CAB ARMOR REPLACEMENT - CONTINUED**

0018 00

**REMOVAL - CONTINUED**

8. Remove four locknuts (22) and washers (23) from bottom of inside rear cab. Remove four bolts (25) and washers (24) from bottom of rear cab armor frame (11). Discard locknuts.

**WARNING**

Use extreme caution when handling heavy parts. Provide adequate support and use assistance during procedure. Failure to follow this warning may cause injury or death to personnel.

9. With assistance, remove nine locknuts (18) and washers (19) from top of inside rear cab. Remove nine bolts (21), washers (20), and rear cab armor frame (11) from rear of cab. Discard locknuts.

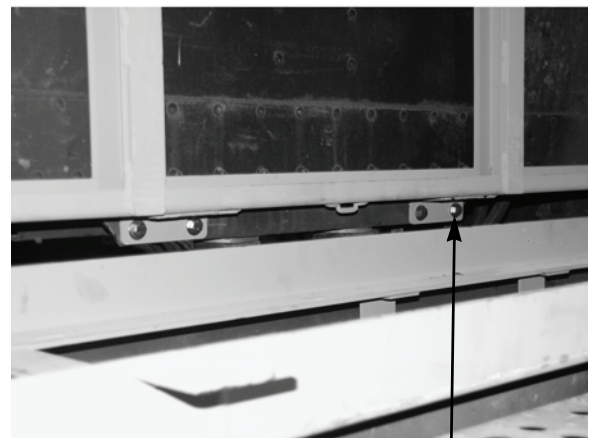
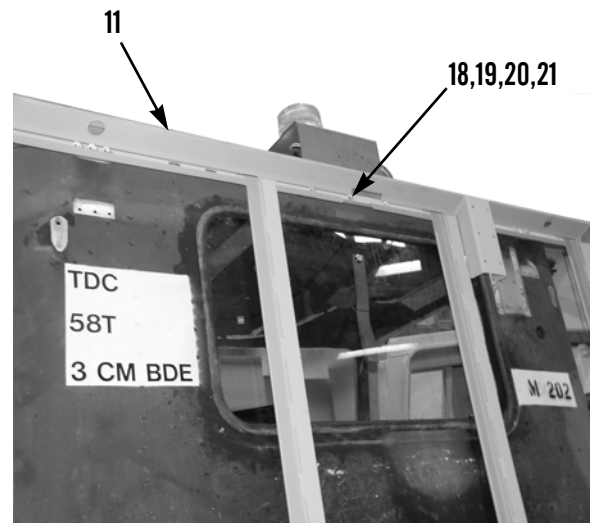
**22,23,24,25**

**CLEANING AND INSPECTION**

Clean and inspect all parts IAW *General Maintenance Instructions* (WP 0011 00).

**INSTALLATION****WARNING**

Use extreme caution when handling heavy parts. Provide adequate support and use assistance during procedure. Failure to follow this warning may cause injury or death to personnel.

1. With assistance, install rear cab armor frame (11), nine washers (20), and bolts (21) on rear cab armor frame (11). Install nine washers (19) and new locknuts (18) on inside rear cab.
2. Install four washers (24) and bolts (25) on bottom of rear cab armor frame (11). Install four washers (23) and new locknuts (22) on bottom of inside rear cab.

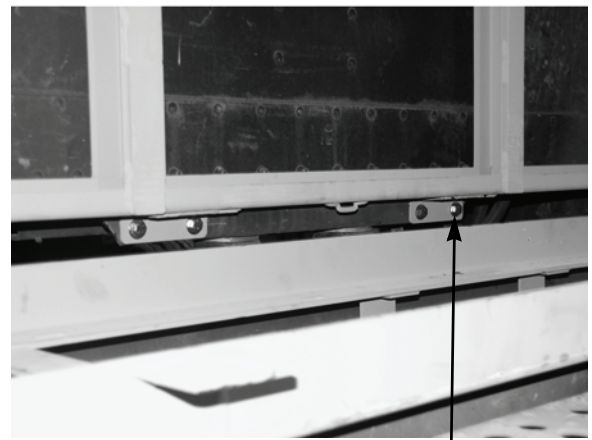
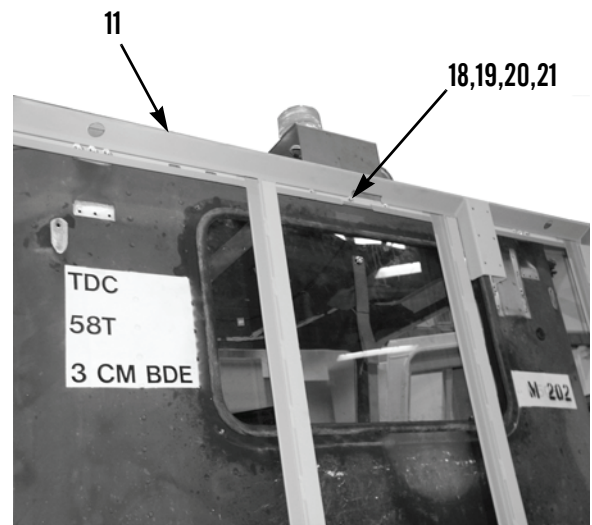

22,23,24,25

**INSTALLATION - CONTINUED**

3. Install two rear grab handles with adapter plates (17), eight washers (16), new lockwashers (15), and nuts (14) on rear cab armor frame (11).

**WARNING**

- Use extreme caution when handling heavy parts. Provide adequate support and use assistance during procedure. Failure to follow this warning may cause injury or death to personnel.
  - For proper threat protection, armor must be installed correctly into the armor frame. During installation, ensure that the surface marked “STRIKE FACE” is facing outward towards the threat. Exposing the passive side of the ballistic panel outward makes the armor less effective. Failure to follow this warning may cause injury or death to personnel.
4. With assistance, install three bottom rear cab armor panels (13) into rear cab armor frame (11).
  5. Install three center support dividers (12) into rear cab armor frame (11).
  6. With assistance, install two top rear cab armor panels (9) into rear cab armor frame (11).
  7. Install emergency egress panel (10) (WP 0019 00).
  8. Install two brackets (5), four washers (4), new lockwashers (3), and bolts (2) on rear cab armor frame (11).
  9. Install two rear cab lights (1) with two washers (7), new lockwashers (8), and nuts (6) on rear cab armor frame (11).

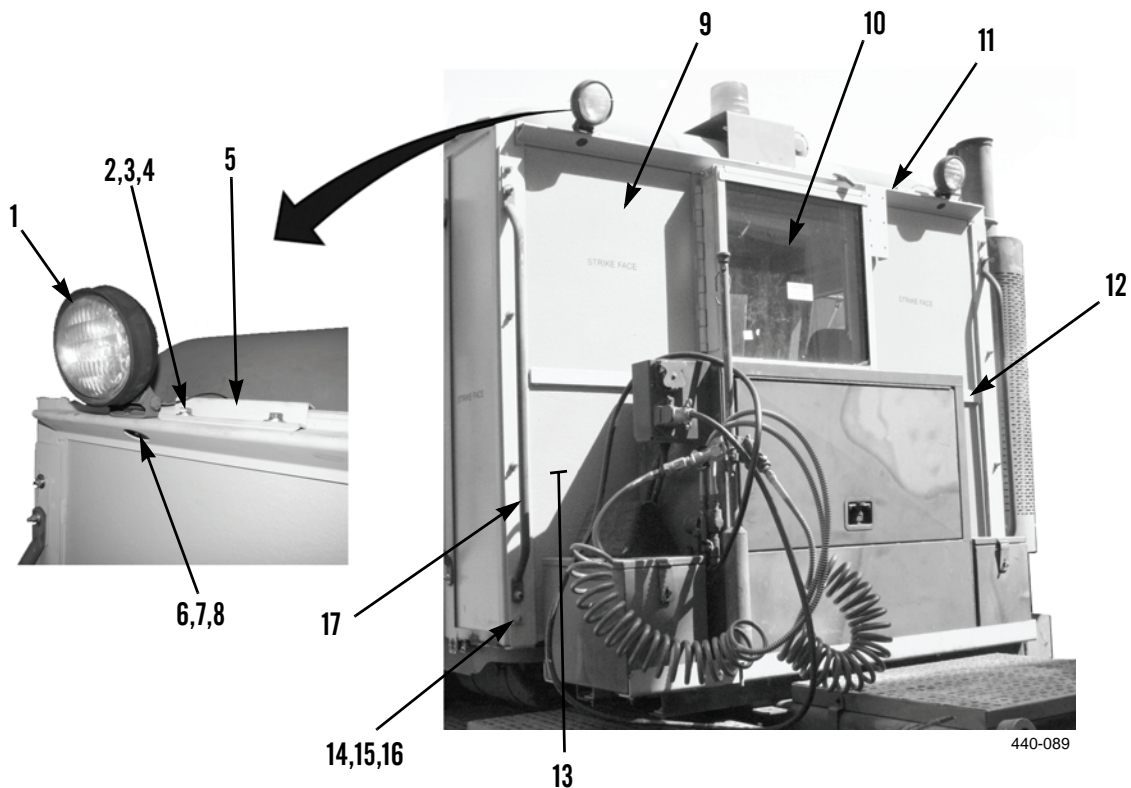

---

**REAR CAB ARMOR REPLACEMENT - CONTINUED**

---

**0018 00**

***INSTALLATION - CONTINUED***

10. Install personal gear storage boxes. For the M915A3P1, M916A3P1, and M917A2P1, refer to TM 9-2320-302-20-2. For the M915A4P1, refer to TM 9-2320-303-24-1. For the M915A2P1, M916A1P1, M916A2P1, and M917A1P1, refer to TM 9-2320-363-20-2.

**END OF WORK PACKAGE**

---

**EMERGENCY EGRESS REPLACEMENT**

**0019 00**

---

**THIS WORK PACKAGE COVERS**

Removal, Cleaning and Inspection, Installation

---

**INITIAL SETUP**

**Maintenance Level**

Unit

**Tools and Special Tools**

Tool Kit, General Mechanic's (Item 9, WP 0035 00)

**Materials/Parts**

Rag, Wiping (Item 9, WP 0036 00)

Lockwasher (10)

**Personnel Required**

Two

**References**

WP 0011 00

**Equipment Conditions**

**(M915A3P1, M916A3P1, and M917A2P1)**

Vehicle parked on level ground (TM 9-2320-302-10)

Parking/Emergency Brake applied (TM 9-2320-302-10)

Engine OFF (TM 9-2320-302-10)

Battery Disconnect Switch in OFF position (TM 9-2320-302-10)

Personal Gear Storage Box removed (TM 9-2320-302-20-2)

**Equipment Conditions - Continued**

**(M915A4P1)**

Vehicle parked on level ground (TM 9-2320-303-10)

Parking/Emergency Brake applied (TM 9-2320-303-10)

Engine OFF (TM 9-2320-303-10)

Battery Disconnect Switch in OFF position (TM 9-2320-303-10)

Personal Gear Storage Box removed (TM 9-2320-303-24-1)

**(M915A2P1, M916A1P1, M916A2P1, and**

**M917A1P1)**

Vehicle parked on level ground (TM 9-2320-363-10)

Parking/Emergency Brake applied (TM 9-2320-363-10)

Engine OFF (TM 9-2320-363-10)

If equipped, Battery Disconnect Switch in OFF position (TM 9-2320-363-10), otherwise, disconnect Battery Cables (TM 9-2320-363-20-2)

---

**REMOVAL**

1. Pull exit strap (7) and pull open emergency egress door (10).
2. Loosen two jamnuts (13) at the top and bottom left side of emergency egress door (10).
3. Remove two bolts (12), jamnuts (13), and washers (14) from emergency egress door (10).

**WARNING**

- Use extreme caution when handling heavy parts. Provide adequate support and use assistance during procedure. Failure to follow this warning may cause injury or death to personnel.
  - Use caution when handling window glass. Glass can break unexpectedly during removal/installation procedure. Wear face shield, apron, and gloves. Failure to follow this warning may cause injury to personnel.
4. With assistance, remove four bolts (15), lockwashers (16), washers (17), and emergency egress door (10) from emergency egress frame (11). Discard lockwashers.
  5. With assistance, remove four bolts (18), lockwashers (19), washers (20), emergency egress door cover (1), and mark threat side of ballistic glass (9) then remove from emergency egress door (10). Discard lockwashers.
  6. Remove two bolts (3), lockwashers (4), washers (5), bracket (2), nut plate (8), and emergency egress frame (11) from rear cab armor frame (6). Discard lockwashers.

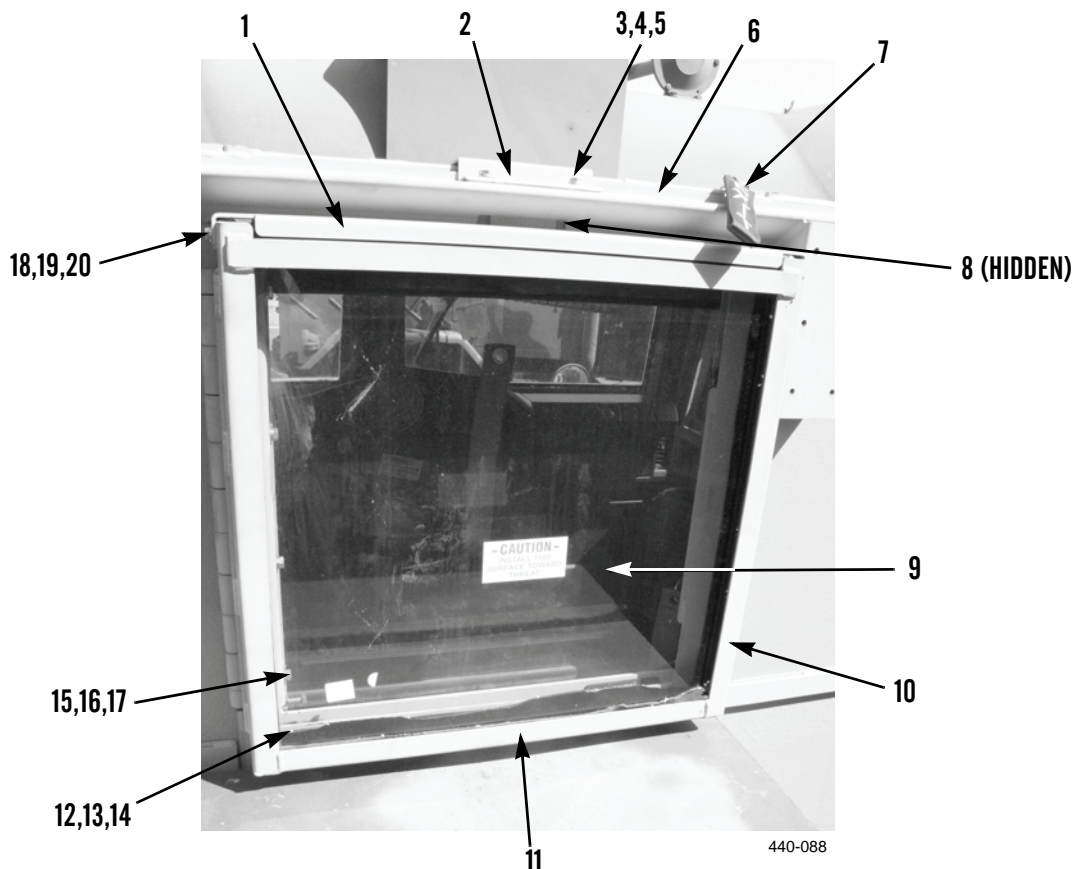

440-088

**CLEANING AND INSPECTION**

Clean and inspect all parts IAW *General Maintenance Instructions* (WP 0011 00).

**INSTALLATION**

1. Install emergency egress frame (11), nut plate (8), bracket (2), two washers (5), new lockwashers (4), and bolts (3) on rear cab armor frame (6).

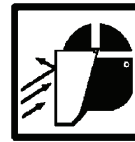
**WARNING**

- Use extreme caution when handling heavy parts. Provide adequate support and use assistance during procedure. Failure to follow this warning may cause injury or death to personnel.
  - Use caution when handling window glass. Glass can break unexpectedly during removal/installation procedure. Wear face shield, apron, and gloves. Failure to follow this warning may cause injury to personnel.
  - For proper threat protection, ballistic glass must be correctly installed onto ballistic glass frame. During installation, ensure that decal “INSTALL THIS SURFACE TOWARDS THREAT” is located on outside of cab. Improperly installed ballistic glass will not protect occupants. Failure to follow this warning may cause injury or death to personnel.
2. With assistance, install ballistic glass (9), threat side out, emergency egress door cover (1), four washers (20), new lockwashers (19), and bolts (18) on emergency egress door (10).
  3. With assistance, install emergency egress door (10), four washers (17), new lockwashers (16), and bolts (15) on emergency egress frame (11).
  4. Install two washers (14), jamnuts (13), and bolts (12) on emergency egress door (10).
  5. Tighten bolts against the rear armor frame then tighten two jamnuts (13).
  6. Pull exit strap (7) and push closed emergency egress door (10).

**END OF WORK PACKAGE**





---

**PLEXIGLASS WINDOW REPLACEMENT**

**0020 00**

---

**THIS WORK PACKAGE COVERS**

Removal, Cleaning and Inspection, Installation

---

**INITIAL SETUP**

**Maintenance Level**

Unit

**Tools and Special Tools**

Tool Kit, General Mechanic's (Item 9, WP 0035 00)

**Materials/Parts**

Detergent, General Purpose, Liquid (Item 7, WP 0036 00)

Rag, Wiping (Item 9, WP 0036 00)

Lockwasher (10)

**Personnel Required**

Two

**References**

WP 0011 00

**Equipment Conditions**

**(M915A3P1, M916A3P1, and M917A2P1)**

Vehicle parked on level ground (TM 9-2320-302-10)

Parking/Emergency Brake applied (TM 9-2320-302-10)

Engine OFF (TM 9-2320-302-10)

Battery Disconnect Switch in OFF position (TM 9-2320-302-10)

**Equipment Conditions - Continued**

**(M915A4P1)**

Vehicle parked on level ground (TM 9-2320-303-10)

Parking/Emergency Brake applied (TM 9-2320-303-10)

Engine OFF (TM 9-2320-303-10)

Battery Disconnect Switch in OFF position (TM 9-2320-303-10)

**(M915A2P1, M916A1P1, M916A2P1, and M917A1P1)**

Vehicle parked on level ground (TM 9-2320-363-10)

Parking/Emergency Brake applied (TM 9-2320-363-10)

Engine OFF (TM 9-2320-363-10)

If equipped, Battery Disconnect Switch in OFF position (TM 9-2320-363-10), otherwise, disconnect Battery Cables (TM 9-2320-363-20-2)

---

**PLEXIGLASS WINDOW REPLACEMENT - CONTINUED**

0020 00

**REMOVAL**

1. Remove, pry out, rear window gasket core (3).
2. Apply liquid detergent inside of rear window gasket (2) and pry plexiglass window (8) out of rear window gasket (2) towards the inside of the cab (1).
3. Remove locknut (6), bolt (4), washer (5), and exit strap (7) from plexiglass window (8). Discard locknut.

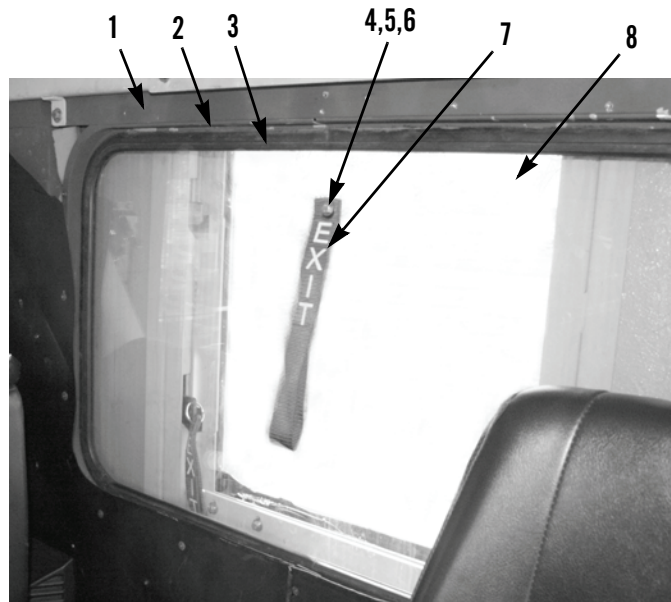

440-092

**CLEANING AND INSPECTION**

Clean and inspect all parts IAW *General Maintenance Instructions* (WP 0011 00).

**INSTALLATION**

1. Install exit strap (7), washer (5), bolt (4), and new locknut (6) on plexiglass window (8).
2. Remove, pry out, rear window gasket core (3).
3. Apply liquid detergent inside of window rear window gasket (2) and press plexiglass window (8) into rear window gasket (2) from the inside of the cab (1)
4. Press rear window gasket core (3) into gasket.

**END OF WORK PACKAGE**

---

**STOWAGE BOX ADAPTER FRAME REPLACEMENT**

---

0021 00

**THIS WORK PACKAGE COVERS**Removal, Cleaning and Inspection, Installation

---

**INITIAL SETUP****Maintenance Level**

Unit

**Tools and Special Tools**

Tool Kit, General Mechanic's (Item 9, WP 0035 00)

**Materials/Parts**

Rag, Wiping (Item 9, WP 0036 00)

Locknut (6)

**Personnel Required**

Two

**References**

WP 0011 00

**Equipment Conditions****(M915A3P1, M916A3P1, and M917A2P1)**

Vehicle parked on level ground (TM 9-2320-302-10)

Parking/Emergency Brake applied (TM 9-2320-302-10)

Engine OFF (TM 9-2320-302-10)

Battery Disconnect Switch in OFF position (TM 9-2320-302-10)

Personal Gear Storage Box removed (TM 9-2320-302-20-2)

**Equipment Conditions - Continued****(M915A4P1)**

Vehicle parked on level ground (TM 9-2320-303-10)

Parking/Emergency Brake applied (TM 9-2320-303-10)

Engine OFF (TM 9-2320-303-10)

Battery Disconnect Switch in OFF position (TM 9-2320-303-10)

Personal Gear Storage Box removed (TM 9-2320-303-24-1)

**(M915A2P1, M916A1P1, M916A2P1, and M917A1P1)**

Vehicle parked on level ground (TM 9-2320-363-10)

Parking/Emergency Brake applied (TM 9-2320-363-10)

Engine OFF (TM 9-2320-363-10)

If equipped, Battery Disconnect Switch in OFF position (TM 9-2320-363-10), otherwise, disconnect Battery Cables (TM 9-2320-363-20-2)

Personal Gear Storage Boxes removed (TM 9-2320-363-20-2)

---

**REMOVAL****WARNING**

Use extreme caution when handling heavy parts. Provide adequate support and use assistance during procedure. Failure to follow this warning may cause injury or death to personnel.

With assistance, remove six locknuts (2), washers (3), bolts (5), washers (4), and stowage box adapter frame (6) from original stowage box frame (1). Discard locknuts.

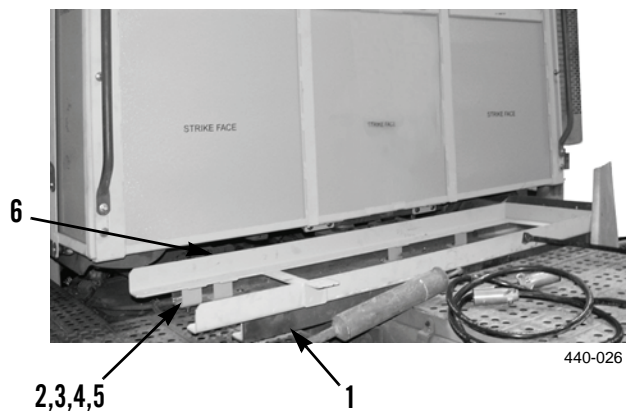
**CLEANING AND INSPECTION**

Clean and inspect all parts IAW *General Maintenance Instructions* (WP 0011 00).

**INSTALLATION****WARNING**

Use extreme caution when handling heavy parts. Provide adequate support and use assistance during procedure. Failure to follow this warning may cause injury or death to personnel.

1. With assistance, install stowage box adapter frame (6), six washers (4), bolts (5), washers (3), and new locknuts (2) on original stowage box frame (1).
2. Install personal gear storage boxes. For the M915A3P1, M916A3P1, and M917A2P1, refer to TM 9-2320-302-20-2. For the M915A4P1, refer to TM 9-2320-303-24-1. For the M915A2P1, M916A1P1, M916A2P1, and M917A1P1, refer to TM 9-2320-363-20-2.

**END OF WORK PACKAGE**

---

**LEFT B-PILLAR ARMOR REPLACEMENT**

**0022 00**

---

**THIS WORK PACKAGE COVERS**

Removal, Cleaning and Inspection, Installation

---

**INITIAL SETUP**

**Maintenance Level**

Unit

**Tools and Special Tools**

Tool Kit, General Mechanic's (Item 9, WP 0035 00)

Link, Bearing (Lifting) (Item 5, WP 0035 00)

Sling, Nylon (Item 8, WP 0035 00)

Lifting Device (500-lb Minimum Capacity)

**Materials/Parts**

Rag, Wiping (Item 9, WP 0036 00)

Locknut (2)

Lockwasher (10)

Rivet (2)

**Personnel Required**

Two

**References**

WP 0011 00

**Equipment Conditions**

**(M915A3P1, M916A3P1, and M917A2P1)**

Vehicle parked on level ground (TM 9-2320-302-10)

Parking/Emergency Brake applied (TM 9-2320-302-10)

**Equipment Conditions - Continued**

**(M915A3P2, M916A3P2, and M917A2P2) - Continued**

Engine OFF (TM 9-2320-302-10)

Battery Disconnect Switch in OFF position (TM 9-2320-302-10)

**(M915A4P2)**

Vehicle parked on level ground (TM 9-2320-303-10)

Parking/Emergency Brake applied (TM 9-2320-303-10)

Engine OFF (TM 9-2320-303-10)

Battery Disconnect Switch in OFF position (TM 9-2320-303-10)

**(M915A2P1, M916A1P1, M916A2P1, and M917A1P1)**

Vehicle parked on level ground (TM 9-2320-363-10)

Parking/Emergency Brake applied (TM 9-2320-363-10)

Engine OFF (TM 9-2320-363-10)

If equipped, Battery Disconnect Switch in OFF position (TM 9-2320-363-10), otherwise, disconnect Battery Cables (TM 9-2320-363-20-2)

---

**LEFT B-PILLAR ARMOR REPLACEMENT - CONTINUED****0022 00****REMOVAL**

1. Remove four nuts (8), lockwashers (9), washers (10), and rear cab grab handle with adapter plates (11) from rear cab armor frame (7). Discard lockwashers.
2. Remove two nuts (19), lockwashers (20), washers (21), and side cab grab handle (18) from B-pillar armor frame (7). Discard lockwashers.
3. Remove two bolts (12), wires (13), washers (14), and lockwashers (15) from work light connector (17). Discard lockwashers.

**WARNING**

Eye protection is required when drilling and when using riveter to install rivets. Failure to follow this warning may cause injury to personnel.

4. Remove two rivets (16) and work light connector (17) from B-pillar armor frame (7). Discard rivets.

**WARNING**

Use extreme caution when handling heavy parts. Provide adequate support and use assistance during procedure. Ensure that any lifting device used is in good condition and of suitable load capacity. Keep clear of heavy parts supported only by lifting device. Failure to follow this warning may cause injury or death to personnel.

5. Install two lifting links on two weld bosses (6).
6. Attach lifting device to two lifting links on B-pillar armor frame (7).
7. Using lifting device, hold B-pillar (7) suspended and remove two locknuts (1), washers (2), bolts (5), washers (3), lockwashers (4), and B-pillar from vehicle. Discard lockwashers and locknuts.

**REMOVAL - CONTINUED**

8. Remove lifting device from B-pillar armor frame (7).
9. Remove two lifting links from two weld bosses (6).

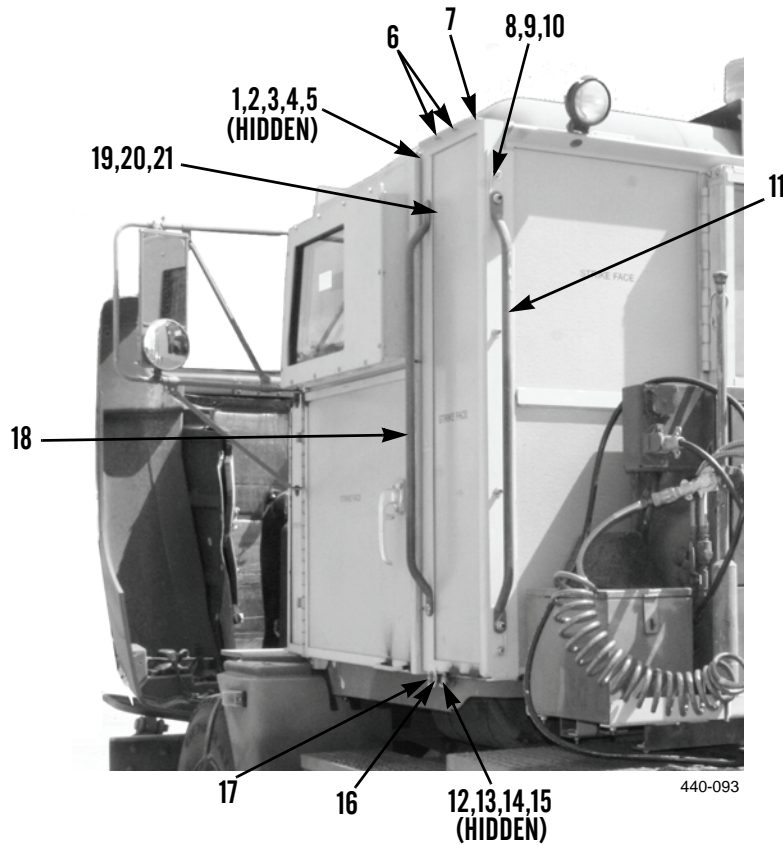

**CLEANING AND INSPECTION**

Clean and inspect all parts IAW *General Maintenance Instructions* (WP 0011 00).

**INSTALLATION****WARNING**

- Use extreme caution when handling heavy parts. Provide adequate support and use assistance during procedure. Ensure that any lifting device used is in good condition and of suitable load capacity. Keep clear of heavy parts supported only by lifting device. Failure to follow this warning may cause injury or death to personnel.
- For proper threat protection, armor must be installed correctly into the armor frame. During installation, ensure that the surface marked “STRIKE FACE” is facing outward towards the threat. Exposing the passive side of the ballistic panel outward makes the armor less effective. Failure to follow this warning may cause injury or death to personnel.

1. Install two lifting links on two weld bosses (6).
2. Attach lifting device to two lifting links on B-pillar armor frame (7).
3. Using lifting device, install B-pillar (7), two new lockwashers (4), washers (3), bolts (5), washers (2), and new locknuts (1) on vehicle.
4. Remove lifting device from B-pillar armor frame (7).
5. Remove two lifting links from two weld bosses (6).

**WARNING**

Eye protection is required when drilling and when using riveter to install rivets. Failure to follow this warning may cause injury to personnel.

6. Install work light connector (17) and two new rivets (16) on B-pillar armor frame (7).
7. Install two new lockwashers (15), washers (14), wires (13), and bolts (12) on work light connector (17).
8. Install side cab grab handle (18), two washers (21), new lockwashers (20), and nuts (19) on B-pillar armor frame (7).



**INSTALLATION - CONTINUED**

9. Install rear cab grab handle with adapter plates (11), four washers (10), new lockwashers (9), and nuts (8) on rear cab armor frame (7).

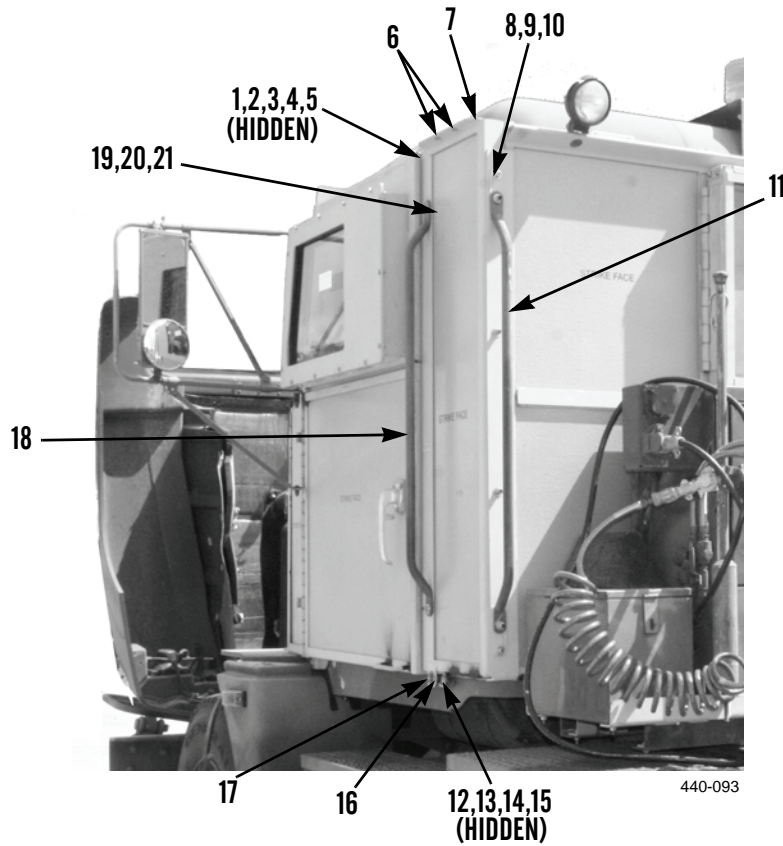

**END OF WORK PACKAGE**



**RIGHT B-PILLAR ARMOR REPLACEMENT**

**0023 00**

**THIS WORK PACKAGE COVERS**

Removal, Cleaning and Inspection, Installation

**INITIAL SETUP**

**Maintenance Level**

Unit

**Tools and Special Tools**

Tool Kit, General Mechanic's (Item 9, WP 0035 00)

Link, Bearing (Lifting) (Item 5, WP 0035 00)

Sling, Nylon (Item 8, WP 0035 00)

Lifting Device (500-lb Minimum Capacity)

**Materials/Parts**

Rag, Wiping (Item 9, WP 0036 00)

Clamp, Seal P/N 04-19249-000

Locknut (6)

Lockwasher (8)

Rivet (2)

**Personnel Required**

Two

**References**

WP 0011 00

**Equipment Conditions**

**(M915A3P1, M916A3P1, and M917A2P1)**

Vehicle parked on level ground (TM 9-2320-302-10)

Parking/Emergency Brake applied (TM 9-2320-302-10)

Engine OFF (TM 9-2320-302-10)

Battery Disconnect Switch in OFF position (TM 9-2320-302-10)

**(M915A4P1)**

Vehicle parked on level ground (TM 9-2320-303-10)

Parking/Emergency Brake applied (TM 9-2320-303-10)

Engine OFF (TM 9-2320-303-10)

Battery Disconnect Switch in OFF position (TM 9-2320-303-10)

**(M915A2P1, M916A1P1, M916A2P1, and M917A1P1)**

Vehicle parked on level ground (TM 9-2320-363-10)

Parking/Emergency Brake applied (TM 9-2320-363-10)

Engine OFF (TM 9-2320-363-10)

If equipped, Battery Disconnect Switch in OFF position (TM 9-2320-363-10), otherwise, disconnect Battery Cables (TM 9-2320-363-20-2)

**REMOVAL**

1. Remove four nuts (1), washers (2), two saddle clamps (4), and exhaust stack (3).

**WARNING**

Use extreme caution when handling heavy parts. Provide adequate support and use assistance during procedure. Ensure that any lifting device used is in good condition and of suitable load capacity. Keep clear of heavy parts supported only by lifting device. Failure to follow this warning may cause injury or death to personnel.

2. Using a lifting device, support muffler (5) and loosen two bolts (7) on seal clamp (6).
3. Using a lifting device, remove four nuts (9), washers (10), two saddle clamps (8), muffler (5), and seal clamp (6).
4. Discard seal clamp (6). Remove lifting device from muffler.
5. Remove four nuts (11), lockwashers (12), washers (13), and rear cab grab handle with adapter plates (14) from rear cab armor frame. Discard lockwashers.

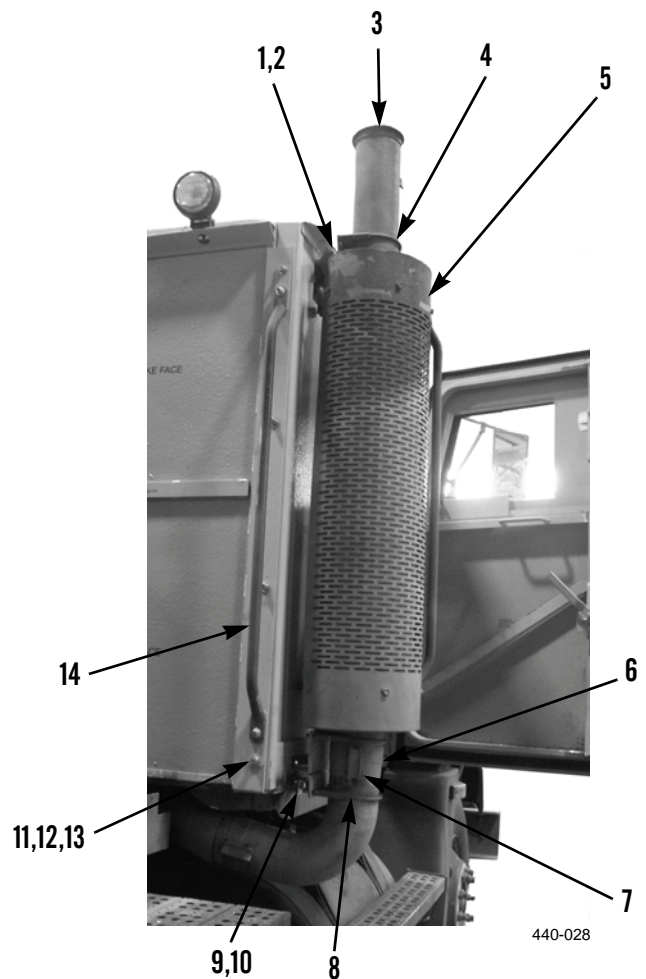

**REMOVAL - CONTINUED**

6. Remove two locknuts (16), washers (17), bolts (19), washers (18), and brackets (15) from upper support bracket (20). Discard locknuts.
7. Remove two locknuts (23), washers (24), bolts (26), washers (25), and brackets (21) from lower support bracket (22). Discard locknuts.

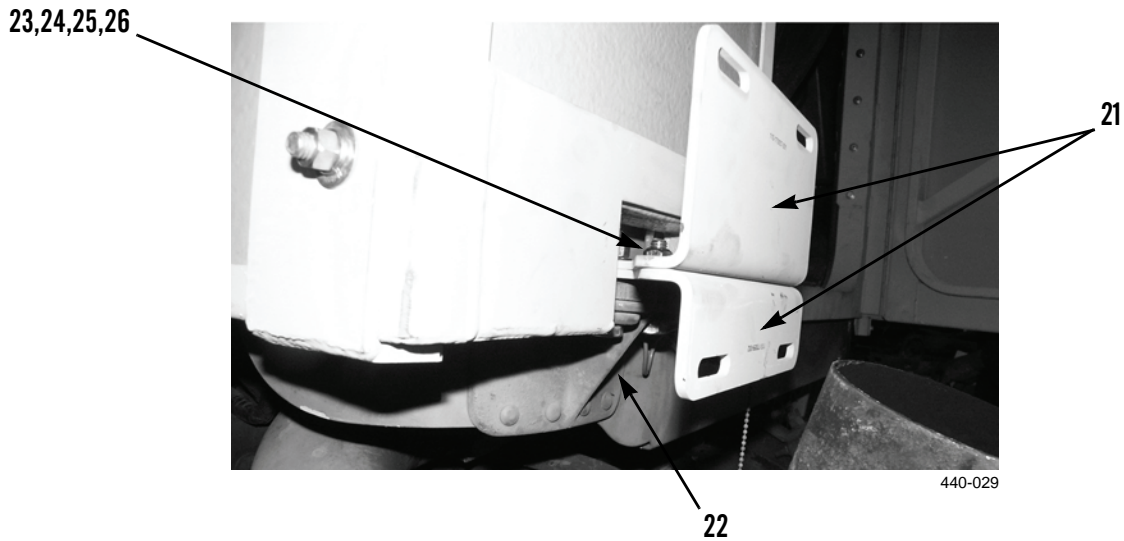
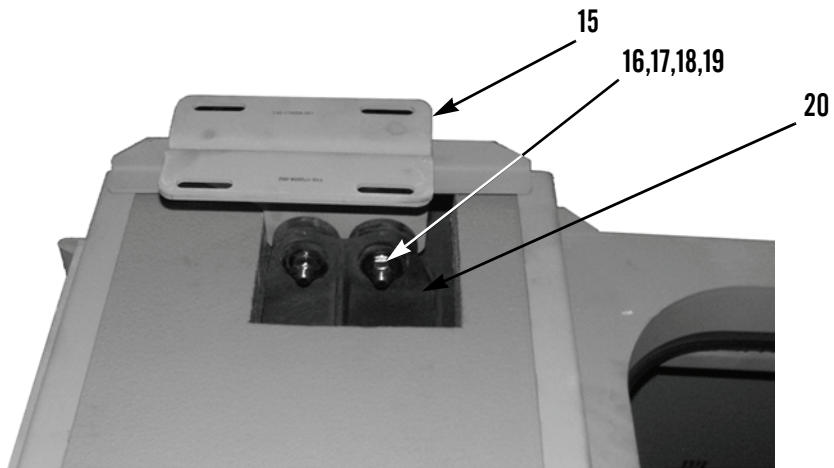

**REMOVAL - CONTINUED**

8. Remove two bolts (36), wires (37), washers (38), and lockwashers (39) from work light connector (35). Discard lockwashers.
9. Remove two rivets (34) and work light connector (35) from B-pillar armor frame (33). Discard rivets.

**WARNING**

Use extreme caution when handling heavy parts. Provide adequate support and use assistance during procedure. Ensure that any lifting device used is in good condition and of suitable load capacity. Keep clear of heavy parts supported only by lifting device. Failure to follow this warning may cause injury or death to personnel.

10. Install two lifting links on two weld bosses (27).
11. Attach lifting device to two lifting links on B-pillar armor frame (33).
12. Using lifting device, hold B-pillar (33) suspended and remove two locknuts (28), washers (29), bolts (32), washers (30), lockwashers (31), and B-pillar (33) from vehicle. Discard lockwashers and locknuts.
13. Remove lifting device from B-pillar armor frame (33).
14. Remove two lifting links from two weld bosses (27).

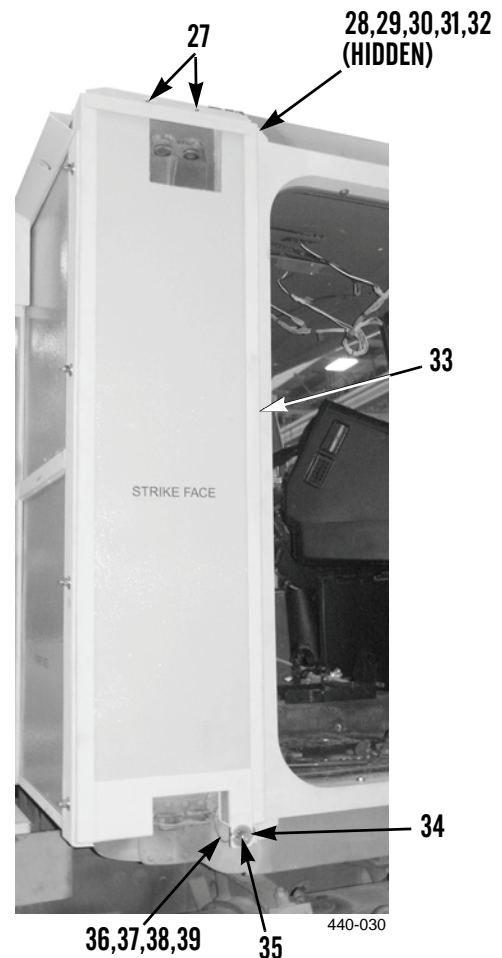

**CLEANING AND INSPECTION**

Clean and inspect all parts IAW *General Maintenance Instructions* (WP 0011 00).

**INSTALLATION****WARNING**

- Use extreme caution when handling heavy parts. Provide adequate support and use assistance during procedure. Ensure that any lifting device used is in good condition and of suitable load capacity. Keep clear of heavy parts supported only by lifting device. Failure to follow this warning may cause injury or death to personnel.
  - For proper threat protection, armor must be installed correctly into the armor frame. During installation, ensure that the surface marked “STRIKE FACE” is facing outward towards the threat. Exposing the passive side of the ballistic panel outward makes the armor less effective. Failure to follow this warning may cause injury or death to personnel.
1. Install two lifting links on two weld bosses (27).
  2. Attach lifting device to two lifting links on B-pillar armor frame (33).
  3. Using lifting device, install B-pillar (33), two new lockwashers (31), washers (30), bolts (32), washers (29), and new locknuts (28) on vehicle.
  4. Remove lifting device from B-pillar armor frame (33).
  5. Remove two lifting links from two weld bosses (27).
  6. Install work light connector (35) and two new rivets (34) on B-pillar armor frame (33).
  7. Install two new lockwashers (39), washers (38), wires (37), and bolts (36) on work light connector (35).

**INSTALLATION - CONTINUED**

8. Install two brackets (21), washers (25), bolts (26), washers (24), and new locknuts (23) on lower support bracket (22).
9. Install two brackets (15), washers (18), bolts (19), washers (17), and new locknuts (16) on upper support bracket (20).

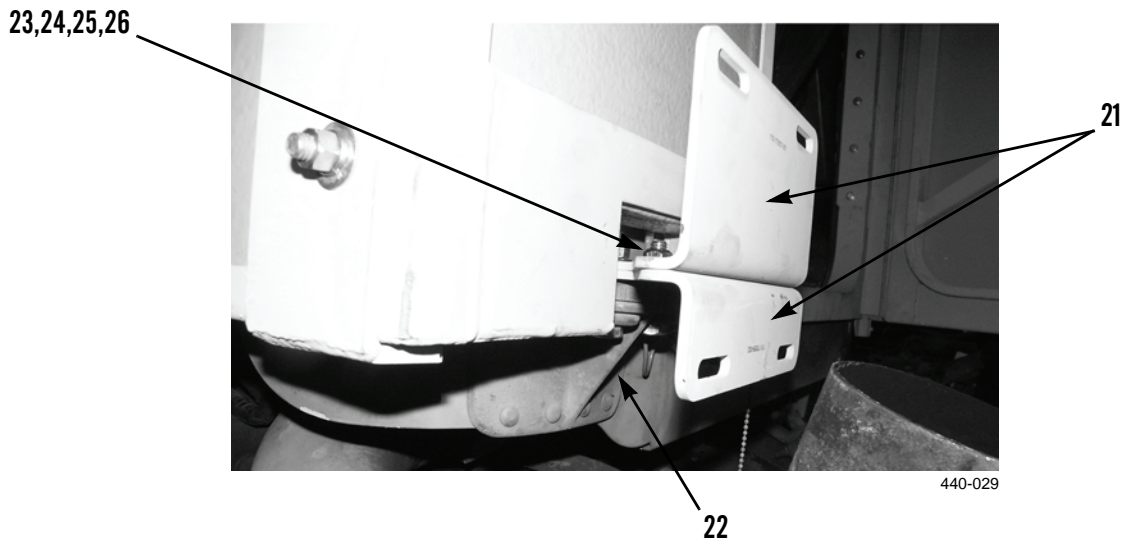
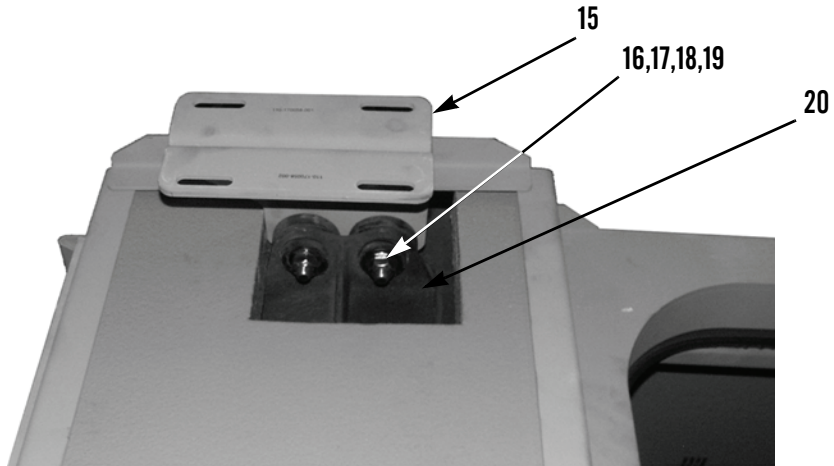



**INSTALLATION - CONTINUED**

10. Install rear cab grab handle with adapter plates (14), four washers (13), new lockwashers (12), and nuts (11) on rear cab armor frame.

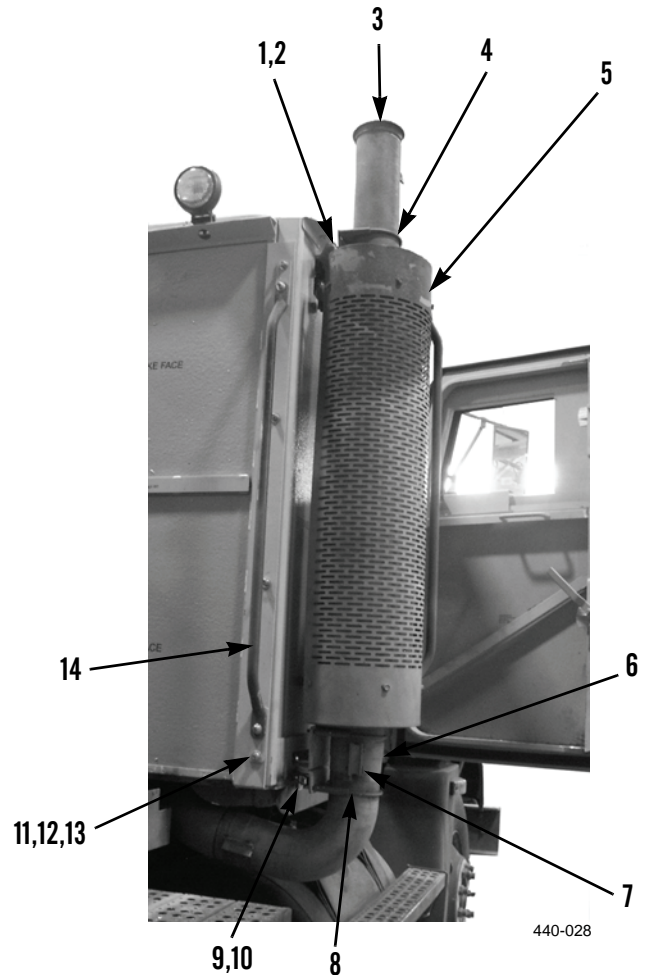
**WARNING**

Use extreme caution when handling heavy parts. Provide adequate support and use assistance during procedure. Ensure that any lifting device used is in good condition and of suitable load capacity. Keep clear of heavy parts supported only by lifting device. Failure to follow this warning may cause injury or death to personnel.

11. Using a lifting device, support muffler (5) and install new seal clamp (6), muffler (5), two saddle clamps (8), four washers (10), and nuts (9).
12. Tighten two bolts (7) on seal clamp (6).
13. Install exhaust stack (3), two saddle clamps (4), four washers (2), and nuts (1). Remove lifting device from muffler.

**END OF WORK PACKAGE**



---

**A-PILLAR ARMOR REPLACEMENT**

**0024 00**

---

**THIS WORK PACKAGE COVERS**

Removal, Cleaning and Inspection, Installation

---

**INITIAL SETUP**

**Maintenance Level**

Unit

**Tools and Special Tools**

Tool Kit, General Mechanic's (Item 9, WP 0035 00)

**Materials/Parts**

Rag, Wiping (Item 9, WP 0036 00)

Locknut (2)

Lockwasher (3)

**Personnel Required**

Two

**References**

WP 0011 00

**Equipment Conditions**

**(M915A3P1, M916A3P1, and M917A2P1)**

Vehicle parked on level ground (TM 9-2320-302-10)

Parking/Emergency Brake applied (TM 9-2320-302-10)

Engine OFF (TM 9-2320-302-10)

Battery Disconnect Switch in OFF position (TM 9-2320-302-10)

**Equipment Conditions - Continued**

**(M915A4P1)**

Vehicle parked on level ground (TM 9-2320-303-10)

Parking/Emergency Brake applied (TM 9-2320-303-10)

Engine OFF (TM 9-2320-303-10)

Battery Disconnect Switch in OFF position (TM 9-2320-303-10)

**(M915A2P1, M916A1P1, M916A2P1, and M917A1P1)**

Vehicle parked on level ground (TM 9-2320-363-10)

Parking/Emergency Brake applied (TM 9-2320-363-10)

Engine OFF (TM 9-2320-363-10)

If equipped, Battery Disconnect Switch in OFF position (TM 9-2320-363-10), otherwise, disconnect Battery Cables (TM 9-2320-363-20-2)

---

**NOTE**

The following procedure is for right A-pillar armor. Use same procedure for left A-pillar armor.

**REMOVAL**

1. Remove two locknuts (5), washers (6), bolts (8), and washers (7) from A-pillar armor (4). Discard locknuts.



**WARNING**

Use extreme caution when handling heavy parts. Provide adequate support and use assistance during procedure. Failure to follow this warning may cause injury to personnel.

2. With assistance, remove three bolts (1), lockwashers (2), washers (3), and A-pillar armor (4) from vehicle cab. Discard lockwashers.

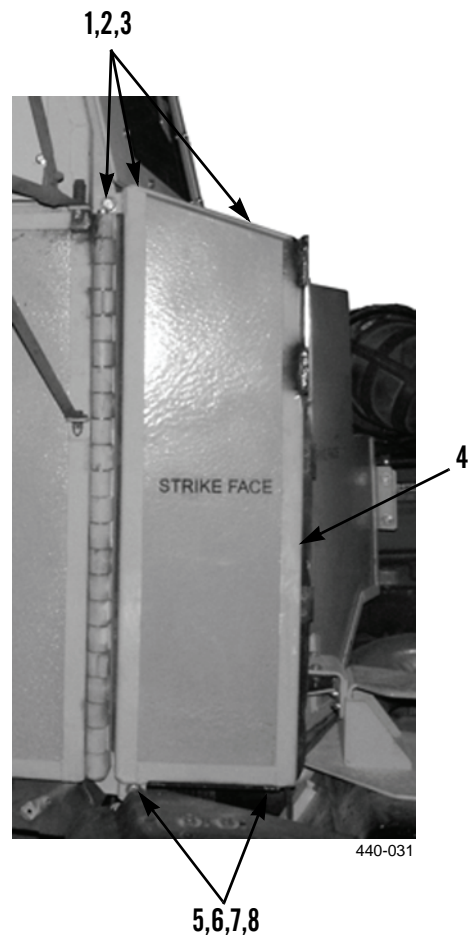

**CLEANING AND INSPECTION**

Clean and inspect all parts IAW *General Maintenance Instructions* (WP 0011 00).

**INSTALLATION****WARNING**

- Use extreme caution when handling heavy parts. Provide adequate support and use assistance during procedure. Failure to follow this warning may cause injury to personnel.
  - For proper threat protection, armor must be installed correctly into the armor frame. During installation, ensure that the surface marked “STRIKE FACE” is facing outward towards the threat. Exposing the passive side of the ballistic panel outward makes the armor less effective. Failure to follow this warning may cause injury or death to personnel.
1. With assistance, install A-pillar armor (4), three washers (3), new lockwashers (2), and bolts (1) on vehicle.
  2. Install two washers (7), bolts (8), washers (6), and new locknuts (5) on A-pillar armor (4).

**END OF WORK PACKAGE**



**THIS WORK PACKAGE COVERS**

Removal, Cleaning and Inspection, Installation

**INITIAL SETUP**

**Maintenance Level**

Unit

**Tools and Special Tools**

Tool Kit, General Mechanic's (Item 9, WP 0035 00)

**Materials/Parts**

Rag, Wiping (Item 9, WP 0036 00)

Locknut (30)

Lockwasher (5)

**Personnel Required**

Two

**References**

WP 0011 00

**Equipment Conditions**

**(M915A3P1, M916A3P1, and M917A2P1)**

Vehicle parked on level ground (TM 9-2320-302-10)

Parking/Emergency Brake applied (TM 9-2320-302-10)

Engine OFF (TM 9-2320-302-10)

Battery Disconnect Switch in OFF position (TM 9-2320-302-10)

Side Light/Turn Signal removed (TM 9-2320-302-20-2)

Fender removed (TM 9-2320-302-20-2)

**Equipment Conditions - Continued**

**(M915A4P1)**

Vehicle parked on level ground (TM 9-2320-303-10)

Parking/Emergency Brake applied (TM 9-2320-303-10)

Engine OFF (TM 9-2320-303-10)

Battery Disconnect Switch in OFF position (TM 9-2320-303-10)

Side Light/Turn Signal removed (TM 9-2320-303-24-1)

Fender removed (TM 9-2320-303-24-1)

**(M915A2P1, M916A1P1, M916A2P1, and M917A1P1)**

Vehicle parked on level ground (TM 9-2320-363-10)

Parking/Emergency Brake applied (TM 9-2320-363-10)

Engine OFF (TM 9-2320-363-10)

If equipped, Battery Disconnect Switch in OFF position (TM 9-2320-363-10), otherwise, disconnect battery cables (TM 9-2320-363-20-2)

Side Light/Turn Signal removed (TM 9-2320-363-20-2)

Fender removed (TM 9-2320-363-20-2)

**REMOVAL**

1. If equipped, remove nut (2), lockwasher (3), washer (4), and washer bottle fill tube (1) from stud plate (5). Discard lockwasher.

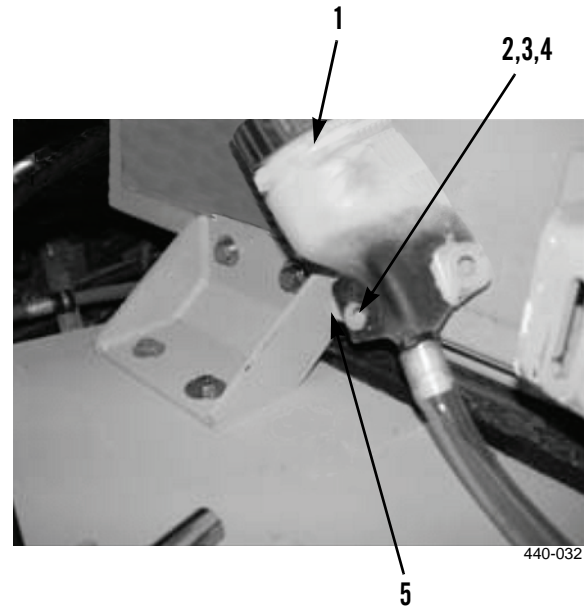
**WARNING**

Use extreme caution when handling heavy parts. Provide adequate support and use assistance during procedure. Failure to follow this warning may cause injury or death to personnel.

**NOTE**

Note orientation of bolts on wheel well blast protection extension panel to aid installation.

2. With assistance, remove seven locknuts (23), washers (24), bolts (26), washers (25), washer plate (27), and wheel well blast deflector extension (19) from forward mounting plate (18). Discard locknuts.
3. Remove two locknuts (13), washers (14), bolts (16), washers (15), bracket (17), and hood latch (12) from bracket (11). Discard locknuts.
4. Remove four locknuts (7), washers (8), bolts (10), washers (9), and bracket (11) from left firewall armor. Discard locknuts.
5. Remove two bolts (29), washers (31), lockwashers (30), nut plate (32), drive shaft plate (6), stud plate (5), and bracket (28) from left firewall armor. Discard lockwashers.
6. Remove two bolts (20), washers (22), lockwashers (21), and forward mounting plate (18) from left firewall armor. Discard lockwashers.



REMOVAL - CONTINUED

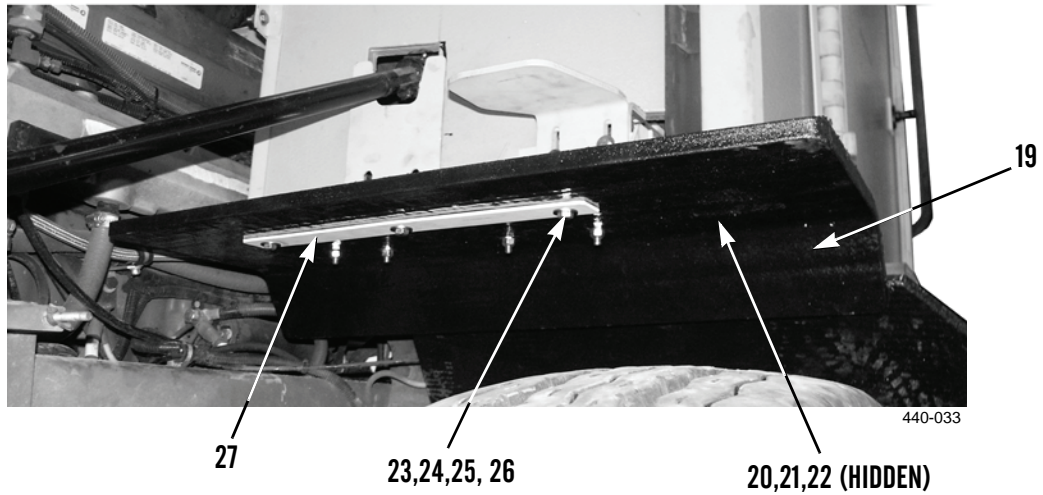
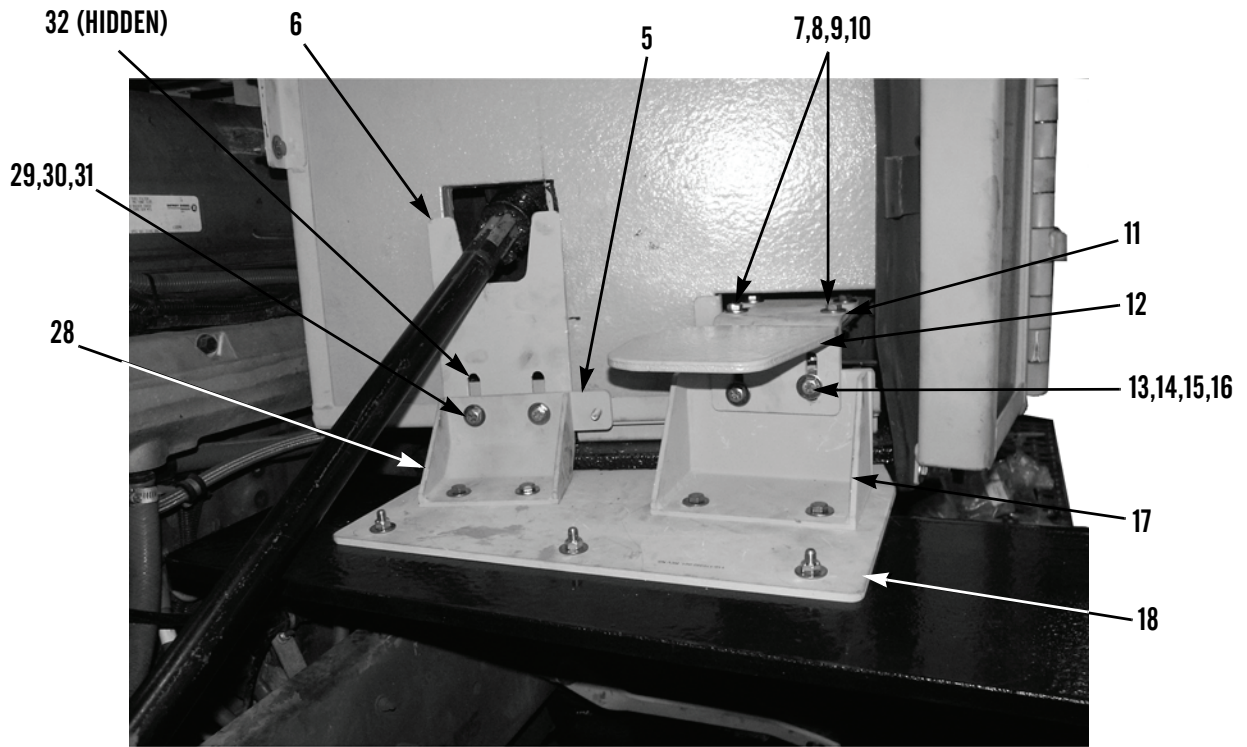

**REMOVAL - CONTINUED**

7. If equipped, remove hose (37), connector (39), four locknuts (33), washers (34), bolts (36), washers (35), and washer fluid box (38) from wheel well blast deflector (40). Discard locknuts.

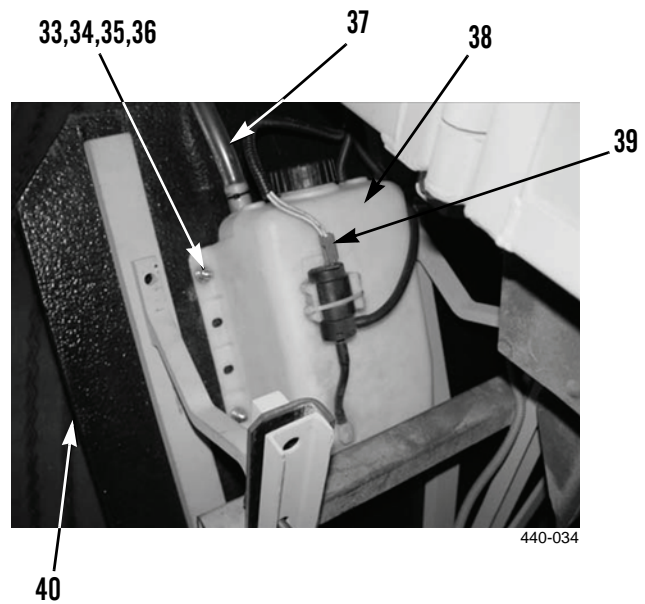

8. Remove two locknuts (41), washers (42), bolts (44), washers (43), and bracket (62) from wheel well blast deflector (40). Discard locknuts.

**WARNING**

Use extreme caution when handling heavy parts. Provide adequate support and use assistance during procedure. Failure to follow this warning may cause injury or death to personnel.

9. With assistance, remove five locknuts (45), washers (46), bolts (48), washers (47), and wheel well blast deflector (40) from wheel well frames (59). Discard locknuts.
10. Remove two locknuts (55), washers (56), bolts (58), washers (57), and bracket (60) from wheel well frame (59). Discard locknuts.
11. Remove four locknuts (51), washers (52), bolts (54), washers (53), bracket (49), two wheel well frames (59), and two cross members (50) from wheel well support bar (61). Discard locknuts.

**CLEANING AND INSPECTION**

Clean and inspect all parts IAW *General Maintenance Instructions* (WP 0011 00).

**INSTALLATION**

1. Install two cross members (50), two wheel well frames (59), bracket (49), four washers (53), bolts (54), washers (52), and new locknuts (51) on wheel well support bar (61).
2. Install bracket (60), two washers (57), bolts (58), washers (56), and new locknuts (55) on wheel well frame (59).

**WARNING**

Use extreme caution when handling heavy parts. Provide adequate support and use assistance during procedure. Failure to follow this warning may cause injury or death to personnel.

3. With assistance, install wheel well blast deflector (40), five washers (47), bolts (48), washers (46), and new locknuts (45) on wheel well frames (59).
4. Install bracket (62), two washers (43), bolts (44), washers (42), and new locknuts (41) on wheel well blast deflector (40).

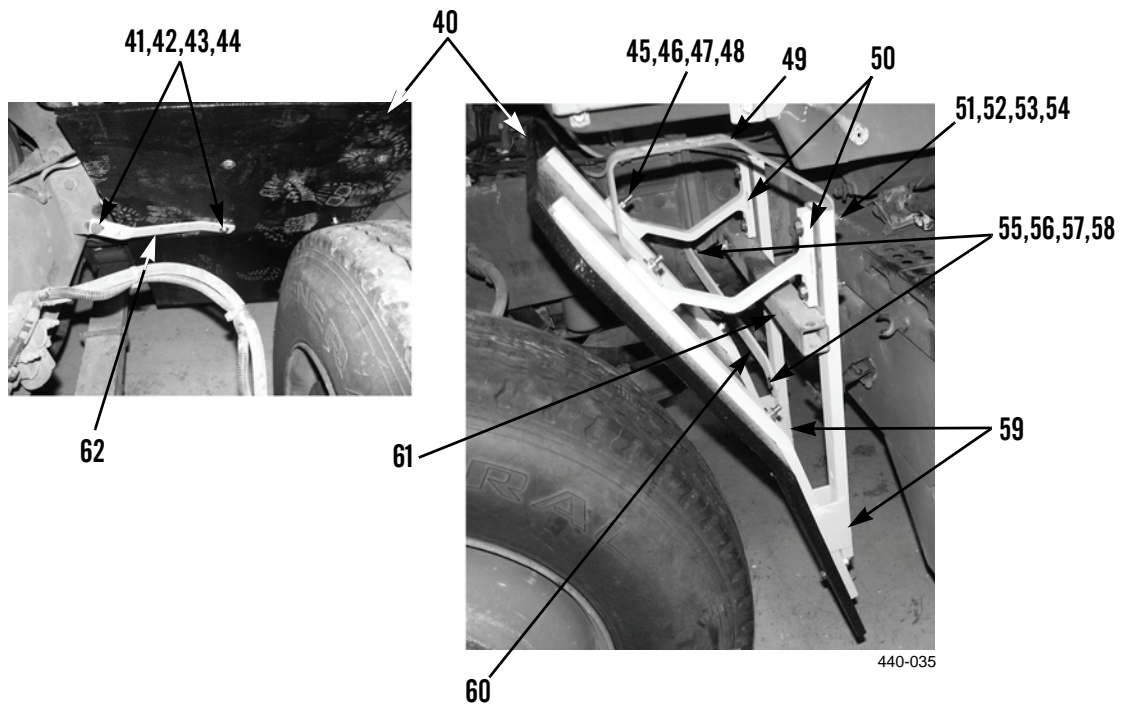

**INSTALLATION - CONTINUED**

5. If equipped, install washer fluid box (38), four washers (35), bolts (36), washers (34), new locknuts (33), connector (39), and hose (37) on wheel well blast deflector (40).

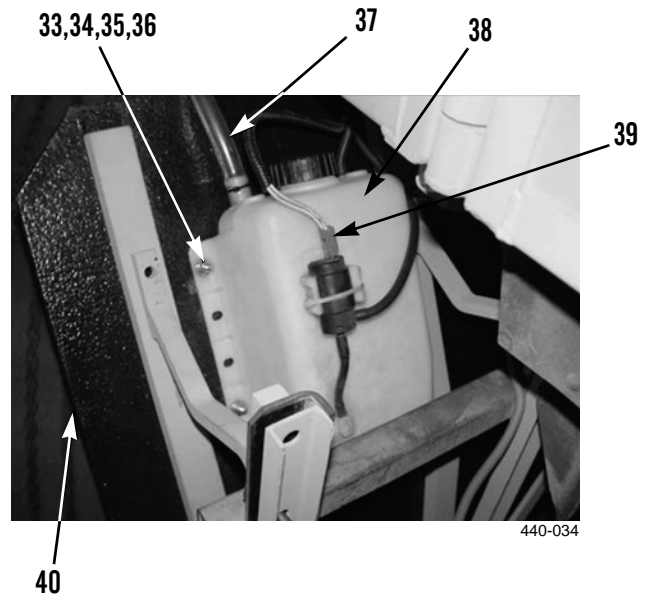

6. Install forward mounting plate (18), two new lockwashers (21), washers (22), and bolts (20) on left firewall armor.
7. Install bracket (28), stud plate (5), drive shaft plate (6), nut plate (32), two new lockwashers (30), washers (31), and bolts (29) on left firewall armor.
8. Install bracket (11), four washers (9), bolts (10), washers (8), and new locknuts (7) on left firewall armor.
9. Install hood latch (12), bracket (17), two washers (15), bolts (16), washers (14), and new locknuts (13) on bracket (11).

**WARNING**

Use extreme caution when handling heavy parts. Provide adequate support and use assistance during procedure. Failure to follow this warning may cause injury or death to personnel.



**INSTALLATION - CONTINUED**

10. With assistance, install wheel well blast deflector extension (19), washer plate (27), seven washers (25), bolts (26), washers (24), and new locknuts (23) on forward mounting plate (18).

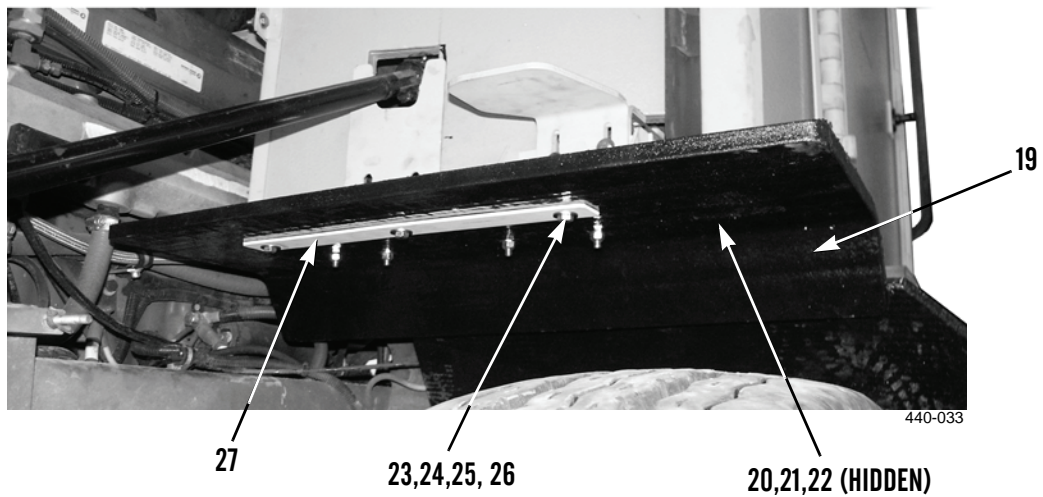
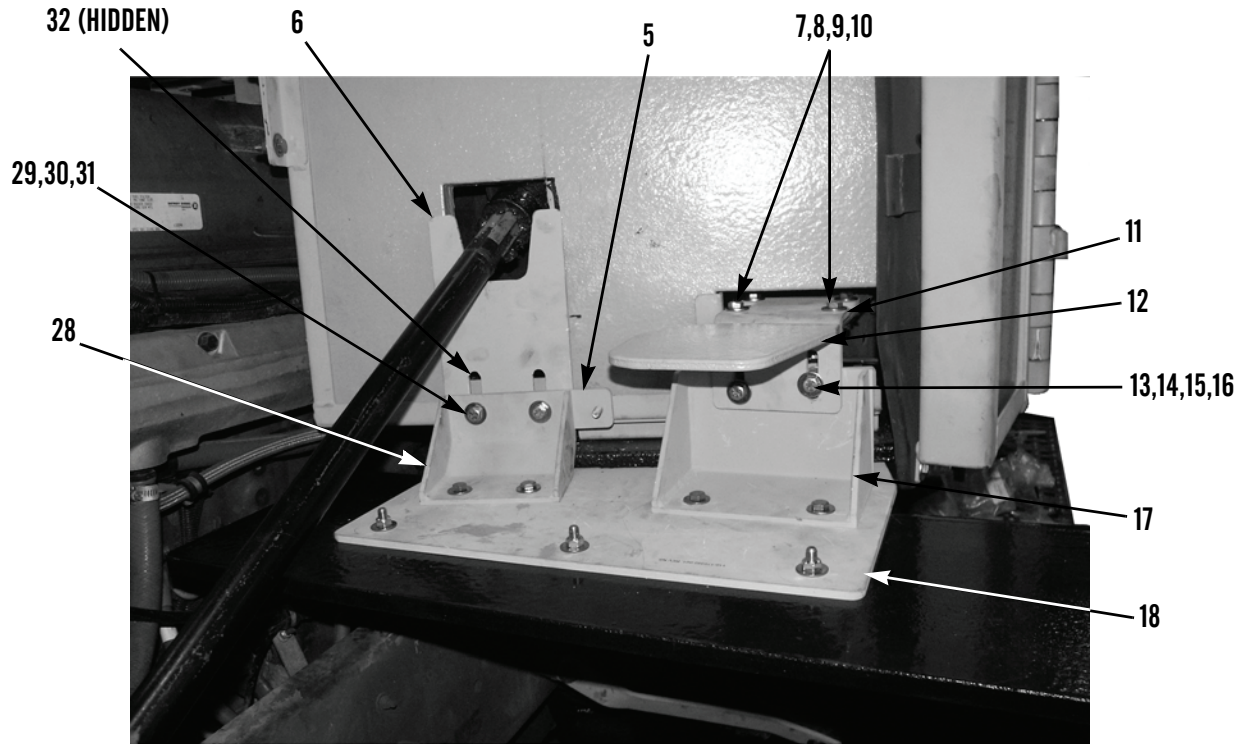

**INSTALLATION - CONTINUED**

11. If equipped, install washer bottle fill tube (1), washer (4), new lockwasher (3), and nut (2) on stud plate (5).

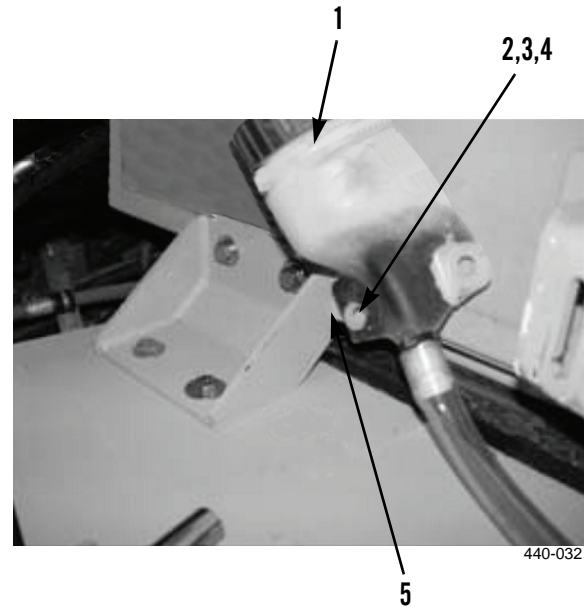

12. Install fender. For the M915A3P1, M916A3P1, and M917A2P1, refer to TM 9-2320-302-20-2. For the M915A4P1, refer to TM 9-2320-303-24-1. For the M915A2P1, M916A1P1, M916A2P1, and M917A1P1, refer to TM 9-2320-363-20-2.
13. Install side light/turn signal. For the M915A3P1, M916A3P1, and M917A2P1, refer to TM 9-2320-302-20-2. For the M915A4P1, refer to TM 9-2320-303-24-1. For the M915A2P1, M916A1P1, M916A2P1, and M917A1P1, refer to TM 9-2320-363-20-2.

**END OF WORK PACKAGE**

---

**RIGHT WHEEL WELL BLAST DEFLECTOR REPLACEMENT**

**0026 00**

---

**THIS WORK PACKAGE COVERS**

Removal, Cleaning and Inspection, Installation

---

**INITIAL SETUP**

**Maintenance Level**

Unit

**Tools and Special Tools**

Tool Kit, General Mechanic's (Item 9, WP 0035 00)

**Materials/Parts**

Rag, Wiping (Item 9, WP 0036 00)

Locknut (24)

Lockwasher (2)

**Personnel Required**

Two

**References**

WP 0011 00

**Equipment Conditions**

**(M915A3P1, M916A3P1, and M917A2P1)**

Vehicle parked on level ground (TM 9-2320-302-10)

Parking/Emergency Brake applied (TM 9-2320-302-10)

Engine OFF (TM 9-2320-302-10)

Battery Disconnect Switch in OFF position (TM 9-2320-302-10)

Side Light/Turn Signal removed (TM 9-2320-302-20-2)

Fender removed (TM 9-2320-302-20-2)

**Equipment Conditions - Continued**

**(M915A4P1)**

Vehicle parked on level ground (TM 9-2320-303-10)

Parking/Emergency Brake applied (TM 9-2320-303-10)

Engine OFF (TM 9-2320-303-10)

Battery Disconnect Switch in OFF position (TM 9-2320-303-10)

Side Light/Turn Signal removed (TM 9-2320-303-24-1)

Fender removed (TM 9-2320-303-24-1)

**(M915A2P1, M916A1P1, M916A2P1, and M917A1P1)**

Vehicle parked on level ground (TM 9-2320-363-10)

Parking/Emergency Brake applied (TM 9-2320-363-10)

Engine OFF (TM 9-2320-363-10)

If equipped, Battery Disconnect Switch in OFF position (TM 9-2320-363-10), otherwise, disconnect battery cables (TM 9-2320-363-20-2)

Side Light/Turn Signal removed (TM 9-2320-363-20-2)

Fender removed (TM 9-2320-363-20-2)

---

**REMOVAL****WARNING**

Use extreme caution when handling heavy parts. Provide adequate support and use assistance during procedure. Failure to follow this warning may cause injury or death to personnel.

**NOTE**

Note orientation of bolts on wheel well blast protection extension panel to aid installation.

1. With assistance, remove five locknuts (10), washers (11), bolts (13), washers (12), washer plate (9), and wheel well blast deflector extension (8) from forward mounting plate (17). Discard locknuts.
2. Remove two locknuts (18), washers (19), bolts (21), washers (20), bracket (7), and hood latch (6) from bracket (5). Discard locknuts.
3. Remove four locknuts (1), washers (2), bolts (4), washers (3), and bracket (5) from right firewall armor. Discard locknuts.
4. Remove two bolts (14), washers (16), lockwashers (15), and forward mounting plate (17) from right firewall armor. Discard lockwashers.



REMOVAL - CONTINUED

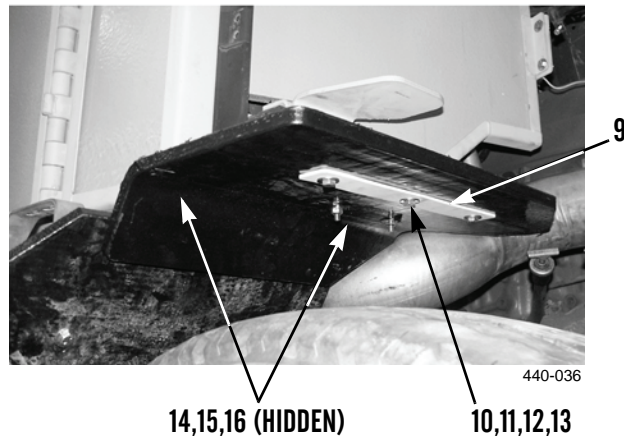
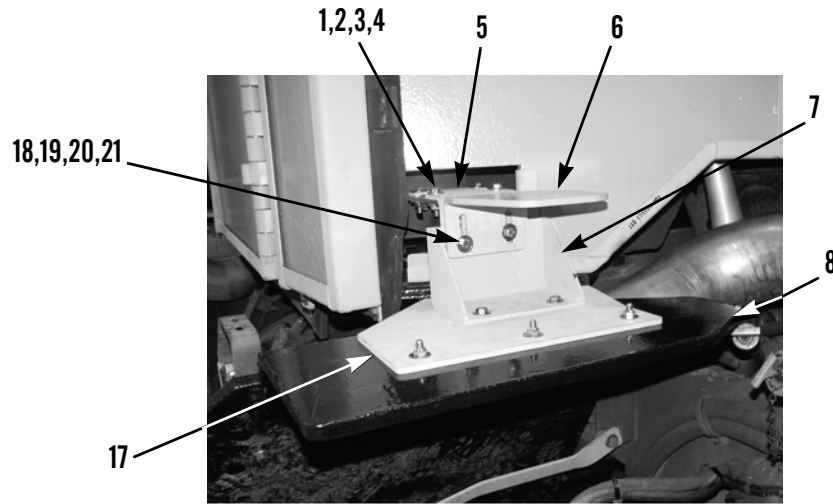

**RIGHT WHEEL WELL BLAST DEFLECTOR REPLACEMENT - CONTINUED**

0026 00

**REMOVAL - CONTINUED**

5. Remove two locknuts (29), washers (30), bolts (32), washers (31), and bracket (33) from wheel well blast deflector (28). Discard locknuts.

**WARNING**

Use extreme caution when handling heavy parts. Provide adequate support and use assistance during procedure. Failure to follow this warning may cause injury or death to personnel.

6. With assistance, remove five locknuts (23), washers (24), bolts (26), washers (25), and wheel well blast deflector (28) from wheel well frames (27). Discard locknuts.
7. Remove two locknuts (35), washers (36), bolts (38), washers (37), and bracket (34) from wheel well frame (27). Discard locknuts.
8. Remove four locknuts (39), washers (40), bolts (42), washers (41), bracket (22), two wheel well frames (27), and two cross members (44) from wheel well support bar (43). Discard locknuts.

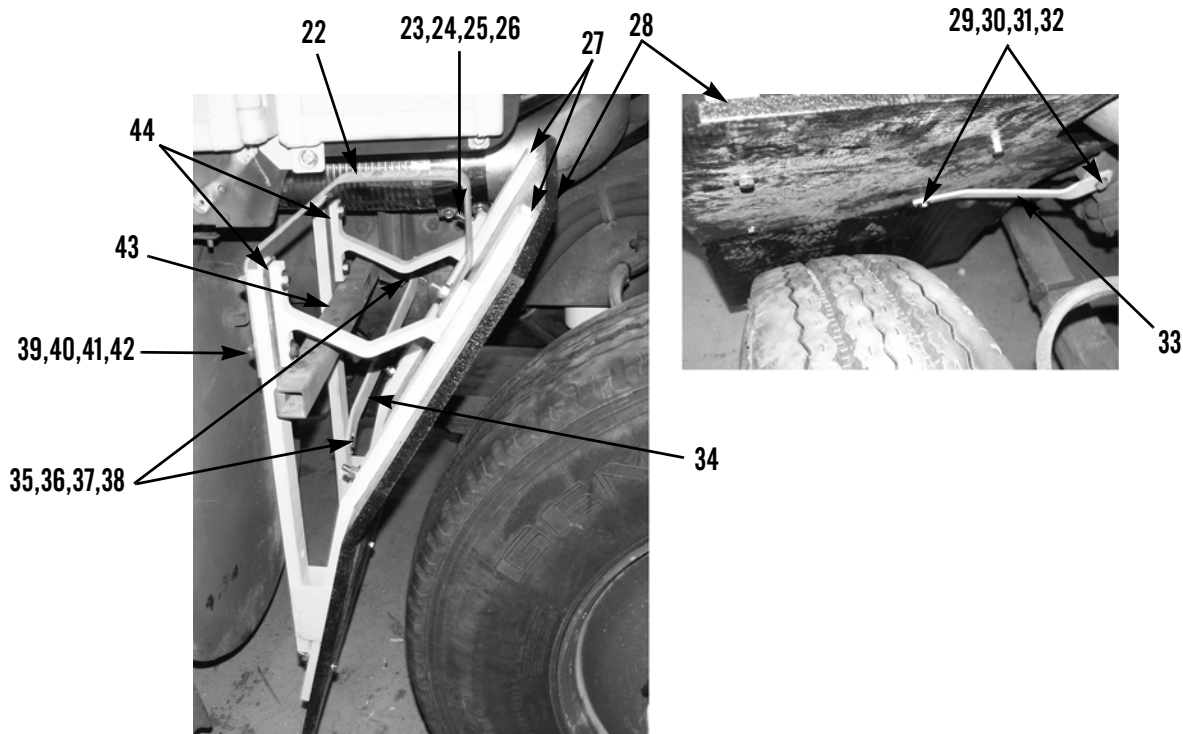

440-037

**CLEANING AND INSPECTION**

Clean and inspect all parts IAW *General Maintenance Instructions* (WP 0011 00).

**INSTALLATION**

1. Install two cross members (44), two wheel well frames (27), bracket (22), four washers (41), bolts (42), washers (40), and new locknuts (39) on wheel well support bar (43).
2. Install bracket (34), two washers (37), bolts (38), washers (36), and new locknuts (35) on wheel well frame (27).

**WARNING**

Use extreme caution when handling heavy parts. Provide adequate support and use assistance during procedure. Failure to follow this warning may cause injury or death to personnel.

3. With assistance, install wheel well blast deflector (28), five washers (25), bolts (26), washers (24), and new locknuts (23) on wheel well frames (27).
4. Install bracket (33), two washers (31), bolts (32), washers (30), and new locknuts (29) on wheel well blast deflector (28).

**INSTALLATION - CONTINUED**

5. Install forward mounting plate (17), two new lockwashers (15), washers (16), and bolts (14) on right firewall armor.
6. Install bracket (5), four washers (3), bolts (4), washers (2), and new locknuts (1) on right firewall armor.
7. Install hood latch (6), bracket (7), two washers (20), bolts (21), washers (19), and new locknuts (18) on bracket (5).



**WARNING**

Use extreme caution when handling heavy parts. Provide adequate support and use assistance during procedure. Failure to follow this warning may cause injury or death to personnel.

8. With assistance, install wheel well blast deflector extension (8), washer plate (9), five washers (12), bolts (13), washers (11), and new locknuts (10) on forward mounting plate (17).

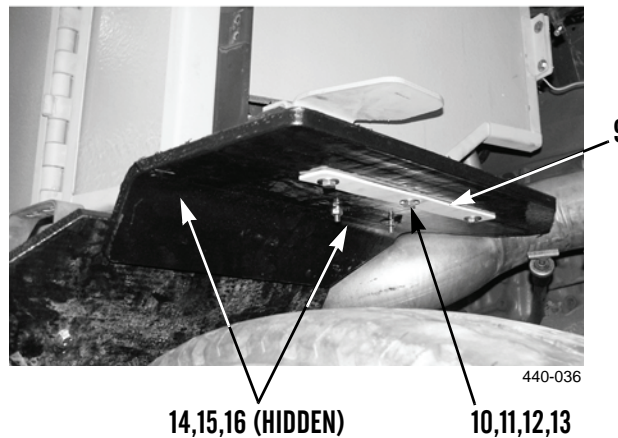
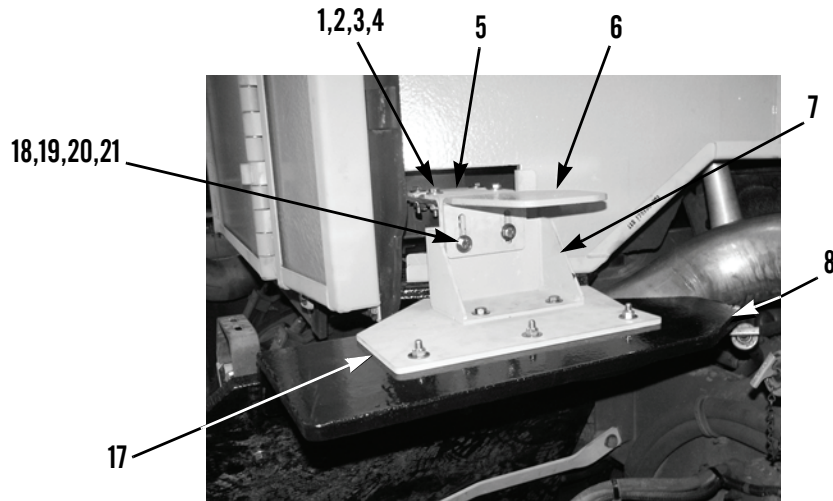

***INSTALLATION - CONTINUED***

9. Install fender. For the M915A3P1, M916A3P1, and M917A2P1, refer to TM 9-2320-302-20-2. For the M915A4P1, refer to TM 9-2320-303-24-1. For the M915A2P1, M916A1P1, M916A2P1, and M917A1P1, refer to TM 9-2320-363-20-2.
10. Install side light/turn signal. For the M915A3P1, M916A3P1, and M917A2P1, refer to TM 9-2320-302-20-2. For the M915A4P1, refer to TM 9-2320-303-24-1. For the M915A2P1, M916A1P1, M916A2P1, and M917A1P1, refer to TM 9-2320-363-20-2.

**END OF WORK PACKAGE**



---

**LEFT FIREWALL ARMOR REPLACEMENT**

**0027 00**

---

**THIS WORK PACKAGE COVERS**

Removal, Cleaning and Inspection, Installation

---

**INITIAL SETUP**

**Maintenance Level**

Unit

**Tools and Special Tools**

Tool Kit, General Mechanic's (Item 9, WP 0035 00)

**Materials/Parts**

Rag, Wiping (Item 9, WP 0036 00)

Locknut (5)

Lockwasher (2)

**References**

WP 0011 00

**Equipment Conditions**

**(M915A3P1, M916A3P1, and M917A2P1)**

Vehicle parked on level ground (TM 9-2320-302-10)

Parking/Emergency Brake applied (TM 9-2320-302-10)

Engine OFF (TM 9-2320-302-10)

Battery Disconnect Switch in OFF position (TM 9-2320-302-10)

Left Wheel Well Blast Deflector Extension removed (WP 0025 00)

**Equipment Conditions - Continued**

**(M915A4P1)**

Vehicle parked on level ground (TM 9-2320-303-10)

Parking/Emergency Brake applied (TM 9-2320-303-10)

Engine OFF (TM 9-2320-303-10)

Battery Disconnect Switch in OFF position (TM 9-2320-303-10)

Left Wheel Well Blast Deflector Extension removed (WP 0025 00)

**(M915A2P1, M916A1P1, M916A2P1, and M917A1P1)**

Vehicle parked on level ground (TM 9-2320-363-10)

Parking/Emergency Brake applied (TM 9-2320-363-10)

Engine OFF (TM 9-2320-363-10)

If equipped, Battery Disconnect Switch in OFF position (TM 9-2320-363-10), otherwise, disconnect battery cables (TM 9-2320-363-20-2)

Left Wheel Well Blast Deflector Extension removed (WP 0025 00)

---

**REMOVAL**

1. Remove two locknuts (2), washers (3), bolts (5), and washers (4) from left firewall armor (1). Discard locknuts.
2. Remove two bolts (6), washers (8), and lockwashers (7) from left firewall armor (1). Discard lockwashers.

**WARNING**

Use extreme caution when handling heavy parts. Provide adequate support and use assistance during procedure. Failure to follow this warning may cause injury or death to personnel.

3. With assistance, remove two locknuts (9), washers (10), bolts (12), washers (11), and left firewall armor (1) from bracket (13). Discard locknuts.

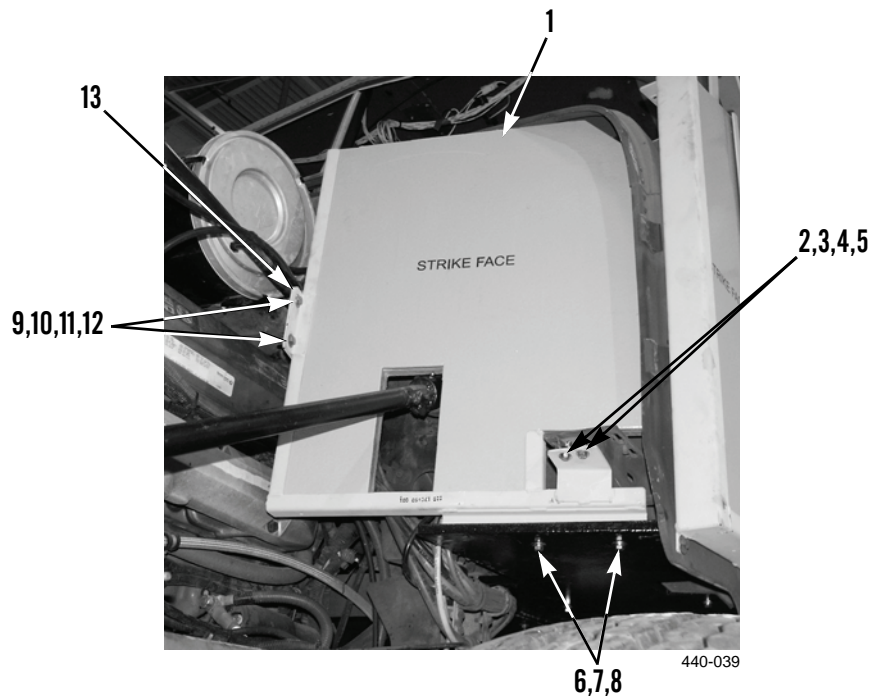



**REMOVAL - CONTINUED**

- Remove locknut (14), washer (15), bolt (17), washer (16), and bracket (13) from radiator core support (18). Discard locknuts.

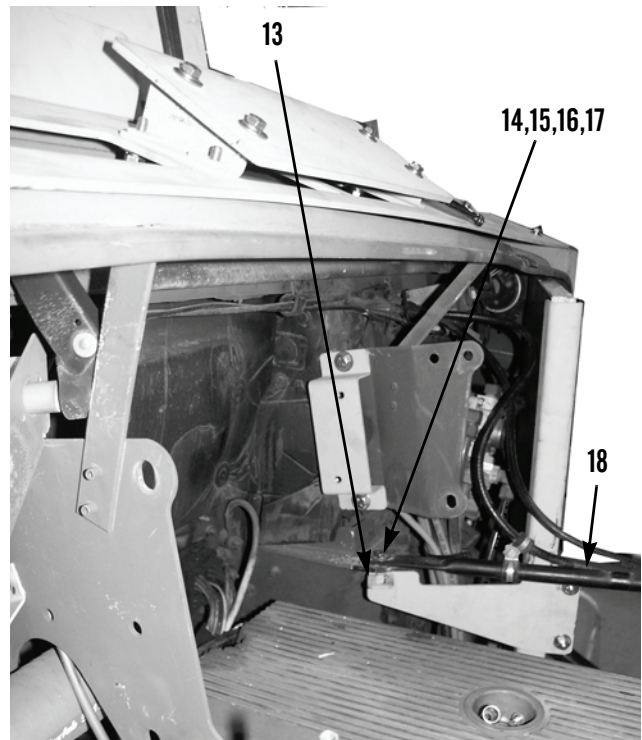

440-094

**CLEANING AND INSPECTION**

Clean and inspect all parts IAW *General Maintenance Instructions* (WP 0011 00).

**INSTALLATION**

- Install bracket (13), washer (16), bolt (17), washer (15), and new locknut (14) on radiator core support (18).

**WARNING**

- Use extreme caution when handling heavy parts. Provide adequate support and use assistance during procedure. Failure to follow this warning may cause injury or death to personnel.
  - For proper threat protection, armor must be installed correctly into the armor frame. During installation, ensure that the surface marked "STRIKE FACE" is facing outward towards the threat. Exposing the passive side of the ballistic panel outward makes the armor less effective. Failure to follow this warning may cause injury or death to personnel.
- With assistance, install left firewall armor (1), two washers (11), bolts (12), washers (10), and new locknuts (9) on bracket (13).
  - Install two new lockwashers (7), washers (8), and bolts (6) on left firewall armor (1).
  - Install two washers (4), bolts (5), washers (3), and new locknuts (2) on left firewall armor (1).
  - Install left wheel well blast deflector extension (WP 0025 00).

**END OF WORK PACKAGE**



**RIGHT FIREWALL ARMOR REPLACEMENT****0028 00****THIS WORK PACKAGE COVERS**

Removal, Cleaning and Inspection, Installation

**INITIAL SETUP****Maintenance Level**

Unit

**Tools and Special Tools**

Tool Kit, General Mechanic's (Item 9, WP 0035 00)

**Materials/Parts**

Rag, Wiping (Item 9, WP 0036 00)

Locknut (5)

Lockwasher (2)

**References**

WP 0011 00

**Equipment Conditions****(M915A3P1, M916A3P1, and M917A2P1)**

Vehicle parked on level ground (TM 9-2320-302-10)

Parking/Emergency Brake applied (TM 9-2320-302-10)

Engine OFF (TM 9-2320-302-10)

Battery Disconnect Switch in OFF position (TM 9-2320-302-10)

Right Wheel Well Blast Deflector Extension removed (WP 0026 00)

**Equipment Conditions - Continued****(M915A4P1)**

Vehicle parked on level ground (TM 9-2320-303-10)

Parking/Emergency Brake applied (TM 9-2320-303-10)

Engine OFF (TM 9-2320-303-10)

Battery Disconnect Switch in OFF position (TM 9-2320-303-10)

Right Wheel Well Blast Deflector Extension removed (WP 0026 00)

**(M915A2P1, M916A1P1, M916A2P1, and M917A1P1)**

Vehicle parked on level ground (TM 9-2320-363-10)

Parking/Emergency Brake applied (TM 9-2320-363-10)

Engine OFF (TM 9-2320-363-10)

If equipped, Battery Disconnect Switch in OFF position (TM 9-2320-363-10), otherwise, disconnect battery cables (TM 9-2320-363-20-2)

Right Wheel Well Blast Deflector Extension removed (WP 0026 00)

**REMOVAL**

1. Remove two hose clamps (2) and air filter elbow (4) from air filter assembly (1) and air filter exhaust pipe (3).

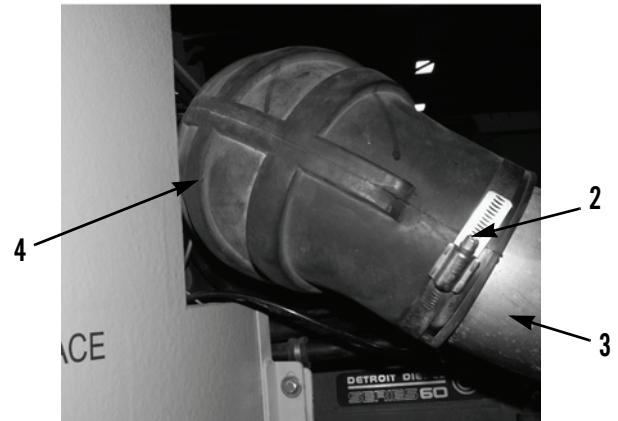
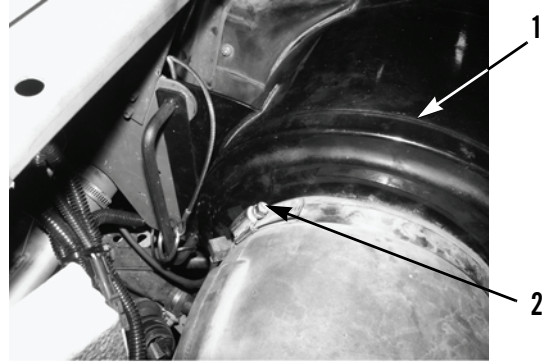

440-042

2. Remove two locknuts (14), washers (15), bolts (17), and washers (16) from right firewall armor (5). Discard locknuts.
3. Remove two bolts (11), washers (13), and lockwashers (12) from right firewall armor (5). Discard lockwashers.

**REMOVAL - CONTINUED****WARNING**

Use extreme caution when handling heavy parts. Provide adequate support and use assistance during procedure. Failure to follow this warning may cause injury or death to personnel.

4. With assistance, remove two locknuts (7), washers (8), bolts (10), washers (9), and right firewall armor (5) from bracket (6). Discard locknuts.

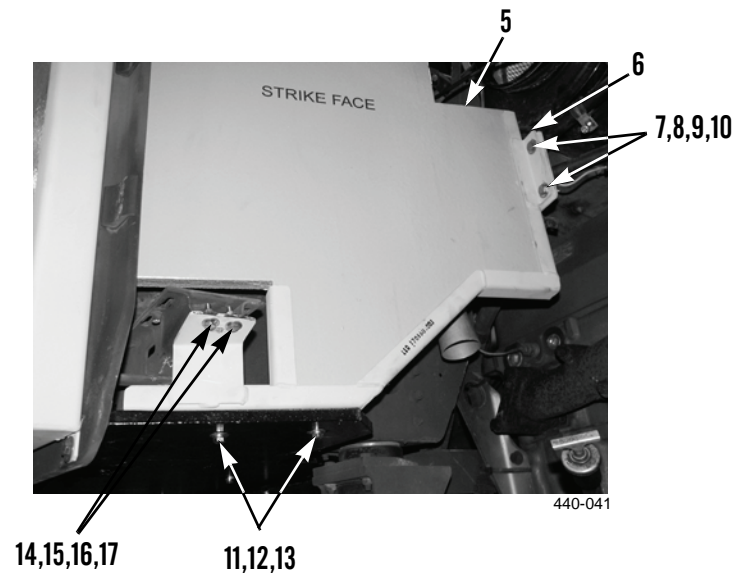

**REMOVAL - CONTINUED**

- Remove locknut (18), washer (19), bolt (21), washer (20), and bracket (6) from radiator core support (22). Discard locknuts.

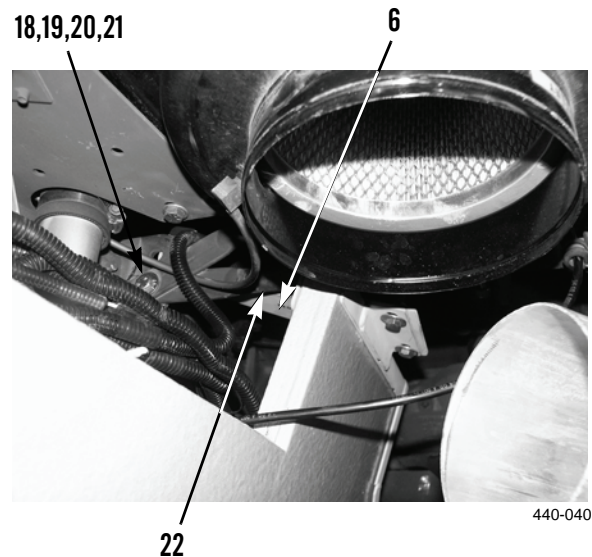
**CLEANING AND INSPECTION**

Clean and inspect all parts IAW *General Maintenance Instructions* (WP 0011 00).

**INSTALLATION**

- Install bracket (6), washer (20), bolt (21), washer (19), and new locknut (18) on radiator core support (22).

**WARNING**

- Use extreme caution when handling heavy parts. Provide adequate support and use assistance during procedure. Failure to follow this warning may cause injury or death to personnel.
  - For proper threat protection, armor must be installed correctly into the armor frame. During installation, ensure that the surface marked “STRIKE FACE” is facing outward towards the threat. Exposing the passive side of the ballistic panel outward makes the armor less effective. Failure to follow this warning may cause injury or death to personnel.
- With assistance, install right firewall armor (5), two washers (9), bolts (10), washers (8), and new locknuts (7) on bracket (6).
  - Install two new lockwashers (12), washers (13), and bolts (11) on right firewall armor (5).

**INSTALLATION - CONTINUED**

4. Install two washers (16), bolts (17), washers (15), and new locknuts (14) on left firewall armor (5).

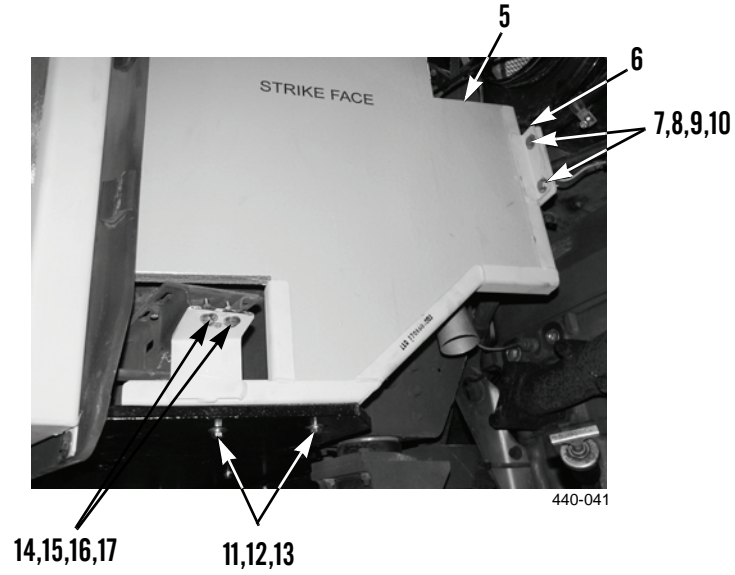

**INSTALLATION - CONTINUED**

5. Install air filter elbow (4) and two hose clamps (2) on air filter assembly (1) and air filter exhaust pipe (3).

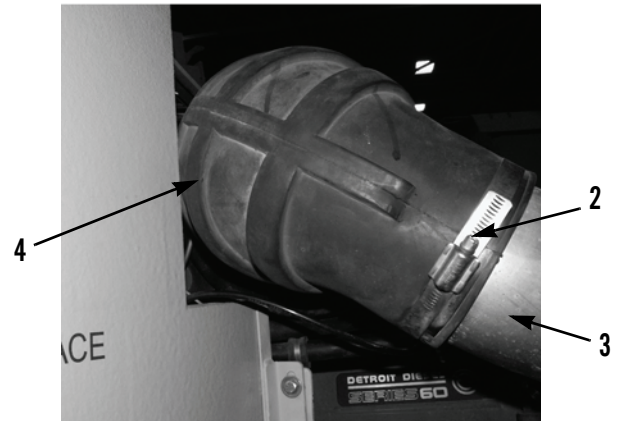
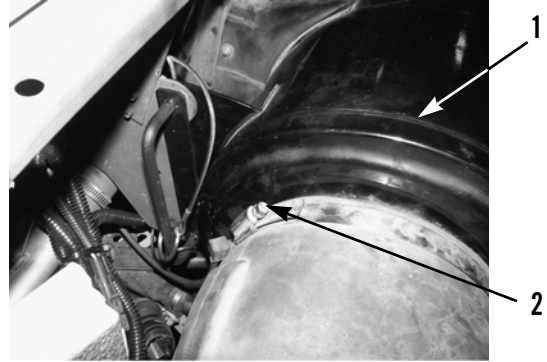

440-042

6. Install right wheel well blast deflector extension (WP 0026 00).

**END OF WORK PACKAGE**



---

**CENTER FIREWALL ARMOR REPLACEMENT**

**0029 00**

---

**THIS WORK PACKAGE COVERS**

Removal, Cleaning and Inspection, Installation

---

**INITIAL SETUP**

**Maintenance Level**

Unit

**Tools and Special Tools**

Tool Kit, General Mechanic's (Item 9, WP 0035 00)

**Materials/Parts**

Rag, Wiping (Item 9, WP 0036 00)

Locknut (5)

Lockwasher (2)

**References**

WP 0011 00

**Equipment Conditions**

**(M915A3P1, M916A3P1, and M917A2P1)**

Vehicle parked on level ground (TM 9-2320-302-10)

Parking/Emergency Brake applied (TM 9-2320-302-10)

Engine OFF (TM 9-2320-302-10)

Battery Disconnect Switch in OFF position (TM 9-2320-302-10)

**Equipment Conditions - Continued**

**(M915A4P1)**

Vehicle parked on level ground (TM 9-2320-303-10)

Parking/Emergency Brake applied (TM 9-2320-303-10)

Engine OFF (TM 9-2320-303-10)

Battery Disconnect Switch in OFF position (TM 9-2320-303-10)

**(M915A2P1, M916A1P1, M916A2P1, and M917A1P1)**

Vehicle parked on level ground (TM 9-2320-363-10)

Parking/Emergency Brake applied (TM 9-2320-363-10)

Engine OFF (TM 9-2320-363-10)

If equipped, Battery Disconnect Switch in OFF position (TM 9-2320-363-10), otherwise, disconnect battery cables (TM 9-2320-363-20-2)

---

**CENTER FIREWALL ARMOR REPLACEMENT - CONTINUED**

0029 00

**REMOVAL**

1. Remove two hose clamps (2) and air filter elbow (4) from air filter assembly (1) and air filter exhaust pipe (3).
2. Remove two quick release pins (7), two air horn hose clamps (6), restriction gauge hose (5), and air filter assembly (1) from vehicle.

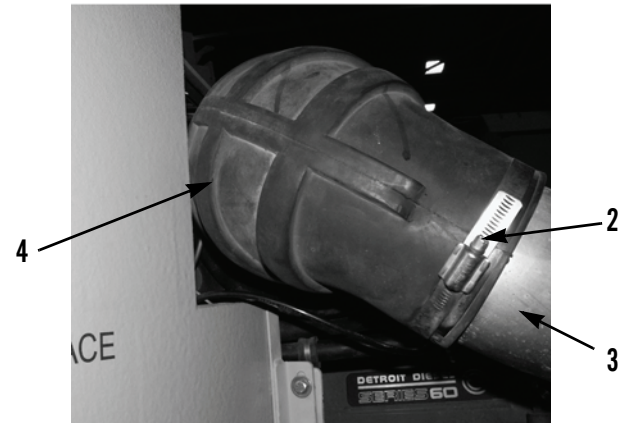
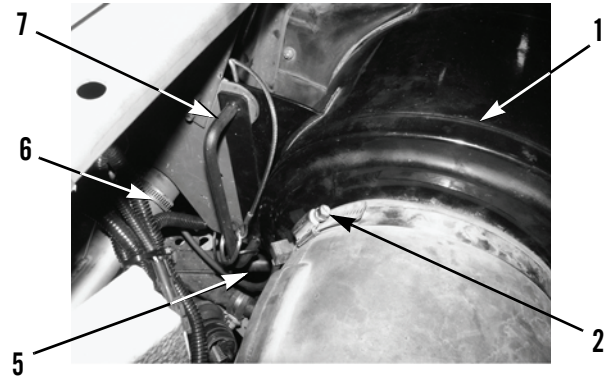

440-042

**REMOVAL - CONTINUED**

3. Remove two locknuts (17), washers (18), bolts (20), and washers (19) from center firewall armor (8). Discard locknuts.

**WARNING**

Use extreme caution when handling heavy parts. Provide adequate support and use assistance during procedure. Failure to follow this warning may cause injury or death to personnel.

4. With assistance, remove two bolts (14), washers (16), lockwashers (15), and center firewall armor (8) from vehicle. Discard lockwashers.
5. Remove two locknuts (9), washers (10), bolts (12), washers (11), and bracket (13) from vehicle. Discard locknuts.

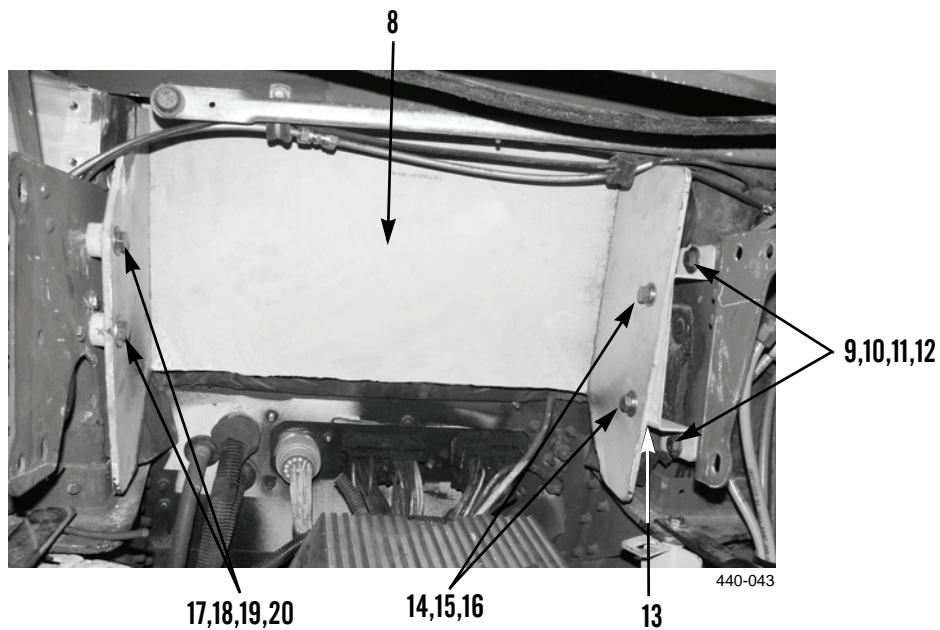
**CLEANING AND INSPECTION**

Clean and inspect all parts IAW *General Maintenance Instructions* (WP 0011 00).

**INSTALLATION**

1. Install bracket (13), two washers (11), bolts (12), washers (10), and new locknut (9) on vehicle firewall.

**WARNING**

Use extreme caution when handling heavy parts. Provide adequate support and use assistance during procedure. Failure to follow this warning may cause injury or death to personnel.

2. With assistance, install center firewall armor (8), two new lockwashers (15), washers (16), and bolts (14) on vehicle.
3. Install two washers (19), bolts (20), washers (18), and new locknuts (17) on center firewall armor (8).

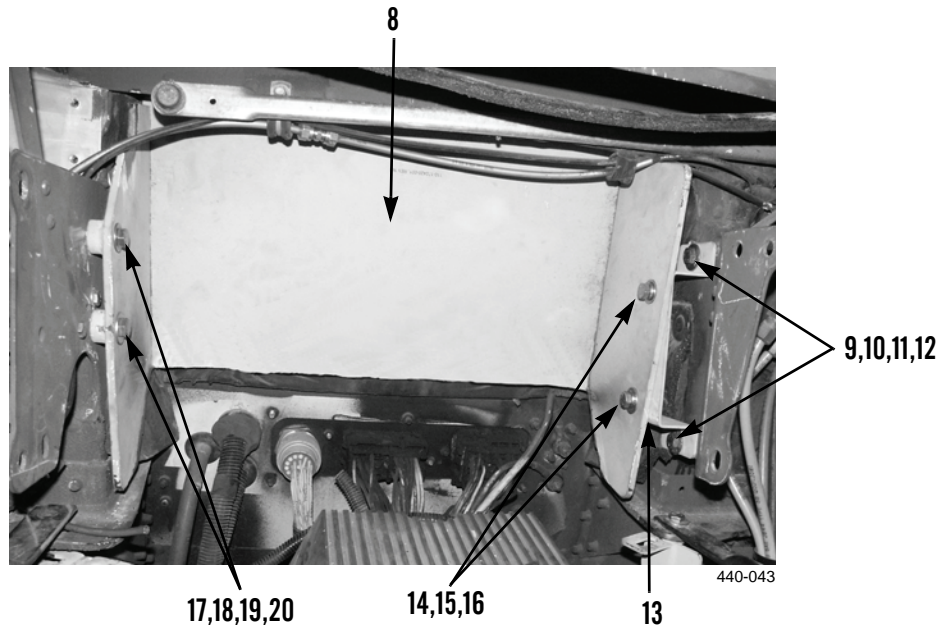

**INSTALLATION - CONTINUED**

4. Install air filter assembly (1), restriction gauge hose (5), two air horn clamps (6), and two quick release pins (7) on vehicle.
5. Install air filter elbow (4) and two hose clamps (2) on air filter assembly (1) and air filter exhaust pipe (3).

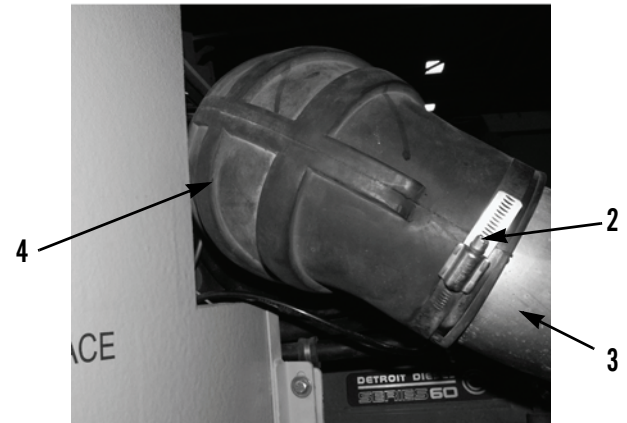
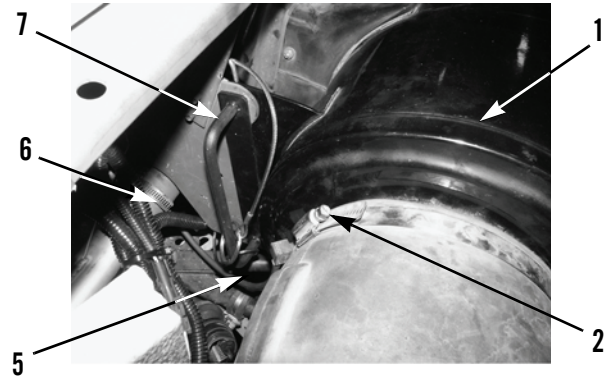

440-042

**END OF WORK PACKAGE**



---

**WINDSHIELD BALLISTIC GLASS REPLACEMENT**

**0030 00**

---

**THIS WORK PACKAGE COVERS**

Removal, Cleaning and Inspection, Installation

---

**INITIAL SETUP**

**Maintenance Level**

Unit

**Tools and Special Tools**

Tool Kit, General Mechanic's (Item 9, WP 0035 00)

**Materials/Parts**

Rag, Wiping (Item 9, WP 0036 00)

Sealing Compound, Urethane (Item 10, WP 0036 00)

Locknut (4)

Lockwasher (34)

**Personnel Required**

Two

**References**

WP 0011 00

**Equipment Conditions**

**(M915A3P1, M916A3P1, and M917A2P1)**

Vehicle parked on level ground (TM 9-2320-302-10)

Parking/Emergency Brake applied (TM 9-2320-302-10)

Engine OFF (TM 9-2320-302-10)

**Equipment Conditions - Continued**

**(M915A3P1, M916A3P1, and M917A2P1) - Continued**

Battery Disconnect Switch in OFF position (TM 9-2320-302-10)

**(M915A4P1)**

Vehicle parked on level ground (TM 9-2320-303-10)

Parking/Emergency Brake applied (TM 9-2320-303-10)

Engine OFF (TM 9-2320-303-10)

Battery Disconnect Switch in OFF position (TM 9-2320-303-10)

**(M915A2P1, M916A1P1, M916A2P1, and M917A1P1)**

Vehicle parked on level ground (TM 9-2320-363-10)

Parking/Emergency Brake applied (TM 9-2320-363-10)

Engine OFF (TM 9-2320-363-10)

If equipped, Battery Disconnect Switch in OFF position (TM 9-2320-363-10), otherwise, disconnect battery cables (TM 9-2320-363-20-2)

---

**CAUTION**

Never use impact tools when removing or installing ballistic glass. Failure to follow this caution may damage ballistic glass.

**REMOVAL**

1. Remove three bolts (3), washers (5), lockwashers (4), and top right surround (2) from right ballistic glass (1). Discard lockwashers.
2. Remove three bolts (28), washers (30), lockwashers (29), and right surround (27) from right ballistic glass (1). Discard lockwashers.
3. Remove three bolts (24), washers (26), lockwashers (25), and bottom right surround (23) from right ballistic glass (1). Discard lockwashers.
4. Remove six bolts (7), washers (9), lockwashers (8), and center surround (6) from right ballistic glass (1) and left ballistic glass (14). Discard lockwashers.
5. Remove three bolts (11), washers (13), lockwashers (12), and top left surround (10) from left ballistic glass (14). Discard lockwashers.
6. Remove three bolts (16), washers (18), lockwashers (17), and left surround (15) from left ballistic glass (14). Discard lockwashers.
7. Remove three bolts (20), washers (22), lockwashers (21), and bottom left surround (19) from left ballistic glass (14). Discard lockwashers.



**REMOVAL - CONTINUED****WARNING**

- Use extreme caution when handling heavy parts. Provide adequate support and use assistance during procedure. Failure to follow this warning may cause injury or death to personnel.
- Use caution when handling window glass. Glass can break unexpectedly during removal/installation procedure. Wear face shield, apron, and gloves. Failure to follow this warning may cause injury to personnel.

8. With assistance, remove right ballistic glass (1) from ballistic glass frame.
9. With assistance, remove left ballistic glass (14) from ballistic glass frame.

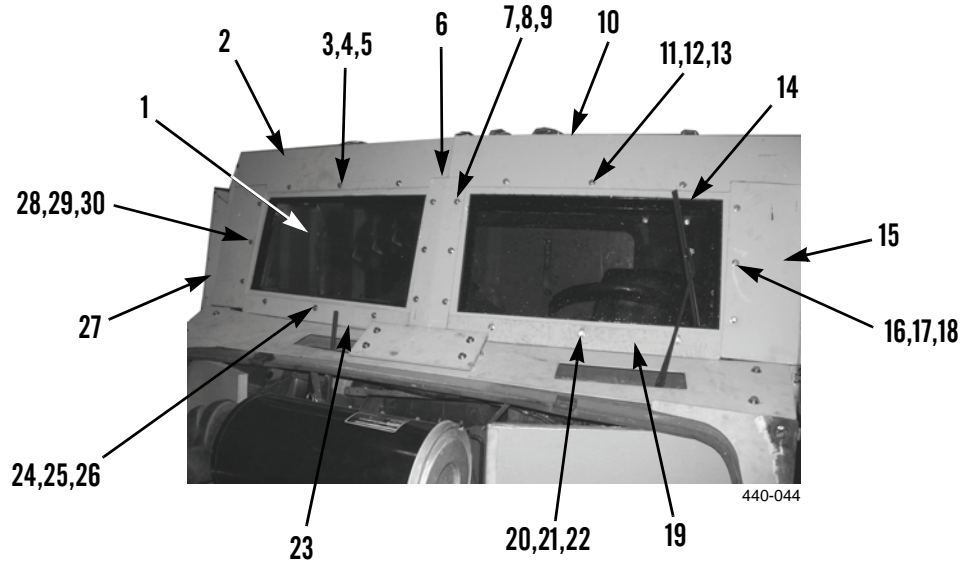

**REMOVAL - CONTINUED****WARNING**

Use extreme caution when handling heavy parts. Provide adequate support and use assistance during procedure. Failure to follow this warning may cause injury or death to personnel.

10. With assistance, remove right frame holder (31) from vehicle cab (32).
11. With assistance, remove left frame holder (33) from vehicle cab (32).

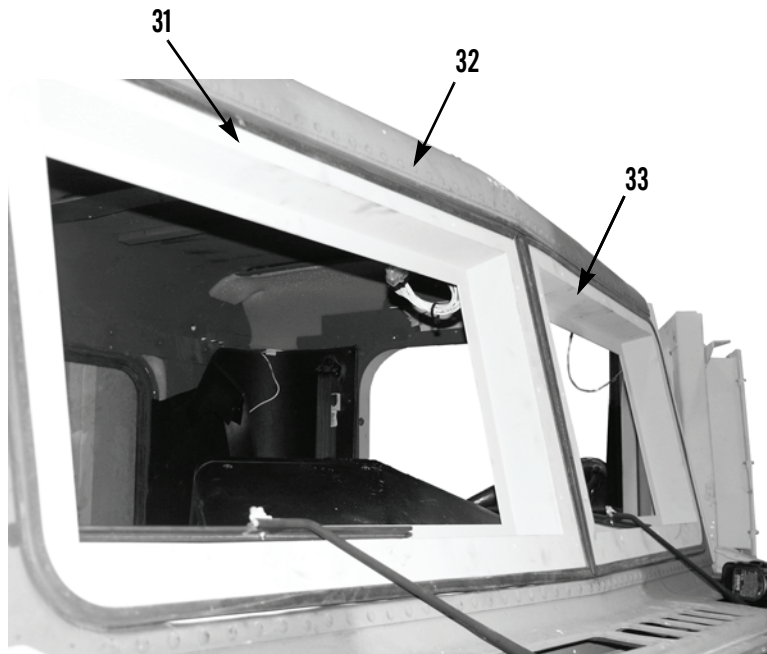

440-045

**REMOVAL - CONTINUED**

12. Remove two locknuts (34), washers (35), bolts (37), and washers (36) from right windshield frame (49). Discard locknuts.
13. Remove five bolts (46), washers (48), lockwashers (47), and right windshield frame (49) from vehicle cab (32). Discard lockwashers.
14. Remove two locknuts (42), washers (43), bolts (45), and washers (44) from left windshield frame (50). Discard locknuts.
15. Remove five bolts (39), washers (41), lockwashers (40), horn pull cord (38), and left windshield frame (50) from vehicle cab (32). Discard lockwashers.

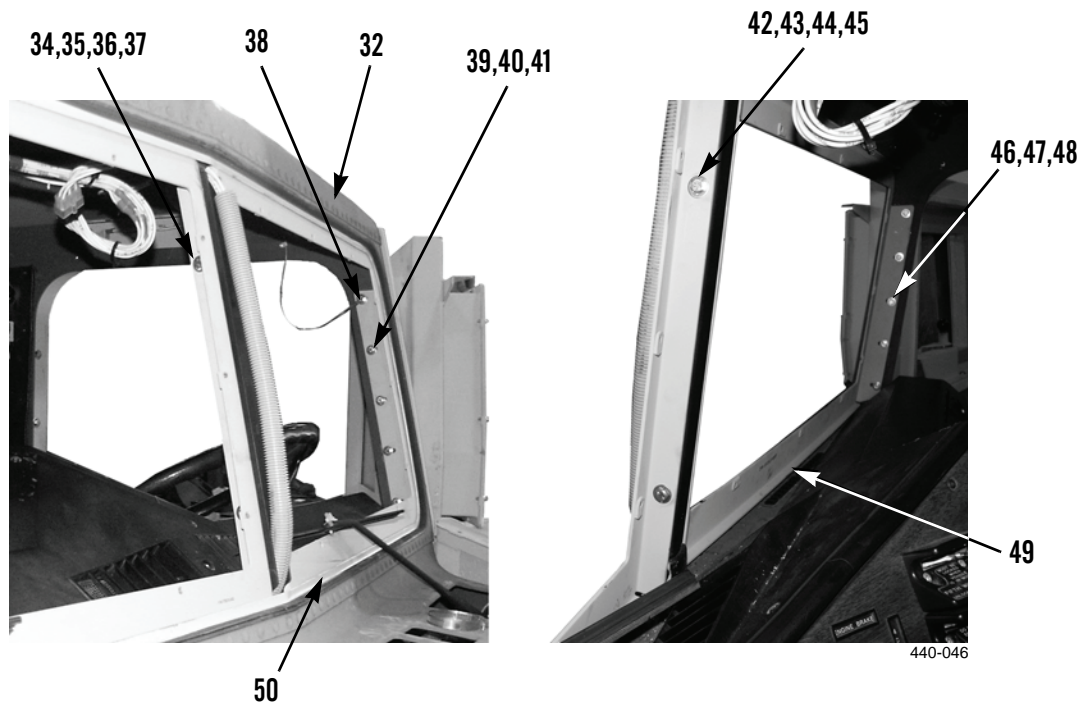

**CLEANING AND INSPECTION**

Clean and inspect all parts IAW *General Maintenance Instructions* (WP 0011 00).

**INSTALLATION**

1. Install left windshield frame (50), horn pull cord (38), five new lockwashers (40), washers (41), and bolts (39) on vehicle cab.
2. Install two washers (44), bolts (45), washers (43), and new locknuts (42) on left windshield frame (50).
3. Install right windshield frame (49), five new lockwashers (47), washers (48), and bolts (46) on vehicle cab.
4. Install two washers (36), bolts (37), washers (35), and new locknuts (34) on left windshield frame (49).

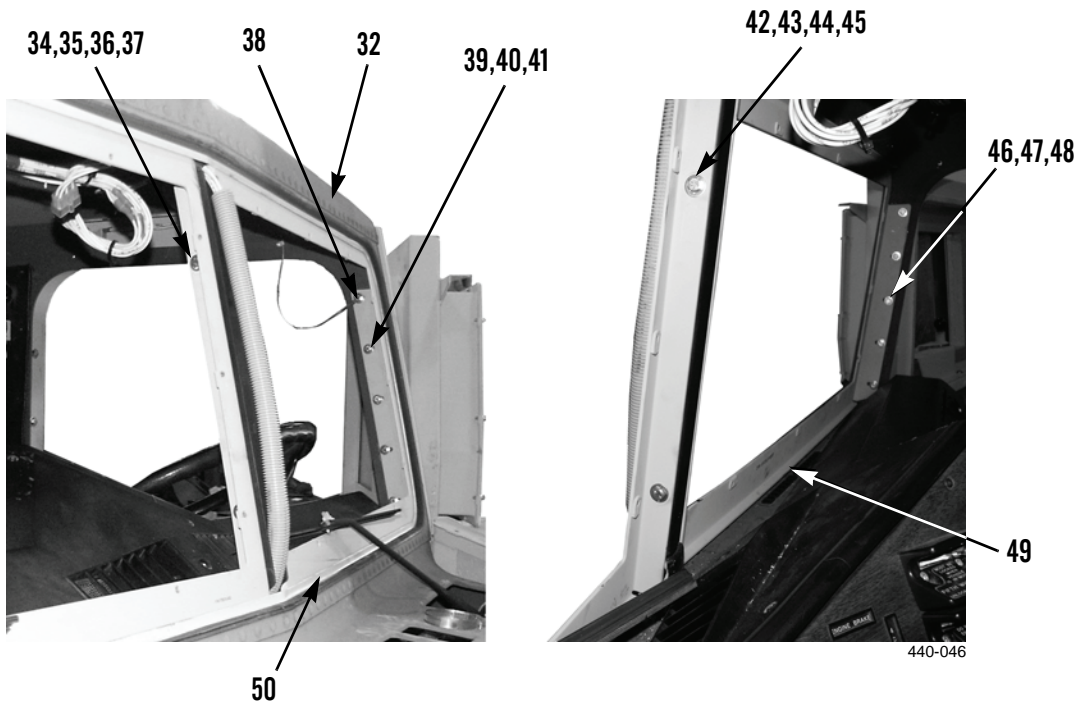

**INSTALLATION - CONTINUED****WARNING**

Use extreme caution when handling heavy parts. Provide adequate support and use assistance during procedure. Failure to follow this warning may cause injury or death to personnel.

5. With assistance, install left frame holder (33) on vehicle cab (32).
6. With assistance, install right frame holder (31) on vehicle cab (32).

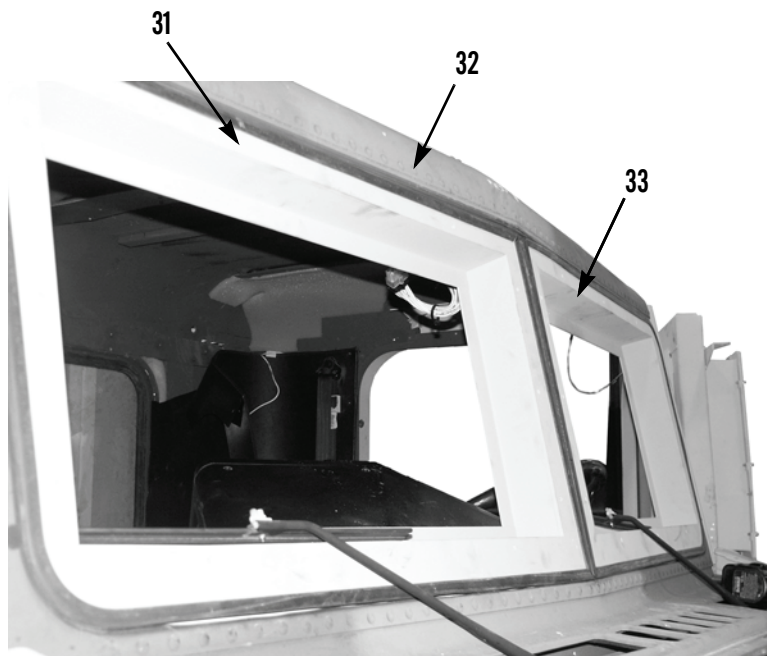

440-045

**INSTALLATION - CONTINUED****WARNING**

- Use extreme caution when handling heavy parts. Provide adequate support and use assistance during procedure. Failure to follow this warning may cause injury or death to personnel.
- Use caution when handling window glass. Glass can break unexpectedly during removal/installation procedure. Wear face shield, apron, and gloves. Failure to follow this warning may cause injury to personnel.
- For proper threat protection, ballistic glass must be correctly installed onto ballistic glass frame. During installation, ensure that decal "INSTALL THIS SURFACE TOWARDS THREAT" is located on outside of cab. Improperly installed ballistic glass will not protect occupants. Failure to follow this warning may cause injury or death to personnel.

**WARNING**

Use caution when using adhesives and sealants. Prolonged inhalation of vapors can cause lung irritation. Contact with skin can cause dermatitis. Wear gloves and safety goggles and use product in a well-ventilated area away from open flame. If ingested, keep individual calm and seek medical attention. DO NOT induce vomiting. If contact with skin or eyes is made, flush thoroughly with water. Dispose of cleanup rags IAW local policy and ordinances. Failure to follow this warning may cause injury to personnel.

7. With assistance, install left ballistic glass (14). Use sealant around outside edge of ballistic glass frame.
8. With assistance, install right ballistic glass (1). Use sealant around outside edge of ballistic glass frame.
9. Install bottom left surround (19), three new lockwashers (21), washers (22), and bolts (20) on left ballistic glass (14).
10. Install left surround (15), three new lockwashers (17), washers (18), and bolts (16) on left ballistic glass (14).
11. Install top left surround (10), three new lockwashers (12), washers (13), and bolts (11) on left ballistic glass (14).
12. Install center surround (6), six new lockwashers (8), washers (9), and bolts (7) on right ballistic glass (1) and left ballistic glass (14).
13. Install bottom right surround (23), three new lockwashers (25), washers (26), and bolts (24) on right ballistic glass (1).
14. Install right surround (27), three new lockwashers (29), washers (30), and bolts (28) on right ballistic glass (1).
15. Install top right surround (2), three new lockwashers (4), washers (5), and bolts (3) on right ballistic glass (1).

INSTALLATION - CONTINUED

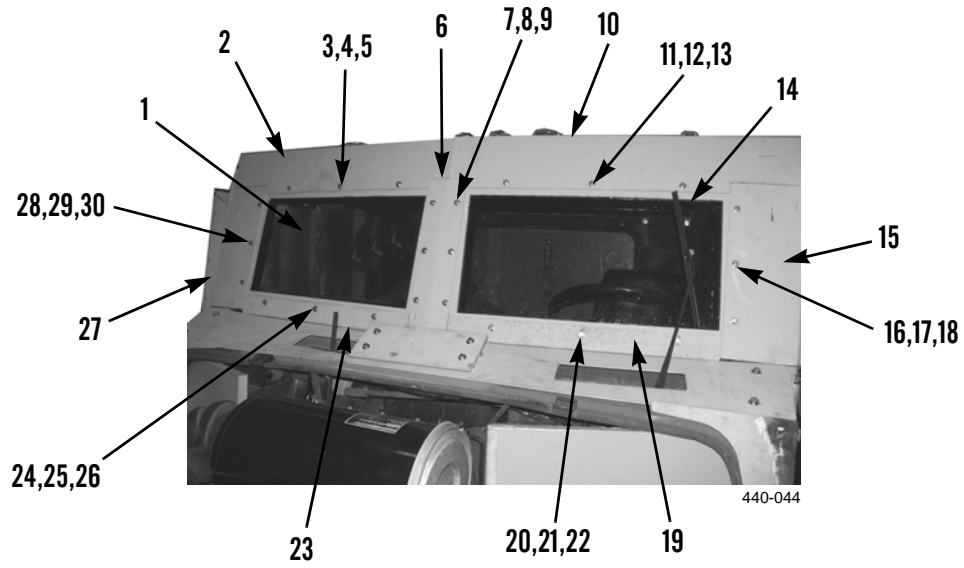

END OF WORK PACKAGE





---

**ROOF ARMOR REPLACEMENT**

**0031 00**

---

**THIS WORK PACKAGE COVERS**

Removal, Cleaning and Inspection, Installation

---

**INITIAL SETUP**

**Maintenance Level**

Unit

**Tools and Special Tools**

Tool Kit, General Mechanic's (Item 9, WP 0035 00)

**Materials/Parts**

Rag, Wiping (Item 9, WP 0036 00)

Lockwasher (22)

**Personnel Required**

Two

**References**

WP 0011 00

**Equipment Conditions**

**(M915A3P1, M916A3P1, and M917A2P1)**

Vehicle parked on level ground (TM 9-2320-302-10)

Parking/Emergency Brake applied (TM 9-2320-302-10)

Engine OFF (TM 9-2320-302-10)

Battery Disconnect Switch in OFF position (TM 9-2320-302-10)

**Equipment Conditions - Continued**

**(M915A4P1)**

Vehicle parked on level ground (TM 9-2320-303-10)

Parking/Emergency Brake applied (TM 9-2320-303-10)

Engine OFF (TM 9-2320-303-10)

Battery Disconnect Switch in OFF position (TM 9-2320-303-10)

**(M915A2P1, M916A1P1, M916A2P1, and M917A1P1)**

Vehicle parked on level ground (TM 9-2320-363-10)

Parking/Emergency Brake applied (TM 9-2320-363-10)

Engine OFF (TM 9-2320-363-10)

If equipped, Battery Disconnect Switch in OFF position (TM 9-2320-363-10), otherwise, disconnect battery cables (TM 9-2320-363-20)

---

**ROOF ARMOR REPLACEMENT - CONTINUED****0031 00****REMOVAL**

1. Remove four nuts (3), lockwashers (4), washers (5), and two roof grab straps (6) from middle roof panel (2). Discard lockwashers.
2. Remove eight nuts (9), lockwashers (10), washers (11), and rear roof bracket (8) from middle roof panel (2). Discard lockwashers.

**WARNING**

Use extreme caution when handling heavy parts. Provide adequate support and use assistance during procedure. Failure to follow this warning may cause injury or death to personnel.

3. With assistance, remove two dividers (1) and middle roof panel (2) from roof frame (12).
4. With assistance, remove left roof panel (7) from roof frame (12).
5. With assistance, remove right roof panel (13) from roof frame (12).

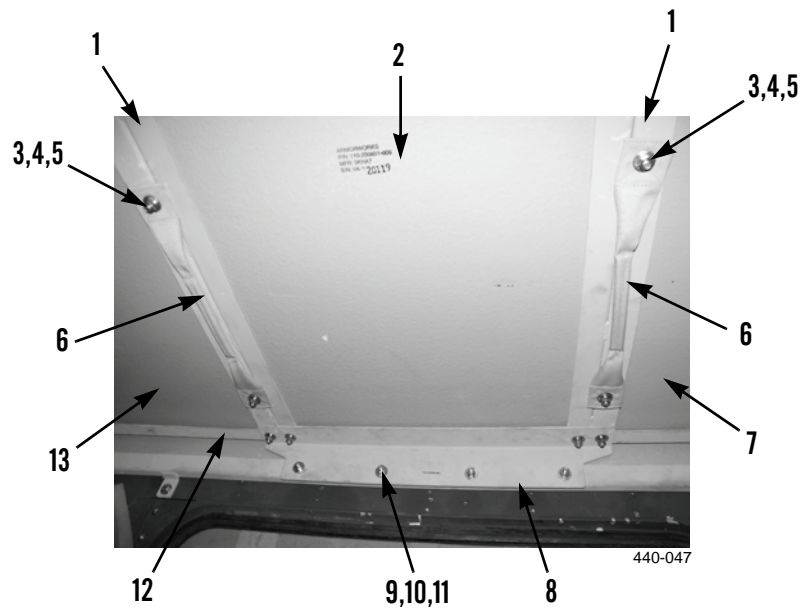

**ROOF ARMOR REPLACEMENT - CONTINUED**

**0031 00**

**REMOVAL - CONTINUED**

6. Remove four bolts (16), lockwashers (17), washers (18), and two brackets (15) from left and right side panel frames (19). Discard lockwashers.
7. Remove two bolts (20), bushings (21), seatbelt connectors (22), two side panel frames (19), and side panel armor (14) from left and right side of vehicle cab.

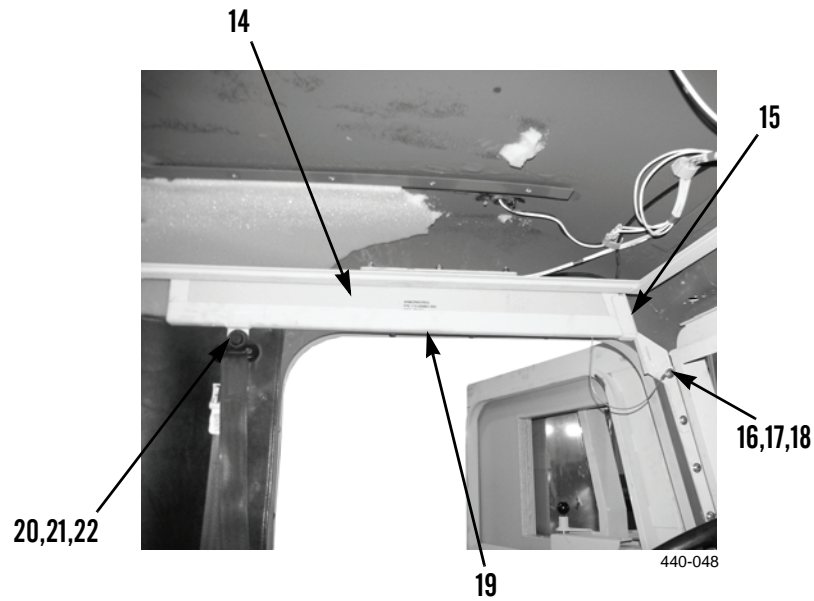

8. Remove four nuts (24), washers (25), bolts (27), washers (26), rear roof armor frame (28), and rear roof armor (23) from rear of cab.

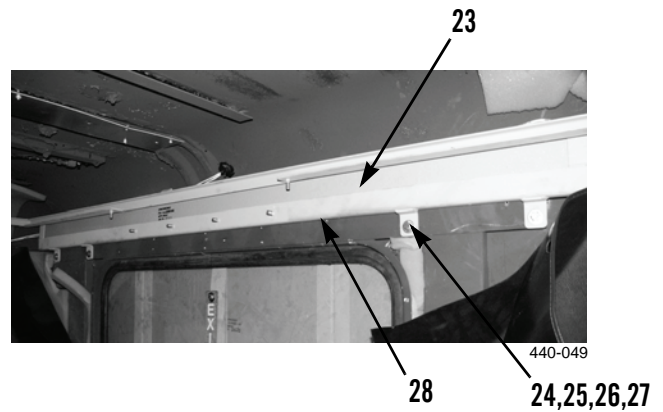

**REMOVAL - CONTINUED**

9. Remove two nuts (29), washers (30), bolts (32), and washers (31) from front of cab.

**WARNING**

Use extreme caution when handling heavy parts. Provide adequate support and use assistance during procedure. Failure to follow this warning may cause injury or death to personnel.

10. With assistance, remove six nuts (33), lockwashers (34), washers (35), and roof frame (12) from left and right side brackets (36). Discard lockwashers.

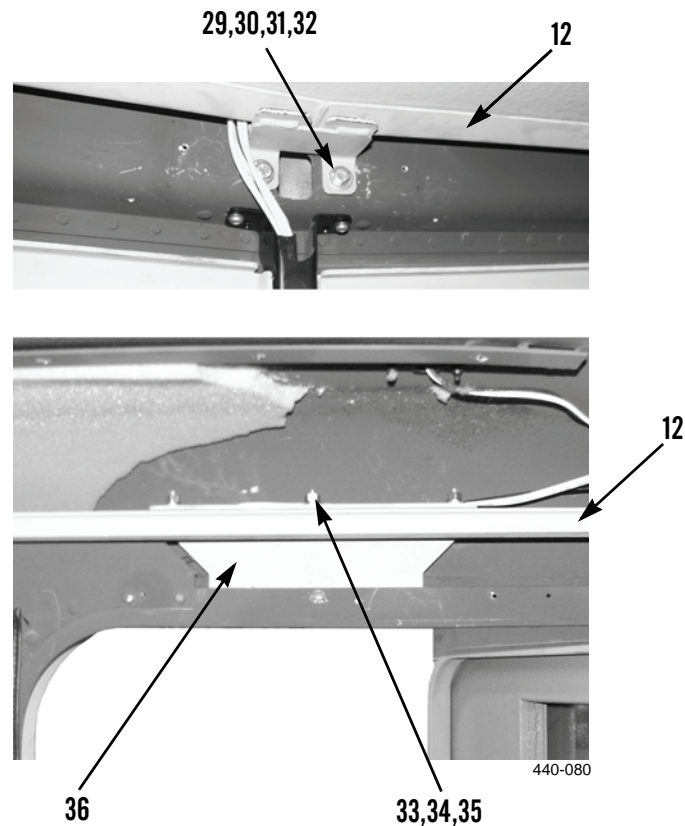
**CLEANING AND INSPECTION**

Clean and inspect all parts IAW *General Maintenance Instructions* (WP 0011 00).

**INSTALLATION****WARNING**

Use extreme caution when handling heavy parts. Provide adequate support and use assistance during procedure. Failure to follow this warning may cause injury or death to personnel.

1. With assistance, install roof frame (12), six washers (35), new lockwashers (34), and nuts (33) on left and right side brackets (36).
2. Install two washers (31), bolts (32), washers (30), and nuts (29) on front of cab.

**WARNING**

For proper threat protection, armor must be installed correctly into the armor frame. During installation, ensure that the surface marked "STRIKE FACE" is facing outward towards the threat. Exposing the passive side of the ballistic panel outward makes the armor less effective. Failure to follow this warning may cause injury or death to personnel.

3. Install rear roof armor (23), rear roof armor frame (28), four washers (26), bolts (27), washers (25), and nuts (24) on rear of cab.

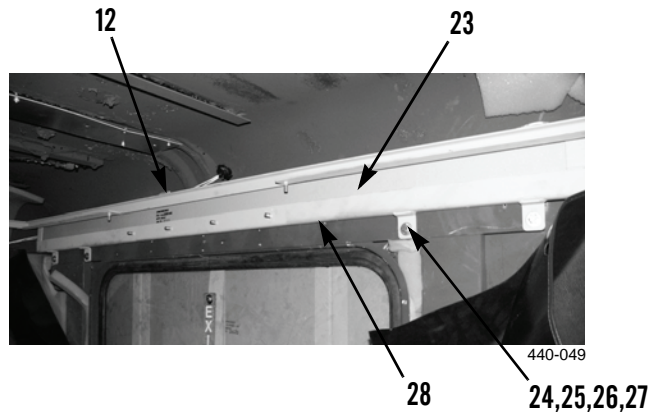

**INSTALLATION - CONTINUED****WARNING**

For proper threat protection, armor must be installed correctly into the armor frame. During installation, ensure that the surface marked "STRIKE FACE" is facing outward towards the threat. Exposing the passive side of the ballistic panel outward makes the armor less effective. Failure to follow this warning may cause injury or death to personnel.

4. Install two side panel armor (14), side panel frames (19), seatbelt connectors (22), bushings (21), and bolts (20) on left and right side of the vehicle cab.
5. Install two brackets (15), four washers (18), new lockwashers (17), and bolts (16) on left and right side panel frames (19).

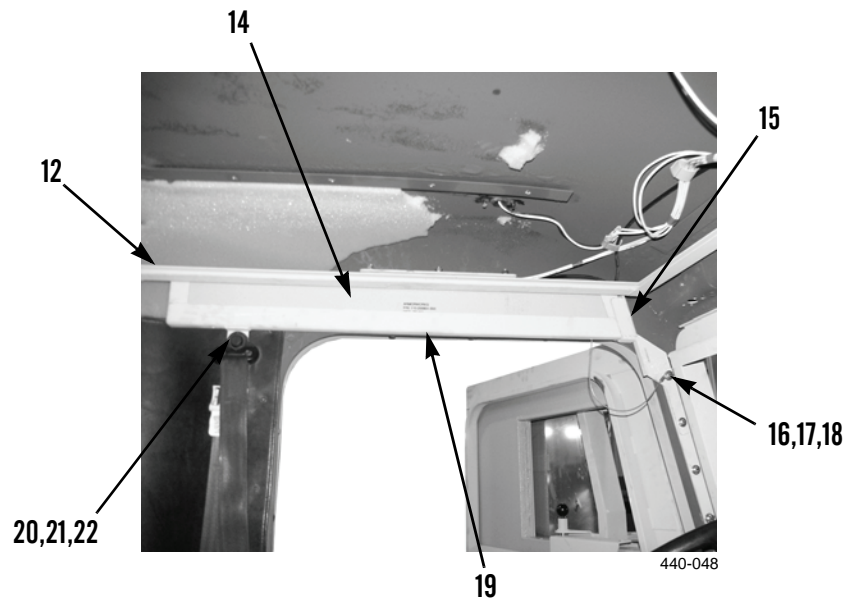

**INSTALLATION - CONTINUED****WARNING**

- Use extreme caution when handling heavy parts. Provide adequate support and use assistance during procedure. Failure to follow this warning may cause injury or death to personnel.
  - For proper threat protection, armor must be installed correctly into the armor frame. During installation, ensure that the surface marked “STRIKE FACE” is facing outward towards the threat. Exposing the passive side of the ballistic panel outward makes the armor less effective. Failure to follow this warning may cause injury or death to personnel.
6. With assistance, install right roof panel (13) on roof frame (12).
  7. With assistance, install left roof panel (7) on roof frame (12).
  8. With assistance, install middle roof panel (2) and two dividers (1) on roof frame (12).
  9. Install rear roof bracket (8), eight washers (11), new lockwashers (10), and nuts (9) on middle roof panel (2).
  10. Install two roof grab straps (6), four washers (5), new lockwashers (4), and nuts (3) on middle roof panel (2).

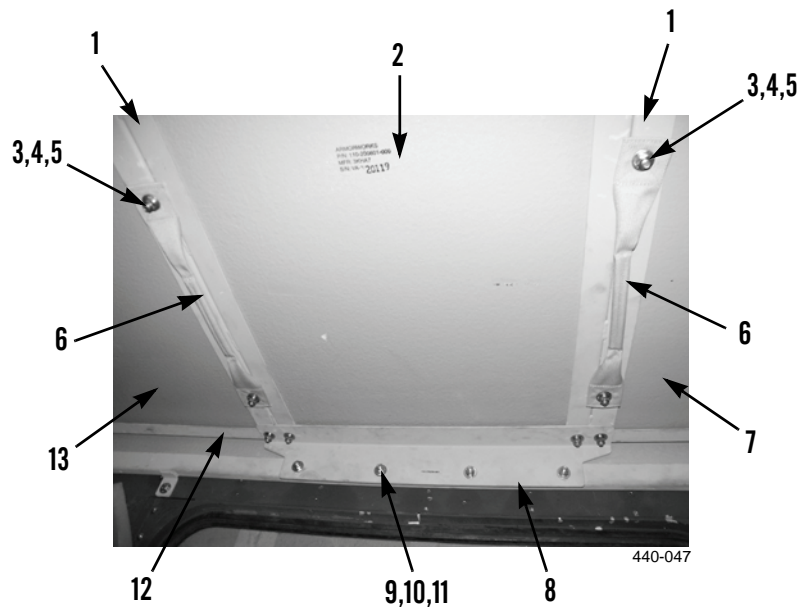
**END OF WORK PACKAGE**





---

**COWL ARMOR REPLACEMENT**

**0032 00**

---

**THIS WORK PACKAGE COVERS**

Removal, Cleaning and Inspection, Installation

---

**INITIAL SETUP**

**Maintenance Level**

Unit

**Tools and Special Tools**

Tool Kit, General Mechanic's (Item 9, WP 0035 00)

**Materials/Parts**

Rag, Wiping (Item 9, WP 0036 00)

Lockwasher (12)

**Personnel Required**

Two

**References**

WP 0011 00

**Equipment Conditions**

**(M915A3P1, M916A3P1, and M917A2P1)**

Vehicle parked on level ground (TM 9-2320-302-10)

Parking/Emergency Brake applied (TM 9-2320-302-10)

Engine OFF (TM 9-2320-302-10)

Battery Disconnect Switch in OFF position (TM 9-2320-302-10)

**Equipment Conditions - Continued**

**(M915A4P1)**

Vehicle parked on level ground (TM 9-2320-303-10)

Parking/Emergency Brake applied (TM 9-2320-303-10)

Engine OFF (TM 9-2320-303-10)

Battery Disconnect Switch in OFF position (TM 9-2320-303-10)

**(M915A2P1, M916A1P1, M916A2P1, and M917A1P1)**

Vehicle parked on level ground (TM 9-2320-363-10)

Parking/Emergency Brake applied (TM 9-2320-363-10)

Engine OFF (TM 9-2320-363-10)

If equipped, Battery Disconnect Switch in OFF position (TM 9-2320-363-10), otherwise, disconnect Battery Cables (TM 9-2320-363-20-2)

---

**REMOVAL****WARNING**

Use extreme caution when handling heavy parts. Provide adequate support and use assistance during procedure. Failure to follow this warning may cause injury or death to personnel.

1. With assistance, remove four bolts (1), washers (3), lockwashers (2), and cowl assembly (4) from vehicle. Discard lockwashers.
2. Remove four bolts (10), washers (12), lockwashers (11), and vent panel (9) from cowl armor (4). Discard lockwashers.
3. Remove four bolts (5), washers (7), lockwashers (6), and two brackets (8) from cowl armor (4). Discard lockwashers.

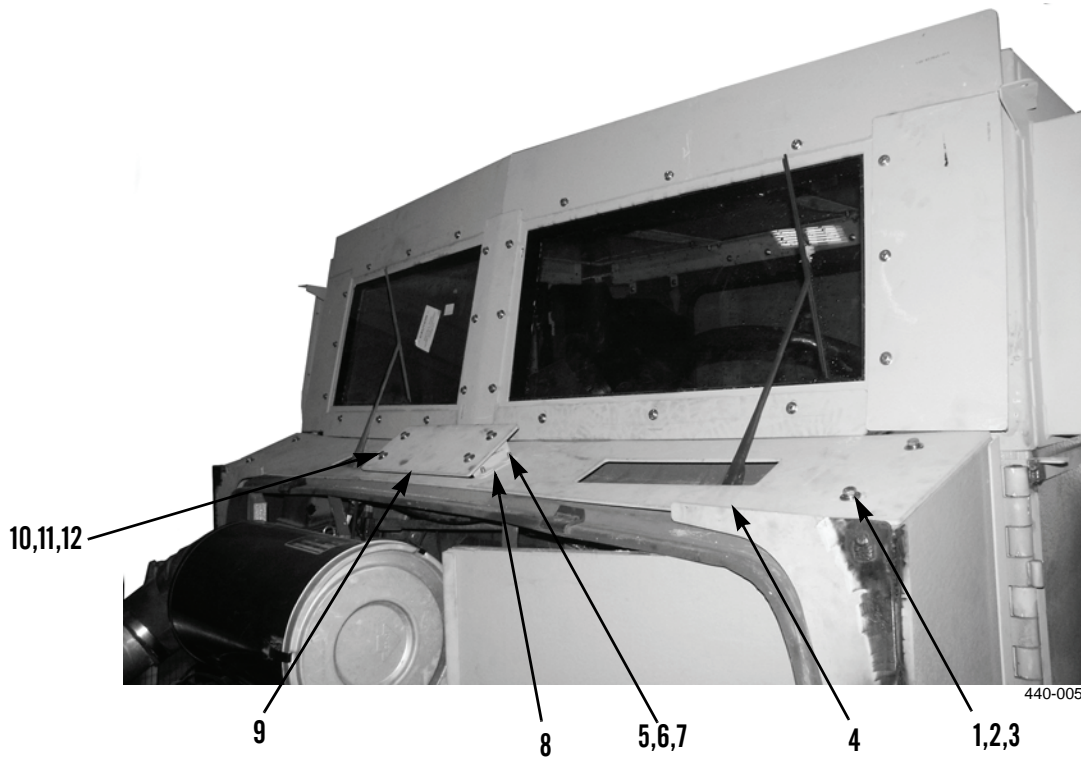
**CLEANING AND INSPECTION**

Clean and inspect all parts IAW *General Maintenance Instructions* (WP 0011 00).

**INSTALLATION**

1. Install two brackets (8), four new lockwashers (6), washers (7), and bolts (5) on cowl armor (4).
2. Install vent panel (9), four new lockwashers (11), washers (12), and bolts (10) on cowl armor (4).

**WARNING**

Use extreme caution when handling heavy parts. Provide adequate support and use assistance during procedure. Failure to follow this warning may cause injury or death to personnel.

3. With assistance, install cowl assembly (4), four new lockwashers (2), washers (3), and bolts (1) on vehicle.

**END OF WORK PACKAGE**



**CHAPTER 5**  
**SUPPORTING INFORMATION**



**SCOPE**

This work package lists all publication indexes, forms, field manuals, technical bulletins, technical manuals, and other publications that are referenced in this manual and that apply to operation and maintenance of the Crew Protection Kit.

**PUBLICATION INDEXES**

The following indexes should be consulted frequently for latest changes or revisions and for new publications relating to material covered in this technical bulletin.

- Consolidated Army Publications and Forms Index. . . . . DA PAM 25-30
- Functional Users Manual for The Army Maintenance Management System (TAMMS). . . . . DA PAM 750-8

**FORMS**

**NOTE**

Refer to DA PAM 750-8, *Functional Users Manual for The Army Maintenance Management System (TAMMS)*, for instructions on the use of maintenance forms.

- Equipment Inspection and Maintenance Worksheet . . . . . DA Form 2404, DA Form 5988-E
- Product Quality Deficiency Report . . . . . SF Form 368
- Recommended Changes to Publications and Blank Forms. . . . . DA Form 2028

**FIELD MANUALS**

- First Aid. . . . . FM 4-25.11

**TECHNICAL BULLETINS**

- CARC Spot Painting . . . . . TB 43-0242
- Color, Marking, and Camouflage Painting of Military Vehicles, Construction Equipment, and Materials Handling Equipment. . . . . TB 43-0209

**TECHNICAL MANUALS**

- Direct Support and General Support Maintenance Manual for Truck, Tractor, M915A3, M917A2, M916A3 Line-Haul. . . . . TM 9-2320-302-34
- Materials Used for Cleaning, Preserving, Abrading, and Cementing Ordnance Materiel and Related Materiels Including Chemicals . . . . . TM 9-247
- Operator’s Manual for Truck, Tractor, Line-Haul: 52,000 GVWR, 6 x 4, M915A2 . . . . . TM 9-2320-363-10
- Operator’s Manual for Truck, Tractor, Line-Haul: 52,000 GVWR, 6 x 4, M915A3 . . . . . TM 9-2320-302-10
- Operator’s Manual for Truck, Tractor, Line-Haul: 52,000 GVWR, 6 x 4, M915A4 . . . . . TM 9-2320-303-10
- Operator’s Manual for Truck, Tractor, Light Equipment Transporter (LET): 68,000 GVWR, 6 x 6, W/Winch, M916A1 . . . . . TM 9-2320-363-10
- Operator’s Manual for Truck, Tractor, Light Equipment Transporter (LET): 68,000 GVWR, 6 x 6, W/Winch, M916A2 . . . . . TM 9-2320-363-10
- Operator’s Manual for Truck, Tractor, Light Equipment Transporter (LET): 68,000 GVWR, 6 x 6, W/Winch, M916A3 . . . . . TM 9-2320-302-10
- Operator’s Manual for Truck, Dump, Heavy, Chassis: 68,000 GVWR, 6 x 6, 14 CU YD, On-Off Highway, M917A1 . . . . . TM 9-2320-363-10
- Operator’s Manual for Truck, Dump, Heavy, Chassis: 68,000 GVWR, 6 x 6, 14 CU YD, On-Off Highway, M917A2 . . . . . TM 9-2320-302-10

**REFERENCES - CONTINUED**

**0033 00**

**TECHNICAL MANUALS - CONTINUED**

Procedures for Destruction of Tank-automotive Equipment to Prevent Enemy Use  
(U. S. Army Tank-automotive Command) . . . . . TM 750-244-6

Unit, Direct Support, and General Support Including Depot Maintenance for Truck,  
Tractor, Line-Haul: 52,000 GVWR, 6 x 4, M915A4 . . . . . TM 9-2320-303-24

Unit, Direct Support, and General Support Including Depot Maintenance RPSTL for Truck,  
Tractor, M915A3, M916A3, M917A2 Line-Haul. . . . . TM 9-2320-302-24P

Unit, Direct Support, and General Support Including Depot Maintenance RPSTL for Truck,  
Tractor, M915A3 Line-Haul . . . . . TM 9-2320-302-24P

Unit, Direct Support, and General Support Including Depot Maintenance RPSTL for Truck,  
Tractor, Line Haul: 52,000 GVWR, 6 x 4, M915A2. . . . . TM 9-2320-363-24P

Unit, Direct Support, and General Support Including Depot Maintenance RPSTL for Truck,  
Tractor, Light Equipment Transporter (LET): 68,000 GVWR, 6 x 6, W/Winch, M916A1 . . . . . TM 9-2320-363-24P

Unit, Direct Support, and General Support Including Depot Maintenance RPSTL for Truck,  
Tractor, Light Equipment Transporter (LET): 68,000 GVWR, 6 x 6, W/Winch, M916A2 . . . . . TM 9-2320-363-24P

Unit, Direct Support, and General Support Including Depot Maintenance RPSTL for Truck,  
Dump, Heavy Chassis: 68,000 GVWR, 6 x 6, 14 cu. yd., On-Off Highway, M917A1, and  
M917A1 W/MCS . . . . . TM 9-2320-363-24P

Unit, Direct Support, and General Support Including Depot Maintenance RPSTL for Truck,  
Tractor, M915A4 Line-Haul . . . . . TM 9-2320-303-24P

Unit Maintenance Manual for Truck, Tractor, Line-Haul: 52,000 GVWR, 6 x 4, M915A2 . . . . . TM 9-2320-363-20

Unit Maintenance Manual for Truck, Tractor, Line-Haul: 52,000 GVWR, 6 x 4, M915A3 . . . . . TM 9-2320-302-20

Unit Maintenance Manual for Truck, Tractor, Light Equipment Transporter (LET):  
68,000 GVWR, 6 x 6, W/Winch, M916A1. . . . . TM 9-2320-363-20

Unit Maintenance Manual for Truck, Tractor, Light Equipment Transporter (LET):  
68,000 GVWR, 6 x 6, W/Winch, M916A2. . . . . TM 9-2320-363-20

Unit Maintenance Manual for Truck, Tractor, Light Equipment Transporter (LET):  
68,000 GVWR, 6 x 6, W/Winch, M916A3. . . . . TM 9-2320-302-20

Unit Maintenance Manual for Truck, Dump, Heavy, Chassis: 68,000 GVWR, 6 x 6,  
14 CU YD, On-Off Highway, M917A1 . . . . . TM 9-2320-363-20

Unit Maintenance Manual for Truck, Dump, Heavy, Chassis: 68,000 GVWR, 6 x 6, 14 CU YD,  
On-Off Highway, M917A2 . . . . . TM 9-2320-302-20

**OTHER PUBLICATIONS**

Standard Abbreviations . . . . . ASME Y14.38-1999

Army Medical Department Expendable/Durable Items . . . . . CTA 8-100

Expendable/Durable Items (Except Medical, Class V, Repair Parts, and Heraldic Items) . . . . . CTA 50-970

**END OF WORK PACKAGE**



**THE ARMY MAINTENANCE SYSTEM MAC**

1. This introduction provides a general explanation of all maintenance and repair functions authorized at the two maintenance levels under the Two-Level Maintenance System concept.
2. The MAC immediately following this introduction designates overall authority and responsibility for the performance of maintenance functions on the identified end item or component. The application of the maintenance functions to the end item or component shall be consistent with the capacities and capabilities of the designated maintenance levels, which are shown in the Maintenance Allocation Chart (MAC) (WP 0035 00) in column (4) as:

Field - includes subcolumns:

- C - Operator/Crew
- O - Unit
- F - Direct Support

Sustainment - includes subcolumns:

- H - General Support
- D - Depot

3. The tools and test equipment requirements (immediately following the MAC) list the tools and test equipment (both special tools and common tool sets) required for each maintenance function as referenced from the MAC.
4. The remarks (immediately following the tools and test equipment requirements) contain supplemental instructions and explanatory notes for a particular maintenance function.

**MAINTENANCE FUNCTIONS**

Maintenance functions are limited to and defined as follows:

1. **Inspect.** To determine the serviceability of an item by comparing its physical, mechanical, and/or electrical characteristics with established standards through examination (e.g., by sight, sound, or feel).
2. **Test.** To verify serviceability by measuring the mechanical, pneumatic, hydraulic, or electrical characteristics of an item and comparing those characteristics with prescribed standards on a scheduled basis, i.e., load testing of lift devices and hydrostatic testing of pressure hoses.
3. **Service.** Operations required periodically to keep an item in proper operating condition; e.g., to clean (includes decontaminate, when required), preserve, drain, paint, or replenish fuel, lubricants, chemical fluids, or gases.
4. **Adjust.** To maintain or regulate, within prescribed limits, by bringing into proper position, or by setting the operating characteristics to specified parameters.
5. **Align.** To adjust specified variable elements of an item to bring about optimum or desired performance.
6. **Calibrate.** To determine and cause corrections to be made or to be adjusted on instruments of test, measuring, and diagnostic equipment used in precision measurement. Calibration consists of comparisons of two instruments, one of which is a certified standard of known accuracy, to detect and adjust any discrepancy in the accuracy of the instrument being compared.
7. **Remove/Install.** To remove and install the same item when required to perform service or other maintenance functions. Installation may be the act of emplacing or seating a spare, repair part, or module (component or assembly) into position in a manner to allow the proper functioning of an equipment or system.
8. **Replace.** To remove an unserviceable item and install a serviceable counterpart in its place. Replacement is authorized by the MAC and the assigned maintenance level is shown as the third position code of the Source, Maintenance, and Recoverability (SMR) code.
9. **Repair.** Repair is the application of maintenance services, including fault location/troubleshooting, removal/installation, disassembly/assembly procedures, and maintenance actions to identify troubles and restore serviceability to an item by correcting specific damage, fault, malfunction, or failure in a part, subassembly, module (component or assembly), end item, or system.

**MAINTENANCE FUNCTIONS - CONTINUED****NOTE**

The following definitions are applicable to the "repair" maintenance function:

- Services - Inspecting, testing, service, adjustment, alignment, calibration, and/or replacement.
  - Fault Location/Troubleshooting - The process of investigating and detecting the cause of equipment malfunctioning; the act of isolating a fault within a system or Unit Under Test (UUT).
  - Disassembly/Assembly - The step-by-step breakdown (taking apart) of a spare/functional group coded item to the level of its least component, assigned a SMR code for the level of maintenance under consideration (i.e., identified as maintenance significant).
  - Actions - Welding, grinding, riveting, straightening, facing, machining, and/or resurfacing.
10. **Overhaul.** That maintenance effort (service/action) prescribed to restore an item to a completely serviceable/operational condition as required by maintenance standards in appropriate technical publications. Overhaul is normally the highest degree of maintenance performed by the Army. Overhaul does not normally return an item to like new condition.
11. **Rebuild.** Consists of those services/actions necessary for the restoration of unserviceable equipment to a like new condition in accordance with original manufacturing standards. Rebuild is the highest degree of materiel maintenance applied to Army equipment. The rebuild operation includes the act of returning to zero those age measurements (hours/miles, etc.) considered in classifying Army equipment/components.

**EXPLANATION OF COLUMNS IN THE MAC, TABLE 1**

1. **Column (1) - Group Number.** Column (1) lists Group numbers, the purpose of which is to identify maintenance significant components, assemblies, subassemblies, and modules with the Next Higher Assembly (NHA).
2. **Column (2) - Component/Assembly.** Column (2) contains the item names of components, assemblies, subassemblies, and modules for which maintenance is authorized.
3. **Column (3) - Maintenance Function.** Column (3) lists the functions to be performed on the item listed in Column (2). (For a detailed explanation of these functions refer to "Maintenance Functions" outlined above.)
4. **Column (4) - Maintenance Level.** Column (4) specifies each level of maintenance authorized to perform each function listed in column (3), by indicating work time required (expressed as manhours in whole hours or decimals) in the appropriate subcolumn. This work time figure represents the active time required to perform that maintenance function at the indicated level of maintenance. If the number or complexity of the tasks within the listed maintenance function varies at different maintenance levels, appropriate work time figures are to be shown for each level. The work time figure represents the average time required to restore an item (assembly, subassembly, component, module, end item, or system) to a serviceable condition under typical field operating conditions. This time includes preparation time (including any necessary disassembly/assembly time), troubleshooting/fault location time, and quality assurance time in addition to the time required to perform the specific tasks identified for the maintenance functions authorized in the MAC. The symbol designations for the various maintenance levels are as follows:

Field:

- C - Operator/Crew Maintenance
- O - Unit Maintenance
- F - Direct Support Maintenance

Sustainment:

- H - General Support Maintenance
- D - Depot Maintenance

**EXPLANATION OF COLUMNS IN THE MAC, TABLE 1- CONTINUED****NOTE**

The "L" maintenance level is not included in column (4) of the MAC. Functions to this level of maintenance are identified by a work time figure in the "H" column of column (4), and an associated reference code is used in the REMARKS CODE column (6). This code is keyed to the remarks, and the SRA complete repair application is explained there.

5. **Column (5) - Tools and Equipment Reference Code.** Column (5) specifies, by code, common tool sets (not individual tools), common Test, Measurement, and Diagnostic Equipment (TMDE), special tools, special TMDE, and special support equipment required to perform the designated function. Codes are keyed to the entries in the tools and test equipment table.
6. **Column (6) - Remarks Code.** When applicable, this column contains a letter code, in alphabetical order, which is keyed to the remarks table entries (Table 3).

**EXPLANATION OF COLUMNS IN THE TOOLS AND TEST EQUIPMENT REQUIREMENTS, TABLE 2**

1. **Column (1) - Tool or Test Equipment Reference Code.** The tool and test equipment reference code correlates with a code used in column (5) of the MAC.
2. **Column (2) - Maintenance Level.** The lowest level of maintenance authorized to use the tool or test equipment.
3. **Column (3) - Nomenclature.** Name or identification of the tool or test equipment.
4. **Column (4) - National Stock Number (NSN).** The NSN of the tool or test equipment.
5. **Column (5) - Tool Number.** The manufacturer's part number, model number, or type number.

**EXPLANATION OF COLUMNS IN THE REMARKS, TABLE 3**

1. **Column (1) - Remarks Code.** The code recorded in column (6) of the MAC.
2. **Column (2) - Remarks.** This column lists information pertinent to the maintenance function being performed as indicated in the MAC.

**END OF WORK PACKAGE**



Table 1. MAC for the Crew Protection Kit.

(1) GROUP NUMBER	(2) COMPONENT/ ASSEMBLY	(3) MAINTENANCE FUNCTION	(4) MAINTENANCE LEVEL				(5) TOOLS AND EQUIPMENT REF CODE	(6) REMARKS CODE	
			FIELD		SUSTAINMENT				
			UNIT		DS	GS			DEPOT
			C	O	F	H			D
<b>33</b>	<b>SPECIAL PURPOSE KITS</b>								
3307	Crew Protection Kit:	Install		46.0			9		
	Vehicle Preparation			16.0					
	A-Pillar Armor	Inspect	0.2					A	
		Install		2.0			9		
		Replace		2.0			9		
	B-Pillar Armor Left	Inspect	0.2					A	
		Install		1.5			5,8,9		
		Replace		1.5			5,8,9		
	B-Pillar Armor Right	Inspect	0.2					A	
		Install		2.5			5,8,9		
		Replace		2.5			5,8,9		
	Cowl Armor	Inspect	0.2					A	
		Install		2.0			9		
		Replace		2.0			9		
	Door and Frame Assembly	Inspect	0.2					A	
		Service	0.2					B	
		Install		2.0			5,6,8,9		
		Replace		2.0			5,6,8,9		
	Door Ballistic Glass and Frame Assembly	Inspect	0.2					A	
		Service	0.2					B	
		Replace		2.0			9		
	Door Cam Latch	Inspect	0.2					A	
		Replace		1.0			9		
	Door Cam Latch Adjustment	Inspect	0.2					A	
		Service		0.5			9		
	Door Handle	Inspect	0.2					A	
		Replace		1.0			9		
	Firewall Armor Center	Inspect	0.2					A	
		Install		1.0			9		
		Replace		1.0			9		
	Firewall Armor Left	Inspect	0.2					A	
		Install		2.0			9		
		Replace		2.0			9		

MAINTENANCE ALLOCATION CHART (MAC) - CONTINUED

0035 00

Table 1. MAC for the Crew Protection Kit - Continued.

(1) GROUP NUMBER	(2) COMPONENT/ ASSEMBLY	(3) MAINTENANCE FUNCTION	(4) MAINTENANCE LEVEL				(5) TOOLS AND EQUIPMENT REF CODE	(6) REMARKS CODE	
			FIELD		SUSTAINMENT				
			UNIT		DS	GS			DEPOT
			C	O	F	H			D
33	<b>SPECIALPURPOSE KITS - Continued</b>								
	Firewall Armor Right	Inspect Install Replace	0.2	2.0				9 9	A
	Rear Cab Armor	Inspect Install Replace	0.2	3.0				9 9	A
	Roof Armor	Inspect Install Replace	0.2	2.0				9 9	A
	Stowage Box Adapter Frame	Inspect Install Replace	0.2	2.0				9 9	A
	Underbody Mine Blast Panels	Inspect Install Replace	0.2	3.0				7,9 7,9	A
	Wheel Well Blast Deflector	Inspect Install Replace	0.2	2.0				9 9	A
	Windshield Ballistic Glass	Inspect Service Install Replace	0.2 0.2	3.0 3.0				9 9	A B

Table 2. Tools and Test Equipment Requirements for the Crew Protection Kit.

(1) ITEM NO.	(2) MAINTENANCE LEVEL	(3) ITEM NAME	(4) NATIONAL STOCK NUMBER	(5) PART NUMBER/ CAGEC
1	O	Clamp, C, 10 In. Size	5120-00-203-6432	5120-00-203-6432 (08292)
2	O	Dispenser, Sealant	5120-00-679-5655	101 (06798)
3	O	Drill Set, Twist: 33/64 to 3/4 In. in 1/64 In. Increments	5133-00-596-8088	B94.11M (05047)
4		Drill, Twist: 7/8 In.		91456 (16568)
5	O	Link, Bearing (Lifting)	5120-01-451-1401	1387575 (11083)
6	O	Shop Equipment, Automotive Maintenance and Repair: Organizational Maintenance, Common No. 1, Less Power	4910-00-754-0654	SC 4910-95CLA74 (19204)
7		Sling, Beam Type	3940-01-353-8561	J-39520
8	O	Sling, Nylon	2835-01-078-2081	4-8FTX2IN (91796)
9	O	Tool Kit, General Mechanic's Automotive	5180-01-454-3787	12B470000 (59678)

Table 3. Remarks for the Crew Protection Kit.

(1) REMARKS CODE	(2) REMARKS
A	Refer to Operator PMCS WP 0009 00.
B	Service by cleaning ballistic glass (WP 0010 00).

END OF WORK PACKAGE





---

**EXPENDABLE AND DURABLE ITEMS LIST**

---

**0036 00****SCOPE**

This work package lists expendable and durable items you will need to install, operate, and maintain the Crew Protection Kit. This listing is for informational purposes only and is not authority to requisition the listed items. These items are authorized to you by CTA 50-970, *Expendable/Durable Items (Except Medical, Class V, Repair Parts, and Heraldic Items)*, or CTA 8-100, *Army Medical Department Expendable/Durable Items*.

**EXPLANATION OF COLUMNS**

1. **Column (1) - Item Number.** This number is assigned to the entry in the listing and is referenced in the narrative instructions to identify the item [e.g., Apply Detergent, General Purpose, Liquid (Item 7, WP 0036 00)].
2. **Column (2) - Level.** This column identifies the lowest level of maintenance that requires the listed item.
  - C - Operator/Crew
  - O - Unit Maintenance
3. **Column (3) - National Stock Number.** This is the National Stock Number assigned to the item which you can use to requisition it.
4. **Column (4) - Description, CAGEC, and Part Number.** This provides the other information you need to identify the item.
5. **Column (5) - Unit of Measure (U/M).** This column shows the physical measurement or count of an item, such as gallon, dozen, gross, etc.

Table 1. Expendable and Durable Items List for Crew Protection Kit.

(1) ITEM NUMBER	(2) LEVEL	(3) NATIONAL STOCK NUMBER	(4) DESCRIPTION, CAGEC, AND PART NUMBER	(5) U/M
1	O	8040-01-250-3969	Adhesive, Thread (05972) 242 50 Milliliter Bottle	BT
2			Block, Wood 4 in. x 4 in. x 4 in.	
3			Block, Wood 2 in. x 4 in. x 48 in.	
4	C	6850-01-474-2318 6850-01-474-2320 6850-01-474-2321	Cleaning Compound, Solvent, Type III (81349) MIL-PRF-680 1 Gallon Can 5 Gallon Can 55 Gallon Drum	CN CN DR
5	O	5350-00-584-4654	Cloth, Abrasive (80204) ANSI B74.18 50 Sheet Package	PG
6	C	8030-00-251-3980	Compound, Antiseize (05972) 051135-08609 1 Pound Can	CN
7	C	7930-00-282-9699 9140-00-286-5294 9140-00-286-5295 9140-00-286-5296	Detergent, General Purpose, Liquid (83421) 7930-00-282-9699 1 Gallon Can Bulk 5 Gallon Can 55 Gallon Drum	CN GL CN DR
8	C	9150-00-189-6727 9150-00-186-6668 9150-00-191-2772	Oil, Lubricating, OE/HDO-10 (81349) MIL-PRF-2104 1 Quart Can 5 Gallon Can 55 Gallon Drum	CN CN DR
9	C	7920-00-205-1711	Rag, Wiping (64067) A-A-431 50 Pound Bale	BL
10	O	8030-01-320-4710	Sealing Compound, Urethane (52157) 051135-08609 10.5 Ounce Cartridge	CA

## EXPENDABLE AND DURABLE ITEMS LIST - CONTINUED

0036 00

Table 1. Expendable and Durable Items List for Crew Protection Kit.

(1) ITEM NUMBER	(2) LEVEL	(3) NATIONAL STOCK NUMBER	(4) DESCRIPTION, CAGEC, AND PART NUMBER	(5) U/M
11	O		Strap, Tiedown Electrical Components (06383) PLT35-C-O	
		5975-01-379-4997	Package of 100	PK
12	O		Tag, Marker (64067) 9905-00-537-8954	
		9905-00-537-8954	Bundle of 50	BD
13	O		Tape, Pressure Sensitive Adhesive (81349) MIL-T-23397	
		7510-00-473-9513	60 Yard Roll	RL

END OF WORK PACKAGE



**SCOPE**

This work package lists standard torque values and provides general information for applying torque. Special torque values and tightening sequences are indicated in the maintenance procedures for applicable components.

**GENERAL**

1. Always use torque values listed in Tables 1 and 2 when a maintenance procedure does not give a specific torque value.
  - a. Table 1 provides torque limits for SAE standard fasteners.
  - b. Table 2 provides torque limits for metric fasteners.
2. Unless otherwise indicated, standard torque tolerance shall be  $\pm 10$  percent.
3. Torque values listed are based on clean, dry threads. Reduce torque by 10 percent when engine oil is used as a lubricant. Reduce torque by 20 percent if new plated capscrews are used.
4. If the maintenance procedures do not specify a tightening order, use the following guides:
  - a. Unless otherwise specified, lubricate threads of fasteners with clean Oil, Lubricating, OE/HDO-10 (Item 8, WP 0036 00).
  - b. When tightening fasteners above 30 lb-ft (41 Nm), use the torque pattern but only tighten to 70 percent of final value (multiply final value by 0.7). Repeat pattern until final value is reached.
  - c. Tighten circular patterns using circular torque pattern and tighten straight patterns using straight torque pattern.

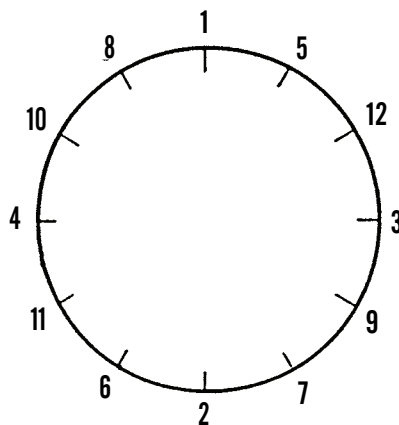

CIRCULAR TORQUE PATTERN

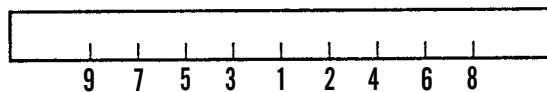

STRAIGHT TORQUE PATTERN

**CAUTION**

If replacement capscrews are of higher grade than originally supplied, use torque specifications for the original. This will prevent equipment damage due to overtightening.

Table 1. Torque Limits - SAE Standard Fasteners.



CURRENT USAGE	MUCH USED	MUCH USED	USED AT TIMES	USED AT TIMES
QUALITY OF MATERIAL	INDETERMINATE	MINIMUM COMMERCIAL	MEDIUM COMMERCIAL	BEST COMMERCIAL
SAE Grade Number	1 or 2	5	6 or 7	8
Cap Screw Head Markings				
Manufacturer's marks may vary				
These are all SAE Grade 5 (3 line)				
<b>CAPSCREW BODY SIZE IN. - THREAD</b>	<b>TORQUE LB-FT (NM)</b>	<b>TORQUE LB-FT (NM)</b>	<b>TORQUE LB-FT (NM)</b>	<b>TORQUE LB-FT (NM)</b>
1/4 20 28	5 (7) 6 (8)	8 (11) 10 (14)	10 (14)	12 (16) 14 (19)
5/16 18 24	11 (15) 13 (18)	17 (23) 19 (26)	19 (26)	24 (33) 27 (37)
3/8 16 24	18 (24) 20 (27)	31 (42) 35 (47)	34 (46)	44 (60) 49 (66)
7/16 14 20	28 (38) 30 (41)	49 (66) 55 (75)	55 (75)	70 (95) 78 (106)
1/2 13 20	39 (53) 41 (56)	75 (102) 85 (115)	85 (115)	105 (142) 120 (163)
9/16 12 18	51 (69) 55 (75)	110 (149) 120 (163)	120 (163)	155 (210) 170 (231)
5/8 11 18	83 (113) 95 (129)	150 (203) 170 (231)	167 (226)	210 (285) 240 (325)
3/4 10 16	105 (142) 115 (156)	270 (366) 295 (400)	280 (380)	375 (508) 420 (569)
7/8 9 14	160 (217) 175 (237)	395 (536) 435 (590)	440 (597)	605 (820) 675 (915)
1 8 14	235 (319) 250 (339)	590 (800) 660 (895)	660 (895)	910 (1234) 990 (1342)

Table 2. Torque Limits - Metric Fasteners.

TORQUE VALUES FOR METRIC THREAD FASTENERS WITH LUBRICATED* OR PLATED THREADS†				
Thread Diameter-Pitch				
	Class 8.8 Bolt	Class 8 Nut	Class 10.9 Bolt	Class 10 Nut
	Torque: lb-ft (Nm)		Torque: lb-ft (Nm)	
M6	5 (7)		7 (9)	
M8	12 (16)		17 (23)	
M8 x 1	13 (18)		18 (24)	
M10	24 (33)		34 (46)	
M10 x 1.25	27 (37)		38 (52)	
M12	42 (57)		60 (81)	
M12 x 1.5	43 (58)		62 (84)	
M14	66 (89)		95 (129)	
M14 x 1.5	72 (98)		103 (140)	
M16	103 (140)		148 (201)	
M16 x 1.5	110 (149)		157 (213)	
M18	147 (199)		203 (275)	
M18 x 1.5	165 (224)		229 (310)	
M20	208 (282)		288 (390)	
M20 x 1.5	213 (313)		320 (434)	
M22	283 (384)		392 (531)	
M22 x 1.5	315 (427)		431 (584)	
M24	360 (488)		498 (675)	
M24 x 2	392 (531)		542 (735)	
M27	527 (715)		729 (988)	
M27 x 2	569 (771)		788 (1,068)	
M30	715 (969)		990 (1,342)	
M30 x 2	792 (1,074)		1,096 (1,486)	

\* All plated and unplated fasteners should be coated with oil before installation.

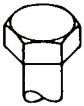
† Use these torque values if either the bolt or nut is lubricated or plated (zinc-phosphate conversion-coated, cadmium-plated, or waxed).

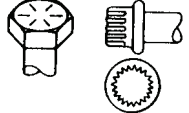
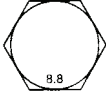
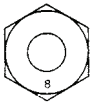
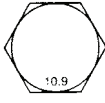
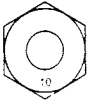
END OF WORK PACKAGE











**ArmorWorks**

Installation Instructions  
M915 A2/A3 Armor Kit  
V-8.0

**M915 A2/A3 ARMOR KIT INSTALLATION**

# M915 A2/A3 ARMOR KIT INSTALLATION INSTRUCTIONS



**P/N 110-170000-001**



**ArmorWorks**

7306 South Harl Avenue  
Tempe, AZ 85283  
480.517.1150 phone  
480.517.1154 fax  
[www.armorworks.com](http://www.armorworks.com)

# TABLE OF CONTENTS

## I. PRE-INSTALLATION INSTRUCTION (VEHICLE PREPARATION)

### Armor Kit Description

Warning .....	5
Safety .....	6
Required Tools.....	7

### Vehicle Preparation

Opening of Crate .....	8
OEM Door Removal .....	9
Overhead Console Removal.....	10
Seat Removal .....	10
Rear Stowage Box Removal.....	11
Handrail Removal .....	12
OEM Glass Removal .....	13
Fender and Mud Flap Removal .....	14
Exhaust and Stack Removal.....	15
Hood Strap Removal.....	16
Hood Support Removal .....	17
B-Pillar Bracket Removal.....	18
Work Light Connector Removal .....	19
Antenna Bracket Removal .....	20
Rear Roof Bracket Bolt Removal.....	21
Washer Fluid Box and Horn Removal.....	22

# TABLE OF CONTENTS

## II. Armor Kit Installation

Door Support Frames .....	24
Underbody Mineblast Panels.....	27
Armored Doors .....	30
Rear Cab Armor and Rear Window .....	32
B-Pillar Armor .....	36
Kick Panel (Lower A-Pillar) Armor .....	39
A-Pillar Corner Plate .....	41
Firewall Armor.....	43
Front Cowl Armor.....	46
Ballistic Windshield.....	48
Windshield surround Armor .....	50
Roof Armor .....	52
Wheel Well Blast Deflectors .....	56
Rear Stowage Box Adapter Frame .....	61
Hood Support Brackets .....	63

## III. Re-Installation of OEM Parts

Side-View Mirrors .....	66
Rear Stowage Box.....	69
Hood Latch Straps .....	71
Exhaust Stack.....	73
Seats .....	75
Dome Lights .....	76

## IV. Appendix

Part Numbers .....	78
--------------------	----

# I. PRE-INSTALLATION INSTRUCTION

# WARNING

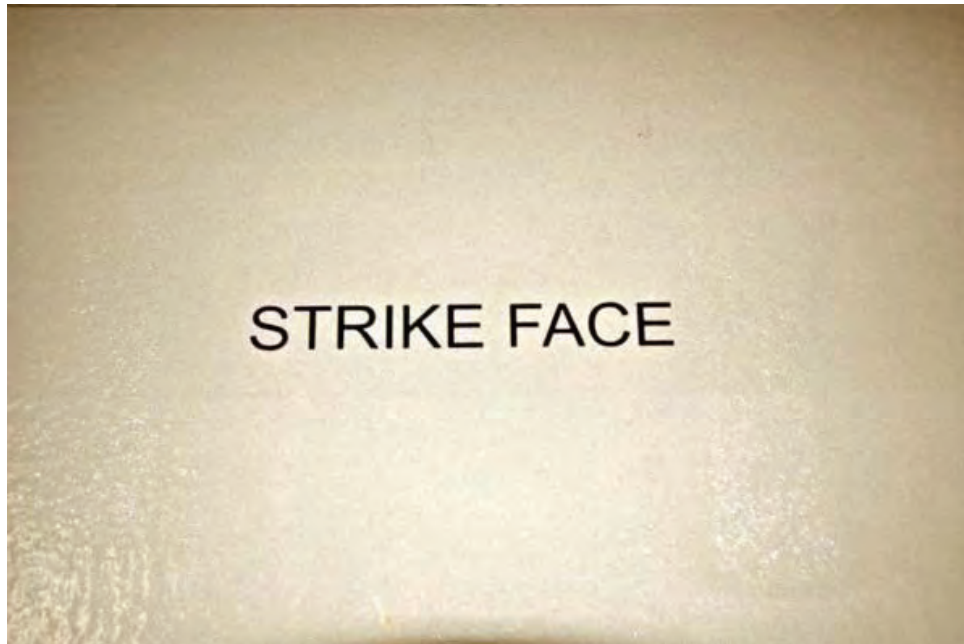

- The surface marked “***strike face***” **must** be facing outward towards the threat.
- There are two sides to a ballistic panel.
- The passive side of the panel is smooth, featureless, and has part number label.

## **DANGER**

**\*Exposing the passive side of the ballistic panel outward makes the armor less effective\***

# SAFETY

- Be sure to power-off and secure all power sources of the vehicle. At no time should any power be left on in the vehicle. Make sure all communication and electrical equipment is powered off.
- Remove negative battery terminal before installation.
- You must inspect the vehicle before installation for flammable material to avoid risk of fire. Inspect for oily or wet substances that may be flammable.
- Installation should be done in an area reasonably clean and free of flammables. Be sure to avoid installing above an oily floor.
- This installation is best done in a spacious environment. Materials will be placed along each side of the vehicle prior to the installation. There is a risk of a trip hazard if the space is too confined.
- Use protective eyewear.
- To avoid injury while lifting some of the bulkier items, it is suggested to use 2 or more individuals.
- Bolts attached to armor should be inspected and tightened every 3,000 miles.
- Torque until flat washers are compressed. **DO NOT OVERTIGHTEN.**



## REQUIRED TOOLS

3/8" Wrench	1.0" Socket and Ratchet Driver and Extension
9/16 Wrench	1/4" Drill Bit and Drill
3/4" Wrench	1/8" Drill Bit and Drill
7/16" Wrench	3/8" Drill Bit and Drill
5/16" Wrench	5/16" Drill Bit and Drill
1/2" Wrench	5/8" Drill Bit and Drill
9/16" Wrench	5/32" Drill Bit and Drill
9/16" Socket with Ratchet Driver	4 Quick Grip Clamps or C-Clamps
3/8" Socket with Ratchet Driver	Thread Locking Compound
7/16" Socket with Ratchet Driver	Floor Jack or Overhead Crane
3/4" Socket with Ratchet	Forklift or Overhead Crane
1/2" Socket with Ratchet	Lifting Straps
1/2" Socket and Ratchet Driver	Non-metallic Dead-Blow Mallet
3/4" Socket and Ratchet Driver	Pop-Rivet Installation Tool

## OPENING OF CRATE



1.) Loosen and remove screws from top of wooden box.



2.) Remove top of box with a two man lift



3.) Remove screws from one side of box.



4.) Move the wooden side slat to extract armor materials.

\*Suggestion: Lie all Armor parts on a covered flooring area to differentiate each part as needed.

# Vehicle Preparation

## DOOR REMOVAL

### REQUIRED TOOLS:

- 3/8" Socket with Ratchet Driver
- 7/16" Socket with Ratchet Driver
- 3/8" Wrench
- 5/32" Socket and Ratchet Driver
- 9/16" Wrench
- 9/16" Socket and Ratchet Driver
- T-20 Torx Bit with Driver
- T-50 Torx Bit with Driver



- 4.) Remove Sill and Mat strips on bottom door frame.  
\*Save strips for later installation



- 1.) Limit strap pins.
- 2.) Remove the 1/4" hinge bolts.
- 3.) Remove Striker Bolt.



- 5.) Remove the 3 bolts attached to mirror from each door with a 9/16" Socket and Ratchet Driver.  
\*Save mirrors and mounting hardware for later re-installation.

## OVERHEAD CONSOLE REMOVAL

### REQUIRED TOOLS:

T20 Torx Bit with Driver

- 1.) Remove sun visors.
- 2.) Remove console.
- 3.) Remove headliner.
- 4.) Remove dome lights/

\*Cut tape on wires so the connector wires can stretch to front of the cab for later Installation.

## SEAT REMOVAL

### REQUIRED TOOLS:

9/16" Socket with Ratchet Driver

13mm Socket



- 1.) Remove the seat from the truck by loosening bolts with a 9/16" Socket and Ratchet Driver (removing seats helps facilitate installation of the armor kit).





2.) Loosen and remove bolts connected to seat belt with a 13 mm socket. Save the seats and mounting hardware for later re-installation.



3.) Disconnect air line.

## REAR STOWAGE BOX REMOVAL

### REQUIRED TOOLS:

9/16" Wrench

9/16" Deep Socket



1.) Disconnect air lines and electrical (12, 24 volt) lines attached to bracket. Remove air line brackets from box and store under truck.

**(Note:** Some models air bracket will be located on the top of the stowage box)



2.) Open Stowage Box and loosen the bolts inside



3.) Remove Stowage Box off truck with a two man lift.

\* Save the boxes and mounting hardware for later re-installation.

## HANDRAIL REMOVAL



### REQUIRED TOOLS:

9/16" Socket with Ratchet Driver

1.) Remove the three indicated handrails using the 9/16" Socket with Ratchet Driver.

\* Save the handrail removed from behind the driver's door for later re-installation.

# OEM GLASS REMOVAL

## FRONT WINDSHIELD

- 1.) Cut gasket around window and remove the glass

## REAR WINDSHIELD REMOVAL



### Required Tools:

Slotted flat headed screwdriver

- 1.) Remove screen from back window.
- 2.) Remove trim around inside of cab window.





3.) Release seal in weather stripping by using a flat headed screwdriver and wedging it in the split.

\*Note: seam that needs to be released may appear inside or outside of vehicle.

4.) If weather stripping appeared on the inside of glass, push glass from outside of the truck cab. If the weather stripping appeared on the outside of the cab push glass from inside the cab to outside.

\* Picture demonstrates stripping on inside and window pushed from outside the truck to inside cab.

## FENDER AND MUD FLAP REMOVAL

### REQUIRED TOOLS:

9/16" Socket with Ratchet Driver

9/16" Wrench



Remove the fenders from the truck to facilitate installation of the wheel well blast deflectors

- 1.) Loosen and remove bolts on top of fender and inside of fender.
- 2.) Remove front mud flaps by extracting bolts.

\* Save the fenders and mounting hard ware for later re-installation.



# EXHAUST STACK REMOVAL

## REQUIRED TOOLS:

3/4" Socket with Ratchet

3/4" Wrench

7/16" Wrench



- 1.) Disconnect the pipe beneath the cab at the rear of the flex pipe.



- 2.) Remove the exhaust stack with 3/4" Socket with Ratchet Driver and 3/4" Wrench from the passenger side of the truck with a two man lift.



- 3.) Remove Forward exhaust pipe with 7/16" wrench

\* Save the exhaust stack, u-bolts, and pipe clamps for later re-installation.

# HOOD STRAP REMOVAL

## REQUIRED TOOLS:

7/16" Socket with Ratchet Driver

7/16" Wrench

- 1.) Loosen and remove the bolts attached to the hood strap located at the bottom frame of the truck.
  
  - 2.) Remove strap hook attached to the hood of the truck.
- \* Repeat process on passenger and

# HOOD SUPPORT REMOVAL

## REQUIRED TOOLS:

1/2" Socket with Ratchet Driver

1/2" Wrench

9/16" Socket with Ratchet Driver

9/16" Wrench



- 1.) Remove the four 5/16" bolts securing each of the two Hood Support / Alignment Posts to the firewall brackets. \* These parts will not be re-installed later.



- 2.) Remove the four 3/8" bolts securing each of the two Hood Alignment Receptacles to the underside of the hood.

\* These parts will not be re-installed later.

# B-PILLAR BRACKET REMOVAL

## REQUIRED TOOLS:

1/4" Drill Bit and Drill

Pin Punch or Center Punch

Hammer

Remove the padlock bracket from the b-pillar on both sides of the cab.



1.) Use the punch and hammer to knock-out the center pins on the two pop rivets securing each bracket.

2.) Drill out the rivet heads and remove the brackets.

# WORK LIGHT CONNECTOR

Remove the work light connector from the b-pillar on both sides of the cab.

## REQUIRED TOOLS:

5/32" Drill Bit and Drill

Small Slotted (Flat-Tip) Screwdriver



- 1.) Drill out the two rivets securing each connector.



- 2.) Pull the connectors out from the b-pillars and disconnect the wires using the small screwdriver.



- 3.) Leave the wires hanging approximately 6" out of the b-pillars as they will be reconnected later.

**NOTE: Re-install the screws on the connectors and save the connectors for later re-installation.**



# ANTENNA BRACKET REMOVAL

## REQUIRED TOOLS:

7/16" Wrench

7/16" Socket and Ratchet Driver

T10 Torx



1.) Loosen and remove bolts.

\*Save hardware for later installation

# REAR ROOF BRACKET BOLT REMOVAL AND REAR CAB LIGHT REMOVAL

## REQUIRED TOOLS:

9/16" Wrench

9/16" Socket and Ratchet Driver

7/16" Wrench

7/16" Socket and Ratchet Driver

1/2" Wrench

1/2" Socket and Ratchet Driver



### TOP BRACKET BOLT REMOVAL

1.) Remove bottom bolts from driver, passenger and center and bracket should remain in place on roof (armor will correlate with bolted areas).

### REAR CAB LIGHT REMOVAL

1.) Loosen and remove screws and store on top of cab for later installation.

# WASHER FLUID BOX AND HORN REMOVAL

## REQUIRED TOOLS:

7/16" Socket and Ratchet Driver

7/16" Wrench

### WASHER FLUID BOX This Applies to A3 Model



- 1.) Disconnect water lines attached to washer box
- 2.) Loosen and remove screws attached to washer box



- 3.) Lift mat on driver side and loosen and remove bolts.

\*Horn removal may not be required.



## II. ARMOR KIT INSTALLATION

# DOOR SUPPORT FRAMES

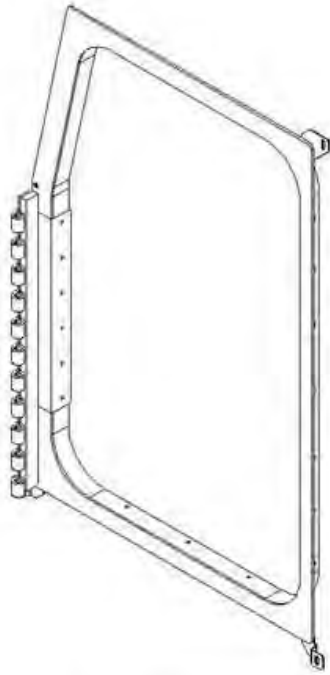

110-170060-001  
DRIVER SIDE

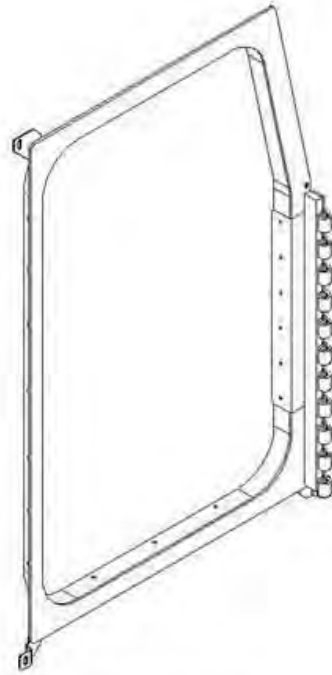

110-170060-002  
PASSENGER SIDE

## HARDWARE LIST:

ITEM NO.	QTY	PART NO.	DESCRIPTION
1	12		1/4-20 x 1-1/2 GRADE 8 HEX BOLT
2	24		5/16-18 x 1-1/4 GRADE 8 HEX BOLT
3	12		1/4 USS HARDENED FLAT WASHER
4	48		5/16 USS HARDENED FLAT WASHER
5	12		1/4 HEAVY-DUTY SPLIT LOCK WASHER
6	24		5/16-18 GRADE 8 ALL-METAL LOCKNUT
7	2	AUSTIN 10795-16	DOOR LATCH STRIKER BOLT

## REQUIRED TOOLS:

- 7/16" Socket with Ratchet Driver
- 1/2" Socket with Ratchet Driver
- 3/4" Socket with Ratchet Driver
- 1/2" Wrench
- 5/16" Drill Bit and Drill
- 4 Quick-Grip Clamps or C-Clamps
- Thread locking compound



- 1.) Place new frame on driver side door frame.
- 2.) Clamp the sides of the frames to the cab.



- 3.) Coat bolts with thread locking compound.



- 4.) Using the provided 1/4-20 bolts and flat washers to first secure the frames to the existing hinge attachment



- 5.) Align drill with the 5/16" drill bit through the remaining holes around the insides of the frames (Snug bolts with 7/16" Socket before drilling).



- 6.) Install Roof Brackets on the top-inside of the door frame.
- 7.) Finish securing the frames with the provided 5/16-18 bolts, flat washers and metal locknuts.
- 8.) Install a Striker Bolt on the threaded boss on the rear face of each frame. Make sure to use thread locking compound on the threads, and tighten using the 3/4" socket with Ratchet Driver.

# UNDERBODY MINEBLAST PANELS

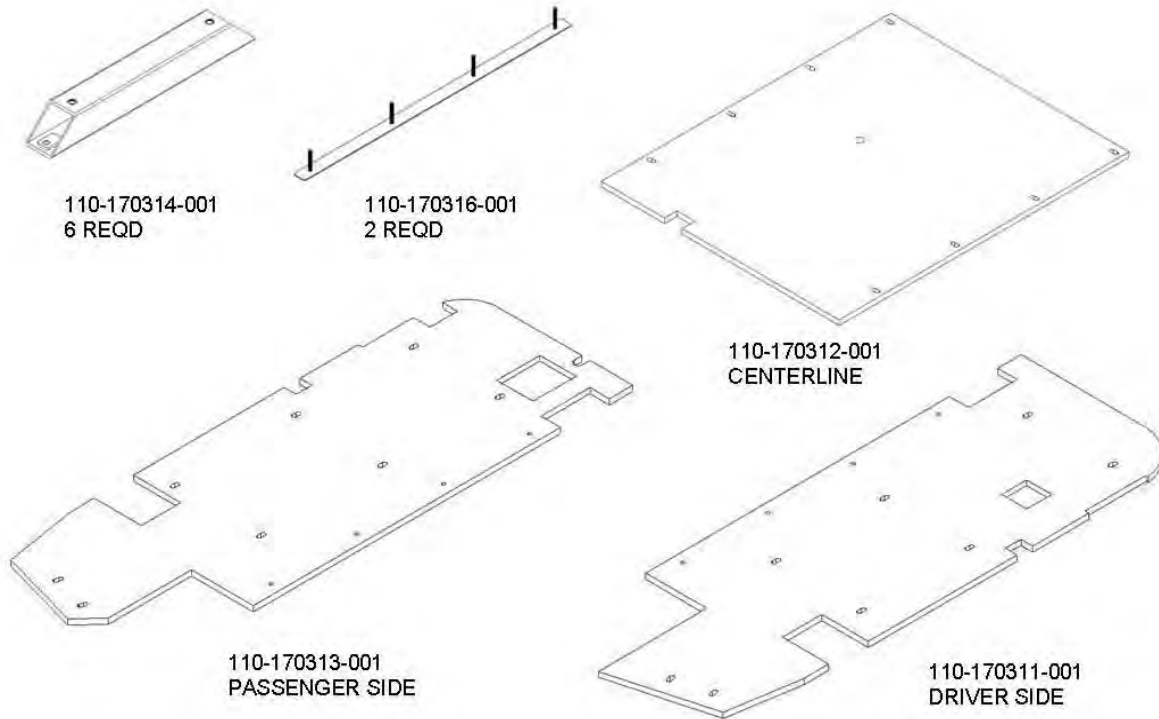

## HARDWARE LIST:

ITEM NO.	QTY	PART NO.	DESCRIPTION
1	12		5/16-18x1 GRADE 8 HEX BOLT
2	12		5/16-18x1-1/2 GRADE 8 HEX BOLT
3	12		5/16 USS HARDENED FLAT WASHER
4	20		3/8 USS HARDENED FLAT WASHER
5	32		5/16 HEAVY-DUTY SPLIT LOCK WASHER
6	8		5/16-18 GRADE 8 HEX NUT

## REQUIRED TOOLS:

Floor Jack or Overhead Crane  
 3/8" Drill Bit and Drill  
 1/2" Socket with Ratchet Driver  
 15/16" Socket with Ratchet Driver and  
 Extension  
 1-1/8" Hole Saw



## PREPARATION:

- 1.) For installation it is necessary to jack up the rear of the cab or utilize a crane if available.
- 2.) Remove the nuts from the rear vibration mounts.
- 3.) Unsnap cables under driver and passenger sides. Remove canon plug on drivers side.

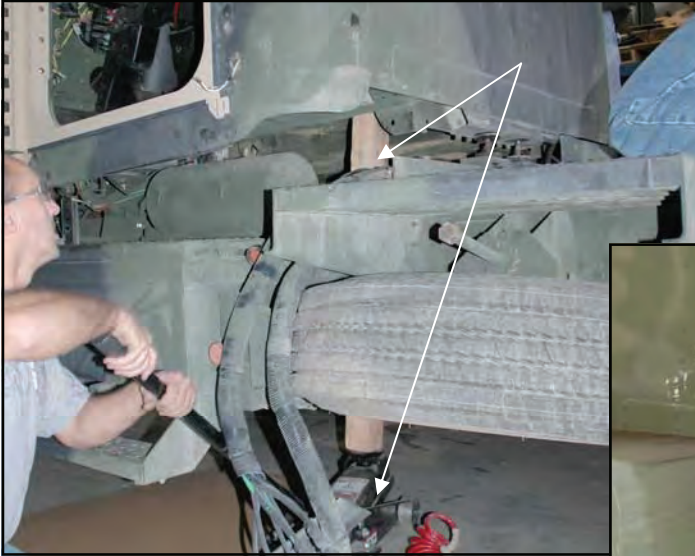

- 4.) Insert a 4X 4 block as shown.

**\*NOTE:** If your vehicle has a shifter cable remove from shifter side and feed through opening in center panel.

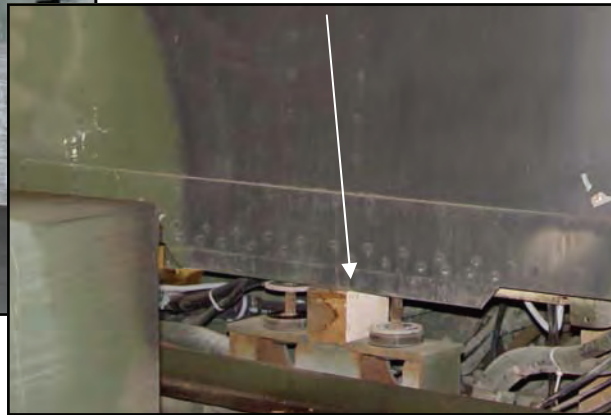

## INSTALLATION:



- 1.) Place templates over floor mats and drill holes accordingly.

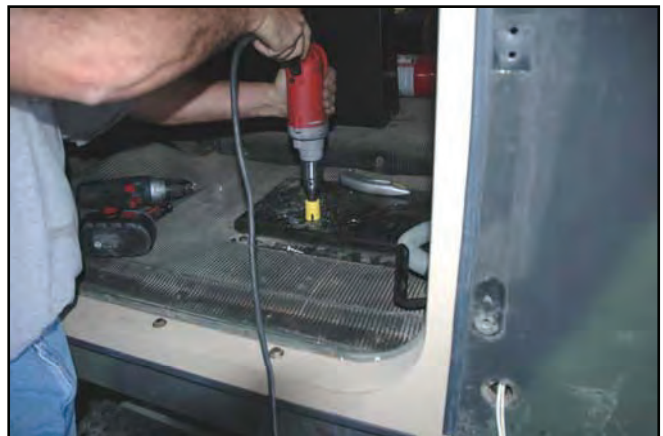

- 2.) Use hole saw to drill a 1-1/8" hole into the seat mounting pedestal
- 3.) Insert mine blast mounting bracket in the back drill holes on underbody
- 4.) Feed electrical cord through armor
- 5.) Insert stud plates through armor



6.) Bolt armor under driver and passenger sides



- 7.) Place two 2X4's across truck frame and place armor on the supports
- 8.) Guide armor with the two support beams and align in the middle of the underbody so bolts on the panels under passenger and driver side align with the middle armor panel. Add nuts, flat washers and lock washers.
- 9.) Insert shifter cables if removed earlier and slowly Jack truck up again and remove 4X4 block
- 10.) Slowly lower cab down with jack (or overhead crane if used)
- 11.) Reinstall nuts on rear vibration mount and tighten. If needed trim the back corner between the brackets.

# ARMORED DOORS

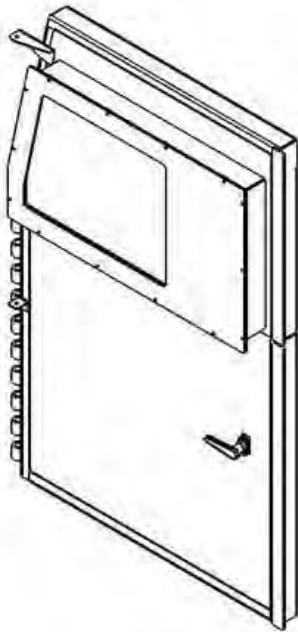

110-170085-001  
DRIVER SIDE



110-170135-001  
2 REQD

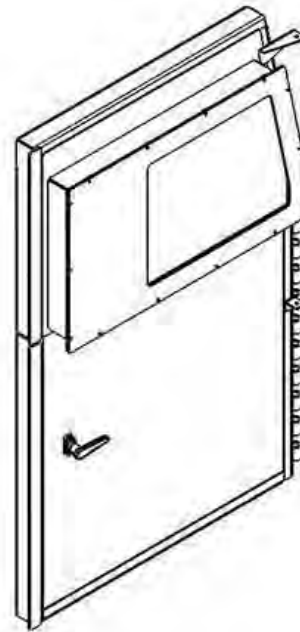

110-170085-002  
PASSENGER SIDE

## HARDWARE LIST:

None

## REQUIRED TOOLS:

- Forklift or Overhead Crane
- Lifting Straps
- Non-metallic Dead-Blow Mallet
- 1/2" Wrench
- 1/2" Drill Bit and Drill





1.) Remove side of crate that contains the doors.



2.) Use a 4 man lift to remove the door from the box



3.) Using a sling place armor door on forklift



4.) Still using the forklift position hingbrackets on the door with brackets on the truck (at least three men are needed for this step)

5.) Hammer hinge pin into hinge brackets

6.) Detach sling from armor

\*Repeat process for both door installations

# REAR CAB ARMOR AND WINDOW

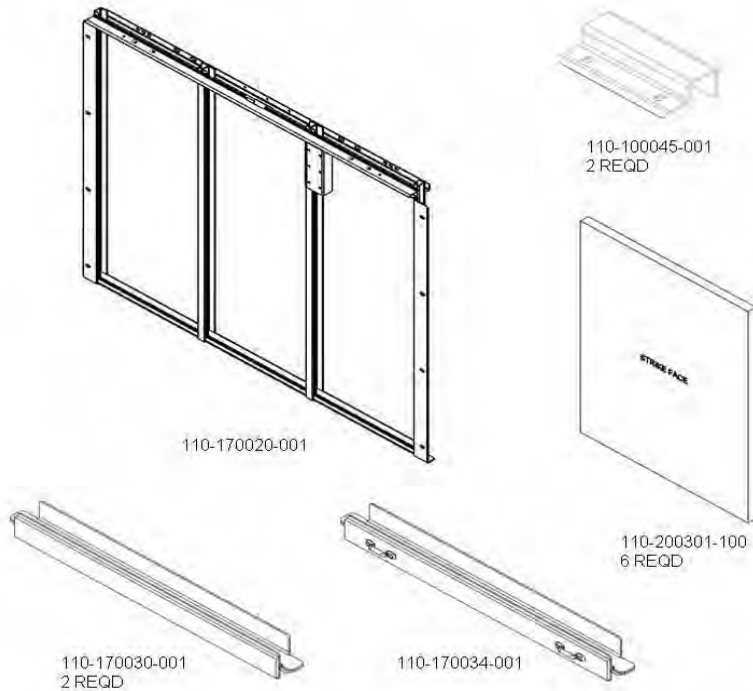

## HARDWARE LIST:

ITEM NO.	QTY	PART NO.	DESCRIPTION
1	9		1/4-20 x 1 GRADE 8 HEX BOLT
2	8		5/16-18 x 1 GRADE 8 HEX BOLT
3	4		3/8-16 x 1-1/4 GRADE 8 HEX BOLT
4	18		1/4 USS HARDENED FLAT WASHER
5	12		5/16 USS HARDENED FLAT WASHER
6	8		3/8 USS HARDENED FLAT WASHER
7	4		5/16 HEAVY-DUTY SPLIT LOCK WASHER
8	9		1/4-20 GRADE 8 ALL-METAL LOCKNUT
9	4		5/16-18 GRADE 8 ALL-METAL LOCKNUT
10	4		3/8-16 GRADE 8 ALL-METAL LOCKNUT

## REQUIRED TOOLS:

3/8" Drill Bit and Drill  
 7/16" Socket with Ratchet Driver  
 1/2" Socket with Ratchet Driver  
 9/16" Socket with Ratchet  
 Driver (M915/A3 only)  
 7/16" Wrench  
 1/2" Wrench  
 9/16" Wrench (M915/A3 only)



- 1.) Remove bottom bolts from caution light bracket
2. Align frame and insert bolts on with washers and nuts and top of frame.
- 3.) Drill bottom holes using the frame as a guide. Install 4 each of bolts, washers and nuts.

\* Note: On the top rail the A2 and A3 models differ in bolts. A2 9X1/4 - 20 Bolts, A3 use 3X1/4 bolts and 4X3/8 - 16 Bolts. The bottom Rail requires same bolts- 4X5/16 bolts



- 4.) Add red exit strap to rear window.



- 5.) Wet the seal of back window that was broken earlier with soapy water. Place glass inside seal using a flat head screwdriver to guide.



- 6.) Lock window in by tucking the bottom of the seal





7.) Slide one armor panel in each of the three frame slots (this would equate to three panels across the bottom of the frame).



8.) Add four brown hand straps to the middle center support bar.



9.) Insert the three center support dividers across the rear cab bottom armor. (Ensure that on the middle bar the two straps facing the rear window are not tucked under but vertical against the rear window)



10) Guide long center strap behind the bottom center panel and loop through bottom hook and lock in place with attached buckle.



11.) Velcro additional red ended straps to long center strap and hold vertically while the second middle panel is placed in slot. Velcro bottom of strap to the top red end of the strap.

12.) Insert the remaining two armor panels.



13.) Align brackets on top of the rear cab frame above passenger and driver sides. Insert bolts and washers.

\* Note: Middle slot does not have bolted bracket because it is held in with the emergency exit strap.

# B-PILLAR ARMOR



110-170040-001 FRAME  
110-200703-001 PANEL  
DRIVER SIDE



110-170050-001 FRAME  
110-200706-001 PANEL  
PASSENGER SIDE

## HARDWARE LIST:

ITEMNO.	QTY	PART NO.	DESCRIPTION
1	8		3/8-16 x 1 GRADE 8 HEX BOLT
2	22		3/8 USS HARDENED FLAT WASHER
3	14		3/8 HEAVY-DUTY SPLIT LOCK WASHER
4	10		3/8-16 GRADE 8 HEX NUT
5	4		3/8-16 GRADE 8 ALL-METAL LOCKNUT
6	2		3/8-16 x 1-1/4 LIFTING EYEBOLT (1 INCH DIA. EYE)
7	4		1/8 DIA x 5/16 ALUMINUM BLIND RIVET

## REQUIRED TOOLS:

- Forklift or Overhead Crane
- 9/16" Socket with Ratchet Driver
- 9/16" Wrench
- Pop-Rivet Installation Tool



## Option One: Forklift



1.) Thread the provided eyebolts into the top angle rail of the Driver Side B-Pillar Armor Frame. These eyebolts can be used to attach a lifting strap from the armor frame to a forklift or overhead crane.

2.) Hoist the armor into position, guiding the four 3/8" threaded studs into their mating slots in the Rear Cab Armor Frame. Secure the studs with the provided 3/8" flat washers, lock washers, and hex nuts.

**NOTE: The hex nuts should only be finger-tight at this time.**

3.) Align the slotted tabs on the top and bottom of the forward side of the armor frame with the mating slotted tabs on the Door Support Frame. Use the provided 3/8" bolts, flat washers, and metal lock-nuts to secure the tabs.

## Option Two: 2-man lift



1.) Rather than using a forklift use a two man lift to hoist B-Pillar.

2.) Hoist the armor into position, guiding the four 3/8" threaded studs into their mating slots in the Rear Cab Armor Frame. Secure the studs with the provided 3/8" flat washers, lock washers, and hex nuts.

**NOTE: The hex nuts should only be finger-tight at this time.**

3.) Align the slotted tabs on the top and bottom of the forward side of the armor frame with the mating slotted tabs on the Door Support Frame. Use the provided 3/8" bolts, flat washers, and metal lock-nuts to secure the tabs.

**NOTE: Do not fully tighten the lock nuts at this time.**



4.) Reconnect the work light connector that was removed in the earlier preparation process.

**OEM GRAB RAIL RE-INSTALLATION (DRIVER SIDE ONLY):**

Install the OEM Grab Rail (removed earlier during Vehicle Preparation) onto the two 3/8" threaded studs on the Driver Side B-Pillar Armor Frame as shown. Use provided 3/8" flat washers, lock washers, and hex nuts to secure the Grab Rail to the frame.

Repeat this installation procedure for the Passenger Side B-Pillar Armor.

Repeat this installation procedure for the Passenger Side B-Pillar Armor.



# KICK PANEL (LOWER A-PILLAR) ARMOR

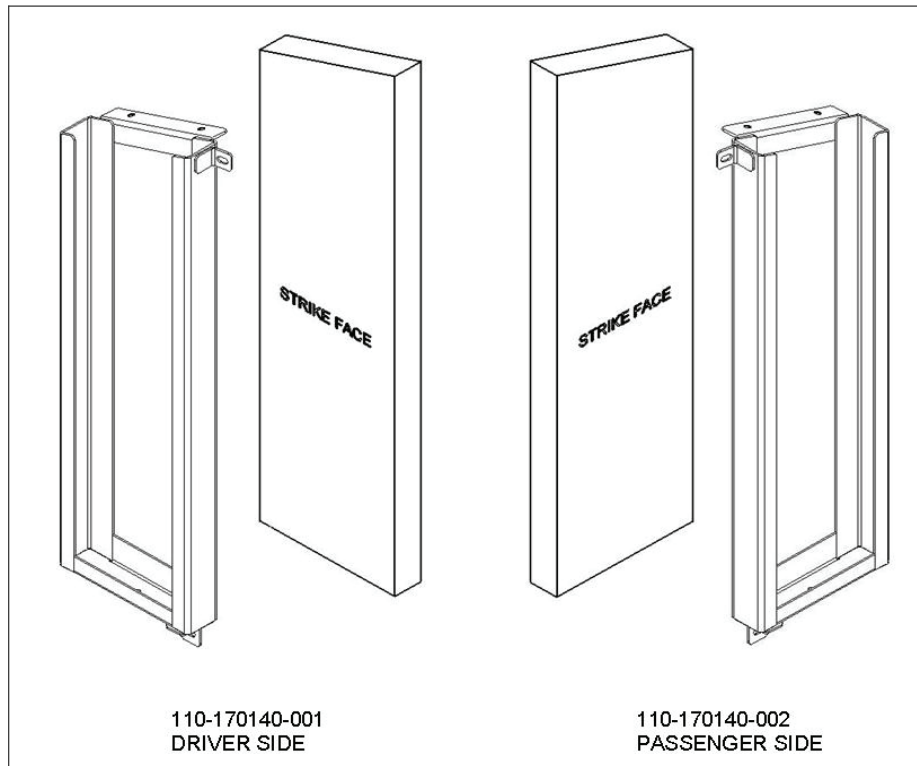

## HARDWARE LIST:

ITEM NO.	QTY	PART NO.	DESCRIPTION
1	6		3/8-16 x 1 GRADE 8 HEX BOLT
2	10		3/8 USS HARDENED FLAT WASHER
3	2		3/8 HEAVY-DUTY SPLIT LOCK WASHER
4	4		3/8-16 GRADE 8 ALL-METAL LOCKNUT

## REQUIRED TOOLS:

3/8" Drill Bit and Drill  
 9/16" Socket with Ratchet Driver  
 9/16" Wrench

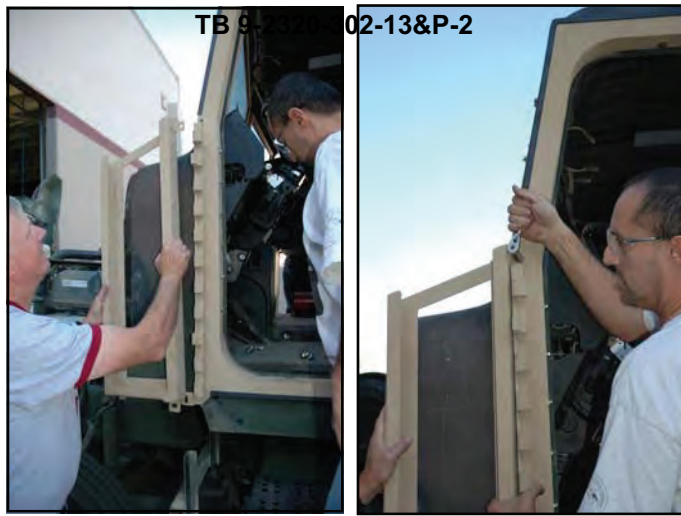

- 1.) First remove the armor panel from the Driver Side Kick Panel Frame. Then position the frame forward of the Driver Door as shown, aligning the slotted angle brackets to the mating brackets on the Door Support Frame.
- 2.) **OPTION 1:** Use a provided 3/8" bolt, lock washer, and flat washer to secure the upper bracket to the Door Support Frame.
- 3.) Use a proved 3/8" bolt, two flat washers (one on the front side, one on the back) and a metal locknut to secure the bottom bracket to the Door Support Frame.

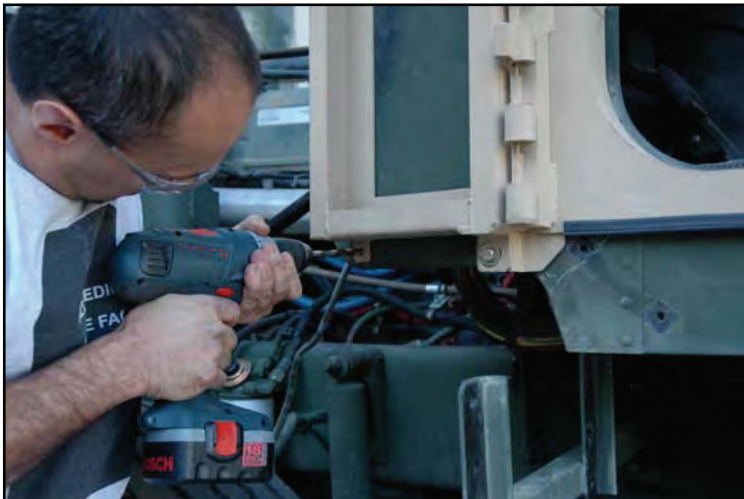

- 4.) Align drill a 3/8" hole through the angle tab on the lower-front corner of the frame and the A-Pillar of the truck cab.

- 5.) Use a proved 3/8" bolt, two flat washers (one on the front side, one on the back) and a metal locknut to secure the bracket to the vehicle. Tighten all hardware to final torque.



- 6.) Slide the Driver Side Kick Panel Armor Panel into the top of the frame.

Repeat this installation procedure for the Passenger Side Kick Panel Armor.

**OPTION 2:** Weld Side Kick Panel Frame to the Door Support Frame.

# A-PILLAR CORNER PLATE

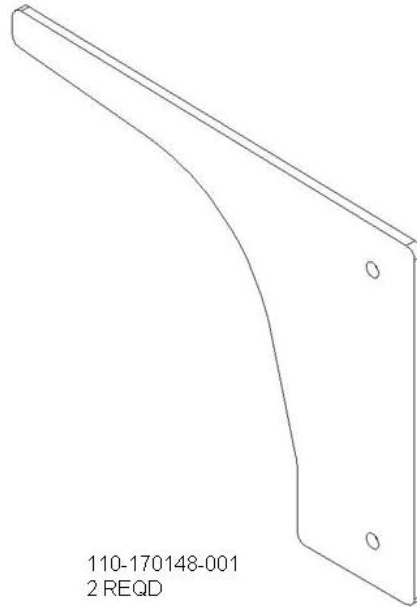

110-170148-001  
2 REQD

## HARDWARE LIST:

## REQUIRED TOOLS:

Welder

**A-Pillar Corner Plate**

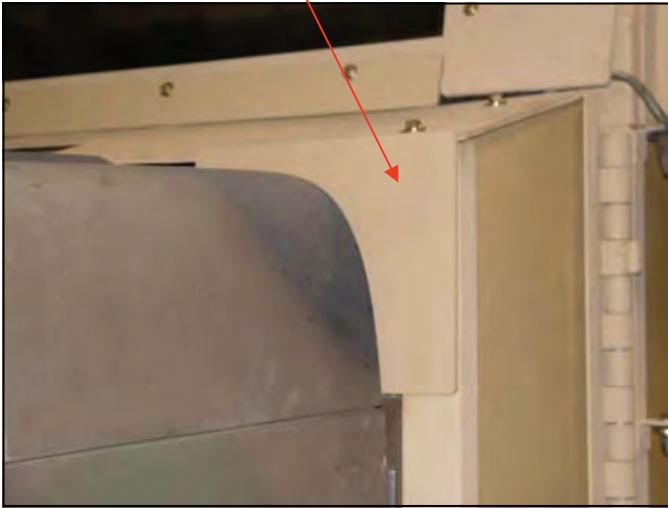

**Plug Weld in two places**

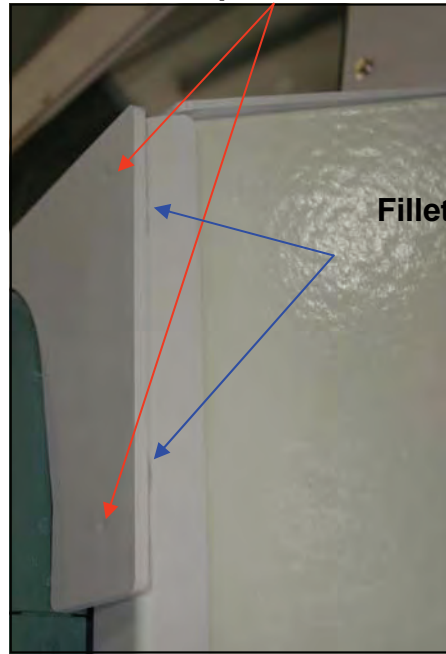

**Fillet Weld in two places**

- 1.) Position plate as shown and secure kick panel frame with two plug welds and two fillet welds.
- 2.) Use touch-up paint as required.

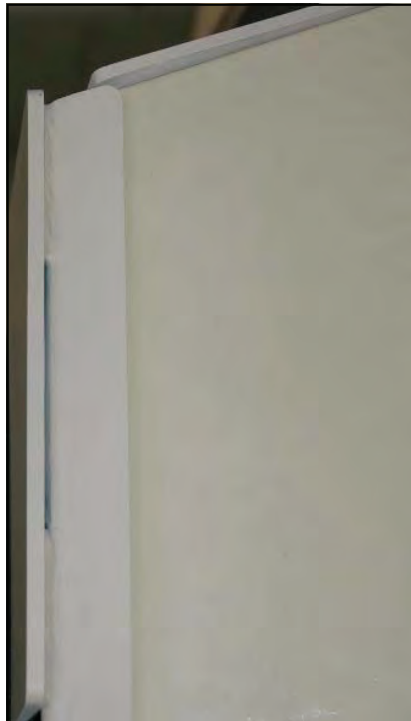

# FIREWALL ARMOR

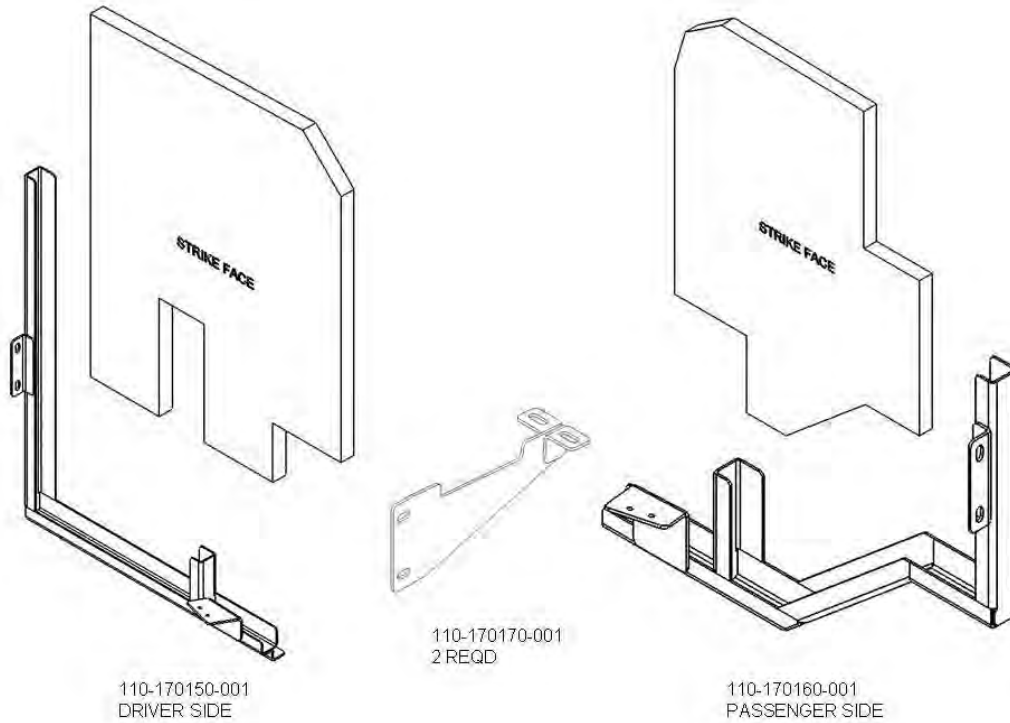

## HARDWARE LIST:

ITEM NO.	QTY	PART NO.	DESCRIPTION
1	4		1/4-20 x 1 GRADE 8 HEX BOLT
2	4		5/16-18 x 1 GRADE 8 HEX BOLT
3	4		5/16-18 x 1-1/2 GRADE 8 HEX BOLT
4	2		3/8-16 x 1-1/4 GRADE 8 HEX BOLT
5	8		1/4 USS HARDENED FLAT WASHER
6	8		5/16 USS HARDENED FLAT WASHER
7	8		3/8 USS HARDENED FLAT WASHER
8	4		5/16 HEAVY-DUTY SPLIT LOCK WASHER
9	4		1/4-20 GRADE 8 ALL-METAL LOCKNUT
10	4		5/16-18 GRADE 8 ALL-METAL LOCKNUT
11	2		3/6-16 GRADE 8 ALL-METAL LOCKNUT

## REQUIRED TOOLS:

- 1/4" Drill Bit and Drill
- 7/16" Socket with Ratchet Driver
- 1/2" Socket with Ratchet Driver
- 9/16" Socket with Ratchet Driver
- 7/16" Wrench
- 1/2" Wrench
- 9/16" Wrench

\* reinstall wire for turn signals before installing firewall armor

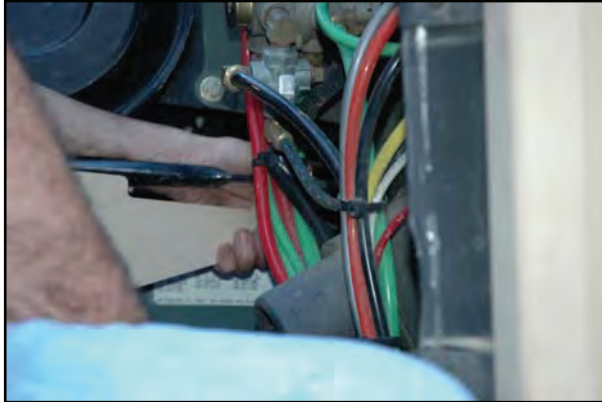

1.) Remove radiator support bar mounting bolt at firewall and **loosely** attach firewall bracket to radiator core support bar using provided 3/8-16X1-1/4 bolt

2.) Place armor panel over steering column and adjust to fit armor frame



3.) Clamp cab frame to armor bracket.

4.) Tighten hardware to bracket attached to truck and the frame of the armor with 5/16X18-1 bolt, washers and nut

5.) Tighten bracket attached to radiator core support that was loosely attached in step one





- 6.) Insert bolts, nuts and washers through the underbody armor panel and tighten armor into armor firewall frame with 5/16X1-1/2 bolts



- 7.) Align cab mount bracket and armor firewall frame bracket and use holes in armor to guide drilling and attach with bolt, flat-washer and 1/2-20 locking nut

# FRONT COWL ARMOR

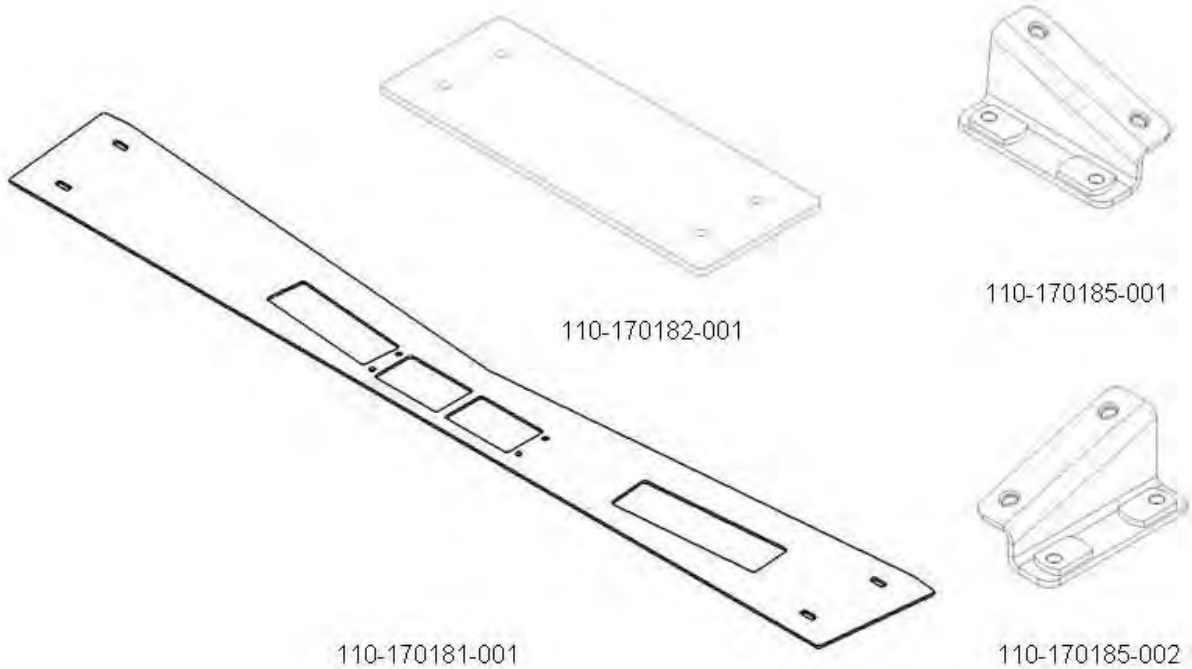

## HARDWARE LIST:

ITEM NO.	QTY	PART NO.	DESCRIPTION
1	8		5/16-18 x 1 GRADE 8 HEX BOLT
2	4		3/8-16 x 1 GRADE 8 HEX BOLT
3	8		5/16 USS HARDENED FLAT WASHER
4	4		3/8 USS HARDENED FLAT WASHER
5	8		5/16 HEAVY-DUTY SPLIT LOCK WASHER
6	4		3/8 HEAVY-DUTY SPLIT LOCK WASHER

## REQUIRED TOOLS:

1/2" Socket with Ratchet Driver  
 9/16" Socket with Ratchet Driver





# BALLISTIC WINDSHIELD

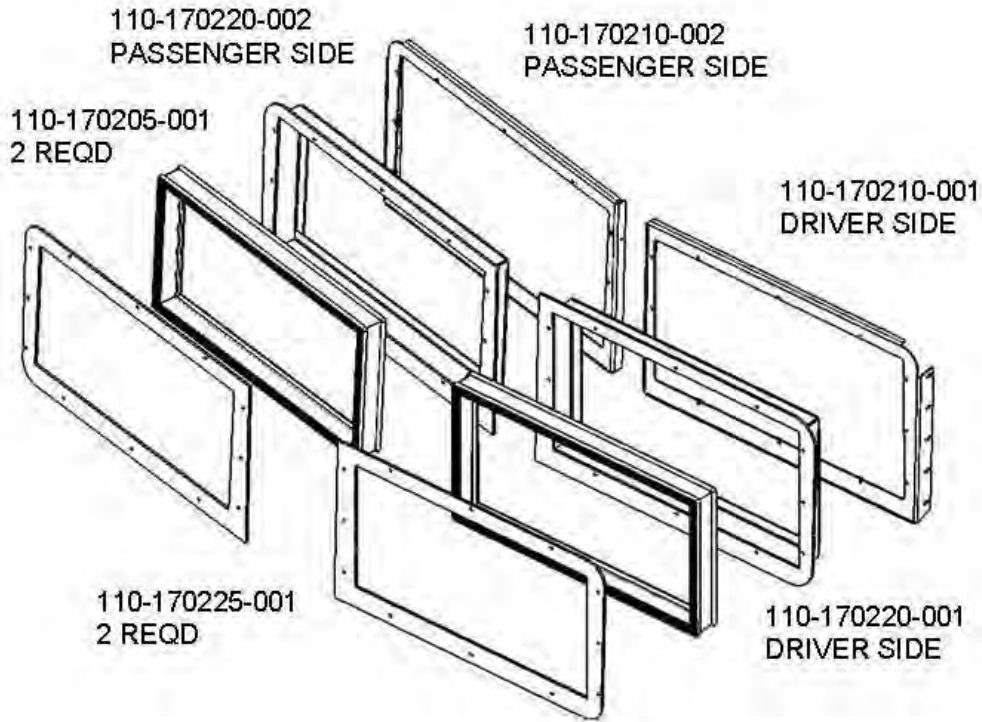

## HARDWARE LIST:

ITEM NO.	QTY	PART NO.	DESCRIPTION
1	4		1/4-20 x 3/4 GRADE 8 HEX BOLT
2	10		1/4-20 x 1 GRADE 8 HEX BOLT
3	24		1/4-20 x 1-3/4 GRADE 8 HEX BOLT
4	42		1/4 USS HARDENED FLAT WASHER
5	34		1/4 HEAVY-DUTY SPLIT LOCK WASHER
6	4		1/4-20 GRADE 8 ALL-METAL LOCKNUT

## REQUIRED TOOLS:

- 1/4" Drill Bit and Drill
- 7/16 " Socket with Ratchet Driver
- 7/16" Wrench
- 4 Quick-Grip Clamps or C-Clamps
- 3/8" Socket with Ratchet Driver



1.) Loosen and remove 1/4-20 bolts from window frame  
\* Note: 001 is driver side and 002 is passenger side

2.) Insert driver and passenger side frames with 1/4-20X1 bolt, flat washer and lock washer on outer holes and center holes require 1/4-20 X 1 3/4 bolts (center holes will need to be drilled).



4.) Insert glass in frame holder.



3.) Insert frame holder (driver and passenger).



5.) Bolt outside frame to glass.

6.) Tighten washers and bolts ONLY on the bottom three bolts leave the top three for later installation.

# WINDSHIELD SURROUND ARMOR

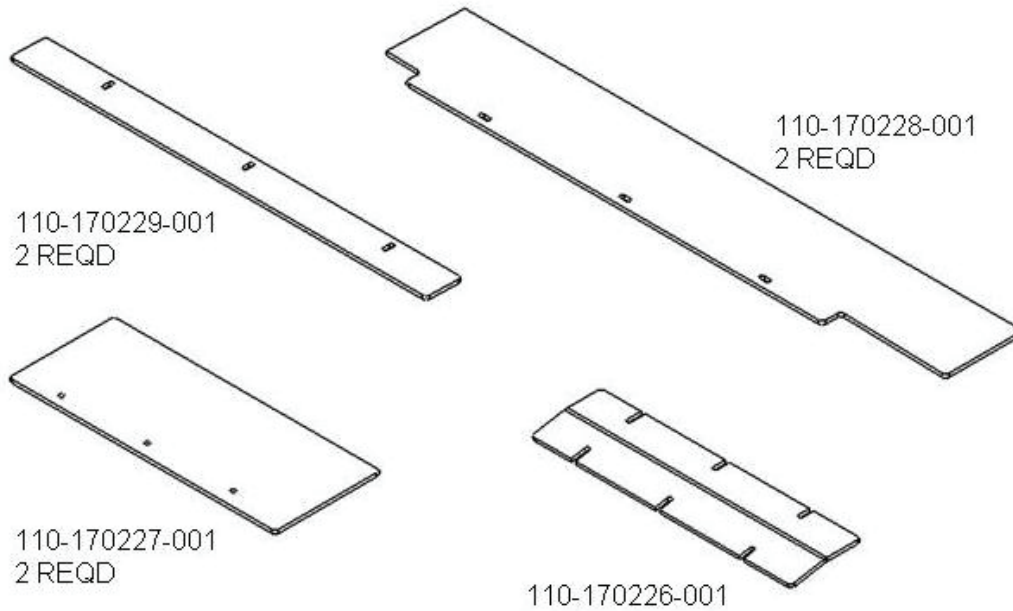

## HARDWARE LIST:

Existing hardware from Windshield installation.

## REQUIRED TOOLS:

7/16 " Socket with Ratchet Driver  
7/16" Wrench



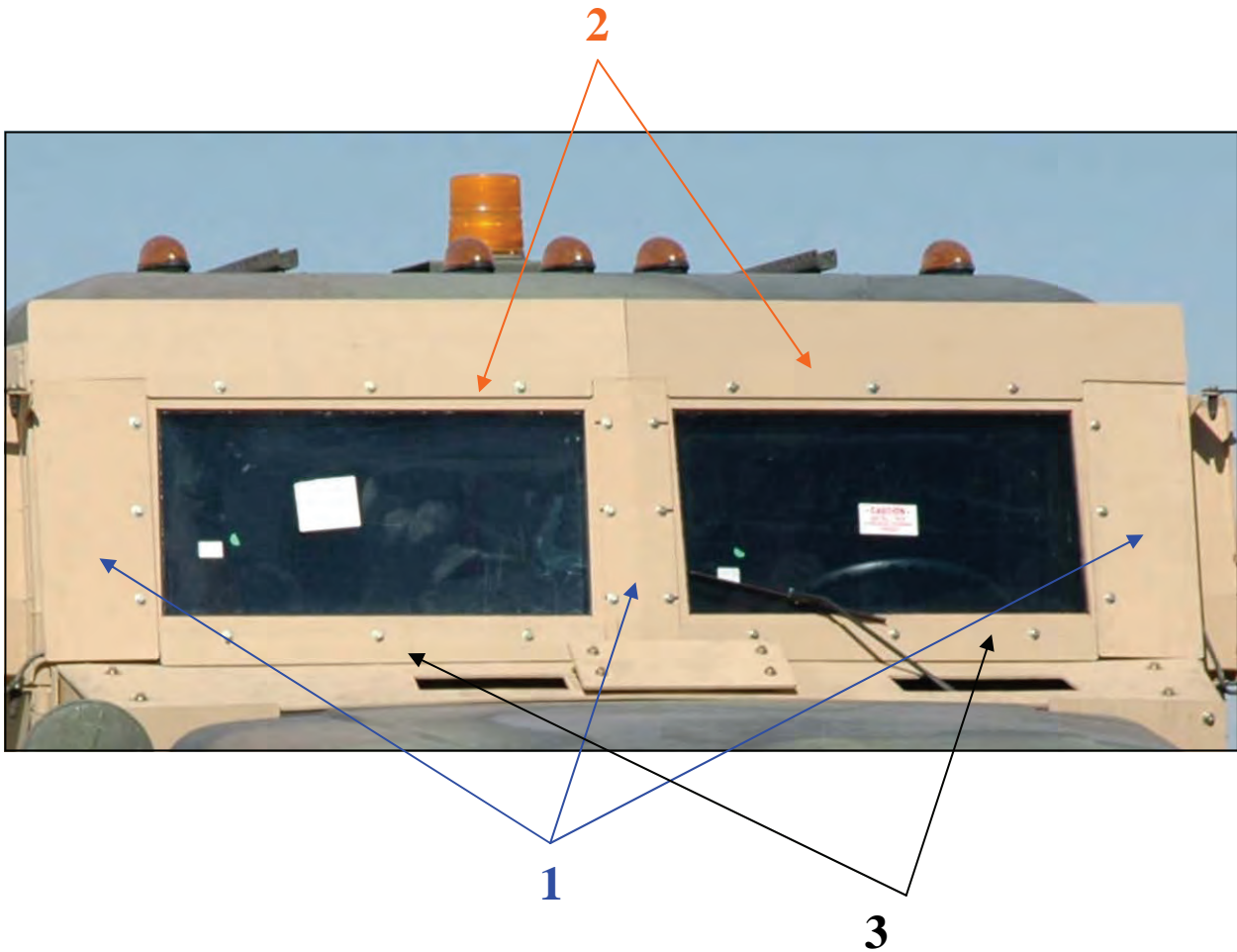

- 1.) Using the existing hardware for Windshield installation align armor that the arrows labeled **1** are pointed to in the picture above. Tighten hardware.
- 2.) Repeat the same process for the armor parts that are labeled **2**.
- 3.) Repeat the same process for the armor parts that are labeled **3**.

# ROOF ARMOR

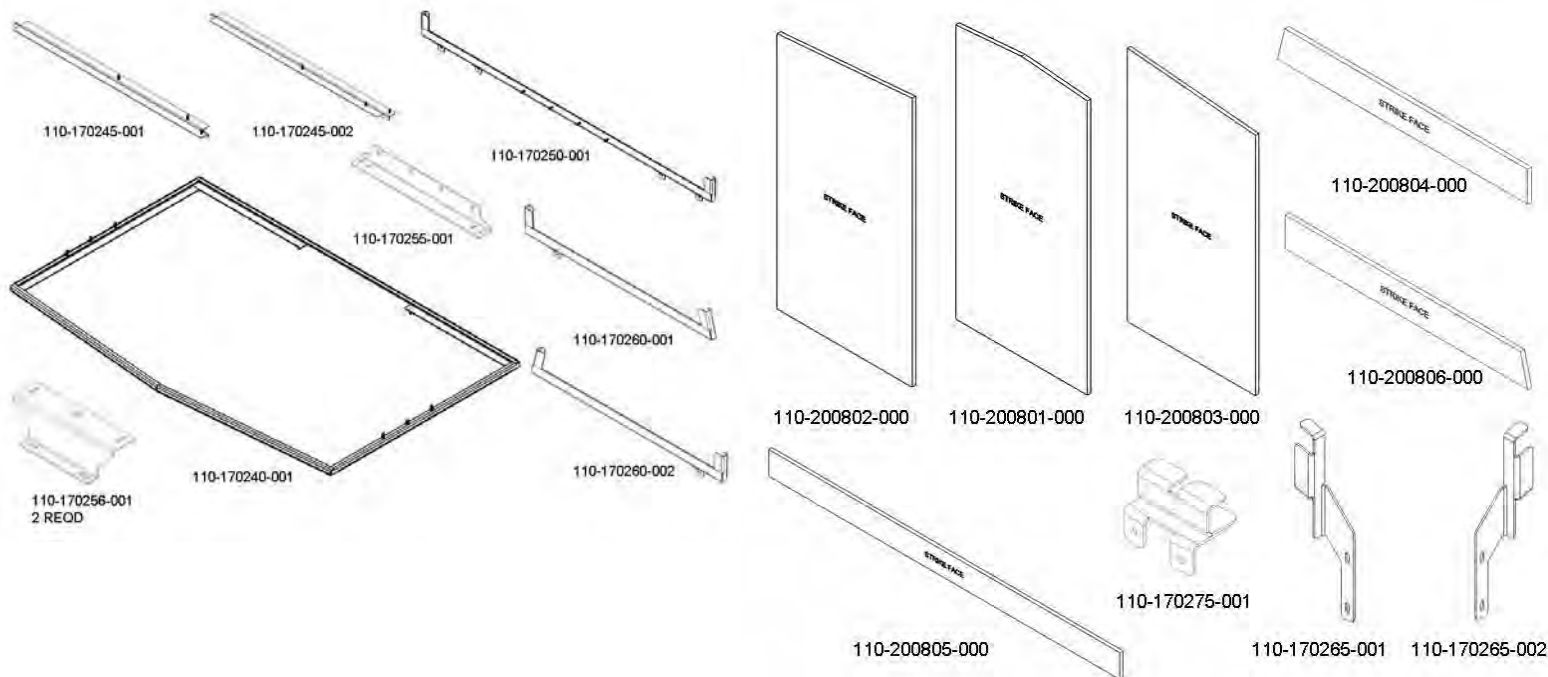

## HARDWARE LIST:

ITEM NO.	QTY	PART NO.	DESCRIPTION
1	2		GRAB STRAPS
2	4		5/16-18 x 1 GRADE 8 HEX BOLT
3	26		5/16 USS HARDENED FLAT WASHER
4	22		5/16 HEAVY-DUTY SPLIT LOCK WASHER
5	22		5/16-18 GRADE 8 HEX NUT

## REQUIRED TOOLS:

3/8" Drill Bit and Drill  
 1/2" Socket with Ratchet Driver  
 1/2" Wrench



1.) Align roof frame with brackets installed earlier.



2.) Add washers and nuts to bolts on the door frame brackets and leave the middle bracket (located where the rear view mirror would be) for later installation.



3.) Tighten bolts on frame of door.



4.) Reinstall rear roof bracket and cab lights to rear cab

5.) Align rear top armor with steel bracket.

6.) Peel back rear cab molding.



7) Insert three armor panels and secure armor panels by inserting two dividers between the middle and each side.



8.) Add nuts and washers to all exposed bolts on rear cab frame.

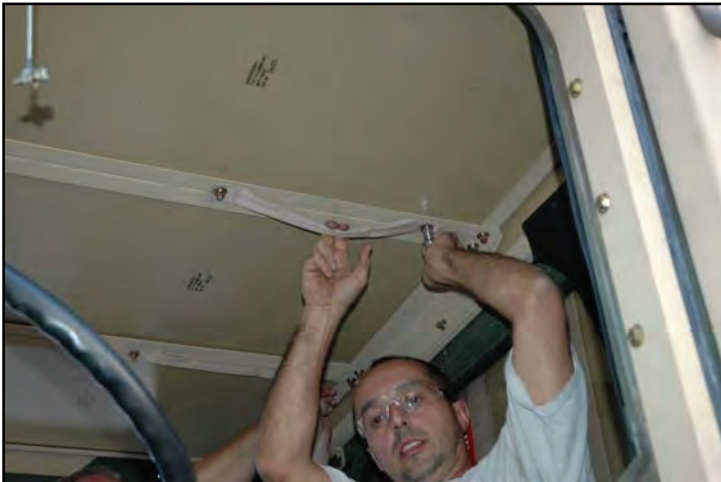

9.) Install roof grab straps.



10.) Place top door frame armor and use bolt attached to seat belt to secure into the back drill hole.





10.) Use drill bit to drill holes for middle top bracket (where rear view mirror would be located) and insert 1/4 X 3/4 bolts, 1/4 washers and 1/4 locknuts.

# WHEEL WELL BLAST DEFLECTORS

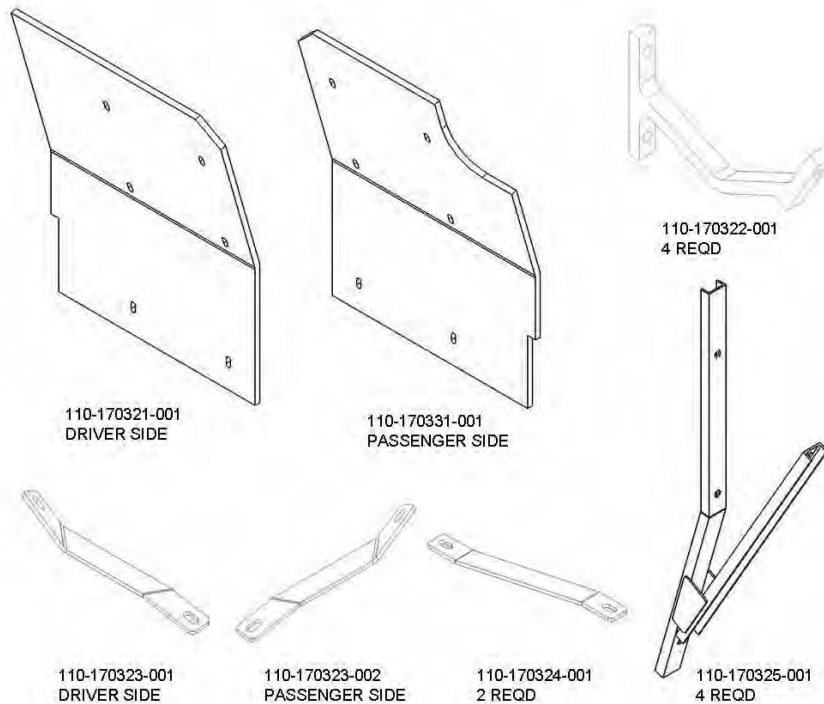

## HARDWARE LIST:

ITEM NO.	QTY	PART NO.	DESCRIPTION
1	6		3/8-16 x 1-1/2 GRADE 8 HEX BOLT
2	12		3/8-16 x 2-1/4 GRADE 8 HEX BOLT
3	4		3/8-16 x 3 GRADE 8 HEX BOLT
4	4		1/2-13 x 2-1/2 GRADE 8 HEX BOLT
5	44		3/8 USS HARDENED FLAT WASHER
6	8		1/2 SAE HARDENED FLAT WASHER
7	22		3/8-16 GRADE 8 ALL-METAL LOCKNUT
8	4		1/2-13 GRADE 8 ALL-METAL LOCKNUT

## REQUIRED TOOLS:

- 9/16" Socket with Ratchet Driver
- 3/4" Socket with Ratchet Driver
- 9/16" Wrench
- 3/4" Wrench



1.) Place two P/N 110-170325-001 on driver side wheel well support bar.

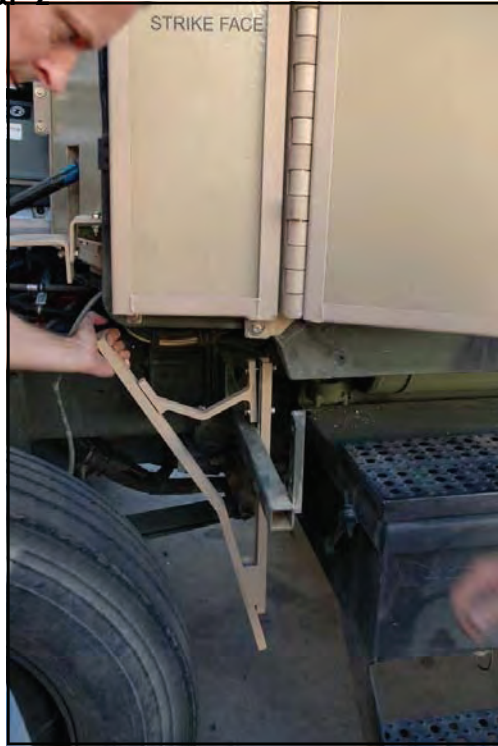

2.) Attach P/N 110-170322-001 to the P/N in step 1.



3.) Attach original bracket that was removed in the preparation of the vehicle.



4.) Align armor panel with wheel well frame and attach hardware.

\*Reinstall exhaust pipe under cab before doing passenger wheel well blast deflector





5.) Attach P/N 110-324-001 to truck underbody support frame.



6.) Attach P/N 110-324-001 to the front of the truck's wheel well underbody support frame.



7.) Reattach horn with the original hardware to the bottom of the driver side door frame as shown above (if removed)

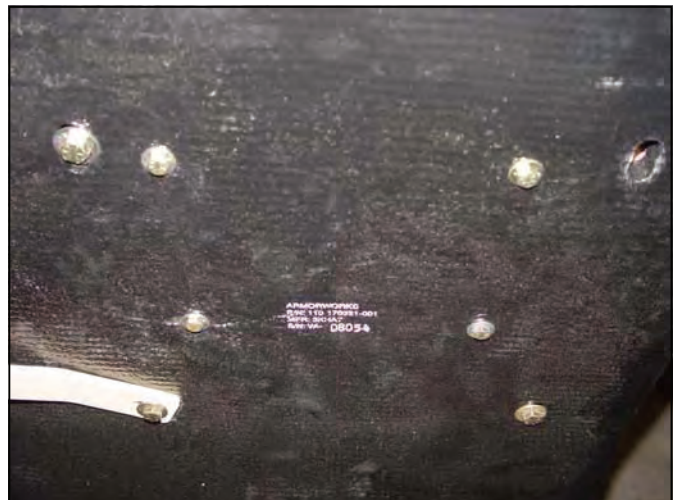

8.) Align washer fluid box to the driver side armor wheel well blast panel and drill holes accordingly. Install with given hardware.





9.) . Reconnect hoses and wires to washer box



10.) Reinstall washer fluid box while installing hood support brackets



11.) Re-install original wheel well deflectors and ensure the wire from the side light has been connected. Note: fenders may need to be trimmed to make armor fit and will need to be trimmed to accommodate armor

# REAR STOWAGE BOX ADAPTER FRAME

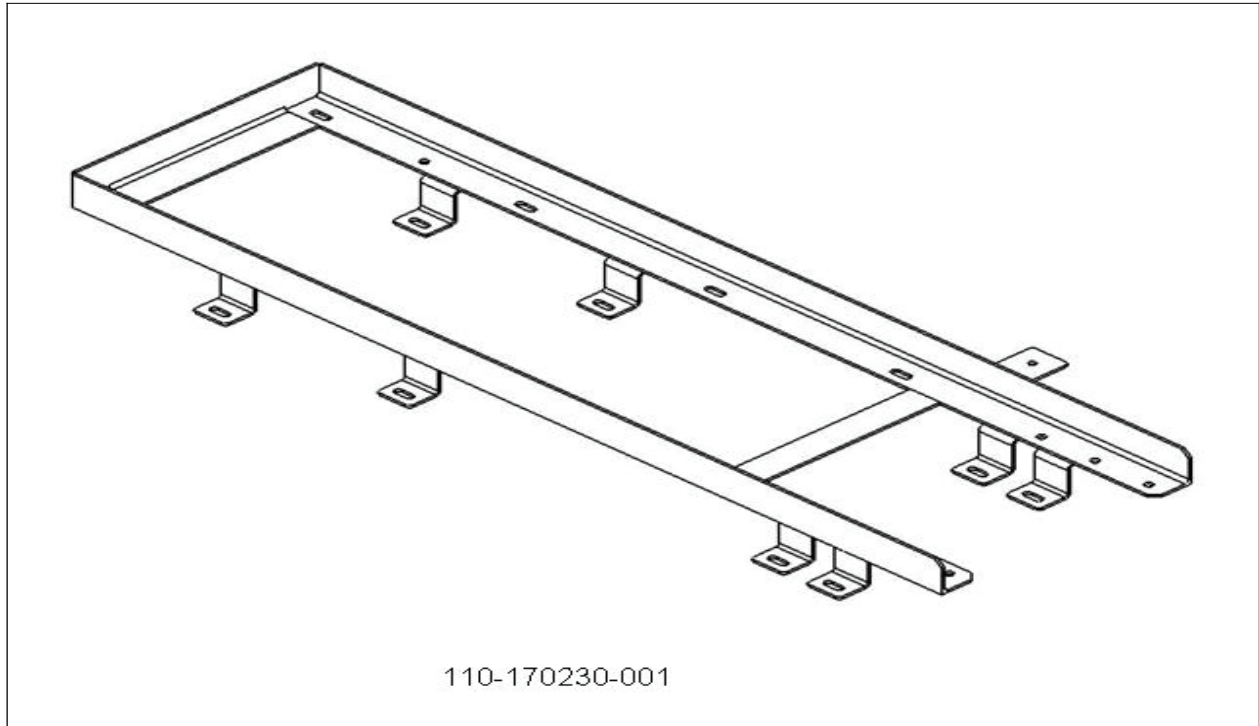

## HARDWARE LIST:

ITEM NO.	QTY	PART NO.	DESCRIPTION
1	6		3/8-16x1-1/4 GRADE 8 HEX BOLT
2	12		3/8 USS HARDENED FLAT WASHER
3	6		3/8-16 GRADE 8 ALL-METAL LOCKNUT

## REQUIRED TOOLS:

9/16" Socket with Ratchet Driver  
9/16" Wrench



1.) Align frame with existing hardware (bolt, washers and locknut).



2.) Install hardware to existing holes and secure. The Rear Cab hardware will require an extension to be used.



# HOOD SUPPORT BRACKETS

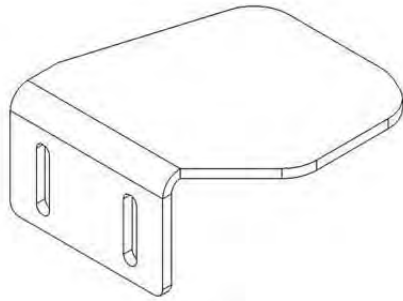

110-170190-001

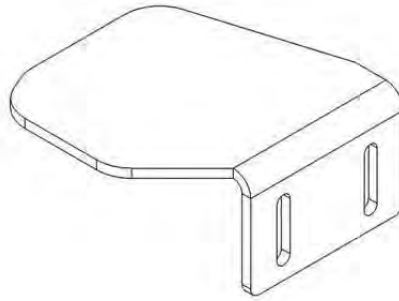

110-170190-002

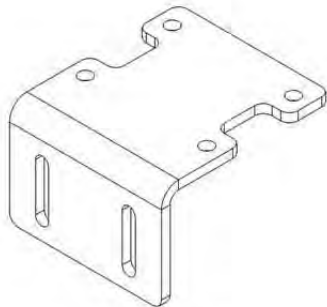

110-170191-001  
2 REQD

## HARDWARE LIST:

ITEM NO.	QTY	PART NO.	DESCRIPTION
1	12		5/16-18x1-1/4 GRADE 8 HEX BOLT
2	24		5/16 USS HARDENED FLAT WASHER
3	12		5/16-18 GRADE 8 ALL-METAL LOCK NUT

## REQUIRED TOOLS:

1/2" Socket with Ratchet Driver

1/2" Wrench



1.) Insert bracket and bolts to the drilled holes.



2.) Attach additional bracket to the bracket attached in step 8.

# III. RE-INSTALLATION OF OEM PARTS

# SIDE-VIEW MIRRORS

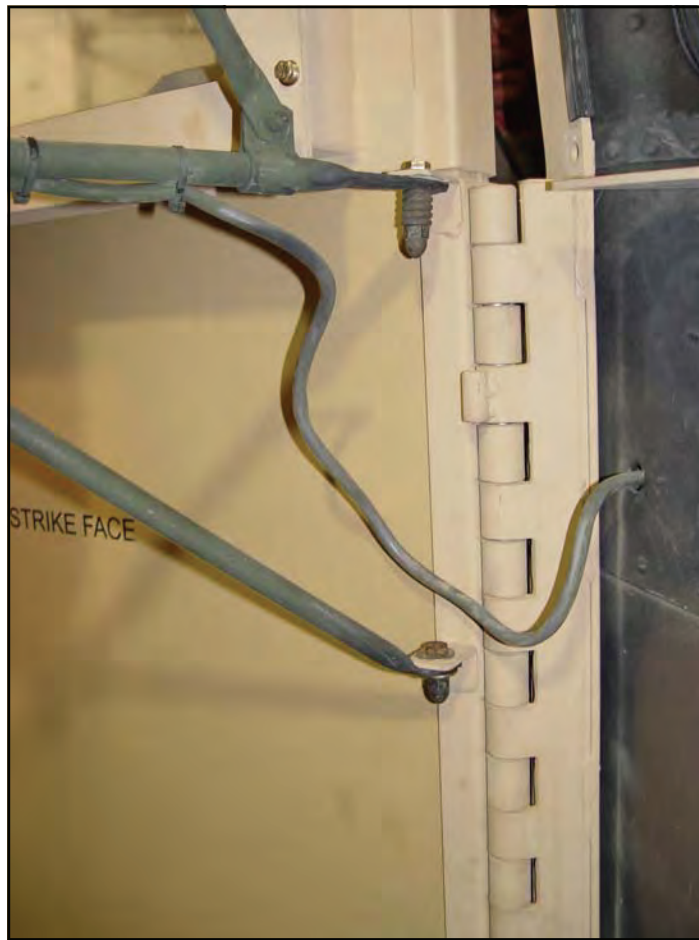

**HARDWARE LIST:** OEM fasteners removed earlier

**REQUIRED TOOLS:**

1/2 inch Drill and Drill Bit  
Pick or Flathead Screwdriver

(Note: some models may not have wires to reconnect).

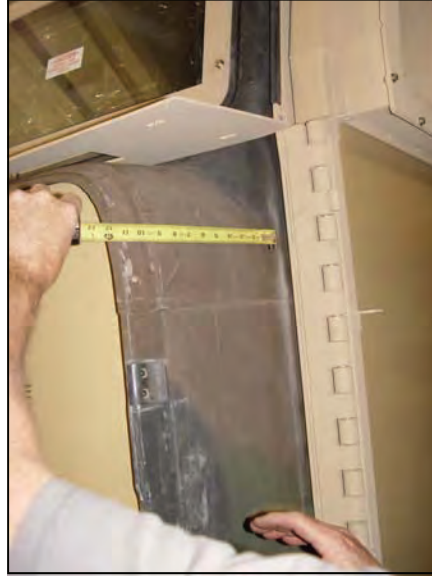

1.) Drill a 1/2 inch hole with Drill and Drill Bit. Drilling should occur 3 and 1/4 inches from the mid body seam and 9 and 1/2 inches from front cowl. Ensure that when drilling that both panels, inner and outer, are drilled through.

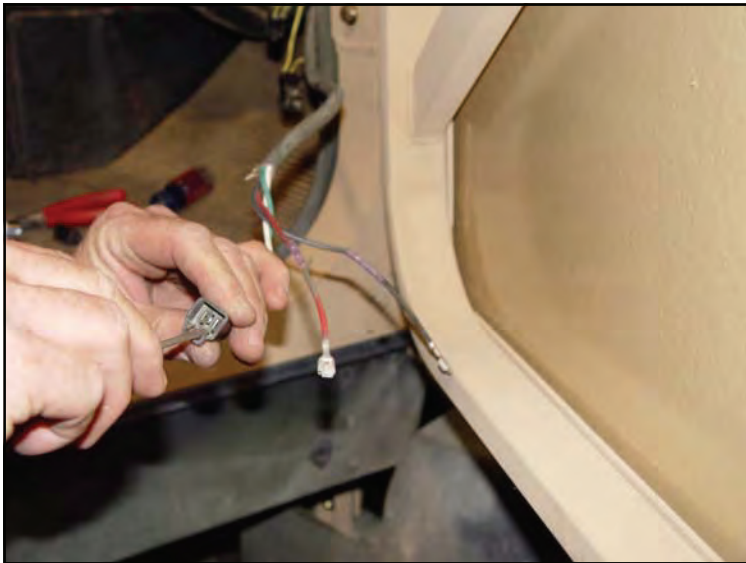

2.) Release connectors with flathead screwdriver.



3.) Guide Wires through hole drilled in step one.





4.) Pull wires through the inside of the cab.

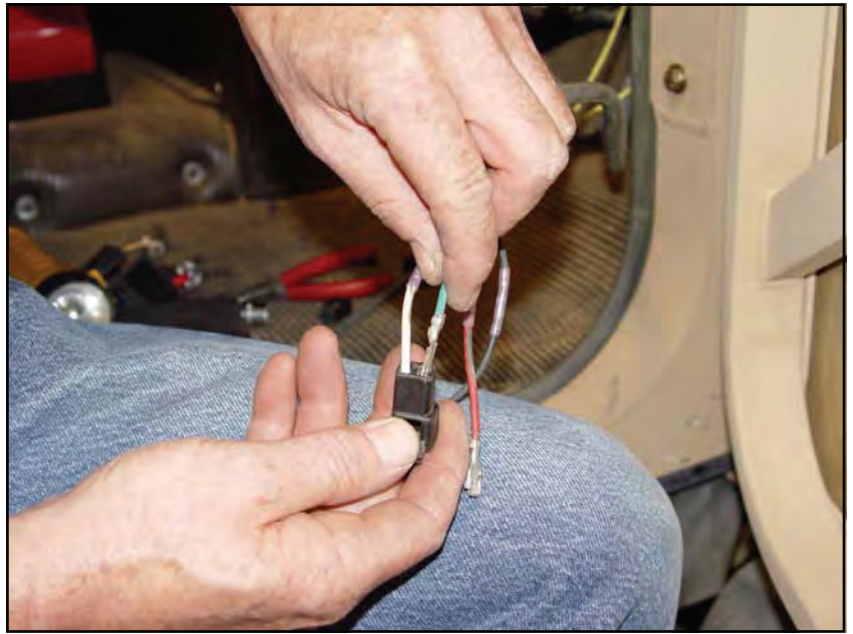

5.) Reinstall wires into connectors.



6.) Reinstall original dash cover.

# REAR STOWAGE BOX AND TRAILOR HOSES

## HARDWARE LIST:

OEM fasteners removed earlier.



1.) Reinstall rear stowage box on installed frame with original fasteners.

Note: Some models have a bracket on top of stowage box. This will need to be cut off and re-welded to the side of the stowage box. The bracket will be a hindrance to the escape hatch if not removed

2. Reinstall BII Boxes if applicable.





2.) Pictured above is the Manifold assembly that was unbolted from the original angle bracket. Position it on the side of the box as shown, align drill with  $\frac{1}{4}$ " holes, and mount it to the box with the original bolts.

3) Next, position the angle bracket with the electrical connectors on the box as shown, align drill with  $\frac{1}{4}$ " holes, and bolt to the box with spares hardware.





# HOOD LATCH STRAPS



## HARDWARE LIST:

ITEM NO.	QTY	PART NO.	DESCRIPTION
1	12		1/4-20 x 1-1/4 GRADE 8 HEX BOLT
2	24		1/4 USS HARDENED FLAT WASHER
3	12		1/4-20 GRADE 8 ALL-METAL LOCKNUT

## REQUIRED TOOLS:

1/4" Drill Bit and Drill  
7/16" Socket with Ratchet Driver  
7/16" Wrench



- 1.) Locate the bend in the bracket with the line on the hood
- 2.) Drill 1/4" holes and use the OEM hardware to reinstall



# EXHAUST STACK

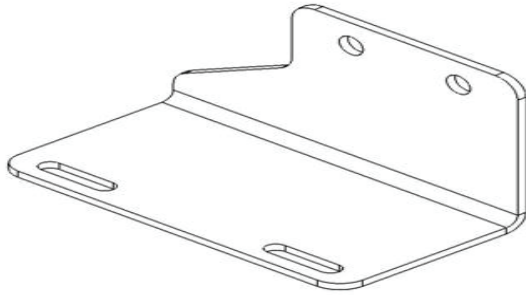

110-170057-001

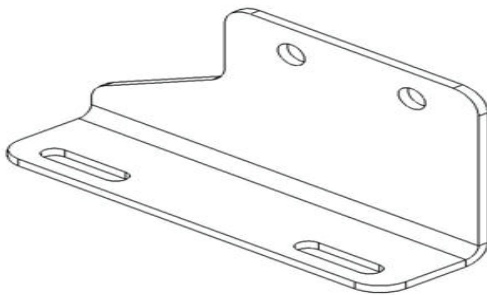

110-170058-001

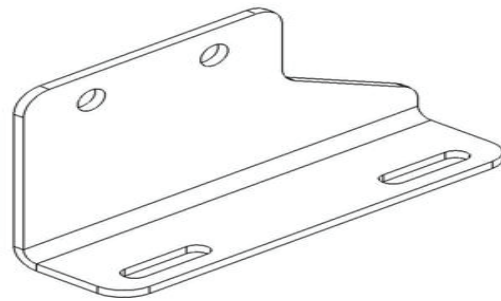

110-170058-002  
2 REQD

## HARDWARE LIST:

ITEM NO.	QTY	PART NO.	DESCRIPTION
1	4		1/2-13 x 2-1/4 GRADE 8 HEX BOLT
2	8		1/2 SAE HARDENED FLAT WASHER
3	4		1/2-13 GRADE 8 ALL-METAL LOCKNUT

## REQUIRED TOOLS:

3/4" Socket with Ratchet Driver  
3/4" Wrench



1.) Install brackets and hardware on top and bottom of existing exhaust stack holes

# SEATS

**HARDWARE LIST:** OEM fasteners removed earlier.



- 1.) Reinstall the seat into the truck by tightening bolts with a 9/16" Socket and Ratchet Driver.
- 2.) Reconnect the airline behind the seat.



# DOME LIGHTS



The dome light can be screwed to cab, above the windshield as shown. No other provisions or brackets were made nor required.

- 1.) Drill 5/32" holes and use the screws that held the light to the headliner.

# IV. APPENDIX

# PART NUMBERS

PART NUMBER	DESCRIPTION
110-170020-001	FRAME ASSY, REAR CAB ARMOR
110-100045-001	CLAMP, BEDSIDE ARMOR PANEL
110-170030-001	REAR PANEL DIVIDER ASSY, OUTBOARD
110-170034-001	REAR PANEL DIVIDER ASSY, CENTER
110-200301-100	ARMOR PANEL, REAR, M915
110-170036-001	REAR WINDOW PANEL, POLYCARBONATE
110-170037-001	PULL STRAP, REAR WINDOW
110-170038-001	STRAP KIT, EMERGENCY EGRESS SYSTEM
110-170040-001	B-PILLAR FRAME ASSY, DRIVER
110-200703-000	ARMOR PANEL, B-PILLAR, PASSENGER, M915
110-170050-001	B-PILLAR FRAME ASSY, PASSENGER
110-200706-000	ARMOR PANEL, B-PILLAR, PASSENGER, M915
110-170055-001	ADAPTER ASSY REAR HANDRAIL
110-170057-001	LOWER BRACKET, EXHAUST STACK
110-170058-001	UPPER BRACKET, EXHAUST STACK
110-170058-002	UPPER BRACKET, EXHAUST STACK (MIRROR)
110-170060-001	DOOR SUPPORT FRAME, DRIVER
110-170085-001	DOOR ASSY, DRIVER
110-170135-001	HINGE PIN, M915A2-A3 DOOR
110-170060-002	DOOR SUPPORT FRAME, PASSENGER
110-170085-002	DOOR ASSY, PASSENGER
110-170135-001	HINGE PIN, M915A2-A3 DOOR
110-170121-002	BALLISTIC WINDOW W/GASKET, PASSENGER DOOR
110-170140-001	KICK PANEL FRAME ASSY, DRIVER
110-200704-000	ARMOR PANEL, A-PILLAR, DRIVER, M915
110-170148-001	ARMOR PLATE, FWD A-PILLAR
110-170140-002	KICK PANEL FRAME ASSY, PASSENGER
110-200705-000	ARMOR PANEL, A-PILLAR, PASSENGER, M915
110-170148-001	ARMOR PLATE, FWD A-PILLAR
110-170150-001	FIREWALL PANEL FRAME ASSY, DRIVER
110-200337-100	ARMOR PANEL, FIREWALL DRIVER, M915
110-170170-001	SUPPORT BRACE ASSY, FIREWALL FRAME
110-170160-001	FIREWALL FRAME ASSY, PASSENGER
110-200336-100	ARMOR PANEL, FIREWALL PASSENGER, M915
110-170170-001	SUPPORT BRACE ASSY, FIREWALL FRAME
110-170181-001	ARMOR PLATE, FRONT COWL
110-170182-001	ARMOR PLATE, INTAKE COVER
110-170185-001	BRACKET ASSY, COWL INTAKE COVER, RIGHT
110-170185-002	BRACKET ASSY, COWL INTAKE COVER, LEFT
110-170190-001	HOOD SUPPORT, M915A2-A3, DRIVER
110-170190-002	HOOD SUPPORT, M915A2-A3 PASSENGER
110-170191-001	MOUNTING BRACKET, M915A2-A3 HOOD SUPPORT
110-170200-001	WINDSHIELD ASSY, DRIVER
110-170200-002	WINDSHIELD ASSY, PASSENGER
110-170205-001	WINDSHIELD GLASS W/GASKET
110-170226-001	ARMOR PLATE, WINDSHIELD CENTER POST
110-170227-001	ARMOR PLATE, WINDSHIELD A-PILLAR POST
110-170228-001	ARMOR PLATE, WINDSHIELD EYEBROW
110-170229-001	ARMOR PLATE, WINDSHEILD-TO-COWL
110-170230-001	ADAPTER FRAME, STORAGE BOX



110-170240-001	FRAME ASSY, ROOF ARMOR
110-170245-001	PANEL DIVIDER ASSY, ROOF, ARMOR, DRIVER
110-170245-001	PANEL DIVIDER ASSY, ROOF ARMOR, PASSENGER
110-170248-001	CEILING HAND STRAP
110-170250-001	REAR ROOF EDGE FRAME ASSY
110-170255-001	SUPPORT ANGLE, CENTER ROOF PANEL
110-170256-001	MOUNTING BRACKET, ROOF-TO-DOOR FRAME
110-170260-001	SIDE ROOF EDGE FRAME ASSY, DRIVER
110-170260-002	SIDE ROOF EDGE FRAME ASSY, PASSENGER
110-170265-001	MOUNTING BRACKET, SIDE ROOF FRAME, DRIVER
110-170265-002	MOUNTING BRACKET, SIDE ROOF FRAME, PASSENGER
110-170275-001	FWD MOUNTING BRACKET, ROOF FRAME
110-200801-000	ARMOR PANEL, ROOF, MIDDLE, M915
110-200802-000	ARMOR PANEL, ROOF, DRIVER, M915
110-200803-000	ARMOR PANEL, ROOF, PASSENGER, M915
110-200804-000	ARMOR PANEL, ROOF, SEAM, DRIVER, M915
110-200805-000	ARMOR PANEL, ROOF REAR SEAM, M915
110-200806-000	ARMOR PANEL, ROOF SEAM, PASSENGER, M915
110-170310-001	MINEBLAST KIT, CAB, FLOOR, M915A2-A3
110-170311-001	BLAST DEFLECTOR, DRIVER FLOOR
110-170312-001	BLAST DEFLECTOR, CENTER FLOOR
110-170313-001	BLAST DEFLECTOR, PASSENGER FLOOR
110-170314-001	BRACKET ASSY, UNDERBODY BLAST DEFLECTOR
110-170316-001	STUD PLATE ASSY, UNDERBODY BLAST DEFLECTOR
110-170320-001	MNEBLAST KIT, DRIVER WHEELWELL, M915A2-A3
110-170321-001	BLAST DEFLECTOR, DRIVER WHEELWELL
110-170322-001	ENERGY ATTENUATOR, WHEELWELL
110-170323-001	FRONT BRACE, WHEELWELL DEFLECTOR, DRIVER
110-170324-001	REAR BRACE, WHEELWELL DEFLECTOR
110-170325-001	FRAME ASSY, WHEELWELL DEFLECTOR
110-170330-001	MINEBLAST KIT, PASSENGER WHEELWELL, M915A2-A3
110-170334-001	BLAST DEFLECTOR, PASSENGER WHEELWELL
110-170322-001	ENERGY ATTENUATOR, WHEELWELL
110-170323-002	FRONT BRACE, WHEELWELL DEFLECTOR, PASSENGER
110-170324-001	REAR BRACE, WHEELWELL DEFLECTOR
110-170325-001	FRAME ASSY, WHEELWELL DEFLECTOR
110-170340-001	HARDWARE KIT, M915A2/A3 ARMOR
110-170370-001	ALIGNMENT GUIDE, DOOR SUPPORT FRAME
110-170382-001	WASHER PLATE, REAR CAB FRAME MOUNTING
110-170390-001	BLAST DEFLECTOR EXTENSION KIT, DRIVER
110-170410-001	BLAST DEFLECTOR EXTENSION KIT, PASSENGER
110-170420-001	ARMOR ASSY, CENTERLINE FIREWALL
110-170430-001	BRACKET ASSY, CENTERLINE FIREWALL ARMOR
110-170435-001	BRACKET ASSY, AIR CLEANER QUICK-RELEASE
110-170440-001	M915 BALLISTIC REAR WINDOW EGRESS KIT









Installation Instructions  
M915 Upgrade Armor Kit  
V-1.0

M915 UPGRADE ARMOR KIT

## M915 UPGRADE ARMOR KIT INSTALLATION INSTRUCTIONS



7306 South Harl Avenue  
Tempe, AZ 85283  
480.517.1150 phone  
480.517.1154 fax  
[www.armorworks.com](http://www.armorworks.com)



## ***TSB 005 – Door Frame Reinforcement***

06 Dec 2005

The following procedure will strengthen the door frames to improve fit, function and durability.

### **REQUIRED TOOLS:**

Mild Steel Bar – .25" x 1" x 34.25"  
Bottle Jack  
Wood Block  
Welder  
Touch-up Paint

### **PROCEDURE:**

**NOTE:** Steel bars supplied by ArmorWorks will be painted, except for 1" on each end for welding. Bars from other sources should be pre-painted in the same manner before installation.

1. Open the door and place the bottle jack on the truck step, under the rear corner of the door frame as shown.
2. Jack up the rear corner of the door until the side of the cab starts to lift.
3. Weld the steel strap across the top of the lower door frame as shown. Be sure to weld both ends.
4. Touch-up the paint





## **TSB 006 - REAR CAB GRAB HANDLE ADAPTER PLATE**

20 Dec 2005

Adapter Plates are provided to allow re-installation of the OEM Grab Rails on the back of the cab.

### **REQUIRED TOOLS:**

1/2" Socket and Ratchet Driver  
4 Armor Brackets- P/N 110-170055-001

### **PROCEDURE:**

1. Install the Adapter Plates to the top and bottom studs on the Rear Armor Frame as shown.



2. Install the OEM Grab Rail with 5/16" flat washers and lock washers and hex nuts.





## **TSB 007 - CENTERLINE FIREWALL PROTECTION (Air filter) AND QUICK RELEASE SYSTEM FOR AIR FILTER**

20 Dec 2005

**WARNING: DISCONNECT ALL OUTLETS TO POWER BEFORE BEGINNING PROCEDURE.**

### **REQUIRED TOOLS:**

3/8" Ratchet Driver  
9/16" Socket and Wrench  
3/8" Drill Bit and Drill

### **PROCEDURE:**

1. Remove air filter housing.
2. Remove dryer mounting bracket bolts.
3. Remove passenger windshield wiper pivot bracket, bolts and nuts.  
\* Use caution when removing bolts to ensure that the studs do not fall into the engine compartment.
4. Use hat bracket to mark mounting hole location (place bracket on back of housing and slide until bend is met as shown with in the picture).

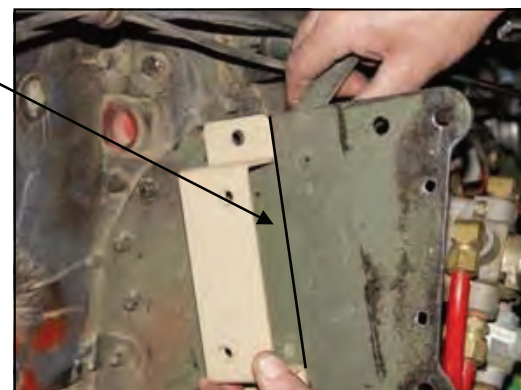





## **TSB 007 - CENTERLINE FIREWALL PROTECTION (Air filter) AND QUICK RELEASE SYSTEM FOR AIR FILTER (CONT)**

5. Mark holes and use 3/8" drill bit.



6. Mount with provided hardware

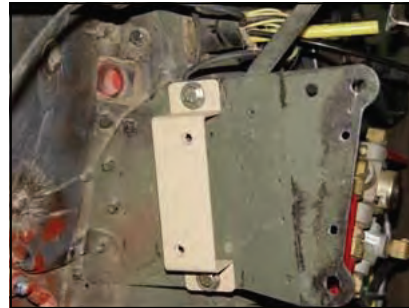

7. Bolt armor to driver side bracket.

8. Align drill 3/8" holes through armor and passenger side air filter housing bracket.

9. Bolt armor to passenger side bracket.

10. Remove 2" hose from air cleaner horn and replace with 6" hose.

11. Reinstall wiper and dryer brackets (If correctly installed armor will clear all power cables.)

12. Remove 4 bolts from Air filter Housing and replace with quick release pins.

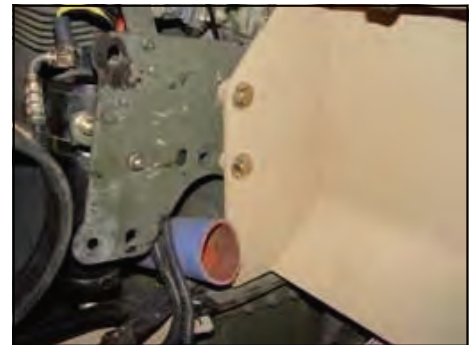



## TSB 008 - WHEEL WELL BLAST PROTECTION

20 Dec 2005

### REQUIRED TOOLS:

21/64" Drill Bit  
1/2" Socket and Wrench

### PROCEDURE:

1. Remove two front bolts from existing underbody mine blast armor panel and attach forward mounting plate.
2. Center nut plate on frame of firewall armor and mark and drill holes accordingly.
3. Install plate on inside of frame with provided hardware.
4. Align brackets and install to drilled holes.  
\*Ensure bracket does not interfere with steering column.

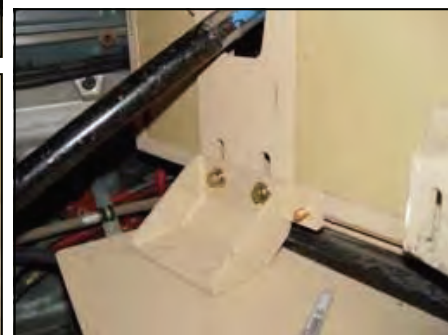





## ***TSB 008 - WHEEL WELL BLAST PROTECTION (CONT)***

5. Install washer bottle fill tube on stud attached to bracket installed in step 4.
6. Remove Hood Latch Bracket bolts and align new forward blast deflector bracket and re-attach hardware.
7. Attach flat bracket to underbody add on armor panel and attach to large forward bracket using provided hardware.

\*Repeat process for passenger side.





## **TSB 009 - DOOR ARMOR ANTI-VIBRATION DAMPENING CORD**

20 Dec 2005

### **REQUIRED TOOLS:**

Flat Head Screwdriver  
Silicon Caulking Gun

### **PROCEDURE:**

1. Place cord between door frame and armor to push armor outward as shown to the right.
2. Once armor is pushed outward remove the cord.



3. Every 3-4 inches apply a 3 inch strip of silicone as shown.



4. Push cord back in 1/2" to 1" on top of applied silicon around the entire door frame with a flat head screw driver.





## TSB 009 - DOOR ARMOR ANTI-VIBRATION DAMPENING CORD (CONT)

5. Caulk the entire frame to seal the cord.



6. Use provided Contact Cement to insert weather stripping on the surround of armor door frame.



Use provided contact cement and roller and apply to weather stripping.



Door latch side should have stripping applied with bulb on outside.



Hinge side should have stripping applied with bulb on inside.

7. Let weather stripping dry for at least 15 minutes.





## TSB 0010 - REAR CAB ARMOR

20 Dec 2005

### REQUIRED TOOLS:

Welder  
Touchup Paint

### PROCEDURE:

1. Move BI box from rear of cab.

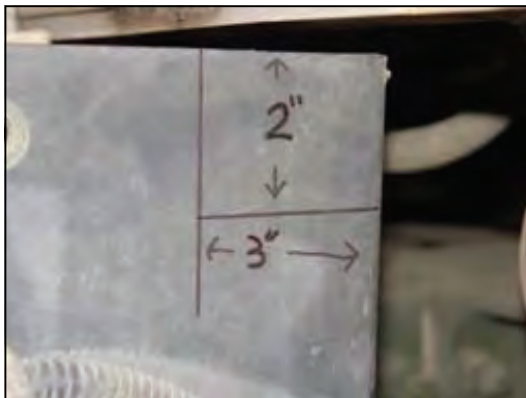

2. Cut original BI box frame as shown above.



3. Weld P/N 110-170048-001 to corner of rear cab armor frame.
4. Weld P/N 110-170039-001 to rear back cab as shown in picture above.
  - Repeat this process for passenger side.
5. Move BI box back onto to the rear of the cab.



## TSB 0011 - Heavy-Duty Door Cam Latch Assembly

20 Dec 2005

### REQUIRED TOOLS:

Welder  
5/16" Drill Bit and Drill  
1/2" Wrench and Ratchet  
7/16" Ratchet  
Phillips Head Screwdriver  
Touchup Paint  
Sawzall or Metal Cutting Wheel

### PROCEDURE:

1. Cut two "V" grooves and two rectangular cuts in door frame as shown.
2. Weld in Angle Guides P/N 110-170361-001
3. Weld Door Cam Latch Assembly P/N 110-170360-001/2 to armor door frame (001 is driver side 002 is passenger).

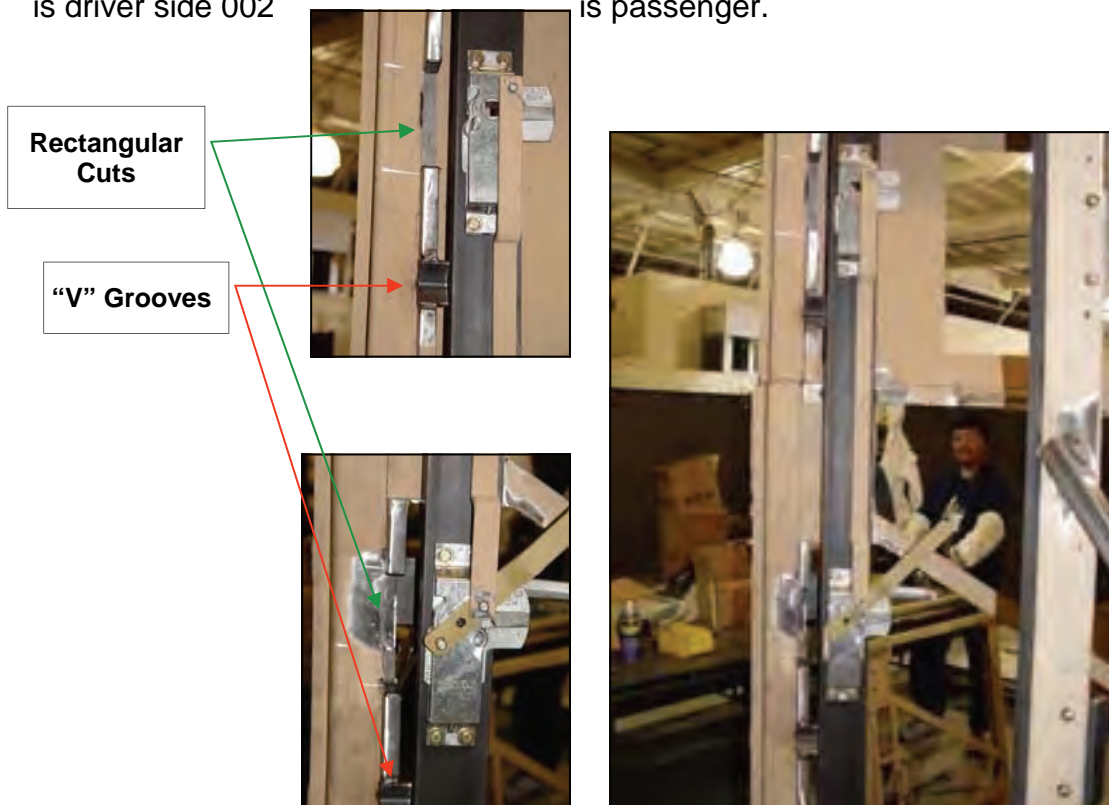



## ***TSB 0011 - Heavy-Duty Door Cam Latch Assembly (CONT)***

4. Using existing bolt and drilled bolts attach Cam Engagement Angles P/N 110-170364-001 to armor frame as shown.
5. Install Angle Alignment Guides P/N 110-170370-001 to armor frame.
6. Adjust and test door.







## ***TSB 011 – Door Cam Latch Installation - 20 DEC 2005***

The new dual cam latch will reduce door vibration, improve door durability, and significantly reduce cab noise.

### **REQUIRED TOOLS:**

- Welder
- 5/16" Drill Bit and Drill
- 7/16" Wrench & Socket
- 1/2" Wrench & Socket
- Phillips Screwdriver
- Touch-up Paint
- Sawzall & Metal Cutoff Wheel



### **PROCEDURE:**

**NOTE:** Be sure that TSB 006 and TSB 009 have been completed before proceeding.

1. Remove the original latch mechanism and outside door handle.
2. Remove the Combat Lock frame by cutting it off at the three locations shown in the pictures. Place a thin metal sheet behind the frame to protect the armor panel when cutting.
3. Mark the two rectangular frame cutouts and the centers of the "V" notches on the door frame per drawing on the next page.





## ***TSB 011 – Door Cam Latch Installation (Continued)***

4. Now that the centers of the “V” notches have been located, mark the cutouts by tracing the Alignment Angles, PN 110-170361-001. Hold the part flush to the inside surface of the door frame by holding it against a flat plate as shown.
5. Cutout the four rectangular and “V” notches using the Sawzall and cutoff wheel.





## ***TSB 011 – Door Cam Latch Installation (Continued)***

6. Weld in the two Alignment Angles, PN 110-170361-001, flush to the rear edge of the door frame as shown.







## ***TSB 011 – Door Cam Latch Installation (Continued)***

7. Weld on the Cam Latch Channel Assembly, PN 110-170360-001 (driver door) or PN 110-170360-002 (passenger door). Slide it all the way back against the Alignment Angles and up until it the center notches hit the frame where indicated.





## ***TSB 011 – Door Cam Latch Installation (Continued)***

8. Drill a 5/16" hole through one wall of the bottom frame tube approximately where shown to provide a drain for any water that may get into the cut frame.
9. Touch-up the paint on the door frame.





## ***TSB 011 – Door Cam Latch Installation (Continued)***

10. Install the new, heavy duty outside door handle.

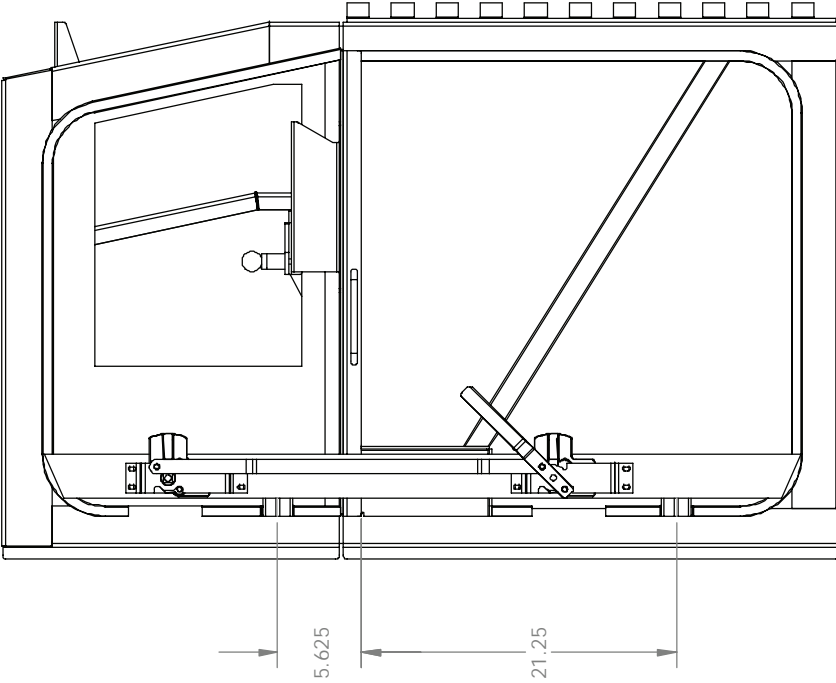

ANGLE NOTCH CENTERS

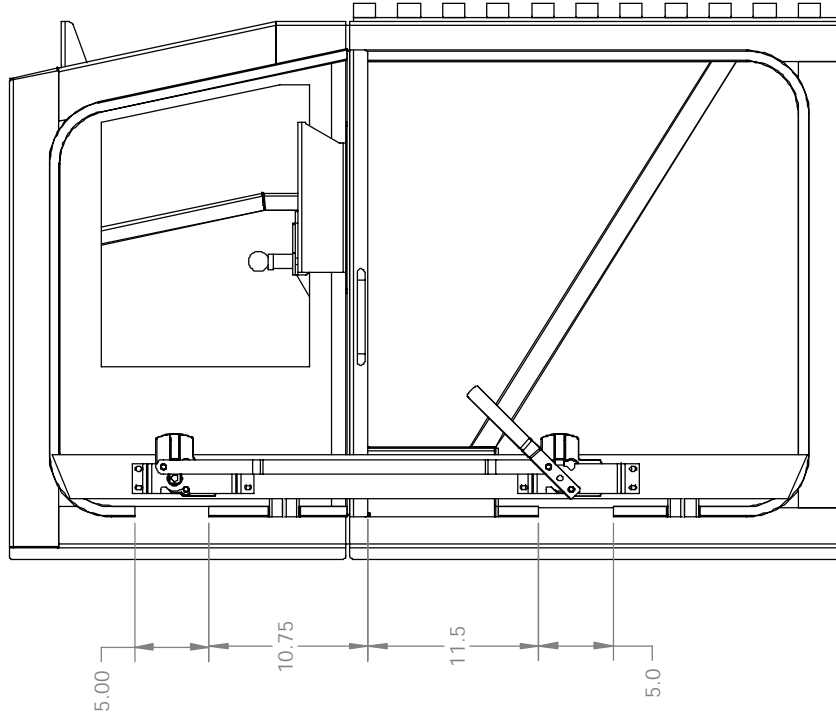

RECTANGULAR FRAME CUTOUTS



## TSB 0012 - LATCH PIN RETENTION

6 Feb 2006

This bulletin modifies the door Cam Latches to ensure permanent retention of the linkage pins.

### REQUIRED TOOLS:

1/8" Drill Bit and Drill  
1/8" x 3/4" Roll Pin  
Hammer  
Welder (Option 2 Only)

### PROCEDURE:

#### OPTION 1:

- 1.) Drill a 1/8" hole through the latch and pin, 3/4" deep, as shown.
- 2.) Install the Roll Pin to ensure permanent retention of the Latch Pin.
- 3.) Repeat for 2nd Pin.

#### OPTION 2:

- 1.) Fillet Weld around the base of both pins.











**ArmorWorks**

Installation Instructions  
M915 A2/A3  
Emergency Egress

## M915 A2/A3 EMERGENCY EGRESS INSTALLATION INSTRUCTIONS

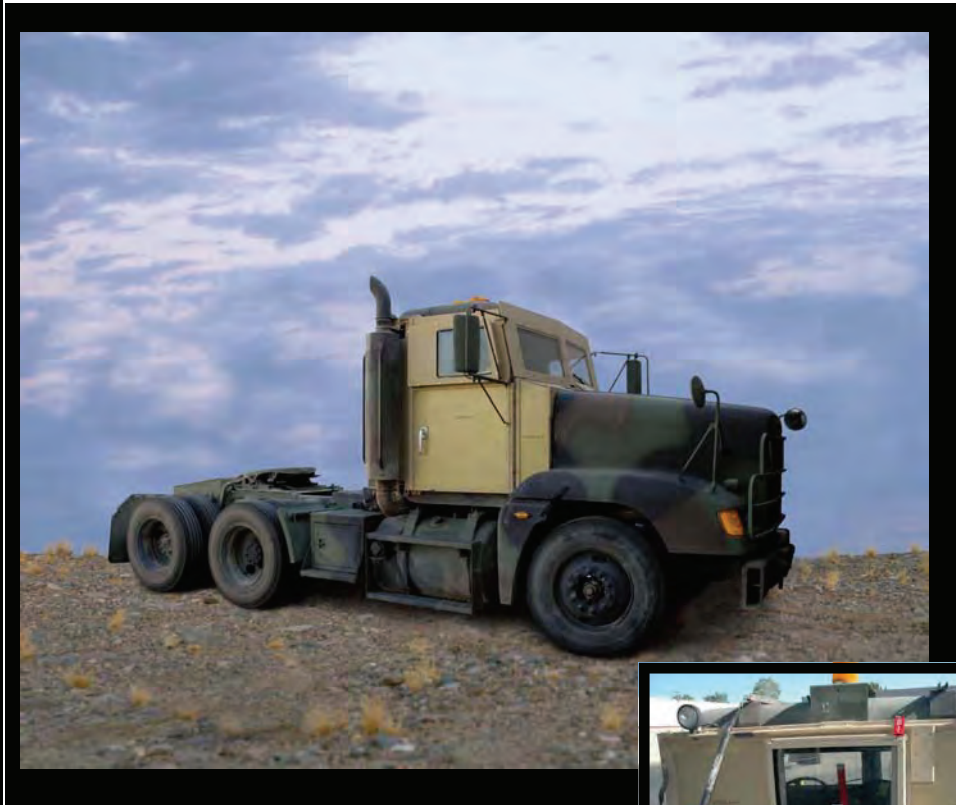

**ArmorWorks**

7306 South Harl Avenue  
Tempe, AZ 85283  
480.517.1150 phone  
480.517.1154 fax  
[www.armorworks.com](http://www.armorworks.com)

# PACKING LIST

PART NUMBER	DESCRIPTION	QTY
110-170440-001	M915 BALLISTIC REAR WINDOW EGRESS KIT	1
110-170445-001	BALLISTIC WINDOW, M915 REAR EGRESS	1
110-170448-001	COVER, EGRESS WINDOW FRAME	1
110-170450-001	WINDOW FRAME ASSY, REAR EGRESS	1
110-170460-001	MOUNTING FRAME ASSY, REAR EGRESS WINDOW	1
110-170485-001	V-GUIDE ASSY, REAR EGRESS WINDOW	1
110-170490-001	NUT PLATE ASSY , REAR EGRESS MOUNTING CLAMP	1
110-100045-001	CLAMP, BEDSIDE ARMOR PANEL	1
110-170495-001	HARDWARE KIT, REAR WINDOW EGRESS KIT	1

# HARDWARE KIT

ITEM	DESCRIPTION	QTY
<b>1</b>	<b>1/4-20 x 3/4 GRADE 8 HEX BOLT</b>	<b>6</b>
<b>2</b>	<b>5/16-18 x 3/4 GRADE 8 HEX BOLT</b>	<b>4</b>
<b>3</b>	<b>5/16-18 x 1 GRADE 8 HEX BOLT</b>	<b>2</b>
<b>4</b>	<b>5/16-18 x 2 (FULL THREAD) GRADE 8 HEX BOLT</b>	<b>2</b>
<b>5</b>	<b>1/4 USS HARDENED FLAT WASHER</b>	<b>6</b>
<b>6</b>	<b>5/16 USS HARDENED FLAT WASHER</b>	<b>8</b>
<b>7</b>	<b>1/4 HEAVY-DUTY SPLIT LOCK WASHER</b>	<b>6</b>
<b>8</b>	<b>5/16 HEAVY-DUTY SPLIT LOCK WASHER</b>	<b>6</b>
<b>9</b>	<b>5/16-18 GRADE 8 HEX NUT</b>	<b>2</b>
<b>10</b>	<b>RUBBER BUMPER</b>	<b>2</b>

# REQUIRED TOOLS

3/8" Wrench
9/16 Wrench
3/4" Wrench
7/16" Wrench
5/16" Wrench
1/2" Wrench
9/16" Wrench
9/16" Socket with Ratchet Driver
3/8" Drill Bit and Drill



1. Remove P/N 110-170034-001. Use a hammer to tap piece out if fit is tight.
2. Remove the existing top armor panel from the center position of the rear cab armor frame as shown.  
**Note: Use 2 man lift technique to remove panel**
3. Remove the Velcro straps and webbing and discard.



4. Cut out the drill template on the last page of the manual.
5. Align the template on the top bar of the rear cab frame as shown and mark the holes.



6. Drill 3/8" holes where marked.

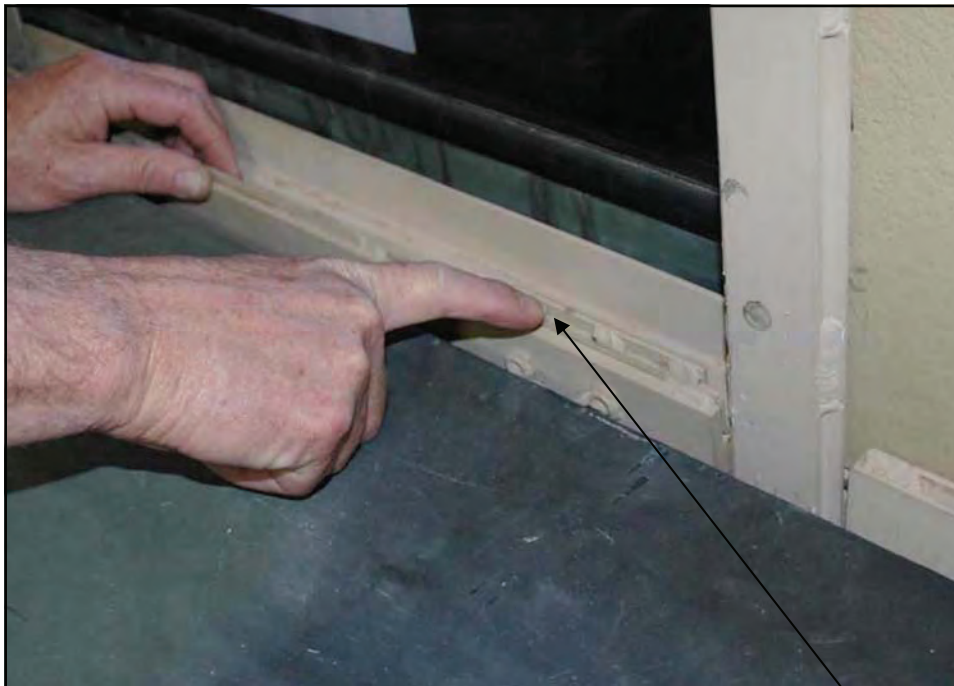

7. Cut off welded spacer plates on the inside of the panel divider channel.





8. Reinstall P/N 110-170034-001

9. Insert the Mounting Frame Assembly. Be sure one Exit Strap is on the Outside and one is on the Inside of the frame



10. Insert the Nut Plate as shown, aligning the threads with the holes drilled earlier.



11. Install the Armor Clamp as shown. Secure with 5/16-18 x 1 bolts, flat washers and lock washers.



12. Install V-Guide Assembly at the bottom of the frame as shown, using 1/4-20 x 3/4 bolts, flat washers and lock washers. Only finger tighten for later adjustment.



13. Install the two Rubber Bumpers in the holes in the Window Frame as shown.



14. Slide the Window Frame over the glass as shown. The glass is NOT square, so be sure that it is positioned to where it fits tightly between the channels of the frame.

**Note that the threat side of the glass faces opposite the hinge.**





15. Flip the Window and Frame Assembly over and install the Frame Cover as shown. Secure with 1/4-20 x 3/4 bolts, flat washers and lock washers.



16. Lift the Window Assembly in place aligning the slots in the hinge with the holes in the Mounting Frame.  
**\*NOTE: THIS IS A TWO MAN LIFT**



17. Install the Window Assembly using 5/16-18 x 3/4 bolts, flat washers and lock washers as shown.



18. Install the frame adjustment hardware - 5/16-18 x 2 bolts, hex jam nut and washer - above and below the hinge as shown. Tighten the bolts to reinforce the Mounting Frame within the channel. Tighten the jam nuts to prevent loosening.





19. Adjust the V-Guide Assembly up or down to engage rod on the back of hinged window frame.
20. Close the Window by pulling up on the Red Exit Strap, pushing the Window closed and releasing the strap. **NOTE: The latch must be manually operated to close the Window. Do not attempt to slam the Window closed.**



# EGRESS WINDOW OPERATION



**FROM OUTSIDE:** Pull up on the Red Exit Strap to unlatch and open the Window. Push the Polycarbonate Cab Window inward to gain access to the cab.

**FROM INSIDE:** Remove the Polycarbonate Cab Window by pulling on the Red Exit Strap. Pull up on the lower Red Exit Strap on the Egress Mounting Frame to unlatch and open the Window.

# DRILL TEMPLATE



DRILL TEMPLATE

**SCOPE**

This RPSTL lists and authorizes spares and repair parts for performance of Unit level maintenance of the M915A3P1, M916A2P1, M916A3P1, M917A2P1, M915A4P1, M917A1P1, M916A1P1, and M916A2P1 Crew Protection Kit. It authorizes the requisitioning, issue, and disposition of spares and repair parts as indicated by the source, maintenance, and recoverability (SMR) codes.

**GENERAL**

In addition to the Introduction work package, this RPSTL is divided into the following work packages:

- a. **Repair Parts Lists Work Package.** Work package containing lists of spares and repair parts authorized by this RPSTL for use in the performance of maintenance. This work package also includes parts which must be removed for replacement of the authorized parts. Parts lists are composed of a single functional group in ascending numeric sequence, with the parts in each figure listed in ascending item number sequence. Repair parts kits are listed separately in their own functional group. Items listed are shown on the associated illustrations.
- b. **Special Tools List Work Package.** There are no special tools for the M915A3P1, M916A2P1, M916A3P1, M917A2P1, M915A4P1, M917A1P1, M916A1P1, and M916A2P1 Crew Protection Kit.
- c. **Cross-Reference Indexes Work Package.** There are two cross-reference indexes in this RPSTL: National Stock Number Index and Part Number Index.

**EXPLANATION OF COLUMNS IN THE REPAIR PARTS LISTS**

- a. **Item No. (Column 1).** Indicates the number used to identify items called out in the illustration.
- b. **SMR Code (Column 2).** The SMR code containing supply/requisitioning information, maintenance level authorization criteria, and disposition instruction, as shown in the following breakout:

SOURCE CODE	MAINTENANCE CODE		RECOVERABILITY CODE
XXxxx	xxXXx		xxxxX
1st two positions	3rd position	4th position	5th position
How you get an item.	Who can install, replace, or use the item.	Who can do complete repair* on the item.	Who determines disposition action on an unserviceable item.

\* *Complete Repair:* Maintenance capacity, capability, and authority to perform all corrective maintenance tasks of the "Repair" function in a use/user environment in order to restore serviceability to a failed item.

**EXPLANATION OF COLUMNS IN THE REPAIR PARTS LISTS - CONTINUED**

- (1) **Source Code.** The source code tells you how to get an item needed for maintenance, repair, or overhaul of an end item/equipment. Explanations of source codes follow:

<u>Code</u>	<u>Application/Explanation</u>
PA PB PC PD PE PF PG	Stocked items; use the applicable NSN to request/requisition items with these source codes. They are authorized to the maintenance category indicated by the code entered in the third position of the SMR code.  <i>Items coded PC are subject to deterioration.</i> .....
KD KF KB	Items with these codes are not to be requested/requisitioned individually. They are part of a kit which is authorized to the maintenance level indicated in the third position of the SMR code. The complete kit must be requisitioned and applied. .....
MO - Made at Unit/ AVUM level MF - Made at DS/AVIM Level MH - Made at GS Level ML - Made at SRA MD - Made at Depot	Items with these codes are not to be requested/requisitioned individually. They must be made from bulk materiel which is identified by the part number in the DESCRIPTION AND USABLE ON CODE (UOC) column and listed in the bulk materiel group work package of the RPSTL. If the item is authorized to you by the third position of the SMR code, but the source code indicates it is made at a higher level, order the item from the higher level of maintenance. .....
AO-Assembled by Unit/ AVUM level AF-Assembled by DS/ AVIM level AH-Assembled by GS level AL-Assembled by SRA AD-Assembled by Depot	Items with these codes are not to be requested/requisitioned individually. The parts that make up the assembled item must be requisitioned or fabricated and assembled at the level of maintenance indicated by the source code. If the third position of the SMR code authorizes you to replace the item, but the source code indicates the item is assembled at a higher level, order the item from the higher level of maintenance.
XA	DO NOT requisition an "XA" coded item. Order the next higher assembly. (Refer to NOTE below).
XB	If an item is not available from salvage, order it using the CAGEC and P/N.
XC	Installation drawings, diagrams, instruction sheets, field service drawings; identified by manufacturer's P/N.
XD	Item is not stocked. Order an XD-coded item through normal supply channels using the CAGEC and P/N given, if no NSN is available.

**NOTE**

Cannibalization of controlled exchange, when authorized, may be used as a source of supply for items with the above source codes, except for those source coded "XA" or those aircraft support items restricted by requirements of AR 750-1.

**EXPLANATION OF COLUMNS IN THE REPAIR PARTS LISTS - CONTINUED**

(2) **Maintenance Code.** Maintenance codes tell you the level(s) of maintenance authorized to use and repair support items. The maintenance codes are entered in the third and fourth positions of the SMR code as follows:

(a) **Third Position.** The maintenance code entered in the third position tells you the lowest maintenance level authorized to remove, replace, and use an item. The maintenance code entered in the third position will indicate authorization to one of the following levels of maintenance:

<u>Code</u>	<u>Application/Explanation</u>
C . . . . .	Crew or Operator maintenance done within Field/AVUM maintenance.
O . . . . .	Unit Level/AVUM maintenance can remove, replace, and use the item.
F . . . . .	Direct Support/AVIM maintenance can remove, replace, and use the item.
H . . . . .	General Support maintenance can remove, replace, and use the item.
L . . . . .	Specialized Repair Activity (SRA) can remove, replace, and use the item.
D . . . . .	Depot Maintenance can remove, replace, and use the item.

(b) **Fourth Position.** The maintenance code entered in the fourth position tells you whether or not the item is to be repaired and identifies the lowest maintenance level with the capability to do complete repair (perform all authorized repair functions).

**NOTE**

Some limited repair may be done on the item at a lower level of maintenance, if authorized by the Maintenance Allocation Chart (MAC) and SMR codes.

<u>Code</u>	<u>Application/Explanation</u>
O . . . . .	Unit/AVUM is the lowest level that can do complete repair of the item.
F . . . . .	Direct Support/AVIM is the lowest level that can do complete repair of the item.
H . . . . .	General Support is the lowest level that can do complete repair of the item.
L . . . . .	Specialized Repair Activity (SRA) is the lowest level that can do complete repair of the item.
D . . . . .	Depot is the lowest level that can do complete repair of the item.
Z . . . . .	Nonrepairable. No repair is authorized.
B . . . . .	No repair is authorized. No parts or special tools are authorized for the maintenance of a "B"-coded item. However, the item may be reconditioned by adjusting, lubricating, etc., at the user level.

**EXPLANATION OF COLUMNS IN THE REPAIR PARTS LISTS - CONTINUED**

- (3) **Recoverability Code.** Recoverability codes are assigned to items to indicate the disposition action on unserviceable items. The recoverability code is entered in the fifth position of the SMR code as follows:

<u>Code</u>	<u>Application/Explanation</u>
Z . . . . .	Nonrepairable item. When unserviceable, condemn and dispose of the item at the level of maintenance shown in the third position of the SMR code.
O . . . . .	Reparable item. When uneconomically repairable, condemn and dispose of the item at the Unit level maintenance.
F . . . . .	Reparable item. When uneconomically repairable, condemn and dispose of the item at Direct Support level.
H . . . . .	Reparable item. When uneconomically repairable, condemn and dispose of the item at General Support level.
D . . . . .	Reparable item. When beyond lower level repair capability, return to depot. Condemnation and disposal of item are not authorized below depot level.
L . . . . .	Reparable item. Condemnation and disposal of item not authorized below Specialized Repair Activity (SRA).
A . . . . .	Item requires special handling or condemnation procedures because of specific reasons (e.g., precious metal content, high dollar value, critical material, or hazardous material). Refer to appropriate manuals/directives for specific instructions.

- c. **NSN - (Column 3).** The NSN for the item is listed in this column.
- d. **CAGEC (Column 4).** The Commercial and Government Entity Code (CAGEC) is a five-digit code which is used to identify the manufacturer, distributor, or Government agency/activity that supplies the item.
- e. **PART NUMBER (Column 5).** Indicates the primary number used by the manufacturer (individual, company, firm, corporation, or Government activity), which controls the design and characteristics of the item by means of its engineering drawings, specifications, standards, and inspection requirements to identify an item or range of items.

**NOTE**

When you use an NSN to requisition an item, the item you receive may have a different part number from the part ordered.

- f. **DESCRIPTION AND USABLE ON CODE (UOC) (Column 6).** This column includes the following information:
  - (1) The Federal item name and, when required, a minimum description to identify the item.
  - (2) P/Ns of bulk materials are referenced in this column in the line entry to be manufactured or fabricated.
  - (3) Hardness Critical Item (HCI). A support item that provides the equipment with special protection from electromagnetic pulse (EMP) damage during a nuclear attack.
  - (4) The statement END OF FIGURE appears just below the last item description in column (6) for a given figure in both the repair parts list and special tools list work packages.

**EXPLANATION OF COLUMNS IN THE REPAIR PARTS LISTS - CONTINUED**

- g. **QTY (Column 7).** The QTY (quantity per figure) column indicates the quantity of the item used in the breakout shown on the illustration/figure, which is prepared for a functional group, subfunctional group, group or an assembly. A “V” appearing in this column in lieu of a quantity indicates that the quantity is variable and the quantity may vary from application to application.

**EXPLANATION OF CROSS-REFERENCE INDEXES WORK PACKAGE FORMAT AND COLUMNS**

- a. **National Stock Number (NSN) Index Work Package.**
  - (1) **STOCK NUMBER Column.** This column lists the NSN by National Item Identification Number (NIIN) sequence. The NIIN consists of the last nine digits of the NSN (i.e., NSN 5305-01-674-1467). When using this column to locate an item, ignore the first four digits of the NSN. However, the complete NSN should be used when ordering items by stock number.
  - (2) **FIG. Column.** This column lists the number of the figure where the item is identified/located. The figures are in numerical order in WP 0042 00.
  - (3) **ITEM Column.** The item number identifies the item associated with the figure listed in the adjacent FIG. column. This item is also identified by the NSN listed on the same line.
- b. **Part Number (P/N) Index Work Package.** Part numbers in this index are listed in ascending alphanumeric sequence (i.e., vertical arrangement of letter and number combination which places the first letter or digit of each group in order A through Z, followed by the numbers 0 through 9 and each following letter or digit in like order).
  - (1) **PART NUMBER Column.** Indicates the P/N assigned to the item.
  - (2) **FIG. Column.** This column lists the number of the figure where the item is identified/located in the repair parts list and special tools list work packages.
  - (3) **ITEM Column.** The item number is the number assigned to the item as it appears in the figure referenced in the adjacent figure number column.

**SPECIAL INFORMATION**

- a. **Usable On Code (UOC).** The UOC appears in the lower left corner of the DESCRIPTION column heading. Usable on codes are shown as “UOC:” in the Description Column (justified left) on the first line under the applicable item/nomenclature. Uncoded items are applicable to all models. Identification of the UOC’s used in the RPSTL are:

<u>Code</u>	<u>Used On</u>
5BK	M915A3P1, M916A2P1, M916A3P1, M917A2P1, M915A4P1, M917A1P1, M916A1P1, and M915A2P1

- b. **Associated Publications.** The publication(s) listed below pertain to the M915A3P1, M916A2P1, M916A3P1, M917A2P1, M915A4P1, M917A1P1 and M916A1P1 and its components:

<b>Publication</b>	<b>Short Title</b>
TM 9-2320-302 Series . . . . .	Series of Manuals for the M915A3P1, M916A3P1, and M917A2P1
TM 9-2320-303 Series . . . . .	Series of Manuals for the M915A4P1
TM 9-2320-363 Series . . . . .	Series of Manuals for the M915A2P1, M916A1P1, M916A2P1 and M917A1P1



**HOW TO LOCATE REPAIR PARTS**

a. **When National Stock Number is Known.**

- (1) **First.** If you have the NSN, look in the STOCK NUMBER column of the NSN index work package. The NSN is arranged in NIIN sequence. Note the figure and item number next to the NSN.
- (2) **Second.** Turn to the figure and locate the item number. Verify that the item is the one you are looking for.

b. **When Part Number is Known.**

- (1) **First.** If you have the P/N and not the NSN, look in the PART NUMBER column of the P/N index work package. Identify the figure and item number.
- (2) **Second.** Look up the item on the figure in the applicable repair parts list work package.

**ABBREVIATIONS**

For standard abbreviations see ASME Y14.38-1999, *Abbreviations and Acronyms*.

<b><u>Abbreviations</u></b>	<b><u>Explanation</u></b>
NIIN .....	National Item Identification Number (consists of the last 9 digits of the NSN)
RPSTL .....	Repair Parts and Special Tools Lists
SMR .....	Source, Maintenance, and Recoverability Code
TMDE .....	Test, Measurement, and Diagnostic Equipment
THK .....	Thickness

**END OF WORK PACKAGE**



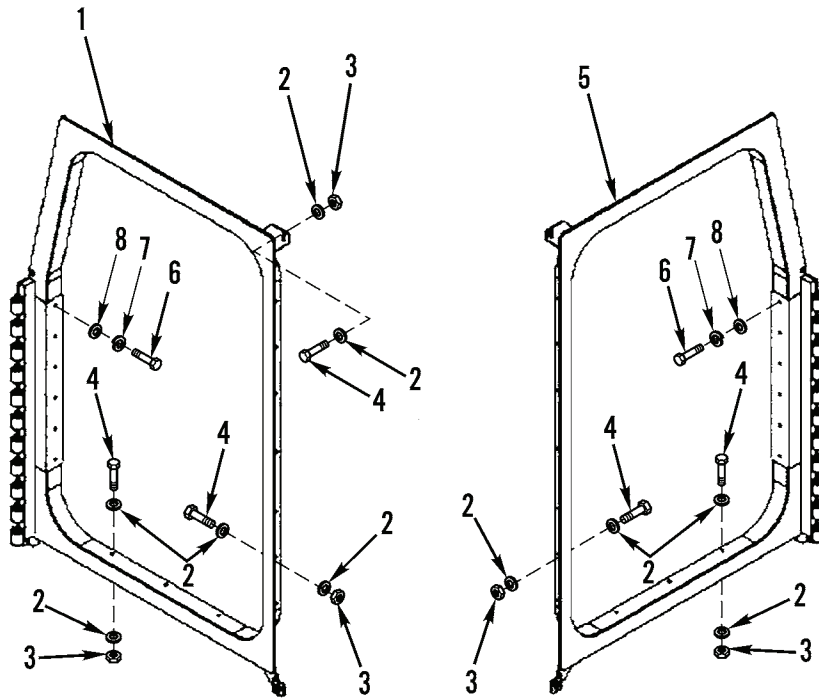

Figure 1. Door Support Frames

(1) ITEM NO	(2) SMR CODE	(3) NSN	(4) CAGEC	(5) PART NUMBER	(6) DESCRIPTION AND USABLE ON CODES(UOC)	(7) QTY
GROUP 33 SPECIAL PURPOSE KITS						
GROUP 3307 SPECIAL PURPOSE KITS						
FIG. 1 DOOR SUPPORT FRAMES						
1	PAOZZ	5340015507540	3KHA7	110-170060-001	DOOR SUPPORT FRAME, LEFT SIDE.....	1
2	PFOZZ	5310000814219	96906	MS27183-12	WASHER,FLAT 5/16 USS HARDENED FLAT WASHER.....	48
3	PFOZZ	5310015313929	81349	M45913/2-5CG8Z	NUT,SELF-LOCKING,HE 5/16-18, GRADE 8 ALL-METAL LOCKNUT.....	24
4	PFOZZ	5306002264829	80204	B1821BH031C125N	BOLT,MACHINE 5/16-18 X 1-1/4, GRADE 8 HEX BOLT.....	24
5	PAOZZ	2510015499881	3KHA7	110-170060-002	DOOR SUPPORT FRAME, RIGHT SIDE.....	1
6	PFOZZ	5305000712509	80204	B1821BH025C150N	SCREW,CAP,HEXAGON H 1/4-20 X 1-1/2, GRADE 8 HEX BOLT.....	12
7	PFOZZ	5310008238804	96906	MS27183-9	WASHER,FLAT 1/4 USS HARDENED FLAT WASHER.....	12
8	PFOZZ	5310005825965	80205	MS35338-44	WASHER,LOCK 1/4 HEAVY-DUTY SPLIT LOCKWASHER.....	12

END OF FIGURE

1  
2 THRU 12

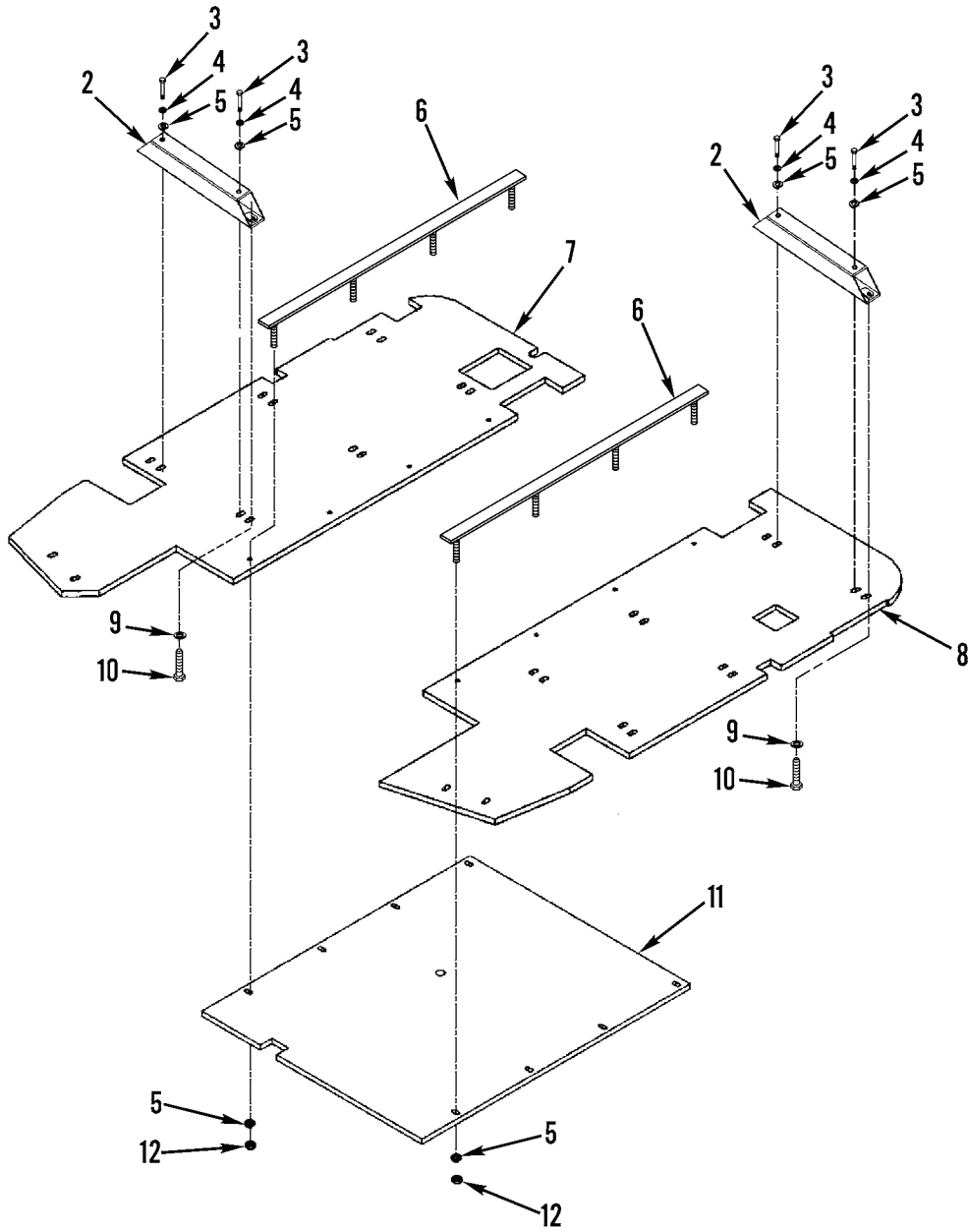

Figure 2. Underbody Mineblast Panels

(1) ITEM NO	(2) SMR CODE	(3) NSN	(4) CAGEC	(5) PART NUMBER	(6) DESCRIPTION AND USABLE ON CODES(UOC)	(7) QTY
GROUP 3307 SPECIAL PURPOSE KITS						
FIG. 2 UNDERBODY MINEBLAST PANELS						
1	PAOOO	2540015500857	3KHA7	110-170310-001	MINEBLAST KIT, CAB.....	1
2	PAOZZ	2590015500860	3KHA7	110-170314-001	.BRACKET ASSY, UNDER.....	6
3	PFOZZ	5305002264831	80204	B1821BH031C150N	.SCREW,CAP,HEXAGON H 5/16-18 X 1-1/2, GRADE 8 HEX BOLT.....	12
4	PFOZZ	5310004079566	80205	MS35338-45	.WASHER,LOCK 5/16 HEAVY-DUTY SPLIT LOCKWASHER.....	32
5	PFOZZ	5310000806004	96906	MS27183-14	.WASHER,FLAT 3/8 USS HARDENED FLAT WASHER.....	20
6	PAOZZ	2590015500992	3KHA7	110-170316-001	.STUD PLATE ASSY, UN.....	2
7	PAOZZ	2540015501139	3KHA7	110-170313-001	.BLAST DEFLECTOR, PA BLAST DEFLECTOR, FLOOR, RIGHT SIDE.....	1
8	PAOZZ	2510015500934	3KHA7	110-170311-001	.BLAST DEFLECTOR, DR BLAST DEFLECTOR, FLOOR, LEFT SIDE.....	1
9	PFOZZ	5310000814219	96906	MS27183-12	.WASHER,FLAT 5/16 USS HARDENED FLAT WASHER.....	12
10	PFOZZ	5306002264827	80204	B1821BH031C100N	.BOLT,MACHINE 5/16-18 X 1, GRADE 8 HEX BOLT.....	12
11	PAOZZ	2540015501134	3KHA7	110-170312-001	.BLAST DEFLECTOR, CE BLAST DEFLECTOR, CENTER, FLOOR.....	1
12	PFOZZ	5310008807744	96906	MS51967-5	.NUT,PLAIN,HEXAGON 5/16-18, GRADE 8 HEX NUT.....	8

END OF FIGURE

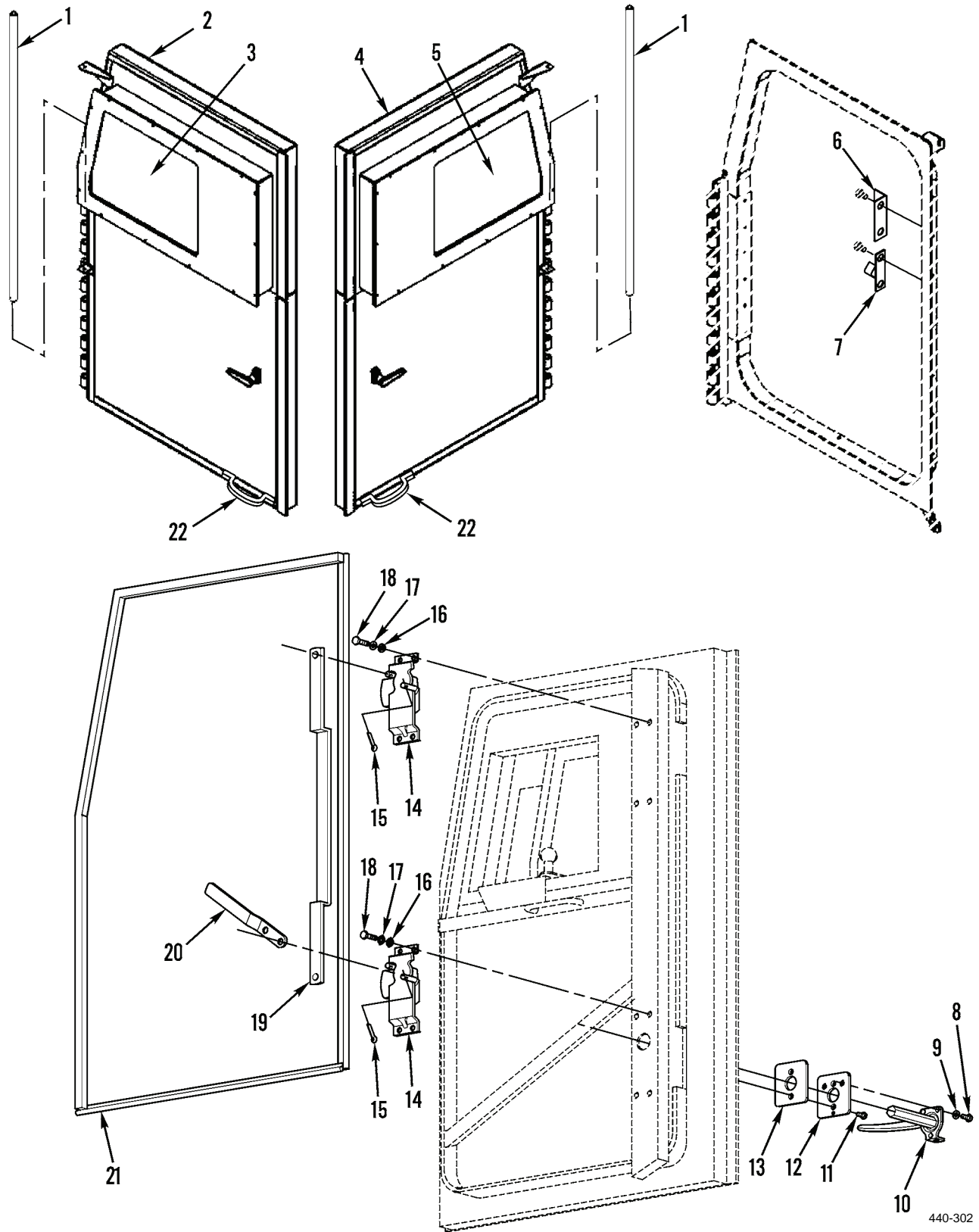

Figure 3. Armored Doors and Door Cam Latch



(1) ITEM NO	(2) SMR CODE	(3) NSN	(4) CAGEC	(5) PART NUMBER	(6) DESCRIPTION AND USABLE ON CODES(UOC)	(7) QTY
GROUP 3307 SPECIAL PURPOSE KITS						
FIG. 3 ARMORED DOORS AND DOOR CAM LATCH						
1	PAOZZ	5315015503808	3KHA7	110-170135-001	HINGE PIN, M915A2-A.....	2
2	PAOZZ	2510015500866	3KHA7	110-170085-001	DOOR ASSY, DRIVER LEFT SIDE.....	1
3	PAOZZ	2540015438448	3KHA7	110-170121-001	ARMOR SET,SUPPLEMEN LEFT DOOR BALLISTIC GLASS WITH GASKET.....	1
4	PAOZZ	2510015499719	3KHA7	110-170085-002	DOOR ASSY, PASSENGE RIGHT SIDE.....	1
5	PAOZZ	2540015438450	3KHA7	110-170121-002	ARMOR SET,SUPPLEMEN RIGHT DOOR BALLISTIC GLASS W/ GASKET.....	1
6	PAOZZ	5340015505380	3KHA7	110-170364-001	ANGLE,CAM LATCH ENG.....	4
7	PAOZZ	5340015507543	3KHA7	110-170370-001	ALIGNMENT GUIDE, DO.....	4
8	PFOZZ	5306002258499	80205	MS90725-34	BOLT,MACHINE GR 8, 5/16" X 1".....	6
9	PFOZZ	5310000814219	96906	MS27183-12	WASHER,FLAT GR 8, 5/16" ID.....	6
10	PAOZZ	2540015501217	3KHA7	5624-52-ZN	OUTSIDE DOOR HANDLE DOOR HANDLE, EXTERIOR.....	2
11	PFOZZ	5306002264833	80204	B1821BH031C200N	BOLT,MACHINE GR 8, 5/16" X 2".....	4
12	PAOZZ	5340015507549	3KHA7	110-170367-001	ESCUTCHEON PLATE,OU ESCUTCHEON PLATE, EXTERIOR DOOR HANDLE.....	2
13	PAOZZ	5310015499043	3KHA7	110-170368-001	NUT PLATE,INSIDE DO NUT PLATE, INTERIOR HANDLE.....	2
14	PAOZZ	2540015500183	3KHA7	7011-C	SINGLE POINT CAM LA.....	4
15	PFOZZ	5315008395822	80205	MS24665-353	PIN,COTTER 1/8" X 1".....	6
16	PFOZZ	5310000045033	80205	MS35338-46	WASHER,LOCK 3/8" ID, GR8.....	16
17	PFOZZ	5310000806004	96906	MS27183-14	WASHER,FLAT 3/8" ID, GR 8.....	16
18	PFOZZ	5305002693211	80205	MS90725-60	SCREW,CAP,HEXAGON H 3/8" X 1", GR 8	16
19	PAOZZ	3040015501250	3KHA7	110-170365-001	LINKAGE BAR,CAM LAT.....	2
20	PAOZZ	2540015499711	3KHA7	110-170366-001	INSIDE DOOR HANDLE INTERIOR DOOR HANDLE.....	2
21	PFOZZ	5330015505379	3KHA7	110-170369-001	RUBBER CORD, VIBRAT.....	2
22	PAOZZ	5340015499056	3KHA7	110-105119-001	HANDLE,DOOR PULL EXTERIOR PULL HANDLE.....	2

END OF FIGURE

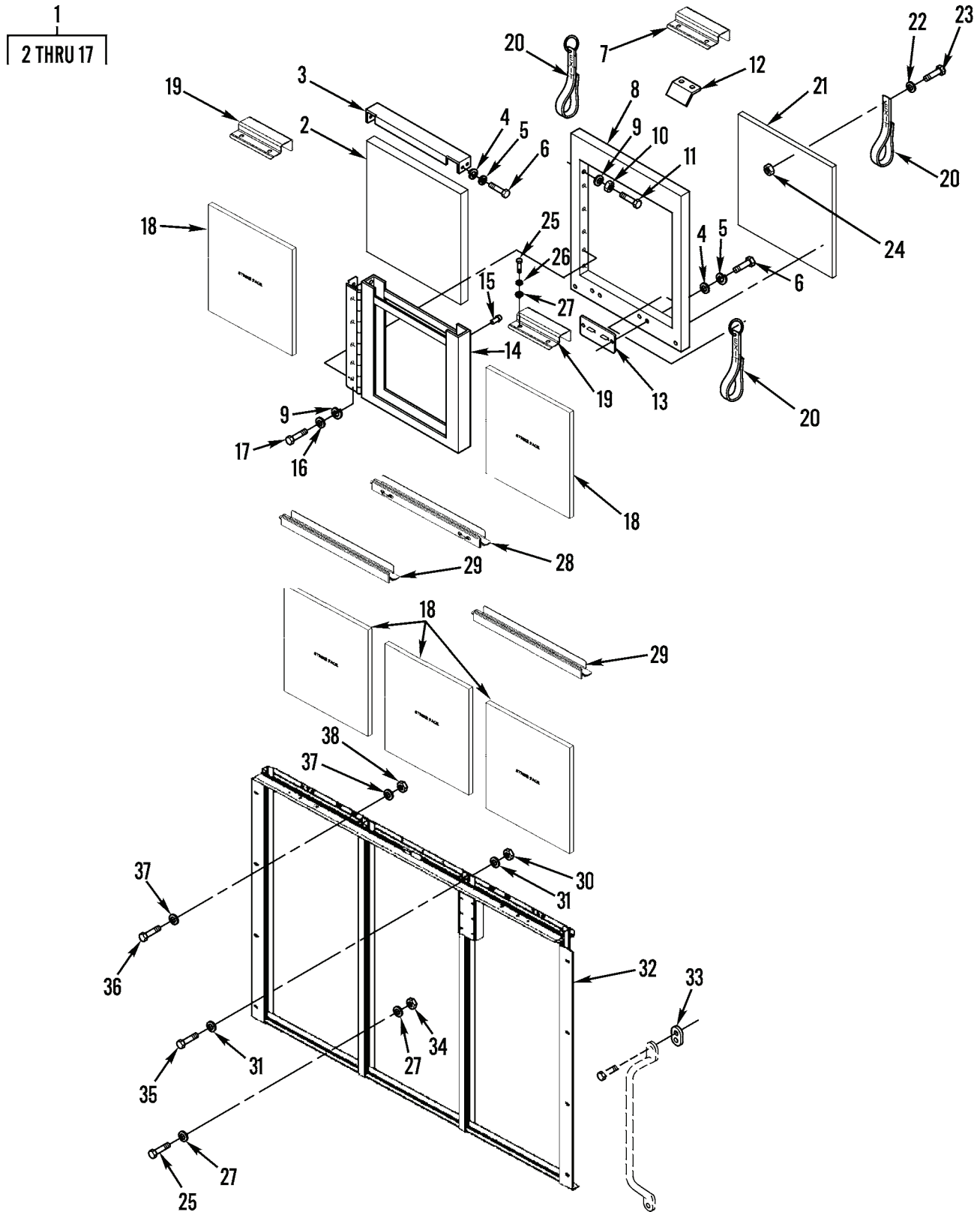

Figure 4. Rear Cab Armor and Window

(1) ITEM NO	(2) SMR CODE	(3) NSN	(4) CAGEC	(5) PART NUMBER	(6) DESCRIPTION AND USABLE ON CODES(UOC)	(7) QTY
GROUP 3307 SPECIAL PURPOSE KITS						
FIG. 4 REAR CAB ARMOR AND WINDOW						
1	PFOZZ	2510015500878	3KHA7	110-170440-001	M915 BALLISTIC REAR.....	1
2	PAOZZ	2540015438447	3KHA7	110-170445-001	ARMOR SET,SUPPLEMEN REAR EGRESS WINDOW.....	1
3	PAOZZ	2510015500328	3KHA7	110-170448-001	.COVER,EGRESS WINDOW.....	1
4	PFOZZ	5310008238804	96906	MS27183-9	.WASHER,FLAT 1/4 USS HARDENED FLAT WASHER, ONLY 12 USED ON M915A3.....	4
5	PFOZZ	5310005825965	80205	MS35338-44	.WASHER,LOCK 1/4 HEAVY-DUTY SPLIT LOCKWASHER.....	6
6	PFOZZ	5305000680508	80204	B1821BH025C075N	.SCREW,CAP,HEXAGON H 1/4-20 X 3/4, GRADE 8 HEX BOLT.....	6
7	PAOZZ	5340015258632	3KHA7	110-100045-001	.CLAMP,LOOP CLAMP, BEDSIDE ARMOR PANEL.....	1
8	PAOZZ	2510015501191	3KHA7	110-170450-001	.WINDOW FRAME ASSY,.....	1
9	PFOZZ	5310000814219	96906	MS27183-12	.WASHER,FLAT 5/16 USS HARDENED FLAT WASHER.....	6
10	PFOZZ	5310008807744	96906	MS51967-5	.NUT,PLAIN,HEXAGON 5/16-18, GRADE 8 HEX NUT.....	2
11	PFOZZ	5305015499180	3A054	92620A591	.SCREW,CAP,HEXAGON H 5/16-18 X 2, GRADE 8 HEX BOLT (FULL THREAD).....	2
12	PAOZZ	5310015505406	3KHA7	110-170490-001	.NUT PLATE ASSY, REA.....	1
13	PAOZZ	2590015501218	3KHA7	110-170485-001	.V-GUIDE ASSY, REAR.....	1
14	PAOZZ	2510015501273	3KHA7	110-170460-001	.MOUNTING FRAME ASSY.....	1
15	PFOZZ	6920012350243	19200	11784609	.STOP,RUBBER.....	2
16	PFOZZ	5310004079566	80205	MS35338-45	.WASHER,LOCK 5/16 HEAVY-DUTY SPLIT LOCKWASHER.....	4
17	PFOZZ	5306002264825	80204	B1821BH031C075N	.BOLT,MACHINE 5/16-18 X 3/4, GRADE 8 HEX BOLT.....	4
18	PAOZZ	2540015266224	3KHA7	110-200301-100	ARMOR,SUPPLEMENTAL, ARMOR PANEL, REAR, M915.....	5
19	PAOZZ	5340015258632	3KHA7	110-100045-001	CLAMP,LOOP CLAMP, BEDSIDE ARMOR PANEL.....	2
20	PFOZZ	5340015507552	3KHA7	110-170037-001	PULL STRAP, REAR WI.....	3
21	PAOZZ	2510015500873	3KHA7	110-170036-001	REAR WINDOW PANEL,.....	1
22	PFOZZ	5310008238804	96906	MS27183-9	WASHER,FLAT.....	1
23	PFOZZ	5305002253843	80204	B1821BH025C100N	SCREW,CAP,HEXAGON H.....	1
24	PFOZZ	5310015317280	81349	M45913/1-4CG8Z	NUT,SELF-LOCKING,HE.....	1
25	PFOZZ	5306002264827	80204	B1821BH031C100N	BOLT,MACHINE 5/16-18 X 1, GRADE 8 HEX BOLT.....	10
26	PFOZZ	5310004079566	80205	MS35338-45	WASHER,LOCK 5/16 HEAVY-DUTY SPLIT LOCKWASHER.....	6
27	PFOZZ	5310000814219	96906	MS27183-12	WASHER,FLAT 5/16 USS HARDENED FLAT WASHER.....	14
28	PAOZZ	2510015500869	3KHA7	110-170034-001	REAR PANEL DIVIDER CENTER DIVIDER ASSEMBLY.....	1
29	PAOZZ	2590015501243	3KHA7	110-170030-001	REAR PANEL DIVIDER OUTBOARD DIVIDER ASSEMBLY.....	2
30	PFOZZ	5310015317280	81349	M45913/1-4CG8Z	NUT,SELF-LOCKING,HE 1/4-20, GRADE 8 ALL-METAL LOCKNUT, ONLY 3 USED ON	9

(1) ITEM NO	(2) SMR CODE	(3) NSN	(4) CAGEC	(5) PART NUMBER	(6) DESCRIPTION AND USABLE ON CODES(UOC)	(7) QTY
					M915A3.....	
32	PAOZZ	2510015500191	3KHA7	110-170020-001	FRAME ASSY, REAR CA.....	1
33	PAOZZ	5365015507556	3KHA7	110-170055-001	ADAPTER ASSY, REAR.....	4
34	PFOZZ	5310015313929	81349	M45913/2-5CG8Z	NUT,SELF-LOCKING,HE 5/16-18, GRADE 8 ALL-METAL LOCKNUT.....	4
35	PFOZZ	5305002253843	80204	B1821BH025C100N	SCREW,CAP,HEXAGON H 1/4-20 X 1, GRADE 8 HEX BOLT, ONLY 3 USED ON M915A3.....	9
36	PFOZZ	5305000680510	05047	B1821BH038C100N	SCREW,CAP,HEXAGON H 3/8-16 X 1, GRADE 8 HEX BOLT, NOT USED ON M915A2	4
37	PFOZZ	5310000806004	96906	MS27183-14	WASHER,FLAT 3/8 USS HARDENED FLAT WASHER, NOT USED ON M915A2.....	8
38	PFOZZ	5310015313912	81349	M45913/2-6CG8Z	NUT,SELF-LOCKING,HE 3/8-16, GRADE 8 ALL-METAL LOCKNUT, NOT USED ON M915A2.....	4

END OF FIGURE



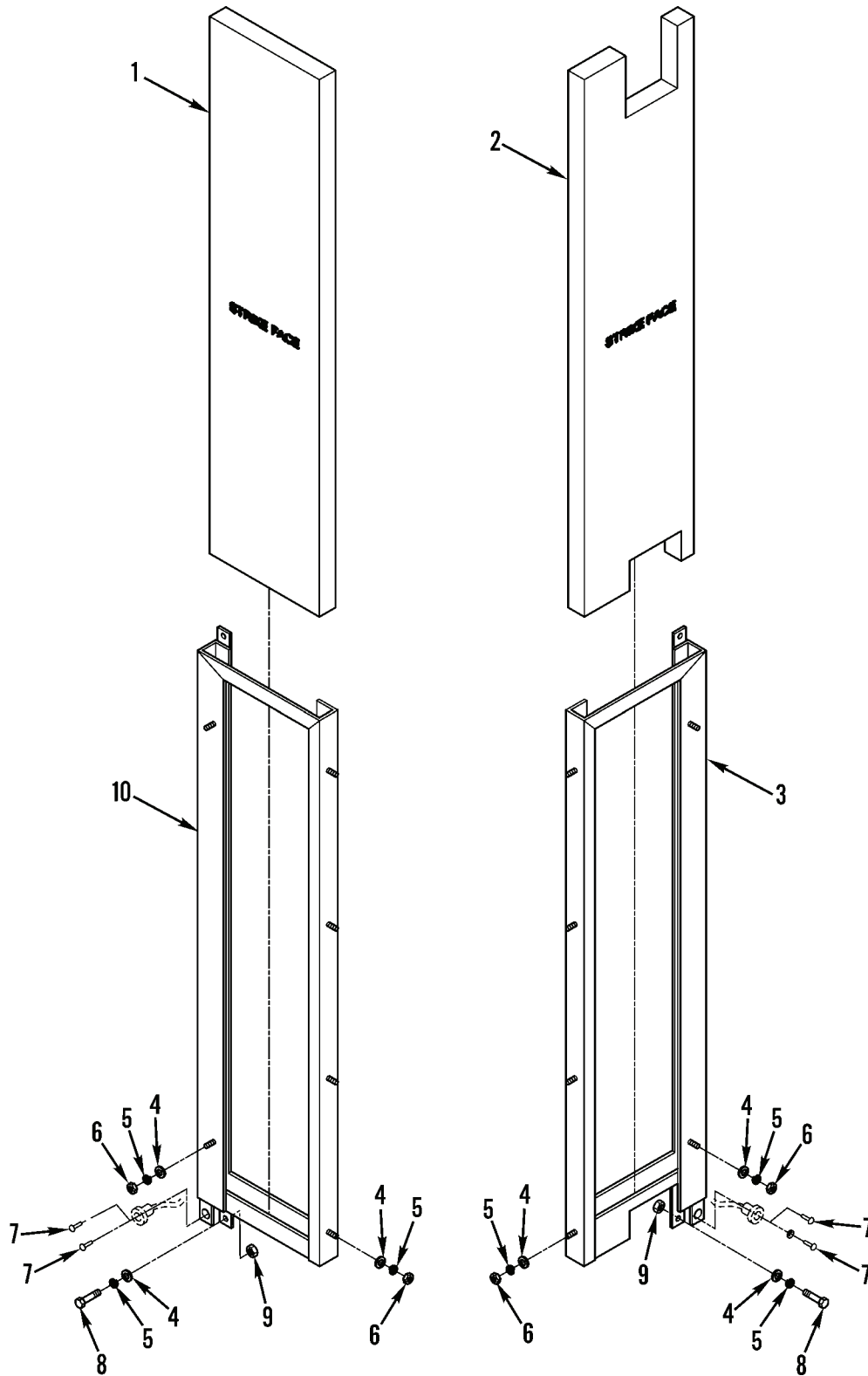

Figure 5. B-Pillar Armor

(1) ITEM NO	(2) SMR CODE	(3) NSN	(4) CAGEC	(5) PART NUMBER	(6) DESCRIPTION AND USABLE ON CODES(UOC)	(7) QTY
GROUP 3307 SPECIAL PURPOSE KITS						
FIG. 5 "B" PILLAR ARMOR						
1	PAOZZ	2540015500887	3KHA7	110-200703-001	ARMOR PANEL, B-PILL ARMOR PANEL, LEFT SIDE, B-PILLAR.....	1
2	PAOZZ	2590015501197	3KHA7	110-200706-001	ARMOR PANEL, B-PILL ARMOR PANEL, RIGHT SIDE, B-PILLAR.....	1
3	PAOZZ	2590015500896	3KHA7	110-170050-001	B-PILLAR FRAME ASSY RIGHT SIDE B- PILLAR FRAME ASSEMBLY.....	1
4	PFOZZ	5310000806004	96906	MS27183-14	WASHER,FLAT 3/8 USS HARDENED FLAT WASHER.....	16
5	PFOZZ	5310000045033	80205	MS35338-46	WASHER,LOCK 3/8 HEAVY-DUTY SPLIT LOCKWASHER.....	16
6	PFOZZ	5310007320558	96906	MS51967-8	NUT,PLAIN,HEXAGON 3/8-16, GRADE 8 HEX NUT.....	12
7	PFOZZ	5320012890030	80205	NAS9301E-4-06	RIVET,BLIND.....	4
8	PFOZZ	5305000680510	05047	B1821BH038C100N	SCREW,CAP,HEXAGON H 3/8-16 X 1, GRADE 8 HEX BOLT.....	4
9	PFOZZ	5310015313912	81349	M45913/2-6CG8Z	NUT,SELF-LOCKING,HE 3/8-16, GRADE 8 ALL-METAL LOCKNUT.....	4
10	PAOZZ	2590015501200	3KHA7	110-170040-001	B-PILLAR FRAME ASSY FRAME ASSEMBLY, LEFT SIDE, B-PILLAR.....	1

END OF FIGURE



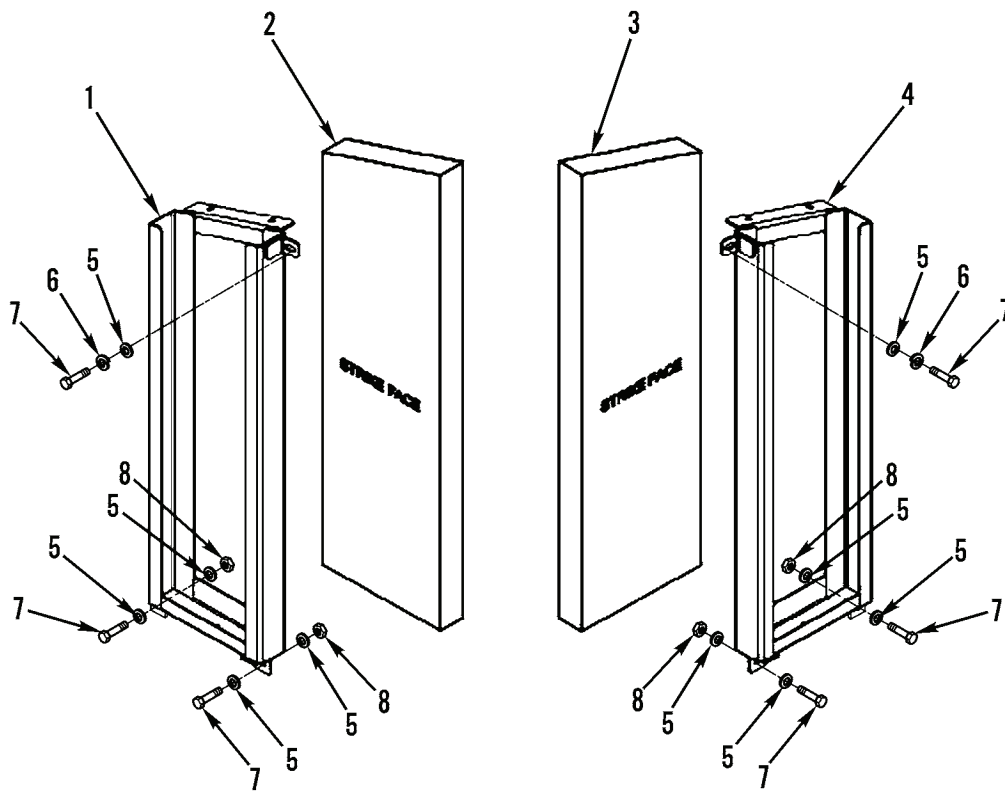

Figure 6. Lower A-Pillar Armor

(1) ITEM NO	(2) SMR CODE	(3) NSN	(4) CAGEC	(5) PART NUMBER	(6) DESCRIPTION AND USABLE ON CODES(UOC)	(7) QTY
GROUP 3307 SPECIAL PURPOSE KITS						
FIG. 6 LOWER "A" PILLAR ARMOR						
1	PAOZZ	2590015501212	3KHA7	110-170140-001	KICK PANEL FRAME AS KICK PANEL FRAME ASSEMBLY, LEFT SIDE.....	1
2	PAOZZ	2540015501279	3KHA7	110-200704-000	ARMOR PANEL, A-PILL ARMOR PANEL, LEFT SIDE, A-PILLAR.....	1
3	PAOZZ	2590015507463	3KHA7	110-200705-000	ARMOR PANEL, A-PILL ARMOR PANEL, RIGHT SIDE, A-PILLAR.....	1
4	PAOZZ	2590015501294	3KHA7	110-170140-002	KICK PANEL FRAME AS KICK PANEL FRAME ASSEMBLY, RIGHT SIDE.....	1
5	PFOZZ	5310000806004	96906	MS27183-14	WASHER,FLAT 3/8 USS HARDENED FLAT WASHER.....	10
6	PFOZZ	5310000045033	80205	MS35338-46	WASHER,LOCK 3/8 HEAVY-DUTY SPLIT LOCKWASHER.....	2
7	PFOZZ	5305000680510	05047	B1821BH038C100N	SCREW,CAP,HEXAGON H 3/8-16 X 1, GRADE 8 HEX BOLT.....	6
8	PFOZZ	5310015313912	81349	M45913/2-6CG8Z	NUT,SELF-LOCKING,HE 3/8-16, GRADE 8 ALL-METAL LOCKNUT.....	4

END OF FIGURE

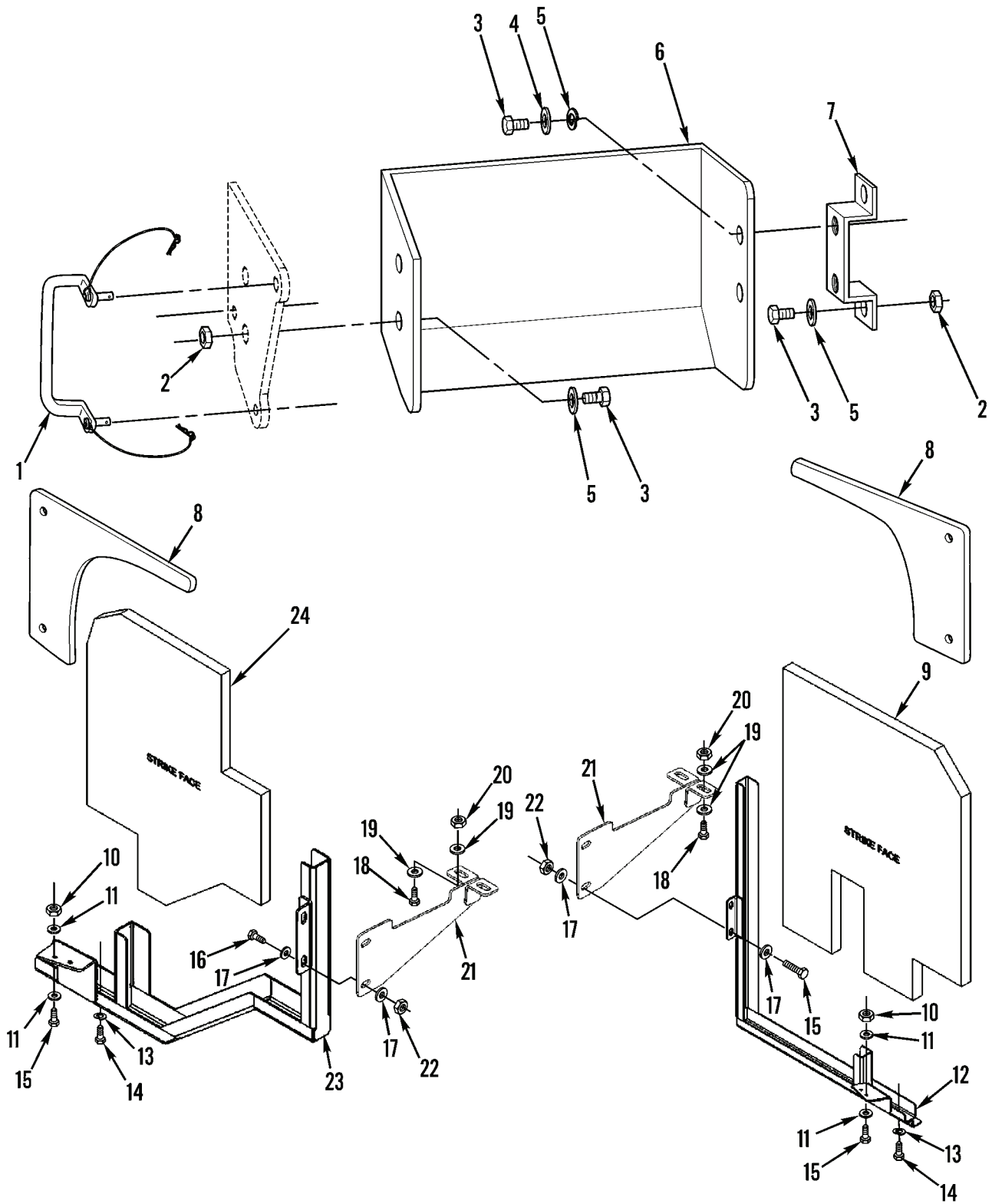

Figure 7. Firewall Armor

(1) ITEM NO	(2) SMR CODE	(3) NSN	(4) CAGEC	(5) PART NUMBER	(6) DESCRIPTION AND USABLE ON CODES(UOC)	(7) QTY
GROUP 3307 SPECIAL PURPOSE KITS						
FIG. 7 FIREWALL ARMOR						
1	PAOZZ	5340015501323	3KHA7	110-170435-001	BRACKET ASSY, AIR C.....	2
2	PFOZZ	5310015313912	81349	M45913/2-6CG8Z	NUT,SELF-LOCKING,HE GR 8, 3/8" ID..	4
3	PFOZZ	5305013258387	80205	MS90725-64	SCREW,CAP,HEXAGON H GR 8, 3/8" X 1 1/2".....	6
4	PFOZZ	5310000806004	96906	MS27183-14	WASHER,FLAT GR 8, 3/8" ID.....	4
5	PFOZZ	5310000045033	80205	MS35338-46	WASHER,LOCK GR 8, 3/8" ID.....	6
6	PAOZZ	2540015501317	3KHA7	110-170420-001	ARMOR ASSY, CENTERL CENTER FIREWALL ARMOR PLATE.....	1
7	PAOZZ	5340015501182	3KHA7	110-170430-001	BRACKET ASSY, CENTE BRACKET, CENTER FIREWALL.....	1
8	PAOZZ	2540015502218	3KHA7	110-170148-001	ARMOR PLATE FORWARD A-PILLAR.....	2
9	PAOZZ	2590015501193	3KHA7	110-200337-100	ARMOR PANEL, FIREWA LEFT SIDE, FIREWALL.....	1
10	PFOZZ	5310015317280	81349	M45913/1-4CG8Z	NUT,SELF-LOCKING,HE 1/4-20, GRADE 8 ALL-METAL LOCKNUT.....	4
11	PFOZZ	5310008238804	96906	MS27183-9	WASHER,FLAT 1/4 USS HARDENED FLAT WASHER.....	8
12	PAOZZ	2590015502558	3KHA7	110-170150-001	FIREWALL PANEL FRAM LEFT SIDE, FIREWALL.....	1
13	PFOZZ	5310004079566	80205	MS35338-45	WASHER,LOCK 5/16 HEAVY-DUTY SPLIT LOCKWASHER.....	4
14	PFOZZ	5305002264831	80204	B1821BH031C150N	SCREW,CAP,HEXAGON H 5/16-18 X 1-1/ 2, GRADE 8 HEX BOLT.....	4
15	PFOZZ	5305002253843	80204	B1821BH025C100N	SCREW,CAP,HEXAGON H 1/4-20 X 1, GRADE 8 HEX BOLT.....	4
16	PFOZZ	5306002264827	80204	B1821BH031C100N	BOLT,MACHINE 5/16-18 X 1, GRADE 8 HEX BOLT.....	4
17	PFOZZ	5310000814219	96906	MS27183-12	WASHER,FLAT 5/16 USS HARDENED FLAT WASHER.....	8
18	PFOZZ	5305000680511	80204	B1821BH038C125N	SCREW,CAP,HEXAGON H 3/8-16 X 1-1/4, GRADE 8 HEX BOLT.....	2
19	PFOZZ	5310000806004	96906	MS27183-14	WASHER,FLAT 3/8 USS HARDENED FLAT WASHER.....	8
20	PFOZZ	5310015313912	81349	M45913/2-6CG8Z	NUT,SELF-LOCKING,HE 3/8-16, GRADE 8 ALL-METAL LOCKNUT.....	2
21	PAOZZ	2590015503310	3KHA7	110-170170-001	SUPPORT BRACE ASSY,.....	2
22	PFOZZ	5310015313929	81349	M45913/2-5CG8Z	NUT,SELF-LOCKING,HE 5/16-18, GRADE 8 ALL-METAL LOCKNUT.....	4
23	PAOZZ	2590015501313	3KHA7	110-170160-001	FIREWALL FRAME ASSY RIGHT SIDE.....	1
24	PAOZZ	2590015501198	3KHA7	110-200336-100	ARMOR PANEL, FIREWA RIGHT SIDE.....	1

END OF FIGURE

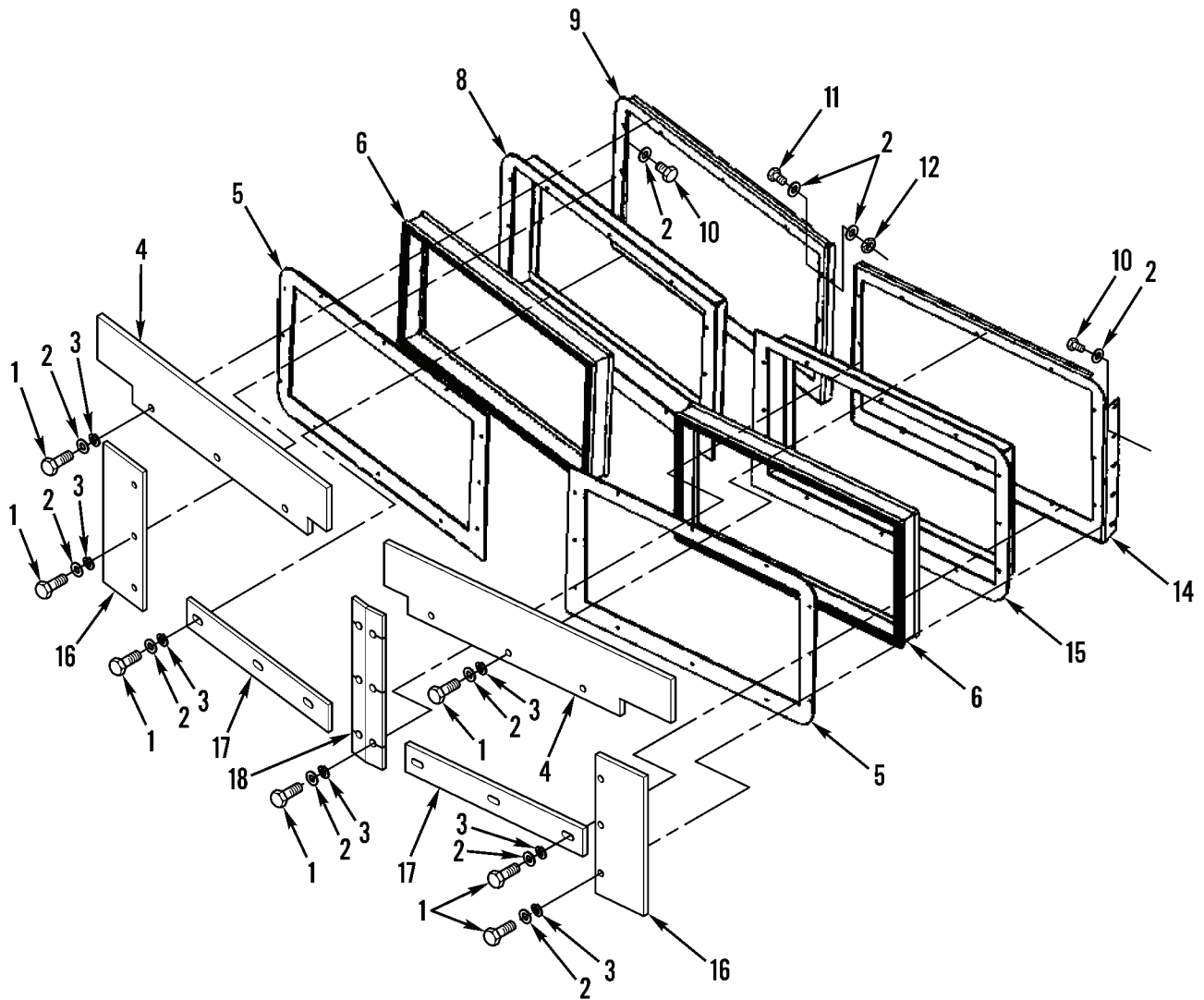
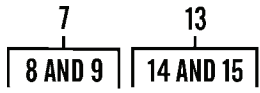

Figure 8. Ballistic Windshield and Surrounding Armor

(1) ITEM NO	(2) SMR CODE	(3) NSN	(4) CAGEC	(5) PART NUMBER	(6) DESCRIPTION AND USABLE ON CODES(UOC)	(7) QTY
GROUP 3307 SPECIAL PURPOSE KITS						
FIG. 8 BALLISTIC WINDSHIELD AND SURROUNDING ARMOR						
1	PFOZZ	5305000712510	80204	B1821BH025C175N	SCREW,CAP,HEXAGON H 1/4-20 X 1-3/4, GRADE 8 HEX BOLT.....	24
2	PFOZZ	5310008238804	96906	MS27183-9	WASHER,FLAT 1/4 USS HARDENED FLAT WASHER.....	42
3	PFOZZ	5310005825965	80205	MS35338-44	WASHER,LOCK 1/4 HEAVY-DUTY SPLIT LOCKWASHER.....	34
4	PAOZZ	2540015502538	3KHA7	110-170228-001	ARMOR PLATE, WINDSH ARMOR, WINDSHIELD EYEBROW.....	2
5	PFOZZ	2510015501174	3KHA7	110-170225-001	OUTSIDE FRAME.....	2
6	PAOZZ	2540015438440	3KHA7	110-170205-001	ARMOR SET,SUPPLEMEN.....	2
7	PAOOO	2510015502564	3KHA7	110-170200-002	WINDSHIELD ASSY, PA RIGHT SIDE.....	1
8	PAOZZ	2510015502551	3KHA7	110-170220-002	.FRAME,WINDOW,VEHICU RIGHT SIDE....	1
9	PAOZZ	2510015501363	3KHA7	110-170210-002	.FRAME,WINDOW,VEHICU RIGHT SIDE....	1
10	PFOZZ	5305002253843	80204	B1821BH025C100N	SCREW,CAP,HEXAGON H 1/4-20 X 1, GRADE 8 HEX BOLT.....	10
11	PFOZZ	5305000680508	80204	B1821BH025C075N	SCREW,CAP,HEXAGON H 1/4-20 X 3/4, GRADE 8 HEX BOLT.....	4
12	PFOZZ	5310015317280	81349	M45913/1-4CG8Z	NUT,SELF-LOCKING,HE 1/4-20, GRADE 8 ALL-METAL LOCKNUT.....	4
13	PAOOO	2510015502556	3KHA7	110-170200-001	WINDSHIELD ASSY, DR LEFT SIDE.....	1
14	PAOZZ	2510015501188	3KHA7	110-170210-001	.FRAME,WINDOW,VEHICU LEFT SIDE.....	1
15	PAOZZ	2510015501175	3KHA7	110-170220-001	.FRAME,WINDOW,VEHICU LEFT SIDE.....	1
16	PAOZZ	2540015501682	3KHA7	110-170227-001	ARMOR PLATE, WINDSH ARMOR PANEL, A- PILLAR POST.....	2
17	PAOZZ	2590015501179	3KHA7	110-170229-001	ARMOR PLATE, WINDSH WINDSHIELD TO COWL ARMOR.....	2
18	PAOZZ	2590015501180	3KHA7	110-170226-001	ARMOR PLATE, WINDSH WINDSHIELD CENTER POST ARMOR.....	1

END OF FIGURE

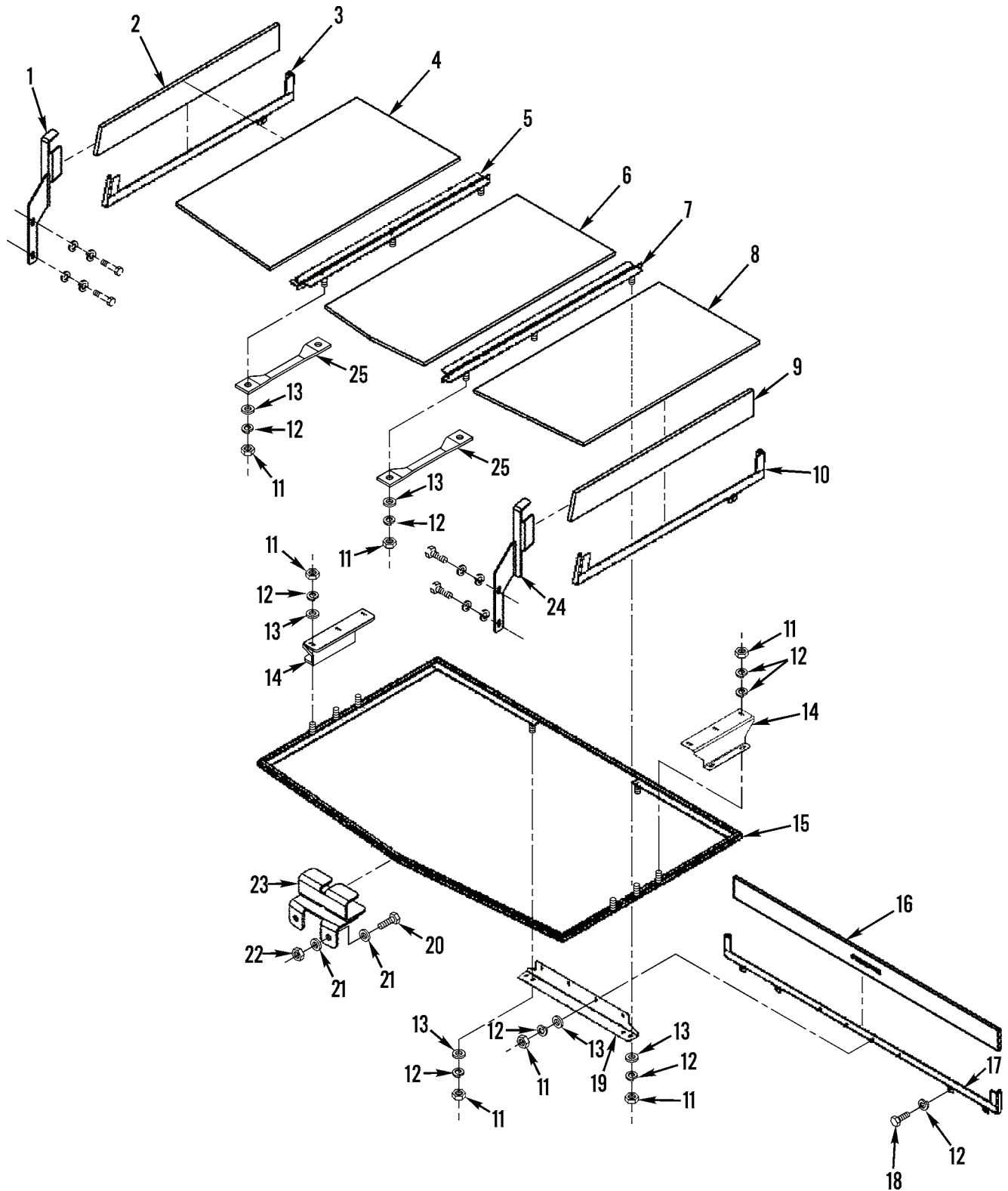

Figure 9. Roof Armor

(1) ITEM NO	(2) SMR CODE	(3) NSN	(4) CAGEC	(5) PART NUMBER	(6) DESCRIPTION AND USABLE ON CODES(UOC)	(7) QTY
GROUP 3307 SPECIAL PURPOSE KITS						
FIG. 9 ROOF ARMOR						
1	PAOZZ	2590015501704	3KHA7	110-170265-002	MOUNTING BRACKET, S RIGHT SIDE ROOF FRAME MOUNTING BRACKET.....	1
2	PAOZZ	2540015501699	3KHA7	110-200806-000	ARMOR PANEL, ROOF S RIGHT SIDE ROOF SEAM ARMOR.....	1
3	PAOZZ	2510015502576	3KHA7	110-170260-002	SIDE ROOF EDGE FRAM RIGHT SIDE ROOF EDGE FRAME ASSEMBLY.....	1
4	PAOZZ	2510015499648	3KHA7	110-200803-000	ARMOR PANEL, ROOF, RIGHT SIDE ROOF ARMOR PANEL.....	1
5	PAOZZ	2590015501689	3KHA7	110-170245-002	PANEL DIVIDER ASSY, RIGHT SIDE PANEL DIVIDER ASSEMBLY.....	1
6	PAOZZ	2540015502584	3KHA7	110-200801-000	ARMOR PANEL, ROOF, CENTER ROOF ARMOR PANEL.....	1
7	PAOZZ	2590015501687	3KHA7	110-170245-001	PANEL DIVIDER ASSY, LEFT SIDE PANEL DIVIDER ASSEMBLY.....	1
8	PAOZZ	2540015502591	3KHA7	110-200802-000	ARMOR PANEL, ROOF, LEFT SIDE ROOF ARMOR PANEL.....	1
9	PAOZZ	2540015503329	3KHA7	110-200804-000	ARMOR PANEL, ROOF S LEFT SIDE ROOF SEAM ARMOR.....	1
10	PAOZZ	2510015502571	3KHA7	110-170260-001	SIDE ROOF EDGE FRAM LEFT SIDE ROOF EDGE FRAME ASSEMBLY.....	1
11	PFOZZ	5310008807744	96906	MS51967-5	NUT,PLAIN,HEXAGON 5/16-18, GR 8 HEX NUT.....	22
12	PFOZZ	5310004079566	80205	MS35338-45	WASHER,LOCK.....	22
13	PFOZZ	5310000814219	96906	MS27183-12	WASHER,FLAT 5/16 USS HARDENED FLAT WASHER.....	26
14	PAOZZ	5340015499698	3KHA7	110-170256-001	MOUNTING BRACKET, R ROOF TO DOOR MOUNTING BRACKET.....	2
15	PAOZZ	2510015501693	3KHA7	110-170240-001	FRAME ASSY, ROOF AR.....	1
16	PAOZZ	2590015501177	3KHA7	110-200805-000	ARMOR PANEL, ROOF R REAR ROOF SEAM ARMOR.....	1
17	PAOZZ	2510015502567	3KHA7	110-170250-001	REAR ROOF EDGE FRAM.....	1
18	PFOZZ	5306002264827	80204	B1821BH031C100N	BOLT,MACHINE 5/16-18 X 1, GRADE 8 HEX BOLT.....	4
19	PAOZZ	2590015501171	3KHA7	110-170255-001	SUPPORT ANGLE, CENT.....	1
20	PFOZZ	5305000680508	80204	B1821BH025C075N	SCREW,CAP,HEXAGON H 1/4 X 3/4 BOLT, GR 8.....	2
21	PFOZZ	5310008238804	96906	MS27183-9	WASHER,FLAT 1/4" WASHER.....	2
22	PFOZZ	5310007616882	96906	MS51967-2	NUT,PLAIN,HEXAGON 1/4" LOCKNUT.....	2
23	PAOZZ	2590015503321	3KHA7	110-170275-001	FWD MOUNTING BRACKE.....	1
24	PAOZZ	2590015503343	3KHA7	110-170265-001	MOUNTING BRACKET, S.....	1
25	PAOZZ	2540015501260	3KHA7	110-170248-001	CEILING HAND STRAP.....	2

END OF FIGURE



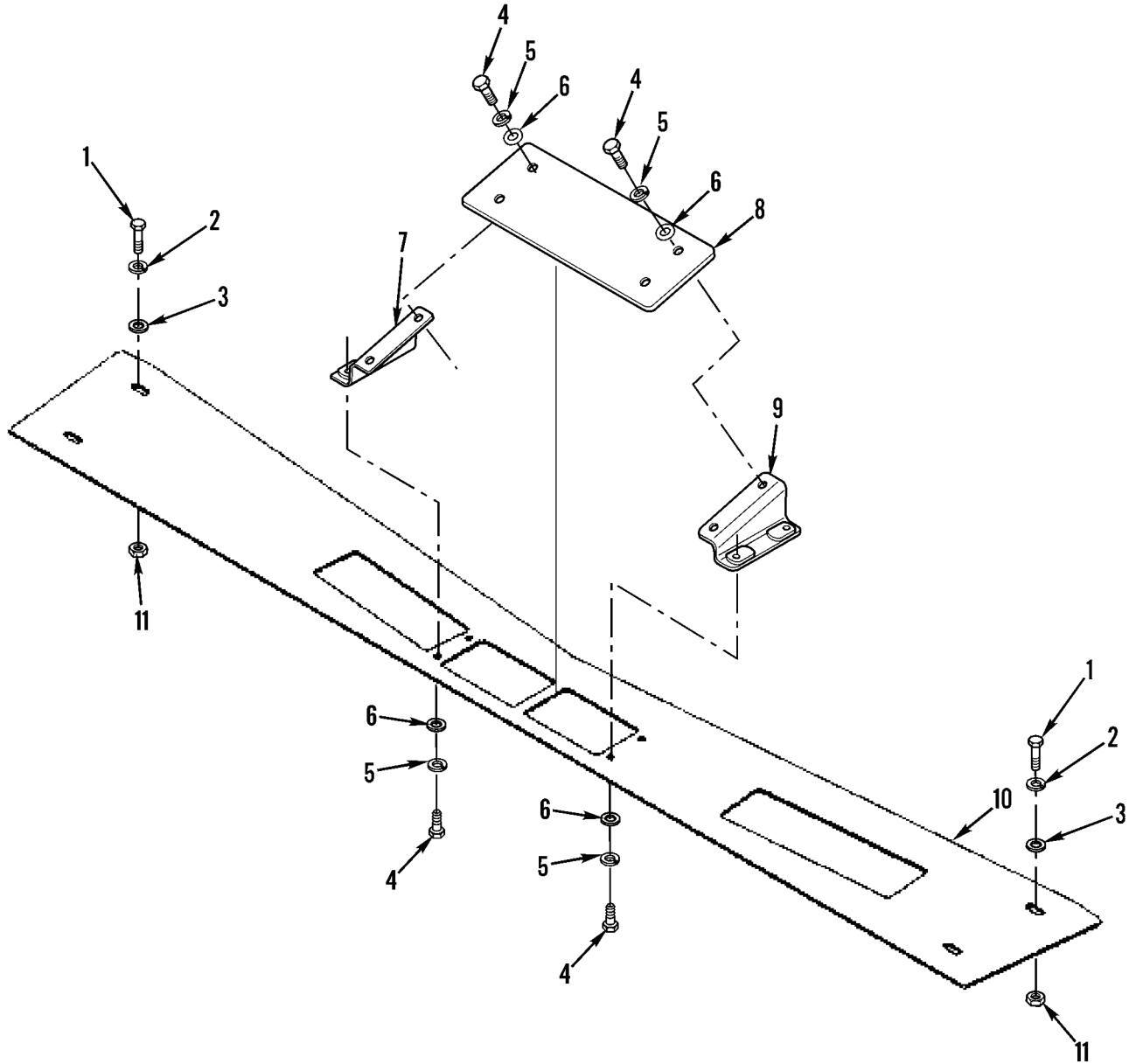

Figure 10. Front Cowl Armor

(1) ITEM NO	(2) SMR CODE	(3) NSN	(4) CAGEC	(5) PART NUMBER	(6) DESCRIPTION AND USABLE ON CODES(UOC)	(7) QTY
GROUP 3307 SPECIAL PURPOSE KITS						
FIG. 10 FRONT COWL ARMOR						
1	PFOZZ	5305000680510	05047	B1821BH038C100N	SCREW,CAP,HEXAGON H 3/8-16 X 1", GR 8 HEX BOLT.....	4
2	PFOZZ	5310000045033	80205	MS35338-46	WASHER,LOCK 3/8"HEAVY DUTY SPLIT LOCKWASHER.....	4
3	PFOZZ	5310000806004	96906	MS27183-14	WASHER,FLAT 3/8 USS HARDENED FLAT WASHER.....	4
4	PFOZZ	5306002264827	80204	B1821BH031C100N	BOLT,MACHINE 5/16-18 X 1", GR 8 HEX BOLT.....	8
5	PFOZZ	5310004079566	80205	MS35338-45	WASHER,LOCK 5/16" HEAVY-DUTY SPLIT LOCKWASHER.....	8
6	PFOZZ	5310000814219	96906	MS27183-12	WASHER,FLAT 5/16 USS HARDENED FLAT WASHER.....	8
7	PAOZZ	2540015501785	3KHA7	110-170182-001	BRACKET ASSEMBLY COWL INTAKE COVER, RIGHT SIDE.....	1
8	PAOZZ	2540015501785	3KHA7	110-170182-001	BRACKET ASSEMBLY INTAKE COVER ARMOR	1
9	PAOZZ	5340015501268	3KHA7	110-170185-002	BRACKET ASSY, COWL LEFT SIDE.....	1
10	PAOZZ	2540015501794	3KHA7	110-170181-001	ARMOR PLATE,FRONT C FRONT COWL ARMOR.....	1
11	PFOZZ	5310015313912	81349	M45913/2-6CG8Z	NUT,SELF-LOCKING,HE 3/8-18 X 1 1/ 4", GR 8 HEX NUT.....	4

END OF FIGURE



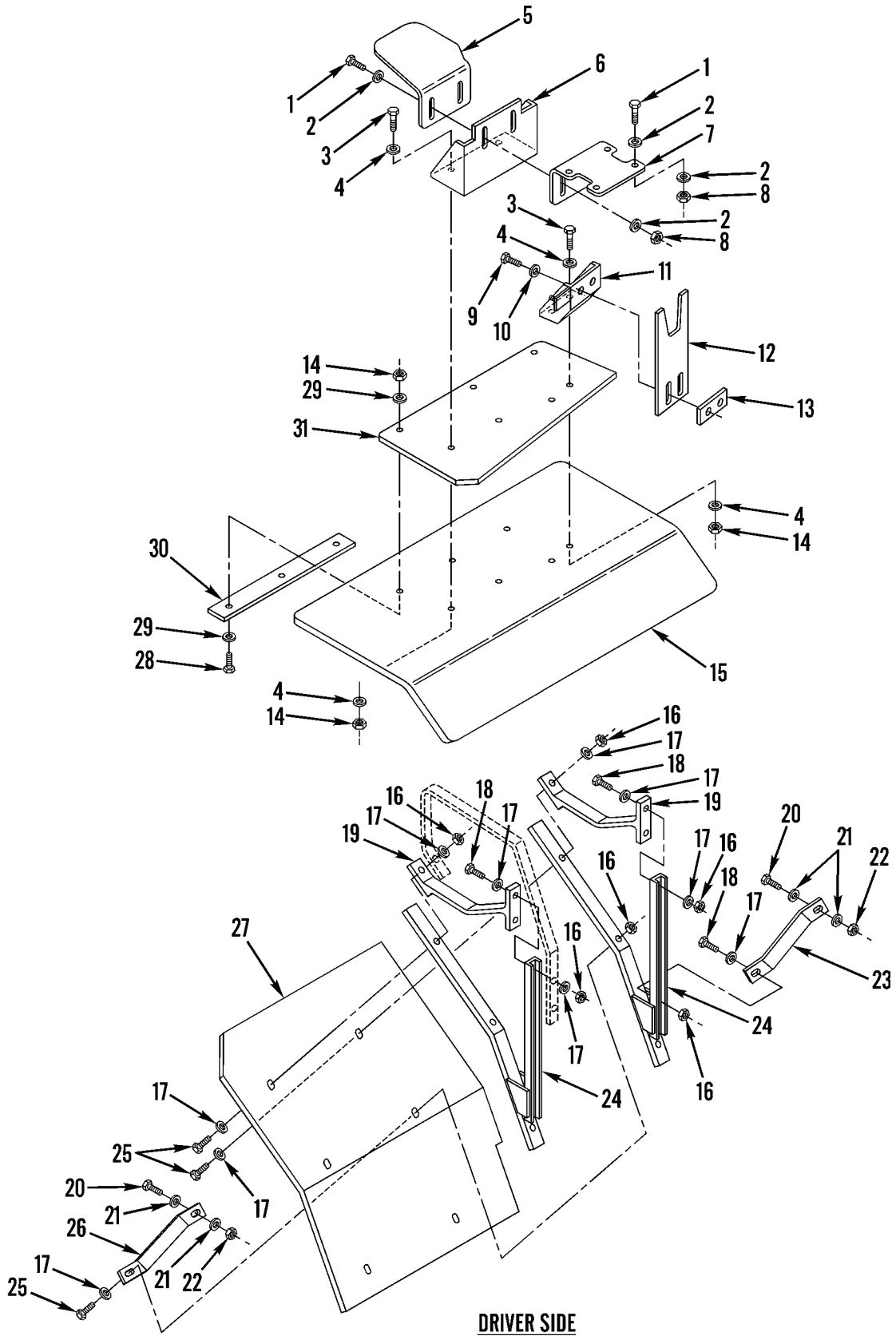

Figure 11. Wheel Well Blast Deflectors and Hood Support Brackets (Sheet 1 of 2)

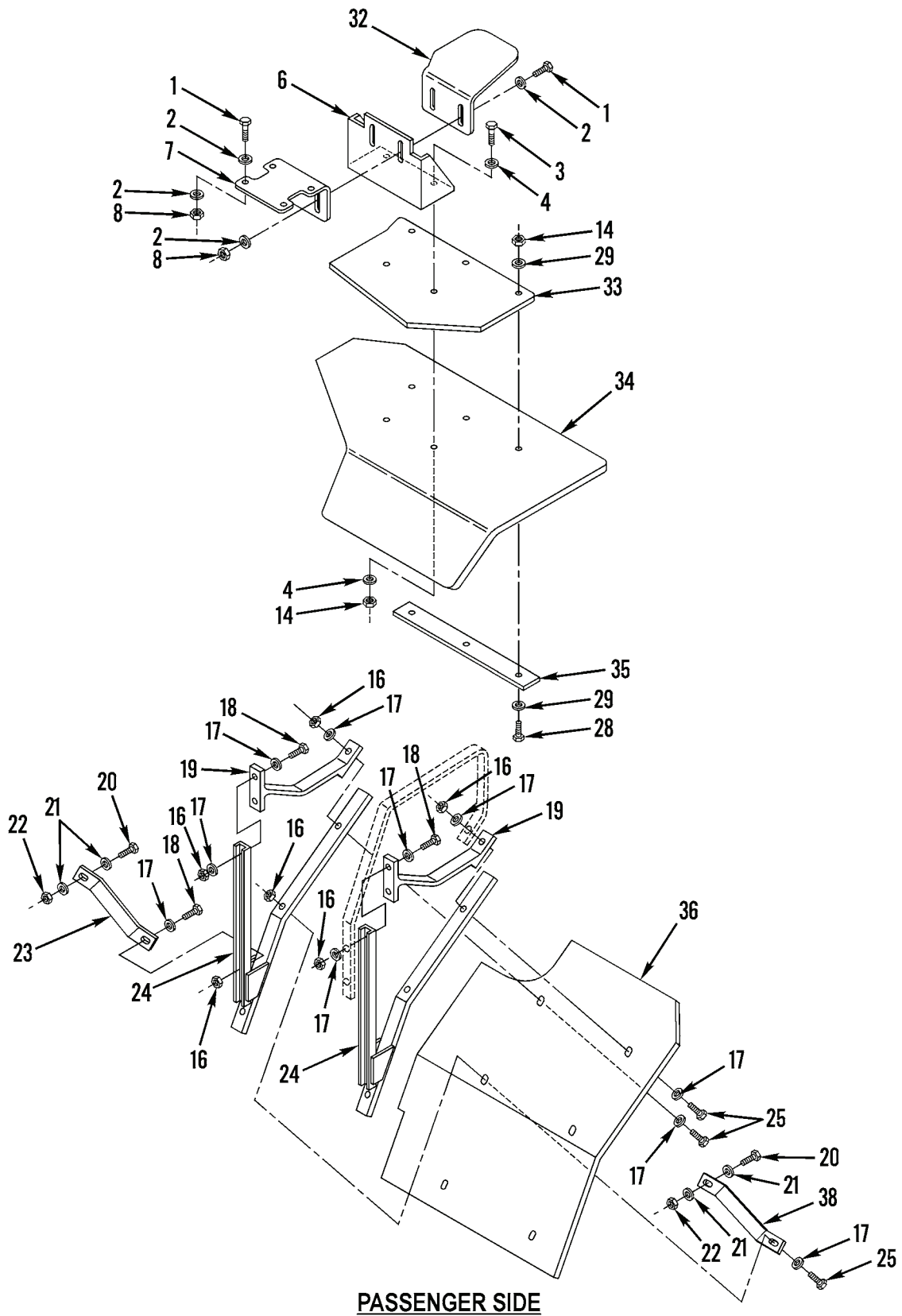

Figure 11. Wheel Well Blast Deflectors and Hood Support Brackets (Sheet 2 of 2)

(1) ITEM NO	(2) SMR CODE	(3) NSN	(4) CAGEC	(5) PART NUMBER	(6) DESCRIPTION AND USABLE ON CODES(UOC)	(7) QTY
GROUP 3307 SPECIAL PURPOSE KITS						
FIG. 11 WHEEL WELL BLAST DEFLECTORS AND HOOD SUPPORT BRACKETS						
1	PFOZZ	5306002264829	80204	B1821BH031C125N	BOLT,MACHINE 5/16-18 X 1-1/4, GRADE 8 HEX BOLT.....	12
2	PFOZZ	5310000814219	96906	MS27183-12	WASHER,FLAT 5/16 USS HARDENED FLAT WASHER.....	24
3	PFOZZ	5305002693218	80205	MS90725-68	SCREW,CAP,HEXAGON H GR 8, 3/8" X 2 1/2".....	6
4	PFOZZ	5310000806004	96906	MS27183-14	WASHER,FLAT 3/8" ID, GR 8.....	6
5	PAOZZ	2590015501751	3KHA7	110-170190-001	HOOD SUPPORT, M915A LEFT SIDE HOOD SUPPORT.....	1
6	PAOZZ	2590015501797	3KHA7	110-170400-001	BRACKET,DEFLECTOR E DEFLECTOR EXTENSION BRACKET,OUTBOARD.....	2
7	PAOZZ	5340015501284	3KHA7	110-170191-001	MOUNTING BRACKET, M HOOD SUPPORT...	2
8	PFOZZ	5310015313929	81349	M45913/2-5CG8Z	NUT,SELF-LOCKING,HE 5/16-18, GRADE 8 ALL-METAL LOCKNUT.....	12
9	PFOZZ	5305002693211	80205	MS90725-60	SCREW,CAP,HEXAGON H.....	2
10	PFOZZ	5310000806004	96906	MS27183-14	WASHER,FLAT 3/8" ID, GR 8.....	2
11	PAOZZ	2590015501714	3KHA7	110-170395-001	BRACKET,DEFLECTOR E LEFT SIDE BRACKET.....	1
12	PAOZZ	2540015501816	3KHA7	110-170394-001	ARMOR PLATE,FIREWAL FIREWALL STEERING SHAFT ARMOR.....	1
13	PAOZZ	5365015502573	3KHA7	110-170405-001	NUT PLATE,FIREWALL LEFT SIDE, FIREWALL ARMOR NUT PLATE.....	1
14	PFOZZ	5310015313912	81349	M45913/2-6CG8Z	NUT,SELF-LOCKING,HE.....	8
15	PAOZZ	2590015501634	3KHA7	110-170391-001	EXTENSION,BLAST DEF LEFT SIDE BLAST DEFLECTOR EXTENSION.....	1
16	PFOZZ	5310015313912	81349	M45913/2-6CG8Z	NUT,SELF-LOCKING,HE 3/8-16, GRADE 8 ALL-METAL LOCKNUT.....	22
17	PFOZZ	5310000806004	96906	MS27183-14	WASHER,FLAT 3/8" USS HARDENED FLAT WASHER.....	44
18	PFOZZ	5305007252317	80204	B1821BH038C150N	SCREW,CAP,HEXAGON H 3/8-16 X 1-1/2, GRADE 8 HEX BOLT.....	6
19	PAOZZ	2590015501831	3KHA7	110-170322-001	ENERGY ATTENUATOR,W WHEEL WELL ENERGY ATTENUATOR.....	4
20	PFOZZ	5305000712073	80204	B1821BH050C250N	SCREW,CAP,HEXAGON H 1/2-13 X 2 1/ 2", GR 8 HEX BOLT.....	4
21	PFOZZ	5310008095997	96906	MS27183-17	WASHER,FLAT 1/2" SAE HARDENED FLAT WASHER.....	8
22	PFOZZ	5310015279522	81349	M45913/2-8CG8Z	NUT,SELF-LOCKING,HE 1/2-13, GRADE 8 ALL-METAL LOCKNUT.....	4
23	PAOZZ	2590015503302	3KHA7	110-170324-001	REAR BRACE, WHEELWE.....	2
24	PAOZZ	2590015501840	3KHA7	110-170325-001	FRAME ASSY,WHEEL WE FRAME ASSEMBLY, WHEELWELL DEFLECTOR.....	4
25	PFOZZ	5305006388920	80204	B1821BH038C225N	SCREW,CAP,HEXAGON H 3/8-16 X 2 1/ 4", GR 8 HEX BOLT.....	12
26	PAOZZ	2590015503313	3KHA7	110-170323-001	FRONT BRACE, WHEELW LEFT WHEELWELL DEFLECTOR FRONT BRACE.....	1
27	PAOZZ	2540015501861	3KHA7	110-170321-001	BLAST DEFLECTOR, DR LEFT SIDE	1

(1) ITEM NO	(2) SMR CODE	(3) NSN	(4) CAGEC	(5) PART NUMBER	(6) DESCRIPTION AND USABLE ON CODES(UOC)	(7) QTY
28	PFOZZ	5305002693218	80205	MS90725-68	WHEELWELL BLAST DEFLECTOR.....	
					SCREW,CAP,HEXAGON H.....	6
29	PFOZZ	5310000806004	96906	MS27183-14	WASHER,FLAT.....	12
30	PAOZZ	5340015499045	3KHA7	110-170393-001	WASHER PLATE,DRIVER LEFT SIDE	1
					WASHER PLATE FOR DEFLECTOR EXTENSION	
31	PAOZZ	2540015502239	3KHA7	110-170392-001	PLATE,DEFLECTOR EXT LEFT SIDE	1
					DEFLECTOR EXTENSION PLATE.....	
32	PAOZZ	2590015501755	3KHA7	110-170190-002	HOOD SUPPORT, M915A RIGHT HOOD	1
					SUPPORT.....	
33	PAOZZ	2540015501746	3KHA7	110-170412-001	PLATE,DEFLECTOR EXT RIGHT SIDE	1
					DEFLECTOR PLATE.....	
34	PAOZZ	2540015501870	3KHA7	110-170411-001	EXTENSION,BLAST DEF RIGHT SIDE	1
					BLAST DEFLECTOR EXTENSION.....	
35	PAOZZ	5340015499054	3KHA7	110-170413-001	WASHER PLATE, PASSE RIGHT SIDE	1
					WASHER PLATE.....	
36	PAOZZ	2590015501277	3KHA7	110-170331-001	BLAST DEFLECTOR, PA RIGHT SIDE	1
					WHEELWELL BLAST DEFLECTOR.....	
37	PAOZZ	5340015501280	3KHA7	110-170323-002	FRONT BRACE, WHEELW RIGHT	1
					WHEELWELL DEFLECTOR FRONT BRACE.....	

END OF FIGURE





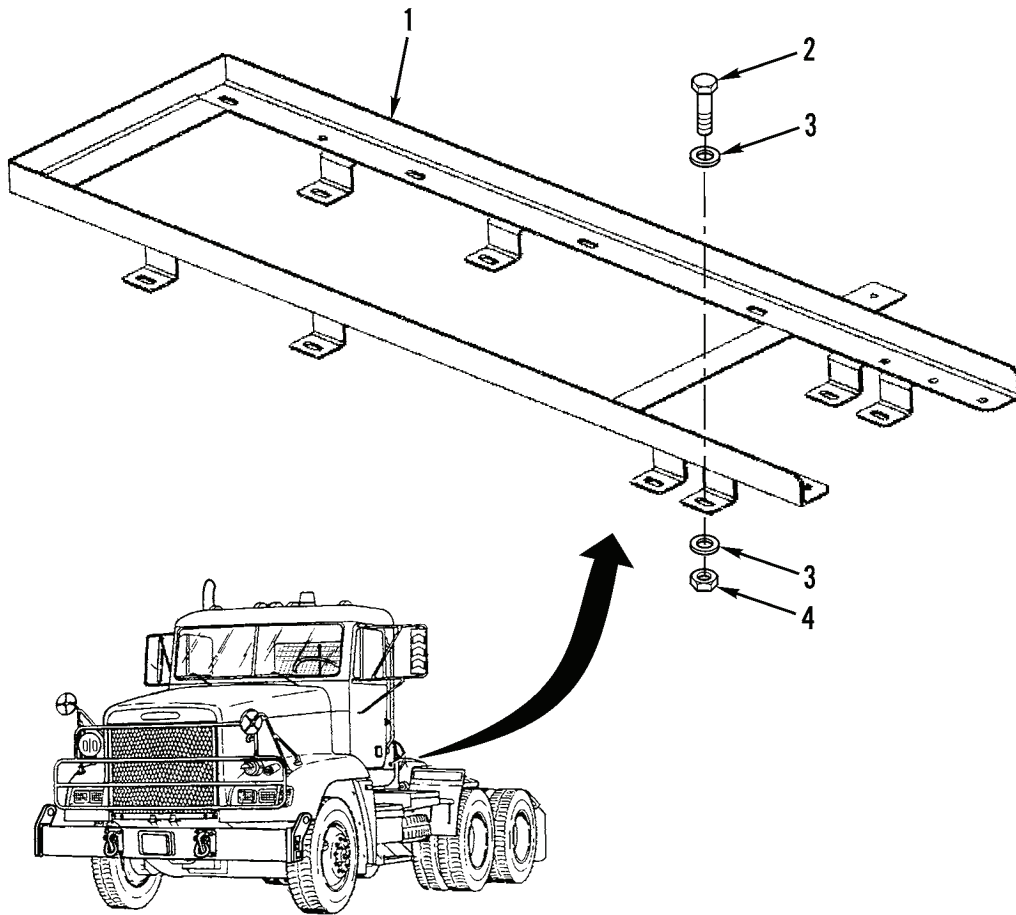

Figure 12. Rear Storage Box Adapter Frame

(1) ITEM NO	(2) SMR CODE	(3) NSN	(4) CAGEC	(5) PART NUMBER	(6) DESCRIPTION AND USABLE ON CODES(UOC)	(7) QTY
GROUP 3307 SPECIAL PURPOSE KITS						
FIG. 12 REAR STOWAGE BOX ADAPTER FRAME						
1	PAOZZ	2510015501763	3KHA7	110-170230-001	ADAPTER FRAME, STOW.....	1
2	PFOZZ	5305000680511	80204	B1821BH038C125N	SCREW,CAP,HEXAGON H 3/8-16 X 1-1/4, GRADE 8 HEX BOLT.....	6
3	PFOZZ	5310000806004	96906	MS27183-14	WASHER,FLAT 3/8 USS HARDENED FLAT WASHER.....	12
4	PFOZZ	5310015313912	81349	M45913/2-6CG8Z	NUT,SELF-LOCKING,HE 3/8-16, GR 8 ALL METAL HEX NUT.....	6

END OF FIGURE

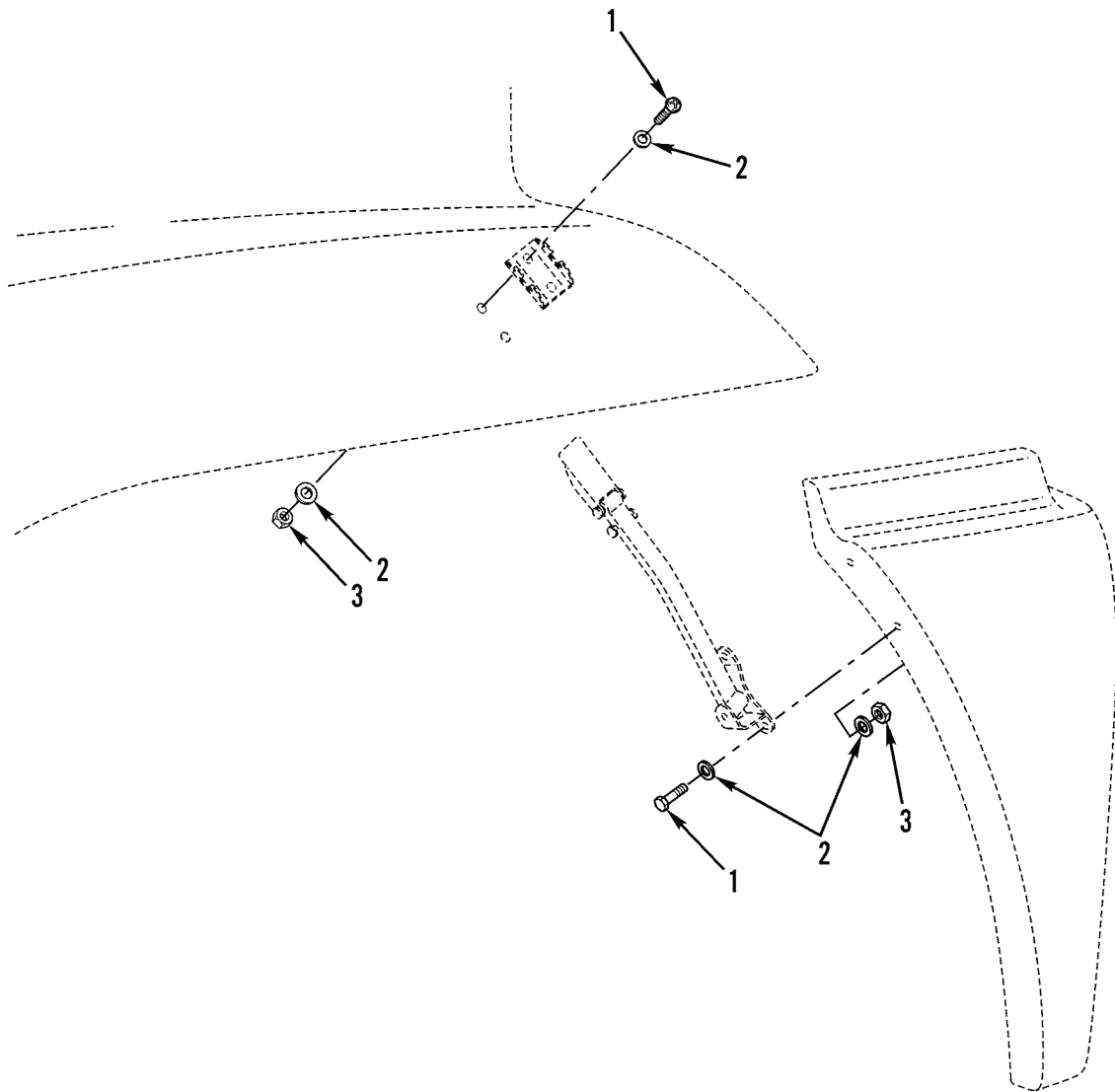

Figure 13. Hood Latch Strap Mounting

(1) ITEM NO	(2) SMR CODE	(3) NSN	(4) CAGEC	(5) PART NUMBER	(6) DESCRIPTION AND USABLE ON CODES(UOC)	(7) QTY
-------------------	--------------------	------------	--------------	-----------------------	---	------------

GROUP 3307 SPECIAL PURPOSE KITS

FIG. 13 HOOD LATCH STRAP MOUNTING

1	PFOZZ	5305000680509	80204	B1821BH025C125N	SCREW,CAP,HEXAGON H 1/4-20 X 1 1/4", GR 8 HEX BOLT.....	12
2	PFOZZ	5310008238804	96906	MS27183-9	WASHER,FLAT 1/4 USS HARDENED FLAT WASHER.....	24
3	PFOZZ	5310015317280	81349	M45913/1-4CG8Z	NUT,SELF-LOCKING,HE 1/4-20, GR 8 HEX NUT.....	12

END OF FIGURE

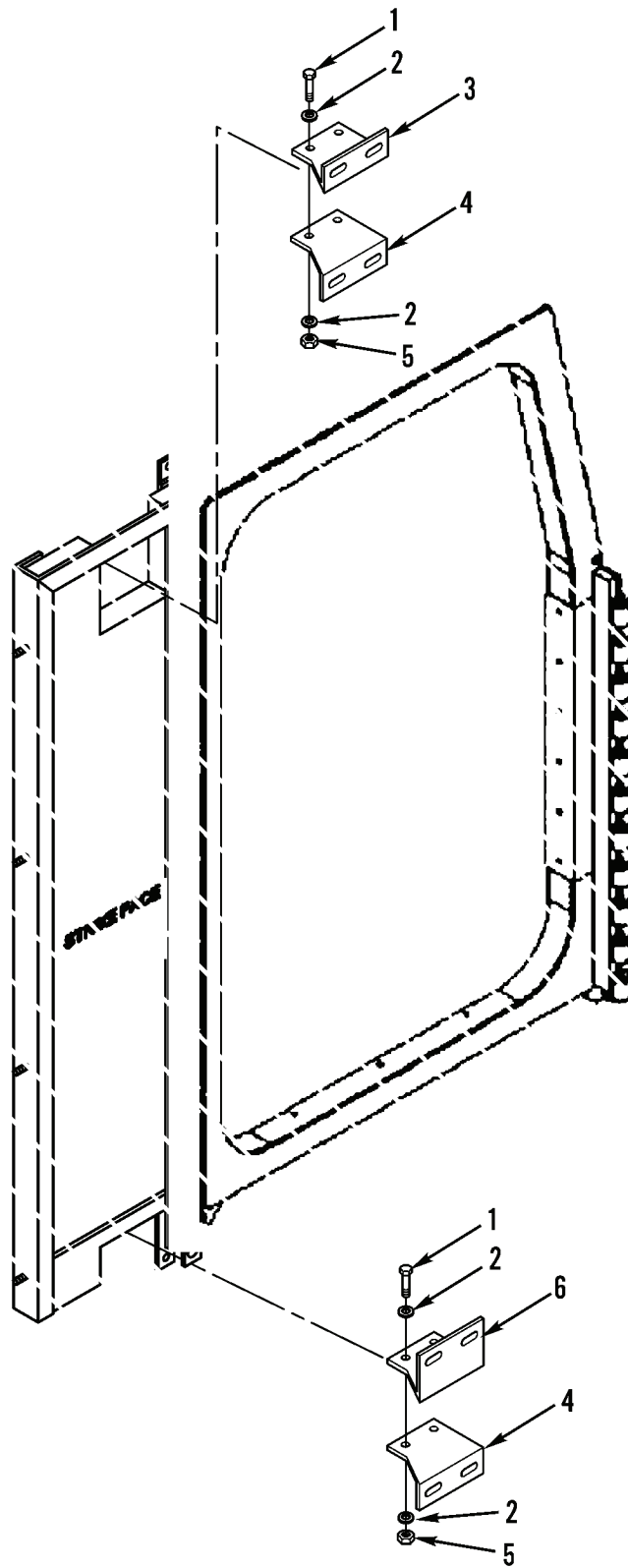

Figure 14. Exhaust Stack Brackets and Mounting

(1) ITEM NO	(2) SMR CODE	(3) NSN	(4) CAGEC	(5) PART NUMBER	(6) DESCRIPTION AND USABLE ON CODES(UOC)	(7) QTY
GROUP 3307 SPECIAL PURPOSE KITS						
FIG. 14 EXHAUST STACK BRACKETS AND MOUNTING						
1	PFOZZ	5305000712072	80204	B1821BH050C225N	SCREW,CAP,HEXAGON H.....	4
2	PFOZZ	5310008095997	96906	MS27183-17	WASHER,FLAT.....	8
3	PAOZZ	2590015501773	3KHA7	110-170058-001	UPPER BRACKET, EXHA UPPER BRACKET..	1
4	PAOZZ	2590015501778	3KHA7	110-170058-002	UPPER BRACKET, EXHA UPPER AND LOWER	2
5	PFOZZ	5310015279522	81349	M45913/2-8CG8Z	NUT,SELF-LOCKING,HE.....	4
6	PAOZZ	2590015501874	3KHA7	110-170057-001	LOWER BRACKET,EXHAU LOWER BRACKET, EXHAUST STACK.....	1

END OF FIGURE



## CROSS-REFERENCE INDEXES

NATIONAL STOCK NUMBER INDEX						
STOCK NUMBER	FIG.	ITEM	STOCK NUMBER	FIG.	ITEM	
5310-00-004-5033	3	16	5306-00-226-4827	9	18	
	5	5		10	4	
	6	6	5306-00-226-4829	1	4	
	7	5		11	1	
5305-00-068-0508	10	2	5305-00-226-4831	2	3	
	4	6		7	14	
	8	11		5306-00-226-4833	3	11
9	20	5305-00-269-3211	3		18	
5305-00-068-0509	13		1	11	9	
5305-00-068-0510	4	36	5305-00-269-3218	11	3	
	5	8		11	28	
	6	7		5310-00-407-9566	2	4
	10	1			4	16
5305-00-068-0511	7	18	4	26		
	12	2	7	13		
	14	1	9	12		
5305-00-071-2072	14	1	9	12		
5305-00-071-2073	11	20	10	5		
5305-00-071-2509	1	6	5310-00-582-5965	1	8	
5305-00-071-2510	8	1		4	5	
5310-00-080-6004	2	5		8	3	
	3	17	5305-00-638-8920	11	25	
	4	37		11	18	
	5	4	5310-00-732-0558	5	6	
	6	5	5310-00-761-6882	9	22	
	7	4	5310-00-809-5997	11	21	
	7	19		14	2	
	10	3	5310-00-823-8804	1	7	
	11	4		4	4	
	11	10		4	22	
	11	17		7	11	
	11	29		8	2	
	12	3		9	21	
	5310-00-081-4219	1		2	13	2
2		9		5315-00-839-5822	3	15
3		9	5310-00-880-7744	2	12	
4		9		4	10	
4		27	9	11		
7		17	6920-01-235-0243	4	15	
9		13	5320-01-289-0030	5	7	
10		6	5305-01-325-8387	7	3	
11		2	5340-01-525-8632	4	7	
5305-00-225-3843		4		23	4	19
	4	35	2540-01-526-6224	4	18	
	7	15		5310-01-527-9522	11	22
	8	10	14		5	
5306-00-225-8499	3	8	5310-01-531-3912	4	38	
5306-00-226-4825	4	17		5	9	
5306-00-226-4827	2	10	6	8		
	4	25	7	2		
	7	16	7	20		



## CROSS-REFERENCE INDEXES

NATIONAL STOCK NUMBER INDEX					
STOCK NUMBER	FIG.	ITEM	STOCK NUMBER	FIG.	ITEM
5310-01-531-3912	10	11	2510-01-550-1191	4	8
	11	14	2590-01-550-1193	7	9
	11	16	2590-01-550-1197	5	2
	12	4	2590-01-550-1198	7	24
5310-01-531-3929	1	3	2590-01-550-1200	5	10
	4	34	2590-01-550-1212	6	1
	7	22	2540-01-550-1217	3	10
	11	8	2590-01-550-1218	4	13
5310-01-531-7280	4	24	2590-01-550-1243	4	29
	4	30	3040-01-550-1250	3	19
	7	10	2540-01-550-1260	9	25
	8	12	5340-01-550-1268	10	9
2540-01-543-8440	13	3	2510-01-550-1273	4	14
	8	6	2590-01-550-1277	11	36
2540-01-543-8447	4	2	2540-01-550-1279	6	2
2540-01-543-8448	3	3	5340-01-550-1280	11	37
2540-01-543-8450	3	5	5340-01-550-1284	11	7
5310-01-549-9043	3	13	2590-01-550-1294	6	4
5340-01-549-9045	11	30	2590-01-550-1313	7	23
5340-01-549-9054	11	35	2540-01-550-1317	7	6
5340-01-549-9056	3	22	5340-01-550-1323	7	1
5305-01-549-9180	4	11	2510-01-550-1363	8	9
2510-01-549-9648	9	4	2590-01-550-1634	11	15
5340-01-549-9698	9	14	2540-01-550-1682	8	16
2540-01-549-9711	3	20	2590-01-550-1687	9	7
2510-01-549-9719	3	4	2590-01-550-1689	9	5
2510-01-549-9881	1	5	2510-01-550-1693	9	15
2540-01-550-0183	3	14	2540-01-550-1699	9	2
2510-01-550-0191	4	32	2590-01-550-1704	9	1
2510-01-550-0328	4	3	2590-01-550-1714	11	11
2540-01-550-0857	2	1	2540-01-550-1746	11	33
2590-01-550-0860	2	2	2590-01-550-1751	11	5
2510-01-550-0866	3	2	2590-01-550-1755	11	32
2510-01-550-0869	4	28	2510-01-550-1763	12	1
2510-01-550-0873	4	21	2590-01-550-1773	14	3
2510-01-550-0878	4	1	2590-01-550-1778	14	4
2540-01-550-0887	5	1	2540-01-550-1785	10	7
2590-01-550-0896	5	3		10	8
2510-01-550-0934	2	8	2540-01-550-1794	10	10
2590-01-550-0992	2	6	2590-01-550-1797	11	6
2540-01-550-1134	2	11	2540-01-550-1816	11	12
2540-01-550-1139	2	7	2590-01-550-1831	11	19
2590-01-550-1171	9	19	2590-01-550-1840	11	24
2510-01-550-1174	8	5	2540-01-550-1861	11	27
2510-01-550-1175	8	15	2540-01-550-1870	11	34
2590-01-550-1177	9	16	2590-01-550-1874	14	6
2590-01-550-1179	8	17	2540-01-550-2218	7	8
2590-01-550-1180	8	18	2540-01-550-2239	11	31
5340-01-550-1182	7	7	2540-01-550-2538	8	4
2510-01-550-1188	8	14	2510-01-550-2551	8	8

CROSS-REFERENCE INDEXES

STOCK NUMBER	NATIONAL STOCK NUMBER INDEX		FIG.	ITEM
	FIG.	ITEM		
2510-01-550-2556	8	13		
2590-01-550-2558	7	12		
2510-01-550-2564	8	7		
2510-01-550-2567	9	17		
2510-01-550-2571	9	10		
5365-01-550-2573	11	13		
2510-01-550-2576	9	3		
2540-01-550-2584	9	6		
2540-01-550-2591	9	8		
2590-01-550-3302	11	23		
2590-01-550-3310	7	21		
2590-01-550-3313	11	26		
2590-01-550-3321	9	23		
2540-01-550-3329	9	9		
2590-01-550-3343	9	24		
5315-01-550-3808	3	1		
5330-01-550-5379	3	21		
5340-01-550-5380	3	6		
5310-01-550-5406	4	12		
2590-01-550-7463	6	3		
5340-01-550-7540	1	1		
5340-01-550-7543	3	7		
5340-01-550-7549	3	12		
5340-01-550-7552	4	20		
5365-01-550-7556	4	33		

## CROSS-REFERENCE INDEXES

CAGEC	PART NUMBER	PART NUMBER INDEX		FIG.	ITEM
			STOCK NUMBER		
80204	B1821BH025C075N	5305-00-068-0508		4	6
				8	11
				9	20
80204	B1821BH025C100N	5305-00-225-3843		4	23
				4	35
				7	15
				8	10
80204	B1821BH025C125N	5305-00-068-0509		13	1
80204	B1821BH025C150N	5305-00-071-2509		1	6
80204	B1821BH025C175N	5305-00-071-2510		8	1
80204	B1821BH031C075N	5306-00-226-4825		4	17
80204	B1821BH031C100N	5306-00-226-4827		2	10
				4	25
				7	16
				9	18
				10	4
80204	B1821BH031C125N	5306-00-226-4829		1	4
				11	1
80204	B1821BH031C150N	5305-00-226-4831		2	3
				7	14
80204	B1821BH031C200N	5306-00-226-4833		3	11
05047	B1821BH038C100N	5305-00-068-0510		4	36
				5	8
				6	7
				10	1
80204	B1821BH038C125N	5305-00-068-0511		7	18
				12	2
80204	B1821BH038C150N	5305-00-725-2317		11	18
80204	B1821BH038C225N	5305-00-638-8920		11	25
80204	B1821BH050C225N	5305-00-071-2072		14	1
80204	B1821BH050C250N	5305-00-071-2073		11	20
80205	MS24665-353	5315-00-839-5822		3	15
96906	MS27183-12	5310-00-081-4219		1	2
				2	9
				3	9
				4	9
				4	27
				7	17
				9	13
				10	6
				11	2
				11	2
			96906	MS27183-14	5310-00-080-6004
	3	17			
	4	37			
	5	4			
	6	5			
	7	4			
	7	19			
	10	3			
	11	4			
	11	10			

## CROSS-REFERENCE INDEXES

CAGEC	PART NUMBER	PART NUMBER INDEX		FIG.	ITEM
			STOCK NUMBER		
96906	MS27183-14	5310-00-080-6004	11	17	
			11	29	
			12	3	
96906	MS27183-17	5310-00-809-5997	11	21	
			14	2	
96906	MS27183-9	5310-00-823-8804	1	7	
			4	4	
			4	22	
			7	11	
			8	2	
			9	21	
80205	MS35338-44	5310-00-582-5965	13	2	
			1	8	
			4	5	
80205	MS35338-45	5310-00-407-9566	8	3	
			2	4	
			4	16	
			4	26	
			7	13	
			9	12	
80205	MS35338-46	5310-00-004-5033	10	5	
			3	16	
			5	5	
			6	6	
			7	5	
96906	MS51967-2	5310-00-761-6882	10	2	
			9	22	
96906	MS51967-5	5310-00-880-7744	2	12	
			4	10	
			9	11	
96906	MS51967-8	5310-00-732-0558	5	6	
80205	MS90725-34	5306-00-225-8499	3	8	
80205	MS90725-60	5305-00-269-3211	3	18	
			11	9	
80205	MS90725-64	5305-01-325-8387	7	3	
80205	MS90725-68	5305-00-269-3218	11	3	
			11	28	
			11	28	
81349	M45913/1-4CG8Z	5310-01-531-7280	4	24	
			4	30	
			7	10	
			8	12	
			13	3	
81349	M45913/2-5CG8Z	5310-01-531-3929	1	3	
			4	34	
			7	22	
			11	8	
81349	M45913/2-6CG8Z	5310-01-531-3912	4	38	
			5	9	
			6	8	
			7	2	
			7	20	

## CROSS-REFERENCE INDEXES

CAGEC	PART NUMBER	PART NUMBER INDEX		FIG.	ITEM
			STOCK NUMBER		
81349	M45913/2-6CG8Z		5310-01-531-3912	10	11
				11	14
				11	16
				12	4
81349	M45913/2-8CG8Z		5310-01-527-9522	11	22
				14	5
80205	NAS9301E-4-06		5320-01-289-0030	5	7
3KHA7	110-100045-001		5340-01-525-8632	4	7
				4	19
3KHA7	110-105119-001		5340-01-549-9056	3	22
3KHA7	110-170020-001		2510-01-550-0191	4	32
3KHA7	110-170030-001		2590-01-550-1243	4	29
3KHA7	110-170034-001		2510-01-550-0869	4	28
3KHA7	110-170036-001		2510-01-550-0873	4	21
3KHA7	110-170037-001		5340-01-550-7552	4	20
3KHA7	110-170040-001		2590-01-550-1200	5	10
3KHA7	110-170050-001		2590-01-550-0896	5	3
3KHA7	110-170055-001		5365-01-550-7556	4	33
3KHA7	110-170057-001		2590-01-550-1874	14	6
3KHA7	110-170058-001		2590-01-550-1773	14	3
3KHA7	110-170058-002		2590-01-550-1778	14	4
3KHA7	110-170060-001		5340-01-550-7540	1	1
3KHA7	110-170060-002		2510-01-549-9881	1	5
3KHA7	110-170085-001		2510-01-550-0866	3	2
3KHA7	110-170085-002		2510-01-549-9719	3	4
3KHA7	110-170121-001		2540-01-543-8448	3	3
3KHA7	110-170121-002		2540-01-543-8450	3	5
3KHA7	110-170135-001		5315-01-550-3808	3	1
3KHA7	110-170140-001		2590-01-550-1212	6	1
3KHA7	110-170140-002		2590-01-550-1294	6	4
3KHA7	110-170148-001		2540-01-550-2218	7	8
3KHA7	110-170150-001		2590-01-550-2558	7	12
3KHA7	110-170160-001		2590-01-550-1313	7	23
3KHA7	110-170170-001		2590-01-550-3310	7	21
3KHA7	110-170181-001		2540-01-550-1794	10	10
3KHA7	110-170182-001		2540-01-550-1785	10	7
				10	8
3KHA7	110-170185-002		5340-01-550-1268	10	9
3KHA7	110-170190-001		2590-01-550-1751	11	5
3KHA7	110-170190-002		2590-01-550-1755	11	32
3KHA7	110-170191-001		5340-01-550-1284	11	7
3KHA7	110-170200-001		2510-01-550-2556	8	13
3KHA7	110-170200-002		2510-01-550-2564	8	7
3KHA7	110-170205-001		2540-01-543-8440	8	6
3KHA7	110-170210-001		2510-01-550-1188	8	14
3KHA7	110-170210-002		2510-01-550-1363	8	9
3KHA7	110-170220-001		2510-01-550-1175	8	15
3KHA7	110-170220-002		2510-01-550-2551	8	8
3KHA7	110-170225-001		2510-01-550-1174	8	5
3KHA7	110-170226-001		2590-01-550-1180	8	18
3KHA7	110-170227-001		2540-01-550-1682	8	16

## CROSS-REFERENCE INDEXES

CAGEC	PART NUMBER	PART NUMBER INDEX		FIG.	ITEM
			STOCK NUMBER		
3KHA7	110-170228-001		2540-01-550-2538	8	4
3KHA7	110-170229-001		2590-01-550-1179	8	17
3KHA7	110-170230-001		2510-01-550-1763	12	1
3KHA7	110-170240-001		2510-01-550-1693	9	15
3KHA7	110-170245-001		2590-01-550-1687	9	7
3KHA7	110-170245-002		2590-01-550-1689	9	5
3KHA7	110-170248-001		2540-01-550-1260	9	25
3KHA7	110-170250-001		2510-01-550-2567	9	17
3KHA7	110-170255-001		2590-01-550-1171	9	19
3KHA7	110-170256-001		5340-01-549-9698	9	14
3KHA7	110-170260-001		2510-01-550-2571	9	10
3KHA7	110-170260-002		2510-01-550-2576	9	3
3KHA7	110-170265-001		2590-01-550-3343	9	24
3KHA7	110-170265-002		2590-01-550-1704	9	1
3KHA7	110-170275-001		2590-01-550-3321	9	23
3KHA7	110-170310-001		2540-01-550-0857	2	1
3KHA7	110-170311-001		2510-01-550-0934	2	8
3KHA7	110-170312-001		2540-01-550-1134	2	11
3KHA7	110-170313-001		2540-01-550-1139	2	7
3KHA7	110-170314-001		2590-01-550-0860	2	2
3KHA7	110-170316-001		2590-01-550-0992	2	6
3KHA7	110-170321-001		2540-01-550-1861	11	27
3KHA7	110-170322-001		2590-01-550-1831	11	19
3KHA7	110-170323-001		2590-01-550-3313	11	26
3KHA7	110-170323-002		5340-01-550-1280	11	37
3KHA7	110-170324-001		2590-01-550-3302	11	23
3KHA7	110-170325-001		2590-01-550-1840	11	24
3KHA7	110-170331-001		2590-01-550-1277	11	36
3KHA7	110-170364-001		5340-01-550-5380	3	6
3KHA7	110-170365-001		3040-01-550-1250	3	19
3KHA7	110-170366-001		2540-01-549-9711	3	20
3KHA7	110-170367-001		5340-01-550-7549	3	12
3KHA7	110-170368-001		5310-01-549-9043	3	13
3KHA7	110-170369-001		5330-01-550-5379	3	21
3KHA7	110-170370-001		5340-01-550-7543	3	7
3KHA7	110-170391-001		2590-01-550-1634	11	15
3KHA7	110-170392-001		2540-01-550-2239	11	31
3KHA7	110-170393-001		5340-01-549-9045	11	30
3KHA7	110-170394-001		2540-01-550-1816	11	12
3KHA7	110-170395-001		2590-01-550-1714	11	11
3KHA7	110-170400-001		2590-01-550-1797	11	6
3KHA7	110-170405-001		5365-01-550-2573	11	13
3KHA7	110-170411-001		2540-01-550-1870	11	34
3KHA7	110-170412-001		2540-01-550-1746	11	33
3KHA7	110-170413-001		5340-01-549-9054	11	35
3KHA7	110-170420-001		2540-01-550-1317	7	6
3KHA7	110-170430-001		5340-01-550-1182	7	7
3KHA7	110-170435-001		5340-01-550-1323	7	1
3KHA7	110-170440-001		2510-01-550-0878	4	1
3KHA7	110-170445-001		2540-01-543-8447	4	2
3KHA7	110-170448-001		2510-01-550-0328	4	3

## CROSS-REFERENCE INDEXES

CAGEC	PART NUMBER	PART NUMBER INDEX		FIG.	ITEM
			STOCK NUMBER		
3KHA7	110-170450-001		2510-01-550-1191	4	8
3KHA7	110-170460-001		2510-01-550-1273	4	14
3KHA7	110-170485-001		2590-01-550-1218	4	13
3KHA7	110-170490-001		5310-01-550-5406	4	12
3KHA7	110-200301-100		2540-01-526-6224	4	18
3KHA7	110-200336-100		2590-01-550-1198	7	24
3KHA7	110-200337-100		2590-01-550-1193	7	9
3KHA7	110-200703-001		2540-01-550-0887	5	1
3KHA7	110-200704-000		2540-01-550-1279	6	2
3KHA7	110-200705-000		2590-01-550-7463	6	3
3KHA7	110-200706-001		2590-01-550-1197	5	2
3KHA7	110-200801-000		2540-01-550-2584	9	6
3KHA7	110-200802-000		2540-01-550-2591	9	8
3KHA7	110-200803-000		2510-01-549-9648	9	4
3KHA7	110-200804-000		2540-01-550-3329	9	9
3KHA7	110-200805-000		2590-01-550-1177	9	16
3KHA7	110-200806-000		2540-01-550-1699	9	2
19200	11784609		6920-01-235-0243	4	15
3KHA7	5624-52-ZN		2540-01-550-1217	3	10
3KHA7	7011-C		2540-01-550-0183	3	14
3A054	92620A591		5305-01-549-9180	4	11

## INDEX

<i>Subject</i>	<i>Work Package/Page</i>
<b>A</b>	
Abbreviations/Acronyms, List of .....	0001 00-2
A-Pillar Armor Replacement .....	0024 00-1
Applying Torque .....	0011 00-5
Armor Replacement	
A-Pillar .....	0024 00-1
Center Firewall .....	0029 00-1
Cowl .....	0032 00-1
Left B-Pillar .....	0022 00-1
Left Firewall .....	0027 00-1
Rear Cab .....	0018 00-1
Right B-Pillar .....	0023 00-1
Right Firewall .....	0028 00-1
Roof .....	0031 00-1
<b>C</b>	
Center Firewall Armor Replacement .....	0029 00-1
Cleaning	
Ballistic Glass .....	0010 00-1
Instructions .....	0011 00-2
Corrosion Prevention and Control (CPC) .....	0001 00-1
Cowl Armor Replacement .....	0032 00-1
Crew Protection Kit Installation Instructions .....	0038 00-1
<b>D</b>	
Description and Use of Operator’s Controls and Indicators .....	0004 00-1
Destruction of Army Materiel to Prevent Enemy Use .....	0001 00-1
Door	
Ballistic Glass and Frame Assembly Replacement .....	0016 00-1
Cam Latch Adjustment .....	0015 00-1
Cam Latch Replacement .....	0014 00-1
Handle Replacement .....	0013 00-1
Door and Frame Assembly Replacement .....	0012 00-1
<b>E</b>	
Emergency Egress Installation Instructions V2.0 .....	0040 00-1
Emergency Egress Operation	
From Inside Cab .....	0006 00-1
From Outside Cab .....	0006 00-2
Emergency Egress Replacement .....	0019 00-1
Equipment Characteristics, Capabilities, and Features .....	0002 00-1
Expendable and Durable Items List .....	0036 00-1



## INDEX - Continued

<i>Subject</i>	<i>Work Package/Page</i>
<b>G</b>	
General Information .....	0001 00-1
General Maintenance Instructions .....	0011 00-1
<b>I</b>	
Initial Adjustments and Daily Checks .....	0005 00-1
Inspection Instructions .....	0011 00-4
Installation Instructions	
Crew Protection Kit .....	0038 00-1
Emergency Egress .....	0040 00-1
M915 Upgrade Armor Kit .....	0039 00-1
<b>L</b>	
Left B-Pillar Armor Replacement .....	0022 00-1
Left Firewall Armor Replacement .....	0027 00-1
Left Wheel Well Blast Deflector Replacement .....	0025 00-1
List of Abbreviations/Acronyms .....	0001 00-2
Location and Description of Major Components .....	0002 00-2
<b>M</b>	
M915 Upgrade Armor Kit Installation Instructions .....	0039 00-1
Maintenance Allocation Chart (MAC)	
Tables .....	0035 00-1
Maintenance Forms, Records, and Reports .....	0001 00-1
<b>O</b>	
Operating Vehicle .....	0005 00-1
Operation	
In Extreme Temperatures .....	0006 00-2
Under Unusual Conditions .....	0006 00-1
Under Usual Conditions .....	0005 00-1
Operator's Controls and Indicators, Description and Use of .....	0004 00-1
<b>P</b>	
Painting Instructions .....	0011 00-4
Plexiglass Window Replacement .....	0020 00-1
Preparation for Storage or Shipment .....	0001 00-2
Preventive Maintenance Checks and Services (PMCS)	
Introduction .....	0008 00-1
Procedures .....	0009 00-1

## INDEX - Continued

<i>Subject</i>	<i>Work Package/Page</i>
<b>R</b>	
Rear Cab Armor Replacement .....	0018 00-1
References .....	0033 00-1
Repair Parts and Special Tools List (RPSTL) Introduction .....	0041 00-1
Repair Parts and Special Tools List (RPSTL) .....	0042 00-1
Reporting Equipment Improvement Recommendations (EIRs) .....	0001 00-1
Right B-Pillar Replacement .....	0023 00-1
Right Firewall Armor Replacement .....	0028 00-1
Right Wheel Well Blast Deflector Replacement .....	0026 00-1
Roof Armor Replacement .....	0031 00-1
<b>S</b>	
Standard Tool Requirements .....	0011 00-4
Storage or Shipment, Preparation for .....	0001 00-2
Stowage and Decal/Data Plate Guide .....	0007 00-1
Stowage Box Adapter Frame Replacement .....	0021 00-1
<b>T</b>	
Tagging Instructions .....	0011 00-5
Theory of Operation .....	0003 00-1
Torque Limits .....	0037 00-1
<b>U</b>	
Underbody Mine Blast Panel Replacement .....	0017 00-1
Use of	
Sealant .....	0011 00-5
Thread Adhesive .....	0011 00-5
<b>W</b>	
Windshield Ballistic Glass Replacement .....	0030 00-1
Work Safety .....	0011 00-2



By Order of the Secretary of the Army:

GEORGE W. CASEY JR.  
*General, United States Army*  
*Chief of Staff*

Official:

  
JOYCE E. MORROW  
*Administrative Assistant to the*  
*Secretary of the Army*  
0624308

**DISTRIBUTION:** To be distributed in accordance with the initial distribution requirements for IDN: 344848, requirements for TB 9-2320-302-13&P-2.



<b>RECOMMENDED CHANGES TO PUBLICATIONS AND BLANK FORMS</b>  For use of this form, see AR 25-30; the proponent agency is ODISC4.	Use Part II (reverse) for Repair Parts and Special Tools Lists (RPSTL) and Supply Catalogs/Supply Manuals (SC/SM)	DATE  Date you filled out this form
TO: (Forward to proponent of publication or form) (Include ZIP Code) AMSTA-LC-LPIT / TECH PUBS, TACOM-RI 1 Rock Island Arsenal Rock Island, IL 61299-7630	FROM: (Activity and location) (Include ZIP Code)  Your mailing address	

**PART I—ALL PUBLICATIONS (EXCEPT RPSTL AND SC/SM) AND BLANK FORMS**

PUBLICATION NUMBER	DATE	TITLE
--------------------	------	-------

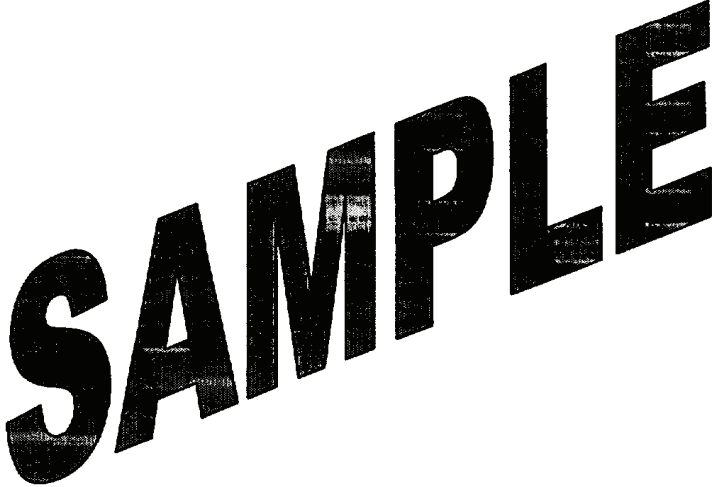
ITEM NO.	PAGE NO.	PARA-GRAPH	LINE NO.*	FIGURE NO.	TABLE NO.	RECOMMENDED CHANGES AND REASON (Provide exact wording of recommended changes, if possible.)
						

*\*Reference to line numbers within the paragraph or subparagraph*

TYPED NAME, GRADE OR TITLE  Your Name	TELEPHONE EXCHANGE/AUTOVON, PLUS EXTENSION	SIGNATURE  Your Signature
---	--	---------------------------------

<b>TO:</b> <i>(Forward direct to addressee listed in publication)</i> AMSTA-LC-LPIT / TECH PUBS, TACOM-RI 1 Rock Island Arsenal Rock Island, IL 61299-7630	<b>FROM:</b> <i>(Activity and location) (Include Zip Code)</i>  Your Address	<b>DATE</b> Date you filled out This form
---	--	---

**PART II—REPAIR PARTS AND SPECIAL TOOL LISTS AND SUPPLY CATALOGS/SUPPLY MANUALS**

PUBLICATION NUMBER			DATE				TITLE	
PAGE NO.	COLM NO.	LINE NO.	NATIONAL STOCK NUMBER	REFERENCE NO.	FIGURE NO.	ITEM NO.	TOTAL NO. OF MAJOR ITEMS SUPPORTED	RECOMMENDED ACTION

**PART III—REMARKS** *(Any general remarks or recommendations, or suggestions for improvement of publications and blank forms. Additional blank sheets may be used if more space is needed.)*

TYPED NAME, GRADE OR TITLE	TELEPHONE EXCHANGE/AUTOVON, PLUS EXTENSION	SIGNATURE

<b>RECOMMENDED CHANGES TO PUBLICATIONS AND BLANK FORMS</b>	Use Part II ( <i>reverse</i> ) for Repair Parts and Special Tools Lists ( <i>RPSTL</i> ) and Supply Catalogs/Supply Manuals ( <i>SC/SM</i> )	DATE
For use of this form, see AR 25-30; the proponent agency is ODISC4.		
TO: ( <i>Forward to proponent of publication or form</i> ) ( <i>Include ZIP Code</i> ) AMSTA-LC-LMPP / TECH PUBS, TACOM-RI 1 Rock Island Arsenal Rock Island, IL 61299-7630	FROM: (Activity and location) ( <i>Include ZIP Code</i> )	

**PART I—ALL PUBLICATIONS (EXCEPT RPSTL AND SC/SM) AND BLANK FORMS**

PUBLICATION NUMBER	DATE	TITLE
TM 9-2320-302-13&P-2	29 June 2007	CREW PROTECTION KIT

ITEM NO.	PAGE NO.	PARA-GRAPH	LINE NO.*	FIGURE NO.	TABLE NO.	RECOMMENDED CHANGES AND REASON ( <i>Provide exact wording of recommended changes, if possible.</i> )

*\*Reference to line numbers within the paragraph or subparagraph*

TYPED NAME, GRADE OR TITLE	TELEPHONE EXCHANGE/AUTOVON, PLUS EXTENSION	SIGNATURE



<b>TO:</b> <i>(Forward direct to addressee listed in publication)</i> AMSTA-LC-LMPP / TECH PUBS, TACOM-RI 1 Rock Island Arsenal Rock Island, IL 61299-7630	<b>FROM:</b> <i>(Activity and location) (Include Zip Code)</i>	<b>DATE</b>
---	--	-------------

**PART II—REPAIR PARTS AND SPECIAL TOOL LISTS AND SUPPLY CATALOGS/SUPPLY MANUALS**

PUBLICATION NUMBER			DATE				TITLE	
TM 9-2320-302-13&P-2			29 June 2007				CREW PROTECTION KIT	
PAGE NO.	COLM NO.	LINE NO.	NATIONAL STOCK NUMBER	REFERENCE NO.	FIGURE NO.	ITEM NO.	TOTAL NO. OF MAJOR ITEMS SUPPORTED	RECOMMENDED ACTION

**PART III—REMARKS** *(Any general remarks or recommendations, or suggestions for improvement of publications and blank forms. Additional blank sheets may be used if more space is needed.)*

TYPED NAME, GRADE OR TITLE	TELEPHONE EXCHANGE/AUTOVON, PLUS EXTENSION	SIGNATURE

<b>RECOMMENDED CHANGES TO PUBLICATIONS AND BLANK FORMS</b>	Use Part II ( <i>reverse</i> ) for Repair Parts and Special Tools Lists ( <i>RPSTL</i> ) and Supply Catalogs/Supply Manuals ( <i>SC/SM</i> )	DATE
For use of this form, see AR 25-30; the proponent agency is ODISC4.		
TO: ( <i>Forward to proponent of publication or form</i> ) ( <i>Include ZIP Code</i> ) AMSTA-LC-LMPP / TECH PUBS, TACOM-RI 1 Rock Island Arsenal Rock Island, IL 61299-7630	FROM: (Activity and location) ( <i>Include ZIP Code</i> )	

**PART I—ALL PUBLICATIONS (EXCEPT RPSTL AND SC/SM) AND BLANK FORMS**

PUBLICATION NUMBER	DATE	TITLE
TM 9-2320-302-13&P-2	29 June 2007	CREW PROTECTION KIT

ITEM NO.	PAGE NO.	PARA-GRAPH	LINE NO.*	FIGURE NO.	TABLE NO.	RECOMMENDED CHANGES AND REASON ( <i>Provide exact wording of recommended changes, if possible.</i> )

*\*Reference to line numbers within the paragraph or subparagraph*

TYPED NAME, GRADE OR TITLE	TELEPHONE EXCHANGE/AUTOVON, PLUS EXTENSION	SIGNATURE

<b>TO:</b> <i>(Forward direct to addressee listed in publication)</i> AMSTA-LC-LMPP / TECH PUBS, TACOM-RI 1 Rock Island Arsenal Rock Island, IL 61299-7630	<b>FROM:</b> <i>(Activity and location) (Include Zip Code)</i>	<b>DATE</b>
---	--	-------------

**PART II—REPAIR PARTS AND SPECIAL TOOL LISTS AND SUPPLY CATALOGS/SUPPLY MANUALS**

PUBLICATION NUMBER			DATE				TITLE	
TM 9-2320-302-13&P-2			29 June 2007				CREW PROTECTION KIT	
PAGE NO.	COLM NO.	LINE NO.	NATIONAL STOCK NUMBER	REFERENCE NO.	FIGURE NO.	ITEM NO.	TOTAL NO. OF MAJOR ITEMS SUPPORTED	RECOMMENDED ACTION

**PART III—REMARKS** *(Any general remarks or recommendations, or suggestions for improvement of publications and blank forms. Additional blank sheets may be used if more space is needed.)*

TYPED NAME, GRADE OR TITLE	TELEPHONE EXCHANGE/AUTOVON, PLUS EXTENSION	SIGNATURE

## THE METRIC SYSTEM AND EQUIVALENTS

<p><b>Linear Measure</b></p> <p>1 Centimeter = 10 Millimeters = 0.01 Meters = 0.3937 Inches          1 Meter = 100 Centimeters = 1000 Millimeters = 39.37 Inches          1 Kilometer = 1000 Meters = 0.621 Miles</p> <p><b>Weights</b></p> <p>1 Gram = 0.001 Kilograms = 1000 Milligrams = 0.035 Ounces          1 Kilogram = 1000 Grams = 2.2 Pounds          1 Metric Ton = 1000 Kilograms = 1 Megagram = 1.1 Short Tons</p> <p><b>Liquid Measure</b></p> <p>1 Milliliter = 0.001 Liters = 0.0338 Fluid Ounces          1 Liter = 1000 Milliliters = 33.82 Fluid Ounces</p>	<p><b>Square Measure</b></p> <p>1 Sq Centimeter = 100 Sq Millimeters = 0.155 Sq Inches          1 Sq Meter = 10,000 Sq Centimeters = 10.76 Sq Feet          1 Sq Kilometer = 1,000,000 Sq Meters = 0.386 Sq Miles</p> <p><b>Cubic Measure</b></p> <p>1 Cu Centimeter = 1,000 Cu Millimeters = 0.06 Cu Inches          1 Cu Meter = 1,000,000 Cu Centimeters = 35.31 Cu Feet</p> <p><b>Temperature</b></p> <p><math>5/9 (^{\circ}\text{F} - 32) = ^{\circ}\text{C}</math>          212° Fahrenheit is equivalent to 100° Celsius          90° Fahrenheit is equivalent to 32.2° Celsius          32° Fahrenheit is equivalent to 0° Celsius  <math>9/5 \text{ C}^{\circ} + 32 = \text{F}^{\circ}</math></p>
--	--

## APPROXIMATE CONVERSION FACTORS

To Change	To	Multiply By
Inches	Centimeters	2.540
Feet	Meters	0.305
Yards	Meters	0.914
Miles	Kilometers	1.609
Sq Inches	Sq Centimeters	6.451
Sq Feet	Sq Meters	0.093
Sq Yards	Sq Meters	0.836
Sq Miles	Sq Kilometers	2.590
Acres	Sq Hectometers	0.405
Cubic Feet	Cubic Meters	0.028
Cubic Yards	Cubic Meters	0.765
Fluid Ounces	Milliliters	29.573
Pints	Liters	0.473
Quarts	Liters	0.946
Gallons	Liters	3.785
Ounces	Grams	28.349
Pounds	Kilograms	0.454
Short Tons	Metric Tons	0.907
Pound-Feet	Newton-Meters	1.356
Pounds per Sq Inch	Kilopascals	6.895
Miles per Gallon	Kilometers per Liter	0.425
Miles per Hour	Kilometers per Hour	1.609

To Change	To	Multiply By
Centimeters	Inches	0.394
Meters	Feet	3.280
Meters	Yards	1.094
Kilometers	Miles	0.621
Sq Centimeters	Sq Inches	0.155
Sq Meters	Sq Feet	10.764
Sq Meters	Sq Yards	1.196
Sq Kilometers	Sq Miles	0.386
Sq Hectometers	Acres	2.471
Cubic Meters	Cubic Feet	35.315
Cubic Meters	Cubic Yards	1.308
Milliliters	Fluid Ounces	0.034
Liters	Pints	2.113
Liters	Quarts	1.057
Liters	Gallons	0.264
Grams	Ounces	0.035
Kilograms	Pounds	2.205
Metric Tons	Short Tons	1.102
Newton-Meters	Pound-Feet	0.738
Kilopascals	Pounds per Sq Inch	0.145
Kilometers per Liter	Miles per Gallon	2.354
Kilometers per Hour	Miles per Hour	0.621

