

## TECHNICAL BULLETIN

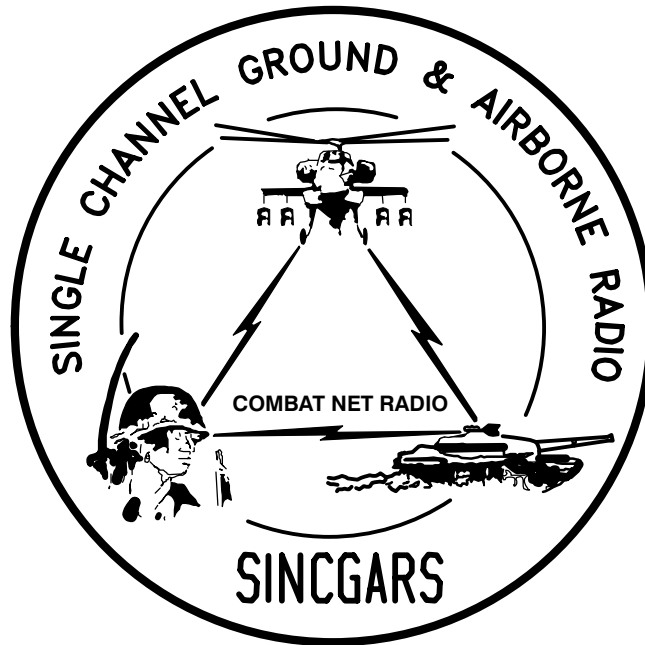

**INSTALLATION INSTRUCTIONS FOR  
INSTALLATION KIT, ELECTRONIC EQUIPMENT MK-2196/VRC  
(NSN 5895-01-229-0670) (EIC: N/A)  
TO PERMIT INSTALLATION OF  
RADIO SET AN/VRC-89/91 SERIES**

**IN A**

**TRUCK, CARGO, 2 1/2 TON, 6x6: M34, M35 A1/A2, M36  
TRUCK, CARGO, 5 TON, 6x6: M54, M813, M814  
TRUCK, WRECKER, MEDIUM, 5 TON, 6x6: M543, M543A2, M816  
TRUCK, TRACTOR, 5 TON, 6x6: M52, M818  
TRUCK, TRACTOR, WRECKER, 5 TON, 6x6: M819  
TRUCK, STAKE, BRIDGE TRANSPORTING, 5 TON, 6x6: M821**

Approved for public release; distribution is unlimited.

---

**HEADQUARTERS, DEPARTMENT OF THE ARMY**

**1 AUGUST 1999**

**INSTALLATION INSTRUCTIONS FOR  
 INSTALLATION KIT, ELECTRONIC EQUIPMENT  
 MK-2196/VRC (NSN 5895-01-229-0670) (EIC: N/A)  
 TO PERMIT INSTALLATION OF  
 RADIO SET AN/VRC-89/91 SERIES  
 IN A  
 TRUCK, CARGO, 2 1/2 TON, 6x6: M34, M35 A1/A2, M36  
 TRUCK, CARGO, 5 TON, 6x6: M54, M813, M814  
 TRUCK, WRECKER, MEDIUM, 5 TON, 6x6: M543, M543A2, M816  
 TRUCK, TRACTOR, 5 TON, 6x6: M52, M818  
 TRUCK, TRACTOR, WRECKER, 5 TON, 6x6: M819  
 TRUCK, STAKE, BRIDGE TRANSPORTING, 5 TON, 6x6: M821**

**REPORTING OF ERRORS AND RECOMMENDING IMPROVEMENTS**

You can help improve this manual. If you find any mistakes, or if you know of a way to improve the procedures, please let us know. Mail your letter, DA Form 2028 (Recommended Changes to Publications and Blank Forms) or DA 2028-2 located in back of this manual direct to: Commander, US Army Communications-Electronics Command Fort Monmouth, ATTN: AMSEL-LC-LEO-D-CS-CFO, Fort Monmouth, New Jersey 07703-5000. The Fax number is 732-532-1413, DSN 992-1413. You may also e-mail your recommendation to AMSEL-LC-LEO-PUBS-CHG@cecom3.monmouth.army.mil.

In either case a reply will be furnished direct to you.

Subject	Section	Page
Scope .....	0.1	1
General Information .....	0.2	1
Maintenance Forms, Records, and Reports .....	0.3	1
Reports of Maintenance and Unsatisfactory Equipment .....	0.3.1	1
Report of Packing and Handling Deficiencies .....	0.3.2	1
Discrepancy in Transportation Deficiency Report (TDR) (SF 361) .....	0.3.3	1
Consolidated Index of Army Publications .....	0.4	1
Purpose of Installation .....	1.	2
End Item or System to be Modified .....	2.	2
Application Times .....	3.	2
Time for Completion of Installation .....	3.1	2
Time for Installation of One Assembly or Component .....	3.2	2
Preparation for Installation .....	4.	2
Preparation of Vehicle .....	4.1	2
Preparation of MK .....	4.2	2
MK, Distribution, and Consumables .....	4.3	3
Tools and Test, Measurement, and Diagnostic Equipment (TMDE) Required .....	4.4	8
Installation Procedures .....	5.	9
Installation of Antenna AS-3900/VRC (antenna) .....	5.1	11
Installation of Antenna Base .....	5.1.1	11
Installation of Top Antenna Assembly .....	5.1.2	14
Installation of Mounting Base, Electrical Equipment MT-6352/VRC (mounting base) .....	5.2	15
Installation of Loudspeaker-Control Unit LS-671/VRC (speaker) .....	5.3	17
Installation of Cables .....	5.4	18
Post-Installation and Checkout .....	5.5	22
Appendix A. References .....		A1

\*This manual supersedes TB 11-5820-890-20-8, dated 1 September 1993.

LIST OF ILLUSTRATIONS

Figure	Title	Page
4-1	MK Illustrated Parts List .....	6
5-1(1)	MK and Radio Installation: MK Equipment Locations .....	9
5-1(2)	MK and Radio Installation: Radio Equipment Locations .....	10
5-2	Antenna Base Installation .....	12
5-3	Top Antenna Assembly Installation .....	14
5-4	Mounting Base Installation .....	15
5-5(1)	Speaker Installation: Dashboard Mounting .....	17
5-5(2)	Speaker Installation: Transmission Hump Mounting .....	18
5-6	Cable Installation: Power, Speaker and RF Cabling .....	19
5-7	Cable Diagram: For AN/VRC-89/91 Series .....	23

LIST OF TABLES

Number	Title	Page
4-1	Parts List for Installation of Radio Set AN/VRC-89/91 Series .....	4

## 0.1 SCOPE

This technical bulletin provides Installation Instructions for Electronic Equipment MK–2196/VRC, commonly referred to as the Mounting Kit (MK). The MK shall be installed into the following type of vehicle(s):

- Truck, Cargo, 21/2 Ton, 6x6, M34, M35 A1/A2, M36
- Truck, Cargo, 5 Ton, 6x6, M54, M813, M814
- Truck, Wrecker, Medium, 5 Ton, 6x6, M543, M543A2, M816
- Truck, Tractor, 5 Ton, 6x6, M52, M818
- Truck, Tractor, Wrecker, 5 Ton, 6x6, M819
- Truck, Stake, Bridge Transporting, 5 Ton, 6x6, M821

The MK is used for installation of radio set components at field locations. The information contained in this technical bulletin is the official authorization to perform the installation at the unit maintenance level.

### NOTES

- This technical bulletin is not an authorization for requisition or turn-in of vehicles.
- This technical bulletin does not establish quantity or types of vehicles assigned to using units.

This technical bulletin does not contain information on the maintenance or replacement of the MKs. This information is contained in the MAC of TM 11–5820–890–20–2 and RPSTL of TM 11–5820–890–20P.

## 0.2 GENERAL INFORMATION.

The MK becomes operable when all the radio set components are installed in the vehicle and correct power is supplied. Refer to TM 11–5820–890–20–1 or TM 11–5820–890–20–2 for installation, Operational (OP) Check instructions, and required maintenance procedures. Refer to TM 11–5820–890–20P for repair parts.

Included in the Radio Set AN/VRC–89/91 Series is:

- Radio Set AN/VRC–89/91 Series (for RT–1523(C)/U)

## 0.3 MAINTENANCE FORMS, RECORDS, AND REPORTS.

**0.3.1 Reports of Maintenance and Unsatisfactory Equipment.** See section 4.2.2.3 for information.

**0.3.2 Report of Packaging and Handling Deficiencies.** See section 4.2.2.1 for information.

**0.3.3 Discrepancy in Transportation Deficiency Report (TDR) (SF361).** See section 4.2.2.2 for information.

## 0.4 CONSOLIDATED INDEX OF ARMY PUBLICATIONS.

Refer to the latest issue of DA Pam 25–30 to determine whether there are new changes, or additional publications pertaining to the equipment.

**1. PURPOSE OF INSTALLATION.**

The Electronic Equipment MK–2196/VRC (MK) contains the items needed to mount Radio Set AN/VRC–89/91 Series in a Truck, Cargo, 2 1/2 Ton, 6x6: M34, M35 A1/A2, M36; Truck, Cargo, 5 Ton, 6x6: M54, M813, M814; Truck, Wrecker, Medium, 5 Ton, 6x6: M543, M543A2, M816; Truck, Tractor, 5 Ton, 6x6: M52, M818; Truck, Tractor, Wrecker, 5 Ton, 6x6: M819 and Truck, Stake, Bridge Transporting, 5 Ton, 6x6: M821 (vehicle).

**2. END ITEM OR SYSTEM TO BE MODIFIED.**

Not applicable.

**3. APPLICATION TIMES.**

**3.1 Time for Completion of Installation.** Using two people, a total of 2.0 work hours is required. Typical vehicle downtime is 3.0 hours.

**3.2 Time for Installation of One Assembly or Component.** The following table lists the time required to install one component. All times have been rounded off to the nearest half hour. The sum of these times will not reflect the typical vehicle downtime.

ITEM	SECTION	TIME
Antenna AS–3900/VRC	5.1	0.5
Mounting Base, Electrical Equipment MT–6352/VRC	5.2	1.5
Cables	5.4	1.0

**4. PREPARATION FOR INSTALLATION.**

This section explains how to prepare the vehicle and MK for installation.

**4.1 Preparation of Vehicle.** To prepare the vehicle for installation, insure that the site includes adequate lighting and a power source when drilling is required. Inspect the vehicle for damage that could affect installation. Have any such damage repaired before installing MK.

**4.1.1 Items to be Removed.** Remove existing AN/VRC–12 radio family installation kit/harness. See TM 11–5820–401–20–2 for removing items used with intercom systems, or TM 11–5820–401–20–1 (used without intercom systems), and TM 9–2320–209–20 (2 1/2 ton series) or TM 9–2320–211–20/TM 9–2320–260–20 (5 ton series).

**4.1.2 List of Items to be Retained.** Not applicable.

**4.2 Preparation of MK.** To prepare MK, unpack, inspect and check inventory.

**4.2.1 Precautions During Handling.** Observe these steps to prevent equipment damage.

- a. Keep dust covers in place on connectors.
- b. Do not disassemble or modify parts in MK unless authorized to do so.
- c. Keep mounting hardware covered and protected until needed.
- d. When exposed to moisture, rain or salt water, keep all parts dry to prevent corrosion.

## **4.2.2 Unpack and Inspect Equipment.**

**4.2.2.1 Inspect Packaging for Evidence of Damage.** Any shipping damage should be reported on SF364 Report of Discrepancy (ROD) as prescribed in AR 735–11–2/DLAR 4140.55/NAVMATINST 4355.73A/AFR 400–64/MCO 4430.3F.

**4.2.2.2 Unpack and Inventory MK.** If any item is missing, fill out and forward Transportation Deficiency Report (TDR) (SF361) as described in AR 55–38/NAVSUPINST 4610.33C/AFR 75–18/MCO P4610.19D/DLAR 4500.15.

**4.2.2.3 Examine Each Item for Damage.** If any item is damaged, fill out and forward SF364 Report of Discrepancy (ROD) as prescribed in AR 735–11–2/DLAR 4140.55/NAVMATINST 4355.73A/AFR 400–64/MCO 4430.3F. All damages should be reported as prescribed by DA Pam 738–750, as contained in Maintenance Management Update.

## **4.3 MK, Distribution, and Consumables.**

**4.3.1 Items Supplied in MK and/or Required for Installation.** Use Table 4–1 and figure 4–1 to identify and inventory MK parts.

### **4.3.2 Distribution and Issue Instructions.**

- a. US Forces: Do not requisition MK. They will be shipped automatically.
- b. US Army Depots: Requisition MK through supply channels.
- c. Multiservice: Instructions shall be included for multiservice modifications.
- d. MAP/MAS Countries: Instructions shall be provided for MAP/MAS countries.

Table 4-1. Parts List for Installation of Radio Set AN/VRC-89/91 Series

NSN	ITEM DESCRIPTION AND PART NUMBER	QUANTITY IN MK	SMR CODE	FIGURE, ITEM NO.
5985-01-297-2971	Antenna AS-3900/VRC (A3017899-1)	2	PAOOF A	4-1, 2
5305-00-847-1159	Screw, Cap, Hexagon (3/8-16 x 1 3/4 in) MS35307-365	8	PAOZZA	
5310-00-913-8881	Nut, Hexagon (3/8-16 in) MS51971-3	8	PAOZZA	
5310-00-061-1258	Washer, Lock, Internal/External-Toothed (3/8 in) MS45904-76	16	PAOZZA	
5310-00-889-2527	Washer, Lock, Internal/External-Toothed (5/16 in) MS45904-72 (Not Used)	4	PAOZZA	
5306-00-225-9086	Bolt, Machine (5/16-24 x 5/8 in) MS90726-31 (Not Used)	2	PAOZZA	
5330-01-205-2864	Gasket (A3013655-1)	2	PAOZZA	
5965-01-222-1420	Loudspeaker-Control Unit LS-671/VRC (A3014065-1)	2	PAOFF A	4-1, 4
5975-01-188-8873	Mounting Base, Electrical Equipment MT-6352/VRC (A3013367-1)	1	PAOOF A	4-1, 1
5306-00-225-9089	Bolt, Machine (5/16-24 x 1 in) MS90726-34 (1 Not Used)	5	PAOZZA	
5310-00-889-2527	Washer, Lock, Internal/External-Toothed (5/16 in) MS45904-72 (2 Not Used)	10	PAOZZA	
5310-00-880-7746	Nut, Hexagon (5/16 - 24 in) MS51968-5 (1 Not Used)	5	PAOZZA	
5995-01-225-7627	Cable Assembly, Power, Electrical CX-13302/VRC (5 ft, 0 in) (A3014039-4)	1	PAOZZA	4-1, 10
5995-01-225-1662	Cable Assembly, Radio Frequency CG-3855/VRC (12 ft, 0 in) (A3014031-12)	1	PAOZZA	4-1, 9
5995-01-219-7035	Cable Assembly, Radio Frequency CG-3855/VRC (18 ft, 0 in) (A3014031-8)	1	PAOZZA	4-1, 9
5995-01-259-9283	Cable Assembly, Special Purpose, Electrical CX-13292/VRC (8 ft, 0 in) (A3014038-12)	1	PAOZZA	4-1, 8
5995-01-219-4704	Cable Assembly, Special Purpose, Electrical CX-13292/VRC (6 ft, 0 in) (A3014038-3)	1	PAOZZA	4-1, 8
5306-00-225-9089	Bolt, Machine (5/16-24 x 1 in) MS90726-34	8	PAOZZA	
5306-01-071-3387	Bolt, U 2 1/4 in (1/4-28 in) NAS3104C18-14	6	PAOZZA	
5306-01-278-4010	Bolt, U 2 1/4 in (1/2-20 in) NAS3108C18-20	4	PAOZZA	
	Bolt, U 2 1/4 in (1/2-20 in) NAS3108C18-28	4	PAOZZA	
	Bracket, Mounting - Antenna (A3050655-1)	2	XBOZZA	4-1, 6
5340-00-809-1490	Clamp, Loop (1/4-1/4 in) MS21333-98	11	PAOZZA	
5340-00-984-8540	Clamp, Loop (1/2-1/4 in) MS21333-102	3	PAOZZA	
5340-00-809-1494	Clamp, Loop (3/4-1/4 in) MS21333-105	1	PAOZZA	
5340-00-088-1254	Clamp, Loop (5/8-1/4 in) MS21333-104	5	PAOZZA	
5340-00-809-1500	Clamp, Loop (1-1/4 in) MS21333-107	1	PAOZZA	

Table 4-1. Parts List for Installation of Radio Set AN/VRC-89/91 Series. Continued

NSN	ITEM DESCRIPTION AND PART NUMBER	QUANTITY IN MK	SMR CODE	FIGURE, ITEM NO.
4020-01-341-8795	Fiber Rope Assembly, Single Leg (A3167672-1)	2	PAOZZA	4-1, 7
5325-00-174-9008	Grommet, Nonmetallic (1/2 in) MS35489-15	1	PAOZZA	
5325-00-174-5315	Grommet, Nonmetallic (1/4 in) MS35489-7	2	PAOZZA	
5965-00-043-3463	Handset H-250/U	2	PAOZZA	4-1, 3
	Lead, Electrical - Ground Strap (1 ft, 6 in) (A3013552-6)	2	XBOZZA	4-1, 11
5310-00-768-0319	Nut, Plain, Hexagon (1/4 -28 in) MS51968-2	12	PAOZZA	
5310-00-761-6882	Nut, Plain, Hexagon (1/4 -20 in) MS51967-2	17	PAOZZA	
5310-00-732-0560	Nut, Plain, Hexagon (1/2 -20 in) MS51968-14	8	PAOZZA	
	Nut Strip (A3014064-1)	4	XBOZZA	4-1, 5
	Plate, Mounting (A3014550-1)	2	XBOZZA	4-1, 13
	Thumbscrew (A3018701-2)	4		
5305-00-068-0502	Screw, Cap, Hexagon (1/4 - 20 x 3/4 in) MS90725-6	18	PAOZZA	
5305-00-432-4253	Screw, Tapping, Pan-Head (1/4 - 14 x 3/4 in) MS51861-67	5	PAOZZA	
5975-00-111-3208	Strap, Tiedown, Electrical Components MS3367-5-9	10	PAOZZA	
	Tube, Metallic (A3014095-1)	2	XBOZZA	4-1, 12
5310-00-809-4058	Washer, Flat (1/4 in) MS27183-10	12	PAOZZA	
5310-00-081-4219	Washer, Flat (5/16 in) MS27183-12	8	PAOZZA	
5310-00-889-2528	Washer, Lock, Internal/External-Toothed (1/4 in) MS45904-68	12	PAOZZA	
5310-00-582-5965	Washer, Lock (1/4 in) MS35338-44	33	PAOZZA	
5310-00-407-9566	Washer, Lock (5/16 in) MS35338-45	8	PAOZZA	
5310-00-584-5272	Washer, Lock (1/2 in) MS35338-48	8	PAOZZA	



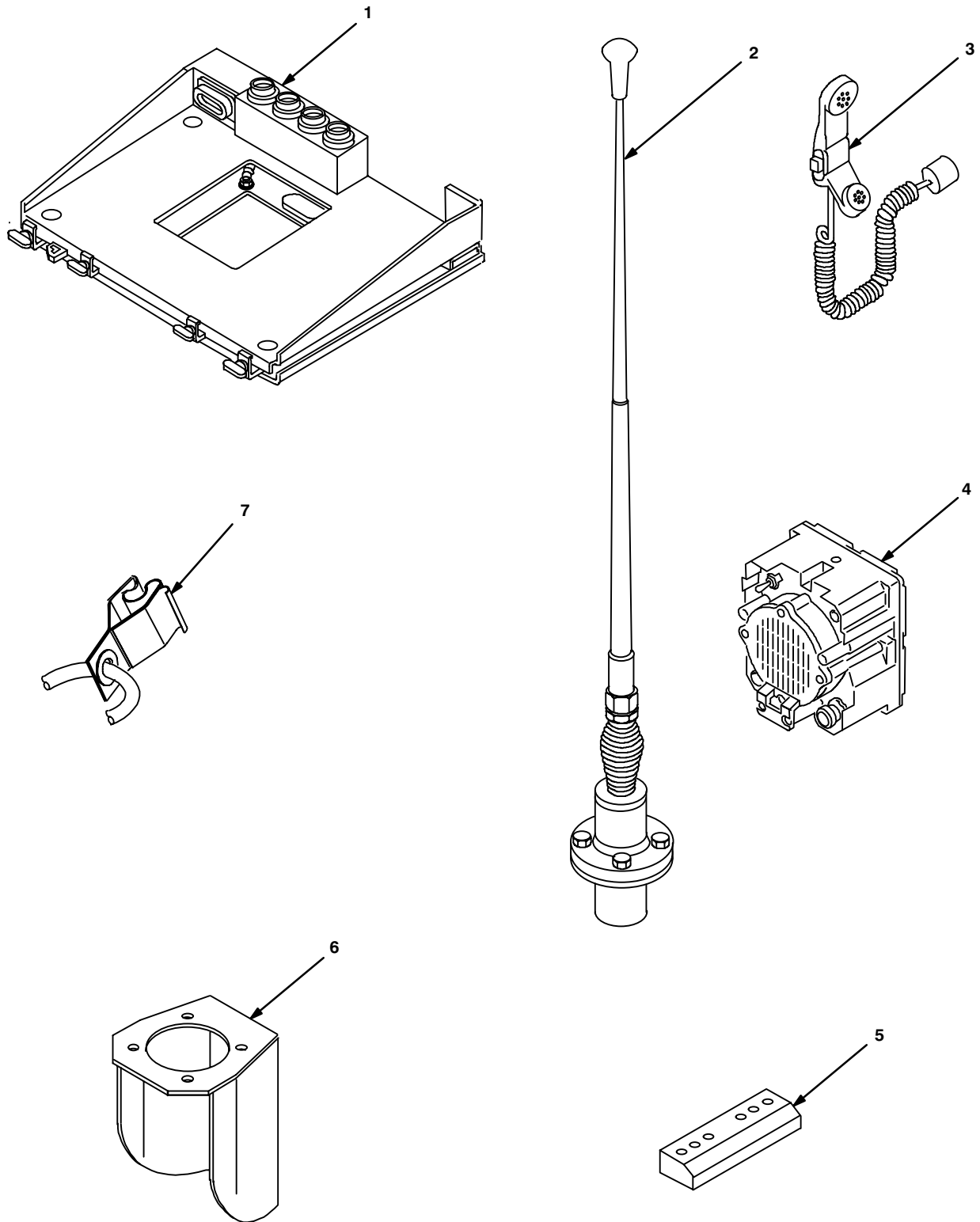

Figure 4-1 (1). MK Illustrated Parts List

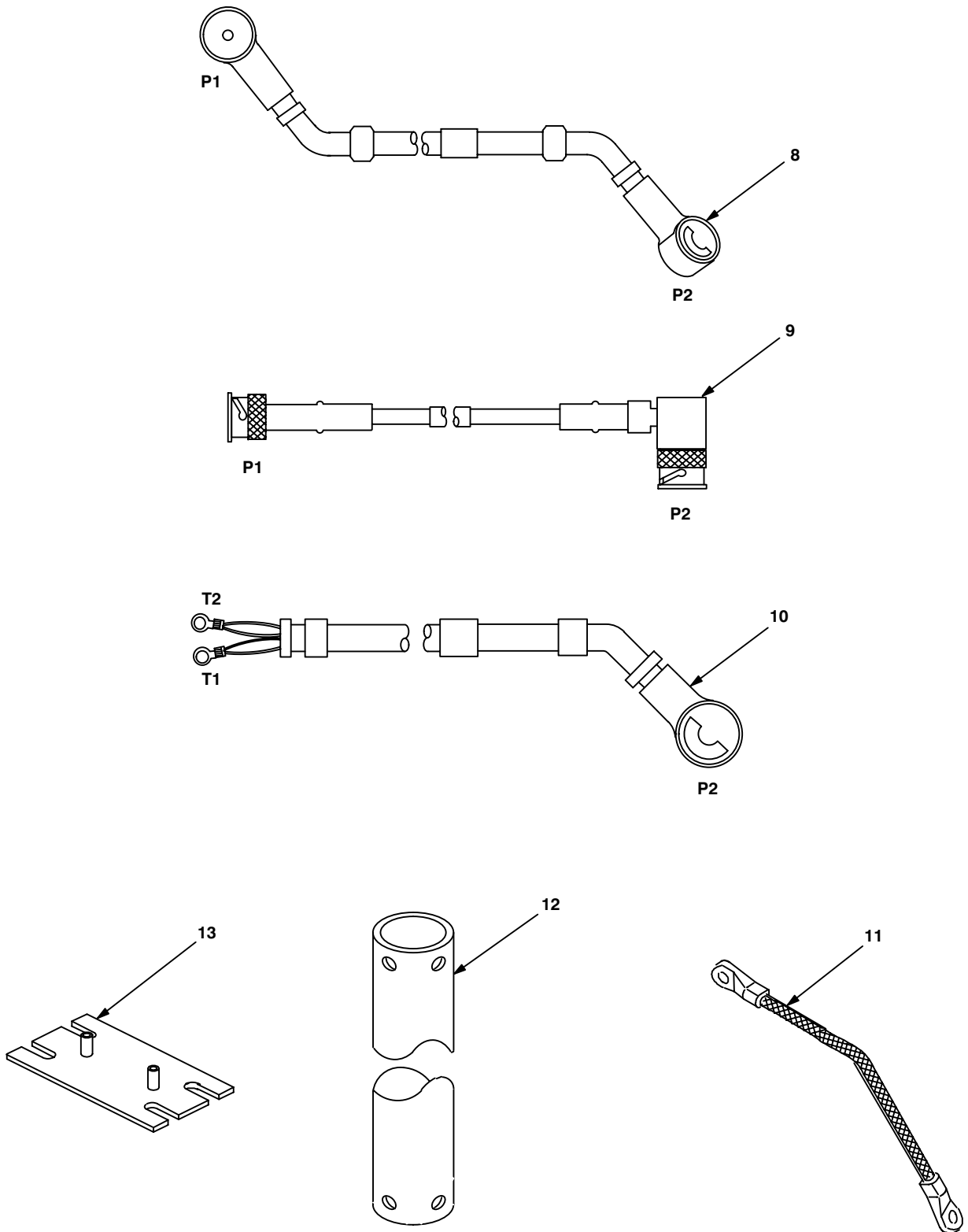

Figure 4-1 (2). MK Illustrated Parts List

**4.3.3 Consumable Materials.** The table below lists materials required for installation but not supplied with MK.

NSN	NOMENCLATURE
8040-00-117-8510	Adhesive-Sealant, Clear, RTV
6850-00-880-7616	Silicone Compound, MIL-S-8660
8030-00-292-1102	Conductive Anti-seize Compound

**4.4 Tools and Test, Measurement, and Diagnostic Equipment (TMDE) Required.** The following tools and TMDE are needed for installation.

NOMENCLATURE	NSN	QUANTITY
Radio Set*		1
Electric Grinder or Equivalent		1
Pocket Knife, Electrician's	5110-00-240-5943	1
Screwdriver, No. 2 Point Phillips, 4 in	5120-00-234-8913	1
Screwdriver, 1/4 in Flatblade, 4 in	5120-00-222-8852	1
Pliers, Round Nose	5120-00-240-6172	1
Pliers, Diagonal Cutting	5110-00-965-0974	1
Wrench, Open/Box: 7/16 in	5120-00-228-9505	1
1/2 in	5120-00-228-9506	1
9/16 in	5120-00-228-9507	1
3/4 in	5120-00-228-9510	1
Handle, Socket Wrench	5120-00-240-5364	1
Socket: 7/16 in	5120-00-227-6703	1
1/2 in	5120-00-237-0977	1
9/16 in	5120-00-227-6704	1
Electric Drill	5130-00-889-8994	1
Drill Bits: 11/32 in	5133-00-227-9664	1
9/32 in	5133-00-222-9374	1
13/64 in	5133-00-243-9612	1
3/4 in	5133-00-266-9471	1

\* Use radio issued with your vehicle if available.

## 5. INSTALLATION PROCEDURES.

This section describes where and how to install all MK items in the vehicle. See figure 5-1 for an overall view of where the MK equipment, as well as radio components, will be installed. When installing MK equipment, be sure to read and follow instructions and illustrations carefully.

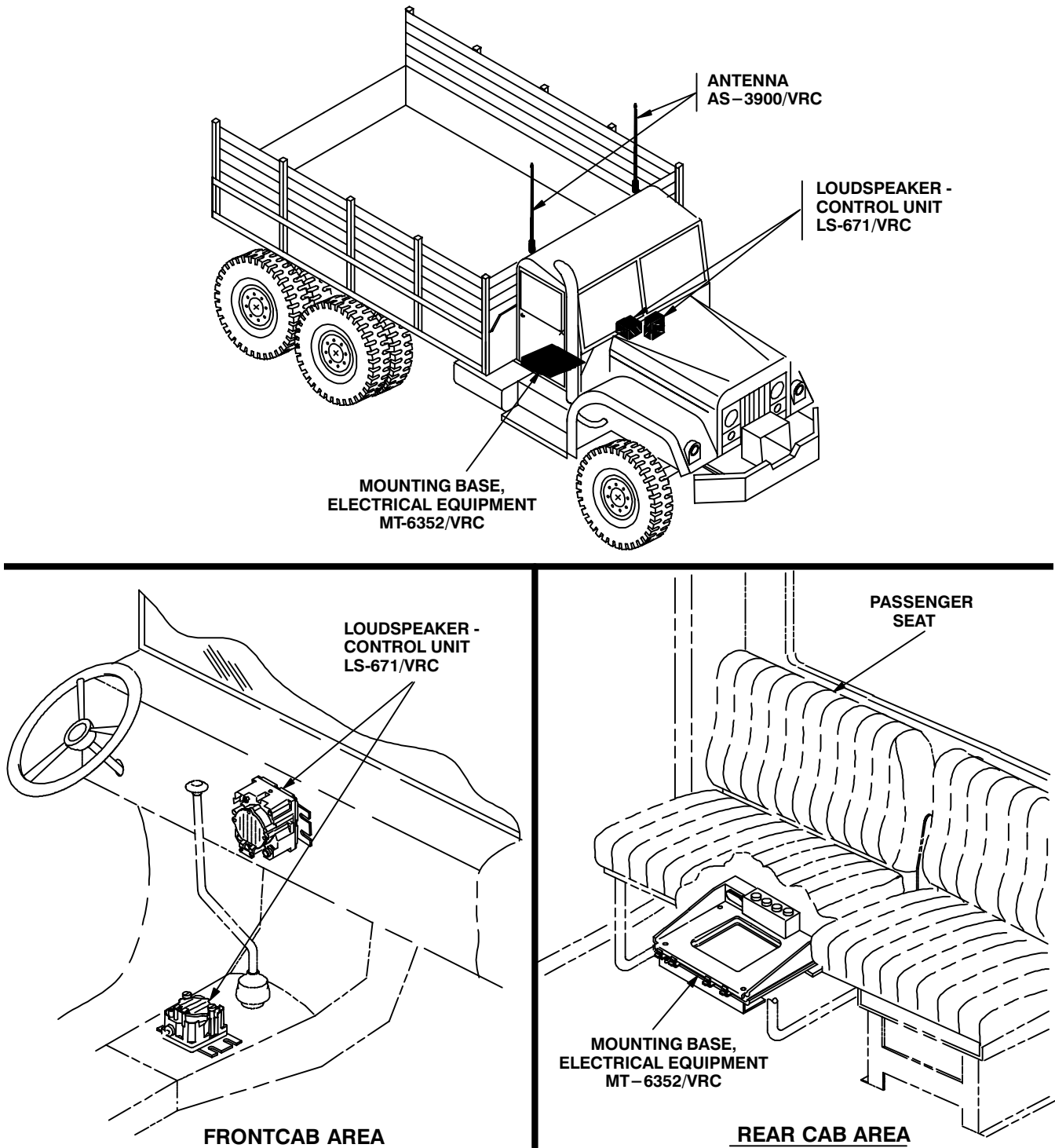

Figure 5-1 (1). MK and Radio Installation: MK Equipment Locations

5. INSTALLATION PROCEDURES. Continued

INSTALLATION  
FOR  
AN/VRC-89/91 Series

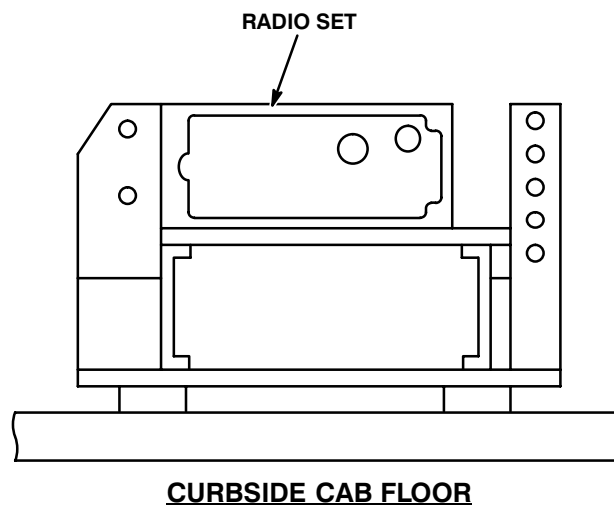

Figure 5-1 (2). MK and Radio Installation: Radio Equipment Locations

**5.1 Installation of Antenna AS-3900/VRC (antenna).** Use the following procedure to install both roadside and curbside antenna bases. Secure loop clamps only after installation and positioning of RF cable is complete. See figures 5-1 (1) for locations.

**5.1.1 Installation of Antenna Base.**

ITEM	ACTION	REMARKS
<b>NOTE</b>		
Apply a thin coat of adhesive-sealant to both sides of each internal/external-toothed (IET) washer during installation, and to the area of contact where IET washer is to be placed.		
a. Two loop clamps (20), cap screw (21), lock washer(13) and nut (19).	Install (without securing) to existing mounting hole in metallic tube (5). See figure 5-2, detail A.	Tools: 7/16 in socket and 7/16 in open/box wrench.
b. Mounting bracket (15) and metallic tube (5).	Position together with tops flush. See figure 5-2.	
c. Three U-bolts (3), six washers (14), six lock washers (13) and six nuts (12).	Install and secure mounting bracket (15) to metallic tube (5).	Tools: 7/16 in socket or 7/16 in open/box wrench.
d. Loop clamp (4), cap screw (1/4-20 x 3/4 in), lock washer (1/4 in) and nut (1/4-20 in).	Install (without securing) on side of mounting bracket (15).	Tools: 7/16 in socket and 7/16 in open/box wrench.
e. Gasket (17).	Place on mounting bracket (15) and aline with mounting holes.	
f. Antenna base (1).	Remove and retain ground strap (7) and mounting hardware.	Tools: Phillips screwdriver.
g. Ground strap (16).	Install and secure to antenna base (1) with mounting hardware retained in step f.	Tools: Phillips screwdriver.
h. Antenna base (1).	Place on top of gasket (17) and aline mounting holes with mounting bracket.	
i. Four cap screws (18), eight internal/external toothed (IET) washers (11) and four nuts (10).	Install and secure to antenna base (1) and mounting bracket (15).	Tools: 9/16 in socket and 9/16 in open/box wrench.
j. RF cable (2) connector P1.	Connect and secure to antenna base (1) connector J1.	Connect 18 ft RF cable to roadside antenna base. Connect 12 ft RF cable to curbside antenna base.
k. RF cable (2) connector P2 and ground strap (16).	Insert upward through loop clamp (4). See figure 5-2.	

5.1.1 Installation of Antenna Base. Continued

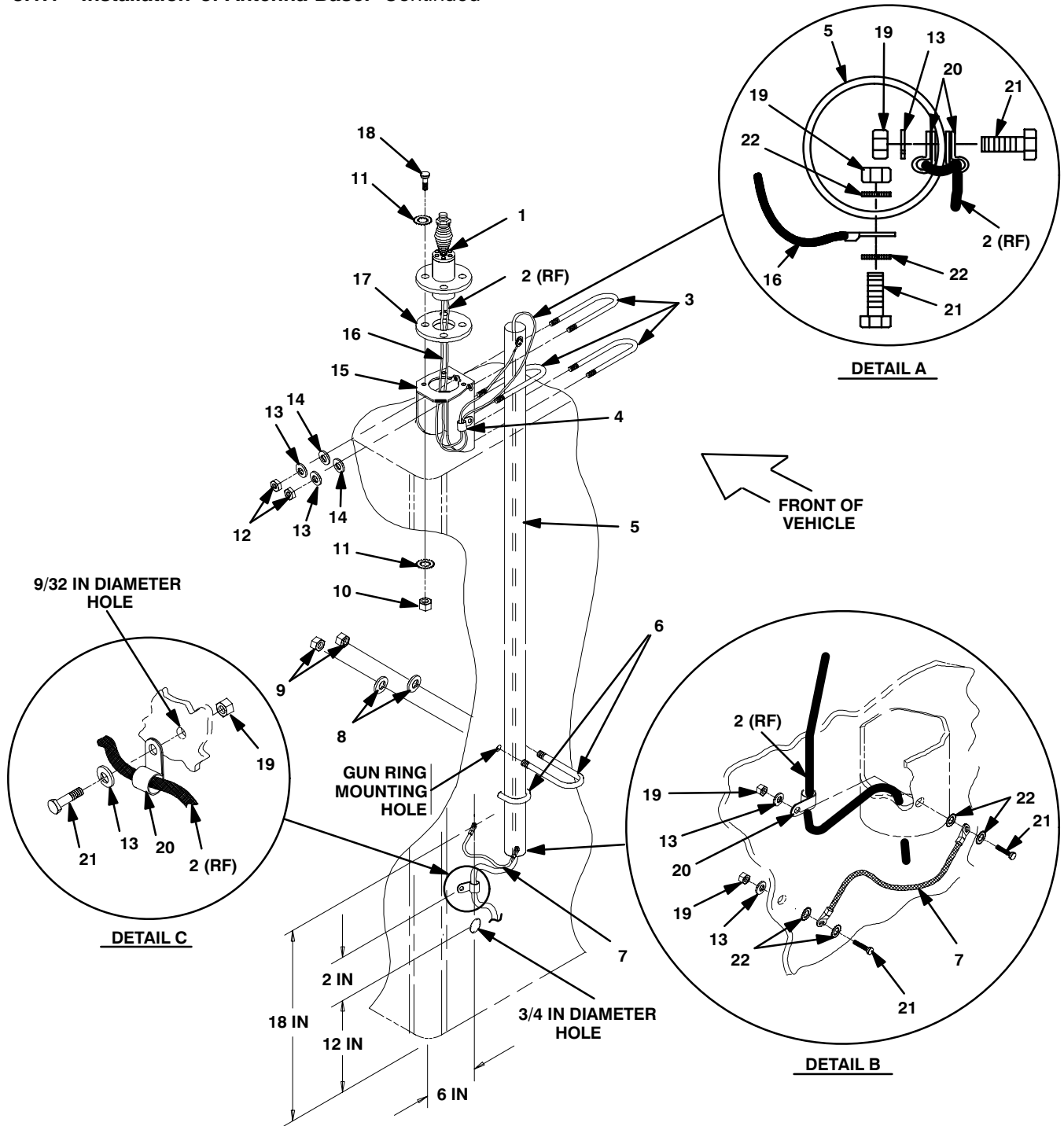

- |   |                                |                                   |
|---|--------------------------------|-----------------------------------|
| 1. ANTENNA BASE   | 6. U-BOLT 2 1/4 in (1/2-20 in) | 15. MOUNTING BRACKET              |
| 2. RF CABLE, CG-3855/VRC (12 FT, 0 IN) or (18 FT, 0 IN) | 7. GROUND STRAP (ANTENNA)      | 16. GROUND STRAP (1 ft, 6 in)     |
| 3. U-BOLT 2 1/4 in (1/4-28 in)                          | 8. LOCK WASHER (1/2 in)        | 17. GASKET                        |
| 4. LOOP CLAMP (1/2-1/4 in)                              | 9. NUT (1/2-20 in)             | 18. CAP SCREW (3/8-16 x 1 3/4 in) |
| 5. METALLIC TUBE  | 10. NUT (3/8-16 in)            | 19. NUT (1/4-20 in)               |
|   | 11. IET WASHER (3/8 in)        | 20. LOOP CLAMP (1/4-1/4 in)       |
|   | 12. NUT (1/4-28 in)            | 21. CAP SCREW (1/4-20 x 3/4 in)   |
|   | 13. LOCK WASHER (1/4 in)       | 22. IET WASHER (1/4 in)           |
|   | 14. FLAT WASHER (1/4 in)       |                                   |

Figure 5-2. Antenna Base Installation

**5.1.1 Installation of Antenna Base.** Continued

ITEM	ACTION	REMARKS
l. Ground strap (16), cap screw (21), two IET washers (22) and nut (19).	Install to mounting hole on metallic tube (5). See figure 5-2, detail A.	Tools: 7/16 in socket and 7/16 in open/box wrench.
m. RF cable (2).	Route through two loop clamps (20), then through metallic tube (5). See figure 5-2, detail A.	
<b>NOTE</b>		
Optional size U-bolts (6) are provided in the kit to be used as required.		
n. Two U-bolts (6), four lock washers (8) and four nuts (9).	Install (without securing) to top two sets of gun ring mounting holes on rear cab wall.	Tools: 3/4 in socket.
o. Assembled metallic tube (5).	Slide down through two U-bolts (6); then position bottom of tube 18 in above cab floor.	
p. Two U-bolts (6), four lock washers (8) and four nuts (9) installed in step n.	Secure to rear cab wall, tightening nuts from inside cab.	Tools: 3/4 in socket.
q. Loop clamp (20), cap screw (21), two IET washers (22), lock washer (13), nut (19) and ground strap (7).	Wrap clamp around RF cable (2); then install to bottom hole in metallic tube (5). See figure 5-2, detail B.	Tools: 7/16 in socket and 7/16 in open/box wrench.
r. Mounting hole for lower end of ground strap.	Using dimensions shown, drill a 9/32 in diameter hole in rear cab wall. See figure 5-2.	Tools: Electric drill and 9/32 in drill bit.
s. Ground strap (7), cap screw (21), two IET washers (22), lock washer (13) and nut (19).	Install to hole drilled in step r. Secure lock washer and nut from inside cab.	Tools: 7/16 in socket and 7/16 in open/box wrench.
t. Mounting hole for grommet.	Using dimensions shown, drill a 3/4 in diameter hole in rear cab wall.	Tools: Electric drill and 3/4 in drill bit.
u. Mounting hole for loop clamp (20).	Using dimensions shown, drill a 9/32 in meter hole in rear cab wall.	Tools: Electric drill and 9/32 in drill bit.
v. Loop clamp (20), cap screw (21), lock washer (13) and nut (19).	Wrap clamp around RF cable (2) and install to hole drilled in step u. See figure 5-2, detail C.	Tools: 7/16 in socket and 7/16 in open/box wrench.



**5.1.2 Installation of Top Antenna Assembly.** The top portion of the antenna includes a lower element and an upper element (with installed cap). Use the following procedure to assemble, install and tie down all antennas.

RF cable

ITEM	ACTION	REMARKS
a. Antenna elements (1, 2).	Apply silicone compound to element threads and assemble. See figure 5-3.	
b. Antenna element (2).	Install and hand-tighten to antenna base (3).	
c. Lock wire (4).	Install to antenna element (2) and antenna base (3). See figure 5-3, detail A.	
	Cut and remove excess wire with diagonal cutting pliers.	
d. Fiber rope assembly (5).	Attach clip to antenna element (1). Tie rope to vehicle to position antenna in desired location. See figure 5-3, detail B.	

- 1. ANTENNA ELEMENT (UPPER)
- 2. ANTENNA ELEMENT (LOWER)
- 3. ANTENNA BASE
- 4. LOCK WIRE
- 5. FIBER ROPE ASSEMBLY

Figure 5-3. Top Antenna Assembly Installation

5.2 Installation of Mounting Base, Electrical Equipment MT-6352/VRC (mounting base). Continued

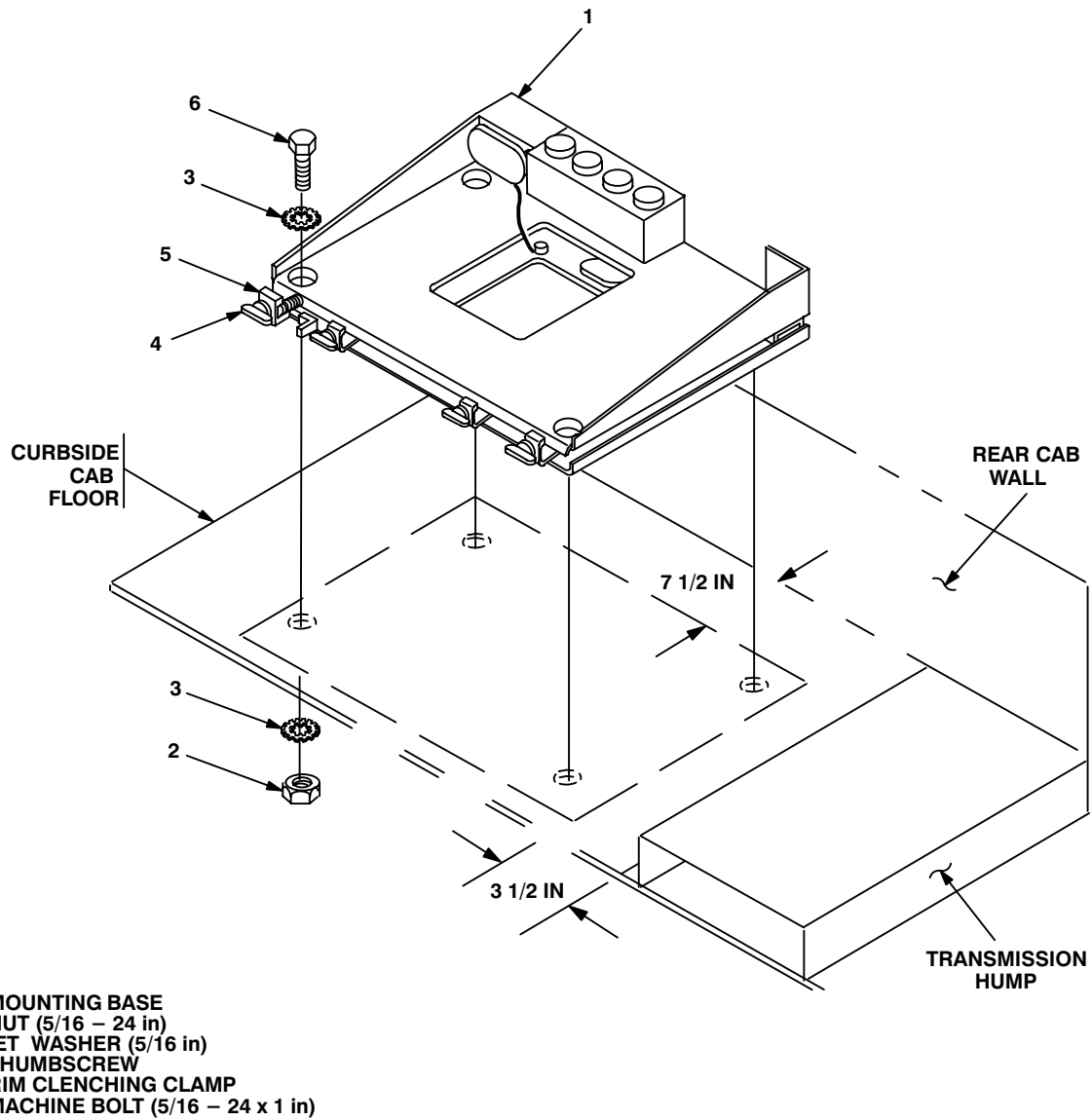

Figure 5-4. Mounting Base Installation

**5.2 Installation of Mounting Base, Electrical Equipment MT–6352/VRC (mounting base).** Remove and retain attaching bag of 5/16 in mounting hardware for installation. To insure good electrical grounding, any rust, corrosion or paint around mounting holes in radio shelf should be removed before installing the mounting base. See figure 5–1 (1) for location; then see figure 5–4 and perform the following steps.

ITEM	ACTION	REMARKS
------	--------	---------

**NOTE**

Apply a thin coat of adhesive–sealant to both sides of each internal/external–toothed (IET) washer during installation, and to the area of contact where IET washer is to be placed.

a. Passenger seat.	Tilt seat cushion up against seat back.	
b. Two outer thumbscrews (4).	Turn ccw until both sets of threads have cleared center of holes.	
c. Mounting base (1)	Position on curbside cab floor, 3 1/2 in from left edge of transmission hump cover and 7 1/2 in forward of rear cab wall.	
d. Mounting base (1) mounting holes.	Using mounting base (1) as a template, drill four 11/32 in diameter holes in cab floor.	Tools: Electric drill and 11/32 in drill bit.
e. Mounting base (1) cab floor.	Remove a 2” square area of paint on the underside of the mounting base (1) around left front and rear mounting holes. Remove a 2” square area of paint on the cab floor around the existing mounting holes that mate with left front and rear mounting holes of mounting base (1). Clean the paint removed areas and apply a thin coat of conductive anti–seize compound.	Tools: Electric grinder or equivalent.
f. Mounting base (1).	Align four holes with matching hole pattern in cab floor.	
g. Four machine bolts (6), eight internal/external–toothed (IET) washers (3) and four nuts (2).	Install mounting base (1) to cab floor. Secure nuts from under cab.	Tools: 1/2 in socket and 1/2 in open/box wrench.
h. Two outer thumbscrews (4).	Tighten and secure to rim clenching clamps (5) and mounting base.	

**5.3 Installation of Loudspeaker-Control Unit LS-671/VRC (speaker).** Perform the following steps to install both speakers. If dashboard installation can not be accomplished, mounting location for speaker may be determined by vehicle commander.

ITEM	ACTION	REMARKS
a. Mounting holes for mounting bracket (7).	Using mounting bracket as a template, drill four 11/32 in diameter holes. See figures 5-5 (1) and (2) for locations and dimensions.	Tools: Electric drill and 11/32 in drill bit.
b. Four machine bolts (4), four lock washers (3), four flat washers (2) and two nut strips (1).	Install and secure to mounting bracket (7) and holes drilled in step a.	Tools: 1/2 in socket.
c. Speaker (5).	Place on mounting bracket (7).	
d. Two externally-relieved body screws (6).	Thread through and secure to speaker (5) and mounting bracket (7).	Tools: Flatblade screw-driver.
e. Handset.	Connect and secure to speaker (5) connector J2.	

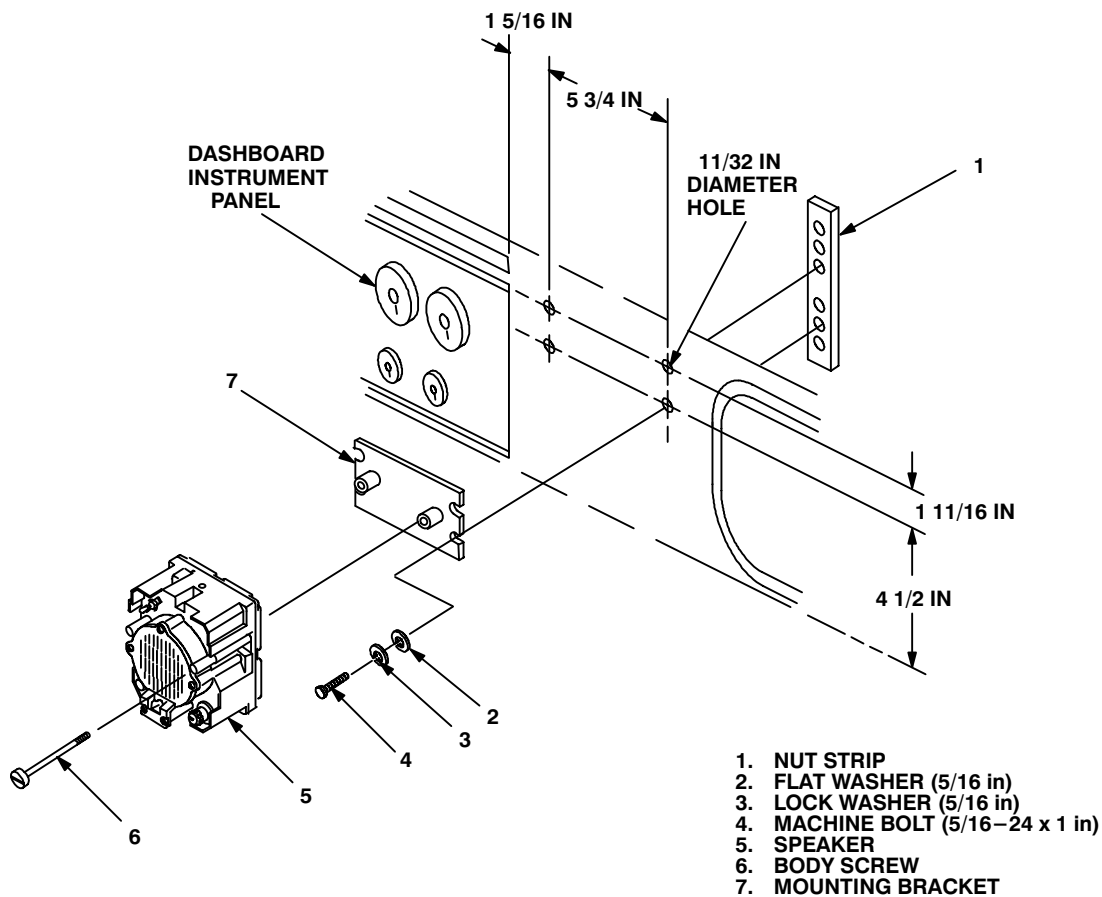

Figure 5-5 (1). Speaker Installation: Dashboard Mounting

5.3 Installation of Loudspeaker-Control Unit LS-671/VRC (speaker). Continued

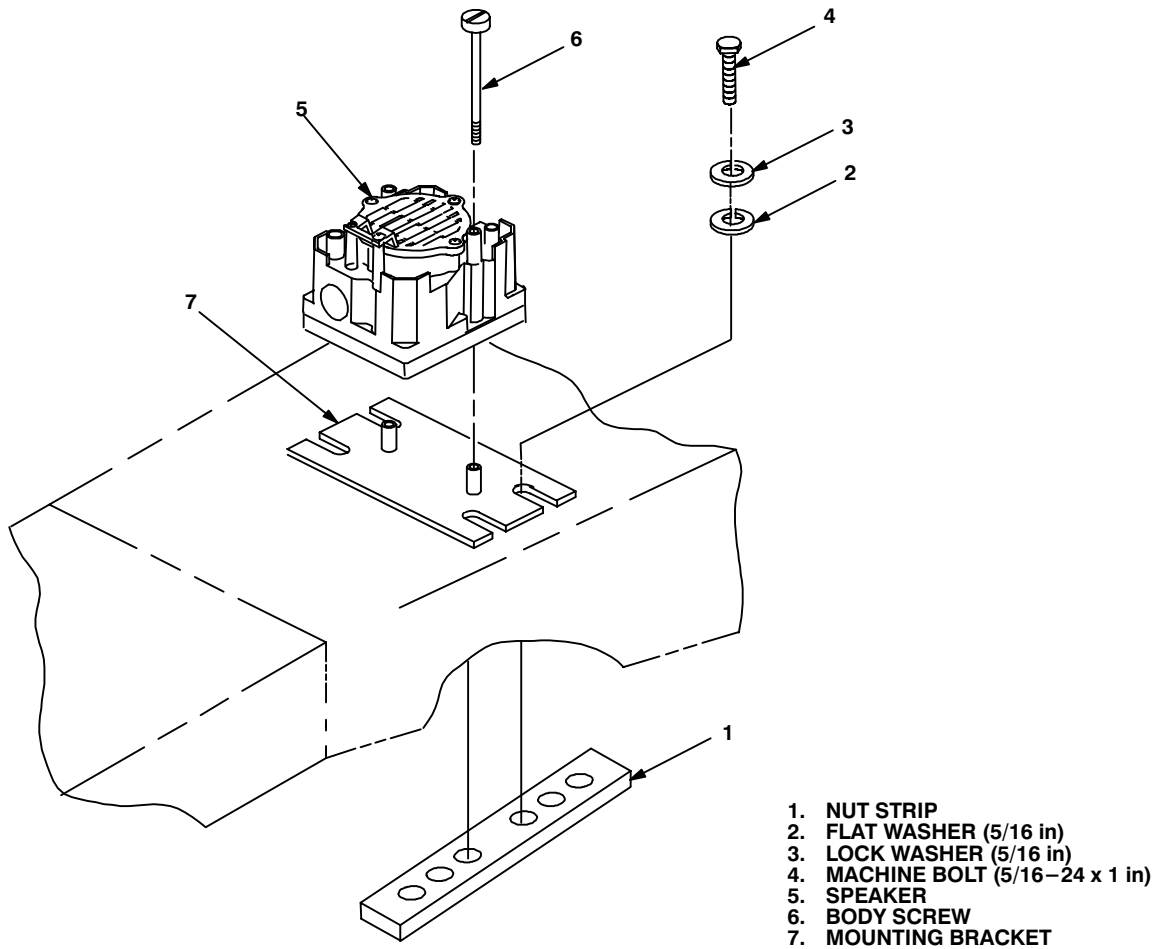

Figure 5-5 (2). Speaker Installation: Transmission Hump Mounting

5.4 Installation of Cables. To accomplish the installation, leave loop clamps and tiedown straps loose enough to adjust cable slack and allow easy adjustment of equipment. When installation is complete, tighten and secure clamps and tiedown straps. If speaker could not be mounted on the dashboard, installation of speaker cable CX-13292/VRC (8 FT, 0 IN) should be determined by vehicle commander.

**WARNING**

Make sure vehicle power source is positioned OFF or disconnected before installing cables.

ITEM	ACTION	REMARKS
a. RF cable (2) connector P2.	From outside cab, install to cable hole drilled in section 5.1.1, step t (behind driver's seat). See figure 5-6.	
b. Grommet (1).	Cut through mark shown; then wrap around RF cable (2) and install to cable hole. See figure 5-6, detail A and figure 5-6 for location.	Tools: Pocket knife.

5.4 Installation of Cables. Continued

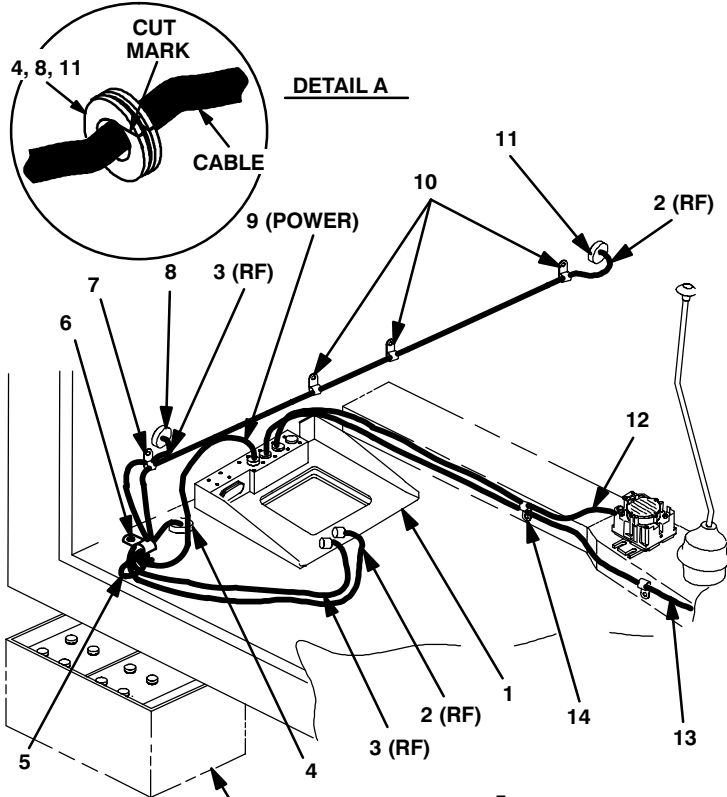

1. MOUNTING BASE
2. RF CABLE, CG-3855/VRC (18 FT, 0 IN)
3. RF CABLE, CG-3855/VRC (12 FT, 0 IN)
4. GROMMET (1/2 in)
5. TIEDOWN STRAP
6. LOOP CLAMP (3/4-1/4 in)  
LOCK WASHER (1/4 in)  
PAN-HEAD SCREW (1/4-14 x 3/4 in)
7. LOOP CLAMP (1/2-1/4 in)  
CAP SCREW (1/4-20 x 3/4 in)  
LOCK WASHER (1/4 in)  
NUT (1/4-20 in)
8. GROMMET (1/4 in)
9. POWER CABLE, CX-13302/VRC (5 FT, 0 IN)
10. LOOP CLAMP (1/4-1/4 in)  
CAP SCREW (1/4-20 x 3/4 in)  
LOCK WASHER (1/4 in)  
NUT (1/4-20 in)
11. GROMMET (1/4 in)
12. SPEAKER CABLE, CX-13292/VRC (6 FT, 0 IN)
13. SP  
EAKER CABLE, CX-13292/VRC (8 FT, 0 IN)
14. LOOP CLAMP (1-1/4 in)  
LOCK WASHER (1/4 in)  
PAN-HEAD SCREW (1/4-14 x 3/4 in)
15. LOOP CLAMP (5/8-1/4 in)  
CAP SCREW (1/4-20 x 3/4 in)  
LOCK WASHER (1/4 in)  
NUT (1/4-20 in)
16. LOOP CLAMP (5/8-1/4 in)  
CAP SCREW (1/4-20 x 3/4 in)  
LOCK WASHER (1/4 in)
17. LOOP CLAMP (5/8-1/4 in)  
LOCK WASHER (1/4 in)  
PAN-HEAD SCREW (1/4-14 x 3/4 in)

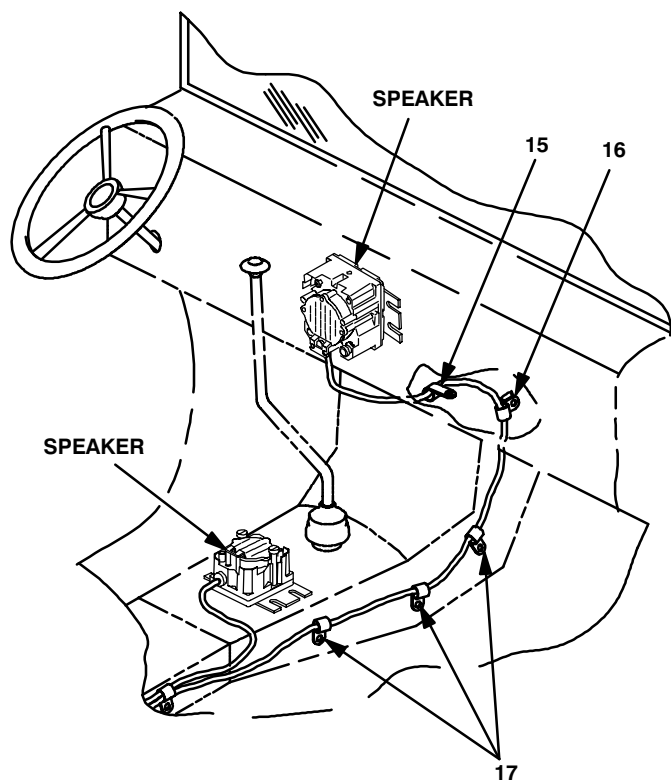
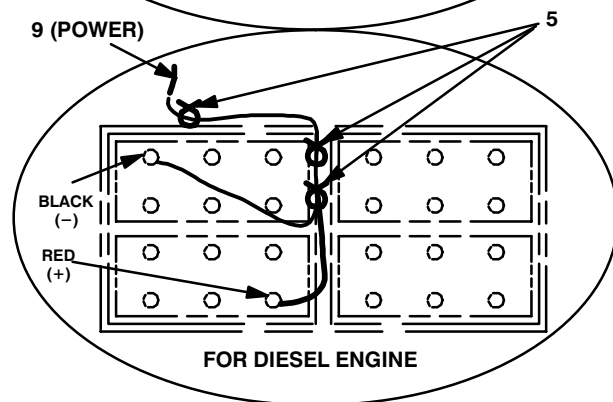
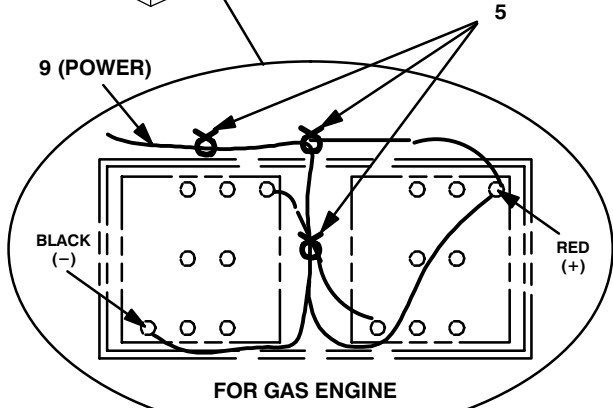

Figure 5-6. Cable Installation: Power, Speaker and RF Cabling

## 5.4 Installation of Cables. Continued

ITEM	ACTION	REMARKS
c. RF cable (2).	Route along rear cab wall and around left side of mounting base (1). See figure 5–6.	
d. RF cable (2) connector P2.	Position on mounting base (1).	
e. RF cable (3) connector P2.	From outside cab, insert through cable hole drilled in section 5.1.1., step t (behind passenger seat).	
f. Grommet (8).	Cut through mark shown; then wrap around RF cable (3) and install to existing cable hole. See figure 5–6, detail A and figure 5–6 for location.	Tools: Pocket knife.
g. RF cable (3).	Route around left side of mounting base (1).	
h. RF cable (3) connector P2.	Position on mounting base (1).	
i. Mounting holes for loop clamps (7, 10).	Drill four 9/32 in holes in rear cab wall, level with grommets (4,11). See figure 5–6 for location(s).	Tools: Electric drill and 9/32 in drill bit.
j. Three loop clamps (10), three cap screws (1/4–20 x 3/4), three lock washers (1/4 in) and three nuts (1/4–20 in).	Wrap clamps around RF cable (2) and then install to three 9/32 in diameter holes drilled in step i.	Tools: 7/16 in socket and 7/16 in open/box wrench.
k. Loop clamp (7), cap screw (1/4–20 x 3/4 in), lock washer (1/4 in) and nut (1/4–20 in).	Wrap clamp around RF cables (2, 3); then install to one hole drilled in step i.	Tools: 7/16 in socket and 7/16 in open/box wrench.
l. Speaker cable (12) connector P2.	Connect and secure to mounting base (1) connector J4.	
m. Speaker cable (13) connector P2.	Connect and secure to mounting base (1) connector J3.	
n. Speaker cables (12, 13).	Route along curbside of transmission hump.	
o. Speaker cable (13) connector P1.	Connect and secure to dashboard speaker connector J1.	
p. Speaker cable (12) connector P1.	Connect and secure to transmission hump speaker connector J1.	
q. Loop clamp (15), cap screw (1/4–20 x 3/4 in), lock washer (1/4 in) and nut (1/4–20 in).	Wrap clamp around speaker cable (13); then install to existing hole in dashboard bottom flange. See figure 5–6 for location(s).	Tools: 7/16 in socket and 7/16 in open/box wrench.

## 5.4 Installation of Cables. Continued

ITEM	ACTION	REMARKS
r. Loop clamp (16), cap screw (1/4-20 x 3/4 in), and lock washer (1/4 in).	Wrap around speaker cable (13), and install to existing weld nut. See figure 5-6 for location(s).	Tools: 7/16 in socket.
s. Mounting holes for loop clamps (14, 17).	Drill four 13/64 in diameter holes in transmission hump.	Tools: Electric drill and 13/64 in drill bit.
t. Three loop clamps (17), three pan-head screws (1/4-14 x 3/4 in) and three lock washers (1/4 in).	Wrap clamp around speaker cable (13); then install to three 13/64 in diameter holes drilled in step s.	Tool: Phillips screwdriver.
u. Loop clamp (14), pan-head screw (1/4-14 x 3/4 in) and lock washer (1/4 in).	Wrap clamp around speaker cables (12, 13); then install to one 13/64 in diameter hole drilled in step s.	Tool: Phillips screwdriver.
v. Power cable (9) connector leads: T1 (red) and T2 (black).	Insert through existing cable hole in rear curbside cab floor behind mounting base (1). See figure 5-6.	
w. Grommet (4).	Cut through mark shown; then wrap around power cable (9) and install to existing cable hole in rear curbside cab floor. See figure 5-6, detail A and figure 5-6 for location.	Tools: Pocket knife.
x. Power cable (9) connector leads: T1 (red) and T2 (black).	Connect and secure to proper terminals on battery. See figure 5-6, detail B.	Red (+) lead connects to positive terminal post. Black (-) lead connects to negative terminal post.
y. Tiedown straps (5).	In battery area, install loosely around power cable (9) and existing cable harness. See figure 5-6, detail B for location(s).	
z. Tiedown strap (5).	Install loosely around RF cables (2, 3) near loop clamp (6) location.	
aa. Mounting hole for loop clamp (6).	Drill a 13/64 in hole diameter in floor left of seat brace.	Tools: Electric drill and 13/64 in drill bit.
ab. Loop clamp (6), pan-head screw (1/4-14 x 3/4 in) and lock washer (1/4 in).	Wrap clamp around RF cables (2, 3) and cable (9); then install to hole drilled in step aa.	Tool: Phillips screwdriver.
ac. Power cable (9) connector P2.	Connect and secure to mounting base (1) connector J1. See figure 5-6.	
ad. Adhesive-sealant.	Apply to and around all newly installed grommets and drilled holes.	
ae. Driver and passenger seats.	Restore to normal position.	



**5.5 Post–Installation and Checkout.** After equipment is installed and cables are connected, perform the following steps.

ITEM	ACTION	REMARKS
a. Equipment.	Check for secure mounting. Check for loose parts, connectors and mounting hardware.	
b. Cables.	Check for proper installation and connection of cables. See figure 5–7 for cable connections. Unused cables should be stowed in appropriate place inside the vehicle.	
c. Loop clamps.	Check that all have been properly installed and tightened.	
d. Protective covers.	Insure that all installed cables are covered when not in use or connected.	
e. Radio issued with vehicle.	Install and connect cables. See TM 11–5820–890–20–1 or TM 11–5820–890–20–2 for installation and Operational (OP) Check instructions.	
f. MK line replaceable units.	See TM 11–5820–890–20P for Repair Parts and Special Tools List (RPSTL) information.	

5.5 Post-Installation and Checkout. Continued

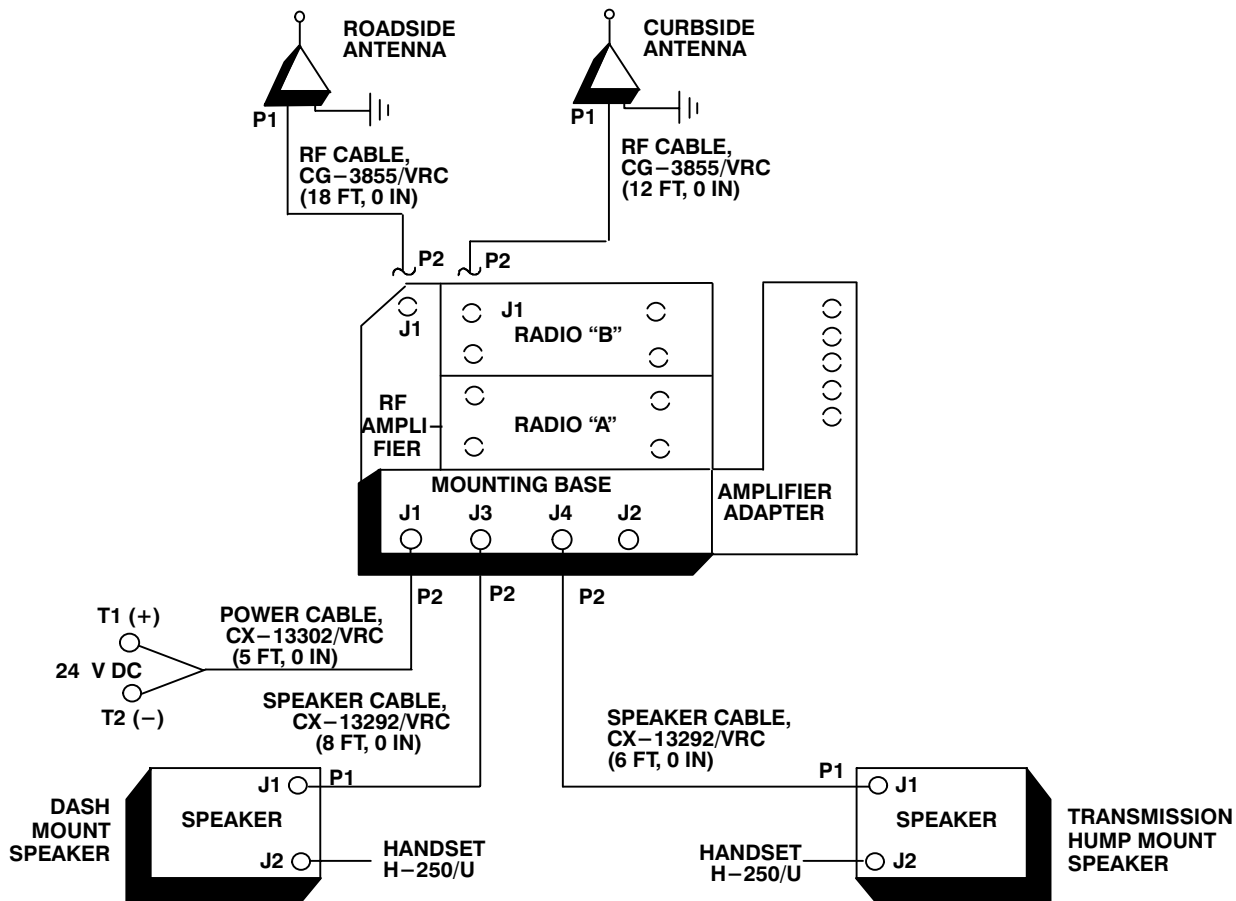

CABLE ASSEMBLY	FROM			TO		
	CABLE CONN.	UNIT	UNIT CONN.	CABLE CONN.	UNIT	UNIT CONN.
CX-13302/VRC (5 FT, 0 IN)	P2	Mounting base	J1	T1: Red (+) T2: Black (-)	Battery box	(+) Post (-) Post
CG-3855/VRC (18 FT, 0 IN)	P1	Roadside antenna base	J1	P2	RF amplifier	J1
CG-3855/VRC (12 FT, 0 IN)	P1	Curbside antenna base	J1	P2	Radio "B"	J1
CX-13292/VRC (8 FT, 0 IN)	P2	Mounting base	J3	P1	Speaker (on dashboard)	J1
CX-13292/VRC (6 FT, 0 IN)	P2	Mounting base	J4	P1	Speaker (on transmission hump)	J1

Figure 5-7. Cable Diagram: For AN/VRC-89/91 Series

## APPENDIX A

### REFERENCES

---

AMDF	Army Master Data File (Microfiche)
AR 710-2	Supply Policy Below the Wholesale Level as Contained in Unit Supply UPDATE
AR 725-50	Requisitioning, Receipt and Issuing System in UPDATE
DA Pam 25-30	Consolidated Index of Army Publications (Microfiche)
DA Pam 710-2-1	Using Unit Supply System Manual Procedures as Contained in Unit Supply UPDATE
SB 11-131	Vehicular Radio Sets and Authorized Installations (SINCGARS)
TM 11-5820-890-10-1	Operator's Manual (ICOM Radio Sets)
TM 11-5820-890-10-3	Operator's Manual (Non-ICOM Radio Sets)
TM 11-5820-890-20-1	Unit Maintenance Manual (ICOM Radio Sets)
TM 11-5820-890-20-2	Unit Maintenance Manual (Non-ICOM Radio Sets)
TM 11-5820-890-20P	Repair Parts and Special Tools List

By Order of the Secretary of the Army:

Official:

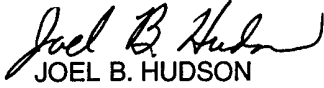

JOEL B. HUDSON  
*Administrative Assistant to the  
Secretary of the Army*

9916703

**ERIC K. SHINSEKI**  
*General, United States Army  
Chief of Staff*

**DISTRIBUTION:**

To be distributed in accordance with the initial distribution number (IDN) 369555 requirements for TB 11-5820-890-20-8.

**SOMETHING WRONG WITH THIS PUBLICATION**



FROM: (PRINT YOUR UNIT'S COMPLETE ADDRESS)

Commander  
Stateside Army Depot  
ATTN: AMSTA-US  
Stateside, NL 0703-5007

DATE SENT

10 July 1995

PUBLICATION NUMBER

TM 11-5840-340-12

PUBLICATION DATE

23 Jan 74

PUBLICATION TITLE

Radar Set AN/PRC-76

BE EXACT PIN-POINT WHERE IT IS

IN THIS SPACE TELL WHAT IS WRONG AND WHAT SHOULD BE DONE ABOUT IT:

PAGE NO	PARA-GRAPH	FIGURE NO	TABLE NO
2-25	2-28		
3-10	3-3		3-1
5-6	5-8		
		FO-3	

Recommend that the installation antenna alignment procedure be changed throughout to specify a 20 IFF antenna lag rather than 10

REASON: Experience has shown that with only a 10 lag, the antenna servo system is too sensitive to gusting in excess of 25 knots, and has a tendency to rapidly accelerate and decelerate as it hunts, causing strain to the drive train. Hunting is minimized by adjusting the lag to 20 without degradation of operation.

Item 5, Functional column. Change  2 dB" to  3 dB".

REASON: The adjustment procedure for the TRANS POWER FAULT indicator call for a 3 dB (500 watts) adjustment to light the TRANS POWER FAULT indicator.

Add new step f.1 to read,  Replace cover plate removed in step d above."

REASON: To replace the cover plate.

ZONE C 3. On J1-2, change  +24 VDC" to  +5 VDC".

REASON: This is the output line of the 5 VDC power supply. +24 VDC is the input voltage.

PRINTED NAME, GRADE OR TITLE AND TELEPHONE NUMBER

SSG I. M. DeSpirito 999-1779

SIGN HERE

TEAR ALONG DOTTED LINE

# SOMETHING WRONG WITH THIS PUBLICATION



FROM: (PRINT YOUR UNIT'S COMPLETE ADDRESS)

DATE SENT

PUBLICATION NUMBER

PUBLICATION DATE

PUBLICATION TITLE

BE EXACT PIN-POINT WHERE IT IS

IN THIS SPACE TELL WHAT IS WRONG AND WHAT SHOULD BE DONE ABOUT IT:

PAGE  
NO

PARA-  
GRAPH

FIGURE  
NO

TABLE  
NO

TEAR ALONG DOTTED LINE

PRINTED NAME, GRADE OR TITLE AND TELEPHONE NUMBER

SIGN HERE

FILL IN YOUR  
UNIT'S ADDRESS

FOLD BACK

DEPARTMENT OF THE ARMY



OFFICIAL BUSINESS

PLEASE  
AFFIX  
STAMP  
POSTAGE  
REQUIRED

TEAR ALONG DOTTED LINE

**Commander**  
**U.S. Army Communications-Electronics Command**  
**and Fort Monmouth**  
**ATTN: AMSEL-LC-LEO-D-CS-CFO**  
**Fort Monmouth, New Jersey 07703-5000**



FOLD BACK

