

# TM 9-2815-204-35

DEPARTMENT OF THE ARMY TECHNICAL MANUAL

---

FIELD AND DEPOT MAINTENANCE

FOR

ENGINE, DIESEL (MULTIFUEL):TURBOSUPERCHARGED,  
FUEL INJECTED, WATER COOLED, 6-CYLINDER,  
ASSEMBLY-2815-897-5061

(CONTINENTAL MODEL LDS-427-2)

AND

CLUTCH, ASSEMBLY (ORD 7748995)  
(LONG MODEL 13CF)

END ITEM APPLICATION:

TRUCK, CARGO: 2½ TON, 6 x 6, M35A1  
(MULTIFUEL)-(TM 9-2320-235)



*HEADQUARTERS, DEPARTMENT OF THE ARMY*

*FEBRUARY 1964*

TECHNICAL MANUAL )  
 )  
 No. 9-2815-204-35 )

HEADQUARTERS  
 DEPARTMENT OF THE ARMY  
 Washington 25, D. C., 19 February 1964

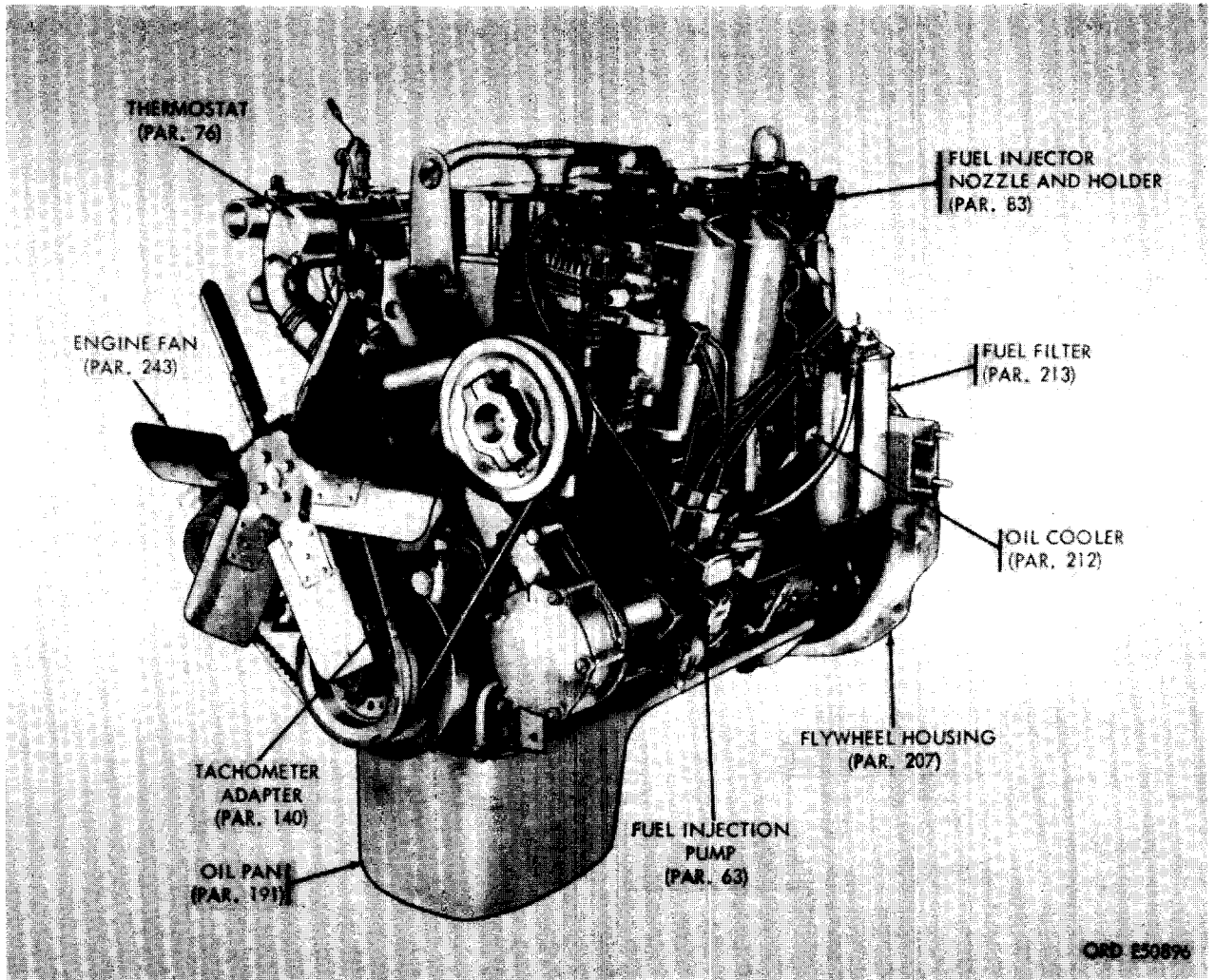
ENGINE, DIESEL (MULTIFUEL): TURBOSUPERCHARGED,  
 FUEL INJECTED, WATER COOLED, 6-C YLINDER,  
 ASSEMBLY-2815-897-5061  
 (CONTINENTAL MODEL LDS-427-2)  
 AND  
 CLUTCH, ASSEMBLY (ORD 7748995)  
 (LONG MODEL 13CF)

END ITEM APPLICATION:

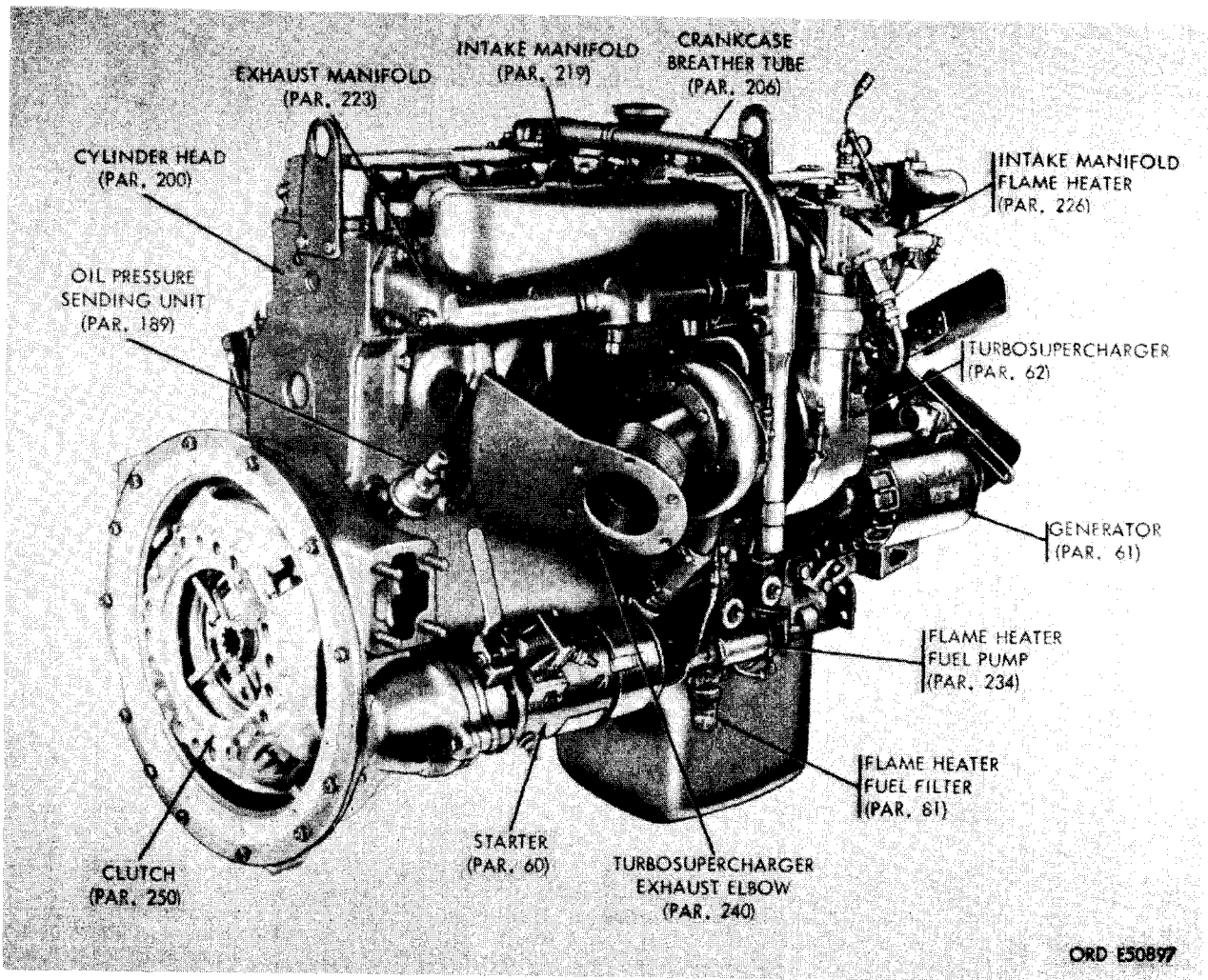
TRUCK, CARGO: 2 3/4 TON, 6 x 6, M35A1  
 (MULTIFUEL)-(TM 9-2320-235)

		Paragraph	Page
CHAPTER 1	INTRODUCTION-----		1
Section I.	General-----	1-3	1
	Operation and description -----	4-36	4
III.	Tabulated data-----	37-40	17
CHAPTER 2	PARTS, SPECIAL TOOLS, AND EQUIPMENT FOR FIELD AND DEPOT MAINTENANCE -----	41-45	21
CHAPTER 3	TROUBLESHOOTING -----		34
Section I.	General-----	46-47	34
II.	Troubleshooting procedures-----	48-56	34
CHAPTER 4	REPLACEMENT OF ENGINE ACCESSORIES, COMPONENTS, AND RELATED SERVICE OPERATIONS -		59
Section I.	General-----	57-58	59
II.	Replacement of engine accessories - - - - -	59-65	60
III.	Replacement and repair of engine components allocated to third echelon maintenance - - - - -	66-100	81
IV.	Service operations-- - - - - -	101-110	143
CHAPTER 5	DISASSEMBLY OF ENGINE-----		148
Section I.	Preparation of engine for disassembly - - - - -	111-115	148
II.	Disassembly of engine into subassemblies - - - - -	116-151	151

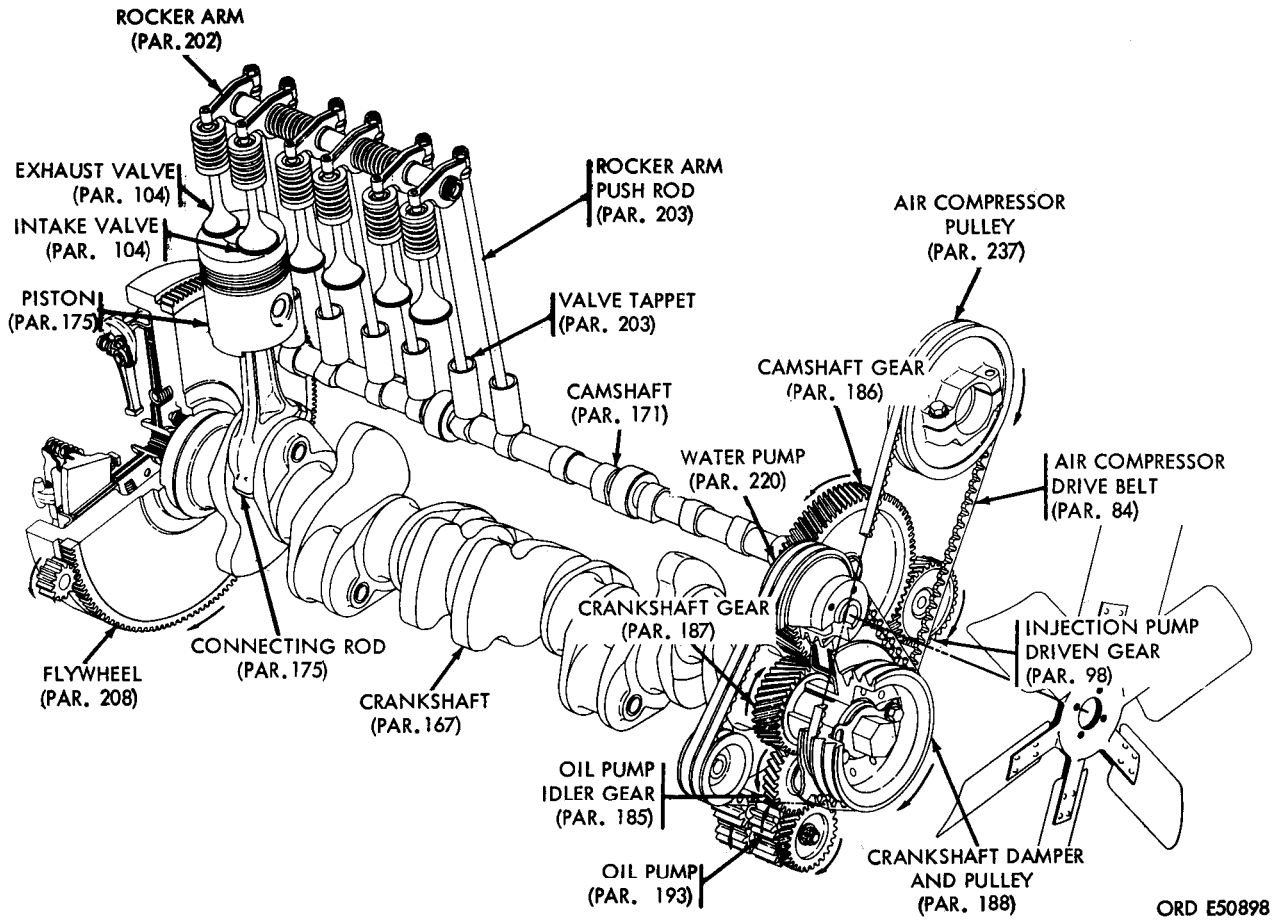
		Paragraph	Page
CHAPTER 6	REBUILD OF ENGINE COMPONENTS - - - - -		186
Section I.	General cleaning, inspection, repair, and assembly p r o c e d u r e s - - - - -	152-156	186
II.	Rebuild of cylinder and crankcase assembly - - - - -	157-163	193
III.	Rebuild of crankshaft assembly - - - - -	164-168	206
Iv.	Rebuild of camshaft assembly and thrust plate - - - - -	169-171	208
V.	Rebuild of pistons, rings, piston pins, and connecting r o d s - - - - -	172-176	209
VI.	Rebuild of miscellaneous engine components - - - - -	177-192	215
VII.	Rebuild of oil pump assembly and related parts - - - - -	193-197	225
VIII.	Rebuild of cylinder head assembly - - - - -	198-201	236
IX.	Rebuild of valve rocker arms, shafts, push rods, tappets, and related cylinder head parts - - - - -	202-203	243
X.	Rebuild of cylinder head covers, breather tube adapter, crankcase breather tube, and related parts - - - - -	204-206	246
XI.	Rebuild of flywheel housing, flywheel assembly, and transmission adapter - - - - -	207-209	248
XII.	Rebuild of oil filters, 'oil cooler and oil filter housing, a n d o i l c o o l e r - - - - -	210-212	251
XIII.	Rebuild of fuel filter assembly, fuel filter hoses, fuel injection tubes, fuel injection pump attaching parts, and fuel injector nozzle and holder assemblies - - - - -	213-217	252
XIV.	Rebuild of thermostat housing, intake manifold, water pump, and related parts- - - - -	218-222	257
XV.	Rebuild of exhaust manifold assembly, flame heater, a n d r e l a t e d p a r t s - - - - -	223-227	260
XVI.	p o n e n t s - - - - -	228-231	263
XVII.	Rebuild of flame heater fuel pump assembly - - - - -	232-236	266
XVIII.	Rebuild of air compressor adjustable pulley, air intake manifold, and miscellaneous engine components - - - - -	237-244	280
CHAPTER 7	C L U T C H A S S E M B L Y - - - - -		286
Section I.	Description, operation, and data - - - - -	245-247	286
II	Rebuild of clutch assembly - - - - -	248-252	287
CHAPTER 8	A S S E M B L Y O F E N G I N E - - - - -		296
Section I.	G e n e r a l - - - - -	253-255	296
II.	Assembly of engine from subassemblies - - - - -	256-286	299
CHAPTER 9	T E S T S A N D A D J U S T M E N T S - - - - -	287-290	326
CHAPTER 10	R E P A I R A N D R E B U I L D S T A N D A R D S - - - - -	291-299	332
	A P P E N D I X - - - - -		350
	I N D E X - - - - -		351



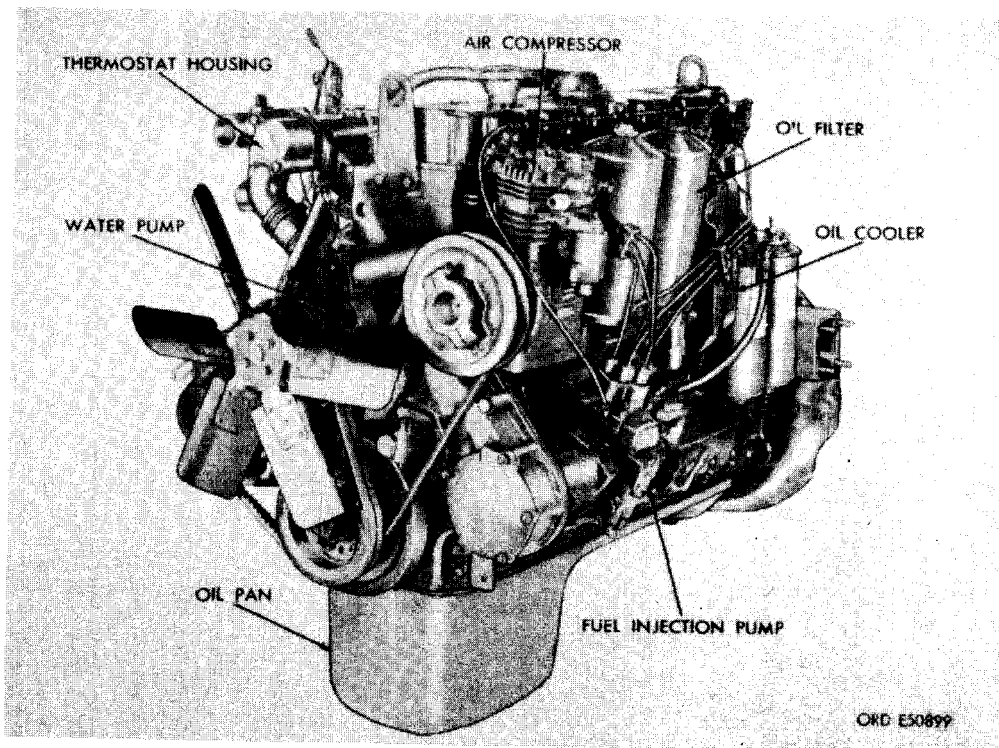
VISUAL GUIDE TO CONTENTS (1 of 3).



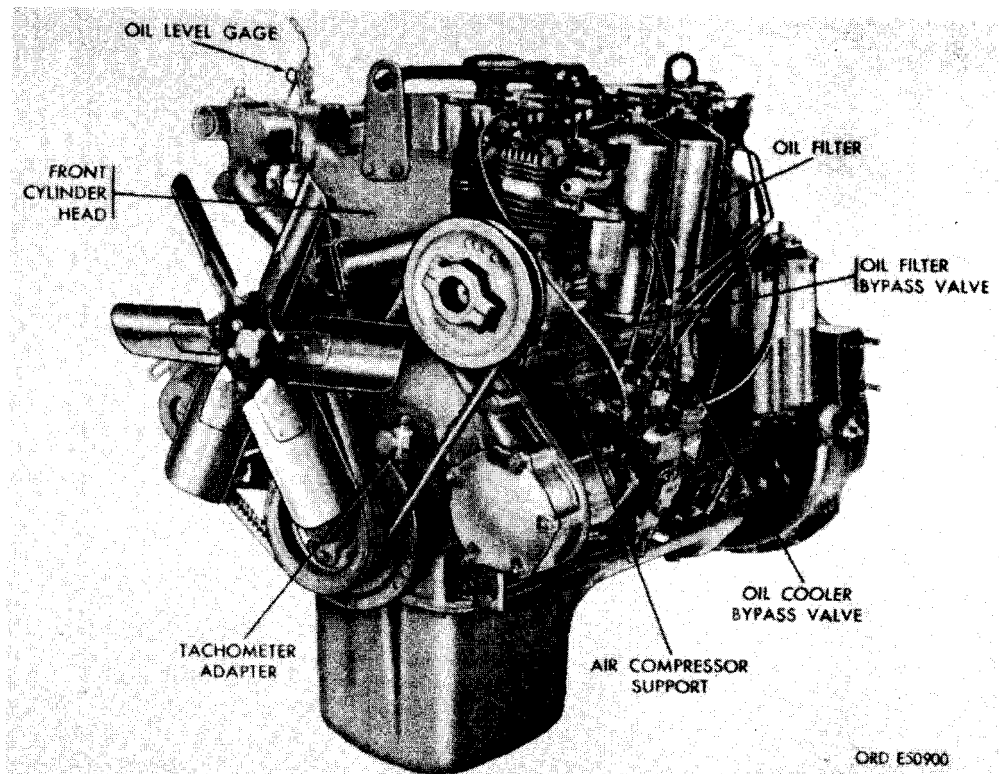
VISUAL GUIDE TO CONTENTS (2 of 3).



VISUAL GUIDE TO CONTENTS (3 of 3).



**FIGURE 1. LATE MODEL LDS-427-2 ENGINE - 3/4 LEFT FRONT VIEW.**



**FIGURE 2. EARLY MODEL LDS-427-2 ENGINE - 3/4 LEFT FRONT VIEW.**

# CHAPTER 1

## INTRODUCTION

### Section I. GENERAL

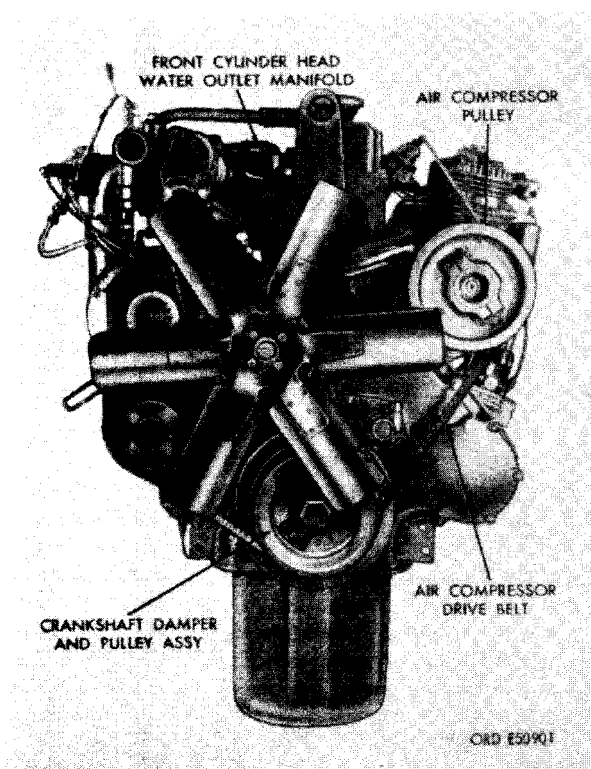
#### 1. SCOPE

a. This technical manual contains instructions for field and depot maintenance of the Model LDS-427-2 Multifuel engine (figs. 1 through 10). It contains description of, and procedures for 3rd echelon services, removal of engine accessories, disassembly, inspection, repair, rebuild, and assembly of the engine.

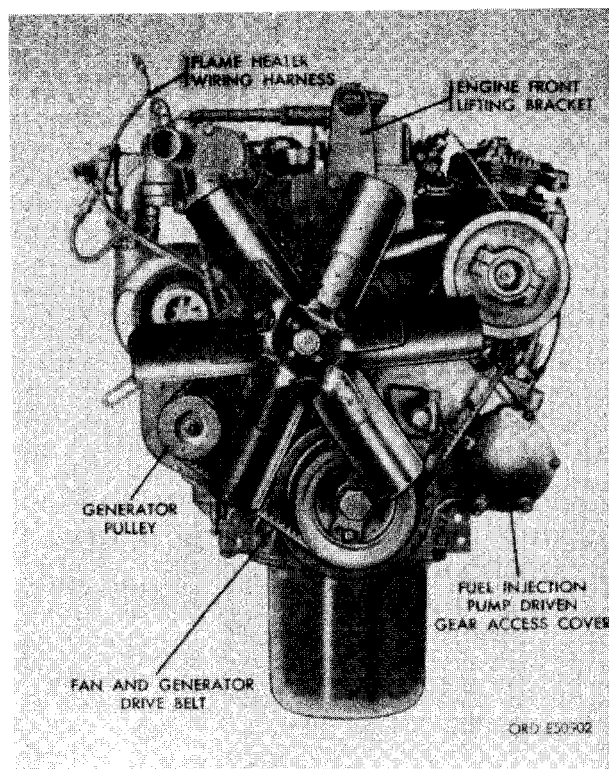
b. The appendix contains a list of current references applicable to the materiel.

c. This manual differs from TM 9-2815-204-35, dated August 1960 as follows:

- (1) Revises and up dates information for early model engine.



**FIGURE 3. LATE MODEL LDS -427-2 ENGINE ASSEMBLY - FRONT VIEW.**



**FIGURE 4. EARLY MODEL LDS-427-2 ENGINE ASSEMBLY - FRONT VIEW.**

- (2) Adds information for late model engine, explaining the difference between models.

Note. All information and instructions are applicable to both model engines unless otherwise specified.

d. Any errors, discrepancies, additions, or deletions should be forwarded on DA Form 2028, Recommended changes to DA Technical Manuals, Parts List or Supply Manuals, to Commanding General, U.S. Army Tank- Automotive Center Attn: SMOTA-N, 28251 Van Dyke, Warren, Michigan, 48090.

e. TM 9-2320-235-10 contains operating instructions as well as all maintenance operations allocated to the vehicle operators.



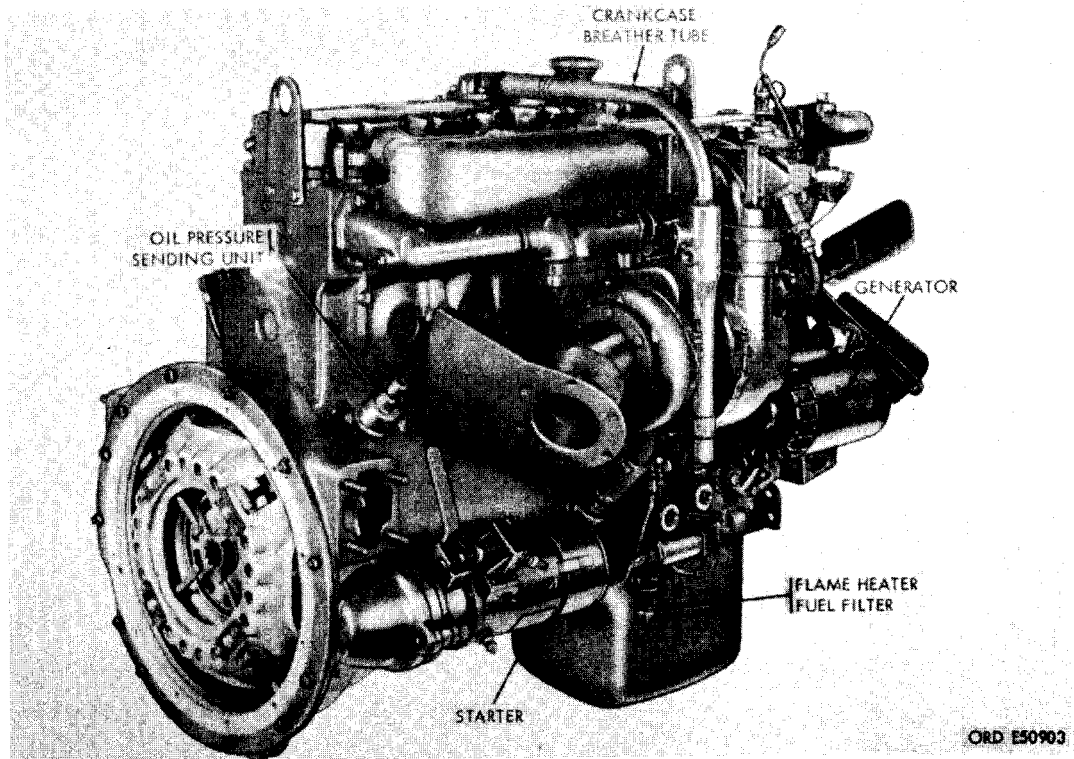


FIGURE 5. LATE MODEL LDS-427-2 ENGINE ASSEMBLY - 3/4 RIGHT REAR VIEW.

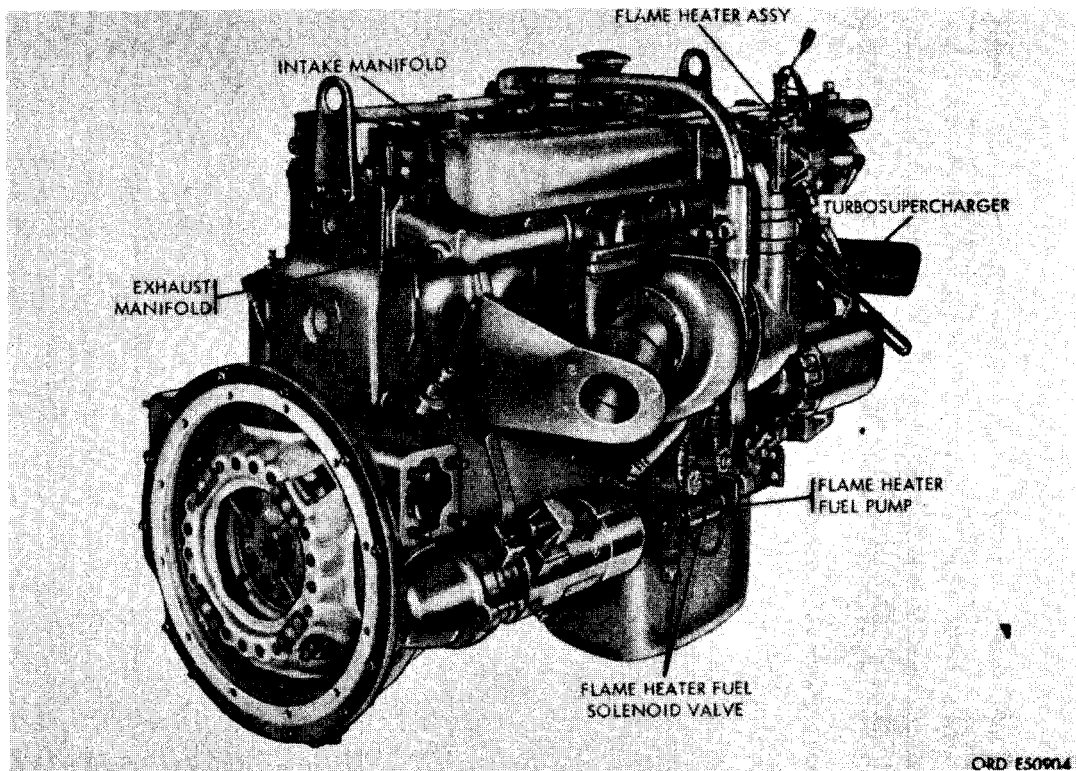
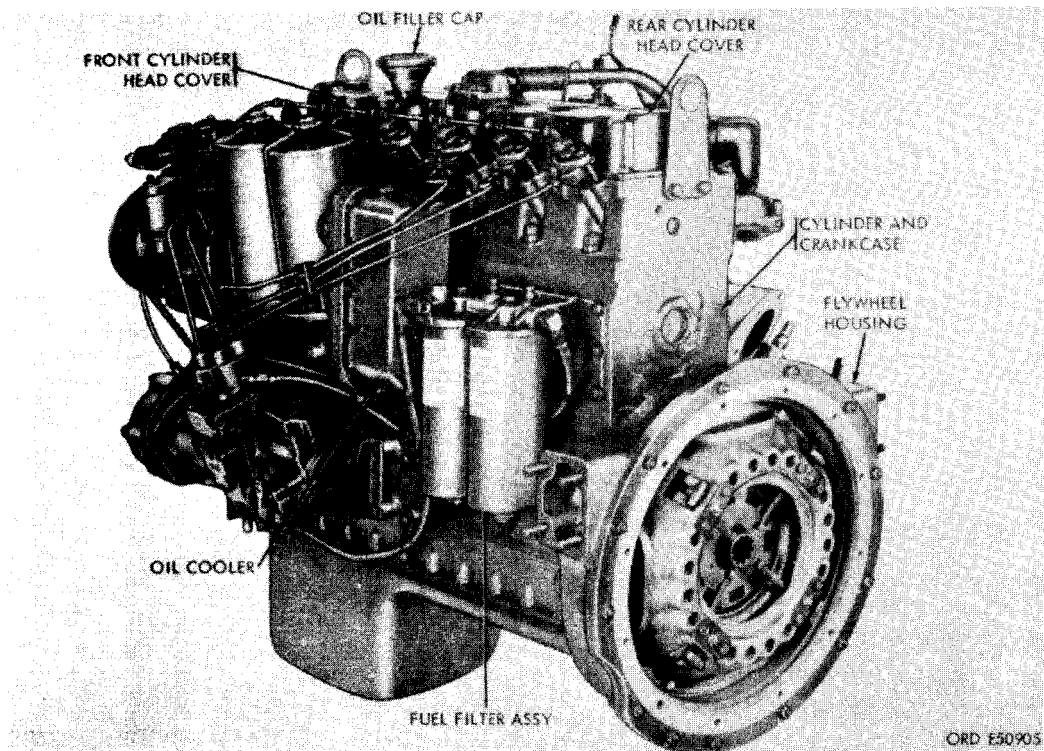
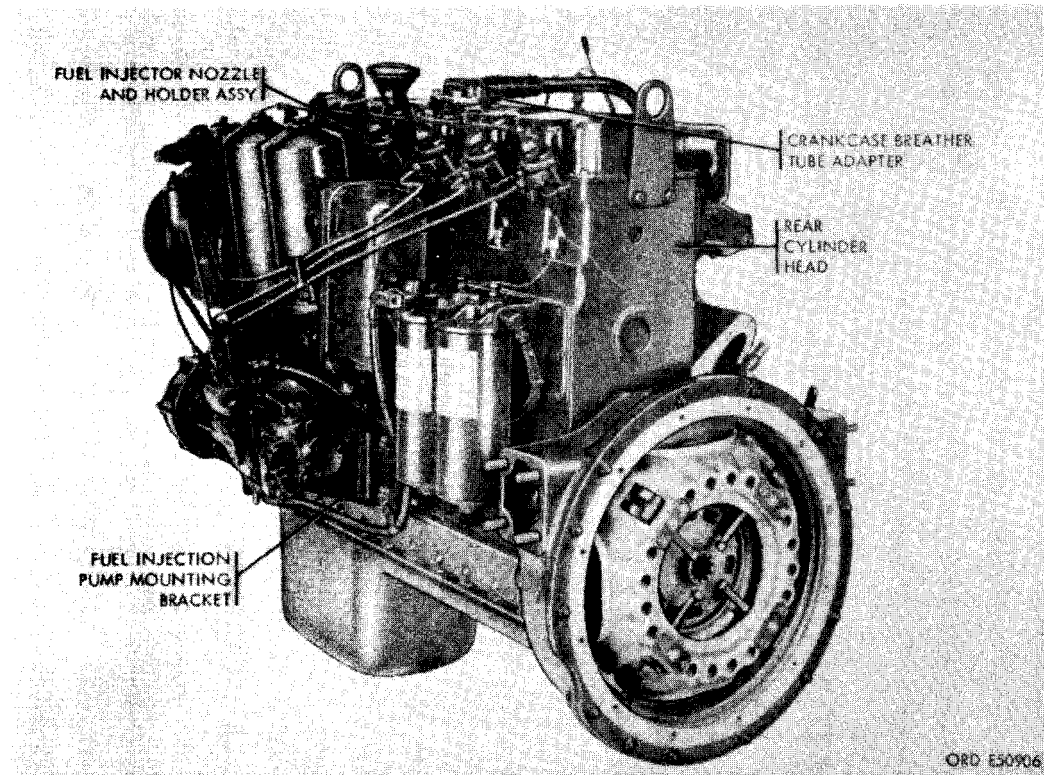


FIGURE 6. EARLY MODEL LDS -427-2 ENGINE ASSEMBLY - 3/4 RIGHT REAR VIEW.



**FIGURE 7. LATE MODEL LDS-427-2 ENGINE ASSEMBLY - 3/4 LEFT REAR VIEW .**



**FIGURE 8. EARLY MODEL LDS -427-2 ENGINE ASSEMBLY - 3/4 LEFT REAR VIEW.**

f. TM 9-2320-235-20 contains instructions for-organizational maintenance.

g. LO 9-2320-235-12 contains lubricating instructions and fuel specifications.

h. Description, maintenance instructions, and-repair parts for the engine accessories are found in the following technical manuals:

Fuel Injection Pump - TM 9-2910-223-35  
Generator (Autolite) - TM 9-2920-209-35  
Generator (Delco- Remy) - TM 9-2920-214-35  
Starter - TM 9-2920-236-35  
Turbosupercharger - TM 9-2990-201-35

## 2. FIELD AND DEPOT MAINTENANCE ALLOCATION

Refer to the maintenance allocation chart in TM 9-2320-235-20.

## 3. FORMS, RECORDS, AND REPORTS

For a current and complete listing of all forms, refer to DA Pam 310-2. For instructions on the use of forms for records and reports, refer to TM 38-750.

## Section II. OPERATION AND DESCRIPTION

### 4. LOCATION OF ENGINE COMPONENTS

a. In this manual the terms defined in b through 1 below will be used to identify the location of engine parts and assemblies.

b. The ends of the engine will be called the "fan end" or "front" and the "flywheel end" or "rear".

c. As viewed from the rear end of the engine toward the front, the side to the right is called the right side. The side to the left is called the left side.

d. The cylinders are referred to as No. 1 through No. 6, viewed from the front of engine.

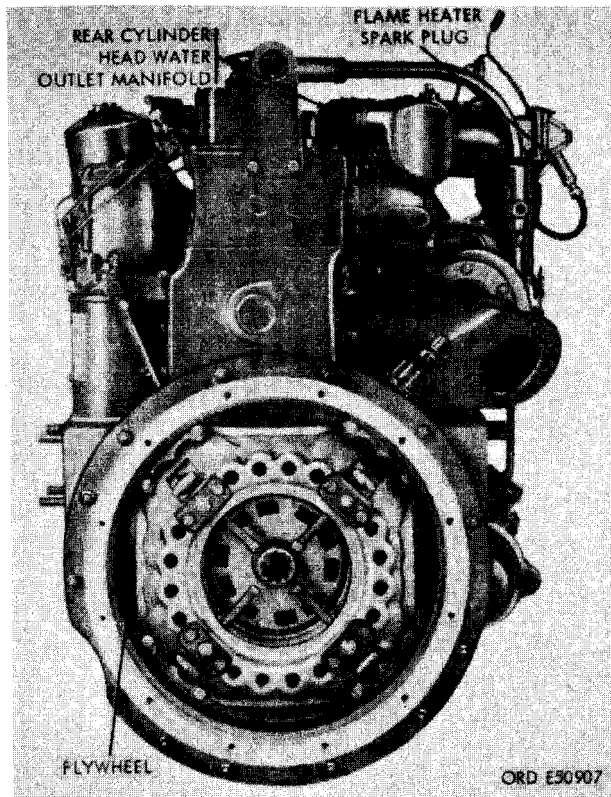


FIGURE 9. LATE MODEL LDS -427-2 ENGINE ASSEMBLY - REAR VIEW.

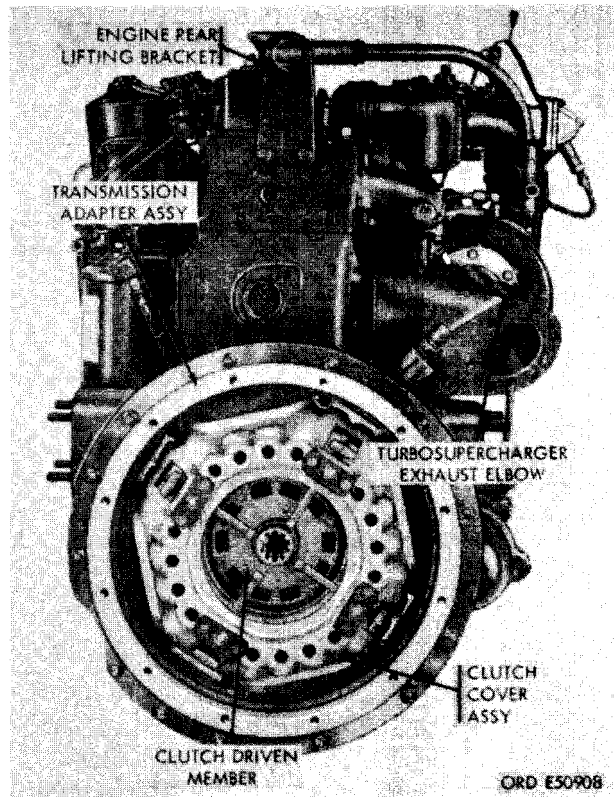


FIGURE 10. EARLY MODEL LDS -427 ENGINE ASSEMBLY - REAR VIEW.

e. Starting from the front, the main bearings are numbered 1 through 7.

f. The connecting rods are numbered from the front, 1 through 6, and are identified by matched numbers stamped on the rod and rod cap bosses.

g. Crankshaft rotation is clockwise and camshaft rotation is counterclockwise as viewed from front of the engine.

h. The elements in the fuel filter assembly are identical and interchangeable. The filter toward the front is the primary filter and the rear filter is the final filter.

i. The two oil filters are identical and interchangeable.

j. The two cylinder heads are identical and are interchangeable. When mentioned, the cylinder heads will be referred to as front cylinder head and rear cylinder head.

k. The two cylinder-head water outlet manifolds are identical and are interchangeable. When mentioned, the manifolds will be referred to as the front cylinder head water outlet manifold and the rear cylinder head water outlet manifold.

l. The assembled rocker arms, shaft, and supports are interchangeable. When mentioned, they will be referred to as the front set of rocker arms and the rear set of rocker arms.

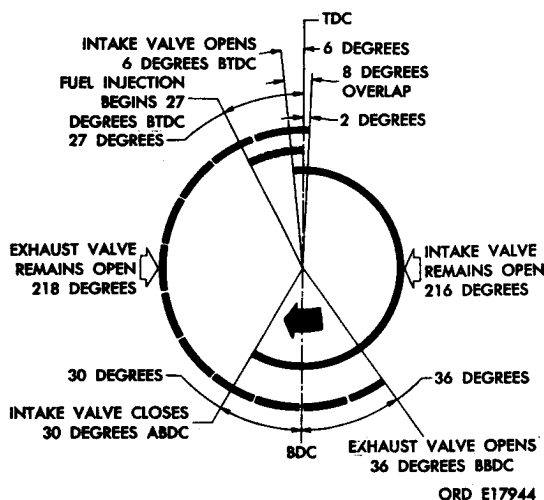


FIGURE 11. ENGINE STROKE CYCLE AND VALVE EVENTS

## 5. PRINCIPLE OF HYPERCYCLE OPERATION

a. **General.** The Model LDS-427-2 hypercycle Multifuel engine operates on a compression ignition four-cycle diesel principle (fig. 11) similar to conventional four-cycle diesel and gasoline engines. Mechanically the four-cycle diesel and gasoline engines are alike in respect to internal moving parts. The hypercycle compression ignition principle is explained in the following paragraphs.

b. **Intake Stroke (fig. 12).** Air is forced into the cylinder through the open intake valve by atmospheric pressure during cranking, or by the turbosupercharger during engine operation. The intake passage in the intake manifold and valve port opening are designed to produce an air swirl in the cylinder as air enters the combustion chamber during the intake stroke of the piston.

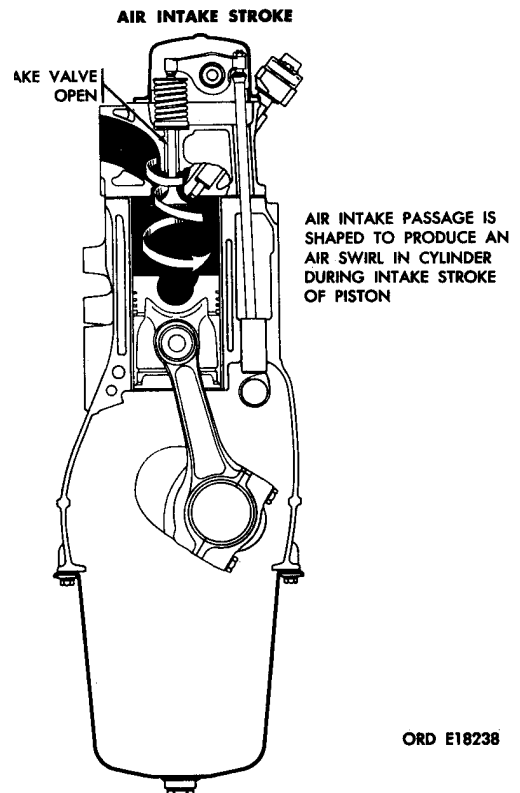
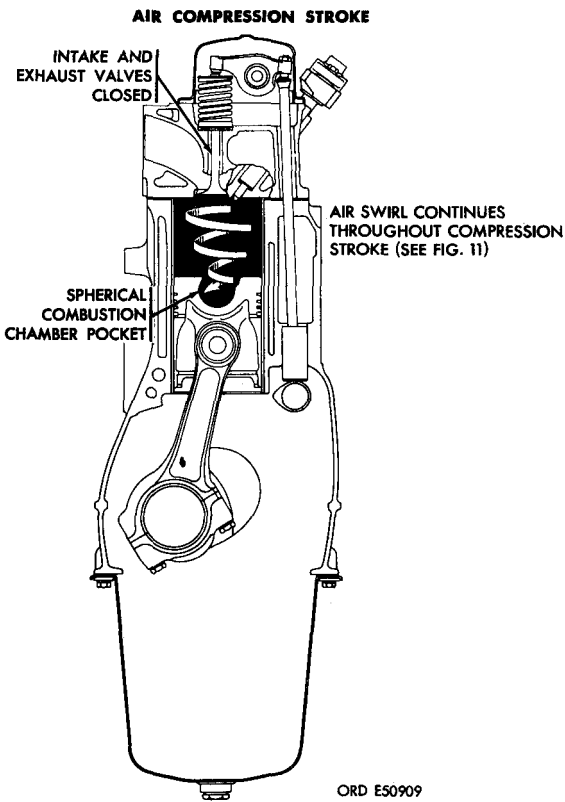


FIGURE 12. AIR INTAKE STROKE.



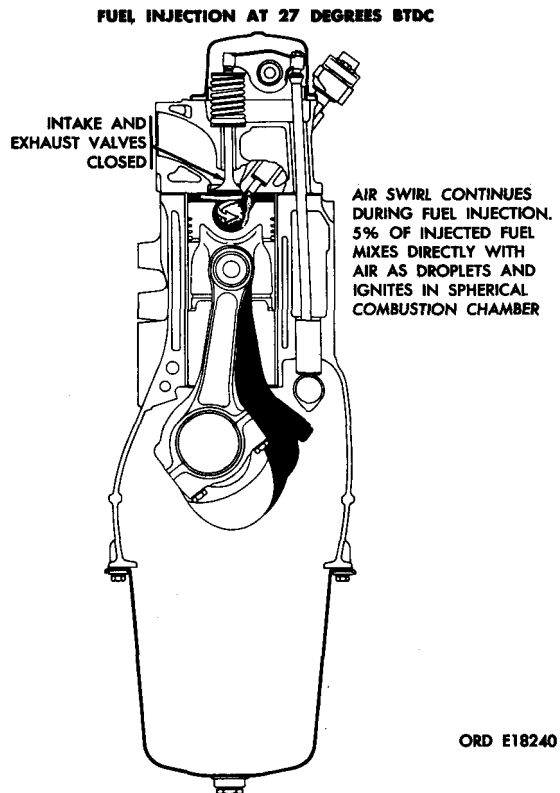
**FIGURE 13. AIR COMPRESSION STROKE.**

c. Compression and Power Stroke (figs. 13 through 15). On the upward movement (compression stroke) of the piston the air swirl continues, raising the compressed air temperature to between 900 and 1000° F. Near the top of the compression stroke, 27 degrees before top dead center (btdc), fuel is injected by the fuel injector nozzle. A small amount (five percent) of injected fuel is deposited as a thin film on the walls of the spherical combustion chamber in the head of the piston.

- (1) This small amount of fuel charge is atomized into the air space in the spherical combustion chamber in the head of the piston and functions as a spark plug for the remainder of the charge.
- (2) During the ignition delay period, the main portion of the charge is exposed to a temperature below its cracking

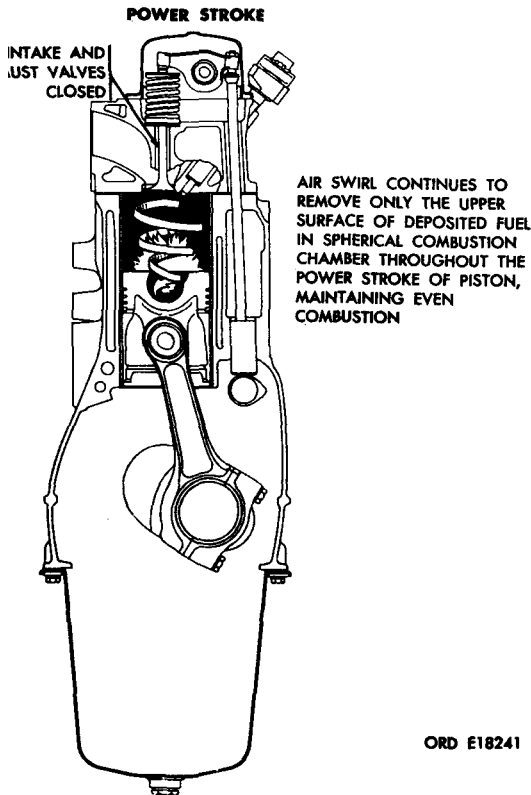
temperature and is undergoing pre-combustion reactions.

- (3) The main portion of the charge is progressively vaporized and swept off the combustion chamber wall by the high velocity rotary air swirl. The air swirl was generated during the intake stroke (par. b above). The vaporized fuel burns smoothly in the spherical combustion chamber as the fuel is swept by the air swirl from the wall progressively over a period of time.
- (4) The following successive portions of fuel also undergo the same sequence of events as they are spread first upon the spherical combustion wall and then gradually removed in vaporized form by the combined action of air swirl and the heat of the fire already in progress in the spherical combustion chamber. The air swirl continues to remove only

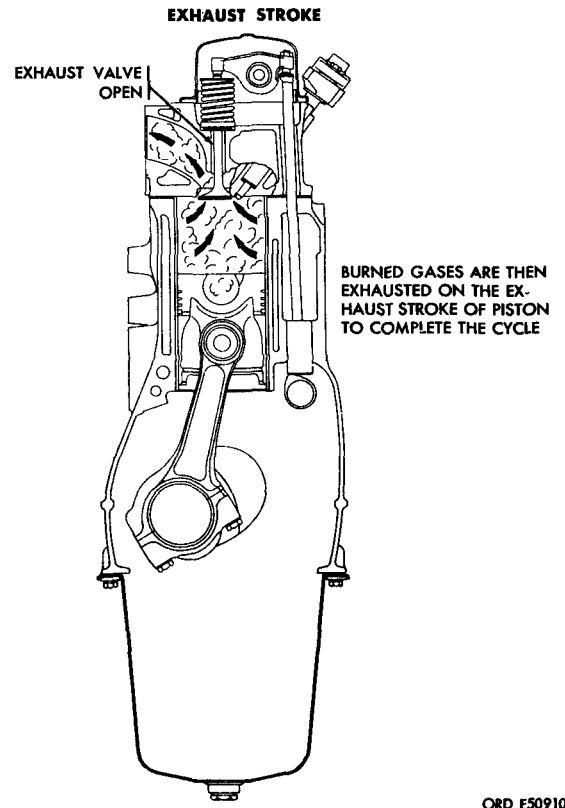


**FIGURE 14. FUEL INJECTION INTO CYLINDER.**

the upper surface of deposited fuel for combustion expansion throughout the power stroke of the piston, maintaining even combustion and eliminating detonation knock.



**FIGURE 15. POWER STROKE.**



**FIGURE 16. EXHAUST STROKE.**

d. Exhaust Stroke (fig. 16). The exhaust stroke is the same as the similar stroke in conventional diesel engines.

## 6. GENERAL DESCRIPTION

a. The Model LDS-427-2 engine is a four-cycle, in-line, six-cylinder, overhead-valve, turbosupercharged, liquid cooled diesel engine rated at 140 horsepower at 2600 rpm.

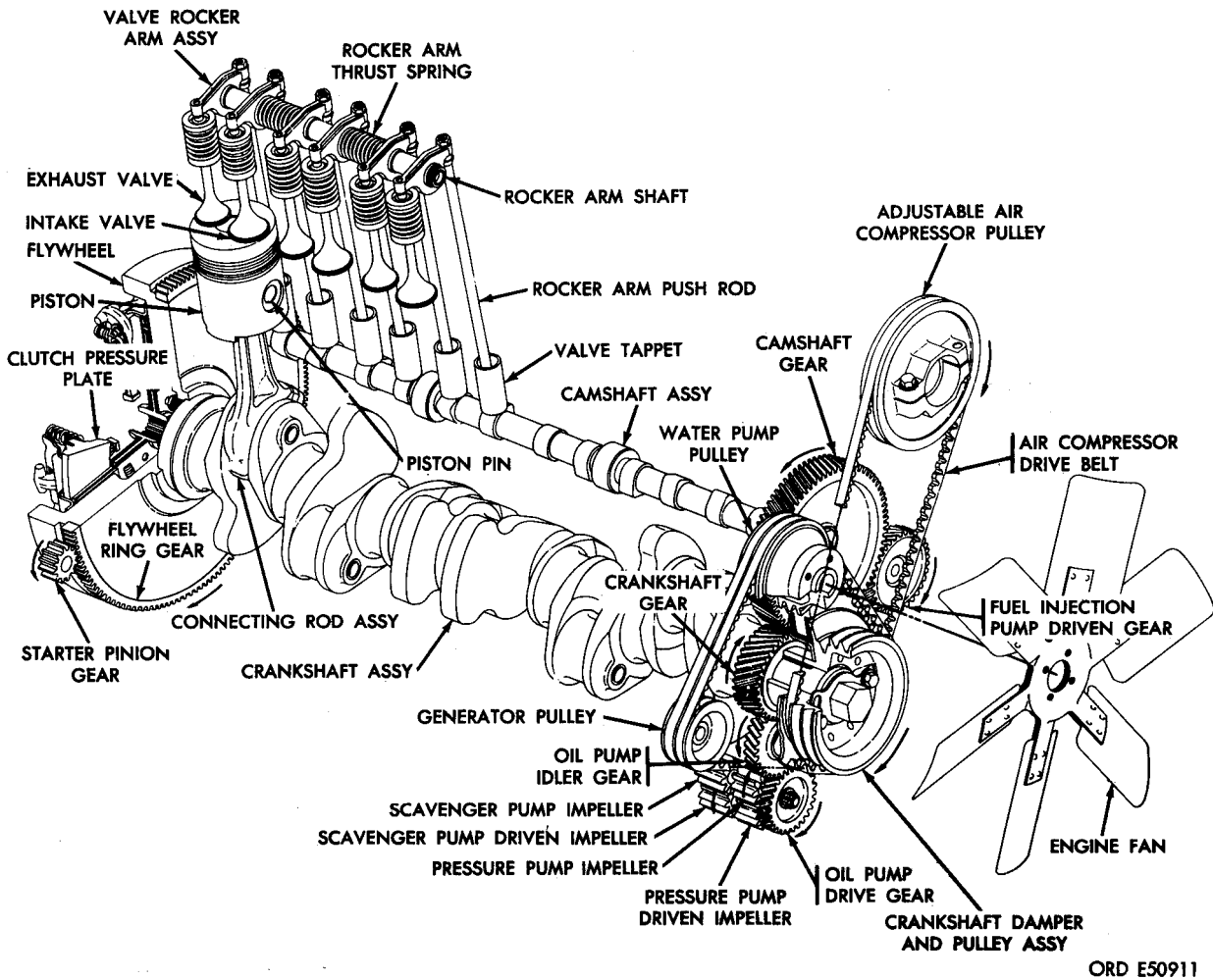
b. The engine will operate successfully on diesel fuel (VV-F-800), compression ignition fuel (MIL-F-45121), or regular gasoline (MIL-G 3056). No modifications or adjustments are necessary when changing grades of fuel. Refer to LO 9-2320-235-12 for proper temperature ranges for the above fuels.

## 7. ENGINE ACCESSORIES.

Refer to par. 1h for publications describing the "engine accessories, except the air compressor which is contained in TM 9-8601.

## 8. CYLINDER AND CRANKCASE

The cylinder and crankcase (cylinder block) is a six-cylinder, in-line design, constructed of cast iron. The cylinder and crankcase has replaceable "dry" cast iron cylinder liners which are pressed in the cylinder bores. The crankcase is designed for maximum rigidity by extending the sides of the crankcase below the center line of the crankshaft. Seven main bearing caps are provided with maximum support by recessing them into transverse webs



ORD E50911

**FIGURE 17. ENGINE GEAR TRAIN.**

which are cast integrally with the crankcase. The seven main bearing caps are an integral part of the cylinder and crankcase. The integrally cast water jacket provides a uniform transfer of heat to the engine coolant.

#### 9. CRANKSHAFT ASSEMBLY (Fig. 17)

The crankshaft assembly is a one-piece unit of forged and hardened steel. A flange is provided for mounting the flywheel. The other end has a machined hub with a key slot to mount the crankshaft gear and crankshaft torsional vibration damper and pulley assembly. All crankpin journals are hollow to reduce weight. Holes are drilled diagonally through each main bearing journal and extended through the crank

cheek and crank pin to provide a direct passage for pressurized oil to the connecting rod and crankshaft main bearings. The crankshaft is dynamically balanced.

#### 10. MAIN BEARINGS (Fig. 18)

The seven main bearings are split, precision type and are steel backed with copper-lead alloy bearing surfaces. The upper half of each main bearing has an oil passage. The center main bearing is double flanged with bearing material to control crankshaft thrust and end play.

#### 11. CONNECTING RODS (Fig. 17)

The six connecting rods are tapered, I-beam section, steel forgings. The connecting rod

bearing caps are joined to the connecting rod at a 45 degree angle to facilitate removal of the piston and connecting rod assemblies through the top of the cylinder bores. The connecting rods and caps are marked for identification and are replaced only as an assembly. A bronze lined, steel-backed, bushing-type bearing is pressed into the piston pin end of connecting rod. The bushing is diamond bored for precise piston pin fit.

## 12. CONNECTING ROD BEARINGS

The six connecting rod bearings are the

split, steel-backed, copper-lead alloy type. The upper and lower halves are interchangeable when new, but must be replaced as a set.

## 13. PISTONS AND PISTON PINS (Fig. 17)

The pistons are aluminum-alloy, die cast castings that are cam ground and tapered to provide an accurate fit in the cylinder bore at operating temperatures. A spherical shaped combustion chamber (fig. 13) is machined in the dome of the piston. Each piston accommodates three compression rings and one oil

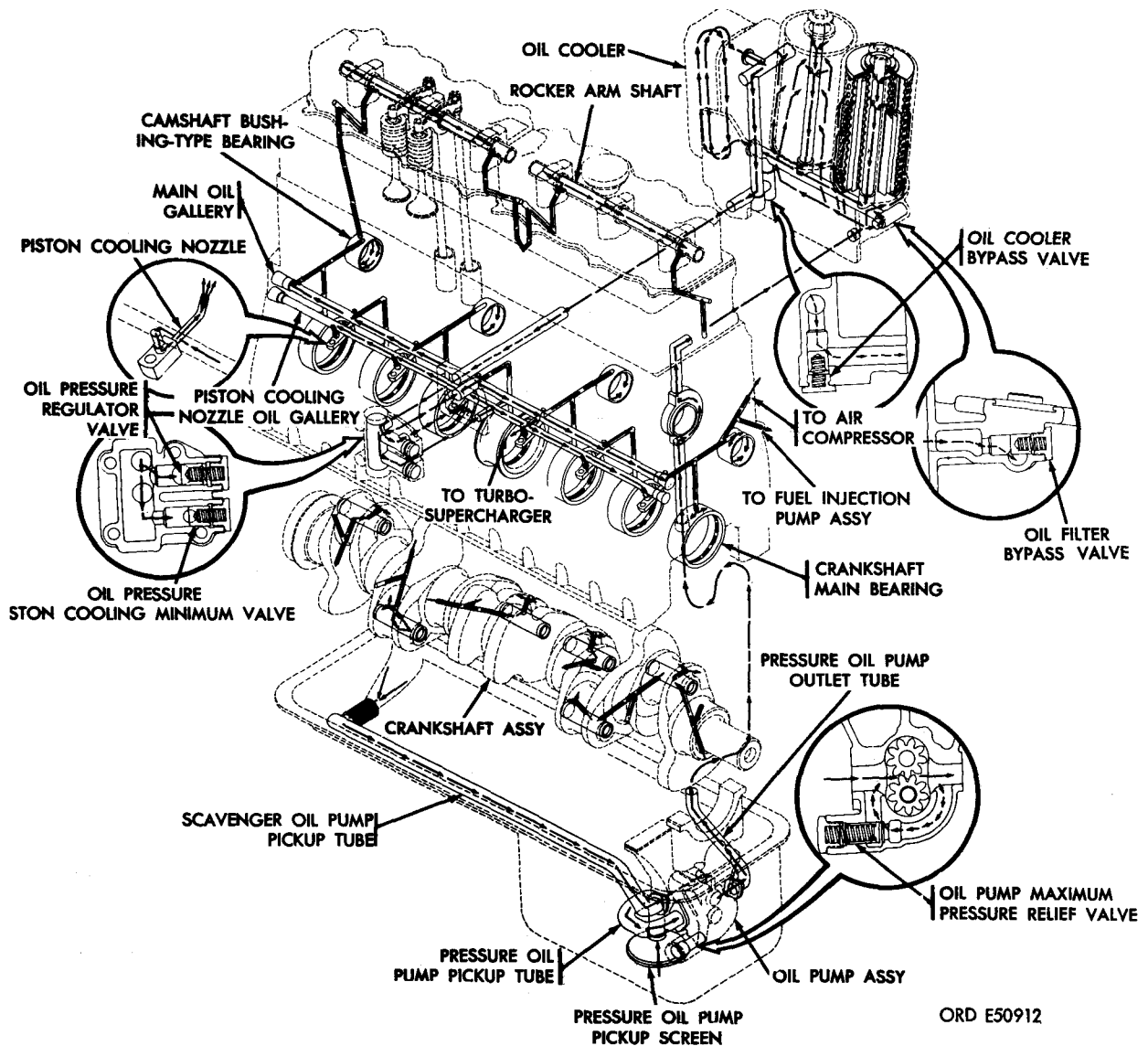


FIGURE 18. ENGINE LUBRICATION SYSTEM DIAGRAM.

ORD E50912



control ring. The piston pins are hollow and are hardened steel to give long service life. The piston pins are held in the piston pin boss by a retaining ring at each end of pin.

#### 14. PISTON RINGS

The two top piston compression rings are double beveled (Keystone) type and chrome faced. The third compression ring is not beveled. The face is tapered and chrome plated. The ring is marked "TOP" on top side of ring. The oil control ring is straight faced and has a chrome face and an expander spring. The spring forces the ring against the cylinder wall.

#### 15. CAMSHAFT ASSEMBLY AND BUSHING-TYPE BEARINGS (Fig. 17)

The camshaft assembly is solid and made of forged steel. The camshaft is supported in the cylinder and crankcase by four steel-backed, copper-alloy replaceable bushing-type bearings. A thrust plate located between the camshaft gear and crankcase is used to control camshaft end play.

#### 16. TAPPETS AND PUSH RODS (Fig. 17)

The 12 tappets are solid and are counter-bored to accept the push rods. The bottom of the counterbore is machined to serve as a bearing surface for the push rods. The tappets are drilled to allow oil drainage. The 12 push rods are tubular with the lower end machined to fit the bearing surface of the tappet. The upper end of the push rod is machined to fit the valve rocker arm adjusting screw bearing surface.

#### 17. CRANKSHAFT AND CAMSHAFT GEARS (Fig. 17)

The helical crankshaft gear is pressed on and keyed to the crankshaft. The crankshaft gear drives the camshaft gear. The steel helical camshaft gear is keyed to the end of the camshaft. Two teeth on the camshaft gear and one tooth on the crankshaft gear are punch marked for proper valve timing alignment.

#### 18. CRANKSHAFT VIBRATION DAMPER AND PULLEY ASSEMBLY (Fig. 17)

The molded rubber type crankshaft torsional vibration damper and pulley assembly is mounted on the front end of the crankshaft. The triple pulley drives the water pump (fig. 1), generator (fig. 3), and air compressor (fig. 1).

#### 19. FLYWHEEL (Fig. 17)

The cast iron flywheel, with a replaceable ring gear, provides for the attachment of the clutch assembly. The flywheel is bolted to the rear flange of the crankshaft and is dynamically balanced.

#### 20. CYLINDER HEADS

The two cylinder heads are identical and interchangeable as assemblies. They incorporate the overhead valve arrangement. The cast iron heads have replaceable valve guides and valve seats. Each cylinder head covers three cylinder bores and has intake and exhaust valve port openings. The intake port openings in the heads are so designed that an air swirl is created as air enters the combustion chamber (par. 5). Each cylinder head has openings for the cylinder head water outlet manifolds.

#### 21. VALVES AND VALVE SPRINGS (Fig. 17)

The six intake and exhaust valves are constructed of a special steel. Each valve has an inner and outer valve spring and a valve rotator. The valve springs are secured in position with a retainer and two keys.

#### 22. ROCKER ARM SHAFTS AND SUPPORTS (Fig. 17)

The two rocker arm shafts are constructed of heat treated seamless or welded steel tubing. The rocker arm shafts are secured to the two cylinder heads by rocker arm shaft supports. The supports are interchangeable and are drilled to permit oil from the oil pressure pump to pass through to the rocker arm shafts. The shafts are also drilled to distribute oil to the individual rocker arms.

#### 23. VALVE ROCKER ARMS (Fig. 17)

The twelve rocker arms are hot-rolled, heat-treated, carbon steel stampings. The steel-backed, bronze-faced, rocker arm bushings are not replaceable.

#### 24. INTAKE MANIFOLD

The one piece cast aluminum intake manifold is water jacketed. Coolant is circulated through the jacket, and heat thus transferred to the induction air improves the cold weather combustion characteristics of the engine. The thermostat housing (fig. 1) is secured to the front flange of the manifold. The intake manifold also houses the water temperature sending unit.

## 25. EXHAUST MANIFOLD

The exhaust manifold consists of three high temperature cast iron sections. The two end sections are joined to the center section by slip joints. To prevent exhaust leaks at these joints, three metal seal rings are used at each center section end.

## 26. CYLINDER HEAD WATER OUTLET MANIFOLDS

The two aluminum cylinder head water outlet manifolds are secured to the two cylinder heads

by cap screws and gaskets and are connected to the water jacketed intake manifold by rubber hoses and clamps.

## 27. CRANKCASE BREATHER TUBE

The cylinder head assemblies and crankcase are vented through an adapter and crankcase breather tube. The adapter is located on top of the front and rear cylinder head covers. The crankcase breather tube is attached to the adapter by a rubber hose and clamps and secured to the turbosupercharger.

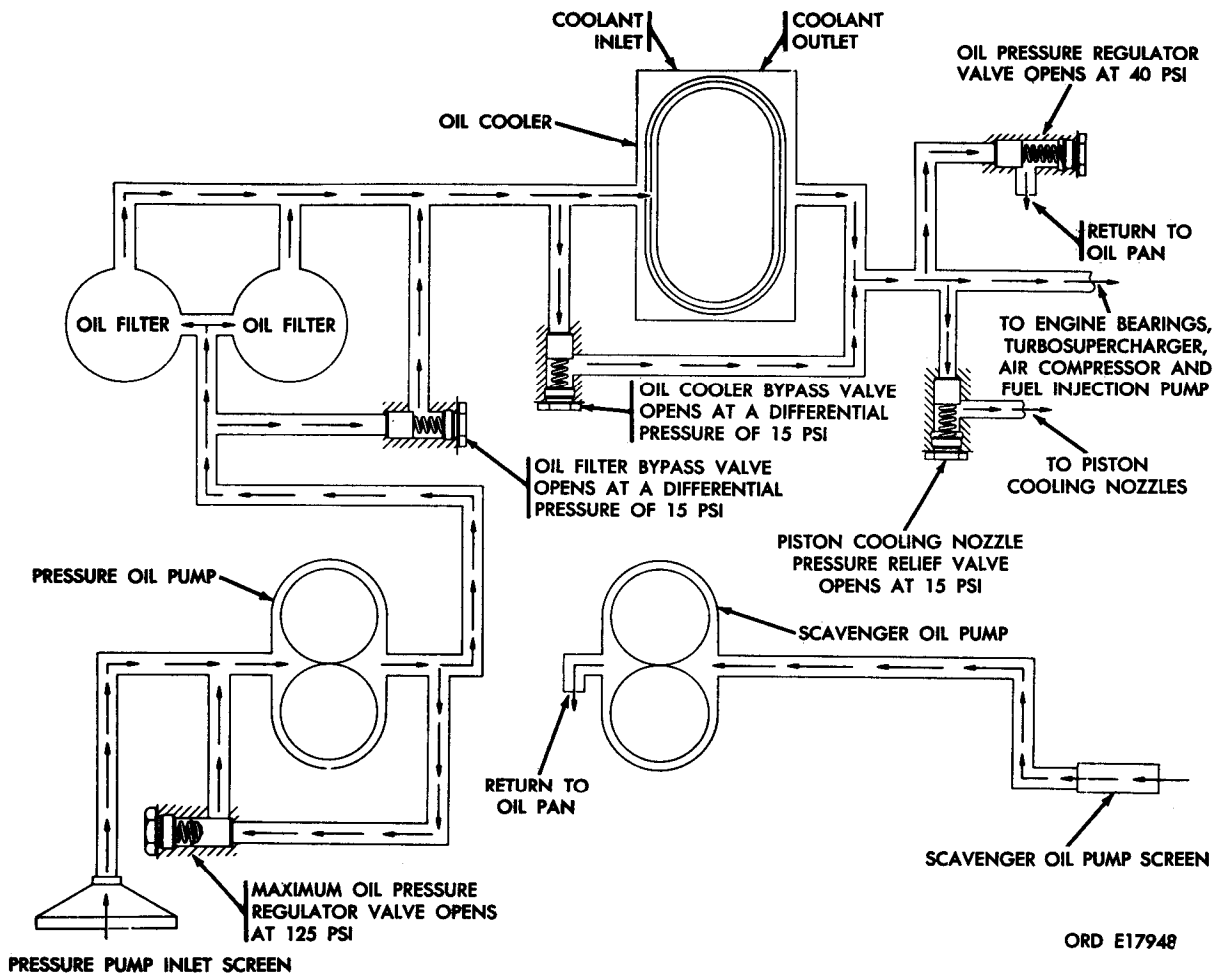


FIGURE 19. ENGINE OIL FLOW CIRCUIT DIAGRAM.

## 28. FLYWHEEL HOUSING

The cast aluminum flywheel housing is attached to the rear machined surface of the cylinder and crankcase. The housing provides for the attachment of the rear engine mounts and the transmission adapter assembly. The housing also covers the flywheel and provides a mount for the starter assembly (fig. 3).

## 29. LUBRICATION SYSTEM (Fig. 18)

**a. General.** The engine has a full-pressure lubricating system. The pressure system insures a continuous delivery of oil to all engine moving parts regardless of the angle at which the vehicle may be inclined. The oil flow is shown on figure 19.

**b. Oil Pump.** The oil pump is a dual unit consisting of a scavenger and a pressure pump. The oil pump is gear driven by the crankshaft gear and an oil pump idler gear mounted on a shaft extending from the No. 1 main bearing cap. The pressure oil pump picks up oil from the oil reservoir at the front of the oil pan and delivers oil under pressure to the oil filters, oil cooler, and engine oil galleries. The scavenger oil pump picks up oil from the rear of the oil pan via a pickup tube and spills oil back into the front reservoir. The scavenger oil pump insures a continuous oil supply to the pressure pump pickup at all times regardless of actual vehicle position.

**c. Oil Filters.** The engine has two replaceable element-type oil filters (fig. 19). Both oil filters are identical and interchangeable. The dual unit oil filters are mounted on the oil cooler and oil filter housing assembly at the left side of the engine. Pressurized lubricating oil is forced through the filters before entering the oil cooler and engine lubricating system. The oil filter bypass valve is located below the front oil filter. This valve routes oil directly to the oil cooler if the oil filters become clogged. The bypass valve opens at a differential pressure of 15 psi.

**d. Oil Pan.** The oil pan is stamped steel with two magnetic drain plugs.

**e. Oil Cooler.** The oil cooler is located at the rear of oil cooler and oil filter housing assembly. The coolant jacketed oil cooler performs two functions, to transfer heat to speed warm-up of lubricating oil during cold starts, and to maintain lubricating oil temperature at

an acceptable level during normal engine operation. The oil cooler bypass valve opens at a pressure differential of 15 psi when the oil cooler becomes clogged routing the oil to the engine oil galleries.

**f. Bearing Lubrication (fig. 18).** The crankshaft, connecting rod, and camshaft bushing-type bearings are lubricated from drilled passages in the cylinder and crankcase and through the crankshaft journals and cheeks. Oil under pressure from the oil filters and oil cooler enters the main oil gallery in the cylinder and crankcase. Oil flows from the oil gallery through oil passages to the crankshaft main bearings and camshaft bushing-type bearings. Oil lubricating the crankshaft main bearings flows around the bearings to the drilled oil passages in the crankshaft journals and cheeks and to the connecting rod bearings. Excess oil leaving the bearings flows back to the oil pan to be recirculated. The valve rocker arm bearings and other components of the valve train are lubricated with oil fed through a passage leading from the rear camshaft bearing.

**g. Piston Cooling Nozzle Assemblies.** The hypercycle principle depends upon proper piston operating temperature. Oil is conveyed through an individual oil gallery and directed to the inside of the piston skirts by six cooling nozzle assemblies. This oil pressure is controlled by an oil pressure control valve located in the oil pressure regulator valve housing. Oil flow to nozzles is controlled by a 15 psi minimum pressure control valve.

**h. Fuel Injection Pump Lubrication.** The fuel injection pump is lubricated by the engine oil system. Oil is directed through oil galleries to an external flexible hose connected to the fuel injection pump advance unit housing. Refer to TM 9-2910-223-35 for complete description of fuel injection pump lubricating system. Oil leaving the injection pump returns to the engine oil pan through passages in the injection pump advance unit. The injection pump driven gear (fig. 17) is lubricated by this return oil.

**i. Turbosupercharger Lubrication.** The turbosupercharger is lubricated by engine oil from the main oil gallery through an external line. Oil from the turbosupercharger is returned to the oil pan. Refer to TM 9-2990-201-35 for a detailed description of turbosupercharger lubrication.

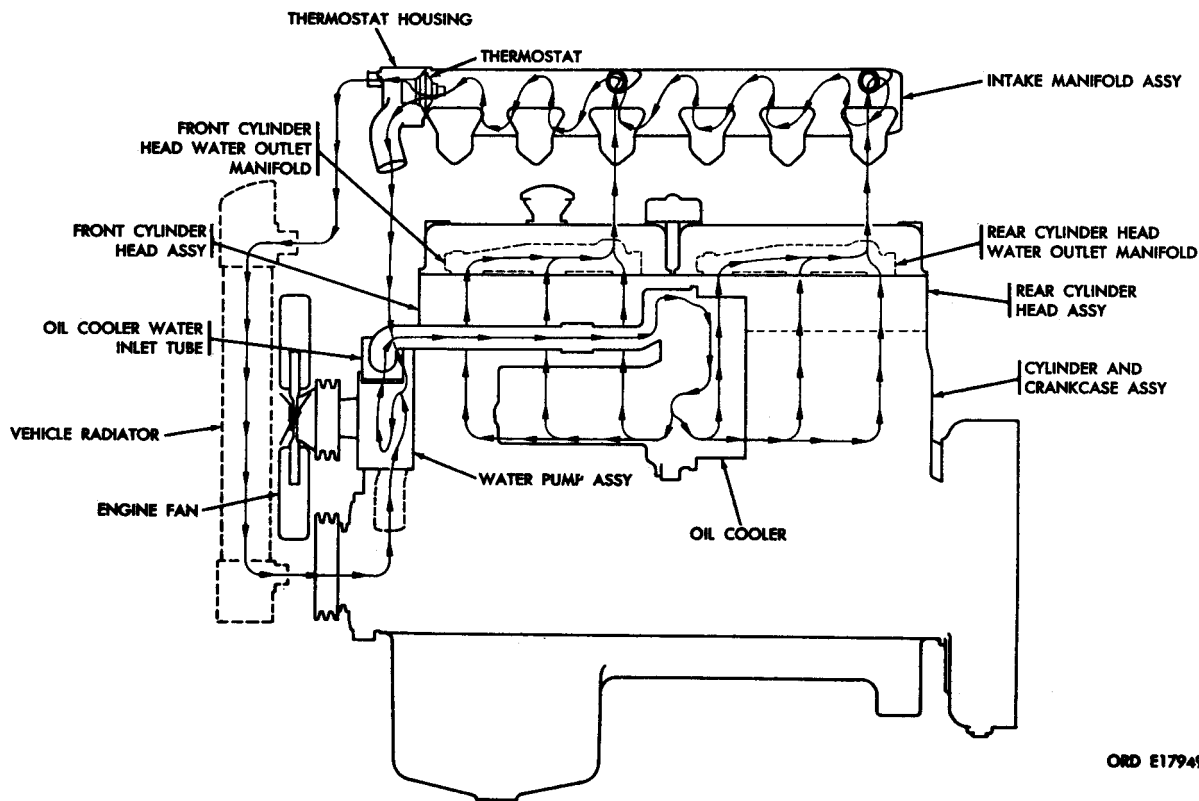
j. Air Compressor Lubrication. The air compressor is lubricated by engine oil from the main oil gallery. Oil is directed through drilled passages in the crankcase and the air compressor support to the air compressor. Oil returning from the compressor drains back into the oil pan through the engine front valve tappet chamber.

### 30. COOLING SYSTEM (Fig. 20)

a. General. The engine is liquid cooled. Coolant is circulated throughout the engine cooling system by the water pump assembly. Temperature of the coolant is controlled by the thermostat. Front and rear cylinder head water outlet manifolds maintain an equal distribution of coolant around each cylinder head.

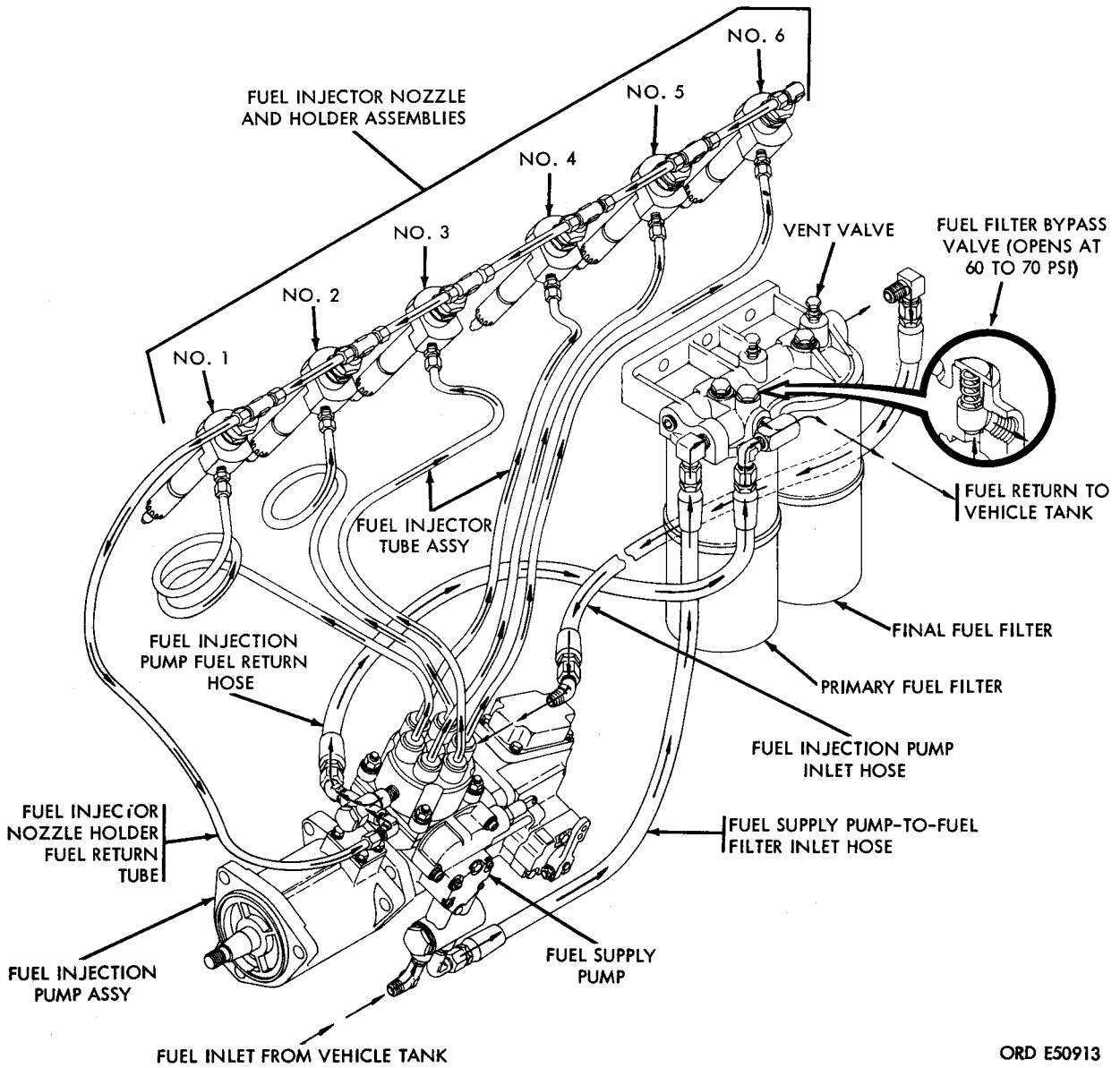
b. Water Pump Assembly. The water pump assembly is mounted on front of the cylinder and crankcase. The pump is belt driven from the crankshaft damper and pulley assembly. The impeller drive shaft rotates in a sealed double ball bearing housing which does not require periodic lubrication. The double water pump pulley is pressed onto the water pump shaft. The water pump has a bypass connection which allows coolant from the thermostat housing to enter for recirculation. Coolant bypasses the radiator when the thermostat is closed during the engine warm-up.

c. Fan (figs. 17 and 20). The fan has six blades and is attached to the water pump pulley. It provides proper air circulation through the vehicle radiator.



ORD E17949

FIGURE 20. ENGINE COOLING SYSTEM DIAGRAM.



**FIGURE 21. ENGINE FUEL SYSTEM DIAGRAM.**

d. Thermostat. Cent rol of coolant flow from the heated engine to the radiator is maintained by a thermostat installed in a housing at the front of the intake manifold. The thermostat is set to open at 180° F.

### 31. FUEL SYSTEM (Fig. 21)

a. General. The fuel system used on the engine makes it possible for the engine to operate on various types and grades of fuel without adjusting the fuel injection pump.

b. Fuel Supply Pump. The fuel supply pump is part of the fuel injection pump assembly. The pump takes fuel from the vehicle fuel tank and delivers it under pressure through the primary and final fuel filters to the fuel injection pump. The injection pump then meters the fuel to the fuel injector nozzle and holder assemblies in firing order sequence. Refer to TM 9-2910-223-35 for a complete detailed description of fuel supply pump.

c. Primary and Final Fuel Filters. The primary and final fuel filters are identical and have interchangeable and replaceable elements. The primary fuel filter removes most foreign material from the fuel. The final fuel filter removes any remaining foreign material which has escaped the filtration of the primary fuel filter.

d. Fuel Injection Pump Assembly. The fuel injection pump assembly is driven by the fuel injection pump driven gear which in turn is driven by the camshaft gear (fig. 17). The pump is used to supply pressurized fuel to each individual fuel injection nozzle and holder assembly in the firing order sequence. The fuel injection pump advance unit automatically provides a gradual 8 degrees advance of fuel injection timing over the engine speed range. For complete description, data, and maintenance of this pump, refer to TM 9-2910-223-35.

e. Fuel Injector Nozzle and Holder Assemblies. The six fuel injector nozzle and holder assemblies are used to inject fuel into the combustion chambers (fig. 14). The injector nozzle and holder assemblies are sealed against leakage by copper gaskets. The fuel injector nozzle and holder assemblies are interconnected by fuel return tubes to return excess fuel to the fuel tank. The nozzle and holders are adjustable to provide a proper opening pressure and spray pattern for economical engine operation and proper performance.

f. Fuel Hoses and Tubes. The fuel supply pump-to-fuel filter inlet hose, fuel iniectiion pump inlet hose, and fuel injection pump fuel return hose are made of a flexible rubber composition. The six fuel injection tubes are soft annealed steel tubing, subjected to high fuel pressure during operation. The tubes are the same length and convey fuel from the fuel injection pump head to each individual fuel injector nozzle and holder assembly. The fuel injector nozzle holder fuel return and fuel excess tubes are made of nylon composition.

### 32. INTAKE MANIFOLD FLAME HEATER AND FUEL SYSTEM

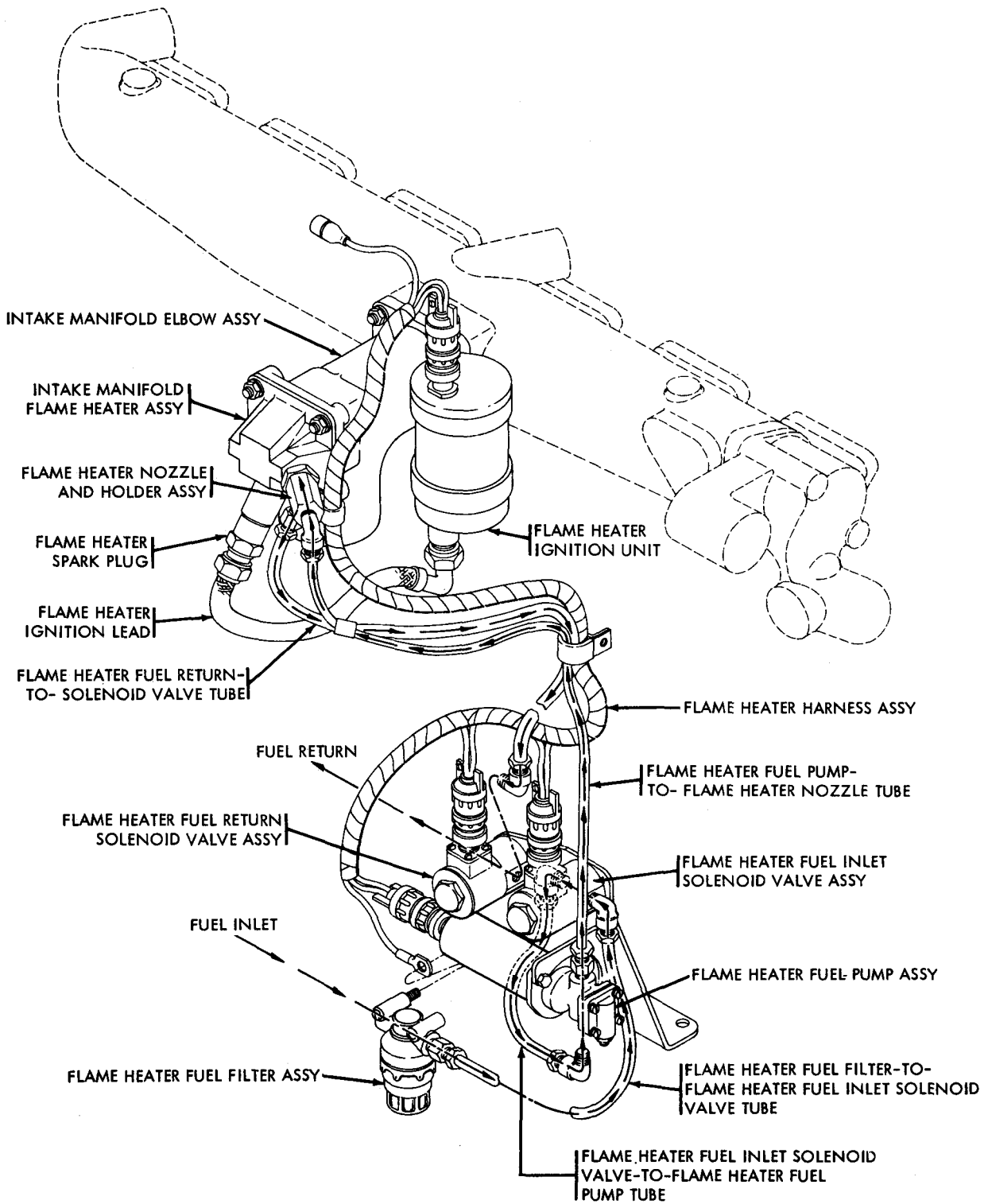
a. General. The engine is equipped with a flame type manifold heater (fig. 22) for heating the induction air during cold weather starting and warmup operation.

b. Flame Heater Assembly. The flame heater assembly is composed of a housing, spark plug, and spray nozzle and holder assembly. The nozzle sprays fuel under pressure into the intake manifold elbow assembly. The fuel vapor is ignited by the spark plug and burns in the manifold, heating the air before it enters the engine combustion chambers. The spark plug is energized by the flame heater ignition unit which is mounted on the intake manifold elbow studs .

c. Flame Heater Fuel Pump Assembly. The flame heater fuel pump assembly is mounted on a bracket near the lower right front of the engine. The fuel pump is a rotary type driven by an enclosed electric motor. The pump is capable of pumping 2.0 gallons of fuel per hour at a pressure of 90 psi. The pump draws fuel from the vehicle fuel tank and supplies it to the flame heater spray nozzle and holder assembly. The fuel pump is energized by an on-off switch on the vehicle instrument panel.

d. Flame Heater Fuel Filter Assembly. The flame heater fuel filter assembly is mounted on the same bracket that mounts the flame heater fuel pump. The filter element is replaceable.

e. Flame Heater Solenoid Valves. Two flame heater fuel solenoid valves (fig. 22) are used. The valves, identical and interchangeable, are energized (opened) whenever the flame heater assembly and flame heater fuel pump are actuated. These valves insure that fuel is delivered



ORD E50914

FIGURE 22. ENGINE FLAME HEATER FUEL SYSTEM DIAGRAM.

only when the system is actuated and stop the flow of fuel the instant flame heater operation is discontinued.

### 33. AIR INDUCTION AND EXHAUST SYSTEM (TURBOSUPERCHARGER)

a. Air Induction. The turbo supercharger increases the velocity and pressure of the intake air, forcing a greater volume of air into the combustion chambers than a non-supercharged engine. This higher volume of air, resulting in a more constant fuel air ratio, increases engine power.

b. Exhaust Gases. The turbosupercharger is essentially an exhaust-gas driven blower which utilizes the kinetic energy usually lost in the exhaust gases to compress air into the cylinders. The exhaust gases from the engine enter the turbosupercharger and are forced around the turbine housing, radially inward, through a nozzle ring. The exhaust gases drive the turbine wheel which in turn drives the compressor wheel. Induction air enters at the center of the compressor wheel and flows radially outward through a diffuser section into the compressor housing. The air then leaves through a tangential outlet on the outside of the compressor housing and enters the intake manifold. The exhaust gases are expelled from the turbosupercharger into the vehicle exhaust system.

### 34. CRANKCASE OIL FILLER AND CRANKCASE BREATHER

The engine has an oil filler cap in the front cylinder head cover for adding oil to the engine.

The crankcase breather adapter is located on top of, and connected between, the front and rear cylinder head covers. The crankcase breather is open to the atmosphere.

### 35. SENDING UNITS

a. Oil Pressure Sending Unit. The oil pressure sending unit is located at the right rear of engine in the main oil gallery above the starter assembly. The unit transmits an electrical interpretation of the engine oil pressure to the oil pressure gage on the vehicle instrument panel.

b. Coolant Temperature Sending Unit. The coolant temperature sending unit is located in the front end of the intake manifold water jacket above the generator. This unit transmits an electrical interpretation of engine coolant temperature to the temperature gage on the vehicle instrument panel.

### 36. CLUTCH ASSEMBLY

The clutch assembly consists of a 13-inch driven member and a clutch cover assembly which are mounted on the engine flywheel. The driven member is built with a center vibration neutralizer spring hub and riveted facings. The cover assembly consists of a spring-loaded pressure plate with four adjustable levers.

---

## Section III. TABULATED DATA

### 37. GENERAL

Refer to TM 9-2320-235-10 for the tabulated data pertaining to the general characteristics

and performance of the engine. The specific tabulated data covering the engine accessories is contained in the applicable technical manual shown in paragraph 1h.



### 38. ACCESSORIES

Accessory	Make	Model or Type
Generator assembly . . . . .	Delco- Remy Div.....	1117495
Generator assembly . . . . .	Electric Autolite Co. . . . .	GHA-4802UT
Starter assembly . . . . .	Electric Autolite Co. . . . .	MBD-4043UT
Fuel injection pump with automatic advance unit . . . . .	American Bosch Div.. . . . .	PSB-6A
Air compressor . . . . .	Military Standard . . . . .	MS51322-1
Turbosupercharger . . . . .	Schwitzer Corp. . . . .	4-450 (Early model engines)
Turbosupercharger . . . . .	Schwitzer Corp. . . . .	4D (Late model engines)
Flame heater fuel pump . . . . .	Bendix-Scintilla Div. . . . .	10-207317
Manifold flame heater . . . . .	Bendix-Scintilla Div. . . . .	10-187565-6
Fuel filters . . . . .	Purolator Products Inc. . . . .	PR-161-4
Oil filters . . . . .	Purolator Products Inc. . . . .	64983
Oil pressure sending unit . . . . .	Military Standard . . . . .	MS24538-1
Coolant temperature sending unit . . . . .	Military Standard . . . . .	MS24537-1
Fuel injector nozzle and holder assembly . . . . .	American Bosch Div. . . . .	KT-7824

### 39. ENGINE ASSEMBLY

Make . . . . .	Continental Motors Corp.
Type . . . . .	in-line. compression ignition, multi-fuel, liquid cooled, turbosupercharged
Model . . . . .	LDS-427-2
Dimensions (excluding clutch):	
Length (from engine fan to face of transmission adapter) . . . . .	48. 04-in.
Width (from air compressor filter inlet to ignition unit lead) . . . . .	33. 00-in.
Height (from oil filler cap to oil drain plug) . . . . .	40. 59-in.
Displacement . . . . .	427 cu in.
Weight, dry (with accessories). . . . .	1500 lbs.
Speed:	
Governed, full load.... . . . .	2600 to 2650 rpm
Governed, no load . . . . .	2750 to 2825 rpm
Idle . . . . .	650 to 700 rpm
Horsepower, gross:	
Diesel fuel (VV-F-800) . . . . .	140 hp at 2600 rpm
Compression ignition fuel (MIL-F-45121) . . . . .	128 hp at 2600 rpm
Gasoline (MIL-G-3056) . . . . .	113 hp at 2600 rpm
Horsepower, net (less accessories):	
Diesel fuel (VV-F-800). . . . .	130 hp at 2600 rpm
Compression ignition fuel (MIL-F-45121) . . . . .	118 hp at 2600 rpm
Gasoline (MIL-G-3056) . . . . .	103 hp at 2600 rpm
Torque, gross:	
Diesel fuel (VV-F-800). . . . .	340 ft-lbs at 1400 rpm
Compression ignition fuel (MIL-F-45121) . . . . .	310 ft-lbs at 1400 rpm
Gasoline (MIL-G-3056) . . . . .	290 ft-lbs at 1400 rpm
Torque, net (less accessories):	
Diesel fuel (VV-F-800) . . . . .	330 ft-lbs at 1400 rpm
Compression ignition fuel (MIL-F-45121) . . . . .	300 ft-lbs at 1400 rpm
Gasoline (MIL-G-3056) . . . . .	280 ft-lbs at 1400 rpm
Cylinders:	
Number . . . . .	6
Arrangement . . . . .	in line

Cylinders: (continued)	
Numbering (from front) . . . . .	1,2,3,4,5,6
Firing order . . . . .	1,5, 3,6,2,4
Bore . . . . .	4.31 in.
Pistons	
Stroke . . . . .	4.87 in.
Compression ratio . . . . .	20:1
Displacement . . . . .	71.1 cu in. per cylinder
Cooling:	
True . . . . .	forced circulation, pressure type, thermostat, engine belt drive water pump, and fan
Engine operating temperature (normal) . . . . .	180° F to 200° F
Control:	
Type . . . . .	thermostat, spring and cartridge type
Opening range . . . . .	180° F
Fully open . . . . .	200° F
Engine capacity (coolant) . . . . .	19- 1/2 qts
Pump . . . . .	centrifugal type
Drive . . . . .	2 "V" wedge belts
Capacity (pump) . . . . .	75 gpm at 2600 rpm and 180° F
Fan . . . . .	6 blade
Drive (from crankshaft) . . . . .	clutch drive from face of flywheel
Crankshaft rotation (viewed from front) . . . . .	clockwise
Camshaft rotation (viewed from front) . . . . .	counterclockwise
Ignition . . . . .	compression
Fuel system:	
Type . . . . .	fuel injection, compression ignition
Air flow (at rated power and speed) . . . . .	410 cfm
Fuel:	
Compression ignition . . . . .	MIL-F-46005
Diesel . . . . .	VV-F- 800
Gasoline . . . . .	MIL-G-3056
NOTE. Do not use high octane action gasoline.	
Supply pressure (minimum at injection pump inlet at 2600 rpm) . . . . .	35 psi min at 2600 rpm
Consumption (at rated power and speed):	
Compression ignition fuel (MIL-F-46005) . . . . .	56 lb/hr
Diesel fuel (VV-F-800) . . . . .	611lb/hr
Gasoline (MIL-G-3056) . . . . .	.501b/hr
Consumption (at idle w/Diesel fuel) . . . . .	2 lb/hr
Injection pump timing (static-retarded advance unit) . . . . .	27 deg btdc
Injection pump automatic advance . . . . .	.8deg
Valve timing (sequence - cold clearance intake valve O. 015-in. , exhaust valve O. 025-in. ):	
Intake opens . . . . .	6 deg btdc
Intake remains open . . . . .	216 deg
Intake closes . . . . .	30 deg abdc
Exhaust opens . . . . .	36degbbdc
Exhaust remains open..... . . . .	218deg
Exhaust closes . . . . .	2 deg atdc
Valves:	
Type and number . . . . .	overhead (two per cylinder)
Lift . . . . .	0.450in.
Clearance (cold engine):	
Exhaust . . . . .	0.025 in.
Intake . . . . .	0.015 in.

Lubrication:

Oil specifications:	
Above +32 IF . . . . .	OE-30(MIL-L-2104)
-16°F to+ 500F . . . . .	OE-10(MIL-L-2104)
-65°F to+100F . . . . .	OES(MIL-L-10295)
Normal oil temperature (after cooler) . . . . .	200° F at 70° F ambient
Maximum oiltemperature (at sump) . . . . .	250" F
Oil pressure (crankcase main gallery):	
650 to 700rpm (idle). . . . .	OE-30at 180 °F,10 psi min
2600 rpm (full load)	OE-30 at 180" F, 50-65 psl
Oil pump output (OE-30;ti8b°F). . . . .	.20gpm@2600rpm
Oil capacity:	
Filters dry . . . . .	..22qts
Filters full . . . . .	18 qts
Oil system type . . . . .	positive, full pressure lubrication
Oil filters . . . . .	full flow (replaceable element)
Induction heater (cold weather starting):	
Type . . . . .	flame type- spark igniter
Sparkplug (igniter) gap . . . . .	0.094-in. to 0.114-in.
Fuel pump (electric) . . . . .	2.0 gph at 90 psi
Spray nozzle flow (CIE fuel). . . . .	1.5t02.21bs/hr
Fuel (type)	same as engine fuel

40. DRIVE RATIOS AND ROTATION (FROMFRONT)

Camshaft . . . . .	...0. 50:1 counterclockwise
Water pump and fan..... . . . .	..1.35.1 clockwise
Generator . . . . .	..2.00 .1 clockwise
Starting motor. . . . .	11.5:1counterclockwise
Injection pump, . . . . .	..1.00 .1 clockwise
Air compressor . . . . .	.. 0.86.1cloclwise
Oilpump . . . . .	..1.22:1 clockwise
Tachometer drive . . . . .	0.50:1 counterclockwise

## CHAPTER 2

### PARTS, SPECIAL TOOLS, AND EQUIPMENT FOR FIELD AND DEPOT MAINTENANCE

#### 41. GENERAL

Tools and equipment and maintenance parts over and above those available to the using organization are supplied to field maintenance units and depot shops for maintaining, repairing, and/or rebuilding the material.

#### 42. REPAIR PARTS

a. Repair parts required for the maintenance of this engine are listed in TM9-2815-204-35P, which is authority for requisitioning replacements.

b. Repair parts for engine installation or replacement (attaching or associated external parts) are listed in TM 9-2320-235-20P and TM 9-2320-235-35P.

c. Repair parts for engine accessories are shown in the technical manuals listed in paragraph lh.

#### 43. COMMON TOOLS AND EQUIPMENT

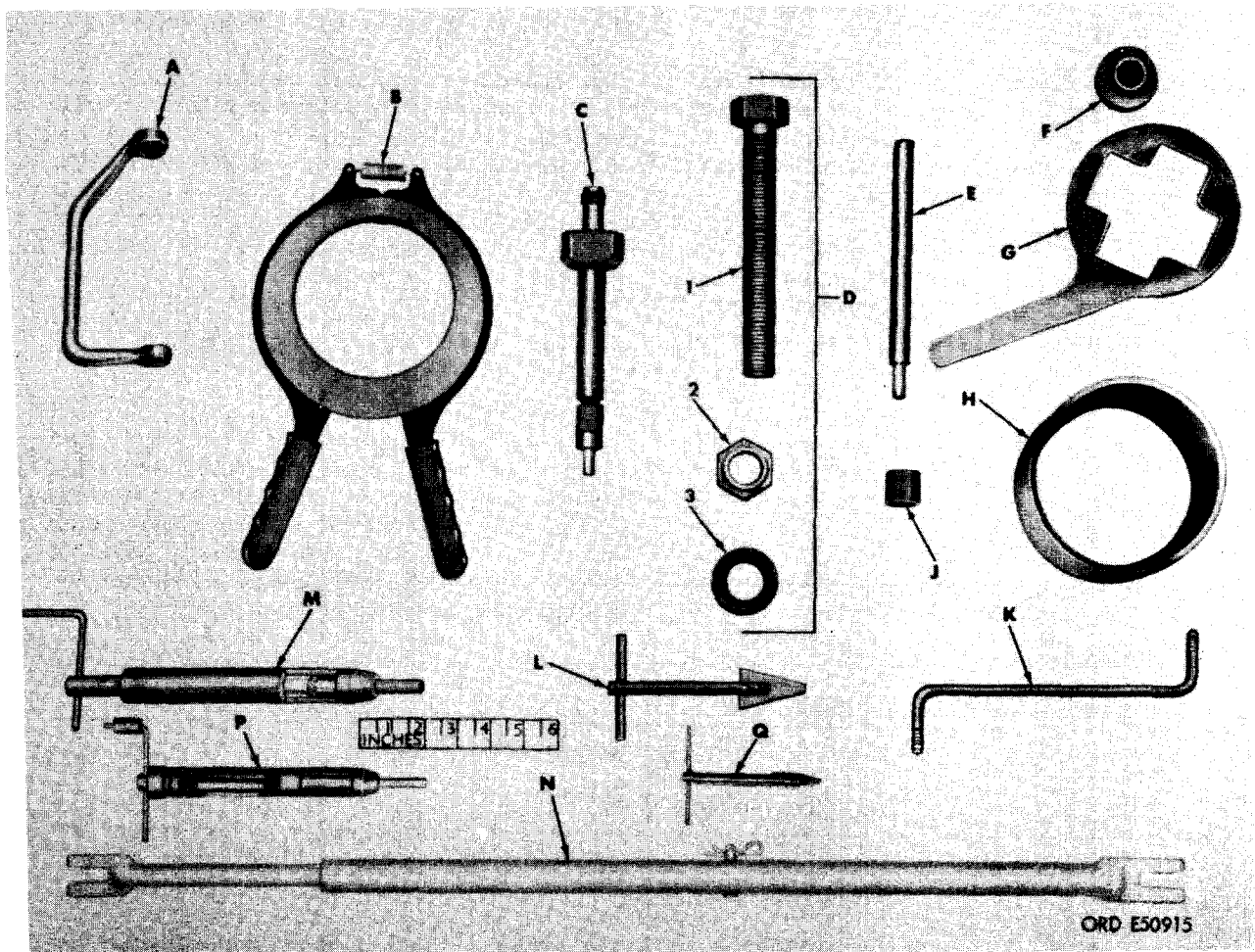
Standard and commonly used tools and equipment having general application to this material are listed in DA Supply Manuals SM 9-4-4910 - A02, A03, A38, A57, A73, A74, A75, A76, A78, A79, A80, A86, A87, A88, SM 9-4-5180-A17, A82, B14, and are authorized for replacement by TA and TOE.

#### 44. SPECIAL TOOLS AND EQUIPMENT

The special tools and equipment illustrated in figures 23 through 30 and listed in Table I are necessary to perform the field and depot maintenance repair and rebuild operations described in this technical manual. This list is not to be used for requisitioning. Refer to TM 9-2815-204-35P for listing of authorized special tools, kits, and equipment.

Table I. Special Tools and Equipment for Field and Depot Maintenance

Item	Identifying No.	Reference		Use
		Fig.	Par.	
ADAPTER, cylinder compression tester	10899183 (4910-870-2127)	23	102	Checking cylinder compression. Use w/GAGE - 10899180.
BRACKET, engine mounting, left front	10899173 (4910-873-1924)	28, and 296	114, 143, 263, and 286	Used for mounting engine on CRADLE ASSY -7950198 and STAND -7950189.
BRACKET, engine mounting, left rear	10912239 (4910-873-1925)	28, and 295	114, 143, 263, and 286	Used for mounting engine on CRADLE ASSY -7950198 and STAND -7950189.
BRACKET, engine mounting, right front	10899191 (4910-873-1923)	28, and 296	114, 143, 263, and 286	Used for mounting engine on CRADLE ASSY -7950198 and STAND -7950189.



A - Cylinder head wrench- 8722924  
 B - Piston ring expander - 10899196  
 C - Cylinder pressure test adapter - 10899183

D - Crankshaft gear replacer- 10899179  
 1 -Replacer bolt- 10899156  
 2 - 1-1in. plain nut- 88044-315-16  
 3 - 1-1in. flat washer- 96906-15795-126

E - Valve guide remover- 10899157

F - Puller guide plug- 10899178  
 G - Adjusting pulley wrench- 10935288  
 H - Piston ring compressor- 10899159

J - Valve guide replacer- 10899158  
 K - Connector tube- 10882963  
 L - Coil thread insert extractor - 7751056

M- Coil thread insert inserter- 10912379  
 N - Lifting sling spreader- 10912586

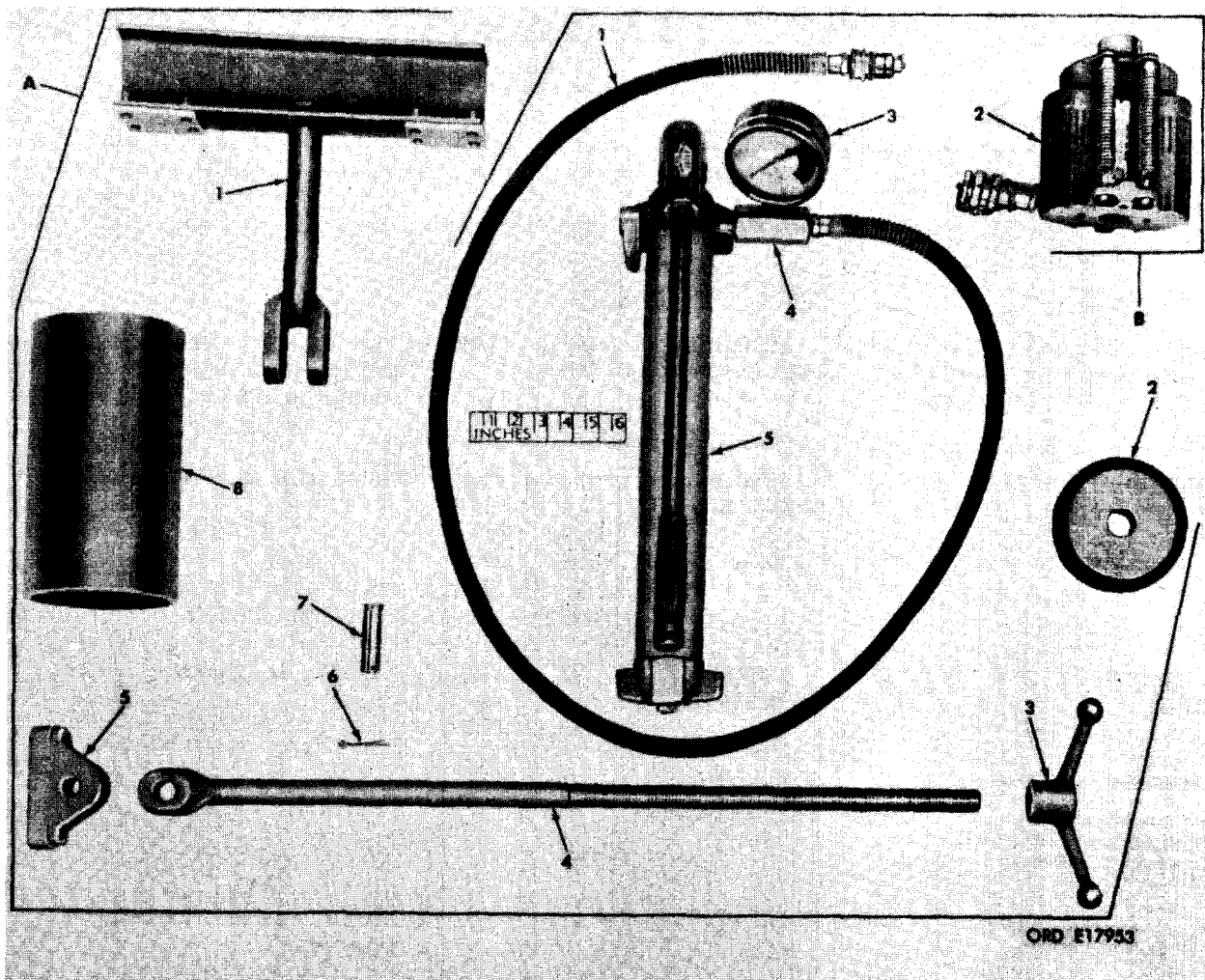
P - Coil thread insert inserter - 5120-251-1525

Q- Coil thread inset extractor - 5120-797-2402

FIGURE 23. SPECIAL TOOLS.

Table I. Special Tools and Equipment for Field and Depot Maintenance - Continued

Item	Identifying No.	Reference		Use
		Fig.	Par.	
<b>BRACKET, engine mounting, right rear</b>	<b>10899188 (4910-873-1926)</b>	28, and 295	114, 143, 263, and 286	<b>Used for mounting engine on CRADLE ASSY — 7950198 and STAND — 7950189.</b>
<b>COMPRESSOR, PISTON RING: 5-in. od, 4.3125 — 4.3145-in. id, 4- 1/2-in. high</b>	<b>10899159 (5120-870-6917)</b>	23, 345, and 480	174	<b>Used for gaging piston ring gap and/or installing piston and rings in cylinders.</b>
<b>CRADLE ASSEMBLY, engine overhaul stand</b>	<b>7950198 (4910-795-0198)</b>	28, 224, 293, 294, and 297	114, 144, 263, and 286	<b>Used w/STAND — 7950189.</b>
<b>EXPANDER, PISTON RING:</b>	<b>10899196 (5120-870-6918)</b>	23, and 339	173, and 176	<b>Removing or replacing piston rings.</b>
<b>EXTRACTOR, COIL THREAD INSERT: threaded inserts 7/16 to 1-in.</b>	<b>7751056 (5120-251-1527)</b>	23	155	<b>Used to remove threaded insert in oil cooler and oil filter housing.</b>
<b>EXTRACTOR, COIL THREAD INSERT:</b>	<b>5120-251-1525</b>	23		<b>Used to remove threaded inserts.</b>
<b>GAGE ASSY, cylinder compression</b>	<b>10899180 (4910-870-6283)</b>	27, and 221	102	<b>Testing cylinder compression. Used w/ADAPTER — 10899183.</b>
<b>Composed of:</b>				
<b>1 — BOX</b>	<b>10899192</b>	27		<b>Used to store or carry GAGE — 10899197.</b>
<b>2 — GAGE, compression</b>	<b>10899197</b>	27, and	102	<b>Used to indicate cylinder compression</b>
<b>3 — COUPLING</b>	<b>10899184</b>	27	102	<b>Used w/GAGE — 10899197.</b>
<b>INSERTER, COIL THREAD INSERT: threaded insert 1-14NS</b>	<b>10912379 (5120-204-0881)</b>	23	155	<b>Used to install threaded insert in oil cooler and oil filter housing.</b>
<b>INSERTER, COIL THREAD INSERT:</b>	<b>5120-797-2402</b>	23		<b>Used to install threaded inserts.</b>



A - Cylinder liner remover and replacer kit - 8722925

1 - Cylinder liner replacer support assembly - 10899161

2 - Cylinder liner replacer plate - 10899171

3 - Cylinder liner remover and replacer handle - 10899187

4 - Cylinder liner remover and replacer rod - 10899166

5 - Cylinder liner remover shoe - 10899168

6 - Cotter pin, 1/8 x 1-1/2 - 96906-24665-357

7 - 3/4 x 2-39/64 clevis pin - 96906-20392-10-73

8 - Cylinder liner remover sleeve - 10899167

B - Hydraulic ram kit - 10912249

1 - Hose assembly- 10912247

2 - Hydraulic ram - 10899160

3 - Pressure gage - 10912248

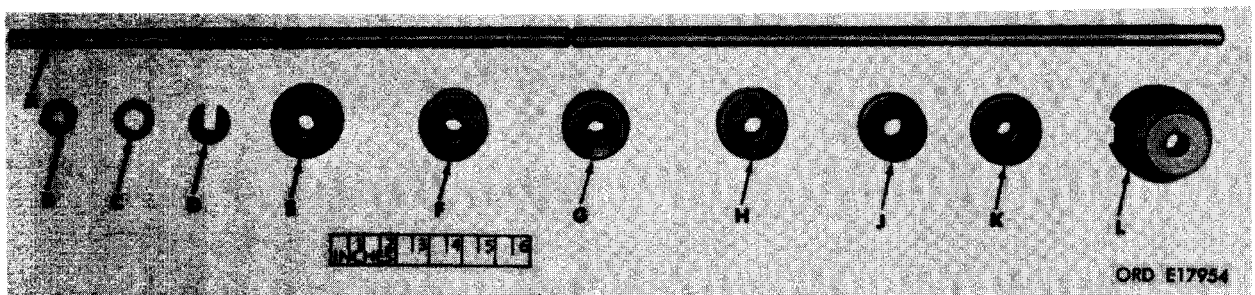
4 - Hose and gage adapter- 10912246

5 - Hydraulic pump assembly- 10899174

FIGURE 24. HYDRAULIC RAM KIT -10912249 AND CYLINDER LINER REMOVER AND REPLACER KIT -8722925.

Table I. Special Tools and Equipment for Field and Depot Maintenance - Continued

Item	Identifying No.	Reference		Use
		Fig.	Par.	
<b>KIT, HYDRAULIC RAM:</b> cylinder liner	<b>10912249</b> (4910-873-1927)	24, 330, 331, and 332	162	Used w/ <b>KIT</b> - 8722925 to re- move and install cylinder liners.
Composed of:				
1 - <b>ADAPTER</b> , hose and gage	10912246			To attach hose assy and gage to hydraulic pump.
2 - <b>GAGE</b> , pressure	10912248			Used to record hydraulic pump pressure.
3 - <b>HOSE</b> , assy	10912247			Used to connect hydraulic pump to hydraulic <b>RAM</b> - 10899160.
4 - <b>PUMP</b> , hydraulic assy	10899174			Used to supply hydraulic pres- sure for hydraulic <b>RAM</b> - 10899160.
5 - <b>RAM</b> , hydraulic	10899160			Used w/ <b>KIT</b> - 8722925.
<b>KIT, MECHANICAL PULLER</b> crankshaft pulley	<b>8708724</b> (5120-338-6721)	26, 203, 215, 217, 287, 291, and 292	96, 97, 98, 139, and 142	Removing crankshaft and cam- shaft gears. Used w/ <b>PLUG</b> - 10899178.



- A - Shaft - 10899139
- B - 3/4-in. plain nut - 96906-35690-1205
- C - 3/4-in. flat washer - 96906-15795-222
- D - Washer - 10899144
- E - No. 1 bearing replacer - 10899140
- F - No. 3 bearing remover - 10899142
- G - No. 2 bearing remover or No. 4 bearing replacer - 10899146
- H - No. 2 bearing replacer - 10899141
- J - No. 1 bearing remover or No. 3 bearing replacer - 10899145
- K - No. 4 bearing remover - 10899143
- L - Yoke assembly - 10899137

FIGURE 25. CAMSHAFT BUSHING-TYPE BEARING  
REMOVER AND REPLACER KIT -10899154.



Table I. Special Tools and Equipment for Field and Depot Maintenance — Continued

Item	Identifying No.	Reference		Use
		Fig.	Par.	
KIT, REMOVER AND RE-PLACER, bearings	10899154 (5120-870-6919)	25, 328, 329	161	Removing or installing cam-shaft bushing-type bearings.
Composed of: 1 - NUT, plain 3/4- in.	96906-35690-1205	25	161	Used to hold YOKE - 10899137 in SHAFT - 10899139.

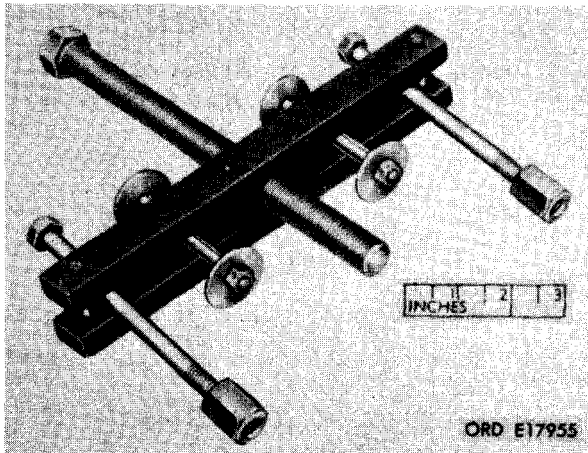
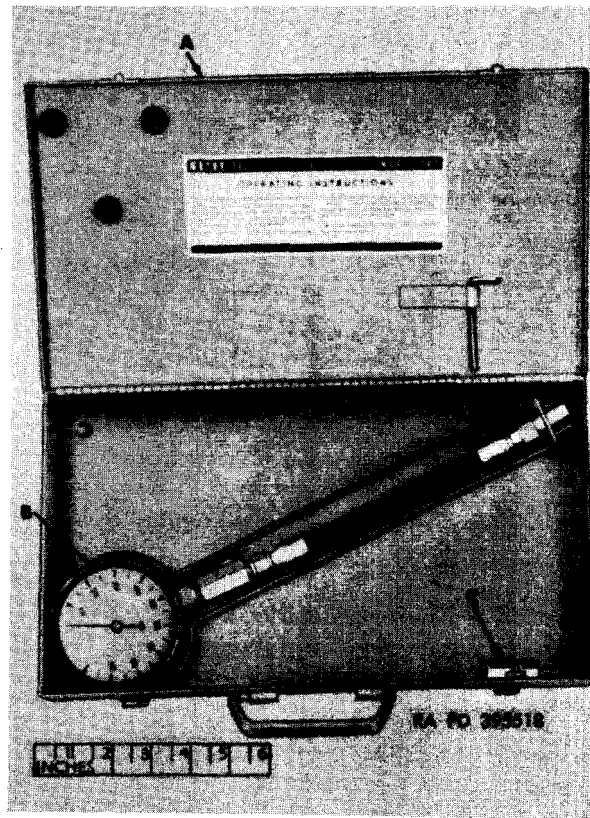


FIGURE 26. MECHANICAL PULLER KIT -8708724.



- A- BOX - 10899192
- B - Compression gage - 10899197
- C - Cylinder compression tester coupling - 10899184

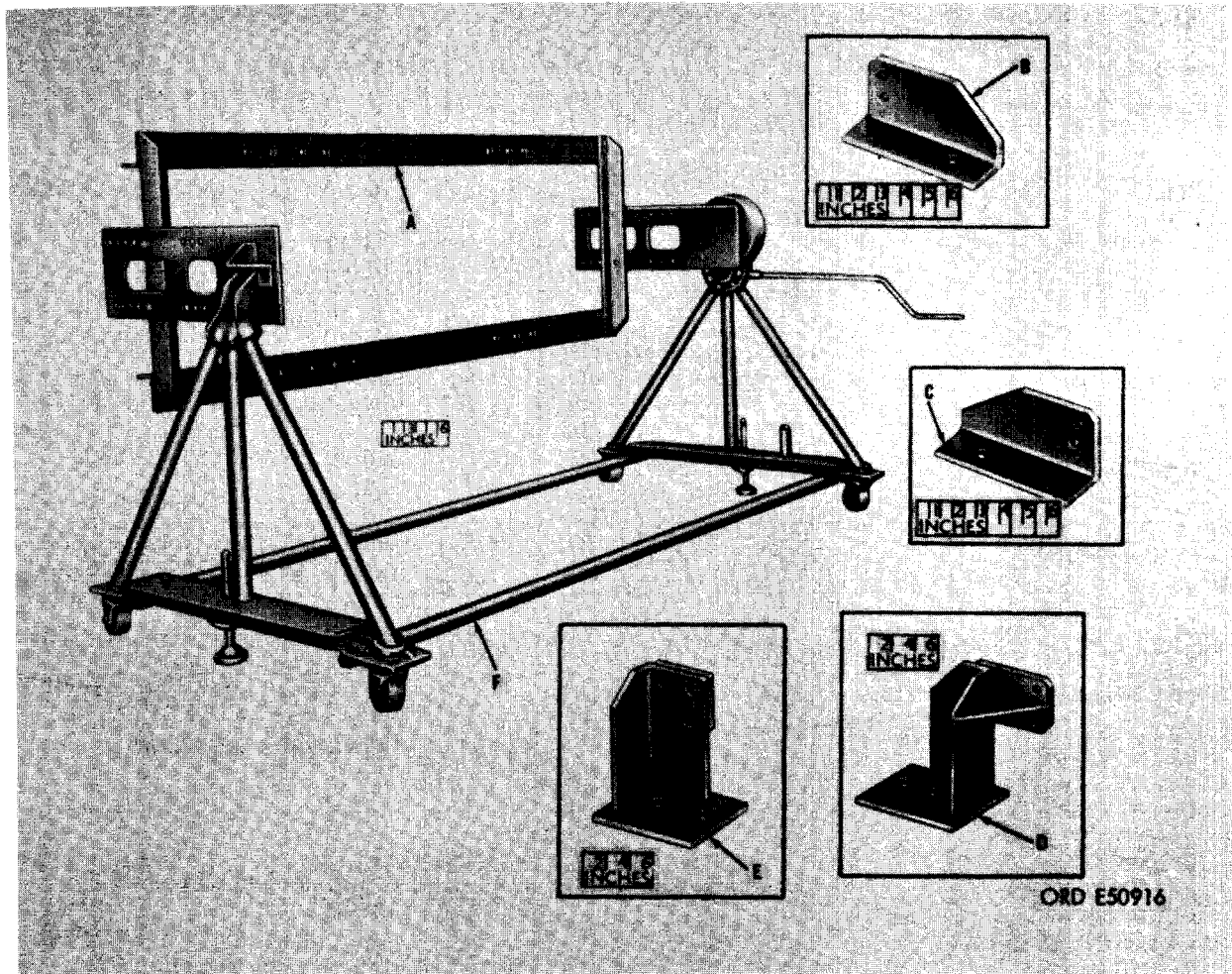
FIGURE 27. CYLINDER COMPRESSION TESTER GAGE KIT -10899180.

Table I. Special Tools and Equipment for Field and Depot Maintenance - Continued

Item	Identifying No.	Reference		Use
		Fig.	Par.	
<b>KIT, REMOVER AND REPLACER – Continued</b>				
2 – REMOVER, No. 3 bearing	10899142	25		Used to remove camshaft bushing-type No. 3 bearing.
3 – REMOVER, No. 4 bearing	10899143	25		Used to remove camshaft bushing-type No. 4 bearing.
4 – REMOVER AND REPLACER, No. 1 and No. 3 bearings.	10899145	25		Used to remove and install camshaft bushing- type No. 1 and 3 bearings.
5 – REMOVER AND REPLACER, No. 2 and No. 4 bearings.	10899146	25, and 329	161	Used to remove and install camshaft bushing- type No. 2 and 4 bearings.
6 – REPLACER, No. 1 bearing	10899140	25		Used to replace camshaft No. 1 bearing.
7 – REPLACER, No. 2 bearing	10899141	25, and 328	161	Used to replace camshaft No. 2 bearing.
8 – SHAFT	10899139	25, and 328	161	Used to support and guide remover and replacer.
9 – WASHER	10899144	25, and 328		Used to hold remover or replacer on SHAFT – 10899139.
10 – WASHER, flat, 3/4-in.	96906-15795-222	25, and 328	161	Used w/NUT – 96906-35690-1205.
11 – YOKE, assy	10899137	25, and 328	161	Used as an arbor when turning NUT – 96906-35690-1205 to remove or replace camshaft bearings.
<b>KIT, REMOVER AND REPLACER, cylinder liner</b>	8722925 (5120-448-0255)	24, 330, 331, and 333,	162	Removing or installing cylinder liner. Used w/HYDRAULIC RAM KIT – 10912249.
<b>Composed of:</b>				
1 – PIN, cotter	96906-24665-357			Used to secure PIN – 96906-20392-10-73.
2 – HANDLE, cylinder liner remover and replacer	10899187			Used to hold SHOE – 10899168 tight against cylinder liner – 10899167 or PLATE – 10899171 tight against SLEEVE – 10899167.
3 – PIN, clevis, 3/4 x 2-39/64	96906-20392-10 73			Used to secure ROD – 10899166.
4 – ROD, cylinder liner remover and replacer	10899166			Used to support HYDRAULIC RAM – 10899160, SHOE – 10899168, and PLATE – 10899171.

Table I. Special Tools and Equipment for Field and Depot Maintenance - Continued

Item	Identifying No.	Reference		Use
		Fig.	Par.	
KIT, REMOVER AND REPLACER - Continued				
5 - PLATE, cylinder liner replacer	10899171			Used to replace cylinder liner.
6 - SHOE, cylinder liner remover	10899168			Used to remove cylinder liner.



- A - Cradle assembly - 7950198
- B - Engine left front mounting bracket - 10899173
- C - Engine right front mounting bracket - 10899191
- D - Engine right rear mounting bracket - 10899188
- E - Engine left rear mounting bracket - 10912239
- F - Engine overhaul stand - 7950189

FIGURE 28. ENGINE OVERHAUL STAND -7950189, CRADLE ASSEMBLY - 7950198, AND ENGINE MOUNTING BRACKETS.

Table I. Special Tools and Equipment for Field and Depot Maintenance - Continued

Item	Identifying No.	Reference		Use
		Fig.	Par.	
7 - SLEEVE, cylinder liner remover	10899167			Used to press cylinder liner into cylinder.
8 - SUPPORT, assy, cylinder liner replacer	10899161			Used w/ROD - 10899166 to install cylinder liner.
PLUG, mechanical puller kit	10899178 (5120-870-6914)	23, 203, 215, 287, and 292		Used w/MECHANICAL PULLER KIT - 8708724.
REMOVER, valve guide, 7-1/2-in. lg. 0.426-0.432-in. dia end	10899157 (5120-871-3513)	23, and 389		Removing or installing intake and exhaust valve guides. Used w/REPLACER - 10899158.
REPLACER, GEAR:	10899179 (5120-870-6920)	23, 208, and 478	96, and 264	Installing crankshaft and pulley assembly.
Composed of: 1 - BOLT, replacer 2 - NUT, plain 1-in. 3 - WASHER, flat, 1-in.	10899156 880044-315-16 96906-15795-126			Installing crankshaft pulley. Installing crankshaft pulley. Installing crankshaft pulley.
REPLACER, valve guide	10899158 (5120-870-6921)	23, and 390	112	Installing intake and exhaust valve guides and used w/REMOVER - 10899157.
SLING, MECHANICAL TILTING, AUTOMOTIVE MAINTENANCE	8715107 (4910-798-7584)	29, and 223		Lifting engine.
SOCKET, WRENCH, FACE SPANNER: 7/16 x 3/8 drive	8390124 (5120-034-8443)	30, 451, and 463	248, and 251	Turning clutch release lever adjusting nuts.
SPREADER, tilting sling	10912586	23, and 223		Used with SLING - 8715107 to spread chain and equalize lift.

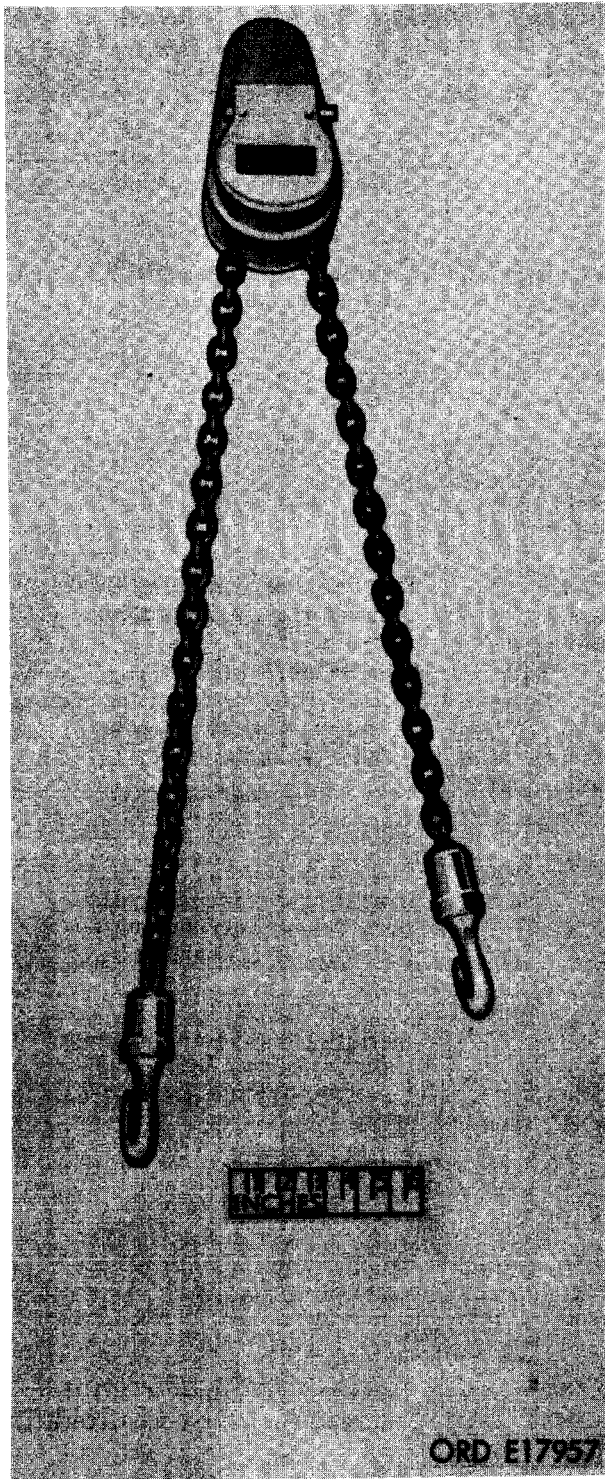


FIGURE 29. ENGINE LIFTING SLING - 8715107.

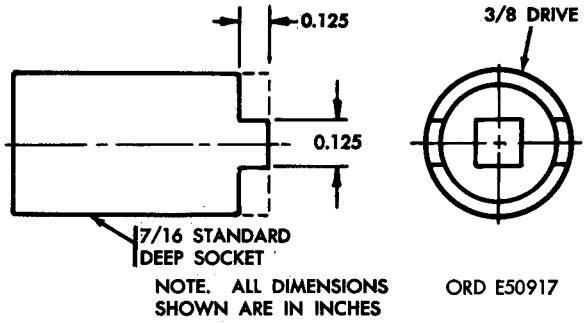


FIGURE 30. FACE SPANNER WRENCH SOCKET - 8390124.

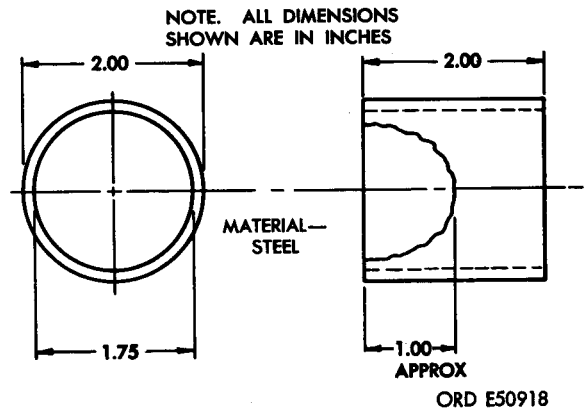


FIGURE 31. IMPROVISED TOOL - WATER PUMP PULLEY REPLACER.

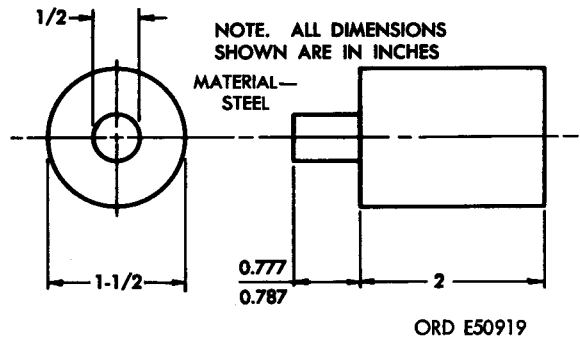


FIGURE 32. IMPROVISED TOOL - WATER PUMP IMPELLER DEPTH GAGE.

Table I. Special Tools and Equipment for Field and Depot Maintenance - Continued

Item	Identifying No.	Reference		Use
		Fig.	Par.	
STAND, MAINTENANCE, AUTOMOTIVE ENGINE:	7950189 (4910-795-0189)	28, 224, 295, and 296	114, 144, 263, and 286	Used w/CRADLE - 7950198, BRACKETS - 10899188, 10912239, 10899191, and 10899173.
TUBE, fuel injector nozzle tester connector	10882963 (4910-795-7953)	23, and 151	103	Used to check fuel injector nozzles.
WRENCH, BOX: 7/8-in.	8722924 (5120-448-0257)	23, 196, and 485	94, and 268	Torque tightening cylinder head nuts.
WRENCH, air compressor pulley	10935288 (5120-390-7779)	23, and 81	65	Adjusting air compressor pulley.

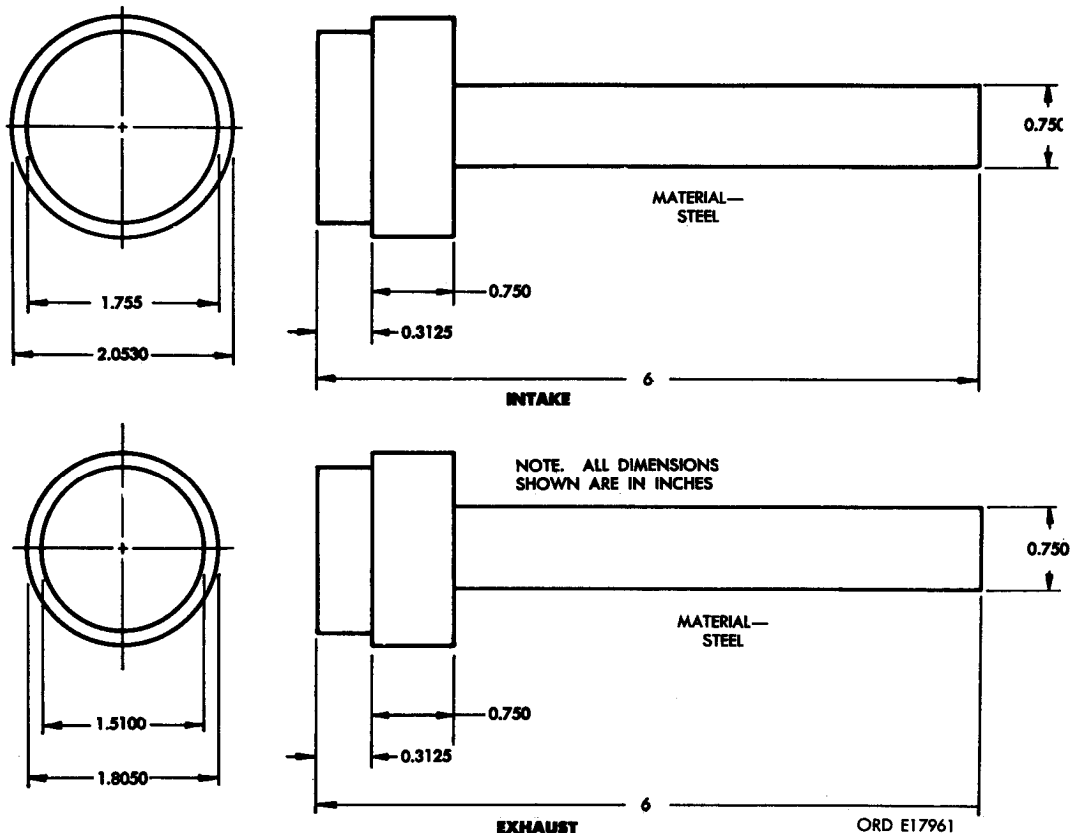


FIGURE 33. IMPROVISED TOOL - INTAKE AND EXHAUST VALVE SEAT INSERT REPLACER.

#### 45. IMPROVISED TOOLS

The improvised tools listed in Table II and the dimensional detailed drawings apply only to field and depot shops to enable these maintenance organizations to fabricate these tools locally if

desired. These tools are of chief value to maintenance organizations engaged in rebuilding a large number of identical components; however, they are not essential for rebuild and are not available for issue. This data is furnished for information only.

Table II. Improved Tools for Field and Depot Maintenance

Item	Reference	Use
1. Gage, depth	Figs. 32 and 131	Installing water pump impeller on shaft.
2. Pin	Figs. 36, 453, and 459	Removing or installing clutch release levers and yoke of clutch.
3. Plate	Figs. 34, 449, 461, and 462	Adjusting clutch release levers.
4. Replacer	Fig. 33	Installing exhaust valve seat insert.
5. Replacer	Figs. 33 and 387	Installing intake valve seat insert.
6. Replacer	Figs. 31 and 130	Installing water pump pulley on shaft.
7. Spacer blocks	Figs. 35, 88, 97, 274, 447, 460, 461, and 483	Release spring tension on clutch release levers.
8. Wrench, box	Figs. 37 and 197	Torque tighten cylinder head nuts after engine run-in.
9. Wrench	Figs. 38 and 73	Removing or installing injection pump hub nut.

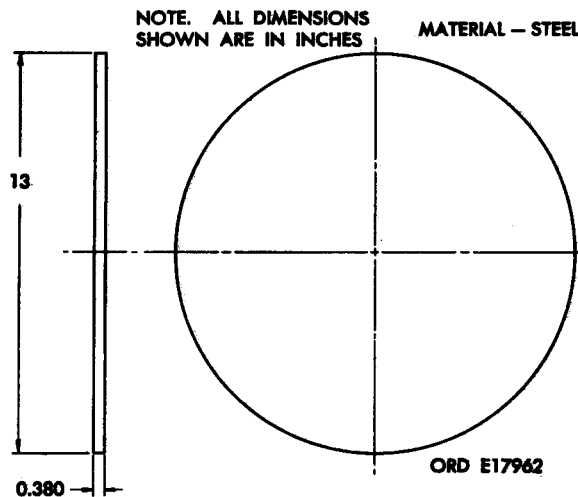


FIGURE 34. IMPROVISED TOOL - CLUTCH SPACER PLATE.

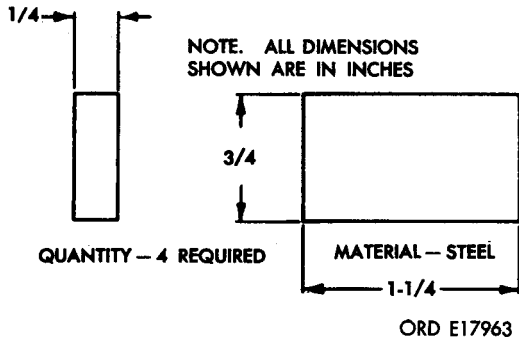


FIGURE 35. IMPROVED TOOL - CLUTCH RELEASE LEVER SPACER BLOCK.

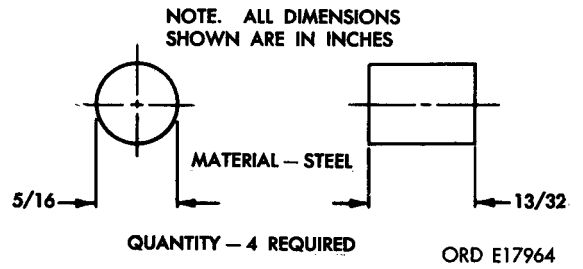


FIGURE 36. IMPROVED TOOL - CLUTCH LEVER BEARING RETAINING PIN.

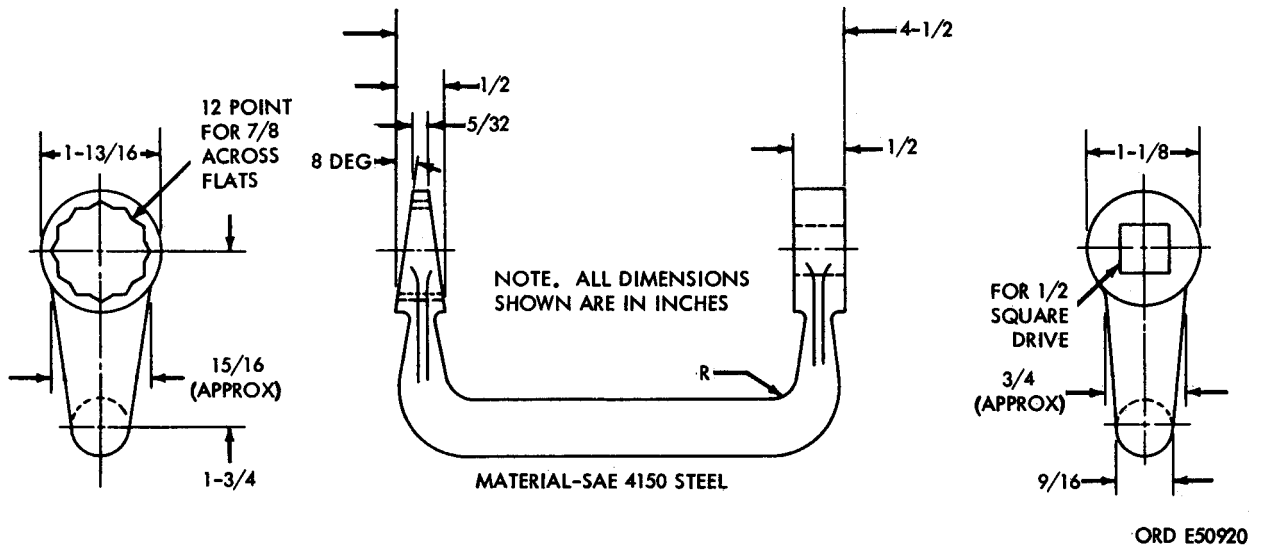


FIGURE 37. IMPROVED TOOL - CYLINDER HEAD INNER NUT WRENCH.

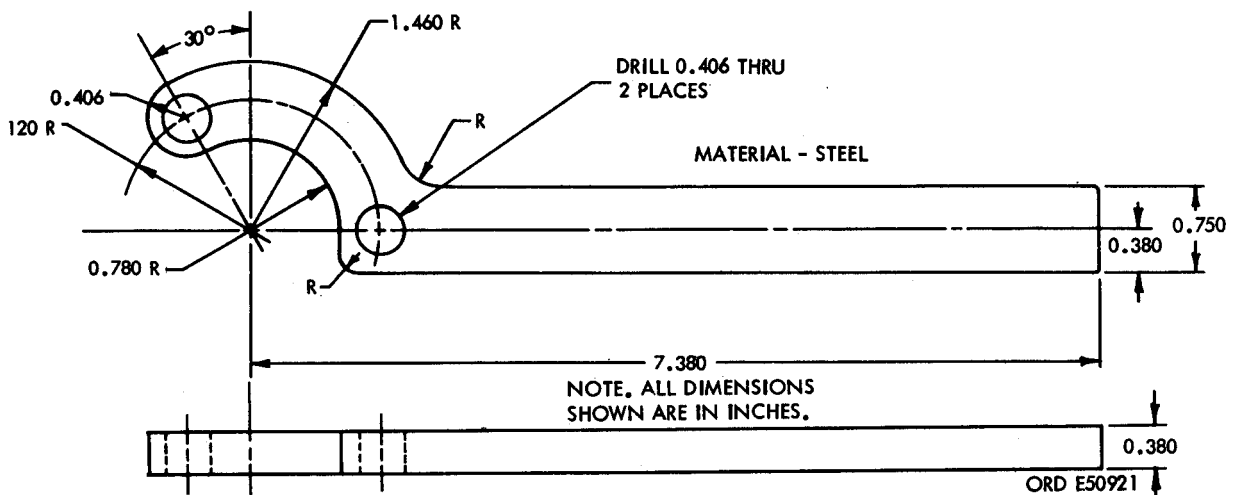


FIGURE 38. IMPROVED TOOL - FUEL INJECTION PUMP DRIVEN GEAR HUB HOLDING WRENCH.



## CHAPTER 3

### TROUBLESHOOTING

---

#### Section I. GENERAL

#### 46. PURPOSE

Note. Information in this chapter is for use of maintenance personnel in conjunction with and as a supplement to the troubleshooting section of the pertinent organizational maintenance manual. It provides the continuation of instructions where a remedy in the organizational maintenance manual refers to higher echelon maintenance personnel for the corrective action.

Operation of a deadlined vehicle without a preliminary examination can cause further damage to a disabled component and possible injury to personnel. By careful inspection and troubleshooting, such damage and injury can be avoided, and in addition, the causes of faulty operation of a vehicle or component can often be determined without extensive disassembly.

#### 47. GENERAL INSTRUCTIONS

This chapter contains inspection and troubleshooting procedures to be performed while a disabled engine is still mounted in the vehicle and after it has been removed.

a. The inspections made while the engine is mounted in the vehicle are for the most part visual and are to be performed before attempting to operate the vehicle. The object of these inspections is to avoid possible damage or injury and also to determine the condition of and, when

possible, what is wrong with the defective engine.

b. Troubleshooting performed while the engine is mounted in the vehicle is beyond the normal scope of the using organization. Check the troubleshooting section of TM 9-2320-235-20, then proceed as outlined in this chapter. These troubleshooting operations are used to determine if the fault can be remedied without removing the engine from the vehicle and, also, when subsequent removal is necessary, to indicate when repair can be made without complete disassembly of engine.

c. Inspection after the engine is removed from the vehicle is performed to verify the diagnosis made while the engine was mounted in the vehicle, to uncover further defects, or to determine faults if the engine alone is received by the maintenance establishment. This inspection is particularly important in the last case because it is often the only means of determining the trouble without completely disassembling the engine.

d. Troubleshooting a disabled engine after it has been removed from the vehicle consists of subjecting it to tests on a dynamometer. This chapter discusses those symptoms which can be diagnosed by using the testing equipment, interprets the results in terms of probable causes, and recommends the appropriate corrective action.

---

#### Section II. TROUBLESHOOTING PROCEDURES

#### 48. GENERAL

Most engine troubles are actually engine accessory troubles. The troubleshooting portion of pertinent organizational maintenance manuals, normally will cover troubleshooting of all engine accessories while mounted on the engine. For

complete coverage of accessories refer to pertinent manuals listed in paragraph 1h. The procedures for troubleshooting the engine assembly, engine accessories, and engine systems are listed in paragraphs 49 through 56. Malfunctions of the engine assembly are referenced to the appropriate accessory system for corrective action when applicable.

#### 49. TROUBLESHOOTING ENGINE ASSEMBLY

Malfunction	Probable causes	Corrective action
<p>1. Engine will not crank.</p>	<p>a. Electrical switch or starter linkage not properly adjusted.</p> <p>b. Failed starter.</p> <p>c. Failed starter drive gear or flywheel ring gear.</p> <p>d. Hydrostatic lock.</p>	<p>a. Adjust starter electrical switch or linkage. Refer to TM 9-2320-235-20 and TM 9-2920-236-35.</p> <p>b. Replace starter (par. 60).</p> <p>c. Remove starter (par. 60a). Inspect ring gear on flywheel. Replace defective starter or damaged flywheel ring gear.</p> <p>d. Remove fuel injector nozzle and holder assemblies (par. 83b). Turn engine over several revolutions to displace liquid from cylinders through nozzle and holder openings. When liquid displaced is engine coolant, investigate cause by removing cylinder head assemblies (par. 94b). Inspect cylinder head assemblies for cracks around valve seats and cylinder and crankcase assembly for cracks around cylinder liners. Inspect the head gaskets (par. 94g). Replace cracked cylinder head assemblies and cylinder and crankcase assembly when cracked. Install new head gaskets. When liquid is fuel, and engine can be turned freely by hand after all liquid is displaced, install nozzle and holder assemblies and start engine. Inspect flame heater fuel inlet solenoid valve.</p>

49. TROUBLESHOOTING ENGINE ASSEMBLY - Continued

Malfunction	Probable causes	Corrective action
<p>1. Engine will not crank - Continued.</p>	<p>e. Seized internal engine parts.</p>	<p>A leaking solenoid valve can cause a hydrostatic lock. When engine cannot be turned freely by hand, internal engine parts have been damaged and engine must be disassembled (pars. 111 through 286). Clean, inspect, and repair necessary component parts (Pars. 152 through 244). Assemble engine (pars. 253 through 286).</p> <p>e. Disassemble the engine (pars. 111 through 286). Clean, inspect, and repair necessary component parts (pars. 152 through 244). Assemble engine (pars. 253 through 286).</p>
<p>2. Engine cranks but will not start.</p>	<p>a. Ambient temperature below + 20°F manifold heater inoperative</p> <p>b. Insufficient cranking speed.</p> <p>c. Faulty fuel filter, tubes, and hoses.</p> <p>d. Fuel injection pump not properly timed.</p> <p>e. Failed fuel supply pump or fuel injection pump.</p> <p>f. Stripped or broken injection pump driven gear, camshaft gear, or crankshaft gear.</p>	<p>a. Check flame heater fuel system. Refer to flame heater fuel system troubleshooting (par. 56).</p> <p>b. Check starter and electrical system. Refer to starting system troubleshooting (par. 50).</p> <p>c. Refer to fuel system troubleshooting (par. 53). Check available fuel supply.</p> <p>d. Time fuel injection pump (par. 106).</p> <p>e. Replace fuel injection pump (par. 63),</p> <p>f. Remove timing gear cover (par. 98) and inspect gears for stripped or broken teeth (par. 98). Replace stripped or broken gears (par. 98).</p>

49. TROUBLESHOOTING ENGINE ASSEMBLY - Continued

Malfunction	Probable causes	Corrective action
<p>2. Engine cranks but will not start - Continued.</p>	<p><u>g.</u> Low cylinder compression.</p>	<p><u>g.</u> Make cylinder compression check (par. 102) and take appropriate action to correct condition as follows:</p> <ol style="list-style-type: none"> <li>(1) Check valve lash. Remove cylinder head cover (par. 130). Check valve lash (par. 104) and reset if necessary.</li> <li>(2) Worn piston rings. Rebuild engine (pars. 111 through 286).</li> <li>(3) Leaking valves. Remove cylinder head and install new cylinder head and valve assembly (par. 94).</li> </ol>
<p>3. Engine runs rough, one or more cylinders not firing.</p>	<p><u>a.</u> Engine operating at below normal temperature.</p> <p><u>b.</u> Dirty fuel, restricted fuel filters.</p> <p><u>c.</u> Leaking fuel injector nozzle and holder tube.</p>	<p><u>a.</u> Remove thermostat (par. 76). Check for open thermostat or replace when necessary (par. 218). Install thermostat (par. 76).</p> <p><u>b.</u> Check for dirt or obstruction in fuel system. Refer to the fuel system troubleshooting (par. 53). Replace fuel injection pump (par. 63) when fuel system is found clean and fuel injection pump adjustments in TM 9-2910-223-35 do not correct malfunctions.</p> <p><u>c.</u> Tighten or replace leaking fuel injector nozzle and holder tube (par. 100).</p>

49. TROUBLESHOOTING ENGINE ASSEMBLY - Continued

Malfunction	Probable causes	Corrective action
<p>3. Engine runs rough, one or more cylinders not firing - Continued.</p>	<p><u>d.</u> Defective fuel injector nozzle and holder assembly.</p> <p><u>e.</u> Low compression on one or more cylinders.</p> <p><u>f.</u> Leaking or blown cylinder head gasket.</p> <p><u>g.</u> Improper valve adjustment.</p> <p><u>h.</u> Bent or broken push rod, worn camshaft lobe, or broken valve tappet. Cracked or damaged piston.</p>	<p><u>d.</u> Loosen fuel injection tube to nozzle and holder assembly, one at a time, and note which one, when disconnected, does not affect engine roughness or engine speed. This check indicates defective nozzle. Repair or replace nozzle and holder assembly (par. 83).</p> <p><u>e.</u> Make cylinder compression check (par. 102) and take appropriate action to correct condition as follows :</p> <p>(1) Worn piston rings. Rebuild engine (pars. 111 through 286).</p> <p>(2) Leaking valves. Remove cylinder head and install new cylinder head and valve assembly (par. 94).</p> <p><u>f.</u> Remove cylinder head (par. 94) and install new gasket.</p> <p><u>g.</u> Check and reset valve clearances (par. 104).</p> <p><u>h.</u> Replace defective valve rocker arm push rod (par. 93). Disassemble engine (par. 111) as necessary to replace worn camshaft, damaged piston, or damaged valve tappet.</p>
<p>4. Engine low on power.</p>	<p><u>a.</u> One or more cylinders not firing.</p>	<p><u>a.</u> Refer to paragraph 49, 3 above for corrective action.</p>

49. TROUBLESHOOTING ENGINE ASSEMBLY - Continued

Malfunction	Probable causes	Corrective action
<p>4. Engine low on power - Continued.</p>	<p><u>b.</u> Fuel injection pump not properly timed.</p> <p><u>c.</u> Operating with less desirable fuel, or fuel system not clean. Air in system.</p> <p><u>d.</u> Failed turbosupercharger.</p> <p><u>e.</u> Improper functioning fuel injection pump or advance unit.</p> <p><u>f.</u> Leaking exhaust system causing reduced pressure to turbosupercharger.</p> <p><u>g.</u> Engine overheated.</p> <p><u>h.</u> Low cylinder compression.</p>	<p><u>b.</u> Check and adjust fuel injection pump timing (par. 106).</p> <p><u>c.</u> Refer to fuel system troubleshooting (par. 53). Check available fuel supply.</p> <p><u>d.</u> Replace turbosupercharger (par. 62).</p> <p><u>e.</u> Replace fuel injection pump (par. 63).</p> <p><u>f.</u> Repair exhaust leaks by replacing manifold gaskets (par. 88) or replace exhaust manifolds or gaskets (par. 88).</p> <p><u>g.</u> Refer to lubrication system troubleshooting (par. 54) and coolant system troubleshooting (par. 55).</p> <p><u>h.</u> Check cylinder compression (par. 102) and take corrective action. Refer to paragraph 49, 2b for corrective action.</p>
<p>5. Excess engine power or engine overspeeds.</p>	<p><u>a.</u> Improper fuel injection pump fuel mixture.</p> <p><u>b.</u> Improper fuel injection pump timing.</p> <p><u>c.</u> Improper fuel injection pump governor setting.</p> <p><u>d.</u> Defective fuel injection pump.</p>	<p><u>a.</u> Adjust fuel injection pump. Refer to TM 9-2910-223-35 for procedures.</p> <p><u>b.</u> Check and adjust fuel injection pump timing (par. 106),</p> <p><u>c.</u> Reset governor. Refer to TM 9-2910-223-35 for procedures.</p> <p><u>d.</u> Replace fuel injection pump (par. 63).</p>

49. TROUBLESHOOTING ENGINE ASSEMBLY - Continued

Malfunction	Probable causes	Corrective action
<p>6. Engine will not idle but runs well under load.</p>	<p><u>a.</u> Defective fuel injection nozzle and holder assembly.</p> <p><u>b.</u> Fuel injection pump not properly timed.</p> <p><u>c.</u> Fuel injection pump governor not properly adjusted.</p> <p><u>d.</u> Defective fuel injection pump.</p>	<p><u>a.</u> Repair defective nozzle and holder assembly (par. 83). Replace (par. 83) when damaged beyond repair.</p> <p><u>b.</u> Check and adjust fuel injection pump (par. 106).</p> <p><u>c.</u> Adjust fuel injection pump governor. Refer to TM 9-2910-223-35 for procedures.</p> <p><u>d.</u> Replace fuel injection pump (par. 83).</p>
<p>7. Engine exhaust smokes. (1) White or gray smoke indicating unburned fuel or engine oil.</p>	<p><u>a.</u> Defective fuel injector nozzle and holder assemblies.</p> <p><u>b.</u> Engine cylinders.</p> <p><u>c.</u> Water in fuel.</p>	<p><u>a.</u> Repair defective fuel injector nozzle and holder assembly (par. 83). Replace (par. 83) when damaged beyond repair.</p> <p><u>b.</u> Refer to TM 9-2320-235-10 for operating instructions of intake manifold flame heater. Operate flame heater intermittently. Start and load engine to increase cylinder head temperature. When engine temperature is not within 180°F to 200°F, remove coolant thermostat, (par. 76), test the thermostat (par. 218), and replace when necessary (par. 76).</p> <p><u>c.</u> Service primary and final fuel filters (par. 72). Refer to TM 9-2320-235-20, drain vehicle fuel tank and fill with clean available fuel.</p>

49. TROUBLESHOOTING ENGINE ASSEMBLY - Continued

Malfunction	Probable causes	Corrective action
<p>7. Engine exhaust smokes - Continued.</p> <p>(2) Blue smoke indicating admittance of engine oil into combustion chamber,</p> <p>(3) Black smoke indicating rich fuel mixture.</p> <p>Note. Black smoke during acceleration is normal.</p>	<p>d. Low compression,</p> <p>a. One or more cylinders not firing.</p> <p>b. Worn or stuck piston rings or worn cylinder liners.</p> <p>c. Worn valve guides.</p> <p>a. Improper fuel injection pump adjustment.</p> <p>b. Fuel injection pump not properly timed.</p> <p>c. Restriction in air supply system or failed turbosupercharger.</p> <p>d. Overloaded or lugging engine.</p>	<p>d. Check cylinder compression (par. 102). Replace damaged parts as necessary (par. 49, 2e above).</p> <p>a. Refer to paragraph 49, 3 above for corrective action.</p> <p>b. Remove cylinder heads (par. 94). Remove oil pan (par. 95). Remove pistons (par. 138) and replace pistons, rings, and/or cylinder liners (par. 162). Install oil pan (par. 95) and cylinder heads (par. 94).</p> <p>c. Remove cylinder heads (par. 94). Disassemble cylinder head (par. 198). Replace valve guides (par. 200). Assemble cylinder head (par. 201) and install cylinder head (par. 94). Replace cylinder head when necessary.</p> <p>a. Adjust fuel injection pump. Refer to TM 9-2910-223-35 for procedures.</p> <p>b. Check and adjust fuel injection pump timing (par. 106).</p> <p>c. Check air cleaners for dirt, check cleaner hoses for restrictions. Refer to TM 9-2320-235-20. Check turbosupercharger as directed in TM 9-2990-201-35 and replace when necessary (par. 62).</p> <p>d. Reduce load by using lower gear range.</p>



49. TROUBLESHOOTING ENGINE ASSEMBLY - Continued

Malfunction	Probable causes	Corrective action
<p>7. Engine exhaust smokes - Continued</p>	<p><u>e.</u> Low engine temperature or operating with less desirable fuel.</p> <p><u>f.</u> Fuel injector nozzle and holder assemblies defective, dripping, leaking, or poor spray pattern.</p> <p><u>g.</u> Fuel injection pump not properly timed while operating at 3/4 or full load condition.</p>	<p><u>e.</u> Check available fuel supply for contamination. Remove thermostat (par. 76). Test thermostat (par. 218). Replace when damaged and install (par. 76). " Refer to cooling system troubleshooting (par. 55) for other probable causes and corrective action.</p> <p><u>f.</u> Remove and repair fuel injector nozzle and holder assemblies (par. 83). Replace when necessary.</p> <p><u>g.</u> Check and adjust fuel injection pump timing (par. 106).</p>
<p>8. Engine noises.</p> <p>(1) Knocking noise.</p>	<p><u>a.</u> Worn cylinder liner and piston.</p> <p><u>b.</u> Loose piston pin or pins.</p> <p>Note. Locate noise by disconnecting fuel injection tubes, one at a time, at fuel injector nozzle and holder until noise is located. When knocking noise changes when tube is disconnected, worn or defective connecting rod bearing, main bearing, piston, or piston pin may be the probable cause.</p>	<p><u>a.</u> Disassemble engine (pars. 111 through 151). Replace worn cylinder liners (par. 162) and replace pistons, pins, and piston rings. Assemble engine (pars. 253 through 286).</p> <p><u>b.</u> Disassemble engine (pars. 111 through 151). Disassemble connecting rod and piston (par. 173). Replace connecting rod piston pin bushing-type bearing (par. 175). Assemble connecting rod and piston with new piston pin (par. 176). Assemble engine (pars. 253 through 286).</p>

49. TROUBLESHOOTING ENGINE ASSEMBLY - Continued

Malfunction	Probable causes	Corrective action
<p>8. Engine noises - Continued.</p> <p>(2) Tapping noise.</p>	<p><u>c.</u> Worn main bearings - normally a heavy dull knock when accelerating under load.</p>	<p><u>c.</u> Disassemble engine (pars. 111 through 151) and examine crankshaft (par. 166). Inspect main bearings for wear and clearance (par. 160b).</p>
	<p><u>d.</u> One or more connecting rod bearings worn. Normally noted at idle or light loads and tends to disappear at full load.</p>	<p><u>d.</u> Disassemble engine (pars. 111 through 151). Clean and inspect parts. Disassemble crankshaft (par. 165). Clean and inspect crankshaft (par. 166). Re grind crankshaft (par. 167), or replace when heavily scored. Replace connecting rod sleeve bearings. Assemble crankshaft (par. 168). Assemble engine (pars. 253 through 286).</p>
	<p><u>e.</u> Broken piston ring or loose piston pin - normally a sharp clicking noise.</p>	<p><u>e.</u> Disassemble engine (pars. 111 through 151). Disassemble connecting rod and piston (par. 173). Replace piston. Replace connecting rod piston pin bushing-type bearing (par. 175). Assemble engine (pars. 253 through 286).</p>
	<p><u>f.</u> Scored piston or cylinder - excessive piston to cylinder clearance.</p>	<p><u>f.</u> Disassemble engine (pars. 111 through 151). Replace pistons and/or cylinder liners (par. 162).</p>
	<p><u>a.</u> Excessive valve clearance.</p>	<p><u>a.</u> Adjust valve clearance (par. 104).</p>
	<p><u>b.</u> Defective or worn valve rocker arm assembly.</p>	<p><u>b.</u> Replace defective valve rocker arm adjusting screw and rocker arm (pars. 91 and 92).</p>
	<p><u>c.</u> Bent push rod.</p>	<p><u>c.</u> Replace defective push rod (par. 93). Remove valve tappet (par. 132). Replace defective tappet. Install tappet (par. 268).</p>

#### 49. TROUBLESHOOTING ENGINE ASSEMBLY - Continued

Malfunction	Probable causes	Corrective action
<p>8. Engine noises - Continued.</p> <p>(3) Grinding or squealing noise.</p>	<p><u>d.</u> Defective valve tappet.</p> <p><u>e.</u> Worn crankshaft and camshaft gears.</p> <p><u>f.</u> Defective water pump causing engine to overheat.</p> <p><u>a.</u> Damaged engine accessories.</p>	<p><u>d.</u> Remove fuel filter assembly (par. 117). Remove fuel injection tube assemblies (par. 118). Remove oil filter elements (par. 119). Remove oil filter and oil cooler housing and tappet chamber cover (par. 120). Remove front and rear sets of rocker arms, valve rocker arm push rods, and valve tappets (par. 132). Replace damaged tappets. Install tappets, rocker arm push rods, and rocker arm sets (par. 268b through d). Install oil cooler and oil filter housing and tappet chamber cover (par. 280). Install fuel injection tube assemblies (par. 284c). Install fuel filter assembly (par. 285).</p> <p><u>e.</u> Remove crankshaft and camshaft gears (par. 98). Inspect and replace when worn or broken. Install crankshaft and camshaft gears (par. 98).</p> <p><u>f.</u> Remove water pump assembly (par. 77a). Overhaul water pump (par. 77b, <u>c.</u> and <u>d.</u>). Install water pump assembly (par. 77d).</p> <p><u>a.</u> Crank engine by hand. If squealing noise persists, check engine accessories and components as follows:</p>

49. TROUBLESHOOTING ENGINE ASSEMBLY - Continued

Malfunction	Probable causes	Corrective action
<p>8. Engine noises - Continued.</p>		<p>(1) Water pump. Remove water pump drive belts (par. 77a). Turn pump by hand and check for rough bearing or when squealing noise is heard, overhaul water pump (par. 77b through d). Install water pump assembly (par. 77).</p> <p>(2) Clutch. Refer to TM 9-2320-235-20 and remove transmission assembly and clutch throwout bearing. Remove clutch (par. 67a). Replace clutch pilot bearing (par. 67d). Install clutch assembly (par. 67e). Refer to TM 9-23--235-20 and install clutch throwout bearing and transmission assembly.</p> <p>(3) Air Compressor. Check belt and belt tension (par. 65h). Check air compressor for failure and replace defective compressor (par. 65).</p> <p>(4) Generator. Check for worn brushes or defective bearings. Refer to TM 9-2920-209-35. Replace defective generator (par. 61). Replace defective drive belts (par. 61). Adjust drive belt tension (par. 61b).</p> <p>(5) Turbosupercharger. Rotate the compressor wheel by hand. Wheel should turn freely. Check end play of compressor wheel. Refer to TM 9-2990-201-35. Replace defective turbosupercharger (par. 62).</p>

49. TROUBLESHOOTING ENGINE ASSEMBLY - Continued

Malfunction	Probable causes	Corrective action
<p>8. Engine noises - Continued.</p>	<p><u>b.</u> Excessively worn crankshaft or camshaft gears and/or fuel injection pump driven gear.</p> <p><u>c.</u> Failed engine bearings caused by no oil pressure.</p>	<p><u>b.</u> Replace all gears (par. 98).</p> <p><u>c.</u> Crank engine by hand. If squealing noise persists, disassemble engine (pars. 111 through 151). Replace crankshaft main bearing, connecting rod bearings, and necessary parts. Rebuild oil pump assembly (par. 193). Check cause of low or no oil pressure. Assemble engine (pars. 253 through 286).</p>
<p>9. Rough or poor engine idling.</p>	<p><u>a.</u> Fuel injection pump out of adjustment.</p> <p><u>b.</u> Defective fuel injector nozzle and holder assemblies caused by long engine idle periods.</p> <p><u>c.</u> Fuel injection pump out of time.</p> <p><u>d.</u> Air leak in intake manifold or gaskets.</p>	<p><u>a.</u> Adjust fuel injection pump idle (par. 107). Refer to TM 9-2910-223-35 for other procedures on fuel injection pump adjustments that require partial disassembly of pump.</p> <p><u>b.</u> Remove fuel injector nozzle and holder assembly (par. 83b). Repair (par. 83c through i). Install fuel injector nozzle and holder assemblies (par. 83j).</p> <p><u>c.</u> Check and adjust fuel injection pump timing (par. 106).</p> <p><u>d.</u> Inspect intake manifold for leaks. Replace defective manifold or gaskets (par. 89).</p>
<p>10. Engine surges at all speeds.</p>	<p><u>a.</u> Throttle linkage sticking or binding.</p>	<p><u>a.</u> Inspect for worn throttle linkage. Clean and repair linkage as directed in TM 9-2320-235-35.</p>

49. TROUBLESHOOTING ENGINE ASSEMBLY - Continued

Malfunction	Probable causes	Corrective action
10. Engine surges at all speeds - Continued.	<ul style="list-style-type: none"> <li>b. Fuel injection pump governor not properly adjusted.</li> </ul>	<ul style="list-style-type: none"> <li>b. Adjust fuel injection pump governor. Refer to TM 9-2320-235-20 and TM 9-2910-223-35. Replace pump when necessary (par. 63).</li> </ul>
11. Poor fuel economy.	<ul style="list-style-type: none"> <li>a. Operating engine at low cylinder temperature. Coolant temperature below 180°F.</li> <li>b. Loss of power or low power.</li> <li>c. Operating with less desirable fuel.</li> <li>d. Clutch worn or defective.</li> </ul>	<ul style="list-style-type: none"> <li>a. Remove thermostat (par. 76). Test thermostat (par. 218). Replace when necessary and install (par. 76).</li> <li>b. Refer to paragraph 49 above and administer corrective action for low on power.</li> <li>c. Check available fuel supply.</li> <li>d. Refer to TM 9-2320-235-35 for procedures to remove clutch when engine is installed in vehicle. Refer to paragraph 67 for clutch removal when engine has been removed from vehicle. Overhaul clutch (pars. 248 through 252) when necessary.</li> </ul>
12. Engine stops suddenly.	<ul style="list-style-type: none"> <li>a. Defective fuel supply system.</li> <li>b. Restriction in air intake system.</li> <li>c. Defective fuel injection pump or fuel supply pump.</li> </ul>	<ul style="list-style-type: none"> <li>a. Troubleshoot the fuel supply system (par. 53).</li> <li>b. Refer to TM 9-2990-201-35 and inspect for obstructions in induction system. Collapsed air intake hoses and/or clogged air cleaner. Refer to TM 9-2320-235-20.</li> <li>c. Replace fuel injection pump (par. 63). Refer to TM 9-2910-223-35 for replacement procedures for fuel supply pump.</li> </ul>

49. TROUBLE SHOOTING ENGINE ASSEMBLY - Continued

Malfunctions	Probable causes	Corrective action
12. Engine stops suddenly - Continued.	<p><u>d.</u> Internal engine seizure caused by seized bearings, pistons, or obstructions in combustion chamber.</p>	<p><u>d.</u> Turn engine manually. When unable to turn engine, check for foreign object in combustion chamber by removing cylinder heads (par. 94 b). Disassembly engine (pars. 111 through 151) and replace failed piston, rod, or bearings (par. 175). Assemble engine (pars. 253 through 286).</p>
13. Engine will not stop when shut off.	<p>Fuel shutoff on fuel injection pump inoperative.</p>	<p>Replace fuel injection pump (par. 63).</p>

50. TROUBLESHOOTING STARTING SYSTEM

1. Starter will not operate.	<p><u>a.</u> Improper starting procedure used.</p> <p><u>b.</u> No electrical current reaching starter.</p> <p><u>c.</u> Failed starter.</p>	<p><u>a.</u> Refer to TM 9-2320-235-10 for proper starting procedures.</p> <p><u>b.</u> Refer to TM 9-2320-235-20 for procedures for troubleshooting vehicle electrical system.</p> <p><u>c.</u> Replace starter (par. 60).</p>
2. Starter runs but will not crank engine.	<p><u>a.</u> Worn or failed starter drive.</p> <p><u>b.</u> Failed ring gear on flywheel.</p>	<p><u>a.</u> Remove starter assembly (par. 60a). Refer to TM 9-2920-36-35 and replace starter drive. Install starter assembly (par. 60b).</p> <p><u>b.</u> Refer to TM 9-2320-235-20 for instructions on transmission removal. Remove the clutch assembly (par. 69a). Remove flywheel (par. 86a). Replace flywheel ring gear (par. 208). Install flywheel (par. 86b through d). Install clutch assembly (par. 67e). Install transmission as directed in TM 9-2320-235-20.</p>

50. TROUBLESHOOTING STARTING SYSTEM - Continued

Malfunction	Probable causes	Corrective action
3. Starter operates but fails to crank engine at proper cranking speed.	<ul style="list-style-type: none"> <li>a. Defective starter.</li> <li>b. Improper grade engine oil.</li> <li>c. Partially seized engine caused by tight engine bearings.</li> </ul>	<ul style="list-style-type: none"> <li>a. Replace starter (par. 60).</li> <li>b. Drain crankcase and re-fill with proper grade oil. Refer to lubrication order LO 9-2320-235-10.</li> <li>c. Turn engine manually. If engine does not turn freely disassemble engine (pars. 111 through 151). Clean parts (par. 152), inspect parts (par. 153), repair parts (par. 154), and replace parts that are damaged. Assemble engine (pars. 253 through 286).</li> </ul>

51. TROUBLESHOOTING GENERATOR SYSTEM

1. Generator does not operate.	<ul style="list-style-type: none"> <li>a. Loose or worn drive belt.</li> <li>b. Failed generator.</li> </ul>	<ul style="list-style-type: none"> <li>a. Replace worn belts (par. 61). Adjust drive belt tension (par. 61).</li> <li>b. Replace generator (par. 61).</li> </ul>
2. Generator rotates but does not charge.	<ul style="list-style-type: none"> <li>a. Defective generator regulator or wiring.</li> <li>b. Failed generator.</li> </ul>	<ul style="list-style-type: none"> <li>a. Refer to TM 9-2320-235-20 and correct regulator adjustments. Replace regulator when necessary.</li> <li>b. Replace generator (par. 61).</li> </ul>

52. TROUBLESHOOTING AIR INDUCTION SYSTEM

1. Restricted turbo-supercharger air intake hoses or system.	<ul style="list-style-type: none"> <li>a. Plugged air cleaner or collapsed hoses.</li> <li>b. Failed turbosupercharger.</li> </ul>	<ul style="list-style-type: none"> <li>a. Refer to TM 9-2320-235-20 and service air cleaner. Replace deteriorated induction system hoses.</li> <li>b. Replace turbosupercharger (par. 62).</li> </ul>
--	--	---



52. TROUBLESHOOTING AIR INDUCTION SYSTEM - Continued

Malfunction	Probable causes	Corrective action
2. Loss of engine power.	<p><u>a.</u> Air leak in intake manifold gaskets or hoses.</p> <p><u>b.</u> Turbosupercharger worn, plugged, or failed.</p>	<p><u>a.</u> Replace manifold gaskets (par. 87). Refer to TM 9-2320-235-20 and replace deteriorated air induction hoses.</p> <p><u>b.</u> Replace turbosupercharger (par. 62). Refer to TM 9-2990-201-35 for turbosupercharger repair and rebuild procedures.</p>

53. TROUBLESHOOTING FUEL SYSTEM

1. No fuel being delivered at fuel injector nozzle and holder assemblies.	<p><u>a.</u> Defect in vehicle fuel delivery system or air in fuel lines.</p> <p><u>b.</u> Plugged primary fuel filter or defective filter bypass valve.</p> <p><u>c.</u> Plugged final fuel filter.</p> <p><u>d.</u> Damaged fuel hoses and/or tubes.</p> <p><u>e.</u> Defective fuel injection pump or fuel return valve on pump.</p>	<p><u>a.</u> Troubleshoot vehicle fuel system. Refer to TM 9-2320-235-20 for procedures.</p> <p><u>b.</u> Replace primary fuel filter (par. 72). Replace defective filter bypass valve (par. 213).</p> <p><u>c.</u> Replace final fuel filter (par. 72).</p> <p><u>d.</u> Replace defective or damaged fuel hoses (par. 78) and fuel injection tubes (par. 100).</p> <p><u>e.</u> Check fuel return valve. Refer to TM 9-2910-223-35. Remove fuel injection pump (par. 63b). Refer to TM 9-2910-223-35 for fuel injection rebuild procedures. Replace pump when necessary. Install pump (par. 63c).</p>
2. Fuel being delivered at nozzles but engine will not run, start, or runs rough on one or more cylinders.	<p><u>a.</u> Defective fuel injector nozzle and holders.</p>	<p><u>a.</u> Remove fuel injector nozzle and holder assemblies (par. 83b). Test, adjust, and/or repair fuel injector nozzle and holder assemblies (par. 83c through i). Install nozzle and holder assemblies (par. 83j). Replace nozzle and holder assemblies only when necessary (par. 83).</p>

53. TROUBLESHOOTING FUEL SYSTEM - Continued

Malfunction	Probable causes	Corrective action
<p>2. Fuel being delivered at nozzles but engine will not run, start, or runs rough on one or more cylinders - Continued.</p>	<p>b. Defective intake manifold flame heater fuel system.</p> <p>c. Partially plugged fuel filters or fuel is contaminated.</p> <p>d. Defective fuel injection pump.</p> <p>e. Leaking fuel return check valve on fuel injection pump.</p>	<p>b. Troubleshoot intake manifold flame heater, ignition unit, spark plug, heater fuel pump, and filters for malfunctioning as directed in troubleshooting intake manifold flame heater fuel system (par. 56).</p> <p>c. Replace primary and final fuel filters (par. 72). Refer to TM 9-2320-235-20 and drain vehicle fuel tank of water or contaminants.</p> <p>d. Remove fuel injection pump (par. 63b). Rebuild fuel injection pump as directed in TM 9-2910-223-35. Replace pump when necessary. Install fuel injection pump (par. 63c).</p> <p>e. Check fuel return valve as directed in TM 9-2910-233-35. Replace fuel injection pump (par. 63) when necessary.</p>
<p>3. Engine runs hot, misfires, or runs rough.</p>	<p>a. Insufficient fuel pressure from supply pump (lean mixture).</p> <p>b. Improperly adjusted fuel injection pump causing decreased fuel delivery.</p> <p>c. Leaking fuel injection tube to nozzle and holder assembly.</p>	<p>a. Replace primary and final fuel filters (par. 72). Remove fuel injection pump (par. 63b). Refer to TM 9-2910-223-35 for instructions on fuel supply pump injection pump (par. 63c).</p> <p>b. Refer to TM 9-2910-223-35 and adjust fuel injection pump.</p> <p>c. Repair or replace fuel injection tube (par. 100).</p>

### 53. TROUBLESHOOTING FUEL SYSTEM - Continued

Malfunction	Probable causes	Corrective action
<p>4. Engine exhaust smoke is excessive and engine runs rough. Sluggish acceleration.</p>	<p>a. Fuel injection pump improperly adjusted causing increased fuel delivery (rich mixture).</p> <p>b. Low oil pressure to fuel injection pump.</p> <p>c. Failed fuel injection pump or turbosupercharger.</p>	<p>a. Refer to TM 9-2910-223-35 and adjust fuel injection pump.</p> <p>b. Refer to lubrication system troubleshooting (par. 54) for causes of low oil pressure to fuel injection pump.</p> <p>c. Replace fuel injection pump (par. 63) or turbosupercharger.</p>

### 54. TROUBLESHOOTING LUBRICATION SYSTEM

<p>1. Low engine oil pressure.</p>	<p>a. Low oil level, faulty oil pressure gage, sending unit, oil diluted, or clogged oil filters.</p> <p>b. Defective oil pressure regulator valve.</p> <p>c. Obstructed oil pick-up tube screens, or obstructed engine oil passages.</p> <p>d. High engine oil temperature, defective water pump, or plugged oil cooler.</p>	<p>a. Add oil, check pressure gage as directed in TM 9-2320-235-20. Replace faulty oil pressure sending unit (par. 74). Change oil to grade recommended in LO 9-2320-235-10. Replace oil filter elements (par. 73).</p> <p>b. Remove oil pressure regulator valve (par. 70a). Clean, inspect, and repair (par. 70b). Install oil pressure regulator valve (par. 70c).</p> <p>c. Remove oil pan (par. 95) check screens for obstructions or plugged condition. Disassemble engine (pars. 111 through 151). Clean and inspect all oil passages. Assemble engine (pars. 253 through 286).</p> <p>d. Refer to cooling system probable causes and corrective actions tabulated in paragraph 55.</p>
------------------------------------	---	--

54. TROUBLESHOOTING LUBRICATION SYSTEM - Continued

Malfunction	Probable causes	Corrective action
<p>1. Low engine oil pressure - Continued.</p>	<p><u>e.</u> Defective oil pump.</p> <p><u>f.</u> Worn main bearings, connecting rod bearings, or camshaft bushing-type bearings.</p>	<p><u>e.</u> Remove oil pan (par. 95) and oil pump assembly (par. 138). Rebuild oil pump (par. 193). Install oil pump assembly (par. 266a). Install oil pan (par. 266a).</p> <p><u>f.</u> Disassemble engine (pars. 111 through 151). Replace crankshaft, main bearings, and connecting rod bearings. Replace camshaft bushing-type bearings (par. 161). Assemble engine (pars. 253 through 286).</p>
<p>2. High engine oil pressure.</p>	<p><u>a.</u> Faulty oil pressure sending unit or improper grade of engine oil for prevailing temperatures.</p> <p><u>b.</u> Defective oil pressure regulator valve.</p> <p><u>c.</u> Obstructed oil passages.</p>	<p><u>a.</u> Change oil to recommended grade as directed in LO 9-2320-235-10. Replace oil pressure sending unit (par. 74). Check engine temperature gage as directed in TM 9-2320-235-20.</p> <p><u>b.</u> Remove oil pressure regulator valve (par. 70a). Clean, inspect, and repair as necessary (par. 70b). Install oil pressure regulator valve (par. 70c).</p> <p><u>c.</u> Refer to 1c, above.</p>
<p>3. No engine oil pressure.</p>	<p><u>a.</u> Low oil level or defective pressure gage.</p> <p><u>b.</u> Obstructed oil passages or defective oil pressure control valve or spring.</p>	<p><u>a.</u> Add oil. Check pressure gage as directed in TM 9-2320-235-20.</p> <p><u>b.</u> Remove oil pressure regulator valve (par. 70a). Clean, inspect, and repair as necessary (par. 70b). Replace damaged parts. Install oil pressure regulator valve (par. 70c). Disassemble engine (pars. 111 through 151). Clean and inspect oil passages. Inspect all parts. Replace worn or damaged parts and assemble engine (pars. 253 through 286).</p>

54. TROUBLESHOOTING LUBRICATION SYSTEM - Continued

Malfunction	Probable causes	Corrective action
<p>3. No engine oil pressure - Continued.</p>	<p><u>c.</u> Defective oil pump or drive gears.</p>	<p><u>c.</u> Remove oil pan (par. 95). Remove oil pump assembly (par. 138). Rebuild oil pump (par. 193). Replace pump when unserviceable. Install pump (par. 266a) and oil pan (par. 266b).</p>
<p>4. High engine oil temperature.</p>	<p><u>a.</u> Improper grade oil for prevailing temperature or defective sending unit.</p> <p><u>b.</u> Insufficient oil in oil pan.</p> <p><u>c.</u> Restricted oil cooler or defective oil cooler bypass valve.</p> <p><u>d.</u> High engine coolant temperature.</p> <p><u>e.</u> Lean fuel mixture.</p> <p><u>f.</u> Tight engine bearings.</p> <p><u>g.</u> Defective piston cooling nozzles.</p>	<p><u>a.</u> Drain crankcase and refill with proper grade oil for prevailing temperature. Refer to TM 9-2320-235-20 and LO 9-2320-235-10. Also check water temperature sending unit (par. 75).</p> <p><u>b.</u> Fill to proper level. Refer to TM 9-2320-235-20.</p> <p><u>c.</u> Remove oil cooler (par. 78a). Clean and inspect. Replace when damaged or restricted beyond repair. Install oil cooler (par. 78c). Replace defective oil-cooler bypass valve (par. 69).</p> <p><u>d.</u> Refer to cooling system troubleshooting (par. 55).</p> <p><u>e.</u> Refer to fuel system troubleshooting (par. 53).</p> <p><u>f.</u> Disassemble engine (pars. 111 through 151). Clean and inspect parts. Replace worn or damaged parts. Assemble engine (pars. 253 through 286).</p> <p><u>g.</u> Remove oil pan (par. 95). Remove piston cooling nozzles (par. 150). Replace piston cooling nozzles (par. 256). Install oil pan (par. 266e).</p>

#### 54. TROUBLESHOOTING LUBRICATION SYSTEM - Continued

Malfunction	Probable causes	Corrective action
5. Low engine oil temperature (winter operation).	<ul style="list-style-type: none"> <li>a. Defective coolant system thermostat or the thermostat has improper heat range.</li> <li>b. Defective water temperature sending unit.</li> </ul>	<ul style="list-style-type: none"> <li>a. Replace coolant thermostat (par. 76).</li> <li>b. Replace defective water temperature sending unit (par. 75).</li> </ul>
6. Excessive oil consumption.	<ul style="list-style-type: none"> <li>a. High oil temperature.</li> <li>b. Restricted crankcase breather tube or adapter.</li> <li>c. Worn piston rings, pistons, or liners.</li> <li>d. Worn valve stems or guides.</li> </ul>	<ul style="list-style-type: none"> <li>a. Refer to 4, above.</li> <li>b. Remove crankcase breather tube (par. 62). Remove crankcase breather adapter (par. 130). Clean or replace crankcase breather. Install crankcase breather adapter (par. 283c). Install crankcase breather tube (par. 62).</li> <li>c. Disassemble engine (pars. 111 through 151). Clean and inspect parts. Replace worn or damaged parts. Assemble engine (pars. 253 through 286).</li> <li>d. Remove cylinder head or heads (par. 94 b). Disassemble cylinder heads (par. 198). Replace valves and valve guides (par. 200). Replace cylinder head or heads when necessary. Assemble cylinder heads (par. 201). Install cylinder head or heads (par. 94g).</li> </ul>

#### 55. TROUBLESHOOTING COOLING SYSTEM

1. Engine overheats.	<ul style="list-style-type: none"> <li>a. Broken fan belts or restricted radiator or engine coolant system.</li> </ul>	<ul style="list-style-type: none"> <li>a. Replace broken fan belts (par. 61). Reverse flush engine coolant system (par. 110).</li> </ul>
----------------------	--	--

55. TROUBLESHOOTING COOLING SYSTEM - Continued

Malfunction	Probable causes	Corrective action
1. Engine overheats - Continued.	<p><u>b.</u> Defective coolant thermostat or sending unit.</p> <p><u>c.</u> Defective or plugged water pump.</p> <p><u>d.</u> Lean fuel mixture.</p> <p><u>e.</u> Defective oil cooler bypass valve or plugged oil cooler.</p>	<p><u>b.</u> Replace coolant thermostat (par. 76). Replace water temperature sending unit (par. 75).</p> <p><u>c.</u> Remove water pump assembly (par. 77a). Rebuild water pump (pars. 77b through d). Install water pump assembly (par. 77e).</p> <p><u>d.</u> Refer to fuel system troubleshooting (par. 53).</p> <p><u>e.</u> Refer to lubrication troubleshooting (par. 54) for high engine oil temperature condition.</p>
2. Engine fails to reach normal operating temperature.	<p><u>a.</u> Defective coolant thermostat or the thermostat has improper heat range.</p> <p><u>b.</u> Defective water temperature sending unit or gage.</p>	<p><u>a.</u> Replace coolant thermostat (par. 76).</p> <p><u>b.</u> Replace defective water temperature sending unit (par. 75).</p>
3. Loss of coolant.	<p><u>a.</u> Loose or damaged hoses. Hose connections or coolant line gaskets leaking.</p> <p><u>b.</u> Water pump seal leaking.</p>	<p><u>a.</u> Refer to TM 9-2320-235-20. Repair or replace hose connections. Check vehicle radiator for leaks. Replace leaking gaskets where necessary.</p> <p><u>b.</u> Remove water pump (par. 77a). Rebuild water pump (pars. 77b through d). Replace water pump when damaged beyond repair. Install water pump (par. 77e).</p>

55. TROUBLESHOOTING COOLING SYSTEM - Continued

Malfunction	Probable causes	Corrective action
<p>3. Loss of coolant - Continued.</p>	<p><u>c.</u> Cylinder head or cylinder head gasket defective, or warped cylinder heads.</p> <p><u>d.</u> Cylinder or crankcase (cylinder block) or cylinder head core hole plugs leaking.</p> <p><u>e.</u> Leaking oil cooler or oil cooler gaskets.</p> <p><u>f.</u> Leaking oil cooler water inlet tube.</p>	<p><u>c.</u> Remove cylinder head or heads (par. 94 b). Check for warped cylinder heads (par. 199b). Reface warped cylinder head or heads (par. 200a). Replace heads that are warped beyond limits specified for refacing. Install new head gaskets and/or heads (par. 94g).</p> <p><u>d.</u> Remove and replace leaking core hole plugs. Refer to paragraph 200 for cylinder head plugs and paragraph 159 for cylinder and crankcase core hole plugs.</p> <p><u>e.</u> Remove oil cooler (par. 78a), inspect cooler core if necessary. Install oil cooler (par. 78c) and install new gasket.</p> <p><u>f.</u> Replace oil cooler water inlet tube (par. 77).</p>

56. TROUBLESHOOTING INTAKE MANIFOLD FLAME HEATER FUEL SYSTEM

<p>1. No fuel to intake manifold flame heater.</p>	<p><u>a.</u> Flame heater fuel filter plugged.</p> <p><u>b.</u> Flame heater fuel pump not operating.</p>	<p><u>a.</u> Clean or replace flame heater fuel filter element (par. 81). Replace filter assembly (par. 81).</p> <p><u>b.</u> Check fuel pump electrical circuit (TM 9-2320-235-20). Remove flame heater fuel pump (par. 64a). Rebuild fuel pump (pars. 232 through 236), or replace if found damaged beyond repair. Install flame heater fuel pump (par. 64b).</p>
--	---	---



56. TROUBLESHOOTING INTAKE MANIFOLD FLAME HEATER FUEL SYSTEM - Continued

Malfunction	Probable causes	Corrective action
<p>1. No fuel to intake manifold flame heater - Continued.</p>	<p><u>c.</u> Defective fuel inlet or outlet solenoid valves.</p> <p><u>d.</u> Broken wires in ignition harness.</p> <p><u>e.</u> Heater spray nozzle or tubes restricted or plugged.</p>	<p><u>c.</u> Replace defective solenoid valves (par. 82).</p> <p><u>d.</u> Replace the harness (par. 124).</p> <p><u>e.</u> Remove restrictions. Replace or repair heater spray nozzle (par. 79).</p>
<p>2. Fuel to intake manifold flame heater will not operate (ignite).</p>	<p><u>a.</u> Defective spark plug.</p> <p><u>b.</u> Defective ignition unit.</p> <p><u>c.</u> Defective ignition harness or ignition unit to heater cable.</p>	<p><u>a.</u> Clean or replace defective spark plug (par. 79).</p> <p><u>b.</u> Replace defective ignition unit (par. 80c).</p> <p><u>c.</u> Repair or replace electrical leads (par. 230).</p>

CHAPTER 4  
REPLACEMENT OF ENGINE ACCESSORIES, COMPONENTS,  
AND RELATED SERVICE OPERATIONS

---

Section I. GENERAL

57. PURPOSE

a. This chapter covers replacement of engine accessories allocated to third echelon maintenance personnel. Some accessories can be replaced while the engine is installed in the vehicle. Engines which have been removed from the vehicles for replacement of accessories must be thoroughly cleaned before replacement of any accessory is attempted. Refer to TM 9-2320-235-20- for instructions on removal and installation of the power plant and separation of the transmission from the engine.

b. In addition to the replacement operations, the service operations allocated to third echelon maintenance are included.

58. REMOVAL AND INSTALLATION INSTRUCTIONS

a. Illustrations.

- (1) General. The illustration sequences provided in the following subparagraphs depict the procedures for removal of the particular item involved. The installation procedures are provided by reversing the illustration and instruction sequence unless otherwise indicated.
- (2) Engine accessories. Figures 39 through 87 provide a pictorial step-by-step procedure for the replacement of engine accessories.

Note. Cover or plug all fuel and oil line connections and all intake and exhaust openings after removing accessories, both on the accessory and engine, to prevent entry of dirt.

- (3) Major external components. Figures 88 through 218 provide a pictorial step-by-step procedure for the replacement of engine major external components.

- (4) Service operations. Figures 219 and 220 provide a pictorial step-by-step procedure for performing the service operations allocated to third echelon.

b. Instructions.

- (1) Removal. The alphabetical order of the letters (A, B, and C) that appear on the illustrations indicate the sequence of instructions to be followed when performing the removal operations.
- (2) Installation. The installation operations should be performed by following the letters, that appear on the illustrations, in reverse order; e.g., C, B, and A. This method of reverse procedure will be used unless otherwise noted.

c. Parts Identification. Callouts will be used to point out related parts involved in the removal operation being performed. Callouts not mentioned in the instructions are related to subsequent installation procedures or are used as references to other pertinent operations in this technical manual.

Note. Parts mentioned in the instructions that carry the operational sequence letters will be called out separately on the illustration only when required to further clarify the instructions.

d. Special Instructions. Instructional "Notes" or "Cautions" accompany some of the illustrations and are used to further define the instructions, eliminate personnel injury, or damage to the equipment.

e. Early and Late Models. Different accessories used on early and late model engines are covered with illustrations of both engines. The figure titles include either the words LATE MODEL ENGINES or EARLY MODEL ENGINES to differentiate between the models.

## Section II. REPLACEMENT OF ENGINE ACCESSORIES

### 59. GENERAL

The engine accessories may be replaced or repaired as outlined. The repair or rebuild of some accessories are not covered in this manual. The list of manuals shown in paragraph 1h covers the rebuild procedures for the various accessories.

### 60. STARTER ASSEMBLY

a. Removal. Remove starter assembly as follows.

- (1) Figure 39. (A) Remove three 5/8-inch plain nuts and 5/8-inch lock washers attaching starter assembly to flywheel housing. (B) Remove the starter by pulling starter straight out from flywheel housing until drive gear clears starter adapter and the mounting flange clears the three studs.

Note. Check condition of starter drive gear teeth. If teeth are damaged, inspect flywheel ring gear (fig. 40) for damaged or broken teeth.

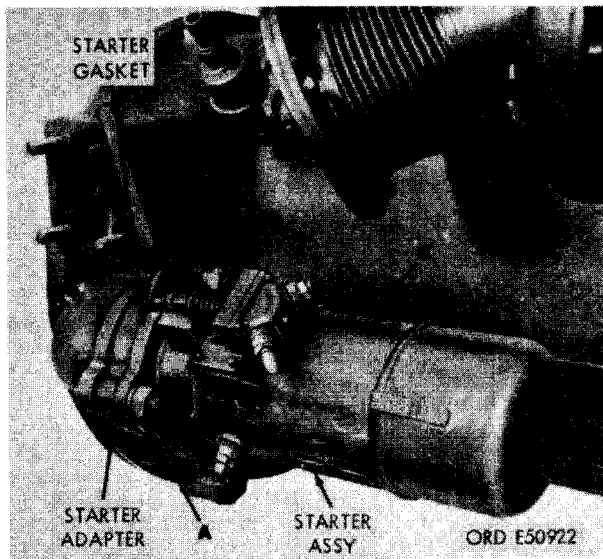


FIGURE 39. REMOVING OR INSTALLING STARTER ASSEMBLY.

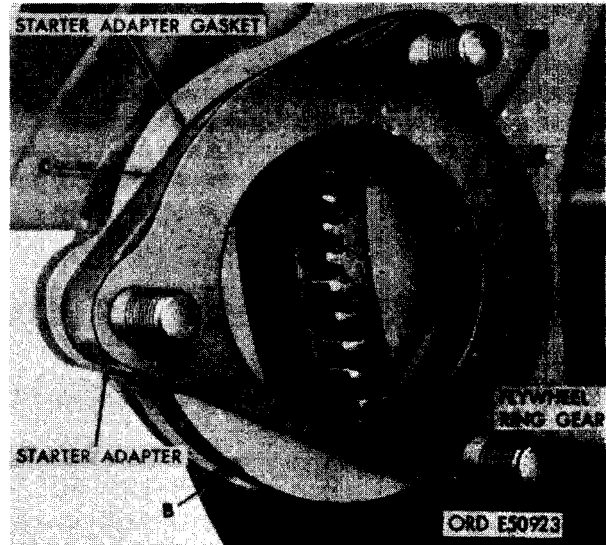


FIGURE 40. REMOVING OR INSTALLING STARTER GASKET, STARTER ADAPTER, STARTER ADAPTER GASKET, AND INSPECTING FLYWHEEL RING GEAR.

- (2) Figure 40. (A) Remove and discard starter gasket. (B) Remove starter adapter. The starter adapter will loosen on the mounting studs during removal of starter assembly (fig. 39). (C) Remove and discard starter adapter gasket. (D) Inspect flywheel ring gear for broken, missing or damaged teeth.

Note. When flywheel ring gear teeth are damaged, remove flywheel (par. 86) and refer to instructions on flywheel ring gear replacement (par. 208).

b. Installation. Refer to figures 39 and 40 and reverse the sequence of illustrations and instructions to install the starter assembly.

### 61. GENERATOR ASSEMBLY

a. Removal. Remove generator assembly as follows.

- (1) Figure 41. (A) Remove 3/8 x 7/8 cap screw, 3/8-inch lock washer, and special flange washer attaching generator adjusting strap to generator. (B) Lift generator assembly up towards engine and

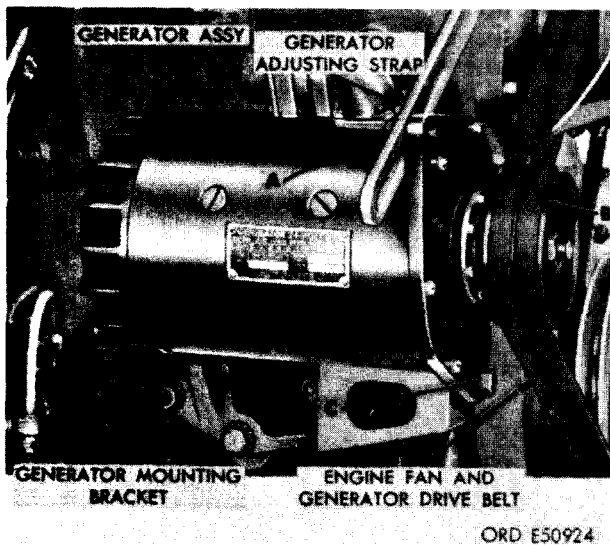


FIGURE 41. REMOVING OR INSTALLING GENERATOR ASSEMBLY AND/OR ENGINE FAN AND GENERATOR DRIVE BELTS.

remove two fan and generator drive belts from generator pulley. Loosen generator attaching nuts to lift generator. (C) Remove two 7/16-inch plain nuts, 7/16-inch lock washers, and 7/16 x 1-1/2-inch cap screws attaching generator assembly to generator mounting bracket. (D) Remove generator assembly.

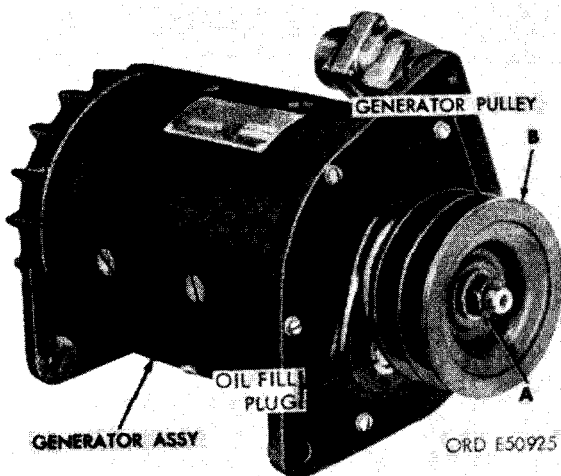


FIGURE 42. REMOVING OR INSTALLING GENERATOR PULLEY.

- (2) Figure 42. (A) Remove 1/2-inch self-locking nut and 1/2-inch flat washer securing generator pulley to generator armature shaft. (B) Remove generator pulley from shaft using a suitable pul-  
ler.

Note. Tape key in armature shaft slot prevent loss.

**b. Installation.**

- (1) Refer to figures 41 and 42 and reverse the sequence of illustrations and instructions to install generator assembly.

Caution: If an Autolite generator is used for replacement, it must be lubricated prior to operation. Fill drive end oil reservoir with 0.400 fluid ounce of engine oil, OE- 10, Specification MIL-0-2104. Use OE- 10 oil in all ambient temperatures.

- (2) The Delco- Remy generator is prelubricated and may be installed and used as furnished. However, this generator does not include the Woodruff key. The key from the original generator must be retained for use with the new generator.



FIGURE 43. ADJUSTING ENGINE FAN AND GENERATOR DRIVE BELT DEFLECTION.

- (3) After installation of generator assembly, adjust engine fan and generator drive belt deflection as follows.
- (4) Figure 43. (A) Loosen 3/8 x 7/8 cap screw securing generator adjusting strap to generator assembly. (B) Pull generator assembly away from engine to decrease engine fan and generator drive belt deflection or push generator toward engine to increase belt deflection. (C) Apply pressure on each drive belt to determine deflection. Proper deflection is 3/4-inch applied at midpoint between water pump pulley and generator pulley. (D) Check tightness of the two 7/16-inch plain nuts and 7/16 x 1- 1/2 cap screws attaching generator assembly to generator mounting bracket after final adjustment is made. (E) Tighten the 3/8 x 7/8 cap screw to secure generator adjusting strap to generator and to maintain proper belt deflection. Both engine fan and generator drive belts must have equal deflection. Engine fan and generator drive belts are furnished as a set.

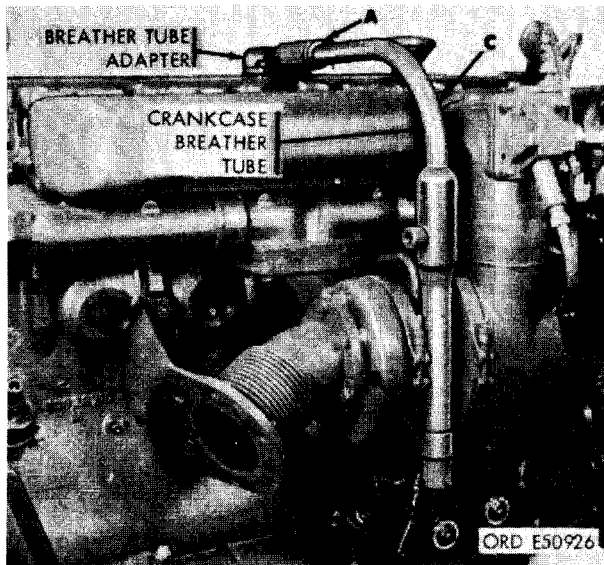


FIGURE 44. REMOVING OR INSTALLING CRANKCASE BREATHER TUBE (LATE MODEL ENGINES).

## 62. TURBOSUPERCHARGER

A. Removal. Turbosupercharger removal from early and late model engines differs. Remove turbosupercharger as follows, referring to the illustrations applicable to the model engine as noted.

- (1) Figure 44. (A) Loosen 1-1/4-inch hose clamp securing rubber hose to breather tube. (B) Remove 1/4-inch plain nut and 1/4-inch lock washer securing crankcase breather tube to turbosupercharger bracket. (C) Remove crankcase breather tube.
- (2) Figure 45. (A) Remove 5/16-inch plain nut, 5/16-inch lock washer, 5/16 x 5/8 cap screw, and 5/16-inch flat washer securing crankcase breather tube and clip to turbosupercharger heat shield.

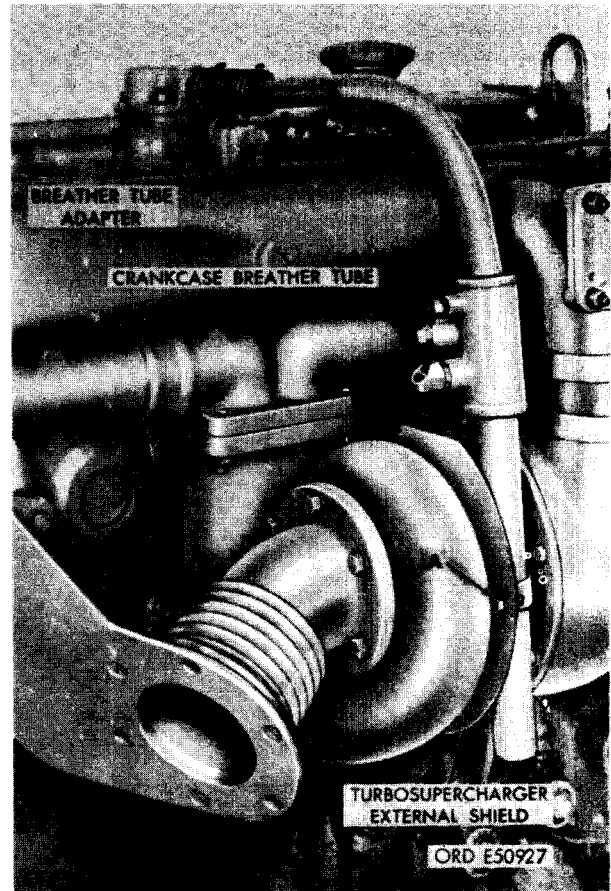


FIGURE 45. REMOVING OR INSTALLING CRANKCASE BREATHER TUBE (EARLY MODEL ENGINES).

(B) Loosen 1-1/4-inch hose clamp securing rubber hose to breather tube adapter and breather tube. Remove breather tube.

- (3) Figure 46. (A) Remove six 3/8 x 1 cap screw securing turbosupercharger exhaust elbow to turbosupercharger turbine housing. (B) Remove three 3/8 x 3/4 cap screws and 3/8-inch lock washers securing turbosupercharger exhaust elbow support to cylinder and crankcase. (C) Remove exhaust elbow and support. Remove and discard turbosupercharger exhaust elbow inlet gasket.

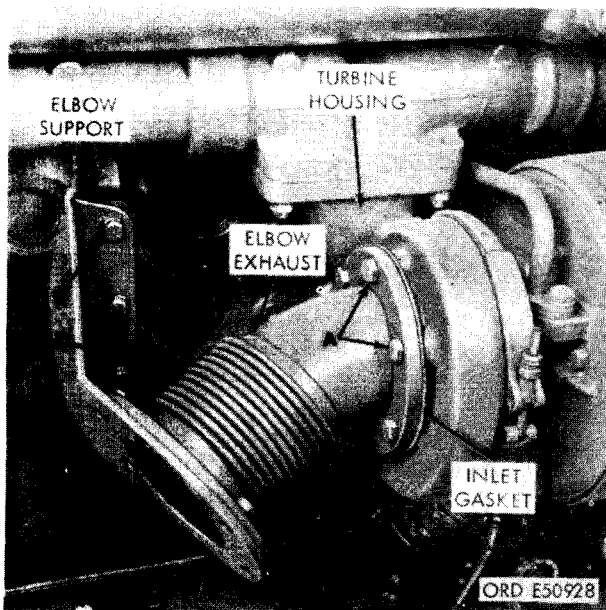


FIGURE 46. REMOVING OR INSTALLING TURBOSUPERCHARGER EXHAUST ELBOW AND SUPPORT (LATE MODEL ENGINES).

- (4) Figure 47. (A) Remove six 3/8 x 1 cap screws securing turbosupercharger exhaust elbow to turbosupercharger turbine housing. (B) Remove three 3/8 x 3/4 cap screws and 3/8-inch lock washers securing turbosupercharger exhaust elbow support to cylinder and crankcase. (C) Remove exhaust elbow and support as an assembly. Remove and discard the turbosupercharger exhaust elbow inlet gasket. (D) Disconnect the turbosupercharger oil inlet tube from 9/16-inch elbow assembly.

Note. Do not disassemble exhaust elbow and support (fig. 48) unless replacement of gasket is necessary.

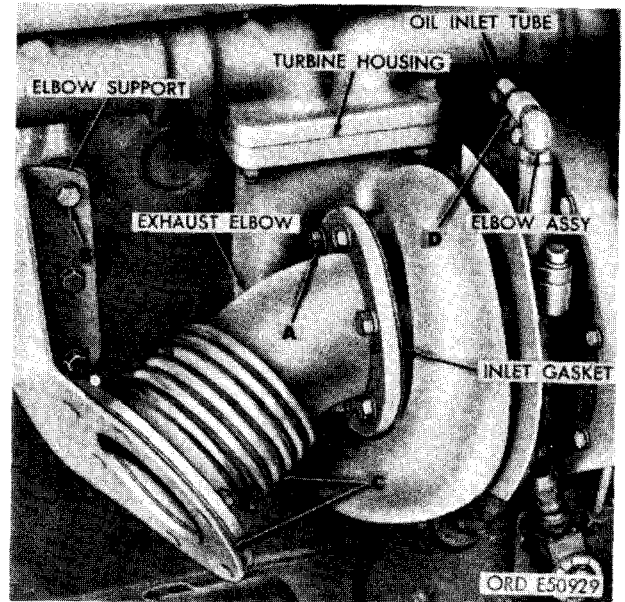


FIGURE 47. REMOVING OR INSTALLING TURBOSUPERCHARGER ELBOW AND DISCONNECTING OR CONNECTING TURBOSUPERCHARGER OIL INLET TUBE (EARLY MODEL ENGINES).

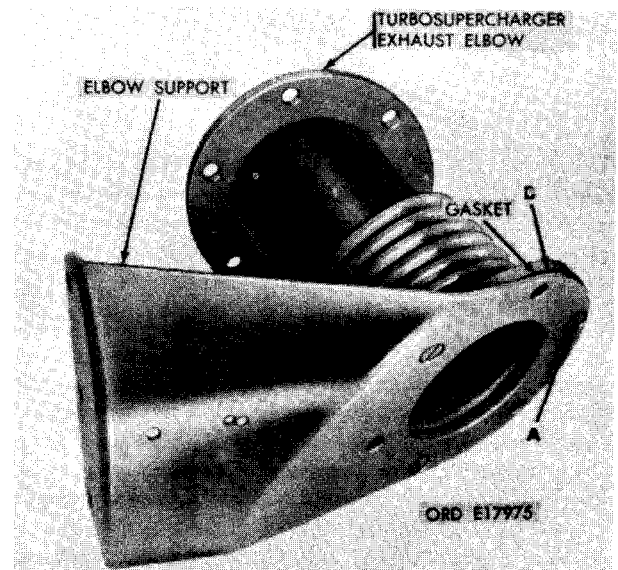


FIGURE 48. DISCONNECTING OR CONNECTING TURBOSUPERCHARGER EXHAUST ELBOW AND/OR ELBOW SUPPORT.

- (5) Figure 48. (A) Remove three 1/4- inch self- locking nuts and 1/4 x 3/4 flat head machine screws securing turbosupercharger exhaust elbow to elbow support. (B) Remove and discard turbosupercharger exhaust elbow outer gasket.
- (6) Figure 49. (A) Loosen lower 3-inch hose clamp securing 3-inch turbo supercharger- to- intake manifold hose to turbosupercharger. (B) Loosen two 1- inch hose clamps securing oil drain tube to adapter in crankcase and slide hose up on drain tube.

not attempt to remove drain hose at this time. The hose is not flexible enough to clear adapter.

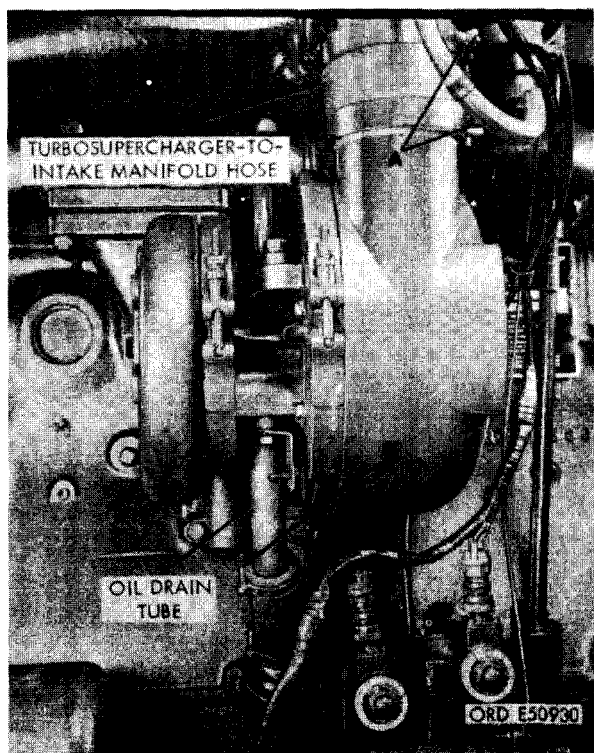


FIGURE 49. DISCONNECTING OR CONNECTING TURBOSUPERCHARGER - TO - INTAKE MANIFOLD HOSE AND OIL DRAIN TUBE (LATE MODEL ENGINES)

- (7) Figure 50. (A) Loosen lower 3-inch hose clamp securing the 3-inch turbosupercharger- to- intake manifold hose to turbosupercharger. (B) Disconnect the turbosupercharger- oil- drain hose from 3/4- inch pipe to tube adapter. Do

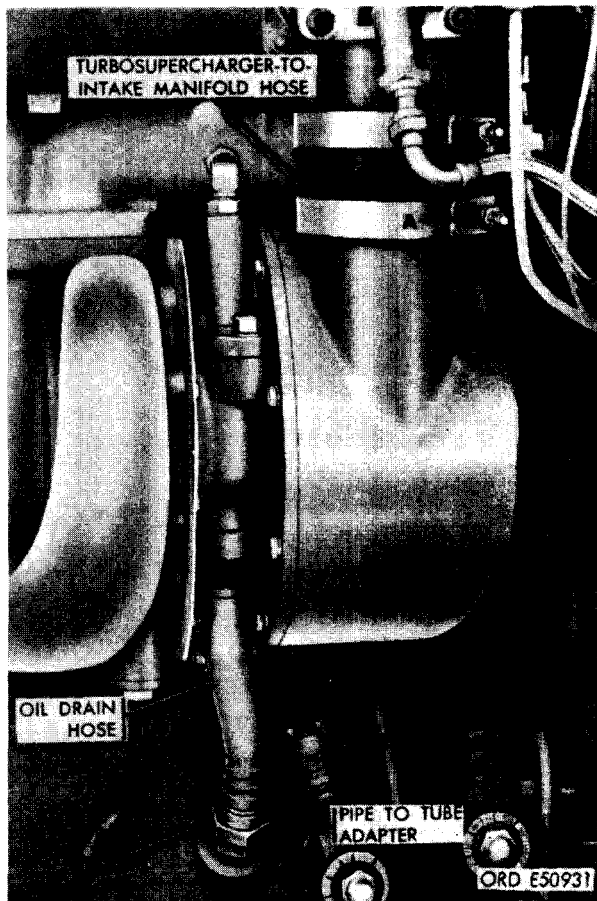
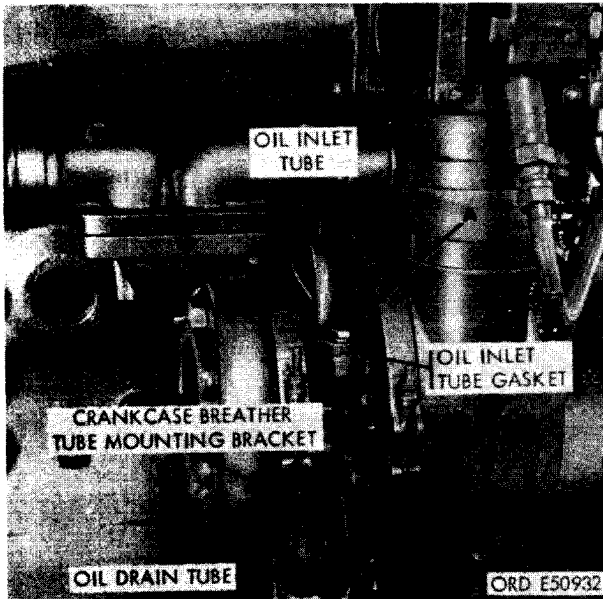


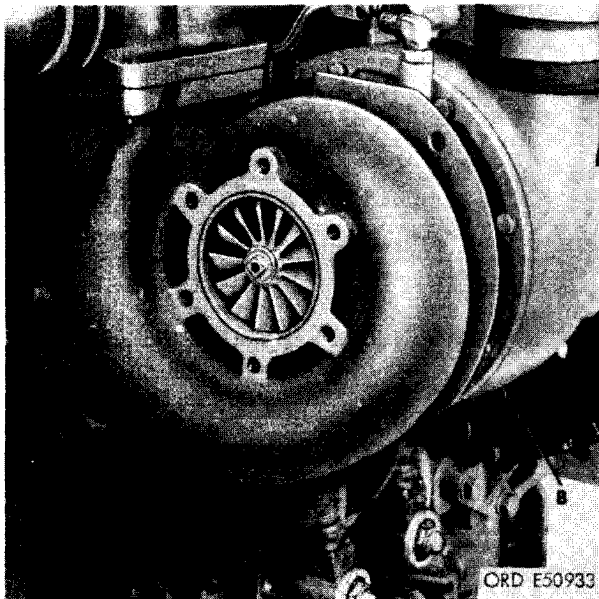
FIGURE 50. DISCONNECTING OR CONNECTING TURBOSUPERCHARGER - TO - INTAKE MANIFOLD HOSE AND OIL DRAIN HOSE (EARLY MODEL ENGINES) .

- (8) Figure 51. (A) Remove two 3/8 x 7/8 cap screws and 3/8- inch lock washers securing oil inlet tube to turbosupercharger. (B) Remove two 3/8 x 7/8 cap screws and 3/8- inch lock washers and remove crankcase breather tube mounting bracket, 1/4 x 5/8 machine bolt, and oil drain tube. (C) Remove four 3/8- inch self- locking nuts securing turbosupercharger to exhaust manifold. (D) Remove turbosupercharger assembly. (E) Remove and discard turbosupercharger gasket and oil inlet tube gasket.

Note. The turbosupercharger - to - intake manifold hose should remain on the intake manifold elbow. Tighten lower hose clamp to prevent loss of clamp.



**FIGURE 51. REMOVING OR INSTALLING TURBOSUPERCHARGER ASSEMBLY (LATE MODEL ENGINES).**



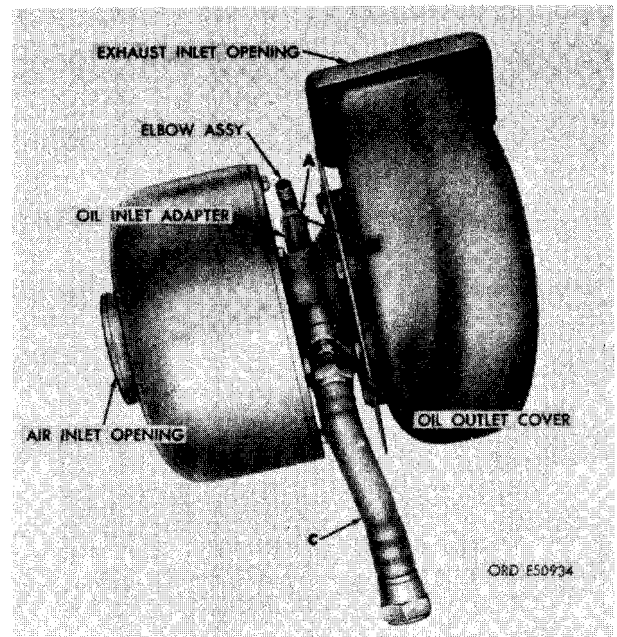
**FIGURE 52. REMOVING OR INSTALLING TURBOSUPERCHARGER ASSEMBLY (EARLY MODEL ENGINES).**

- (9) Figure 52. (A) Remove four 3/8- inch self-locking nuts securing turbosupercharger to exhaust manifold. (B) Remove turbosupercharger assembly. (C) Remove and discard turbosupercharger gasket.

Note. The turbosupercharger -to-intake manifold hose should remain on the intake manifold elbow. Tighten lower hose clamp to prevent loss of clamp.

- (10) Figure 53. (A) Loosen 9/16-inch plain nut and remove tube-to- adapter elbow assembly. (B) Remove and discard 15/32 id x 5/64 thk preformed packing from elbow. (C) Remove turbosupercharger oil drain hose from oil outlet cover.

Note. Plug and seal all turbosupercharger openings to prevent entrance of foreign material.



**FIGURE 53. REMOVING OR INSTALLING TURBOSUPERCHARGER OIL DRAIN HOSE AND OIL INLET ELBOW ASSEMBLY (EARLY MODEL ENGINES).**



b. Installation.

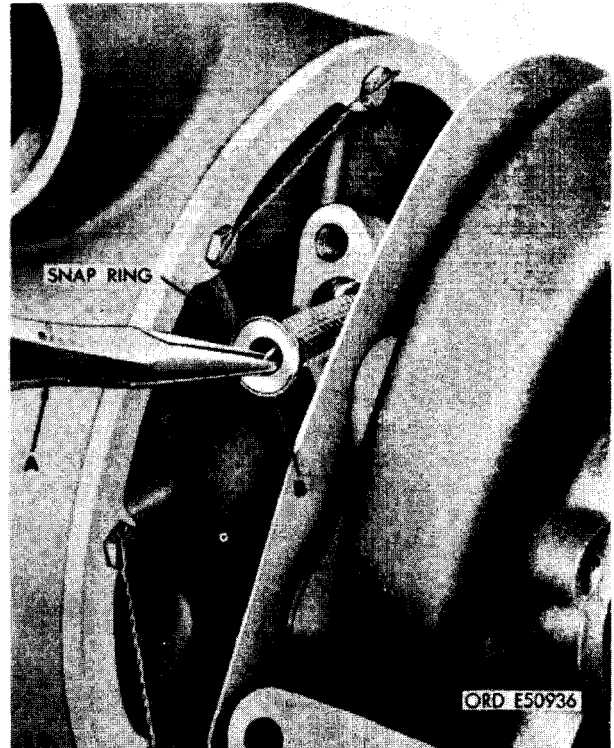
Caution: All early model turbosuperchargers were supplied with a filter at the oil inlet adapter which must be removed and discarded before installation on the engine. Late model turbosuperchargers do not have this screen. When this filter is not removed damage may result to the turbosupercharger sleeve bearings due to dirt accumulation at the filter causing a restriction of oil supply to the bearings.

- (1) Remove oil inlet filter as follows.
- (2) Figure 54. (A) Remove two socket-head cap screws and lock washers attaching oil inlet adapter to bearing housing. (B) Remove oil inlet adapter.



**FIGURE 54. REMOVING OR INSTALLING TURBOSUPERCHARGER OIL INLET ADAPTER (EARLY MODEL ENGINES).**

- (3) Figure 55. (A) Remove turbosupercharger oil inlet filter and snap ring. The snap ring retains the filter by spring action against the wall of the bore in bearing housing. The snap ring is removed when filter is removed. (B) Discard snap ring and filter.



**FIGURE 55. REMOVING TURBOSUPERCHARGER OIL INLET FILTER AND SNAP RING (EARLY MODEL ENGINES).**

- (4) Refer to figure 54 and reverse the sequence of instructions to install oil inlet adapter. Use a new inlet adapter gasket when necessary.
- (5) Refer to figures 44 through 53 and reverse the sequence of illustrations and instructions to install the turbosupercharger assembly.

### 63. FUEL INJECTION PUMP ASSEMBLY

a. General. Before the fuel injection pump assembly is removed from the engine align engine and the injection pump timing marks. In some cases, a faulty diagnosis of an injection pump malfunction (par. 53) can be traced to an improperly timed pump installed on the engine.

b. Removal. Remove fuel injection pump as follows.

Note. Mounting for the fuel injection pump differs between early and late model engines.

- (1) Figure 56. (A) Disconnect crankcase-to-fuel injection pump pressure oil hose from tee connection at bottom of fuel injection pump automatic advance unit. (B) Slip the six dust caps from the fuel injection tube nuts at the fuel injection pump hydraulic head.

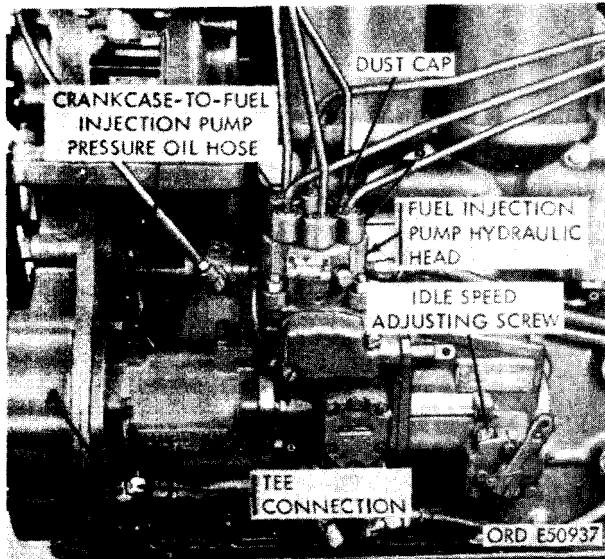


FIGURE 56. DISCONNECTING OR CONNECTING CRANKCASE - TO - FUEL INJECTION PUMP PRESSURE OIL HOSE AT PUMP AND LIFTING DUST CAPS.

- (2) Figure 57. (A) Disconnect fuel injector supply-to-fuel filter outlet hose from 1/4 pipe x 3/8 tube elbow in injection pump hydraulic head. Cover the elbow opening and hose to prevent entrance of dirt. (B) Disconnect fuel return-to-fuel injection pump overflow valve tube from 1/4 tube x 1/8 pipe, 90 degree elbow. Cover the elbow opening and tube to prevent entrance of dirt. (C) Remove two 1/4-inch self locking nuts, 1/4-inch flat washers, and 1/4 x 3/8 cap screws securing inner clamp to outer clamp and remove clamps from injector tubes. (D) Disconnect cylinder No. 1, 2, and 3 fuel injection tube assemblies from fuel injection pump hydraulic head.

Note. The fuel injection pump assembly fuel discharge sequence is counter-clockwise around hydraulic head in the following order: cylinder No. 1,5,3, 6, 2, and 4.

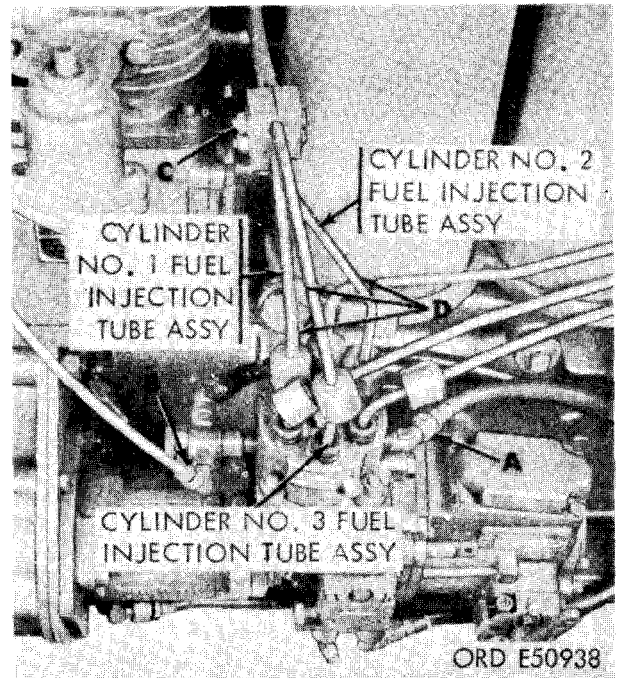


FIGURE 57. DISCONNECTING OR CONNECTING FUEL INJECTION PUMP FUEL HOSE AND CYLINDER NO. 1, 2, AND 3 FUEL INJECTION TUBES .

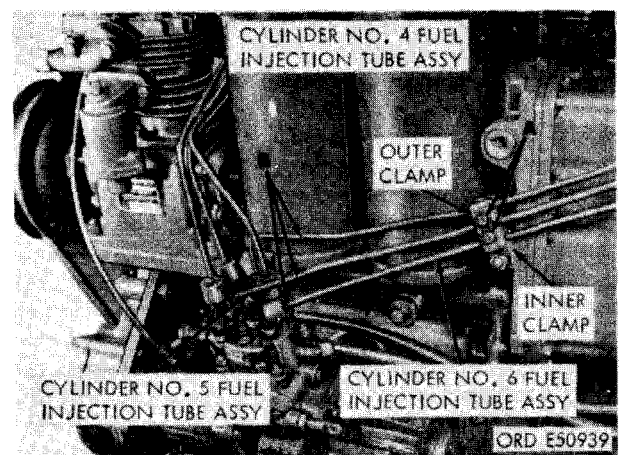


FIGURE 58. DISCONNECTING OR CONNECTING CYLINDER NO. 4, 5, AND 6 FUEL INJECTION TUBES.

- (3) Figure 58. (A) Remove two 1/4- inch self- locking nuts, 1/4- inch flat washers, and 1/4 x 1-3/8 cap screws securing outer clamp to inner clamp. Remove outer clamp. (B) Disconnect cylinder No. 4, 5, and 6 fuel injection tube assemblies from fuel injection pump assembly.
- (4) Figure 59. (A) Plug fuel injection tube openings and tubes in fuel injection pump hydraulic head to prevent entry of dirt. (B) Disconnect fuel supply pump-to-fuel filter inlet hose from 3/8 tube x 1/4 pipe, 90 degree elbow at bottom of fuel supply pump assembly. (C) Disconnect fuel injection overflow and fuel return-to- fuel filter inlet hose from 3/8 tube x 1/4 pipe, 45 degree elbow in overflow valve assembly.

Note. When installing fuel return-to-fuel filter inlet hose on overflow valve assembly, rotate valve slightly so as not to kink fuel return hose.

- (5) Figure 60. (A) Plug fuel injection tube openings in injection pump hydraulic head and tubes to prevent entry of dirt. (B) Disconnect swivel end of fuel supply pump-to-fuel filter inlet hose from 3/8 tube x 1/4 pipe, 45 degree elbow at bottom of fuel supply pump assembly. (C) Remove 1/4-inch plain nut, 1/4-inch lock washer, and hose clamp attaching fuel hoses to stud in the fuel injection pump bracket assembly. (D) Disconnect fuel injection overflow and fuel return-to- fuel filter inlet hose from 3/8-inch tube tee in fuel filter assembly. Disconnect other end of hose from overflow valve assembly in fuel injection pump assembly. Plug all openings to prevent entrance of dirt.

Note. When installing fuel return-to-fuel filter inlet hose on overflow valve assembly, rotate valve slightly so as not to kink fuel return hose.

- (6) Check timing of fuel injection pump (figs. 61 through 65) before removing pump from engine. The crankshaft damper and pulley assembly is marked at 27 degrees btdc (before top dead center) (F, fig. 61) indicating correct fuel injection pump timing, providing cylinder No. 1 piston is on compression stroke.

- (7) Figure 61. (A) Remove two 3/8-inch plain nuts and 3/8- inch lock washers and the 3/8 x 3-3/4 cap screws (B) Remove three 3/8- inch plain nuts and 3/8-inch lock washers from studs. (C) Remove fuel injection pump drive gear access cover and cover gasket. Discard gasket. (D) Remove four 1/4 x 5/8 machine screws and 1/4- inch lock washers securing timing cover to injection pump automatic advance unit. Remove cover and cover gasket. (E) Remove two 1/4 x 1- 1/4 fillister- head screws and 1/4-inch lock washers securing timing window cover to fuel injection pump assembly. Remove cover. (F) Rotate crankshaft clockwise, viewed from front of engine, until mark (F) on crankshaft damper and pulley assembly aligns with pointer on gear cover.

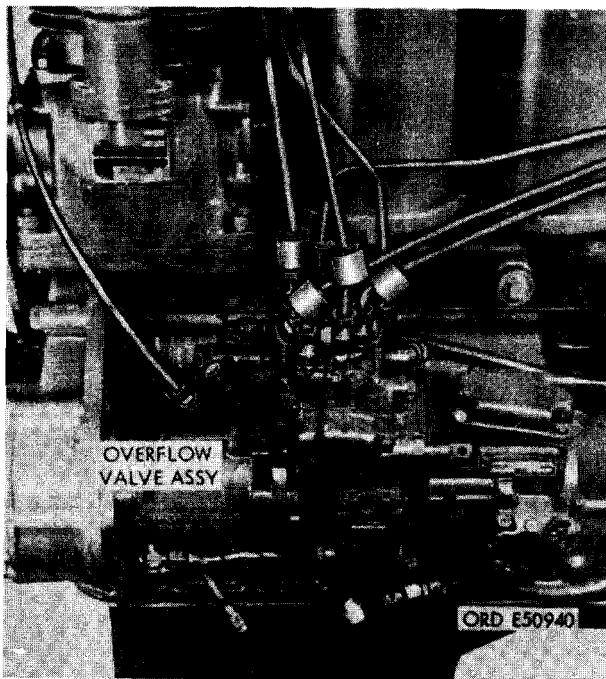
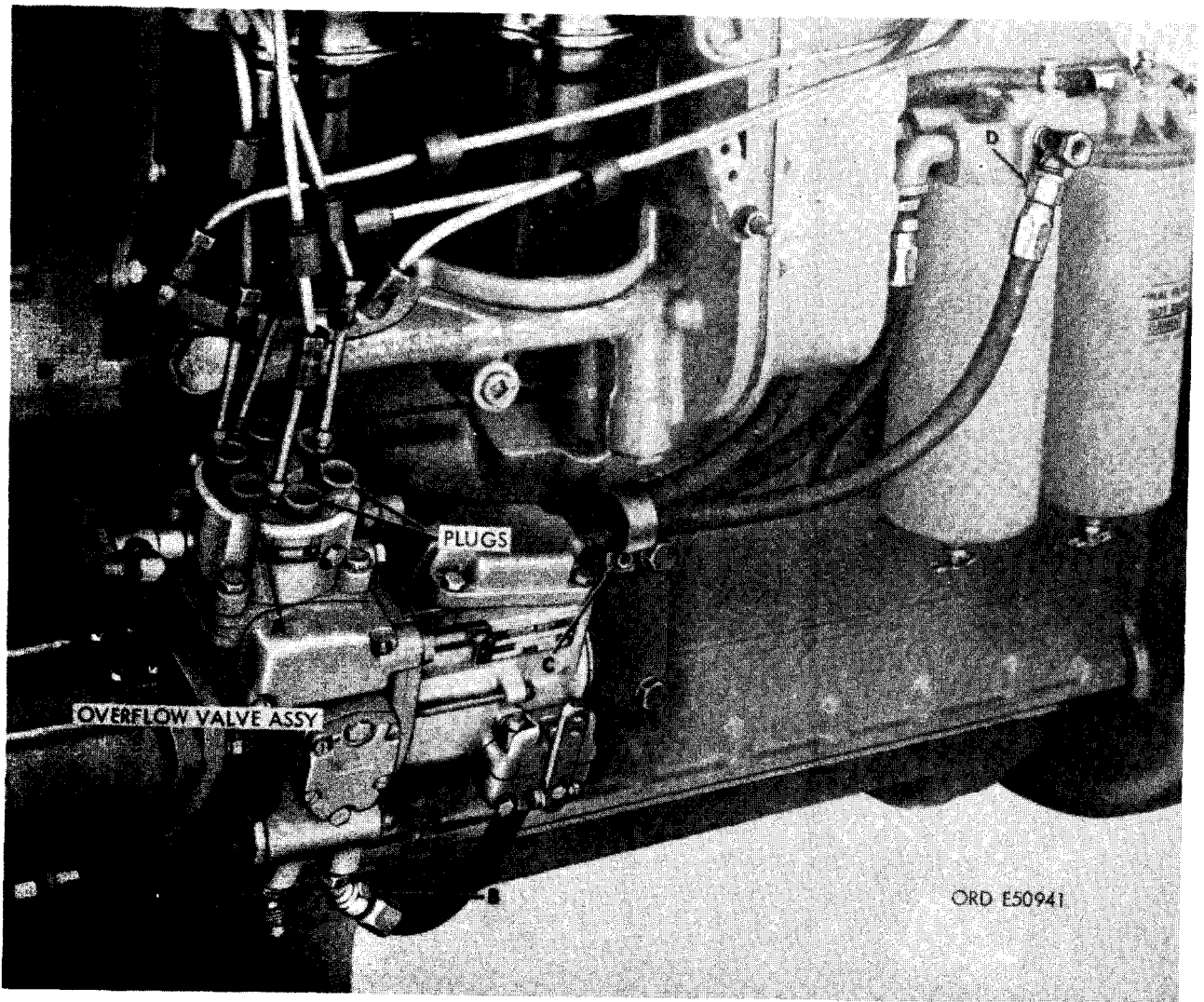
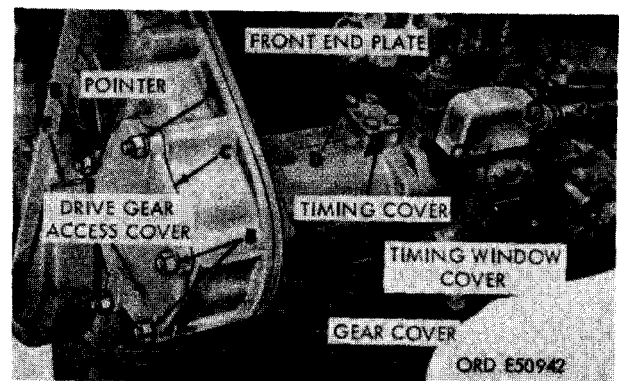


FIGURE 59. DISCONNECTING OR CONNECTING FUEL HOSES FROM FUEL INJECTION PUMP (LATE MODEL ENGINES).



**FIGURE 60. DISCONNECTING OR CONNECTING FUEL HOSES FROM FUEL INJECTION PUMP ASSEMBLY AND FUEL FILTER ASSEMBLY (EARLY MODEL ENGINES).**

Note. To determine when piston in cylinder No. 1 is on compression stroke, remove the front cylinder head cover to observe position of valve rocker arms. Refer to figures 62 and 63 for procedures on determining position of No. 1 piston.



**FIGURE 61. REMOVING OR INSTALLING INJECTION PUMP ACCESS COVERS .**

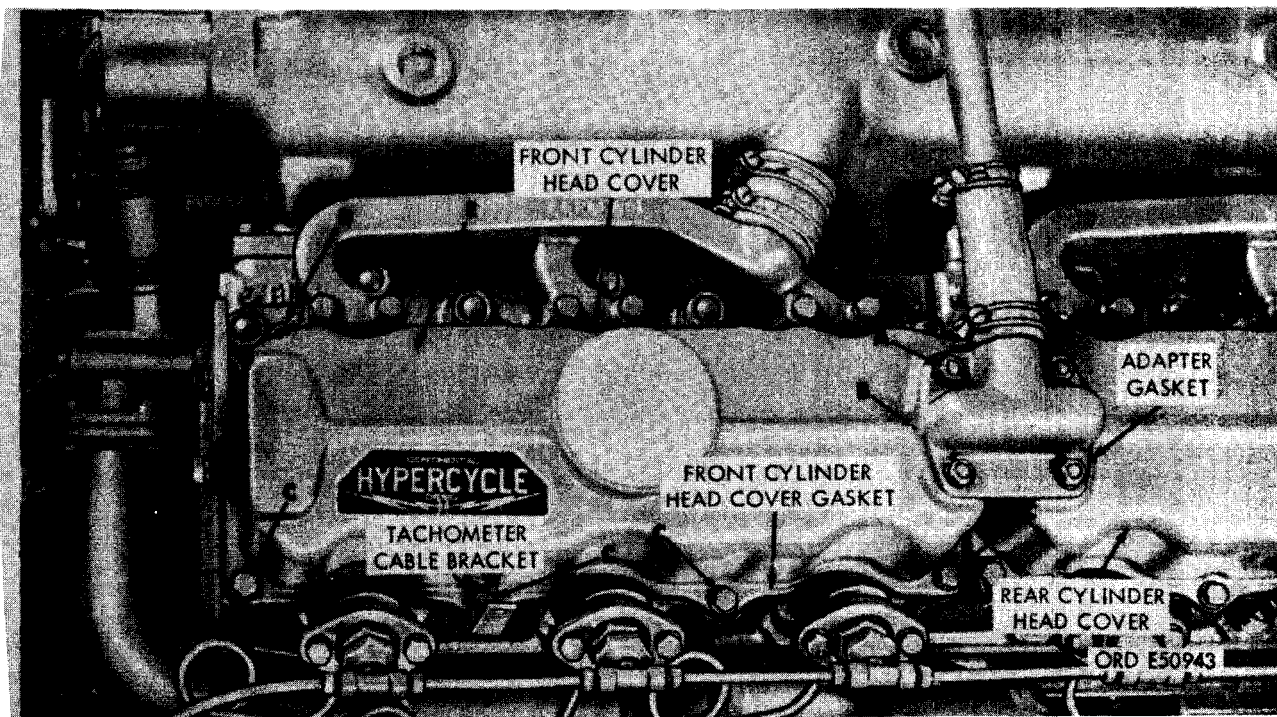


FIGURE 62. REMOVING OR INSTALLING FRONT CYLINDER HEAD COVER.

- (8) Figure 62. (A) Remove four 5/16-inch plain nuts and 5/16-inch lock washers securing crankcase breather adapter to the front and rear cylinder head covers. (B) Lift breather adapter from cylinder head covers and swing adapter clear of studs in cylinder head covers. Remove and discard two crankcase breather adapter gaskets. (C) Remove seven 5/16 x 7/8 cap screws and 5/16-inch lock washers securing front cylinder head cover to cylinder head. Remove tachometer cable bracket. (D) Remove one 5/16-inch self-locking nut from stud on right front corner of cylinder head cover. Early model engines cylinder head covers were secured with a lock washer and a plain nut at the right front corner. When installing cylinder head cover cap screws and nuts, torque tighten screws and nuts to 30-60 pound inches. (E) Remove front cylinder head cover. Remove and discard cover gasket.

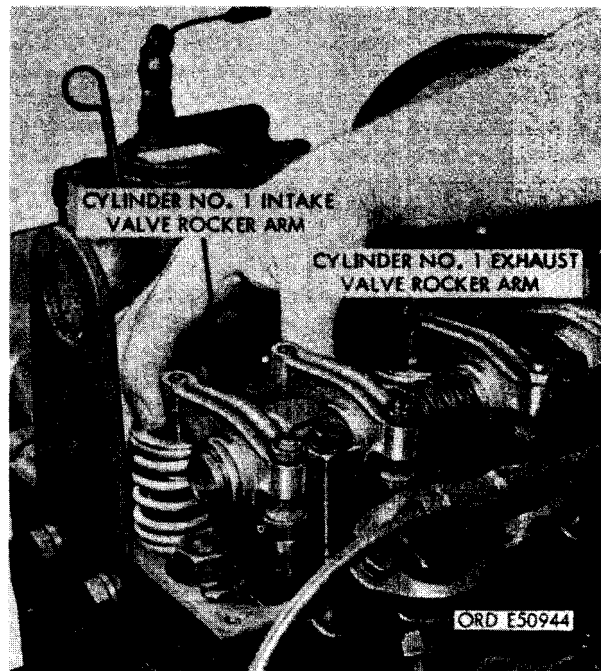


FIGURE 63. CHECKING FUEL INJECTION PUMP TIMING (CYLINDER NO. 1 INTAKE AND EXHAUST VALVES CLOSED).

- (9) After removing front cylinder head cover ((8) above) check position of cylinder No. 1 intake or exhaust valves as shown in figure 63. When both valves

are open, no clearance exists between valve stem and rocker arm. Rotate crankshaft clockwise, viewed from front of engine, until both valves are closed and timing mark on crankshaft damper and pulley assembly is alined with pointer on gear cover as shown in figure 61.

- (10) Observe timing mark on fuel injection pump advance unit hub as shown in figure 64. Timing mark must aline with pointer as shown and timing mark on crankshaft damper and pulley assembly must aline with pointer on gear cover as shown in figure 61.

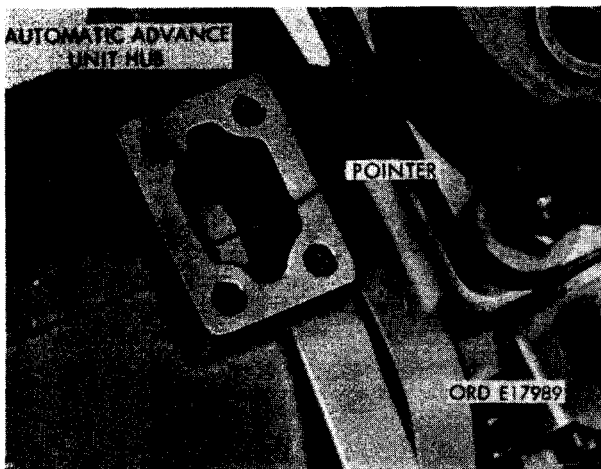


FIGURE 64. CHECKING TIMING MARK AND POINTER ALINEMENT AT FUEL INJECTION PUMP AUTOMATIC ADVANCE UNIT HUB .

- (11) Observe timing mark on fuel injection pump plunger drive gear through timing window cover opening as shown in figure 65. The marked tooth must be visible when pointer in automatic advance unit is alined with timing mark on hub (fig. 64) and mark on crankshaft damper and pulley assembly is alined with pointer on gear cover (fig. 61).

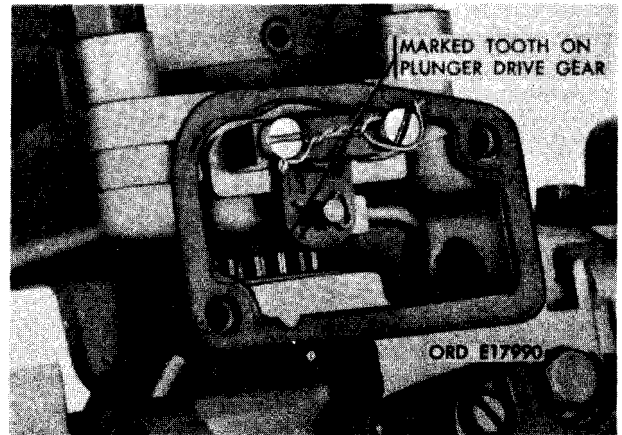


FIGURE 65. CHECKING MARKED TOOTH POSITION THROUGH FUEL INJECTION PUMP TIMING WINDOW COVER .

- (12) Complete removal of fuel injection pump as follows.
- (13) Figure 66. (A) Remove three 3/8 x 1- 1/4 cap screws and 3/8-inch lock washers securing fuel injection pump driven gear retaining plate. (B) Remove retaining plate.

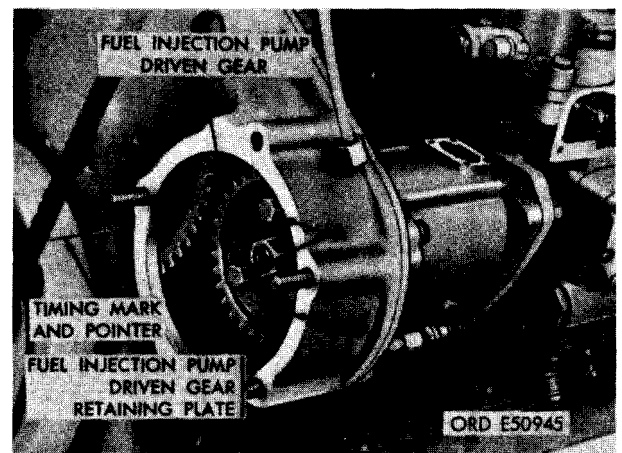


FIGURE 66. REMOVING OR INSTALLING FUEL INJECTION PUMP DRIVEN GEAR RETAINING PLATE .

- (14) Remove fuel injection pump driven gear as shown in figure 67.



FIGURE 67. REMOVING OR INSTALLING FUEL INJECTION PUMP DRIVEN GEAR.



FIGURE 68. REMOVING OR INSTALLING FUEL INJECTION PUMP BRACKET (LATE MODEL ENGINES).

- (15) Figure 68. (A) Remove two 5/16 x 5/8 cap screws and 5/16-inch lock washers securing fuel injection pump assembly to fuel pump bracket. (B) Remove two 5/16 x 5/8 cap screws and 5/16-inch lock washers securing bracket to crankcase. (C) Remove bracket assembly.

- (16) Figure 69. (A) Remove two 5/16 x 3/4 cap screws and 5/16-inch lock washers securing fuel injection pump assembly to fuel injection pump bracket assembly. (B) Remove two 1/2 x 1-3/8 cap screws and 1/2-inch lock washers securing bracket assembly to cylinder and crankcase. (C) Remove bracket assembly.

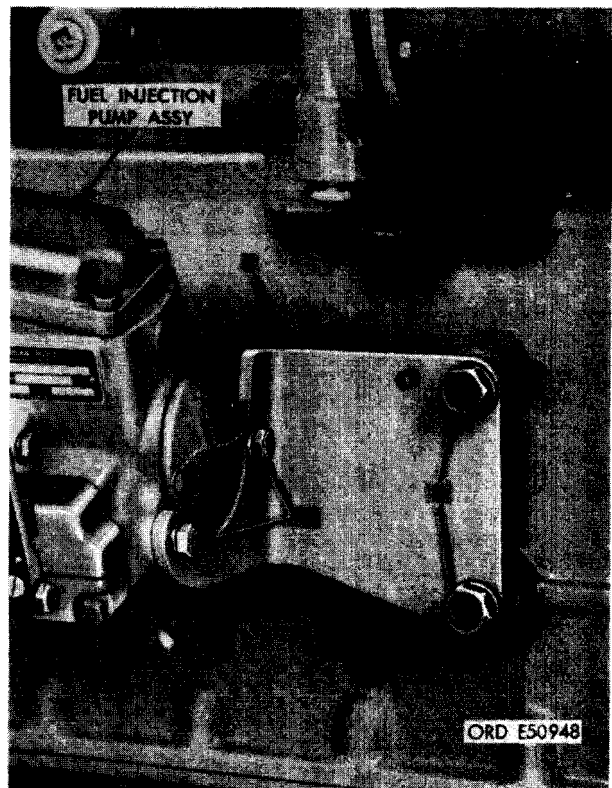


FIGURE 69. REMOVING OR INSTALLING FUEL INJECTION PUMP BRACKET (EARLY MODEL ENGINES).

- (17) Figure 70. (A) Remove 3/8-inch plain nut and 3/8-inch lock washer from stud extending through the fuel injection pump automatic advance unit and flange of fuel injection pump housing. (B) Remove two 3/8 x 1-1/8 cap screws and 3/8-inch lock washers securing fuel injection pump assembly to fuel injection pump adapter assembly.

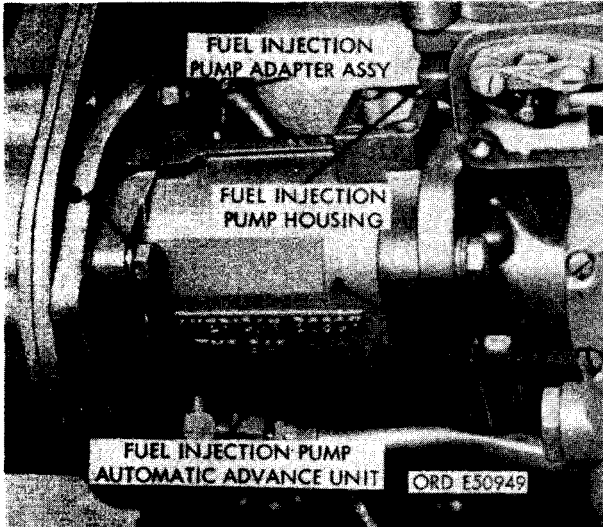


FIGURE 70. DISCONNECTING OR CONNECTING FUEL INJECTION PUMP AT FUEL INJECTION PUMP ADAPTER UNIT.

- (18) Refer to figure 71 and remove the fuel injection pump assembly.

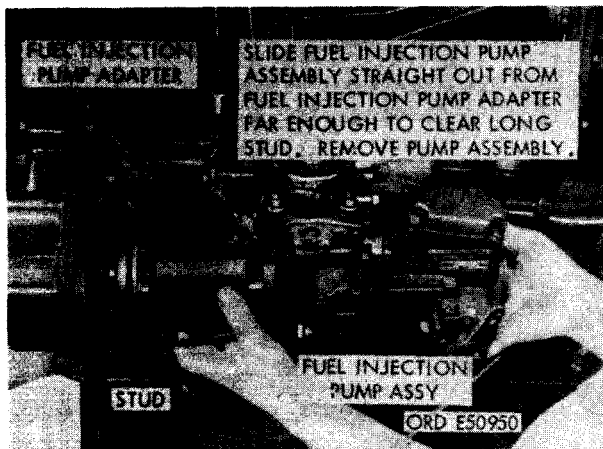


FIGURE 71. REMOVING OR INSTALLING FUEL INJECTION PUMP ASSEMBLY.

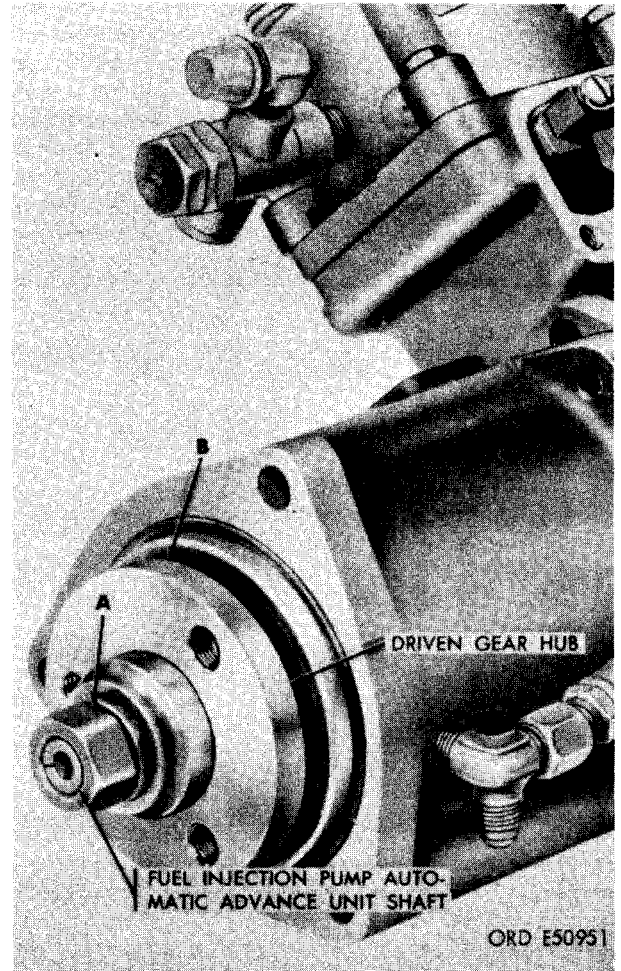


FIGURE 72. REMOVING OR INSTALLING FUEL INJECTION PUMP DRIVEN GEAR HUB.

- (19) Figure 72. (A) Remove 9/16-inch plain nut and 9/16-inch lock washer from fuel injection pump automatic advance unit shaft using improvised tool (fig. 38) as shown in figure 73. (B) Remove fuel injection pump driven gear hub from shaft using a suitable puller.

Note. When installing plain nut on shaft the nut must be torque tightened. For early model injection pumps equipped with a Woodruff key in shaft (fig. 75) torque tighten nut to torque of 50 pound feet. Late model injection pumps do not have a Woodruff key (fig. 74) and nut must be torque tightened to 70 pound feet.



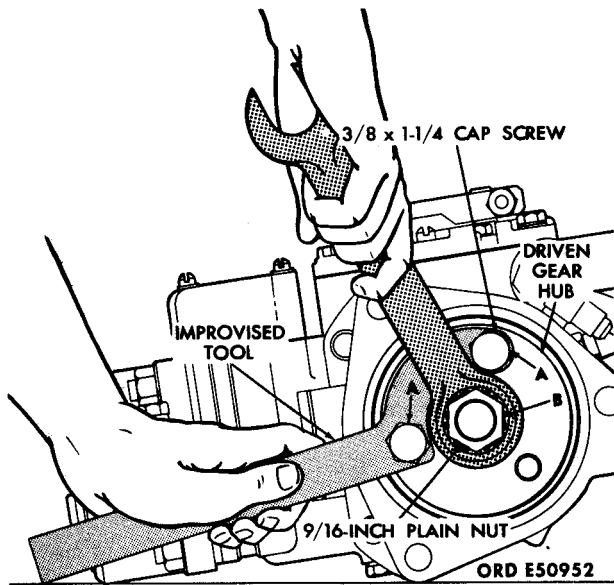


FIGURE 73. REMOVING OR INSTALLING PLAIN NUT FROM FUEL INJECTION PUMP ADVANCE UNIT SHAFT.

(20) Figure 73. (A) Install two 3/8 x 1- 1/4 cap screws through the holes in curved portion of improvised tool and into two tapped holes in driven gear hub. (B) Remove 9/16- inch plain nut and lock washer from shaft, holding driven gear hub stationary with improvised tool while turning nut.

(21) Figure 74. (A) Remove 3/8 tube x 1/4 pipe, 45 degree elbow from fuel inlet port in fuel supply pump. (B) Remove 3/8 tube x 1/4 pipe, 90 degree elbow from fuel outlet port in fuel supply pump. (C) Remove 3/8 tube x 1/4 pipe, 45 degree elbow from fuel injection pump assembly. (D) Remove 1/4 tube x 1/8 pipe, 90 degree elbow from overflow valve assembly. (E) Remove 3/8 tube x 1/4 pipe, 45 degree elbow from overflow valve assembly.

(22) Figure 75. (A) Wrap tape around fuel injection pump automatic advance unit shaft to prevent Woodruff key from

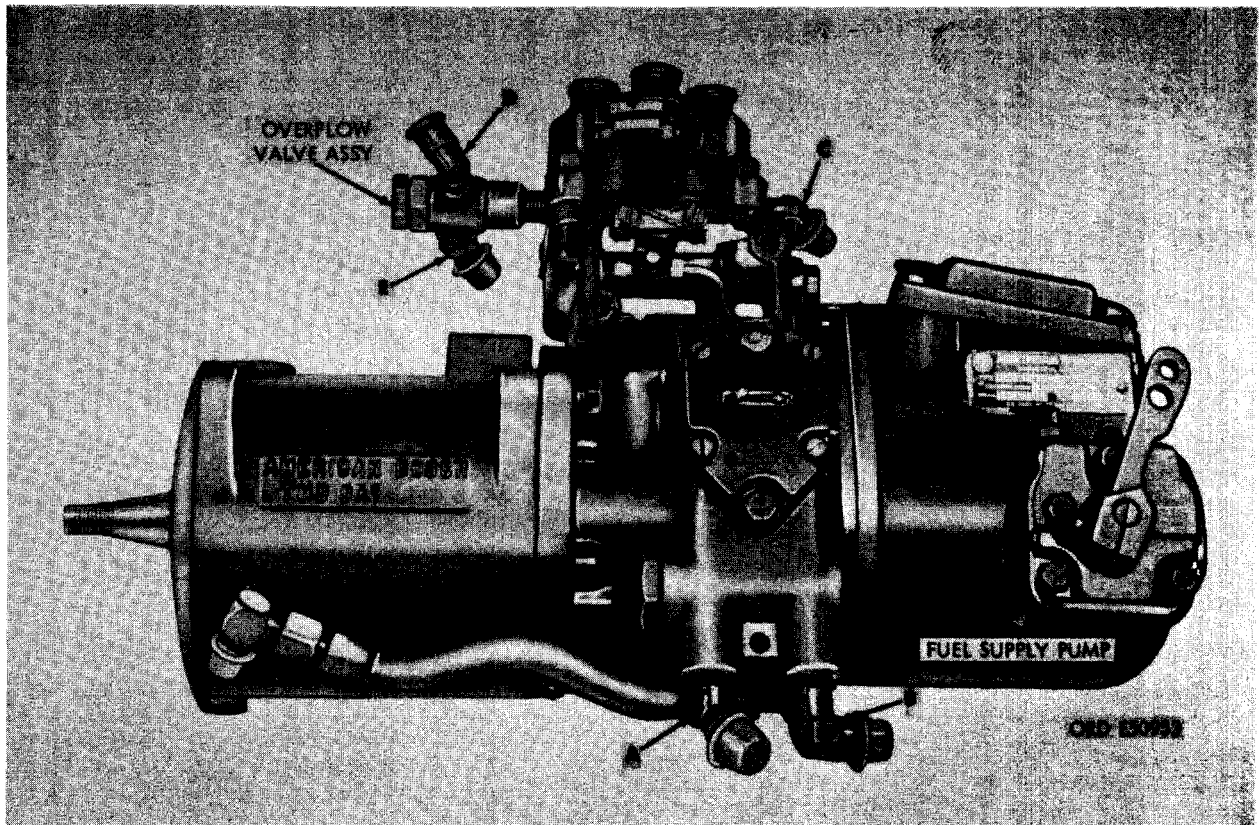


FIGURE 74. REMOVING OR INSTALLING PUMP FITTINGS (LATE MODEL ENGINES).

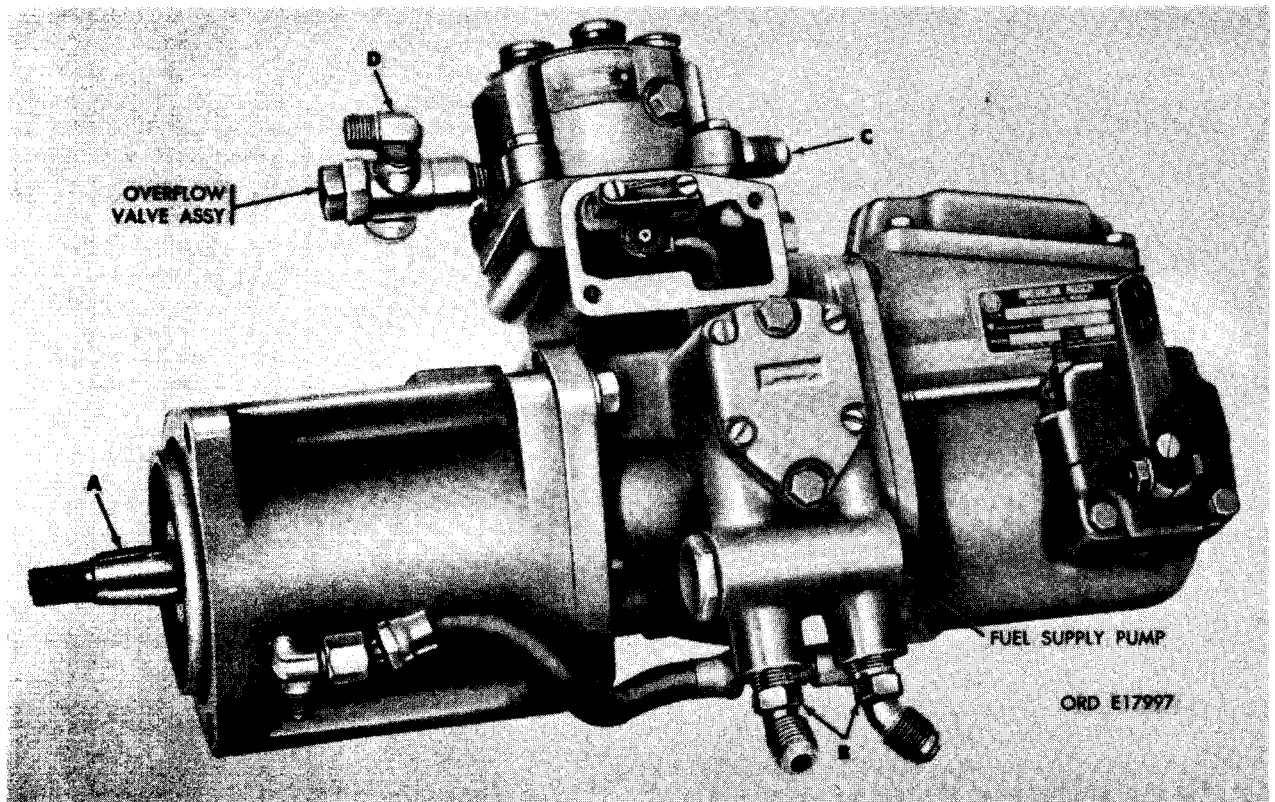


FIGURE 75. REMOVING OR INSTALLING PUMP FITTINGS (EARLY MODEL ENGINES).

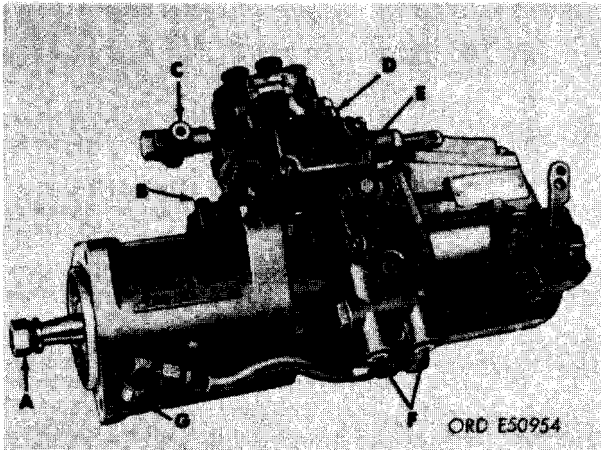
being lost. (B) Remove two 3/8 tube x 1/4 pipe, 45 degree elbows from fuel inlet and outlet ports in fuel supply pump. (C) Remove 1/4 pipe x 3/8 tube connector from fuel injection pump assembly. (D) Remove 1/4 tube x 1/8 pipe, 90 degree elbow from overflow valve assembly.

(23) Install covers and seal fuel injection pump as shown in figure 76.

(24) Figure 76. (A) Install 9/16-inch lock washer and 9/16- inch plain nut on fuel injection pump automatic advance unit shaft. (B) Position timing cover gasket and timing cover over opening in fuel injection pump automatic advance unit. Secure cover to advance unit with four 1/4-inch lock washers and 1/4 x 5/8

machine screws. (C) Plug openings in overflow valve assembly to prevent entrance of dirt. (D) Plug opening in hydraulic head to prevent entrance of dirt. (E) Position timing window cover gasket and cover over opening in fuel injection pump assembly. Secure cover with two 1/4- inch lock washers and 1/4 x 1-1/4 fillister-head screws. (F) Plug fuel inlet and outlet openings at bottom of fuel supply pump to prevent entrance of dirt. (G) Cap tee connection opening to prevent entrance of dirt.

Note. The fuel injection pump assembly, at this point, is ready for shipment to qualified personnel for repair or rebuild. A new or rebuilt pump for replacement will be plugged and equipped in the same manner as shown.



**FIGURE 76. SEALING FUEL INJECTION PUMP ASSEMBLY AFTER REMOVAL FROM ENGINE.**

**c. Preparation of Fuel Injection Pump for Installation.** Prepare the fuel injection pump for installation as described in (1) through (5) below.

- (1) Remove injection pump timing covers. Refer to figure 76 and reverse the sequence of instructions to remove timing cover, timing window cover, dirt plugs or caps, and automatic advance unit shaft lock washer and nut.
- (2) Install fuel tube or hose elbows and connector. Refer to figures 74 and 75 and reverse the sequence of instructions to install tube and hose elbows and connector.
- (3) Install fuel injection pump driven gear hub Refer to figures 72 and 73 and reverse the sequence of instructions to install the fuel injection pump driven gear hub.
- (4) Time fuel injection pump assembly. The timing mark on the "automatic advance unit hub (fig. 64) must be alined with pointer when the marked tooth in the timing window (fig. 65) is visible. It is possible to have the timing marks in the advance unit alined and not have the marked tooth on the plunger drive gear in the timing window visible. When the marked tooth is visible and the advance unit marks are alined, the pump is properly timed. If the marked tooth is not visible, rotate the gear hub 360 degrees, in either direction so the timing marks do aline. This insures proper timing when the pump is installed on the engine.

Note. The pump camshaft contains an over-center lobe which tends to prevent the timing mark on the hub from remaining in line with its mating pointer. These marks must be alined when installing injection pump driven gear and retaining plate (fig. 77).

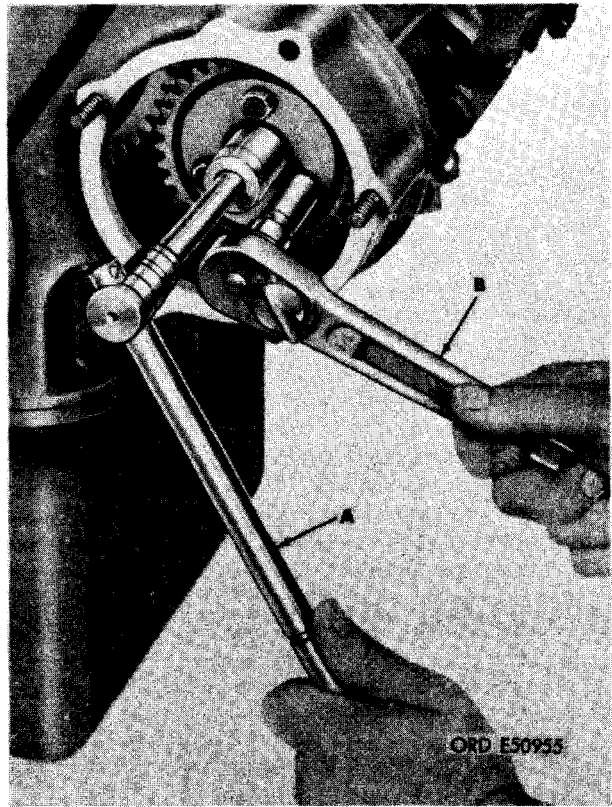
- (5) Check engine timing before installing fuel injection pump. The engine timing is correct when the mark on crankshaft damper and pulley assembly is alined with the pointer as shown in figure 66, and when No. 1 piston is on the compression stroke. For convenience, the engine timing marks were alined before the pump was removed. When engine timing marks are not alined, rotate the engine clockwise as viewed from the front until timing mark on damper and pulley assembly is alined with pointer, and No. 1 piston is on compression stroke as illustrated and instructed in figures 62 and 63.

**d. Installation.** Install fuel injection pump on engine as described in (1) through (7) below.

Note. Whenever connector "C" in figure 76 is installed in the fuel injection pump, the pump must be flushed to clean out any loose metal which may result from installing the connector. Failure to do so can result in major damage to the pump distributor head assembly.

- (1) Install fuel injection pump assembly on engine. Refer to figures 64 through 71 and reverse the sequence of illustrations and instructions to install fuel injection pump assembly on engine.
- (2) Install fuel injection pump driven gear and time pump in relation to engine timing. Refer to figures 66 and 67 and reverse the sequence of illustrations and instructions to install fuel injection pump driven gear. Do not tighten the three 3/8 x 1-1/4 cap screws securing driven gear and driven gear retaining plate at this time.
- (3) Check fuel injector pump timing in relation to engine timing Before completing fuel injection pump installation, check pump to engine timing. Rotate crankshaft 90 degrees from timing marks. Return crankshaft to timing mark position and check alinement.

- (a) Mark on crankshaft damper and pulley assembly must be alined with pointer on timing gear cover (fig. 66).
  - (b) Both the intake and exhaust valves must be closed (fig. 63).
  - (c) The mark on fuel injection pump automatic advance hub must be alined with pointer (fig. 64) and the marked tooth on plunger drive gear must be visible through timing window (fig. 65).
  - (d) When timing marks on fuel injection pump and engine are not alined remove fuel injection pump driven gear retaining plate and gear following the instructions which accompany figures 66 and 67. Check engine and pump timing (c (4) and (5) above) and repeat step (2) above.
- (4) **Secure Fuel Injection Pump Driven Gear.** Tighten cap screws securing fuel injection pump driven gear and driven gear retaining plate as follows.
- (5) Figure 77. (A) Rotate fuel injection pump automatic advance unit shaft as necessary in either direction until mark on hub alines with pointer (fig. 64). Hold shaft in alined position. (B) Tighten three 3/8 x 1-1/4 cap screws to a torque of 275 to 325 pound inches to secure fuel injection pump driven gear and retaining plate.



**FIGURE 77. TIGHTENING FUEL INJECTION PUMP DRIVEN GEAR RETAINING SCREWS AFTER PUMP TIMING HAS BEEN SET.**

#### 64. FLAME HEATER FUEL PUMP ASSEMBLY

**a. Removal.** Remove flame heater fuel pump assembly as follows.

- Note.** The three elongated bolt holes in fuel injection pump driven gear (fig. 67) allow about 20 degrees free rotation around the injection pump driven gear hub. In extreme cases, remove the driven gear retaining plate and driven gear to reposition the gear on the hub.
- (6) **Install front cylinder head cover.** Refer to figure 62 and reverse the sequence of instructions to install the front cylinder head cover.
  - (7) **Complete installation of fuel injection pump assembly.** Refer to figures 56 through 61 and reverse the sequence of illustrations and instructions to complete installation of the fuel injection pump assembly.
- (1) Figure 78. (A) Disconnect flame heater fuel inlet solenoid valve-to-flame heat fuel pump, tube from 1/4 tube x 1/8 pipe, 90 degree elbow. (B) Remove 1/8 pipe adapter and 1/4 tube x 1/8 pipe, 90 degree elbow from flame heater fuel pump. (C) Disconnect flame heater fuel pump-to-flame heater nozzle tube from adapter in fuel pump. (D) Remove 1/8 tube x 1/8 pipe union from fuel pump. (E) Disconnect flame heater harness from receptacle connector at rear of pump. (F) Remove two No. 10 plain nuts, No. 10 lock washers, and No. 10 x 7/8 ma-

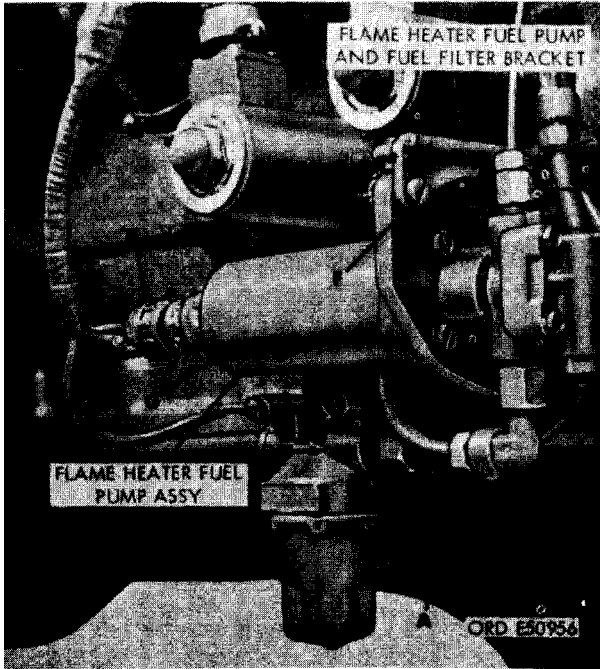


FIGURE 78. REMOVING OR INSTALLING FLAME HEATER FUEL PUMP ASSEMBLY.

chine screws securing fuel pump assembly to flame heater fuel pump and fuel filter bracket. (G) Remove flame heater fuel pump assembly.

- (2) Figure 79 illustrates the flame heater fuel pump after removal from the engine.

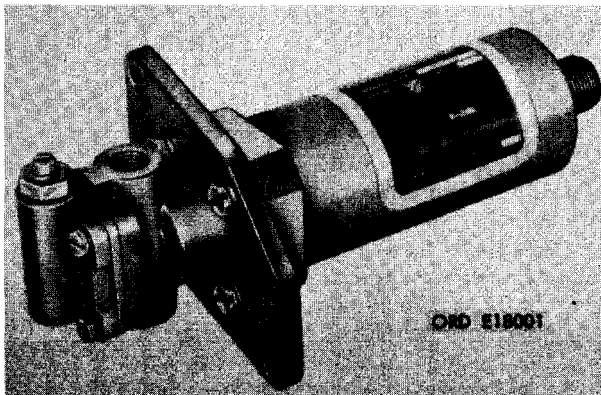


FIGURE 79. FLAME HEATER FUEL PUMP ASSEMBLY.

**Caution:** The electrical system in the flame heater fuel pump is negative grounded. "A" pin is positive, and "B" pin is negative. Do not reverse polarity during checking or installation. Reverse polarity will cause permanent damage to the pump.

- b. **Installation.** Refer to figure 78 and reverse the sequence of instructions to install the flame heater pump assembly.

#### 65. AIR COMPRESSOR ASSEMBLY

a. **Removal.** Remove the air compressor assembly as follows.

- (1) Refer to figure 80 and loosen the air compressor pulley adjusting flange cap screws.
- (2) Refer to figure 81 and loosen the air compressor pulley adjusting flange.



FIGURE 80. LOOSENING OR TIGHTENING AIR COMPRESSOR PULLEY ADJUSTING FLANGE SCREWS.



FIGURE 81. LOOSENING OR TIGHTENING COMPRESSOR PULLEY ADJUSTING FLANGE.



FIGURE 82. REMOVING OR INSTALLING AIR COMPRESSOR DRIVE BELT.

- (3) Refer to figure 82 and remove the air compressor drive belt.
- (4) Figure 83. (A) Remove 1/4-inch cap screw and clip holding fuel return-to-fuel injection pump overflow valve tube to air compressor. Install cap screw on air compressor. (R) Remove four 7/16-inch plain nuts and 7/16-inch lock washers securing air compressor assembly to air compressor support assembly. Remove tachometer cable bracket. (C) Remove air compressor assembly. (D) Remove and discard air compressor-to-support gasket.

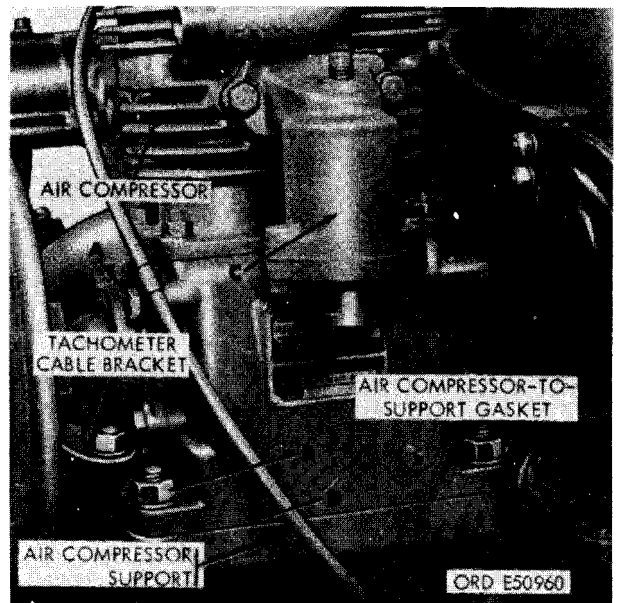
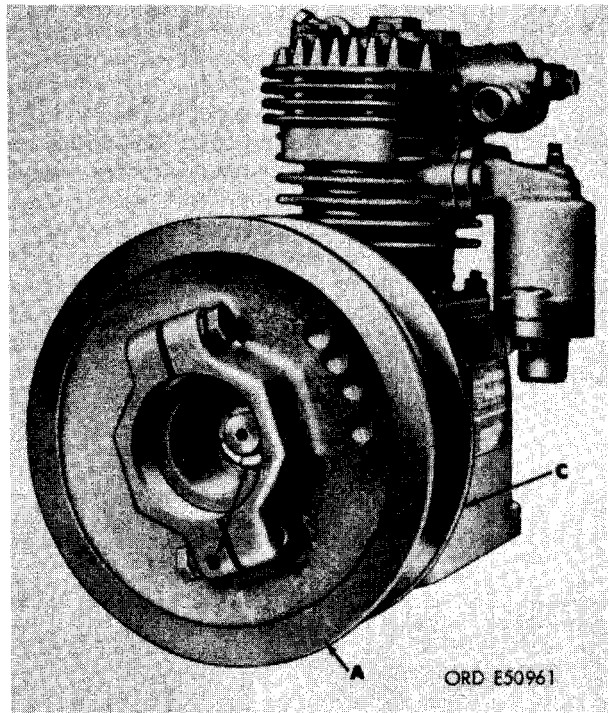


FIGURE 83. REMOVING OR INSTALLING AIR COMPRESSOR ASSEMBLY.

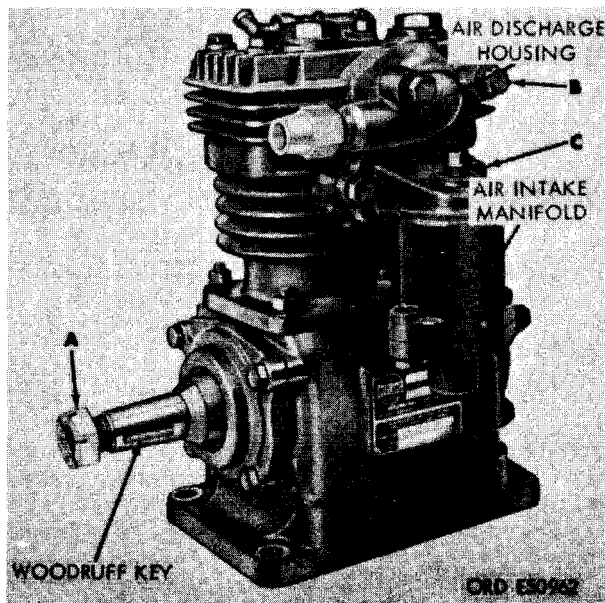
**b. Disassembly.** The air compressor assembly must be partially disassembled. Remove the air compressor adjustable pulley, air intake manifold, and air discharge housing from the air compressor assembly as follows.

- (1) Figure 84. (A) Remove air compressor pulley adjusting flange from hub on compressor pulley. (B) Remove 3/4-inch self-locking nut securing pulley to compressor shaft. (C) Remove air compressor pulley using a suitable puller.

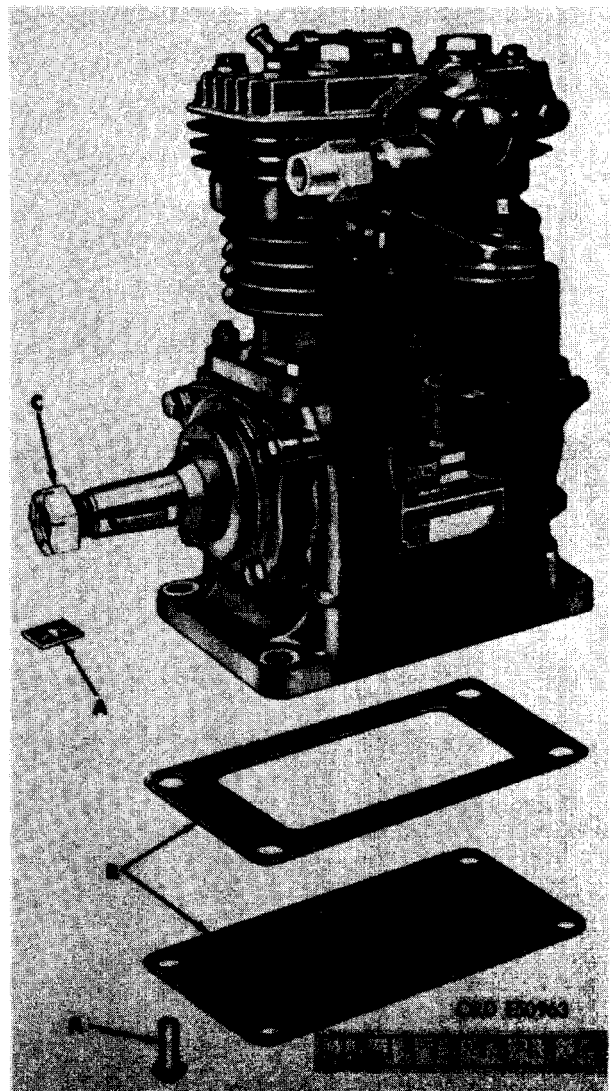


**FIGURE 84. REMOVING OR INSTALLING AIR COMPRESSOR ADJUSTING FLANGE AND PULLEY.**

- (2) Figure 85. (A) Install the 3/4- inch self-locking nut on air compressor shaft. Tape Woodruff key in position to prevent loss. (B) Remove two 5/16 x 1-3/4- inch hex head bolts and 5/16- inch lock washers and remove discharge housing. Remove and discard discharge housing gasket. (C) Remove two 5/16 x 3/4- inch hex head bolts and 5/16- inch lock washers and remove intake manifold. Remove and discard intake manifold gasket.



**FIGURE 85. REMOVING OR INSTALLING AIR INTAKE MANIFOLD AND AIR DISCHARGE HOUSING FROM AIR COMPRESSOR ASSEMBLY.**



**FIGURE 86. AIR COMPRESSOR ASSEMBLY WITH AIR DISCHARGE HOUSING AND AIR INTAKE MANIFOLD INSTALLED.**

c. Cleaning. Clean the air intake manifold air filter as instructed in TM 9-2320-235-20.

d. Assembly. Refer to figure 85 and reverse the sequence of instructions to install the air intake manifold assembly and air discharge housing on air compressor assembly.

e. Installation. Install the air compressor assembly on engine and adjust drive belt deflection as follows.

Note. All replacement air compressors are furnished with replacement cover and gasket as shown in figure 86. The protective gasket and cover must be installed on the unserviceable air compressor.

- (1) Figure 86. (A) Remove four clips and rivets attaching replacement cover and replacement cover gasket to mounting base. (B) Remove replacement cover and gasket and install cover and gasket on unserviceable compressor. (C) Remove 3/4-inch slotted nut from end of compressor crankshaft and install pulley by reversing sequence of instructions which accompany figure 84.
- (2) Refer to figures 81 through 83 and install air compressor assembly and drive belt.
- (3) Figure 87. (A) Rotate air compressor pulley adjusting flange clockwise using wrench- 10935288 (fig. 81) until excessive slack is removed from belt. (B) Check drive belt deflection using a straight edge and scale as shown. Total belt deflection at free span of belt

should be 3/4-inch. Tighten or loosen pulley adjusting flange as necessary to obtain proper belt deflection. (C) Tighten the two 3/8 x 1-1/2 cap screws to secure pulley adjusting flange to hub of pulley after proper belt deflection has been obtained.

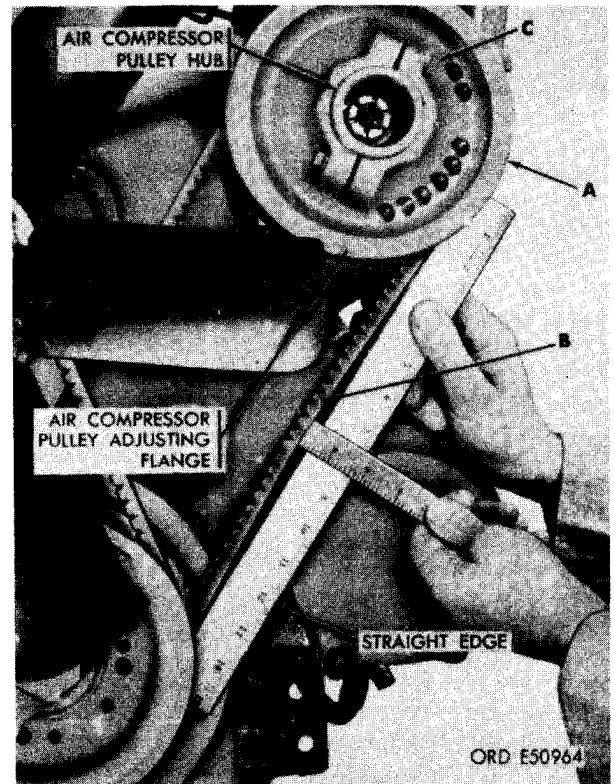


FIGURE 87. ADJUSTING AIR COMPRESSOR DRIVE BELT DEFLECTION .

### Section III. REPLACEMENT AND REPAIR OF ENGINE COMPONENTS ALLOCATED TO THIRD ECHELON MAINTENANCE

#### 66. GENERAL

This section of the manual covers replacement of external engine components allocated to third echelon maintenance personnel. For instructional purposes, engine components are replaced with the engine removed from the vehicle.

#### 67. CLUTCH ASSEMBLY AND PILOT BEARING

a. Removal and Disassembly. Remove and

disassemble clutch assembly as follows.

- (1) Figure 88. (A) Depress clutch release levers, one at a time, and place a clutch release lever spacer block (fig. 35) between lever and clutch cover as shown. (B) Remove eight 3/8 x 15/16 cap screws and 3/8-inch lock washers securing clutch cover assembly to flywheel. (C) Remove clutch cover assembly and driven member assembly as shown in figure 89.



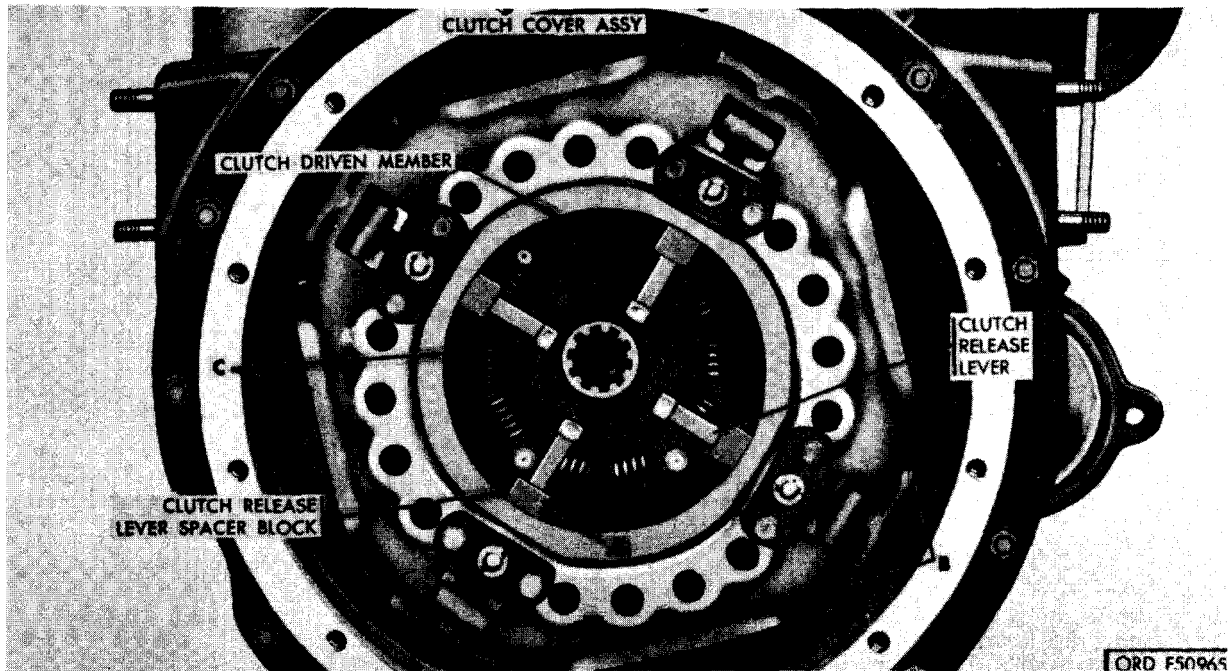


FIGURE 88. CLUTCH ASSEMBLY - INSTALLED VIEW,

Note. The clutch cover assembly should not be disassembled, repaired, or rebuilt at the field maintenance level. When inspection indicates pressure plate (fig. 90) is cracked, damaged, or scored, the clutch cover assembly must be replaced.

- (2) Remove clutch driven member assembly from clutch cover assembly as shown in figure 90.

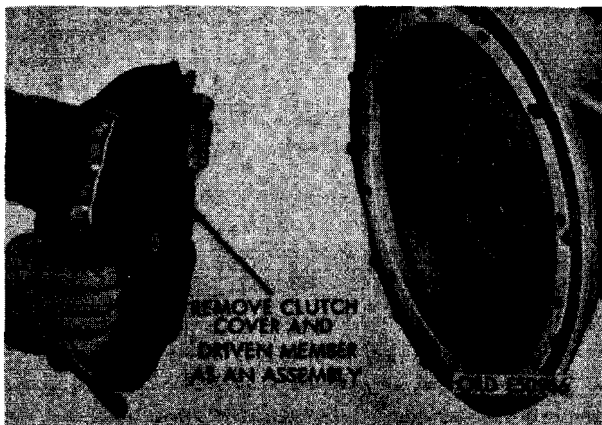


FIGURE 89. REMOVING CLUTCH COVER ASSEMBLY AND DRIVEN MEMBER ASSEMBLY.

Note. Replace driven member assembly when drive hub is loose, damper springs are broken or missing, or retainer plate rivets are loose. When inspection procedures indicate driven member is serviceable, remove facings.

- (3) Figure 91. (A) Check driven member drive hub for worn splines and for looseness on driven plate. (B) Check for broken or missing damper springs and for loose rivets securing retainer plate to driven plate. (C) Inspect clutch facings for burned condition, looseness, or damage. (D) Drill off star set on 30 rivets securing clutch facings to driven plate. Drive out remainder of 30 rivets. Remove two facings.
- (4) Figure 92. (A) Inspect drive plate for cracks, warpage, or worn areas. (B) Inspect for elongated rivet holes in driven member.

Note. When inspection indicates driven plate unserviceable due to elongated rivet holes or wear, replace drive member assembly. When driven plate is serviceable, install new clutch facings as shown in figure 93.

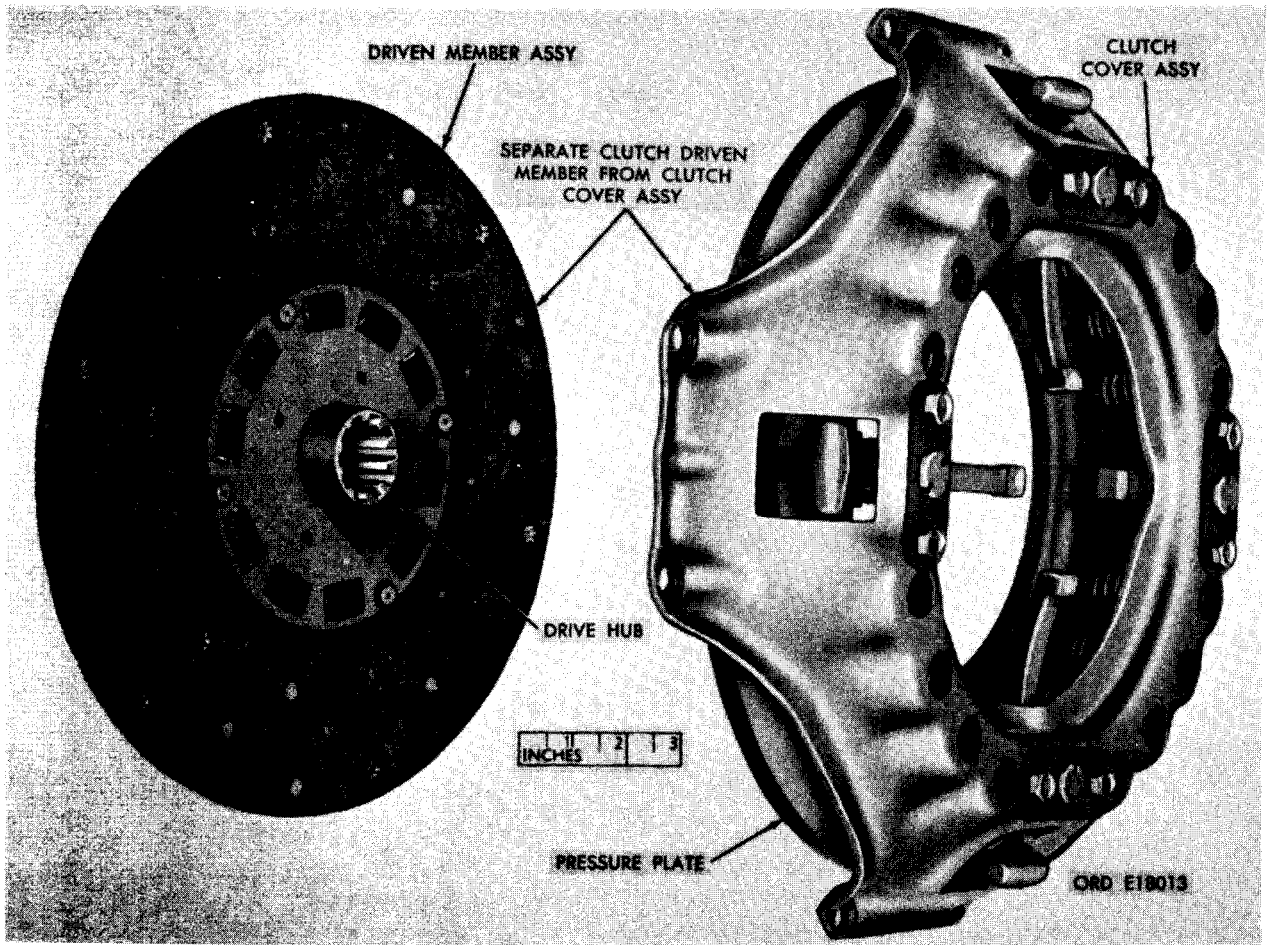


FIGURE 90. CLUTCH ASSEMBLY - PARTIAL EXPLODED VIEW.

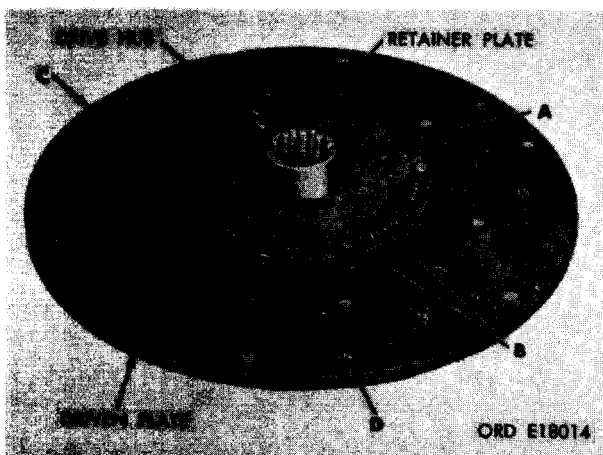


FIGURE 91. REMOVING CLUTCH FACINGS FROM DRIVEN MEMBER ASSEMBLY.

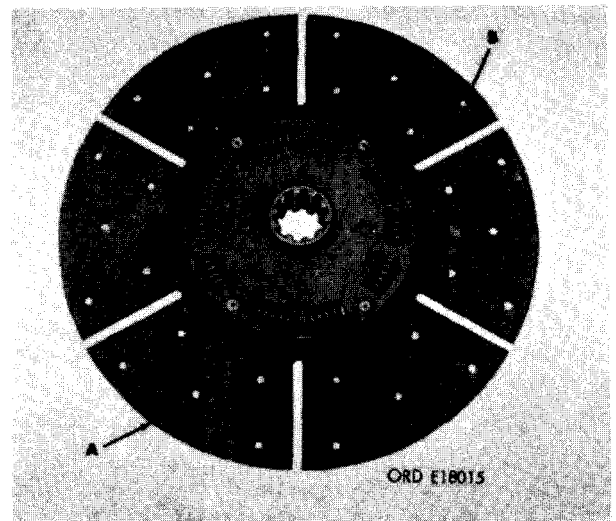
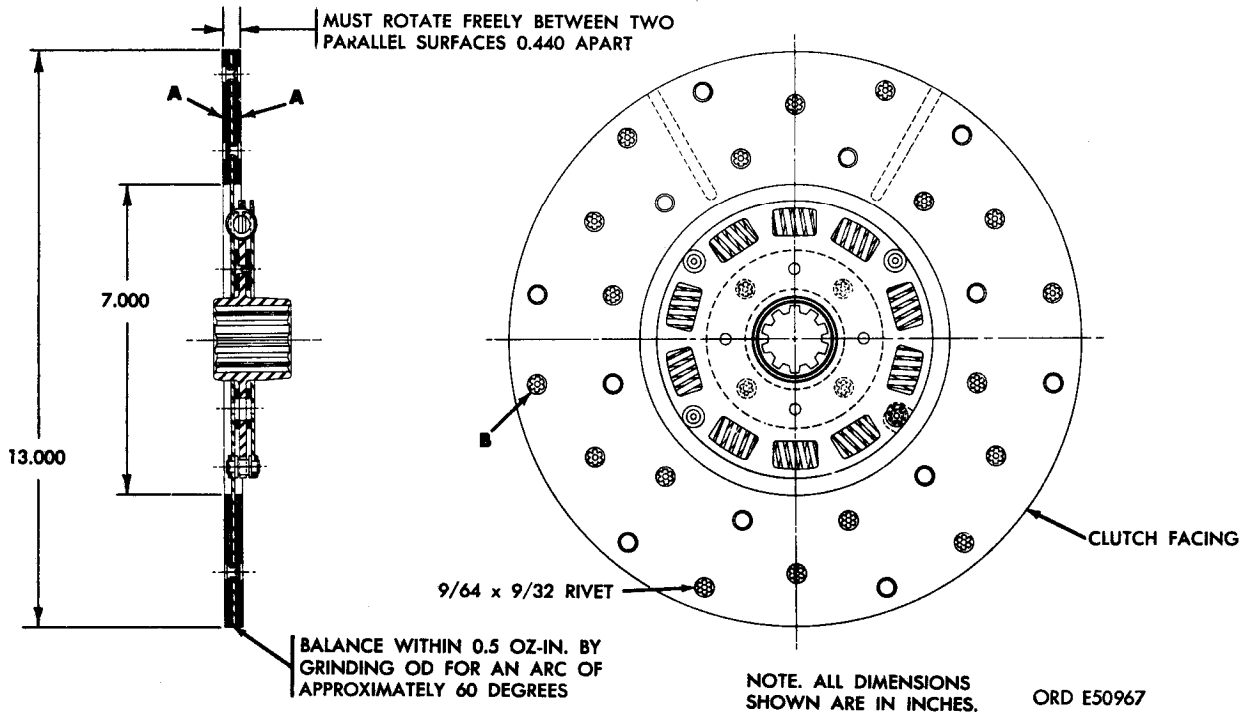


FIGURE 92. INSPECTING DRIVEN PLATE FOR DAMAGE .



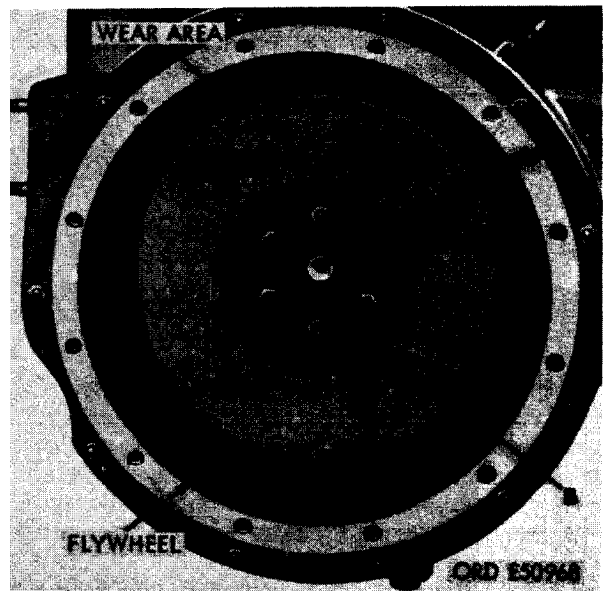
**FIGURE 93. INSTALLING NEW CLUTCH FACINGS AND/OR CHECKING DRIVEN MEMBER RUNOUT.**

- (5) Figure 93. (A) Position new clutch facings against driven plate with counter-sunk side of rivet holes out, away from plate. (B) Install 30 new 9/64 x 9/32 rivets and star set as shown.

Note. Check driven member between two parallel surfaces spaced 0.440- inch apart. It must rotate freely without frictional drag and have no more than 0.025- inch runout.

b. Bushing-Type Pilot Bearing. With the clutch assembly removed, inspect driven member wear surface on flywheel and condition of bushing-type pilot bearing in end of crankshaft. Remove pilot bearing and inspect wear surface on flywheel as follows.

Note. This composition type (OILITE) bearing can be easily damaged during installation. When bearing is chipped or cracked during installation, replace the bearing. Lubricate the pilot bearing with a small amount of high melting point grease (BR) (Spec. 14-L-3C). Do not overgrease.



**FIGURE 94. REMOVING OR INSTALLING BUSHING-TYPE PILOT BEARING AND INSPECTING FLYWHEEL DRIVEN MEMBER WEAR AREA.**

- (1) Figure 94. (A) Remove damaged, worn, or out-of-round pilot bearing. Install new bearing using a 0.7503-inch od bushing installer. (B) Clean driven member wearing surface on flywheel using crocus cloth dampened in dry-cleaning solvent or mineral spirits paint thinner. Inspect surface for heat cracks, scorching, and discoloring, caused by clutch slippage. When flywheel clutch surface is damaged and cannot be repaired by polishing, the flywheel must be replaced. Replace flywheel as directed in paragraph 86.

**Note.** Length of new pilot bearing is 1.20 inches.

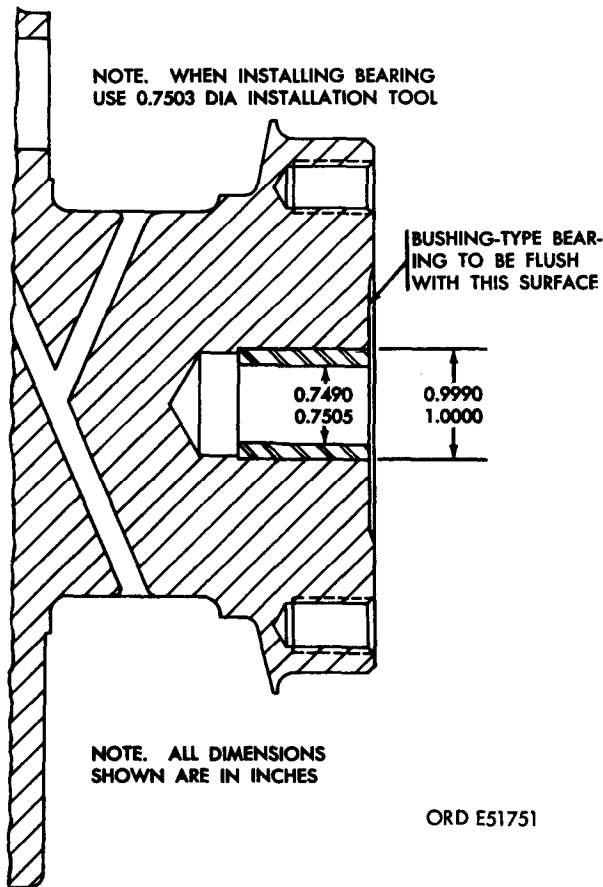


FIGURE 95. BUSHING-TYPE PILOT BEARING INSTALLATION INSTRUCTIONS .

- (2) Refer to figure 95 and check edge of bearing. Edge of bearing must be flush with flange on crankshaft.

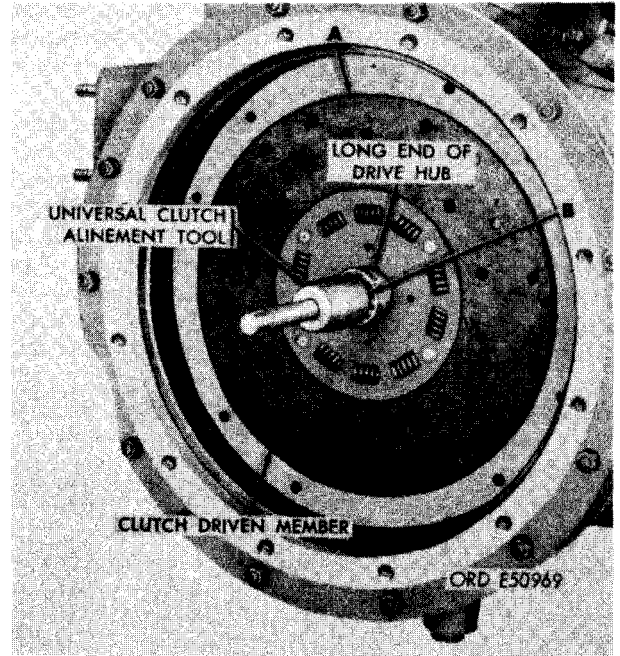


FIGURE 96. INSTALLING CLUTCH DRIVEN MEMBER ASSEMBLY USING UNIVERSAL ALINEMENT TOOL.

c. Installation. Install clutch driven member and-clutch cover assembly as follows.

- (1) Figure 96. (A) Position clutch driven member assembly against flywheel with long end of drive hub away from flywheel. (B) Aline splines of driven member hub with bushing-type pilot bearing bore using a universal clutch alinement tool. Do not remove alinement tool until clutch cover is installed (fig. 97).

**Note.** Before positioning clutch cover assembly against driven member, lay cover assembly face down against flat surface. Depress each clutch release lever, one at a time, and place a clutch release lever spacer block (fig. 35) between lever and cover as shown. This will prevent distorting or damaging clutch cover when cover attaching screws are drawn tight to secure clutch cover assembly to flywheel.

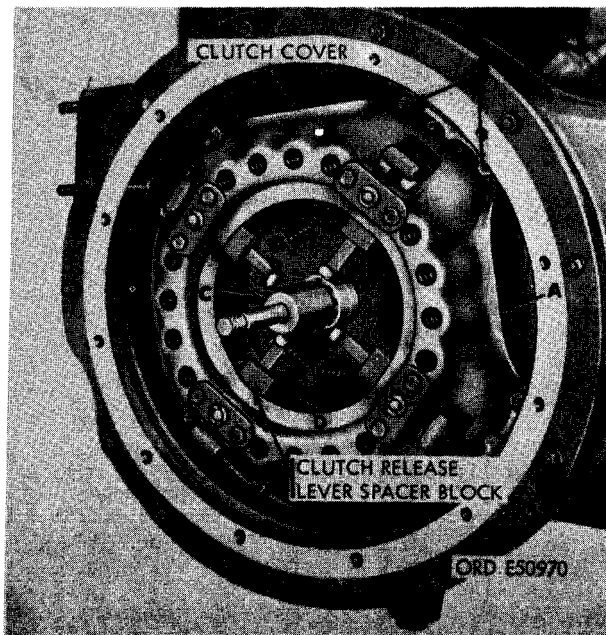


FIGURE 97. INSTALLING CLUTCH COVER ASSEMBLY.

- (2) Figure 97. (A) Position clutch cover assembly over driven member assembly and align screw holes. (B) Secure cover assembly to flywheel using eight 3/8 lock washers and 3/8 x 15/16 cap screws. Tighten cap screws to a torque of 275 to 325 pound inches. (C) Depress clutch release levers, one at a time, and remove four clutch release lever spacer blocks. (D) Remove clutch alignment tool.

**d. Adjustment of Clutch Release Levers.**

After clutch assembly is installed, adjust clutch release levers to 1-5/8 inch from surface of clutch spacer plate to release lever' crown as shown in figure 98.

**68. OIL FILTER BYPASS VALVE**

**a. Removal and Inspection.** Figure 99. (A) Remove oil filter bypass valve plug and plain washer from oil cooler and filter housing. Discard plain washer. (B) Remove oil filter bypass spring and plunger from machined bore in oil cooler and filter housing. (C) Inspect oil filter bypass valve plunger bore in housing for burs,

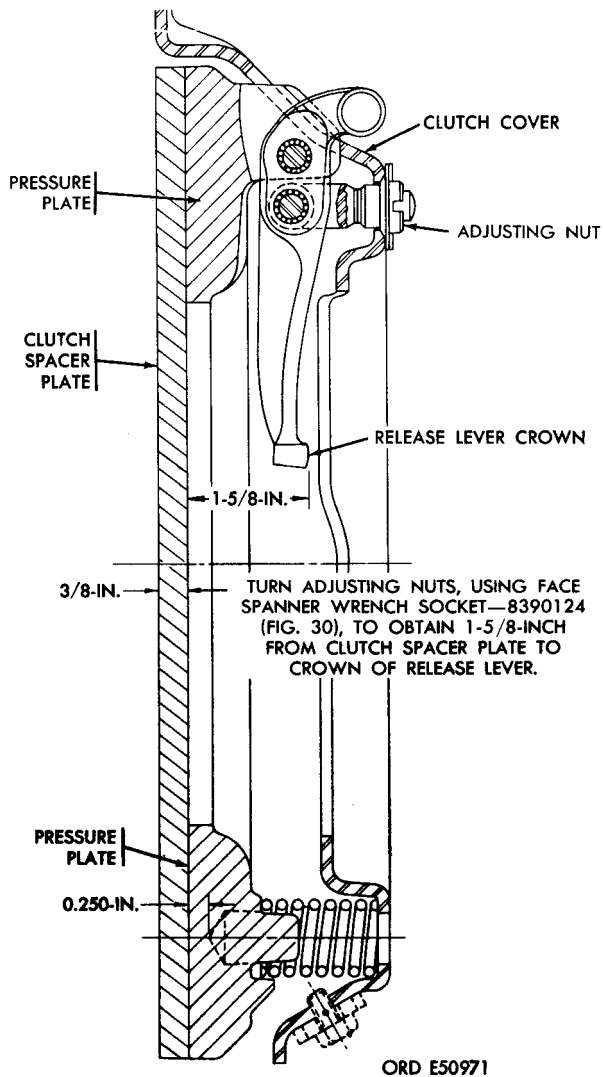


FIGURE 98. ADJUSTING CLUTCH RELEASE LEVER.

scratches, wear, or obstructions. Clean bore thoroughly using dry-cleaning solvent or mineral spirits paint thinner. Remove slight burs and scratches in bore with crocus cloth.

**b. Repair.** Repair of the oil filter bypass valve components is limited to replacement of parts.



FIGURE 99. REMOVING, INSTALLING, AND INSPECTING OIL FILTER BYPASS VALVE.

**c. Installation.** Refer to figure 99 and reverse the sequence of instructions to install oil filter bypass valve components. Use a new plain washer when installing plug.

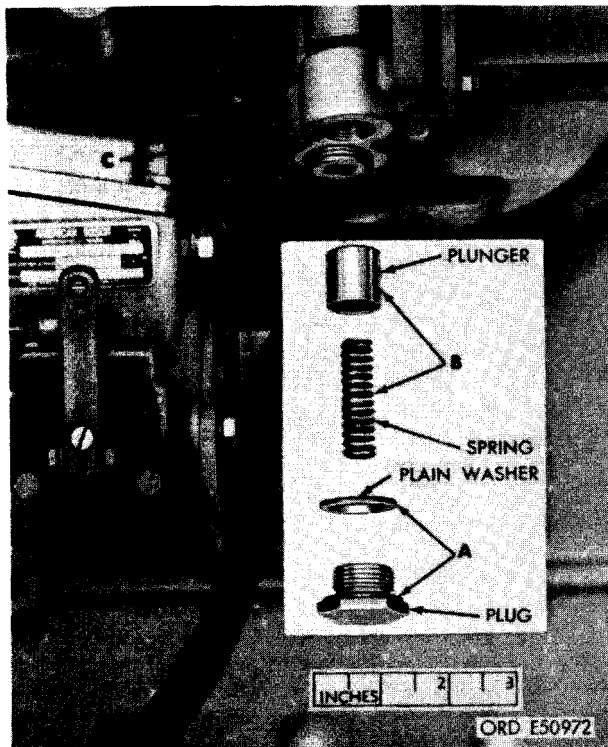


FIGURE 100. REMOVING, INSTALLING, AND INSPECTING OIL COOLER BYPASS VALVE.

## 69. OIL COOLER BYPASS VALVE

**Note.** Components of the oil cooler bypass valve are the same as the oil filter bypass valve (fig. 99).

**a. Removal and Inspection.** Figure 100. (A) Remove oil cooler bypass valve plug and plain washer from oil cooler and filter housing. Discard plain washer. (B) Remove oil cooler bypass spring and plunger from machined bore in oil cooler and filter housing. (C) Inspect oil cooler bypass valve plunger bore in housing for burrs, scratches, wear, or obstructions. Clean bore thoroughly using dry-cleaning solvent or mineral spirits pain thinner. Remove slight burrs and scratches in bore with crocus cloth.

**b. Repair.** Repair of the oil cooler bypass valve components is limited to replacement of parts.

**c. Installation.** Refer to figure 100 and reverse the sequence of instructions and install the oil cooler bypass valve components. Use a new plain washer when installing oil cooler bypass valve plug.

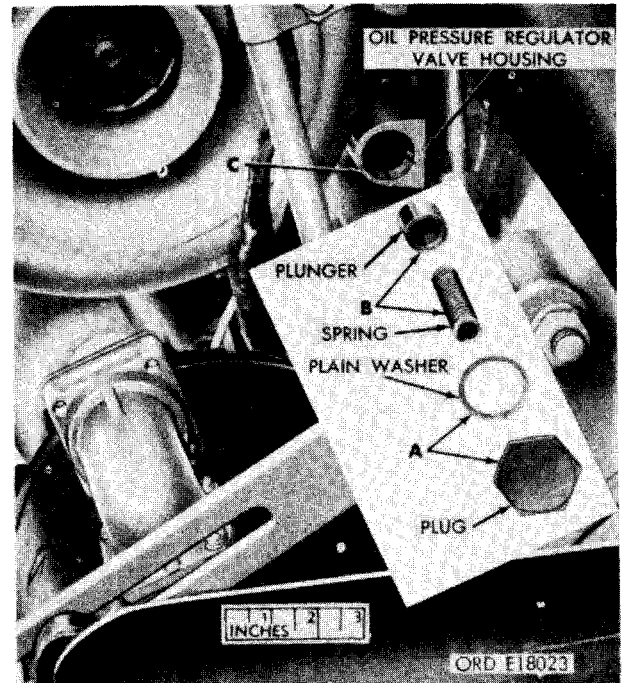


FIGURE 101. REMOVING, INSTALLING, AND INSPECTING OIL PRESSURE REGULATOR VALVE.

## 70. OIL PRESSURE REGULATOR VALVE

**Note.** Components of the oil pressure regulator valve are the same as the oil filter bypass valve (fig. 99) and the oil cooler bypass valve (fig. 100) and piston oil cooling nozzle oil pressure relief valve (fig. 102) except for the spring which is longer. Do not interchange springs.

**a. Removal.** Figure 101. (A) Remove oil pressure regulator valve plug and plain washer from oil pressure regulator valve housing. Discard plain washer. (B) Remove oil pressure regulator spring and plunger from oil pressure regulator valve housing. (C) Inspect oil pressure regulator plunger bore in oil pressure regulator valve housing for burrs, scratches, wear, or obstructions. Clean bore thoroughly using dry-cleaning solvent or mineral spirits paint thinner. Remove slight scratches and burrs in the bore with crocus cloth.

**b. Repair.** Repairs to the oil pressure regulator valve components are limited to replacement of parts.

**c. Installation.** Refer to figure 101 and reverse the sequence of instructions to install the oil pressure regulator valve components. Use a new plain washer when installing plug.

## 71. PISTON OIL COOLING NOZZLE OIL PRESSURE RELIEF VALVE

**Note.** The piston oil cooling nozzle oil pressure relief valve components are identical to the components of the oil filter bypass valve (fig. 99), and oil cooler bypass valve (fig. 100).

**a. Removal and Inspection.** Figure 102. (A) Remove piston oil cooling nozzle oil pressure relief valve plug and plain washer from oil pressure regulator valve housing. Discard plain washer. (B) Remove piston oil cooling nozzle oil pressure relief spring and plunger from bore in oil pressure regulator valve housing. (C) Inspect piston oil cooling nozzle oil pressure relief plunger bore in oil pressure regulator valve housing for burrs, scratches, wear, or obstructions. Clean bore thoroughly using dry-cleaning solvent or mineral spirits paint thinner. Remove slight scratches and burrs in bore with crocus cloth.

**b. Repair.** Repairs to the piston oil cooling nozzle oil pressure relief valve are limited to replacement of parts.

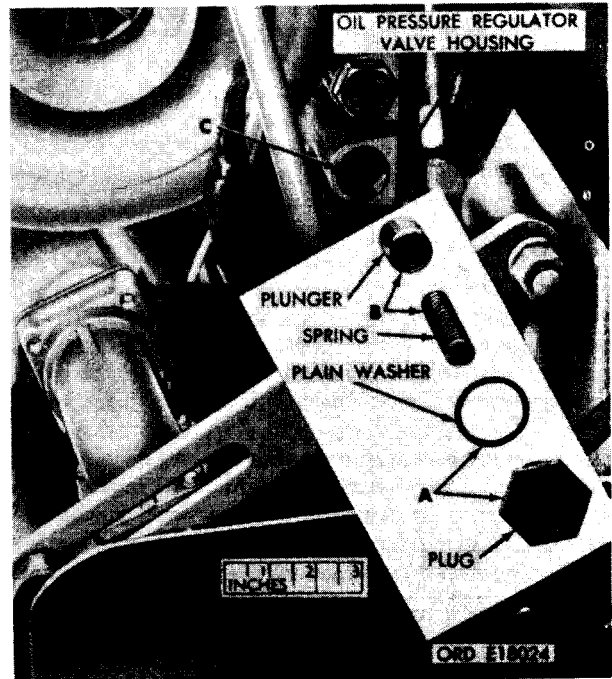


FIGURE 102. REMOVING, INSTALLING, AND INSPECTING PISTON OIL COOLING NOZZLE OIL PRESSURE RELIEF VALVE.

**c. Installation.** Refer to figure 102 and reverse the sequence of instructions to install the piston cooling nozzle oil pressure relief valve components. Use a new plain washer when installing plug.

## 72. FUEL FILTER ELEMENTS

**Note.** The primary and final fuel filter elements are the same and are replaced in the same way. For instructional purposes, the final fuel filter element is replaced. The filter elements are available in a parts kit which includes element washers and gaskets. Refer to TM 9-2815-204-35P for components of the kit.

**a. Removal.** Remove the fuel filter elements as follows.

- (1) Figure 103. (A) Turn the fuel filter vent valve counterclockwise to open position so that air will displace the fuel as it drains from the filter case. (B) Open drain cock on bottom of filter and drain fuel into a suitable container. (C) Remove case nut, flat washer, and preformed packing securing fuel filter

case to head. Remove preformed packing from nut and discard packing and flat washer. (D) When installing full filters, torque case nut to 275 to 325 pound inches.



FIGURE 103. PRIMARY AND FINAL FUEL FILTERS - INSTALLED VIEW.

- (2) Figure 104. (A) Remove fuel filter case. (B) Remove fuel filter element. (C) Remove and discard fuel filter case gasket from filter head.

Note. Leave vent valve open until engine fuel system has been purged.

#### b. Installation.

Note. Clean fuel filter case with dry-cleaning solvent or mineral spirits paint thinner before installing new element.

Refer to figures 103 and 104 and reverse the sequence of illustrations and instructions to install the new final fuel filter element and gasket. The element must be properly located on pilot in filter head before installing case.



FIGURE 104. REMOVING OR INSTALLING FUEL FILTER ELEMENT AND FUEL FILTER CASE.

### 73. OIL FILTER ELEMENTS

Note. The oil filter elements are the same and are replaced in the same manner. If either oil filter element requires replacing, both must be replaced. For instructional purposes, the rear oil filter element is replaced. The filter elements are available in a parts kit which includes the element and gaskets. Refer to TM 9-2815-204-35P for components of the kit. One of the gaskets, part No. 8725201, included in this universal kit is not applicable to this engine and must be discarded.

a. Removal. Remove oil filter elements as follows.

- (1) Figure 105. (A) Remove 3/8-inch pipe plug from oil filter and oil cooler housing and allow oil to drain into a suitable container. (B) Unscrew bar securing rear oil filter case to oil filter and oil



cooler housing. (C) When installing oil filters, torque bar to 60 foot-pounds.

Note. The bar and case are removed as assembly as shown in figure 106.

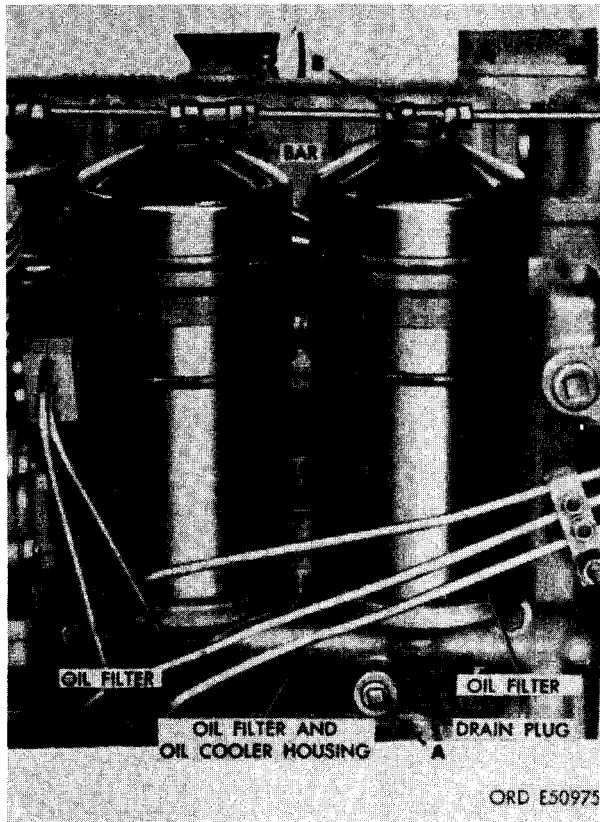


FIGURE 105. OIL FILTERS - INSTALLED VIEW.

- (2) Figure 106. (A) Remove oil filter case and bar as an assembly. (B) Remove and discard oil filter element (C) Remove and discard oil filter case gasket and bar gasket.

Note. Before installing new oil filter element, clean oil filter case and gasket seat in oil filter and oil cooler housing using dry - cleaning solvent or mineral spirits paint thinner.

b. Installation. Refer to figures 105 and 106 and reverse the sequence of illustrations and instructions to install the primary and secondary oil filter elements.

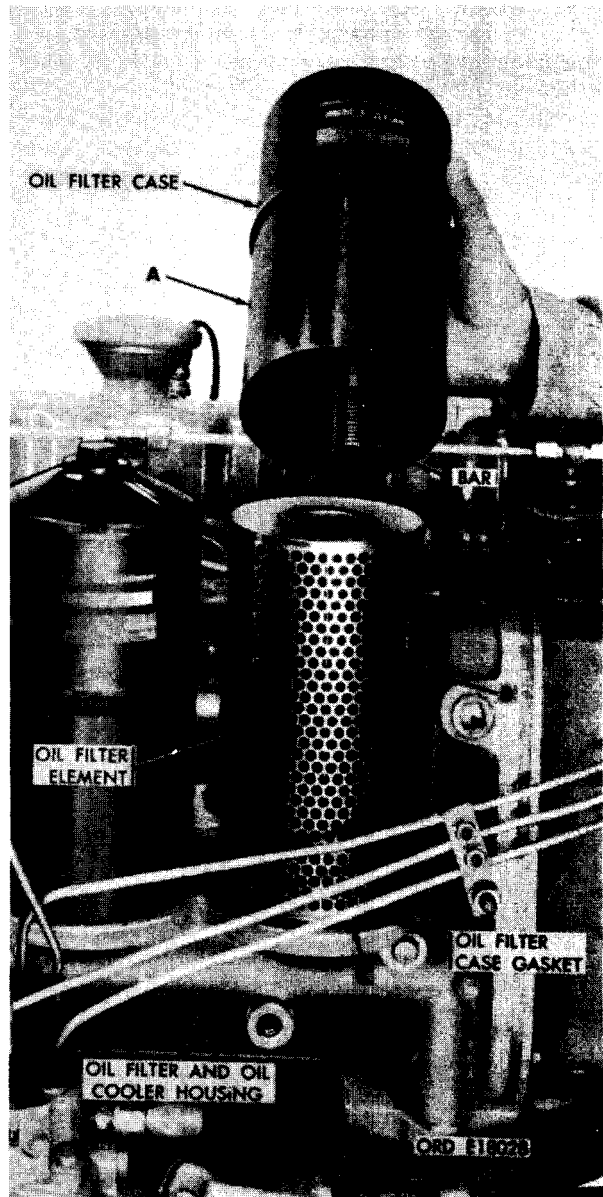


FIGURE 106. REMOVING OR INSTALLING OIL FILTER ELEMENT.

#### 74. OIL PRESSURE SENDING UNIT

a. Removal. Refer to figure 107 and remove the oil pressure sending unit and/or water jacket drain cock.

b. Installation. Refer to figure 107 and reverse the instructions to install oil pressure sending unit or cylinder block water jacket drain cock.

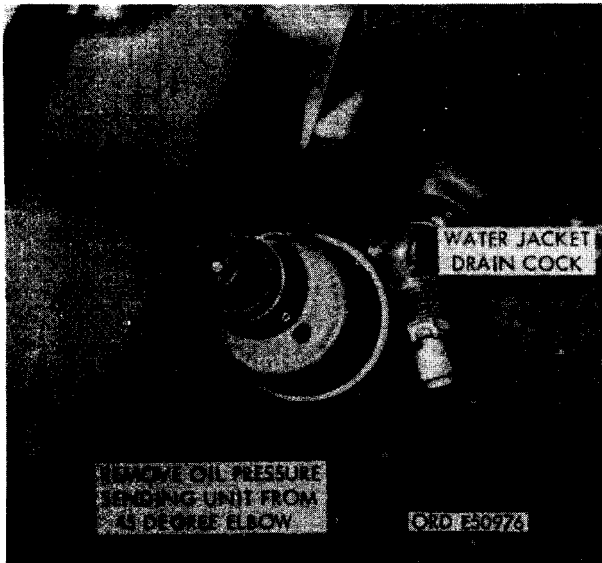


FIGURE 107. REMOVING OR INSTALLING OIL PRESSURE SENDING UNIT AND/OR CYLINDER BLOCK WATER JACKET DRAIN COCK.

#### 75. WATER TEMPERATURE SENDING UNIT

a. Removal. Refer to figure 108 and remove water temperature sending unit.

b. Installation. Refer to figure 108 to install the-water temperature sending unit.

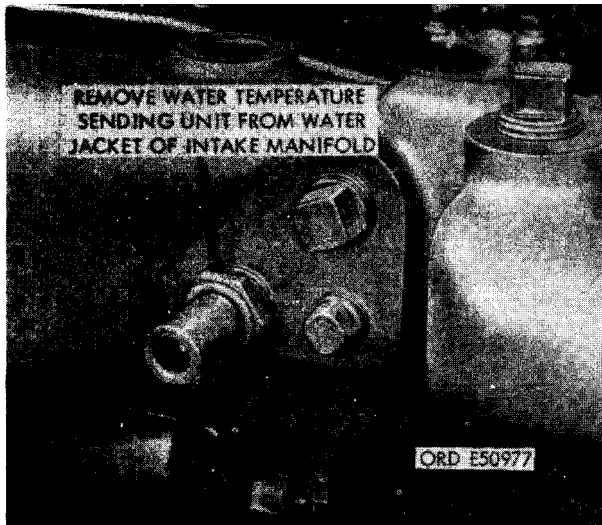


FIGURE 108. REMOVING OR INSTALLING WATER TEMPERATURE SENDING UNIT.

#### 76. COOLANT THERMOSTAT AND SEAL

a. Removal. Remove coolant thermostat and seal as follows.

- (1) Figure 109. (A) Remove two 3/8 x 3-5/8 cap screws and 3/8- inch plain washers securing thermostat housing assembly to intake manifold. (B) Loosen two 2- inch clamps securing thermostat housing-to- water pump hose.

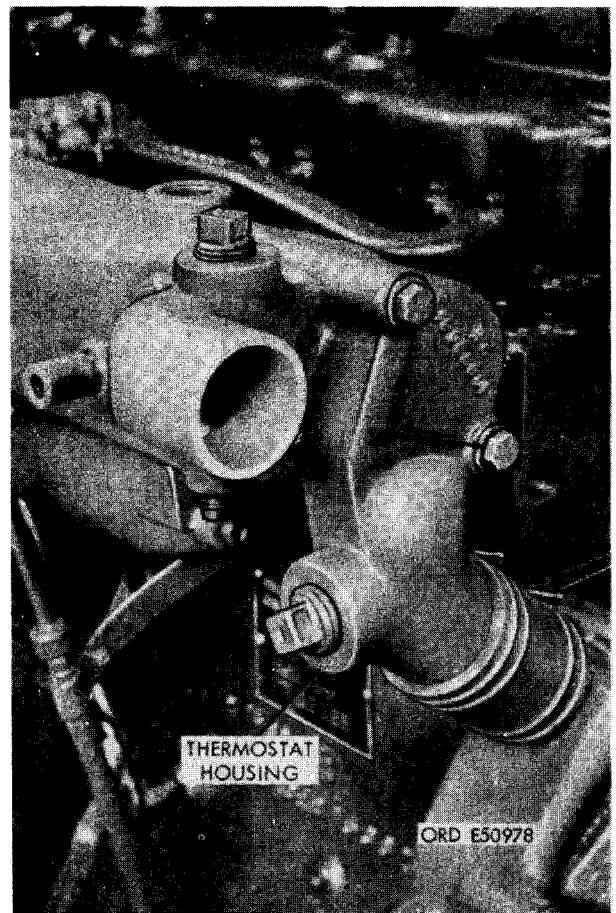


FIGURE 109. THERMOSTAT HOUSING - INSTALLED VIEW.

- (2) Figure 110. (A) Remove thermostat housing assembly with thermostat installed. (B) Remove and discard intake manifold-to-thermostat housing gasket.

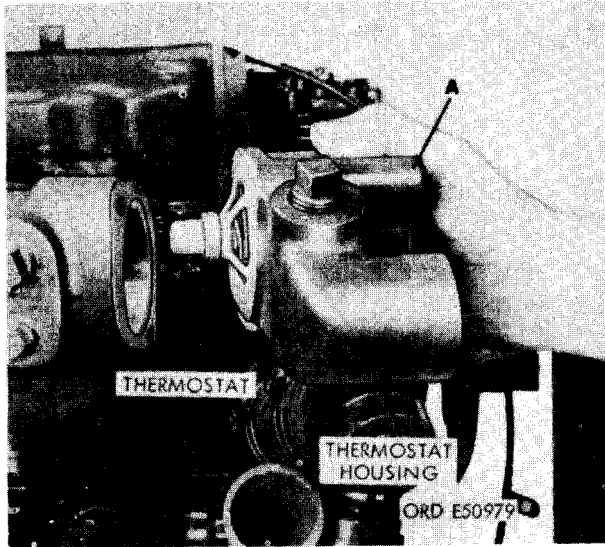


FIGURE 110. REMOVING OR INSTALLING THERMOSTAT HOUSING AND THERMOSTAT.

- (3) Figure 111. (A) Remove thermostat from thermostat housing assembly. (B) Inspect thermostat seal. When defects are noted, replace seal.

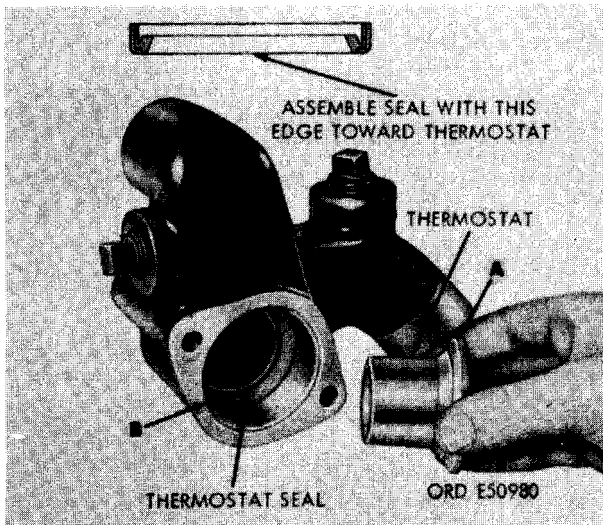


FIGURE 111. REMOVING OR INSTALLING THERMOSTAT AND THERMOSTAT SEAL.

- b. Installation.** Refer to figures 109 through 111 and reverse the sequence of illustrations and instructions to install a new thermostat and/or seal. Install a new intake manifold-to-thermostat housing gasket.

## 77. WATER PUMP ASSEMBLY

- a. Removal.** Remove water pump assembly as follows.

- (1) Figure 112. (A) Remove four 5/16 x 3/4 cap screws and 5/16- inch lock washers securing engine fan to water pump pulley. (B) Remove engine fan from pulley.

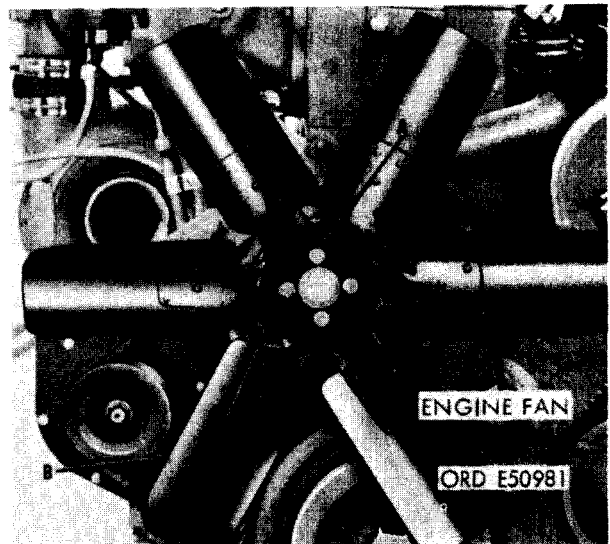
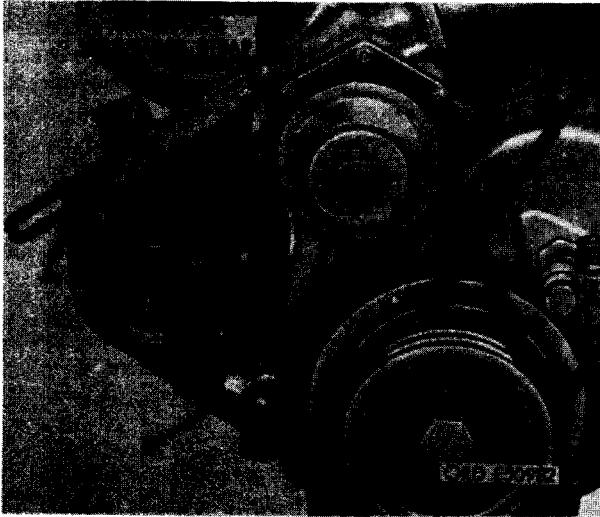
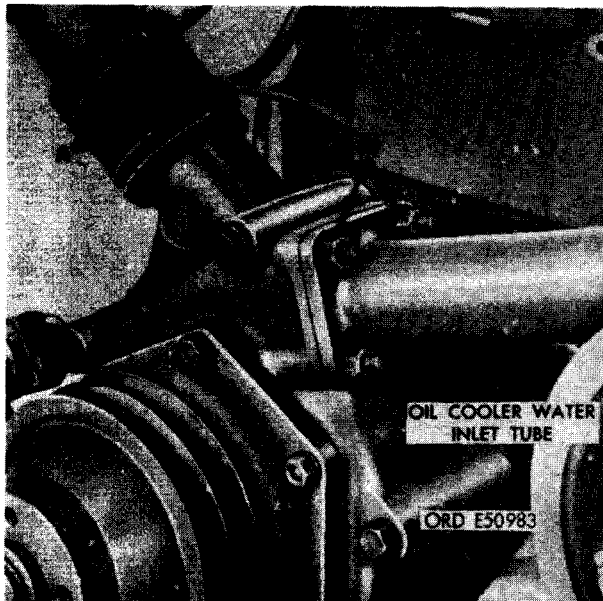


FIGURE 112. REMOVING OR INSTALLING ENGINE FAN.

- (2) Figure 113. (A) Remove 3/8 x 7/8 cap screws, 3/8- inch lock washer, and special flanged washer securing generator adjusting strap to generator assembly. (B) Push generator assembly toward engine and remove the two engine fan and generator drive belts from generator pulley, water pump pulley, (C) Remove 3/8- inch plain nut and 3/8- inch lock washer securing generator adjusting strap to water pump. Remove adjusting strap.

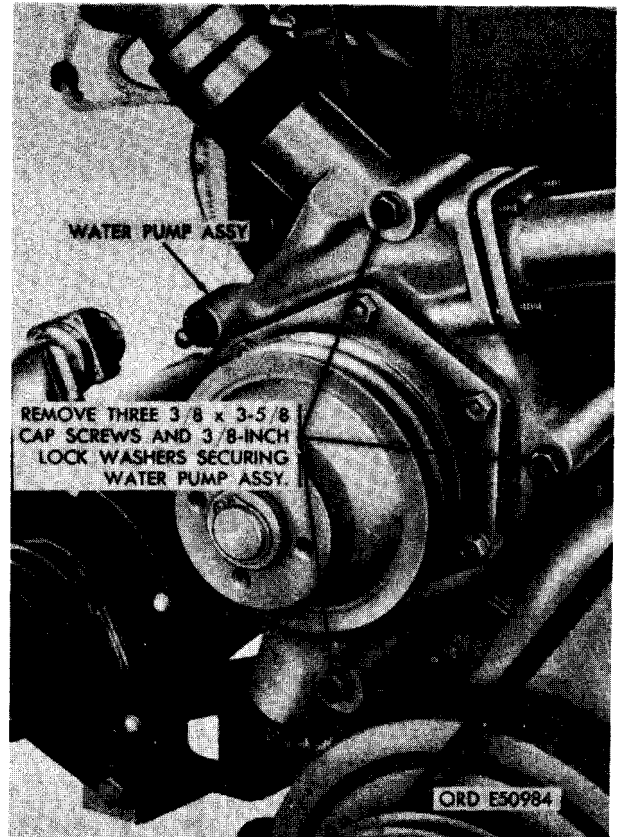


**FIGURE 113. REMOVING OR INSTALLING ENGINE FAN AND GENERATOR DRIVE BELTS FOR WATER PUMP REPLACEMENT.**



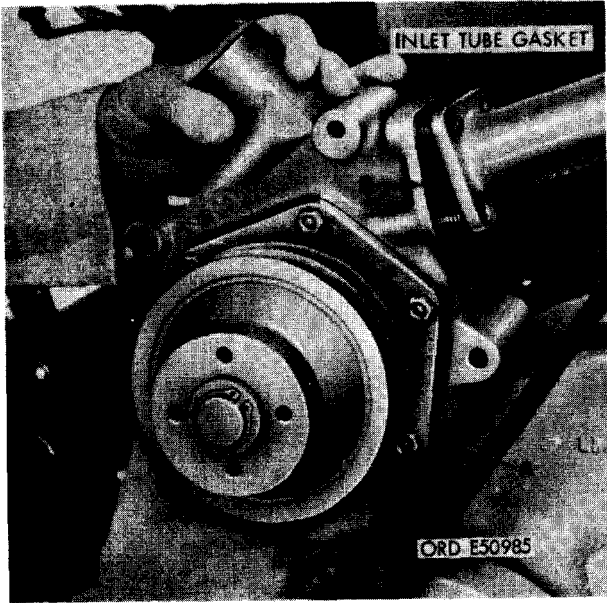
**FIGURE 114. DISCONNECTING OR CONNECTING THERMOSTAT HOUSING-TO-WATER PUMP HOSE AND OIL COOLER WATER INLET TUBE AT WATER PUMP.**

- (3) Figure 114. (A) Loosen the two 2-inch diameter hose clamps securing the thermostat housing - to- water pump hose. Slide the hose up on thermostat housing assembly until hose clears water pump assembly. (B) Remove four 5/16- inch plain nuts and 5/16- inch lock washers securing oil cooler water inlet tube to water pump assembly. Separate flange of inlet tube from pump.
- (4) Refer to figure 115 and disconnect water pump assembly.

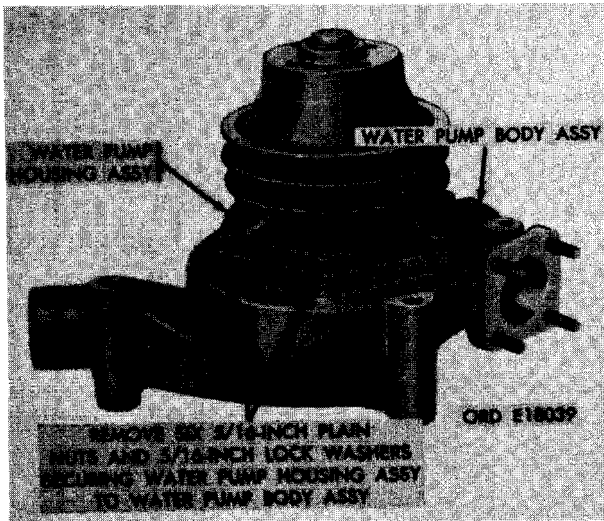


**FIGURE 115. DISCONNECTING OR CONNECTING WATER PUMP ASSEMBLY.**

- (5) Figure 116. (A) Remove water pump assembly by lowering pump from nose and away from flange on oil cooler water inlet tube. (B) Remove and discard oil cooler water inlet tube gasket.



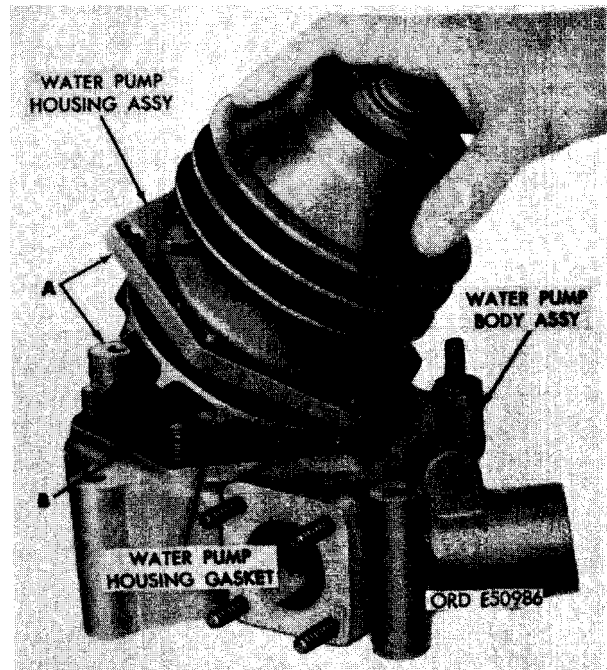
**FIGURE 116. REMOVING OR INSTALLING WATER PUMP ASSEMBLY.**



**FIGURE 117. REMOVING WATER PUMP HOUSING FROM WATER PUMP BODY ASSEMBLY.**

**b. Disassembly.** Disassemble water pump assembly as follows.

- (1) Refer to figure 117 and remove nuts and lock washers securing water pump housing to water pump body.
- (2) Figure 118. (A) Separate water pump housing assembly from water pump body assembly. (B) Remove and discard water pump housing gasket.



**FIGURE 118. SEPARATING OR ASSEMBLING WATER PUMP HOUSING AND WATER PUMP BODY.**

- (3) Refer to figure 119 and remove water pump pulley retaining ring.
- (4) Figure 120. (A) Mount water pump housing assembly in an arbor press so that pulley is supported on press plates as shown. (B) Remove water pump housing assembly and drive shaft out of pulley using a suitable pressing arbor.

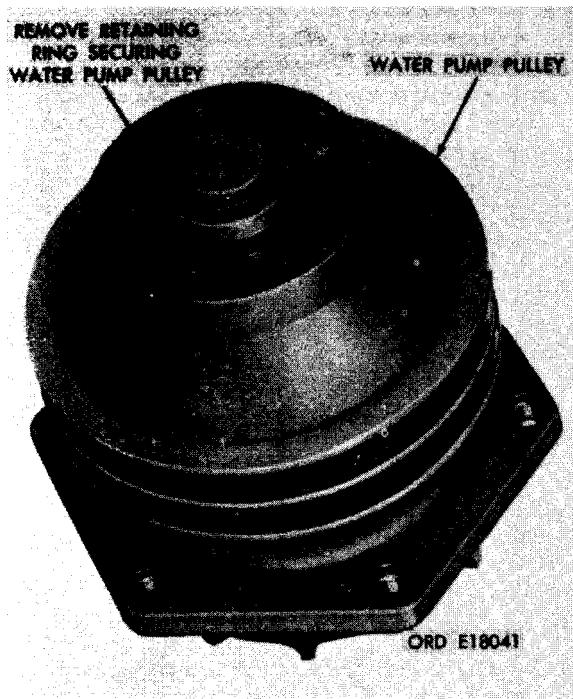


FIGURE 119. REMOVING OR INSTALLING WATER PUMP PULLEY RETAINING RING.

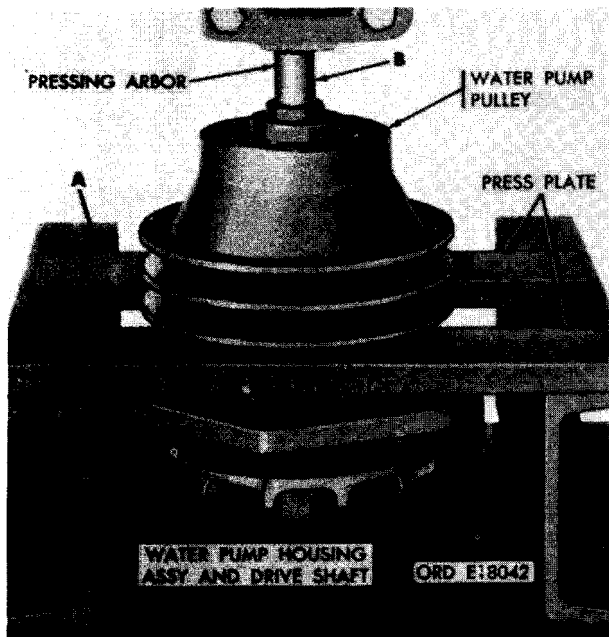


FIGURE 120. REMOVING WATER PUMP HOUSING AND DRIVE SHAFT FROM WATER PUMP PULLEY.

- (5) Figure 121. (A) Mount water pump housing assembly in an arbor press. Support the assembly under impeller with two press plates. (B) Remove water pump housing assembly and drive shaft from impeller.

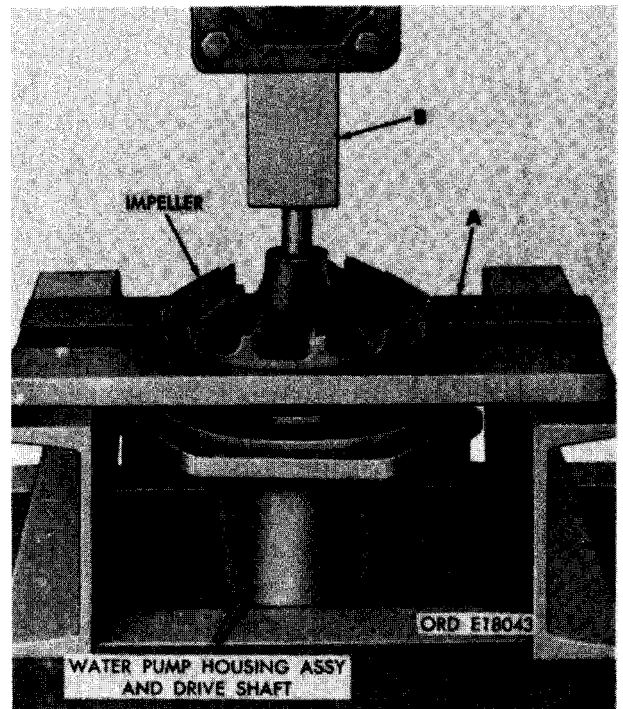


FIGURE 121. REMOVING WATER PUMP HOUSING AND DRIVE SHAFT FROM WATER PUMP IMPELLER.



FIGURE 122. REMOVING OR INSTALLING WATER PUMP DRIVE SHAFT FROM WATER PUMP HOUSING ASSEMBLY.

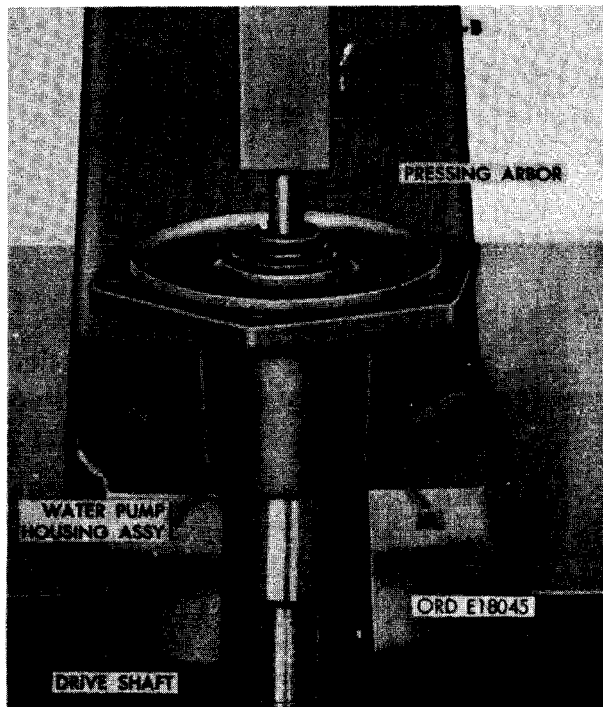


FIGURE 123. REMOVING WATER PUMP DRIVE SHAFT FROM WATER PUMP HOUSING ASSEMBLY.

- (6) Refer to figure 122 and remove water pump drive shaft retaining ring.
- (7) Figure 123. (A) Mount the water pump

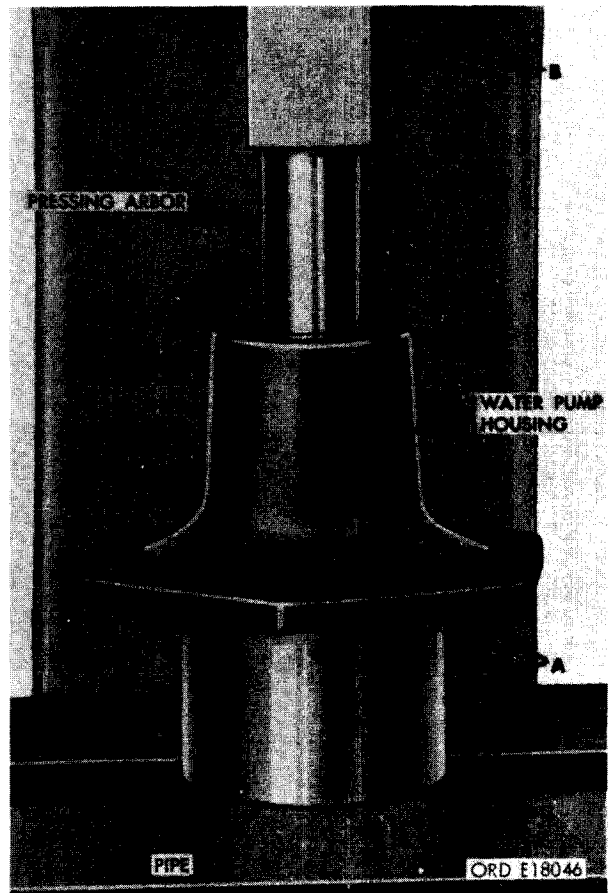


FIGURE 124. REMOVING WATER SEAL FROM WATER PUMP HOUSING.

- (8) Figure 124. (A) Mount water pump housing over a piece of pipe, with an inside diameter large enough to completely clear water pump seal. Support pipe and pump housing on press plates as shown. (B) Remove water pump seal out of water pump housing using a suitable pressing arbor.

- (9) Figure 125. (A) Remove water pump seal seat from impeller. (B) Remove water pump seal seat housing from water pump impeller.

Note. The grooved surface on seal seat faces the seal seat housing when properly assembled.

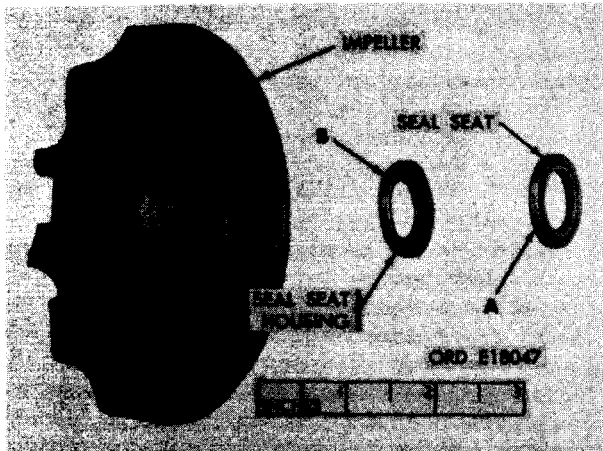


FIGURE 125. REMOVING OR INSTALLING WATER PUMP SEAL SEAT HOUSING AND SEAL SEAT.

- (10) Refer to figure 126 and remove pipe plug from water pump body.

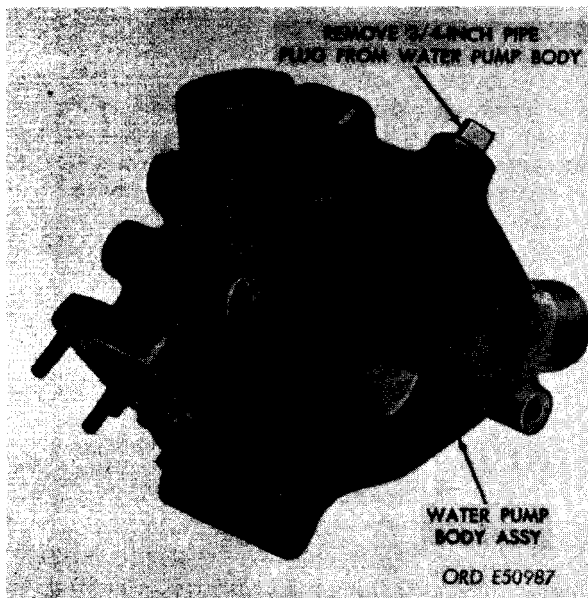


FIGURE 126. REMOVING PIPE PLUG FROM WATER PUMP BODY ASSEMBLY.

c. Cleaning, Inspection, and Repair.

Note. The key letters shown below in parentheses refer to figure 127 except where otherwise indicated.

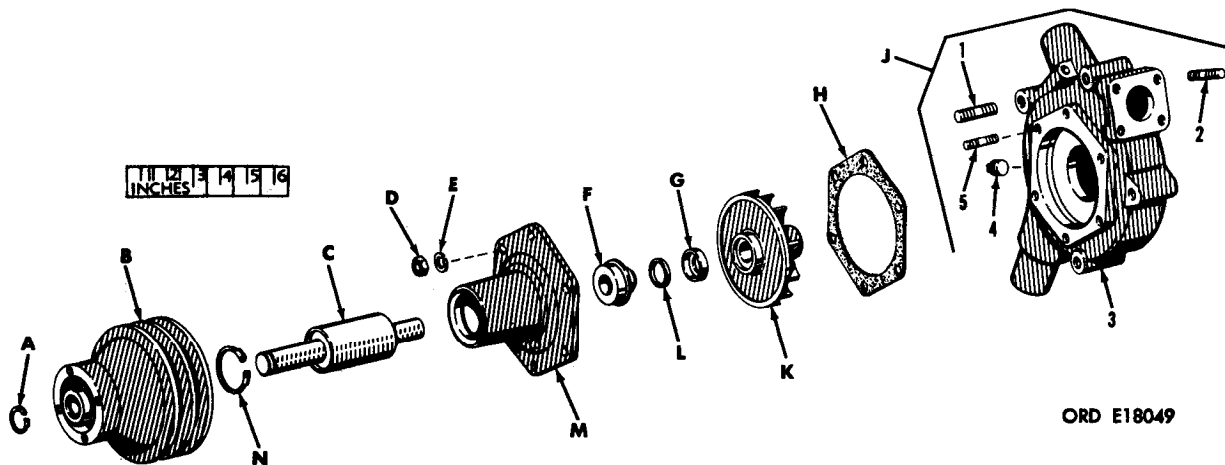
- (1) Cleaning. Clean all water pump parts thoroughly with dry-cleaning solvent or mineral spirits paint thinner. Clean scale deposits from inside body assembly (J) and impeller (K) using a scraper. Remove heavy grease deposits from pulley (B), housing (M), and body (J-3). Dry all parts with compressed air.
- (2) Inspection. Inspect water pump body assembly (J) for cracks, damaged gasket surfaces, and damaged studs (J-1, J-2, and J-5). Replace body when cracked. Inspect water pump housing (M), for cracks and damaged bearing bore hole or damaged mating gasket surfaces. Replace housing when cracked or damaged. Inspect water pump impeller (K) for broken impeller blades and heavy scale deposits or damaged drive shaft bore. Replace impeller when broken, cracked, or unserviceable. Inspect water pump pulley (B) for cracks and damage. Replace pulley when broken or cracked. Discard water pump drive shaft (C), seal (F), impeller seal seat housing (G), and seal seat (L).
- (3) Repair. Remove burrs on mating gasket surfaces of body assembly (J) and housing (M) using a fine mill file. Replace damaged studs (J-1, J-2, and J-5) in body assembly. Repair damaged threads in body assembly (J) and pulley (B) using a worn tap. Replace body assembly when threads are severely damaged or stripped.

Note. Oversize studs are available for the water pump body assembly. Refer to Table III or to TM 9-2815-204-35P for stud replacement.

d. Assembly. Assemble the water pump assembly as follows.

- (1) Refer to figure 126 and reverse the instructions to install 3/4-inch pipe plug in water pump body assembly.





ORD E18049

- A - Pulley retaining ring
- B - Pulley
- C - Drive shaft
- D - 5/16-in. plain nut
- E - 5/16-in. lock washer
- F - Seal
- G - Seal seat housing
- H - Housing gasket
- J - Body assembly
  - 1- 3/8 X 1-5/16 stud
  - 2- 5/16 X 1- 1/4 stud
  - 3- Body
  - 4- 1/2-in. pipe plug
  - 5- 5/16 x 1- 1/4-stud
- K - Impeller
- L - Seal seat
- M - Water pump housing
- N - Shaft retaining ring

FIGURE 127. WATER PUMP ASSEMBLY - EXPLODED VIEW.

- (2) Refer to figure 125 and reverse the sequence of instructions to install the seal seat and seal seat housing in impeller.

Note. The grooved surface on seal seat must face the seal seat housing.

- (3) Figure 128. (A) Mount water pump housing on a press plate as shown. (B) Install water pump seal in water pump housing using a suitable pressing arbor, until flange of seal properly seats against housing. The carbon face of seal must be toward impeller side of housing.

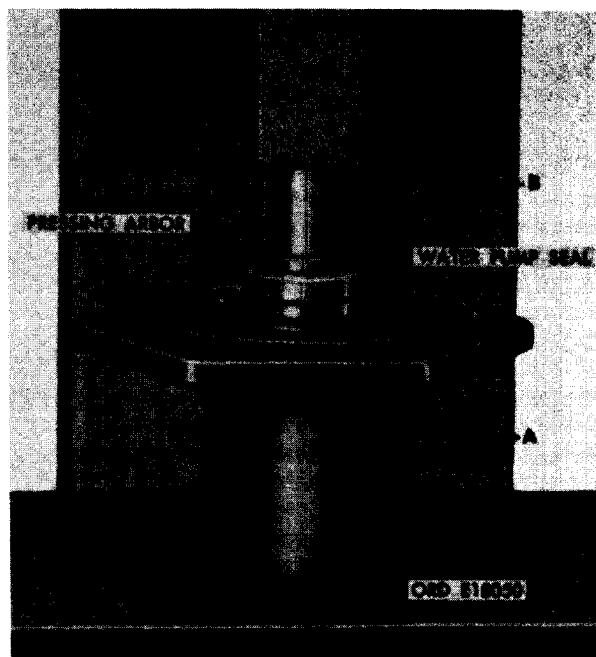


FIGURE 128. INSTALLING WATER PUMP SEAL IN WATER PUMP HOUSING.

- (4) Figure 129. (A) Position water pump housing assembly on a piece of pipe which has an inside diameter large enough to clear the installed water pump seal. (B) Start drive shaft bearing into housing bore and press in housing until bearing area of shaft passes retaining ring groove.

Note. The drive shaft bearing can be pressed past the retaining ring groove. If this occurs, press drive shaft out of housing as shown in figure 123 until bearing is flush with groove. Drive shaft must be installed with water pump pulley retaining ring groove toward pulley side of housing.

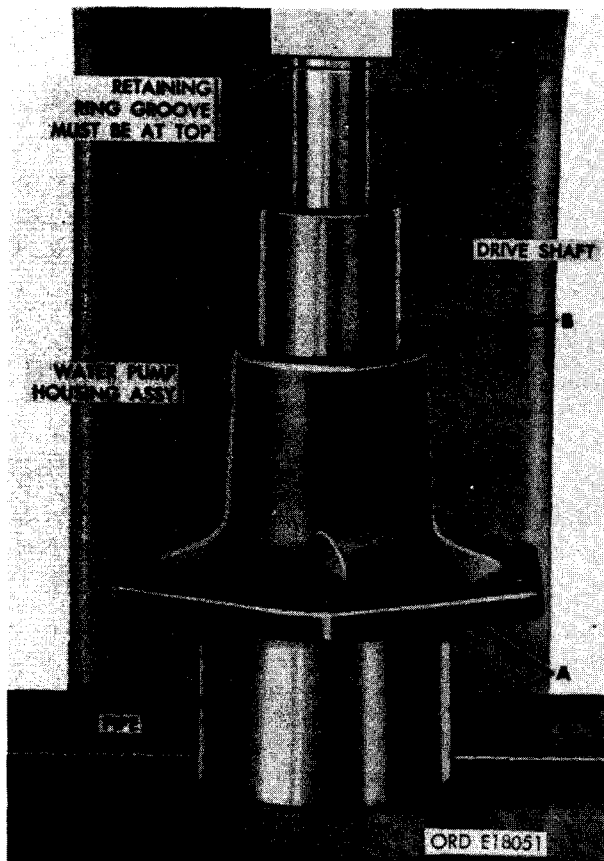


FIGURE 129. INSTALLING WATER PUMP DRIVE SHAFT IN WATER PUMP HOUSING ASSEMBLY.

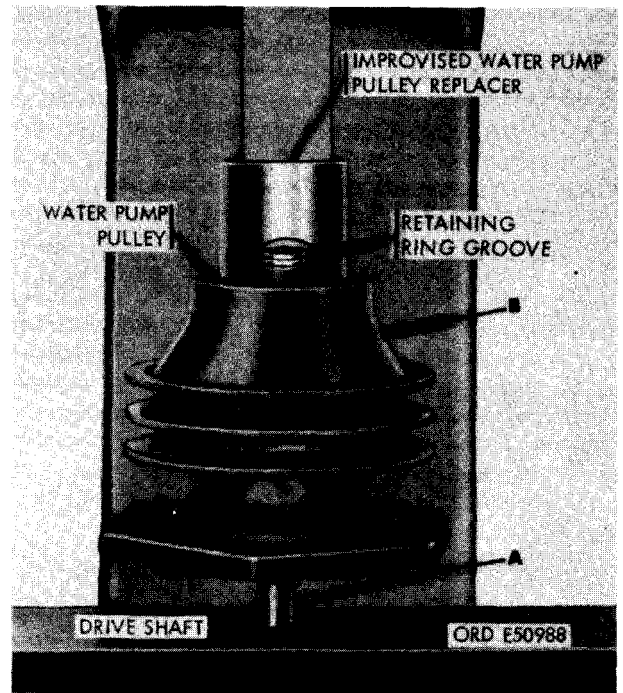


FIGURE 130. INSTALLING WATER PUMP PULLEY ON DRIVE SHAFT USING IMPROVED PULLEY REPLACER.

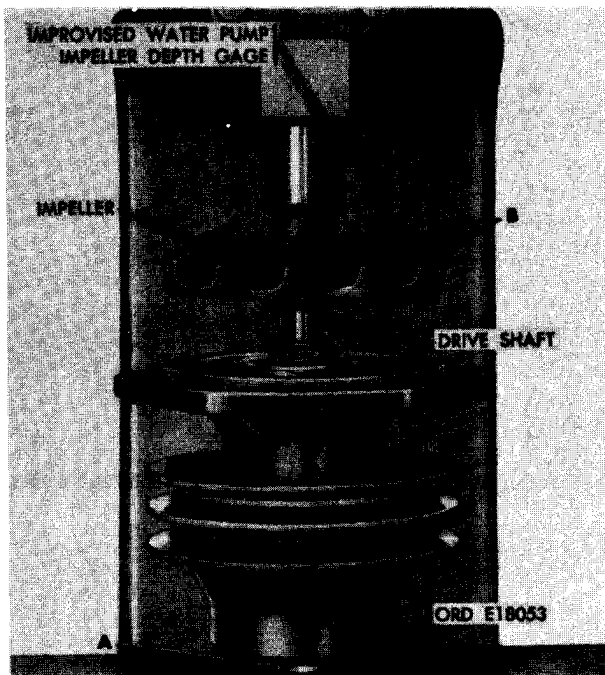
- (5) Refer to figure 122 and reverse the instructions to install water pump drive shaft retaining ring.
- (6) Figure 130. (A) Position the impeller end of water pump shaft on a press plate as shown. (B) Start water pump pulley on drive shaft and press it into position using the improved water pump pulley replacer (fig. 31).

Note. Opening on side of water pump pulley replacer allows mechanic to tell when retaining ring groove has just cleared the pulley, allowing for installation of the ring.

- (7) Refer to figure 119 and reverse the sequence of instructions to install water pump pulley retaining ring.

- (8) Figure 131. (A) Position water pump pulley end of drive shaft on press plate as shown. (B) Start water pump impeller on drive shaft with blades facing up and press impeller on shaft using the improvised water pump impeller depth gage (fig. 32). Measure depth of shaft in impeller. Shaft distance must be from 0.777-inch to 0.787-inch. Press shaft to meet this distance.

**Note.** After installing impeller on shaft rotate impeller several times to see that it is rotating freely. If impeller binds, disassemble pump and replace unserviceable parts.



**FIGURE 131. INSTALLING WATER PUMP IMPELLER ON WATER PUMP DRIVE SHAFT USING IMPROVISED DEPTH GAGE.**

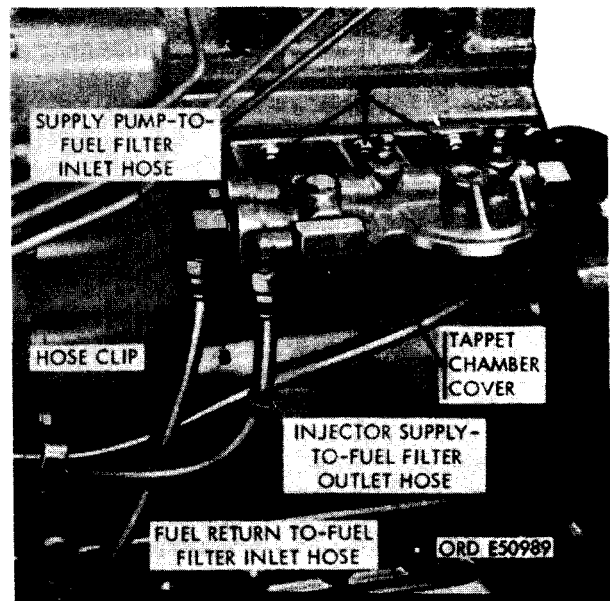
- (9) Refer to figures 117 and 118 and reverse the sequence of illustrations and instructions to assemble the water pump housing assembly and body assembly. A new water pump housing gasket must be used.

e. **Installation.** Refer to figures 112 through 116 and reverse the sequence of illustrations and instructions to install the water pump assembly. Adjust engine fan and generator drive belt deflection as directed in figure 43.

## 78. OIL COOLER

a. **Removal.** Remove oil cooler as follows.

- (1) Refer to figures 103 and 104 and follow the sequence of instructions to remove the primary and final fuel filter elements.
- (2) Figure 132. (A) Disconnect fuel injection overflow hose from 3/8-inch, 90 degree elbow. (B) Disconnect fuel supply pump-to-fuel filter inlet hose from 3/8-inch, 90 degree elbow. (C) Disconnect fuel injection pump supply-to-fuel filter outlet hose from 3/8-inch, 90 degree elbow. (D) Remove three 3/8-inch plain nuts and 3/8-inch lock washers securing fuel filter head to tappet chamber cover. Remove fuel filter head.



**FIGURE 132. REMOVING OR INSTALLING FUEL FILTER HEAD.**

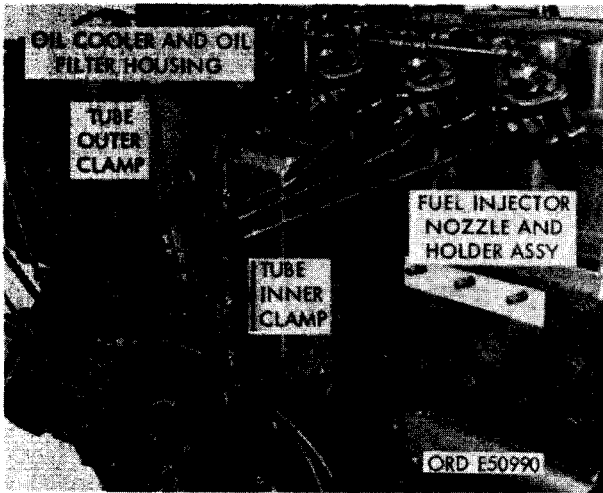


FIGURE 133. REMOVING OR INSTALLING CYLINDER NO. 4, 5, AND 6 FUEL INJECTION TUBES.

- (3) Figure 133. (A) Remove two 1/4-inch self-locking nuts, 1/4-inch flat washers, and 1/4 x 1-3/8 cap screws securing injection tube outer clamp to inner clamp. Remove outer clamp. (B) Remove 3/8-inch plain nut, 3/8-inch lock washer and flat washer, securing fuel injection tube inner clamp to oil cooler and oil filter housing stud. (C) Disconnect cylinder No. 4, 5, and 6 fuel injection tubes from fuel injector nozzle and holder assemblies and at fuel injection pump hydraulic head. Remove tubes.

Note. Plug or cap tubes and injection tube openings in the nozzle holders and injection pump hydraulic head to prevent entrance of dirt.

- (4) Figure 134. (A) Remove twelve 1/4-inch plain nuts and 1/4-inch lock washers securing oil cooler cover to oil cooler and oil filter housing. (B) Remove oil cooler cover.

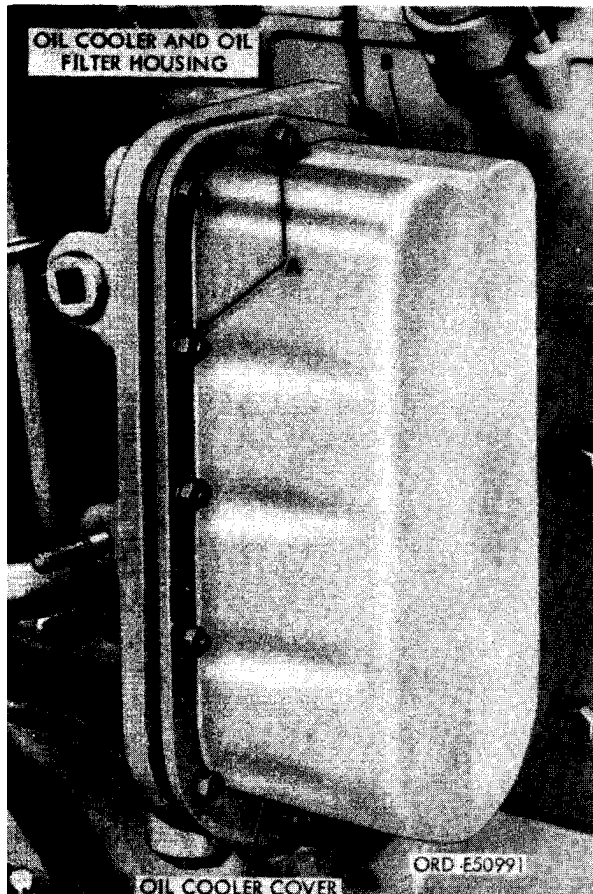


FIGURE 134. REMOVING OR INSTALLING OIL COOLER COVER.

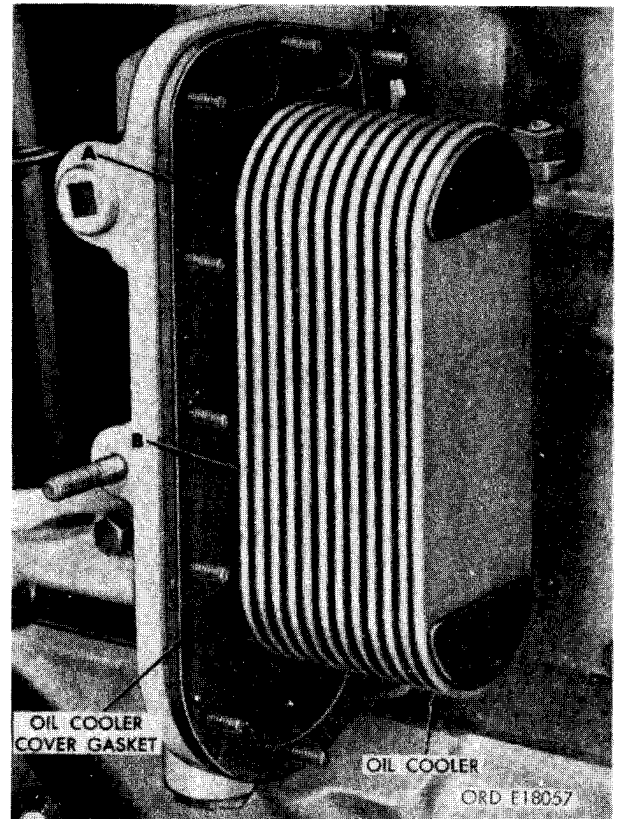
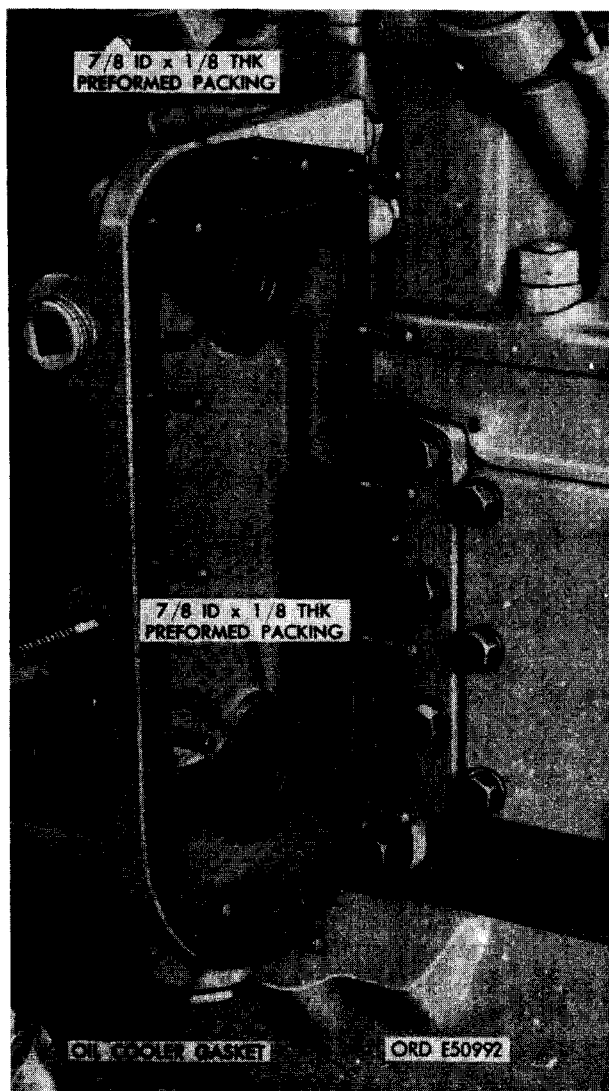


FIGURE 135. REMOVING OR INSTALLING OIL COOLER COVER GASKET AND OIL COOLER.

- (5) Figure 135. (A) Remove and discard oil cooler cover gasket. (B) Remove oil cooler.
- (6) Figure 136. (A) Remove and discard two 7/8 id x 1/8 thick preformed packings. (B) Remove and discard oil cooler gasket.



**FIGURE 136. REMOVING OR INSTALLING PREFORMED PACKINGS AND OIL COOLER GASKET.**

**b. Cleaning.** Clean scale from exterior surfaces of oil cooler. Immerse the oil cooler in dry-cleaning solvent and allow it to soak until

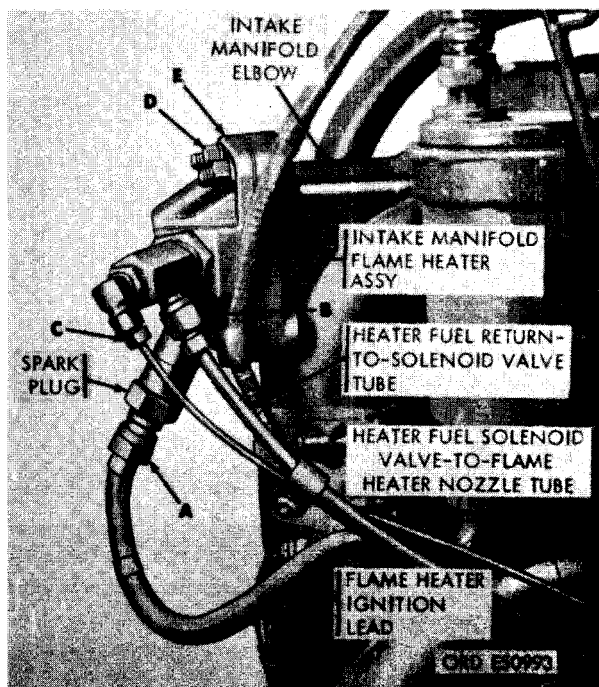
oil passages are clean and unobstructed. Use probes, if necessary, to clean passages. Clean all gaskets and preformed packing areas.

**c. Inspection.** Examine all gasket and packing-areas for damage. Plug one oil opening in the oil cooler and apply 150 pounds per square inch air pressure to the other opening. Immerse the oil cooler in water and check for leaks. If leaks are present, replace the oil cooler.

**d. Repair.** Repair minor damage to the gasket and packing areas, such as nicks or burrs, with a fine mill file or crocus cloth. If any other damage exists, replace the oil cooler.

**e. Installation.**

- (1) Refer to figures 132 through 136 and reverse the sequence of illustrations and instructions to install the oil cooler. Use new preformed packings and gaskets.
- (2) Refer to figures 103 and 104 and reverse the sequence of illustrations and instructions to install the primary and final fuel filters.



**FIGURE 137. REMOVING OR INSTALLING INTAKE MANIFOLD FLAME HEATER ASSEMBLY.**

## 79. INTAKE MANIFOLD HEATER ASSEMBLY

a. Removal and Disassembly. Remove and disassemble intake manifold flame heater assembly as follows.

- (1) Figure 137. (A) Disconnect flame heater ignition lead from spark plug. (B) Disconnect flame heater fuel return-to-solenoid valve tube from 1/8 pipe x 1/4 tube union in nozzle and holder assembly. (C) Disconnect flame heater fuel solenoid valve-to- flame heater nozzle tube from 1/8 pipe x 1/8 tube, 90 degree elbow in nozzle and holder assembly. (D) Remove four 5/16- inch plain nuts and 5/16- inch lock washers securing intake manifold flame heater assembly to intake manifold elbow. (E) Remove intake manifold flame heater assembly. Remove and discard flame heater gasket.

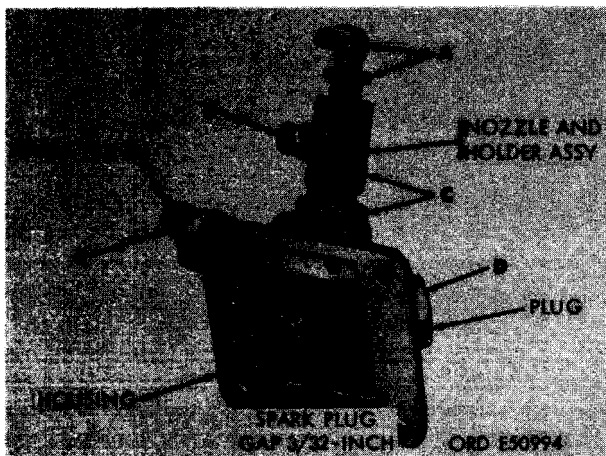
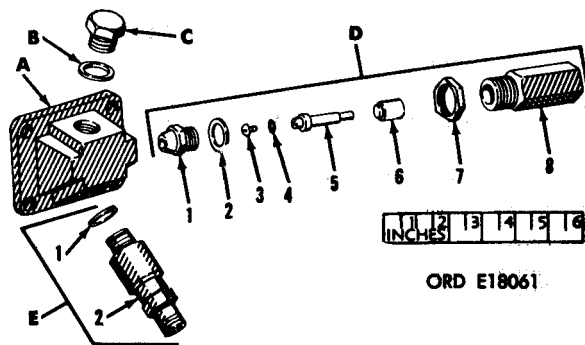


FIGURE 138. DISASSEMBLING OR ASSEMBLING INTAKE MANIFOLD FLAME HEATER.

- (2) Figure 138. (A) Remove 1/8 pipe x 1/8 tube, 90 degree elbow from 1/8 pipe x 1/4 pipe bushing and bushing from nozzle and holder assembly. (B) Remove 1/4 tube x 1/8 pipe union from nozzle and holder assembly. (C) Loosen nut and remove nozzle and holder assembly. (D) Remove plug and plug gasket from housing (early model engines). Late model engines do not have plug or gasket in housing. (E) Remove spark plug and spark plug gasket from housing.



- A - Housing
- B - Gasket (early model engines)
- C - Plug (early model engines)
- D - Nozzle and holder assembly
  - 1- Body
  - 2- Gasket
  - 3- Seat
  - 4- Gasket
  - 5- Valve
  - 6- Filter
  - 7- Nut
  - 8- Holder
- E - Spark plug with gasket assembly
  - 1- Spark plug gasket
  - 2- Spark plug

FIGURE 139. INTAKE MANIFOLD FLAME HEATER - EXPLODED VIEW.

b. Disassembly of Flame Heater Nozzle and Holder Assembly (fig. 139). Disassemble flame heater nozzle and holder assembly by removing body (D- 1) and body gasket (D-2). Remove seat (D- 3), seat gasket (D-4), valve (D- 5), and filter (D-6). Remove nut (D-7) from holder (D-8).

### c. Cleaning, Inspection, and Repair.

- (1) Cleaning. Clean all intake manifold flame heater components with dry-cleaning solvent or mineral spirits paint thinner. Remove all heavy carbon deposits using a stiff brush or scraper. Do not attempt to clean the body with brush and/or scraper. Refer to TM 9-8638 for cleaning instructions for spark plug (E-2).
- (2) Inspection. Inspect intake manifold flame heater housing (A) for cracks, damaged threads, and damaged gasket surfaces. Inspect nozzle and holder

components for damaged valve seat surfaces, damaged threads, and other damage which might make components unserviceable. Replace all damaged parts.

(3) Repair. Damaged flame heater component must be replaced.

d. Assembly of Flame Heater Nozzle and Holder (fig. 139). Assemble flame heater nozzle and holder by installing nut (D-7) on holder (D-8). Install filter (D-6), valve (D-5), seat gasket (D-4), and seat (D-3). Install body gasket (D-2) and body (D-1).

e. Assembly of Intake Manifold Flame Heater. Refer to figure 138 and reverse the sequence of instructions to assemble intake manifold flame heater.

f. Installation. Refer to figure 137 and reverse the sequence of instructions to install the intake manifold flame heater assembly.

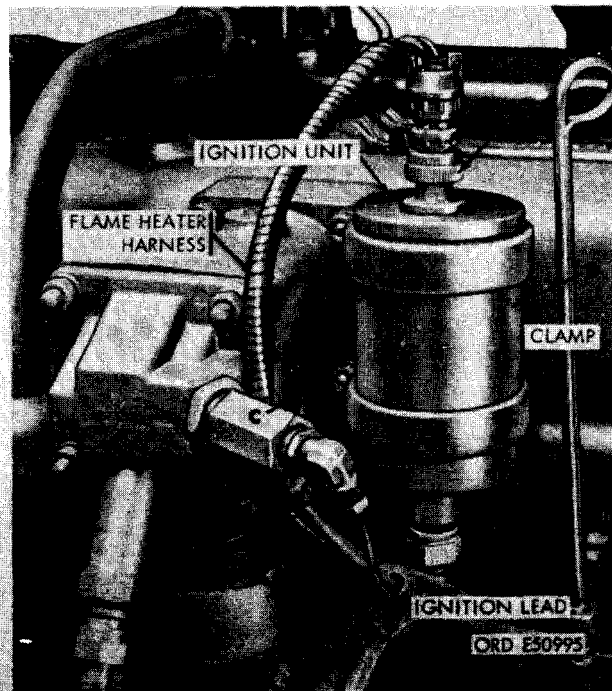


FIGURE 140. REMOVING OR INSTALLING FLAME HEATER IGNITION UNIT.

## 80. FLAME HEATER IGNITION UNIT

Warning: The voltage output of the ignition unit is sufficient to cause a dangerous electrical shock. Do not touch any uninsulated or live connection during operation. Refer to WARNING notice decal on unit.

a. Removal. Figure 140. (A) Disconnect flame heater ignition lead from flame heater ignition unit. (B) Disconnect flame heater harness from ignition unit. (C) Remove two 5/16- inch plain nuts and 5/16- inch lock washers securing the two clamps which secure ignition unit to intake manifold elbow. (D) Remove ignition unit and clamps and remove clamps from unit.

b. Installation. Refer to figure 140 and reverse the sequence of instructions to install the flame heater ignition unit.

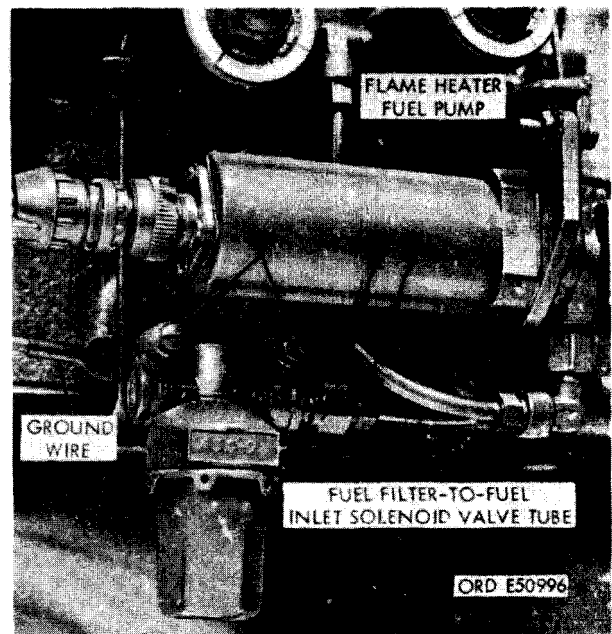


FIGURE 141. REMOVING OR INSTALLING FLAME HEATER FUEL FILTER ASSEMBLY.

## 81. FLAME HEATER FUEL FILTER ASSEMBLY

a. Removal and Disassembly. Remove and disassemble flame heater fuel filter assembly as follows.

- (1) Figure 141. (A) Disconnect fuel filter-to-fuel inlet solenoid valve tube from 1/4 tube x 1/8 pipe union in filter outlet port. (B) Remove union from fuel filter. (C) Remove two No. 10 plain nuts, No. 10 lock washers and No. 10 x 1-3/4 machine screws securing fuel filter to flame heater fuel pump and filter bracket. Remove fuel filter. Disconnect ground wire when machine screw is removed.
- (2) Figure 142. (A) Remove filter bowl from filter head. (B) Remove gasket from filter element. (C) Remove filter element assembly from filter bowl. (D) Remove spring from filter element. (E) Remove and discard 1-19/64 id x 7/64 thk preformed packing from filter bowl.

b. Cleaning. The flame heater fuel filter element can be cleaned by blowing compressed air through element. Replace element when it appears extremely dirty or deteriorated or when spring or gasket is defective.

Warning: Particles blown by compressed air are hazardous. Direct the air stream away from personnel.

c. Assembly. Refer to figure 142 and reverse the sequence of instructions to assemble the flame heater fuel filter. Use a new preformed packing.

D. Installation. Refer to figure 141 and reverse the sequence of instructions to install the flame heater fuel filter assembly.

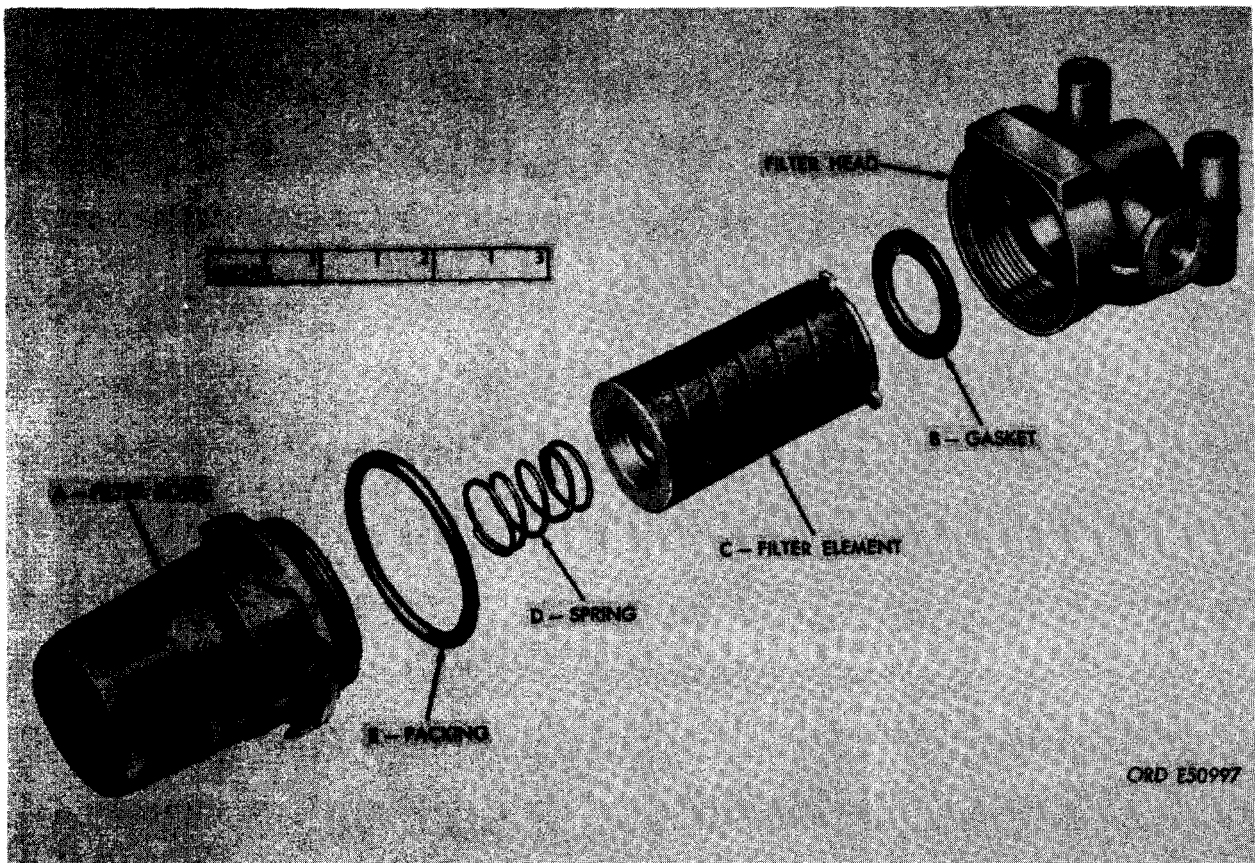


FIGURE 142. FLAME HEATER FUEL FILTER - EXPLODED VIEW.



## 82. FLAME HEATER SOLENOID VALVES

a. Removal. Remove flame heater solenoid valves as follows.

- (1) Figure 143. (A) Disconnect harness ground wire by removing No. 10 plain nut and No. 10 lock washer from No. 10 x 1-3/4 machine screw. (B) Disconnect flame heater harness from receptacle connector at rear of flame heater fuel pump. (C) Disconnect flame heater harness from fuel return solenoid valve and fuel inlet solenoid valve. (D) Disconnect 1/8-inch tube nut from fuel pump outlet union. (E) Disconnect 1/4-inch tube nut on fuel return-to-fuel solenoid valve tube from 90 degree elbow in solenoid valve.

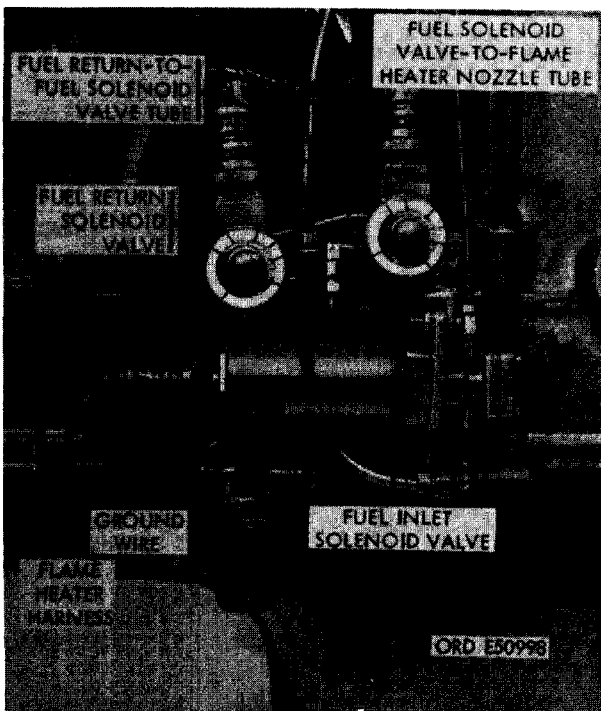


FIGURE 143. DISCONNECTING OR CONNECTING FLAME HEATER SOLENOID VALVE TUBES AND HARNESS.

- (2) Refer to figure 144 and remove flame heater fuel pump and fuel filter bracket.
- (3) Figure 145. (A) Disconnect 1/4-inch tube nut on fuel filter-to-fuel inlet solenoid valve tube from 90 degree elbow in solenoid valve. (B) Disconnect 1/4-

inch tube nut on fuel inlet solenoid valve-to-fuel pump tube from 90 degree elbow in solenoid valve.

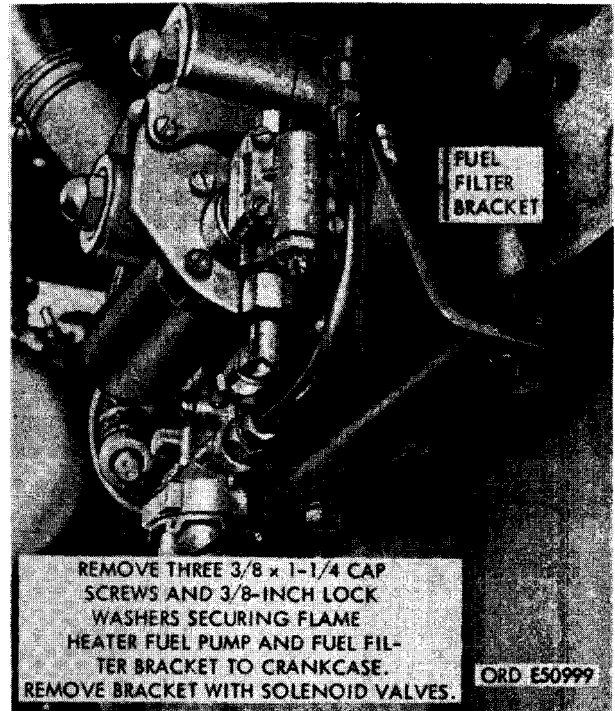


FIGURE 144. REMOVING OR INSTALLING FLAME HEATER FUEL PUMP AND FUEL FILTER BRACKET.

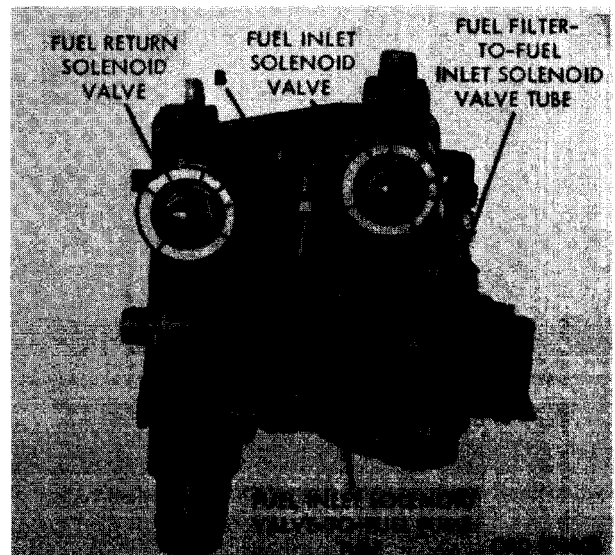
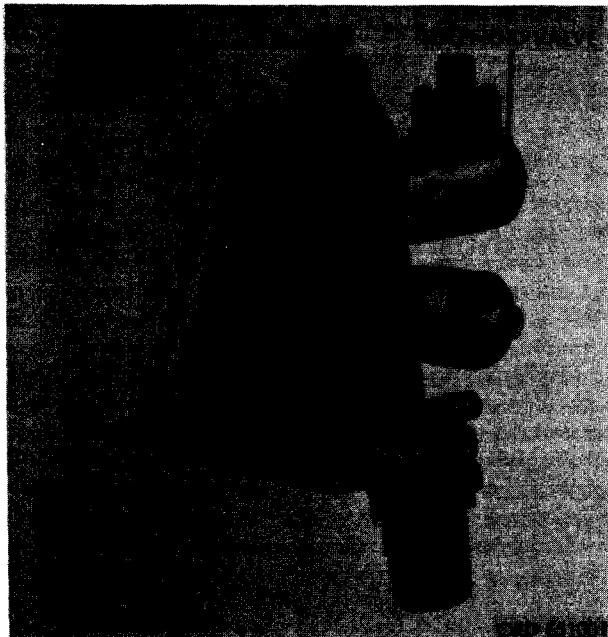


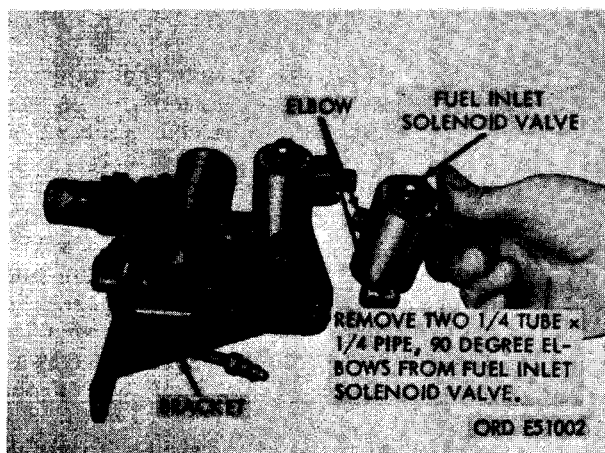
FIGURE 145. DISCONNECTING OR CONNECTING FUEL INLET SOLENOID VALVE TUBES AND HARNESS.

- (4) Refer to figure 146 and disconnect solenoid valves from flame heater fuel pump and fuel filter bracket.
- (5) Refer to figure 146 and remove solenoid valves from flame heater fuel pump and fuel filter bracket.



**FIGURE 146. REMOVING OR INSTALLING FUEL INLET SOLENOID VALVE.**

- (6) Refer to figure 147 and remove elbows from flame heater solenoid valve.



**FIGURE 147. REMOVING OR INSTALLING FUEL INLET SOLENOID VALVE ELBOWS.**

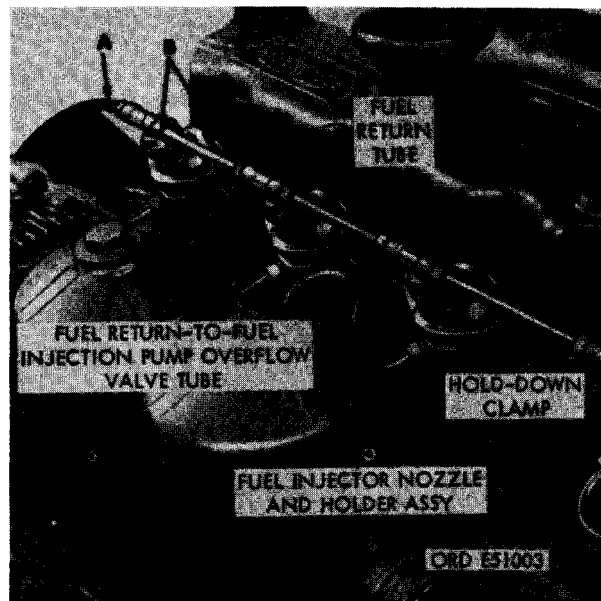
- b. Installation. Refer to figures 143 through 147 and reverse the sequence of illustrations and instructions to install the flame heater solenoid valves.

### 83. FUEL INJECTOR NOZZLE AND HOLDER ASSEMBLIES

- a. General. All injector nozzle and holder assemblies are replaced and repaired in the same manner.

- b. Removal. Remove fuel injector nozzle and holder assemblies as follows.

- (1) Figure 148. (A) Disconnect fuel return-to-fuel injection pump overflow valve tube from 1/4-inch tube tee in nozzle and holder assembly. (B) Disconnect the fuel injector nozzle fuel return tube from the 1/4-inch tube tee in fuel injector nozzle and holder assembly. Remove tube. (C) Disconnect fuel injector tube from fuel injector nozzle and holder assembly, (D) Remove two 5/16 x 2-1/2 cap screws and 5/16-inch lock washers securing fuel injector nozzle hold-down clamp and fuel injector nozzle and holder assembly to cylinder head.



**FIGURE 148. DISCONNECTING OR CONNECTING FUEL INJECTOR NOZZLE AND HOLDER FUEL RETURN TUBE, FUEL INJECTION TUBE, AND HOLD-DOWN CLAMPS.**

- (2) Figure 149. (A) Remove fuel injector nozzle and holder assembly. (B) Remove and discard fuel injector nozzle-to-head gasket.



FIGURE 149. REMOVING OR INSTALLING FUEL INJECTOR NOZZLE AND HOLDER ASSEMBLY.

- (3) Figure 150. (A) Remove 1/4 tube x 1/8 pipe tee from nozzle and holder assembly and seal opening in nozzle. (B) Remove hold-down clamp. Note the dowel pin hole in clamp and locating dowel pin in holder. The hold-down clamp must be installed with dowel pin entering hole to properly position the nozzle and holder assembly in the cylinder head.

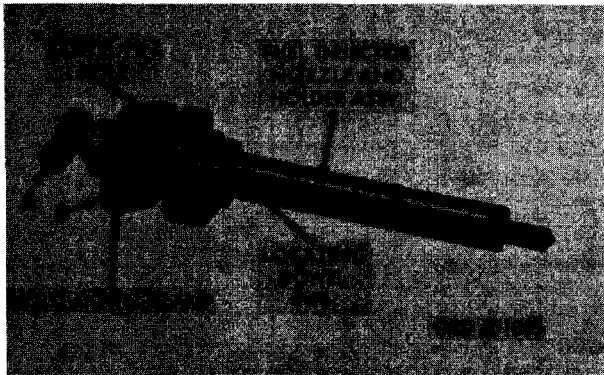


FIGURE 150. REMOVING OR INSTALLING FUEL INJECTOR NOZZLE AND HOLDER TUBE TEE AND HOLD-DOWN CLAMP.

c. Installation of Nozzle and Holder Assembly-in Nozzle Tester.

- (1) Before testing nozzle and holder assembly, clean the external area to remove carbon and dirt. Do not allow dirt to enter the fuel inlet opening. Install the nozzle and holder assembly in the nozzle tester as follows.

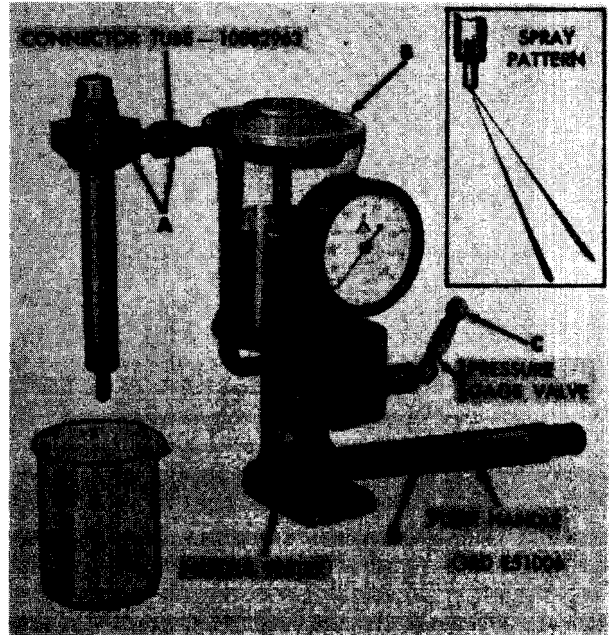


FIGURE 151. TESTING FUEL INJECTOR NOZZLE AND HOLDER ASSEMBLY.

- (2) Figure 151. (A) Mount the injector nozzle and holder assembly on the nozzle tester using the connector tube - 10882963. (B) Fill nozzle tester container with sufficient fuel. (C) Close the pressure gage valve and actuate the pump handle approximately 25 strokes to clear all air from the nozzle and holder assembly. (D) Open the pressure gage valve and depress the pump handle slowly to raise the pressure. Note pressure on gage at which nozzle opens.

Warning: The penetrating power of atomized fuel under pressure is sufficient to puncture the skin and may cause blood poisoning. Keep hands away from nozzle during test.

#### d. Test Nozzle and Holder Assembly

- (1) New nozzles should have an opening pressure of 2750 to 2800 psi and used nozzles should have an opening pressure of 2500 plus or minus 25 psi to be considered serviceable. Adjust nozzle pressure by turning the adjusting screw clockwise to increase the opening pressure and counterclockwise to decrease the opening pressure. Refer to figure 152 for instructions on removing nozzle and holder cap to gain access to the adjusting screw.
- (2) Figure 152. (A) Clamp fuel injector nozzle and holder assembly in a soft-jawed vise. (B) Hold lock nut to prevent turning adjusting screw when cap is removed. (C) Remove cap. Remove and discard cap gasket.



FIGURE 152. REMOVING OR INSTALLING NOZZLE AND HOLDER ASSEMBLY CAP.

- (3) Check nozzle leakage. With the pressure valve open, actuate tester slowly to build up pressure. As correct pressure is approached, observe spray orifices. If drops of fuel form or if fuel issues as a stream below 2750 psi, the nozzle is leaking and must be replaced.

Note. Normally a nozzle will chatter or “bark” as it opens. This noise generally accompanies a properly functioning nozzle and indicates that the valve is free and that the seating surface is good.

- (4) Check nozzle spray pattern. Close the gage valve and operate the pump handle at approximately 15 strokes per minute. If the two spray holes are clean, the spray pattern should be clean and sharp with a uniform conical pattern of fuel discharge. If the spray pattern is poor and does not improve with increased operation, fuel impurities may have corroded or eroded the spray holes and the nozzle must be replaced. Properly operating nozzles should not be disassembled and cleaned. Install locking nut and cap by reversing sequence of instructions for figure 152. Recheck spray pattern after adjustment.

e. Disassembly. Disassemble nozzle and holder assembly as follows.

Caution: Valve should not be handled with bare hands. Such handling will wipe oil film from part and may cause a sticking valve. Do not permit polished surface of valve or body to come in contact with any hard substance. Remove valve carefully to prevent damage to surfaces.

- (1) Refer to figure 152 and remove cap and cap gasket from nozzle and holder assembly.
- (2) Figure 153. (A) Loosen locknut. (B) Remove adjusting screw and lock nut. Remove and discard lock nut gasket. (C) Remove spring. (D) Remove spindle.

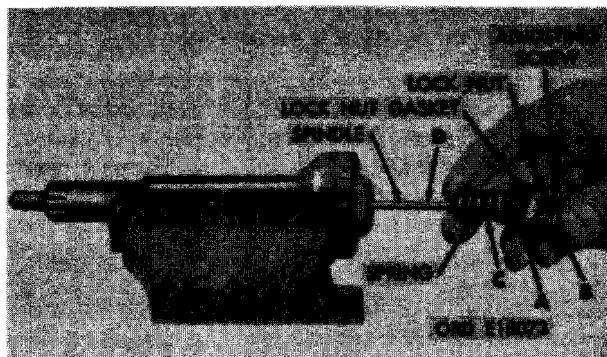


FIGURE 153. REMOVING OR INSTALLING LOCK NUT, ADJUSTING SCREW, SPRING, SPINDLE, AND GASKET.

- (3) Figure 154. (A) Position nozzle holder in vise as shown. (B) Remove nozzle cap nut. (C) Remove nozzle body and valve as an assembly.

Note. The nozzle assembly must be centered in the cap nut when installing cap nut on nozzle holder.

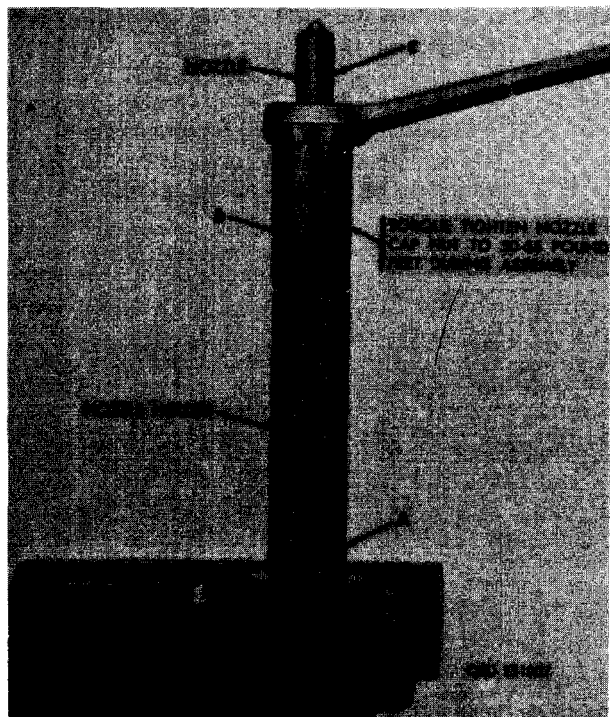


FIGURE 154. REMOVING OR INSTALLING NOZZLE CAP NUT AND NOZZLE ASSEMBLY.

- (4) Refer to figure 155 and remove the valve from the nozzle assembly.

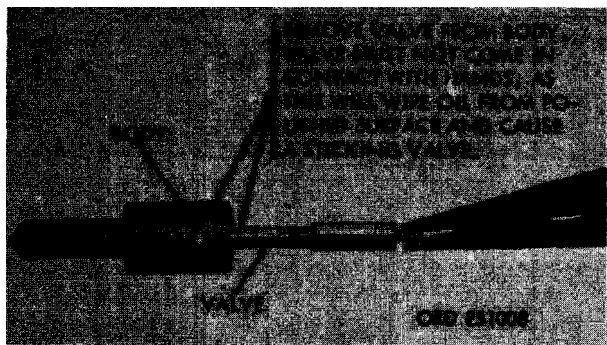
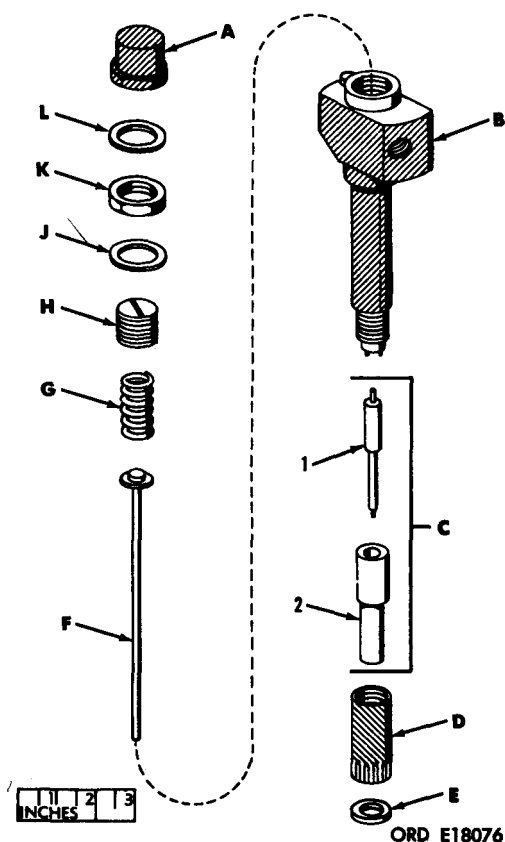


FIGURE 155. REMOVING OR INSTALLING VALVE.

f. Cleaning (fig. 156).

- (1) Soak the valve (C- 1) and nozzle body (C-2) in a carbon removing solvent to remove major carbon deposits.



- |                     |                     |
|---------------------|---------------------|
| A - Cap             | F - Spindle         |
| B - Body            | G - Spring          |
| C - Nozzle assembly | H - Adjusting screw |
| 1- Valve            | J - Lock nut gasket |
| 2- Nozzle body      | K - Lock nut        |
| D - Nozzle cap nut  | L - Cap gasket      |
| E - Gasket          |                     |

FIGURE 156. FUEL INJECTOR AND HOLDER ASSEMBLY - EXPLODED VIEW.

- (2) Clean the valve (C- 1) with a soft cloth or a felt pad and mutton tallow. The valve can be held by the stem in a revolving chuck during this operation. A piece of soft wood, well soaked in oil, may be used for cleaning carbon from the valve.

Caution: Do not scrape carbon from valve or inner surface of body with any sharp tool, abrasive material, or wire brush. Highly polished surfaces may be severely damaged.

- (3) Clean carbon from spray nozzle holes in nozzle body (C-2) by probing with a 0.010- inch diameter cleaning wire.

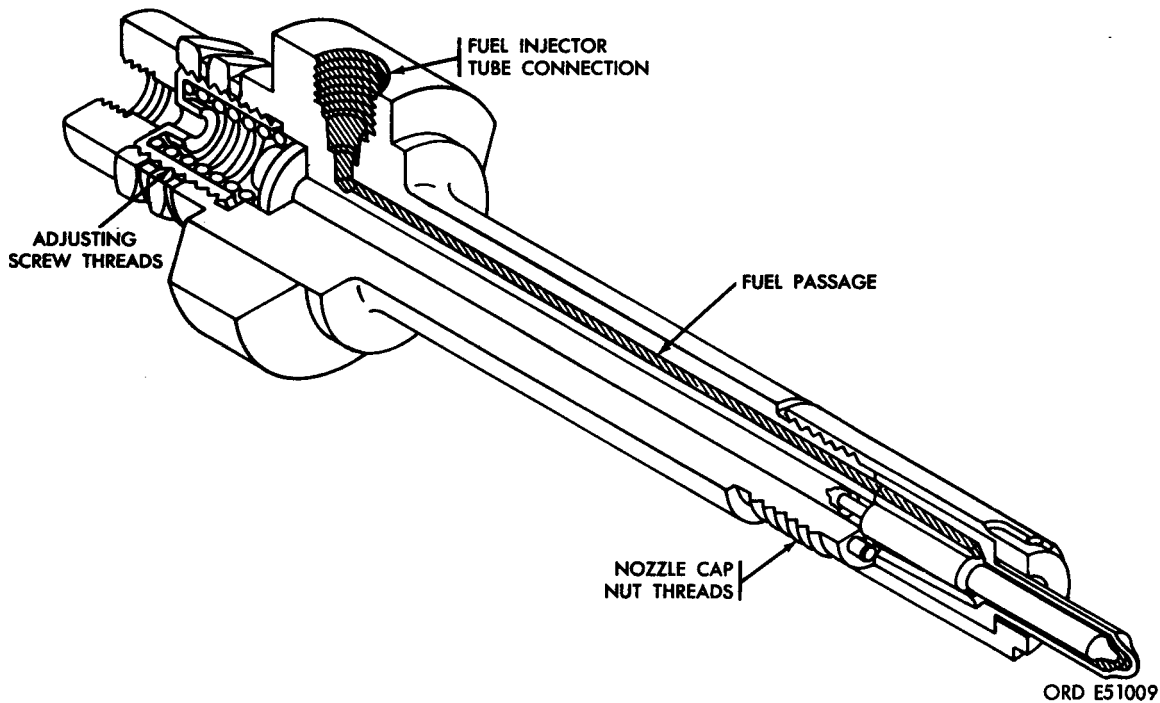
Note. Use extreme care while cleaning to prevent breakage of cleaning wire in holes as it is often impossible to remove broken pieces.

- (4) Clean the inside of the nozzle body (C-2) with a formed piece of soft wood, well soaked in oil. The point of the wooden probe should correspond to the angle of the valve seat. Clean the outer surface of the body with a soil cloth soaked in carbon solvent. Do not scrape carbon from the surface around the orifices.

- (5) Clean the body (B), spindle (F), spring (G), adjusting screw (H), lock nut (K), and cap (A) with dry- cleaning solvent or mineral spirits paint thinner. Remove sludge and gum deposits from fuel passage in body (fig. 157) by probing with an 0.010- inch diameter cleaning wire.

g. Inspection (fig. 156).

- (1) Inspect seat of valve (C-1) and nozzle body (C-2) for evidence of wear, distortion of the valve seat due to pounding, discoloration due to overheating, and for pitting. Inspect the highly polished shoulder for scratches and discoloration. Check fit of valve in the nozzle body (C- 2). The valve should slide freely to its seat without aid. Inspect the body valve seat using a strong light and a magnifying glass for scratches, dis-



**FIGURE 157. FUEL INJECTOR NOZZLE AND HOLDER ASSEMBLY - SECTIONAL VIEW.**

coloration, wear, pitting, and evidence of pounding. Defective parts are cause for replacement.

- (2) Inspect nozzle spring (G) for cracks and evidence of wear.
- (3) Check nozzle cap nut threads (fig. 157), fuel injector tube connection threads (fig. 157), and adjusting screw threads (fig. 157) for damage. Replace nozzle and holder assembly when these threads are stripped or damaged beyond repair.

**h. Repair** (fig. 156). Repair of defective parts is limited to the reconditioning of damaged threads and the lapping of the valve (C-1) to the valve nozzle body (C-2). Repair damaged threads, and lap the valve in the body to remove minor discolorations. Replace parts showing wear, pounding, or pitting. Replace the nozzle assembly if the spray holes are oversized or if they cannot be freed of obstructions. Replace nozzle assembly when lapped sealing surface of body (B) is badly scratched or nicked or when polishing on a lapping plate does not remove the defects. Remove minor scratches from sealing surface with fine compound on a lapping plate. The nozzle body (B) must be held flat on the lapping plate during this operation. Replace nozzle body if locating dowel pin is loose or damaged.

**i. Assembly.** Refer to figures 152 through 155 and reverse the sequence of illustrations and instructions to assemble the fuel injector nozzle and holder assemblies. Test nozzle and holder assembly after assembly following instructions for figure 151.

**Note.** The fuel injector nozzle and holder assembly is precision manufactured and assembly requires special precautions. The nozzle must be clean and free of any grease deposits or finger stains. Store nozzle and holder assembly in a suitable container to prevent entrance of dirt.

**j. Installation.** Refer to figures 148 through 150 and reverse the sequence of illustrations and instructions to install the fuel injector nozzle and holder assemblies. Use a new fuel injector-to-nozzle gasket. Hold gasket in place at nozzle end by applying a light coating of grease around gasket. Torque the hold-down clamp cap screws to 150 to 175 pound inches.

## 84. DRIVE BELTS

### a. Engine Fan and Generator Drive Belts.

- (1) Remove engine fan and generator drive belts following instructions which accompany figure 41.
- (2) Refer to figure 41 and reverse the sequence of instructions to install engine fan and generator drive belts.

Note. When one engine fan and generator drive belt is worn or broken, replace both belts.

- (3) Adjust engine fan and generator drive belt deflection following instructions in figure 43.

### b. Air Compressor Drive Belt.

- (1) Remove engine fan and generator drive belts following instructions for figure 41.
- (2) Remove air compressor drive belt following instructions for figures 80 through 82.
- (3) Refer to figures 80 through 82 and reverse the sequence of illustrations and instructions to install air compressor drive belt.
- (4) Adjust air compressor drive belt deflection following instructions for figure 87.
- (5) Refer to figure 41 and reverse the sequence of instructions to install engine fan and generator drive belts.
- (6) Adjust engine fan and generator drive belt deflection following instructions for figure 43.

## 85. ENGINE FAN

**a. Removal.** Remove engine fan following the instructions for figure 112.

**b. Installation.** Refer to figure 112 and reverse the sequence of instructions to install the engine fan.

## 86. TRANSMISSION ADAPTER AND FLYWHEEL

a. Removal. Remove transmission adapter and flywheel as follows.

- (1) Remove clutch cover assembly and driven member assembly following the instructions for figures 88 and 89.

Note. To replace transmission adapter only, do not remove the clutch cover and driven member assemblies.

- (2) Figure 158. (A) Remove thirteen 3/8-inch plain nuts and 3/8-inch lock washers securing transmission adapter to flywheel housing. (B) Remove transmission adapter. (C) Remove and discard transmission adapter gasket.

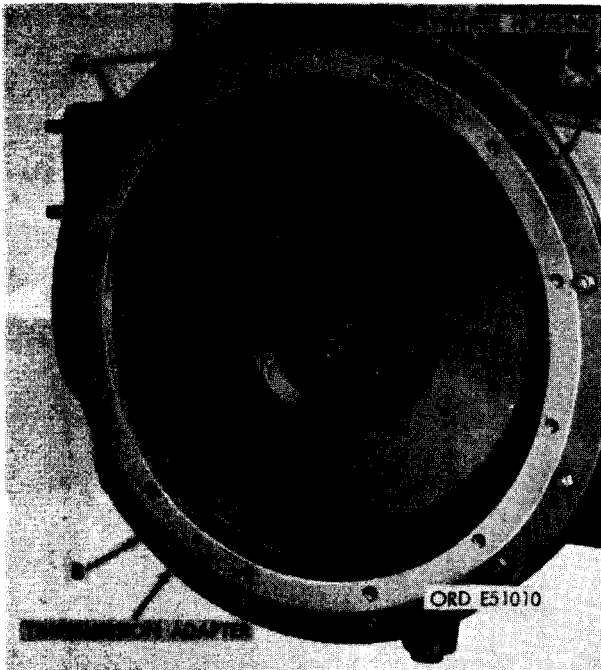


FIGURE 158. REMOVING OR INSTALLING TRANSMISSION ADAPTER.

- (3) Figure 159. (A) Remove six 1/2 x 1-1/8 cap screws securing flywheel to end of crankshaft. (B) Remove flywheel.

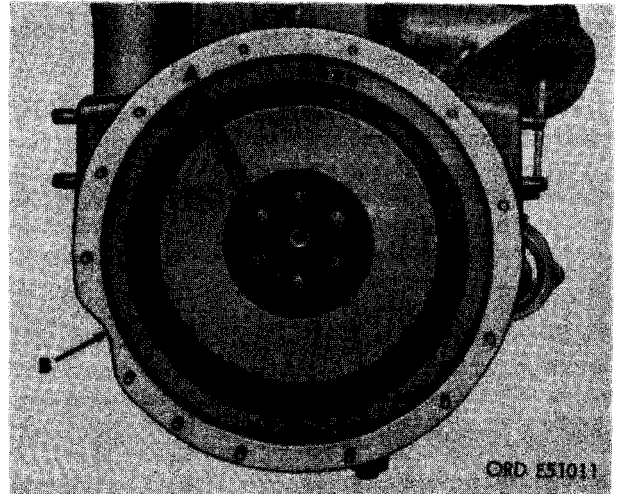


FIGURE 159. REMOVING OR INSTALLING FLYWHEEL.

### b. Installation.

Note. One flywheel cap screw hole in flywheel and threaded hole in the end of crankshaft assembly is off location so that flywheel can be installed in only one position.

- (1) Fabricate a pilot from a 1/2-20 x 3-1/3 bolt. Cut off bolt head and grind any burrs from shank. Install pilot in top threaded hole in end of crankshaft assembly as shown in figure 160.

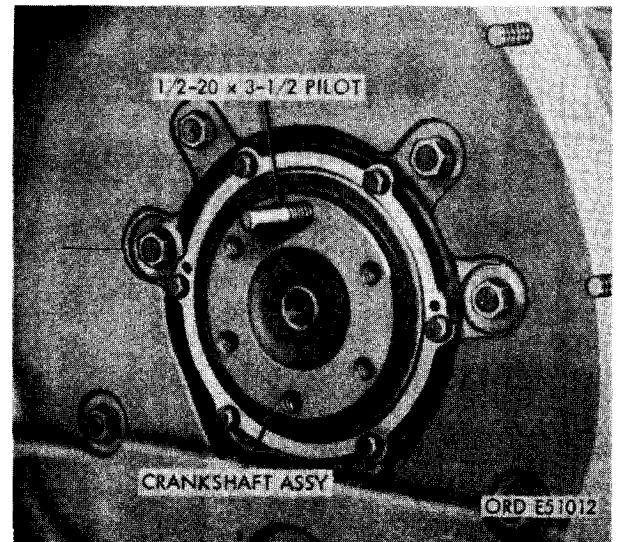


FIGURE 160. REAR FLANGE OF CRANKSHAFT WITH FABRICATED PILOT INSTALLED.



- (2) Refer to figure 159 and reverse the sequence of instructions to install the flywheel. Remove pilot after flywheel is properly positioned and all cap screw holes align. Tighten the six 1/2 x 1- 1/8 cap screws to a torque of 650 to 700 pound inches.

c. Check Flywheel Runout. Figure 161. (A) Install a small steel plate on flywheel housing and secure to transmission adapter stud using a 3/8-inch plain nut. (B) Mount magnetic base dial indicator on steel plate. Position indicator arm against flywheel face. Dial indicator gage must contact a clean surface on the flywheel during runout check. (C) Rotate flywheel one full revolution while pressing against crankshaft to eliminate the possibility of a false reading due to end play. Repeat the checking procedure to insure an accurate reading.

Note. Replace flywheel if runout exceeds a maximum of 0.008-inch.

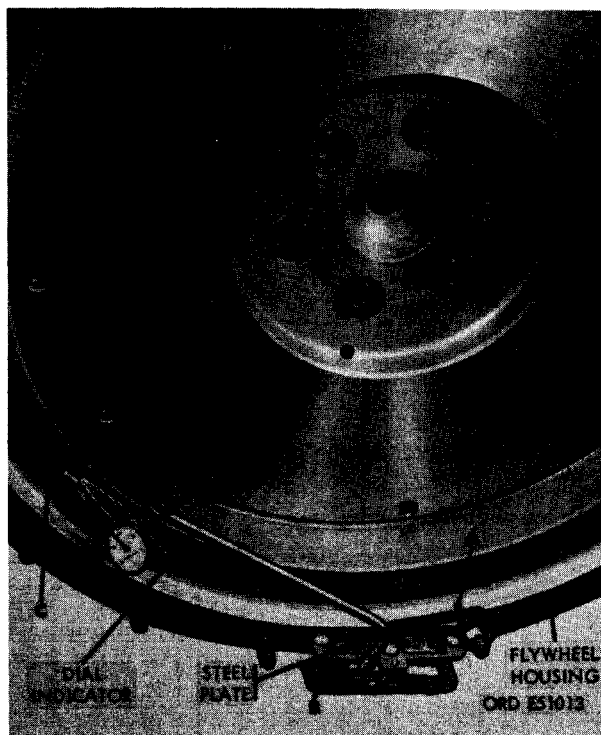


FIGURE 161. CHECKING FLYWHEEL RUN- USING A DIAL INDICATOR.

d. Install and Check Transmission Adapter Face Runout.

- (1) Refer to figure 158 and reverse the sequence of instructions to install transmission adapter.
- (2) Figure 162. (A) Mount a magnetic base dial indicator on face of flywheel. Set dial indicator arm against transmission adapter face. (B) Turn the crankshaft one complete revolution and check adapter face runout. Exert pressure against flywheel to eliminate the possibility of crankshaft end play causing a false reading. Maximum runout should not exceed 0.008- inch.

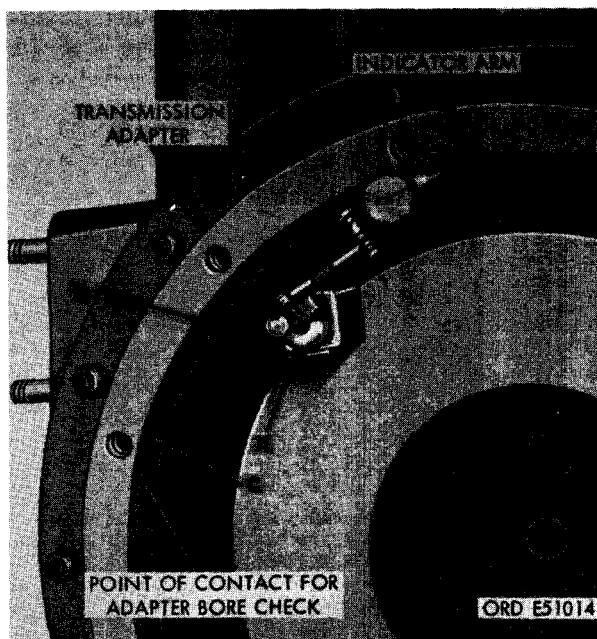


FIGURE 162. CHECKING TRANSMISSION ADAPTER FACE AND BORE RUNOUT USING A DIAL INDICATOR.

Note. When transmission adapter face runout exceeds 0.008-inch, check to determine the cause of excessive runout. Runout can be caused by foreign material wedged between the transmission adapter and face of flywheel housing. If no foreign material is present, replace the adapter. (C) Check transmission adapter bore in the same manner except ball point on dial indicator

gage should contact bore face as indicated. Maximum bore runout should not exceed 0.008-inch. Replace adapter when runout exceeds maximum runout.

e. Install Clutch Driven Member and Clutch Cover. Refer to figures 88 and 89 and reverse the sequence of illustrations and instructions to install clutch driven member and clutch cover assemblies.

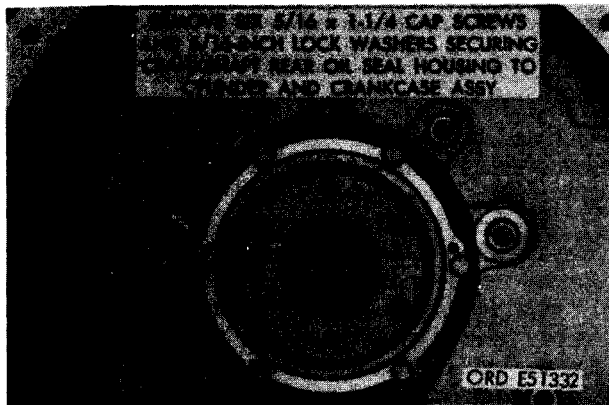


FIGURE 163. REMOVING OR INSTALLING CRANKSHAFT REAR OIL SEAL AND HOUSING ASSEMBLY CAP SCREWS.

## 87. CRANKSHAFT REAR OIL SEAL

a. Removal. Remove crankshaft rear oil seal as follows.

- (1) Remove clutch cover assembly and clutch driven member assembly following instructions which accompany figures 88 and 89.
- (2) Remove transmission adapter and flywheel following instructions in figures 158 and 159.
- (3) Refer to figure 163 and remove cap screws securing crankshaft rear oil seal and housing assembly to cylinder and crankcase.
- (4) Figure 164. (A) Remove crankshaft rear oil seal and housing assembly. (B) Remove and discard crankshaft rear oil seal housing gasket. (C) Note the dowel pin holes in oil seal housing and locating dowel pins in crankcase. Dowel pins insure proper housing alignment so oil seal lip is concentric with crankshaft seal surface.

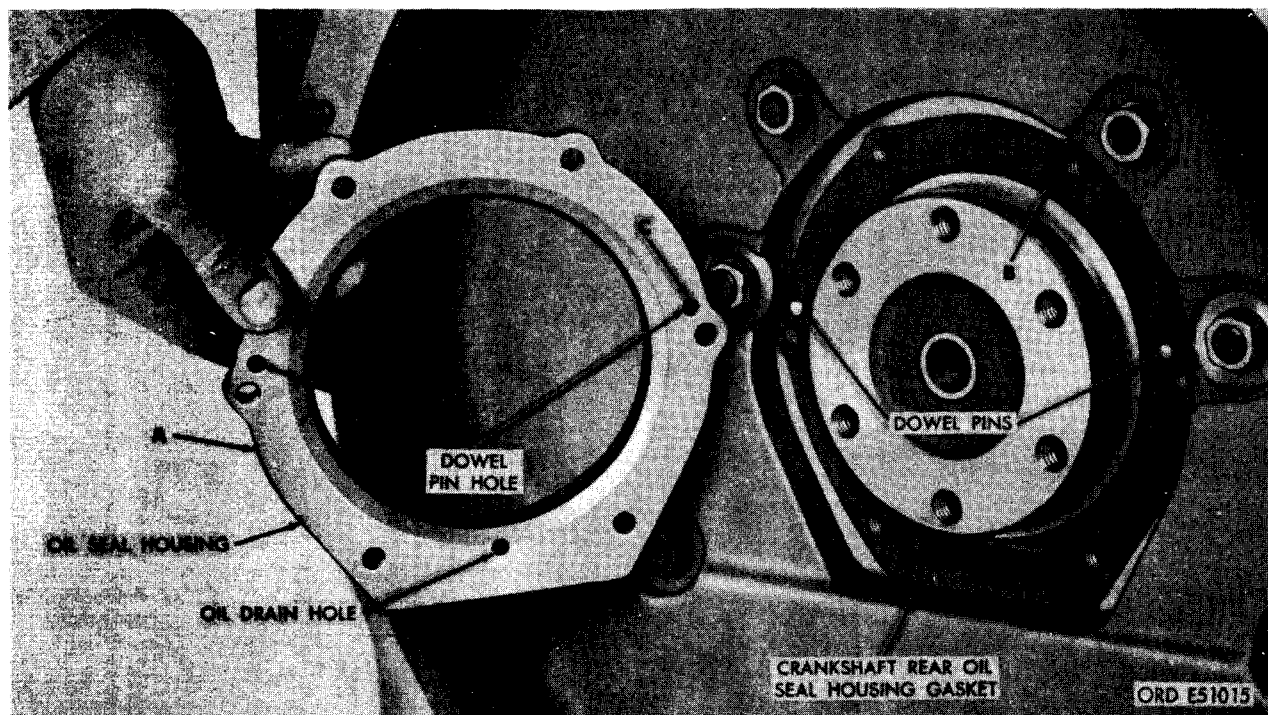


FIGURE 164. REMOVING AND INSTALLING CRANKSHAFT REAR OIL SEAL AND HOUSING ASSEMBLY AND GASKET.

- (5) Refer to figure 165 and remove rear oil seal from oil seal housing.

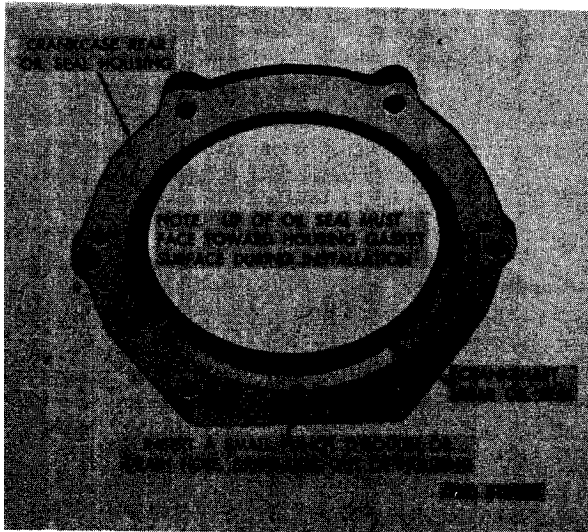


FIGURE 165. REMOVING CRANKSHAFT REAR OIL SEAL FROM HOUSING.



FIGURE 166. INSTALLING CRANKSHAFT REAR OIL SEAL IN OIL SEAL HOUSING.

- b. Installation. Install crankshaft rear oil seal and oil seal housing as follows.

- (1) Figure 166. (A) Position crankshaft rear oil seal housing, gasket surface down, on press table as shown. (B) Start crankshaft rear oil seal into "housing making sure oil seal lip is facing housing gasket surface as shown in figure 167. (C) Install oil seal into housing using a suitable pressing plate having a slightly smaller diameter than the oil seal casing.

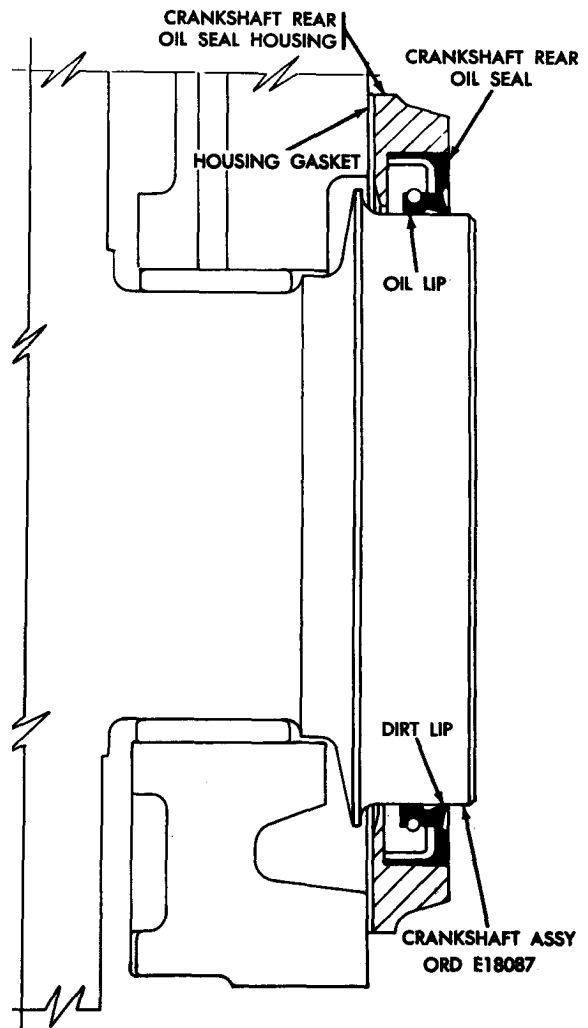


FIGURE 167. CRANKSHAFT REAR OIL SEAL IN OIL SEAL HOUSING.

- (2) Refer to figures 163 and 164 and reverse the sequence of illustrations and instructions to install the crankshaft rear oil seal and housing assembly on the engine.

Note. Apply a light coating of lubricant around lip of oil seal before installing seal and housing assembly on engine. Lubricant will prevent lip of seal from crimping as seal is slipped over pilot sleeve or seal surface of crankshaft flange. Use a seal pilot sleeve to prevent damage to seal lip.

- (3) Refer to figures 159 and 160 and reverse the sequence of illustrations and instructions to install the flywheel. Remove pilot after flywheel is properly positioned with all cap screw holes in flywheel aligned with screw holes in crankshaft. Tighten the six 1/2 x 1- 1/8 place bolts to a torque of 650 to 700 pound inches.
- (4) Check flywheel runout following instructions for figure 161.
- (5) Refer to figure 158 and reverse the sequence of instructions to install transmission adapter.
- (6) Check transmission adapter face runout following instructions for figure 162.
- (7) Refer to figures 88 and 89 and reverse the sequence of illustrations and instructions to install clutch driven member and clutch cover assemblies.

## 88. EXHAUST MANIFOLD

a. General. When it becomes necessary to remove the exhaust manifold assembly for replacement or for gasket replacement, the intake manifold will also have to be removed. Both the intake and exhaust manifolds must be removed at the same time, neither can be removed separately.

b. Removal. Remove exhaust manifold as follows.

- (1) Refer to figures 109 through 112 and follow the sequence of illustrations and instructions to remove the thermostat housing.

- (2) Remove turbosupercharger assembly following the sequence of illustrations and instructions for figures 44 through 47 and 49 through 52.
- (3) Figure 168. (A) Remove No. 12 plain nut, No. 12 lock washer, and No. 12 x 5/8 machine screw securing oil level gage rod support to oil gage rod bracket. (B) Disconnect 1/4- inch tube nut on flame heater fuel return-to- solenoid valve tube from 1/8- inch pipe union in flame heater nozzle and holder assembly. (C) Disconnect 1/8- inch tube nut on flame heater fuel solenoid valve-to- flame heater nozzle tube from 1/4 tube x 1/8 pipe, 90 degree elbow in flame heater nozzle and holder assembly. (D) Disconnect flame heater ignition lead from flame heater ignition unit. (E) Remove oil level gage rod from rod support.

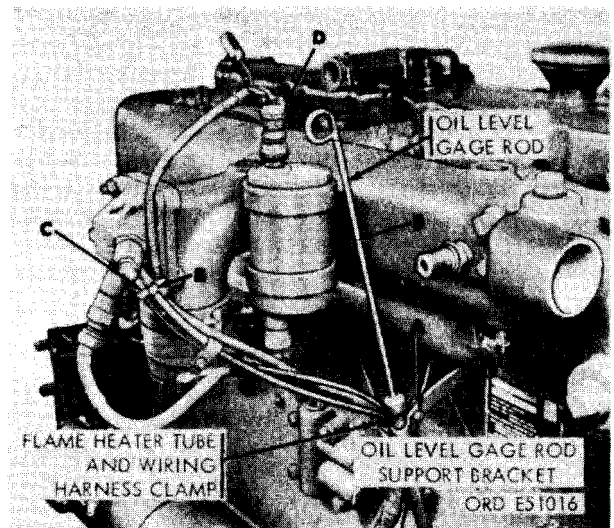


FIGURE 168. DISCONNECTING OR CONNECTING INTAKE MANIFOLD FLAME HEATER FUEL TUBES, IGNITION LEAD, AND OIL LEVEL GAGE SUPPORT BRACKET.

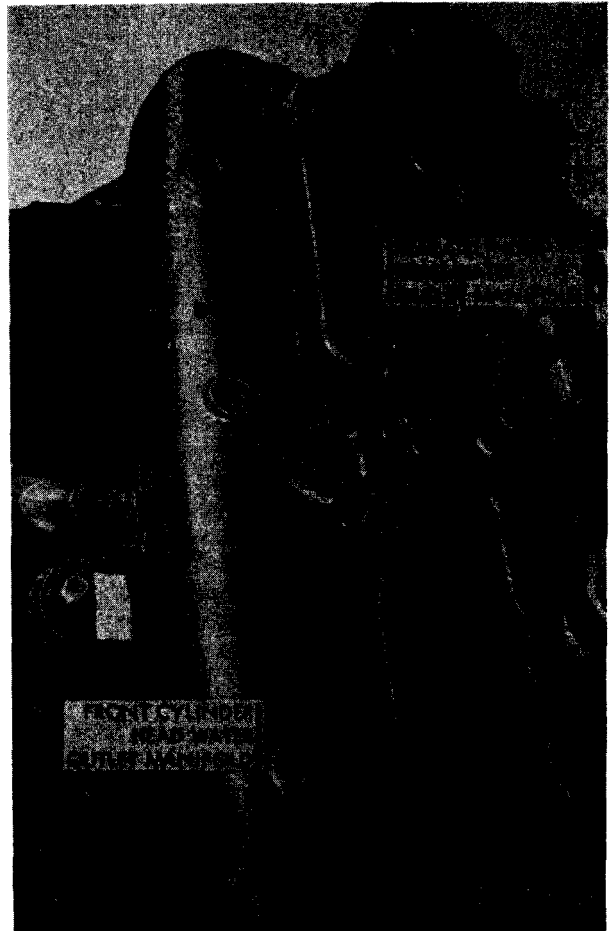
- (4) Figure 169. (A) Disconnect turbosupercharger oil inlet tube from 3/8 tube x 3/8 pipe, 90 degree elbow in crankcase and remove tube. (B) Remove six 7/16- inch self- locking nuts and 7/16- inch flat washers securing bottom flanges of exhaust manifold sections to cylinder heads. (C) Remove oil level gage rod



**FIGURE 169. DISCONNECTING OR CONNECTING MANIFOLDS - BOTTOM VIEW.**

support from crankcase and bracket. (D) Remove the oil level gage rod support clamp bracket. (E) Remove six 5/16-inch plain nuts and 5/16-inch flat washers securing bottom flanges of intake manifold to front and rear cylinder heads.

- (5) Figure 170. (A) Remove twelve 5/16 x 2-1/4 cap screws and 5/16-inch lock washers securing front and rear cylinder head water outlet manifolds to front and rear cylinder head assemblies. (B) Remove twelve 5/16-inch plain nuts and 5/16-inch flat washers securing top flanges of intake manifold to front and rear cylinder head assemblies. (C) Remove six 7/16-inch self-locking nuts and 7/16-inch flat washers securing top flanges of exhaust manifold to front and rear cylinder head assemblies.



**FIGURE 170. DISCONNECTING OR CONNECTING MANIFOLDS - TOP VIEW.**

- (6) Refer to figure 171 and remove intake, exhaust and cylinder head water outlet manifolds as a unit.

Note. The intake and exhaust manifolds may be separated after they have been removed from the cylinder head studs.

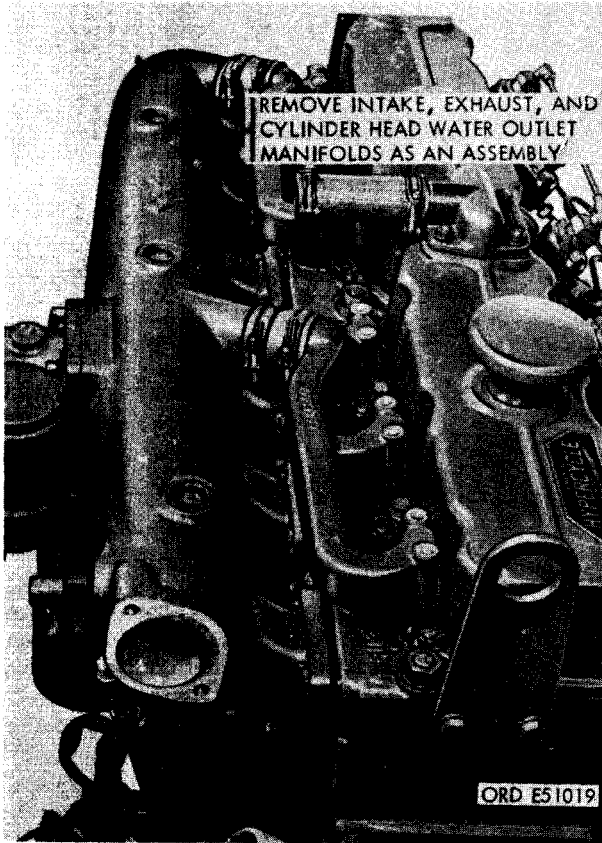


FIGURE 171. REMOVING OR INSTALLING INTAKE, EXHAUST, AND CYLINDER HEAD WATER OUTLET MANIFOLDS AT CYLINDER HEAD ASSEMBLIES - TOP VIEW.

- (7) Figure 172. (A) Remove and discard six cylinder head water outlet manifold gaskets. (B) Remove and discard six intake manifold gaskets. (C) Remove and discard six exhaust manifold gaskets.

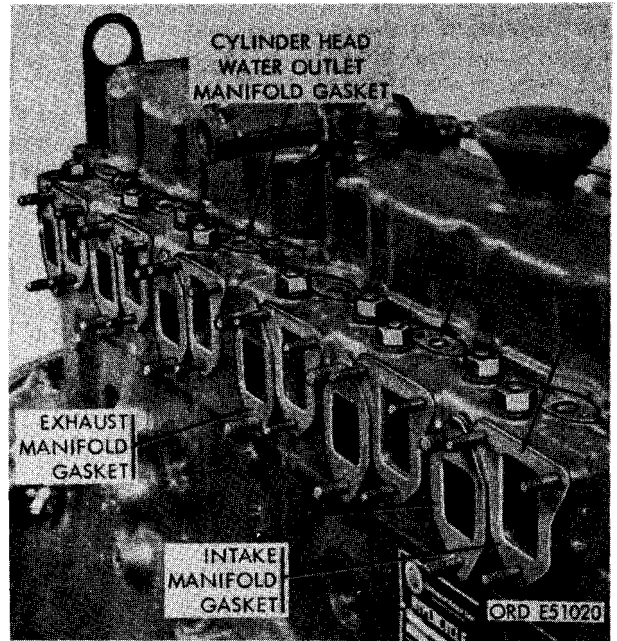


FIGURE 172. REMOVING OR INSTALLING INTAKE, EXHAUST, AND CYLINDER HEAD WATER OUTLET MANIFOLD GASKETS.

- (8) Figure 173. (A) Apply heat to joint of front exhaust manifold section and separate the front section from the center section. (B) Remove the rear exhaust manifold section from the center section in the same manner.

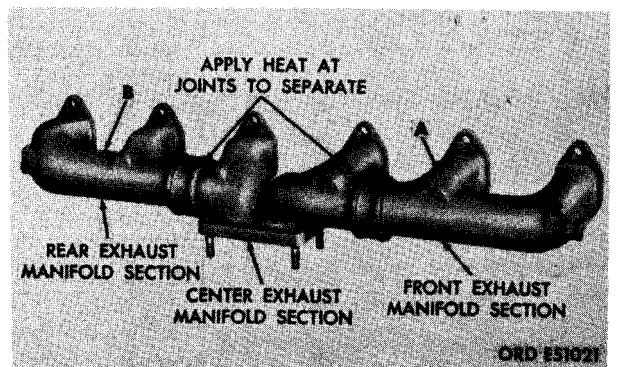


FIGURE 173. EXHAUST MANIFOLD ASSEMBLY SHOWING HEAT APPLICATION POINTS FOR SEPARATION OF SECTIONS.

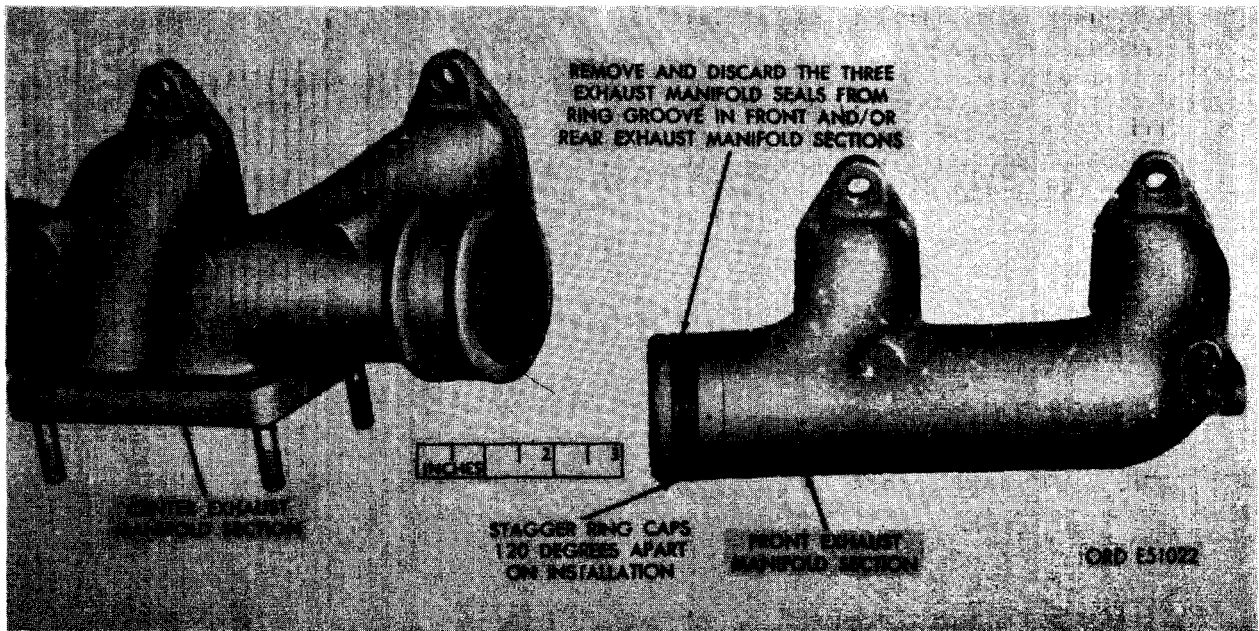


FIGURE 174. REMOVING OR INSTALLING EXHAUST MANIFOLD RING TYPE SEALS.

- (9) Refer to figure 174 and separate the three exhaust manifold sections. The sections may be replaced separately. To replace a section the entire manifold assembly must be removed from the engine. Remove the seals from the manifold sections.

c. Installation.

Note. The intake and exhaust manifolds must be installed at the same time. Neither can be installed separately due to the interference between studs and manifold mounting flanges.

- (1) Refer to figures 168 through 174 and reverse the sequence of illustrations and instructions to install the exhaust manifold assembly. Install new intake, exhaust, and cylinder head water outlet manifold gaskets.

Note. Tighten nuts alternately before torquing to avoid damage to manifolds.

- (2) Refer to figures 44 through 47 and 49 through 52 and reverse the sequence of illustrations and instructions to install

the turbosupercharger assembly. Use new turbosupercharger-to- intake manifold hose if necessary.

- (3) Refer to figures 109 through 112 and reverse the sequence of illustrations and instructions to install the thermostat housing, using a new gasket.

89. INTAKE MANIFOLD

a. Removal. To remove the intake manifold assembly exhaust manifold assembly must be removed (par. 88). Neither can be removed separately. Remove intake manifold as follows.

- (1) Refer to figures 109 through 111 and follow instructions to remove thermostat housing.
- (2) Remove turbosupercharger assembly following the sequence of illustrations and instructions for figures 44 through 47 and 49 through 52.
- (3) Remove the intake manifold assembly following instructions for figures 168 through 172.

**b. Disassembly.** Disassemble the intake manifold assembly as follows.

- (1) Figure 175. (A) Loosen the two 1-5/8-inch hose clamps and remove front cylinder head water outlet manifold from intake manifold. (B) Loosen the two 1-5/8-inch hose clamps and remove rear cylinder head water outlet manifold from intake manifold.

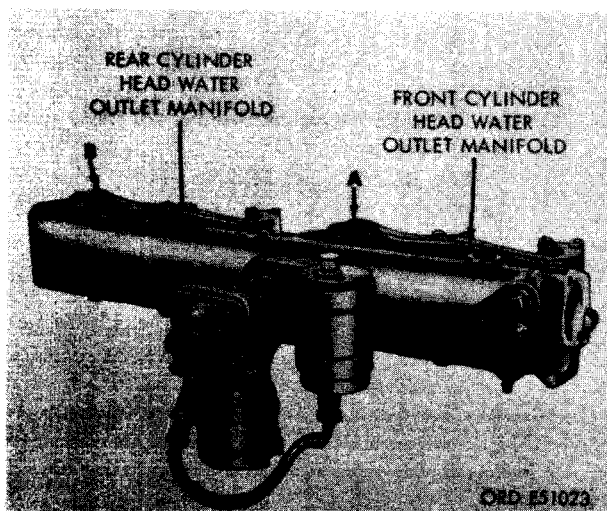


FIGURE 175. REMOVING OR INSTALLING CYLINDER HEAD WATER OUTLET MANIFOLDS.

- (2) Figure 176. (A) Disconnect flame heater ignition lead from spark plug. (B) Remove two 5/16-inch plain nuts and 5/16-inch lock washers securing the two clamps which hold ignition unit to intake manifold elbow. (C) Remove ignition unit with clamps and flame heater ignition lead. (D) Remove two 5/16-inch plain nuts and 5/16-inch lock washers securing intake manifold elbow to intake manifold. (E) Remove elbow with attached intake manifold flame heater assembly.

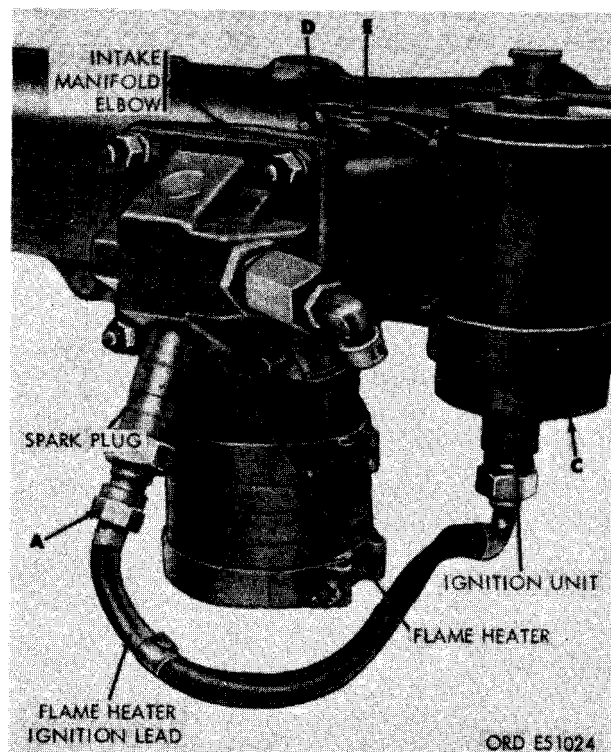


FIGURE 176. REMOVING OR INSTALLING INTAKE MANIFOLD ELBOW WITH FLAME HEATER INSTALLED.

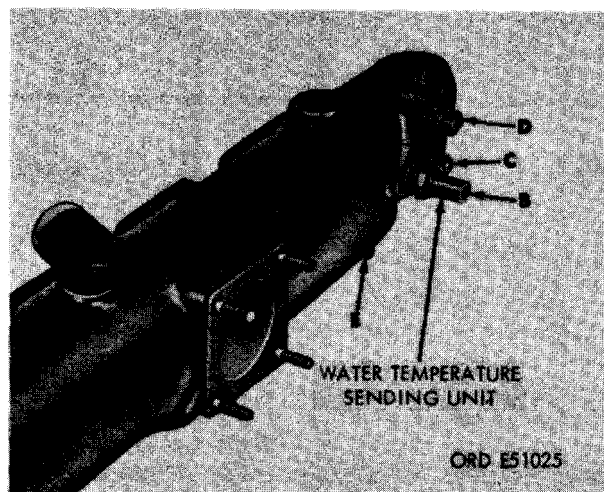


FIGURE 177. REMOVING OR INSTALLING INTAKE MANIFOLD ELBOW GASKET, WATER TEMPERATURE SENDING UNIT, AND PIPE PLUGS.



- (3) Figure 177. (A) Remove and discard intake manifold elbow gasket. (B) Remove water temperature sending unit. (C) Remove 3/8-inch square head pipe plug. (D) Remove 1/2- inch square head pipe plug. (E) Remove 1/4- inch square head pipe plug.

c. Assembly. Refer to figures 175 through 177 an reverse the sequence of illustrations and instructions to assemble the intake manifold assembly. Use a new intake manifold elbow gasket. Replace the turbosupercharger -to - intake manifold hose when necessary.

d. Installation.

- (1) Refer to figures 168 through 172 and reverse the sequence of illustrations and instructions to install the intake manifold assembly. Install new intake, exhaust, and cylinder head water outlet manifold gaskets.
- (2) Refer to figures 44 through 47 and 49 through 52 and reverse the sequence of illustrations and instructions to install the turbosupercharger assembly.
- (3) Refer to figures 109 through 111 and re-



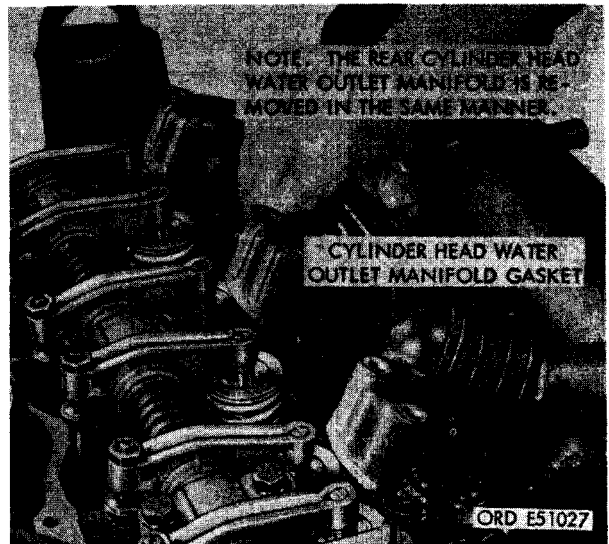
**FIGURE 178. DISCONNECTING OR CONNECTING FRONT CYLINDER HEAD WATER OUTLET MANIFOLD.**

**90. FRONT AND/OR REAR CYLINDER HEAD WATER OUTLET MANIFOLDS**

a. General. For instructional purposes, the front cylinder head water outlet manifold will be removed and installed.

b. Removal. Remove water outlet manifolds as follows.

- (1) Remove front cylinder head cover and gasket following instructions for figure 62.
- (2) Figure 178. (A) Loosen the two 1-5/8-inch hose clamps securing cylinder head water outlet manifold-to- intake manifold hose. (B) Remove six 5/16 x 2-1/4 cap screws and 5/16- inch lock washers securing front cylinder head water outlet manifold to f rent cylinder head.



**FIGURE 179. REMOVING OR INSTALLING FRONT CYLINDER HEAD WATER OUTLET MANIFOLD.**

- (3) Figure 179. (A) Remove front cylinder head water outlet manifold. (B) Remove and discard three cylinder head water outlet manifold gaskets.

c. Installation.

- (1) Refer to figures 178 and 179 and reverse the sequence of illustrations and instructions to install the front cylinder

head water outlet manifold. Use new cylinder head water outlet manifold gaskets.

Note. The rear cylinder head water outlet manifold is installed in the same manner.

- (2) Refer to figure 62 and reverse the sequence of instructions to install the front cylinder head cover. Use new gaskets under cover and breather adapter.

## 91. VALVE ROCKER ARM ADJUSTING SCREWS

a. General. When one or more valve rocker arm adjusting screw-s need replacement, remove the front and/or rear set of rocker arms. For instructional purposes, the front set of rocker arms will be removed.

b. Removal. Remove valve rocker arm adjusting screws as follows.

- (1) Remove front cylinder head cover and gasket following instructions for figure 62.
- (2) Figure 180. (A) Loosen six valve rocker adjusting screw lock nuts and alternately loosen valve rocker adjusting screws to relieve valve spring tension.

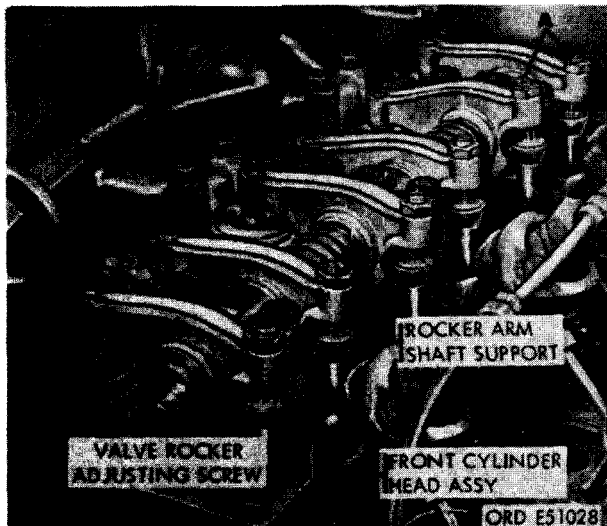


FIGURE 180. REMOVING OR INSTALLING CAP SCREWS SECURING ROCKER ARM SHAFT SUPPORTS.

(B) Remove six 3/8 x 2- 1/2 cap screws and 3/8- inch lock washers securing the three rocker arm shaft supports to the cylinder head.

- (3) Refer to figure 181 and remove front rocker arms.

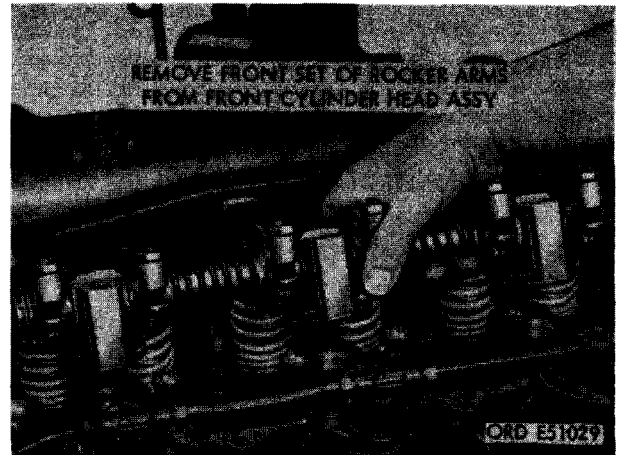


FIGURE 181. REMOVING OR INSTALLING FRONT ROCKER ARMS.

- (4) Figure 182. (A) Remove valve rocker adjusting screw lock nut. (B) Turn rocker arm adjusting screw clockwise to remove it from rocker arm assembly.

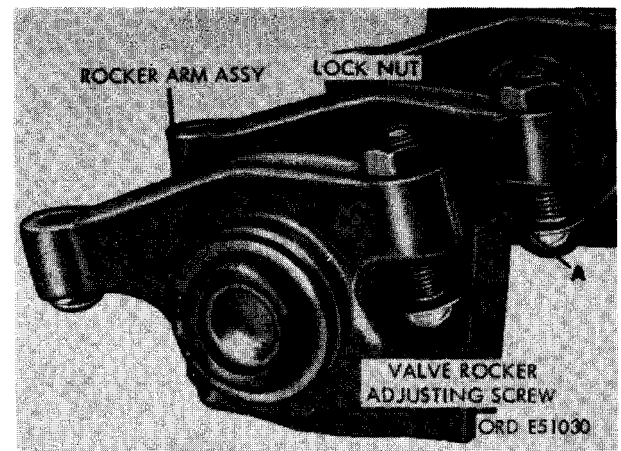


FIGURE 182. REMOVING OR INSTALLING VALVE ROCKER ARM ADJUSTING SCREW.

c. Installation. Refer to figures 180 through 182 and reverse the sequence of illustrations and instructions to install the valve rocker arm

adjusting screws. Do not tighten valve rocker arm adjusting screw lock nuts until valve clearance has been adjusted.

**d. Adjustment.** Adjust valve clearance as follows.

**Note.** Before adjusting valve clearance, rotate crankshaft as necessary to bring tappets on base circle of camshaft for valve being adjusted. Determine position of tappets by observing the up and down movement of the push rod as the crankshaft is rotated.

- (1) Figure 183. (A) Turn intake valve rocker arm adjusting screw as necessary to obtain a clearance of 0.015- inch. Tighten valve rocker arm adjusting screw lock nut after proper clearance is obtained, holding adjusting screw stationary while tightening lock nut. (B) Turn exhaust valve rocker arm adjusting screw as necessary to obtain a clearance of 0.025- inch. Tighten valve rocker arm adjusting screw lock nut after proper clearance is obtained, holding adjusting screw stationary while tightening lock nut.

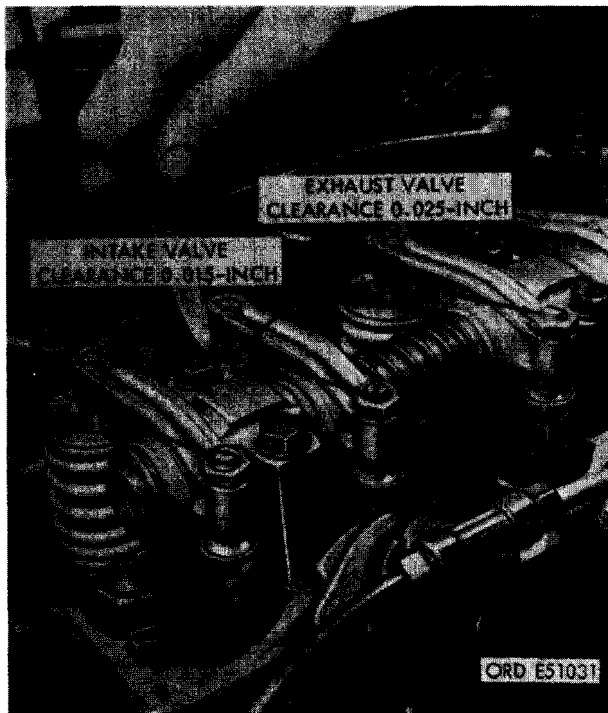


FIGURE 183. ADJUSTING INTAKE AND EXHAUST VALVE CLEARANCE.

(C) Adjust remaining valves in same manner. The intake valve is the front valve and exhaust valve is the rear valve.

- (2) Refer to figure 62 and reverse the sequence of instructions to install the front cylinder head cover. Use a new cover gasket and breather adapter gasket.

## 92. VALVE ROCKER ARM SHAFTS AND/OR ROCKER ARM ASSEMBLIES

**a. General.** The front and rear set of valve rocker arm shafts and rocker arm assemblies are replaced in the same manner. For instructional purposes, the front set of valve rocker arms will be removed for replacement of rocker arm shaft or rocker arm assemblies and for repair of the rocker arm assemblies.

**b. Removal.** Remove rocker arm assemblies as follows.

- (1) Remove front cylinder head cover and gasket following instructions which accompany figure 62.
- (2) Remove front set of rocker arms following instructions which accompany figures 180 and 181.

**c. Disassembly.** Disassemble rocker arm assembly as follows.

**Note.** Cylinder No. 3 (or No. 6) exhaust valve rocker arm assembly must be removed from the rear end of rocker arm shaft, due to a locating dowel pin.

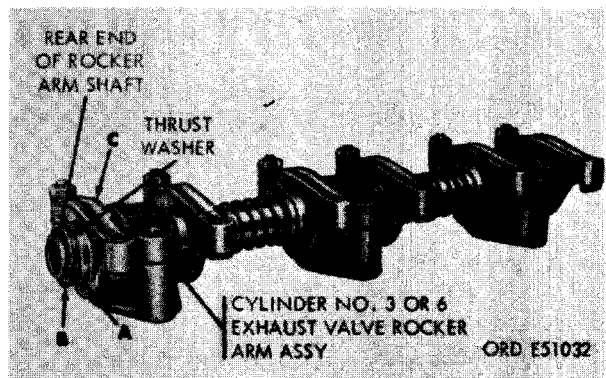


FIGURE 184. REMOVING OR INSTALLING CYLINDER NO. 3 (OR 6) EXHAUST VALVE ROCKER ARM ASSEMBLY.

- (1) Figure 184. (A) Remove valve rocker arm retaining ring securing cylinder No. 3 exhaust valve rocker arm assembly to valve rocker arm shaft. (B) Remove valve rocker arm thrust washer, (C) Remove cylinder No. 3 exhaust valve rocker arm assembly. Refer to figure 185 and note locating dowel pin in the valve rocker arm shaft and notch in valve rocker arm shaft support. Pin prevents shaft from rotating and locates rocker arm bearing oil holes.

Note. The remaining five valve rocker arm assemblies, three supports, and two thrust springs are removed from the front end of valve rocker arm shaft.

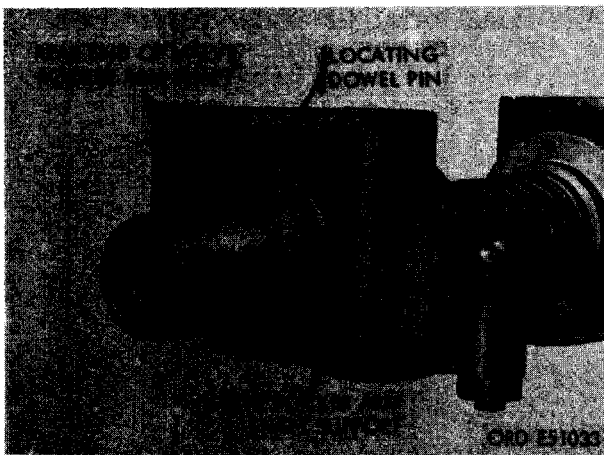


FIGURE 185. CYLINDER NO. 3 (OR 6) EXHAUST VALVE ROCKER ARM REMOVED SHOWING LOCATING DOWEL PIN AT REAR OF ROCKER ARM SHAFT.

- (2) Figure 186. (A) Carefully remove valve rocker arm retaining ring securing cylinder No. 1 intake valve rocker arm assembly to valve rocker arm shaft. (B) Remove valve rocker arm thrust washer. (C) Remove valve rocker arm assembly. (D) Remove valve rocker arm shaft support. (E) Remove the remaining valve rocker arm assemblies, thrust springs, and supports. Keep parts in order of removal.

Caution: The rocker arms are spring loaded by the tension of the two thrust springs.

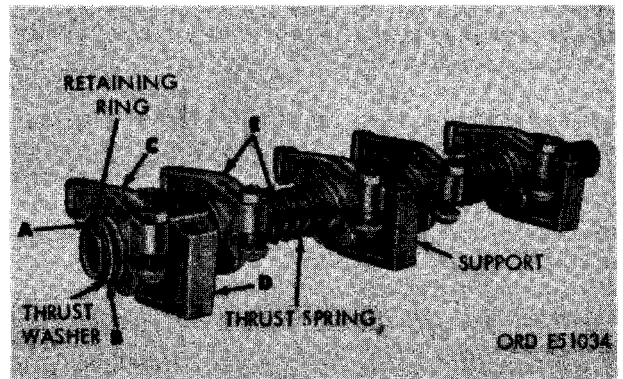
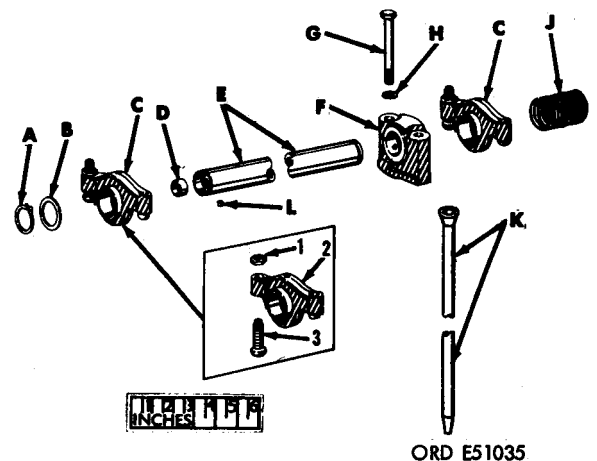


FIGURE 186. DISASSEMBLING OR ASSEMBLING FRONT VALVE ROCKER ARMS.

d. Cleaning and Inspection (fig. 187).

- (1) Clean valve rocker arm assemblies (C), rocker arm shaft (E), thrust springs (J), and the three supports (F) thoroughly



- A - Retaining ring
- B - Thrust washer
- C - Valve rocker arm assembly
  - 1- Lock nut
  - 2- Rocker arm
  - 3- Rocker arm adjusting screw
- D - Plug
- E - Rocker arm shaft
- F - Rocker arm support
- G - 3/8 x 2- 1/2 cap screw
- H - 3/8-in. lock washer
- J - Thrust spring
- K - Valve rocker arm push

FIGURE 187. ROCKER ARM ASSEMBLIES, SHAFT, AND SUPPORTS - EXPLODED VIEW.

using dry-cleaning solvent or mineral spirits paint thinner. Dry all parts and blow out all oil passages in shaft and rocker arm assemblies using compressed air. Use a thin wire as a probe to remove heavy gum deposits from oil passages when necessary.

- (2) Inspect valve rocker arm assemblies (C) for worn valve stem contact surface and damaged valve rocker arm adjusting screw (C-3). Inspect valve rocker arm shaft (E) for worn bearing surfaces, plugged oil passages and evidence of oil leaking past plug (D) at each end of shaft. Inspect for broken or weak thrust springs (J). Inspect for cracked or damaged rocker arm shaft supports (F). Inspect the valve rocker arm retaining ring (A) for weakness or distortion. Inspect rocker arm thrust washer (B) for excessive wear or distortion.

**e. Repair.** Replace unserviceable parts.

**f. Assembly.** Refer to figures 184 through 186 and reverse the sequence of illustrations and instructions to assemble the front set of rocker arms.

**g. Installation.**

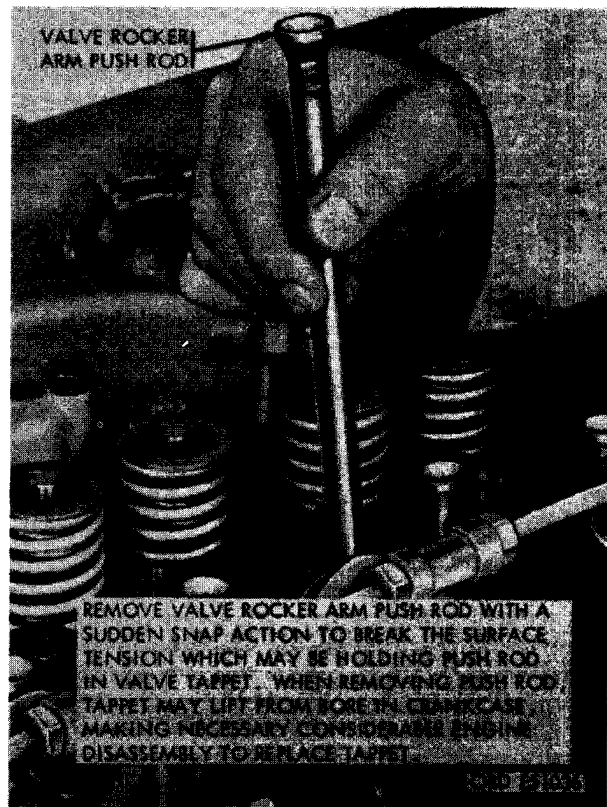
- (1) Refer to figures 180 and 181 and reverse the sequence of illustrations and instructions to install the front set of rocker arms. Do not tighten valve rocker arm adjusting screw lock nuts until valve clearance has been adjusted.
- (2) Adjust valve clearance following instructions for figure 183.
- (3) Refer to figure 62 and reverse the sequence of instructions to install the front cylinder head cover. Use new cylinder head cover gaskets and breather adapter gaskets.

## 93. VALVE ROCKER ARM PUSH RODS

**a. General.** Each of the 12 valve rocker arm push rods is removed in the same manner. For instructional purposes, the push rod for cylinder No. 2 exhaust valve rocker arm assembly will be removed.

**b. Removal.** Remove valve rocker arm push rod—as follows.

- (1) Remove front cylinder head cover and cover gasket following instructions for figure 62.
- (2) Remove the front set of rocker arms following instructions in figures 180 and 181.
- (3) Refer to figure 188 and remove the valve rocker arm push rod.



**FIGURE 188. REMOVING OR INSTALLING VALVE ROCKER ARM PUSH ROD.**

**c. Installation.**

- (1) Refer to figure 188 and install valve rocker arm push rod. Push rod must seat properly in valve tappet.
- (2) Refer to figures 180 and 181 and reverse the sequence of illustrations and instructions to install the front set of rocker arms.

- (3) Adjust valve clearance following instructions for figure 183.
- (4) Refer to figure 62 and reverse the sequence of instructions to install the front cylinder head cover. Use new gaskets under cover and breather adapter.

#### 94. CYLINDER HEAD ASSEMBLY OR CYLINDER HEAD GASKET

**a. General.** The front and rear cylinder head assemblies are identical and interchangeable. For instructional purposes the front cylinder head assembly will be replaced or the cylinder head will be removed for cylinder head gasket replacement.

**b. Removal.** Remove cylinder head assembly as follows.

- (1) Remove cylinder No. 1, 2, and 3 fuel injection tubes following instructions for figure 57, steps C and D and figure 148, step C.
- (2) Remove turbosupercharger assembly following the instructions for figures 44 through 47 and 49 through 52.

- (3) Remove front cylinder head cover and gasket following instructions for figure 62.

- (4) Remove intake, exhaust, and cylinder head water outlet manifolds as assemblies following instructions in figures 168 through 172.

- (5) Figure 189. (A) Disconnect 1/4-inch tube nut on fuel return-to-fuel injection pump overflow valve tube from 1/4-inch tube tee in cylinder No. 1 fuel injector nozzle and holder assembly. (B) Disconnect the 1/4-inch tube nuts on fuel injector nozzle fuel return tubes from the 1/4-inch tube tee in fuel injector nozzle and holder assembly for cylinder No. 3. (C) Loosen six valve rocker adjusting screw lock nuts and alternately loosen valve rocker adjusting screws to relieve valve spring tension. (D) Remove six 3/8 x 2-1/2 cap screws and 3/8-inch lock washers securing the front set of rocker arms to front cylinder head. Remove the front set of rocker arms.

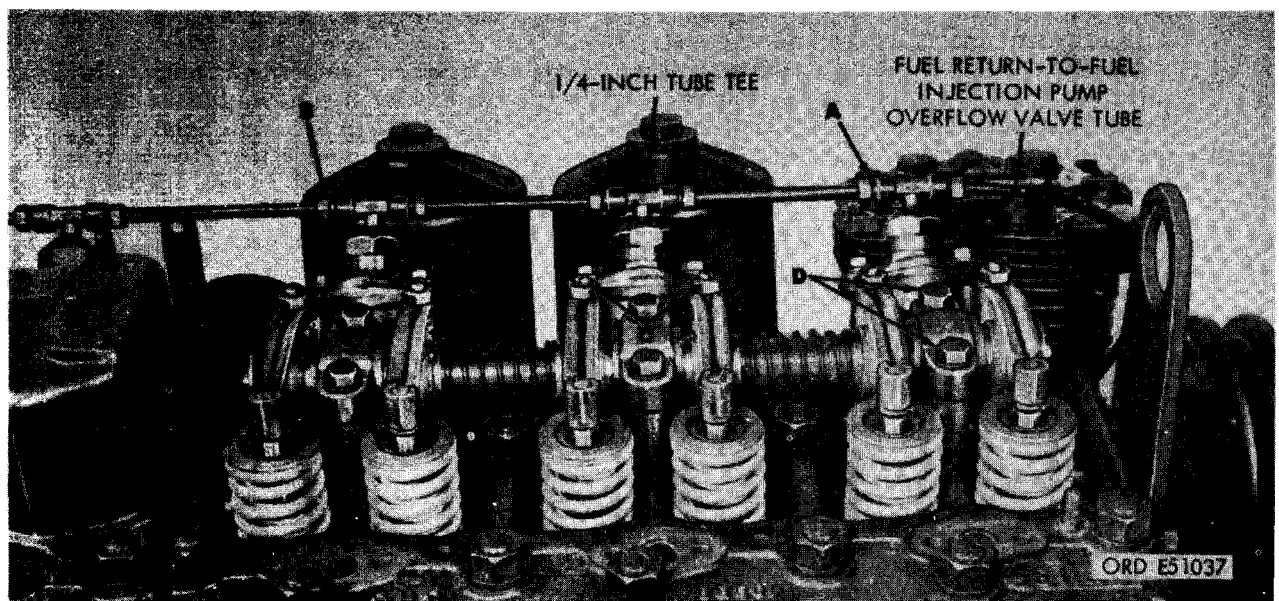


FIGURE 189. DISCONNECTING OR CONNECTING FUEL RETURN TUBES AND/OR REMOVING OR INSTALLING FRONT SET OF ROCKER ARMS.

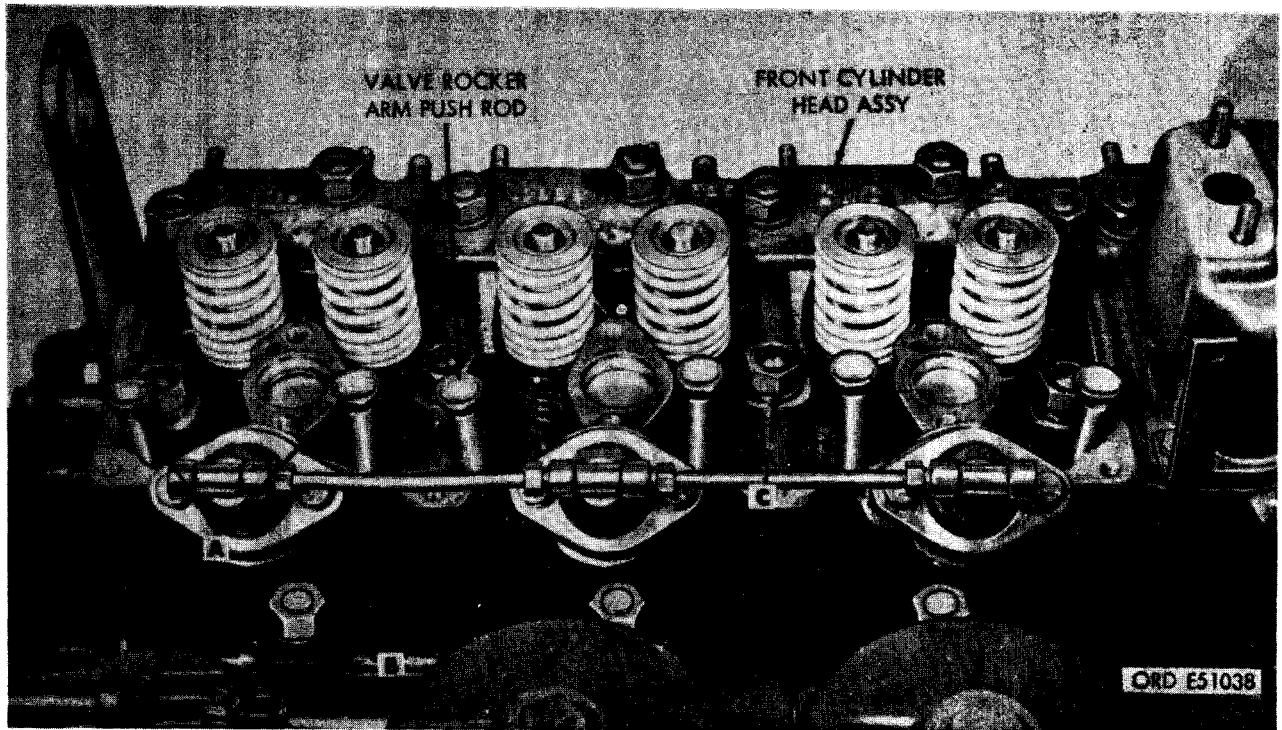


FIGURE 190. REMOVING OR INSTALLING PUSH RODS AND FRONT CYLINDER HEAD ASSEMBLY.

- (6) Figure 190. (A) Refer to figure 188 and remove valve rocker arm push rods. (B) Remove three 9/16-inch plain nuts, and 9/16 id x 3/8 thk special washers on left side of front cylinder head. (C) Remove eleven 9/16- inch plain nuts and 9/16 id x 1/8 thk special washer securing front cylinder head to crankcase.

- (7) Refer to figure 191 and remove the front cylinder head assembly.

Caution: Place the front cylinder head assembly on suitable blocks as shown in figure 193 to prevent damage to the nozzle tips extending from the head.

- (8) Refer to figure 192 and remove front cylinder head gasket.

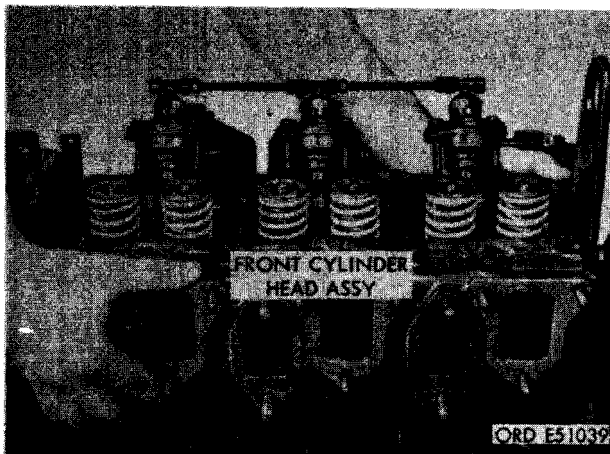
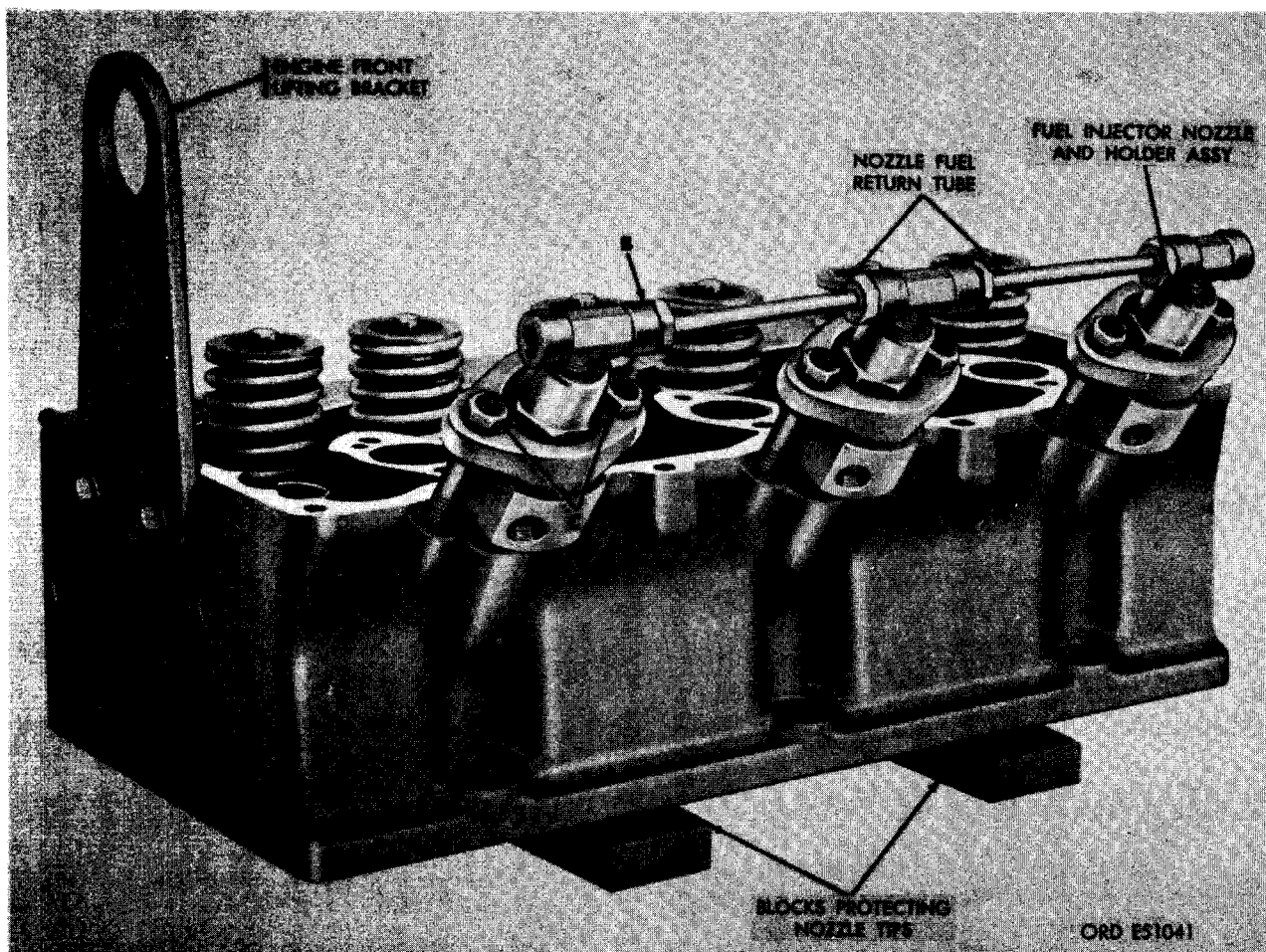


FIGURE 191. REMOVING OR INSTALLING FRONT CYLINDER HEAD ASSEMBLY.



FIGURE 192. REMOVING OR INSTALLING FRONT CYLINDER HEAD GASKET.



**FIGURE 193. REMOVING OR INSTALLING ENGINE FRONT LIFTING BRACKET AND FUEL RETURN TUBES.**

c. Disassemble Disassemble front cylinder head assembly as follows.

- (1) Figure 193. (A) Remove two 7/16 x 7/8 cap screws and 7/16-inch lock washers securing engine front lifting bracket to front cylinder head assembly. Remove bracket. (B) Disconnect the 1/4-inch tube nuts on the two fuel injector nozzle fuel return tubes from 1/4-inch tube tees in fuel injector nozzle and holder assemblies. Remove the two tubes from between the tube tees. (C) Remove the two 5/16 x 2-1/2 cap screws and 5/16-inch lock washers securing each fuel injector nozzle and holder assembly and hold-down clamp to front cylinder head assembly.

Note. Replacement cylinder heads are furnished complete with valves, springs, rotators, and retainers.

- (2) Figure 194. (A) Remove the three fuel injector nozzle and holder assemblies from front cylinder head assembly. (B) Remove and discard the three fuel injector nozzle-to-head gaskets (C) Remove 1/4 tube x 1/8 tube tees from each nozzle and holder assembly. Remove hold-down clamps and note the dowel pin hole in clamp and the locating dowel pin in holder. The hold-down clamp must be installed so that the dowel pin will enter hole to properly position nozzle and holder assembly in cylinder head.



Note. After the three fuel injector nozzle and holder assemblies are removed from cylinder head, test nozzle and holder spray pattern as directed in paragraphs 83c and d.

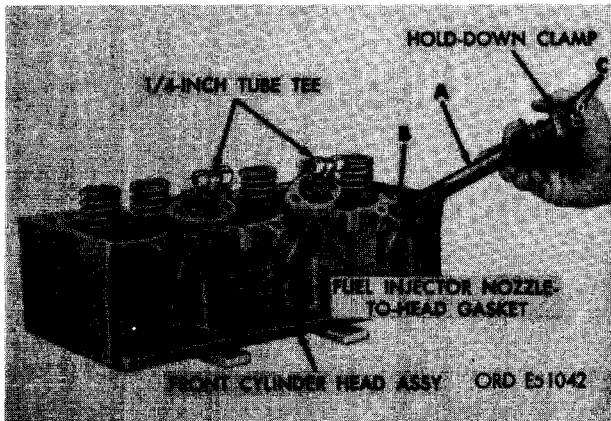


FIGURE 194. REMOVING OR INSTALLING FUEL INJECTOR NOZZLE AND HOLDER ASSEMBLIES.

d. Cleaning and Inspection.

- (1) Clean cylinder head assembly thoroughly using dry-cleaning solvent or mineral spirits paint thinner. Remove hard carbon deposits using a wire brush or scraper.

Note. When cylinder head gasket shows signs of leaking or having been blown, inspect cylinder head closely for damage.

- (2) Inspect cylinder head assembly for cracks around valve seats and for damaged gasket surface. Check for evidence of cracked or warped intake and exhaust valves. Replace cylinder head assembly when cracked or when valve seats show evidence of burning. Check threads on studs and in tapped holes for good condition. Core hole plugs must be tight and not show signs of coolant leakage.

Note. Thermo fatigue cracks found at bridge between valve seats are not cause to reject a head unless coolant leakage is evident.

e. Repair. Replace all studs having stripped threads. Repair all damaged threads in tapped holes using a good used tap. Remove small scratches and raised metal from gasket surface using emery cloth or fine mill file. Replace

cylinder head assembly when found unserviceable.

f. Assembly. Refer to figures 193 and 194 and reverse the sequence of illustrations and instructions to assemble the front cylinder head assembly. Use a new fuel injector nozzle-to-head gasket. Hold gasket in place at nozzle end by applying a light coating of grease. This insures proper gasket seating and prevents gasket from sliding off end of nozzle and holder assembly during installation.

g. Installation.

- (1) Refer to figures 190 through 192 reverse the sequence of illustrations and instructions to install cylinder head gasket and the front cylinder head assembly and tighten nuts in the sequence outlined in figure 195. Install the new head gasket properly.

Note. Stud threads must be lubricated with OE 10 oil to obtain proper torque reading.

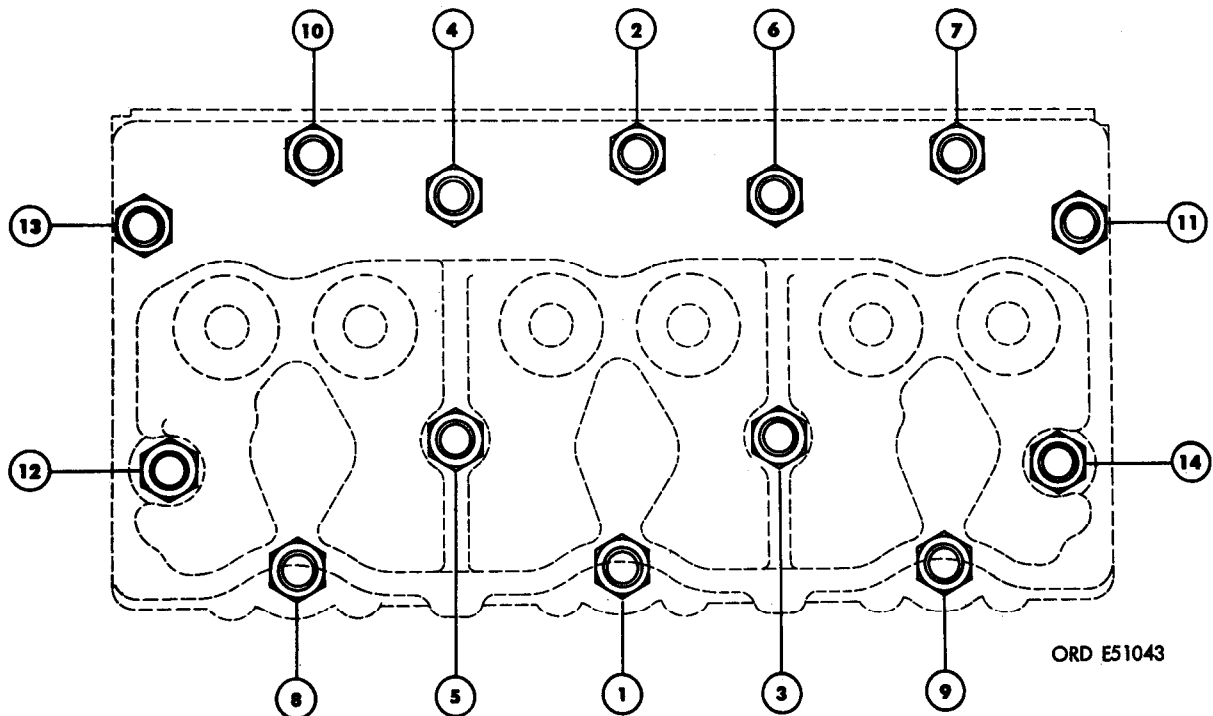
- (2) Torque tighten front cylinder head nuts with special wrench as shown in figure 196.
- (3) Refer to figure 189 and reverse the sequence of instructions to install the front set of rocker arms and to connect fuel injector nozzle fuel return tubes.
- (4) Adjust valve clearance following instructions which accompany figure 183.
- (5) Refer to figure 62 and reverse the sequence of instructions to install front cylinder head cover gasket and cover. Install new gaskets under cover and breather adapter.
- (6) Refer to figures 168 through 172 and reverse the sequence of illustrations and instructions to install the intake, exhaust, and cylinder head water outlet manifolds as an assembly. Install new manifold gaskets.
- (7) Refer to figures 44 through 47 and 49 through 52 and reverse the sequence of illustrations and instructions to install the turbosupercharger assembly. Install new gaskets and check hoses for serviceable condition. Oil inlet tube and outlet hose connections must be tight.
- (8) Refer to figure 57, steps C and D and figure 148, step C, and reverse the sequence of instructions to connect fuel injector tubes to nozzle assemblies. Re-

fer to figure 189, steps A and B, and reverse the sequence of instructions to connect fuel return tubes to nozzle assemblies.

#### h. Torque Tightening Cylinder Head Nuts After Engine Run-in.

- (1) The cylinder head nuts must be re-tightened to a torque of 130 pound feet after the engine has run whenever new cylinder head gaskets and/or cylinder head assemblies have been installed. Start engine and run until coolant temperature gage indicates 170°F. Stop engine and torque cylinder head nuts as directed in (2) and (3) below.
- (2) Remove front cylinder head cover and cover gasket following instructions which accompany figure 62. The rear cylinder head cover and gasket can be removed in the same manner.
- (3) Torque tighten the front and/or rear cylinder head nuts in sequence as shown in figure 195, using cylinder head nut wrench as shown in figure 196 and improvised tool to tighten inner cylinder head nuts as shown in figure 197. Torque all nuts to 130 pound feet.
- (4) After cylinder head nuts have been properly torque tightened to specifications, reassemble engine as directed in (5) and (6) below.
- (5) Adjust intake and exhaust valve clearance following instructions in figure 183.
- (6) Refer to figure 62 and reverse the sequence of instructions to install the front and rear cylinder head cover gaskets and covers. Install new gaskets under covers and breather adapter if gaskets are damaged during cover removal after engine warmup.

NOTE: TORQUE TIGHTEN CYLINDER HEAD NUTS IN SEQUENCE 1 THROUGH 14 USING CYLINDER HEAD WRENCH — 8722924 IN THREE STEPS, AS FOLLOWS:  
 STEP 1 TORQUE TIGHTEN TO 60 POUND FEET  
 STEP 2 TORQUE TIGHTEN TO 100 POUND FEET  
 STEP 3 TORQUE TIGHTEN TO 130 POUND FEET



ORD E51043

FIGURE 195. TORQUE TIGHTENING SEQUENCE FOR CYLINDER HEAD NUTS.

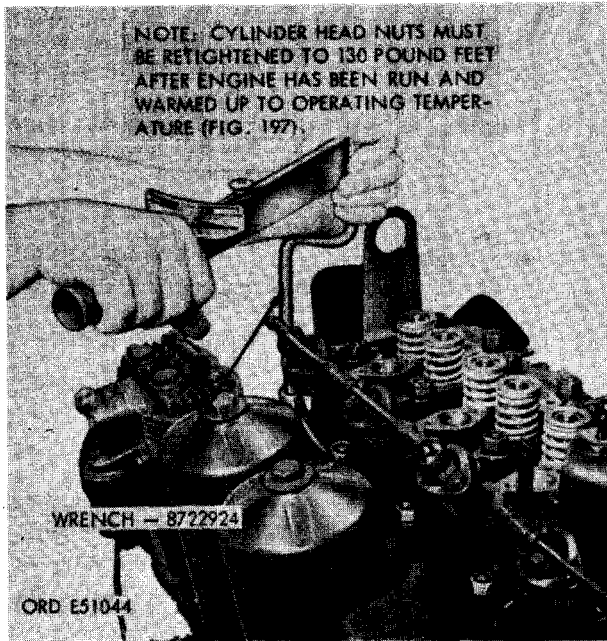


FIGURE 196. TIGHTENING CYLINDER HEAD NUTS USING WRENCH -8722954.

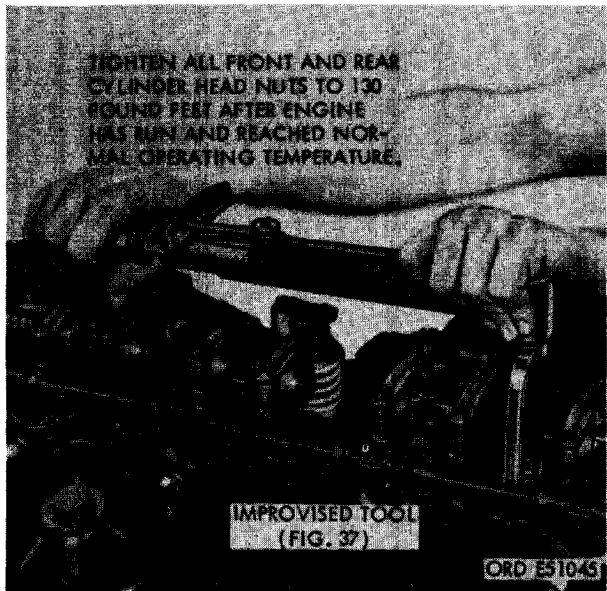


FIGURE 197. TORQUE TIGHTENING FRONT AND REAR CYLINDER HEAD NUTS AFTER ENGINE WARMUP.

#### 95. OIL PAN AND/OR OIL PAN GASKET

a. Removal. Remove oil pan and oil pan gasket and inspect oil pump component as follows.

- (1) Figure 198. (A) Remove oil drain plugs and drain engine oil into a suitable container. Replace plugs after draining. (B) Remove three 3/8 x 1- 1/4 cap screws and 3/8- inch lock washer and remove fuel filter bracket. (C) Remove oil level gage rod from oil gage rod support.

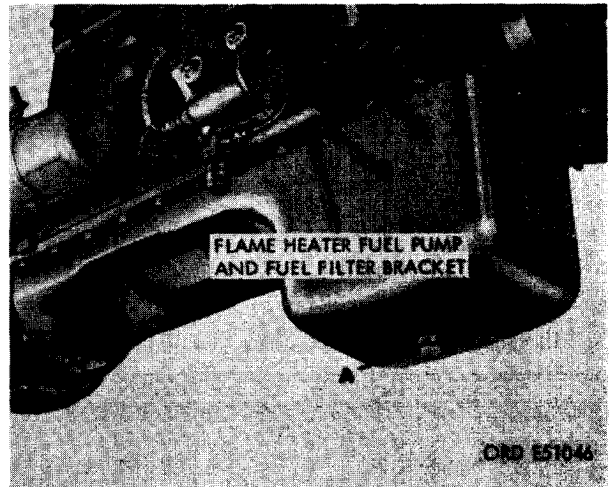


FIGURE 198. DRAINING ENGINE OIL AND DISCONNECTING OR CONNECTING FLAME HEATER FUEL PUMP AND FUEL FILTER BRACKET.

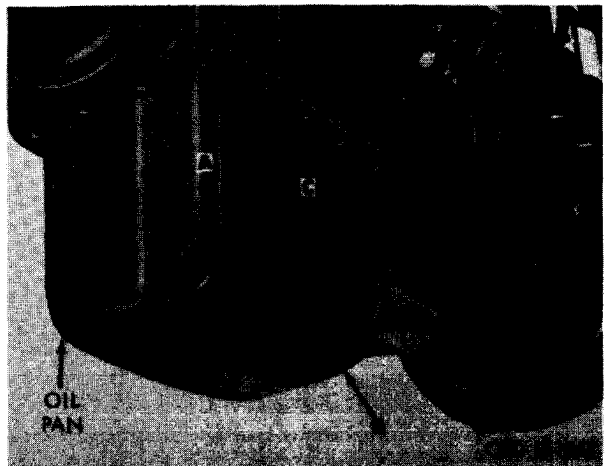


FIGURE 199. REMOVING OR INSTALLING OIL PAN.

- (2) Figure 199. (A) Remove twenty-seven 3/8 xl-inch cap screws and 3/8-inch lock washers securing oil pan to cylinder and crankcase. (B) Remove oil pan. (C) Remove and discard oil pan gasket.
- (3) Figure 200. (A) Check oil pressure pump pickup tube screen for dirt and foreign material. Screen must not be plugged or broken. (B) Check scavenger oil pump pickup tube screen for dirt and foreign material. Screen must not be plugged or broken. (C) Check oil pump driven gear and idler gear for evidence of wear, scored teeth, or other damage.

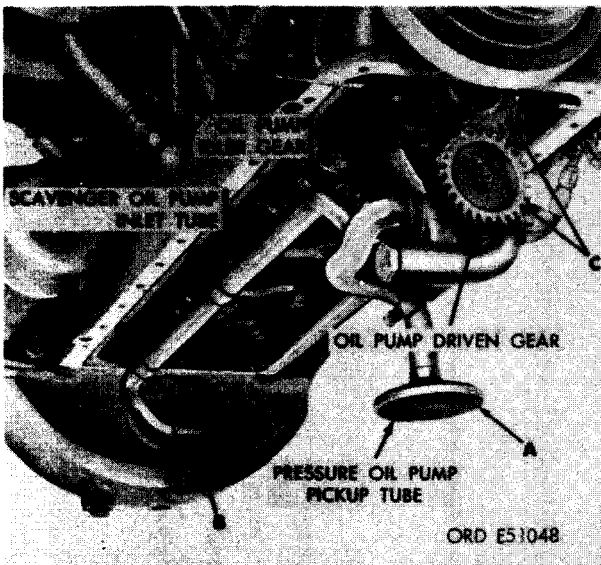


FIGURE 200. INSPECTING OIL PUMP PICKUP TUBE SCREENS AND PUMP GEARS.

**b. Installation.** Refer to figures 198 through 200 and reverse the sequence of illustrations and instructions to install new oil pan gasket, oil pan, and flame heater bracket.

**Note.** When gasket cement is used to hold oil pan gasket in position, apply cement to flange of oil pan only.

## 96. CRANKSHAFT DAMPER AND PULLEY ASSEMBLY

**a. General.** The crankshaft damper and pulley assembly must be removed from the crankshaft in order to replace the pulley and/or damper.

**b. Removal.** Remove crankshaft damper and pulley assembly as follows.

- (1) Remove engine fan from water pump pulley following instructions for figure 112.
- (2) Remove engine fan and generator drive belts following instructions for figure 41.
- (3) Remove air compressor drive belt following instructions in figures 80 through 82.
- (4) Figure 201. (A) Remove two 3/8 x 3/4 cap screws and 3/8- inch lock washers securing lock plate. (B) Remove lock plate.

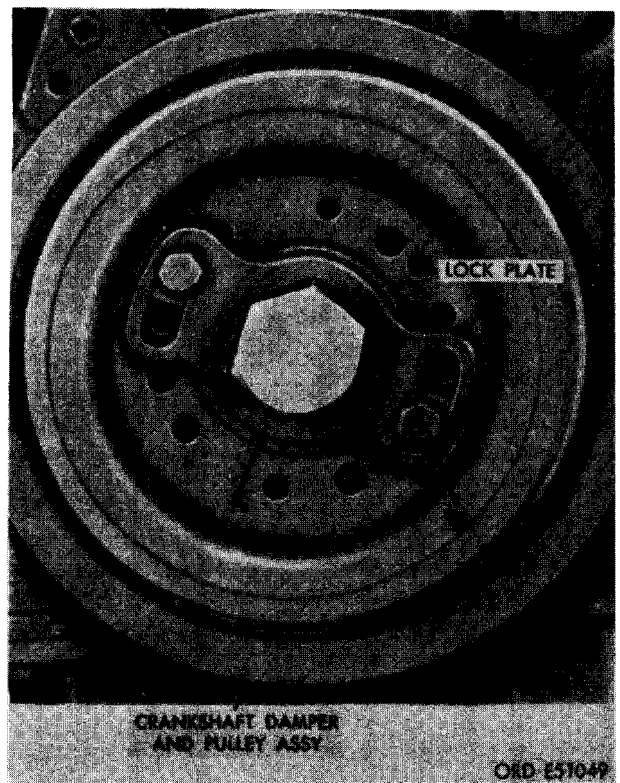


FIGURE 201. REMOVING OR INSTALLING LOCK PLATE.

- (5) Figure 202. (A) Remove crankshaft damper pulley retaining bolt. (B) Remove crankshaft damper pulley retaining plate.

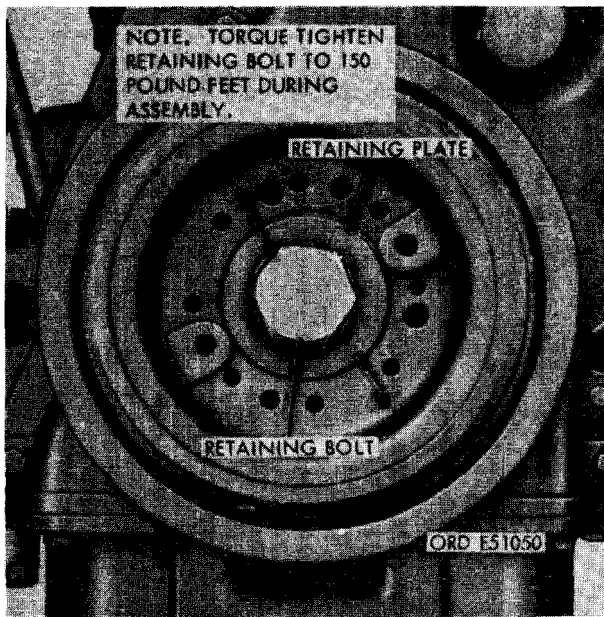


FIGURE 202. REMOVING OR INSTALLING CRANKSHAFT DAMPER AND PULLEY RETAINING BOLT AND PLATE

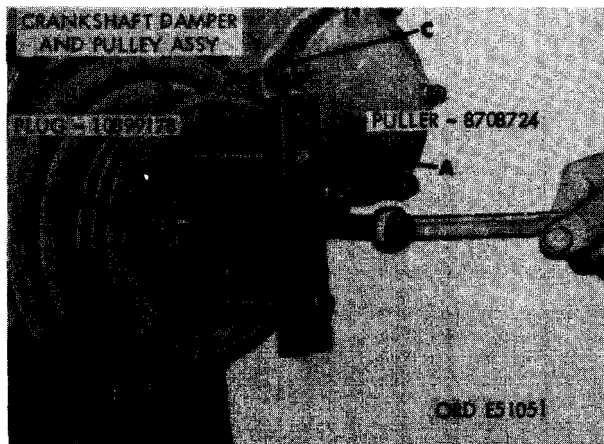


FIGURE 203. REMOVING CRANKSHAFT DAMPER AND PULLEY ASSEMBLY USING MECHANICAL PULLER -8708724 AND PLUG -1089178.

- (6) Figure 203. (A) Install mechanical puller -8708724 on hub of pulley as shown. (B) Install small end of puller plug-

10899178 in end of crankshaft and run puller screw tight against plug to hold it in position. (C) Remove crankshaft damper and pulley assembly.

**c. Disassembly.** Disassemble and inspect crankshaft damper and pulley assembly as follows.

- (1) Refer to figure 204 and remove eight cap screws securing crankshaft damper.



FIGURE 204. REMOVING OR INSTALLING CAP SCREWS AND LOCK WASHERS SECURING CRANKSHAFT DAMPER TO CRANKSHAFT PULLEY ASSEMBLY.

- (2) Figure 205. (A) Separate the crankshaft damper from the crankshaft pulley assembly. (B) Inspect locating dowel pins and mating holes for damage. Replace damaged pins. (C) Inspect oil seal contact surface for nicks or burs which may damage oil seal. Remove minor damage with crocus cloth soaked in dry-cleaning solvent or mineral spirits paint thinner. (D) Check keyway for burs or damage.

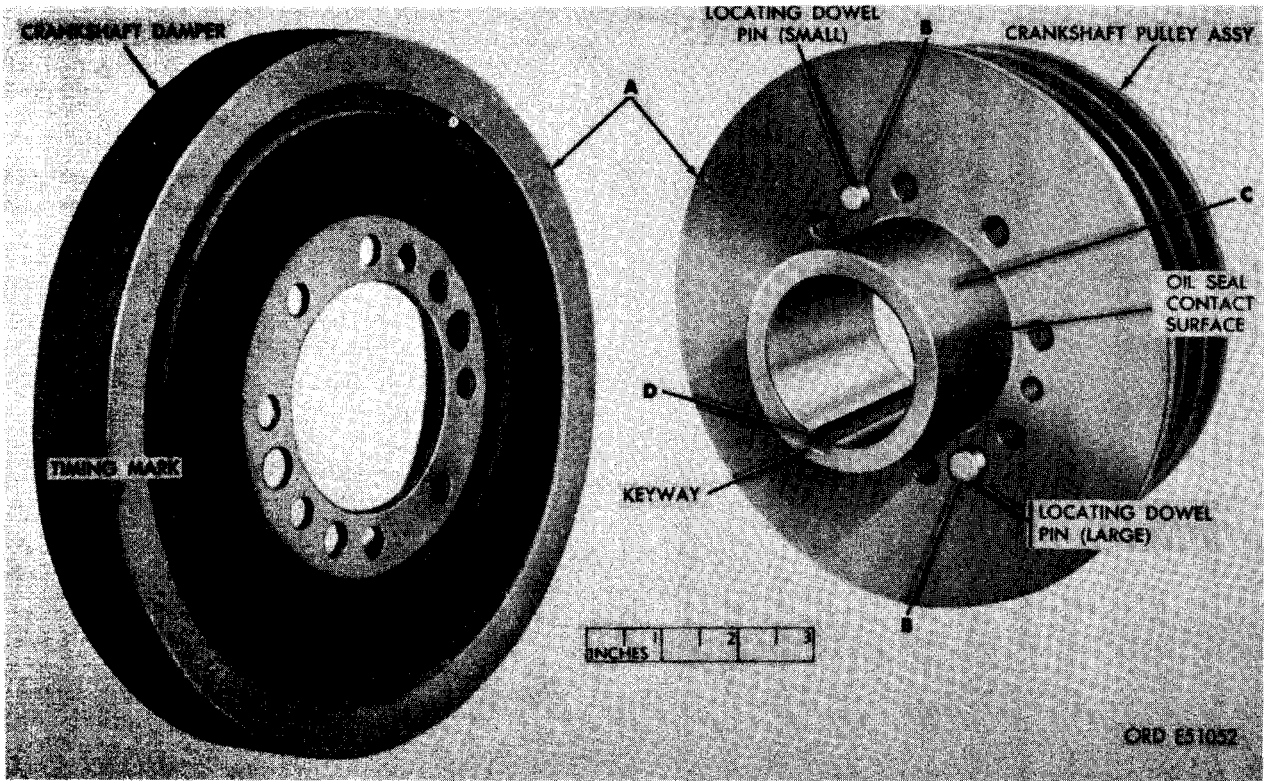


FIGURE 205. DISASSEMBLING, ASSEMBLING, AND INSPECTING CRANKSHAFT DAMPER AND PULLEY ASSEMBLY.

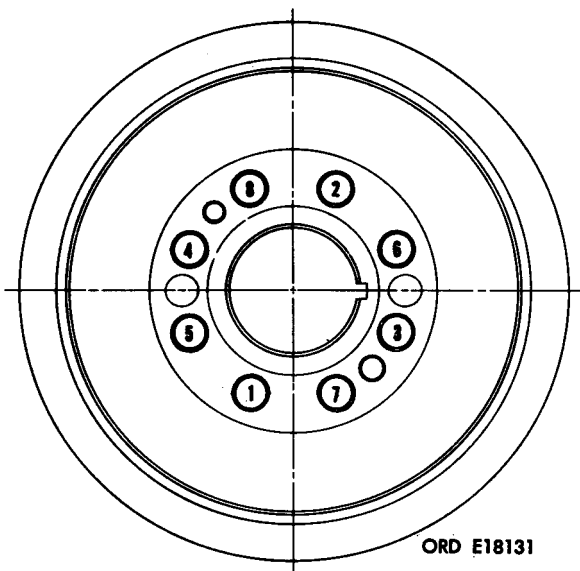


FIGURE 206. TIGHTENING SEQUENCE FOR CRANKSHAFT DAMPER AND PULLEY ASSEMBLY ATTACHING SCREWS.

#### d. Assembly.

- (1) Refer to figures 204 and 205 and reverse the sequence of illustrations and instructions to assemble the crankshaft damper and pulley assembly.
- (2) Tighten the eight cap screws securing the crankshaft damper to the pulley assembly to a torque of 300 pound inches following the sequence shown in figure 206.

Note. After once torquing the cap screws to 300 pound inches, they again must be retorqued to 360 pound inches in proper sequence (fig. 206).

#### e. Installation.

Note. Before installing crankshaft damper and pulley assembly on crankshaft, coat lip of crankshaft front oil seal (fig. 207) and sealing surface on pulley with lubricating oil to prevent damage to oil seal lip when pulley is installed.

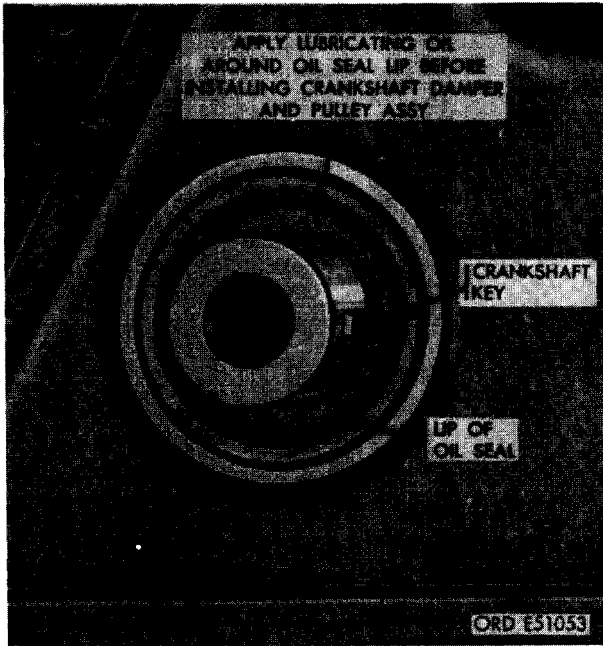


FIGURE 207. LUBRICATING OIL SEAL LIP BEFORE INSTALLING CRANKSHAFT DAMPER AND PULLEY ASSEMBLY.

- (1) Aline keyway in crankshaft pulley hub with key in crankshaft and start crankshaft damper and pulley assembly on end of crankshaft. Install crankshaft damper and pulley assembly on crankshaft following instructions for figure 208.

**Note.** Hold replacer bolt stationary while turning plain nut to seat damper and pulley assembly.



FIGURE 208. INSTALLING CRANKSHAFT DAMPER AND PULLEY ASSEMBLY.

- (2) Refer to figures 202 and 203 and reverse the sequence of illustrations and instructions to install the retaining bolt and the lock plate.

**Note.** When bolt holes in lock plate do not aline with threaded holes in pulley, the plate can be turned over and positioned so the holes are alined.

- (3) Refer to figures 80 through 82 and reverse the sequence of illustrations and instructions to install air compressor drive belt.
- (4) Adjust air compressor drive belt deflection following instructions for figure 87.
- (5) Refer to figure 41 and reverse the sequence of instructions to install the engine fan and generator drive belts.
- (6) Adjust engine fan and generator drive belt deflection following instructions for figure 43.
- (7) Refer to figure 112 and follow the sequence of instructions to install the engine fan.

## 97. CRANKSHAFT FRONT OIL SEAL

a. **Removal.** Remove crankshaft front oil seal as follows.

- (1) Remove engine fan from water pump pulley following instructions in figure 112.
- (2) Remove engine fan and generator drive belts following instructions in figure 41.
- (3) Remove air compressor drive belt following the instructions in figures 80 through 82.
- (4) Remove water pump assembly following instructions in figures 114 through 116.
- (5) Remove crankshaft damper and pulley assembly following instructions in figures 201 through 203.
- (6) Remove oil pan and flame heater fuel pump and fuel filter bracket following instructions in figures 198 through 200.

- (7) Remove tachometer adapter, drive shaft, and mounting adapter as shown in figure 209.



FIGURE 209. REMOVING OR INSTALLING TACHOMETER ADAPTER.

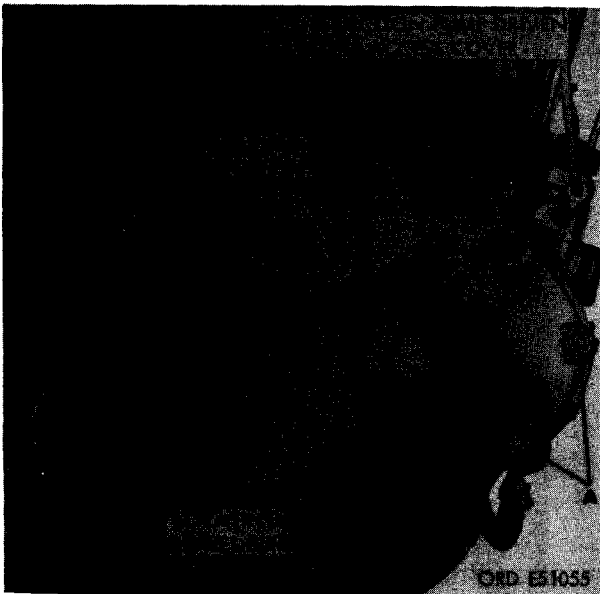


FIGURE 210. REMOVING OR INSTALLING TIMING GEAR COVER ASSEMBLY.

- (8) Figure 210. (A) Remove three 3/8-inch plain nuts and 3/8-inch lock washers from the three studs. (B) Remove two 3/8-inch plain nuts, 3/8-inch heavy lock washers, and 3/8 x 3-3/4 cap screws. (C) Remove fuel injection pump driven gear access cover. Remove and discard cover gasket. (D) Remove 3/8-inch plain nut, 3/8-inch lock washer, and 3/8 x 1-1/4 cap screw. (E) Remove 1/2-inch plain nut, 1/2-inch heavy lock washer, and 1/2 x 2-3/4 cap screw. (F) Remove seven 3/8 x 1-1/4 cap screws and 3/8-inch lock washers securing timing gear cover assembly (G) Remove timing gear cover assembly. Remove and discard timing gear cover gasket.

- (9) Remove crankshaft front oil seal from timing gear cover assembly.

**b. Installation.** Install crankshaft front oil seal as follows.

- (1) The crankshaft front oil seal has a double lip which must be installed in the timing gear cover assembly with flange edge away from cover mounting flange. Refer to figure 211 for installation instructions.

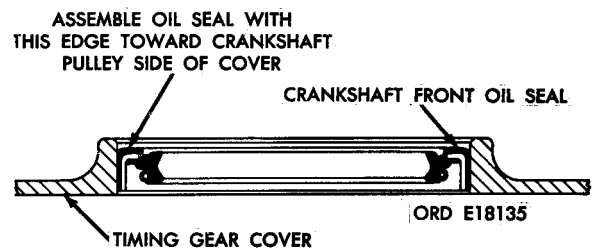


FIGURE 211. INSTALLATION INSTRUCTIONS FOR CRANKSHAFT FRONT OIL SEAL.

- (2) Figure 212. (A) Position crankshaft front oil seal in bore of timing gear cover assembly. (B) Install seal in bore using arbor press and suitable press plate.



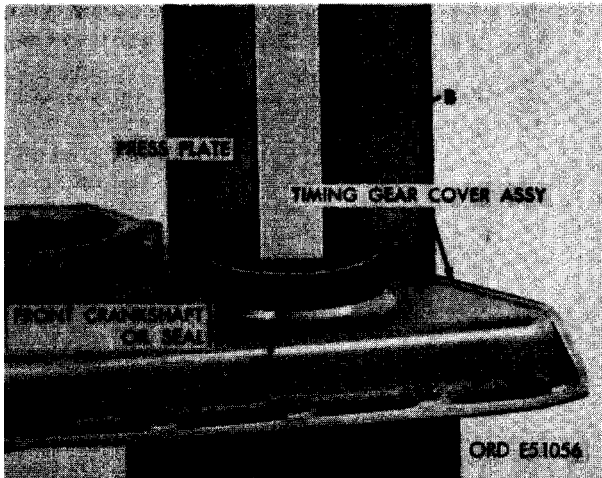


FIGURE 212. INSTALLING CRANKSHAFT FRONT OIL SEAL.

- (3) Refer to figure 210 and reverse the sequence of instructions to install timing gear cover gasket and timing gear cover assembly.

**Note.** The timing gear cover assembly is positioned on two locating dowel pins. When installing cover, cover must be properly positioned on pins before tightening cap screws.

- (4) Refer to figure 209 and install tachometer mounting adapter, drive shaft, and tachometer adapter.
- (5) Refer to figures 198 and 199 and reverse the sequence of instructions to install oil pan gasket and oil pan.
- (6) Refer to paragraph 96e (1) for instructions on installation of crankshaft damper and pulley assembly.
- (7) Refer to figures 114 through 116 and reverse the sequence of illustrations and instructions to install the water pump assembly.
- (8) Refer to figures 80 through 82 and reverse the sequence of illustrations and instructions to install air compressor drive belt.

- (9) Adjust air compressor drive belt deflection following instructions for figure 87.
- (10) Refer to figure 41 and reverse the sequence of instructions to install the engine fan and generator drive belts.
- (11) Adjust engine fan and generator drive belt deflection following instructions for figure 43.
- (12) Refer to figure 112 and reverse the sequence of instructions to install the engine fan.

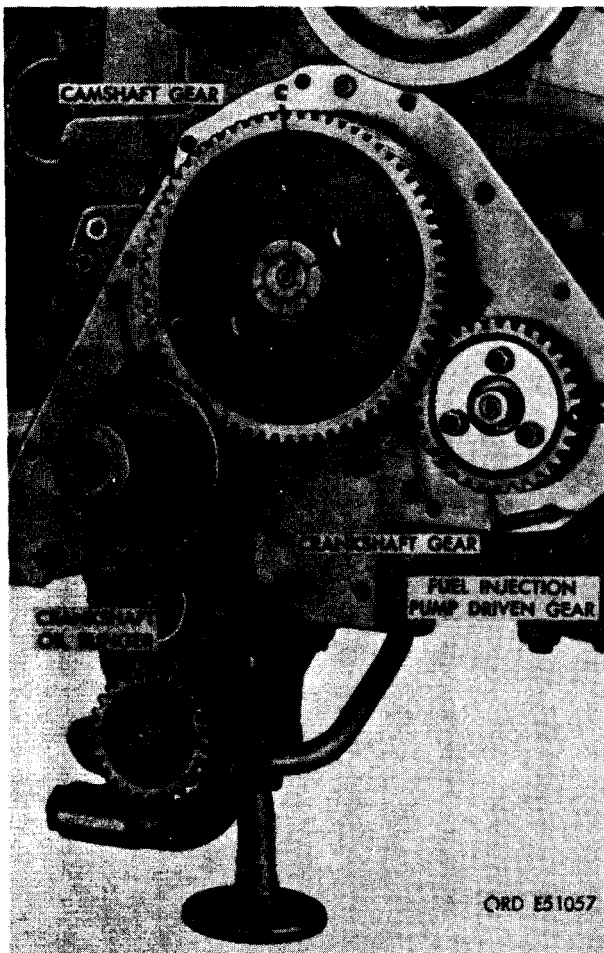
## 98. CRANKSHAFT GEAR, INJECTION PUMP DRIVEN GEAR, AND CAMSHAFT GEAR

**a. Removal.** Remove crankshaft gear, injection pump driven gear, and camshaft gear as follows.

- (1) Remove engine fan from water pump pulley following instructions for figure 112.
- (2) Remove engine fan and generator drive belts following instructions for figure 41.
- (3) Remove air compressor drive belt following instructions for figures 80 through 82.
- (4) Remove water pump assembly following instructions for figures 114 through 116.
- (5) Remove crankshaft damper and pulley assembly following instructions for figures 201 through 203.
- (6) Remove oil pan and flame heater fuel pump and fuel filter bracket following instructions for figures 198 through 200.
- (7) Remove tachometer drive adapter, drive shaft, and mounting adapter as shown in figure 209.
- (8) Remove timing gear cover assembly following instructions for figure 210.

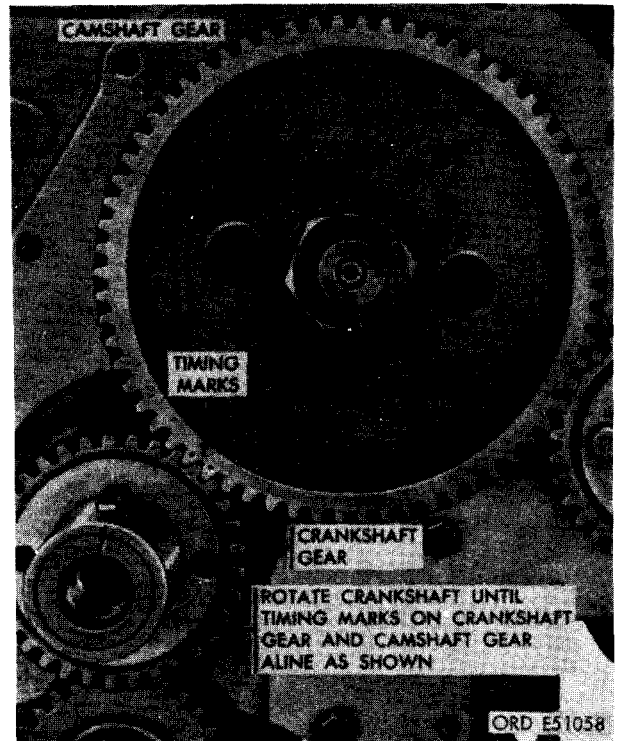
Note. When either crankshaft gear, camshaft gear, or injection pump driven gear need replacement, the three gears must be replaced as a matched set, part No. 5702649.

- (9) Figure 213. (A) Remove crankshaft oil slinger from end of crankshaft. (B) Wedge a piece of wood or brass rod between injection pump driven gear and camshaft gear to prevent gears from turning while camshaft gear retaining nut is being loosened. (C) Loosen camshaft gear retaining nut.



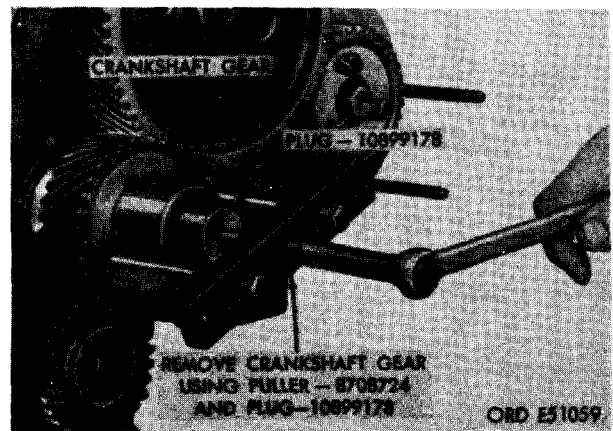
**FIGURE 213. REMOVING OR INSTALLING CRANKSHAFT OIL SLINGER AND LOOSENING CAMSHAFT GEAR RETAINING NUT.**

- (10) Align timing marks on crankshaft and camshaft gears as shown in figure 214.



**FIGURE 214. CRANKSHAFT AND CAMSHAFT GEAR TIMING MARKS ALINED.**

- (11) Remove crankshaft gear as shown in figure 215.



**FIGURE 215. REMOVING CRANKSHAFT GEAR USING MECHANICAL PULLER KIT - 8708724 AND PLUG - 10899178.**

- (12) Figure 216. (A) Remove three 3/8 x 1-1/4 cap screws and 3/8- inch lock washers securing injection pump driven gear and retaining plate. (B) Remove injection pump driven gear retaining plate and gear. (C) Remove camshaft gear retaining nut.

Note. Removing injection pump driven gear will disturb fuel injection pump timing in relation to engine valve timing. The fuel injection pump must be retimed when gear is installed (par. 106).

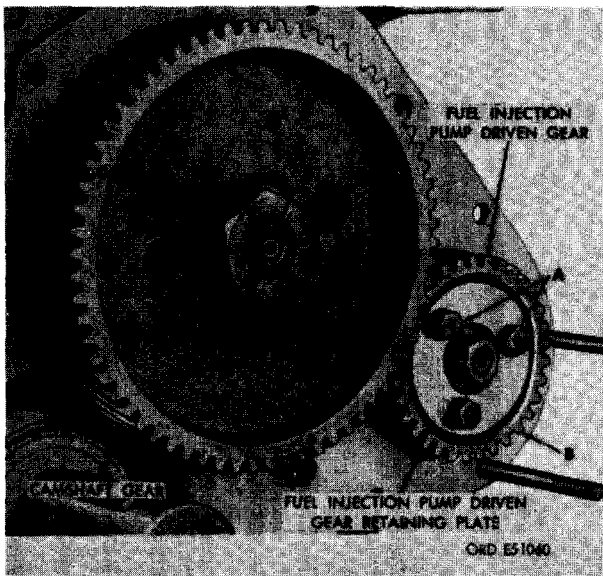


FIGURE 216. REMOVING INJECTION PUMP DRIVEN GEAR AND/OR REMOVING OR INSTALLING CAMSHAFT GEAR RETAINING NUT.

- (13) Refer to figure 217 and remove camshaft gear.

b. Inspection and Installation. Inspect and install crankshaft gear, injection pump driven gear, and camshaft gear as follows.

- (1) Figure 218. (A) Check condition of camshaft gear key. Key must be in proper position, not worn, and must fit tight

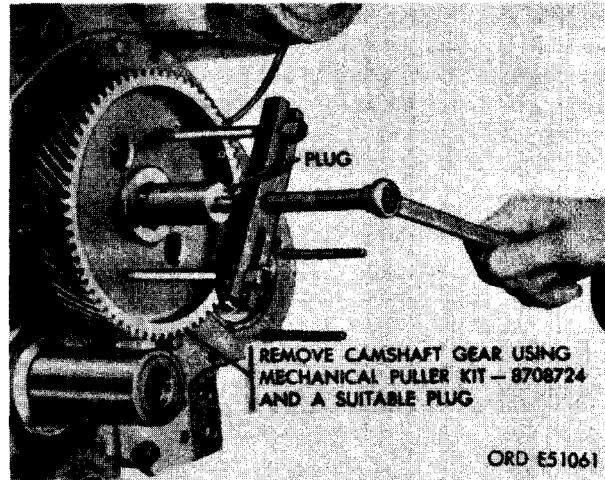


FIGURE 217. REMOVING CAMSHAFT GEAR USING MECHANICAL PULLER KIT - 8708724.

in keyway. (B) Check thrust surface of camshaft thrust plate. Thrust plate must have an even wear pattern and no signs of damage which may cause excessive camshaft end play. (C) Thrust plate retaining screws must be tight.

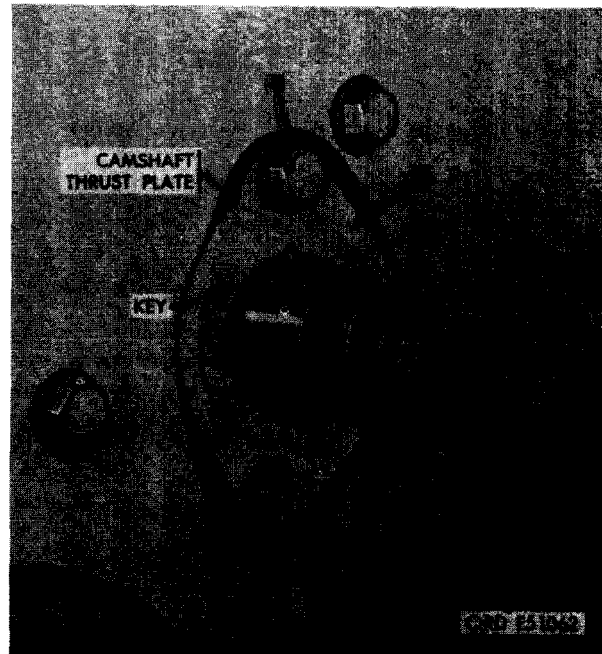
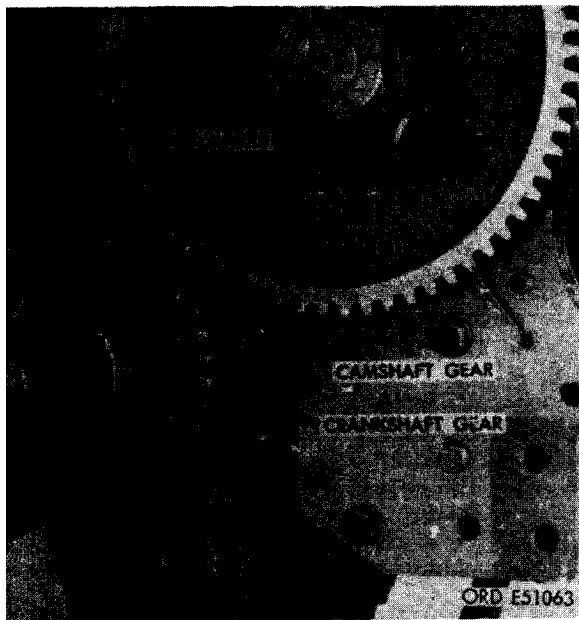


FIGURE 218. CHECKING CONDITION OF CAMSHAFT GEAR KEY AND THRUST PLATE WEAR.

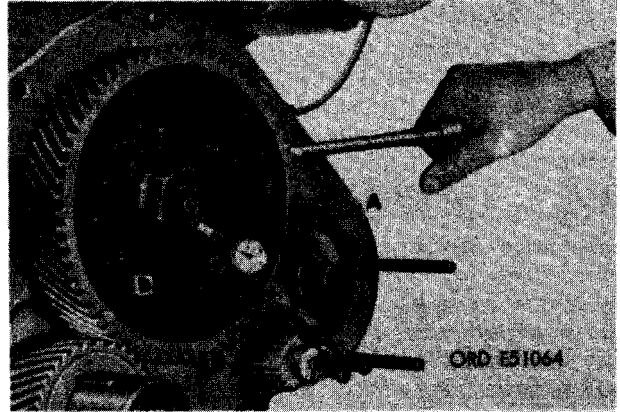
Note. When camshaft thrust plate is worn or damaged, remove two 3/8 x 1 cap screws and 3/8-inch lock washers securing thrust plate to crankcase. Remove and discard unserviceable thrust plate. Install new thrust plate.

- (2) Figure 219. (A) Install crankshaft gear on end of crankshaft, with key on crankshaft entering keyway in gear. (B) Position camshaft gear on camshaft with key on camshaft entering keyway in gear and timing marks on camshaft gear in mesh with timing marks on crankshaft gear. (C) Lock the crankshaft and camshaft gears using a suitable wedge. (D) Install camshaft gear retaining nut and torque tighten nut to a torque of 145 pound feet. Remove wedge.



**FIGURE 219. INSTALLING CRANKSHAFT GEAR AND CAMSHAFT GEAR WITH TIMING MARKS ALIGNED.**

- (3) Figure 220. (A) Install magnetic dial indicator on gear cover mounting surface. (B) Check camshaft end play on dial indicator. End play should be from 0.006-inch minimum to 0.015-inch maximum.



**FIGURE 220. CHECKING CAMSHAFT END PLAY USING A DIAL INDICATOR.**

Note. When camshaft end play exceeds 0.015-inch, remove camshaft gear and thrust plate (fig. 218), and install new thrust plate. When camshaft end play is less than 0.006-inch, remove camshaft gear and thrust plate and lap thrust plate until a minimum of 0.006-inch end play is obtained.

- (4) Check backlash between crankshaft and camshaft gears. Backlash must be 0.002 to 0.004-inch.
- (5) Install crankshaft oil slinger, reversing the instructions given in step A, figure 213.
- (6) Refer to figure 210 and reverse the sequence of instructions given in steps D, E, F, and G to install the timing gear cover gasket and timing gear cover.
- (7) Refer to paragraph 96e and install crankshaft damper and pulley assembly.
- (8) Remove front cylinder head cover following instructions which accompany figure 62 and check valve clearance on cylinder No. 1 intake and exhaust valves as shown in figure 183.
- (9) Rotate crankshaft enough to align timing pointer on camshaft gear cover with the timing mark on crankshaft damper pulley (approximately 27 degrees). See figure 61 for position of pointer and timing mark.

- (10) Remove fuel injection pump timing cover and timing window cover (steps D and E of figure 61).
  - (11) Check position of fuel injection pump timing marks. The timing pointer in the automatic advance unit housing must be alined with the timing mark on the advance unit hub as shown in figure 64.
  - (12) Check position of marked tooth on fuel injection pump plunger drive gear. Marked tooth must be visible through timing window as shown in figure 65.
  - (13) The engine and fuel injection pump are properly timed when the following conditions are met simultaneously:
    - (a) Cylinder No. 1 intake and exhaust valves are closed (fig. 63).
    - (b) Timing pointer on camshaft gear cover is alined with timing mark on damper pulley (fig. 61).
    - (c) Marked tooth is visible through timing window (fig. 65).
    - (d) Timing pointer in advance unit housing is alined with timing mark and advance unit hub (fig. 64).
  - (14) Install fuel injection pump driven gear and retaining plate by reversing the sequence of illustrations and instructions in figures 66, 67, and 77.
  - (15) Check backlash between camshaft gear and fuel injection pump driven gear. Backlash must be 0.002 to 0.006-inch.
  - (16) Install fuel injection pump timing cover, timing window cover, fuel injection pump drive gear access cover, and cover gasket by reversing the instructions in steps A through E of figure 61.
  - (17) Refer to figure 209 and reverse the sequence of instructions to install the tachometer mounting adapter, drive shaft, and tachometer adapter.
  - (18) Refer to figure 199 and reverse the sequence of instructions to install the oil pan gasket and oil pan.
  - (19) Refer to figure 198 and attach flame heater fuel pump and fuel filter mounting bracket.
  - (20) Refer to figures 114 through 116 and reverse the sequence of illustrations and instructions to install the water pump assembly.
  - (21) Refer to figures 80 through 82 and figure 87 and reverse the sequence of illustrations and instructions to install the air compressor drive belt and to adjust air compressor drive belt deflection.
  - (22) Refer to figure 113 and reverse the sequence of instructions to install engine fan and generator drive belts. Adjust belt deflection as shown in figure 43.
  - (23) Refer to figure 112 and reverse the sequence of instructions to install the engine fan.
99. CRANKCAUSE BREATHER TUBE AND ADAPTER
- a. Removal.
    - (1) Remove crankcase breather tube following instructions for figure 44 and 45.
    - (2) Remove the crankcase breather adapter following steps A and B for figure 62.
  - b. Cleaning and Inspection. Clean crankcase breather tube and adapter in dry-cleaning solvent or mineral spirits paint thinner. Remove heavy gum and dirt deposits using a stiff wire brush. Clean out heavy sludge and gum deposits from inside tube and adapter using a wire to break loose obstructions. Dry and blow out passages using compressed air.
  - c. Repair. Crankcase breather tube and adapter are limited to welding cracked components, refacing gasket flange surface of the adapter and reconditioning damaged threads in breather tube. Replace damaged parts.

d. Installation.

- (1) Refer to figure 62 and reverse the sequence of instructions A and B to install the crankcase breather adapter, using new gaskets.
- (2) Refer to figures 44 and 45 and reverse the sequence of instructions to install the crankcase breather tube.

## 100. FUEL INJECTION TUBE ASSEMBLIES

a. Removal. Remove fuel injection tube assemblies as follows.

- (1) Remove cylinder No. 1, 2, and 3 fuel injection tube assemblies by following steps C and D, figure 57 and step C, figure 148.
- (2) Remove cylinder No. 4, 5, and 6 fuel injection tube assemblies following instructions in figure 133.

Note. It is not necessary to remove primary and final fuel filters or the fuel filter housing as shown in figure 133 to remove the injection tube assemblies.

b. Replacement. The fuel injection tube assemblies are furnished for replacement ready for installation. The tube assemblies are performed to fit their respective location in fuel injection pump hydraulic head and fuel injector nozzle and holder assembly. The tube assemblies include two nuts and dust cap.

c. Installation.

- (1) Refer to figure 133 and reverse the sequence of instructions to install cylinder No. 4, 5, and 6 fuel injection tube assemblies.
- (2) Refer to figure 57, steps C and D and figure 148, step C to install cylinder No. 1, 2, and 3 fuel injection tube assemblies.

## Section IV. SERVICE OPERATIONS

### 101. GENERAL

This section covers service operations allocated to third echelon maintenance personnel.

### 102. CHECKING CYLINDER COMPRESSION

a. General. Check cylinder compression when the is at operating temperature. Remove the six fuel injector nozzle and holder assemblies and test all cylinders. When troubleshooting (par. 49) indicates a compression test is required for only one cylinder, check that cylinder by removing the fuel injector nozzle and holder assembly.

b. Compression Test.

- (1) Refer to TM 9-2320-235-10 for proper engine starting procedure. Start engine and allow it to warm up to normal operating temperature and stop engine.
- (2) Remove the six fuel injector nozzle and holder assemblies following instructions for figures 148 and 149 (par. 83).

- (3) Test cylinder compression on all cylinders as follows. Figure 221. (A) Position a new fuel injector nozzle to head gasket on end of adapter- 10899183 and install the adapter into the injector nozzle opening. Secure the adapter to cylinder head using two 5/16 x 2- 1/2 cap screws and 5/16- inch lock washers provided for securing the nozzle and holder assembly clamp. Apply a light coating of grease on the gasket to prevent gasket from falling off adapter as it is installed in the head. (B) Connect compression tester gage -10899180 and coupling -10899184 to the adapter - 10899183 and tighten the connection securely. (C) Crank engine several seconds at 150 to 180 rpm using the engine starter motor. Observe cylinder compression reading on gage. Cylinder compression should be from 500 to 550 psi at engine cranking speed. (D) Depress pressure gage vent to release pressure to reset gage to zero reading after first test. Release gage vent and repeat test.

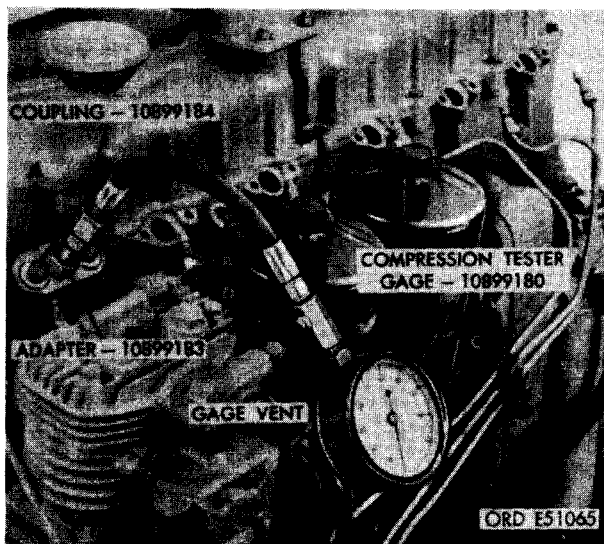


FIGURE 221. CHECKING CYLINDER COMPRESSION USING COMPRESSION TESTER GAGE -10899180, COUPLING -10899184, AND ADAPTER - 10899183.

**Note.** Compression pressure readings between cylinders should not vary more than 25 psi and pressure should not fall below 475 psi. Low compression on one or more cylinders causes starting difficulty and poor engine performance. When compression is low on one or more cylinders, refer to paragraph 49 for troubleshooting engine assembly and for corrective action.

- (4) During the cylinder compression test operation, check all fuel injector nozzle and holder assemblies for satisfactory operation. Remove fuel return tee (step A, fig. 150) and test fuel injector nozzle and holder assemblies as directed in paragraph 83c and d 1
- (5) Install fuel return tee in nozzle assembly. Refer to figures 148 and 149 (par. 83) and reverse the sequence of illustrations and instructions to install the fuel injector nozzle and holder assemblies.

### 103. CHECKING NOZZLE OPENING BREAK PRESSURE AND SPRAY PATTERN

a. **General.** For instructional purposes in this section assumed that troubleshooting indicated defective nozzles and the nozzle and holders have been removed from the engine.

b. **Install Injector Nozzle and Holder Assembly-in Tester.** Install nozzle and holder assembly on the fuel injector nozzle tester (par. 83c) and perform tests outlined in paragraph 83d.

c. **Repair and Replacement.** Repair or replace defective nozzles as directed in paragraph 83e through i.

### 104. ADJUSTING INTAKE AND EXHAUST VALVES

a. **General.** When checking and/or adjusting valve clearance, it is necessary to remove the crankcase breather adapter and the cylinder head covers.

b. **Removal of Components before Valve Adjustment.** Remove the crankcase breather adapter and the front cylinder head cover following instructions in figure 62. The rear cover is removed in the same manner as the front cover.

#### c. Valve Clearance Adjustment.

**Note.** Before checking or adjusting valve clearance both valves must be closed on the cylinder being checked. Refer to figure 183 and follow the sequence of instructions to adjust intake and exhaust valve clearance. Valve clearance must be checked and set when the tappet is on the base circle of the camshaft.

- (1) Rotate the crankshaft clockwise as viewed at the fan end, until cylinder No. 1 intake valve rocker arm is in its open position (valve open). At this position cylinder No. 1 exhaust valve is closed and tappet is on base circle of camshaft. Clearance adjustment should be made at this point.

**Note.** In each cylinder the valve to the fan end is the intake valve, and the valve to the flywheel end is the exhaust valve.

- (2) Insert the correct size feeler gage between the valve stem and the rocker arm pad and check the clearance (fig. 183). The correct intake valve clearance is 0.015-inch (cold) and the correct exhaust valve clearance is 0.025 - inch (cold). Loosen adjusting screw nut and turn adjusting screw to obtain proper clearance. After adjustment is made, tighten adjusting screw lock nut.

- (3) Check valve clearance on remaining valves in a similar manner. The remaining valves can be adjusted by rotating the crankshaft in 120 degree increments with valve adjustments being made in the following sequence:

No. 1 exhaust and No. 3 intake,  
No. 5 exhaust and No. 6 intake,  
No. 3 exhaust and No. 2 intake,  
No. 6 exhaust and No. 4 intake,  
No. 2 exhaust and No. 1 intake,  
No. 4 exhaust and No. 5 intake.

- (4) After adjustment is correct, use new gaskets and install the cylinder head covers and the crankcase breather adapter by reversing the sequence of instructions for figure 62.

#### 105. CHECKING VALVE TIMING

**Note.** The camshaft is timed during assembly of the engine and should require no further attention except during the replacement of crankshaft and camshaft gears (par. 98) or during major overhaul. However, the valve timing can be readily checked in the following manner:

a. Remove the timing gear cover (par. 97).

b. Locate the timing marks on the crankshaft gear and the camshaft gear (fig. 214).

**Note.** The crankshaft gear is marked with a single mark on one gear tooth. The camshaft drive gear is marked with a single punch mark in two adjacent gear teeth.

c. Rotate the crankshaft until the marks on both gears are together. The timing is correct if the marked tooth of the crankshaft gear is meshed between the two marked camshaft gear teeth (fig. 214).

**Note.** The crankshaft gear turns two revolutions while the camshaft gear turns one revolution. Rotate crankshaft until timing marks are alined.

d. If the timing marks do not aline in the above manner, remove the self-locking nut and remove the camshaft gear from the engine, using puller -8708724 (fig. 217). Rotate the camshaft and gear until the marked teeth are

properly meshed, install the gear and secure with self-locking nut. Tighten nut securely.

**Caution:** To prevent valves from being struck by pistons, do not rotate crankshaft with camshaft gear removed.

e. Install timing gear cover and check the fuel injection pump timing (par. 106 below).

#### 106. CHECKING AND ADJUSTING FUEL INJECTION PUMP TIMING

##### a. Procedure.

- (1) Remove the valve rocker cover on front cylinder head following instructions in figure 62.

- (2) Remove the two injection pump timing covers to expose the pump timing marks following instructions in figure 61, steps D and E.

- (3) Rotate the crankshaft clockwise as viewed from front of engine until No. 1 intake valve has completely closed. Continue rotating the crankshaft approximately 1/4 of a revolution until the mark on the damper is alined with the pointer on the timing gear cover (fig. 61). Cylinder No. 1 should then be on the compression stroke, with injection for No. 1 cylinder just beginning. The injection pump is properly timed when the mark on the damper is alined with the pointer on the timing gear cover, the injection pump timing pointer on the injection pump automatic advance unit hub (fig. 64) is alined with pointer, and the marked gear tooth is visible through the window cover at the side of the injection pump (fig. 65). If these conditions are not observed, the injection pump must be retimed as follows:

##### b. Retiming Fuel Injection Pump.

- (1) Remove fuel injection pump driven gear excess cover and timing covers (fig. 61).

- (2) Loosen three hex head screws securing driven gear and retaining plate to drive hub (fig. 66).



Note. Three slots in the injection pump driven gear allow approximately 20 degrees of free rotation of the injection pump driven gear on the hub. The hub is tapered and is keyed to the injection pump drive shaft on early injection pumps only. Late pumps do not have Woodruff key.

- (3) Rotate the injection pump driven gear hub nut (fig. 77) until the marked gear tooth appears in the window (fig. 65) on the side of the head of the injection pump and the timing mark (fig. 64) on automatic advance unit hub aligns with the pointer in the advance housing. With the marks aligned, tighten the three hex head screws retaining the gear to the hub (fig. 77).

Note. In extreme cases it may be necessary to remove the driven gear retaining screws to reposition the gear on the hub so the mark and pointer can be aligned.

- (4) Recheck the timing to make certain the adjustment has not been disturbed.
- (5) Refer to figure 61 and reverse the sequence of instructions to install the fuel injection pump access cover and timing covers. Use a new gasket.
- (6) Refer to figure 62 and reverse the sequence of instructions to install cylinder head cover. Install new gaskets under cover and breather adapter.

#### 107. FUEL INJECTION PUMP IDLE ADJUSTMENT

Loosen the lock nut (fig. 56) and turn the idle adjusting screw to obtain 550 to 600 rpm. After setting the idle speed, tighten the lock nut without permitting the idle screw to turn.

Note. Any tampering or adjustment of the maximum speed governor adjustment screw from its factory setting will nullify the warranty.

#### 108. AIR COMPRESSOR BELT DEFLECTION ADJUSTMENT

Refer to figure 82 and loosen pulley adjusting flange nuts. Adjust pulley adjustable flange using

wrench -10935288 (fig. 82) to obtain proper belt deflection as shown in figure 83. Replace worn, heat checked, or cracked belts, and belts which cannot be adjusted to proper deflection.

#### 109. ENGINE FAN AND GENERATOR DRIVE BELT DEFLECTION ADJUSTMENT

Adjust fan and generator drive belt deflection following instructions in figure 43. Replace both belts as a set when frayed, cracked, or unserviceable or when proper deflection cannot be attained.

#### 110. REVERSE FLUSHING ENGINE COOLING SYSTEM

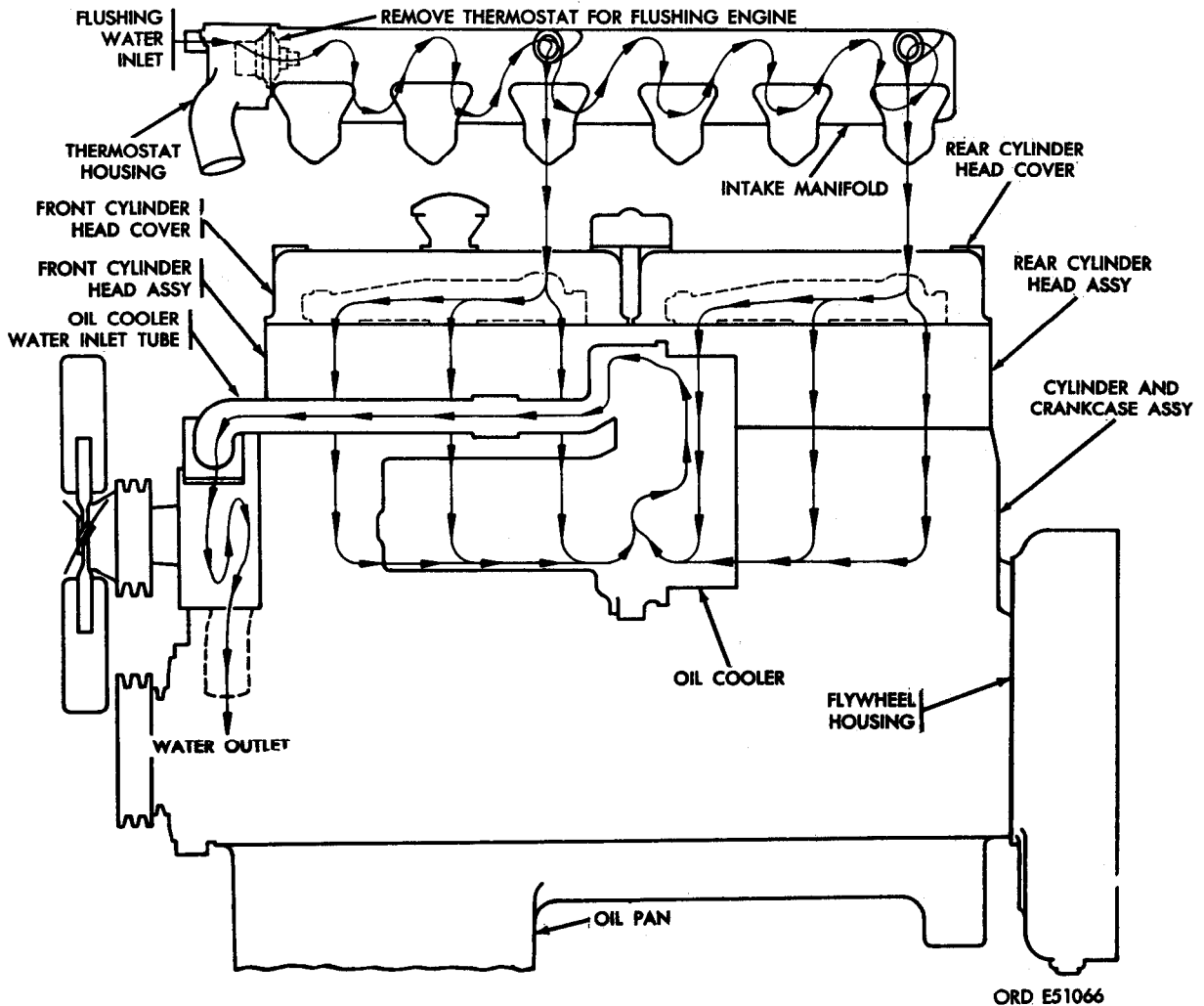
a. General. Whenever the cooling system is badly rusted, as indicated by overflow loss or abnormally high operating temperatures, the system must be cleaned. Reverse flow flushing will effectively remove the heavy deposits of sludge, rust, and scale.

##### b. Procedure.

- (1) Provide suitable drainage for coolant during flushing operation. Open the drain cock (fig. 107) located at the right side of the crankcase and allow coolant to drain. Remove two pipe plugs from the crankcase water jacket on the right side of engine behind turbosupercharger assembly.

Caution: Allow sufficient time for crankcase to cool before actually flushing system.

- (2) Remove the coolant thermostat housing and thermostat following instructions in figures 109 through 111. Install the thermostat housing (without thermostat) on intake manifold by reversing the sequence of instructions in figures 109 and 110.
- (3) Clamp flushing gun to water outlet on thermostat housing (fig. 222). Turn water on and fill coolant system.
- (4) Apply air pressure gradually. Do not exceed 10 psi air pressure. Blow water out through water pump inlet. Alternately fill the system with water, and blow out with air until flushing streams are clean. Disconnect flushing gun.



**FIGURE 222. REVERSE FLUSHING ENGINE COOLING SYSTEM.**

(5) Install pipe plugs in crankcase behind the turbosupercharger. Close drain cock (fig. 107). Remove thermostat housing following instructions in figures 109 and 110. Install thermostat in housing (fig. 111). Refer to figures 109 and 110 and reverse the sequence of

illustrations and instructions to install thermostat housing on intake manifold. Use a new gasket. Refer to TM 9-1007 for approved anti-freeze compound containing rust or corrosion inhibitor, or water with corrosion inhibitor added.

## CHAPTER 5

### DISASSEMBLY OF ENGINE

#### Section I. PREPARATION OF ENGINE FOR DISASSEMBLY

##### 111. GENERAL

This chapter covers disassembly of the engine into subassemblies described in an illustrated, step-by-step procedure. Engines which have been removed from vehicle for overhaul must be thoroughly drained, cleaned, and stripped of all accessories before proceeding with

disassembly. When necessary to remove power plant from the vehicle, refer to TM 9-2320-235-20 for instructions. Refer to TM 9-2320-235-35 for instructions on separation of transmission from engine assembly. The clutch assembly, while not part of the engine assembly, is covered herein because of its close relationship to the engine,

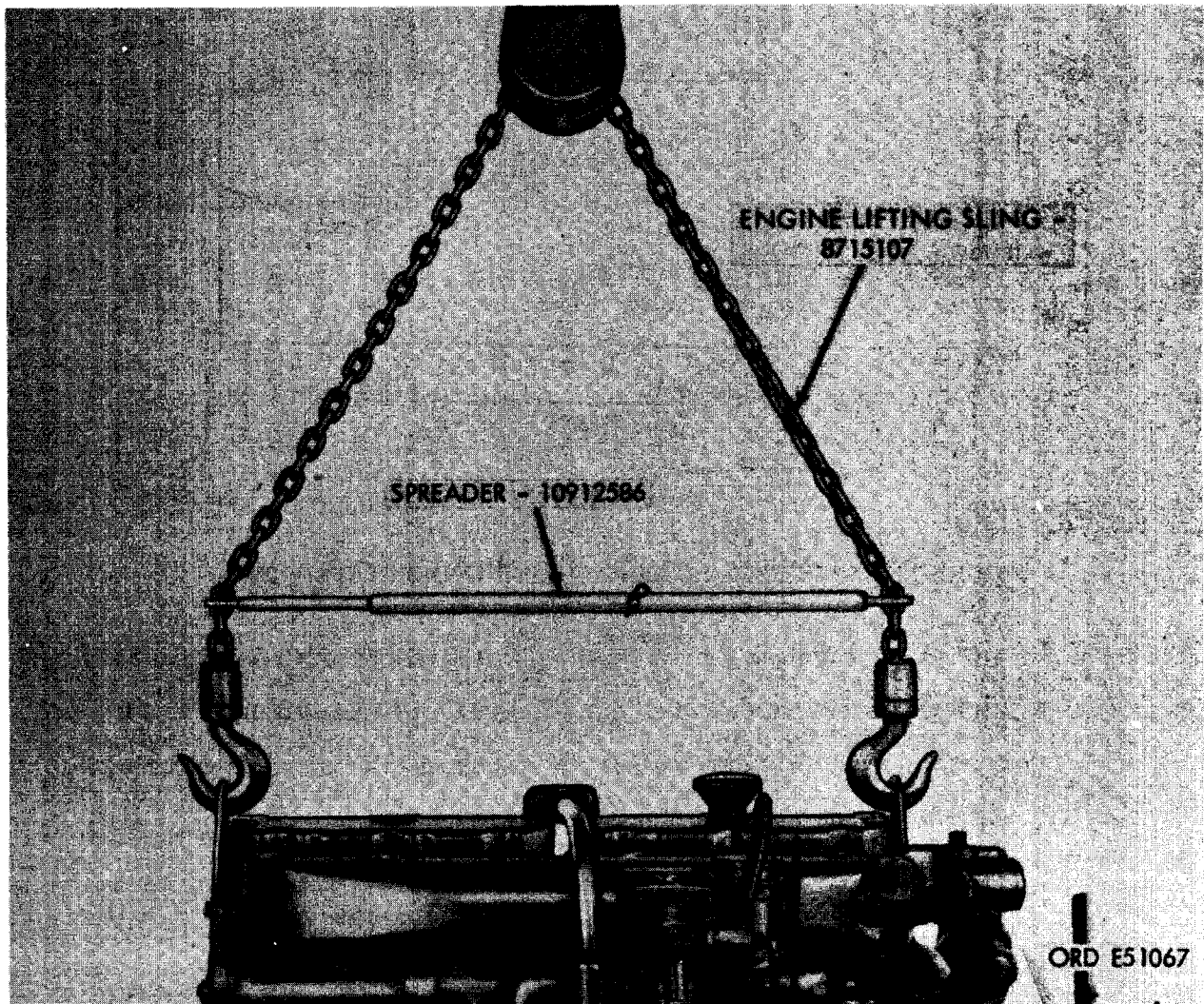


FIGURE 223. LIFTING ENGINE USING ENGINE LIFTING SLING.

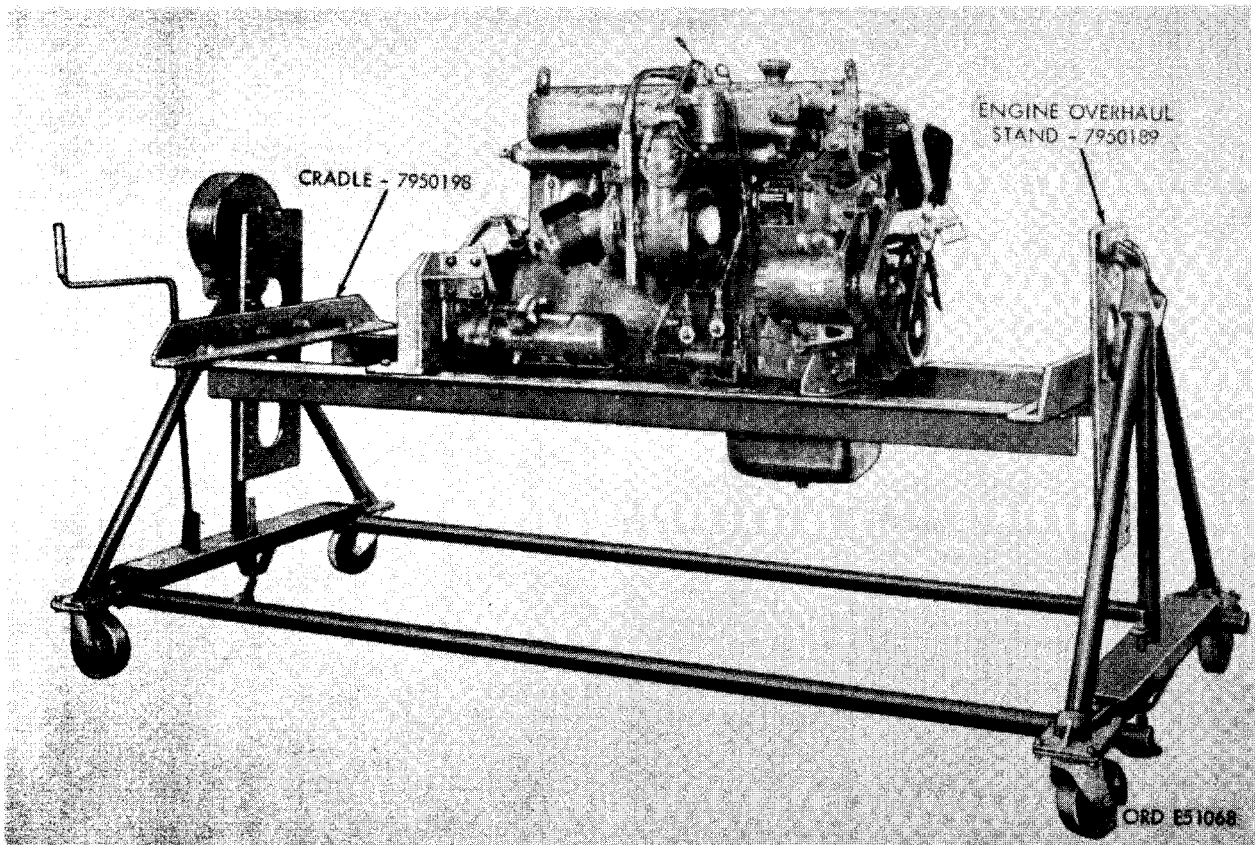


FIGURE 224. ENGINE ASSEMBLY MOUNTED ON ENGINE OVERHAUL STAND.

## 112. LIFTING ENGINE ASSEMBLY

Lifting the engine for draining and for installation in the overhaul stand (fig. 28) is accomplished using engine lifting sling -8715107 (fig. 29). This type of sling is more maneuverable and aids in installing engine on overhaul stand and tilting engine for draining.

## 113. DRAINING OF ENGINE AND COMPONENTS

a. General. Draining of engine coolant, oil, and fuel before engine disassembly is important in maintaining a clean work area. Before installing engine in overhaul stand, drain engine as directed in paragraphs b through d below.

b. Drain Engine Coolant. Place a suitable container below coolant drain cock (fig. 107), tilt engine so front of engine is higher than rear. Open drain cock and allow coolant to drain. Close drain cock after draining.

c. Drain Engine Oil. Place suitable container beneath engine oil filter drain plug (fig. 105). Remove drain plug and drain oil cooler. Replace plug after draining. Remove drain plugs (fig. 198) from oil pan and drain oil in a suitable container. Install drain plugs after draining.

d. Drain Fuel. Place a container beneath fuel filter assembly (fig. 103). Open vent valves. Open drain cock at bottom of primary and final fuel filters and drain fuel. Close drain cocks after draining.

## 114. INSTALLATION OF ENGINE ASSEMBLY ON OVERHAUL STAND

a. Install Engine Mounting Brackets. Lift engine using sling- 8715107 and spreader - 10912586 (fig. 223) and position engine over overhaul stand -7950189 and cradle -7950198 with flywheel toward overhaul stand gear box. Install the right rear engine mounting bracket - 10899188 and left rear engine mounting bracket

-10912239 on flywheel housing studs and secure brackets with eight 1/2-inch plain nuts and 1/2-inch lock washers. Install right and left front mounting brackets -10899191 and 10899173 on the left and right sides of engine front plate and secure with four 7/16 x 1-3/8 cap screws and 7/16-inch plain nuts.

b. Install Engine Assembly on Overhaul Stand. Lower the engine assembly on the engine overhaul stand. Aline the engine mounting bracket holes with the slotted openings in the cradle side rails. Secure engine cradle side rails using four 5/8 x 1-3/4 cap screws and 5/8-inch plain nuts through each engine mounting bracket as shown in figure 224.

#### 115. REMOVAL OF ENGINE ACCESSORIES DURING ENGINE DISASSEMBLY

Remove engine accessories from engine after installing the engine on overhaul stand. The accessories will then be sent to qualified personnel for rebuild.

Note. To prevent entry of dirt, cover all fuel and oil line connections and all air and exhaust openings on accessories and engine after removal.

a. Starter Assembly. Remove starter assembly following instructions for figure 39.

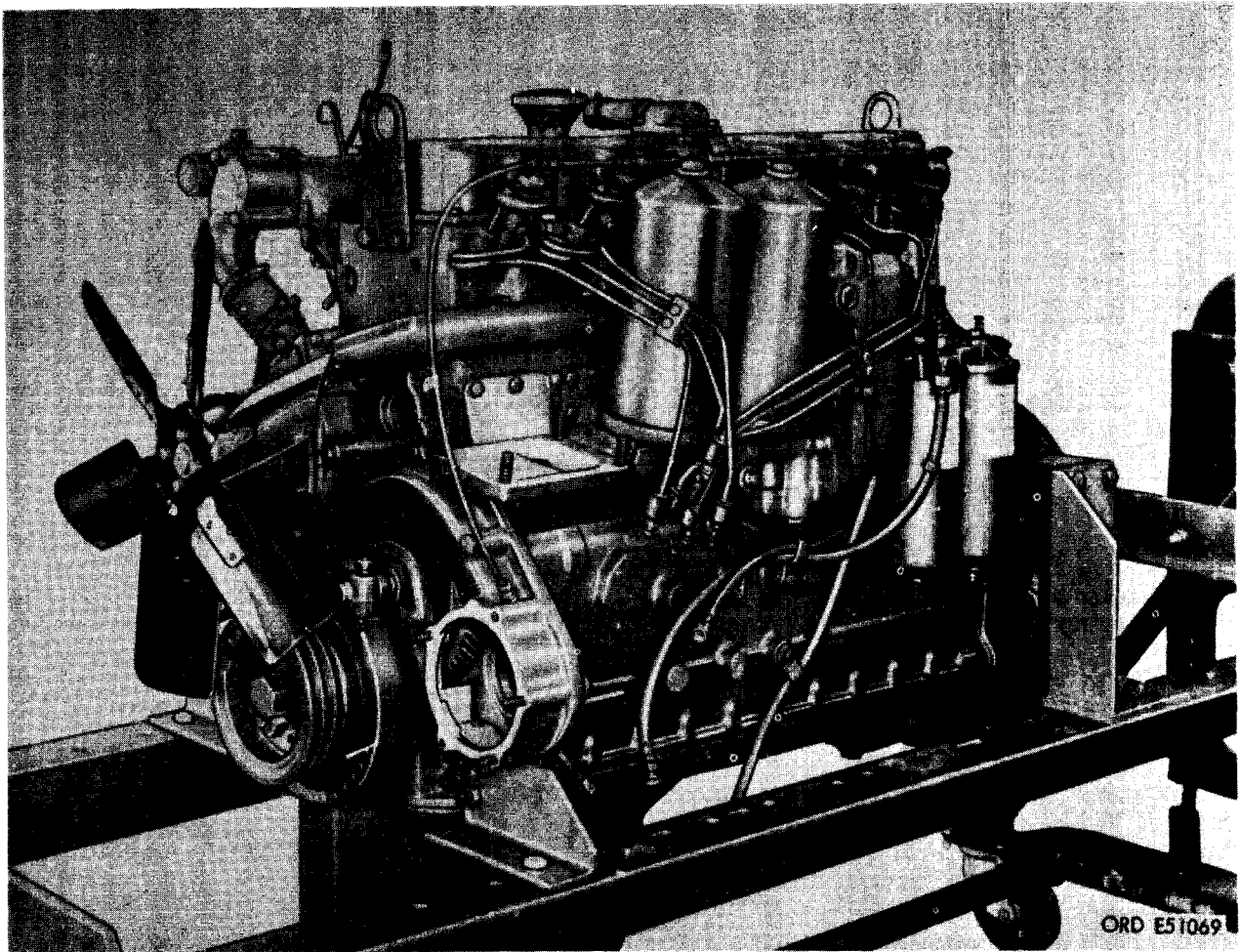


FIGURE 225. ENGINE ASSEMBLY MOUNTED ON OVERHAUL STAND - 3/4 LEFT FRONT VIEW.

**b. Generator Assembly.** Remove generator assembly and drive belts following instructions for figure 41. Remove generator pulley following instructions for figure 42.

**c. Turbosupercharger Assembly.** Remove turbosupercharger assembly following instructions for figures 44 through 47 and 49 through 53.

**d. Fuel Injection Pump Assembly.** Remove fuel injection pump assembly following instructions for figures 56 through 61 and 66 through 76.

**e. Flame Heater Fuel Pump Assembly.** Remove flame heater fuel pump assembly following instructions for figures 78 through 80.

**f. Air Compressor Assembly.** Remove air compressor assembly and drive belt following instructions for figures 80 through 85.

## 116. GENERAL

Figure 225 shows the engine assembly with the accessories removed and ready for disassembly. For instructional purposes the disassembly procedures will begin on the left side of engine and continue until all components are removed from that side. The remainder of the disassembly procedure will continue to the right side until partially disassembled. To complete the disassembly procedures, remove the engine from the overhaul stand. Figures 226 through 312 present a step-by-step procedure for disassembly of the engine.

## 117. REMOVAL OF FUEL FILTER ASSEMBLY

**a. General.** The fuel filter assembly, consisting of two filters, primary and secondary, is mounted on the upper left rear of the engine.

**b. Removal.** Remove the fuel filter assembly as follows.

- (1) Figure 226. (A) Disconnect and remove supply pump-to-fuel filter inlet hose from  $3/8 \times 1/4$  pipe reducer in filter head. (B) Disconnect and remove fuel injection overflow and fuel return-to-fuel filter inlet hose from  $3/8$ -inch pipe tee. (C) Disconnect and remove fuel filter outlet-to-fuel injector supply hose from  $3/8$ -inch, 90 degree street elbow.

- (2) Refer to figure 227 and remove fuel and oil hoses from the engine.



FIGURE 226. DISCONNECTING FUEL HOSES AT FUEL FILTER ASSEMBLY.

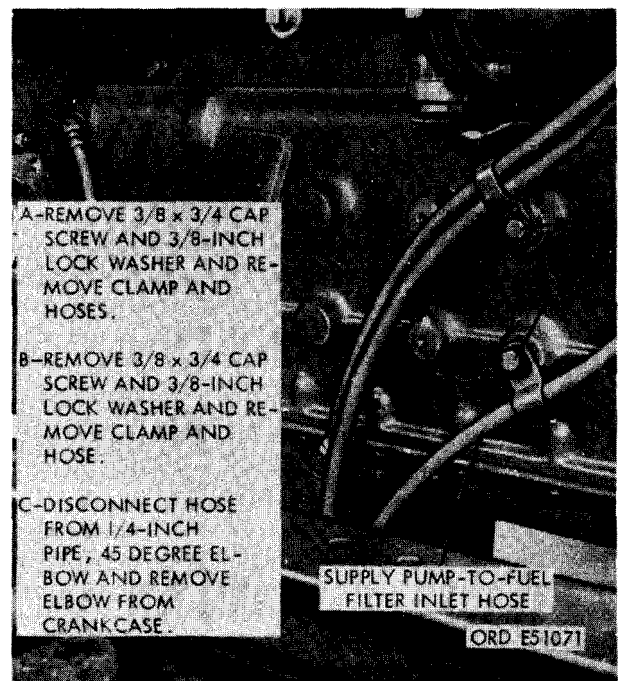


FIGURE 227. REMOVING OR INSTALLING FUEL AND OIL HOSES FROM ENGINE.

- (3) Figure 228. (A) Remove nuts, flat washers, and preformed packings securing primary and final fuel filter cases to fuel filter head. Remove preformed packings from nuts and discard packings. (B) Remove primary and final fuel filter cases. Remove and discard fuel filter elements. (C) Remove and discard fuel filter head preformed packings.

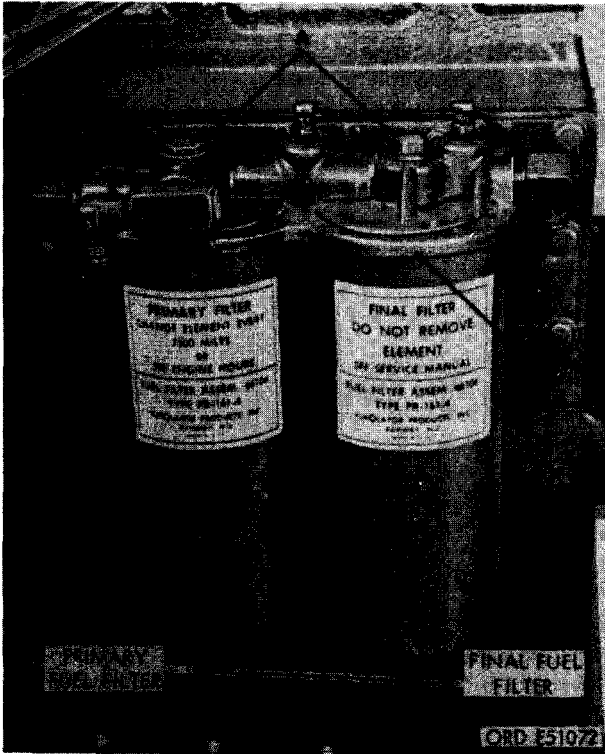


FIGURE 228. REMOVE OR INSTALLING. PRIMARY AND FINAL FUEL FILTER ELEMENTS.

- (4) Figure 229. (A) Remove three 3/8- inch plain nuts and 3/8- inch lock washers securing fuel filter head to studs which extend through tappet chamber cover. (B) Remove fuel filter head.

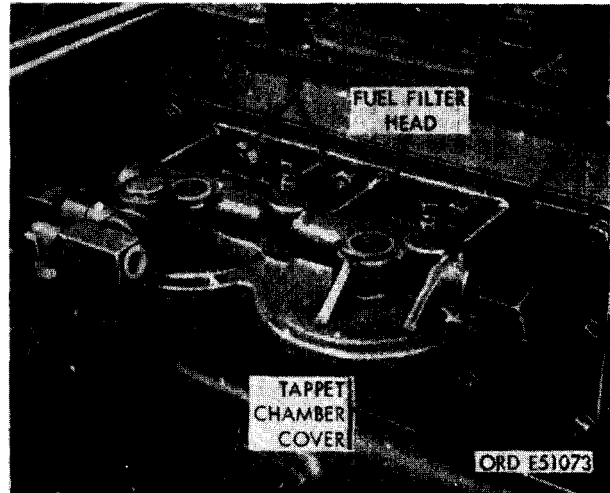


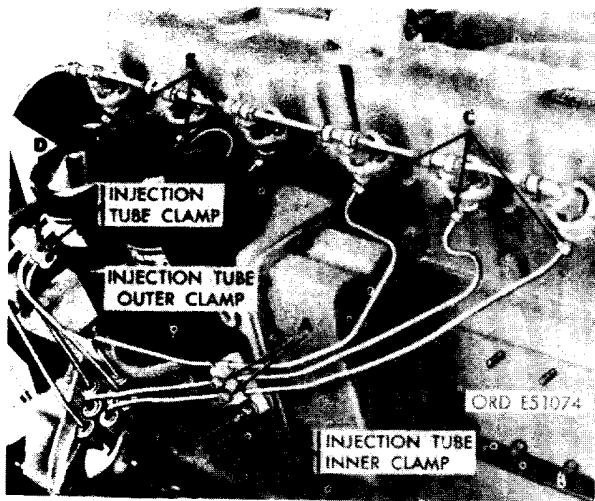
FIGURE 229. REMOVING OR INSTALLING FUEL FILTER HEAD.

#### 118. REMOVAL OF FUEL INJECTION TUBE ASSEMBLIES AND FUEL INJECTOR NOZZLE AND HOLDER ASSEMBLIES

a. General. The fuel injection tube assemblies carry the fuel from the injection pump to the fuel injector nozzle and holder assemblies.

b. Removal. Remove the tube assemblies and nozzle and holder assemblies as follows.

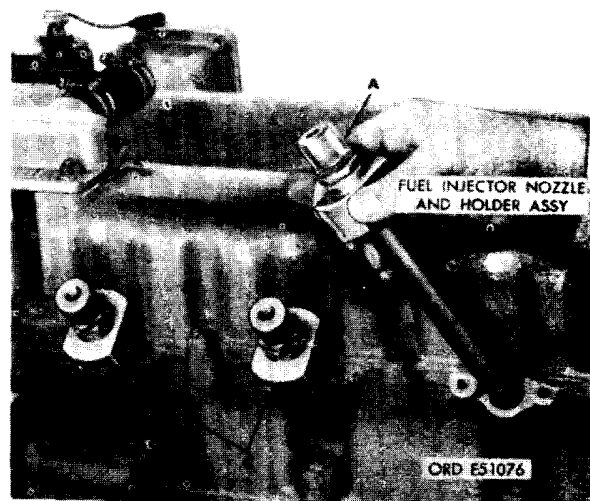
- (1) Figure 230. (A) Remove two 1/4-inch self-locking nuts, 1/4- inch plain washers, and 1/4 x 1-3/8 cap screws securing fuel injection tube outer clamp to inner clamp. (B) Remove 3/8-inch plain nut, 3/8-inch plain washer, and 3/8-inch lock washer securing inner fuel injection tube clamp to stud in oil cooler and oil filter housing. (C) Disconnect and remove cylinder No. 4, 5, and 6 fuel injection tubes from fuel injector nozzle and holder assemblies. (D) Remove two 1/4-inch self-locking nuts, 1/4- inch flat washers, and 1/4 x 1-3/8 cap screws securing fuel injection tube clamps to cylinder No. 1, 2, and 3 fuel injection tubes. Remove clamps. (E) Disconnect and remove cylinder No. 1, 2, and 3 fuel injection tubes from fuel injector nozzle and holder assemblies.



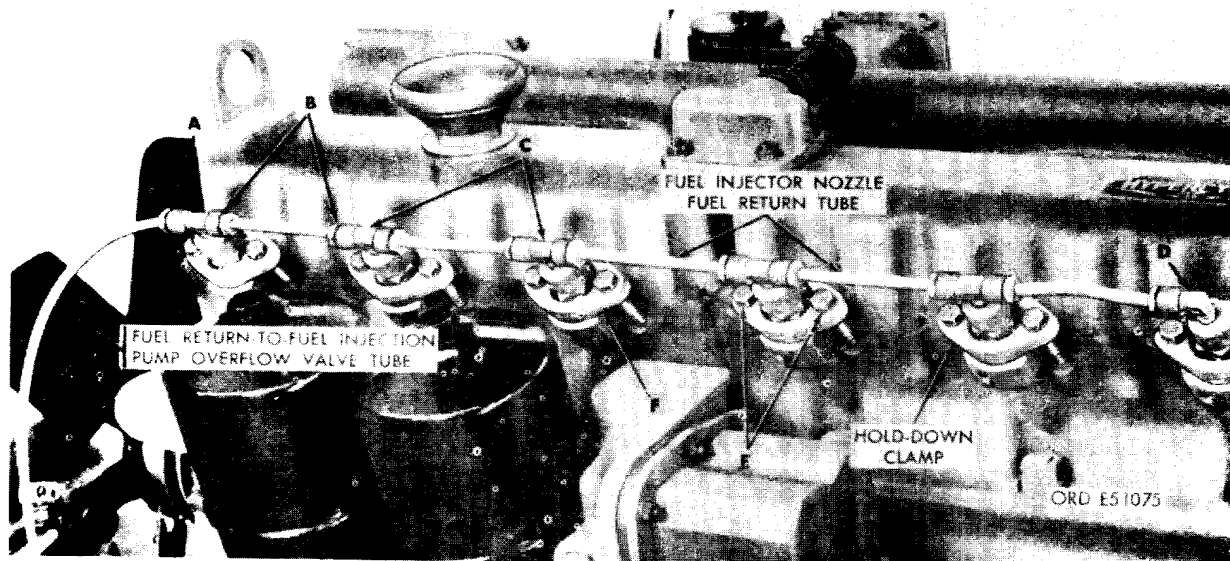
**FIGURE 230. REMOVING FUEL INJECTION TUBES AND CLAMPS.**

- (2) Figure 231. (A) Disconnect and remove fuel return-to-fuel injection pump overflow valve tube from 1/4-inch tube tee in nozzle and holder assembly. (B) Disconnect and remove five fuel injector nozzle fuel return tubes from the 1/4-inch tube tees in fuel injector nozzle and holder assemblies. (C) Remove the five 1/4-inch tube tees from cylinder No. 1 through 5 fuel injector nozzle and holder assemblies. (D) Remove 1/8 x 1/4, 90

degree elbow from cylinder No. 6 fuel injector nozzle and holder assembly. (E) Remove two 5/16 x 2-1/2 cap screws and 5/16-inch lock washers securing each hold-down clamp securing fuel injector nozzle and holder assembly to cylinder head. (F) Remove hold-down clamp from each fuel injector nozzle and holder assembly.



**FIGURE 232. REMOVING FUEL INJECTOR NOZZLE AND HOLDER ASSEMBLIES.**



**FIGURE 231. REMOVING INJECTOR NOZZLE FUEL RETURN TUBES AND NOZZLE AND HOLDER ASSEMBLY HOLD-DOWN CLAMPS.**



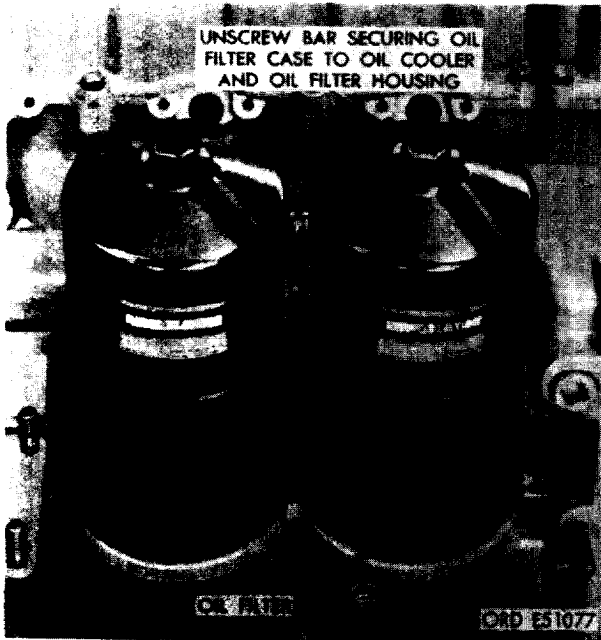
- (3) **Figure 232.** (A) Remove fuel injector nozzle and holder assembly. (B) Remove and discard fuel injector to head gasket. (C) Remove the remaining five fuel injector nozzle and holder assemblies and gaskets in the same manner.

## 119. REMOVAL OF OIL FILTER ELEMENTS

a. General. The oil filter elements are installed in the oil filter cases mounted at the upper left center of the engine.

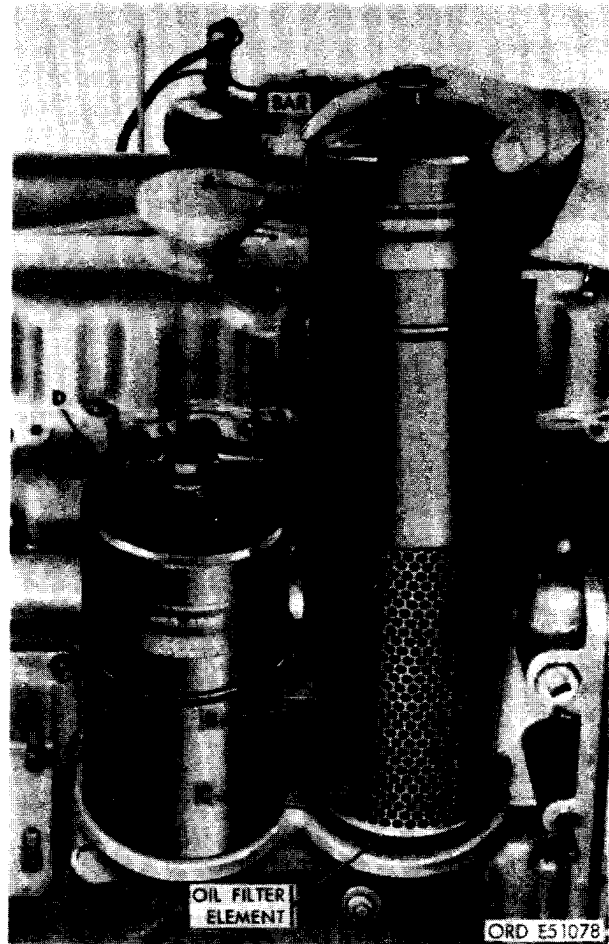
b. Removal. Remove the oil filter elements as follows.

- (1) Refer to figure 233 and disconnect oil filter cases.



**FIGURE 233. DISCONNECTING REAR OIL FILTER CASE AT OIL FILTER HOUSING.**

- (2) **Figure 234.** (A) Remove rear oil filter case and bar. (B) Remove and discard rear oil filter element. (C) Remove and discard oil filter case gasket. (D) Unscrew bar securing front oil filter case to oil cooler and oil filter housing and remove case, element, and gasket in the same way.



**FIGURE 234. REMOVING FRONT AND REAR OIL FILTER ELEMENTS.**

## 120. REMOVAL OF OIL COOLER, OIL COOLER AND OIL FILTER HOUSING AND TAPPET CHAMBER COVER

a. General. The engine lubricating oil is cooled as it passes through the oil cooler. The oil cooler is mounted on the oil cooler and filter housing assembly forward of the oil filter.

b. Removal. Remove the oil cooler, oil cooler and filter housing, and tappet chamber cover as follows.

- (1) **Figure 235.** (A) Loosen two 2-inch id hose clamps securing oil cooler water inlet hose. Slide hose back on oil cooler water inlet tube. (B) Remove four 5/16-inch plain nuts and 5/16-inch lock washers securing oil cooler water inlet tube to water pump body. (C) Disconnect

and remove tube. Remove hose from tube. (D) Remove and discard oil cooler water inlet tube gasket.

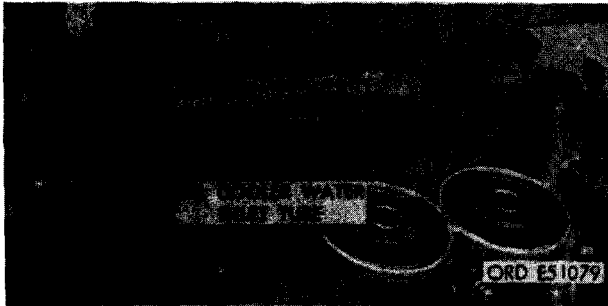


FIGURE 235. REMOVING OR INSTALLING OIL COOLER WATER INLET TUBE.

- (2) Figure 236. (A) Remove twelve 1/4-inch plain nuts and 1/4-inch lock washers securing oil cooler cover to oil cooler and oil filter housing. (B) Remove oil cooler cover. (C) Remove and discard oil cooler cover gasket.

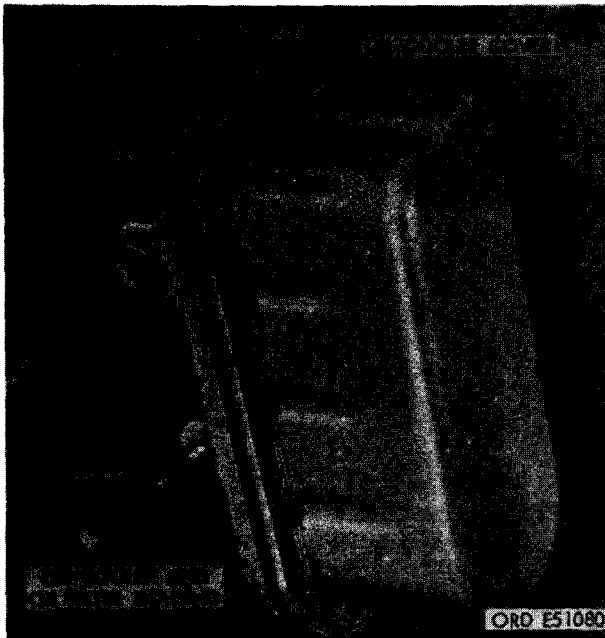


FIGURE 236. REMOVING OR INSTALLING OIL COOLER COVER.

- (3) Figure 237. (A) Remove oil cooler. (B) Remove and discard oil cooler gasket.

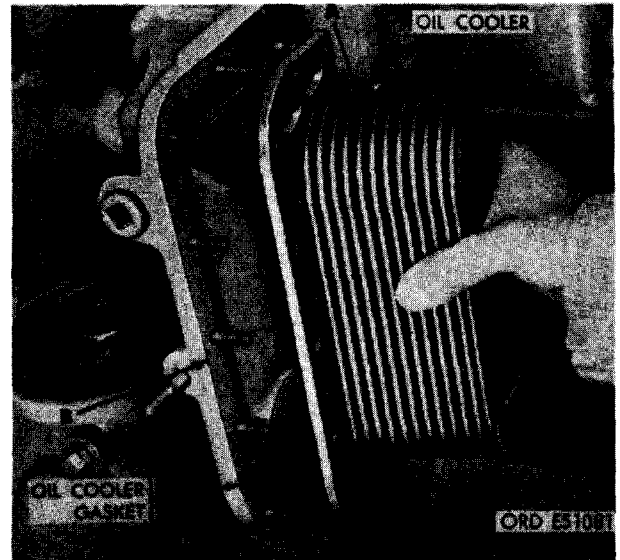


FIGURE 237. REMOVING OR INSTALLING OIL COOLER AND OIL COOLER GASKET.

- (4) Figure 238. (A) Remove and discard two 7/8 id x 1/8 thk preformed packings. (B) Remove one 3/8 x 5-1/8 self-locking bolt and 3/8-inch flat washer. (C) Remove sixteen 3/8 x 7/8 cap screws and 3/8-inch flat washers securing oil cooler and oil filter housing to cylinder and crankcase. (D) Remove oil cooler and filter housing from crankcase.

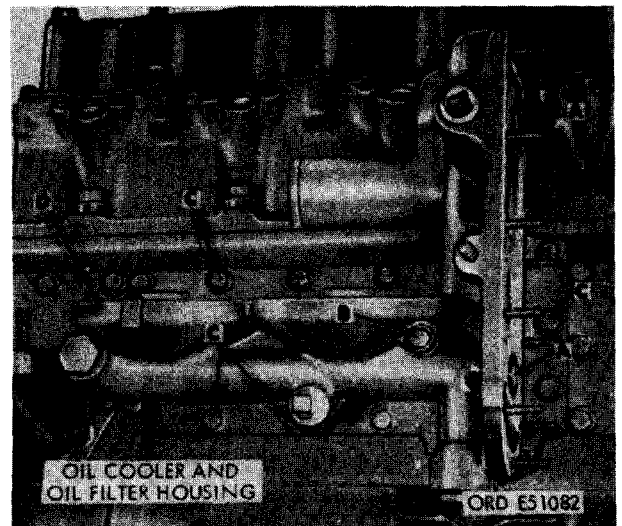
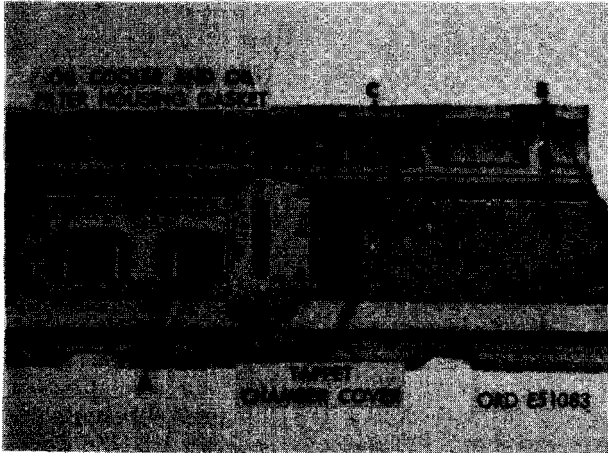


FIGURE 238. REMOVING OR INSTALLING OIL COOLER AND OIL FILTER HOUSING ASSEMBLY.

- (5) Figure 239. (A) Remove and discard oil cooler and oil filter housing gasket. (B) Remove eleven 3/8 x 7/8 cap screws and 3/8-inch lock washers securing tappet chamber cover to cylinder and crankcase. (C) Remove tappet chamber cover.



**FIGURE 239. REMOVING OR INSTALLING TAPPET CHAMBER COVER.**

- (6) Figure 240. (A) Remove and discard tappet chamber cover gasket. (B) Remove cylinder and crankcase water baffle.



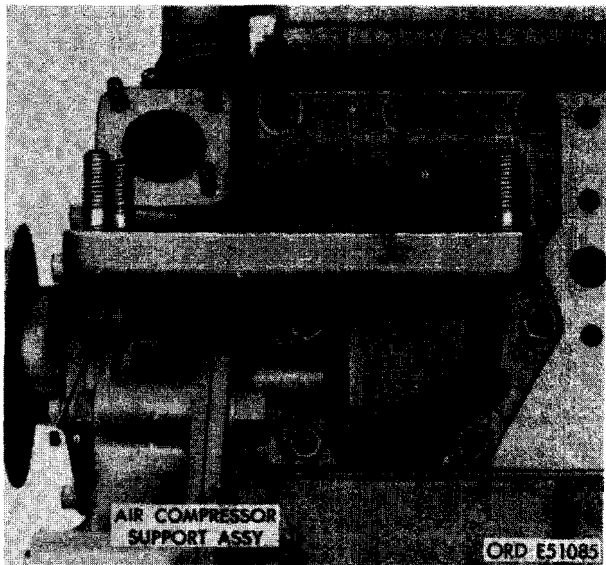
**FIGURE 240. REMOVING OR INSTALLING CYLINDER AND CRANKCASE WATER BAFFLE.**

## 121. REMOVAL OF AIR COMPRESSOR SUPPORT AND FUEL INJECTION PUMP ADAPTER ASSEMBLIES

**a. General.** A support for mounting the air compressor is provided at the upper left front of the engine. The fuel injection pump adapter assembly is mounted at the left rear of the engine front plate.

**b. Removal.** Remove air compressor support and fuel injection pump adapter assemblies as follows.

- (1.) Figure 241. (A) Remove seven 3/8 x 7/8 cap screws and 3/8-inch lock washers securing air compressor support assembly to cylinder and crankcase. (B) Remove air compressor support assembly.



**FIGURE 241. REMOVING OR INSTALLING AIR COMPRESSOR SUPPORT ASSEMBLY.**

- (2) Refer to figure 242 and remove air compressor support gasket.



FIGURE 242. REMOVING OR INSTALLING AIR COMPRESSOR SUPPORT GASKET.



FIGURE 243. REMOVING OR INSTALLING FUEL INJECTION PUMP ADAPTER ASSEMBLY.

- (3) Figure 243. (A) Remove two 3/8-inch plain nuts and 3/8-inch lock washers securing fuel injection pump adapter assembly to engine front plate. (B) Remove fuel injection pump adapter assembly. (C) Remove and discard fuel injection pump adapter gasket.

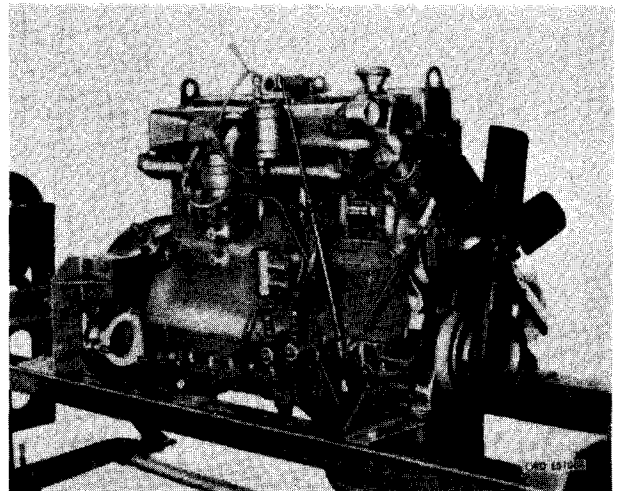


FIGURE 244. PARTIALLY STRIPPED ENGINE IN OVERHAUL STAND - 3/4 RIGHT FRONT VIEW.

## 122. REMOVAL OF COMPONENTS FROM RIGHT SIDE OF ENGINE

a. Figure 244 shows the engine partially disassembled and mounted on overhaul stand - 7950189 and cradle - 7950198.

b. Continue to disassemble the engine by removing components from the right side following instructions for figures 245 through 256.

## 123. REMOVAL OF INTAKE MANIFOLD FLAME HEATER AND ELBOW

a. General. The intake manifold flame heater is installed in an elbow mounted on the intake manifold. Air moving from the turbosupercharger to the intake manifold passes through the elbow and can be heated to aid in starting the engine in cold weather.

b. Removal. Remove the intake manifold flame heater and elbow as follows.

- (1) Figure 245. (A) Disconnect flame heater fuel solenoid valve-to-flame heater nozzle tube from 1/8 pipe x 1/4 tube, 90 degree elbow in flame heater nozzle and holder assembly. (B) Disconnect flame heater fuel return-to-solenoid valve tube from 1/8 pipe x 1/4 tube connector in flame heater nozzle and holder assembly. (C) Disconnect flame heater ignition lead from spark plug and ignition unit. Remove ignition lead. (D) Remove four 5/16-inch plain nuts and 5/16-inch lock washers securing intake manifold flame heater assembly to intake manifold elbow. Remove flame heater harness clamp. (E) Remove the flame heater assembly.

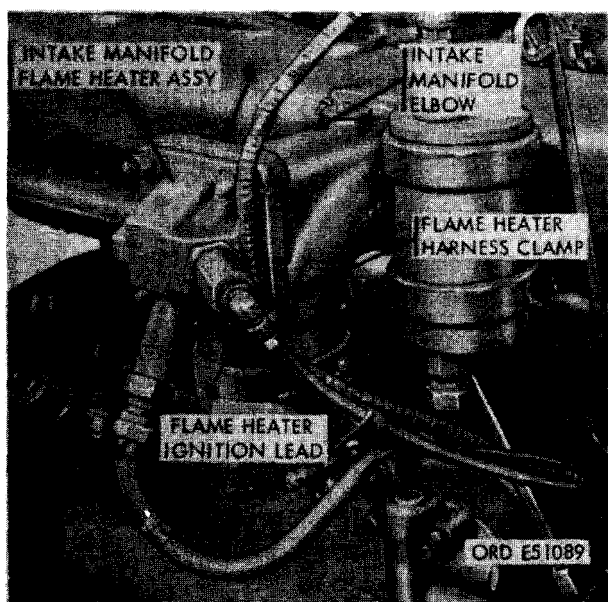


FIGURE 245. REMOVING OR INSTALLING INTAKE MANIFOLD FLAME HEATER ASSEMBLY

- (2) Figure 246. (A) Remove and discard flame heater gasket. (B) Disconnect flame heater harness from ignition unit. (C) Remove two 5/16-inch plain nuts and 5/16-inch lock washers securing two clamps which hold ignition unit to intake manifold elbow. (D) Remove ignition unit and clamps. Remove clamps from ignition unit.

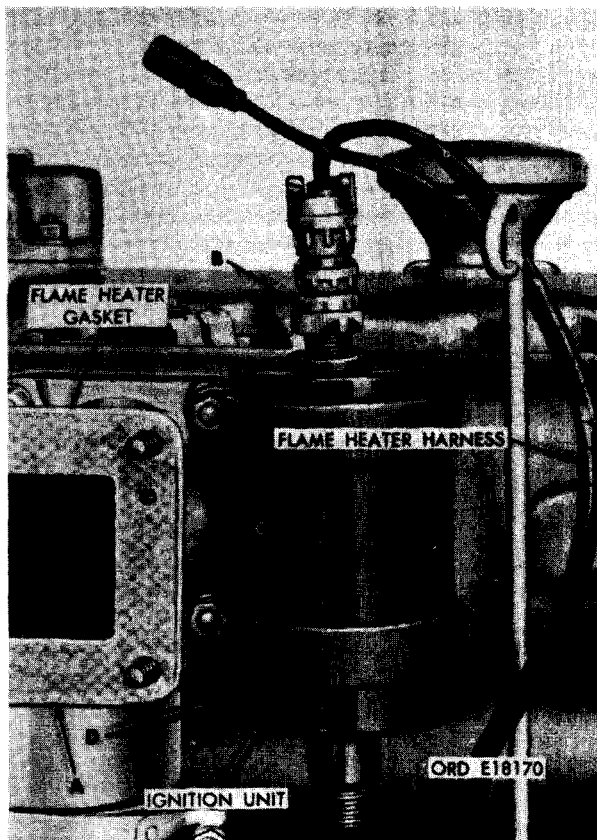


FIGURE 246. REMOVING OR INSTALLING FLAME HEATER IGNITION UNIT.

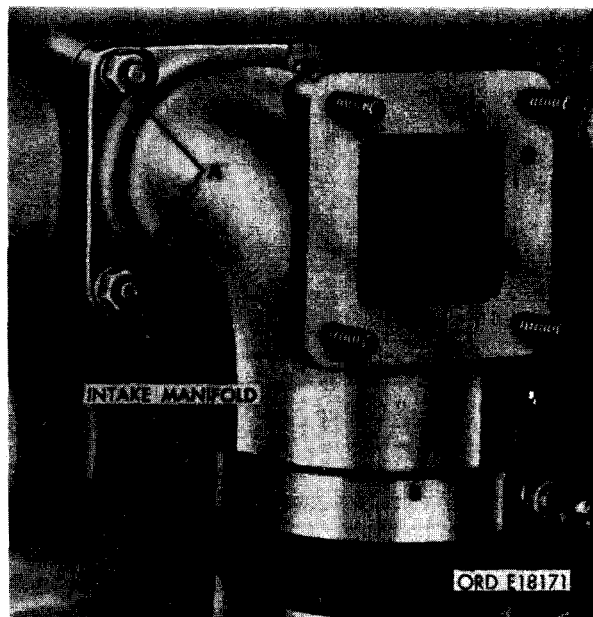


FIGURE 247. REMOVING OR INSTALLING INTAKE MANIFOLD ELBOW.

- (3) Figure 247. (A) Remove two 5/16-inch plain nuts and 5/16-inch lock washers securing the intake manifold elbow to the intake manifold. (B) Remove intake manifold elbow with the turbosupercharger-to-intake manifold hose and clamps attached.
- (4) Figure 248. (A) Remove and discard intake manifold elbow gasket. (B) Unscrew and withdraw oil level gage. (C) Remove No. 12 plain nut, No. 12 lock washer, and No. 12 x 5/8 machine screw securing oil level gage rod support to oil level gage rod support bracket. Disconnect flame heater harness from clamp.



FIGURE 248. DISCONNECTING OR CONNECTING FLAME HEATER HARNESS AT OIL LEVEL GAGE SUPPORT BRACKET.

#### 124. REMOVAL OF FLAME HEATER FUEL PUMP AND FUEL FILTER BRACKET

**A. General.** The flame heater fuel pump, solenoid valves, and fuel filter are supported by a bracket mounted on the lower left side of the engine. The bracket is secured with three oil pan mounting capscrews.

**b. Removal.** Remove the flame heater fuel pump and fuel filter bracket as follows.

- (1) Figure 249. (A) Disconnect 1/4-inch tube nut on fuel pump-to-fuel inlet solenoid valve tube from 90 degree elbow in solenoid valve and remove tube. (B) Disconnect 1/4-inch tube nut on fuel return-to-fuel solenoid valve tube from 90 degree elbow in solenoid valve and remove tube. (C) Remove No. 10 plain nut, No. 10 lock washer, No. 10 x 3/8 machine screw, and cushioned clamp holding fuel tubes together and remove tubes. (D) Disconnect 1/4-inch tube nut on fuel filter-to-fuel inlet solenoid valve from 90 degree elbow in solenoid valve. (E) Disconnect fuel filter-to-fuel inlet solenoid valve tube from 1/4 tube x 1/8 pipe union in filter outlet port and remove tube. (F) Remove No. 10 plain nut, No. 10 lock washer, and No. 10 x 1-3/4 machine screw securing flame heater harness ground wire. Disconnect ground wire. (G) Disconnect flame heater harness from solenoid valves. Remove flame heater harness.

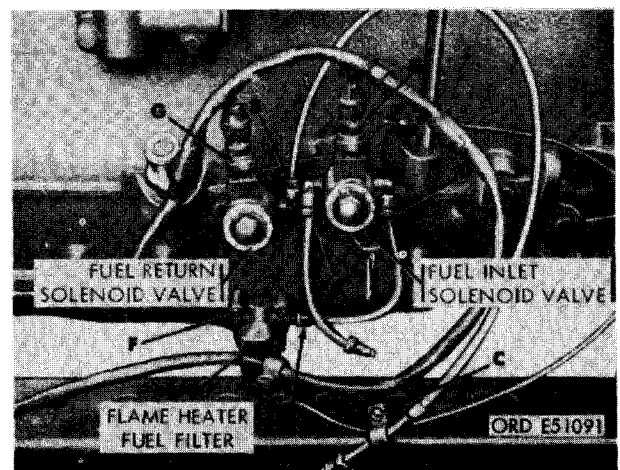
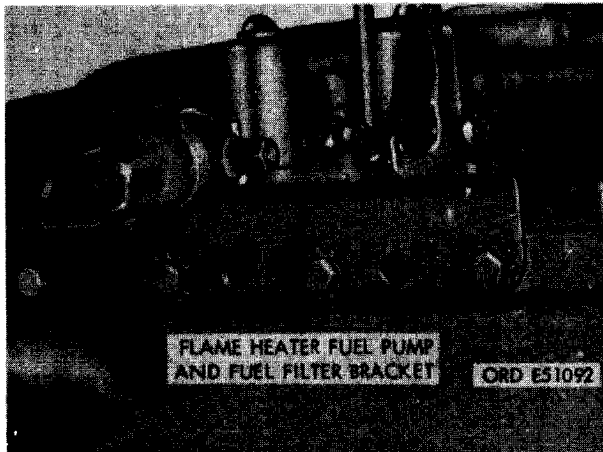
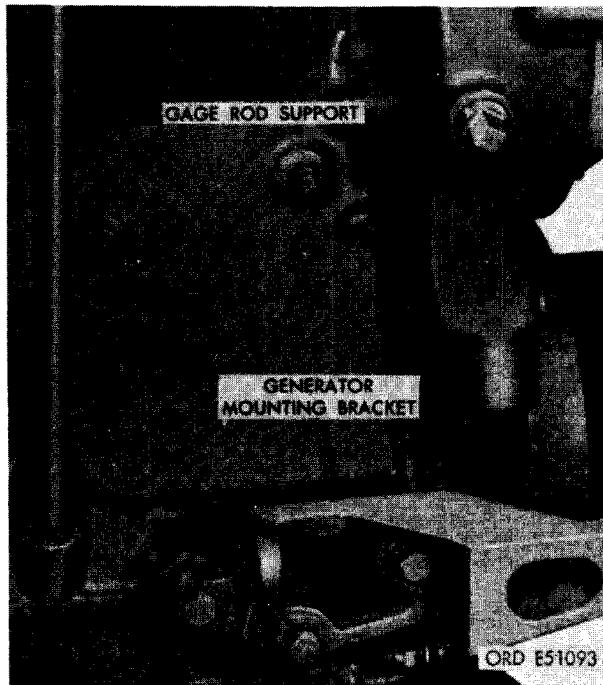


FIGURE 249. DISCONNECTING OR CONNECTING FLAME HEATER FUEL TUBES AND HARNESS AT SOLENOID VALVES.

- (2) Figure 250. (A) Remove three 3/8 x 1-1/4 cap screws and 3/8-inch lock washers securing flame heater fuel pump and fuel filter bracket to crankcase. (B) Remove bracket with assembled solenoid valves and fuel filter.



**FIGURE 250. REMOVING OR INSTALLING FLAME HEATER FUEL PUMP AND FUEL FILTER.**



**FIGURE 251. REMOVING OR INSTALLING OIL GAGE ROD SUPPORT AND GENERATOR MOUNTING BRACKET.**

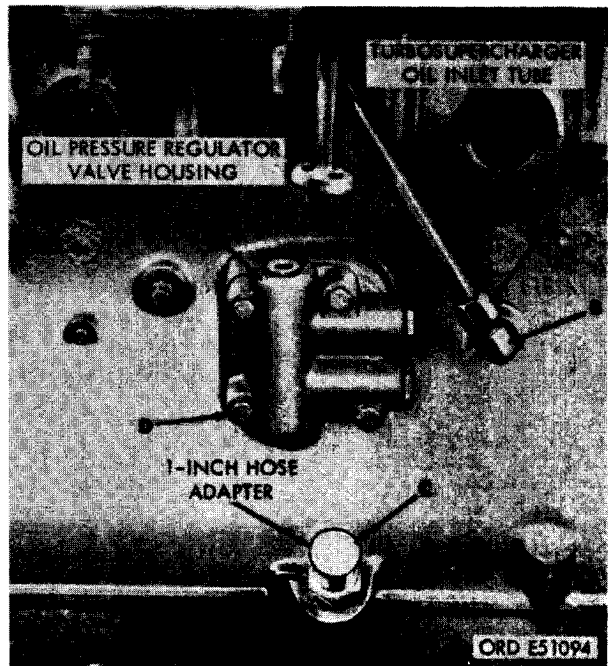
## 125. REMOVAL OF OIL GAGE ROD SUPPORT AND GENERATOR MOUNTING BRACKET

**a. General.** The oil gage rod support screws into a tapped hole in the crankcase and is supported at the top by a bracket. The generator mounting bracket is installed at the lower left front corner of the engine.

**b. Removal.** Figure 251. (A) Remove oil gage rod support. (B) Remove three 7/16 x 1-1/2 cap screws and 7/16-inch lock washers securing generator mounting bracket to crankcase. (C) Remove generator mounting bracket.

## 126. REMOVAL OF TURBOSUPERCHARGER OIL INLET TUBE AND OIL PRESSURE REGULATOR VALVE HOUSING ASSEMBLY

**a. General.** The turbosupercharger oil inlet tube is connected to an elbow in the crankcase. The oil pressure regulator valve housing assembly is mounted near the center of the left side of the engine.



**FIGURE 252. REMOVING TURBOSUPERCHARGER OIL INLET TUBE, FITTINGS, AND OIL PRESSURE REGULATOR VALVE HOUSING ATTACHING PARTS (LATE MODEL ENGINES).**

**b. Removal.** Remove the turbosupercharger oil inlet tube and regulator valve housing as follows.

- (1) Figure 252. (A) Disconnect and remove turbosupercharger oil inlet tube from 1/2-inch tube, 90 degree elbow. (B) Remove 1/2-inch tube, 90 degree elbow from crankcase. (C) Remove 1-inch hose adapter from crankcase. (D) Remove four 3/8 x 2 cap screws and 3/8-inch lock washers securing oil pressure regulator valve housing assembly to crankcase.
- (2) Figure 253. (A) Disconnect and remove turbosupercharger oil inlet tube from 3/8-inch tube x 1/4 pipe, 90 degree elbow. (B) Remove 3/8-inch tube x 1/4 pipe, 90 degree elbow from crankcase. (C) Remove 3/4-inch pipe to tube adapter from crankcase. (D) Remove four 3/8 x 2 cap screws and 3/8-inch lock washers securing oil pressure regulator valve housing assembly to crankcase.



FIGURE 253. REMOVING TURBOSUPERCHARGER OIL INLET TUBE, FITTINGS, AND OIL PRESSURE REGULATOR VALVE HOUSING ATTACHING PARTS (EARLY MODEL ENGINES).

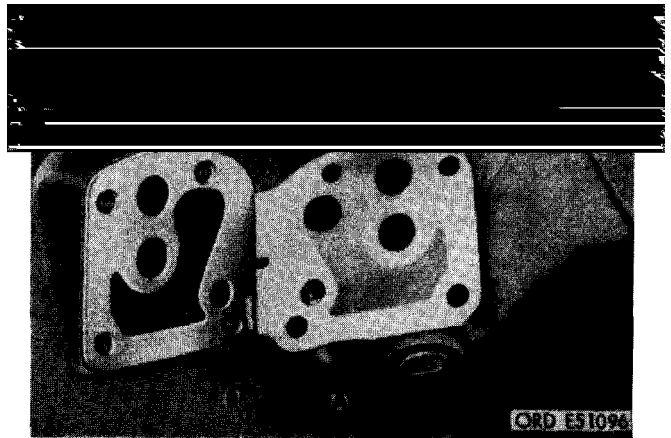


FIGURE 254. REMOVING OR INSTALLING OIL PRESSURE REGULATOR VALVE HOUSING ASSEMBLY.

- (3) Figure 254. (A) Remove oil pressure regulator valve housing assembly. (B) Remove and discard oil pressure regulator valve housing gasket.

#### 127. REMOVAL OF OIL PRESSURE SENDING UNIT AND STARTER ADAPTER

**a. General.** The oil pressure sending unit is mounted next to the coolant drain cock at the left rear of the engine. The starter adapter encircles the starter mounting hole in the flywheel housing.

**b. Removal.** Remove oil pressure sending unit and starter adapter as follows.

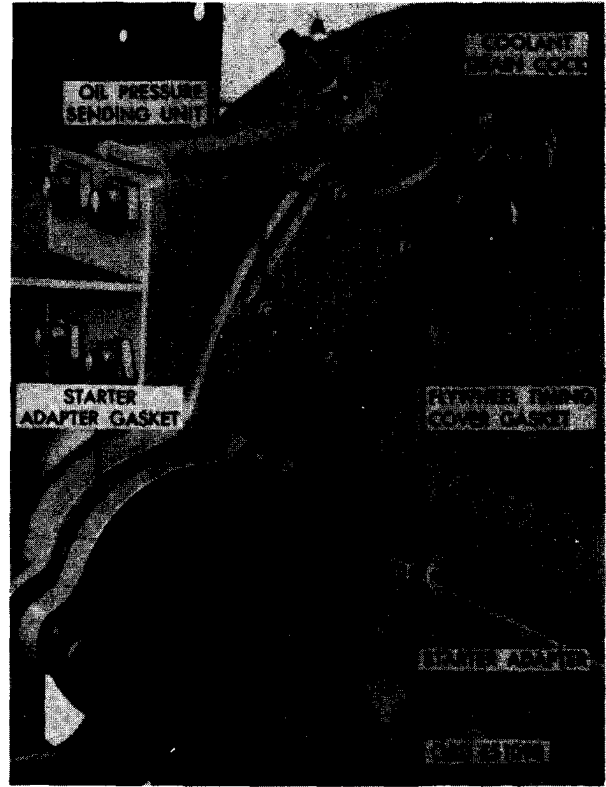
- (1) Figure 255. (A) Remove oil pressure sending unit from 1/4-inch pipe adapter. (B) Remove 1/4-inch pipe adapter from elbow. (C) Remove 1/4-inch pipe, 45 degree elbow from crankcase. (D) Remove coolant drain cock from 1/4-inch pipe, 45 degree elbow. (E) Remove 1/4-inch pipe, 45 degree elbow from crankcase. (F) Remove starter adapter. (G) Remove and discard starter adapter gasket.

**Note.** Starter adapter thickness should be 0.782, if over size, rework to 0.778/0.782.





**FIGURE 255. REMOVING OR INSTALLING OIL PRESSURE SENDING UNIT AND STARTER ADAPTER (LATE MODEL ENGINES).**



**FIGURE 256. REMOVING OR INSTALLING OIL PRESSURE SENDING UNIT AND STARTER ADAPTER (EARLY MODEL ENGINES).**

- (2) Figure 256. (A) Remove oil pressure sending unit from 1/4-inch pipe, 45 degree elbow. (B) Remove 1/4-inch pipe, 45 degree elbow from cylinder and crankcase. (C) Remove coolant drain cock from 1/4-inch pipe, 45 degree elbow. (D) Remove 1/4-inch pipe, 45 degree elbow. (E) Remove four 1/4-inch plain nuts and 1/4-inch lock washers securing flywheel timing cover to flywheel housing. (F) Remove flywheel timing cover and cover gasket. Discard gasket. (G) Remove starter adapter and adapter gasket. Discard gasket.

#### 128. REMOVAL OF ENGINE FAN, THERMOSTAT HOUSING, AND WATER PUMP ASSEMBLY

a. General. The engine fan, mounted on the water pump pulleys, is located at the front of the engine. The thermostat housing is mounted between the water outlet manifold and the water pump assembly.



FIGURE 257. REMOVING ENGINE FAN.

**b. Removal.** Remove engine fan, thermostat housing, and water pump assembly as follows.

- (1) Figure 257. (A) Remove four 5/16 x 3/4 cap screws and 5/16-inch lock washers securing engine fan to water pump pulley. (B) Remove engine fan.

- (2) Figure 258. (A) Remove 3/8-inch plain nut and 3/8-inch lock washer securing generator adjusting strap to water pump assembly. (B) Remove generator adjusting strap. (C) Loosen two 2-inch od hose clamps securing thermostat housing-to-water pump hose. (D) Remove two 3/8 x 3-5/8 cap screws and 3/8-inch flat washers securing thermostat housing to intake manifold.

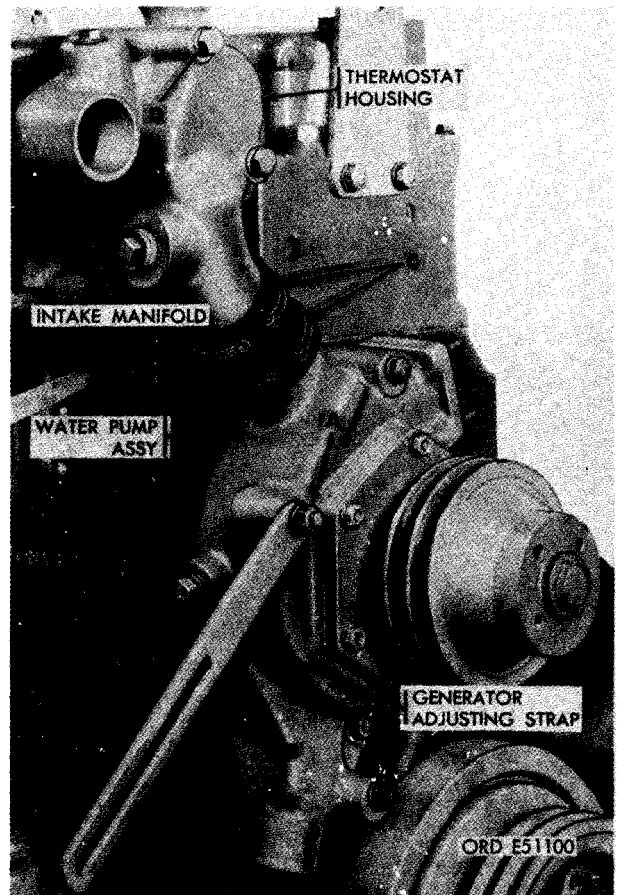


FIGURE 258. DISCONNECTING OR CONNECTING THERMOSTAT HOUSING.

- (3) Figure 259. (A) Remove thermostat housing with thermostat. (B) Remove and discard thermostat housing gasket. (C) Remove the two 2-inch od hose clamps and hose from thermostat housing.

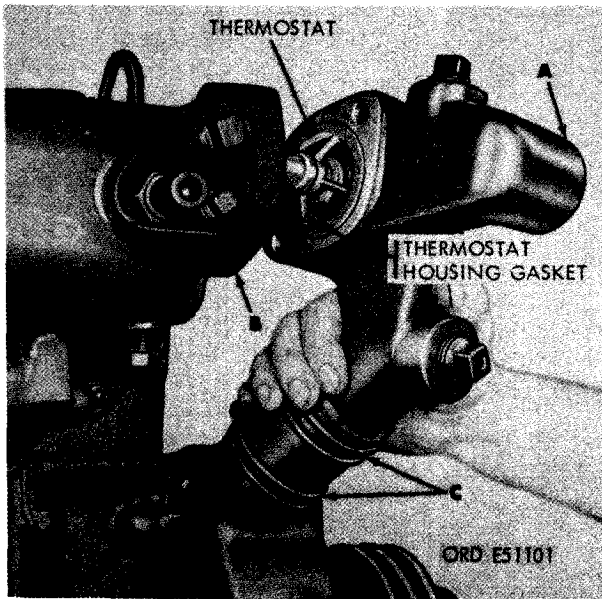


FIGURE 259. REMOVING OR INSTALLING THERMOSTAT HOUSING AND THERMOSTAT.

- (4) Figure 260. (A) Remove three 3/8 x 3-5/8 cap screws and 3/8-inch lock washers securing water pump assembly to cylinder and crankcase. (B) Remove water pump assembly.

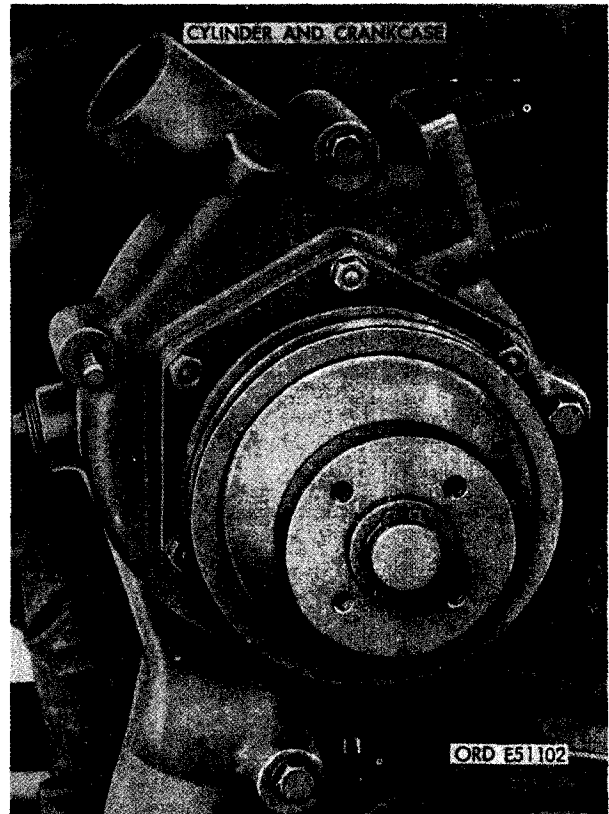


FIGURE 260. REMOVING OR INSTALLING WATER PUMP ASSEMBLY.

#### 129. REMOVAL OF ENGINE FRONT AND REAR LIFTING BRACKETS

a. General. The engine is provided with two lifting brackets mounted on the front end of the front cylinder head and rear of the rear cylinder head.

b. Removal. Remove the engine front and rear lifting brackets as follows.

- (1) Figure 261. (A) Remove two 7/16 x 7/8 cap screws and 7/16-inch lock washers securing engine front lifting bracket to front cylinder head assembly. (B) Remove engine front lifting bracket.

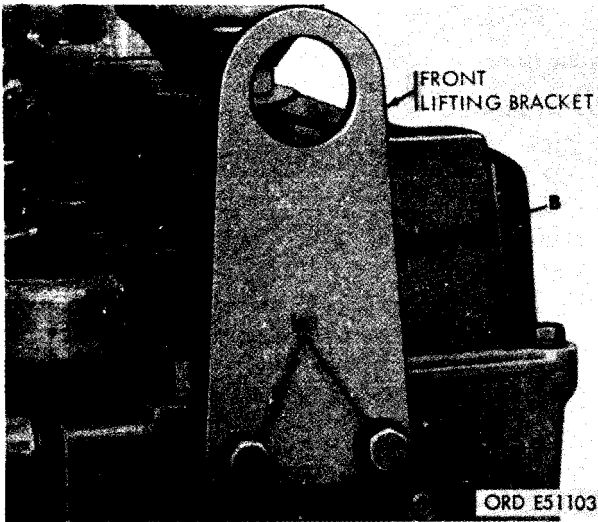


FIGURE 261. REMOVING OR INSTALLING ENGINE FRONT LIFTING BRACKET.

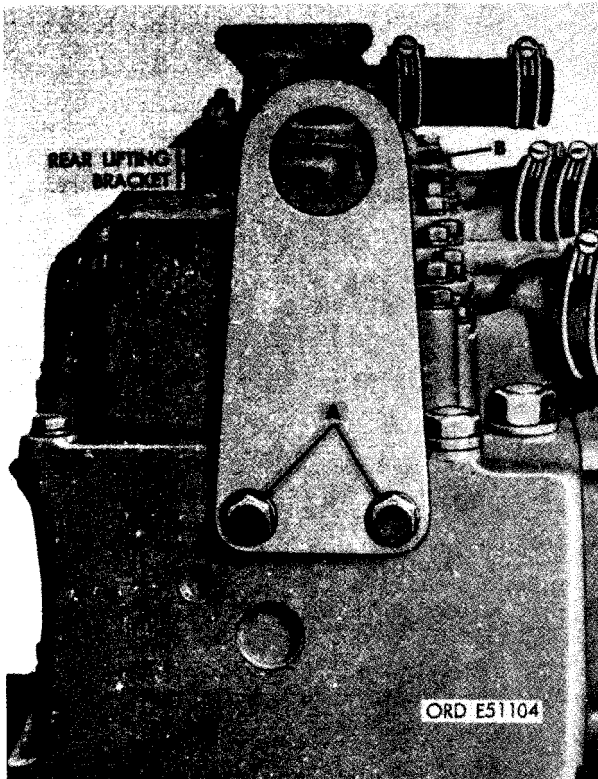


FIGURE 262. REMOVING OR INSTALLING ENGINE REAR LIFTING BRACKET.

- (2) Figure 262. (A) Remove two 7/16 x 7/8 cap screws and 7/16-inch lock washers securing engine rear lifting bracket to rear cylinder head assembly. (B) Remove engine rear lifting bracket.

### 130. REMOVAL OF CRANKCASE BREATHER ADAPTER AND CYLINDER HEAD COVERS

a. General. The crankcase breather tube attaches to an adapter mounted on top and between the cylinder head covers. The sheet metal cylinder head covers enclose the rocker arms.

b. Removal. Remove the crankcase breather adapter and cylinder head covers as follows.

Note. Attaching parts and removal of either front or rear cylinder head covers are identical.

- (1) Figure 263. (A) Remove four 5/16-inch plain nuts and 5/16-inch lock washers securing crankcase breather adapter to front and rear cylinder head covers. (B) Remove crankcase breather adapter with hose and clamps.

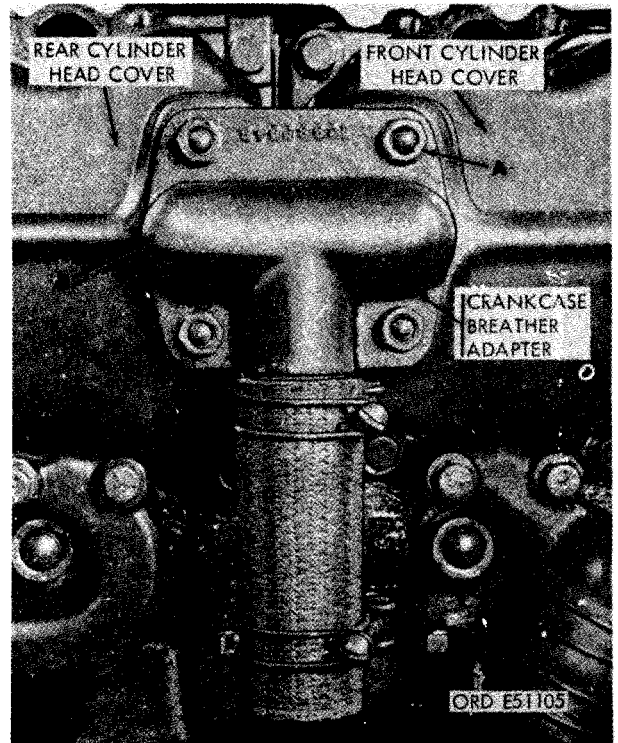


FIGURE 263. REMOVING CRANKCASE BREATHER ADAPTER.

- (2) Figure 264. (A) Remove and discard crankcase breather adapter gaskets from front and rear cylinder head covers. (B) Remove oil filler cap. (C) Remove seven 5/16 x 7/8 cap screws and 5/16-inch lock washers securing front cylinder head cover and tachometer cable bracket to front cylinder head assembly. (D) On late model en-

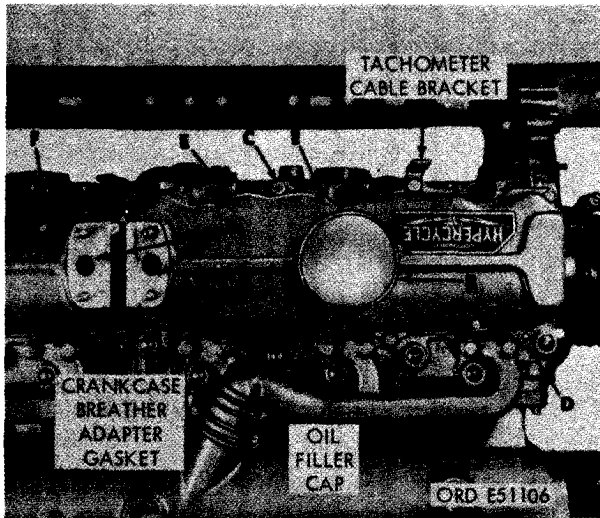


FIGURE 264. REMOVING FRONT AND REAR CYLINDER HEAD COVERS.

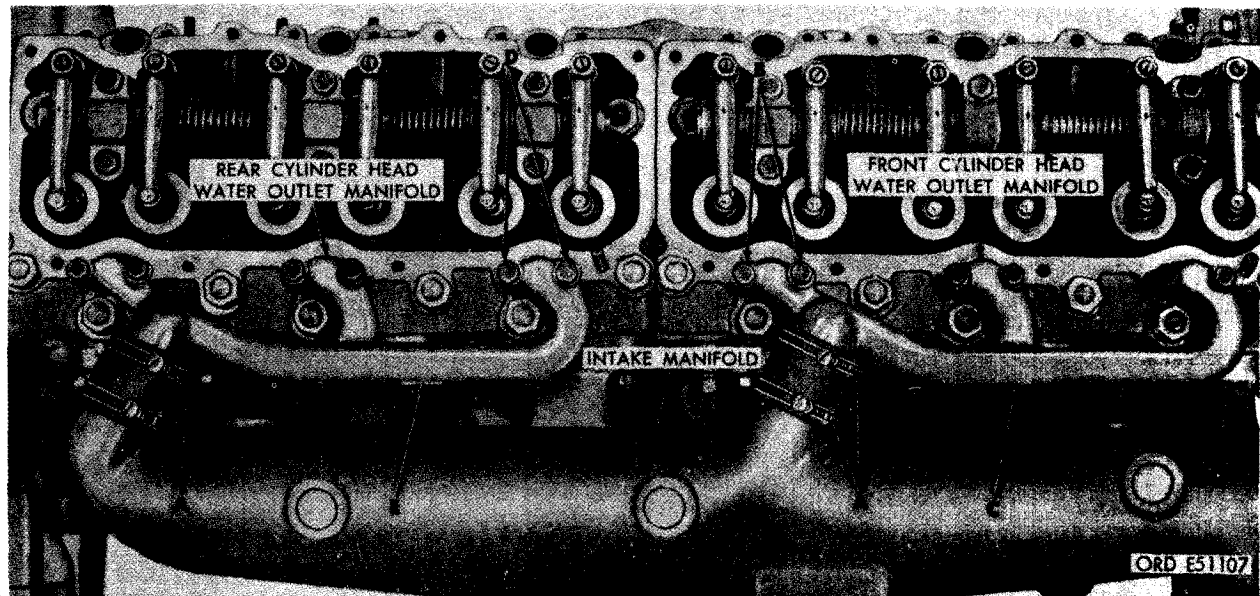


FIGURE 265. REMOVING OR INSTALLING FRONT AND REAR CYLINDER HEAD WATER OUTLET MANIFOLDS.

gines, remove one 5/16-inch self-locking nut and plain washer in lieu of 5/16-inch plain nut and 5/16-inch plain washer. (E) Remove front cylinder head cover, tachometer cable bracket, and cover gasket. Discard gasket. (F) Remove the rear cylinder head cover in the same manner by repeating steps C, D, and E above.

### 131. REMOVAL OF CYLINDER HEAD WATER OUTLET, INTAKE, AND EXHAUST MANIFOLDS

**a. General.** The water outlet manifolds connect to the two cylinder heads and provide a passage for the coolant back to the radiator through the thermostat housing. Intake and exhaust manifolds are attached to the left side of the cylinder heads.

**b. Removal.** Remove water outlet manifolds, intake manifold, and exhaust manifolds as follows.

- (1) Figure 265. (A) Loosen two 1-5/8-inch id hose clamps securing front and rear cylinder head water outlet manifold-to-intake manifold hoses. (B) Remove six 5/16 x 2-1/4 cap screws and 5/16-inch lock washers securing front cylinder head water outlet manifold to front

cylinder head assembly. (C) Remove front cylinder head water outlet manifold. (D) Remove six 5/16 x 2-1/4 cap screws and 5/16-inch lock washers securing rear cylinder head water outlet manifold to rear cylinder head assembly. (E) Remove rear cylinder head water outlet manifold.

- (2) Figure 266. (A) Remove and discard six cylinder head water outlet manifold gaskets. (B) Remove twelve 5/16-inch plain nuts and 5/16-inch flat washers securing top flanges of intake manifold to cylinder head assemblies. (C) Remove six 7/16-inch self-locking nuts

and 7/16-inch flat washers securing top flanges of exhaust manifold to cylinder head assemblies.

- (3) Figure 267. (A) Remove six 5/16-inch plain nuts and 5/16-inch flat washers securing bottom flanges of intake manifold to cylinder head assemblies. (B) Remove two 7/16-inch self-locking nuts and remove oil level gage rod support clamp brackets. (C) Remove four 7/16-inch self-locking nuts and 7/16-inch flat washers securing bottom flanges of exhaust manifold to cylinder head assemblies. (D) Remove intake and exhaust manifolds.

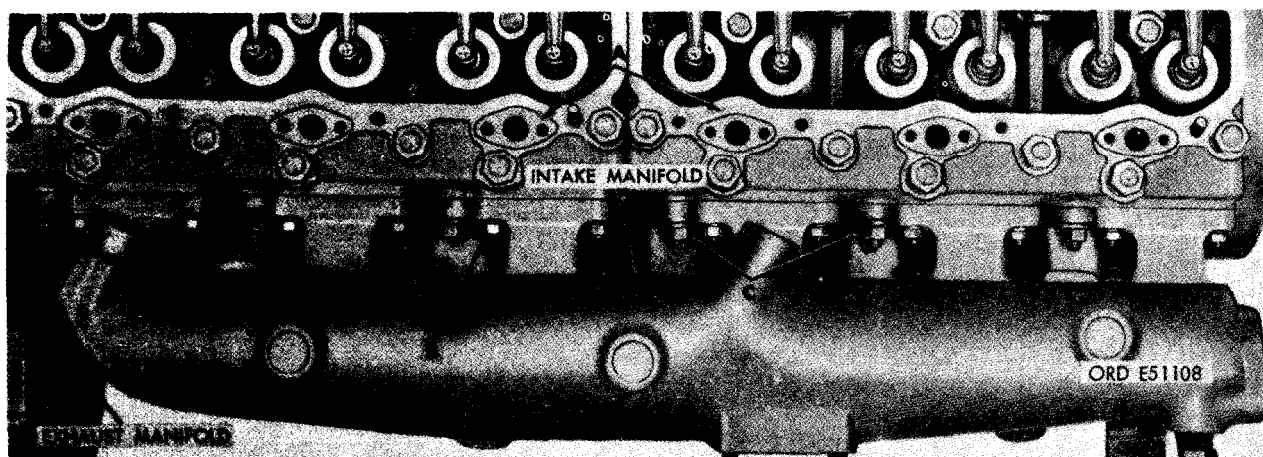


FIGURE 266. DISCONNECTING OR CONNECTING INTAKE AND EXHAUST MANIFOLDS AT CYLINDER HEAD ASSEMBLIES - TOP VIEW.

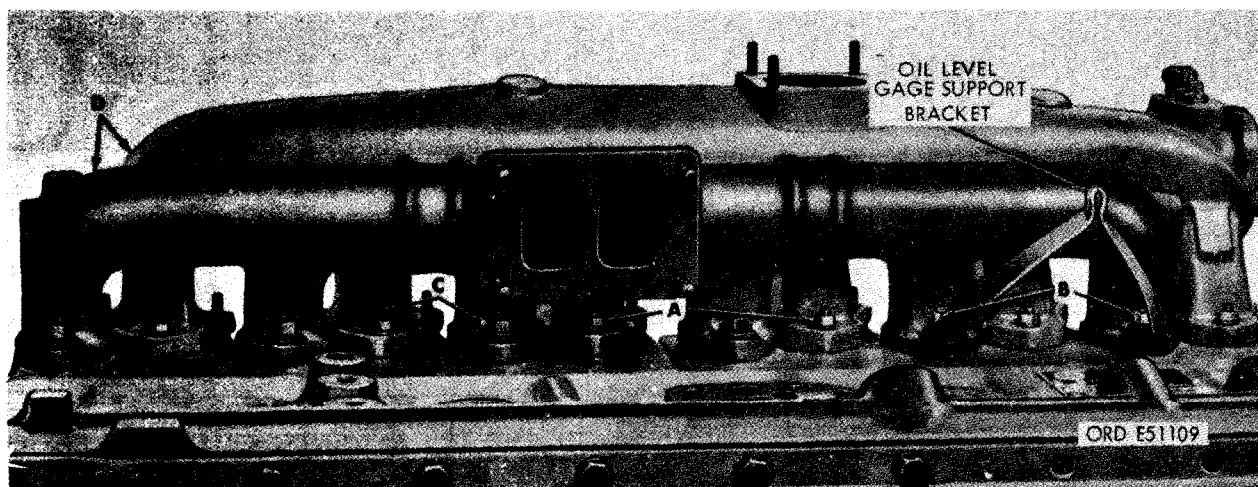


FIGURE 267. REMOVING OR INSTALLING INTAKE AND EXHAUST MANIFOLDS AS A UNIT.

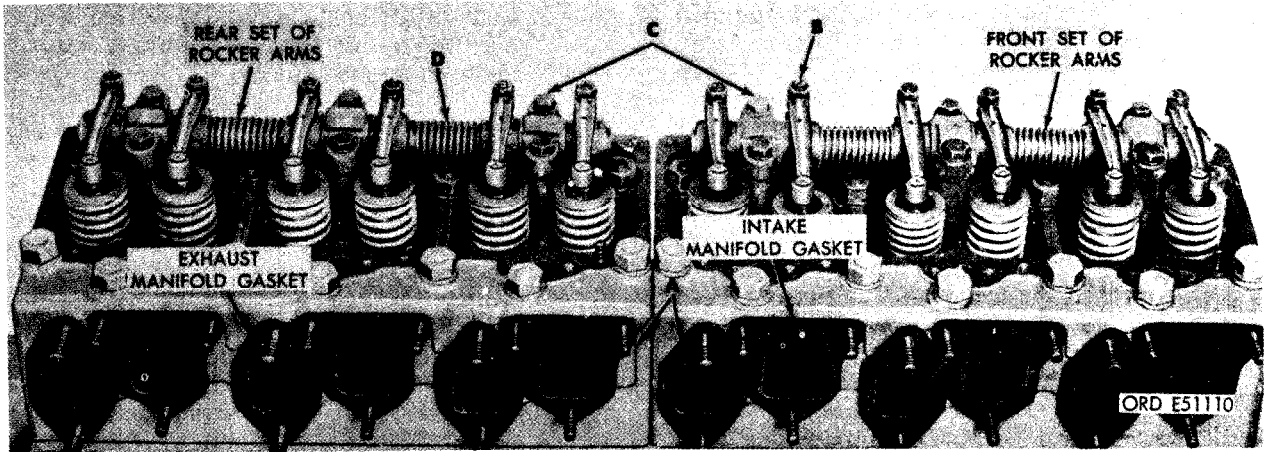


FIGURE 268. REMOVING OR INSTALLING INTAKE MANIFOLD GASKET AND ROCKER ARMS.

132. REMOVAL OF ROCKER ARMS, ROCKER ARM PUSH RODS, AND VALVE TAPPETS

**a. General.** After removing the cylinder head covers (par. 130) the rocker arms and rocker arm push rods are accessible at the top of the cylinder heads. The valve tappets can be removed through the tappet cover openings on the left side of the engine when the rocker arm push rods have been removed.

**b. Removal.** Remove rocker arms, rocker arm push rods, and valve tappets as follows.

- (1) Figure 268. (A) Remove and discard intake and exhaust manifold gaskets. (B) Loosen rocker arm adjusting screw lock nuts and turn adjusting screws to release valve spring tension before removing cap screws. (C) Remove twelve  $3/8 \times 2-1/2$  cap screws and  $3/8$ -inch lock washers securing front and rear rocker arms to front and rear cylinder head assemblies. (D) Remove front and rear sets of rocker arms.

- (2) Refer to figure 269 and remove rocker arm push rods.

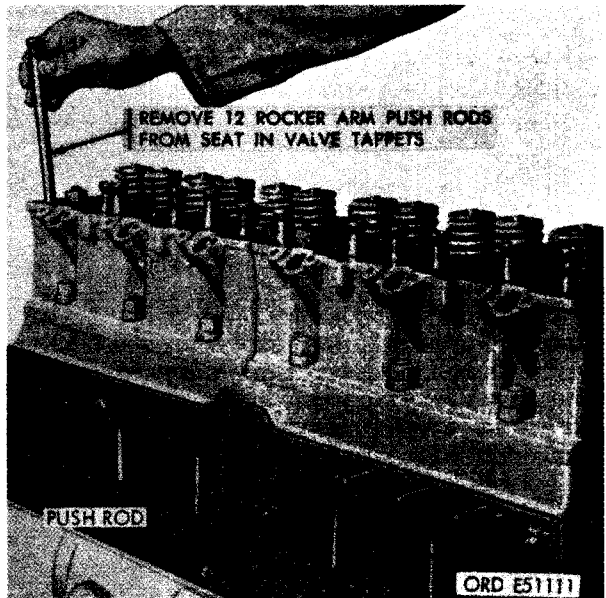


FIGURE 269. REMOVING OR INSTALLING ROCKER ARM PUSH RODS.

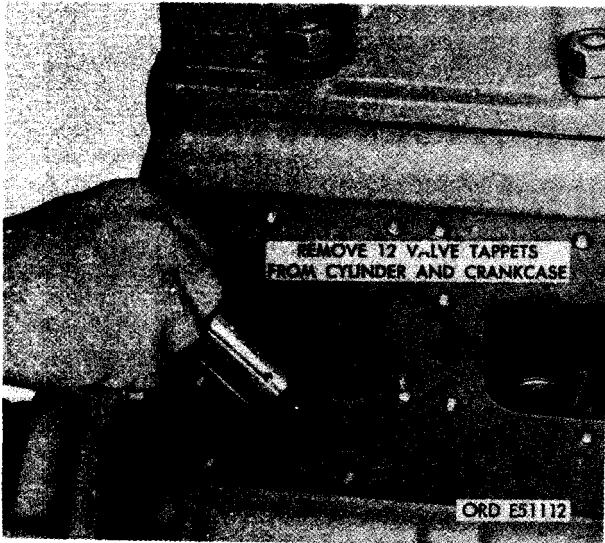


FIGURE 270. REMOVING OR INSTALLING VALVE TAPPETS.

(3) Refer to figure 270 and remove valve tappets.

### 133. REMOVAL OF CYLINDER HEAD ASSEMBLIES

a. General. The two cylinder head assemblies, mounted at the top of the cylinder and crankcase assembly, contain the valves, valve springs, and valve rotators. The heads form the tops of the cylinders.

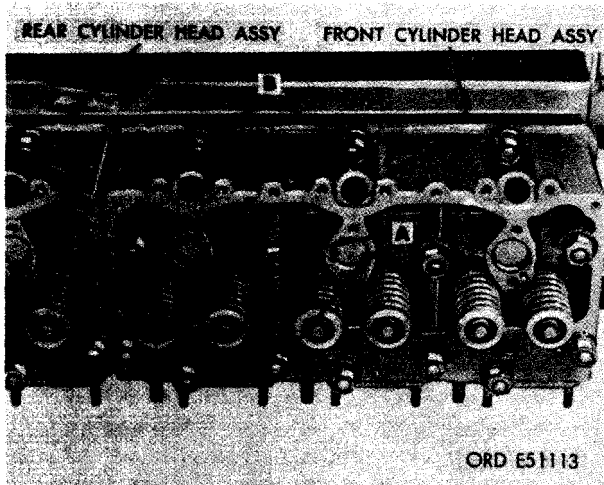


FIGURE 271. REMOVING OR INSTALLING CYLINDER HEAD ATTACHING PARTS.

b. Removal. Remove the cylinder head assemblies as follows.

- (1) Figure 271. (A) Remove eleven 9/16-inch plain nuts and 9/16 x 1/8 thk flat washers. (B) Remove three 9/16-inch plain nuts and 9/16 x 3/8 thk spacers securing front cylinder head assembly to cylinder and crankcase. (C) Repeat steps A and B to remove nuts securing rear cylinder head.

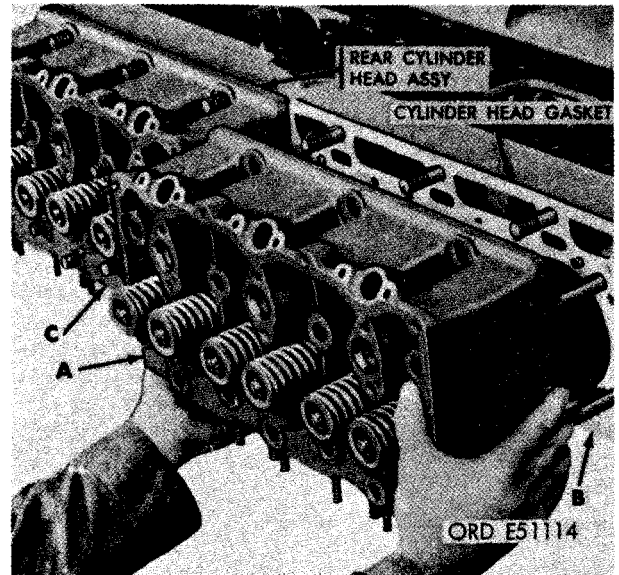


FIGURE 272. REMOVING OR INSTALLING FRONT CYLINDER HEAD ASSEMBLY.

- (2) Figure 272. (A) Remove front cylinder head assembly. (B) Remove and discard cylinder head gasket. (C) Remove rear cylinder head assembly in the same manner. Remove and discard cylinder head gasket.



### 134. REMOVAL OF TRANSMISSION ADAPTER, CLUTCH ASSEMBLY, AND FLYWHEEL

a. General. The clutch assembly mounts on the flywheel. Facilities for mounting the transmission are provided by the transmission adapter.

b. Removal. Remove transmission adapter, clutch assembly, and flywheel as follows.

- (1) Figure 273. (A) Remove thirteen 3/8-inch plain nuts and 3/8-inch lock washers securing transmission adapter to flywheel housing. (B) Remove transmission adapter.

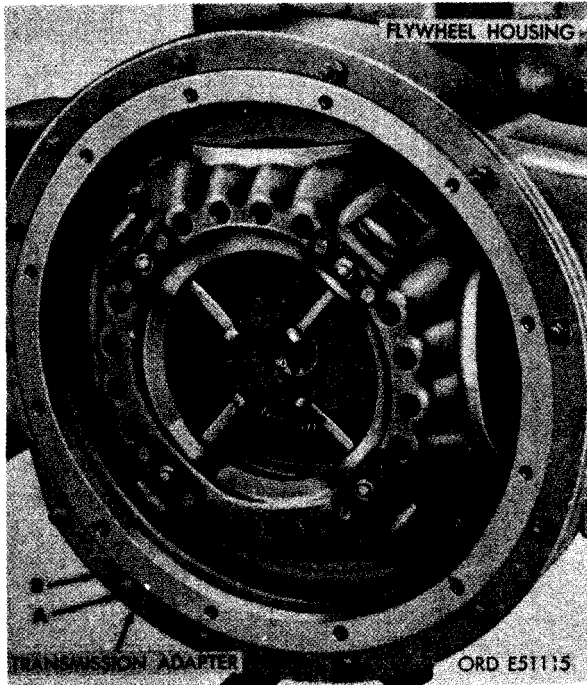


FIGURE 273. REMOVING OR INSTALLING TRANSMISSION ADAPTER.

- (2) Figure 274. (A) Remove and discard transmission adapter gasket. (B) Depress clutch release levers, one at a time, and place a clutch release lever spacer block (fig. 25) between lever and clutch cover as shown. The spacer blocks relieve clutch cover spring tension against cap screws securing clutch cover assembly to flywheel. (C) Remove

eight 3/8 x 15/16 cap screws and 3/8-inch lock washers securing clutch cover assembly to flywheel. Remove clutch cover and driven member assemblies as shown in figure 275.

Note. Fabricate a pilot bolt from a 1/2-20 x 3-1/2 bolt by cutting off hexagon head and grinding sharp edges from shoulder. Refer to figure 160 for pilot bolt details.

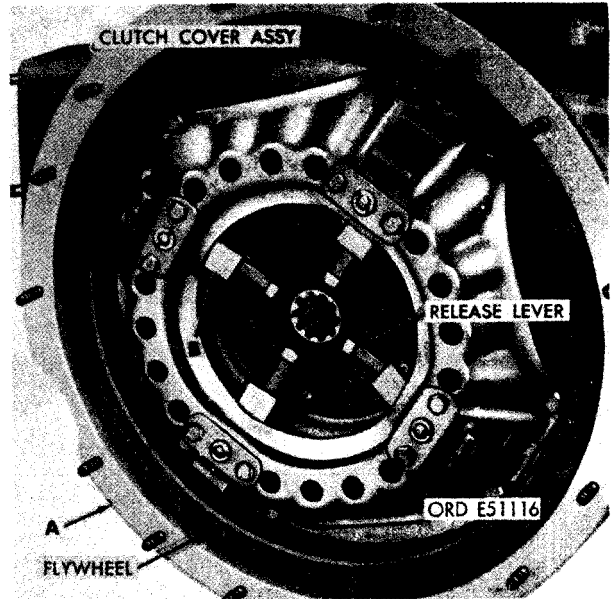


FIGURE 274. DISCONNECTING CLUTCH COVER ASSEMBLY.

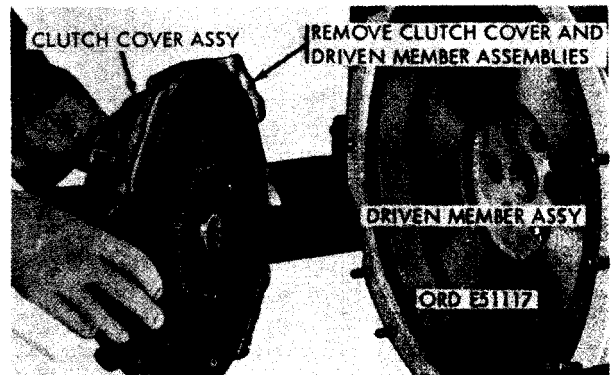


FIGURE 275. REMOVING CLUTCH COVER AND DRIVEN MEMBER ASSEMBLY.

- (3) Figure 276. (A) Remove top 1/2 x 1-1/8 place bolt and install pilot bolt to guide flywheel during removal. (B) Remove the remaining five 1/2 x 1-1/8 place bolts securing flywheel to crankshaft. (C) Remove flywheel.

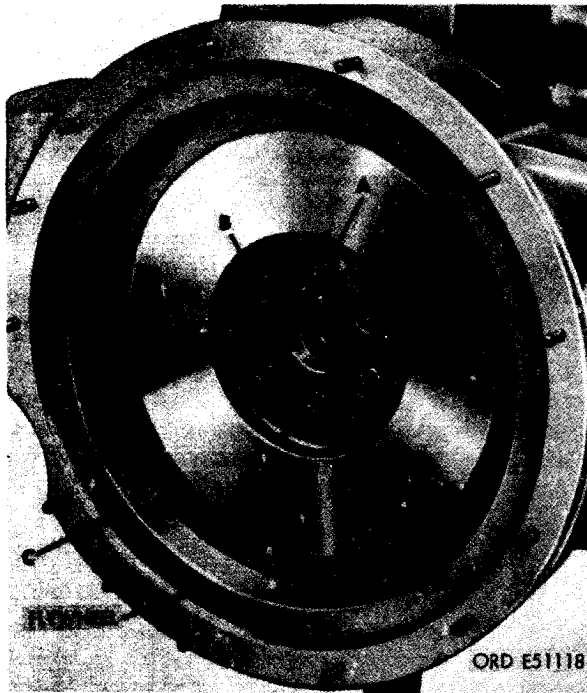


FIGURE 276. REMOVING OR INSTALLING FLYWHEEL.

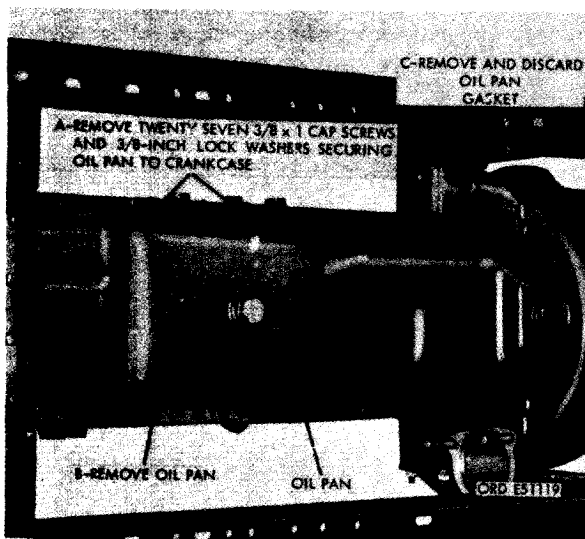


FIGURE 277. REMOVING OR INSTALLING ENGINE OIL PAN.

### 135. REMOVAL OF OIL PAN

**a. General.** The oil pan encloses the lower portion of the engine, houses the oil pump and components, and provides for storage of the lubricating oil.

**Note.** Rotate cradle - 7950198 in engine overhaul stand - 7950189 to bring oil pan area up to the side for ease of removal.

**b. Removal.** Refer to figure 277 and remove the oil pan and oil pan gaskets.

### 136. REMOVAL OF PRESSURE OIL PUMP PICKUP TUBE, SCAVENGER PUMP INLET TUBE, AND OIL PUMP OUTLET TUBE

**a. General.** The pressure oil pump and scavenger pump pickup and inlet tubes carry oil to the oil pump. The oil pump outlet tube delivers oil from the pump to the oil galleries in the cylinder and crankcase assembly and to all points pressure lubricated within the engine.

**b. Removal.** Remove pressure oil pump pickup tube, scavenger pump inlet tube, and oil pump outlet tube as follows.

- (1) Figure 278. (A) Remove two 1/4 x 7/8 cap screws and 1/4-inch lock washers securing pressure oil pump pickup tube to pump inlet. (B) Remove one 1/4 x 3 cap screw and 1/4-inch lock washer securing pickup tube to pump cover. (C) Remove pressure oil pump pickup tube. (D) Remove and discard pressure oil pump pickup tube gasket.

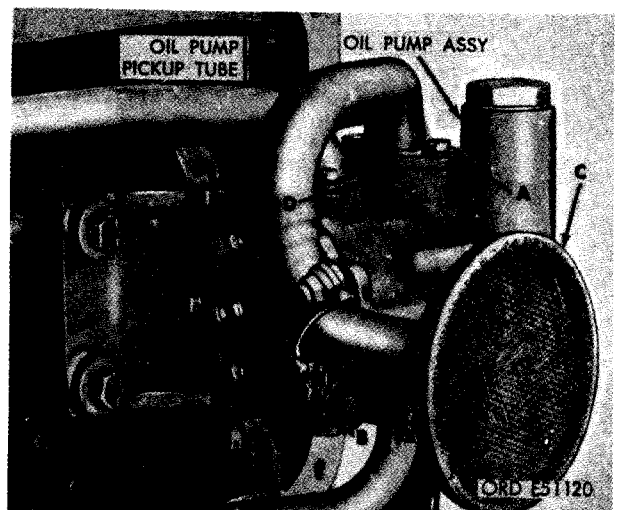


FIGURE 278. REMOVING OR INSTALLING PRESSURE OIL PUMP PICKUP TUBE.

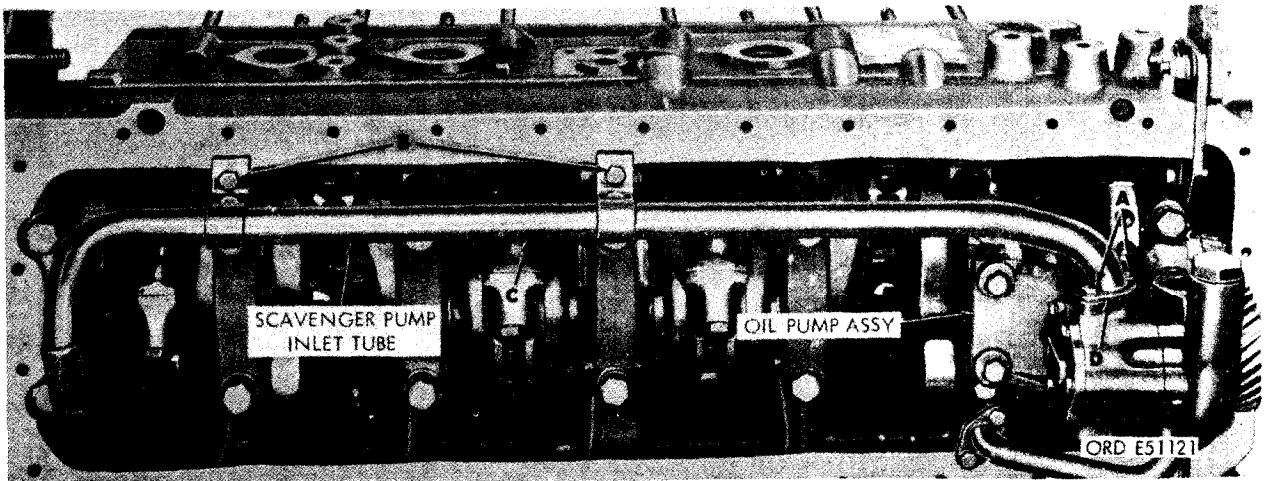


FIGURE 279. REMOVING OR INSTALLING SCAVENGER PUMP INLET TUBE.

- (2) Figure 279. (A) Remove two 1/4 x 7/8 cap screws and 1/4-inch lock washers securing scavenger pump inlet tube to pressure oil pump. (B) Remove two 5/16 x 5/8 cap screws and 5/16-inch lock washers securing scavenger pump inlet tube to crankcase. (C) Remove scavenger pump inlet tube. (D) Remove and discard scavenger pump inlet tube gasket.

- (3) Figure 280. (A) Remove two 1/4 x 7/8 cap screws and 1/4-inch lock washers securing oil pump outlet tube to pressure oil pump. (B) Remove two 5/16 x 7/8 cap screws and 5/16-inch lock washers securing oil pump outlet tube to crankcase. (C) Remove oil pump outlet tube and adapter. (D) Remove and discard outlet tube and gasket. (E) Remove and discard 3/4 id x 3/32 thk preformed packing from tube.

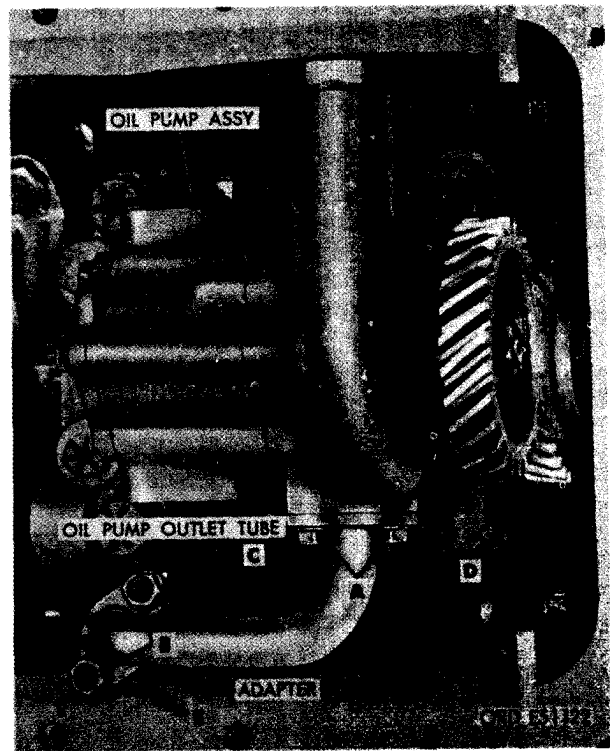


FIGURE 280. REMOVING OR INSTALLING OIL PUMP OUTLET TUBE.

### 137. REMOVAL OF OIL PUMP ASSEMBLY

**a. General.** After removing oil pump tubes the oil pump assembly can be removed from the front main bearing cap.

**b. Removal.** Remove oil pump assembly as follows.

- (1) Refer to figure 281 and remove two hexagon head bolts securing oil pump assembly to front main bearing cap.

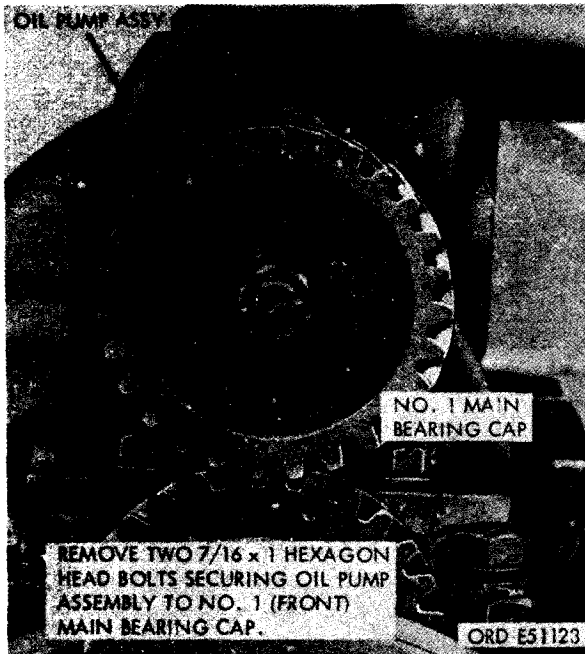


FIGURE 281. DISCONNECTING OR CONNECTING OIL PUMP ASSEMBLY AT FRONT MAIN BEARING CAP.

- (2) Figure 282. (A) Remove two 7/16 x 1 hexagon head bolts securing oil pump to No. 2 front intermediate main bearing cap. (B) Remove oil pump assembly.

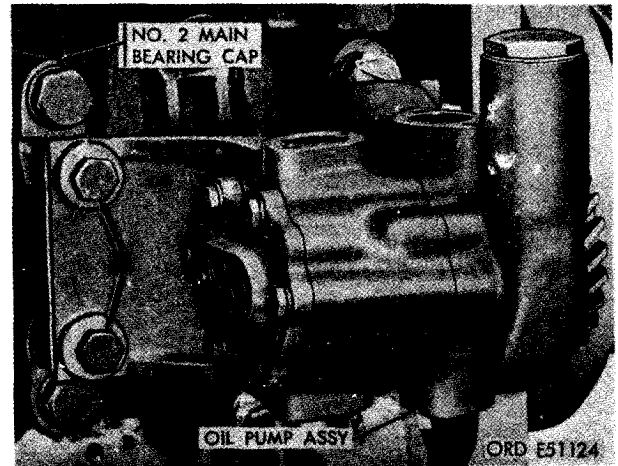


FIGURE 282. DISCONNECTING OR CONNECTING OIL PUMP AT NO. 2 MAIN BEARING CAP.

### 138. REMOVAL OF PISTON AND CONNECTING ROD ASSEMBLIES

**a. General.** The piston and connecting rod assemblies are disconnected from the crankshaft at the lower part of the crankcase and removed through the top of the cylinder.

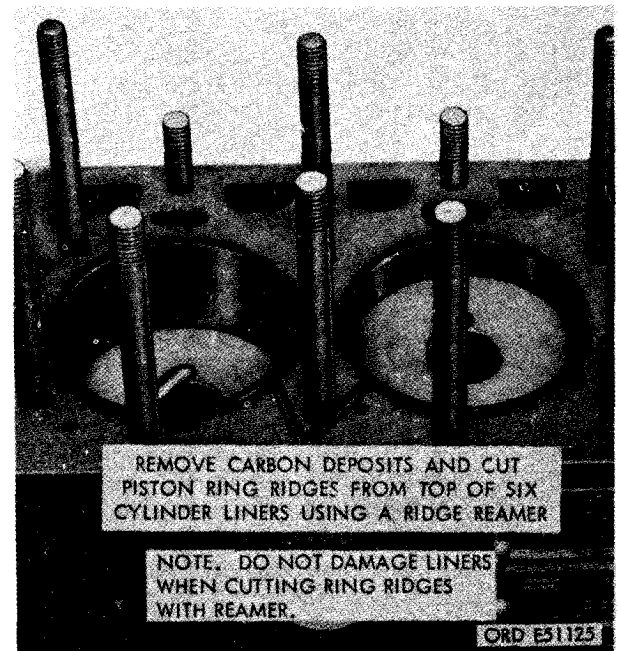


FIGURE 283. REMOVING CARBON DEPOSITS AND CUTTING PISTON RING RIDGES FROM TOP OF CYLINDER LINERS.

**b. Removal.** Remove piston and connecting rod assemblies as follows.

- (1) Remove carbon deposits and ridge ream cylinders as shown in figure 283.

**Note.** It will be necessary to rotate the crankshaft to facilitate connecting rod cap bolt removal.

- (2) Figure 284. (A) Remove two connecting rod bolts. (B) Remove connecting rod cap and bearings.

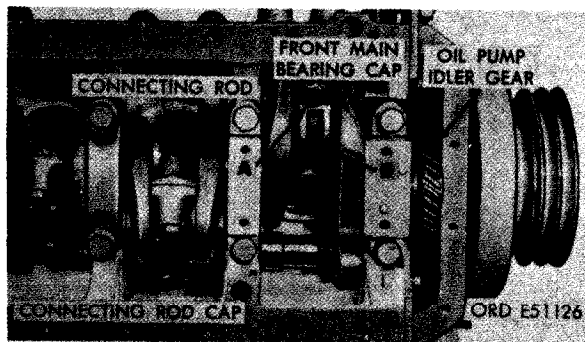


FIGURE 284. REMOVING OR INSTALLING CONNECTING ROD BEARING CAP AND BEARING.

**Note.** Keep bearings with their respective cap and rod. The connecting rod caps and connecting rods are marked with matched numbers (1 through 6) to insure proper installation in respective cylinders. Numbers are marked on the camshaft side of connecting rods. Rods and caps must be installed with numbers facing camshaft. Rotate crankshaft until cylinder No. 1 and 6 connecting rods are at bottom dead center (bdc). Remove cylinder No. 1 and 6 connecting rod caps. Remove piston and connecting rod assemblies. Remove remaining four connecting rod caps, piston and connecting rod assemblies in the same manner following a sequence of cylinders No. 2 and 5, and 3 and 4.

- (3) Refer to figure 285 and remove piston and connecting rod assemblies.

**Note.** Exercise care in removal of piston and connecting rods. Connecting rods must not scratch or score cylinder liners during removal. Rotate crankshaft as necessary to get piston near top center and allow connecting rods to pass through cylinder liners. It may be necessary to tap connecting rod with a hammer handle, or nylon dowel, to force piston and rings out of cylinder liners.

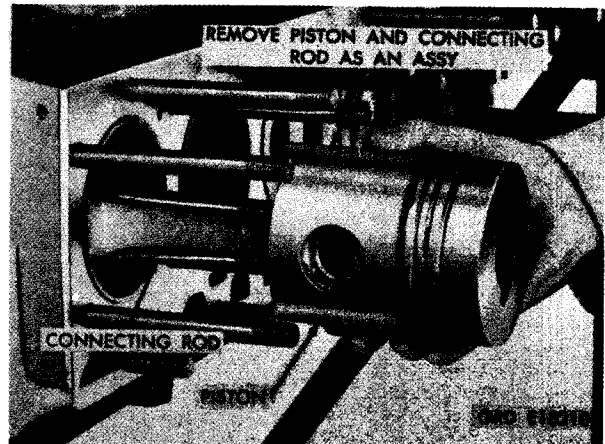


FIGURE 285. REMOVING PISTON AND CONNECTING ROD.

### 139. REMOVAL OF CRANKSHAFT DAMPER AND PULLEY ASSEMBLY

**a. General.** A crankshaft damper and pulley assembly is mounted to the front end of the crankshaft. The damper provides balance for the crankshaft and the pulley assembly drives the fan drive belts and generator drive belt.

**b. Removal.** Remove crankshaft damper and pulley assembly as follows.

- (1) Figure 286. (A) Remove two 3/8 x 3/4 cap screws and 3/8-inch lock washers securing lock plate. (B) Remove lock plate. (C) Remove crankshaft bolt securing crankshaft damper and pulley assembly. (D) Remove crankshaft damper pulley retaining plate.



FIGURE 286. REMOVING OR INSTALLING CRANKSHAFT BOLT LOCK PLATE.

(2) Figure 287. (A) Install 3/8-16 puller screws of mechanical puller kit - 8708724 into the puller screw holes. Insert small end plug - 10899178 in threaded end of crankshaft and run puller jack screw against plug. (B) Pull crankshaft damper and pulley assembly from crankshaft.

#### 140. REMOVAL OF TACHOMETER DRIVE ADAPTER

a. General. To drive the engine tachometer mounted on the vehicle control panel, a tachometer drive adapter is mounted on the timing gear cover and is driven by the camshaft.

b. Removal. Figure 288. (A) Remove tachometer drive adapter and drive shaft from tachometer take-off adapter. (B) Remove tachometer take-off adapter and adapter gasket.

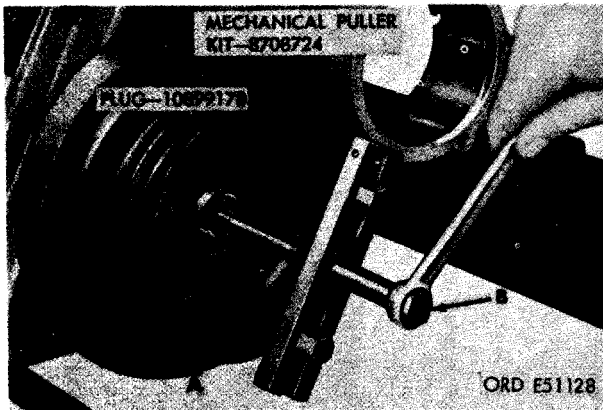


FIGURE 287. REMOVING CRANKSHAFT DAMPER AND PULLEY ASSEMBLY USING MECHANICAL PULLER KIT - 8708724 AND PLUG - 10899178.

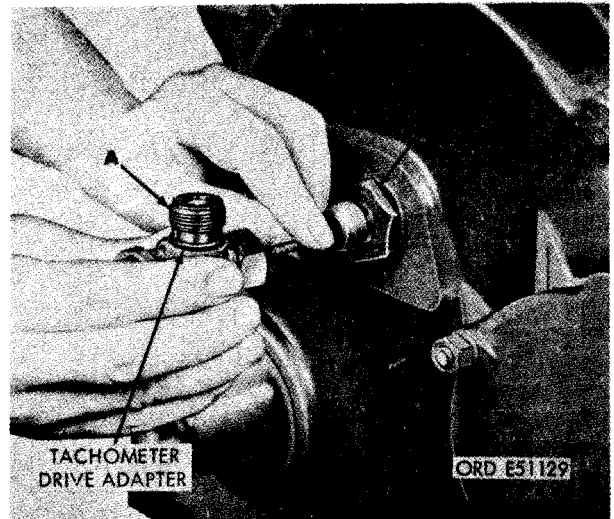


FIGURE 288. REMOVING OR INSTALLING TACHOMETER ADAPTER.

#### 141. REMOVAL OF TIMING GEAR COVER ASSEMBLY

a. General. The timing gear cover assembly houses the crankshaft gear, camshaft gear, and oil pump idler gear.

b. Removal. Figure 289. (A) Remove seven 3/8 x 1-1/4 cap screws and 3/8-inch lock washers. (B) Remove 3/8-inch plain nut, 3/8-inch lock washer, and 3/8 x 1-1/4 cap screw. (C) Remove 1/2-inch plain nut, 1/2-inch lock washer, and 1/2 x 2-3/4 cap screw. (D) Remove timing gear cover assembly.

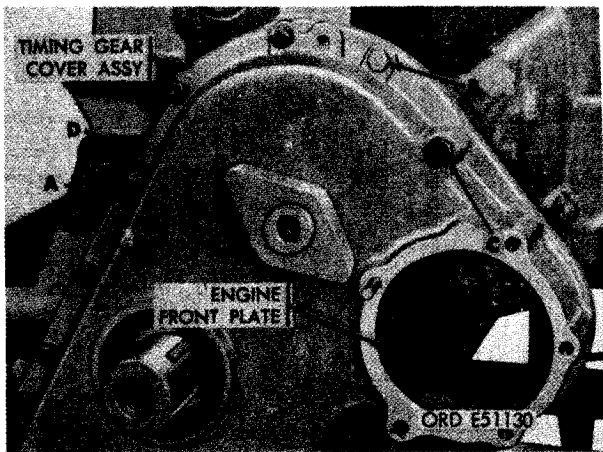


FIGURE 289. REMOVING OR INSTALLING TIMING GEAR COVER ASSEMBLY.

#### 142. REMOVAL OF CAMSHAFT GEAR AND CRANKSHAFT GEAR

a. General. The camshaft gear is driven by the crankshaft gear. The two gears have timing marks on the teeth to aid in timing the engine.

b. Removal. Remove camshaft gear and crankshaft gear as follows.

- (1) Figure 290. (A) Remove and discard cover gasket. (B) Remove crankshaft oil slinger. (C) Wedge a wooden block between camshaft and crankshaft gears to prevent gears from turning while camshaft gear retaining nut is loosened. (D) Loosen camshaft gear retaining nut.

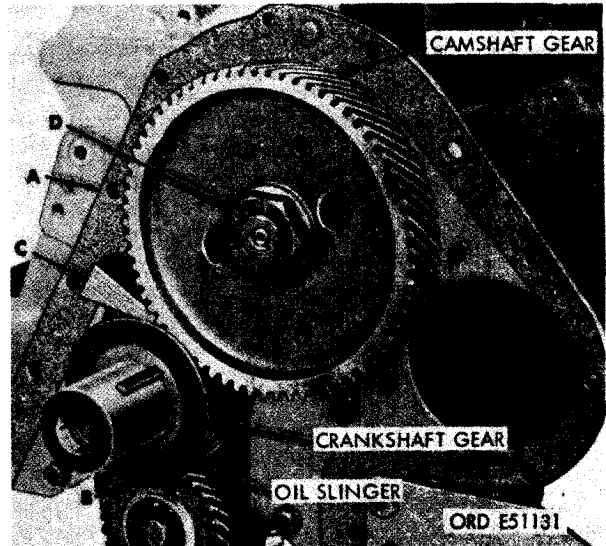


FIGURE 290. REMOVING CRANKSHAFT OIL SLINGER AND LOOSENING GEAR RETAINING NUT.

- (2) Figure 291. (A) Install 3/8-16 puller screws of mechanical puller kit - 8708724 into puller screw holes in camshaft gear. Insert suitable plug against end of camshaft assembly and run puller jack screw against plug. (B) Pull camshaft gear from end of camshaft assembly.



FIGURE 291. REMOVING CAMSHAFT GEAR USING MECHANICAL PULLER KIT - 8708724.

- (3) Figure 292. (A) Install 3/8-16 puller screws of mechanical puller kit - 8708724 into puller screw holes in crankshaft gear. Insert plug - 10899178 against crankshaft and run jack screw of puller against plug. (B) Pull crankshaft gear from end of crankshaft.
- (4) Figure 293 shows the stripped engine on the overhaul stand.

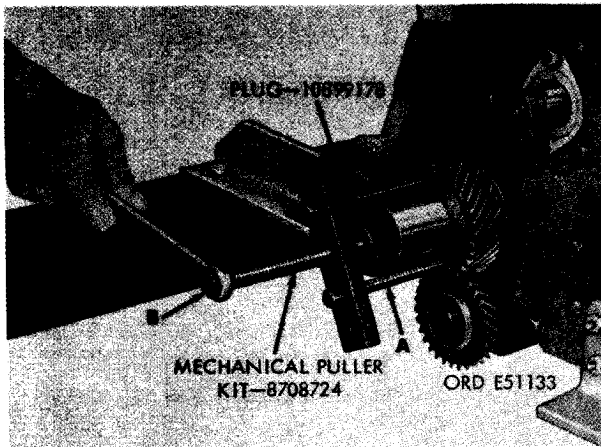


FIGURE 292. REMOVING CRANKSHAFT GEAR USING MECHANICAL PULLER KIT - 8708724.

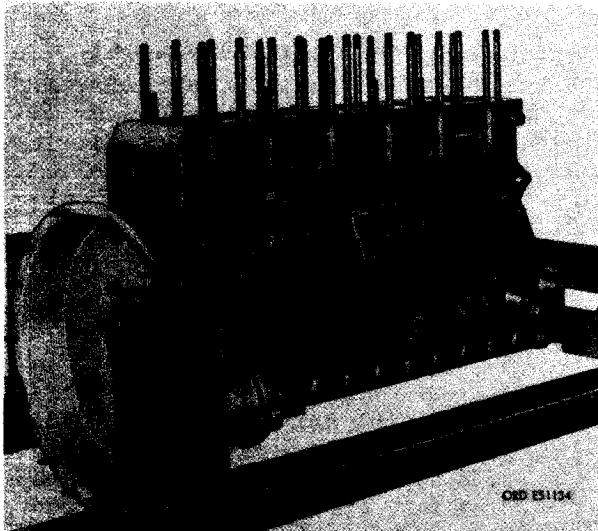


FIGURE 293. STRIPPED ENGINE BEFORE REMOVAL FROM ENGINE OVERHAUL STAND - 3/4 RIGHT REAR VIEW.

#### 143. REMOVAL OF ENGINE MOUNTING BRACKETS

a. General. The engine must be supported by sling - 8715107 and the sling connected to a hoist before removing the engine mounting brackets. Refer to figure 294 for a front view of the stripped engine.

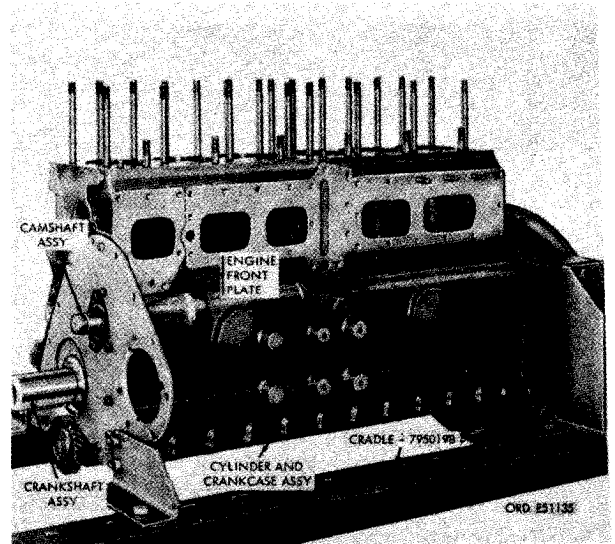


FIGURE 294. STRIPPED ENGINE BEFORE REMOVAL FROM ENGINE OVERHAUL STAND - 3/4 LEFT FRONT VIEW.

Note. Rotate engine and cradle 180 degrees (oil pan flange up). Install sling and take up slack in sling to support cylinder and crankcase assembly before removing mounting brackets.



**b. Removal.** Remove engine mounting brackets as follows.

- (1) Figure 295. (A) Remove eight 1/2-inch plain nuts and 1/2-inch lock washers securing left and right rear mounting brackets to engine. (B) Remove two 5/8 x 1-3/4 cap screws and 5/8-inch plain nuts securing brackets to cradle. (C) Remove both rear mounting brackets.

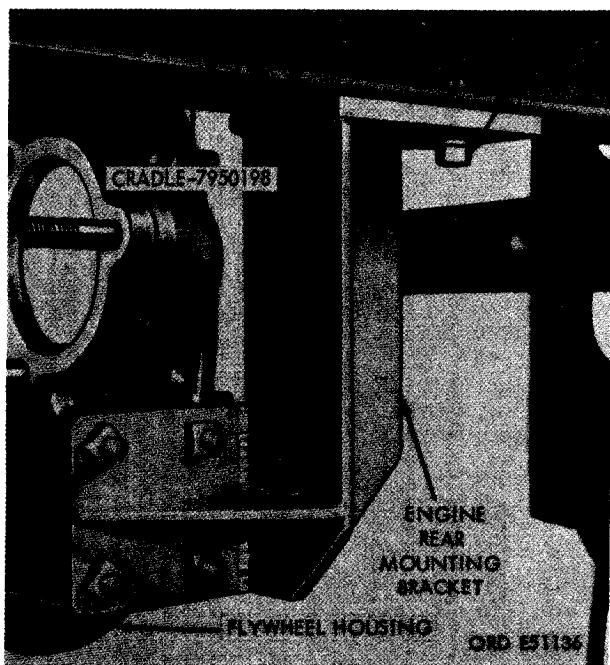


FIGURE 295. REMOVING OR INSTALLING ENGINE REAR MOUNTING BRACKETS.

- (2) Figure 296. (A) Remove four 7/16 x 1-3/8 cap screws and 7/16-inch plain nuts securing left and right front mounting brackets to engine. (B) Remove two 5/8 x 1-3/4 cap screws and 5/8-inch plain nuts securing mounting brackets to cradle. (C) Remove both front mounting brackets.

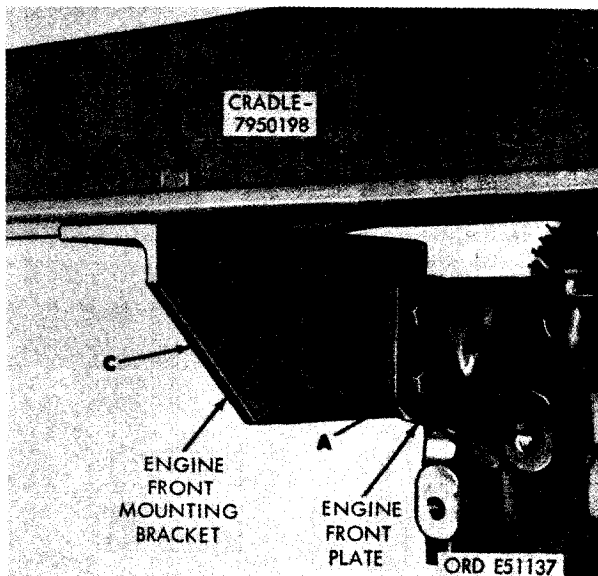


FIGURE 296. REMOVING OR INSTALLING ENGINE FRONT MOUNTING BRACKETS.

#### 144. REMOVAL OF ENGINE FROM OVERHAUL STAND FOR COMPLETION OF DISASSEMBLY

**a. General.** The flywheel housing (fig. 293), crankshaft assembly (fig. 294), camshaft assembly (fig. 294), and engine front plate (fig. 294) cannot be removed from the cylinder and crankcase assembly until engine is removed from engine overhaul stand - 7950189 and cradle - 7950198.

**b. Removal.** Remove engine from cradle - 7950198 as follows.

- (1) Figure 297. (A) Remove four 5/8-inch plain nuts, 5/8-inch lock washers, and 5/8 x 2 capscrews and remove one side rail from cradle assembly. (B) Remove overhaul stand and cradle assembly from work area. Reverse the instructions in step A above and install side rail on cradle assembly.

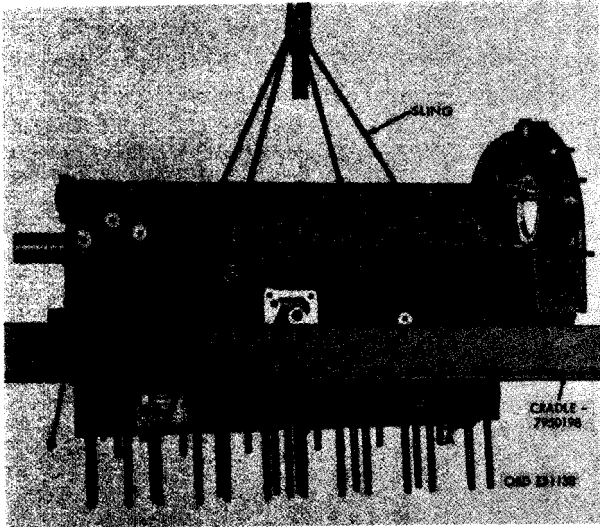


FIGURE 297. REMOVING STRIPPED ENGINE FROM OVERHAUL STAND.

- (2) Figure 298. (A) Position support blocks between cylinder head studs as shown. (B) Lower engine assembly on blocks and remove sling.

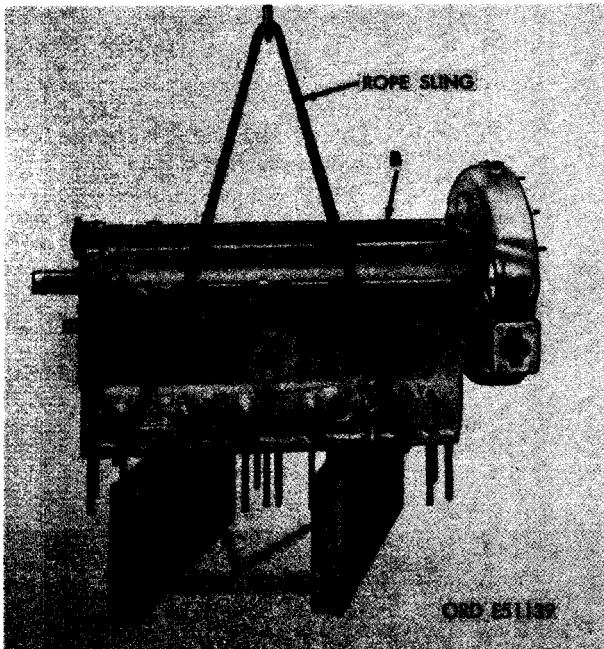


FIGURE 298. STRIPPED ENGINE POSITIONED ON SUPPORT BLOCKS.

## 145. REMOVAL OF FLYWHEEL HOUSING

a. General. The flywheel housing is mounted at the rear of the cylinder and crankcase assembly.

b. Removal. Figure 299. (A) Remove two 1/2-inch plain nuts and 17/32 x 1/8 thk flat washers. (B) Remove six 1/2-inch plain nuts and 17/32 x 1/16 thk flat washers securing flywheel housing to cylinder and crankcase assembly. (C) Remove flywheel housing.

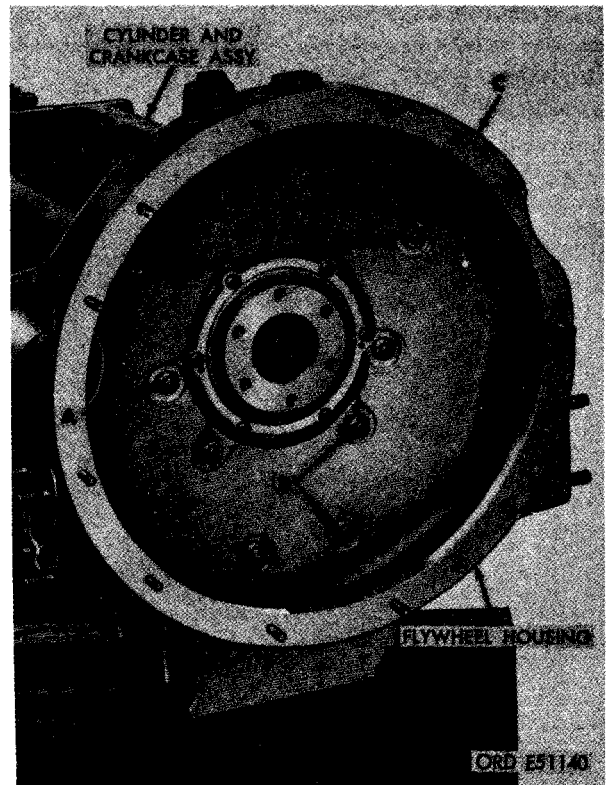


FIGURE 299. REMOVING OR INSTALLING FLYWHEEL HOUSING.

## 146. REMOVAL OF CRANKSHAFT REAR OIL SEAL AND HOUSING

**a. General.** The crankshaft rear oil seal provides a leak-proof seal at the rear end of the crankshaft.

**b. Removal.** Figure 300. (A) Remove and discard flywheel housing gasket. (B) Remove six 5/16 x 1-1/4 cap screws and 5/16-inch lock washers securing crankshaft rear oil seal housing to cylinder and crankcase assembly. (C) Remove oil seal housing and oil seal. (D) Remove crankshaft rear oil seal housing gasket.

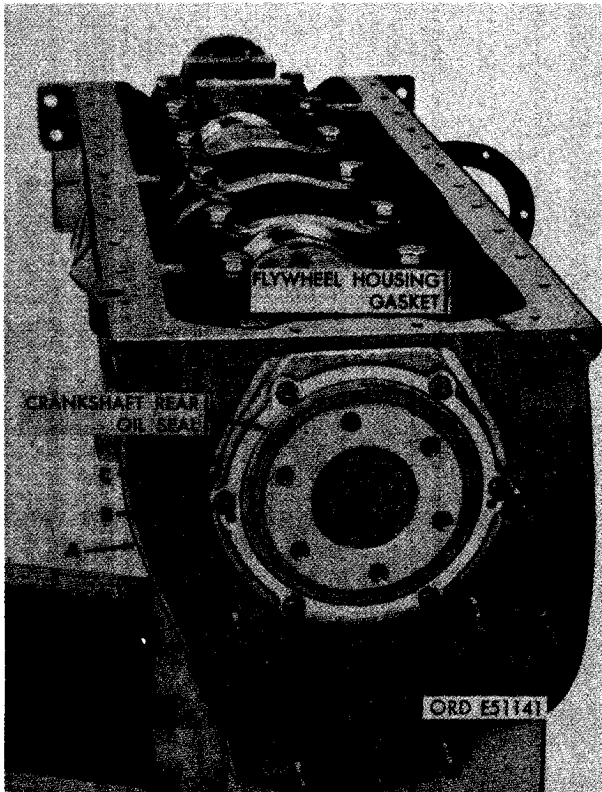


FIGURE 300. REMOVING OR INSTALLING CRANKSHAFT REAR OIL SEAL HOUSING.

## 147. REMOVAL OF OIL PUMP IDLER GEAR

**a. General.** The oil pump idler gear is driven by the camshaft gear and is mounted at the lower front of the crankcase.

**b. Removal.** Remove oil pump idler gear as follows.

- (1) Figure 301. (A) Remove retaining ring from groove in idler gear shaft. (B) Remove thrust washer. (C) Remove idler gear and bearing.

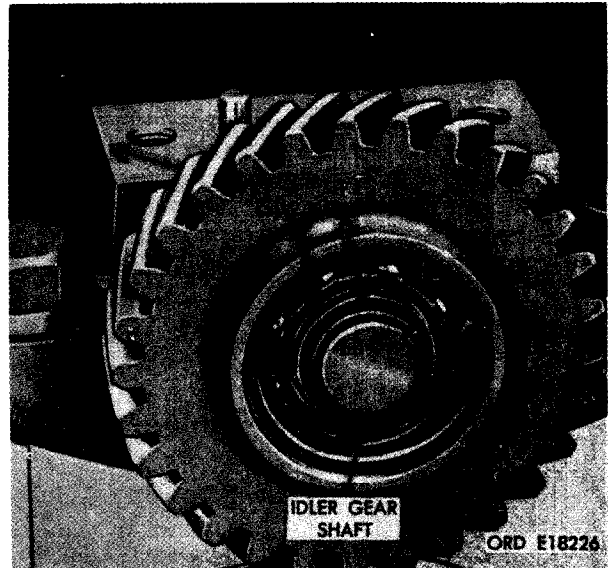


FIGURE 301. REMOVING OR INSTALLING OIL PUMP IDLER GEAR.

- (2) Refer to figure 302 and remove oil pump idler gear spacer.



FIGURE 302. REMOVING OR INSTALLING OIL PUMP IDLER GEAR SPACER.

## 148. REMOVAL OF ENGINE FRONT PLATE

a. General. The engine front plate is mounted on the front of the crankcase and provides mounting facilities for the timing gear cover assembly.

b. Removal. Figure 303. (A) Remove six  $\frac{3}{8}$  x  $\frac{1}{2}$  cap screws and  $\frac{3}{8}$ -inch lock washers securing engine front plate to cylinder and crankcase assembly. (B) Remove engine front plate. (C) Remove engine front plate gasket.

Note. Two dowel pins are used to locate engine front plate on cylinder and crankcase assembly.

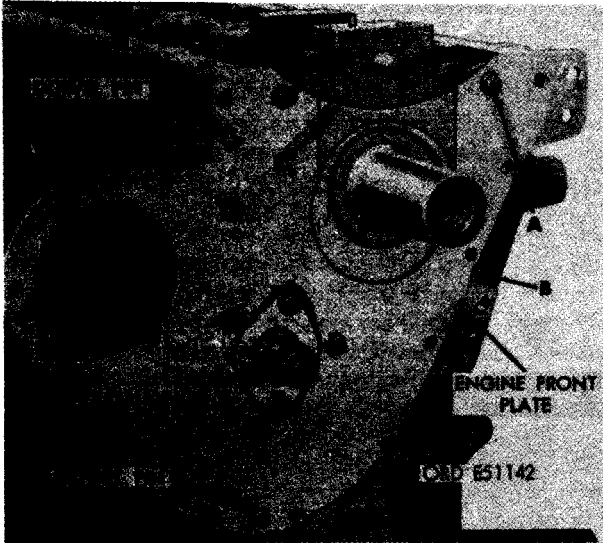


FIGURE 303. REMOVING OR INSTALLING ENGINE FRONT PLATE.

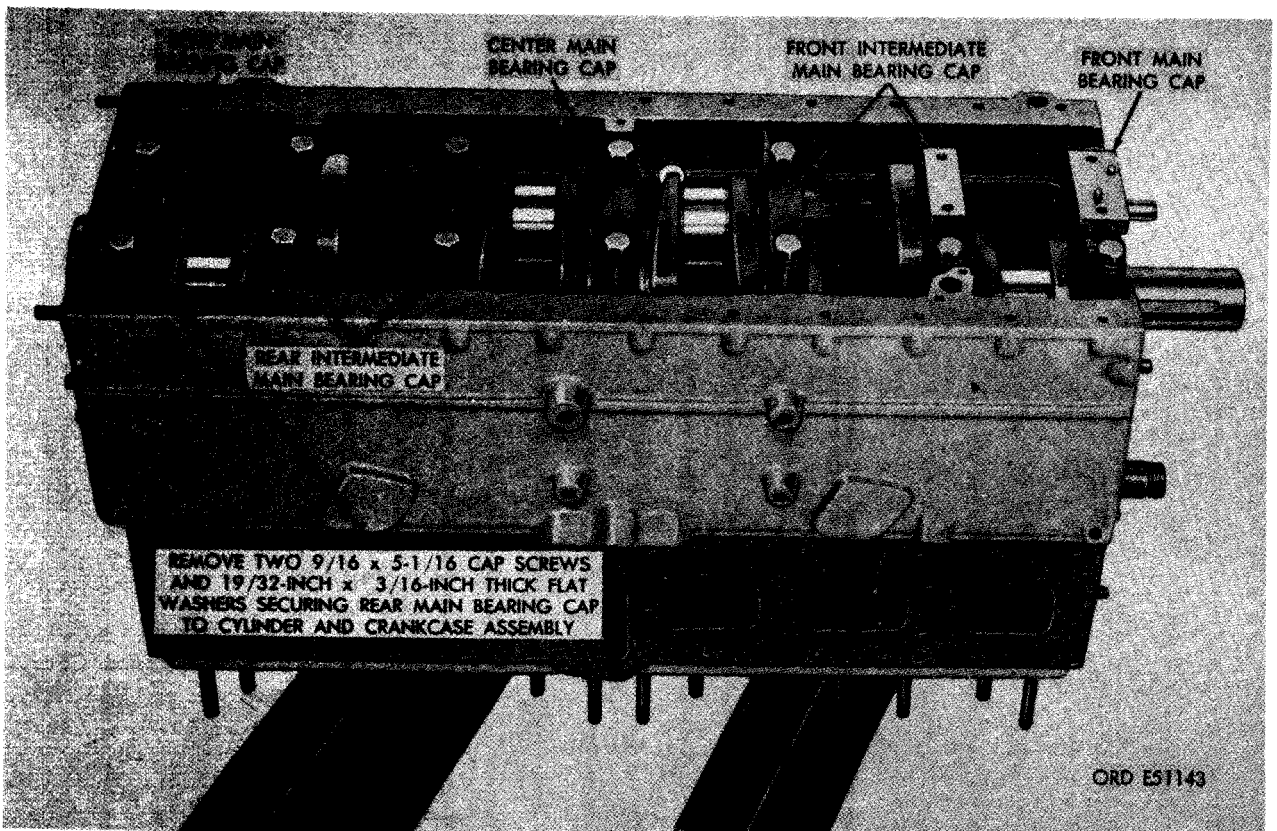


FIGURE 304. REMOVING OR INSTALLING MAIN BEARING CAP SCREWS.

#### 149. REMOVAL OF MAIN BEARING CAPS, CRANKSHAFT ASSEMBLY, AND MAIN BEARINGS

a. General. Three of the seven main bearing caps are marked for identification and proper installation in cylinder and crankcase assembly. The three marked caps are identical in appearance and marked only for that reason. The caps are marked 3, 5, and 6 starting with the bearing cap third from front. No. 5 and 6 caps are between the center thrust and rear bearing caps. The front main bearing cap can be identified by the oil pump idler gear shaft and oil pump positioning dowel pins. The front intermediate main bearing cap can be identified by the oil pump mounting surface. The center main bearing cap is identified by its width and shoulder for thrust bearing. The rear main bearing cap can be identified by oil pan gasket surface and two seals positioned on each side of cap.

b. Removal. Remove main bearing caps, crankshaft assembly, and main bearings as follows.

- (1) Refer to figure 304 and remove the rear main bearing cap screws.
- (2) Figure 305. (A) Remove rear main bearing cap and lower bearing half.

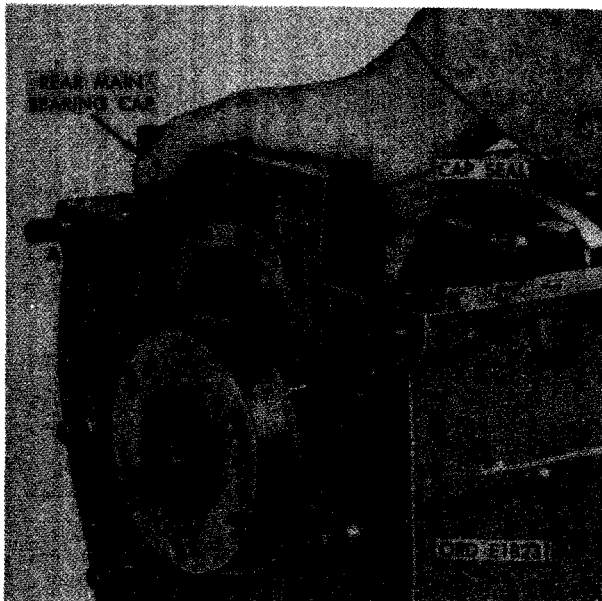


FIGURE 305. REMOVING OR INSTALLING REAR MAIN BEARING CAP AND CAP SEALS.

- (B) Remove and discard cap seals from each side of rear main bearing cap.
- (C) Remove the remaining six main bearing cap screws and washers and remove the caps and bearings in the same manner.

Note. Keep bearing halves with their respective caps as shown in figure 306. Check to see if bearings are identified. If not, use grease pencil and mark bearing tab for installation purposes. The thrust bearing is distinctive and is not normally numbered as it is always installed in the No. 4 (center) bearing position.

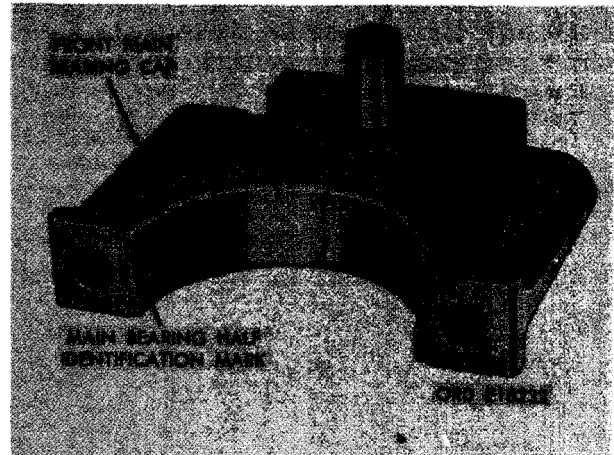


FIGURE 306. MARKING MAIN BEARING HALF FOR IDENTIFICATION.

- (3) Figure 307. (A) Wrap a rope sling around crankshaft journals as shown to balance crankshaft assembly. (B) Remove crankshaft assembly from cylinder and crankcase assembly.
- (4) Refer to figure 308 and remove the seven main bearing upper halves.

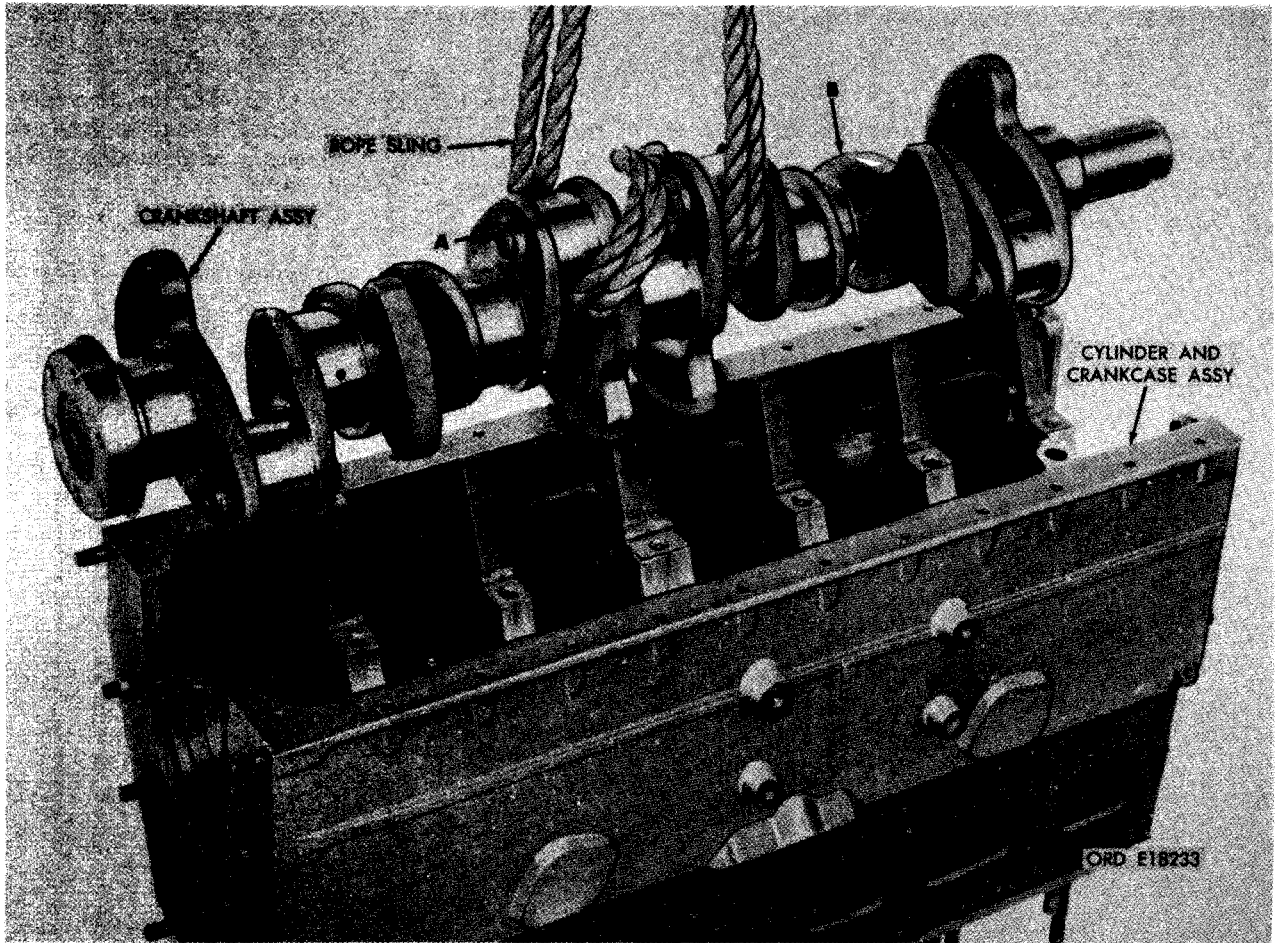


FIGURE 307. REMOVING OR INSTALLING CRANKSHAFT ASSEMBLY.

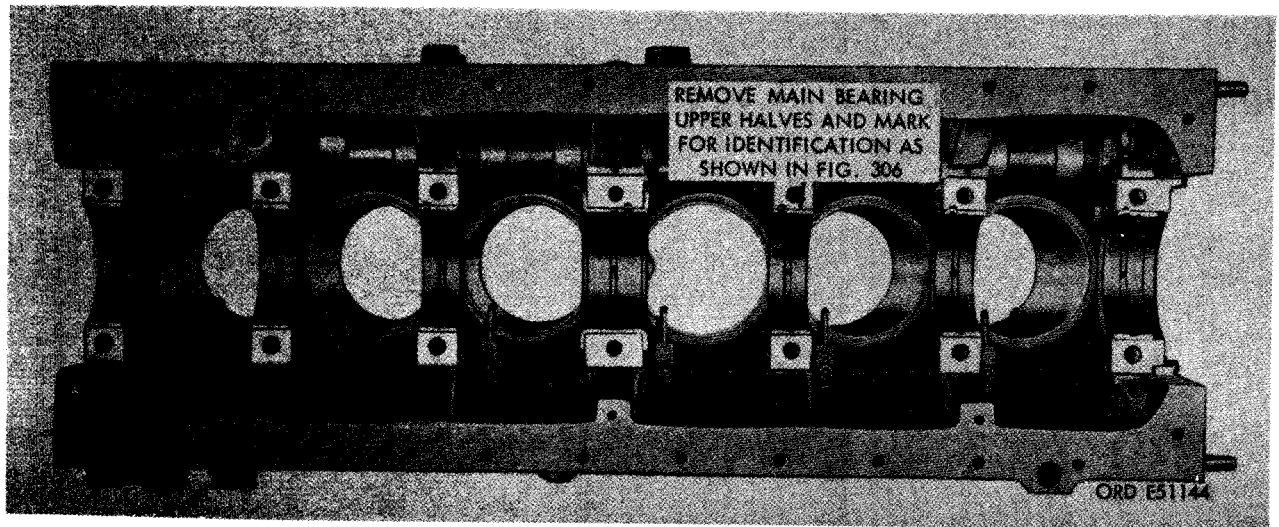


FIGURE 308. REMOVING OR INSTALLING MAIN BEARING UPPER HALVES.

## 150. REMOVAL OF PISTON COOLING NOZZLES

**a. General.** To aid in cooling the pistons during operation of the engine, six nozzles deliver oil to the inside of the pistons. The nozzles are mounted alongside the bearing caps.

**b. Removal.** Figure 309. (A) Remove six 5/16-inch plain nuts securing the six piston cooling nozzles to cylinder and crankcase assembly. (B) Remove six piston cooling nozzles.

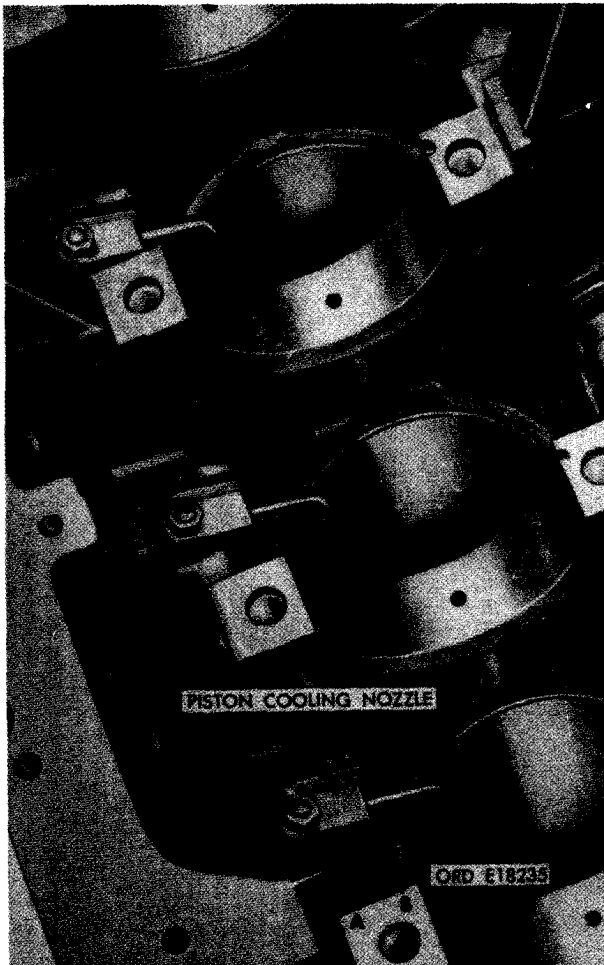


FIGURE 309. REMOVING PISTON COOLING NOZZLES.

## 151. REMOVAL OF CAMSHAFT ASSEMBLY

**a. General.** The camshaft operates the valve tappets and rocker arm push rods. Mounts and bearings for the camshaft are provided along the left side of the engine.

**b. Removal.** Remove camshaft assembly as follows.

- (1) Figure 310. (A) Remove two 3/8 x 1 cap screws and 3/8-inch lock washers securing camshaft thrust plate to cylinder and crankcase assembly. (B) Remove camshaft thrust plate.

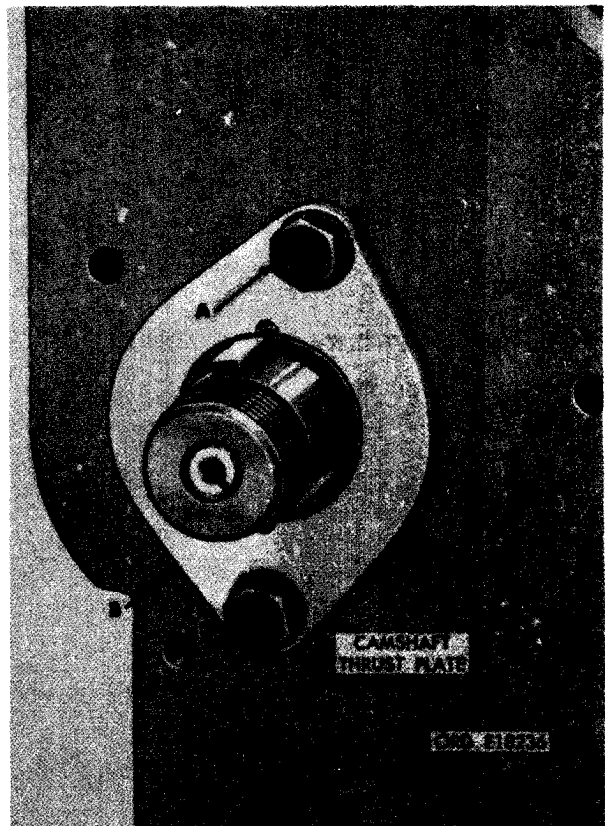


FIGURE 310. REMOVING OR INSTALLING CAMSHAFT THRUST PLATE.

(2) Refer to figure 311 and remove the camshaft assembly.



FIGURE 311. REMOVING OR INSTALLING CAMSHAFT ASSEMBLY.

(3) Refer to figure 312 and remove camshaft rear bearing plug.

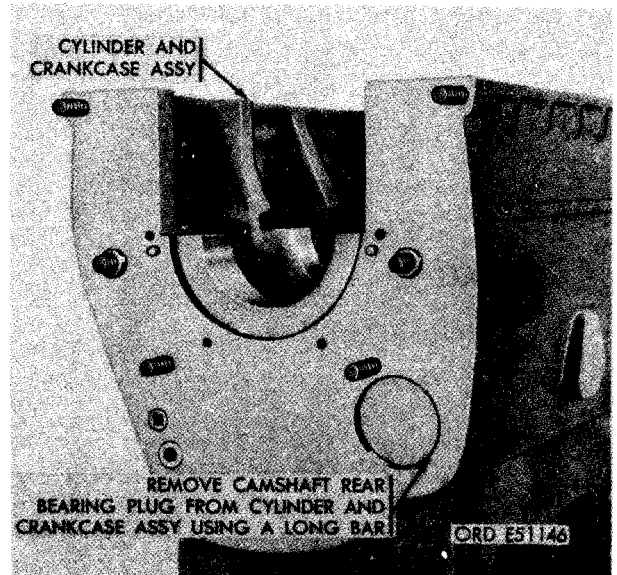


FIGURE 312. REMOVING OR INSTALLING CAMSHAFT REAR BEARING PLUG.



## CHAPTER 6

### REBUILD OF ENGINE COMPONENTS

---

#### Section I. GENERAL CLEANING, INSPECTION, REPAIR, AND ASSEMBLY PROCEDURES

##### 152. CLEANING.

a. General. The procedures for cleaning will be the same for a great percentage of the parts and components which comprise the engine subassemblies. To avoid repetition of instructions, the general procedures for cleaning are detailed in paragraphs b through f. Any cleaning procedures which are peculiar to a specific part or component are covered in the section or paragraph relating to that item.

b. Cleaning Instructions. The importance of cleaning must be thoroughly understood by maintenance personnel. Great care and conscientious effort are required in all cleaning operations. The presence of dirt or foreign substances is a constant threat to satisfactory engine operation and maintenance. The following should apply to all cleaning operations:

- (1) Clean all parts before inspection, after repair, and before assembly.
- (2) Hands should be kept free of any accumulation of grease which can collect dust and grit.
- (3) After cleaning, all parts should be covered or wrapped in plastic or suitable paper to protect them from dust and dirt.

##### c. Castings.

- (1) Clean the inner and outer surfaces of castings and all areas subject to oil and grease with dry-cleaning solvent or mineral spirits paint thinner.
- (2) Remove sludge and gum deposits from castings using a stiff brush.
- (3) Blow out all tapped holes with compressed air and dry castings, after cleaning, with compressed air.

Caution: Particles blown by compressed air are hazardous. Make certain the air stream is directed away from the user and any other persons in the area.

d. Oil Passages. Particular attention must be given to all oil passages in castings and machined parts. All oil passages must be clean and free of obstructions.

- (1) Clean passages with wire or probes to break up any sludge or gum deposits.
- (2) Wash passages by flushing with dry-cleaning solvent or mineral spirits paint thinner.
- (3) Dry passages by blowing them out with dry, compressed air.

e. Oil Seals, Electrical Cables, and Flexible Hoses. Clean seals, cables, and flexible hoses with soap and water.

Caution: Do not allow dry-cleaning solvent or mineral spirits paint thinner to be in contact with seals, cables, and flexible hoses. These cleaners cause leather, rubber, and synthetic materials to dry out, rot, and lose pliability thus making them unserviceable.

f. Ball Bearings. Refer to TM 9-214 for information on care and maintenance of bearings.

##### 153. INSPECTION

a. General. The procedures for inspection will be the same for a great percentage of the parts and components which comprise the engine subassemblies. To avoid repetition of instructions, the general procedures for inspection are detailed in paragraphs b through g. Any inspection procedures which are peculiar to a specific part or component are covered in the section or paragraph relating to that item. The

engines are precision built and the repair and rebuild standards found in paragraphs 291 through 298 for the component parts have been fixed at extremely close tolerances. The following should apply to all inspection procedures. Use modern inspection equipment for inspecting component parts having extremely close tolerances where cracks and other damage cannot be spotted visually. Extreme care must be exercised in all phases of inspection. Inspect components as follows:

b. Castings.

- (1) Inspect all ferrous (cast iron, steel, etc) castings for cracks with magnaflux equipment. Inspect all non-ferrous (aluminum) castings for cracks using a magnifying glass and a strong light. Check particularly, the areas adjacent to studs, pipe plugs, threaded inserts, and in sharp corners and fillets.
- (2) Inspect machined surfaces of castings for nicks, burs, or raised metal. Mark damaged areas for repair.
- (3) Check all mating flanges on housings and supports for warpage with a straight edge or on a surface plate. Inspect mating flanges for discoloration which may indicate persistent oil leakage.
- (4) Inspect all pipe plug and cap screw tapped openings for damaged or stripped threads.
- (5) Check all castings for conformance to the applicable repair and rebuild standards in paragraphs 291 through 298.

c. Ball Bearings. Refer to TM 9-214 for inspection of ball bearings. Check all bearings for conformance to the applicable repair and rebuild standards in paragraphs 291 through 298.

d. Studs. Inspect all studs for stripped or damaged threads, bent or loose condition, and for evidence of stretching.

e. Gears.

Note. There are no established wear limits on gear teeth. Good judgement is required to determine need for replacement.

- (1) Inspect all gears for cracks using magnaflux equipment. When magnaflux equipment is not available, use a magnifying glass and a strong light.
- (2) Inspect all gear teeth for wear, sharp fins, burs, and galled or pitted surfaces.
- (3) Check all gears for conformance to the applicable repair and rebuild standards in paragraphs 291 through 298.

f. Bushings and Bushing-type Bearings.

- (1) Check all bushings and bushing-type bearings for secure fit in their respective casting or mating part and for evidence of heating which may be indicated by discoloration of the bushing or bearing surface.
- (2) Inspect bushings and bushing-type bearings for wear, burs, nicks, or out-of-round condition.
- (3) Check for dirt in lubrication holes or grooves of bushings or bushing-type bearings. Holes and grooves must be clean and free from damage to insure proper lubrication.
- (4) Check all bushings and bushing-type bearings for conformance to the applicable repair and rebuild standards in paragraphs 291 through 298.

g. Helical Coil Inserts.

- (1) Description. To permit higher stresses on studs and bolts which are set in aluminum castings, it is common practice to install inserts of a stronger metal into which the studs or bolts are threaded. Helical coil inserts are designed to perform this function. The inserts are steel spiral coils with a bar or tang at the bottom end which is engaged by an inserting tool used for threading the insert into the casting. Some inserts have a serrated tooth section at the top end of the coil to stake them in place in the castings. Other inserts have several turns near the center of the coil in the form of a

square. This provides a locking effect upon the stud or bolt when it is threaded into the insert.

- (2) Inspection. Inspect all helical coil inserts for secure fit in the casting and for galled or stripped threads.

h. Oil Seals. Metal encased oil seals should not be replaced unless inspection indicates damage.

- (1) Inspect feather edge of oil seal for damage.
- (2) Check seal for loss of pliability and resiliency.

i. Core Hole Plugs. Inspect core hole plugs for evidence of leakage. Replace seals if leaking or damaged.

## 154. REPAIR

a. General. The procedures for repair will be the same for a great percentage of the parts and components which comprise the engine sub-assemblies. To avoid repetition of instructions, the general procedures for repair are detailed in paragraphs b through g. Any repair procedures which are peculiar to a specific part or component are covered in the section or paragraph relating to that item. After repair, clean all parts thoroughly to prevent metal chips from repair operations, or abrasives used in repair operations, from entering working parts of the engine.

### b. Castings.

- (1) Replace all cracked castings.
- (2) Replace all castings which do not conform to tolerances specified in repair and rebuild standards in paragraphs 291 through 298.
- (3) Repair minor damage to machined surfaces with a fine mill file or crocus cloth dipped in dry-cleaning solvent or mineral spirits paint thinner. Replace all castings on which machined surfaces are burred or nicked to the point of impairing subsequent assembly or operation.

- (4) Repair minor warpage of mounting flanges and gasket surfaces by working surface across a sheet of crocus cloth held tightly on a surface plate or similar flat surface. Replace castings having flanges which are warped to the point of impairing assembly or operation.

- (5) Repair damaged pipe or cap screw threads in tapped holes with a used tap.

Note. Pipe plug threads in castings must be in good condition to prevent oil or water leakage.

### c. Ball Bearings.

- (1) Replace all galled, pitted, or damaged ball bearings.
- (2) Replace all ball bearings which do not conform to tolerances specified in repair and rebuild standards in paragraphs 291 through 298.
- (3) Refer to TM 9-214 for maintenance of ball bearings.

d. Studs. Replace all bent or loose studs or studs showing evidence of stretching. Repair minor thread damage with a thread chaser. Replace all studs having stripped or damaged threads. Remove and replace studs as outlined in (1) and (2) below.

- (1) Removal. Using stud extractor, back studs out slowly to avoid heating and possible seizure. When studs are broken off too short to use stud extractor, drill stud and extract with a suitable remover. Short studs may also be removed by welding a piece of bar stock or a nut to stud and removing with a wrench.

Caution: Avoid damage to casting while using welding equipment. Refer to TM 9-8252 for welding instructions.

- (2) Replacement. Only standard studs are supplied for replacement in steel or iron castings. Unless threads in castings are damaged beyond repair, use standard studs. If threaded openings are damaged and retapping will not

clean up the threads, drill and tap opening in casting and install a suitable threaded insert.

Note. Special application studs have a nylok insert for sealing the threaded opening. The nylok insert end of the stud is inserted in the casting.

- (3) Over-size studs. Only 0.003-inch over-size studs are furnished for field replacement of studs in aluminum castings. If a standard stud is replaced, it should be replaced with a 0.003-inch over-size stud. For identification purposes, 0.003-inch over-size studs are dipped in red dye.

Note. Studs may have a coarse thread on one end and a fine thread on the other end. The coarse thread end must enter the aluminum casting. Studs having coarse threads on both ends are used in particular applications and normally the short threaded end is in the aluminum casting. Special application studs have a nylok insert for sealing threads of studs. The nylok insert end of stud is inserted in casting. Marking on coarse thread end of stud determines when stud is standard or over-size.

All replacement studs have a special coating and must have a small amount of mica-base antiseize compound (MIL-A-13881) applied on threads before the stud is installed in casting. Thread replacement stud into opening slowly to prevent overheating. Observe setting height given in Table III.

- (4) Figures 313 and 314 show stud location. Other studs referred to in Table III are located on various illustrations as indicated in table.

e. Gears.

- (1) Replace all cracked gears.
- (2) Replace all gears which do not conform to tolerances specified in repair and rebuild standards paragraphs 291 through 298.

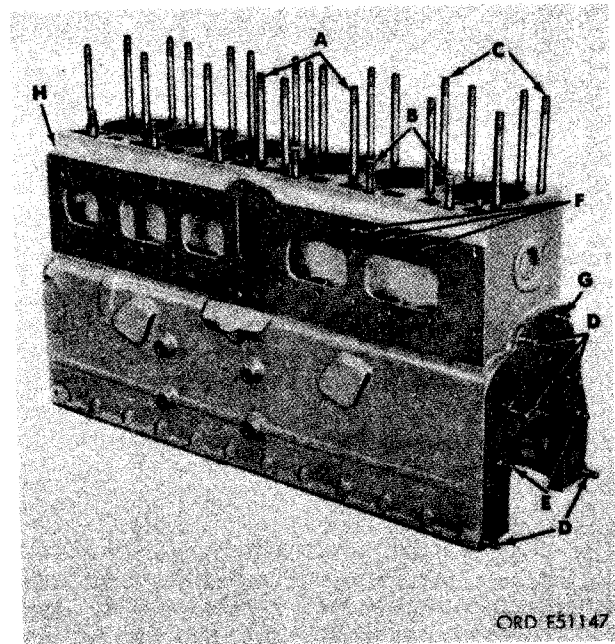


FIGURE 313. CYLINDER AND CRANKCASE STUDDING - LEFT REAR VIEW.

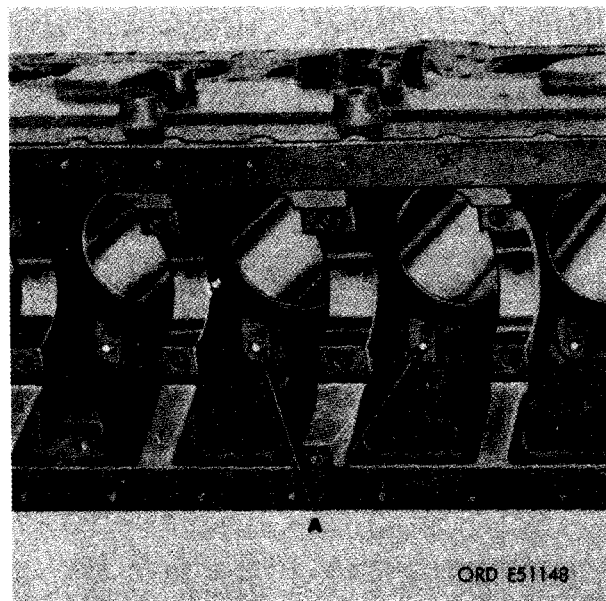


FIGURE 314. CYLINDER AND CRANKCASE STUDDING - BOTTOM VIEW.

Table III. Stud Identification

Fig. No.	Ref Ltr	Setting Height	No. Req'd	Stud Size and Length	Ord No.
127	J-1	25/32	1	3/8- 16NC (9/16) x 3/8- 16UNC-3A (1/2) x 1-5/16 (STD) (0.003-in. OS)	10899075 10899091
127	J-2	3/4	4	5/16- 18NC (1/2) (Nylok Insert) x 5/16- 18UNC- 3A (9/16) x 1- 1/4 (STD) (0.003-in. OS)	10899074 10899083
127	J-5	25/32	6	5/16- 18NC (1/2) (Nylok Insert) x 5/16- 18 UNC- 3A (9/16) x 1-1/4 (STD) (0.003-in. OS)	10899074 10899083
313	A	5-9/32	8	9/16- 12NC (7/8) (Nylok Insert) x 9/16- 18 UNF-3A (1) x 6-5/32 (STD)	10889987
313	B	1-49/64	6	9/16- 12NC (7/8) (Nylok Insert) x 9/16- 18 UNF-3A (1) x 2-5/8 (STD)	10889985
313	C	5-1/2	14	9/16- 12NC (7/8) (Nylok Insert) x 9/16- 18UNF-3A (1) x 6-3/8 (STD)	10889986
313	D	15/16	5	1/2-13NC (13/16) x 1/2- 13UNC-3A (5/8) x 1-3/4 (STD)	8758528
313	E	53/64	2	1/2- 13NC (3/4) x 1/2- 13UNC-3A (1) x 2 (STD)	10889981
313	F	1-21/64	3	3/8- 16NC (9/16) (Nylok Insert) x 3/8- 16 UNC-3A (13/16) x 1-7/8 (STD)	10912536
313	G	15/16	1	1/2- 13NC (13/16) (Nylok Insert) x 1/2- 13UNC-3A (5/8) x 1-3/4 (STD)	10912431
313	H	1-7/32	1	3/8- 16NC (9/16) (Nylok Insert) x 3/8- 16 UNC-3A (3/4) x 1-25/32 (STD)	10912432
314	A	45/64	6	5/16-18NC (7/16) x 5/16- 18UNC-3A (31/64) x 1-1/8 (STD)	10912381
322	B-3	1-5/32	4	7/16-14NC (23/32) x 7/16-14UNC-3A (15/16) x 1-7/8 (STD) (0.003-in. OS)	10899078 10899085
351	G-1	5-25/32	1	3/8- 16NC (9/16) (Nylok Insert) x 3/8- 16UNC-3A (7/8) x 6-3/8 (STD)	10912515
351	G-3	3-11/16	2	3/8-16NC (5/8) x 3/8-16UNC-3A (1-1/4) x 4-1/8 (STD)	10898712
351	T-1	1	2	3/8- 16NC (3/8) (Nylok Insert) x 3/8- 16UNC-3A (5/8) x 1-3/8 (STD)	10912509

Table III. Stud Identification - Continued

Fig. No.	Ref Ltr	Setting Height	No. Req'd	Stud Size and Length	Ord No.
352	B-3	1-1/16	1	3/8- 16NC (5/8) (Nylok Insert) x 3/8- 16UNC-3A (11/16) x 1-5/8 (STD) (0. 003-in. OS)	10912511 10899092
385	K-6	3/4	2	5/16- 18NC (1/2) (Nylok Insert) x 5/16- 18 UNC-3A (5/8) x 1- 1/4 (STD)	10899135
385	K-17	1-1/8	12	7/16- 14NC (3/4) (Nylok Insert) x 7/16- 14UNC- 3A (15/16) x 1-7/8 (STD)	10899026
385	K-18	1-1/32	18	5/16-18NC(29/64) x 5/16-24 UNF-3A (3/4) x 1-1/2 (STD)	10889984
393	C-2 J-1	27/32	4	5/16-18NC(3/8) x 5/16-18 UNC-3A (17/32) x 1-3/16 (STD)	10889976
395	F-1	5/8	4	1/4-20NC (3/8) x 1/4-20UNC-3A (1/2) x 1 (STD) (0. 003-in. OS) Engine serial Nos. 1001 thru 5968 only	10899068 10899087
395	F-3	1	13	3/8-16NC(5/8) x 3/8-16 UNC-3A (11/16) x 1-5/8 (STD) (0. 003-in. OS)	10899066 10899092
395	F-4	1-17/64	8	1/2-13NC(3/4) x 1/2- 13UNC-3A (1) x 2 (STD) (0. 003-in. OS)	10899069 10899088
395	F-7	2-17/64	3	5/8- 11NC (5/8) x 5/8- 11UNC-3A (1) x 2-7/8 (STD) (0. 003-in. OS)	10899067 10899086
395	M-2	1	12	3/8-16NC(9/16) x 3/8-16 UNF-3A (3/4) x 1-9/16 (STD) (0. 003-in. OS) Engine serial Nos. 1001 thru 2937 only	10899070 10899090
402	B-3	1	12	1/4-20NC (3/8) x 1/4-20UNC-3A (1/2) x 1-3/8 (STD) (0. 003-in. OS)	10899077 10899095
402	B-5	1-1/16	1	3/8-16NC (9/16) x 3/8-16UNC-3A (1/2) x 1-5/8 (STD) (0. 003-in. OS)	10912393-1 10912393-2
407	EE-2	5/8	1	1/4-20NC(3/8) x 1/4-20UNC-3A (3/8) x 7/8 (STD) Engine serial Nos. 1001 thru 6550 only	10889969
408	H-4	1-5/64	4	5/16- 18NC (5/8) (Nylok Insert) x 5/16- 18 UNC-3A (11/16) x 1-11/16 (STD) (0. 003-in. OS)	10899072 10899093
410	C-2	1-1/4	4	3/8- 16NC (1/2) x 3/8- 16UNC-3A (3/4) x 1-3/4 (STD)	10889983
410	F-2	7/8	4	5/16-18NC(1/2) x 5/16-18 UNC-3A (5/8) x 1-3/8 (STD) (0. 003-in. OS)	10899073 10899084

Note. There are no established wear limits for gear teeth. Good judgement is required to determine need for replacement.

- (3) Replace gears having worn, pitted, or galled teeth. Remove sharp fins and burrs from gear teeth with crocus cloth dipped in dry-cleaning solvent or mineral spirits paint thinner.

f. Bushings and Bushing-type Bearings.

When bushings and bushing-type bearings are damaged or worn beyond specified limits (pars. 291 through 298), generally the associated parts with which they are used must also be replaced. Reference to (1) and (2) below will be made in the rebuild section for the particular part when replacement of bushings and bushing-type bearings is required.

- (1) Removal. Remove bushings or bushing-type bearings by pressing out the part with a suitable arbor press or with the special tools provided. Refer to Table I for listing of special tools and equipment.
- (2) Installation. Aline bushing or bushing-type bearing in casting or retaining cage. Press into place with a suitable arbor press or with the special tools provided. Clean repaired parts thoroughly before assembly or installation.
- (3) The bushing-type bearings in the oil pump must be finished reamed to the sizes specified in repair and rebuild standards (par. 293c) after installation. All other bushing-type bearings are machined for proper clearance and need no reaming.

g. Oil Seals. Oil seals must be replaced when thin feather edge is damaged or when seal material has become hard or brittle.

- (1) Removal. Press or pry damaged oil seal from casting or adapter being careful not to damage bore in casting or adapter.
- (2) Repair. When oil seal bore in casting or adapter is burred or damaged to a point where an oil-tight seal is impossible, replace casting or adapter. Re-

move slight nicks, burrs, and scratches from bore in casting or adapter with crocus cloth dipped in dry-cleaning solvent or mineral spirits paint thinner.

- (3) Installation. Install new oil seal in bore of casting or adapter using proper oil seal replacer tool.

## 155. REPLACEMENT OF HELICAL COIL THREADED INSERTS

a. General. Replace helical coil inserts which do not fit securely in the casting or when casting threads have become galled or stripped.

b. Replacement. Replace helical coil threaded inserts as follows.

- (1) Refer to figure 315 and remove helical coil insert from oil cooler and filter housing.

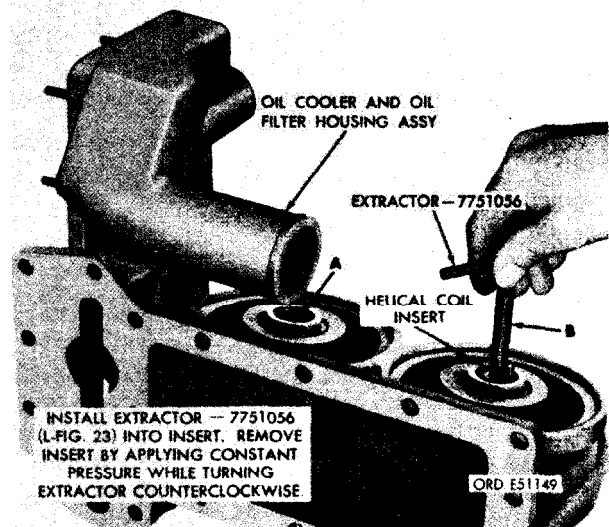


FIGURE 315. REMOVING HELICAL COIL INSERT FROM OIL COOLER AND OIL FILTER HOUSING USING EXTRACTOR - 7751056.

- (2) Figure 316. (A) Thread new helical coil insert into threaded guide of inserter - 10912379 (M, fig. 23) by slowly turning the pilot until insert is flush with end of tool. (B) Insert pilot of inserter into threaded hole in oil cooler and oil filter housing with face of in-

serter resting solidly against the housing as shown. (C) Slowly turn handle of pilot clockwise until no further resistance is felt. The insert will then be flush with housing. Remove the inserter.



FIGURE 316. INSTALLING HELICAL COIL INSERT IN OIL COOLER AND OIL FILTER HOUSING.

## 156. ASSEMBLY INSTRUCTIONS

**a. General.** Extreme care must be exercised in all component assembly operations to insure satisfactory engine performance. General rules for assembly are outlined below. Step-by-step procedures for assembling the various components are covered in the paragraph relating to the specific component.

### b. Precautionary Rules.

- (1) Cleanliness is essential in all component assembly operations. Dirt and dust, even in minute quantities, are abrasive. Parts must be cleaned as specified and kept clean. Wrap or cover parts and components when assembly procedures are not immediately completed.
- (2) Coat all bearings and all contact surfaces with engine oil OE-10 (MIL-0-2104) to insure lubrication of parts during initial engine starting.
- (3) Replace all gaskets and preformed packings removed in disassembly.
- (4) Some screws and bolts in this engine are fabricated with nylon inserts in the threaded end. This type of screw does not require additional locking devices.

## Section II. REBUILD OF CYLINDER AND CRANKCASE ASSEMBLY

### 157. GENERAL

**a.** This section covers disassembly, cleaning, inspection, repair, and assembly of the cylinder and crankcase assembly and its related parts. The related parts are those that are machined with the crankcase, and removed during engine disassembly. The main bearing caps and cylinder sleeves are included in this group along with other miscellaneous items.

**b.** During rebuild of the engine and components, replacement parts will be needed. For engine model identification, and ordering replacement parts, note the engine name plate (fig. 317), located at the upper right side of the crankcase and cylinder block.

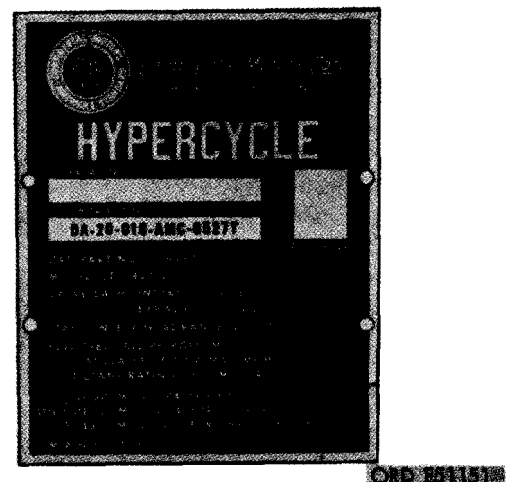


FIGURE 317. ENGINE NAME PLATE.



158. REMOVAL OF MISCELLANEOUS ITEMS FROM CYLINDER AND CRANKCASE

a. General. To completely strip the cylinder and crankcase, pipe plugs, core hole plugs, and the name plate must be removed.

b. Removal. Remove miscellaneous items from the cylinder and crankcase as follows.

- (1) Figure 318. (A) Remove two 1/8-inch hex-socket pipe plugs. (B) Remove 3/8-inch square head pipe plug. (C) Remove 3/8-inch hex-socket pipe plug. (D) Remove 1/4-inch hex-socket pipe plug.

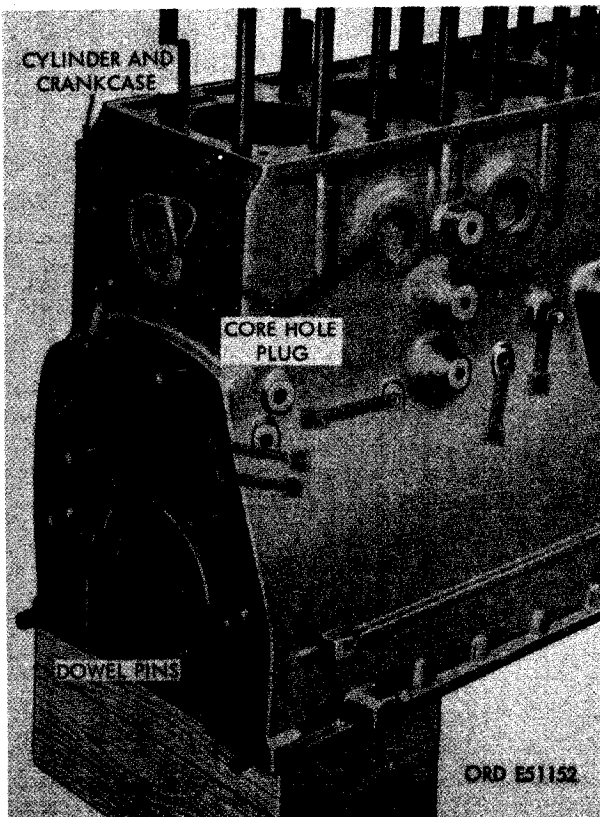


FIGURE 318. REMOVING OR INSTALLING CYLINDER AND CRANKCASE PIPE PLUGS - RIGHT REAR VIEW.

- (2) Figure 319. (A) Remove two 1/8-inch hex-socket pipe plugs. (B) Remove 1/4-inch hex-socket pipe plug. (C) Remove 3/8-inch, hex-socket pipe plug. (D) Remove 1/4-inch square socket pipe plug.

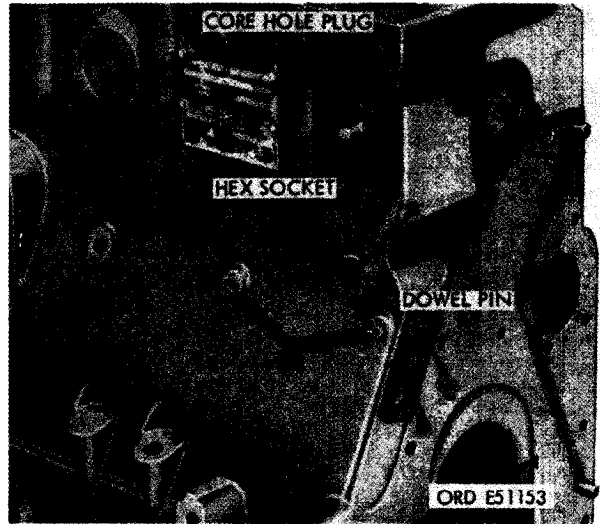


FIGURE 319. REMOVING OR INSTALLING CYLINDER AND CRANKCASE PIPE PLUGS - RIGHT FRONT VIEW.

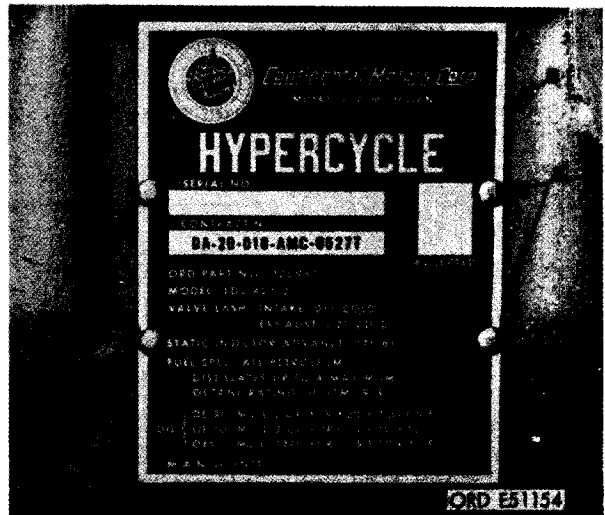


FIGURE 320. REMOVING OR INSTALLING ENGINE NAME PLATE FOR CORE HOLE INSPECTION.

- (3) Figure 320. (A) Remove four 1/8 x 1/4 pins securing name plate to cylinder and crankcase. (B) Remove nameplate to inspect core hole plug (fig. 321). Inspect plug as described in par. 159b(8).

Note. Do not remove name plate unless inspection indicates a coolant leak at core hole plug behind name plate. Rust or scale will be evident on side of engine below name plate if leak is present.

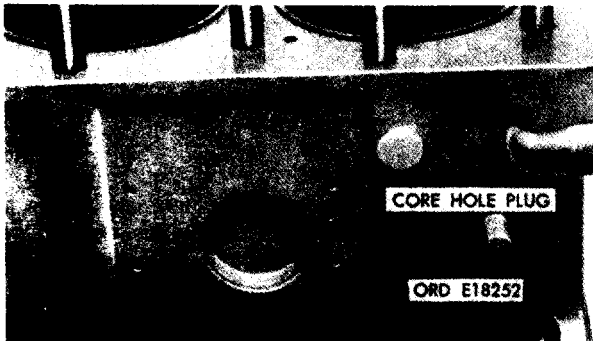


FIGURE 321. LOCATION OF CORE HOLE PLUGS BEHIND ENGINE NAME PLATE.

c. Cleaning. When all pipe plugs, core hole plugs (if applicable), and related parts have been removed from the cylinder and crankcase, clean cylinder and crankcase as instructed in paragraph 159.

#### 159. CLEANING AND INSPECTION OF CYLINDER AND CRANKCASE AND MISCELLANEOUS ITEMS

Note. The key letters shown below in parentheses refer to figure 322 except where otherwise indicated.

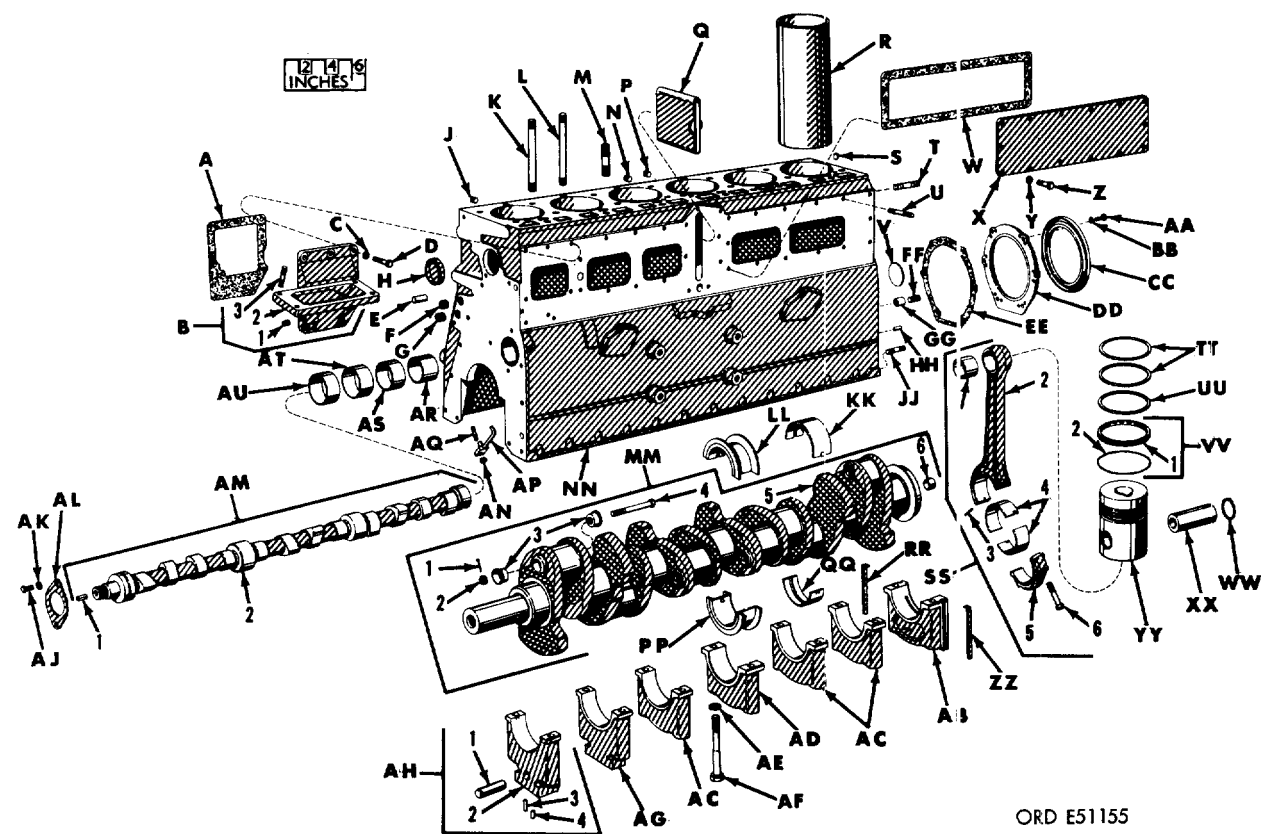
a. Cleaning. Refer to paragraph 152b and c for general instructions on cleaning the cylinder and crankcase. Clean the twelve main bearing halves (KK and QQ) and the two thrust bearing halves (LL and PP) by washing them in dry-cleaning solvent or mineral spirits paint thinner. Use a stiff brush or wooden scraper to remove sludge or gum deposits from bearing grooves or oil holes. Care must be taken not to remove bearing identification markings made when bearings were removed during engine disassembly. Thoroughly clean cylinder and crankcase oil passages using compressed air and brass wire probes as directed in paragraph 152d. Flush cylinder and crankcase water jacket thoroughly.

#### b. General Inspection.

- (1) Castings. Inspect the cylinder and crankcase (NN) and main bearing caps (AB, AC, AD, AG, and AH) according to instructions covering castings (par. 153b). Check cylinder and crankcase and related parts against limits specified in repair and rebuild standards (par. 292). Check for obstructions in the oil passages. The main bearing caps are line bored with the crankcase and replacement of any one part will necessitate replacement of the entire cylinder and crankcase assembly.

Note. Main bearing caps cannot be replaced individually.

- (2) Cylinder liner bore. Remove heavy carbon deposits from cylinder liners with a scraper or blunt tool which will not nick or scratch the surface. Clean the liner bores with dry-cleaning solvent or mineral spirits paint thinner. Check the liners for cracks, deep scratches, scoring, or metal pickup. Check for ring ridge near top of liner bore at point of highest piston ring travel.



ORD E51155

FIGURE 322. CYLINDER AND CRANKCASE, CRANKSHAFT, PISTON, AND RELATED PARTS - EXPLODED VIEW.

- |   |                                      |
|---|--------------------------------------|
| A - Air compressor support gasket       | R - Cylinder liner                   |
| B - Air compressor support assembly     | S - 3/8 x 3/4 dowel pin              |
| 1- 1/8-in. pipe plug                    | T - 1/2 x 1-3/4 nylok insert stud    |
| 2- Support                              | U - 3/8 x 1-7/8 plain stud           |
| 3- 7/16 x 1-7/8 plain stud              | V - 2-3/8-in. expansion plug         |
| C - 3/8-in. lock washer                 | W - Tappet chamber cover gasket      |
| D - 3/8 x 7/8 cap screw                 | X - Tappet chamber cover             |
| E - 1/2 x 1- 1/16 headless straight pin | Y - 13/32-in. flat washer            |
| F - 1/4-in. pipe plug                   | Z - 3/8 x 7/8 cap screw              |
| G - 3/8-in. pipe plug                   | AA- 5/16 x 1- 1/4 cap screw          |
| H - Core hole plug                      | BB- 5/16-in. lock washer             |
| J - 1/8-in. pipe plug                   | CC - Crankshaft rear oil seal.       |
| K - 9/16 x 6-5/32 plain stud            | DD - Oil seal housing                |
| L - 9/16 x 6-3/8 plain stud             | EE - Oil seal housing gasket         |
| M - 9/16 x 2- 5/8 plain stud            | FF - 1/2 x 2 plain stud              |
| N - 1/8-in. pipe plug                   | GG - Positioning ring                |
| P - 3/8-in. pipe plug                   | HH - 1/4 x 5/8 headless straight pin |
| Q - Cylinder and crankcase water baffle | JJ - 1/2 x 1-3/4 plain stud          |

FIGURE 322. CYLINDER AND CRANKCASE, CRANKSHAFT, PISTON, AND RELATED PARTS - EXPLODED VIEW - CONTINUED.

- KK - Upper rear intermediate main sleeve bearing half
- LL - Upper center main thrust sleeve bearing half
- MM - Crankshaft assembly
  - 1 - 1/16 x 3/4 cotter pin (early model engines)
  - 2 - 1/4-in. slotted nut (early model engines)
  - 3 - Crankpin plug (early model engines)
  - 4 - 1/4 x 3-3/8 cap screw (early model engines)
  - 5 - Crankshaft
  - 6 - Bushing-type pilot bearing
- NN - Cylinder and crankcase
- PP - Lower center main thrust sleeve bearing half
- QQ - Lower rear intermediate main sleeve bearing half
- RR - Rear bearing cap seal (right)
- SS - Connecting rod assembly
  - 1 - Piston pin bushing-type bearing
  - 2 - Connecting rod
  - 3 - 1/8 x 9/16 spring steel pin
  - 4 - Connecting rod sleeve bearing set
  - 5 - Connecting rod cap
  - 6 - Connecting rod cap bolt
- TT - Piston compression ring (No. 1 and 2)
- UU - Piston compression ring (No. 3)
- VV - Piston oil control ring set assembly
  - 1 - Ring
  - 2 - Expander
- WW - Piston pin retaining ring
- XX - Piston pin
- YY - Piston
- ZZ - Rear bearing cap seal (left)
- AB - Rear main bearing cap (No. 7)
- AC - Intermediate main bearing cap (No. 3, 5, and 6)
- AD - Center thrust main bearing cap (No. 4)
- AE - 19/32-in. main bearing cap flat washer
- AF - Main bearing cap screw
- AG - Front intermediate main bearing cap (No. 2)
- AH - Front main bearing cap (No. 1)
  - 1 - Oil pump idler gear shaft
  - 2 - Cap
  - 3 - 1/4 x 5/8 headless straight pin
  - 4 - 3/16 x 1 headless straight pin
- AJ - 3/8 x 1 cap screw
- AK - 3/8-in. lock washer
- AL - Camshaft thrust plate
- AM - Camshaft assembly
  - 1 - Tachometer drive sleeve
  - 2 - Camshaft
- AN - 5/16-in. plain nut
- AP - Piston cooling nozzle
- AQ - 5/16 x 1- 1/4 plain stud
- AR - Rear camshaft bushing-type bearing
- AS - Rear intermediate camshaft bushing-type bearing
- AT - Front intermediate camshaft bushing-type bearing
- AU - Front camshaft bushing-type bearing

FIGURE 322. CYLINDER AND CRANKCASE, CRANKSHAFT, PISTON, AND RELATED PARTS - EXPLODED VIEW - CONTINUED

- (3) Cylinder liner bore dimensions. Check dimensions against limits specified in repair and rebuild standards. Figure 323. (A) With liner at room temperature, take two measurements of cylinder liner bore near top, just below ring travel. Measure diameter approximately parallel to crankshaft center line and then take cross measurement (90 degrees) to first measurement. Average the two measurements. (B) Take two measurements of liner diameter bore at bottom of ring travel at lower end of liner. Measure diameter of bore approximately parallel to crankshaft center line, and then take cross measurement (90 degrees) to first measurement. Average the two measurements.

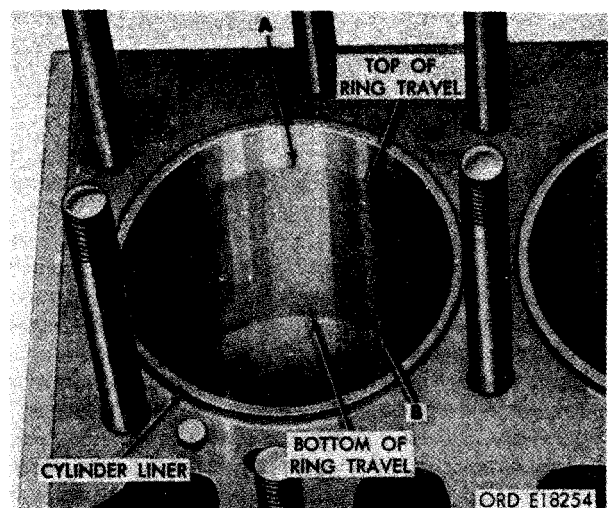


FIGURE 323. POINTS OF MEASUREMENT FOR CHECKING CYLINDER LINER BORES.

Note. Top bore average must not exceed bottom bore average. Compare the two top measurements taken 90 degrees apart. These measurements must compare within 0.0015-inch or liner must be considered as being out-of-round and must be replaced (par. 162).

- (4) Tappet bore. Inspect tappet bores against limits specified in repair and rebuild standards (par. 292) by following instructions on figure 324.

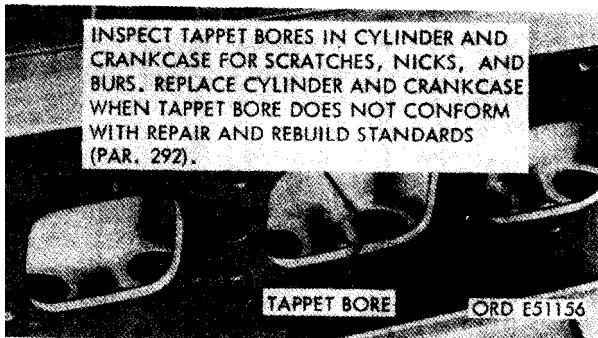


FIGURE 324. CHECKING TAPPET BORE CLEARANCE.

- (5) Camshaft bearings. Inspect camshaft bearings (AR, AS, AT, and AU) for pitting, galling, burs, nicks, and cracks. Check for discoloration, which indicates overheating. Check bore diameters against limits specified in repair and rebuild standards (par. 292).
- (6) Piston cooling nozzle. Check piston cooling nozzle (AP) for dents, kinks, nicks, scratches, or burs. Check 0.060-inch diameter hole in nozzle to make certain it is open. Clean opening with a wire probe and wash nozzle in dry-cleaning solvent or mineral spirits paint thinner. Clear opening with compressed air. Replace unserviceable nozzles.
- (7) Miscellaneous attaching parts. Inspect main bearing cap screws (AF) and washers (AE). Check for damaged threads, nicks, burs, and other unserviceable conditions. Replace all unserviceable parts.

- (8) Core hole plugs. Inspect core hole plugs (figs. 318, 319, and 321) for evidence of coolant leakage. Mark areas which show evidence of coolant leaks for repair (par. 160).

- (9) Dowel pins. Inspect dowel pins (figs. 318 and 319) for loose fit or damage. Mark damaged pins for repair.

- (10) Preparation for main bearing bore inspection. Serviceable bearing halves must be used for main bearing bore check. If original bearing halves are used, they must be installed in their original locations.

- (11) Check center main thrust bearing side clearance. Figure 325. (A) Apply Prussian blue and position upper center main thrust sleeve bearing half in bore of cylinder and crankcase assembly. (B) Check clearance between bearing flange and shoulder of cylinder and crankcase bore using a feeler gage. Clearance should be from 0.002 to 0.006-inch.

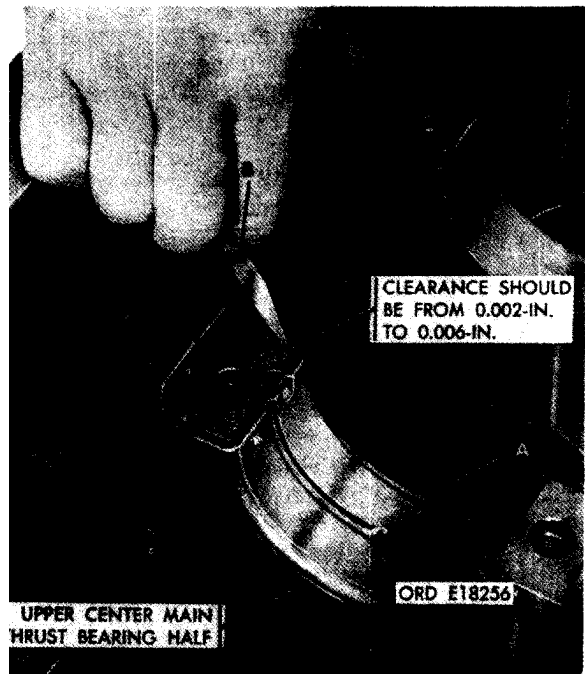


FIGURE 325. CHECKING CLEARANCE BETWEEN UPPER CENTER MAIN THRUST SLEEVE BEARING HALF AND BEARING BORE FLANGE OF CYLINDER AND CRANKCASE.

Note. Check lower main thrust sleeve bearing half in bore of thrust bearing cap in the same manner.

- (12) Check main bearing bores. Apply a thin coat of Prussian blue to backs of upper and lower bearing halves. The blue transfer will show bearing contact area in crankcase bore. Check main bearing bores as follows.

- (a) Figure 326. (A) Install the remaining six upper main sleeve bearing halves in their original location in bearing bore of cylinder and crankcase. Install the remaining six lower main sleeve bearing halves in their respective bearing caps. (B) Apply a light coating of engine oil OE-10 (MIL-0-2104) to the edges of the seven main bearing caps with sleeve bearing halves installed. Install bearing caps with bearing halves in their proper location in the crankcase, according to the location numbers stamped on the cap. The location numbers appear on the camshaft side of the cap. (C) Apply a small amount of mica-base antiseize compound (MIL-A-13881) to the threaded area of each main bearing cap screw. Install two plain washers and cap screws through each main bearing cap. Tighten each pair of cap screws alternately to a final torque of 1100 pound inches as shown.

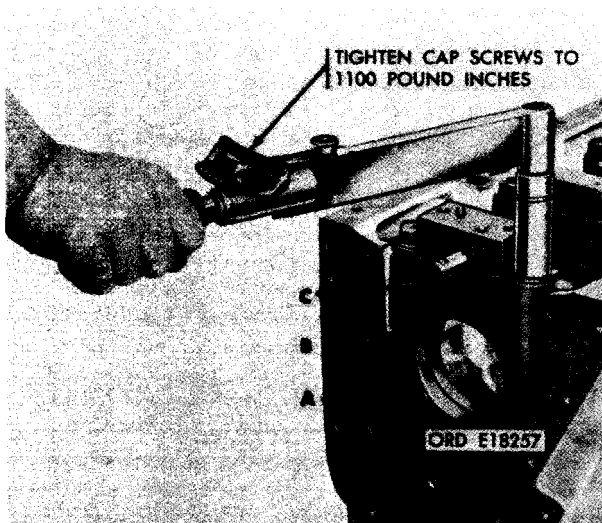


FIGURE 326. TORQUE TIGHTENING MAIN BEARING CAP SCREWS PRIOR TO MAIN BEARING BORE CHECK.

- (b) Figure 327. (A) Check inside diameter of the main bearings with a dial indicator as shown, and against limits specified in repair and rebuild standards (par. 292). Replace bearing halves not meeting the repair and rebuild requirements. Remove the main bearing caps and bearing halves from the crankcase and check the contact surface as indicated by Prussian blue transfer. Replace bearing halves that do not make 75 percent contact with crankcase bearing bores and recheck new bearings. (B) Check the remaining bearing bores in the same manner.

Note. After main bearing bores have been checked, remove all main bearing caps and bearing halves from cylinder and crankcase.

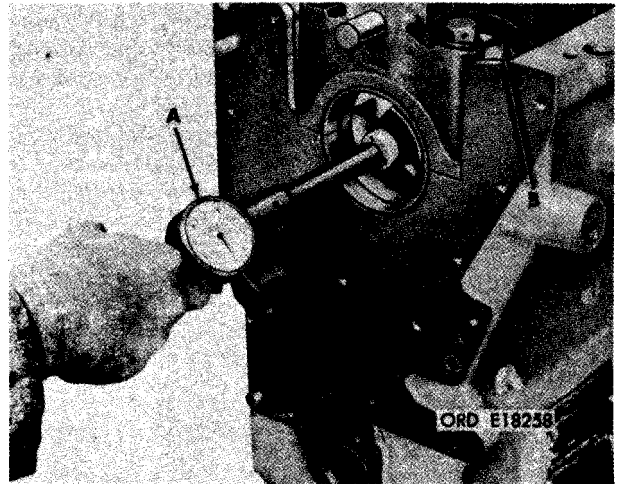


FIGURE 327. CHECKING BEARING BORE WITH SLEEVE BEARING HALVES INSTALLED USING A DIAL INDICATOR.

## 160. REPAIR OF CYLINDER AND CRANKCASE AND MISCELLANEOUS ITEMS

a. Cylinder and Crankcase. Repair cylinder and crankcase and main bearing caps having nicks, burs, and raised metal surfaces as outlined in paragraph 154b.

b. Main Sleeve Bearing Halves. Repairs to the main sleeve bearing halves are limited to replacement of unserviceable bearings.

c. Piston Cooling Nozzles. Repair piston cooling nozzles and main bearing cap screws as outlined in paragraph 159b (6) through (8) above. Remove burrs with crocus cloth moistened with dry-cleaning solvent or mineral spirits paint thinner.

d. Core Hole Plugs. Replace core hole plugs showing evidence of coolant leakage. Install new core hole plugs.

## 161. REPLACEMENT OF CAMSHAFT BUSHING-TYPE BEARINGS

a. Replace camshaft bushing-type bearings which do not meet requirements specified in repair and rebuild standards (par. 292). Replace damaged or worn camshaft bushing-type bearings as follows:

Note. The crankcase is designed with seven transverse webs for rigidity purposes. Each web contains a seat for the seven replaceable main bearings, which are numbered 1 through 7, beginning at the front. The four camshaft bearings are also located in the crankcase webs. For orientation purposes, camshaft bearings are numbered 1, 2, 3, and 4, beginning at the front. The camshaft bearing positions in relation to the main bearing positions as shown below.

<u>Main Bearing Cap Position No.</u>	<u>Corresponding Camshaft Bearing Position Number</u>
1	<b>1</b>
2	(oil transfer liner)
3	2
4	None
5	3
6	None
7	4

- (1) An oil transfer liner, similar in appearance and position to a camshaft bearing, is located in the bearing web which corresponds to main bearing number 2. Its function is to direct lubricating oil through the number 2 web and into the main oil gallery.

Warning: This liner is not to be disturbed or removed.

- (2) When necessary to replace defective camshaft bearings use remover and replacer kit - 10899154 (fig. 25). This kit is composed of a shaft, yoke assembly, special washer, flat washer, plain nut, and several removers and replacers. Some of the removers and replacers are dual purpose tools and are titled "remover" or "replacer". The proper remover or replacer can be determined by referring to Table IV, below. The removal procedure is the same for all four bearings. Replacement of the bearing in the No. 2 position, adjacent to main bearing number 3, has been selected as typical.

b. Mark the location of the drilled hole in each camshaft bearing bore with chalk or grease pencil on web of crankcase. These marks can be used as a guide to align the oil hole when installing new bearings.

c. Select remover and replacer - 10899146 (fig. 328). Position the large diameter end of this dual purpose tool in the No. 2 camshaft bearing bore from the rear of crankcase. Position the unthreaded end of shaft - 10899139 through camshaft bearing bores from the front until shaft is through far enough past bearing being removed to expose the slot nearest the unthreaded end. Install special "U" washer - 10899144 in slot and push shaft and washer forward against remover and replacer. Install yoke assembly - 10899137, flat washer - 96906-15795-222, and plain nut - 96906-35690-1205 on threaded end of shaft in the order named. Tighten plain nut until yoke and remover and replacer are properly seated. Slowly tighten plain nut until bearing is removed from bore. If necessary use a suitable pin through drilled hole in the threaded end of the shaft to keep it from turning (fig. 328).

d. Removal of remaining bearings will be similar to the above. Select proper remover and/or replacer from Table IV and remove bearings.

e. Installation of the new camshaft bearing is accomplished in a similar manner; i.e., from the rear side of the bore. Select replacer - 10899141 (fig. 329). Position new camshaft bearing over replacer. Hold replacer and bearing in position at the rear of the No. 2 bearing bore, and insert shaft, "U" shaped washer,

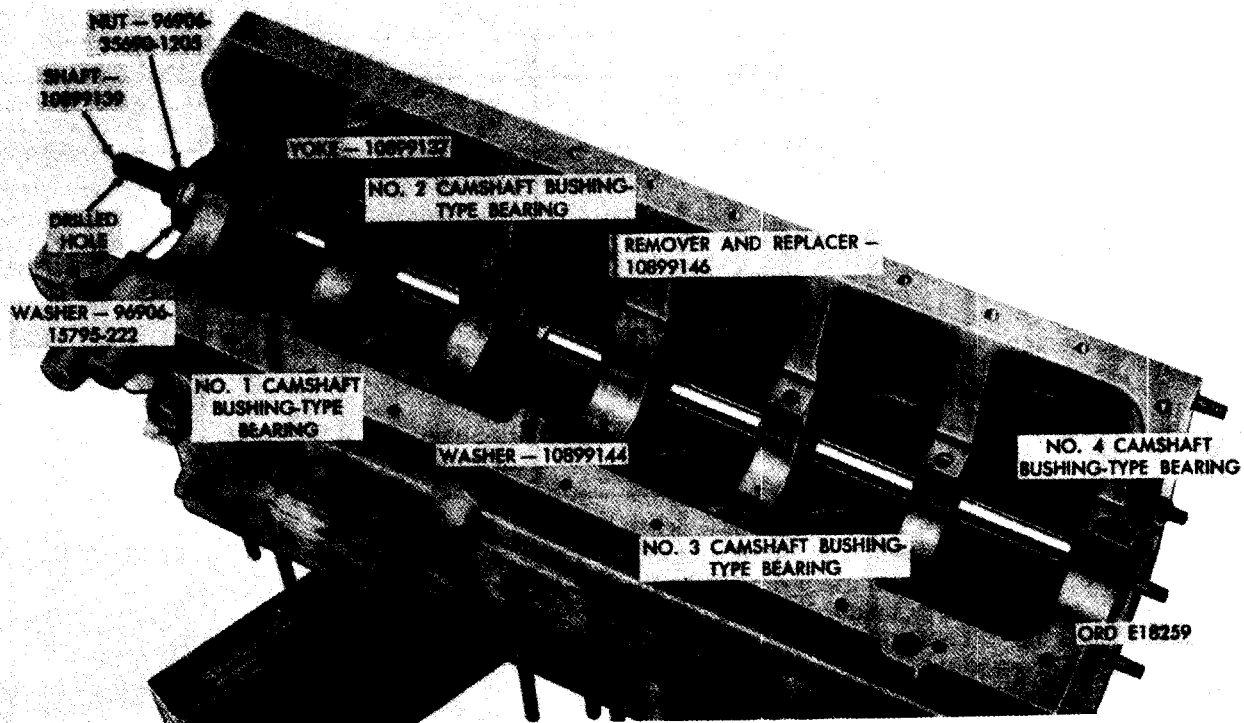


FIGURE 328. REMOVING NO. 2 CAMSHAFT BUSHING-TYPE BEARING.

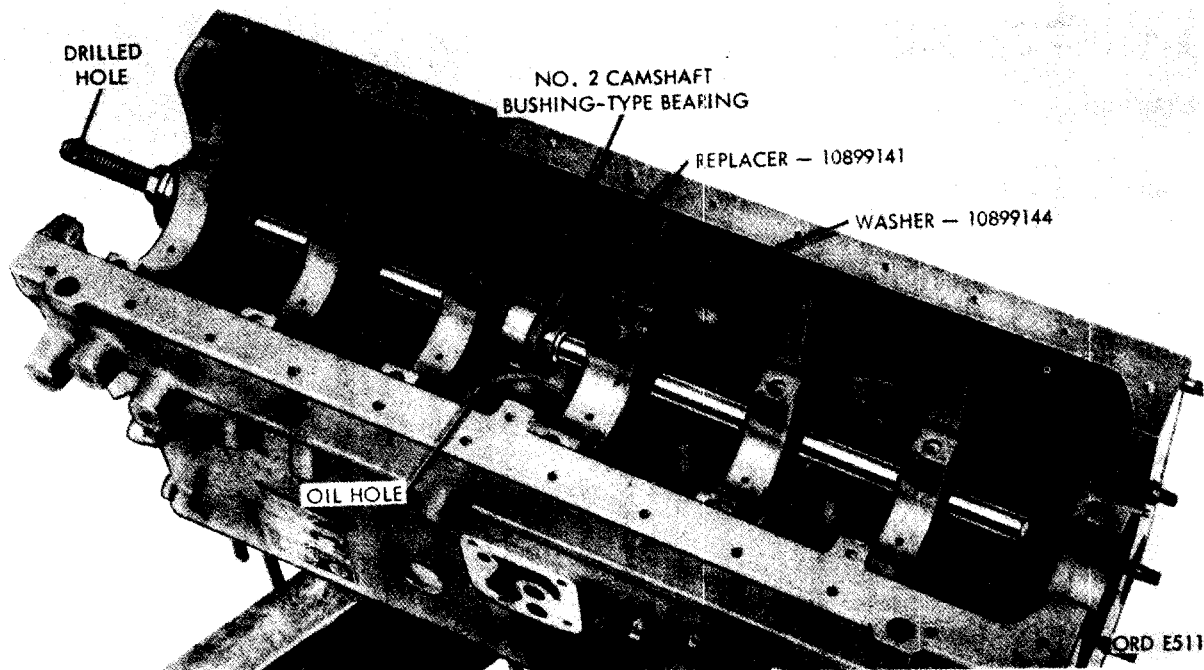


FIGURE 329. INSTALLING NO. 2 CAMSHAFT BUSHING-TYPE BEARING.



Table IV. Camshaft Bushing-Type Bearing Remover and Replacer Tool Positions

Bearing Position	Removal Tools			Replacement Tools		
	Tool Name	Ordnance No.	Application	Tool Name	Ordnance No.	Application
No. 1	Remover and Replacer	10899145	Large diameter end	Replacer	10899140	Single purpose tool
No. 2	Remover and Replacer	10899146	Large diameter end	Replacer	10899141	Single purpose tool
No. 3	Remover	10899142	Single purpose tool	Remover and Replacer	10899145	Small diameter end
No. 4	Remover	10899143	Single purpose tool	Remover and Replacer	10899146	Small diameter end

yoke assembly, flat washer, and plain nut as outlined in c. above. Tighten plain nut until all parts are seated and aligned. Apply a light coating of engine oil OE-10 (MIL-0-2104) on outside diameter of bearing. Oil hole in bearing must be aligned with grease pencil mark made in b. above. Slowly tighten plain nut until bearing is pulled into bore and flush with front edge. Use a suitable pin through hole in the threaded end of the shaft to keep it from turning (fig. 329).

f. Installation of remaining bearings will be similar to the above. Select proper remover and/or replacer from Table IV and install bearings.

Note. Replacement camshaft bushing-type bearings are finished to size and do not need machining after installation.

## 162. REPLACEMENT OF CYLINDER LINERS

a. General. Replace cylinder liners which do not meet requirements specified in repair and rebuild standards (par. 292). When necessary to replace cylinder liners use remover and replacer kit - 8722925 and hydraulic ram kit - 10912249 (figs. 24, 330, and 331).

### b. Removal.

- (1) Assemble remover and replacer rod - 10899166 and remover shoe - 10899168 and secure with clevis pin - 96906-20392-10-73 and cotter pin - 96906-24665-375.

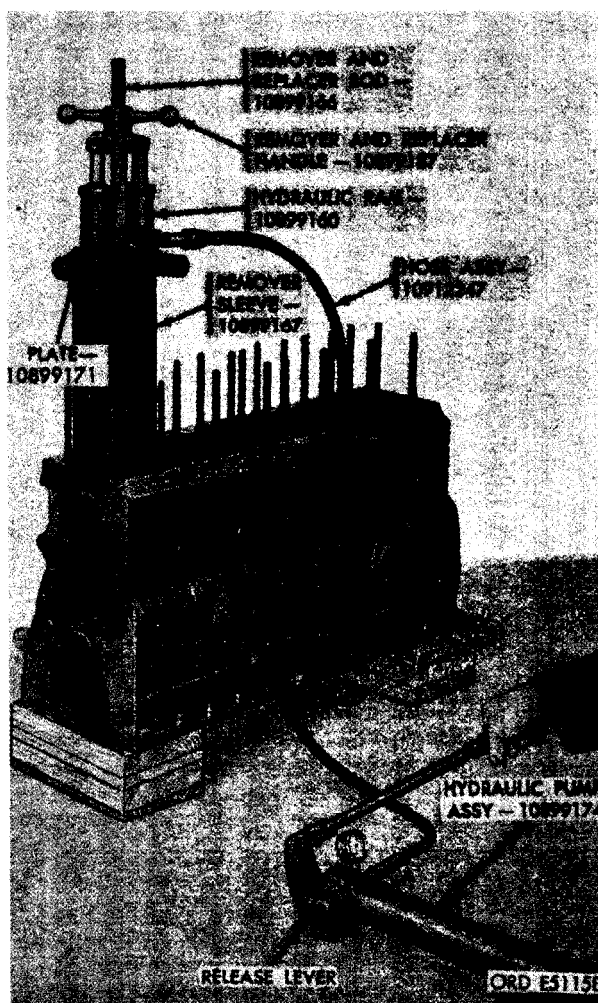


FIGURE 330. REMOVING NO. 1 CYLINDER LINER.

- (2) Position the rod up through the cylinder liner, from bottom of crankcase, until the shoe seats in the bottom of the liner. With an assistant holding the rod and shoe in position, position remover sleeve - 10899167 over liner to be removed.
- (3) Install remover and replacer plate - 10899171 on sleeve with large diameter away from sleeve.
- (4) Position the hydraulic ram - 10899160 and remover and replacer handle - 10899187 on rod. Tighten handle clockwise until shoe, sleeve, plate, and ram are properly seated.
- (5) Remove protective caps from hydraulic ram inlet. Install hose and gage adapter - 10912246 in the hydraulic pump assembly - 10899174 and connect hose assembly to the ram inlet.

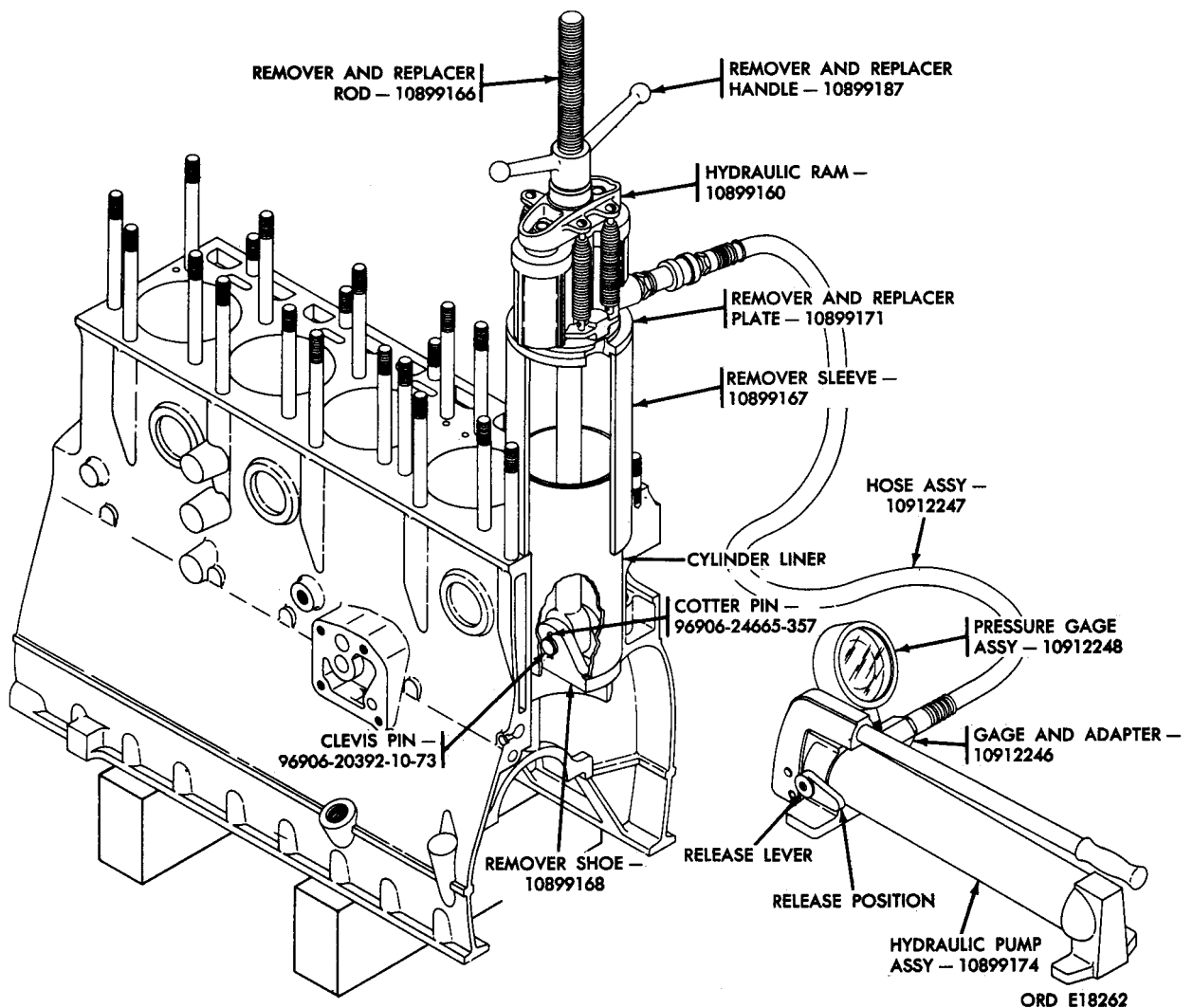


FIGURE 331. CYLINDER LINER REMOVER AND REPLACER KIT - 8722925 SHOWING POSITION OF SHOE AGAINST LINER DURING LINER REMOVAL - SECTIONAL VIEW.

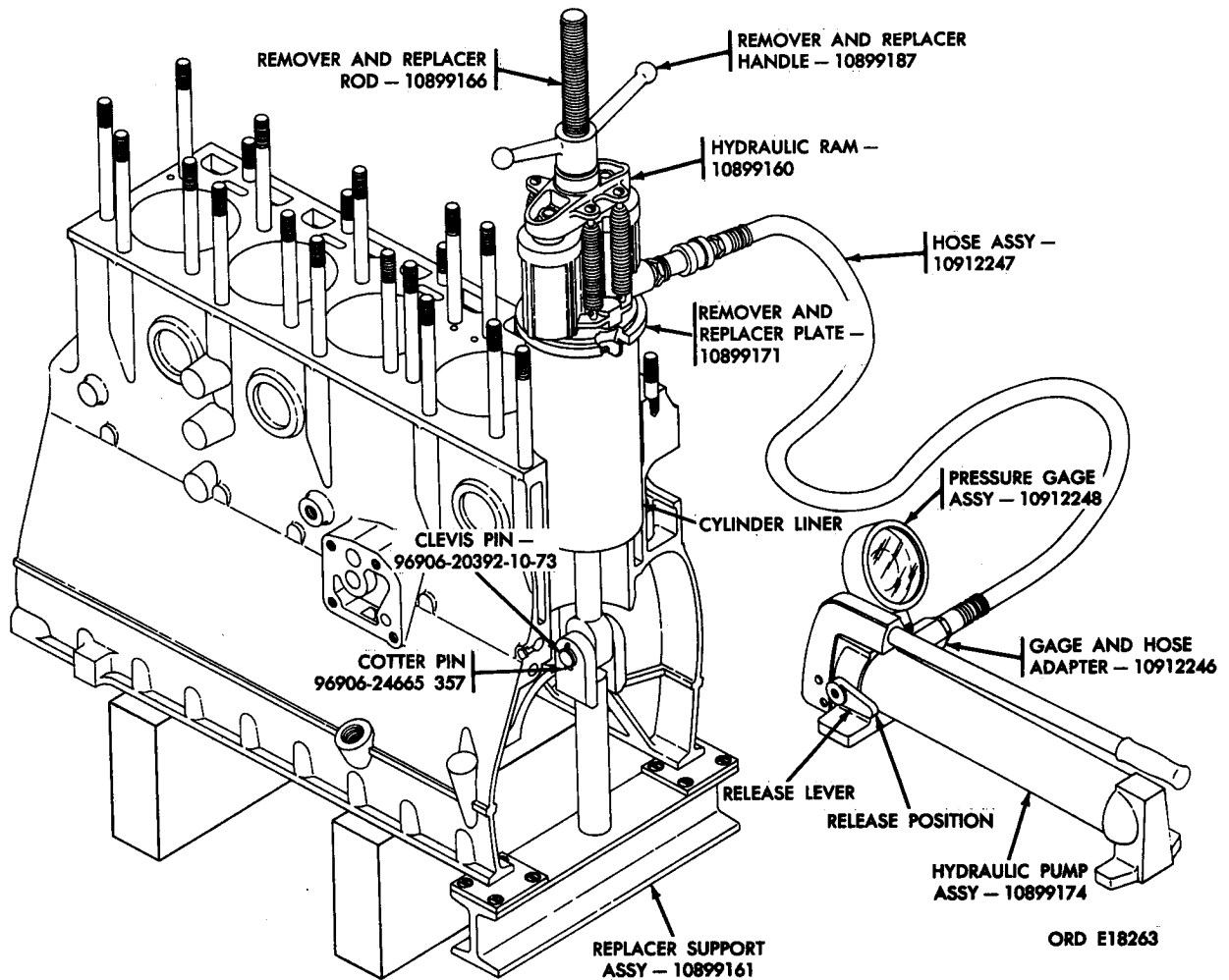


FIGURE 332. CYLINDER SLEEVE REMOVER AND REPLACER KIT - 8722925 AND RAM KIT - 10912249 SHOWING PROPER METHOD OF CYLINDER LINER INSTALLATION.

**Note.** The pistons in the hydraulic ram have a two-inch maximum travel. It will be necessary to remove the liner in two-inch increments.

- (6) Place hydraulic pump release lever in proper position for pumping (lever to left). Actuate the pump arm with slow even strokes. When the sleeve has been raised approximately two inches, turn hydraulic pump release lever to release position (lever to right). This will allow the ram piston to drop into position for another 2-inch lift. Turn handle down against hydraulic ram, reposition re-

lease lever on pump, and repeat the pumping operation. Remove the liner from cylinder. Refer to figures 330 and 331.

- (7) Remove hydraulic ram kit, remover and replacer kit, and liner.
- (8) Clean the cylinder bore with crocus cloth dipped in dry-cleaning solvent or mineral spirits paint thinner. Clean bore thoroughly and wash with dry-cleaning solvent or mineral spirits paint thinner.

c. Installation (fig. 332).

- (1) Place oil pan gasket surface of crankcase on suitable blocks. Position the replacer support - 10899161 under the cylinder bore requiring a new cylinder liner.
- (2) Remove cotter pin - 96906-24665-357, clevis pin - 96906-20392-10-73, and the remover shoe - 10899168 from remover and replacer rod - 10899166.

Note. The shoe and remover sleeve-10899167 are not required when installing new cylinder liner.

- (3) Insert rod down through cylinder bore and engage rod eye with clevis of support. Install clevis pin through support clevis and rod eye and secure with cotter pin - 96906-24665-357.
- (4) Position new cylinder liner over cylinder bore with flange end up. Place remover and replacer plate - 10899171 over liner with small diameter seated in liner.
- (5) Position the hydraulic ram - 10899160 and remover and replacer handle - 10899187 on rod.
- (6) Tighten handle until ram plate is properly seated. The cylinder liner must be properly aligned with cylinder bore before attempting to press it in.

Note. Nominal fit of cylinder liner in bore is 0.002 to 0.003-inch interference (tight) fit.

- (7) Connect hose assembly - 10912247 to hydraulic ram inlet.

Note. The pistons in the hydraulic ram have a two-inch maximum travel. It will be necessary to install the liner in two-inch increments.

- (8) Place hydraulic pump release lever in proper position (to left) for pumping. Actuate the pump arm with slow even strokes. When the sleeve has been pressed into the bore approximately

two-inches, turn hydraulic pump release lever to release position (to right). This will allow ram pistons to drop into position for another two-inch press.

Caution: Pressure gage attached to pump indicates pressure exerted for cylinder liner installation. If indicator needle moves into "danger zone" (red area), stop pumping action immediately and investigate cause. If cylinder liner cannot be installed without needle entering danger zone, remove liner as directed in paragraph 162b. Repeat installation procedure using a different liner.

- (9) Turn handle down against hydraulic ram, reposition release lever on pump, and repeat pumping operation. Continue this procedure until liner flange is properly seated in crankcase.
- (10) Remove hydraulic ram kit - 10912249 and remover and replacer kit - 8722925.

d. Honing. New cylinder liners must be honed to 4.3125 to 4.3145-inches. Refer to repair and rebuild standards (par. 292). Lower end of bore must be 0.0000 to 0.0005-inch larger than top end after honing. Scratch pattern should be 90 to 120 degrees. Surface roughness should be 25 to 40 micro-inches after final honing.

### 163. INSTALLATION OF MISCELLANEOUS ITEMS ON CYLINDER AND CRANKCASE

a. Preliminary Instructions. Refer to assembly instructions (par. 156) before proceeding with assembly of cylinder and crankcase.

b. Core Hole Plugs. Install core hole plugs (figs. 318, 319, and 321), if they were removed.

c. Engine Name Plate. Refer to figure 320 and reverse the sequence of instructions to install engine name plate.

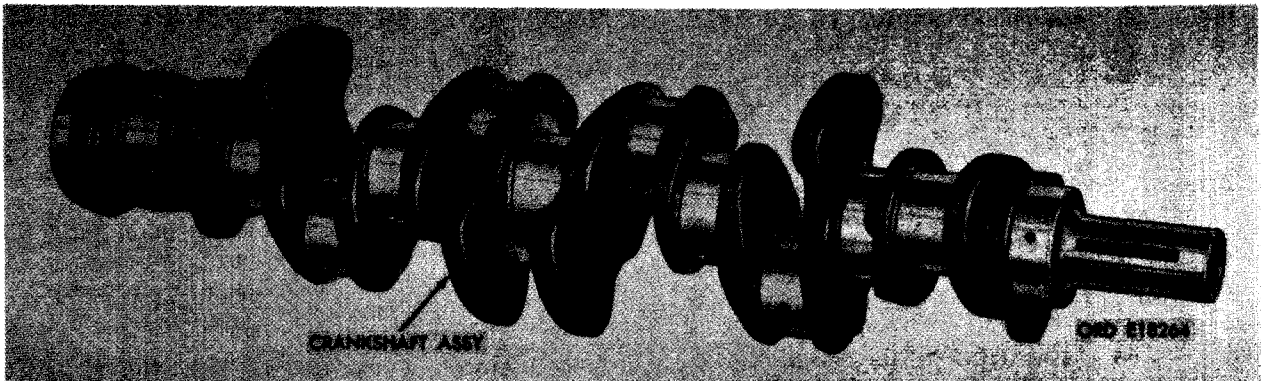
d. Pipe Plugs. Refer to figures 318 and 319 and reverse the sequence of illustrations and instructions to install pipe plugs.

e. Dowel pins. Install new dowel pins (figs. 318 and 319) if inspection indicates looseness of damage.

### Section III. REBUILD OF CRANKSHAFT ASSEMBLY

#### 164. GENERAL

a. This section covers disassembly, cleaning, inspection, repair, and assembly of the crankshaft assembly. Figure 333 illustrates a crankshaft assembly as removed from the engine.



**FIGURE 333. CRANKSHAFT ASSEMBLY AS REMOVED FROM ENGINE.**

b. Late model engines, serial Nos. 5261 and up, have a crankshaft in which the drilled oil passages do not enter the crankpin journal bore, eliminating the need for crankpin plugs.

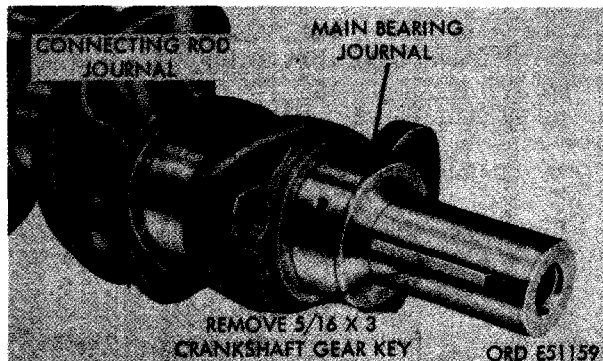
c. Early model engines, serial Nos. 1001 through 5260 are equipped with a crankshaft which utilizes connecting rod journal crankpin plugs. The journals have drilled oil passages as shown in figure 336. Crankpin plugs seal the connecting rod journal bores at the ends, maintaining a pressurized lubrication system. Early model crankshafts are identified by oil passages

visible inside the crankpin holes as shown in figure 336.

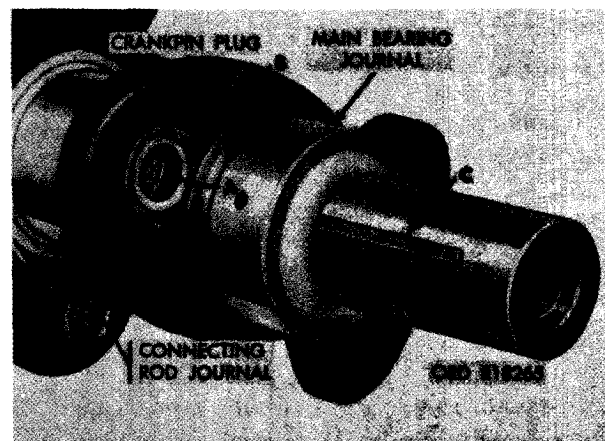
#### 165. DISASSEMBLY

a. Late Model Engine Crankshaft Assembly. Refer to figure 334 and disassemble the crankshaft assembly.

b. Early Model Engine Crankshaft Assembly. Figure 335. (A) Remove six 1/16 x 3/4 cotter pins, 1/4-inch slotted nuts, and 1/4 x 3-3/8 cap screws. (B) Remove 12 crankpin plugs. (C) Remove 5/16 x 3 crankshaft gear key.



**FIGURE 334. REMOVING OR INSTALLING CRANKSHAFT GEAR KEY (LATE MODEL ENGINES).**



**FIGURE 335. REMOVING OR INSTALLING CRANKSHAFT GEAR KEY (EARLY MODEL ENGINES).**

## 166. CLEANING AND INSPECTION

Note. The key letters shown below in parentheses refer to figure 322 except where otherwise indicated.

a. Cleaning. Refer to paragraph 152d for general cleaning instructions for the crankshaft (MM-5). Thoroughly clean the crankshaft oil passages with compressed air and brass wire probes as required. Refer to figure 336 for location of connecting rod journal crankpin oil passages in early model engines.



FIGURE 336. POINTS FOR CLEANING CRANKSHAFT CRANKPIN OIL HOLES (EARLY MODEL ENGINES).

### b. Inspection.

- (1) Inspect crankshaft (MM-5) for cracks with magnaflux equipment when available. When magnaflux equipment is not available use a magnifying glass and a strong light. Pay particular attention to areas around crankshaft oil holes and fillets adjacent to the crank cheeks.

- (2) Inspect radii of crankshaft connecting rod journals (fig. 334) for evidence of specific points of wear or damage that would indicate a bent or twisted connecting rod has been rubbing or touching crankshaft during operation.
- (3) Check diameters of main bearing journals (fig. 334) and connecting rod journals against limits specified in repair and rebuild standards (par. 292). Check runout of crankshaft by supporting end journals in "V" blocks and measuring the runout at the center journals with a dial indicator. Runout should not exceed 0.003-inch at No. 4 main bearing journal. Out-of-round must not exceed 0.0005-inch.
- (4) Inspect journals for nicks, burs, grooves, scratches, galling, scuffing, or discoloration. Mark minor defect areas for repair.
- (5) Check crankshaft bushing-type pilot bearing (MM-6) for cracks or other visible damage. Check bore of bearing against limits specified in repair and rebuild standards (par. 292.) See figure 337.

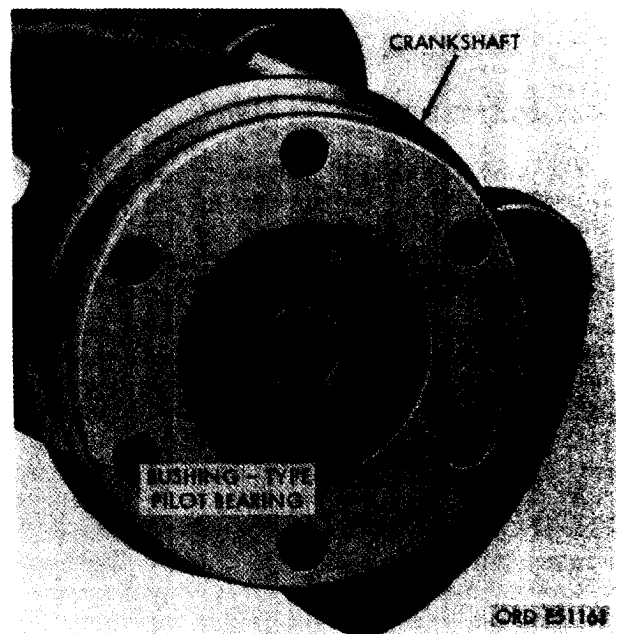


FIGURE 337. LOCATION OF BUSHING-TYPE BEARING IN CRANKSHAFT ASSEMBLY.

- (6) Inspect crankshaft gear key (M, fig. 351) for nicks and snug fit in keyway. Nicks in key may be removed with a fine oil stone. A loose key must be replaced.
- (7) Inspect crankpin plug (MM-3) (early models) for bent condition or cracks around bolt hole. Replace bent or cracked plugs.

#### 167. REPAIR

**a. Regrinding.** Crankshafts having out-of-round bearing journals or when either connecting rods or main bearing journals are worn beyond limits specified in repair and rebuild standards (par. 292), regrind crankshaft to a limit of 0.010 or 0.020-inch undersize. Undersize bearing sets are available for rebuild. The crankshaft must be held to limits established in repair and rebuild standards and to the following instructions.

- (1) Surface roughness on crankpins and journals must not exceed 20 micro inches.
- (2) Crankshaft must be inspected by the electro magnaflux method for fractures and surface cracks after finishing.

- (3) Replace crankshaft when journals are deeply nicked, burned, grooved, scratched, galled, scuffed, or if crankshaft is discolored from overheating. Repair minor imperfections in journals by polishing with crocus cloth dipped in dry-cleaning solvent or mineral spirits paint thinner.
- (4) Replace a cracked crankshaft or a crankshaft showing evidence of wear due to bent or twisted connecting rods.

#### b. Crankshaft Bushing-type Pilot Bearing Replacement (fig. 337).

- (1) Remove damaged or worn bushing-type pilot bearing (MM-6, fig. 322) (par. 67) following step A for figure 94.
- (2) Install new bushing-type pilot bearing (MM-6, fig. 322) (par. 67). Refer to figure 95.

#### 168. ASSEMBLY

Refer to figures 334 and 335 and reverse the sequence of instructions to assembly the crankshaft.

---

### Section IV. REBUILD OF CAMSHAFT ASSEMBLY AND THRUST PLATE

#### 169. DISASSEMBLY

The only component part removed from the camshaft assembly is the camshaft gear Woodruff key (fig. 338). The tachometer drive sleeve is a press fit in the end of the camshaft and is not removed unless it is damaged.

#### 170. CLEANING AND INSPECTION

**a. Cleaning.** Refer to paragraph 152 for general cleaning procedures.

#### **b. Inspection.**

- (1) Camshaft. Inspect camshaft (AM, fig.

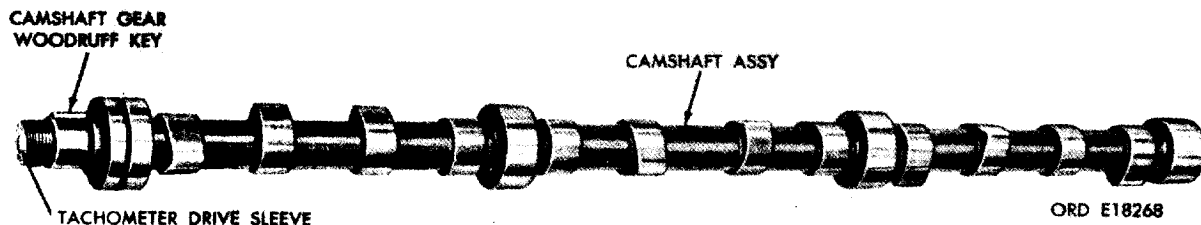


FIGURE 338. CAMSHAFT ASSEMBLY AS REMOVED FROM ENGINE.

322) for cracks using magnaflux equipment. When magnaflux equipment is not available use a magnifying glass and a strong light. Inspect camshaft lobes and bearing surfaces for wear, scuffing, and scoring. Check camshaft against limits specified in repair and rebuild standards (par. 292). Inspect camshaft for stripped or damaged threads. Check keyway for damage.

- (2) Woodruff key. Inspect camshaft gear Woodruff key (fig. 338) for nicks and for snug fit in keyway. A damaged key, or loose fitting key, will be cause for replacement of key or camshaft.
- (3) Tachometer drive sleeve. Inspect tachometer drive sleeve (AM-1, fig. 322) in front end of camshaft. Check for cracks or rounded edges on drive slot. A damaged or loose fitting sleeve will be cause for replacement of camshaft.
- (4) Camshaft thrust plate. Inspect face of camshaft thrust plate (AL, fig. 322) for

evidence of wear. Refer to figure 514, repair and rebuild. If plate is grooved or worn excessively, replace.

## 171. REPAIR AND ASSEMBLY

a. Repair. No repairs can be made to the camshaft (AM-2, fig. 322) except for the removal of minor scratches and nicks from camshaft lobes and bearing contact surfaces. Remove minor scratches and raised metal surfaces using crocus cloth soaked in mineral spirits paint thinner or a fine mill file. Replace camshaft assembly when bearing surfaces fail to meet repair and rebuild standards (par. 292) or when camshaft lobes are excessively damaged or worn. Slight nicks and scratches can be removed from the camshaft thrust plate using crocus cloth soaked in mineral spirits paint thinner. Lay crocus cloth on a flat surface and polish thrust plate as necessary until slight nicks and scratches are removed.

b. Assembly. Refer to figure 338 and install camshaft gear Woodruff key.

## Section V. REBUILD OF PISTONS, RINGS, PISTON PINS, AND CONNECTING RODS

### 172. GENERAL

This section covers the disassembly, cleaning, inspection, repair, and assembly of the pistons, rings, piston pins, and connecting rods.

### 173. DISASSEMBLY

Note. Before removing piston rings, check to see if rings are free in the piston ring grooves. Mark sticking rings for further detailed inspection. Mark all rings so they can be identified with the piston grooves from which they were removed. If rings are reused, install rings in their original location.

a. Remove Piston Rings. Figure 339. (A) Place connecting rod and piston assembly in a soft-jawed vise. (B) Remove top compression piston ring using piston ring expander - 10899196. Remove remaining two compression rings in same manner. (C) Remove oil control ring using piston ring expander - 10899196. Remove oil control ring expander spring following instructions in figure 340.

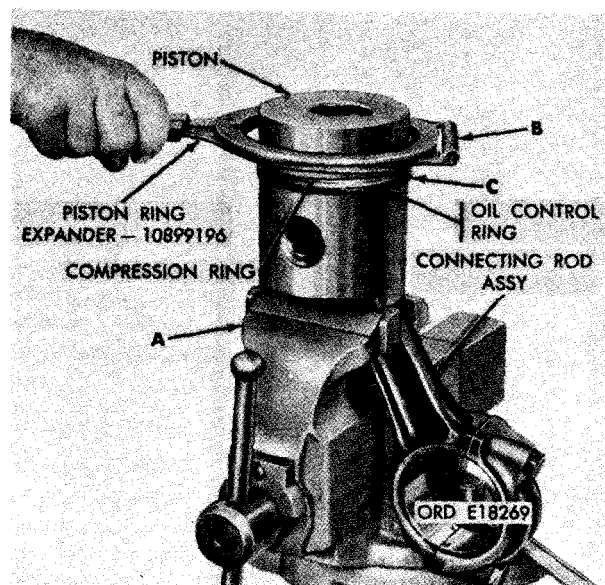


FIGURE 339. REMOVING OR INSTALLING PISTON RINGS USING PISTON RING EXPANDER - 10899196.





FIGURE 340. REMOVING OR INSTALLING OIL CONTROL EXPANDER SPRING.



FIGURE 341. REMOVING OR INSTALLING PISTON PIN RETAINING RING.

**b. Remove Connecting Rod.**

- (1) Refer to figure 341 and remove piston pin retaining ring.
- (2) Figure 342. (A) Mark piston to identify it with the rod from which it is removed. The pistons and rods must be kept together for installation. (B) Remove piston pin from piston and connecting rod bore. (C) Remove piston from connecting rod. (D) Remove two connecting rod bolts and remove connecting rod cap and bearing halves.

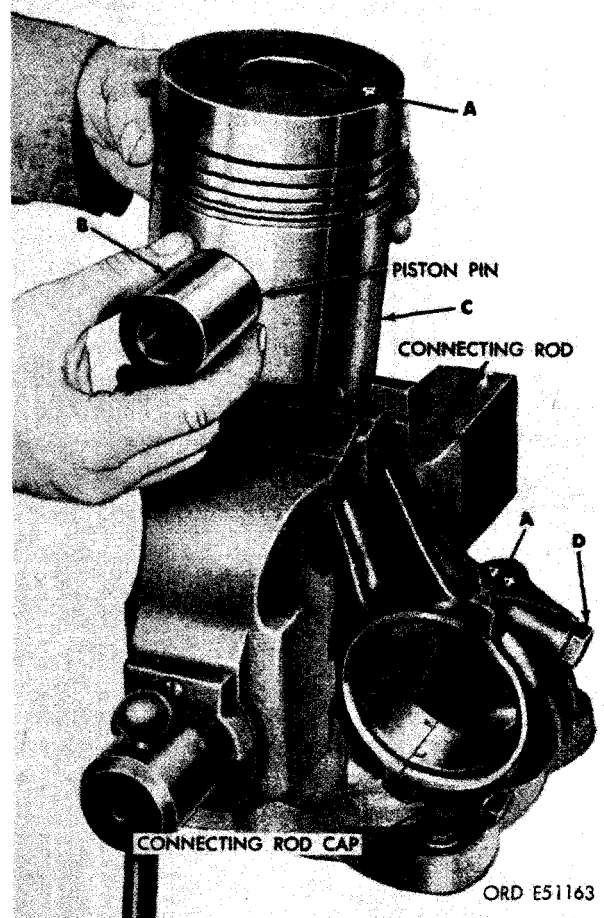


FIGURE 342. DISCONNECTING OR CONNECTING PISTON AT CONNECTING ROD.

Note. The connecting rods and caps are stamped with a location number on one side of the bosses. For example, "4" would identify the connecting rod

and cap for cylinder No. 4. Connecting rod sleeve bearings are also marked to indicate their locations. The connecting rod sleeve bearing halves (fig. 343) for No. 4 connecting rod are marked "4R" for the half that fits into the rod, "4C" for the bearing that fits into the cap. The identification marks appear inside the alignment tang of each bearing half. If the connecting rod, cap, or bearing markings are obliterated, mark with a grease pencil for installation in their original positions. Install rod cap on connecting rod using the two connecting rod bolts after connecting rod sleeve bearing halves have been removed.

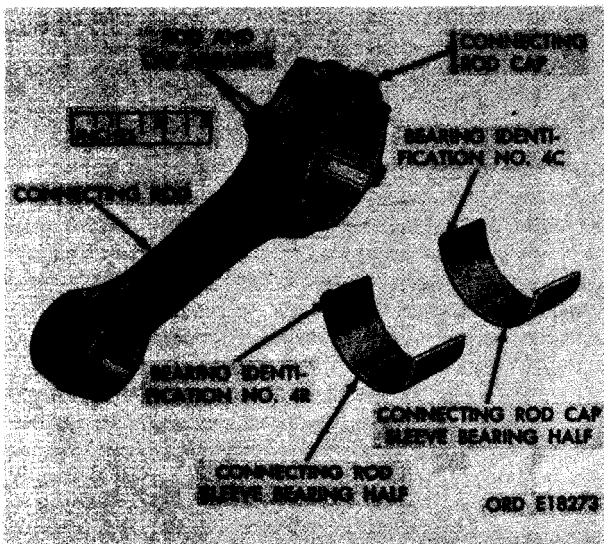


FIGURE 343. CONNECTING ROD SLEEVE BEARING AND CONNECTING ROD IDENTIFICATION NUMBER LOCATIONS.

#### 174. CLEANING AND INSPECTION

**Note.** The key letters shown below in parentheses refer to figure 322 except where otherwise indicated.

**a. Cleaning.** Clean piston (YY), rings (TT, UU, and VV), piston pin (XX), and retaining rings (WW) by soaking in carbon removing compound (MIL-S-12382 (ORD) type 1). Do not destroy or remove connecting rod or bearing location markings. Scrape remaining carbon deposits from piston ring grooves with a scraper or a broken piston ring. Do not scratch or gouge

ring lands. Clean oil holes in oil rings and oil ring grooves. Remove carbon from oil holes (fig. 344) in ring grooves of piston with a No. 23 drill (0.154-inch). Remove carbon from cavity and swirl inlet in piston head. Clean carbon from piston pins and bores with crocus cloth dipped in dry-cleaning solvent or mineral spirits paint thinner. Clean connecting rod sleeve bearing halves with cloth dipped in dry-cleaning solvent or mineral spirits paint thinner. Refer to paragraph 152 for general cleaning instructions for cleaning connecting rods and caps.

**Caution:** Use goggles, rubber gloves, and rubber apron when cleaning parts in carbon removing compound. Provide adequate ventilation. Avoid inhalation of fumes and skin contact. If compound is splashed on skin, flush with water and wash with alcohol. Alcohol containing 2 to 3 percent camphor is preferred.

#### b. Inspection.

- (1) **Piston.** Inspect piston for cracks, burned piston ring lands, and damaged piston skirt. Thoroughly inspect piston. Figure 344. (A) Inspect general condition of No. 1 and No. 2 compression ring grooves in piston. Place a 0.1125-inch diameter pin on each side of piston in tapered ring groove as shown. Refer to repair and rebuild standards (par. 292) for wear limits. Measure the distance between pins using a micrometer. Measurement should be from 4.2920 for used piston to 4.3040 for new piston. Replace piston when measurement is below 4.2920 or the tapered ring groove is worn beyond limits specified. (B) Check condition of the spherical combustion chamber at top of each piston using a new piston for comparison. Chamber must not be burned or distorted. (C) Check piston pin bore against limits specified in repair and rebuild standards (par. 292). Replace piston and piston pin when piston pin bore is over-size. (D) Check piston against limits specified in repair and rebuild standards (par. 292).
- (2) **Piston rings.** Inspect compression rings (TT and UU) and oil control rings (VV) for scuffing, scoring, chipping, scratches, or abrasions. Pay particular attention to rings which were found to

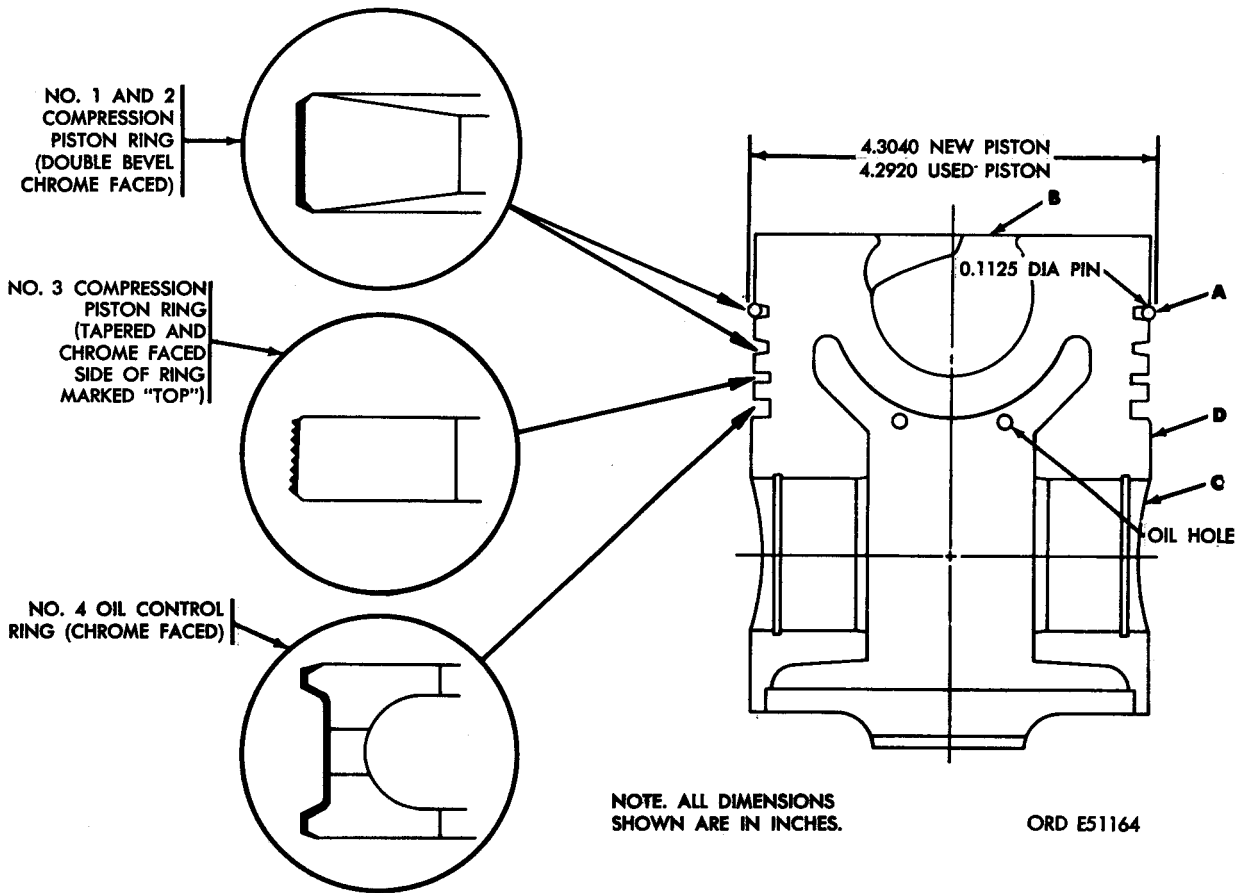


FIGURE 344. INSPECTION POINTS FOR PISTON.

be sticking in piston ring grooves. Check side clearance of rings in piston grooves as described in (a) through (d) below.

- (a) Check side clearance (ring width) on No. 1 and 2 top compression rings by measuring the thickness of the ring at the outer edge. Check the dimension against the limits specified in repair and rebuild standards (par. 292).

Note. These rings must be checked in this manner because they are tapered.

- (b) The side clearance of the third compression ring and oil control ring can be checked by installing them in their proper locations on the piston using piston ring expander - 10899196. Measure the side clearance of these two

lower rings using a feeler gage. Push rings into groove as far as possible and insert feeler gage, by trial, until one is found that will enter this area with a slight drag. Check the thickness dimensions of this gage against the limits specified in repair and rebuild standards (par. 292). Mark all rings for replacement that are not within limits specified.

Note. The third compression ring and oil control ring side clearance must also be checked after rings are installed on piston as shown in figure 348.

- (c) Excessive side clearance may be caused by the rings being worn or by piston ring groove wear.
- (d) Less than normal clearance indicates a broken or damaged ring land.

- (3) Piston ring gap. Measure end gap of all rings by placing rings in compressor - 10899159 as shown in figure 345. Mark for replacement all rings that do not conform to limits specified in repair and rebuild standards (par. 292).



FIGURE 345. MEASURING PISTON RING GAP USING PISTON RING COMPRESSOR - 10899159.

- (4) Piston pin. Inspect piston pin (XX) for wear, cracks, nicks, or scratches. Check diameter of pins against limits specified in repair and rebuild standards (par. 292). Replace unserviceable pins. Replace cracked or unserviceable piston pin retaining rings.
- (5) Connecting rod bearings. Inspect connecting rod bearing halves (SS-4) in the same manner as described in paragraph 159 for the main sleeve bearing halves. Apply a thin coating of Prussian blue to the backs of the connecting rod bearing halves and install the bearing halves in their respective connecting rod and cap according to location markings (fig. 343). Assemble rod and cap and tighten connecting rod bolts to a torque of 800 pound inches. Check bearing inside diameter, using a micrometer, as shown

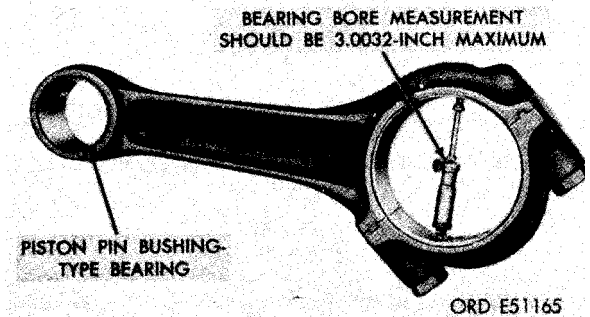


FIGURE 346. CHECKING CONNECTING ROD BEARING BORE USING MICROMETER.

in figure 346. Check this measurement against limits specified in repair and rebuild standards (par. 292). Remove connecting rod bolts, cap, and bearing halves and check the contact surface as indicated by Prussian blue transfer. Replace bearings that do not make at least 75 percent of total contact.

- (6) Connecting rod. Check connecting rod and cap (SS-2 and SS-5) against limits specified in repair and rebuild standards (par. 292). Check rods for cracks and for twisted or bent condition using suitable checking tools. Inspect piston pin bushing-type bearing bore for conformance to tolerances specified in repair and rebuild standards and for pitting, galling, scoring, or discoloration. Mark damaged or worn bearing for replacement.

## 175. REPAIR (FIG. 322)

### a. Piston.

- (1) Replace any piston (YY) which is cracked or distorted, or when it shows evidence of flaws in spherical combustion chamber.
- Note. Spherical combustion chamber lip cracks under 3/4" in length and are not cause for replacement.
- (2) Replace pistons which are not within limits specified in repair and rebuild standards (par. 295).
- (3) Replace pistons which are cracked, worn, or abraded in the piston pin bore.

- (4) Replace piston if oil holes in ring lands cannot be cleared or if lands are damaged or broken.
- (5) Replace pistons which are badly burred, nicked, or scratched. Remove minor burs, nicks, or scratches from pistons with crocus cloth dipped in dry-cleaning solvent or mineral spirits paint thinner.

**b. Piston Rings.** Replace rings (SS, TT, and UU) that are scuffed, scored, chipped, or scratched or when they show signs of abrasion. Replace rings when not within limits specified in repair and rebuild standards (par. 292) for side clearance in piston grooves and for end gap. Replace oil control rings if oil drain holes cannot be cleaned.

**Note.** Piston rings cannot be repaired. If a ring must be replaced, replace all rings on that piston.

**c. Piston Pins.** Replace piston pins (XX) which are cracked or have deep nicks or scratches. Remove minor nicks or scratches with crocus cloth dipped in dry-cleaning solvent or mineral spirits paint thinner. Replace piston pins which are not within limits specified in repair and rebuild standards (par. 292). Replace cracked or damaged piston pin retaining rings (WW).

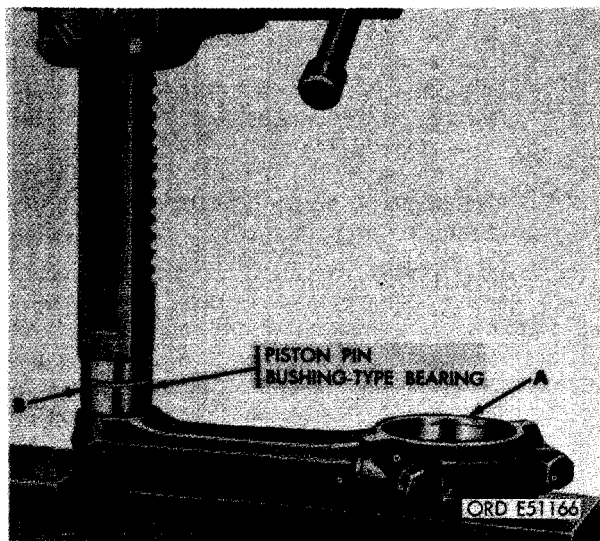


FIGURE 347. REMOVING OR INSTALLING PISTON PIN BUSHING-TYPE BEARING.

**d. Connecting Rod Sleeve Bearing Halves.** Replace all connecting rod sleeve bearing halves (SS-4) that do not check within limits specified in repair and rebuild standards (par. 292) or when bearings do not show at least 75 percent contact by Prussian blue transfer after bore check (par. 174b(5), above).

**e. Piston Pin Bushing-type Bearings.** Replace worn or damaged piston pin bushing-type bearing (SS-1). Figure 347. (A) Position connecting rod on suitable supports as shown. Bore new bushing to 1.6265 to 1.6267-inches.

**f. Connecting Rods, Caps, and Bolts.**

- (1) Replace connecting rod assemblies (SS) which are not within limits specified in repair and rebuild standards (par. 292). Rods with damaged piston pin bushings can be repaired as outlined in e above.
- (2) Replace rod cap bolts (SS-6) that have damaged threads.
- (3) Replace bolts that are cracked, scratched, or that show any evidence of stretching.

176. ASSEMBLY

**a. General.** Refer to paragraph 156 for assembly instructions.

**b. Assemble Pistons and Connecting Rods.** Refer to figures 341 and 342 and reverse the sequence of illustrations and instructions to assemble the piston and connecting rods. The number stamped on top of piston, must correspond with numbers marked on connecting rod and rod cap. The number on piston must be on the same side as rod marks.

**Note.** Lubricate piston pins, piston pin bore in piston, and piston pin bushing-type bearing in connecting rod with engine oil OE-10 (MIL-0-2104) during assembly.

c. Installing Piston Oil Control Ring and No. 3 Compression Ring.

- (1) Refer to figure 340 and install oil control expander spring as shown.
- (2) Refer to figure 339 and install oil control ring using piston ring expander - 10899196.
- (3) Refer to figure 339 and install No. 3 compression ring using piston ring expander - 10899196.

Note. No. 3 compression ring is marked "TOP" on one face and this side is installed toward head of piston. The face of the ring is tapered as shown in figure 344. The other piston rings are not marked.

- (4) Check No. 3 compression ring clearance between ring and ring land on piston using a feeler gage as shown in figure 348. Clearance should not exceed 0.0065-inch. When excessive clearance exists, piston ring lands are worn and piston should be replaced.
- (5) Refer to figure 339 and install No. 1 and No. 2 compression rings as shown using piston ring expander - 10899196.

Note. The clearance between No. 1 and No. 2 compression rings and ring lands on piston cannot be accurately checked because piston rings and ring grooves are tapered. See figure 344.

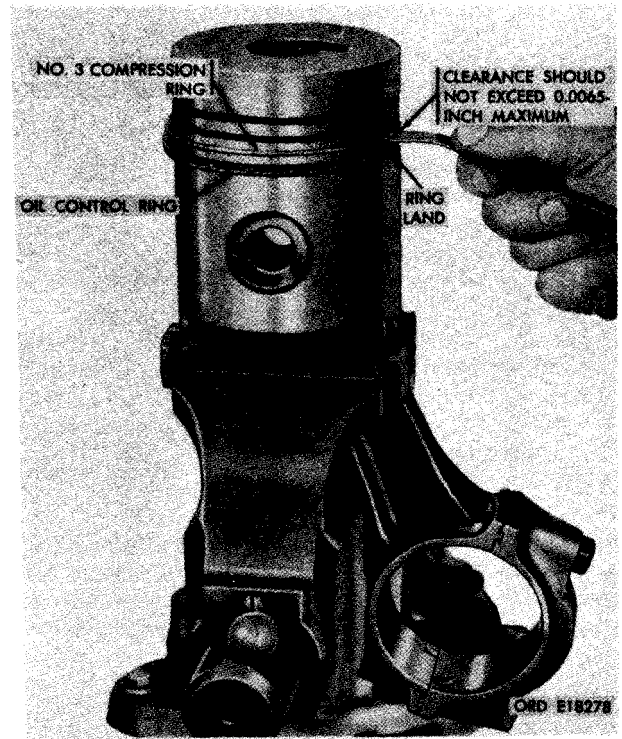


FIGURE 348. CHECKING NO. 3 COMPRESSION RING CLEARANCE USING A FEELER GAGE.

---

Section VI. REBUILD OF MISCELLANEOUS ENGINE COMPONENTS

177. CRANKSHAFT REAR OIL SEAL HOUSING

Note. The key letters shown below in parentheses refer to figure 322 except where otherwise indicated.

a. Disassembly. Remove crankshaft rear oil seal (CC) from oil seal housing (DD) using a suitable drift following instructions for figure 165. Discard seal.

b. Cleaning and Inspection. Thoroughly clean crankshaft rear oil seal (CC) as directed in paragraph 152e. Inspect crankshaft rear oil seal housing (DD) as directed in paragraph 153b.

c. Repair. Repair crankshaft rear oil seal housing (DD) as directed in paragraph 154b.

d. Assembly. Install new crankshaft rear oil seal (CC) following instructions for figures 166 and 167.

178. AIR COMPRESSOR SUPPORT ASSEMBLY

Note. The key letters shown below in parentheses refer to figure 322 except where otherwise indicated.

a. Disassembly. Disassembly of the air compressor support assembly (B) is limited to re-

removal of 1/8-inch pipe plug (B-1) and replacement of the four 7/16 x 1-7/8 plain studs (B-3). Remove pipe plug from air compressor support following instructions on figure 349.

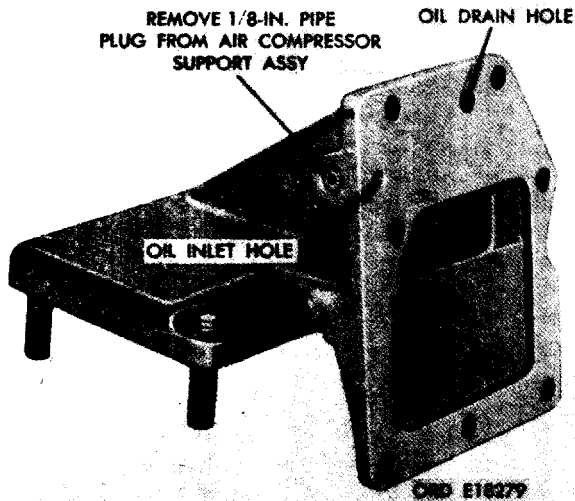


FIGURE 349. REMOVING OR INSTALLING PIPE PLUGS IN AIR COMPRESSOR SUPPORT ASSEMBLY.

b. Cleaning and Inspection.

- (1) Cleaning. Clean air compressor support assembly (B) as directed in paragraph 152c.
- (2) Inspection. Figure 350. (A) Inspect the four 1-7/8 plain studs for stripped threads and for looseness in support. (B) Inspect oil inlet hole in compressor mounting gasket face for obstructions. Use a wire probe to clean out oil hole, pushing probe through and out oil inlet hole in support gasket surface (fig. 349). Clean out oil hole, after probing, with compressed air. (C) Inspect gasket surface for nicks, sticking gasket material, and damage.

c. Repair. Repair air compressor support assembly as directed in paragraph 154b. Replace damaged studs (B-3) as directed in paragraph 154d. Replace air compressor support if cracked or when stud holes are stripped or elongated.

d. Assembly. Install 1/8-inch pipe plug (B-1) in air compressor support assembly as shown in figure 349.

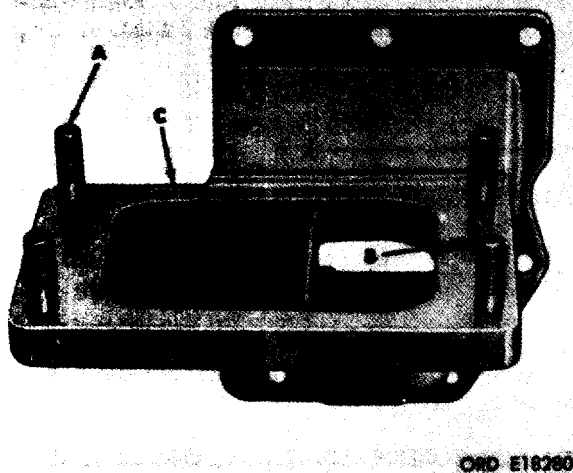


FIGURE 350. INSPECTING AIR COMPRESSOR SUPPORT.

179. TAPPET CHAMBER COVER

Note. The key letters shown below in parentheses refer to figure 322 except where otherwise indicated.

a. Cleaning and Inspection.

- (1) Cleaning. Clean tappet chamber cover (X) directed in paragraph 152c.
- (2) Inspection. Inspect tappet chamber cover (X) as directed in paragraph 153b. surface must be clean and smooth.

b. Repair. Repair tappet chamber cover (X) as directed paragraph 154b. Remove raised metal from cover gasket surface using a fine mill file.

## 180. CYLINDER AND CRANKCASE WATER BAFFLE

Note. The key letters shown below in parentheses refer to figure 322 except where otherwise indicated.

### a. Cleaning and Inspection.

- (1) Cleaning. Clean the cylinder and crankcase water baffle (Q) as directed in paragraph 152. Remove any hard scale using a scraper.
- (2) Inspection. Inspect cylinder and crankcase water baffle (Q) for dents, obstructions, and other damage.

b. Repair. Repair cylinder and crankcase water baffle (Q) by removing slight dents and straightening bent metal edges.

## 181. FUEL INJECTION PUMP ADAPTER

Note. The key letters shown below in parentheses refer to figure 351 except where otherwise indicated.

a. Disassembly. Disassembly of the fuel injection pump adapter assembly (G) is limited to removal of studs (G-1 and G-3). Do not remove studs unless they are damaged and require replacement.

### b. Cleaning and Inspection.

- (1) Cleaning. Clean the fuel injection pump adapter (G) as directed in paragraph 152b and c.
- (2) Inspection. Inspect the general condition of adapter as directed in paragraph 153b and studs as directed in paragraph 153d.

c. Repair. Repair fuel injection pump adapter (G) as directed in paragraph 154b. Replace damaged studs (G-1 and G-3) as directed in paragraph 154d. Replace adapter if it is cracked or when stud holes are stripped or elongated.

d. Assembly. Install studs (G-1 and G-3) in fuel injection pump adapter (G-2).

## 182. ENGINE FRONT PLATE ASSEMBLY

Note. The key letters shown below in parentheses refer to figure 351 except where otherwise indicated.

a. Disassembly. Disassembly of engine front plate assembly (T) is limited to the replacement of two studs (T-1).

b. Cleaning and Inspection. Clean engine front plate assembly (R) as directed in paragraph 152b. Inspect general condition of plate as directed in paragraph 153 and inspect two studs (T-1) as directed in paragraph 153d. Gasket surface (fig. 353) on both sides of front plate must be free from nicks and gasket material.

c. Repair. Repair engine front plate (T) as directed paragraph 154. Replace damaged studs (T-1) as directed in paragraph 154d. Replace front plate when cracked, distorted, bent, or damaged around gasket surfaces or when stud holes are stripped. Replace plate when dowel pin holes (fig. 362) are elongated.

d. Assembly. Assembly of the engine front plate assembly (T) is limited to the installation of two studs (T-1).

## 183. TIMING GEAR COVER

Note. The key letters shown below in parentheses refer to figure 352 except where otherwise indicated.

a. Disassembly. Press crankshaft front oil seal (U) out of timing gear cover assembly (B) from the back side. Do not damage oil seal housing bore. The timing pin (B-1) should not be removed from cover. Remove stud (B-3) only when replacement is necessary.

b. Cleaning and Inspection. Clean timing gear cover assembly (B) as directed in paragraph 152c. Inspect condition of cover as directed in paragraph 153b. Gasket surfaces and oil seal housing bore must be in good condition. Remove all traces of sticking gasket material. Inspect condition of stud (B-3) as directed in paragraph 153d.

c. Repair. Repair timing gear cover (B) as directed in paragraph 154b. Replace damaged stud (B-3) as directed in paragraph 154d. Re-



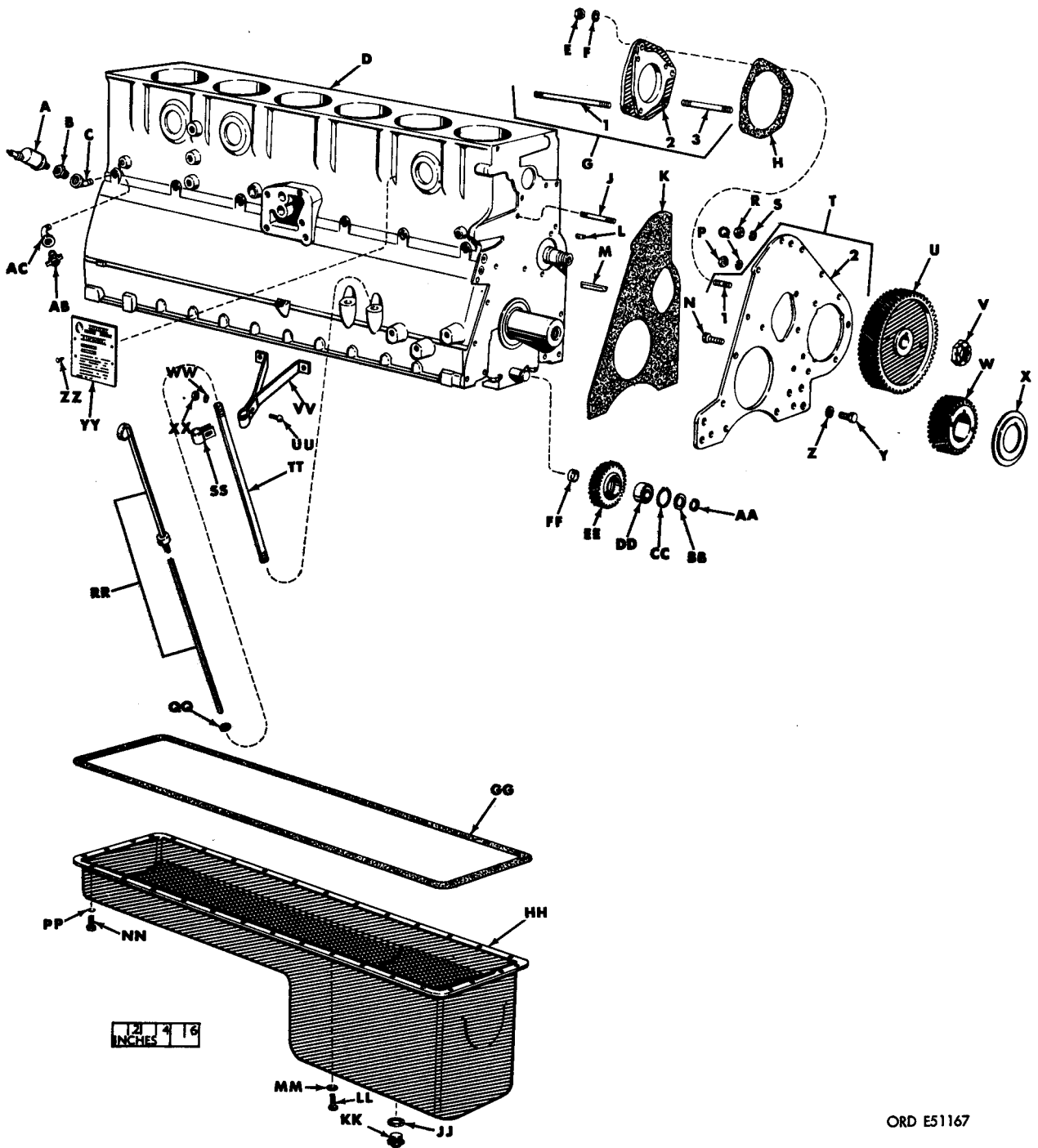


FIGURE 351. CYLINDER AND CRANKCASE, TIMING GEARS, OIL PAN, AND RELATED PARTS - EXPLODED VIEW.

A - Oil pressure sending unit	AA - Retaining ring
B - 1/4 pipe adapter	BB - Bearing thrust washer
C - 1/4-in. 45 degree elbow	CC - Bearing retaining ring
D - Cylinder and crankcase	DD - Idler gear ball bearing
E - 3/8-in. plain nut	EE - Oil pump idler gear
F - 3/8-in. lock washer	FF - Idler gear spacer
G - Fuel injection pump adapter assembly	GG - Oil pan gasket
1 - 3/8 x 6-3/8 plain stud	HH - Oil pan
2 - Adapter	JJ - Drain plug gasket
3 - 3/8 x 4- 1/8 plain stud	KK - Oil drain plug
H - Fuel injection pump adapter gasket	LL - 3/8 x 1- 1/4 cap screw
J - 3/8 x 1.840 plain stud	MM - 3/8-in. lock washer
K - Engine front plate gasket	NN - 3/8 x 1-1/2 cap screw
L - 1/4 x 7/8 Woodruff key	PP - 3/8-in. lock washer
M - Crankshaft gear key	QQ - Oil gage rod collar seal
N - 3/8 x 3-3/4 cap screw	RR - Oil gage rod
P - 1/2- in. plain nut	SS - 3/16- in. oil level gage support clamp
Q - 1/2-in. lock washer	TT - Oil gage rod support
R - 3/8-in. plain nut	UU - No. 12 x 5/8 machine screw
S - 3/8-in. lock washer	VV - Oil level gage rod support bracket
T - Engine front plate assembly	WW - No. 12 lock washer
1 - 3/8 x 1-5/16 plain stud	XX - No. 12 plain nut
2 - Plate	YY - Name plate
U - Camshaft gear	ZZ - Drive pin
V - 1- 1/4-in. self-locking nut	AB - Coolant drain cock
W - Crankshaft gear	AC - 1/4-in., 45 degree elbow
X - Oil slinger	
Y - 3/8 x 1 cap screw	
Z - 3/8-in. lock washer	

FIGURE 351. CYLINDER AND CRANKCASE, TIMING GEARS, OIL PAN, AND RELATED PARTS - EXPLODED VIEW - CONTINUED.

place cover when cracked or damaged and when gasket surfaces are deeply gouged. Replace cover when dowel pin holes are elongated.

d. Assembly. Install new crankshaft front oil seal (U) in timing gear cover following instructions for figure 212 (par. 97).

#### 184. FUEL INJECTION PUMP DRIVE GEAR ACCESS COVER

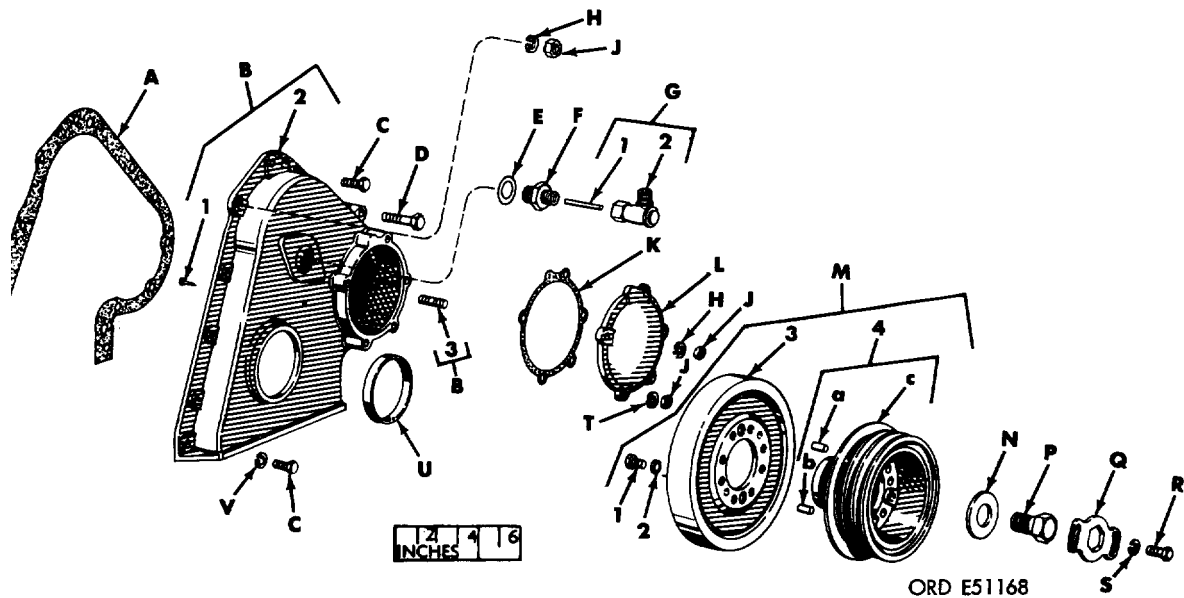
Note. The key letters shown below in parentheses refer to figure 352 except where otherwise indicated.

#### a. Cleaning and Inspection.

(1) Cleaning. Clean fuel injection pump drive gear access cover (L) as directed in paragraph 152c.

(2) Inspection. Inspect injection pump drive gear access cover (L) as directed in paragraph 153. Gasket surface must be smooth and not gouged or damaged. Screw and stud holes must not be elongated. Replace cover when distorted or damaged.

b. Repair. Repair fuel injection pump drive gear access cover (L) as directed in paragraph 154b.



- A - Timing gear cover gasket
- B - Timing gear cover assembly
  - 1- Timing pin
  - 2- Cover
  - 3- 3/8 x 1-5/8 plain stud
- C - 3/8 x 1-1/4 cap screw
- D - 1/2 x 2-3/4 cap screw
- E - Adapter gasket
- F - Tachometer take-off adapter
- G - Tachometer adapter assembly
  - 1- Adapter shaft
  - 2- Tachometer adapter
- H - 3/8-in. lock washer
- J - 3/8-in. plain nut
- K - Injection pump drive gear access cover gasket
- L - Injection pump drive gear access cover
- M - Crankshaft damper and pulley assembly
  - 1- 3/8 x 7/8 cap screw
  - 2- 3/8-in. lock washer
  - 3- Damper
  - 4- Pulley assembly
    - a - 3/8 x 3/4 dowel pin
    - b - 7/16 x 3/4 dowel pin
    - c - Pulley
- N - Retaining plate
- P - Crankshaft bolt
- Q - Crankshaft bolt lock plate
- R - Crankshaft bolt lock plate 3/8 x 3/4 cap screw
- S - 3/8-in. lock washer
- T - 3/8-in. lock washer
- U - Crankshaft front oil seal
- V - 3/8-in. lock washer

FIGURE 352. CRANKSHAFT DAMPER AND PULLEY AND RELATED PARTS - EXPLODED VIEW.

### 185. OIL PUMP IDLER GEAR

Note. The key letters shown below in parentheses refer to figure 351 except where otherwise indicated.

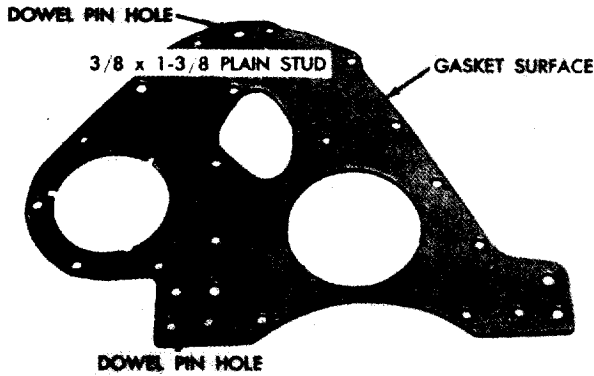
a. Disassembly. Remove bearing from oil pump idler gear (E E) as follows.

- (1) Refer to figure 354 and remove bearing retaining ring.

- (2) Figure 355. (A) Position oil pump idler gear on press plates with bearing retaining ring groove side of gear down. (B) Remove idler gear bearing from oil pump idler gear using suitable pressing arbor.

#### b. Cleaning.

- (1) Refer to paragraph 152b for general cleaning instructions for the oil pump idler gear (EE).



ORD E51169

FIGURE 353. ENGINE FRONT PLATE AS REMOVED FROM ENGINE .

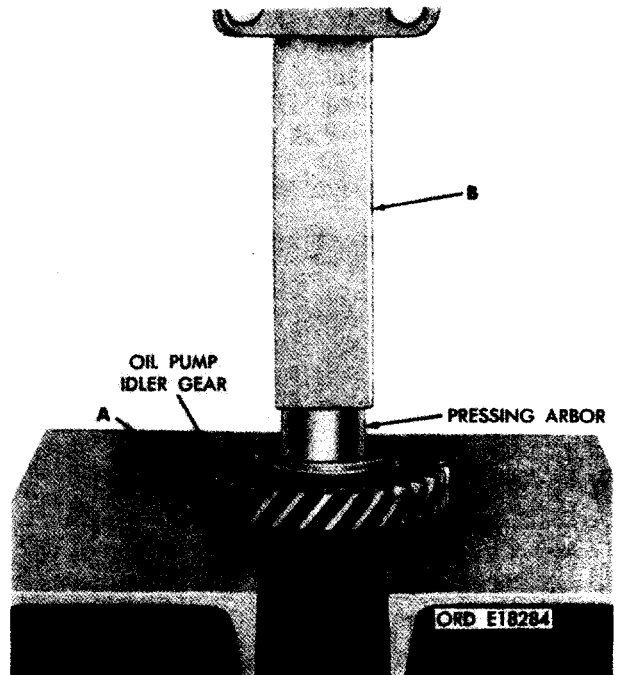


FIGURE 355. REMOVING IDLER GEAR BALL BEARING FROM OIL PUMP IDLER GEAR.

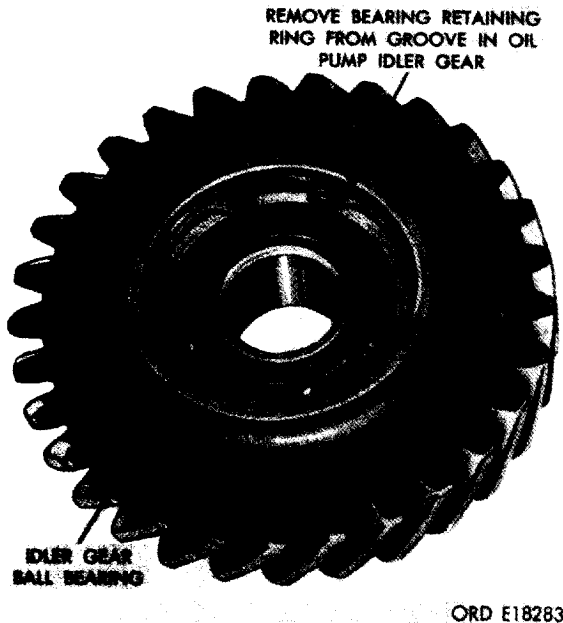


FIGURE 354. REMOVING OR INSTALLING OIL PUMP IDLER GEAR BEARING RETAINING RING.

- (2) Clean oil pump idler gear ball bearing (DD) as directed in TM 9-214 and paragraph 152b.

c. Inspection.

- (1) Gears. Inspect the oil pump idler gear EE as directed in paragraph 153e, for damaged gear teeth and scored bearing surfaces. Check bearing bore against limits specified in repair and rebuild standards (par. 293).
- (2) Ball bearing. Refer to TM 9-214 for inspection, care, and maintenance of ball bearing (DD). Inspect bearing for looseness of roughness. Check bearing against limits specified in repair and rebuild standards (par. 293).

d. Repair. Replace oil pump idler gear (EE) if it is cracked, chipped, or when it does not meet limits specified in repair and rebuild standards (par. 293). Replace unserviceable ball bearing (DD). Replace damaged retaining ring (AA).

e. Assembly. Figure 356. (A) Position oil pump idler gear on press plates with bearing retaining ring groove in gear up. (B) Install idler gear ball bearing in oil pump idler gear using a suitable pressing arbor the same diameter as bearing outer race. Install oil pump idler gear bearing retaining ring (fig. 354).

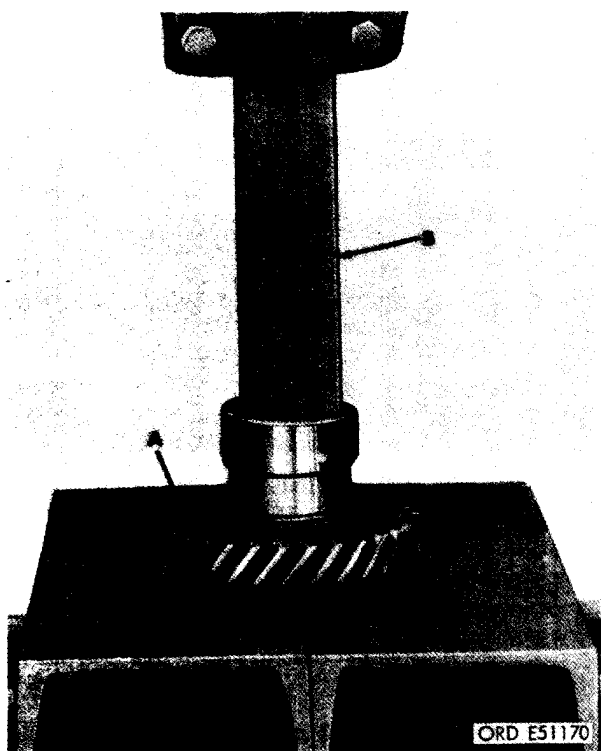


FIGURE 356. INSTALLING IDLER GEAR BALL BEARING IN OIL PUMP IDLER GEAR.

#### 186. CAMSHAFT GEAR

Note. The key letters shown below in parentheses refer to figure 351 except where otherwise indicated.

##### a. Cleaning and Inspection.

- (1) Cleaning. Clean camshaft gear (U) as directed in paragraph 152.
- (2) Inspection. Inspect camshaft gear (U) as directed in paragraph 153e.

b. Repair. Replace camshaft gear (U) if it is nicked, cracked, or when gear does not meet limits specified in repair and rebuild standards (par. 293). Remove raised metal surfaces and

nicks from gear keyway using a fine mill file. Repair minor thread damage in puller screw holes using a tap.

Note. When camshaft gear (U), crankshaft gear or fuel injection pump driven gear require replacement, replace all three gears.

#### 187. CRANKSHAFT GEAR

Note e. The key letters shown below in parentheses refer to figure 351 except where otherwise indicated.

##### a. Cleaning and Inspection.

- (1) Cleaning. Clean crankshaft gear (W) as directed to paragraph 152.
- (2) Inspection. Inspect crankshaft gear (W) as directed in paragraph 153e.

b. Repair. Replace crankshaft gear (W) if it is nicked, cracked, or when gear does not meet limits specified in repair and rebuild standards (par. 293). Repair minor thread damage in puller screw holes using a tap. Replace gear when threads are stripped. Remove nicks and raised metal surfaces from gear keyway using a fine mill file.

#### 188. CRANKSHAFT DAMPER AND PULLEY ASSEMBLY

Note. The key letters shown below in parentheses refer to figure 352 except where otherwise indicated.

a. Disassembly. Disassemble crankshaft damper and pulley assembly following instructions for figures 204 and 205.

##### b. Cleaning and Inspection.

- (1) Cleaning. Clean crankshaft damper and pulley assembly as directed in paragraph 152e.

Caution: Do not immerse the damper assembly in dry-cleaning solvent or mineral spirits paint thinner or allow it to come in prolonged contact with these cleaners. The hub and damper are set in molded rubber and cleaners cause rubber to dry out, become hard, and lose its resiliency.

- (2) Inspection. Inspect crankshaft damper and pulley assembly as directed in paragraph 153. Check fit of dowel pins (M-4-a and M-4-b) in pulley (M-4-c). Replace pulley assembly if dowel pins are loose or damaged. Check rubber insert in damper (M-3) for hardness, cracks, cuts, or looseness. If any of these defects are found, or if rubber has parted from steel hub or rim, replace damper.

c. Repair. Repair crankshaft damper and pulley assembly as directed in paragraph 154b. There is no recommended repair for the rubber insert in the damper. Replace damper if insert is damaged.

d. Assembly. Refer to figures 204 and 205 and reverse the sequence of illustrations and instructions to assemble the crankshaft damper and pulley assembly. Refer to figure 206 for torquing sequence of damper and pulley attaching cap screws. Dowel pins must be alined with dowel holes. The dowel pins are of a different size and alinement can only be accomplished at one point. Severe damage can result when attempting to force the damper over the pulley dowel pins if improperly alined,

Note. Tighten the hex-head cap screws in the sequence indicated in figure 206. Tighten cap screws to 300 pound inches, then to 360 pound inches. The face of the pulley must be in contact with the mating face of the damper before getting an accurate torque reading.

#### 189. COOLANT DRAIN COCK AND OIL PRESSURE SENDING UNIT

Note. The key letters shown below in parentheses refer to figure 351 except where otherwise indicated.

##### a. Cleaning and Inspection.

- (1) Cleaning. Clean coolant drain cock (AB), oil pressure sending unit (A), and elbows (C and AC) as directed in paragraphs 152b and d.
- (2) Inspection. Inspect drain cock (AB), for corrosion and thread damage. Be certain wing nut turns freely. Inspect oil pressure sending unit (A) for thread damage and for evidence of leaking

around seams and connector threads. Inspect 45 degree elbows (C and AC) for damaged threads.

- b. Repair. Replace coolant drain cock (AB), oil-pressure sending unit (A), and 45 degree elbows (C and AC) when damaged.

#### 190. OIL GAGE ROD, SUPPORT, AND SUPPORT CLAMP BRACKETS

Note. The key letters shown below in parentheses refer to figure 351 except where otherwise indicated.

a. Disassembly. The oil gage rod (RR), oil gage rod support (TT), and oil gage rod support bracket (VV) were removed during engine disassembly (par. 125).

##### b. Cleaning and Inspection.

- (1) Cleaning. Clean oil gage rod (RR), oil gage rod support (TT), and gage rod support bracket (VV) as directed in paragraph 152b and d.
- (2) Inspection. Inspect oil gage rod (RR) for cracks, bent condition, and damaged threads. Inspect oil gage rod support (TT) for damaged threads. Inspect oil gage rod support bracket (VV) for cracks or bent condition.

c. Repair. Replace oil gage rod (RR), oil gage rod support (TT) and gage rod support bracket (VV) when damaged excessively.

d. Assembly. The oil gage rod (RR), gage rod support (TT), and gage rod support bracket (VV) are installed during engine assembly.

#### 191. OIL PAN

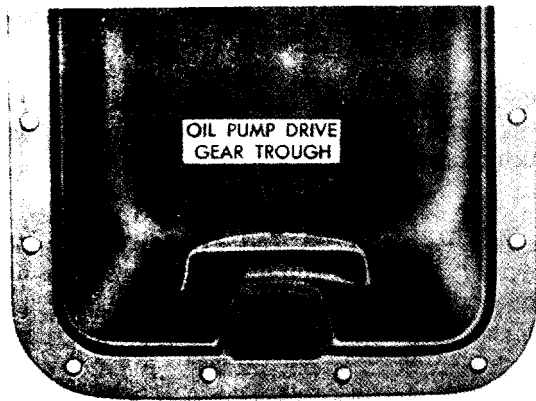
Note. The key letters shown below in parentheses refer to figure 351 except where otherwise indicated.

a. Disassembly. Disassembly of the oil pan (HH) is limited to removal of oil drain plugs (KK) and gaskets (JJ). Remove oil drain plugs and discard gaskets.

##### b. Cleaning and Inspection.

- (1) Cleaning. Clean oil pan (HH) as directed in paragraph 152c.

- (2) Inspection. Inspect oil drain plugs (KK) and oil pan drain hole in oil pan for damaged threads. Check oil pan gasket surface for nicks and damage that might cause an oil leak. Check oil pump drive gear oil trough (fig. 357) in front portion of oil pan for damage.



ORD E51171

FIGURE 357. FRONT SECTION OF OIL PAN SHOWING OIL PUMP IDLER GEAR TROUGH.

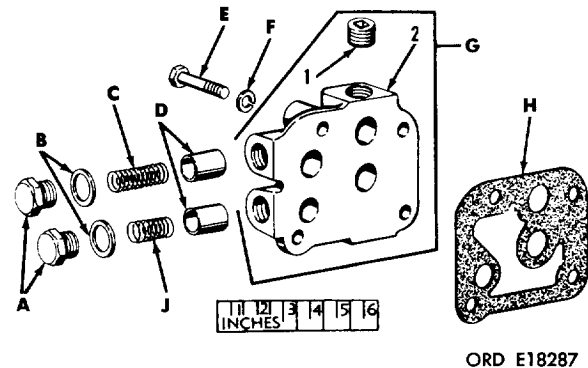
c. Repair. Remove all nicks, raised metal, and warpage on oil pan gasket surface using a fine mill file. Repair damaged drain plug threads in pan and on drain plugs (KK). Replace oil pan when damaged beyond minor repairs.

d. Assembly. Loosely install drain plugs (KK) in threaded holes in oil pan using new gaskets (JJ).

## 192. OIL PRESSURE RELIEF VALVE HOUSING

Note. The key letters shown below in parentheses refer to figure 358 except where otherwise indicated.

a. Disassembly. Remove plug (A), plain washer (gasket) (B), oil pressure relief plunger spring (C), and oil pressure relief plunger (D) from oil pressure relief valve housing assembly (G). Remove plug, plain washer (gasket), piston oil cooling relief plunger spring (J), and piston cooling relief plunger (D) from oil pressure relief valve housing assembly. Remove two 3/8-inch pipe plugs (G-1) from housing (G-2).



- A - 3/8-in. hex head plug  
 B - Plain washer (gasket)  
 C - Oil pressure relief plunger spring  
 D - Oil pressure or piston oil cooling relief plunger  
 E - 3/8 x 2 cap screw  
 F - 3/8-in. lock washer  
 G - Oil pressure relief valve housing assembly  
 1- 3/8-in. pipe plug  
 2- Oil pressure relief valve housing  
 H - Housing gasket  
 J - Piston oil cooling relief plunger spring

FIGURE 358. OIL PRESSURE RELIEF VALVE HOUSING AND RELATED PARTS - EXPLODED VIEW.

### b. Cleaning and Inspection.

- (1) Cleaning. Clean oil pressure relief valve housing (G-2) and components as directed in paragraph 152c and d.
- (2) Inspection. Inspect oil pressure relief valve housing (G- 2) for cracks, stripped threads, nicks, scratches, and burrs on mounting faces. Check oil passages for cleanliness and freedom from obstructions. Inspect plunger bores for scoring or evidence of wear. Inspect plugs (A) for damaged threads and cracks. Inspect the springs (C and J) for cracks and wear and against limits specified in repair and rebuild standards (par. 293). Inspect plungers (D) for cracks, burrs,

and against limits specified in repair and rebuild standards (par. 293).

c. Repair. Repair oil pressure relief valve housing (G-2) as directed in paragraph 154b. Replace cracked plugs. Repair damaged threads with a used tap or die. Replace springs that are cracked, worn, or do not meet limits specified in repair and rebuild standards (par. 293). Remove minor burrs and raised metal from plungers with crocus cloth dipped in dry-cleaning solvent or mineral spirits paint thinner. Replace plungers if badly burred or scratched or if they do not meet limits specified in repair and re-

build standards (par. 293).

d. Assembly. Install two 3/8-inch pipe plugs (G-1) in openings at top and bottom of housing (G-2). Install plunger (D), spring (J), plain washer (gasket) (B), and plug (A) in bottom opening of housing. Install plunger, spring (C), plain washer (gasket), and plug, in top opening of housing.

Note. Do not interchange springs (C and J). The oil pressure relief plunger spring (C) is the longer of the two springs and must be installed in the top opening.

## Section VII. REBUILD OF OIL PUMP ASSEMBLY AND RELATED PARTS

### 193. OIL PUMP ASSEMBLY

Note. The key letters shown below in parentheses refer to figure 371 except where otherwise indicated.

a. Disassembly. Disassemble oil pump assembly as follows.

- (1) Figure 359. (A) Remove 3/32 x 1-1/8 cotter pin. (B) Remove 1/2-inch slotted nut securing oil pump drive gear to drive shaft impeller.

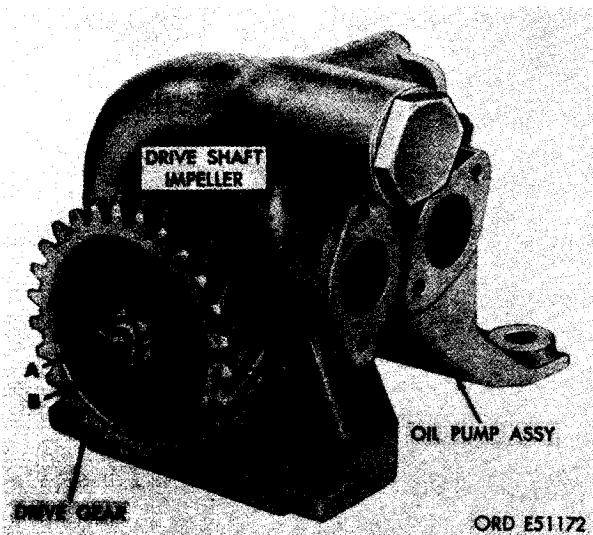


FIGURE 359. REMOVING OR INSTALLING SLOTTED NUT SECURING OIL PUMP DRIVE GEAR.

- (2) Refer to figure 360 and remove oil pump drive gear.

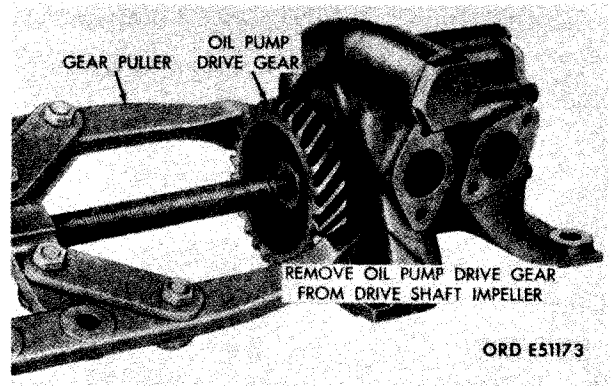


FIGURE 360. REMOVING OIL PUMP DRIVE GEAR USING A GEAR PULLER.

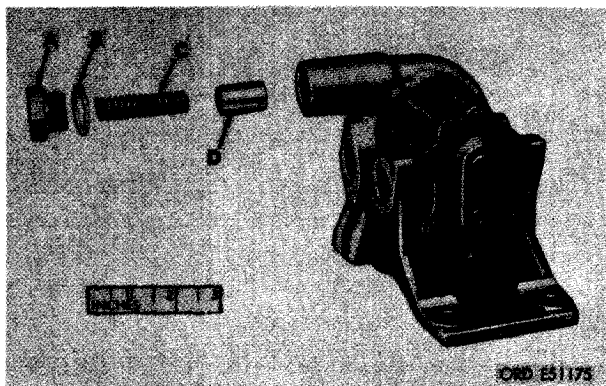


- (3) Refer to figure 361 and remove drive shaft impeller Woodruff key.



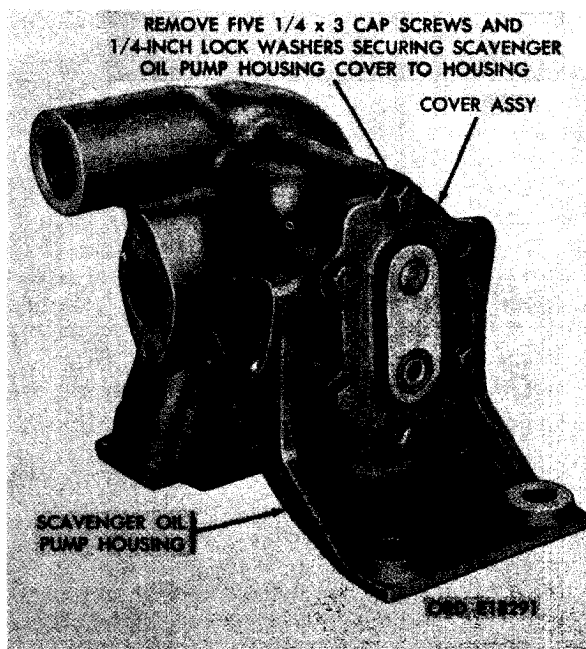
**FIGURE 361. REMOVING OR INSTALLING DRIVE SHAFT IMPELLER WOODRUFF KEY.**

- (4) Figure 362. (A) Remove relief valve cap. (B) Remove and discard relief valve cap gasket. (C) Remove relief valve spring. (D) Remove relief valve plunger.

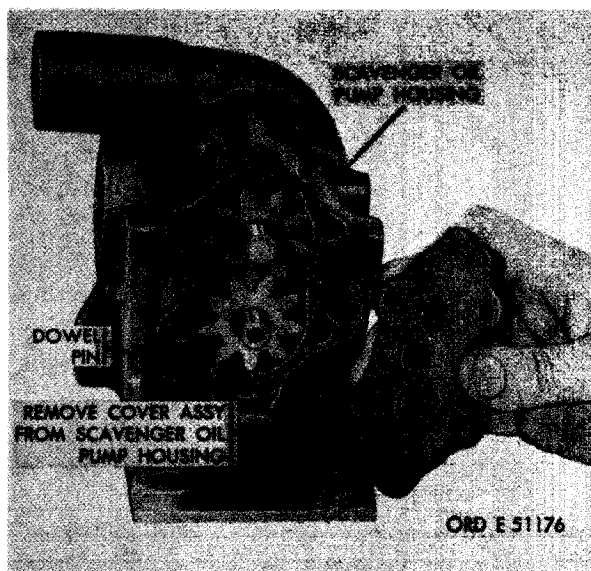


**FIGURE 362. REMOVING OR INSTALLING OIL PUMP PRESSURE RELIEF VALVE.**

- (5) Refer to figure 363 and remove cap screws securing scavenger oil pump housing cover assembly.



**FIGURE 363. REMOVING OR INSTALLING CAP SCREWS SECURING COVER ASSEMBLY TO SCAVENGER OIL PUMP HOUSING.**



**FIGURE 364. REMOVING OR INSTALLING SCAVENGER OIL HOUSING COVER ASSEMBLY.**



- (6) Refer to figure 364 and remove scavenger oil pump housing cover assembly.
- (7) Refer to figure 365 and remove scavenger oil pump driven impeller.
- (8) Refer to figure 366 and separate scavenger oil pump housing from pressure oil pump housing.

FIGURE 365. REMOVING OR INSTALLING SCAVENGER OIL PUMP DRIVEN IMPELLER.

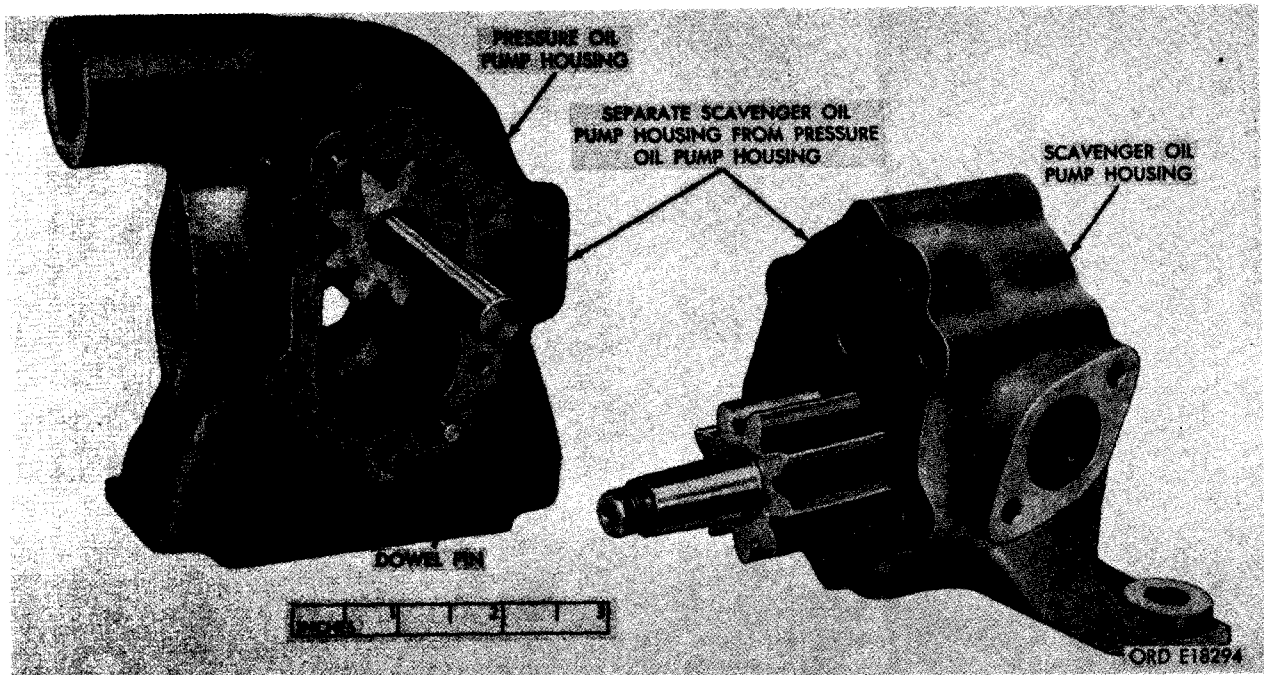


FIGURE 366. SEPARATING OR ASSEMBLING SCAVENGER OIL PUMP HOUSING AND PRESSURE OIL PUMP HOUSING.

- (9) Refer to figure 367 and remove pressure oil pump driven impeller.



FIGURE 367. REMOVING OR INSTALLING PRESSURE OIL PUMP DRIVEN IMPELLER.

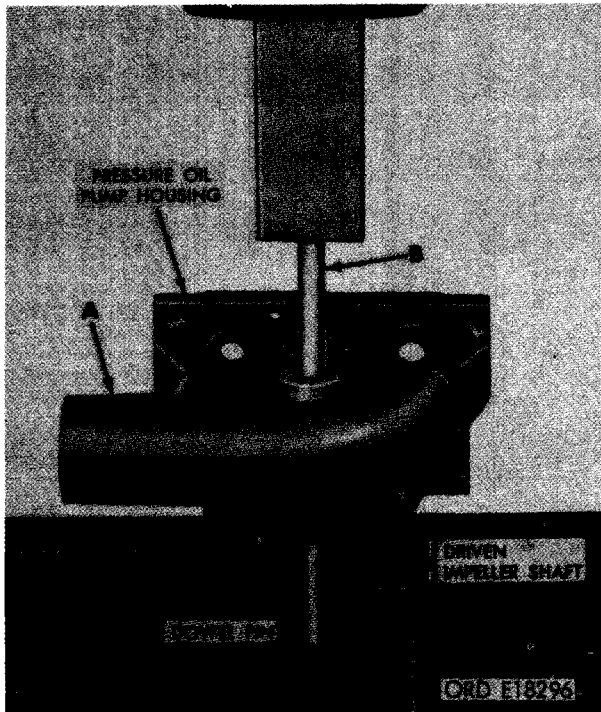


FIGURE 368. REMOVING DRIVEN IMPELLER SHAFT FROM PRESSURE OIL PUMP HOUSING.

- (10) Figure 368. (A) Position pressure oil pump housing on press plates as shown. Position press plates so as not to interfere with dowel pins. (B) Using a suitable pressing arbor, press the driven impeller shaft from the pressure oil pump housing.

- (11) Figure 369. (A) Position scavenger oil pump housing in an arbor press on press plates as shown. (B) Using a suitable arbor, press the drive shaft impeller through the scavenger oil pump drive impeller and out of the housing. (C) Remove scavenger oil pump drive impeller.

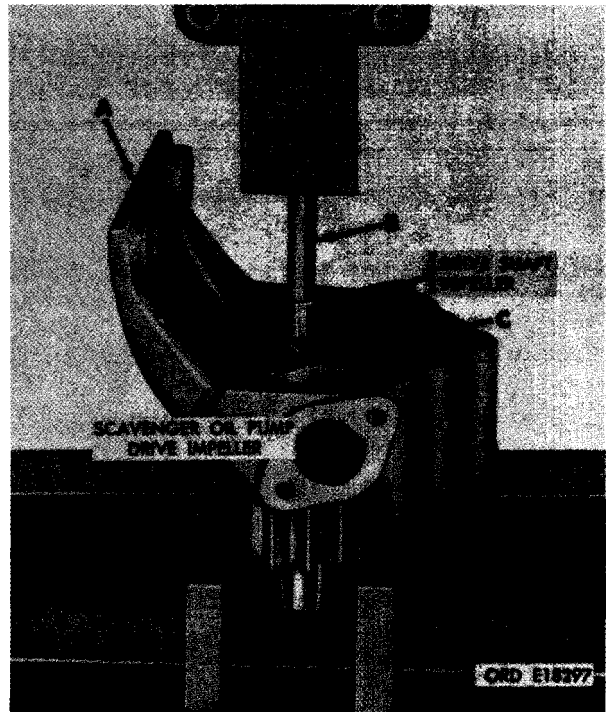
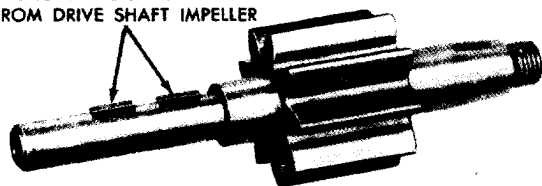


FIGURE 369. REMOVING DRIVE SHAFT IMPELLER FROM SCAVENGER OIL PUMP DRIVE IMPELLER.

- (12) Refer to figure 370 and remove Woodruff keys from drive shaft impeller.

REMOVE WOODRUFF KEYS  
FROM DRIVE SHAFT IMPELLER



ORD E18298

FIGURE 370. REMOVING OR INSTALLING  
DRIVE SHAFT IMPELLER WOODRUFF  
KEYS.

b. Cleaning and Inspection.

- (1) Cleaning. Clean pressure oil pump housing assembly (AA- 1), scavenger oil pump housing assembly (AA-4), and scavenger oil pump housing cover assembly (AA- 6) as directed in paragraph 152c. Clean drive gear (DD), drive shaft impeller (AA-3), scavenger oil pump drive impeller (AA- 5), scavenger oil pump driven impeller (AA- 9), pressure oil pump driven impeller (AA- 11), relief valve plunger (AA- 12), spring (AA- 13), and cap (AA- 15) in dry-cleaning solvent or mineral spirits paint thinner. Dry all parts with compressed air.
- (2) Inspection of housing. Inspect pressure oil pump housing assembly (AA- 1), scavenger oil pump housing assembly (AA-4), and scavenger oil pump housing cover assembly (AA- 6) as directed in paragraph 153b. Using a straight edge, check all housing and cover mating surfaces for warpage. Check diameter of bushing-type bearings (AA-1-a, AA-4-a, AA-6-b) in housings and cover against limits specified in repair and rebuild standards (par. 293).

- (3) Inspection of Impeller. Inspect all oil pump drive and driven impellers (AA-3, AA-5 AA- 9 and AA- 11) as directed in paragraph 153e. Check the drive shaft impeller (AA-3) and driven impeller shaft (AA- 10) against limits specified in repair and rebuild standards (par. 293). Check bushing-type bearings (AA- 9-a and AA- n-a) for burs, out-of-round condition and against limits specified in repair and rebuild standards (par. 293). Replace all damaged or un-serviceable parts.
- (4) Inspection of relief valve. Inspect relief valve cap (AA- 15) for damaged threads and cracks. Inspect spring (AA- 13) for cracks and wear and against limits specified in repair and rebuild standards (par. 293). Inspect plunger (AA- 12) for cracks, burs, and against limits specified in repair and rebuild standards (par. 293).

c. Repair.

- (1) The only recommended repairs to oil pump components are the replacement of bushing-type bearings in the oil pump housing assembly (AA- 1), scavenger oil pump housing assembly (AA-4), pressure oil pump driven impeller assembly (AA-11), pump housing cover assembly (AA- 6), and oil pump driven impeller assembly (AA- 9). Minor nicks or raised metal on wearing parts can be removed using a fine mill file.
- (2) Replace bushing type bearings as follows.
  - (a) Figure 372. (A) Position pressure oil pump housing on press plates as shown. (B) Position a new bushing-type bearing against, and in alignment with, old bushing-type bearing in housing. (C) Using a suitable pressing arbor, press the new bushing-type bearing into pressure oil pump housing while pressing worn bushing-type bearing out of housing. The old bearing will act as a guide and prevent new bearing from becoming cocked and distorted.

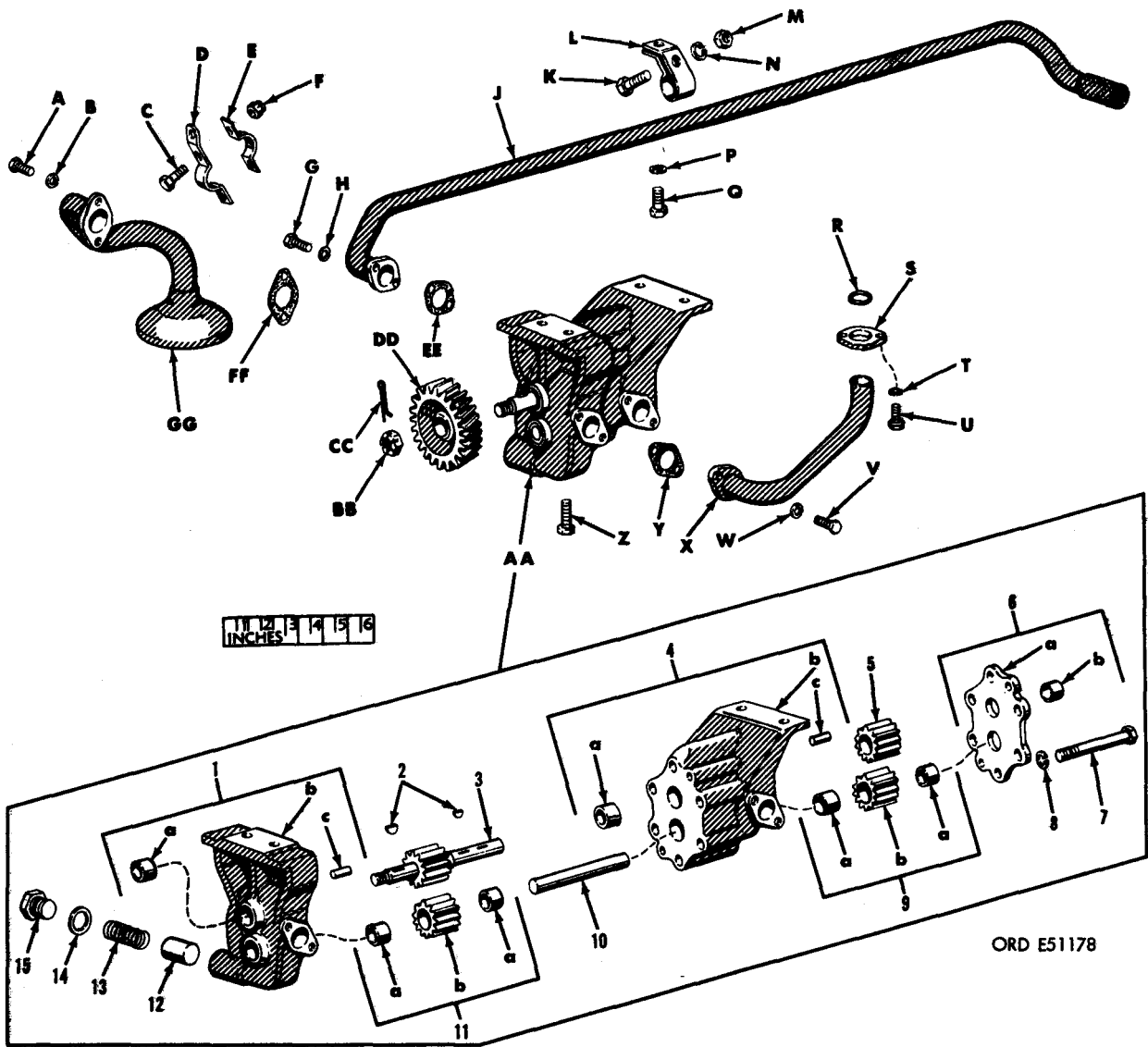


FIGURE 371. OIL PUMP ASSEMBLY AND RELATED PARTS - EXPLODED VIEW.

- A - 1/4 x 7/8 cap screw
- B - 1/4-in. lock washer
- C - 1/4 x 5/8 cap screw
- D - Pickup tube lower clamp
- E - Pickup tube upper clamp
- F - 1/4-in. self-locking nut
- G - 1/4 x 7/8 cap screw
- H - 1/4-in. lock washer
- J - Scavenger oil pump inlet tube
- K - 1/4 x 1/2 cap screw
- L - Scavenger oil pump inlet tube bracket
- M - 1/4-in. lock washer
- N - 1/4-in. plain nut
- P - 5/16-in. lock washer
- Q - 5/16 x 5/8 cap screw
- R - 3/4 id x 15/16 od x 3/32 thk preformed packing
- S - Oil pump outlet tube adapter
- T - 5/16-in. lock washer
- U - 5/16 x 7/8 cap screw
- V - 1/4 x 7/8 cap screw
- W - 1/4-in. lock washer
- X - Oil pump outlet tube
- Y - Tube gasket
- Z - 7/16 x 1 hexagon head bolt
- AA - Oil pump assembly
  - 1 - Pressure oil pump housing assembly
    - a - Bushing-type bearing
    - b - Pressure oil pump housing
    - c - Dowel pin
  - 2 - Woodruff key
- 3 - Drive shaft impeller
- 4 - Scavenger oil pump housing assembly
  - a - Bushing-type bearing
  - b - Scavenger oil pump housing
  - c - Dowel pin
- 5 - Scavenger oil pump drive impeller
- 6 - Scavenger oil pump housing cover assembly
  - a - Scavenger oil pump housing cover
  - b - Bushing-type bearing
- 7 - 1/4 x 3 cap screw
- 8 - 1/4-in. lock washer
- 9 - Scavenger oil pump driven impeller assembly
  - a - Bushing-type bearing
  - b - Scavenger oil pump driven impeller
- 10 - Driven impeller shaft
- 11 - Pressure oil pump driven impeller assembly
  - a - Bushing-type bearing
  - b - Pressure oil pump driven impeller
- 12 - Pressure relief valve plunger
- 13 - Relief valve spring
- 14 - Valve cap gasket
- 15 - Relief valve cap
- BB - 1/2-in. slotted nut
- CC - 3/32 x 1-1/8 cotter pin
- DD - Drive gear
- EE - Scavenger tube gasket
- FF - Pickup tube gasket
- GG - Pressure oil pump pickup tube

FIGURE 371. OIL PUMP ASSEMBLY AND RELATED PARTS - EXPLODED VIEW - CONTINUED

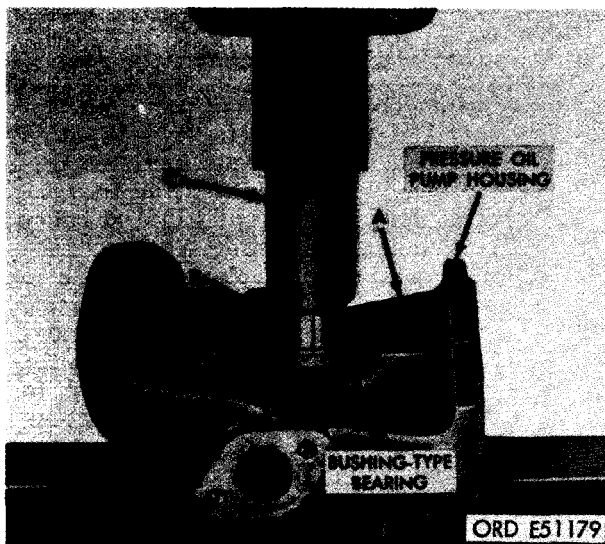
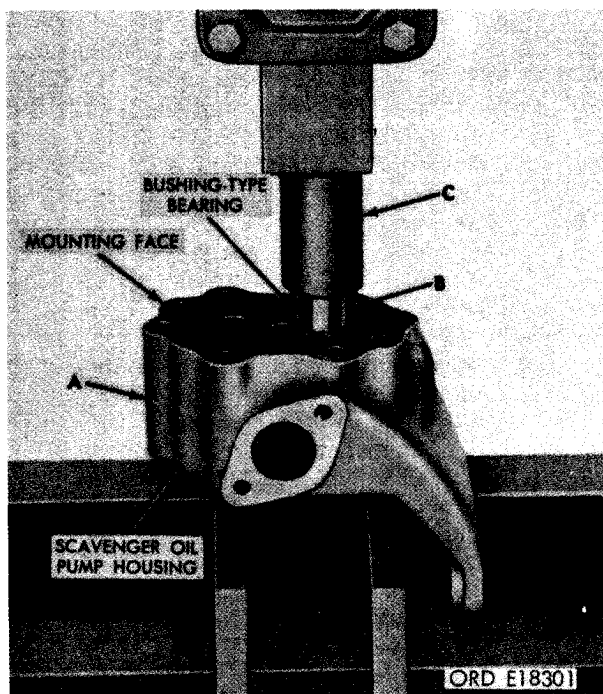


FIGURE 372. REPLACING SCAVENGER OIL PUMP HOUSING BUSHING-TYPE BEARING.

Note. Bushing-type bearing must be 0.040 to 0.050-inch below surface of impeller bore when properly installed.

- (b) Figure 373. (A) Position scavenger oil pump housing on press plates as shown. (B) Position a new bushing-type bearing against, and in alignment with, old bushing-type bearing in scavenger oil pump housing. (C) Using a suitable pressing arbor, press new bushing-type bearing into housing while pressing worn bushing-type bearing out of housing. The old bearing will act as a guide and prevent new bearing from becoming cocked and distorted.

Note. Bushing-type bearing must be 0.040 to 0.050-inch below pressure oil pump mounting face when properly installed.

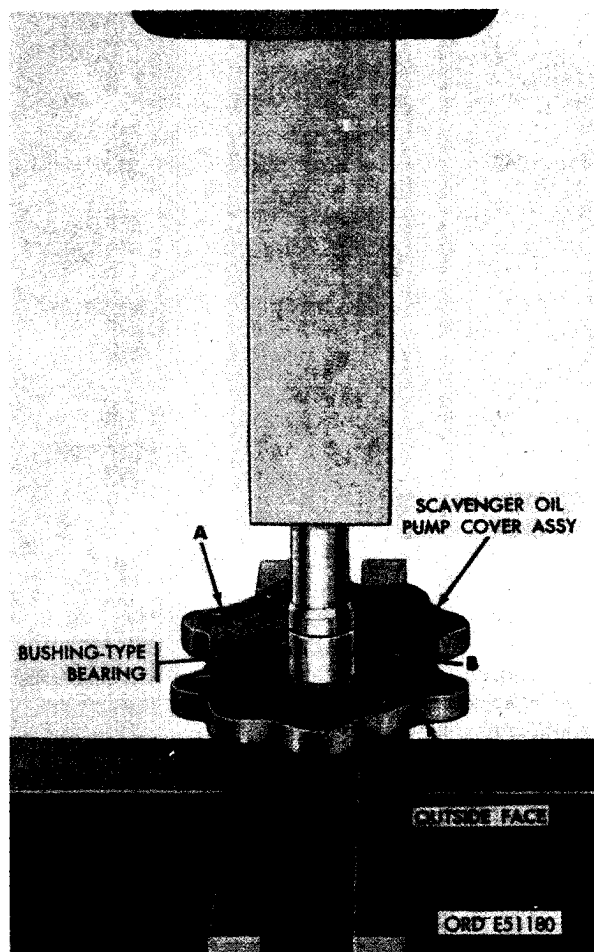


**FIGURE 373. REPLACING PRESSURE OIL PUMP HOUSING BUSHING-TYPE BEARING.**

(c) Figure 374. (A) Position oil pump cover assembly on press plates as shown. (B) Position a new bushing-type bearing against, and in alignment with, old bushing-type bearing in cover assembly. (C) Using a suitable pressing arbor, press new bushing-type bearing into cover while pressing old bearing out of housing. The old bearing will act as a guide and prevent new bearing from becoming cocked or distorted.

**Note.** Bushing-type bearing must be flush with outside face of cover when properly installed.

(d) Figure 375. (A) Position the pressure oil pump or the scavenger oil pump driven impeller on press plates as shown. Allow enough clearance for the two old bushing-type bearings to clear press plates as they are pressed out of impeller. (B) Position a new bushing-type bearing against, and in alignment with, old bushing-type bearing in driven impeller. (C) Using a suitable pressing arbor, press one new



**FIGURE 374. REPLACING OIL PUMP COVER BUSHING-TYPE BEARING.**

bushing-type bearing into impeller until the two old bushing-type bearings are removed. Continue pressing new bushing-type bearing until bottom end of bearing is flush to 0.010-inch below bottom end of impeller. The old bushing-type bearing acts as a guide to prevent new bearing from becoming cocked or distorted. Press the second bushing-type bearing into impeller until top end of bearing is flush to 0.010-inch below top end of impeller.

**Note.** Each driven impeller contains two bushing-type bearings. The length of the two bearings is less than the total length of the impeller. The bushing-type bearings must be installed flush to 0.010-inch below the ends

of the driven impeller. This allows for an oil groove, or channel, between the two bearings.

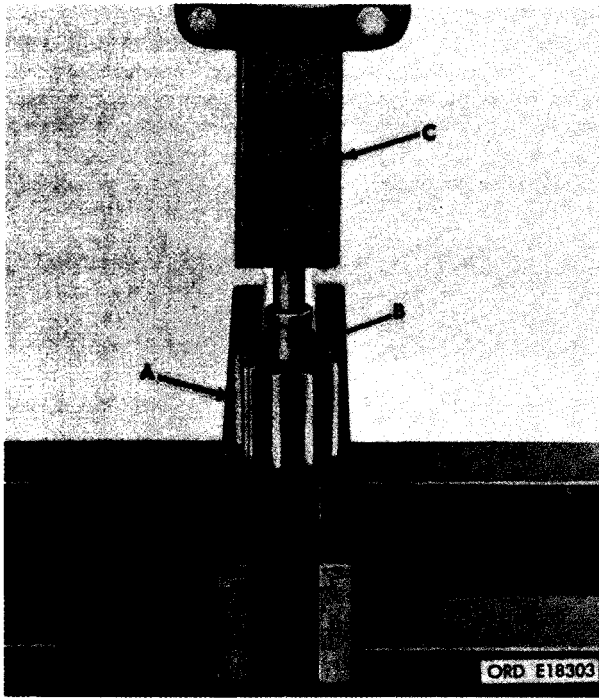


FIGURE 375. REPLACING PRESSURE OIL OR SCAVENGER OIL PUMP DRIVEN IMPELLER BUSHING-TYPE BEARINGS.

- (3) Repair of the pressure relief valve consists of replacing cracked or damaged cap (AA-15), cracked or worn springs (AA-13), or springs that do not meet limits specified in repair and rebuild standards (par. 293). Remove minor burrs and raised metal from plungers (AA-12) with crocus cloth dipped in dry-cleaning solvent or mineral spirits paint thinner. Replace badly burred or scratched plungers or if they do not meet limits specified in repair and rebuild standards (par. 293).

d. Assembly.

- (1) Install drive shaft impeller Woodruff keys. Refer to figure 370 and reverse the instructions to install the drive shaft impeller Woodruff keys.

Assemble drive shaft impeller, scavenger oil pump housing, and drive impeller. Figure 376. (A) Lubricate bearing surface of drive shaft impeller with engine oil (OE-10). Slide shaft through bushing-type bearing, with the Woodruff keys clear of bearing surface and keys not displaced. (B) Position scavenger oil pump drive impeller to align the keyway in impeller with Woodruff keys in drive shaft impeller. (C) Using a suitable pressing arbor, press drive impeller on drive shaft impeller until it bottoms against bearing surface on shaft.

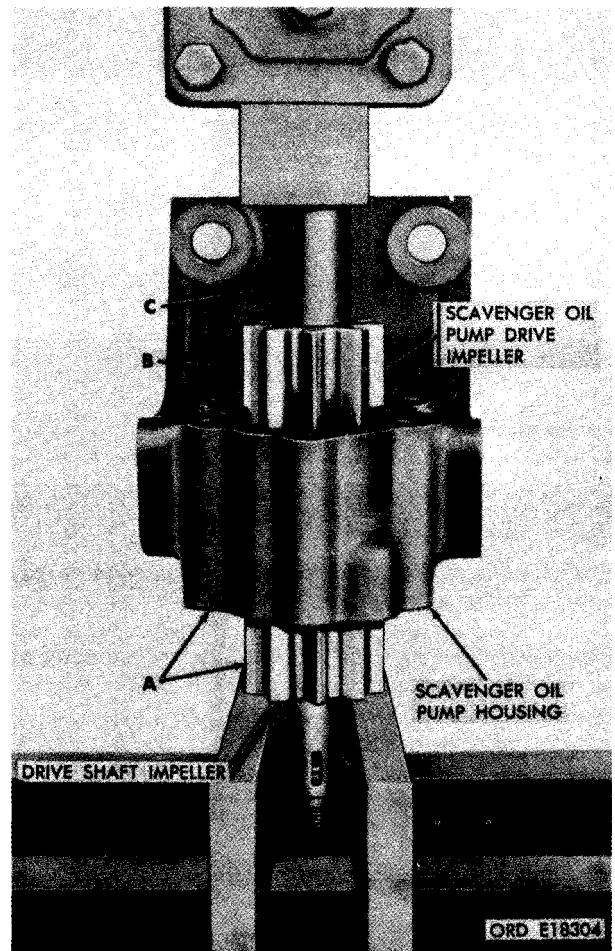


FIGURE 376. INSTALLING SCAVENGER OIL PUMP DRIVE IMPELLER ON DRIVE SHAFT IMPELLER.



- (3) Install pressure oil pump driven impeller shaft. Figure 377. (A) Position pressure oil pump housing on press plates as shown. (B) Start driven impeller shaft straight into shaft bore in pressure oil pump housing. (C) Press shaft into housing until bottom end of shaft is flush with outer edge of shaft bore.

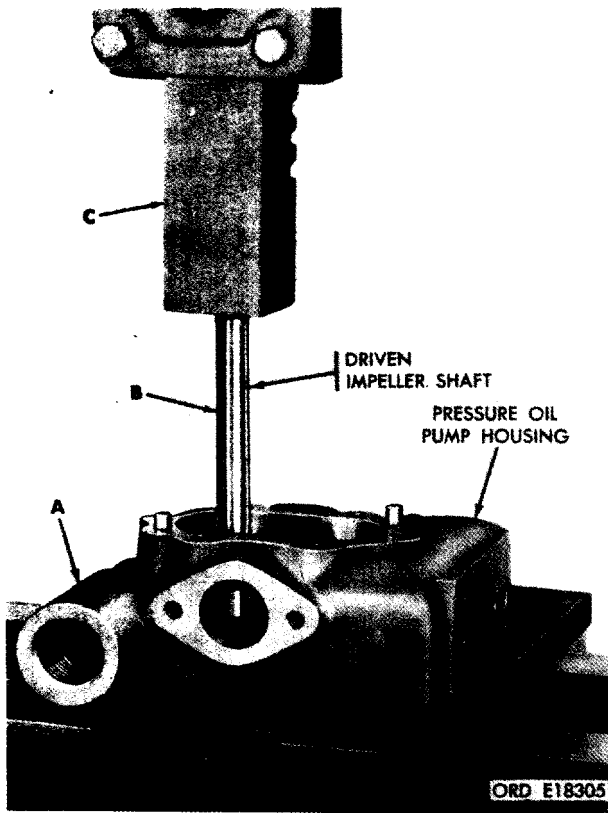


FIGURE 377. INSTALLING DRIVEN IMPELLER SHAFT IN PRESSURE OIL PUMP HOUSING.

- (4) Install impellers and assemble pressure oil pump and scavenger oil pump housings. Refer to figures 363 and 367 and reverse the sequence of illustrations and instructions to install impellers and to assemble pressure oil pump and scavenger oil pump housings.
- (5) Install oil pump pressure relief valve. Refer to figure 362 and reverse the sequence of instructions to install the oil pump pressure relief valve.

- (6) Install oil pump drive gear. Refer to figures 359 and 361 and reverse the sequence of illustrations and instructions to install oil pump drive gear.

#### 194. PRESSURE OIL PUMP PICKUP TUBE

Note. The key letters shown below in parentheses refer to figure 371 except where otherwise indicated,

a. Disassembly. Figure. 378. (A) Scribe alignment marks across pickup tube upper clamp and pressure oil pump pickup tube to insure proper assembly. (B) Remove two 1/4-inch self-locking nuts and 1/4 x 5/8 cap screws securing pickup tube upper clamp and pickup tube lower clamp to pressure oil pump pickup tube.

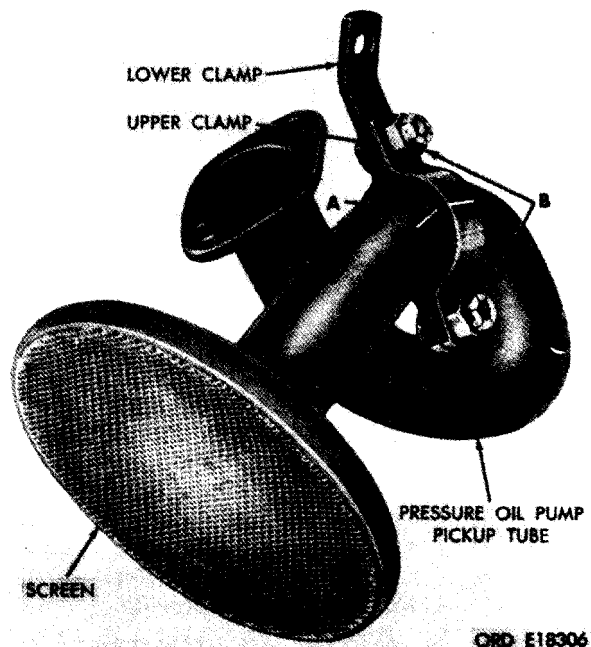


FIGURE 378. REMOVING OR INSTALLING PRESSURE OIL PUMP PICKUP TUBE CLAMP.

#### b. Cleaning and Inspection.

- (1) Cleaning. Clean pressure oil pump pickup tube (GG), upper clamp (E), and lower clamp (D) as directed in paragraph 152 b. Use a wire brush to remove deposits of carbon and sludge. Blow out screen and tube with compressed air and dry thoroughly.

- (2) Inspection. Inspect pressure oil pump pickup tube (GG) for dents, cracks, loose flange, and flattened areas. Check pickup tube screen for cracks. Check mounting flange with a straight edge for warpage. Inspect pickup tube upper clamp (E) and pickup tube lower clamp (D) for cracks and deformity.

c. Repair. Minor warpage of the mounting flange of the pressure oil pump pickup tube (GG) can be corrected by working the flange across a sheet of crocus cloth held tightly on a flat surface. Replace a pickup tube that is damaged, broken, or unserviceable. Replace damaged or unserviceable pickup tube upper clamp (E) and pickup tube lower clamp (D).

d. Assembly. Refer to figure 378 and reverse the sequence of instructions to assemble the clamps to the pressure oil pump pickup tube,

#### 195. SCAVENGER OIL PUMP INLET TUBE

Note. The key letters shown below in parentheses refer to figure 371 except where otherwise indicated.

a. Disassembly. Figure 379. (A) Scribe alignment marks across scavenger oil pump inlet tube brackets and inlet tube to insure proper assembly. (B) Remove 1/4-inch plain nuts, 1/4-inch lock washers, and 1/4 x 5/8 cap screws securing bracket to the scavenger oil pump inlet tube. Spread bracket to remove. (C) Remove the remaining bracket in the same manner.

#### b. Cleaning and Inspection.

- (1) Cleaning. Clean scavenger oil pump inlet tube (J) and bracket (L) as directed in paragraph 152 b and d. Clean inlet

tube screen with a wire brush to remove deposits of carbon and sludge. Blow out screen and tube with compressed air and dry thoroughly.

- (2) Inspection. Inspect scavenger oil pump inlet tube (J) for dents, cracks, loose flange, and flattened areas. Check inlet tube screen for cracks. Check mounting flange with a straight edge for warpage. Inspect both brackets (L) for cracks and deformity.

c. Repair. Correct minor warpage of the mounting flange of the scavenger oil pump inlet tube (J) by working the flange across a sheet of crocus cloth held tightly on a flat surface. Replace inlet tube that is damaged, broken, or unserviceable. Replace damaged or unserviceable inlet tube bracket (L).

d. Assembly. Refer to figure 379 and reverse the sequence of instructions to assemble the scavenger oil pump inlet tube.

#### 196. PRESSURE OIL PUMP OUTLET TUBE

Note. The key letters shown below in parentheses refer to figure 371 except where otherwise indicated.

a. Disassembly. Removal and disassembly of the pressure oil pump outlet tube (X) and adapter (S) was performed during engine disassembly (par. 136).

#### b. Cleaning and Inspection.

- (1) Cleaning. Clean the pressure oil pump outlet tube (X) and adapter (S) as directed in paragraph 152 b and d. Blow out adapter and tube with compressed air and dry thoroughly.

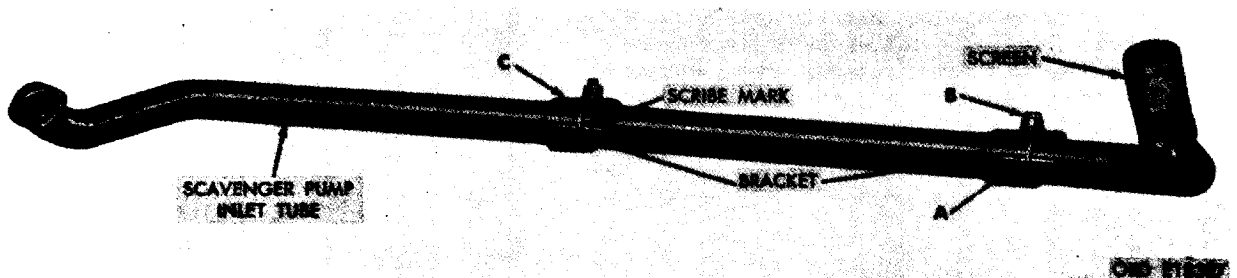


FIGURE 379. REMOVING OR INSTALLING SCAVENGER OIL PUMP INLET TUBE BRACKETS,

- (2) Inspection. Inspect pressure oil pump outlet tube (X) for dents, cracks, loose flange, and flattened areas. Check mounting flange and adapter with a straight edge for warpage.

c. Repair. Correct minor warpage of the mounting flange of the pressure oil pump outlet tube (X) or the outlet tube adapter by working the part across a sheet of crocus cloth held tightly on a flat surface. Replace an outlet tube or adapter if damaged, broken, or unserviceable.

d. Assembly. The assembly and installation of the pressure oil pump outlet tube (X) and adapter (S) is performed during assembly of the engine (par. 266).

## 197. TACHOMETER ADAPTER

Note. The key letters shown below in parentheses refer to figure 352.

a. Removal. The removal of the tachometer adapter associated parts was performed during disassembly of the engine (par. 140).

## b. Cleaning and Inspection.

- (1) Cleaning. Clean tachometer adapter (G), and tachometer take-off adapter (F) as directed in paragraph 152 b.

- (2) Inspection. Inspect tachometer adapter (G) for damaged threads and cracks. Inspect adapter shaft (G1) for burrs and wear. Insert shaft in tachometer adapter and rotate shaft. Shaft must rotate freely. Inspect tachometer take-off adapter (F) for damaged threads and cracks.

c. Repair. Repair damaged threads on tachometer adapter (G) with a die. Remove minor burrs and scratches from adapter shaft (G-1) with crocus cloth dipped in dry-cleaning solvent or mineral spirits paint thinner. Replace bent or scratched shaft. Replace tachometer adapters which do not rotate freely. Repair damaged threads on tachometer take-off adapter (F) with a die. Replace cracked take-off adapters.

d. Installation. Installation of the tachometer adapter is performed during assembly of the engine (par. 264).

---

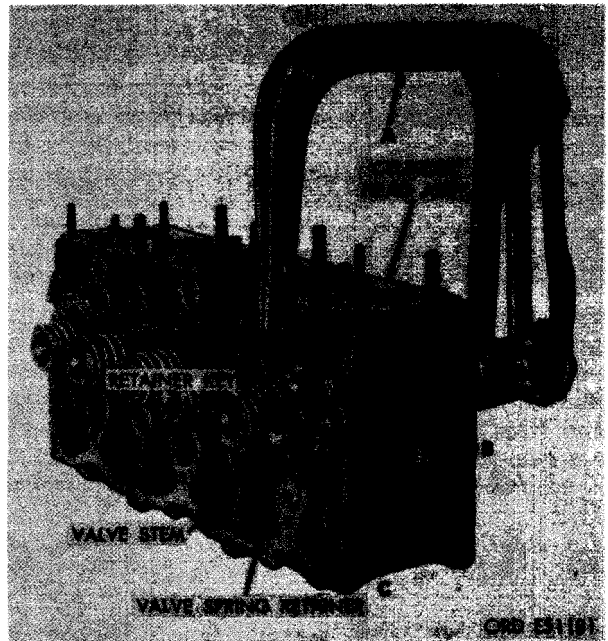
## Section VIII. REBUILD OF CYLINDER HEAD ASSEMBLY

### 198. DISASSEMBLY

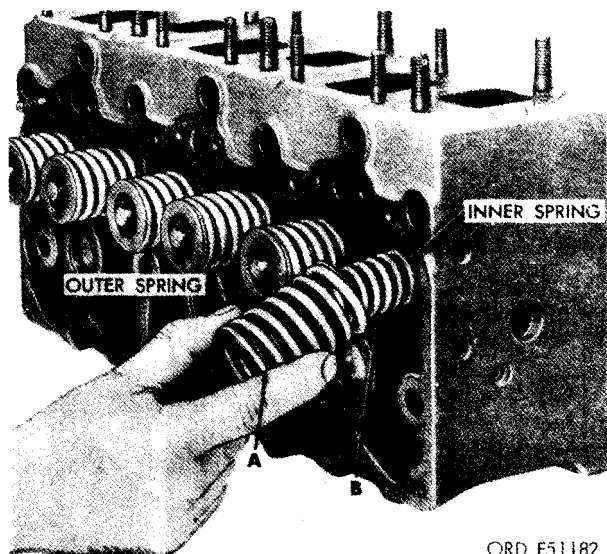
a. General. The front and rear cylinder head assemblies identical and are interchangeable. For instructional purposes the front cylinder head will be overhauled.

b. Disassembly. Disassemble the front cylinder head as follows.

- (1) Figure 380. (A) Compress exhaust valve springs using a suitable valve spring compressor. (B) Remove two exhaust valve spring retainer keys from valve stem. Carefully release valve spring compressor to relieve valve spring tension. (C) Remove valve spring retainer.



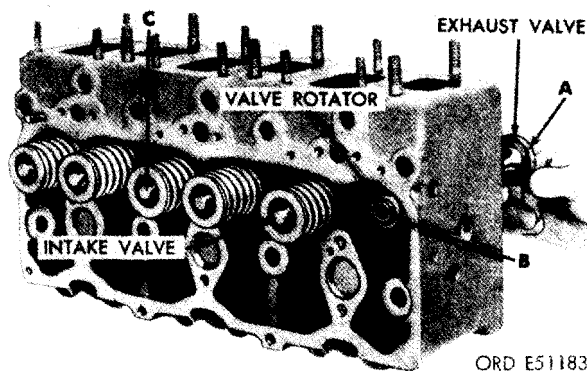
**FIGURE 380. COMPRESSING EXHAUST VALVE SPRINGS.**



ORD E51182

**FIGURE 381. REMOVING OR INSTALLING EXHAUST VALVE INNER AND OUTER SPRINGS.**

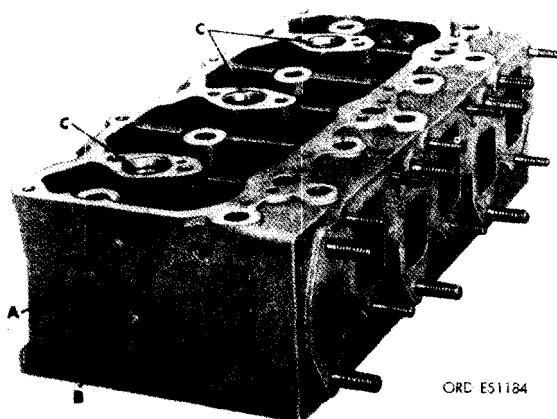
- (2) Figure 381. (A) Remove exhaust valve outer spring. (B) Remove exhaust valve inner spring.
- (3) Figure 382. (A) Remove exhaust valve. (B) Remove valve rotator. (C) Remove remaining exhaust valves and rotators in the same manner.



ORD E51183

**FIGURE 382. REMOVING OR INSTALLING EXHAUST VALVE AND VALVE ROTATOR.**

- (4) Figure 383. (A) Remove 1/8-inch pipe plug from the rear end of front cylinder head. (B) Remove core hole plug only if inspection (par. 198 d (5)) indicates a coolant leak. (C) Remove core hole plugs from top of cylinder head as necessary if inspection (par. 198 d (5)) indicates coolant leakage.

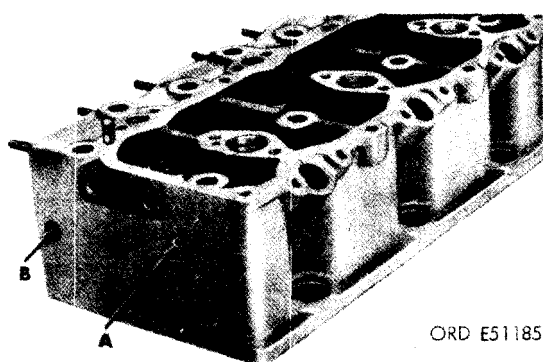


ORD E51184

**FIGURE 383. REMOVING OR INSTALLING PIPE PLUG AT REAR OF CYLINDER HEAD.**

- (5) Figure 384. (A) Remove 1/8-inch pipe plug from front end of front cylinder head. (B) Remove core hole plug if inspection (par. 198 d (5)) indicates a coolant leak.

Note. The rear cylinder head pipe plugs and core hole plugs are removed in the same manner.



ORD E51185

**FIGURE 384. REMOVING OR INSTALLING PIPE PLUG AT FRONT END OF FRONT CYLINDER HEAD.**

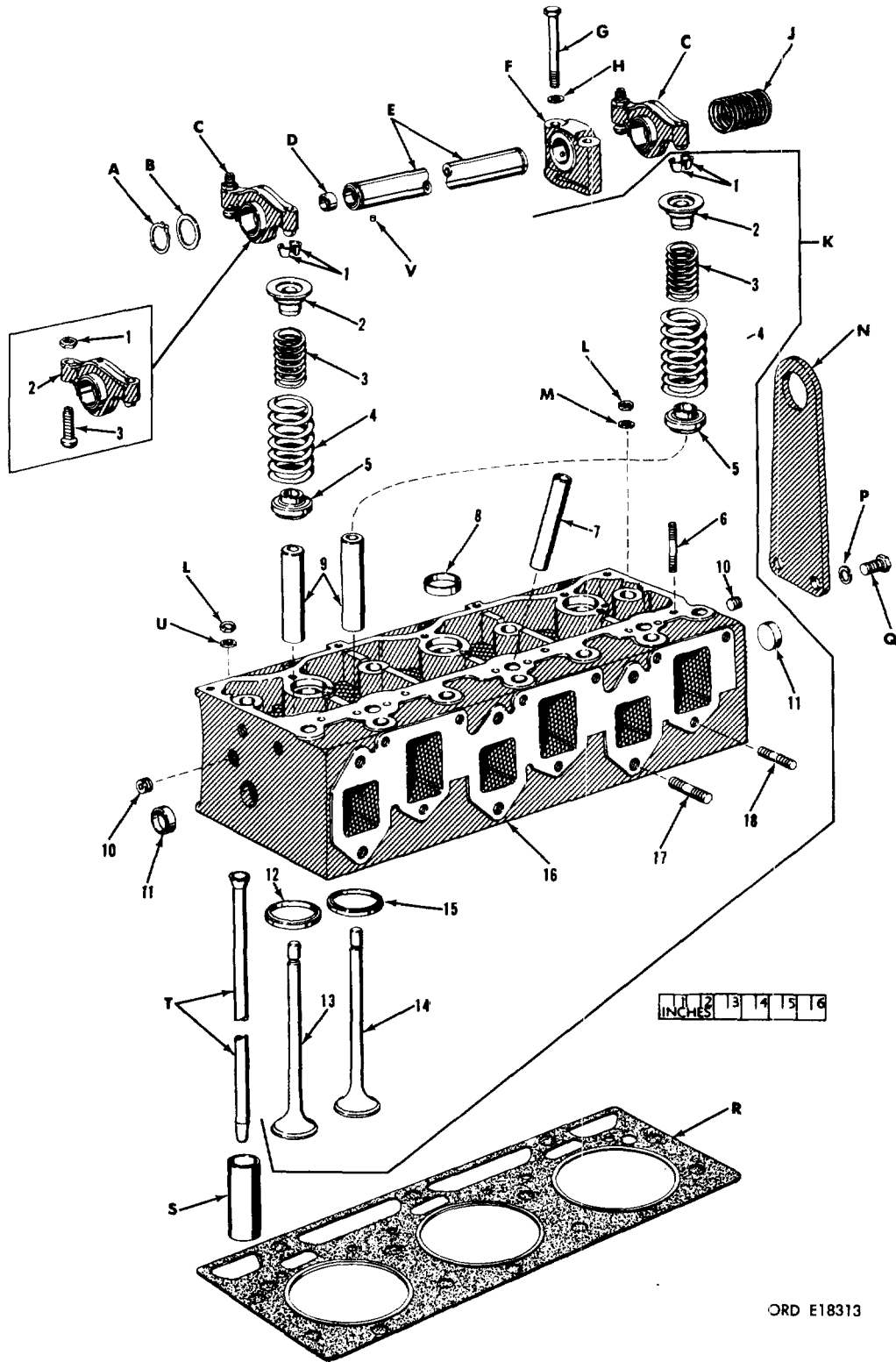


FIGURE 385. CYLINDER HEAD ASSEMBLY AND RELATED PARTS - EXPLODED VIEW.

- |   |  |
|---|--|
| A - Retaining ring                        | 9 - Intake and exhaust valve guide               |
| B - Thrust washer                         | 10- 1/8-in. pipe plug                            |
| C - Valve rocker arm assembly             | 11- Core hole plug                               |
| 1- Lock nut                               | 12- Exhaust valve seat                           |
| 2- Rocker arm                             | 13- Exhaust valve                                |
| 3- Rocker arm adjusting screw             | 14- Intake valve                                 |
| D - Core hole plug                        | 15- Intake valve seat                            |
| E - Rocker arm shaft                      | 16- Cylinder head                                |
| F - Rocker arm support                    | 17- 7/16 x 1-7/8 plain stud                      |
| G - 3/8 x 2- 1/2 cap screw                | 18- 5/16 x 1- 1/2 plain stud                     |
| H - 3/8- in. lock washer                  | L - 9/16-in. plain cylinder head nut             |
| J - Thrust spring                         | M - 9/16 x 1/8 thk cylinder head nut spacer      |
| K - Cylinder head assembly                | N - Front engine lifting bracket                 |
| 1 - Valve spring retainer lock            | P - 7/16-in. lock washer                         |
| 2 - Valve spring retainer                 | Q - 7/16 x 7/8 cap screw                         |
| 3 - Intake and exhaust valve inner spring | R - Cylinder head gasket                         |
| 4 - Intake and exhaust valve outer spring | S - Valve tappet                                 |
| 5 - Valve rotator                         | T - Valve rocker arm push rod                    |
| 6 - 5/16 x 3 plain stud                   | U - 9/16 x 3/8 thk cylinder head nut flat washer |
| 7 - Coolant transfer tube                 | V - Locating pin                                 |
| 8 - Core hole plug                        |  |

FIGURE 385. CYLINDER HEAD ASSEMBLY AND RELATED PARTS - EXPLODED VIEW - CONTINUED.

#### 199. CLEANING AND INSPECTION

Note. The key letters shown below in parentheses refer to figure 385 except where otherwise indicated.

a. Cleaning. Clean front cylinder head assembly (K), valve springs (K-3 and K-4), intake valves (K- 14), exhaust valves (K- 13), and valve rotators (K- 5) as directed in paragraph 152 c. Remove heavy carbon deposits with a scraper or a wire brush. Do not nick or scratch the gasket and valve seat surfaces. Remove carbon from injector nozzle and holder seats.

#### b. Inspection.

- (1) Valve guides. Inspect valve guides (K- 9) for cracks, galling, erosion, and scuffing. Check guides for secure fit in cylinder head. Check valve guides against limits specified in repair and rebuild standards (par. 294).
- (2) Valve seats. Check intake valve seats (K-15) and exhaust valve seats (K-12) for secure fit and for burned or pitted condition. Check valve contact on seat by coating the face with Prussian blue and placing a new valve in position on the seat. Rotate the valve one- half turn and check valve contact area. Identify valve seats that do not show perfect contact for future repair. Replace valve seats that are damaged beyond repair or when they are cracked or loose (par. 20 a (2)).
- (3) Valves. Check intake valve (K-14) and exhaust valves (K-13) for evidence of pitting, imperfect seating, or warpage on valve head. Heavy discoloration, burning, erosion, or a heavy carbon deposit on valve face indicates a warped valve. A light frosted appearance or minor discoloration on valve face does not indicate a warped or unserviceable valve. Inspect valve stems and locking grooves in stems for pitting, scoring, cracks, or damaged tips. Check valves against limits specified in repair and rebuild standards (par. 294). Replace valves that are cracked, warped, or otherwise unserviceable.
- (4) Valve springs. Inspect inner spring (K- 3) and outer spring (K- 4) for wear, cracks, set, or other evidence of failure. Check springs against limits specified in repair and rebuild standards (par. 294).

- (5) Valve spring retainers, rotators, and locks. Inspect valve spring retainers (K-2) for wear cracks. Check valve rotator (K-5) by rotating inner section, which must rotate freely in one direction. Inspect rotator for wear or cracks. Inspect spring retainer locks (K-1) for wear or cracks. Worn locks will have ridges on top face.
- (6) Cylinder head assembly. Check cylinder head assembly (K) for cracks, especially near fillets and around studs and pipe plug openings. Check gasket surfaces for burrs or nicks. Replace cracked cylinder head. Check the cylinder head for straightness as shown in figure 386. The maximum permissible out of flat when checking lengthwise is 0.005-inch. The maximum out of flat when checking crosswise is 0.003-inch. Inspect studs (K- 6, K- 17, and K- 18) for bent condition or damaged threads. Inspect core hole plugs (K- 8 and K- 11) for secure fit and for evidence of coolant leakage.



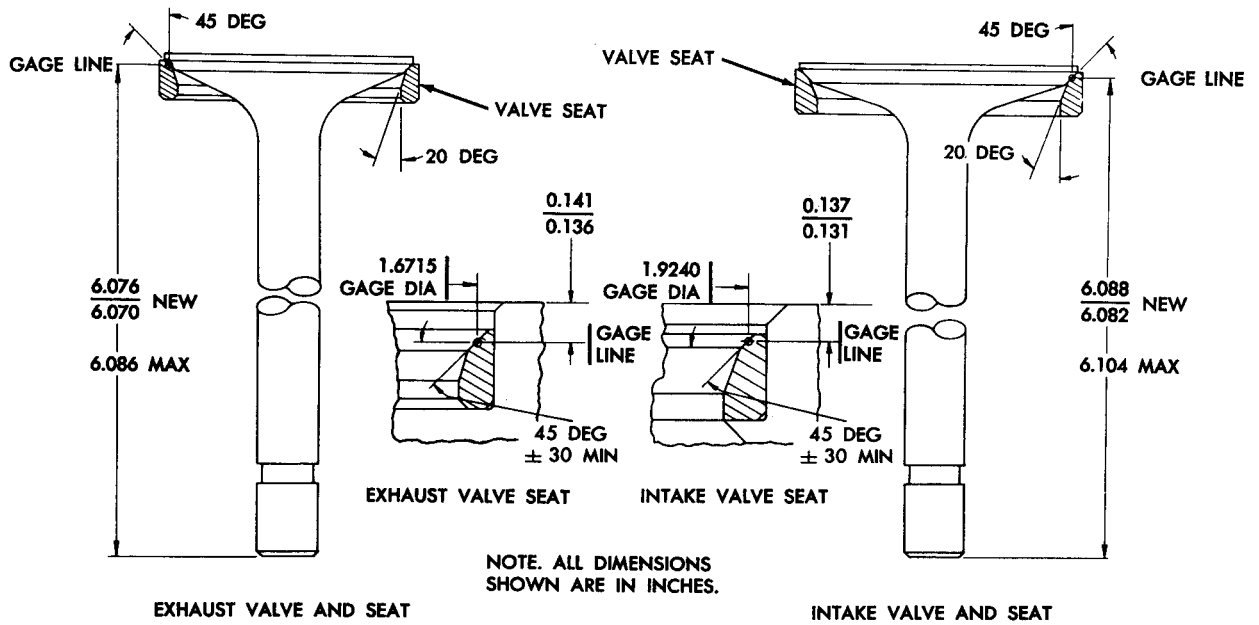
FIGURE 386. CHECKING CYLINDER HEAD FOR STRAIGHTNESS.

## 200. REPAIR

Note. The key letters shown below in parentheses refer to figure 385 except where otherwise indicated.

a. Cylinder Head. Replace studs (K-6, K- 17, and K- 18) that are stripped or broken. Replace all leaking core hole plugs (K-8 and K-11). Replace complete cylinder head assembly when cracked, warped, or beyond repairs described in paragraphs (1) through (5), below.

- (1) Cylinder head refacing. When a cylinder head is warped beyond the maximum permissible clearance described in figure 386, the cylinder head can be refaced using a surface grinder. When cylinder head is refaced, grind valve seats as directed in paragraph (2) below. Replace the cylinder head when excessive grinding is required to straighten out gasket surface.
- (2) Valve seat grinding. When valve seats can be repaired by regrinding or when valve seats are to be replaced, grind as described in (a) through (c) below.
  - (a) Use a 45 degree angle grinding stone to grind valve seats.
  - (b) After grinding seat, check valve contact as described in paragraph 198 b (2).
  - (c) Keep valve seat as near as possible to center of valve face. Narrow seat as necessary using a 20 degree grinding stone. Valves should never seat at the top or bottom of the face.
- (3) Valve seat replacement. Replace valve seats (K- 12 and K- 15) that cannot be repaired by grinding. Remove seat using any method which will not damage counterbore of cylinder head machined surface. Install new intake valve seat (K- 15) using improvised replacer (fig. 36) and use improvised replacer (fig. 36) to install exhaust valve seat. Grind seat as described in (a) above and as shown in figure 387. Shrink the insert by immersing in dry ice before installation (fig. 388).



ORD E51186

FIGURE 387. INTAKE AND EXHAUST VALVE FACE AND VALVE SEAT GRINDING DIAGRAM.

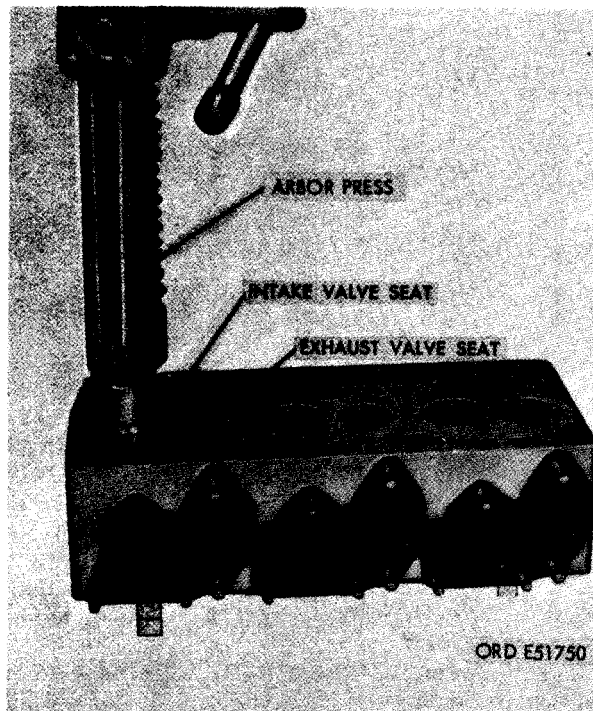


FIGURE 388. INSTALLING INTAKE VALVE SEAT USING IMPROVED REPLACER.



- (4) Valve guide replacement. Replace cracked, galled, eroded, or scuffed intake and exhaust valve guides (K-9) or guide which does not meet limits specified in repair and rebuild standards (par. 294). Replace valve guides as follows.

- (a) Figure 389. (A) Position cylinder head on press plates as shown so that valve guide being removed is directly below arbor press ram. Insert small end of valve guide remover - 10899157 through valve stem bore of guide. (B) Press valve guide from cylinder head.

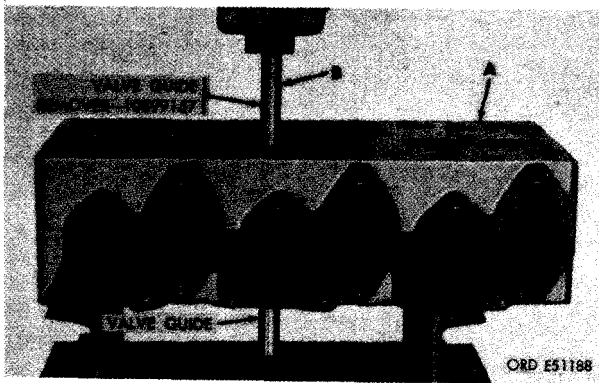


FIGURE 389. REMOVING VALVE GUIDE FROM CYLINDER HEAD USING VALVE GUIDE REMOVER - 10899157.

- (b) Figure 390. (A) Position cylinder head on press plates as shown with the cylinder head gasket surface on plates. Position head with valve guide bore directly below arbor press ram. (B) Start new valve guide into bore and press guide into cylinder head using valve guide replacer - 10899158 in combination with valve guide remover -10899157. Continue pressing guide until valve guide replacer - 10899158 contacts cylinder head.

Note. The intake and exhaust valve guides installed in the same manner. The guides must be installed from the top of the cylinder head to maintain a depth dimension of 0.760-inch from top of guide to bottom of counterbore as shown in figure 391. Replacer -10899157 is designed to maintain this dimension when used to install the guide. Intake and exhaust valve guides are machined to the proper size as furnished, and require no machining after installation.

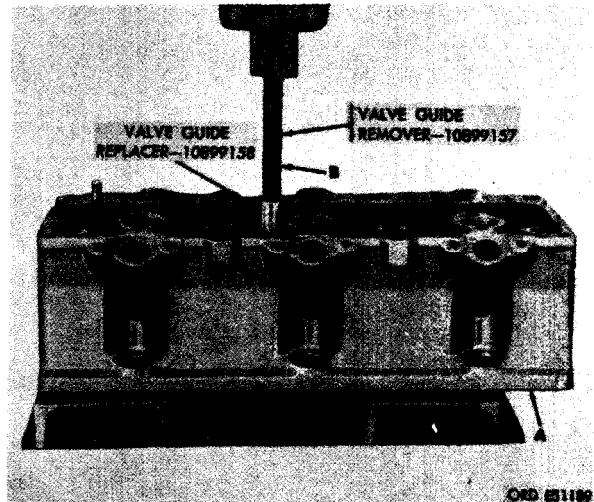


FIGURE 390. INSTALLING VALVE GUIDE IN CYLINDER HEAD USING VALVE GUIDE REMOVER - 10899157 AND VALVE REPLACER -10899158.

- (5) Minor repairs. Repair minor nicks and raised metal with a fine mill file or crocus cloth dipped in dry-cleaning solvent or mineral spirits paint thinner. Clean damaged stud threads with a thread chaser. Replace bent or loose studs as described in paragraph 154 d. Clean tapped holes with a tap.

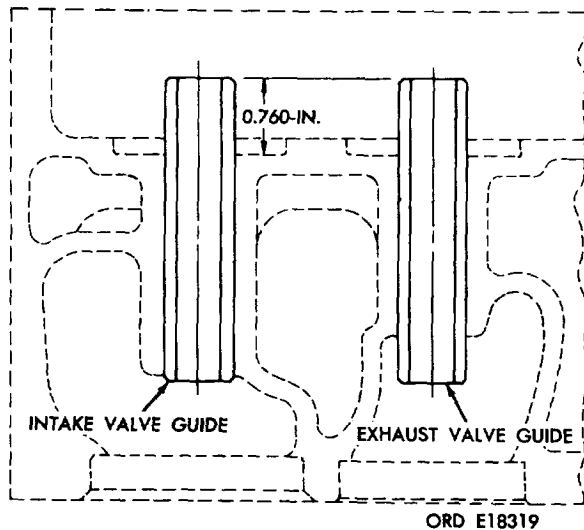


FIGURE 391. SECTIONAL VIEW SHOWING SETTING HEIGHT OF VALVE GUIDES IN CYLINDER HEAD.

b. Valves, Springs, Retainers, Rotators, and Valve Spring Retainer Locks.

- (1) Valves. Replace warped intake valves (K-14) or exhaust valves (K-13) or valves which do not meet limits specified in repair and rebuild standards (par. 294). Replace valves having badly pitted or burned faces. Replace valves having badly pitted, scored, or scratched stems. Replace valves if locking grooves

are damaged. Grind slightly pitted or burned valves that do not seat perfectly to limits specified in figure 387. Replace valves that cannot be ground to these limits. Check valve length from seat contact to tip of stem after grinding as shown in figure 387. Replace valve if length is not within limits specified in repair and rebuild standards (par. 294).

- (2) Valve springs. Replace inner spring (K-3) and outer spring (K-4) when worn, cracked, or otherwise damaged. Replace springs that do not meet limits specified in repair and rebuild standards (par. 294).
- (3) Valve spring retainers. Replace worn or cracked valve spring retainer (K-2).
- (4) Valve rotators. Replace valve rotators (K-5) when inner section does not rotate freely, or when it is worn or cracked.
- (5) Valve spring retainer locks. Replace valve spring retainer lock (K-1) if worn or cracked.

201. ASSEMBLY

Refer to figures 380 through 384 and reverse the sequence of illustrations and instructions to assemble the front cylinder head. Assemble the rear cylinder head in the same manner.

Section IX. REBUILD OF VALVE ROCKER ARMS, SHAFTS, PUSH RODS, TAPPETS, AND RELATED CYLINDER HEAD PARTS.

202. VALVE ROCKER ARMS AND SHAFTS

Note. The key letters shown below in parentheses refer to figure 385 except where otherwise indicated.

a. Disassembly. The front and rear sets of valve rocker arms are identical and interchangeable. For instructional purposes, the front set of valve rocker arms will be disassembled. Disassemble the front set of rocker arms (par. 92 c) following instructions for figures 184 through 186. Disassemble the rear set of rocker arms in the same manner.

b. Cleaning and Inspection.

- (1) Cleaning. Clean six valve rocker arms (C), rocker arm shaft (E), three rocker arm supports (F) and two thrust springs (J) as directed in paragraphs 152 c and d.
- (2) Inspection.
  - (a) Inspect valve rocker arm assemblies (C) for cracks using a magnifying glass and strong light. Check bearing against limits specified in repair and rebuild standards (par. 294). Inspect

adjusting screw (C-3) for stripped or damaged threads. Check pad for scoring, nicks, burs, or scratches. Check nut (C- 1) for damaged threads.

- (b) Inspect rocker arm shaft (E) for cracks, nicks, and scoring. Check plug (D) to be certain it is secure in the shaft, and that oil passage is clean and free of obstructions. Check shaft to limits specified in repair and rebuild standards (par. 294).
- (c) Inspect valve rocker supports (F) for cracks, nicks, and scoring. Check oil passage to be sure it is clean and free of obstructions. Inspect thrust washer (B) for wear, cracks, and distortion.
- (d) Inspect thrust springs (J) for wear, cracks, set, or other evidence of failure. Check springs against limits specified in repair and rebuild standards (par. 295).

Note. Valve rocker arms do not incorporate replaceable bushing-type bearings. Replace rocker arms if bearings are worn or damaged.

#### c. Repair.

- (1) Replace valve rocker arm assemblies (C) when cracked, or when bearing surfaces are loose, scored, or when arms do not meet limits specified in repair and rebuild standards (par. 294). Replace adjusting screw and nut when threads are damaged or when screw binds in rocker arm.
- (2) Replace cracked or deeply scored valve rocker arm shaft (E). Replace shafts that do not meet limits specified in repair and rebuild standards (par. 294).
- (3) Replace damaged rocker arm supports (F), thrust washer (B), and retaining ring (A).
- (4) Replace thrust springs (J) when worn or cracked. Replace springs that do not meet limits specified in repair and rebuild standards (par. 294).

d. Assembly. Refer to paragraph 92 f and figures 184 through 186 and reverse the sequence

of illustrations and instructions to assemble the front set of valve rocker arms.

### 203. VALVE ROCKER ARM PUSH RODS AND TAPPETS

Note. The key letters shown below in parentheses refer to figure 385 except where otherwise indicated.

#### a. Cleaning and Inspection.

- (1) Cleaning. Clean the 12 valve rocker arm push rods (T) and 12 valve tappets (S) as directed in paragraph 152.
- (2) Inspection. Check valve tappets (fig. 392) for scuffing, discoloration, scratches, and evidence of a wear pattern. Check push rod socket for damage from pounding. Check tappet against limits specified in repair and rebuild standards (par. 294). Inspect the valve rocker arm push rods (fig. 392) for roughness, scratches, grooves, or evidence of loose ball or socket ends. Check rod straightness by rolling on surface plate. Replace bent push rods. Replace rods which do not meet limits specified in repair and rebuild standards (par. 294).

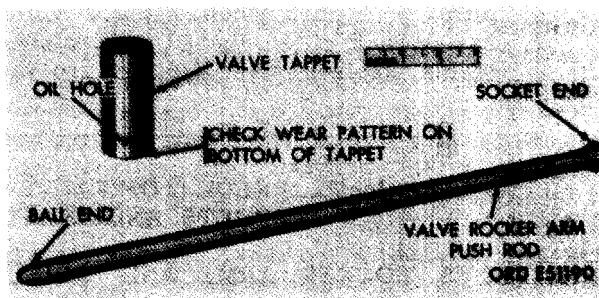
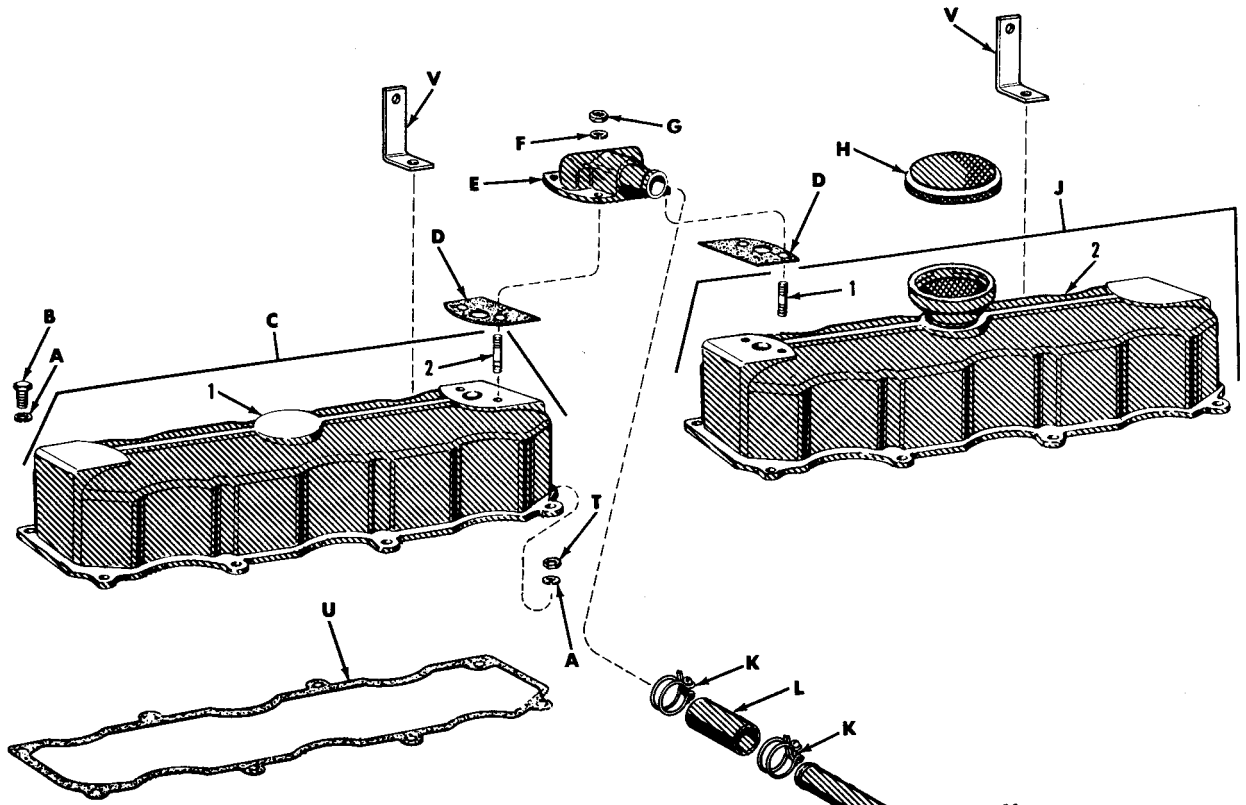


FIGURE 392. INSPECTION POINTS FOR VALVE ROCKER ARM PUSH RODS AND VALVE TAPPETS.

b. Repair. Remove slight discoloration from tappets and valve rocker arm push rods using crocus cloth soaked in mineral spirits paint thinner. Replace tappets when scored or when minor repairs fail to make tappets serviceable. Replace tappets when not within limits specified in repair and rebuild standards (par. 294).



- A - 5/16-in. lock washer
- B - 5/16 x 7/8 cap screw
- C - Rear cylinder head cover assembly
  - 1- Cover
  - 2- 5/16 x 1-3/16 plain stud
- D - Breather tube adapter gasket
- E - Breather tube adapter
- F - 5/16- in. lock washer
- G - 5/16-in. plain nut
- H - Oil filler cap
- J - Front cylinder head cover assembly
- K - 1-1/4-in. hose clamp.
- L - 1.0 id x 4.0 lg rubber hose
- M- Crankcase breather tube
- N - 5/16 x 5/8 cap screw
- P - 11/32- in. flat washer
- Q - Breather tube clip
- R - 5/16- in. lock washer
- S - 5/16-in. plain nut
- T - Cylinder head cover 5/16- in. plain nut
- U - Cylinder head gasket
- V - Tachometer cable bracket



FIGURE 393. CYLINDER HEAD COVERS, CRANKCASE BREATHER, AND RELATED PARTS - EXPLODED VIEW, ORD E51191

Section X. REBUILDS OF CYLINDER HEAD COVERS, BREATHER TUBE ADAPTER, CRANKCASE BREATHER TUBE , AND RELATED PARTS

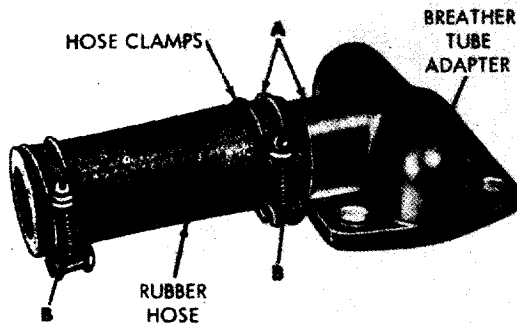
204. CYLINDER HEAD COVERS

Note. The key letters shown below in parentheses refer to figure 393 except where otherwise indicated.

a. Cleaning and Inspection.

- (1) Cleaning. Clean the oil filler cap (H) with warm water and soap. Clean the front and rear cylinder head covers (J and C) as directed in paragraph 152 c.
- (2) Inspection. Inspect the front and rear cylinder head covers (J and C) for cracks and dents. Inspect the oil filler cap (H) for cracks and damage to lock tabs on inside of cap. Inspect sealing gasket inside of cap for tears or damage that would prevent a tight seal.

b. Repair. Straighten minor dents in front and rear cylinder head covers (J and C). Replace cracked or severely dented cylinder head covers. Replace the oil filler cap (H) when cracked, lock tabs are damaged, or gasket is damaged.



- A — LOOSEN 1-INCH HOSE CLAMP AND SLIDE RUBBER HOSE AND CLAMPS FROM BREATHING TUBE ADAPTER.  
B — REMOVE TWO 1-INCH HOSE CLAMPS FROM 1.0 id X 4.0 LONG HOSE.

ORD E51192

FIGURE 394. SEPARATING OR ASSEMBLING BREATHING TUBE ADAPTER AND RUBBER HOSE.

Note. Early model front cylinder head covers incorporated a screen soldered to the lower end of the oil filler tube. If screen is present, unsolder and discard screen.

205. BREATHING TUBE ADAPTER

Note. The key letters shown below in parentheses refer to figure 393 except where otherwise indicated,

a. Disassembly. Disassemble the breathing tube adapter and rubber hose following instructions on figure 394.

b. Cleaning and Inspection.

- (1) Cleaning. Clean the breathing tube adapter (E), and hose clamps (K) as directed in paragraph 152 c. Clean the rubber hose (L) with warm water and soap.
- (2) Inspection. Inspect the breathing tube adapter (E) as directed in paragraph 153 b. Inspect the rubber hose (L) for cracks, hardening, and set condition. Inspect hose clamps (K) for cracks and bends.

c. Repair. Repair the breathing tube adapter (E) as directed in paragraph 154 b. Replace the rubber hose (L) when cracked, hardened, or in a set condition. Replace the hose clamps (K) when cracked or bent.

d. Assembly. Refer to figure 394 and reverse the sequence of instructions to assemble the breathing tube adapter and rubber hose.

206. CRANKCASE BREATHING TUBE

Note. The key letters shown below in parentheses refer to figure 393 except where otherwise indicated.

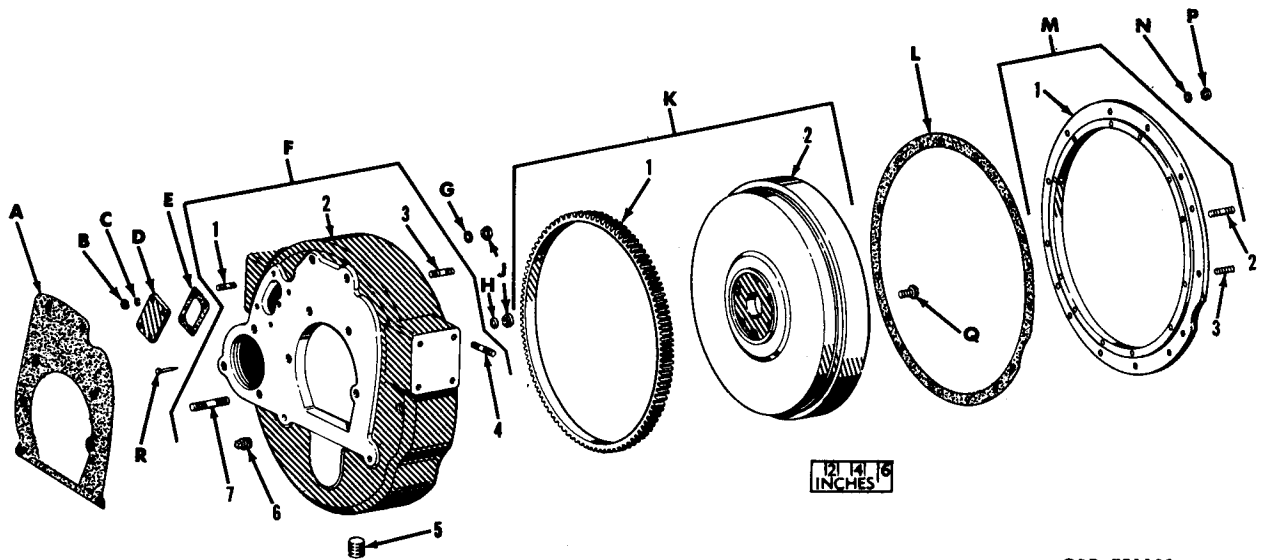
a. Disassembly. No disassembly of the crankcase breathing tube is required.

**b. Cleaning and Inspection.**

- (1) Cleaning. Clean the crankcase breather tube (M) and clip (Q) as directed in paragraph 152 c.
- (2) Inspection. Inspect the crankcase breather tube (M) for dents and cracks.

Inspect the clip (Q) for cracks and bends.

c. Repair. Replace crankcase breather tube (M) when dented or cracked. Straighten minor bends in the clip (Q). Replace clip when cracked or severely bent.



ORD E51193

- A - Flywheel housing gasket
- B - 1/4-in. plain nut (early model engines)
- C - 1/4-in. lock washer (early model engines)
- D - Flywheel timing cover (early model engines)
- E - Flywheel timing cover gasket (early model engines)
- F - Flywheel housing assembly
  - 1- 1/4 x 1 plain stud (early model engines)
  - 2- Flywheel housing
  - 3- 3/8 x 1-5/8 plain stud
  - 4- 1/2 x 2 plain stud
  - 5- 3/4-in. pipe plug
  - 6- 1/4-in. pipe plug
  - 7- 5/8 x 2-7/8 plain stud
- G - 17/32 x 1/16 thk flat washer
- H - 17/32 x 1/8 thk flat washer
- J - 1/2- in. lock nut
- K - Flywheel assembly
  - 1- Ring gear
  - 2- Flywheel
- L - Transmission adapter gasket
- M - Transmission adapter assembly
  - 1- Transmission adapter
  - 2- 3/8 x 1-9/16 plain stud (early model engines)
  - 3- 3/8 x 21/32 helical coil insert (late model engines)
- N - 3/8-in. lock washer
- P - 3/8- in. plain nut
- Q - 1/2 x 1-1/8 place bolt
- R - Timing pointer

FIGURE 395. FLYWHEEL HOUSING, FLYWHEEL, TRANSMISSION ADAPTER, AND RELATED PARTS - EXPLODED VIEW.

Section XI. REBUILD OF FLYWHEEL HOUSING, FLYWHEEL ASSEMBLY AND TRANSMISSION ADAPTER

207. FLYWHEEL HOUSING

Note. The key letters shown below in parentheses refer to figure 395 except where otherwise indicated.

a. Disassembly. Disassemble the flywheel housing following instructions on figures 396 and 397.

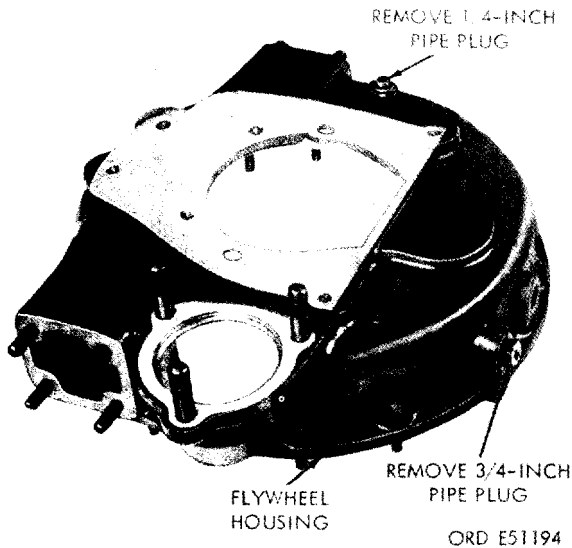


FIGURE 396. REMOVING OR INSTALLING PIPE PLUGS (LATE MODEL ENGINES).

b. Cleaning and Inspection.

- (1) Cleaning. Clean the flywheel housing (F-2) as directed in paragraph 152 c.
- (2) Inspection. Inspect the flywheel housing (F-2) directed in paragraph 153 b.

c. Repair. Repair the flywheel housing (F-2) as directed in paragraph 154 b. Repair studs (F-1, F-3, F-4, and F-7) as directed in paragraph 154 d.

d. Assembly. Refer to figures 396 and 397 and reverse the sequence of instructions to install the pipe plugs.

208. FLYWHEEL ASSEMBLY

Note. The key letters shown below in parentheses refer to figure 395 except where otherwise indicated.

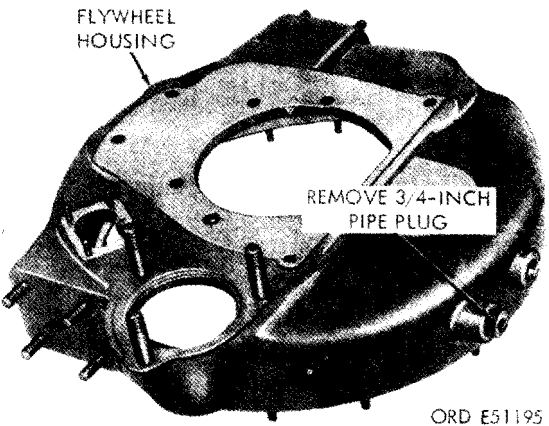


FIGURE 397. REMOVING OR INSTALLING PIPE PLUG (EARLY MODEL ENGINES).



FIGURE 398. REMOVING RING GEAR FROM FLYWHEEL.

a. Cleaning and Inspection.

- (1) Cleaning. Clean the flywheel assembly (K) directed in paragraph 152 c.

- (2) Inspection. Inspect the flywheel assembly directed in paragraph 153 b. Examine the teeth of the ring gear (fig. 398) for cracks, broken teeth, and wear. Inspect the face of the flywheel (fig. 399) for scoring and burns.

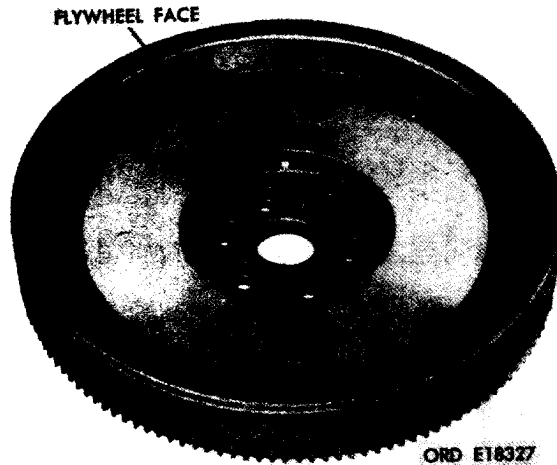


FIGURE 399. INSPECTING FLYWHEEL FACE.

b. Repair. Repair the flywheel assembly (K) as directed in paragraph 154 b. Replace the gear ring when teeth are broken, cracked, or worn. This is accomplished by cutting ring gear with hacksaw and splitting the ring gear with a cold chisel as instructed in figure 398. Heat new ring gear using welding equipment until gear heats up to 400° F. Position ring gear on flywheel using pliers, making sure the beveled edge of the ring gear teeth face crankshaft mounting recess in flywheel. Minor scoring and burns of the flywheel may be repaired by resurfacing the flywheel face (fig. 399). Total amount of stock removed from flywheel face will not exceed 0.062 from new part size. Replace flywheel when excessively damaged.

#### 209. TRANSMISSION ADAPTER

Note. The key letters shown below in parentheses refer to figure 395 except where otherwise indicated.

##### a. Cleaning and Inspection.

- (1) Cleaning Clean. the transmission adapter assembly (M) as directed in paragraph 152 c.

- (2) Inspection. Inspect transmission adapter (M-1) as directed in paragraph 153 b. Examine transmission adapter (figs. 400 and 401) for cracks, burs, and distortion on mating surfaces. Inspect helical coil inserts (M-3) for damage (late models). Studs (M-2) must be in good condition and not loose (early models).

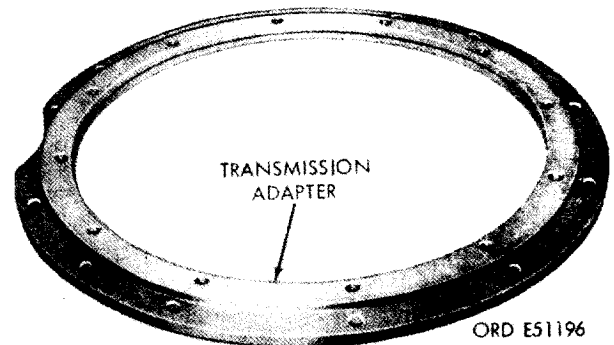


FIGURE 400. INSPECTING TRANSMISSION ADAPTER (LATE MODEL ENGINES).

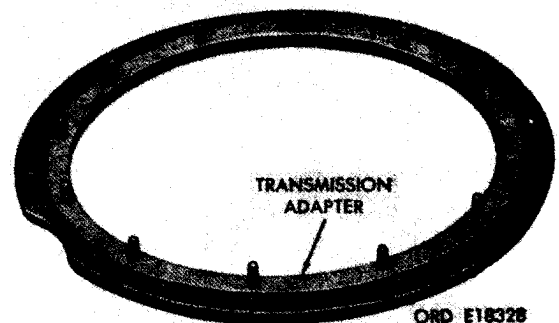
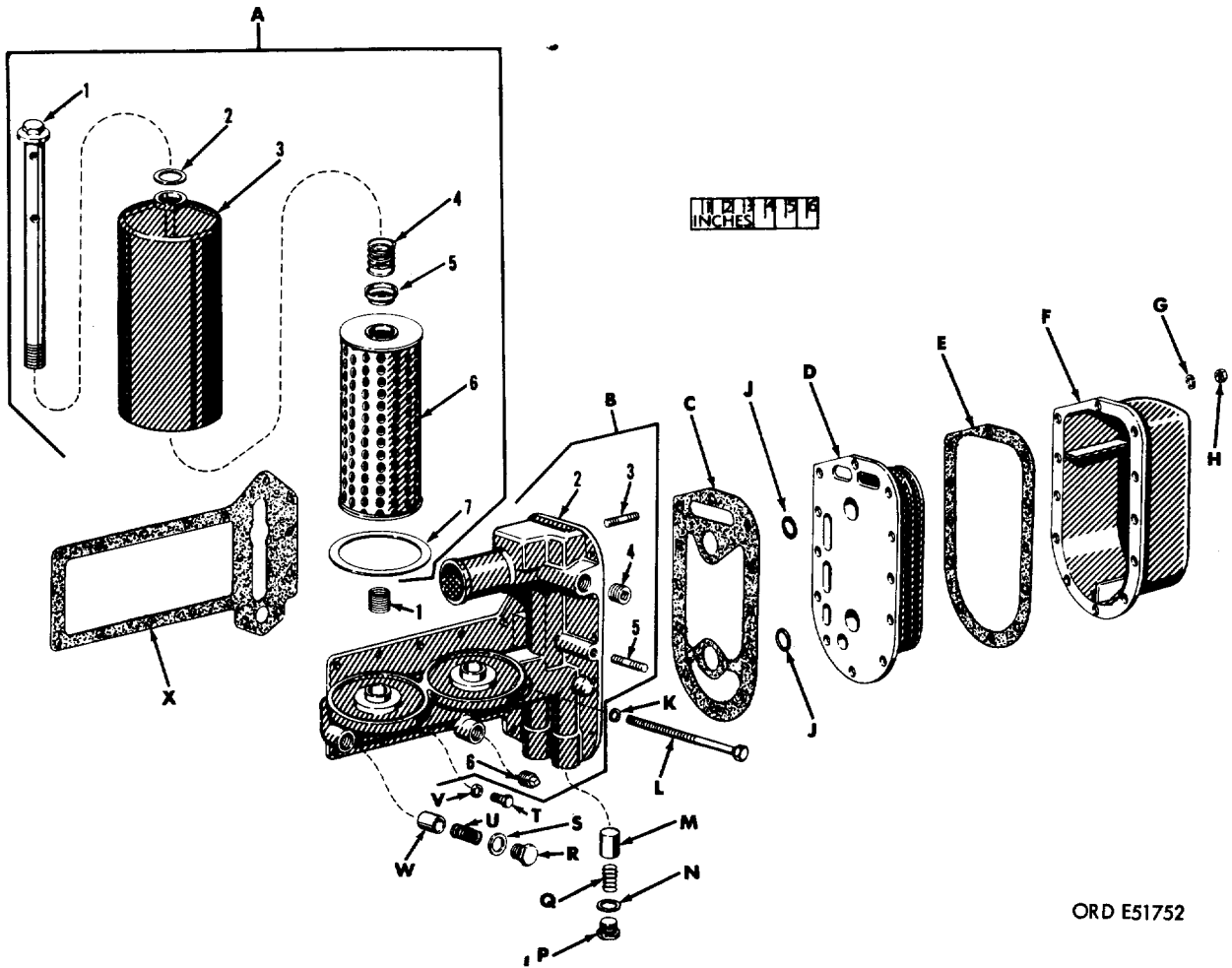


FIGURE 401. INSPECTING TRANSMISSION ADAPTER (EARLY MODEL ENGINES).

b. Repair. Repair the transmission adapter assembly (M) as directed in paragraph 154 b. Replace damaged helical coil inserts (M-3) (late models). Repair studs (M-2) as directed in paragraph 154 d (early models). Replace the transmission adapter when distorted or cracked. Repair minor burs with crocus cloth or a fine mill file. Repair minor thread damage with a used die.





**A - Oil filter assembly**

- 1 - Bar
- 2 - Washer
- 3 - Filter case
- 4 - Retaining spring
- 5 - Sealing cup
- 6 - Filter element
- 7 - Filter element gasket

**B - Oil cooler and oil filter housing assembly**

- 1 - 1 x 1-1/2 lg helical coil insert
- 2 - Housing
- 3 - 1/4 x 1-1/4 plain stud
- 4 - 3/4-in. pipe plug
- 5 - 3/8 x 2-1/8 plain stud
- 6 - 3/8-in. pipe plug

**C - Oil cooler gasket**

**D - Oil cooler**

**E - Oil cooler cover gasket**

**F - Oil cooler cover**

**G - 1/4-in. lock washer**

**H - 1/4-in. plain nut**

**J - 7/8 id x 1-1/8 od x 1/8 thk preformed packing**

**K - 13/32-in. flat washer**

**L - 3/8 x 5-1/8 cap screw**

**M - Oil cooler bypass valve plunger**

**N - Oil cooler bypass valve plain washer**

**P - Oil cooler bypass valve plug**

**Q - Oil cooler bypass valve plunger spring**

**R - Oil filter bypass valve plug**

**S - Oil filter bypass valve plain washer**

**T - 3/8 x 7/8 cap screw**

**U - Oil filter bypass valve plunger spring**

**V - 13/32-in. flat washer**

**W - Oil filter bypass valve plunger**

**X - Oil cooler and oil filter housing gasket**

ORD E51752

FIGURE 402. OIL FILTERS, OIL COOLER, AND OIL FILTER HOUSING - EXPLODED VIEW.

## Section XII. REBUILD OF OIL FILTERS, OIL COOLER AND OIL FILTER HOUSING, AND OIL COOLER

### 210. OIL FILTERS

Note. The key letters shown below in parentheses refer to figure 402 except where otherwise indicated.

a. General. Both oil filters are identical. For instructional purposes only one oil filter will be overhauled.

b. Disassembly. Remove the sealing cup (A-5) and retaining spring (A-4) from the bar (A-1). Pull bar out of filter case (A-3) and discard washer (A-2).

c. Cleaning and Inspection.

(1) Cleaning. Clean the filter case (A-3) and related parts as directed in paragraph 152 c.

(2) Inspection. Inspect the filter case (A-3) for dents and damaged gasket surfaces. Inspect bar (A-1) for cracks, damaged threads, and damaged gasket surfaces. Examine the retaining spring (A-4) for cracked and set condition.

d. Repair. Repair minor damage to filter case (A-3) and bar (A-1). Gasket surfaces may be resurfaced using crocus cloth placed on a flat surface. Replace filter case and bar when cracked, distorted, or when gasket surfaces cannot be repaired. Replace the retaining spring (A-4) when cracked or in a set condition.

e. Assembly. Position new washer (A-2) on bar (A-1) and insert bar into filter case (A-3). Position retaining spring (A-4) and install sealing cup (A-5) on bar.

### 211. OIL COOLER AND OIL FILTER HOUSING

Note. The key letters shown below in parentheses refer to figure 402 except where otherwise indicated.

a. Disassembly. Figure 403. (A) Remove oil cooler bypass valve plug from oil cooler and oil filter housing. (B) Remove and discard oil cooler bypass valve plain washer (gasket). (C) Remove oil cooler bypass valve plunger spring. (D) Remove oil cooler bypass valve plunger. (E) Remove the oil filter bypass valve plug and

related parts in the same manner as described in steps A through D, above. (F) Remove two 3/4- inch pipe plugs. (G) Remove 3/8- inch pipe plug.

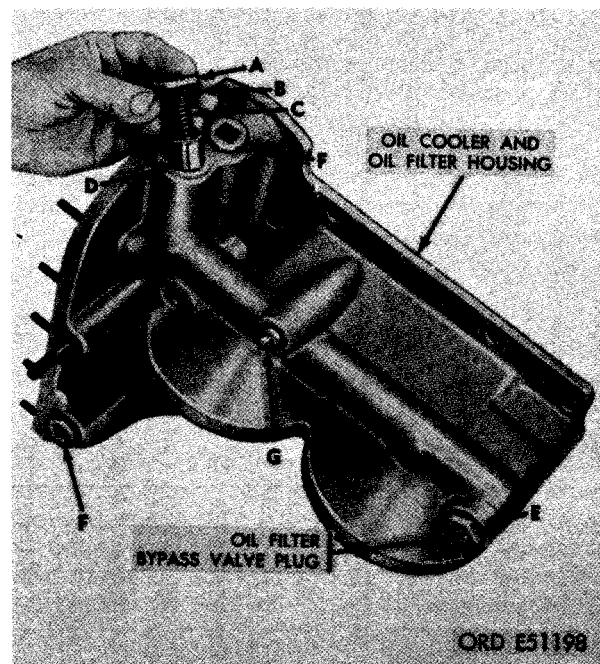


FIGURE 403. REMOVING OR INSTALLING BYPASS VALVE PLUNGERS AND PIPE PLUGS.

b. Cleaning and Inspection.

(1) Cleaning. Clean the housing (B-2) and related parts as directed in paragraph 152 c.

(2) Inspection. Inspect the housing (B-2) as directed in paragraph 153 b. Inspect the helical coil inserts (B-1) as directed in paragraph 153 g. Inspect studs (B-3 and B-5) as directed in paragraph 153 d. Check the bypass valve plungers (M and W), housing (B-2), and valve plunger springs (Q and U) against limits specified in repair and rebuild standards (par. 296). Inspect the bypass valve plungers and plunger bores in the housing for scratches and wear patterns. Inspect valve plunger springs for cracked and set condition.

c. Repair. Repair the housing (B-2) as directed in paragraph 154 b. Refer to figures 315 and 316 for replacement of the helical coil inserts (B- 1). Replace the bypass valve plungers (M and W), housing (B-2), and valve plunger springs (Q and U) when they do not meet requirements specified in repair and rebuild standards (par. 296). Repair studs (B- 3 and B-5) as directed in paragraph 154 d. Replace the bypass valve plungers and housing when scratched or any evidence of a wear pattern exists. Replace the valve plunger springs when cracked or in a set condition.

d. Assembly. Refer to figure 403 and reverse the sequence of instructions to assemble the oil cooler and oil filter housing and related parts.

## 212. OIL COOLER

Note. The key letters shown below in parentheses refer to figure 402 except where otherwise indicated.

### a. Cleaning and Inspection.

- (1) Cleaning. Clean the oil cooler (D) and oil cooler cover (F) as directed in paragraph 152 c.
- (2) Inspection. Inspect the oil cooler cover directed in paragraph 153 b. Inspect oil cooler (D) for cracks and damaged gasket surfaces. Pressure check oil cooler by sealing openings and pumping engine oil (OE-10) into cooler at 150 psi static pressure. Cooler must not leak at 150 psi. Release pressure, drain oil, and flush with dry- cleaning solvent or mineral spirits paint thinner. Blow dry with compressed air.

b. Repair. Repair the oil cooler cover (F) as directed in paragraph 154 b. Repair minor damage to gasket surfaces of oil cooler (D) with a crocus cloth. Replace oil cooler when cracked, damaged, or when it does not pass pressure test.

---

## Section XIII. REBUILD OF FUEL FILTER ASSEMBLY, FUEL FILTER HOSES, FUEL INJECTION TUBES, FUEL INJECTION PUMP ATTACHING PARTS, AND FUEL INJECTOR NOZZLE AND HOLDER ASSEMBLIES

## 213. FUEL FILTER ASSEMBLY

Note. The key letters shown below in parentheses refer to figure 404 except where otherwise indicated.

a. Disassembly. Disassemble the fuel filter assembly as follows.

- (1) The primary and final fuel filter cases (M), elements (T), case nuts (G), case nut flat washers (H), preformed packings (J), and case gaskets (U) were removed from the fuel filter head (B) during engine disassembly (par. 117). Remove pin (L) from stud in fuel filter case. Remove spring seat (S), spring seat packing (R), washer (Q), and element spring (P) from case. Remove drain cock (N) from case.
- (2) Figure 405. (A) Remove two 3/8 tube x 3/8 pipe, 90 degree elbows from inlet and outlet openings in filter head. (B) Remove 3/8 tube x 1/4-inch pipe, 90 degree elbow from tee in fuel inlet opening. (C) Remove 1/4- inch pipe tee

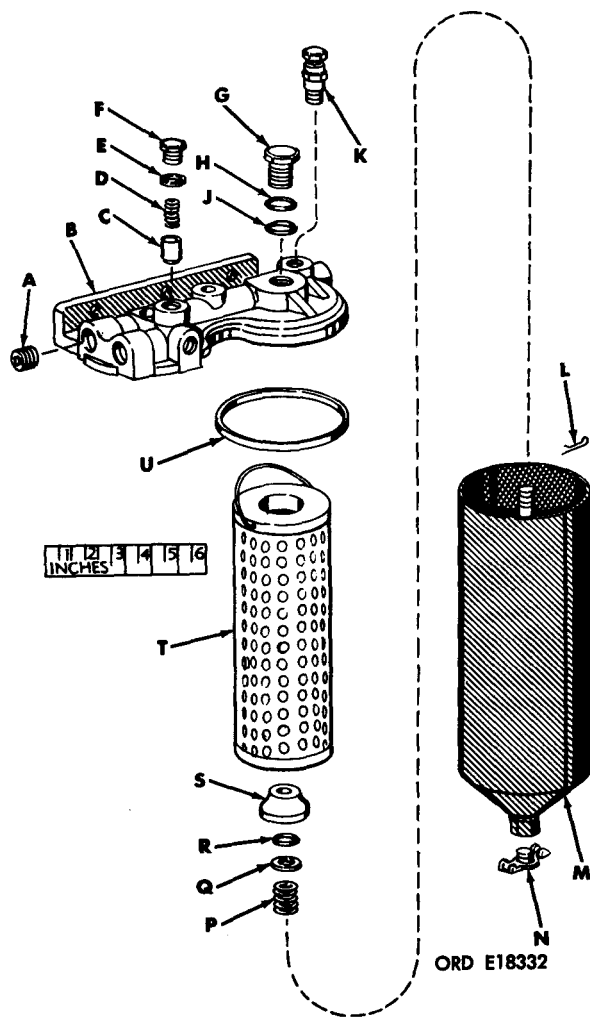
from fuel filter head. (D) Remove 3/8-inch pipe plug from filter head. (E) Remove two vent valves from filter head.

- (3) Figure 406. (A) Remove relief valve cap. (B) Remove plunger spring. (C) Remove valve plunger. (D) Remove preformed packing from valve cap and discard packing.

### b. Cleaning and Inspection.

- (1) Cleaning. Clean fuel filter case (M), fuel filter head (B), vent valves (K), and relief valve parts as directed in paragraphs 152 b and d.
- (2) Inspection. Inspect fuel filter case (M), fuel filter head (B), vent valves (K), and relief valve parts as directed in paragraph 153 b.

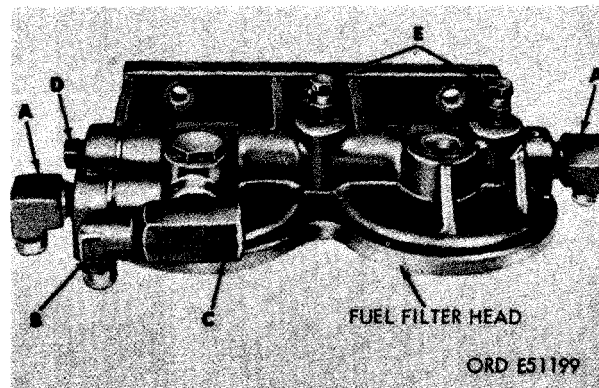
c. Repair. Remove minor burs and nicks using a fine mill file. Repair minor thread damage using a pipe tap. Replace cracked or damaged elbows, pipe reducers, and the complete fuel filter assembly when minor repairs fail to return filter to serviceable condition.



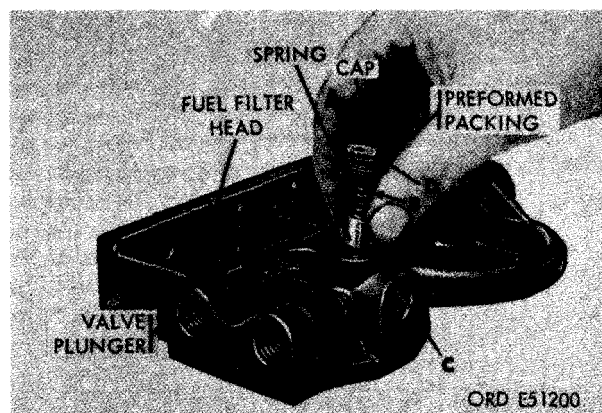
**FIGURE 404. FUEL FILTER ASSEMBLY - EXPLODED VIEW.**

- |                                      |                         |
|--------------------------------------|-------------------------|
| A - 3/8 in. pipe plug                | L - Pin                 |
| B - Fuel filter head                 | M - Fuel filter case    |
| C - Fuel filter relief valve plunger | N - Drain cock          |
| D - Plunger spring                   | P - Element spring      |
| E - Cap gasket                       | Q - Spring seat         |
| F - Relief valve cap                 | R - Spring seat packing |
| G - Case nut                         | S - Spring seat         |
| H - Flat washer                      | T - Fuel filter element |
| J - Preformed packing                | U - Case gasket         |
| K - Vent valve                       |                         |

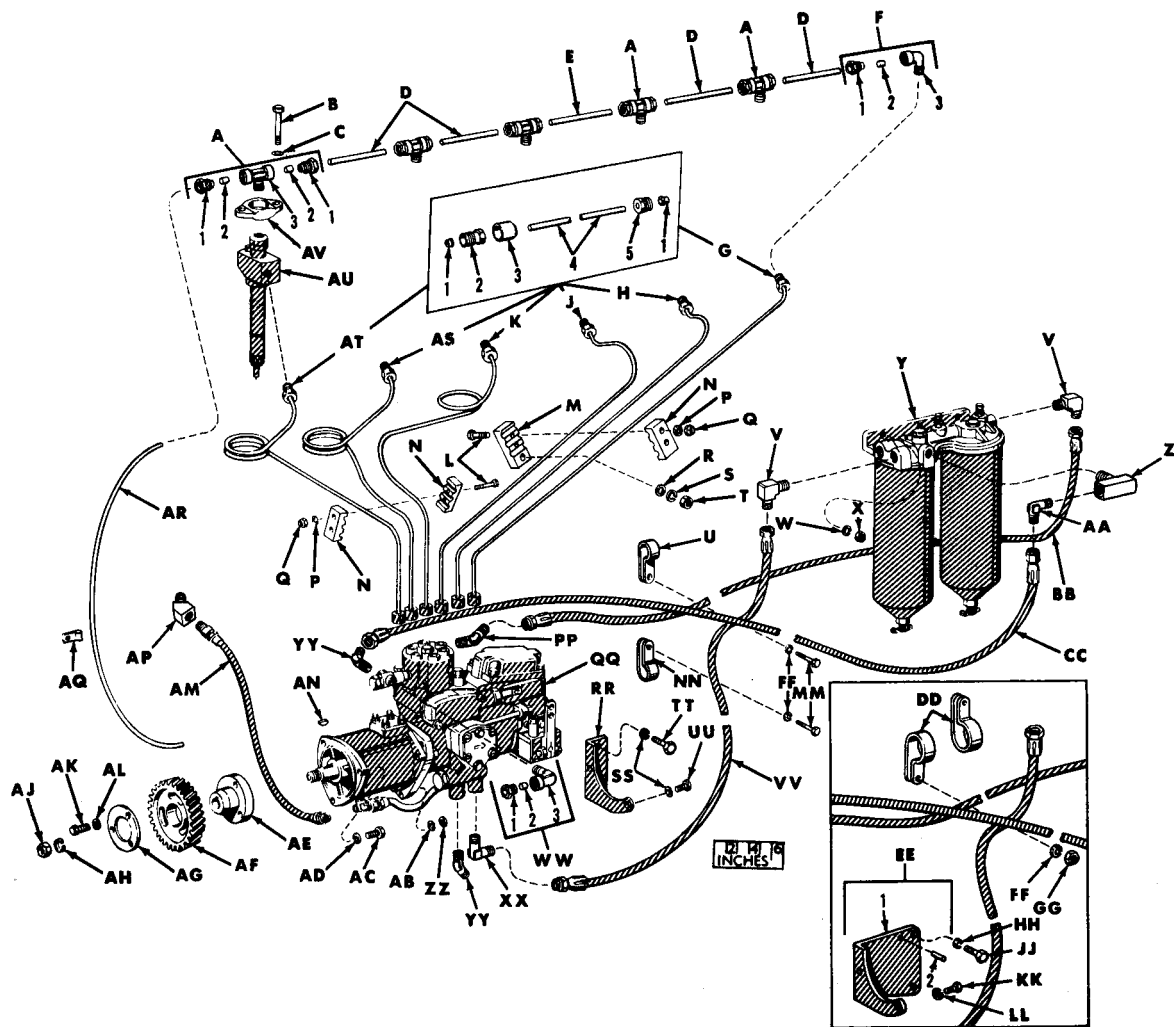
d. Assembly. Refer to figures 405 and 406 and reverse the sequence of illustrations and instructions to assemble the fuel filter head. Position element spring (P), washer (Q), new spring seat packing (R), and spring seat over stud in fuel filter case (M) in that order. Push down on spring seat (S) and install pin (L). The fuel filter elements (T), case gaskets (U), and fuel filter cases are installed on the fuel filter head (B) during engine assembly.



**FIGURE 405. REMOVING OR INSTALLING FUEL FILTER ELBOWS, TEE, AND VENT VALVES.**



**FIGURE 406. REMOVING OR INSTALLING FUEL FILTER RELIEF VALVE.**



ORD E51201

- 7A - Tee assembly  
 1- 1/2-in. tube nut  
 2- 1/4-in. tube sleeve  
 3- 1/8-27NPTF x 1/2-20NF-2A tee  
 B - 5/16 x 2- 1/2 cap screw  
 C - 5/16-in. lock washer  
 D - 4.380-in. lg plastic tubing  
 E - 4.880-in. lg plastic tubing  
 F - Elbow assembly  
 1- 1/2-in. tube nut  
 2- 1/2-in. tube sleeve  
 3- 1/8-27NPTF x 1/2-20NF-2A elbow

- G - Cylinder No. 6 fuel injection tube assembly  
 1- 1/2-in. tube sleeve  
 2- 5/8- 18UNF x 1/4 tube fitting  
 3- Dust cap  
 4- 1/4-in. tube  
 5- 1/2-in. tube nut  
 H - Cylinder No. 5 fuel injection tube assembly  
 1- 1/4-in. tube sleeve  
 2- 5/8- 18UNF x 1/4 tube fitting  
 3- Dust cap  
 4- 1/4-in. tube  
 5- 1/2-in. tube nut

FIGURE 407. FUEL INJECTION TUBE ASSEMBLIES, FUEL INJECTION PUMP ASSEMBLY, FUEL HOSES, AND RELATED PARTS - EXPLODED VIEW.

- J - Cylinder No. 4 fuel injection tube assembly
  - 1 - 1/4-in. tube sleeve
  - 2 - 5/8-18UNF x 1/4 tube fitting
  - 3 - Dust cap
  - 4 - 1/4-in. tube
  - 5 - 1/2-in. tube nut
- K - Cylinder No. 3 fuel injection tube assembly
  - 1 - 1/4-in. tube sleeve
  - 2 - 5/8-18UNF x 1/4 tube fitting
  - 3 - Dust cap
  - 4 - 1/4-in. tube
  - 5 - 1/2-in. tube nut
- L - 1/4 x 1-3/8 cap screw
- M - Tube inner clamp
- N - Tube outer clamp
- P - 1/4-in. flat washer
- Q - 1/4-in. self-locking nut
- R - 13/32-in. flat washer
- S - 3/8-in. lock washer
- T - 3/8-in. plain nut
- U - 1-1/2-in. hose clip
- V - 3/8-in., 90 degree pipe elbow
- W - 3/8-in. lock washer
- X - 3/8-in. plain nut
- Y - Fuel filter assembly
- Z - 1/4-in. tube-to-pipe tee
- AA - 1/4-in. tube, 9/16-in. pipe, 90 degree elbow
- BB - Fuel filter outlet-to-fuel injection pump hose
- CC - Fuel injection pump overflow and fuel return-to-fuel filter hose
- DD - 1-1/2-in. hose clip (early model engines)
- EE - Fuel injection pump bracket assembly (early model engines)
  - 1 - Bracket
  - 2 - 1/4 x 7/8 plain stud
- FF - 1/4-in. lock washer
- GG - 1/4-in. plain nut (early model engines)
- HH - 1/2-in. lock washer (early model engines)
- JJ - 1/2 x 1-3/8 cap screw (early model engines)
- KK - 5/16 x 3/4 cap screw (early model engines)
- LL - 5/16-in. lock washer (early model engines)
- MM - 3/8 x 3/4 cap screw (early model engines)
- NN - 1/2-in. hose clamp (early model engines)
- PP - 3/8 tube, 1/4 pipe, 45 degree elbow
- QQ - Fuel injection pump assembly
- RR - Fuel injection pump bracket (late model engines)
- SS - 5/16-in. lock washer (late model engines)
- TT - 5/16 x 3/4 cap screw (late model engines)
- UU - 5/16 x 5/8 cap screw (late model engines)
- VV - Fuel supply pump-to-fuel filter hose
- WW - Elbow assembly
  - 1 - 1/2-in. tube nut
  - 2 - 1/4-in. tube sleeve
  - 3 - 1/8-NPTF x 1/2-20NF pipe-to-tube elbow
- XX - 3/8-in. tube, 90 degree elbow
- YY - 3/8-in. tube, 45 degree elbow
- ZZ - 3/8-in. plain nut
- AB - 3/8-in. lock washer
- AC - 3/8 x 1-1/8 cap screw
- AD - 3/8-in. lock washer
- AE - Fuel injection pump driven gear hub
- AF - Fuel injection pump driven gear
- AG - Fuel injection pump driven gear retaining plate
- AH - 9/16-in. lock washer
- AJ - 9/16-in. plain nut
- AK - 3/8 x 1-1/4 cap screw
- AL - 3/8-in. lock washer
- AM - Fuel injection pump oil inlet hose
- AN - 5/32 x 5/8 Woodruff key (early model engines)
- AP - 1/8-in., 45 degree elbow
- AQ - 1/4-in. tube clip
- AR - Fuel return-to-fuel injection pump overflow valve tube
- AS - Cylinder No. 2 fuel injection tube assembly
  - 1 - 1/4-in. tube sleeve
  - 2 - 5/8-UNF x 1/4 tube fitting
  - 3 - Dust cap
  - 4 - 1/4-in. tube
  - 5 - 1/2-20UNF tube nut
- AT - Cylinder No. 1 fuel injection tube assembly
  - 1 - 1/4-in. tube sleeve
  - 2 - 5/8-UNF x 1/4 tube fitting
  - 3 - Dust cap
  - 4 - 1/4-in. tube
  - 5 - 1/2-20UNF tube nut
- AU - Fuel injector nozzle and holder assembly
- AV - Hold-down clamp

**FIGURE 407. FUEL INJECTION TUBE ASSEMBLIES, FUEL INJECTION PUMP ASSEMBLY, FUEL HOSES, AND RELATED PARTS - EXPLODED VIEW - CONTINUED.**

## 214. FUEL FILTER HOSES

Note. The key letters shown below in parentheses refer to figure 407 except where otherwise indicated.

### a. Cleaning and Inspection.

- (1) Cleaning. Clean fuel filter outlet-to-fuel injection pump hose (BB), fuel injection pump overflow and fuel return-to-fuel filter hose (CC), fuel supply pump-to-fuel filter hose (VV), and fuel injection pump oil inlet hose (AM) (par. 152 e.)
- (2) Inspection. Inspect hoses (BB, CC, VV, and AM) for cracks, damaged connector threads; and deterioration. Replace all hoses when deteriorated and when threads are stripped or show evidence of leaking.

b. Repair. Repair minor thread damage on connector ends of fuel filter outlet-to-fuel injection pump hose (BB), fuel injection pump overflow and fuel return-to-fuel filter hose (CC), fuel supply pump-to-fuel filter hose (VV), and fuel injection pump oil inlet hose (AM). Replace hoses when threads are damaged beyond minor repair.

## 215. FUEL INJECTION TUBES, FUEL RETURN TUBES, TEES, AND CLAMPS

Note. The key letters shown below in parentheses refer to figure 407 except where otherwise indicated.

### a. Cleaning and Inspection.

- (1) Cleaning. Clean fuel injection tube assemblies (G, H, J, K, AS, and AT) or the fuel return tubes (D and E), and fuel return-to-fuel injection pump overflow valve tube (AR) as directed in paragraph 152 e. Flush tubes with a high pressure type flushing device normally used for this type of operation. Be certain all obstructions are removed from the tubes. Seal the tube ends, after flushing, to prevent the entrance of dirt.
- (2) Inspection. Inspect fuel injection tube assemblies for cracks, dents, splits, and evidence of leaking around coupling nuts. Inspect nuts for stripped or dam-

aged threads. Inspect fuel return tubes for cracks and evidence of leaking around sleeves (A-2) and nuts (A-1). Inspect nuts for stripped and damaged threads. Inspect tees (A) for stripped or damaged threads. Replace tees as an assembly with sleeves (A-2) and nuts (A-1) when stripped.

Note. When fuel return tubes (D, E, and AH) are damaged and require replacement, tees (A) must also be replaced. The tees are supplied with sleeves (A-2) and nuts (A-1) which are used with the fuel return tubes.

b. Repair. The only repairs recommended for the fuel injection tube assemblies (G, H, J, K, AS, and AT) are minor repairs to coupling nut threads and minor straightening of tubes. Replace tube assemblies damaged beyond minor repairs. Replace tube tees (A) and fuel return tubes (D, E, and AR) when damaged. The four fuel return tubes (D) are 4.380-inches long and the fuel return tube (E) is 4.880-inches long. Cut tubes from stock to length and install sleeves (A-2) and nuts (A-1), which are part of tee, as the return tubes are installed on engine.

## 216. FUEL INJECTION PUMP ATTACHING PARTS

Note. The key letters shown, below in parentheses refer to figure 407 except where otherwise indicated.

### a. Cleaning and Inspection.

- (1) Cleaning. Clean fuel injection pump driven gear retaining plate (AG), fuel injection pump driven gear (AF), and fuel injection pump brackets (EE and RR) as directed in paragraph 152.
- (2) Inspection. Inspect fuel injection pump driven gear (AF) as directed in paragraph 152 e and brackets (EE and RR) as directed in paragraph 153 d. Check threads in fuel injection pump driven gear hub (AE) for good condition. Stud (EE-2) in injection pump bracket must be tight and in good condition.

Note. On early model injection pumps, check keyway in gear hub and on shaft for damage. Check key for damage.

b. Repair. Remove minor nicks from fuel injection pump driven gear teeth using a fine mill file. Replace gear when teeth show excessive wear or damage. Repair fuel injection pump brackets (EE and RR) as directed in paragraph 154 d. Repair fuel injection pump driven gear retaining plate (AG) as directed in paragraph 154 b.

#### 217. FUEL INJECTOR NOZZLE AND HOLDER ASSEMBLIES

Note. Test all fuel injector nozzle and holder assemblies before attempting any disassembly. Disassemble only the nozzle and holder assemblies that leak or do not meet pressure requirements.

a. Testing. Refer to paragraph 83 c for instructions on installing nozzle and holder assembly and test as directed in paragraph 83 d.

b. Disassembly. Disassemble fuel injector nozzle and holder assemblies following the instructions for figures 152 through 155.

#### c. Cleaning and Inspection.

(1) Cleaning. Clean fuel injector nozzle and holder components as directed in paragraph 83 f.

(2) Inspection. Inspect fuel injector nozzle and holder components as directed in paragraph 83 g.

d. Repair. Repair fuel injector nozzle and holder components as directed in paragraph 83 h.

e. Assembly. Assemble fuel injector nozzle and holder components as directed in paragraph 83 i.

---

### Section XIV. REBUILD OF THERMOSTAT HOUSING, INTAKE MANIFOLD, WATER PUMP AND RELATED PARTS

#### 218. THERMOSTAT HOUSING

Note. The key letters shown below in parentheses refer to figure 408 except where otherwise indicated.

a. Disassembly. Loosen 2-inch hose clamp (DD) and remove 2-inch id rubber hose (EE) from housing (C- 2). Remove thermostat (E) and thermostat seal (D) from housing. Discard thermostat seal. Remove 3/4- inch pipe plug (C- 1) and 1/2-inch pipe plug (C-3) from housing.

#### b. Cleaning and Inspection.

(1) Cleaning. Clean housing (C- 2), hose clamps (DD), and thermostat (E) as directed in paragraph 152 c. Clean the rubber hose (EE) with warm water and soap.

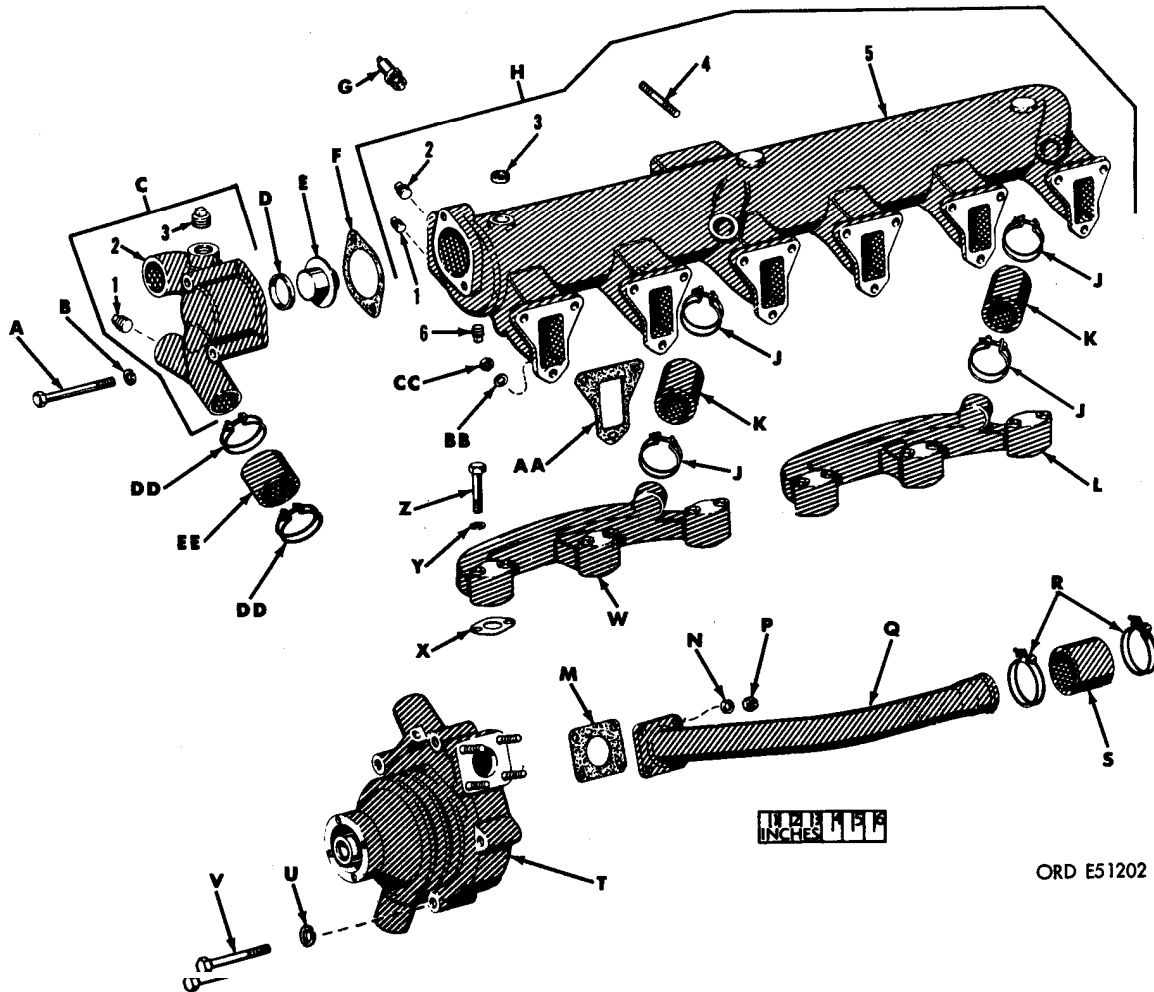
(2) Inspection. Inspect the housing (C- 2) as directed in paragraph 153 b. Inspect hose clamps (DD) for cracks and bends. Inspect the thermostat (E) for cracks. Even though the thermostat appears in good condition, check operation of ther-

mostat. Immerse thermostat in container of water as shown in figure 409. Slowly raise temperature to 200° F. The thermostat must begin to expand at 180° F and continue until water is raised to 200° F. Total expansion between 180° F and 200° F must be 0.310 to 0.345-inch. Inspect rubber hose (EE) for cracks, hardening, and set condition.

c. Repair. Repair the housing (C-2) as directed paragraph 154 b. Replace the hose clamps (DD) when cracked or bent. Replace thermostat (E) when cracked or if it does not pass expansion test. Replace rubber hose (EE) when cracked, hardened, or in a set condition.

d. Assembly. Install 3/4-inch pipe plug (C-1) and 1/2-inch plug (C-3) in housing (C-2). Install new thermostat seal (D) as shown in figure 111. Insert thermostat (E) in housing making sure that the long case end properly enters the thermostat seal. Install 2-inch id rubber hose (EE) and 2-inch hose clamps (DD) loosely on housing. Further adjustment and tightening will be accomplished during assembly of the engine.





ORD E51202

- 3/8 x 3-5/8 cap screw
- 13/32-in. plain washer
- Thermostat housing assembly
- 1 - 3/4-in. pipe plug
- 2 - Housing
- 3 - 1/2-in. pipe plug
- Thermostat seal
- Thermostat
- Thermostat housing gasket
- Water temperature sending unit
- Intake manifold assembly
- 1 - 3/8-in. pipe plug
- 2 - 1/2-in. pipe plug
- 3 - 1-in. core hole plug
- 4 - 5/16 x 1-13/16 plain stud
- 5 - Intake manifold
- 6 - 1/4-in. pipe plug
- 2-in. hose clamp
- 1-5/8-in. id rubber hose

- L - Rear cylinder head water outlet manifold
- M - Oil cooler water inlet tube gasket
- N - 5/16-in. lock washer
- P - 5/16-in. plain nut
- Q - Oil cooler water inlet tube
- R - 2-1/2-in. hose clamp
- S - 2-1/32-in. id x 2-3/4-in. lg rubber hose
- T - Water pump assembly
- U - 3/8-in. lock washer
- V - 3/8 x 3-1/2 cap screw
- W - Front cylinder head water outlet manifold
- X - Water outlet manifold gasket
- Y - 5/16-in. lock washer
- Z - 5/16 x 2-1/4 cap screw
- AA - Intake manifold gasket
- BB - 11/32-in. flat washer
- CC - 5/16-in. plain nut
- DD - 2-1/4-in. hose clamp
- EE - 2-in. id rubber hose

FIGURE 408. INTAKE MANIFOLD, CYLINDER HEAD WATER OUTLET MANIFOLDS, AND RELATED PARTS - EXPLODED VIEW.

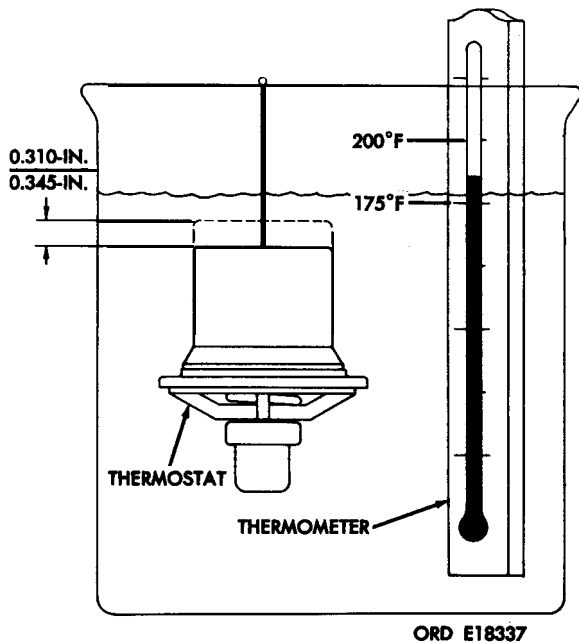


FIGURE 409. TESTING THERMOSTAT.

## 219. INTAKE MANIFOLD

Note. The key letters shown below in parentheses refer to figure 408 except where otherwise indicated.

a. Disassembly. Remove water temperature sending unit G from intake manifold (H-5). Remove 3/8-inch pipe plug (H- 1), 1/2-inch pipe plug (H- 2), 1/4- inch pipe plug (H- 6), and 1-inch core hole plugs (H- 3) from intake manifold if necessary.

### b. Cleaning and Inspection.

- (1) Cleaning. Clean the intake manifold (H-5) water temperature sending unit (G) as directed in paragraph 152 c.
- (2) Inspection. Inspect the intake manifold (H-5) as directed in paragraph 153 b. Inspect studs (H-4) as directed in paragraph 153 d. Inspect the water temperature sending unit (G) for dents, damaged threads, and damage at the electrical connector end.

c. Repair. Repair the intake manifold as directed in paragraph 154 b. Repair studs (H-4) as directed in paragraph 154 d Replace the

water temperature sending unit (G) when dented, threads are damaged, or electrical connector end is damaged.

d. Assembly. Install 3/8-inch pipe plug (H- 1), 1/2-inch pipe plug (H-2), 1/4-inch pipe plug (H- 6), and 1-inch core hole plug (H- 3) in the intake manifold (H-5). Install water temperature sending unit (G) in intake manifold.

## 220. WATER PUMP

a. Disassembly. Disassemble the water pump as directed in paragraph 77 b.

### a. Cleaning and Inspection.

- (1) Cleaning. Clean the water pump as directed in paragraph 77 c.
- (2) Inspection. Inspect water pump as directed in paragraph 77 c.

c. Repair. Repair the water pump as directed in paragraph 77 c.

d. Assembly. Assemble the water pump as directed in paragraph 77 d.

## 221. CYLINDER HEAD WATER OUTLET MANIFOLDS

Note. The key letters shown below in parentheses refer to figure 408 except where otherwise indicated.

a. Disassembly. Loosen hose clamp (J) and remove hose (K) from front and rear cylinder head water outlet manifolds (W and L).

### b. Cleaning and Inspection.

- (1) Cleaning. Clean the rubber hoses (K) with warm water and soap. Clean the hose clamps (J) and the rear and front cylinder head water outlet manifolds (L and W) as directed in paragraph 152 c.
- (2) Inspection. Inspect the front and rear cylinder head water outlet manifolds (W and L) as directed in paragraph 153 b Inspect the rubber hoses (K) for cracks, hardening, and set condition. Inspect hose clamps (J) for cracks and bends.

c. Repair. Repair the front and rear cylinder head water outlet manifolds (W and L) as directed in paragraph 154b. Replace the rubber hoses (K) when cracked, hardened, or in a set condition. Replace the hose clamps (J) when cracked or bent.

d. Assembly. Position hose (K) and hose clamp J on front cylinder head water outlet manifold (W) and rear cylinder head water outlet manifold (L). Do not tighten hose clamp until manifolds are properly positioned on cylinder heads and intake manifold (par. 271).

## 222. OIL COOLER WATER INLET TUBE

Note. The key letters shown below in parentheses refer to figure 408 except where otherwise indicated.

a. Disassemble Remove hose (S) and two hose clamps R from oil cooler water inlet tube (Q).

### b. Cleaning and Inspection.

- (1) Cleaning. Clean the rubber hose (S) with warm water and soap. Clean the hose clamps (R) and the oil cooler water inlet tube (Q) as directed in paragraph 152 c.
- (2) Inspection. Inspect the oil cooler water inlet tube (Q) for dents and cracks. Inspect the rubber hose (S) for cracks, set condition, and hardening. Inspect hose clamps (R) for cracks and bends.

c. Repair. Straighten minor dents in oil cooler water inlet tube (Q). Replace oil cooler water inlet tube when cracked or severely dented. Replace the rubber hose (S) when cracked or hardened. Replace the hose clamps (R) when cracked or bent.

d. Assembly. Position hose (S) and two clamps (R) on oil cooler water inlet tube (Q). Do not tighten hose clamps at this time.

---

## Section XV. REBUILD OF EXHAUST MANIFOLD ASSEMBLY, FLAME HEATER, AND RELATED PARTS

### 223. EXHAUST MANIFOLD ASSEMBLY

Note. The key letters shown below in parentheses refer to figure 410 except where otherwise indicated.

a. Disassembly. Refer to figures 173 and 174 for instructions covering disassembly of exhaust manifold assembly.

#### b. Cleaning and Inspection.

- (1) Cleaning. Clean the exhaust manifold rear section (TT), exhaust manifold center section (C-1), and exhaust manifold front section (D) as directed in paragraph 152 c.
- (2) Inspection. Inspect the exhaust manifold rear section (TT), exhaust manifold center section (C-1), and exhaust manifold front section (D) as directed in paragraph 153 b. Inspect studs (C-2) as directed in paragraph 153 g.

c. Repair. Repair the exhaust manifold rear section (TT), exhaust manifold center section

(C-1), and exhaust manifold front section (D) as directed in paragraph 154 b. Repair studs (C-2) as directed in paragraph 154d.

d. Assembly. Refer to figures 173 and 174 and reverse the sequence of illustrations and instructions to assemble the exhaust manifold assembly.

### 224. INTAKE MANIFOLD ELBOW

Note. The key letters shown below in parentheses refer to figure 410 except where otherwise indicated.

a. Disassemble . Loosen turbosupercharger-to-intake manifold hose clamp (R) and separate the 3-inch id rubber hose (S) from the elbow (F-1). Remove the hose clamps from the rubber hose.

#### b. Cleaning and Inspection.

- (1) Cleaning. Clean turbosupercharger-to-intake manifold hose clamps (R) and the elbow (F-1) as directed in paragraph 152 c. Clean rubber hose (S) with warm water and soap.

- (2) Inspection. Inspect the elbow (F-1) as directed in paragraph 153 b. Inspect the turbosupercharger-to-intake manifold hose clamps (R) for cracks and bends. Inspect the rubber hose (S) for cracks, hardening, and set condition. Inspect studs (F-2) as directed in paragraph 153 d.

c. Repair. Repair the elbow (F-1) as directed in paragraph 154 b. Replace the turbosupercharger-to-intake-manifold hose clamps (R) when cracked or bent. Replace the rubber hose (S) when cracked, hardened, or in a set condition. Repair studs (F-2) as directed in paragraph 154 d.

d. Assembly. Install 3-inch id rubber hose (S) and turbosupercharger-to-intake manifold hose clamps (R) loosely elbow (F-1). Further adjustment and tightening will be accomplished during engine assembly.

## 225. IGNITION UNIT

Note. The key letters shown below in parentheses refer to figure 410 except where otherwise indicated.

a. Disassembly. Remove the two ignition unit clamps (H) from the ignition unit (L).

### b. Cleaning and Inspection.

- (1) Cleaning. Clean the ignition lead (M) and ignition unit (L) with warm water and soap. Clean the ignition unit clamps (H) using soap and water.
- (2) Inspection. Inspect the ignition lead (M) for cracks and frayed insulation. Check the ignition lead for continuity using a suitable continuity tester. Inspect the ignition unit (L) for cracks and dents. Check the ignition unit for continuity using a suitable continuity tester. Inspect the ignition unit clamps (H) for cracks and bends.

c. Repair. Replace the ignition lead (M) when cracked, frayed, or fails to pass continuity test. Replace the ignition unit (L) when cracked, dented, or fails to pass continuity test. Replace the ignition unit clamps (H) when cracked or bent.

d. Assembly. Install two ignition unit clamps (H)-on ignition unit (L).

## 226. INTAKE MANIFOLD FLAME HEATER ASSEMBLY

a. Disassembly. Disassemble the intake manifold flame heater assembly as directed in paragraph 79 d.

### b. Cleaning and Inspection.

- (1) Cleaning. Clean the intake manifold flame heater assembly as directed in paragraph 79 d.
- (2) Inspection. Inspect the intake manifold flame heater assembly as directed in paragraph 79 d.

c. Repair. Repair the intake manifold flame heater assembly as directed in paragraph 79 d.

d. Assembly. Assemble the intake manifold flame heater assembly as directed in paragraph 79 f.

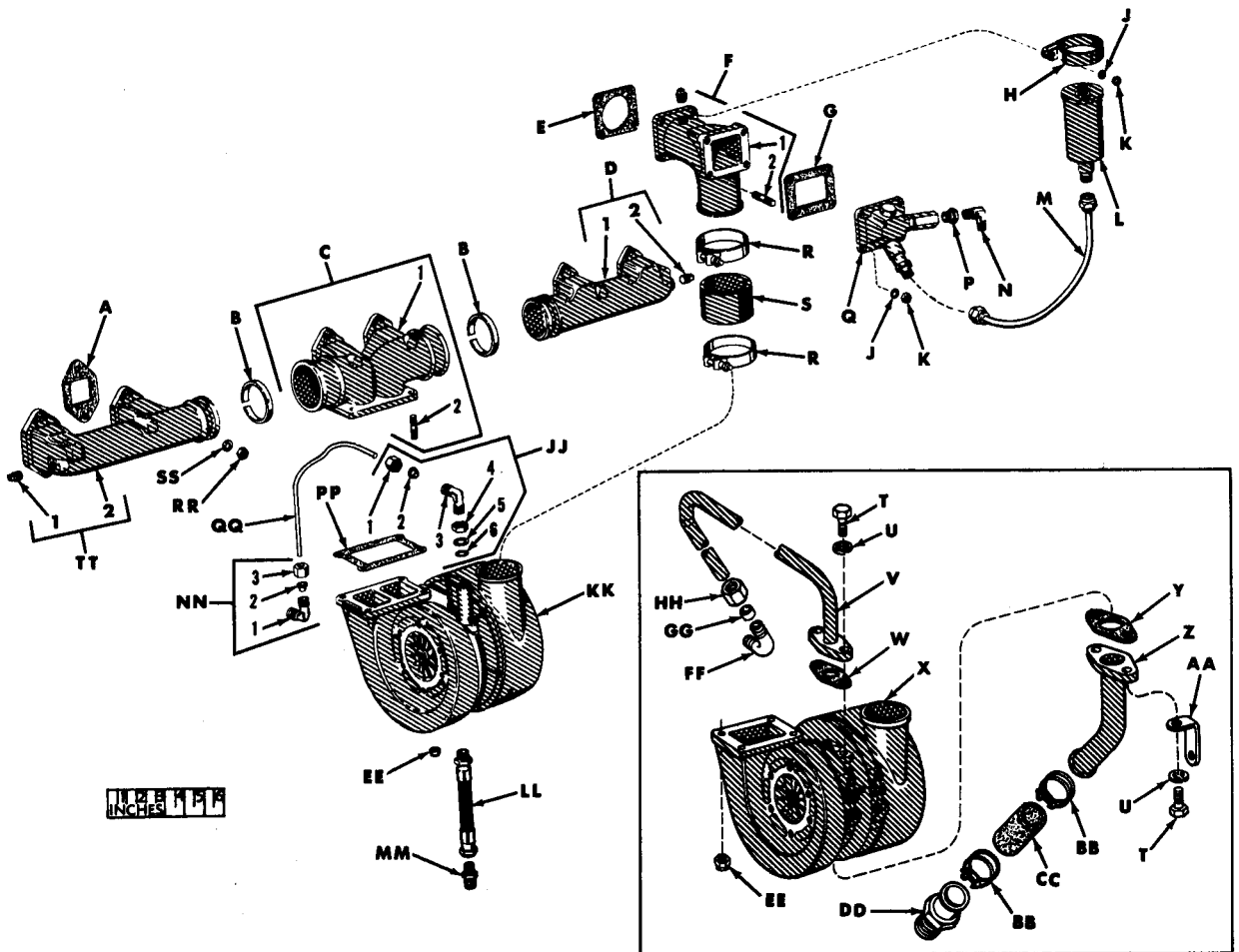
## 227. TURBOSUPERCHARGER OIL DRAIN HOSE AND OIL INLET TUBE

Note. The key letters shown below in parentheses refer to figure 410 except where otherwise indicated.

### a. Cleaning and Inspection.

- (1) Cleaning. Clean the oil inlet tubes (V and QQ) with dry-cleaning solvent. Flush tube with solvent and blow dry with compressed air. Clean the turbosupercharger oil drain hose (LL) (early models) with warm water and soap. Clean oil drain tube (Z) (late models) with dry-cleaning solvent.
- (2) Inspection. Inspect the oil inlet tubes and QQ) for cracks and dents. Inspect the turbosupercharger oil drain hose (LL) (early models) for frayed covering, hardening, and deterioration. Inspect oil drain tube (Z) (late models) for cracks and dents.

b. Repair. Replace oil inlet tubes (V and QQ) when cracked or dented. Replace the turbosupercharger oil drain hose (LL) (early models) when frayed, hardened, or deteriorated. Replace damaged oil drain tubes (Z) (late models).



ORD E51203

FIGURE 410. EXHAUST MANIFOLD, FLAME HEATER, AND RELATED PARTS - EXPLODED VIEW.

A - Exhaust manifold gasket	BB - 1-in. hose clamp (late model engines)
B - Exhaust manifold seal	CC - Oil drain hose (late model engines)
C - Exhaust manifold center section assembly	DD - 3/4-in. hose adapter (late model engines)
1- Exhaust manifold center section	EE - 3/8- in. self-locking nut
2- 3/8 x 1- 3/4 plain stud	FF - 1/2- in. tube, 90 degree elbow
D - Exhaust manifold front section assembly	GG - 1/2- in. tube sleeve
1- 1/2-in. pipe plug	HH - 1/2- in. sleeve nut
2- Exhaust manifold front section	JJ - 90 degree elbow assembly (early model engines)
E - Intake manifold elbow gasket	1- 9/16-in. tube nut
F - Intake manifold elbow assembly	2- 3/8-in. tube sleeve
1- Elbow	3- 9/16- 18UNF- 2A, 90 degree elbow
2- 5/16 x 1-3/8 plain stud	4- 9/16-in. plain nut
G - Flame heater gasket	5- 9/16-in. flat washer
H - Ignition unit clamp	6- 15/32 id x 5/64 thk preformed packing
J - 5/16- in. lock washer	KK - Turbosupercharger assembly (early model engines)
K - 5/16- in. plain nut	LL - Turbosupercharger oil drain hose (early model engines)
L - Ignition unit	MM - 3/4-in. tube union half (early model engines)
M - Ignition lead	NN - 90 degree elbow assembly (early model engines)
N - 1/8 pipe x 1/4 tube, 90 degree elbow	1- 1/4-NPT x 1/2- 18UNF 90 degree elbow
P - 1/4 x 1/8 pipe bushing	2- 3/8-in. tube sleeve
Q - Intake manifold flame heater assembly	3- 1/2-in. tube nut
R - Turbosupercharger- to- intake manifold hose clamp	PP - Turbosupercharger-to- exhaust manifold gasket
S - 3-in. id rubber hose	QQ - Oil inlet tube (early model engines)
T - 3/8 x 7/8 cap screw (late model engines)	RR - 7/16- in. self-locking nut
U - 3/8-in. lock washer (late model engines)	SS - 7/16- in. flat washer
V - Oil inlet tube (late model engines)	TT - Exhaust manifold rear section assembly
W - Oil inlet tube gasket (late model engines)	1- 1/2-in. pipe plug
Turbosupercharger assembly (late model engines)	2- Exhaust manifold rear section
Y - Oil outlet tube gasket (late model engines)	
Z - Oil outlet tube (late model engines)	
AA- Crankcase breather tube bracket (late model engines)	

FIGURE 410. EXHAUST MANIFOLD, FLAME HEATER, AND RELATED PARTS - EXPLODED VIEW - CONTINUED.

## Section XVI. REBUILD OF FLAME HEATER FUEL SYSTEM COMPONENTS

### 228. SOLENOID VALVES

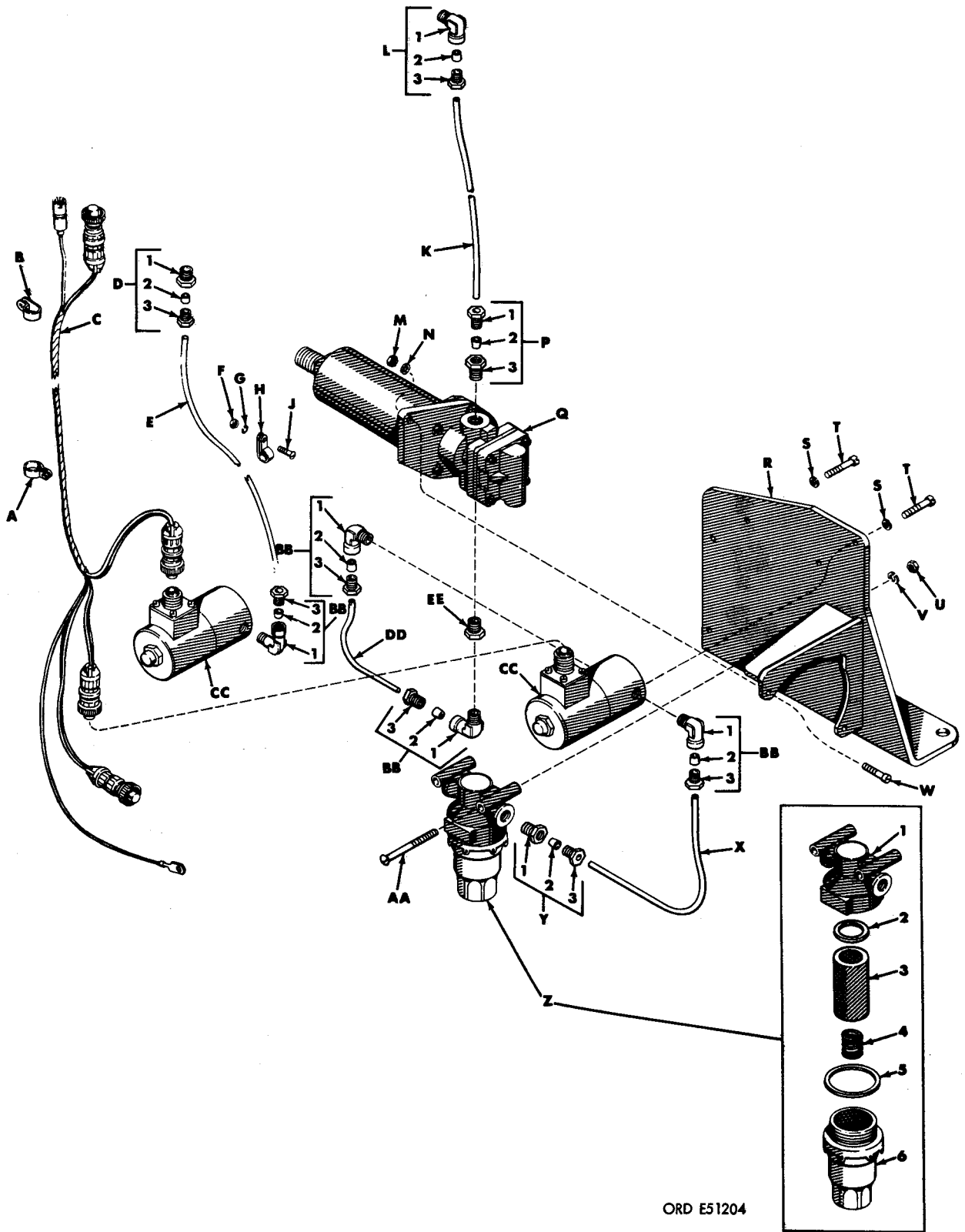
Note. The key letters shown below in parentheses refer to figure 411.

a. Removal. Remove four No. 10 x 1 machine screw No. 10 lock washers (S) and remove two solenoid valves (CC) from the flame heater fuel pump and fuel filter bracket.

b. Disassembly. Remove three elbows (BB-1) from solenoid valves (CC).

### c. Cleaning and Inspection.

- (1) Cleaning. Plug valve inlet and outlet openings to prevent entrance of foreign material. Clean the solenoid valves with a cloth moistened with dry-cleaning solvent. The valves contain rubber parts and should not be immersed in solvent.
- (2) Inspection. Inspect the solenoid valves for cracks and dents. Install suitable fittings, actuate solenoid valve with 24



ORD E51204

FIGURE 411. FLAME HEATER FUEL SYSTEM COMPONENTS - EXPLODED VIEW.

- A - Harness clamp
- B - Harness clamp
- C - Flame heater harness assembly
- D - Pipe connector assembly  
1-1/8-NPTF x 5/16-24NF-2A tube  
connector  
2-1/4-in. tube sleeve  
3-5/16-in. tube nut
- E - Heater fuel return-to- solenoid valve tube
- F - No. 10 plain nut
- G - No. 10 lock washer
- H - Cushioned tube clamp
- J - No. 10 x 3/8 machine screw
- K - Heater fuel pump-to-flame heater nozzle  
tube
- L - Elbow assembly  
1-1/8-NPTF x 5/16-24NF-2A 90 degree  
elbow  
2-1/8-in. tube sleeve  
3-5/16-in. tube nut
- M - No. 10 plain nut
- N - No. 10 lock washer
- P - Pipe connector assembly  
1-5/16-in. tube nut  
2-1/4-in. tube sleeve  
3-1/8-NPTF x 5/16-24NF-2A tube  
connector
- Q - Flame heater fuel pump assembly
- R - Flame heater fuel pump and fuel filter  
bracket
- S - No. 10 lock washer
- T - No. 10 x 1 machine screw
- U - No. 10 plain nut
- V - No. 10 lock washer
- W - No. 10 x 7/8 machine screw
- X - Fuel filter-to- solenoid valve tube
- Y - Pipe connector assembly  
1-1/8-NPTF x 5/16-24NF-2A tube  
2-1/4-in. tube sleeve  
3-5/16-in. tube nut
- Z - Flame heater fuel filter assembly  
1- Head  
2- Gasket  
3- Element  
4- Spring  
5- Packing  
6- Bowl
- AA- No. 10 x 1-3/4 machine screw
- BB - Elbow assembly  
1- 1/8-NPTF X 1/2-20NF X 2A  
90 degree elbow  
2- 1/4-in. tube sleeve  
3- 1/2-in. tube nut
- cc - Solenoid valve
- DD - Heater fuel pump-to-solenoid valve tube
- EE - 1/8-27NPT pipe coupling

FIGURE 411. FLAME HEATER FUEL SYSTEM COMPONENTS -  
EXPLODED VIEW - CONTINUED.

volt dc current, and pump fuel through the valve. When fuel flows freely, valve is functioning normally. Restricted fuel flow indicates a faulty electrical circuit or improper torque setting of acorn nut. Loosen acorn nut and torque tighten nut to 50 pound inches. Recheck solenoid operation. If valve is still inoperative, replace valve.

Note. Solenoid valves are normally closed and electrical current will open valves.

d. Repair. Replace the solenoid valves when cracked, dented, or they fail to pass electrical test.

e. Assembly Install three elbows (BB-1) in solenoid valve CC).

f. Installation. Position two solenoid valves (BB) on fuel pump and fuel filter bracket (R) and secure with four No. 10 lock washers (S) and No. 10 x 1 machine screws (T).

## 229. FLAME HEATER FUEL FILTER ASSEMBLY

Note. The key letters shown below in parentheses refer to figure 411 except where otherwise indicated.

a. Disassembly. Remove No. 10 plain nut (U), No. 10 lock washer (V and No. 10 x 1-3/4 machine screw (AA) and remove flame heater fuel filter assembly (Z) from flame heater fuel pump and fuel filter bracket (R). Disassemble the flame heater fuel filter assembly as directed in paragraph 81 b.

### b. Cleaning and Inspection.

- (1) Cleaning. Clean the flame heater fuel assembly as directed in paragraph 81 b.
- (2) Inspection. Inspect the flame heater fuel filter assembly as directed in paragraph 81 b.



c. Repair. Repair the flame heater fuel filter assembly as directed in paragraph 81 b.

d. Assembly. Assemble the flame heater fuel filter assembly as directed in paragraph 81 c. Position the flame heater fuel filter assembly (Z) on the flame heater fuel pump and fuel filter bracket (R) and secure with No. 10 plain nut (U), No. 10 lock washer (V), and No. 10 x 1-3/4 machine screw (AA).

Note. The other machine screw, lock washer, and nut securing flame heater fuel filter to bracket is installed during engine assembly.

### 230. FLAME HEATER HARNESS ASSEMBLY AND FLAME HEATER FUEL PUMP AND FUEL FILTER BRACKET

Note. The key letters shown below in parentheses refer to figure 411 except where otherwise indicated.

#### a. Cleaning and Inspection.

- (1) Cleaning. Clean the flame heater fuel pump and fuel filter bracket (R) as directed in paragraph 152 c. Wipe the flame heater harness assembly (C) with a clean dry cloth.
- (2) Inspection. Inspect the flame heater fuel pump and fuel filter bracket (R) as di-

rected in paragraph 153 b. Inspect the flame heater harness assembly (C) for cracked, frayed, and deteriorated insulation. Inspect for continuity using a low voltage circuit tester.

b. Repair. Repair the flame heater fuel pump and fuel filter bracket (R) as directed in paragraph 154 b. Replace the flame heater harness assembly (C) when insulation is cracked, frayed, or deteriorated or when it fails to pass continuity test.

### 231. TUBES AND CLAMPS

Note. The key letters shown below in parentheses refer to figure 411.

#### a. Cleaning and Inspection.

- (1) Cleaning. Clean tubes (E, K, X, and DD) and clamps (A, B, and H) with a clean dry cloth.
- (2) Inspection. Inspect tubes (E, K, X and DD) for deterioration, cracks, and kinks. Inspect clamps (A, B, and H) for cracks and bends.

b. Repair. Replace tubes (E, K, X, and DD) when deteriorated, cracked, or kinked. Replace clamps (A, B, and H) when cracked or bent.

---

## Section XVII. REBUILD OF FLAME HEATER FUEL PUMP ASSEMBLY

### 232. DISASSEMBLY

a. Remove Relief Valve Housing. Remove relief valve housing as follows.

- (1) Refer to figure 412 and scribe alignment marks on housing and base.

- (2) Figure 413. (A) Remove 5/16- inch check nut. (B) Remove relief valve adjusting screw from relief valve housing. (C) Remove 7/64 id x 0.070 thk preformed packing from relief valve adjusting screw and discard. (D) Remove compression spring. (E) Remove relief valve ball guide. (F) Remove relief valve ball.

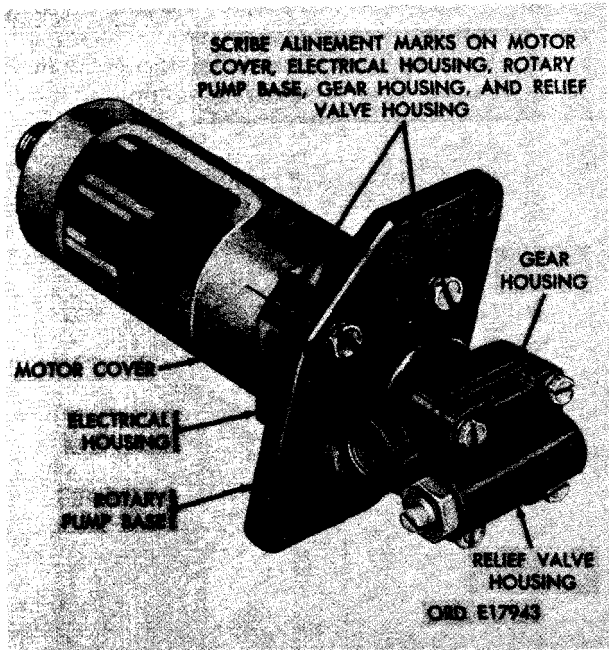


FIGURE 412. LOCATION OF ALIENMENT MARKS ON FLAME HEATER FUEL PUMP ASSEMBLY.

(3) Figure 414. (A) Remove four assembled washer screws securing relief valve housing to rotary pump base. (B) Remove relief valve housing.

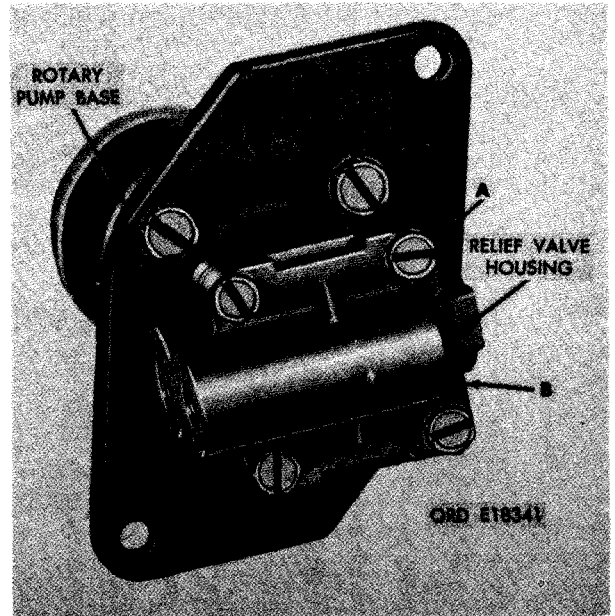


FIGURE 414. REMOVING OR INSTALLING RELIEF VALVE HOUSING.

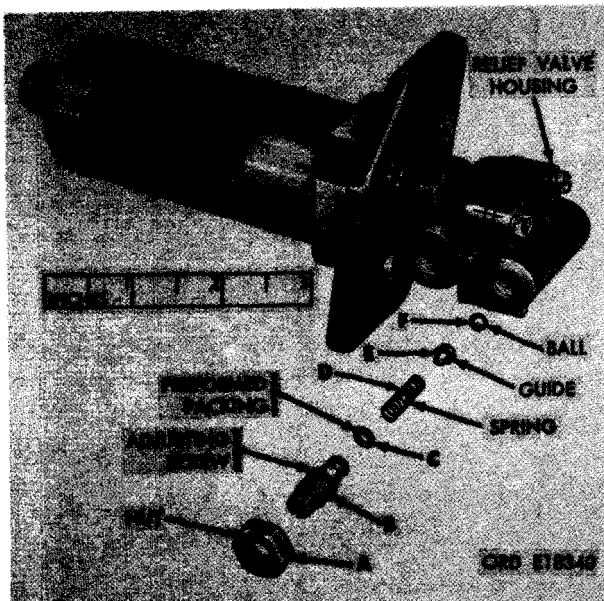


FIGURE 413. REMOVING OR INSTALLING RELIEF VALVE.

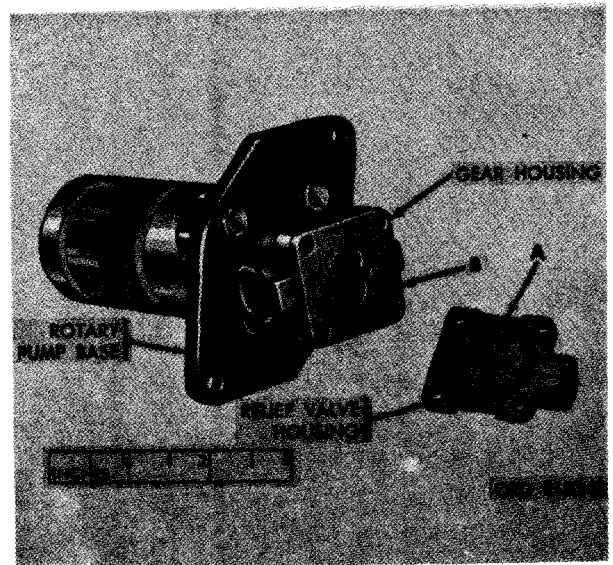


FIGURE 415. REMOVING OR INSTALLING GEAR HOUSING.

b. Remove Rotary Pump Base. Remove rotary pump base as follows.

- (1) Figure 415. (A) Remove 43/64 id x 0.070 thk preformed packing from relief valve housing and discard packing. (B) Remove gear housing from rotary pump base.
- (2) Figure 416. (A) Remove 43/64 id x 0.070 thk preformed packing from rotary pump base and discard packing. (B) Remove spur gearshaft and spur gear from rotary pump housing.

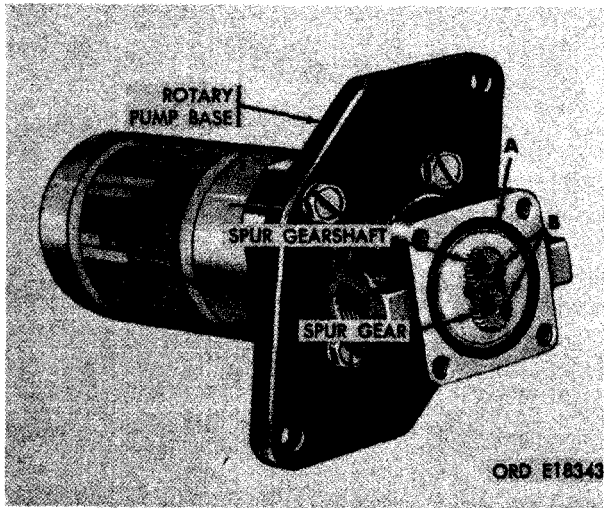


FIGURE 416. REMOVING OR INSTALLING SPUR GEAR AND SPUR GEARSHAFT.

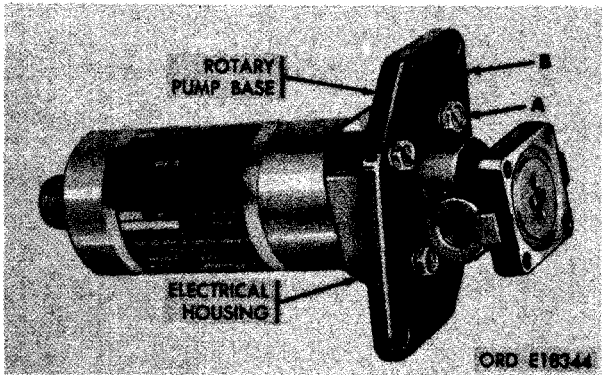


FIGURE 417. REMOVING OR INSTALLING ROTARY PUMP BASE .

- (3) Figure 417. (A) Remove four assembled washer screws securing rotary pump base to electrical housing. (B) Remove rotary pump base from electrical housing.
- (4) Refer to figure 418 and remove and discard housing gasket.

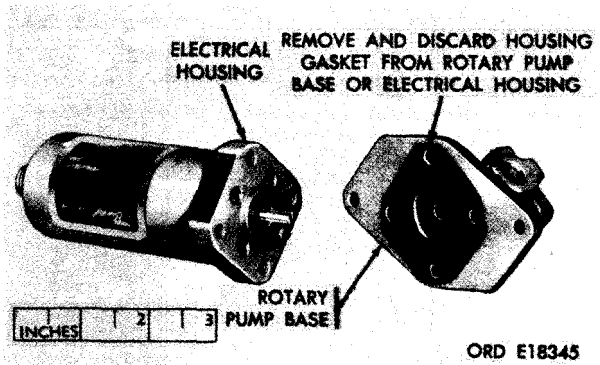


FIGURE 418. REMOVING OR INSTALLING HOUSING GASKET.

- (5) Remove large plain seal from base (fig. 419).

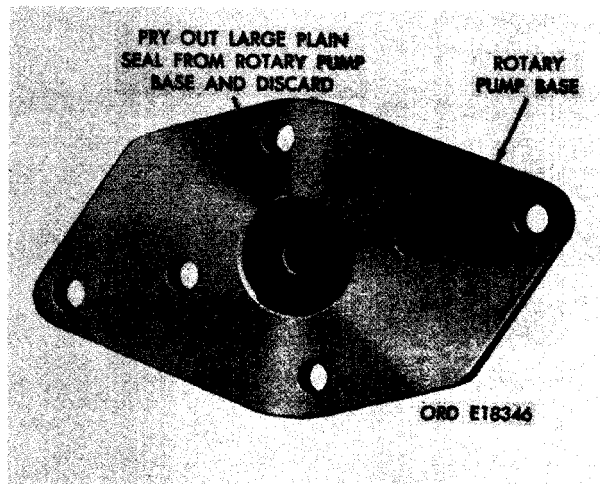


FIGURE 419. REMOVING OR INSTALLING LARGE PLAIN SEAL.

- (6) Figure 420. (A) Pry out retaining ring from rotary pump base and discard retaining ring. (B) Pry out small plain seal and discard seal.

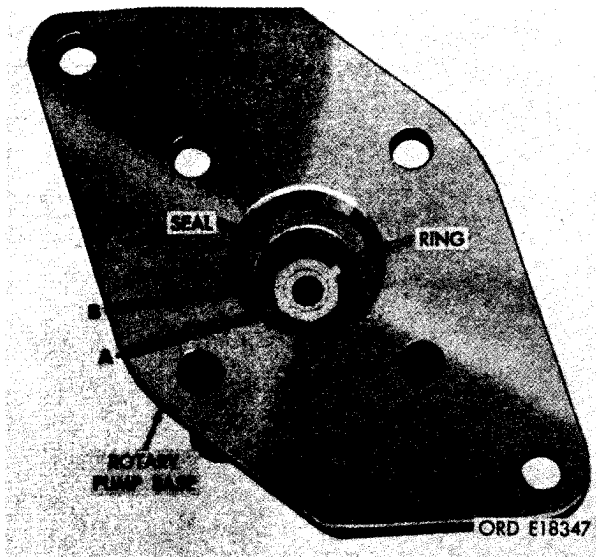


FIGURE 420. REMOVING OR INSTALLING SMALL PLAIN SEAL.

c. Remove Connector Receptacle, Motor Cover and Field Magnets. Remove receptacle, cover, and magnets as follows.

- (1) Figure 421. (A) Remove two No. 4 x 7/8 pan head machine screws and seal washers. (B) Remove two No. 4 x 3/8 pan head machine screws and seal

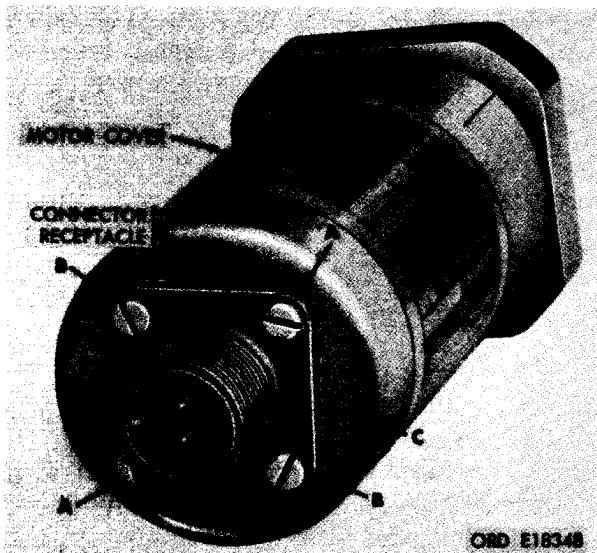


FIGURE 421. PARTIAL DISASSEMBLING OR ASSEMBLING OF CONNECTOR RECEPTACLE.

washers securing connector receptacle to motor cover. (C) Partially pull off connector receptacle as shown in figure 422.

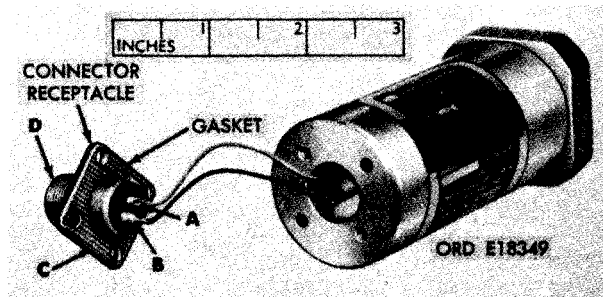


FIGURE 422. REMOVING OR INSTALLING CONNECTOR RECEPTACLE.

- (2) Figure 422. (A) Unsolder red wire from terminal marked "A" of connector receptacle. (B) Unsolder black wire from terminal marked "B" of connector receptacle. (C) Remove and discard connector receptacle gasket. (D) Remove connector receptacle.
- (3) Figure 423. (A) Twist cover clockwise to release and remove from preformed packing. (B) Scribe alignment marks on rotating housing and motor frame to insure proper alignment during assembly.

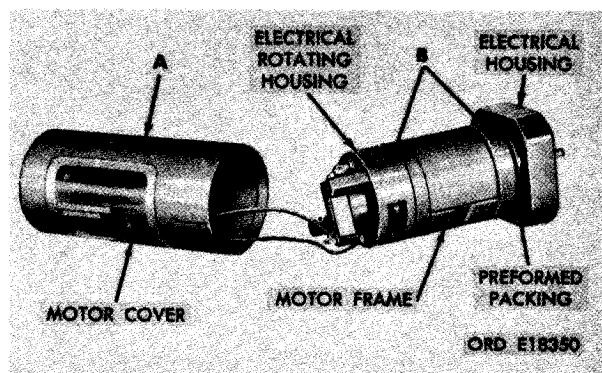


FIGURE 423. REMOVING OR INSTALLING MOTOR COVER.

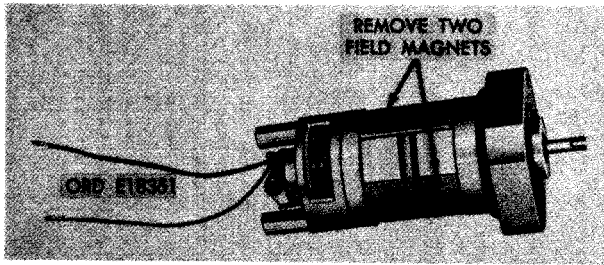


FIGURE 424. REMOVING OR INSTALLING FIELD MAGNETS.

(4) Remove field magnets (fig. 424).

d. Remove Electrical Housing and Armature.  
Remove housing and armature as follows.

(1) Figure 425. (A) Pull back on the brush spring. (B) Roll the brush out just far enough to clear the commutator. Hold brushes in raised position with spring resting against brush. Holding brushes with spring will prevent brushes from striking ball bearing on end of commutator during electrical housing removal (fig. 427). (C) Perform the same steps to remove the remaining brush.

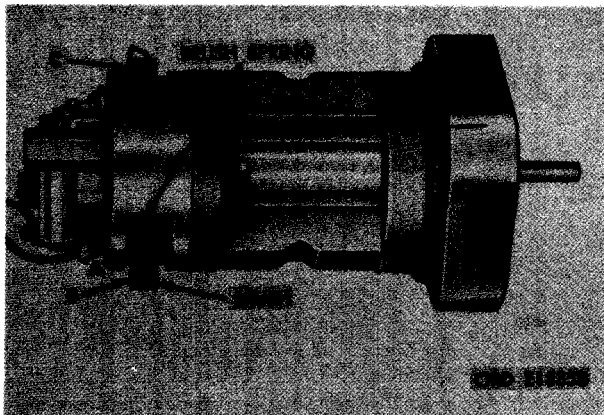


FIGURE 425. POSITIONING BRUSHES IN BRUSH HOLDERS.

(2) Figure 426. (A) Remove two mounting studs securing electrical rotating housing to motor frame. (B) Remove electrical rotating housing and associated parts from motor frame.

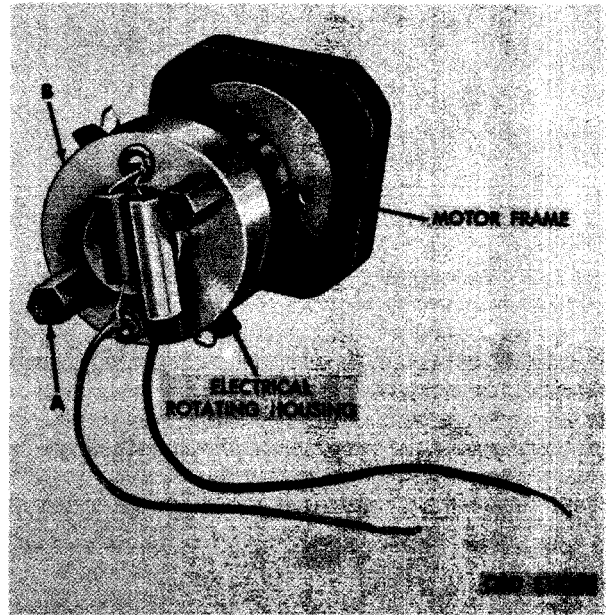


FIGURE 426. REMOVING ELECTRICAL ROTATING HOUSING AND ASSOCIATED PARTS FROM MOTOR FRAME.

(3) Figure 427. (A) Remove magnetized spring washer from ball bearing. (B) Remove shims from electrical rotating housing. Count number of shims used and save for assembly.

(4) Remove armature from motor frame (fig. 428).

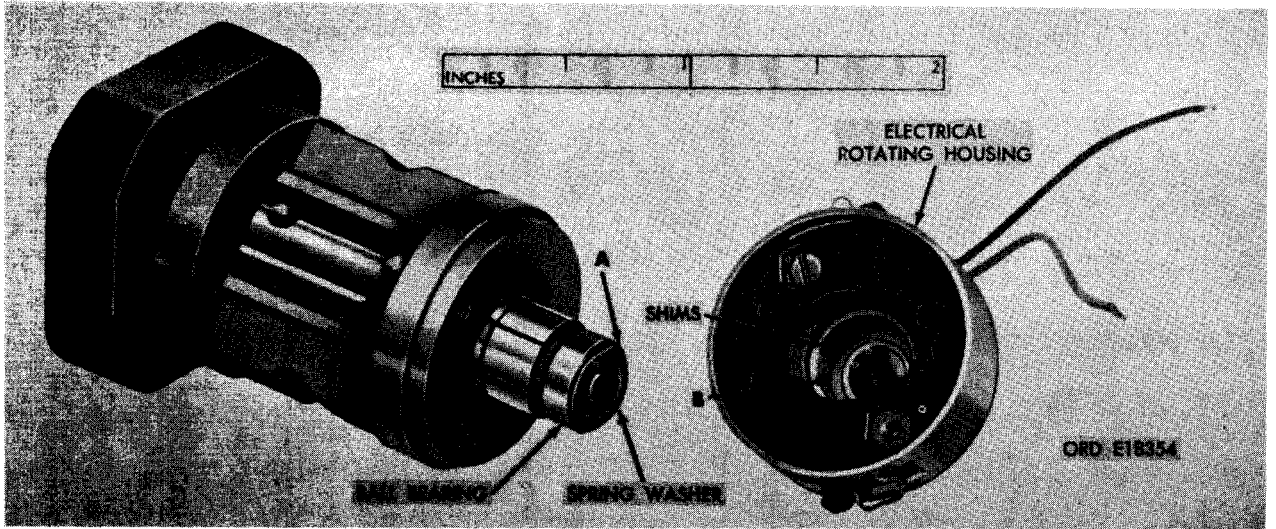


FIGURE 427. REMOVING SPRING WASHER AND SHIMS.

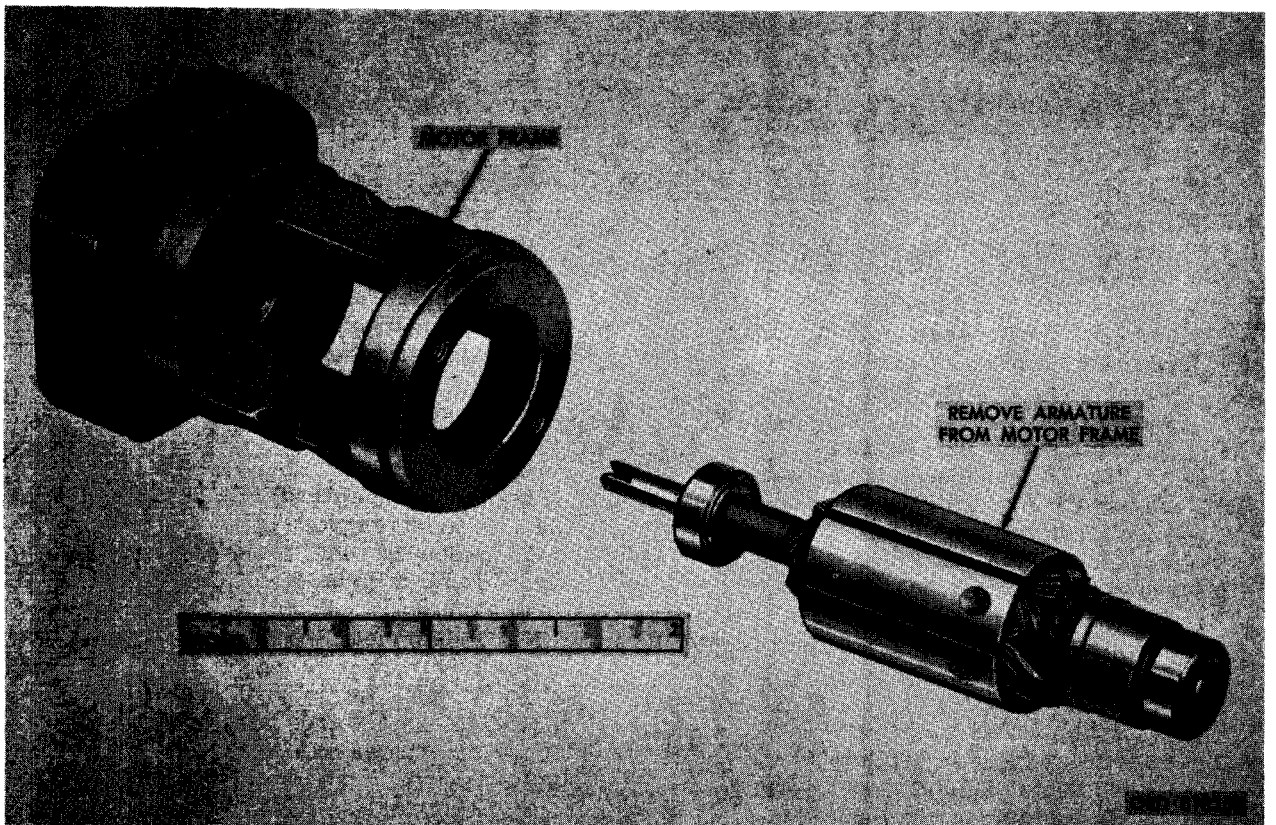


FIGURE 428. REMOVING ARMATURE FROM MOTOR FRAME.

- (5) Figure 429. (A) Remove four No. 4 x 3/4 pan head machine screws and seals securing the electrical housing to the motor frame. (B) Remove the electrical housing.

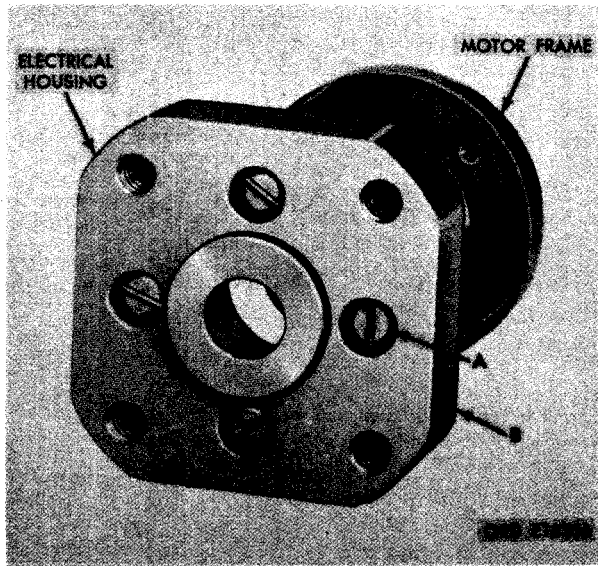


FIGURE 429. REMOVING ELECTRICAL HOUSING.

- A - No. 4 x 3/8 pan-head machine screw
- B - Machine screw seal washer
- C - Connector receptacle
- D - Connector receptacle gasket
- E - Motor identification plate
- F - Pump identification plate
- G - Motor cover
- H - Machine screw seal washer
- J - No. 4 x 7/8 pan-head machine screw
- K - Electrical insulator
- L - Insulated choke
- M - Capacitor
- N - No. 4 x 3/4 pan-head screw
- P - Screw seal washer
- Q - No. 3 x 3/8 round head machine screw
- R - Electrical terminal
- S - No. 3 flat washer
- T - Upset insulating washer
- U - Electrical rotating housing
- Y - Brush holder insulator
- W - Brush holder
- X - Electrical terminal

- (6) Remove packing from electrical housing (fig. 430).

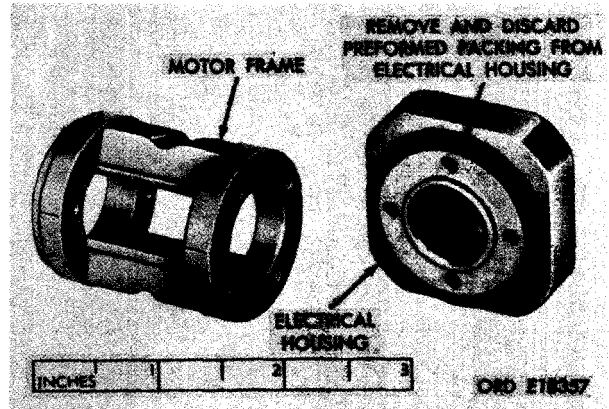


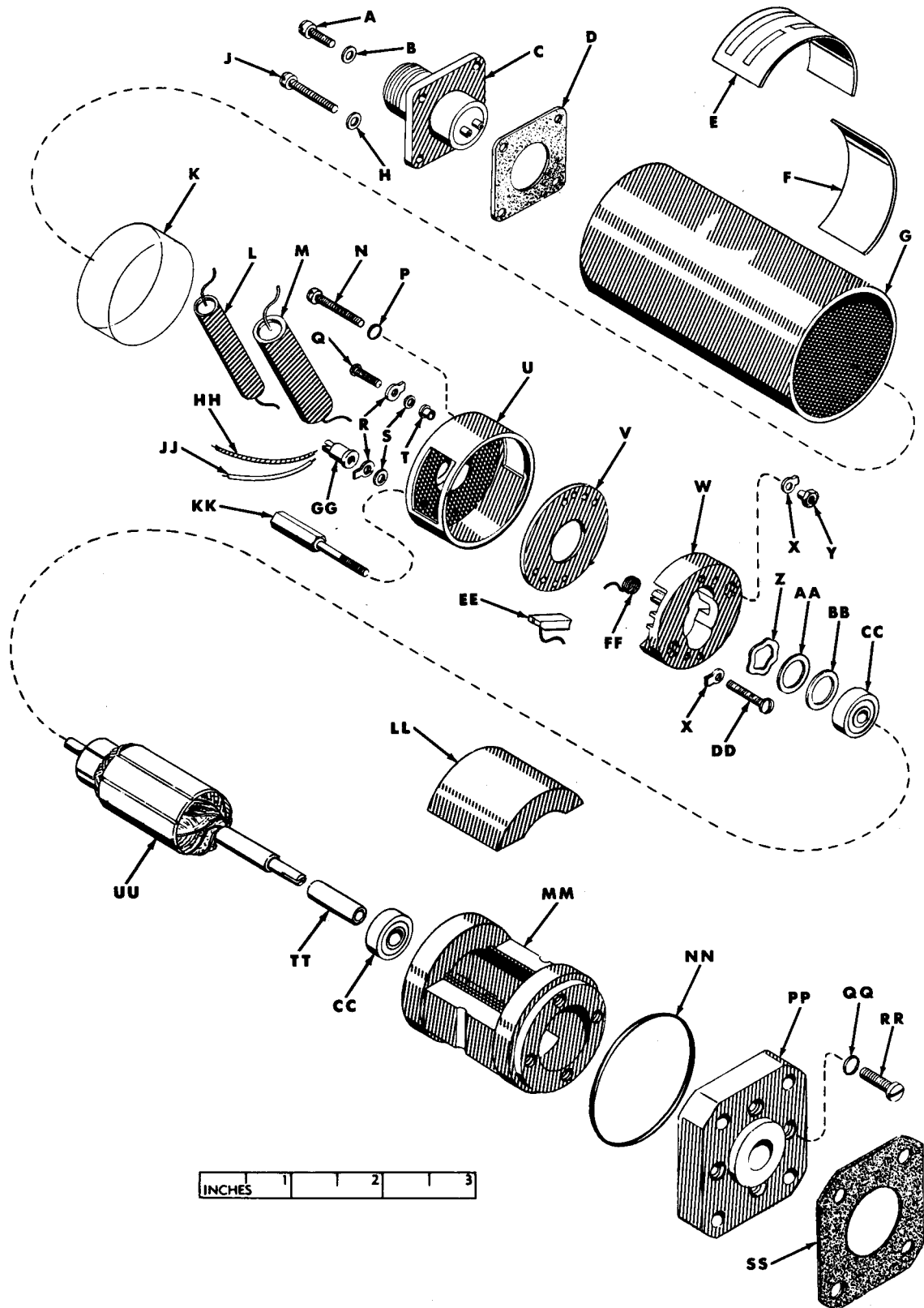
FIGURE 430. REMOVING OR INSTALLING PREFORMED PACKING.

### 233. CLEANING

Note. The key letters shown below in parentheses refer to figure 431 except where otherwise indicated.

- Y - Terminal nut
- Z - Spring washer
- AA - End play adjusting shim
- BB - End play adjusting shim
- CC - Armature ball bearing
- DD - No. 4 x 1/2 pan-head machine screw
- EE - Brush
- FF - Brush spring
- GG - Terminal nut
- HH - Black wire (lead)
- JJ - Red wire (ground)
- KK - Mounting stud
- LL - Field magnet
- MM - Motor frame
- NN - Preformed packing
- PP - Electrical housing
- QQ - Machine screw seal washer
- RR - No. 4 x 3/4 pan-head machine screw
- SS - Housing gasket
- TT - Bearing spacer
- UU - Armature

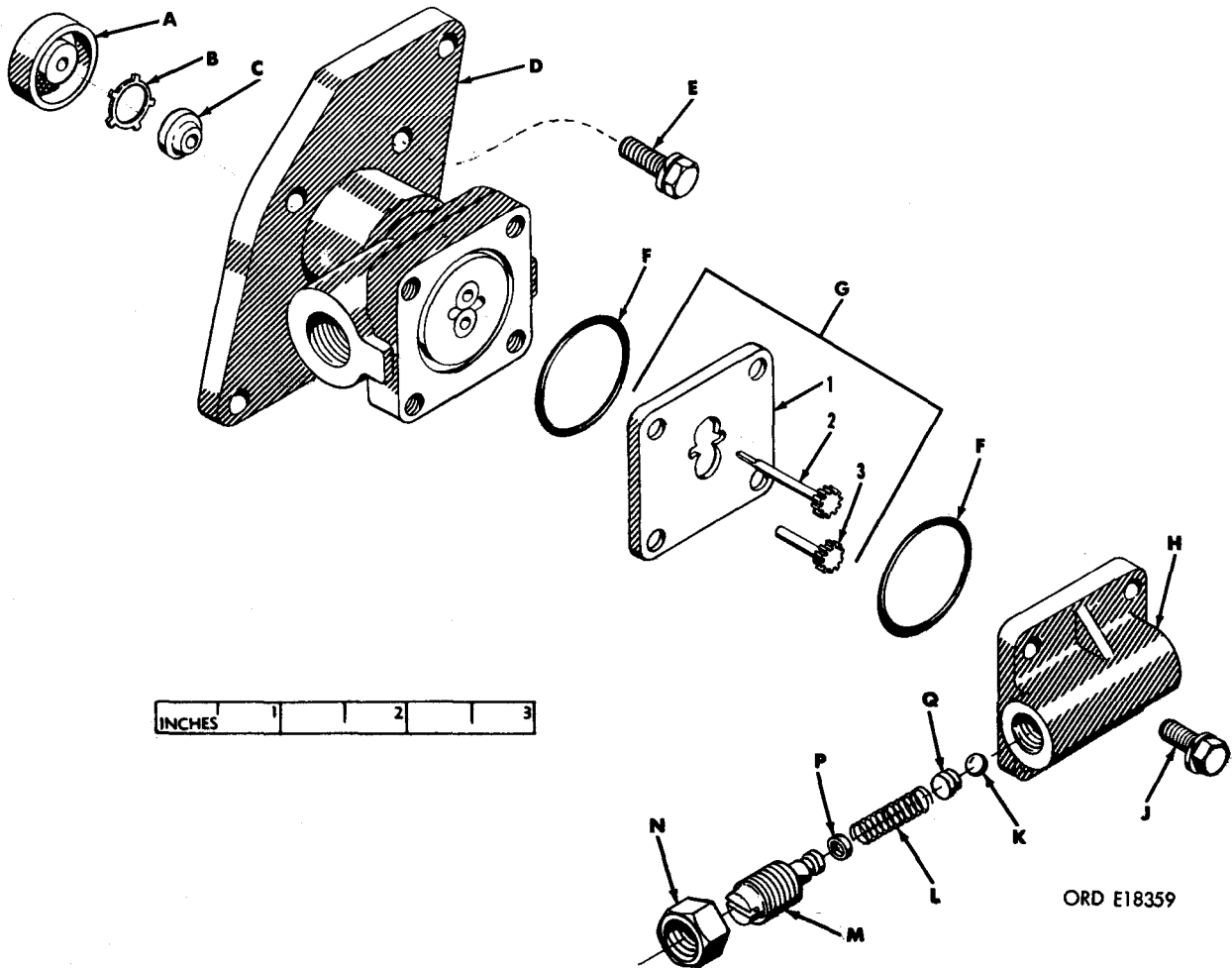
FIGURE 431. FLAME HEATER FUEL PUMP ASSEMBLY - EXPLODED VIEW - LEGEND.



ORD E18358

FIGURE 431. FLAME HEATER FUEL PUMP ASSEMBLY - EXPLODED VIEW.





ORD E18359

- A - Large plain seal
- B - Retaining ring
- C - Small plain seal
- D - Rotary pump base
- E - No. 10 x 1/2 assembled washer screw
- F - 43/64 id x 0.070 thk preformed packing
- G - Gear and housing assembly
  - 1- Gear housing
  - 2- Spur gearshaft
  - 3- Spur gear

- H - Relief valve housing
- J - Assembled washer screw
- K - Relief valve ball
- L - Compression spring
- M - Relief valve adjusting screw
- N - 5/16-in. check nut
- P - 7/64 id x 0.070 thk preformed packing
- Q - Relief valve ball guide

FIGURE 432. ROTARY FUEL PUMP - EXPLODED VIEW.

**a. General.** Special cleaning instructions for electricals are detailed in paragraphs b through e, below. Clean castings as directed in paragraph 152b.

**b. Armature.** Remove loose particles from armature with compressed air and wipe clean with a cloth dampened with dry-cleaning solvent. Clean commutator lightly with No. 00

sandpaper and remove all traces of dust with compressed air.

**Caution:** Do not spin ball bearings (CC) with compressed air or attempt cleaning them with dry-cleaning solvent. Bearings are prelubricated and sealed. Refer to TM 9-214 for care and maintenance of ball bearings.

c. Brushes. Clean brushes (EE) with a clean, dry cloth only. Do not permit dry-cleaning solvent to contact the brushes.

d. Insulated Choke and Capacitor. Wipe the insulated choke (L) and capacitor (M) with a clean, dry cloth. Do not allow dry-cleaning solvent to contact the insulated choke and capacitor.

e. Brush Holder and Insulator. Clean brush holder (W) and insulator (V) with a cloth dampened with dry-cleaning solvent. Dry thoroughly with compressed air.

#### 234. INSPECTION AND REPAIR

**Note.** The key letters shown below in parentheses refer to figure 431 except where otherwise indicated.

a. General. Refer to paragraphs 153 and 154 for general inspection and repair instructions. Special inspection and repair instructions are listed in paragraphs b through f below.

b. Relief Valve Housing. Inspect the relief valve ball (K, fig. 432) and the ball seating area in the relief valve housing (H, fig. 432) for scores, scratches, and wear patterns. Replace parts when any of the above conditions exist.

##### c. Insulated Choke and Capacitor.

(1) Inspection. Inspect the insulated choke and capacitor (M) for frayed or cracked insulation. Test the insulated choke for continuity using a continuity tester. Remove either if defective.

(2) Removal. Figure 433. (A) Unsolder capacitor and insulated choke leads from terminal. (B) Unsolder remaining capacitor lead and black wire lead from terminal. (C) Remove capacitor and black wire. (D) Unsolder remaining insulated choke lead and red wire lead

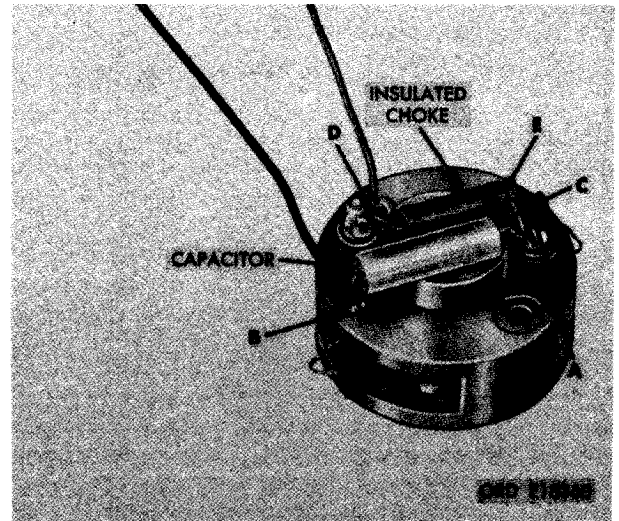


FIGURE 433. REMOVING OR INSTALLING CAPACITOR AND INSULATED CHOKE.

from terminal. (E) Remove insulated choke and red wire.

##### d. Brushes and Brush Springs.

(1) Inspection. Inspect brushes (EE) and brush springs (FF) for cracks or breaks.

(2) Check brush length. Figure 434. (A) Pull brushes out of brush holders. (B) Measure brush length. New brushes are 3/8-inch long. Serviceable brushes should be at least 5/16-inch long.

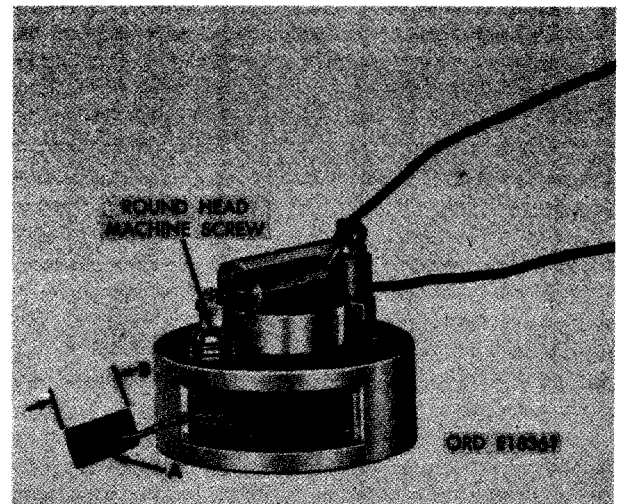


FIGURE 434. MEASURING BRUSH LENGTH.

Note. When brushes are worn to 5/16-inches less, remove and replace the two brushes and brush springs following instructions which accompany figures 435 through 437.

- (3) Remove brush holder. Figure 435. (A) Remove No. 4 x 1/2 pan-head machine screw securing brush holder to electrical rotating housing. (B) Remove No. 3 x 3/8 round-head machine screw (fig. 434) securing brush holder to electrical rotating housing. (C) Remove brush holder from electrical rotating housing.

Note. It is not necessary to unsolder insulated choke, capacitor, or wire leads to replace brushes.

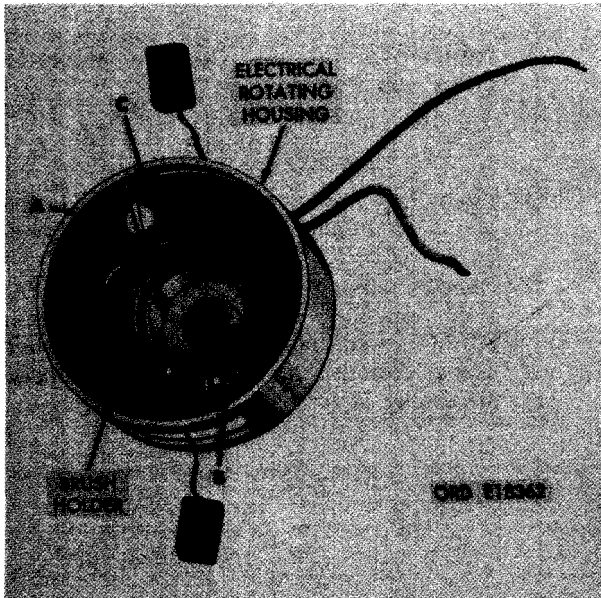


FIGURE 435. REMOVING OR INSTALLING BRUSH HOLDER.

- (4) Remove brush holder insulator. Refer to figure 436 and remove brush holder insulator.

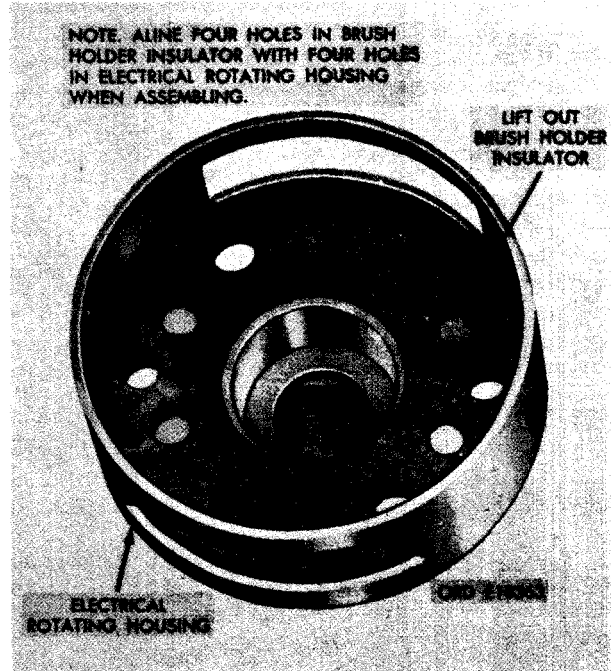


FIGURE 436. REMOVING OR INSTALLING BRUSH HOLDER INSULATOR.

- (5) Remove brush and brush springs. Figure 437. (A) Pull brushes out of brush holders. (B) Pull brush springs from brush holders.

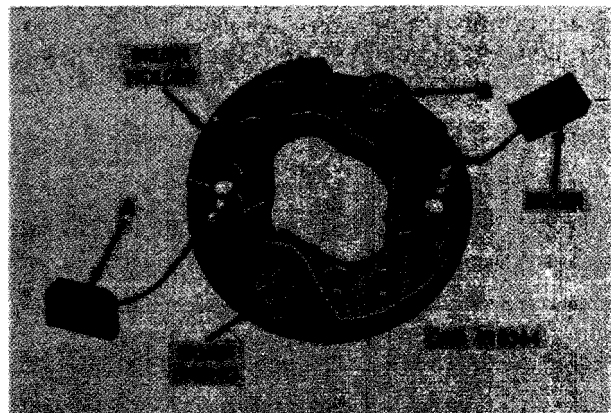


FIGURE 437. REMOVING OR INSTALLING BRUSHES AND BRUSH SPRINGS.

e. Armature and Ball Bearings.

- (1) Test armature for grounds. Test the armature (UU) for grounds as shown in figure 438. Use a 24-volt dc test lamp and contact one lead to end of armature shaft. Touch each commutator bar in turn with the other lead. When test lamp lights, as one individual bar is connected, a short circuit exists in the armature insulation between armature shaft and commutator bar. Replace armature when bars are short-circuited.

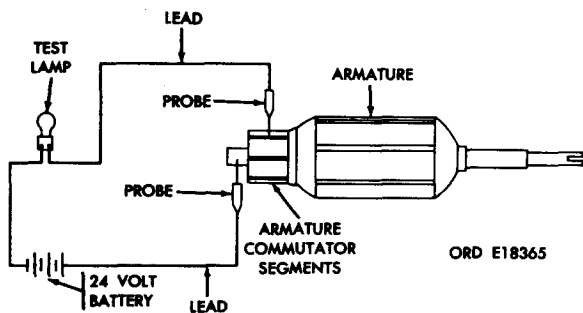


FIGURE 438. TESTING ARMATURE FOR GROUNDS USING TEST LAMP.

- (2) Check armature commutator bar and clean mica insulation.
  - (a) Check brush contact area on commutator bars for excessive wear. When

worn excessively, replace armature. Turning down armature and undercutting mica is not recommended when commutator is damaged. Clean the insulation between commutator bars by carefully running a sharp knife blade between the bars. Cleaning grooves will remove any possible brush carbon or metal filings which would possibly short out bars. Remove two ball bearings (CC) and spacer (TT), to replace a damaged or defective armature.

- (b) Remove ball bearings as follows. Figure 439. (A) Remove front ball bearing using a suitable bearing puller. (B) Remove rear ball bearing using a suitable bearing puller. (C) Remove rear ball bearing spacer.

Note. Install new ball bearings by pushing them onto armature shaft, by hand, until tight against shoulder on shaft. If necessary, use a small hollow tube, with inside diameter a little larger than armature shaft diameter, to butt against ball bearing inner race to tap bearings into position.

- (3) Ball bearings. Inspect the ball bearing (CC) on each end of armature shaft for roughness or uneven rolling action. When ball bearings are unserviceable, replace both ball bearings (fig. 439).

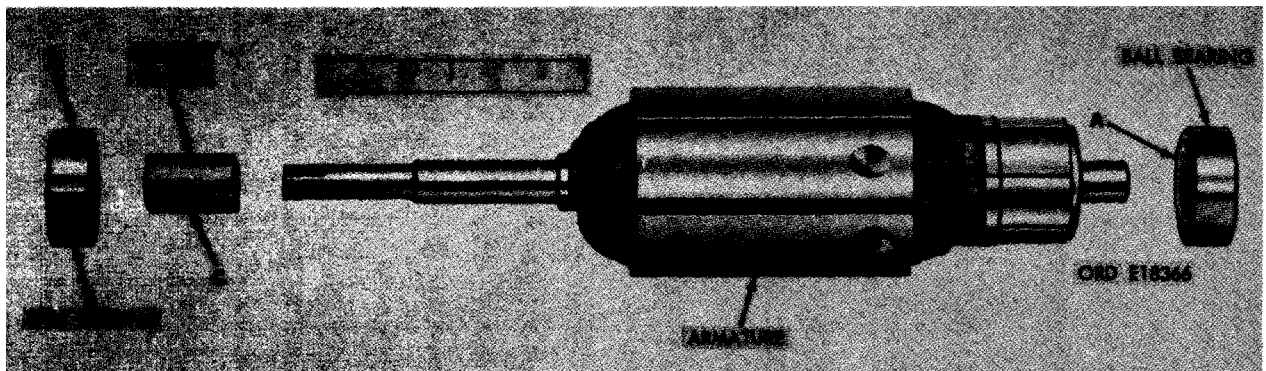


FIGURE 439. REMOVING OR INSTALLING ARMATURE BALL BEARINGS.

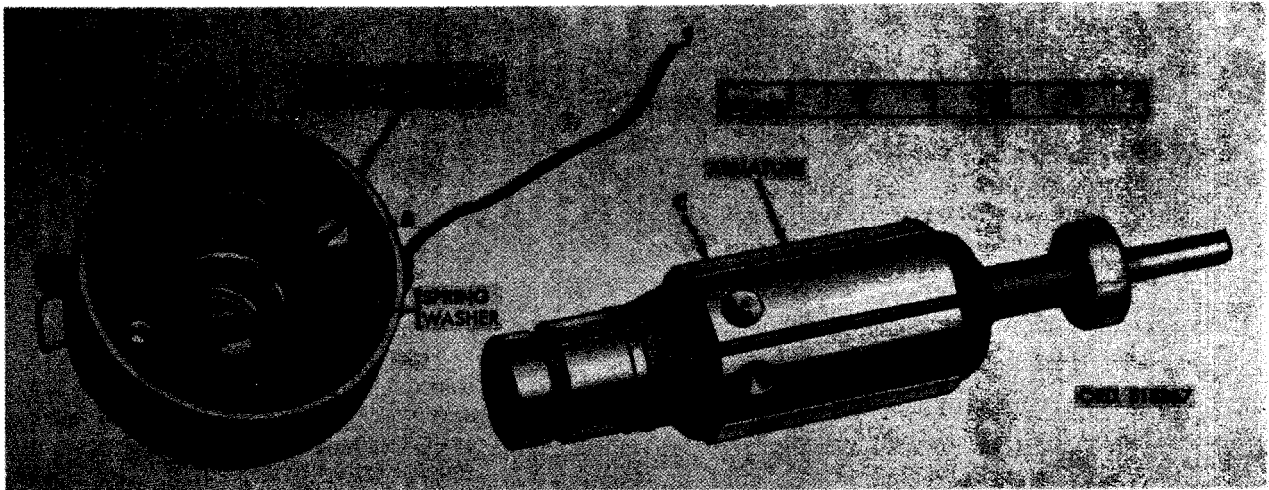


FIGURE 440. POSITIONING ARMATURE IN ELECTRICAL HOUSING.

235. ASSEMBLY

a. Install Armature and Electrical Housing.  
Install armature and electrical housing as follows.

- (1) Figure 440. (A) Install the same number of shims as were removed during disassembly (fig. 427). (B) Install the spring washer. (C) Position the armature in the electrical rotating housing, against spring washer.

Note. Armature end play is controlled by these shims. The amount of shims

and thickness of shim pack cannot be determined at this stage of assembly. Refer to figure 443.

- (2) Figure 441. (A) Position motor frame so alignment mark, made at disassembly, aligns with the alignment mark on the electrical rotating housing. (B) Install two mounting studs.
- (3) Figure 442. (A) Install preformed packing as shown in figure 430 over base of electrical housing. (B) Position electrical housing so alignment mark, made at disassembly, aligns with the alignment mark on the motor frame. (C) Install four No. 4 x 3/4 pan-head machine screws and seals. (D) Position brushes in brush holder.

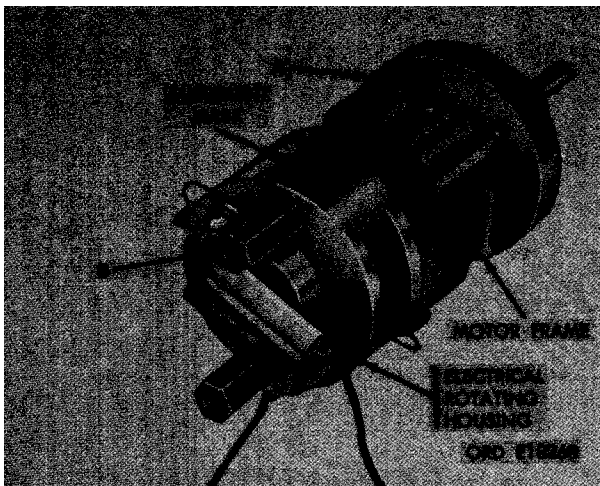


FIGURE 441. INSTALLING MOTOR FRAME

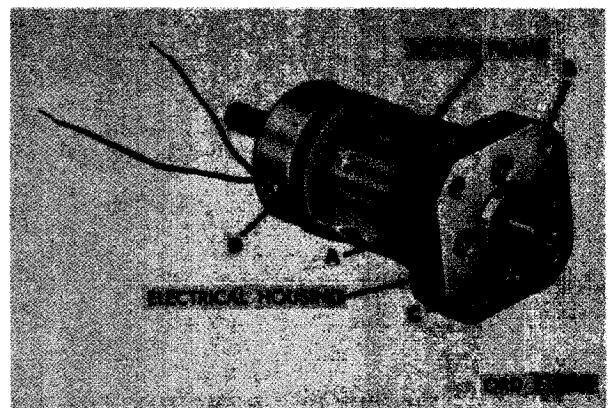


FIGURE 442. INSTALLING ELECTRICAL HOUSING.

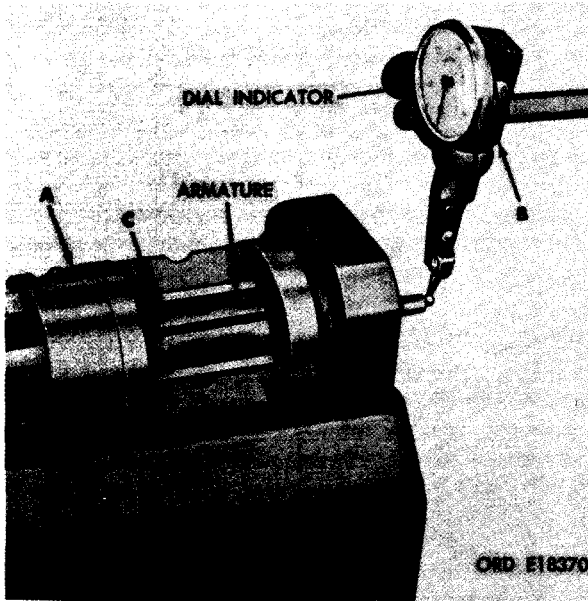


FIGURE 443. CHECKING ARMATURE END PLAY USING DIAL INDICATOR.

**b. Check Armature End Play.** Figure 443. (A) Mount armature and associated parts in a soft-jawed vise. (B) Set up a suitable dial indicator so arm rests on armature shaft. (C)

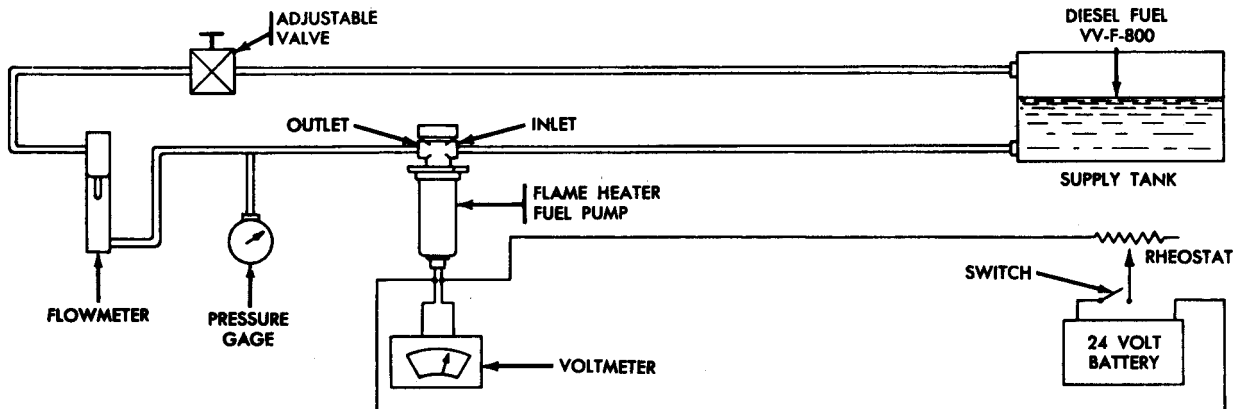
Slide armature back and fourth and take end play reading on dial indicator. Correct end play should be from 0.003 to 0.005-inch.

**Note.** When end play is not between 0.003-inch and 0.005-inch, refer to figures 441 and 442 and reverse the sequence of illustrations and instructions to partially disassemble pump motor. Add or subtract spacer shims as required until proper end play is established.

**c. Field Magnets, Motor Cover, and Connector Receptacle.** Refer to figures 421 through 424 and reverse the sequence of illustrations and instructions to install the field magnets, motor cover, and connector receptacle.

**d. Rotary Pump Base.** Refer to figures 417 through 420 and reverse the sequence of illustrations and instructions to install the rotary pump base.

**e. Relief Valve Housing.** Refer to figures 413 through 415 and reverse the sequence of illustrations and instructions to install relief valve housing.



TESTS

INPUT VOLTAGE	INPUT CURRENT	OUTPUT PRESSURE	OUTPUT FLOW
14VDC $\pm$ 0.5	3.0 amps max	90 psig $\pm$ 5	3.5 GPH min
29VDC $\pm$ 0.5	3.0 amps max	120 psig $\pm$ 5	3.75 GPH min
		150 psig max	Set at zero flow

ORD E51205

FIGURE 444. FUEL PUMP TEST EQUIPMENT.

## 236. TESTS

Caution: The flame heater fuel pump electrical system is negative grounded. Pin "A" is positive and pin "B" is negative. Do not reverse polarity of pump during checking or installation. Reversing polarity will permanently damage pump.

a. Relief Valve Setting. Refer to figure 444 and connect test equipment as shown. Connect a 0-200 psi pressure gage to the outlet of the flame heater fuel pump. Connect a hose from the inlet to a source of Diesel fuel (V-V- F- 800).

Connect a 24-volt power supply to the two terminals of the fuel pump. Loosen check nut (N, fig. 432) and turn the relief valve adjusting screw (M, fig. 432) until a reading of 90-100 psi is obtained on the pressure gage. Lock the relief valve adjusting screw with 5/16- inch check nut.

b. Flow Tests. Connect the flame heater fuel pump as shown in figure 444. Adjust the rheostat to give the input voltages shown on figure 444. The output pressure and output flow must meet the requirements shown.

---

## Section XVIII. REBUILD OF AIR COMPRESSOR ADJUSTABLE PULLEY, AIR INTAKE MANIFOLD, AND MISCELLANEOUS ENGINE COMPONENTS

### 237. AIR COMPRESSOR ADJUSTABLE PULLEY

Note. The key letters shown below in parentheses refer to figure 445 except where otherwise indicated.

a. Removal. Remove air compressor adjustable pulley as follows.

- (1) Remove two 3/8 x 1-1/2 cap screws (C) and 3/8- inch lock washers (D) securing the adjustable flange pulley (E) to the adjustable pulley (B). Using adjusting pulley wrench -10935288 (figs. 23 and 81), turn the adjustable flange pulley counterclockwise to remove it.

Note. The removal of two cap screws is not required for disassembly, it just permits closer inspection of the threaded holes.

- (2) Remove 3/4- inch self-locking nut (F) securing the adjustable pulley (B) to compressor crankshaft. Using a universal puller, remove the adjustable pulley from the crankshaft.
- (3) Remove 1/4 x 1 Woodruff key (A-11) from compressor crankshaft.

b. Cleaning and Inspection.

- (1) Cleaning. Clean adjustable flange pulley (E), adjustable pulley (B), and related parts using dry- cleaning solvent and mineral spirits paint thinner as

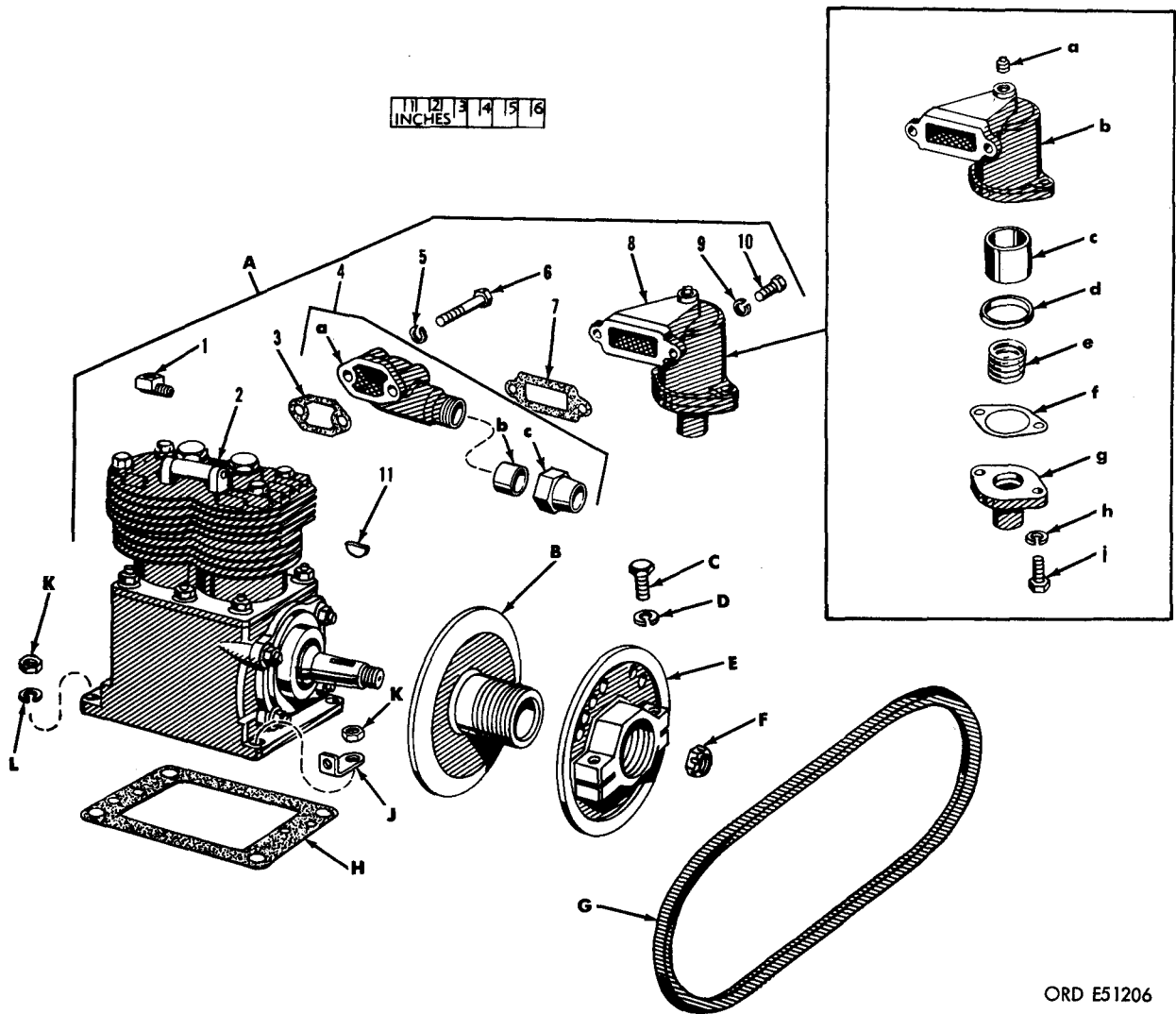
directed in paragraph 152c. Dry all parts with compressed air.

- (2) Inspection. Inspect adjustable flange pulley (E) and adjustable pulley (B) for cracks and damage. Carefully inspect all threads for galled, stripped, or damaged areas. Check clamping sections of the adjustable flange pulley for broken or distorted sections. Check belt surface of both pulley sections for nicks, wear, and damage. Check keyway of the adjustable pulley for galling due to loose operation on the compressor crankshaft.

c. Repair. Repair minor damage to belt surfaces of the adjustable flange pulley (E) and adjustable pulley (B) with a fine mill file or crocus cloth dipped in dry-cleaning solvent or mineral spirits paint thinner. Repair damaged threads of the adjustable pulley using a fine mill file. If threads for 3/8 x 1-1/2 cap screws are slightly damaged, use a tap to repair the threads. Replace the adjustable flange pulley and adjustable pulley if either part is broken, cracked, or damaged beyond repair.

d. Installation. Install air compressor adjustable pulley as follows.

- (1) Install 1/4 x 1 Woodruff key (A-11) in keyway of compressor shaft.
- (2) Use a soft-faced hammer to drive the adjustable pulley (B) on the compressor crankshaft. Install 3/4- inch self- locking nut (F) to secure the adjustable pulley.



ORD E51206

- A - Air compressor assembly
  - 1- 90 degree elbow
  - 2- Air compressor
  - 3- Discharge housing gasket
  - 4- Discharge housing assembly
    - a - Discharge housing
    - b - Tube sleeve
    - c - Tube nut
  - 5- 5/16-in. lock washer
  - 6- 5/16 x 1-1/4 cap screw
  - 7- Air intake manifold-to-compressor gasket
  - 8- Air intake manifold assembly
    - a - 1/8-in. pipe plug
    - b - Manifold
    - c - Filter
    - d - Plate
    - e - Spring
  - 9- 5/16-in. lock washer
  - 10- 5/16 x 3/4 cap screw
  - 11- 1/4 x 1 Woodruff key
- B - Adjustable pulley
- C - 3/8 x 1-1/2 cap screw
- D - 3/8 in. lock washer
- E - Adjustable flange pulley
- F - 3/4 in. self-locking nut
- G - Air compressor drive belt
- H - Air compressor-to- support gasket
- J - Tachometer cable bracket
- K - 7/16- in. plain nut
- L - 7/16- in. lock washer
- f - Gasket
- g - Cap
- h - 5/16-in. lock washer
- j - 5/16 x 3/4 cap screw

FIGURE 445. AIR COMPRESSOR AND RELATED PARTS - EXPLODED VIEW.



- (3) Using adjusting pulley wrench - 10935288, turn the adjustable flange pulley (E) clockwise on the adjustable pulley. Install two 3/8 x 1-1/2 cap screws (C) and 3/8-inch lock washers (D).

Note. It is not necessary to tighten the two cap screws at this time. Tighten cap screws after the compressor drive belt tension has been adjusted (par. 108).

### 238. AIR COMPRESSOR AIR INTAKE MANIFOLD ASSEMBLY

Note. The key letters shown below in parentheses refer to figure 445 except where otherwise indicated.

a. Removal. Remove two 5/16 x 3/4 cap screws (A-10) and 5/16-inch lock washers (A-9) securing air intake manifold assembly (A-8) to the air compressor. Remove and discard air intake manifold to compressor gasket (A-7).

b. Disassembly. Remove two 5/16 x 3/4 cap (A-8-h) securing air intake manifold cap (A-8-g) to the manifold (A-8-b). Remove and discard air intake manifold gasket (A-8-f) and filter (A-8-c). Remove spring (A-8-e), plate (A-8-d), and filter from the manifold. Remove 1/8-inch pipe plug (A-8-2) from manifold. Discard filter.

#### c. Cleaning and Inspection.

- (1) Cleaning. Clean manifold (A-8-b), spring (A-8-e), cap (A-8-g), and related parts as directed in paragraph 152c. Dry parts with compressed air.
- (2) Inspection. Inspect manifold (A-8-b) and air intake manifold cap (A-8-g) for cracks and damage. Inspect machined surfaces for nicks, burs, or raised metal. Check mating flange surfaces with a straight edge for warpage. Check pipe plug opening and threaded holes for stripped or damaged threads. Check air intake manifold spring (A-8-e) for cracks or evidence of set.

d. Repair. Repair minor warpage of mounting flanges of the manifold (A-8-b) and air intake manifold cap (A-8-g) by working the surface across a sheet of crocus cloth held tightly on a

flat surface. Repair damaged threads in the manifold with a tap. Replace the manifold or air intake manifold cap if cracked or damaged beyond repair. Replace air intake manifold spring (A-8-e) if it is cracked, broken, or set.

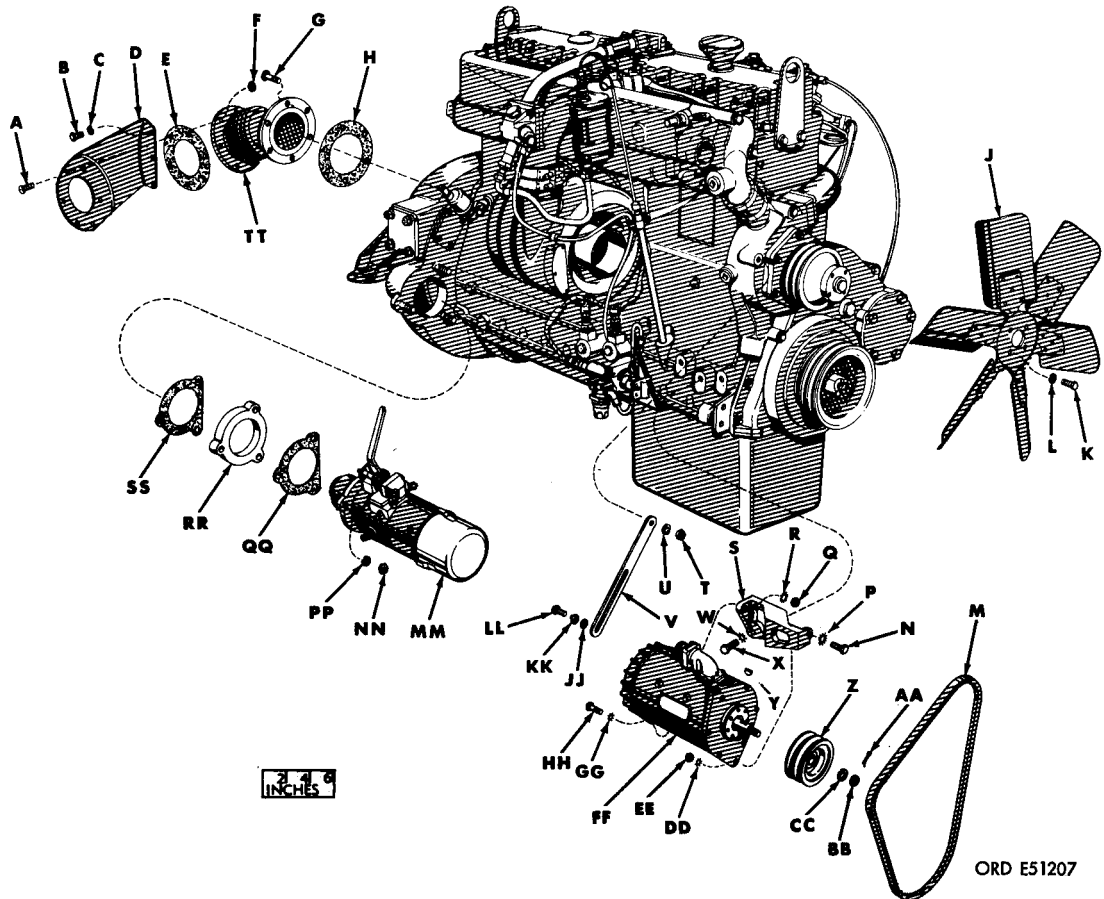
e. Assembly. Install 1/8-inch pipe plug (A-8-a) in top of manifold (A-8-b). Install the intake manifold filter (A-8-c), plate (A-8-d), and spring (A-8-e) in manifold. Position new air intake manifold gasket (A-8-f) on the manifold. Carefully position air intake manifold cap (A-8-g) on the air intake manifold spring and compress the spring. Install and tighten two 5/16 x 3/4 cap screws and 5/16-inch lock washers to secure air intake manifold cap to manifold.

f. Installation. Position new air intake manifold-to-compressor gasket (A-7) on the air compressor. Position and secure air intake manifold assembly (A-8) on the air compressor with two 5/16 lock washers (A-9) and 5/16 x 3/4 cap screws (A-10).

### 239. AIR COMPRESSOR DISCHARGE HOUSING

Note. The key letters shown below in parentheses refer to figure 445 except where otherwise indicated.

a. Removal. Remove two 5/16 x 1-3/4 cap screws and 5/16-inch lock washers (A-5) securing the air compressor discharge housing



- |  |                                      |
|--|--------------------------------------|
| A - 1/4x 3/4 flat head countersunk machine screw | W - 7/16-in. lock washer             |
| B - 3/8 x 3/4 cap screw                          | X - 7/16 x 1- 1/2 cap screw          |
| C - 3/8-in. lock washer                          | Y - Generator pulley Woodruff key    |
| D - Turbosupercharger exhaust elbow support      | Z - Generator pulley                 |
| E - Turbosupercharger exhaust elbow outer gasket | AA - Cotter pin                      |
| F - 1/4-in. self-locking nut                     | BB - 1/2-in. self-locking nut        |
| G - 3/8 x 1 cap screw                            | CC - 1/2- in. plain washer           |
| H - Turbosupercharger exhaust elbow inlet gasket | DD - 7/16- in. lock washer           |
| J - Engine fan                                   | EE - 7/16- in. plain nut             |
| K - 5/16 x 3/4 cap screw                         | FF - Generator assembly              |
| L - 5/16-in. lock washer                         | GG - 7/16- in. plain washer          |
| M - Engine fan and generator drive belt          | HH - 7/16 x 1-1/2 cap screw          |
| N - 7/16 x 1-1/2 cap screw                       | JJ - 3/8- in. lock washer            |
| P - 7/16- in. plain washer                       | KK - Special flange washer           |
| Q - 7/16-in. plain nut                           | LL - 3/8 x 7/8 cap screw             |
| R - 7/16-in. lock washer                         | MM - Starter assembly                |
| S - Generator mounting bracket                   | NN - 5/8- in. plain nut              |
| T - 3/8-in. plain nut                            | PP - 5/8- in. lock washer            |
| U - 3/8-in. lock washer                          | QQ - Starter gasket                  |
| V - Generator adjusting strap                    | RR - Starter adapter                 |
|  | Ss - Starter adapter gasket          |
|  | TT - Turbosupercharger exhaust elbow |

FIGURE 446. ENGINE AND MISCELLANEOUS COMPONENTS - EXPLODED VIEW.

c. Repair. Repair minor warpage of mounting-flange of air compressor discharge housing assembly (A- 4) by working the surface across a sheet of crocus cloth held tightly on a flat surface. Repair damaged threads with a die. Replace air compressor discharge housing if cracked or damaged beyond repair. Replace 90 degree elbow (A- 1) if damaged.

d. Installation. Install the air compressor discharge housing and 90 degree elbow following instructions below.

- (1) Position new discharge housing gasket (A- 3) on the air compressor assembly. Install tube nut (A-4-c) on discharge housing. Position and secure discharge housing (A- 4) to the air compressor with two 5/16 x 1-1/4 cap screws (A-6) and 5/16-inch lock washers (A- 5).
- (2) Screw 90 degree elbow (A-1) into the air compressor cylinder head. When elbow is tightened securely, be sure elbow is positioned correctly.

#### 240. TURBOSUPERCHARGER EXHAUST ELBOW

Note. The key letters shown below in parentheses refer to figure 446 except where otherwise indicated.

a. Disassembly . Scribe alinement marks on the parts. Remove three 1/4 x 3/4 flat head countersunk machine screws (A) and 1/4- inch self- locking nuts (F) securing the turbo supercharger exhaust elbow support (D) to turbosupercharger exhaust elbow (TT). Separate the support and elbow. Remove and discard turbosupercharger exhaust elbow outer gasket (E).

##### b. Cleaning and Inspection.

- (1) Cleaning. Clean turbosupercharger exhaust elbow (TT) and turbosupercharger exhaust elbow support (D) as directed in paragraph 152c. Remove all of the turbosupercharger exhaust elbow outer gasket material.
- (2) Inspection. Inspect turbosupercharger exhaust elbow (TT) for heat cracks and burned areas or holes. Check both flanges for warpage or burned surface sections due to leakage of exhaust gases.

Carefully check the welded joints and seams for cracks and the expansion bellows for separation. Inspect the turbosupercharger exhaust elbow support (D) for breaks due to vibration. Check mating surface with straight edge for warpage.

c. Repair. Replace damaged or unserviceable turbo supercharger exhaust elbow (TT) and turbosupercharger exhaust elbow support (D). Repair of these parts is not practical.

d. Assembly. Position the turbosupercharger exhaust elbow outer gasket (E) on the turbosupercharger exhaust elbow. Aline the scribe marks on the parts, then install three 1/4 x 3/4 flat head countersunk machine screws (A) and 1/4- inch self- locking nuts (F) to secure the turbosupercharger exhaust elbow support (D) to turbosupercharger exhaust elbow (TT).

#### 241. STARTER ADAPTER

Note. The key letters shown below in parentheses refer to figure 446 except where otherwise indicated.

a. Disassembly. There is no disassembly of the-starter adapter (RR).

##### b. Cleaning and Inspection.

- (1) Cleaning. Clean the starter adapter (RR) as directed in paragraph 152c.
- (2) Inspection. Inspect the starter adapter (RR) cracks and damage. Check mating surfaces with straight edge for warpage.

c. Repair. Repair minor warpage of mating surfaces of the starter adapter (RR) by working the surface across a sheet of crocus cloth held tightly on a flat surface. Replace starter adapter if it is cracked or damaged beyond repair.

d. Assembly. No assembly is required for the-starter adapter (RR).

#### 242. GENERATOR MOUNTING BRACKET, ADJUSTING STRAP, AND PULLEY

Note. The key letters shown below in parentheses refer to figure 446 except where otherwise indicated.

a. Removal.

- (1) Removal of the generator mounting bracket (S) was performed during engine disassembly (par. 125). The adjusting strap (V) was removed during removal of water pump (par. 128).
- (2) Remove the generator pulley (Z) as follows. Remove 1/2- inch self-locking nut (BB) and 1/2-inch flat washer (CC) securing the generator pulley (Z) to the armature shaft. Using a universal puller or an arbor press, remove the generator pulley from the shaft. Tape Woodruff key (Y) on shaft of generator assembly (FF).

b. Disassembly. There is no further disassembly of these components. Refer to TM 9-2920-214-35 for overhaul procedures for the Delco- Remy generator. Refer to TM 9-2920-209-35 for the overhaul procedures for the Autolite generator.

c. Cleaning and Inspection.

- (1) Cleaning. Clean generator mounting bracket (S), adjusting strap (V), and pulley (Z) as directed in paragraph 152c.
- (2) Inspection. Inspect generator mounting bracket (S) and adjusting strap (V) for breaks and distorted bolt holes. Check mating surfaces for raised metal and for straightness using a straight edge. Inspect generator pulley (Z) for breaks and damage. Check the belt surface for nicks, wear, and damage. Check key-way for galling due to looseness.

d. Repair. Remove raised metal from mating surfaces of generator mounting bracket (S) with a fine mill file. Replace the generator mounting bracket or adjusting strap (V) if either part is broken or damaged beyond repair. Repair minor damage to the belt surface of the generator pulley (Z) with a fine mill file or crocus cloth dipped in dry-cleaning solvent or mineral spirits paint thinner.

e. Assembly. These are single item components and require no assembly.

f. Installation. Install generator pulley (Z) as follows. Install Woodruff key (Y) in shaft of generator assembly (FF). Use a soft-faced hammer to drive the generator pulley (Z) onto the armature shaft. Install 1/2- inch flat washer (CC). Install and tighten 1/2-inch self-locking nut (BB) to secure generator pulley to the armature shaft.

243. ENGINE FAN

Note. The key letters shown below in parentheses refer to figure 446 except where otherwise indicated.

a. Cleaning and Inspection.

- (1) Cleaning. Clean engine fan (J) as directed in paragraph 152c.
- (2) Inspection. Inspect engine fan (J) for nicks, cracks, and damage. Check to be sure all rivets and fan blades are secure and fan blades are not bent.

b. Repair. Minor nicks on the engine fan (J) can be repaired with a fine mill file. Minor straightening of the fan blades is permissible and is a matter of good judgment. Replace the engine fan if a crack is evident or if the rivets are loose.

244. ENGINE FAN AND GENERATOR DRIVE BELTS AND AIR COMPRESSOR DRIVE BELT

Note. The key letters shown below in parentheses refer to figure 446 except where otherwise indicated.

a. Cleaning and Inspection.

- (1) Cleaning. Clean engine fan and generator drive belts (M) and air compressor drive belt (G, fig. 445) with soap and water.
- (2) Inspection. Check engine fan and generator drive belts (M) and air compressor drive belt (G, fig. 445) for deep checks, breaks, and hard glazed wear surfaces.

b. Repair. Replace both engine fan and generator belts (M) or the air compressor drive belt (G, fig. 445) when either is defective.

## CHAPTER 7. CLUTCH ASSEMBLY

### Section I. DESCRIPTION, OPERATION, AND DATA

#### 245. DESCRIPTION AND OPERATION

**a. Description.** The clutch assembly (fig. 447) consists of the driven member assembly and clutch cover assembly. The driven member assembly is made up of the driven plate and facing assembly, hub and ring, and retainer plate. The clutch cover assembly contains the pressure plate, four release lever and yoke assemblies, sixteen pressure springs, and clutch cover.

#### **b. Operation.**

- (1) The two assemblies in the clutch, which is a conventional dry disk-type operating by friction, work in conjunction with the engine flywheel and the transmission. The clutch disconnects the engine from the transmission to permit changing of gear ratios in the vehicle drive train and to stop the vehicle.
- (2) The clutch cover assembly and flywheel are the driving members for the driven member assembly. The driven member assembly is located between the machined face of the pressure plate and the rear face of the flywheel. The clutch cover assembly is bolted to the flywheel and rotates at crankshaft speed while the driven member assembly is splined to the transmission input shaft by the hub and ring. The driven member assembly is held against the flywheel at all times by the pressure plate through action of the pressure springs, except when the vehicle clutch pedal is depressed.
- (3) Depressing the clutch pedal moves the throwout bearing against the release

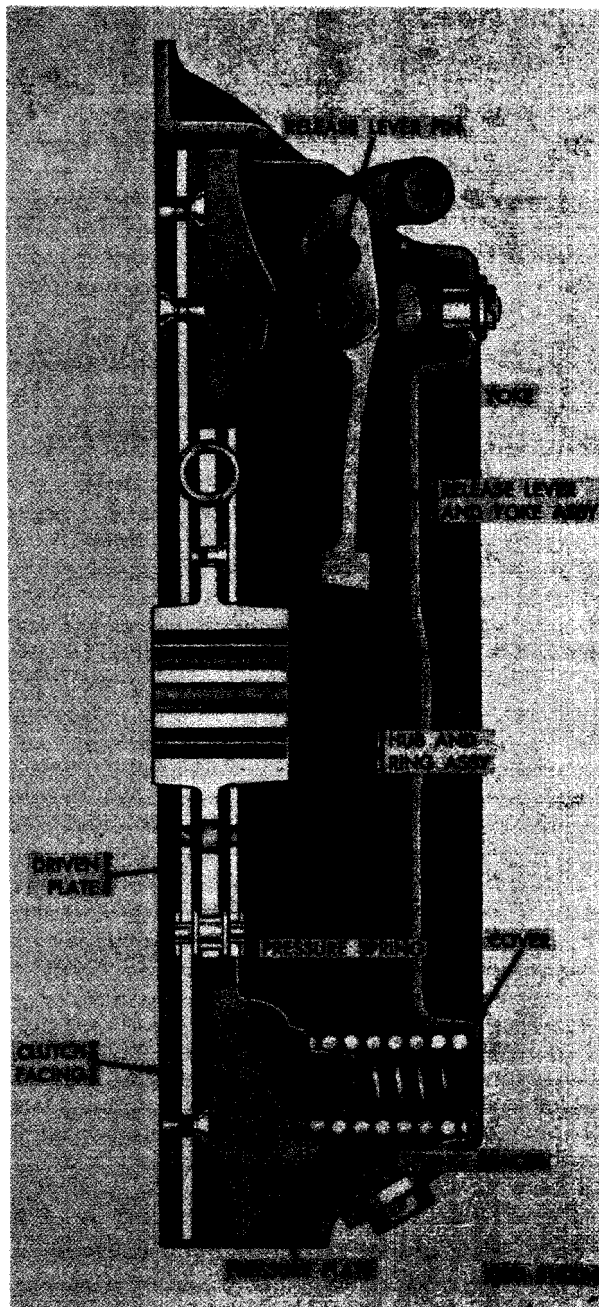


FIGURE 447. CLUTCH ASSEMBLY - SECTIONAL VIEW.

levers. The release levers pivot on release lever pins moving the pressure plate away from the driven member assembly and against the pressure springs. Although the clutch cover assembly still rotates at flywheel speed, the driven member assembly slows down and stops. When the clutch pedal is released, the throwout bearing moves away from the release levers and the pressure springs force the pressure plate toward the flywheel. This engages the driven member assembly and transmits flywheel motion to the transmission input shaft.

## 246. DATA

Make . . . . . Long  
 Model . . . . .  
 Type . . . . . dry, single plate  
 Ordnance number . . . . . 7748995

## 247. IMPROVISED TOOLS

Three improvised tools are needed to rebuild the clutch assembly: clutch spacer plate (fig. 34), four clutch release lever spacer blocks (fig. 35), and four clutch lever bearing retaining pins (fig. 36). The tools are listed in paragraph 45 and tabulated in Table II.

## Section II. REBUILD OF CLUTCH ASSEMBLY

### 248. DISASSEMBLY

a. Remove Spacer Blocks. Figure 448. (A) Position clutch cover assembly on a flat surface as shown. Push down on four release levers. (B) Remove four clutch release lever spacer blocks.

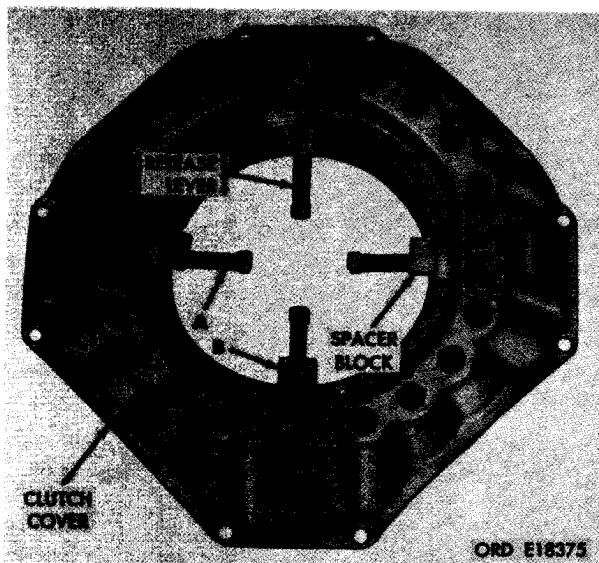


FIGURE 448. REMOVING OR INSTALLING SPACER BLOCKS BETWEEN RELEASE LEVERS AND CLUTCH COVER.

Note. The four spacer blocks were installed before the clutch cover was removed from the engine (fig. 274). The spacer blocks prevent clutch cover distortion as the cover retaining screws are removed.

b. Scribe Alinement Marks. Refer to figure 449 and scribe alinement marks to aid in assembly.

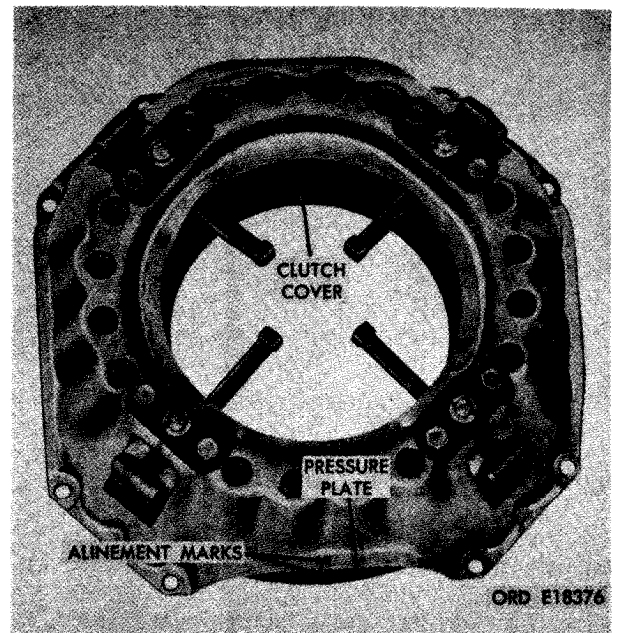


FIGURE 449. ALINEMENT MARKS SCRIBED ON CLUTCH COVER AND PRESSURE PLATE.

c. Remove Lock Plates. Figure 450. (A) place clutch on clutch spacer plate (fig. 34) and place in bed of arbor press. (B) Press clutch down using a suitable bar across clutch cover as shown with the cross bar clearing all lock plate cap screws. Press down until springs are depressed enough to relieve the spring tension against the lock plates. (C) Remove eight 5/16 x 1/2 self-tapping cap screws securing lock plates to clutch cover. (D) Remove four lock plates.

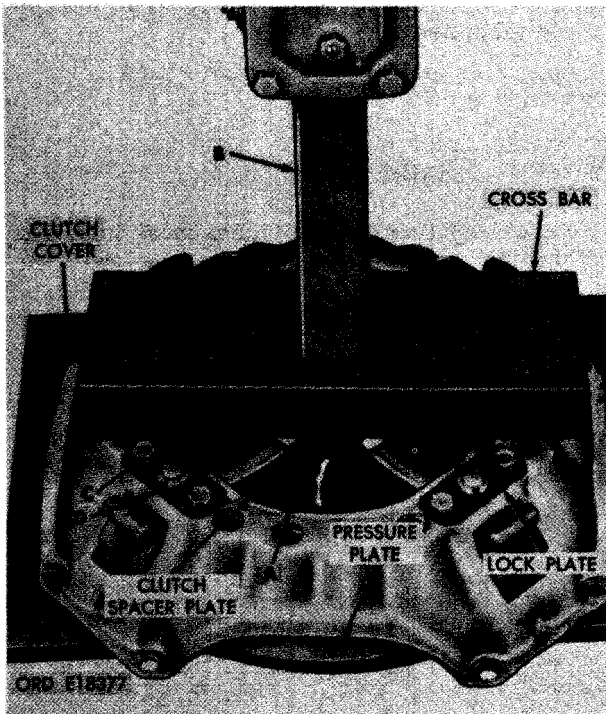


FIGURE 450. REMOVING LOCK PLATES USING CLUTCH SPACER PLATE.

d. Remove Clutch Cover. Figure 451. (A) Remove four release lever adjusting nuts using face spanner wrench socket -8390124. (B) Carefully relieve pressure on clutch cover and remove cross bar. (C) Lift off clutch cover.

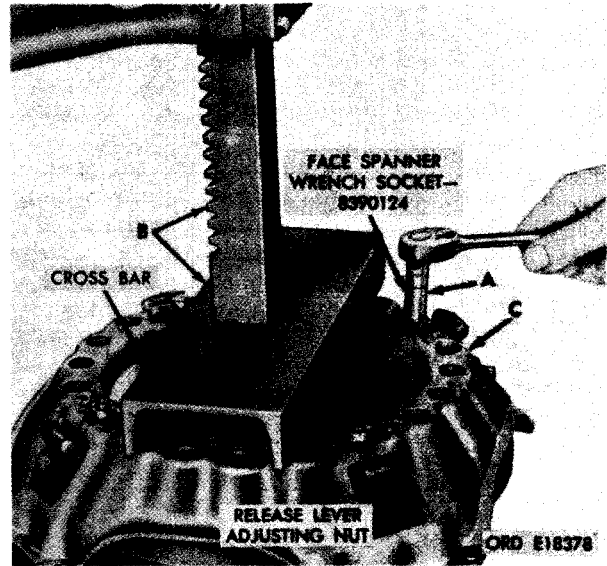


FIGURE 451. REMOVING OR INSTALLING CLUTCH COVER USING FACE SPANNER WRENCH.



FIGURE 452. REMOVING OR INSTALLING PRESSURE SPRINGS FROM PRESSURE PLATE.

e. Remove Pressure Springs. Refer to figure 452 and remove pressure springs from pressure plate.

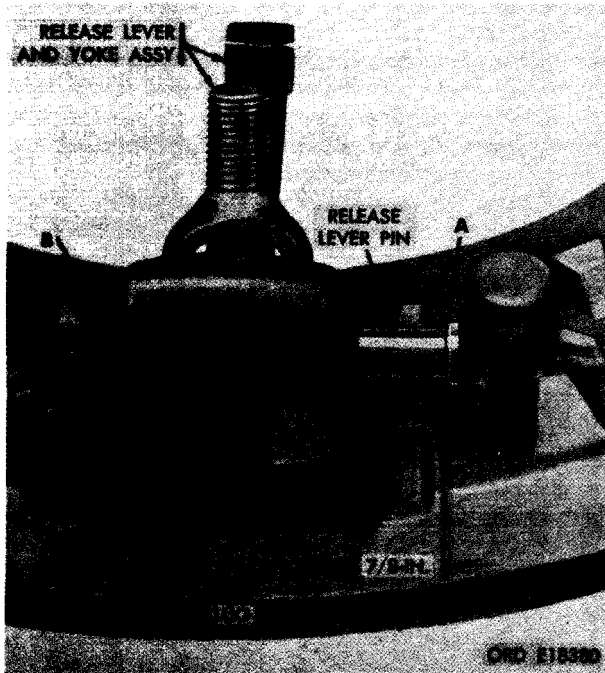


FIGURE 453. REMOVING OR INSTALLING RELEASE LEVER PIN.

f. Remove Release Lever Pin. Figure 453. (A) File off mushroomed end of one release lever pin. Drive pin out of pressure plate lug and release lever far enough so that distance from head of release lever pin to machined surface of pressure plate lug is approximately 7/8-inch. (B) Install clutch lever bearing retaining pin through hole in pressure bearing retaining pin and into needle rollers in release lever. Continue to drive out release lever pin until release lever and yoke assembly can be removed.

Note. Be careful not to lose the 19 needle rollers when driving out release lever pins.

g. Remove Release Levers and Needle Rollers. Figure 454. (A) Remove bearing retaining pin and 19 needle rollers from release lever. (B) Remove the remaining three release levers and needle bearings from pressure plate (fig. 453).

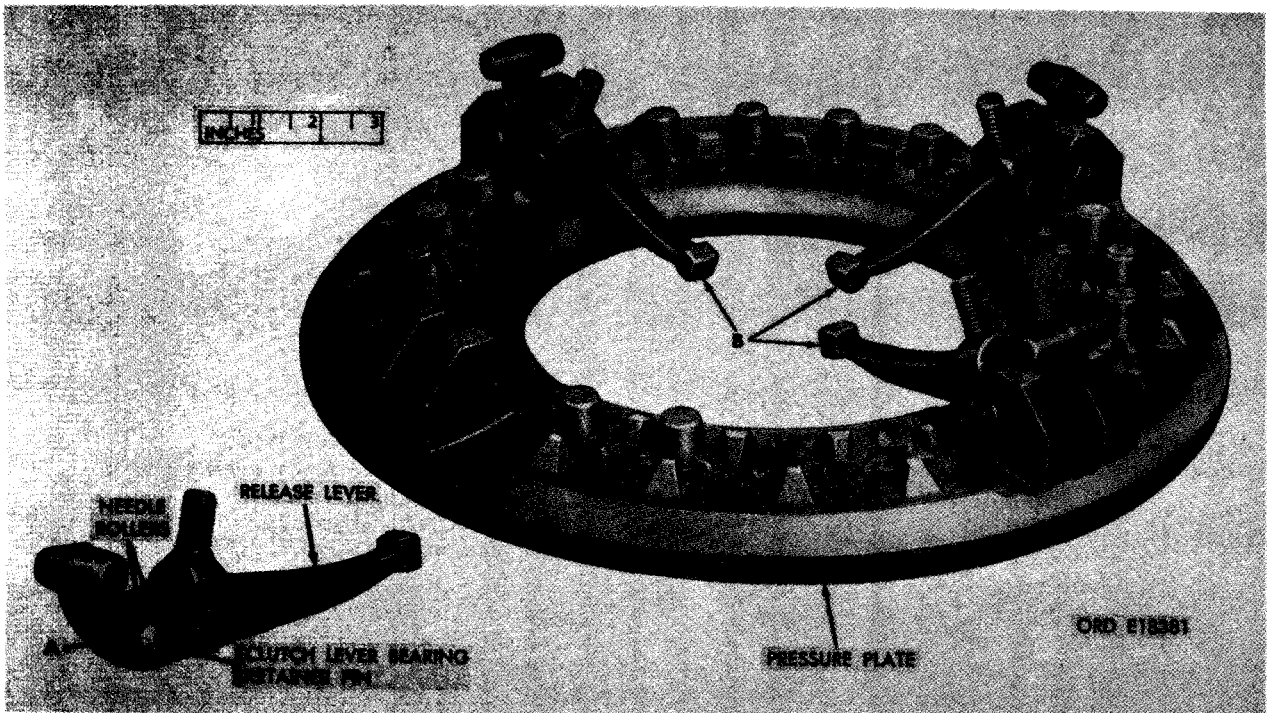
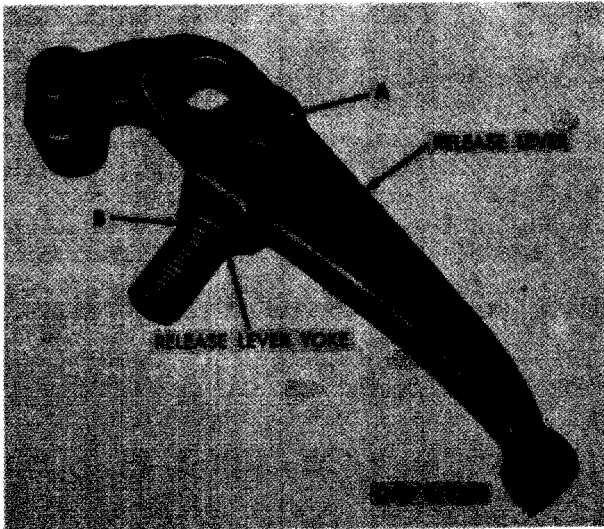


FIGURE 454. REMOVING OR INSTALLING RELEASE LEVERS AND NEEDLE ROLLERS.





**FIGURE 455. REMOVING OR INSTALLING RELEASE LEVER YOKE.**

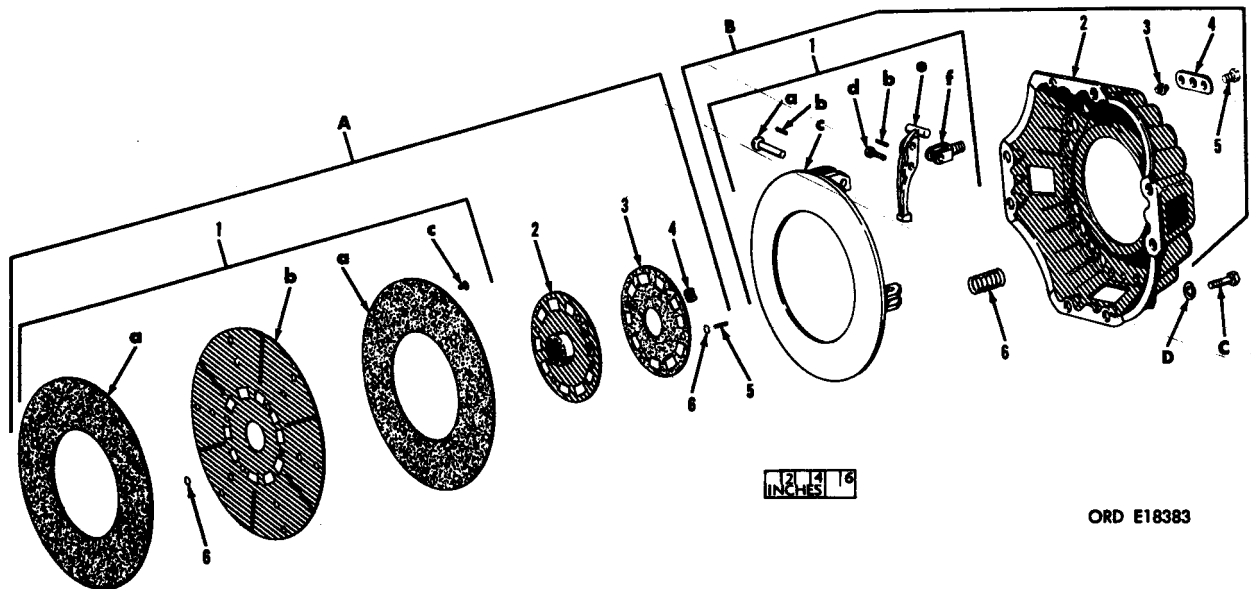
h. Remove Release Lever Yokes. Figure 455. (A) File off mushroomed end of pin opposite pin head and drive out the yoke pin. (B) Remove release lever yoke from release lever. Remove bearing reattaining pin and 19 needle rollers.

Note. Remove the three remaining release lever yokes and bearing rollers in the same manner.

#### 249. CLEANING AND INSPECTION

Note. The key letters shown below in parentheses refer to figure 456 except where otherwise indicated.

a. Cleaning. Thoroughly clean clutch cover parts, except driven member assembly (A) and clutch facings (A-1-a) as directed in paragraph 152b. Clean driven member clutch facings using



- A. - Driven member assembly
  - 1- Driven plate and facing assembly
    - a - Clutch facing
    - b - Driven plate
    - c - Clutch facing rivet
  - 2- Hub and ring
  - 3- Retainer plate
  - 4- Damper spring
  - 5- Stop pin
  - 6- Reinforcement washer
- B - Clutch cover assembly
  - 1- Pressure plate and lever assembly

- a - Release lever pin
- b - Release lever needle roller
- c - Pressure plate
- d - Yoke pin
- e - Release lever
- f - Release lever yoke
- 2 - Clutch cover
- 3 - Release lever adjusting nut
- 4 - Thrust plate
- 5 - 5/16 x 1/2 self-tapping cap screw
- 6 - Pressure spring
- C - 3/8 x 15/16 cap screw
- D - 3/8-in. lock washer

**FIGURE 456. CLUTCH COVER AND DRIVEN MEMBER - EXPLODED VIEW.**

a wire brush. Clean splines of hub and ring assembly (A- 2) with cloth soaked in dry- cleaning solvent or mineral spirits paint thinner.

**b. Inspection.**

- (1) Clutch cover. Inspect the clutch cover (B-2) for cracks and distorted mounting flanges. Inspect clutch cover screw holes (fig. 457) for elongation and the lock plate retaining screw hole threads for damage (fig. 457). Inspect the pressure spring seats (fig. 457) for cracks and indentations.

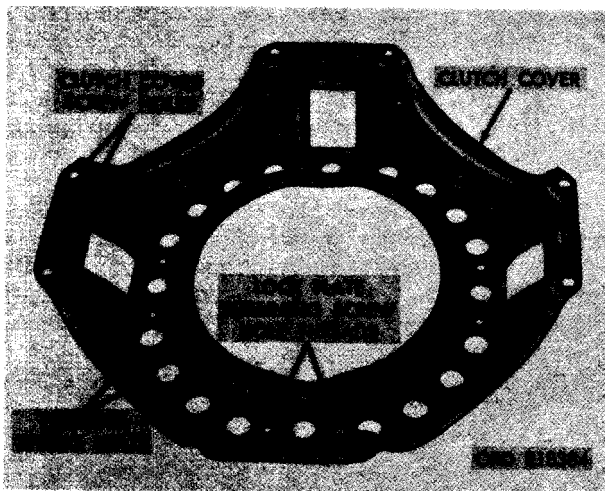


FIGURE 457. INSPECTING CLUTCH COVER PRESSURE SPRING SEATS AND SCREW HOLES.

- (2) Pressure springs. Inspect the 16 pressure springs (B- 6) for distorted and set condition. Check free length of each pressure spring using a height gage. Free length of pressure springs should be 2-11/32-inches as shown in figure 458.

- (3) Pressure plate. Inspect pressure plate (B-1-c) for cracks and possible warpage, caused by severe heat due to clutch slippage. Inspect the clutch facing surface (fig. 459) for deep scores and rough surface. Replace pressure plate clutch facing surface as directed in paragraph; below, when scores are not deep and slight surface cracks are evident.

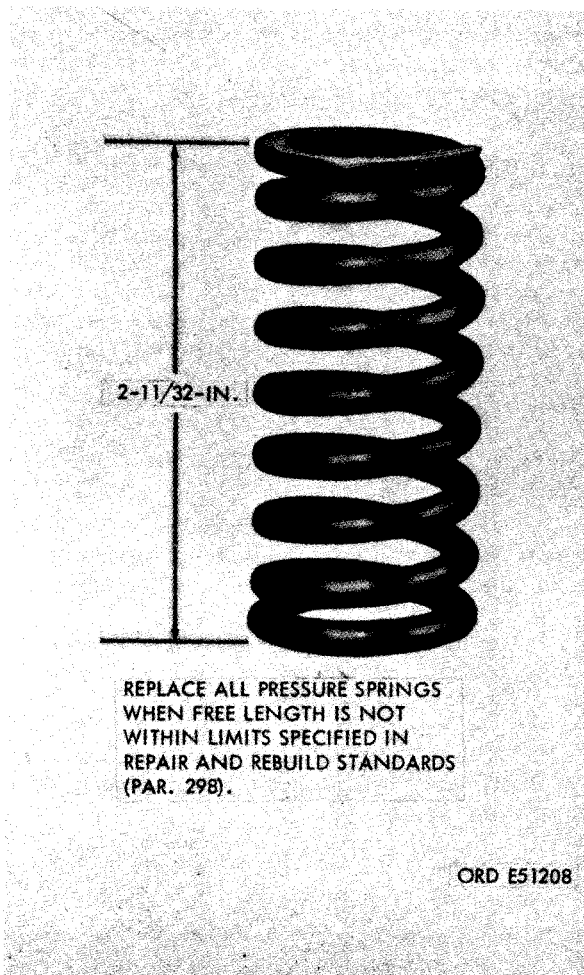


FIGURE 458. CHECKING FREE LENGTH OF PRESSURE SPRING.

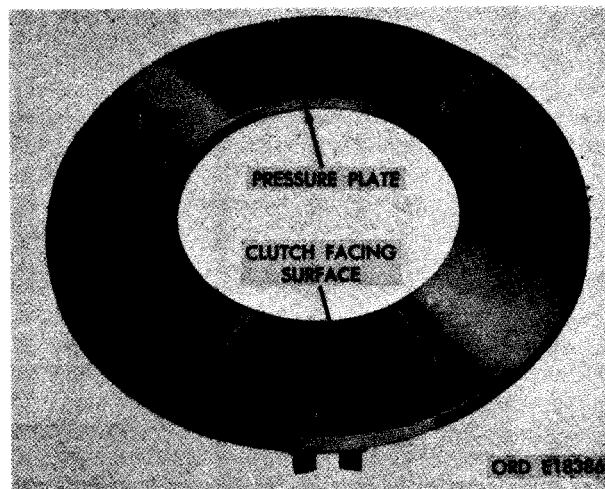


FIGURE 459. INSPECTING PRESSURE PLATE CLUTCH FACING SURFACE.

- (4) Release levers and needle rollers. Inspect the four release levers (B-1-e) against limits specified in repair and rebuild standards (par. 298). Inspect release levers for cracks and 152 bearing rollers (B-1-b) for roughness and wear. Inspect the four release lever pins (B-1-a) and the four yoke pins (B-1-d) against limits specified in repair and rebuild standards (par. 298).
- (5) Driven member assembly. Inspect driven member assembly following instructions for figure '91, excluding step C.

## 250. REPAIR

Note. The key letters shown below in parentheses refer to figure 456 except where otherwise indicated.

a. General. Refer to paragraph 154 for general repair instructions. Special repair instructions are listed below.

b. Driven Member Assembly. Refer to paragraph 67b and c for repair of the driven member assembly (A).

c. Clutch Cover. Replace the clutch cover (B-2) when cracked or warped. Repair minor thread damage using a used tap. Replace the clutch cover when screw holes are elongated or warped. Replace the clutch cover when pressure spring seats are cracked or contain indentations that will affect spring tension.

d. Pressure Springs. Replace the pressure springs (B-6) when distorted, cracked, or in a set condition. Replace any pressure springs that do not have the correct free length.

e. Pressure Plate. Replace the pressure plate (B-1-c) when cracked, warped, or when the pressure plate clutch facing surface is burned or scored beyond a 1/16-inch resurfacing limit. Regrind a scored or slightly cracked pressure plate using a surface grinder. Do not grind surface more than 1/16-inch to achieve a good surface. If more grinding is required, replace the pressure Plate.

f. Release Levers and Needle Rollers. Replace any release levers (B-1-e) that do not meet limits specified in repair and rebuild standards (par. 298). Replace worn or damaged needle rollers in sets only. Replace worn release lever and yoke pins.

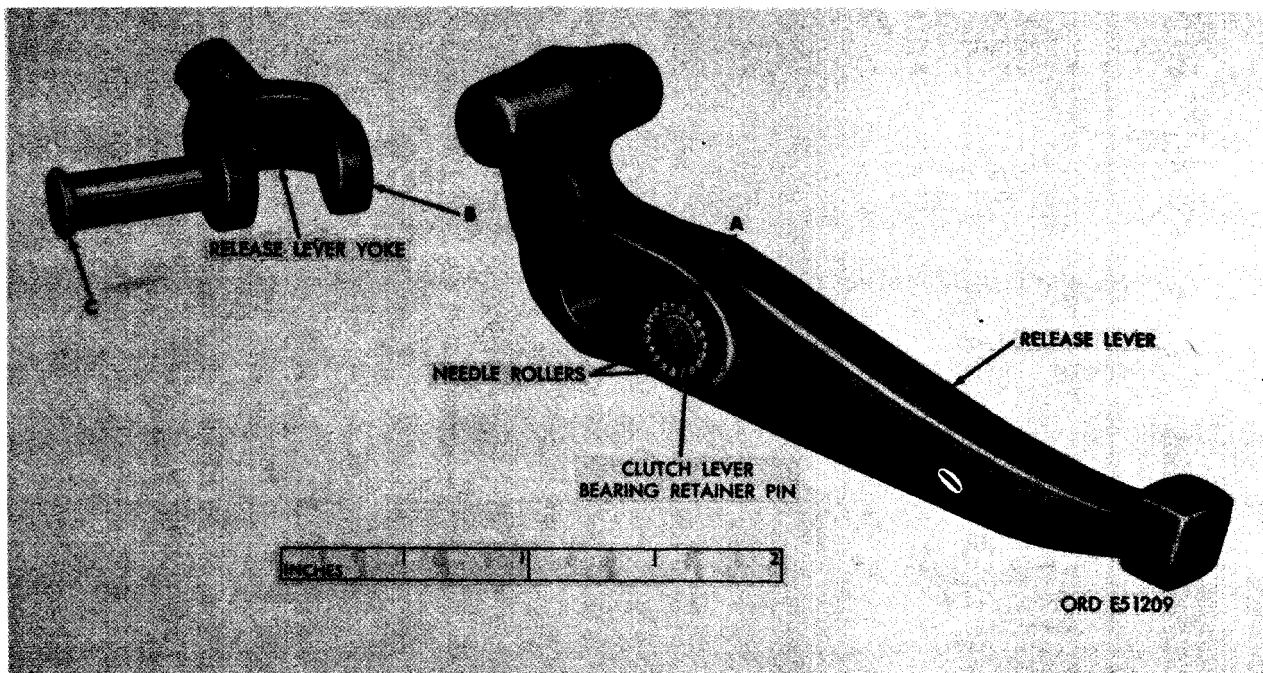


FIGURE 460. INSTALLING RELEASE LEVER NEEDLE ROLLERS AND YOKE USING BEARING RETAINING PIN.

## 251. ASSEMBLY

a. Install Release Lever Needle Rollers and Yokes. Figure 460. (A) Coat 152 needle rollers with grease (GAA) (MIL-G-10924). Insert 19 release lever needle rollers in yoke pin bore in release lever, using one bearing retaining pin to hold rollers in position as they are installed. (B) Install yoke, guiding yoke pin through needle rollers. Yoke pin must enter needle roller pack as pin is pushed into position to push out the temporary bearing retaining pin. (C) Place head of yoke pin on a flat hard surface and mushroom or split headless end of yoke pin to prevent pin from working out of position.

Note. Install the needle rollers and yokes on the remaining three release levers in the same manner.

b. Install Release Levers. Coat 19 release lever needle rollers with grease (GAA) (MIL-G 10924). Insert the 19 release lever' needle rollers in release lever pin bore using one bearing retaining pin to hold rollers in position as they are installed, as shown in figure 454. Refer to figure 453 and reverse the sequence of instructions to install the four release lever and yoke assemblies on the pressure plate.

Note. Spread or split headless end of release lever pins to prevent them from working out of position.

c. Install Pressure Springs. If pressure plate has been resurfaced, install 1/32- inch thick spacers (fig. 447) under pressure springs for each 1/32- inch removed from the pressure plate surface. The spacers will be necessary in maintaining original spring tension. Refer to figure 452 and reverse the sequence of instructions to install pressure springs.

d. Install Clutch Cover. Refer to figures 450 and 451 and reverse the sequence of illustrations and instructions to assemble the clutch cover and pressure plate assembly. Aline scribe marks on clutch cover and pressure plate (fig. 449) before installing release lever adjusting nuts.

Note. Do not install lock plates (fig. 450) and Cap screws until release lever height has been adjusted.

e. Adjust Height of Release Levers. Adjust height of release levers as follows.

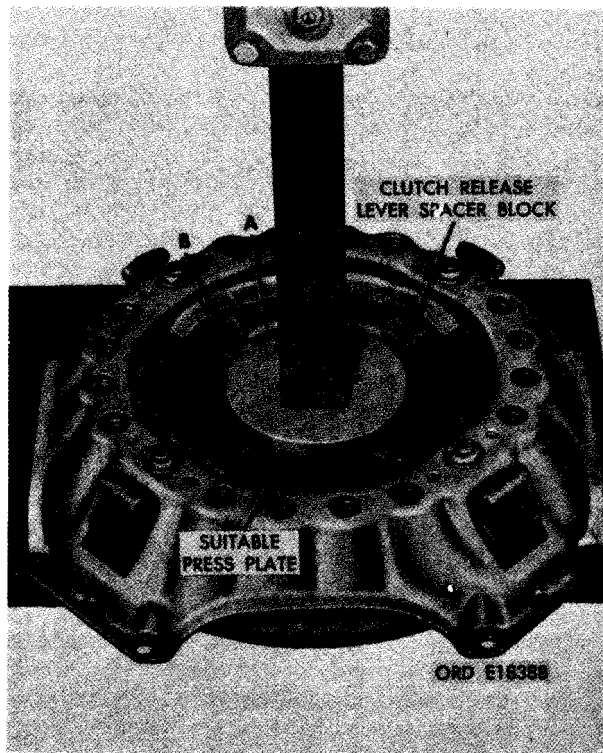


FIGURE 461. INSTALLING CLUTCH RELEASE LEVER SPACER BLOCKS BEFORE RELEASE LEVER HEIGHT ADJUSTMENT.

- (1) Figure 461. (A) Remove cross bar (fig. 451) and position a suitable press plate on throw-out bearing contact surface of release levers. The use of press plate, instead of cross bar (fig. 451), will allow more release lever travel for clutch release lever spacer block installation. (B) Install one clutch release lever spacer and clutch block between release lever and clutch cover as shown.
- (2) Figure 462. (A) Position clutch spacer plate (fig. 34) against clutch cover pressure plate clutch facing surface as you would when positioning driven member during clutch installation. (B) Secure

clutch cover assembly and spacer plate on flywheel with eight 3/8-inch lock washers and 3/8 x 15/16 cap screws.

Note. The nominal height setting for the four release levers is 1-5/8 -inch from the crown of the release levers to the surface of the clutch spacer plate. The spacer plate is 0.380-inch thick. See figure 34 for details. Total distance from release lever crown to face of flywheel is 2.00 -inch with spacer plate removed.



FIGURE 462. INSTALLING CLUTCH COVER ASSEMBLY AND SPACER PLATE IN FLYWHEEL.

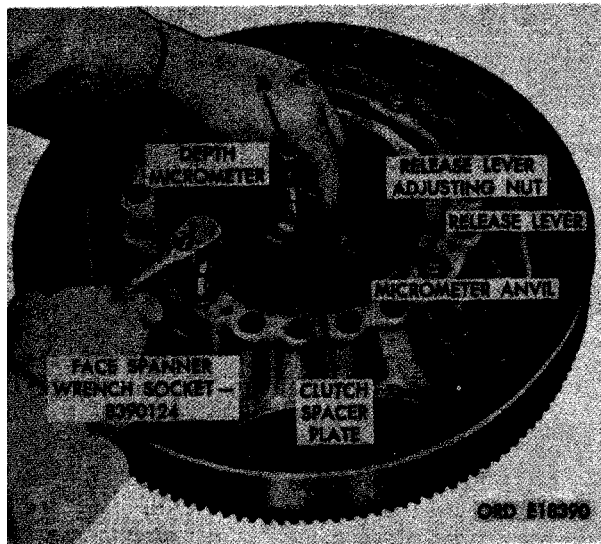


FIGURE 463. ADJUSTING RELEASE LEVER HEIGHT.

- (3) Figure 463. (A) Set depth micrometer to 1.625-inch and check distance between crown of release lever and surface of clutch spacer plate (fig. 464). (B) Turn release lever adjusting nut as necessary using face spanner wrench socket- 8390124, until crown of release lever contacts depth micrometer with micrometer anvil contacting clutch spacer plate. (C) Adjust remaining three release levers in the same manner.

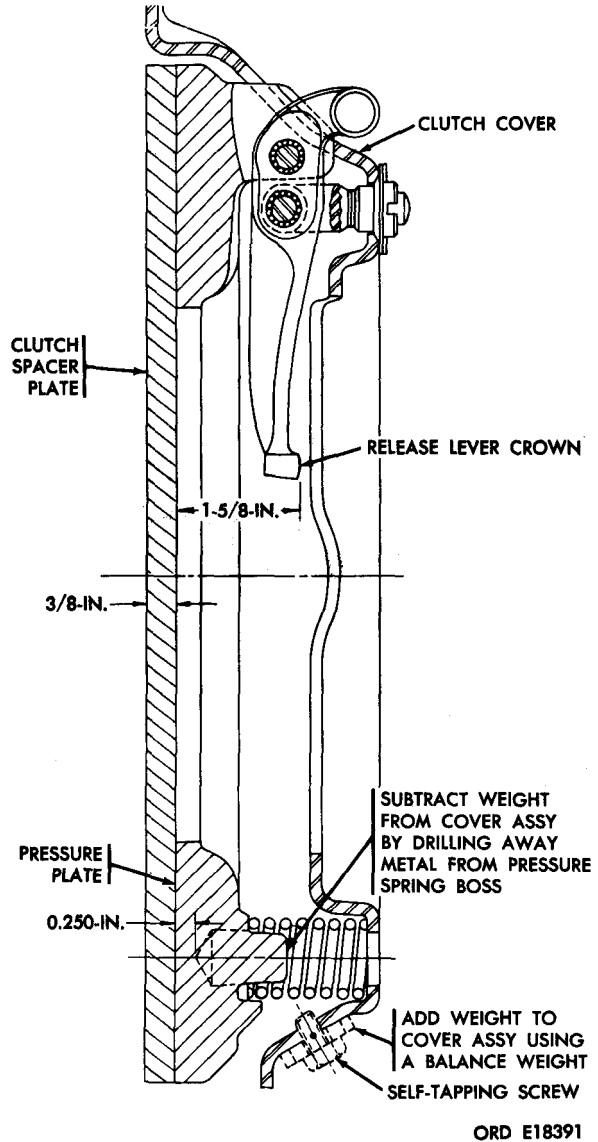


FIGURE 464. CLUTCH COVER BALANCING INSTRUCTIONS AND RELEASE LEVER ADJUSTMENT HEIGHT DIMENSIONS.

Note. When the overall 1.625-inch diameter has been obtained on the four release fingers, check to be certain that all release lever heights are within 0.015-inch of each other.

f. Install Lock Plates. After correct release lever height has been established, remove the eight 3/8 x 15/16 cap screws and 3/8-inch lock washers and remove clutch from the flywheel assembly. Install four lock plates (fig. 450) and secure with eight 5/16 x 1/2 self-tapping cap screws. Tighten screws to 20 pound-feet torque.

## 252. BALANCING PRESSURE PLATE WITH CLUTCH COVER ASSEMBLY

a. General. Whenever a pressure plate or clutch cover is replaced or when resurfacing of the pressure plate is necessary, the entire pressure plate with clutch cover must be balanced.

b. Balancing by Drilling Holes. Install assembly on suitable balancing fixture and determine where and how much the assembly is out of balance. Remove the required amount of metal by drilling 0.687-inch diameter holes in center of pressure spring bosses on pressure plate (fig. 464). Drilled holes must not be less than 0.25- inch to face of pressure plate (fig. 464). Assembly must be balanced to within 1.0 ounce inches.

c. Balancing by Adding Weights. If balance cannot be obtained by drilling plate, drill 0.250 to 0.260-inch diameter hole or holes in clutch cover (fig. 464) and install balancing weights with 1/4- inch self-tapping screws. Maximum thickness of balancing weights must not exceed 0.219- inch per screw. Tighten screws to 15 pound-feet torque.

## CHAPTER 8

### ASSEMBLY OF ENGINE

---

#### Section I. GENERAL

##### 253. CLEANLINESS

The engine is a precision product and extreme care and cleanliness must be exercised in all phases of assembly operations to insure satisfactory engine performance. Dirt and dust, even in minute quantities, are abrasive. After cleaning, and just before assembly, coat all bearings and moving parts with engine oil (OE-10). This will insure sufficient lubrication until the engine is started.

##### 254. GENERAL ASSEMBLY INSTRUCTIONS

**a. Gaskets.** Use new gaskets, preformed packings, and annular copper gaskets when assembling the engine. An engine overhaul gasket and preformed packing set -5702654, consisting of all necessary gaskets, preformed packings, and oil seals is available for engine overhaul.

**b. Kits and Sets.** Several of the components of the engine are available in kits or sets. Whenever a kit or set is used for parts replacement, all components of the kit should be installed.

**c. Attaching Parts.** All bolts and nuts should be tightened in accordance with the specifications listed in paragraph 299. When other torque values apply, they will be noted in the text. Torque wrenches with indicating scales are provided for tightening to specified limits (par. 299). Readings on the torque wrench scales are worthless unless the wrenches are properly used. It must be understood that it is not the force required to turn the nut that is important, but the resultant pull on the stud. Therefore, resistance of the nut to turning must be reduced to a minimum. Threads must be undamaged and clean, and lubricated with antiseize compound (MIL-13881) to reduce friction.

**Note.** When using a torque wrench, the final reading must be taken while the nut is turning. When torque reading is close to that specified when the wrench is at the end of its swing, back off slightly, and change wrench position; then pull to the desired reading while the nut is turning. To start a partially tightened nut will require a much higher torque than that required to keep a nut turning. The ratio of pounds torque to pounds pull on a stud is not an even ratio

and excess torque may easily overstress the stud. Do not exceed torque specified.

**d. Locking Devices.** Many of the cap screws used in this engine are designed with a nylon insert in the shank. Cap screws of this type need no additional locking device. Most, but not all, nuts and cap screws require either lock washers, cotter pins, or locking wire. Pay particular attention during engine assembly to use the locking device indicated. Many engine failures have been traced to neglect of this simple precaution.

##### 255. INSTALLATION INSTRUCTIONS

**a. General.** Usually the subassemblies are installed on the engine by reversing the removal procedure. When instructions under removal call for locking wire to be cut, install new locking wire in the specified location. When instructions under removal call for removing and discarding of a gasket, install a new gasket. All instructions will be a step-by-step, or figure-by-figure, reversal of the removal sequence. For example, using the letters C, B, and A on the illustration in this order is reversing the removal instructions A, B, and C. This method of reverse procedure will be used throughout this chapter unless otherwise indicated by additional instructions in the following paragraphs.

**b. Engine Assembly Reference Table.** An engine components assembly guide (table V) is provided as a reference to the engine assembly procedures contained in this chapter. The table lists the main components, assemblies, and subassemblies of the engine and the applicable paragraph and figure references which contain the assembly instructions.

**c. Parts Identification.** Callouts, referenced to the exploded view illustrations, will be used to point out related parts involved in assembly operations. Callouts not mentioned in the instructions are related to subsequent installation procedures or are used as references to other pertinent operations in this technical manual.

**Note.** Parts mentioned in the instructions will called out separately on the illustration only when required to further clarify the instructions.

Table V. Engine Components Assembly Guide

Component	Paragraph	Figure
Adapter, fuel injection pump - - - - -	279a	243
Adapter, starter - - - - -	274a	255,256
Adapter, transmission - - - - -	267c	273
Baffle, cylinder and crankcase water - - - - -	280a	240
Bearing, connecting rod - - - - -	265	284
Bearing, main sleeve - - - - -	257	308
Bracket, flame heater fuel pump and fuel filter - - - - -	277	250
Bracket, front engine lifting - - - - -	272	261
Bracket, generator mounting - - - - -	276	251
Bracket, rear engine lifting - - - - -	272	262
Bracket, rear mounting - - - - -	263	295
Camshaft - - - - -	256	310,311
Cap, connecting rod - - - - -	265b	284
Cap, rear main bearing - - - - -	259b	305
Cap, thrust bearing - - - - -	258a	466
Compressor, air - - - - -	286a	81-83
Cover, clutch - - - - -	267B	484
Cover, flywheel timing - - - - -	283B	256
Cover, front cylinder head - - - - -	283C	503,504
Cover, fuel injection pump driven gear access - - - - -	283A	502
Cover, rear cylinder head - - - - -	271	487
Cover, tappet chamber - - - - -	280	239
Cover, timing gear - - - - -	264	289
Crankshaft - - - - -	257b	307
Damper and pulley, crankshaft - - - - -	264	479
Drain cock, coolant - - - - -	274b	255,256
Driven member, clutch - - - - -	267B	483
Elbow, intake manifold - - - - -	278	247
Fan, engine - - - - -	273c	488
Filter, fuel - - - - -	285A	228,229
Filter, oil - - - - -	281A	492
Flywheel, engine - - - - -	267A	276
Gage, oil level - - - - -	278	248
Gear, camshaft - - - - -	260c	471
Gear, crankshaft - - - - -	260c	471
Gear, fuel injection pump driven - - - - -	282c	499
Generator - - - - -	286d	41,42
Head, cylinder - - - - -	268a	271, 272,485
Heater, flame - - - - -	278	245
Holder, fuel injector nozzle - - - - -	284a	505
Hoses, fuel - - - - -	285b	511,512
Housing, crankshaft rear oil seal - - - - -	262b	300,301
Housing, flywheel - - - - -	262c	299
Housing, oil cooler and oil filter - - - - -	280b	235-238
Housing, thermostat - - - - -	273b	258,259



Table V. Engine Components Assembly Guide - (cont. )

Component	Paragraph	Figure
Manifold, exhaust -----	270	266,267
Manifold, intake -----	270	266,267
Pan, oil -----	266d	277
Piston and connecting rod - - - - -	265	480
Plate, camshaft thrust - - - - -	256	310
Plate, engine front - - - - -	260	303
Plate, lock, crankshaft bolt - - - - -	264	286
Pump, flame heater fuel - - - - -	286b	77,78
Pump, fuel injection - - - - -	282	495-501
Pump, oil -----	266	281,282
Pump, water -----	273	260
Rocker arm -----	268d	268
Rod, rocker arm push -----	268c	269
Slinger, crankshaft gear oil -----	264	290
Starter -----	286e	39,40
Strap, generator adjusting -----	273b	258
Support, air compressor ---	279b	241,242
Support, oil level gage rod-----	276	251
Tachometer adapter - - - - -	264c	288
Tappet, valve - - - - -	268	269
Tube, fuel injection - - - - -	284c	507-512
Tube, fuel return - - - - -	284e	506
Tube, oil pump outlet - - - - -	266d(1)	280
Tube, oil pump pickup - - - - -	266d(3)	278
Tube, scavenger pump inlet - - - - -	266d(2)	279
Turbosupercharger - - - - -	286c	44-63
Unit, flame heater ignition -----	278	246
Unit, oil pressure sending -----	274b	255,256
Valve, oil pressure regulator -----	275	489,490
Valve, oil pump oil pressure relief - - - - -	266	362

## Section II. ASSEMBLY OF ENGINE FROM SUBASSEMBLIES

### 256. INSTALLATION OF CAMSHAFT ASSEMBLY AND PISTON COOLING NOZZLES

a. Preparations. Support the cylinder and crankcase on suitable blocks, with the cylinder head mounting surface resting on the blocks.

b. Camshaft Assembly. Refer to figure 310 and 311 and reverse the sequence of illustrations to install camshaft assembly and thrust plate.

Note. The camshaft rear bearing plug should not be installed until after the camshaft end play is established (par. 261).

c. Piston Cooling Nozzles. Figure 465. (A) Install piston cooling nozzle. (B) Secure piston cooling nozzle by installing 5/16-inch plain nut. (C) Install remaining five piston cooling nozzles in same manner.



FIGURE 465. INSTALLING PISTON COOLING NOZZLE.

### 257. INSTALLATION OF UPPER MAIN SLEEVE BEARINGS AND CRANKSHAFT ASSEMBLY

a. Upper Main Sleeve Bearing Halves. Refer to figure 308 to install the upper main sleeve bearing halves in cylinder and crankcase.

Note. Upper main bearing sleeve halves are properly installed when number on bearing tab corresponds to number on main bearing cap and the number is on camshaft side of engine.

b. Crankshaft Assembly. Refer to figure 307 and reverse sequence of instructions to install crankshaft assembly.

### 258. CHECKING CRANKSHAFT END PLAY

a. Install Main Thrust Bearing Cap. Install main thrust bearing cap, with assembled lower sleeve bearing, in center (No. 4) position. Install two 19/32-inch x 3/16-inch thick flat washers and 9/16 x 5-1/16 cap screws to secure thrust bearing cap. Do not tighten the cap screws more than is necessary to keep bearing cap in position.

b. Check Crankshaft End Play. Figure 466. (A) Mount dial indicator on crankcase so indicator point rests on front end of crankshaft assembly. (B) Using a heavy screwdriver between center main bearing cap and crankshaft counterweight, push crankshaft toward rear end of cylinder and crankcase to align thrust bearing flanges. Tighten main bearing cap screws to a torque of 1100 pound inches. (C) Set indicator on zero reading ("O"). (D) Using heavy duty screwdriver, push crankshaft toward front end of cylinder and crankcase to check end play. Crankshaft end play must be within 0.008 to 0.015-inch.

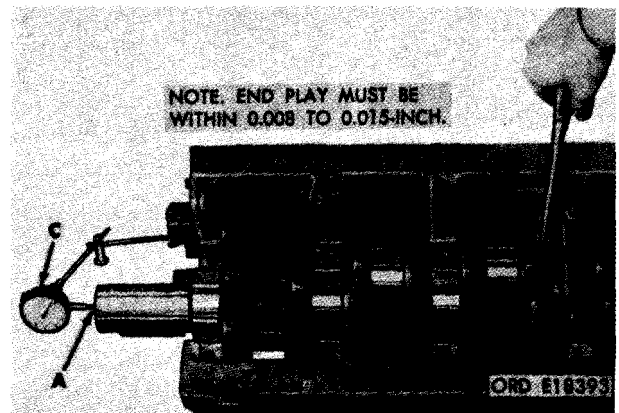


FIGURE 466. CHECKING CRANKSHAFT END PLAY.

Note. When end play is not within limits specified, remove the thrust bearing cap and thrust sleeve bearing halves. Install new thrust sleeve bearing halves. Install bearing cap and recheck end play.

#### 259. INSTALLATION OF REAR MAIN BEARING CAP SEALS, MAIN BEARING CAPS, AND CHECKING FLYWHEEL FLANGE RUNOUT

##### a. Install Rear Main Bearing Cap Oil Seals.

Figure 467. (A) Apply a coating of Minnesota Mining and Manufacturing Co. cement (No. EC847) to the bottom surface of left rear main bearing seal tab and to the mating surface on the main bearing cap. Allow cement to set at least three minutes before installing seal. (B) Install left seal in bearing cap. The seals are designated as "left" or "right" depending on which side the tab extends when facing the grooved edge of the seal. (C) Install right rear main bearing seal in the same manner as steps A and B above.

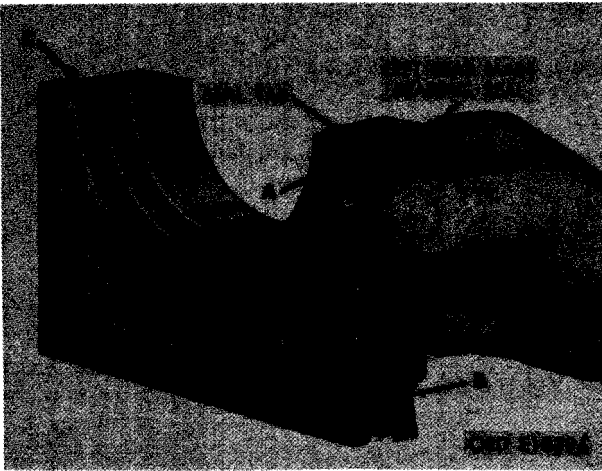


FIGURE 467. INSTALLING REAR MAIN BEARING CAP OIL SEALS.

b. Install Remaining Main Bearing Caps and Lower Main Bearing Halves. Lower main sleeve bearing halves were installed in their respective main bearing caps during inspection of bearing bores (par. 159b (10)). Install the front two bearing caps in positions shown in figure 304. Refer to figures 304 and 305 and reverse the sequence of instructions to install the five remaining main bearing caps and attached sleeve bearing halves. Refer to figure 468 and check the rear main bearing cap for flush mounting before torquing cap screws.

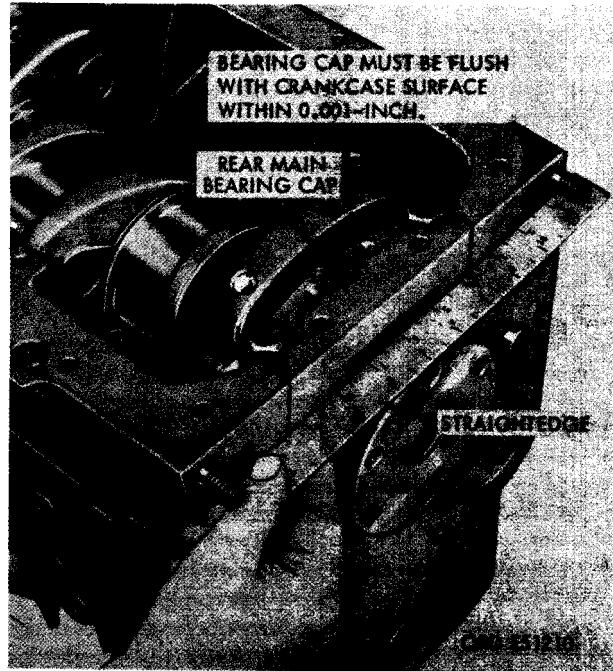


FIGURE 468. CHECKING ALINEMENT OF REAR MAIN BEARING.

Note. The bearing cap numbers must correspond with the correct sleeve bearing half number as shown in figure 306. The web in cylinder and crankcase must correspond with the numbers stamped on the caps, and the numbered ends of the caps must be toward the camshaft side.

##### c. Torque Tighten Main Bearing Cap Screws.

Torque tighten the main bearing cap screw following instructions on figure 469.



FIGURE 469. TORQUE TIGHTENING MAIN BEARING CAP SCREWS.

d. Check Flywheel Flange Runout. Figure 470. (A) Mount dial indicator on cylinder and crankcase so indicator point rests on flywheel mounting flange as shown. (B) Set indicator on zero reading ("0"). (C) Rotate crankshaft assembly and check flange runout. Runout should be within 0.002-inch total indicator reading (TIR).

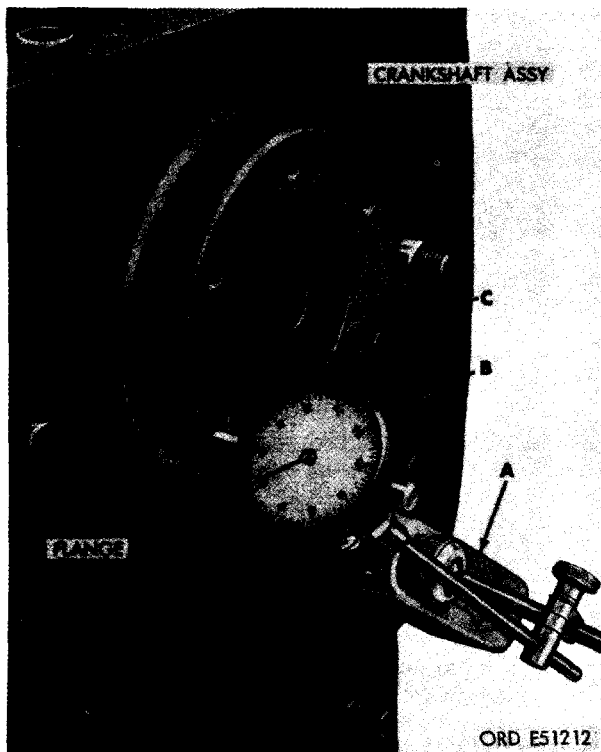


FIGURE 470. CHECKING FLYWHEEL FLANGE RUNOUT USING DIAL INDICATOR.

## 260. INSTALLATION OF ENGINE FRONT PLATE, OIL PUMP IDLER GEAR, CRANKSHAFT GEAR, AND CAMSHAFT GEAR

a. Install Engine Front Plate. Refer to figure 303 and reverse the sequence of illustrations and instructions to install the front plate gasket and engine front plate.

b. Install Oil Pump Idler Gear. Refer to figure 301 and 302 and reverse the sequence of illustrations and instructions to install the oil pump idler gear.

c. Install Crankshaft Gear and Camshaft Gear. Install crankshaft and camshaft gears as follows.

- (1) Figure 471. (A) Install crankshaft gear on crankshaft. The keyway in gear must be aligned with key in crankshaft. Push gear into position, engaging gear teeth with gear teeth of oil pump idler gear. Timing dot must be toward front. (B) Align timing dots on camshaft gear with single timing dot on crankshaft gear and install camshaft gear. Align keyway in gear with key in camshaft as gear is installed.

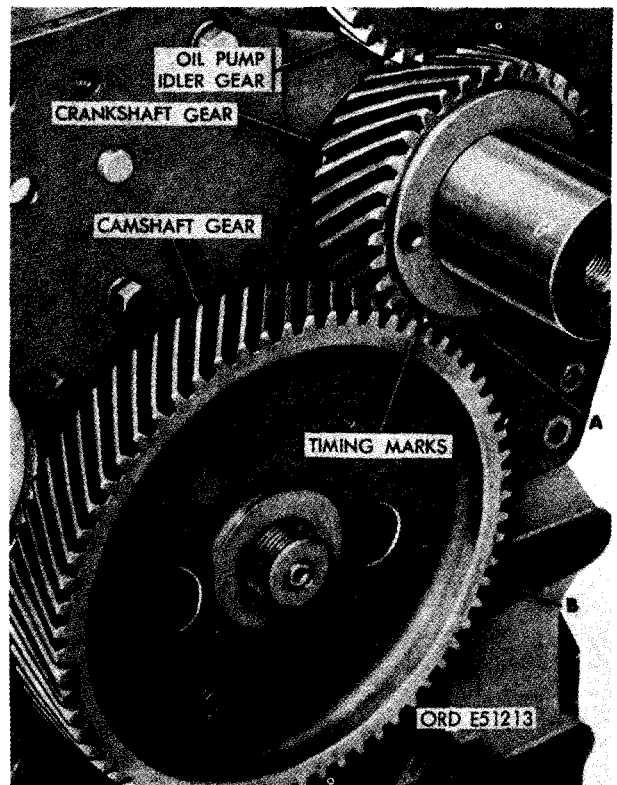


FIGURE 471. INSTALLING CRANKSHAFT GEAR AND CAMSHAFT GEAR.

Note. Timing dots must be aligned after installation of gears.

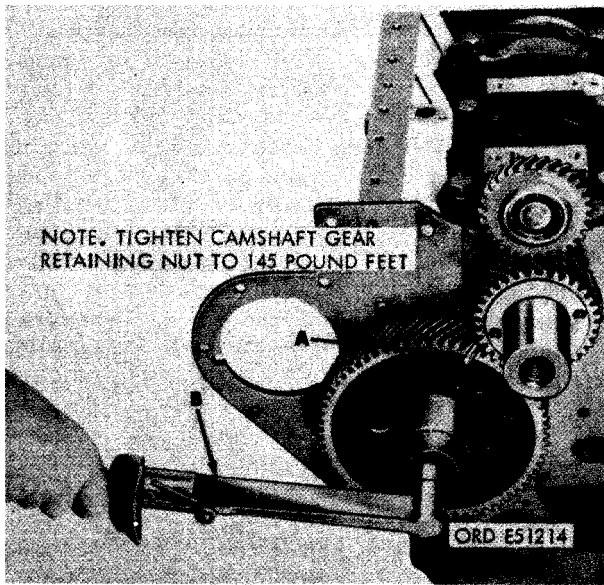


FIGURE 472. TIGHTENING CAMSHAFT GEAR RETAINING NUT.

- (2) Figure 472. (A) Position a brass rod between the teeth of the camshaft gear and the crankshaft gear to hold gears from rotating. (B) Install camshaft gear retaining nut and tighten to 145 pound feet, using a torque wrench. Remove brass rod after camshaft retaining nut is properly torqued.

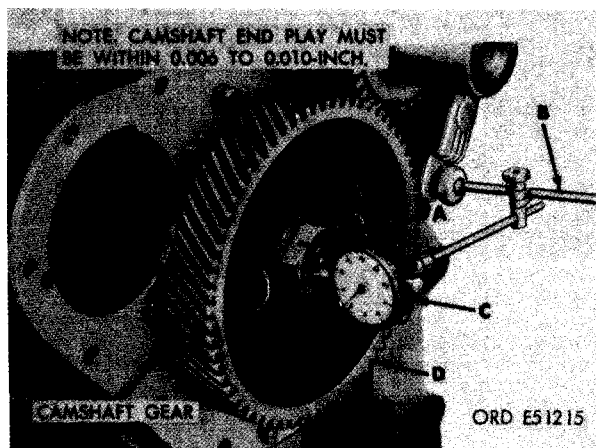


FIGURE 473. CHECKING CAMSHAFT END PLAY USING A DIAL INDICATOR.

## 261. CHECKING CAMSHAFT END PLAY AND CRANKSHAFT AND CAMSHAFT GEAR BACKLASH

**a. Check Camshaft End Play.** Figure 473. (A) Tap camshaft gear retaining nut using a soft-faced hammer and force camshaft and gear toward rear of crankcase and cylinder assembly as far as possible. (B) Mount dial indicator on front plate so indicator point rests on end of camshaft assembly. (C) Set indicator on zero reading ("0"). (D) Insert heavy duty screwdriver between camshaft gear and front plate and move gear and camshaft through limit of travel to check end play. End play must be within 0.006 to 0.010-inch.

**Note.** When end play exceeds limits specified, remove the camshaft gear and replace camshaft thrust plate following instructions in (1) through (5) below.

- (1) Remove camshaft gear following instructions for figures 290 and 291.
- (2) Remove and discard camshaft thrust plate following instructions for figure 310.
- (3) Refer to figure 310 and reverse the sequence of instructions to install new camshaft thrust plate.
- (4) Install camshaft gear following instructions for figures 471 and 472.
- (5) Recheck camshaft end play following instructions for figure 473.

**Note.** When end play is less than dimension specified (fig. 473), remove the camshaft gear and camshaft thrust plate as outlined in (1) and (2) above. Lap the thrust plate until the minimum end play dimension is attained. Install thrust plate and camshaft gear as directed in (3) and (4) above, and recheck end play following instructions in figure 473.

**b. Check Crankshaft and Camshaft Gear Backlash.** Refer to figure 474 and check backlash between crankshaft and camshaft gears. If backlash is not within limits specified, remove and discard camshaft gear, crankshaft gear, and fuel injection pump driven gear. Replace all three gears as a set.

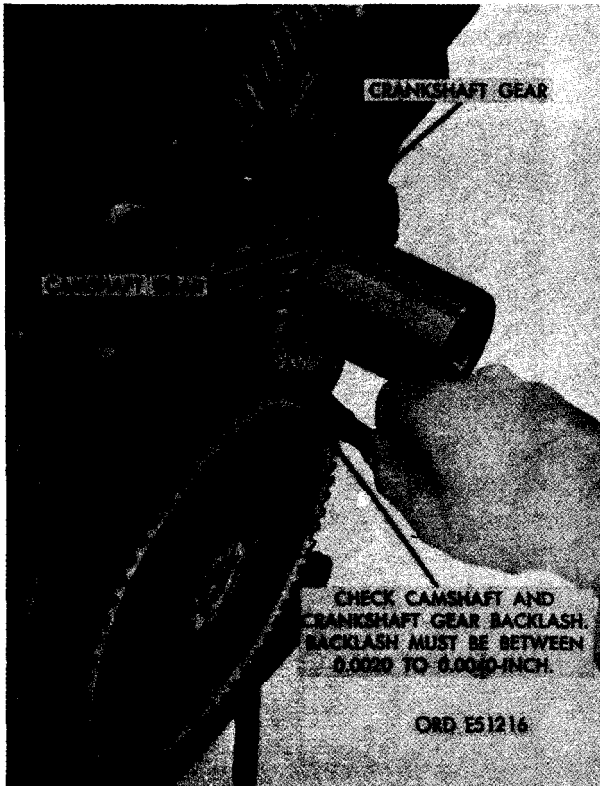


FIGURE 474. CHECKING CAMSHAFT AND CRANKSHAFT GEAR BACKLASH USING A FEELER GAGE.

262. INSTALLATION OF CAMSHAFT REAR BEARING PLUG, CRANKSHAFT REAR OIL SEAL HOUSING, AND FLYWHEEL HOUSING

a. Install Camshaft Rear Bearing Plug. Install camshaft rear bearing plug (fig. 312) and tap with a hammer to expand plug.

Note. Lubricate crankshaft hub and oil seal before installation.

b. Install Crankshaft Rear Oil Seal Housing. Refer to figure 300 and reverse the sequence of illustrations and instructions to install the crankshaft rear oil seal housing. Use a new rear oil seal housing gasket.

c. Install Flywheel Housing. Refer to figure 299 and reverse the sequence of instructions

to install flywheel housing. A new flywheel housing gasket (fig. 300) must be properly positioned before installing flywheel housing. Tighten flywheel housing nuts to a torque of 550-600 pound inches.

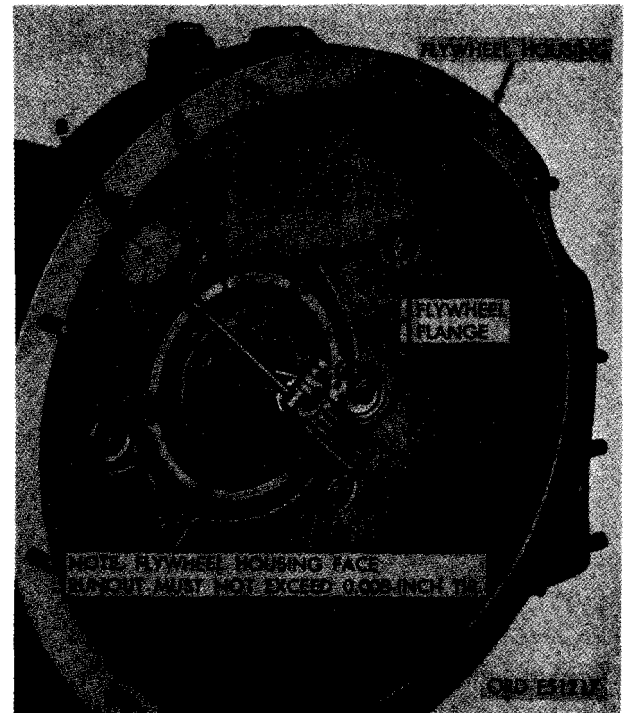


FIGURE 475. CHECKING FLYWHEEL HOUSING FACE RUNOUT USING DIAL INDICATOR.

d. Check Flywheel Housing Face Runout.

Figure 475. (A) Mount dial indicator on crankshaft flywheel "flange" so indicator point rests on the flywheel housing mounting face as shown. (B) Set indicator on zero reading ("0"). (C) Rotate crankshaft 360 degrees pushing toward front of engine and check runout.

e. Check Flywheel Housing Inside Rim for Out-of-Round Condition. Figure 476. (A) Mount dial indicator on crankshaft flywheel flange so indicator point rests on inside rim of flywheel housing as shown. (B) Set indicator to zero reading ("0"). (C) Rotate crankshaft 360 degrees and check out-of-round.

Note. Replace flywheel housing when out-of-round not within limits specified and recheck out-of-round condition.

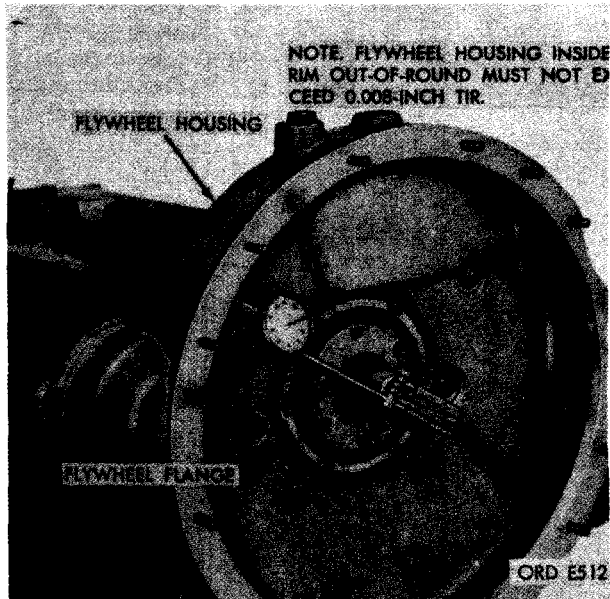


FIGURE 476. CHECKING FLYWHEEL HOUSING INSIDE RIM FOR OUT-OF- ROUND.

263. INSTALLATION OF ENGINE MOUNTING BRACKETS AND INSTALLATION OF ENGINE ON OVERHAUL STAND

a. Install Engine Mounting Brackets. Figure 477. (A) Install engine rear mounting brackets

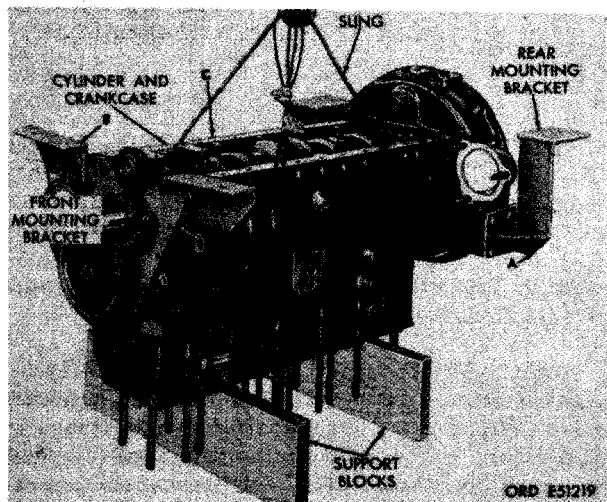


FIGURE 477. INSTALLING ENGINE MOUNTING BRACKETS AND LIFTING STRIPPED ENGINE FROM SUPPORT BLOCKS.

in flywheel housing and secure with eight 1/2-inch plain nuts and 1/2-inch lock washers. B) Install engine front mounting brackets on engine front plate and secure with four 7/16 x 3/8 cap screws and 7/16- inch plain nuts. C) Install rope sling around cylinder and crankcase assembly and lift engine from blocks.

b. Install Stripped Engine on Overhaul Stand. install stripped engine on overhaul stand as follows.

Note. Engine overhaul stand must be inverted and one side rail removed to install engine.

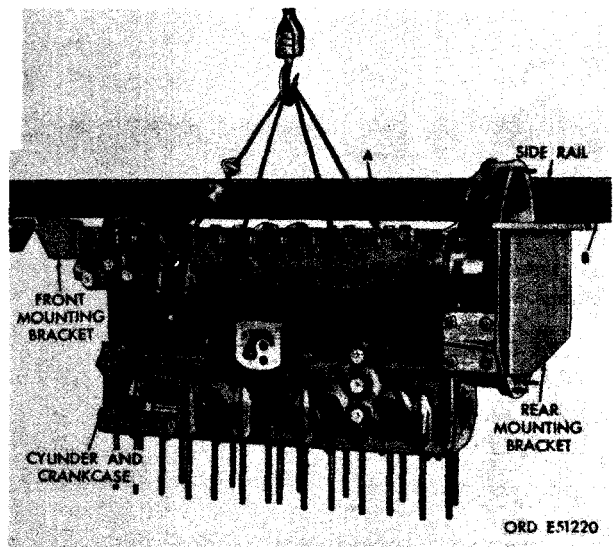


FIGURE 478. INSTALLING STRIPPED ENGINE ON CRADLE -7950198 OF ENGINE OVERHAUL STAND - 7950189.

- (1) Figure 478. (A) Lift engine to overhaul stand and side rail as shown. (B) Install side rail by reversing the sequence of instructions given in step A of figure 297.
- (2) Refer to figure 296 and reverse the instructions in step B to secure the front mounting brackets to side rails.
- (3) Refer to figure 295 and reverse the instructions in step B to secure rear mounting brackets to side rails.
- (4) Remove rope sling.

c. Position Engine for Further Assembly. Rotate cradle- 7950198 and engine overhaul stand -7950189 until engine is in an upright position. Lock cradle in position.

264. INSTALLATION OF CRANKSHAFT OIL GEAR SLINGER, TIMING GEAR COVER, TACHOMETER ADAPTER, AND CRANKSHAFT DAMPER AND PULLEY ASSEMBLY

a. Install Crankshaft Gear Oil Slinger and Timing Gear Cover Gasket. Refer to figure 290, steps A and B and reverse the sequence of instructions to install crankshaft gear oil slinger and timing gear cover gasket.

Note. Crankshaft gear oil slinger must be installed with shouldered side of slinger towards the gear.

b. Install Timing Gear Cover. Refer to figure 289 and reverse the sequence of instructions to install the timing gear cover.

Note. Apply a light coating of automotive and artillery grease (GAA) to the inside diameter of the front crankshaft oil seal.

c. Install Tachometer Adapter. Refer to figure 288 and reverse the sequence of instructions to install the tachometer adapter, adapter shaft, and tachometer mounting adapter in timing gear cover. Use a new mounting adapter gasket.

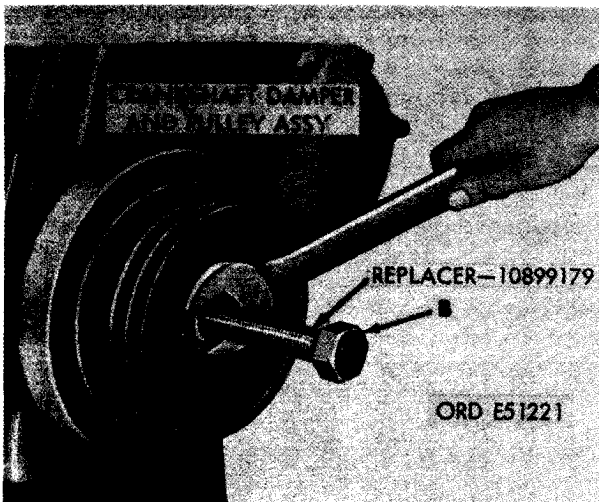


FIGURE 479. INSTALLING CRANKSHAFT DAMPER AND PULLEY ASSEMBLY USING REPLACER - 10899179.

d. Install Crankshaft Damper and Pulley Assembly. Figure 479.(A) Start crankshaft damper and pulley assembly on front end of crankshaft assembly with keyway in damper hub aligned with key in crankshaft. (B) Push crankshaft damper and pulley assembly on end of crankshaft using replacer- 10899179 as shown.

Note. Place a wrench on head of replacer - 10899179 to hold replacer while turning plain nut to seat damper and pulley assembly.

e. Install Damper Retaining Plate, Crankshaft Bolt, and Bolt Lock Plate. Refer to figure 286 and reverse the sequence of illustrations and instructions to install damper retaining plate, crankshaft bolt, and bolt lock plate. Tighten crankshaft bolt to 150 pound feet.

Note. When lock plate is properly positioned over hexagon head of crankshaft bolt, the elongated slots in the lock plate and the cap screw holes will be aligned.

265. INSTALLATION OF PISTON AND CONNECTING ROD ASSEMBLIES

a. Install No. 1 Piston and Connecting Rod.

- (1) Rotate engine on stand until center line of cylinder bore is parallel to the floor, and lock engine stand in position. Coat the pistons, rings, and cylinder liner with engine oil (OE-10). Stagger the piston ring gaps 90 degrees apart.

Note. The piston and connecting rod assembly must be installed with the "swirl" and connecting rod number toward the camshaft (left) side of the engine. Install correct connecting rod in the correct cylinder. For example, connecting rod number 1 in cylinder number 1. Turn the crankshaft to get the connecting rod journal of the crankshaft at bottom center for piston and rod installation. The connecting rod journals for pistons No. 1 and 6 will be at bottom center together. Journals for pistons No. 2 and 5 and No. 3 and 4 will also be together when crankshaft is rotated for installation of respective piston and connecting rod assemblies.



- (2) Figure 480. (A) Position piston ring compressor- 10899159 over cylinder liner with small inside diameter end toward liner. (B) Install connecting rod through compressor. Guide piston skirt through compressor and gently tap the piston with a wooden hammer handle (or other suitable tool) until top piston ring enters cylinder liner. Remove piston ring compressor -10899159. With the aid of an assistant to guide connecting rod, continue to tap piston until bearing seats on crankshaft journal.

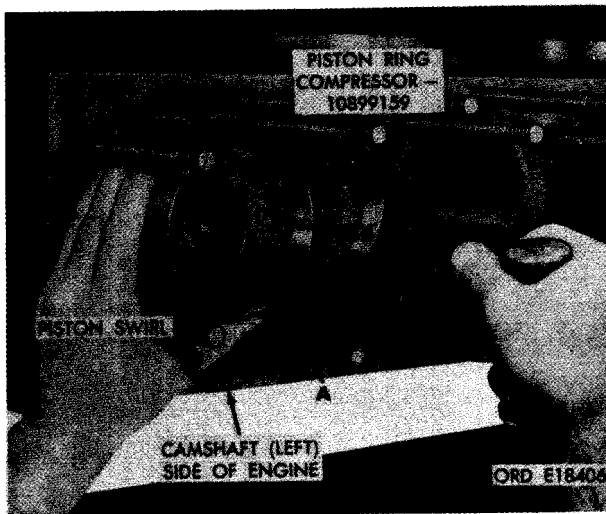


FIGURE 480. INSTALLING PISTON AND CONNECTING ROD ASSEMBLY USING PISTON RING COMPRESSOR - 10899159.

**b. Install No. 1 Connecting Rod Cap.** Install the-connecting rod cap and sleeve bearings on No. 1 connecting rod (fig. 284). The location number on cap (fig. 343) must correspond to the number on connecting rod and numbers must be toward the camshaft side of the engine. Secure the cap to the rod by installing two connecting rod bolts. Tighten the connecting rod bolts to a torque of 800 pound inches.

**c. Install Remaining Piston and Connecting Rod Assemblies and Rod Caps.**

- (1) Install remaining piston and connecting rod assemblies in the same manner following instructions for figure 480. Rotate crankshaft so that connecting rod journal for respective piston and

connecting rod being installed is at bottom center. The remaining piston and connecting rod assemblies can be installed in a sequence of No. 6, No. 2 and 5, and 3 and 4, to prevent unnecessary crankshaft rotation.

- (2) Install remaining connecting rod caps with assembled connecting rod sleeve bearings as directed in paragraph b above.

**266. INSTALLATION OF OIL PUMP ASSEMBLY, OIL PUMP TUBES, AND OIL PAN**

**a. Install Oil Pump Assembly.** Refer to figure-s 281 and 282 and reverse the sequence of illustrations and instructions to install the oil pump assembly.

**b. Check oil Pump Drive Gear and Oil Pump Idler Gear Backlash.**

- (1) Check oil pump drive gear and oil pump idler gear backlash following instructions on figure 481.



FIGURE 481. CHECKING OIL PUMP DRIVE GEAR AND OIL PUMP IDLER GEAR BACKLASH.

- (2) When oil pump drive gear and oil pump idler gear backlash is not within specifications, remove oil pump assembly following instructions for figures 281 and 282.
- (3) Refer to figure 304 and remove front main bearing cap with assembled oil pump idler gear.

Note. It is not necessary to remove the timing gear cover assembly (fig. 289) to remove the front main bearing cap with attached oil pump idler gear.

- (4) Remove oil pump drive gear following instructions for figures 359 and 360.
- (5) Remove oil pump idler gear from front main bearing cap following instructions for figures 301 and 302.
- (6) Refer to figures 301 and 302 and reverse the sequence of illustrations and instructions to install the new oil pump idler gear.
- (7) Refer to figures 359, 360 and 361 and reverse the sequence of illustrations and instructions to install the new oil pump drive gear.
- (8) Refer to figures 304 and 305 and reverse the sequence of illustrations and instructions to install front main bearing cap with attached oil pump idler gear. Tighten main bearing cap screws to a torque of 1100 pound inches.
- (9) Refer to figures 281 and 282 and reverse the sequence of illustrations and instructions to install the oil pump assembly. Check oil pump drive gear and idler gear backlash as instructed on figure 481.

#### c. Install Oil Pump Tubes.

- (1) Oil pump outlet tube. Refer to figure 280 and reverse the sequence of instructions to install the, oil pump outlet tube using new gaskets.
- (2) Scavenger pump inlet tube. Refer to figure 279 and reverse the sequence of instructions to install the scavenger pump inlet tube using new scavenger inlet tube gasket.
- (3) Pressure oil pump pickup tube. Refer to figure 278 and reverse the sequence of instructions to install the pressure oil pickup tube. Install new oil pump pickup tube gasket.

Caution: When gasket cement is used during installation of oil pan, apply cement only between the gasket and the oil pan. Never apply cement to the cylinder and crankcase gasket surface.

d. Install Oil Pan. Refer to figure 277 and reverse the sequence of illustrations and instructions to install the oil pan.

Note. The three cap screws along the right side the oil pan, near the front, are not installed until the flame heater fuel pump mounting bracket is installed (par. 277).

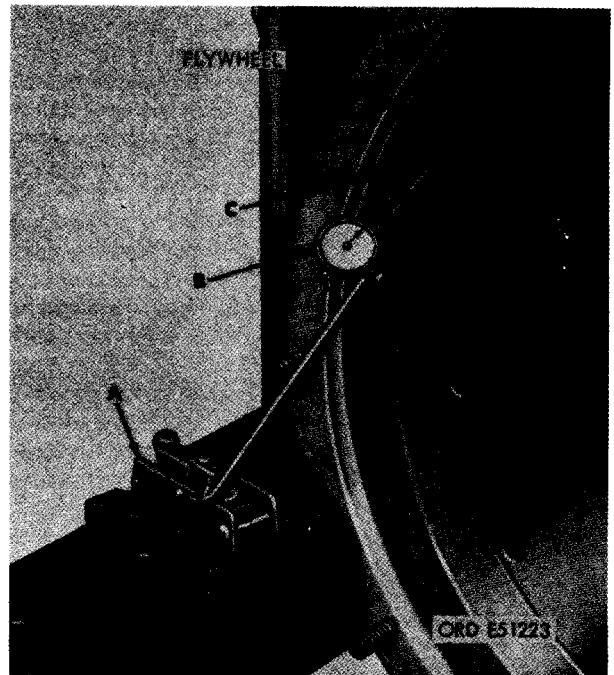


FIGURE 482. CHECKING FLYWHEEL RUNOUT USING DIAL INDICATOR.

## 267. INSTALLATION OF FLYWHEEL, CLUTCH ASSEMBLY, AND TRANSMISSION ADAPTER

### a. Install Flywheel.

- (1) Refer to figure 276 and reverse the sequence of instructions to install the flywheel. Use the pilot bolt (fig. 160) to position flywheel. Tighten flywheel mounting place bolts to torque of 650 to 700 pound inches.

- (2) Check flywheel runout. Figure 482. (A) Mount dial indicator on engine rear mounting bracket so indicator point sets on outer flywheel face as shown. (B) Set indicator on zero reading ("0"). (C) Turn crankshaft assembly 360 degrees and check runout. Replace flywheel if runout exceeds 0.008-inch TIR. Recheck runout of new flywheel in the same manner.

**b. Install Clutch Assembly.** Install clutch assembly as follows.

- (1) Figure 483. (A) Position clutch driven member against flywheel with long portion of hub facing out away from flywheel. (B) Install universal clutch alignment tool through hub splines and into bushing-type pilot bearing in end of crankshaft. The alignment tool will hold clutch driven member in position while installing clutch cover assembly (fig. 484).

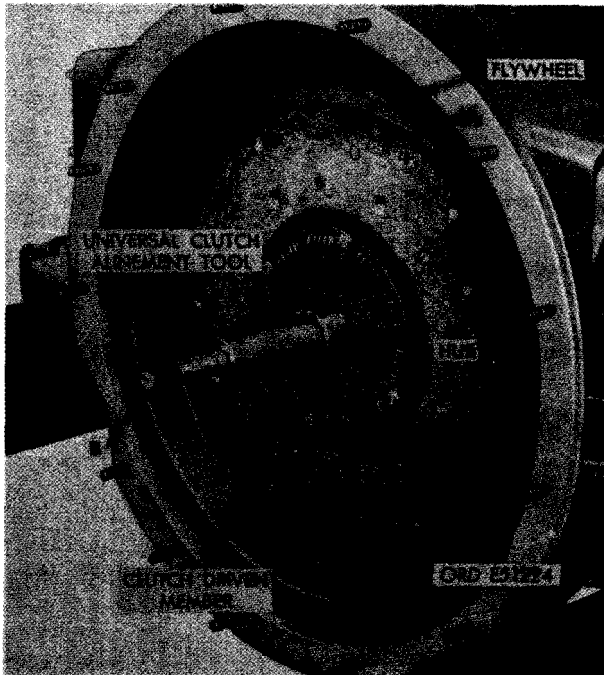


FIGURE 483. INSTALLING CLUTCH DRIVEN MEMBER USING UNIVERSAL CLUTCH ALIGNMENT TOOL.

- (2) Figure 484. (A) Position clutch cover assembly against driven member and align screw holes in clutch cover with holes in flywheel. (B) Secure clutch cover assembly to flywheel using eight 3/8-inch lock washers and 3/8 x 15/16 cap screws. (C) Depress clutch release levers and remove the four clutch release lever spacers. (D) Remove the universal clutch alignment tool.

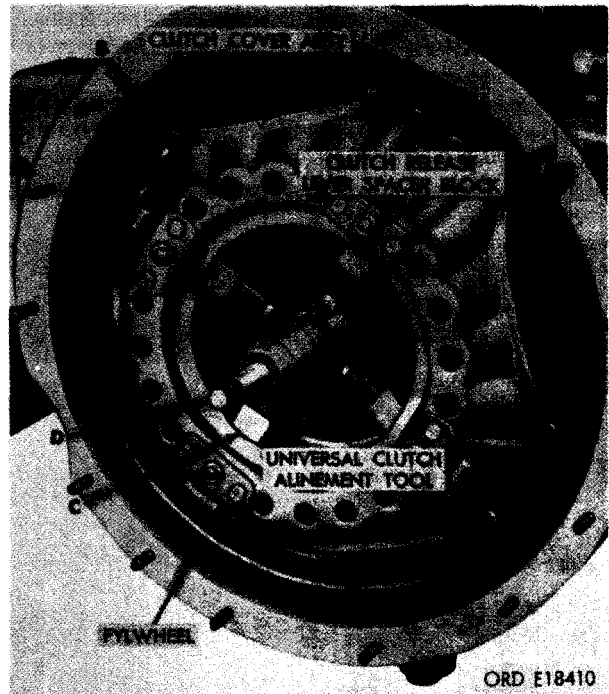


FIGURE 484. INSTALLING CLUTCH COVER ASSEMBLY.

**c. Install Transmission Adapter.** Refer to figure 273 and reverse the sequence of instructions to install transmission adapter. Install a new transmission adapter gasket between adapter and flywheel housing.

**d. Check Transmission Adapter Runout.** Check transmission adapter runout following instructions for figure 162. Runout must be within 0.008-inch TIR.

## 268. INSTALLATION OF CYLINDER HEAD ASSEMBLIES, VALVE TAPPETS, ROCKER ARM PUSH RODS, AND ROCKER ARMS

### a. Install Cylinder Head Assemblies.

Note. Cover fuel injector nozzle and holder openings in cylinder heads to prevent entrance of dirt and foreign objects.

- (1) Refer to figure 272 and reverse the sequence of instructions to position the front and rear cylinder head assemblies and cylinder head gaskets.
- (2) Refer to figure 271 and reverse the sequence of instructions to install cylinder head attaching parts.
- (3) Torque tighten cylinder head attaching nuts following instructions which accompany figure 485. Tighten cylinder head nuts in sequence, twice to 60 pound feet, 100 pound feet, and then to 130 pound feet for final torque tightness.



FIGURE 485. TIGHTENING CYLINDER HEAD NUTS USING BOX WRENCH -8722929 AND TORQUE WRENCH.

b. Install Valve Tappets. Refer to figure 270 to install the 12 valve tappets.

c. Install Rocker Arm Push Rods. Refer to figure 269 to install the 12 rocker arm push rods.

d. Install Front and Rear Rocker Arms. Refer to figure 268 and reverse the sequence of instructions B and D to install the front and rear rocker arm sets. Set intake and exhaust valve clearance as directed in paragraph 269.

Note. Back off valve adjusting screws as far as possible to prevent the rocker arm pad from driving any valve down far enough to hit a piston that may be on top center. Tighten the 3/8 x 2-1/2 cap screws evenly to seat valve rocker supports properly in the cylinder head and over dowel pins.

## 269. ADJUSTING VALVE CLEARANCE

Note. The valve clearances must be set when the valves are closed (tappets on base circle of camshaft). Set intake valves at 0.015 - inch (cold) and exhaust valves at 0.025-inch (cold).

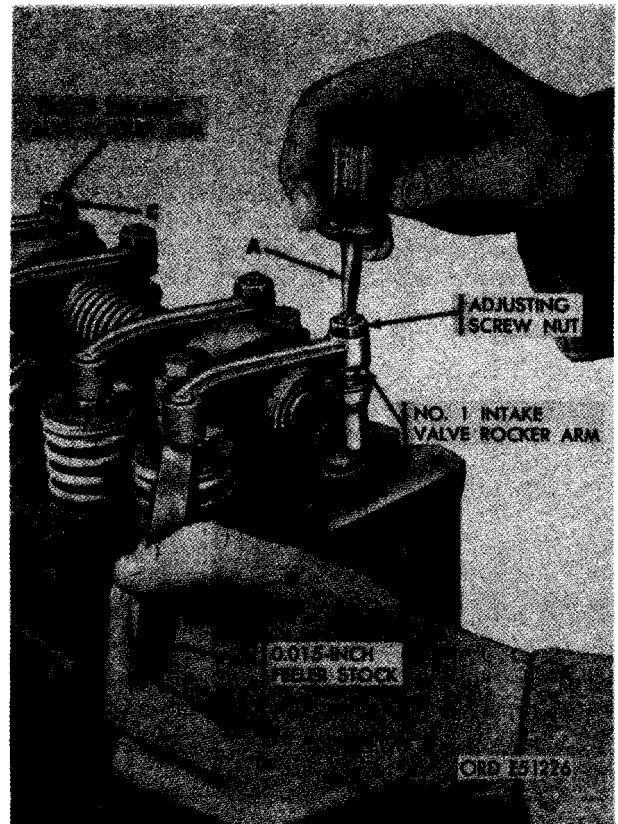


FIGURE 486. TYPICAL PROCEDURE FOR SETTING VALVE CLEARANCE.

a. Preparation for Valve Clearance Adjustment.

- (1) Rotate the crankshaft clockwise, as viewed from the fan end, until the No. 2 intake valve is in the wide open position. This can be determined when the valve rocker pad is holding the valve down as far as it will go, and its push rod is as high as it will go. When the No. 2 intake valve is in the wide open position, the No. 2 exhaust valve, and No. 1 intake valve are completely closed and in position to be adjusted.
- (2) Set No. 1 intake and No. 2 exhaust valve clearance. Figure 486. (A) Loosen adjusting screw nut and screw as necessary. (B) Place a 0.015-inch feeler gage between No. 1 intake valve rocker arm and the valve stem. Tighten the adjusting screw until the feeler gage can be withdrawn with a slight drag. Tighten the adjusting screw nut to secure the setting. (C) Set No. 2 exhaust valve clearance to 0.025-inch in the same manner.

b. Valve Adjusting Sequence. Turn crankshaft clockwise, as viewed from the fan end, approximately 120 degrees until No. 4 intake valve is fully open, With No. 4 intake valve fully open, adjust No. 4 exhaust valve and No. 5 intake valve. Following the sequence of turning the crankshaft clockwise approximately 120 degrees each time, set remaining valves as follows.

- (1) With No. 1 intake valve fully open, adjust No. 1 exhaust and No. 3 intake valves.
- (2) With No. 5 intake valve fully open, adjust No. 5 exhaust and No. 6 intake valves.
- (3) With No. 3 intake valve fully open, adjust No. 3 exhaust and No. 2 intake valves.
- (4) With No. 6 intake valve fully open, adjust No. 6 exhaust and No. 4 intake valves.

**270. INSTALLATION OF INTAKE AND EXHAUST MANIFOLDS AND OIL LEVEL GAGE SUPPORT CLAMP BRACKET**

a. Install Intake and Exhaust Manifold Gaskets. Refer to figure 268, step A and install new intake and exhaust manifold gaskets on intake and exhaust port studs.

b. Install Intake and Exhaust Manifolds and Oil Level Gage Support Clamp Brackets. Refer to figures 266 and 267 and reverse the sequence of illustrations and instructions to install the intake and exhaust manifolds and oil level gage support brackets.

Note. Intake and exhaust manifolds must be installed simultaneously.

**271. INSTALLATION OF CYLINDER HEAD WATER OUTLET MANIFOLDS AND REAR CYLINDER HEAD COVER**

Note. The front cylinder head cover will not be installed until after the fuel injection pump has been installed and timed to the engine (par. 282).

a. Position Cylinder Head Water Outlet Manifold Gaskets. Refer to figure 266 step A and position the six cylinder head water outlet manifold gaskets.

b. Install Front and Rear Cylinder Head Water Outlet Manifolds. Refer to figure 265 and reverse the sequence of instructions to install the front and rear cylinder head water outlet manifolds.

Note. Install new rear cylinder head cover gasket rear cylinder head.

c. Install Rear Cylinder Head Cover. Figure 487. (A) Position rear cylinder head cover over gasket. (B) Secure rear cylinder head cover and tachometer cable bracket to cylinder head using seven 5/16- inch lock washers and 5/16 x 7/8 cap screws. (C) Install one 5/16- inch plain washer and 5/16-inch self- locking nut.

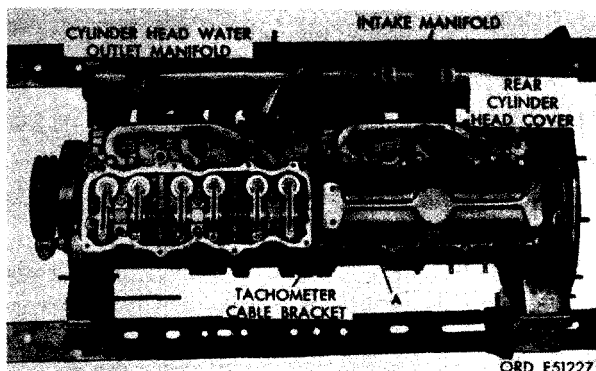


FIGURE 487. INSTALLING REAR CYLINDER HEAD COVER.

272. INSTALLATION OF FRONT AND REAR ENGINE LIFTING BRACKETS

a. Install Engine Rear Lifting Bracket. Refer to figure 262 and reverse the sequence of instructions to install the rear engine lifting bracket.

b. Install Engine Front Lifting Bracket. Refer to figure 261 and reverse the sequence of instructions to install front engine lifting bracket.

273. INSTALLATION OF WATER PUMP ASSEMBLY, THERMOSTAT HOUSING, GENERATOR ADJUSTING STRAP, AND ENGINE FAN

a. Install Water Pump Assembly. Refer to figure 260 and reverse the sequence of instruction to install the water pump assembly.

b. Install Thermostat Housing and Generator Adjusting Strap. Refer to figures 258 and 259 and reverse the sequence of illustrations and instructions to install thermostat housing and generator adjusting strap. Use a new thermostat housing gasket.

Note. Do not tighten the nut securing generator adjusting strap until generator drive belts have been installed and adjusted (par. 286d).

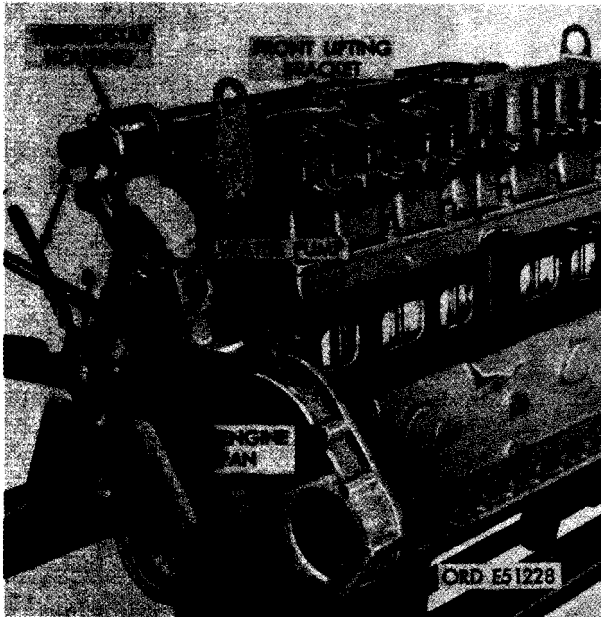


FIGURE 488. INSTALLING ENGINE FAN.

c. Install Engine Fan. Figure 488. (A) Position engine fan against water pump pulley and align screw holes. (B) Secure fan to water pump pulley using four 5/16-inch lock washers and 5/16 x 3/4 cap screws.

274. INSTALLATION OF STARTER ADAPTER, OIL PRESSURE SENDING UNIT, AND COOLANT DRAIN COCK

a. Install Starter Adapter. Refer to figures 255 and 256 and reverse the sequence of instructions to install the starter adapter. Install a new starter adapter gasket.

b. Install Oil Pressure Sending Unit and Coolant Drain Cock. Refer to figures 255 and 256 and reverse the sequence of instructions to install the oil pressure sending unit and coolant drain cock.

275. INSTALLATION OF OIL PRESSURE REGULATOR VALVE HOUSING, TURBO-SUPERCHARGER OIL INLET TUBE, AND DRAIN HOSE ADAPTER

a. Late Model Engines. Figure 489. (A) Position a new regulator valve housing gasket (fig. 254) on cylinder and crankcase and position

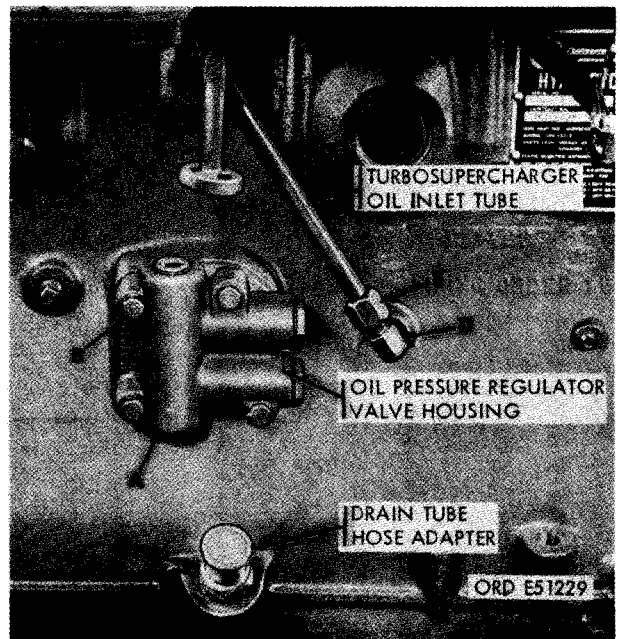


FIGURE 489. INSTALLING OIL PRESSURE REGULATOR VALVE HOUSING, TURBO-SUPERCHARGER OIL INLET TUBE, AND OIL DRAIN TUBE ADAPTER (LATE MODEL ENGINES).

regulator housing against gasket, alining screw holes. (B) Install four 3/8-inch lock washers and 3/8 x 2 cap screws to secure oil pressure regulator valve housing. (C) Install turbosupercharger drain tube hose adapter in cylinder and crankcase and tighten securely. Install dust cap in opening to prevent entrance of dirt and foreign material. (D) Install 3/8-inch pipe x 1/2-inch tube, 90 degree elbow and tighten to position shown. (E) Connect turbosupercharger oil inlet tube to 90 degree elbow.

**Note.** It may be necessary to turn 90 degree elbow with attached tube to permit alinement of turbosupercharger oil inlet flange during installation of turbo supercharger.

**b. Early Model Engines. Figure 490.** (A) Position a new regulator valve housing gasket on cylinder and crankcase (fig. 254) and position regulator valve housing against gasket, alining screw holes. (B) Secure oil pressure regulator valve housing to cylinder and crankcase using four 3/8-inch lock washers and 3/8 x 2 cap screws. (C) Install turbosupercharger oil drain hose adapter in cylinder and crankcase. Tighten securely and install dust cap to prevent entry of dirt and foreign material. (D) Install 1/4-inch pipe x 3/8 tube, 90 degree elbow and tighten to approximate position shown. (E) Connect turbosupercharger oil inlet tube to 90 degree elbow. Tighten to approximate position shown. (F) Plug open end of oil inlet tube to prevent entry of dirt and foreign material.

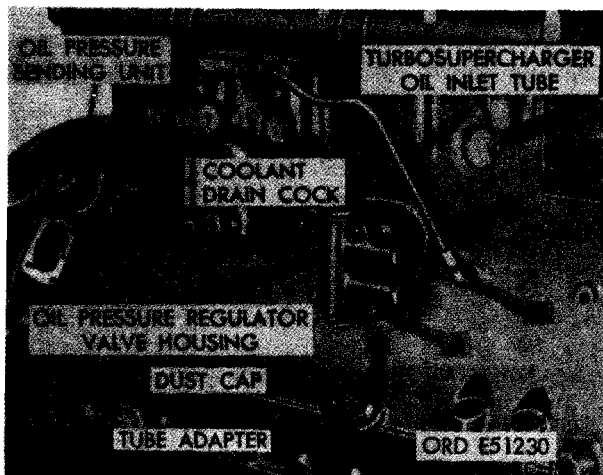


FIGURE 490. INSTALLING OIL PRESSURE REGULATOR VALVE HOUSING, TURBOSUPERCHARGER OIL INLET TUBE, AND OIL DRAIN HOSE ADAPTER (EARLY MODEL ENGINES).

**Note.** It may be necessary to turn 90 degree elbow with attached tube to permit alinement with turbosupercharger oil inlet connector during installation of turbosupercharger.

#### 276. INSTALLATION OF OIL LEVEL GAGE ROD SUPPORT AND GENERATOR MOUNTING BRACKET

Refer to figure 251 and reverse the sequence of instructions to install the oil level gage rod support and generator mounting bracket.

#### 277. INSTALLATION OF FLAME HEATER FUEL PUMP AND FUEL FILTER BRACKET

Refer to figure 250 and reverse the sequence of instructions to install the flame heater fuel pump and fuel filter bracket.

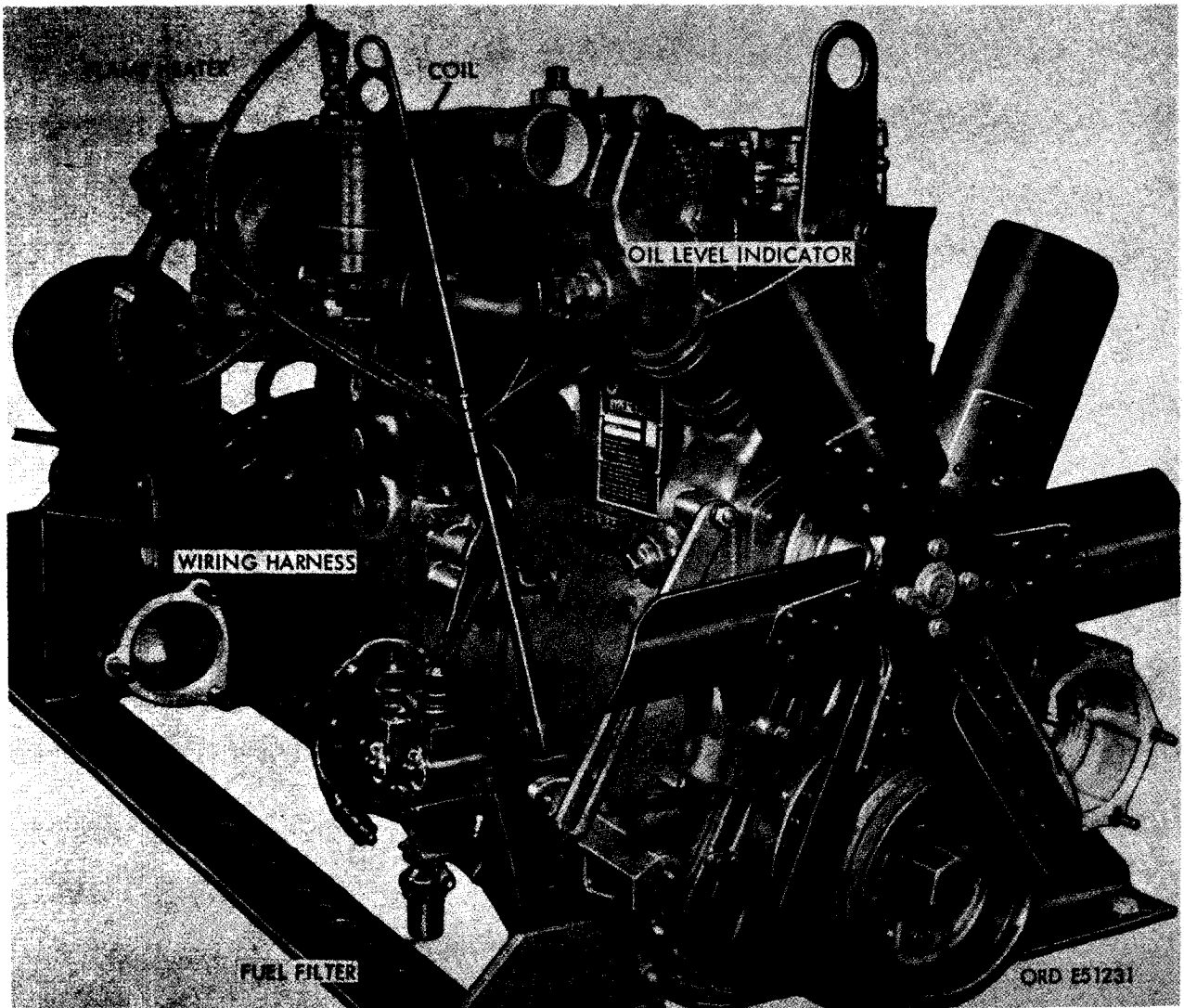
#### 278. INSTALLATION OF FLAME HEATER FUEL TUBES, WIRING HARNESS, OIL LEVEL GAGE, INTAKE MANIFOLD ELBOW, FLAME HEATER IGNITION UNIT, AND FLAME HEATER ASSEMBLY

Refer to figures 245 through 249 and reverse the sequence of illustrations and instructions to install flame heater fuel tubes, wiring harness, oil level gage, intake manifold elbow, flame heater ignition unit, and flame heater assembly.

#### 279. INSTALLATION OF FUEL INJECTION PUMP ADAPTER, PRESSURE OIL HOSE ELBOW, AND AIR COMPRESSOR SUPPORT

**a. Install Fuel Injection Pump Adapter.** Refer to figure 243 and reverse the sequence of instructions to install fuel injection pump adapter. Use a new gasket between adapter and engine front plate.

**b. Install Fuel Injection Pump Pressure Oil-Hose Elbow and Air Compressor Support.** Refer to figures 241 and 242 and reverse the sequence of illustrations and instructions to install fuel injection pump pressure oil hose elbow and the air compressor support using a new air compressor support gasket. Figure 491 shows the right side of the partially assembled engine.



**FIGURE 491. RIGHT FRONT VIEW OF ENGINE PARTIALLY ASSEMBLED.**

**280. INSTALLATION OF CYLINDER AND CRANKCASE WATER BAFFLE, TAPPET CHAMBER COVER, AND OIL COOLER AND OIL FILTER HOUSING ASSEMBLY**

**a. Install Cylinder and Crankcase Water Baffle and Tappet Chamber Cover.** Refer to figures 239 and 240 and reverse the sequence of illustrations and instructions to install cyl-

inder and crankcase water baffle and tappet chamber cover.

**b. Install Oil Cooler and Oil Filter Housing and Oil Cooler Water Inlet Tube.** Refer to figures 235 through 238 and reverse the sequence of illustrations and instructions to install the oil cooler and oil filter housing and oil cooler water inlet, tube using a new gasket.



## 281. INSTALLATION OF OIL FILTERS AND FUEL INJECTION PUMP OIL SUPPLY HOSE

**a. Install Oil Filters.** Figure 492. (A) Position rear oil filter case gasket in the recess provided in oil cooler and oil filter housing. (B) Position rear oil filter element on housing. (C) Position rear oil filter case over element and start bar threads into helical coil threaded insert in oil cooler and oil filter housing. (D) Secure rear oil filter case by tightening bar to a torque of 60 pound feet. Case must be properly seated against case gasket.

**Note.** The front oil filter element and case are installed in the same manner.

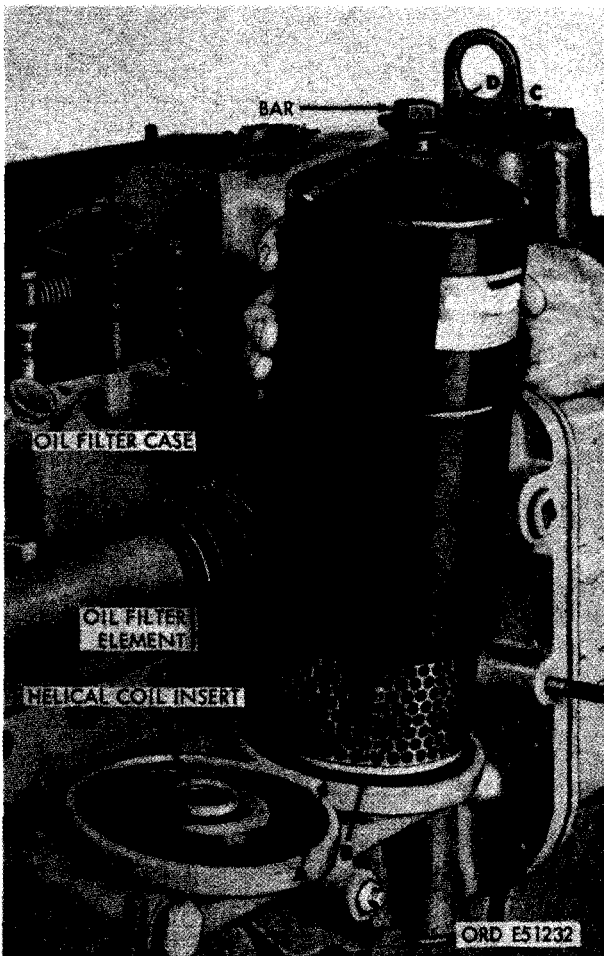


FIGURE 492. INSTALLING OIL FILTERS.

**b. Install Fuel Injection Pump Oil Supply Hose.** Refer to figure 493 and install fuel injection pump oil supply hose.

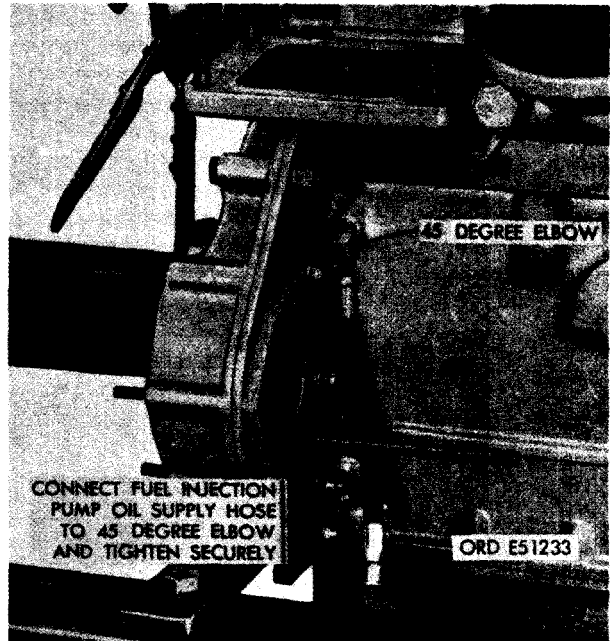


FIGURE 493. CONNECTING FUEL INJECTION PUMP OIL SUPPLY HOSE.

## 282. INSTALLATION OF FUEL INJECTION PUMP ASSEMBLY

**a. Preparation of Fuel Injection Pump Assembly for Installation.**

- (1) **General.** A new or rebuilt fuel injection pump is supplied for installation as shown in figure 76. The injection pump is prepared for installation following the procedures outlined in (2) through (5) below.
- (2) **Remove injection pump timing covers.** Refer to figure 76 and reverse the sequence of instructions to remove timing cover, timing window cover, dirt plugs or caps, and automatic advance unit shaft lock washer and nut.
- (3) **Install fuel tube and hose elbows and connector.** Refer to figures 74 and 75, and reverse the sequence of instructions to install tube and hose elbows and connector.

- (4) Install fuel injection pump driven gear hub. Refer to figures 72 and 73 and reverse the sequence of instructions to install the fuel injection pump driven gear hub.
- (5) Timing fuel injection pump assembly. The timing mark on the automatic advance unit hub (fig. 64) must be alined with pointer when the marked tooth in the timing window (fig. 65) is visible. It is possible to have the timing marks in the advance unit alined and not have the marked tooth on the plunger drive gear in the timing window visible. When the marked tooth is visible and the advance unit marks are alined, the pump is properly timed. If the marked tooth is not visible, rotate the gear hub 360 degrees, in either direction, so the timing marks do aline. This insures proper timing when the pump is installed on the engine.

Note. The injection pump camshaft and plunger spring assembly pressure tends to prevent timing mark on hub from remaining in line with its mating pointer. These marks must be alined when installing injection pump driven gear (fig. 77).

b. Check Engine Timing Before Installing Fuel Injection Pump (fig. 494).

- (1) Rotate crankshaft clockwise, as viewed from fan end, until cylinder No. 1 intake and exhaust valves are closed. When valve clearance is evident at both rocker arms, both valves are closed.
- (2) The timing mark on the vibration damper and pulley assembly must be alined with the pointer on timing gear cover.

Note. The engine is properly timed when timing mark on the vibration damper is alined with pointer on timing gear cover and cylinder No. 1 is on the compression stroke (both intake and exhaust valves closed).

c. Install Fuel Injection Pump Assembly.

Install the fuel injection pump assembly as follows.

- (1) Figure 495. (A) Timing marks of fuel injection pump assembly and vibration damper must remain alined as pump is installed on engine. Use new preformed packing if original pump is installed on engine. New pump assemblies include

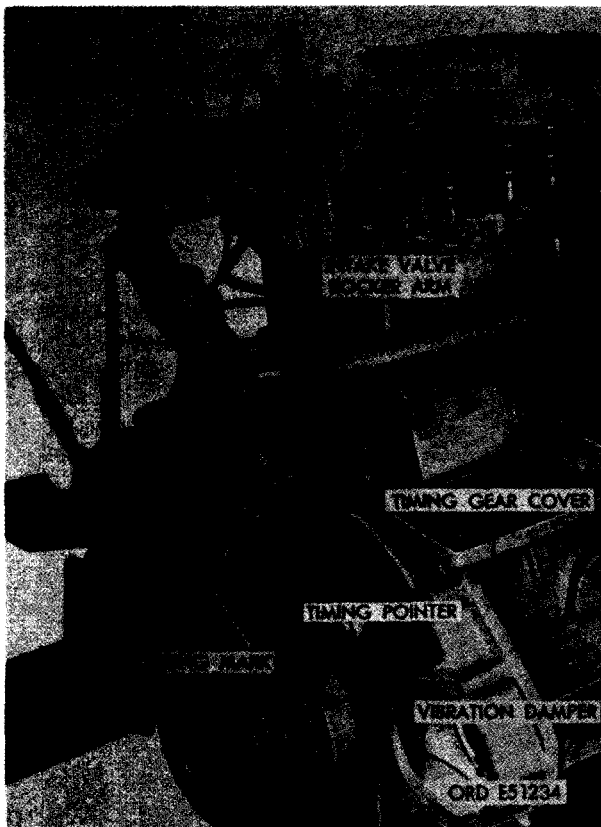


FIGURE 494. CHECKING ENGINE TIMING PRIOR TO FUEL INJECTION PUMP INSTALLATION.

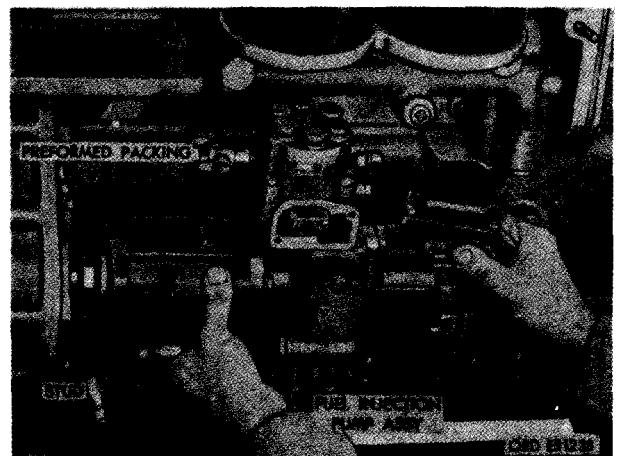
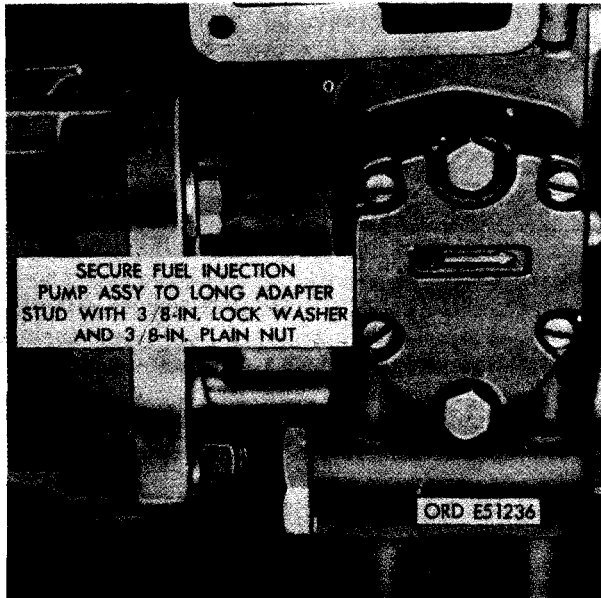


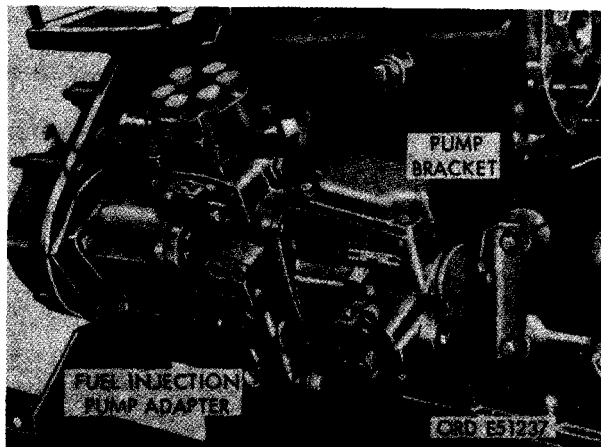
FIGURE 495. INSTALLING FUEL INJECTION PUMP ASSEMBLY.

the preformed packing. (B) Install fuel injection pump assembly using the long stud as a guide and to hold pump in approximate position until secured with nut and cap screws (figs. 496 through 498).

- (2) Secure pump to adapter stud as shown in figure 496.



**FIGURE 496. SECURING FUEL INJECTION PUMP ASSEMBLY TO LONG ADAPTER STUD.**

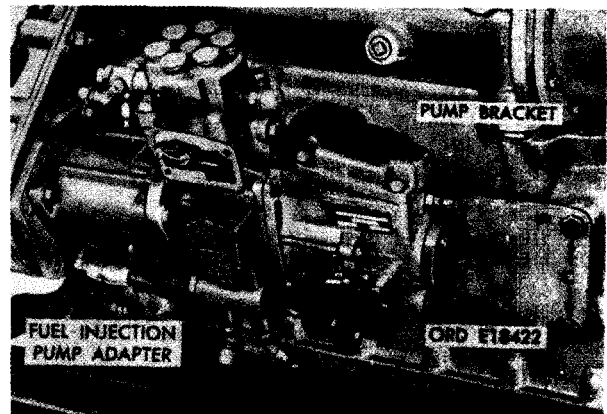


**FIGURE 497. SECURING FUEL INJECTION PUMP ASSEMBLY TO ADAPTER AND INSTALLING PUMP BRACKET (LATE MODEL ENGINES).**

- (3) Figure 497. (A) Secure fuel injection pump to fuel injection pump adapter using two 3/8-inch lock washers and 3/8 x 1-1/8 cap screws. (B) Position fuel injection pump bracket assembly on cylinder and crankcase assembly and align screw holes. (C) Secure pump bracket to crankcase using two 1/2-inch lock washers and 1/2 x 1-3/8 cap screws. (D) Secure fuel injection pump assembly to bracket using two 5/16-inch lock washers and 5/16 x 3/4 cap screws.

- (4) Figure 498. (A) Secure fuel injection pump to fuel injection pump adapter using two 3/8-inch lock washers and 3/8 x 1-1/8 cap screws. (B) Position fuel injection pump bracket assembly on cylinder and crankcase assembly and align screw holes. (C) Secure pump bracket to crankcase using two 1/2-inch lock washers and 1/2 x 1-3/8 cap screws. (D) Secure fuel injection pump assembly to bracket using two 5/16-inch lock washers and 5/16 x 3/4 cap screws.

Note. Install a new fuel injection pump drive gear when a new crankshaft and camshaft gear are installed (par. 261b).



**FIGURE 498. SECURING FUEL INJECTION PUMP ASSEMBLY TO ADAPTER AND INSTALLING PUMP BRACKET ASSEMBLY (EARLY MODEL ENGINES).**

- (5) Figure 499. (A) Position fuel injection pump drive gear on fuel injection pump driven gear hub aligning elongated bolt holes in gear with threaded elongated screw holes in hub. The elongated bolt holes allow for adjustment of the gear for precise fuel injection pump timing in relation to engine timing. (B) Position fuel injection pump driven gear retaining plate against driven gear and align bolt holes. (C) Install three 3/8-inch lock washers and 3/8 x 1- 1/4 cap screws to hold retaining plate until injection pump timing has been completed.

Note. Tighten cap screws after the fuel injection pump timing marks are aligned.

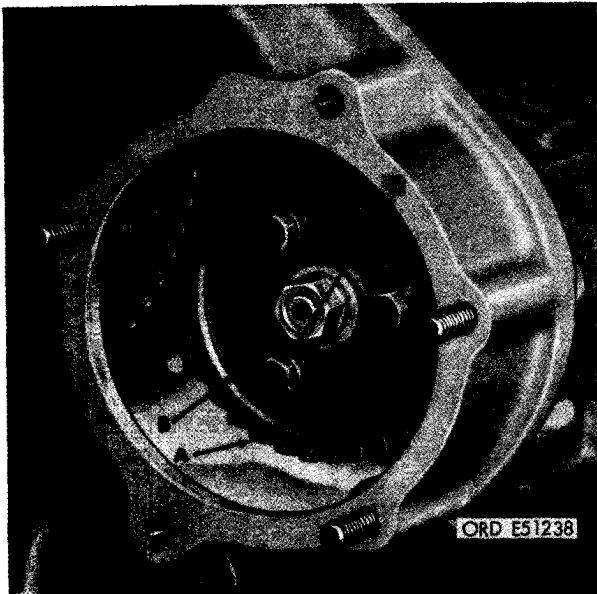


FIGURE 499. INSTALLING FUEL INJECTION PUMP DRIVEN GEAR AND RETAINING PLATE.

Caution: Do not allow the engine vibration damper, or plunger drive gear in timing window in pump head to move off timing marks while setting the advance unit timing marks.

- (6) Figure 500. (A) Using a suitable socket wrench on the hex nut securing the driven gear hub to the fuel injection pump shaft, turn the wrench slightly, in either direction, until the automatic advance unit timing mark on fuel injection pump is

aligned with its pointer. Retain this position. (B) With timing marks aligned, tighten the three cap screws securing the driven gear and plate to the hub. After tightening the three cap screws, check driven gear and camshaft gear backlash. Backlash should be within 0.0020 to 0.0060-inch.

Note. The three slots in the driven gear all approximately 20 degrees of free rotation on the injection pump drive shaft and gear hub. In extreme cases, remove the driven gear and plate and reposition the gear on the hub to gain satisfactory alignment.

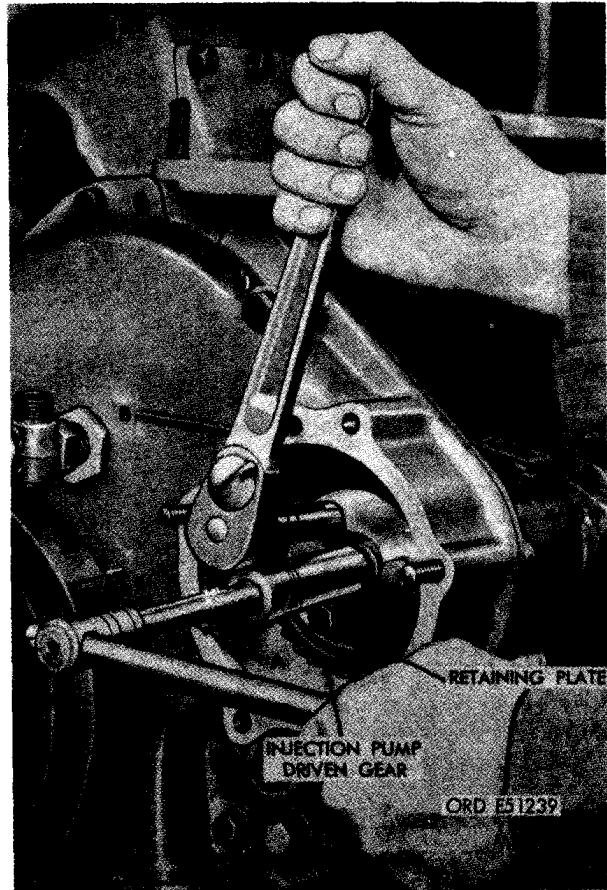


FIGURE 500. SETTING FUEL INJECTION PUMP TIMING IN RELATION TO ENGINE TIMING.

- (7) Figure 501. (A) Position injection pump automatic advance unit timing cover on advance unit opening using a new gasket. (B) Secure timing cover with four 1/4- inch lock washers and 1/4 x 5/8 machine screws. (C) Position timing window cover over opening in fuel injection pump assembly using a new gasket. (D) Secure cover with two 1/4- inch lock washers and 1/4 x 1- 1/4 filler-head screws. (E) Connect fuel injection pump oil inlet hose to special tee connection in automatic advance unit.

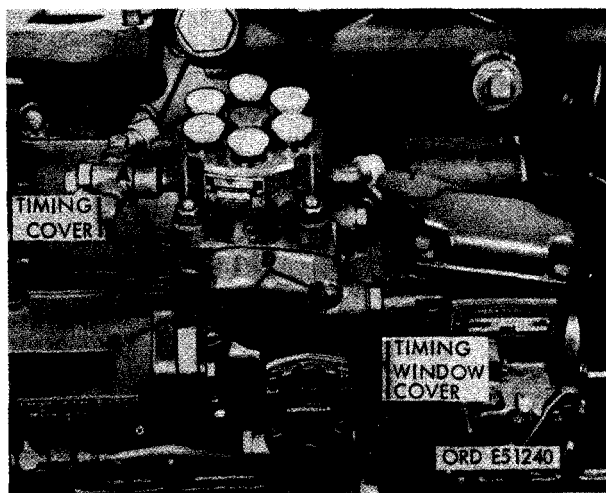


FIGURE 501. INSTALLING TIMING COVER, TIMING WINDOW COVER, AND CONNECTING FUEL INJECTION PUMP OIL INLET HOSE.

d. Check Alinement of Fuel Injection Pump and Engine Timing Marks.

- (1) The engine and fuel injection pump are properly timed when the following conditions can be observed.
- (a) The timing mark on the vibration damper is alined with the timing pointer on timing gear cover and the No. 1 cylinder is on its compression stroke (fig. 63).
  - (b) The automatic advance unit hub timing mark is alined with its pointer (fig. 64).

- (c) The marked tooth on the pump plunger drive gear is visible through the timing window (fig. 65).

- (2) Turn the crankshaft counterclockwise, as viewed from the fan end, approximately 45 degrees. Turn crankshaft clockwise until timing mark on vibration damper is alined with the timing pointer on the camshaft gear cover. If the timing marks on the automatic advance unit hub and pump plunger drive gear are not alined, recheck engine timing and pump timing as follows.

Refer to figure 499 and reverse the sequence of instructions to remove fuel injection pump driven gear. It is not necessary to remove injection pump. Check injection pump timing as directed in paragraph a above.

- (b) Check engine timing as directed in paragraph b above.

Install fuel injection pump driven gear and retaining plate following instructions for figure 499.

Set fuel injection pump timing in relation to engine timing following instructions for figure 500.

- (e) After timing is correct, install timing covers and connect oil inlet hose (fig. 501).

283. INSTALLATION OF INJECTION PUMP DRIVEN GEAR ACCESS COVER, FRONT CYLINDER HEAD COVER, AND CRANKCASE BREATHER ADAPTER

a. Install Injection Pump Driven Gear Access Cover. Figure 502. (A) Position new driven gear access cover gasket on timing gear cover, with stud and cap screw holes alined. (B) Position driven gear access cover over gasket. (C) Install three 3/8- inch lock washers and 3/8- inch plain nuts on studs. (D) Install two 3/8 x 3-3/4 cap screws, 3/8- inch lock washers, and 3/8- inch plain nuts to secure cover.

b. Install Flywheel Timing Cover (Early Model Engines). Refer to figure 256 and reverse steps E and F and install flywheel timing cover. Use a new cover gasket.

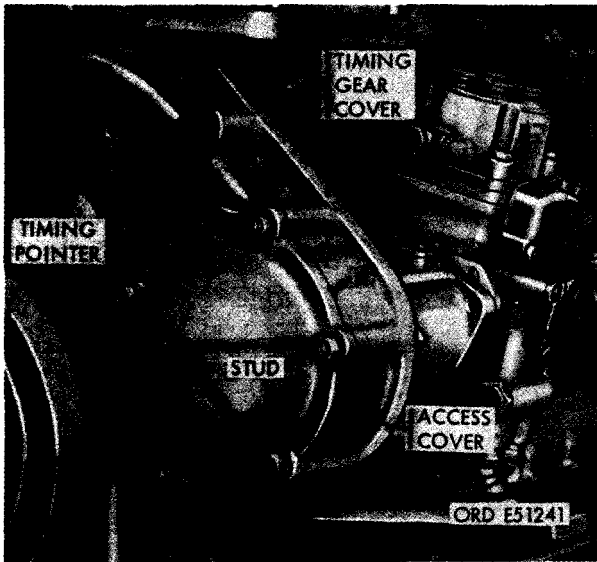


FIGURE 502. INSTALLING FUEL INJECTION PUMP DRIVEN GEAR ACCESS COVER.

c. Install Front Cylinder Head and Crankcase Breather Adapter. Install front cylinder head and crankcase breather adapter as follows.

Figure 503. (A) Position a new front cylinder head cover gasket and cover on front cylinder head and align screw holes. (B) Install seven 5/16- inch lock washers and 5/16 x 7/8 cap screws to temporarily hold cylinder head cover to cylinder head. Install one 5/16-inch plain washer and 5/16- inch self-locking nut. (C) Install oil filler cap. (D) Position a new crankcase breather adapter gasket on each cylinder head cover.

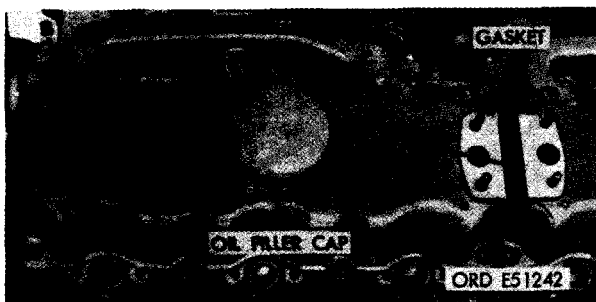


FIGURE 503. INSTALLING FRONT CYLINDER HEAD COVER.

(2) Figure 504. (A) Position crankcase breather adapter, with attached hose, on front and rear cylinder head covers as shown. (B) Secure adapter to cylinder head covers using four 5/16- inch lock washers and 5/16- inch plain nuts.

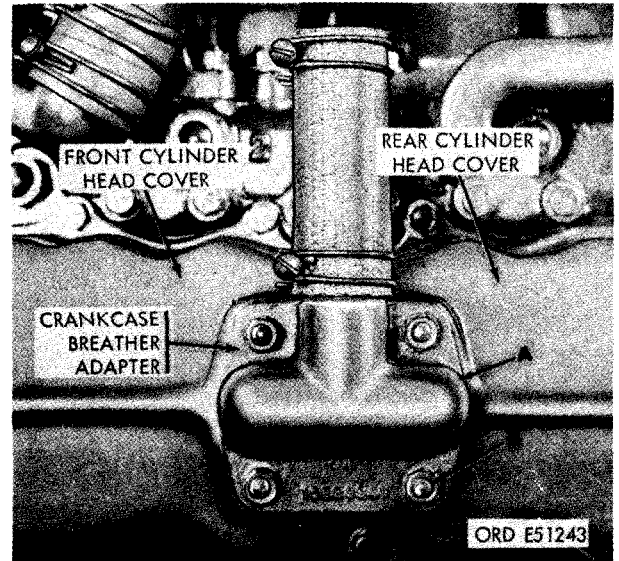


FIGURE 504. INSTALLING CRANKCASE BREATHER ADAPTER.

## 284. INSTALLATION OF FUEL INJECTOR NOZZLE AND HOLDER ASSEMBLIES, FUEL RETURN TUBES, AND FUEL INJECTION TUBES

a. Install Fuel Injector Nozzle and Holder Assemblies. Figure 505. (A) Remove protective plugs from fuel injector nozzle and holder openings. (B) Install nozzle hold-down clamp

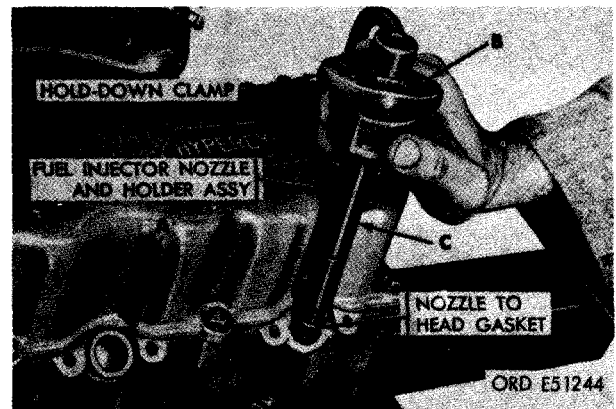


FIGURE 505. INSTALLING FUEL INJECTOR NOZZLE AND HOLDER ASSEMBLY.

on nozzle holder with clamp properly positioned on dowel pin. (C) Install nozzle and holder assembly. Install remaining nozzle and holder assemblies as described above.

**Note.** Use new nozzle to head gaskets when installing nozzles. Apply a light coating of heavy grease to gasket to insure proper gasket seating and preventing gasket from sliding off the end of the nozzle.

**b. Secure Fuel Injector Nozzle and Holder Assemblies and Connect Fuel Return Tubes.**

Figure 506. (A) Aline the dowel pin holes in the nozzle hold-down clamps with the dowel pins in the nozzle and holders. Install twelve 5/16-inch lock washers and 5/16 x 2-1/2 cap screws. (B) Install one 1/8-inch pipe x 1/4-inch tube

90 degree elbow in cylinder No. 6 nozzle holder. (C) Install five 1/8-inch pipe x 1/4-inch tube tees in the remaining nozzle holders. (D) Connect the long fuel injector nozzle fuel return tube between cylinder No. 3 and 4 fuel return tees. (E) Connect the remaining short fuel injector nozzle fuel return tubes between tees for cylinder No. 1 and 2, 2 and 3, 4 and 5, and 5 and 6. (F) Connect fuel return-to-fuel injection pump overflow valve tube at cylinder No. 1 return tee. (G) Install fuel return tube clip. Clip will be attached to the front corner of the air compressor when compressor is installed (par. 286a).

**Note.** Before installing fuel injection tubes refer to figure 507 for fuel injection pump port identification.

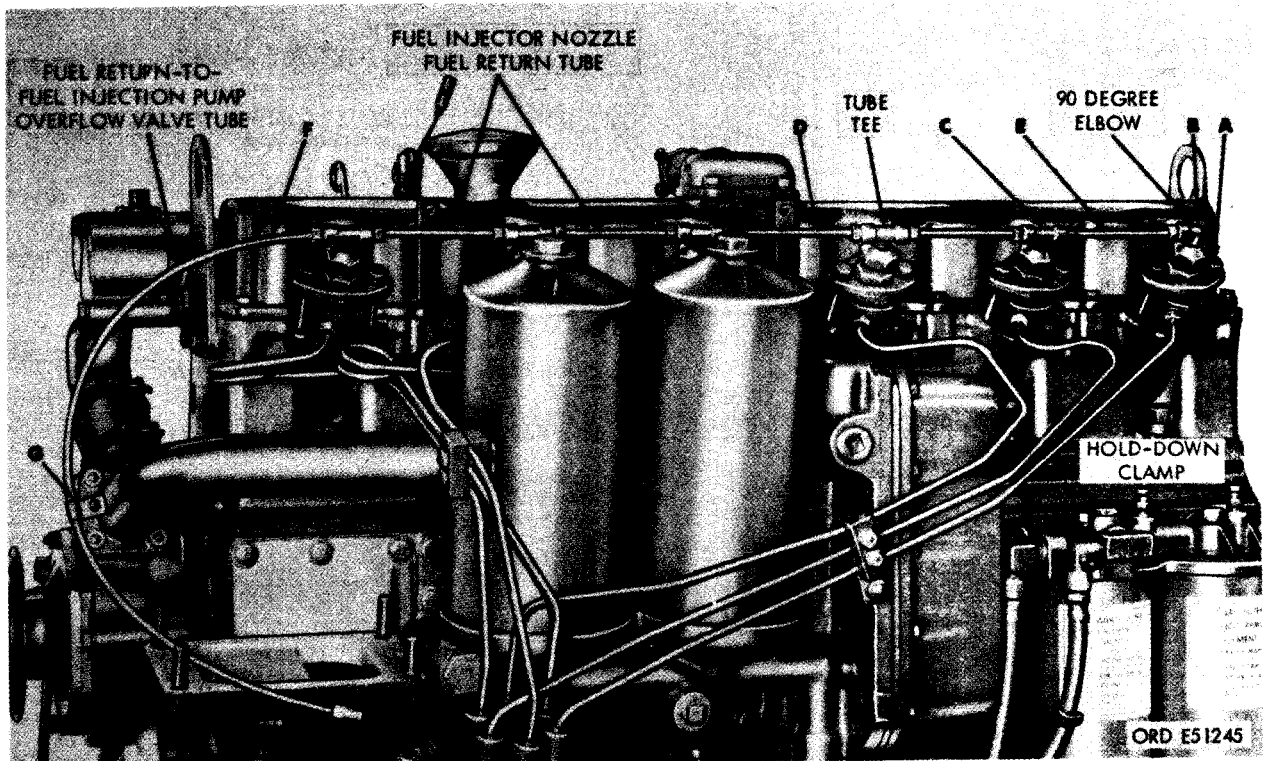
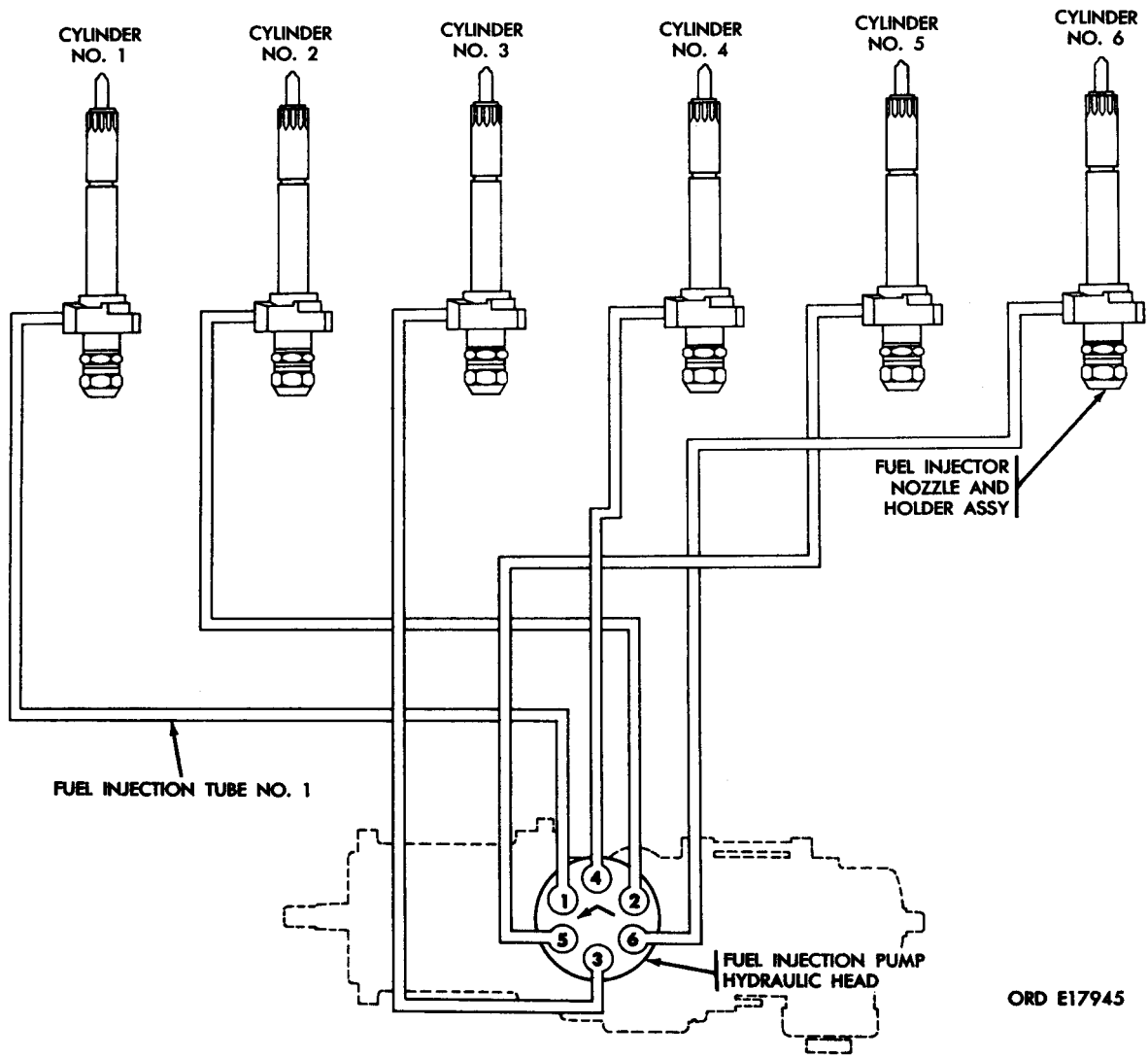


FIGURE 506. INSTALLING FUEL INJECTOR NOZZLE AND HOLDER FUEL RETURN TUBES.



ORD E17945

**FIGURE 507. FUEL INJECTION TUBE AND INJECTION PORT IDENTIFICATION.**





FIGURE 508. CONNECTING CYLINDER NO. 1, 2, AND 3 FUEL INJECTION TUBES.

c. Install Fuel Injection Tubes. Install fuel injection tubes as follows.

- (1) Figure 508. (A) Connect fuel injection tube to nozzle and holder in cylinder No. 1. Remove dust cover from No. 1 port opening in pump hydraulic head and connect tube. (B) Connect fuel injection tube to nozzle and holder in cylinder No. 2. Remove dust cover from No. 2 port opening in pump hydraulic head and connect tube. (C) Connect fuel injection tube to nozzle and holder in cylinder No. 3. Remove dust cover from No. 3 port opening in pump hydraulic head and connect tube. (D) Install two fuel injection tube clamps and secure with two 1/4 x 1-3/8 cap screws, 1/4-inch plain washers, and 1/4-inch self-locking nuts. (E) Slide dust caps over tube nuts and injection pump ports.

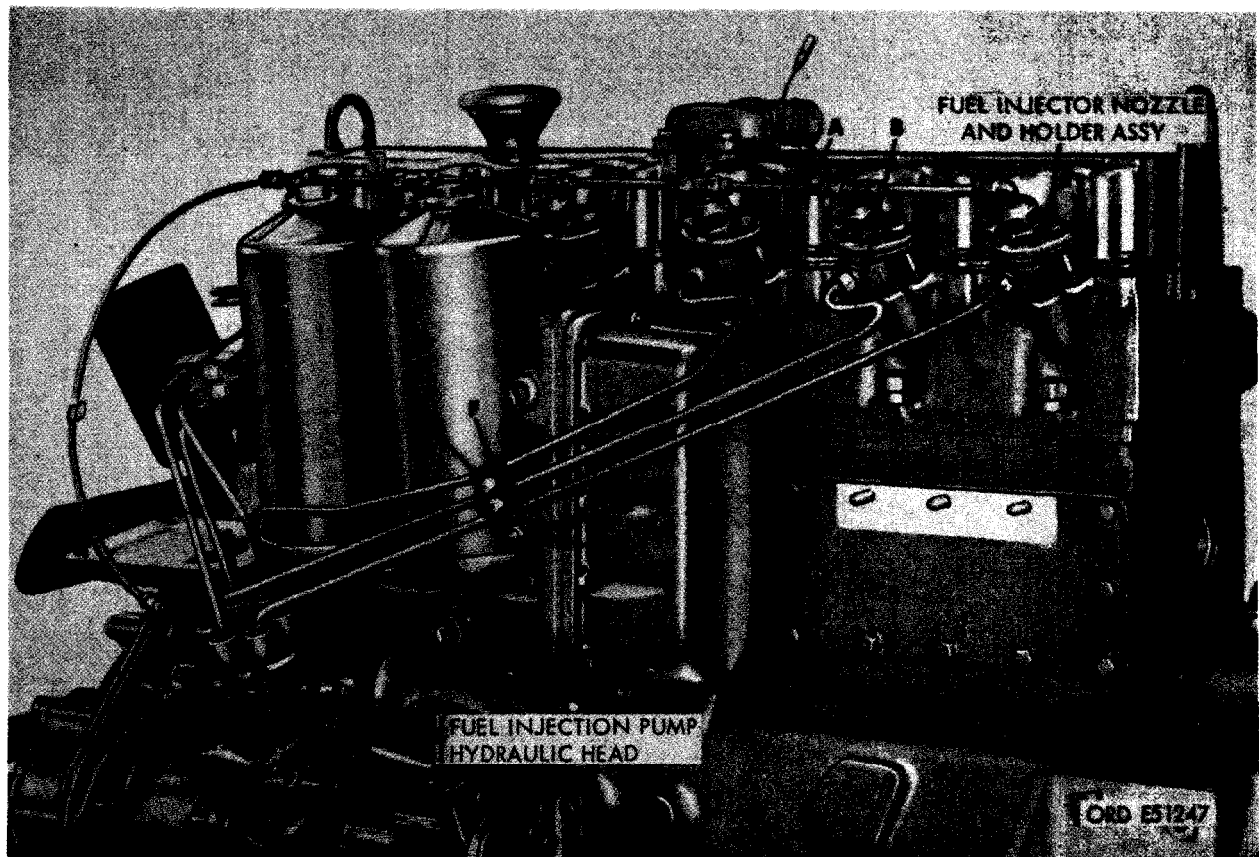


FIGURE 509. CONNECTING CYLINDER NO. 4, 5, AND 6 FUEL INJECTION TUBES (LATE MODEL ENGINE).

- (2) Figure 509. (A) Connect fuel injection tube to nozzle and holder in cylinder No. 4. Remove dust cover from No. 4 port opening in pump hydraulic head and connect tube to head. (B) Connect fuel injection tube to nozzle and holder in cylinder No. 5. Remove dust cover from No. 5 port opening in pump hydraulic head and connect tube to head. (C) Connect fuel injection tube to nozzle and holder in cylinder No. 6. Remove dust cover from No. 6 port opening in pump hydraulic head and connect tube to head. (D) Install injection tube inner clamp on oil cooler and oil filter housing stud. Position clamp so tubes fit in recesses. (E) Install 3/8-inch plain washer, 3/8-inch lock washer, and 3/8-inch plain nut to secure inner clamp. (F) Install fuel injection tube outer clamp over fuel injection tubes. (G) Install two 1/4 x 1-3/8 cap screws, 1/4-

inch plain washers, and 1/4-inch self-locking nuts to secure fuel injection tube clamps together. (H) Move fuel injection tube dust caps down over tube nuts and fuel injection pump ports.

- (3) Figure 510. (A) Connect fuel injection tube to nozzle and holder in cylinder No. 4. Remove dust cover from No. 4 port opening in pump hydraulic head and connect tube. (B) Connect fuel injection tube to nozzle and holder in cylinder No. 5. Remove dust cover from No. 5 port opening in pump hydraulic head and connect tube. (C) Connect fuel injection tube to nozzle and holder in cylinder No. 6. Remove dust cover from No. 6 port opening in pump hydraulic head and connect tube. (D) Install injection tube inner clamp on oil cooler and oil filter housing stud. Position clamp so tubes fit in recesses.

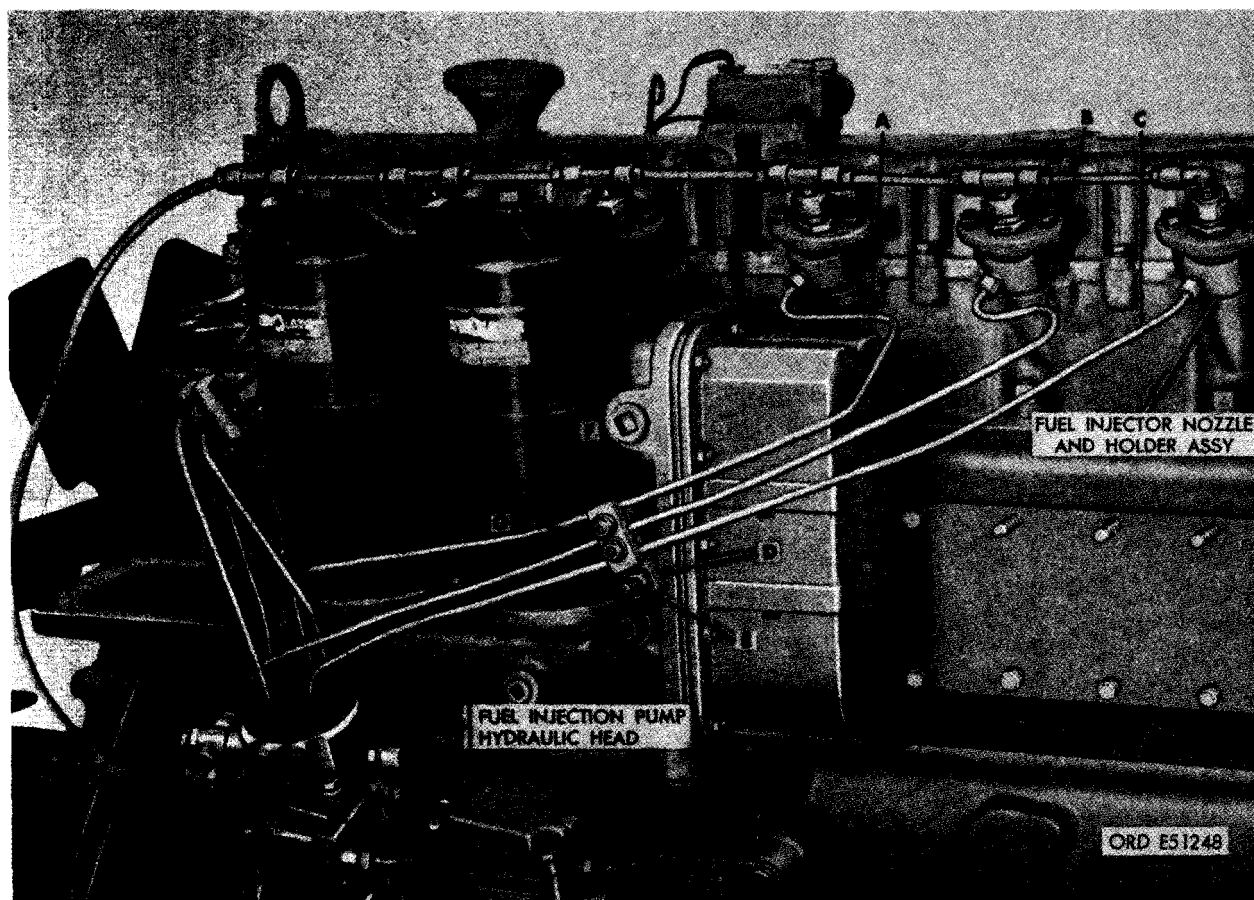


FIGURE 510. CONNECTING CYLINDER NO. 4, 5, AND 6 FUEL INJECTION TUBES (EARLY MODEL ENGINES).

(E) Install 3/8-inch plain washer, 3/8-inch lock washer, and 3/8-inch plain nut to secure inner clamp. (F) Install fuel injection tube outer clamp over fuel injection tubes. (G) Install two 1/4 x 1-3/8 cap screws, 1/4-inch plain washers, and 1/4-inch self locking nuts to secure fuel injection tube inner and outer clamps together. (H) Move fuel injection tube dust caps down over tube nuts and fuel injection pump ports.

## 285. INSTALLATION OF FUEL FILTER ASSEMBLY AND FUEL HOSES

**a. Install Fuel Filter Assembly.** Use two new fuel filter elements, gaskets, and preformed packings when installing filter elements and cases. Refer to figures 228 and 229 and reverse the sequence of illustrations and instructions to install the fuel filter assembly.

**b. Connect Fuel Hoses.** The three fuel hoses are similar in appearance, however two of them are 29 inches long, and the third one is 25-inches long. The shorter hose must be installed on the fuel injection pump fuel supply pump-to-filter inlet elbow. Connect fuel hoses as follows.

- (1) Figure 511. (A) Connect end of 25-inch long fuel supply pump-to-fuel filter inlet hose to 90 degree elbow at fuel filter inlet. (B) Connect other end of hose to 90 degree elbow at fuel supply pump outlet. (C) Connect one end of injector supply-to-fuel filter outlet hose to 90 degree elbow at fuel filter outlet. (D) Connect other end of hose to 45 degree elbow in fuel injection pump hydraulic head. (E) Connect one end of fuel return-to-fuel filter inlet hose to 45 degree elbow in overflow return tee. (F) Connect other end of hose to 90

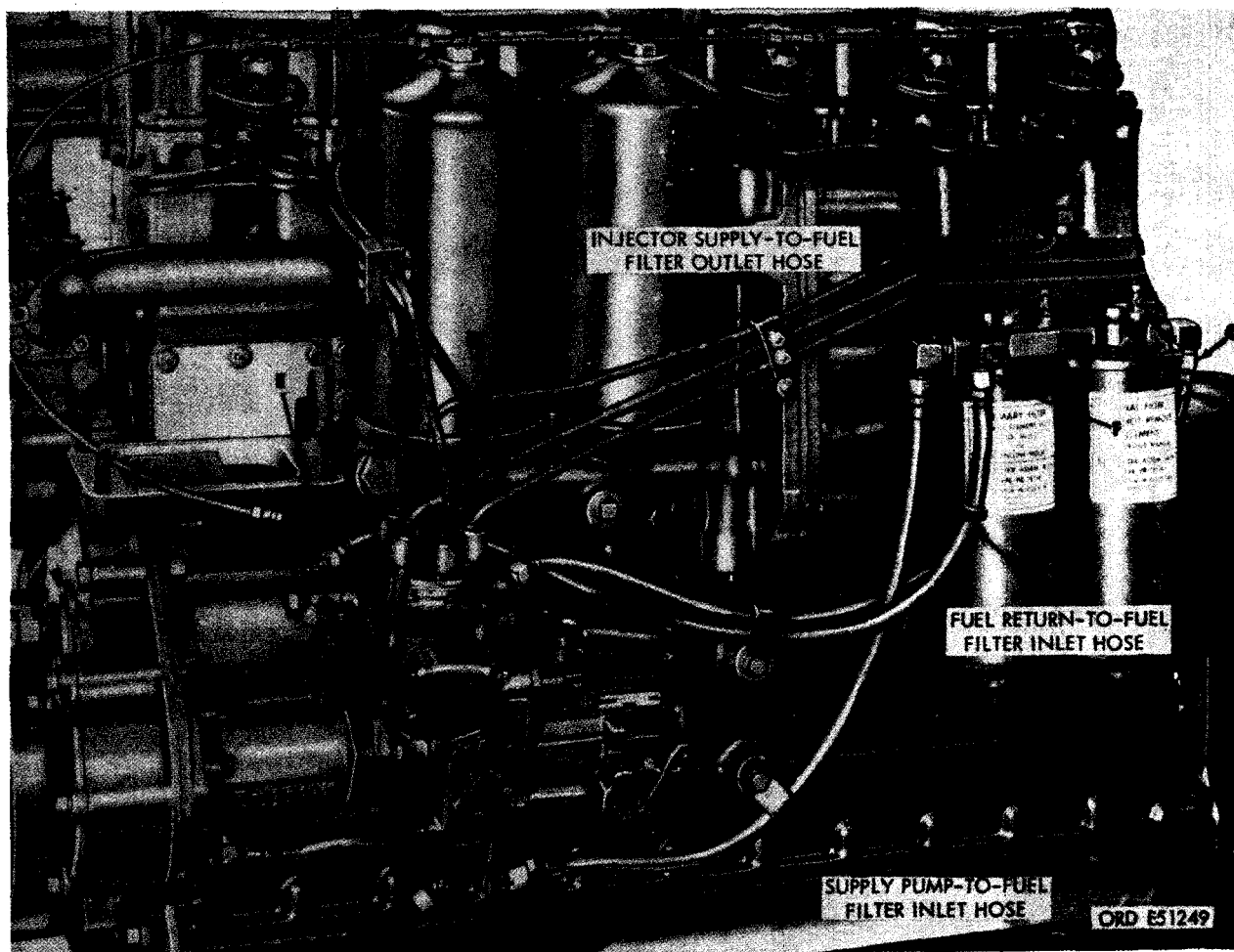


FIGURE 511. CONNECTING FUEL HOSES (LATE MODEL ENGINES).

degree elbow in fuel filter overflow return tee. (G) Install cushioned clamp around injector supply-to-fuel filter outlet hose and fuel return- to- fuel filter inlet hose and secure clamp to crankcase with 3/8 x 3/4 cap screw and 3/8-inch lock washer. (H) Install cushioned clamp around supply pump-to- fuel filter inlet hose and secure clamp to crankcase with 3/8 x 3/4 cap screw and 3/8-inch lock washer.

- (2) Figure 512. (A) Connect fixed end of 25- inch long fuel supply pump-to-fuel filter inlet hose in the fuel filter inlet elbow. (B) Connect swivel end to fuel supply pump outlet 45 degree elbow. (C) Connect fixed end of injector supply-to-fuel filter outlet hose to 90 degree elbow in fuel filter outlet. (D) Connect the swivel end to the connector in the fuel injection pump hydraulic head. (E) Connect fixed end of fuel return-to-fuel filter inlet hose to overflow valve in injection pump hydraulic head. (F) Connect the swivel end to the fuel filter overflow return tee. (G) Install cushioned clamp over all three fuel hoses. (H) Install cushioned clamp on fuel injection pump bracket stud and secure with one 1/4- inch lock washer and 1/4- inch plain nut.

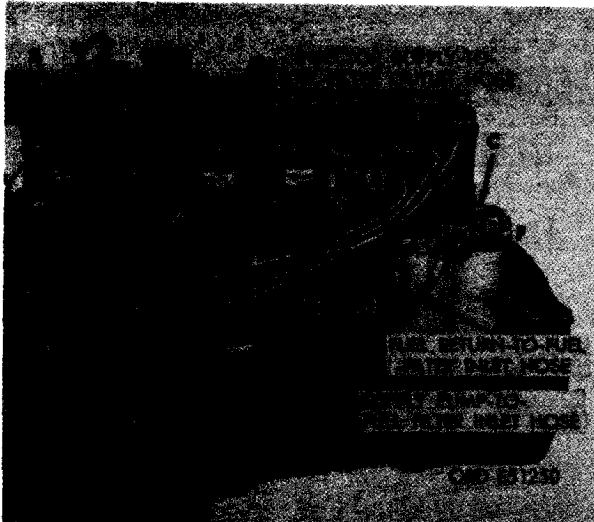


FIGURE 512. CONNECTING FUEL HOSES (EARLY MODEL ENGINES).

## 286. INSTALLATION OF ENGINE ACCESSORIES

**a. Install Air Compressor Assembly.** Refer to figures 81 through 83 and reverse the sequence of illustrations and instructions to install the air compressor assembly and air compressor drive belt. Use a new gasket. Adjust air compressor drive belt deflection following instructions for figure 87. Connect fuel return-to-fuel injection pump overflow valve tube to fuel injection pump (Refer to fig. 57, step B).

**b. Install Flame Heater Fuel Pump Assembly.** Refer to figure 78 and reverse the sequence of instructions to install the flame heater fuel pump.

**c. Install Turbosupercharger Assembly.** Refer to figures 44 through 53 and reverse the sequence of illustrations and instructions to install the turbosupercharger assembly. Install new gaskets and tighten oil inlet tube and oil outlet hose connections securely.

**d. Install Generator Assembly and Drive Belts.** Refer to figures 41 and 42 and reverse the sequence of illustrations and instructions to install the generator assembly. Adjust engine fan and generator drive belt deflection following instructions for figure 43.

**e. Install Starter Assembly.** Refer to figures 39 and 40 and reverse the sequence of illustrations and instructions to install the starter assembly using new starter gasket.

**f. Remove Engine From Overhaul Stand.** Hook engine lifting sling -8715107 to front and rear engine lifting brackets as shown in figure 223. Install spreader -10912586 in sling (fig. 223). Lift engine assembly until most of the engine weight is supported by sling. Remove 5/8- inch plain nut, and 5/8 x 1-3/4 cap screw securing each engine mounting bracket to cradle -7950198 of engine overhaul stand -7950189. Refer to figure 296, step A and follow the instructions to remove front mounting brackets from engine. Refer to figure 295, step A and follow the instructions to remove the rear mounting brackets from the engine.

**g. Test and Adjust Engine.** After the engine has been completely assembled, the engine should be run in, tested, and adjusted as directed in Chapter 9.

CHAPTER 9  
TESTS AND ADJUSTMENTS

---

287. ENGINE SPECIFICATIONS

**a. Speed Range.** The engine shall operate satisfactorily under all conditions through a speed range of 1000 to 2600 rpm full load, and 1000 to 2850 maximum rpm no load, and must idle satisfactorily at 650 to 700 rpm using Diesel fuel W-F- 800. The engine shall maintain a minimum idle speed of 600 rpm when using compression ignition fuel (MIL-F-46005), and gasoline (MIL-G 3056) without changing the idle speed adjustment as set for Diesel fuel (W- F- 800).

**b. Gross Horsepower (bare engine).** Bare engine is defined as an engine with air cleaner installed, with water pump, generator, and air compressor operative (but unloaded), and engine operating without muffler, cooling fan, and all other power consuming accessories not considered essential for the operation of the engine. Horsepower is defined as the horsepower output of the bare engine at the flywheel. At full throttle setting, the engine shall develop the following horsepower values when tested under the following conditions.

(1) Conditions for all fuels.

- (a) Cooling and induction air temperature of 70 to 90° F.
- (b) Atmospheric pressure of 29.00 to 29.40 (in. Hg) inches of mercury.
- (c) Fuel temperature of 80° F, plus or minus 50° F.

(2) Gross horsepower values.

Diesel fuel (V-F- 800) 140 to 145 hp at 2600 rpm.

Compression ignition fuel (MIL-F-46005) 128 hp at 2600 rpm.

Gasoline (MIL-G3056) 113 hp at 2600 rpm.

**c. Gross Torque (bare engine).** At full throttle setting, the engine shall develop the following nominal gross torque values when tested using the following fuels.

- (1) Diesel fuel (W-F-800) 330 pound feet (rein) at 1400 rpm.
- (2) Compression ignition fuel (MIL-F-46005) 310 pound feet at 1400 rpm.
- (3) Gasoline (MIL-G3056) 290 pound feet at 1400 rpm.

**d. Oil Specifications.** Refer to e below, or paragraph 39 for recommended oil specifications. Refer also to LO 9-2320-235-12 for oil change frequencies and related lubrication information.

**e. Oil Consumption.** The engine shall not consume more than 0.007 pounds of oil per observed brake horsepower hour (lbs/bhp/hr) after 25 hours of operation, when operating at full throttle throughout the speed range with oil sump temperature at 140 to 250° F, using the following oil.

- (1) OE-30 (MIL-L-2104) for temperatures between +20 to +115° F.
- (2) OE-10 (MIL-L-2104) for temperatures between -10 to +50° F.
- (3) OES (MIL-L-10295) for temperatures between -65 to +20° F.

**f. Oil Temperature.** The temperature in sump of oil pan shall not exceed 250° F.

**g. Oil Pressure.**

- (1) Engine oil pressure shall be between 50 to 65 psi with oil temperature of 180 to 200° F when measured at the oil pressure sending unit opening when engine is running at 2600 rpm using OE-30 (MIL-L-2104).
- (2) Oil pressure shall not be less than 15 psi at idle (650 to 700 rpm) when using OE- 30 (MIL-L-2 104).

**h. Fuel Consumption (without accessories).** When operating at full throttle, full load, on a dynamometer, at a speed of 2600 rpm, the engine shall consume the following nominal amounts of fuel in pounds per hour (lbs/hr).

<u>Fuels</u>	<u>lbs/hr</u>
Diesel Fuel (W-F-800)	61
Compression Ignition Fuel (MIL-F-46005)	56
Gasoline (MIL-G-3056)	50

i. Fuel Pressure and Temperature. The fuel pressure at the fuel injection pump inlet shall be 50 to 60 psi at 2600 rpm. Fuel temperature shall be maintained at 80° F ±5° F.

j. Coolant Specifications (also refer to TM 9-2-20-235-10).

- (1) O-A-548 Antifreeze Ethylene Glycol, Inhibited.
- (2) MIL-C-11755 Compound, Antifreeze, Arctic Type.
- (3) 0-1-490 Inhibitor Corrosion, Liquid Cooling System.

k. Coolant Temperature. Coolant Temperature shall be maintained at 180 to 200° F throughout the speed range. Coolant temperature rise through the engine shall not exceed 10° F from inlet to outlet when the engine, with thermostat fully open, is operating at full throttle and 2600 rpm. Coolant temperature shall never exceed 220° F with a 4 psi pressure in the external cooling System.

l. Induction Air Temperature. Induction air temperature, before turbosupercharger, shall be 70 to 90° F.

m. Turbosupercharger Manifold Pressure. The turbosupercharger shall develop a minimum intake manifold pressure of 47- inches of mercury absolute when operating a full load at 2600 rpm using Diesel fuel (VV-F-800).

n. Intake Manifold Flame Heater. The intake manifold flame heater shall ignite and function properly when a minimum of 10 volts is applied across the terminals.

o. Smoke Density. The maximum smoke density at full throttle at speeds above 1400 rpm through the remaining speed range, measured within 3 feet of the turbosupercharger outlet, shall not exceed a No. 3 smoke condition (light gray) when using any of the approved fuels.

**Smoke Density Chart**  
(Robert Bosch Model EFAW-68 Meter)

<u>Exhaust Smoke Color</u>	<u>Classification</u>
Clear	No. 1
Haze	No. 2
Light Gray	No. 3
Medium Gray	No. 4
Dark Gray or Black	No. 5

p. Fuel Injection Pump Governor Setting. The governor shall maintain engine rpm between 2600 and 2650 rpm at full load; 2850 rpm maximum at no load. The engine speed shall stabilize within 3 seconds after full throttle position is reached. Seal governor adjustment.

**288. LEAKAGE TEST**

a. General. The engine must be pressure tested to determine whether or not all connections are watertight and airtight. The instructions below describe a method that can be used without submerging the engine in water.

b. Seal Openings. Seal all openings as directed in (1) through (9) below.

- (1) Tape exhaust outlet opening on turbosupercharger exhaust elbow (figs. 46 and 47).
- (2) Tape air inlet opening at turbosupercharger (figs. 53 and 54).
- (3) Tape water outlet opening on thermostat housing (fig. 109).
- (4) Tape water inlet opening on water pump (fig. 116).
- (5) Tape air compressor air intake manifold and outlet openings (fig. 85).
- (6) Tape fuel inlet fitting on fuel injection pump fuel supply pump (figs. 21 and 22).
- (7) Tape fuel return tee opening in fuel filter head (fig. 21).
- (8) Tape 1/8- inch pipe tap opening (upper) in breather tube (figs. 44 and 45).
- (9) Tape open end of breather tube (figs. 44 and 45).

c. Apply Air Pressure. Install a tee in the 1/4-inch pipe tap opening in the crankcase breather tube (figs. 44 and 45). Connect manometer and air hose connection in tee. Apply air pressure and regulate to 8 to 10 inches of mercury on manometer.

d. Apply Soap Solution. Apply soap solution to all locations listed in (1) through (9) below.

- (1) Air induction system and intake manifold.
- (2) Exhaust system.
- (3) Pipe plugs and core hole plugs in cylinder heads and cylinder and crankcase.
- (4) Oil pan flange and oil cooler and filter housing.
- (5) Oil hose connections.
- (6) Fuel injector nozzle and holder assembly (at cylinder head).
- (7) Oil filler cap.
- (8) Oil level indicator and support.
- (9) Cylinder head cover flanges.

e. Air leakage. All leaks should be repaired as directed in paragraph below during this test procedure, and rechecked. Mark any area where leaks are evident so that repairs can be made.

- (1) Reduce air pressure to zero psi.
- (2) Pressurize engine to indicate 6.5-inches of mercury on manometer.
- (3) Test pressure loss after 5 minutes exposure time, internal pressure loss must not exceed 6.0- inches of mercury.

f. Repair leaks. Examine marked area e above for loose hose clamps, loose attaching parts at mounting flanges, defective gaskets, or hoses. Repair leaks by replacing defective parts, or by tightening loose hose clamps or loose mounting flange attaching parts.

## 289. ENGINE RUN-IN

a. General. This paragraph describes the run-in schedules for overhauled or rebuilt engines prior to being placed in service. Engine run-in is performed after rebuild to assist in breaking in new parts, to detect faulty assembly, to check for oil leaks, and to determine whether the engine will perform satisfactory when installed in the vehicle.

### b. Preparation for Run-in.

Note. The cylinder head nuts must be re-torqued during engine run-in, after period 4 (tables VI and VII).

- (1) Couple the engine to a suitable load. Load may be a water brake or an electric dynamometer.
- (2) The engine cooling system must be connected to a suitable heat exchanger or radiator, similar to vehicle type, to properly cool the engine. Fill cooling system with water.
- (3) Remove oil filler cap and add 22 quarts of proper grade oil. Refer to LO 9-2320-235-12 to be certain the proper grade of oil for ambient temperature is being used. Check oil level gage to be certain oil level is between the "ADD" and "FULL" mark before starting engine.
- (4) Connect an external source of fuel to the inlet fitting in the fuel injection pump fuel supply pump. The air intake should be located so that only cool, fresh air will be drawn into the engine. A means must be provided for conducting the exhaust gases away from the test area.

### c. Starting Procedure.

Caution: Do not operate starting motor continuously for more than one minute. Allow a two minute cool-off period before another starting attempt is made.

- (1) Prime fuel system and purge air from fuel filters.
- (2) Crank the engine several revolutions with the fuel shutoff in the "OFF" position to make certain the engine is not hydrostatically locked.

- (3) Place fuel shutoff in "ON" position.
- (4) Start engine by operating electric starting motor with the throttle depressed 25 percent.
- (5) Engine oil pressure should register at least 15 psi with cold oil within 30 seconds of starting. If pressure has not reached 15 psi within 30 seconds, STOP THE ENGINE IMMEDIATELY by holding the fuel shutoff in the "OFF" position. Determine the cause of low oil pressure. Refer to troubleshooting, Chapter 3.

**Note.** After starting engine, run at idle (650-700 rpm) for five minutes to permit the engine to warm up, and to properly circulate oil and coolant.

**d. Retorque Cylinder Head Nuts.** After the engine has been started and has run approximately 20 minutes at 1200 rpm, the cylinder

heads must be retightened to a torque of 130 pound feet. Refer to paragraph 94h(l) through (8), for procedures. Retightening cylinder head nuts after engine warmup is important before continuing with the engine run-in schedules, outlined in Tables VI and VII.

**e. Run-in Schedules.** A rebuilt engine should be started and run-in in accordance with one of the following procedures.

- (1) When any of the original bearings or piston rings have been replaced and the cylinder liners re honed, during rebuild, use the long run-in schedule, Table VI.
- (2) When original bearings and rings were re-installed during rebuild, use the short run-in schedule, Table VII.

**f. Performance Curve.** Figure 513 gives typical performance curves for three types of fuel.

Table VI. Run-in Schedule (Long)

**Note.** The long run-in schedule is for rebuilt engines in which new bearings and piston rings have been installed or the cylinder liners re honed. Install engine in combination with a dynamometer or other variable loading device and operate in accordance with following schedule.

Period	Duration (minutes)	Engine Speed	Gross brake horsepower (bare engine)	Fuel
<b>1</b>	5	650-700	0	Diesel
<b>2</b>	5	1000	15	Diesel
<b>3</b>	10	1200	15	Diesel
<b>4</b>	Shutdown and retorque all cylinder head nuts to 130 pound feet.			
<b>5</b>	5	650	Idle	Diesel
<b>6</b>	15	1000	15	Diesel
<b>7</b>	15	1200	15	Diesel
<b>8</b>	15	1600	33	Diesel
<b>9</b>	30	2000	64	Diesel
<b>10</b>	30	2400	110	Diesel
<b>11</b>	15	2600	140	Diesel
<b>12</b>	(Adjust full throttle position and set governor)	2600	140-145	Diesel
<b>13</b>	Power check (full throttle)	1400	92 minimum	Diesel
<b>14</b>	(Set idle adjustment)	650-700	0	Diesel



Table VII. Run-in Schedule (Short)

Note. The short run-in schedule is for rebuilt engines with original bearings and piston rings. Install engine in combination with a dynamometer or other variable loading device and operate in accordance with the following schedule.

Period	Duration (minutes)	Engine speed	Gross brake horsepower (bare engine)	Fuel
1	5	650-700	0	Diesel
2	5	1000	15	Diesel
3	10	1200	15	Diesel
4	Shut down and retorque all cylinder head nuts to 130 pound feet.			
5		650-700	-0	Diesel
6		1000	15	Diesel
7		1200	15	Diesel
8		1600	33	Diesel
9		2000	64	Diesel
10		2400	110	Diesel
11		2600	140	Diesel
12	(Adjust full throttle position and set governor)	2600	140-145	Diesel
13	Power check (full)	1400	92 minimum	Diesel
14		650-700	0	Diesel

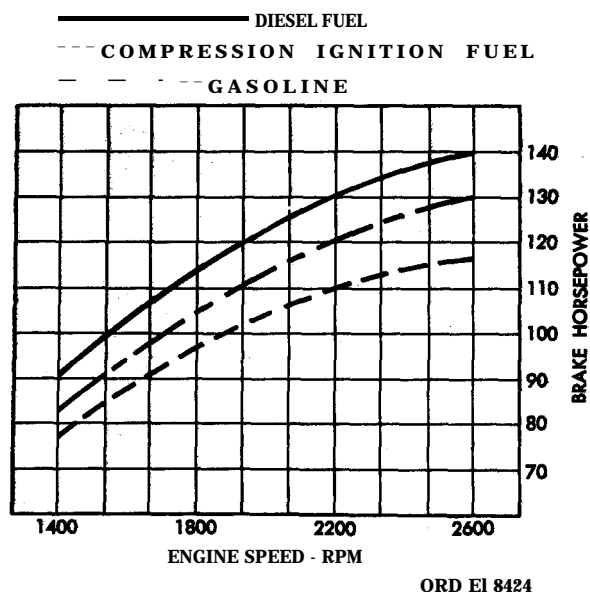


FIGURE 513. TYPICAL ENGINE PERFORMANCE CURVE.

## 290. TEST, ADJUSTMENT, AND PREPARATION FOR STORAGE

**a. Oil Pressure.** Oil pressure may be measured by removing the oil pressure sending unit (figs. 489 and 480) from the main oil gallery and installing an oil pressure gage. When oil pressure cannot be maintained between 50 to 60 psi replace oil pressure regulator valve spring (fig. 101). If spring replacement does not bring oil pressure to specified limits, check oil pressure regulator valve (par. 87) against limits specified in repair and rebuild standards (par. 293). Replace faulty plunger, if necessary.

**b. Idle Speed.** Must for smooth idle at 650 to 00 rpm by turning the idle adjusting screw on the fuel injection pump (fig. 56). Turn the screw clockwise to increase idle speed and counterclockwise to decrease idle speed.

c. Intake Manifold Flame Heater Operation.

Place hand on the intake manifold elbow. Turn on flame heater fuel pump. When heater is operating, heat will be felt at the intake manifold elbow. When no heat is felt, check wiring harness, heater spark plug, ignition unit, and lead for faulty connections. Inspect flame heater fuel pump and manifold heater nozzle and holder assembly for proper operation. Repair faulty connections, or replace flame heater fuel pump or heater nozzle.

Caution: Do not operate heater unless engine is cranking or idling.

d. Oil Consumption Check.

- (1) Operate engine and inspect for leaks.
- (2) Idle engine for 5 minutes to allow engine to cool. Shut off engine. Allow engine to set approximately one minute. Check and note oil level.

Note. Do not screw gage in for oil level check.

- (3) Operate engine for 5 hours at 2600 rpm and maximum horsepower.
- (4) Idle engine for 5 minutes to allow engine to cool. Shut off engine. Allow engine to set approximately one minute to allow oil to settle. Check oil level ((2) above).

- (5) Add oil as required to bring oil up to level observed on gage ((2) above), carefully measuring amount added.
- (6) Maximum allowable oil consumption at 2600 rpm, with OE-30 (MIL-L-2104) is 1.4 pounds (approximately 0.75 quarts per hour).
- (7) Install oil level gage and screw in tight.

e. Lubricating Oil Temperature. Lubricating oil temperature outlets are provided in the main oil gallery line on right side of engine for the installation of thermocouples.

f. Coolant Temperature. Engine coolant temperature can be taken by removing pipe plug from intake manifold and installing thermocouple.

g. Induction Air Temperature. Induction air temperature can be taken by placing a thermocouple in front of the turbosupercharger air inlet opening.

h. Manifold Pressure. Manifold pressure can be taken by removing flame heater spark plug and installing a suitable adapter and pressure gage.

i. Preparation of Engine for Storage. When engine assembly is to be stored or shipped, engine should be processed in accordance with instructions provided in Specification MIL-E 10062.

## CHAPTER 10

### REPAIR AND REBUILD STANDARDS

#### 291. GENERAL

The repair and rebuild standards contained herein give the minimum, maximum, and key clearances of new or rebuilt parts. They also give wear limits which indicate that point to which a part or parts may be worn before replacement, in order to receive maximum service with minimum replacement. Normally, all

parts which have not been worn beyond the dimension shown in the "Wear limits" columns or damaged from corrosion will be approved for service. An asterisk (\*) in the "Wear limits" column indicates that the part or parts should be replaced when worn beyond the limits given in the "Sizes and fits of new parts" column. In the "Sizes and fits of new parts" column, the letter "L" indicates a loose fit (clearance) and the letter "T" indicates a tight fit (interference).

#### 292. CYLINDER AND CRANKCASE, CRANKSHAFT ASSEMBLY, CAMSHAFT ASSEMBLY, PISTON AND CONNECTING RODS

Note. The inside diameter of replacement camshaft bushing-type bearings and cylinder sleeves should not be gaged until they are installed in the cylinder and crankcase assembly.

Fig. No.	Ref. letter	Point of measurement	Sizes and fits of new parts	Wear limits	
				Field maint	Depot maint

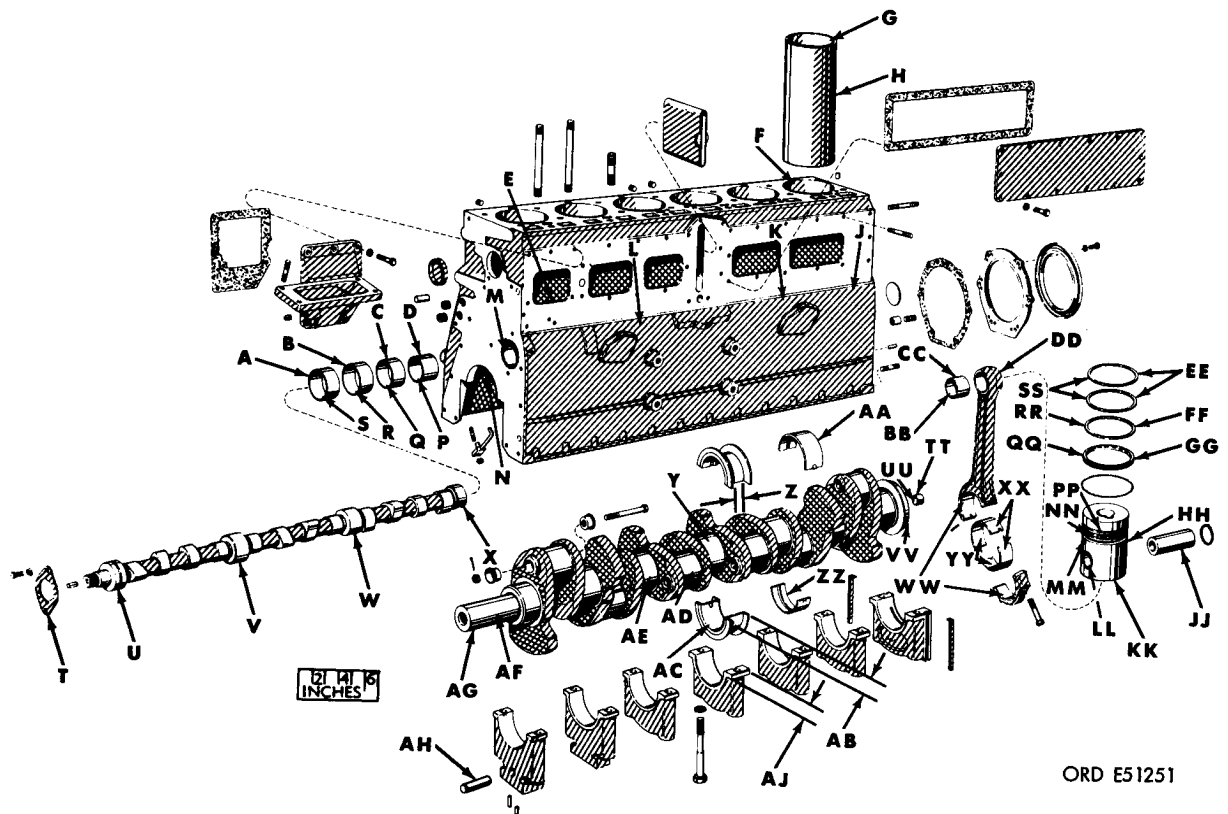
##### a. Camshaft, Bushing-type Bearings, and Camshaft Thrust Plate.

##### (1) Outside diameter of bushing-type bearings.

514	A	Outside diameter of front bushing-type bearing. (Press fit in bore dimension M below. )
	B	Outside diameter of front intermediate bushing-type bearing. (Press fit in bore dimension L below. )
	C	Outside diameter of rear intermediate bushing-type bearing. (Press fit in bore dimension K below. )
	D	Outside diameter of rear bushing-type bearing. (Press fit in bore dimension J below. )

##### (2) Inside diameter of bushing-type bearing bores in cylinder and crankcase.

514	J	Rear bearing bore -----	2.1245 to 2.1255	*	*
	K	Rear intermediate bearing bore ----	2.4370 to 2.4380	*	*
	L	Front intermediate bearing bore ----	2.4995 to 2.5005	*	*
	M	Front bearing bore -----	2.5620 to 2.5630	*	*



ORD E51251

FIGURE 514. REPAIR AND REBUILD STANDARD POINTS OF MEASUREMENT FOR CYLINDER AND CRANKCASE, CAMSHAFT, CRANKSHAFT AND RELATED PARTS.

(3) Camshaft journals and inside diameter of camshaft bushing-type bearings.

Fig. No.	Ref. letter	Point of measurement	Sizes and fits of new parts	Wear limits	
				Field maint	Depot maint
514	P	Inside diameter of rear bushing-type bearing.	1.9940 to 1.9950	1.9980	1.9970
	x	Outside diameter of rear camshaft journal.	1.9920 to 1.9930	1.9910	1.9915
	P-x	Fit of rear camshaft journal in bushing-type bearing.	0.0010L to 0.0030L	0.0060L	0.0045L
	Q	Inside diameter of rear intermediate bushing-type bearing.	2.3065 to 2.3075	2.3105	2.3095
	W	Outside diameter of rear intermediate camshaft journal.	2.3045 to 2.3055	2.3035	2.3040
	Q-W	Fit of rear intermediate camshaft journal in bushing-type bearing.	0.0010L to 0.0030L	0.0060L	0.0045L
	R	Inside diameter of front intermediate bushing-type bearing.	2.3690 to 2.3700	2.3730	2.3720
	V	Outside diameter of front intermediate camshaft journal.	2.3670 to 2.3680	2.3660	2.3665
R-V	Fit of front intermediate camshaft journal in bushing-type bearing.	0.0010L to 0.0030L	0.0060L	0.0045L	

Fig. No.	Ref. letter	Point of measurement	Sizes and fits of new parts	Wear limits	
				Field maint	Depot maint
514	S	Inside diameter of front bushing-type bearing.	2.4315 to 2.4325	2.4355	2.4345
	U	Out side diameter of front camshaft journal.	2.4295 to 2.4305	2.4285	2.4290
	S-U	Fit of front camshaft journal in bushing type bearing.	0.0010L to 0.0030L	0.0060L	0.0045L
	T	Camshaft thrust plate thickness -----	0.2400 to 0.2420		

b. Valve Tappets and Tappet Bores in Cylinder and Crankcase.

514	E	Inside diameter of tappet bore in crankcase.	1.2513 to 1.2523	1.2543	1.2533
519	K	Outside diameter of valve tappet measured at major diameter of hyperbolic surface (fig. 380).	1.2485 to 1.2490	1.2475	1.2480
	K	Outside diameter of valve tappet with straight surf ace.	1.2473 to 1.2483	1,2463	1.2468
		Fit of straight tappet in bore -----	0.0030 to 0.0050	0.0070	0.0060
514	E-K	Fit of valve tappet in bore -----	0.0023L to 0.0038L	0.0060L	0.0050L

c. Cylinder Liners, Pistons, and Piston Pins.

(1) Cylinder liners.

514	F	Inside diameter of cylinder liner bore in cylinder and crankcase.	4.5525 to 4.5545	*	*
	H	Outside diameter of cylinder liner ---	4.5555 to 4.5559	*	*
	F-H	Fit of cylinder liner in cylinder and crankcase bore.	0.0010T to 0.0034T		
	G	Inside diameter of cylinder liner after honing.	4.3125 to 4.3145	4.3165	4.3155

(2) Pistons.

514	HH	Diameter at top of piston skirt, 90 degrees to piston pin.	4.3030 to 4.3040	4.3000	4.3010
	KK	Diameter at bottom of piston skirt, 90 degrees to piston pin.	4.3053 to 4.3065	4.3033	4.3043

(3) Piston pin.

514		Outside diameter of piston pin -----	1.6247 to 1.6249	1.6243	1.6245
	JJ	Inside diameter of piston pin bore in piston.	1.6250 to 1.6252	1.6262	1.6257
	JJ-LL	Fit of piston pin in piston -----	0.0001L to 0.0005L	0.0010L	0.0010L

d. Piston Rings and Ring Grooves.

(1) Piston rings (grooves 1 and 2).

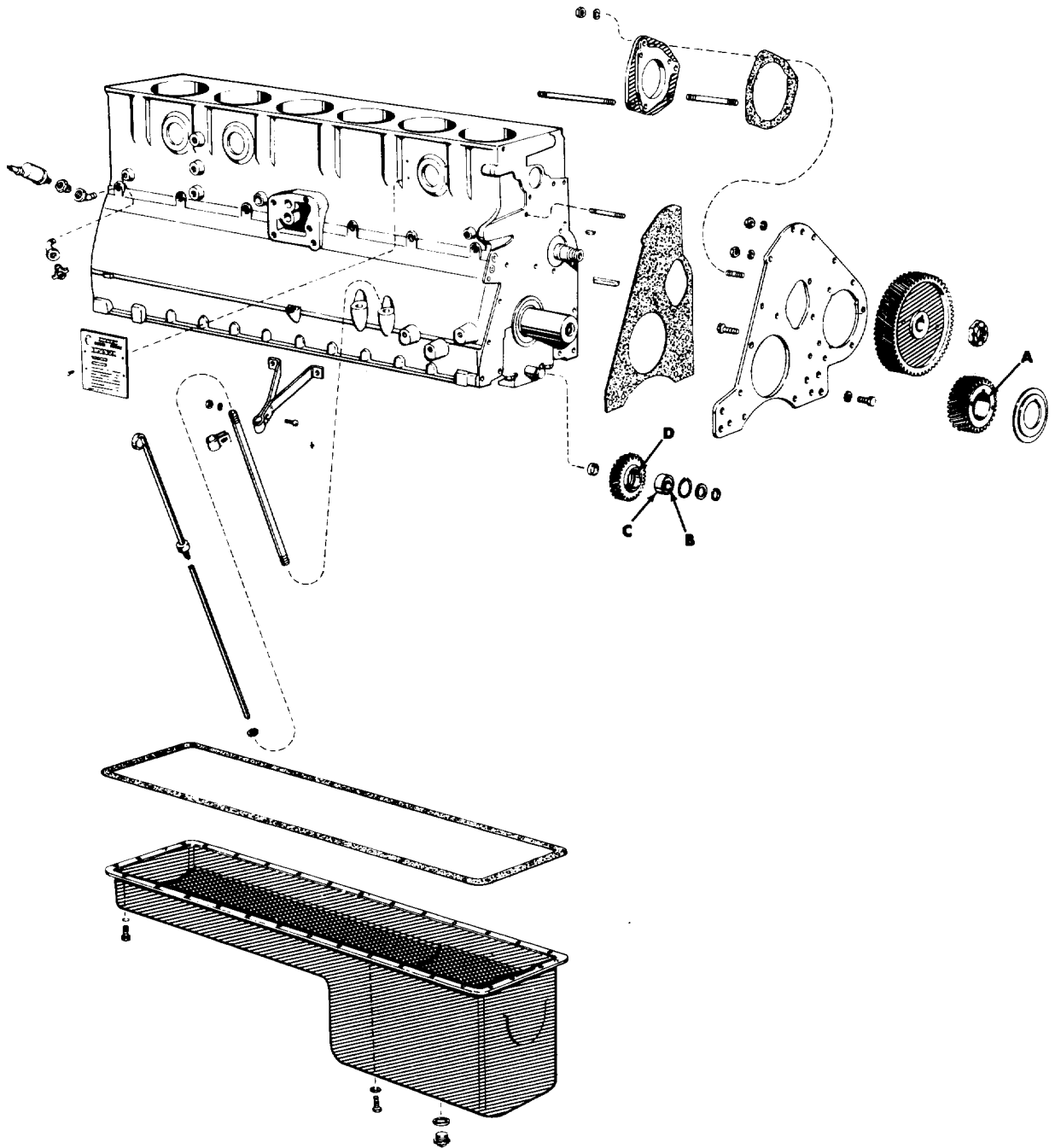
514	EE	Width of two top compression rings --	0.1225 to 0.1240	0.1205	0.1220
	PP	Diameter of two top ring grooves in piston, measured over 0.1125 diameter pins (fig. 334).	4.2980 to 4.3040	4.2860	4.2920

Fig. No.	Ref. letter	Point of measurement	Sizes and fits of new parts	Wear limits	
				Field maint	Depot maint
514	Ss	Gap clearance of two top compression rings when fitted in gage.	0.0250 to O. Q350	0.0050	0.0450
(2) <u>Piston ring (groove 3).</u>					
514	FF	Width of No. 3 compression ring ----	0.0925 to 0.0935	0.0905	0.0920
	NN	Width of No. 3 compression ring groove in piston.	0.0970 to 0.0980	0.1010	0.0990
	FF-NN	Clearance between No. 3 ring and ring land of piston.	0.0035L to 0.0055L	0.0065L	0.0065L
	RR	Gap clearance of No. 3 compression ring when fitted in gage.	0.0250 to 0.0350	0.0500	0.0450
(3) <u>Oil control ring.</u>					
514	GG	Width of oil control ring -----	0.1855 to 0.1865	0.1850	0.1850
	MM	Width of oil control ring groove in piston.	0.1880 to 0.1890	0.1910	0.1900
	GO-MM	Fit of oil control ring in piston -----	0.0015L to 0.0035L	0.0050L	0.0045L
	QQ	Gap clearance of oil control ring when fitted in gage.	0.0130 to 0.0280	0.0430	0.0380
e. <u>Connecting Rods.</u>					
(1) <u>Piston pin end.</u>					
514	BB	Inside diameter of bushing-type bearing.	1.6265 to 1.6267	1.6277	1.6272
	JJ	Outside diameter of piston pin -----	1.6247 to 1.6249	1.6243	1.6245
	BB-JJ	Fit of pin in bushing-type bearing ----	0.0016L to 0.0020L	0.0030L	0.0025L
	CC	Outside diameter of piston pin bushing-type bearing. (Press fit in bore dimension DD below).			
	DD	Inside diameter of bearing bore in connecting rod.	1.7490 to 1.7500		
(2) <u>Connecting rod journals and sleeve bearings (standard),</u>					
514	WW	Inside diameter of sleeve bearing bore in rod.	3.2510 to 3.2520		
	x x	Thickness of connecting rod sleeve bearing.	0.1249 to 0.1254	0.1239	0.1245
	YY	Inside diameter of sleeve bearing at proper torque tightness.	3.0020 to 3.0022	3.0042	3.0032
	AD	Outside diameter of connecting rod journal.	2.9960 to 2.9970	2.9945	2.9950
	YY-AD	Theoretical oil clearance between connecting rod sleeve bearing and crankshaft connecting rod journal.	0.0050L to 0.0062L	0.0082L	0.0070L

Fig. No.	Ref. letter	Point of measurement	Sizes and fits of new parts	Wear limits	
				Field maint	Depot maint
<u>(3) Connecting rod journals and sleeve bearings (0.0100-inch undersize).</u>					
514	WW	Inside diameter of sleeve bearing bore in rod.	3.2510 to 3.2520	*	*
	x x	Thickness of connecting rod sleeve bearing.	0.1299 to 0.1304	0.1289	0.1295
	YY	Inside diameter of sleeve bearing at proper torque tightness.	2.9902 to 2.9922	2.9942	2.9932
	AD	Outside diameter of connecting rod journal.	2.9860 to 2.9870	2.9845	2.9850
	YY-AD	Theoretical oil clearance between connecting rod sleeve bearing and crankshaft connecting rod journal. Journal out-of-round condition must not exceed 0.0005-inch.	0.0032L to 0.0062L	0.0082L	0.0070L
<u>(4) Connecting rod journals and sleeve bearings (0.0200-inch undersize).</u>					
514	WW	Inside diameter of sleeve bearing bore in rod.	3.2510 to 3.2520	*	*
	x x	Thickness of connecting rod sleeve bearing.	0.1349 to 0.1354	0.1339	0.1345
	YY	Inside diameter of sleeve bearing at proper torque tightness.	2.9802 to 2.9822	2.9842	2.9832
	AD	Outside diameter of connecting rod journal.	2.9760 to 2.9770	2.9745	2.9750
	YY-AD	Theoretical oil clearance between connecting rod sleeve bearing and crankshaft connecting rod journal.	0.0032L to 0.0062L	0.0082L	0.0070L
<u>(5) Connecting rod alinement.</u>					
514		Allowable twist of connecting rod per inch of bearing length.	0.0005	*	*
f. <u>Crankshaft Assembly, Main Bearing Sleeves, and Related Components.</u>					
<u>(1) Crankshaft journal and main bearing sleeves (standard).</u>					
514	N	Inside diameter of main bearing sleeve bores in crankcase.	3.9370 to 3.9380	*	*
	AA	Thickness of main bearing sleeve ----	0.1554 to 0.1559	0.1544	0.1549
	ZZ	Inside diameter of main bearing sleeve at proper torque tightness (theoretical).	3.6252 to 3.6272	3.6292	3.63282
	AE	Outside diameter of main bearing sleeve journals.	3.6200 to 3.6210	3.6185	3.6195
	ZZ-AE	Theoretical oil clearance between main bearing sleeve and crankshaft main bearing journal.	0.0042L to 0.0072L	0.0092L	0.0085L

Fig. No.	Ref. letter	Point of measurement	Sizes and fits of new parts	Wear limits	
				Field maint	Depot maint
<u>(2) Crankshaft journal and main bearing sleeves (0.0100-inch undersize).</u>					
514	N	Inside diameter of main bearing sleeve bores in crankcase.	3.9370 to 3.9380	*	*
	AA	Thickness of main bearing sleeve ----	0.1604 to 0.1609	0.1594	0.1599
	Zz	Inside diameter of main bearing sleeve at proper torque tightness.	3.6152 to 3.6172	3.6192	3.6182
	AE	Outside diameter of main bearing sleeve journals.	3.6100 to 3.6110	3.6085	3.6095
	Z Z-AE	Theoretical oil clearance between main bearing sleeve and crankshaft main bearing journal.	0.0042L to 0.0072L	0.0092L	0.0085L
<u>(3) Crankshaft journal and main bearing sleeves (0.0200-inch undersize).</u>					
514	N	Inside diameter of main bearing sleeve bores in crankcase.	3.9370 to 3.9380	*	*
	AA	Thickness of main bearing sleeve ----	0.1654 to 0.1659	0.1644	0.1649
	ZZ	Inside diameter of main bearing sleeve at proper torque thickness.	3.6052 to 3.6072	3.6092	3.6082
	AE	Outside diameter of main bearing sleeve journals.	3.6000 to 3.6010	3.5985	3.5995
	ZZ-AE	Theoretical oil clearance between main bearing sleeve and crankshaft main bearing journal.	0.0042L to 0.0072L	0.0092L	0.0085L
<u>(4) Crankshaft center main bearing thrust sleeve.</u>					
514	Y	Inside width of center main bearing thrust sleeve crankshaft journal.	2.1370 to 2.1390	2.1420	2.1400
	A B	Outside width of center main bearing thrust sleeve.	2.1250 to 2.1270	2.1200	2.1220
	Y-AB	Theoretical crankshaft end play between center main bearing thrust sleeve and crankshaft thrust surface.	0. 0.00L to 0.0140L	0.0180L	0.0150L
	z	Inside width of center main bearing thrust sleeve face.	1.80'10 to 1.8030	*	*
	AJ	Outside width of center main bearing thrust sleeve cap and thrust surface on crankcase.	1.7970 to 1.7990	*	*
	Z-AJ	Fit of center main bearing sleeve over bearing cap and thrust surface on crankcase.	0.0020L to 0.0060L	*	*
	AC	Thickness of center main bearing thrust flange.	0.1610 to 0.1630	0.1580	0.1590
<u>(5) Crankshaft bushing-type pilot bearing.</u>					
514	UU	Inside diameter of crankshaft bushing-type pilot bearing.	0.7490 to 0.7505	0.7525	0.7515
	TT	Outside diameter of crankshaft bushing-type pilot bearing.	1.0030 to 1.0040	*	*
	VV	Inside diameter of crankshaft bushing type pilot bearing bore in crankshaft.	0.9990 to 1.0000	1.0010	1.0005
	TT-VV	Fit of crankshaft bushing-type pilot bearing in bearing bore.	0.0030T to 0.0050T	*	*

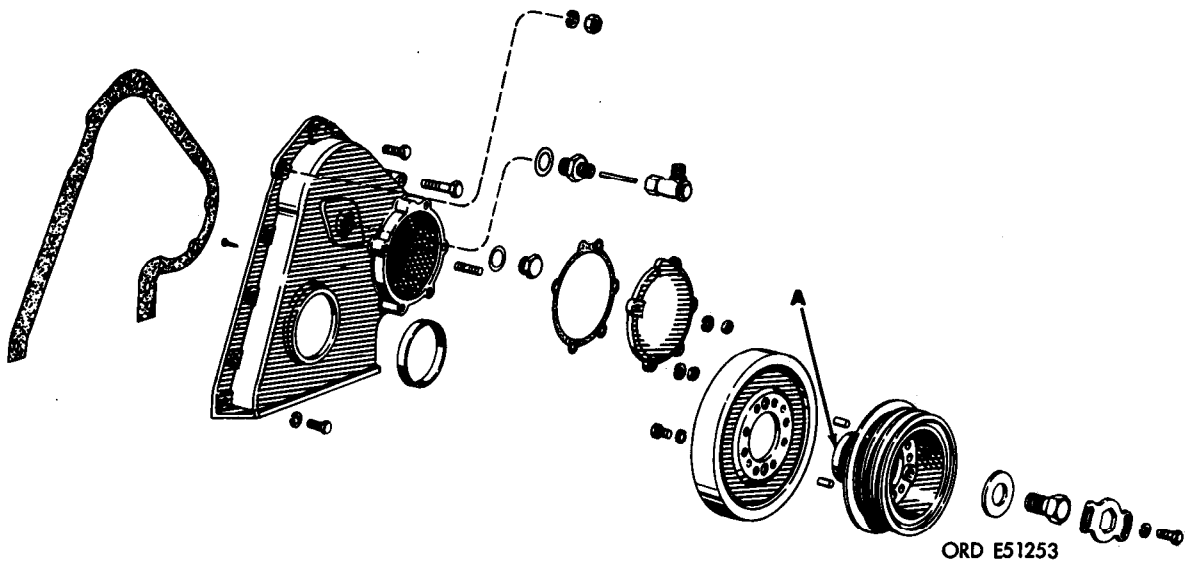




ORD E51252

**FIGURE 515. REPAIR AND REBUILD STANDARD POINTS OF MEASUREMENT FOR CRANKSHAFT GEAR AND OIL PUMP IDLER GEAR.**

Fig. No.	Ref. letter	Point of measurement	Sizes and fits of new parts	Wear limits	
				Field maint	Depot maint
(6) Crankshaft gear.					
515	A	Inside diameter of crankshaft gear ---	2.2495 to 2.2500	*	*
	AF	Outside diameter of crankshaft -----	2.2492 to 2.2498	*	*
	A-AF	Fit of crankshaft gear on crankshaft--	0.0003T to 0.0008L	*	*
(7) Crankshaft damper and pulley assembly.					
516	A	Inside diameter of pulley bore -----	2.2487 to 2.2492	*	
514	AG	Outside diameter of crankshaft pulley end.	2.2487 to 2.2492	*	
	B-AG	Fit of pulley on crankshaft -----	0.0005T to 0.0007L	*	



**FIGURE 516. REPAIR AND REBUILD STANDARD POINTS OF MEASUREMENT FOR CRANKSHAFT DAMPER AND PULLEY ASSEMBLY.**

293. OIL PUMP IDLER GEAR, OIL PRESSURE REGULATOR VALVE AND OIL PUMP ASSEMBLY.

Fig. No.	Ref. letter	Point of measurement	Sizes and fits of new parts	Wear limits	
				Field maint	Depot maint
<b>a. Oil Pump Idler Gear.</b>					
515	B	Inside diameter of oil pump idler gear bearing.	0.7870 to 0.7874	0.7876	0.7876
	AH	Outside diameter of oil pump idler gear shaft.	0.7869 to 0.7873	0.7867	0.7867
	C-AH	Fit of oil pump idler gear bearing on shaft .	0.0003T to 0.0005L	0.0008L	0.0006L
	c	Out side diameter of oil pump idler gear bearing.	1.8499 to 1.8504	1.8496	1.8496
	D	Inside diameter of oil pump idler gear.	1.8494 to 1.8504	1.8506	1.8506
	C-D	Fit of bearing in oil pump idler gear.	0.0010 T to 0.0005L	0..000L	0.0006L
<b>b. Oil Pressure Regulator Valves and Springs.</b>					
517	A	Oil pressure regulator valve plunger spring: Free length ----- Load at 1.750-inches ----- Maximum solid height -----	2.2800 27.45 lbs ± 0.3 lbs 1.4990	*	*
	B	Outside diameter of plungers -----	0.8000 to 0.8010	0.7990	0.7995
	c	Inside diameter of plunger bores in housing.	0.8030 to 0.8040	0.8050	0.8045
	B-C	Fit of plungers in housing bores ----	0.0020L to 0.00040L	0.0050L	0.0045L
	D	Piston cooling relief valve plunger spring: Free length ----- Load at 1.380-inches ----- Maximum solid height -----	1.6200 7.65 lbs ± 0.7 lbs 0.9520		

c. Oil Pump Assembly.

(1) Oil pressure relief **valve** and spring.

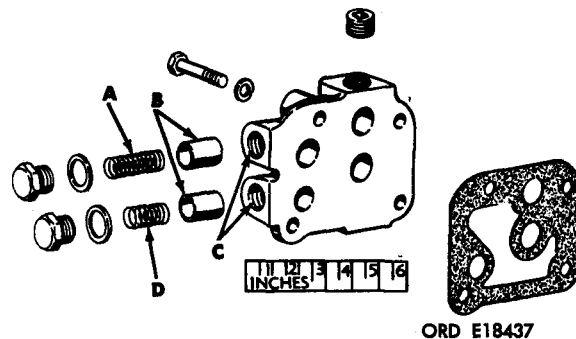
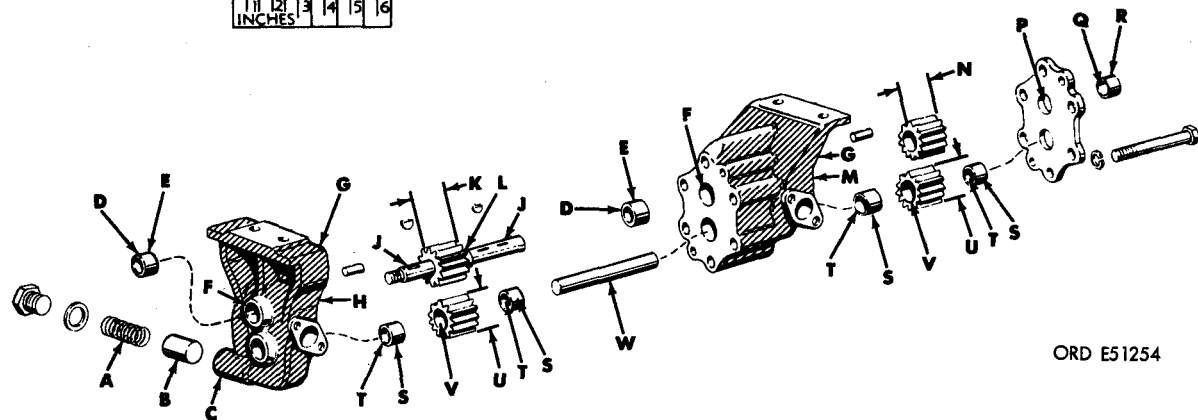
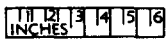
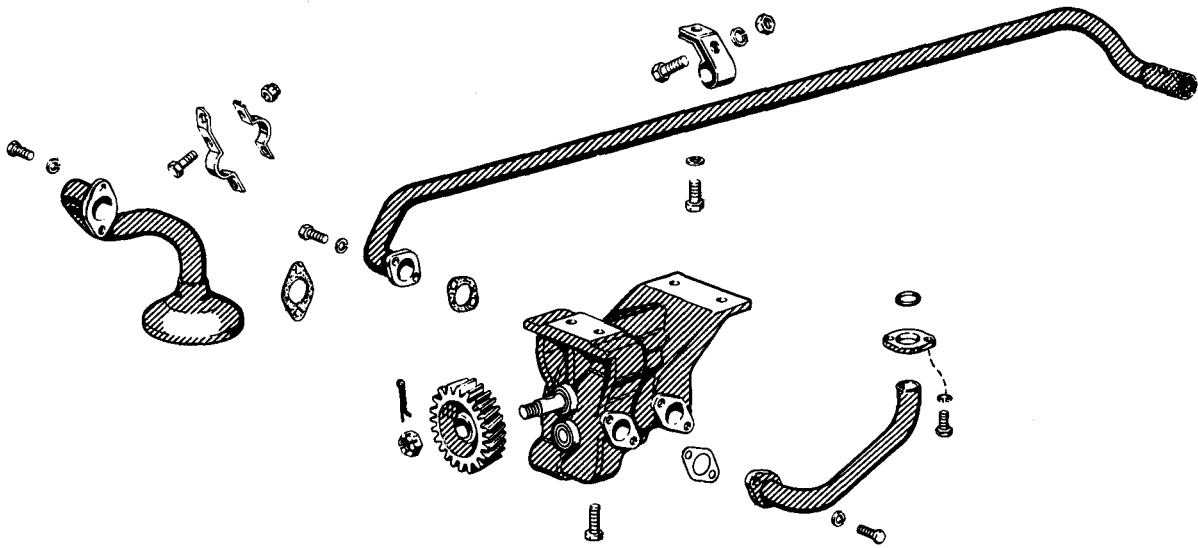


FIGURE 517. REPAIR AND REBUILD STANDARD POINTS OF MEASUREMENT FOR OIL PUMP REGULATOR VALVE.

Fig. No.	Ref. letter	Point of measurement	Sizes and fits of new parts	Wear limits	
				Field maint	Depot maint
518	A	Relief valve spring:			
		Free length -----	2.3400		
		Load at 2.100-inches -----	51 lbs ± 0.5 lbs		
		Maximum solid height -----	1.8800		
	B	Outside diameter of relief valve -----	0.8110 to 0.8120	0.8100	0.8105
C	Inside diameter of pressure relief valve housing bore.	0.8140 to 0.8150	0.8160	0.8155	
B-C	Fit of relief valve in housing -----	0.0020L to 0.0040L	0.0050L	0.0045L	

(2) Oil pump impeller shafts, impellers, and bushing-type bearings.

D	Inside diameter of bushing-type bearings .	0.6910 to 0.6920	0.6940	0.6930
J	Outside diameter of pressure pump and scavenger pump bearing surfaces on oil pump impeller drive shaft.	0.6890 to 0.6900	0.6880	0.6885
D-J	Fit of oil pump impeller shaft in bushing-type bearing.	0.0010L to 0.0030L	0.0050L	0.0035L
E	Outside diameter of split bearings. (Press fit in bore dimension F below).			
F	Inside diameter of oil pump impeller shaft bushing-type bearing bores in oil pressure and scavenger pump housings.	0.8120 to 0.8130	0.8135	0.8130
L	Outside diameter of scavenger pump cover bearing surface end of impeller drive shaft.	0.4985 to 0.4990	0.4975	0.4980
Q	Inside diameter of impeller drive shaft bushing-type bearing cover.	0.4995 to 0.5005	0.5025	0.5015
L-Q	Fit of impeller drive shaft in bushing-type bearing.	0.0005L to 0.0020L	0.0040L	0.0030L
P	Inside diameter of scavenger oil pump housing bore.	0.6245 to 0.6255	0.6260	0.6255
R	Outside diameter of bushing-type bearing. (Press fit in bore dimension P above).			
S	Outside diameter of bushing-type bearing. (Press fit in impeller bore dimension V below).			
T	Inside diameter of driven impeller bushing-type bearing.	0.5035 to 0.5045	0.5065	0.5055
W	Outside diameter of oil pump driven impeller shaft.	0.5020 to 0.5025	0* 5015	0.5017
T-W	Fit of driven impeller shaft in bushing-type bearing.	0.0010L to 0.0025L	0.0045L	0.0035L
X	Inside diameter of driven impeller shaft bore in pressure oil pump housing.	0.5000 to 0.5010	0.5015	0.5012
W-X	Fit of driven impeller shaft in housing bore.	0.0010T to 0.0025T	0.0005T	0.0008T
V	Inside diameter of pressure and scavenger oil pump driven impeller.	0.6245 to 0.6255	0.6260	0.6257



ORD E51254

FIGURE 518. REPAIR AND REBUILD STANDARD POINTS OF MEASUREMENT FOR OIL PUMP ASSEMBLY.

Fig. No.	Ref. letter	Point of measurement	Sizes and fits of new parts	Wear limits	
				Field maint	Depot maint
(3) Oil pump impellers and impeller bores.					
518	G	Inside diameter of pressure and scavenger pump impeller bores.	1.7130 to 1.7150	1.7160	1.7155
	u	Outside diameter of oil pressure and scavenger pump drive and driven impellers.	1.7080 to 1.7090	1.7070	1.7075
	G-U	Fit (radial clearance) of impellers in housing.	0.0040L to 0.0090L	0.0100L	0.0090L
	H	Depth of pressure pump impeller bores.	1.3770 to 1.3790	1.3820	1.3800

Fig. No.	Ref. letter	Point of measurement	Sizes and fits of new parts	Wear limits	
				Field maint	Depot maint
518	K	Length of pressure pump impellers -- End play between impellers and pressure pump housing (correctly assembled).	1.3735 to 1.3750	1.3705	1.3720
	H-K		0.0020L to 0.0055L	0.0080L	0.0065L
	M	Depth of scavenger pump impeller bores.	1.6270 to 1.6290	1.6330	1.6310
	N	Length of scavenger pump impellers. End play between impellers and scavenger pump housing (correctly assembled).	1.6235 to 1.6250	1.6205	1.6220
M-N	0.0020L to 0.0055L		0.0080L	0.0065L	

294. CYLINDER HEADS, VALVE ROCKER ARMS AND SHAFTS, VALVES, VALVE GUIDE AND ROCKER ARM PUSH RODS

a. Valve Rocker Arms, Shafts, and Thrust Springs.

519	A	Inside diameter of bearing in valve rocker arm.	1.0007 to 1.0022	1.0055	1.0035
	B	Outside diameter of valve rocker arm shaft .	0.9998 to 1.0005	0.9978	0.9988
	A-B	Fit of valve rocker arm on shaft ----	0.0002L to 0.0024L	0.0050L	0.0035L
	c	Valve rocker arm thrust spring:			
		Free length -----	3.5000		
		Scale reading at 2-inch length -----	8.81bs±1lb	7 lbs	7 lbs
		Maximum solid height -----	0.7300		

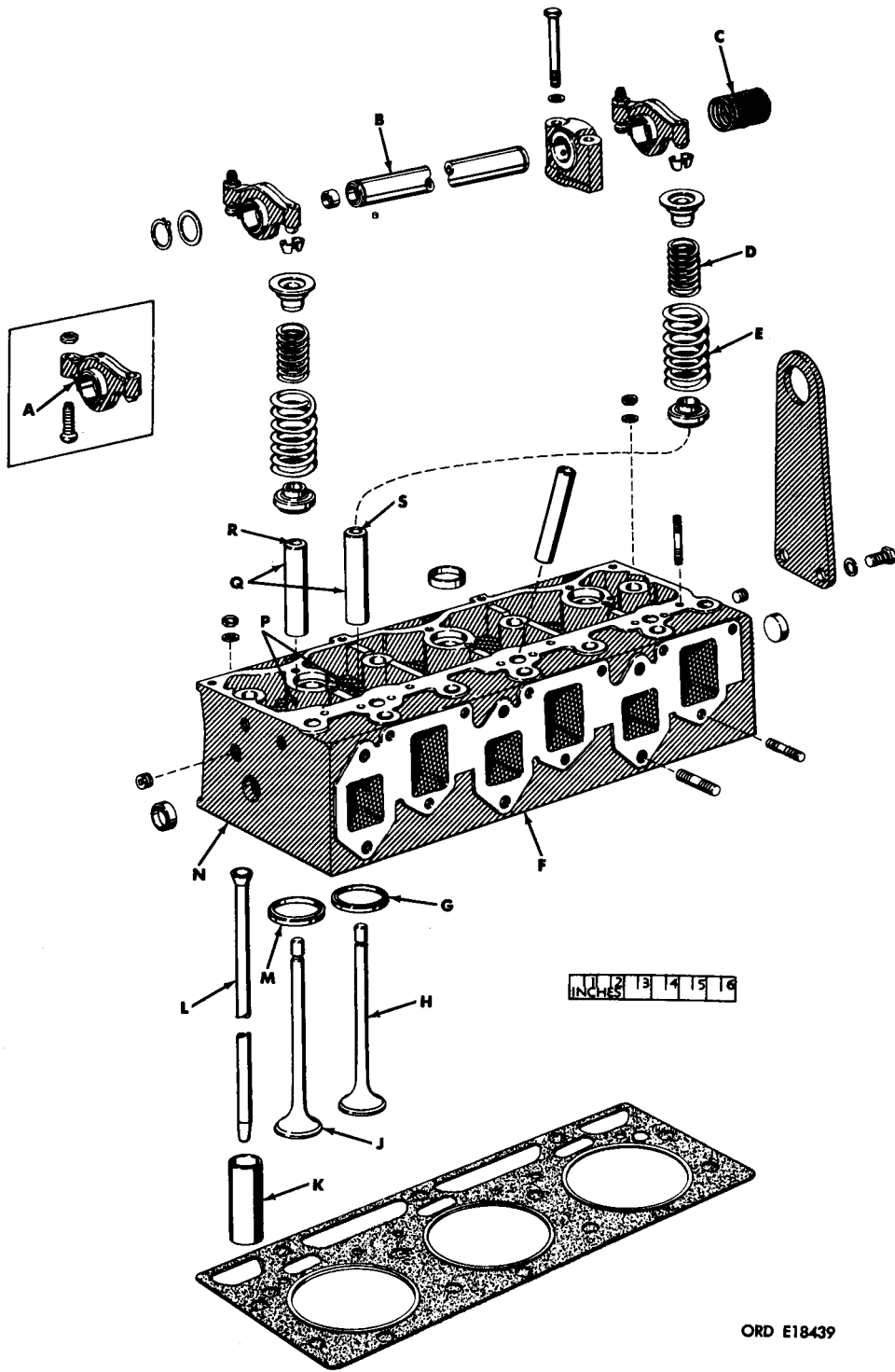
b. Valve Springs, Valve Seats, Valves, and Valve Guide.

(1) Valve springs.

519	D	Inner valve springs:			
		Free length -----	2.1100		
		Scale reading at 1.33-inch length ---	86.5 lbs ±9 lbs	86. 5±9	86.5±9
		Scale reading at 1.78-inch length ---	36.5 lbs +2 lbs	36. 5+2	36. 5+2
		Maximum solid height -----	1.0700		
	E	Outer valve springs:			
Free length -----		2.4300			
Scale reading at 1.64-inch length ---		160.7 lbs ±14.0 lbs	160. 7*14	160. 7*14	
Scale reading at 2.12-inch length ---		65.7 lbs ±3.0 lbs	65.7±3.0	65.7±3.0	
	Maximum solid height -----	1.5500			

(2) Intake and exhaust valve seats.

519	F	Inside diameter of intake valve seat bore in cylinder head.	2.0580 to 2.0590	2.0595	2.0595
	G	Outside diameter of intake valve seat-	2.0615 to 2.0625	*	*
	F-G	Fit of intake valve seat in bore -----	0.0025T to 0.0045T	0.0020T	0.0020T
	M	Outside diameter of exhaust valve seat	1.8120 to 1.8130	*	*
	N	Inside diameter of exhaust valve seat bore in cylinder head.	1.8080 to 1.8090	1.8095	1.8095
	M-N	Fit of exhaust valve seat in bore ----	0.0030T to 0.0050T	0.0025T	0.0025T



ORD E18439

**FIGURE 519. REPAIR AND REBUILD STANDARD POINTS OF MEASUREMENT FOR CYLINDER HEAD ASSEMBLY, VALVES, VALVE GUIDES, ROCKER ARMS, AND ROCKER ARM PUSH RODS.**

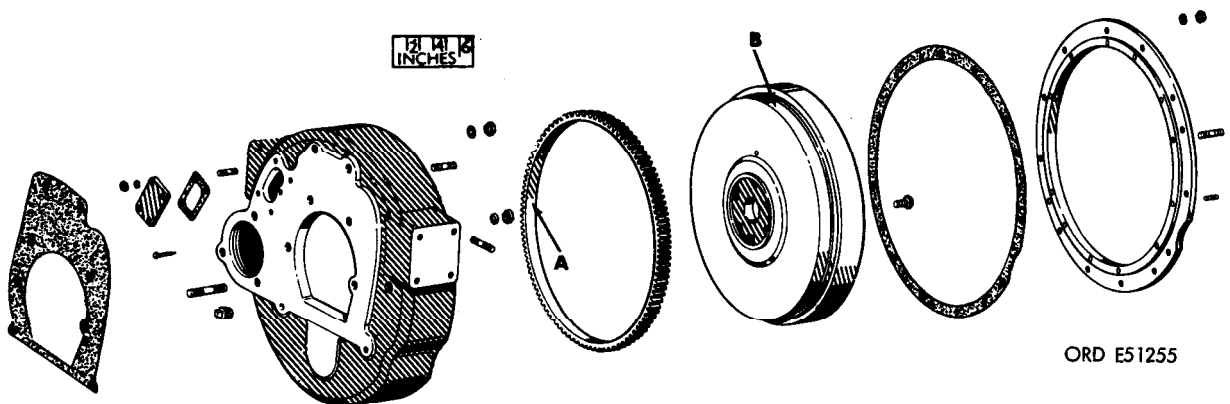
Fig. No.	Ref. letter	Point of measurement	Sizes and fits of new parts	Wear limits	
				Field maint	Depot maint
<b>(3) Valves and valve guides.</b>					
519	H	Intake valve length from gage line to tip of valve.	6.0820 to 6.0880	6.1080	6.1040
	H	Angle of intake valve seat with stem--	45 deg ±30 min.		
	H	Outside diameter of intake valve stem	0.4361 to 0.4369	0.4356	0.4356
	S	Inside diameter of intake valve guide installed in cylinder head.	0.4384 to 0.4394	0.4406	0.4399
	H-S	Fit of intake valve stem in guide ----	0.0015L to 0.0033L	0.0045L	0.0038L
	J	Exhaust valve length from gage line to tip of valve.	6.0700 to 6.0760	6.0860	6.0860
	J	Angle of exhaust valve seat with stem	45 deg ±30 min.		
	J	Outside diameter of exhaust valve stem.	0.4344 to 0.4352	0.4339	0.4339
	R	Inside diameter of exhaust valve guide installed in cylinder head.	0.4384 to 0.4394	0.4406	0.4399
	J-R	Fit of exhaust valve stem in guide ---	0.0032L to 0.0050L	0.0062L	0.0055L
	P	Inside diameter of valve guide bore in cylinder head.	0.6865 to 0.6875	*	*
	Q	Outside diameter of valve guides ----	0.6880 to 0.6890	*	*
	P-Q	Fit of valve guides in cylinder head bores.	0.0005T to 0.0025T	*	*

**(4) Rocker arm push rods.**

L Runout of outside diameter of rocker arm push rods must not exceed 0.0200-inch indicator reading when checked between centers.

**295. FLYWHEEL AND RING GEAR**

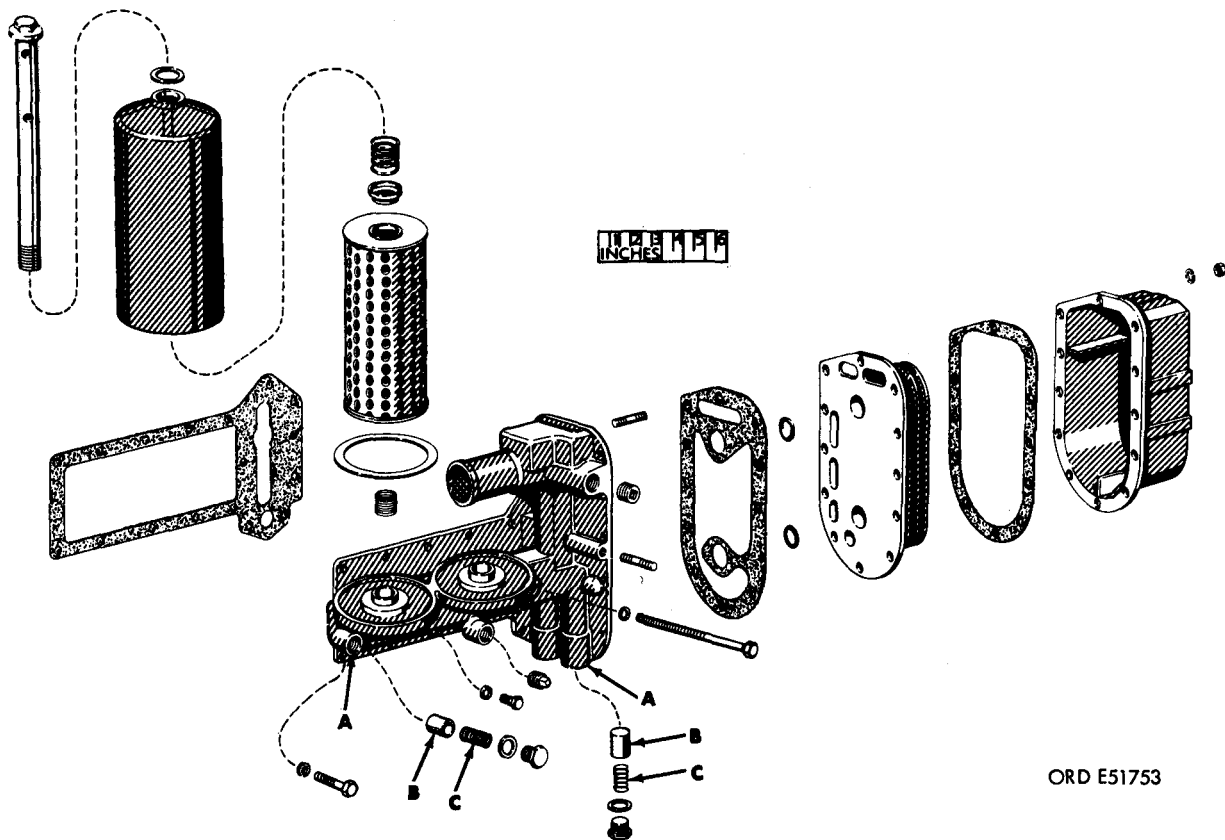
520	A	Inside diameter of ring gear -----	16.2260 to 16.2340	16.2380	16.2360
	B	Outside diameter of flywheel -----	16.2480 to 16.2520	16.2440	16.2360
	A-B	Fit of ring gear on flywheel -----	0.0140T to 0.0260T	0.0100T	0.0120T



**FIGURE 520. REPAIR AND REBUILD STANDARD POINTS OF MEASUREMENT FOR FLYWHEEL AND RING GEAR**



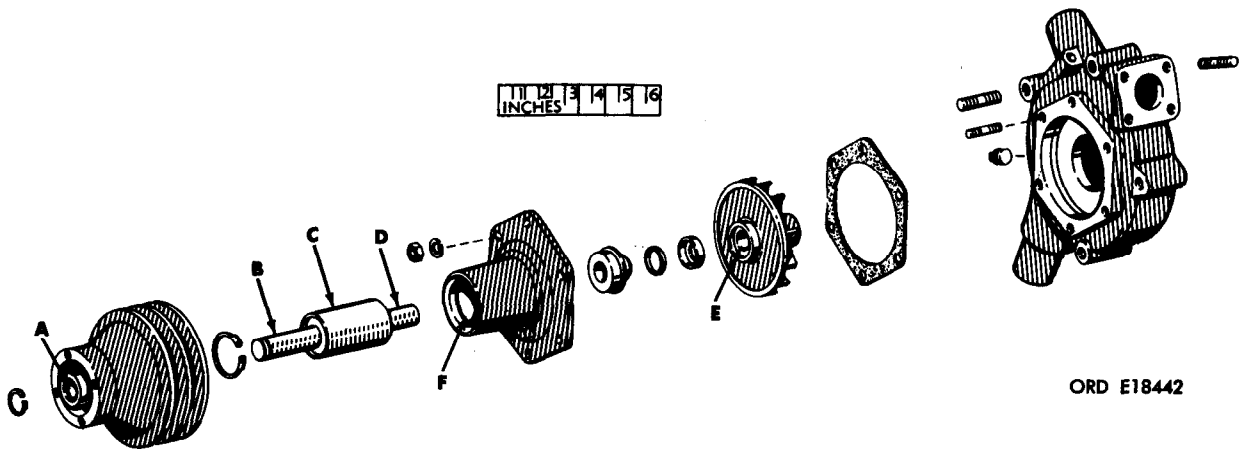
Fig. No.	Ref. letter	Point of measurement	Sizes and fits of new parts	Wear limits	
				Field maint	Depot maint
296. OIL COOLER AND OIL FILTER HOUSING ASSEMBLY					
521	A	Inside diameter of oil filter and oil cooler bypass valve bores in housing.	0.8030 to 0.8040	0.8050	0.8045
	B	Outside diameter of valve plungers --	0.8000 to 0.8010	0.7990	0.7995
	A-B	Fit of plungers in housing bores ----	0.0020L to 0.0040L	0.0050L	0.0045L
	C	Oil cooler and oil filter bypass valve springs:			
		Fret? length -----	1.6200		
		Load at 1.380 inches -----	7.65 lbs ±0.7 lbs	*	*
		Maximum solid height -----	0.9520		



ORD E51753

FIGURE 521. REPAIR AND REBUILD STANDARD POINTS OF MEASUREMENT FOR OIL COOLER AND OIL FILTER HOUSING ASSEMBLY.

Fig. No.	Ref. letter	Point of measurement	Sizes and fits of new parts	Wear limits	
				Field maint	Depot maint
<b>297. WATER PUMP ASSEMBLY</b>					
541	A	Inside diameter of water pump pulley-	0.9968 to 0.9978	0.9980	0.9980
	B	Outside diameter of shaft (pulley end)	0.9995 to 1.0000	0.9993	0.9993
	A-B	Fit of water pump pulley on shaft ---	0.0017T to 0.0032T	0.0015T	0.0015T
	c	Outside diameter of water pump shaft (bearing) assembly.	1.8745 to 1.8750	1.8740	1.8740
	F	Inside diameter of water pump shaft bore in housing.	1.8710 to 1.8720	1.8725	1.8725
	C-F	Fit of shaft (bearing) in housing -----	0.0025T to 0.0040T	0.0020T	0.0020T
	D	Outside diameter of shaft (impeller end).	0.6262 to 0.6267	*	*
	E	Inside diameter of water pump impeller shaft bore.	0.6235 to 0.6245	*	*
	D-E	Fit of water pump impeller on shaft --	0.0017T to 0.0032T	*	*



ORD E18442

FIGURE 522. REPAIR AND REBUILD STANDARD POINTS OF MEASUREMENT FOR WATER PUMP ASSEMBLY.

## 298. CLUTCH ASSEMBLY

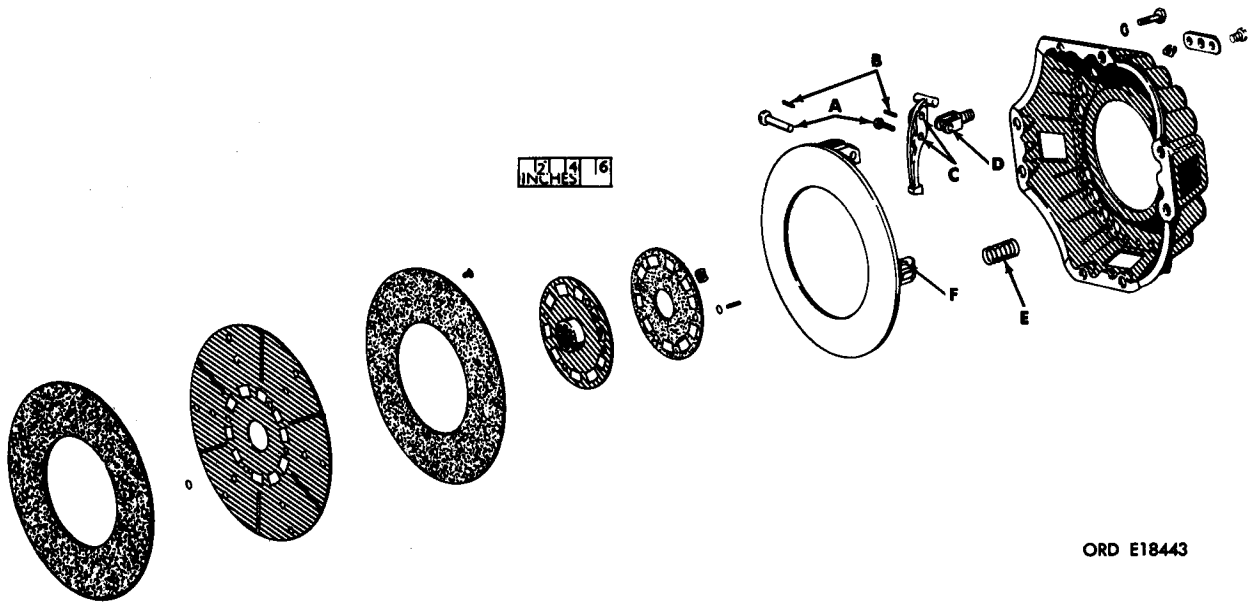
### a. Clutch Cover, Release Fingers, and Pressure Plate.

542	A	Outside diameter of release lever pins	0.3181 to 0.3185	0.3179	0.3180
	B	Outside diameter of needle rollers ---	0.0623 to 0.0627	*	*
	A-B	Fit of pin in needle rollers (theoretical).	0.000IT to 0.0004L	0.0010L	0.0008L
	D	Inside diameter of hole in release lever yoke.	0.3170 to 0.3180	0.3182	0.3182
	A-D	Fit of release lever yoke pin in yoke -	.000IT to 0.0015T	0.0001L	0.0001L
	c	Inside diameter of holes in release lever.	0.4438 to 0.4448	0.4450	0.4449
	B-C	Inside diameter of hole with needle rollers installed in release lever.	0.3184 to 0.3185	0.3190	0.3187

Fig. No.	Ref. letter	Point of measurement	Sizes and fits of new parts	Wear limits	
				Field maint	Depot maint
E		Clutch cover pressure springs:			
		Free length -----	2.3400		
		Load at 1.562-inches -----	130 lbs ±5 lbs	120 lbs	120 lbs
F		Maximum solid height -----	1.3800		
		Inside diameter of release lever yoke pin hole in pressure plate.	0.3182 to 0.3197	0.3199	0.3197
A-F		Fit of release lever yoke pin in pressure plate yoke pin-hole.	0.0003T to 0.0016L	0.0018L	0.0018L

**b. Clutch Driven Member.**

Frictional lag between two parallel surf aces. 0.0200 to 0.0600



ORD E18443

FIGURE 523. REPAIR AND REBUILD STANDARD POINTS OF MEASUREMENT FOR CLUTCH ASSEMBLY.

299. TORQUE SPECIFICATIONS

a. Special Torque Values.

Camshaft nut-----	145	pound feet
Connecting rod bolts -----	800	pound inches
Crankshaft damper and pulley bolts -----	360	pound inches
Cylinder head nuts -----	130	pound feet
Flywheel bolts -----	650-700	pound inches
Main bearing cap screws-----	1100	pound inches
Nozzle hold-down clamp bolts-----	150-175	pound inches
Damper pulley retaining bolts-----	150	pound feet
Fuel injection pump hub nut-----	50	pound feet
Oil filter bar-----	60	pound feet

b. Standard Torque Values.

Thread Diameter (inches)	Torque
1 / 4 -----	75-100 pound inches
5 / 16 -----	150-175 pound inches
3 / 8 -----	275-325 pound inches
7 / 16 -----	400-500 pound inches
1 / 2 -----	550-600 pound inches
9 / 16 -----	800-850 pound inches

## APPENDIX

### 1. PUBLICATION INDEXES

The following indexes should be consulted frequently for latest changes or revisions of references given in this appendix and for new publications relating to materiel covered in this technical manual.

Index of Army Motion Pictures, Television Recordings and Film Strips	--	DA Pam 108-1
Military Publications:		
Index of Administrative Publications	-----	DA Pam 310-1
Index of Blank Forms	-----	DA Pam 310-2
Index of Graphic Training Aids and Devices	-----	DA Pam 310-5
Index of Supply Manuals Ordnance Corps	-----	DA Pam 310-29
Index of Technical Manuals, Technical Regulations, Technical Bulletins, Supply Bulletins, Lubrication Orders, and Modifi- cation Work Orders.	-----	DA Pam 310-4
Index of Training Publications	-----	DA Pam 310-3

### 2. SUPPLY MANUALS

The following Department of the Army Supply Manuals pertain to this materiel:

#### a. Repair and Rebuild.

Repair Parts and Special Tools for Engine (Continental Model LDS-427-2).	-----	TM 9-2815-204-35P
---	-------	-------------------

#### b. Vehicle.

Truck, Cargo: 2-1/2 Ton, 6 x 6, M35A1 (Multifuel)	-----	TM 9-2320-235-20P
Truck, Cargo: 2- 1/2 Ton, 6 x 6, M35A1 (Multifuel)	-----	TM 9-2320-235-35P

### 3. FORMS

DA Form 2028, Recommended Changes to DA Technical Manual Parts Lists or Supply Manual 7, 8, or 9, is used to report publication errors or omissions. For use of maintenance forms, refer to TM 38-750. the Army Equipment Record Svstems and Procedures. Forms pertaining to the Army Safety Program are prescribed in SR 385-10-40.

### 4. OTHER PUBLICATIONS

#### a. General.

Cooling Systems: Vehicle and Powered Ground Equipment	-----	TM9-2858
Lubrication Order for Cargo Truck M35A1 (Multifuel)	-----	LO 9-2320-235-12
S p a r k P l u g s	-----	TM9-8638 (TB9-8638-2)

#### b. Operation.

Operation of Truck, Cargo: 2-1/2 Ton, 6 x 6, M35A1 (Multifuel)	-----	TM9-2320-235-10
--	-------	-----------------

#### c. Maintenance and Repair.

Organizational Maintenance for Truck, Cargo: 2-1/2 Ton 6 x 6, M35A1 (Multifuel)	--	TM9-2320-235-20
--	----	-----------------

Ordnance Maintenance: Power Brake Equipment (Midland Steel Products) - TM 9-8601

d. Repair and Rebuild.

Abrasives, Cleaning, Preserving, Sealing, Adhesive, and Related - - - - TM 9-1007  
Materials Issued for Ordnance Material  
Generator, Engine, Electrical (Autolite Model GHA-4802UT) - - - - - TM9-2920-209-35  
Generator, Engine, Electrical (Delco-Remy Model 1117495) - - - - - TM9-2920-214-35  
Instruction Guide, Care and Maintenance of Ball and Roller Bearings - - - TM 9-214  
Pump, Metering, Fuel Injection (American Bosch Model PSB-6BT) - - - - TM9-2910-223-35  
Starter, Engine, Electrical (Autolite Model MBD-4043UT) - - - - - TM9-2920-236-35  
Truck, Cargo: 2-1/2 Ton, 6 x 6, M35A1 (Multifuel) - - - - - TM9-2320-235-35  
Turbosupercharger, Air Induction (Schwitzer Model 4-450) - - - - - TM9-2920-201-35

## INDEX

Item	Paragraph	Figure	Page
<b>Accessories:</b>			
Description -----	7	1-10	7
Illustration instruction -----	58a		59
Installation instruction -----	58b		59
Parts identification -----	58c		59
Purpose' of replacement -----	57a		59
Removal instructions -----	58b		
Replacement -----	59-65	39-87	60-81
Service operation-----	58a	221,222	59
Special instructions-----	58d		59
Tabulate data -----	37-40		17-20
Troubleshooting-----	48		34
<b>Adapter, crankcase breather:</b>			
Assembly-----	205d	394	246
Cleaning-----	99b		142
	205b		246
Disassembly -----	205a	394	246
Inspection -----	99b		142
	205b		246
Installation-----	99d	62	143
	283c	504	318
Removal -----	99a	62	142
	130-	263	165
Repair -----	99C		142
	205c		246
<b>Adapter, injection pump:</b>			
Assembly -----	181d	351,352	217
Cleaning-----	181b		217
Disassembly-----	181a	351,352	217
Inspection -----	181b		217
Installation-----	279a	243	312
Removal-----	121	243	156
Repair -----	181c		217
<b>Adapter, starter:</b>			
Cleaning-----	241b		284
Inspection-----	241b		284
Installation -----	274a	256	311
Removal -----	127	256	161
Repair -----	214c		284
<b>Adapter, transmission:</b>			
Check face runout -----	86d	162	113
Cleaning -----	209a		249
Inspection -----	209a		249
Installation -----	86c	158	113
	267c	273	307
Removal -----	86a	158	113
	134	273	170
Repair -----	209b		249
Air compressor support (see Support, air compressor)-----			
Allocation, field and depot maintenance -----	2		4
Appendix-----			350

INDEX - Continued

Item	Paragraph	Figure	Page
Arm, rocker:			
Assembly-----	92f	184-186	124
	202d	184-186	244
Cleaning-----	92d	187	122
	202b		243
Disassembly-----	92c	184-186	122
	202a	184-186	243
Inspection-----	92d	187	122
	202b		243
Installation-----	92g	180,181	124
	268d	268	309
Removal-----	92b	180,181	121
	132	268	168
Repair-----	92e		124
	202c		243
Assembly (see specific item)-----			
Assembly instructions-----	254		296
Assembly procedure-----	156		193
Baffle, cylinder and crankcase water:			
Cleaning-----	180a		217
Inspection-----	180a		217
-Installation-----	280a	240	313
Removal-----	120	240	154
Repair-----	180b		217
Bearing, camshaft:			
Inspection-----	159b		195
Replacement-----	161		200
Bearing, main:			
Installation-----	257	283	299
Removal-----	149	283	182
Belt, air compressor drive:			
Adjustment-----	84b	87	112
Installation-----	84b	80-82	112
Removal-----	84b	80-82	112
Belt, engine fan and generator drive:			
Adjustment-----	84a	43	112
Installation-----	84a	41	112
Removal-----	84a	41	112
Bracket, engine front lifting:			
Installation-----	272	261	311
Removal-----	129	261	164
Bracket, engine rear lifting:			
Installation-----	272	262	311
Removal-----	129	262	164
Bracket, engine rear mounting:			
Installation-----	263	295	304
Removal-----	144	295	178
Bracket, fuel filter:			
Cleaning-----	230a		266
Inspection-----	230a		266
Installation-----	277	250	312



INDEX - Continued

Item	Paragraph	Figure	Page
Bracket, fuel filter - continued:			
Removal -----	124	250	159.
Repair -----	230b		266
Bracket, generator mounting:			
Cleaning -----	242c		284
Inspection -----	242c		284
Installation -----	276	251	312.
Removal -----	125	251	160
Repair -----	242d		284
Camshaft:			
Assembly -----	171b		209
Cleaning -----	170a		208
Disassembly -----	169		208
Inspection -----	170b		208
Installation -----	256	310,311	299
Removal -----	151	311	184
Repair -----	171a		209
Camshaft gear (see Gear, camshaft)			
Camshaft thrust plate (see Plate, camshaft thrust)			
Cap, main bearing:			
Installation -----	259b	305	300
Removal -----	149	305	182
Cleaning (see also specific item)			
Cleaning:			
Ball bearings -----	152f		186
Castings -----	152c		186
General -----	152c		186
Instructions -----	152b		186
Oil passages -----	152d		186
Oil seals, cables, and hoses -----	152e		186
Cleanliness -----	253	-	186
Clutch:			
Assembly -----	251	448-455.	293
Balancing -----	252	464	295
Cleaning -----	249a		290
Data -----	246		287
Description -----	245a	447	286
Disassembly -----	248	448-455	287
Improvised tools -----	247		287
Inspection -----	67b	91	
	249b		290
Installation -----	67e	97,98	81
	267b	483,484	307
Operation -----	245b	447	286
Removal -----	67a	88-90	81
	134-	275	170
Repair -----	250		292
Common tools and equipment -----	43		21
Compression test, cylinder -----	102	221	143
Compressor, air:			
Data -----	38		18

INDEX - Continued

Item	Paragraph	Figure	Page
Compressor, air - continued:			
Installation-----	65h	81-83	80
Removal-----	65b	80-83	78
Connecting rod (see Rod, connecting)			
Coolant specifications-----	287j		326
Coolant temperature-----	287k		326
Cooler, oil:			
Cleaning-----	78b		100
	212a		252
Inspection-----	78c		100
	212a		252
Installation-----	78e	132-136	101
	280b	237	313
Removal-----	78a	132-136	100
	120	237	154
Repair-----	78d		101
	212b		252
Cover, clutch:			
Cleaning-----	249a		290
Inspection-----	249b		290
Installation-----	251d	450,451	294
Removal-----	248	451	287
Repair-----	250c		292
Cover, cylinder head:			
Cleaning-----	204a		246
Inspection-----	204a		246
installation-----	283c	503,504	318
Removal-----	130	264	165
Repair-----	204b		246
Cover, fuel injection pump drive gear access:			
Cleaning-----	184a		219
Inspection-----	184a		219
Installation-----	283a	502	318
Removal-----	63	61	66
Repair-----	184b		219
Cover, oil cooler:			
Installation-----	280b	236	313
Removal-----	120	236	154
Cover, tappet chamber:			
Cleaning-----	179a		216
Inspection-----	179a		216
Installation-----	280	239	313
Removal-----	120	239	154
Repair-----	179b		216
Cover, timing gear:			
Assembly-----	183d	351,352	218
Cleaning-----	183b		217
Disassembly-----	183a	351,352	217
Inspection-----	183b		217
Installation-----	264	289	305
Removal-----	141	289	176
Repair-----	183c		218

INDEX - Continued

Item	Paragraph	Figure	Page
Crankcase (see Cylinder and crankcase)			
Crankcase breather adapter (see Adapter, crankcase breather)			
Crankshaft:			
A s s e m b l y -----	168	334,335	208
C l e a n i n g -----	166a		207
D i s a s s e m b l y -----	165	334,335	206
I n s p e c t i o n -----	166b		207
I n s t a l l a t i o n -----	257b	307	299
R e m o v a l -----	149-	307	182
R e p a i r -----	167		208
Crankshaft damper and pulley (see Damper and Pulley, crankshaft)			
Crankshaft gear (see Gear, crankshaft)			
Crankshaft rear oil seal housing (see Housing, crankshaft rear oil seal)			
Cylinder and crankcase:			
C l e a n i n g -----	159a		195
I n s p e c t i o n -----	159b		196
R e p a i r -----	160a		199
Cylinder and crankcase water baffle (see Baffle, cylinder and crankcase water)			
Cylinder block (see Cylinder and crankcase)			
Cylinder head (See Head, cylinder)			
Cylinder head cover (see Cover, cylinder head)			
Cylinder head water outlet manifold (see Manifold, cylinder head water outlet)			
Damper and pulley, crankshaft:			
A s s e m b l y -----		204,205	135
C l e a n i n g -----	188d	204,205	223
D i s a s s e m b l y -----	188b		222
I n s p e c t i o n -----	96c	204,205	135
I n s t a l l a t i o n -----	188a	204,205	222
R e m o v a l -----	188b		222
R e p a i r -----	96e	202,203	135
D a t a -----	264	479	305
D e s c r i p t i o n -----	96b	201,203	133
D a t a -----	139	287	174
D e s c r i p t i o n -----	188c		223
D a t a -----	37-40		17-20
Description:			
A i r i n d u c t i o n a n d e x h a u s t s y s t e m -----	33	5	<b>17</b>
C a m s h a f t a s s e m b l y -----		17	<b>10</b>
C l u t c h a s s e m b l y -----	36	5	<b>17</b>
C o n n e c t i n g r o d b e a r i n g s -----	12	17	<b>9</b>
C o n n e c t i n g r o d s -----	11	17	<b>8</b>
C o o l i n g s y s t e m:			
F a n -----	30c	17,20	14
O i l c o o l e r -----	30e		15
T h e r m o s t a t -----	30d		15
W a t e r p u m p a s s e m b l y -----	30b		13
C r a n k c a s e b r e a t h e r -----	27	7	11
C r a n k c a s e o i l f i l l e r a n d c r a n k c a s e b r e a t h e r -----	34	7	17

INDEX - Continued

Item	Paragraph	Figure	Page
Description - continued:			
Crankshaft and camshaft gears -----	17	17	10
Crankshaft assembly-----	9	17	8
Crankshaft torsional vibration damper-----	18	17	10
Cylinder and crankcase-----	8	7	7
Cylinder head water outlet manifolds-----	26	3,9	11
Cylinder heads -----	20	1,5	10
Exhaust manifold-----	25	5	11
Flywheel -----	19	17	10
Flywheel housing-----	28	7	12
Fuel system:			
Fuel hoses and tubes-----	31f	21	15
Fuel injection pump assembly-----	31d	21	15
Fuel injector nozzle and holder assemblies -----	313	21	15
Fuel supply pump -----	31d	21	15
Primary and final fuel filters-----	31c	21	15
General-----	6	9	7
Intake manifold-----	24	5	10
Intake manifold flame heater and fuel system:			
Flame heater assembly -----	32b	22	16
Flame heater fuel filter assembly-----	32d	22	16
Flame heater fuel pump assembly -----	32c	22	16
Flame heater fuel solenoid valves-----	32e	22	17
Lubrication system:			
Air compressor -----	29j	-	13
Bearings -----	29f	18	12
Fuel injection pump and gear train -----	29h	-	12
Oil coder-----	29e	-	12
Oil filters -----	29c	-	12
Oil pan -----	29d	-	12
Oil pump -----	29b	-	12
Piston cooling nozzle assemblies-----	29g	-	12
Turbosupercharger-----	29i	-	12
Main bearings -----	10	17	8
Piston rings -----	14	17	10
Pistons andpiston pins-----	13	17	9
Rocker arm shafts and supports-----	22	17	10
Rocker arms -----	23	17	10
Sending units-----	35	5	17
Tappets and push rods -----	16	17	10
Valves and valve springs-----	21	17	10
Disassembly (see specific item)			
Disassembly, preparation for:			
Draining -----	113		149
General-----	111		148
Lifting engine-----	112	223	149
Mounting on overhaul stand -----	114	223	149
Removal of accessories-----	115		150
Elbow, intake manifold:			
Assembly -----	224a	410	261
Cleaning -----	224b		260

INDEX - Continued

Item	Paragraph	Figure	Page
Elbow, intake manifold - continued:			
Disassembly -----	224a	410	260
Inspection -----	224b		260
Installation -----	278	247	312
Removal -----	123	247	157
Repair -----	224c		261
Elbow, turbosupercharger exhaust:			
Assembly -----	240d	446	284
Cleaning -----	240b		284
Disassembly -----	240a	446	284
Inspection -----	240b		284
Repair -----	240c		284
Element, fuel filter:			
Installation -----	72b	103,104	88
Removal -----	72a	103,104	88
Element, oil filter:			
Installation -----	73b	105,106	89
	281a	492	314
Removal -----	73a	105,106	89
	119-	233,234	154
Engine, assembly:			
Data -----	39		18
Engine fan (see Fan, engine)			
Engine front lifting bracket (see Bracket, engine front lifting)			
Engine front plate (see Plate, engine front)			
Engine rear lifting bracket (see Bracket, engine rear lifting)			
Engine rear mounting bracket (see Bracket, engine rear mounting)			
Exhaust manifold (see Manifold, exhaust)			
Fan, engine:			
Cleaning -----	243a		285
Inspection -----	243a		285
Installation -----	85b	112	112
	273c	488	311
Removal -----	85a	112	112
	128	257	162
Repair -----	243b		285
Filter, flame heater fuel:			
Assembly -----	81d	142	105
	229d		265
Cleaning -----	81c		105
	229b		265
Disassembly -----	81b	142	105
	229a	411	265
Inspection -----	229b		265
Installation -----	81e	141	105
Removal -----	81a	141	105
Repair -----	229c		265
Filter, fuel:			
Assembly -----	213d	404	253
Cleaning -----	213b		252
Data -----	38		18

INDEX - Continued

Item	Paragraph	Figure	Page
Filter, fuel - continued:			
Disassembly -----	213a	404	252
Inspection -----	213b		252
Instalhtion-----	285a	228,229	324
Removal -----	1 17	226-229	151
Repair-----	213c		252
Filter, oil:			
Assembly-----	210e	402	251
Fleming-----	210c		251
Data -----	3 8		18
Disassembly-----	210b	402	251
Inspection-----	210c		251
Repair-----	2106		251
Flame heater fuel pump (see pump, flame heater fuel)			
Flame heater ignition unit (see Ignition unit, flame heater)			
Flushing, engine cooling system -----	110	222	146
Flywheel:			
Check runout-----	86C	161	114
Cleaning-----	208a		248
Inspection -----	208a		248
Instdlation-----	86b	159,160	113
	267a	276	307
Removal-----	86a	158,159	113
	134	276	170
Repair-----	208		249
Flywheel housing (see Housing, flywheel)			
F o r m s -----	3		4
	3		4
Fuel consumption -----	287h		326
Fuel filter (see Filter, fuel)			
Fuel filter bracket (see Bracket, fuel filter)			
Fuel injection tube (see Tube, fuel injection)			
Fuel injector nozzle and holder (see Nozzle and holder, fuel injector)			
Fuel pressure-----	287i		326
Fuel temperature-----	287i		326
Gear, camshaft:			
Cleaning -----	186a		222
Inspection-----	186a		222
Installation -----	98b	220	138
	260c	471	301
Removal -----	98a	213-217	138
	142	291	176
Repair-----	186b		222
Gear, crankshaft:			
Cleaning-----	187a		222
Inspection-----	187a		222
Installation -----	98b	221	138
	260c	471	301
Removal -----	98a	213-217	138
	142	292	176

INDEX - Continued

Item	Paragraph	Figure	Page
Gear, crankshaft - continued:			
Repair-----	187b		222
Gear, injection pump driven:			
Installation-----	98b	216	138
Removal-----	98a	213-217	138
Gear, oil pump idler:			
A s s e m b l y-----	185e	356	221
Cleaning-----	185b		220
Disassembly-----	185a	354,355	220
Inspection-----	185c		220
Installation-----	260b	301	301
Removal-----	147	301	180
Repair-----	185d		221
Generator:			
Data-----	38		18
Installation-----	61b	41-42	60
Removal-----	61a	41-42	60
Generator mounting bracket (see Bracket, generator mounting)			
Governor setting-----	287p		326
Head, cylinder:			
Assembly-----	94f	193,194	130
	201	380-384	243
Cleaning-----	94d		130
	199a		239
Disassembly-----	94c	193,194	129
	198	380-384	236
Inspection-----	94d		130
	199b		239
Installation-----	94g	190-192	130
	268a	272	309
Removal-----	94b	189-192	127
	133	272	169
Repair-----	94e		130
	200a		240
Torque tightening-----	94h	195	131
Heater, intake manifold flame:			
Assembly-----	79f	138	103
Cleaning-----	79d		103
	226b		261
Data-----	38		18
Disassembly-----	79b	138	103
	226a		261
Inspection-----	79d		103
	226b		261
Installation-----	79g	137	103
	278	234	312
Removal-----	79a	137	103
	123	245	157
Repair-----	79d		103
	226c		261
Horsepower, gross-----	287b		326

INDEX - Continued

Item	Paragraph	Figure	Page
Housing, air compressor discharge:			
Cleaning-----	239b		282
Inspection-----	239b	.	282
Installation-----	239d	433	283
Removal-----	239a	433	282
Repair-----	239c		283
Housing, crankshaft rear oil seal:			
Assembly-----	177d		215
Cleaning-----	177b		215
Disassembly-----	177a		215
Inspection-----	177b		215
Installation-----	262b	300	303
Removal-----	146	300	180
Repair-----	177c		215
Housing, flywheel:			
Assembly-----	207d	397	248
Cleaning-----	207b		248
Disassembly-----	207a	397	248
Inspection-----	207b		248
installation-----	262c	299	303
Removal-----	145	299	217
Repair:-----	207c		248
Housing, oil cooler and oil filter:			
Assembly-----	211d	403	251
Cleaning-----	211b		251
Disassembly-----	211a	403	251
Inspection-----	211b		251
Installation-----	280b	238	313
Removal-----	120	238	154
Repair-----	211c		251
Housing, oil pressure regulator valve:			
Assembly-----	192d	358	224
Cleaning-----	192b		224
Disassembly-----	192a	358	224
Inspection-----	192b		224
Installation-----	275	490	311
Removal-----	126	254	160
Repair-----	192c		224
Housing, thermostat:			
Assembly-----	218d	408	258
Cleaning-----	218b		257
Disassembly-----	218a	408	257
Inspection-----	218b		257
Installation-----	273b	259	311
Removal-----	128	259	162
Repair-----	218c		258
Idle adjustment, fuel injection pump-----	107	56	146
Ignition unit, flame heater:			
Assembly-----	225d	410	261
Cleaning-----	225b		261
Disassembly-----	225a	410	261



INDEX - Continued

Item	Paragraph	Figure	Page
Ignition unit, flame heater - continued:			
Inspection-----	225b		261
Installation-----	80b	140	104
	2 7 8	246	312
Removal-----	80a	140	104
	1 2 3	246	157
Repair-----	225c		261
Improvised tools-----	45-		31
Induction air temperature-----	2871		326
Injection pump adapter (see Adapter, injection pump)			
Inserts, Heli-coil:			
Replacement-----	155		192
Inspection:			
Ball bearings-----	153c		187
Bushings and bearings-----	153f		187
Casting-----	153b		187
Gears-----	153e		187
General-----	153a		186
Heli-coil inserts-----	153g		187
Studs-----	153d		187
Inspection (see also specific item)			
Installation (see specific item)			
Installation instructions-----	255		296
Intake manifold (see Manifold, intake)			
Intake manifold elbow (see Elbow, intake manifold)			
Intake manifold flame heater (see Heater, intake manifold flame)			
Leakage test-----	288		327
Lever, release:			
Cleaning-----	249a		290
Inspection-----	249b		291
Installation-----	251b	453,454	291
Removal-----	2 4 8	454	287
Repair-----	250f		292
Liner, cylinder:			
Installation-----	162c	332	205
Removal-----	162b	330	202
Location, engine component-----	4		4
Main bearing (see Bearing, main)			
Main bearing cap (see Cap, main bearing)			
Manifold, sir compressor air intake:			
Assembly-----	238e	445	282
Cleaning-----	238c		282
Disassembly-----	238b	445	282
Inspection-----	238c		282
Installation-----	238f	445	282
Removal-----	238a	445	282
Repair-----	238d		282
Manifold, cylinder head water outlet:			
Assembly-----	221d	408	259
Cleaning-----	221b		259

INDEX - Continued

Item	Paragraph	Figure	Page
Manifold, cylinder head water outlet - continued:			
Disassembly -----	221a	408	259
Inspection -----	221b		259
Installation -----	90c	178,179	122
	271b	265	310
Removal -----	90b	178,179	122
	131	265	166
Repair -----	221c		259
Manifold, exhaust:			
Assembly -----	223d	173,174	260
Cleaning -----	223b		260
Disassembly -----	223;	173, 174	260
Inspection -----	223b		260
Installation -----	88c	168-174	120
	270	267	310
Removal -----	88b	168-174	117
	131	267	166
Repair -----	223c	-	260
Manifold, intake:			
Assembly -----	89c	175-177	121
	219d	408	259
Cleaning -----	219b		259
Disassembly -----	89b	175-177	120
	219a	408	259
Inspection -----	219b		259
Installation -----	89d	168-172	121
	270	267	310
Removal -----	89a	168-172	120
	131	267	166
Repair -----	219c		259
Manifold pressure, turbosupercharger -----	287m		326
Nozzle, piston cooling:			
Inspection -----	159b		198
Installation -----	256c	465	299
Removal -----	150	309	184
Repair -----	160c		199
Nozzle and holder, fuel injector:			
Assembly -----	83i	152-155	112
	217e	152-155	257
Cleaning -----	83f	156	110
	217c		257
Data -----	38		18
Disassembly -----	83e	152-155	109
	217b	152*155	257
Inspection -----	83g	156	111
	217c		257
Installation -----	83j	148-150	112
	284a	505	319
Removal -----	83b	148-150	107
	118	232	152

INDEX - Continued

Item	Paragraph	Figure	Page
Nozzle and holder, fuel injector - continued:			
Repair-----	83h 217d	156	112 257
Testing-----	83d		109
Oil consumption-----	287e	-	326
Oil cooler (see Cooler, oil)			
Oil cooler and oil filter housing (see Housing, oil cooler and oil filter)			
Oil cooler cover (see Cover, oil cooler)			
Oilcooler water inlet tube (see Tube, oil cooler water inlet)			
Oil filter element (see Element, oil filter)			
Oil gage rod support (see Support, oil gage rod)			
Oil pan (see Pan, oil)			
Oil pressure-----	287g		326
Oil pressure regulator valve housing (see Housing, oil pressure regulator valve)			
Oil pressure sending unit (see Sending unit, oil pressure)			
Oil pump (see Pump, oil)			
Oil pump idler gear (see Gear, oil pump idler)			
Oil pump oil pressure relief valve (see Valve, oil pump oil pressure relief)			
Oil pump outlet tube (see Tube, pressure oilpump outlet)			
Oil temperature-----	287f		326
Operation, hypercycle-----	5	12	5
Pan, oil:			
Assembly-----	191d	351,352	223
Cleaning-----	191b		223
Disassembly-----	19a	351,352	223
Inspection-----	191b		223
Installation-----	95b 266d	198-200 277	132 306
Removal-----	95a 135	198-200 277	132 171
Repair-----	191c		223
Pin, piston:			
Assembly-----	178b	342	214
Cleaning-----	174a		211
Disassembly-----	173	342	209
Inspection-----	174b		212
Repair-----	175c	322	213
Pin, release lever:			
Cleaning-----	249a		290
Inspection-----	249b		291
Installation-----	251b	453	294
Removal-----	248	453	287
Repair-----	250a		292
Piston:			
Assembly-----	176b	342	214
Cleaning-----	174a		211
Disassembly-----	173-	342	252

INDEX - Continued

Item	Paragraph	Figure	Page
Piston - continued:			
Inspection -----	174b		212
Installation -----	265-	480	305
Removal -----	138	285	173
Repair -----	175a	322	213
Piston cooling nozzle (see Nozzle, piston cooling)			
Plate, camshaft thrust:			
Inspection -----	170b		208
Installation -----	2 5 6	310	299
Removal -----	151	310	184
Plate, engine front:			
Assembly -----	182d	351,352	217
Cleaning -----	182b		217
Disassembly -----	182a	351,352	217
Inspection -----	182b		217
Installation -----	260	303	301
Removal -----	148	303	181
Repair -----	182c		217
Plate, lock:			
Cleaning, -----	249a		290
Inspection -----	249b		291
Installation -----	251f	450	294
Removal -----	2 4 8	450	287
Repair -----	250a		292
Pressure oil pump pickup tube (see Tube, pressure oil pump pickup)			
Publication indexes -----			1
Publications -----	-		4
Pulley, air compressor adjustable:			
Cleaning -----	237b		280
Inspection -----	237b		280
Installation -----	237d	445	281
Removal -----	237a	445	280
Repair -----	237c		281
pulley, generator:			
Cleaning -----	242c		284
Inspection -----	242c		284
Installation -----	242f	446	284
Removal -----	242a	446	284
Repair -----	242d		284
Pump, flame heater fuel:			
Assembly -----	235	412-30	278
Cleaning -----	233		272
Data -----	38		18
Disassembly -----	232	412-430	266
Inspection -----	234		275
Installation -----	64b	78	
	286b	78	325
Removal -----	64a	78	77
	124	250	159
Repair -----	234		275
Testing -----	236	444	280

INDEX - Continued

Item	Paragraph	Figure	Page
Pump, fuel injection:			
Data-----	38		18
Installation-----	63c	56-76	76
Removal-----	63b	56-76	66
Pump, oil:			
Assembly-----	193d	376,377	233
Cleaning-----	193b		229
Disassembly-----	193a	359-370	225
Inspection-----	193b		229
Installation-----	266	282	306
Removal-----	137	282	173
Repair-----	193c		229
Pump, timing, fuel injection-----	106		145
Pump, water:			
Assembly-----	77d	117-126	97
	220d		259
Cleaning-----	77c		97
	220b		259
Disassembly-----	77b	117-126	94
	220a		259
Inspection-----	77c		97
	220b		259
Installation-----	77e	112-116	100
	273	260	311
Removal-----	77a	112-116	92
	128	260	162
Repair-----*	77c		97
	220c		259
Records-----	3		4
Removal (see specific item)			
Repair:			
Ball bearings-----	154c		188
earings-----	154f		192
Castings-----	154b		188
Gears-----	154e		189
General-----	154a		188
Oil seals-----	154g		192
Studs-----	154d		188
Repair (see also specific item)			
Repair and rebuild standards:			
Camshaft-----	292a	514	332
Camshaft thrust plate-----	292a	514	332
Clutch cover-----	298a	523	347
Clutch driven member-----	298b		348
Connecting rod-----	292e	514	335
Crankshaft-----	292f	514	336
Crankshaft damper and pulley-----	292f	515	339
Crankshaft gear-----	292f	515	339
Cylinder and crankcase-----	292b	514	334
Cylinder liner-----	292c	514	334
Flywheel-----	295	520	345

INDEX - Continued

Item	Paragraph	Figure	Page
Repair and rebuild standards - continued:			
Main bearing sleeve-----	292f	514	337
Oil cooler and oil filter housing -----	2 9 6	521	346
Oil pressure regulator spring -----	293b	517	340
Oil pressure regulator valve -----	293b	517	340
O i l   p u m p -----	293c	518	340
Oil pump idler gear -----	293a	514	340
P i s t o n -----	292c	514	334
Piston pin -----	292c	514	334
P i s t o n   r i n g -----	292d	514	334
Pressure plate-----	298a	523	347
Release finger-----	298a	523	347
R i n g   g e a r -----	2 9 5	520	345
Rocker arm thrust spring -----	294a	519	343
V a l v e -----	294b	519	343
V a l v e   g u i d e -----	294b	519	343
Valve rocker arm -----	2 9 a	519	343
Valve rocker arm shaft-----	294a	519	343
Valve seat -----	294b	519	343
Valve spring -----	294b	519	343
Valve tappet-----	292b	519	334
Water pump-----	2 9 7	522	347
Repair parts-----	42		21
Reports -----	3		4
Ring, piston:			
Cleaning -----	174a		211
Inspection -----	174b		212
Installation -----	176c	339,340	212
Removal-----	1 7 3	339	209
Repair-----	175b	322	212
Rocker arm (see Arm, rocker)			
Rocker arm push rod (see Rod, rocker arm push)			
Rod, connecting:			
Assembly -----	176b	342	214
Cleaning -----	176a		211
Disassembly -----	1 7 3	342	209
Inspection -----	174b		212
Installation -----	2 6 5	480	305
Removal -----	139	285	174
Repair -----	175f	322	213
Rod, oil gage:			
Cleaning -----	190b		223
Inspection -----	190b		223
Installation -----	2 7 8	248	312
Removal -----	123	248	157
Repair -----	190c		223
Rod, rocker arm push:			
Cleaning -----	203a		244
Inspection -----	203a		244
Installation -----	93c	188	126
	268c	269	309

INDEX - Continued

Item	Paragraph	Figure	Page
Rod, rocker arm push - continued:			
Removal-----	93b	188	126
	132	269	168
Repair-----	203b		244
Run-in, engine-----	289		328
Scavenger oil pump inlet tube (see Tube, scavenger oil pumpinlet)			
Scope-----	1		1
Screw, valve rocker arm adjusting:			
Installation-----	91c	180-182	123
Removal-----	91b	180-182	123
Seal, crankshaft front oil:			
Installation-----	97b	210	136
Removal-----	97a	210	136
Seal, crankshaft rear oil:			
Installation-----	87b	166	116
Removal-----	87a	165	115
Sending unit, oil pressure:			
Cleaning-----	189a		223
Data-----	38		18
Inspection-----	189a		223
Installation-----	74b	107	90
	274b	256	311
Removal-----	74a	107	90
	127	256	161
Repair-----	189b		223
Sending unit, water temperature:			
Data-----	38		18
Installation-----	75b	108	91
Removal-----	75a	108	91
Service operations-----	101		143
Shaft, rocker arm:			
Assembly-----	202d	184-186	243
Cleaning-----	202b	-	243
Disassembly-----	202a	184-186	243
Inspection-----	202b		243
Repair-----	202c		243
Smoke density-----	280o		326
Special tools and equipment:			
Description, Table I-----	44		21
Field and depot maintenance-----	44	23-30	21-30
General-----	41		
Specifications, engine-----	287		326
Speed range-----	287a		326
Spray pattern, nozzle-----	103		144
Spring pressure:			
Cleaning-----	249a		290
Inspection-----	249b		290
Installation-----	251c	452	294
Removal-----	248	452	287
Repair-----	250d		292

INDEX - Continued

Item	Paragraph	Figure	Page
Starter:			
Data -----	38		18
Installation -----	60b	39,40	60
Removal -----	60a	39,40	60
Starter adapter (see Adapter, starter)			
Storage, preparation for -----	290		330
Supply manuals -----	2		4
Support, aircompressor:			
Assembly -----	178d	349	215
Cleaning -----	178b		215
Disassembly -----	178a	349	215
Inspection -----	178b		215
Installation -----	279b	241	312
Removal -----	121	241	156
Repair -----	178c		215
Support, oil gage rod:			
Cleaning -----	190b		223
Inspection -----	190b		223
Installation -----	276	251	312
Removal -----	125	251	160
Repair -----	190c		223
Tachometer adapter:			
Installation -----	140	209	175
Removal -----	140	209	175
Repair -----	197		236
Tappet chamber cover (see Cover, tappet chamber)			
Tappet, valve:			
Cleaning -----	203a		204
Inspection -----	203a		204
Installation -----	268	270	309
Removal -----	132	270	168
Repair -----	203b		244
Thermostat, coolant:			
Installation -----	76b	109-111	91
Removal -----	76a	109-111	91
Thermostat housing (see Housing, thermostat)			
Timing gear cover (see Cover, timing gear)			
Torque, gross -----	287c		326
Torque specifications -----	899-		349
Transmission adapter (see Adapter, transmission)			
Troubleshooting:			
Accessories -----	48		34
Air induction syetem -----	52		49
Cooling system -----			55,56
E n g i n e -----	-		35-47
Fuel system -----	53		50,51
Generator system -----	51		49
Intake manifold flame heater fuel system -----	56		57,58
Lubrication system -----	54		52-54
Starting system -----	50		48



INDEX - Continued

Item	Paragraph	Figure	Page
Tube, crankcase breather:			
Assembly -----	206d	394	247
Cleaning -----	99b		142
	206b		247
Disassembly -----	206a	394	246
Inspection -----	99b		142
	206b		247
Installation -----	99d	44,45	142
Removal -----	99a	44,45	142
Repair -----	99c		142
	206c		247
Tube, fuel injection:			
Cleaning -----	215a		256'
Inspection -----	215a		256
Installation -----	100c	133,189	143
	284c	507-510	319
Removal -----	100a	133-189	143
	118	230	152
Repair -----	215b		256
Replacement -----	100b		143
Tube, fuel return:			
Cleaning -----	215a		256
Inspection -----	215a		256
Installation -----	284b	506	319
Removal -----	63	57	66
Repair -----	215b		256
Tube, oil cooler water inlet:			
Assembly -----	222d	408	260
Cleaning -----	222b		260
Disassembly -----	222a	408	260
Inspection -----	222b		260
Installation -----	280b	235	313
Removal -----	120-	235	154
Repair -----	2225		260
Tube, pressure oil pump outlet:			
Assembly -----	196d	371	235
Cleaning -----	196b		235
Disassembly -----	196a	371	235
Inspection -----	196b		235
Installation -----	266d	280	306
Removal -----	136	280	171
Repair -----	196c		235
Tube, pressure oil pump pickup:			
Assembly -----	194d	378	234
Cleaning -----	194b		234
Disassembly -----	194a	378	234
Inspection -----	194b		234
Installation -----	26d	278	306
Removal -----	136	278	171
Repair -----	194c		234
Tube, scavenger oil pump inlet:			
Assembly -----	195d	379	<b>235</b>

INDEX - Continued

Item	Paragraph	Figure	Page
Tube, scavenger oil pump inlet - continued:			
Cleaning-----	195b	-	235
Disassembly-----	195a	379	235
Inspection-----	195b	-	235
Installation-----	266d	279	306
Removal-----	136	279	171
Repair-----	195c	-	235
Tube, turbosupercharger oil inlet:			
Cleaning-----	227a	-	261
Inspection-----	227a		261
Installation-----	275	489,490	311
Removal-----	126	252	160
Repair-----	227b		261
Turbosupercharger:			
<b>Data --</b> -----	38	-	18
Installation-----	62b	44-53	66
Removal-----	62a	44-53	62
Turbosupercharger oil inlet tube (see Tube, turbosupercharger oil inlet)			
Valve adjustment, intake and exhaust-----	104		144
Valve, flame heater solenoid:			
Assembly-----	228e	411	264
Cleaning-----	228c		264
Disassembly-----	228b	411	263
Inspection-----	228c		264
Installation-----	82b	143-147	106
	228f	399	264
Removal-----	82a	143-147	106
	228a	411	263
Repair-----	228d		264
Valve, oil cooler bypass:			
Installation-----	69c	100	87
Removal-----	69a	100	87
Repair-----	69b		87
Valve, oil filter bypass:			
Installation-----	68c	99	87
Removal-----	68a	99	87
Repair-----	68b		87
Valve, Oil pressure regulator:			
Installation-----	70c	101	88
Removal-----	70a	101	88
Repair-----	70b		88
Valve, piston oil cooling nozzle oil pressure relief:			
Installation-----	71c	102	88
Removal-----	71a	102	88
Repair-----	71b	102	88
Valve, pressure oil pump pressure relief:			
Assembly-----	197d	371	236
Cleaning-----	197b	-	236
Disassembly-----	197a	371	236
Inspection-----	197b	-	236

INDEX - Continued

Item	Paragraph	Figure	Page
Valve, pressure oil pump pressure relief - continued:			
Installation -----	266	362	306
Removal -----	137	362	173
Repair -----	197c	-	236
Valve tappet (see Tappet, valve)			
Valve timing -----	105	-	145
Water pump (see Pump, water)			
Yoke, release lever:			
Cleaning -----	249a	-	290
Inspection -----	249b	-	290
Installation -----	251a	460	293
Removal -----	248	455	287
Repair -----	250a	-	292

By Order of the Secretary of the Army:

EARLE G. WHEELER,  
Geneml, United States Army,  
Chief of Staff.

OFFICIAL:

J. C. LAMBERT,  
Major General; United States Army,  
The Adjutant Geneml.

DISTRIBUTION:

Active Army:

DCSLOG (1)	USAOSA (1)
CNGB (1)	Ord PG (10)
USCONARC (3)	POE (2)
ARADCOM (2)	USA Tmns Tml Cored (2)
ARADCOM Rgn (2)	Army Tml (2)
OS Maj Cored (2)	Ord Arsenal (5) except
OS Base Cored (2)	Frankford (1 O)
LOGCOMD (2)	Joliet (4)
Armies (3) except	Springfield Armory (2)
Sixth USA (1)	Procurement Dist (1) except
Corps (2)	Cleveland (2)
Div (2)	New York (5)
USAMOCOM (2)	Philadelphia (4)
USAWECOM (2)	St Louis (3)
USAMUCOM (2)	Ord Plants (5) except
USAMICOM (2)	Lake City (3)
USASMCOM (2)	Kingsbury (none)
USAECOM (2)	Radford (1), Ravenna (2)
USA Moint Bd (6)	Mil Msn (1)
Instl (1) except	Cen (2)
Ft Belvoir (7), Ft Bmng (2),	Units ord under fol TOE:
Ft Sill (6), Ft Meade (3),	(Two copies each)
Ft Bliss (9), Ft Hoad (7),	9-7
Ft Sam Houston (7)	9-12
Svc Colleges (2)	9-25
Br Svc Sch (2) except	9-26
USA Ord Sch (50)	9-27
USA Tk Autmv Cen (105)	9-65
GENDEP (OS) (2)	9-66
Ord Sec GENDEP (OS) (5)	9-67
Ord Dep (OS) (1)	9-76
A Dess (1) except	9-127
Black Hills (5), Letterkenny (2),	9-137
Savanna (5), Sierra (3),	9-197
Sierra (3), Sioux (2), Tooele (4)	9-357
Umatilla (3), Wingate (3)	9-500 (CA-CB)
San Jacinto (4)	29-55

NG: State AG (3).

USAR: None.

For explanation of abbreviations used, see AR 320-50.

RECOMMENDED CHANGES TO EQUIPMENT TECHNICAL PUBLICATIONS



THEN...JOT DOWN THE  
DOPE ABOUT IT ON THIS FORM.  
CAREFULLY TEAR IT OUT, FOLD IT  
AND DROP IT IN THE MAIL.

SOMETHING WRONG WITH PUBLICATION

FROM: (PRINT YOUR UNIT'S COMPLETE ADDRESS)

DATE SENT

PUBLICATION NUMBER

PUBLICATION DATE

PUBLICATION TITLE

BE EXACT PIN-POINT WHERE IT IS

PAGE  
NO.

PARA-  
GRAPH

FIGURE  
NO.

TABLE  
NO.

IN THIS SPACE, TELL WHAT IS WRONG  
AND WHAT SHOULD BE DONE ABOUT IT.

TEAR ALONG PERFORATED LINE

PRINTED NAME, GRADE OR TITLE AND TELEPHONE NUMBER

SIGN HERE

# THE METRIC SYSTEM AND EQUIVALENTS

## WEIGHT MEASURE

1 Centimeter = 10 Millimeters = 0.01 Meters = 0.3937 Inches  
 1 Meter = 100 Centimeters = 1000 Millimeters = 39.37 Inches  
 1 Kilometer = 1000 Meters = 0.621 Miles

## WEIGHTS

1 Gram = 0.001 Kilograms = 1000 Milligrams = 0.035 Ounces  
 1 Kilogram = 1000 Grams = 2.2 lb.  
 1 Metric Ton = 1000 Kilograms = 1 Megagram = 1.1 Short Tons

## LIQUID MEASURE

1 Milliliter = 0.001 Liters = 0.0338 Fluid Ounces  
 1 Liter = 1000 Milliliters = 33.82 Fluid Ounces

## SQUARE MEASURE

1 Sq. Centimeter = 100 Sq. Millimeters = 0.155 Sq. Inches  
 1 Sq. Meter = 10,000 Sq. Centimeters = 10.76 Sq. Feet  
 1 Sq. Kilometer = 1,000,000 Sq. Meters = 0.386 Sq. Miles

## CUBIC MEASURE

1 Cu. Centimeter = 1000 Cu. Millimeters = 0.06 Cu. Inches  
 1 Cu. Meter = 1,000,000 Cu. Centimeters = 35.31 Cu. Feet

## TEMPERATURE

$5/9(^{\circ}\text{F} - 32) = ^{\circ}\text{C}$   
 212° Fahrenheit is equivalent to 100° Celsius  
 90° Fahrenheit is equivalent to 32.2° Celsius  
 32° Fahrenheit is equivalent to 0° Celsius  
 $9/5^{\circ}\text{C} + 32 = ^{\circ}\text{F}$

## APPROXIMATE CONVERSION FACTORS

TO CHANGE	TO	MULTIPLY BY
Inches	Centimeters	2.540
Feet	Meters	0.305
Yards	Meters	0.914
Miles	Kilometers	1.609
Square Inches	Square Centimeters	6.451
Square Feet	Square Meters	0.093
Square Yards	Square Meters	0.836
Square Miles	Square Kilometers	2.590
Acres	Square Hectometers	0.405
Cubic Feet	Cubic Meters	0.028
Cubic Yards	Cubic Meters	0.765
Fluid Ounces	Milliliters	29.573
its	Liters	0.473
arts	Liters	0.946
allons	Liters	3.785
Ounces	Grams	28.349
Pounds	Kilograms	0.454
Short Tons	Metric Tons	0.907
Pound-Feet	Newton-Meters	1.356
Pounds per Square Inch	Kilopascals	6.895
Miles per Gallon	Kilometers per Liter	0.425
Miles per Hour	Kilometers per Hour	1.609

TO CHANGE	TO	MULTIPLY BY
Centimeters	Inches	0.394
Meters	Feet	3.280
Meters	Yards	1.094
Kilometers	Miles	0.621
Square Centimeters	Square Inches	0.155
Square Meters	Square Feet	10.764
Square Meters	Square Yards	1.196
Square Kilometers	Square Miles	0.386
Square Hectometers	Acres	2.471
Cubic Meters	Cubic Feet	35.315
Cubic Meters	Cubic Yards	1.308
Milliliters	Fluid Ounces	0.034
Liters	Pints	2.113
Liters	Quarts	1.057
ers	Gallons	0.264
ms	Ounces	0.035
ograms	Pounds	2.205
Metric Tons	Short Tons	1.102
Newton-Meters	Pounds-Feet	0.738
Kilopascals	Pounds per Square Inch	0.145
ometers per Liter	Miles per Gallon	2.354
ometers per Hour	Miles per Hour	0.621



**PIN: 018420-000**