

# FM 20-22

DEPARTMENT OF THE ARMY FIELD MANUAL

---

## VEHICLE RECOVERY OPERATIONS

---



HEADQUARTERS, DEPARTMENT OF THE ARMY  
OCTOBER 1962

FIELD MANUAL } HEADQUARTERS,  
 No. 20-22 } DEPARTMENT OF THE ARMY  
 WASHINGTON 25, D.C., 31 October 1962

## VEHICLE RECOVERY OPERATIONS

	Paragraphs	Page
CHAPTER 1. INTRODUCTION.....	1-3	3
2. FUNDAMENTALS OF RECOVERY		
Section I. Basic principles.....	4-7	6
II. Sources of power.....	8-10	21
III. Resistance.....	11-17	29
CHAPTER 3. RIGGING FOR RECOVERY		
Section I. Distribution of effort and resistance.	18-21	36
II. Rope and chain.....	22-24	39
III. Anchors.....	25-27	41
IV. Recovery procedures.....	28-35	49
V. Recovery techniques.....	36, 37	54
VI. Safety.....	38-40	65
CHAPTER 4. FIELD EXPEDIENTS.....	41-92	71
5. VEHICLE RECOVERY		
Section I. Similar vehicles.....	93-100	130
II. Special purpose vehicles.....	101-111	140
APPENDIX. REFERENCES.....		159
INDEX.....		160



# CHAPTER 1

## INTRODUCTION

---

### 1. Purpose

This manual provides the necessary information and guidance for troops of all branches of the Army to recover vehicles and equipment that have become disabled, including disability that may result from the effects of terrain, enemy action, or mechanical malfunction.

### 2. Scope

*a.* This manual contains formulas for use in field recovery operations and, in some instances, brief background material on which the formulas are based. It covers the application of rigging and safety precautions to be observed in vehicle recovery, expedient repairs, and operation of general and special purpose vehicles and equipment used to keep vehicles operational. In certain instances, it may be necessary to combine two or more of the principles given to accomplish a specific recovery. The material presented is applicable, without modification, to both nuclear and nonnuclear warfare.

*b.* Users of this manual are encouraged to submit recommended changes or comments to im-

prove the manual. Comments should be keyed to the specific page, paragraph, and line of the text in which the change is recommended. Reasons should be provided for each comment to insure understanding and complete evaluation. Comments should be forwarded direct to U.S. Army Armor School.

### 3. Definitions

In recovery, certain terms are common to all branches. These terms are defined below as they will be used throughout this text. When a term involves equipment, the equipment will be described and, if necessary, illustrated as it is introduced in the text.

*a. Effort*—an active force as distinguished from passive resistance. Effort usually expresses a single action rather than a continuous activity. Effort is required to start movement, but effort may be made with no movement resulting if the object to be moved is too heavy.

*b. Force*—the active energy or physical strength that is used to produce or modify motion. Therefore, after effort is exerted to start movement, some force is required to continue the action. Force includes the accomplishment of movement.

*Note.* There is only a fine line of distinction between force and effort, and in some instances they may be used interchangeably. Force produces a result; effort may not.

*c. Power*—the rate of transfer to energy. Power is the product of force and distance divided by time. Power would be used to move a weight

time (*f* below).

*d. Resistance*—any opposing action that tends to prevent motion. Resistance is usually considered constant in nature but can easily be affected by its surroundings. Terrain provides resistance to movement of a vehicle, the degree of resistance depending on the type of terrain and its condition. On a level surface, the resistance will change materially as a vehicle moves from hard surface to sand and to mud. On a grade, movement downhill is opposed by less resistance than in movement uphill.

*e. Strength*—ability to resist force, or the capability of a body to endure the application of force without breaking or yielding. A rope has strength, according to its size and material, to endure the application of a certain amount of force without breaking.

*f. Work*—the product of force and the distance through which the force acts. If a resistance is overcome and an object is moved from one place to another, work has been performed.

## CHAPTER 2

### FUNDAMENTALS OF RECOVERY

---

#### Section I. BASIC PRINCIPLES

#### 4. Effort and Resistance

The application of effort to overcome a resistance has been a challenge to man since the beginning of civilization. Great strides have been made in overcoming resistances encountered in everyday life. Today's routine acts in overcoming resistance were yesterday's feats, and not too many years ago, these feats were considered impossible. The energy released by the burning of a small amount of gasoline in an engine to provide the effort required to move at high speed an automobile weighing more than a ton is considered commonplace. Without the engine to drive it, the automobile, when on level surface, resists movement to the point where one man has difficulty pushing it, except for a short distance. If it becomes necessary to push the car up even a short incline, the resistance is too great for one man to overcome. The man would exert effort but would not overcome the resistance to movement. The resistance would be overcome if the man could increase his effort or if he could get additional men to help push. He can easily move the car, of course, if he starts the

engine and makes use of the mechanical devices available within the automobile.

## 5. Mechanical Advantage

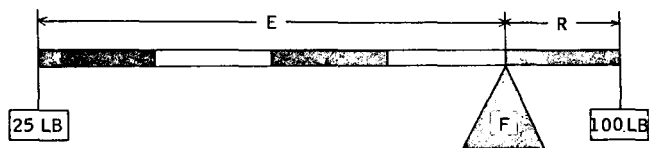
The devices built into an automobile provide mechanical advantage. Mechanical advantage is the ability to use a small force, moved through a long distance, to move a large resistance (object) a short distance. In an automobile, many applications are made of mechanical advantage between the piston in the engine and the wheels on the road. But there are more common applications during which everyday work is performed that are beyond our strength unless some device is used to give assistance. A can opener is used to open cans; by moving the handle through a large arc, a relatively small cut is made in the can lid. We would not be able to open a can without this assistance. A wrench is used to tighten a nut; by moving the wrench through a large arc, the resistance of the threads is overcome. During World War II, the *Missouri*, a 34,000-ton battleship, was uprighted at Pearl Harbor by use of twenty-six 5-horsepower electric motors working through a series of ropes and pulleys. All of these examples prove the worth of mechanical advantage.

## 6. Lever

Mechanical advantage may be gained through the use of the principle of the lever. In each instance cited in paragraph 5, the principle of the lever was used. Probably the simplest form of lever is a rigid bar, free to turn on a fixed pivot



called a fulcrum. When an effort is exerted on one end of the bar, the bar has a tendency to rotate around the fulcrum. When a resistance is applied to the other end of the bar, the resistance opposes the effort and tends to cause the bar to operate in the opposite direction. That part of the bar between the point of application of effort and the fulcrum is called the effort arm or E; that part of the bar from the fulcrum to the center of resistance is called the resistance arm or R. A simple lever is illustrated in figure 1.



*Figure 1. A simple lever.*

There are several ways the mechanical advantage of the lever may be determined. From figure 2, it will be noted that the work performed is the same on both sides of the fulcrum. Five pounds of effort applied through a 4-foot arm equals 20 pounds-feet; 10 pounds of resistance times 2 feet of arm equals 20 pounds-feet. It is equally true that the distance B times 5 (pounds) would equal distance A times 10 (pounds). Arm E (effort) is twice as long as arm R (resistance); the distance B is twice as great as distance A. Although the work performed is the same, the result is just the

reverse; a small effort (5 pounds) moved an object of resistance twice its weight (10 pounds). This makes the advantage gained 2 to 1. Mechanical advantage is always expressed as a ratio or the value of one item as related to another like item. So, the mechanical advantage can be figured as the relative lengths of the arms of the lever, or the amount of resistance moved in relation to the force applied. This remains true as long as friction does not cause a loss in the efficiency of the mechanism. Friction will be discussed separately in paragraph 15.

a. Levers are divided into classes. The class of a lever is determined by the location of the fulcrum.

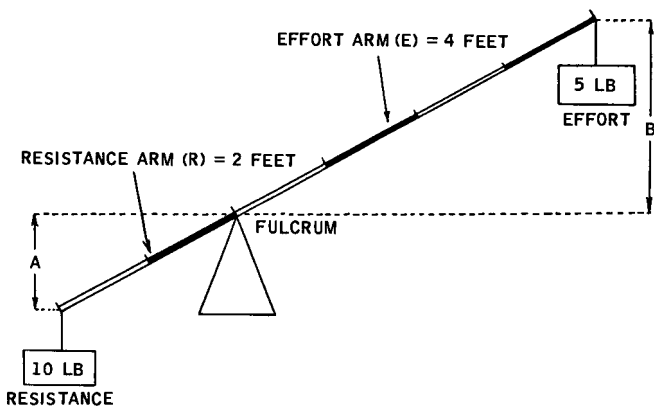


Figure 2. First-class lever.

- (1) A first-class lever has the fulcrum between the effort and the resistance as illustrated in figure 1. Examples of first-class levers are scissors and pliers.
- (2) A second-class lever has the point of resistance between the fulcrum and the effort. A second-class lever is illustrated in figure 3. A wheelbarrow is a good example of a second-class lever.

b. The principle of the lever is used in many ways that we are familiar with but may have never recognized as such. Some of these ways are used in gears, in most machinery, in the elevator, in the winch, and in many other pieces of equipment.

#### 7. Tackle

Tackle is a combination of ropes and blocks used to gain mechanical advantage. Tackle uses the

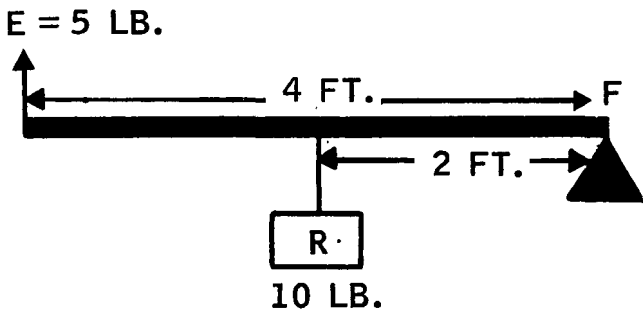
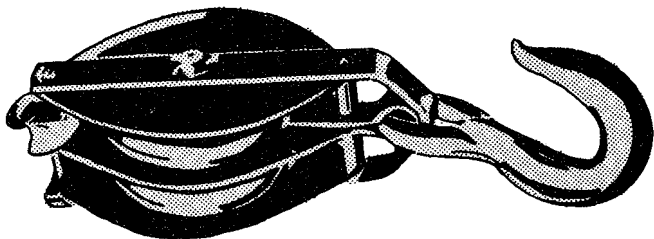


Figure 3. Second-class lever.

principle of the lever in such a manner that any effort exerted will move a greater resistance.

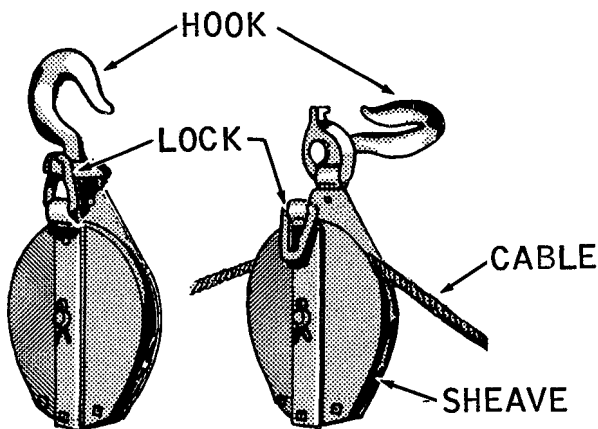
a. A block consists of a shell or frame in which is mounted one or more grooved pulleys called sheaves. The sheaves are mounted on a pin that is supported by the shell. The shell also has a means of fastening the block in the tackle. The most frequently used fastening is a hook; however, the block may be equipped with a becket (a metal loop) in addition to the hook, especially if it is designed to be used with fiber rope. Types of blocks most commonly used in the military service are illustrated in figure 4.



A—Conventional block

*Figure 4. Types of blocks.*

A block is described by its type, the kind of rope with which it is intended to be used, the number of sheaves, the length of the shell in inches, the diameter of the groove, and its capacity. Blocks with 1, 2, or 3 sheaves are called single, double, or



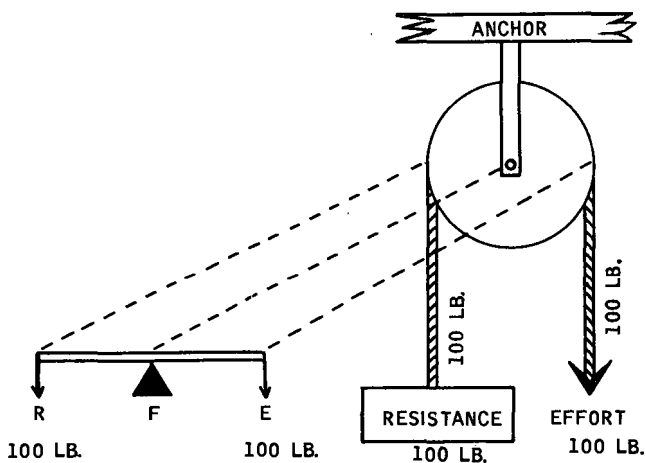
B—Snatch lock  
*Figure 4—Continued.*

triple. They are also identified by features of their construction and by the manner in which they are used in rigging. A conventional block, (A, fig. 4) is used mostly with fiber rope that must be reeved or threaded to be used. The block illustrated at B is a snatch-type block. The snatch block, sometimes called a gate block, is constructed so the shell opens at the base to admit a cable without reeving. The snatch block can be identified by the

hinge and lock on its side. It is generally used with wire rope or cable with fittings on the end that will not permit them to be threaded, as a fiber rope. The complete name of a block might be listed as "block, snatch, wire rope, single, 12-inch sheave, 1¼-inch diameter rope, 90-ton." From the name we know that it is a snatch block with one 12-inch sheave grooved to fit a 1¼-inch rope, and with a capacity to support a 90-ton load. Only the size rope for which the sheave was grooved should be used with a block. If a smaller rope is used, it has a tendency to flatten out in the groove. If a larger rope is used, it will not go down into the groove completely and the edge of the groove may cut the strands of the rope. In either case, the rope will be damaged.

b. Blocks are classified as to their use in the rigging.

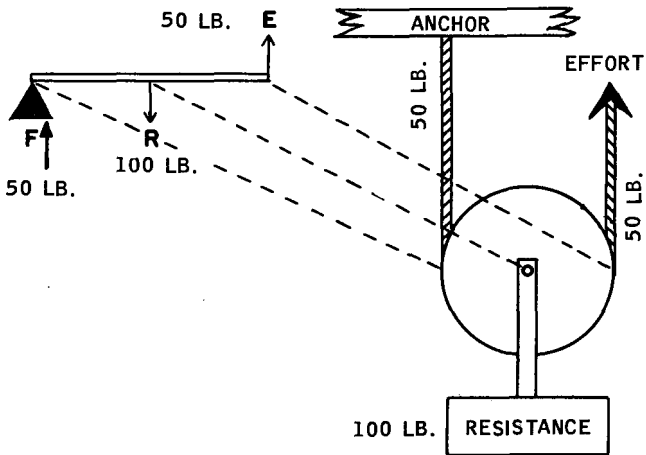
- (1) When a block is fastened to a stationary object, it is called a fixed block or leading block. A fixed block permits a change in direction of the rope but does not affect mechanical advantage (fig. 5).
- (2) A running block or traveling block is fastened to the object to be moved and moves with the object. The running block will produce a mechanical advantage (fig. 6).
- (3) An exception is made to the general rules stated in (1) and (2) above when the source of power is a part of the object to be moved. For example, when the cable



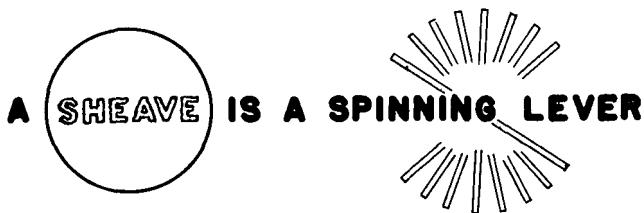
*Figure 5. The sheave as a first-class lever.*

from a truck winch is passed through a block and the end of the cable is returned and fastened to the truck, the block will offer mechanical advantage.

c. Any block, in effect, is a lever. A block performs the function of the lever more efficiently in some ways than the bar illustrated in figure 1, because instead of the necessity of positioning the bar each time it moves through its arc, the sheave offers a continuous lever action. A block, in effect, becomes a spinning lever (fig. 7). One disadvantage of the block, however, is that the sheave rolls on an axle (the pin) and friction is created between the sheave and its axle (par. 15).



*Figure 6. The sheave as a second-class lever.*

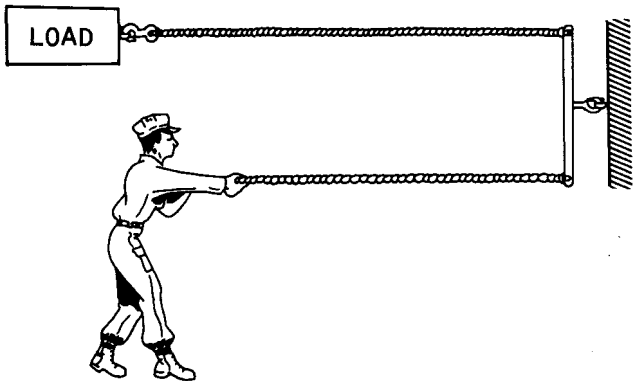
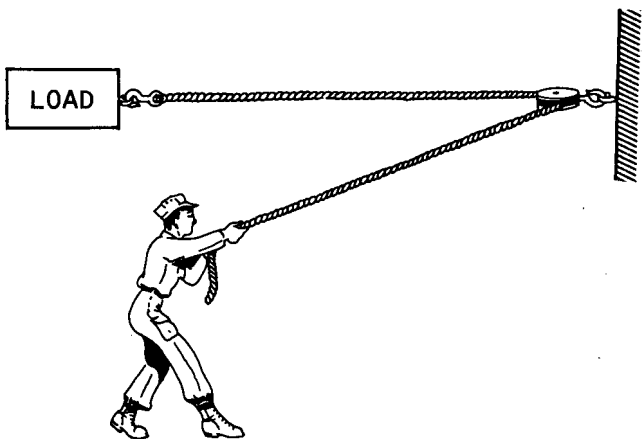


*Figure 7. Spinning lever.*

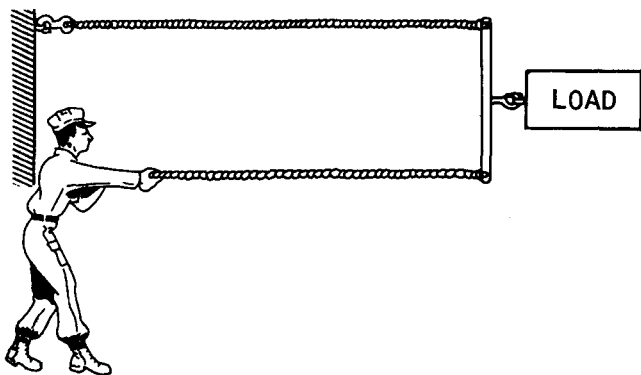
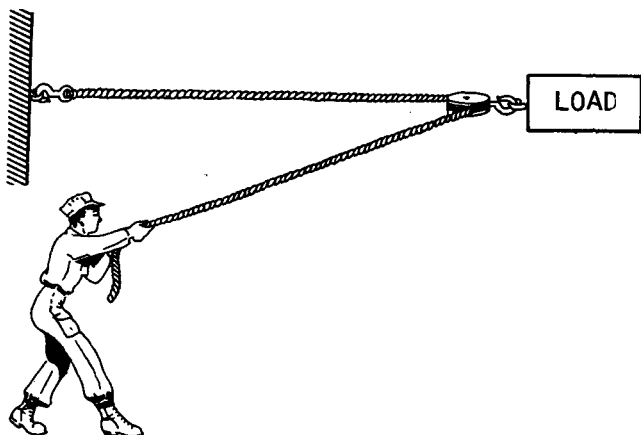


- (1) A fixed block is generally a first-class lever (fig. 8). This is so because the cable enters one side of the block from a source of power that creates the effort, passes around the block, and returns to the resistance. The pin on which the sheave revolves becomes the fulcrum. From paragraph 6, it was learned that the mechanical advantage could be determined by the relative lengths of the E and R arms. Since the radius is the same on one side as on the other, the ratio is 1 to 1 and no advantage is gained.
- (2) With a running block, the action is somewhat different. The sheave is still reeved in the same manner; however, the fulcrum moves from the center to the edge of the sheave. The point of resistance is now the pin in the center of the sheave and the effort is placed on the other edge of the sheave. The sheave becomes a second-class lever as illustrated in figure 9.

*d.* The other item used in the tackle is rope or, in some instances, chain. Rope may be made of fiber or steel wire. Rope has strength throughout its length; it resists being pulled apart. It has very little resistance to bending however, and is considered flexible. Rope is used for many purposes and is, by far, the most important single item used in recovery. When wire rope is used on a winch, the rope is generally called a cable.



*Figure 8. Mechanical advantage: 1 to 1.*



*Figure 9. Mechanical advantage: 2 to 1.*

Rope is discussed in detail in TM 5-725. Rope, as it is used in recovery, is discussed in chapter 3, this manual.

e. Whenever the resistance to be moved is greater than the effort available, mechanical advantage must be used to perform the work. In recovery, this means we must resort to the use of tackle. Tackle is classified as simple or compound. Simple tackle is one rope reeved on one or more blocks to attain a mechanical advantage (fig. 10). Compound tackle uses more than 1 rope; it is a combination of 2 or more simple tackles, the output of 1 being used as the source of power for the next (fig. 11). Since the equipment with which recovery is performed generally has only one line

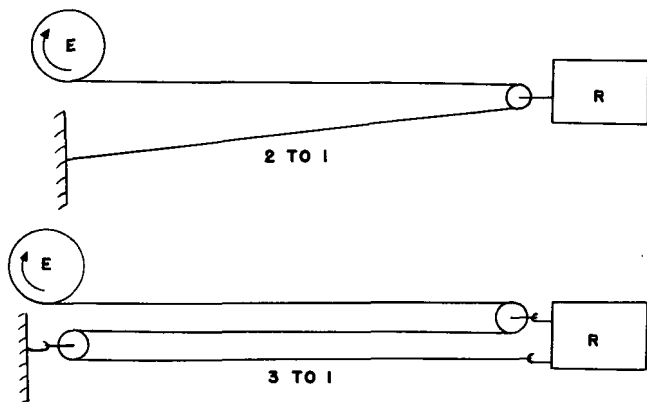
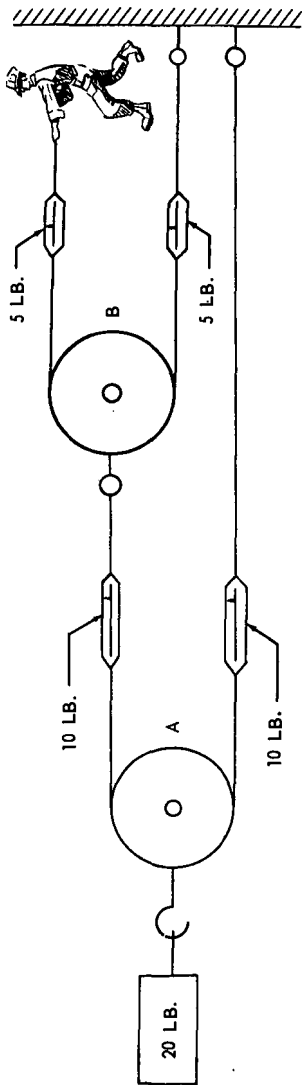


Figure 10. Simple tackle.



*Figure 11. Compound tackle.*

from the source of power, simple tackle will nearly always be used. Compound tackle is described in TM 5-725; only simple tackle will be discussed in this manual.

## Section II. SOURCES OF POWER

### 8. Winches

In recovery, because the force applied to move a disabled vehicle sometimes must be very great to overcome the resistance, mechanical means must be used. For this purpose, the most frequently used source of power is the winch. A mechanical winch is usually operated by a shaft driven from the power train of the vehicle on which it is mounted. The shaft operates through a worm gear drive to turn a shaft on which the winch drum is mounted. The principle of the inclined plane is used in the worm gear, and a mechanical advantage of from 20 to 1 to 50 to 1 may be gained in the winch, depending on the type, make, model, etc. The drum is usually mounted on its shaft in such a manner that it can be engaged when work is to be performed, or disengaged so the cable can be paid out by manpower. A dog clutch of some sort is usually used to lock the drum to the shaft. A friction device is usually used against the end of the drum to prevent the drum from rolling too freely and allowing the cable to overrun the drum when the rate of payout slows down. Winches used in military vehicles have some means of braking themselves automatically when the power fails under load.

*a.* A winch is most effective when the pull is exerted on the bare drum of the winch. As shown in figure 12, the leverage changes as each successive layer of cable is wound onto the drum. When a winch is rated at a capacity, that rating applies only as the first layer of cable is being wound onto the drum. The winch capacity is reduced as each layer of cable is wound onto the drum due to the increased diameter of the drum; the capacity of the winch may be reduced by as much as 50 per cent when the last layer is being wound onto the drum. (See table I for examples.) For this reason, it is desirable to unreel all or most of the cable from the winch when it is used on heavy loads. Another advantage is gained by using the full length of cable, because its natural elasticity or stretch prevents it from breaking so readily in instances where sudden loads are applied.

Table I. Winch Variable Capacities

Layer	10,000-lb. winch ½-inch cable			20,000-lb. winch 5/8-inch cable			45,000-lb. winch ¾-inch cable		
	Drum diam	Cable (ft.)	Capacity (lb.)	Drum diam	Cable (ft.)	Capacity (lb.)	Drum diam	Cable (ft.)	Capacity (lb.)
1	5 ½	39	10,000	6 ⅝	41	20,000	7 ¾	42	45,000
2	6 ½	85	8,450	7 ⅞	91	16,900	9 ¼	93	37,700
3	7 ½	138	7,340	9 ⅛	148	14,500	10 ¾	153	32,500
4	8 ½	199	6,460	10 ⅜	213	12,800	12 ¼	220	28,500
5	9 ½	266	5,780	11 ⅝	287	11,400	13 ¾	296	25,300
6	---	---	---	---	---	---	15 ¼	380	22,800

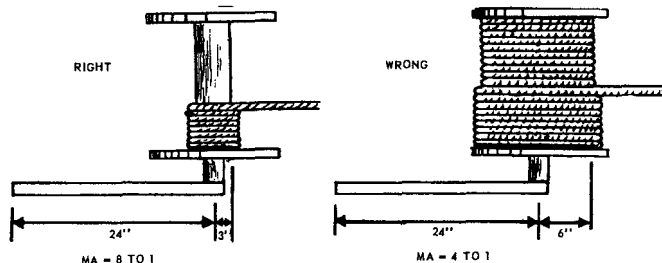


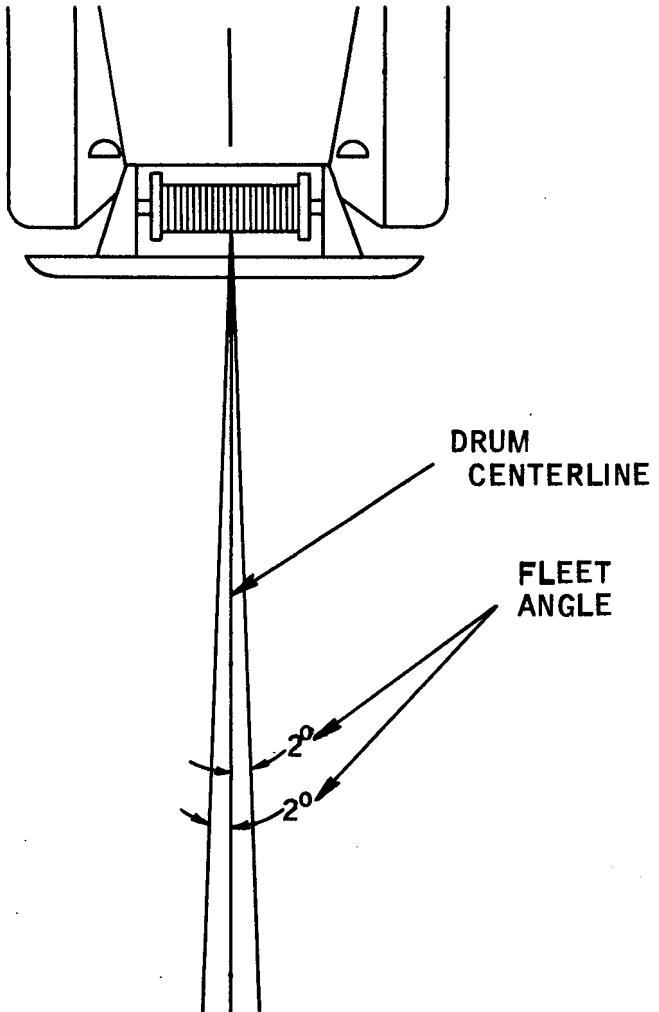
Figure 12. Right and wrong uses of winch.



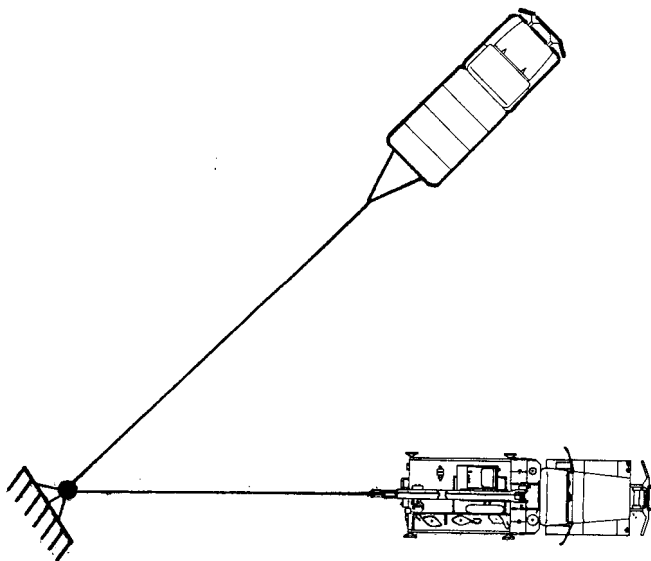
b. Ideally, the winch cable should be used in such a manner that a line drawn through the length of the cable will continue through the centerline of the vehicle. If the cable is very far off this line, it will lead to one side or the other of the winch drum, pile up, and become damaged. The cable should not be used with more than  $2^\circ$  deflection from straightaway. This deflection is called *fleet angle* (fig. 13) and becomes a very important consideration in recovery when the winch is not equipped with a level winding device. To maintain the angle within the allowable limits, it sometimes becomes necessary to use an additional block, secured to a tree or other stationary object and alined with the axis of the winching vehicle, and make the pull through an angle. This is illustrated in figure 14. Some winches are equipped with a device that travels back and forth across the drum and guides the cable as it is reeled in. When a winch is equipped with such a device, fleet angle can be disregarded as long as the angle is not too sharp to permit the level wind unit to operate.

## 9. Windlass

Where the resistance is not too great and a winch is not readily available, it is sometimes possible to construct a windlass. A windlass consists of a cylindrical device (like the log in fig. 15), on which a rope is wound, and which is turned by a handle fastened at or near the end of the cylinder. The mechanical advantage gained by use of the windlass can be determined by the radius of the



*Figure 13. Fleet angle.*



*Figure 14. Pull through an angle.*

arc described by the handle in relation to the radius of the cylinder receiving the rope. Additional advantage may be gained if the windlass is used in connection with tackle. When such a combination is used, the mechanical advantage gained by the tackle is multiplied by the mechanical advantage of the windlass to determine the total mechanical advantage. For example, in figure 15, which illustrates such a combination, the mechanical advantage gained by the tackle is 3 to 1; the handle of the windlass is 7 times as long as the radius of the log used as the cylinder, giving a

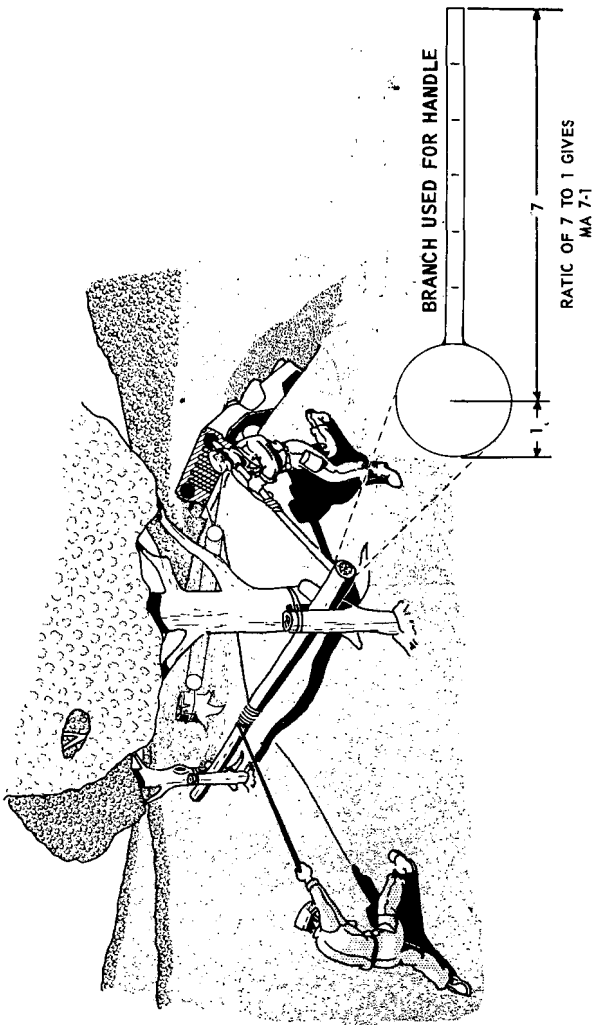


Figure 15. Windlass used with tackle.

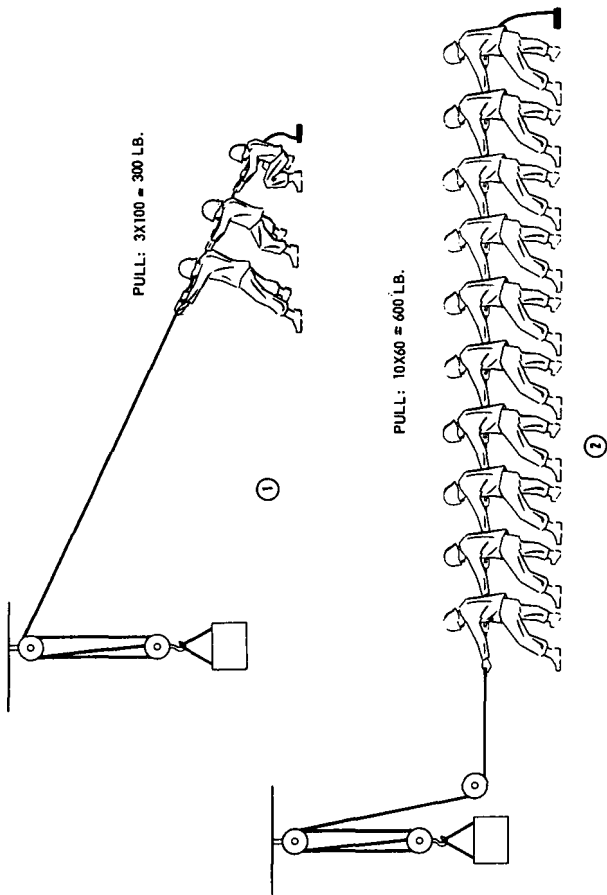


Figure 16. Fixed block rigged for better use of manpower.

mechanical advantage of 7 to 1. By multiplying 3 to 1 by 7 to 1, the total mechanical advantage is then 21 to 1. In the illustration, a tree has been cut into a log and one of the branches used as the handle. The log is held in place by lashing it to two trees. Other forms of this source of power can be applied depending on the ingenuity of the personnel performing the job.

#### 10. Other Sources of Power

Power may be obtained, in many cases, by using any available vehicle. A vehicle on sound, level hardstand can usually move an object equal to its own weight. If available, manpower may be used to perform the work. One man can usually lift about 100 pounds on a vertical pull, and pull about 60 pounds on a horizontal pull. Sometimes, when a load must be lifted vertically, it is best to use a block to change the direction of the rope so the pull can be made horizontally. Although one man pulls less, more men can be placed along a rope in the horizontal plane than a rope in a vertical plane (fig. 16).

### Section III. RESISTANCE

#### 11. Forms of Resistance

Up to this point most of the discussion has been on the effort, force, or power used to move an object or overcome a resistance. Resistance has not been discussed to any extent except to indicate that it was something that took force or power to overcome. In recovery, we are concerned with

several forms of resistance. The vehicle weight, combined with other factors, is used to determine the resistance to be overcome in any recovery problem. There are means of making fast estimates that will be accurate enough for most cases. Resistance is created by the contact among mechanical parts of the vehicle when effort is made to move it. The type of terrain on which the vehicle is situated, whether it be mud, sand, or a smooth-surface road, will affect the resistance created. The grade or slope over which the vehicle must be moved must also be considered. Some resistance is created by the tackle and must be added to that created by the vehicle to determine the total resistance. When a vehicle is overturned a resistance must be overcome to bring it upright. These forms of resistance are explained in paragraphs 12 through 17 and the method of computing them is given.

## 12. Rolling Resistance

The opposition to movement created by friction when a vehicle is rolled over level ground is called rolling resistance. Rolling resistance is affected by the type of terrain. Exact figures are available for specific conditions of roadway but there are too many variables to be of practical value; quick estimates are all that is necessary in recovery. For example, a vehicle on a smooth hard-surface road will create a resistance equal to about one twenty-fifth of the weight of the vehicle. The same vehicle in mud will create a resistance equal to or greater than its own weight. Table II gives the factors that may be used to estimate rolling resistance.

For mud, it will be noted that there is no factor given other than the minimum. Resistance will increase with the increase in consistency and depth of the mud. The rate of increase is given in paragraph 17.

*Table II. Terrain Factors*

<i>Type of terrain</i>	<i>Load on drawbar</i>
Smooth road -----	<u>Vehicle weight</u> 25
Grass -----	<u>Vehicle weight</u> 7
Gravel -----	<u>Vehicle weight</u> 5
Soft sand -----	<u>Vehicle weight</u> 4
Mud -----	Minimum is vehicle weight. Maximum pull depends upon its depth and con- sistency.

### 13. Grade Resistance

Grade resistance is caused by gravity when a vehicle is being moved up a slope, and it is determined by that part of the vehicle weight which, because of gravity, is acting downhill. Table III gives the factor to be used to determine the amount of resistance. The angle of the slope may be measured in either mils or degrees. Mil readings may be taken from the gunner's quadrant or the degree of slope may be estimated. To use the table, determine the amount of slope in degrees. (If the angle is measured in mils, divide the number of mils by 17.8 to obtain degrees.) Multi-



Table III. Factors Used to Determine Grade Resistance

Angle of slope in degrees*	Factor (percent)	Angle of slope in degrees*	Factor (percent)	Angle of slope in degrees*	Factor (percent)	Angle of slope in degrees*	Factor (percent)
1	.02	23	.39	45	.71	68	.93
2	.03	24	.41	46	.72	69	.93
3	.05	25	.42	47	.73	70	.94
4	.07	26	.44	48	.74	71	.95
5	.09	27	.45	49	.75	72	.95
6	.10	28	.47	50	.77	73	.96
7	.12	29	.49	51	.78	74	.96
8	.14	30	.50	52	.79	75	.97
9	.16	31	.52	53	.80	76	.97
10	.17	32	.53	54	.81	77	.97
11	.19	33	.54	55	.82	78	.98
12	.21	34	.56	56	.83	79	.98
13	.23	35	.57	57	.84	80	.98
14	.24	36	.59	58	.85	81	.99
15	.26	37	.60	59	.86	82	.99
16	.28	38	.62	60	.87	83	.99
17	.29	39	.63	61	.87	84	.99
18	.31	40	.64	62	.88	85	1.00
19	.33	41	.66	63	.89	86	1.00
20	.34	42	.67	64	.90	87	1.00
21	.36	43	.68	65	.91	88	1.00
22	.37	44	.70	66	.91	89	1.00
				67	.92	90	1.00

\* If the angle has been measured in mils, divide the number of mils by 17.8 to get degrees.

ply the weight of the vehicle by the factor opposite the degree of slope to obtain the resistance created by the grade. Add the results of this calculation to

the rolling resistance. Without use of the table, a quick estimate can be made of the grade resistance by taking one-sixtieth of the weight of the vehicle and multiplying by the number of degrees of slope.

#### 14. Overturning Resistance

Overturning resistance is that part of the weight of the vehicle that acts against the force exerted to bring it back on its wheels or tracks. Since half the weight of the vehicle is the maximum weight that will ever be beyond the center of gravity from the point of recovery, only half the weight of the vehicle will be resisting recovery. So at any time an overturned vehicle is to be uprighted, the resistance should be figured as half the weight of the vehicle.

#### 15. Tackle Resistance

The resistance of the tackle must be figured whenever tackle is used. The resistance from all other sources created by the vehicle becomes a factor in determining how much resistance is created by tackle. Due to the friction created by the sheave rolling on the pin, the flexing on the cable, the cable scuffing in the groove of the sheave, and other factors, there is a loss in energy as the cable passes around each sheave. This loss is considered as resistance because it must be overcome before the load will be moved by the effort exerted. This resistance varies slightly among different size cables, but the variable is so small that for purposes of recovery it need not be considered. Each sheave in the tackle can be expected

to create a resistance equal to approximately 10 percent of all resistances created by the vehicle and terrain. For example, if a vehicle to be recovered creates a resistance of 40,000 pounds, and 3 sheaves are used in the tackle, a resistance of 30 percent of 40,000 pounds would be created by the tackle, or 12,000 pounds.

#### 16. Total Resistance

When all the resistances created are added together we have the total resistance to be overcome. The resistance will vary, of course, as conditions vary. If recovery includes towing the vehicle, the steepest grade will have to be considered. The type of terrain over which the vehicle must be towed is also important. As an example, if a 20,000-pound vehicle were to be towed up a  $6^\circ$  slope on paved road the total resistance would be 10 percent (from table III) of 20,000 pounds plus  $\frac{1}{25}$ th of 20,000 pounds or a total of 2,800 pounds of resistance. The same vehicle moved over a level sand road would create nearly twice as much resistance:  $\frac{1}{4}$ th (table II) of 20,000 pounds or 5,000 pounds. If the same vehicle became mired to the point where it could no longer proceed under its own power, the resistance would increase to at least the weight of the vehicle. Tackle resistance would be considered if tackle were used.

#### 17. Field Method of Determining Resistance

It is seldom necessary to arrive at a precise weight in recovery; a close estimate will generally suffice. It is also difficult to use a mathematical

formula to determine the resistance of a vehicle in mud. A practical estimate may be made in the following manner: when a vehicle becomes mired to the extent that it can no longer propel itself, the resistance to be overcome is at least equal to the weight of the vehicle. (The weight of the vehicle can be obtained from the data plate in the vehicle or from the vehicle technical manual.) Vehicle weight can be used as an estimate until the mud comes up to the top of the wheels. If the vehicle is mired to the fenders, the weight of the vehicle should be multiplied by two to estimate its resistance. If the vehicle is mired to the turret or cab, the weight should be multiplied by three. The total resistance of the object to be moved then, becomes the resistance created by the vehicle plus the resistance created by the sheaves in the rigging. The method for determining tackle resistance remains the same as explained in paragraph 15.

## CHAPTER 3

### RIGGING FOR RECOVERY

---

#### Section I. DISTRIBUTION OF EFFORT AND RESISTANCE

#### 18. Rigging

Rigging is the application of fiber rope, wire rope, or chain in various tackle and lever combinations to raise or move a load. Rigging includes the installation of all items necessary to employ the effort available and may or may not result in a gain in mechanical advantage. Rigging can be used to change the direction of pull and take advantage of terrain features. Rigging may also include the assembly of tackle that creates mechanical advantage. To be able to employ rigging, it is necessary to know its various parts and how effort and resistance will be distributed among them. A law of physics (for each action there is an equal and opposite reaction) is applied frequently. When an effort is exerted on one end of a rope there is an equal resistance applied at the other end. There is an equal amount of resistance or effort, depending on how you look at it, applied through the length of the rope even though the rope may change direction as it passes through blocks. A typical outlay used in rigging, and names of its various parts, are illustrated in figure 17.

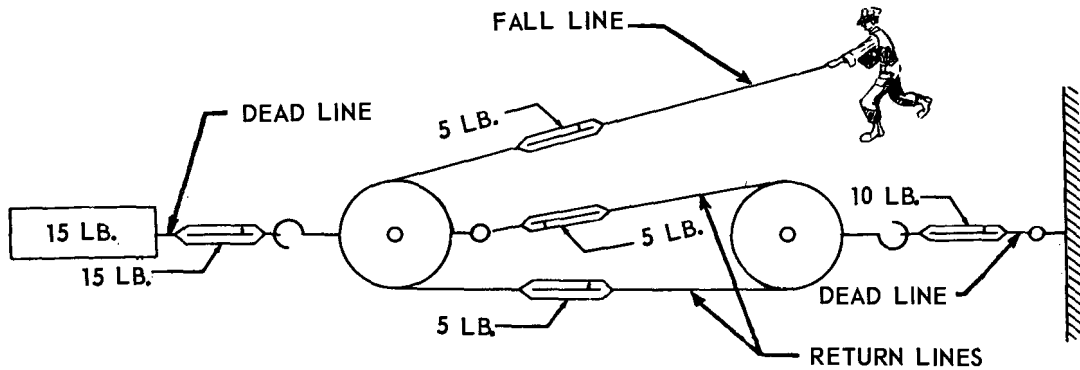


Figure 17. Diagram showing tackle terminology.

## 19. Fall Line

The line from the source of power to the first block is called the fall line. In recovery, the effort available at the fall line is a factor that must be considered in every problem. Tackle must be used whenever the resistance to be moved exceeds the effort available. If recovery is to be accomplished, mechanical advantage must be increased until the total resistance divided by the mechanical advantage results in a figure less than the effort available at the fall line.

## 20. Return Lines

The lines between the blocks, and the line from the last block in the rigging to the point where the end of the line is fastened, are return lines. Due to the equal and opposite reaction referred to in paragraph 18, each return line will exert a force in each direction equal to the effort placed on the fall line. Since this is true, each line going to or away from the load to be moved will exert a force on the load equal to that on the fall line. Since each line going to or away from the load exerts an equal force, the mechanical advantage derived from the tackle is equal to the number of lines supporting the load. In figure 17 the fall line and 2 return lines support the load to provide a mechanical advantage of 3 to 1.

## 21. Dead Lines

The equipment that is used to fasten items in the rigging but that does not become active during

the performance of work makes up the dead line. Dead lines are used to fasten blocks to the load, to fasten blocks to an anchor of some sort, or to fasten the end of the line from the source of power to the load or anchor. In most instances, the dead line must withstand more than any other line in the rigging because when it is used to fasten a block, it must withstand the force coming to and going away from the block. The strength of the dead line should be checked very closely before recovery is attempted.

## Section II. ROPE AND CHAIN

### 22. Fiber Rope

There are several kinds of fiber rope available and each has a different strength. The strength of rope of the same type will vary after it has been used, after it has been wet, or after it has collected dirt between the strands. Fiber rope has very little use in recovery except for relatively light loads. The strength of new rope can be estimated by using the formula  $T=4D^2$ . The  $T$  equals the capacity in tons;  $D$  equals the diameter of the rope. Therefore, with a  $\frac{1}{2}$ -inch rope,  $T=4 \times (\frac{1}{2} \times \frac{1}{2})=4 \times \frac{1}{4}=1$  ton. If the rope is to be used to handle expensive loads or if personnel would be endangered if the rope broke, the results should be divided by 4 to provide safe working strength. Fiber rope should be inspected closely, before it is used, for any indication of weakness that might cause it to break easily. Rope should not be pulled over sharp edges or abrasive material.



## 23. Wire Rope

Construction of wire rope is explained in TM 5-725. Wire rope is used on winches and for tow cables. The strength of wire rope that the Army uses can be estimated by application of the formula  $T=40D^2$ . As in fiber rope,  $T$  equals the strength in tons;  $D$  equals the diameter of the rope. In most instances, where the size of the rope is stated in fractions of an inch, it is easiest to convert the fraction to a decimal before making the computations. As an example, the strength of a  $\frac{3}{4}$ -inch wire rope would be  $\frac{3}{4} \times \frac{3}{4}$  or  $.75 \times .75 = .5625 \times 40 = 22.5$ . The strength of the rope is 22½ tons. Safety precautions to be observed when wire rope is used are outlined in paragraphs 38 through 40. The breaking strength of certain sizes of wire rope as computed by the formula is shown in table IV. The strength will be slightly less than that shown for a new wire rope.

*Table IV. Breaking Strength of Fiber and Wire Rope in Tons*

Diam in inches	Rope capacities in tons	
	Fiber (sisal)	Wire (IPS)
½	1	10
⅝	1.56	15.62
¾	2.25	22.5
⅞	3.06	30.62
1	4	40
1 ⅛	5.06	50.62
1 ¼	6.25	62.5

*Note.* For safe working strength, divide the breaking strength of fiber rope by 4; of wire rope by 5.

## 24. Chain

The strength of chain is calculated by the same formula as for wire rope. To determine the diameter of chain, one side of the link is measured. Chain should be inspected frequently for cracks in the links, especially at the weld if welded links are used. Chain should not be painted because a crack may not be detected through the paint and result in a hazard to personnel and equipment.

### Section III. ANCHORS

## 25. General

*a.* Frequently, it is necessary to have some means of anchoring when heavy loads are handled by means of tackle.

*b.* Natural and temporary or permanent man-made anchors may be used for rigging. Wherever possible, for speed and economy, natural anchors should be used. Temporary anchors include pickets, holdfasts, and deadmen. Permanent anchors may be made up of steel anchors set in concrete or fastened to permanent structures. Lines should always be fastened to anchors at a point as close to the ground as possible. The line from the anchor should be as nearly parallel to the ground as possible to avoid pulling the anchor out of the ground. It is better to link two or more anchors together than to use a single anchor, because multiple anchors spread the load over a greater area of the ground. Greater strength too can be attained by linking anchors together, secur-

ing a point high on one anchor to a point near the ground on the anchor behind it.

## 26. Natural Anchors

*a.* Trees, stumps, or rocks can be made to serve as natural anchors for rapid recovery in the field. Always attach lines near the ground on trees or stumps. Avoid dead or rotten trees or stumps because as anchors they are likely to snap when a strain is placed on the line. It is always advisable to lash the first tree or stump to a second one, to provide added support for the line.

*b.* When using rocks as natural anchors, examine the rocks carefully to be sure that they are large and embedded firmly in the ground. An outcropping of rock or a heavy boulder buried partially in the ground will serve as a satisfactory anchor.

## 27. Constructed Anchors

There are several ways of constructing anchors when natural anchors are not available.

*a.* A picket holdfast may be constructed by driving a single steel or wooden picket into the ground as a stake. You may make a stronger holdfast of two or more sound pickets at least 3 inches in diameter and 5 feet long (fig. 18). Drive the pickets 3 feet into the ground, 3 to 6 feet apart, and in line with the dead line. If fiber rope is used, tie it to the front picket with a clove hitch and make from 4 to 6 turns around both pickets, from the bottom of the rear to the top of the front

picket. Then, fasten the rope to the rear picket with a clove hitch just above the turns, pass a stake between the rope turns, and tighten the rope by twisting it and driving the stake into the ground. Repeat this operation for each successive pair of pickets. The strength of the holdfast depends mainly upon the strength of the first or front picket. To reinforce the front picket, drive two or more pickets into the ground close together, and lash them before lashing the front and rear pickets (fig. 19). In wet earth, the holding power of holdfasts is greatly reduced. The approximate strengths of picket holdfasts are shown in table V.

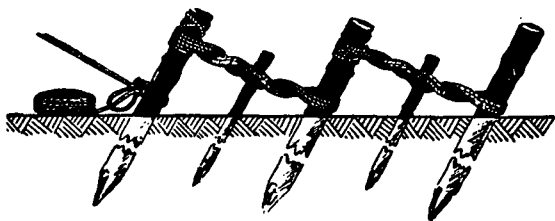
*Table V. Holding Power of Picket Holdfast in Loamy Soil*

Holdfast	Pounds
Single picket .....	700
1-1 picket holdfast combination .....	1,400
1-1-1 picket holdfast combination .....	1,800
2-1 picket holdfast combination .....	2,000
3-2-1 picket holdfast combination .....	4,000

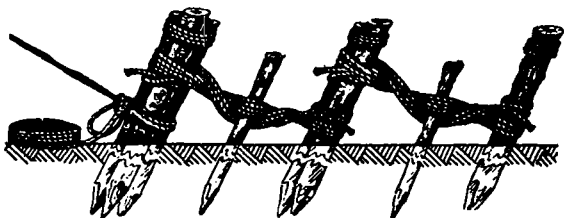
*Note.* Wet earth factors:

Clay and gravel mixtures.....	0.9
River clay and sand.....	0.5

*b.* For heavier loads in soft or wet earth, you may use the combination log-picket holdfast. With this holdfast you must fasten the anchor or dead line to a timber supported against several (4-6) picket holdfasts (fig. 20). The strength of this type of holdfast depends upon the strength of the timber as well as of the pickets. You must, there-



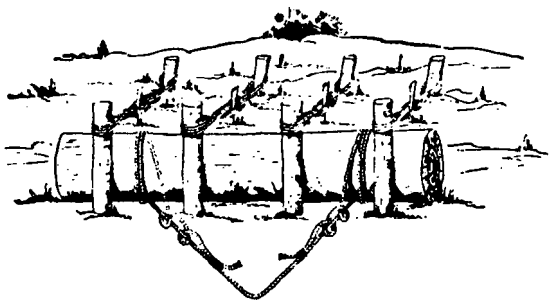
*Figure 18. 1-1-1 combination picket holdfast.*



*Figure 19. 3-2-1 combination picket holdfast.*

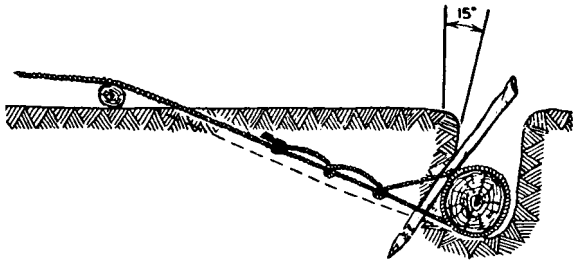
fore, select a timber big and strong enough to stand the maximum pull on the dead line without bending appreciably.

c. A deadman is one of the best types of anchor. It is used for heavy loads or more permanent installations. The deadman consists of a log, timber, steel beam, or similar object buried in the ground with the dead line connected to it at the center.



*Figure 20. Combination log-picket holdfast.*

When constructing a deadman, place it where the direction of pull is as nearly horizontal as possible. Take advantage of sharp banks or crests to decrease the inclination of dead lines and to increase the holding power with less digging. Dig the hole large enough for the deadman and as deep as necessary for good bearing. You should also slant the bank in the direction of the pull at an angle of about  $15^{\circ}$  from the vertical and undercut toward the load. To strengthen the anchor, drive stakes in front of the deadman at each end. Dig a narrow trench on an incline for the dead line, bearing to the center of the deadman. Tie the dead line to the center of the deadman so the main or standing part of the line leads from the bottom of the deadman. This helps to prevent the deadman from rotating out of the hole. If the dead line has a tendency to cut into the ground, place a log or small board under the line at the outlet to the inclined trench.

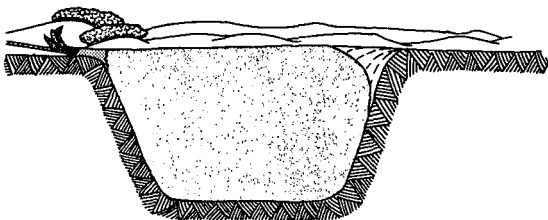


*Figure 21. Log deadman.*

A log deadman is illustrated in figure 21. The strength of the deadman depends partly on the strength of the log or object buried, but mainly on the holding power of the earth.

*d.* In sandy areas with no trees, a sand parachute may be used as an anchor. A sand parachute is constructed by digging a large, deep hole, and lining it with a tarpaulin. The tarpaulin is then filled with the sand removed from the hole, the four corners are lashed together, and the rigging is attached. The sand parachute is illustrated in figure 22.

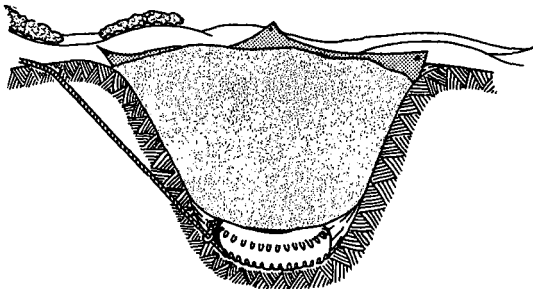
*e.* A variation of the sand parachute, the sand parachute deadman, may be constructed in a similar manner as the sand parachute. After the hole is dug, the spare tire and wheel assembly is placed in the hole. The dead line is secured to the wheel, the tarpaulin emplaced, and the hole re-filled. Unlike the sand parachute, the corners of



*Figure 22. Sand parachute.*

the tarpaulin are not drawn together. Figure 23 illustrates a sand parachute deadman.

f. Each wrecker truck is equipped with two ground anchor sets as items of issue. One set consists of 3 anchors, 10 stakes, and one 10-pound sledge hammer. The anchor is installed as illus-



*Figure 23. Sand parachute deadman.*



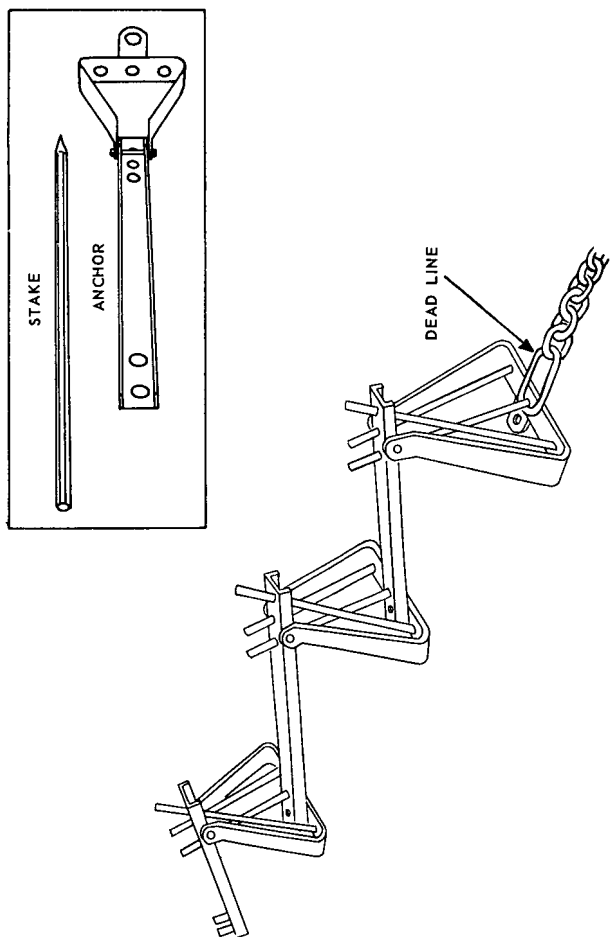


Figure 24. Truck ground anchor.

trated in figure 24. The stakes are driven into the ground until only 6 to 8 inches remain above the anchor. If more than one anchor is used, they may be set in series, as illustrated. In clay soil, each stake is capable of holding slightly more than 1 ton. One anchor with 5 stakes will hold approximately 6 tons; 2 anchors with 10 stakes, about 12 tons. To remove the stakes after the anchor has been used, the stakes should be struck a solid blow at the base; this will usually loosen them enough to remove them. If the ground is too hard, the wrecker boom can be used to pull up the stakes. No more than 2 sets of these anchors should be placed in series (10 stakes) without reinforcing the stake to which the dead line is attached. A force greater than 12 tons will cause the stake to bend.

*g.* Another vehicle can be used as an anchor if it is available. The resistance offered by the vehicle, with its brakes set, very often is adequate to resist the pull of another vehicle during recovery. The vehicle can be used in conjunction with other anchors, to give it additional resistance, by using a chain or rope between it and the other anchor.

#### Section IV. RECOVERY PROCEDURES

##### 28. Reconnoitering the Area

Check the terrain for an approach to the load, method of rigging, and natural anchors. As with a tactical mission, a recovery crew must know the problem before decisions are made. A complete

reconnaissance should be made of the area if the tactical situation permits. The reconnaissance should include selection of the best route of approach, which is usually the reverse of the route taken when the vehicle became disabled. When positioning a recovery vehicle, the crew should always take care to prevent its becoming disabled and to insure proper fleet angle of the winch cable. The recovery vehicle should be positioned so the fall line will remain at or near a right angle to the winch drum. If this is impossible or difficult to achieve, an anchor should be used to fasten a block in such a manner that the cable will pull through an angle. The method of erecting rigging should be determined according to the distance between the disabled vehicle and recovery vehicle, as explained in paragraph 36. Consideration should be given to the location and use of available natural anchors to support part of the rigging or to anchor the recovery vehicle.

#### 29. Estimating the Situation

Determine the resistance of the load and the capacity of the effort available. An estimate of the minimum resistance to movement of the disabled vehicle will be the weight of the vehicle plus its cargo. The resistance will vary, depending upon the type of disablement, as explained in paragraphs 14 and 17. The amount of effort available should also be determined. For a recovery vehicle, this would be the capacity of the winch. The winch capacity is usually stated on the winch data plate,

and is always stated in the vehicle technical manual.

### 30. Calculating the Ratio

The need for a mechanical advantage becomes necessary whenever the resistance of the load exceeds the capacity of the effort available. The amount of mechanical advantage for the rigging may be estimated by dividing the resistance of the load by the effort available. The reason the mechanical advantage is estimated at this stage is because the tackle resistance is unknown. It is possible that because of limited equipment during some recovery operations, sufficient mechanical advantage cannot be rigged. In this case, another recovery vehicle should be brought in to provide the additional effort required.

### 31. Obtaining Total Resistance

Before the load can be moved, the amount of resistance to movement created by both the tackle and the load must be overcome. Total resistance is determined as explained in paragraphs 16 and 17. Tackle resistance can develop into a major factor of the total resistance.

### 32. Verifying the Solution

Compute line forces and compare them with the winch and dead line capacities. This step is the key to quick, safe, and successful vehicle recovery. The mechanical advantage estimated in paragraph 30 is checked for accuracy by computing the effort required on the fall line and then comparing it to

the capacity of the winch. The effort needed is determined by dividing the total resistance by the mechanical advantage. To move the load, the effort required on the fall line must be less than the capacity of the winch. If the effort required, is greater than the capacity of the winch, the mechanical advantage of the rigging must be increased. The force imposed on all dead lines is also computed and compared to their capacity to insure that they are not overloaded. Dead line force is determined by multiplying the amount of fall line force by the number of lines the dead line supports. The capacity of wire rope and chain that may be used as dead lines is explained in paragraphs 23 and 24. Verifying the solution will not only save time by preventing rerigging, but will also contribute to safety by reducing the element of chance to a minimum.

### 33. Erecting the Rigging

Orient the crew and instruct them to assemble the rigging and then move to a safe location. The recovery chief should advise other crewmembers of the plan and assign them duties to erect the rigging. To save time, work should be distributed so each individual has a task that will be finished in approximately the same time as the next man's. Crews should be instructed that those who finish first should assist those who have difficulty. After erecting the rigging, the crew will be moved to a safe location (par. 39).

### 34. Rechecking the Rigging

Insure that the rigging is erected for proper and safe operation. The recovery chief will direct the operator to remove most of the slack from the rigging; he then will inspect the rigging to insure that all fastenings are installed properly and safety keyed, that the cable has no loops, and that the hook points are facing upward. Make any corrections necessary in the rigging at this time. The recovery chief then moves to a safe location where he can observe the entire recovery operation. He directs the operator to close his hatch and observe through the periscope for signals.

### 35. You Are Ready for Recovery

Signal the operator to apply power to the winch and recover the load. Power should be applied slowly to prevent an impact (par. 40c). The recovery chief must be alert during the recovery operation, insuring that nothing obstructs the rigging, and that no one is endangered. After the vehicle is free, he signals the operator to place slack in the rigging, and instructs the crew to disassemble the rigging and stow the equipment.

*Note.* To accomplish vehicle recovery successfully, all personnel concerned must follow some workable plan. A haphazard approach to a recovery problem usually results in unsafe practices and, more often than not, in failure. Paragraphs 28 through 35 outline an eight-step procedure, in the proper sequence, that should be followed during all recovery operations requiring winching. To assist in memorizing these steps and their sequence, they are so arranged that when placed in the proper sequence, the first letter of each step will spell out the word recovery (fig.

## RECOVERY PROCEDURE

**R**ECONNOITER AREA

**E**STIMATE SITUATION

**C**ALCULATE RATIO

**O**BTAIN RESISTANCE

**V**ERIFY SOLUTION

**E**RECT RIGGING

**R**ECHECK RIGGING

**Y**OU ARE READY

*Figure 25. Recovery procedure.*

25). This plan is not restricted to recovery crews for application and supervision, but is also of value to commanders for determining the efficiency of their recovery crews and the need for training.

### Section V. RECOVERY TECHNIQUES

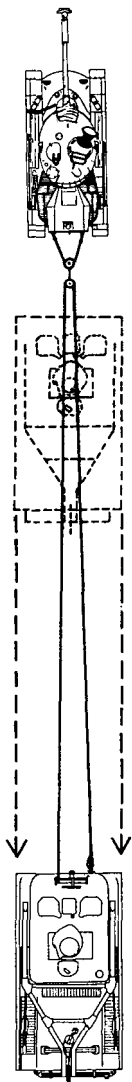
#### 36. Assembling the Rigging

a. The backup method is used when the recovery problem is such that the recovery vehicle

can approach very close to the vehicle to be recovered, thus requiring little effort on the part of the crew to erect the rigging. The winch rope can be handled by crewmen, reeved through the sheaves, and anchored as necessary because only a small amount of the rope must be removed from the winch and handled. The dotted outline in figure 26 shows the vehicles in position to hook up. However, the hookup is only the first step when recovery is being made because, as explained in paragraph 8a, to be most effective, the pull from the winch must be made as the first layer of rope is being wound onto the drum. After the hookup is complete, the winch must be in neutral, the brake released, and the recovery vehicle backed up until most of the rope is off the winch drum. The solid outline in figure 26 shows the vehicles in position to start recovery. The capability of the winch will be increased as each layer of rope leaves the drum. It may also be said that as each layer of rope is wound onto the drum, the capacity decreases. Sometimes, when a pull is being made and the recovered vehicle must be pulled a relatively long distance through mire, it may be necessary to use the backup method to regain winch capacity and complete the job.

b. The lead method is used when the mired vehicle has gone so far into the mire before becoming immobilized that it would not be advisable to get close enough with the recovery vehicle to use the backup method (*a* above). The lead method consists of using the auxiliary winch to haul the





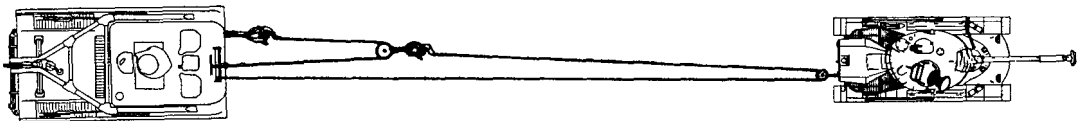
*Figure 26. Backup method of erecting rigging.*

main winch cable to the mired vehicle. The auxiliary winch cable weighs less and can be handled by crewmembers, while they would probably be unable to carry the main one. To rig for the lead method, the auxiliary winch cable should be payed out to give a two-part line from the recovery vehicle to the mired vehicle. The main winch cable can then be payed out far enough to reeve the snatch block into a loop; the end of the cable should be anchored at the recovery vehicle. It is now possible to attach the auxiliary winch cable to the block on the main winch cable and, with the winch in neutral and the brakes released on the main winch, to use the auxiliary winch to pull the larger cable out to the disabled vehicle. This will provide a 2 to 1 advantage from the main winch cable when it is lead to the disabled vehicle (fig. 27). Figure 28 shows the relative positions of the vehicles and the rigging necessary to lead a 3 to 1 mechanical advantage to a disabled vehicle.

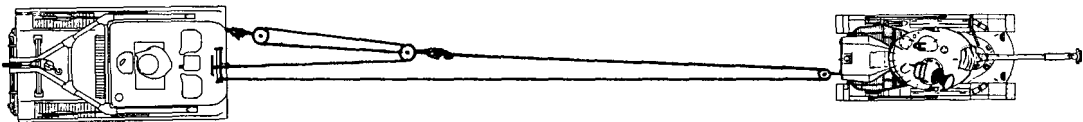
c. No problem exists in handling cables for the wheeled wrecker. The cable is lighter and may be carried by crewmembers to where it is needed.

### 37. Attachments to Vehicle To Be Recovered

In recovery operations, it is important that rigging be attached to the vehicle in such a manner as to avoid damage. For example, in recovery of a disabled wheeled vehicle, the winch cable should not be attached to the bumper because the bumper might be damaged. The frame could be pulled out of alinement if the cable were attached where the effort was applied to a single frame member.

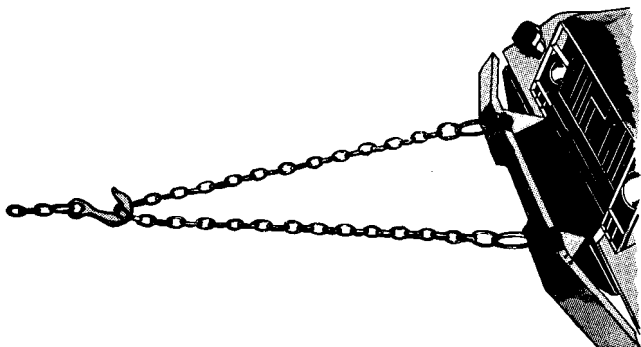


*Figure 27. Leading 2 to 1 mechanical advantage rigging.*



*Figure 28. Leading 3 to 1 mechanical advantage rigging.*

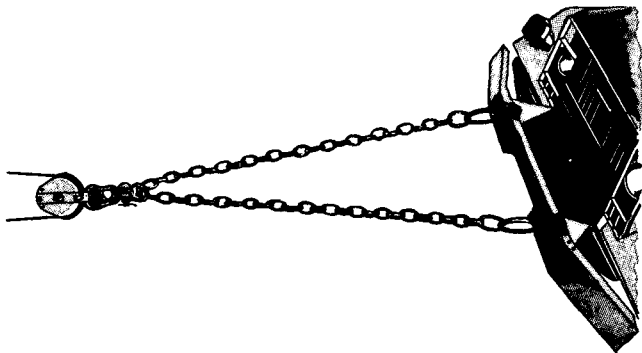
a. On wheeled vehicles, whether the pull is made from the front or rear, the effort should be applied to the lifting shackles (fig. 29). To apply the effort equally to both shackles, a sling should be used between the two shackles and the effort applied to the sling. A chain is the best item to use as a sling. If mechanical advantage is used, the block will be attached to the sling and the winch cable reeved through the block (fig. 30). When a sling is used in this manner the effort exerted on each side of the sling will be slightly greater than half the effort exerted by the winch. As the angle of the sling increases (the sling becomes shorter) the load on the sling becomes greater. To keep the load within safe limits, the angle of the sling should be kept at less than  $30^{\circ}$ ; the apex of the



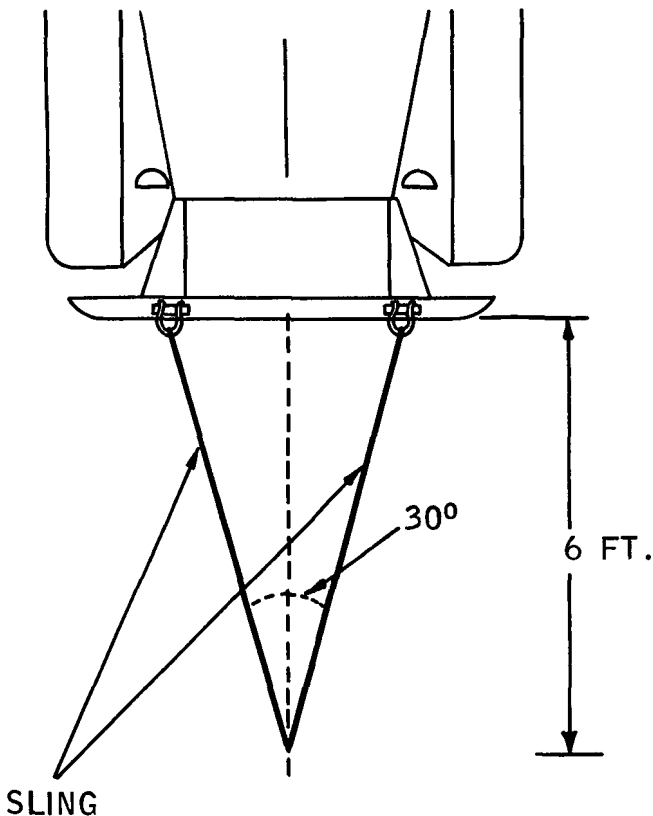
*Figure 29. Wheeled vehicle rigged for a direct pull.*

angle formed by the sling should be at least 6 feet from the vehicle (fig. 31). The formula for measuring the load on a sling can be found in TM 5-725.

b. When attaching the rigging to a tracked vehicle, always use the towing hooks or towing eyes. The lifting eyes and towing pintle of a tracked vehicle are not designed to withstand the load necessary for recovery. To prevent pulling the vehicle sideways and increasing the load, it is best to use a hookup that will distribute the effort equally to each side of the vehicle. To save time, consideration should also be given to whether the vehicle will be able to proceed under its own power or will have to be towed after it is recovered. Time



*Figure 30. Wheeled vehicle rigged for a 2 to 1 mechanical advantage.*



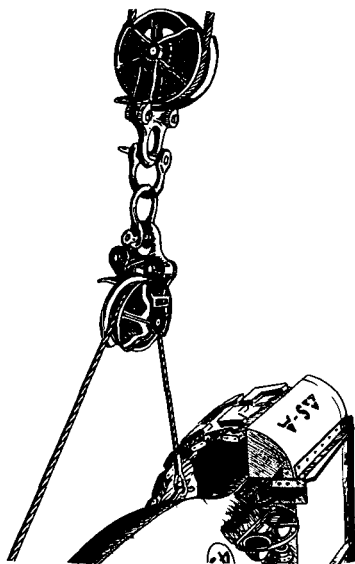
*Figure 31. Sling arrangement.*

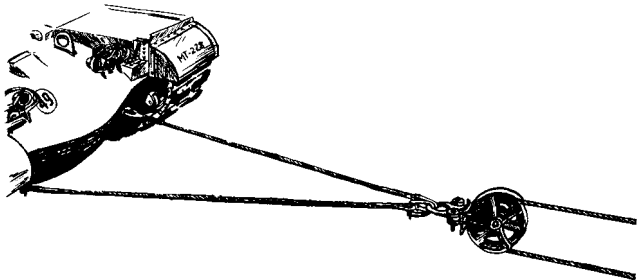
and effort will be saved if the one hookup can be used for both winching and towing.

- (1) If the disabled vehicle will not require towing and the mechanical advantage

does not exceed 2 to 1, the best method for recovery is by use of the floating block (fig. 32). This hookup is easy to install and will give an equal distribution of the effort to both towing hooks. To rig a floating block, hook the ends of the tow cable to the two tow hooks; place a snatch block in the sling formed by the tow cable, and use heavy-duty shackles to attach the winch rigging to the block.

- (2) If the disabled vehicle will have to be towed over extremely rough terrain after recovery, it is best to use two tow cables (fig. 33). Attach a tow cable to each tow hook. Form a sling by fastening the two free ends to the block with shackles. At-



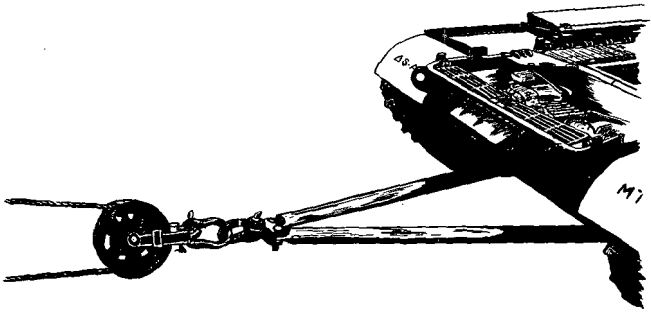


*Figure 33. Tow cables.*

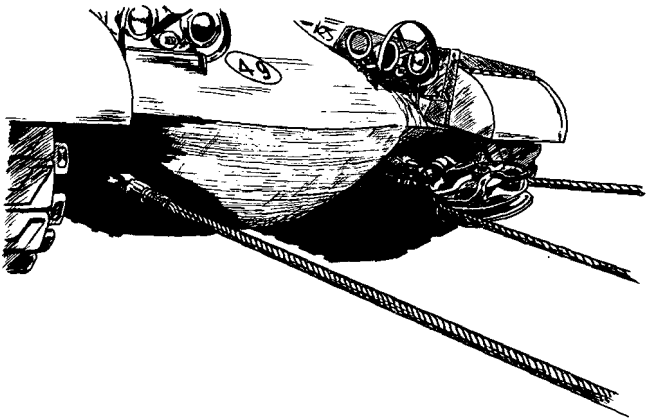
tach the winch cable to the shackles. After the recovery, disconnect the winch cable, cross the two tow cables, and attach them to the tow hooks on the recovery vehicle.

- (3) If the vehicle is to be recovered and towed over relatively level terrain or on a highway, the best hookup can be made with a tow bar (fig. 34). The tow bar can be attached to the towing eyes of the disabled vehicle; the block on the winch cable can be fastened to the tow bar by shackles. After the recovery operation is complete, the tow bar can be attached to the towing pintle of the recovery vehicle and the disabled vehicle towed to its destination.





*Figure 34. Tow bar.*



*Figure 35. Tracked vehicle rigged for a 3 to 1 mechanical advantage.*

- (4) If a 3 to 1 mechanical advantage is to be used, the end of the winch cable can be fastened to one of the tow hooks on the disabled vehicle. The snatch block through which the winch cable is passed can be fastened to the towing eye on the other side of the vehicle by using a heavy duty shackle (fig. 35).

## Section VI. SAFETY

### 38. Handling Cables

When cables must be handled by hand, heavy, leather-palmed gloves should be used to protect the hands from being cut by any broken wires in the rope. A broken wire will cause a severe cut, which is generally slow to heal. Care should be used to prevent the wires from breaking during use. Cables or ropes should not be drawn over sharp rocks, around sharp corners, or through sheaves that are designed for larger or smaller cables or ropes, and they should not be struck with an object that would cause a nick or burr to form and weaken the strand.

### 39. Observing

To avoid accidents from taut cables or ropes, the following precautions should be observed:

- a. Stand clear of any cable under tension. When a cable is drawn taut and then suddenly released by a break, its recoil or backlash can cut a man in half. A winch line under tension stretches like a

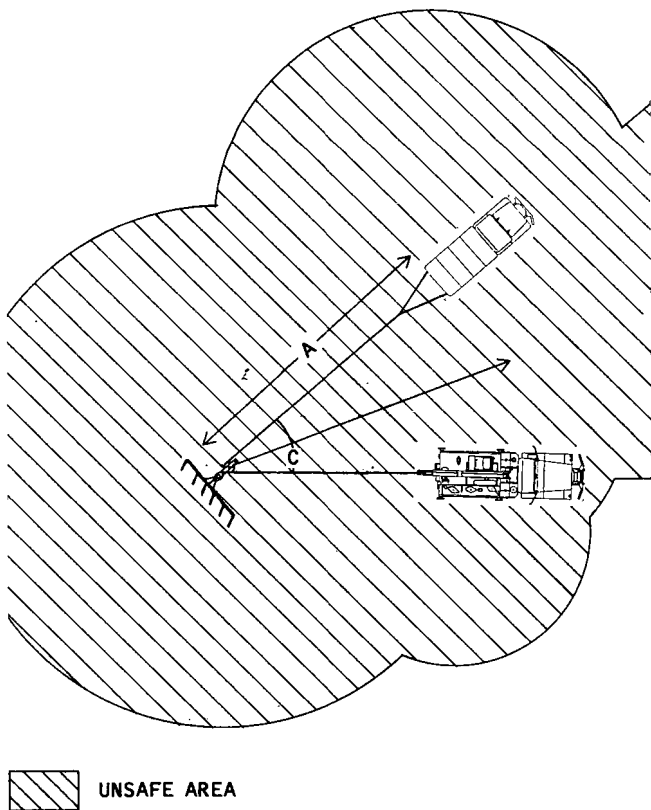
rubber band and stores up a lot of energy. If such a line should break, its snapping back could be compared to a rifle bullet except that when the bullet strikes, it makes a fairly clean hole; the winch cable makes a messy wound. The idea is to treat a cable under stress with the same respect you would a loaded gun.

*b.* Before a pull is begun, all persons must be evacuated from within the angle formed by the cable. A winch line is similar to a slingshot in that if a deadline to a snatch block breaks, a 200-pound block can be thrown as far as 300 yards. All persons observing the operation should stand outside the angle formed by a cable under load and at a distance equal to at least the distance between the two most distant points in the rigging. Unsafe areas are illustrated in figure 36.

#### 40. Miscellaneous Safety Precautions

There are several other areas where the safety of personnel and equipment must be observed.

*a.* Operators and other persons in either the recovery or disabled vehicles should keep the hatches closed during a recovery operation if the amount of rope (cable) between the two vehicles is equal to or greater than the distance between the persons and the closest point of the rope. If a 10-foot tow rope is being used between two vehicles, all hatches within a 10-foot radius of the rope (from both ends of the rope) should be closed if the compartment is occupied.



*Figure 36. Unsafe areas.*

*b.* All loops in cables should be straightened while the rope is slack and before the load is applied. When a load is applied to a looped wire rope, a kink will result; the strands separate or

break, and the rope is damaged and weakened. To remove a loop, the rope should be bent back opposite from the direction in which the loop was formed. The loop cannot be straightened by pulling the rope taut; this merely separates or breaks the wire in the strands of the rope (fig. 37).

c. Loads should not be applied suddenly. Sudden loads are caused by operators who permit an object to drop or roll until the slack is taken up in the rigging, causing the load to stop suddenly, or who accelerate the recovery vehicle and take up the slack in the rigging suddenly. In either case the same effect occurs—an excessive strain is



*Figure 37. Kink in wire rope pulled taut shows separated wires in the strand.*

placed on the rope. This sudden force, like the blow of a hammer, is hard to compute accurately, but it is very great.

*d.* Except for certain cases such as towing, cables and ropes should be rigged so that no lines will cross and rub one another. Two cables under load will cause a great pressure to be exerted, as well as the loss of power by friction. The wire or fiber in the strands may be broken where they cross and rub. Such a condition can usually be avoided by proper placement of the ropes in the block. If such a condition occurs, ropes should be rerigged and the rubbing eliminated before effort is applied.

*e.* Blocks or chains in the rigging should be placed so that when strain is placed on the rigging, the point of the hook will be pointing upward. The hook will probably be one of the most vulnerable points in the rigging; it will have a tendency to straighten out under load. By placing the point of the hook upward, the tendency will be for the rigging to travel downward when or if the hook straightens. Therefore, less damage is likely to result than if the rigging traveled upward unrestrained.

*f.* To prevent damage to equipment, it is better to employ a greater mechanical advantage than required than to use a hookup that loads the equipment to capacity. Equipment will last longer, cables that have been weakened will not break as readily, and operations will be more successful, generally. Recovery crews will take more pride in

their work if their operations are consistently successful. Less work will be necessary if the time required for rerigging is held to a minimum.

*g.* When rigging is being connected or disconnected during a recovery operation, the engine in both vehicles should be shut off. The possibility of a vehicle being placed in gear accidentally and injuring somebody is eliminated if the engine is not running. It is also necessary to insure that parking brakes are in good condition, and applied.

*h.* Safety keys should be in place on all tow hooks and shackles.

## CHAPTER 4

### FIELD EXPEDIENTS

---

#### 41. General

Any vehicle may become disabled from time to time. Because tactical vehicles do not always operate on or near roads where help would be easy to find, at times you and your disabled vehicle may be alone. If so, it may be your job to get the vehicle to operate again without the aid of recovery vehicles. You may have only the equipment on the vehicle, the natural surroundings, and your own commonsense and good judgment. If you are in this predicament, a little thought before you start anything may save several hours of unnecessary labor or keep you from having to wait until a recovery crew can find you. You should consider use of the methods below to return a vehicle to operation under these conditions. These methods are called field expedients. You should be familiar with field expedients and be prepared to use them. Always remember to observe the safety precautions outlined in paragraphs 38 through 40.

#### 42. Steering Action

A number of field expedients for tracked vehicles are based on the way the steering controls



work. If your vehicle has thrown or broken a track, you can move the vehicle by applying steering action in a forward or reverse range. This transmits power to the side with the good track, and moves your vehicle either forward or backward. However, if you do not apply steering action, the vehicle will not move, because the power is transmitted only to the sprocket without the track, which will be free to turn.

#### 43. One Track Spinning

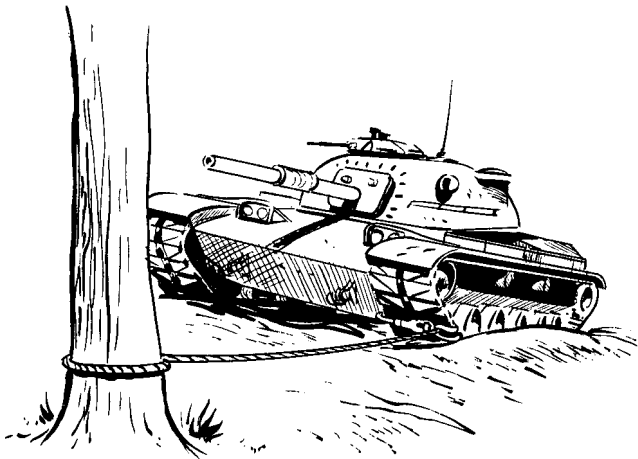
To move a tracked vehicle that has one track on solid ground and the other spinning in the mud, apply steering action to the spinning track. This will stop the differential action and cause power to be transmitted to both tracks. If one track is on solid ground, it will move the vehicle. As soon as the effect of steering is felt and the vehicle begins to turn, return the steering to straight ahead.

#### 44. Slippery Hill

To move a tracked vehicle up a slippery hill or incline, attach one end of a cable to a track, and the other end to an anchor (fig. 38). If the other track slips, apply steering action and move the vehicle until the end of the cable passes the end roadwheel. Stop the vehicle, disconnect the cable and, if the vehicle still cannot gain traction, repeat the procedure.

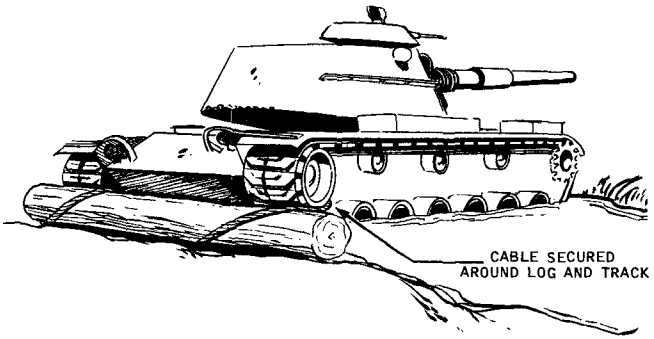
#### 45. Bellied Tracked Vehicle

Very often vehicles become bellied (high centered) on stumps, rocks, dry ridges, or mire.

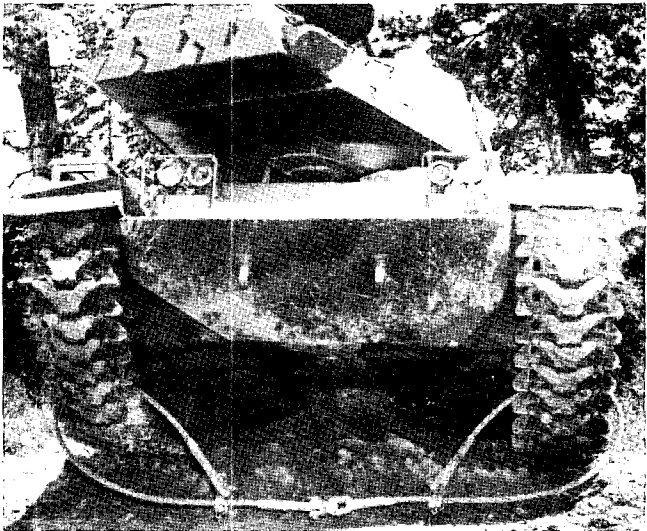


*Figure 38. Anchoring one track with cable.*

In this position, tracked vehicles are helpless because both tracks are held clear of the ground and cannot get enough traction to move the vehicle (fig. 39). To recover a vehicle bellied on an obstacle, attach a log to both tracks at one end of the vehicle. If there is no log available, connect the two tow cables of the tank together and, using the towing hooks from the vehicle, attach to both tracks. Then apply power gradually to the tracks; the log or tow cables will strike the obstacle and move the vehicle. Care must be taken to stop the vehicle when the log or cable reaches the rear or front of the tracks, or it will damage the fenders and tow cable. A log is preferable for use in mud.



*Figure 39. Log used to anchor tracks.*



*Figure 40. Cable used to anchor tracks.*

#### 46. Broken or Damaged Suspension System

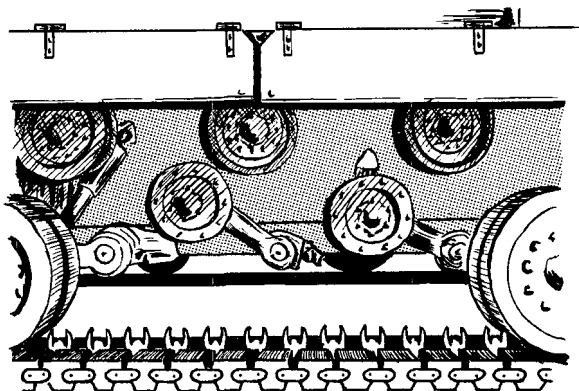
To operate a vehicle with a damaged roadwheel, spindle, or roadwheel arm, the arm should be tied up out of the way (fig. 41). To tie the roadwheel up, the torsion bar should be removed. This can be done by placing the tank across a ditch narrow enough to permit the front and rear roadwheels to be supporting most of the weight of the vehicle, and deep enough to permit the track to sag away from the affected roadwheel. If a ditch is not available, a trench can be dug. With the tank in this position, the tension on the torsion bar has been released and the bar can be removed. The roadwheel can be tied up and out of the way. This expedient cannot be used on the front or rear roadwheels.

#### 47. Thrown Tracks

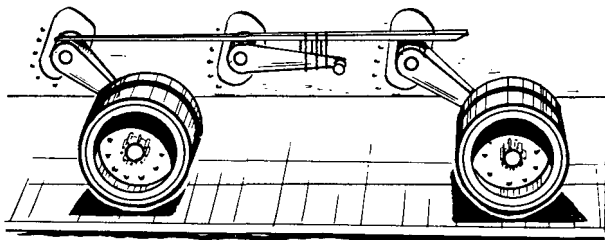
To move a tracked vehicle when both tracks have been thrown, use one sprocket as a winch. To do this attach a cable to the sprocket so it will wind up when the sprocket turns. Attach the other end of the cable to an anchor, then apply steering action to move the vehicle (fig. 42).

#### 48. Breaking a Thrown Track

To break a thrown track under emergency or combat conditions, or when time is a major factor, it has been found practical to remove the center guide and, using the oxyacetylene welding equipment found on wreckers or recovery vehicles, cut the track connector on each side of the track.

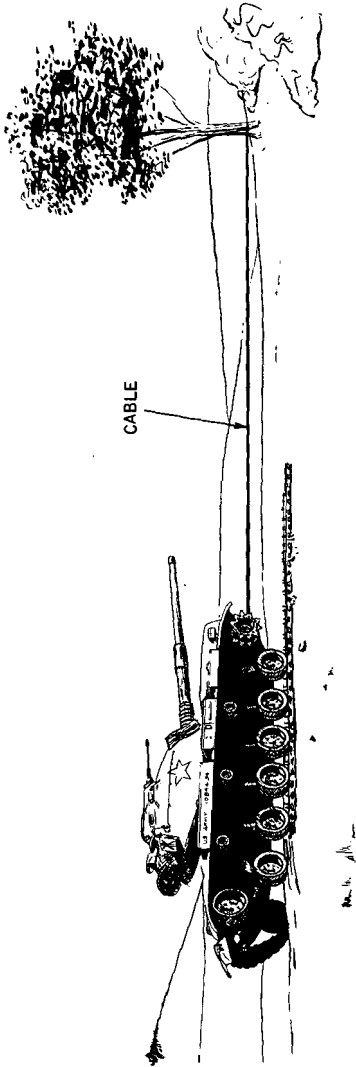


A. THIRD AND FOURTH ROADWHEEL  
ARMS TIED UP.



B. SINGLE ROADWHEEL ARM TIED  
UP TO CROWBAR.

*Figure 41. Damaged roadwheels tied up away from track (roadwheels removed).*



*Figure 42. Remounting a track.*

#### 49. Remounting a Track

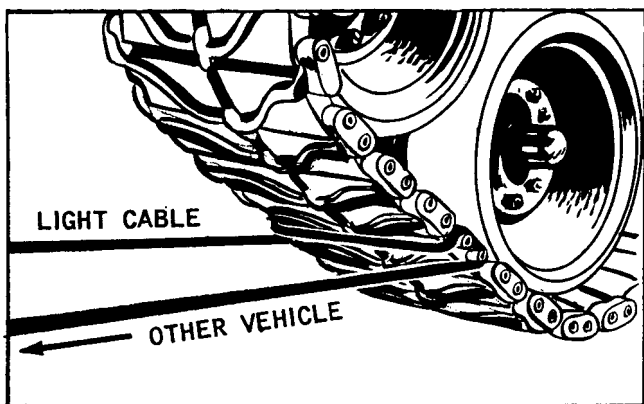
To remount a track, lay the track out in front or rear of the vehicle in line with the roadwheels. Then shift into forward or reverse range (whichever is desired) and apply steering action; the vehicle will then pull onto the broken track. To remount both tracks, lay them out in front or rear of the vehicle in line with the roadwheels. Attach one end of a cable to one of the sprockets so that it will wind around the sprocket hub, and attach the other end to a suitable anchor. Place the shift lever in gear, and apply steering action. The power transmitted to the sprockets will cause the cable to wind around the sprocket hub and pull the roadwheels up onto the broken tracks.

#### 50. Linking a Broken Track

Very often a track must be linked together without the aid of a track jack. To do this, link a double-pin-type track together by winding a light cable around the track pins as shown in figure 43, attaching the cable ends to another vehicle, and pulling the two track ends together. When the pins become close enough to each other, install the track connectors part way, remove the cable, hammer the connectors into position, and install the wedges and center guide.

#### 51. Slave Cable Starting

Slave cables are available in both second-echelon special toolsets and the equipment of wrecker trucks and recovery vehicles. Slave cable starting



*Figure 43. Linking a broken track.*

is intended for engines on vehicles that have discharged or partially discharged batteries. It is done by using another vehicle with fully charged batteries as the source of power. The starting procedure is outlined in TB ORD 537 and in your vehicle technical manual. Become familiar with the procedure. Much damage can be done by using incorrect slaving procedures.

## 52. Use of an A-Frame (Shears)

Frequently a truck will become nosed in a shell-hole or narrow ditch. When a truck becomes disabled in this manner, both lifting and pulling forces are required to make the recovery. The lifting force can be obtained from an A-frame when



a wrecker truck is not available. To construct an A-frame, 2 poles approximately 8 feet long and large enough in diameter to support the front end of the truck will be needed. The poles should be lashed together at the top by a figure-8 or girth hitch. The lower ends should be placed in the ground 10 to 12 inches deep to prevent them from sliding when power is applied. The upper end of the A-frame should be laid across the hood of the vehicle and the attachment made as in figure 44. If the nosed truck is equipped with a winch, the winch cable should be rigged for a 2 to 1 mechanical advantage, with the end of the cable secured to the apex of the A-frame. If a separate truck is needed because the nosed truck is not equipped with a winch, a block should be attached to the apex of the A-frame and a 2 to 1 mechanical advantage rigged from the truck emplaced in front of and alined with the nosed vehicle.

### 53. Use of Logs to Cross Ditches

In field operations, ditches will often be encountered that are too deep to drive through. A convoy of mixed wheeled vehicles may cross such a ditch by using five logs. The logs should be approximately 10 inches in diameter, from 3 to 4 feet longer than the span, and positioned as illustrated in figure 45. This arrangement will pass a wheeled vehicle convoy without rearrangement of the logs. To prevent the logs from spreading apart, stakes should be driven into the ground on both sides of the logs and the logs should be lashed together at the center with a chain, wire,



*Figure 44. Recovering a nosed truck with an A-frame.*

GIRTH HITCH  
ON  
A-FRAME

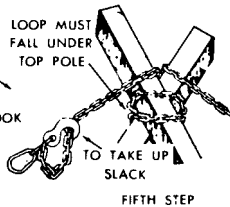
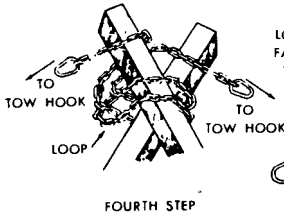
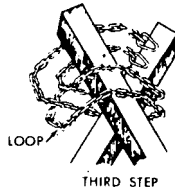
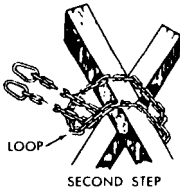
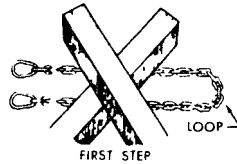
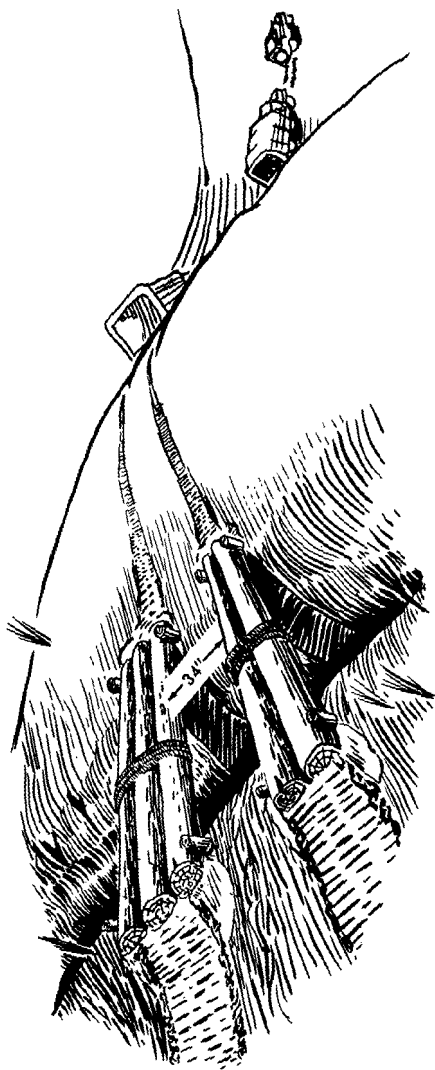


Figure 44—Continued.

or rope. Only two logs would be required to pass a dual-wheeled vehicle across the ditch. The front wheels can be converted to duals by using the spare wheels or by removing the outer wheels of one of the sets of rear duals, and allowing the dual wheels to straddle the logs as the vehicle crosses. Four logs would be necessary to pass a vehicle equipped with single wheels. By lashing the logs together in pairs, the wheels would ride between the logs. To permit a narrow-tread vehicle to cross, the logs may be moved closer together or



*Figure 45. Use of logs to cross a ditch.*

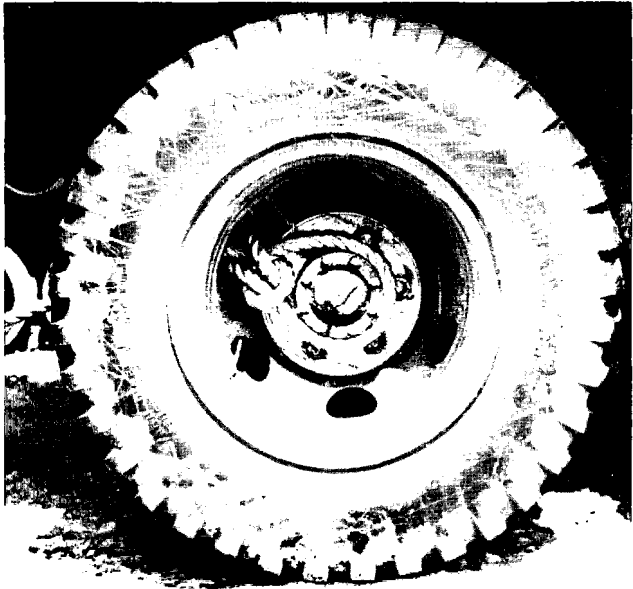
a fifth log may be added. Vehicles must be driven slowly, in low gear, and a guide must be provided to insure that the vehicle and the logs are aligned properly.

#### 54. Use of Wheels for a Winch

When a wheeled vehicle is not equipped with a winch, the rear wheels may be used to assist in recovering the vehicle. On a dual-wheeled truck, a rope with one end fastened to the wheel hub and the other end anchored can be wound up on the wheel or hub to give the same results as a winch. The end of the rope that is fastened to the wheels should be run between the duals and through one of the holes in the wheel disk. A bowline knot can then be tied in the end of the rope and slipped over the end of the hub (fig. 46). By placing the vehicle in reverse gear, the rope will wind between the two duals and the vehicle will move to the rear (fig. 47). Care should be taken to place the rope through a hole in the wheel where the valve stem will not be damaged. If the truck has single wheels, the same system can be used by placing a bar through the hole in the end of the axle flange. The rope can be started by fastening it to the bar with a figure-8 hitch, and the rope will wind in behind the bar, as illustrated in figure 48.

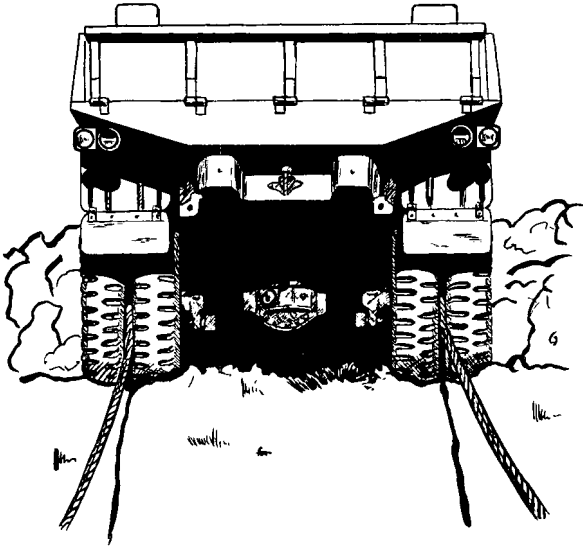
#### 55. Recovery Vehicle Used as a Tramway

Wheeled vehicles may be transported across a river or ravine by a tramway erected by using a recovery vehicle and its winches. The recovery



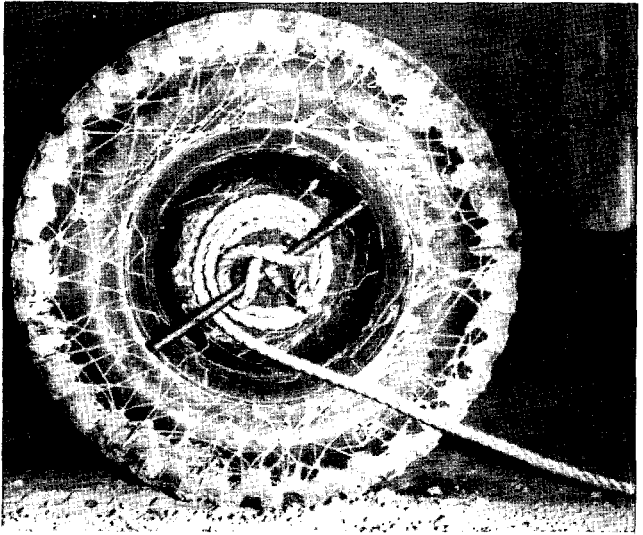
*Figure 46. Attachment of rope to dual wheels to be used as a winch.*

vehicle should be on solid footing, as close to the edge of the bank as possible, and with working space in front of the vehicle. One crewmember will be required to reach the opposite bank with either a light rope or, if available, a length of telephone field wire long enough to span the river or ravine to be crossed. In the case of a river, it is probable that the crewman will have to swim to the opposite shore with the rope. The rope or



*Figure 47. Using wheels as a winch.*

field wire, now stretched across the ravine or river, can be used to pull a snatch block, an anchor chain, and the auxiliary winch cable from the recovery vehicle to the opposite side. On the opposite side the block should be anchored to a tree or other suitable anchor, and the winch cable reeved through the sheave and passed back across the river. (It is sometimes possible to do this by attaching a weight to one end of the rope or telephone wire, swinging it around to create momentum, and throwing it across the river.) When the crewmember at the vehicle receives the rope,



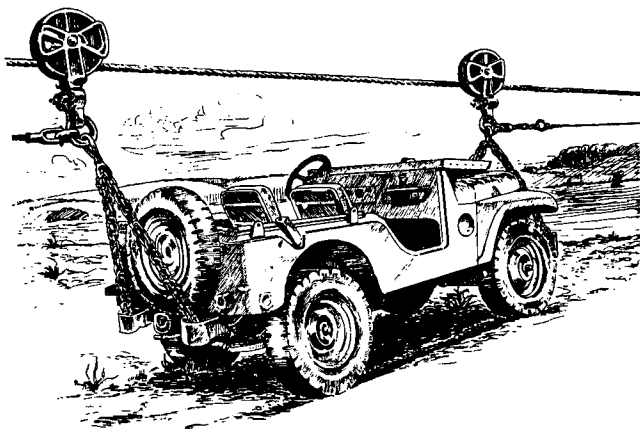
*Figure 48. Attachment of rope to single wheel to be used as a winch.*

he can pull the end of the auxiliary winch cable back to the recovery vehicle. The main winch cable and the boom winch cable can now be attached to the auxiliary cable and drawn across the ravine or river by reeling in the auxiliary winch cable. The main winch cable must be anchored so it will withstand the load to be placed upon it. By reeling in the boom winch cable, the end of the auxiliary winch cable will be drawn back across the ravine or river to the recovery vehicle. The main winch cable is now in a posi-



tion to act as a trolley line. The vehicle to be transported should be placed under the main winch cable (track cable). The two large snatch blocks, part of the equipment of the recovery vehicle, should be placed on the track cable (fig. 49). A chain may be used as a sling from each of the two snatch blocks and secured to the lifting shackles at the front and rear of the vehicle to be transported. The auxiliary winch cable, attached at the front of the vehicle, will be used to propel the vehicle across the ravine, and the boom winch cable, attached at the rear of the vehicle, may be used to control the forward movement (fig. 50). When the vehicle reaches the opposite bank it may be lowered by slacking off on the main winch cable. The boom winch cable and the auxiliary winch cable can now be fastened together and the blocks and cables returned to transport the next vehicle. On later model recovery vehicles, which do not have an auxiliary winch, the boom winch would be used instead, and a heavy rope, pulled by crewmen, would be substituted for the boom winch to retard the vehicle's forward progress and to return the equipment to transport the second vehicle.

**Caution:** Extreme caution must be exercised not to overload the track cable. The approximate safe load that the track cable will support at the center of a 200-foot span, with 5 feet of deflection in the cable, can be determined by dividing the capacity of the cable by 10. With the same length span and 10-foot deflection, the capacity should be divided by 5.



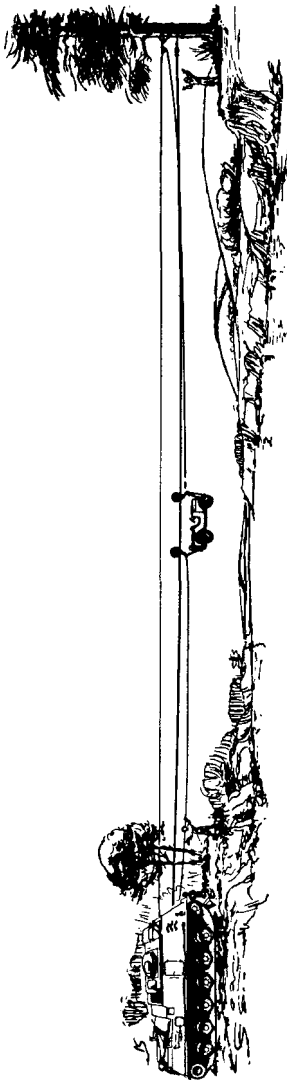
*Figure 49. Vehicle rigged to track cable.*

### 56. Use of a Pry

In most places where a vehicle may become disabled by terrain, the ground is good enough to grow timber. When pioneer tools are available, they can be used to make many wooden tools to aid in recovery. Figure 51 illustrates the use of a pole to pry a vehicle out of a ditch.

### 57. Anchoring a Wheel

When one of the driving wheels of a vehicle is mired in a deep hole, and towing equipment or a winch is not available, the vehicle may be recovered by tying a log to the wheel (fig. 52). Caution



*Figure 50. Transporting vehicle on a tramway.*

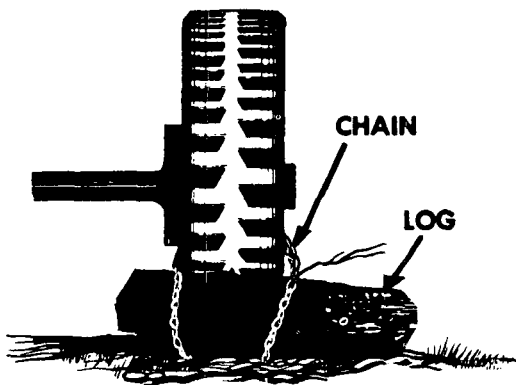


*Figure 51. Pole used as a pry.*

will have to exercised to apply power gradually to prevent the wheel from spinning. If the wheel spins, the log will damage the fender and other parts of the vehicle. After the wheel is lifted clear of the hole, log should be forced under the wheel to prevent it from falling back into the hole.

#### **58. Substitutes for a Jack**

*a.* If an outside dual tire becomes flat, and a jack is not available, the inside dual may be run up on a small log or rock as a substitute for a jack. This takes the weight from the outside



*Figure 52. An anchored wheel.*

wheel and allows it to be removed for repair or replacement (fig. 53).

b. Very often a tandem wheel must be raised when no jack is available. A substitute may be provided by cutting a piece of timber slightly longer than the distance from the axle to the ground. Place the timber against the axle at an angle and drive the vehicle up on the timber (fig. 54). Set the brakes and block the vehicle securely.

c. To raise the front wheels, a piece of timber approximately 5 feet long can be cut and secured to the front bumper at an angle with a chain or rope. The vehicle can then be moved forward until the timber is in a vertical position and the



*Figure 58. Substitute for a jack to remove outside dual wheel.*

wheel clears the ground (fig. 55). Set the brake and block the vehicle securely.

#### 59. The Skid

When the driver finds himself in an isolated area with a flat tire or bad wheel and does not have the equipment to repair it, a skid may be

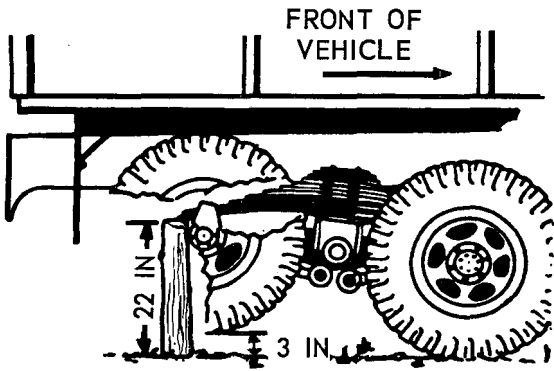


Figure 54. Substitute for a jack to remove tandem wheels.

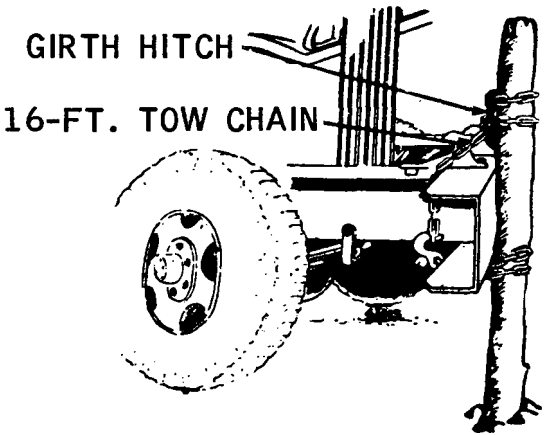


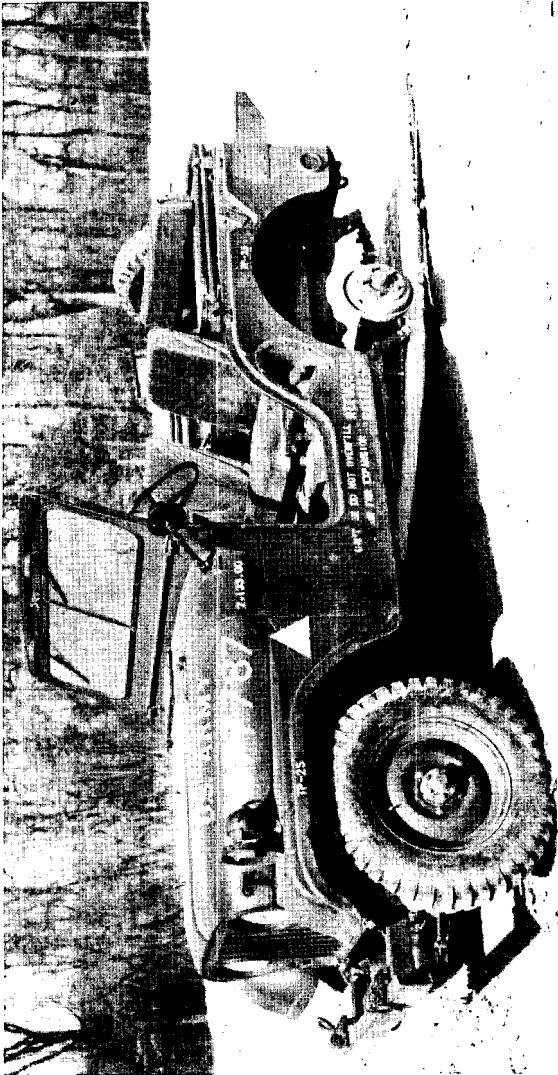
Figure 55. Substitute for a jack to remove front wheels.

used if the vehicle is of the 4-wheel-drive type. The skid should be used on the rear wheel (fig. 56). (Wheels can be changed from one hub to another to accomplish this.) A pole approximately 4 inches in diameter and 6 to 8 feet long should be used. One end of the pole should be placed above the frame crossmember near the transmission and the other end on the ground. The pole should pass under the spring U-bolts, aline with the spring, and be lashed securely to the spring. The pole will then support the weight of the vehicle on the side with the defective wheel. By engaging the front wheel drive, the vehicle will move under its own power. Starting may be difficult, but once the vehicle is moving, it will ride and handle surprisingly well.

#### 60. Disabled Tandem Wheel or Axle

When a tandem wheel has a burned-out bearing or damaged wheel that would disable the vehicle or cause further damage if continued in operation, the axle may be tied up and made inoperative. The disabled wheel should be moved onto a rock, log, or similar object to raise the wheel as high as possible (fig. 57). While the wheel is raised, the axle should be tied as tightly as possible to the frame by using heavy wire or a tow chain (fig. 58). Caution should be exercised to prevent the chain or wire from causing damage to the brakelines. If the bearing is burned out, or for some similar reason the wheel should not turn, the axle shaft should be removed from the axle housing and the hole in the hub





*Figure 56. Skid expedition.*

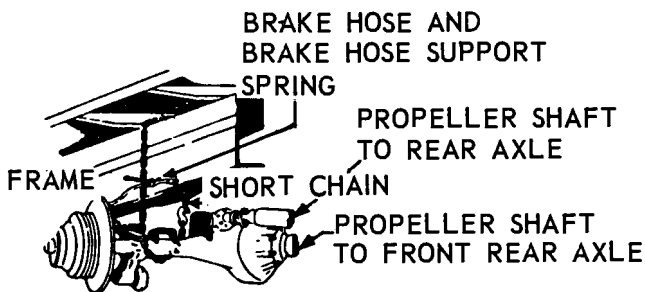
stuffed with rags to keep out foreign matter. This expedient will allow the other wheels to drive while the damaged wheel is held off the ground. This same expedient may be applied to both ends of the axle if both wheels are defective (fig. 59). When both wheels are tied up, the truck should not be loaded too heavily or should be offloaded.

#### 61. Defective Differential or Final Drive

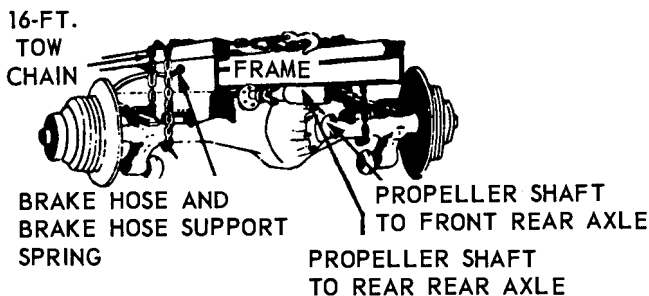
If the defect is in the differential of a 4 x 4 or 6 x 6 vehicle, the propeller shaft and drive axles may be removed from the defective assembly and



*Figure 57. Raising tandem axle.*



*Figure 58. Attaching tandem axle to frame.*



*Figure 59. Disabled tandem axle.*

the vehicle operated on power supplied by the other axles. When the axle shafts are removed, the openings in the ends must be covered securely to keep out dirt and foreign matter (fig. 60).

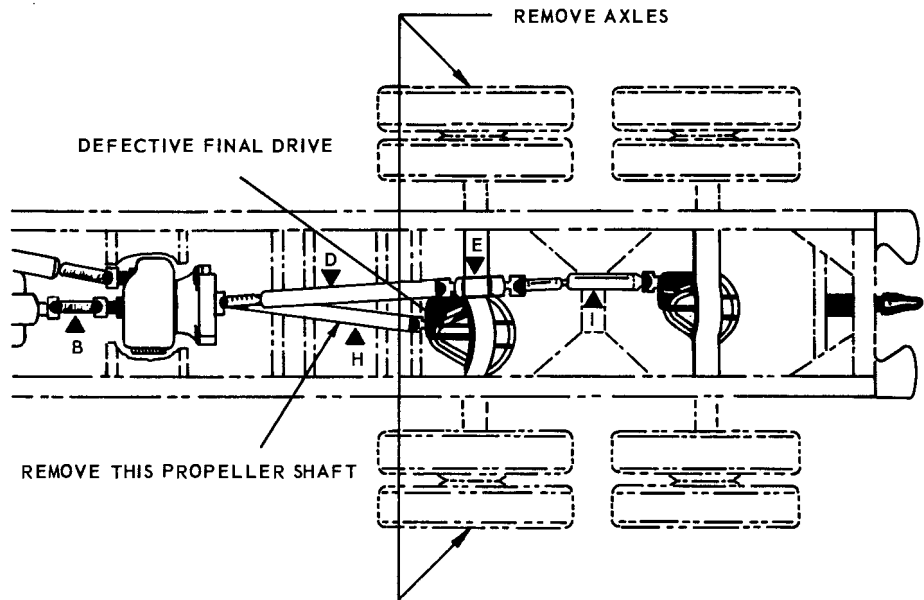


Figure 60. Defective final drive or differential.

## 62. Defective Center Bearing

If the propeller shaft center bearing is defective and it is evident that operation will cause further damage, both propeller shafts to the rear axle should be removed (fig. 61). This will prevent the center bearing from operating, and the vehicle may still be driven.

## 63. Broken Tandem Spring

Occasionally, it may be necessary in the field to remove a broken tandem spring when special equipment is not available to jack up the vehicle. The rear wheel of the vehicle should be driven onto a log, rock, or similar item, causing the intermediate axle to be lowered away from the frame. A wooden block 10 inches long can now be placed between the intermediate axle and the frame. When the vehicle is driven off the rock or log, the block will support the weight of the vehicle on the intermediate axle. The spring can then be removed for repair or replacement (fig. 62).

## 64. Shorted Distributor Cap

A cracked distributor cap is usually more noticeable in damp weather, when moisture fills the crack and causes a short (fig. 63). It may short from any terminal to ground, causing a rhythmic miss, or it may short from one terminal to another, causing a miss of unequal frequency on different cylinders and an occasional backfire. In some cases, the distributor may not be cracked

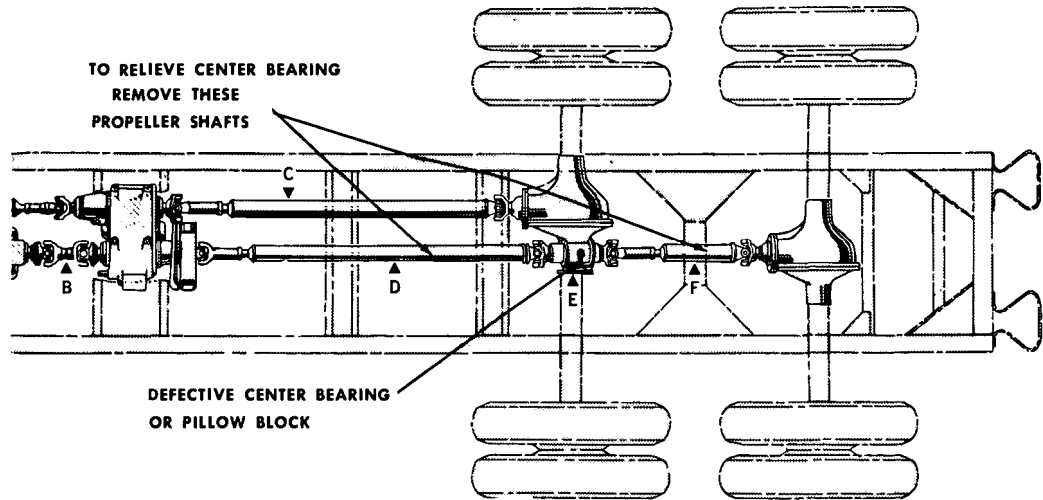
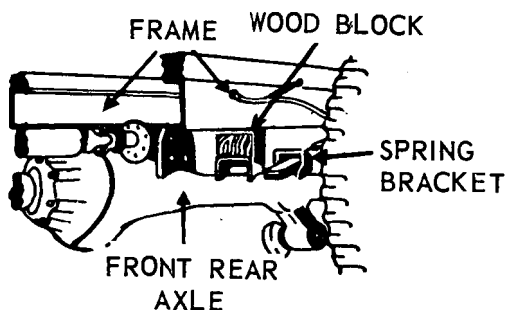


Figure 61. Defective center bearing.



*Figure 62. Removal of tandem spring.*

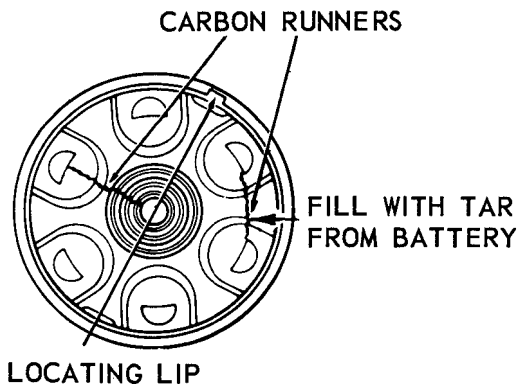
but may have a carbon runner caused by a wet and dirty distributor cap. The spark jumping across will cause a carbon runner or track that will continue to short the cap even after it has been cleaned and dried. The short may be corrected by cleaning the distributor cap, scraping the crack or runner, and filling the crack with tar obtained from the top of the storage battery.

#### 65. Broken Rotor Spring

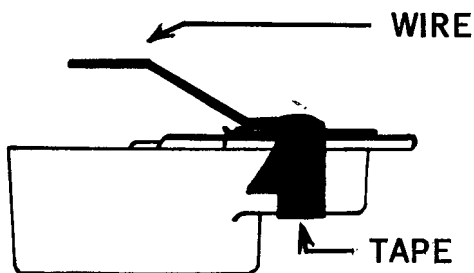
If the high-voltage contact spring is broken on the distributor rotor, a piece of welding rod, cotter key, or wire may be bent in the same shape and fastened to the rotor with friction tape (fig. 64).

#### 66. Broken Distributor Point Spring

A broken distributor point spring will result in the engine cutting out and finally stopping.



*Figure 63. Shorted distributor cap.*



*Figure 64. Broken rotor spring.*

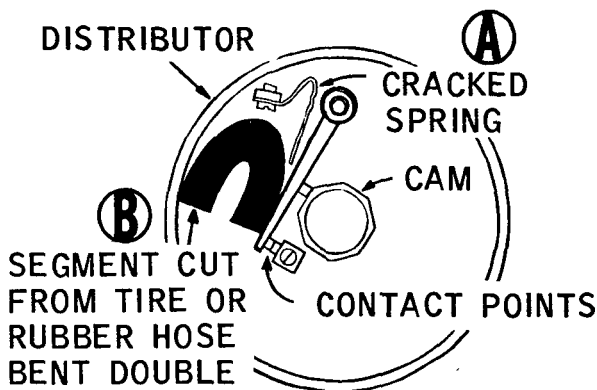
This usually occurs at high speeds. Once the engine stops, it cannot be started. Removal of the distributor cap will reveal the broken spring (A,



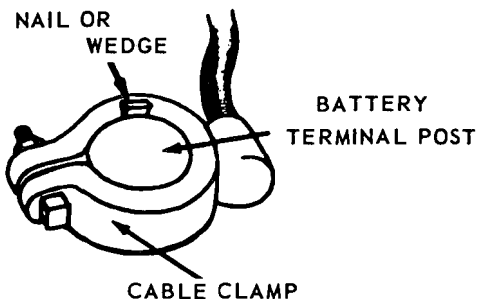
fig. 65). Cut a piece of rubber from a tire, or a piece of vacuum hose, and double it and place it behind the spring (B, fig. 65). The rubber will act as a distributor point spring. The engine will then start and perform at low speeds, but the rubber cannot close the points fast enough to perform properly at high speed. The rubber may work itself out of position and have to be replaced occasionally.

#### 67. Corroded Battery Cable Clamp

When time does not permit the prescribed cleaning and permanent repair on a corroded battery cable terminal, a nail or wedge may be driven between the battery cable clamp and the battery terminal (fig. 66). This will make a fast con-



*Figure 65. Broken distributor point spring.*



*Figure 66. Corroded battery cable clamp.*

nection, complete the circuit, and allow the vehicle to start and operate normally.

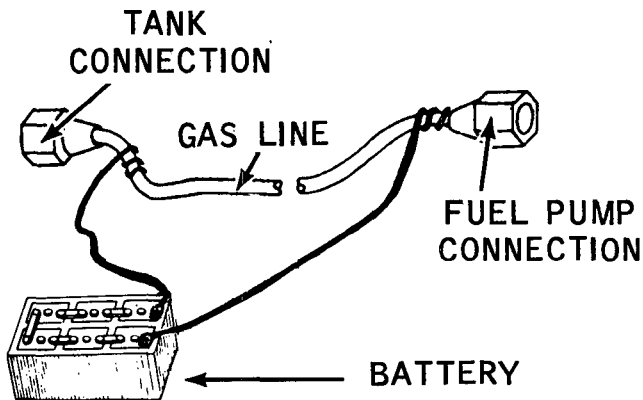
#### 68. Frozen Fuel Line

Frozen fuel lines may be thawed by connecting wire leads to each end of the fuel line and running current through the line. The line will heat up and thaw the ice (fig. 67).

**Caution:** Do not arc the wire against the line. This is a precaution against burning a hole in the line and starting a fire. First attach the wires securely on the fuel line and then connect them firmly but momentarily at the battery.

#### 69. Leaking Line Fitting

To repair a leaky line fitting, a string or rag may be wound tightly around the line behind the flare (fig. 68). Slide the coupling nut over the



*Figure 67. Frozen fuel line.*

material, screw it onto its connection, and tighten it securely against the packing string with a wrench. The string will act as a gasket and seal the leak. The string should be wound clockwise—in the same direction the coupling nut is turned to be tightened.

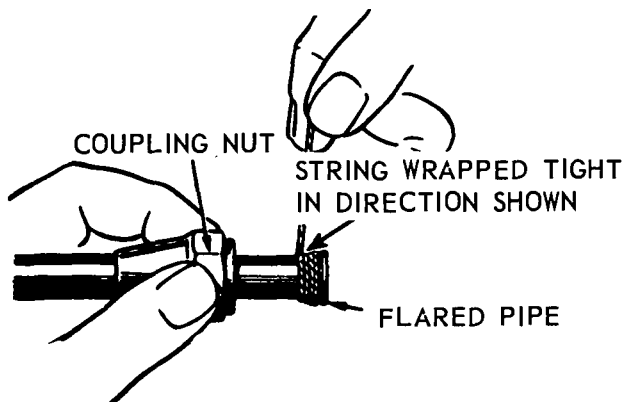
#### 70. Cracked Oil or Fuel Line

Cracked oil or fuel lines are usually caused from extreme pressure, vibration, or defective metal. Fuel lines will also freeze and crack due to condensation of water vapor during low temperatures. The leak may be stopped by wrapping the line tightly with friction tape held in place by wire. The wire will help the tape withstand

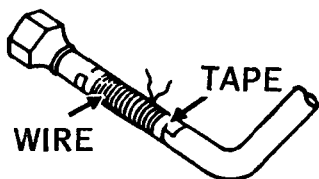
pressure, and usually the leak will be stopped until a better repair can be made (fig. 69).

#### 71. Fuel Pump Failure Due to Vapor Lock (Mechanical)

Vapor lock in the fuel system is caused by liquid fuel becoming so hot that it changes to



*Figure 68. Leaking line fitting.*



*Figure 69. Cracked oil or fuel line.*

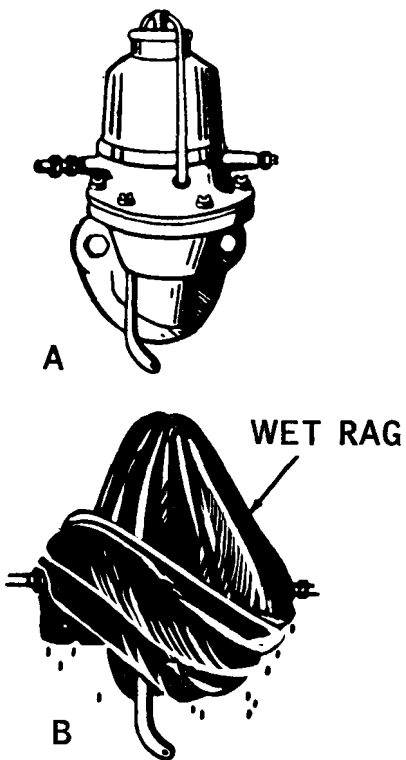
vapor. The fuel pump (A, fig. 70) will not pump vapor. This failure is prevalent in extremely hot climates or when engine operating temperature becomes too high. A simple method of remedying this condition is to wrap the fuel pump with a piece of burlap or other cloth that has been soaked in water (B, fig. 70). This will lower the temperature of the fuel enough to hold it in a liquid state. This refrigerant action is caused by the evaporation of moisture from the wet cloth. When a cloth is not available, cold water may be poured over the fuel pump and lines. Damp dirt or sand is also suitable when applied in such a manner as to cool the fuel pump and lines.

## 72. Punctured Fuel Tank

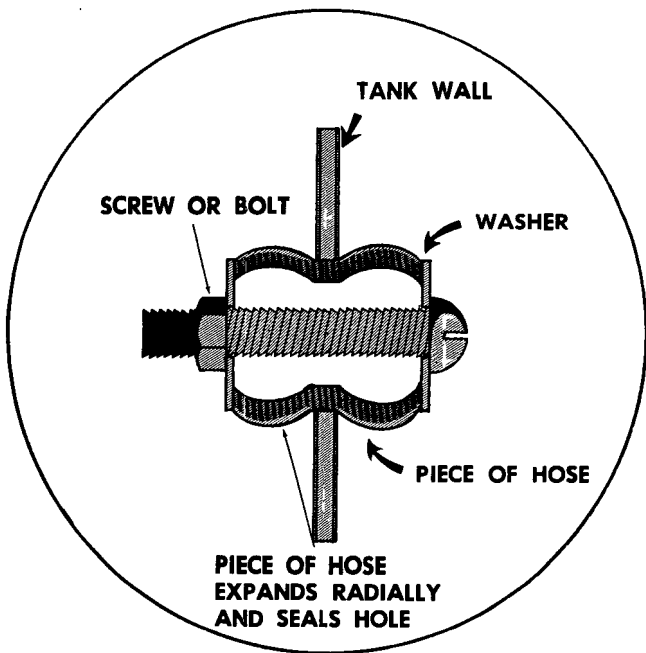
To repair a punctured fuel tank, use a piece of hose about the size of the punctured hole in the fuel tank, a bolt, nut, and two flat washers. Assemble the washers and piece of hose on the bolt and screw the nut down snugly. Enlarge the hole in the fuel tank, if necessary, so the assembled bolt and hose will pass into it and fit snugly; then hold the hose to prevent its turning, and tighten down on the bolt. This will cause the piece of hose to expand in the hole and seal the leak (fig. 71).

## 73. Punctured Radiator Core

Radiators are punctured frequently when vehicles are operating in wooded or combat areas. When this happens, the cooling fins should be cut and pushed back from the tubes in front of

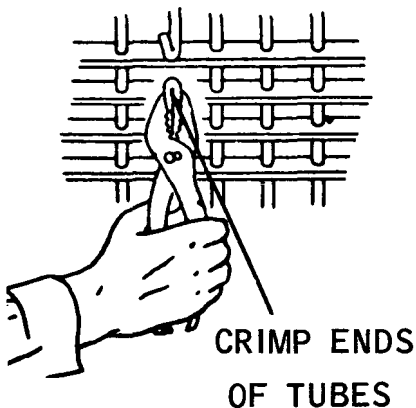


*Figure 70. Cooling vapor lock of the mechanical fuel pump.*



*Figure 71. Punctured fuel tank.*

the leaky tube to have enough room to work. Cut the leaking tube in half, and fold the ends back about three-fourths of an inch. Close the ends by pressing them flat with pliers (fig. 72). This repair may hold permanently, but the cooling efficiency of the radiator is reduced when several tubes are cut, and the engine may overheat.



*Figure 72. Punctured radiator core.*

#### **74. Broken Fan Belt**

A broken fan belt could happen on any vehicle at any time. Wear and tear on a belt should be detected during periodic preventive maintenance checks and the belt should be replaced at that time. If, however, the belt breaks when one is not readily available, a fiber rope from the vehicle tarpaulin or a piece of field telephone wire may be used to replace the broken belt. The rope should be looped around the pulley 3 or 4 times and tied with a square knot (fig. 73).

#### **75. Broken Brake Lines**

If a brake line is broken and repair cannot be made, the vehicle may be operated by bending the



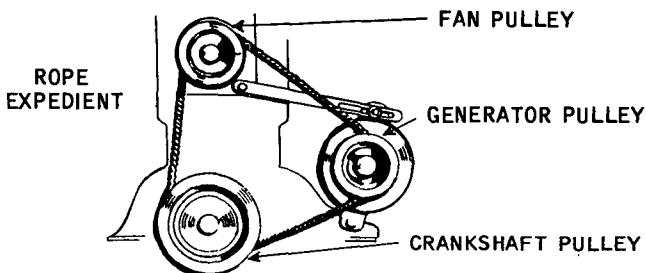


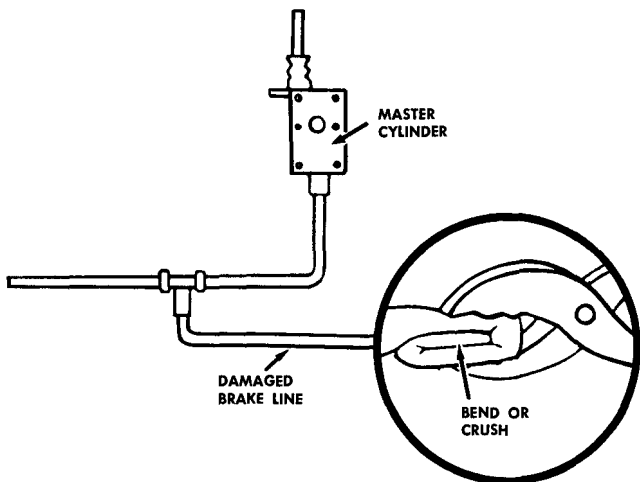
Figure 73. Broken fan belt.

line and crimping or pinching it together with pliers or a hammer. (See fig. 74 for hydraulic lines and fig. 75 for air lines.) Brakes may work after some fluid is lost but they are not dependable. If brake fluid is not available to refill the master cylinder, a substitute may be used temporarily. The basic content of brake fluid is castor oil and alcohol. Therefore, any alcoholic fluid and light vegetable oil may be used. Water may be added if the temperature is above freezing. Anti-freeze may be added in freezing temperatures.

**Caution:** Do not use engine oil or any other mineral oil; it will deteriorate the rubber parts of the brake system. At the first opportunity, drain the brake fluid substitute, flush the system, and fill it with clean brake fluid.

#### 76. Shearpin Substitute

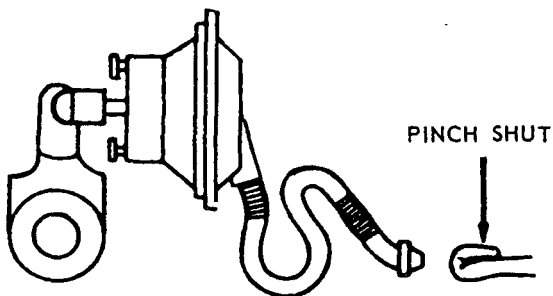
A substitute for a broken shearpin may be made by punching out the remains of the broken



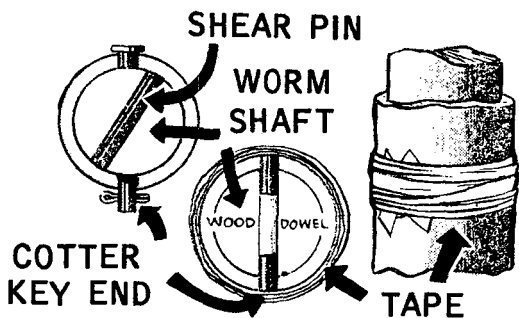
*Figure 74. Broken hydraulic brake line.*

shearpin, cutting the remains in half, and inserting the two shearpin halves with a short, wooden dowel between them as illustrated in figure 76. Wrap friction tape around the shaft to cover the shearpin hole and prevent the end of the substitute shearpin from dropping out.

**Caution:** Never use a steel bolt, spike, nail, or screwdriver blade as a substitute shearpin, because it may result in damage to the winch or cable and injury to personnel.



*Figure 75. Broken airbrake line.*



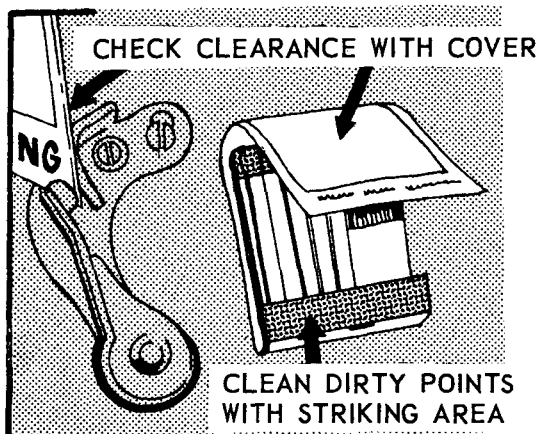
*Figure 76. Substitute for a shear pin.*

## 77. Dirty Ignition Points

If the engine will not run because the ignition points are too dirty, the distributor cap, rotor, or magneto cover may be removed and the breaker points cleaned with the striking area of a match book cover (fig. 77). The match book cover can be used to check the point opening or clearance.

## 78. Pinhole-Size Leaks in Fuel Tanks

To repair a fuel tank that has a pinhole-size leak, remove a self-tapping screw and a washer from the body or cab of the vehicle. Procure a small piece of rubber from a tire or a piece of leather from a tarpaulin strap. Punch a hole in

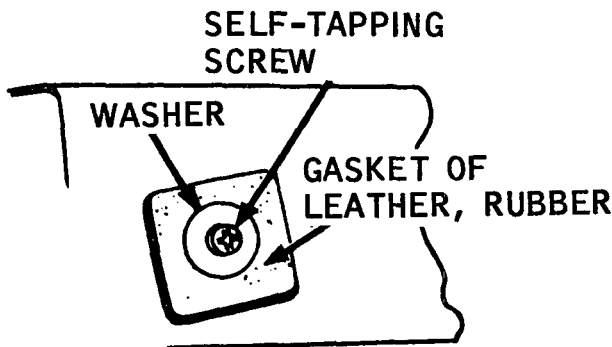


*Figure 77. Dirty ignition points.*

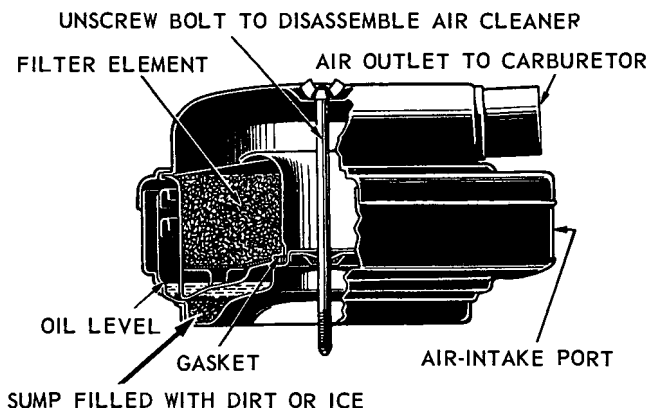
the piece of leather or rubber and assemble the screw, washer, and rubber or leather (fig. 78). Screw the self-tapping screw into the pinhole in the fuel tank until it is tight and the rubber or leather washer has expanded slightly. Chewing gum squeezed through the hole also will work satisfactorily. Either will stop the leak temporarily, but the fuel tank should be replaced at the first opportunity.

### 79. Clogged Air Filter

With a clogged air filter, the engine usually acts as if it were being overchoked. It surges, has very little power, and discharges black smoke from the exhaust pipe. To clear up the trouble, remove the air filter sump (fig. 79). If possible, clean the sump and refill it to proper level with



*Figure 78. Pinhole-size leaks in fuel tanks.*



*Figure 79. Clogged air filter.*

seasonal grade engine oil and clean the filter element. If the trouble recurs and facilities are not available for servicing the air cleaner as described above, or if water has frozen in the sump, remove the sump and operate the vehicle without it.

**Caution:** Service the sump and the filter element and replace it at the first opportunity. Operating an engine without its air filter shortens the life of the engine and creates a fire hazard.

#### 80. Broken Fan Blade

A broken fan blade will cause excessive vibration of the engine. It is dangerous to operate an

engine with a broken or bent fan blade. If the vehicle must be operated, the fan blade on the opposite side should be cut or broken off, as illustrated in figure 80, to prevent vibration. The vehicle may be operated as long as it does not overheat.

**Caution:** This applies only to fans having an even number of equally spaced blades.

#### 81. Broken Fuel or Oil Line

Broken fuel or oil lines under low pressures or vacuum may be spliced temporarily by forcing a piece of hose over the broken ends of the line (fig. 81). A piece of hose cut from the windshield wiper may be used.

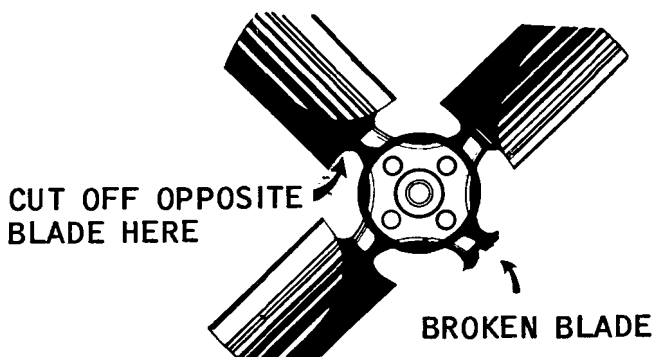
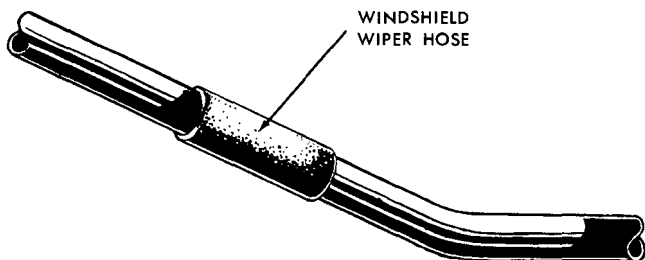


Figure 80. Broken fan blade.



*Figure 81. Broken fuel or oil line.*

### 82. Defective Fuel Pump

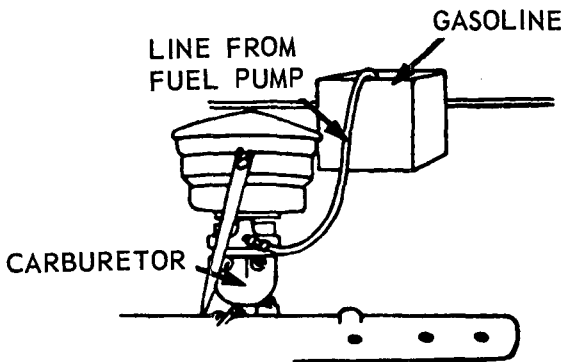
If, after stroking the auxiliary lever of the fuel pump, the engine does not start, a can may be mounted in a convenient position higher than the carburetor. Attach the original fuel pump line or a piece of windshield wiper hose to the bottom of the container, or run a line over the top, forming a siphon, and connect it to the carburetor. When the can is filled with fuel, gravity will feed the fuel to the carburetor. The engine will run as long as fuel is supplied in the can (fig. 82).

*Note.* If the siphon system is used, be sure to prime the siphon.

### 83. Governor Stuck Closed

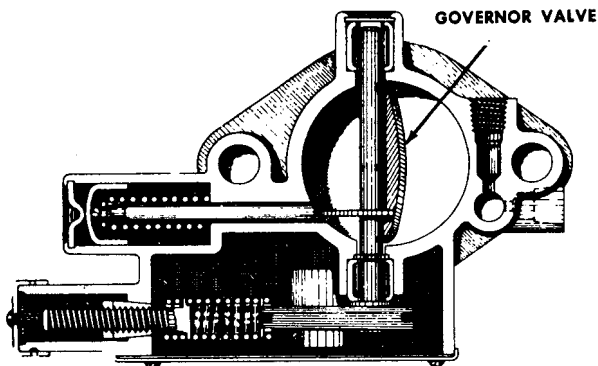
An indication of a governor stuck in a closed position is given when the engine stops after





*Figure 82. Defective fuel pump.*

quick acceleration and fails to start again. It may be detected by viewing the governor valve through the carburetor throat with the carburetor throttle valve open (fig. 83). If the governor valve is stuck closed, it may be opened by passing a small rod or stick down through the carburetor and tapping the governor valve lightly, first on one side and then on the other. If the trouble recurs, remove the governor from the system and use shorter bolts, obtained from the chassis, to attach the carburetor to the manifold. The carburetor may be wired in place if the air cleaner is left off. This will work for short distances only, as the wire will tend to stretch and allow air to enter the manifold where it is joined to the carburetor.



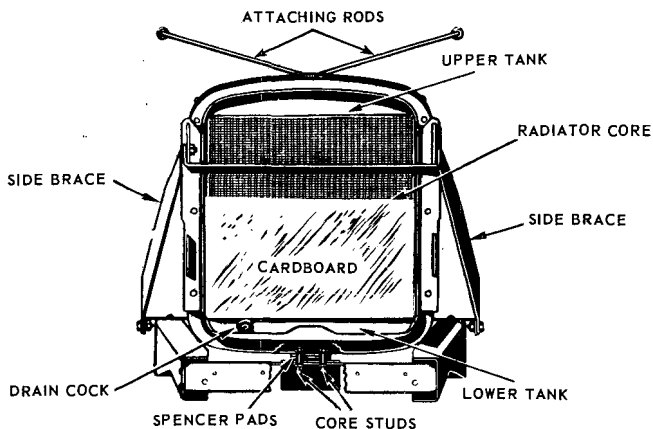
*Figure 83. Governor stuck closed.*

#### 84. Thermostat Stuck Closed

If the thermostat is stuck in the closed position, the engine will overheat. The thermostat may be removed from the system (fig. 84). A piece of cardboard may be placed in front of the radiator to reduce time for initial warmup.

#### 85. Collapsed Radiator Hose

A collapsed radiator hose usually causes the engine to overheat at high speeds. This trouble will be encountered in the lower radiator hose only which, after becoming oil soaked and subjected to engine heat, becomes soft and collapses due to suction from the water pump. The hose will usually collapse and cause overheating at high speeds. At low speeds, the hose will usually open



(A)

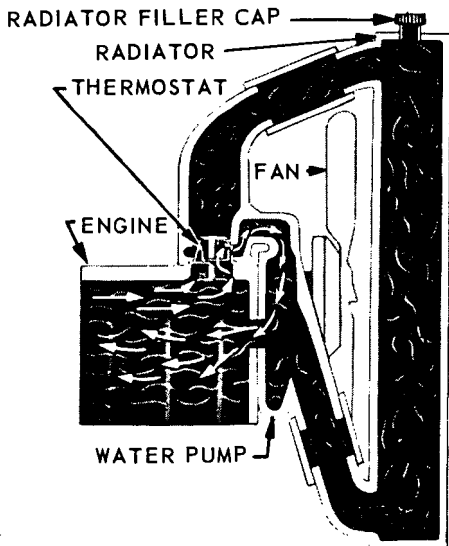
Figure 84. Thermostat stuck closed.

and allow coolant to circulate and cool the engine properly. To remedy the trouble, a piece of heavy wire may be made into a coil the same diameter as the inside of the hose and inserted into the hose. The coil of wire will prevent the hose from collapsing (fig. 85).

*Note.* Many vehicles are equipped with this coil in the lower radiator hose at the factory.

## 86. Improvised Hose Clamp

Very often, a hose clamp of correct size is not available. To keep vehicles in service, you should improvise a hose clamp. A temporary clamp may be made by placing a loop in one end of the wire



(B)  
Figure 84—Continued.

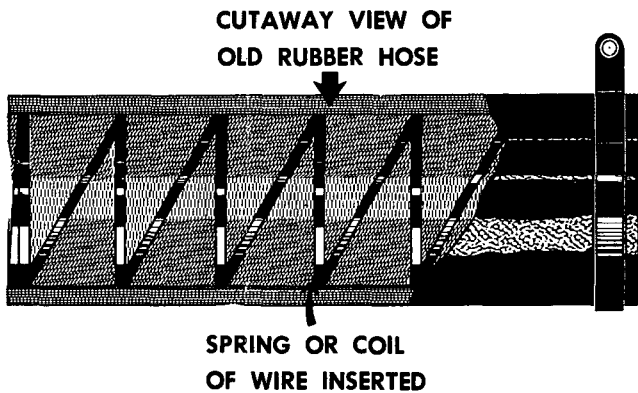
and pulling the other end through the loop with a pair of pliers and fastening them (fig. 86).

#### 87. Stripped or Broken Axle Flange Studs

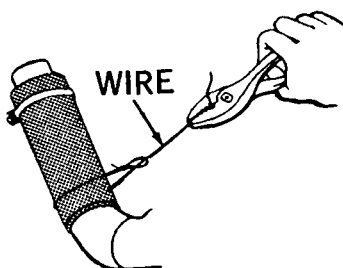
Remove the broken axle studs with a punch or chisel and hammer, and replace them with a common bolt or capscrew taken from the body of the vehicle (fig. 87).

#### 88. Bleeding Brakes

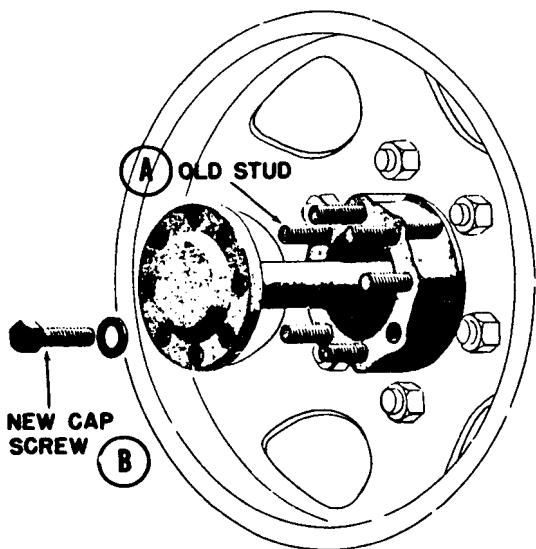
Hydraulic brakes may be bled by holding a finger over the bleeder valve of the cylinder being



*Figure 85. Collapsed radiator hose.*

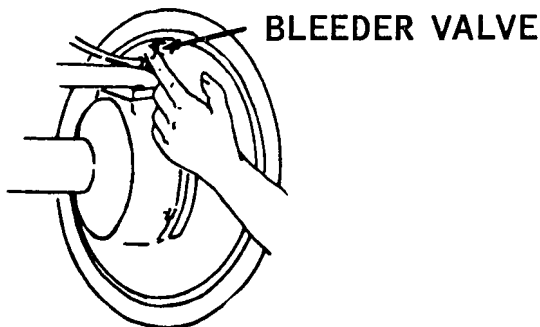


*Figure 86. Improvised hose clamp.*



*Figure 87. Stripped or broken axle flange studs.*

bled (fig. 88). A bleeder hose is not mandatory. The finger will act as a one-way valve, preventing air from entering the system but allowing the fluid to be forced out as the pedal is depressed. When a solid stream of brake fluid flows from under the finger, the cylinder is bled sufficiently. This method is suitable in the field where the fluid may leak onto the ground, but if used in a shop or on a floor, a container or rag should be held under the bleeder valve to catch the fluid.

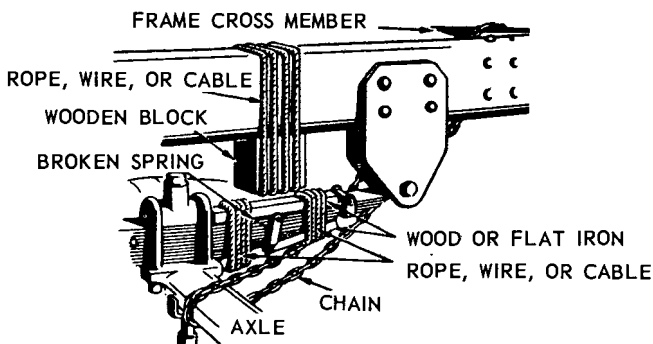


*Figure 88. Bleeding brakes.*

*Note.* Bleed only the minimum amount of fluid, to prevent waste.

### **89. Broken Spring**

It is dangerous to operate a vehicle with a broken spring. If the broken spring is on a driving axle, it will usually cause the axle to shift and the vehicle to veer to one side. A broken spring may cause the propeller shaft to be pulled from its socket and drop loose or lock the wheels and cause a serious accident. Temporary repair can be made by prying the axle back into position and securing it with a chain. If the spring will not stay alined, pry it back in place and lash two pieces of wood to it, as illustrated in figure 89. If the spring will not support the weight, lash a



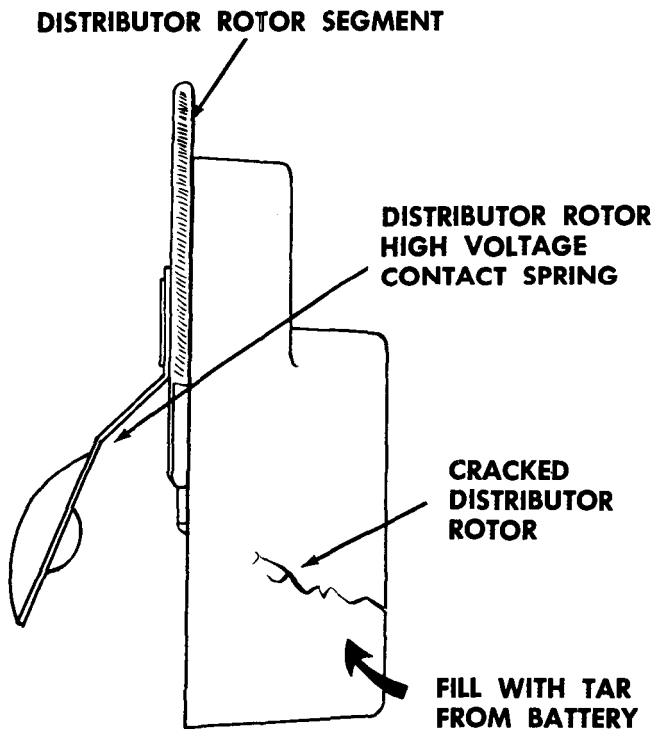
*Figure 89. Broken spring.*

block of wood to the frame in a manner to relieve the weight from the spring.

#### 90. Cracked Distributor Rotor

A cracked rotor (fig. 90) may often cause difficulty for mechanics as well as drivers. Like the distributor cap, it usually causes trouble on damp mornings and prevents the engine from starting until late in the day, after the rotor has dried out. To detect a shorted or cracked distributor rotor, remove the distributor cap from the distributor body. This will expose the rotor for inspection. Remove the coil secondary wire from the distributor cap and hold it about one-fourth of an inch from the top of the rotor. With the ignition on, turn the engine over. If a spark jumps from the wire to the rotor, the rotor is





*Figure 90. Cracked distributor rotor.*

shorted. If the rotor reveals a crack, scrape the crack thoroughly and fill it with tar from the storage battery. Repeat the test to determine whether the trouble has been corrected.

#### 91. Grounded Spark Plug Wire (Waterproof Ignition)

If, in a waterproof ignition system, a spark plug wire is grounded to its shielding, pull the wire from the shielding and place the wire back

in position. The engine can then be operated satisfactorily in this manner.

## **92. Defective Starter Relay Circuit**

On some tracked vehicles, the starter relay and the master relay switches are similar. If one cannot be procured, the other may be substituted.

## CHAPTER 5

### VEHICLE RECOVERY

---

#### Section I. SIMILAR VEHICLES

##### 93. Use of Similar-Type Vehicles

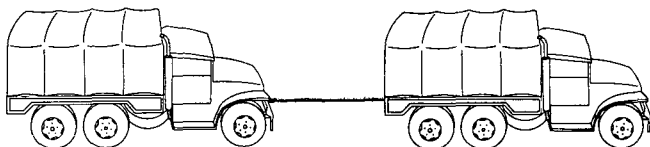
Occasionally, vehicles become mired and a special purpose vehicle is not available to make the recovery. During combat, it may be of the utmost importance that your cargo reach its destination, that you pick up personnel or cargo at a given time or, if driving a combat vehicle, that you attack at a specific time. Vehicles of similar type or larger can generally pull a disabled vehicle to a place where it can proceed under its own power. Much may depend on your knowledge of how to accomplish such recovery. However, during combat, it is also very important to know when to use general purpose or combat vehicles to aid in recovery. Normally, vehicles that have been committed to combat should not be withdrawn to assist another vehicle that has become mired or stuck. The importance of the mission of the assisting vehicle should always be first consideration. Although not always issued during peacetime, during combat equipment that is needed for emergency recovery is authorized for each vehicle.

#### 94. Use of Similar-Type Wheeled Vehicles

To recover a mired truck by use of a similar-type vehicle, a tow chain can be used. (If a tow chain is not available, a rope, tire chain, or other means of connecting the vehicles can be substituted.) The direction in which the mired truck is recovered depends upon the situation; usually, it is easier to recover any vehicle in the opposite direction from that in which it was traveling. Connect the chain between the two trucks by means of their *lifting shackles* (fig. 91), and direct both drivers to shift into low range and apply power gradually and at the same time. Caution should be exercised to prevent an impact load or a jerk being applied to the chain or rope. If the truck to be recovered is mired too deeply or if it cannot apply power to its wheels, a similar-type vehicle should not be used; a wrecker truck should be called upon.

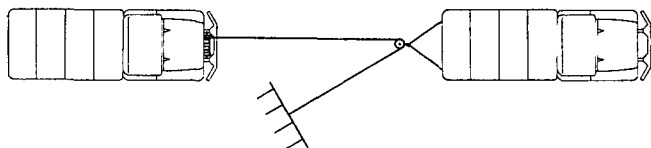
#### 95. Use of a Similar-Type Vehicle Equipped with a Winch

A truck of equal or greater capacity, equipped with a winch, could be used to recover a truck



*Figure 91. Pulling with a similar-type vehicle.*

that is mired but, after recovery, could move under its own power. All trucks with winches are authorized 1 single snatch block and 1 tow chain for rigging. Mechanical advantage should be used because, in most cases, the resistance of the mired vehicle is greater than the capacity of the winch. Aline the winching truck with the disabled truck for correct fleet angle. Attach the snatch block to the disabled truck with the tow chain, forming a sling from the snatch block to the lifting shackles. Rig a 2 to 1 mechanical advantage with the winch cable by attaching the end of the cable to the lifting shackles of the winching truck and placing the cable loop in the snatch block (fig. 92). For additional power, signal the driver of the mired vehicle to apply power to the wheels gradually at the same time power is applied to the winch. Continue the winching operation until the mired vehicle is in a position from which it can drive off under its own power. If a mired or nosed truck is equipped with a winch, it may be recovered by using the tow chain to anchor



*Figure 92. Winching with a similar-type vehicle.*

the snatch block in front of the truck, attaching the end of the winch cable to the lifting shackles on the truck and placing the cable loop in the snatch block (2 to 1 mechanical advantage) (fig. 93), and gradually applying power to the winch and wheels at the same time.

#### 96. Towing Disabled Truck with a Similar-Type Vehicle

A vehicle of the same size as or larger than a disabled vehicle can use a tow chain to tow the disabled vehicle. (If a tow chain is not available, a rope, tire chain, or other means of connecting the vehicles can be substituted.) Connect the chain from a lifting shackle on the towing vehicle to a lifting shackle on the disabled vehicle (fig. 94). A driver will be needed in the towed vehicle



*Figure 93. Winching with component winch.*



*Figure 94. Towing disabled truck with a similar-type vehicle.*

to steer it and to operate the brakes. Check the vehicle technical manual for precautions to be observed and use extreme care to prevent additional damage while towing the vehicle. This method of towing should not be used in cities or areas of heavy traffic. For towing in a city or in heavy traffic, the front lifting shackles of the towed truck may be tied tightly to the rear lifting shackles of the towing truck. Turns must be made with caution because there will be skidding when the towed truck tries to follow the towing vehicle. If both trucks have airbrakes, the air lines should be connected between the two vehicles. With the air lines connected, it is not necessary to have a driver in the towed vehicle. Speed should not exceed 15 MPH while any type of wheeled vehicle is being towed. If the distance is over 10 miles, and the situation permits, it is best that a wrecker truck be used to tow.

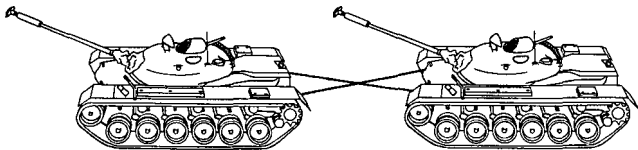
#### 97. Mired Tank

To recover a mired tank (if it is only mired and can move under its own power after it is recovered), 1 or 2 more tanks from the platoon and their tow cables can be used. The number of tanks necessary for the recovery will depend upon the extent to which the vehicle is mired (par. 17). The average tracked vehicle can pull a load equivalent to its own weight on dry, level terrain. All main battle tanks carry 2 tow cables; light tracked vehicles carry 1 tow cable. The strength of a tow cable is equal to or slightly greater than the effort of one pulling tank. If 2 tanks are used

to pull, 2 tow cables must be used between the mired tank and the tank next to it to withstand the effort applied. One cable may be used between the 2 pulling tanks (fig. 95). When two tow cables are used, they should be crossed to prevent the cable from becoming entangled with the track on turns (fig. 96). The tow cable between the tanks should be connected to the tow hooks of the tanks; all drivers should shift into *low range* and gradually apply power to the tracks at the same time. If the mired tank is disabled to the extent that it cannot apply power to its tracks, and the situation permits, a recovery vehicle should be called to perform the recovery.



*Figure 95. Recovering mired tank with similar-type vehicles.*



*Figure 96. Towing disabled tank with another tank.*

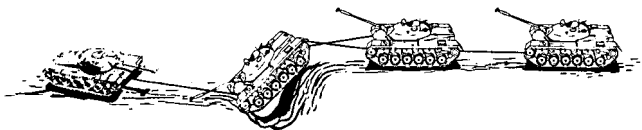


## 98. Nosed Tank

To recover a nosed tank, 2 or 3 tanks from the platoon and their tow cables may be used. The tow cables should be connected between the tanks the same as for recovery (fig. 95), except the towing tanks pull in reverse. The tank should be recovered in the direction opposite that in which it was moving when it nosed. In an extreme situation, a source of power may also be necessary to cause the front of the nosed tank to be lifted. To use a lifting tank, two or more tow cables should be connected together with tow hooks to gain additional length and allow a safe working distance. The connection should be made from the front of the lifting tank to the front of the nosed tank by means of their tow hooks (fig. 97). All the drivers should shift into reverse and, at the same time, gradually apply power until the nosed tank reaches a near horizontal position, then the lifting tank should be signaled to move forward, while still supporting the load, until the tank is recovered. Caution should be exercised to prevent pulling the lifting tank into the ditch. Usually, fuel will have spilled from the nosed tank; therefore, smoking or open flames should not be permitted, and the exhaust of the pulling tanks should be pointed away from the nosed tank.

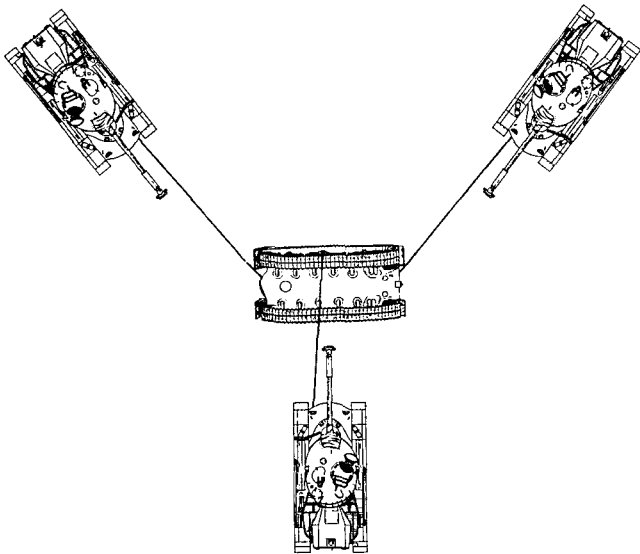
## 99. Overturned Tank

An overturned tank may be righted by use of three tanks from the platoon and their tow cables. One tank will be used for pulling the over-



*Figure 97. Recovering nosed tank with similar-type vehicles.*

turned tank upright; the other 2 tanks will be used to hold and retard the fall of the overturned tank. Tow cables should be connected together in pairs to gain additional length and to allow a safe working distance. One pair of cables should be connected from the tow hook on the pulling tank to the roadwheel arm housing near the center of the high side of the overturned tank (fig. 98). To prevent damage, never connect to any other part of the suspension system, turret, or tiedown eyes. The two tanks used for holding, with their tow cables connected together for length, will have connections made from the tow-



*Figure 98. Recovering overturned tank with similar-type vehicles.*

ing hook on each tank to the towing hook on the high side of the overturned tank. The two holding tanks should be positioned at a  $30^{\circ}$  to  $45^{\circ}$  angle from the overturned tank to prevent damage to the tow cables or the fenders and lights of the overturned tank when it is uprighted. Drivers of the holding tanks should shift into low range; the pulling tank should apply power gradually, in reverse, and the holding tanks should move forward only enough to keep slack out of the cables until the overturned tank passes the

vertical. After the overturned tank passes the vertical, the holding tanks move forward slowly, supporting the overturned tank and lowering it to its suspension system. Because of spilled fuel and oil, extreme caution must be exercised to prevent smoking or open flames near the overturned tank, and the exhaust of all recovery tanks should be pointed away from the overturned tank. If the overturned tank is on its turret, the use of two tanks may be necessary to pull it to the vertical position. The tanks may then be repositioned as illustrated.

#### 100. Towing Disabled Tank

A disabled tank can be towed by another tank of the same weight class using its two tow cables. The tow cables should be crossed, to prevent entanglement with tracks, and connected between the tanks by means of the tow hooks (fig. 98). A driver will be required in the towed tank to steer it and to operate the brakes. It will be necessary to have a man in each turret to watch the cables and to signal instructions. Because of the danger of carbon monoxide gas from the towing tank, the driver in the towed tank should be changed frequently (every 5-10 minutes). Check the vehicle technical manual for precautions to be used during towing to prevent additional damage to the tank. If the disabled tank has defective brakes, or the universal joints are disconnected, another tank will be necessary for holding. The holding tank is connected to the rear of the disabled tank for holding. Never exceed a



*Figure 99. Towing disabled tank downhill.*

speed of 12 MPH while towing any type of tracked vehicle. If the towing distance is over 1 mile, and the tactical situation permits, a recovery vehicle should be used to tow.

## Section II. SPECIAL PURPOSE VEHICLES

### 101. Wrecker Trucks and Recovery Vehicles

This section describes and explains recovery using wrecker trucks and recovery vehicles. Such recovery is usually performed at company and battalion levels, in support of the platoons, when other methods are unsuccessful or unsuitable. Wrecker trucks are designed to recover wheeled vehicles, and recovery vehicles are designed to recover tracked vehicles.

**Caution:** All safety precautions in paragraphs 38 through 40 and those listed in the technical manuals pertaining to the special purpose vehicle will be exercised during any recovery operation.

### 102. Mired Truck

To recover a mired truck with a wrecker truck, align the wrecker truck with the mired truck if

possible (fig. 100). This will permit more effective use of the anchors. If the wrecker truck cannot be positioned in alignment with the disabled vehicle because terrain or some object is in the way, a fixed block can be used to change the direction of pull. Compare the winch capacity to the estimated resistance and determine whether mechanical advantage is necessary (par. 17). In most cases, a direct pull will recover all 2½-ton trucks and lighter vehicles. Attach a tow chain to the lifting shackles on the mired truck to form a sling (fig. 31). Use the wrecker truck ground spades or the front winch as an additional anchor, if necessary. Signal the driver to apply power to the winch gradually, and recover the truck. Caution must be exercised to prevent damage to the frame when attaching rigging to trucks. Always use a sling attached to the lifting shackles (front or rear).

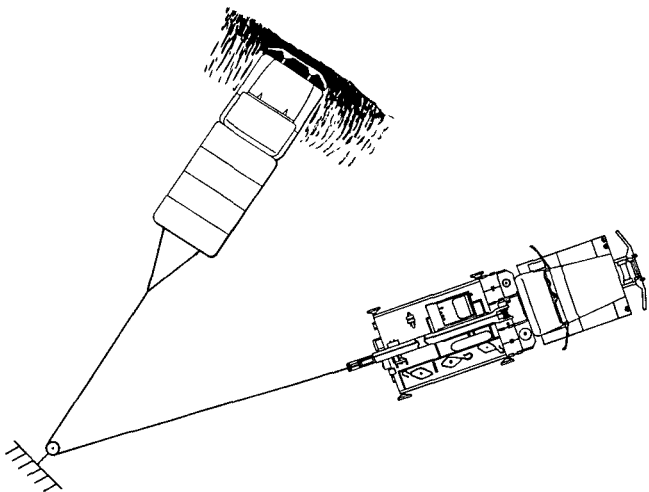
### 103. Nosed Truck

To recover a nosed truck or a truck over an embankment, position the wrecker truck parallel

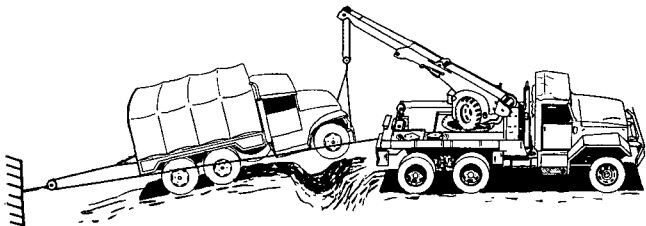


*Figure 100. Recovering mired truck with a wrecker truck.*

with and as close as possible to the shoulder of the road. The wrecker truck ground spades and outriggers should be used to stabilize the wrecker truck during this operation. Secure a single snatch block to an anchor on the opposite shoulder of the road from the disabled vehicle, to get a change of direction, rig the winch cable through the block, and attach the cable to the nosed truck by means of a tow chain attached as a sling to the lifting shackles (fig. 101). Signal the wrecker truck operator to apply power to the winch gradually, and winch the nosed truck up the embankment until its rear wheels are on the road. Rig



*Figure 101. Winching nosed truck with a wrecker truck.*



*Figure 102. Lifting nosed truck with a wrecker truck.*

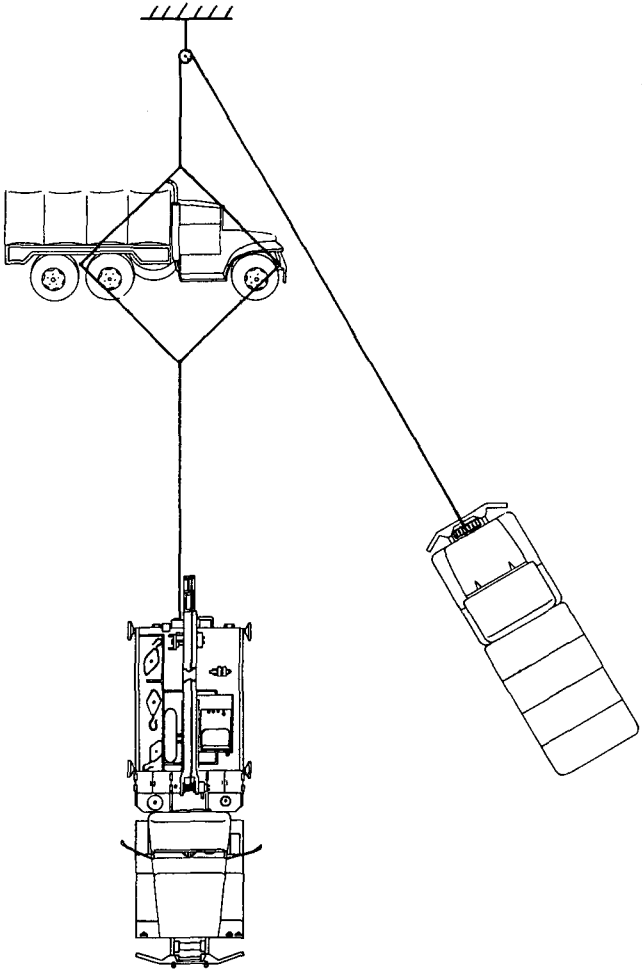
the wrecker truck crane to the front of the nosed truck with a tow chain forming a sling from the lifting shackles (fig. 102). Signal the wrecker truck operator to lift the front of the nosed truck to a horizontal position; signal the truck driver to set the parking brake on the truck. Disconnect the winch cable. Start the engine of the truck and release the brake. Then, through a coordinated movement, signal the truck driver to apply power to the wheels in reverse and the wrecker truck operator to traverse the crane, until the truck is turned parallel with the road and recovered.

#### 104. Overturned Truck

To upright an overturned truck, 2 sources of power are necessary: one for pulling the truck upright; and the second for a holding effort to keep the overturned truck from dropping too



hard, which will damage its suspension system. Caution must be exercised. A sling method of attachment must be used on the overturned truck for both sources of power, because a pulling force or holding force applied to only one point of the frame usually results in a bent frame. For the uprighting rigging, connect 1 end of a sling made of chain or 1-inch fiber rope to the frame just behind the front bumper on the high side, and the other end of the sling to the frame at a point above the spring seat bearing on the high side; then attach the end of the winch cable to the center of the sling (fig. 103). Use the wrecker truck ground spades for additional anchors if necessary. For the holding rigging, connect a second sling to the overturned truck frame at the same points as the uprighting sling. The holding source of power may be either crewmen or another truck. If the holding truck does not have a winch, use the 1-inch fiber rope from the wrecker truck, and attach it from the lifting shackles on the holding truck through a fixed block for a change of direction, and to the center of the holding sling. Signal the wrecker truck operator to apply power to the winch gradually until the overturned truck is past vertical, and the driver of the holding truck to move forward slowly to support and lower the overturned truck to rest on its own suspension system. If a holding truck is not available, crewmen may be used with a fiber rope tackle. One man, using a tackle with a 4 to 1 mechanical advantage and 3 turns



*Figure 103. Recovering overturned truck with a wrecker truck.*

around a tree with the fall line, can control the dropping speed when uprighting the truck. Caution must be exercised to prevent smoking or open flames near the overturned truck because of the danger of igniting spilled fuel and oil.

#### 105. Towing Wheeled Vehicles

Frequently, it will be necessary to tow the recovered vehicle to a repair shop with a wrecker truck. The method of towing a vehicle depends primarily upon the terrain over which it is to be towed. A wrecker truck is capable of towing vehicles by the following methods:

*a. Highway Tow.* The towbar is used whenever possible. Attach the towbar from the wrecker truck towing pintle to the front of the disabled truck (fig. 104). All wheels of the disabled truck are on the ground. No driver is necessary in the disabled truck. Precautions as prescribed in the technical manual for the vehicle should be complied with before towing.

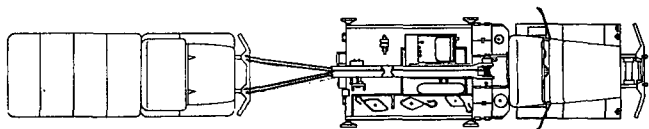
*b. Crosscountry Tow.* To tow crosscountry, better control of the disabled truck over rough terrain is necessary. Attach a sling to the lifting shackles on the disabled truck; place the sling through the hook on the boom winch. Attach a tow chain from the wrecker truck towing pintle to the lifting shackles of the disabled vehicle. Raise the front end of the disabled truck until its front wheels are approximately 12 inches off the ground (fig. 105). Extend the boom until both chains become taut. This prevents the truck from

swaying while it is being towed. No driver is necessary in the disabled truck. For some trucks, it may be necessary to extend the boom shipper braces to allow the boom to ride high enough to lift the front wheels of the disabled truck to a safe height off the ground. The boom shipper braces should always be used to take the strain off the boom hoist ram and swing gears. A hoisting bar, if available, may be used instead of the hoist sling and the tow chain may be connected between the bar and the pintle hook on the wrecker truck.

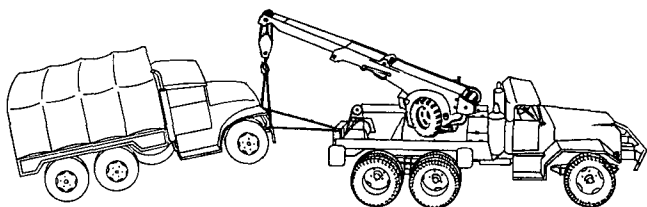
*c. Tandem Tow.* When terrain makes it impossible to tow a vehicle with one wrecker truck, the tandem tow method can be used. To rig a tandem tow, align 2 wrecker trucks in front of the disabled vehicle, with a distance of approximately 50 feet between vehicles. Form a sling by attaching a tow chain to the lifting shackles of the disabled truck. Attach a single snatch block to the sling. Rig the rear winch cable from the wrecker truck nearest the disabled vehicle, through the block, and back underneath the wrecker to the towing pintle of the front wrecker truck (fig. 106). With this rigging, one wrecker may serve as an anchor while the other pulls with a mechanical advantage; or both wreckers may pull together. Extreme caution is necessary to keep the cable taut and not allow it to become entangled with the wheels of the middle vehicle.

#### 106. Towing Precautions for Wheeled Vehicles

Extreme care must be exercised when towing disabled wheeled vehicles to prevent additional



*Figure 104. Highway tow with a wrecker truck.*



*Figure 105. Crosscountry tow with a wrecker truck.*



*Figure 106. Tandem tow with wrecker trucks.*

damage while they are being towed. The vehicle technical manual should be checked for towing precautions peculiar to the vehicle. The following general safety precautions should be exercised.

a. *Short Hauls* (less than 10 miles). On trucks with Hydra-Matic transmissions, shift the transmission to NEUTRAL position and the transfer to DOWN NEUTRAL position. For trucks with standard transmissions, shift the transmission and the transfer to NEUTRAL position.

b. *Long Hauls* (over 10 miles). To prevent damage to the transmission and transfer, remove all propeller shafts of wheels that remain on the ground.

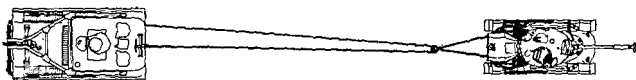
c. *Speed*. Never exceed 15 MPH while towing any type of wheeled vehicle.

#### 107. Mired Tank

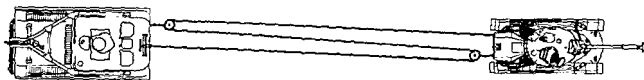
a. *Recovery With One Recovery Vehicle*. To recover a mired tank with one recovery vehicle, position the recovery vehicle in proper relation with the mired tank to obtain the correct fleet angle (par. 8a). Compare the capacity of the winch to the estimated load resistance and determine the amount of mechanical advantage necessary (par. 17). Use the backup or lead method described in paragraph 36 to erect the rigging. When a 2 to 1 mechanical advantage is desired (fig. 107), the block should be attached to the towing hooks on the mired tank by means of either a *floating block, tow cables, or a tow bar* (par. 37b(1)-(3)). Connecting the block to one

towing eye would cause the tank to be pulled sideways and increase the load resistance. To rig a 3 to 1 mechanical advantage (fig. 108), one block is connected to one towing eye with a shackle, and the end of the winch cable to the other towing eye. After rigging is erected, signal the recovery vehicle to apply power to the winch gradually and recover the tank.

*b. Recovery With Two Recovery Vehicles.*  
When 1 recovery vehicle with a 3 to 1 mechanical advantage is insufficient to recover a mired tank,



*Figure 107. Recovering mired tank with recovery vehicle using 2 to 1 mechanical advantage.*

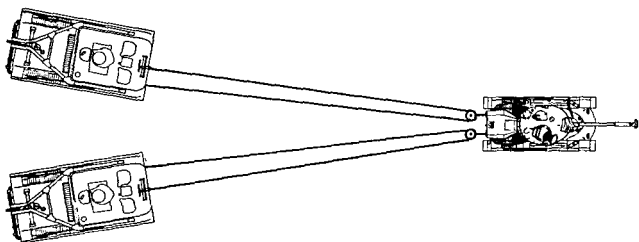


*Figure 108. Recovering mired tank with recovery vehicle using 3 to 1 mechanical advantage.*

a second recovery vehicle will be necessary to increase the effort available. Rig each recovery vehicle with the same mechanical advantage by using the backup or lead method (par. 36) to erect the rigging. The recovery vehicles should be positioned side by side to allow the same lengths of winch cable to be used because of their variable capacity winches (par. 8a). To rig the recovery vehicles with a 2 to 1 mechanical advantage, attach the block of each rigging to a towing eye with a shackle (fig. 109). To synchronize winch speeds, both recovery vehicle operators should set their engine speed at the desired r.p.m. with the hand throttle, and compensate with the foot accelerator to maintain taut cables.

#### 108. Nosed Tank

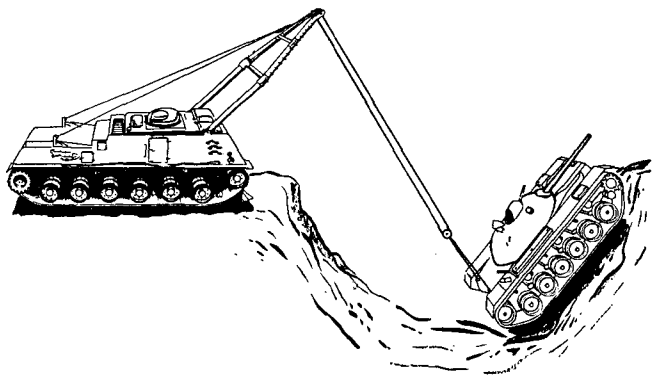
To recover a tank nosed in a deep ditch or ravine with a recovery vehicle, position the re-



*Figure 109. Recovering mired tank using two recovery vehicles.*



covery vehicle as close as possible to, in alinement with and facing, the disabled vehicle. Using the boom with its maximum mechanical advantage, connect the boom hoist block to the towing hooks on the nosed tank by means of a V-chain (fig. 110). Signal the recovery vehicle operator to apply power gradually to the boom winch, and the tank driver to apply power to the tracks at the same time, and recover the tank. In extreme situations, it may be necessary to use a combination winching and lifting operation and recover the nosed tank to the same side of the ditch on which the recovery vehicle is positioned. Smoking or open flames must not be permitted near the nosed tank because of the danger of igniting fuel and oil that may have spilled.



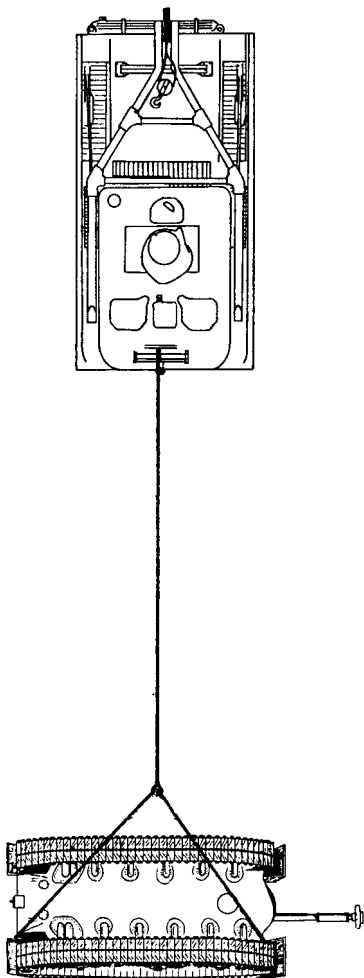
*Figure 110. Recovering nosed tank with recovery vehicle.*

## 109. Overturned Tank

When a recovery vehicle is used to upright an overturned tank that is down an embankment, the recovery vehicle should be positioned facing the bottom side of the overturned tank, and as far away as possible. Rig a sling with 2 tow cables by connecting 1 end of each cable with a towing hook or shackle to the overturned tank's lifting eyes on the high side. Use a shackle to connect the opposite ends of each tow cable to the main winch cable of the recovery vehicle (fig. 111). Signal the recovery vehicle operator to apply power gradually to the winch and upright the tank against the embankment. Clear the tank of all spilled fuel or oil. With the rigging still attached to prevent the tank from overturning, signal the tank driver to apply power to the tracks and climb the embankment.

***Caution:*** Do not allow the cables to become entangled in the track.

If the embankment is too steep for the tank to climb, the tank driver should apply power to the tracks and turn the tank into a position that will prevent its overturning, disconnect the uprighting, rigging, and rerig for a winching operation to pull the tank up the embankment. If the overturned tank cannot be uprighted against an embankment, a source of power similar to that described in paragraph 99 should be used to prevent the tank from falling too hard on its suspension system. Extreme care should be exercised to prevent smoking or open flames near the over-



*Figure 111. Recovering overturned tank with recovery vehicle.*

turned tank because of the possibility of igniting fuel and oil that may have spilled.

*Note.* In an emergency, expedite the recovery operation by omitting the holding source of power.

### 110. Towing Tracked Vehicles

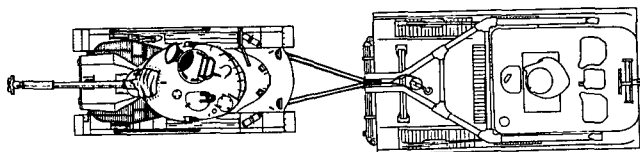
Frequently, it will be necessary for the recovery vehicle to tow a recovered vehicle to a repair shop. The method of towing depends primarily upon the terrain over which the vehicle will be towed. A recovery vehicle is capable of towing vehicles by the following methods:

*a.* On the highway, attach the tow bar from the recovery vehicle towing pintle to the front towing eyes on the disabled vehicle (fig. 112). No driver is required in the disabled tank.

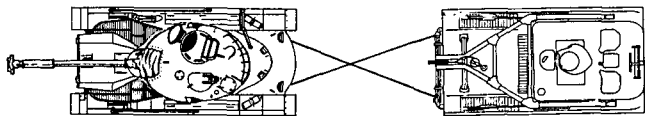
*b.* To tow crosscountry or over rough terrain, connect two tow cables between the vehicle by means of the tow hooks (fig. 113). When using two tow cables, they should be crossed to prevent entanglement with the tracks or fenders when a turn is made. A driver will be needed in the towed vehicle to steer it and to operate the brakes; a man will be required in each turret to watch the cables and to signal instructions. The driver of the towed tank can steer by shifting into low range momentarily for turning, and then shifting back into neutral.

*c.* In combat, the V-chain is used for towing when it is necessary to make a towing connection with the least possible exposure of personnel when under fire. The V-chain is attached to the towing

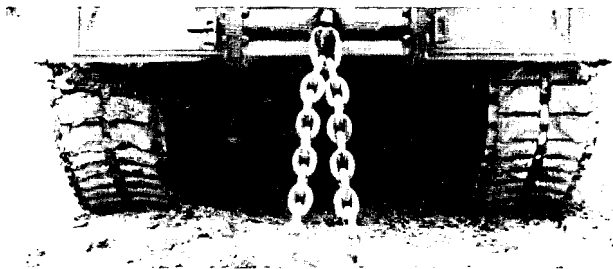
pintle of the recovery vehicle before entering the combat area, (fig. 114). The recovery vehicle is then backed into position by viewing from the commander's cupola periscope until contact is made with the front of the disabled tank. One of the tank crewmembers can then slip through the escape hatch, crawl under the vehicle, and connect the V-chain arms to the towing hooks of the disabled tank. If the sides of the vehicles are exposed to fire, another tank can be called to furnish cover by taking position parallel to the operation on the side drawing fire.



*Figure 112. Highway tow with recovery vehicle.*



*Figure 113. Crosscountry tow with recovery vehicle.*



*Figure 114. V-chain attachment for combat tow hookup.*

### 111. Towing Precautions for Tracked Vehicles

When a disabled tracked vehicle is being towed, care must be exercised to prevent additional damage to the towed vehicle. The vehicle technical manual should be checked for towing precautions peculiar to the vehicle. The following general safety precautions should always be exercised:

a. For short hauls (less than 1 mile), the power train is connected with the gearshift control lever in NEUTRAL position. If tow cables are used, a driver will be needed to control the towed vehicle.

b. For long hauls (over 1 mile), to prevent damage to the transmission, the power train should be disconnected at the universal joints to the final drives. The tow bar must be used when the power train is disconnected, to control the disabled tank.

*c.* Never exceed speed of 12 MPH while towing any tracked vehicle.

*d.* Other precautions are the same as those used when one tank tows another (par. 100).

## APPENDIX

### REFERENCES

---

#### 1. Field Manuals

- |          |                                     |
|----------|-------------------------------------|
| FM 21-5  | Military Training.                  |
| FM 21-6  | Techniques of Military Instruction. |
| FM 21-30 | Military Symbols.                   |

#### 2. Regulations

- |           |   |
|-----------|---|
| AR 320-5  | Dictionary of United States Army Terms.     |
| AR 320-50 | Authorized Abbreviations and Brevity Codes. |

#### 3. Miscellaneous

- |              |  |
|--------------|--|
| TM 5-725     | Rigging.   |
| DA Pam 310-4 | Index of Technical Manuals, Technical Bulletins, Supply Bulletins, Lubrication Orders, and Modification Work orders. |
| TB ORD 537   | Combat Vehicles and Tactical Transport Vehicles: Procedures for Starting Engines with Slave Cable.                   |



## INDEX

	Paragraph	Page
A-frame, use-----	52	79
Air filter clogged-----	79	116
Anchoring a wheel-----	57	89
Anchors-----	25-27	41
Use of other vehicles as-----	27	42
Assembly of rigging-----	36	54
Attachment of rigging-----	37	57
Auxiliary winch-----	36	54
Axle flange studs stripped or broken-----	87	123
Axle or wheel disabled-----	60	95
Backup method of assembling rigging-----	36	54
Battery clamp corroded-----	67	104
Bellied tank-----	45	72
Bleeding brakes-----	88	123
Blocks-----	7	10
Brake lines broken-----	75	111
Brakes, bleeding-----	88	123
Breaking strength-----	22-24	39
Chain-----	24	41
Fiber rope-----	22	39
Formula for determining-----	22-24	39
Wire rope-----	23	40
Breaking thrown track-----	48	75
Broken distributor point spring-----	66	102
Axle flange studs-----	87	123
Brake line-----	75	111
Fan belt-----	74	111
Fan blade-----	80	117
Fuel or oil line-----	81	118
Spring-----	89	126
Tandem spring-----	63	100

	Paragraph	Page
Calculating ratio of mechanical advantage.....	30	51
Center bearing defective.....	62	100
Chain.....	24	41
Clogged air filter.....	79	116
Compound tackle.....	7	10
Connecting broken track.....	50	78
Controlled steering.....	42-44	71
Conventional block.....	7	10
Corroded battery clamp.....	67	104
Cracked distributor rotor.....	90	127
Crosscountry tow.....	105	146
Crossed cables.....	40	66
Damaged roadwheel or arm.....	46	75
Dead line.....	21	38
Deadman.....	27	42
Defective differential.....	61	97
Defective final drive (wheeled vehicle).....	61	97
Center bearing.....	62	100
Defective fuel pump.....	82	119
Differential defective.....	61	97
Distribution of effort or force.....	18	36
Distributor cap shorted.....	64	100
Distributor point spring broken.....	66	102
Distributor rotor cracked.....	90	127
Effort and resistance.....	3-4	4
Engines—shut off during hookup.....	40	66
Erection of rigging.....	33	52
Estimating resistance.....	29	50
Fall line.....	19	38
Fan belt broken.....	74	111
Fan blade broken.....	80	80
Fiber rope.....	22	39
Field expedients.....	41	71
Field method of determining resistance.....	17	34
Final drive defective (wheeled vehicle).....	61	97
Fixed block.....	7	10
Fleet angle.....	8	21

	Paragraph	Page
Force.....	3	4
Frozen fuel line.....	68	105
Fuel line frozen.....	68	105
Fuel or oil line broken.....	81	118
Fuel pump defective.....	82	119
Fuel pump failure due to vapor lock.....	71	107
Fuel tank, punctured.....	72	108
Pinhole leak.....	78	115
Governor, stuck.....	83	119
Grade resistance.....	13	31
Ground anchors.....	27	42
Grounded spark plug wire.....	91	128
Handling cables.....	38	65
High centered.....	45	72
Highway tow, wheeled vehicle.....	105	146
Hookup.....	37	57
Hooks in rigging.....	40	66
Hose clamp improvised.....	86	122
Ignition points dirty.....	77	115
Improvised hose clamp.....	86	122
Jack, substitute.....	58	91
Lead method of assembling rigging.....	36	54
Leading block.....	7	10
Leaking line fittings.....	69	105
Level wind.....	8	21
Lever.....	6	7
Lifting shackles.....	37	57
Linking broken track.....	50	78
Log as substitute for jack.....	58	91
Log-picket holdfast.....	27	42
Logs, use of to cross ditches.....	53	80
Loops in cable.....	40	66
Manpower.....	10	29
Mechanical advantage.....	5	7
Fixed blocks.....	7	10
Ratio.....	30	51

	Paragraph	Page
Natural anchors.....	26	42
Nosed tank.....	98	136
Nosed truck, recovery.....	103	141
Observing, safe areas.....	39	65
Oil or fuel line:		
Broken.....	81	118
Cracked.....	70	106
Leaking.....	69	105
Oil or fuel line broken.....	81	118
One track spins.....	44	72
Overturned tank.....	99	136
Overturning resistance.....	14	33
Parachute.....	27	42
Picket holdfast.....	27	42
Pole used as a pry.....	56	89
Power.....	3	4
Precautions when towing wheeled vehicles.....	106	147
Tracked vehicle.....	111	157
Pry, use.....	56	89
Punctured fuel tank.....	72	108
Radiator core.....	73	108
Radiator hose collapsed.....	85	121
Rechecking rigging.....	34	53
Reconnaissance of area.....	28	49
Recovery, using similar type vehicles.....	93-100	130
Overturned tank.....	99	136
Tanks mired.....	97	134
Tanks nosed.....	98	136
Wheeled vehicles.....	94	131
Recovery vehicles.....	101	140
Precautions to be used.....	111	157
To recover mired tank.....	107	149
To rcover nosed tank.....	108	151
To recover overturned tank.....	109	153
To tow tracked vehicles.....	110	155
Remounting thrown track.....	49	78
Resistance.....	3, 11	4, 29
Field method of determining.....	17	34

Resistance—Continued	Paragraph	Page
Grade-----	13	31
How incurred-----	11	29
Overturning-----	14	33
Rolling-----	12	30
Sources-----	11	29
Tackle-----	15	33
Terrain-----	12	30
Total-----	31	51
Return line-----	20	38
Rigging-----	18	36
Assembly-----	36	54
Attachment to vehicles-----	37	57
Backup method-----	36	54
Lead method-----	36	54
Wheeled vehicles-----	36	54
Roadwheel or arm damaged-----	46	75
Rocks as anchors-----	26	42
Rolling resistance-----	12	30
Rotor, distributor, cracked-----	90	127
Rotor spring broken-----	65	102
Running block-----	7	10
Safety-----	38-40	65
Safety keys-----	40	66
Sand parachute-----	27	42
Deadman-----	27	42
Shearpin, substitute-----	76	112
Shears use-----	52	79
Shorted distributor cap-----	64	100
Similar type vehicles used for recovery-----	93	130
Wheeled vehicles-----	94	131
With winch-----	95	131
Simple tackle-----	7	10
Skid, use-----	59	93
Slave-cable starting-----	51	78
Sling, attaching to vehicle-----	37	57
Snatch block-----	7	10
Sources of power-----	8-10	21

	Paragraph	Page
Spark plug wire grounded.....	91	128
Spring broken.....	89	126
Sprocket as a winch.....	47	75
Starter relay defective.....	92	129
Steering action.....	42	71
Strength.....	3	4
Anchors.....	27	42
Fiber rope.....	22	39
Wire rope.....	23	40
Tackle.....	7	10
Tackle resistance.....	15	33
Tandem spring broken.....	63	100
Tandem tow with wheeled wreckers.....	105	146
Tandem wheel or axle disabled.....	60	95
Thermostat stuck closed.....	84	121
Thrown track, breaking.....	48	75
Total resistance.....	31	51
Tow hooks.....	37	57
Towing with similar type vehicle, tracked and wheeled.	96	133
Track breaking thrown.....	48	75
Remounting.....	49	78
Tramway: Recovery vehicle used for.....	55	84
Traveling block.....	7	10
Trees as anchors.....	26	42
Vapor lock.....	71	107
Verifying solution.....	32	51
Wheel or axle disabled.....	60	95
Winch, wheels used.....	54	84
Sprocket hub used.....	47	75
Winches.....	8	21
Windlass.....	9	24
Wire rope.....	23	40
Wrecker trucks.....	101-106	140

By Order of the Secretary of the Army:

EARLE G. WHEELER,  
*General, United States Army,*  
*Chief of Staff.*

Official:

J. C. LAMBERT,  
*Major General, United States Army,*  
*The Adjutant General.*

Distribution:

*Active Army:*

DCSOPS (2)	USAIS (25)
DCSLOG (2)	USA Ord Sch (20)
CARROTC (2)	USATSch (100)
CNGB (2)	Specialist Sch (2)
CRD (2)	USATC Armor (25)
CofEngrs (5)	USATC AD (25)
CSigO (5)	USATC Engr (25)
TSG (5)	USATC Inf (25)
CofT (5)	USATC FA (25)
USA Maint Bd (10)	PMS Sr Div Unit (2)
USCONARC (10)	PMS Mil Sch Div Unit (2)
OS Maj Comd (10)	PMS Jr Div Unit (2)
OS Base Comd (5)	GENDEP (2)
LOGCOMD (5)	Sup Sec, GENDEP (2)
MDW (5)	Dep (2)
Armies (10)	USA Trans Tml Comd (2)
Corps (5)	Army Tml (2)
Div (5)	PG (2)
Bde (5)	Arsenals (2)
Regt/Gp/bg (5)	Plants/Works (2)
Bn (5)	Fld Maint Shop (2)
Co/Btry (5)	Div Engr (2)
Instls (5)	Dist Engr (2)
USAARMS (3,930)	USA Corps (2)
USAAMS (5)	MAAG (2)
USAES (120)	Mil Msn (2)

*NG*: State AG (3)—units—same as Active Army except allowance is one copy each unit.

*USAR*: Same as Active Army except allowance is one copy each unit.

For explanation of abbreviations used, see AR 320-50.

☆ U. S. GOVERNMENT PRINTING OFFICE: 1962—650528