

ARMY *TM 9-2320-272-23-2

AIR FORCE *TO 36A12-1C-1155-2-2

TECHNICAL MANUAL FIELD MAINTENANCE MANUAL FOR

TRUCK, 5-TON, 6X6, M939, M939A1, AND M939A2 SERIES TRUCKS (DIESEL)

TRUCK, CARGO: 5-TON, 6X6 DROPSIDE M923 NSN 2320-01-050-2084 (EIC BRY) M923A1 NSN 2320-01-206-4087 (EIC BSS) M923A2 NSN 2320-01-230-0307 (EIC BS7) M925 NSN 2320-01-047-8769 (EIC BRT) M925A1 NSN 2320-01-206-4088 (EIC BST) M925A2 NSN 2320-01-230-0308 (EIC BS8)	TRUCK, DUMP: 5-TON, 6X6 M929 NSN 2320-01-047-8756 (EIC BTH) M929A1 NSN 2320-01-206-4079 (EIC BSY) M929A2 NSN 2320-01-230-0305 (EIC BTN) M930 NSN 2320-01-047-8755 (EIC BTG) M930A1 NSN 2320-01-206-4080 (EIC BSZ) M930A2 NSN 2320-01-230-0306 (EIC BT7)	TRUCK, VAN, EXPANSIBLE: 5-TON, 6X6 M934 NSN 2320-01-047-8750 (EIC BTB) M934A1 NSN 2320-01-205-2682 (EIC BS4) M934A2 NSN 2320-01-230-0300 (EIC BTR)
TRUCK, CARGO: 5-TON, 6X6 XLWB M927 NSN 2320-01-047-8771 (EIC BRV) M927A1 NSN 2320-01-206-4089 (EIC BSW) M927A2 NSN 2320-01-230-0309 (EIC BS9) M928 NSN 2320-01-047-8770 (EIC BRU) M928A1 NSN 2320-01-206-4090 (EIC BSX) M928A2 NSN 2320-01-230-0310 (EIC BTM)	TRUCK, TRACTOR: 5-TON, 6X6 M931 NSN 2320-01-047-8753 (EIC BTE) M931A1 NSN 2320-01-206-4077 (EIC BS2) M931A2 NSN 2320-01-230-0302 (EIC BTP) M932 NSN 2320-01-047-8752 (EIC BTD) M932A1 NSN 2320-01-205-2684 (EIC BSZ) M932A2 NSN 2320-01-230-0303 (EIC BTQ)	TRUCK, MEDIUM WRECKER: 5-TON, 6X6 M936 NSN 2320-01-047-8754 (EIC BTF) M936A1 NSN 2320-01-206-4078 (EIC BS6) M936A2 NSN 2320-01-230-0304 (EIC BTT)

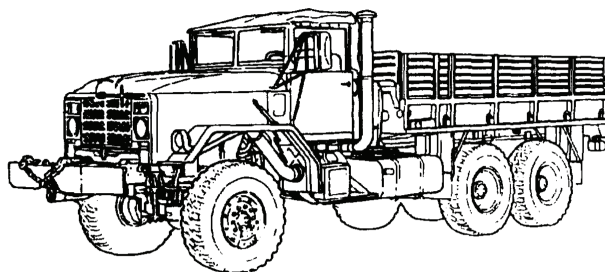

***SUPERSEDURE NOTICE** - This manual supersedes TM 9-2320-272-24-1, TM 9-2320-272-24-2, TM 9-2320-272-24-3, TM 9-2320-272-24-4 and TO 36A12-1C-1155-2-1, TO 36A12-1C-1155-2-2, TO 36A12-1C-1155-2-3, & TO 36A12-1C-1155-2-4, dated 30 June 1998, including all changes.

DISTRIBUTION STATEMENT A - Approved for public release; distribution is unlimited.

HEADQUARTERS, DEPARTMENTS OF THE ARMY AND THE AIR FORCE
10 SEPTEMBER 2012

WARNING SUMMARY

This warning summary contains general safety warnings and hazardous materials warnings that must be understood and applied during operation and maintenance of the vehicle. Failure to observe these precautions or operating this vehicle without training or instruction may result in serious injury or death to personnel.

FIRST AID DATA

For information on first aid, refer to FM 4-25.11, First Aid.

EXPLANATION OF SAFETY WARNING ICONS



EAR PROTECTION - Headphones over ears show that noise level will harm ears.



ELECTRICAL - Electrical wire to hand with electricity symbol running through hand shows that shock hazard is present.

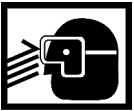

EYE PROTECTION - Person with goggles shows that the material will injure the eyes.



FIRE - Flame shows that a material may ignite and cause burns.



HEAVY OBJECT - Human figure stooping over heavy object shows physical injury potential from improper lifting technique.



HEAVY PARTS - Hand with heavy object on top shows that heavy parts can crush and harm.



HEAVY PARTS - Foot with heavy object on top shows that heavy parts can crush and harm.



HEAVY PARTS - Heavy object pinning human figure against wall shows that heavy, moving parts present a danger to life or limb.

WARNING SUMMARY - Continued

EXPLANATION OF SAFETY WARNING ICONS - Continued



HEAVY PARTS - Heavy object on human figure shows that heavy parts present a danger to life or limb.



HOT AREA - Hand over object radiating heat shows that part is hot and can burn.



MOVING PARTS - Hand with fingers caught between gears shows that the moving parts of the equipment present a danger to life or limb.



RADIATION - Three circular wedges shows that the material emits radioactive energy and can injure human tissue.



SLICK FLOOR - Wavy line on floor with legs prone shows that slick floor presents a danger for falling.



VAPOR - Human figure in a cloud shows that material vapors present a danger to life or health.

WARNING SUMMARY - Continued

GENERAL SAFETY WARNINGS DESCRIPTION

WARNING



Ensure electrical power is off prior to working on all electrical connections. Prior to working on or around vehicle, remove all jewelry, such as rings, ID tags, bracelets, etc. Jewelry, and tools can catch on equipment, contact positive electrical circuits, and cause a direct short, severe burns, or electrical shock. Failure to comply may result in injury or death to personnel.

WARNING



Personnel hearing can be permanently damaged if exposed to constant high noise levels of 85 dB or greater. Failure to comply may result in injury to personnel.

WARNING

Unless otherwise specified, perform all maintenance procedures with all attachments lowered to the ground, pilot shutoff lever in the up position, and engine shut off. Failure to comply may result in injury or death to personnel.

WARNING SUMMARY - Continued

EXPLANATION OF HAZARDOUS MATERIALS ICONS



BIOLOGICAL - Abstract symbol bug shows that a material may contain bacteria or viruses that present a danger to life or health.



CHEMICAL - Drops of liquid on hand shows that the material will cause burns or irritation to human skin or tissue.



EXPLOSION - Rapidly expanding symbol shows that the material may explode if subjected to high temperatures, sources of ignition, or high pressure.



POISON - Skull and crossbones symbol shows that dangerous gases, sprays, vapors, liquids, or materials contain compounds that present a danger to life or health.

WARNING SUMMARY - Continued

HAZARDOUS MATERIALS DESCRIPTIONS

WARNING



CARBON MONOXIDE

- Carbon monoxide is a colorless, odorless, deadly poison which, when breathed, deprives the body of oxygen and causes suffocation. Exposure to air containing carbon monoxide produces symptoms of headache, dizziness, loss of muscular control, apparent drowsiness, and coma. Permanent brain damage or death to personnel can result from severe exposure.
- Carbon monoxide occurs in exhaust fumes from internal combustion engines. It also occurs in exhaust fumes from engine coolant heater (arctic machine only). Carbon monoxide can become dangerously concentrated under conditions of inadequate ventilation. The following precautions must be observed to ensure safety of personnel when engine of vehicle is operated.
 1. DO NOT operate engine in enclosed area without adequate ventilation.
 2. DO NOT idle engine without adequate ventilation.
 3. DO NOT drive machine with inspection plates or cover plates removed.
 4. BE ALERT for exhaust poisoning symptoms. They are:
 - Headache
 - Dizziness
 - Sleepiness
 - Loss of muscular control
 5. If you see another person with exhaust poisoning symptoms:
 - Remove person from area
 - Expose to fresh air
 - Keep person warm
 - DO NOT permit physical exercise
 - Administer cardiopulmonary resuscitation (CPR) if necessary
 - Notify a Medic
 6. BE AWARE. The field protective mask for Nuclear-Biological-Chemical (NBC) protection will not protect you from carbon monoxide poisoning.

WARNING SUMMARY - Continued**HAZARDOUS MATERIALS DESCRIPTIONS - Continued****WARNING****CHEMICAL AGENT RESISTANT COATING (CARC) PAINT**

Chemical Agent Resistant Coating (CARC) paint contains isocyanate which is highly irritating to skin and respiratory system. High concentrations of isocyanate can produce symptoms of itching and reddening of skin, a burning sensation in the throat and nose, and watering of the eyes. In extreme concentrations, isocyanate can cause cough, shortness of breath, pain during respiration, increased sputum production, and chest tightness. First aid for ingestion: do not induce vomiting. Seek immediate medical attention. First aid for skin contact: remove contaminated clothing. Wash skin thoroughly with soap and water. If symptoms persist, seek medical attention. First aid for inhalation: move to fresh air. If not breathing, provide artificial respiration. If symptoms persist, seek medical attention. Failure to comply may result in injury or death to personnel.

WARNING SUMMARY - Continued**HAZARDOUS MATERIALS DESCRIPTIONS - Continued****WARNING****SOLVENT CLEANING COMPOUND**

Solvent cleaning compound MIL-PRF-680 type II and III may be irritating to the eyes and skin. Use protective gloves and goggles. Use in well ventilated areas. Use respirator as needed.

Accidental ingestion can cause irritation of digestive tract and repository tract, and may cause lung and central nervous system damage. Can be fatal if swallowed. First aid for ingestion: do not induce vomiting. Seek immediate medical attention.

First aid for skin contact: remove contaminated clothing, Wash skin thoroughly with soap and water. If symptoms persist, seek medical attention.

First aid for eye contact: flush with water for 15 minutes or until irritation subsides. If symptoms persist, seek medical attention.

Inhalation of high/massive concentrations can cause coma or be fatal. First aid for inhalation: move to fresh air. If not breathing, provide artificial respiration. If symptoms persist, seek medical attention.

Keep away from open flames and other sources of ignition. Failure to comply may result in injury or death to personnel. The flash point for type II solvent cleaning compound is 141°F to 198°F (61°C to 92°C) and type III is 200°F to 241°F (93°C to 116°C). Fire extinguishers should be placed nearby when using solvent cleaning compound.

Improper cleaning methods and use of unauthorized cleaning solvents may injure personnel and damage equipment.

Cloths or rags saturated with solvent cleaning compound must be disposed of using authorized facilities procedures.

Eye shields must be worn when cleaning with a wire brush. Flying rust and metal particles may cause injury.

WARNING SUMMARY - Continued

HAZARDOUS MATERIALS DESCRIPTIONS - Continued

WARNING



LUBRICATING OIL

Prolonged contact with lubricating oil may cause skin rash. Remove saturated clothing immediately and wash skin thoroughly that comes in contact with lubricating oil. Failure to comply may result in injury or death to personnel.

Spilled hydraulic oil is slippery and creates a hazardous condition. Clean up and properly dispose of hydraulic oil. Failure to comply may result in injury or death to personnel.

WARNING



NUCLEAR, BIOLOGICAL, OR CHEMICAL

If Nuclear, Biological, or Chemical (NBC) exposure is suspected, all filter media should be handled by personnel wearing protective equipment. Consult your unit NBC Officer or NBC NCO for appropriate handling or disposal instructions. Failure to comply may result in injury or death to personnel.

WARNING SUMMARY - Continued

HAZARDOUS MATERIALS DESCRIPTIONS - Continued

WARNING



LEAD-ACID BATTERIES

Avoid battery electrolyte contact with skin, eyes, and clothing. If battery electrolyte spills, take the following immediate action to stop burning effects:

External - If battery electrolyte contacts skin, immediately flush affected area with cold running water. Failure to comply may result in injury or death to personnel.

Eyes - If battery electrolyte contacts eyes, immediately flush eyes with cold water for 15 minutes and seek immediate medical attention. **IMPORTANT** - If only one eye is affected, ensure the affected eye is always kept lower than the unaffected eye, during both flushing and transport. This will keep the the affected eye from draining into and contaminating the unaffected eye. Failure to comply may result in injury or death to personnel.

Internal - If battery electrolyte is ingested, drink large amounts of water or milk. Follow with milk of magnesia, a beaten egg or vegetable oil and seek immediate medical attention. Failure to comply may result in injury or death to personnel.

Clothing or vehicle - immediately flush area with cold water and neutralize battery electrolyte with baking soda or household ammonia solution. Failure to comply may result in injury or death to personnel.

Batteries produce explosive gases. Do not smoke or use open flame near batteries. Do not allow hot, parking or glowing objects near batteries. If batteries are giving off gases, the presence of heat, flame, or spark may cause fire and/or explosion. Failure to comply may result in injury or death to personnel.

Wear proper eye protection, gloves, and an apron when working near batteries. Failure to comply may result in injury or death to personnel.

WARNING SUMMARY - Continued

HAZARDOUS MATERIALS DESCRIPTIONS - Continued

WARNING



DIESEL FUEL

- Diesel fuel is highly flammable and can be accidentally ignited. Do not smoke or allow open flame or sparks in the vicinity while working on any part of the fuel system. Keep fire extinguisher within easy reach when working with fuel. Failure to comply may result in injury or death to personnel.
- Spilled fuel is slippery and creates a hazardous condition. Clean up and properly disposed of spilled fuel as soon as possible. Failure to comply may result in injury or death to personnel.
- Do not work on fuel system when engine is hot. Failure to comply may result in injury or death to personnel.
- Safety glasses must be worn when working on pressurized systems. Failure to comply may result in injury or death to personnel.

WARNING



ADHESIVES AND SEALANTS

Adhesives and sealants are flammable, can give off harmful vapors, and are harmful to skin and clothing. Keep away from open fire and use in a well-ventilated area. If adhesive or sealant contacts eye, flush with large amounts of water, and seek medical attention. If adhesive or sealant get on skin or clothing, flush with large amounts of water. If irritation persists, seek medical attention. Failure to comply may result in serious injury or death to personnel.

LIST OF EFFECTIVE PAGES/WORK PACKAGES

NOTE: *Supersedes TM 9-2320-272-24-1, TM 9-2320-272-24-2, TM 9-2320-272-24-3, TM 9-2320-272-24-4 and TO 36A12-1C-1155-2-1, TO 36A12-1C-1155-2-2, TO 36A12-1C-1155-2-3, & TO 36A12-1C-1155-2-4, dated 30 June 1998. Zero in the Change No. Column indicates an original page or work package.

Date of issue for the original manual is:

Original 10 September 2012

TOTAL NUMBER OF VOLUMES IS 5, TOTAL NUMBER OF PAGES FOR FRONT AND REAR MATTER IS 74 AND TOTAL NUMBER OF WORK PACKAGES IS 196 CONSISTING OF THE FOLLOWING:

Page/WP No.	Change No.	Page/WP No.	Change No.
VOLUME 2		WP 0188 (10 pages)	0
Front Cover (2 pages)	0	WP 0189 (4 pages)	0
WARNING SUMMARY (10 pages)	0	WP 0190 (4 pages)	0
i-xxxvii/xxxviii blank (38 pages)	0	WP 0191 (4 pages)	0
Chapter 4 Title Page (2 pages)	0	WP 0192 (2 pages)	0
WP 0154 (6 pages)	0	WP 0193 (4 pages)	0
WP 0155 (2 pages)	0	WP 0194 (2 pages)	0
WP 0156 (16 pages)	0	WP 0195 (4 pages)	0
WP 0157 (4 pages)	0	WP 0196 (4 pages)	0
WP 0158 (4 pages)	0	WP 0197 (4 pages)	0
WP 0159 (6 pages)	0	WP 0198 (2 pages)	0
WP 0160 (8 pages)	0	WP 0199 (4 pages)	0
WP 0161 (8 pages)	0	WP 0200 (4 pages)	0
WP 0162 (8 pages)	0	WP 0201 (2 pages)	0
WP 0163 (8 pages)	0	WP 0202 (10 pages)	0
WP 0164 (4 pages)	0	WP 0203 (8 pages)	0
WP 0165 (4 pages)	0	WP 0204 (6 pages)	0
WP 0166 (6 pages)	0	WP 0205 (2 pages)	0
WP 0167 (6 pages)	0	Chapter 6 Title Page	0
WP 0168 (4 pages)	0	WP 0206 (2 pages)	0
WP 0169 (6 pages)	0	WP 0207 (44 pages)	0
WP 0170 (6 pages)	0	WP 0208 (12 pages)	0
WP 0171 (6 pages)	0	WP 0209 (2 pages)	0
WP 0172 (6 pages)	0	Chapter 7 Title Page	0
WP 0173 (6 pages)	0	WP 0210 (2 pages)	0
WP 0174 (4 pages)	0	WP 0211 (56 pages)	0
WP 0175 (6 pages)	0	WP 0212 (8 pages)	0
WP 0176 (6 pages)	0	WP 0213 (40 pages)	0
WP 0177 (6 pages)	0	WP 0214 (4 pages)	0
WP 0178 (6 pages)	0	WP 0215 (2 pages)	0
WP 0179 (6 pages)	0	WP 0216 (10 pages)	0
WP 0180 (6 pages)	0	WP 0217 (4 pages)	0
WP 0181 (6 pages)	0	WP 0218 (6 pages)	0
WP 0182 (4 pages)	0	WP 0219 (6 pages)	0
WP 0183 (2 pages)	0	WP 0220 (4 pages)	0
WP 0184 (4 pages)	0	WP 0221 (6 pages)	0
WP 0185 (6 pages)	0	WP 0222 (16 pages)	0
Chapter 5 Title Page	0	WP 0223 (10 pages)	0
WP 0186 (4 pages)	0	WP 0224 (4 pages)	0
WP 0187 (2 pages)	0	WP 0225 (4 pages)	0

LIST OF EFFECTIVE PAGES/WORK PACKAGES - Continued

Page/WP No.	Change No.	Page/WP No.	Change No.
WP 0226 (6 pages)	0	WP 0277 (6 pages)	0
WP 0227 (4 pages)	0	WP 0278 (10 pages)	0
WP 0228 (6 pages)	0	WP 0279 (6 pages)	0
WP 0229 (10 pages)	0	WP 0280 (14 pages)	0
WP 0230 (6 pages)	0	WP 0281 (8 pages)	0
WP 0231 (10 pages)	0	WP 0282 (6 pages)	0
WP 0232 (10 pages)	0	WP 0283 (6 pages)	0
WP 0233 (8 pages)	0	WP 0284 (6 pages)	0
WP 0234 (10 pages)	0	WP 0285 (10 pages)	0
WP 0235 (6 pages)	0	WP 0286 (6 pages)	0
WP 0236 (2 pages)	0	WP 0287 (6 pages)	0
WP 0237 (14 pages)	0	WP 0288 (6 pages)	0
WP 0238 (6 pages)	0	WP 0289 (10 pages)	0
WP 0239 (4 pages)	0	WP 0290 (8 pages)	0
WP 0240 (12 pages)	0	WP 0291 (4 pages)	0
WP 0241 (6 pages)	0	WP 0292 (4 pages)	0
WP 0242 (18 pages)	0	WP 0293 (6 pages)	0
WP 0243 (6 pages)	0	WP 0294 (8 pages)	0
WP 0244 (4 pages)	0	WP 0295 (4 pages)	0
WP 0245 (8 pages)	0	WP 0296 (6 pages)	0
WP 0246 (6 pages)	0	WP 0297 (6 pages)	0
WP 0247 (6 pages)	0	WP 0298 (6 pages)	0
WP 0248 (6 pages)	0	WP 0299 (6 pages)	0
WP 0249 (10 pages)	0	WP 0300 (10 pages)	0
WP 0250 (8 pages)	0	WP 0301 (12 pages)	0
WP 0251 (12 pages)	0	WP 0302 (6 pages)	0
WP 0252 (6 pages)	0	WP 0303 (6 pages)	0
WP 0253 (8 pages)	0	WP 0304 (4 pages)	0
WP 0254 (12 pages)	0	WP 0305 (6 pages)	0
WP 0255 (6 pages)	0	WP 0306 (4 pages)	0
WP 0256 (10 pages)	0	WP 0307 (10 pages)	0
WP 0257 (4 pages)	0	WP 0308 (6 pages)	0
WP 0258 (12 pages)	0	WP 0309 (6 pages)	0
WP 0259 (6 pages)	0	WP 0310 (14 pages)	0
WP 0260 (6 pages)	0	WP 0311 (6 pages)	0
WP 0261 (4 pages)	0	WP 0312 (6 pages)	0
WP 0262 (4 pages)	0	WP 0313 (6 pages)	0
WP 0263 (6 pages)	0	WP 0314 (6 pages)	0
WP 0264 (4 pages)	0	WP 0315 (6 pages)	0
WP 0265 (4 pages)	0	WP 0316 (2 pages)	0
WP 0266 (6 pages)	0	WP 0317 (2 pages)	0
WP 0267 (6 pages)	0	WP 0318 (2 pages)	0
WP 0268 (8 pages)	0	WP 0319 (4 pages)	0
WP 0269 (12 pages)	0	WP 0320 (8 pages)	0
WP 0270 (6 pages)	0	WP 0321 (2 pages)	0
WP 0271 (6 pages)	0	WP 0322 (6 pages)	0
WP 0272 (4 pages)	0	WP 0323 (4 pages)	0
WP 0273 (4 pages)	0	WP 0324 (4 pages)	0
WP 0274 (6 pages)	0	WP 0325 (8 pages)	0
WP 0275 (6 pages)	0	WP 0326 (6 pages)	0
WP 0276 (6 pages)	0	WP 0327 (24 pages)	0

LIST OF EFFECTIVE PAGES/WORK PACKAGES - Continued

Page/WP No.	Change No.	Page/WP No.	Change No.
WP 0328 (4 pages)	0	WP 0341 (2 pages)	0
WP 0329 (8 pages)	0	WP 0342 (10 pages)	0
WP 0330 (6 pages)	0	WP 0343 (6 pages)	0
WP 0331 (6 pages)	0	WP 0344 (6 pages)	0
WP 0332 (6 pages)	0	WP 0345 (6 pages)	0
WP 0333 (4 pages)	0	WP 0346 (6 pages)	0
WP 0334 (4 pages)	0	WP 0347 (4 pages)	0
WP 0335 (2 pages)	0	WP 0348 (4 pages)	0
WP 0336 (4 pages)	0	WP 0349 (6 pages)	0
WP 0337 (4 pages)	0	WP 0350 (6 pages)	0
WP 0338 (4 pages)	0	Index 1 - Index 5/6 blank	0
WP 0339 (2 pages)	0	Inside Back Cover	0
WP 0340 (4 pages)	0	Back Cover	0

HEADQUARTERS
DEPARTMENTS OF THE ARMY AND THE AIR FORCE
WASHINGTON, D.C., 10 SEPTEMBER 2012

TECHNICAL MANUAL
FIELD MAINTENANCE MANUAL
FOR

TRUCK, 5-TON, 6X6, M939, M939A1, AND M939A2 SERIES TRUCKS (DIESEL)

TRUCK, CARGO: 5-TON, 6X6 DROPSIDE M923 NSN 2320-01-050-2084 (EIC BRY) M923A1 NSN 2320-01-206-4087 (EIC BSS) M923A2 NSN 2320-01-230-0307 (EIC BS7) M925 NSN 2320-01-047-8769 (EIC BRT) M925A1 NSN 2320-01-206-4088 (EIC BST) M925A2 NSN 2320-01-230-0308 (EIC BS8)	TRUCK, DUMP: 5-TON, 6X6 M929 NSN 2320-01-047-8756 (EIC BTH) M929A1 NSN 2320-01-206-4079 (EIC BSY) M929A2 NSN 2320-01-230-0305 (EIC BTN) M930 NSN 2320-01-047-8755 (EIC BTG) M930A1 NSN 2320-01-206-4080 (EIC BSZ) M930A2 NSN 2320-01-230-0306 (EIC BT7)	TRUCK, VAN, EXPANSIBLE: 5-TON, 6X6 M934 NSN 2320-01-047-8750 (EIC BTB) M934A1 NSN 2320-01-205-2682 (EIC BS4) M934A2 NSN 2320-01-230-0300 (EIC BTR)
TRUCK, CARGO: 5-TON, 6X6 XLWB M927 NSN 2320-01-047-8771 (EIC BRV) M927A1 NSN 2320-01-206-4089 (EIC BSW) M927A2 NSN 2320-01-230-0309 (EIC BS9) M928 NSN 2320-01-047-8770 (EIC BRU) M928A1 NSN 2320-01-206-4090 (EIC BSX) M928A2 NSN 2320-01-230-0310 (EIC BTM)	TRUCK, TRACTOR: 5-TON, 6X6 M931 NSN 2320-01-047-8753 (EIC BTE) M931A1 NSN 2320-01-206-4077 (EIC BS2) M931A2 NSN 2320-01-230-0302 (EIC BTP) M932 NSN 2320-01-047-8752 (EIC BTD) M932A1 NSN 2320-01-205-2684 (EIC BSZ) M932A2 NSN 2320-01-230-0303 (EIC BTQ)	TRUCK, MEDIUM WRECKER: 5-TON, 6X6 M936 NSN 2320-01-047-8754 (EIC BTF) M936A1 NSN 2320-01-206-4078 (EIC BS6) M936A2 NSN 2320-01-230-0304 (EIC BTT)

REPORTING ERRORS AND RECOMMENDING IMPROVEMENTS

You can help improve this publication. If you find any mistakes, or if you know of a way to improve the procedures, please let us know: Reports, as applicable by the requiring service, should be submitted as follows:

(A) Army - Mail your letter or DA Form 2028 (Recommended Changes to Publications and Blank Forms), located in the back of this manual directly to: U.S. Army TACOM Life Cycle Management Command, ATTN: AMSTA-LCL-MPP/ TECH PUBS, MS 727, 6501 E. 11 Mile Road, Warren, MI 48397-5000. You may also send in your recommended changes via electronic mail or by fax. Our fax number is DSN 786-1856 or Commercial (586) 282-1856. Our email address is tacomlcmc.daform2028@us.army.mil.

(F) Air Force - By Air Force AFTO Form 22 directly to WR/ALC/GRVEB, Robins GA. You may also send in your recommended changes electronically via email. Email AFTO form 22 to robins.ce.afto22@robins.af.mil. A reply will be furnished to you.

***SUPERSEDURE NOTICE** - This manual supersedes TM 9-2320-272-24-1, TM 9-2320-272-24-2, TM 9-2320-272-24-3, TM 9-2320-272-24-4 and TO 36A12-1C-1155-2-1, TO 36A12-1C-1155-2-2, TO 36A12-1C-1155-2-3, & TO 36A12-1C-1155-2-4, dated 30 June 1998, including all changes

DISTRIBUTION STATEMENT A - Approved for public release; distribution is unlimited.

TABLE OF CONTENTS

	Page No.
	<u>WP Sequence No.</u>
Volume 2	
Chapter 4 - ABS TROUBLESHOOTING PROCEDURES	
ANTILOCK BRAKE SYSTEM (ABS) ELECTRONIC DIAGNOSTIC TROUBLESHOOTING.....	WP 0154
Figure 1. ABS Wiring Harness ECU Connector.....	0154-3
Table 1. Diagnostic Fault Codes.....	0154-4
ABS TROUBLESHOOTING INDEX.....	WP 0155
TROUBLESHOOTING ABS WITHOUT DIAGNOSTIC TOOLS.....	WP 0156
Figure 1. Wheel Speed Sensor Leads.....	0156-2
Figure 2. ABS Solenoid Valve Connectors.....	0156-3
Figure 3. ABS Wiring Harness 28-pin ECU Connector.....	0156-4
Figure 4. ABS Power Supply Connection.....	0156-6
Figure 5. ABS Power Supply Connection.....	0156-8
Figure 6. Battery Test Points.....	0156-10
Figure 7. ABS Power Supply Connection.....	0156-11
Figure 8. ABS Power Supply Connection.....	0156-12
ABS - CODE EO - E9, EA - EF (ECU FAULT).....	WP 0157
Figure 1. ABS ECU.....	0157-2
ABS - CODE SOL 80, ECU 93, OR ECU 99 (ECU FAULT).....	WP 0158
Figure 1. ABS ECU.....	0158-2
ABS - CLEAR HISTORICAL CODES WITH THE HALDEX INFO CENTER (SCAN TOOL).....	WP 0159
Figure 1. Info Centre Fault Code "OK 07" Display.....	0159-2
Figure 2. Info Centre "BUSY" Display.....	0159-3
Figure 3. Info Centre Fault Code Display.....	0159-4
Figure 4. Info Centre "CLR CA" Display.....	0159-4
Figure 5. Info Centre Fault Code "OK 07" Display.....	0159-5
WHEEL SPEED SENSOR OUTPUT TEST.....	WP 0160
Figure 1. Info Centre Fault Code "OK 07" Display.....	0160-2

TABLE OF CONTENTS - Continued

	Page No.
	<u>WP Sequence No.</u>
Figure 2. Info Centre "WHL" Display.....	0160-3
Figure 3. Info Centre "S2A" Display.....	0160-3
Figure 4. Wheel Speed Sensor.....	0160-4
Figure 5. Info Centre "S2B" Display.....	0160-5
Figure 6. Wheel Speed Sensor.....	0160-6
ABS - START - RETRIEVING FAULT CODES WITH THE HALDEX INFO CENTER (SCAN TOOL).....	WP 0161
Figure 1. Info Centre Fault Code "OK 07" Display.....	0161-2
Figure 2. Info Centre "BUSY" Display.....	0161-3
Figure 3. Info Centre Fault Code Display.....	0161-4
Figure 4. Info Centre "CLR CA" Display.....	0161-4
Figure 5. Info Centre Fault Code "OK 07" Display.....	0161-6
ABS - CODE S2A 03 (LEFT SIDE - BLUE CHANNEL).....	WP 0162
Figure 1. Wheel Speed Sensor Connector.....	0162-2
Figure 2. ABS Wiring Harness 28-pin ECU Connector.....	0162-4
Figure 3. ABS Wiring Harness 28-pin ECU Connector.....	0162-6
ABS - CODE S2B 04 (RIGHT SIDE - YELLOW CHANNEL).....	WP 0163
Figure 1. Wheel Speed Sensor Connector.....	0163-2
Figure 2. ABS Wiring Harness 28-pin ECU Connector.....	0163-4
Figure 3. ABS Wiring Harness 28-pin ECU Connector.....	0163-6
ABS - CODE S2A 13 (LEFT SIDE - BLUE CHANNEL).....	WP 0164
Figure 1. Wheel Speed Sensor Connector.....	0164-2
ABS - CODE S2B 14 (RIGHT SIDE - YELLOW CHANNEL).....	WP 0165
Figure 1. Wheel Speed Sensor Connector.....	0165-2
ABS - CODE S2A 23 (LEFT SIDE - BLUE CHANNEL).....	WP 0166
Figure 1. Wheel Bearing.....	0166-2
Figure 2. ABS Exciter Ring.....	0166-3
Figure 3. ABS Wheel Speed Sensor.....	0166-4

TABLE OF CONTENTS - Continued

	Page No.
	<u>WP Sequence No.</u>
ABS - CODE S2A 24 (RIGHT SIDE - YELLOW CHANNEL).....	WP 0167
Figure 1. Wheel Bearing.....	0167-2
Figure 2. ABS Exciter Ring.....	0167-3
Figure 3. ABS Wheel Speed Sensor.....	0167-4
ABS - CODE SLW 42 (LEFT SIDE - BLUE CHANNEL).....	WP 0168
Figure 1. Front Relay Valve.....	0168-2
Figure 2. Front Modulator Valve.....	0168-3
ABS - CODE SLW 43 (RIGHT SIDE - YELLOW CHANNEL).....	WP 0169
Figure 1. Rear Relay Valve.....	0169-2
Figure 2. Rear Modulator Valve.....	0169-3
ABS - CODE BUHd 62 (LEFT SIDE - BLUE CHANNEL).....	WP 0170
Figure 1. Front Relay Valve Solenoid Connector.....	0170-2
Figure 2. Front Relay Valve Solenoid Connector.....	0170-3
Figure 3. ABS Wiring Harness 28-pin ECU Connector.....	0170-4
ABS - CODE YEHd 63 (RIGHT SIDE - YELLOW CHANNEL).....	WP 0171
Figure 1. Rear Relay Valve Solenoid Connector.....	0171-2
Figure 2. Rear Relay Valve Solenoid Connector.....	0171-3
Figure 3. ABS Wiring Harness 28-pin ECU Connector.....	0171-4
ABS - CODE BUDU 68 (LEFT SIDE - BLUE CHANNEL).....	WP 0172
Figure 1. Front Relay Valve Solenoid Connector.....	0172-2
Figure 2. Front Relay Valve Solenoid Connector.....	0172-3
Figure 3. ABS Wiring Harness 28-pin ECU Connector.....	0172-4
ABS - CODE YEDU 69 (RIGHT SIDE - YELLOW CHANNEL).....	WP 0173
Figure 1. Rear Relay Valve Solenoid Connector.....	0173-2
Figure 2. Rear Relay Valve Solenoid Connector.....	0173-3
Figure 3. ABS Wiring Harness 28-pin ECU Connector.....	0173-4
ABS - CODE BUHd 72 (LEFT SIDE - BLUE CHANNEL).....	WP 0174

TABLE OF CONTENTS - Continued

	Page No.
	<u>WP Sequence No.</u>
Figure 1. Front Relay Valve Solenoid Connector.....	0174-2
Figure 2. ABS Wiring Harness 28-pin ECU Connector.....	0174-4
ABS - CODE YEhd 73 (RIGHT SIDE - YELLOW CHANNEL).....	WP 0175
Figure 1. Rear Relay Valve Solenoid Connector.....	0175-2
Figure 2. ABS Wiring Harness 28-pin ECU Connector.....	0175-4
ABS - CODE BUDU 78 (LEFT SIDE - BLUE CHANNEL).....	WP 0176
Figure 1. Front Relay Valve Solenoid Connector.....	0176-2
Figure 2. ABS Wiring Harness 28-pin ECU Connector.....	0176-4
ABS - CODE YEDU 79 (RIGHT SIDE - YELLOW CHANNEL).....	WP 0177
Figure 1. Rear Relay Valve Solenoid Connector.....	0177-2
Figure 2. ABS Wiring Harness 28-pin ECU Connector.....	0177-4
ABS - CODE BUhd 82 (LEFT SIDE - BLUE CHANNEL).....	WP 0178
Figure 1. Front Relay Valve Solenoid Connector.....	0178-2
Figure 2. ABS Wiring Harness 28-pin ECU Connector.....	0178-4
ABS - CODE YEhd 83 (RIGHT SIDE - YELLOW CHANNEL).....	WP 0179
Figure 1. Rear Relay Valve Solenoid Connector.....	0179-2
Figure 2. ABS Wiring Harness 28-pin ECU Connector.....	0179-4
ABS - CODE BUDU 88 (LEFT SIDE - BLUE CHANNEL).....	WP 0180
Figure 1. Front Relay Valve Solenoid Connector.....	0180-2
Figure 2. ABS Wiring Harness 28-pin ECU Connector.....	0180-4
ABS - CODE YEDU 89 (RIGHT SIDE - YELLOW CHANNEL).....	WP 0181
Figure 1. Rear Relay Valve Solenoid Connector.....	0181-2
Figure 2. ABS Wiring Harness 28-pin ECU Connector.....	0181-4
ABS - CODE B+LO 90 (ABS VOLTAGE BELOW 21.0 VOLTS).....	WP 0182
Figure 1. Battery Test Points.....	0182-2
ABS - CODE ISO1 91 (ABS VOLTAGE BELOW 8.0 VOLTS).....	WP 0183
ABS - CODE B+HI 92 (ABS VOLTAGE ABOVE 32.0 VOLTS).....	WP 0184

TABLE OF CONTENTS - Continued

	Page No.
	<u>WP Sequence No.</u>
Figure 1. Battery Test Points.....	0184-2
ABS - NO DATA (BLANK SCREEN ON HALDEX INFO-CENTER).....	WP 0185
Figure 1. ABS Wiring Harness 28-pin ECU Connector.....	0185-2
Chapter 5 - STE/ICE TROUBLESHOOTING PROCEDURES	
STE/ICE TROUBLESHOOTING.....	WP 0186
Table 1. Go-Chain Test Index, Combined Mode Chain.....	0186-2
Table 2. No-Go-Chain Test Index, Combined Mode Chain.....	0186-3
STE/ICE TROUBLESHOOTING INDEX.....	WP 0187
G01: VTM CONNECTION AND CHECKOUT (PART 1).....	WP 0188
Figure 1. STE/ICE Setup.....	0188-2
Figure 2. VTM Display.....	0188-3
Figure 3. VTM Display.....	0188-4
Figure 4. VTM Display.....	0188-5
Table 1. Confidence Test.....	0188-5
Figure 5. VTM Display.....	0188-6
Figure 6. Test 99.....	0188-7
Figure 7. PASS Prompt Message.....	0188-7
Figure 8. PASS Prompt Message.....	0188-8
Figure 9. VTM Display.....	0188-9
Table 2. Vehicle Identification Number.....	0188-9
Table 3. Offset Test.....	0188-10
Table 4. Fuel Pressure Test.....	0188-10
Figure 10. Calibration Prompt Message.....	0188-10
G02: FIRST PEAK TEST- STARTER CURRENT.....	WP 0189
Figure 1. CAL Prompt Message.....	0189-2
Figure 2. GO Prompting Message.....	0189-3
G03: ENGINE START- LUBRICATION CHECK.....	WP 0190

TABLE OF CONTENTS - Continued

	Page No.
	<u>WP Sequence No.</u>
G04: CHARGING CIRCUIT AND BATTERY VOLTAGE TEST.....	WP 0191
Table 1. Battery Voltage Test.....	0191-1
G05: ENGINE WARMUP/COOLANT CHECK/OIL PRESSURE TEST.....	WP 0192
Table 1. Engine RPM Test.....	0192-2
Table 2. Engine Oil Pressure Specification.....	0192-2
G06: GOVERNOR CHECK/POWER TEST.....	WP 0193
Table 1. Maximum Governor Speed.....	0193-1
Table 2. Power Test.....	0193-2
Figure 1. CIP Prompting Message.....	0193-2
Table 3. Power Minimum Test Limits.....	0193-3
G07: IDLE SPEED/GOVERNOR CHECK.....	WP 0194
Table 1. Engine RPM Test.....	0194-1
G08: COMPRESSION UNBALANCE TEST.....	WP 0195
Table 1. Engine RPM Test.....	0195-2
Figure 1. GO Prompting Message.....	0195-2
Figure 2. CAL Prompting Message.....	0195-2
DC VOLTAGE TEST.....	WP 0196
Figure 1. STE/ICE Test.....	0196-2
Table 1. Voltage Test.....	0196-2
Figure 2. CAL Prompt Message.....	0196-3
NG05: LOW PRESSURE CHECK.....	WP 0197
Figure 1. STE/ICE Setup.....	0197-2
Figure 2. CAL Prompt Message.....	0197-2
Figure 3. Pass Prompt Message.....	0197-3
Table 1. Oil Pressure Limits.....	0197-3
Figure 4. Pass Prompt Message.....	0197-4
Table 2. Oil Pressure Limits.....	0197-4

TABLE OF CONTENTS - Continued

	Page No.
	<u>WP Sequence No.</u>
NG20: NO CRANK- NO START.....	WP 0198
NG30: ENGINE CRANK - NO START.....	WP 0199
Table 1. Engine RPM Test.....	0199-1
Figure 1. CAL Prompt Message.....	0199-2
Table 2. Pressure Test.....	0199-3
NG31: GAUGE TEST.....	WP 0200
Table 1. Voltage Test.....	0200-2
Figure 1. CAL Prompt Message.....	0200-2
NG50: CHARGING CIRCUIT TESTS.....	WP 0201
Table 1. Voltage Test.....	0201-2
NG80: STARTER CIRCUIT TESTS.....	WP 0202
Table 1. Starter Circuit Resistance Test.....	0202-2
Figure 1. CAL Message.....	0202-2
Figure 2. Prompt Message.....	0202-3
Table 2. Starter Circuit Resistance.....	0202-4
Table 3. Starter Circuit Tests.....	0202-5
Table 4. Starter Motor Voltage Test.....	0202-6
Table 5. Starter Voltage.....	0202-6
Table 6. Starter Negative Cable Drop Tests.....	0202-7
Table 7. Starter Solenoid Voltage Test.....	0202-8
Table 8. Starter Voltage.....	0202-8
Table 9. Battery Voltage Test.....	0202-9
NG81: BATTERY TESTS.....	WP 0203
Figure 1. CAL Prompting Message.....	0203-1
Figure 2. Battery Tests.....	0203-2
Figure 3. CAL Prompting Message.....	0203-3
Figure 4. GO Prompting Message.....	0203-4

TABLE OF CONTENTS - Continued

	Page No.
	<u>WP Sequence No.</u>
Table 1. Battery Resistance Change Test.....	0203-4
Figure 5. OFF Prompting Message.....	0203-4
Table 2. Maximum Resistance Change.....	0203-5
Table 3. Battery Resistance Test.....	0203-6
Figure 6. Prompt Message.....	0203-6
Table 4. Maximum Resistance.....	0203-6
NG90: GOVERNOR/POWER TEST FAULT ISOLATION.....	WP 0204
Figure 1. CAL Prompting Message.....	0204-3
Table 1. Pressure Test.....	0204-4
Table 2. Minimum Fuel Pressure.....	0204-4
Table 3. Engine RPM Test.....	0204-5
Figure 2. Prompt Message.....	0204-5
Table 4. Compression Unbalance Test Limits.....	0204-6
NG130: ENGINE TIGHTNESS TEST.....	WP 0205
Chapter 6 - PREVENTIVE MAINTENANCE INSTRUCTIONS	
PREVENTIVE MAINTENANCE CHECKS AND SERVICES (PMCS) INTRODUCTION.....	WP 0206
PREVENTIVE MAINTENANCE CHECKS AND SERVICES FOR MODELS M939/A1/A2 (SEMIANNUAL).....	WP 0207
Table 1. Field Preventive Maintenance Checks and Services.....	0207-2
Figure 1. Front Winch.....	0207-11
Figure 2. Front Winch.....	0207-13
Figure 3. Wheel Assembly.....	0207-17
Figure 4. Steering System.....	0207-21
Figure 5. Power Steering Pump.....	0207-23
Figure 6. Springs and Shackles.....	0207-24
Figure 7. Front Shackle.....	0207-24
Figure 8. Differential.....	0207-26
Figure 9. Differential.....	0207-39

TABLE OF CONTENTS - Continued

	Page No.
	<u>WP Sequence No.</u>
Table 2. PMCS Mandatory Replacement Parts List.....	0207-42
PREVENTIVE MAINTENANCE CHECKS AND SERVICES FOR MODELS M939/A1/A2 (ANNUAL).....	WP 0208
Table 1. Field Preventive Maintenance Checks and Services.....	0208-2
Figure 1. Engine Mounts.....	0208-3
Figure 2. Air System.....	0208-5
Figure 3. Air System.....	0208-6
Table 2. PMCS Mandatory Replacement Parts List.....	0208-11
PREVENTIVE MAINTENANCE CHECKS AND SERVICES FOR MODELS M939/A1/A2 (BIENNIAL).....	WP 0209
Table 1. Field Preventive Maintenance Checks and Services.....	0209-2
Chapter 7 - MAINTENANCE INSTRUCTIONS	
SERVICE UPON RECEIPT.....	WP 0210
POWER PLANT REPLACEMENT (M939/A1).....	WP 0211
Figure 1. Sending Unit Disconnect.....	0211-2
Figure 2. Alternator Removal.....	0211-3
Figure 3. Hose Disconnect.....	0211-5
Figure 4. Power Plant Throttle Cable Removal.....	0211-7
Figure 5. Power Plant Engine Air Hoses Removal.....	0211-9
Figure 6. Power Plant Tachometer Cables Removal.....	0211-11
Figure 7. Power Plant Ether Cylinder Lines Removal.....	0211-13
Figure 8. Power Plant Starter Wires Removal.....	0211-15
Figure 9. Power Plant Transmission Shifter Cable Removal.....	0211-17
Figure 10. Power Plant Transmission Electrical Wires Removal.....	0211-19
Figure 11. Power Plant Transmission Module Removal.....	0211-21
Figure 12. Power Plant Ground Wires Removal.....	0211-23
Figure 13. Power Plant Engine Mounts Removal.....	0211-26
Figure 14. Power Plant Maintenance Stand.....	0211-27

TABLE OF CONTENTS - Continued

	Page No.
	<u>WP Sequence No.</u>
Figure 15. Power Plant Water Cooler Removal.....	0211-28
Figure 16. Power Plant Air Lines Assembly.....	0211-29
Figure 17. Power Plant Heater Shutoff Valves.....	0211-30
Figure 18. Power Plant Lifting Points.....	0211-31
Figure 19. Power Plant Engine Mounts Installation.....	0211-33
Figure 20. Power Plant Transmission Wires Installation.....	0211-35
Figure 21. Power Plant Transmission Module Installation.....	0211-37
Figure 22. Power Plant Transmission Shifter Cable Installation.....	0211-39
Figure 23. Power Plant Electrical Wire Installation.....	0211-41
Figure 24. Power Plant Air Line Installation.....	0211-43
Figure 25. Power Plant Ether Line Installation.....	0211-45
Figure 26. Power Plant Throttle Cable Installation.....	0211-47
Figure 27. Power Plant Power Steering Hoses Installation.....	0211-49
Figure 28. Power Plant Alternator Wiring Installation.....	0211-51
Figure 29. Power Plant Temperature Wiring Installation.....	0211-52
Figure 30. In-Chassis Run-In.....	0211-53
Figure 31. In-Chassis Run-In.....	0211-54
ENGINE AND CONTAINER REPLACEMENT.....	WP 0212
Figure 1. Engine and Container Removal.....	0212-2
Figure 2. Engine and Container Removal.....	0212-3
Figure 3. Engine and Container Installation.....	0212-5
Figure 4. Engine and Container Installation.....	0212-7
POWER PLANT REPLACEMENT (M939A2).....	WP 0213
Figure 1. Tachometer Cable and Drive Removal.....	0213-2
Figure 2. Air Intake System Removal.....	0213-3
Figure 3. Fuel Supply and Electrical System Removal.....	0213-5
Figure 4. Power System and Linkage Removal.....	0213-7

TABLE OF CONTENTS - Continued

	Page No.
	<u>WP Sequence No.</u>
Figure 5. Air Compressor and Power Steering Line Removal.....	0213-8
Figure 6. Alternator and Engine Harness Removal.....	0213-9
Figure 7. Starter Cable and Oil Cooler Hose Removal.....	0213-10
Figure 8. Oil Cooler Return Hose Removal.....	0213-11
Figure 9. Transmission Supply Hose Removal.....	0213-11
Figure 10. Coolant System Hose Removal.....	0213-13
Figure 11. Vent Tube and Sending Unit Lead Removal.....	0213-14
Figure 12. Transmission Cables and Electrical Lead Removal.....	0213-15
Figure 13. Transmission and Engine Mount Removal.....	0213-17
Figure 14. Power Plant Removal.....	0213-19
Figure 15. Power Plant Installation.....	0213-21
Figure 16. Transmission and Engine Mount Installation.....	0213-23
Figure 17. Transmission Shift Cable, Electrical Leads, Oil Cooler Return, and Supply Hose Installation.....	0213-25
Figure 18. Oil Cooler Return Hose Installation.....	0213-26
Figure 19. Transmission Supply Hose Installation.....	0213-26
Figure 20. Starter Lead And Water Heater Hoses Installation.....	0213-27
Figure 21. Alternator Lead Installation.....	0213-29
Figure 22. Air Line and Power Steering Hose Installation.....	0213-30
Figure 23. Fuel Pump Lines and Linkage Installation.....	0213-31
Figure 24. Fuel Supply and Electrical System Installation.....	0213-32
Figure 25. Air Intake, Tachometer Cable, and Drive Installation.....	0213-33
Figure 26. Priming Lube System.....	0213-34
Figure 27. Priming Lube System.....	0213-35
Figure 28. Priming Lube System.....	0213-37
Figure 29. Accelerator Linkage Adjustment.....	0213-38
ENGINE LIFT EYES REPLACEMENT (M939/A1).....	WP 0214
Figure 1. Engine Lift Eyes Removal.....	0214-2

TABLE OF CONTENTS - Continued

	Page No.
	<u>WP Sequence No.</u>
Figure 2. Engine Lift Eyes Installation.....	0214-3
ENGINE LIFTING BRACKETS REPLACEMENT (M939A2).....	WP 0215
Figure 1. Engine Lifting Brackets Removal.....	0215-1
Figure 2. Engine Lifting Brackets Installation.....	0215-2
ENGINE MOUNTING BRACKETS AND ISOLATORS REPLACEMENT.....	WP 0216
Figure 1. Engine Mounting Bracket Removal.....	0216-3
Figure 2. Engine Mounting Bracket Removal.....	0216-4
Figure 3. Engine Mounting Bracket Removal.....	0216-5
Figure 4. Engine Mounting Bracket Installation.....	0216-6
Figure 5. Engine Mounting Bracket Installation.....	0216-7
Figure 6. Engine Mounting Bracket Installation.....	0216-8
Figure 7. Engine Mounting Bracket Installation.....	0216-9
Figure 8. Engine Mounting Bracket Installation.....	0216-10
ENGINE ACCESS COVER REPLACEMENT (M939/A1).....	WP 0217
Figure 1. Engine Access Cover Removal.....	0217-2
Figure 2. Engine Access Cover Installation.....	0217-3
CRANKSHAFT VIBRATION DAMPENER REPLACEMENT (M939/A1).....	WP 0218
Figure 1. Vibration Dampener Runout and Wobble Check.....	0218-2
Figure 2. Vibration Dampener Removal.....	0218-3
Figure 3. Vibration Dampener Inspection.....	0218-4
Figure 4. Vibration Dampener Installation.....	0218-5
VIBRATION DAMPENER REPLACEMENT (M939A2).....	WP 0219
Figure 1. Vibration Dampener Removal.....	0219-3
Figure 2. Vibration Dampener Installation.....	0219-5
FLYWHEEL ASSEMBLY REPLACEMENT (M939/A1).....	WP 0220
Figure 1. Flywheel Assembly Removal.....	0220-2
Figure 2. Flywheel Assembly Installation.....	0220-3

TABLE OF CONTENTS - Continued

	Page No.
	<u>WP Sequence No.</u>
FLEXPLATE AND FLYWHEEL ASSEMBLY REPLACEMENT (M939A2).....	WP 0221
Figure 1. Flexplate and Flywheel Assembly Removal.....	0221-3
Figure 2. Flexplate and Flywheel Assembly Installation.....	0221-5
Figure 3. Flexplate and Flywheel Assembly Torque Sequence.....	0221-6
VALVE COVER REPLACEMENT (M939A2).....	WP 0222
Figure 1. Breather Tube Removal.....	0222-3
Figure 2. Radiator Inlet Tube Removal.....	0222-5
Figure 3. Surge Tank Assembly Removal.....	0222-7
Figure 4. Valve Cover Removal.....	0222-8
Figure 5. Valve Cover Installation.....	0222-11
Figure 6. Surge Tank Assembly Installation.....	0222-13
Figure 7. Radiator Inlet Tube Installation.....	0222-14
Figure 8. Breather Tube Installation.....	0222-15
Figure 9. Air Lines Installation.....	0222-16
CRANKCASE BREATHER AND TUBE REPLACEMENT (M939/A1/A2).....	WP 0223
Figure 1. Crankcase Breather and Tube Removal.....	0223-3
Figure 2. Crankcase Breather and Tube Removal.....	0223-5
Figure 3. Crankcase Breather and Tube Installation.....	0223-7
Figure 4. Crankcase Breather and Tube Installation.....	0223-9
OIL PUMP PICKUP HOSE REPLACEMENT (M939/A1).....	WP 0224
Figure 1. Oil Pump Pickup Hose Removal.....	0224-2
Figure 2. Oil Pump Pickup Hose Installation.....	0224-3
OIL PUMP RETURN HOSE REPLACEMENT (M939/A1).....	WP 0225
Figure 1. Oil Pump Return Hose Removal.....	0225-2
Figure 2. Oil Pump Return Hose Installation.....	0225-3
FRONT SUMP TUBE REPLACEMENT (M939/A1).....	WP 0226
Figure 1. Front Sump Tube Removal.....	0226-2

TABLE OF CONTENTS - Continued

	Page No.
	<u>WP Sequence No.</u>
Figure 2. Front Sump Tube Installation.....	0226-4
ENGINE SAMPLING VALVE REPLACEMENT.....	WP 0227
Figure 1. Engine Sampling Valve Removal.....	0227-2
Figure 2. Engine Sampling Valve Installation.....	0227-3
OIL DIPSTICK TUBE REPLACEMENT.....	WP 0228
Figure 1. Dipstick Tube Removal.....	0228-3
Figure 2. Dipstick Tube Installation.....	0228-5
ENGINE OIL COOLER MAINTENANCE (M939A2).....	WP 0229
Figure 1. Engine Oil Cooler Removal.....	0229-3
Figure 2. Engine Oil Cooler Disassembly.....	0229-5
Figure 3. Engine Oil Cooler Assembly.....	0229-7
Figure 4. Engine Oil Cooler Installation.....	0229-9
OIL PAN AND OIL SUCTION TUBE (M939A2).....	WP 0230
Figure 1. Oil Pan and Suction Tube Removal.....	0230-3
Figure 2. Oil Pan and Suction Tube Installation.....	0230-5
ENGINE OIL PAN REPLACEMENT (M939/A1).....	WP 0231
Figure 1. Engine Oil Pan Removal.....	0231-2
Figure 2. Engine Oil Pan Removal.....	0231-3
Figure 3. Engine Oil Pan Disassembly.....	0231-5
Figure 4. Engine Oil Pan Assembly.....	0231-7
Figure 5. Engine Oil Pan Installation.....	0231-9
Figure 6. Engine Oil Pan Installation.....	0231-10
ENGINE OIL FILTER REPLACEMENT.....	WP 0232
Figure 1. Engine Oil Drain Plugs.....	0232-2
Figure 2. Engine Oil Drain Plugs.....	0232-3
Figure 3. Engine Oil Drain Plugs.....	0232-4
Figure 4. Oil Filter Removal.....	0232-5

TABLE OF CONTENTS - Continued

	Page No.
	<u>WP Sequence No.</u>
Figure 5. Oil Filter Removal.....	0232-5
Figure 6. Filter Shell and Bolt Disassembly.....	0232-6
Figure 7. Engine Oil Filter Cleaning and Inspection.....	0232-7
Figure 8. Filter Shell and Bolt Assembly.....	0232-8
Figure 9. Engine Oil Filter Installation.....	0232-9
Figure 10. Engine Oil Filter Installation.....	0232-10
ENGINE OIL COOLER REPAIR (M939/A1).....	WP 0233
Figure 1. Engine Oil Cooler Removal.....	0233-3
Figure 2. Engine Oil Cooler Disassembly.....	0233-4
Figure 3. Engine Oil Cooler Cleaning and Inspection.....	0233-5
Figure 4. Engine Oil Cooler Assembly.....	0233-6
Figure 5. Engine Oil Cooler Installation.....	0233-7
ENGINE AIR INTAKE MANIFOLD REPLACEMENT (M939/A1).....	WP 0234
Figure 1. Engine Air Intake Manifold Removal.....	0234-3
Figure 2. Engine Air Intake Manifold Disassembly.....	0234-5
Figure 3. Engine Air Intake Manifold Assembly.....	0234-7
Figure 4. Engine Air Intake Manifold Installation.....	0234-9
ENGINE EXHAUST MANIFOLD REPLACEMENT (M939/A1).....	WP 0235
Figure 1. Engine Exhaust Manifold Removal.....	0235-3
Figure 2. Engine Exhaust Manifold Installation.....	0235-5
EXHAUST MANIFOLD REPLACEMENT (M939A2).....	WP 0236
Figure 1. Exhaust Manifold Removal.....	0236-1
Figure 2. Exhaust Manifold Installation.....	0236-2
Figure 3. Torque Sequence.....	0236-2
ENGINE ACCESSORY DRIVE AND PULLEY REPLACEMENT (M939/A1).....	WP 0237
Figure 1. Drive Pulley Removal.....	0237-2
Figure 2. Engine Drive Pulley Removal.....	0237-3

TABLE OF CONTENTS - Continued

	Page No.
	<u>WP Sequence No.</u>
Figure 3. Drive Disassembly.....	0237-5
Figure 4. Engine Accessory Cleaning and Inspection.....	0237-7
Figure 5. Drive Assembly.....	0237-9
Figure 6. Drive Installation.....	0237-10
Figure 7. Drive Installation.....	0237-11
Figure 8. Drive Installation.....	0237-12
Figure 9. Engine Accessory Drive and Pulley Installation.....	0237-13
FUEL INJECTOR REPLACEMENT (M939A2).....	WP 0238
Figure 1. Fuel Injector Removal.....	0238-3
Figure 2. Fuel Injector Installation.....	0238-4
PRIMING FUEL SYSTEM SERVICING (M939A2).....	WP 0239
Figure 1. Fuel System Priming.....	0239-3
FUEL PUMP REPLACEMENT (M939/A1).....	WP 0240
Figure 1. Fuel Pump Removal.....	0240-1
Figure 2. Fuel Pump Removal.....	0240-2
Figure 3. Fuel Pump Removal.....	0240-3
Figure 4. Fuel Pump Removal.....	0240-4
Figure 5. Fuel Pump Removal.....	0240-5
Figure 6. Fuel Pump Installation.....	0240-5
Figure 7. Fuel Pump Installation.....	0240-6
Figure 8. Fuel Pump Installation.....	0240-7
Figure 9. Fuel Pump Installation.....	0240-7
Figure 10. Fuel Pump Installation.....	0240-9
Figure 11. Fuel Pump Adjustments.....	0240-10
Figure 12. Fuel Pump Adjustments.....	0240-11
FUEL INJECTOR TUBES REPLACEMENT (M939A2).....	WP 0241
Figure 1. Fuel Injector Tubes Removal.....	0241-3

TABLE OF CONTENTS - Continued

	Page No.
	<u>WP Sequence No.</u>
Figure 2. Fuel Injector Tubes Installation.....	0241-5
FUEL INJECTION PUMP REPLACEMENT (M939A2).....	WP 0242
Figure 1. Fuel Injection Pump Removal.....	0242-3
Figure 2. Fuel Injection Pump Removal.....	0242-5
Figure 3. Fuel Injection Pump Removal.....	0242-6
Figure 4. Fuel Injection Pump Removal.....	0242-7
Figure 5. Fuel Injection Pump Removal.....	0242-9
Figure 6. Fuel Injection Pump Installation.....	0242-11
Figure 7. Fuel Injection Pump Installation.....	0242-12
Figure 8. Fuel Injection Pump Installation.....	0242-13
Figure 9. Fuel Injection Pump Installation.....	0242-15
Figure 10. Fuel Injection Pump Adjustment.....	0242-17
FUEL TRANSFER PUMP AND SUPPLY LINES REPLACEMENT (M939A2).....	WP 0243
Figure 1. Fuel Transfer Pump and Supply Lines Removal.....	0243-3
Figure 2. Fuel Transfer Pump and Supply Lines Installation.....	0243-5
AIR FUEL CONTROL (AFC) TUBE REPLACEMENT (M939A2).....	WP 0244
Figure 1. Air Fuel Control Tube Removal.....	0244-2
Figure 2. Air Fuel Control Tube Installation.....	0244-3
AIR CLEANER ASSEMBLY AND MOUNTING BRACKET REPLACEMENT.....	WP 0245
Figure 1. Air Cleaner Removal.....	0245-3
Figure 2. Air Cleaner Disassembly.....	0245-4
Figure 3. Air Cleaner Assembly.....	0245-5
Figure 4. Air Cleaner Installation.....	0245-7
AIR CLEANER INTAKE PIPE REPLACEMENT (M939/A1).....	WP 0246
Figure 1. Air Cleaner Intake Pipe Removal.....	0246-3
Figure 2. Air Cleaner Intake Pipe Installation.....	0246-5
AIR CLEANER INDICATOR AND TUBE REPLACEMENT.....	WP 0247

TABLE OF CONTENTS - Continued

	Page No.
	<u>WP Sequence No.</u>
Figure 1. Air Cleaner Indicator and Tube Removal.....	0247-2
Figure 2. Air Cleaner Indicator and Tube Removal.....	0247-3
Figure 3. Air Cleaner Indicator and Tube Installation.....	0247-4
Figure 4. Air Cleaner Indicator and Tube Installation.....	0247-5
AIR CLEANER HOSE MAINTENANCE (M939A2).....	WP 0248
Figure 1. Air Cleaner Hose Removal.....	0248-2
Figure 2. Air Cleaner Hose Disassembly.....	0248-3
Figure 3. Air Cleaner Hose Assembly.....	0248-4
Figure 4. Air Cleaner Hose Installation.....	0248-5
Figure 5. Air Cleaner Hose Inspection.....	0248-6
TURBOCHARGER HOSES AND CLAMPS REPLACEMENT (M939A2).....	WP 0249
Figure 1. Turbocharger Hoses and Clamps Removal.....	0249-2
Figure 2. Turbocharger Hoses and Clamps Removal.....	0249-3
Figure 3. Turbocharger Hoses and Clamps Removal.....	0249-5
Figure 4. Turbocharger Hoses and Clamps Installation.....	0249-7
Figure 5. Turbocharger Hoses and Clamps Installation.....	0249-8
Figure 6. Turbocharger Hoses and Clamps Installation.....	0249-9
FUEL TANK REPLACEMENT.....	WP 0250
Figure 1. Fuel Tank Removal.....	0250-3
Figure 2. Fuel Tank Removal.....	0250-3
Figure 3. Fuel Tank Fitting Removal.....	0250-4
Figure 4. Fuel Tank Installation.....	0250-5
Figure 5. Fuel Tank Installation.....	0250-6
Figure 6. Personnel Heater Fuel Line Installation.....	0250-7
FUEL TANK REPLACEMENT (M936/A1/A2).....	WP 0251
Figure 1. Fuel Tank Removal (M936/A1/A2).....	0251-3
Figure 2. Fuel Tank Components Removal/Installation.....	0251-5

TABLE OF CONTENTS - Continued

	Page No.
	<u>WP Sequence No.</u>
Figure 3. Fuel Tank Components Installation.....	0251-7
Figure 4. Fuel Tank Assembly.....	0251-9
Figure 5. Fuel Tank Installation.....	0251-10
FUEL TANK FILLER CAP AND SPOUT REPLACEMENT.....	WP 0252
Figure 1. Fuel Tank Filler Cap and Spout Removal.....	0252-3
Figure 2. Fuel Tank Filler Cap and Spout Installation.....	0252-5
FUEL TANK HANGERS AND RETAINING STRAPS REPLACEMENT.....	WP 0253
Figure 1. Fuel Tank Hangers and Retaining Straps Removal.....	0253-3
Figure 2. Fuel Tank Hangers and Retaining Straps Inspection.....	0253-5
Figure 3. Fuel Tank Hangers and Retaining Straps Installation.....	0253-7
FUEL TANK LINES REPLACEMENT (M939A2).....	WP 0254
Figure 1. Fuel Tank Lines Removal.....	0254-3
Figure 2. Fuel Return and Supply Lines Removal.....	0254-5
Figure 3. Fuel Return and Supply Lines Removal.....	0254-7
Figure 4. Fuel Return and Supply Lines Installation.....	0254-9
Figure 5. Fuel Return and Supply Lines Installation.....	0254-10
Figure 6. Fuel Return and Supply Lines Installation.....	0254-11
FUEL SELECTOR VALVE, MOUNTING BRACKET, AND INDICATOR PLATE REPLACEMENT.....	WP 0255
Figure 1. Fuel Selector Valve Removal.....	0255-3
Figure 2. Fuel Selector Valve Installation.....	0255-5
FUEL DRAIN AND BYPASS TUBING REPLACEMENT (M939/A1).....	WP 0256
Figure 1. Fuel Bypass Tubing Removal.....	0256-3
Figure 2. Fuel Bypass Tubing Removal.....	0256-5
Figure 3. Fuel Bypass Tubing Installation.....	0256-7
Figure 4. Fuel Bypass Tubing Installation.....	0256-9
FUEL SELECTOR VALVE FLEX HOSE REPLACEMENT.....	WP 0257
Figure 1. Fuel Selector Valve Flex Hose Removal.....	0257-3

TABLE OF CONTENTS - Continued

	Page No.
	<u>WP Sequence No.</u>
Figure 2. Fuel Selector Valve Flex Hose Installation.....	0257-4
FUEL FILTER AND COVER REPLACEMENT.....	WP 0258
Figure 1. Fuel Filter Removal.....	0258-3
Figure 2. Fuel Filter Removal.....	0258-5
Figure 3. Fuel Filter Removal.....	0258-6
Figure 4. Fuel Filter Removal.....	0258-7
Figure 5. Fuel Filter Cleaning and Inspection.....	0258-8
Figure 6. Fuel Filter Installation.....	0258-9
Figure 7. Fuel Filter Installation.....	0258-10
Figure 8. Fuel Filter Installation.....	0258-11
AFC FUEL PUMP FILTER REPLACEMENT (M939/A1).....	WP 0259
Figure 1. AFC Fuel Pump Filter Removal.....	0259-3
Figure 2. AFC Fuel Pump Filter Installation.....	0259-4
FUEL PUMP WITH VS GOVERNOR FILTER REPLACEMENT (M939/A1).....	WP 0260
Figure 1. Fuel Pump with VS Governor Filter Removal.....	0260-3
Figure 2. Fuel Pump with VS Governor Filter Installation.....	0260-4
FUEL PRIMER PUMP REPLACEMENT (M939/A1).....	WP 0261
Figure 1. Fuel Primer Pump Removal.....	0261-2
Figure 2. Fuel Primer Pump Installation.....	0261-3
ETHER START SWITCH REPLACEMENT (M939/A1).....	WP 0262
Figure 1. Ether Start Switch Removal.....	0262-2
Figure 2. Ether Start Switch Installation.....	0262-3
ETHER CYLINDER AND VALVE REPLACEMENT (M939/A1).....	WP 0263
Figure 1. Ether Cylinder Removal.....	0263-3
Figure 2. Ether Valve Removal.....	0263-4
Figure 3. Ether Valve Installation.....	0263-5
Figure 4. Ether Cylinder Installation.....	0263-6

TABLE OF CONTENTS - Continued

	Page No.
	<u>WP Sequence No.</u>
ETHER THERMAL CLOSE VALVE AND BUSHING REPLACEMENT (M939/A1).....	WP 0264
Figure 1. Ether Thermal Close Valve and Bushing Removal.....	0264-2
Figure 2. Ether Thermal Close Valve and Bushing Installation.....	0264-3
ETHER ATOMIZER REPLACEMENT (M939/A1).....	WP 0265
Figure 1. Ether Atomizer Removal.....	0265-2
Figure 2. Ether Atomizer Installation.....	0265-3
ETHER ATOMIZER AND TEMPERATURE SENSOR REPLACEMENT (M939A2).....	WP 0266
Figure 1. Ether Atomizer and Temperature Sensor Removal.....	0266-3
Figure 2. Ether Atomizer and Temperature Sensor Installation.....	0266-4
ETHER TUBING REPLACEMENT (M939/A1).....	WP 0267
Figure 1. Ether Tubing Removal.....	0267-3
Figure 2. Ether Tubing Installation.....	0267-5
ACCELERATOR LINKAGE REPLACEMENT (M939/A1).....	WP 0268
Figure 1. Accelerator Linkage Removal.....	0268-3
Figure 2. Accelerator Linkage Installation.....	0268-5
Figure 3. Accelerator Linkage Adjustment.....	0268-7
ACCELERATOR LINKAGE REPLACEMENT (M939A2).....	WP 0269
Figure 1. Accelerator Linkage Removal.....	0269-3
Figure 2. Accelerator Linkage Disassembly.....	0269-5
Figure 3. Accelerator Linkage Assembly.....	0269-7
Figure 4. Accelerator Linkage Installation.....	0269-9
Figure 5. Accelerator Linkage Adjustment.....	0269-11
THROTTLE CONTROL CABLE REPLACEMENT.....	WP 0270
Figure 1. Throttle Control Cable Removal.....	0270-3
Figure 2. Throttle Control Cable Installation.....	0270-5
EMERGENCY STOP CONTROL CABLE REPLACEMENT.....	WP 0271
Figure 1. Emergency Stop Control Cable Removal.....	0271-3

TABLE OF CONTENTS - Continued

	Page No.
	<u>WP Sequence No.</u>
Figure 2. Emergency Stop Control Cable Installation.....	0271-5
ACCELERATOR PEDAL, BRACKET, ROD, AND STOPSCREW REPLACEMENT.....	WP 0272
Figure 1. Accelerator Pedal Removal.....	0272-2
Figure 2. Accelerator Pedal Installation.....	0272-3
EXHAUST STACK REPLACEMENT.....	WP 0273
Figure 1. Exhaust Stack Removal.....	0273-2
Figure 2. Exhaust Stack Installation.....	0273-3
MUFFLER AND SHIELD REPLACEMENT.....	WP 0274
Figure 1. Muffler and Shield Removal.....	0274-3
Figure 2. Muffler and Shield Installation.....	0274-5
REAR EXHAUST PIPE, SUPPORT BRACKET, AND CAB HEAT SHIELD REPLACEMENT.....	WP 0275
Figure 1. Rear Exhaust Pipe, Support Bracket, and Cab Heat Shield Removal.....	0275-3
Figure 2. Rear Exhaust Pipe, Support Bracket, and Cab Heat Shield Installation.....	0275-5
FRONT EXHAUST PIPE REPLACEMENT.....	WP 0276
Figure 1. Front Exhaust Pipe Replacement.....	0276-3
Figure 2. Front Exhaust Pipe Installation.....	0276-5
RADIATOR AND MOUNTING HARDWARE REPLACEMENT (M939A2 ONLY).....	WP 0277
Figure 1. Radiator and Mounting Hardware Removal.....	0277-3
Figure 2. Radiator and Mounting Hardware Installation.....	0277-5
SURGE TANK, RADIATOR VENT HOSE, AND MANIFOLD RETURN HOSE REPLACEMENT (M939/A1).....	WP 0278
Figure 1. Radiator Vent and Manifold Return Hoses Removal.....	0278-3
Figure 2. Surge Tank Removal.....	0278-5
Figure 3. Surge Tank Installation.....	0278-7
Figure 4. Radiator Vent and Manifold Return Hoses Installation.....	0278-9
SURGE TANK AND BRACKET REPLACEMENT (M939A2).....	WP 0279
Figure 1. Surge Tank and Bracket Removal.....	0279-3
Figure 2. Surge Tank and Bracket Installation.....	0279-5

TABLE OF CONTENTS - Continued

	Page No.
	<u>WP Sequence No.</u>
COOLANT HOSES AND TUBES REPLACEMENT (M939/A1).....	WP 0280
Figure 1. Radiator Inlet Hoses and Tube Removal.....	0280-2
Figure 2. Thermostat Housing Hose, Radiator Bypass Tube, and Hose Removal.....	0280-3
Figure 3. Surge Tank Hose Removal.....	0280-4
Figure 4. Radiator Outlet Hoses and Tee Removal.....	0280-5
Figure 5. Transmission Oil Cooler Hoses and Tube Removal.....	0280-7
Figure 6. Transmission Oil Cooler Hoses and Tubes Installation.....	0280-9
Figure 7. Radiator Outlet Hoses and Tee Installation.....	0280-10
Figure 8. Surge Tank Hose Installation.....	0280-11
Figure 9. Thermostat Housing Hose, Radiator Bypass Tube, and Hose Installation.....	0280-12
Figure 10. Radiator Inlet Hoses and Tube Installation.....	0280-13
RADIATOR AND MOUNTING HARDWARE REPLACEMENT (M939/A1).....	WP 0281
Figure 1. Radiator (M939/A1) Removal.....	0281-2
Figure 2. Radiator (M939/A1) Removal.....	0281-3
Figure 3. Radiator (M939/A1) Removal.....	0281-4
Figure 4. Radiator (M939/A1) Installation.....	0281-5
Figure 5. Radiator (M939/A1) Installation.....	0281-6
Figure 6. Radiator (M939/A1) Installation.....	0281-7
RADIATOR FAN SHROUD REPLACEMENT (M939/A1).....	WP 0282
Figure 1. Radiator Fan Shroud Removal.....	0282-3
Figure 2. Radiator Fan Shroud Installation.....	0282-5
FAN AND FAN SHROUD REPAIR (M939A2).....	WP 0283
Figure 1. Fan and Shroud Removal.....	0283-3
Figure 2. Fan and Shroud Installation.....	0283-5
AIR COMPRESSOR COOLANT SUPPLY AND RETURN TUBES REPLACEMENT (M939/A1).....	WP 0284
Figure 1. Supply Tube Removal.....	0284-2
Figure 2. Return Tube Inspection.....	0284-3

TABLE OF CONTENTS - Continued

	Page No.
	<u>WP Sequence No.</u>
Figure 3. Supply Tube Installation.....	0284-4
Figure 4. Return Tube Installation.....	0284-5
COOLANT HOSES AND LINES REPLACEMENT (M939A2).....	WP 0285
Figure 1. Coolant Hoses and Lines Removal.....	0285-2
Figure 2. Coolant Hoses and Lines Removal.....	0285-3
Figure 3. Coolant Hoses and Lines Removal.....	0285-4
Figure 4. Coolant Hoses and Lines Removal.....	0285-5
Figure 5. Coolant Hoses and Lines Installation.....	0285-6
Figure 6. Coolant Hoses and Lines Installation.....	0285-7
Figure 7. Coolant Hoses and Lines Installation.....	0285-8
Figure 8. Coolant Hoses and Lines Installation.....	0285-9
UPPER RADIATOR HOSES AND BRACKETS REPLACEMENT (M939A2).....	WP 0286
Figure 1. Upper Radiator Hoses and Brackets Removal.....	0286-2
Figure 2. Upper Radiator Hoses and Brackets Removal.....	0286-3
Figure 3. Upper Radiator Hoses and Brackets Installation.....	0286-4
Figure 4. Upper Radiator Hoses and Brackets Installation.....	0286-5
COOLING SYSTEM SERVICE.....	WP 0287
Figure 1. Cooling System.....	0287-3
Table 1. Guide for Preparation of Antifreeze Solutions.....	0287-4
Figure 2. Cooling System.....	0287-5
THERMOSTAT AND HOUSING REPLACEMENT (M939/A1).....	WP 0288
Figure 1. Thermostat and Housing Removal.....	0288-3
Figure 2. Thermostat and Housing Installation.....	0288-5
THERMOSTATS AND HOUSING REPLACEMENT (M939A2).....	WP 0289
Figure 1. Thermostat and Housing Removal.....	0289-3
Figure 2. Thermostat and Housing Installation.....	0289-5
Figure 3. Thermostat and Housing Removal.....	0289-7

TABLE OF CONTENTS - Continued

	Page No.
	<u>WP Sequence No.</u>
Figure 4. Thermostat and Housing Installation.....	0289-9
ENGINE WATER MANIFOLD REPLACEMENT (M939/A1).....	WP 0290
Figure 1. Engine Water Manifold Removal.....	0290-3
Figure 2. Engine Water Manifold Disassembly.....	0290-4
Figure 3. Engine Water Manifold Assembly.....	0290-5
Figure 4. Engine Water Manifold Installation.....	0290-6
WATER HEADER PLATES REPLACEMENT (M939/A1).....	WP 0291
Figure 1. Water Header Plates Removal.....	0291-2
Figure 2. Water Header Plates Installation.....	0291-3
WATER PUMP REPLACEMENT (M939A2).....	WP 0292
Figure 1. Water Pump Removal.....	0292-2
Figure 2. Water Pump Installation.....	0292-3
WATER PUMP REPLACEMENT (M939/A1).....	WP 0293
Figure 1. Water Pump Removal.....	0293-2
Figure 2. Water Pump Removal.....	0293-3
Figure 3. Water Pump Installation.....	0293-4
Figure 4. Water Pump Installation.....	0293-5
WATER PUMP DRIVEBELT REPLACEMENT (M939/A1).....	WP 0294
Figure 1. Water Pump Drivebelt Adjustment.....	0294-3
Figure 2. Water Pump Drivebelt Removal.....	0294-5
Figure 3. Water Pump Drivebelt Installation.....	0294-7
FAN DRIVE CLUTCH REPLACEMENT (M939/A1).....	WP 0295
Figure 1. Fan Drive Clutch Removal.....	0295-1
Figure 2. Fan Drive Clutch Removal.....	0295-2
Figure 3. Fan Drive Clutch Installation.....	0295-3
Figure 4. Fan Drive Clutch Installation.....	0295-4
FAN DRIVEBELT AND DRIVEBELT TENSIONER REPLACEMENT (M939A2).....	WP 0296

TABLE OF CONTENTS - Continued

	Page No.
	<u>WP Sequence No.</u>
Figure 1. Fan Drivebelt and Drivebelt Tensioner Removal.....	0296-3
Figure 2. Fan Drivebelt and Drivebelt Tensioner Installation.....	0296-5
FAN DRIVEBELTS MAINTENANCE (M939/A1).....	WP 0297
Figure 1. Fan Drivebelt Adjustment.....	0297-3
Figure 2. Fan Drivebelt Removal.....	0297-5
Figure 3. Fan Drivebelt Installation.....	0297-6
RADIATOR FAN BLADE REPLACEMENT (M939/A1).....	WP 0298
Figure 1. Radiator Fan Blade Removal.....	0298-3
Figure 2. Radiator Fan Blade Installation.....	0298-5
AFTERCOOLER AND TUBES REPLACEMENT (M939A2).....	WP 0299
Figure 1. Aftercooler and Tubes Removal.....	0299-2
Figure 2. Aftercooler and Tubes Removal.....	0299-3
Figure 3. Aftercooler and Tubes Installation.....	0299-4
Figure 4. Aftercooler and Tubes Installation.....	0299-5
ALTERNATOR, MOUNTING BRACKET, AND PULLEY REPLACEMENT (M939/A1).....	WP 0300
Figure 1. Alternator and Mounting Bracket Removal.....	0300-2
Figure 2. Alternator and Mounting Bracket Removal.....	0300-3
Figure 3. Alternator Pulley Removal.....	0300-5
Figure 4. Alternator Pulley Installation.....	0300-7
Figure 5. Alternator and Mounting Bracket Installation.....	0300-8
Figure 6. Alternator and Mounting Bracket Installation.....	0300-9
ALTERNATOR, MOUNTING BRACKET, AND PULLEY REPLACEMENT (M939A2).....	WP 0301
Figure 1. Alternator and Mounting Bracket Removal.....	0301-3
Figure 2. Pulley Removal.....	0301-5
Figure 3. Pulley Installation.....	0301-7
Figure 4. Alternator and Mounting Bracket Installation.....	0301-9
Figure 5. Alternator, Mounting Bracket, and Pulley Adjustment.....	0301-11

TABLE OF CONTENTS - Continued

	Page No.
	<u>WP Sequence No.</u>
ALTERNATOR DRIVEBELTS REPLACEMENT (M939/A1).....	WP 0302
Figure 1. Alternator Drivebelts Removal.....	0302-2
Figure 2. Alternator Drivebelts Installation.....	0302-3
Figure 3. Alternator Drivebelts Installation.....	0302-3
Figure 4. Alternator Drivebelts Installation.....	0302-4
Figure 5. Alternator Drivebelts Installation.....	0302-4
STARTER REPLACEMENT.....	WP 0303
Figure 1. Starter Replacement Removal.....	0303-3
Figure 2. Starter Installation.....	0303-5
THROTTLE CONTROL SOLENOID REPLACEMENT (M939A2).....	WP 0304
Figure 1. Throttle Control Solenoid Removal.....	0304-2
Figure 2. Throttle Control Solenoid Installation.....	0304-3
FUEL PUMP METERING VALVE REPLACEMENT (M939/A1).....	WP 0305
Figure 1. Manual Shutoff Valve Removal.....	0305-2
Figure 2. Fuel Pump Metering Valve Removal.....	0305-3
Figure 3. Fuel Pump Metering Valve Installation.....	0305-4
Figure 4. Manual Shutoff Valve Installation.....	0305-5
FUEL PUMP METERING VALVE REPLACEMENT (M936 Wrecker).....	WP 0306
Figure 1. Fuel Pump Metering Valve Removal.....	0306-2
Figure 2. Fuel Pump Metering Valve Installation.....	0306-3
ELECTRICAL SWITCHES AND CIRCUIT BREAKER REPLACEMENT.....	WP 0307
Figure 1. Switch Removal.....	0307-1
Figure 2. Wire Removal.....	0307-2
Figure 3. Wire Connector Installation.....	0307-2
Figure 4. Blower Motor Switch Installation.....	0307-3
Figure 5. Battery and Switch Removal.....	0307-3
Figure 6. Battery and Starter Switch Removal.....	0307-4

TABLE OF CONTENTS - Continued

	Page No.
	<u>WP Sequence No.</u>
Figure 7. Battery and Switch Installation.....	0307-5
Figure 8. Battery and Starter Switch Installation.....	0307-5
Figure 9. Circuit Breaker Removal.....	0307-7
Figure 10. Circuit Breaker Installation.....	0307-9
SPRING BRAKE PRESSURE SWITCH REPLACEMENT.....	WP 0308
Figure 1. Spring Brake Pressure Switch Removal.....	0308-3
Figure 2. Spring Brake Pressure Switch Installation.....	0308-5
INSTRUMENT PANEL REPLACEMENT.....	WP 0309
Figure 1. Instrument Panel Removal.....	0309-3
Figure 2. Instrument Panel Installation.....	0309-4
INSTRUMENT CLUSTER REPLACEMENT.....	WP 0310
Figure 1. Cable Removal.....	0310-2
Figure 2. Cable Removal.....	0310-3
Figure 3. Instrument Cluster Removal.....	0310-4
Figure 4. Instrument Cluster Removal.....	0310-5
Figure 5. Instrument Cluster Disassembly.....	0310-7
Figure 6. Instrument Cluster Assembly.....	0310-9
Figure 7. Instrument Cluster Installation.....	0310-10
Figure 8. Instrument Cluster Installation.....	0310-11
Figure 9. Instrument Cluster Installation.....	0310-12
Figure 10. Instrument Cluster Installation.....	0310-13
INDICATOR PANEL LIGHT AND LAMP REPLACEMENT.....	WP 0311
Figure 1. Indicator Panel Light Removal.....	0311-2
Figure 2. Indicator Panel Light Installation.....	0311-3
Figure 3. Lamp Removal.....	0311-4
Figure 4. Lamp Installation.....	0311-5
ELECTRICAL GAUGES REPLACEMENT.....	WP 0312

TABLE OF CONTENTS - Continued

	Page No.
	<u>WP Sequence No.</u>
Figure 1. Gauges Removal.....	0312-3
Figure 2. Gauges Installation.....	0312-4
AUXILIARY OUTLET SOCKET AND RECEPTACLE REPLACEMENT.....	WP 0313
Figure 1. Auxiliary Outlet Socket and Receptacle Removal.....	0313-3
Figure 2. Auxiliary Outlet Installation.....	0313-5
FUEL SELECTOR VALVE SWITCH REPLACEMENT.....	WP 0314
Figure 1. Fuel Selector Valve Switch Removal.....	0314-3
Figure 2. Fuel Selector Valve Switch Installation.....	0314-5
MAIN LIGHT SWITCH REPLACEMENT.....	WP 0315
Figure 1. Main Light Switch Removal.....	0315-3
Figure 2. Main Light Switch Installation.....	0315-5
HIGH BEAM SELECTOR SWITCH REPLACEMENT.....	WP 0316
Figure 1. High Beam Selector Switch Removal.....	0316-1
Figure 2. High Beam Selector Switch Installation.....	0316-2
TURN SIGNAL CONTROL AND INDICATOR LAMP REPLACEMENT.....	WP 0317
Figure 1. Turn Signal Removal.....	0317-1
Figure 2. Turn Signal Installation.....	0317-2
TURN SIGNAL FLASHER REPLACEMENT.....	WP 0318
Figure 1. Turn Signal Removal.....	0318-1
Figure 2. Turn Signal Installation.....	0318-2
PROTECTIVE CONTROL BOX REPLACEMENT.....	WP 0319
Figure 1. Protective Control Box Removal.....	0319-2
Figure 2. Protective Control Box Installation.....	0319-3
FLOODLIGHT CONTROL SWITCH REPLACEMENT.....	WP 0320
Figure 1. Floodlight Switch Installation Removal.....	0320-2
Figure 2. Floodlight Switch Disassembly.....	0320-3
Figure 3. Floodlight Switch Inspection.....	0320-4

TABLE OF CONTENTS - Continued

	Page No.
	<u>WP Sequence No.</u>
Figure 4. Floodlight Switch Assembly.....	0320-5
Figure 5. Floodlight Switch Installation.....	0320-6
AMBER WARNING LIGHT REPLACEMENT.....	WP 0321
Figure 1. Amber Warning Light Removal.....	0321-1
Figure 2. Amber Warning Light Installation.....	0321-2
CTIS WIRING HARNESS REPLACEMENT.....	WP 0322
Figure 1. Wiring Harness Removal.....	0322-3
Figure 2. Wiring Harness Installation.....	0322-5
SPEED SIGNAL GENERATOR REPLACEMENT.....	WP 0323
Figure 1. Speed Signal Generator Removal.....	0323-2
Figure 2. Speed Signal Generator Installation.....	0323-3
PRESSURE SWITCH REPLACEMENT.....	WP 0324
Figure 1. Pressure Switch Removal.....	0324-2
Figure 2. Pressure Switch Installation.....	0324-3
HEADLIGHT REPAIR.....	WP 0325
Figure 1. Headlight Removal.....	0325-2
Figure 2. Headlight Removal.....	0325-3
Figure 3. Headlight Installation.....	0325-4
Figure 4. Headlight Installation.....	0325-5
Figure 5. Headlight Alignment.....	0325-6
BLACKOUT LIGHT REPAIR.....	WP 0326
Figure 1. Blackout Light Removal.....	0326-2
Figure 2. Blackout Light Disassembly.....	0326-3
Figure 3. Blackout Light Assembly.....	0326-4
Figure 4. Blackout Light Installation.....	0326-5
FRONT AND REAR COMPOSITE LIGHT AND BRACKET REPLACEMENT.....	WP 0327
Figure 1. Front Composite Light Removal.....	0327-3

TABLE OF CONTENTS - Continued

	Page No.
	<u>WP Sequence No.</u>
Figure 2. Front Composite Light Installation.....	0327-4
Figure 3. Rear Composite Light Removal.....	0327-5
Figure 4. Rear Composite Light Installation.....	0327-6
Figure 5. Rear Composite Light Removal.....	0327-7
Figure 6. Rear Composite Light Installation.....	0327-9
Figure 7. Rear Composite Light and Bracket Removal.....	0327-11
Figure 8. Rear Composite Light and Bracket Installation.....	0327-13
Figure 9. Rear Composite Light and Bracket Removal.....	0327-15
Figure 10. Rear Composite Light and Bracket Installation.....	0327-17
Figure 11. Rear Composite Light Removal.....	0327-19
Figure 12. Rear Composite Light Installation.....	0327-21
Figure 13. Rear Composite Bulb Removal.....	0327-22
Figure 14. Rear Composite Bulb Installation.....	0327-23
FLOODLIGHT SEALED BEAM LAMP AND DOOR REPLACEMENT.....	WP 0328
Figure 1. Floodlight Removal.....	0328-3
Figure 2. Floodlight Installation.....	0328-4
FLOODLIGHT REPAIR.....	WP 0329
Figure 1. Floodlight Removal.....	0329-2
Figure 2. Floodlight Disassembly.....	0329-3
Figure 3. Floodlight Disassembly.....	0329-4
Figure 4. Floodlight Assembly.....	0329-5
Figure 5. Floodlight Assembly.....	0329-6
Figure 6. Floodlight Installation.....	0329-7
SIDE MARKER LIGHTS AND BRACKET REPLACEMENT.....	WP 0330
Figure 1. Side Marker Lamp Removal.....	0330-2
Figure 2. Side Marker Light Removal.....	0330-3
Figure 3. Side Marker Light Installation.....	0330-4

TABLE OF CONTENTS - Continued

	Page No.
	<u>WP Sequence No.</u>
Figure 4. Side Marker Lamp Installation.....	0330-5
BOOM FLOODLIGHT WIRE REPLACEMENT.....	WP 0331
Figure 1. Boom Floodlight Wire Removal.....	0331-3
Figure 2. Boom Floodlight Wire Installation.....	0331-4
FUEL LEVEL SENDING UNIT REPLACEMENT.....	WP 0332
Figure 1. Fuel Level Sending Unit Removal.....	0332-3
Figure 2. Fuel Level Sending Unit Installation.....	0332-4
OIL PRESSURE SENDING UNIT REPLACEMENT.....	WP 0333
Figure 1. Oil Pressure Sending Unit Removal.....	0333-2
Figure 2. Oil Pressure Sending Unit Installation.....	0333-3
WATER TEMPERATURE SENDING UNIT REPLACEMENT.....	WP 0334
Figure 1. Water Temperature Sending Unit Removal.....	0334-2
Figure 2. Water Temperature Sending Unit Installation.....	0334-3
STOPLIGHT SWITCH REPLACEMENT.....	WP 0335
Figure 1. Stoplight Switch Removal.....	0335-1
Figure 2. Stoplight Switch Installation.....	0335-2
FAILSAFE WARNING MODULE REPLACEMENT.....	WP 0336
Figure 1. Failsafe Warning Module Removal.....	0336-2
Figure 2. Failsafe Warning Module Installation.....	0336-3
ETHER START FUEL PRESSURE SWITCH REPLACEMENT.....	WP 0337
Figure 1. Ether Start Fuel Pressure Switch Removal.....	0337-2
Figure 2. Ether Start Fuel Pressure Switch Installation.....	0337-3
TACHOMETER PULSE SENSOR REPLACEMENT.....	WP 0338
Figure 1. Tachometer Pulse Sender Removal.....	0338-2
Figure 2. Tachometer Pulse Sender Installation.....	0338-3
TACHOMETER PULSE SENSOR REPLACEMENT (M939A2).....	WP 0339
Figure 1. Tachometer Pulse Sender Removal.....	0339-1

TABLE OF CONTENTS - Continued

	Page No.
	<u>WP Sequence No.</u>
Figure 2. Tachometer Pulse Sender Installation.....	0339-2
FUEL PRESSURE TRANSDUCER REPLACEMENT.....	WP 0340
Figure 1. Fuel Pressure Transducer Removal.....	0340-2
Figure 2. Fuel Pressure Transducer Installation.....	0340-3
TRANSMISSION TEMPERATURE TRANSMITTER REPLACEMENT.....	WP 0341
Figure 1. Transmission Temperature Transmitter Removal.....	0341-1
Figure 2. Transmission Temperature Transmitter Installation.....	0341-2
PRIMARY AND SECONDARY LOW AIR PRESSURE SWITCH REPLACEMENT.....	WP 0342
Figure 1. Primary and Secondary Air Pressure Removal.....	0342-3
Figure 2. Primary and Secondary Air Pressure Removal.....	0342-5
Figure 3. Primary and Secondary Air Pressure Removal.....	0342-7
Figure 4. Primary and Secondary Air Pressure Installation.....	0342-9
HORN, SOLENOID, AND BRACKET REPLACEMENT.....	WP 0343
Figure 1. Horn, Solenoid, and Bracket Removal.....	0343-3
Figure 2. Horn, Solenoid, and Bracket Installation.....	0343-5
HORN SWITCH REPLACEMENT.....	WP 0344
Figure 1. Horn Switch Removal.....	0344-3
Figure 2. Horn Switch Installation.....	0344-5
HORN CONTACT BRUSH REPLACEMENT.....	WP 0345
Figure 1. Horn Contact Removal.....	0345-1
Figure 2. Horn Contact Removal.....	0345-3
Figure 3. Horn Contact Installation.....	0345-5
Figure 4. Horn Contact Installation.....	0345-6
BATTERY REPLACEMENT.....	WP 0346
Figure 1. Battery Removal.....	0346-3
Figure 2. Battery Inspection and Cleaning.....	0346-4
Figure 3. Battery Installation.....	0346-5

TABLE OF CONTENTS - Continued

	Page No.
	<u>WP Sequence No.</u>
BATTERY BOX REPLACEMENT.....	WP 0347
Figure 1. Battery Box Removal.....	0347-2
Figure 2. Battery Box Installation.....	0347-3
BATTERY BOX COVER REPLACEMENT.....	WP 0348
Figure 1. Battery Box Cover Removal.....	0348-2
Figure 2. Battery Box Cover Installation.....	0348-3
BATTERY CABLE AND TERMINAL ADAPTER REPLACEMENT.....	WP 0349
Figure 1. Battery Cable Removal.....	0349-3
Figure 2. Battery Cable Installation.....	0349-5
BATTERY GROUND CABLE REPLACEMENT.....	WP 0350
Figure 1. Battery Ground Cable Disconnection.....	0350-3
Figure 2. Battery Ground Cable Connection.....	0350-4
Index	

HOW TO USE THIS MANUAL

WARNINGS, CAUTIONS, AND NOTES

Read all WARNINGS, CAUTIONS, and NOTES before performing any procedure.

Warnings, cautions, notes, subject headings, and other essential information is printed in **BOLD** type, making them easier for the user to see.

GENERAL INFORMATION

This manual is divided into CHAPTERS and WORK PACKAGES. For a specific Chapter or Work Package, refer to the TABLE OF CONTENTS.

VOLUME 2

- The TABLE OF CONTENTS lists the titles of each Chapter and Work Package.
- CHAPTER 4 provides the ABS troubleshooting procedures.
- CHAPTER 5 provides the STE/ICE troubleshooting procedures.
- CHAPTER 6 provides PMCS maintenance instructions.
- CHAPTER 7 provides maintenance instructions.

The illustrations throughout this manual contain numerical callouts pointing to various components mentioned in the procedural steps. Mandatory replacement parts must be discarded after removal and replaced with a new part, which is listed in the Materials/Parts section located at the beginning of the task.

Prior to performing any maintenance functions on the 5-ton, 6x6, M939, M939A1, and M939A2 Diesel Truck series, ALWAYS do the following:

- Read and follow all WARNINGS in all work packages.
- Read the Safety Summary.
- Read the Equipment Description and Data located in Chapter 1.
- Read completely through the maintenance procedure to familiarize yourself with the procedure and the affected parts before beginning work.

Troubleshooting section is setup by either how a physical problem is occurring or how an active or stored trouble code is read from a diagnostic tool. By following a prescribed flow path through making decisions will lead you to a solution to remedy the problem. RPSTL manual, TM 9-2320-272-24P, is to be used in conjunction with this manual to help find needed parts for procurement. RPSTL manual lists and authorized spares and repair parts; special tools, special Test, Measurement, and Diagnostic Equipment (TMDE); and other special support equipment required for performance of Field Maintenance on the 5-ton, 6x6, M939, M939A1, and M939A2 Diesel Truck series. It authorizes the requisitioning, issue, and disposition of spares, repair parts, and special tools as indicated by the Source, Maintenance, and Recoverability (SMR) codes.

METRIC SYSTEM

The equipment described herein contains metric components and requires metric, common, and special tools. Therefore, metric units and English units will be used throughout this publication. An English-to-Metric conversion table is included as the last page of this manual inside the back cover.

CHAPTER 4
ABS TROUBLESHOOTING PROCEDURES

FIELD MAINTENANCE
ANTILOCK BRAKE SYSTEM (ABS) ELECTRONIC DIAGNOSTIC TROUBLESHOOTING

INTRODUCTION

1. The Antilock Brake System (ABS) is designed to prevent rear wheel lockup by automatically regulating brake pressure on rear wheels, as needed, for maximum adhesion. The ABS improves handling and controllability during emergency stops and normal braking in rain, snow, ice, or sand.
2. The ABS consists of two wheel-end tone rings and wheel speed sensors located on the rear-rear axle hubs, two modulator valves, and an Electronic Control Unit (ECU). The ABS system interfaces with the vehicle's electrical and pneumatic systems. The controlling unit of the entire system is the ECU. The ECU receives signals from the wheel speed sensors and instructs the appropriate modulator valves to adjust brake pressure as necessary.
3. This chapter contains troubleshooting information and tests for locating and correcting malfunctions which may develop in the ABS on vehicles covered in this manual. Each symptom or malfunction given for an individual component or system is followed by step(s) you should take to determine the cause and corrective action needed to remedy the problem.
4. The following is a list of definitions used in the troubleshooting procedures:
 - a. Clear Mode – Clears faults from memory of the ECU.
 - b. Electronic Control Unit (ECU) – Receives signals from wheel sensors on rear-rear axle hubs and activates the appropriate response.
 - c. Fault – A malfunction detected and/or stored in the memory of the ECU.
 - d. Active Fault – A condition that currently exists in the system, even when battery switch has been turned OFF, then ON, and vehicle driven in excess of 5 mph. The ABS warning lamp will come on and remain on. Active faults must be repaired before they can be cleared from ECU memory.
 - e. Stored Fault – An active fault that has not been cleared from ECU memory, or intermittent fault that has occurred, but no longer exists. The ABS warning lamp will come on and stay on after vehicle has been driven in excess of 5 mph and go off after battery switch has been turned OFF.
5. Disconnect power from ABS system by placing battery switch and start switch in the OFF position and disconnecting battery ground cable before testing for shorted or open leads or making any repairs.
6. Most ABS problems are related to:
 - a. Cut, corroded or abraded leads.
 - b. Corroded connectors or terminals.
 - c. Connectors not latched or seated correctly to mating connectors.
7. Diagnostic Code Descriptions.
 - a. Code 00, 07, 8.8, and C1. Indicates that the system is working ok. Diagnostic tester will indicate code 00 with vehicle moving and code 07 when vehicle is stationary indicating that there are no active faults. Code 8.8 is a self diagnostic test. Code C1 indicates that the ABS is a 2S/2M system (two sensors with modulator valves).
 - b. Code 03 or 04. Indicates that a wheel sensor or wheel sensor lead has a short or open circuit. Disconnect wheel sensor lead from wiring harness lead and measure the resistance between the two pins of wheel sensor lead. The multimeter reading should be between 980 and 2350 Ohms. Replace wheel sensor if not within limits. To check wiring harness lead, disconnect ABS main wiring harness connector from ECU and check for short or open circuit between sensor lead pins 1 and 10 (figure 1) for 2A right rear wheel sensor and pins 2 and 11 for 2B left rear wheel sensor. Also check for damaged connector pins. Replace or repair as necessary.

INTRODUCTION - Continued

- c. Codes 13 or 14.

NOTE

If the gap on both sensors is too great, you may not show a fault. The ECU will think the vehicle is not moving and you will not have ABS brakes.

Occurs when vehicle is moving and indicates that the wheel sensor output is insufficient for a moving vehicle. The most likely reason for this code is that the gap between wheel sensor and tone ring is too great. Lift and support rear-rear axle wheels, disconnect wheel sensor leads and connect a multimeter to right or left wheel sensor leads. Measure AC voltage while rotating wheel at a rate of one revolution every two seconds. The output voltage should be at least 200 millivolts (.002 VAC). If less than limit, try pushing wheel sensor in until sensor connects tone ring and recheck voltage. If voltage is not within limit, replace wheel sensor.

- d. Codes 23 or 24. Occurs when vehicle is moving and indicates that there is an intermittent loss of sensor signal. This type of fault is often difficult to diagnose. The most likely causes include:
 - a. Dragging brake
 - b. Pinched or kinked air delivery hose. Defective modulator valve or failed primary air system.
 - c. Check brakes to ensure that they release completely and look for visual external damage to delivery hoses or delivery tubes. Check exhaust ports of ABS valves for obstruction. Repair or replace defective hardware as necessary.
- e. Code 62, 63, 68, or 69 indicates that a solenoid or its cable has an open circuit internally. The most likely causes include bad solenoid or loose solenoid connection. Disconnect the appropriate solenoid connector and check resistance at the solenoid pins. Check for 30 to 60 Ohms between either bottom pin or the top pin. Check the female terminals on the connector for excessive pin spread or corrosion. Replace defective solenoid or connector as required. Additional possible causes are a bad solenoid cable, ABS main wiring harness connector not completely latched into the ECU, or a damaged harness pin. Attach the solenoid cable (figure 1) to solenoid. Remove main wiring harness connector from ECU and check the resistance between pins 3 and 13, 3 and 23, and 13 and 23 for forward (BLUE) valve cable or between 4 and 14, 4 and 24, and 14 and 24 for rear (YELLOW) valve cable (figure 1). The resistance should be approximately 32 Ohms between pins 3 and 13 and 4 and 14 and resistance should be approximately 16 Ohms between pins 3 and 23, 13 and 23, 4 and 24, and 14 and 24 (figure 1). Replace ECU or ABS main wiring harness as necessary.

INTRODUCTION - Continued

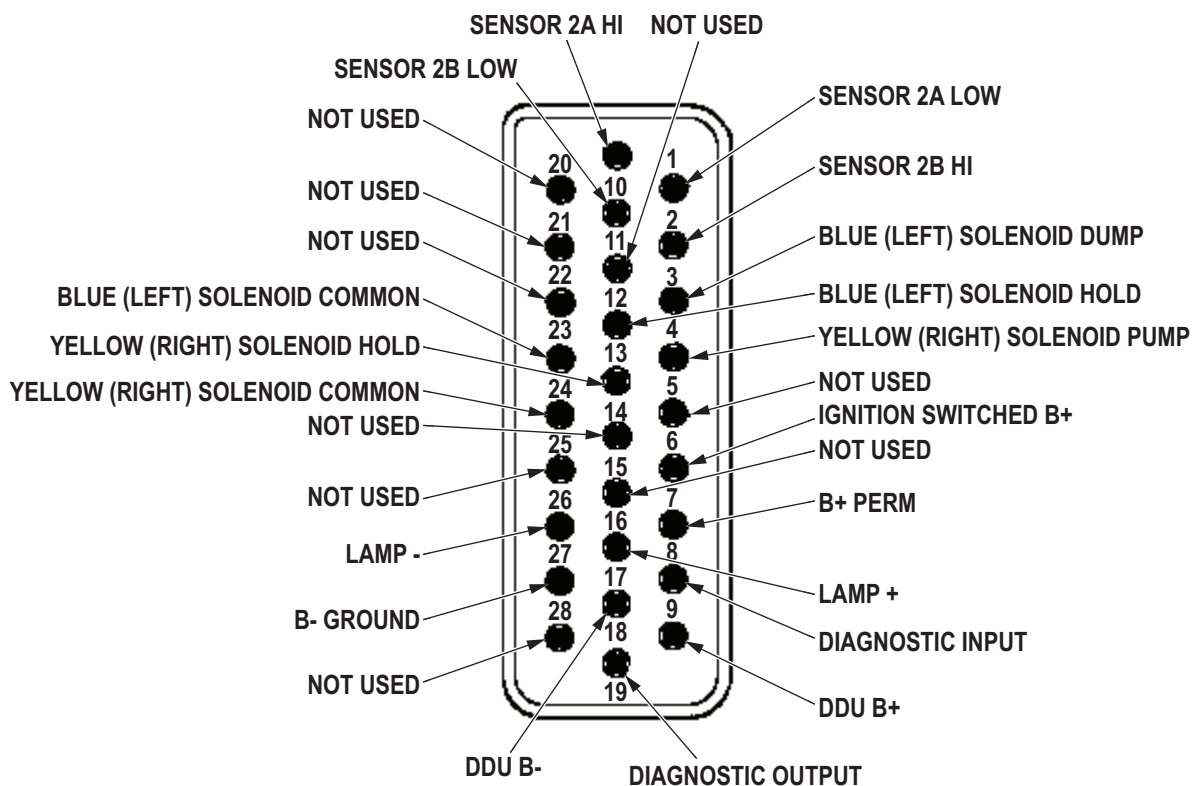

T0832DAA

Figure 1. ABS Wiring Harness ECU Connector.

- f. Codes 72, 73, 78, and 79 indicate that a solenoid or its cable has a short to ground. The most likely cause is a damaged cable or solenoid. To check this, remove ABS main wiring harness connector from ECU and check for continuity between pins 3, 13, and 23 for (BLUE) forward valve cable and 4, 14, and 24 for (YELLOW) rear valve cable and vehicle B+, with battery and starter switches in the ON or RUN position. If resistance is less than 10 MΩ in any test, move battery and starter switches to the OFF position. Repair or replace ABS main wiring harness connector or defective ECU.
 - g. Code 91 indicates that ABS voltage is below 8 volts. The most likely causes include, damaged, or corroded lead terminals, blown 3 amp fuse, or a splice in the ABS power supply circuit. Check ground, 3 AMP fuse connections, and ABS power supply connections. If power is coming from somewhere other than the vehicle electrical system, make sure the test battery is fully charged or the voltage converter has adequate voltage (21.0 to 33.0 volts) and current capacity (11 amp). DO NOT USE A BATTERY CHARGER.
 - h. Code 92 indicates that the ABS power supply voltage is above 33.1 volts. The most suspect cause is a malfunctioning voltage regulator. Repair or replace as necessary.
 - i. Code 80, 93, E0-E9, or EA-EF indicates that the ECU is likely defective. Replace ECU and recheck.
 - j. Code 13, 14, 23, 24, 42, and 43 will not be set or erased from memory until the vehicle is driven above 6 mph.
 - k. A CA code is an invitation to clear all faults stored in history.
 - l. A CC code will be displayed during the third consecutive time that a clear all is attempted. This is an invitation to clear configuration and should be avoided. If a CC is displayed, power down the system and then power up the system.
8. This chapter cannot list all malfunctions that may occur. If a malfunction occurs that is not listed in the table, notify supervisor.
 9. If malfunction corrective action does not correct malfunction, notify supervisor.

DIAGNOSTIC FAULT COTES

Table 1. Diagnostic Fault Codes

00	System is OK, vehicle is moving > 6 MPH	Not a problem
03 04	(A) sensor/wiring open or short circuit rear axle left side (B) sensor/wiring open or short circuit rear axle right side	Sensor loose, sensor faulty, or damaged cable
07	System is OK, no sensor output. Rotate wheel to generate wheel signal	Not a problem
13 14	(A) sensor system fault, rear axle left side (2A) (B) sensor system fault, rear axle right side (2B) (Low Sensor Output Group)	Sensor worn or maladjusted, damaged sensor or cable
23 24	(A) sensor system fault, rear axle left side (2A) (B) sensor system fault, rear axle right side (2B) (Intermittent Low Sensor Output Group)	Wheel bearing worn, loose, maladjusted; exciter damaged, loose. Damaged or corroded sensor electrical connection
42 43	Slow recovery of one wheel of blue channel left side Slow recovery of one wheel of yellow channel right side	Brake drag, damaged modulator, or pinched hose. Failed primary reservoir
62, 63 68, 69	Hold solenoid open circuit, blue channel (62), yellow channel (63) Dump solenoid open circuit, blue channel (68), yellow channel (69)	Solenoid cable damaged, solenoid damaged, loose connection
72, 73 78, 79	Hold solenoid short circuit, blue channel (72), yellow channel (73) Dump solenoid short circuit, blue channel (78), yellow channel (79)	Solenoid cable damaged, solenoid damaged
82, 83 88, 89	Hold solenoid circuit fault, blue channel (82), yellow channel (83) Dump solenoid circuit fault, blue channel (88), yellow channel (89)	Solenoid cable damaged, solenoid damaged, or ECU damaged
90 91 92	Supply voltage below 21.0 V Supply voltage at the controller < 8V Supply voltage at the controller >33V	Power cable wire, terminal, or splice damaged or corroded
C1 CA, CC A(x)	C1 - 2S/2M configuration CA - Erase memory signal, CC – Clear configuration (power down if this occurs) Software options	Not a problem
8.8	Self diagnostic check at power-up	Not a problem

DIAGNOSTIC FAULT COTES - Continued

Table 1. Diagnostic Fault Codes - Continued

E0-E9 EA-EF 93, 99	Defective ECU Defective ECU Defective ECU	Replace ECU and retest
Blank Hi, Lo	No power to diagnostic unit Low power or communication issue	Faulty power supply, open or short in communication line No power to line 10 mixed, hardware

EXPLANATION OF TROUBLESHOOTING PROCEDURES

Troubleshooting procedures are defined as follows:

1. **STEP:** An action or process taken to isolate cause of fault.
2. **CONDITION/INDICATION:** States possible fault that may cause the symptom.
3. **DECISION:** Action required to move forward with next step or correct the fault.

END OF WORK PACKAGE

**FIELD MAINTENANCE
ABS TROUBLESHOOTING INDEX**

ABS TROUBLESHOOTING INDEX

Malfunction/Symptom**Troubleshooting Procedure****ANTILOCK BRAKE SYSTEM**

1.	TRUBLESHOOTING ABS WITHOUT DIAGNOSTIC TOOLS.....	WP 0156
2.	ABS - CODE EO - E9, EA - EF (ECU FAULT).....	WP 0157
3.	ABS - CODE SOL 80, ECU 93, OR ECU 99 (ECU FAULT).....	WP 0158
4.	ABS - CLEAR HISTORICAL CODES WITH THE HALDEX INFO CENTER (SCAN TOOL).....	WP 0159
5.	WHEEL SPEED SENSOR OUTPUT TEST.....	WP 0160
6.	ABS - START - RETRIEVING FAULT CODES WITH THE HALDEX INFO CENTER (SCAN TOO).....	WP 0161
7.	ABS - CODE S2A 03 (LEFT SIDE - BLUE CHANNEL).....	WP 0162
8.	ABS - CODE S2B 04 (RIGHT SIDE - YELLOW CHANNEL).....	WP 0163
9.	ABS - CODE S2A 13 (LEFT SIDE - BLUE CHANNEL).....	WP 0164
10.	ABS - CODE S2B 14 (RIGHT SIDE - YELLOW CHANNEL).....	WP 0165
11.	ABS - CODE S2A 23 (LEFT SIDE - BLUE CHANNEL).....	WP 0166
12.	ABS - CODE S2A 24 (RIGHT SIDE - YELLOW CHANNEL).....	WP 0167
13.	ABS - CODE SLW 42 (LEFT SIDE - BLUE CHANNEL).....	WP 0168
14.	ABS - CODE SLW 43 (RIGHT SIDE - YELLOW CHANNEL).....	WP 0169
15.	ABS - CODE BUHd 62 (LEFT SIDE - BLUE CHANNEL).....	WP 0170
16.	ABS - CODE YEHd 63 (RIGHT SIDE - YELLOW CHANNEL).....	WP 0171
17.	ABS - CODE BUDU 68 (LEFT SIDE - BLUE CHANNEL).....	WP 0172
18.	ABS - CODE YEDU 69 (RIGHT SIDE - YELLOW CHANNEL).....	WP 0173
19.	ABS - CODE BUHd 72 (LEFT SIDE - BLUE CHANNEL).....	WP 0174
20.	ABS - CODE YEHd 73 (RIGHT SIDE - YELLOW CHANNEL).....	WP 0175
21.	ABS - CODE BUDU 78 (LEFT SIDE - BLUE CHANNEL).....	WP 0176
22.	ABS - CODE YEDU 79 (RIGHT SIDE - YELLOW CHANNEL).....	WP 0177
23.	ABS - CODE BUHd 82 (LEFT SIDE - BLUE CHANNEL).....	WP 0178
24.	ABS - CODE YEHd 83 (RIGHT SIDE - YELLOW CHANNEL).....	WP 0179
25.	ABS - CODE BUDU 88 (LEFT SIDE - BLUE CHANNEL).....	WP 0180
26.	ABS - CODE YEDU 89 (RIGHT SIDE - YELLOW CHANNEL).....	WP 0181
27.	ABS - CODE B+LO 90 (ABS VOLTAGE BELOW 21.0 VOLTS).....	WP 0182

ABS TROUBLESHOOTING INDEX - Continued

Malfunction/Symptom

Troubleshooting Procedure

- 28. ABS - CODE ISO1 91 (ABS VOLTAGE BELOW 8.0 VOLTS)..... WP 0183
- 29. ABS - CODE B+HI 92 (ABS VOLTAGE ABOVE 32.0 VOLTS)..... WP 0184
- 30. ABS - NO DATA (BLANK SCREEN ON HALDEX INFO-CENTER)..... WP 0185

END OF WORK PACKAGE

**FIELD MAINTENANCE
TROUBLESHOOTING ABS WITHOUT DIAGNOSTIC TOOLS**

INITIAL SETUP:**Tools and Special Tools**

Tool Kit, General Mechanic's: Automotive
(Volume 5, WP 0826, Table 1, Item 56)
Multimeter
(Volume 5, WP 0826, Table 1, Item 34)
Test Set, Electronic Systems
(Volume 5, WP 0826, Table 1, Item 51)

Personnel Required

(2)

References

Point to Point Schematics
WP 0346

References (cont.)

Volume 3, WP 0352
Volume 3, WP 0452
Volume 3, WP 0463
Volume 3, WP 0464
Volume 3, WP 0465
Volume 3, WP 0467
Volume 3, WP 0468
Volume 5, WP 0805

Equipment Condition

Vehicle parked and engine shut down.
(TM 9-2320-272-10)

TROUBLESHOOTING PROCEDURE
TROUBLESHOOTING ABS WITHOUT DIAGNOSTIC TOOLS**NOTE**

It is important to perform a complete and thorough visual inspection of all electrical connections pertaining to the ABS system, checking for corrosion, damage and soundness at every one.

TROUBLESHOOTING ABS WITHOUT DIAGNOSTIC TOOLS - Continued**STEP****1. ARE BOTH WHEEL SPEED SENSOR LEADS OK?**

Check both left and right wheel speed sensor leads for damage, corrosion, and soundness. Refer to point to point schematics.

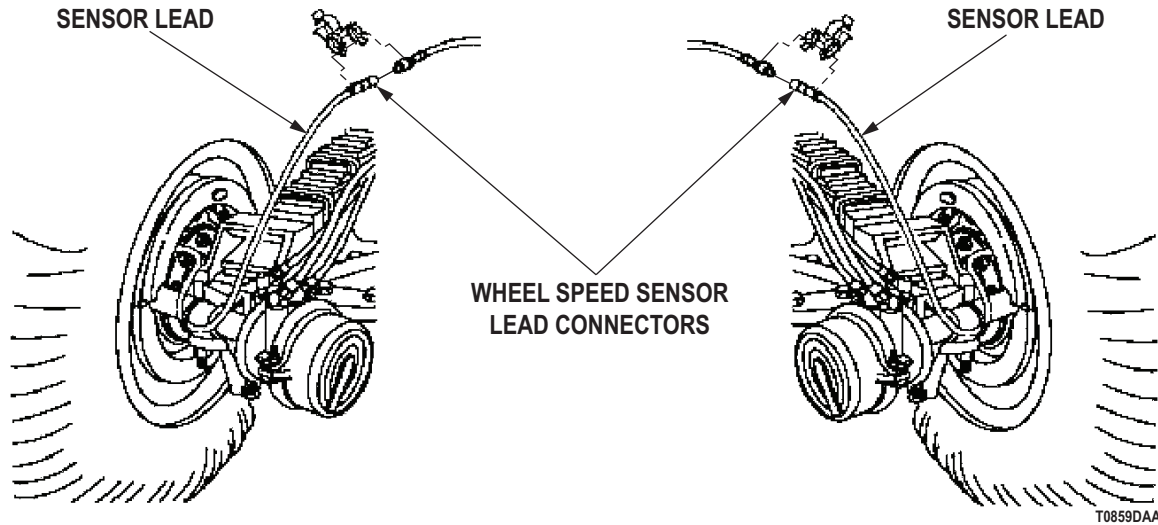

Figure 1. Wheel Speed Sensor Leads.

CONDITION/INDICATION

ARE BOTH WHEEL SPEED SENSOR LEADS OK?

DECISION

NO - Replace damaged wheel speed sensor (Volume 3, WP 0468). Go to Step (15) to verify problem is solved.
 YES - Go to Step (2).

STEP**2. ARE BOTH FRONT AND REAR ABS SOLENOID VALVE CONNECTIONS OK?**

Check both the front and rear solenoid valve connections for corrosion, damage, and sound connection. Refer to point to point schematics.

TROUBLESHOOTING ABS WITHOUT DIAGNOSTIC TOOLS - Continued

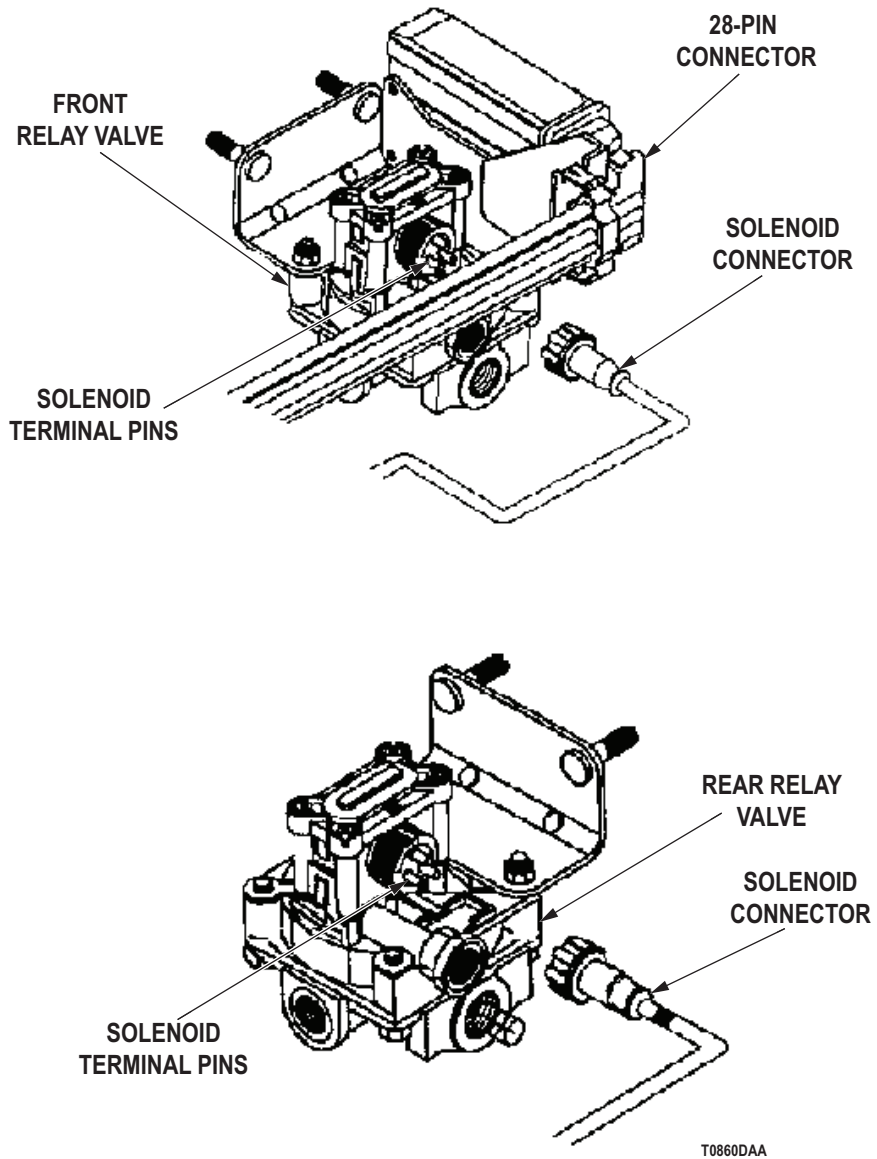

Figure 2. ABS Solenoid Valve Connectors.

CONDITION/INDICATION

ARE BOTH FRONT AND REAR ABS SOLENOID VALVE CONNECTIONS OK?

DECISION

NO - Replace ABS wiring harness (Volume 3, WP 0467). Go to Step (15) to verify problem is solved.
 YES - Go to Step (3).

TROUBLESHOOTING ABS WITHOUT DIAGNOSTIC TOOLS - Continued

STEP

3. IS THE ABS WIRING HARNESS 28-PIN CONNECTOR OK?

- a. Ensure battery and start switches are in the OFF position.

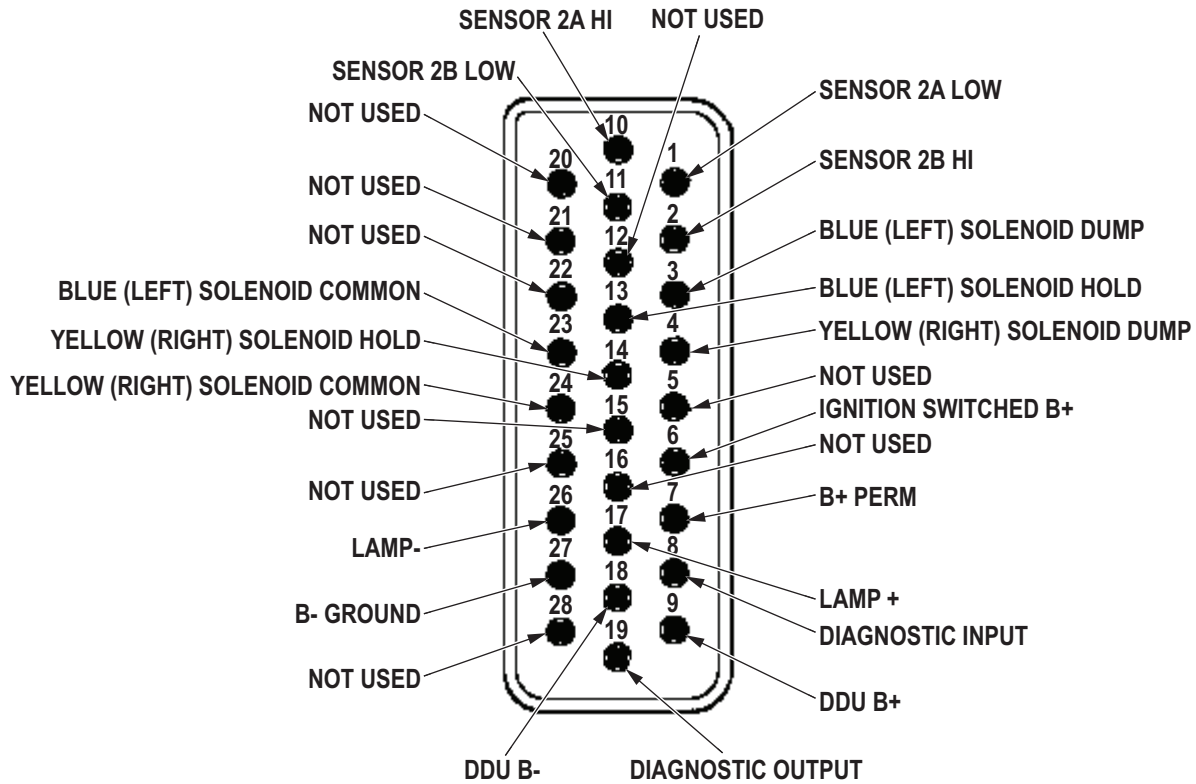

T0853DAA

Figure 3. ABS Wiring Harness 28-pin ECU Connector.

- b. Disconnect main 28-pin connector at ECU (Volume 3, WP 0452).
- c. Inspect 28-pin connector for bent or damaged pins or corrosion. Refer to point to point schematics.

TROUBLESHOOTING ABS WITHOUT DIAGNOSTIC TOOLS - Continued**CONDITION/INDICATION**

IS THE ABS WIRING HARNESS 28-PIN CONNECTOR OK?

DECISION

NO - Replace ABS wiring harness (Volume 3, WP 0467). Go to Step (15) to verify problem is solved.

YES - Go to Step (4).

STEP

4. IS THE ABS WIRING HARNESS OK?

Inspect the ABS wiring harness for sign of damage that could possibly cause an open or shorted condition in the harness.

CONDITION/INDICATION

IS THE ABS WIRING HARNESS OK?

DECISION

NO - Replace ABS wiring harness (Volume 3, WP 0467). Go to Step (15) to verify problem is solved.

YES - Go to Step (5).

TROUBLESHOOTING ABS WITHOUT DIAGNOSTIC TOOLS - Continued

STEP

5. IS THE ABS POWER SUPPLY CONNECTION OK?
 - a. Ensure battery and start switches are in the OFF position.
 - b. Hood raised & secured.

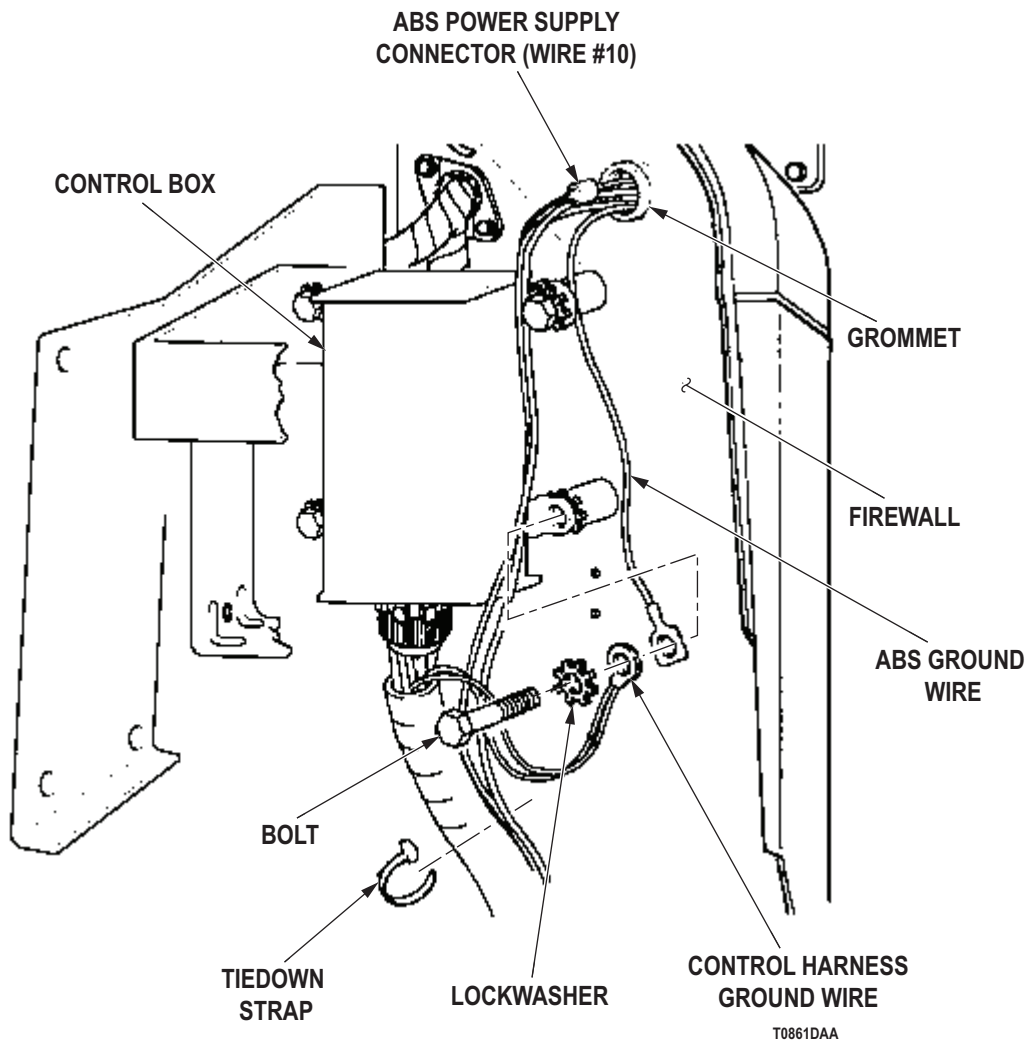

Figure 4. ABS Power Supply Connection.

TROUBLESHOOTING ABS WITHOUT DIAGNOSTIC TOOLS - Continued

- c. Verify that the ABS power supply wire is connected to circuit #10 and the grommet on the firewall the wires pass through is in place and not damaged. Refer to point to point schematics.

CONDITION/INDICATION

IS THE ABS POWER SUPPLY CONNECTION OK?

DECISION

NO - Replace ABS wiring harness (Volume 3, WP 0464). Go to Step (15) to verify problem is solved.
YES - Go to Step (6).

TROUBLESHOOTING ABS WITHOUT DIAGNOSTIC TOOLS - Continued

STEP

6. IS THE ABS GROUND WIRE OK?
 - a. Ensure battery and start switches are in the OFF position.
 - b. Hood raised & secured.

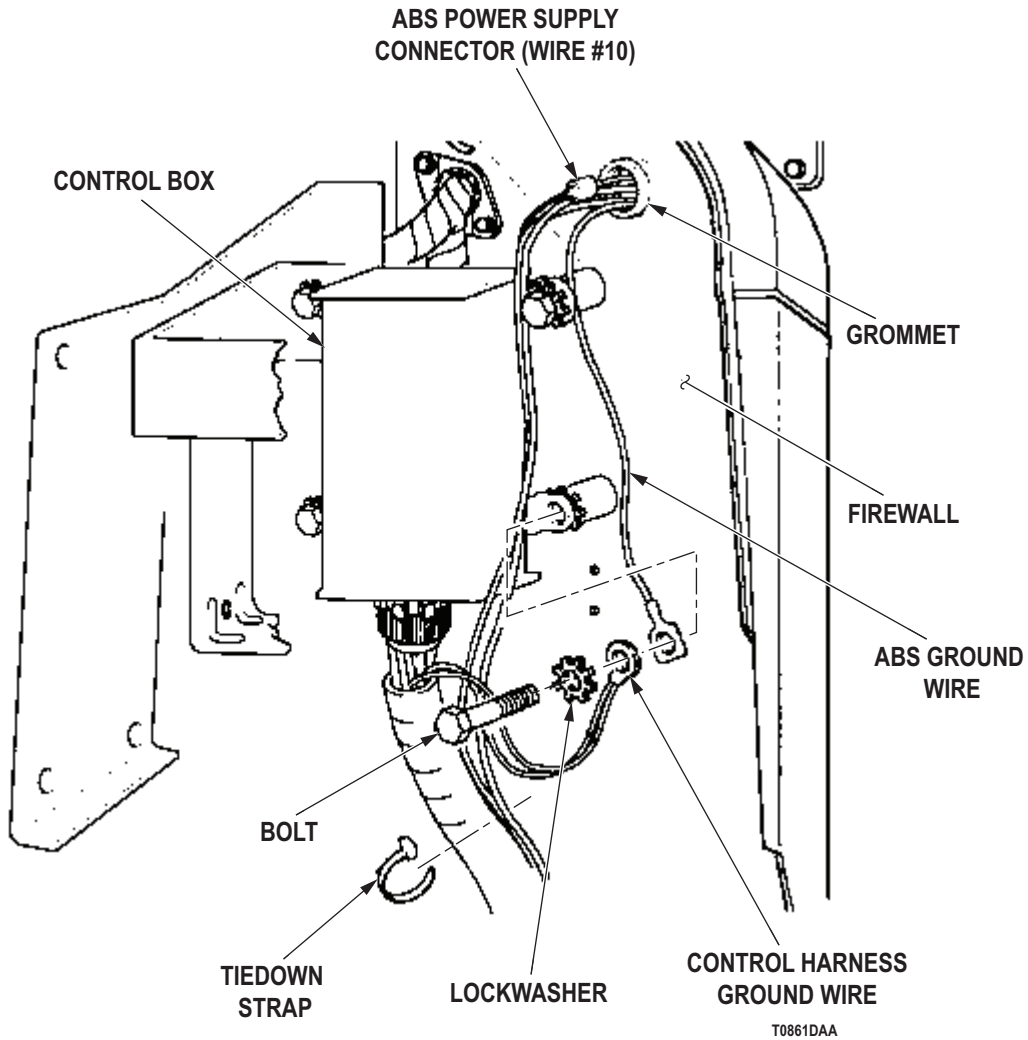

Figure 5. ABS Power Supply Connection.

- c. Check the ABS ground wire for damage and a sound connection. Refer to point to point schematics.

CONDITION/INDICATION

IS THE ABS GROUND WIRE OK?

DECISION

NO - Repair or replace ABS ground harness (Volume 3, WP 0465). Go to Step (15) to verify problem is solved.
 YES - Go to Step (7).

TROUBLESHOOTING ABS WITHOUT DIAGNOSTIC TOOLS - Continued**STEP**

7. ARE ALL UNDER DASH ABS HARNESS CONNECTIONS OK?
 - a. Ensure battery and start switches are in the OFF position.
 - b. Using point to point schematics, locate the nine (four connecting to the ABS warning lamp and five connecting to the ABS wiring harness) and verify all connections are correct and sound.

CONDITION/INDICATION

ARE ALL UNDER DASH ABS HARNESS CONNECTIONS OK?

DECISION

NO - Replace ABS wiring harness (Volume 3, WP 0467). Go to Step (15) to verify problem is solved.
YES - Go to Step (8).

STEP

8. IS CIRCUIT #54 FROM THE START SWITCH OK?
 - a. Ensure battery and start switches are in the OFF position.
 - b. Using point to point schematics, locate the circuit #54 wire and jumper ("Y" lead connector contains the 3 amp fuse) from the start switch, and verify that all connections are sound.

CONDITION/INDICATION

IS CIRCUIT #54 FROM THE START SWITCH OK?

DECISION

NO - Repair or replace "Y" lead connector wire harness and 3 amp fuse (Volume 3, WP 0463). Go to Step (15) to verify problem is solved.
YES - Go to Step (9).

TROUBLESHOOTING ABS WITHOUT DIAGNOSTIC TOOLS - Continued

STEP

9. IS BATTERY VOLTAGE OK?

- a. Set multimeter to measure VDC.

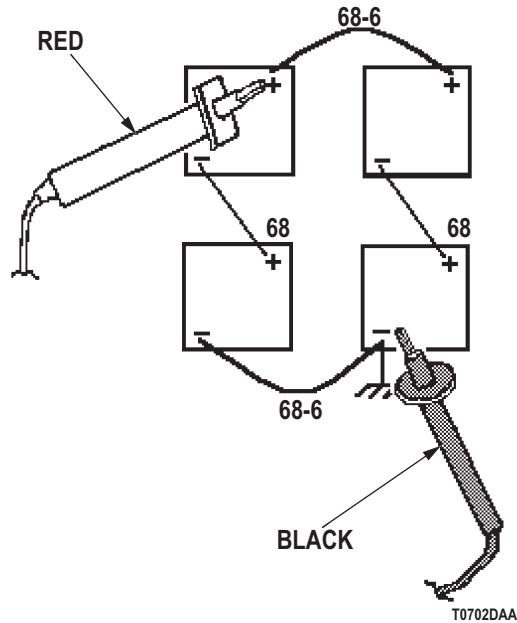

Figure 6. Battery Test Points.

- b. Connect multimeter red lead to battery positive (+) terminal. Refer to point to point schematics.
- c. Connect multimeter black lead to battery negative (-) terminal.
- d. Meter reading should be between 21 and 24 VDC.

CONDITION/INDICATION

IS BATTERY VOLTAGE OK?

DECISION

NO - Service batteries (WP 0346). Go to Step (15) to verify problem is solved.
 YES - Go to Step (10).

STEP

10. IS ABS SUPPLY VOLTAGE OK?

- a. Hood raised & secured.
- b. Turn battery switch ON.

TROUBLESHOOTING ABS WITHOUT DIAGNOSTIC TOOLS - Continued

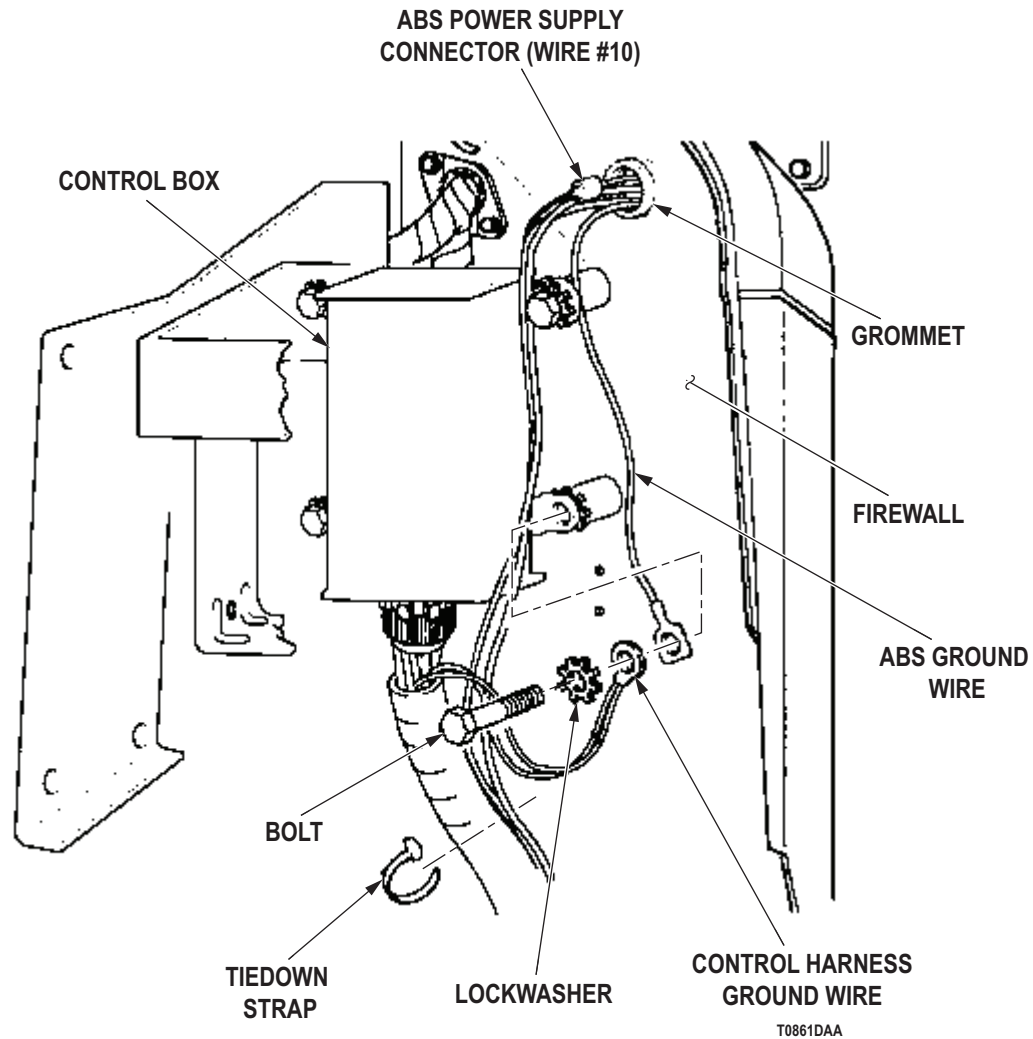

Figure 7. ABS Power Supply Connection.

- c. Locate the ABS connector to wire #10 where the wiring harness exits the firewall through a grommet near the vehicle control box.
- d. Connect multimeter red lead to wire #10 terminal. Refer to point to point schematics.
- e. Connect multimeter black lead to a known good ground.
- f. Meter reading should be between 21 and 24 VDC.

CONDITION/INDICATION

IS ABS SUPPLY VOLTAGE OK?

DECISION

NO - Replace wiring #10 (Volume 3, WP 0352). Go to Step (15) to verify problem is solved.
 YES - Go to Step (11).

TROUBLESHOOTING ABS WITHOUT DIAGNOSTIC TOOLS - Continued

STEP

11. IS THE ABS SYSTEM GROUND OK?

- a. Hood raised & secured.
- b. Turn battery switch ON.

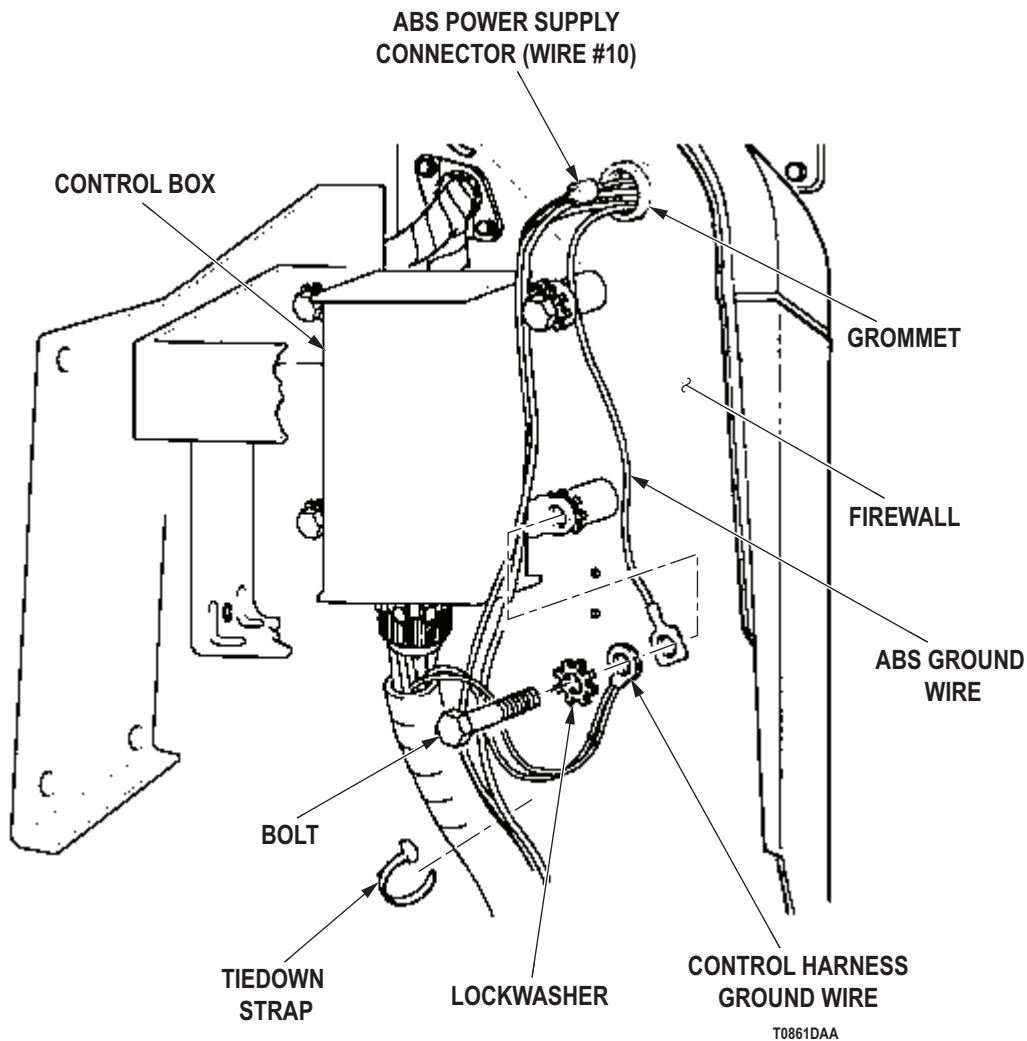

Figure 8. ABS Power Supply Connection.

- c. Locate the ABS ground wire where it attaches to the lower, right corner of the vehicle control box.
- d. Locate and disconnect the #10 wire connector at the top of the vehicle control box near where the wiring harness exits the cab through a grommet on the firewall.
- e. Connect multimeter red lead to wire #10 terminal. Refer to point to point schematics.
- f. Connect multimeter black lead to ABS ground wire.
- g. Meter reading should be between 21 and 24 VDC.

TROUBLESHOOTING ABS WITHOUT DIAGNOSTIC TOOLS - Continued**CONDITION/INDICATION**

IS THE ABS SYSTEM GROUND OK?

DECISION

NO - Repair or replace ABS ground jumper wire (Volume 3, WP 0465). Go to Step (15) to verify problem is solved.

YES - Go to Step (12).

STEP

12. IS THE 3 AMP FUSE OK?

- a. Turn battery switch ON.
- b. Turn start switch to RUN.
- c. Locate the yellow conductor wire from the ABS harness under the vehicle dash.
- d. Disconnect the jumper lead from the yellow wire.
- e. Connect multimeter red lead to jumper lead terminal. Refer to point to point schematics.
- f. Connect multimeter black lead to a known good ground.
- g. Meter reading should be between 21 and 24 VDC.

CONDITION/INDICATION

IS THE 3 AMP FUSE OK?

DECISION

NO - Repair or replace 3 amp fuse or jumper wire (Volume 3, WP 0463). Go to Step (15) to verify problem is solved.

YES - Go to Step (13).

TROUBLESHOOTING ABS WITHOUT DIAGNOSTIC TOOLS - Continued**STEP**

13. IS THE 15 AMP FUSE OK?
- Turn battery switch ON.
 - Turn start switch to RUN.
 - Locate the red conductor wire from the ABS harness under the vehicle dash.
 - Disconnect the jumper lead from the red wire.
 - Connect multimeter red lead to jumper lead terminal. Refer to point to point schematics.
 - Connect multimeter black lead to a known good ground.
 - Meter reading should be between 21 and 24 VDC.

CONDITION/INDICATION

IS THE 15 AMP FUSE OK?

DECISION

NO - Repair or replace 15 amp fuse or jumper wire (Volume 3, WP 0464). Go to Step (15) to verify problem is solved.

YES - Go to Step (14).

STEP

14. IS THERE EVIDENCE OF AN AIR LEAK FROM A BRAKE SYSTEM COMPONENT?
- Start vehicle and build air supply to normal operating pressure.
 - Assistant fully applies and holds service brakes.
 - Listen for and locate any air leaks. Refer to point to point schematics.

CONDITION/INDICATION

IS THERE EVIDENCE OF AN AIR LEAK FROM A BRAKE SYSTEM COMPONENT?

DECISION

YES - Replace damaged air lines (Volume 5, WP 0805). Go to Step (15) to verify problem is solved.

NO - Notify supervisor. It is possible that another troubleshooting work package applies.

STEP

15. IS YOUR ORIGINAL PROBLEM STILL PRESENT?
- Ensure vehicle is returned to normal operating condition.
 - Start vehicle.
 - Operate vehicle to a speed of 20 miles per hour.
 - Make one quick hard stop to initiate an ABS event.
 - Check of ABS warning lamp comes on while operating vehicle.
 - Return vehicle to park position.
 - Shut off engine.

TROUBLESHOOTING ABS WITHOUT DIAGNOSTIC TOOLS - Continued**NOTE**

ABS warning lamp should come on briefly at power up and then turn off. This indicates that warning lamp system is operating properly. If lamp fails to illuminate or stays on, it indicates a system problem and further testing is necessary.

- h. Turn battery switch ON.
- i. Turn start switch to RUN.
- j. Check to see if your original fault code still exists.

CONDITION/INDICATION

IS YOUR ORIGINAL PROBLEM STILL PRESENT?

DECISION

YES - Notify supervisor.
NO - Problem fixed.

END OF WORK PACKAGE

FIELD MAINTENANCE
ABS - CODE EO - E9, EA - EF (ECU FAULT)

INITIAL SETUP:**Tools and Special Tools**

Tool Kit, General Mechanic's: Automotive
(Volume 5, WP 0826, Table 1, Item 56)
ABS Diagnostic Info Centre (TM 9-2320-272-10)
Test Set, Electronic Systems
(Volume 5, WP 0826, Table 1, Item 51)

References (cont.)

WP 0161
Volume 3, WP 0452

Equipment Condition

Vehicle parked and engine shut down.
(TM 9-2320-272-10)

Personnel Required

(2)

References

Point to Point Schematics

TROUBLESHOOTING PROCEDURE**ABS - CODE EO - E9, EA - EF (ECU FAULT)****NOTE**

These fault code indicates an internal ECU fault has occurred.

ABS - CODE EO - E9, EA - EF (ECU FAULT) - Continued**STEP**

1. ABS ECU IS DEFECTIVE, WOULD YOU LIKE TO REPLACE THE ABS ECU?

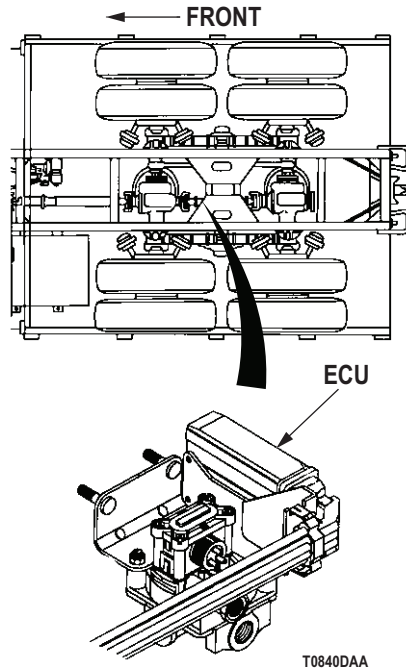

Figure 1. ABS ECU.

CONDITION/INDICATION

ABS ECU IS DEFECTIVE, WOULD YOU LIKE TO REPLACE THE ABS ECU?

DECISION

YES - Replace ABS ECU (Volume 3, WP 0452). Go to Step (2) to verify problem is solved.
NO - Notify supervisor.

ABS - CODE EO - E9, EA - EF (ECU FAULT) - Continued**STEP****2. IS YOUR ORIGINAL PROBLEM STILL PRESENT?**

- a. Ensure vehicle is returned to normal operating condition.
- b. Perform ABS - Start- Retrieving Fault Codes With Haldex Info Center (Scan Tool) (WP 0161).
- c. Check to see if your original fault code still exists.

CONDITION/INDICATION

IS YOUR ORIGINAL PROBLEM STILL PRESENT?

DECISION

YES - Notify supervisor.
NO - Problem fixed.

END OF WORK PACKAGE

FIELD MAINTENANCE
ABS - CODE SOL 80, ECU 93, OR ECU 99 (ECU FAULT)

INITIAL SETUP:**Tools and Special Tools**

Tool Kit, General Mechanic's: Automotive
(Volume 5, WP 0826, Table 1, Item 56)
ABS Diagnostic Info Centre (TM 9-2320-272-10)
Test Set, Electronic Systems
(Volume 5, WP 0826, Table 1, Item 51)

References (cont.)

WP 0161
Volume 3, WP 0452

Equipment Condition

Vehicle parked and engine shut down.
(TM 9-2320-272-10)

Personnel Required

(2)

References

Point to Point Schematics

TROUBLESHOOTING PROCEDURE**ABS - CODE SOL 80, ECU 93, OR ECU 99 (ECU FAULT)****NOTE**

These fault code indicates an internal ECU fault has occurred.

ABS - CODE SOL 80, ECU 93, OR ECU 99 (ECU FAULT) - Continued**STEP**

1. ABS ECU IS DEFECTIVE, WOULD YOU LIKE TO REPLACE THE ABS ECU?

ABS ELECTRONIC CONTROL UNIT (ECU)

Figure 1. ABS ECU.

CONDITION/INDICATION

ABS ECU IS DEFECTIVE, WOULD YOU LIKE TO REPLACE THE ABS ECU?

DECISION

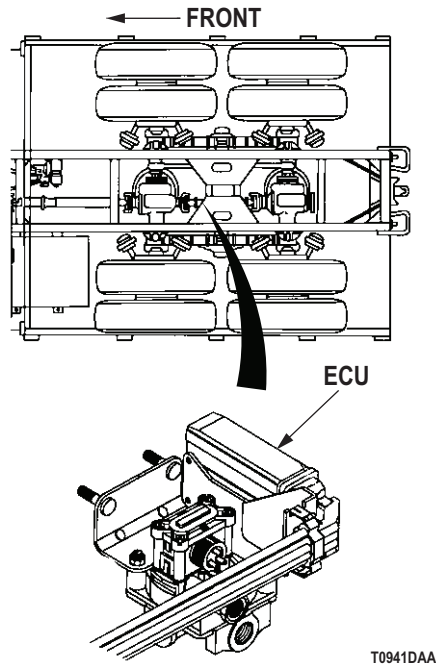
- YES - Replace ABS ECU (Volume 3, WP 0452). Go to Step (2) to verify problem is solved.
- NO - Notify supervisor.

ABS - CODE SOL 80, ECU 93, OR ECU 99 (ECU FAULT) - Continued**STEP****2. IS YOUR ORIGINAL PROBLEM STILL PRESENT?**

- a. Ensure vehicle is returned to normal operating condition.
- b. Perform ABS - Start- Retrieiving Fault Codes With Haldex Info Center (Scan Tool) (WP 0161).
- c. Check to see if your original fault code still exists.

CONDITION/INDICATION

IS YOUR ORIGINAL PROBLEM STILL PRESENT?

DECISION

YES - Notify supervisor.
NO - Problem fixed.

END OF WORK PACKAGE

FIELD MAINTENANCE
ABS - CLEAR HISTORICAL CODES WITH THE HALDEX INFO CENTER (SCAN TOOL)

INITIAL SETUP:**Tools and Special Tools**

Tool Kit, General Mechanic's: Automotive
(Volume 5, WP 0826, Table 1, Item 56)
ABS Diagnostic Info Centre (TM 9-2320-272-10)
Test Set, Electronic Systems
(Volume 5, WP 0826, Table 1, Item 51)

References

Point to Point Schematics
WP 0185

Equipment Condition

Vehicle parked and engine shut down.
(TM 9-2320-272-10)

Personnel Required

(2)

TROUBLESHOOTING PROCEDURE**ABS - CLEAR HISTORICAL CODES WITH THE HALDEX INFO CENTER (SCAN TOOL)****NOTE**

ABS warning lamp should come on briefly at power up and then turn off. This indicates that warning lamp system is operating properly. If lamp fails to illuminate or stays on, it indicates a system problem and further testing is necessary.

ABS - CLEAR HISTORICAL CODES WITH THE HALDEX INFO CENTER (SCAN TOOL) - Continued**STEP**

1. IS CODE "OK 07" DISPLAYED ON INFO CENTRE?

NOTE

Code "OK 07" indicates ABS is fully functional when vehicle is stationary.

- a. Connect Info Centre to ABS diagnostic connector.
- b. Turn battery switch ON.
- c. Turn starter switch to RUN position.
- d. Check display on Info Centre.

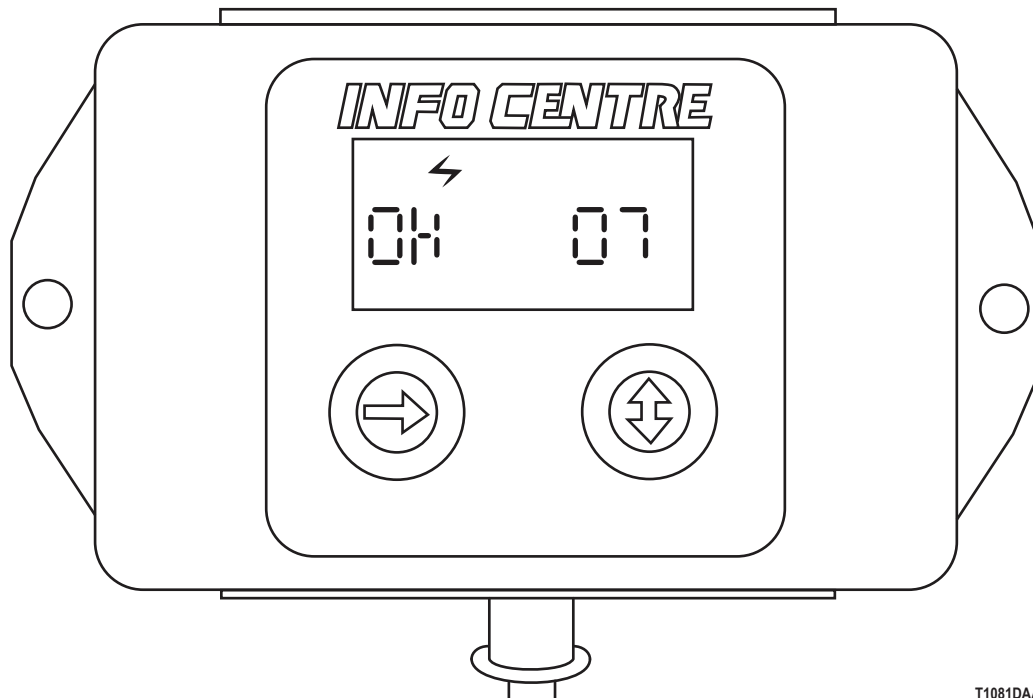

T1081DAA

Figure 1. Info Centre Fault Code "OK 07" Display.

- e. Code "OK 07" should be displayed on Info Centre.

CONDITION/INDICATION

IS CODE "OK 07" DISPLAYED ON INFO CENTRE?

DECISION

- NO - Screen is blank. Perform ABS No Data troubleshooting (WP 0185).
- NO - Screen displays COMFAIL. Perform ABS No Data troubleshooting (WP 0185).
- NO - Screen displays another fault code. Perform troubleshooting for fault code displayed.
- YES - Go to Step (2).

ABS - CLEAR HISTORICAL CODES WITH THE HALDEX INFO CENTER (SCAN TOOL) - Continued**STEP**

2. IS CODE "OK 07" DISPLAYED AFTER CLEARING HISTORICAL CODES?

CAUTION

Do not attempt to clear codes three consecutive times. Clearing codes 3 times will damage equipment.

NOTE

Stored fault codes are displayed in groups of five. If more than five faults are stored, there will be a delay between groups.

- a. Press and hold right button on Info Centre for two second until "BUSY" is displayed.

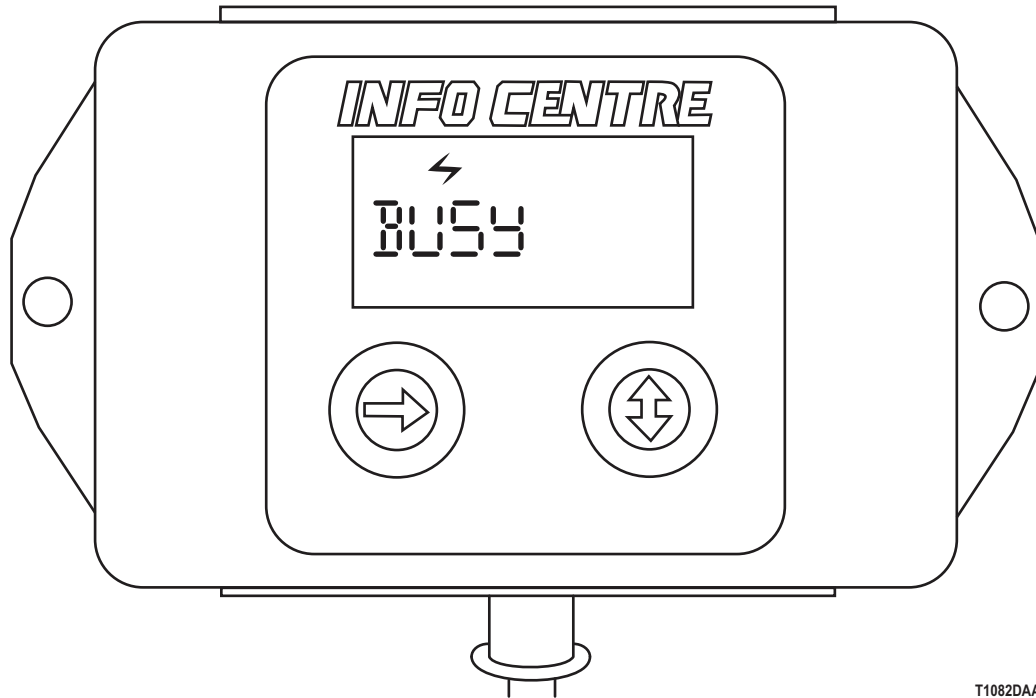

T1082DAA

Figure 2. Info Centre "BUSY" Display.

- b. Check Info Centre display for stored fault code. Note code.

ABS - CLEAR HISTORICAL CODES WITH THE HALDEX INFO CENTER (SCAN TOOL) - Continued

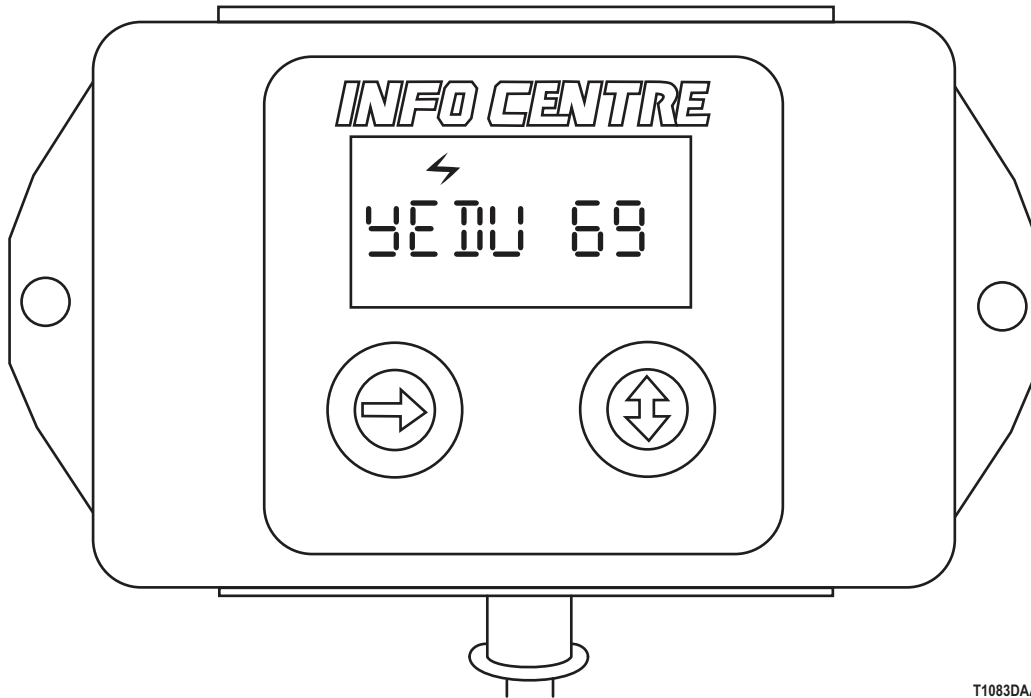

T1083DAA

Figure 3. Info Centre Fault Code Display.

- c. Repeat Steps (a) and (b) until "CLR CA" is displayed.

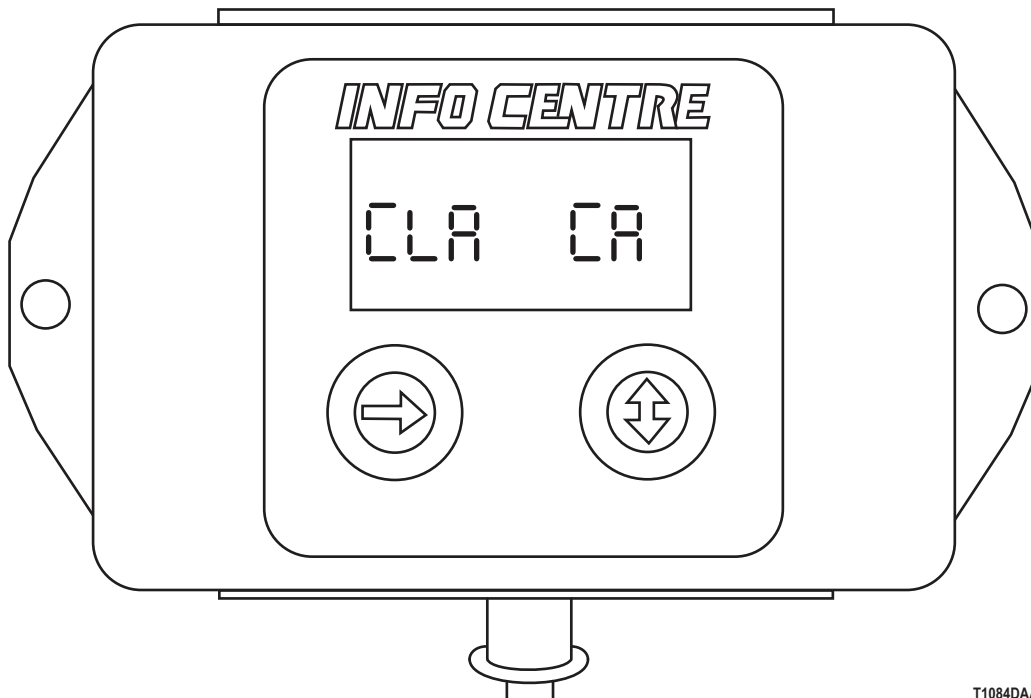

T1084DAA

Figure 4. Info Centre "CLR CA" Display.

- d. Press and hold right button in Info Center until "OK 07" is displayed.

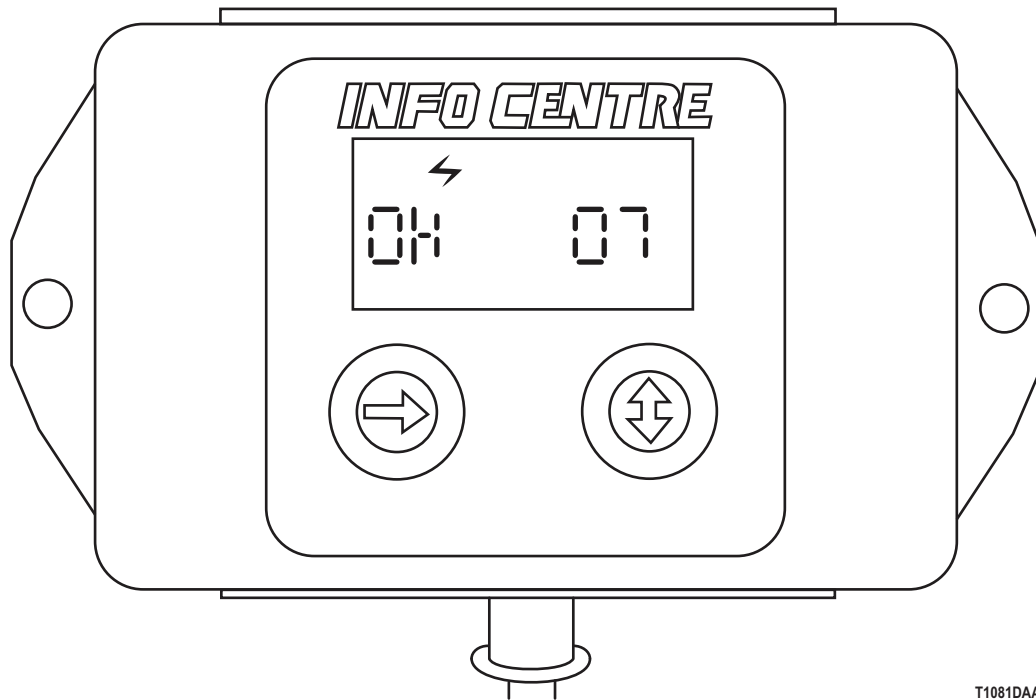
ABS - CLEAR HISTORICAL CODES WITH THE HALDEX INFO CENTER (SCAN TOOL) - Continued

T1081DAA

Figure 5. Info Centre Fault Code "OK 07" Display.

CONDITION/INDICATION

IS CODE "OK 07" DISPLAYED AFTER CLEARING HISTORICAL CODES?

DECISION

NO - Perform troubleshooting for fault code displayed.

YES - Codes are cleared.

END OF WORK PACKAGE

**FIELD MAINTENANCE
WHEEL SPEED SENSOR OUTPUT TEST**

INITIAL SETUP:**Tools and Special Tools**

Tool Kit, General Mechanic's: Automotive
(Volume 5, WP 0826, Table 1, Item 56)
ABS Diagnostic Info Centre (TM 9-2320-272-10)
High Boy Jack Stands
(Volume 5, WP 0826, Table 1, Item 24)
Test Set, Electronic Systems
(Volume 5, WP 0826, Table 1, Item 51)

References (cont.)

WP 0161
WP 0185
Volume 3, WP 0468
Volume 3, WP 0484
Volume 3, WP 0485

Personnel Required

(2)

Equipment Condition

Vehicle parked and engine shut down.
(TM 9-2320-272-10)

References

Point to Point Schematics

TROUBLESHOOTING PROCEDURE**WHEEL SPEED SENSOR OUTPUT TEST****NOTE**

- This test checks for valid wheel speed sensor outputs. This test may be helpful when codes S2A03, S2B04, S2A13, S2B14, S2A23, S2B24, S2A42, or S2B43 are present.
- Code "OK 07" displayed when vehicle is stationary indicates ABS is fully functional.

WHEEL SPEED SENSOR OUTPUT TEST - Continued**STEP**

1. DOES LEFT REAR-REAR WHEEL SPEED SENSOR INDICATE A VALID SIGNAL WHEN TESTED?
 - a. Cage left rear-rear wheel brakes.
 - b. Raise left rear-rear wheels until they are off the ground M939 (Volume 3, WP 0484), M939A1/A2 (Volume 3, WP 0485). Support vehicle with jack stand.
 - c. Connect Info Centre to ABS diagnostic connector.
 - d. Turn battery switch ON.
 - e. Turn starter switch to RUN position.

NOTE

If Info Centre display is blank, or displays "COMFAIL", perform ABS No Data troubleshooting (WP 0185).

- f. Check display on Info Centre.

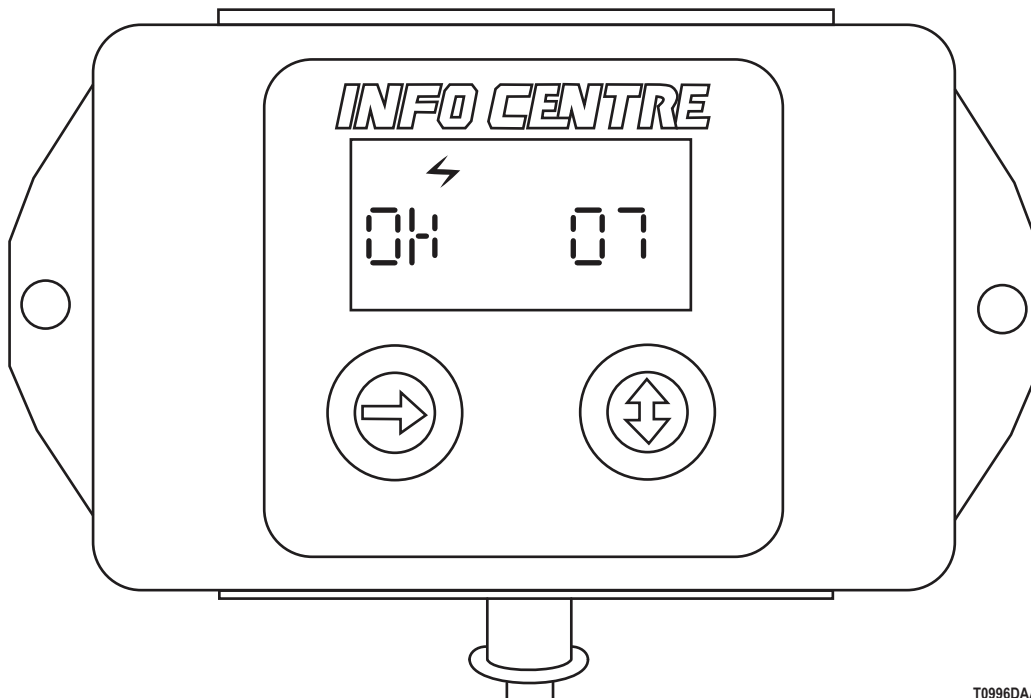

T0996DAA

Figure 1. Info Centre Fault Code "OK 07" Display.

- g. Code "OK 07" should be displayed on Info Centre.

WHEEL SPEED SENSOR OUTPUT TEST - Continued

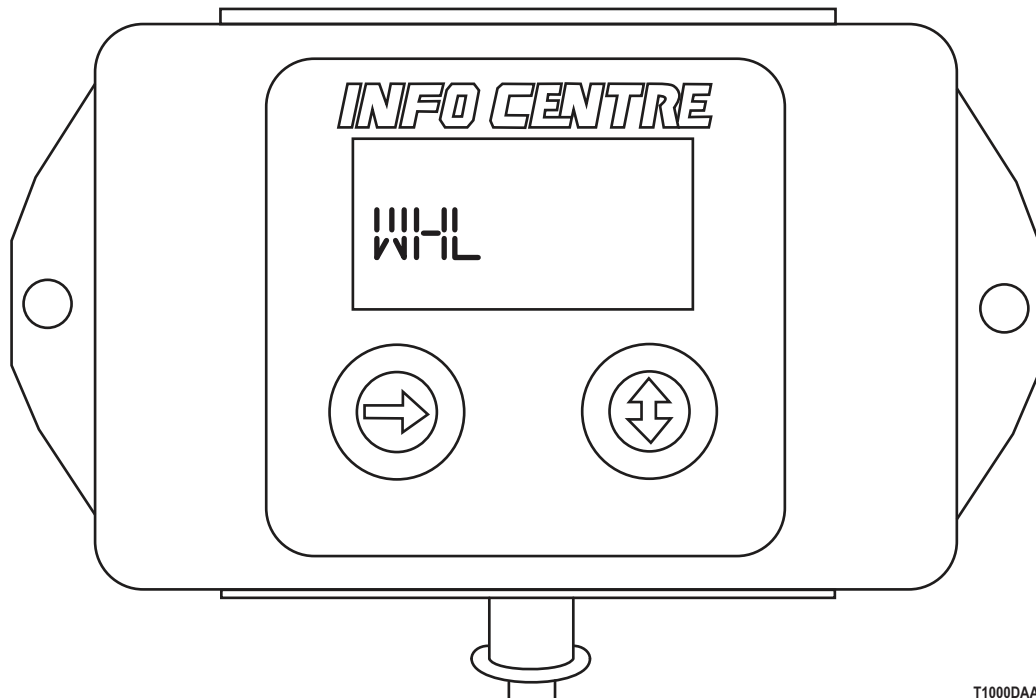

T1000DAA

Figure 2. Info Centre "WHL" Display.

- h. Press right button on Info Centre to display "WHL".
- i. Rotate left rear-rear wheel at least 2 revolutions in 4 seconds.

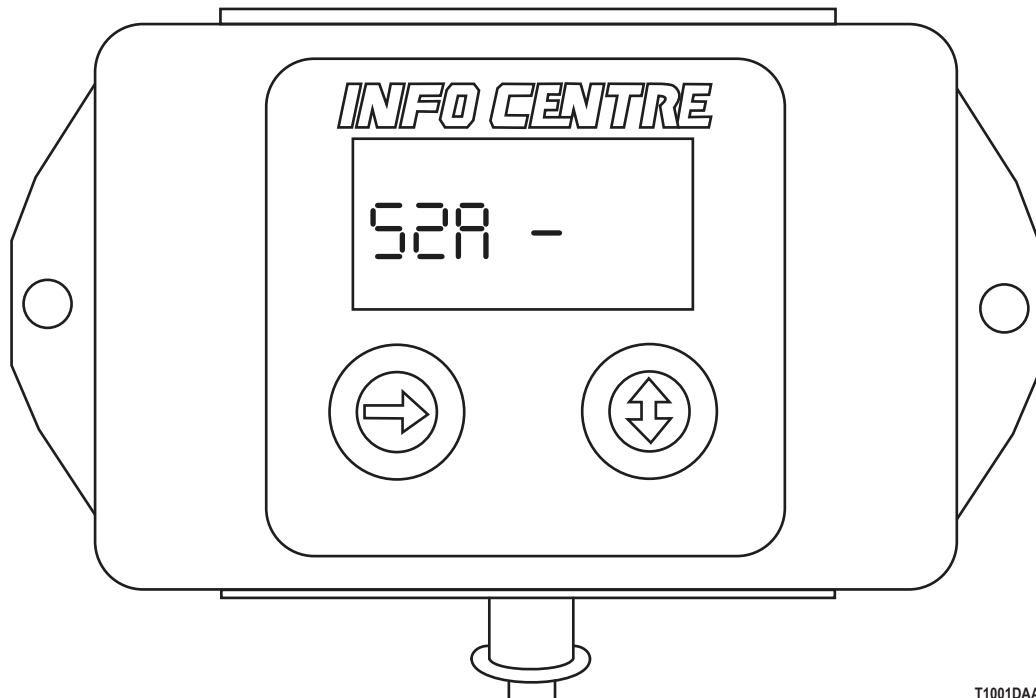

T1001DAA

Figure 3. Info Centre "S2A" Display.

WHEEL SPEED SENSOR OUTPUT TEST - Continued

- j. Code "S2A" should be displayed on Info Centre.

CONDITION/INDICATION

DOES LEFT REAR-REAR WHEEL SPEED SENSOR INDICATE A VALID SIGNAL WHEN TESTED?

DECISION

- NO - Go to Step (2).
- YES - Go to Step (3).

STEP

- 2. IS LEFT REAR-REAR WHEEL SPEED SENSOR PROPERLY CONNECTED AND ALIGNED?
 - a. Turn starter switch to OFF position.
 - b. Turn battery switch OFF.
 - c. Check left rear-rear wheel speed sensor for proper connection.

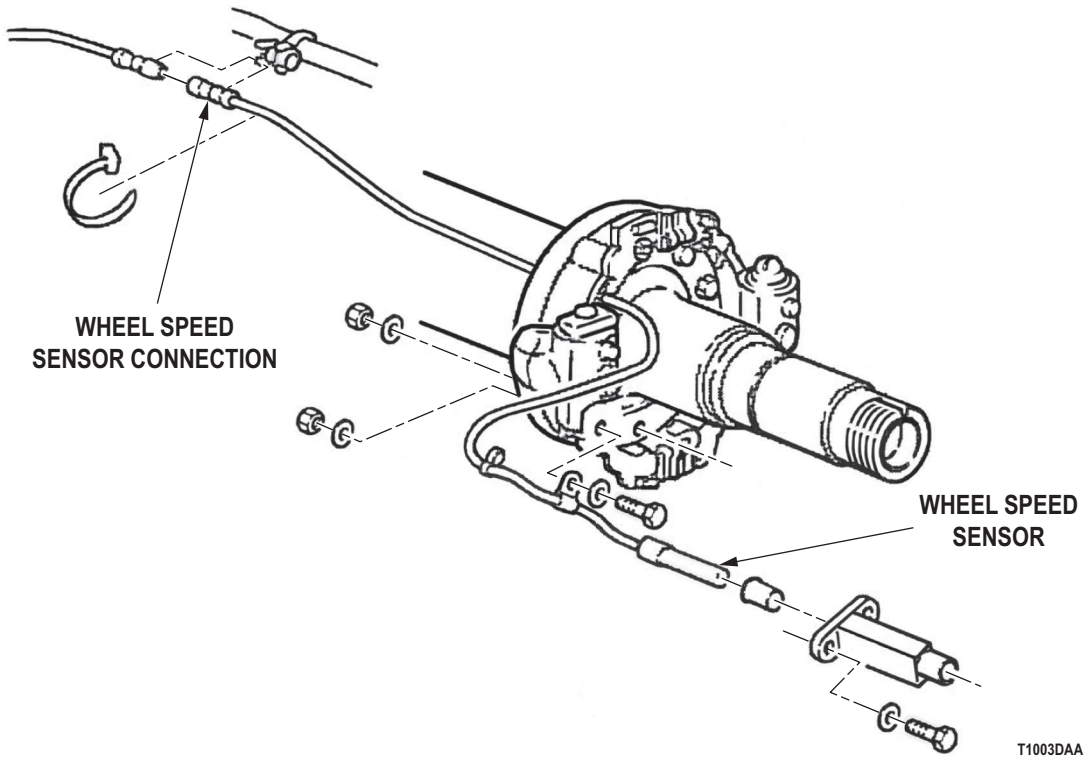

Figure 4. Wheel Speed Sensor.

- d. Check left rear-rear wheel speed sensor for proper alignment. (Volume 3, WP 0468).
- e. If wheel speed sensor is properly connected and aligned, remove jack stand and lower wheel.
- f. If wheel speed sensor is properly connected and aligned, uncage brake.

CONDITION/INDICATION

IS LEFT REAR-REAR WHEEL SPEED SENSOR PROPERLY CONNECTED AND ALIGNED?

WHEEL SPEED SENSOR OUTPUT TEST - Continued**DECISION**

NO - Reconnect and align wheel speed sensor (Volume 3, WP 0468). Go to Step (5) to verify problem is solved.
 YES - Perform ABS - Start - Retrieving Codes With Haldex Info Center to retrieve stored codes (WP 0161).

STEP

3. DOES RIGHT REAR-REAR WHEEL SPEED SENSOR INDICATE A VALID SIGNAL WHEN TESTED?
 - a. Remove jack stand and lower left rear-rear wheel.
 - b. Uncage left rear-rear brake.
 - c. Cage right rear-rear wheel brakes.
 - d. Raise right rear-rear wheels until they are off the ground M939 (Volume 3, WP 0484), M939A1/A2 (Volume 3, WP 0485). Support vehicle with jackstand.
 - e. Ensure Info Center is connected to ABS diagnostic connector.
 - f. Rotate right rear-rear wheel at least 2 revolutions in 4 seconds.

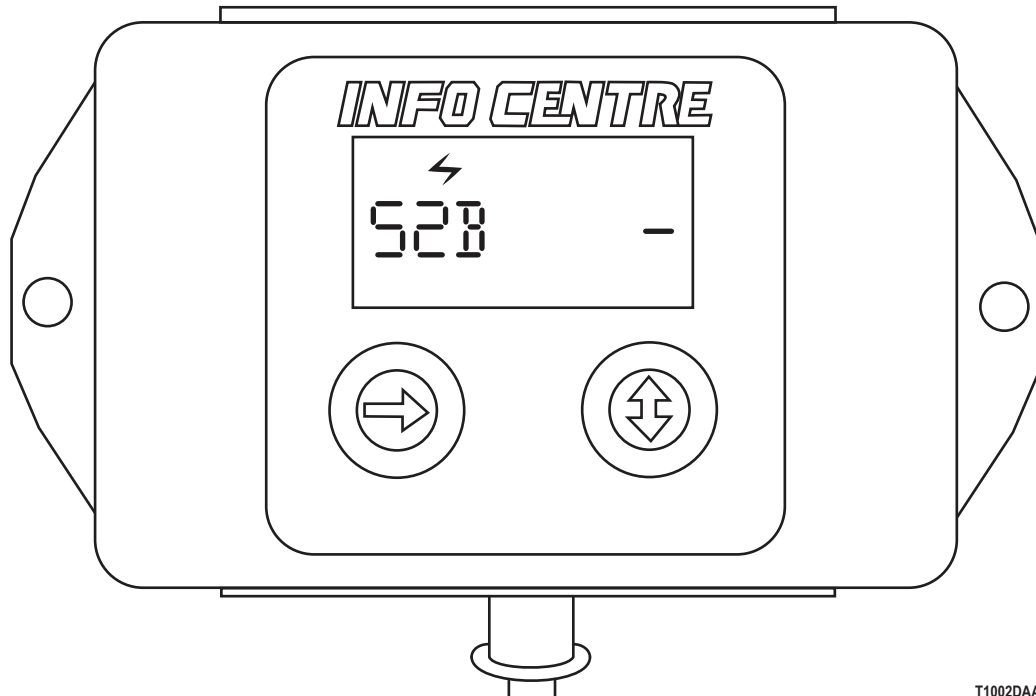

T1002DAA

Figure 5. Info Centre "S2B" Display.

- g. Code "S2B" should be displayed on Info Centre.

CONDITION/INDICATION

DOES RIGHT REAR-REAR WHEEL SPEED SENSOR INDICATE A VALID SIGNAL WHEN TESTED?

DECISION

NO - Go to Step (4).
 YES - Go to Step (5).

WHEEL SPEED SENSOR OUTPUT TEST - Continued**STEP**

4. IS RIGHT REAR-REAR WHEEL SPEED SENSOR PROPERLY CONNECTED AND ALIGNED?
 - a. Turn starter switch to OFF position.
 - b. Turn battery switch OFF.
 - c. Check right rear-rear wheel speed sensor for proper connection.

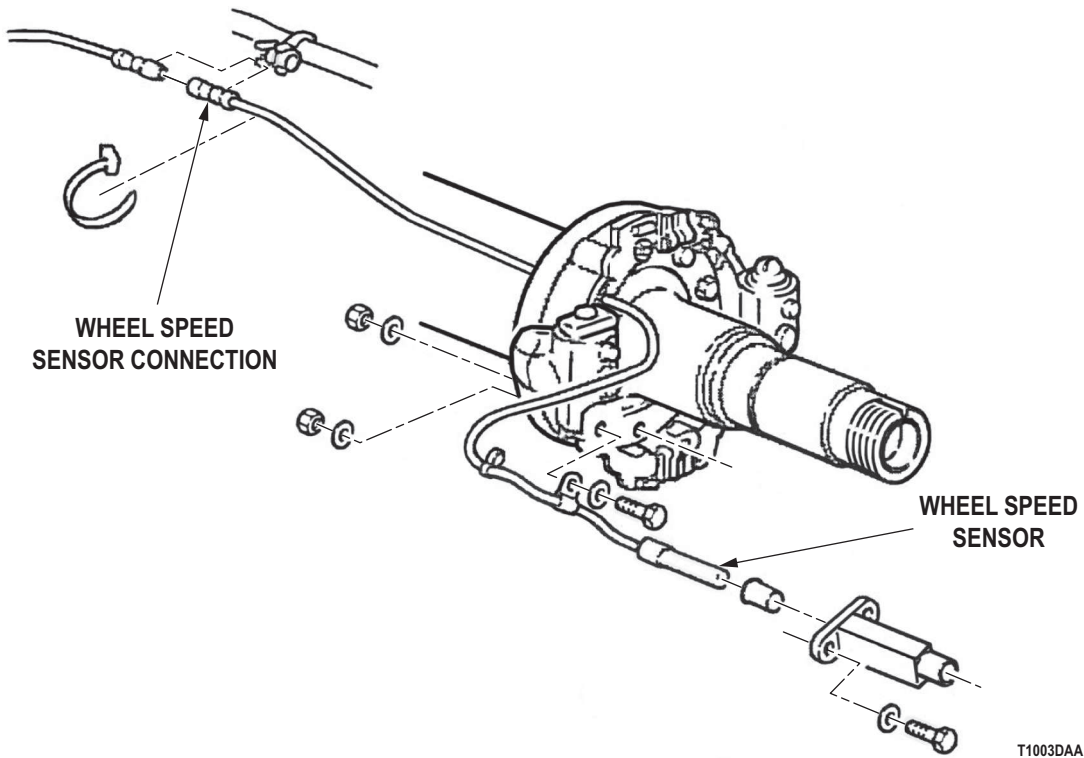

Figure 6. Wheel Speed Sensor.

- d. Check right rear-rear wheel speed sensor for proper alignment. (Volume 3, WP 0468).
- e. If wheel speed sensor is properly connected and aligned, remove jack stand and lower wheel.
- f. If wheel speed sensor is properly connected and aligned, uncage brake.

CONDITION/INDICATION

IS LEFT REAR-REAR WHEEL SPEED SENSOR PROPERLY CONNECTED AND ALIGNED?

DECISION

NO - Reconnect and align rear-rear wheel speed sensor (Volume 3, WP 0468). Go to Step (5) to verify problem is solved.

YES - Perform ABS - Start - Retrieving Codes With Haldex Info Center to retrieve stored codes (WP 0161).

WHEEL SPEED SENSOR OUTPUT TEST - Continued**STEP**

5. IS YOUR ORIGINAL PROBLEM STILL PRESENT?
 - a. Ensure vehicle is returned to normal operating condition.
 - b. Check to see if your original problem still exists.

CONDITION/INDICATION

IS YOUR ORIGINAL PROBLEM STILL PRESENT?

DECISION

YES - Notify supervisor.
NO - Problem fixed.

END OF WORK PACKAGE

FIELD MAINTENANCE
ABS - START - RETRIEVING FAULT CODES WITH THE HALDEX INFO CENTER (SCAN TOOL)

INITIAL SETUP:**Tools and Special Tools**

Tool Kit, General Mechanic's: Automotive
(Volume 5, WP 0826, Table 1, Item 56)
ABS Diagnostic Info Centre (TM 9-2320-272-10)
Test Set, Electronic Systems
(Volume 5, WP 0826, Table 1, Item 51)

References

Point to Point Schematics
WP 0185

Equipment Condition

Vehicle parked and engine shut down.
(TM 9-2320-272-10)

Personnel Required

(2)

TROUBLESHOOTING PROCEDURE**ABS - START - RETRIEVING FAULT CODES WITH THE HALDEX INFO CENTER (SCAN TOOL)****NOTE**

- Conduct these malfunction tests if vehicle ABS system is malfunctioning. This procedure will check for active and stored ABS fault codes.
- ABS warning lamp should come on briefly at power up and then turn off. This indicates that warning lamp system is operating properly. If lamp fails to illuminate or stays on, it indicates a system problem and further testing is necessary.

ABS - START - RETRIEVING FAULT CODES WITH THE HALDEX INFO CENTER (SCAN TOOL) - Continued

STEP

1. IS CODE "OK 07" DISPLAYED ON INFO CENTRE?

NOTE

Code "OK 07" indicates ABS is fully functional when vehicle is stationary.

- a. Connect Info Centre to ABS diagnostic connector.
- b. Turn battery switch ON.
- c. Turn starter switch to RUN position.
- d. Check display on Info Centre.

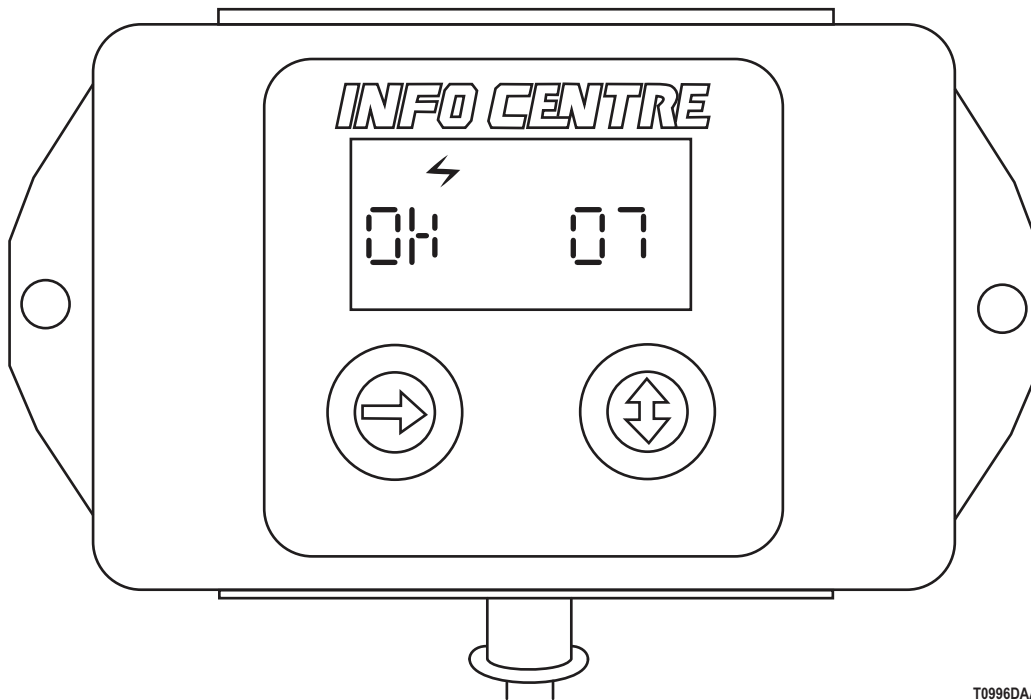

T0996DAA

Figure 1. Info Centre Fault Code "OK 07" Display.

- e. Code "OK 07" should be displayed on Info Centre.

CONDITION/INDICATION

IS CODE "OK 07" DISPLAYED ON INFO CENTRE?

DECISION

- NO - Screen is blank. Perform ABS No Data troubleshooting (WP 0185).
- NO - Screen displays COMFAIL. Perform ABS No Data troubleshooting (WP 0185).
- NO - Screen displays another fault code. Perform troubleshooting for fault code displayed.
- YES - Go to Step (2).

ABS - START - RETRIEVING FAULT CODES WITH THE HALDEX INFO CENTER (SCAN TOOL) - Continued**STEP****2. ARE ABS HISTORICAL CODES PRESENT?****NOTE**

Stored fault codes are displayed in groups of five. If more than five faults are stored, there will be a delay between groups.

- a. Press and hold right button on Info Centre for two second until "BUSY" is displayed.

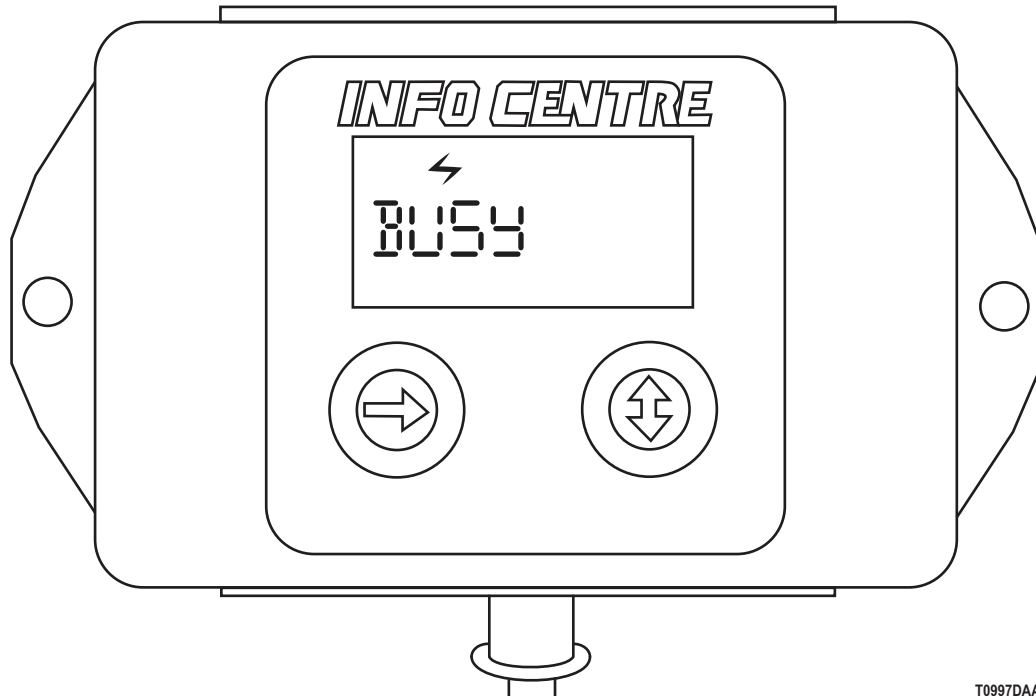

T0997DAA

Figure 2. Info Centre "BUSY" Display.

- b. Check Info Centre display for stored fault code. Note code.

ABS - START - RETRIEVING FAULT CODES WITH THE HALDEX INFO CENTER (SCAN TOOL) - Continued

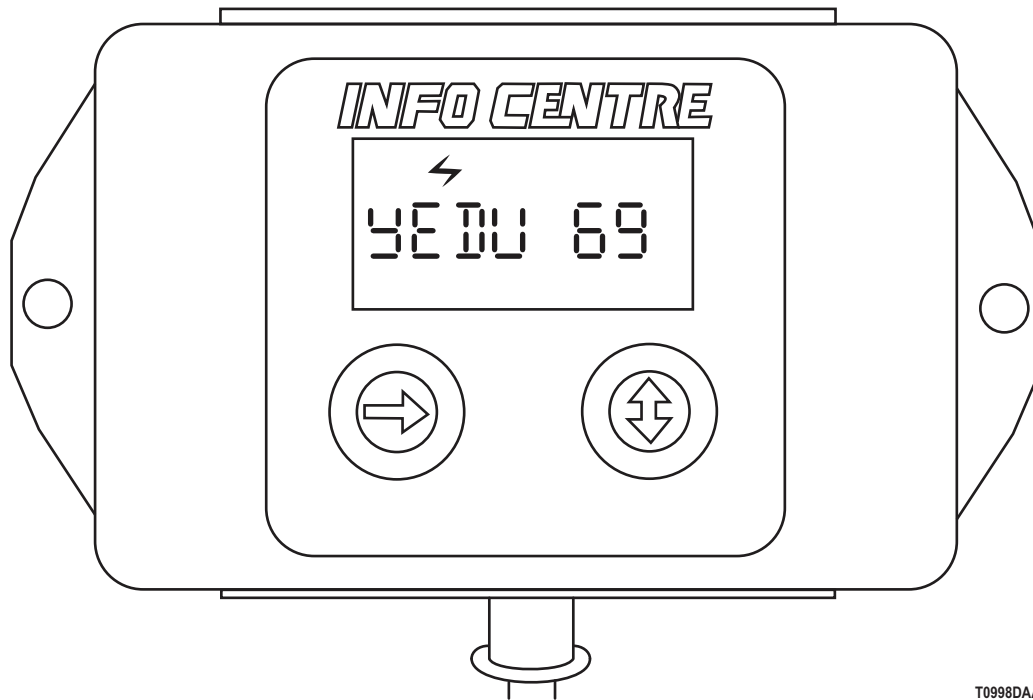

T0998DAA

Figure 3. Info Centre Fault Code Display.

- c. Repeat Steps (a) and (b) until "CLR CA" is displayed.

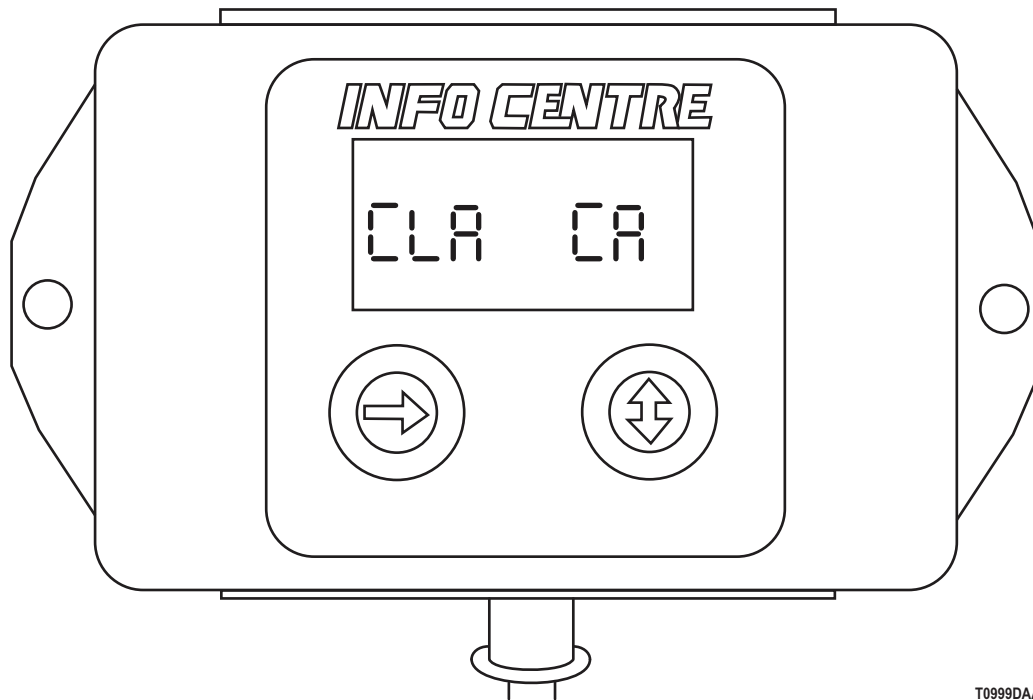

T0999DAA

Figure 4. Info Centre "CLR CA" Display.

ABS - START - RETRIEVING FAULT CODES WITH THE HALDEX INFO CENTER (SCAN TOOL) - Continued**CONDITION/INDICATION**

ARE ABS HISTORICAL CODES PRESENT?

DECISION

YES - Perform troubleshooting for fault code displayed.

NO - Go to Step (3).

ABS - START - RETRIEVING FAULT CODES WITH THE HALDEX INFO CENTER (SCAN TOOL) - Continued**STEP****3. DOES ABS FUNCTION PROPERLY DURING A ROAD TEST?**

- a. Start vehicle.

NOTE

During the road test, the Info Center should display "OK 07" when vehicle is stationary, and "OK 00" when moving. The ABS indicator should remain OFF.

- b. Operate vehicle to a speed of 20 miles per hour.
- c. Make one quick hard stop to initiate an ABS event.

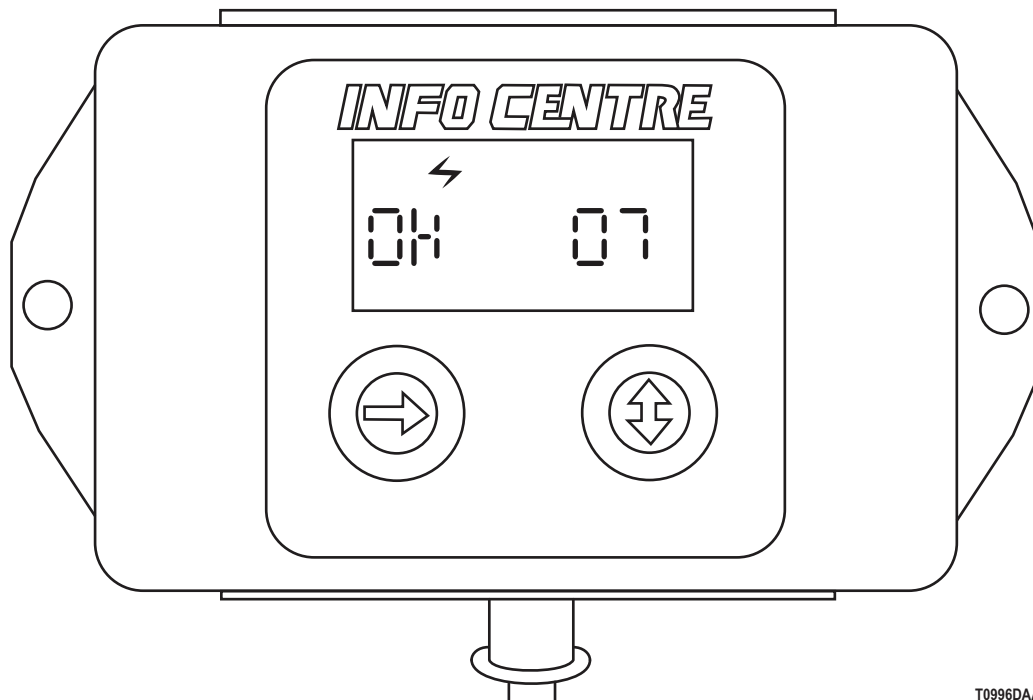

T0996DAA

Figure 5. Info Centre Fault Code "OK 07" Display.

- d. Check Info Centre for fault codes. Note codes.
- e. Return vehicle to park position.
- f. Shut off engine.

CONDITION/INDICATION

DOES ABS FUNCTION PROPERLY DURING A ROAD TEST?

DECISION

- YES - Perform troubleshooting for fault code displayed.
 NO - Go to Step (4) to verify problem is solved.

ABS - START - RETRIEVING FAULT CODES WITH THE HALDEX INFO CENTER (SCAN TOOL) - Continued**STEP**

4. IS YOUR ORIGINAL PROBLEM STILL PRESENT?
 - a. Ensure vehicle is returned to normal operating condition.
 - b. Check to see if your original problem still exists.

CONDITION/INDICATION

IS YOUR ORIGINAL PROBLEM STILL PRESENT?

DECISION

YES - Notify supervisor.
NO - Problem fixed.

END OF WORK PACKAGE

FIELD MAINTENANCE
ABS - CODE S2A 03 (LEFT SIDE - BLUE CHANNEL)

INITIAL SETUP:**Tools and Special Tools**

Tool Kit, General Mechanic's: Automotive
(Volume 5, WP 0826, Table 1, Item 56)
ABS Diagnostic Info Centre (TM 9-2320-272-10)
Multimeter
(Volume 5, WP 0826, Table 1, Item 34)
Test Set, Electronic Systems
(Volume 5, WP 0826, Table 1, Item 51)

Personnel Required

(2)

References

Point to Point Schematics

References (cont.)

WP 0159
WP 0161
Volume 3, WP 0452
Volume 3, WP 0467
Volume 3, WP 0468

Equipment Condition

Vehicle parked and engine shut down.
(TM 9-2320-272-10)

TROUBLESHOOTING PROCEDURE

ABS - CODE S2A 03 (LEFT SIDE - BLUE CHANNEL)**STEP**

1. IS LEFT REAR-REAR WHEEL SPEED SENSOR OPEN OR SHORTED?
 - a. Ensure battery and start switches are in the OFF position.

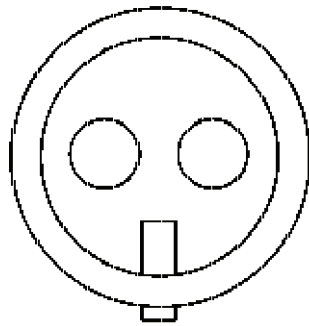
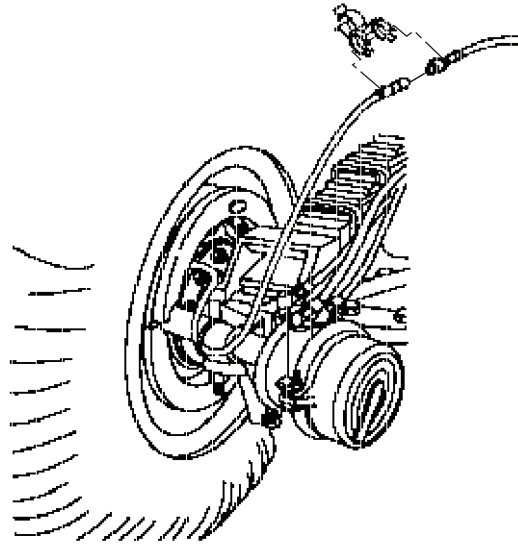

T0851DAA

Figure 1. Wheel Speed Sensor Connector.

ABS - CODE S2A 03 (LEFT SIDE - BLUE CHANNEL) - Continued

- b. Disconnect the left rear-rear wheel speed sensor.
- c. Set multimeter to measure resistance.
- d. Connect multimeter red lead to wheel speed sensor connector terminal. Refer to point to point schematics.
- e. Connect multimeter black lead to wheel speed sensor connector other terminal.
- f. Meter reading should be between 980 and 2,350 ohms.
- g. If meter reading is correct, connect wheel speed sensor connector.

CONDITION/INDICATION

IS LEFT REAR-REAR WHEEL SPEED SENSOR OPEN OR SHORTED?

DECISION

YES - Replace wheel speed sensor (Volume 3, WP 0468). Go to Step (4) to verify problem is solved.
NO - Go to Step (2).

ABS - CODE S2A 03 (LEFT SIDE - BLUE CHANNEL) - Continued

STEP

2. IS LEFT WHEEL SPEED SENSOR WIRING OPEN OR SHORTED?

- a. Ensure battery and start switches are in the OFF position.

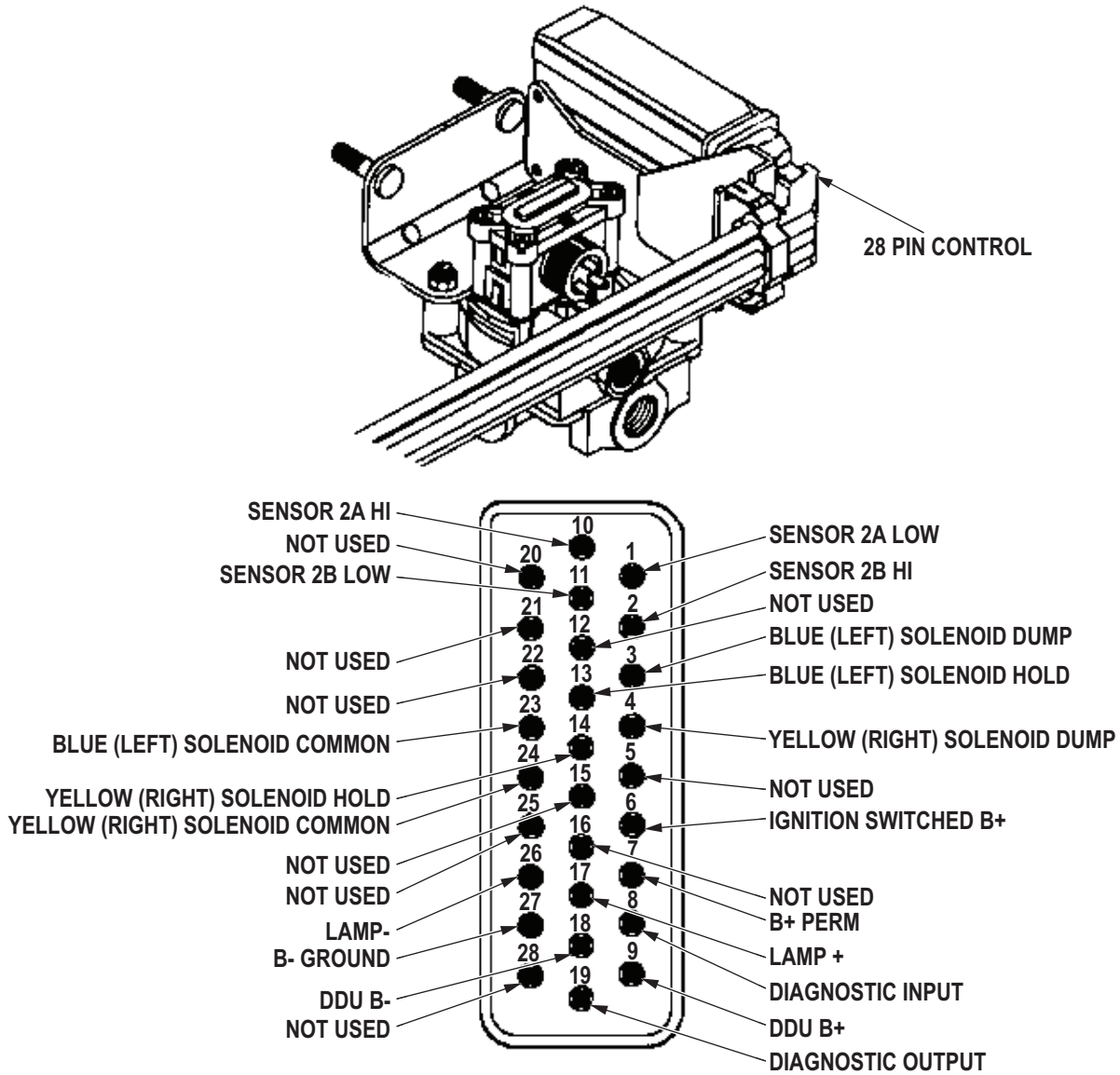

T0854DAA

Figure 2. ABS Wiring Harness 28-pin ECU Connector.

- b. Disconnect main 28-pin connector at ECU (Volume 3, WP 0452).
- c. Connect multimeter red lead to 28-pin connector, terminal 1. Refer to point to point schematics.
- d. Connect multimeter black lead to 28-pin connector, terminal 10.

ABS - CODE S2A 03 (LEFT SIDE - BLUE CHANNEL) - Continued

- e. Meter reading should be between 980 and 2,350 ohms.
- f. If meter reading is correct, connect ECU connector. Listen for locks to "click" in place to ensure a sound connection.

CONDITION/INDICATION

IS LEFT WHEEL SPEED SENSOR WIRING OPEN OR SHORTED?

DECISION

YES - Replace ABS wiring harness (Volume 3, WP 0467). Go to Step (4) to verify problem is solved.

NO - Go to Step (3).

ABS - CODE S2A 03 (LEFT SIDE - BLUE CHANNEL) - Continued

STEP

3. IS LEFT REAR-REAR WHEEL SPEED SENSOR CIRCUIT WIRING SHORTED TO ANOTHER CIRCUIT?
 - a. Ensure battery and start switches are in the OFF position.

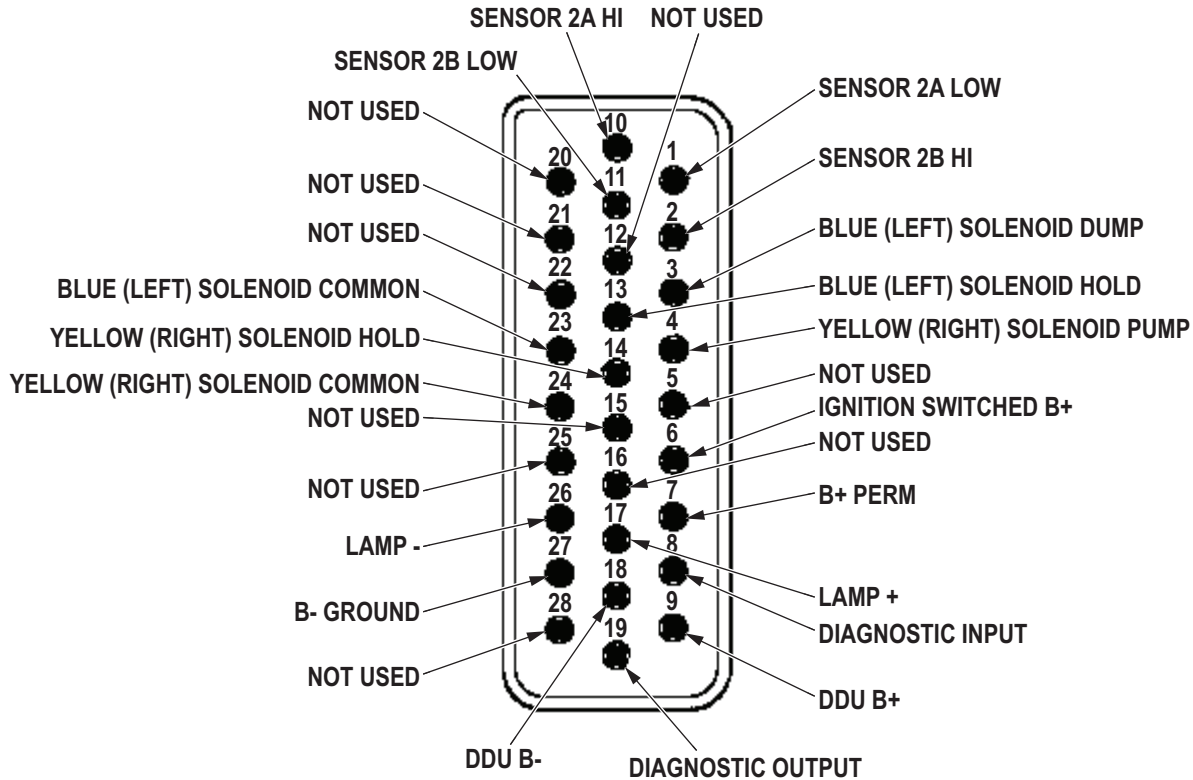

T0947DAA

Figure 3. ABS Wiring Harness 28-pin ECU Connector.

- b. Disconnect main 28-pin connector at ECU (Volume 3, WP 0452).
- c. Connect multimeter red lead to 28-pin connector, terminal 1. Refer to point to point schematics.
- d. Connect mutimeter black lead to the remaining 28-pin connector terminals, except terminal 10.
- e. Meter readings should be greater than 10,000 ohms for each measurement. Note readings.
- f. Connect multimeter black lead to 28-pin connector, terminal 10.
- g. Connect mutimeter black lead to the remaining 28-pin connector terminals, except terminal 1.
- h. Meter readings should be greater than 10,000 ohms for each measurement. Note readings.

CONDITION/INDICATION

IS LEFT REAR-REAR WHEEL SPEED SENSOR CIRCUIT WIRING SHORTED TO ANOTHER CIRCUIT?

DECISION

- YES - Replace ABS wiring harness (Volume 3, WP 0467). Go to Step (4) to verify problem is solved.
 NO - Replace ABS ECU (Volume 3, WP 0452). Go to Step (4) to verify problem is solved.

ABS - CODE S2A 03 (LEFT SIDE - BLUE CHANNEL) - Continued**STEP**

4. IS YOUR ORIGINAL PROBLEM STILL PRESENT?
 - a. Ensure vehicle is returned to normal operating condition.
 - b. Perform Clear Historical Codes Procedure (WP 0159).
 - c. Perform ABS - Start- Retrieving Fault Codes With Haldex Info Center (Scan Tool) (WP 0161).
 - d. Check to see if your original fault code still exists.

CONDITION/INDICATION

IS YOUR ORIGINAL PROBLEM STILL PRESENT?

DECISION

YES - Notify supervisor.
NO - Problem fixed.

END OF WORK PACKAGE

FIELD MAINTENANCE
ABS - CODE S2B 04 (RIGHT SIDE - YELLOW CHANNEL)

INITIAL SETUP:**Tools and Special Tools**

Tool Kit, General Mechanic's: Automotive
(Volume 5, WP 0826, Table 1, Item 56)
ABS Diagnostic Info Centre (TM 9-2320-272-10)
Multimeter
(Volume 5, WP 0826, Table 1, Item 34)
Test Set, Electronic Systems
(Volume 5, WP 0826, Table 1, Item 51)

Personnel Required

(2)

References

Point to Point Schematics

References (cont.)

WP 0159
WP 0161
Volume 3, WP 0452
Volume 3, WP 0467
Volume 3, WP 0468

Equipment Condition

Vehicle parked and engine shut down.
(TM 9-2320-272-10)

TROUBLESHOOTING PROCEDURE

ABS - CODE S2B 04 (RIGHT SIDE - YELLOW CHANNEL)**STEP**

1. IS RIGHT REAR-REAR WHEEL SPEED SENSOR OPEN OR SHORTED?
 - a. Ensure battery and start switches are in the OFF position.

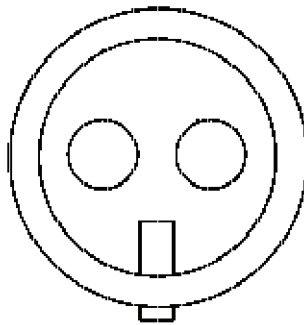
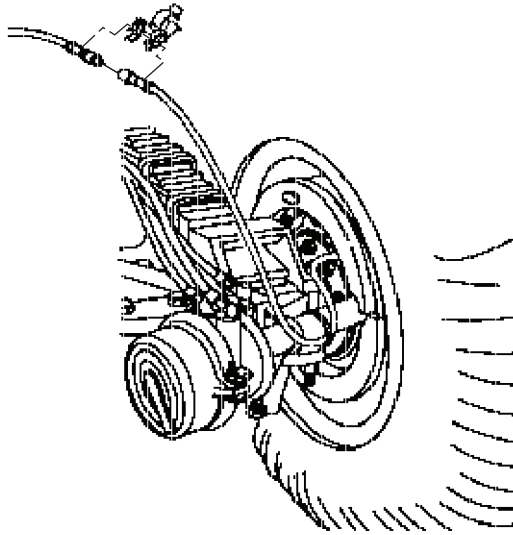

T0850DAA

Figure 1. Wheel Speed Sensor Connector.

ABS - CODE S2B 04 (RIGHT SIDE - YELLOW CHANNEL) - Continued

- b. Disconnect the right rear-rear wheel speed sensor.
- c. Set multimeter to measure resistance.
- d. Connect multimeter red lead to wheel speed sensor connector terminal. Refer to point to point schematics.
- e. Connect multimeter black lead to wheel speed sensor connector other terminal.
- f. Meter reading should be between 980 and 2,350 ohms.
- g. If meter reading is correct, connect wheel speed sensor connector.

CONDITION/INDICATION

IS RIGHT REAR-REAR WHEEL SPEED SENSOR OPEN OR SHORTED?

DECISION

YES - Replace wheel speed sensor (Volume 3, WP 0468). Go to Step (4) to verify problem is solved.
NO - Go to Step (2).

ABS - CODE S2B 04 (RIGHT SIDE - YELLOW CHANNEL) - Continued

STEP

2. IS WHEEL SPEED SENSOR WIRING OPEN OR SHORTED?

- a. Ensure battery and start switches are in the OFF position.

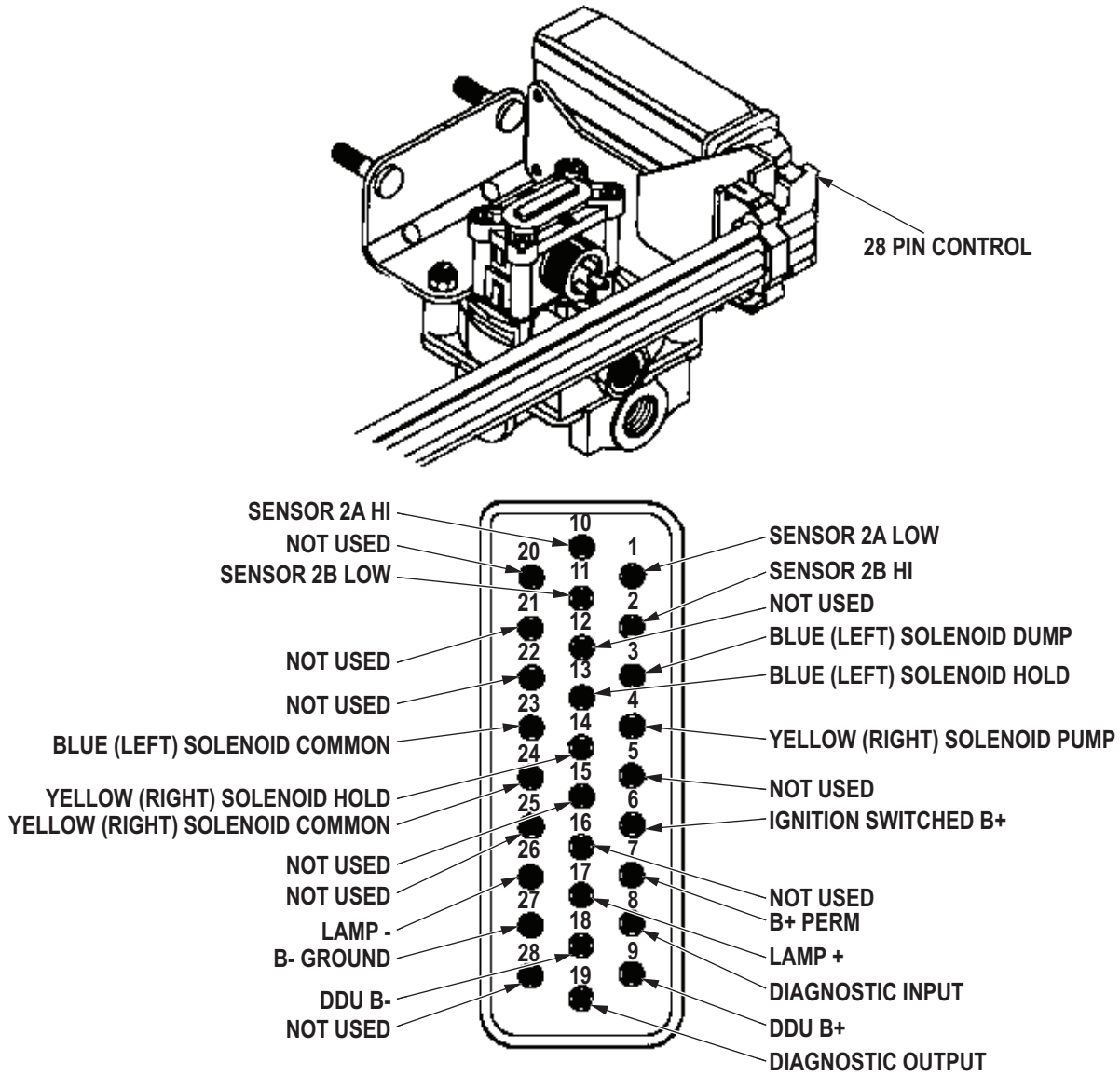

T0960DAA

Figure 2. ABS Wiring Harness 28-pin ECU Connector.

ABS - CODE S2B 04 (RIGHT SIDE - YELLOW CHANNEL) - Continued

- b. Disconnect main 28-pin connector at ECU (Volume 3, WP 0452).
- c. Connect multimeter red lead to 28-pin connector, terminal 2. Refer to point to point schematics.
- d. Connect multimeter black lead to 28-pin connector, terminal 11.
- e. Meter reading should be between 980 and 2,350 ohms.
- f. If meter reading is correct, connect ECU connector. Listen for locks to "click" in place to ensure a sound connection.

CONDITION/INDICATION

IS WHEEL SPEED SENSOR WIRING OPEN OR SHORTED?

DECISION

YES - Replace ABS wiring harness (Volume 3, WP 0467). Go to Step (4) to verify problem is solved.
NO - Go to Step (3).

ABS - CODE S2B 04 (RIGHT SIDE - YELLOW CHANNEL) - Continued

STEP

3. IS RIGHT REAR-REAR WHEEL SPEED SENSOR CIRCUIT WIRING SHORTED TO ANOTHER CIRCUIT?
 - a. Ensure battery and start switches are in the OFF position.

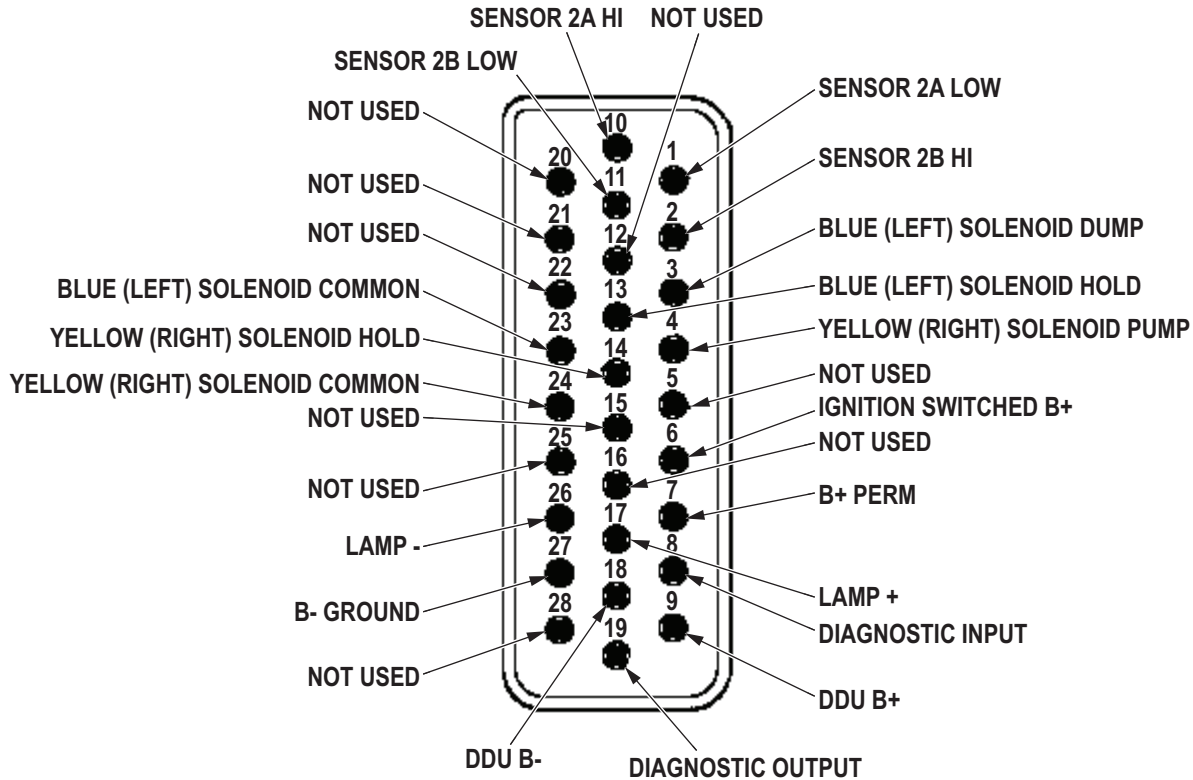

T0948DAA

Figure 3. ABS Wiring Harness 28-pin ECU Connector.

- b. Disconnect main 28-pin connector at ECU (Volume 3, WP 0452).
- c. Connect multimeter red lead to 28-pin connector, terminal 2. Refer to point to point schematics.
- d. Connect mutimeter black lead to the remaining ECU connector terminals, except terminal 11.
- e. Meter readings should be greater than 10,000 ohms for each measurement. Note readings.
- f. Connect multimeter black lead to 28-pin connector, terminal 11.
- g. Connect mutimeter black lead to the remaining 28-pin connector terminals, except terminal 2.
- h. Meter readings should be greater than 10,000 ohms for each measurement. Note readings.

CONDITION/INDICATION

IS RIGHT REAR-REAR WHEEL SPEED SENSOR CIRCUIT WIRING SHORTED TO ANOTHER CIRCUIT?

DECISION

- YES - Replace ABS wiring harness (Volume 3, WP 0467). Go to Step (4) to verify problem is solved.
 NO - Replace ABS ECU (Volume 3, WP 0452). Go to Step (4) to verify problem is solved.

ABS - CODE S2B 04 (RIGHT SIDE - YELLOW CHANNEL) - Continued**STEP**

4. IS YOUR ORIGINAL PROBLEM STILL PRESENT?
 - a. Ensure vehicle is returned to normal operating condition.
 - b. Perform Clear Historical Codes Procedure (WP 0159).
 - c. Perform ABS - Start- Retrieving Fault Codes With Haldex Info Center (Scan Tool) (WP 0161).
 - d. Check to see if your original fault code still exists.

CONDITION/INDICATION

IS YOUR ORIGINAL PROBLEM STILL PRESENT?

DECISION

YES - Notify supervisor.
NO - Problem fixed.

END OF WORK PACKAGE

FIELD MAINTENANCE
ABS - CODE S2A 13 (LEFT SIDE - BLUE CHANNEL)

INITIAL SETUP:**Tools and Special Tools**

Tool Kit, General Mechanic's: Automotive
(Volume 5, WP 0826, Table 1, Item 56)
ABS Diagnostic Info Centre (TM 9-2320-272-10)
High Boy Jack Stands
(Volume 5, WP 0826, Table 1, Item 24)
Multimeter
(Volume 5, WP 0826, Table 1, Item 34)
Test Set, Electronic Systems
(Volume 5, WP 0826, Table 1, Item 51)

References (cont.)

WP 0159
WP 0161
Volume 3, WP 0468
Volume 3, WP 0484
Volume 3, WP 0485

Equipment Condition

Vehicle parked and engine shut down.
(TM 9-2320-272-10)

Personnel Required

(2)

References

Point to Point Schematics

TROUBLESHOOTING PROCEDURE

ABS - CODE S2A 13 (LEFT SIDE - BLUE CHANNEL)**STEP**

1. IS LEFT WHEEL SPEED SENSOR OUTPUT VOLTAGE OK?
 - a. Ensure battery and start switches are in the OFF position.
 - b. Cage left rear-rear wheel brakes.
 - c. Raise left rear-rear wheels until they are off the ground M939 (Volume 3, WP 0484), M939A1/A2 (Volume 3, WP 0485). Support vehicle with jack stand.

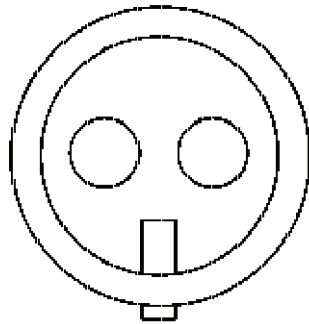
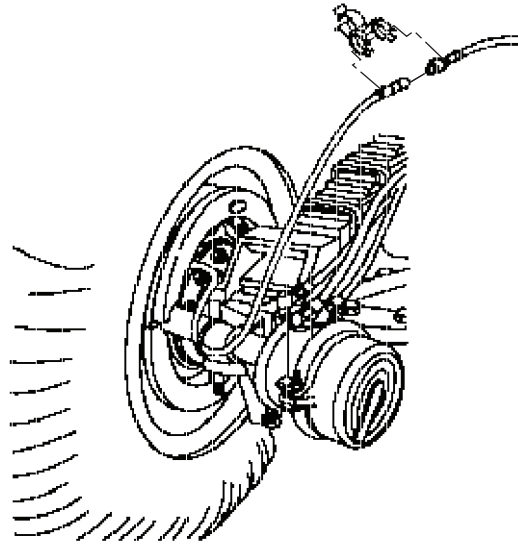

T0943DAA

Figure 1. Wheel Speed Sensor Connector.

- d. Disconnect the left rear-rear wheel speed sensor.
- e. Set multimeter to measure VAC.

NOTE

Battery does not need to be connected to perform this test. ABS wheel speed sensors generate a voltage signal when sensed wheels are in motion.

ABS - CODE S2A 13 (LEFT SIDE - BLUE CHANNEL) - Continued

- f. Connect multimeter red lead to wheel speed sensor connector terminal. Refer to point to point schematics.
- g. Connect multimeter black lead to wheel speed sensor connector other terminal.
- h. Measure AC voltage while rotating wheel at a rate of one revolution every two seconds.
- i. Meter reading should be at least 200 millivolts (.002 volts).
- j. If meter reading is correct, connect wheel speed sensor connector.
- k. Remove jack stand and lower wheel.
- l. Uncage brake.

CONDITION/INDICATION

IS LEFT WHEEL SPEED SENSOR OUTPUT VOLTAGE OK?

DECISION

NO - Replace wheel speed sensor (Volume 3, WP 0468). Go to Step (2) to verify problem is solved.
YES - Go to Step (2) to verify problem is solved.

STEP

2. IS YOUR ORIGINAL PROBLEM STILL PRESENT?
 - a. Ensure vehicle is returned to normal operating condition.
 - b. Perform Clear Historical Codes Procedure (WP 0159).

NOTE

Fault code S2A 13 will only occur when vehicle speed is greater than 6 MPH.

- c. Start vehicle.
- d. Operate vehicle to a speed of 20 miles per hour.
- e. Return vehicle to park position.
- f. Perform ABS - Start- Retrieving Fault Codes With Haldex Info Center (Scan Tool) (WP 0161).
- g. Check to see if your original fault code still exists.

CONDITION/INDICATION

IS YOUR ORIGINAL PROBLEM STILL PRESENT?

DECISION

YES - Notify supervisor.
NO - Problem fixed.

END OF WORK PACKAGE

FIELD MAINTENANCE
ABS - CODE S2B 14 (RIGHT SIDE - YELLOW CHANNEL)

INITIAL SETUP:**Tools and Special Tools**

Tool Kit, General Mechanic's: Automotive
(Volume 5, WP 0826, Table 1, Item 56)
ABS Diagnostic Info Centre (TM 9-2320-272-10)
High Boy Jack Stands
(Volume 5, WP 0826, Table 1, Item 24)
Multimeter
(Volume 5, WP 0826, Table 1, Item 34)
Test Set, Electronic Systems
(Volume 5, WP 0826, Table 1, Item 51)

References (cont.)

WP 0159
WP 0161
Volume 3, WP 0468
Volume 3, WP 0484
Volume 3, WP 0485

Equipment Condition

Vehicle parked and engine shut down.
(TM 9-2320-272-10)

Personnel Required

(2)

References

Point to Point Schematics

TROUBLESHOOTING PROCEDURE

ABS - CODE S2B 14 (RIGHT SIDE - YELLOW CHANNEL)**STEP**

1. IS RIGHT WHEEL SPEED SENSOR OUTPUT VOLTAGE OK?
 - a. Ensure battery and start switches are in the OFF position.
 - b. Cage right rear-rear wheel brakes.
 - c. Raise right rear-rear wheels until they are off the ground M939 (Volume 3, WP 0484), M939A1/A2 (Volume 3, WP 0485). Support vehicle with jack stand.

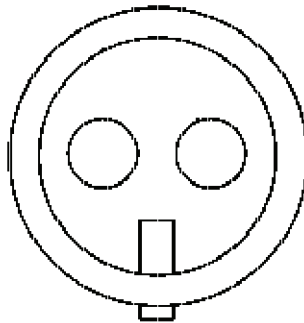
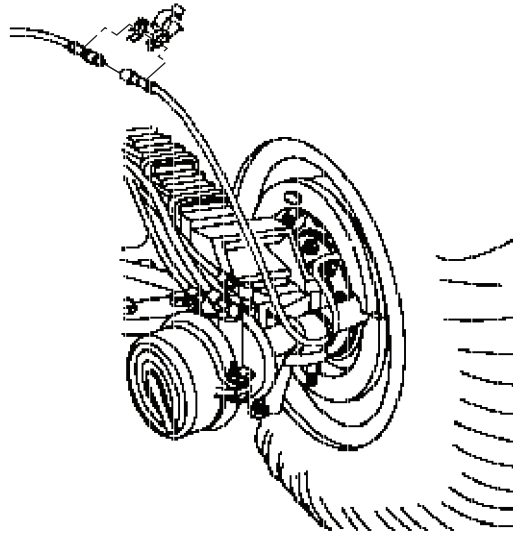

T0942DAA

Figure 1. Wheel Speed Sensor Connector.

- d. Disconnect the right rear-rear wheel speed sensor.
- e. Set multimeter to measure VAC.

NOTE

Battery does not need to be connected to perform this test. ABS wheel speed sensors generate a voltage signal when sensed wheels are in motion.

ABS - CODE S2B 14 (RIGHT SIDE - YELLOW CHANNEL) - Continued

- f. Connect multimeter red lead to wheel speed sensor connector terminal. Refer to point to point schematics.
- g. Connect multimeter black lead to wheel speed sensor connector other terminal.
- h. Measure AC voltage while rotating wheel at a rate of one revolution every two seconds.
- i. Meter reading should be at least 200 millivolts (.002 volts).
- j. If meter reading is correct, connect wheel speed sensor connector.
- k. Remove jack stand and lower wheel.
- l. Uncage brake.

CONDITION/INDICATION

IS RIGHT WHEEL SPEED SENSOR OUTPUT VOLTAGE OK?

DECISION

NO - Replace wheel speed sensor (Volume 3, WP 0468). Go to Step (2) to verify problem is solved.

YES - Go to Step (2) to verify problem is solved.

STEP

2. IS YOUR ORIGINAL PROBLEM STILL PRESENT?
 - a. Ensure vehicle is returned to normal operating condition.
 - b. Perform Clear Historical Codes Procedure (WP 0159).

NOTE

Fault code S2A 13 will only occur when vehicle speed is greater than 6 MPH.

- c. Start vehicle.
- d. Operate vehicle to a speed of 20 miles per hour.
- e. Return vehicle to park position.
- f. Perform ABS - Start- Retrieving Fault Codes With Haldex Info Center (Scan Tool) (WP 0161).
- g. Check to see if your original fault code still exists.

CONDITION/INDICATION

IS YOUR ORIGINAL PROBLEM STILL PRESENT?

DECISION

YES - Notify supervisor.

NO - Problem fixed.

END OF WORK PACKAGE

FIELD MAINTENANCE
ABS - CODE S2A 23 (LEFT SIDE - BLUE CHANNEL)

INITIAL SETUP:**Tools and Special Tools**

Tool Kit, General Mechanic's: Automotive
(Volume 5, WP 0826, Table 1, Item 56)
ABS Diagnostic Info Centre (TM 9-2320-272-10)
High Boy Jack Stands
(Volume 5, WP 0826, Table 1, Item 24)
Test Set, Electronic Systems
(Volume 5, WP 0826, Table 1, Item 51)

References (cont.)

WP 0161
Volume 3, WP 0452
Volume 3, WP 0467
Volume 3, WP 0468
Volume 3, WP 0469
Volume 3, WP 0480
Volume 3, WP 0482
Volume 3, WP 0483
Volume 3, WP 0484
Volume 3, WP 0485

Personnel Required

(2)

References

Point to Point Schematics
WP 0159

Equipment Condition

Vehicle parked and engine shut down.
(TM 9-2320-272-10)

TROUBLESHOOTING PROCEDURE**ABS - CODE S2A 23 (LEFT SIDE - BLUE CHANNEL)****STEP**

1. ARE ANY CONNECTORS, CABLES, OR LOOSE, CORRODED, OR DAMAGED?
 - a. Ensure battery and start switches are in the OFF position.
 - b. Inspect all connectors and cables for damage or corrosion. Refer to point to point schematics.
 - c. Check for any loose connections.

CONDITION/INDICATION

ARE ANY CONNECTORS, CABLES, OR LOOSE, CORRODED, OR DAMAGED?

DECISION

YES - Replace ABS wiring harness (Volume 3, WP 0468). Go to Step (5) to verify problem is solved.
NO - Go to Step (2).

ABS - CODE S2A 23 (LEFT SIDE - BLUE CHANNEL) - Continued**STEP****2. ARE WHEEL BEARINGS LOOSE OR DAMAGED?**

- a. Raise rear-rear wheels until they are off the ground M939 (Volume 3, WP 0484), M939A1/A2 (Volume 3, WP 0485). Support vehicle with jack stands.

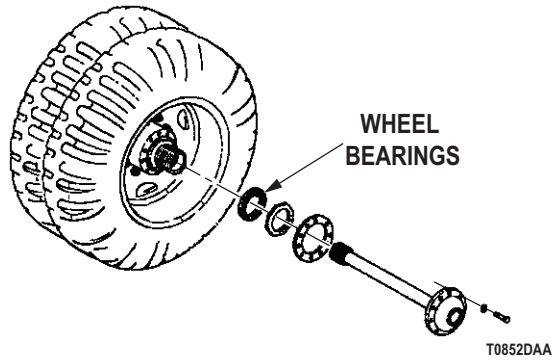

Figure 1. Wheel Bearing.

- b. Check wheel bearings for excessive play or roughness.

CONDITION/INDICATION

ARE WHEEL BEARINGS LOOSE OR DAMAGED?

DECISION

YES - Replace or adjust wheel bearings (Volume 3, WP 0483). Go to Step (5) to verify problem is solved.
NO - Go to Step (3).

ABS - CODE S2A 23 (LEFT SIDE - BLUE CHANNEL) - Continued**STEP****3. IS EXCITER RING OK?**

- a. Remove left rear-rear axle hub and drum assembly M939/A1 (Volume 3, WP 0480), M939A2 (Volume 3, WP 0482).

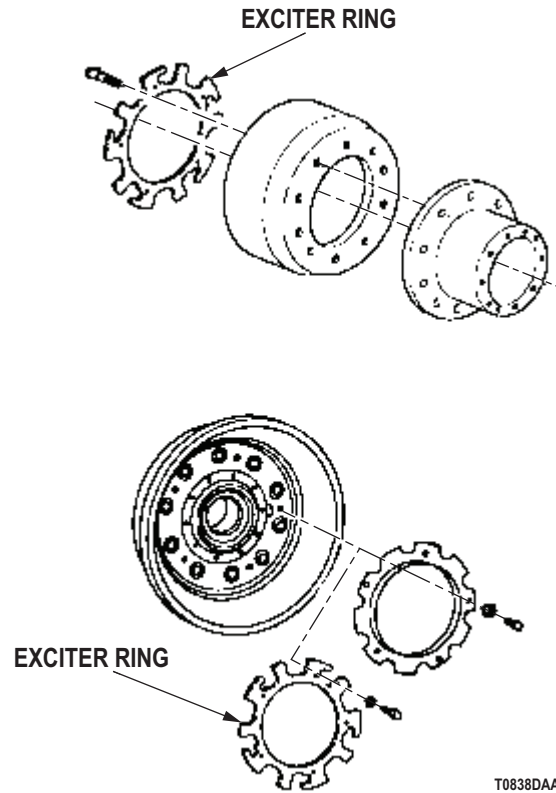

Figure 2. ABS Exciter Ring.

- b. Inspect exciter ring for loose mounting, damage, or debris filled windows.

CONDITION/INDICATION

IS EXCITER RING OK?

DECISION

NO - Clean or replace exciter ring (Volume 3, WP 0469). Go to Step (5) to verify problem is solved.
YES - Go to Step (4).

ABS - CODE S2A 23 (LEFT SIDE - BLUE CHANNEL) - Continued

STEP

4. IS THE WHEEL SPEED SENSOR SECURELY MOUNTED?
 - a. Raise rear-rear wheels until they are off the ground M939 (Volume 3, WP 0484), M939A1/A2 (Volume 3, WP 0485). Support vehicle with jack stands.
 - b. Check wheel speed sensor mounting clip for loose fit or damage.

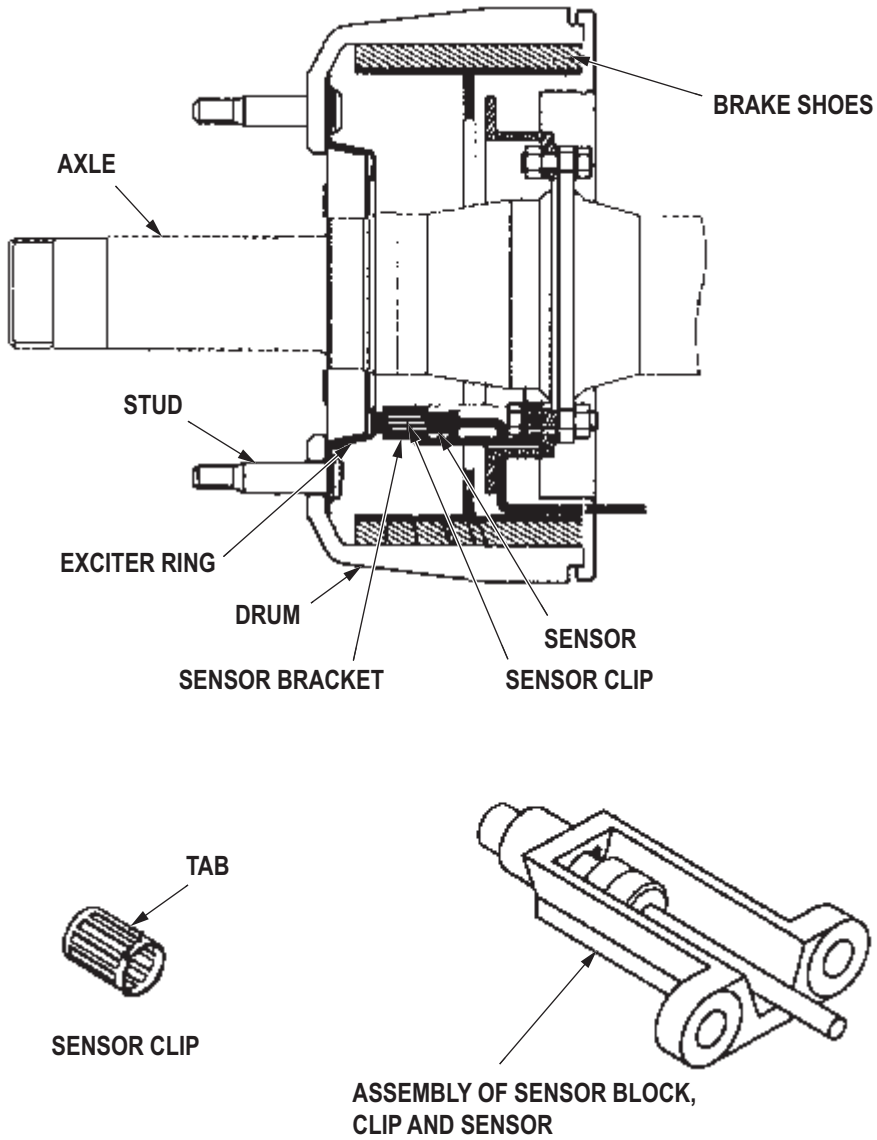

T0835DAA

Figure 3. ABS Wheel Speed Sensor.

ABS - CODE S2A 23 (LEFT SIDE - BLUE CHANNEL) - Continued**CONDITION/INDICATION**

IS THE WHEEL SPEED SENSOR SECURELY MOUNTED?

DECISION

YES - Go to Step (5) to verify problem is solved.

NO - Repair or replace wheel speed sensor (Volume 3, WP 0468). Go to Step (5) to verify problem is solved.

STEP**5. IS YOUR ORIGINAL PROBLEM STILL PRESENT?**

- a. If removed, install left rear-rear hub and drum assembly M939/A1 (Volume 3, WP 0480), M939A2 (Volume 3, WP 0482).
- b. If raised, remove jack stands and lower wheel.
- c. Ensure vehicle is returned to normal operating condition.
- d. Perform Clear Historical Codes Procedure (WP 0159).

NOTE

Fault code S2A 23 will only occur when vehicle speed is greater than 6 MPH.

- e. Start vehicle.
- f. Operate vehicle to a speed of 20 miles per hour.
- g. Return vehicle to park position.
- h. Perform ABS - Start- Retrieving Fault Codes With Haldex Info Center (Scan Tool) (WP 0161).
- i. Check to see if your original fault code still exists.

CONDITION/INDICATION

IS YOUR ORIGINAL PROBLEM STILL PRESENT?

DECISION

YES - Notify supervisor.

NO - Problem fixed.

END OF WORK PACKAGE

FIELD MAINTENANCE
ABS - CODE S2A 24 (RIGHT SIDE - YELLOW CHANNEL)

INITIAL SETUP:**Tools and Special Tools**

Tool Kit, General Mechanic's: Automotive
(Volume 5, WP 0826, Table 1, Item 56)
ABS Diagnostic Info Centre (TM 9-2320-272-10)
High Boy Jack Stands
(Volume 5, WP 0826, Table 1, Item 24)
Test Set, Electronic Systems
(Volume 5, WP 0826, Table 1, Item 51)

References (cont.)

WP 0161
Volume 3, WP 0452
Volume 3, WP 0467
Volume 3, WP 0468
Volume 3, WP 0469
Volume 3, WP 0480
Volume 3, WP 0482
Volume 3, WP 0483
Volume 3, WP 0484
Volume 3, WP 0485

Personnel Required

(2)

References

Point to Point Schematics
WP 0159

Equipment Condition

Vehicle parked and engine shut down.
(TM 9-2320-272-10)

TROUBLESHOOTING PROCEDURE**ABS - CODE S2A 24 (RIGHT SIDE - YELLOW CHANNEL)****STEP**

1. ARE ANY CONNECTORS, CABLES, OR LOOSE, CORRODED, OR DAMAGED?
 - a. Ensure battery and start switches are in the OFF position.
 - b. Inspect all connectors and cables for damage or corrosion. Refer to point to point schematics.
 - c. Check for any loose connections.

CONDITION/INDICATION

ARE ANY CONNECTORS, CABLES, OR LOOSE, CORRODED, OR DAMAGED?

DECISION

YES - Replace ABS wiring harness (Volume 3, WP 0468). Go to Step (5) to verify problem is solved.
NO - Go to Step (2).

ABS - CODE S2A 24 (RIGHT SIDE - YELLOW CHANNEL) - Continued**STEP****2. ARE WHEEL BEARINGS LOOSE OR DAMAGED?**

- a. Raise rear-rear wheels until they are off the ground M939 (Volume 3, WP 0484), M939A1/A2 (Volume 3, WP 0485). Support vehicle with jack stands.

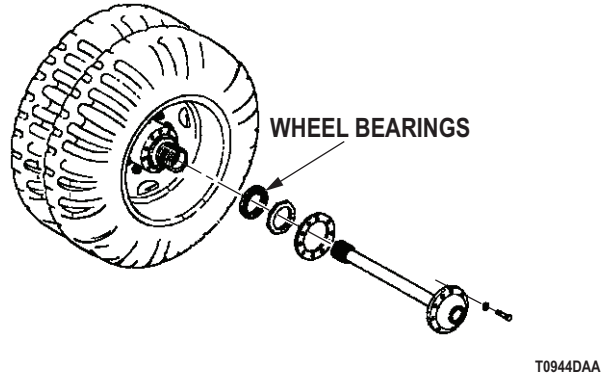

Figure 1. Wheel Bearing.

- b. Check wheel bearings for excessive play or roughness.

CONDITION/INDICATION

ARE WHEEL BEARINGS LOOSE OR DAMAGED?

DECISION

YES - Replace or adjust wheel bearings (Volume 3, WP 0483). Go to Step (5) to verify problem is solved.
NO - Go to Step (3).

ABS - CODE S2A 24 (RIGHT SIDE - YELLOW CHANNEL) - Continued**STEP****3. IS EXCITER RING OK?**

- a. Remove right rear-rear axle hub and drum assembly M939/A1 (Volume 3, WP 0480), M939A2 (Volume 3, WP 0482).

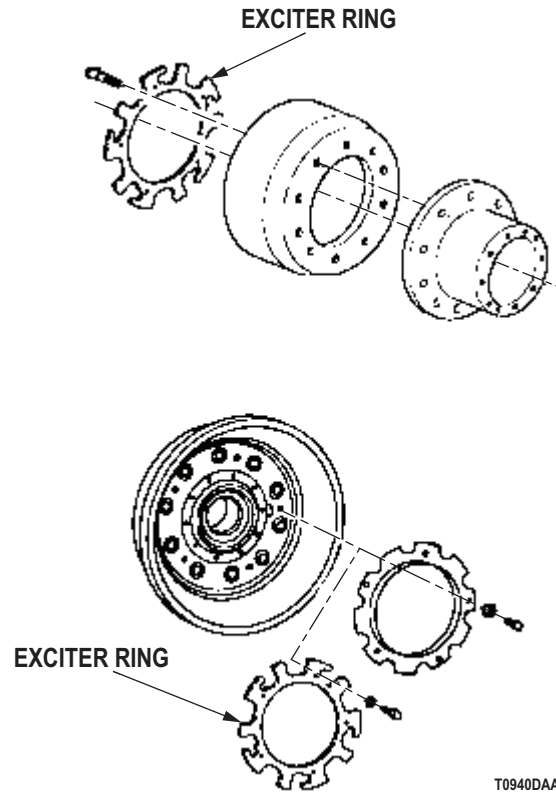

Figure 2. ABS Exciter Ring.

- b. Inspect exciter ring for loose mounting, damage, or debris filled windows.

CONDITION/INDICATION

IS EXCITER RING OK?

DECISION

NO - Clean or replace exciter ring (Volume 3, WP 0469). Go to Step (5) to verify problem is solved.
 YES - Go to Step (4).

ABS - CODE S2A 24 (RIGHT SIDE - YELLOW CHANNEL) - Continued

STEP

4. IS THE WHEEL SPEED SENSOR SECURELY MOUNTED?

- a. Raise rear-rear wheels until they are off the ground M939 (Volume 3, WP 0484), M939A1/A2 (Volume 3, WP 0485). Support vehicle with jack stands.
- b. Check wheel speed sensor mounting clip for loose fit or damage.

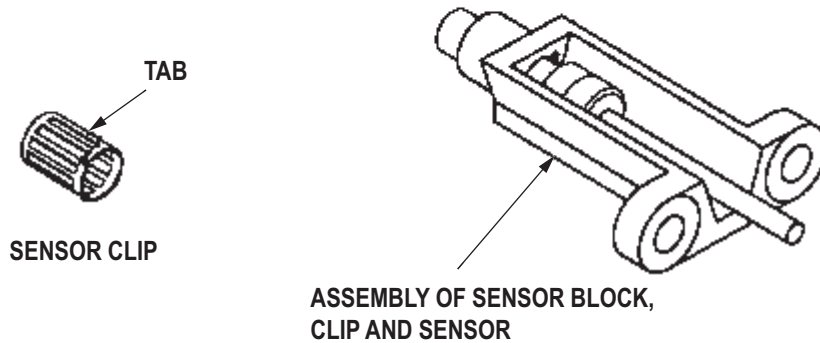
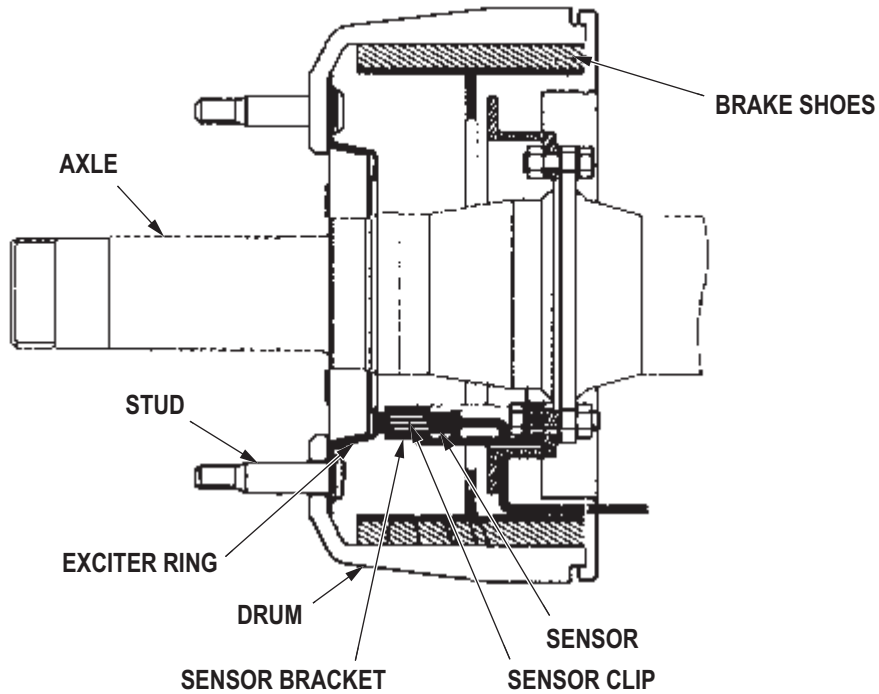

T0939DAA

Figure 3. ABS Wheel Speed Sensor.

ABS - CODE S2A 24 (RIGHT SIDE - YELLOW CHANNEL) - Continued**CONDITION/INDICATION**

IS THE WHEEL SPEED SENSOR SECURELY MOUNTED?

DECISION

YES - Go to Step (5) to verify problem is solved.

NO - Repair or replace wheel speed sensor (Volume 3, WP 0468). Go to Step (5) to verify problem is solved.

STEP**5. IS YOUR ORIGINAL PROBLEM STILL PRESENT?**

- a. If removed, install right rear-rear hub and drum assembly M939/A1 (Volume 3, WP 0480), M939A2 (Volume 3, WP 0482).
- b. If raised, remove jack stands and lower wheel.
- c. Ensure vehicle is returned to normal operating condition.
- d. Perform Clear Historical Codes Procedure (WP 0159).

NOTE

Fault code S2A 23 will only occur when vehicle speed is greater than 6 MPH.

- e. Start vehicle.
- f. Operate vehicle to a speed of 20 miles per hour.
- g. Return vehicle to park position.
- h. Perform ABS - Start- Retrieving Fault Codes With Haldex Info Center (Scan Tool) (WP 0161).
- i. Check to see if your original fault code still exists.

CONDITION/INDICATION

IS YOUR ORIGINAL PROBLEM STILL PRESENT?

DECISION

YES - Notify supervisor.

NO - Problem fixed.

END OF WORK PACKAGE

FIELD MAINTENANCE
ABS - CODE SLW 42 (LEFT SIDE - BLUE CHANNEL)

INITIAL SETUP:**Tools and Special Tools**

Tool Kit, General Mechanic's: Automotive
(Volume 5, WP 0826, Table 1, Item 56)
ABS Diagnostic Info Centre (TM 9-2320-272-10)
Test Set, Electronic Systems
(Volume 5, WP 0826, Table 1, Item 51)

References (cont.)

WP 0159
WP 0161
WP 0207
Volume 3, WP 0432
Volume 3, WP 0458
Volume 5, WP 0805

Personnel Required

(2)

Equipment Condition

Vehicle parked and engine shut down.
(TM 9-2320-272-10)

References

Point to Point Schematics

TROUBLESHOOTING PROCEDURE**ABS - CODE SLW 42 (LEFT SIDE - BLUE CHANNEL)****STEP**

1. IS DELIVERY HOSE AND TUBING DAMAGED?

Visually inspect delivery hose and tubing for signs of damage. Refer to point to point schematics.

CONDITION/INDICATION

IS DELIVERY HOSE AND TUBING DAMAGED?

DECISION

YES - Replace hose or tubing (Volume 5, WP 0805). Go to Step (6) to verify problem is solved.
NO - Go to Step (2).

ABS - CODE SLW 42 (LEFT SIDE - BLUE CHANNEL) - Continued

STEP

2. IS FRONT RELAY VALVE CONTROL PORT OBSTRUCTED?

Check control port of the front relay valve for obstruction. Refer to point to point schematics.

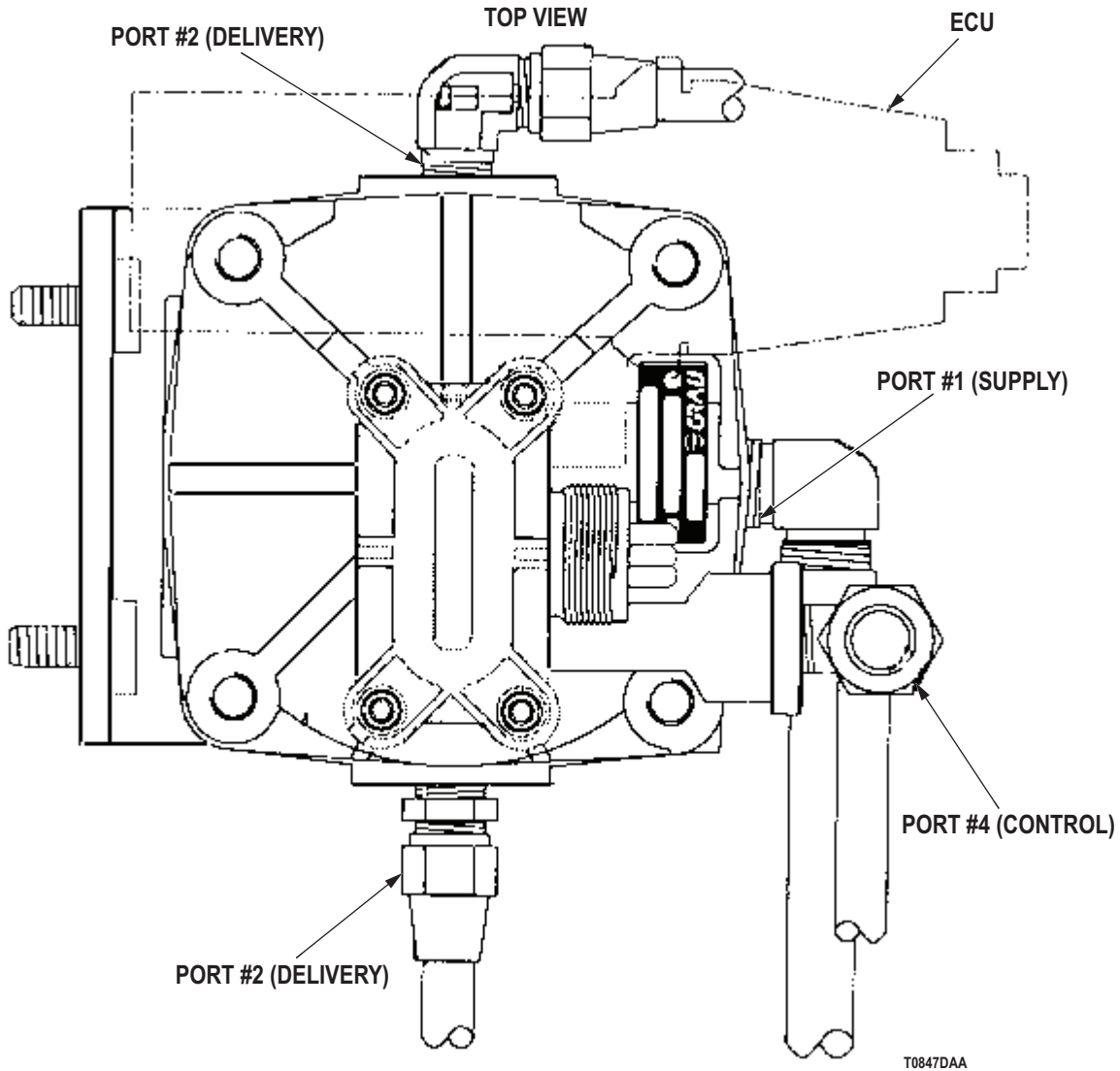

Figure 1. Front Relay Valve.

CONDITION/INDICATION

IS FRONT RELAY VALVE CONTROL PORT OBSTRUCTED?

DECISION

YES - Replace front relay valve (Volume 3, WP 0458). Go to Step (6) to verify problem is solved.
 NO - Go to Step (3).

ABS - CODE SLW 42 (LEFT SIDE - BLUE CHANNEL) - Continued**STEP****3. IS MODULATOR VALVE FAULTY?**

Check modulator valve at front relay valve for proper operation by cycling battery and start switches ON and OFF while listening for modulator valve to cycle. Refer to point to point schematics.

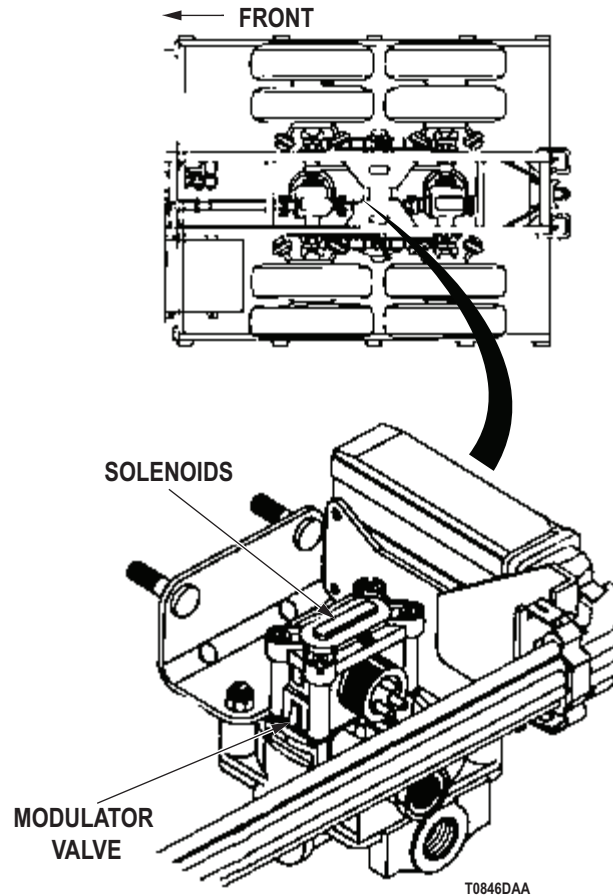

Figure 2. Front Modulator Valve.

CONDITION/INDICATION

IS MODULATOR VALVE FAULTY?

DECISION

YES - Replace front relay valve (Volume 3, WP 0458). Go to Step (6) to verify problem is solved.

YES - Go to Step (4).

ABS - CODE SLW 42 (LEFT SIDE - BLUE CHANNEL) - Continued**STEP**

4. IS PRIMARY AIR SYSTEM OPERATING PROPERLY?

Check for a primary air system fault. Refer to point to point schematics.

CONDITION/INDICATION

IS PRIMARY AIR SYSTEM OPERATING PROPERLY?

DECISION

NO - Perform semi-annual PMCS on air lines and brake chambers (WP 0207).

YES - Go to Step (6) to verify problem is solved.

STEP

5. ARE BRAKES IN PROPER ADJUSTMENT AND WORKING ORDER?

Check brakes for mechanical or adjustment problems (Volume 3, WP 0432).

CONDITION/INDICATION

ARE BRAKES IN PROPER ADJUSTMENT AND WORKING ORDER?

DECISION

NO - Repair or adjust brakes as needed (Volume 3, WP 0432). Go to Step (6) to verify problem is solved.

YES - Notify supervisor. It is possible another troubleshooting work package applies.

STEP

6. IS YOUR ORIGINAL PROBLEM STILL PRESENT?

- a. Ensure vehicle is returned to normal operating condition.
- b. Perform Clear Historical Codes Procedure (WP 0159).
- c. Start vehicle.
- d. Operate vehicle to a speed of 20 miles per hour. Applying brakes several times.
- e. Return vehicle to park position.
- f. Perform ABS - Start- Retrieving Fault Codes With Haldex Info Center (Scan Tool) (WP 0161).
- g. Check to see if your original fault code still exists.

CONDITION/INDICATION

IS YOUR ORIGINAL PROBLEM STILL PRESENT?

DECISION

YES - Notify supervisor.

NO - Problem fixed.

END OF WORK PACKAGE

FIELD MAINTENANCE
ABS - CODE SLW 43 (RIGHT SIDE - YELLOW CHANNEL)

INITIAL SETUP:**Tools and Special Tools**

Tool Kit, General Mechanic's: Automotive
(Volume 5, WP 0826, Table 1, Item 56)
ABS Diagnostic Info Centre (TM 9-2320-272-10)
Test Set, Electronic Systems
(Volume 5, WP 0826, Table 1, Item 51)

References (cont.)

WP 0159
WP 0161
WP 0207
Volume 3, WP 0432
Volume 3, WP 0457
Volume 5, WP 0805

Personnel Required

(2)

Equipment Condition

Vehicle parked and engine shut down.
(TM 9-2320-272-10)

References

Point to Point Schematics

TROUBLESHOOTING PROCEDURE**ABS - CODE SLW 43 (RIGHT SIDE - YELLOW CHANNEL)****STEP**

1. IS DELIVERY HOSE AND TUBING DAMAGED?

Visually inspect delivery hose and tubing for signs of damage. Refer to point to point schematics.

CONDITION/INDICATION

IS DELIVERY HOSE AND TUBING DAMAGED?

DECISION

YES - Replace hose or tubing (Volume 5, WP 0805). Go to Step (6) to verify problem is solved.
NO - Go to Step (2).

ABS - CODE SLW 43 (RIGHT SIDE - YELLOW CHANNEL) - Continued

STEP

2. IS REAR RELAY VALVE CONTROL PORT OBSTRUCTED?

Check control port of the rear relay valve for obstruction. Refer to point to point schematics.

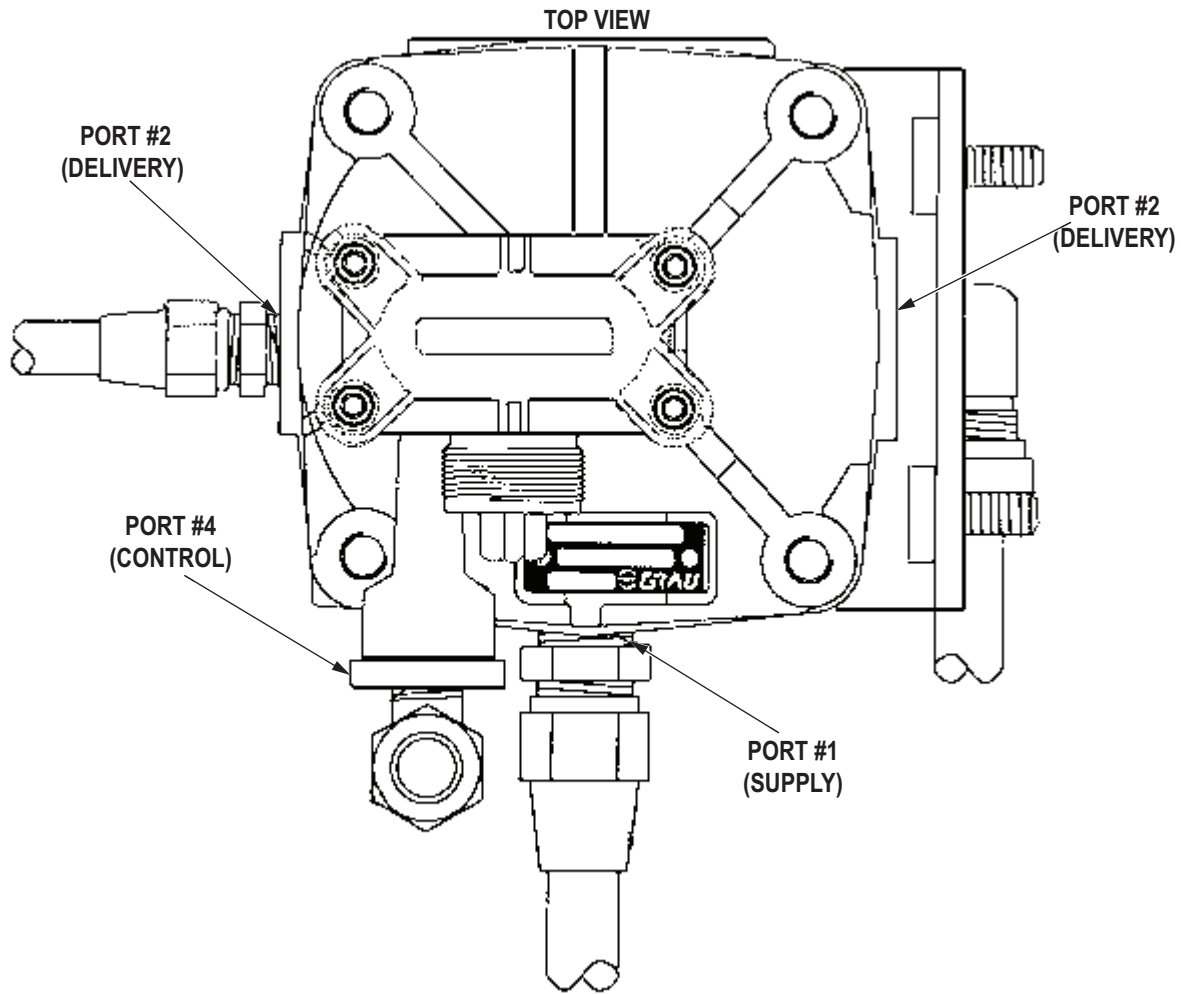

T0848DAA

Figure 1. Rear Relay Valve.

ABS - CODE SLW 43 (RIGHT SIDE - YELLOW CHANNEL) - Continued**CONDITION/INDICATION**

IS REAR RELAY VALVE CONTROL PORT OBSTRUCTED?

DECISION

YES - Replace rear relay valve (Volume 3, WP 0457). Go to Step (6) to verify problem is solved.

NO - Go to Step (3).

ABS - CODE SLW 43 (RIGHT SIDE - YELLOW CHANNEL) - Continued

STEP

3. IS MODULATOR VALVE FAULTY?

Check modulator valve at rear relay valve for proper operation by cycling battery and start switches ON and OFF while listening for modulator valve to cycle. Refer to point to point schematics.

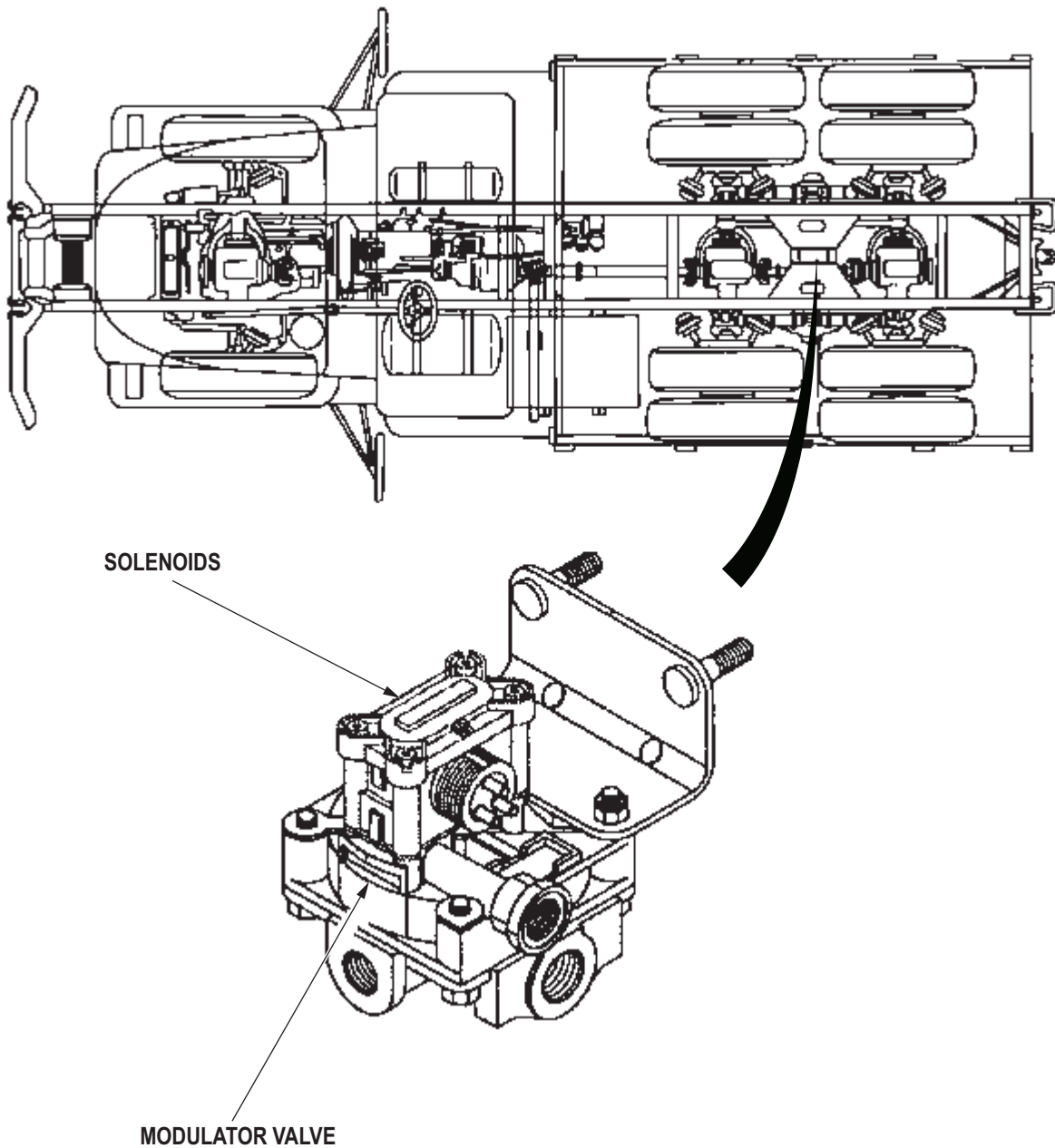

Figure 2. Rear Modulator Valve.

ABS - CODE SLW 43 (RIGHT SIDE - YELLOW CHANNEL) - Continued**CONDITION/INDICATION**

IS MODULATOR VALVE FAULTY?

DECISION

YES - Replace rear relay valve (Volume 3, WP 0457). Go to Step (6) to verify problem is solved.

YES - Go to Step (4).

STEP**4. IS PRIMARY AIR SYSTEM OPERATING PROPERLY?**

Check for a primary air system fault. Refer to point to point schematics.

CONDITION/INDICATION

IS PRIMARY AIR SYSTEM OPERATING PROPERLY?

DECISION

NO - Perform semi-annual PMCS on air lines and brake chambers (WP 0207).

YES - Go to Step (6) to verify problem is solved.

STEP**5. ARE BRAKES IN PROPER ADJUSTMENT AND WORKING ORDER?**

Check brakes for mechanical or adjustment problems (Volume 3, WP 0432).

CONDITION/INDICATION

ARE BRAKES IN PROPER ADJUSTMENT AND WORKING ORDER?

DECISION

NO - Repair or adjust brakes as needed (Volume 3, WP 0432). Go to Step (6) to verify problem is solved.

YES - Notify supervisor. It is possible another troubleshooting work package applies.

ABS - CODE SLW 43 (RIGHT SIDE - YELLOW CHANNEL) - Continued**STEP**

6. IS YOUR ORIGINAL PROBLEM STILL PRESENT?
 - a. Ensure vehicle is returned to normal operating condition.
 - b. Perform Clear Historical Codes Procedure (WP 0159).
 - c. Start vehicle.
 - d. Operate vehicle to a speed of 20 miles per hour. Applying brakes several times.
 - e. Return vehicle to park position.
 - f. Perform ABS - Start- Retrieving Fault Codes With Haldex Info Center (Scan Tool) (WP 0161).
 - g. Check to see if your original fault code still exists.

CONDITION/INDICATION

IS YOUR ORIGINAL PROBLEM STILL PRESENT?

DECISION

YES - Notify supervisor.
NO - Problem fixed.

END OF WORK PACKAGE

FIELD MAINTENANCE
ABS - CODE BUHD 62 (LEFT SIDE - BLUE CHANNEL)

INITIAL SETUP:**Tools and Special Tools**

Tool Kit, General Mechanic's: Automotive
(Volume 5, WP 0826, Table 1, Item 56)
ABS Diagnostic Info Centre (TM 9-2320-272-10)
Multimeter
(Volume 5, WP 0826, Table 1, Item 34)
Test Set, Electronic Systems
(Volume 5, WP 0826, Table 1, Item 51)

Personnel Required

(2)

References

Point to Point Schematics

References (cont.)

WP 0159
WP 0161
Volume 3, WP 0452
Volume 3, WP 0458
Volume 3, WP 0467

Equipment Condition

Vehicle parked and engine shut down.
(TM 9-2320-272-10)

TROUBLESHOOTING PROCEDURE

ABS - CODE BUHd 62 (LEFT SIDE - BLUE CHANNEL)

STEP

1. DOES AN OPEN CIRCUIT EXIST IN THE LEFT (BLUE), HOLD SOLENOID OR CABLE?
 - a. Ensure battery and start switches are in the OFF position.
 - b. Ensure main wiring harness 28 pin connector is properly connected and fully seated.

FRONT RELAY VALVE WITH ECU (BLUE CHANNEL)

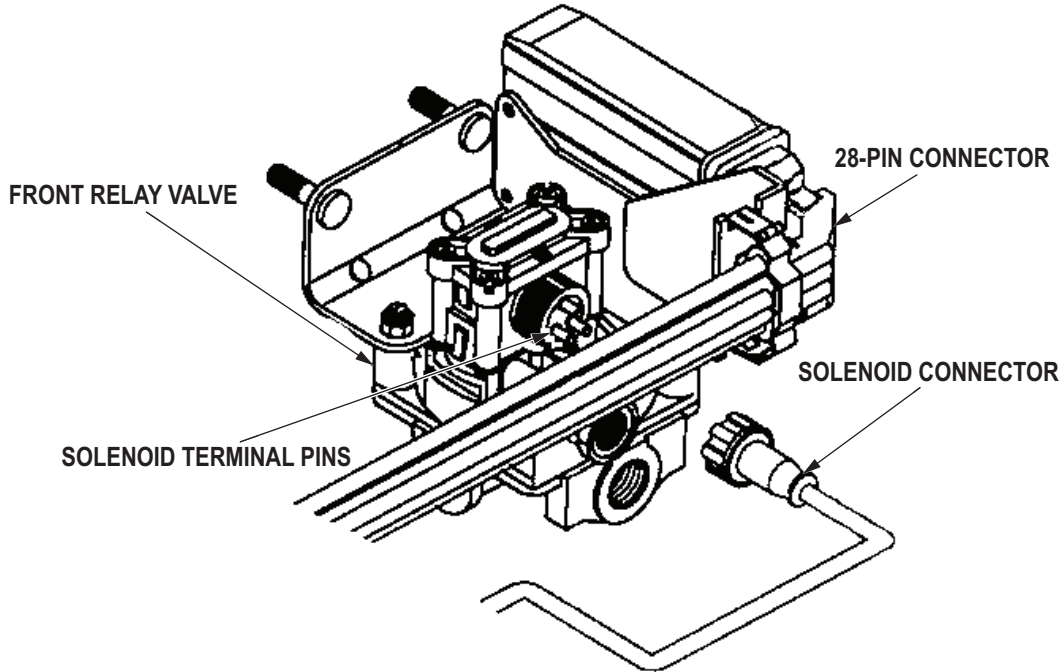

RESISTANCE VALUES - SOLENOID TERMINAL PINS

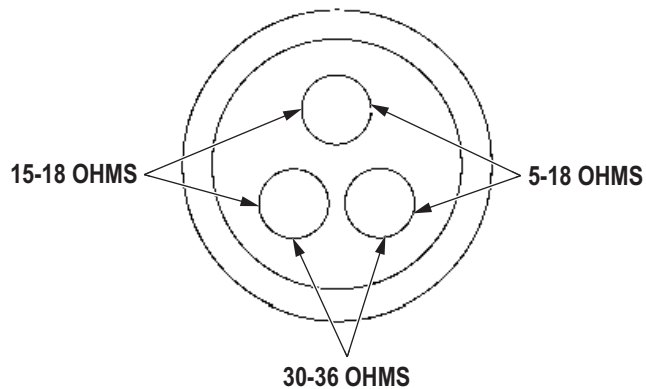

T0856DAA

Figure 1. Front Relay Valve Solenoid Connector.

ABS - CODE BUHd 62 (LEFT SIDE - BLUE CHANNEL) - Continued

- c. Disconnect solenoid connector at front relay valve.
- d. Set multimeter to measure resistance.
- e. Connect multimeter red lead to solenoid connector bottom terminal. Refer to point to point schematics.
- f. Connect multimeter black lead to solenoid connector other bottom terminal.
- g. Meter reading should be between 30 and 36 ohms. Note reading.
- h. Repeat measurements between solenoid connector top solenoid and each of the bottom terminals.
- i. Meter reading should be 16 ohms. Note readings.

CONDITION/INDICATION

DOES AN OPEN CIRCUIT EXIST IN THE LEFT (BLUE), HOLD SOLENOID OR CABLE?

DECISION

YES - Replace front relay valve (Volume 3, WP 0458). Go to Step (4) to verify problem is solved.
NO - Go to Step (2).

STEP

2. IS THE HOLD SOLENOID CABLE CONNECTOR DAMAGED OR CORRODED?
 - a. Ensure battery and start switches are in the OFF position.

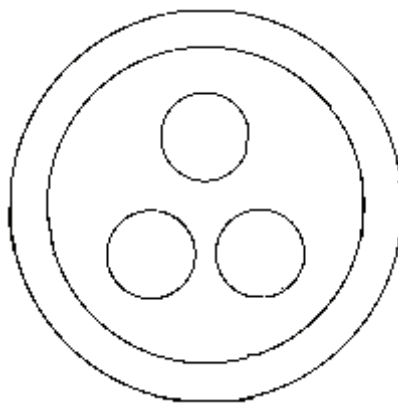

SOLENOID CONNECTOR TERMINALS

T0858DAA

Figure 2. Front Relay Valve Solenoid Connector.

- b. Check hold solenoid cable connector female terminals for excessive pin spread or corrosion. Refer to point to point schematics.

CONDITION/INDICATION

IS THE HOLD SOLENOID CABLE CONNECTOR DAMAGED OR CORRODED?

DECISION

YES - Replace ABS wiring harness (Volume 3, WP 0467). Go to Step (4) to verify problem is solved.
NO - Go to Step (3).

ABS - CODE BUHd 62 (LEFT SIDE - BLUE CHANNEL) - Continued

STEP

3. IS THE MAIN WIRING HARNESS OK?
 - a. Ensure battery and start switches are in the OFF position.
 - b. Connect hold solenoid cable connector at front relay valve.

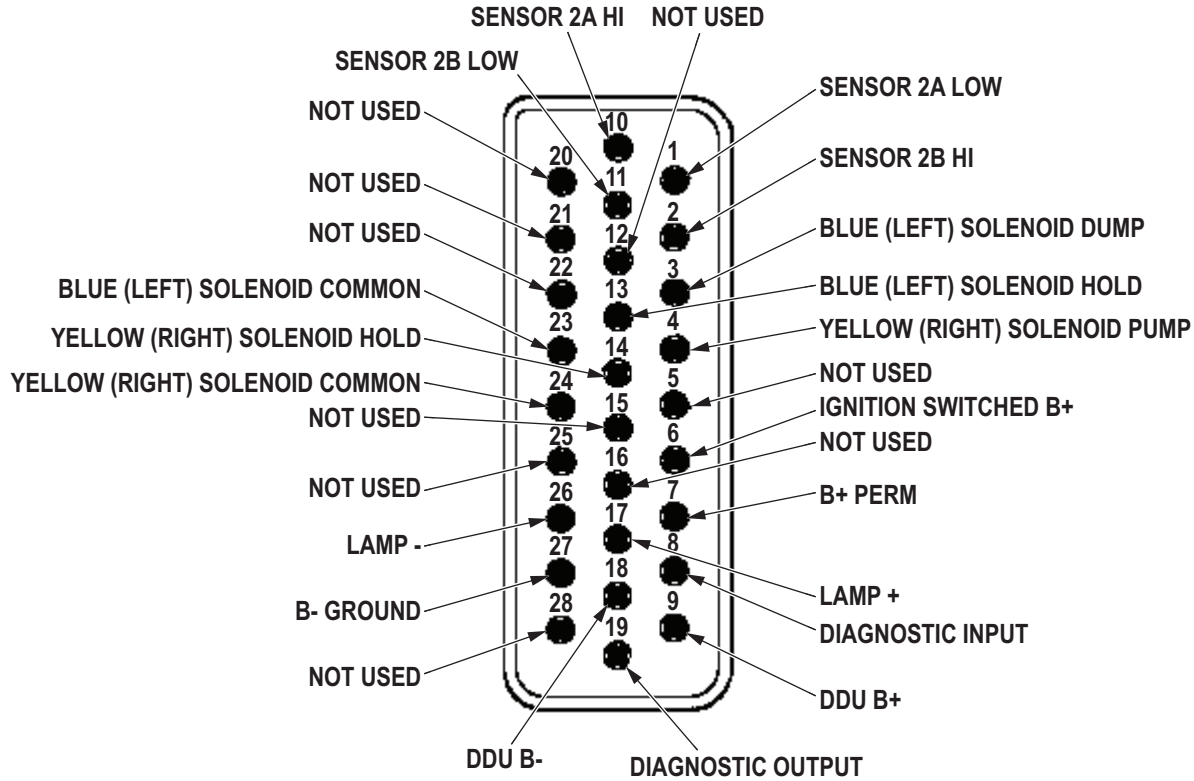

T0949DAA

Figure 3. ABS Wiring Harness 28-pin ECU Connector.

- c. Disconnect main 28-pin connector at ECU (Volume 3, WP 0452).
- d. Connect multimeter red lead to 28-pin connector, terminal 3. Refer to point to point schematics.
- e. Connect multimeter black lead to 28-pin connector, terminal 13.
- f. Meter reading should be between 30 and 36 ohms. Note reading.
- g. Connect multimeter red lead to 28-pin connector, terminal 3.
- h. Connect multimeter black lead to 28-pin connector, terminal 23.
- i. Meter reading should be between 15 and 18 ohms. Note reading.
- j. Connect multimeter red lead to 28-pin connector, terminal 13.
- k. Connect multimeter black lead to 28-pin connector, terminal 23.
- l. Meter reading should be between 15 and 18 ohms. Note reading.

ABS - CODE BUHd 62 (LEFT SIDE - BLUE CHANNEL) - Continued**CONDITION/INDICATION**

IS THE MAIN WIRING HARNESS OK?

DECISION

NO - Replace ABS wiring harness (Volume 3, WP 0467). Go to Step (4) to verify problem is solved.

YES - Replace ABS ECU (Volume 3, WP 0452). Go to Step (4) to verify problem is solved.

STEP**4. IS YOUR ORIGINAL PROBLEM STILL PRESENT?**

- a. If disconnected, connect main harness 28-pin connector at ECU. Listen for locks to "click" in place to ensure a sound connection.
- b. Ensure vehicle is returned to normal operating condition.
- c. Perform Clear Historical Codes Procedure (WP 0159).
- d. Start vehicle.
- e. Operate vehicle to a speed of 20 miles per hour. Applying brakes several times.
- f. Return vehicle to park position.
- g. Perform ABS - Start- Retrieving Fault Codes With Haldex Info Center (Scan Tool) (WP 0161).
- h. Check to see if your original fault code still exists.

CONDITION/INDICATION

IS YOUR ORIGINAL PROBLEM STILL PRESENT?

DECISION

YES - Notify supervisor.

NO - Problem fixed.

END OF WORK PACKAGE

FIELD MAINTENANCE
ABS - CODE YEHD 63 (RIGHT SIDE - YELLOW CHANNEL)

INITIAL SETUP:**Tools and Special Tools**

Tool Kit, General Mechanic's: Automotive
(Volume 5, WP 0826, Table 1, Item 56)
ABS Diagnostic Info Centre (TM 9-2320-272-10)
Multimeter
(Volume 5, WP 0826, Table 1, Item 34)
Test Set, Electronic Systems
(Volume 5, WP 0826, Table 1, Item 51)

Personnel Required

(2)

References

Point to Point Schematics

References (cont.)

WP 0159
WP 0161
Volume 3, WP 0452
Volume 3, WP 0457
Volume 3, WP 0467

Equipment Condition

Vehicle parked and engine shut down.
(TM 9-2320-272-10)

TROUBLESHOOTING PROCEDURE

ABS - CODE YEHd 63 (RIGHT SIDE - YELLOW CHANNEL)

STEP

1. DOES AN OPEN CIRCUIT EXIST IN THE RIGHT (YELLOW), HOLD SOLENOID OR CABLE?
 - a. Ensure battery and start switches are in the OFF position.
 - b. Ensure main wiring harness 28 pin connector is properly connected and fully seated.

REAR RELAY VALVE (YELLOW CHANNEL)

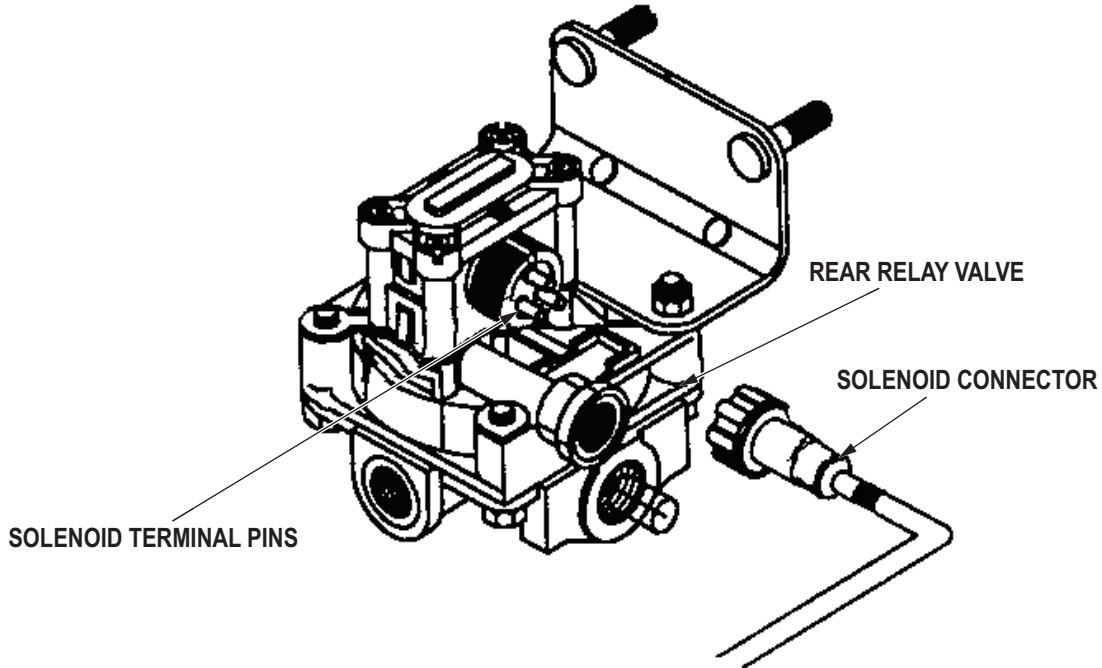

RESISTANCE VALUES - SOLENOID TERMINAL PINS

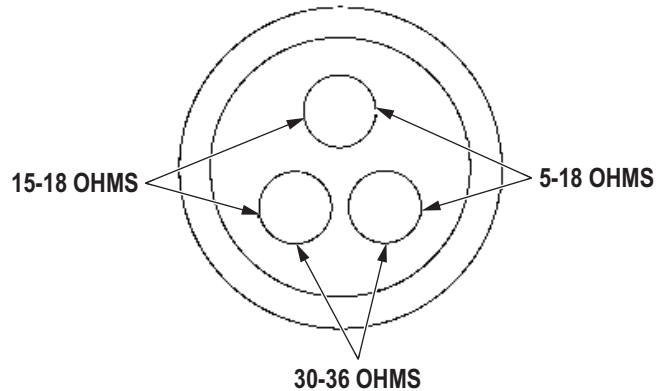

T0857DAA

Figure 1. Rear Relay Valve Solenoid Connector.

- c. Disconnect solenoid connector at rear relay valve.
- d. Set multimeter to measure resistance.

ABS - CODE YEHd 63 (RIGHT SIDE - YELLOW CHANNEL) - Continued

- e. Connect multimeter red lead to solenoid connector bottom terminal. Refer to point to point schematics.
- f. Connect multimeter black lead to solenoid connector other bottom terminal.
- g. Meter reading should be between 30 and 36 ohms. Note reading.
- h. Repeat measurements between solenoid connector top solenoid and each of the bottom terminals.
- i. Meter reading should be 16 ohms. Note readings.

CONDITION/INDICATION

DOES AN OPEN CIRCUIT EXIST IN THE RIGHT (YELLOW), HOLD SOLENOID OR CABLE?

DECISION

YES - Replace rear relay valve (Volume 3, WP 0457). Go to Step (4) to verify problem is solved.
 NO - Go to Step (2).

STEP

2. IS THE HOLD SOLENOID CABLE CONNECTOR DAMAGED OR CORRODED?
 - a. Ensure battery and start switches are in the OFF position.

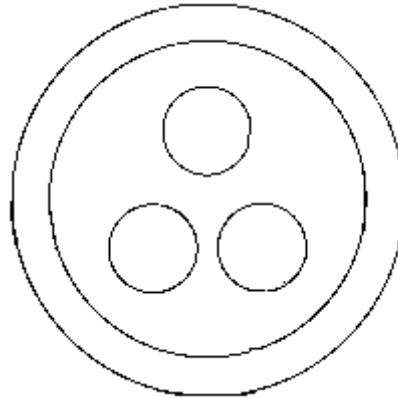

SOLENOID CONNECTOR TERMINALS

T0971DAA

Figure 2. Rear Relay Valve Solenoid Connector.

- b. Check hold solenoid cable connector female terminals for excessive pin spread or corrosion. Refer to point to point schematics.

CONDITION/INDICATION

IS THE HOLD SOLENOID CABLE CONNECTOR DAMAGED OR CORRODED?

DECISION

YES - Replace ABS wiring harness (Volume 3, WP 0467). Go to Step (4) to verify problem is solved.
 NO - Go to Step (3).

ABS - CODE YEHd 63 (RIGHT SIDE - YELLOW CHANNEL) - Continued

STEP

3. IS THE MAIN WIRING HARNESS OK?
 - a. Ensure battery and start switches are in the OFF position.
 - b. Connect hold solenoid cable connector at front relay valve.

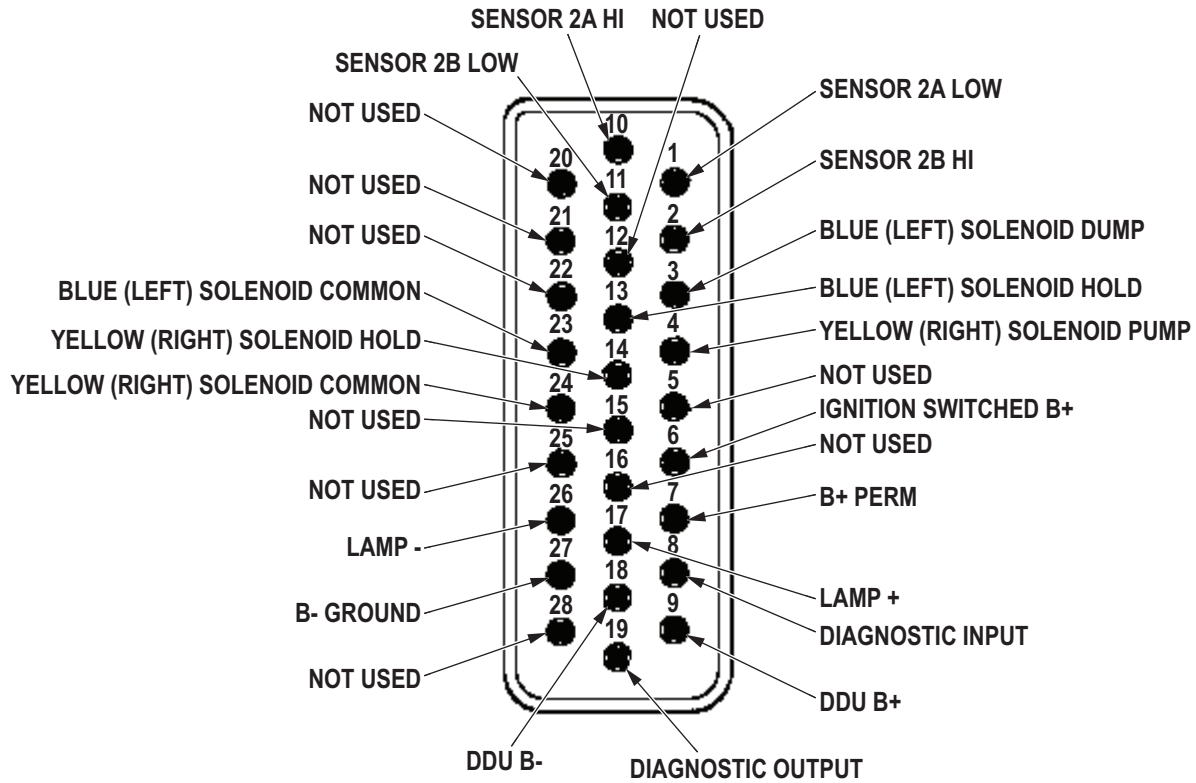

T0950DAA

Figure 3. ABS Wiring Harness 28-pin ECU Connector.

- c. Disconnect main 28-pin connector at ECU (Volume 3, WP 0452).
- d. Connect multimeter red lead to 28-pin connector, terminal 4. Refer to point to point schematics.
- e. Connect multimeter black lead to 28-pin connector, terminal 14.
- f. Meter reading should be between 30 and 36 ohms. Note reading.
- g. Connect multimeter red lead to 28-pin connector, terminal 4.
- h. Connect multimeter black lead to 28-pin connector, terminal 24.
- i. Meter reading should be between 15 and 18 ohms. Note reading.
- j. Connect multimeter red lead to 28-pin connector, terminal 14.
- k. Connect multimeter black lead to 28-pin connector, terminal 24.
- l. Meter reading should be between 15 and 18 ohms. Note reading.

ABS - CODE YEHd 63 (RIGHT SIDE - YELLOW CHANNEL) - Continued**CONDITION/INDICATION**

IS THE MAIN WIRING HARNESS OK?

DECISION

NO - Replace ABS wiring harness (Volume 3, WP 0467). Go to Step (4) to verify problem is solved.

YES - Replace ABS ECU (Volume 3, WP 0452). Go to Step (4) to verify problem is solved.

STEP**4. IS YOUR ORIGINAL PROBLEM STILL PRESENT?**

- a. If disconnected, connect main harness 28-pin connector at ECU. Listen for locks to "click" in place to ensure a sound connection.
- b. Ensure vehicle is returned to normal operating condition.
- c. Perform Clear Historical Codes Procedure (WP 0159).
- d. Start vehicle.
- e. Operate vehicle to a speed of 20 miles per hour. Applying brakes several times.
- f. Return vehicle to park position.
- g. Perform ABS - Start- Retrieving Fault Codes With Haldex Info Center (Scan Tool) (WP 0161).
- h. Check to see if your original fault code still exists.

CONDITION/INDICATION

IS YOUR ORIGINAL PROBLEM STILL PRESENT?

DECISION

YES - Notify supervisor.

NO - Problem fixed.

END OF WORK PACKAGE

FIELD MAINTENANCE
ABS - CODE BUDU 68 (LEFT SIDE - BLUE CHANNEL)

INITIAL SETUP:**Tools and Special Tools**

Tool Kit, General Mechanic's: Automotive
(Volume 5, WP 0826, Table 1, Item 56)
ABS Diagnostic Info Centre (TM 9-2320-272-10)
Multimeter
(Volume 5, WP 0826, Table 1, Item 34)
Test Set, Electronic Systems
(Volume 5, WP 0826, Table 1, Item 51)

Personnel Required

(2)

References

Point to Point Schematics

References (cont.)

WP 0159
WP 0161
Volume 3, WP 0452
Volume 3, WP 0458
Volume 3, WP 0467

Equipment Condition

Vehicle parked and engine shut down.
(TM 9-2320-272-10)

TROUBLESHOOTING PROCEDURE

ABS - CODE BUDU 68 (LEFT SIDE - BLUE CHANNEL)

STEP

1. DOES AN OPEN CIRCUIT EXIST IN THE LEFT (BLUE), DUMP SOLENOID OR CABLE?
 - a. Ensure battery and start switches are in the OFF position.
 - b. Ensure main wiring harness 28 pin connector is properly connected and fully seated.

FRONT RELAY VALVE WITH ECU (BLUE CHANNEL)

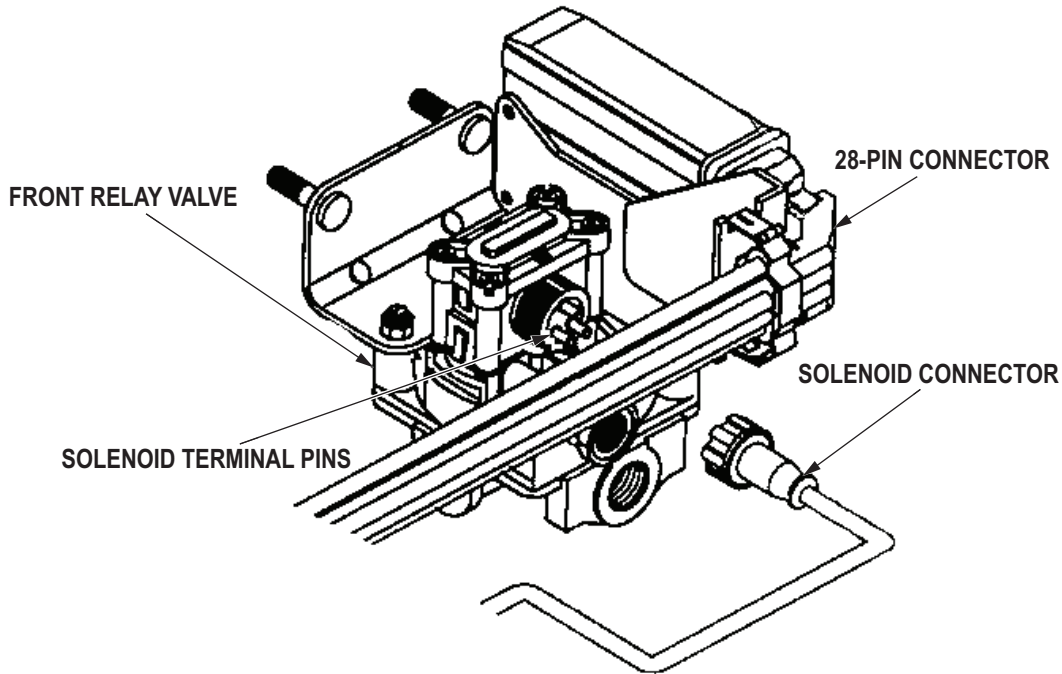

RESISTANCE VALUES - SOLENOID TERMINAL PINS

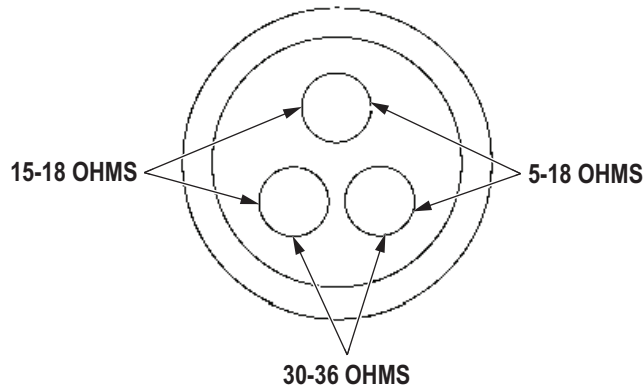

T0961DAA

Figure 1. Front Relay Valve Solenoid Connector.

- c. Disconnect solenoid connector at front relay valve.
- d. Set multimeter to measure resistance.

ABS - CODE BUDU 68 (LEFT SIDE - BLUE CHANNEL) - Continued

- e. Connect multimeter red lead to solenoid connector bottom terminal. Refer to point to point schematics.
- f. Connect multimeter black lead to solenoid connector other bottom terminal.
- g. Meter reading should be between 30 and 36 ohms. Note reading.
- h. Repeat measurements between solenoid connector top solenoid and each of the bottom terminals.
- i. Meter reading should be 16 ohms. Note readings.

CONDITION/INDICATION

DOES AN OPEN CIRCUIT EXIST IN THE LEFT (BLUE), DUMP SOLENOID OR CABLE?

DECISION

YES - Replace front relay valve (Volume 3, WP 0458). Go to Step (4) to verify problem is solved.
 NO - Go to Step (2).

STEP

2. IS THE DUMP SOLENOID CABLE CONNECTOR DAMAGED OR CORRODED?
 - a. Ensure battery and start switches are in the OFF position.

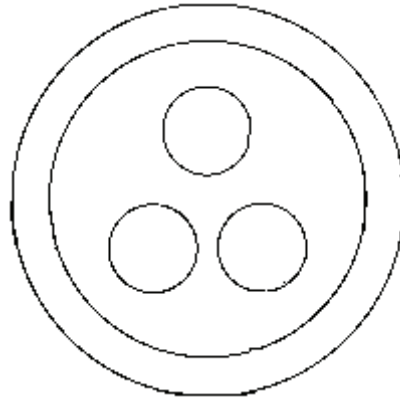

SOLENOID CONNECTOR TERMINALS

T0972DAA

Figure 2. Front Relay Valve Solenoid Connector.

- b. Check dump solenoid cable connector female terminals for excessive pin spread or corrosion. Refer to point to point schematics.

CONDITION/INDICATION

IS THE DUMP SOLENOID CABLE CONNECTOR DAMAGED OR CORRODED?

DECISION

YES - Replace ABS wiring harness (Volume 3, WP 0467). Go to Step (4) to verify problem is solved.
 NO - Go to Step (3).

ABS - CODE BUDU 68 (LEFT SIDE - BLUE CHANNEL) - Continued

STEP

3. IS THE MAIN WIRING HARNESS OK?
 - a. Ensure battery and start switches are in the OFF position.
 - b. Connect dump solenoid cable connector at front relay valve.

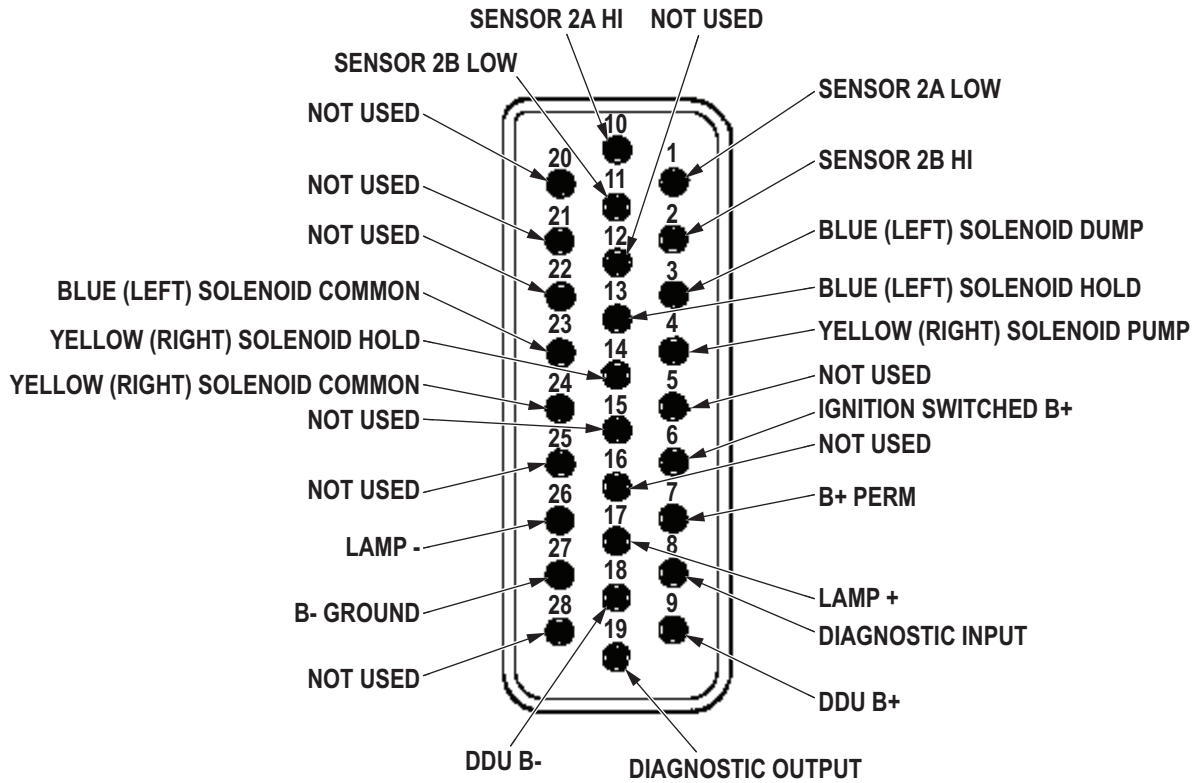

T1060DAA

Figure 3. ABS Wiring Harness 28-pin ECU Connector.

- c. Disconnect main 28-pin connector at ECU (Volume 3, WP 0452).
- d. Connect multimeter red lead to 28-pin connector, terminal 3. Refer to point to point schematics.
- e. Connect multimeter black lead to 28-pin connector, terminal 13.
- f. Meter reading should be between 30 and 36 ohms. Note reading.
- g. Connect multimeter red lead to 28-pin connector, terminal 3.
- h. Connect multimeter black lead to 28-pin connector, terminal 23.
- i. Meter reading should be between 15 and 18 ohms. Note reading.
- j. Connect multimeter red lead to 28-pin connector, terminal 13.
- k. Connect multimeter black lead to 28-pin connector, terminal 23.
- l. Meter reading should be between 15 and 18 ohms. Note reading.

ABS - CODE BUDU 68 (LEFT SIDE - BLUE CHANNEL) - Continued**CONDITION/INDICATION**

IS THE MAIN WIRING HARNESS OK?

DECISION

NO - Replace ABS wiring harness (Volume 3, WP 0467). Go to Step (4) to verify problem is solved.

YES - Replace ABS ECU (Volume 3, WP 0452). Go to Step (4) to verify problem is solved.

STEP**4. IS YOUR ORIGINAL PROBLEM STILL PRESENT?**

- a. If disconnected, connect main harness 28-pin connector at ECU. Listen for locks to "click" in place to ensure a sound connection.
- b. Ensure vehicle is returned to normal operating condition.
- c. Perform Clear Historical Codes Procedure (WP 0159).
- d. Start vehicle.
- e. Operate vehicle to a speed of 20 miles per hour. Applying brakes several times.
- f. Return vehicle to park position.
- g. Perform ABS - Start- Retrieving Fault Codes With Haldex Info Center (Scan Tool) (WP 0161).
- h. Check to see if your original fault code still exists.

CONDITION/INDICATION

IS YOUR ORIGINAL PROBLEM STILL PRESENT?

DECISION

YES - Notify supervisor.

NO - Problem fixed.

END OF WORK PACKAGE

FIELD MAINTENANCE
ABS - CODE YEDU 69 (RIGHT SIDE - YELLOW CHANNEL)

INITIAL SETUP:**Tools and Special Tools**

Tool Kit, General Mechanic's: Automotive
(Volume 5, WP 0826, Table 1, Item 56)
ABS Diagnostic Info Centre (TM 9-2320-272-10)
Multimeter
(Volume 5, WP 0826, Table 1, Item 34)
Test Set, Electronic Systems
(Volume 5, WP 0826, Table 1, Item 51)

Personnel Required

(2)

References

Point to Point Schematics

References (cont.)

WP 0159
WP 0161
Volume 3, WP 0452
Volume 3, WP 0457
Volume 3, WP 0467

Equipment Condition

Vehicle parked and engine shut down.
(TM 9-2320-272-10)

TROUBLESHOOTING PROCEDURE

ABS - CODE YEDU 69 (RIGHT SIDE - YELLOW CHANNEL)

STEP

1. DOES AN OPEN CIRCUIT EXIST IN THE RIGHT (YELLOW), DUMP SOLENOID OR CABLE?
 - a. Ensure battery and start switches are in the OFF position.
 - b. Ensure main wiring harness 28 pin connector is properly connected and fully seated.

REAR RELAY VALVE (YELLOW CHANNEL)

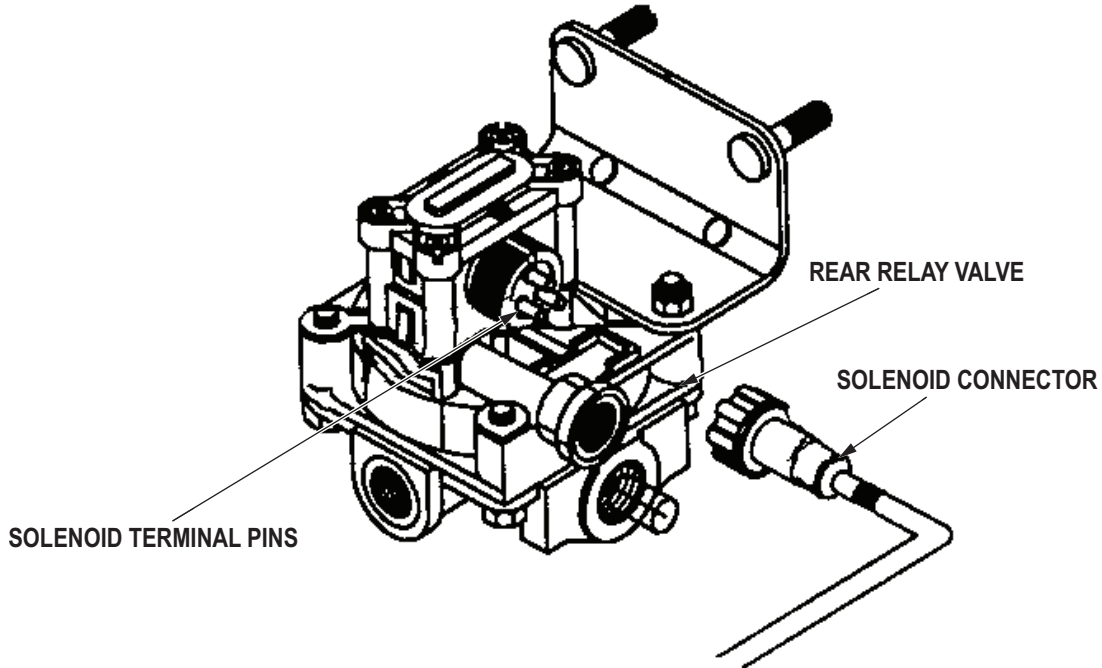

RESISTANCE VALUES - SOLENOID TERMINAL PINS

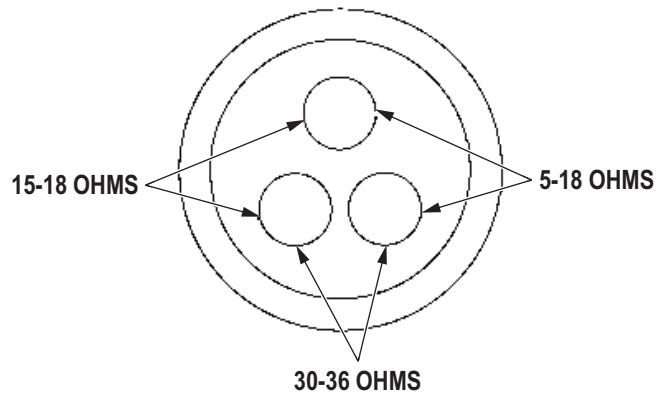

T0966DAA

Figure 1. Rear Relay Valve Solenoid Connector.

- c. Disconnect solenoid connector at rear relay valve.
- d. Set multimeter to measure resistance.

ABS - CODE YEDU 69 (RIGHT SIDE - YELLOW CHANNEL) - Continued

- e. Connect multimeter red lead to solenoid connector bottom terminal. Refer to point to point schematics.
- f. Connect multimeter black lead to solenoid connector other bottom terminal.
- g. Meter reading should be between 30 and 36 ohms. Note reading.
- h. Repeat measurements between solenoid connector top solenoid and each of the bottom terminals.
- i. Meter reading should be 16 ohms. Note readings.

CONDITION/INDICATION

DOES AN OPEN CIRCUIT EXIST IN THE RIGHT (YELLOW), DUMP SOLENOID OR CABLE?

DECISION

YES - Replace rear relay valve (Volume 3, WP 0457). Go to Step (4) to verify problem is solved.
NO - Go to Step (2).

STEP

- 2. IS THE DUMP SOLENOID CABLE CONNECTOR DAMAGED OR CORRODED?
 - a. Ensure battery and start switches are in the OFF position.

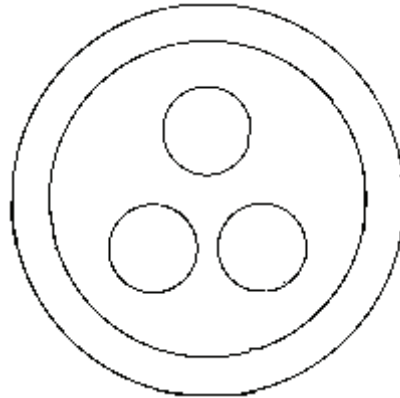

SOLENOID CONNECTOR TERMINALS

T0973DAA

Figure 2. Rear Relay Valve Solenoid Connector.

- b. Check dump solenoid cable connector female terminals for excessive pin spread or corrosion. Refer to point to point schematics.

CONDITION/INDICATION

IS THE DUMP SOLENOID CABLE CONNECTOR DAMAGED OR CORRODED?

DECISION

YES - Replace ABS wiring harness (Volume 3, WP 0467). Go to Step (4) to verify problem is solved.
NO - Go to Step (3).

ABS - CODE YEDU 69 (RIGHT SIDE - YELLOW CHANNEL) - Continued

STEP

3. IS THE MAIN WIRING HARNESS OK?
 - a. Ensure battery and start switches are in the OFF position.
 - b. Connect dump solenoid cable connector at front relay valve.

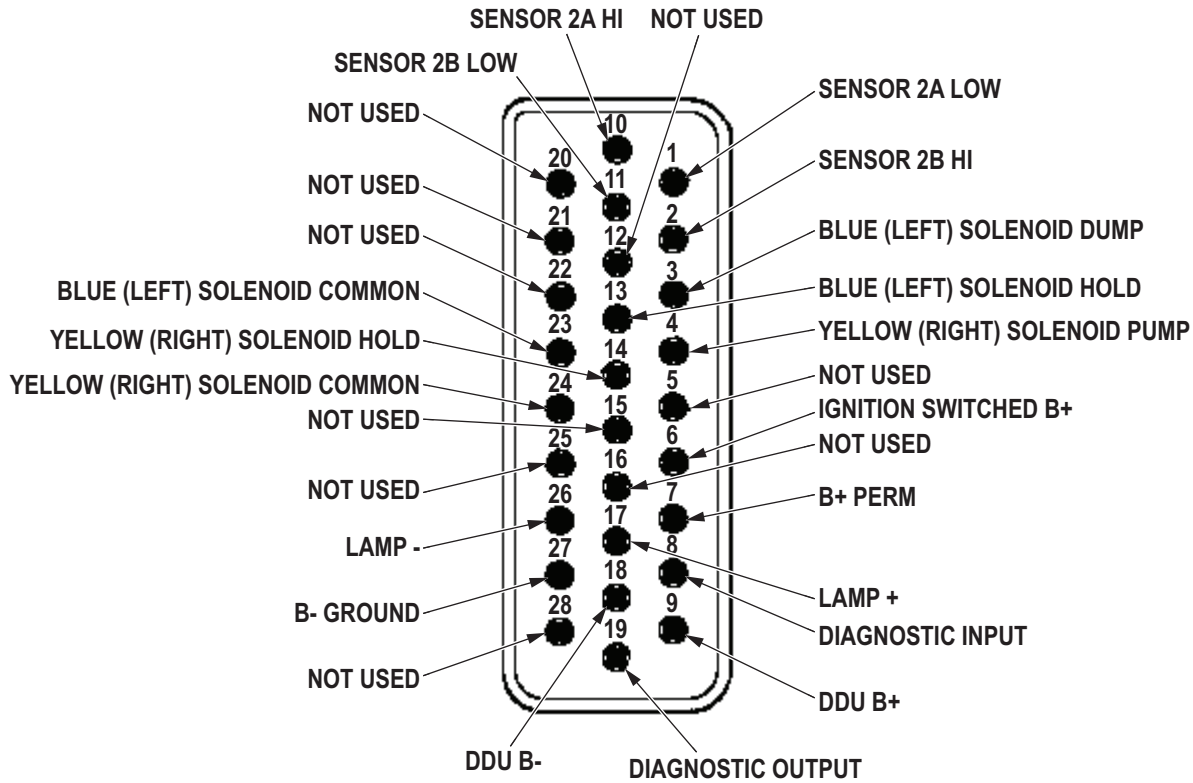

T0951DAA

Figure 3. ABS Wiring Harness 28-pin ECU Connector.

- c. Disconnect main 28-pin connector at ECU (Volume 3, WP 0452).
- d. Connect multimeter red lead to 28-pin connector, terminal 4. Refer to point to point schematics.
- e. Connect multimeter black lead to 28-pin connector, terminal 14.
- f. Meter reading should be between 30 and 36 ohms. Note reading.
- g. Connect multimeter red lead to 28-pin connector, terminal 4.
- h. Connect multimeter black lead to 28-pin connector, terminal 24.
- i. Meter reading should be between 15 and 18 ohms. Note reading.
- j. Connect multimeter red lead to 28-pin connector, terminal 14.
- k. Connect multimeter black lead to 28-pin connector, terminal 24.
- l. Meter reading should be between 15 and 18 ohms. Note reading.

ABS - CODE YEDU 69 (RIGHT SIDE - YELLOW CHANNEL) - Continued**CONDITION/INDICATION**

IS THE MAIN WIRING HARNESS OK?

DECISION

NO - Replace ABS wiring harness (Volume 3, WP 0467). Go to Step (4) to verify problem is solved.

YES - Replace ABS ECU (Volume 3, WP 0452). Go to Step (4) to verify problem is solved.

STEP**4. IS YOUR ORIGINAL PROBLEM STILL PRESENT?**

- a. If disconnected, connect main harness 28-pin connector at ECU. Listen for locks to "click" in place to ensure a sound connection.
- b. Ensure vehicle is returned to normal operating condition.
- c. Perform Clear Historical Codes Procedure (WP 0159).
- d. Start vehicle.
- e. Operate vehicle to a speed of 20 miles per hour. Applying brakes several times.
- f. Return vehicle to park position.
- g. Perform ABS - Start- Retrieving Fault Codes With Haldex Info Center (Scan Tool) (WP 0161).
- h. Check to see if your original fault code still exists.

CONDITION/INDICATION

IS YOUR ORIGINAL PROBLEM STILL PRESENT?

DECISION

YES - Notify supervisor.

NO - Problem fixed.

END OF WORK PACKAGE

FIELD MAINTENANCE
ABS - CODE BUHD 72 (LEFT SIDE - BLUE CHANNEL)

INITIAL SETUP:**Tools and Special Tools**

Tool Kit, General Mechanic's: Automotive
(Volume 5, WP 0826, Table 1, Item 56)
ABS Diagnostic Info Centre (TM 9-2320-272-10)
Multimeter
(Volume 5, WP 0826, Table 1, Item 34)
Test Set, Electronic Systems
(Volume 5, WP 0826, Table 1, Item 51)

Personnel Required

(2)

References

Point to Point Schematics

References (cont.)

WP 0159
WP 0161
Volume 3, WP 0452
Volume 3, WP 0458
Volume 3, WP 0467

Equipment Condition

Vehicle parked and engine shut down.
(TM 9-2320-272-10)

TROUBLESHOOTING PROCEDURE

ABS - CODE BUHd 72 (LEFT SIDE - BLUE CHANNEL)

STEP

1. DOES A SHORT CIRCUIT TO GROUND EXIST IN THE LEFT (BLUE), HOLD SOLENOID?
 - a. Ensure battery and start switches are in the OFF position.
 - b. Ensure main wiring harness 28 pin connector is properly connected and fully seated.

FRONT RELAY VALVE WITH ECU (BLUE CHANNEL)

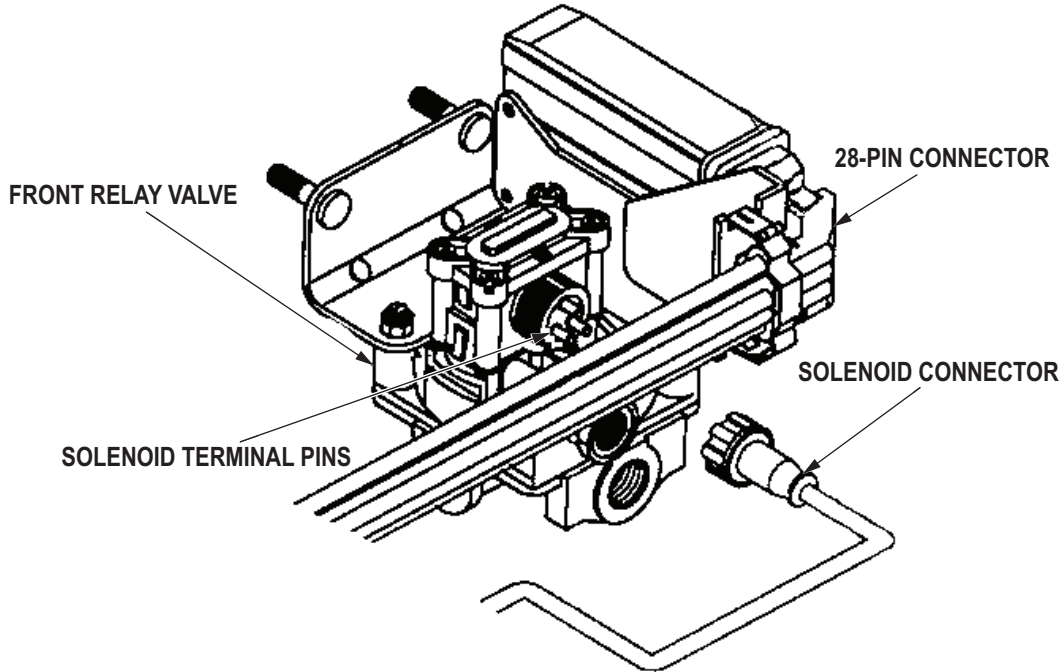

RESISTANCE VALUES - SOLENOID TERMINAL PINS

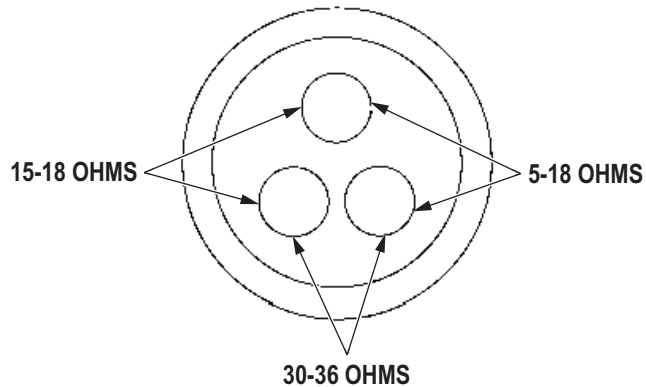

T0962DAA

Figure 1. Front Relay Valve Solenoid Connector.

ABS - CODE BUHd 72 (LEFT SIDE - BLUE CHANNEL) - Continued

- c. Disconnect solenoid connector at front relay valve.
- d. Set multimeter to measure resistance.
- e. Connect multimeter red lead to solenoid connector bottom terminal. Refer to point to point schematics.
- f. Connect multimeter black lead to solenoid connector other bottom terminal.
- g. Meter reading should be between 30 and 36 ohms. Note reading.
- h. Repeat measurements between solenoid connector top solenoid and each of the bottom terminals.
- i. Meter reading should be 16 ohms. Note readings.

CONDITION/INDICATION

DOES A SHORT CIRCUIT TO GROUND EXIST IN THE LEFT (BLUE), HOLD SOLENOID?

DECISION

YES - Replace front relay valve (Volume 3, WP 0458). Go to Step (3) to verify problem is solved.
NO - Go to Step (2).

ABS - CODE BUHd 72 (LEFT SIDE - BLUE CHANNEL) - Continued

STEP

2. DOES A SHORT CIRCUIT TO GROUND EXIST IN THE HOLD CIRCUIT?

- a. Ensure battery and start switches are in the OFF position.

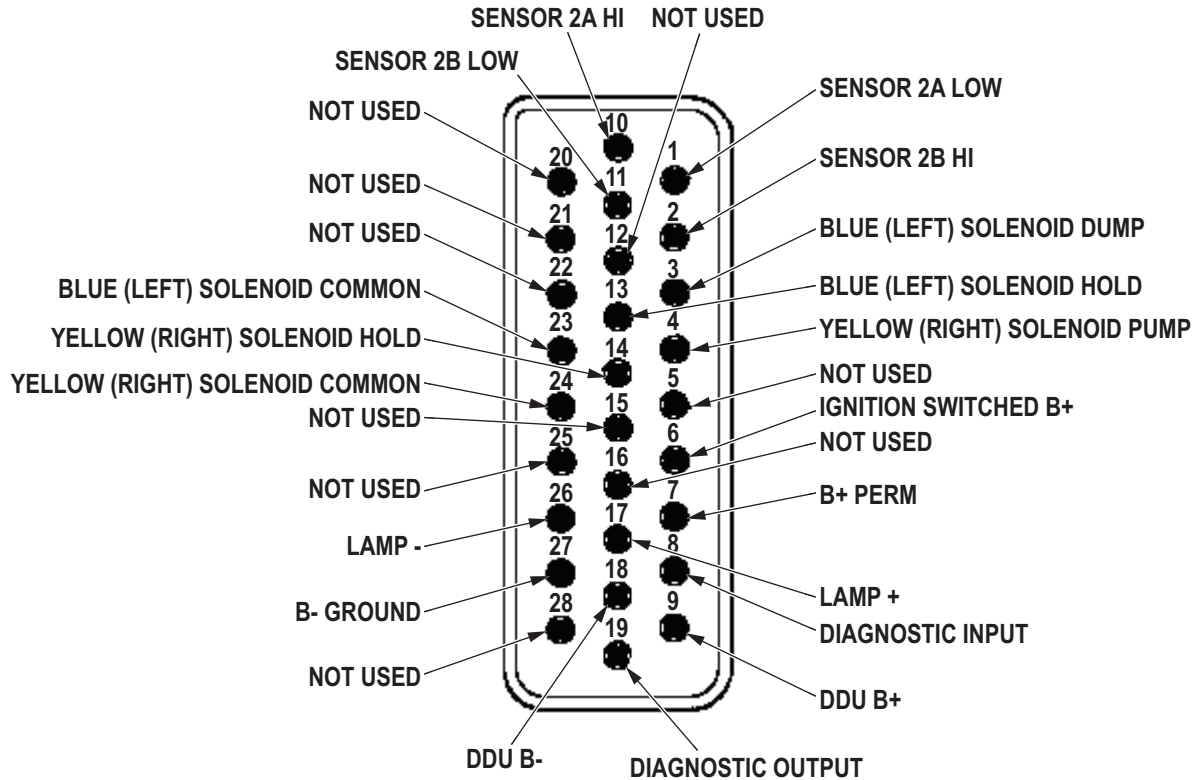

T0952DAA

Figure 2. ABS Wiring Harness 28-pin ECU Connector.

- b. Disconnect main 28-pin connector at ECU (Volume 3, WP 0452).
- c. Connect multimeter red lead to 28-pin connector, terminal 3. Refer to point to point schematics.
- d. Connect multimeter black lead to a known good ground.
- e. Meter reading should be infinite (greater than 10M ohms). Note reading.
- f. Connect multimeter red lead to 28-pin connector, terminal 13.
- g. Connect multimeter black lead to a known good ground.
- h. Meter reading should be infinite (greater than 10M ohms). Note reading.
- i. Connect multimeter red lead to 28-pin connector, terminal 23.
- j. Connect multimeter black lead to a known good ground.
- k. Meter reading should be infinite (greater than 10M ohms). Note reading.

ABS - CODE BUHd 72 (LEFT SIDE - BLUE CHANNEL) - Continued**CONDITION/INDICATION**

DOES A SHORT CIRCUIT TO GROUND EXIST IN THE HOLD CIRCUIT?

DECISION

YES - Replace ABS wiring harness (Volume 3, WP 0467). Go to Step (3) to verify problem is solved.

NO - Replace ABS ECU (Volume 3, WP 0452). Go to Step (3) to verify problem is solved.

STEP

3. IS YOUR ORIGINAL PROBLEM STILL PRESENT?
 - a. Connect solenoid connector at front relay valve.
 - b. If disconnected, connect main harness 28-pin connector at ECU. Listen for locks to "click" in place to ensure a sound connection.
 - c. Ensure vehicle is returned to normal operating condition.
 - d. Perform Clear Historical Codes Procedure (WP 0159).
 - e. Start vehicle.
 - f. Operate vehicle to a speed of 20 miles per hour. Applying brakes several times.
 - g. Return vehicle to park position.
 - h. Perform ABS - Start- Retrieving Fault Codes With Haldex Info Center (Scan Tool) (WP 0161).
 - i. Check to see if your original fault code still exists.

CONDITION/INDICATION

IS YOUR ORIGINAL PROBLEM STILL PRESENT?

DECISION

YES - Notify supervisor.

NO - Problem fixed.

END OF WORK PACKAGE

FIELD MAINTENANCE
ABS - CODE YEHD 73 (RIGHT SIDE - YELLOW CHANNEL)

INITIAL SETUP:**Tools and Special Tools**

Tool Kit, General Mechanic's: Automotive
(Volume 5, WP 0826, Table 1, Item 56)
ABS Diagnostic Info Centre (TM 9-2320-272-10)
Multimeter
(Volume 5, WP 0826, Table 1, Item 34)
Test Set, Electronic Systems
(Volume 5, WP 0826, Table 1, Item 51)

Personnel Required

(2)

References

Point to Point Schematics

References (cont.)

WP 0159
WP 0161
Volume 3, WP 0452
Volume 3, WP 0457
Volume 3, WP 0467

Equipment Condition

Vehicle parked and engine shut down.
(TM 9-2320-272-10)

TROUBLESHOOTING PROCEDURE

ABS - CODE YEHd 73 (RIGHT SIDE - YELLOW CHANNEL)

STEP

1. DOES A SHORT CIRCUIT TO GROUND EXIST IN THE RIGHT (YELLOW), HOLD SOLENOID?
 - a. Ensure battery and start switches are in the OFF position.
 - b. Ensure main wiring harness 28 pin connector is properly connected and fully seated.

REAR RELAY VALVE (YELLOW CHANNEL)

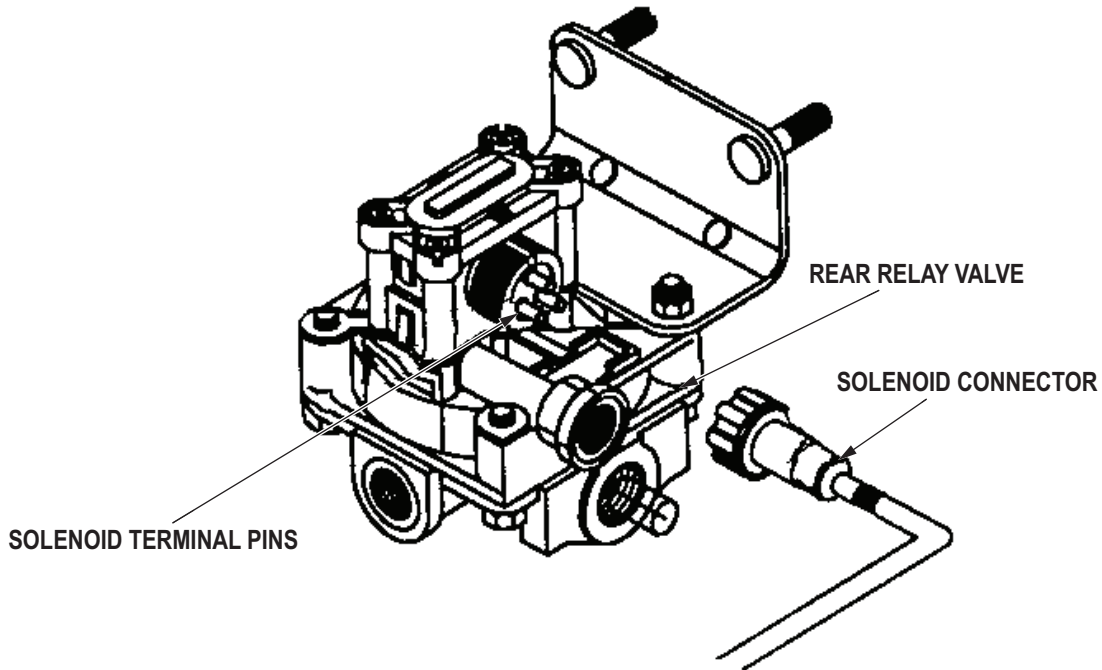

RESISTANCE VALUES - SOLENOID TERMINAL PINS

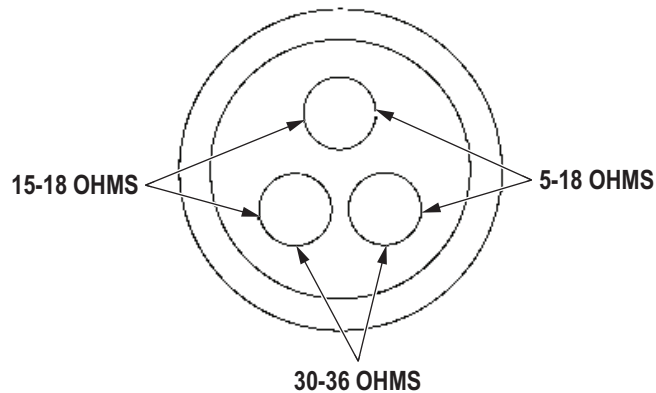

T0967DAA

Figure 1. Rear Relay Valve Solenoid Connector.

ABS - CODE YEHd 73 (RIGHT SIDE - YELLOW CHANNEL) - Continued

- c. Disconnect solenoid connector at rear relay valve.
- d. Set multimeter to measure resistance.
- e. Connect multimeter red lead to solenoid connector bottom terminal. Refer to point to point schematics.
- f. Connect multimeter black lead to solenoid connector other bottom terminal.
- g. Meter reading should be between 30 and 36 ohms. Note reading.
- h. Repeat measurements between solenoid connector top solenoid and each of the bottom terminals.
- i. Meter reading should be 16 ohms. Note readings.

CONDITION/INDICATION

DOES A SHORT CIRCUIT TO GROUND EXIST IN THE RIGHT (YELLOW), HOLD SOLENOID?

DECISION

YES - Replace rear relay valve (Volume 3, WP 0457). Go to Step (3) to verify problem is solved.
NO - Go to Step (2).

ABS - CODE YEHd 73 (RIGHT SIDE - YELLOW CHANNEL) - Continued

STEP

2. DOES A SHORT CIRCUIT TO GROUND EXIST IN THE HOLD CIRCUIT?

- a. Ensure battery and start switches are in the OFF position.

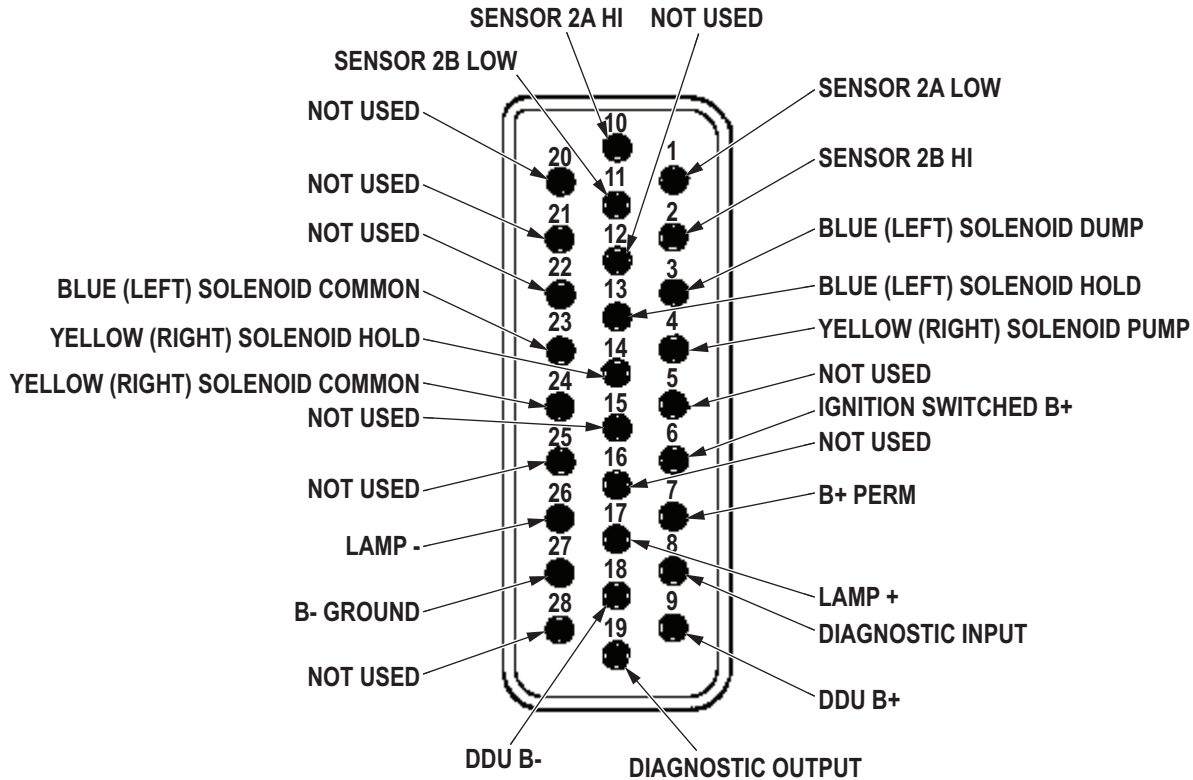

T0953DAA

Figure 2. ABS Wiring Harness 28-pin ECU Connector.

- b. Disconnect main 28-pin connector at ECU (Volume 3, WP 0452).
- c. Connect multimeter red lead to 28-pin connector, terminal 4. Refer to point to point schematics.
- d. Connect multimeter black lead to a known good ground.
- e. Meter reading should be infinite (greater than 10M ohms). Note reading.
- f. Connect multimeter red lead to 28-pin connector, terminal 14.
- g. Connect multimeter black lead to a known good ground.
- h. Meter reading should be infinite (greater than 10M ohms). Note reading.
- i. Connect multimeter red lead to 28-pin connector, terminal 24.
- j. Connect multimeter black lead to a known good ground.
- k. Meter reading should be infinite (greater than 10M ohms). Note reading.

ABS - CODE YEHd 73 (RIGHT SIDE - YELLOW CHANNEL) - Continued**CONDITION/INDICATION**

DOES A SHORT CIRCUIT TO GROUND EXIST IN THE HOLD CIRCUIT?

DECISION

YES - Replace ABS wiring harness (Volume 3, WP 0467). Go to Step (3) to verify problem is solved.

NO - Replace ABS ECU (Volume 3, WP 0452). Go to Step (3) to verify problem is solved.

STEP

3. IS YOUR ORIGINAL PROBLEM STILL PRESENT?
 - a. Connect solenoid connector at rear relay valve.
 - b. If disconnected, connect main harness 28-pin connector at ECU. Listen for locks to "click" in place to ensure a sound connection.
 - c. Ensure vehicle is returned to normal operating condition.
 - d. Perform Clear Historical Codes Procedure (WP 0159).
 - e. Start vehicle.
 - f. Operate vehicle to a speed of 20 miles per hour. Applying brakes several times.
 - g. Return vehicle to park position.
 - h. Perform ABS - Start- Retrieving Fault Codes With Haldex Info Center (Scan Tool) (WP 0161).
 - i. Check to see if your original fault code still exists.

CONDITION/INDICATION

IS YOUR ORIGINAL PROBLEM STILL PRESENT?

DECISION

YES - Notify supervisor.

NO - Problem fixed.

END OF WORK PACKAGE

FIELD MAINTENANCE
ABS - CODE BUDU 78 (LEFT SIDE - BLUE CHANNEL)

INITIAL SETUP:**Tools and Special Tools**

Tool Kit, General Mechanic's: Automotive
(Volume 5, WP 0826, Table 1, Item 56)
ABS Diagnostic Info Centre (TM 9-2320-272-10)
Multimeter
(Volume 5, WP 0826, Table 1, Item 34)
Test Set, Electronic Systems
(Volume 5, WP 0826, Table 1, Item 51)

Personnel Required

(2)

References

Point to Point Schematics

References (cont.)

WP 0159
WP 0161
Volume 3, WP 0452
Volume 3, WP 0458
Volume 3, WP 0467

Equipment Condition

Vehicle parked and engine shut down.
(TM 9-2320-272-10)

TROUBLESHOOTING PROCEDURE

ABS - CODE BUDU 78 (LEFT SIDE - BLUE CHANNEL)

STEP

1. DOES A SHORT CIRCUIT TO GROUND EXIST IN THE LEFT (BLUE), DUMP SOLENOID?
 - a. Ensure battery and start switches are in the OFF position.
 - b. Ensure main wiring harness 28 pin connector is properly connected and fully seated.

FRONT RELAY VALVE WITH ECU (BLUE CHANNEL)

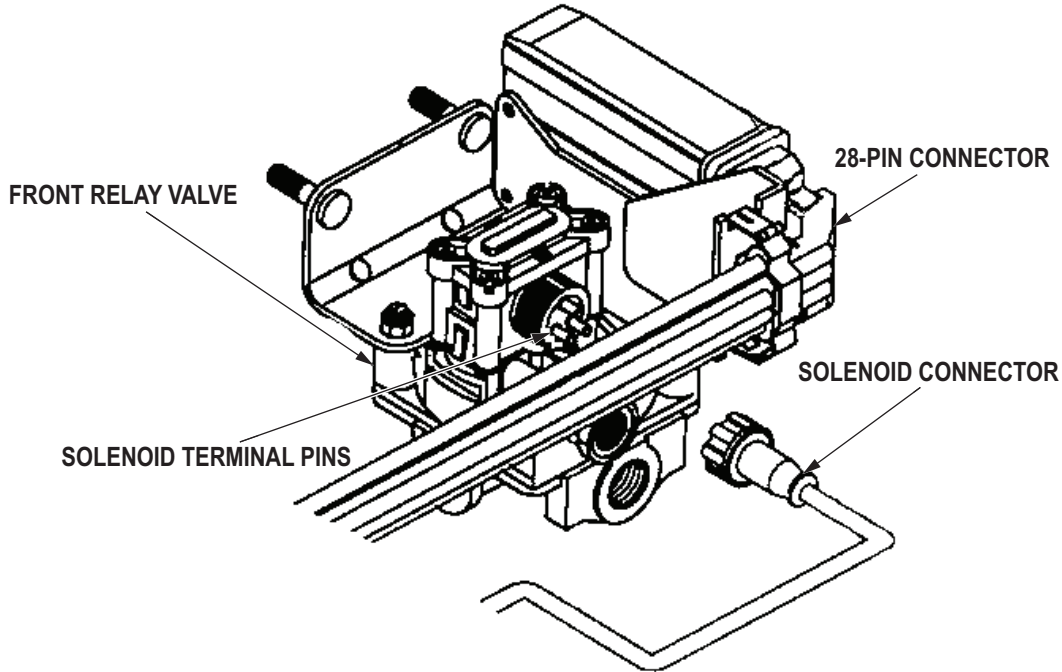

RESISTANCE VALUES - SOLENOID TERMINAL PINS

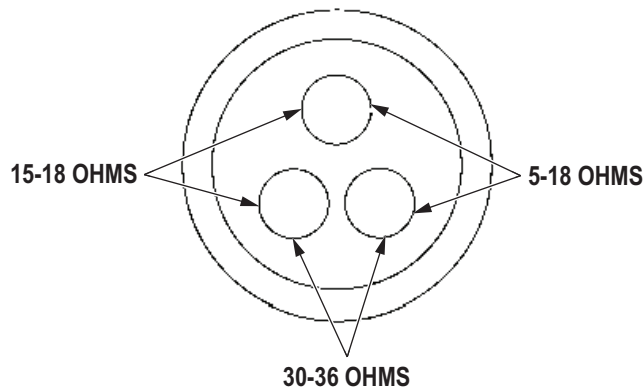

T0963DAA

Figure 1. Front Relay Valve Solenoid Connector.

ABS - CODE BUDU 78 (LEFT SIDE - BLUE CHANNEL) - Continued

- c. Disconnect solenoid connector at front relay valve.
- d. Set multimeter to measure resistance.
- e. Connect multimeter red lead to solenoid connector bottom terminal. Refer to point to point schematics.
- f. Connect multimeter black lead to solenoid connector other bottom terminal.
- g. Meter reading should be between 30 and 36 ohms. Note reading.
- h. Repeat measurements between solenoid connector top solenoid and each of the bottom terminals.
- i. Meter reading should be 16 ohms. Note readings.

CONDITION/INDICATION

DOES A SHORT CIRCUIT TO GROUND EXIST IN THE LEFT (BLUE), DUMP SOLENOID?

DECISION

YES - Replace front relay valve (Volume 3, WP 0458). Go to Step (3) to verify problem is solved.
NO - Go to Step (2).

ABS - CODE BUDU 78 (LEFT SIDE - BLUE CHANNEL) - Continued

STEP

2. DOES A SHORT CIRCUIT TO GROUND EXIST IN THE DUMP CIRCUIT?

- a. Ensure battery and start switches are in the OFF position.

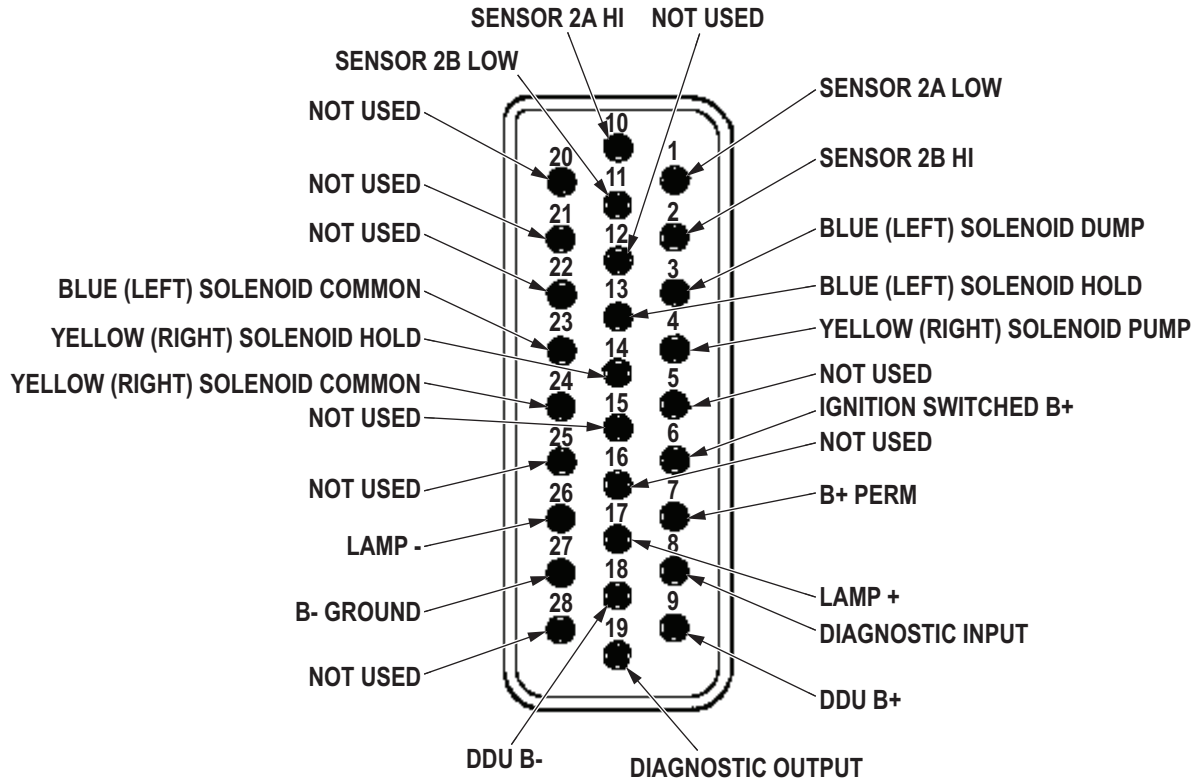

T0954DAA

Figure 2. ABS Wiring Harness 28-pin ECU Connector.

- b. Disconnect main 28-pin connector at ECU (Volume 3, WP 0452).
- c. Connect multimeter red lead to 28-pin connector, terminal 3. Refer to point to point schematics.
- d. Connect multimeter black lead to a known good ground.
- e. Meter reading should be infinite (greater than 10M ohms). Note reading.
- f. Connect multimeter red lead to 28-pin connector, terminal 13.
- g. Connect multimeter black lead to a known good ground.
- h. Meter reading should be infinite (greater than 10M ohms). Note reading.
- i. Connect multimeter red lead to 28-pin connector, terminal 23.
- j. Connect multimeter black lead to a known good ground.
- k. Meter reading should be infinite (greater than 10M ohms). Note reading.

ABS - CODE BUDU 78 (LEFT SIDE - BLUE CHANNEL) - Continued**CONDITION/INDICATION**

DOES A SHORT CIRCUIT TO GROUND EXIST IN THE DUMP CIRCUIT?

DECISION

NO - Replace ABS wiring harness (Volume 3, WP 0467). Go to Step (3) to verify problem is solved.

YES - Replace ABS ECU (Volume 3, WP 0452). Go to Step (3) to verify problem is solved.

STEP

3. IS YOUR ORIGINAL PROBLEM STILL PRESENT?
 - a. Connect dump solenoid cable connector at front relay valve.
 - b. If disconnected, connect main harness 28-pin connector at ECU. Listen for locks to "click" in place to ensure a sound connection.
 - c. Ensure vehicle is returned to normal operating condition.
 - d. Perform Clear Historical Codes Procedure (WP 0159).
 - e. Start vehicle.
 - f. Operate vehicle to a speed of 20 miles per hour. Applying brakes several times.
 - g. Return vehicle to park position.
 - h. Perform ABS - Start- Retrieving Fault Codes With Haldex Info Center (Scan Tool) (WP 0161).
 - i. Check to see if your original fault code still exists.

CONDITION/INDICATION

IS YOUR ORIGINAL PROBLEM STILL PRESENT?

DECISION

YES - Notify supervisor.

NO - Problem fixed.

END OF WORK PACKAGE

FIELD MAINTENANCE
ABS - CODE YEDU 79 (RIGHT SIDE - YELLOW CHANNEL)

INITIAL SETUP:**Tools and Special Tools**

Tool Kit, General Mechanic's: Automotive
(Volume 5, WP 0826, Table 1, Item 56)
ABS Diagnostic Info Centre (TM 9-2320-272-10)
Multimeter
(Volume 5, WP 0826, Table 1, Item 34)
Test Set, Electronic Systems
(Volume 5, WP 0826, Table 1, Item 51)

Personnel Required

(2)

References

Point to Point Schematics

References (cont.)

WP 0159
WP 0161
Volume 3, WP 0452
Volume 3, WP 0457
Volume 3, WP 0467

Equipment Condition

Vehicle parked and engine shut down.
(TM 9-2320-272-10)

TROUBLESHOOTING PROCEDURE

ABS - CODE YEDU 79 (RIGHT SIDE - YELLOW CHANNEL)

STEP

1. DOES A SHORT CIRCUIT TO GROUND EXIST IN THE RIGHT (YELLOW), DUMP SOLENOID?
 - a. Ensure battery and start switches are in the OFF position.
 - b. Ensure main wiring harness 28 pin connector is properly connected and fully seated.

REAR RELAY VALVE (YELLOW CHANNEL)

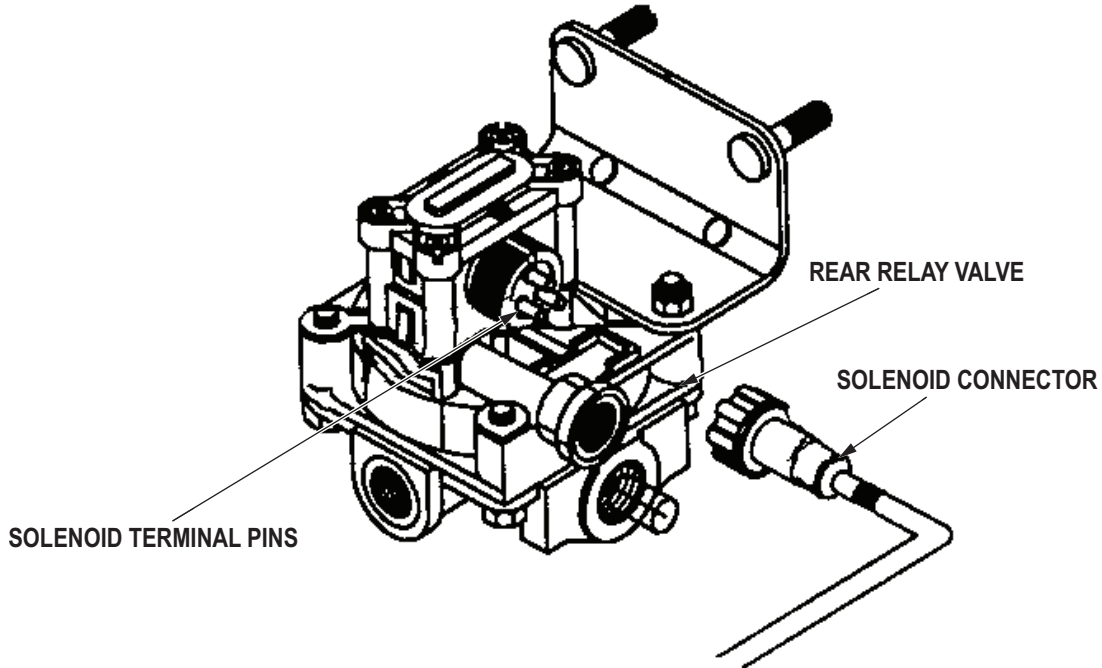

RESISTANCE VALUES - SOLENOID TERMINAL PINS

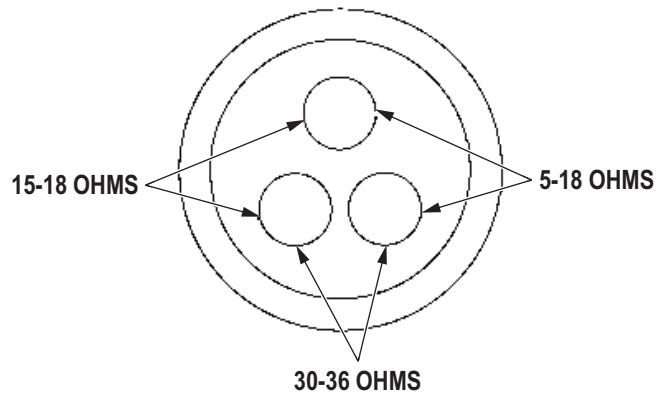

T0968DAA

Figure 1. Rear Relay Valve Solenoid Connector.

ABS - CODE YEDU 79 (RIGHT SIDE - YELLOW CHANNEL) - Continued

- c. Disconnect solenoid connector at rear relay valve.
- d. Set multimeter to measure resistance.
- e. Connect multimeter red lead to solenoid connector bottom terminal. Refer to point to point schematics.
- f. Connect multimeter black lead to solenoid connector other bottom terminal.
- g. Meter reading should be between 30 and 36 ohms. Note reading.
- h. Repeat measurements between solenoid connector top solenoid and each of the bottom terminals.
- i. Meter reading should be 16 ohms. Note readings.

CONDITION/INDICATION

DOES A SHORT CIRCUIT TO GROUND EXIST IN THE RIGHT (YELLOW), DUMP SOLENOID?

DECISION

YES - Replace rear relay valve (Volume 3, WP 0457). Go to Step (3) to verify problem is solved.
NO - Go to Step (2).

ABS - CODE YEDU 79 (RIGHT SIDE - YELLOW CHANNEL) - Continued

STEP

2. DOES A SHORT CIRCUIT TO GROUND EXIST IN THE DUMP CIRCUIT?

- a. Ensure battery and start switches are in the OFF position.

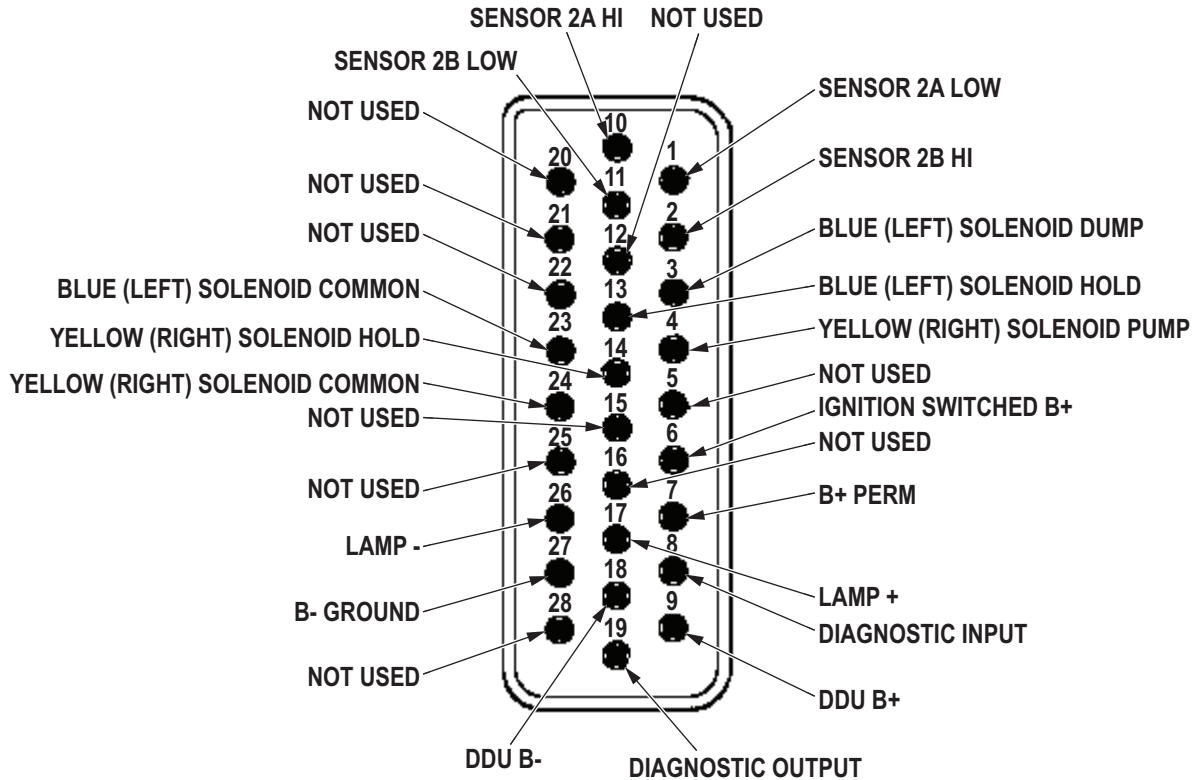

T0955DAA

Figure 2. ABS Wiring Harness 28-pin ECU Connector.

- b. Disconnect main 28-pin connector at ECU (Volume 3, WP 0452).
- c. Connect multimeter red lead to 28-pin connector, terminal 4. Refer to point to point schematics.
- d. Connect multimeter black lead to a known good ground.
- e. Meter reading should be infinite (greater than 10M ohms). Note reading.
- f. Connect multimeter red lead to 28-pin connector, terminal 14.
- g. Connect multimeter black lead to a known good ground.
- h. Meter reading should be infinite (greater than 10M ohms). Note reading.
- i. Connect multimeter red lead to 28-pin connector, terminal 24.
- j. Connect multimeter black lead to a known good ground.
- k. Meter reading should be infinite (greater than 10M ohms). Note reading.

ABS - CODE YEDU 79 (RIGHT SIDE - YELLOW CHANNEL) - Continued**CONDITION/INDICATION**

DOES A SHORT CIRCUIT TO GROUND EXIST IN THE DUMP CIRCUIT?

DECISION

YES - Replace ABS wiring harness (Volume 3, WP 0467). Go to Step (3) to verify problem is solved.

NO - Replace ABS ECU (Volume 3, WP 0452). Go to Step (3) to verify problem is solved.

STEP

3. IS YOUR ORIGINAL PROBLEM STILL PRESENT?
 - a. Connect dump solenoid cable connector at front relay valve.
 - b. If disconnected, connect main harness 28-pin connector at ECU. Listen for locks to "click" in place to ensure a sound connection.
 - c. Ensure vehicle is returned to normal operating condition.
 - d. Perform Clear Historical Codes Procedure (WP 0159).
 - e. Start vehicle.
 - f. Operate vehicle to a speed of 20 miles per hour. Applying brakes several times.
 - g. Return vehicle to park position.
 - h. Perform ABS - Start- Retrieving Fault Codes With Haldex Info Center (Scan Tool) (WP 0161).
 - i. Check to see if your original fault code still exists.

CONDITION/INDICATION

IS YOUR ORIGINAL PROBLEM STILL PRESENT?

DECISION

YES - Notify supervisor.

NO - Problem fixed.

END OF WORK PACKAGE

FIELD MAINTENANCE
ABS - CODE BUHD 82 (LEFT SIDE - BLUE CHANNEL)

INITIAL SETUP:**Tools and Special Tools**

Tool Kit, General Mechanic's: Automotive
(Volume 5, WP 0826, Table 1, Item 56)
ABS Diagnostic Info Centre (TM 9-2320-272-10)
Multimeter
(Volume 5, WP 0826, Table 1, Item 34)
Test Set, Electronic Systems
(Volume 5, WP 0826, Table 1, Item 51)

Personnel Required

(2)

References

Point to Point Schematics

References (cont.)

WP 0159
WP 0161
Volume 3, WP 0452
Volume 3, WP 0458
Volume 3, WP 0467

Equipment Condition

Vehicle parked and engine shut down.
(TM 9-2320-272-10)

TROUBLESHOOTING PROCEDURE

ABS - CODE BUHd 82 (LEFT SIDE - BLUE CHANNEL)

STEP

1. DOES A SHORT CIRCUIT TO BATTERY POSITIVE EXIST IN THE LEFT (BLUE), HOLD SOLENOID?
 - a. Ensure battery and start switches are in the OFF position.
 - b. Ensure main wiring harness 28 pin connector is properly connected and fully seated.

FRONT RELAY VALVE WITH ECU (BLUE CHANNEL)

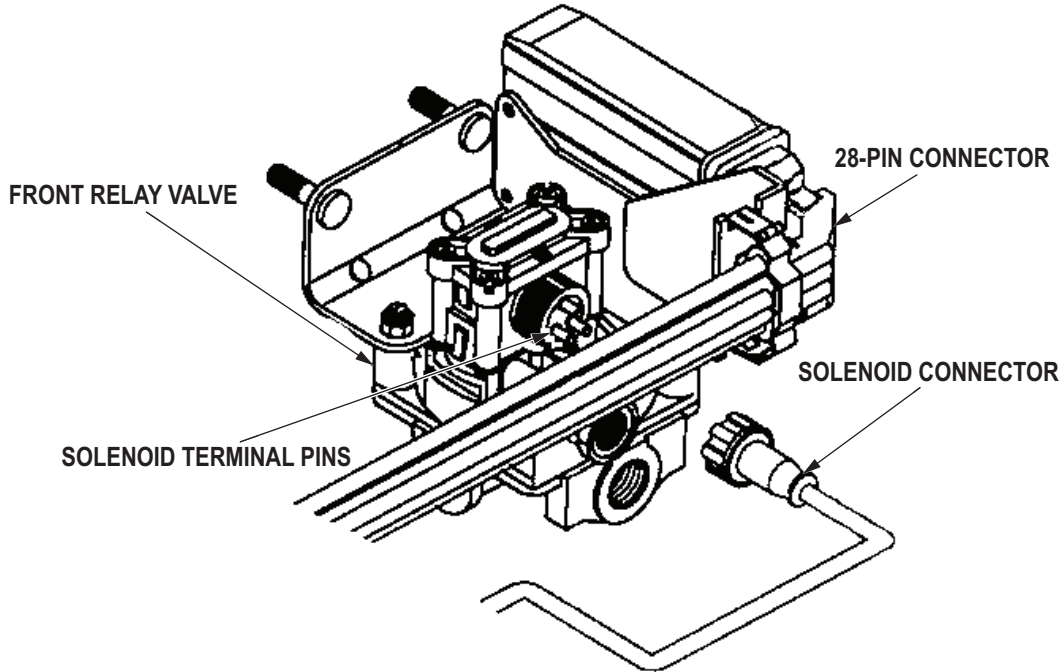

RESISTANCE VALUES - SOLENOID TERMINAL PINS

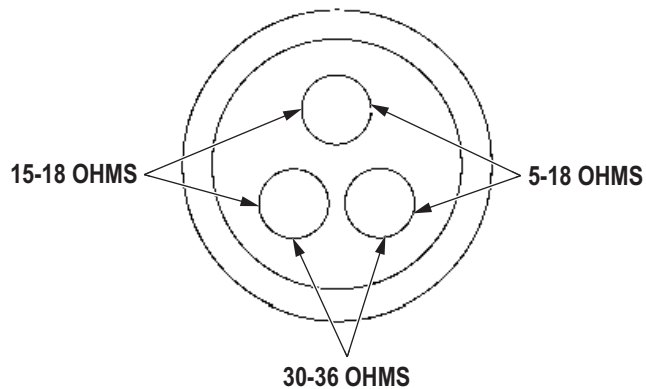

T0964DAA

Figure 1. Front Relay Valve Solenoid Connector.

ABS - CODE BUHd 82 (LEFT SIDE - BLUE CHANNEL) - Continued

- c. Disconnect solenoid connector at front relay valve.
- d. Set multimeter to measure resistance.
- e. Connect multimeter red lead to solenoid connector bottom terminal. Refer to point to point schematics.
- f. Connect multimeter black lead to solenoid connector other bottom terminal.
- g. Meter reading should be between 30 and 36 ohms. Note reading.
- h. Repeat measurements between solenoid connector top solenoid and each of the bottom terminals.
- i. Meter reading should be 16 ohms. Note readings.

CONDITION/INDICATION

DOES A SHORT CIRCUIT TO BATTERY POSITIVE EXIST IN THE LEFT (BLUE), HOLD SOLENOID?

DECISION

YES - Replace front relay valve (Volume 3, WP 0458). Go to Step (3) to verify problem is solved.
NO - Go to Step (2).

ABS - CODE BUHd 82 (LEFT SIDE - BLUE CHANNEL) - Continued

STEP

2. DOES A SHORT CIRCUIT TO BATTERY POSITIVE EXIST IN THE HOLD CIRCUIT?

- a. Ensure battery and start switches are in the OFF position.

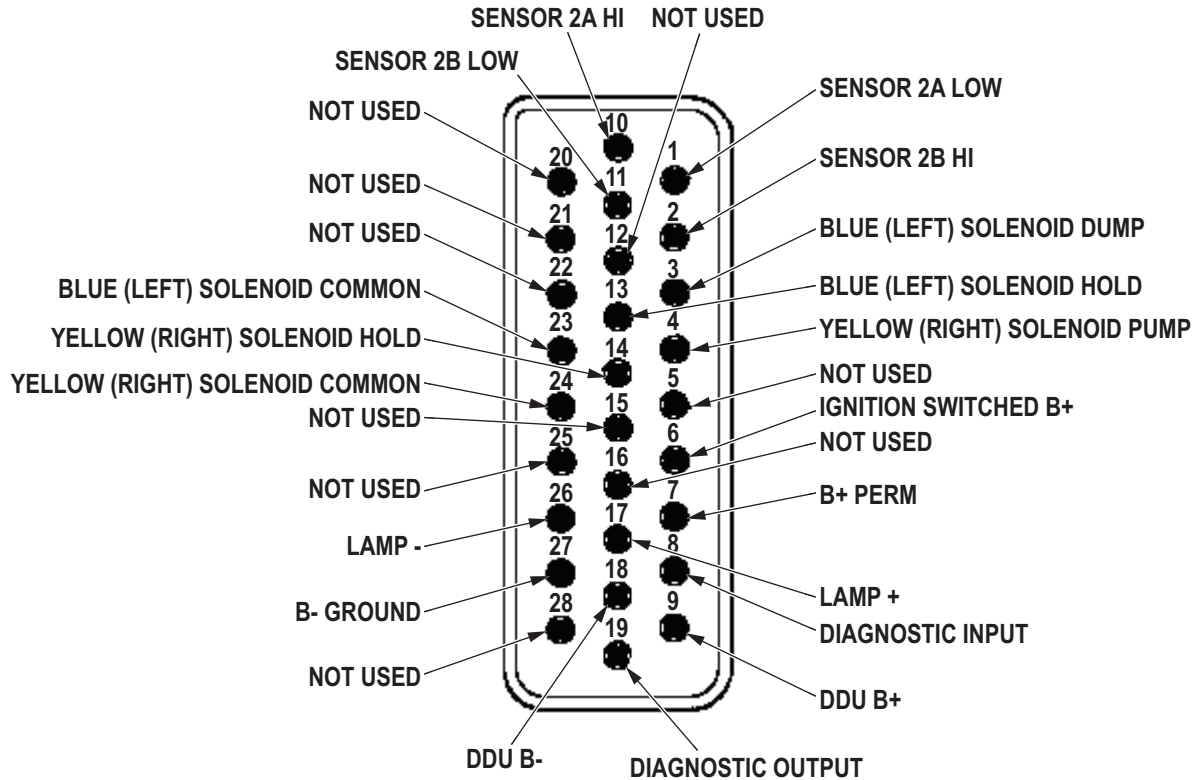

T0956DAA

Figure 2. ABS Wiring Harness 28-pin ECU Connector.

- b. Disconnect main 28-pin connector at ECU (Volume 3, WP 0452).
- c. Connect multimeter red lead to 28-pin connector, terminal 3. Refer to point to point schematics.
- d. Connect multimeter black lead to battery positive.
- e. Meter reading should be infinite (greater than 10M ohms). Note reading.
- f. Connect multimeter red lead to 28-pin connector, terminal 13.
- g. Connect multimeter black lead to battery positive.
- h. Meter reading should be infinite (greater than 10M ohms). Note reading.
- i. Connect multimeter red lead to 28-pin connector, terminal 23.
- j. Connect multimeter black lead to battery positive.
- k. Meter reading should be infinite (greater than 10M ohms). Note reading.

ABS - CODE BUHd 82 (LEFT SIDE - BLUE CHANNEL) - Continued**CONDITION/INDICATION**

DOES A SHORT CIRCUIT TO BATTERY POSITIVE EXIST IN THE HOLD CIRCUIT?

DECISION

YES - Replace ABS wiring harness (Volume 3, WP 0467). Go to Step (3) to verify problem is solved.

NO - Replace ABS ECU (Volume 3, WP 0452). Go to Step (3) to verify problem is solved.

STEP

3. IS YOUR ORIGINAL PROBLEM STILL PRESENT?
 - a. Connect solenoid connector at front relay valve.
 - b. If disconnected, connect main harness 28-pin connector at ECU. Listen for locks to "click" in place to ensure a sound connection.
 - c. Ensure vehicle is returned to normal operating condition.
 - d. Perform Clear Historical Codes Procedure (WP 0159).
 - e. Start vehicle.
 - f. Operate vehicle to a speed of 20 miles per hour. Applying brakes several times.
 - g. Return vehicle to park position.
 - h. Perform ABS - Start- Retrieving Fault Codes With Haldex Info Center (Scan Tool) (WP 0161).
 - i. Check to see if your original fault code still exists.

CONDITION/INDICATION

IS YOUR ORIGINAL PROBLEM STILL PRESENT?

DECISION

YES - Notify supervisor.

NO - Problem fixed.

END OF WORK PACKAGE

FIELD MAINTENANCE
ABS - CODE YEHD 83 (RIGHT SIDE - YELLOW CHANNEL)

INITIAL SETUP:**Tools and Special Tools**

Tool Kit, General Mechanic's: Automotive
(Volume 5, WP 0826, Table 1, Item 56)
ABS Diagnostic Info Centre (TM 9-2320-272-10)
Multimeter
(Volume 5, WP 0826, Table 1, Item 34)
Test Set, Electronic Systems
(Volume 5, WP 0826, Table 1, Item 51)

Personnel Required

(2)

References

Point to Point Schematics

References (cont.)

WP 0159
WP 0161
Volume 3, WP 0452
Volume 3, WP 0457
Volume 3, WP 0467

Equipment Condition

Vehicle parked and engine shut down.
(TM 9-2320-272-10)

TROUBLESHOOTING PROCEDURE

ABS - CODE YEHd 83 (RIGHT SIDE - YELLOW CHANNEL)

STEP

1. DOES A SHORT CIRCUIT TO BATTERY POSITIVE EXIST IN THE RIGHT (YELLOW), HOLD SOLENOID?
 - a. Ensure battery and start switches are in the OFF position.
 - b. Ensure main wiring harness 28 pin connector is properly connected and fully seated.

REAR RELAY VALVE (YELLOW CHANNEL)

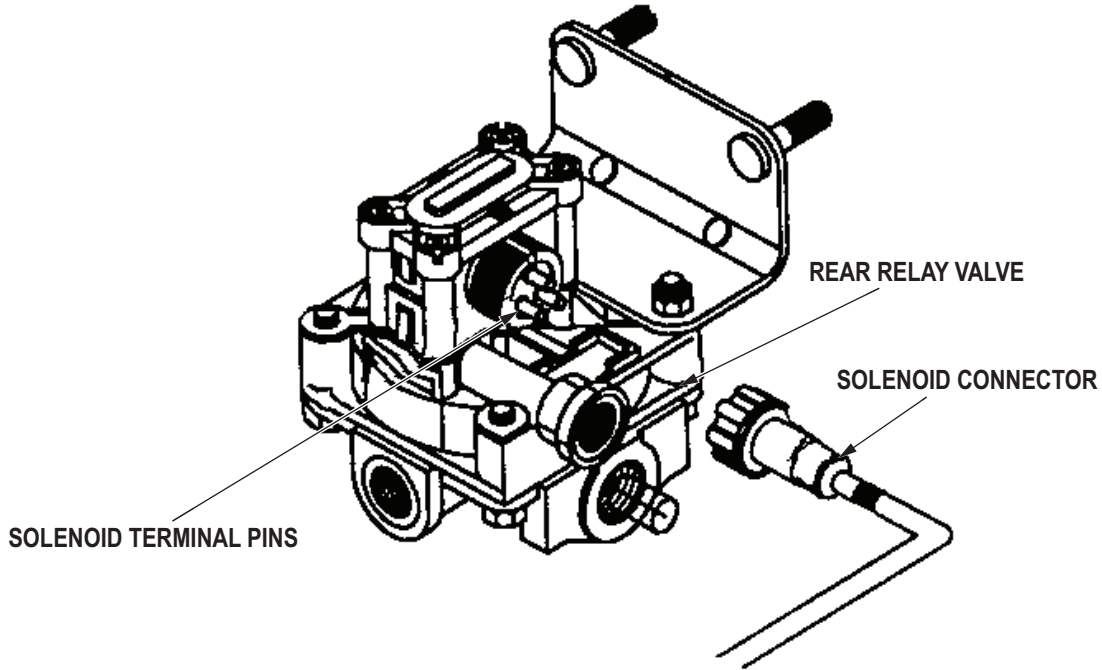

RESISTANCE VALUES - SOLENOID TERMINAL PINS

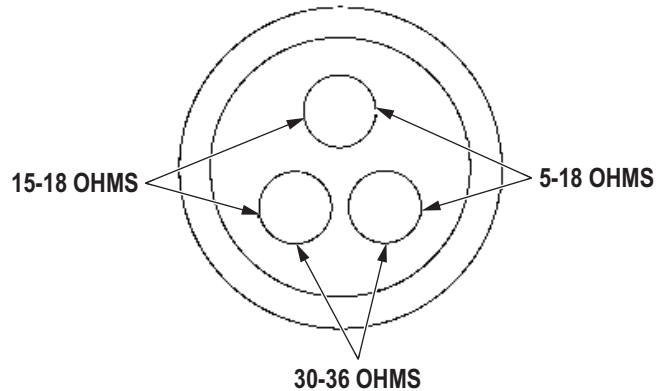

T0969DAA

Figure 1. Rear Relay Valve Solenoid Connector.

ABS - CODE YEHd 83 (RIGHT SIDE - YELLOW CHANNEL) - Continued

- c. Disconnect solenoid connector at rear relay valve.
- d. Set multimeter to measure resistance.
- e. Connect multimeter red lead to solenoid connector bottom terminal. Refer to point to point schematics.
- f. Connect multimeter black lead to solenoid connector other bottom terminal.
- g. Meter reading should be between 30 and 36 ohms. Note reading.
- h. Repeat measurements between solenoid connector top solenoid and each of the bottom terminals.
- i. Meter reading should be 16 ohms. Note readings.

CONDITION/INDICATION

DOES A SHORT CIRCUIT TO BATTERY POSITIVE EXIST IN THE RIGHT (YELLOW), HOLD SOLENOID?

DECISION

YES - Replace rear relay valve (Volume 3, WP 0457). Go to Step (3) to verify problem is solved.
NO - Go to Step (2).

ABS - CODE YEHd 83 (RIGHT SIDE - YELLOW CHANNEL) - Continued

STEP

2. DOES A SHORT CIRCUIT TO BATTERY POSITIVE EXIST IN THE HOLD CIRCUIT?

- a. Ensure battery and start switches are in the OFF position.

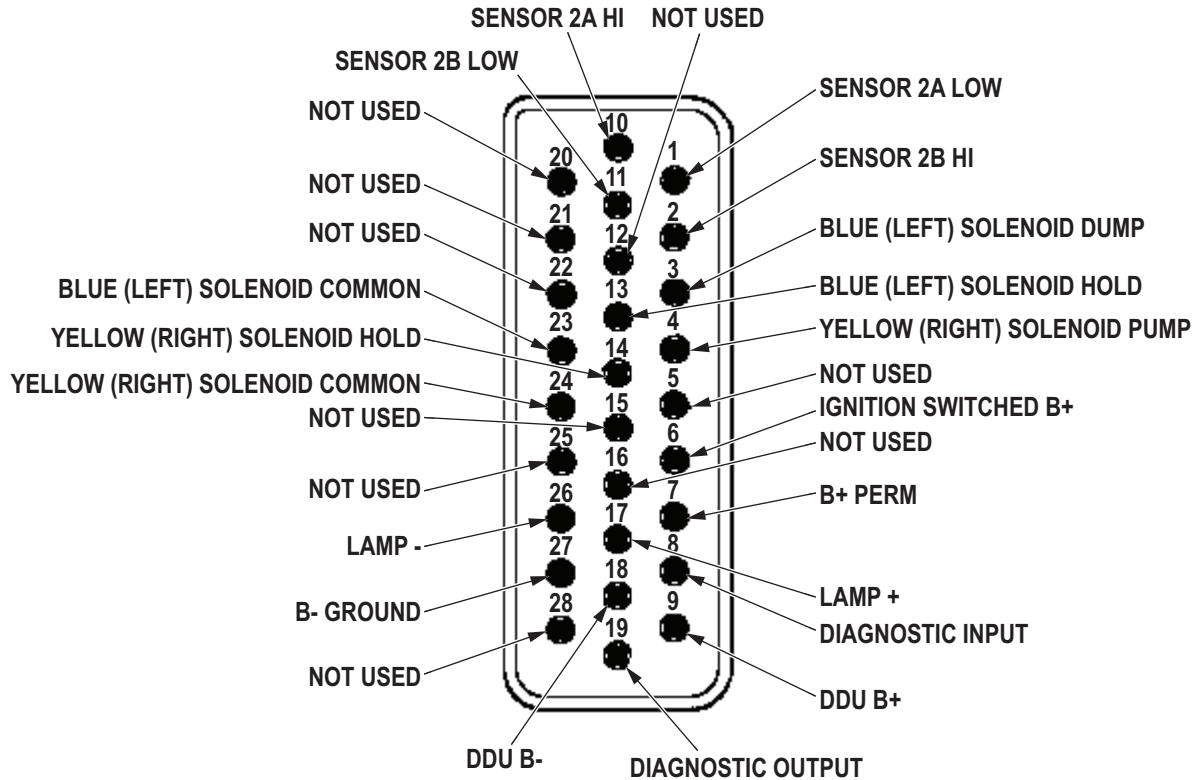

T1061DAA

Figure 2. ABS Wiring Harness 28-pin ECU Connector.

- b. Disconnect main 28-pin connector at ECU (Volume 3, WP 0452).
- c. Connect multimeter red lead to 28-pin connector, terminal 4. Refer to point to point schematics.
- d. Connect multimeter black lead to battery positive.
- e. Meter reading should be infinite (greater than 10M ohms). Note reading.
- f. Connect multimeter red lead to 28-pin connector, terminal 14.
- g. Connect multimeter black lead to battery positive.
- h. Meter reading should be infinite (greater than 10M ohms). Note reading.
- i. Connect multimeter red lead to 28-pin connector, terminal 24.
- j. Connect multimeter black lead to battery positive.
- k. Meter reading should be infinite (greater than 10M ohms). Note reading.

ABS - CODE YEHd 83 (RIGHT SIDE - YELLOW CHANNEL) - Continued**CONDITION/INDICATION**

DOES A SHORT CIRCUIT TO BATTERY POSITIVE EXIST IN THE HOLD CIRCUIT?

DECISION

YES - Replace ABS wiring harness (Volume 3, WP 0467). Go to Step (3) to verify problem is solved.

NO - Replace ABS ECU (Volume 3, WP 0452). Go to Step (3) to verify problem is solved.

STEP

3. IS YOUR ORIGINAL PROBLEM STILL PRESENT?
 - a. Connect solenoid connector at rear relay valve.
 - b. If disconnected, connect main harness 28-pin connector at ECU. Listen for locks to "click" in place to ensure a sound connection.
 - c. Ensure vehicle is returned to normal operating condition.
 - d. Perform Clear Historical Codes Procedure (WP 0159).
 - e. Start vehicle.
 - f. Operate vehicle to a speed of 20 miles per hour. Applying brakes several times.
 - g. Return vehicle to park position.
 - h. Perform ABS - Start- Retrieving Fault Codes With Haldex Info Center (Scan Tool) (WP 0161).
 - i. Check to see if your original fault code still exists.

CONDITION/INDICATION

IS YOUR ORIGINAL PROBLEM STILL PRESENT?

DECISION

YES - Notify supervisor.

NO - Problem fixed.

END OF WORK PACKAGE

FIELD MAINTENANCE
ABS - CODE BUDU 88 (LEFT SIDE - BLUE CHANNEL)

INITIAL SETUP:**Tools and Special Tools**

Tool Kit, General Mechanic's: Automotive
(Volume 5, WP 0826, Table 1, Item 56)
ABS Diagnostic Info Centre (TM 9-2320-272-10)
Multimeter
(Volume 5, WP 0826, Table 1, Item 34)
Test Set, Electronic Systems
(Volume 5, WP 0826, Table 1, Item 51)

Personnel Required

(2)

References

Point to Point Schematics

References (cont.)

WP 0159
WP 0161
Volume 3, WP 0452
Volume 3, WP 0458
Volume 3, WP 0467

Equipment Condition

Vehicle parked and engine shut down.
(TM 9-2320-272-10)

TROUBLESHOOTING PROCEDURE

ABS - CODE BUDU 88 (LEFT SIDE - BLUE CHANNEL)

STEP

1. DOES A SHORT CIRCUIT TO BATTERY POSITIVE EXIST IN THE LEFT (BLUE), DUMP SOLENOID?
 - a. Ensure battery and start switches are in the OFF position.
 - b. Ensure main wiring harness 28 pin connector is properly connected and fully seated.

FRONT RELAY VALVE WITH ECU (BLUE CHANNEL)

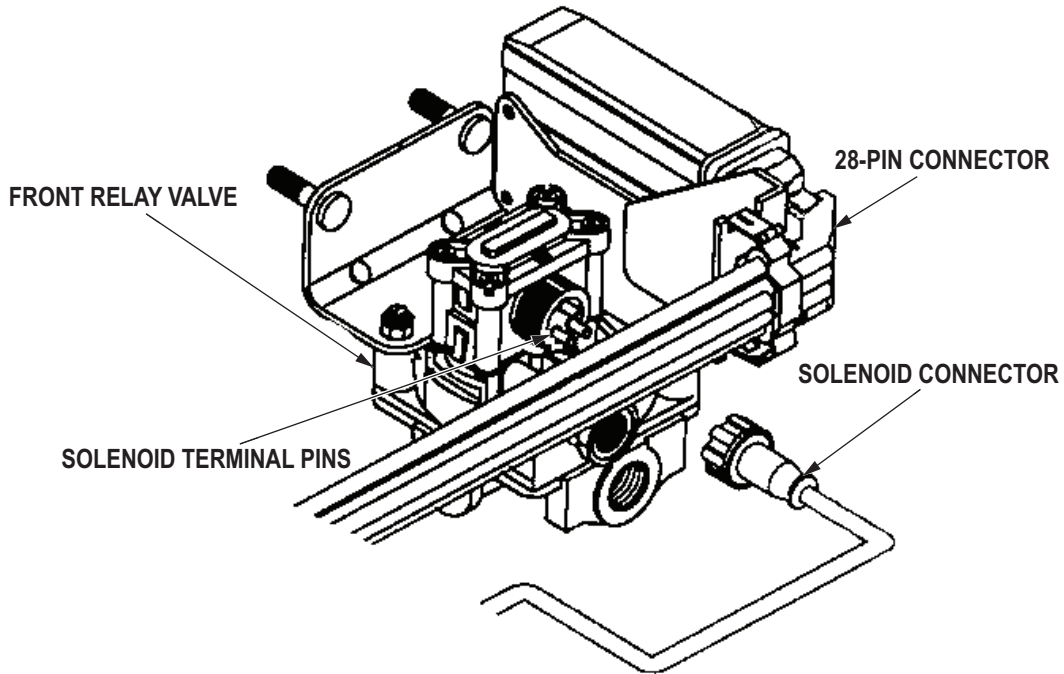

RESISTANCE VALUES - SOLENOID TERMINAL PINS

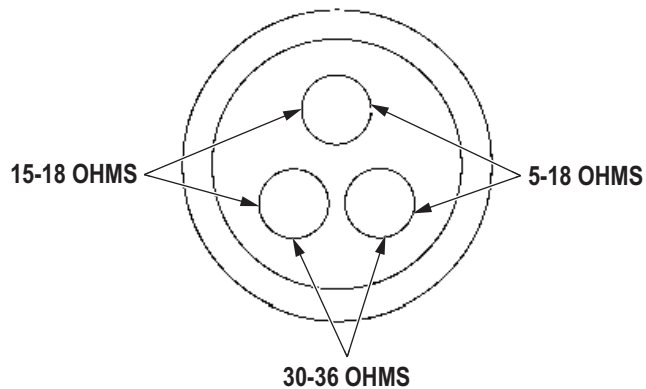

T0965DAA

Figure 1. Front Relay Valve Solenoid Connector.

ABS - CODE BUDU 88 (LEFT SIDE - BLUE CHANNEL) - Continued

- c. Disconnect solenoid connector at front relay valve.
- d. Set multimeter to measure resistance.
- e. Connect multimeter red lead to solenoid connector bottom terminal. Refer to point to point schematics.
- f. Connect multimeter black lead to solenoid connector other bottom terminal.
- g. Meter reading should be between 30 and 36 ohms. Note reading.
- h. Repeat measurements between solenoid connector top solenoid and each of the bottom terminals.
- i. Meter reading should be 16 ohms. Note readings.

CONDITION/INDICATION

DOES A SHORT CIRCUIT TO BATTERY POSITIVE EXIST IN THE LEFT (BLUE), DUMP SOLENOID?

DECISION

YES - Replace front relay valve (Volume 3, WP 0458). Go to Step (3) to verify problem is solved.
NO - Go to Step (2).

ABS - CODE BUDU 88 (LEFT SIDE - BLUE CHANNEL) - Continued

STEP

2. DOES A SHORT CIRCUIT TO BATTERY POSITIVE EXIST IN THE DUMP SOLENOID?

- a. Ensure battery and start switches are in the OFF position.

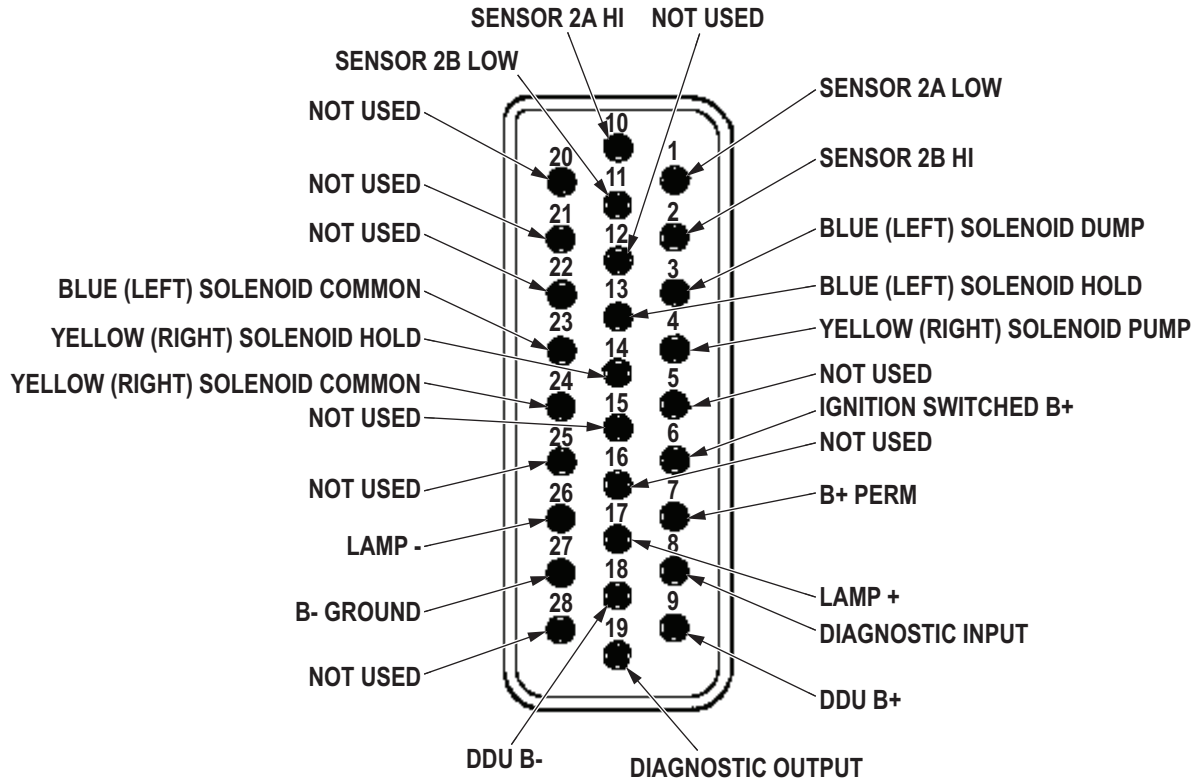

T0957DAA

Figure 2. ABS Wiring Harness 28-pin ECU Connector.

- b. Disconnect main 28-pin connector at ECU (Volume 3, WP 0452).
- c. Connect multimeter red lead to 28-pin connector, terminal 3. Refer to point to point schematics.
- d. Connect multimeter black lead to battery positive.
- e. Meter reading should be infinite (greater than 10M ohms). Note reading.
- f. Connect multimeter red lead to 28-pin connector, terminal 13.
- g. Connect multimeter black lead to battery positive.
- h. Meter reading should be infinite (greater than 10M ohms). Note reading.
- i. Connect multimeter red lead to 28-pin connector, terminal 23.
- j. Connect multimeter black lead to battery positive.
- k. Meter reading should be infinite (greater than 10M ohms). Note reading.

ABS - CODE BUDU 88 (LEFT SIDE - BLUE CHANNEL) - Continued**CONDITION/INDICATION**

DOES A SHORT CIRCUIT TO BATTERY POSITIVE EXIST IN THE DUMP SOLENOID?

DECISION

YES - Replace ABS wiring harness (Volume 3, WP 0467). Go to Step (3) to verify problem is solved.

NO - Replace ABS ECU (Volume 3, WP 0452). Go to Step (3) to verify problem is solved.

STEP

3. IS YOUR ORIGINAL PROBLEM STILL PRESENT?
 - a. Connect dump solenoid cable connector at front relay valve.
 - b. If disconnected, connect main harness 28-pin connector at ECU. Listen for locks to "click" in place to ensure a sound connection.
 - c. Ensure vehicle is returned to normal operating condition.
 - d. Perform Clear Historical Codes Procedure (WP 0159).
 - e. Start vehicle.
 - f. Operate vehicle to a speed of 20 miles per hour. Applying brakes several times.
 - g. Return vehicle to park position.
 - h. Perform ABS - Start- Retrieving Fault Codes With Haldex Info Center (Scan Tool) (WP 0161).
 - i. Check to see if your original fault code still exists.

CONDITION/INDICATION

IS YOUR ORIGINAL PROBLEM STILL PRESENT?

DECISION

YES - Notify supervisor.

NO - Problem fixed.

END OF WORK PACKAGE

FIELD MAINTENANCE
ABS - CODE YEDU 89 (RIGHT SIDE - YELLOW CHANNEL)

INITIAL SETUP:**Tools and Special Tools**

Tool Kit, General Mechanic's: Automotive
(Volume 5, WP 0826, Table 1, Item 56)
ABS Diagnostic Info Centre (TM 9-2320-272-10)
Multimeter
(Volume 5, WP 0826, Table 1, Item 34)
Test Set, Electronic Systems
(Volume 5, WP 0826, Table 1, Item 51)

Personnel Required

(2)

References

Point to Point Schematics

References (cont.)

WP 0159
WP 0161
Volume 3, WP 0452
Volume 3, WP 0457
Volume 3, WP 0467

Equipment Condition

Vehicle parked and engine shut down.
(TM 9-2320-272-10)

TROUBLESHOOTING PROCEDURE

ABS - CODE YEDU 89 (RIGHT SIDE - YELLOW CHANNEL)

STEP

1. DOES A SHORT CIRCUIT TO BATTERY POSITIVE EXIST IN THE RIGHT (YELLOW), DUMP SOLENOID?
 - a. Ensure battery and start switches are in the OFF position.
 - b. Ensure main wiring harness 28 pin connector is properly connected and fully seated.

REAR RELAY VALVE (YELLOW CHANNEL)

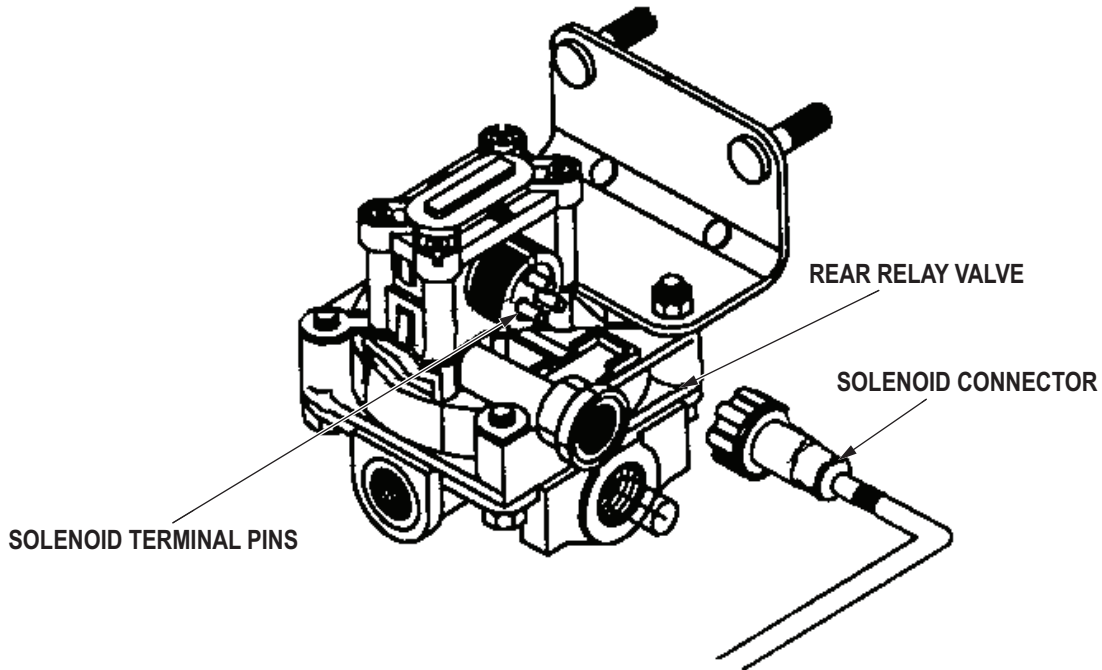

RESISTANCE VALUES - SOLENOID TERMINAL PINS

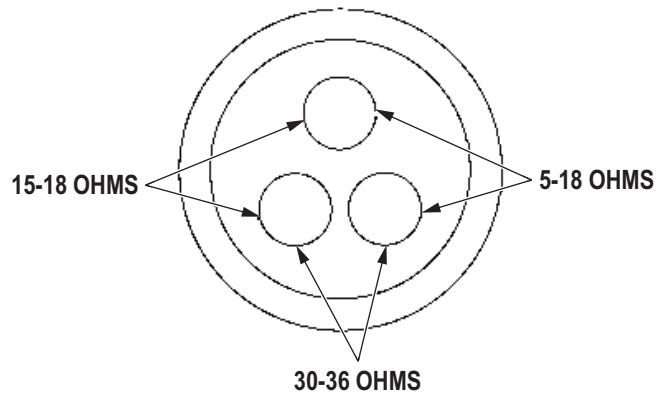

T0970DAA

Figure 1. Rear Relay Valve Solenoid Connector.

ABS - CODE YEDU 89 (RIGHT SIDE - YELLOW CHANNEL) - Continued

- c. Disconnect solenoid connector at rear relay valve.
- d. Set multimeter to measure resistance.
- e. Connect multimeter red lead to solenoid connector bottom terminal. Refer to point to point schematics.
- f. Connect multimeter black lead to solenoid connector other bottom terminal.
- g. Meter reading should be between 30 and 36 ohms. Note reading.
- h. Repeat measurements between solenoid connector top solenoid and each of the bottom terminals.
- i. Meter reading should be 16 ohms. Note readings.

CONDITION/INDICATION

DOES A SHORT CIRCUIT TO BATTERY POSITIVE EXIST IN THE RIGHT (YELLOW), DUMP SOLENOID?

DECISION

YES - Replace rear relay valve (Volume 3, WP 0457). Go to Step (3) to verify problem is solved.
NO - Go to Step (2).

ABS - CODE YEDU 89 (RIGHT SIDE - YELLOW CHANNEL) - Continued

STEP

2. DOES A SHORT CIRCUIT TO BATTERY POSITIVE EXIST IN THE DUMP CIRCUIT?

- a. Ensure battery and start switches are in the OFF position.

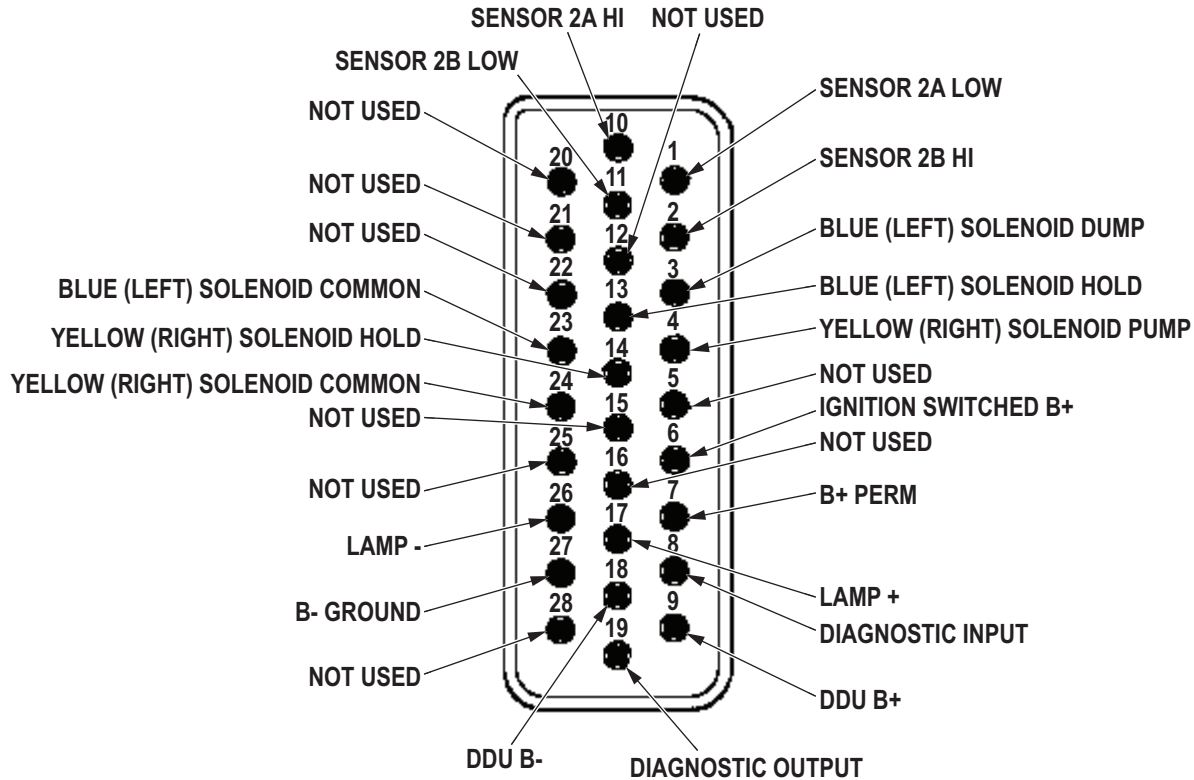

T0958DAA

Figure 2. ABS Wiring Harness 28-pin ECU Connector.

- b. Disconnect main 28-pin connector at ECU (Volume 3, WP 0452).
- c. Connect multimeter red lead to 28-pin connector, terminal 4. Refer to point to point schematics.
- d. Connect multimeter black lead to battery positive.
- e. Meter reading should be infinite (greater than 10M ohms). Note reading.
- f. Connect multimeter red lead to 28-pin connector, terminal 14.
- g. Connect multimeter black lead to battery positive.
- h. Meter reading should be infinite (greater than 10M ohms). Note reading.
- i. Connect multimeter red lead to 28-pin connector, terminal 24.
- j. Connect multimeter black lead to battery positive.
- k. Meter reading should be infinite (greater than 10M ohms). Note reading.

ABS - CODE YEDU 89 (RIGHT SIDE - YELLOW CHANNEL) - Continued**CONDITION/INDICATION**

DOES A SHORT CIRCUIT TO BATTERY POSITIVE EXIST IN THE DUMP CIRCUIT?

DECISION

YES - Replace ABS wiring harness (Volume 3, WP 0467). Go to Step (3) to verify problem is solved.

NO - Replace ABS ECU (Volume 3, WP 0452). Go to Step (3) to verify problem is solved.

STEP

3. IS YOUR ORIGINAL PROBLEM STILL PRESENT?
 - a. Connect dump solenoid cable connector at front relay valve.
 - b. If disconnected, connect main harness 28-pin connector at ECU. Listen for locks to "click" in place to ensure a sound connection.
 - c. Ensure vehicle is returned to normal operating condition.
 - d. Perform Clear Historical Codes Procedure (WP 0159).
 - e. Start vehicle.
 - f. Operate vehicle to a speed of 20 miles per hour. Applying brakes several times.
 - g. Return vehicle to park position.
 - h. Perform ABS - Start- Retrieving Fault Codes With Haldex Info Center (Scan Tool) (WP 0161).
 - i. Check to see if your original fault code still exists.

CONDITION/INDICATION

IS YOUR ORIGINAL PROBLEM STILL PRESENT?

DECISION

YES - Notify supervisor.

NO - Problem fixed.

END OF WORK PACKAGE

FIELD MAINTENANCE
ABS - CODE B+LO 90 (ABS VOLTAGE BELOW 21.0 VOLTS)

INITIAL SETUP:**Tools and Special Tools**

Tool Kit, General Mechanic's: Automotive
(Volume 5, WP 0826, Table 1, Item 56)
ABS Diagnostic Info Centre (TM 9-2320-272-10)
Multimeter
(Volume 5, WP 0826, Table 1, Item 34)
Test Set, Electronic Systems
(Volume 5, WP 0826, Table 1, Item 51)

References (cont.)

WP 0159
WP 0161
WP 0346
WP 0349
WP 0350

Personnel Required

(2)

Equipment Condition

Vehicle parked and engine shut down.
(TM 9-2320-272-10)

References

Point to Point Schematics

TROUBLESHOOTING PROCEDURE

ABS - CODE B+LO 90 (ABS VOLTAGE BELOW 21.0 VOLTS)**STEP****1. IS BATTERY VOLTAGE OK?**

- a. Set multimeter to measure VDC.

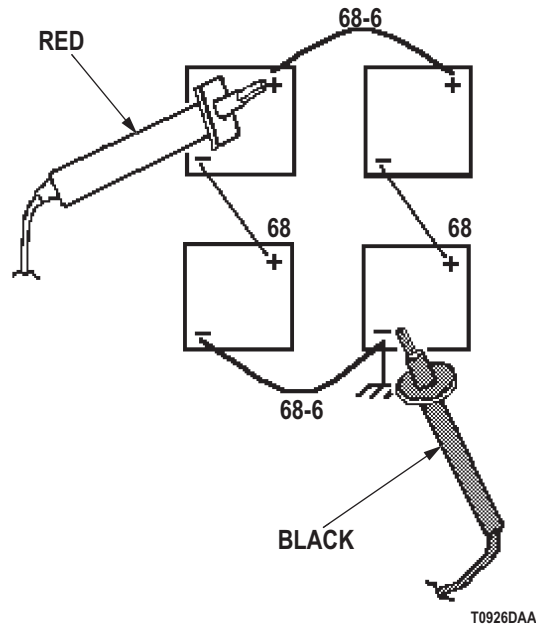

Figure 1. Battery Test Points.

- b. Connect multimeter red lead to battery positive (+) terminal. Refer to point to point schematics.
- c. Connect multimeter black lead to battery negative (-) terminal.
- d. Meter reading should be between 21 and 24 VDC.

CONDITION/INDICATION

IS BATTERY VOLTAGE OK?

DECISION

YES - Go to Step (2).

NO - Service batteries (WP 0346). Go to Step (3) to verify problem is solved.

ABS - CODE B+LO 90 (ABS VOLTAGE BELOW 21.0 VOLTS) - Continued**STEP****2. ARE BATTERY CABLES AND CONNECTIONS OK?**

Check all battery cables for loose or damaged connections. Refer to point to point schematics.

CONDITION/INDICATION

ARE BATTERY CABLES AND CONNECTIONS OK?

DECISION

YES - Notify supervisor. It is possible that another troubleshooting work package applies.

NO - Repair or replace faulty battery cable (WP 0349) or battery ground cable (WP 0350). Go to Step (3) to verify problem is solved.

STEP**3. IS YOUR ORIGINAL PROBLEM STILL PRESENT?**

- a. Ensure vehicle is returned to normal operating condition.
- b. Perform Clear Historical Codes Procedure (WP 0159).
- c. Start vehicle.
- d. Operate vehicle to a speed of 20 miles per hour. Applying brakes several times.
- e. Return vehicle to park position.
- f. Perform ABS - Start- Retrieving Fault Codes With Haldex Info Center (Scan Tool) (WP 0161).
- g. Check to see if your original fault code still exists.

CONDITION/INDICATION

IS YOUR ORIGINAL PROBLEM STILL PRESENT?

DECISION

YES - Notify supervisor.

NO - Problem fixed.

END OF WORK PACKAGE

FIELD MAINTENANCE
ABS - CODE ISO1 91 (ABS VOLTAGE BELOW 8.0 VOLTS)

INITIAL SETUP:**Tools and Special Tools**

Tool Kit, General Mechanic's: Automotive
(Volume 5, WP 0826, Table 1, Item 56)
ABS Diagnostic Info Centre (TM 9-2320-272-10)
Multimeter
(Volume 5, WP 0826, Table 1, Item 34)
Test Set, Electronic Systems
(Volume 5, WP 0826, Table 1, Item 51)

References (cont.)

WP 0159
WP 0161
Volume 3, WP 0467

Equipment Condition

Vehicle parked and engine shut down.
(TM 9-2320-272-10)

Personnel Required

(2)

References

Point to Point Schematics

TROUBLESHOOTING PROCEDURE**ABS - CODE ISO1 91 (ABS VOLTAGE BELOW 8.0 VOLTS)****STEP**

1. IS ABS POWER SUPPLY CIRCUIT OK?

NOTE

If power is coming from somewhere other than vehicle, make sure tester battery is fully charged or voltage converter has adequate voltage (21.0 – 33.0 volts) and current capacity (11 amps). Do not use a battery charger.

Check ABS power supply circuit, including ground wire "Y" connector, power cable "W" connector to wire 54, and both fuses, for damage, corrosion, splices, and sound connections. Refer to point to point schematics.

CONDITION/INDICATION

IS ABS POWER SUPPLY CIRCUIT OK?

DECISION

YES - Notify supervisor. It is possible that another troubleshooting work package applies.
NO - Replace ABS wiring harness (Volume 3, WP 0467). Go to Step (2) to verify problem is solved.

ABS - CODE ISO1 91 (ABS VOLTAGE BELOW 8.0 VOLTS) - Continued**STEP**

2. IS YOUR ORIGINAL PROBLEM STILL PRESENT?
 - a. Ensure vehicle is returned to normal operating condition.
 - b. Perform Clear Historical Codes Procedure (WP 0159).
 - c. Start vehicle.
 - d. Operate vehicle to a speed of 20 miles per hour. Applying brakes several times.
 - e. Return vehicle to park position.
 - f. Perform ABS - Start- Retrieving Fault Codes With Haldex Info Center (Scan Tool) (WP 0161).
 - g. Check to see if your original fault code still exists.

CONDITION/INDICATION

IS YOUR ORIGINAL PROBLEM STILL PRESENT?

DECISION

YES - Notify supervisor.
NO - Problem fixed.

END OF WORK PACKAGE

FIELD MAINTENANCE
ABS - CODE B+HI 92 (ABS VOLTAGE ABOVE 32.0 VOLTS)

INITIAL SETUP:**Tools and Special Tools**

Tool Kit, General Mechanic's: Automotive
(Volume 5, WP 0826, Table 1, Item 56)
ABS Diagnostic Info Centre (TM 9-2320-272-10)
Multimeter
(Volume 5, WP 0826, Table 1, Item 34)
Test Set, Electronic Systems
(Volume 5, WP 0826, Table 1, Item 51)

References (cont.)

Volume 1, WP 0091
WP 0159
WP 0161

Equipment Condition

Vehicle parked and engine shut down.
(TM 9-2320-272-10)

Personnel Required

(2)

References

Point to Point Schematics

TROUBLESHOOTING PROCEDURE

ABS - CODE B+HI 92 (ABS VOLTAGE ABOVE 32.0 VOLTS)**STEP**

1. IS ABS SUPPLY VOLTAGE ABOVE 33.1 VDC?
 - a. Start engine.
 - b. Set multimeter to measure VDC.

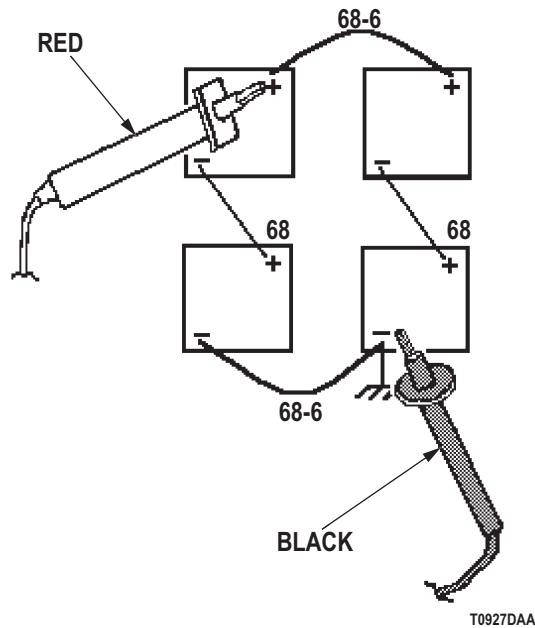

Figure 1. Battery Test Points.

- c. Connect multimeter red lead to battery positive (+) terminal. Refer to point to point schematics.
- d. Connect multimeter black lead to battery negative (-) terminal.
- e. Meter reading should be between 21 and 28 VDC.

ABS - CODE B+HI 92 (ABS VOLTAGE ABOVE 32.0 VOLTS) - Continued**CONDITION/INDICATION**

IS ABS SUPPLY VOLTAGE ABOVE 33.1 VDC?

DECISION

YES - Perform Alternator Overcharging, Battery Indicator Gauge In Red Position troubleshooting (Volume 1, WP 0091). Go to Step (2) to verify problem is solved.

NO - Notify supervisor. It is possible that another troubleshooting work package applies.

STEP

2. IS YOUR ORIGINAL PROBLEM STILL PRESENT?
 - a. Ensure vehicle is returned to normal operating condition.
 - b. Perform Clear Historical Codes Procedure (WP 0159).
 - c. Start vehicle.
 - d. Operate engine at high RPM.
 - e. Return vehicle to park position.
 - f. Perform ABS - Start- Retrieving Fault Codes With Haldex Info Center (Scan Tool) (WP 0161).
 - g. Check to see if your original fault code still exists.

CONDITION/INDICATION

IS YOUR ORIGINAL PROBLEM STILL PRESENT?

DECISION

YES - Notify supervisor.

NO - Problem fixed.

END OF WORK PACKAGE

FIELD MAINTENANCE
ABS - NO DATA (BLANK SCREEN ON HALDEX INFO-CENTER)

INITIAL SETUP:**Tools and Special Tools**

Tool Kit, General Mechanic's: Automotive
(Volume 5, WP 0826, Table 1, Item 56)
ABS Diagnostic Info Centre (TM 9-2320-272-10)
Multimeter
(Volume 5, WP 0826, Table 1, Item 34)
Test Set, Electronic Systems
(Volume 5, WP 0826, Table 1, Item 51)

References (cont.)

WP 0159
WP 0161
WP 0307
WP 0349
WP 0350
Volume 3, WP 0352
Volume 3, WP 0452
Volume 3, WP 0463
Volume 3, WP 0467

Personnel Required

(2)

References

Point to Point Schematics

Equipment Condition

Vehicle parked and engine shut down.
(TM 9-2320-272-10)

TROUBLESHOOTING PROCEDURE**ABS - NO DATA (BLANK SCREEN ON HALDEX INFO-CENTER)****STEP**

1. IS COMMUNICATION LINK LOOSE OR DAMAGED?

Check diagnostic equipment connections and cables for damage and sound connections.

CONDITION/INDICATION

IS COMMUNICATION LINK LOOSE OR DAMAGED?

DECISION

NO - Replace wire harness (Volume 3, WP 0467). Go to Step (7) to verify problem is solved.
YES - Go to Step (2).

STEP

2. ARE BATTERIES, CABLES, AND CONNECTIONS OK?

Check condition of batteries, cable, and connections. Refer to point to point schematics.

CONDITION/INDICATION

ARE BATTERIES, CABLES, AND CONNECTIONS OK?

DECISION

NO - Repair or replace faulty battery cable (WP 0349) or battery ground cable (WP 0350). Go to Step (7) to verify problem is solved.
YES - Go to Step (3).

ABS - NO DATA (BLANK SCREEN ON HALDEX INFO-CENTER) - Continued

STEP

3. IS BATTERY VOLTAGE PRESENT AT ABS ECU?

- a. Ensure battery and start switches are in the OFF position.

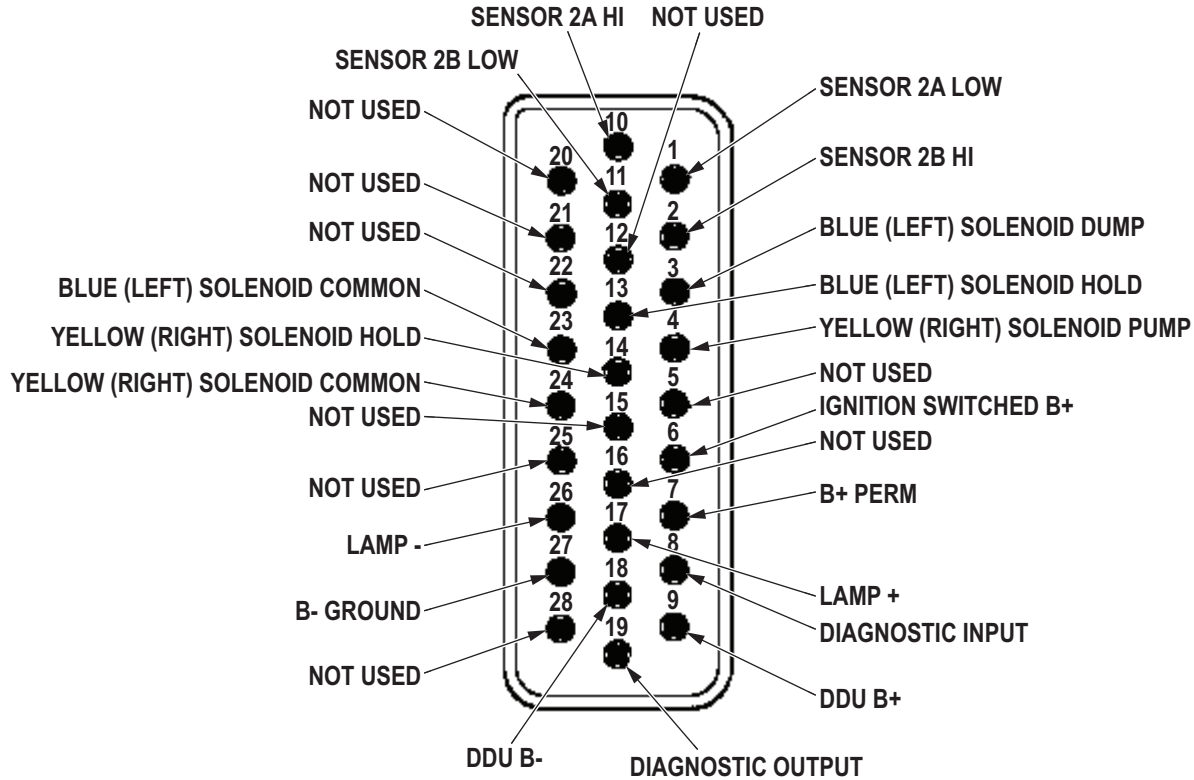

T0959DAA

Figure 1. ABS Wiring Harness 28-pin ECU Connector.

- b. Disconnect main 28-pin connector at ECU (Volume 3, WP 0452).
- c. Turn battery switch ON.
- d. Turn start switch to RUN position.
- e. Set multimeter to measure VDC.
- f. Connect multimeter red lead to 28-pin connector, terminal 6. Refer to point to point schematics.
- g. Connect multimeter black lead to a known good ground.
- h. Meter reading should be between 21 and 24 VDC. Note reading.
- i. Connect multimeter red lead to 28-pin connector, terminal 7.
- j. Connect multimeter black lead to a known good ground.
- k. Meter reading should be between 21 and 24 VDC. Note reading.

ABS - NO DATA (BLANK SCREEN ON HALDEX INFO-CENTER) - Continued**CONDITION/INDICATION**

IS BATTERY VOLTAGE PRESENT AT ABS ECU?

DECISION

YES - Notify supervisor. It is possible another troubleshooting work package applies.

NO - Go to Step (4).

STEP

4. IS BATTERY VOLTAGE PRESENT AT BOTH SIDES OF 3 AMP AND 15 AMP FUSES?
 - a. Turn battery switch ON.
 - b. Turn start switch to RUN position.
 - c. Connect multimeter red lead to 3 amp fuse connector terminal. Refer to point to point schematics.
 - d. Connect multimeter black lead to a known good ground.
 - e. Meter reading should be between 21 and 24 VDC. Note reading.
 - f. Connect multimeter red lead to 3 amp fuse connector other terminal.
 - g. Connect multimeter black lead to a known good ground.
 - h. Meter reading should be between 21 and 24 VDC. Note reading.
 - i. Connect multimeter red lead to 15 amp fuse connector terminal.
 - j. Connect multimeter black lead to a known good ground.
 - k. Meter reading should be between 21 and 24 VDC. Note reading.
 - l. Connect multimeter red lead to 15 amp fuse connector other terminal.
 - m. Connect multimeter black lead to a known good ground.
 - n. Meter reading should be between 21 and 24 VDC. Note reading.
 - o. Turn start switch to OFF position.
 - p. Turn battery switch OFF.

CONDITION/INDICATION

IS BATTERY VOLTAGE PRESENT AT BOTH SIDES OF 3 AMP AND 15 AMP FUSES?

DECISION

NO - No voltage at 3 amp fuse (both sides). Go to Step (5).

NO - No voltage at one side of 3 amp fuse. Replace 3 amp fuse (Volume 3, WP 0463). Go to Step (7) to verify problem is solved.

NO - No voltage at 15 amp fuse (both sides). Go to Step (6).

NO - No voltage at one side of 15 amp fuse. Replace 15 amp fuse (Volume 3, WP 0464). Go to Step (7) to verify problem is solved.

YES - Replace ABS wiring harness (Volume 3, WP 0467). Go to Step (7) to verify problem is solved.

ABS - NO DATA (BLANK SCREEN ON HALDEX INFO-CENTER) - Continued**STEP**

5. IS BATTERY VOLTAGE PRESENT AT START SWITCH TERMINAL R?
 - a. Turn battery switch ON.
 - b. Turn start switch to RUN position.
 - c. Connect multimeter red lead to start switch, terminal R. Refer to point to point schematics.
 - d. Connect multimeter black lead to a known good ground.
 - e. Meter reading should be between 21 and 24 VDC.
 - f. Turn start switch to OFF position.
 - g. Turn battery switch OFF.

CONDITION/INDICATION

IS BATTERY VOLTAGE PRESENT AT START SWITCH TERMINAL R?

DECISION

YES - Notify supervisor. It is possible another troubleshooting work package applies.
NO - Replace start switch (WP 0307). Go to Step (7) to verify problem is solved.

STEP

6. IS BATTERY VOLTAGE PRESENT AT WIRE #10 CONNECTOR AT ABS WIRE HARNESS?
 - a. Turn battery switch ON.
 - b. Turn start switch to RUN position.
 - c. Connect multimeter red lead to wire #10 connector at ABS wire harness. Refer to point to point schematics.
 - d. Connect multimeter black lead to a known good ground.
 - e. Meter reading should be between 21 and 24 VDC.
 - f. Turn start switch to OFF position.
 - g. Turn battery switch OFF.

CONDITION/INDICATION

IS BATTERY VOLTAGE PRESENT AT WIRE #10 CONNECTOR AT ABS WIRE HARNESS?

DECISION

NO - Replace wire (Volume 3, WP 0464). Go to Step (7) to verify problem is solved.
YES - Notify supervisor. It is possible another troubleshooting work package applies.

ABS - NO DATA (BLANK SCREEN ON HALDEX INFO-CENTER) - Continued**STEP**

7. IS YOUR ORIGINAL PROBLEM STILL PRESENT?
 - a. Ensure vehicle is returned to normal operating condition.
 - b. Perform ABS - Start - Retrieving Fault Codes With Haldex Info Center (Scan Tool) (WP 0161).
 - c. Check to see if your original fault code still exists.

CONDITION/INDICATION

IS YOUR ORIGINAL PROBLEM STILL PRESENT?

DECISION

YES - Notify supervisor.
NO - Problem fixed.

END OF WORK PACKAGE

CHAPTER 5

STE/ICE TROUBLESHOOTING PROCEDURES

FIELD MAINTENANCE STE/ICE TROUBLESHOOTING

INTRODUCTION

1. This chapter is applicable only if STE/ICE is available. This section contains information and tests which may be used with STE/ICE to locate malfunctions that may develop in the vehicle. The tests can be used during troubleshooting, Preventive Maintenance Checks and Service (PMCS), or after replacing parts to isolate malfunctions, anticipate failures, and ensure that proper repairs have been made.
2. STE/ICE is used primarily with the vehicle electrical system. These tests cannot cover all possible troubles which may occur. If a particular malfunction is not covered, refer to Electrical Troubleshooting (Volume 1, WP 0004), and locate the troubleshooting procedure for the malfunction observed.
3. These procedures are a step-by-step approach to a problem that directs tests and inspections toward the source of a problem and a successful solution.
4. Each malfunction symptom given for an individual component or system is followed by step(s) to determine the cause and corrective action you must take to remedy the problem.
5. Before taking any corrective action for a possible malfunction, the following rules should be followed:
 - a. Question operator to obtain any additional information that might help you to determine the cause of the problem.
 - b. Never overlook the chance the problem could be of a simple origin. The problem could require only a minor adjustment.
 - c. Use all senses to observe and locate troubles.
 - d. Use test instruments and gauges to help you determine and isolate problems.
 - e. Always isolate the system where the malfunction occurs and locate the defective component.
 - f. Use standard automotive theories and principles when troubleshooting the vehicles covered in this manual.
 - g. Operate the vehicle yourself to ensure the operator's description of the problem is correct.
6. This chapter cannot list all malfunctions that may occur. If a malfunction occurs that is not listed in the tables, notify supervisor.
7. If malfunction corrective action does not correct malfunction, notify supervisor.

CHAIN INDEXES

Use vehicle entry 06 on test select switches for M939/A1 series vehicles; 31 for M939A2 series vehicles.

CHAIN INDEXES - Continued

Table 1. Go-Chain Test Index, Combined Mode Chain.

GO TEST NUMBER	MODE	TEST TITLE
GO1	DCA	VTM Connections and Checkout (WP 0188)
GO2	TK	First Peak Test - Starter Current (WP 0189)
GO3	TK	Engine Start - Lubrication Check (WP 0190)
GO4	DCA	Charging Circuit and Battery Voltage Test (WP 0191)
GO5	DCA	Engine Warm-up/Coolant Check/Oil Pressure Test (WP 0192)
GO6	DCA	Governor Check/Power Test (WP 0193)
GO7	DCA	Idle Speed/Governor Check (WP 0194)
GO8	DCA	Compression Unbalance Test (WP 0195)
—	—	DC Voltage Test (WP 0196)

CHAIN INDEXES - Continued

Table 2. No-Go-Chain Test Index, Combined Mode Chain.

GO TEST NUMBER	MODE	TEST TITLE
NG05	TK	Low Oil Pressure Check (WP 0197)
NG20	DCA	No Crank - No Start (WP 0198)
NG30	DCA	Engine Crank - No Start (WP 0199)
NG31	DCA	Gauge Test (WP 0200)
NG50	DCA	Charging Circuit Tests (WP 0201)
NG80	DCA-TK	Starter Circuit Tests (WP 0202)
NG81	DCA	Battery Tests (WP 0203)
NG90	DCA	Governor/Power Test Fault Isolation (WP 0204)
NG130	DCA	Engine Tightness Test (WP 0181)

EXPLANATION OF TROUBLESHOOTING PROCEDURES

Troubleshooting procedures are defined as follows:

1. **STEP:** An action or process taken to isolate cause of fault.
2. **CONDITION/INDICATION:** States possible fault that may cause the symptom.
3. **DECISION:** Action required to move forward with next step or correct the fault.

END OF WORK PACKAGE

FIELD MAINTENANCE
STE/ICE TROUBLESHOOTING INDEX

STE/ICE TROUBLESHOOTING INDEX

Malfunction/Symptom

Troubleshooting Procedure

STE/ICE TROUBLESHOOTING GO CHAIN TEST

1. VTM Connections and Checkout.....	WP 0188
2. First Peak Test - Starter Current.....	WP 0189
3. Engine Start - Lubrication Check.....	WP 0190
4. Charging Circuit and Battery Voltage Test.....	WP 0191
5. Engine Warmup/Coolant Check/Oil Pressure Test.....	WP 0192
6. Governor Check/Power Test.....	WP 0193
7. Idle Speed/Governor Check.....	WP 0194
8. Compression Unbalance Test.....	WP 0195
9. DC Voltage Test.....	WP 0196

STE/ICE TROUBLESHOOTING NO-GO CHAIN TEST

1. Low Oil Pressure Check.....	WP 0197
2. No Crank - No Start.....	WP 0198
3. Engine Crank - No Start.....	WP 0199
4. Gauge Test.....	WP 0200
5. Charging Circuit Tests.....	WP 0201
6. Starter Circuit Tests.....	WP 0202
7. Battery Tests.....	WP 0203
8. Governor/Power Test Fault Isolation.....	WP 0204
9. Engine Tightness Test.....	WP 0205

END OF WORK PACKAGE

FIELD MAINTENANCE
G01: VTM CONNECTION AND CHECKOUT (PART 1)

INITIAL SETUP:

Personnel Required
(2)

References (cont.)
TM 9-6140-200-14
WP 0189

References
TM 9-4910-571-12&P

Equipment Condition
Vehicle parked and engine shut down.
(TM 9-2320-272-10)

TROUBLESHOOTING PROCEDURE**G01: VTM CONNECTION AND CHECKOUT (Part 1)****CAUTION**

VTM or DCA cable can be damaged by electrical arcing. Do not connect or disconnect VTM while vehicle is running. Connect DCA cable to VTM before connecting to diagnostic connector.

G01: VTM CONNECTION AND CHECKOUT (Part 1) - Continued

STEP

1. Setup VTM.
 - a. Pull OFF VTM power switch.
 - b. Connect DCA cable to VTM.
 - c. Connect DCA cable to vehicle.

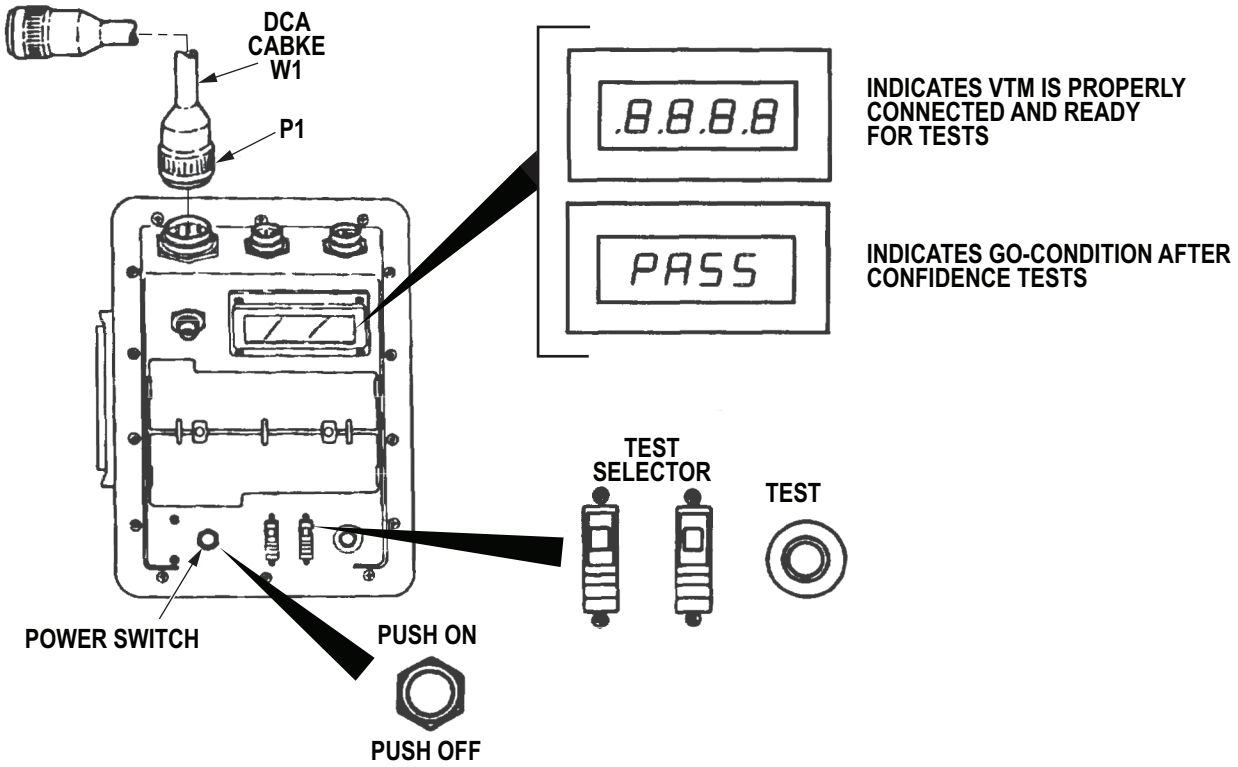

T0001DAA

Figure 1. STE/ICE Setup.

- d. Push ON VTM power switch.
- e. Check that display indicates .8.8.8.8 for approximately 2 seconds and then change to - - - -.

G01: VTM CONNECTION AND CHECKOUT (Part 1) - Continued

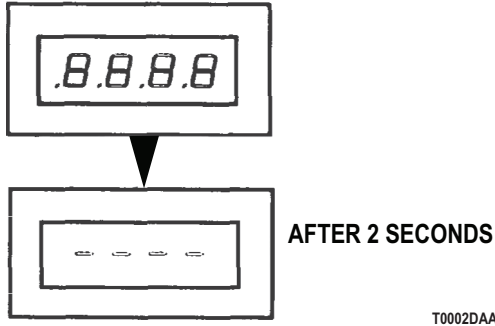

Figure 2. VTM Display.

CONDITION/INDICATION

Does VTM display .8.8.8.8 for approximately 2 seconds and then change to ----?

DECISION

- YES - Go to Step (5).
- NO - Go to Step (2).

STEP

2. Does display light up?

NOTE

If only a portion of .8.8.8.8 or ---- is displayed, a display module may be burned out. Check if display lights up.

CONDITION/INDICATION

Does display light up?

DECISION

- NO - Go to Step (3).
- YES - Refer to TM 9-4910-571-12&P for module replacement. Then go to Step (1).

G01: VTM CONNECTION AND CHECKOUT (Part 1) - Continued**STEP**

3. Display does not light up, proceed as follow.
 - a. Pull OFF VTM power switch.
 - b. Check and clean all battery connections.
 - c. Check and clean all interconnecting cables.
 - d. Push ON VTM power switch.
 - e. Check that display indicates .8.8.8.8 then change to — — — —.

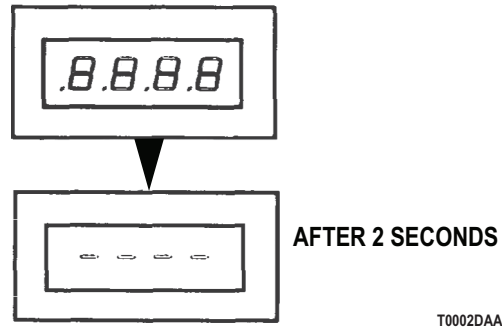

Figure 3. VTM Display.

CONDITION/INDICATION

Does VTM display .8.8.8.8 then change to — — — —?

DECISION

YES - Go to Step (5).
 NO - Go to Step (4).

STEP

4. Check STE/ICE operation.
 - a. Connect to a known good battery to see if problem is the vehicle or the VTM.
 - b. Pull OFF power switch.
 - c. Use W5 to connect to a known good battery.
 - d. Push ON power switch.
 - e. Check if VTM display .8.8.8.8 and the change to — — — —.

G01: VTM CONNECTION AND CHECKOUT (Part 1) - Continued

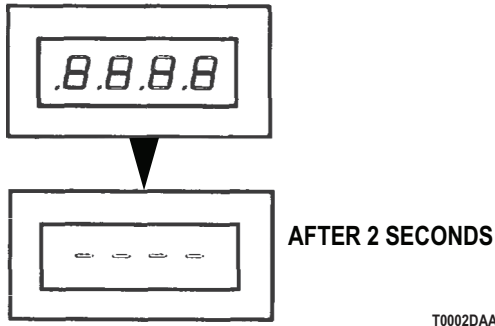

T0002DAA

Figure 4. VTM Display.

CONDITION/INDICATION

Does VTM display .8.8.8.8 and the change to — — —?

DECISION

YES - Refer to TM 9-6140-200-14 to check vehicle battery specific gravity. Go to Step (1) to restart.
 NO - Refer to TM 9-4910-571-12&P for module replacement.

STEP

5. Perform confidence test.
 - a. Dial 66 into TEST SELECT and press and release TEST.

Table 1. Confidence Test.

TEST NO.	TEST
66	Confidence Test

- b. Check if VTM display and hold 0066.

CONDITION/INDICATION

Does VTM display and hold 0066?

DECISION

YES - Go to Step (7).
 NO - Go to Step (6).

G01: VTM CONNECTION AND CHECKOUT (Part 1) - Continued

STEP

6. Rerun confidence test.
 - a. Pull OFF power switch.
 - b. Push ON VTM power switch.
 - c. Check that display indicates .8.8.8.8 for approximately 2 seconds and then change to ----.

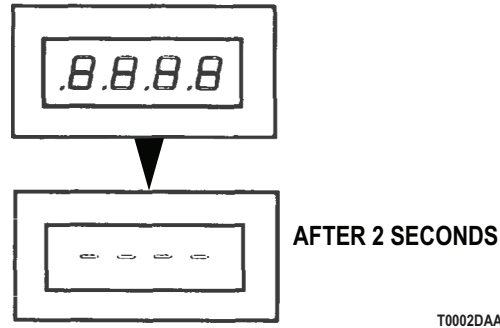

Figure 5. VTM Display.

- d. Re-Dial 66 and press and release TEST.
- e. Check if VTM display and hold 0066.

CONDITION/INDICATION

Does VTM display and hold 0066?

DECISION

YES - Go to Step (7).
 NO - STE-ICE is faulty, notify supervisor.

STEP

7. Run test 99.

NOTE

During the test, several numbers will appear on display. Wait for display of PASS. VTM can fail Confidence Test if bad transducer is connected to it. If VTM fails Confidence Test when powered by W1 (DCA mode), remove all cables from VTM and connect W5, then clip W5 to vehicle batteries. If it passes Confidence Test this way, there is a bad transducer in the vehicle DCA. If it fails, VTM has failed internally.

- a. Dial 99 into TEST SELECT and press and release TEST.

G01: VTM CONNECTION AND CHECKOUT (Part 1) - Continued

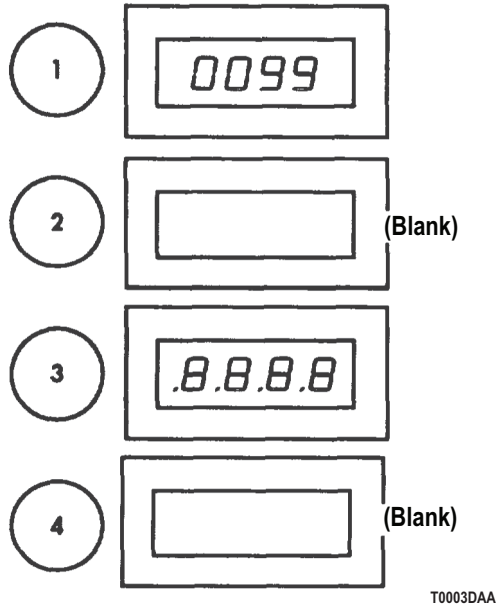

Figure 6. Test 99.

- b. Look for these displays.
- c. Check if VTM displays PASS.

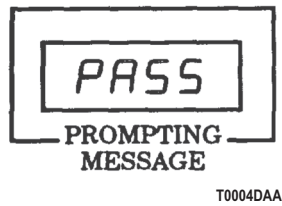

Figure 7. PASS Prompt Message.

CONDITION/INDICATION

Does VTM display PASS?

DECISION

- YES - Go to Step (9).
- NO - Go to Step (8).

G01: VTM CONNECTION AND CHECKOUT (Part 1) - Continued**STEP**

8. Perform VTM test.
 - a. Dial 66 into TEST SELECT and press and release TEST.
 - b. Check if VTM displays PASS.



Figure 8. PASS Prompt Message.

CONDITION/INDICATION

Does VTM display and PASS?

DECISION

- YES - Go to Step (9).
NO - STE-ICE is faulty, notify supervisor.

G01: VTM CONNECTION AND CHECKOUT (Part 1) - Continued

STEP

- 9. Enter vehicle identification number (VID).
 - a. Dial 60 into TEST SELECT and press TEST.



T0005DAA

Figure 9. VTM Display.

- b. When UEH appears, Dial Vehicle Identification Number.

Table 2. Vehicle Identification Number.

Vehicle	VID Number
M939/A1	06
M939A2	31

- c. VID entered should appear on display.

CONDITION/INDICATION

Does VTM display the vehicle identification number?

DECISION

- YES - Go to Step (10).
- NO - STE-ICE is faulty, notify supervisor.

G01: VTM CONNECTION AND CHECKOUT (Part 1) - Continued

STEP

- 10. Perform DCA transducer offset test.
 - a. Engine must be off.
 - b. Refer to table below.

Table 3. Offset Test.

DCA OFFSET TEST	
Test Number	24
Offset	45

Table 4. Fuel Pressure Test.

TEST NO.	TEST
24	Fuel Supply Pressure

- c. Dial test number listed into TEST/SELECT switches.
- d. Press and hold TEST each time until message CAL appears on display.

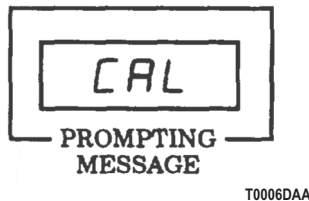

Figure 10. Calibration Prompt Message.

- e. When CAL appears, release TEST.
- f. Compare results on VTM for vehicle being tested with specification listed for each DCA offset.

CONDITION/INDICATION

Is transducer offset below its limit?

DECISION

YES - Go to GO2: First Peak Test - Starter Current. (WP 0189)
 NO - Refer to TM9-4910-571-12&P to troubleshoot DCA harness. Repeat offset test. If no fault is found, notify supervisor.

END OF WORK PACKAGE

FIELD MAINTENANCE
G02: FIRST PEAK TEST- STARTER CURRENT

INITIAL SETUP:

Personnel Required
(2)

References
TM 9-4910-571-12&P

References (cont.)
WP 0190
WP 0198
WP 0202
WP 0203

TROUBLESHOOTING PROCEDURE

G02: FIRST PEAK TEST– STARTER CURRENT**STEP**

1. Condition current probe – do offset.
 - a. Connect P1 of transducer cable W4 to J2 on VTM.
 - b. Connect P2 of cable W4 to connector on the current probe.
 - c. Clamp current probe around positive battery cable number 6 connected to starter.
 - d. Point arrow on the probe toward starter.

NOTE

If engine does not crank, go to NG20: No Crank No Start (WP 0198).

- e. Crank engine for several cycles with fuel shut off.
- f. Turn off all vehicle electrical accessories.
- g. Dial 72 into TEST SELECT.
- h. Press and hold TEST until CAL message appears on display.

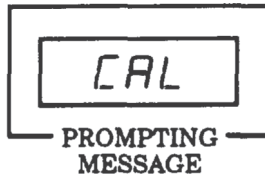

T0007DAA

Figure 1. CAL Prompt Message.

- i. Release TEST.
- j. Wait for offset to appear.

CONDITION/INDICATION

Is offset value within limits of -225 to +225?

DECISION

YES - Go to Step (2).

NO - Proceed to TM 9-4910-571-12&P for offset fault isolation.

G02: FIRST PEAK TEST– STARTER CURRENT - Continued**STEP**

2. Measure starter current - first peak test.
 - a. Press TEST.
 - b. Wait for prompting message GO to appear on display.

NOTE

While cranking the engine with bad or discharged batteries, it is possible for the VTM to lose power and come on again after the cranking has stopped, displaying — — —. If this ever occurs, immediately proceed to NG81: Battery Test (WP 0203).

- c. When GO appears shut off fuel and depress starter switch until OFF or an error message is displayed.

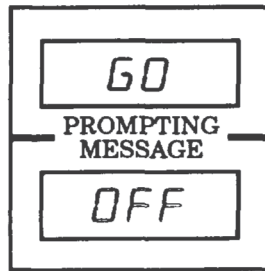

T0008DAA

Figure 2. GO Prompting Message.

CONDITION/INDICATION

Is a number displayed?

DECISION

- YES - Go to Step (3).
NO - Perform NG80: Starter Circuit Tests. (WP 0202)

G02: FIRST PEAK TEST– STARTER CURRENT - Continued

STEP

3. Check if first peak current is within specification.
 - a. Compare first peak current test results to table below.

VEHICLE	FIRST PEAK CURRENT
M939	800 - 1,400 AMPS
M939A1	1,700 - 1,800 AMPS
M939A2	1,195 - 1,662 AMPS

- b. Reset fuel shut off valves.

CONDITION/INDICATION

Is first peak current reading within specification?

DECISION

- YES - Perform G03: Engine Start – Lubrication Check. (WP 0190)
- NO - Perform NG80: Starter Circuit Tests. (WP 0202)

END OF WORK PACKAGE

FIELD MAINTENANCE
G03: ENGINE START- LUBRICATION CHECK

INITIAL SETUP:**Personnel Required**

(2)

References

TM 9-2320-272-10

WP 0191

References (cont.)

WP 0197

WP 0198

WP 0199

WP 0200

Volume 5, WP 0820

TROUBLESHOOTING PROCEDURE

G03: ENGINE START- LUBRICATION CHECK**STEP**

1. Check fluid levels.

CAUTION

Check oil level before starting engine.

- a. Check oil level.

Add oil if necessary (Volume 5, WP 0820).

WARNING

Do not remove cap from surge tank when engine is hot. Wait until engine cools.

CAUTION

When filling cooling system on M939A2 series vehicles, ensure drain valve on aftercooler is open. Failure to do so may result in damage to equipment.

- b. Remove surge tank cap, check coolant level.

Add coolant if necessary (Volume 5, WP 0820).

- c. Check battery electrolyte level.

Add distilled water if necessary.

CAUTION

Ensure all hydraulic power switches are off. Disengage manual hydraulic levers if vehicle is so equipped. Damage could result to vehicle.

- d. Start engine (TM 9-2320-272-10).

CONDITION/INDICATION

Does engine crank and start?

DECISION

YES - Go to Step (3).

NO - Go to Step (2).

STEP

2. Check if engine cranks.

CONDITION/INDICATION

Does engine crank?

DECISION

YES - Perform NG30: Engine Crank -No Start Test (WP 0199).

NO - Perform NG20: No Crank -No Start Test (WP 0198).

G03: ENGINE START- LUBRICATION CHECK - Continued**STEP**

3. Check oil pressure gauge.
 - a. Check oil pressure gauge for minimum oil pressure, 10 PSI (69 kPa).
 - b. If pressure is not within minimum, shut off engine (TM 9-2320-272-10).

CONDITION/INDICATION

Is oil pressure above limit?

DECISION

YES - Go to Step (4).
NO - Perform NG05: Low Oil Pressure Check. (WP 0197)

STEP

4. Generator operation.

Check generator indicator for normal reading.

CONDITION/INDICATION

Does generator indicator gauge read normal?

DECISION

YES - Perform G04: Charging Circuit and Battery Voltage Test (WP 0191).
NO - Go to Step (5).

G03: ENGINE START- LUBRICATION CHECK - Continued**STEP**

5. Check gauges.

Check all other vehicle gauges for normal readings.

CONDITION/INDICATION

Do all gauges show normal readings?

DECISION

YES - Perform G04: Charging Circuit and Battery Voltage Test (WP 0191).

NO - Go to Step (6).

STEP

6. Gauge operation.

Check if gauges operate properly.

CONDITION/INDICATION

Did suspect gauge stay at zero or immediately go to full scale when engine was started?

DECISION

YES - Perform NG31: Gauge Test (WP 0200).

NO - Perform gauge inoperative troubleshooting for faulty gauge. After completing repairs, rerun GO-Chain test to verify the problem is solved and no other problems exist.

END OF WORK PACKAGE

FIELD MAINTENANCE
G04: CHARGING CIRCUIT AND BATTERY VOLTAGE TEST

INITIAL SETUP:

Personnel Required
(2)

References
TM 9-2320-272-10
Volume 1, WP 0108

References (cont.)
WP 0192
WP 0201
WP 0300
WP 0301
Volume 5, WP 0780

TROUBLESHOOTING PROCEDURE

G04: CHARGING CIRCUIT AND BATTERY VOLTAGE TEST

STEP

1. Measure battery voltage.
 - a. Adjust engine speed to fast idle (TM 9-2320-272-10).
 - b. Turn headlights and accessories on (TM 9-2320-272-10).
 - c. Dial 67 into TEST SELECT and press TEST.

Table 1. Battery Voltage Test.

TEST NO.	TEST
67	Battery Voltage

- d. Watch display and verify battery voltage is within 26.5 - 29.5 VDC.

CONDITION/INDICATION

Is battery voltage within limits?

DECISION

- YES - Go to Step (2).
NO - Go to Step (3).

G04: CHARGING CIRCUIT AND BATTERY VOLTAGE TEST - Continued**STEP**

2. Generator operation.
 - a. Check generator indicator for normal reading.
 - b. Turn headlights and accessories off (TM 9-2320-272-10).
 - c. Shut off engine (TM 9-2320-272-10).

CONDITION/INDICATION

Does generator indicator gauge read normal?

DECISION

YES - Perform G05: Engine Warmup/Coolant Check/Oil Pressure Test (WP 0192).
NO - Perform Battery/Alternator Gauge Inoperative troubleshooting (Volume 1, WP 0108).

STEP

3. Battery voltage.

Check battery voltage.

CONDITION/INDICATION

Is battery voltage low?

DECISION

YES - Go to Step (4).
NO - If voltage is high, replace alternator M939/A1 60 amp (WP 0300), M939A2 60 amp (WP 0301), 100 amp (Volume 5, WP 0780). After repairs are complete rerun GO-chain test to verify problem is fixed.

STEP

4. Battery voltage test.
 - a. Battery voltage low.
 - b. Allow vehicle to run 5 minutes and watch display.
 - c. If voltage is not within limits, turn headlights and accessories off (TM 9-2320-272-10).
 - d. If voltage is not within limits, shut off engine (TM 9-2320-272-10).

CONDITION/INDICATION

Is battery voltage within limits?

DECISION

YES - Go to Step (5).
NO - Perform NG50: Charging Circuit Test (WP 0201).

G04: CHARGING CIRCUIT AND BATTERY VOLTAGE TEST - Continued**STEP**

5. Battery gauge reading.
 - a. Check if battery gauge read normal.
 - b. Turn headlights and accessories off (TM 9-2320-272-10).
 - c. Shut off engine (TM 9-2320-272-10).

CONDITION/INDICATION

Does battery gauge read normal?

DECISION

YES - Perform G05: Engine Warmup/Coolant Check/ Oil Pressure Test (WP 0192).

NO - Perform Battery /Alternator Gauge Inoperative troubleshooting (Volume 1, WP 0108).

END OF WORK PACKAGE

FIELD MAINTENANCE
G05: ENGINE WARMUP/COOLANT CHECK/OIL PRESSURE TEST

INITIAL SETUP:**Personnel Required**

(2)

References (cont.)

WP 0193

WP 0197

WP 0200

References

Volume 1, WP 0028

TROUBLESHOOTING PROCEDURE
G05: ENGINE WARMUP/COOLANT CHECK/OIL PRESSURE TEST**STEP**

1. Check for leaks and coolant temperature.
 - a. Check vehicle for oil, fuel, and coolant leaks.
 - b. Refer to appropriate maintenance section to repair any leaks.
 - c. Warm up engine to normal operating temperature 175°F to 200°F (79°C to 93°C).

CONDITION/INDICATION

Does temperature gauge read within limits above after a normal warmup period?

DECISION

YES - Go to Step (3).

NO - Go to Step (2).

STEP

2. Engine temperature.

Check engine temperature gauge indicates normal operating temperature.

CONDITION/INDICATION

Is temperature too high?

DECISION

YES - Perform Engine Overheats troubleshooting, (Volume 1, WP 0028) after completing repairs rerun GO-Chain tests. If no problems are found, perform NG31: Gauge Test (WP 0200).

NO - Perform NG31: Gauge Test (WP 0200).

G05: ENGINE WARMUP/COOLANT CHECK/OIL PRESSURE TEST - Continued

STEP

3. Check oil pressure.
 - a. Dial 10 into TEST SELECT and press TEST.

Table 1. Engine RPM Test.

TEST NO.	TEST
10	Engine RPM

NOTE

If VTM does not display RPM, refer to Electrical Troubleshooting, to check DCA wiring and pulse tachometer. Speeds given are approximate. If exact speed cannot be reached, check oil pressure at closest possible speed.

- b. Increase engine speed to 2,100 RPM.
- c. Watch vehicle oil pressure gauge.
- d. Verify oil pressure is within the limits.

Table 2. Engine Oil Pressure Specification.

Vehicle	Oil Pressure
M939/A1	55-75 PSI (379-517 kPa)
M939A2	30-80 PSI (207-552 kPa)

CONDITION/INDICATION

Is oil pressure within limits specified?

DECISION

- YES - Perform G06: Governor Check/Power Test (WP 0193).
 NO - Perform NG05: Low Oil Pressure Check (WP 0197).

END OF WORK PACKAGE

**FIELD MAINTENANCE
G06: GOVERNOR CHECK/POWER TEST**

INITIAL SETUP:

Personnel Required
(2)

References (cont.)
WP 0194
WP 0204

References
TM 9-2320-272-10

TROUBLESHOOTING PROCEDURE

G06: GOVERNOR CHECK/POWER TEST

CAUTION

Governor operation must be checked before performing the power test to avoid possible damage.

STEP

1. Governor operation.
 - a. Start engine (TM 9-2320-272-10).
 - b. Watch VTM display.
 - c. Gradually increase engine speed to maximum governor speed.

Table 1. Maximum Governor Speed.

Vehicle	Maximum Governor Speed
Loaded	2,100 RPM
Unloaded	2,100 RPM +300 -400 RPM

- d. Press farther on accelerator to full throttle.

CONDITION/INDICATION

Does engine RPM remain below maximum at full throttle?

DECISION

- YES - Go to Step (2).
NO - Notify supervisor.

G06: GOVERNOR CHECK/POWER TEST - Continued

STEP

CAUTION

Do not perform power test if engine temperature is above normal operating temperature. However, engine should be at operating temperature before performing power test.

NOTE

The vehicle identification number of G01 must have been entered prior to power test. This will prevent an error message (E004) and unsuccessful completion of the power test.

- 2. Perform power test.
 - a. Dial 13 into TEST SELECT and press TEST.

Table 2. Power Test.

Test No.	Test
13	Power Test (%Power)
P01	22
P02	81
P03	2

- b. Wait for prompting message CIP to appear.
- c. When CIP appears, press down on accelerator and hold it to floor until VTM display is off.

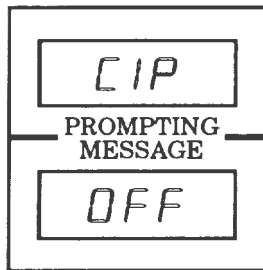

T0009DAA

Figure 1. CIP Prompting Message.

- d. When OFF appears, release accelerator.
- e. A number representing percent power will appear on VTM.

G06: GOVERNOR CHECK/POWER TEST - Continued

Table 3. Power Minimum Test Limits.

% Power Minimum Test Limit			
Vehicle	Altitude		
	0 to 2,000 FT	2,000 to 4,000	Above 4,000 FT
M939A2	75%	66%	60%

CONDITION/INDICATION

Is power within limits?

DECISION

YES - Perform G07: Idle Speed/Governor Check (WP 0194).

NO - Perform NG90: Governor/Power Test Fault Isolation (WP 0204).

END OF WORK PACKAGE

**FIELD MAINTENANCE
G07: IDLE SPEED/GOVERNOR CHECK**

INITIAL SETUP:

Personnel Required
(2)

References
WP 0195

TROUBLESHOOTING PROCEDURE

G07: IDLE SPEED/GOVERNOR CHECK

STEP

1. Check engine idle speed.
 - a. Dial 10 into TEST SELECT and press TEST.

Table 1. Engine RPM Test.

TEST NO.	TEST
10	Engine RPM

- b. Adjust engine idle speed to 500-650 RPM.
 - c. Watch VTM readout display for about 10 seconds to verify idle speed remains within tolerance.

CONDITION/INDICATION

Is engine idle speed within limits?

DECISION

- YES - Go to Step (2).
- NO - Notify supervisor.

STEP

2. Shut down engine.

CONDITION/INDICATION

DECISION

- YES - Perform G08:Compression Unbalance Test Test (WP 0195).
- NO - Notify supervisor.

END OF WORK PACKAGE

FIELD MAINTENANCE
G08: COMPRESSION UNBALANCE TEST

INITIAL SETUP:

Personnel Required
(2)

TROUBLESHOOTING PROCEDURE**G08: COMPRESSION UNBALANCE TEST****CAUTION**

Do not perform more than 2 compression unbalance tests in a row or vehicle batteries may be discharged.
Engine must be at normal operating temperature before performing compression unbalanced test.

G08: COMPRESSION UNBALANCE TEST - Continued

STEP

NOTE

Compression unbalanced test takes approximately 15 seconds to run.

1. Run compression unbalance test.
 - a. Shut off fuel supply so engine will not start.
 - b. Dial 14 into TEST SELECT and press TEST.

Table 1. Engine RPM Test.

TEST NO.	TEST
14	Compression Unbalance

- c. Wait for prompting message GO to appear.



Figure 1. GO Prompting Message.

- d. When GO appears, crank engine.
- e. Just after starting to crank, VTM display should change to - - - -, indicating VTM is accepting data.
- f. Stop cranking when VTM displays OFF or E013.

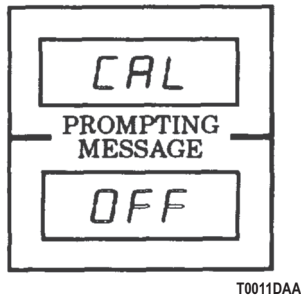

Figure 2. CAL Prompting Message.

- g. Wait for a number to be displayed.

G08: COMPRESSION UNBALANCE TEST - Continued**CONDITION/INDICATION**

Does VTM display a number?

DECISION

YES - Go to Step (4).

NO - Go to Step (2).

STEP

2. Check VTM display message.

Check if VTM displays GO.

CONDITION/INDICATION

Does VTM display GO?

DECISION

YES - Go to Step (1).

NO - Go to Step (3).

STEP

3. Check VTM display message.

Check if VTM displays FAIL.

CONDITION/INDICATION

Does VTM display FAIL?

DECISION

YES - Go to Step (1). If FAIL message still appears, notify supervisor.

NO - VTM displays E013, this may indicate discharged batteries or low cranking speed. Also, operator may have stopped cranking during test. Check and repeat test.

STEP

4. Check test limits.

Compression unbalance test limit is 0-15%.

CONDITION/INDICATION

Is compression unbalance within limits?

DECISION

YES - End of Go-chain testing.

NO - Rerun compression unbalanced test. If unbalanced test is still out of limits, notify supervisor.

END OF WORK PACKAGE

**FIELD MAINTENANCE
DC VOLTAGE TEST**

INITIAL SETUP:

Not Applicable

TROUBLESHOOTING PROCEDURE

DC VOLTAGE TEST

NOTE

Perform VTM CONNECTIONS AND Checkout Instructions, G01.

DC VOLTAGE TEST - Continued

STEP

1. Perform offset test.
 - a. Attached P1 of test probe cable W2 to J4 on VTM.

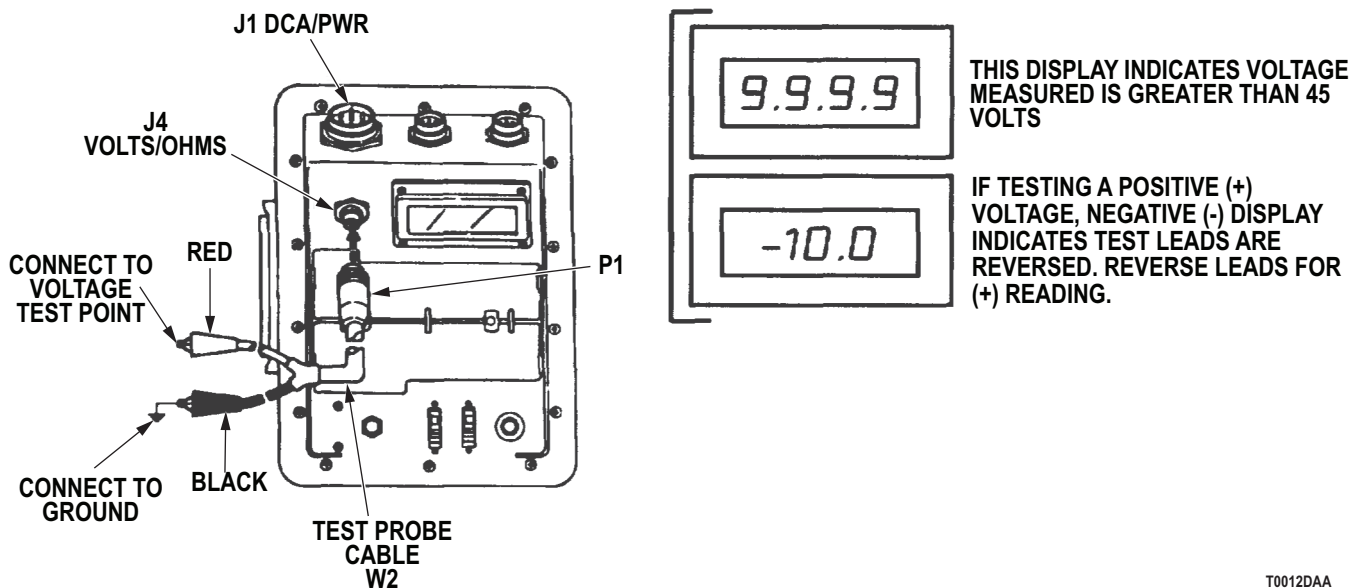

Figure 1. STE/ICE Test.

- b. Short red and black clip leads of the cable together.
- c. Dial 89 into TEST SELECT.

Table 1. Voltage Test.

TEST NO.	TEST
89	0-45 Volts DC
27	Fuel Solenoid Voltage
82	Alt/Gen Output Voltage
84	Alt/Gen Negative Cable Voltage Drop

- d. Press and hold TEST in until message CAL appears on display.

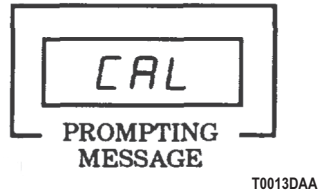
DC VOLTAGE TEST - Continued*Figure 2. CAL Prompt Message.*

- e. Release test.
- f. Wait for offset value to appear on display.

CONDITION/INDICATION

Is offset value within limits of -6.8 to +6.8?

DECISION

- YES - Go to Step (2).
- NO - STE/ICE bad, replace.

STEP**NOTE**

DC VOLTAGE (TEST 89). This test allows VTM to be used as a voltmeter. Voltmeter is automatically ranged (autoranged) through three voltage ranges: 0-0.5 volt, 0-4.5 volts, and 0-45 volts DC. Decimal point will automatically move to correct position. Each time you want to make a measurement, connect read lead to positive (+) side and black lead to negative (-) side of cable or item being tested. If polarity is reversed, you will get a minus (-) sign in readout; numerical value is correct.

- 2. Connect test equipment.
 - a. Connect red clip lead to voltage test point. This is positive (+) point if a + voltage is being tested.
 - b. Connect black clip lead to ground.

STEP

- 3. Perform voltage test.
 - a. Turn ON circuit if voltage is not voltage is not already present.
 - b. Press TEST.
 - c. If VTM reads .9.9.9.9, voltage measured is greater than 45 volts.

CONDITION/INDICATION

Displaced value is the test result.

DECISION**END OF WORK PACKAGE**

**FIELD MAINTENANCE
NG05: LOW PRESSURE CHECK**

INITIAL SETUP:

Personnel Required

(2)

References

TM 9-2320-272-10
TM 9-4910-571-12&P

References (cont.)

Volume 1, WP 0017
WP 0200
WP 0232
Volume 5, WP 0820

TROUBLESHOOTING PROCEDURE

STEP

1. Install transducer, do offset.
 - a. Stop vehicle engine (TM 9-2320-272-10).
 - b. Remove oil pressure sending unit.
 - c. Install pressure transducer TK item 17 (blue stripe) in place of sending unit on engine.
 - d. Connect P1 of transducer cable W4 to J1 or J2 on VTM.
 - e. Connect P2 of transducer cable to connector on pressure transducer.

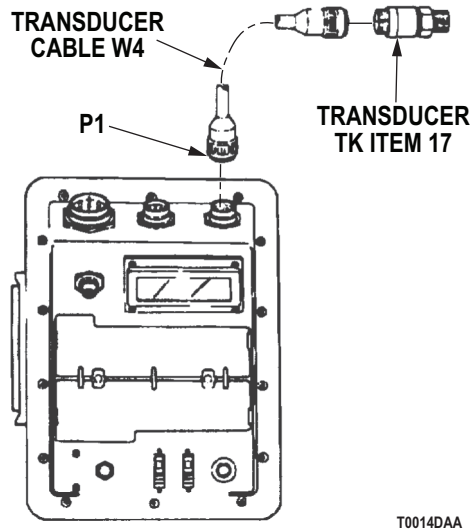

Figure 1. STE/ICE Setup.

- f. Dial 50 into TEST SELECT.
- g. Press and hold TEST until CAL message appears on display.

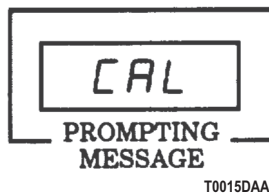

Figure 2. CAL Prompt Message.

- h. Release TEST.
- i. Wait for offset value to appear on display.

CONDITION/INDICATION

Is offset vaue within the limits -150 to +150?

DECISION

- YES - Go to Step (2).
- NO - Proceed to TM 9-4910-571-12&P for offset fault isolation.

STEP

2. Perform oil pressure check.
 - a. Dial 01 into TEST SELECT and press TEST.
 - b. When PASS appears, dial 50 into TEST SELECT and press TEST. VTM will display RPM and oil pressure alternately.



Figure 3. Pass Prompt Message.

- c. Start engine and hold engine speed at 2,100 RPM (TM 9-2320-272-10).
- d. Check VTM display for correct oil pressure.

Table 1. Oil Pressure Limits

VEHICLE	Oil Pressure Limits
M939/A1	55-75 PSI (397-517 kPa)
M939A2	30-80 PSI (207-552 kPa)

- e. If oil pressure is not within limits, stop engine immediately (TM 9-2320-272-10).

CONDITION/INDICATION

Is oil pressure within limits?

DECISION

- YES - Go to NG31: Gauge Test (WP 0200).
- NO - Go to Step (3).

STEP

3. Check oil type, change oil filter, and recheck oil pressure.
 - a. Refer to lubrication instructions to check oil type and replace oil if necessary (Volume 5, WP 0820).
 - b. Replace oil filter (WP 0232).
 - c. Dial 01 into TEST SELECT and press TEST.
 - d. When PASS appears, dial 50 into TEST SELECT and press TEST. VTM will display RPM and oil pressure alternately.

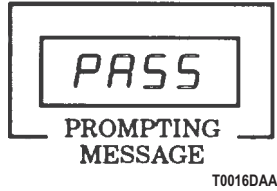

Figure 4. Pass Prompt Message.

- e. Start engine and hold engine speed at 2,100 RPM (TM 9-2320-272-10).
- f. Check VTM display for correct oil pressure.

Table 2. Oil Pressure Limits

VEHICLE	Oil Pressure Limits
M939/A1	55-75 PSI (397-517 kPa)
M939A2	30-80 PSI (207-552 kPa)

- g. If oil pressure is not within limits, stop engine immediately (TM 9-2320-272-10).

CONDITION/INDICATION

Is oil pressure within limits?

DECISION

- NO - Perform Low Oil Pressure troubleshooting (Volume 1, WP 0017).
 YES - After completing repair, rerun Go-Chain test to verify problem is solved and no other problem exists.

END OF WORK PACKAGE

FIELD MAINTENANCE
NG20: NO CRANK- NO START

INITIAL SETUP:**Personnel Required**

(2)

References (cont.)

WP 0202

WP 0220

WP 0221

WP 0303

References

TM 9-2320-272-10

TM 9-4910-571-12&P

TROUBLESHOOTING PROCEDURE**NG20: NO CRANK- NO START****STEP**

1. Try to crank engine.
 - a. Set vehicle controls to crank engine (TM 9-2320-272-10).
 - b. Depress starter switch and listen to starter motor.

CONDITION/INDICATION

Does starter motor sound like it is running overspeed?

DECISION

YES - Go to Step (2).

NO - Perform NG80: Starter Circuit Tests (WP 0202).

STEP

2. Check teeth on flywheel.
 - a. Remove starter (WP 0303).
 - b. Check for missing and/or damaged teeth on flywheel.

CONDITION/INDICATION

Are all teeth good?

DECISION

YES - Replace starter (WP 0303). After completing repair, rerun GO-chain tests to verify the problem is fixed and no other problem exists.

NO - Replace flexplate M939/A1 (WP 0220), M939A2 (WP 0221). After completing repair, rerun GO-chain tests to verify the problem is fixed and no other problem exists.

END OF WORK PACKAGE

FIELD MAINTENANCE
NG30: ENGINE CRANK - NO START

INITIAL SETUP:**Personnel Required**

(2)

References (cont.)

Volume 1, WP 0021

WP 0202

WP 0239

WP 0258

References

TM 9-2320-272-10

TM 9-4910-571-12&P

TROUBLESHOOTING PROCEDURE**NG30: ENGINE CRANK - NO START****STEP**

1. Perform crank speed test.
 - a. Shut off fuel.
 - b. Dial 10 into TEST SELECT and press TEST.

Table 1. Engine RPM Test.

TEST NO.	TEST
10	Engine RPM (Average)

- c. Crank engine and watch readout display.
- d. Compare result with minimum cranking speed of 100 RPM.

CONDITION/INDICATION

Is cranking speed OK?

DECISION

YES - Go to Step (2).

NO - Go to NG80: Starter Circuit Test (WP 0202).

NG30: ENGINE CRANK - NO START - Continued**STEP**

2. Check fuel supply.
 - a. Verify there is fuel in tank.
 - b. If fuel filters have been changed or if fuel tank has been run dry, bleed air out of fuel system as necessary M939/A1 (TM 9-2320-272-10), M939A2 (WP 0239).
 - c. Drain any water from primary fuel filter. Continue to drain until fuel appears (TM 9-2320-272-10).
 - d. Check for kinked, flattened, or broken fuel lines from tank to filters and engine.
 - e. If equipped with quick-disconnect fitting, check for blockage in quick-disconnect.
 - f. Check fuel shutoff solenoid and circuitry, and emergency fuel shutoff.

CONDITION/INDICATION

Is fuel supply OK?

DECISION

YES - Go to Step (4) (M939/A1 vehicles). Go to Step (3) (M939A2 vehicles).
 NO - Go to Step (7).

STEP

3. Install transducer— do offset.
 - a. Stop vehicle engine.
 - b. Remove plug on transfer pump.
 - c. Install blue stripe TK pressure transducer in place of plug on transfer pump.
 - d. Connect P1 of transducer cable W4 to J1 or J2 on VTM.
 - e. Connect P2 of transducer cable to connector on pressure transducer.
 - f. Dial 50 into TEST SELECT.
 - g. Press and hold TEST until CAL message appears on display.



Figure 1. CAL Prompt Message.

- h. Release TEST.
- i. Wait for offset value to appear on display.

NG30: ENGINE CRANK - NO START - Continued**CONDITION/INDICATION**

Is offset value within limits -150 to +150?

DECISION

YES - Go to Step (4).

NO - Proceed to TM 9-4910-571-12&P for offset fault isolation.

STEP

4. Perform fuel pressure test.
 - a. Turn on fuel and accessory switch.
 - b. Dial 50 into TEST SELECT and press TEST.

Table 2. Pressure Test.

TEST NO.	TEST
50	0-1,000 PSIG Pressure

- c. Crank engine and watch readout display.
- d. Number on display should be above 3 PSI (21 kPa).

CONDITION/INDICATION

Is fuel pressure above limit specified?

DECISION

YES - Go to Step (5).

NO - Go to Step (6).

STEP

5. Check engine shutoff device and air intake system, and retest system.
 - a. Refer to TM 9-2320-272-10 for proper operation of engine shutoff device.
 - b. Check for restricted air intake.
 - c. Attempt to start engine (TM 9-2320-272-10).

CONDITION/INDICATION

Does engine start?

DECISION

YES - After completing repair, rerun GO-Chain tests to verify problem is solved and no other problem exists.

NO - If engine still does not start and weather is cold, perform Engine Cranks But Will Not Start In Cold Weather (Fuel System Operating Properly) troubleshooting (Volume 1, WP 0021).

NG30: ENGINE CRANK - NO START - Continued**STEP**

6. Measure fuel pressure during crank.

NOTE

If display is negative (-), then it is not greater than 2 IN HG.

- a. Turn on fuel and accessory switch.
- b. Press TEST.
- c. Crank engine and watch VTM display.

CONDITION/INDICATION

Is reading greater than 2IN. HG?

DECISION

YES - Go to Step (7).

NO - Replace fuel filter (WP 0258). Repeat Step (4). If pressure is still low, fuel pump is defective.

STEP

7. Inspect fuel lines.
- a. In freezing temperatures, check for ice in lines or thickening of fuel.
 - b. Inspect fuel lines and in tank filters (if any) for kinks, blockage, or damage.
 - c. Check fuel tank vent.
 - d. Check operation of in tank pump (if any).
 - e. Repair as necessary.
 - f. Attempt to start engine (TM 9-2320-272-10).

CONDITION/INDICATION

Does engine start?

DECISION

YES - After completing repair, rerun GO-Chain tests to verify the problem is solved and no other problems exist.

NO - Notify supervisor.

END OF WORK PACKAGE

**FIELD MAINTENANCE
NG31: GAUGE TEST**

INITIAL SETUP:

Personnel Required
(2)

References
Volume 1, WP 0106
WP 0334

TROUBLESHOOTING PROCEDURE

NG31: GAUGE TEST

STEP

1. Perform offset test.
 - a. Connect P1 of test probe cable W2 to J4 on VTM.
 - b. Short red and black clips together.
 - c. Dial 89 into TEST SELECT.

Table 1. Voltage Test.

TEST NO.	TEST
89	0-45 Volts DC

- d. Press and hold TEST until CAL message appears on display.

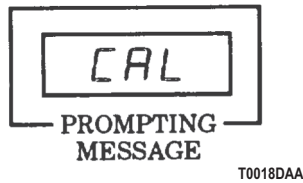

Figure 1. CAL Prompt Message.

- e. Release TEST.
- f. Wait for offset value to appear on display.

CONDITION/INDICATION

Is offset value within limits of -6.8 to +6.8?

DECISION

- YES - Go to Step (2).
- NO - STE/ICE is bad. Notify supervisor.

NG31: GAUGE TEST - Continued**STEP**

2. Perform voltage test.
 - a. Remove wire from temperature sending unit on vehicle.
 - b. Connect red clip lead of W2 to wire removed from sending unit.
 - c. Connect black clip lead to a good ground.
 - d. Turn vehicle accessory switch ON.

CONDITION/INDICATION

Does VTM indicate battery voltage?

DECISION

YES - Replace temperature sending unit (WP 0334). After completing repair, rerun GO-Chain tests to verify problem is solved and no other problem exists.

NO - Perform Temperature Gauge Inoperative (Coolant) troubleshooting (Volume 1, WP 0106).

END OF WORK PACKAGE

FIELD MAINTENANCE
NG50: CHARGING CIRCUIT TESTS

INITIAL SETUP:**Personnel Required**

(2)

References

Volume 1, WP 0089

Volume 1, WP 0090

WP 0202

WP 0296

References (cont.)

WP 0297

WP 0300

WP 0301

WP 0302

WP 0349

WP 0350

Volume 5, WP 0780

TROUBLESHOOTING PROCEDURE**NG50: CHARGING CIRCUIT TESTS****STEP****WARNING**

Turn vehicle engine off.

1. Check drivebelt.

Refer to No Alternator Output troubleshooting 60 amp (Volume 1, WP 0089), 100 amp (Volume 1, WP 0090), to check alternator/generator drive belts for proper tension.

CONDITION/INDICATION

Are drivebelts OK?

DECISION

YES - Go to Step (2).

NO - Replace drivebelts M939/A1 (WP 0302), M939A2 (WP 0296). After completing repair, rerun GO-Chain tests to verify problem is solved and no other problem exists.

NG50: CHARGING CIRCUIT TESTS - Continued

STEP

2. Perform charging system test.
 - a. Start vehicle engine.
 - b. Turn on vehicle lights.
 - c. Set engine speed to fast idle.
 - d. Dial 89 into TEST SELECT and press TEST.

Table 1. Voltage Test.

TEST NO.	TEST
89	Alt/Gen Output Voltage

CONDITION/INDICATION

Is reading between 26.5 and 29.5 VDC?

DECISION

YES - Repair bad connections or broken cables in charging system output (WP 0349) and ground circuits (WP 0350). If problem still exists, replace alternator M939/A1 60 amp (WP 0300), M939A2 60 amp (WP 0301), 100 amp (Volume 5, WP 0780). After completing repair, rerun GO-Chain tests to verify problem is solved and no other problem exists.

NO - Go to NG80: Starter Circuit Test (WP 0202).

END OF WORK PACKAGE

FIELD MAINTENANCE
NG80: STARTER CIRCUIT TESTS

INITIAL SETUP:**Personnel Required**

(2)

References

TM 9-4910-571-12&P

References (cont.)

WP 0203

WP 0205

WP 0303

WP 0349

TROUBLESHOOTING PROCEDURE**NG80: STARTER CIRCUIT TESTS****NOTE**

While cranking engine with bad or discharged batteries, it is possible for VTM to lose power and come on again after cranking has stopped, displaying - - - -. If this occurs, clean battery posts and clamps and try again. If VTM still loses power, connect VTM power cable to good batteries in another vehicle and perform the following tests using test probe cable W2.

NG80: STARTER CIRCUIT TESTS - Continued

STEP

1. Setup test equipment.
 - a. M939/A1.

NOTE

Current probe should be at least 10 in. (24.5 cm) from alternator.

- (1) Install current probe on positive starter cable connected to starter. Point arrow on probe toward starter.
 - (2) Ensure current probe is closed.
 - (3) Try to crank engine for several cycles with fuel shutoff.
 - (4) Unclamp current probe from battery cable.
- b. M939A2.
 - (1) Install current probe around output wire on alternator.
 - (2) Point arrow on probe away from alternator.
2. Do current probe offset.
 - a. Turn off all vehicle electrical power.
 - b. Dial 74 into TEST SELECT.

Table 1. Starter Circuit Resistance Test.

Test NO.	Test
74	Starter Circuit Resistance

- c. Press and hold TEST until CAL message appears on the display.

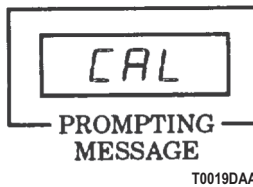

Figure 1. CAL Message.

- d. Release TEST.
 - e. Wait for offset value to appear.

CONDITION/INDICATION

Is offset value within limits of -225 to +225?

DECISION

- YES - Go to Step (3).
- NO - Proceed to TM 9-4910-571-12&P for offset fault isolation.

NG80: STARTER CIRCUIT TESTS - Continued**STEP**

3. Perform starter circuit resistance test.
 - a. Shut off fuel.
 - b. Press TEST.
 - c. When GO appears, attempt to crank engine.

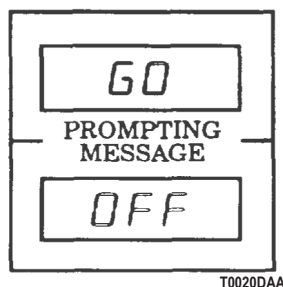

Figure 2. Prompt Message.

NOTE

Error message indicates short circuit, frozen starter, or tight engine.

- d. Stop cranking engine when VTM displays OFF or an error message.

CONDITION/INDICATION

Is a number displayed?

DECISION

YES - Go to Step (5).

NO - Go to Step (4).

STEP

4. Check VTM display.
Check if GO is displayed.

CONDITION/INDICATION

Is GO still displayed?

DECISION

YES - Try again. If GO is still displayed after crank attempt, starter not being energized, go to Step (9).

NO - Go to Step (7).

NG80: STARTER CIRCUIT TESTS - Continued

STEP

5. Compare test results.

Compare number to test limits in table below.

Table 2. Starter Circuit Resistance.

Vehicle	Starter Circuit Resistance (Milliohms)
M939/A1	30
M939A2	10.4 to 12.8

CONDITION/INDICATION

Is starter circuit resistance within limits specified in table?

DECISION

YES - Go to NG81: Battery Tests (WP 0203).

NO - Go to Step (6).

STEP

6. Resistance reading.

Check if resistance is higher or lower than test limits.

CONDITION/INDICATION

Is resistance high?

DECISION

YES - Go to Step (9).

NO - No resistance, look for short in starter circuit. If none found, replace starter (WP 0303). After completing repair, rerun GO-Chain tests to verify problem is solved and no other problem exists.

NG80: STARTER CIRCUIT TESTS - Continued

STEP

- 7. Perform starter current test.
 - a. Dial 90 into TEST SELECT and press TEST.

Table 3. Starter Circuit Tests.

Test NO.	Test
89	0-45 VOLTS DC
90	0-1,500 AMPS DC

- b. Crank engine for a few seconds with fuel off.

CONDITION/INDICATION

Is starter current above 100 AMPS?

DECISION

YES - Go to Step (8).
 NO - Go to NG81: Battery Tests (WP 0203).

STEP

- 8. Perform repairs.
 - a. Error message E013, displayed in Step (3), indicates short circuit, frozen starter, or tight engine.
 - b. Check wiring to starter for short circuits. Repair as necessary.

CONDITION/INDICATION

Were repairs made?

DECISION

YES - Rerun GO-Chain tests to verify problem is solved and no other problem exists.
 NO - Go to NG130: Engine Tightness Test (WP 0205).

NG80: STARTER CIRCUIT TESTS - Continued

STEP

9. Perform starter voltage drop.
 - a. Dial 68 into TEST SELECT and press TEST.

Table 4. Starter Motor Voltage Test.

Test NO.	Test
68	Starter Motor Voltage

- b. Crank engine and observe displayed voltage.

Table 5. Starter Voltage.

Vehicle	Starter Solenoid Voltage
M939/A1	17 Volts
M939A2	18.5 Volts

CONDITION/INDICATION

Is voltage above minimum starter solenoid voltage?

DECISION

- YES - Go to Step (10).
- NO - Go to Step (11).

NG80: STARTER CIRCUIT TESTS - Continued**STEP**

10. Perform starter negative cable drop.
- a. Dial 69 or 89 into TEST SELECT and press TEST.

Table 6. Starter Negative Cable Drop Tests.

Test NO.	Test
69, 89*	Starter Negative Cable Drop
* for M939/A1	

- b. Crank engine and observe displayed voltage.

CONDITION/INDICATION

Is cable drop less than limit on VTC?

DECISION

YES - Replace starter motor (WP 0303). After completing repair, rerun GO-Chain tests to verify problem is solved and no other problem exists.

NO - Inspect and clean all ground cables from starter, engine, and batteries, and check for integrity. Repair as necessary. After completing repair, rerun GO-Chain tests to verify problem is solved and no other problem exists.

NG80: STARTER CIRCUIT TESTS - Continued

STEP

- 11. Perform starter solenoid voltage test.
 - a. Dial 70 into TEST SELECT and press TEST.

Table 7. Starter Solenoid Voltage Test.

Test NO.	Test
70	Starter Solenoid Voltage

- b. Crank engine and observe displayed voltage.

Table 8. Starter Voltage.

Vehicle	Starter Solenoid Voltage
M939/A1	17 Volts
M939A2	18.5 Volts

CONDITION/INDICATION

Is starter solenoid voltage above minimum starter solenoid voltage?

DECISION

YES - If starter resistance was high in Step (3), check positive battery cables (WP 0349) and connections to starter solenoid. Repair if necessary. If OK replace solenoid. If GO message occurred during Start Circuit Resistance Test in Step (3), check switches and wiring to solenoid. If OK, Replace starter motor (WP 0303). After completing repair, rerun GO-Chain tests to verify problem is solved and no other problem exists.
 NO - Go to Step (12).

NG80: STARTER CIRCUIT TESTS - Continued

STEP

- 12. Perform battery voltage while cranking test.
 - a. Dial 67 into TEST SELECT and press TEST.

Table 9. Battery Voltage Test.

Test NO.	Test
67	Battery Voltage

- b. Crank engine and observe displayed voltage.

CONDITION/INDICATION

Was battery voltage above 19 volts while cranking?

DECISION

YES - Check switches and wiring to starter solenoid. Repair as necessary. After completing repair, rerun GO-Chain tests to verify problem is solved and no other problem exists.
 NO - Go to NG81: Battery Tests (WP 0203).

END OF WORK PACKAGE

**FIELD MAINTENANCE
NG81: BATTERY TESTS**

INITIAL SETUP:**Personnel Required**
(2)**References**
TM 9-4910-571-12&P
WP 0346

TROUBLESHOOTING PROCEDURE**NG81: BATTERY TESTS****NOTE**

Each battery is best tested individually. During this test, supply must be shut off to keep engine from starting.

STEP

1. Perform offset test.
 - a. Connect test probe cable W2 to J4 on VTM.
 - b. Short red and black clips leads of W2 together.
 - c. Dial 89 into TEST SELECT.
 - d. Press and hold TEST until CAL appears on display.

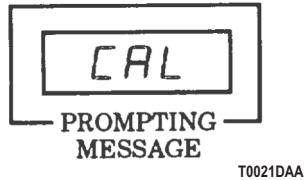

Figure 1. CAL Prompting Message.

- e. Release TEST.
- f. Wait for offset value to appear on display.

CONDITION/INDICATION

Is offset value within limits of -6.8 to +6.8?

DECISION

- YES - Go to Step (2).
NO - Proceed to TM 9-4910-571-12&P for offset fault isolation.

NG81: BATTERY TESTS - Continued

STEP

2. Perform current probe offset test.
 - a. Connect red clip lead of W2 to positive battery being tested.
 - b. Connect black clip lead of W2 to negative battery being tested.
 - c. Connect P1 of transducer cable W4 to J3 of VTM.
 - d. Connect P2 of transducer cable W4 to current probe.

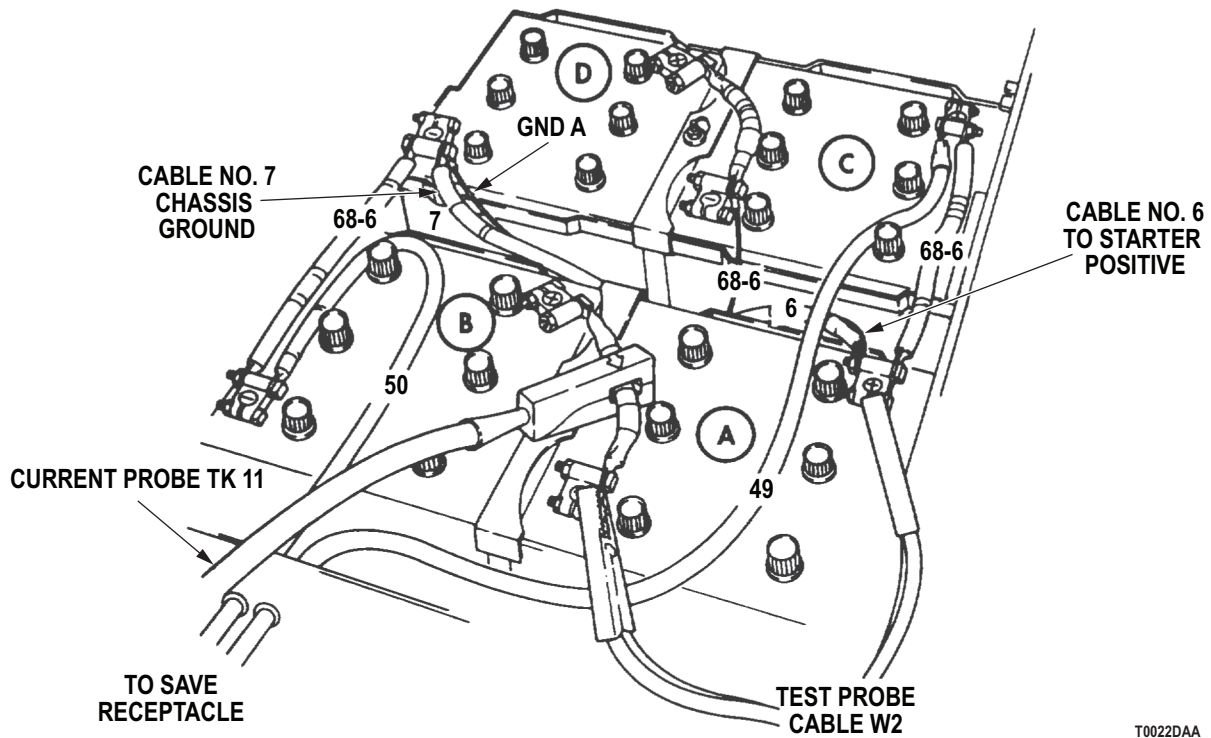

Figure 2. Battery Tests.

NG81: BATTERY TESTS - Continued**NOTE**

- Test each battery of a series pair, then proceed to batteries of next series pair.
 - To find series pair of batteries is connected by a cable to positive terminal of another battery. This makes two batteries a series pair. For example, in figure below, batteries A and B are a series pair, and batteries C and D are also a series pair.
 - To test battery A or B, clamp current probe around cable connecting battery A and battery B. Point arrow on current probe in direction of negative post connected to cable.
 - Test probe cable W2 is first connected to battery A for testing battery A.
 - Test probe cable W2 is first connected to battery B for testing battery B. (Current probe in same place as for testing battery A.)
 - To test battery C or D, clamp current probe around cable connecting battery C and battery D. Point arrow on current probe in direction of negative post connected to cable.
 - Test probe cable W2 is first connected to battery C for testing battery C.
 - Test probe cable W2 is first connected to battery D for testing battery D.
- e. Clamp probe around battery cable which connects series pair of batteries containing battery to be tested. Point arrow on current probe toward negative post connected to battery cable, as shown.
 - f. Attempt to crank engine for several cycles.
 - g. Turn off all vehicle electrical power.
 - h. Dial 90 into TEST SELECT.
 - i. Press and hold TEST until CAL message appears on the display.



Figure 3. CAL Prompting Message.

- j. Release TEST.
- k. Wait for offset value to appear.

CONDITION/INDICATION

Is offset value within limits of -225 to +225?

DECISION

YES - Go to Step (3).

NO - Proceed to TM 9-4910-571-12&P for offset fault isolation.

NG81: BATTERY TESTS - Continued

STEP

3. Measure battery resistance change.

Dial 79 into TEST SELECT and press TEST.

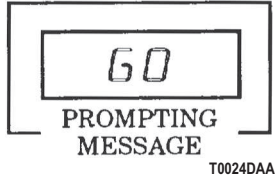

Figure 4. GO Prompting Message.

Table 1. Battery Resistance Change Test.

Test NO.	Test
79	Battery Resistance Change

CONDITION/INDICATION

Does GO appear?

DECISION

YES - Go to Step (4).

NO - Error message is displayed. Refer to TM 9-4910-571-12&P, correct as necessary, and repeat Step (3).

STEP

4. Perform resistance test.

a. Depress starter switch until OFF appears on display.



Figure 5. OFF Prompting Message.

b. Wait for display to change.

CONDITION/INDICATION

Is a number displayed?

DECISION

YES - Go to Step (6).

NO - Go to Step (5).

NG81: BATTERY TESTS - Continued**STEP**

5. Check batteries.
 - a. If display shows GO, there is a bad connection in starter circuit. Check cables and connections to starter and retest. If display still shows GO, then you may have a very poor battery in series pair being tested. Test other battery in the pair.
 - b. If display shows .9.9.9.9, there may be a bad connection on battery being tested. Clean and tighten connections on battery and retest.
 - c. If display shows E013, - - - -, or .9.9.9.9, the battery being tested may be in a discharged state. Check battery electrolyte level, charge battery , and then retest.

NOTE

After completing repair rerun GO-Chain tests to verify problem is fixed and no other problems exists.

- d. If display shows E013, - - - -, or .9.9.9.9 after battery has been charged, replace battery (WP 0346).

CONDITION/INDICATION**DECISION****STEP**

6. Test results.

Compare reading with resistance change given below.

Table 2. Maximum Resistance Change.

Vehicle	Maximum Resistance Change
All	25.0 Milliohms/Second

CONDITION/INDICATION

Is battery resistance change less than above limit?

DECISION

- YES - Go to Step (7).
 NO - Go to Step (9).

NG81: BATTERY TESTS - Continued

STEP

- 7. Perform battery resistance test.
 - a. Dial 77 into TEST SELECT and press TEST.

Table 3. Battery Resistance Test.

Test NO.	Test
77	Battery Resistance

- b. If GO appears, depress starter switch until OFF appears on VTM display.

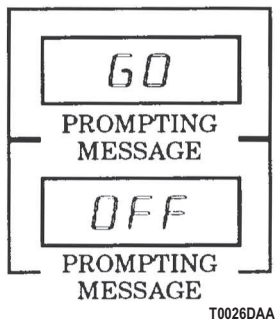

Figure 6. Prompt Message.

Table 4. Maximum Resistance.

Vehicle	Maximum Resistance
All	13.0 Milliohms/Second

- c. If error message appears, refer to TM 9-4910-571-12&P, correct as necessary, and repeat test.

CONDITION/INDICATION

Is battery resistance less than above limit?

DECISION

- YES - Go to Step (8).
- NO - Go to Step (9).

NG81: BATTERY TESTS - Continued**STEP**

8. Are all batteries OK?

CONDITION/INDICATION

Have all batteries been tested?

DECISION

YES - If all batteries are OK and engine does not crank. Engine is tight. Notify supervisor.

NO - Perform test on next battery. Go to Step (1).

STEP

9. Check battery condition.
- a. Check electrolyte level.
 - b. Clean battery terminals.

NOTE

If battery fails in freezing weather, crank engine for 5 seconds and retest. This will warm battery slightly.

- c. Refer to TM 9-6140-200-14 to check battery specific gravity.
- d. Charge battery, if necessary.

NOTE

If battery has been charged and battery resistance change is still greater than the limit, battery is faulty.

- e. Retest battery, go to Step (1).

CONDITION/INDICATION

Does battery pass test?

DECISION

YES - Rerun Go-Chain test to verify problem is solved and no other problem exist.

NO - Replace battery (WP 0346). After repair, rerun Go-Chain test to verify problem is solved and no other problems exist.

END OF WORK PACKAGE

FIELD MAINTENANCE
NG90: GOVERNOR/POWER TEST FAULT ISOLATION

INITIAL SETUP:**Personnel Required**

(2)

References

TM 9-2320-272-10

TM 9-4910-571-12&P

References (cont.)

WP 0193

WP 0195

WP 0205

WP 0245

WP 0246

TROUBLESHOOTING PROCEDURE**NG90: GOVERNOR/POWER TEST FAULT ISOLATION****STEP**

1. Perform G06: Power Test.

CAUTION

Check that air inlet, is clear of tools, debris, dirt, and dust before performing test.

- a. Remove air cleaner from intake housing (WP 0246).
- b. Repeat G06: Power Test Step (2) (WP 0193).

CONDITION/INDICATION

Does engine pass power test with air cleaner out?

DECISION

YES - Replace air filter (WP 0246). After completing repair, rerun GO-Chain tests to verify problem is fixed and no other problems exists.

NO - Go to Step (2).

NG90: GOVERNOR/POWER TEST FAULT ISOLATION - Continued**STEP**

2. Perform air cleaner pressure drop test
 - a. Reinstall air cleaner (WP 0245).

CAUTION

Do not perform more than 2 compression unbalance tests in a row to prevent discharge of vehicle batteries.

Engine must be at normal operating temperature before performing compression unbalance test.

NOTE

The compression unbalance test takes approximately 15 seconds to run.

- b. Dial 28 into TEST SELECT and press TEST.
- c. Hold engine at high idle.

CONDITION/INDICATION

Is air cleaner pressure drop less than 10 in. (25.4 cm) of water?

DECISION

YES - Go to Step (3).

NO - Replace air filter (WP 0246). Repeat G06: Power Test Step (2) to verify this was the only fault (WP 0193).

NG90: GOVERNOR/POWER TEST FAULT ISOLATION - Continued**STEP**

3. Install transducer and perform offset.
 - a. Stop vehicle engine.
 - b. Remove plug on transfer pump.
 - c. Install blue stripe TK pressure transducer in place of plug on transfer pump.
 - d. Connect P1 of transducer cable W4 to J1 or J2 on VTM.
 - e. Connect P2 of transducer cable to connector on pressure transducer.
 - f. Dial 50 into TEST SELECT.
 - g. Press and hold TEST until CAL message appears on display.

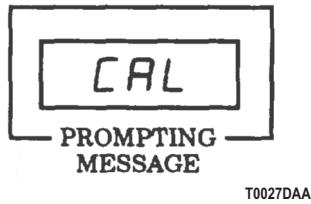

Figure 1. CAL Prompting Message.

- h. Release TEST.
- i. Wait for offset value to appear on display.

CONDITION/INDICATION

Is offset value within limits -150 to +150?

DECISION

- YES - Go to Step (4).
NO - Proceed to TM 9-4910-571-12&P for offset fault isolation.

NG90: GOVERNOR/POWER TEST FAULT ISOLATION - Continued

STEP

4. Perform high idle fuel pressure test.
 - a. Turn on fuel and accessory switch.
 - b. Dial test number into TEST SELECT and press TEST.

Table 1. Pressure Test.

VEHICLE	TEST NO.	TEST
M939/A1	50	0-1,000 PSIG Pressure
M939A2	24	

- c. Start engine (TM 9-2320-272-10).
- d. Accelerate engine to high idle.
- e. Display fuel pressure should be greater then minimum value.

Table 2. Minimum Fuel Pressure.

VEHICLE	MINIMUM FUEL PRESSURE
M939/A1	25 PSI (172 kPa)
M939A2	15 PSI (103 kPa)

CONDITION/INDICATION

Is fuel pressure OK?

DECISION

YES - Go to Step (5).
 NO - Check for crimped or broken fuel lines. Drain fuel filter and check for water or dirt. Replace if necessary, Check vehicle throttle linkage for full travel and proper adjustment. After completing repair, rerun GO-Chain tests to verify the problem is fixed and no other problems exist.

NG90: GOVERNOR/POWER TEST FAULT ISOLATION - Continued

STEP

5. Perform compression unbalance test.
 - a. Stop engine.
 - b. Shut off fuel supply so engine will not start.
 - c. Dial 14 into TEST SELECT and press TEST.

Table 3. Engine RPM Test.

TEST NO.	TEST
14	Compression Unbalance

- d. When GO appears, crank engine.

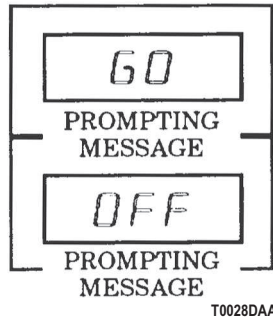

Figure 2. Prompt Message.

- e. Stop cranking when OFF or E013 is displayed.

CONDITION/INDICATION

Does VTM display a number?

DECISION

- YES - Go to Step (6).
- NO - Go to Step (7).

NG90: GOVERNOR/POWER TEST FAULT ISOLATION - Continued

STEP

6. Compare test results.

Ensure compression unbalanced test readings are within limits.

Table 4. Compression Unbalance Test Limits.

VEHICLE	COMPRESSION UNBALANCE TEST LIMITS
M939/A1	8-10%
M939A2	0-15%

CONDITION/INDICATION

Is compression unbalance within the limits specified?

DECISION

YES - Go to NG130: Engine Tightness Test (WP 0205).

NO - Repeat G08: Compression Unbalance Test (WP 0195). If still NO, notify supervisor. After completing repair, rerun GO-Chain tests to verify the problem is fixed and no other problems exist.

STEP

7. Check if VTM displays GO.

CONDITION/INDICATION

Does VTM display GO?

DECISION

YES - Repeat Step (5).

NO - Go to Step (8).

STEP

8. Check if VTM displays FAIL.

CONDITION/INDICATION

Does VTM display FAIL?

DECISION

YES - Repeat G08: Compression Unbalance Test (WP 0195).

NO - VTM displays E013. This may indicate discharged batteries or low cranking speed. Also, operator may have stopped cranking during test. Check and repeat test.

END OF WORK PACKAGE

**FIELD MAINTENANCE
NG130: ENGINE TIGHTNESS TEST**

INITIAL SETUP:

Personnel Required
(2)

References (cont.)
WP 0212
WP 0303

References
WP 0211

TROUBLESHOOTING PROCEDURE**NG130: ENGINE TIGHTNESS TEST****STEP****WARNING**

Ensure engine fuel is shut off before proceeding. Failure to comply may result in injury or death to personnel.

1. Perform engine tightness test.
Rotate engine by hand and check for tightness.

CONDITION/INDICATION

Does engine rotate freely?

DECISION

YES - Replace starter (WP 0303). After completing repair, GO-Chain tests to verify problem is solved and no other problem exists.
NO - Replace engine M939/A1 (WP 0211), M939A2 (WP 0212).

END OF WORK PACKAGE

CHAPTER 6

PREVENTIVE MAINTENANCE INSTRUCTIONS

FIELD MAINTENANCE PREVENTIVE MAINTENANCE CHECKS AND SERVICES (PMCS) INTRODUCTION

INTRODUCTION

The best way to maintain vehicles covered by this manual is to inspect them on a regular basis so minor faults can be discovered and corrected before they result in serious damage, failure of vehicle and equipment, or injury to personnel. This section contains systematic instructions for inspection, adjustment, and correction of vehicle components to avoid costly repairs or major breakdowns. This is referred to as Preventive Maintenance Checks and Services (PMCS).

INTERVALS

NOTE

Designated intervals are performed under usual operating conditions. PMCS must be performed more frequently when operating under unusual conditions.

Field Maintenance, assisted by operator/crew, will perform the PMCS at the following intervals:

Semiannual. Every 6 months or 6,000 miles (9,656 kilometers), whichever occurs first.

Annual. Every 12 months or 12,000 miles (19,312 kilometers), whichever occurs first.

Biennial. Every 24 months or 24,000 miles (38,624 kilometers), whichever occurs first.

Perform all semiannual inspections in addition to annual inspections at the time of the annual inspection. Perform all annual and semiannual inspections in addition to biennial inspections at the time of the biennial inspection.

REPORTING REPAIRS

All uncorrected defects will be recorded on Equipment Inspection and Maintenance Worksheet, DA Form 2404, in accordance with DA Pam 738-750.

GENERAL SERVICE AND INSPECTION PROCEDURES

While performing specific PMCS procedures, ensure items are correctly assembled, secure, serviceable, not worn, not leaking, and adequately lubricated as defined below:

- An item is **CORRECTLY ASSEMBLED** when all parts are present and in proper position.
- When wires, nuts, washers, hoses, or attaching hardware cannot be moved by hand, wrench, or prybar, they are secure.
- An item is **UNSERVICEABLE** if it is worn beyond established wear limits or is likely to fail before the next scheduled inspection.
- An item is **WORN** if there is play between joining parts, or warning and caution plates are not readable.
- If an item meets the requirements specified by lubrication instructions, (Volume 5, WP 0820), then it is **ADEQUATELY LUBRICATED**.

Where the instruction "tighten" appears in a procedure, you must tighten with a wrench to the given torque value even when the item appears to be secure.

Where the instruction "clean" appears in a procedure, refer to the General Maintenance instructions (Volume 5, WP 0819).

CORROSION PREVENTION AND CONTROL (CPC)

Corrosion Prevention and Control (CPC) of Army materiel is a continuing concern. It is important that any corrosion problems with this item be reported so that the problem can be corrected and improvements can be made to prevent the problem in future items.

Corrosion specifically occurs with metals. It is an electrochemical process that causes the degradation of metals. It is commonly caused by exposure to moisture, acids, bases, or salts. An example is the rusting of iron. Corrosion damage in metals can be seen, depending on the metal, as tarnishing, pitting, fogging, surface residue, and/or cracking.

SF Form 368, Product Quality Deficiency Report should be submitted to the address specified in DA PAM 750-8, The Army Maintenance Management System (TAMMS) Users Manual.

PMCS COLUMN DESCRIPTION

The preventive maintenance checks and services for which you are responsible are provided in the PMCS tables. The checks and services listed are arranged in logical order.

The following columns are left to right on the PMCS schedule:

Item Number. Provides logical order for PMCS performance and is used as a source number for DA Form 2404, on which your PMCS results will be recorded.

Interval. Indicates when check or service is to be performed.

Item To Check or Serviced. Lists the system, common name, or location of the item to be inspected.

Procedure. Provides instructions for servicing, inspection, replacement, or adjustment and, in some cases, having an item repaired at a higher level. If a defect is found, repair, fill, replace, or adjust as needed.

Equipment Not Ready/Available If. Provides information for deadlining a vehicle when checks or services reveal a defect or deficiency of a component(s) of the vehicle.

FLUID LEAKAGE

It is necessary for you to know how fluid leakage affects the status of the (enter component/equipment name). Following are types/classes of leakage you need to know to be able to determine the status of the (enter component/equipment name). Learn these leakage definitions and remember - when in doubt, notify your supervisor. Equipment operation is allowed with minor leakage (Class I or II). Consideration must be given to fluid capacity in the item/system being checked/inspected. When in doubt, notify your supervisor.

When operating with Class I or II leaks, continue to check fluid levels as required in the PMCS. Class III leaks should be reported immediately to your supervisor.

Wetness around seals, gaskets, fittings, or connections indicates leakage. A stain also denotes leakage. If a fitting or connector is loose, tighten it. If broken or defective, report it.

Class I. Leakage indicated by wetness or discoloration not great enough to form drops.

Class II. Leakage great enough to form drops, but not enough to cause drops to drip from item being checked/inspected.

Class III. Leakage great enough to form drops that fall from the item being checked/inspected.

END OF WORK PACKAGE

**FIELD MAINTENANCE
PREVENTIVE MAINTENANCE CHECKS AND SERVICES FOR MODELS M939/A1/A2 (SEMIANNUAL)**

INITIAL SETUP:

Tools and Special Tools

- Tool Kit, General Mechanic's: Automotive
(Volume 5, WP 0826, Table 1, Item 56)
- Grease Gun
(Volume 5, WP 0826, Table 1, Item 21)
- Wrench, Torque, Click, Ratcheting, 1/2" Drive,
250 Ft-Lb
(Volume 5, WP 0826, Table 1, Item 63)
- Wrench, Torque, Click, Ratcheting, 3/4" Drive,
600 Ft-Lb
(Volume 5, WP 0826, Table 1, Item 61)

References (cont.)

- WP 0244
- WP 0250
- WP 0254
- WP 0255
- WP 0258
- WP 0259
- WP 0260
- WP 0270
- WP 0283
- WP 0284
- WP 0287
- WP 0294
- WP 0296
- WP 0297
- WP 0298
- WP 0302
- WP 0319
- WP 0332
- WP 0341
- WP 0346
- WP 0347
- WP 0349
- Volume 3, WP 0352
- Volume 3, WP 0353
- Volume 3, WP 0362
- Volume 3, WP 0381
- Volume 3, WP 0388
- Volume 3, WP 0394
- Volume 3, WP 0400
- Volume 3, WP 0401
- Volume 3, WP 0402
- Volume 3, WP 0403
- Volume 3, WP 0405
- Volume 3, WP 0411
- Volume 3, WP 0412
- Volume 3, WP 0413
- Volume 3, WP 0426
- Volume 3, WP 0432
- Volume 3, WP 0433
- Volume 3, WP 0434
- Volume 3, WP 0435
- Volume 3, WP 0438
- Volume 3, WP 0450
- Volume 3, WP 0470
- Volume 3, WP 0478
- Volume 3, WP 0485
- Volume 3, WP 0486

Materials/Parts

- Antifreeze: Arctic Grade, Permanent Type
(Volume 5, WP 0825, Table 1, Item 5)
- Antifreeze: Ethylene Glycol, Permanent Type,
Inhibited
(Volume 5, WP 0825, Table 1, Item 6, 7, 8)
- Grease, Automotive and Artillery
(Volume 5, WP 0825, Table 1, Item 28)
- Lubricating Oil, Engine: OE/HDO 10W
(Volume 5, WP 0825, Table 1, Item 36, 37,
38)
- Lubricating Oil, Engine: OE/HDO 30W
(Volume 5, WP 0825, Table 1, Item 39, 40, 41,
42)
- Lubricating Oil, Exposed Gear: CW
(Volume 5, WP 0825, Table 1, Item 43)
- Lubricating Oil, Gear, Multipurpose: GO 75W90
(Volume 5, WP 0825, Table 1, Item 44, 45, 46,
47)
- Lubricating Oil, Gear, Multipurpose: GO 80W90
(Volume 5, WP 0825, Table 1, Item 48, 49,
50)
- Rag, Wiping
(Volume 5, WP 0825, Table 1, Item 53)

Personnel Required

- Wheeled Vehicle Mechanic 91B (2)

References

- TB 9-2300-247-40
- TM 3-4230-204-12&P
- TM 3-6665-225-12
- TM 9-1005-245-14
- Volume 1, WP 0004
- WP 0232

References (cont.)

- Volume 3, WP 0491
- Volume 3, WP 0504
- Volume 3, WP 0505
- Volume 3, WP 0506
- Volume 3, WP 0507
- Volume 3, WP 0509
- Volume 3, WP 0510
- Volume 3, WP 0539
- Volume 3, WP 0541
- Volume 3, WP 0544
- Volume 4, WP 0559
- Volume 4, WP 0560

References (cont.)

- Volume 4, WP 0672
- Volume 4, WP 0673
- Volume 4, WP 0714
- Volume 5, WP 0790
- Volume 5, WP 0819
- Volume 5, WP 0820

Equipment Condition

Vehicle parked and shut down.
(TM 9-2320-272-10)

Table 1. Field Preventive Maintenance Checks and Services.

ITEM NO.	INTERVAL	ITEM TO BE CHECKED OR SERVICED	PROCEDURE	EQUIPMENT NOT READY/ AVAILABLE IF:
1	Semiannual	Starter	<p style="text-align: center;">NOTE</p> <p>Prior to road test, perform all Before operations and Weekly checks listed in TM 9-2320-272-10 in addition to those that follow.</p> <p>Start engine (TM 9-2320-272-10). While starting engine, listen for unusual noises and difficult cranking.</p>	Starter is inoperative or makes excessive grinding noise.
2	Semiannual	Accelerator Pedal and Engine	<p>a. Observe response to accelerator pedal.</p> <p>(1) Listen for unusual noises.</p> <p>(2) Observe for hesitation or varying idle speed.</p> <p>(3) Check for sticking or binding of pedal. If accelerator pedal binds or sticks, troubleshoot (Volume 1, WP 0004).</p> <p>b. Be alert for excessive vibration, fuel odor, oil, coolant or exhaust dripping, and any indication of malfunction.</p>	Accelerator pedal is sticking or binding. Engine knocks, rattles, or smokes excessively.
3	Semiannual	Throttle	Check throttle control travel and freedom of movement. Pull throttle control all the way out, rotate, and release. Throttle control should return to original position. If control sticks or binds, lubricate (Volume 5, WP 0820) or replace (WP 0270).	Throttle control is sticking or binding.

Table 1. Field Preventive Maintenance Checks and Services - Continued.

ITEM NO.	INTERVAL	ITEM TO BE CHECKED OR SERVICED	PROCEDURE	EQUIPMENT NOT READY/ AVAILABLE IF:
4	Semiannual	Brakes	<p style="text-align: center;">NOTE</p> <ul style="list-style-type: none"> • Perform all During operation checks listed in TM 9-2320-272-10 PMCS in addition to those that follow. Drive vehicle at least 5 mi (8 km) over varied terrain, both on and off road. This will provide ample time to check reported malfunctions and to locate unreported malfunctions. • Lubrication intervals of every 1,000 mi (1,600 km) or monthly, and 3,000 mi (4,800 km) or 3 months, will be performed with maintenance, or when practical, lubrication services will be made to coincide with the semiannual preventive maintenance services. For this purpose, a 10% tolerance (variation) in specified lubrication point mileage is permissible. <ul style="list-style-type: none"> a. Check brake pedal for free travel. Adjust brake pedal if required (Volume 3, WP 0433). b. Reach a desired speed and lightly apply brake pedal with steady force. Vehicle should slow down immediately and stop smoothly, without side pull or chatter. c. After stopping vehicle, and with transmission select lever in 1-5 (drive), release brake pedal. All wheel brakes should release immediately and without difficulty. 	Any wheel does not immediately release.
5	Semiannual	Engine	<p style="text-align: center;">NOTE</p> <p>Ensure engine tachometer does not exceed maximum governed speed of 2,400 rpm with no load.</p> <ul style="list-style-type: none"> a. Check engine throughout the range of operating speeds. Refer to TM 9-2320-272-10. b. Check engine instruments. Refer to TM 9-2320-272-10 for proper readings. 	Any engine instrument not properly reading.
6	Semiannual	Transmission	<ul style="list-style-type: none"> a. Check transmission oil temperature gauge. Normal range is 120°F to 220°F (49°C to 104°C) b. Check for response to shifting and smoothness of operation is all speed ranges. Refer to TM 9-2320-272-10 for proper shifting speed ranges. 	Oil temperature exceeds 300°F (149°C). Transmission does not shift at correct speeds.

Table 1. Field Preventive Maintenance Checks and Services - Continued.

ITEM NO.	INTERVAL	ITEM TO BE CHECKED OR SERVICED	PROCEDURE	EQUIPMENT NOT READY/ AVAILABLE IF:
7	Semiannual	Transfer Case	Shift transfer case lever between HI and LOW positions to ensure proper operation. Observe for smoothness of engagements. Refer to TM 9-2320-272-10 for proper shifting speed ranges and operation.	Transfer hard to shift from low to high.
8	Semiannual	Suspension	Observe how vehicle responds to road shock. Constant bouncing or swaying from side-to-side is an indication of a malfunction.	
9	Semiannual	Emergency Engine Stop Control	<p style="text-align: center;">NOTE</p> <ul style="list-style-type: none"> • Before M939/A1 series vehicles can be restarted, fuel shutoff valve control lever under the hood must be reset. • This check will be performed with engine running, transmission in N (neutral), and parking brake applied. <p>Check emergency engine stop control:</p> <p>(1) Pull emergency engine stop control out until engine stops. If engine does not stop before emergency engine stop control is pulled completely out, place battery switch in the OFF position, and troubleshoot.</p> <p>(2) Push emergency engine stop control in until original position is obtained.</p>	Engine fails to shut off.

Table 1. Field Preventive Maintenance Checks and Services - Continued.



ITEM NO.	INTERVAL	ITEM TO BE CHECKED OR SERVICED	PROCEDURE	EQUIPMENT NOT READY/ AVAILABLE IF:
10	Semiannual	Air Filter	<p style="text-align: center;">WARNING</p> <div style="display: flex; justify-content: center; gap: 20px;">   </div> <p>If NBC exposure is suspected, all air filter media should be handled by personnel wearing protective equipment. Consult your unit NBC officer or NBC NCO for appropriate handling caution or disposal instructions.</p> <p style="text-align: center;">NOTE</p> <p>Perform all After, Weekly, and Monthly checks in TM 9-2320-272-10, then make the following inspections in the order given, including kit items on vehicles so equipped.</p> <p>a. Inspect filter element for tears and presence of dirt and oil.</p> <p>(1) If dirt is present, clean filter element (TM 9-2320-272-10).</p> <p>(2) If oil is present, replace filter element.</p> <p>b. Check for oil in air cleaner manifold. If present:</p> <p>(1) Check for oil in transmission and transfer case. If oil levels are excessive, drain excess (Volume 3, WP 0362).</p> <p>(2) Check for fuel diluting the oil. If necessary, change oil and filters (Volume 3, WP 0362).</p> <p>(3) If oil levels are low, check transfer case interlock air cylinders for leaks (Volume 3, WP 0394).</p>	

Table 1. Field Preventive Maintenance Checks and Services - Continued.

ITEM NO.	INTERVAL	ITEM TO BE CHECKED OR SERVICED	PROCEDURE	EQUIPMENT NOT READY/ AVAILABLE IF:
11	Semiannual	Batteries	<p style="text-align: center;">WARNING</p> <div style="text-align: center;">  </div> <ul style="list-style-type: none"> • Wear safety glasses or goggles when checking batteries. Always check electrolyte level with engine stopped. Do not smoke or use exposed flame when checking batteries; explosive gases are present. Failure to comply may result in injury or death to personnel. • Remove all jewelry such as rings, dog tags, bracelets, etc. If jewelry contacts battery terminal, a direct short may result in instant heating of tools, damage to equipment. Failure to comply may result in injury or death to personnel. • Remove or disconnect batteries, and turn master battery disconnect switch off prior to performing maintenance in immediate area or working on electrical system. Such disconnections prevent electrical shock to personnel and equipment. Failure to comply may result in damage to equipment, injury, or death to personnel. • Ensure seatbelts do not come in contact with electrolyte. Damage to strapping will result. Failure to comply may result in injury or death to personnel. • Ensure seatbelts are not caught inside battery box when closing cover. Failure to comply may result in injury or death to personnel. <p style="margin-left: 40px;">a. Clean and inspect batteries (WP 0346). Replace if required.</p> <p style="margin-left: 40px;">b. Inspect battery box for security of mounting and completeness of assembly (WP 0347).</p>	

Table 1. Field Preventive Maintenance Checks and Services - Continued.

ITEM NO.	INTERVAL	ITEM TO BE CHECKED OR SERVICED	PROCEDURE	EQUIPMENT NOT READY/ AVAILABLE IF:
			<p>c. Inspect battery cables and terminals for frays, splits, and security. Repair battery cables or terminals (Volume 3, WP 0352), or replace as necessary (WP 0349).</p> <p>d. Inspect slave receptacle and wiring for security of mounting and damage. Repair (Volume 3, WP 0352), or replace (Volume 3, WP 0353) if damaged.</p> <p>e. Lightly coat battery terminals and slave receptacles with grease (Volume 5, WP 0820).</p> <p>f. Inspect seatbelts for serviceability and security of mounting. Replace seatbelts if unserviceable or show signs of contact with electrolyte (Volume 5, WP 0790).</p> <p>g. Lubricate hinges on battery box cover and map compartment every 1,000 mi (1,600 km) or monthly, whichever occurs first (Volume 5, WP 0820).</p> <p>h. Inspect battery box cover and map compartment cover and seals on both for condition and security of installation. Replace seal(s) on battery box cover and/or map compartment cover if damaged.</p>	

Table 1. Field Preventive Maintenance Checks and Services - Continued.

ITEM NO.	INTERVAL	ITEM TO BE CHECKED OR SERVICED	PROCEDURE	EQUIPMENT NOT READY/ AVAILABLE IF:
12	Semiannual	Cab Components	<p style="text-align: center;">WARNING</p>  <p>If transmission oil temperature is above 220°F (104°C), allow transmission oil to cool before removing dipstick. Failure to comply may result in injury or death to personnel.</p> <p style="text-align: center;">CAUTION</p> <ul style="list-style-type: none"> • Do not remove transmission dipstick before cleaning dirt away from access plate, filler tube, and dipstick. Dirt may enter and damage transmission. • Do not overfill transmission. Internal transmission component damage will result. • Change transmission oil when contamination by fuel, water, or other foreign materials is evident. Failure to do so may result in failure of internal transmission components. • Shut off engine if transmission exceeds 300°F (149°C). Continuing to operate transmission under these conditions may result in failure of internal transmission components. <p style="text-align: center;">NOTE</p> <ul style="list-style-type: none"> • Steps (a) through (c) apply to M939/A1 series vehicles only. • Transmission dipstick and temperature sending unit cannot be accessed through cab floors on M939A2 series vehicles. <p style="margin-left: 20px;">a. Open access door in floor cab. Lubricate access door hinge every 1,000 mi (1,600 km) or monthly. Whichever occurs first (Volume 5, WP 0820).</p> <p style="margin-left: 20px;">b. Inspect transmission dipstick and oil:</p> <p style="margin-left: 40px;">(1) Check for evidence of metal particles. Notify your supervisor if metal particles are found.</p>	

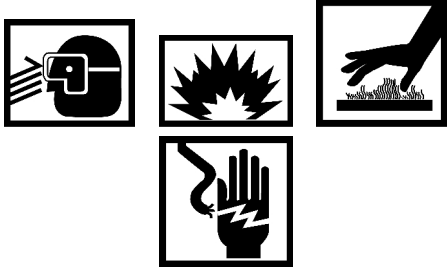
Table 1. Field Preventive Maintenance Checks and Services - Continued.

ITEM NO.	INTERVAL	ITEM TO BE CHECKED OR SERVICED	PROCEDURE	EQUIPMENT NOT READY/ AVAILABLE IF:
			<p>(2) Check for evidence of dilution from coolant. If oil is diluted by coolant, refer to mechanical troubleshooting.</p> <p>(3) Check oil level in transmission. If oil levels are excessive, drain the excess (Volume 3, WP 0362).</p> <p>c. Inspect transmission temperature ending unit for security of mounting and wiring for fraying, splits, breaks, and missing insulation.</p> <p>d. On vehicles with winch, lubricate winch and Power Takeoff (PTO) control levers every 1,000 mi (1,600 km) or monthly, whichever occurs first (Volume 5, WP 0820).</p> <p>e. Lubricate power brake treadle with 3 to 4 drops of oil every 1,000 mi (1,600 km) or monthly, whichever occurs first (Volume 5, WP 0820).</p> <p>f. Lubricate transfer case shift linkage pins every 1,000 mi (1,600 km) or monthly, whichever occurs first (Volume 5, WP 0820).</p> <p>g. On M929/A1/A2 and M930/A1/A2 vehicles, lubricate dump lever and crossshaft every 1,000 mi (1,600 km) or monthly, whichever occurs first (Volume 5, WP 0820).</p> <p>h. Inspect instrument panel cluster and cab portion of front wiring harness for frays, splits, missing or damaged insulation, or poor connections. Repair or replace affected wiring (Volume 3, WP 0352).</p>	

Table 1. Field Preventive Maintenance Checks and Services - Continued.

ITEM NO.	INTERVAL	ITEM TO BE CHECKED OR SERVICED	PROCEDURE	EQUIPMENT NOT READY/ AVAILABLE IF:
13	Semiannual	Front Winch	<p>a. Inspect winch for security of mounting, loose or missing mounting bolts, and broken or missing parts.</p> <p style="text-align: center;">WARNING</p> <div style="text-align: center;">  </div> <ul style="list-style-type: none"> • Wire rope can become frayed or contain broken wires. Wear heavy leather-palmed work gloves when handling wire rope. Frayed or broken wires can injure hands. Failure to comply may result in injury or death to personnel. • Never let moving wire rope slide through hands, even when wearing gloves. A broken wire could cut through glove and cut hand. Failure to comply may result in injury or death to personnel. <p>b. Unwind entire cable, soak and clean with oil, and inspect for kinks, frays, and wear. Refer to TM 9-2320-272-10 for operation.</p> <p>c. On M936/A1 vehicles, lubricate sheave bearing (Figure 1, Item 1) swivel fitting (Figure 1, Item 3), trolley wheel (Figure 1, Item 4), and level wind frame (Figure 1, Item 2) every 3,000 mi (4,800 km) or 6 months, whichever occurs first. If operation is frequent, continuous, or under sever condition, service weekly (Volume 5, WP 0820).</p> <p>d. Lubricate tensioner sheave pins (Figure 1, Item 5), vertical cable rollers (Figure 1, Item 6), and horizontal cable rollers (Figure 1, Item 7) every 3,000 mi (4,800 km) or 6 months, whichever occurs first. If operation is frequent, continuous, or under sever condition, service weekly (Volume 5, WP 0820).</p>	Any kinks, frays, or worn cables.

Table 1. Field Preventive Maintenance Checks and Services - Continued.

ITEM NO.	INTERVAL	ITEM TO BE CHECKED OR SERVICED	PROCEDURE	EQUIPMENT NOT READY/ AVAILABLE IF:
			<p>e. Check gearcase level.</p> <p>(1) Clean around and remove oil level sight plug (Figure 2, Item 6) and check oil level.</p> <p>NOTE</p> <p>Perform Steps (2) through (4) only if oil level is low.</p> <p>(2) Clean around and remove gearcase fill plug (Figure 2, Item 2). If necessary to drain, remove drain plug (Figure 2, Item 7) and reinstall.</p> <p>(3) Fill to bottom opening of oil level sight plug (Figure 2, Item 6).</p> <p>(4) Install filter plug (Figure 2, Item 2) and oil level sight plug (Figure 2, Item 6)</p> <p>f. Check end frame oil level.</p>	

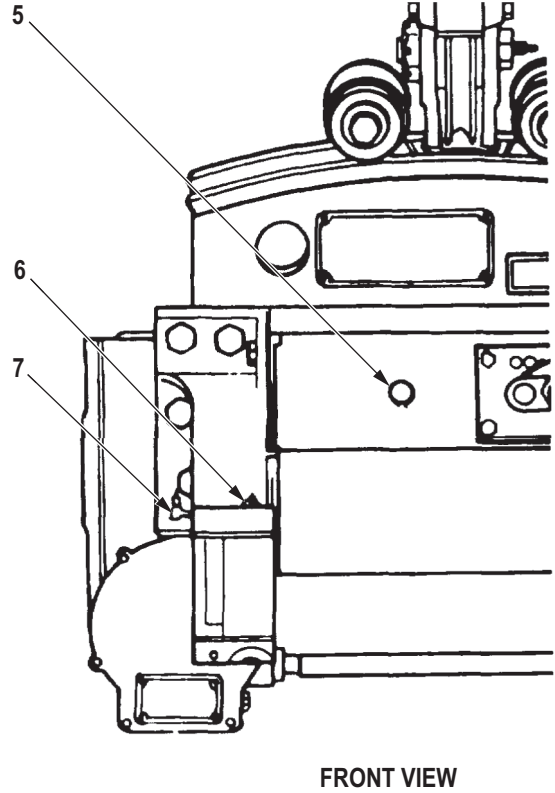
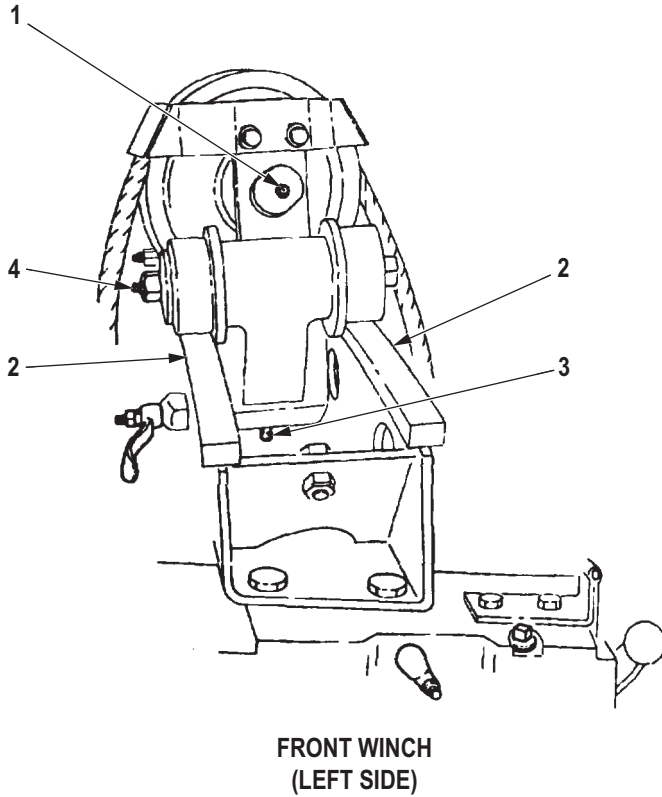

100001DAA

Figure 1. Front Winch.

Table 1. Field Preventive Maintenance Checks and Services - Continued.

ITEM NO.	INTERVAL	ITEM TO BE CHECKED OR SERVICED	PROCEDURE	EQUIPMENT NOT READY/ AVAILABLE IF:
			<p>(1) Clean around and remove end frame level plug (Figure 2, Item 8) and fill plug (Figure 2, Item 1) and check end frame gearcase oil level.</p> <p style="text-align: center;">NOTE</p> <p>Perform Steps (2) and (3) only if oil level is low.</p> <p>(2) Fill to opening of level plug (Figure 2, Item 8) and install level plug (Figure 2, Item 8).</p> <p>(3) Install filler plug (Figure 2, Item 1).</p> <p>g. Check sight plug (Figure 2, Item 6) and filler plug (Figure 2, Item 2) on gearcase and filler plug (Figure 2, Item 1), level plug (Figure 2, Item 8), and drain plug (Figure 2, Item 9) on end frame for tightness.</p> <p>h. On M936/A1 model vehicles, lubricate trolley lock (Figure 2, Item 3) every 1,000 mi (1,600 km) or monthly, whichever occurs first (Volume 5, WP 0820).</p> <p>i. Lubricate drum lock (Figure 2, Item 4) and tensioner control lever lock (Figure 2, Item 5) every 1,000 mi (1,600 km) or monthly, whichever occurs first (Volume 5, WP 0820).</p>	

Table 1. Field Preventive Maintenance Checks and Services - Continued.

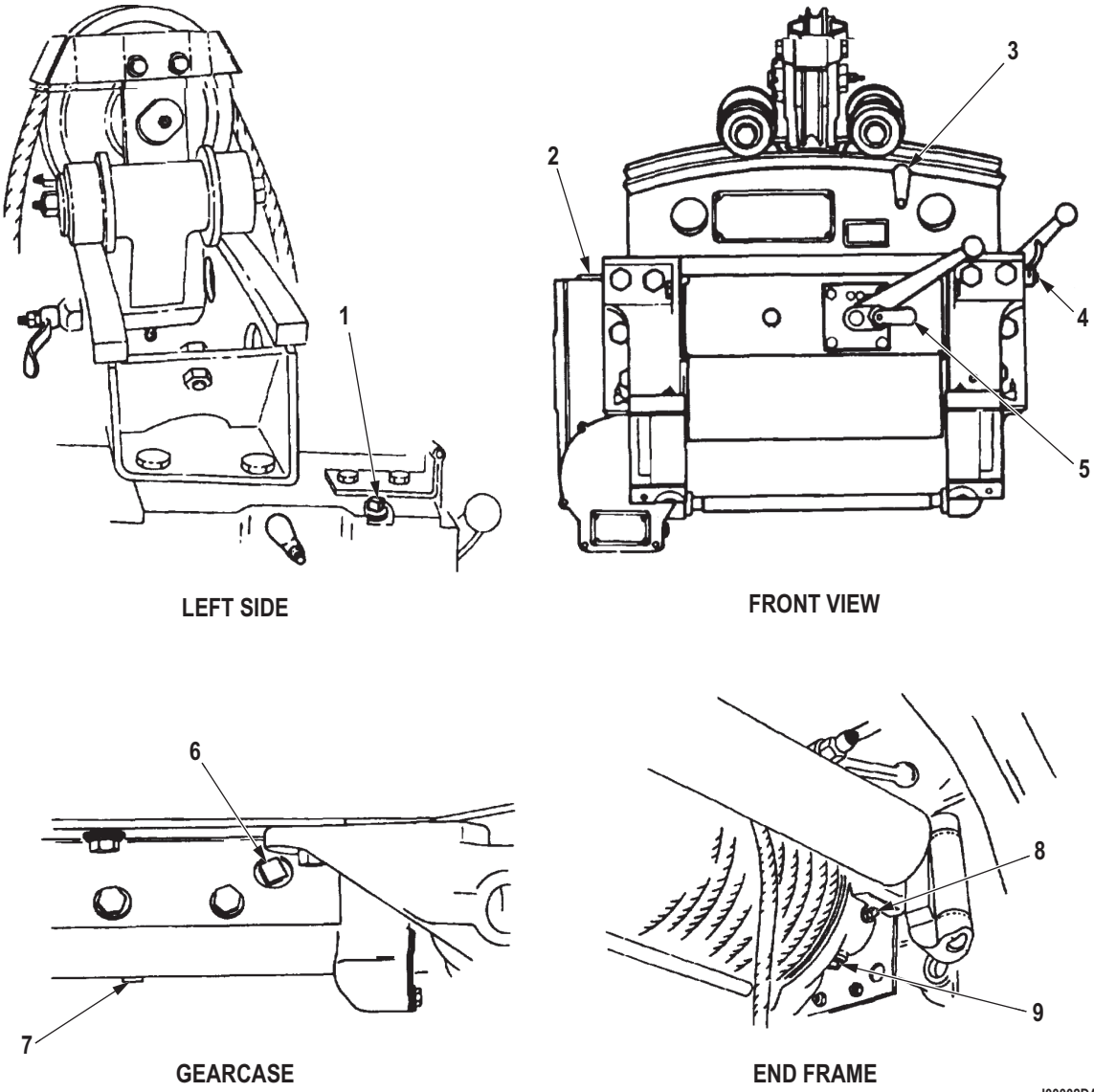
ITEM NO.	INTERVAL	ITEM TO BE CHECKED OR SERVICED	PROCEDURE	EQUIPMENT NOT READY/ AVAILABLE IF:
				
			<p>j. Test drag brake for proper operation (Volume 4, WP 0673).</p> <p>k. Test winch automatic brake for proper operation (Volume 4, WP 0672).</p>	

100002DAA

Table 1. Field Preventive Maintenance Checks and Services - Continued.

ITEM NO.	INTERVAL	ITEM TO BE CHECKED OR SERVICED	PROCEDURE	EQUIPMENT NOT READY/ AVAILABLE IF:
14	Semiannual	Hood	<p>a. Inspect hood support bar and locking pins for condition and security of mounting. If support bar or locking pins are defective, repair or replace as required (Volume 4, WP 0559).</p> <p>b. Inspect hood stop cables for condition and security of mounting. If stop cables are defective, repair or replace as required (Volume 4, WP 0560).</p> <p>c. Lubricate hood trunnion every 6,000 mi (9,656 km) or 6 months, whichever occurs first (Volume 5, WP 0820).</p> <p>d. Lubricate hood hinges every 1,000 mi (1,600 km) or monthly, whichever occurs first (Volume 5, WP 0820).</p>	
15	Semiannual	Front Lights and Cable Assembly	<p>Inspect front light cable assembly wiring for frays, splits, missing or damaged insulation, or poor connections. Repair affected wiring (Volume 3, WP 0352).</p>	
16	Semiannual	Motor Mount Trunnions	<p>a. Check two front engine mounting trunnion screws for tightness. If engine mounting trunnion screws are loose, tighten.</p> <p>b. Tighten five lower trunnion mount screws 65 to 75 lb-ft (88 to 102 N·m).</p> <p>c. On M939A2 series vehicles, check front mounting locknuts for tightness. Tighten mounting locknuts 75 to 85 lb-ft (102 to 115 N·m).</p>	
17	Semiannual	Emergency and Service Compressed Air Systems	<p>a. Inspect front emergency and service air and dummy couplings for serviceability and seals.</p> <p style="text-align: center;">NOTE</p> <p>Inspection of emergency and service air lines and fittings will be accomplished over complete vehicle. Tighten, repair, and/or replace components of these compressed air systems as required. If maintenance is required at a higher level, records should reflect closest point of reference to ensure proper identification of components requiring service.</p> <p>b. Inspect air lines, fittings, and emergency shutoff valve for security of mounting, tightness of connections, and damage that could cause air leaks (Volume 5, WP 0819).</p>	

Table 1. Field Preventive Maintenance Checks and Services - Continued.

ITEM NO.	INTERVAL	ITEM TO BE CHECKED OR SERVICED	PROCEDURE	EQUIPMENT NOT READY/ AVAILABLE IF:
			<p>c. Ensure front emergency shutoff valve is closed and emergency and service air dummy couplings are securely fastened (TM 9-2320-272-10).</p>	
18	Semiannual	Frame and Crossmembers	<p style="text-align: center;">NOTE</p> <p>Inspection of crossmembers, bolts, and rivets will be accomplished over complete vehicle. Tighten, repair, and/or replace components of these compressed air systems as required. If maintenance is required at a higher level, records should reflect closest point of reference to ensure proper identification of components requiring service.</p> <p>Inspect crossmembers for missing rivets, screws, obstructions to other components and breaks (TB 9-2300-247-40).</p> <p>(1) Using a 0.001 in. feeler gauge, check for space between rivet head and the riveted frame members. Penetration of the feeler gauge between the rivet head and riveted member is reason to suspect the riveted connection and/or rivet should be replaced.</p> <p>(2) Thoroughly clean, grease, and oil rivet. Using an oil can, apply lubricating oil around the connection. Allow approximately 10 to 20 seconds for oil to penetrate. Wipe rivet and riveted connection free of oil. Tap rivet with an 8-pound hammer. Any indication of oil around the rivet indicates a loose rivet. Replace all loose rivets (TB 9-2300-247-40). Check all riveted connections for signs of movement, such as bare or shiny spots or other indications of movement between rivet and frame. If movement is indicated, rivet and connection are loose.</p>	Screws or rivets loose or missing.

Table 1. Field Preventive Maintenance Checks and Services - Continued.



ITEM NO.	INTERVAL	ITEM TO BE CHECKED OR SERVICED	PROCEDURE	EQUIPMENT NOT READY/ AVAILABLE IF:
19	Semiannual	Front Wheels, Hubs, and Drums	<p style="text-align: center;">WARNING</p> <div style="display: flex; justify-content: center; gap: 20px;">   </div> <ul style="list-style-type: none"> • Completely deflate tire before removing from axle if there is obvious damage to wheel components. Failure to comply may result in injury or death to personnel. • Use caution when inflating tires. Ensure tire is in a tire cage and properly seated on rim before inflating. An improperly seated tire can burst with explosive force. Failure to comply may result in injury or death to personnel. • Do not work on any component supported only by lift jacks or hoist. Always use blocks or proper stands to support the component prior to any work. Equipment may fall. Failure to comply may result in injury or death to personnel. • Air in system is under pressure. Ensure engine is shut down and all air reservoirs are drained before disconnecting CTIS components. Failure to comply may result in injury or death to personnel. <p style="text-align: center;">NOTE</p> <ul style="list-style-type: none"> • Similar left and right side components are inspected in the same manner and will be accomplished simultaneously. Procedures cover left side only. • When documenting discrepancies for similar left and right side components, indicate which side is affected. • To simplify maintenance, perform Items (19a) through (19g) simultaneously with Items (20a) through (20c). <p>a. On M939 series vehicles, inspect split locking ring (Figure 3, Item 1) for dents or breaks that could</p>	

Table 1. Field Preventive Maintenance Checks and Services - Continued.

ITEM NO.	INTERVAL	ITEM TO BE CHECKED OR SERVICED	PROCEDURE	EQUIPMENT NOT READY/ AVAILABLE IF:
			<p>cause them to pop off. Replace any damaged wheel (Volume 3, WP 0485).</p> <p>b. On M939/A1/A2 series vehicles, inspect wheels (Figure 3, Item 2) for loose or missing rim nuts (Figure 3, Item 3). Tighten rim nuts (Figure 3, Item 3) 210 to 240 lb-ft (285 to 325 N-m). Replace any wheel (Figure 3, Item 2) that is broken or has stripped threads .</p> <p>c. Inspect axle drive companion flange for oil leaks. If oil appears to be leaking from expansion plug (Figure 3, Item 4) on axle drive companion flange (Figure 3, Item 5), notify your supervisor.</p>	
<div data-bbox="285 800 1421 1266"> </div>				
<p><i>Figure 3. Wheel Assembly.</i></p>				
<p>CAUTION</p> <p>On M939A2 series vehicles, use care not to damage CTIS air seals when removing axle components. Failure to do so may result in further damage to axle and wheel bearings, in addition to improper operation of CTIS system.</p>				
<p>NOTE</p> <p>Lugnuts on left side have left-handed threads and can be identified by an L, while lugnuts on right side have right-hand threads, and can be identified by an R.</p>				
<p>d. Clean, inspect, and lubricate axle shaft and universal joints (Volume 3, WP 0411).</p>				

Table 1. Field Preventive Maintenance Checks and Services - Continued.

ITEM NO.	INTERVAL	ITEM TO BE CHECKED OR SERVICED	PROCEDURE	EQUIPMENT NOT READY/ AVAILABLE IF:
			<p>(1) Check bearing sleeve inside spindle for signs of damage. If bearing sleeve is damaged, replace bearing sleeve (Volume 3, WP 0413).</p> <p>(2) Replace drive flange gasket with RTV sealant.</p> <p>e. On M939A2 series vehicles, replace filter in wheel valves (Volume 3, WP 0486).</p> <p style="text-align: center;">WARNING</p> <p>Do not allow grease or oil to contact brake linings. Linings can absorb grease and oil, causing early glazing and very poor braking action. Failure to comply may result in injury or death to personnel.</p> <p>f. Check brake shoes for condition and brake shoe-to-drum clearance (Volume 3, WP 0432). Replace brake shoes if worn beyond chamfer on linings (Volume 3, WP 0426).</p> <p>g. Inspect CV boots for rips, cracking, punctures, and other damage that could cause a loss of lubrication around CV joint. Replace CV boots if ripped, punctured, or damaged (Volume 3, WP 0478).</p>	
20	Semiannual	Air Lines and Brake Chambers	<p>a. Inspect front service brake air lines and fittings for loose connections, cracks, splits, or damage that could cause potential air leaks. Tighten loose air lines and fittings connections, and replace any air line or fitting that has cracks, splits, or damage that could cause potential air leaks.</p> <p>b. Inspect front service brake chambers for condition and security of mounting. Replace any service brake chamber that is damaged, defective, or inoperative (Volume 3, WP 0434).</p> <p style="text-align: center;">NOTE</p> <p>Inspection of CTIS air lines and fittings will be accomplished over complete vehicle. Tighten, repair, and/or replace components of the compressed air system as required. If maintenance is required at a higher level, records should reflect closest point of reference to ensure proper identification of components requiring service.</p> <p>c. On M939A2 series vehicles, inspect CTIS air lines and fittings for loose connections, cracks, splits, or damage that could cause potential air leaks.</p>	

Table 1. Field Preventive Maintenance Checks and Services - Continued.

ITEM NO.	INTERVAL	ITEM TO BE CHECKED OR SERVICED	PROCEDURE	EQUIPMENT NOT READY/ AVAILABLE IF:
21	Semiannual	Steering System	<p>a. Inspect steering knuckles, steering gear, tie rod assembly, steering arms, drag link, pitman arm, lower steering gear shaft, and power steering cylinder if broken, cracked, worn, or signs of unserviceable condition are present.</p> <p>(1) Treat for corrosion or steering knuckles, tie rod assembly, steering arms, drag link, pitman arm, or steering gear shaft.</p> <p>(2) Replace tie rod shaft assembly, drag link, pitman arm, lower steering gear shaft, or power steering cylinder if broken, cracked, worn, or signs of an unserviceable condition are present.</p> <p>(3) If steering knuckles, steering arms, or steering gear are broken, cracked, worn, or have other signs of an unserviceable condition, Repair or replace as required (Volume 3, WP 0412).</p> <p style="text-align: center;">NOTE</p> <p>Lubricate grease fittings every 3,000 mi (4,800 km) or 3 months, whichever occurs first (Volume 5, WP 0820). When practical, lubrication services will be made to coincide with the semiannual preventive maintenance service. For this purpose, a 10% tolerance (variation) in specified lubrication point mileage is permissible.</p> <p>b. Lubricate at steering knuckle grease fittings (Figure 4, Item 1), tie rod assembly grease fittings (Figure 4, Item 4), steering shaft grease fittings (Figure 4, Items 7 and 8), drag link grease fittings (Figure 4, Item 2), and power steering assist cylinder grease fittings (Figure 4, Item 6).</p> <p style="text-align: center;">NOTE</p> <p>An assistant is required to perform the following step.</p> <p>c. Inspect steering stops for presence and security. If any stop is missing or has broken welds, notify supervisor.</p> <p>d. With engine shut off, turn steering wheel slowly right and left.</p> <p>(1) Inspect steering gear U-joints while steering wheel is rotated.</p> <p>(2) Check for free play between steering knuckles and tie rod ends, power assist cylinder, and drag link and</p>	<p>Movement between cross and cap is present.</p>

Table 1. Field Preventive Maintenance Checks and Services - Continued.

ITEM NO.	INTERVAL	ITEM TO BE CHECKED OR SERVICED	PROCEDURE	EQUIPMENT NOT READY/ AVAILABLE IF:
			<p>pitman arm to drag link. If free play is present, tighten four steering knuckle nuts (Figure 4, Item 5) and drag link-to-pitman arm nut (Figure 4, Item 3) 140 to 180 lb-ft (190 to 244 N·m). Tighten to minimum torque and continue to tighten as needed to align slot in nut and cotter pin hole. Do not tighten over 275 lb-ft (373 N·m).</p>	

Table 1. Field Preventive Maintenance Checks and Services - Continued.

ITEM NO.	INTERVAL	ITEM TO BE CHECKED OR SERVICED	PROCEDURE	EQUIPMENT NOT READY/ AVAILABLE IF:
			<p>(3) Repeat Step (2). If free play is still present, notify your supervisor.</p> <p>e. Inspect power steering assist assembly.</p>	

100004DAA

Figure 4. Steering System.

Table 1. Field Preventive Maintenance Checks and Services - Continued.

ITEM NO.	INTERVAL	ITEM TO BE CHECKED OR SERVICED	PROCEDURE	EQUIPMENT NOT READY/ AVAILABLE IF:
			<p>(1) Remove stone shield (Volume 3, WP 0510).</p> <p>(2) Inspect power steering assist cylinder for condition and security of mounting (Volume 3, WP 0509).</p> <p>(3) Inspect hydraulic hoses and fittings between frame and cylinder for loose connections, cracks, splits, or damage that could cause hydraulic leaks. Tighten hydraulic lines and fittings connections. Replace any hydraulic line or fitting that has cracks, splits, or damage that could cause hydraulic leaks (Volume 3, WP 0506).</p> <p>(4) Install stone shield (Volume 3, WP 0510).</p> <p>f. Inspect power steering pump for security of mounting, leaks, and signs of damage. Tighten loose mounting hardware.</p> <p>g. On M939/A1 series vehicles, inspect power steering pump belts for tension and serviceability (Volume 3, WP 0504).</p> <p>h. Inspect power steering pressure and return hoses and fittings for loose connections, cracks, splits, or damage that could cause potential hydraulic leaks. Tighten loose hydraulic lines and fittings and replace any hydraulic line or fitting that has cracks, splits, or damage that could cause potential hydraulic leaks. Refer to (Volume 3, WP 0504) for Ross steering gear, or (Volume 3, WP 0505) for Sheppard steering gear.</p> <p>i. Inspect power steering hydraulic lines between steering gear and steering assist cylinder and fittings for security of mounting, loose connections, cracks, splits, or damage that could cause hydraulic leaks. Tighten loose hydraulic lines and fittings, and replace any hydraulic line or fitting that has cracks, splits, or damage that could cause hydraulic leaks (Volume 3, WP 0507).</p> <p>j. Inspect steering gear for security of mounting and signs of leaks.</p> <p>(1) Loosen bracket mounting screws (Figure 5, Item 3).</p> <p>(2) Tighten steering gear mounting locknuts (Figure 5, Item 1) 260 to 280 lb-ft (353 to 380 N·m).</p> <p>(3) Tighten locknuts (Figure 5, Item 2) 60 to 70 lb-ft (81 to 95 N·m).</p>	

Table 1. Field Preventive Maintenance Checks and Services - Continued.

ITEM NO.	INTERVAL	ITEM TO BE CHECKED OR SERVICED	PROCEDURE	EQUIPMENT NOT READY/ AVAILABLE IF:
 <p style="text-align: right; margin-right: 50px;">I00005DAA</p>				
<p><i>Figure 5. Power Steering Pump.</i></p>				
22	Semiannual	Front Springs, Propeller Shaft, Universal and Slip Joints, and Axle	<p>a. Inspect axle (Figure 6, Item 4) for security of mounting on springs (Figure 6, Item 6). Tighten nuts (Figure 6, Item 2) on spring U-bolts 350 to 400 lb-ft (475 to 542 N·m).</p> <p>b. Inspect springs (Figure 6, Item 6) and shackles (Figure 6, Item 5) for cracks, breaks, and security of mounting. Tighten spring shackle mounting nuts (Figure 6, Item 1) 70 lb-ft (95 N·m).</p> <p style="text-align: center;">CAUTION</p> <p>Wipe fittings clean before servicing to prevent damage to shackle pins and bushings.</p> <p>c. Lubricate spring U-bolts (Figure 6, Item 3) and shackles (Figure 6, Item 5) every 3,000 mi (4,800 km) or 6 months, whichever occurs first (Volume 5, WP 0820).</p>	

Table 1. Field Preventive Maintenance Checks and Services - Continued.

ITEM NO.	INTERVAL	ITEM TO BE CHECKED OR SERVICED	PROCEDURE	EQUIPMENT NOT READY/ AVAILABLE IF:
		 <p style="text-align: right; margin-right: 50px;">100006DAA</p>	<p style="text-align: center;"><i>Figure 6. Springs and Shackles.</i></p> <p>(1) Apply lubricant to spring pins (Figure 7, Item 1) until it appears between front spring pin (Figure 7, Item 1) and bushing (Figure 7, Item 3) at both ends of shackle (Figure 7, Item 2). If spring pin (Figure 7, Item 1) does not accept lubricant, remove spring pin (Figure 7, Item 1).</p> <p>(2) Inspect front spring pin (Figure 7, Item 1) and bushing (Figure 7, Item 3) at both ends of shackle (Figure 7, Item 2).</p>	 <p style="text-align: right; margin-right: 50px;">100007DAA</p> <p style="text-align: center;"><i>Figure 7. Front Shackle.</i></p>

Table 1. Field Preventive Maintenance Checks and Services - Continued.

ITEM NO.	INTERVAL	ITEM TO BE CHECKED OR SERVICED	PROCEDURE	EQUIPMENT NOT READY/ AVAILABLE IF:
			<p style="text-align: center;">NOTE</p> <p>Lubrication of universal and slip joints will be accomplished while performing other inspection tasks in that same area. Tighten, repair, and/or replace components of universal, slip joints, and propeller shafts when found to be damaged or worn, as required. If maintenance is required at a higher level, records should reflect closest point of reference to ensure proper identification of components requiring service.</p> <p>d. Lubricate universal and slip joints on transfer case-to-front axle propeller shaft adapter every 3,000 mi (4,800 km) or 3 months, whichever occurs first (Volume 5, WP 0820).</p> <p>e. Inspect universal and slip joints on transfer case-to-front axle propeller shaft for damage or worn components. Replace worn components (Volume 3, WP 0402).</p> <p style="text-align: center;">CAUTION</p> <p>Breather and axle around breather must be wiped clean before servicing to prevent damage to axle from contamination.</p> <p>f. Remove, clean, and lubricate axle breathers every 1,000 mi (1,600 km) or monthly, whichever occurs first (Volume 3, WP 0405).</p> <p>g. Remove differential fill plug (Figure 8, Item 1) and check oil level in differential (Figure 8, Item 4) every 3,000 mi (4,800 km) or 3 months, whichever occurs first (Volume 5, WP 0820). Fill if necessary. Level should be within 1/2 in. (12.7 mm) from hole of plug (Figure 8, Item 1) when oil is cold, and to the hole of fill plug when hot.</p> <p>h. Inspect differential drain plug (Figure 8, Item 3) and fill plug (Figure 8, Item 1) for tightness and signs of leakage. Tighten drain plug (Figure 8, Item 3) 35 to 60 lb-ft (47 to 81 N-m) and fill plug (Figure 8, Item 1) 80 to 135 lb-ft (108 to 183 N-m).</p>	

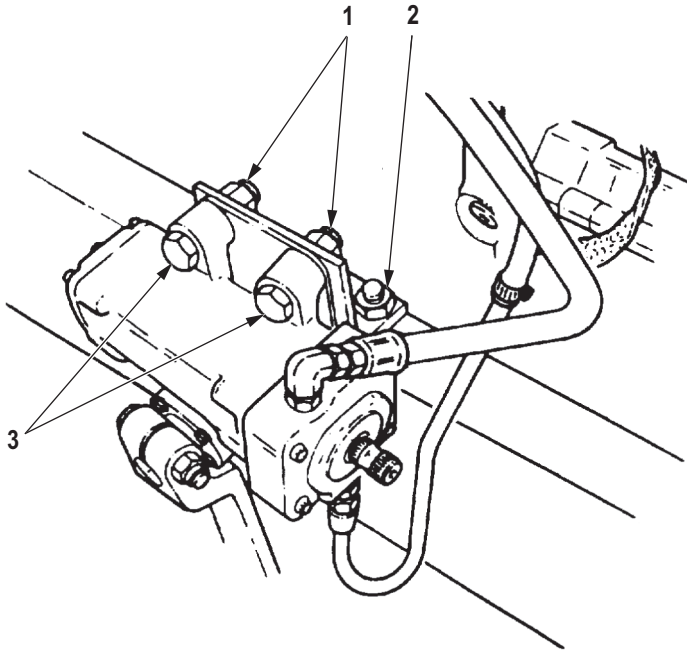
Table 1. Field Preventive Maintenance Checks and Services - Continued.

ITEM NO.	INTERVAL	ITEM TO BE CHECKED OR SERVICED	PROCEDURE	EQUIPMENT NOT READY/ AVAILABLE IF:
 <p style="text-align: right; margin-right: 100px;">I00008DAA</p> <p style="text-align: center;"><i>Figure 8. Differential.</i></p>				
23	Semiannual	Underside of Engine and Transmission	<p style="margin-left: 40px;">i. Inspect differential seals (Figure 8, Item 2) for leaks.</p> <p style="margin-left: 40px;">a. Inspect underside of engine for fuel, water, and oil leaks.</p> <p style="margin-left: 40px;">b. Inspect oil pan and drain plug for leaks. if oil pan is loose or if leaks are present, tighten oil pan screws 35 to 40 lb-ft (47 to 54 N·m). If drain plug is loose or if leaks are present, tighten drain plug 100 lb-ft (136 N·m) (M939/A1 vehicles), 60 lb-ft (80 N·m) (M939A2 vehicles). Notify your supervisor if leaks still occur.</p> <p style="margin-left: 40px;">c. Inspect transmission body for cracks or loose bolts that could cause leaks.</p> <p style="margin-left: 40px;">d. Inspect transmission shift linkage for bends, cracks, and wear that could cause failure.</p> <p style="margin-left: 40px;">e. Tighten transmission oil pan mounting bolts 5 lb-ft (7 N·m). Tighten oil pan drain plug 15 to 20 lb-ft (20 to 27 N·m).</p>	
24	Semiannual	Cooling System	<p style="margin-left: 40px;">a. Inspect coolant lines, hoses, and fittings for loose connections, cracks, frays, wear, and damage that could cause leaks. Tighten loose connections. Replace any oil line, hose, or fitting that is cracked, frayed, worn, or damaged and could cause leaks.</p>	

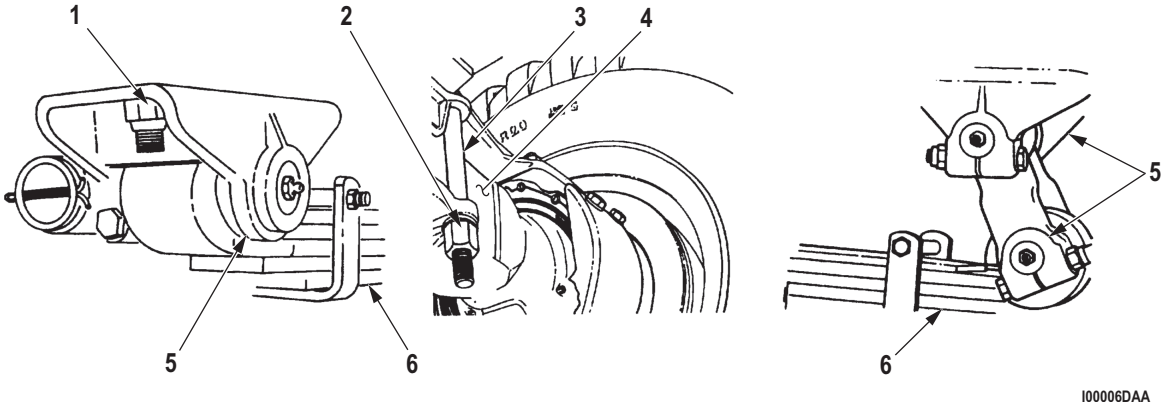
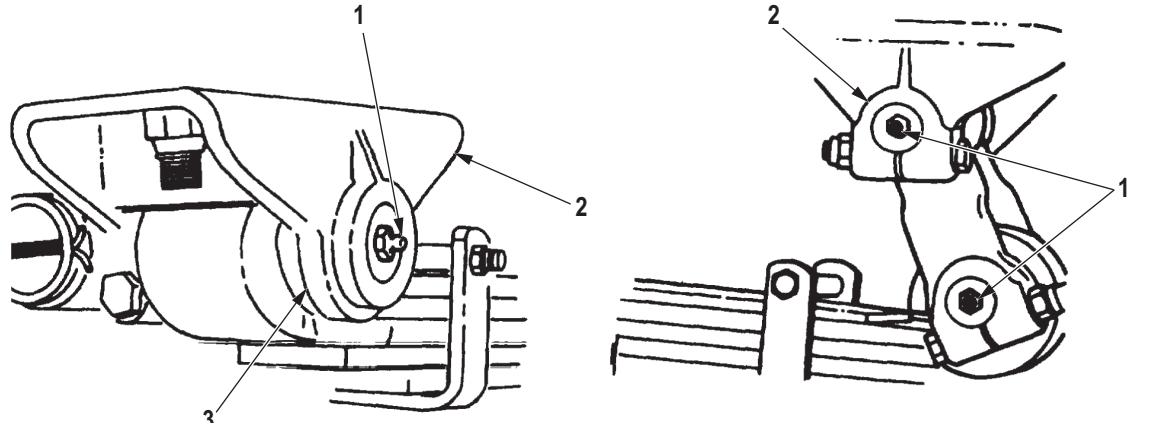
Table 1. Field Preventive Maintenance Checks and Services - Continued.

ITEM NO.	INTERVAL	ITEM TO BE CHECKED OR SERVICED	PROCEDURE	EQUIPMENT NOT READY/ AVAILABLE IF:
			<p>b. Inspect fan actuator and sensor for security of mounting. Inspect air hoses and fittings for loose connections, cracks, frays, wear, and damage that could cause leaks. Tighten loose connections. Replace any air line, hose, or fitting that is cracked, frayed, worn, or damaged and could cause leaks.</p> <p>c. Inspect radiator core for clogged or bent fins, leaks, and protruding debris. Clean clogged core and remove debris (Volume 5, WP 0819).</p> <p>d. Inspect water pump vent/drain for obstructions.</p> <p>e. Inspect water pump pulley and fan for play.</p> <p>f. On M939A2 series vehicles, inspect power steering cooler core for clogged or bent fins, leaks, and protruding debris. Clean clogged core and remove debris.</p> <p>g. Check drivebelt(s) for proper tension.</p> <p>(1) For M939A2 series vehicles, check belt tensioner for security of mounting 30 lb-ft (41 N-m) and condition of fan drivebelt (WP 0296).</p> <p>(2) For M939/A1 series vehicles, check fan drivebelt tension and adjust as required (WP 0297).</p> <p>(3) For M939/A1 series vehicles, check power steering pump drivebelt tension (Volume 3, WP 0504).</p> <p>(4) For M939/A1 series vehicles, check water pump drivebelt tension and adjust as required (WP 0294).</p> <p>(5) For M939/A1 series vehicles, check alternator drivebelt tension (WP 0302).</p> <p>h. Inspect fan blade for security, breaks, missing or loose screws and rivets, and damage which could cause an out-of-balance condition. For M939/A1 series vehicles, refer to (WP 0298) and for M939A2 series vehicles, refer to (WP 0283). Replace fan blade as required.</p> <p>i. Inspect surge tank, water manifold, thermostat housing, radiator, engine oil, transmission oil cooler, transmission oil cooler, and hoses for leaks, conditions and security of mounting(s).</p> <p>j. Inspect temperature sending unit for security of mounting. Inspect sending unit wiring for frays, splits, breaks, and worn or missing insulation.</p> <p>k. Check antifreeze protection temperature and adjust if necessary refer to (WP 0287).</p>	

Table 1. Field Preventive Maintenance Checks and Services - Continued.

ITEM NO.	INTERVAL	ITEM TO BE CHECKED OR SERVICED	PROCEDURE	EQUIPMENT NOT READY/ AVAILABLE IF:
25	Semiannual	Compressor	<p>a. Check compressor for security of mounting and leaks.</p> <p>(1) If M939/A1 series engine-mounted compressor is loose, notify your supervisor.</p> <p>(2) If M939A2 series engine-mounted compressor is loose, replace locknut and tighten to 55 lb-ft (77 N-m).</p> <p>b. Check condition and security of cooling lines to air compressor. Tighten cooling lines, if loose. Replace cooling lines if split, cracked, or damaged in such a manner as to cause leaks (WP 0284).</p> <p>c. On M939A2 series engines, check condition of compressor oil line and fittings. Tighten fittings and oil line if loose. Replace oil line if split, cracked, worn, or damaged in such a manner as to cause leaks (Volume 3, WP 0470).</p> <p>d. Check condition and security of input tube and hoses, output air line, and governor control air line. Tighten output and governor control air lines, if loose. Replace input tube or hoses if split, cracked, collapsed, distorted, or damaged in such a manner as to prevent a tight seal or restrict incoming air (WP 0284).</p>	
26	Semiannual	Engine Lubrication System and Oil Lines	<p>a. Inspect all engine oil lines, hoses, and fittings for loose connections, cracks, frays, wear, and damage that could cause leaks. Tighten loose connections, and replace any oil lines, hoses, and fittings, that are cracked, frayed, worn, or damaged and could cause leaks.</p> <p style="text-align: center;">NOTE</p> <ul style="list-style-type: none"> • Oil filter is located on lower front left side of engine on M939/A1 series vehicles and lower front right side of engine on M939A2 series vehicles. • M939/A1 series vehicles utilize an element-type engine oil filter, while M939A2 series vehicles use one of two styles of cartridge-type engine oil filters. <p>b. Inspect M939/A1 series vehicles for security of oil filter housing. Ensure filter center bolt is tight. If center bolt is loose, tighten 25 to 35 lb-ft (34 to 48 N-m).</p> <p>c. Inspect M939A2 series vehicles for security of oil filter head. Ensure spin-on oil filter is tight. If spin-on oil filter is loose, hand-tighten, then tighten an additional 3/4 turn with a wrench.</p>	

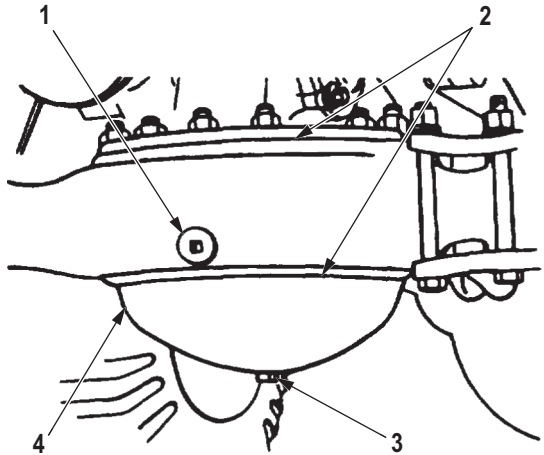
Table 1. Field Preventive Maintenance Checks and Services - Continued.

ITEM NO.	INTERVAL	ITEM TO BE CHECKED OR SERVICED	PROCEDURE	EQUIPMENT NOT READY/ AVAILABLE IF:
			<p>d. Check engine oil and dipstick for metal particles. Notify your supervisor if metal particles are found.</p> <p style="text-align: center;">WARNING</p> <div style="text-align: center;">  </div> <p>Accidental or intentional introduction of liquid contaminants into the environment is in violation of state, federal, and military regulations. Refer to local Unit SOP for information concerning storage, use, and disposal of these liquids. Failure to comply may result in injury or death to personnel.</p> <p>e. Inspect valve cover(s) and gasket(s) for evidence of leaks. Notify your supervisor if leak(s) are detected.</p>	

Table 1. Field Preventive Maintenance Checks and Services - Continued.

ITEM NO.	INTERVAL	ITEM TO BE CHECKED OR SERVICED	PROCEDURE	EQUIPMENT NOT READY/ AVAILABLE IF:
27	Semiannual	Fuel System Engine	<p style="text-align: center;">NOTE</p> <ul style="list-style-type: none"> • Steps (a) and (b) apply to M939A1 series vehicles and Step (e) applies to M939A2 series vehicles. All other steps are common to both vehicles. • Replace fuel filter every 3,000 mi (4,800 km) or 3 months, whichever occurs first. <ul style="list-style-type: none"> a. Replace filter in standard AFC fuel pump on all M939/A1 series vehicles except M936/A1 models (WP 0259) or in VS fuel pump on M936/A1 models (WP 0260). b. Inspect fuel filter/water separator mounting and housing for dents and cracks, and damage to inlet, outlet, and bleeder fittings that could cause leaks (Volume 5, WP 0819). c. Install fuel filter element on M939/A1 series vehicles, or fuel filter on M939A2 series vehicles (WP 0258). d. Inspect fuel lines for tightness of connections (WP 0254). e. Check fuel system components of M939A2 series vehicles. <ul style="list-style-type: none"> (1) Inspect fuel injector lines, injector pump lines, and manifold line and screws for leaks and damage. Tighten fuel injector lines, injector pump lines, and manifold pipe and screws if leaking and replace if damaged (WP 0244). (2) Inspect injector line holddown screws for security of mounting. If loose, tighten (WP 0244). (3) Replace in-line fuel filter (WP 0258). f. Check fuel priming pump on M939/A1 series vehicles or fuel priming transfer pump on M939A2 series vehicles for security of mounting and proper operation. g. Lubricate throttle control and modulator linkages. 	
28	Semiannual	Protective Control Box	Inspect control box and quick-disconnect for security of mounting and connection. Tighten control box mounting screws and/or quick-disconnect, if loose (WP 0319).	
29	Semiannual	Engine Compartment Electrical Wiring	Inspect all engine compartment wiring for frays, splits, missing or damaged insulation, or poor connections. Repair or replace affected wiring (Volume 3, WP 0352).	

Table 1. Field Preventive Maintenance Checks and Services - Continued.

ITEM NO.	INTERVAL	ITEM TO BE CHECKED OR SERVICED	PROCEDURE	EQUIPMENT NOT READY/ AVAILABLE IF:
30	Semiannual	Fuel Lines and Tank	<p style="text-align: center;">NOTE</p> <p>On dual tank fuel systems, inspect left side of tank when performing other tasks conducted in that area of the vehicle. Ensure any problem found while inspecting right and left side component systems is noted in maintenance forms.</p> <p>a. Inspect fuel tank(s) for dents, cracks, and broken welds that could cause leaks.</p> <p>b. Visually inspect fuel sending unit(s) and wiring for loose connections, presence, frays, splits, and missing insulation (Volume 3, WP 0352). Repair or replace wiring that is missing or shows signs of frayed, split, or missing insulation. Tighten loose connections (WP 0332).</p> <p>c. Visually inspect tube(s) and hose(s) at fuel tank(s) for loose connections, cracks, and splits. Replace fuel tank tube(s) and hose(s) that are cracked or split (WP 0250). Tighten loose fuel tank tube(s) and hose connections.</p> <p>d. Inspect fuel tank selector valve on dual tank model vehicles for freedom of operation and security of mounting and check flex lines for leaks (WP 0255).</p> <p>e. Check fuel tank selector valves for proper operation (TM 9-2320-272-10).</p>	

Table 1. Field Preventive Maintenance Checks and Services - Continued.



ITEM NO.	INTERVAL	ITEM TO BE CHECKED OR SERVICED	PROCEDURE	EQUIPMENT NOT READY/ AVAILABLE IF:
31	Semiannual	Transmission and Transfer Case	<p style="text-align: center;">WARNING</p> <div style="display: flex; justify-content: center; gap: 20px;">   </div> <ul style="list-style-type: none"> • If transmission oil temperature is above 220°F (104°C), allow transmission oil to cool before removing dipstick. Failure to comply may result in injury or death to personnel. • Accidental or intentional introduction of liquid contaminants into the environment is in violation of state, federal, and military regulations. Refer to local Unit SOP for information concerning storage, use, and disposal of these liquids. Failure to comply may result in injury or death to personnel. <p style="text-align: center;">CAUTION</p> <ul style="list-style-type: none"> • Do not remove transmission dipstick before cleaning dirt away from access plate, filler tube, and dipstick. Dirt may enter and damage transmission. • Do not overfill transmission. Internal transmission component damage will result. • Change transmission oil when contamination by fuel, water, or other foreign materials is evident. Failure to do so may result in failure of internal transmission components. <p style="text-align: center;">NOTE</p> <p>Change transmission oil every 24,000 mi (38,000 km) or 24 months, whichever occurs first.</p> <p style="margin-left: 20px;">a. On M939A2 series vehicles, inspect transmission dipstick and oil.</p> <p style="margin-left: 20px;">(1) Check for evidence of metal particles. Notify your supervisor if metal particles are found.</p> <p style="margin-left: 20px;">(2) Check for evidence of dilution by coolant. If oil is diluted, by coolant, refer to: mechanical troubleshooting.</p>	

Table 1. Field Preventive Maintenance Checks and Services - Continued.

ITEM NO.	INTERVAL	ITEM TO BE CHECKED OR SERVICED	PROCEDURE	EQUIPMENT NOT READY/ AVAILABLE IF:
			<p>(3) Check oil level in transmission. If oil levels are excessive, drain excess (Volume 3, WP 0362).</p> <p>b. Inspect transmission oil lines, hoses, and fittings for loose connections, cracks, frays, wear, and damage that could cause leaks. Tighten loose connections, or notify your supervisor if any oil line, hose, or fitting is cracked, frayed, worn, or damaged and could cause leaks.</p> <p>c. Inspect transmission oil filter housing for security of mounting. Ensure spin-on oil filter is tight. If spin-on oil filter is loose, hand-tighten, then tighten an additional 3/4 turn by hand. If leak continues, replace filter (Volume 3, WP 0381).</p> <p>d. For M939A2 series vehicles, inspect transmission temperature sending unit for security and signs of leaks, and wiring for frays, splits, breaks, and missing insulation. Tighten temperature sending unit if loose or leaking. Replace if necessary (WP 0341). Repair or replace wiring that is missing, or shows signs of frayed, split, or missing insulation. Tighten loose connections (WP 0341).</p> <p>e. Inspect transmission PTO unit (winch models and dump trucks only).</p> <p>(1) Inspect for security of mounting and leaks. Notify your supervisor if mounting is loose or leakage is present.</p> <p>(2) Inspect oil line and fittings between transmission and PTO unit for loose connections, cracks, frays, wear, and damage that could cause leaks. Notify your supervisor if mounting is loose or leakage is present.</p> <p>(3) Inspect hydraulic pump for security of mounting, leaks, and signs of damage that could cause leaks. Notify your supervisor if mounting is loose or leakage is present.</p> <p>(4) Inspect hydraulic lines and fittings for loose connections, cracks, frays, wear, and damage that could cause leaks. Notify your supervisor if mounting is loose or leakage is present.</p> <p>f. Remove transfer case fill plug and check oil level in transfer case every 3,000 mi (4,800 km) or 3 months, whichever occurs first (Volume 5, WP 0820). Fill if necessary. Level should be within 1/2 in. (12.7 mm) from fill hole when oil is cold, or to the fill hole when hot.</p>	

Table 1. Field Preventive Maintenance Checks and Services - Continued.

ITEM NO.	INTERVAL	ITEM TO BE CHECKED OR SERVICED	PROCEDURE	EQUIPMENT NOT READY/ AVAILABLE IF:
			<p>g. Inspect transfer case drain plug and fill plug for tightness and signs of leakage.</p> <p>h. Inspect transfer case for leaks. Notify your supervisor if leaks are detected.</p> <p>i. Inspect shift linkage for cracks, bends, and wear.</p> <p>j. Inspect transfer case PTO unit (M936/A1/A2 only).</p> <p>(1) Inspect for security of mounting and leaks.</p> <p>(2) Inspect oil and air lines and fittings on transfer case and PTO for loose connections, cracks, frays, wear, and damage that could cause leaks. Tighten loose connections. Replace any oil or air line, hose, or fitting that is cracked, frayed, worn, or damaged and could cause leaks.</p> <p>(3) Inspect hydraulic pump for security of mounting, leaks, and signs of damage that could cause leaks. Tighten mounting of hydraulic pump (Volume 4, WP 0714).</p> <p>(4) Inspect hydraulic lines and fittings for loose connections, cracks, frays, wear, and damage that could cause leaks. Tighten loose connections. Replace any oil line, hose, or fitting that is cracked, frayed, worn, or damaged and could cause leaks.</p>	

Table 1. Field Preventive Maintenance Checks and Services - Continued.

ITEM NO.	INTERVAL	ITEM TO BE CHECKED OR SERVICED	PROCEDURE	EQUIPMENT NOT READY/ AVAILABLE IF:
32	Semiannual	Propeller Shafts, and Universal and Slip Joints	<p>a. On front winch and M929/A1/A2 model vehicles only, lubricate transmission PTO universal joint every 3,000 mi (4,800 km) or 3 months, whichever occurs first (Volume 5, WP 0820).</p> <p>b. On M936/A1/A2 series vehicles, lubricate transfer case PTO universal joint every 3,000 mi (4,800 km) or 3 months, whichever occurs first (Volume 5, WP 0820).</p> <p style="text-align: center;">NOTE</p> <p>Lubrication of universal and slip joints will be accomplished while performing other inspection tasks in that same area. Tighten, repair, and/or replace components of universal, slip joints, and propeller shafts when found to be damaged or worn, as required. If maintenance is required at a higher level, records should reflect closest point of reference to ensure proper identification of components requiring service.</p> <p>c. Lubricate universal and slip joints on transmission-to-transfer case, transfer case-to-differential, differential-to-differential propeller shafts, and speedometer adapter every 3,000 mi (4,800 km) or 3 months, whichever occurs first (Volume 5, WP 0820).</p> <p>d. Inspect universal and slip joints on transmission PTO, transfer case PTO, and transfer case-to-front axle, transmission-to-transfer case (Volume 3, WP 0403), transfer case-to-differential (Volume 3, WP 0401) or (Volume 3, WP 0400), and differential-to-differential (Volume 3, WP 0388) propeller shafts for damaged or worn components.</p>	
33	Semiannual	Air Intake Tubes	<p>a. Inspect vent lines for serviceability and security of connections (Volume 5, WP 0819).</p> <p>b. Inspect air intake piping and air cleaner assembly for condition and security of mounting. Replace defective components and secure loose mountings (TM 9-2320-272-10).</p> <p>c. Test air cleaner indicator for proper operation (TM 9-2320-272-10).</p>	
34	Semiannual	Air Reservoir and Double Check Valves	<p>a. Inspect reservoir tanks, double check valves, and fittings for leaks (Volume 5, WP 0819).</p> <p>b. Inspect condition of reservoir tank for damage that could cause leaks (Volume 5, WP 0819).</p>	

Table 1. Field Preventive Maintenance Checks and Services - Continued.



ITEM NO.	INTERVAL	ITEM TO BE CHECKED OR SERVICED	PROCEDURE	EQUIPMENT NOT READY/ AVAILABLE IF:
35	Semiannual	Winch Reservoir	Check hydraulic oil level in tank. If low, fill to top notch on dipstick.	
36	Semiannual	Rear Wheels, Hubs, and Suspension	<p style="text-align: center;">WARNING</p> <div style="display: flex; justify-content: center; gap: 20px;">   </div> <ul style="list-style-type: none"> • Completely deflate tire before removing from axle if there is obvious damage to wheel components. Failure to comply may result in injury or death to personnel. • Use caution when inflating tires. Ensure tire is in a tire cage and properly seated on rim before inflating. An improperly seated tire can burst with explosive force. Failure to comply may result in injury or death to personnel. • Do not work on any component supported only by lift jacks or hoist. Always use blocks or proper stands to support the component prior to any work. Equipment may fall. Failure to comply may result in injury or death to personnel. • Air in system is under pressure. Ensure engine is shut down and all air reservoirs are drained before disconnecting CTIS components. Failure to comply may result in injury or death to personnel. <p style="text-align: center;">NOTE</p> <ul style="list-style-type: none"> • Similar left and right side, and forward-rear and rear-rear components are inspected in the same manner and will be accomplished simultaneously, although procedures are written for left side only. • When documenting discrepancies for similar left and right side, and forward-rear and rear-rear components, indicate which area is affected. 	

Table 1. Field Preventive Maintenance Checks and Services - Continued.

ITEM NO.	INTERVAL	ITEM TO BE CHECKED OR SERVICED	PROCEDURE	EQUIPMENT NOT READY/ AVAILABLE IF:
			<ul style="list-style-type: none"> • Lugnuts on left side have left-hand threads and can be identified by an L, while lugnuts on right side have right-hand threads, and can be identified by an R. a. On M939 series vehicles, inspect split locking ring for dents or breaks that could cause them to pop off. If ring is loose, inspect for damage to rim or tire. Replace any damaged wheel (Volume 3, WP 0485). b. On M939A1/A2 series vehicles, inspect wheels for any loose or missing rim nut. Tighten rim nuts 210 to 240 lb-ft (285 to 325 N-m). Replace any rim stud that is broken or has stripped threads. has stripped threads (Volume 3, WP 0485). c. Clean, inspect, and lubricate inner and outer rear wheel bearings. d. Inspect service and service/spring brake air lines and fittings for loose connections, cracks, splits, or damage that could cause air leaks. Tighten loose air lines and fittings and replace any air line or fitting that has cracks, splits, or damage that could cause air leaks. e. Check brake shoe-to-drum clearance and condition of brake shoes (Volume 3, WP 0432). If clearance is more than 0.06 in. (1.5 mm), manually adjust brakes or notify your supervisor of inoperative adjusters. Replace brake shoes if worn beyond chamfer on linings (Volume 3, WP 0426). f. Inspect service brake chambers for condition and security of mounting. Replace service brake chambers and/or component parts if condition could impair operation of brakes (Volume 3, WP 0434). g. Inspect service/spring brake chambers for condition and security of mounting. Replace service/ spring brake chambers and/or component parts if condition could impair operation of brakes (Volume 3, WP 0435). h. Inspect rear relay valve for condition and security of mounting and air lines and fittings for loose connections. Replace rear relay valve and/or component parts if condition could impair operation of brakes. Tighten loose air lines and fittings. i. Inspect air manifold tee for condition and security of mounting and air lines and fittings for loose connections. Replace air manifold tee and/or component 	

Table 1. Field Preventive Maintenance Checks and Services - Continued.

ITEM NO.	INTERVAL	ITEM TO BE CHECKED OR SERVICED	PROCEDURE	EQUIPMENT NOT READY/ AVAILABLE IF:
			<p>parts if condition could impair operation of brakes (Volume 3, WP 0438). Tighten loose air lines and fittings.</p> <p>j. Inspect M939A2 series vehicles CTIS air lines and fittings for loose connections, cracks, splits, or damage that could cause air leaks. Tighten loose air lines and fittings.</p> <p>k. Lubricate spring trunnion bearings every 3,000 mi (4,800 km) or 3 months, whichever occurs first (Volume 5, WP 0820).</p> <p>l. Visually inspect spring leaves, retaining clips, and center screws for cracks, breaks, and security of mounting. Replace spring leaves, retaining clips, or center screws if cracked or broken (Volume 3, WP 0539). Secure mounting if loose.</p> <p>m. Inspect torque rods.</p> <p>(1) Visually inspect rubber for cracks, splits, or out-of-round condition. Replace torque rods if rubber is cracked or out-of-round (Volume 3, WP 0544).</p> <p>(2) Check torque rod nuts for tightness. For inspection purposes, torque rod nuts should be 350 to 700 lb-ft (475 to 949 N·m). If loose, tighten torque rod nuts 350 to 400 lb-ft (475 to 542 N·m). Continue to tighten until cotter pins can be installed.</p> <p>n. Inspect both front and rear wear pads for wear. Replace if wear pads are rubbing the spring bracket (Volume 3, WP 0541).</p> <p>o. Tighten nuts on spring U-bolts 300 to 400 lb-ft (407 to 542 N·m).</p> <p style="text-align: center;">CAUTION</p> <p>Clean breathers and axle around breathers before servicing to prevent damage to axle from contamination.</p> <p>p. Remove, clean, and lubricate axle breathers every 1,000 mi (1,600 km) or monthly, whichever occurs first (Volume 5, WP 0820).</p> <p>q. Remove fill plug (Figure 9, Item 3) on forward-rear and rear-rear differential (Figure 9, Item 1) and check oil level in differential (Figure 9, Item 1) every 3,000 mi (4,800 km) or 3 months, whichever occurs first (Volume 5, WP 0820). If necessary, fill differential (Figure 9, Item 1). Level in differential (Figure 9, Item 1) should be within 1/2 in. (12.7 mm)</p>	

Table 1. Field Preventive Maintenance Checks and Services - Continued.

ITEM NO.	INTERVAL	ITEM TO BE CHECKED OR SERVICED	PROCEDURE	EQUIPMENT NOT READY/ AVAILABLE IF:
			<p>from hole of fill plug (Figure 9, Item 3) when oil is cold, and to hole of fill plug (Figure 9, Item 3) when hot.</p> <p>r. Inspect differential drain plug (Figure 9, Item 2) and fill plug (Figure 9, Item 3) for tightness and signs of leakage. Tighten drain plug (Figure 9, Item 2) 35 to 60 lb-ft (47 to 81 N·m) and fill plug (Figure 9, Item 3) 80 to 135 lb-ft (108 to 183 N·m).</p>  <p style="text-align: right; font-size: small;">100009DAA</p>	
			<p>s. Inspect differential seals for leaks.</p> <p>t. On M939A2 series vehicles, replace filter and install wheel valves (Volume 3, WP 0491).</p>	
37	Semiannual	Towing Pintle and Glad Hand Connections	Lubricate towing pintle every 3,000 mi (4,800 km) or 3 months, whichever occurs first (Volume 5, WP 0820).	
38	Semiannual	Glad Hand and Air Lines	<p>a. Inspect emergency and service air and dummy couplings for serviceability and tightness of seal (Volume 3, WP 0450).</p> <p>b. Inspect emergency and service air lines, fittings, and shutoff valve for security of mounting, tightness of connections, and damage that could cause air leaks (Volume 3, WP 0450).</p>	Replace emergency or service air or dummy coupling(s) that are broken, bent, cracked, or have seals that leak.
39	Semiannual	Rear Lighting and Trailer Receptacle	Inspect rear lights, trailer receptacle, and wiring for damage. Repair if damaged (Volume 3, WP 0352).	

Table 1. Field Preventive Maintenance Checks and Services - Continued.

ITEM NO.	INTERVAL	ITEM TO BE CHECKED OR SERVICED	PROCEDURE	EQUIPMENT NOT READY/ AVAILABLE IF:
40	Semiannual	Special Body Items	<p>a. For M927/A1/A2 and M928/A1/A2 model vehicles, lubricate propeller shaft center bearing every 3,000 mi (4,800 km) or 3 months, whichever occurs first (Volume 5, WP 0820).</p> <p style="text-align: center;">WARNING</p> <div style="text-align: center;">  </div> <p>Support weight of dump body on safety braces when performing maintenance on hoist mechanism with dump body in raised position. Failure to comply may result in injury or death to personnel.</p> <p>b. For M929/A1/A2 and M930/A1/A2 model vehicles:</p> <p>(1) Lubricate safety latch, lifting arm, cylinder crosshead, body hinge pins, lifting arm rollers, and trunnion pins every 3,000 mi (4,800 km) or 3 months, whichever occurs first (Volume 5, WP 0820).</p> <p>(2) Lubricate tailgate bearings every 1,000 mi (1,600 km) or monthly, whichever occurs first (Volume 5, WP 0820).</p> <p>c. For M931/A1/A2 and M932/A1/A2 vehicles:</p> <p>(1) Lubricate bushing pins, coupler jaw pin, and walking beam every 1,000 mi (1,600 km) or monthly, whichever occurs first (Volume 5, WP 0820).</p> <p>(2) Lubricate lock plunger shaft every 1,000 mi (1,600 km) or monthly, whichever occurs first (Volume 5, WP 0820). Unwind entire cable; soak and clean and soak and soak with OE/HDO 30. Wipe off excess and coat cable and drum with lubricating oil before rewinding (TM 9-2320-272-10). If operation is frequent, continuous, or under severe conditions, service weekly.</p> <p>(3) Lubricate hoist cable sheaves, boom hinge pins, boom cylinder pins, boom sheave pins, block sheave pins, block hook, cable guide rollers, boom winch drum shaft bearings, and turntable gear every 3,000 mi (4,800 km) or 3 months, whichever occurs first (Volume 5, WP 0820). If operation if frequent, continuous, or under severe conditions, service weekly. Rotate turntable through full range of travel while lubricating turntable gear.</p>	

Table 1. Field Preventive Maintenance Checks and Services - Continued.

ITEM NO.	INTERVAL	ITEM TO BE CHECKED OR SERVICED	PROCEDURE	EQUIPMENT NOT READY/ AVAILABLE IF:
			<p>(4) Lubricate level wind frame, end frame bearing, and sheave frame pin bearing every 3,000 mi (4,800 km) or 3 months, whichever occurs first (Volume 5, WP 0820). If operation is frequent, continuous, or under severe conditions, service weekly.</p> <p>(5) Lubricate tensioner sheave pins, level wind sheave bearing and level wind trolley wheels every 1,000 mi (1,600 km) or monthly, whichever occurs first (Volume 5, WP 0820).</p> <p>(6) Lubricate level wind trolley lock and tensioner rocker lever pins every 1,000 mi (1,600 km) or monthly, whichever occurs first (Volume 5, WP 0820).</p> <p>(7) Lubricate turntable bearing every 6,000 mi (9,600 km) or 6 months, whichever occurs first (Volume 5, WP 0820). Rotate turntable through full range of travel while lubricating turntable bearings.</p> <p>(8) Drain and fill hoist gearcase with oil every 6,000 mi (9,600 km) or 6 months, whichever occurs first (Volume 5, WP 0820). Remove level plugs, fill plugs, drain plugs, and drain gearcases. Install drain plugs and fill to level plugs. Install level plugs and fill plug.</p> <p>(9) Check hydraulic oil reservoir for proper level every 1,000 mi (1,600 km) or monthly, whichever occurs first (Volume 5, WP 0820). Fill as required.</p>	
41	Semiannual	Rifle Mounting Kit	<p>a. Check rifle top and lower mounts for looseness, binding, and damage.</p> <p>b. Check handle for excessive looseness and damage.</p>	
42	Semiannual	Machine Gun Mount	Refer to TM 9-1005-245-14 for Preventive Maintenance Checks and Services (PMCS).	
43	Semiannual	M-8 Chemical Alarm	Refer to TM 3-6665-225-12 for PMCS.	
44	Semiannual	M-11 Decontamination Unit	Refer to TM 3-4230-204-12&P for PMCS.	

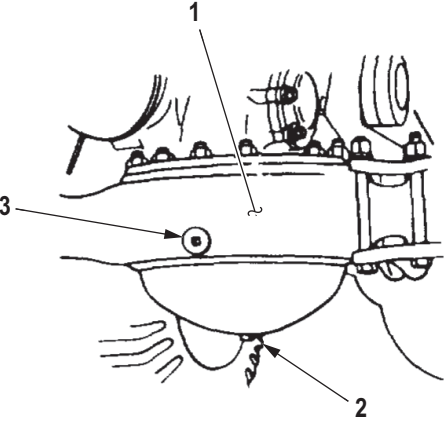
PMCS Mandatory Replacement Parts List

Table 2. PMCS Mandatory Replacement Parts List.

	ITEM NO.	PART NUMBER (CAGEC)	NSN	NOMENCLATURE	QTY	STEP NUMBER
	1	MS35338-46	5310-00-722-5658	Lockwasher	10	11a
*	2	MS35338-48	5310-00-003-4094	Lockwasher	20	19d
*	3	7979374		Seal, Plain, Encased	2	19d
	4	MS35335-33	5310-00-209-0786	Lockwasher	20	19d
	5	10935405	5340-00-450-5718	Protective Caps	A/R	19d
	6	1229-S-513-C	5310-01-062-3384	Lockwasher	8	19d
*	7	5139123	5310-00-700-7069	Keyway Insert	2	19d
**	8	1229-U-1009	5310-00-321-9974	Keyway Insert	2	19d
**	9	MS28775-206	5330-01-133-5858	O-ring	2	19d
**	10	A-1205-Z-2132	5330-01-271-9410	Seal, Plain, Encased	2	19d
**	11	2297-N-5630	4730-01-272-0582	Seal, Conical, Flared	2	19d
**	12	2208-S-1033	5330-01-272-1148	Gasket	2	19d
**	13	A-1205-N-2120	5330-01-272-1147	Retainer, Oil Seal (Air Seals)	4	19d
**	14	599791	4460-01-284-2344	Filter Element, Fluid	2	19e
	15	MS35769-21	5330-01-352-7768	Gasket	1	22g
	16	C2AZ9324C	4720-00-845-0630	Hose, Nonmetallic	1	26e
***	17	154088	5330-00-013-7806	Seal, Cap	1	27a
*	18	146483	5310-00-291-9490	Filter Element	1	27a
***	19	145504	5330-01-051-4243	Packing, Preformed	1	27a
*	20	256476	2910-00-152-2033	Kit, Fluid Pressure	1	27c
**	21	3313281	2940-01-157-6309	Filter Element, Fluid	1	27c
**	22	FF-5079	4330-01-309-6189	Filter, Fluid, In-Line	1	27e3
**	23			O-ring (Wheel Valve-to-Axle)	4	36c

PMCS Mandatory Replacement Parts List - Continued

Table 2. PMCS Mandatory Replacement Parts List - Continued.

	ITEM NO.	PART NUMBER (CAGEC)	NSN	NOMENCLATURE	QTY	STEP NUMBER
**	24	A3994-1	4720-01-279-3034	O-ring (Wheel Valve Filter)	4	36c
**	25	131245		Locknut	8	36c
**	26	10947447-2		Locknut	40	36c
**	27	A-1205-Z-2132	5330-01-271-9410	Oil Seal, Axle	4	36c
**	28	1229-U-1009	5310-00-321-9974	Keyway Insert	4	36c
**	29	A-1205-N-2120	5330-01-272-1147	Retainer, Oil Seal (Rear Air Seals)	4	36c
**	30	A-1205-D-2165	5330-01-308-0175	Retainer, Oil Seal (Front Air Seals)	4	36c
**	31	3286-P-1056	2530-01-285-3563	Slinger Ring	4	36c
*	32	10947447		Locknut	40	36c
*	33	5139123	5310-00-700-7089	Keyway Insert	4	36c
*	34	741344		Seal Assembly	4	36c
*	35	12375801	5330-01-444-8350	Seal Assembly	4	36c
*	36	7409553	2590-00-740-9553	Wiper	4	36c
	37	MS24665-500	5315-00-187-9567	Cotter Pin	12	36m2
	38	MS35769-21	5330-01-352-7768	Gasket	4	36q
**	39	599791	4460-01-284-2344	Filter Element, Fluid	4	36t
* M939/A1 ** M939A2 *** M936/A1						

END OF TASK

END OF WORK PACKAGE

**FIELD MAINTENANCE
PREVENTIVE MAINTENANCE CHECKS AND SERVICES FOR MODELS M939/A1/A2 (ANNUAL)**

INITIAL SETUP:**Tools and Special Tools**

- Tool Kit, General Mechanic's: Automotive
(Volume 5, WP 0826, Table 1, Item 56)
- Wrench, Torque, Click, Ratcheting, 1/2" Drive,
250 Ft-Lb
(Volume 5, WP 0826, Table 1, Item 63)
- Wrench, Torque, Click, Ratcheting, 3/4" Drive,
600 Ft-Lb
(Volume 5, WP 0826, Table 1, Item 61)

Materials/Parts

- Antifreeze: Arctic Grade, Permanent Type
(Volume 5, WP 0825, Table 1, Item 5)
- Antifreeze: Ethylene Glycol, Permanent Type,
Inhibited
(Volume 5, WP 0825, Table 1, Item 6, 7, 8)
- Lubricating Oil, Engine: OE/HDO 10W
(Volume 5, WP 0825, Table 1, Item 36, 37,
38)
- Lubricating Oil, Engine: OE/HDO 30W
(Volume 5, WP 0825, Table 1, Item 39, 40, 41,
42)
- Lubricating Oil, Exposed Gear: CW
(Volume 5, WP 0825, Table 1, Item 43)
- Lubricating Oil, Gear, Multipurpose: GO 75W90
(Volume 5, WP 0825, Table 1, Item 44, 45, 46,
47)
- Lubricating Oil, Gear, Multipurpose: GO 80W90
(Volume 5, WP 0825, Table 1, Item 48, 49,
50)
- Rag, Wiping
(Volume 5, WP 0825, Table 1, Item 53)

Personnel Required

- Wheeled Vehicle Mechanic 91B (2)

References

- DA FORM 5988-E or DA FORM 2404
TM 9-2320-272-10
- Volume 3, WP 0420
- Volume 3, WP 0426
- Volume 3, WP 0492
- Volume 3, WP 0517
- Volume 3, WP 0540
- Volume 3, WP 0543
- Volume 4, WP 0568
- Volume 4, WP 0569
- Volume 4, WP 0670
- Volume 4, WP 0672
- Volume 4, WP 0704
- Volume 5, WP 0811
- Volume 5, WP 0819
- Volume 5, WP 0820

Equipment Condition

- Vehicle parked and shut down.
(TM 9-2320-272-10)
-

Table 1. Field Preventive Maintenance Checks and Services.

ITEM NO.	INTERVAL	ITEM TO BE CHECKED OR SERVICED	PROCEDURE	EQUIPMENT NOT READY/ AVAILABLE IF:
1	Annual	Front End	<p style="text-align: center;">NOTE</p> <p>After all services and inspections have been completed, perform a short road test to ensure all corrections have been implemented. Correct any defects or malfunctions that may occur during this test.</p> <p style="text-align: center;">NOTE</p> <ul style="list-style-type: none"> • Lubricate vehicle in accordance with (Volume 5, WP 0820). • Perform all semiannual checks listed in (WP 0207). <p>a. Check front end alignment with toe-in gauge. Correct toe-in is 1/16 to 3/16 in. (1.588 to 4.763 mm). When toe-in is correct, tighten crossshaft screws and nuts 35 to 55 lb-ft (47 to 75 N·m).</p> <p>b. Inspect axle housings and differentials for cracks.</p> <p>c. Inspect shock absorbers and mounting brackets for looseness, wear, cracks, serviceability, and leaks. Replace leaking shock absorbers if more than a Class I leak is detected (Volume 3, WP 0492).</p> <p>d. Check each tire using a tire depth gauge. Tread depth should be at least 1/8 in. (3 mm) or as indicated on tire depth chart.</p>	
2	Annual	Engine Compartment and Cab	<p>a. Inspect front cab mounting brackets for security, wear, cracks, splits, broken welds, loose bushings, and missing screws. Replace front cab mounting brackets if worn, cracked, split, or welds are broken. Replace loose insulators and missing screws (Volume 4, WP 0568).</p> <p>b. Inspect rear cab mounting brackets for security, wear, cracks, splits, broken welds, loose bushings, and missing screws. Replace rear cab mounting brackets if worn, cracked, split, or welds are broken. Replace loose bushings and missing screws (Volume 4, WP 0569).</p> <p>c. Tighten front cab mounting screws.</p> <p>d. Check the following items on M939A2 vehicles:</p> <p>(1) Inspect front and rear engine mounting brackets for security, wear, cracks, splits, broken welds, loose bushings, and missing bolts.</p> <p>(2) Check left-side engine mounting locknuts (Figure 1, Item 1) and right-side engine mounting screws</p>	

Table 1. Field Preventive Maintenance Checks and Services - Continued.

ITEM NO.	INTERVAL	ITEM TO BE CHECKED OR SERVICED	PROCEDURE	EQUIPMENT NOT READY/ AVAILABLE IF:
			<p>(Figure 1, Item 6) for looseness. If loose, tighten 120 to 140 lb-ft (163 to 190 N·m).</p> <p>(3) Check two upper locknuts (Figure 1, Item 4) securing left engine mount (Figure 1, Item 2). If loose, tighten 90 lb-ft (122 N·m). Check two lower locknuts (Figure 1, Item 3) for looseness. If loose, tighten 60 lb-ft (82 N·m).</p> <p>(4) Check two upper locknuts (Figure 1, Item 7) securing right engine mount (Figure 1, Item 5) for looseness. If loose, tighten 90 lb-ft (122 N·m). Check two lower locknuts (Figure 1, Item 8) for looseness. If loose, tighten 60 lb-ft (81 N·m).</p>	

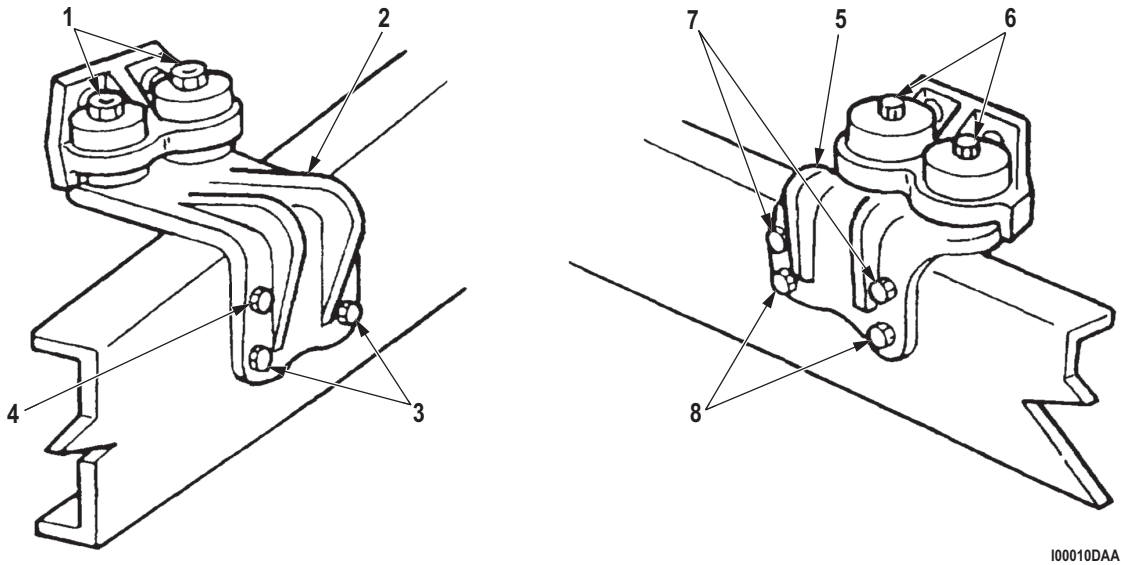

100010DAA

Figure 1. Engine Mounts.

Table 1. Field Preventive Maintenance Checks and Services - Continued.

ITEM NO.	INTERVAL	ITEM TO BE CHECKED OR SERVICED	PROCEDURE	EQUIPMENT NOT READY/ AVAILABLE IF:
3	Annual	Rear Suspension	<p>a. Inspect forward-rear and rear-rear axle housings and differentials for cracks.</p> <p style="text-align: center;">WARNING</p> <p>Do not allow grease or oil to contact brake linings. Linings can absorb grease and oil, causing early glazing and very poor braking action. Failure to comply may result in injury or death to personnel.</p> <p>b. Tighten forward-rear and rear-rear axle drive flange screws 60 to 100 lb-ft (81 to 136 N·m).</p> <p>c. Ensure all differential companion flange mounting screws and U-joint mounting screws are tight. Tighten companion flange mounting screws 30 to 40 lb-ft (41 to 54 N·m) and U-joint mounting screws 90 to 110 lb-ft (122 to 149 N·m).</p> <p>d. Test spring seat bearing free play by placing jack under spring seat bracket. Raise vehicle so spring moves freely up and down in guide brackets. Put prybar between U-bolt saddle and lift pin. Pull up on prybar. If there is free play, adjust spring seat bearing (Volume 3, WP 0540).</p>	
4	Annual	Compressed Air System	<p style="text-align: center;">WARNING</p> <div style="text-align: center;">  </div> <ul style="list-style-type: none"> • Chock vehicle wheels. Failure to comply may result in injury or death to personnel. • Wear safety goggles while performing inspection. Line is under pressure. Failure to comply may result in injury or death to personnel. <p>Check for faulty check valves at the primary and secondary air tanks and crossed hoses. Crossed hoses occur from (A) treadle valve air supply hoses at the primary and secondary air tanks, and (B) primary and secondary air gauge lines at the treadle valve.</p>	

Table 1. Field Preventive Maintenance Checks and Services - Continued.

ITEM NO.	INTERVAL	ITEM TO BE CHECKED OR SERVICED	PROCEDURE	EQUIPMENT NOT READY/ AVAILABLE IF:
<div style="border: 1px solid black; padding: 5px; margin-bottom: 5px;"> Build up air pressure in primary and secondary air systems to 50 to 60 psi (344.75 to 413.70 kPa). Trace the air line from wet tank (Figure 3, Item 3) to drainvalve (Figure 3, Item 5). Open the drainvalve (Figure 3, Item 5). </div> <div style="display: flex; justify-content: space-between;"> <div style="width: 45%;"> <div style="border: 1px solid black; padding: 5px; margin-bottom: 5px;"> Air pressure drops to zero in either primary (Figure 3, Item 6) or secondary (Figure 3, Item 2) air tanks. Replace faulty check valve(s) (Figure 3, Item 1) at affected tank(s). </div> <div style="border: 1px solid black; padding: 5px; margin-bottom: 5px;"> Build up pressure in the primary and secondary air system to 50 to 60 psi (344.75 to 413.70 kPa). Remove air gauge line at the primary (lower) air gauge port (Figure 3, Item 9) of the treadle valve (Figure 3, Item 7). Do not allow air to bleed out slowly as this may affect results. Observe the gauges. </div> <div style="border: 1px solid black; padding: 5px; margin-bottom: 5px;"> Secondary air gauge (Figure 3, Item 7) drops to zero. </div> <div style="border: 1px solid black; padding: 5px; margin-bottom: 5px;"> Follow air line from primary air tank (Figure 3, Item 6) to drainvalve (Figure 3, Item 4). Open drainvalve (Figure 3, Item 4). </div> <div style="display: flex; justify-content: space-between;"> <div style="width: 45%;"> <div style="border: 1px solid black; padding: 5px; margin-bottom: 5px;"> Air pressure released when drainvalve (Figure 3, Item 4) is opened. </div> <div style="border: 1px solid black; padding: 5px; margin-bottom: 5px;"> No air pressure released when drainvalve (Figure 3, Item 4) is opened. </div> </div> <div style="width: 45%;"> <div style="border: 1px solid black; padding: 5px; margin-bottom: 5px;"> Air systems maintain pressure. </div> <div style="border: 1px solid black; padding: 5px; margin-bottom: 5px;"> Primary air gauge (Figure 3, Item 8) drops to zero. </div> <div style="border: 1px solid black; padding: 5px; margin-bottom: 5px;"> Follow air line from primary air tank (Figure 3, Item 6) to drainvalve (Figure 3, Item 4). Open drainvalve (Figure 3, Item 4). </div> <div style="display: flex; justify-content: space-between;"> <div style="width: 45%;"> <div style="border: 1px solid black; padding: 5px; margin-bottom: 5px;"> Air pressure released when drainvalve (Figure 3, Item 4) is opened. </div> <div style="border: 1px solid black; padding: 5px; margin-bottom: 5px;"> No air pressure released when drainvalve (Figure 3, Item 4) is opened. Air lines are installed properly. Inspection is complete. Reconnect lower air gauge line at treadle valve (Figure 3, Item 7). See View D below. </div> </div> </div> </div> </div> </div> </div> <div data-bbox="219 1514 1494 1770" data-label="Diagram"> <p>The diagram illustrates four different configurations of the air system, labeled VIEW A, VIEW B, VIEW C, and VIEW D (NORMAL). Each view shows a central TREADLE valve with two air tanks (SEC TANK and PRI TANK) and two gauges (SEC GA and PRI GA). A DRAIN valve is also connected to the system. In VIEW A, the primary air gauge line is connected to the secondary air tank. In VIEW B, the primary air gauge line is connected to the primary air tank. In VIEW C, the secondary air gauge line is connected to the primary air tank. In VIEW D (NORMAL), the secondary air gauge line is connected to the secondary air tank.</p> </div> <div data-bbox="1437 1789 1523 1810" data-label="Text"> <p>100011DAA</p> </div> <div data-bbox="732 1845 979 1877" data-label="Caption"> <p>Figure 2. Air System.</p> </div> <div data-bbox="805 1967 898 1999" data-label="Page-Footer"> <p>0208-5</p> </div>				

Table 1. Field Preventive Maintenance Checks and Services - Continued.

ITEM NO.	INTERVAL	ITEM TO BE CHECKED OR SERVICED	PROCEDURE	EQUIPMENT NOT READY/ AVAILABLE IF:
<p>Figure 3. Air System.</p>				

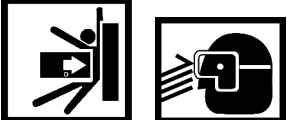
100012DAA

Table 1. Field Preventive Maintenance Checks and Services - Continued.

ITEM NO.	INTERVAL	ITEM TO BE CHECKED OR SERVICED	PROCEDURE	EQUIPMENT NOT READY/ AVAILABLE IF:
5	Annual	Wiring Harnesses and Compressed Air Lines	Inspect starter mounting bolts and starter wiring for corrosion and loose connections. Tighten starter mounting bolts 55 lb-ft (75 N-m).	
6	Annual	Spare Tire Carrier	Inspect spare tire carrier for security, completeness of assembly, and proper operation.	
7	Annual	Parking Brake	Inspect brake lever travel (Volume 3, WP 0420). Replace brake shoes if brake lever travel is greater than 2 in. (5.1 cm) (Volume 3, WP 0426).	
8	Annual	Air Dryer System	<p>a. Inspect air dryer, two purge valves, and check valve for security of mounting and signs of damage that could cause leaks.</p> <p style="text-align: center;">NOTE</p> <p>Air dryer will whistle when filter needs to be replaced.</p> <p>b. Replace filter in air dryer (Volume 5, WP 0806).</p> <p>c. Inspect filter in water separator (Volume 5, WP 0811).</p> <p>d. Inspect all tubes and fittings for damage or cracks that could cause leaks.</p>	
9	Annual	Towing Pintle	Check operation of towing pintle hook. Inspect pintle and bracket for cracks, breaks, wear, and play of 0.003 to 0.017 in. (0.07 to 0.43 mm) (Volume 3, WP 0517).	
10	Annual	Special Body Items	a. M929/A1/A2 and M930/A1/A2.	

Table 1. Field Preventive Maintenance Checks and Services - Continued.



ITEM NO.	INTERVAL	ITEM TO BE CHECKED OR SERVICED	PROCEDURE	EQUIPMENT NOT READY/ AVAILABLE IF:
			<p style="text-align: center;">WARNING</p> <div style="display: flex; justify-content: center; gap: 10px;">    </div> <ul style="list-style-type: none"> • Support weight of dump body on safety braces when performing maintenance on hoist mechanism with dump body in raised position. Failure to comply may result in injury or death to personnel. • Do not drain oil from dump hydraulic pump, reservoir, or cylinder or remove lines containing oil when dump body is supported by hydraulic cylinder. Failure to comply may result in injury or death to personnel. • Do not drain oil from dump hydraulic pump, reservoir, or cylinder or remove lines containing oil when oil is hot. Failure to comply may result in injury or death to personnel. • Do not remove hoses while engine is running or start engine with hoses removed. High-pressure fluids may cause hoses to whip violently and spray randomly. Failure to comply may result in injury or death to personnel. • Accidental or intentional introduction of liquid contaminants into the environment is in violation of state, federal, and military regulations. Refer to local Unit SOP for information concerning storage, use, and disposal of these liquids. Failure to comply may result in injury or death to personnel. <p>(1) Inspect dump body for completeness of assembly. Ensure dump body is aligned with frame.</p> <p>(2) Inspect dump hydraulic lines, hoses, and fittings for leaks and splits. Check hydraulic pump for tightness of mounting.</p> <p>(3) Inspect transmission PTO, hydraulic pump propeller shaft, and hydraulic pump for tight mounting and leaks.</p>	

Table 1. Field Preventive Maintenance Checks and Services - Continued.

ITEM NO.	INTERVAL	ITEM TO BE CHECKED OR SERVICED	PROCEDURE	EQUIPMENT NOT READY/ AVAILABLE IF:
			<p>(4) Ensure tailgate control rod hand lever locks and unlocks tailgate lower latch. Inspect control linkage for security, bends, and binding.</p> <p>(5) Operate dump body and observe for smooth raising and lowering of dump body.</p> <p>(6) With dump body raised, inspect cylinder piston rods for scoring and wear.</p> <p style="text-align: center;">CAUTION</p> <p>Remove filler plug slowly to release pressure. Do not overfill.</p> <p>(7) Drain, clean, and fill winch hydraulic oil reservoir and replace filter every 12 months (Volume 4, WP 0704).</p> <p>b. On M934/A1/A2 model vehicles:</p> <p>(1) Expand van body and inspect for damaged or broken hinges, fasteners, and latches (Volume 5, WP 0819).</p> <p>(2) Check for bent or binding of components or damaged seals or panels that would allow light to shine through and prevent a tight seal. Repair or replace defective components (Volume 5, WP 0819).</p> <p>(3) Lubricate worm gear, worm, winch handle shaft, wire rope, winch barrel shaft, and swing davit base every 12,000 mi (19,000 km) or 12 months, whichever occurs first (Volume 5, WP 0820).</p> <p>(4) Lubricate support rollers, end rollers, retractor beams, sprocket, and sprocket bushings every 12,000 mi (19,000 km) or 12 months, whichever occurs first (Volume 5, WP 0820).</p> <p>c. On M936/A1/A2 model vehicles:</p>	

Table 1. Field Preventive Maintenance Checks and Services - Continued.



ITEM NO.	INTERVAL	ITEM TO BE CHECKED OR SERVICED	PROCEDURE	EQUIPMENT NOT READY/ AVAILABLE IF:
			<p style="text-align: center;">WARNING</p> <div style="display: flex; justify-content: center; gap: 20px;">   </div> <ul style="list-style-type: none"> • Do not drain oil from wrecker hydraulic pump, reservoir, cylinders, or motors, or remove lines containing oil when oil is hot. Failure to comply may result in injury or death to personnel. • Do not remove hoist or winch hydraulic hoses when engine is running or start engine with hoist or winch hydraulic hoses removed. High pressure fluids may cause hoses to whip violently and spray randomly. Failure to comply may result in injury or death to personnel. • Do not drain oil from wrecker hydraulic pump, reservoir, or cylinders or remove lines containing oil when crane boom is supported by hydraulic cylinder, or hoist or winch cables are supporting a load. Failure to comply may result in injury or death to personnel. • Accidental or intentional introduction of liquid contaminants into the environment is in violation of state, federal, and military regulations. Refer to local Unit SOP for information concerning storage, use, and disposal of these liquids. Failure to comply may result in injury or death to personnel. <p>(1) Inspect rear winch and winch controls for loose mounting and broken or missing parts. If mounting is loose, tighten. If parts are missing or broken, replace (Volume 4, WP 0674).</p> <p>(2) Inspect hydraulic pump for leaks. If leaks are present, notify your supervisor.</p> <p>(3) Test automatic hoist drum brake for proper operation (Volume 4, WP 0672).</p> <p>(4) With boom raised, inspect crane cylinder piston rods for bends and scoring. If crane cylinder piston rods are bent or scored, notify your supervisor.</p> <p>(5) While operating crane, observe that fuel pump governor is maintaining 1,250 to 1,300 rpm during</p>	

Table 1. Field Preventive Maintenance Checks and Services - Continued.

ITEM NO.	INTERVAL	ITEM TO BE CHECKED OR SERVICED	PROCEDURE	EQUIPMENT NOT READY/ AVAILABLE IF:
			hoisting operation. notify your supervisor if engine is surging erratically (TM 9-2320-272-10). (6) Inspect and clean hydraulic tank swing motor and hoist crane motor breather caps (Volume 5, WP 0819). (7) Inspect reservoir filter case for leaks. Replace filter element (Volume 4, WP 0704). (8) Drain, clean, and fill hydraulic oil reservoir every 12 months (Volume 5, WP 0820).	

PMCS Mandatory Replacement Parts List

Table 2. PMCS Mandatory Replacement Parts List.

	ITEM NO.	PART NUMBER (CAGEC)	NSN	NOMENCLATURE	QTY	STEP NUMBER
****	1	PF297 (70040)	2940-00-950-8410	Oil Filter Element	1	7
**** M939/A1 only (except M936/A1)						

END OF TASK

END OF WORK PACKAGE

**FIELD MAINTENANCE
PREVENTIVE MAINTENANCE CHECKS AND SERVICES FOR MODELS M939/A1/A2 (BIENNIAL)**

INITIAL SETUP:**Tools and Special Tools**

Tool Kit, General Mechanic's: Automotive
(Volume 5, WP 0826, Table 1, Item 56)
Wrench, Torque, Click, Ratcheting, 1/2" Drive,
250 Ft-Lb
(Volume 5, WP 0826, Table 1, Item 63)
Wrench, Torque, Click, Ratcheting, 3/4" Drive,
600 Ft-Lb
(Volume 5, WP 0826, Table 1, Item 61)

Materials/Parts

Antifreeze: Arctic Grade, Permanent Type
(Volume 5, WP 0825, Table 1, Item 5)
Antifreeze: Ethylene Glycol, Permanent Type,
Inhibited
(Volume 5, WP 0825, Table 1, Item 6, 7, 8)
Lubricating Oil, Engine: OE/HDO 10W
(Volume 5, WP 0825, Table 1, Item 36, 37,
38)
Lubricating Oil, Engine: OE/HDO 30W
(Volume 5, WP 0825, Table 1, Item 39, 40, 41,
42)

Materials/Parts (cont.)

Lubricating Oil, Exposed Gear: CW
(Volume 5, WP 0825, Table 1, Item 43)
Lubricating Oil, Gear, Multipurpose: GO 75W90
(Volume 5, WP 0825, Table 1, Item 44, 45, 46,
47)
Lubricating Oil, Gear, Multipurpose: GO 80W90
(Volume 5, WP 0825, Table 1, Item 48, 49,
50)
Rag, Wiping
(Volume 5, WP 0825, Table 1, Item 53)

Personnel Required

Wheeled Vehicle Mechanic 91B (2)

References

Volume 3, WP 0362

Table 1. Field Preventive Maintenance Checks and Services.

ITEM NO.	INTERVAL	ITEM TO BE CHECKED OR SERVICED	PROCEDURE	EQUIPMENT NOT READY/ AVAILABLE IF:
1	Biennial	Transmission	Change transmission oil, and internal, external, and governor oil filters every 24,000 mi (38,000 km) or 24 months, whichever occurs first (Volume 3, WP 0362).	
2	Biennial	Transfer Case	Inspect tightness of transfer case mounting bolts and mounting brackets. Tighten three transfer case mounting bracket-to-frame bolts 50 to 60 lb-ft (68 to 81 N·m). Tighten seven transfer case-to-mounting bracket bolts 125 to 135 lb-ft (170 to 183 N·m).	
3	Biennial	Special Body Items	<p>a. On M929/A1/A2 and M930/A1/A2 model vehicles, tighten all dump body mounting bolts 240 lb-ft (325 N·m).</p> <p>b. On M931/A1/A2 and M932/A1/A2 model vehicles, inspect fifth wheel for completeness of assembly. Ensure mounting screws are tightened 160 to 170 lb-ft (217 to 231 N·m).</p>	

PMCS Mandatory Replacement Parts List

There are no replacement parts for these PMCS procedures.

END OF TASK

END OF WORK PACKAGE

CHAPTER 7
MAINTENANCE INSTRUCTIONS

**FIELD MAINTENANCE
SERVICE UPON RECEIPT**

INITIAL SETUP:**References**

DA PAM 750-8
DD FORM 361
DD FORM 1397
TB 750-651

References (cont.)

TM 9-2320-272-10
TM 9-6140-200-14
Volume 5, WP 0820

UNPACKING

Upon receipt of a new, used, or reconditioned vehicle, you must determine if the vehicle has been properly prepared for service. The following steps should be performed.

The operator will assist when performing service upon receipt inspections.

Read Processing and Deprocessing Record of Shipment, Storage, and Issue of Vehicles and Spare Engines tag DD Form 1397, and follow all precautions listed. This tag should be attached to steering wheel shift lever, or battery switch.

Check all Basic Issue Items (BII) and Components of End Item (COEI) TM 9-2320-272-10 to ensure every item is present, in good condition, and is properly mounted or stowed.

Inspect the equipment for damage incurred during shipment. If the equipment has been damaged, report the damage on DD FORM 361 Transportation Discrepancy Report.

Check the equipment against the packing slip to see if the shipment is complete. Report all discrepancies in accordance with applicable service instructions. See DA PAM 750-8.

Check to see whether the equipment has been modified.

END OF TASK

SERVICE BEFORE OPERATION

1. The operator will assist when performing service upon receipt inspections and services.
2. Inspect all assemblies, subassemblies, and accessories to ensure they are in proper working order.
3. Perform the semiannual, six months or 6,000 miles (9,654 kilometers), Preventive Maintenance Checks and Services (PMCS).
4. Lubricate the vehicle according to the instructions found in (Volume 5, WP 0820). Do not lubricate gear cases or engine unless processing tag states that the oil is unsuitable for 500 miles (805 kilometers) of operation. If oil is suitable, just check level.

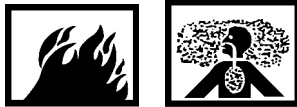
WARNING

Solvent cleaning compound is flammable and will not be used near an open flame. A fire extinguisher will be kept nearby when solvent is used. Use only in well-ventilated places. Failure to comply may result in damage to equipment, injury, or death to personnel.

5. Using solvent cleaning compound, clean all exterior surfaces coated with rust preventive compounds.
6. Secure, clean, lubricate, or adjust as needed.
7. Inspect fuel system for evidence of leakage.
8. Fill fuel tank, if required.
9. Check to ensure that boom has been load tested within the last 12 months.
10. If vehicle is delivered with a dry-charged battery, activate it according to TM 9-6140-200-14.
11. Check vehicle coolant level and determine if solution is proper for climate TB 750-651.

END OF TASK**END OF WORK PACKAGE**

**FIELD MAINTENANCE
POWER PLANT REPLACEMENT (M939/A1)**

INITIAL SETUP:**Tools and Special Tools**

Tool Kit, General Mechanic's: Automotive
(Volume 5, WP 0826, Table 1, Item 56)
Chain Assembly
(Volume 5, WP 0826, Table 1, Item 15)
Engine and Transmission Sling
(Volume 5, WP 0826, Table 1, Item 17)
Hoist Assembly
Oil Primer Pump
(Volume 5, WP 0826, Table 1, Item 37)
Spring Pack Tool
(Volume 5, WP 0826, Table 1, Item 50)
Wrench, Torque, Click, Ratcheting, 1/2" Drive,
250 Ft-Lb
(Volume 5, WP 0826, Table 1, Item 63)

Materials/Parts

Adhesive, Silicone Rubber
(Volume 5, WP 0825, Table 1, Item 4)
Cap Set, Protective, Dust and Moisture Seal
(Volume 5, WP 0825, Table 1, Item 13)
Twine, Fibrous: Cotton (string), 16 ply
(Volume 5, WP 0825, Table 1, Item 68)
Cotter Pin
(Volume 5, WP 0827, Table 1, Item 331)
Qty: 1
Cotter Pin
(Volume 5, WP 0827, Table 1, Item 340)
Qty: 1
Gasket (Volume 5, WP 0827, Table 1, Item 12)
Qty: 1
Locknut (Volume 5, WP 0827, Table 1, Item 289)
Qty: 2
Locknut (Volume 5, WP 0827, Table 1, Item 312)
Qty: 2
Locknut (Volume 5, WP 0827, Table 1, Item 314)
Qty: 1
Lockwasher (Volume 5, WP 0827, Table 1, Item
406) Qty: 1
Lockwasher (Volume 5, WP 0827, Table 1, Item
215) Qty: 1
Lockwasher (Volume 5, WP 0827, Table 1, Item
403) Qty: 1

Materials/Parts (cont.)

Lockwasher (Volume 5, WP 0827, Table 1, Item
404) Qty: 2
Lockwasher (Volume 5, WP 0827, Table 1, Item
405) Qty: 5
Lockwasher (Volume 5, WP 0827, Table 1, Item
408) Qty: 10
Lockwasher (Volume 5, WP 0827, Table 1, Item
410) Qty: 1
Lockwasher (Volume 5, WP 0827, Table 1, Item
420) Qty: 1
Lockwasher (Volume 5, WP 0827, Table 1, Item
425) Qty: 1
Seal (Volume 5, WP 0827, Table 1, Item 101)
Qty: 1
Tiedown Strap
(Volume 5, WP 0827, Table 1, Item 370)
Qty: 1

Personnel Required

(2)

Equipment Condition

Parking brake set. (TM 9-2320-272-10)
Battery ground cables disconnected. (WP 0350)
Air reservoirs drained. (TM 9-2320-272-10)
Engine oil drained. (WP 0232)
Transmission oil drained. (Volume 3, WP 0362)
Hood removed. (Volume 4, WP 0565)
Radiator drained and removed. (WP 0281)
Coolant hoses and tubes removed. (WP 0280)
Front exhaust pipe removed. (WP 0276)
Engine oil dipstick and tube removed. (WP 0228)
Air cleaner intake pipe. (WP 0246)
Transmission PTO-to-hydraulic pump drive shaft
removed, if equipped. (Volume 4, WP 0713)
Transmission-to-transfer case propeller
shaft removed. (Volume 3, WP 0403)
Surge tank removed. (WP 0278)
Radiator fan blade assembly removed.
(WP 0298)

PRELIMINARY DISCONNECTIONS**NOTE**

If a special purpose kit is installed on vehicle, refer to applicable kit section(s) and make necessary disconnection(s).

1. Disconnect wires (Figure 1, Items 2 and 3) from water temperature sending unit (Figure 1, Item 4) and engine high temperature sending unit (Figure 1, Item 1).

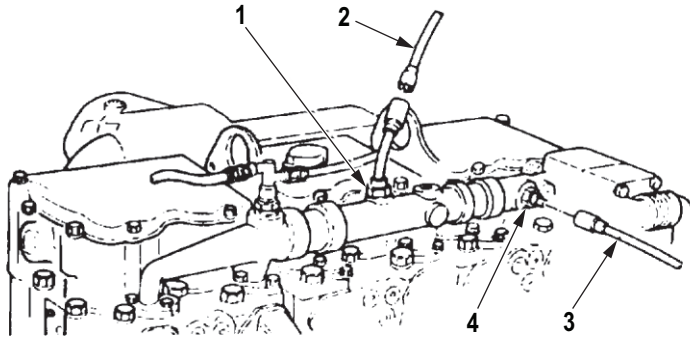

M9225DAA

Figure 1. Sending Unit Disconnect.

2. Remove hose clamp (Figure 2, Item 4) and hose (Figure 2, Item 2) from water heater shutoff (Figure 2, Item 3). Tie hose clear of engine (Figure 2, Item 1).
3. Remove hose clamp (Figure 2, Item 6) and hose (Figure 2, Item 5) from water heater shutoff (Figure 2, Item 7). Tie hose clear of engine (Figure 2, Item 1).
4. Remove two screw assembled lockwashers (Figure 2, Item 20) and terminal cover (Figure 2, Item 15) from alternator (Figure 2, Item 21). Discard screw assembled lockwashers.
5. Remove two screws (Figure 2, Item 14), lockwashers (Figure 2, Item 13), and retainer (Figure 2, Item 12) from alternator (Figure 2, Item 21). Discard lockwashers.
6. Remove screw (Figure 2, Item 27), lockwasher (Figure 2, Item 26), and wire (Figure 2, Item 25) from alternator (Figure 2, Item 21). Discard lockwasher.
7. Remove nut (Figure 2, Item 11), lockwasher (Figure 2, Item 10), washer (Figure 2, Item 9), and wire (Figure 2, Item 8) from alternator (Figure 2, Item 21). Discard lockwasher.
8. Remove nut (Figure 2, Item 16), lockwasher (Figure 2, Item 17), washer (Figure 2, Item 18), and wire (Figure 2, Item 19) from alternator (Figure 2, Item 21). Discard lockwasher.
9. Disconnect plug (Figure 2, Item 23) from connector (Figure 2, Item 24).
10. Remove tiedown strap (Figure 2, Item 22) from wires (Figure 2, Item 25) and (Figure 2, Item 8). Discard tiedown strap.

PRELIMINARY DISCONNECTIONS - Continued

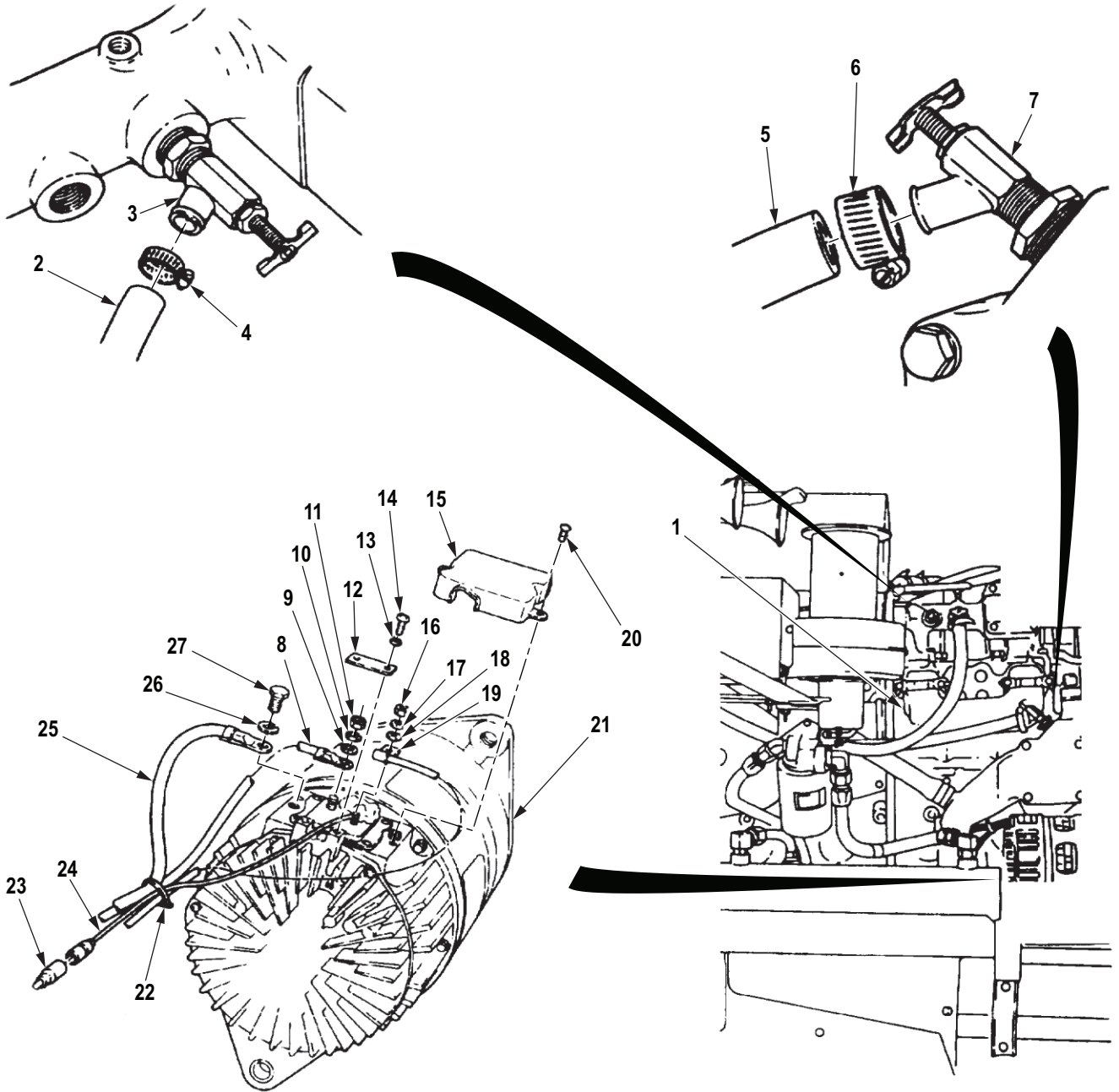

M9226DAA

Figure 2. Alternator Removal.

PRELIMINARY DISCONNECTIONS - Continued**NOTE**

Plug all openings and tag lines for installation.

11. Disconnect hose (Figure 3, Item 1) from elbow (Figure 3, Item 2) and tie hose to engine (Figure 3, Item 3).
12. Disconnect hose (Figure 3, Item 4) from transmission oil cooler (Figure 3, Item 5) and tie hose to engine (Figure 3, Item 3).
13. Disconnect hose (Figure 3, Item 8) from fitting (Figure 3, Item 7) and tie hose to engine (Figure 3, Item 3).
14. Loosen clamp (Figure 3, Item 10), disconnect hose (Figure 3, Item 9) from reservoir (Figure 3, Item 6), and tie hose to engine (Figure 3, Item 3).

PRELIMINARY DISCONNECTIONS - Continued

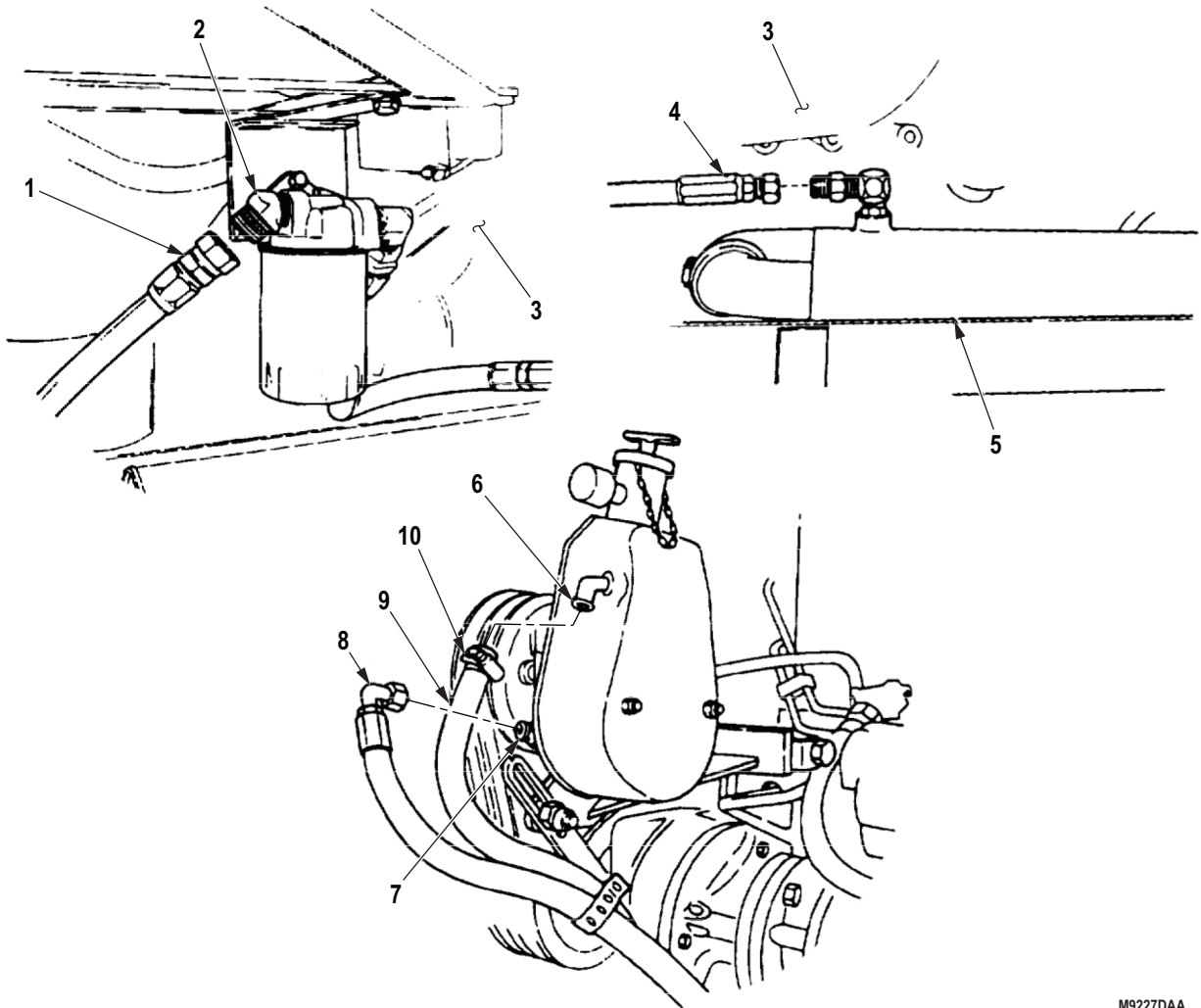

M9227DAA

Figure 3. Hose Disconnect.

PRELIMINARY DISCONNECTIONS - Continued

15. Remove screw (Figure 4, Item 9) and connector (Figure 4, Item 1) from emergency stop cable (Figure 4, Item 3).
16. Remove nut (Figure 4, Item 8), screw (Figure 4, Item 5), washer (Figure 4, Item 4), and clamp (Figure 4, Item 6) from bracket (Figure 4, Item 7), and pull cable (Figure 4, Item 3) through swivel block (Figure 4, Item 2).
17. Install connector (Figure 4, Item 1) on cable (Figure 4, Item 3) with screw (Figure 4, Item 9).
18. Install clamp (Figure 4, Item 6) on bracket (Figure 4, Item 7) with screw (Figure 4, Item 5), washer (Figure 4, Item 4), and nut (Figure 4, Item 8).
19. Remove nut (Figure 4, Item 12) and two wires (Figure 4, Item 11) from fuel shutoff solenoid (Figure 4, Item 10).
20. Remove locknut (Figure 4, Item 14), screw (Figure 4, Item 16), and accelerator rod (Figure 4, Item 15) from throttle lever (Figure 4, Item 13), and tie accelerator rod clear of engine. Discard locknut.
21. Remove locknut (Figure 4, Item 17), screw (Figure 4, Item 26), and link (Figure 4, Item 18) from throttle lever (Figure 4, Item 13). Discard locknut.
22. Remove return spring (Figure 4, Item 25), two nuts (Figure 4, Item 22), screws (Figure 4, Item 24), cable clamp (Figure 4, Item 23), and shim (Figure 4, Item 21) from fuel primer pump bracket (Figure 4, Item 20).
23. Remove modulator cable (Figure 4, Item 19) from fuel primer pump bracket (Figure 4, Item 20), and tie cable clear of engine.

PRELIMINARY DISCONNECTIONS - Continued

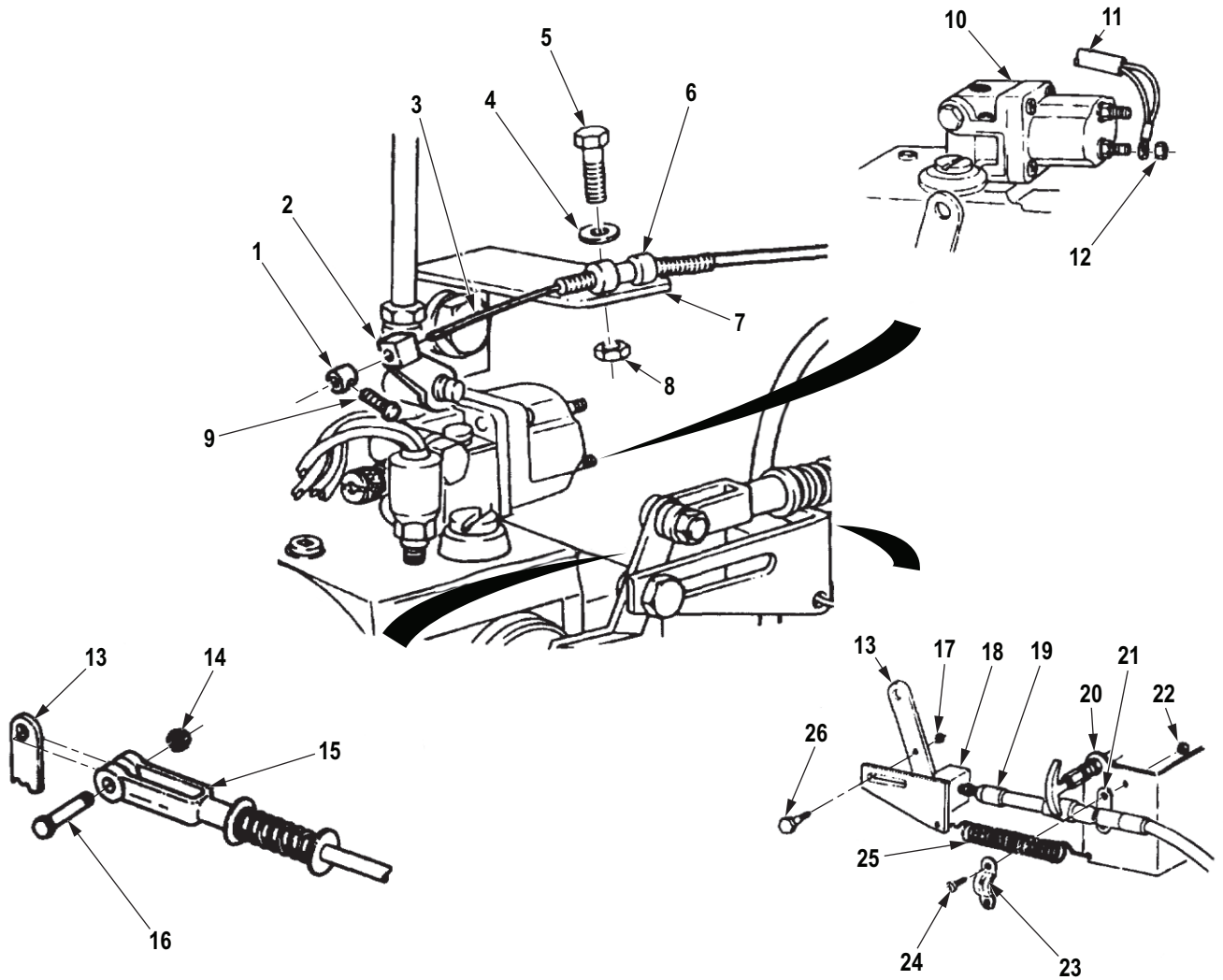

M9228DAA

Figure 4. Power Plant Throttle Cable Removal.

PRELIMINARY DISCONNECTIONS - Continued

24. Disconnect air line (Figure 5, Item 3) from air governor (Figure 5, Item 4).

NOTE

Perform Step (25) for M936/A1 Wrecker model vehicles only.

25. Disconnect air line (Figure 5, Item 1) from VS governor (Figure 5, Item 2).

NOTE

Step (26) does not apply to M936/A1 Wrecker model vehicles.

26. Disconnect connector (Figure 5, Item 12) from fuel pressure transducer (Figure 5, Item 13).
27. Disconnect fuel line (Figure 5, Item 9) from fuel pump (Figure 5, Item 8).
28. Disconnect air line (Figure 5, Item 7) from air compressor (Figure 5, Item 10).
29. Disconnect connector (Figure 5, Item 5) from oil pressure sending unit (Figure 5, Item 6).
30. Disconnect tachometer drive cable (Figure 5, Item 11) from tachometer pulse sender (Figure 5, Item 14).
31. Disconnect tachometer pulse sender connector (Figure 5, Item 15) from pulse sender harness (Figure 5, Item 16).

PRELIMINARY DISCONNECTIONS - Continued

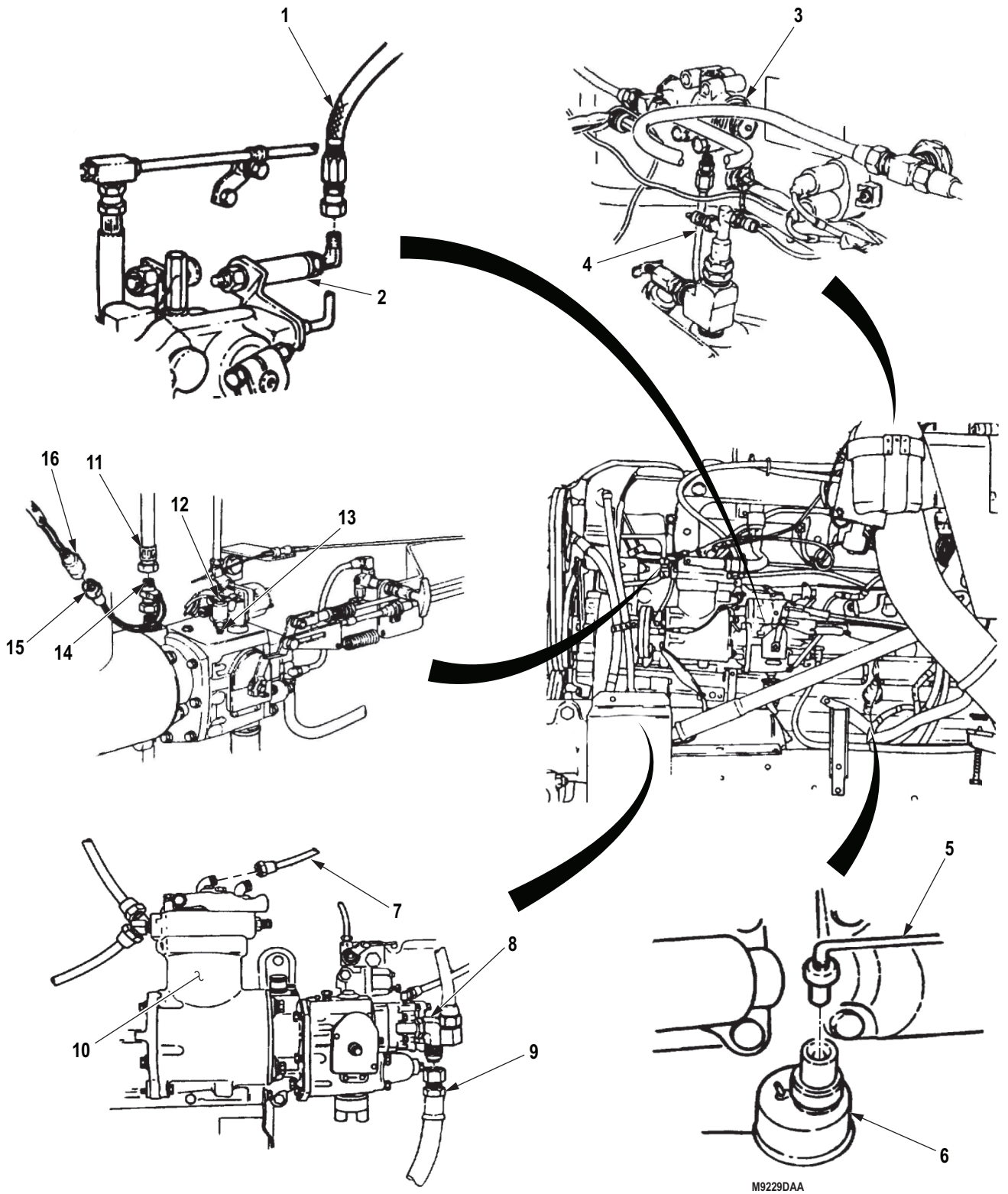
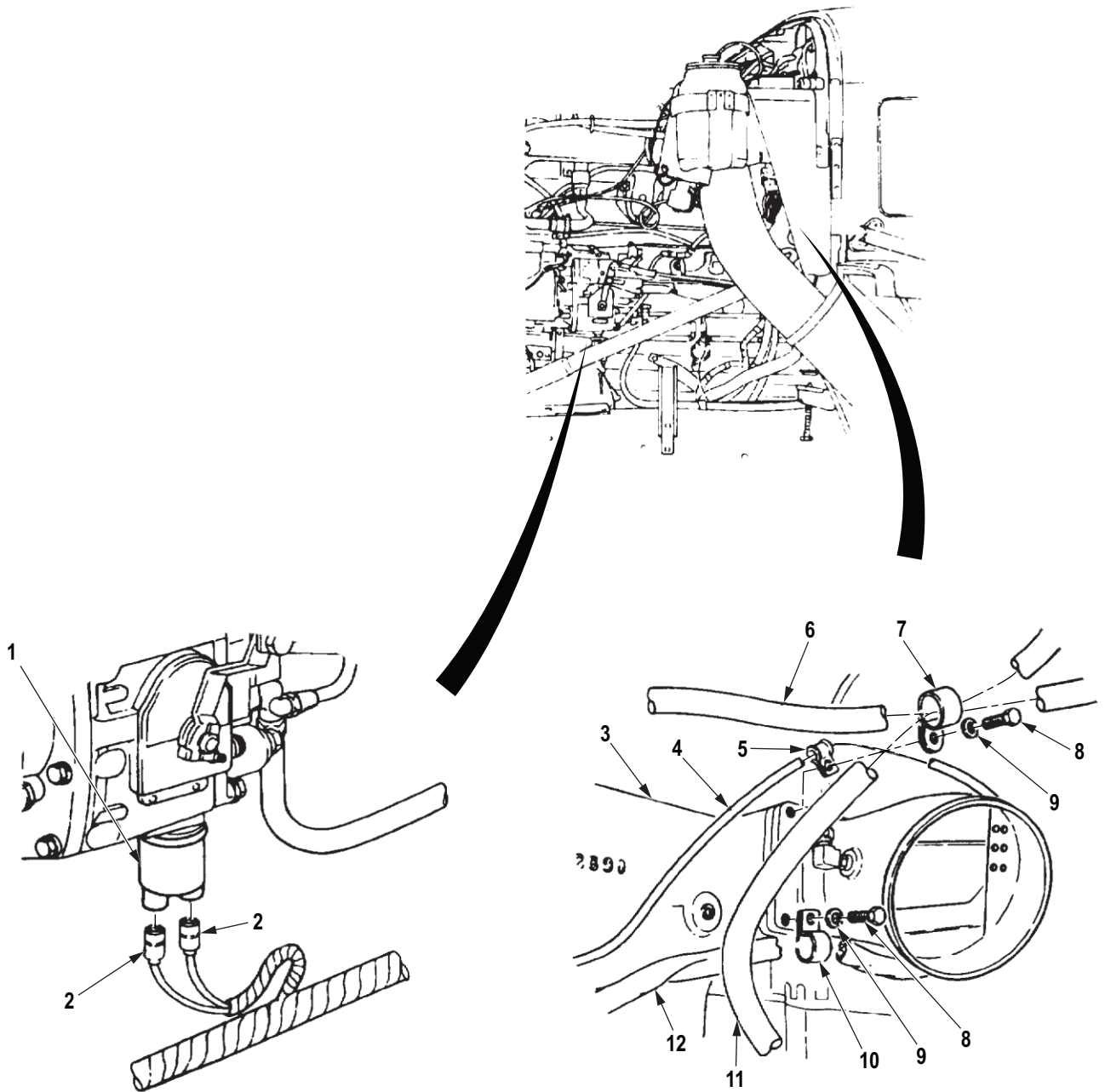

Figure 5. Power Plant Engine Air Hoses Removal.

PRELIMINARY DISCONNECTIONS - Continued

32. Remove two screws (Figure 6, Item 8), washers (Figure 6, Item 9), clamps (Figure 6, Items 5, 7, and 10), and air line (Figure 6, Item 4) from air intake manifold (Figure 6, Item 3).
33. Remove tachometer cable (Figure 6, Item 6), speedometer cable (Figure 6, Item 11), and harness (Figure 6, Item 12) from air intake manifold (Figure 6, Item 3). Tie cables and harness clear of engine.
34. Disconnect two connectors (Figure 6, Item 2) from ether start switch (Figure 6, Item 1).

PRELIMINARY DISCONNECTIONS - Continued



M9231DAA

Figure 6. Power Plant Tachometer Cables Removal.

PRELIMINARY DISCONNECTIONS - Continued

35. Disconnect fuel line (Figure 7, Item 2) from fuel pump return hose (Figure 7, Item 1). Tie fuel line clear of engine (Figure 7, Item 3).
36. Disconnect ether supply line (Figure 7, Item 4) from ether start safety valve (Figure 7, Item 5) and ether cylinder valve (Figure 7, Item 10). Tie ether supply line clear of engine (Figure 7, Item 3).
37. Disconnect ether cylinder relief line (Figure 7, Item 6) from safety valve (Figure 7, Item 5) and atomizer (Figure 7, Item 7). Tie ether cylinder relief line clear of engine (Figure 7, Item 3).
38. Disconnect tube (Figure 7, Item 9) from fitting (Figure 7, Item 8). Tie tube clear of engine (Figure 7, Item 3).

PRELIMINARY DISCONNECTIONS - Continued

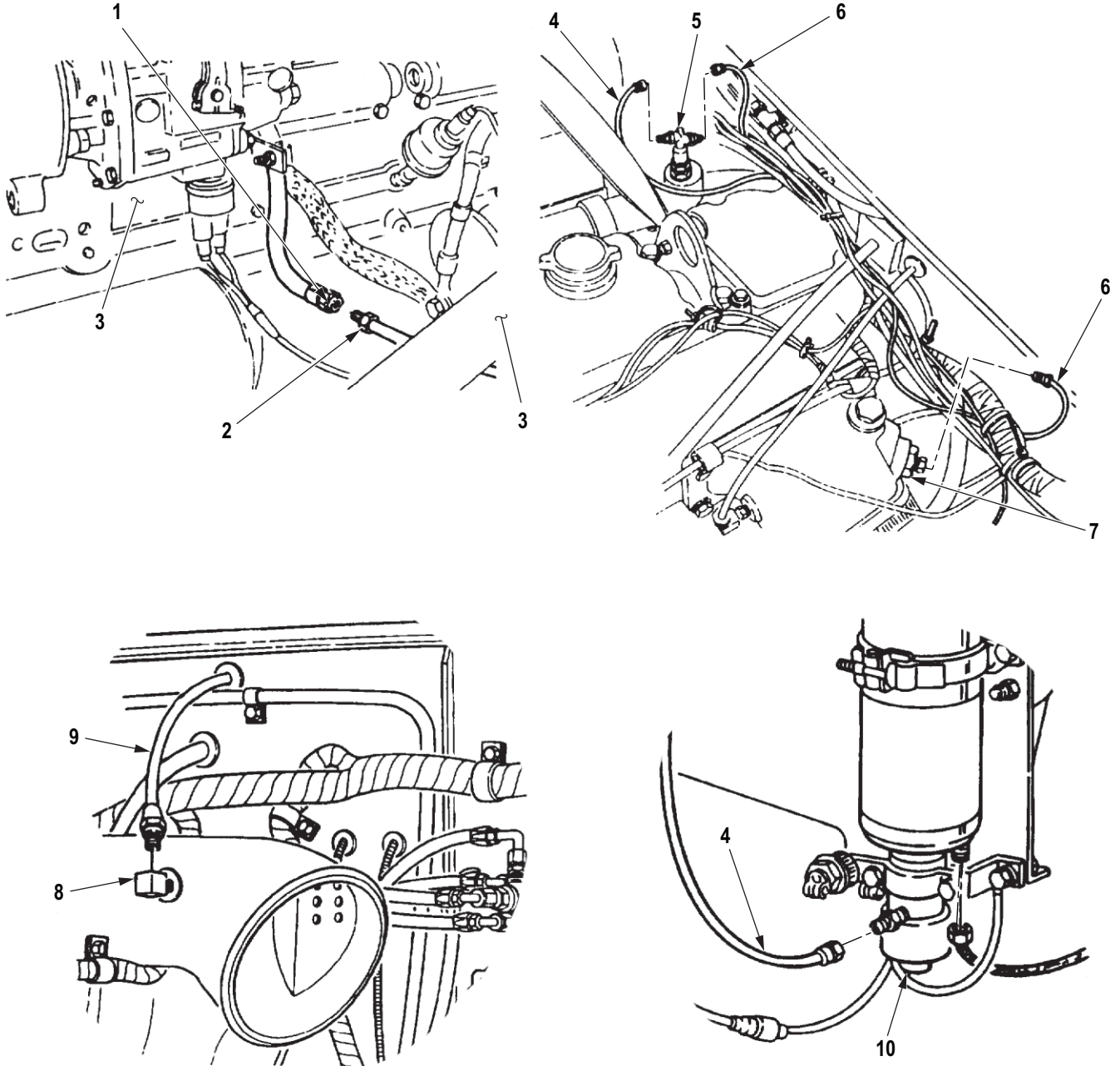

M9232DAA

Figure 7. Power Plant Ether Cylinder Lines Removal.

PRELIMINARY DISCONNECTIONS - Continued

39. Remove nut (Figure 8, Item 12), washer (Figure 8, Item 13), and wires (Figure 8, Items 11 and 14) from starter solenoid (Figure 8, Item 4). Tie wires clear of engine.
40. Remove screw (Figure 8, Item 3), clip (Figure 8, Item 2), and wire (Figure 8, Item 1) from starter solenoid (Figure 8, Item 4). Tie wire clear of engine.
41. Remove nut (Figure 8, Item 8), washer (Figure 8, Item 9), wires (Figure 8, Items 7 and 10), and ground strap (Figure 8, Item 6) from starter motor (Figure 8, Item 5). Tie wires clear of engine.
42. Disconnect air line (Figure 8, Item 15) from fitting (Figure 8, Item 16).

PRELIMINARY DISCONNECTIONS - Continued

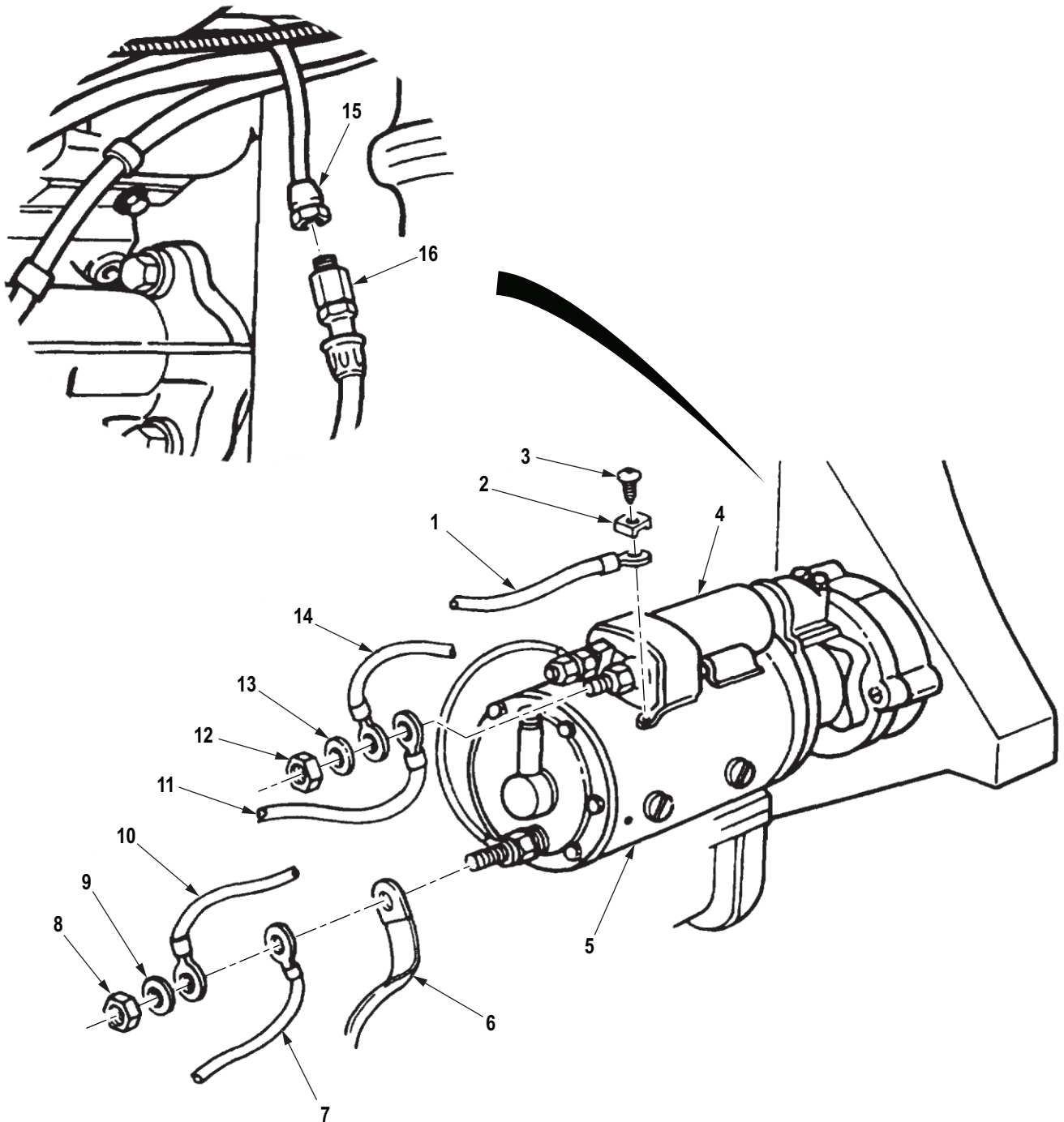

M9233DAA

Figure 8. Power Plant Starter Wires Removal.

PRELIMINARY DISCONNECTIONS - Continued**NOTE**

Access for Steps (43) through (45) is through door in cab floor.

43. Disconnect wire (Figure 9, Item 2) from transmission oil temperature sending unit (Figure 9, Item 1). Tie wire clear of transmission.
44. Disconnect wires (Figure 9, Items 2 and 5) from two clips (Figure 9, Item 3) on transmission flange (Figure 9, Item 4). Tie wires clear of transmission.
45. Remove transmission dipstick (Figure 9, Item 7) from tube (Figure 9, Item 6). Plug opening in tube.

NOTE

Perform Step (46) and (47) only on vehicles equipped with a transmission Power Takeoff (PTO).

46. Remove two nuts (Figure 9, Item 8), screws (Figure 9, Item 12), retaining strap (Figure 9, Item 11), and spacer plate (Figure 9, Item 10) from PTO cable (Figure 9, Item 13) and bracket (Figure 9, Item 9).
47. Remove cotter pin (Figure 9, Item 17), washer (Figure 9, Item 16), cable pin (Figure 9, Item 14), and PTO cable (Figure 9, Item 13) from PTO select lever (Figure 9, Item 15). Discard cotter pin, and tie PTO cable clear of transmission.

PRELIMINARY DISCONNECTIONS - Continued

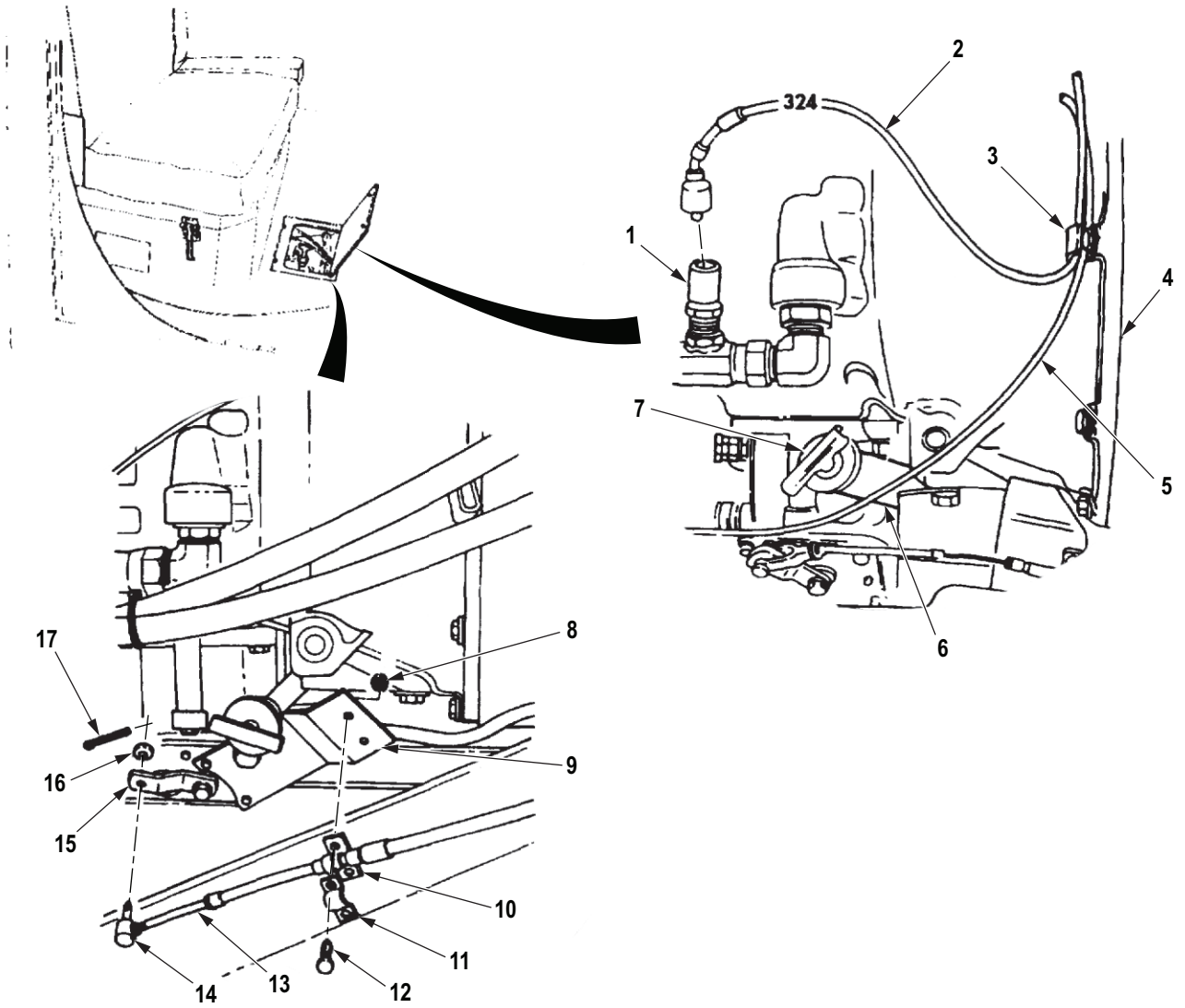

M9234DAA

Figure 9. Power Plant Transmission Shifter Cable Removal.

PRELIMINARY DISCONNECTIONS - Continued

48. Disconnect breather vent line (Figure 10, Item 3) from adapter elbow (Figure 10, Item 2). Tie breather vent line clear of transmission (Figure 10, Item 1).
49. Remove two locknuts (Figure 10, Item 5), U-bolt (Figure 10, Item 7), and shim (Figure 10, Item 6) from support bracket (Figure 10, Item 4) and cable (Figure 10, Item 8). Discard locknuts.
50. Remove cotter pin (Figure 10, Item 10) and cable pin (Figure 10, Item 9) from shift lever (Figure 10, Item 11). Discard cotter pin and tie cable (Figure 10, Item 8) clear of transmission (Figure 10, Item 1).
51. Disconnect wire (Figure 10, Item 13) and 5th gear lock-in solenoid (Figure 10, Item 14) from connector (Figure 10, Item 15). Tie wire to transmission (Figure 10, Item 1).
52. Disconnect transorb diode wire (Figure 10, Item 12) from connector (Figure 10, Item 15).

PRELIMINARY DISCONNECTIONS - Continued

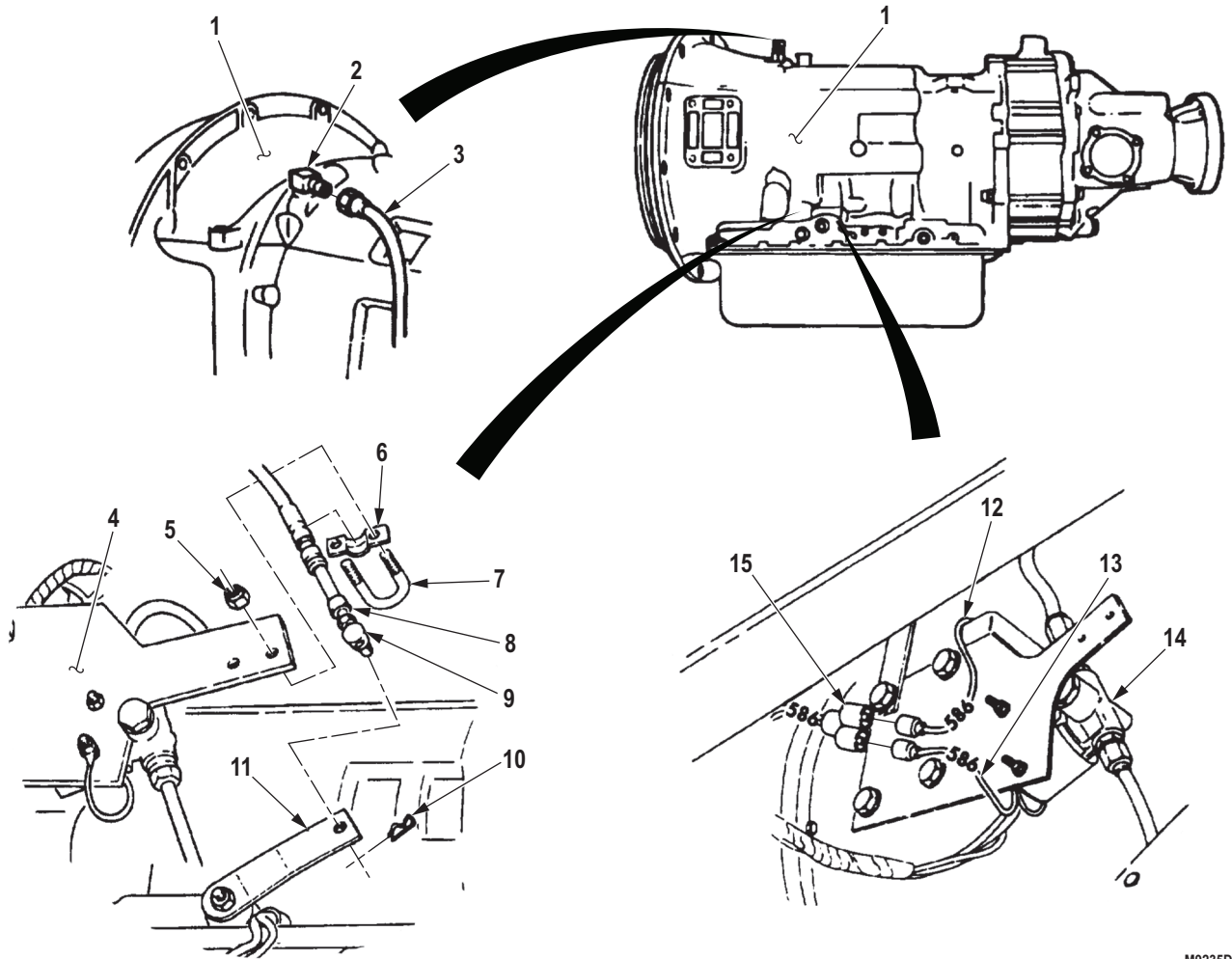

M9235DAA

Figure 10. Power Plant Transmission Electrical Wires Removal.

PRELIMINARY DISCONNECTIONS - Continued

53. Remove nut (Figure 11, Item 13), screw (Figure 11, Item 11), clamps (Figure 11, Items 10 and 12), modulator cable (Figure 11, Item 8), and speedometer cable (Figure 11, Item 9) from transmission bracket (Figure 11, Item 2). Tie modulator cable and speedometer cable clear of transmission (Figure 11, Item 1).
54. Remove screw (Figure 11, Item 5), bracket (Figure 11, Item 4), modulator (Figure 11, Item 7), and gasket (Figure 11, Item 6) from transmission (Figure 11, Item 1). Discard gasket.
55. Remove screw (Figure 11, Item 3) and bracket (Figure 11, Item 2) from transmission (Figure 11, Item 1).
56. Disconnect two wires (Figure 11, Item 15) from neutral start switch (Figure 11, Item 14). Tie wires clear of transmission (Figure 11, Item 1).

PRELIMINARY DISCONNECTIONS - Continued

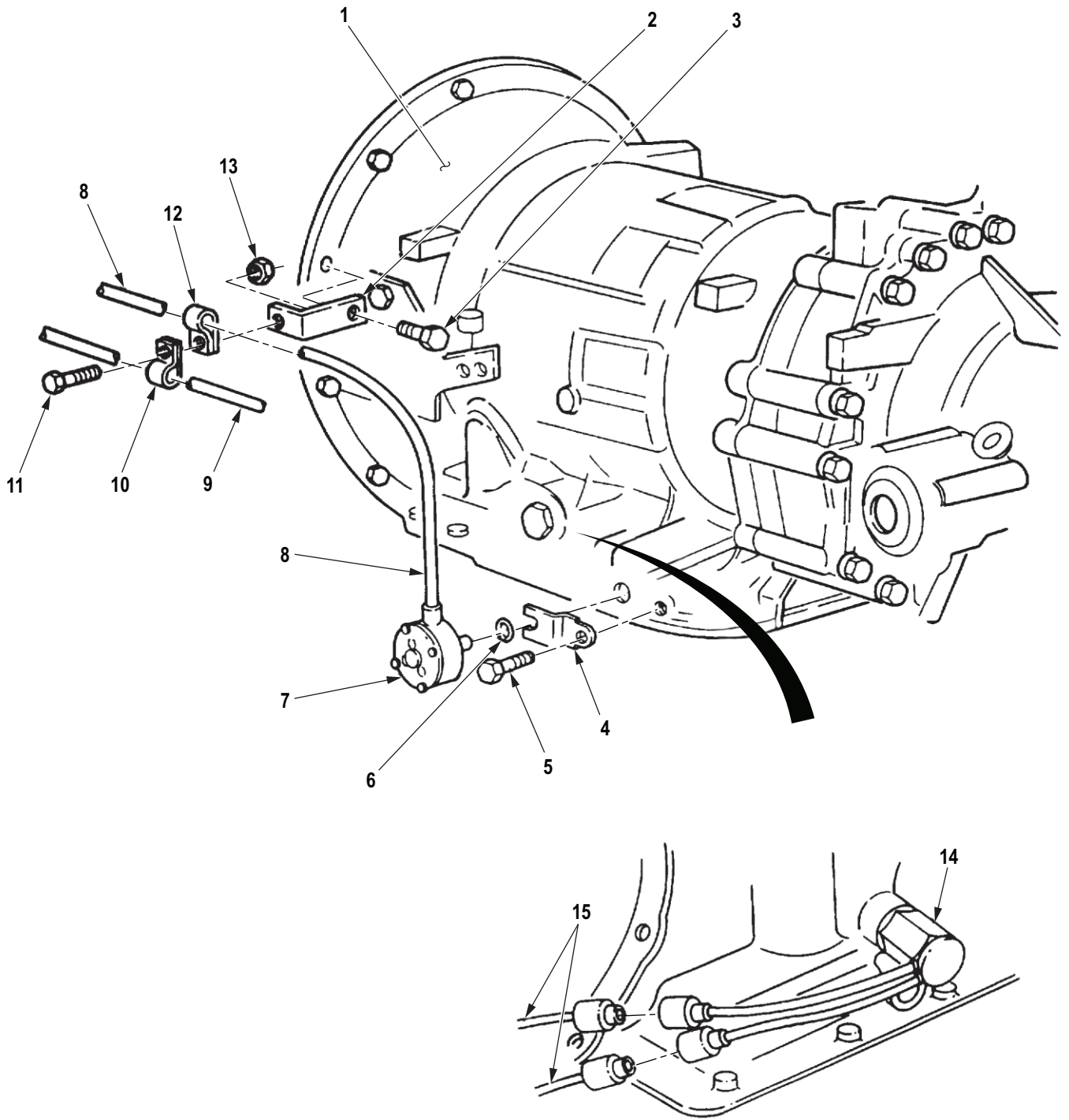

Figure 11. Power Plant Transmission Module Removal.

PRELIMINARY DISCONNECTIONS - Continued

57. Remove screw (Figure 12, Item 7), lockwasher (Figure 12, Item 6), washer (Figure 12, Item 5), ground strap (Figure 12, Item 4), and lockwasher (Figure 12, Item 3) from air compressor (Figure 12, Item 2). Discard lockwashers. Tie ground strap clear of engine (Figure 12, Item 1).
58. Remove screw assembled washer (Figure 12, Item 9), ground wire (Figure 12, Item 10), ground strap (Figure 12, Item 11), and lockwasher (Figure 12, Item 12) from air intake manifold (Figure 12, Item 8). Discard lockwasher. Tie ground strap and ground wire clear of engine (Figure 12, Item 1).

NOTE

Step (59) is performed only on vehicles equipped with front winch with level wind.

59. Remove four screws (Figure 12, Item 14), lockwashers (Figure 12, Item 15), and winch level wind (Figure 12, Item 13) from winch (Figure 12, Item 16). Discard lockwashers. Place winch level wind clear of vehicle.

END OF TASK**REMOVAL**

1. Remove two screws (Figure 12, Item 17) and lockwashers (Figure 12, Item 18) from transmission rear support bracket (Figure 12, Item 19). Discard lockwashers.

REMOVAL - Continued

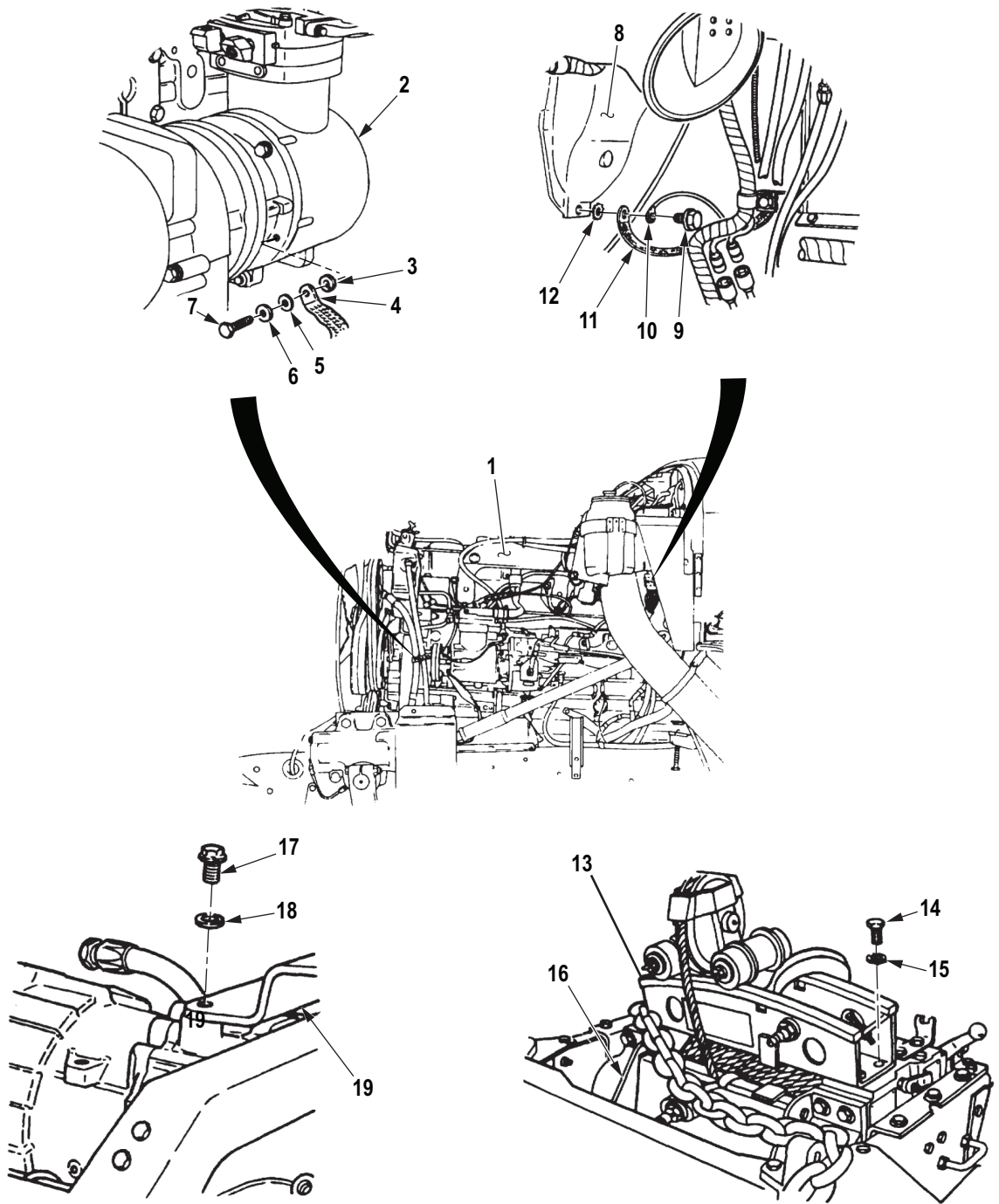

M9237DAA

Figure 12. Power Plant Ground Wires Removal.

REMOVAL - Continued**NOTE**

Front of cab must be raised 4 in. (102 mm) to permit engine oil pan sump to clear the front axle differential housing. Two permanently mounted jack screws under the left and right cab A-posts permit raising front of cab.

2. Remove two locknuts (Figure 13, Item 5), washers (Figure 13, Item 4), and rubber cushions (Figure 13, Item 3) from cab A-post support brackets (Figure 13, Item 2). Discard locknuts.
3. Turn left and right jack screws (Figure 13, Item 6) until A-posts (Figure 13, Item 1) are approximately 4 in. (102 mm) above support brackets (Figure 13, Item 2).

WARNING

Lifting device must have a weight capacity greater than the combined weight of the engine and transmission. Failure to comply may result in damage to equipment, injury, or death to personnel.

4. Attach the adjustable end of an adjustable chain hoist (Figure 13, Item 9) to hoist hook and each adjustable chain hoist hook to engine lifting eyes (Figure 13, Item 8). Raise hoist until all slack is removed from adjustable chain hoist, ensuring that hoist does not support weight of engine (Figure 13, Item 7).
5. Remove two screws (Figure 13, Item 12), lockwashers (Figure 13, Item 11), five screws (Figure 13, Item 14), lockwashers (Figure 13, Item 15), trunnion cap (Figure 13, Item 10), and trunnion mount (Figure 13, Item 13) from frame crossmember (Figure 13, Item 16). Discard lockwashers.
6. Remove two nuts (Figure 13, Item 21), lockwashers (Figure 13, Item 22), screws (Figure 13, Item 17), and washers (Figure 13, Item 18) from left and right engine supports (Figure 13, Item 20) and flywheel housing (Figure 13, Item 19). Discard lockwashers.

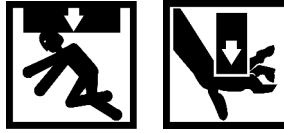
REMOVAL - Continued**WARNING**

- All personnel not participating in engine removal must stand clear during hoisting operations. A snapped cable, or swinging or shifting load, may occur. Failure to comply may result in injury or death to personnel.
- Do not use hands to free engine of hangups. Use tanker or prybars. Failure to comply may result in injury or death to personnel.

CAUTION

Always remove engine slowly. Lift out of chassis in short lifts and closely observe all engine and transmission attachments during removal to prevent damage to equipment.

NOTE

- Mechanic will direct all hoisting operations in Steps (7) through (10) while assistant operates hoist or assists mechanic.
 - Chain hoist must be adjusted to lower rear of transmission downward so engine is suspended at approximately a 15° to 20° angle to clear front axle.
7. Using socket wrench, adjust engine angle to 15° to 20° with adjustable chain hoist (Figure 13, Item 9).
 8. Lift engine (Figure 13, Item 7) slowly upward until clear of vehicle.

REMOVAL - Continued

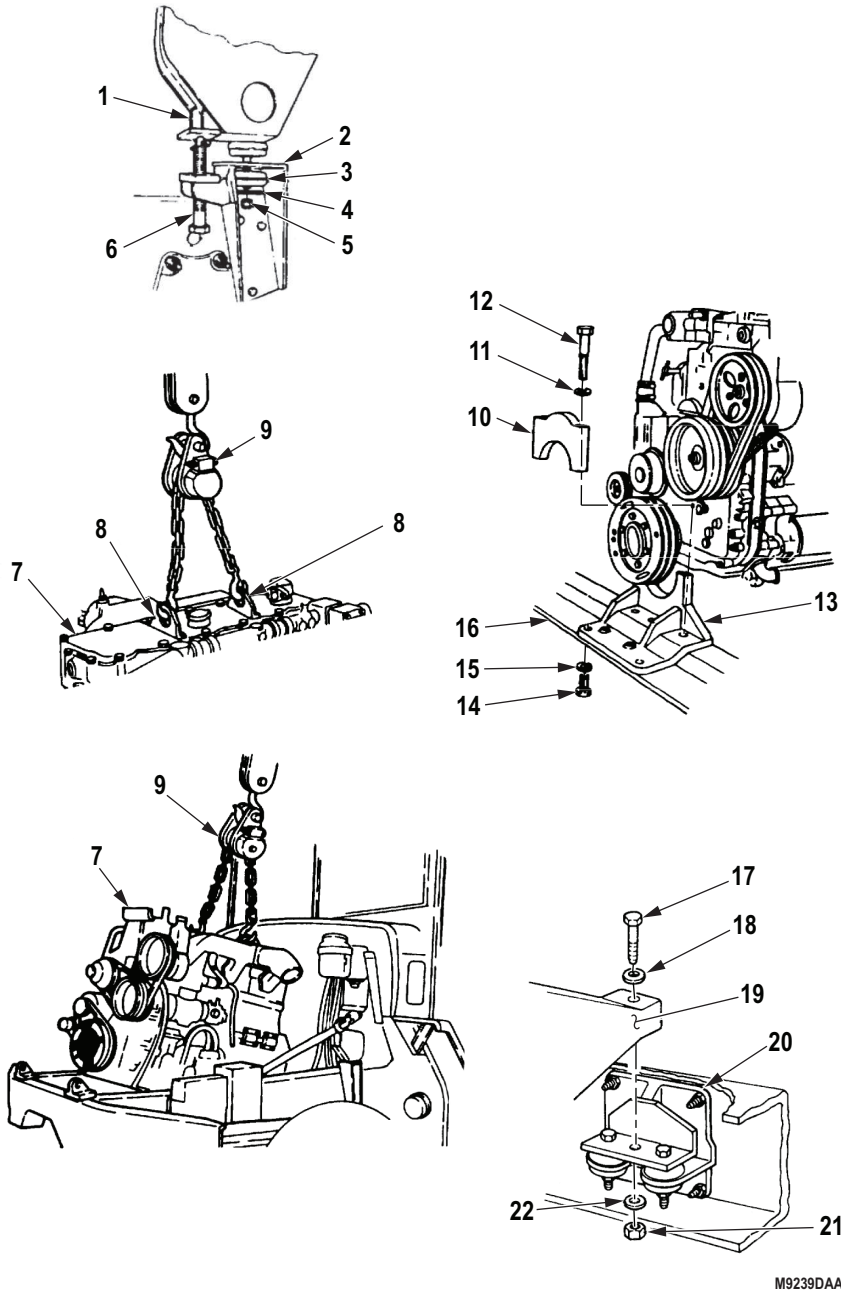

M9239DAA

Figure 13. Power Plant Engine Mounts Removal.

NOTE

Adjust chain hoist so engine and transmission are level for placement on trestles.

9. Lower engine (Figure 14, Item 2) and transmission (Figure 14, Item 3) onto engine transporter. Ensure two trestles of the transporter are positioned under each side of front gearcase cover (Figure 14, Item 5) and two trestles are positioned under each end of flywheel (Figure 14, Item 4).

REMOVAL - Continued

WARNING



Do not detach chain hoist from engine until engine is equally distributed and is stable on transporter. An improperly supported engine may fall. Mounting engine on transport stand is solely temporary and is not intended as a supporting requirement for engine repair. When repairing engine, use repair stand. Failure to comply may result in damage to equipment, injury, or death to personnel.

10. Disconnect adjustable chain hoist from two engine lifting eyes (Figure 14, Item 1).

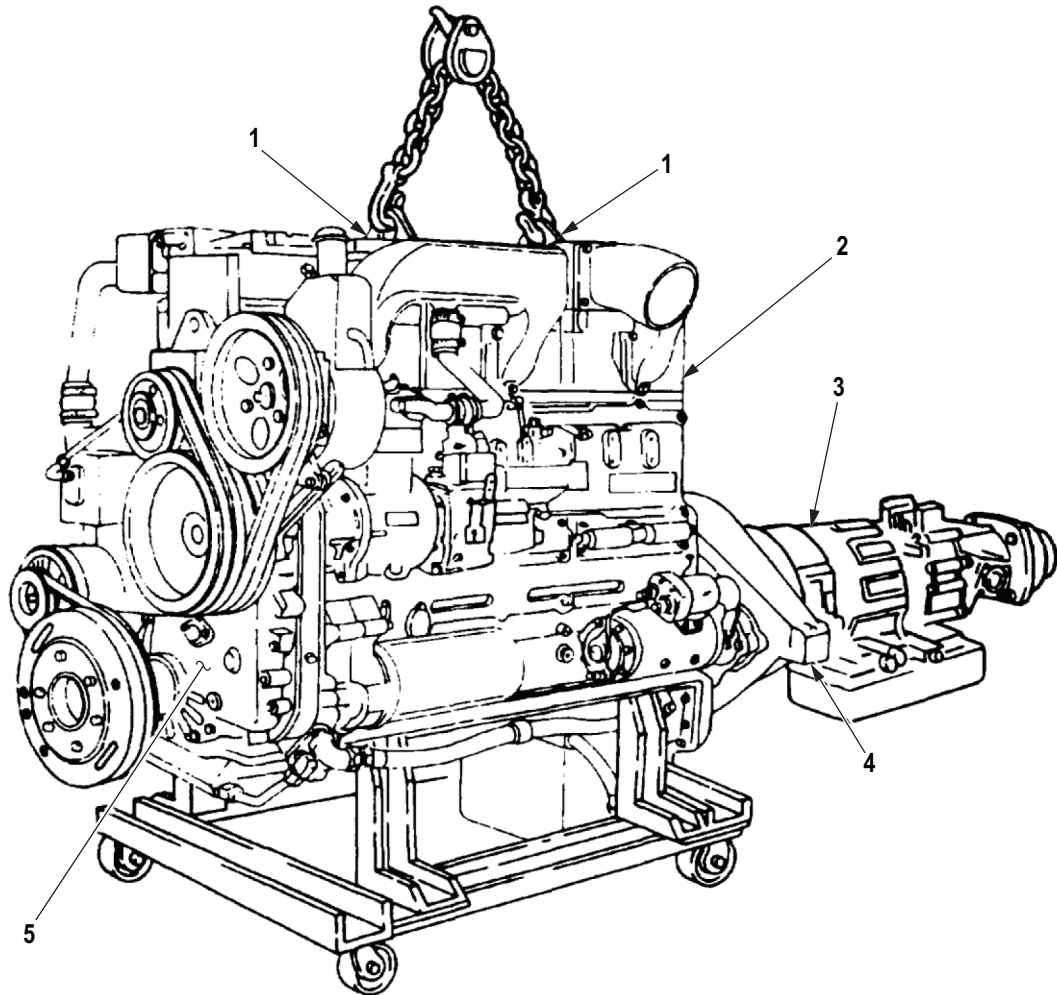

M9240DAA

Figure 14. Power Plant Maintenance Stand.

END OF TASK

DISASSEMBLY**CAUTION**

Plug all open ports to prevent dirt or contamination from entering engine.

NOTE

Perform this task when preparing removed engine for installation in shipping container.

1. Remove the shutoff valve (Figure 15, Item 1) and adapter (Figure 15, Item 2) from engine oil cooler (Figure 15, Item 8).
2. Remove shutoff valve (Figure 15, Item 6) and adapter (Figure 15, Item 5) from water manifold (Figure 15, Item 3).
3. Remove water temperature sending unit (Figure 15, Item 7) from water manifold (Figure 15, Item 3).
4. Remove high-temperature switch (Figure 15, Item 4) from water manifold (Figure 15, Item 3), if installed.

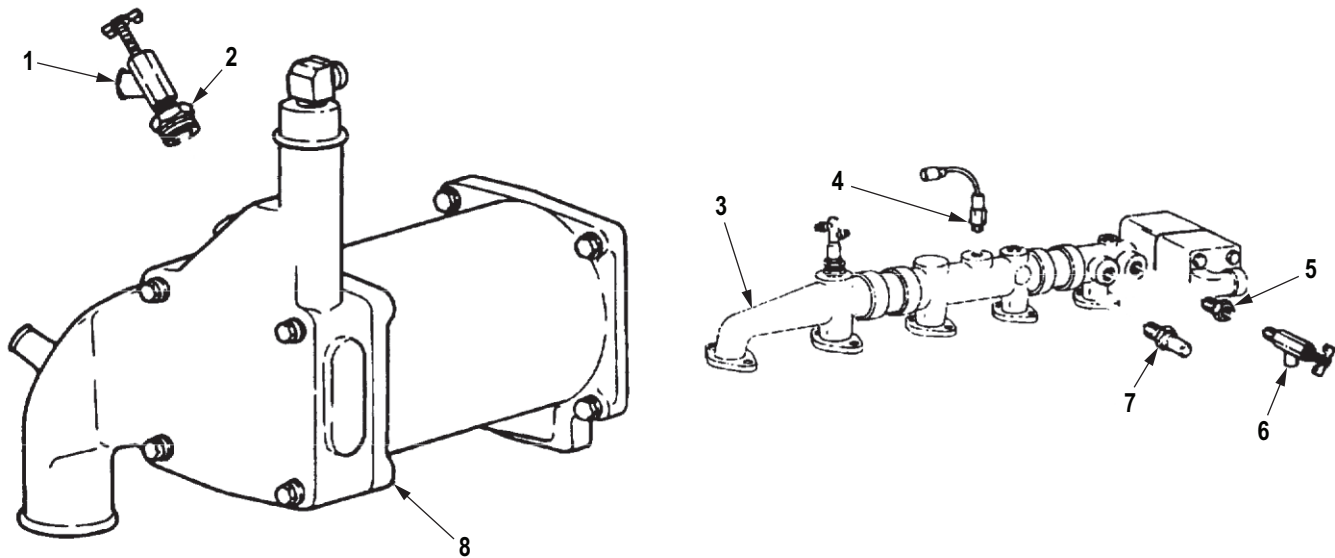

M9370DAA

Figure 15. Power Plant Water Cooler Removal.

DISASSEMBLY - Continued

5. Remove two screws (Figure 16, Item 4), lockwashers (Figure 16, Item 5), washers (Figure 16, Item 3), clamps (Figure 16, Item 1), and transmission oil cooler lines (Figure 16, Item 2) from access plate (Figure 16, Item 6). Discard lockwashers.
6. Install two washers (Figure 16, Item 3), new lockwashers (Figure 16, Item 5), and screws (Figure 16, Item 4) on access plate (Figure 16, Item 6). Tag oil cooler line (Figure 16, Item 2) for installation.
7. Disconnect two air lines (Figure 16, Item 8) from elbows (Figure 16, Item 7).

END OF TASK**ASSEMBLY****NOTE**

Wrap all male pipe threads with antiseize tape before installation.

1. Connect air line (Figure 16, Item 10) to fitting (Figure 16, Item 9).
2. Install two elbows (Figure 16, Item 7) on air compressor (Figure 16, Item 11).
3. Remove two screws (Figure 16, Item 4), lockwashers (Figure 16, Item 5), and washers (Figure 16, Item 3) from access plate (Figure 16, Item 6). Discard lockwasher.
4. Install two transmission oil cooler lines (Figure 16, Item 2) on access plate (Figure 16, Item 6) with two clamps (Figure 16, Item 1), washers (Figure 16, Item 3), lockwashers (Figure 16, Item 5), and screws (Figure 16, Item 4).

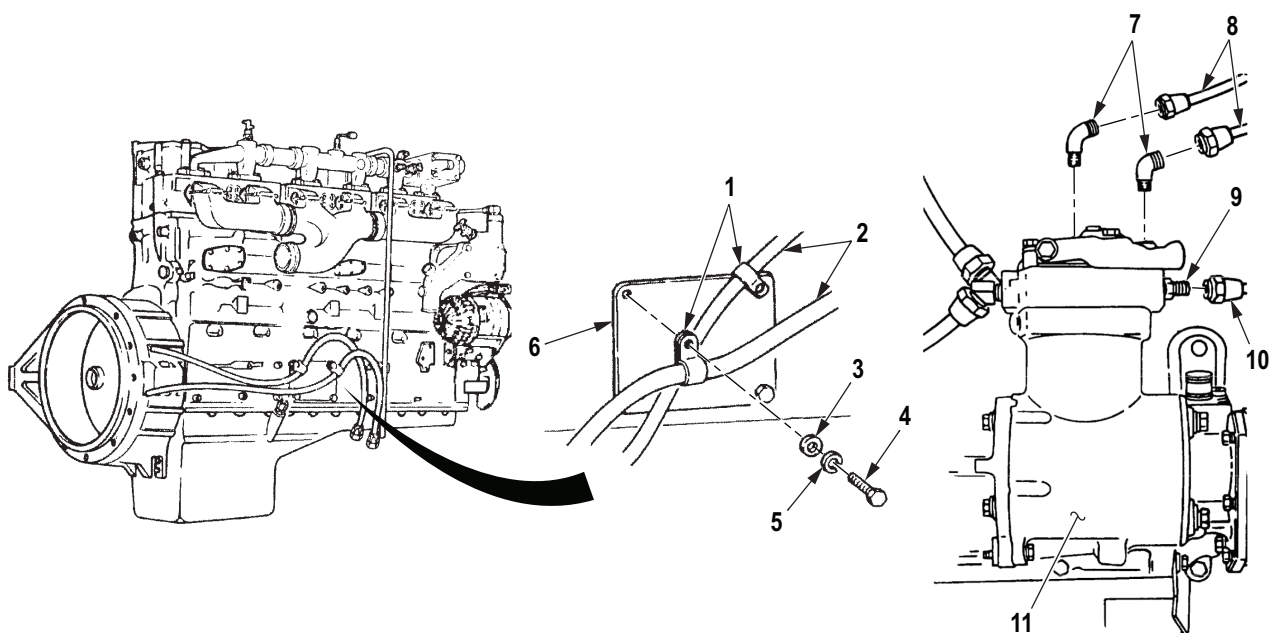
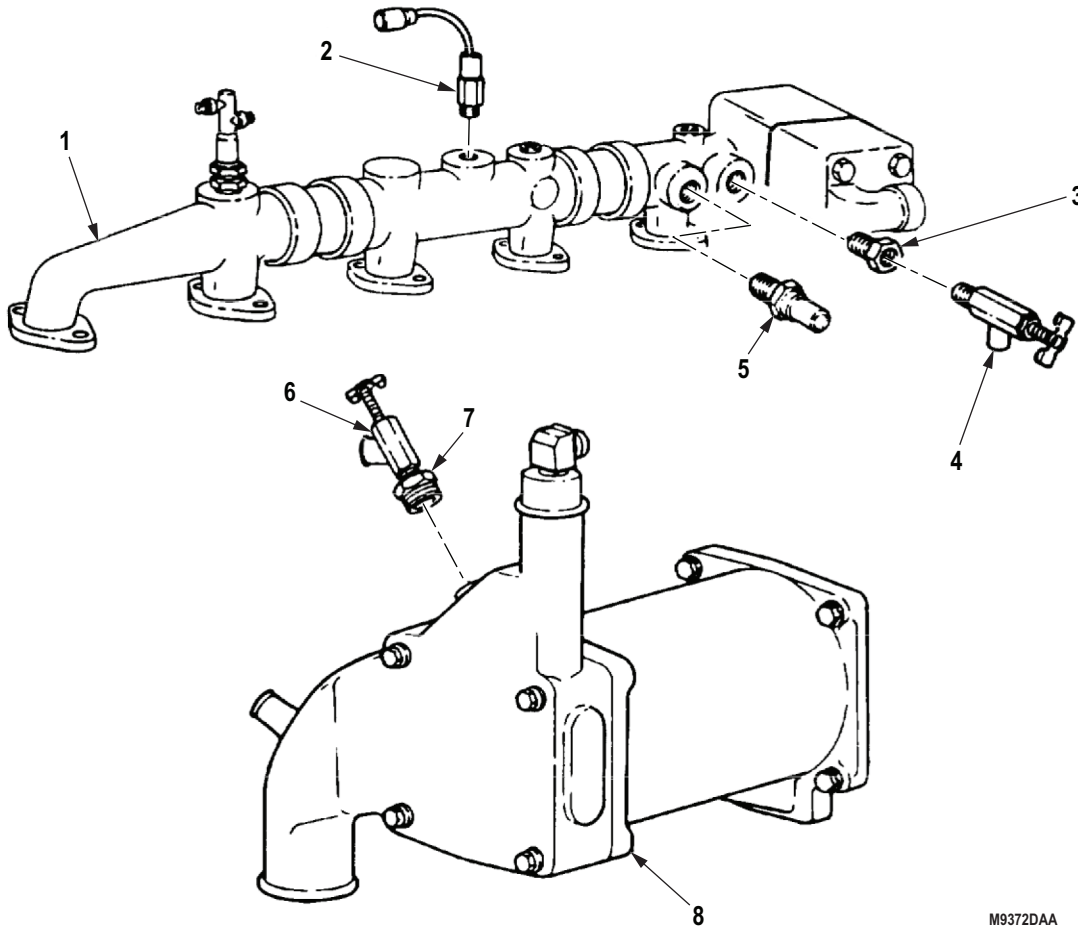

Figure 16. Power Plant Air Lines Assembly.

ASSEMBLY - Continued

5. Install water temperature sending unit (Figure 17, Item 5) on water manifold (Figure 17, Item 1).
6. Install high-temperature switch (Figure 17, Item 2) on water manifold (Figure 17, Item 1), if removed.
7. Install adapter (Figure 17, Item 3) and shutoff valve (Figure 17, Item 4) on water manifold (Figure 17, Item 1).
8. Install adapter (Figure 17, Item 7) and shutoff valve (Figure 17, Item 6) on oil cooler (Figure 17, Item 8).



M9372DAA

Figure 17. Power Plant Heater Shutoff Valves.

END OF TASK

INSTALLATION**NOTE**

When replacing engine, the transmission will be installed on new engine.

1. Attach adjustable chain hoist and both chain hooks to engine lifting eyes (Figure 18, Item 1). Raise lifting device until all slack is removed from chain, ensuring lifting device does not support weight of engine (Figure 18, Item 2).

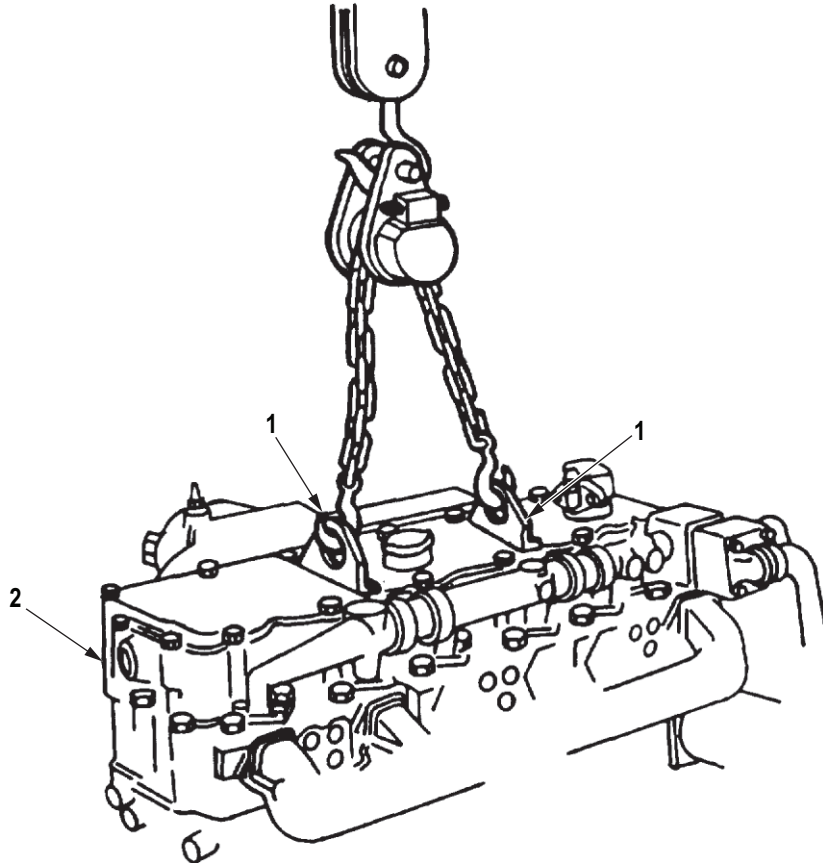

M9241DAA

Figure 18. Power Plant Lifting Points.

INSTALLATION - Continued**WARNING**

Personnel not participating in engine removal must stand clear during hoisting operations. A snapped cable, or swinging or shifting load, may occur. Failure to comply may result in injury or death to personnel.

CAUTION

Lower engine and transmission into chassis carefully and closely observe all engine and transmission components to prevent damage to equipment. Always remove engine slowly.

NOTE

- For Steps (2) through (4), if engine is removed in the field, an additional assistant will be needed to operate the wrecker crane. Shop removal of engine requires a mechanic and one assistant if overhead hoist is available.
 - Chain hoist must be adjusted so transmission points downward at approximately a 15 to 20° angle for engine to clear front axle.
2. Install trunnion mount (Figure 19, Item 6) on frame crossmember (Figure 19, Item 9) with five lockwashers (Figure 19, Item 8) and screws (Figure 19, Item 7). Do not tighten screws.
 3. Raise engine (Figure 19, Item 1) and transmission (Figure 19, Item 2) over front bumper (Figure 19, Item 4) directly above engine compartment (Figure 19, Item 3).
 4. Using socket wrench, adjust engine angle to 15° to 20° with adjustable ratchet on lifting device.
 5. Slowly lower engine (Figure 19, Item 1) and transmission (Figure 19, Item 2) into engine compartment (Figure 19, Item 3).
 6. Lower engine (Figure 19, Item 1) and transmission (Figure 19, Item 2) until resting on trunnion mount (Figure 19, Item 6) and left and right rear engine supports (Figure 19, Item 15).
 7. Using a drift pin, align holes in left and right rear engine supports (Figure 19, Item 15) and engine flywheel housing (Figure 19, Item 14), and install two washers (Figure 19, Item 13), screws (Figure 19, Item 12), lockwashers (Figure 19, Item 17), and nuts (Figure 19, Item 16). Tighten nuts 140 to 160 lb-ft (190 to 217 N·m).
 8. Install transmission (Figure 19, Item 18) on rear support bracket (Figure 19, Item 21) with two lockwashers (Figure 19, Item 20) and screws (Figure 19, Item 19). Tighten screws 75 to 85 lb-ft (102 to 115 N·m).
 9. Turn left and right jack screws (Figure 19, Item 27) until rubber cushions (Figure 19, Item 28) of A-posts (Figure 19, Item 22) rest on A-post support brackets (Figure 19, Item 23). Ensure jack screws are turned all the way down in A-post support brackets.
 10. Install cab A-posts (Figure 19, Item 22) on each A-post support bracket (Figure 19, Item 23) with rubber cushions (Figure 19, Item 24), washer (Figure 19, Item 25), and locknut (Figure 19, Item 26).
 11. Install trunnion cap (Figure 19, Item 10) on trunnion mount (Figure 19, Item 6) with two lockwashers (Figure 19, Item 11) and screws (Figure 19, Item 5). Tighten screws 150 lb-ft (203 N·m).
 12. Tighten screws (Figure 19, Item 7) 65 to 75 lb-ft (88 to 102 N·m).

INSTALLATION - Continued

13. Disconnect lifting device, adjustable chain hoist, and chain from two engine lifting eyes (Figure 19, Item 1) and hoist hook.

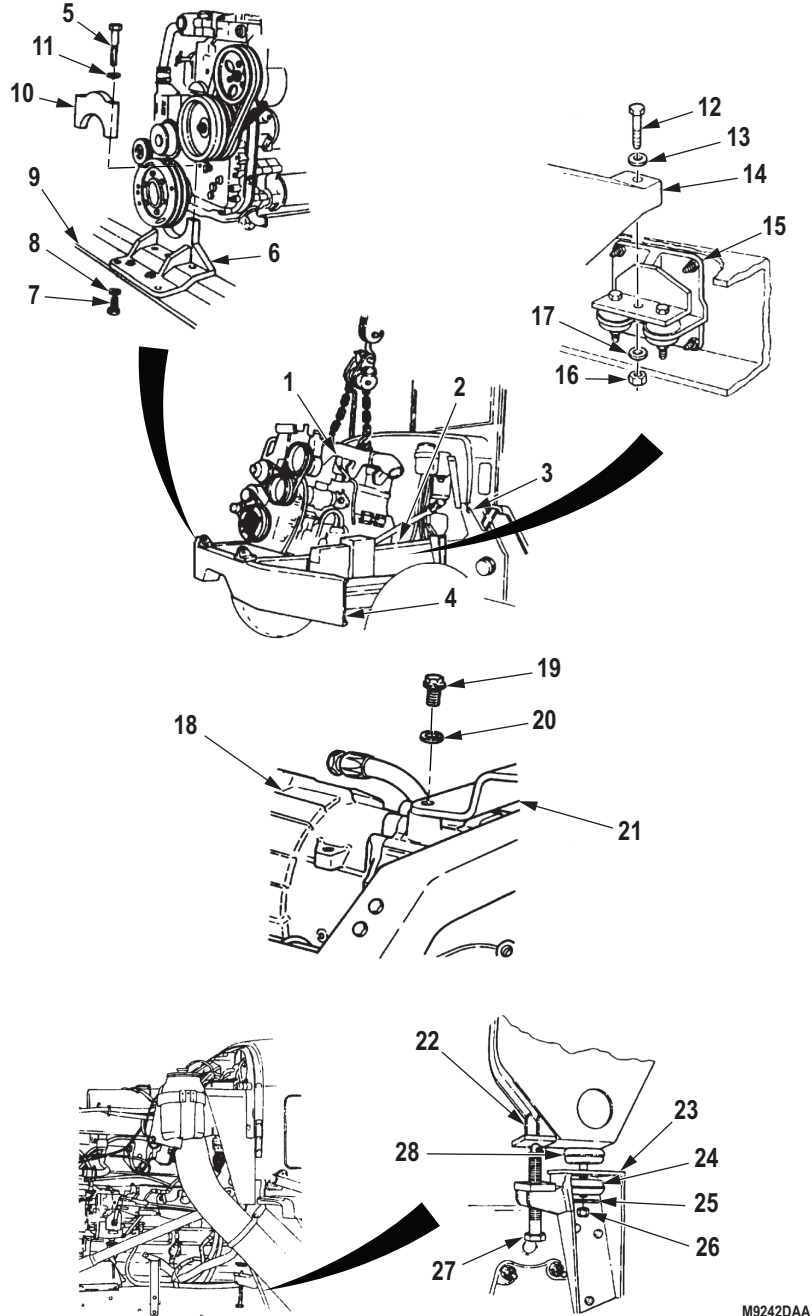

M9242DAA

Figure 19. Power Plant Engine Mounts Installation.

INSTALLATION - Continued**NOTE**

Step (14) applies only to vehicles equipped with a front winch with level wind.

14. Install winch level wind (Figure 20, Item 2) on winch (Figure 20, Item 5) with four lockwashers (Figure 20, Item 4) and screws (Figure 20, Item 3). Tighten screws 70 to 90 lb-ft (95 to 122 N·m).
15. Connect two wires (Figure 20, Item 7) to neutral start switch (Figure 20, Item 8) on transmission (Figure 21, Item 6).
16. Connect wires (Figure 20, Items 10 and 11) to 5th gear lock-in connector (Figure 20, Item 9).

INSTALLATION - Continued

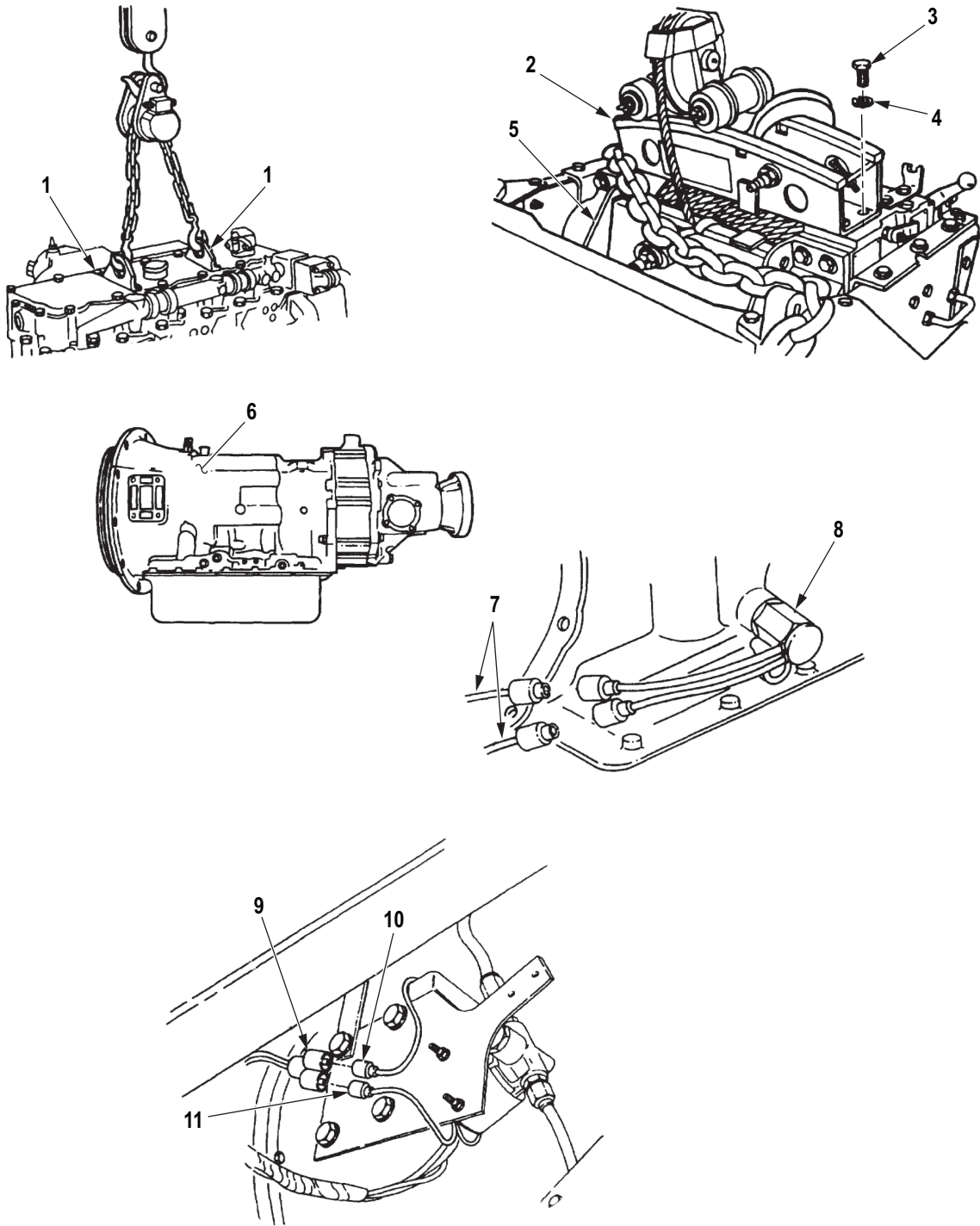

M9244DAA

Figure 20. Power Plant Transmission Wires Installation.

INSTALLATION - Continued

17. Connect breather vent line (Figure 21, Item 3) to transmission adapter elbow (Figure 21, Item 2).
18. Install transmission shift cable (Figure 21, Item 8) and cable pin (Figure 21, Item 9) on shift lever (Figure 21, Item 11) with cotter pin (Figure 21, Item 10).
19. Install transmission shift cable (Figure 21, Item 8) on support bracket (Figure 21, Item 4) with shim (Figure 21, Item 6), u-bolt (Figure 21, Item 7), and two locknuts (Figure 21, Item 5).
20. Install bracket (Figure 21, Item 12), gasket (Figure 21, Item 14), and modulator (Figure 21, Item 15) on transmission (Figure 21, Item 1) with screw (Figure 21, Item 13).
21. Install bracket (Figure 21, Item 21) and modulator cable (Figure 21, Item 16) with clamp (Figure 21, Item 19) and speedometer cable (Figure 21, Item 17) with clamp on transmission (Figure 21, Item 1) with screws (Figure 21, Items 18 and 22) and nut (Figure 21, Item 20).

INSTALLATION - Continued

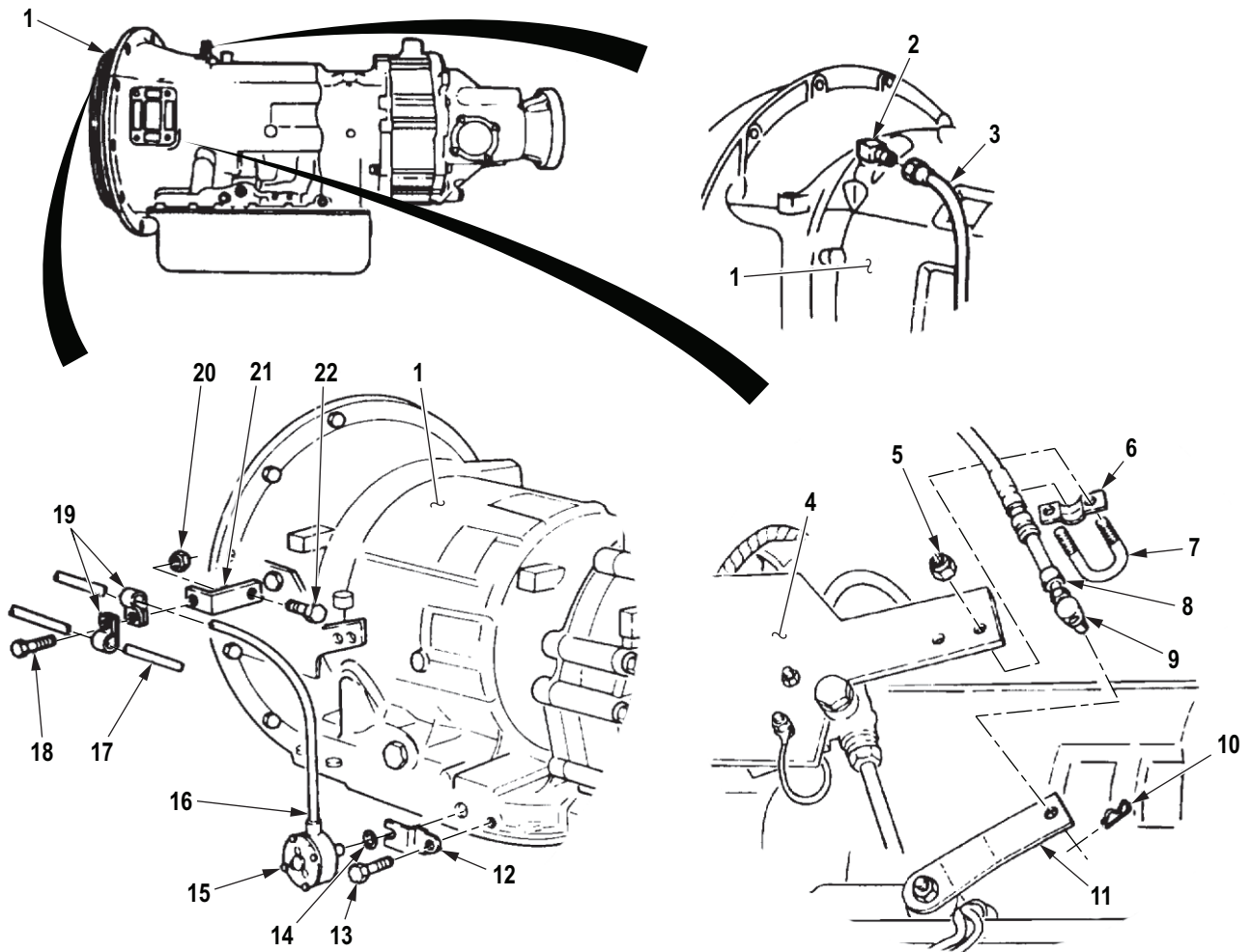

M9246DAA

Figure 21. Power Plant Transmission Module Installation.

INSTALLATION - Continued**NOTE**

- Step (22) applies only to vehicles equipped with a transmission PTO.
 - Transmission connections listed in Steps (22) through (25) can be made through access door in cab floor.
22. Install PTO cable (Figure 22, Item 7) and cable pin (Figure 22, Item 8) on select lever (Figure 22, Item 9) with washer (Figure 22, Item 10) and cotter pin (Figure 22, Item 1), and PTO cable on bracket (Figure 22, Item 3) with spacer plate (Figure 22, Item 4), retaining strap (Figure 22, Item 5), two screws (Figure 22, Item 6), and nuts (Figure 22, Item 2).
 23. Install transmission oil dipstick (Figure 22, Item 16) in dipstick tube (Figure 22, Item 15).
 24. Install wires (Figure 22, Items 12 and 14) in two spring tension clips (Figure 22, Item 13).
 25. Connect wire (Figure 22, Item 12) to transmission oil temperature sending unit (Figure 22, Item 11).

INSTALLATION - Continued

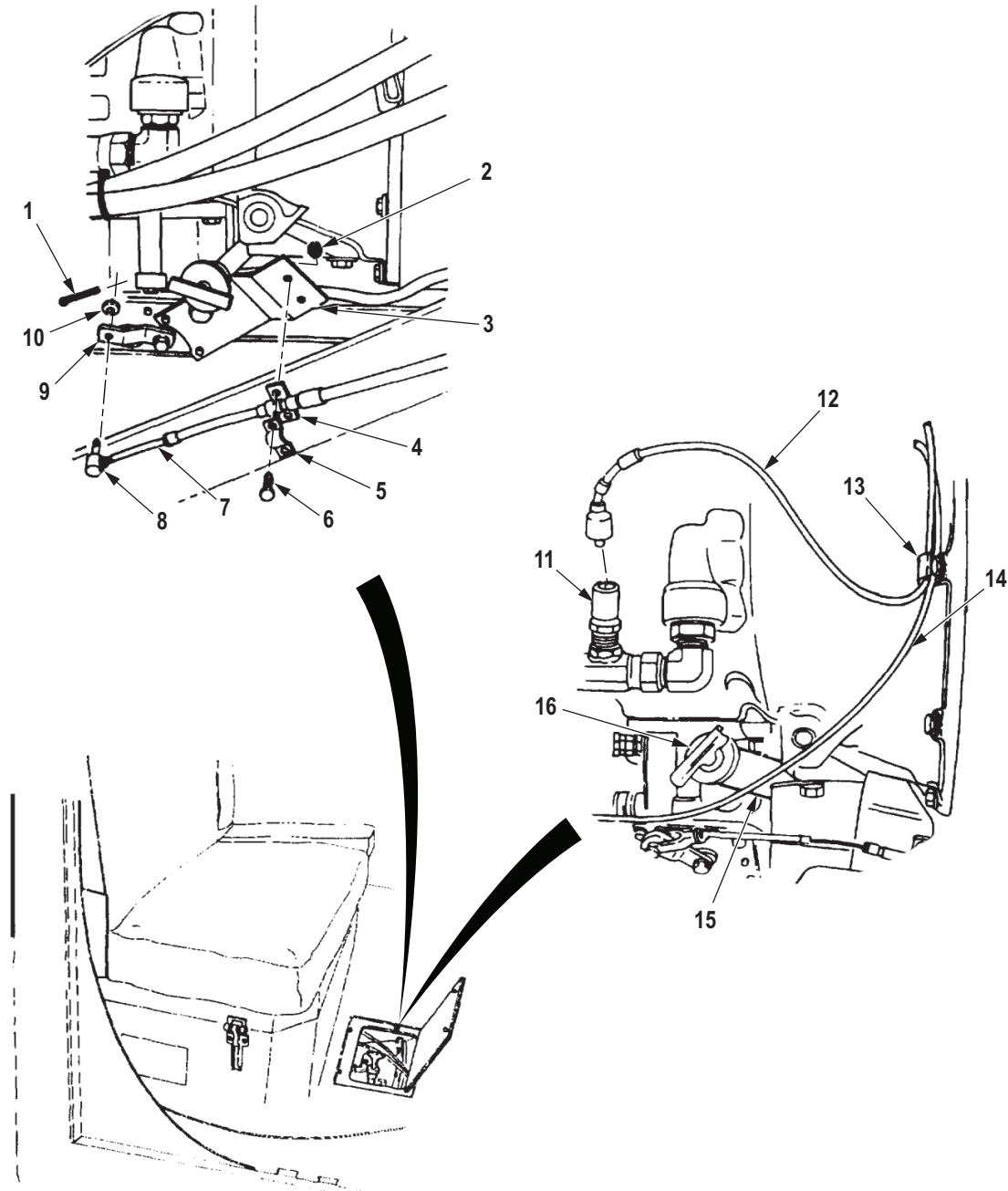

M9247DAA

Figure 22. Power Plant Transmission Shifter Cable Installation.

INSTALLATION - Continued

26. Install ground strap (Figure 23, Item 3) on air compressor (Figure 23, Item 1) with lockwasher (Figure 23, Item 2), washer (Figure 23, Item 4), lockwasher (Figure 23, Item 5), and screw (Figure 23, Item 6).
27. Install ground strap (Figure 23, Item 10) and ground wire (Figure 23, Item 9) on air intake manifold (Figure 23, Item 7) with lockwasher (Figure 23, Item 11) and screw assembled washer (Figure 23, Item 8).
28. Connect air line (Figure 23, Item 12) to fitting (Figure 23, Item 13).
29. Install ground strap (Figure 23, Item 20) and wires (Figure 23, Items 21 and 24) on terminal post (Figure 23, Item 19) with washer (Figure 23, Item 23) and nut (Figure 23, Item 22).
30. Install wires (Figure 23, Items 14 and 25) on starter solenoid (Figure 23, Item 18) with washer (Figure 23, Item 27) and nut (Figure 23, Item 26).
31. Install wire (Figure 23, Item 15) on starter solenoid (Figure 23, Item 18) with clip (Figure 23, Item 17) and screw (Figure 23, Item 16).

INSTALLATION - Continued

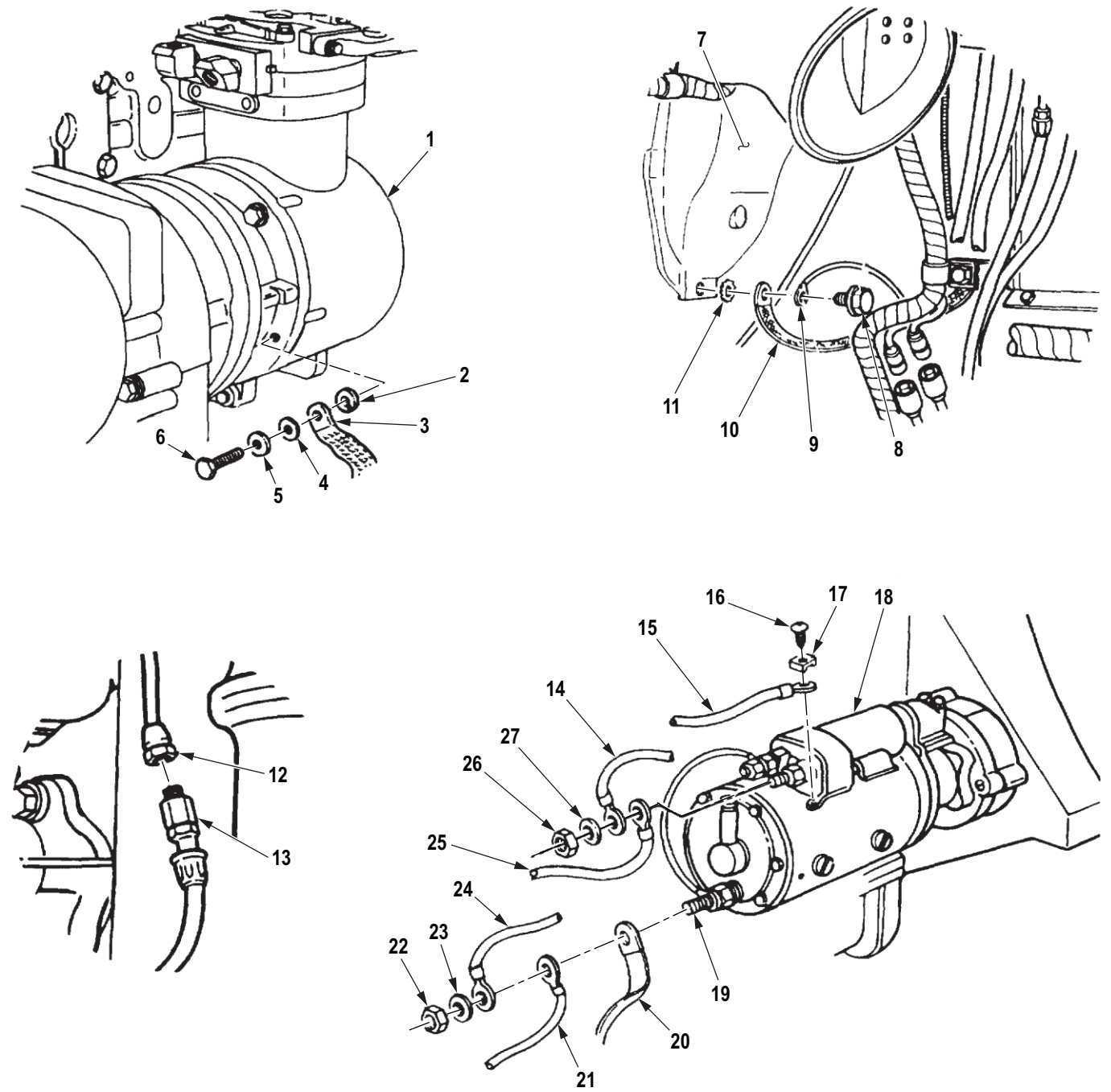

M9248DAA

Figure 23. Power Plant Electrical Wire Installation.

INSTALLATION - Continued

32. Connect air line (Figure 24, Item 1) to air governor (Figure 24, Item 2).
33. Connect air line (Figure 24, Item 4) to compressor (Figure 24, Item 3).
34. Connect air line (Figure 24, Item 9) to VS governor (Figure 24, Item 10).
35. Connect connector (Figure 24, Item 16) to fuel pressure transducer (Figure 24, Item 11).
36. Connect fuel line (Figure 24, Item 5) to rear of fuel pump (Figure 24, Item 6).
37. Connect tachometer drive cable (Figure 24, Item 14) to tachometer pulse sender (Figure 24, Item 15).
38. Connect harness (Figure 24, Item 12) to tachometer pulse sender connector (Figure 24, Item 13).
39. Connect wire (Figure 24, Item 7) to oil pressure sending unit (Figure 24, Item 8).

INSTALLATION - Continued

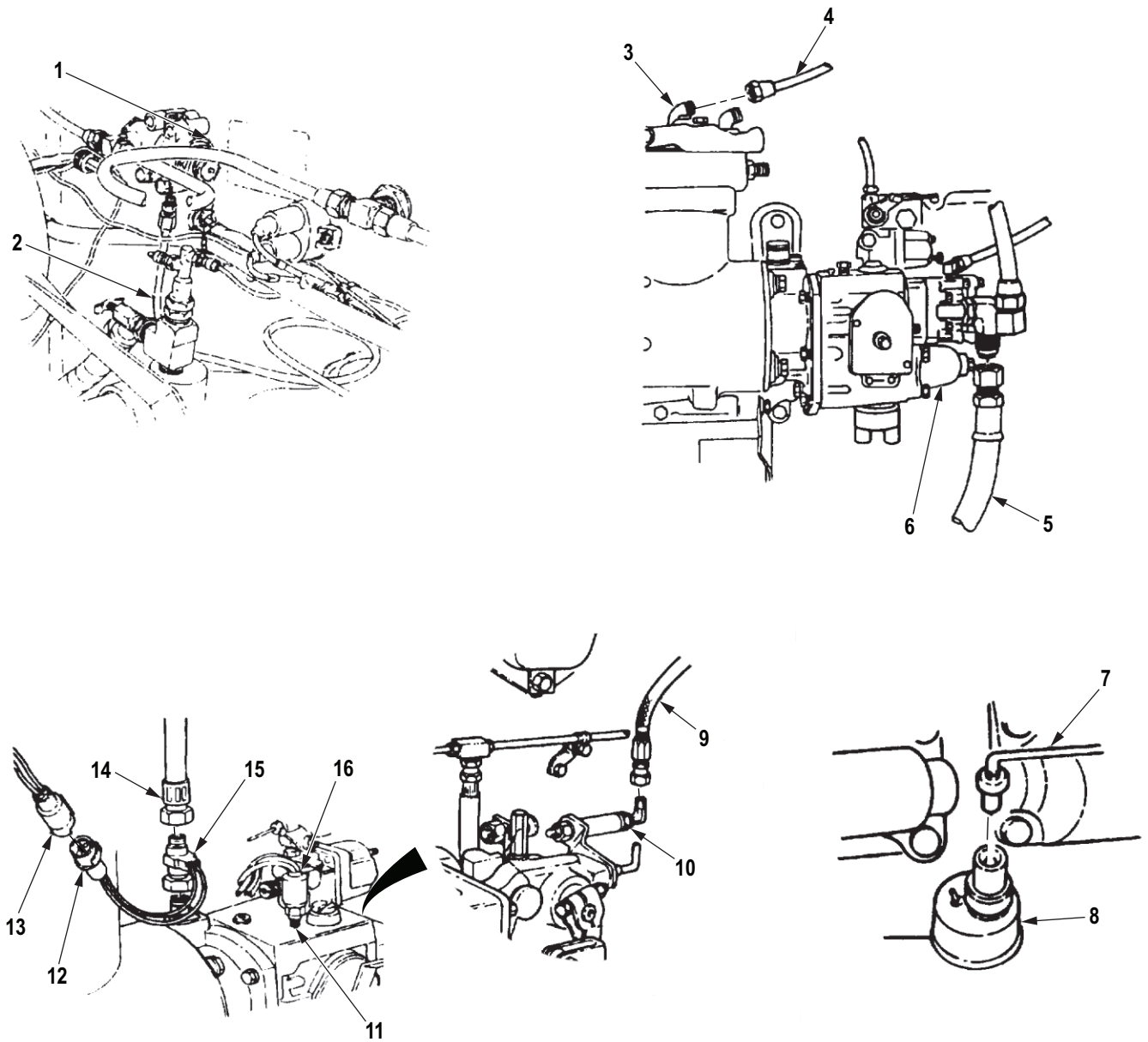

M9249DAA

Figure 24. Power Plant Air Line Installation.

INSTALLATION - Continued

40. Connect fuel line (Figure 25, Item 21) to fuel pump return hose (Figure 25, Item 22).
41. Connect atomizer line (Figure 25, Item 3) to ether start safety valve (Figure 25, Item 2) and ether atomizer (Figure 25, Item 6).
42. Connect line (Figure 25, Item 4) from ether cylinder valve (Figure 25, Item 5) to ether start safety valve (Figure 25, Item 2).
43. Connect tube (Figure 25, Item 7) to fitting (Figure 25, Item 8).
44. Connect two wires (Figure 25, Item 19) to ether start switch (Figure 25, Item 20).
45. Connect air line (Figure 25, Item 18), tachometer cable (Figure 25, Item 9), speedometer cable (Figure 25, Item 15), and harness (Figure 25, Item 16) to air intake manifold (Figure 25, Item 17) with clamps (Figure 25, Items 10, 11, and 14), two washers (Figure 25, Item 13), and screws (Figure 25, Item 12).

INSTALLATION - Continued

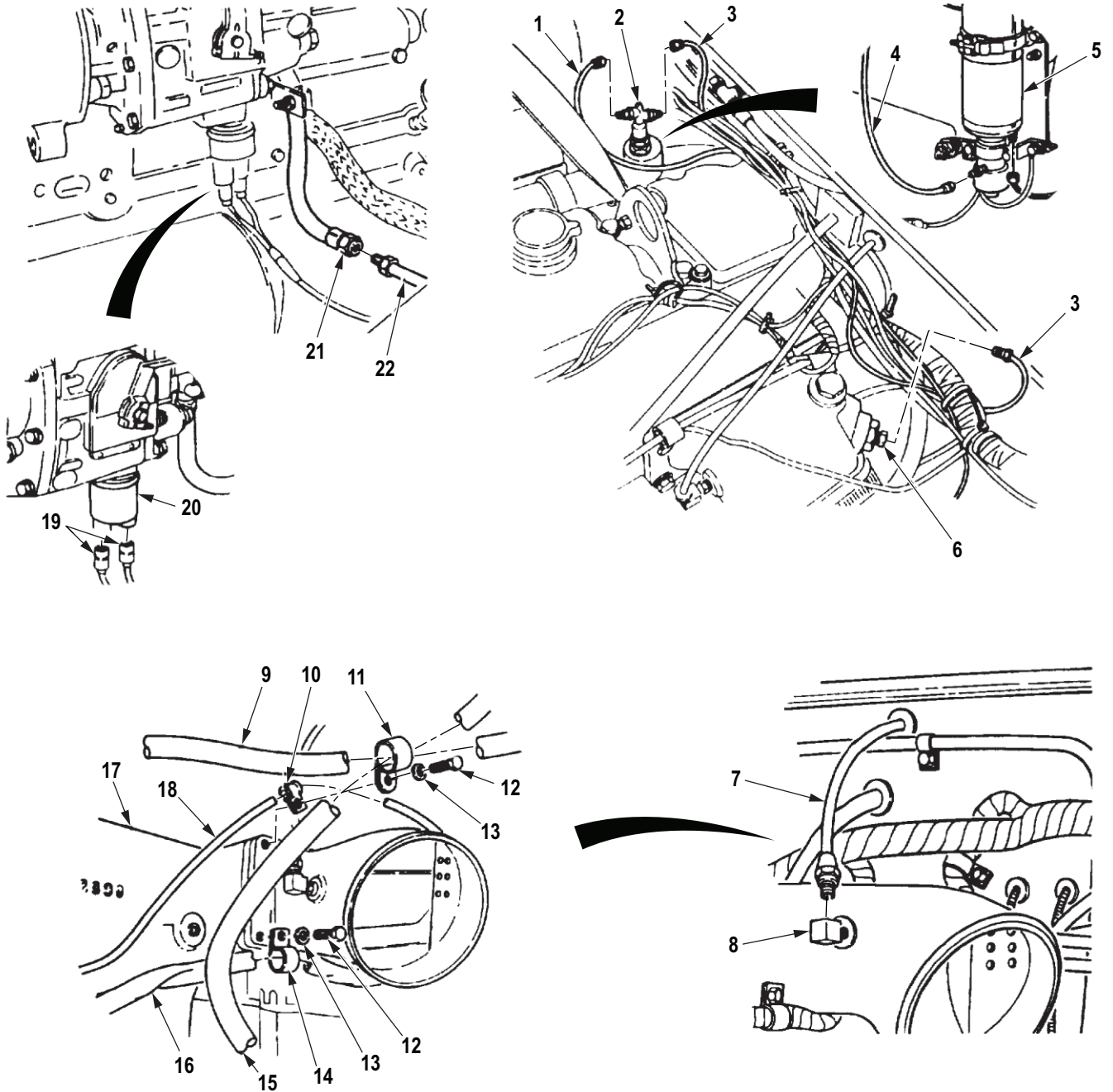

M9250DAA

Figure 25. Power Plant Ether Line Installation.

INSTALLATION - Continued

46. Install emergency stop cable (Figure 26, Item 1) in swivel block (Figure 26, Item 10).
47. Install connector (Figure 26, Item 12) on cable (Figure 26, Item 1) and tighten connector screw (Figure 26, Item 11).
48. Install cable (Figure 26, Item 1) on clamp bracket (Figure 26, Item 9) with clamp (Figure 26, Item 7), washer (Figure 26, Item 5), screw (Figure 26, Item 6), and nut (Figure 26, Item 8).
49. Install wires (Figure 26, Items 13 and 14) on fuel shutoff solenoid (Figure 26, Item 2) with nut (Figure 26, Item 15).
50. Install pump throttle lever (Figure 26, Item 3) on accelerator rod (Figure 26, Item 4) with screw (Figure 26, Item 27) and locknut (Figure 26, Item 26).
51. Install pump throttle lever (Figure 26, Item 3) on link (Figure 26, Item 24) with screw (Figure 26, Item 25) and locknut (Figure 26, Item 16).
52. Install modulator cable (Figure 26, Item 19) on fuel primer pump bracket (Figure 26, Item 20) with shim (Figure 26, Item 17), clamp (Figure 26, Item 22), two screws (Figure 26, Item 23), and nuts (Figure 26, Item 18).
53. Connect return spring (Figure 26, Item 21) to link (Figure 26, Item 24) and fuel primer pump bracket (Figure 26, Item 20).

INSTALLATION - Continued

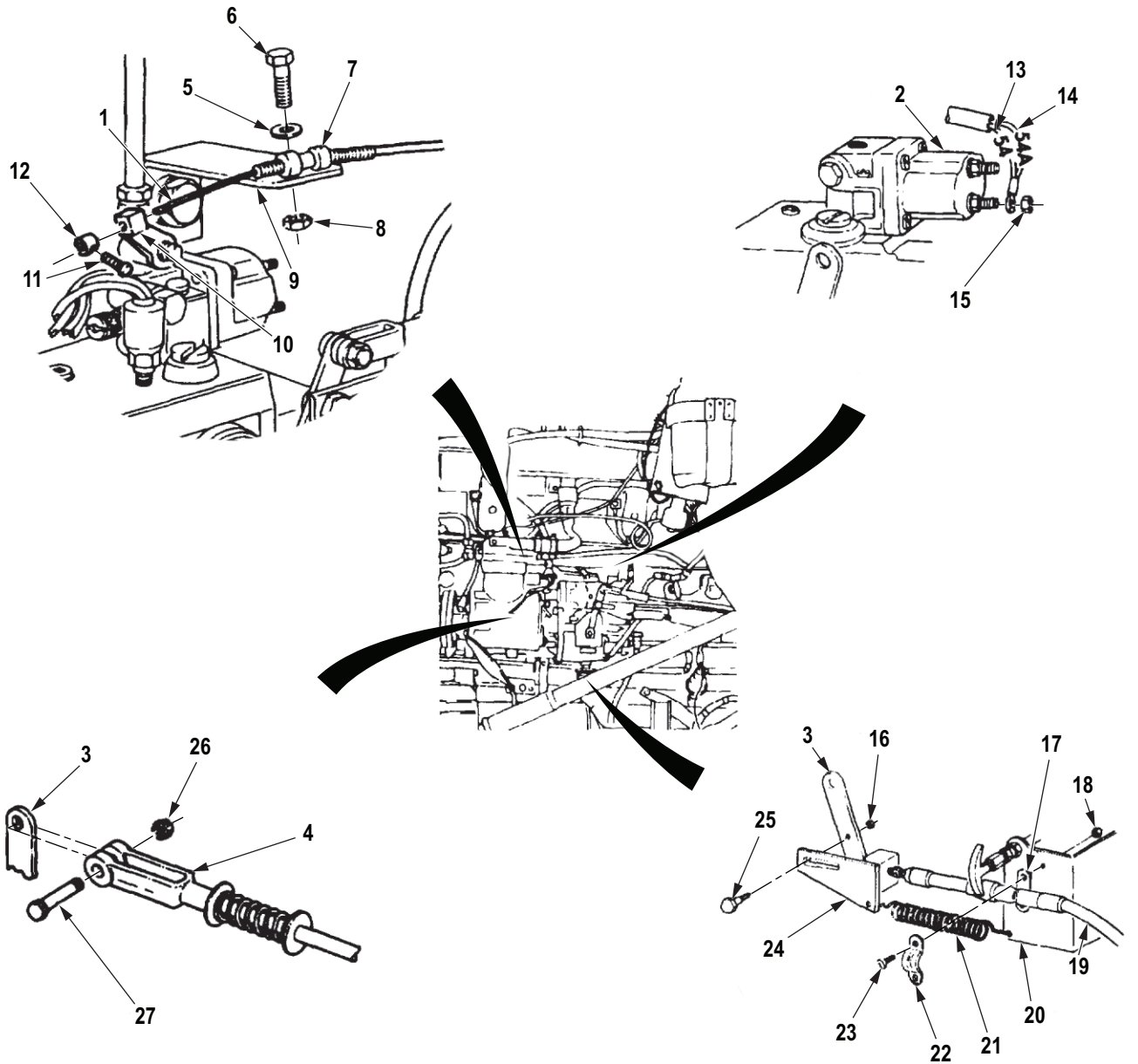

M9251DAA

Figure 26. Power Plant Throttle Cable Installation.

INSTALLATION - Continued

54. Connect hose (Figure 27, Item 1) to elbow (Figure 27, Item 2).
55. Connect hose (Figure 27, Item 9) to transmission oil cooler (Figure 27, Item 10).
56. Connect hose (Figure 27, Item 6) to fitting (Figure 27, Item 5) on power steering pump (Figure 27, Item 3).
57. Install return hose (Figure 27, Item 7) on flange (Figure 27, Item 4) of power steering pump reservoir (Figure 27, Item 3) and tighten clamp (Figure 27, Item 8).

INSTALLATION - Continued

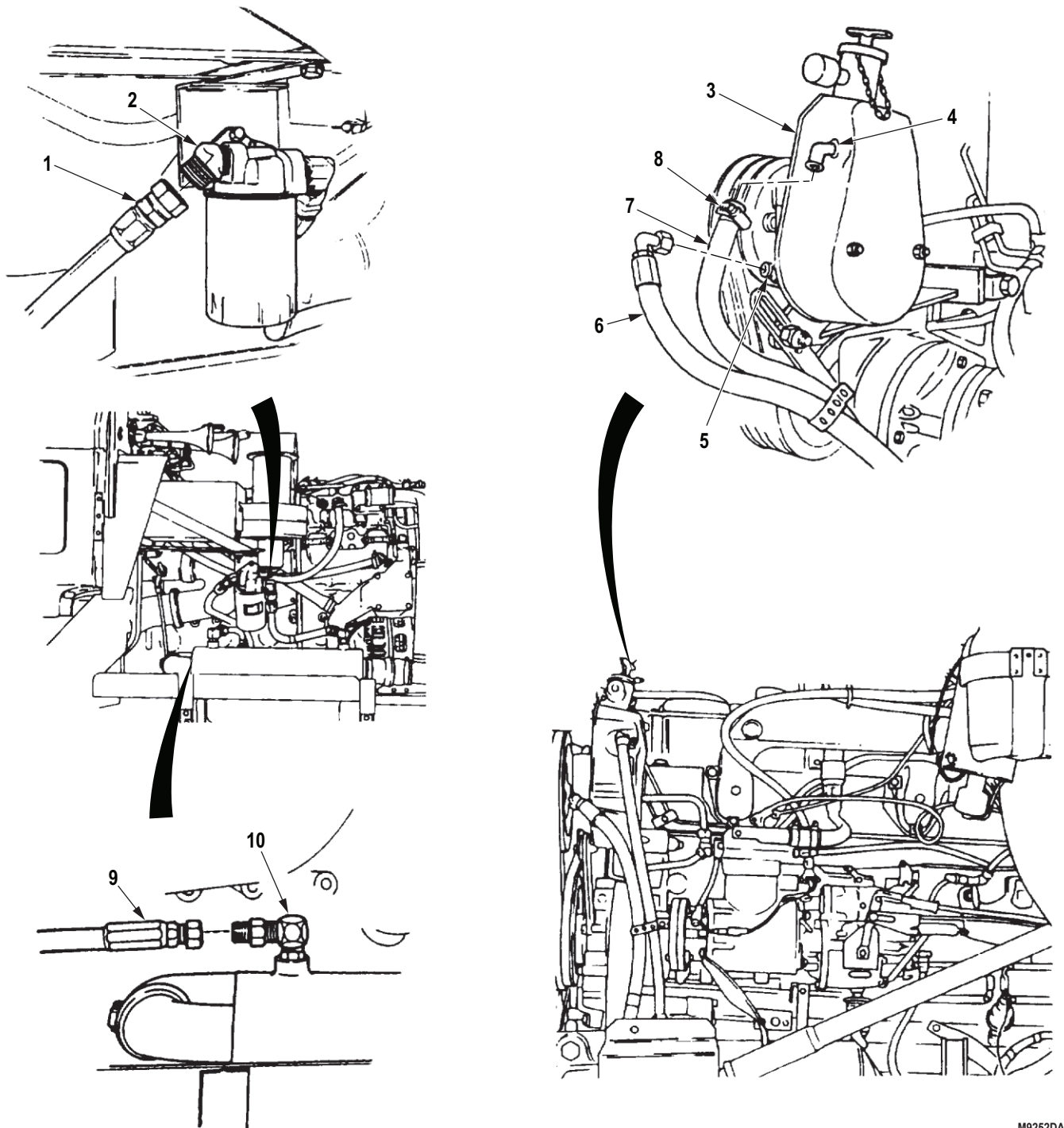

M9252DAA

Figure 27. Power Plant Power Steering Hoses Installation.

INSTALLATION - Continued

58. Install hose (Figure 28, Item 3) on water heater shutoff valve (Figure 28, Item 1) with clamp (Figure 28, Item 2).
59. Install hose (Figure 28, Item 4) on water heater shutoff valve (Figure 28, Item 6) with clamp (Figure 28, Item 5).
60. Install wire (Figure 28, Item 21) on alternator (Figure 28, Item 23) with washer (Figure 28, Item 20), lockwasher (Figure 28, Item 19), and nut (Figure 28, Item 18).
61. Install wire (Figure 28, Item 10) on alternator (Figure 28, Item 23) with washer (Figure 28, Item 11), lockwasher (Figure 28, Item 12), and nut (Figure 28, Item 13).
62. Install wire (Figure 28, Item 7) on alternator (Figure 28, Item 23) with lockwasher (Figure 28, Item 8) and screw (Figure 28, Item 9).
63. Install wire retaining strap (Figure 28, Item 14) on alternator (Figure 28, Item 23) with two lockwashers (Figure 28, Item 15) and screws (Figure 28, Item 16).
64. Seal wires (Figure 28, Items 10 and 21) completely with adhesive sealant, and install terminal cover (Figure 28, Item 17) on alternator (Figure 28, Item 23) with two screw assembled lockwashers (Figure 28, Item 22).
65. Connect wire (Figure 28, Item 25) to connector (Figure 28, Item 24).
66. Install tiedown strap (Figure 28, Item 26) around all wires.

INSTALLATION - Continued

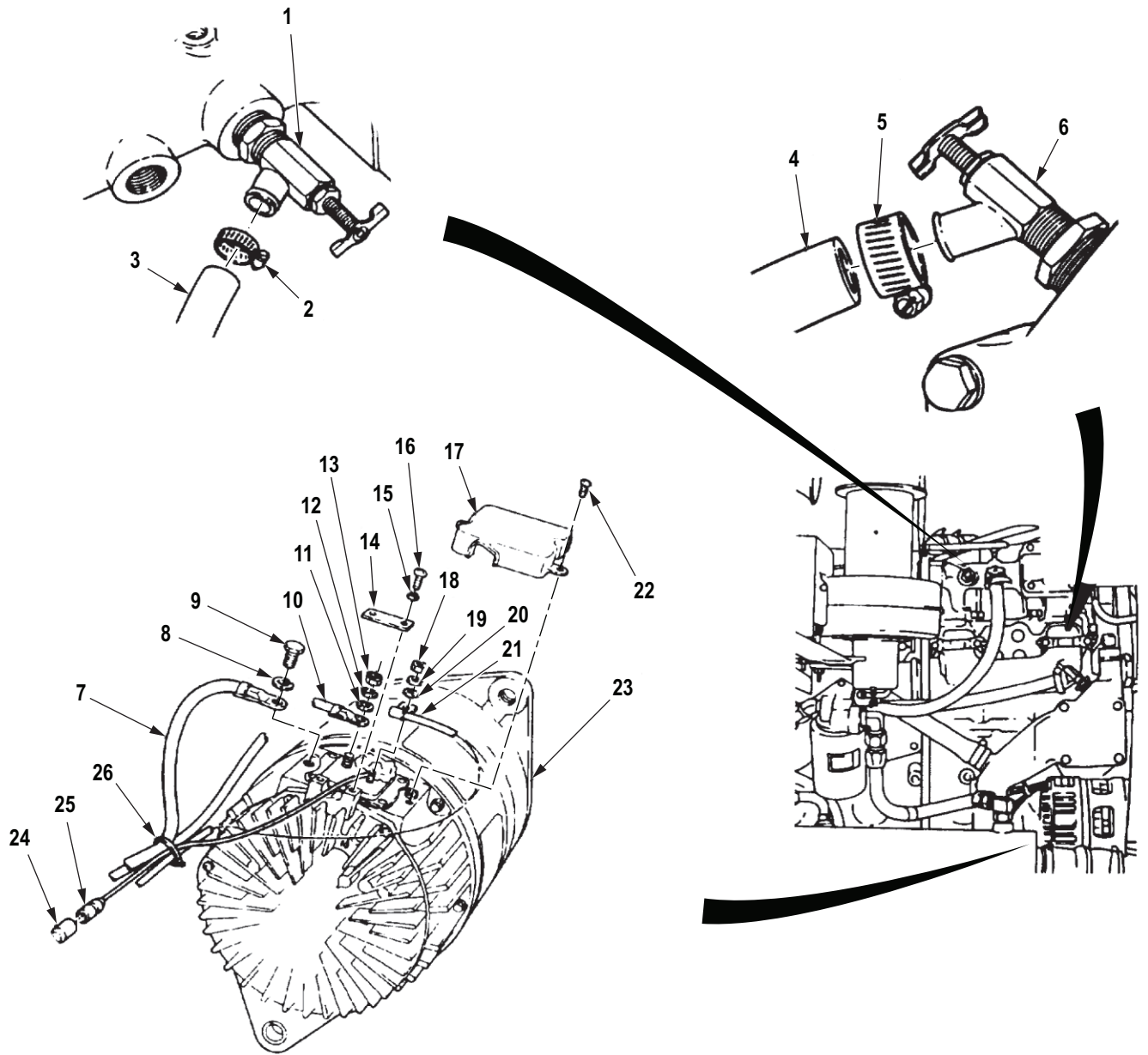

M9253DAA

Figure 28. Power Plant Alternator Wiring Installation.

INSTALLATION - Continued

67. Connect wire (Figure 29, Item 1) to water temperature sending unit (Figure 29, Item 2).

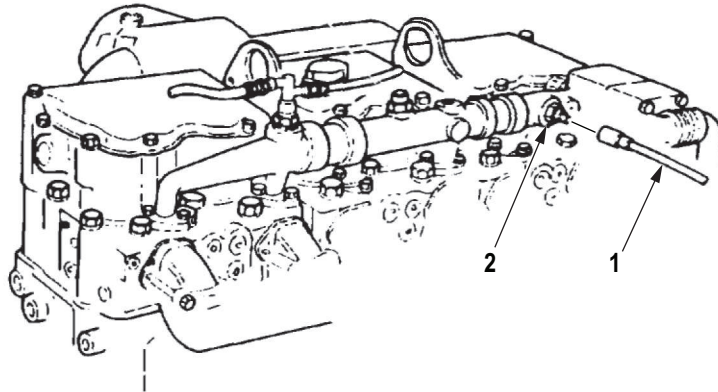

M9254DAA

Figure 29. Power Plant Temperature Wiring Installation.

END OF TASK**INSTALLATION**

1. Inspect engine coolant and oil levels (TM 9-2320-272-10).
2. Pull emergency stop control (Figure 30, Item 4) out all the way to prevent engine from starting while priming.
3. Crank engine until oil pressure registers on oil pressure gauge (Figure 30, Item 3).
4. Push emergency stop control (Figure 30, Item 4) in all the way and reset fuel pump lever.
5. Start and run engine at 1,000 to 2,000 rpm as indicated on tachometer (Figure 30, Item 1) for 30 minutes, observing oil pressure (Figure 30, Item 3) and water temperature (Figure 30, Item 2) gauges for proper ranges (TM 9-2320-272-10).
6. Inspect engine for leaks (TM 9-2320-272-10).
7. Start and idle engine at 800 to 1,000 rpm for 5 to 10 minutes, observing oil pressure (TM 9-2320-272-10).

CAUTION

If oil pressure drops below 10 psi (68 kPa) or rises sharply above 30 psi (207 kPa), stop the engine and correct as required.

8. Stop engine and inspect coolant and oil levels (TM 9-2320-272-10).
9. Inspect engine for leaks (TM 9-2320-272-10).
10. Start and run engine at 1/4 to 1/2 throttle until water temperature gauge (Figure 30, Item 2) reaches 165°F to 195°F (73°C to 90°C).
11. Stop engine and inspect coolant and oil levels (TM 9-2320-272-10).
12. Inspect engine for leaks (TM 9-2320-272-10).
13. Start and idle engine at 800 to 1,000 rpm as indicated on tachometer (Figure 30, Item 1) for 5 to 10 minutes, observing oil pressure gauge (Figure 30, Item 3) for proper range (TM 9-2320-272-10).

INSTALLATION - Continued

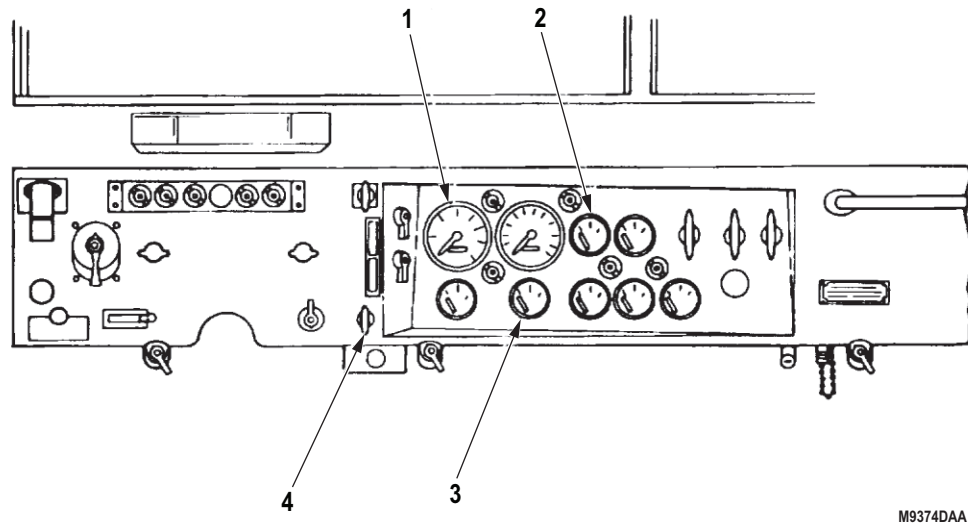

Figure 30. In-Chassis Run-In.

NOTE

Coolant should not exceed 195°F (90°C) or drop below 175°F (79°C).

14. Check engine idle speed. If idle speed is not 625 ± 25 rpm on M939/A1 series vehicles, perform Steps (9) through (14).

END OF TASK

IN-CHASSIS RUN-IN

1. Start and idle engine 800 to 1,000 rpm for 5 to 10 minutes, observing oil pressure (TM 9-2320-272-10).

CAUTION

If oil pressure drops below 10 psi (68 kPa) or rises sharply above 30 psi (207 kPa), stop engine and correct as required.

2. Stop engine and inspect coolant and oil levels (TM 9-2320-272-10).
3. Inspect engine for leaks (TM 9-2320-272-10).
4. Start and run engine at 1/4 to 1/2 throttle until water temperature gauge (Figure 31, Item 2) reaches 165°F to 195°F (73°C to 90°C).
5. Stop engine and inspect coolant and oil levels (TM 9-2320-272-10).
6. Inspect engine for leaks (TM 9-2320-272-10).
7. Start and idle engine at 800 to 1,000 rpm as indicated on tachometer (Figure 31, Item 1) for 5 to 10 minutes, observing oil pressure gauge (Figure 31, Item 3) for proper range (TM 9-2320-272-10).

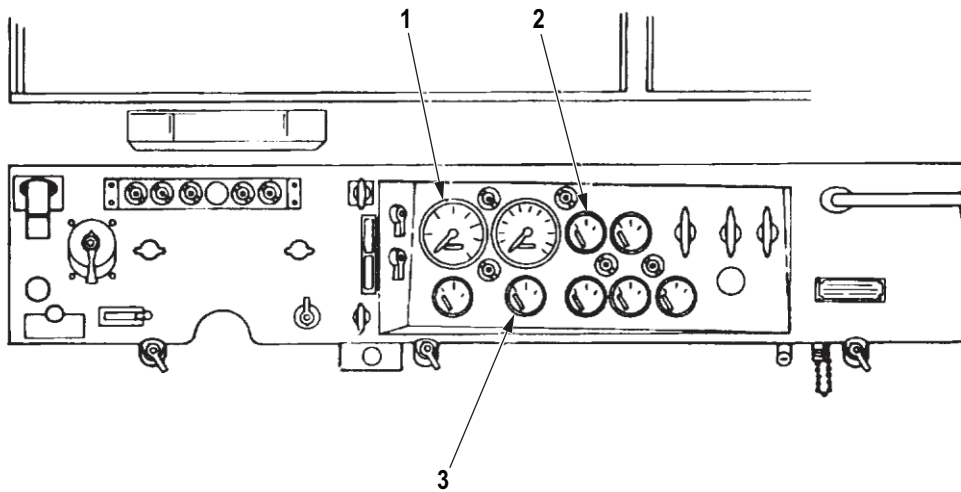

M9280DAA

Figure 31. In-Chassis Run-In.

END OF TASK

FOLLOW-ON MAINTENANCE

1. Change engine oil after first 500 miles (805 km). (Volume 5, WP 0820)
2. Install transmission-to-transfer case propeller shaft. (Volume 3, WP 0403)
3. Install transmission PTO-to-hydraulic pump driveshaft, if equipped. (Volume 4, WP 0713)
4. Install air cleaner intake pipe. (WP 0246)
5. Install engine oil dipstick and tube. (WP 0228)
6. Install front exhaust pipe. (WP 0276)
7. Install radiator fan blade assembly. (WP 0298)
8. Install radiator. (WP 0281)
9. Install surge tank. (WP 0278)
10. Install coolant hoses and tubes. (WP 0280)
11. Install hood assembly. (Volume 4, WP 0565)
12. Fill steering system (Volume 5, WP 0820) to proper oil level. (WP 0287)
13. Fill cooling system (WP 0232) to proper coolant level. (Volume 3, WP 0362)
14. Fill engine (Volume 5, WP 0822) to proper oil level. (Volume 3, WP 0362)
15. Fill transmission to proper oil level. (Volume 3, WP 0365)
16. Close air reservoir drain valves. (WP 0270)
17. Connect battery ground cables. (WP 0271)
18. Adjust modulator cable. (WP 0268)
19. Adjust throttle control cable. (WP 0271)
20. Adjust emergency stop control cable. (WP 0268)
21. Adjust accelerator linkage. (WP 0268)

END OF TASK**END OF WORK PACKAGE**

**FIELD MAINTENANCE
ENGINE AND CONTAINER REPLACEMENT**

INITIAL SETUP:**Tools and Special Tools**

Tool Kit, General Mechanic's: Automotive
(Volume 5, WP 0826, Table 1, Item 56)
Chain Assembly
(Volume 5, WP 0826, Table 1, Item 15)
Lifting Device

Materials/Parts (cont.)

(Volume 5, WP 0827, Table 1, Item 2)
Qty: 42
Lockwasher
(Volume 5, WP 0827, Table 1, Item 408)
Qty: 4

Materials/Parts

Lockwasher

Personnel Required

(2)

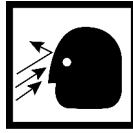
REMOVAL**WARNING**

Engine container is pressurized. Ensure pressure is released before opening container.
Failure to comply may result in injury or death to personnel.

1. Remove 42 nuts (Figure 1, Item 2), lockwashers (Figure 1, Item 3), screws (Figure 1, Item 5), and upper container section (Figure 1, Item 1) from lower container section (Figure 1, Item 6) and seal (Figure 1 Item 4). Discard lockwashers.

NOTE

Perform Step (2) for late model engines.

2. Loosen two hose clamps (Figure 1, Item 9) and remove breather tube (Figure 1, Item 8) from breather (Figure 1, Item 7) and elbow (Figure 1, Item 10).

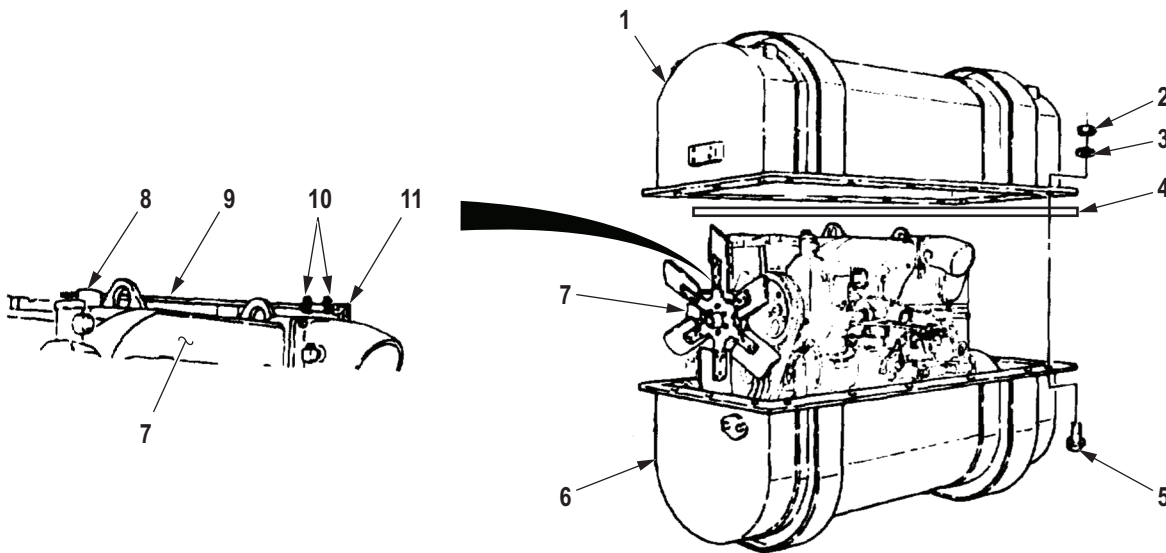

M9272DAA

Figure 1. Engine and Container Removal.

3. Remove two screws (Figure 2, Item 1), lockwashers (Figure 2, Item 5), and trunnion cap (Figure 2, Item 4) from front trunnion mount (Figure 2, Item 3) and engine (Figure 2, Item 2). Discard lockwashers.
4. Remove two screws (Figure 2, Item 6), lockwashers (Figure 2, Item 8), and washers (Figure 2, Item 10) from rear trunnion mount (Figure 2, Item 9) and flywheel housing (Figure 2, Item 7). Discard lockwashers.

REMOVAL - Continued

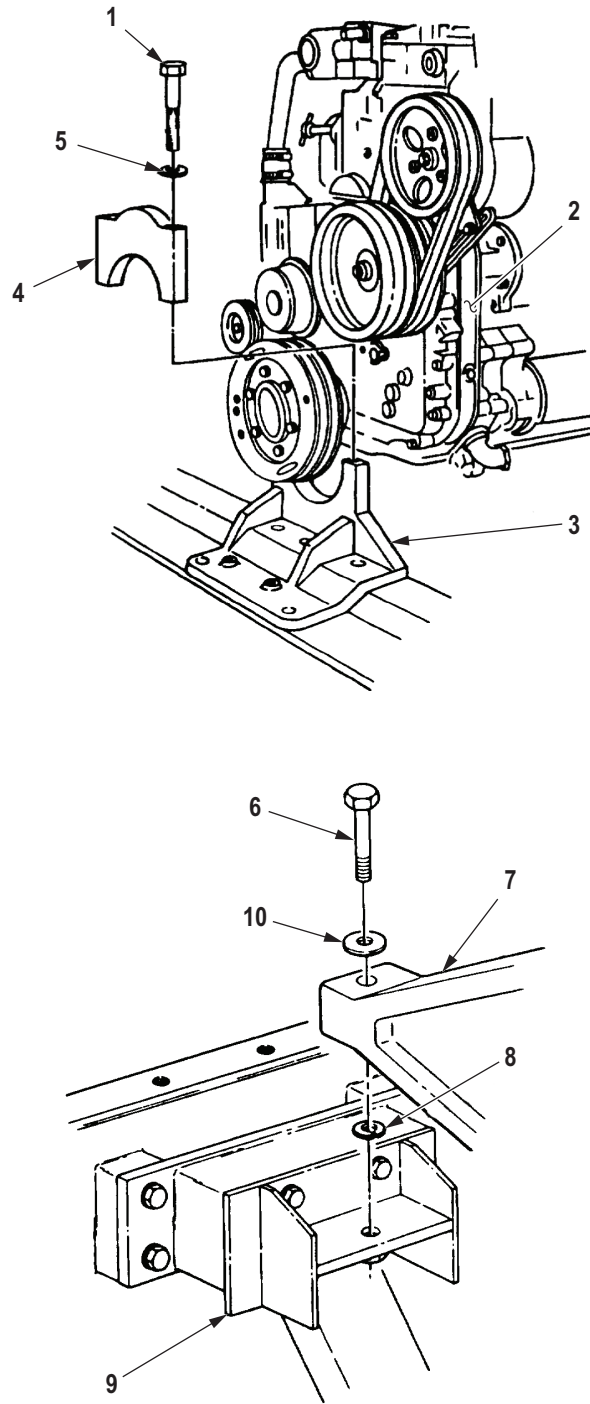

M9273DAA

Figure 2. Engine and Container Removal.

REMOVAL - Continued

5. Install utility chain and lifting device on two engine lifting eyes (Figure 3, Item 1).

WARNING

All personnel must stand clear during lifting operations. A snapped chain, or shifting or swinging load, may result in injury to personnel. Failure to comply may result in injury or death to personnel.

NOTE

Assistant will help with Steps (6) and (7).

6. Remove engine (Figure 3, Item 2) from lower container section (Figure 3, Item 3).
7. Lift engine (Figure 3, Item 2) onto transporter stand.
8. Remove utility chain and lifting device from engine lifting eyes (Figure 3, Item 1).

NOTE

Prepare engine for installation.

END OF TASK**INSTALLATION**

1. Install utility chain and lifting device on two engine lifting eyes (Figure 3, Item 1).

WARNING

All personnel must stand clear during lifting operations. A snapped chain, or shifting or swinging load, may result in injury to personnel. Failure to comply may result in injury or death to personnel.

NOTE

Assistant will help with Steps (2) and (3).

2. Remove engine (Figure 3, Item 2) from transporter stand and install in lower container section (Figure 3, Item 3), ensuring all mounting holes are aligned.

INSTALLATION - Continued

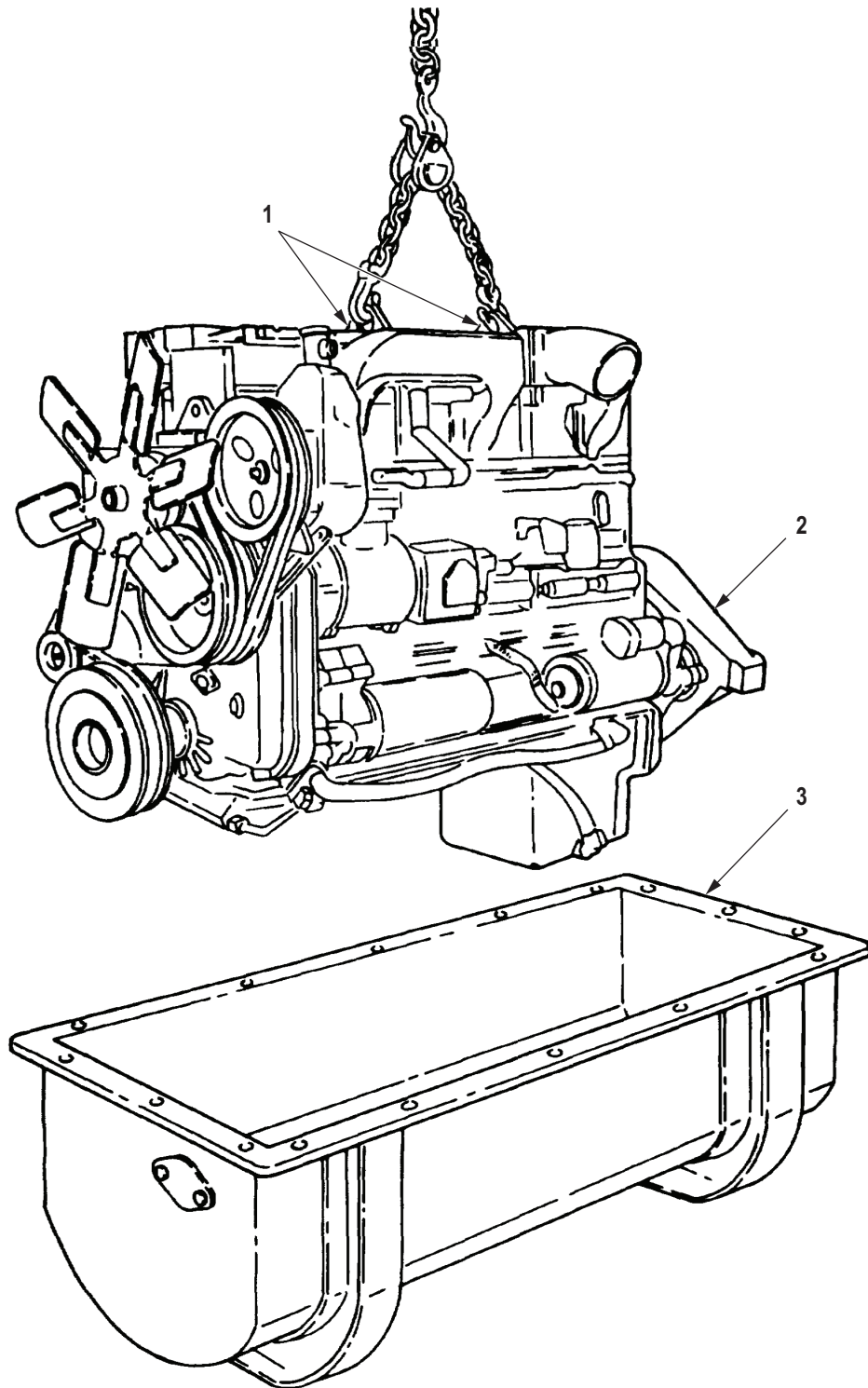

M9274DAA

Figure 3. Engine and Container Installation.

INSTALLATION - Continued**NOTE**

Perform Step (3) for late model engines.

3. Install breather tube (Figure 4, Item 8) on breather (Figure 4, Item 7) and elbow (Figure 4, Item 10) and tighten two hose clamps (Figure 4, Item 9).
4. Install flywheel housing (Figure 4, Item 13) on rear trunnion mount (Figure 4, Item 14) with two washers (Figure 4, Item 16), lockwashers (Figure 4, Item 15), and screws (Figure 4, Item 12).
5. Remove utility chain and lifting device from two engine lifting eyes (Figure 3, Item 1).
6. Install trunnion cap (Figure 4, Item 19) on front trunnion mount (Figure 4, Item 18) and engine (Figure 4, Item 7) with two lockwashers (Figure 4, Item 20) and screws (Figure 4, Item 17).

NOTE

Ensure seal is seated in groove on container lid.

7. Install upper container section (Figure 4, Item 1) and seal (Figure 4, Item 4) on lower container section (Figure 4, Item 6) with 42 screws (Figure 4, Item 5), lockwashers (Figure 4, Item 3), and nuts (Figure 4, Item 2). Tighten nuts to 85 to 105 lb-ft (115 to 142 N-m).

INSTALLATION - Continued

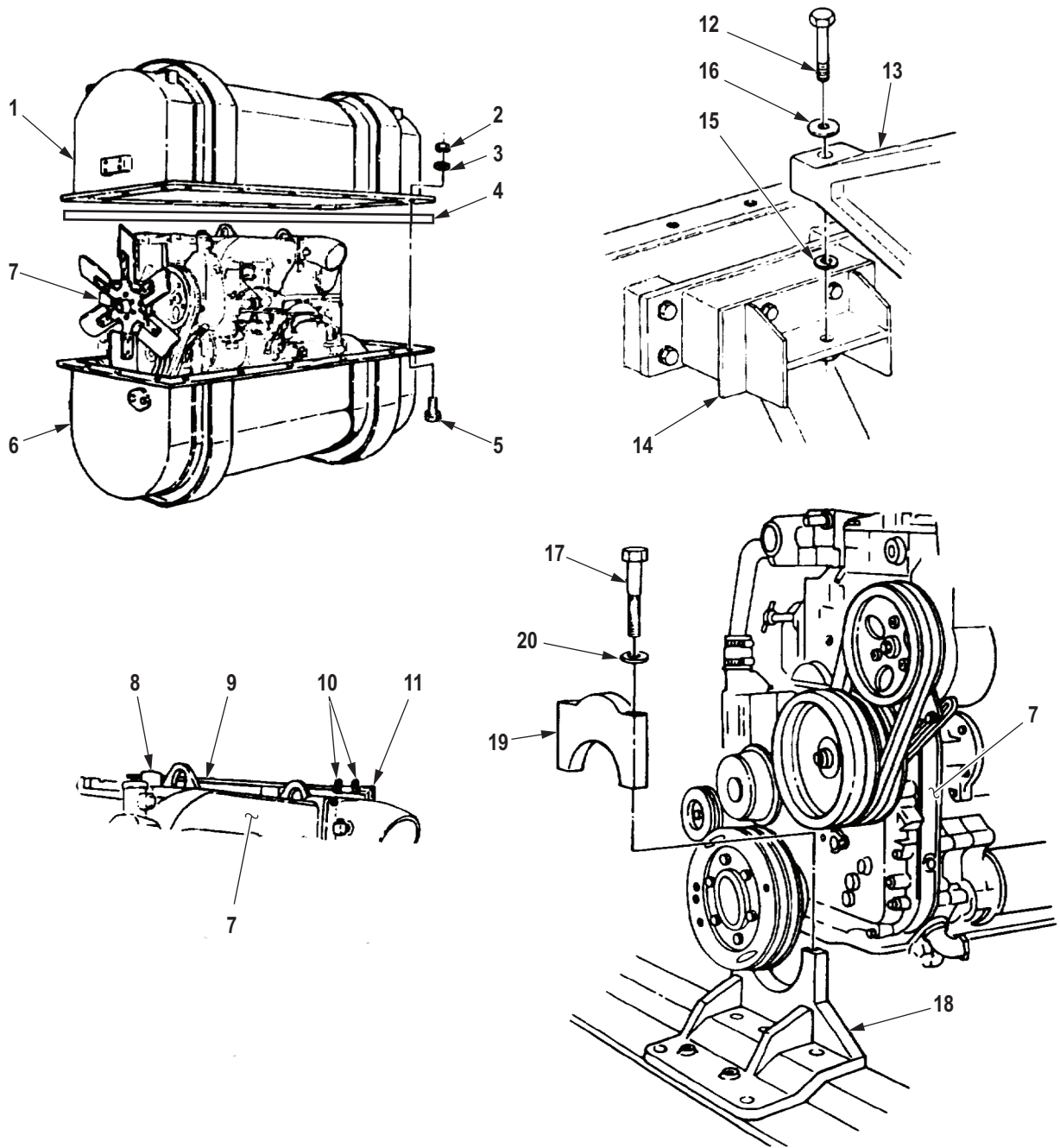

M9275DAA

Figure 4. Engine and Container Installation.

END OF TASK

END OF WORK PACKAGE

**FIELD MAINTENANCE
POWER PLANT REPLACEMENT (M939A2)**

INITIAL SETUP:**Tools and Special Tools**

Tool Kit, General Mechanic's: Automotive
(Volume 5, WP 0826, Table 1, Item 56)
Adjusting Tool (M939/A1)
(Volume 5, WP 0826, Table 1, Item 2)
Chain Assembly
(Volume 5, WP 0826, Table 1, Item 15)
Hoist Assembly
Oil Primer Pump (M939/A1)
(Volume 5, WP 0826, Table 1, Item 37)
Wrench, Torque, Click, Ratcheting, 1/2" Drive,
250 Ft-Lb
(Volume 5, WP 0826, Table 1, Item 63)

Materials/Parts

Adhesive, Silicone Rubber
(Volume 5, WP 0825, Table 1, Item 4)
Cap Set, Protective, Dust and Moisture Seal
(Volume 5, WP 0825, Table 1, Item 13)
Tape, Antiseizing
(Volume 5, WP 0825, Table 1, Item 65)
Twine, Fibrous
(Volume 5, WP 0825, Table 1, Item 68)
Cotter Pin
(Volume 5, WP 0827, Table 1, Item 340)
Qty: 1
Locknut (Volume 5, WP 0827, Table 1, Item 282)
Qty: 3
Locknut (Volume 5, WP 0827, Table 1, Item 314)
Qty: 2
Locknut (Volume 5, WP 0827, Table 1, Item 430)
Qty: 4
Lock Pin (Volume 5, WP 0827, Table 1, Item 11)
Qty: 2
Lockwasher
(Volume 5, WP 0827, Table 1, Item 406)
Qty: 5
Lockwasher
(Volume 5, WP 0827, Table 1, Item 215)
Qty: 2
Lockwasher
(Volume 5, WP 0827, Table 1, Item 403)
Qty: 1
Lockwasher
(Volume 5, WP 0827, Table 1, Item 420)
Qty: 1

Materials/Parts (cont.)

Lockwasher
(Volume 5, WP 0827, Table 1, Item 425)
Qty: 1
Seal (Volume 5, WP 0827, Table 1, Item 101)
Qty: 1
Tiedown Strap
(Volume 5, WP 0827, Table 1, Item 373)
Qty: 1
Tiedown Strap
(Volume 5, WP 0827, Table 1, Item 376)
Qty: 1

Personnel Required

(2)

Equipment Condition

Parking brake set. (TM 9-2320-272-10)
Air reservoirs drained. (TM 9-2320-272-10)
Battery ground cables disconnected. (WP 0350)
Transmission oil drained. (Volume 3, WP 0362)
Engine oil drained. (WP 0232)
Power steering system drained.
(Volume 5, WP 0820)
Hood removed. (Volume 4, WP 0565)
Upper radiator hose and bracket removed.
(WP 0286)
Transmission PTO-to-hydraulic pump propeller
shaft removed, if equipped.
(Volume 4, WP 0713)
Transmission-to-transfer case propeller shaft
removed. (Volume 3, WP 0403)
Transmission-to-transfer case propeller shaft
removed. (Volume 3, WP 0403)
Remove and drain radiator. (WP 0277)
Remove surge tank and bracket. (WP 0279)

PRELIMINARY DISCONNECTIONS**CAUTION**

- Cap or plug all openings after disconnecting lines and hoses to prevent contamination. Failure to do so may cause damage to equipment.
- Tie all loose connections away from engine. Failure to do so may cause damage to equipment.

NOTE

- If a special purpose kit is installed on vehicle, refer to Chapter 4, section XV, and make necessary disconnections and connections.
 - Tag all loose leads, lines, and tubes for installation.
1. Disconnect tachometer cable (Figure 1, Item 2) from tachometer drive (Figure 1, Item 3) on front of engine (Figure 1, Item 1).

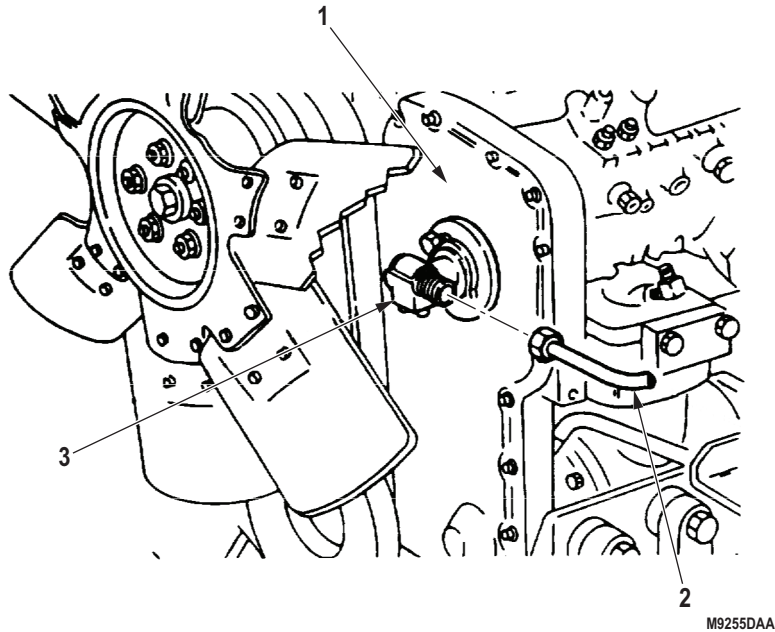

Figure 1. Tachometer Cable and Drive Removal.

PRELIMINARY DISCONNECTIONS - Continued

2. Remove tiedown strap (Figure 2, Item 9) and tachometer cable (Figure 2, Item 10) from air intake tube (Figure 2, Item 7). Discard tiedown strap.
3. Remove clamp (Figure 2, Item 3) and air indicator tube (Figure 2, Item 2) from air intake tube adapter (Figure 2, Item 4).
4. Remove air intake tube adapter (Figure 2, Item 4) from intake tube (Figure 2, Item 7).
5. Remove two nuts (Figure 2, Item 6), bracket (Figure 2, Item 5), and U-bolt (Figure 2, Item 17) from air intake tube (Figure 2, Item 7) and bracket (Figure 2, Item 15).
6. Remove clamps (Figure 2, Items 1 and 8) and air intake tube (Figure 2, Item 7) from pipe (Figure 2, Item 13) and turbocharger (Figure 2, Item 11).
7. Remove two screws (Figure 2, Item 18), washers (Figure 2, Item 16), bracket (Figure 2, Item 15), and two spacers (Figure 2, Item 14) from engine (Figure 2, Item 12).

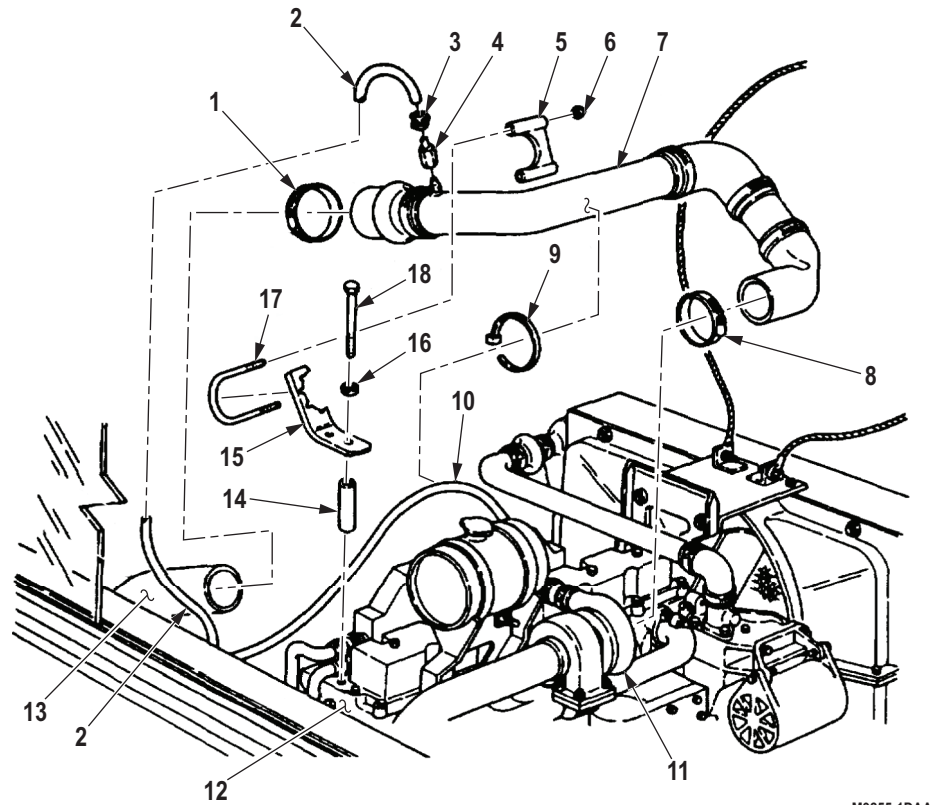

Figure 2. Air Intake System Removal.

PRELIMINARY DISCONNECTIONS - Continued

8. Remove tiedown strap (Figure 3, Item 5) from cables (Figure 3, Item 3), air line (Figure 3, Item 9), and temperature sensor leads (Figure 3, Item 8). Discard tiedown strap.
9. Disconnect connector (Figure 3, Item 6) from temperature sensor connector (Figure 3, Item 7).
10. Remove screw (Figure 3, Item 15), washer (Figure 3, Item 14), ground strap (Figure 3, Item 13), lockwasher (Figure 3, Item 12), and temperature sensor (Figure 3, Item 11) from engine (Figure 3, Item 4). Discard lockwasher.
11. Disconnect air line (Figure 3, Item 9) from air compressor line (Figure 3, Item 10).
12. Disconnect connector (Figure 3, Item 23) from throttle control solenoid connector (Figure 3, Item 22).
13. Disconnect connector (Figure 3, Item 21) from transfer pump connector (Figure 3, Item 20).

NOTE

- Have drainage container ready to catch fuel.
 - Use drain pans to retain leaking/draining fluids. Refer to local procedures and plans for preventing and responding to fluid spills or leaks. Comply with local regulations when disposing of clean up material and leaked and spilled fluids.
14. Disconnect fuel supply line (Figure 3, Item 18) from transfer pump (Figure 3, Item 19).
 15. Disconnect connector (Figure 3, Item 17) from oil pressure sending unit (Figure 3, Item 16).
 16. Disconnect ether supply tube (Figure 3, Item 25) from ether atomizer nozzle (Figure 3, Item 24).
 17. Remove two screws (Figure 3, Item 2), clamps (Figure 3, Item 1), and cables (Figure 3, Item 3) from engine (Figure 3, Item 4).

PRELIMINARY DISCONNECTIONS - Continued

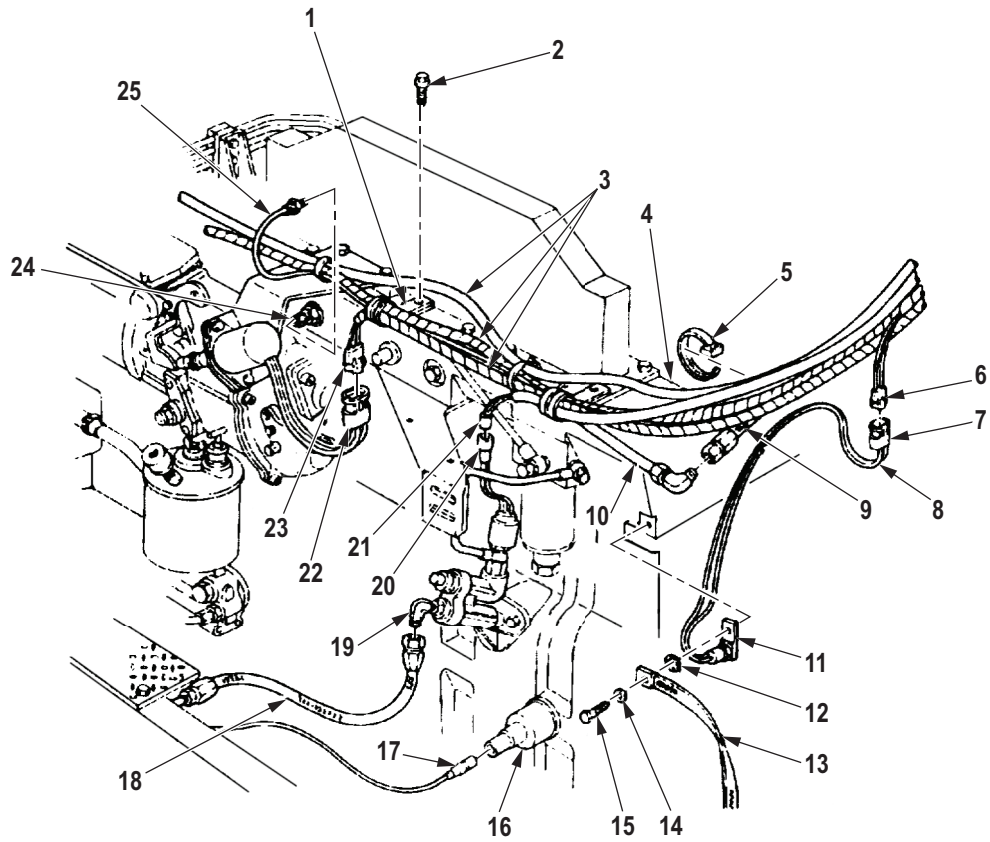

M9256DAA

Figure 3. Fuel Supply and Electrical System Removal.

PRELIMINARY DISCONNECTIONS - Continued**NOTE**

- Have drainage container ready to catch fuel.
 - Use drain pans to retain leaking/draining fluids. Refer to local procedures and plans for preventing and responding to fluid spills or leaks. Comply with local regulations when disposing of clean up material and leaked and spilled fluids.
18. Loosen clamp (Figure 4, Item 20) and remove fuel return line (Figure 4, Item 19) from fuel pump (Figure 4, Item 1).
 19. Remove screw (Figure 4, Item 17), bracket (Figure 4, Item 18), and fuel return line (Figure 4, Item 19) from gearcase housing (Figure 4, Item 21).
 20. Pull sleeve (Figure 4, Item 15) away from socket (Figure 4, Item 16), and remove accelerator linkage (Figure 4, Item 14) from throttle control lever (Figure 4, Item 2).
 21. Remove spring (Figure 4, Item 11) from modulator cable (Figure 4, Item 8) and bracket (Figure 4, Item 3).
 22. Remove cotter pin (Figure 4, Item 6), washer (Figure 4, Item 7), and modulator cable (Figure 4, Item 8) from throttle control lever (Figure 4, Item 2). Discard cotter pin.
 23. Remove two locknuts (Figure 4, Item 4), U-bolt (Figure 4, Item 10), two shims (Figure 4, Item 5), and modulator cable (Figure 4, Item 8) from bracket (Figure 4, Item 3). Discard locknuts.
 24. Remove nut (Figure 4, Item 13), washer (Figure 4, Item 12), and screw (Figure 4, Item 9) from modulator cable (Figure 4, Item 8).
 25. Remove cotter pin (Figure 4, Item 30), washer (Figure 4, Item 31), and emergency stop cable (Figure 4, Item 26) from fuel pump bracket (Figure 4, Item 22). Discard cotter pin.
 26. Remove screw (Figure 4, Item 23), sleeve (Figure 4, Item 24), and screw (Figure 4, Item 25) from emergency stop cable (Figure 4, Item 26).
 27. Remove screw (Figure 4, Item 29), clamp (Figure 4, Item 27), and emergency stop cable (Figure 4, Item 26) from bracket (Figure 4, Item 28).

PRELIMINARY DISCONNECTIONS - Continued

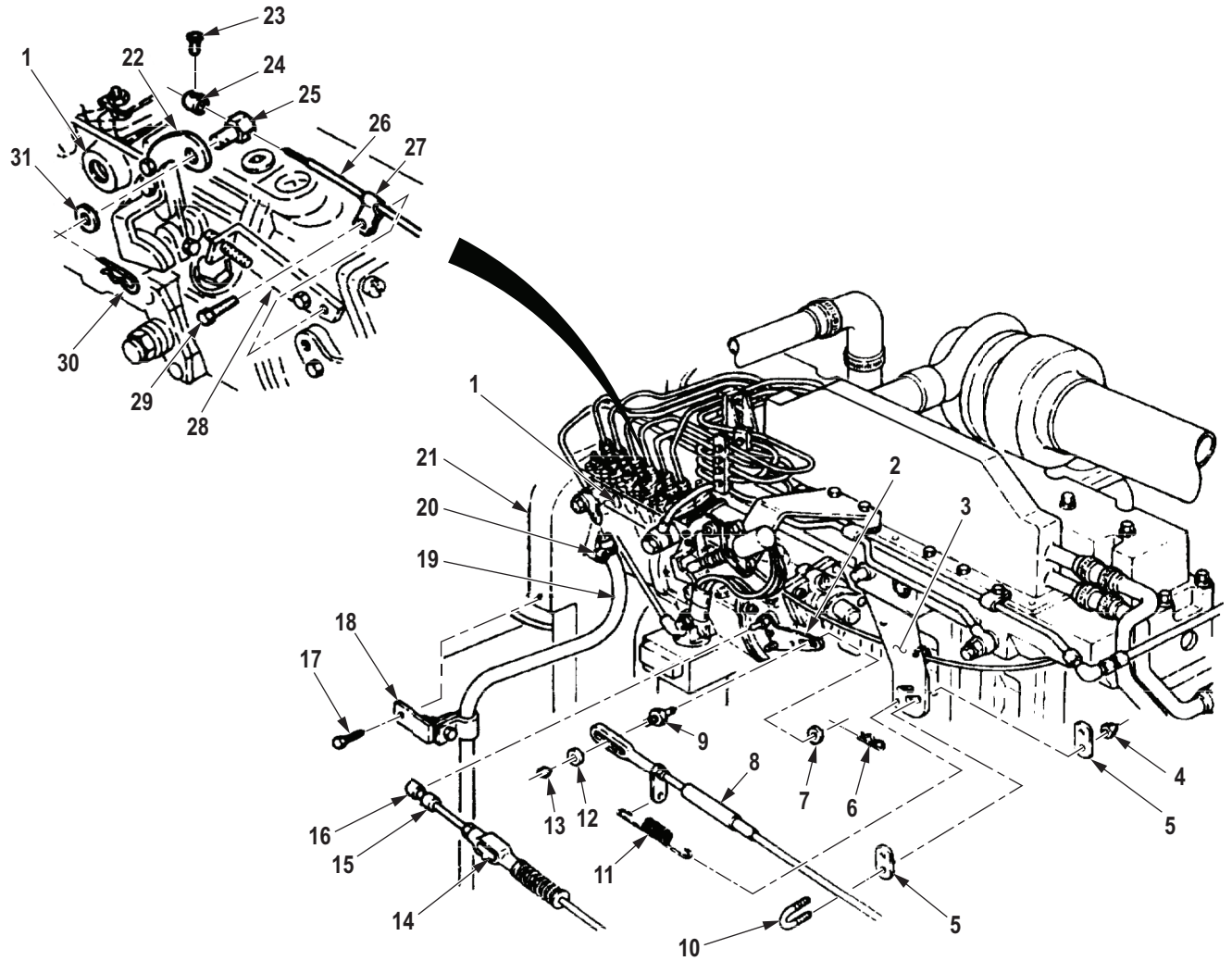

M9257DAA

Figure 4. Power System and Linkage Removal.

PRELIMINARY DISCONNECTIONS - Continued**NOTE**

- Have drainage container ready to catch oil.
- Use drain pans to retain leaking/draining fluids. Refer to local procedures and plans for preventing and responding to fluid spills or leaks. Comply with local regulations when disposing of clean up material and leaked and spilled fluids.

28. Disconnect power steering inlet line (Figure 5, Item 4) from power steering pump (Figure 5, Item 2).
29. Loosen clamp (Figure 5, Item 8) and remove outlet line (Figure 5, Item 9) from power steering pump (Figure 5, Item 2).
30. Disconnect air line (Figure 5, Item 10) from air compressor (Figure 5, Item 1).
31. Remove screw (Figure 5, Item 7), washer (Figure 5, Item 6), clamp (Figure 5, Item 5), and air line (Figure 5, Item 10) from engine (Figure 5, Item 3).

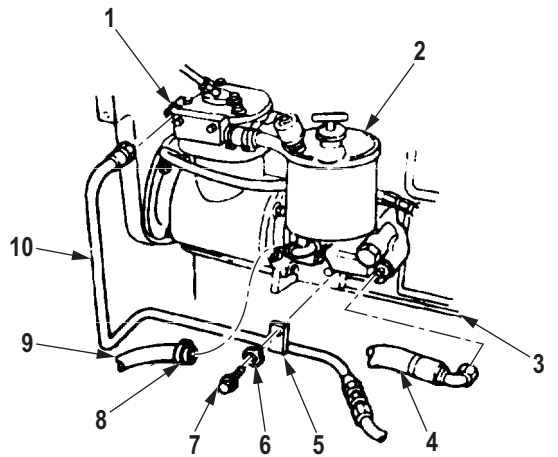

M9258-1DAA

Figure 5. Air Compressor and Power Steering Line Removal.

32. Loosen two screws (Figure 6, Item 1) and screw (Figure 6, Item 2), and rotate alternator (Figure 6, Item 24) upward.

NOTE

All sealant must be removed prior to removing wires. Tag all wires for installation.

33. Remove two screw assembled lockwashers (Figure 6, Item 11) and terminal cover (Figure 6, Item 10) from alternator (Figure 6, Item 24). Discard screw assembled lockwashers.
34. Remove screw (Figure 6, Item 12), lockwasher (Figure 6, Item 13), and negative wire (Figure 6, Item 3) from alternator (Figure 6, Item 24). Discard lockwasher.
35. Remove nut (Figure 6, Item 6), lockwasher (Figure 6, Item 5), and accessory wire (Figure 6, Item 4) from alternator (Figure 6, Item 24). Discard lockwasher.
36. Remove nut (Figure 6, Item 9), lockwasher (Figure 6, Item 8), and positive wire (Figure 6, Item 7) from alternator (Figure 6, Item 24). Discard lockwasher.
37. Disconnect lead (Figure 6, Item 15) from AC wire (Figure 6, Item 14).

PRELIMINARY DISCONNECTIONS - Continued

38. Remove screw (Figure 6, Item 19), clamp (Figure 6, Item 21), and harness (Figure 6, Item 18) from oil cooler housing (Figure 6, Item 23).
39. Remove screw (Figure 6, Item 16), clamp (Figure 6, Item 17), and harnesses (Figure 6, Items 18 and 20) from engine (Figure 6, Item 22).
40. Disconnect lead (Figure 6, Item 31) from temperature sending unit (Figure 6, Item 25).
41. Remove screw (Figure 6, Item 28), washer (Figure 6, Item 27), ground strap (Figure 6, Item 26), three ground wires (Figure 6, Item 29), and lockwasher (Figure 6, Item 30) from engine (Figure 6, Item 22). Discard lockwasher.

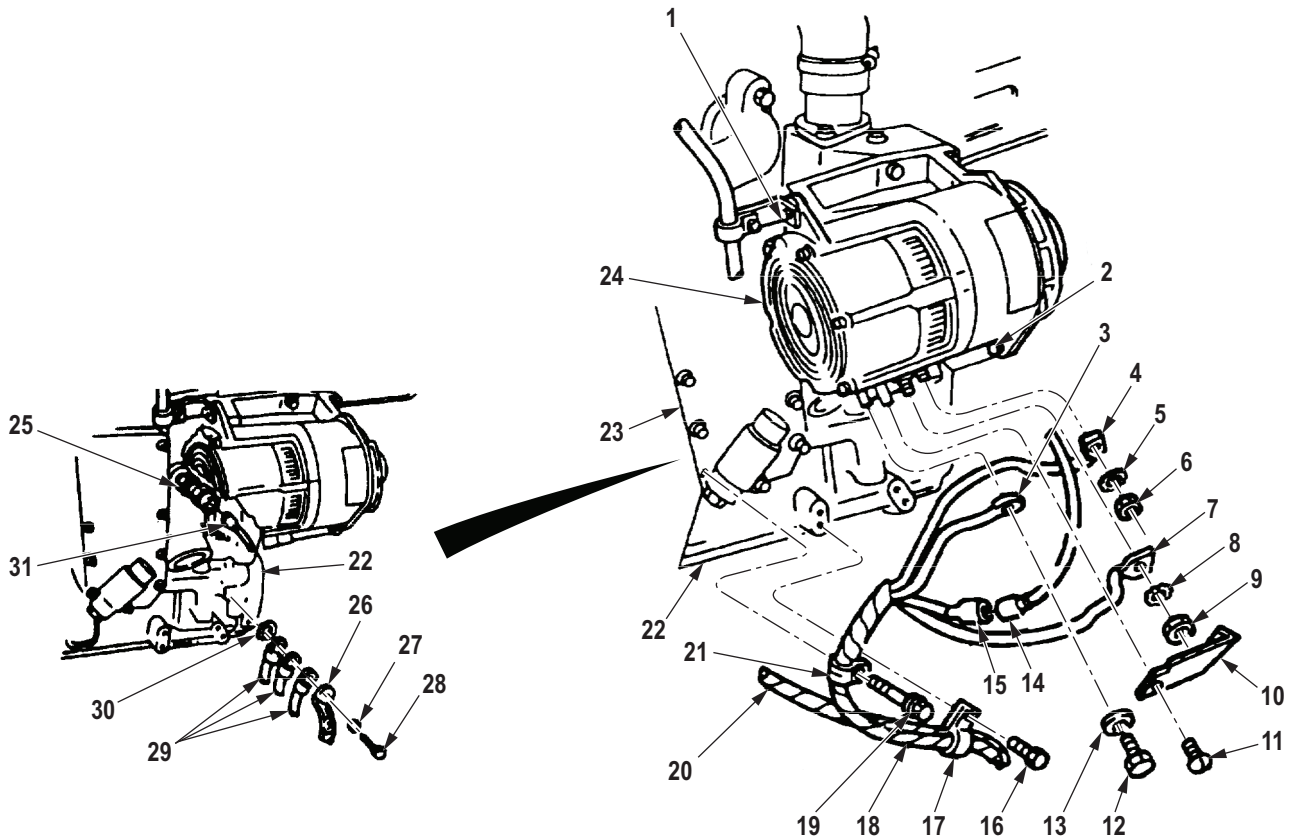

M9258DAA

Figure 6. Alternator and Engine Harness Removal.

PRELIMINARY DISCONNECTIONS - Continued

42. Remove nut (Figure 7, Item 21), lockwasher (Figure 7, Item 20), and wire (Figure 7, Item 4) from starter solenoid (Figure 7, Item 17). Discard lockwasher.
43. Remove nut (Figure 7, Item 7), lockwasher (Figure 7, Item 8), and wires (Figure 7, Items 9 and 10) from starter solenoid (Figure 7, Item 17). Discard lockwasher.
44. Remove nut (Figure 7, Item 19), lockwasher (Figure 7, Item 18), and wire (Figure 7, Item 16) from starter solenoid (Figure 7, Item 17). Discard lockwasher.
45. Remove nut (Figure 7, Item 11), lockwasher (Figure 7, Item 12), and wires (Figure 7, Items 13 and 14) from starter (Figure 7, Item 15). Discard lockwasher.
46. Loosen clamps (Figure 7, Item 2) and remove hoses (Figure 7, Items 1 and 5) from fittings (Figure 7, Items 3 and 6).

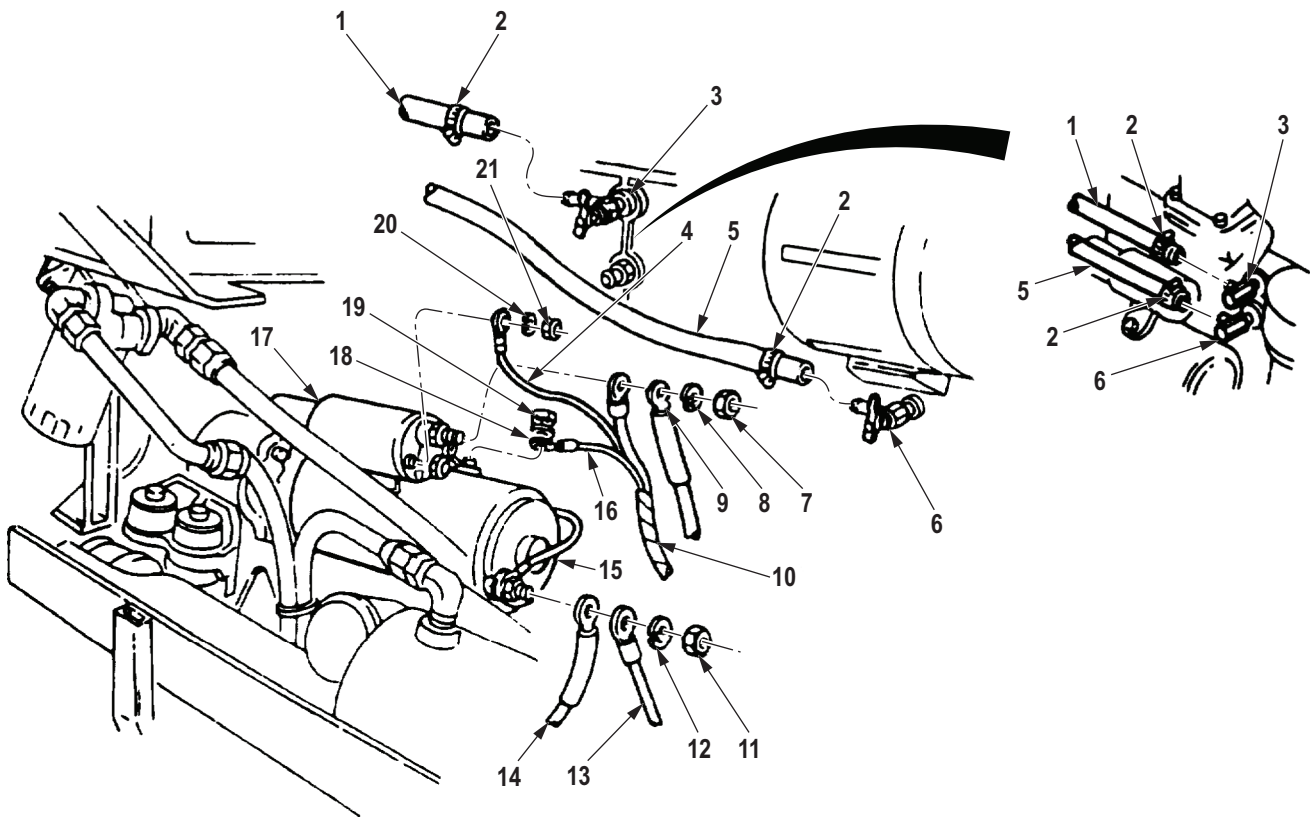

M9259-1DAA

Figure 7. Starter Cable and Oil Cooler Hose Removal.

PRELIMINARY DISCONNECTIONS - Continued

47. Disconnect oil cooler return hose (Figure 8, Item 1) from temperature transmitter adapter (Figure 8, Item 2).

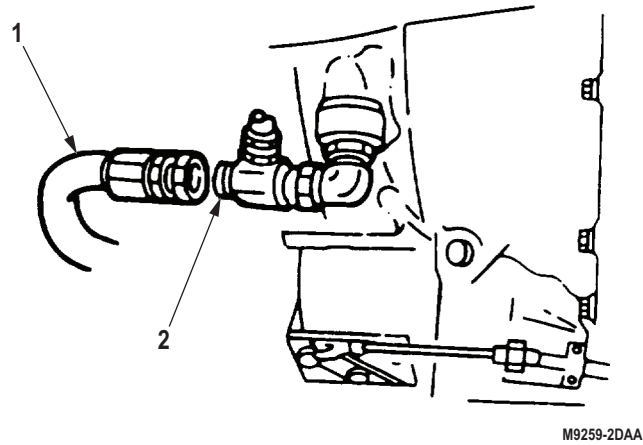

Figure 8. Oil Cooler Return Hose Removal.

48. Disconnect transmission supply hose (Figure 9, Item 2) from lubrication valve adapter (Figure 9, Item 1).

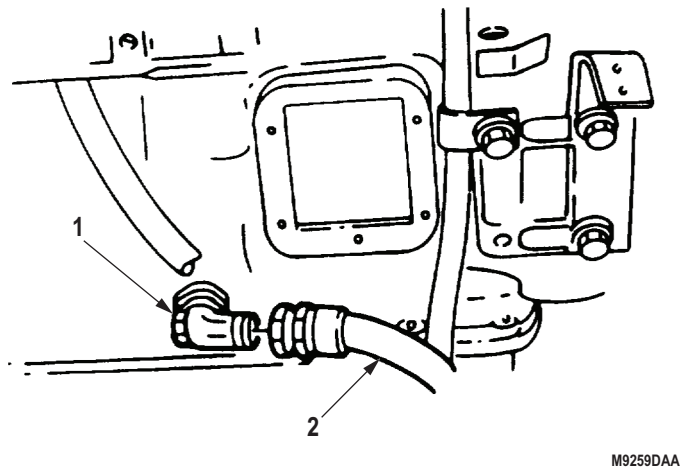

Figure 9. Transmission Supply Hose Removal.

PRELIMINARY DISCONNECTIONS - Continued

49. Remove nut (Figure 10, Item 4), screw (Figure 10, Item 9), clamp (Figure 10, Item 8), and hose (Figure 10, Item 7) from bracket (Figure 10, Item 5).
50. Remove clamps (Figure 10, Items 10 and 28) and hose (Figure 10, Item 7) from surge tank fitting (Figure 10, Item 1) and tube (Figure 10, Item 23).

NOTE

Perform Steps (51) and (52) for internal bypass systems.

51. Remove two clamps (Figure 10, Item 17) and hose (Figure 10, Item 18) from fitting (Figure 10, Item 27) and thermostat canister (Figure 10, Item 16).
52. Remove two clamps (Figure 10, Item 19), thermostat canister (Figure 10, Item 16), and hose (Figure 10, Item 20) from tube (Figure 10, Item 13).

NOTE

Perform Step (53) for external bypass systems.

53. Remove two clamps (Figure 10, Item 17) and hose (Figure 10, Item 18) from fitting (Figure 10, Item 3) and tube (Figure 10, Item 13).
54. Remove two clamps (Figure 10, Item 11), hump hose (Figure 10, Item 12), two clamps (Figure 10, Item 14), hump hose (Figure 10, Item 15), and tube (Figure 10, Item 13) from outlet tube (Figure 10, Item 6) and transmission oil cooler (Figure 10, Item 26).
55. Remove two clamps (Figure 10, Item 25), elbow (Figure 10, Item 24), two clamps (Figure 10, Item 22), elbow (Figure 10, Item 21), and tube (Figure 10, Item 23) from outlet port (Figure 10, Item 2) and transmission oil cooler (Figure 10, Item 26).

PRELIMINARY DISCONNECTIONS - Continued

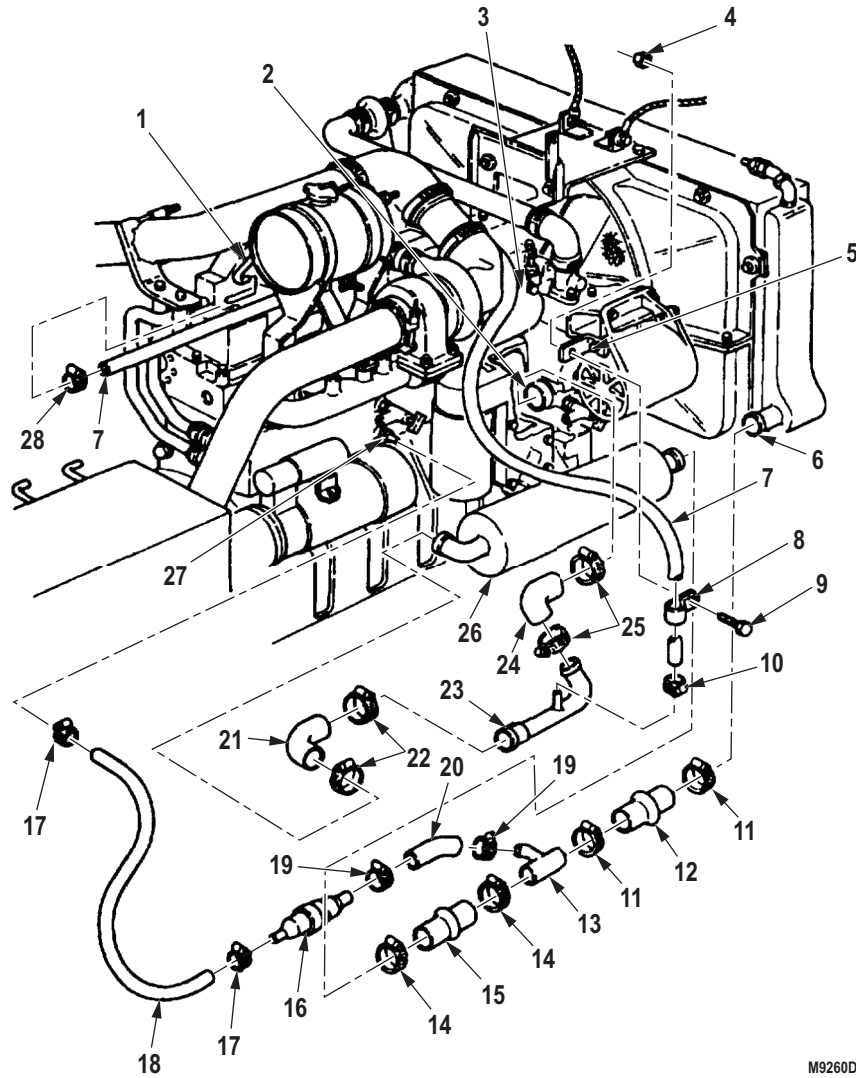

M9260DAA

Figure 10. Coolant System Hose Removal.

PRELIMINARY DISCONNECTIONS - Continued

56. Disconnect breather vent tube (Figure 11, Item 3) from elbow (Figure 11, Item 4).
57. Disconnect lead (Figure 11, Item 2) from transmission temperature sending unit (Figure 11, Item 1).

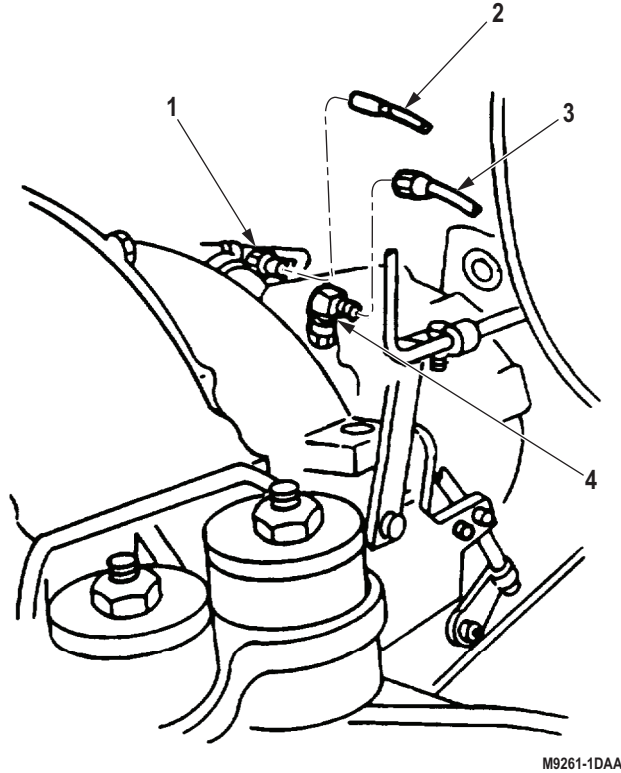

M9261-1DAA

Figure 11. Vent Tube and Sending Unit Lead Removal.

58. Disconnect two leads (Figure 12, Item 15) from neutral safety switch wires (Figure 12, Item 16).
59. Disconnect lead (Figure 12, Item 4) from solenoid connector (Figure 12, Item 9).
60. Remove cotter pin (Figure 12, Item 14) and transmission shift cable (Figure 12, Item 11) from shift lever (Figure 12, Item 17). Discard cotter pin.
61. Remove two nuts (Figure 12, Item 10), u-bolt (Figure 12, Item 13), spacer (Figure 12, Item 12), and transmission shift cable (Figure 12, Item 11) from transmission adapter plate (Figure 12, Item 18).
62. Remove nut (Figure 12, Item 1), lockwasher (Figure 12, Item 2), ground wire (Figure 12, Item 3), screw (Figure 12, Item 6), clamp (Figure 12, Item 5), and modulator cable (Figure 12, Item 7) from bracket (Figure 12, Item 8). Discard lockwasher.

PRELIMINARY DISCONNECTIONS - Continued

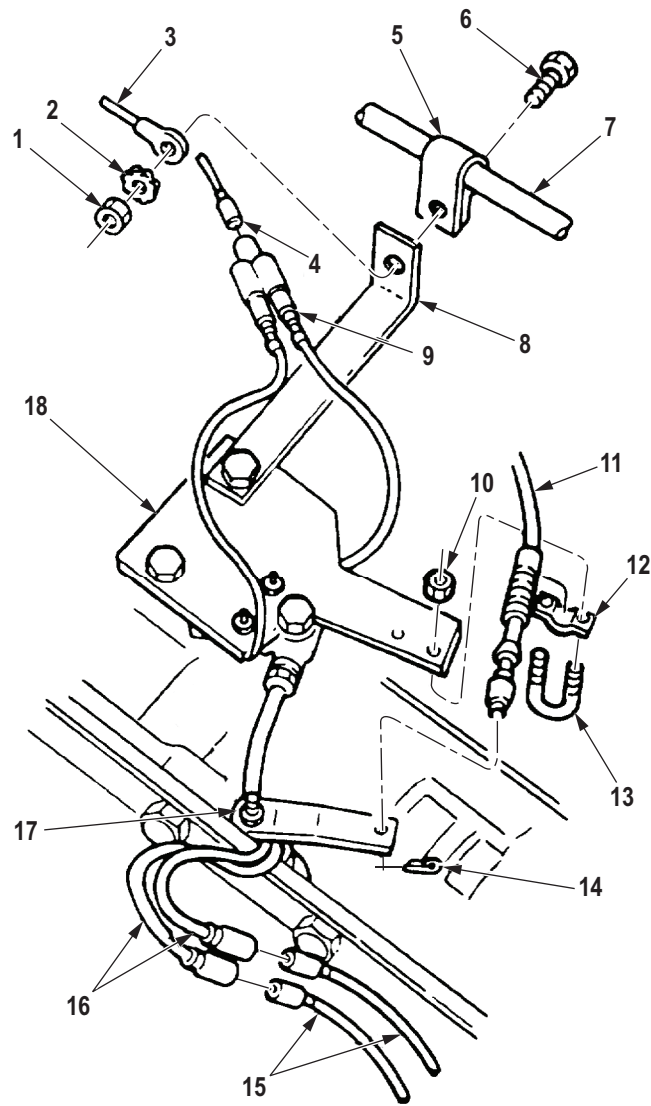

M9261DAA

Figure 12. Transmission Cables and Electrical Lead Removal.

END OF TASK

REMOVAL

1. Install utility chain on two lifting brackets (Figure 13, Item 5).
2. Install lifting device on chain. Raise lifting device enough to remove slack from chain.
3. Remove three screws (Figure 13, Item 6), lockwashers (Figure 13, Item 7), and transmission mounting bracket (Figure 13, Item 9) from transmission (Figure 13, Item 10) and isolator (Figure 13, Item 8). Discard lockwashers.
4. Remove two locknuts (Figure 13, Item 16), washers (Figure 13, Item 17), and back plate (Figure 13, Item 18) from studs (Figure 13, Item 20) and crossmember (Figure 13, Item 19). Discard locknuts.
5. Remove two screws (Figure 13, Item 1), washers (Figure 13, Item 2), and isolators (Figure 13, Item 3) from right engine mount bracket (Figure 13, Item 4).
6. Remove two locknuts (Figure 13, Item 11), washers (Figure 13, Item 12), screws (Figure 13, Item 15), and isolators (Figure 13, Item 13) from left engine mount bracket (Figure 13, Item 14). Discard locknuts.

REMOVAL - Continued

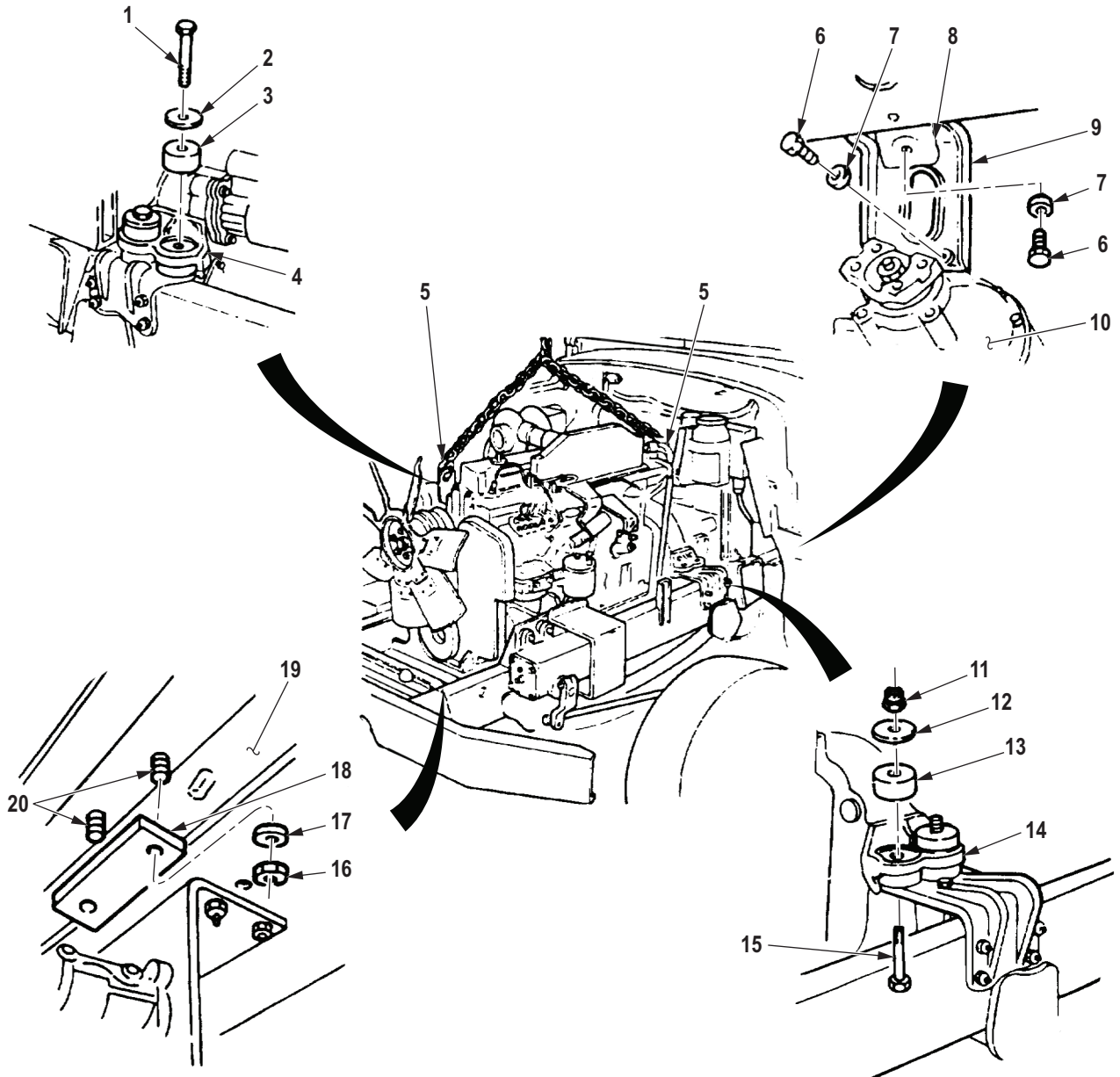

M9262DAA

Figure 13. Transmission and Engine Mount Removal.

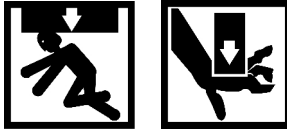
REMOVAL - Continued**WARNING**

- Lifting device must have a weight capacity greater than the combined weight of the engine and transmission. Failure to comply may result in damage to equipment, injury, or death to personnel.
- All personnel must stand clear during lifting operations. A snapped cable, or swinging or shifting load, may occur. Failure to comply may result in injury or death to personnel.
- Do not put hands between frame and engine supports during lifting operations. Use prybar to adjust position of engine during lifting operations. Failure to comply may result in injury or death to personnel.

CAUTION

Always remove engine slowly. Lift out of chassis in short lifts and closely observe all engine and transmission attachments during removal to prevent damage to equipment.

NOTE

Engine must be adjusted constantly during lifting operations.

7. Remove engine (Figure 14, Item 3) and transmission (Figure 14, Item 2) from vehicle.
8. Remove six isolators (Figure 14, Item 4) and two washers (Figure 14, Item 7) from crossmember (Figure 14, Item 8) and left (Figure 14, Item 6) and right (Figure 14, Item 5) engine mounts.
9. Remove two screws (Figure 14, Item 11), washers (Figure 14, Item 10), and radiator brackets (Figure 14, Item 9) from front engine mount (Figure 14, Item 12).
10. Remove two screws (Figure 14, Item 13), washers (Figure 14, Item 14), and isolators (Figure 14, Item 15) from front engine mount (Figure 14, Item 12).

WARNING

- Do not detach chain from engine until engine is supported. Failure to comply may result in injury or death to personnel.
 - Engine must be securely mounted on repair stand. Failure to comply may result in injury or death to personnel.
11. Remove lifting device and utility chain from two engine lifting brackets (Figure 14, Item 1).

REMOVAL - Continued

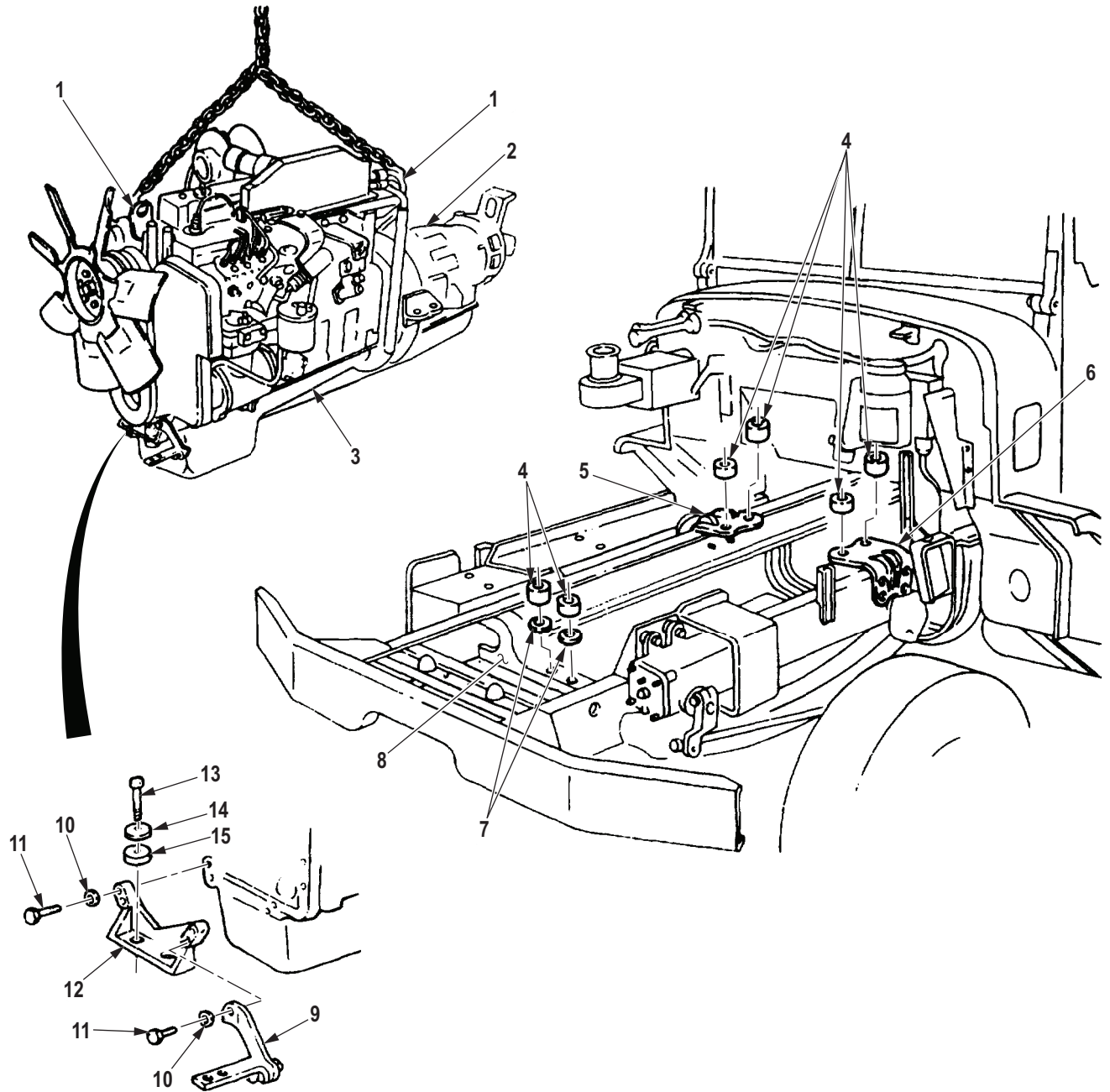

M9263DAA

Figure 14. Power Plant Removal.

END OF TASK

INSTALLATION

1. Install chain on two engine lifting brackets (Figure 15, Item 1).
2. Install lifting device on chain. Raise lifting device enough to remove slack from chain.
3. Install two isolators (Figure 15, Item 15), washers (Figure 15, Item 14), and screws (Figure 15, Item 13) on front engine mount (Figure 15, Item 12).
4. Install two radiator brackets (Figure 15, Item 9) on front engine mount (Figure 15, Item 12) with two washers (Figure 15, Item 10) and screws (Figure 15, Item 11).

WARNING

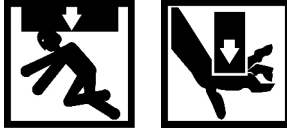

- All personnel must stand clear during lifting operations. A snapped cable, or swinging or shifting load, may occur. Failure to comply may result in injury or death to personnel.
- Do not put hands between frame and engine supports during lowering operations. Use prybar to adjust position of engine lowering operations. Failure to comply may result in injury or death to personnel.

NOTE

Chain must be adjusted so transmission points downward to allow clearance of engine over front axle.

5. Raise engine (Figure 15, Item 3) and transmission (Figure 15, Item 2) and position on vehicle.

CAUTION

Do not lower engine completely. Ensure all attaching components are clear and free from obstruction. Failure to do so may cause damage to engine components.

6. Position two washers (Figure 15, Item 7) and six isolators (Figure 15, Item 4) on crossmember (Figure 15, Item 8) and left (Figure 15, Item 6) and right (Figure 15, Item 5) engine mounts.
7. Slowly lower engine (Figure 15, Item 3) and transmission (Figure 15, Item 2) into vehicle.
8. Level engine (Figure 15, Item 3) and align screws (Figure 15, Item 13) with holes in crossmember (Figure 15, Item 8).
9. Lower engine (Figure 15, Item 3) until it rests on crossmember (Figure 15, Item 8) and left (Figure 15, Item 6) and right (Figure 15, Item 5) engine mounts.

INSTALLATION - Continued

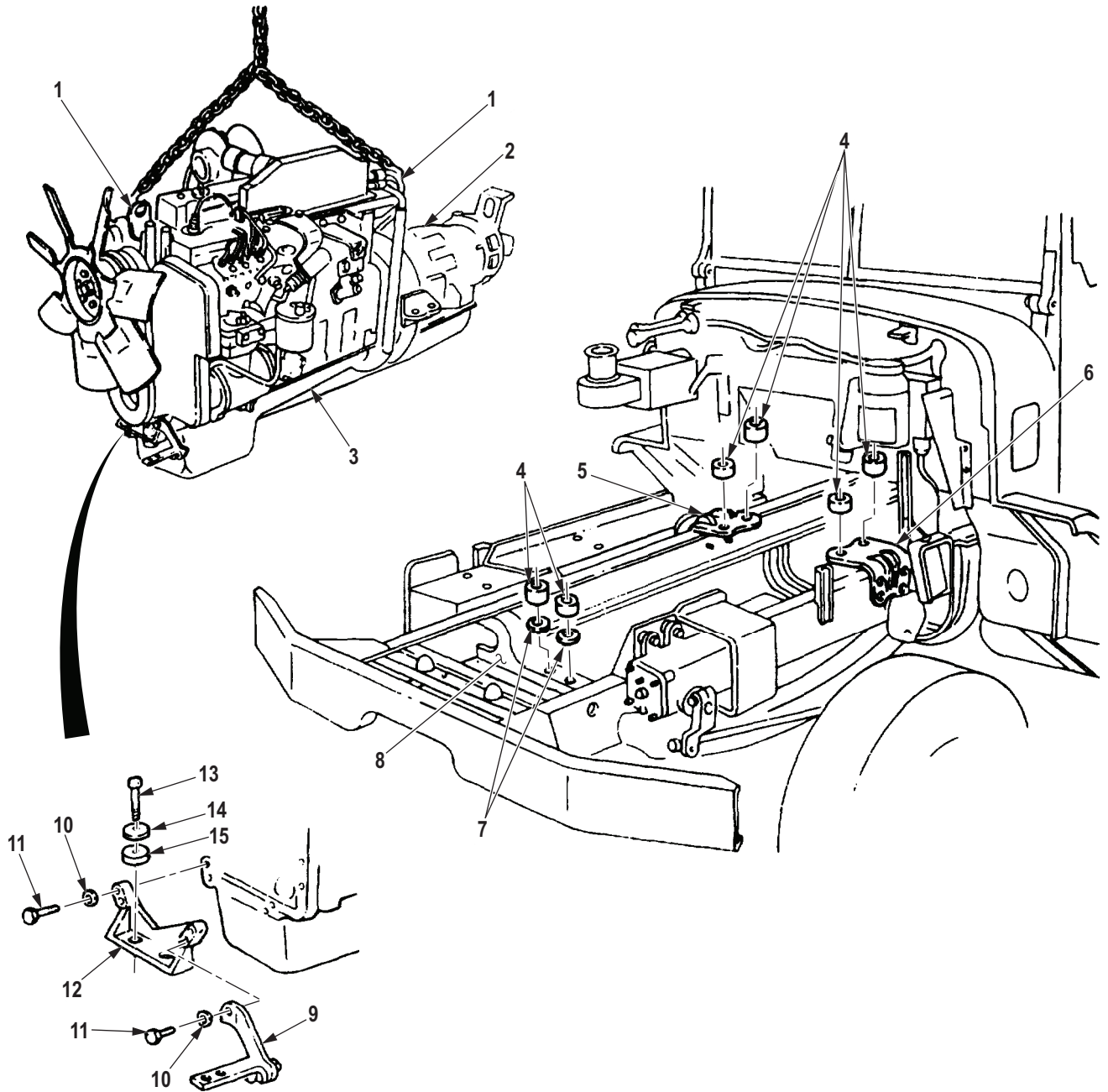

M9384DAA

Figure 15. Power Plant Installation.

INSTALLATION - Continued

10. Install two screws (Figure 16, Item 17), isolators (Figure 16, Item 15), washers (Figure 16, Item 14), and locknuts (Figure 16, Item 13) on left engine mounting bracket (Figure 16, Item 16). Finger-tighten locknuts.
11. Install two isolators (Figure 16, Item 3), washers (Figure 16, Item 2), and screws (Figure 16, Item 1) on right engine mounting bracket (Figure 16, Item 4). Finger-tighten screws.
12. Install backing plate (Figure 16, Item 20) on crossmember (Figure 16, Item 21) and screws (Figure 16, Item 22) with two washers (Figure 16, Item 19) and locknuts (Figure 16, Item 18). Finger-tighten locknuts.
13. Install transmission mounting bracket (Figure 16, Item 9) on transmission (Figure 16, Item 12) with two lockwashers (Figure 16, Item 7) and screws (Figure 16, Item 6).
14. Raise transmission (Figure 16, Item 12) and install transmission mounting brackets (Figure 16, Item 9) on isolator (Figure 16, Item 8) with lockwasher (Figure 16, Item 10) and screw (Figure 16, Item 11).
15. Tighten locknuts (Figure 16, Item 13) 120 to 140 lb-ft (163 to 190 N·m).
16. Tighten screws (Figure 16, Item 1) 120 to 140 lb-ft (163 to 190 N·m).
17. Tighten locknuts (Figure 16, Item 18) 75 to 85 lb-ft (102 to 115 N·m).
18. Remove lifting device and utility chain from two engine lifting brackets (Figure 16, Item 5).

INSTALLATION - Continued

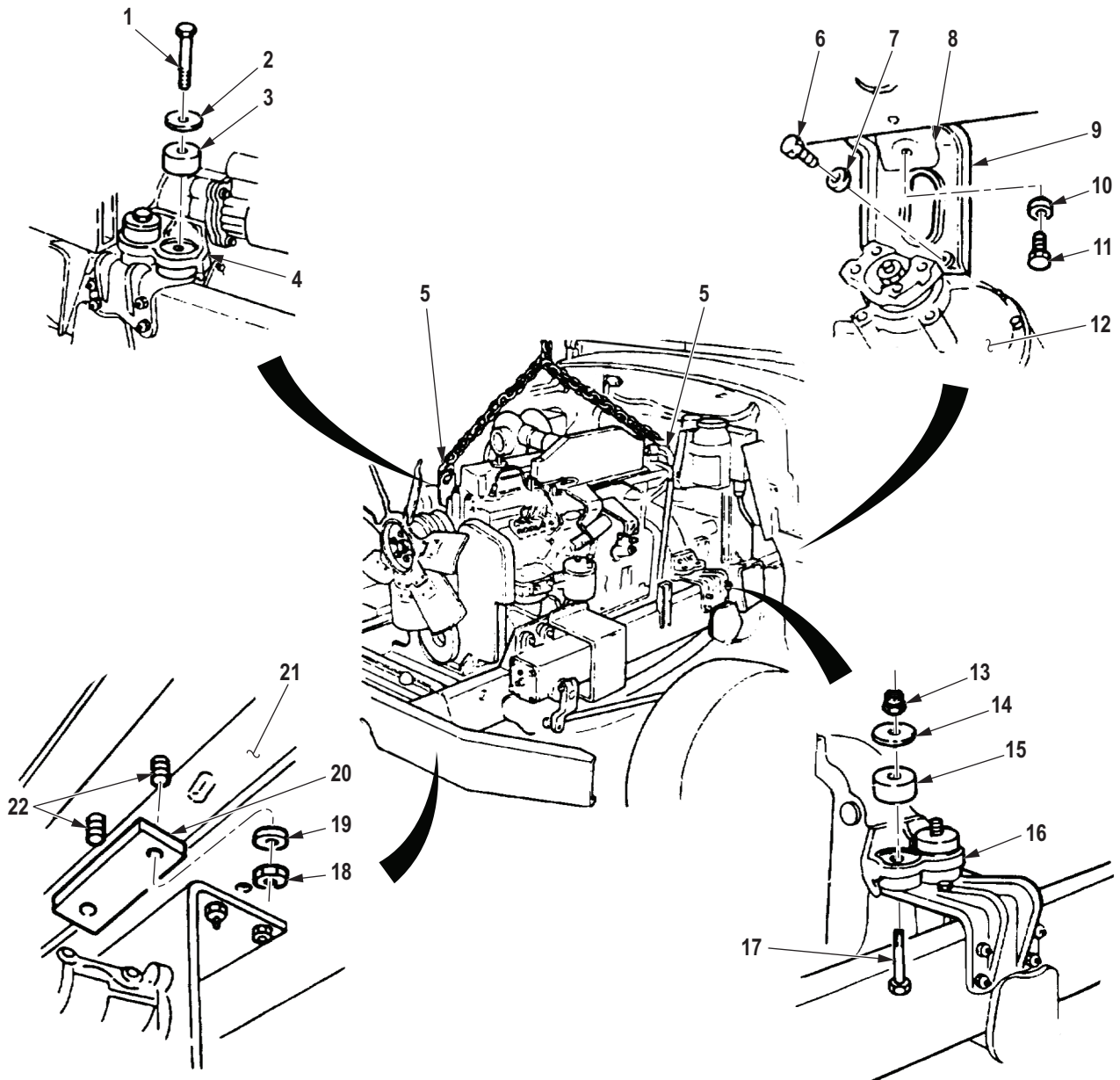

M9264DAA

Figure 16. Transmission and Engine Mount Installation.

INSTALLATION - Continued

19. Install transmission shift cable (Figure 17, Item 8) on shift lever (Figure 17, Item 13) with cotter pin (Figure 17, Item 12).
20. Install transmission shift cable (Figure 17, Item 8) on transmission adapter plate (Figure 17, Item 11) with spacer (Figure 17, Item 9), u-bolt (Figure 17, Item 10), and two nuts (Figure 17, Item 7).
21. Connect two leads (Figure 17, Item 14) to neutral safety switch wires (Figure 17, Item 15).
22. Connect lead (Figure 17, Item 18) to solenoid connector (Figure 17, Item 17).
23. Install modulator cable (Figure 17, Item 6), clamp (Figure 17, Item 4), and ground wire (Figure 17, Item 3) on bracket (Figure 17, Item 16) with screw (Figure 17, Item 5), lockwasher (Figure 17, Item 2), and nut (Figure 17, Item 1).
24. Connect lead (Figure 17, Item 20) to transmission temperature sending unit (Figure 17, Item 19).

NOTE

Wrap all male pipe threads with antiseize tape before installation.

25. Install breather vent tube (Figure 17, Item 21) on elbow (Figure 17, Item 22).

INSTALLATION - Continued

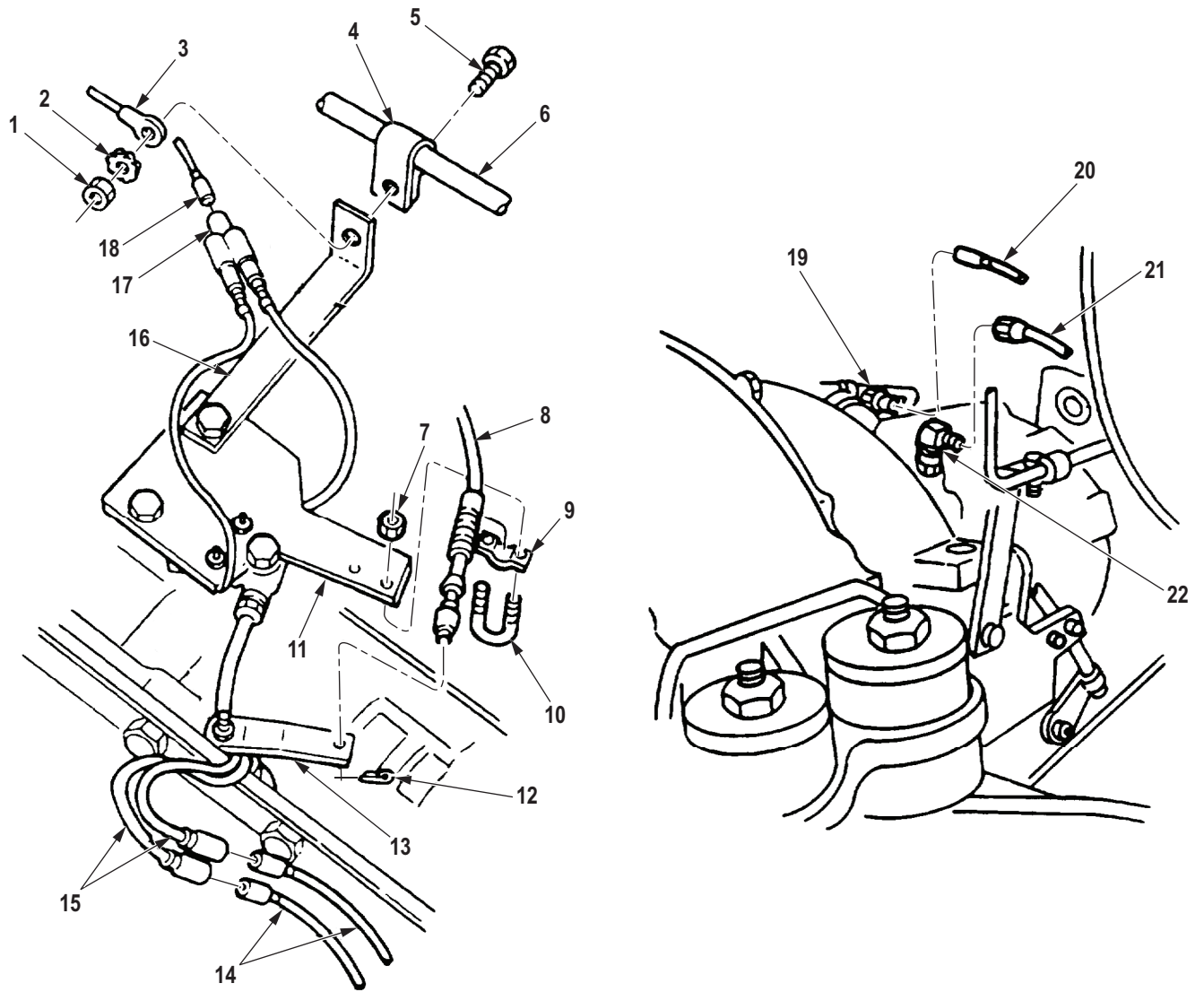

M9265DAA

Figure 17. Transmission Shift Cable, Electrical Leads, Oil Cooler Return, and Supply Hose Installation.

INSTALLATION - Continued

26. Connect oil cooler return hose (Figure 18, Item 1) on temperature transmitter adapter (Figure 18, Item 2).

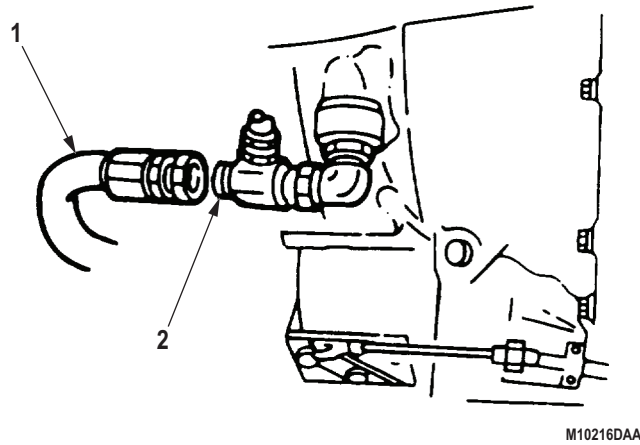

Figure 18. Oil Cooler Return Hose Installation.

27. Connect transmission supply hose (Figure 19, Item 2) on lubrication valve adapter (Figure 19, Item 1).

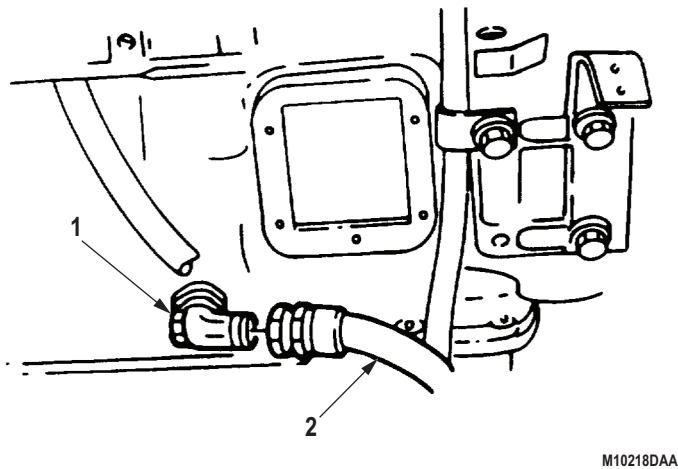
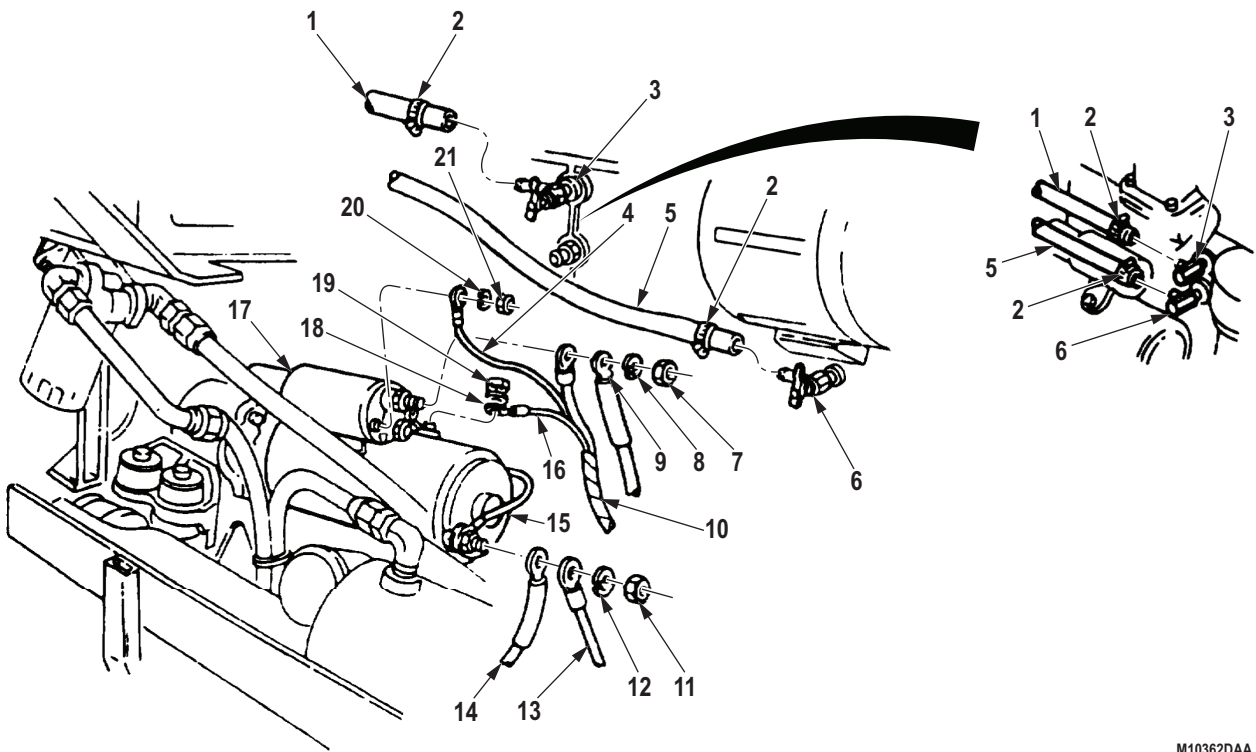

Figure 19. Transmission Supply Hose Installation.

INSTALLATION - Continued

28. Install wires (Figure 20, Items 13 and 14) on starter (Figure 20, Item 15) with lockwasher (Figure 20, Item 12) and nut (Figure 20, Item 11).
29. Install wires (Figure 20, Items 9 and 10) on starter solenoid (Figure 20, Item 17) with lockwasher (Figure 20, Item 8) and nut (Figure 20, Item 7).
30. Install wire (Figure 20, Item 16) on starter (Figure 20, Item 15) with lockwasher (Figure 20, Item 18) and nut (Figure 20, Item 19).
31. Install wire (Figure 20, Item 4) on starter solenoid (Figure 20, Item 17) with lockwasher (Figure 20, Item 20) and nut (Figure 20, Item 21).
32. Connect water heater hoses (Figure 20, Items 1 and 5) on valves (Figure 20, Items 3 and 6) and tighten two clamps (Figure 20, Item 2).



M10362DAA

Figure 20. Starter Lead And Water Heater Hoses Installation.

INSTALLATION - Continued

33. Install lockwasher (Figure 21, Item 3), three ground wires (Figure 21, Item 7), and ground strap (Figure 21, Item 4) on engine (Figure 21, Item 2) with washer (Figure 21, Item 6) and screw (Figure 21, Item 5).
34. Route lead (Figure 21, Item 8) over engine (Figure 21, Item 2) and connect to temperature sending unit (Figure 21, Item 1).
35. Connect lead (Figure 21, Item 22) to AC wire (Figure 21, Item 21).

NOTE

Ensure terminals are clean prior to installing wires.

36. Install accessory wire (Figure 21, Item 12) on alternator (Figure 21, Item 31) with lockwasher (Figure 21, Item 13) and nut (Figure 21, Item 14). Tighten nut 20 to 25 lb-ft (2 to 3 N·m).
37. Install negative wire (Figure 21, Item 11) on alternator (Figure 21, Item 31) with lockwasher (Figure 21, Item 23) and screw (Figure 21, Item 20). Tighten screw 82 to 102 lb-ft (9 to 12 N·m).
38. Install positive wire (Figure 21, Item 15) on alternator (Figure 21, Item 31) with lockwasher (Figure 21, Item 16) and nut (Figure 21, Item 17). Tighten nut 45 to 55 lb-ft (5 to 6 N·m).

NOTE

Completely seal wires and inside of terminal cover with silicone rubber adhesive.

39. Install terminal cover (Figure 21, Item 18) on alternator (Figure 21, Item 31) with two screw assembled lockwasher (Figure 21, Item 19).
40. Install harnesses (Figure 21, Items 26 and 28) and clamp (Figure 21, Item 25) on engine (Figure 21, Item 2) with screw (Figure 21, Item 24).
41. Install harness (Figure 21, Item 26) and clamp (Figure 21, Item 29) on oil cooler housing (Figure 21, Item 30) with screw (Figure 21, Item 27).
42. Rotate alternator (Figure 21, Item 31) downward and tighten screw (Figure 21, Item 9).
43. Tighten two screws (Figure 21, Item 10) 35 lb-ft (47 N·m).

INSTALLATION - Continued

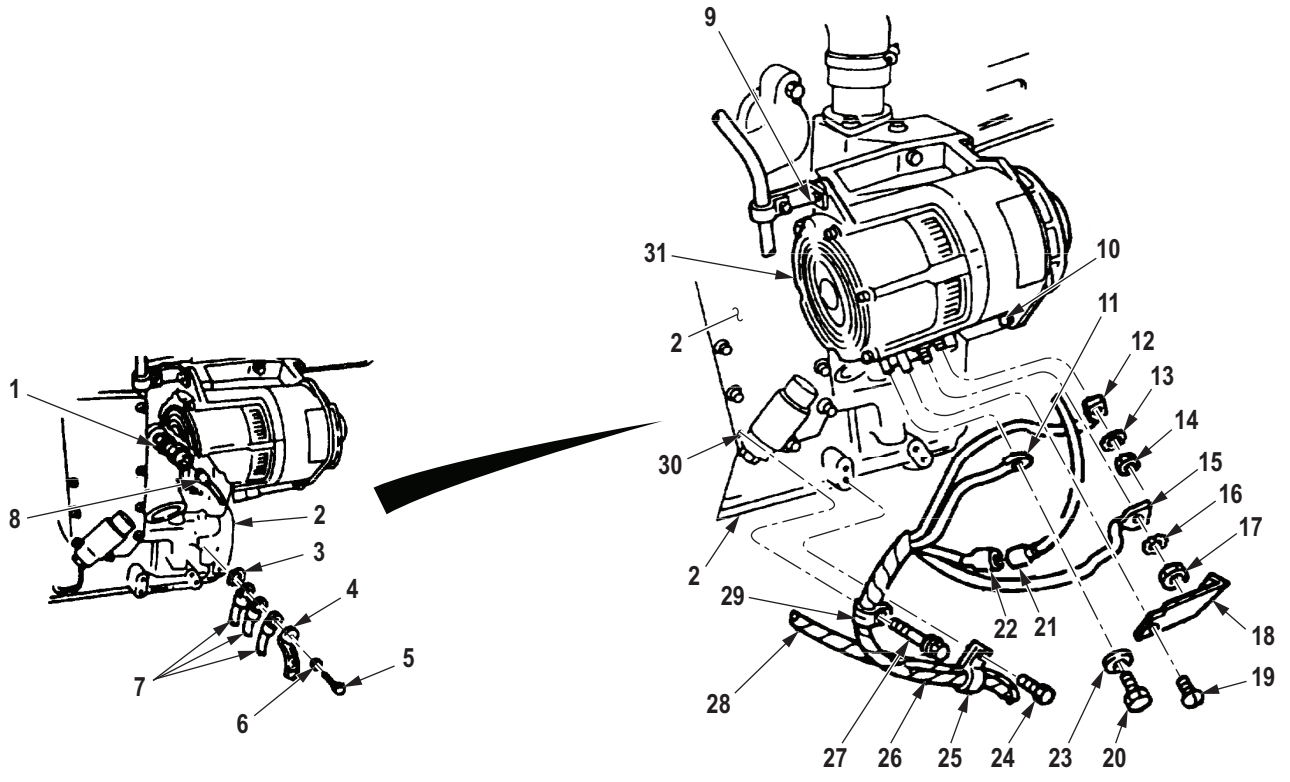

M10361DAA

Figure 21. Alternator Lead Installation.

INSTALLATION - Continued**NOTE**

Wrap all male pipe threads with antiseize tape before installation.

44. Connect air line (Figure 22, Item 10) on air compressor (Figure 22, Item 1).
45. Install air line (Figure 22, Item 10) on engine (Figure 22, Item 3) with clamp (Figure 22, Item 5), washer (Figure 22, Item 6), and screw (Figure 22, Item 7).
46. Install power steering inlet (Figure 22, Item 4) and outlet (Figure 22, Item 9) lines on power steering pump (Figure 22, Item 2) and tighten clamp (Figure 22, Item 8).

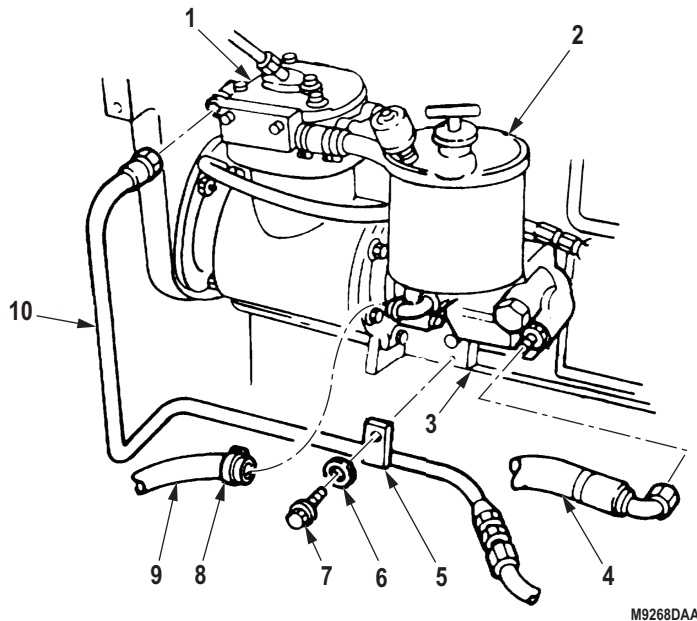
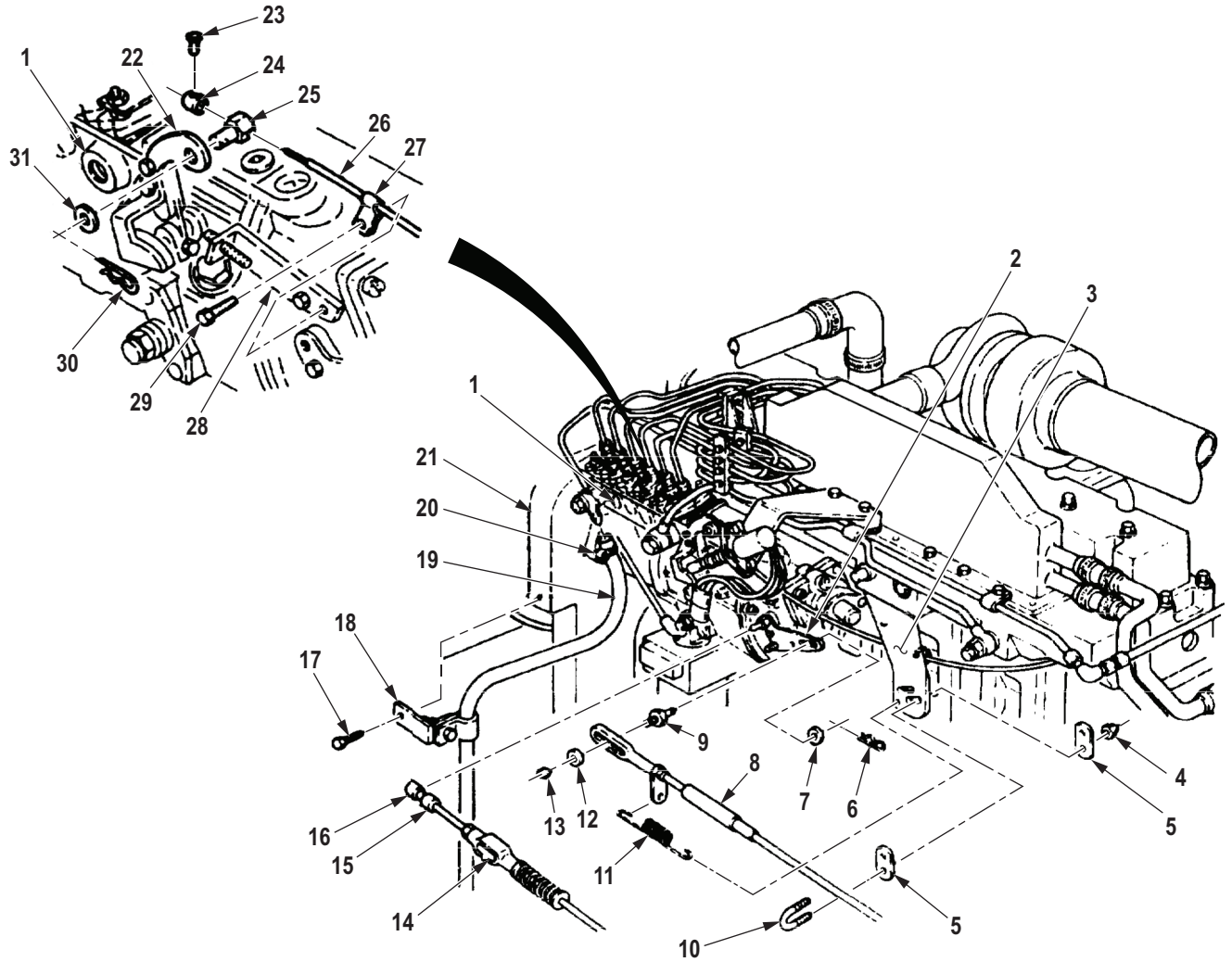

Figure 22. Air Line and Power Steering Hose Installation.

47. Install emergency stop cable (Figure 23, Item 26) on screw (Figure 23, Item 25) with sleeve (Figure 23, Item 24) and screw (Figure 23, Item 23).
48. Install emergency stop cable (Figure 23, Item 26) on fuel pump bracket (Figure 23, Item 22) with washer (Figure 23, Item 31) and cotter pin (Figure 23, Item 30).
49. Install emergency stop cable (Figure 23, Item 26) on fuel pump bracket (Figure 23, Item 28) with clamp (Figure 23, Item 27) and screw (Figure 23, Item 29).
50. Install screw (Figure 23, Item 9) on modulator cable (Figure 23, Item 8) with washer (Figure 23, Item 12) and nut (Figure 23, Item 13).
51. Install modulator cable (Figure 23, Item 8) and screw (Figure 23, Item 9) on throttle control lever (Figure 23, Item 2) with washer (Figure 23, Item 7) and cotter pin (Figure 23, Item 6).
52. Install surge tank and bracket (WP 0279).
53. Install radiator (WP 0277).
54. Pull sleeve (Figure 23, Item 15) away from socket (Figure 23, Item 16) and install accelerator linkage (Figure 23, Item 14) on throttle control lever (Figure 23, Item 2).

INSTALLATION - Continued

55. Install modulator cable (Figure 23, Item 8) on bracket (Figure 23, Item 3) with two shims (Figure 23, Item 5), u-bolt (Figure 23, Item 10), and locknuts (Figure 23, Item 4).
56. Install spring (Figure 23, Item 11) on modulator cable (Figure 23, Item 8) and bracket (Figure 23, Item 3).
57. Install fuel return line (Figure 23, Item 19) on fuel pump (Figure 23, Item 1) and tighten clamp (Figure 23, Item 20).
58. Install fuel return line (Figure 23, Item 19) and bracket (Figure 23, Item 18) on gearcase housing (Figure 23, Item 21) with screw (Figure 23, Item 17).



M9269DAA

Figure 23. Fuel Pump Lines and Linkage Installation.

INSTALLATION - Continued

59. Connect ether supply tube (Figure 24, Item 1) to ether atomizer nozzle (Figure 24, Item 24).
60. Connect connector (Figure 24, Item 17) to oil pressure sending unit (Figure 24, Item 16).
61. Connect fuel supply line (Figure 24, Item 18) to fuel transfer pump (Figure 24, Item 19).
62. Connect connector (Figure 24, Item 21) to fuel transfer pump (Figure 24, Item 20).
63. Connect connector (Figure 24, Item 23) to throttle control solenoid connector (Figure 24, Item 22).
64. Connect air line (Figure 24, Item 8) to air compressor line (Figure 24, Item 9).
65. Install temperature sensor (Figure 24, Item 11), lockwasher (Figure 24, Item 12), and ground strap (Figure 24, Item 13) on engine (Figure 24, Item 10) with washer (Figure 24, Item 14) and screw (Figure 24, Item 15).
66. Connect wire (Figure 24, Item 6) to temperature sensor wire (Figure 24, Item 7).
67. Install cables (Figure 24, Item 5) on engine (Figure 24, Item 10) with two clamps (Figure 24, Item 2) and screws (Figure 24, Item 3).
68. Install tiedown strap (Figure 24, Item 4) on cables (Figure 24, Item 5) and temperature sensor wire (Figure 24, Item 6).

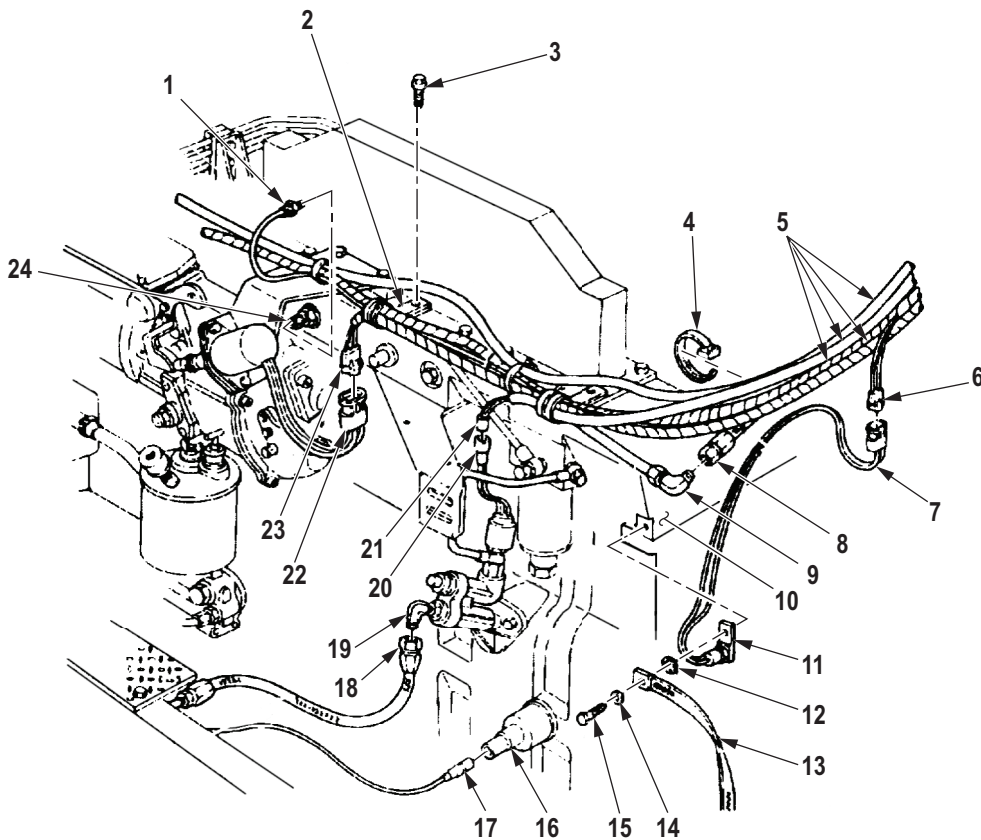

M9270-1DAA

Figure 24. Fuel Supply and Electrical System Installation.

INSTALLATION - Continued

69. Install two spacers (Figure 25, Item 12) and bracket (Figure 25, Item 13) on engine (Figure 25, Item 10) with two washers (Figure 25, Item 17) and screws (Figure 25, Item 16).
70. Install air intake tube (Figure 25, Item 6) on turbocharger (Figure 25, Item 9) and pipe (Figure 25, Item 11) with clamps (Figure 25, Items 7 and 14).
71. Install bracket (Figure 25, Item 4) and u-bolt (Figure 25, Item 15) on air intake tube (Figure 25, Item 6) and bracket (Figure 25, Item 13) with two nuts (Figure 25, Item 5).
72. Install air intake tube adapter (Figure 25, Item 3) on air intake tube (Figure 25, Item 6).
73. Install air indicator tube (Figure 25, Item 1) on air intake tube adapter (Figure 25, Item 3) with clamp (Figure 25, Item 2).
74. Connect tachometer cable (Figure 25, Item 18) on tachometer drive (Figure 25, Item 19).
75. Secure tachometer cable (Figure 25, Item 18) to air intake tube (Figure 25, Item 6) with tiedown strap (Figure 25, Item 8).

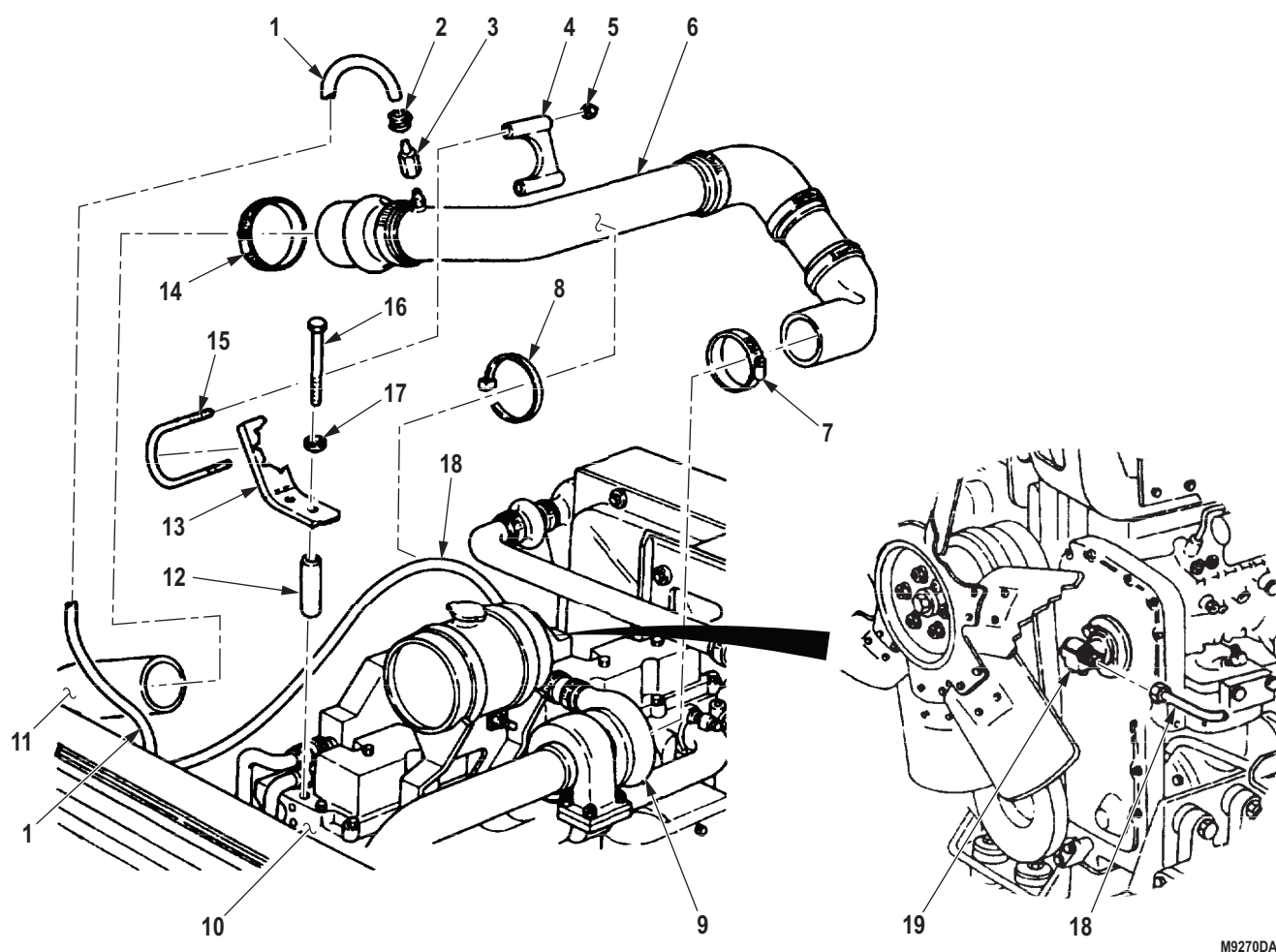

Figure 25. Air Intake, Tachometer Cable, and Drive Installation.

END OF TASK

PRIMING LUBRICATION SYSTEM**CAUTION**

All follow-on maintenance tasks must be complete before starting lubrication procedures.

1. Perform follow-on maintenance tasks.

CAUTION

Engine lubrication system cannot be primed through bypass filter.

2. Remove pipe plug (Figure 26, Item 3) from gearcase cover flange (Figure 26, Item 1) on left side of engine (Figure 26, Item 2).
3. Connect oil primer pump to orifice (Figure 26, Item 4) in gearcase cover flange (Figure 26, Item 1).
4. Prime until 30 psi (207 kPa) of pressure is obtained.

CAUTION

Do not crank engine continuously for more than 30 seconds. Wait 2 to 5 minutes before repeating to prevent starter motor damage.

5. Close fuel shutoff valve and crank engine 15 seconds while maintaining 15 psi (103 kPa) pump pressure.
6. Disconnect oil primer pump and replace pipe plug (Figure 26, Item 3) in gearcase cover flange (Figure 26, Item 1). Tighten pipe plug 60 to 70 lb-ft (81 to 95 N-m).

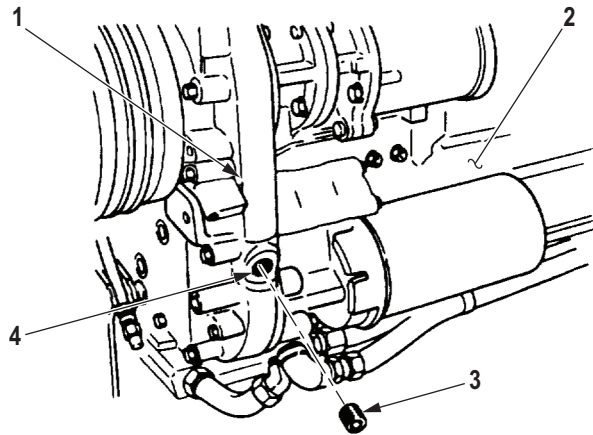

M9380DAA

Figure 26. Priming Lube System.

7. Check oil level (TM 9-2320-272-10).

END OF TASK

IN-CHASSIS RUN-IN**WARNING**

Ensure engine compartment is clear of tools and other materials before starting engine. Failure to comply may result in injury or death to personnel.

1. Inspect engine coolant and oil levels (TM 9-2320-272-10).
2. Pull emergency stop control (Figure 27, Item 4) out all the way to prevent engine from starting while priming.

CAUTION

- Do not operate M939A2 series vehicles starters continuously for more than 30 seconds at a time. Wait two minutes between periods of starter operation. Failure to do so may cause damage to equipment.
 - If oil pressure drops below 10 psi (68 kPa) or rises sharply above 30 psi (207 kPa), stop engine and correct as required.
3. Crank engine until oil pressure registers on oil pressure gauge (Figure 27, Item 3).
 4. Push emergency stop control (Figure 27, Item 4) in all the way.
 5. Start and run engine at 1,000 to 2,000 rpm as indicated on tachometer (Figure 27, Item 1) for 30 minutes, observing oil pressure (Figure 27, Item 3) and water temperature (Figure 27, Item 2) gauges for proper ranges (TM 9-2320-272-10).
 6. Inspect engine for leaks (TM 9-2320-272-10).

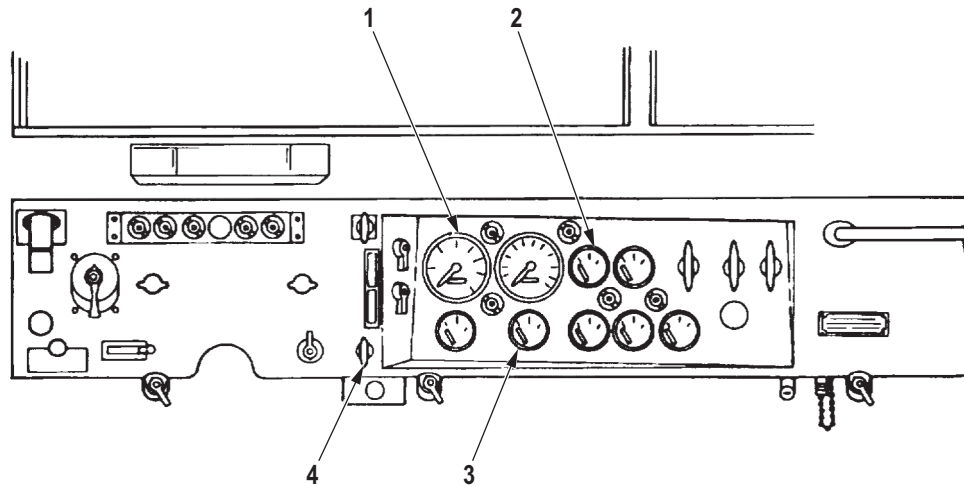

M9381DAA

Figure 27. Priming Lube System.

IN-CHASSIS RUN-IN - Continued**NOTE**

Coolant should not exceed 195°F (90°C) or drop below 175°F (79°C).

7. Check engine idle speed. If idle speed is not 550 to 650 rpm on M939A2 series vehicles, perform Steps (14) through (18).
8. Break special seal (Figure 28, Item 2) and remove pipe plug (Figure 28, Item 3) from governor spring pack cover (Figure 28, Item 4). Discard special seal.
9. Using spring pack tool, turn adjusting screw (Figure 28, Item 5) in to increase idle speed; out to decrease idle speed. Correct idle speed is 625 ± 25 rpm.
10. Install pipe plug (Figure 28, Item 3) on spring pack cover (Figure 28, Item 4).
11. Thread wire of special seal (Figure 28, Item 2) through pipe plug (Figure 28, Item 3) and two hex-head cover screws (Figure 28, Item 1), and twist wire of special seal (Figure 28, Item 2) until secure.

IN-CHASSIS RUN-IN - Continued

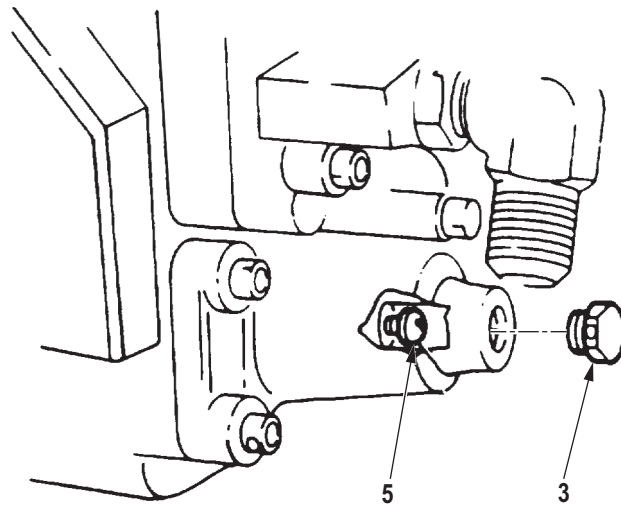
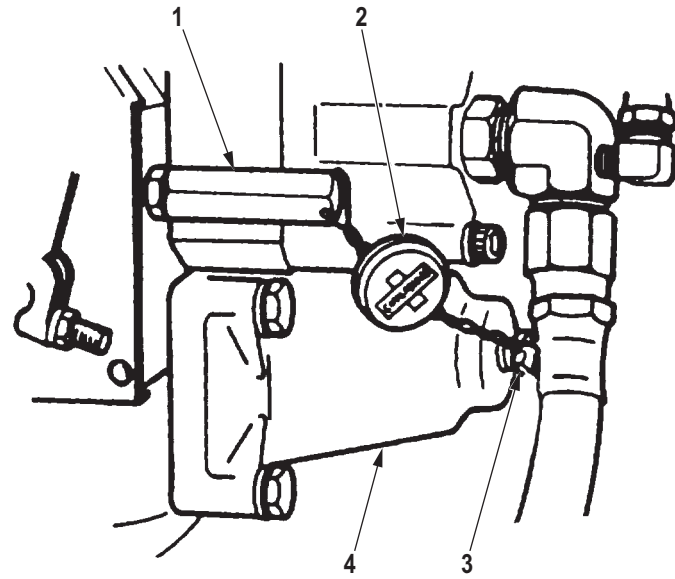

M9382DAA

Figure 28. Priming Lube System.

IN-CHASSIS RUN-IN - Continued

12. Stop engine and inspect coolant and oil levels (TM 9-2320-272-10).
13. Inspect engine for leaks (TM 9-2320-272-10).
14. Loosen locknut (Figure 29, Item 3) on accelerator linkage (Figure 29, Item 2).
15. Turn throttle rod (Figure 29, Item 1) clockwise to increase idle speed; counterclockwise to decrease idle speed.
16. Tighten locknut (Figure 29, Item 3) on accelerator linkage (Figure 29, Item 2).

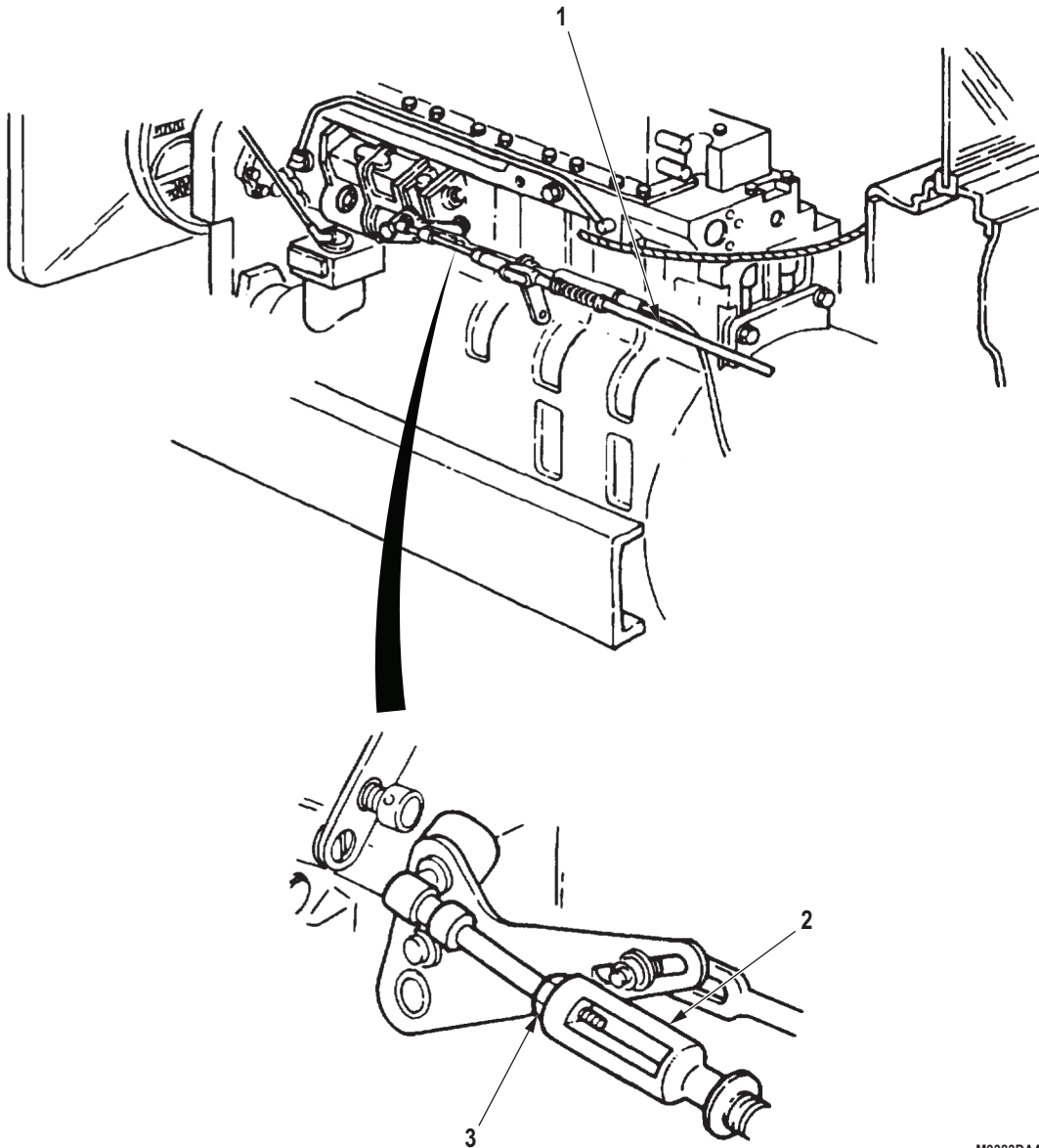

M9383DAA

Figure 29. Accelerator Linkage Adjustment.

17. Stop engine and inspect coolant and oil levels (TM 9-2320-272-10).

IN-CHASSIS RUN-IN - Continued

18. Inspect engine for leaks (TM 9-2320-272-10).

END OF TASK**FOLLOW-ON MAINTENANCE**

1. Install surge tank and bracket. (WP 0279)
2. Install and fill radiator. (WP 0277)
3. Install transmission-to-transfer case propeller shaft. (Volume 3, WP 0403)
4. Install transmission PTO-to-hydraulic pump propeller shaft, if equipped. (Volume 4, WP 0713)
5. Install upper radiator hose and bracket. (WP 0286)
6. Install hood assembly. (Volume 4, WP 0565)
7. Fill steering system to proper oil level. (Volume 5, WP 0820)
8. Fill engine to proper oil level. (Volume 4, WP 0742)
9. Fill transmission to proper oil level. (Volume 3, WP 0362)
10. Close air reservoirs drain valve. (TM 9-2320-272-10)
11. Connect battery ground cables. (WP 0350)
12. Adjust modulator cable. (Volume 3, WP 0365)
13. Adjust accelerator linkage. (WP 0268)
14. Fill coolant system to proper coolant level. (WP 0287)

CAUTION

Never start a new or repaired engine without performing run-in starting procedures.

15. Perform engine run-in starting procedures.
16. Start engine, allow air pressure to build up to normal operating range, and check for leaks. Road test vehicle. (TM 9-2320-272-10)
17. Change engine oil after first 500 mi (805 km). (Volume 5, WP 0820)

END OF TASK**END OF WORK PACKAGE**

**FIELD MAINTENANCE
ENGINE LIFT EYES REPLACEMENT (M939/A1)**

INITIAL SETUP:**Tools and Special Tools**

Tool Kit, General Mechanic's: Automotive
(Volume 5, WP 0826, Table 1, Item 56)

Equipment Condition

Parking brake set. (TM 9-2320-272-10)
Left and right splash shields removed.
(TM 9-2320-272-10)

Materials/Parts

Locknut (Volume 5, WP 0827, Table 1, Item 277)
Qty: 1

REMOVAL

1. Remove locknut (Figure 1, Item 3) and screw (Figure 1, Item 2) from surge tank support (Figure 1, Item 1) and rear lift eye (Figure 1, Item 4). Discard locknut.
2. Remove four screws (Figure 1, Item 6) and two lift eyes (Figure 1, Items 4 and 7) from rocker lever housings (Figure 1, Item 5).

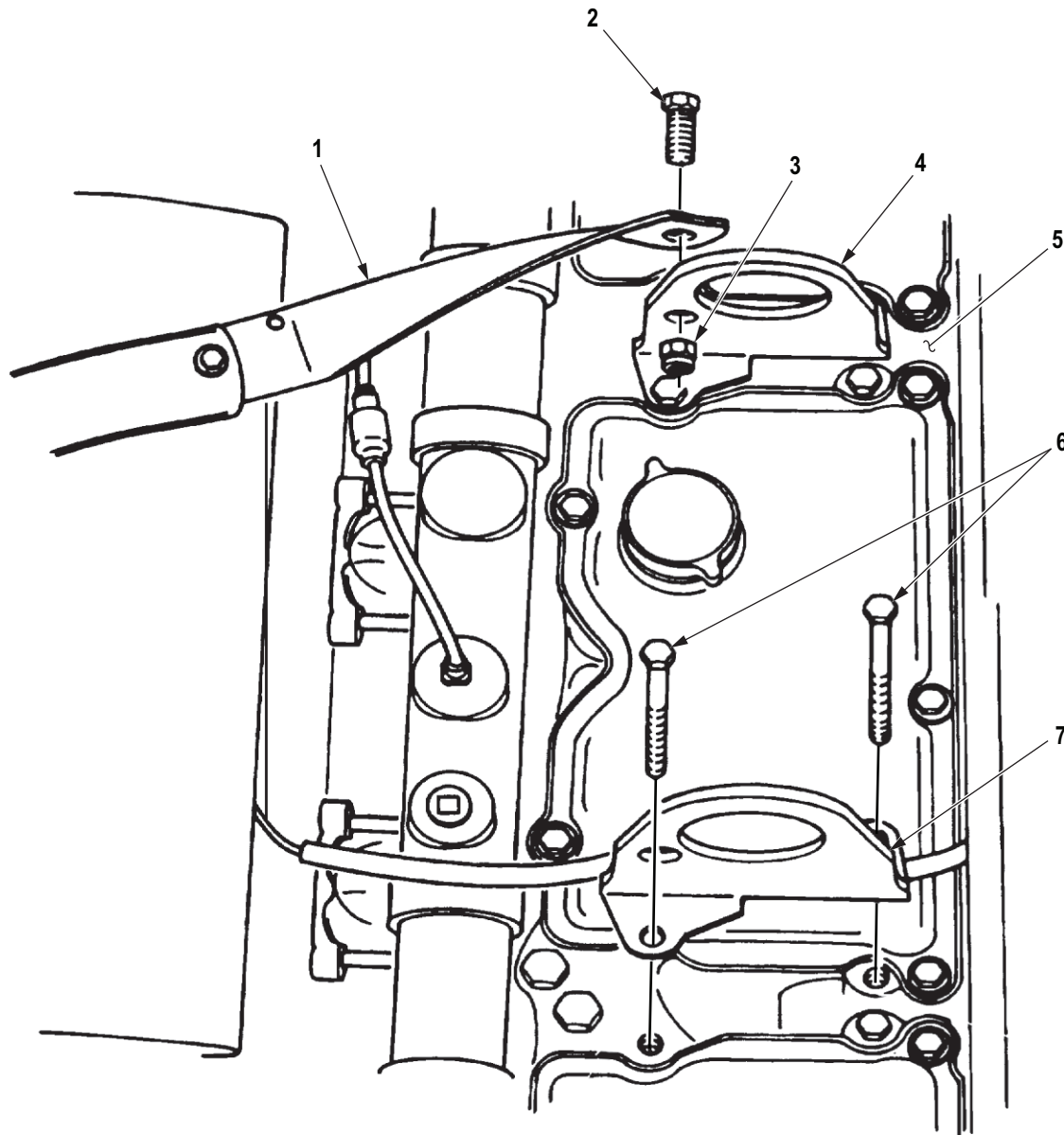

M9302DAA

Figure 1. Engine Lift Eyes Removal.

END OF TASK

INSTALLATION

1. Install two lift eyes (Figure 2, Items 4 and 7) on rocker lever housings (Figure 2, Item 5) with four screws (Figure 2, Item 6).
2. Install surge tank support (Figure 2, Item 1) on rear lift eye (Figure 2, Item 4) with screw (Figure 2, Item 2) and locknut (Figure 2, Item 3).

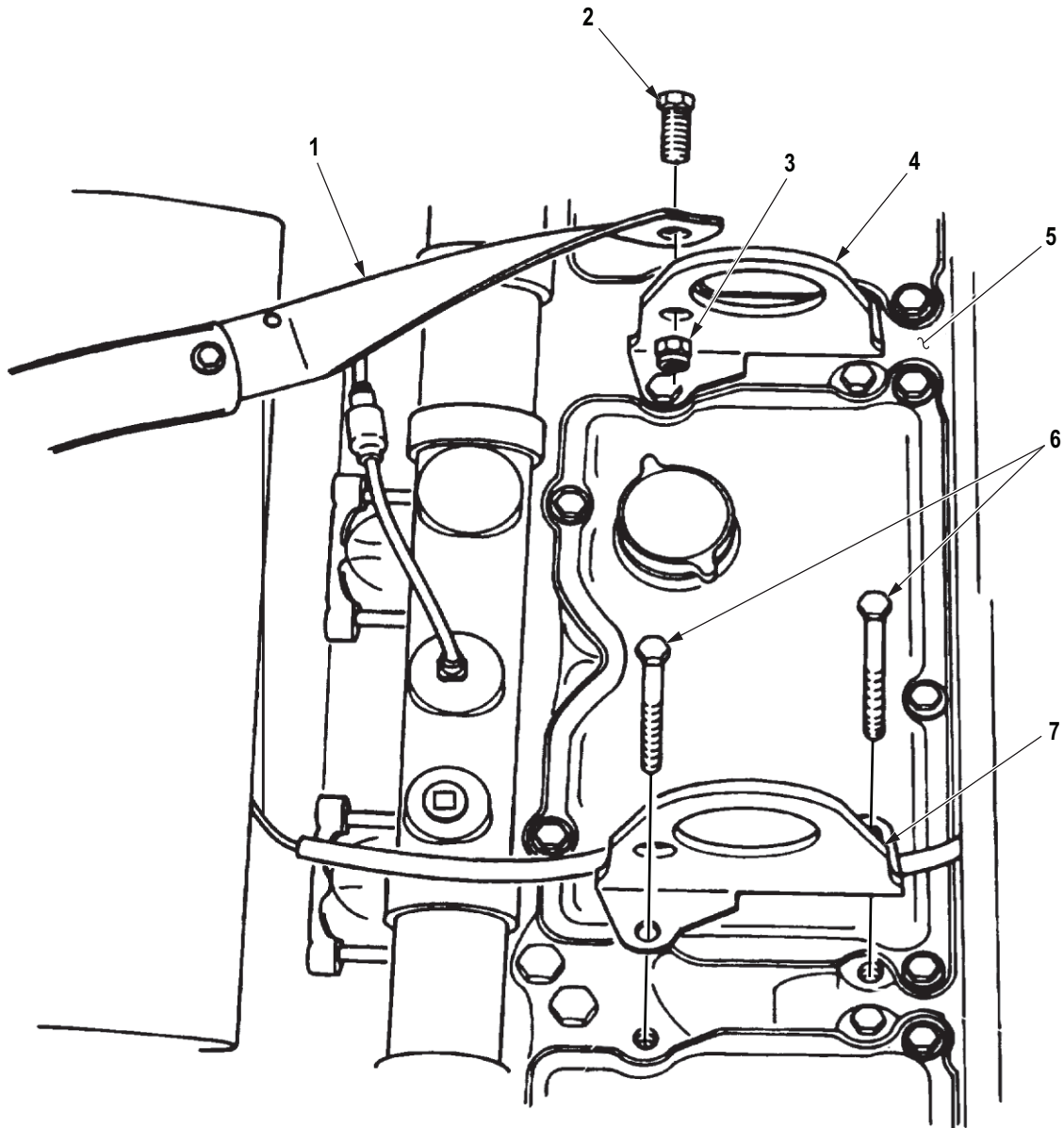

M10041DAA

Figure 2. Engine Lift Eyes Installation.

END OF TASK

FOLLOW-ON MAINTENANCE

Install left and right splash shield. (TM 9-2320-272-10)

END OF TASK

END OF WORK PACKAGE

FIELD MAINTENANCE ENGINE LIFTING BRACKETS REPLACEMENT (M939A2)

INITIAL SETUP:

Tools and Special Tools

Tool Kit, General Mechanic's: Automotive
(Volume 5, WP 0826, Table 1, Item 56)

Equipment Condition (cont.)

Hood raised and secured. (TM 9-2320-272-10)
Thermostat and thermostat housing removed.
(WP 0289)

Materials/Parts

Tiedown Strap
(Volume 5, WP 0827, Table 1, Item 379)
Qty: 1

Equipment Condition

Parking brake set. (TM 9-2320-272-10)

REMOVAL

1. Remove tiedown strap (Figure 1, Item 2) and overflow hose (Figure 1, Item 1) from lifting bracket (Figure 1, Item 6). Discard tiedown strap.
2. Remove two screws (Figure 1, Item 7) and lifting bracket (Figure 1, Item 6) from engine (Figure 1, Item 5).
3. Remove two screws (Figure 1, Item 4) and lifting bracket (Figure 1, Item 3) from engine (Figure 1, Item 5).

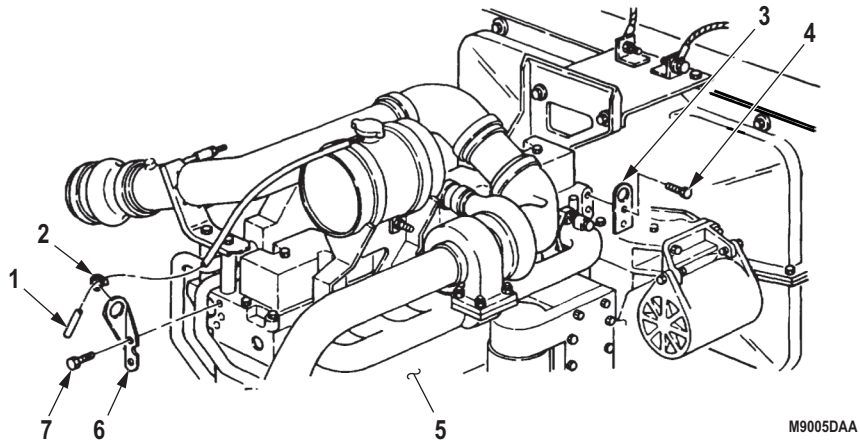

Figure 1. Engine Lifting Brackets Removal.

END OF TASK

INSTALLATION

1. Install lifting bracket (Figure 2, Item 3) on engine (Figure 2, Item 5) with two screws (Figure 2, Item 4).
2. Install lifting bracket (Figure 2, Item 6) on engine (Figure 2, Item 5) with two screws (Figure 2, Item 7).
3. Install overflow hose (Figure 2, Item 1) on lifting bracket (Figure 2, Item 6) with tiedown strap (Figure 2, Item 2).

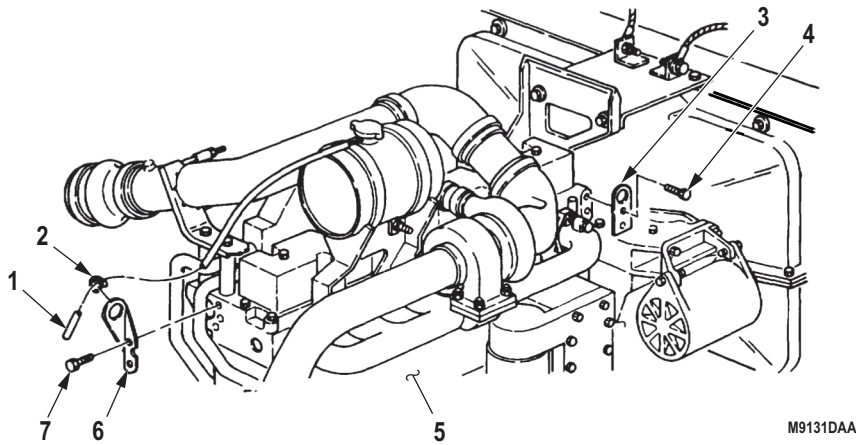

Figure 2. Engine Lifting Brackets Installation.

END OF TASK

FOLLOW-ON MAINTENANCE

Install thermostat and thermostat housing. (WP 0289)

END OF TASK

END OF WORK PACKAGE

**FIELD MAINTENANCE
ENGINE MOUNTING BRACKETS AND ISOLATORS REPLACEMENT**

INITIAL SETUP:**Tools and Special Tools**

Tool Kit, General Mechanic's: Automotive
(Volume 5, WP 0826, Table 1, Item 56)
Chain Assembly
(Volume 5, WP 0826, Table 1, Item 15)
Wrench, Torque, Click, Ratcheting, 1/2" Drive,
250 Ft-Lb
(Volume 5, WP 0826, Table 1, Item 63)

Materials/Parts

Locknut (Volume 5, WP 0827, Table 1, Item 238)
Qty: 5

Materials/Parts (cont.)

Locknut (Volume 5, WP 0827, Table 1, Item 247)
Qty: 9
Tiedown Strap
(Volume 5, WP 0827, Table 1, Item 45)
Qty: 1

Personnel Required

(2)

Equipment Condition

Parking brake set. (TM 9-2320-272-10)
Surge tank removed. (WP 0279)
Vibration damper removed. (WP 0219)
Air cleaner hose removed. (WP 0248)

REMOVAL**NOTE**

Assistant will help with this procedure.

1. Remove tiedown strap (Figure 1, Item 3) from hose (Figure 1, Item 5). Discard tiedown strap.
2. Loosen two clamps (Figure 1, Item 1) and remove hose (Figure 1, Item 5) from thermostat housing connector (Figure 1, Item 4) and radiator inlet tube (Figure 1, Item 2).
3. Remove two locknuts (Figure 1, Item 16), washers (Figure 1, Item 15), and backing plate (Figure 1, Item 17) from two screws (Figure 1, Item 7) and cross-member (Figure 1, Item 18). Discard locknuts.
4. Install chain and lifting device on two engine lifting brackets (Figure 1, Item 6). Place tension on chain.
5. Remove two screws (Figure 1, Item 7), washers (Figure 1, Item 8), isolators (Figure 1, Item 9), washers (Figure 1, Item 8), and isolators (Figure 1, Item 9) from front bracket (Figure 1, Item 14).
6. Remove four screws (Figure 1, Item 13), washers (Figure 1, Item 12), and front bracket (Figure 1, Item 14) from engine (Figure 1, Item 10) and radiator bracket (Figure 1, Item 11).

REMOVAL - Continued

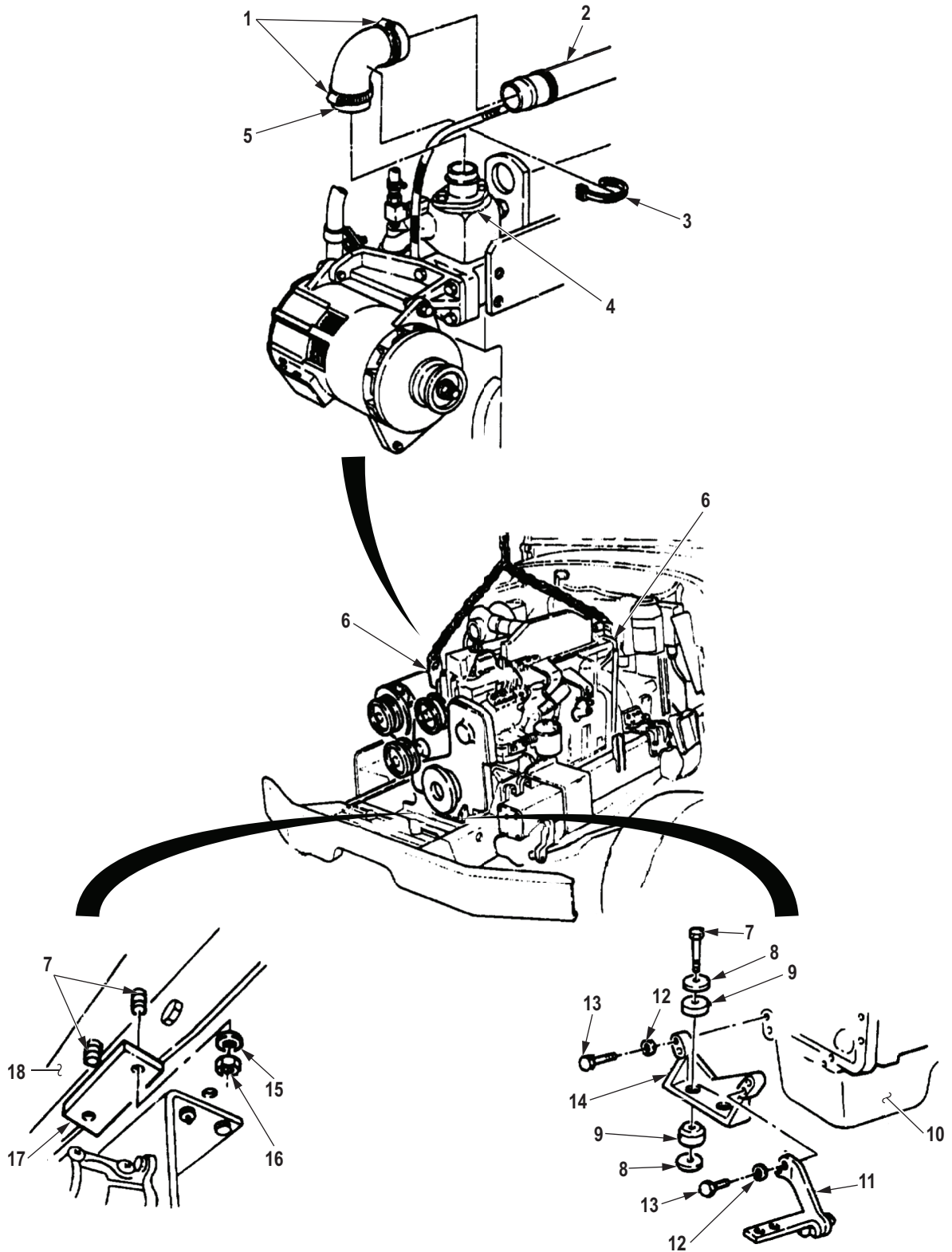

M9001DAA

Figure 1. Engine Mounting Bracket Removal.

REMOVAL - Continued

NOTE

- Tag mounting brackets for installation.
 - Perform Steps (7) through (9) for removing right engine mounting brackets.
7. Remove two screws (Figure 2, Item 1), washers (Figure 2, Item 2), and four isolators (Figure 2, Item 3) from upper mounting bracket (Figure 2, Item 9) and lower mounting bracket (Figure 2, Item 8).
 8. Remove four locknuts (Figure 2, Item 7), washers (Figure 2, Item 6), screws (Figure 2, Item 4), and lower mounting bracket (Figure 2, Item 8) from frame rail (Figure 2, Item 5). Discard locknuts.
 9. Remove four screws (Figure 2, Item 10), washers (Figure 2, Item 11), and upper mounting bracket (Figure 2, Item 9) from flywheel housing (Figure 2, Item 12).

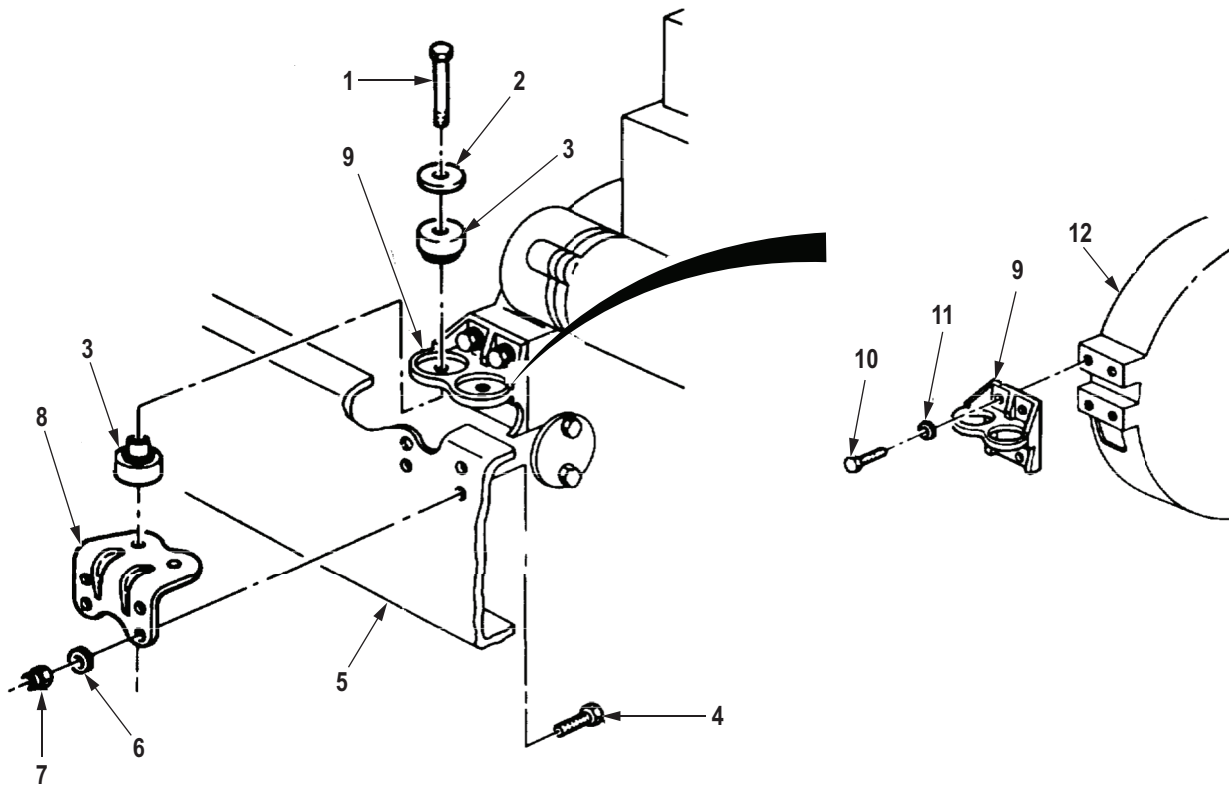

M9002DAA

Figure 2. Engine Mounting Bracket Removal.

REMOVAL - Continued

NOTE

Perform Steps (10) through (13) for removing left engine mounting brackets.

10. Remove two locknuts (Figure 3, Item 1), washers (Figure 3, Item 2), isolators (Figure 3, Item 3), screws (Figure 3, Item 9), and isolators (Figure 3, Item 3) from upper mounting bracket (Figure 3, Item 18) and lower mounting bracket (Figure 3, Item 6). Discard locknuts.
11. Remove locknut (Figure 3, Item 12), washer (Figure 3, Item 13), screw (Figure 3, Item 14), washer (Figure 3, Item 13), locknut (Figure 3, Item 15), washer (Figure 3, Item 5), screw (Figure 3, Item 4), washer (Figure 3, Item 5), shim (Figure 3, Item 17), and engine support (Figure 3, Item 16) from frame rail (Figure 3, Item 10) and lower mounting bracket (Figure 3, Item 6). Discard locknuts.
12. Remove four locknuts (Figure 3, Item 8), washers (Figure 3, Item 7), screws (Figure 3, Item 11), and lower mounting bracket (Figure 3, Item 6) from frame rail (Figure 3, Item 10). Discard locknuts.
13. Remove four screws (Figure 3, Item 21), washers (Figure 3, Item 20), and upper mounting bracket (Figure 3, Item 18) from flywheel housing (Figure 3, Item 19).

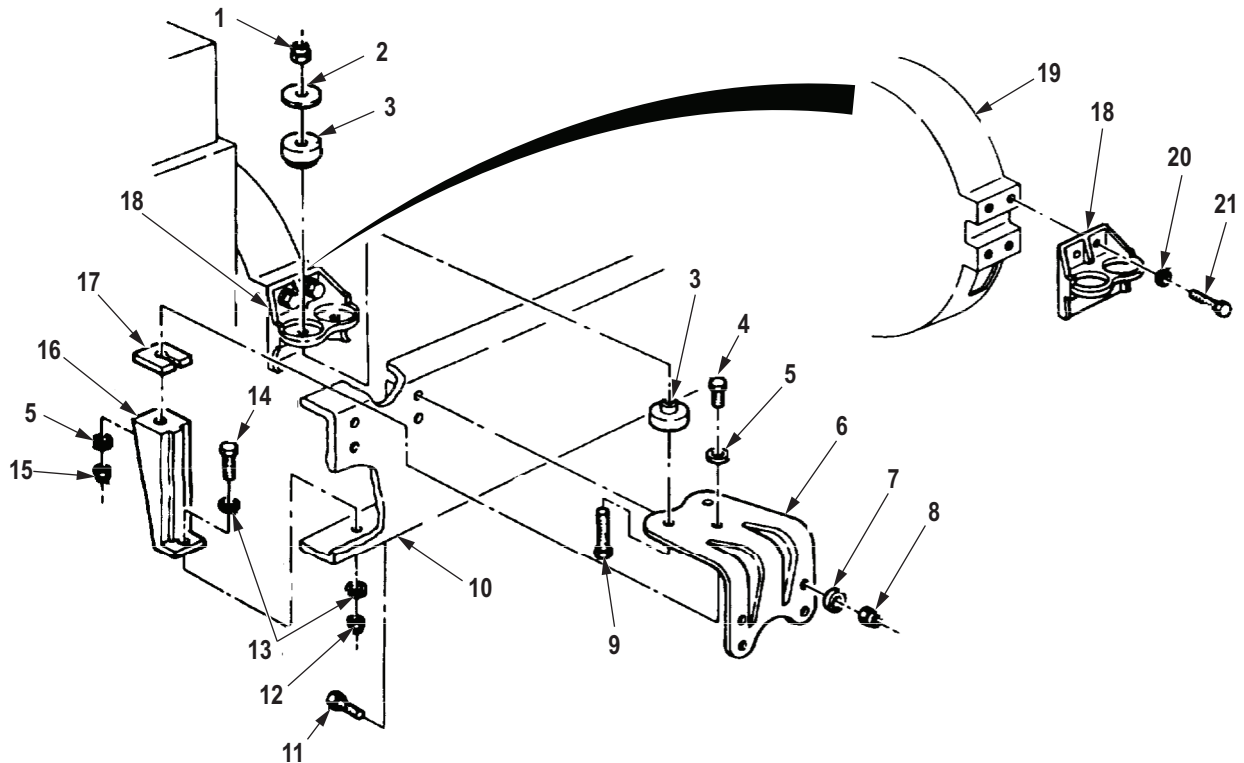

M9535DAA

Figure 3. Engine Mounting Bracket Removal.

END OF TASK

INSTALLATION

NOTE

Perform Steps (1) through (4) for installing left engine mounting brackets.

1. Install upper mounting bracket (Figure 4, Item 18) on flywheel housing (Figure 4, Item 19) with four washers (Figure 4, Item 20) and screws (Figure 4, Item 21). Tighten screws 70 to 90 lb-ft (95 to 122 N·m).
2. Install lower mounting bracket (Figure 4, Item 6) on frame rail (Figure 4, Item 10) with four screws (Figure 4, Item 11), washers (Figure 4, Item 7), and locknuts (Figure 4, Item 8). Tighten top two locknuts 80 to 95 lb-ft (109 to 129 N·m). Tighten bottom two locknuts 55 to 70 lb-ft (75 to 95 N·m).
3. Install shim (Figure 4, Item 17) and engine support (Figure 4, Item 18) on frame rail (Figure 4, Item 10) and lower mounting bracket (Figure 4, Item 6) with washer (Figure 4, Item 5), screw (Figure 4, Item 4), washer (Figure 4, Item 5), locknut (Figure 4, Item 15), washer (Figure 4, Item 13), screw (Figure 4, Item 14), washer (Figure 4, Item 13), and locknut (Figure 4, Item 12). Tighten locknuts 85 lb-ft (115 N·m).
4. Install four isolators (Figure 4, Item 3) on upper (Figure 4, Item 18) and lower (Figure 4, Item 6) mounting brackets with two screws (Figure 4, Item 9), washers (Figure 4, Item 2), and locknuts (Figure 4, Item 1). Finger-tighten screws.

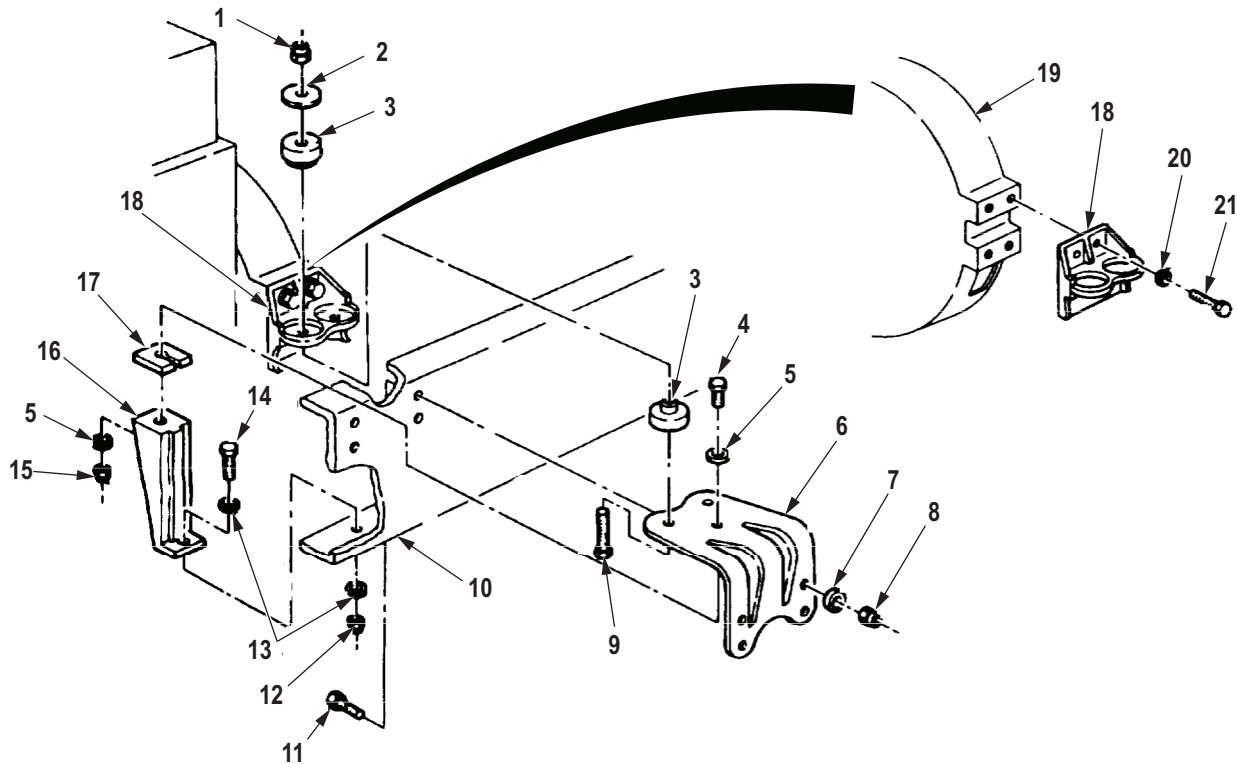

M9536DAA

Figure 4. Engine Mounting Bracket Installation.

INSTALLATION - Continued

NOTE

Perform Steps (5) through (7) for installing right engine mounting brackets.

5. Install upper mounting bracket (Figure 5, Item 9) on flywheel housing (Figure 5, Item 12) with four washers (Figure 5, Item 11) and screws (Figure 5, Item 10). Tighten screws 70 to 90 lb-ft (95 to 122 N-m).
6. Install lower mounting bracket (Figure 5, Item 8) on frame rail (Figure 5, Item 5) with four screws (Figure 5, Item 4), washers (Figure 5, Item 6), and locknuts (Figure 5, Item 7).
7. Install four isolators (Figure 5, Item 3) on upper mounting bracket (Figure 5, Item 9) and lower mounting bracket (Figure 5, Item 8) with two washers (Figure 5, Item 2) and screws (Figure 5, Item 1). Finger-tighten screws.

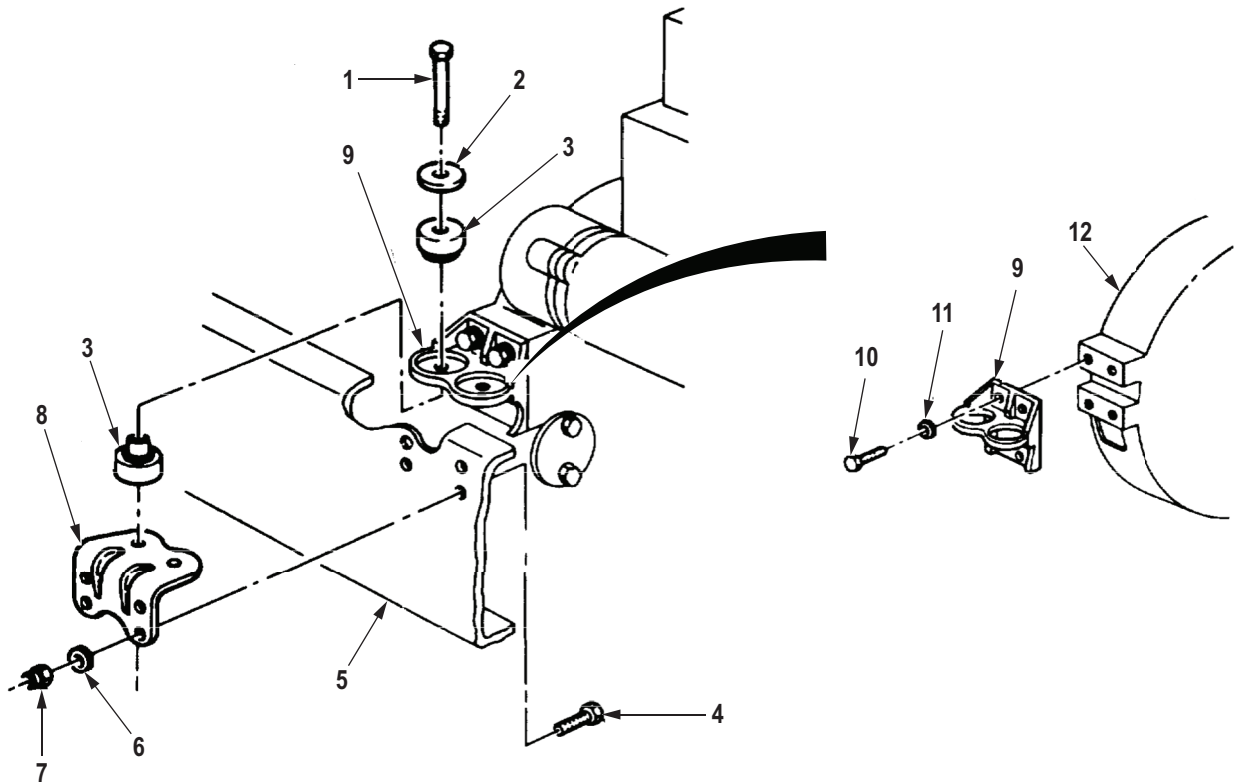

M9534DAA

Figure 5. Engine Mounting Bracket Installation.

INSTALLATION - Continued

8. Position front bracket (Figure 6, Item 9), four isolators (Figure 6, Item 4), washers (Figure 6, Item 3), and two screws (Figure 6, Item 2) on crossmember (Figure 6, Item 13) and install backing plate (Figure 6, Item 12) with two washers (Figure 6, Item 10) and locknuts (Figure 6, Item 11). Tighten locknuts 75 to 85 lb-ft (102 to 115 N-m).
9. Slowly release tension on chain and lower engine (Figure 6, Item 5) while aligning holes in front bracket (Figure 6, Item 9) and radiator bracket (Figure 6, Item 6) with holes in engine.
10. Install front bracket (Figure 6, Item 9) and radiator bracket (Figure 6, Item 6) on engine (Figure 6, Item 5) with four washers (Figure 6, Item 7) and screws (Figure 6, Item 8). Tighten screws 80 lb-ft (109 N-m).

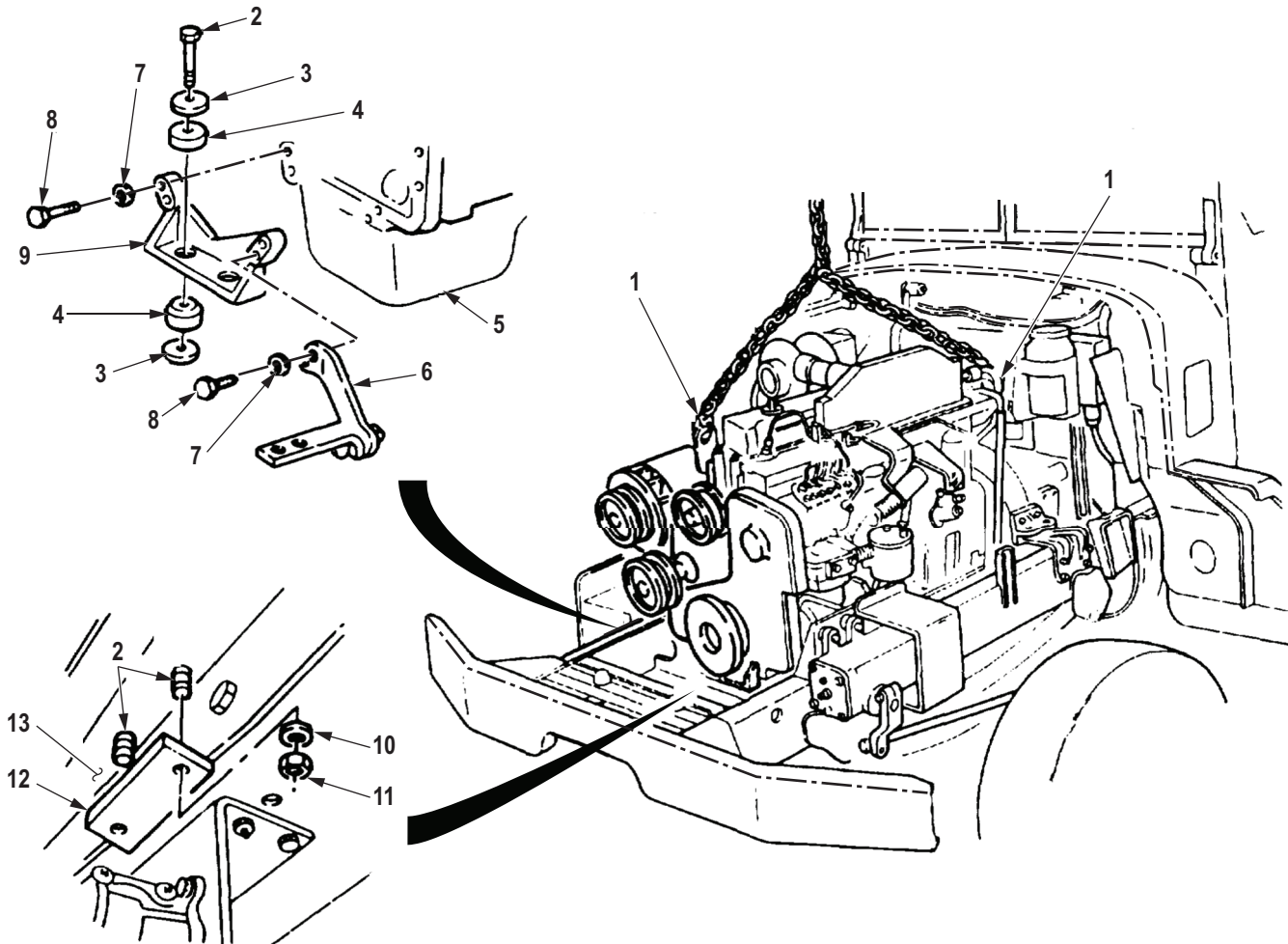

M9003DAA

Figure 6. Engine Mounting Bracket Installation.

INSTALLATION - Continued

11. Tighten two screws (Figure 7, Item 1) and locknuts (Figure 7, Item 2) 120 to 140 lb-ft (163 to 190 N·m).

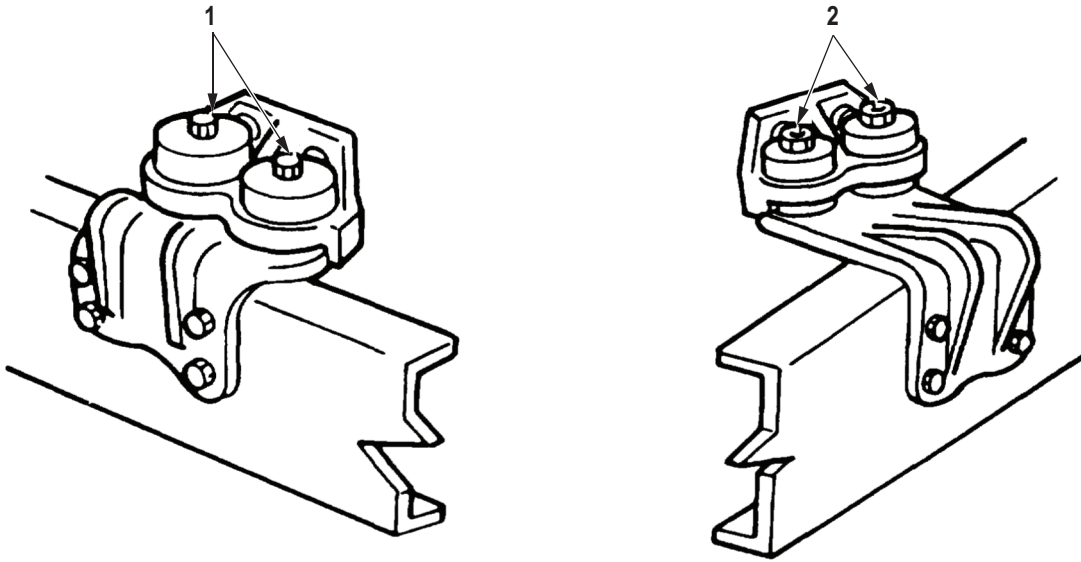

M9004DAA

Figure 7. Engine Mounting Bracket Installation.

INSTALLATION - Continued

12. Remove lifting device and chain from two engine lifting brackets.
13. Install hose (Figure 8, Item 5) on radiator inlet tube (Figure 8, Item 2) and thermostat housing connector (Figure 8, Item 4) with two clamps (Figure 8, Item 1) and tiedown strap (Figure 8, Item 3).

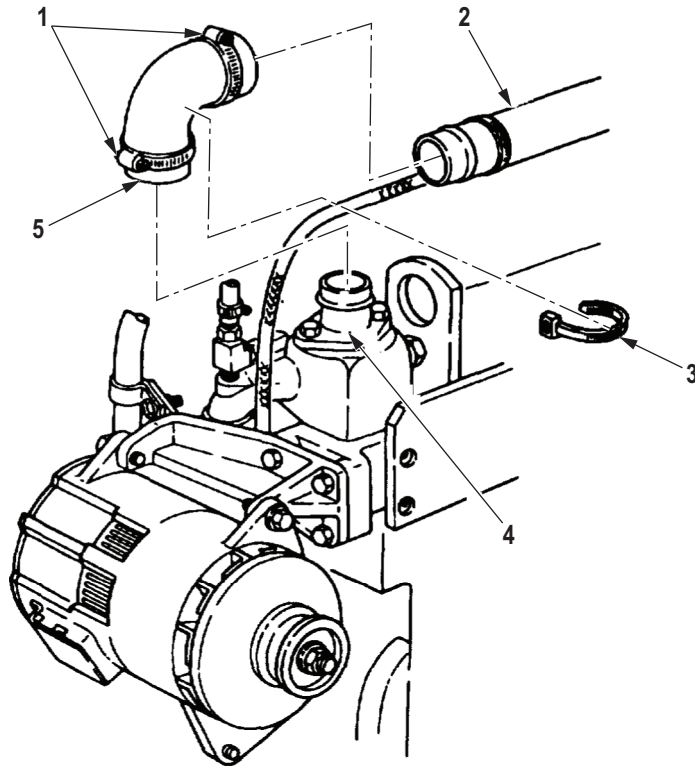

M9537DAA

Figure 8. Engine Mounting Bracket Installation.

END OF TASK**FOLLOW-ON MAINTENANCE**

1. Install air cleaner hose. (WP 0248)
2. Install vibration damper. (WP 0219)
3. Install surge tank. (WP 0279)

END OF TASK**END OF WORK PACKAGE**

**FIELD MAINTENANCE
ENGINE ACCESS COVER REPLACEMENT (M939/A1)**

INITIAL SETUP:**Tools and Special Tools**

Tool Kit, General Mechanic's: Automotive
(Volume 5, WP 0826, Table 1, Item 56)

Equipment Condition (cont.)

Right splash shield removed. (TM 9-2320-272-10)
Engine oil drained. (Volume 5, WP 0820)

Materials/Parts

Gasket (Volume 5, WP 0827, Table 1, Item 1)
Qty: 1
Lockwasher
(Volume 5, WP 0827, Table 1, Item 406)
Qty: 4

Equipment Condition

Parking brake set. (TM 9-2320-272-10)

REMOVAL

1. Remove two screws (Figure 1, Item 9), lockwashers (Figure 1, Item 10), washers (Figure 1, Item 8), and clamps (Figure 1, Item 11) from engine access cover (Figure 1, Item 2) and move transmission cooler lines (Figure 1, Item 7) to one side. Discard lockwashers.
2. Remove two screws (Figure 1, Item 4), lockwashers (Figure 1, Item 5), washers (Figure 1, Item 3), engine access cover (Figure 1, Item 2), and gasket (Figure 1, Item 1) from cylinder block (Figure 1, Item 6). Discard lockwashers and gasket.

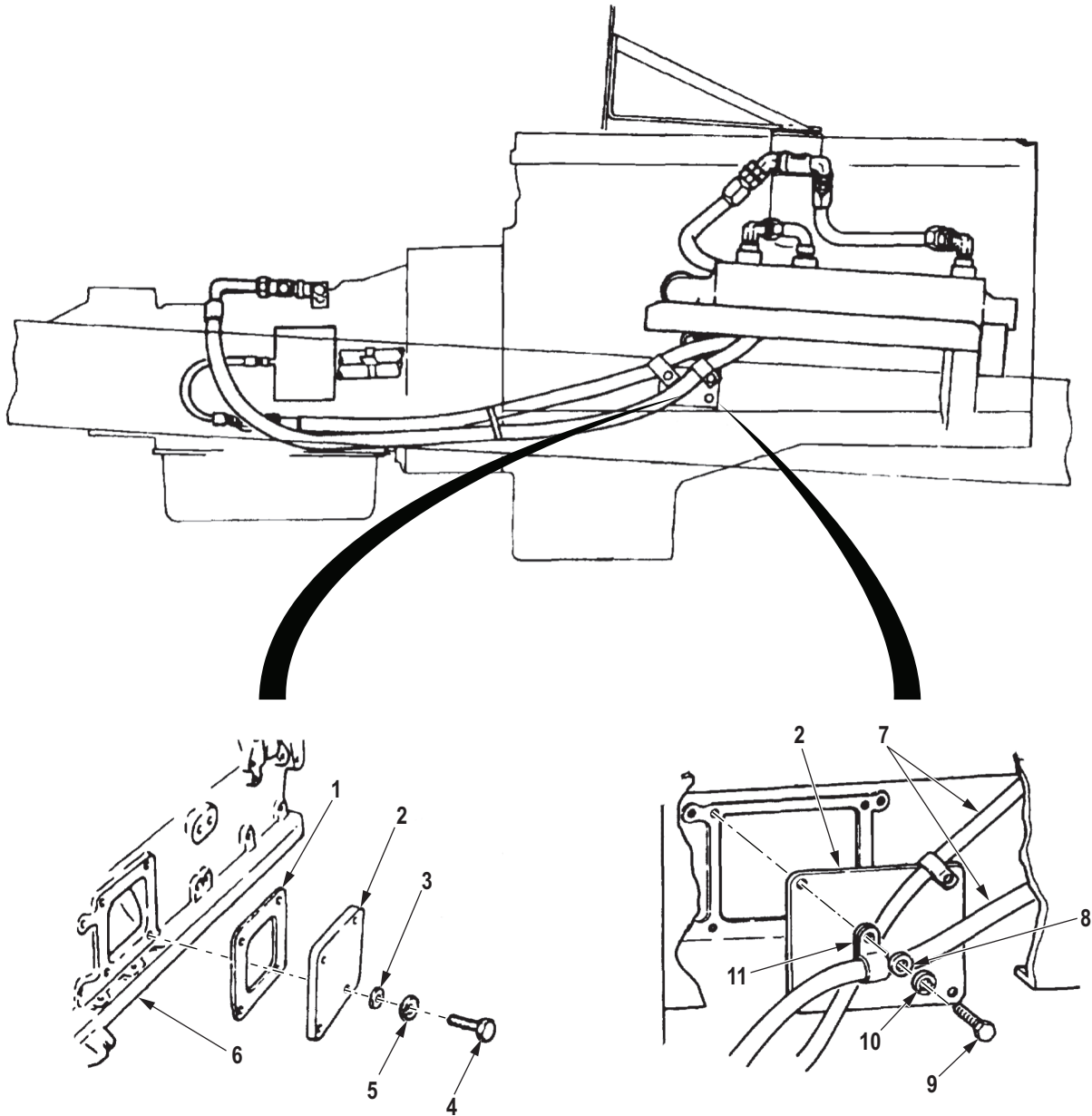

M9305DAA

Figure 1. Engine Access Cover Removal.

END OF TASK

INSTALLATION

1. Install gasket (Figure 2, Item 1) and engine access cover (Figure 2, Item 2) on cylinder block (Figure 2, Item 6) with two washers (Figure 2, Item 3), lockwashers (Figure 2, Item 5), and screws (Figure 2, Item 4).
2. Install transmission cooler lines (Figure 2, Item 7) on engine access cover (Figure 2, Item 2) with two clamps (Figure 2, Item 11), washers (Figure 2, Item 8), lockwashers (Figure 2, Item 10), and screws (Figure 2, Item 9).

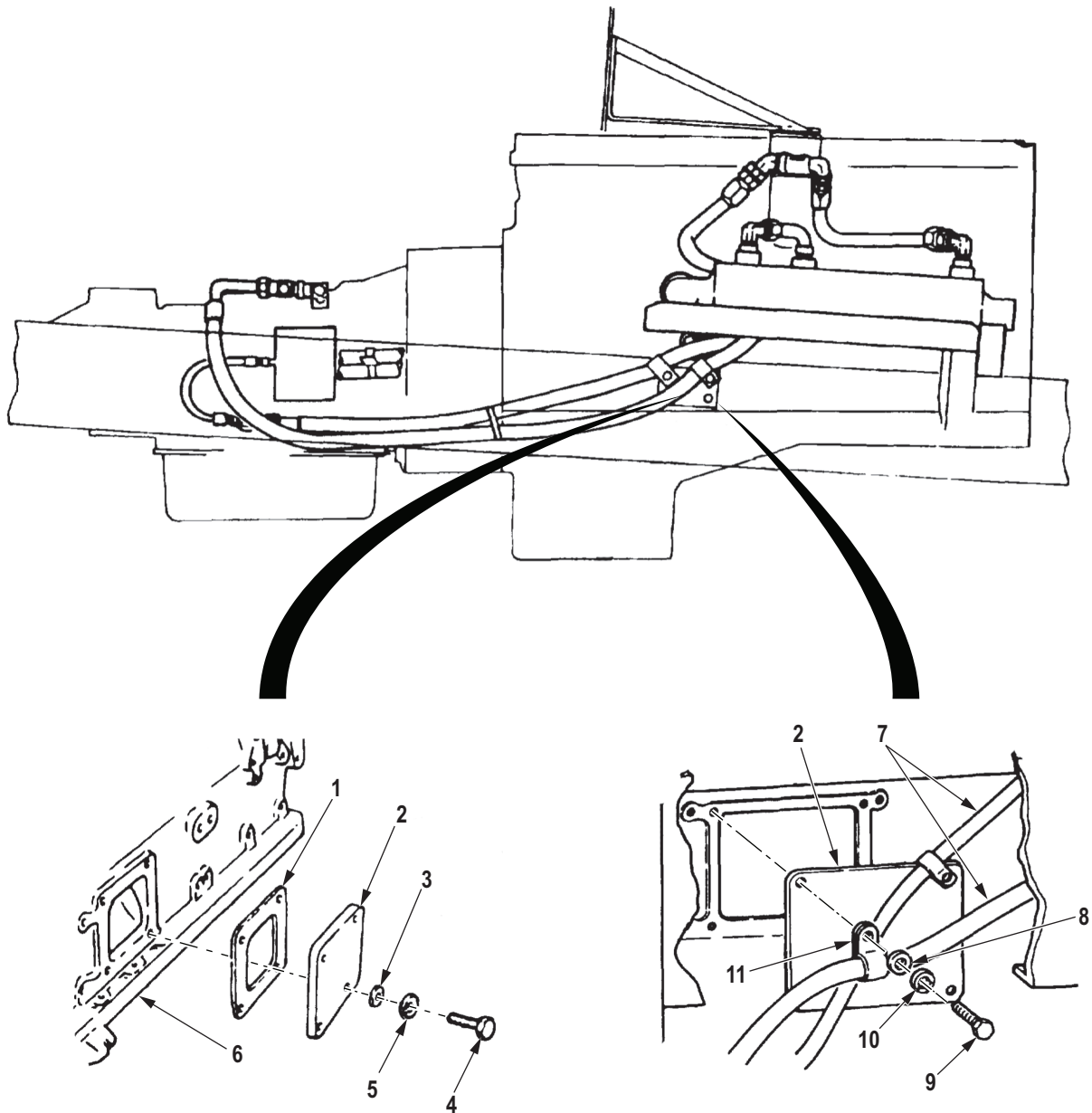

M9420DAA

*Figure 2. Engine Access Cover Installation.***END OF TASK**

FOLLOW-ON MAINTENANCE

1. Install right splash shield. (TM 9-2320-272-10)
2. Fill engine to proper oil level. (Volume 5, WP 0820)

END OF TASK**END OF WORK PACKAGE**

**FIELD MAINTENANCE
CRANKSHAFT VIBRATION DAMPENER REPLACEMENT (M939/A1)**

INITIAL SETUP:**Tools and Special Tools**

Tool Kit, General Mechanic's: Automotive
(Volume 5, WP 0826, Table 1, Item 56)
Barring Tool, Engine
(Volume 5, WP 0826, Table 1, Item 7)
Indicator, Dial
(Volume 5, WP 0826, Table 1, Item 25)

Equipment Condition (cont.)

Radiator fan blade removed. (WP 0298)
Alternator belts removed. (WP 0302)

Materials/Parts

Lockwasher
(Volume 5, WP 0827, Table 1, Item 405)
Qty: 6

Equipment Condition

Radiator fan shroud removed. (WP 0282)

RUNOUT AND WOBBLE CHECK**NOTE**

Perform Steps (1) through (3) to check for runout.

1. Mount dial indicator and holding fixture on front gearcase cover (Figure 1, Item 2).
2. Position dial arm on vibration damper (Figure 1, Item 1) at surface (Figure 1, Item 3) and zero-dial indicator.
3. Using barring tool, rotate vibration damper (Figure 1, Item 1) and take reading. If reading exceeds 0.025 in. (0.64 mm), replace vibration damper.

NOTE

- Perform Steps (4) through (6) to check for runout.
 - Crankshaft must be kept at front or rear limit of thrust while checking vibration damper for wobble.
4. Using mounted dial indicator, position dial arm on vibration damper (Figure 1, Item 1) at surface (Figure 1, Item 4) and zero-dial indicator.
 5. Using barring tool, rotate vibration damper (Figure 1, Item 1) and take reading. If reading exceeds 0.030 in. (0.76 mm), replace vibration damper.
 6. Remove dial indicator and fixture.

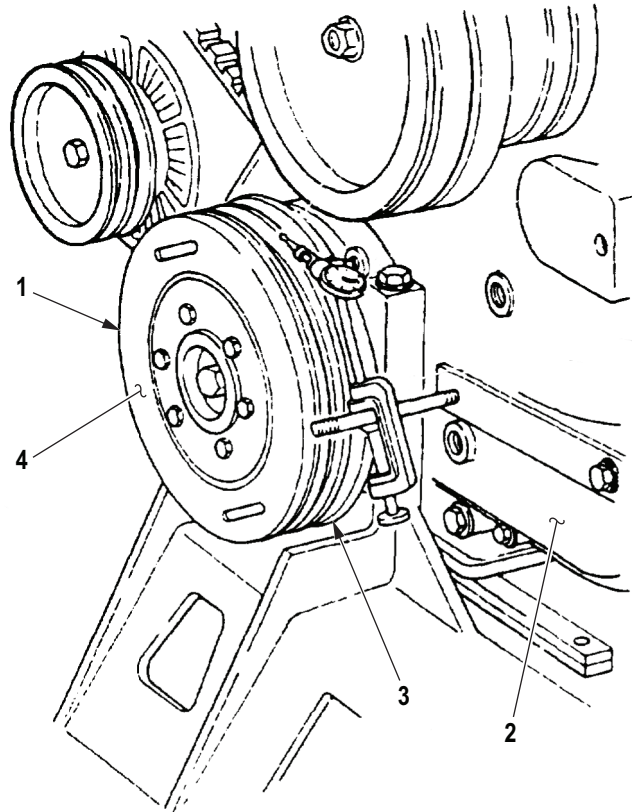

M9306DAA

Figure 1. Vibration Dampener Runout and Wobble Check.

END OF TASK

REMOVAL

Remove six screws (Figure 2, Item 3), lockwashers (Figure 2, Item 4), and vibration damper (Figure 2, Item 1) from crankshaft flange (Figure 2, Item 2). Discard lockwashers.

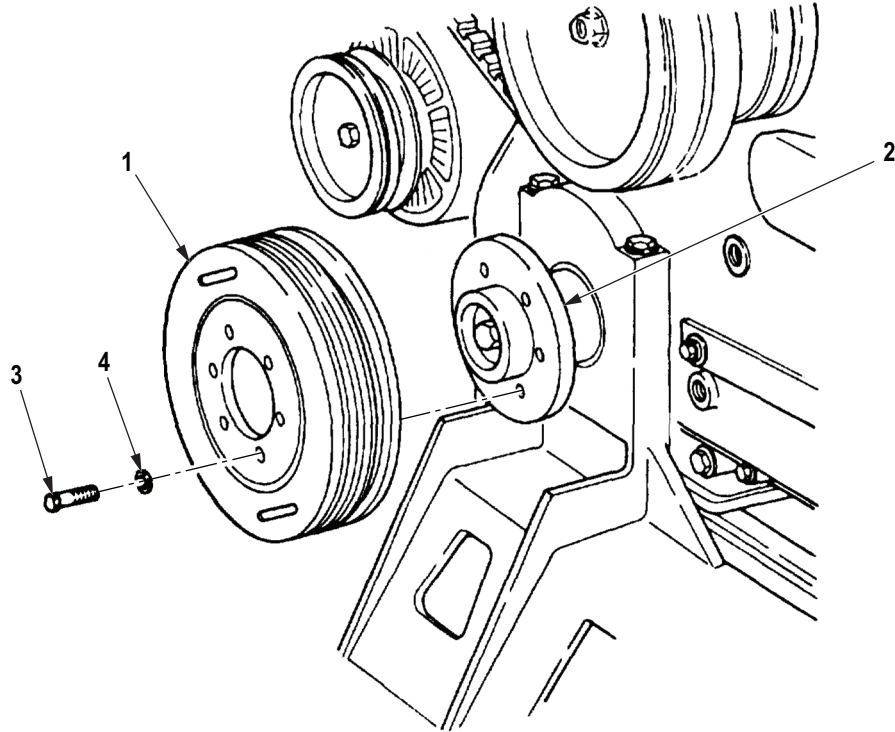

M9455DAA

Figure 2. Vibration Dampener Removal.

END OF TASK

INSPECTION

Inspect vibration damper (Figure 3, Item 1) to ensure mark (Figure 3, Item 3) on hub (Figure 3, Item 4) aligns with mark (Figure 3, Item 2) on member (Figure 3, Item 5). If alignment marks are not within 0.062 in. (1.57 mm), replace vibration damper.

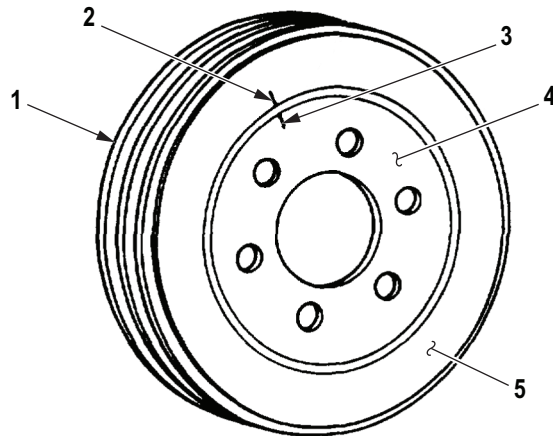

M9307DAA

Figure 3. Vibration Dampener Inspection.

END OF TASK

INSTALLATION

Install vibration damper (Figure 4, Item 1) on crankshaft flange (Figure 4, Item 2) with six lockwashers (Figure 4, Item 4) and screws (Figure 4, Item 3). Tighten screws (Figure 4, Item 3) 55 to 60 lb-ft (75 to 81 N·m).

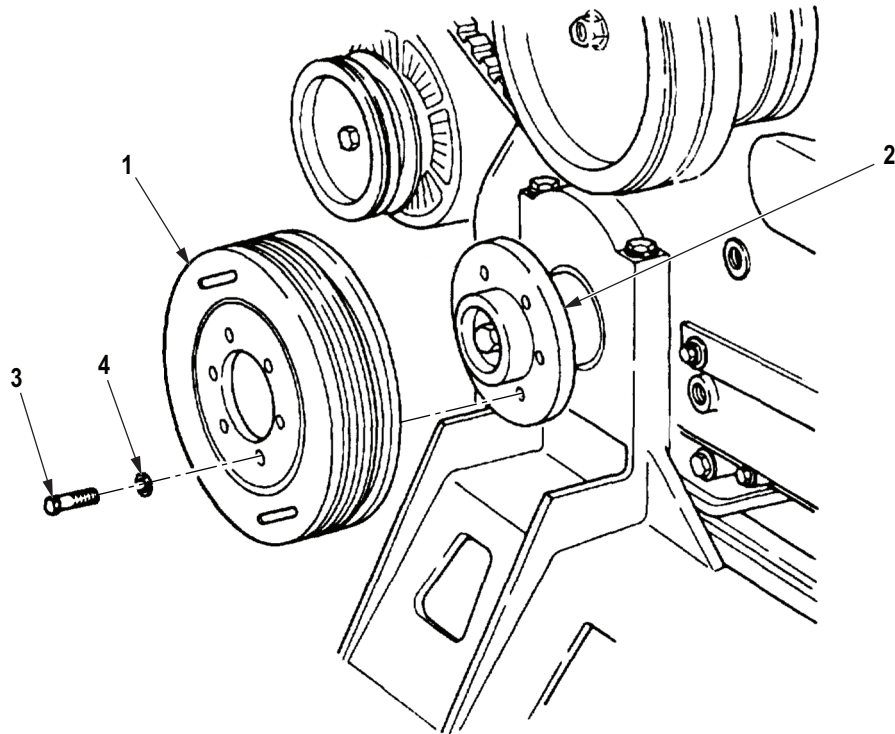

M9456DAA

Figure 4. Vibration Dampener Installation.

END OF TASK

FOLLOW-ON MAINTENANCE

1. Install alternator belts. (WP 0302)
2. Install radiator fan blade. (WP 0298)
3. Install radiator fan shroud. (WP 0282)

END OF TASK

END OF WORK PACKAGE

**FIELD MAINTENANCE
VIBRATION DAMPENER REPLACEMENT (M939A2)**

INITIAL SETUP:**Tools and Special Tools**

Tool Kit, General Mechanic's: Automotive
(Volume 5, WP 0826, Table 1, Item 56)
Barring Tool, Engine
(Volume 5, WP 0826, Table 1, Item 7)
Wrench, Torque, Click, Ratcheting, 1/2" Drive,
250 Ft-Lb
(Volume 5, WP 0826, Table 1, Item 63)

Personnel Required

(2)

Equipment Condition

Parking brake set. (TM 9-2320-272-10)
Engine drivebelt removed. (WP 0296)
Fan and fan shroud removed. (WP 0283)

Materials/Parts

Packing, Preformed (Volume 5, WP 0827, Table 1,
Item 134) Qty: 1

REMOVAL**NOTE**

Assistant will help with this procedure.

1. Remove plug (Figure 1, Item 4) and preformed packing (Figure 1, Item 3) from flywheel housing (Figure 1, Item 2). Discard preformed packing.
2. Using engine barring tool (Figure 1, Item 9), prevent crankshaft (Figure 1, Item 1) from turning.
3. Remove four screws (Figure 1, Item 6) and vibration damper (Figure 1, Item 5) from crankshaft (Figure 1, Item 1).
4. Inspect vibration damper (Figure 1, Item 5) for bends, breaks, and damaged pulley grooves. Replace vibration damper (Figure 1, Item 5) if bent, broken, or grooves are damaged.
5. Inspect vibration damper alignment marks (Figure 1, Item 8). Replace vibration damper (Figure 1, Item 5) if alignment marks are 0.063 in. (1.60 mm) out of alignment.
6. Inspect rubber member (Figure 1, Item 7) for wear and damage. Replace vibration damper (Figure 1, Item 5) if damaged or worn more than 0.125 in. (3.18 mm) deeper than face of vibration damper.

REMOVAL - Continued

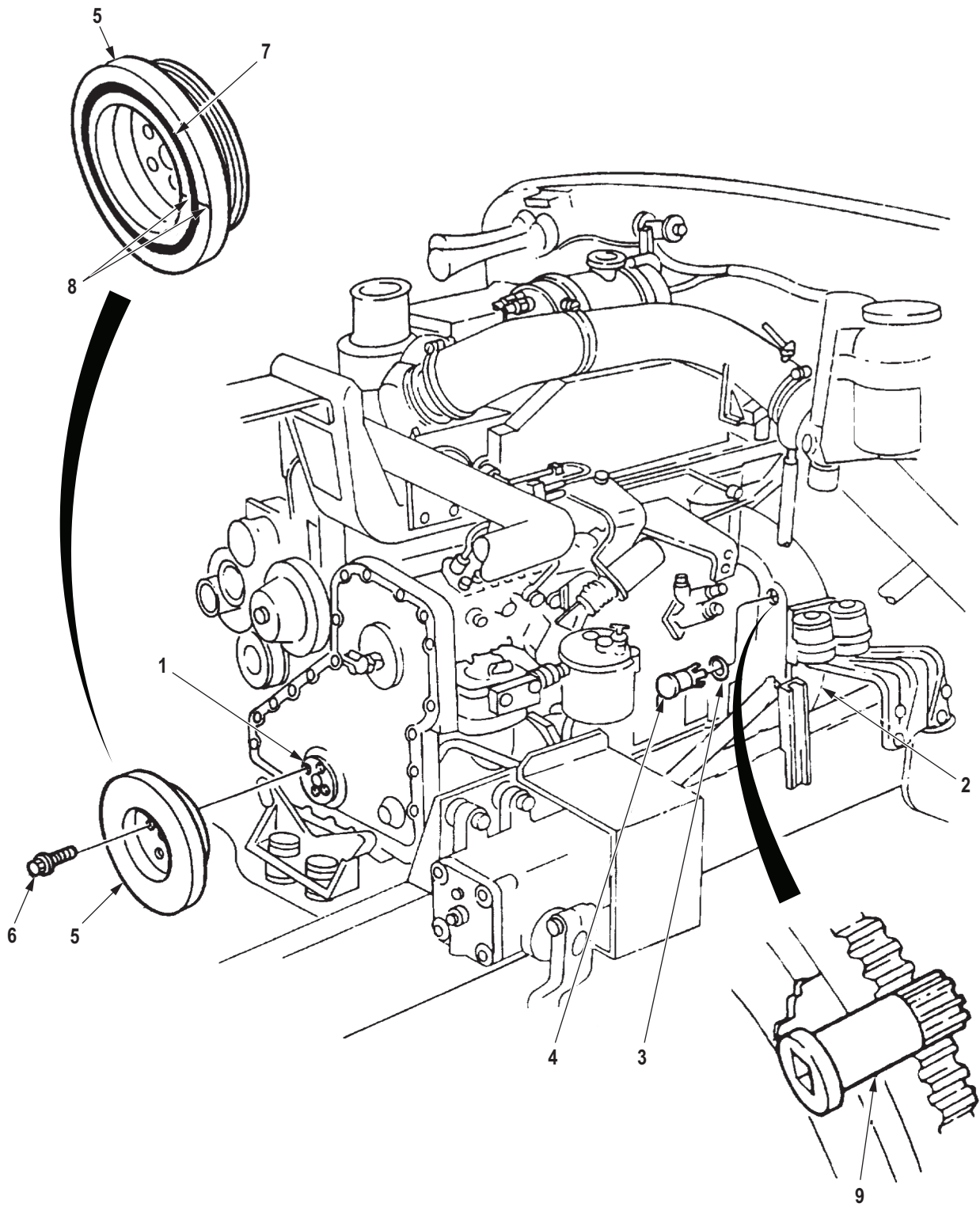

M9012DAA

Figure 1. Vibration Dampener Removal.

END OF TASK

INSTALLATION

1. Using engine barring tool (Figure 2, Item 9), prevent crankshaft (Figure 2, Item 1) from turning.
2. Install vibration damper (Figure 2, Item 5) on crankshaft (Figure 2, Item 1) with four screws (Figure 2, Item 6). Tighten screws 150 lb-ft (203 N-m).
3. Install preformed packing (Figure 2, Item 3) and plug (Figure 2, Item 4) in flywheel housing (Figure 2, Item 2).

INSTALLATION - Continued

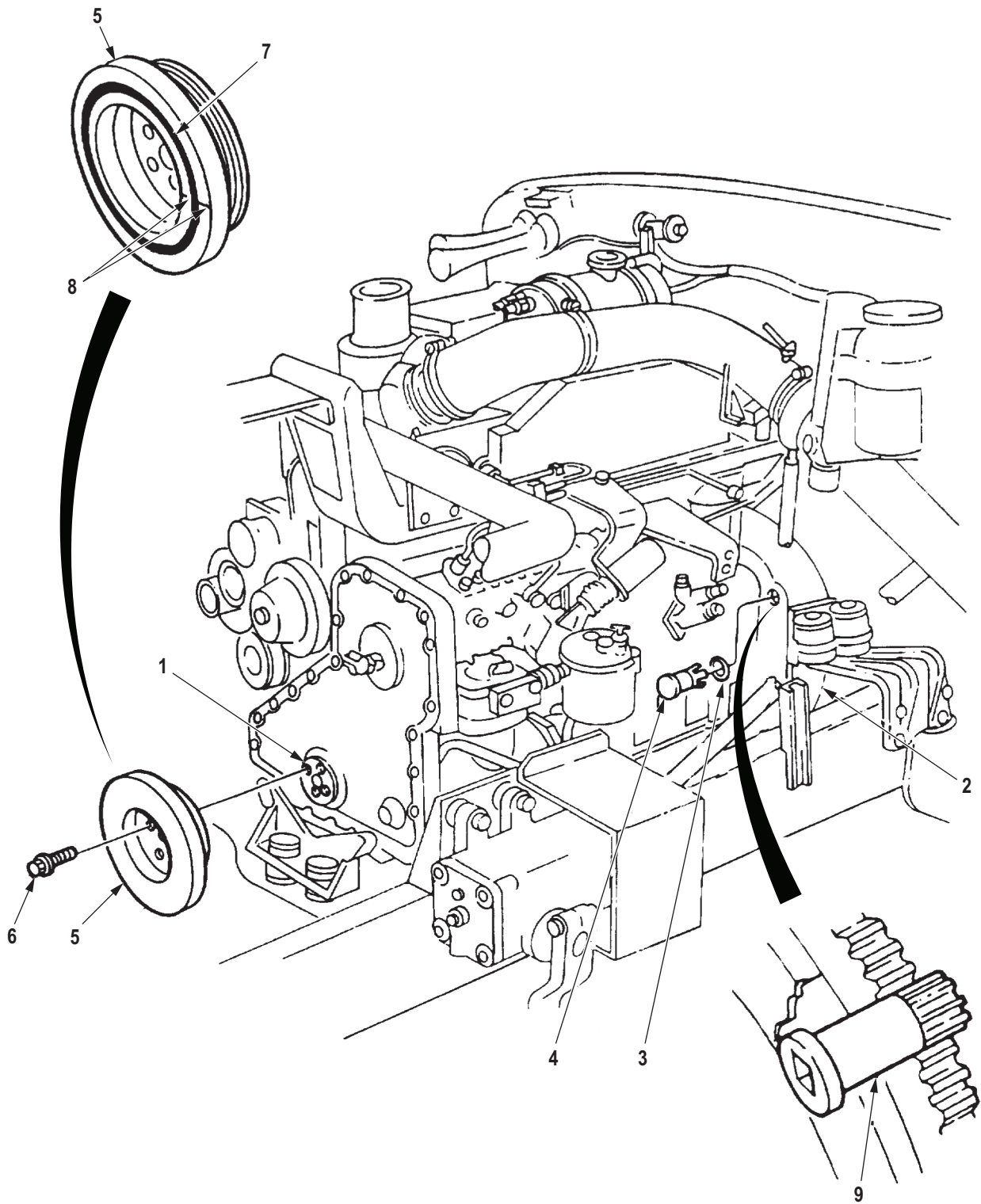

M9132DAA

Figure 2. Vibration Dampener Installation.

END OF TASK

FOLLOW-ON MAINTENANCE

1. Install fan and fan shroud. (WP 0283)
2. Install engine drivebelt. (WP 0296)

END OF TASK**END OF WORK PACKAGE**

**FIELD MAINTENANCE
FLYWHEEL ASSEMBLY REPLACEMENT (M939/A1)**

INITIAL SETUP:**Tools and Special Tools**

Tool Kit, General Mechanic's: Automotive
(Volume 5, WP 0826, Table 1, Item 56)
Wrench, Torque, Click, Ratcheting, 1/2" Drive,
250 Ft-Lb

Tools and Special Tools (cont.)

(Volume 5, WP 0826, Table 1, Item 63)

Equipment Condition

Transmission removed. (Volume 3, WP 0372)

REMOVAL**WARNING**

Support ring gear when removing flywheel screws. Ring gear may fail if not supported. Failure to comply may result in injury or death to personnel.

CAUTION

Lock flywheel to prevent crankshaft from turning before removing screws.

NOTE

Flywheel and ring gear will be an assembly.

Remove six screws (Figure 1, Item 1), washers (Figure 1, Item 2), clutch space (Figure 1, Item 3), flywheel (Figure 1, Item 4), and adapter plate (Figure 1, Item 5) from crankshaft rear flange (Figure 1, Item 6).

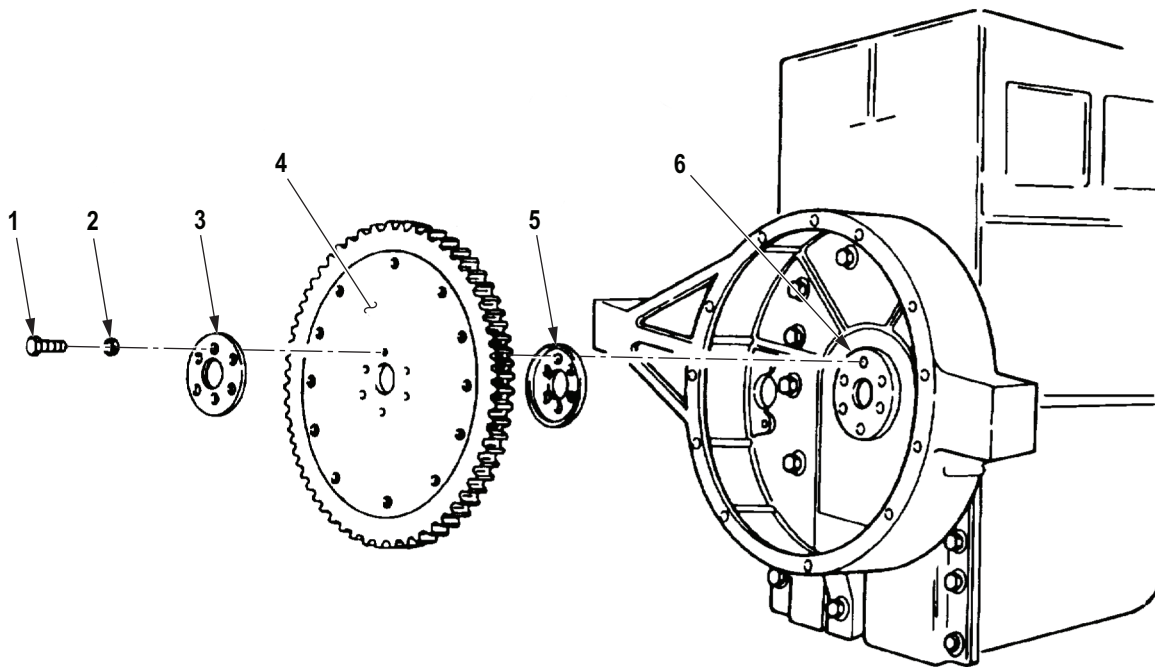

M9308DAA

Figure 1. Flywheel Assembly Removal.

END OF TASK

INSTALLATION

Install adapter plate (Figure 2, Item 5), flywheel (Figure 2, Item 4), and clutch spacer (Figure 2, Item 3) on crankshaft rear flange (Figure 2, Item 6) with six washers (Figure 2, Item 2) and screws (Figure 2, Item 1). Tighten screws alternately 200 to 220 lb-ft (271 to 298 N·m).

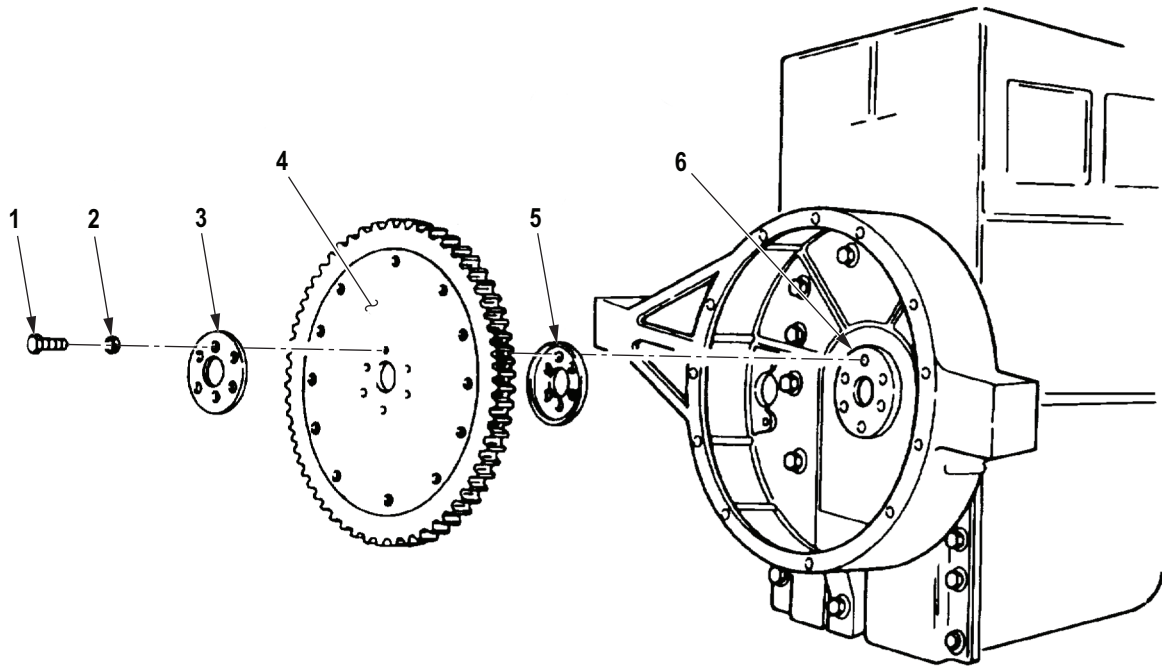

M9308-1DAA

Figure 2. Flywheel Assembly Installation.

END OF TASK**END OF WORK PACKAGE**

**FIELD MAINTENANCE
FLEXPLATE AND FLYWHEEL ASSEMBLY REPLACEMENT (M939A2)**

INITIAL SETUP:**Tools and Special Tools**

Tool Kit, General Mechanic's: Automotive
(Volume 5, WP 0826, Table 1, Item 56)
Barring Tool, Gear
(Volume 5, WP 0826, Table 1, Item 8)
Wrench, Torque, Click, Ratcheting, 3/8" Drive,
75 Ft-Lb
(Volume 5, WP 0826, Table 1, Item 62)
Wrench, Torque, Click, Ratcheting, 1/2" Drive,
250 Ft-Lb
(Volume 5, WP 0826, Table 1, Item 63)

Materials/Parts

Gasket Sealant
(Volume 5, WP 0825, Table 1, Item 4)
Lubricating Oil, Engine
(Volume 5, WP 0825, Table 1, Item 39, 40, 41,
42)

Materials/Parts (cont.)

Tape, Antiseizing: Pipe Thread Tape, White
(Volume 5, WP 0825, Table 1, Item 65)
Gasket (Volume 5, WP 0827, Table 1, Item 132)
Qty: 1
Gasket (Volume 5, WP 0827, Table 1, Item 265)
Qty: 1

Personnel Required

(2)

Equipment Condition

Transmission removed. (Volume 3, WP 0372)

REMOVAL**CAUTION**

Do not use timing pin to prevent engine from turning. Doing so may cause damage to timing pin.

NOTE

Assistant will help with this procedure.

1. Using engine barring tool, prevent crankshaft (Figure 1, Item 10) from turning.
2. Remove eight screws (Figure 1, Item 9), clamping ring (Figure 1, Item 8), flexplate (Figure 1, Item 7), and crankshaft adapter (Figure 1, Item 6) from crankshaft (Figure 1, Item 10).
3. Remove 12 screws (Figure 1, Item 5), flywheel housing (Figure 1, Item 4), and gasket (Figure 1, Item 3) from rear cover (Figure 1, Item 11). Discard gasket.

NOTE

Perform Step (4) if dowel pins are damaged.

4. Remove two dowel pins (Figure 1, Item 2) from engine block (Figure 1, Item 1).

REMOVAL - Continued

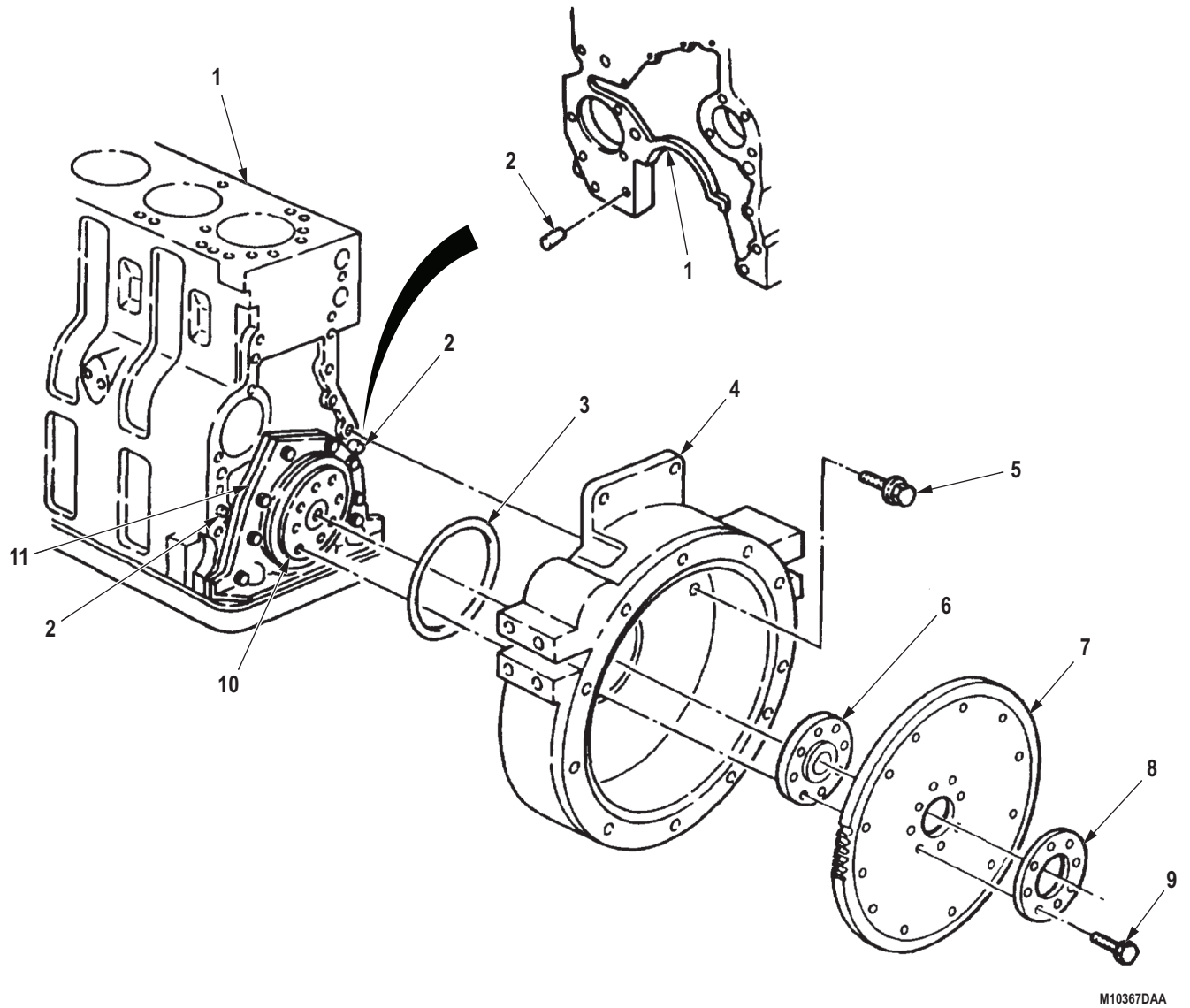

M10367DAA

Figure 1. Flexplate and Flywheel Assembly Removal.

END OF TASK

INSTALLATION**NOTE**

Perform Step (1) if dowel pins were removed.

1. Install new dowel pins (Figure 2, Item 2) on engine block (Figure 2, Item 1).
2. Install new seal (Figure 2, Item 3) on rear cover (Figure 2, Item 11).
3. Apply gasket sealant to threads of 12 screws (Figure 2, Item 5) and mating surfaces of flywheel housing (Figure 2, Item 4) and engine block (Figure 2, Item 1).
4. Position flywheel housing (Figure 2, Item 4) on engine block (Figure 2, Item 1). Ensure flywheel housing is properly aligned on dowel pins (Figure 2, Item 2) and gasket (Figure 2, Item 4) is not damaged.
5. Install flywheel housing (Figure 2, Item 4) on engine block (Figure 1, Item 1) with 12 screws (Figure 2, Item 5). Tighten screws to 45 lb-ft (61 N·m) in sequence shown in Figure 3.
6. Lubricate eight screws (Figure 2, Item 9) with clean engine oil.

CAUTION

Do not use timing pin to prevent engine from turning. Doing so may cause damage to timing pin.

7. Install crankshaft adapter (Figure 2, Item 6), flexplate (Figure 2, Item 7), and clamping ring (Figure 2, Item 8) on crankshaft (Figure 2, Item 10) with eight screws (Figure 2, Item 9). Tighten screws to 100 lb-ft (136 N·m) in sequence shown in Figure 3.

INSTALLATION - Continued

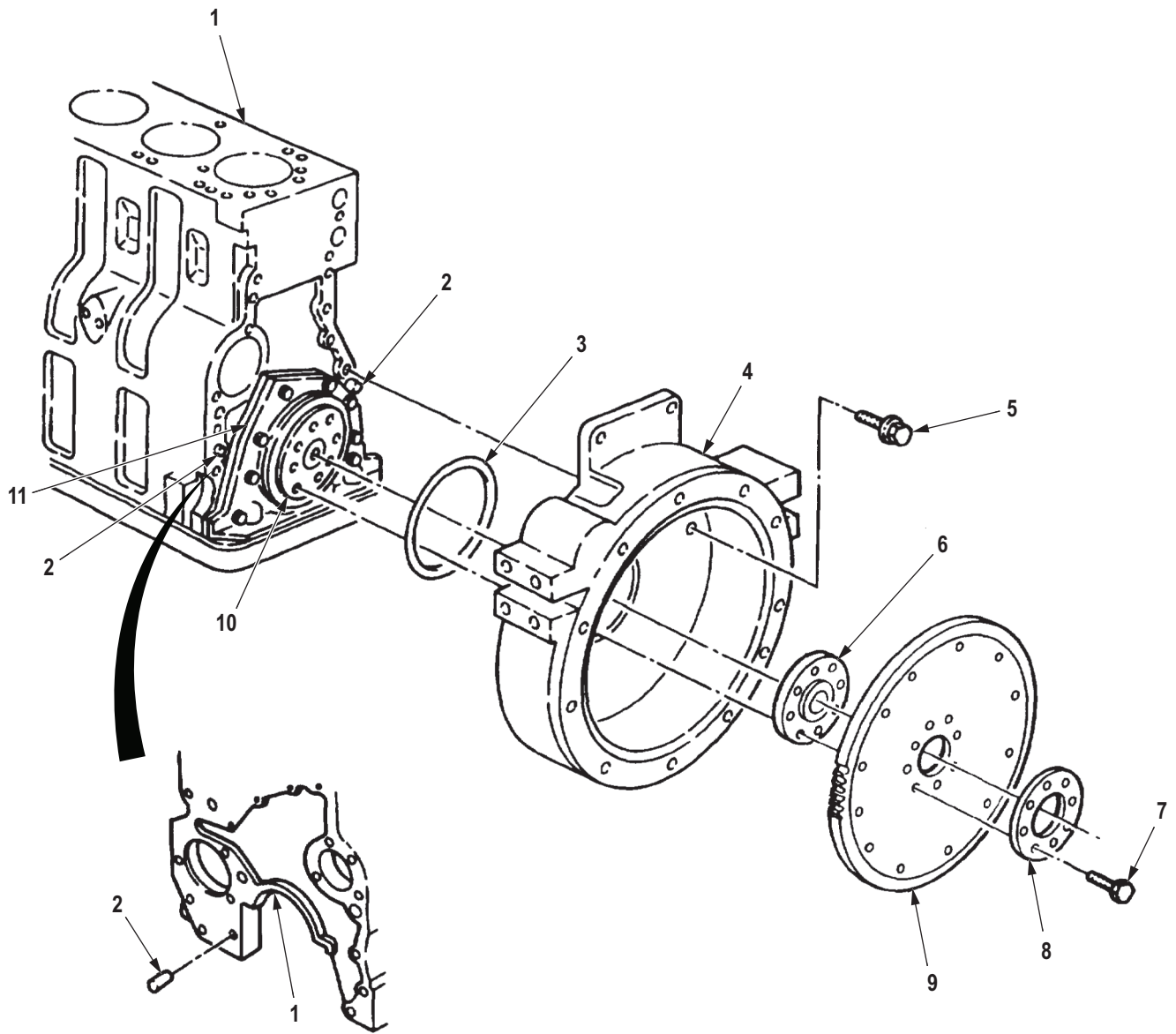

M10368DAA

Figure 2. Flexplate and Flywheel Assembly Installation.

INSTALLATION - Continued

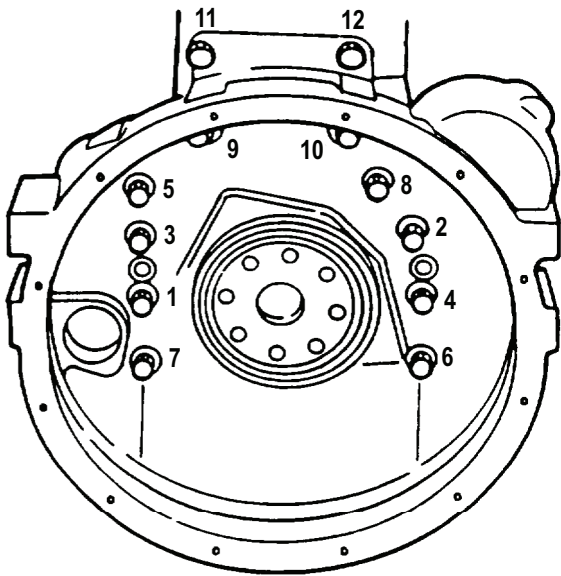

**FLYWHEEL HOUSING
TORQUE SEQUENCE**

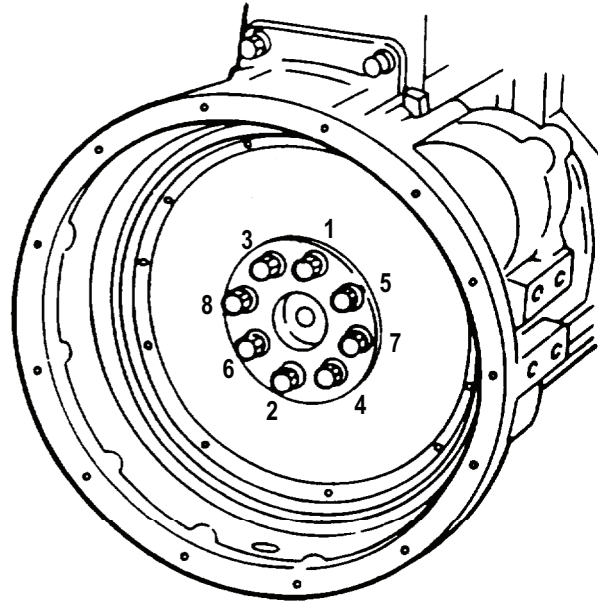

**FLEXPLATE
TORQUE SEQUENCE**

M10380DAA

Figure 3. Flexplate and Flywheel Assembly Torque Sequence.

END OF TASK

FOLLOW-ON MAINTENANCE

Install transmission. (Volume 3, WP 0372)

END OF TASK

END OF WORK PACKAGE

**FIELD MAINTENANCE
VALVE COVER REPLACEMENT (M939A2)**

INITIAL SETUP:**Tools and Special Tools**

Tool Kit, General Mechanic's: Automotive
(Volume 5, WP 0826, Table 1, Item 56)
Wrench, Torque, Click, Ratcheting, 1/2" Drive,
250 Ft-Lb
(Volume 5, WP 0826, Table 1, Item 63)

Materials/Parts

Cap Set, Protective, Dust and Moisture Seal
(Volume 5, WP 0825, Table 1, Item 13)
Gasket (Volume 5, WP 0827, Table 1, Item 130)
Qty: 1
Locknut (Volume 5, WP 0827, Table 1, Item 273)
Qty: 2

Materials/Parts (cont.)

O-ring (Volume 5, WP 0827, Table 1, Item 133)
Qty: 1
O-ring (Volume 5, WP 0827, Table 1, Item 136)
Qty: 6
Seal (Volume 5, WP 0827, Table 1, Item 127)
Qty: 1

Equipment Condition

Parking brake set. (TM 9-2320-272-10)
Hood raised and secured. (TM 9-2320-272-10)
Reservoirs drained. (TM 9-2320-272-10)
Coolant drained. (WP 0287)
Air cleaner hose removed. (WP 0248)

REMOVAL**CAUTION**

Cover turbocharger ports immediately after removing attaching parts to prevent foreign objects from lodging in blades of turbocharger.

NOTE

- Tag all lines and connections for later installation.
 - Plug all lines when removed to prevent dripping fluids and contaminated lines.
1. Disconnect air lines (Figure 1, Items 14 and 16) from elbows (Figure 1, Items 13 and 15).
 2. Remove four clamps (Figure 1, Item 10) and two hoses (Figure 1, Item 11) from aftercooler tubes (Figure 1, Item 7) and aftercooler (Figure 1, Item 12).
 3. Remove two screws (Figure 1, Item 4) and clamps (Figure 1, Item 5) from breather tube (Figure 1, Item 3) and valve cover (Figure 1, Item 6).
 4. Remove two clamps (Figure 1, Item 1) and hose (Figure 1, Item 2) from vent connector (Figure 1, Item 17) and breather tube (Figure 1, Item 15).
 5. Remove clamp (Figure 1, Item 8) and hose (Figure 1, Item 9) from breather tube (Figure 1, Item 3).

REMOVAL - Continued

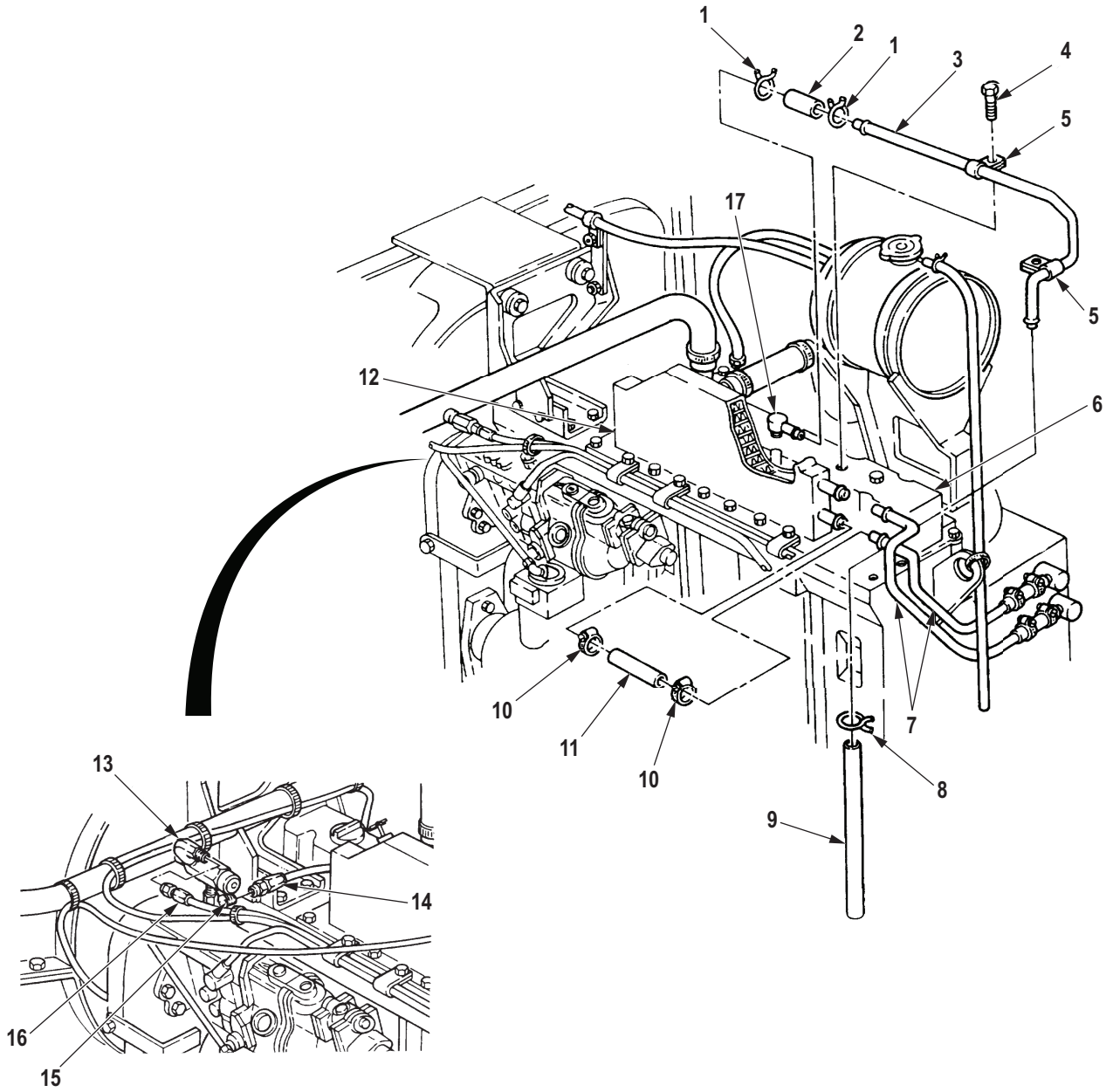

M0014DAA

Figure 1. Breather Tube Removal.

REMOVAL - Continued

6. Remove clamps (Figure 2, Item 12) from radiator inlet tube (Figure 2, Item 13), hose (Figure 2, Item 8), and cable (Figure 2, Item 9).
7. Remove two locknuts (Figure 2, Item 4), washers (Figure 2, Item 3), screws (Figure 2, Item 1), and washers (Figure 2, Item 2) from bracket (Figure 2, Item 7) and inlet tube (Figure 2, Item 13). Discard locknuts.
8. Loosen clamps (Figure 2, Items 5 and 10) on elbow (Figure 2, Item 6) and hose (Figure 2, Item 11).
9. Remove radiator inlet tube (Figure 2, Item 13) from elbow (Figure 2, Item 6) and hose (Figure 2, Item 11).

REMOVAL - Continued

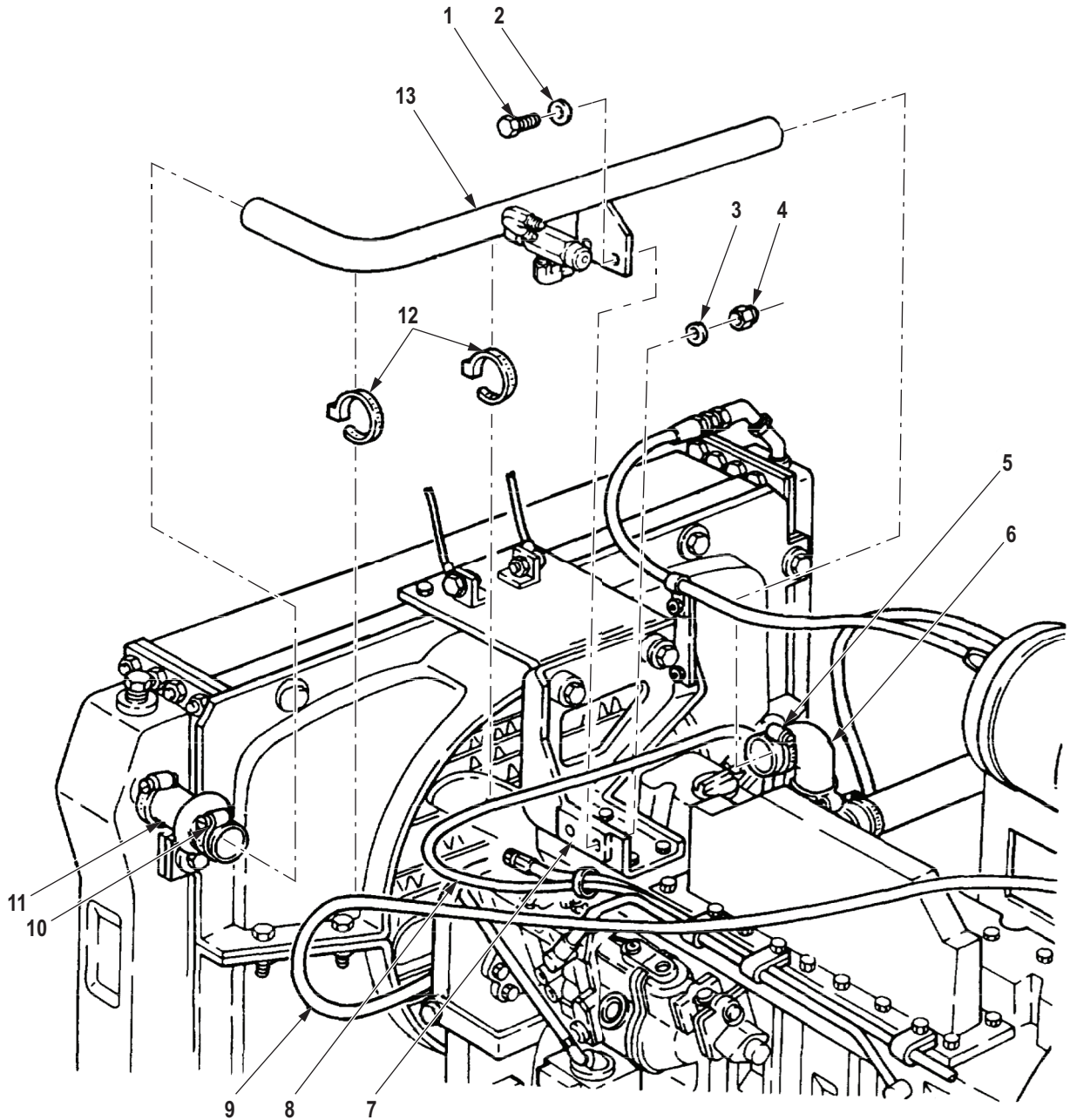

M0015DAA

Figure 2. Radiator Inlet Tube Removal.

REMOVAL - Continued

10. Loosen clamps (Figure 3, Items 6, 11, and 13) on hoses (Figure 3, Items 5, 10, and 12).
11. Remove hoses (Figure 3, Items 4, 5, 10, and 12) from surge tank assembly (Figure 3, Item 2).
12. Remove nut (Figure 3, Item 7) and screw (Figure 3, Item 1) from surge tank assembly (Figure 3, Item 2) and angle support bracket (Figure 3, Item 8).
13. Remove two screws (Figure 3, Item 3) and surge tank assembly (Figure 3, Item 2) from exhaust manifold (Figure 3, Item 9).

REMOVAL - Continued

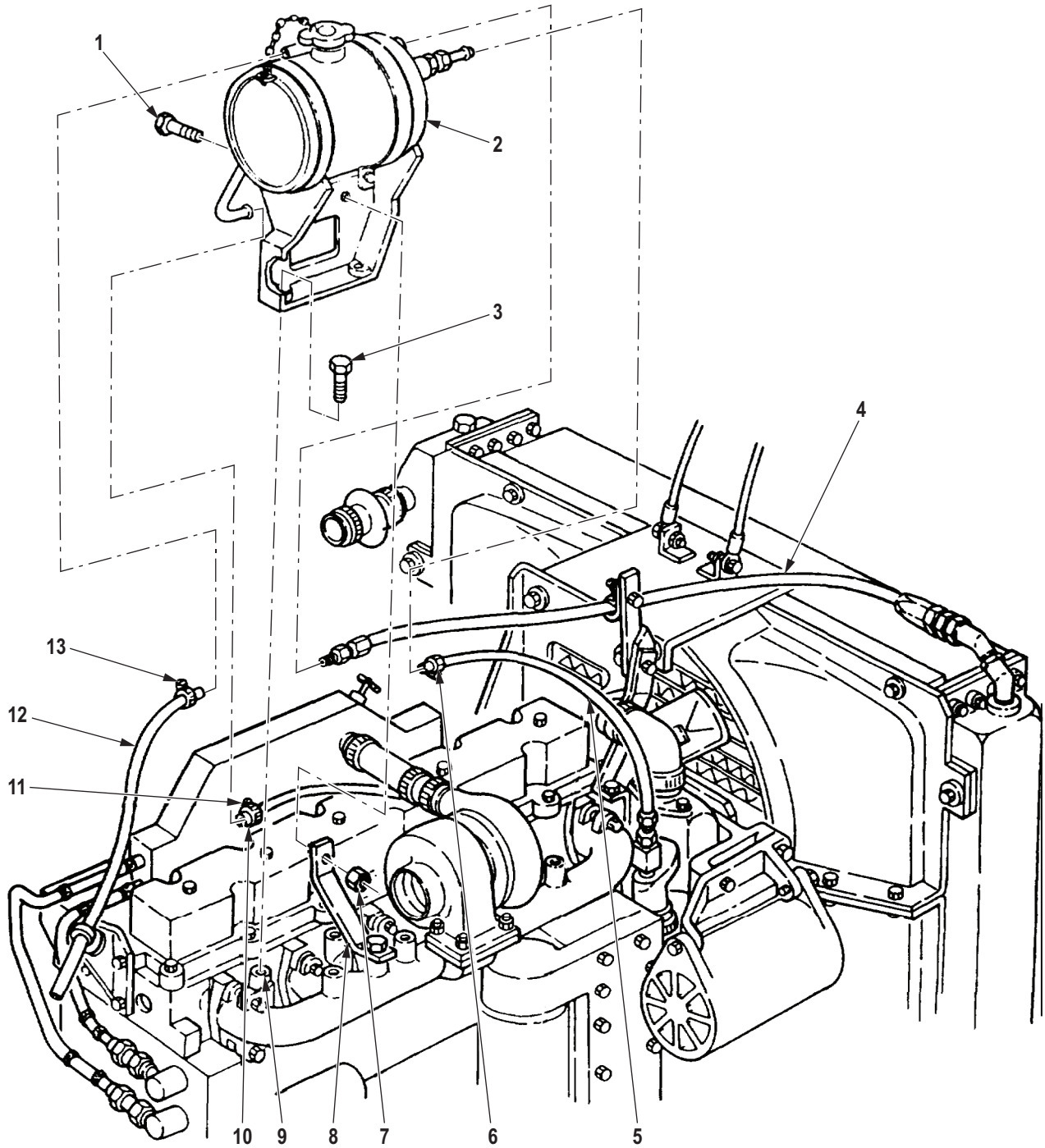

M0016DAA

Figure 3. Surge Tank Assembly Removal.

REMOVAL - Continued

14. Loosen four clamps (Figure 4, Item 4) on crossover tube (Figure 4, Item 5) and two hoses (Figure 4, Item 6).
15. Slide two hoses (Figure 4, Item 6) over crossover tube (Figure 4, Item 5) and remove crossover tube from turbocharger (Figure 4, Item 9) and aftercooler (Figure 4, Item 11).
16. Remove six screws (Figure 4, Item 15), o-rings (Figure 4, Item 14), valve cover (Figure 4, Item 13) and gasket (Figure 4, Item 12) from cylinder head (Figure 4, Item 10). Discard o-rings.
17. Turn valve cover (Figure 4, Item 13) upside down, depress locking tabs (Figure 4, Item 3) on vent connector (Figure 4, Item 2), and remove vent connector (Figure 4, Item 2) and o-ring (Figure 4, Item 1) from valve cover (Figure 4, Item 13). Discard o-ring.
18. Remove filler cap (Figure 4, Item 7) and seal (Figure 4, Item 8) from valve cover (Figure 4, Item 13). Discard seal.

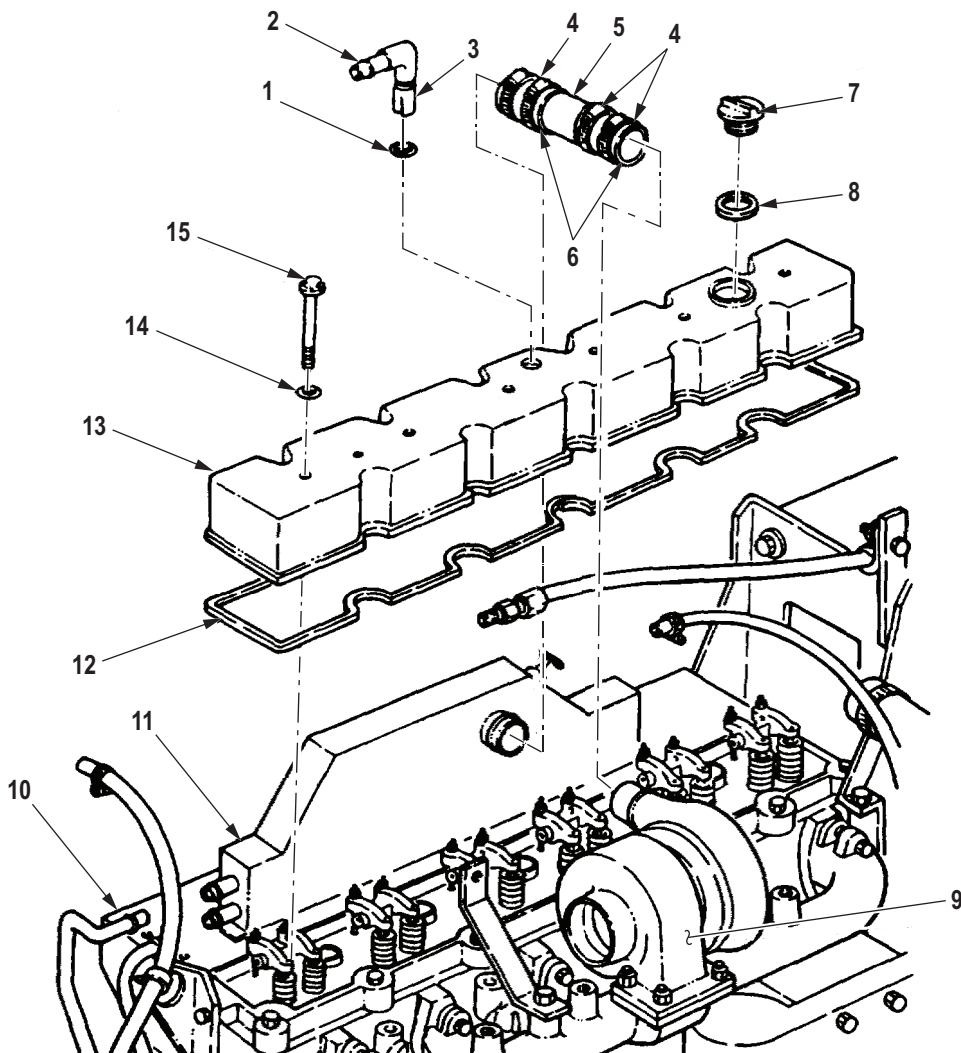

M0017DAA

Figure 4. Valve Cover Removal.

END OF TASK

CLEANING AND INSPECTION**WARNING**

Solvent cleaning compound is flammable and toxic. Do not use near an open flame and always have a fire extinguisher nearby when solvents are used. Use only in well-ventilated places, wear protective clothing, and dispose of cleaning rags in approved container. Failure to comply may result in damage to equipment, injury, or death to personnel.

1. Clean remains of valve cover gasket and gasket sealant from valve cover and cylinder head.
2. Clean breather tube with solvent cleaning compound and dry with clean rag.
3. Inspect breather tube for obstructions or collapsed and bent sections that could cause restrictions. Remove obstructions or replace breather tube if bent.
4. Inspect hoses for obstructions, tears, flat spots, or other deformities that could cause restrictions. Remove obstructions or replace hoses if torn or deformed.
5. Inspect vent connector. Replace if nicked, cracked, or damaged.
6. Inspect valve cover for distortion, cracks, or nicks in casting that would prevent a tight seal. Replace if damaged.

END OF TASK

INSTALLATION

1. Install seal (Figure 5, Item 8) and filler cap (Figure 5, Item 7) on valve cover (Figure 5, Item 13).

CAUTION

Valve cover gasket must extend into overlap area. Trim excess overlap, and do not stretch valve cover gasket. Damage to gasket may result.

2. Turn valve cover (Figure 5, Item 13) upside down and install valve cover gasket (Figure 5, Item 12) on valve cover, overlapping ends in the overlap area (Figure 5, Item 16). Apply gasket sealant to overlap area.
3. Compress locking tabs (Figure 5, Item 3) of vent connector (Figure 5, Item 2), and install o-ring (Figure 5, Item 1) and vent connector on valve cover (Figure 5, Item 13).
4. Install valve cover (Figure 5, Item 13) on cylinder head (Figure 5, Item 10) with six o-rings (Figure 5, Item 12) and screws (Figure 5, Item 15). Tighten screws 18 lb-ft (24 N·m).

CAUTION

Ensure covers are removed from turbocharger intake output port and aftercooler inlet port prior to installing crossover tube. Failure to do so may cause damage to equipment.

5. Install crossover tube (Figure 5, Item 5) by sliding two hoses (Figure 5, Item 6) onto turbocharger (Figure 5, Item 9) and aftercooler (Figure 5, Item 11) and tighten four clamps (Figure 5, Item 4).

INSTALLATION - Continued

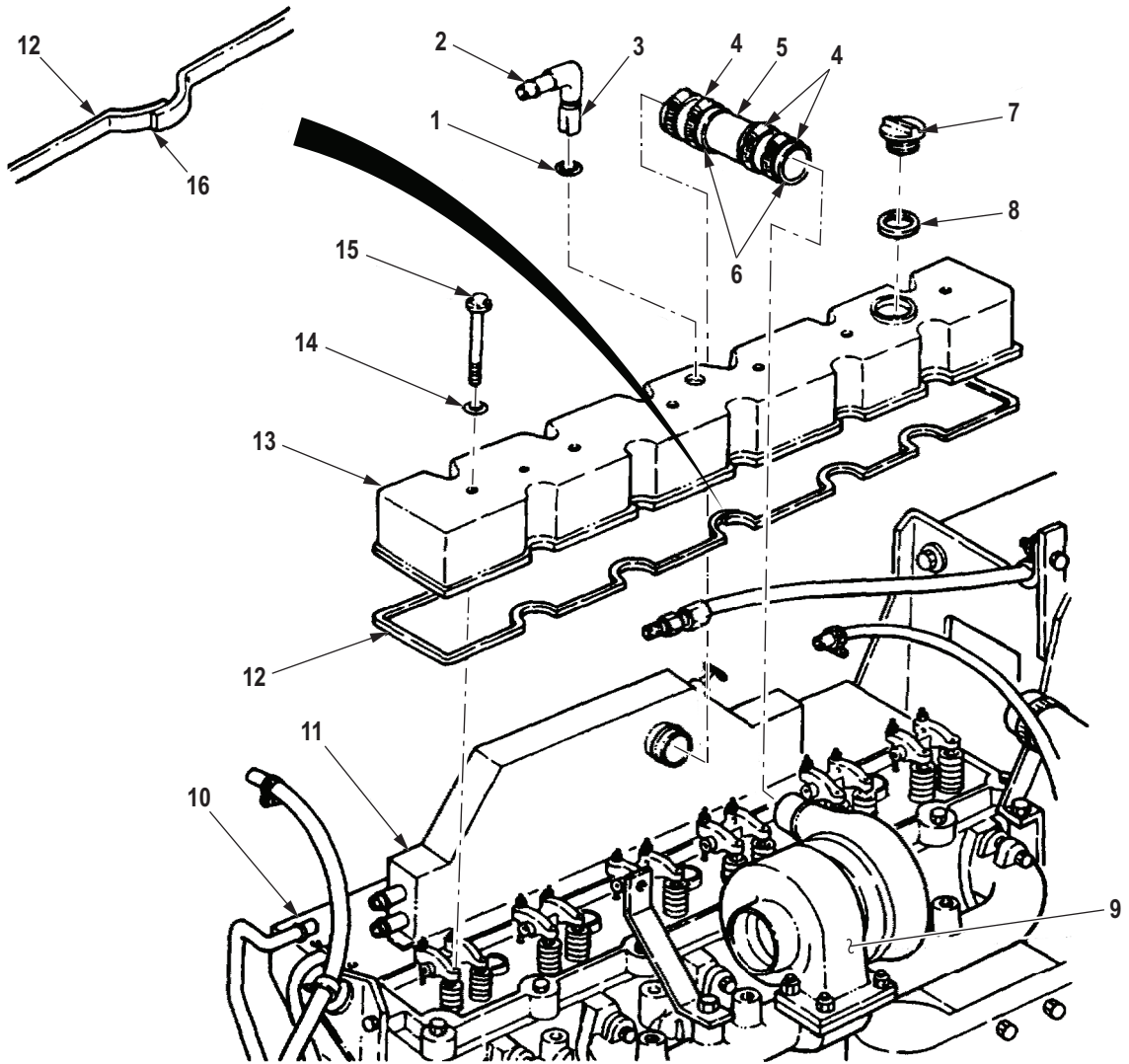

M0018DAA

Figure 5. Valve Cover Installation.

INSTALLATION - Continued

6. Install surge tank assembly (Figure 6, Item 2) on exhaust manifold (Figure 6, Item 9) with two screws (Figure 6, Item 3). Tighten screws 50 to 55 lb-ft (68 to 75 N·m).
7. Install surge tank assembly (Figure 6, Item 2) on angle support bracket (Figure 6, Item 8) with screw (Figure 6, Item 1) and nut (Figure 6, Item 7). Tighten screw 35 to 40 lb-ft (47 to 54 N·m).
8. Install hoses (Figure 6, Items 4, 5, 10, and 12) on surge tank assembly (Figure 6, Item 2) and tighten clamps (Figure 6, Items 6, 11, and 13).

INSTALLATION - Continued

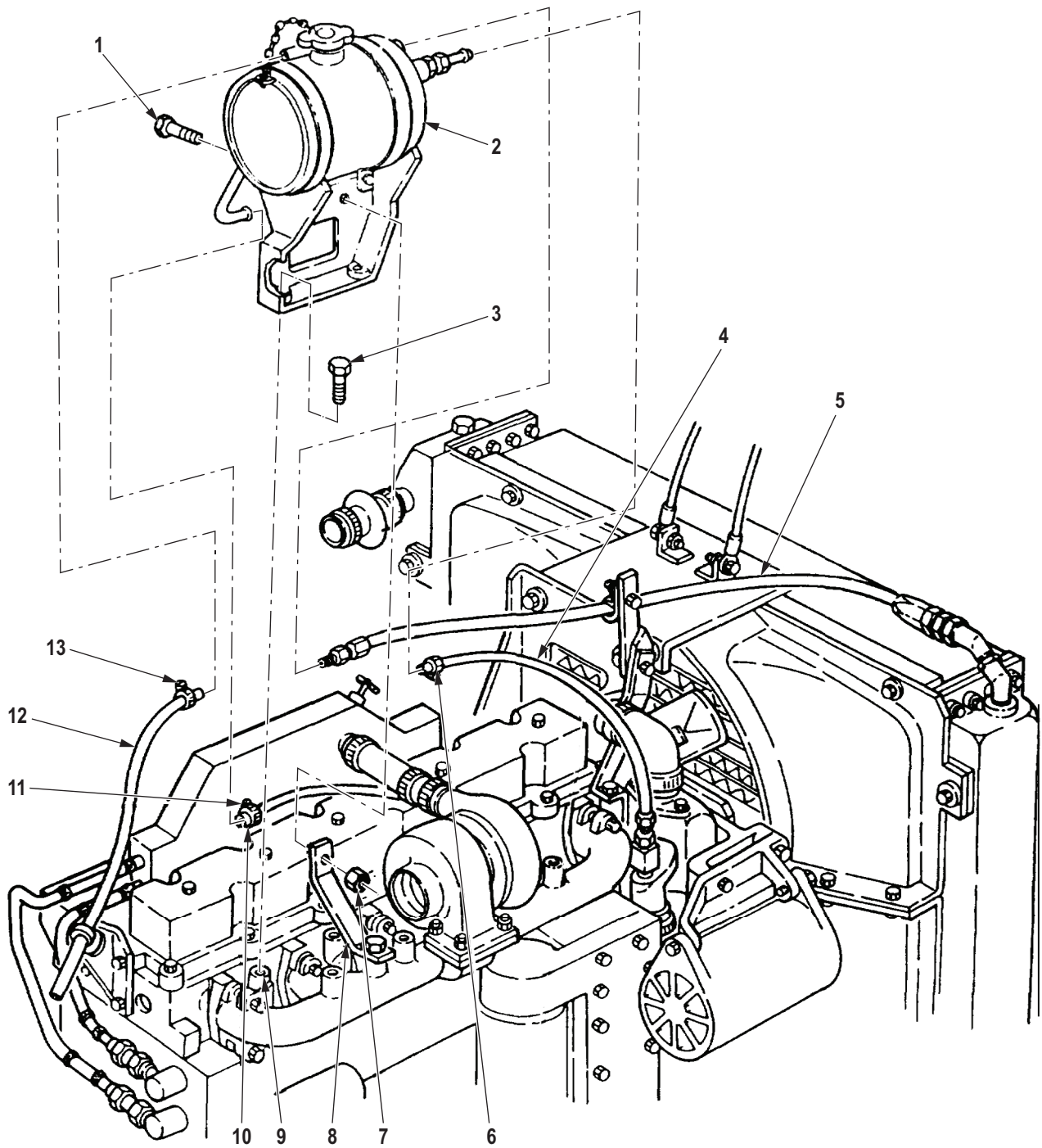

M0019DAA

Figure 6. Surge Tank Assembly Installation.

INSTALLATION - Continued

9. Install radiator inlet tube (Figure 7, Item 1) on hose (Figure 7, Item 12) and elbow (Figure 7, Item 7) and tighten clamps (Figure 7, Items 6 and 11).
10. Install radiator inlet tube (Figure 7, Item 1) on bracket (Figure 7, Item 8) with two washers (Figure 7, Item 3), screws (Figure 7, Item 2), washers (Figure 7, Item 4), and locknuts (Figure 7, Item 5).
11. Connect hose (Figure 7, Item 9) and cable (Figure 7, Item 10) to inlet tube (Figure 7, Item 1) with tiedown straps (Figure 7, Item 13), as required, to keep hose and cable (Figure 7, Item 10) clear of moving parts.

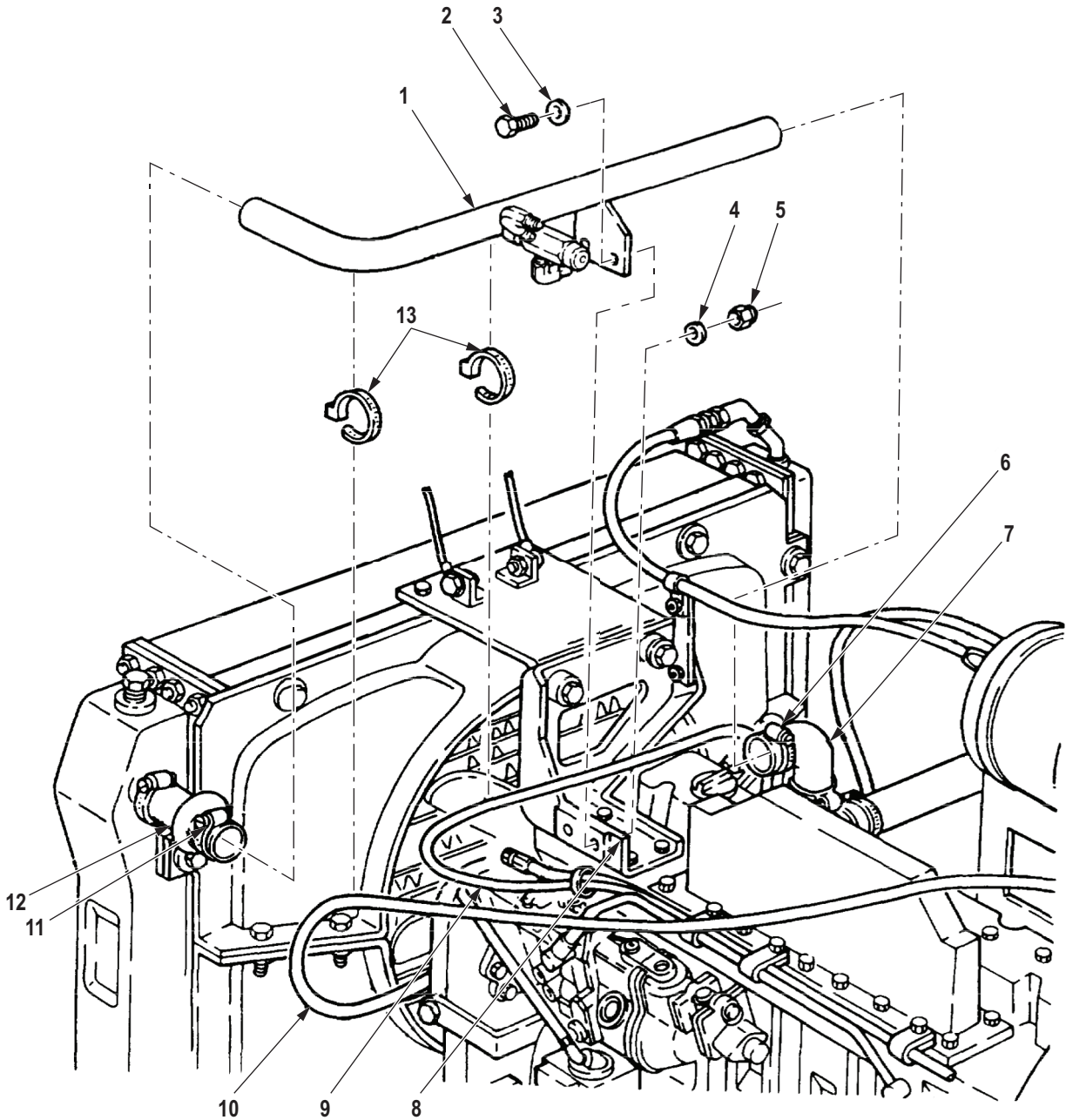

Figure 7. Radiator Inlet Tube Installation.

INSTALLATION - Continued

12. Install breather tube (Figure 8, Item 3) and hose (Figure 8, Item 2) on vent connector (Figure 8, Item 13) with two clamps (Figure 8, Item 1).
13. Install hose (Figure 8, Item 9) on breather tube (Figure 8 Item 3) with clamp (Figure 8, Item 8).
14. Install two clamps (Figure 8, Item 5) on breather tube (Figure 8, Item 3) and valve cover (Figure 8, Item 6) with two screws (Figure 8, Item 4).

NOTE

Remove plugs from all lines before making connections. Be prepared to catch any dripping of fluids when lines are uncapped.

15. Install two hoses (Figure 8, Item 11) on aftercooler (Figure 8, Item 12) and aftercooler tubes (Figure 8, Item 7) with four clamps (Figure 8, Item 10).

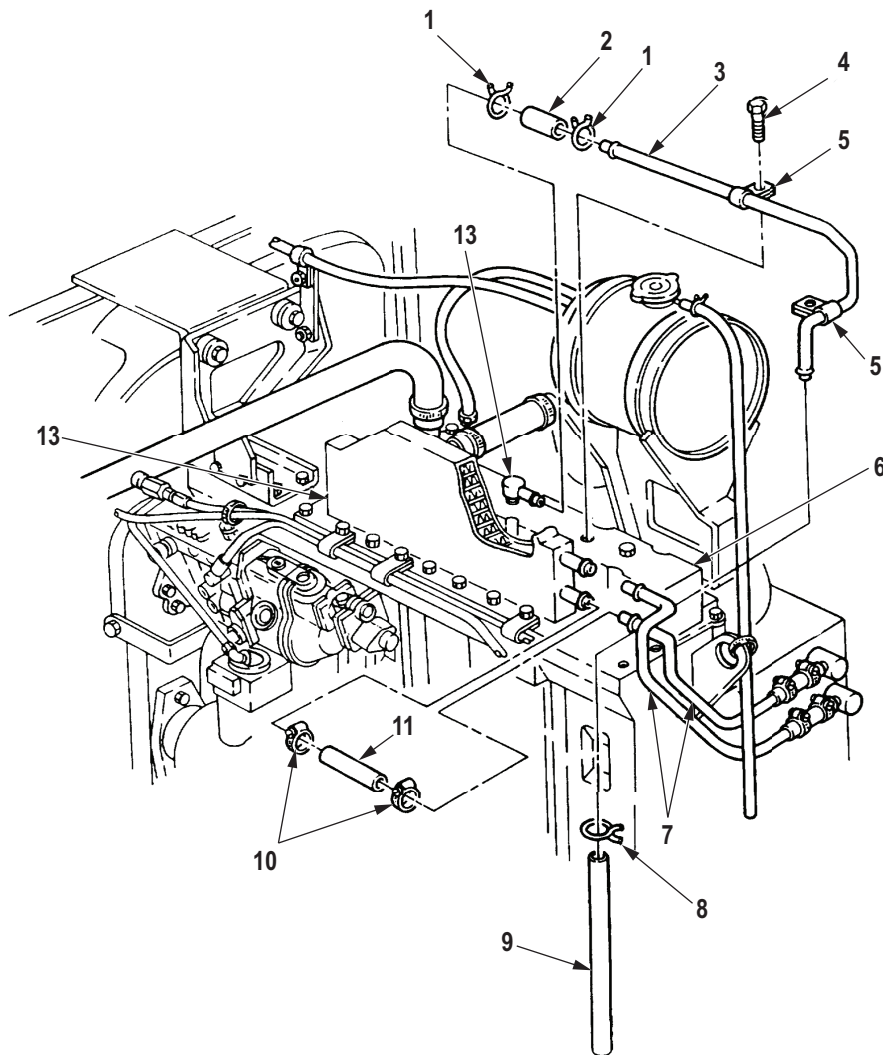

M0021DAA

Figure 8. Breather Tube Installation.

INSTALLATION - Continued**CAUTION**

Ensure drain valve on aftercooler is open when filling cooling system. Failure to do so may result in damage to equipment.

16. Connect air lines (Figure 9, Items 3 and 5) to elbows (Figure 9, Items 1 and 4). Secure air lines (Figure 9, Items 3 and 5) to radiator inlet tube (Figure 9, Item 16) with tiedown straps (Figure 9, Item 2), as required.

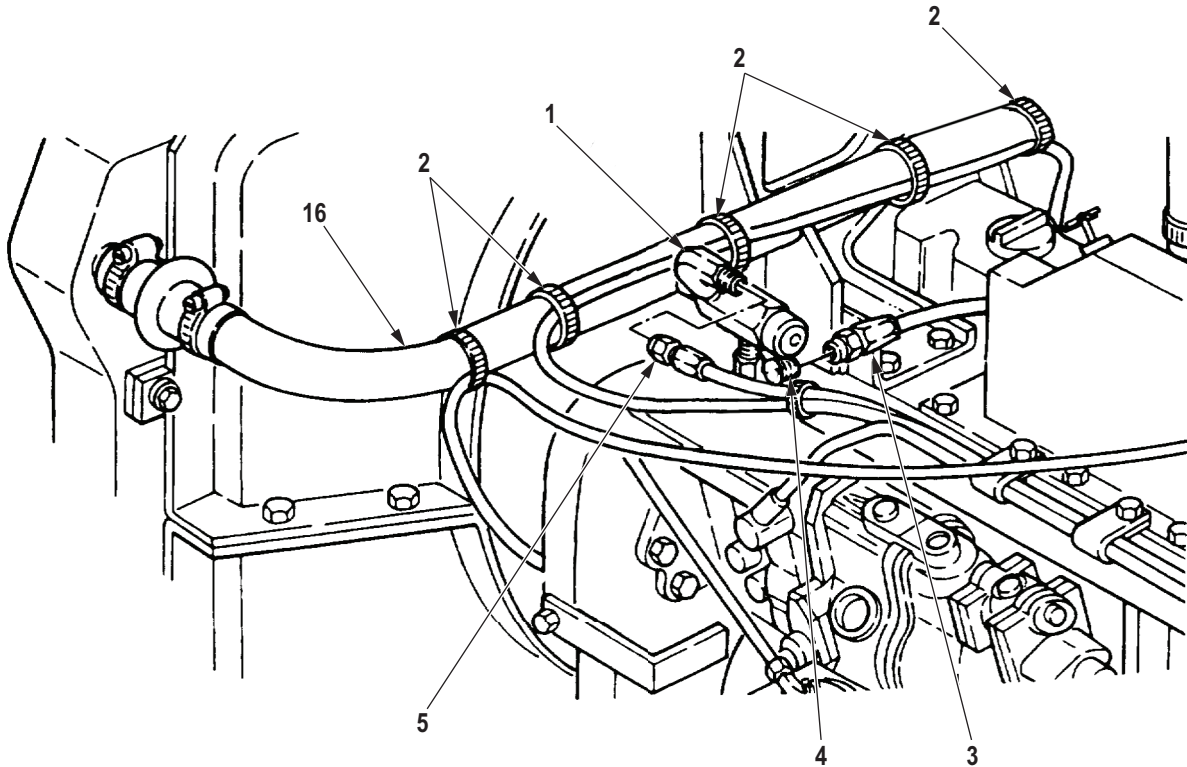

M0022DAA

Figure 9. Air Lines Installation.

END OF TASK**FOLLOW-ON MAINTENANCE**

1. Install air cleaner hose. (WP 0248)
2. Fill coolant to proper level. (WP 0287)
3. Start engine and check for leaks. (TM 9-2320-272-10)
4. Check coolant level and add coolant as necessary. (TM 9-2320-272-10)

END OF TASK**END OF WORK PACKAGE**

FIELD MAINTENANCE
CRANKCASE BREATHER AND TUBE REPLACEMENT (M939/A1/A2)

INITIAL SETUP:**Tools and Special Tools**

Tool Kit, General Mechanic's: Automotive
(Volume 5, WP 0826, Table 1, Item 56)

Materials/Parts

Antiseize Compound
(Volume 5, WP 0825, Table 1, Item 9)
Cleaning Compound, Solvent
(Volume 5, WP 0825, Table 1, Item 16, 17)
Rag, Wiping
(Volume 5, WP 0825, Table 1, Item 53)
Sealing Compound
(Volume 5, WP 0825, Table 1, Item 56)
Locknut (M939/A1 Early Model Engines)
(Volume 5, WP 0827, Table 1, Item 320)
Qty: 1
Lockwasher (Early Model Engines)
(Volume 5, WP 0827, Table 1, Item 186)
Qty: 1

Equipment Condition (cont.)

Hood raised and secured. (TM 9-2320-272-10)
Right splash shield removed (M939/A1).
(TM 9-2320-272-10)
Coolant drained (M939A2). (WP 0287)

Equipment Condition

Parking brake set. (TM 9-2320-272-10)

BREATHER AND TUBE REMOVAL (M939/A1)**NOTE**

- References to early model engines refer to engines with a serial number before 11246664 used in M939/A1 series vehicles.
 - Perform Steps (1) and (2) on M939/A1 vehicles with late model engines and Steps (3) through (5) on M939/A1 vehicles early model engines.
1. Remove four clamps (Figure 1, Item 2), two breather hoses (Figure 1, Item 3), and breather tube (Figure 1, Item 4) from crankcase breather (Figure 1, Item 1) and elbow (Figure 1, Item 5).
 2. Remove elbow (Figure 1, Item 5) from air connector (Figure 1, Item 6).
 3. Remove locknut (Figure 1, Item 14), screw (Figure 1, Item 10), and clamp (Figure 1, Item 13) from mounting bracket (Figure 1, Item 9) and breather tube (Figure 1, Item 4). Discard locknut.
 4. Remove screw (Figure 1, Item 12), lockwasher (Figure 1, Item 11), and mounting bracket (Figure 1, Item 9) from engine (Figure 1, Item 8). Discard lockwasher.
 5. Remove two clamps (Figure 1, Item 2), breather hose (Figure 1, Item 3), and breather tube (Figure 1, Item 4) from crankcase breather (Figure 1, Item 1).

CAUTION

Perform Step (6) only if crankcase breather requires replacement. Removal will permanently damage breather, and it must be replaced.

6. Mark position of crankcase breather (Figure 1, Item 1) on valve cover (Figure 1, Item 7) and remove breather.

BREATHER AND TUBE REMOVAL (M939/A1) - Continued

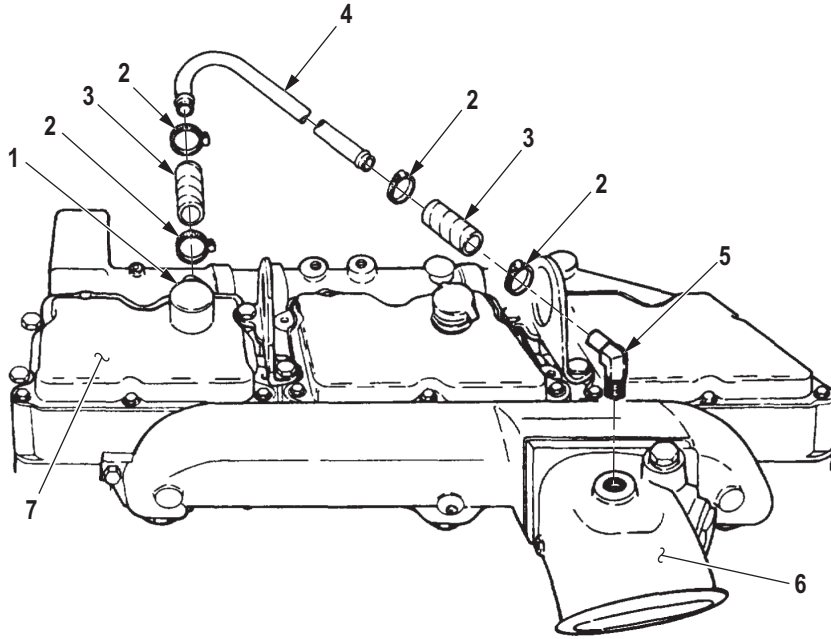

M939/A1 LATE MODEL ENGINE

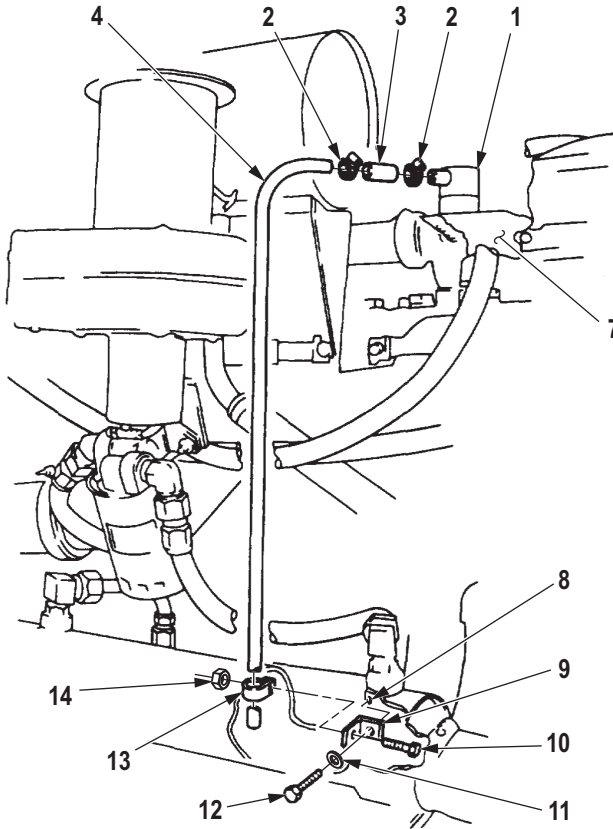

M939/A1 EARLY MODEL ENGINE

M0001DAA

Figure 1. Crankcase Breather and Tube Removal.

END OF TASK

BREATHING TUBE REMOVAL (M939A2)

1. Remove four hose clamps (Figure 2, Item 11) and two hoses (Figure 2, Item 12) from aftercooler tubes (Figure 2, Item 8) and aftercooler (Figure 2, Item 13).
2. Remove two screws (Figure 2, Item 4), clamps (Figure 2, Item 5), and breathing tube (Figure 2, Item 6) from valve cover (Figure 2, Item 7).
3. Remove two hose clamps (Figure 2, Item 3) and hose (Figure 2, Item 2) from vent connector (Figure 2, Item 1) and breathing tube (Figure 2, Item 6).
4. Remove hose clamp (Figure 2, Item 9) and hose (Figure 2, Item 10) from breathing tube (Figure 2, Item 6).

BREATHER TUBE REMOVAL (M939A2) - Continued

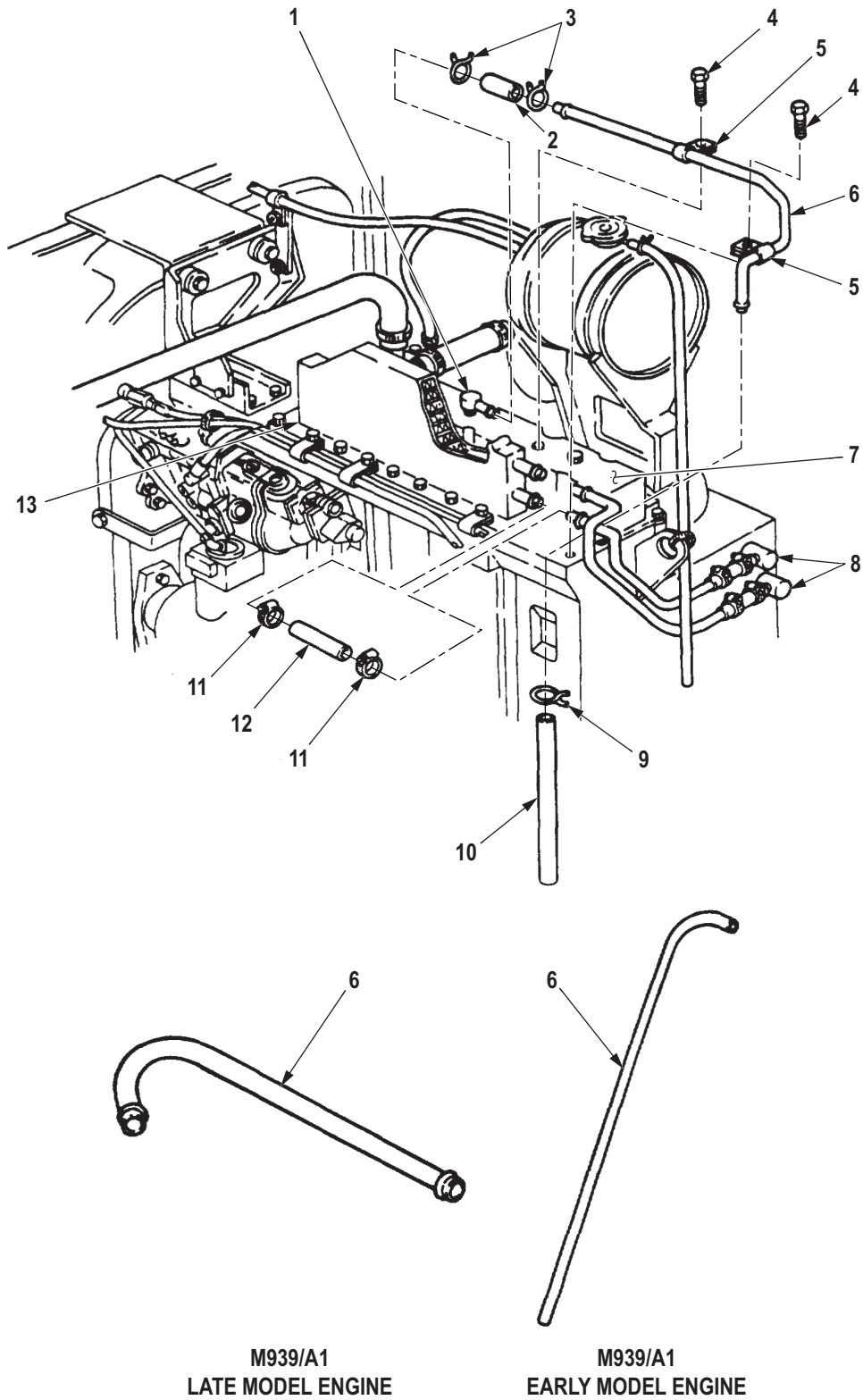

Figure 2. Crankcase Breather and Tube Removal.

END OF TASK

BREATHER TUBE INSTALLATION (M939A2)

1. Install hose (Figure 3, Item 10) on breather tube (Figure 3, Item 6) with clamp (Figure 3, Item 9).
2. Install hose (Figure 3, Item 2) on breather tube (Figure 3, Item 6) and vent connector (Figure 3, Item 1) with two clamps (Figure 3, Item 3).
3. Install two clamps (Figure 3, Item 5) on valve cover (Figure 3, Item 7) with two screws (Figure 3, Item 4).

CAUTION

For M939A2 series vehicles, ensure drain valve on aftercooler is open when filling cooling system. Failure to do so may result in damage to equipment.

4. Install two hoses (Figure 3, Item 12) on aftercooler (Figure 3, Item 13) and aftercooler tubes (Figure 3, Item 8) with four clamps (Figure 3, Item 11).

BREATHER TUBE INSTALLATION (M939A2) - Continued

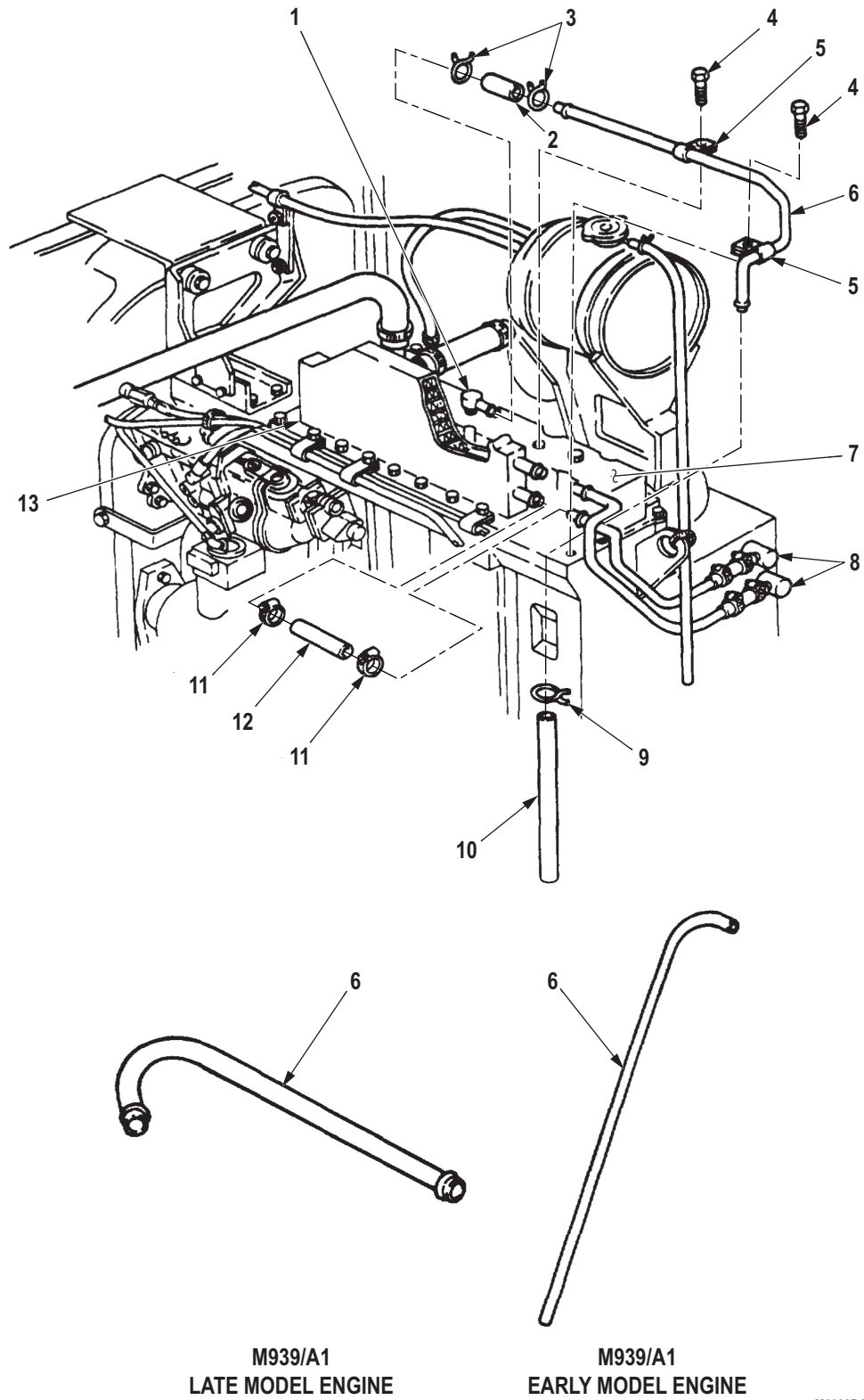

M0003DAA

Figure 3. Crankcase Breather and Tube Installation.

END OF TASK

BREATHER AND TUBE INSTALLATION (M939/A1)**NOTE**

Perform Steps (1) and (2) if breather was removed.

1. Apply adhesive sealant to mating surfaces of crankcase breather (Figure 4, Item 1) and valve cover (Figure 4, Item 7).
2. Install crankcase breather (Figure 4, Item 1) on valve cover (Figure 4, Item 7) and align with mark.

NOTE

Perform Steps (3) and (4) on vehicles with late model engines and Steps (5) through (7) on vehicles with early model engines.

3. Apply antiseize compound to threads of elbow (Figure 4, Item 5) and install on air connector (Figure 4, Item 6).
4. Install two breather hoses (Figure 4, Item 3) and breather tube (Figure 4, Item 4) on elbow (Figure 4, Item 5) and crankcase breather (Figure 4, Item 1) with four hose clamps (Figure 4, Item 2).
5. Install breather hose (Figure 4, Item 17) and breather tube (Figure 4, Item 15) on crankcase breather (Figure 4, Item 1) with two clamps (Figure 4, Item 16).
6. Install mounting bracket (Figure 4, Item 9) on engine (Figure 4, Item 8) with lockwasher (Figure 4, Item 11) and screw (Figure 4, Item 12).
7. Install clamp (Figure 4, Item 13) on mounting bracket (Figure 4, Item 9) and breather tube (Figure 4, Item 15) with screw (Figure 4, Item 10) and locknut (Figure 4, Item 14).

BREATHER AND TUBE INSTALLATION (M939/A1) - Continued

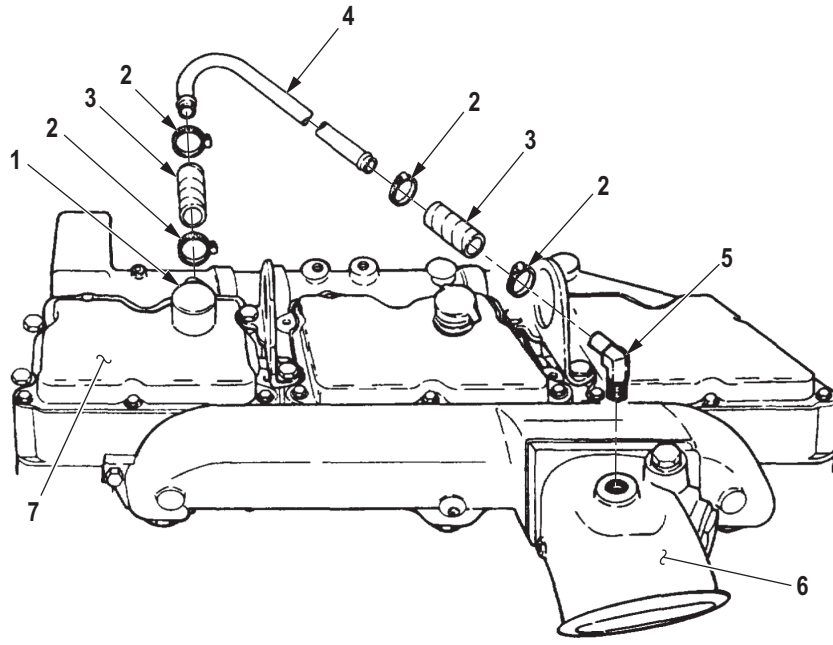

M939/A1 LATE MODEL ENGINE

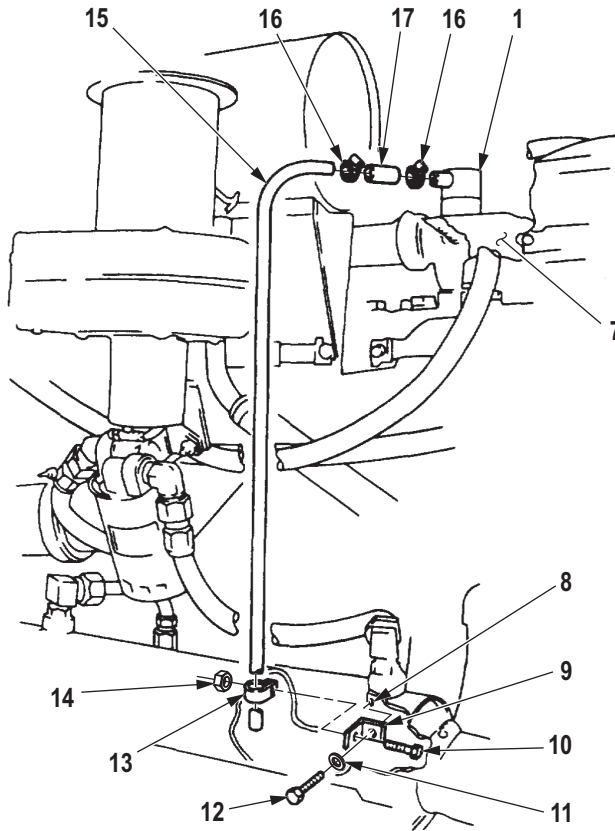

M939/A1 EARLY MODEL ENGINE

M0004DAA

Figure 4. Crankcase Breather and Tube Installation.

END OF TASK

FOLLOW-ON MAINTENANCE

1. Fill cooling system to proper level (M939A2). (WP 0287)
2. Install right splash shield (M939/A1). (TM 9-2320-272-10)

END OF TASK**END OF WORK PACKAGE**

**FIELD MAINTENANCE
OIL PUMP PICKUP HOSE REPLACEMENT (M939/A1)**

INITIAL SETUP:**Tools and Special Tools**

Tool Kit, General Mechanic's: Automotive
(Volume 5, WP 0826, Table 1, Item 56)
Wrench, Torque, Click, Ratcheting, 3/8" Drive,
75 Ft-Lb
(Volume 5, WP 0826, Table 1, Item 62)

Materials/Parts

Tape, Antiseizing
(Volume 5, WP 0825, Table 1, Item 65)

References

Volume 5, WP 0820

Equipment Condition

Parking brake set. (TM 9-2320-272-10)
Hood raised and secured. (TM 9-2320-272-10)
Left splash shield removed. (TM 9-2320-272-10)
Engine oil drained. (WP 0232)

REMOVAL**NOTE**

- Engine oil pan is mounted with screw-assembled washers on late model engines.
 - Have adequate drainage container ready to catch oil.
1. Remove two screws (Figure 1, Item 5), washers (Figure 1, Item 6), and clamps (Figure 1, Item 4) from oil pump pickup and return hoses (Figure 1, Items 1 and 7) and engine oil pan (Figure 1, Item 2).
 2. Disconnect oil pump pickup hose (Figure 1, Item 1) from adapter flange (Figure 1, Item 3) and oil pump (Figure 1, Item 8).

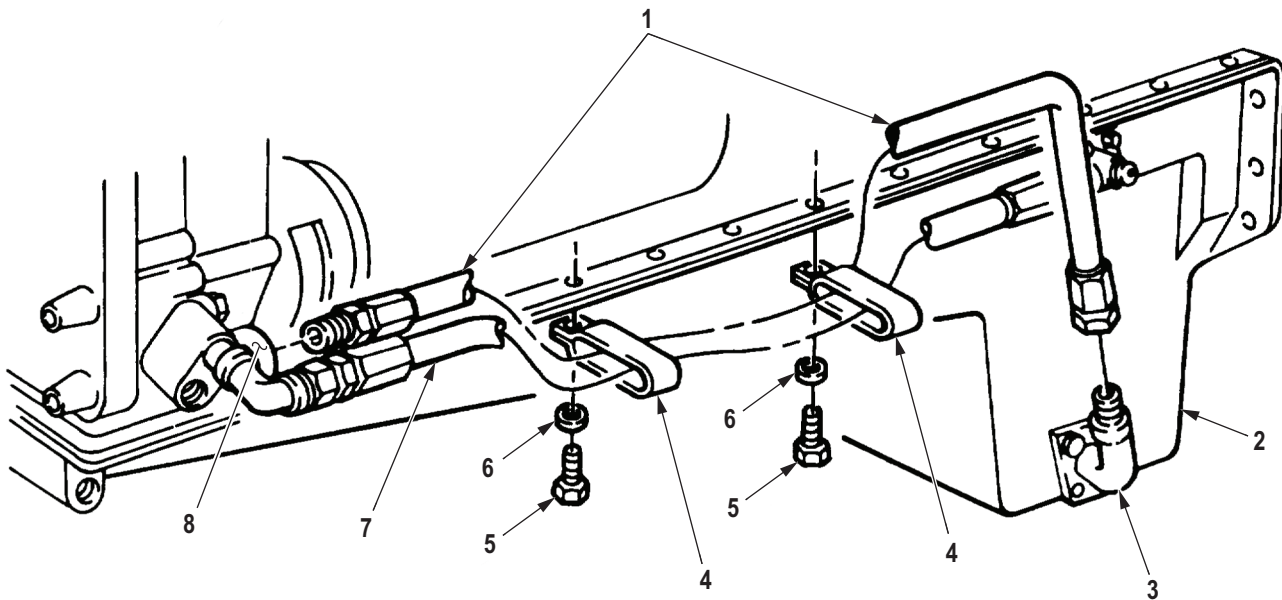

M9433DAA

Figure 1. Oil Pump Pickup Hose Removal.

END OF TASK**INSPECTION**

Inspect oil pump pickup hose. Replace if threads are stripped or hose is cracked or frayed.

END OF TASK

INSTALLATION

1. Apply antiseize tape to male pipe threads of oil pump pickup hose (Figure 2, Item 1) and adapter flange (Figure 2, Item 3).
2. Connect oil pump pickup hose (Figure 2, Item 1) to oil pump (Figure 2, Item 8) and adapter flange (Figure 2, Item 3).
3. Install two clamps (Figure 2, Item 4) on oil pump pickup and return hoses (Figure 2, Items 1 and 7) and engine oil pan (Figure 2, Item 2) with two washers (Figure 2, Item 6) and screws (Figure 2, Item 5). Tighten screws 35 to 40 lb-ft (47 to 54 N-m).

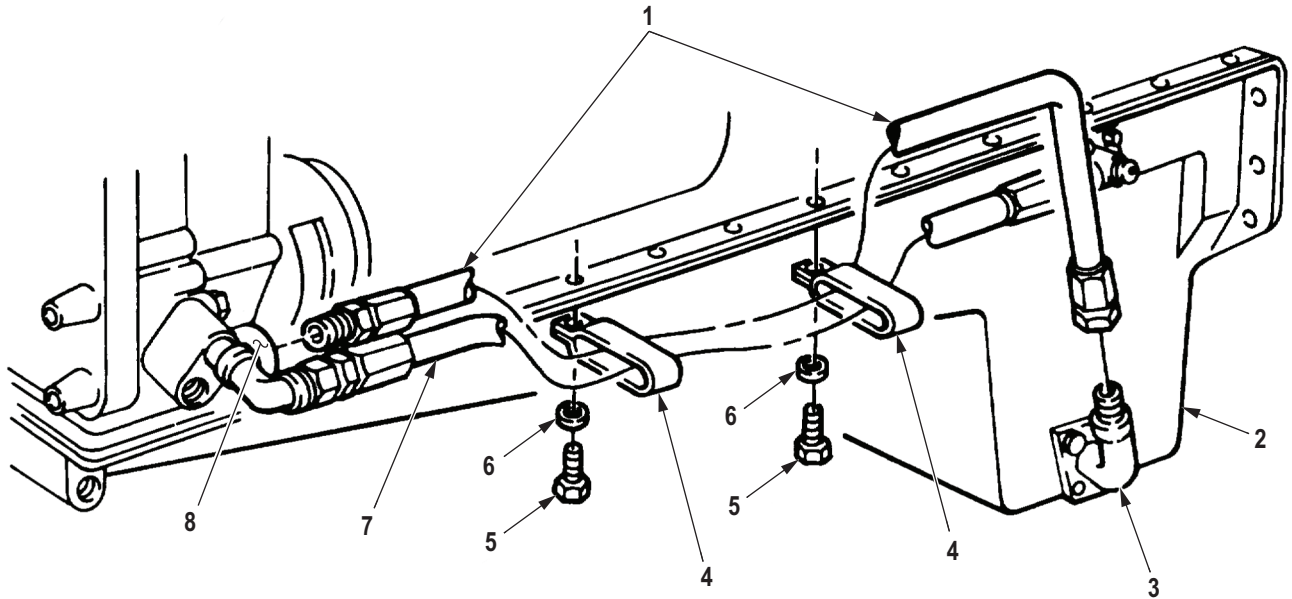

M0023DAA

Figure 2. Oil Pump Pickup Hose Installation.

END OF TASK**FOLLOW-ON MAINTENANCE**

1. Fill engine with oil to proper level. (Volume 5, WP 0820)
2. Start engine and check for leaks. (TM 9-2320-272-10)
3. Check oil level and add oil as necessary. (TM 9-2320-272-10)
4. Install left splash shield. (TM 9-2320-272-10)

END OF TASK**END OF WORK PACKAGE**

FIELD MAINTENANCE
OIL PUMP RETURN HOSE REPLACEMENT (M939/A1)

INITIAL SETUP:**Tools and Special Tools**

Tool Kit, General Mechanic's: Automotive
(Volume 5, WP 0826, Table 1, Item 56)
Wrench, Torque, Click, Ratcheting, 3/8" Drive,
75 Ft-Lb
(Volume 5, WP 0826, Table 1, Item 62)

Equipment Condition (cont.)

Hood raised and secured. (TM 9-2320-272-10)
Left splash shield removed. (TM 9-2320-272-10)
Engine oil drained. (WP 0232)

Materials/Parts

Tape, Antiseizing
(Volume 5, WP 0825, Table 1, Item 65)

Equipment Condition

Parking brake set. (TM 9-2320-272-10)

REMOVAL**NOTE**

Have adequate drainage container ready to catch oil.

1. Remove two screws (Figure 1, Item 7), washers (Figure 1, Item 6), and clamps (Figure 1, Item 5) from oil pump pickup and return hose (Figure 1, Items 1 and 2) and engine oil pan (Figure 1, Item 4).
2. Disconnect oil pump return hose (Figure 1, Item 2) from adapter (Figure 1, Item 8) and oil pan aerator (Figure 1, Item 3).
3. Remove adapter (Figure 1, Item 8), elbow (Figure 1, Item 9), and nipple (Figure 1, Item 10) from oil pump (Figure 1, Item 11).

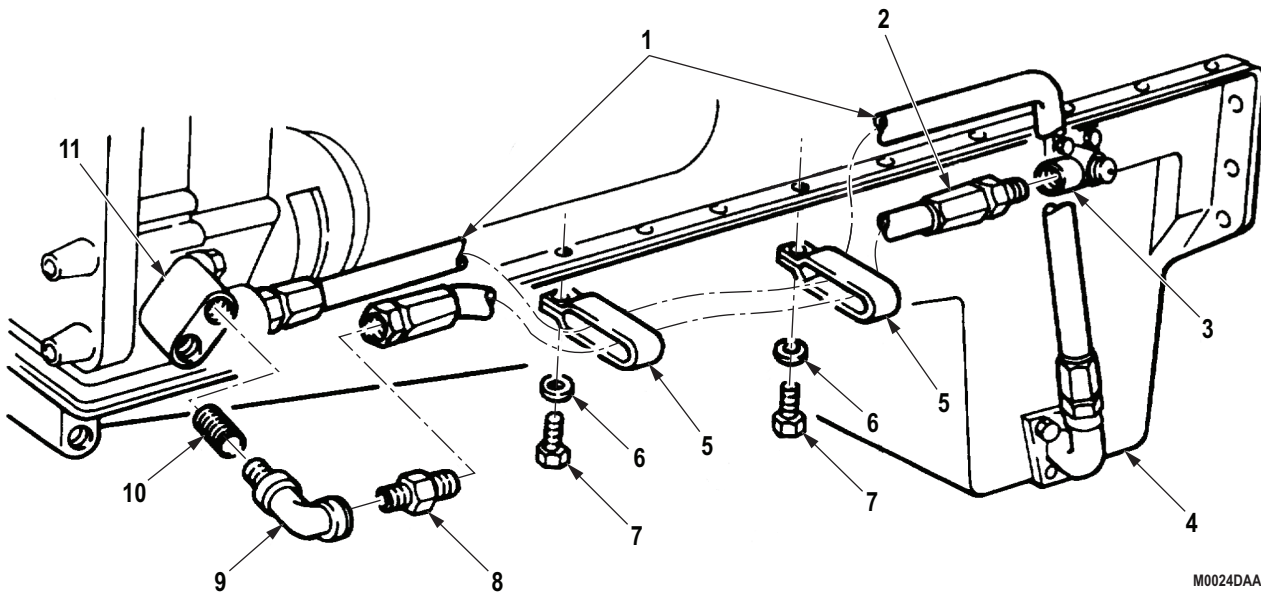

Figure 1. Oil Pump Return Hose Removal.

END OF TASK**INSPECTION**

1. Inspect oil return hose. Replace hose if cracked, frayed, or split.
2. Inspect adapter, elbow, and nipple. Replace if adapter, elbow, or nipple have cracks or threads are stripped or crossed.

END OF TASK

INSTALLATION

1. Apply antiseize tape to male pipe threads of oil pump return hose (Figure 2, Item 2), adapter (Figure 2, Item 9), and nipple (Figure 2, Item 10).
2. Install nipple (Figure 2, Item 10), elbow (Figure 2, Item 9), and adapter (Figure 2, Item 8) on oil pump (Figure 2, Item 11).
3. Connect oil pump return hose (Figure 2, Item 2) to oil pan aerator (Figure 2, Item 3) and adapter (Figure 2, Item 8).
4. Install two clamps (Figure 2, Item 5) and oil pump pickup and return hoses (Figure 2, Items 1 and 2) on engine oil pan (Figure 2, Item 4) with two washers (Figure 2, Item 6) and screws (Figure 2, Item 7). Tighten screws 35 to 40 lb-ft (47 to 54 N·m).

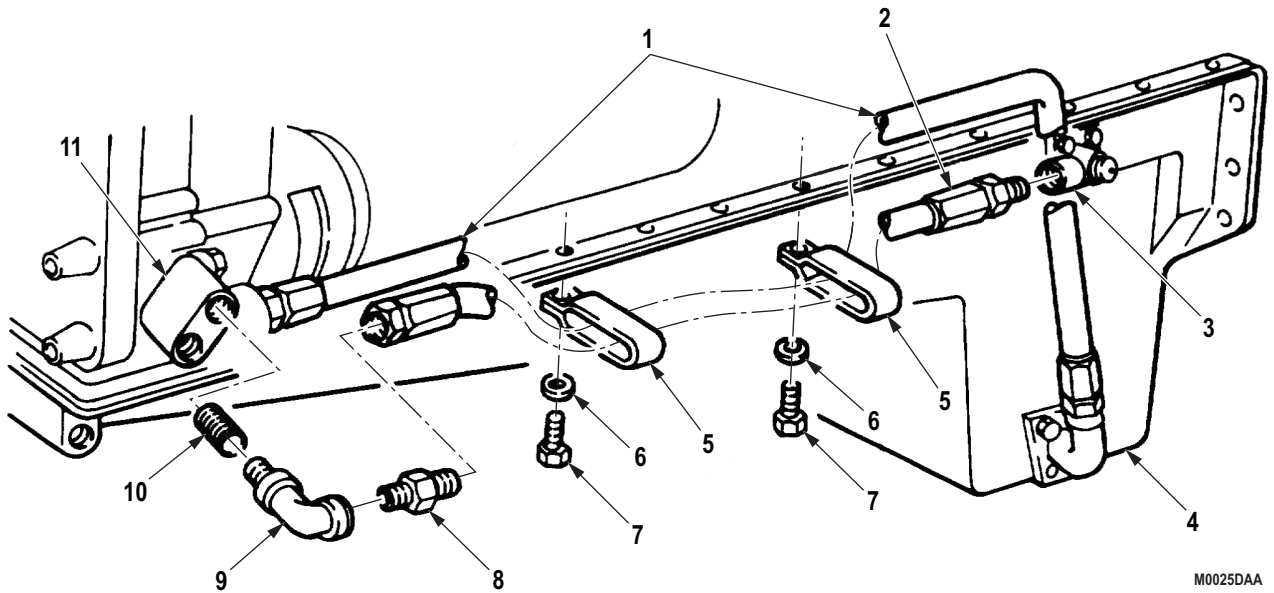

M0025DAA

Figure 2. Oil Pump Return Hose Installation.

END OF TASK**FOLLOW-ON MAINTENANCE**

1. Fill engine with oil to proper level. (Volume 5, WP 0820)
2. Start engine and check for leaks. (TM 9-2320-272-10)
3. Check oil level and add oil as necessary. (TM 9-2320-272-10)
4. Install left splash shield. (TM 9-2320-272-10)

END OF TASK**END OF WORK PACKAGE**

**FIELD MAINTENANCE
FRONT SUMP TUBE REPLACEMENT (M939/A1)**

INITIAL SETUP:**Tools and Special Tools**

Tool Kit, General Mechanic's: Automotive
(Volume 5, WP 0826, Table 1, Item 56)

Equipment Condition (cont.)

Hood raised and secured. (TM 9-2320-272-10)
Left splash shield removed. (TM 9-2320-272-10)

Materials/Parts

Tape, Antiseizing
(Volume 5, WP 0825, Table 1, Item 65)
Bushing
(Volume 5, WP 0827, Table 1, Item 442)
Qty: 2

Equipment Condition

Parking brake set. (TM 9-2320-272-10)

REMOVAL**NOTE**

Have adequate drainage container ready to catch oil.

1. Loosen two nuts (Figure 1, Item 5) on sump tube (Figure 1, Item 6), and slide nuts toward center of front sump tube.
2. Tighten elbow (Figure 1, Item 3) 1/4 turn to free sump tube (Figure 1, Item 6). Remove sump tube from adapter (Figure 1, Item 7) and elbow.
3. Remove two bushings (Figure 1, Item 4) from sump tube (Figure 1, Item 6). Discard bushings.

NOTE

Mark position of elbow for installation.

4. Remove adapter (Figure 1, Item 7) from oil pan (Figure 1, Item 2), and elbow (Figure 1, Item 3) from oil pump (Figure 1, Item 1).

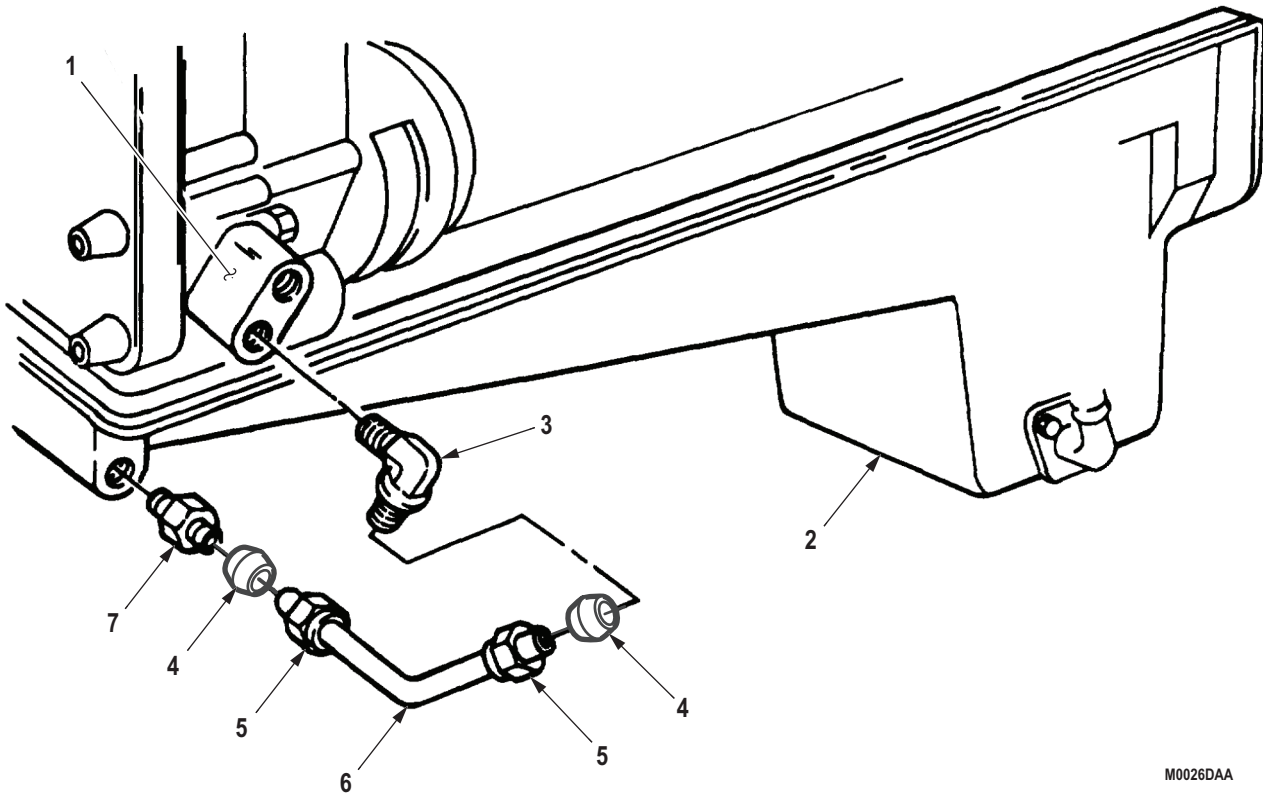

M0026DAA

Figure 1. Front Sump Tube Removal.

END OF TASK

INSPECTION

1. Inspect two nuts, elbow, and adapter. Replace nuts, elbow, or adapter if threads are damaged.
2. Inspect sump tube. Replace if cracked.

END OF TASK

INSTALLATION

1. Apply antiseize tape to male pipe threads of adapter (Figure 2, Item 7) and elbow (Figure 2, Item 3).

NOTE

Ensure elbow is less than 1/8 turn from final position to allow room for installation of front sump tube.

2. Install adapter (Figure 2, Item 7) on oil pan (Figure 2, Item 2), and elbow (Figure 2, Item 3) on oil pump (Figure 2, Item 1).
3. Install two nuts (Figure 2, Item 5) and bushings (Figure 2, Item 4) on sump tube (Figure 2, Item 6), and slide toward center of sump tube.
4. Position one end of sump tube (Figure 2, Item 6) on adapter (Figure 2, Item 7), and start elbow (Figure 2, Item 3) in other end of sump tube. Turn elbow to tighten into final position, pressing front sump tube into elbow and aligning front sump tube with elbow.
5. Connect sump tube (Figure 2, Item 6) to adapter (Figure 2, Item 7) and elbow (Figure 2, Item 3) by tightening two nuts (Figure 2, Item 5).

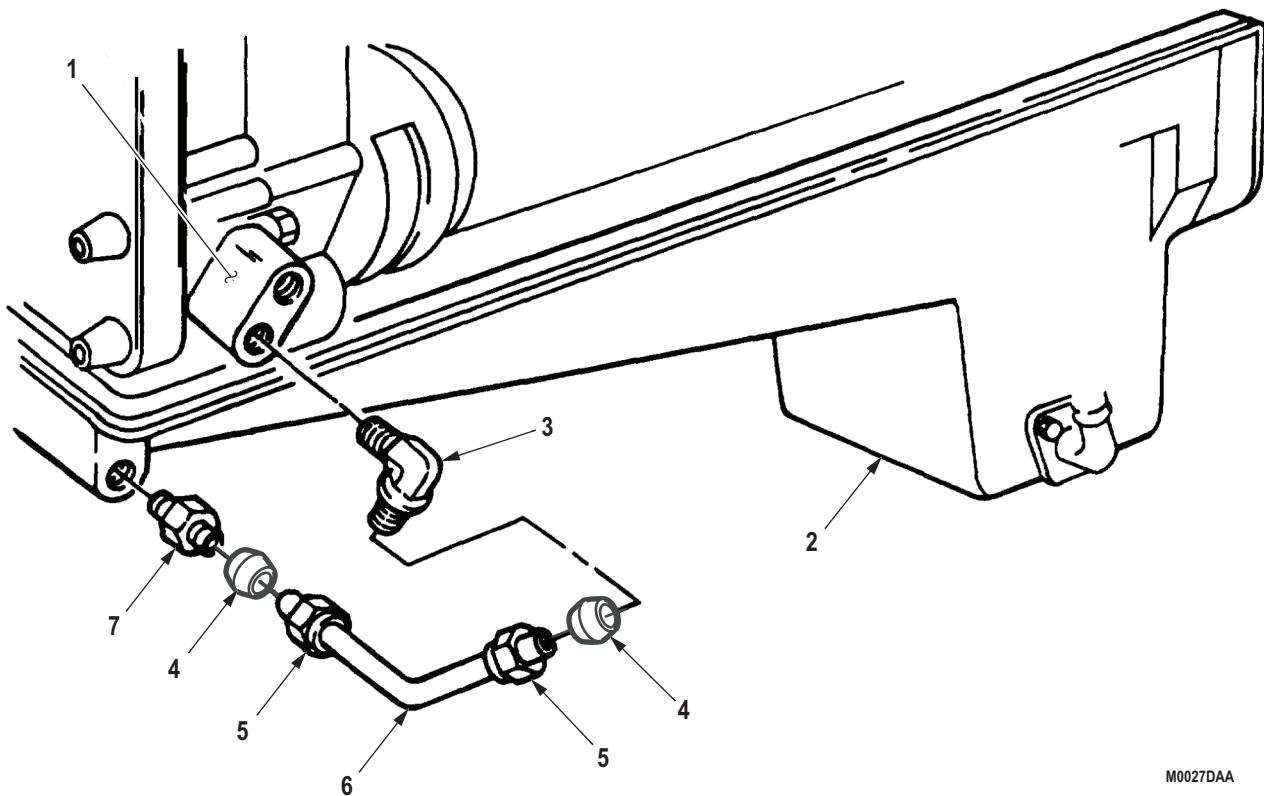

M0027DAA

Figure 2. Front Sump Tube Installation.

END OF TASK

FOLLOW-ON MAINTENANCE

1. Start engine and check for leaks. (TM 9-2320-272-10)
2. Check oil level and add oil as necessary. (TM 9-2320-272-10)
3. Install left splash shield. (TM 9-2320-272-10)

END OF TASK**END OF WORK PACKAGE**

**FIELD MAINTENANCE
ENGINE SAMPLING VALVE REPLACEMENT**

INITIAL SETUP:**Tools and Special Tools**

Tool Kit, General Mechanic's: Automotive
(Volume 5, WP 0826, Table 1, Item 56)

Materials/Parts

Adhesive, Silicone Rubber
(Volume 5, WP 0825, Table 1, Item 4)
Bag, Plastic
(Volume 5, WP 0825, Table 1, Item 10)
Bottles, Oil Sample

Materials/Parts (cont.)

(Volume 5, WP 0825, Table 1, Item 11)
Hose, Nonmetallic
(Volume 5, WP 0825, Table 1, Item 34)
Sack, Shipping
(Volume 5, WP 0825, Table 1, Item 54)

Equipment Condition

Hood raised and secured. (TM 9-2320-272-10)
Right splash shield removed. (TM 9-2320-272-10)

REMOVAL**WARNING**

Do not perform this task when engine is hot. Failure to comply may result in injury or death to personnel.

NOTE

- Have adequate drainage container ready to catch oil.
- Perform Step (1) for M939/A1 series vehicles and Step (2) for M939A2 series vehicles.

1. Remove oil sampling valve (Figure 1, Item 2) from engine oil cooler (Figure 1, Item 1).
2. Remove oil sampling valve (Figure 1, Item 2) from engine block (Figure 1, Item 3).

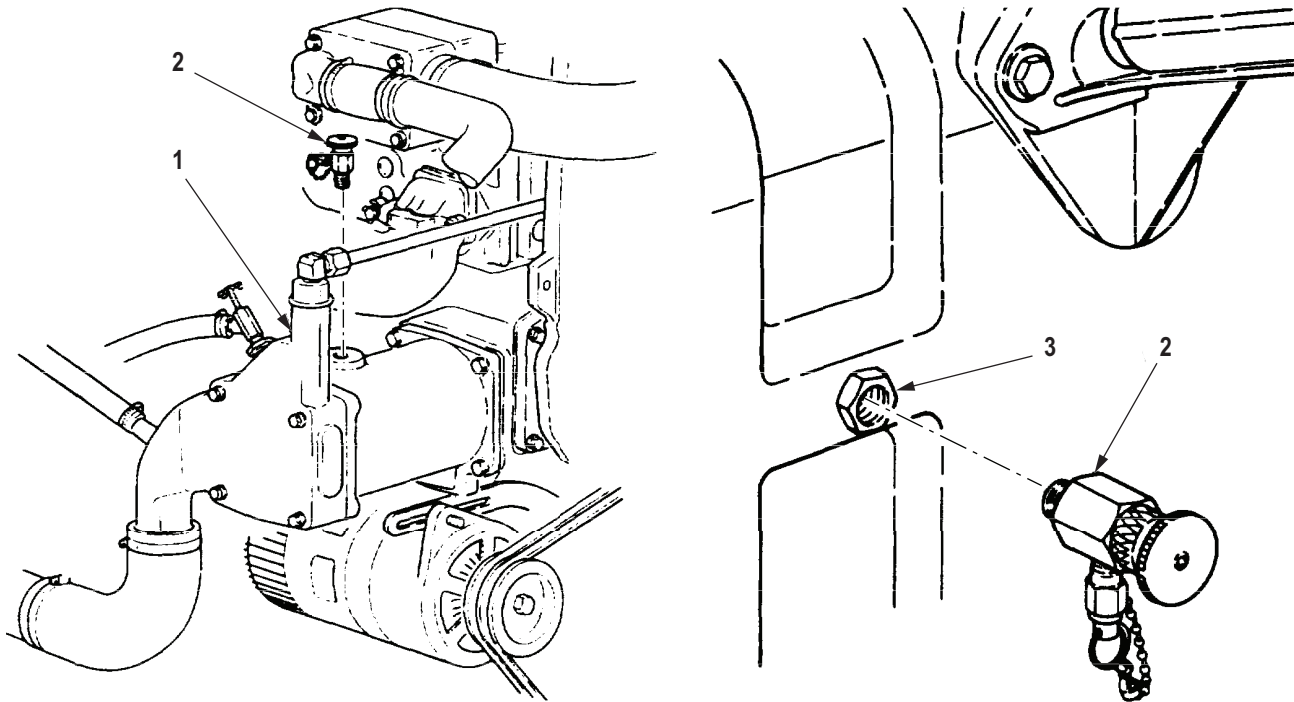

M10372DAA

Figure 1. Engine Sampling Valve Removal.

END OF TASK

INSTALLATION

1. Apply a thin coat of gasket sealant to male threads of oil sampling valve (Figure 2, Item 2).

NOTE

Perform Step (2) for M939/A1 series vehicles and Step (3) for M939A2 series vehicles.

2. Install oil sampling valve (Figure 2, Item 2) on engine oil cooler (Figure 2, Item 1).
3. Install oil sampling valve (Figure 2, Item 2) on engine block (Figure 2, Item 3).

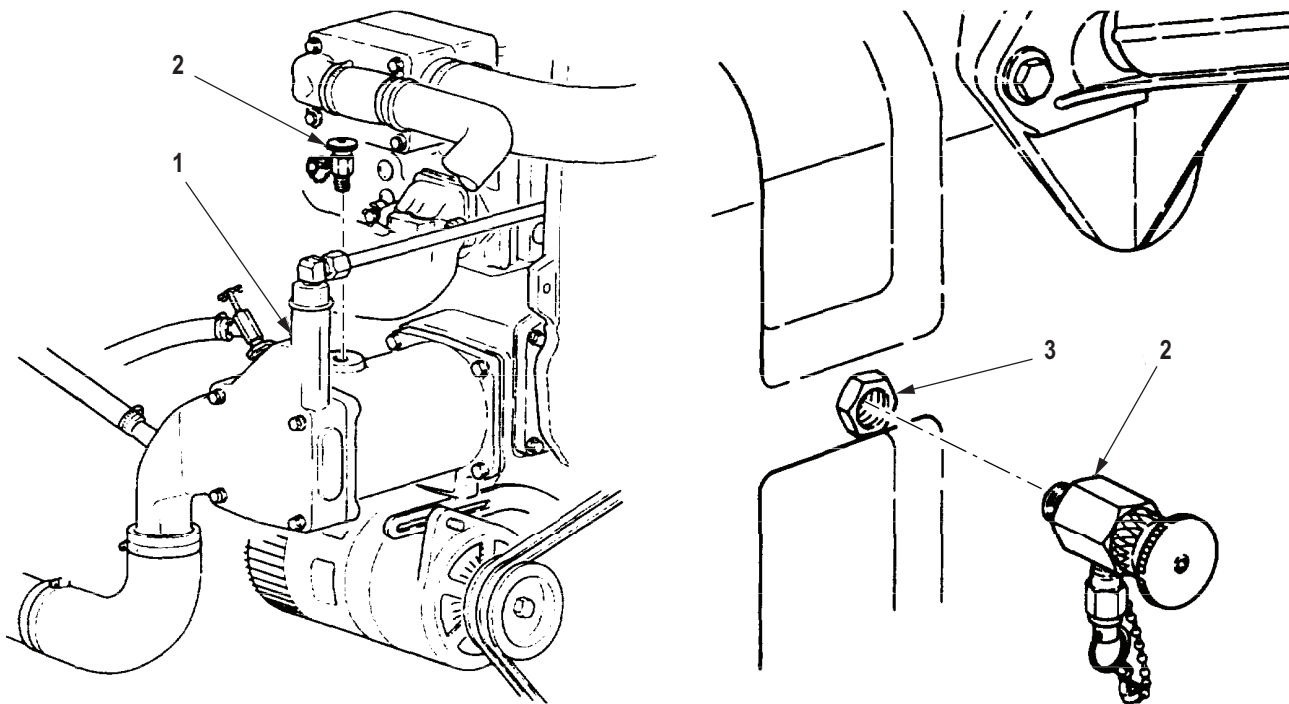

M10373DAA

Figure 2. Engine Sampling Valve Installation.

END OF TASK**FOLLOW-ON MAINTENANCE**

1. Start engine and check for leaks. (TM 9-2320-272-20)
2. Check oil level and add oil as necessary. (TM 9-2320-272-10)
3. Install right splash shield. (TM 9-2320-272-10)

END OF TASK**END OF WORK PACKAGE**

**FIELD MAINTENANCE
OIL DIPSTICK TUBE REPLACEMENT**

INITIAL SETUP:**Tools and Special Tools**

Tool Kit, General Mechanic's: Automotive
(Volume 5, WP 0826, Table 1, Item 56)

Equipment Condition (cont.)

Parking brake set. (TM 9-2320-272-10)
Right splash shield removed. (TM 9-2320-272-10)

Materials/Parts

Adhesive, Silicone Rubber
(Volume 5, WP 0825, Table 1, Item 3)
Lockwasher
(Volume 5, WP 0827, Table 1, Item 186)
Qty: 1
Lockwasher
(Volume 5, WP 0827, Table 1, Item 356)
Qty: 1

Equipment Condition

Hood raised and secured. (TM 9-2320-272-10)

REMOVAL (M939/A1)

1. Remove dipstick (Figure 1, Item 13) from dipstick tube (Figure 1, Item 9).
2. Remove nut (Figure 1, Item 12), lockwasher (Figure 1, Item 11), washer (Figure 1, Item 10), screw (Figure 1, Item 7), and clamp (Figure 1, Item 8) from dipstick tube (Figure 1, Item 9) and bracket (Figure 1, Item 4). Discard lockwasher.
3. Remove dipstick tube (Figure 1, Item 9) from oil pan (Figure 1, Item 6).
4. Remove screw (Figure 1, Item 2), lockwasher (Figure 1, Item 3), and bracket (Figure 1, Item 4) from engine block (Figure 1, Item 5). Discard lockwasher.

END OF TASK**REMOVAL (M939A2)**

1. Remove dipstick (Figure 1, Item 14) from dipstick tube (Figure 1, Item 15).
2. Remove dipstick tube (Figure 1, Item 15) from engine block (Figure 1, Item 5).

REMOVAL (M939A2) - Continued

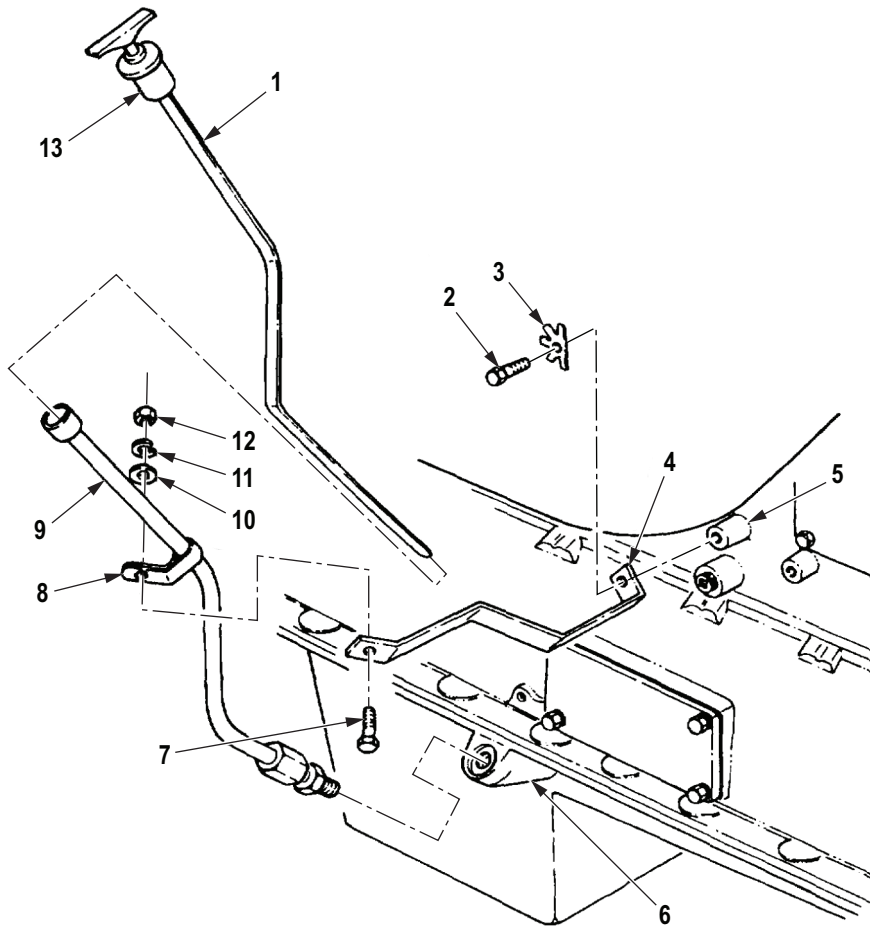

M939/A1

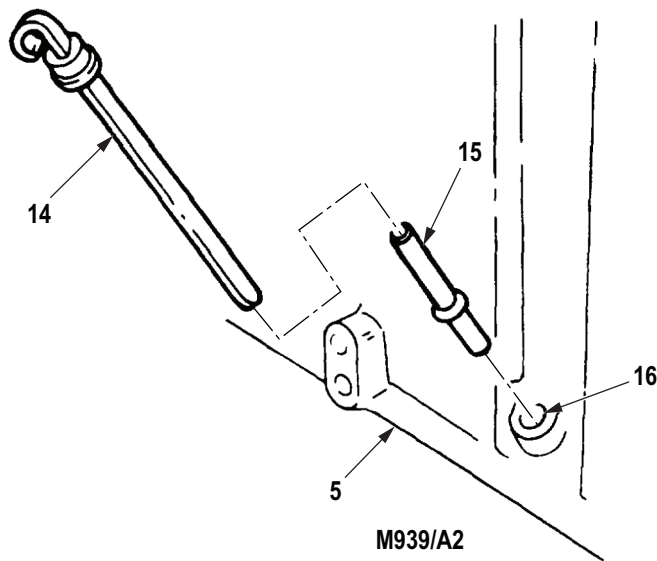

M939/A2

M0005DAA

Figure 1. Dipstick Tube Removal.

END OF TASK

INSTALLATION (M939/A1)

1. Install bracket (Figure 2, Item 4) on engine block (Figure 2, Item 5) with lockwasher (Figure 2, Item 3) and screw (Figure 2, Item 2).
2. Install dipstick (Figure 2, Item 9) on oil pan (Figure 2, Item 6).
3. Install clamp (Figure 2, Item 8) on dipstick tube (Figure 2, Item 9) and bracket (Figure 2, Item 4) with screw (Figure 2, Item 7), washer (Figure 2, Item 10), lockwasher (Figure 2, Item 11), and nut (Figure 2, Item 12).
4. Install dipstick (Figure 2, Item 1) in dipstick tube (Figure 2, Item 9).

END OF TASK**INSTALLATION (M939A2)**

1. Apply silicone rubber adhesive to mating surface of oil dipstick tube.
2. Align oil dipstick tube (Figure 2, Item 15) with bore (Figure 2, Item 16) and, using soft-headed hammer, drive oil dipstick tube until it seats in the bore of engine block (Figure 2, Item 5).
3. Install dipstick (Figure 2, Item 14) in dipstick tube (Figure 2, Item 15).

INSTALLATION (M939A2) - Continued

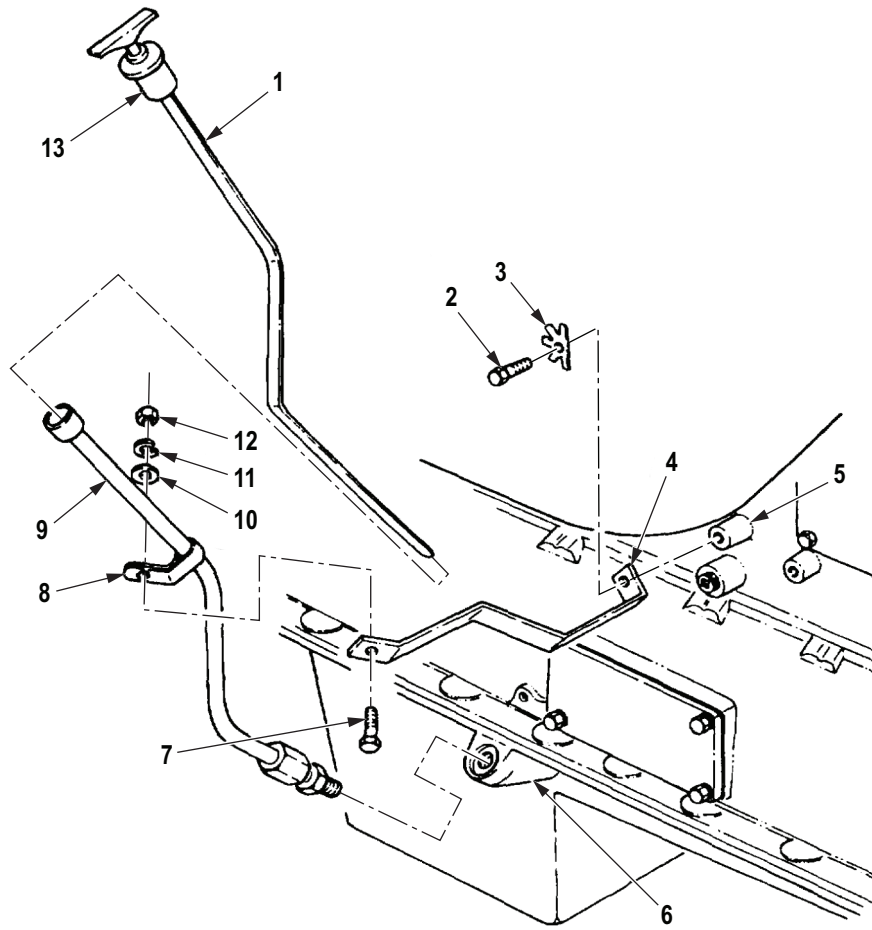

M939/A1

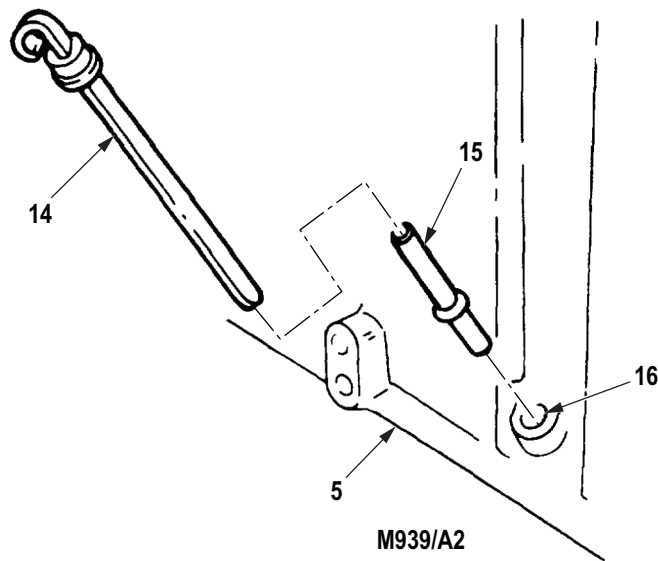

M939/A2

M0006DAA

Figure 2. Dipstick Tube Installation.

END OF TASK

FOLLOW-ON MAINTENANCE

1. Install right splash shield. (TM 9-2320-272-10)
2. Start engine and check for oil leaks. (TM 9-2320-272-10)

END OF TASK**END OF WORK PACKAGE**

**FIELD MAINTENANCE
ENGINE OIL COOLER MAINTENANCE (M939A2)**

INITIAL SETUP:**Tools and Special Tools**

Tool Kit, General Mechanic's: Automotive
(Volume 5, WP 0826, Table 1, Item 56)
Caps, Vise Jaw
(Volume 5, WP 0826, Table 1, Item 14)
Wrench, Torque, Ratcheting, Click 1/2" Drive,
250 Ft-Lb
(Volume 5, WP 0826, Table 1, Item 63)

Materials/Parts

Tape, Antiseizing
(Volume 5, WP 0825, Table 1, Item 65)
Bypass Valve
(Volume 5, WP 0827, Table 1, Item 159)
Gasket (Volume 5, WP 0827, Table 1, Item 145)
Qty: 1
Gasket (Volume 5, WP 0827, Table 1, Item 154)
Qty: 1

Materials/Parts (cont.)

O-ring (early model engines only)
(Volume 5, WP 0827, Table 1, Item 114)
Qty: 1
Washer (Volume 5, WP 0827, Table 1, Item 125)
Qty: 1

References

Volume 5, WP 0819

Equipment Condition

Parking brake set. (TM 9-2320-272-10)
Hood raised and secured. (TM 9-2320-272-10)
Right splash shield removed. (TM 9-2320-272-10)
Coolant drained. (WP 0287)
Engine oil drained and filter removed. (WP 0232)
Alternator removed. (WP 0301)

REMOVAL**NOTE**

References to early model engines refer to engines with a serial number before 44487830 used in M939A2 series vehicles.

1. Loosen clamp (Figure 1, Item 12) and remove hose (Figure 1, Item 13) from nipple (Figure 1, Item 11).

NOTE

Perform Step (2) on vehicles with late model engines and Step (3) on early model engines.

2. Remove oil supply line (Figure 1, Item 1), adapter (Figure 1, Item 2), and o-ring (Figure 1, Item 3) from oil filter head (Figure 1, Item 4). Discard o-ring.
3. Remove oil supply line (Figure 1, Item 1) and elbow (Figure 1, Item 15) from oil filter head (Figure 1, Item 4).
4. Remove 11 screws (Figure 1, Item 6), clamp (Figure 1, Item 5), wiring harness (Figure 1, Item 7), oil filter head (Figure 1, Item 4), gasket (Figure 1, Item 8), oil cooler core (Figure 1, Item 9), and gasket (Figure 1, Item 10) from engine block (Figure 1, Item 14). Discard gaskets.

REMOVAL - Continued

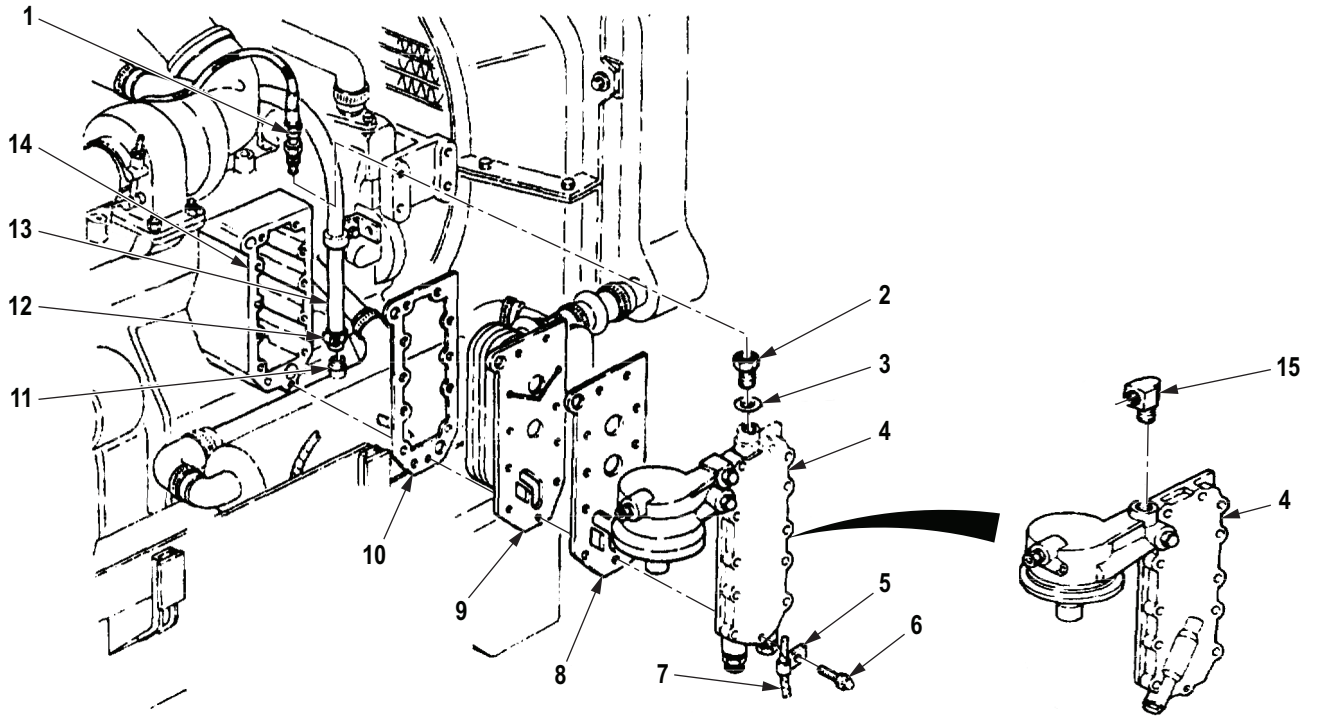

M0008DAA

Figure 1. Engine Oil Cooler Removal.

END OF TASK

DISASSEMBLY

1. Install oil filter head (Figure 2, Item 3) in soft-jawed vise (Figure 2, Item 12).

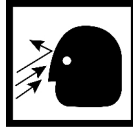
WARNING

Pressure regulator is under spring tension. Use care when removing plug. Failure to comply may result in injury or death to personnel.

2. Remove plug (Figure 2, Item 7), washer (Figure 2, Item 6), spring (Figure 2, Item 8), and pressure regulator plunger (Figure 2, Item 9) from port (Figure 2, Item 10) and bore (Figure 2, Item 11). Discard washer.
3. Remove oil filter adapter (Figure 2, Item 1) from oil filter head (Figure 2, Item 3).
4. Remove plugs (Figure 2, Items 2 and 4) from oil filter head (Figure 2, Item 3).

CAUTION

When removing bypass valve, be careful not to score oil filter head. Failure to do so may result in damage to engine.

5. Using screwdriver, position blade of screwdriver behind bypass valve (Figure 2, Item 5) and pry bypass valve out of oil filter head (Figure 2, Item 3). Discard bypass valve.
6. Remove filter head (Figure 2, Item 3) from soft-jawed vise (Figure 2, Item 12).

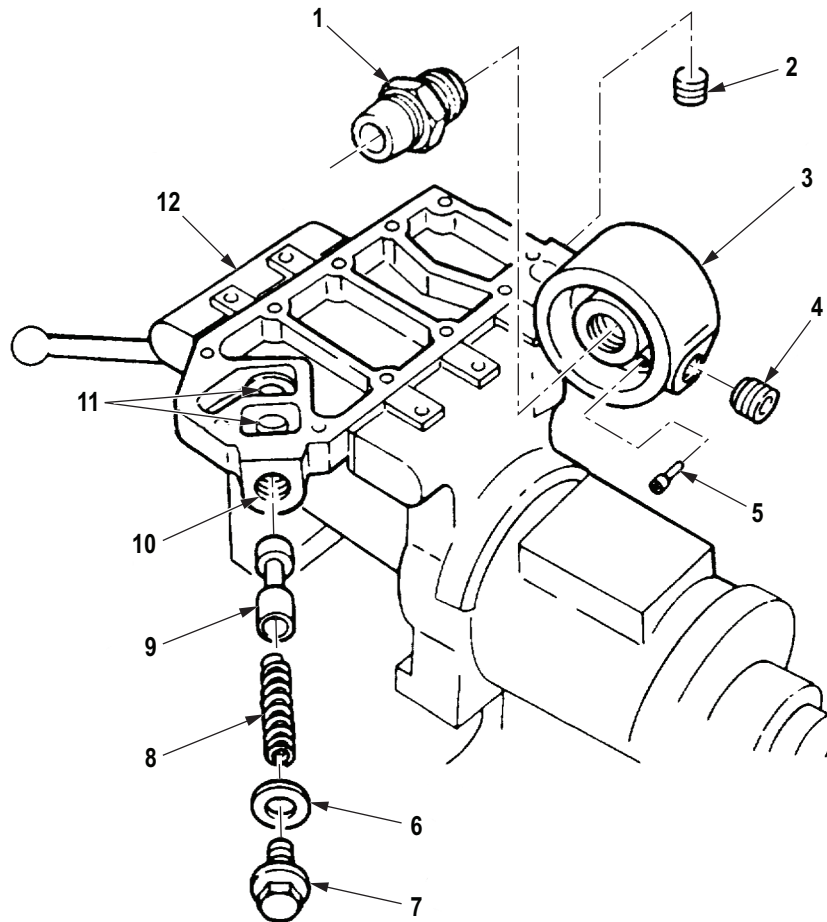
DISASSEMBLY - Continued

M0009DAA

Figure 2. Engine Oil Cooler Disassembly.

END OF TASK**CLEANING AND INSPECTION**

1. For General Cleaning Instructions, refer to (Volume 5, WP 0819).
2. For General Inspection Instructions, refer to (Volume 5, WP 0819).
3. Inspect pressure regulator plunger for freedom of movement in bore. Replace plunger if sticking or binding in bore.
4. Inspect spring for pits and cracks. Replace spring if damaged.

END OF TASK

ASSEMBLY**NOTE**

Ensure bypass valve is completely seated in oil filter head.

1. Install oil filter head (Figure 3, Item 3) in soft-jawed vise (Figure 3, Item 12). Install bypass valve (Figure 3, Item 5) on oil filter head.
2. Wrap male threads of oil filter adapter (Figure 3, Item 1) and plugs (Figure 3, Items 2, 4, and 7) with antiseize tape.
3. Install oil filter adapter (Figure 3, Item 1) on oil filter head (Figure 3, Item 3). Tighten oil filter adapter 60 lb-ft (81 N·m).
4. Install pressure regulator plunger (Figure 3, Item 9), spring (Figure 3, Item 8), washer (Figure 3, Item 6), and plug (Figure 3, Item 7) in bore (Figure 3, Item 11) at port (Figure 3, Item 10). Tighten plug 60 lb-ft (81 N·m).
5. Install plugs (Figure 3, Items 2 and 4) on oil filter head (Figure 3, Item 3).
6. Remove oil filter head (Figure 3, Item 3) from soft-jawed vise (Figure 3, Item 12).

ASSEMBLY - Continued

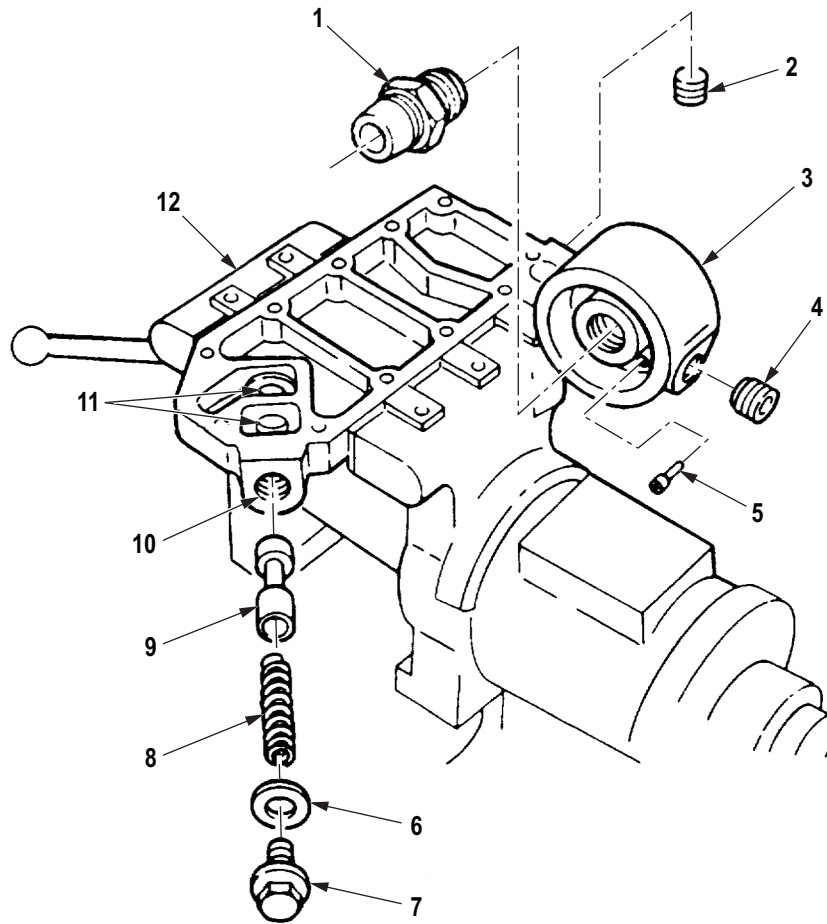

M9625DAA

Figure 3. Engine Oil Cooler Assembly.

END OF TASK

INSTALLATION**NOTE**

- If a late model engine oil filter head is to be installed on an early model engine, the oil supply system must be replaced, including oil pump, pressure regulator valve, oil supply line, and elbow.
 - Perform Step (1) if oil cooler core is being installed.
 - Perform Step (3) on vehicles with late model engines and Step (4) on vehicles with early model engines.
1. Remove two shipping plugs (Figure 4, Item 12) from oil cooler core (Figure 4, Item 9). Discard shipping plugs.
 2. Install gasket (Figure 4, Item 12), oil cooler core (Figure 4, Item 9), gasket (Figure 4, Item 8), oil filter head (Figure 4, Item 4), wiring harness (Figure 4, Item 7), and clamp (Figure 4, Item 5) on engine block (Figure 4, Item 15) with 11 screws (Figure 4, Item 6).
 3. Install o-ring (Figure 4, Item 3) and adapter (Figure 4, Item 2) on oil filter head (Figure 4, Item 4) and connect oil supply line (Figure 4, Item 1) to adapter.
 4. Install elbow (Figure 4, Item 16) on oil filter head (Figure 4, Item 4) and connect oil supply line (Figure 4, Item 1) to elbow.

CAUTION

When filling cooling system on M939A2 series vehicles, ensure drain valve on aftercooler is open. Failure to do so may result in damage to equipment.

5. Install hose (Figure 4, Item 14) on nipple (Figure 4, Item 12) with clamp (Figure 4, Item 13).

INSTALLATION - Continued

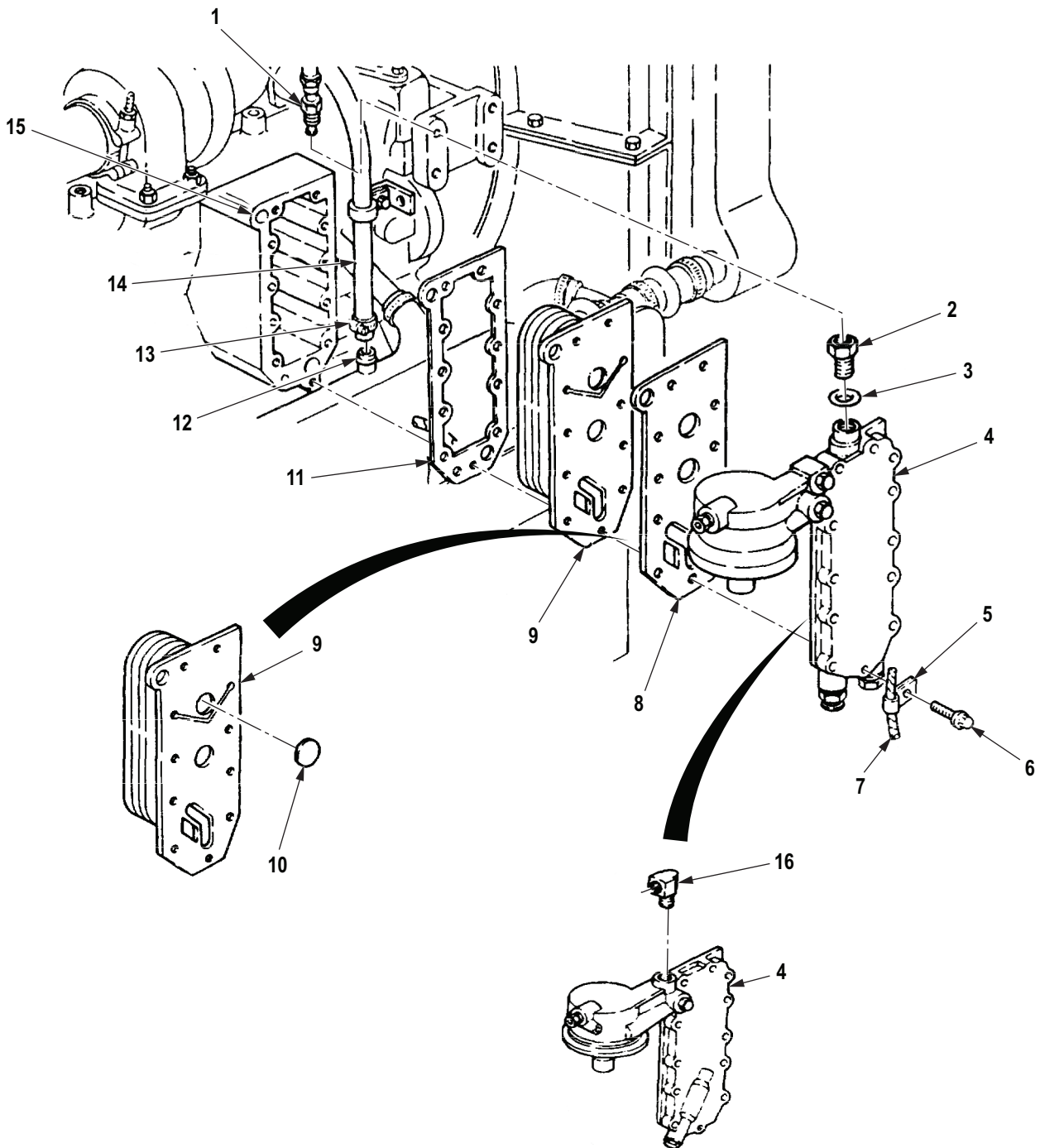

M0011DAA

Figure 4. Engine Oil Cooler Installation.

END OF TASK

FOLLOW-ON MAINTENANCE

1. Fill cooling system to proper level. (WP 0287)
2. Install alternator. (WP 0301)
3. Install filter and fill engine oil. (WP 0232)
4. Start engine and check for leaks. (TM 9-2320-272-10)
5. Install right splash shield. (TM 9-2320-272-10)

END OF TASK**END OF WORK PACKAGE**

**FIELD MAINTENANCE
OIL PAN AND OIL SUCTION TUBE (M939A2)**

INITIAL SETUP:**Tools and Special Tools**

Tool Kit, General Mechanic's: Automotive
(Volume 5, WP 0826, Table 1, Item 56)

Materials/Parts

Sealing Compound
(Volume 5, WP 0825, Table 1, Item 59)
Sealing Compound
(Volume 5, WP 0825, Table 1, Item 60)
Gasket (Volume 5, WP 0827, Table 1, Item 100)
Qty: 1
Gasket (Volume 5, WP 0827, Table 1, Item 162)
Qty: 1
Locknut (Volume 5, WP 0827, Table 1, Item 131)
Qty: 1
Lockwasher
(Volume 5, WP 0827, Table 1, Item 135)
Qty: 32

Materials/Parts (cont.)

Washer (Volume 5, WP 0827, Table 1, Item 126)
Qty: 1
Washer, Flat
(Volume 5, WP 0827, Table 1, Item 156)
Qty: 1

References

Volume 5, WP 0819
Volume 5, WP 0820

Equipment Condition

Parking brake set. (TM 9-2320-272-10)
Engine oil drained. (WP 0247)

REMOVAL

1. Remove 32 screws (Figure 1, Item 5), washers (Figure 1, Item 4), lockwashers (Figure 1, Item 3), oil pan (Figure 1, Item 6), and gasket (Figure 1, Item 2) from engine block (Figure 1, Item 1). Discard gasket and lockwashers.
2. Remove two plugs (Figure 1, Item 8), flat washer (Figure 1, Item 7), and washer (Figure 1, Item 9) from oil pan (Figure 1, Item 6). Discard flat washer and washer.
3. Remove two screws (Figure 1, Item 12) and bracket (Figure 1, Item 11) from engine block (Figure 1, Item 1).
4. Remove two screws (Figure 1, Item 14), spacers (Figure 1, Item 15), oil suction tube (Figure 1, Item 13), and gasket (Figure 1, Item 10) from engine block (Figure 1, Item 1). Discard gasket.
5. Remove locknut (Figure 1, Item 18), washer (Figure 1, Item 17), screw (Figure 1, Item 16), and bracket (Figure 1, Item 11) from oil suction tube (Figure 1, Item 13). Discard locknut.

REMOVAL - Continued

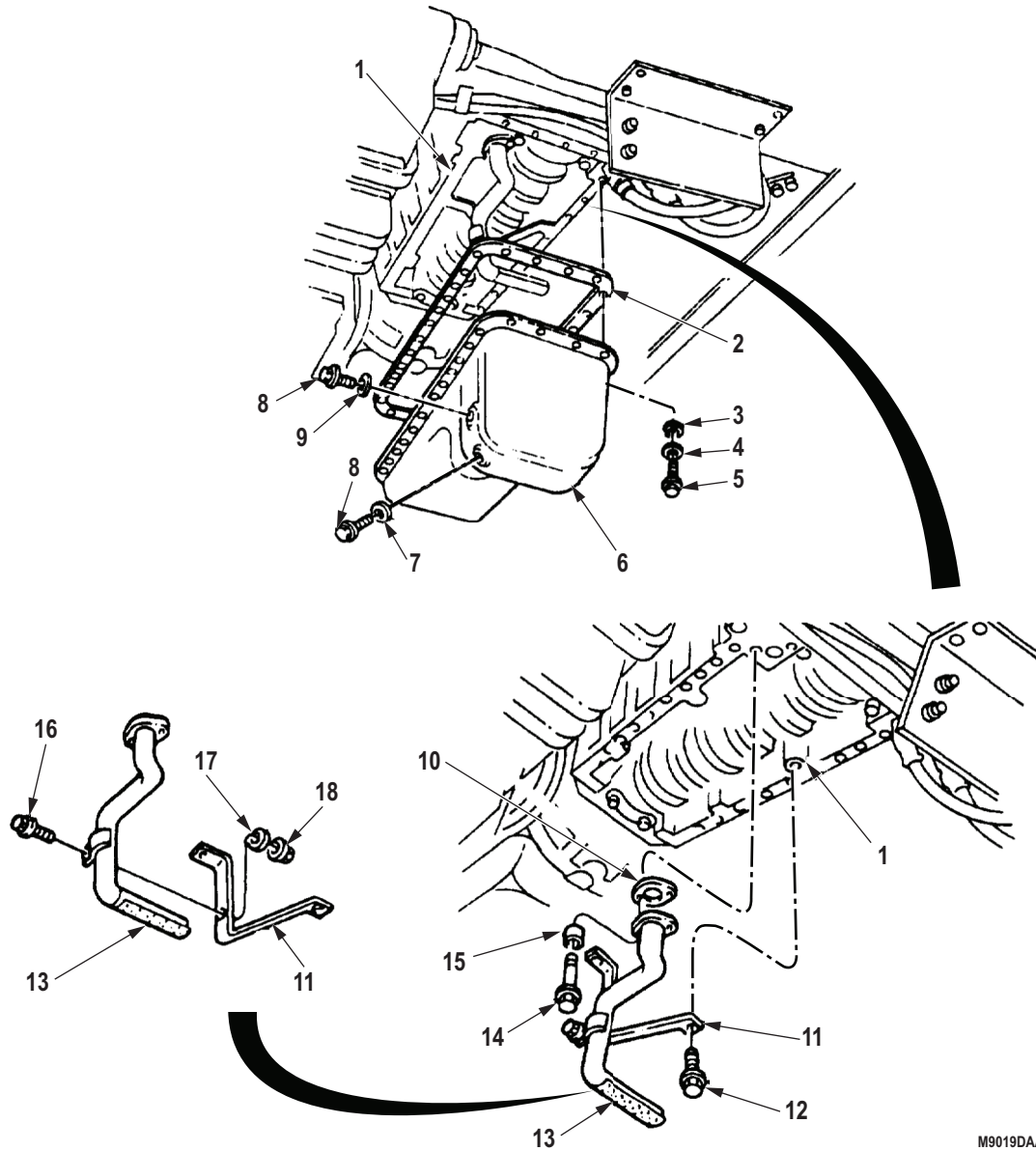

M9019DAA

Figure 1. Oil Pan and Suction Tube Removal.

6. For General Cleaning Instructions, refer to (Volume 5, WP 0819).
7. For General Inspections Instructions, refer to (Volume 5, WP 0819).
8. Replace all parts failing inspection.

END OF TASK

INSTALLATION

1. Install bracket (Figure 2, Item 11) on oil suction tube (Figure 2, Item 13) with screw (Figure 2, Item 16), washer (Figure 2, Item 17), and locknut (Figure 2, Item 18).
2. Install gasket (Figure 2, Item 10) and oil suction tube (Figure 2, Item 13) on engine block (Figure 2, Item 1) with two spacers (Figure 2, Item 15) and screws (Figure 2, Item 14).
3. Install bracket (Figure 2, Item 11) on engine block (Figure 2, Item 1) with two screws (Figure 2, Item 12).

NOTE

Prior to installation, fill joint between oil pan rail, front gear case cover, and rear cover with sealing compound.

4. Apply sealing compound to mating surfaces of engine block (Figure 2, Item 1) and oil pan (Figure 2, Item 6).
5. Position gasket (Figure 2, Item 2) on oil pan (Figure 2, Item 6) with raised bead facing oil pan.
6. Install oil pan (Figure 2, Item 6) on engine block (Figure 2, Item 1) with 32 lockwashers (Figure 2, Item 3), washers (Figure 2, Item 4), and screws (Figure 2, Item 5).
7. Install flat washer (Figure 2, Item 7), washer (Figure 2, Item 9), and two plugs (Figure 2, Item 8) on oil pan (Figure 2, Item 6).

INSTALLATION - Continued

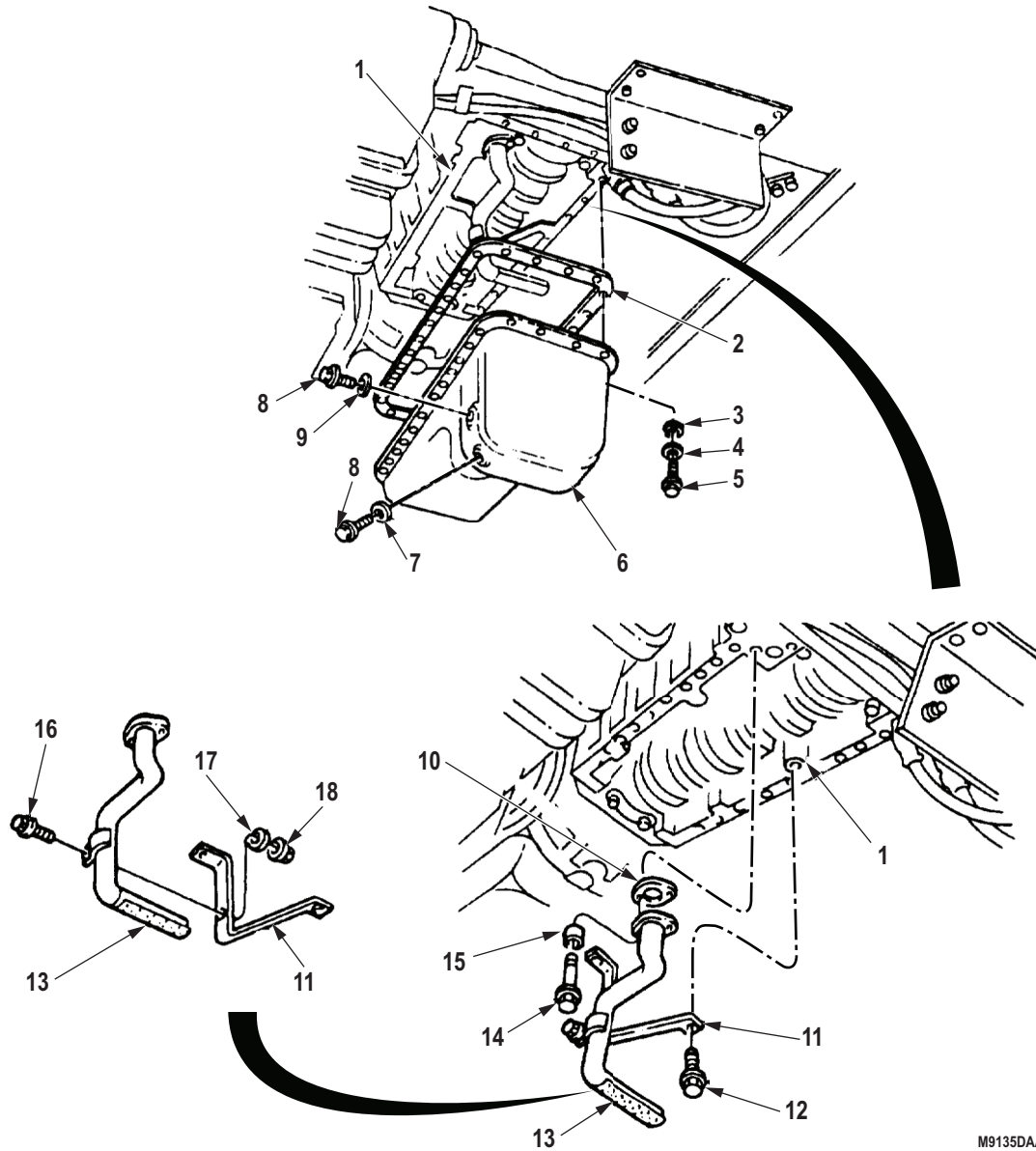

M9135DAA

Figure 2. Oil Pan and Suction Tube Installation.

END OF TASK

FOLLOW-ON MAINTENANCE

1. Fill engine crankcase to proper level. (Volume 5, WP 0820)
2. Check oil pan for leaks.

END OF TASK

END OF WORK PACKAGE

**FIELD MAINTENANCE
ENGINE OIL PAN REPLACEMENT (M939/A1)**

INITIAL SETUP:**Tools and Special Tools**

Tool Kit, General Mechanic's: Automotive
(Volume 5, WP 0826, Table 1, Item 56)
Wrench, Torque, Click, Ratcheting, 3/8" Drive,
75 Ft-Lb
(Volume 5, WP 0826, Table 1, Item 62)

Materials/Parts

Sealing Compound
(Volume 5, WP 0825, Table 1, Item 60)
Gasket (Volume 5, WP 0827, Table 1, Item 20)
Qty: 1
Gasket (Volume 5, WP 0827, Table 1, Item 75)
Qty: 1
Lockwasher
(Volume 5, WP 0827, Table 1, Item 215)
Qty: 3

Materials/Parts (cont.)

Oil Pan Gasket
(Volume 5, WP 0827, Table 1, Item 117)
Qty: 1
Spacer Ring
(Volume 5, WP 0827, Table 1, Item 192)
Qty: 1

References

Volume 5, WP 0819
Volume 5, WP 0820

Equipment Condition

Front sump tube removed. (WP 0226)
Oil dipstick tube removed. (WP 0232)
Engine oil drained. (WP 0232)

REMOVAL

1. Disconnect oil return hose (Figure 1, Item 6) from aerator (Figure 1, Item 3).
2. Disconnect oil pickup hose (Figure 1, Item 2) from suction flange (Figure 1, Item 5).
3. Remove two screws (Figure 1, Item 7), washers (Figure 1, Item 8), clamps (Figure 1, Item 1), oil return hose (Figure 1, Item 6), and pickup hose (Figure 1, Item 2) from oil pan (Figure 1, Item 4).

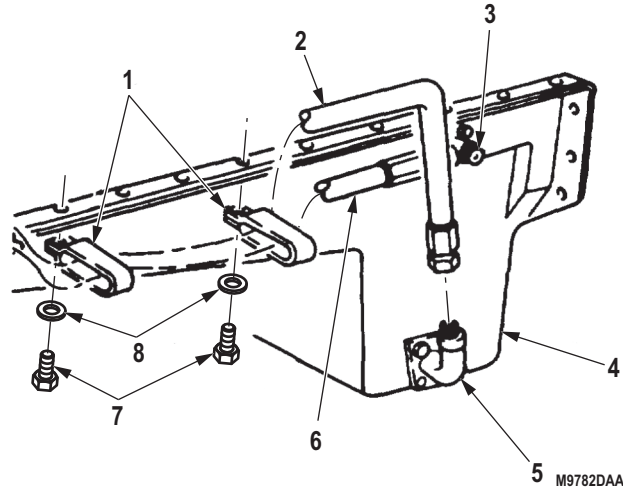

Figure 1. Engine Oil Pan Removal.

4. Remove six screws (Figure 2, Item 7) and washers (Figure 2, Item 6) from oil pan (Figure 2, Item 8) and flywheel housing (Figure 2, Item 2).
5. Remove four screws (Figure 2, Item 5) and washers (Figure 2, Item 4) from rear of oil pan (Figure 2, Item 8).
6. Remove 30 screws (Figure 2, Item 10), washers (Figure 2, Item 9), four screws (Figure 2, Item 12), washers (Figure 2, Item 13), brace (Figure 2, Item 11), oil pan (Figure 2, Item 8), and oil pan gasket (Figure 2, Item 3) from engine block (Figure 2, Item 14), and front gearcase cover (Figure 2, Item 1). Discard oil pan gasket.
7. Clean gasket remains from mating surfaces of brace, oil pan, engine block, and front gearcase cover.

REMOVAL - Continued

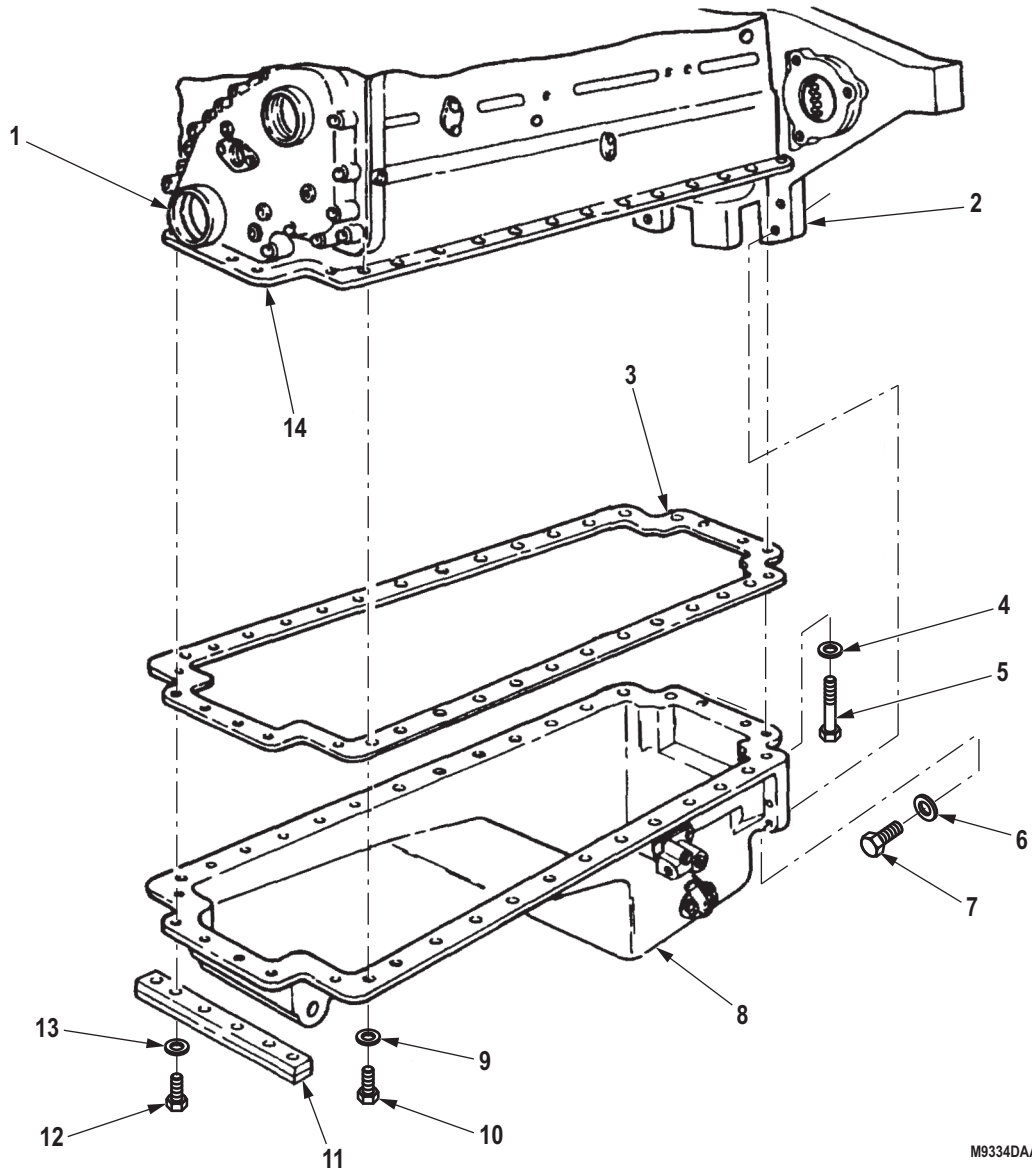

Figure 2. Engine Oil Pan Removal.

END OF TASK

DISASSEMBLY

1. Remove four screws (Figure 3, Item 1), strainer screen (Figure 3, Item 2), drain plug (Figure 3, Item 4), and spacer (Figure 3, Item 3) from oil pan (Figure 3, Item 14). Discard spacer.
2. Remove three screws (Figure 3, Item 9), lockwashers (Figure 3, Item 8), washers (Figure 3, Item 7), aerator (Figure 3, Item 6), and gasket (Figure 3, Item 5) from oil pan (Figure 3, Item 14). Discard lockwashers and aerator gasket and clean gasket remains from oil pan mating surfaces.
3. Remove two screws (Figure 3, Item 10), washers (Figure 3, Item 11), suction flange (Figure 3, Item 12), and gasket (Figure 3, Item 13) from oil pan (Figure 3, Item 14). Discard gasket and clean gasket remains from oil pan mating surfaces.
4. Clean oil pan (Figure 3, Item 14), aerator (Figure 3, Item 6), drain plug (Figure 3, Item 4), suction flange (Figure 3, Item 12), and screen (Figure 3, Item 2) (Volume 5, WP 0819).
5. Inspect oil pan (Figure 3, Item 14), aerator (Figure 3, Item 6), drain plug (Figure 3, Item 4), suction flange (Figure 3, Item 12), and screen (Figure 3, Item 2) (Volume 5, WP 0819).
6. Check oil pan (Figure 3, Item 14) for cracks, screen (Figure 3, Item 2) for damage or tears, and oil pan, aerator (Figure 3, Item 6), drain plug (Figure 3, Item 4), suction flange (Figure 3, Item 12), and screen for damaged threads and uneven gasket mating surfaces. Replace oil pan if damaged or cracked. Replace screen if damaged or torn. Repair or replace oil pan if threads are damaged.

DISASSEMBLY - Continued

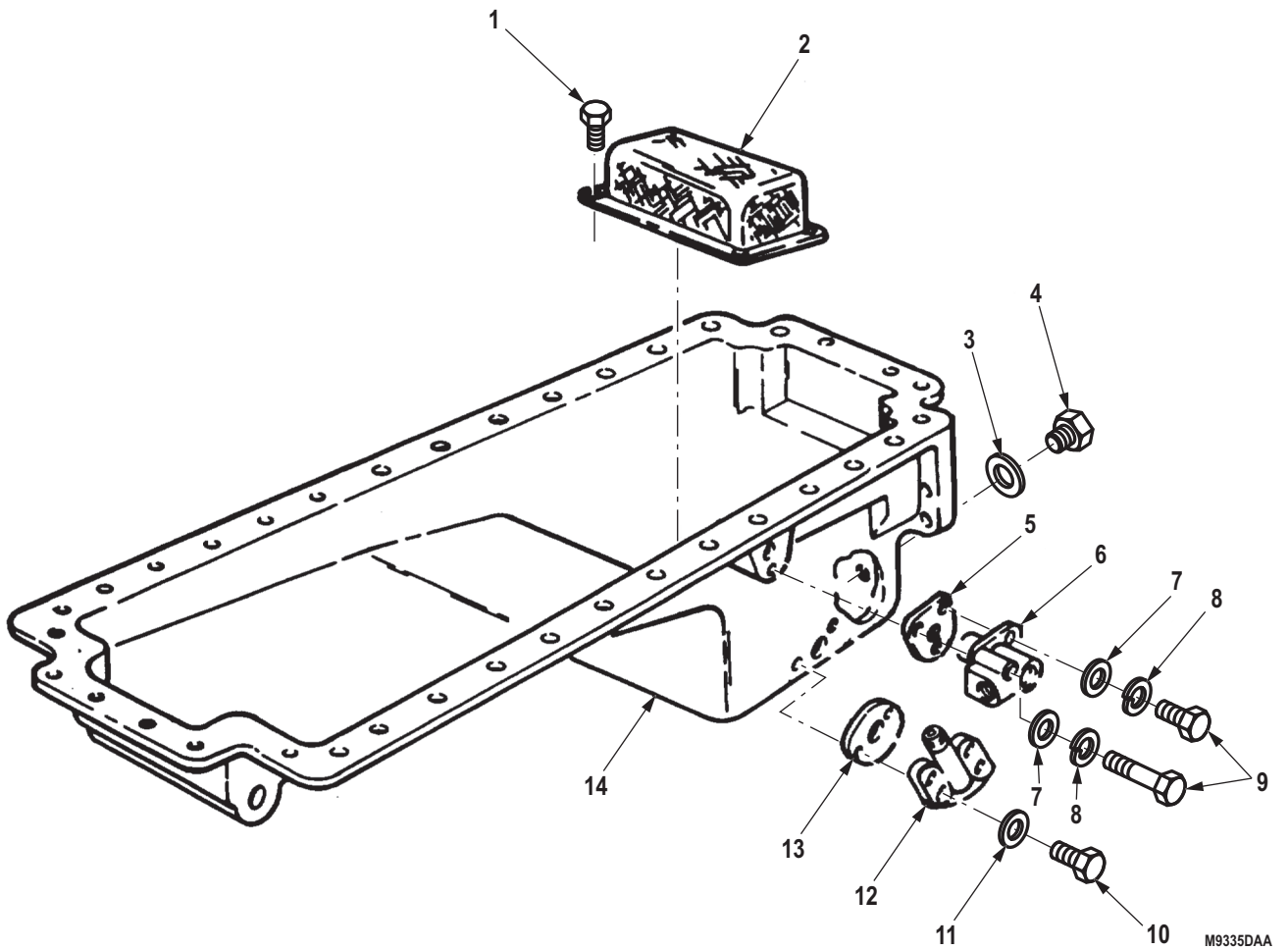

M9335DAA

Figure 3. Engine Oil Pan Disassembly.

END OF TASK

ASSEMBLY

1. Install strainer screen (Figure 4, Item 2) on oil pan (Figure 4, Item 14) with four screws (Figure 4, Item 1).
2. Install spacer (Figure 4, Item 3) and drain plug (Figure 4, Item 4) on oil pan (Figure 4, Item 14).
3. Apply thin coating of sealing compound to aerator gasket (Figure 4, Item 5).
4. Install aerator gasket (Figure 4, Item 5) and aerator (Figure 4, Item 6) on oil pan (Figure 4, Item 14) with three washers (Figure 4, Item 7), lockwashers (Figure 4, Item 8), and screws (Figure 4, Item 9). Tighten screws 10 to 12 lb-ft (14 to 16 N·m).
5. Apply a thin coating of sealing compound to suction flange gasket (Figure 4, Item 13).
6. Install suction flange gasket (Figure 4, Item 13) and suction flange (Figure 4, Item 12) on oil pan (Figure 4, Item 14) with two washers (Figure 4, Item 11) and screws (Figure 4, Item 10). Tighten screws 19 to 22 lb-ft (26 to 30 N·m).

ASSEMBLY - Continued

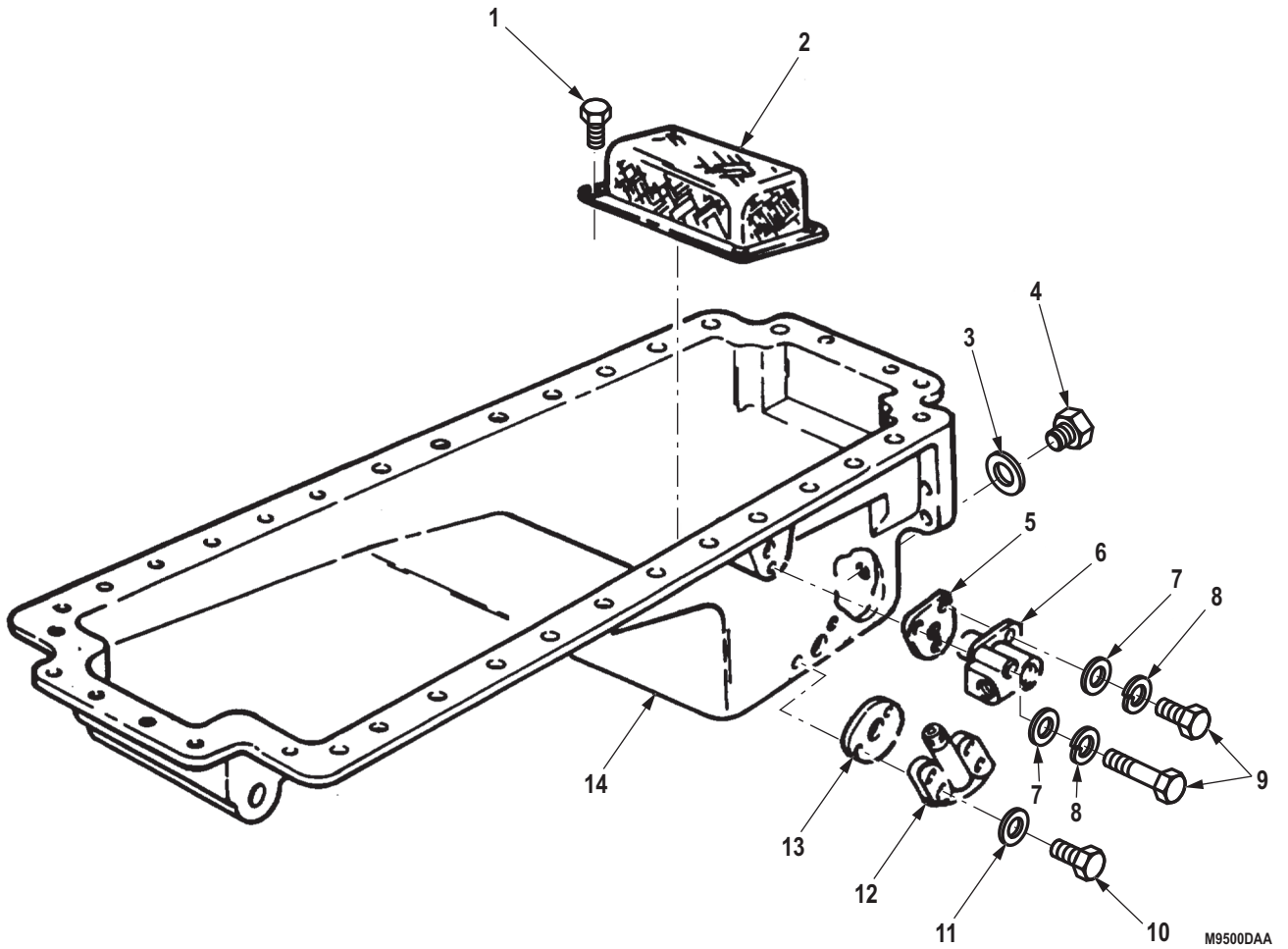

M9500DAA

Figure 4. Engine Oil Pan Assembly.

END OF TASK

INSTALLATION**NOTE**

Engine oil pan is mounted using screw-assembled washers on late model engines.

1. Install engine oil pan gasket (Figure 5, Item 3) and oil pan (Figure 5, Item 8) on engine block (Figure 5, Item 14) and front gearcase cover (Figure 5, Item 1) with brace (Figure 5, Item 11), four washers (Figure 5, Item 13), screws (Figure 5, Item 12), 30 washers (Figure 5, Item 9), and screws (Figure 5, Item 10). Do not tighten screws.
2. Install rear of oil pan (Figure 5, Item 8) on flywheel housing (Figure 5, Item 2) with four washers (Figure 5, Item 4) and screws (Figure 5, Item 5). Do not tighten screws.
3. Install engine oil pan gasket (Figure 5, Item 3) and oil pan (Figure 5, Item 8) on flywheel housing (Figure 5, Item 2) with six washers (Figure 5, Item 6) and screws (Figure 5, Item 7). Tighten screws alternately 70 to 80 lb-ft (95 to 109 N·m).
4. Alternately tighten screws (Figure 5, Item 12) 35 to 40 lb-ft (48 to 54 N·m).
5. Alternately tighten screws (Figure 5, Item 10) 15 to 40 lb-ft (20 to 54 N·m).

INSTALLATION - Continued

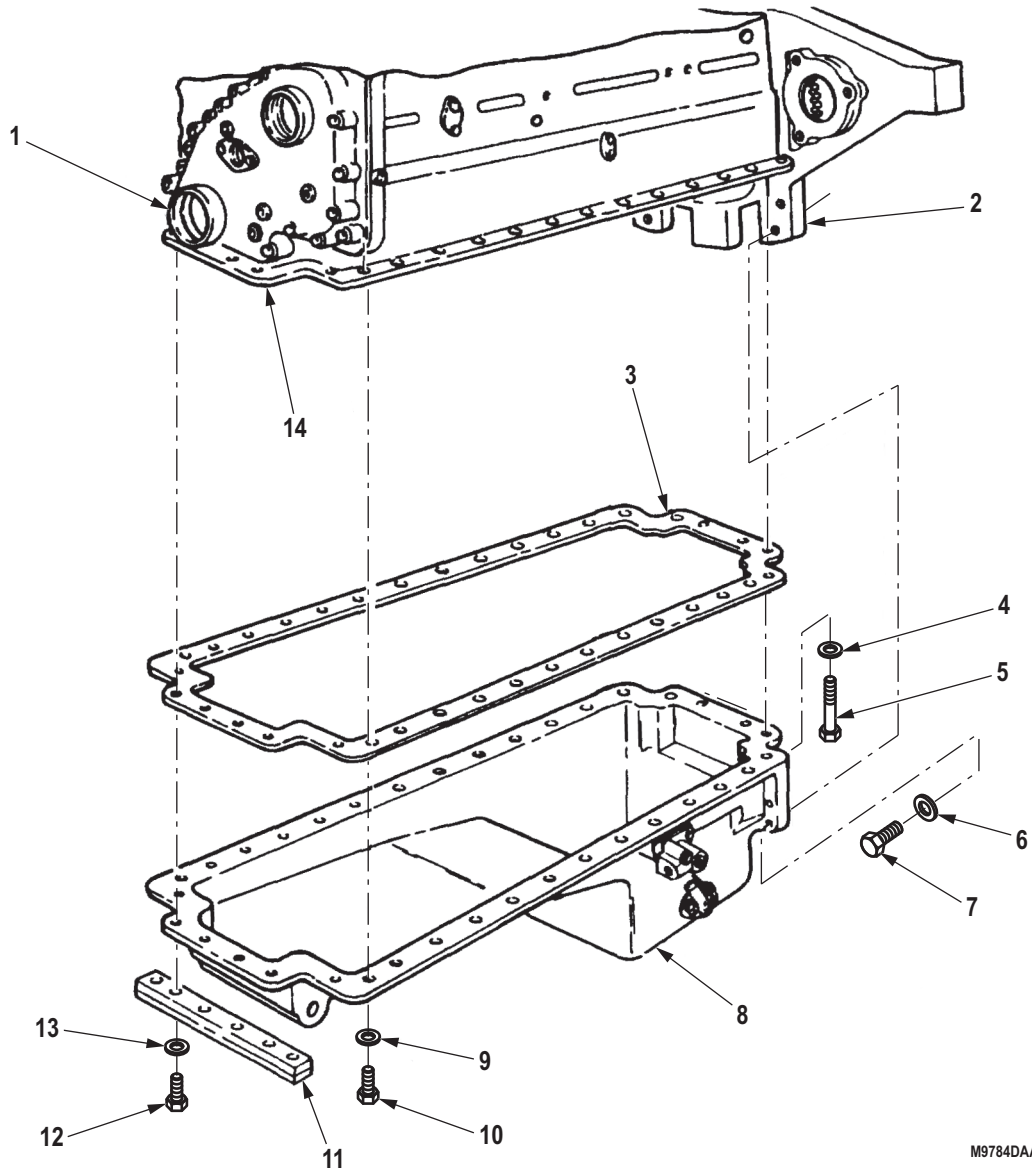

M9784DAA

Figure 5. Engine Oil Pan Installation.

INSTALLATION - Continued

6. Connect oil pickup hose (Figure 6, Item 2) to suction flange (Figure 6, Item 5).
7. Connect oil return hose (Figure 6, Item 6) to aerator (Figure 6, Item 3).
8. Install oil pickup hose (Figure 6, Item 2) and return hose (Figure 6, Item 6) on oil pan (Figure 6, Item 4) with two clamps (Figure 6, Item 1), washers (Figure 6, Item 8), and screws (Figure 6, Item 7). Tighten screws 35 to 40 lb-ft (48 to 54 N-m).

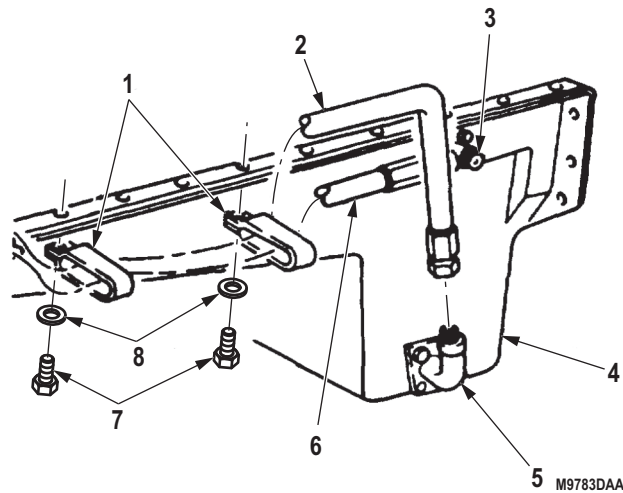

Figure 6. Engine Oil Pan Installation.

END OF TASK**FOLLOW-ON MAINTENANCE**

1. Install front sump tube. (WP 0226)
2. Install oil dipstick tube. (TM 9-2320-272-10)
3. Refill engine oil. (Volume 5, WP 0820)

END OF TASK**END OF WORK PACKAGE**

**FIELD MAINTENANCE
ENGINE OIL FILTER REPLACEMENT**

INITIAL SETUP:**Tools and Special Tools**

Tool Kit, General Mechanic's: Automotive
(Volume 5, WP 0826, Table 1, Item 56)
Wrench, Torque, Click, Ratcheting, 1/2" Drive,
250 Ft-Lb
(Volume 5, WP 0826, Table 1, Item 63)

Materials/Parts

Cleaning Compound, Solvent
(Volume 5, WP 0825, Table 1, Item 16, 17)
Diesel Fuel, DF-1, Winter
(Volume 5, WP 0825, Table 1, Item 24, 25,
26)
Rag, Wiping
(Volume 5, WP 0825, Table 1, Item 53)
Filter (M939A2)
(Volume 5, WP 0827, Table 1, Item 176)
Qty: 1
Filter Kit (M939/A1)
(Volume 5, WP 0827, Table 1, Item 76)
Gasket (M939/A1)
(Volume 5, WP 0827, Table 1, Item 71)
Qty: 1
Lockwasher
(Volume 5, WP 0827, Table 1, Item 215)
Qty: 1

Materials/Parts (cont.)

Packing Assembly
(Volume 5, WP 0827, Table 1, Item 72)
Qty: 1
Spacer, Ring
(Volume 5, WP 0827, Table 1, Item 192)
Qty: 1
Washer, Flat
(Volume 5, WP 0827, Table 1, Item 156)
Qty: 1

References

Volume 5, WP 0820

Equipment Condition

Parking brake set. (TM 9-2320-272-10)
Hood raised and secured. (TM 9-2320-272-10)
Right splash shield removed (M939A2).
(TM 9-2320-272-10)
Left splash shield removed (M939/A1).
(TM 9-2320-272-10)

DRAINING OIL**WARNING**

- Accidental or intentional introduction of liquid contaminants into the environment is in violation of state, federal, and military regulations. Refer to local Unit SOP for information concerning storage, use, and disposal of these liquids. Failure to comply may result in injury or death to personnel.
- Do not drain oil from engine or remove lines containing oil when engine is hot. Failure to comply may result in injury or death to personnel.

NOTE

- References to early model engines refer to engines with a serial number before 444487830 used in M939A2 series vehicles.
 - Have adequate drainage container ready to catch oil.
 - Perform Steps (1) and (2) for M939/A1 series vehicles.
1. Remove drain plug (Figure 1, Item 2) from filter shell (Figure 1, Item 1) and drain oil completely from filter shell (Figure 1, Item 1).
 2. Install drain plug (Figure 1, Item 2) in filter shell (Figure 1, Item 1) and tighten drain plug (Figure 1, Item 2) 25 to 35 lb-ft (34 to 47 N·m).

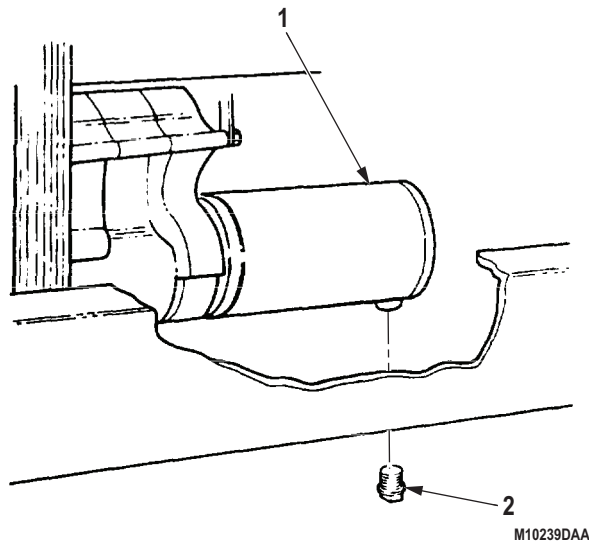

Figure 1. Engine Oil Drain Plugs.

DRAINING OIL - Continued

- Remove drain plug (Figure 2, Item 4) and ring spacer (Figure 2, Item 3) from oil pan (Figure 2, Item 1) and drain oil. Discard ring spacer.

WARNING

- Solvent cleaning compound is flammable and toxic. Do not use near an open flame and always have a fire extinguisher nearby when solvents are used. Use only in well-ventilated places, wear protective clothing, and dispose of cleaning rags in approved container. Failure to comply may result in damage to equipment, injury, or death to personnel.
 - Eyeshields must be worn when cleaning with compressed air. Compressed air source will not exceed 30 psi (207 kPa). Failure to comply may result in injury or death to personnel.
- Clean drain plug (Figure 2, Item 4) with solvent cleaning compound and wipe area around drain hole (Figure 2, Item 2).
 - Install ring spacer (Figure 2, Item 3) and drain plug (Figure 2, Item 4) on oil pan (Figure 2, Item 1). Tighten drain plug 100 lb-ft (136 N·m) on M939/A1 series vehicles.

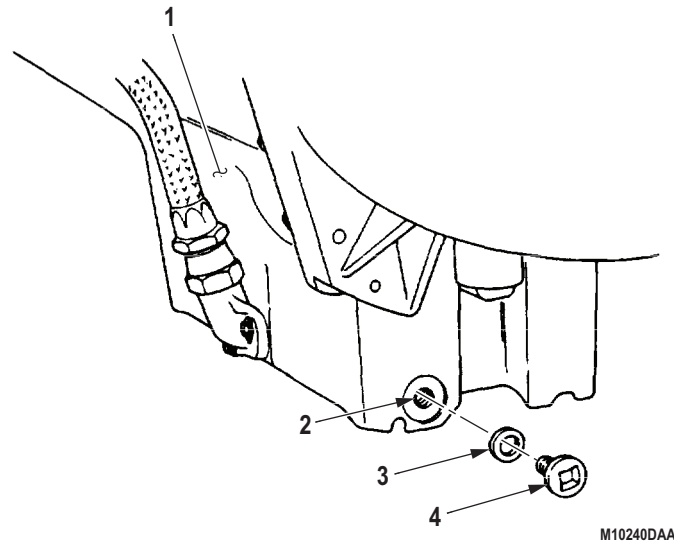
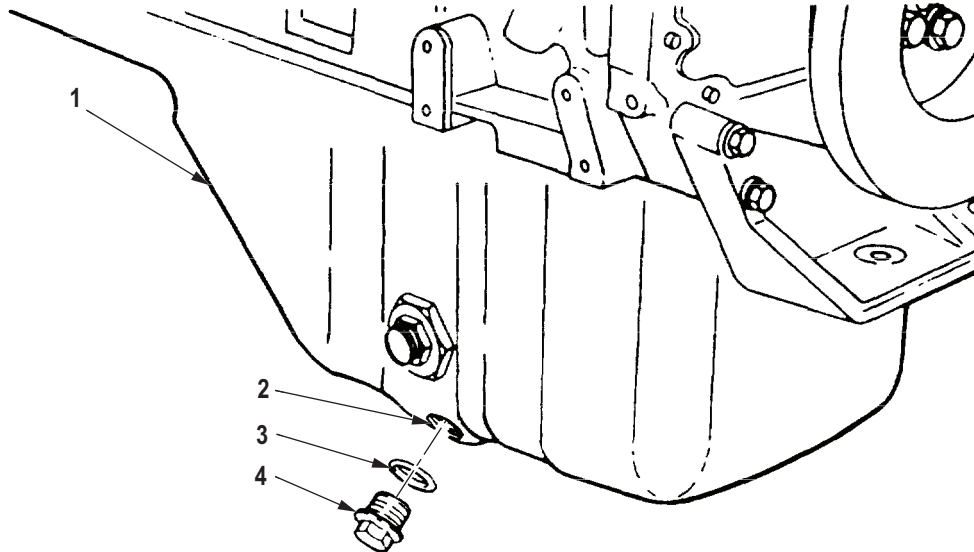

Figure 2. Engine Oil Drain Plugs.

DRAINING OIL - Continued

6. Install flat washer (Figure 3, Item 3) and drain plug (Figure 3, Item 4) on oil pan (Figure 3, Item 1). Tighten drain plug 60 lb-ft (81 N·m) on M939A2 series vehicles.



M0012DAA

Figure 3. Engine Oil Drain Plugs.

END OF TASK**OIL FILTER REMOVAL****NOTE**

- Perform Steps (1) and (2) for oil filter on M939/A1 series vehicles and Step (3) for oil filter on M939A2 series vehicles.
 - Support oil filter shell while loosening center bolt. Lightly tap filter shell with palm of hand to loosen from filter base.
1. Loosen center bolt (Figure 4, Item 5) until oil filter shell (Figure 4, Item 4) can be removed from filter base (Figure 4, Item 1), and remove oil filter shell from filter base.
 2. Remove oil filter element (Figure 4, Item 3) and packing assembly (Figure 4, Item 2) from oil filter shell (Figure 4, Item 4). Discard oil filter element and packing assembly.

OIL FILTER REMOVAL - Continued

Figure 4. Oil Filter Removal.

3. Remove oil filter (Figure 5, Item 2) from adapter (Figure 5, Item 1). Discard oil filter.

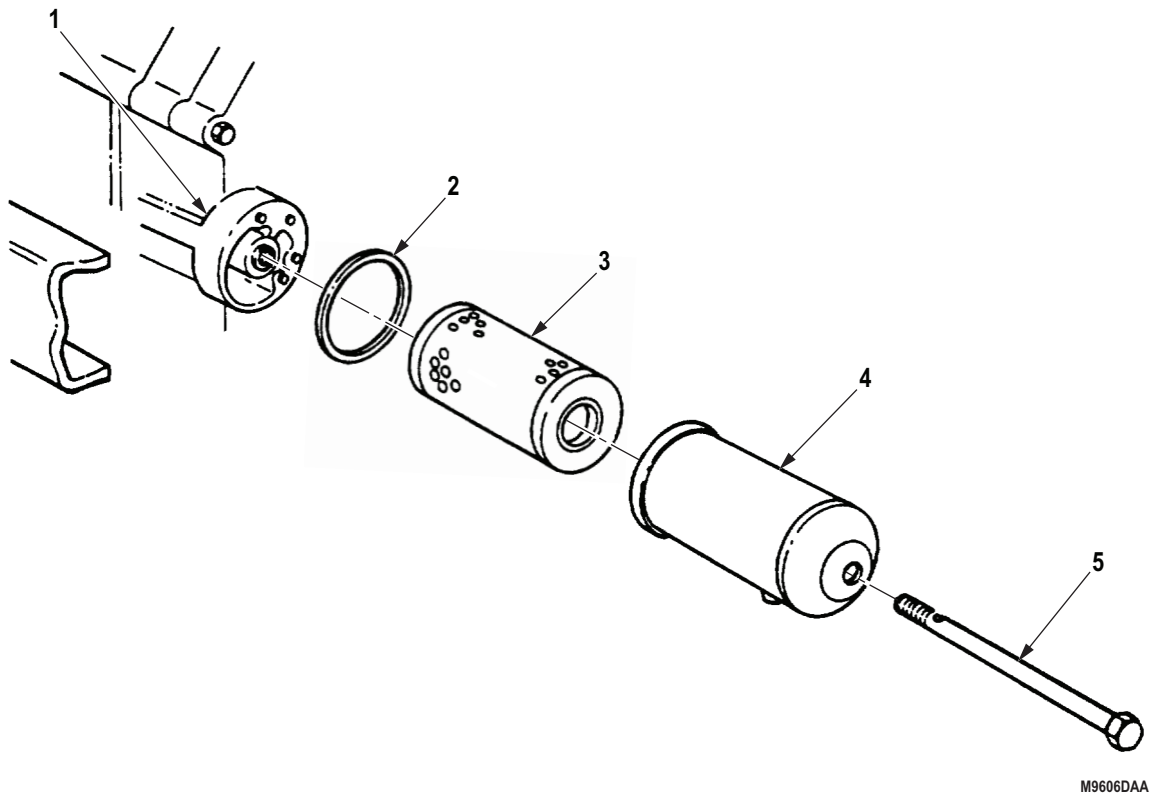
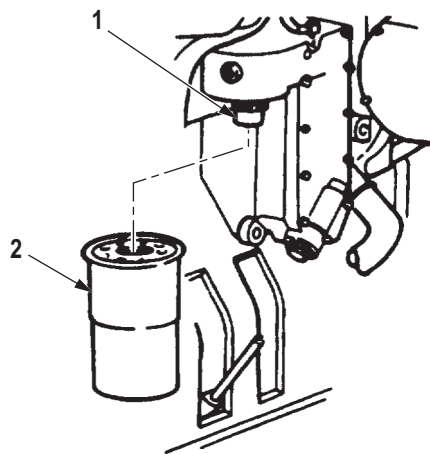

Figure 5. Oil Filter Removal.

END OF TASK

FILTER SHELL AND BOLT DISASSEMBLY (M939/A1)

1. Remove center bolt retaining pin (Figure 6, Item 1), filter element support (Figure 6, Item 2), gasket (Figure 6, Item 3), washer (Figure 6, Item 4), and spring (Figure 6, Item 5) from center bolt (Figure 6, Item 6) and oil filter shell (Figure 6, Item 8). Discard gasket.
2. Remove center bolt lockwasher (Figure 6, Item 7) and center bolt (Figure 6, Item 6) from oil filter shell (Figure 6, Item 8). Discard center bolt lockwasher.

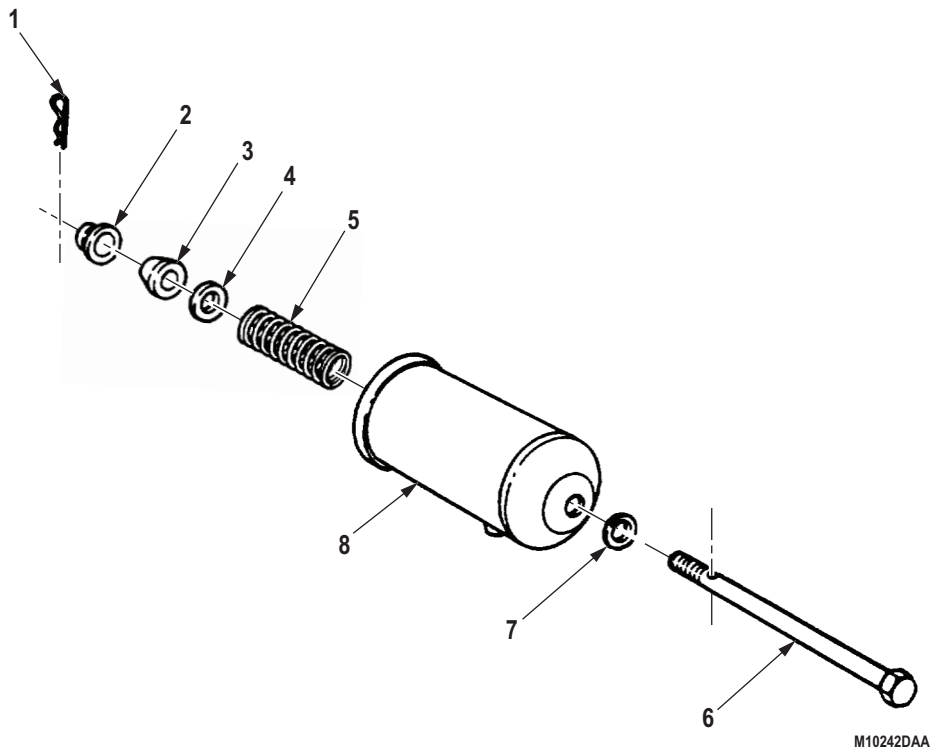

Figure 6. Filter Shell and Bolt Disassembly.

END OF TASK

CLEANING AND INSPECTION

WARNING



- Solvent cleaning compound is flammable and toxic. Do not use near an open flame and always have a fire extinguisher nearby when solvents are used. Use only in well-ventilated places, wear protective clothing, and dispose of cleaning rags in approved container. Failure to comply may result in damage to equipment, injury, or death to personnel.
 - Eyeshields must be worn when cleaning with compressed air. Compressed air source will not exceed 30 psi (207 kPa). Failure to comply may result in injury or death to personnel.
1. Clean center bolt (Figure 7, Item 4) and oil filter shell (Figure 7, Item 5) with solvent cleaning compound and dry with compressed air.
 2. Inspect center bolt (Figure 7, Item 4). Replaced if threads are stripped.
 3. Inspect filter base (Figure 7, Item 1). If cracked, nicked, or threads are stripped, notify supervisor.
 4. Inspect filter element support (Figure 7, Item 2). Replace if cracked or grooved.
 5. Inspect spring (Figure 7, Item 3). Replace if cracked or broken.

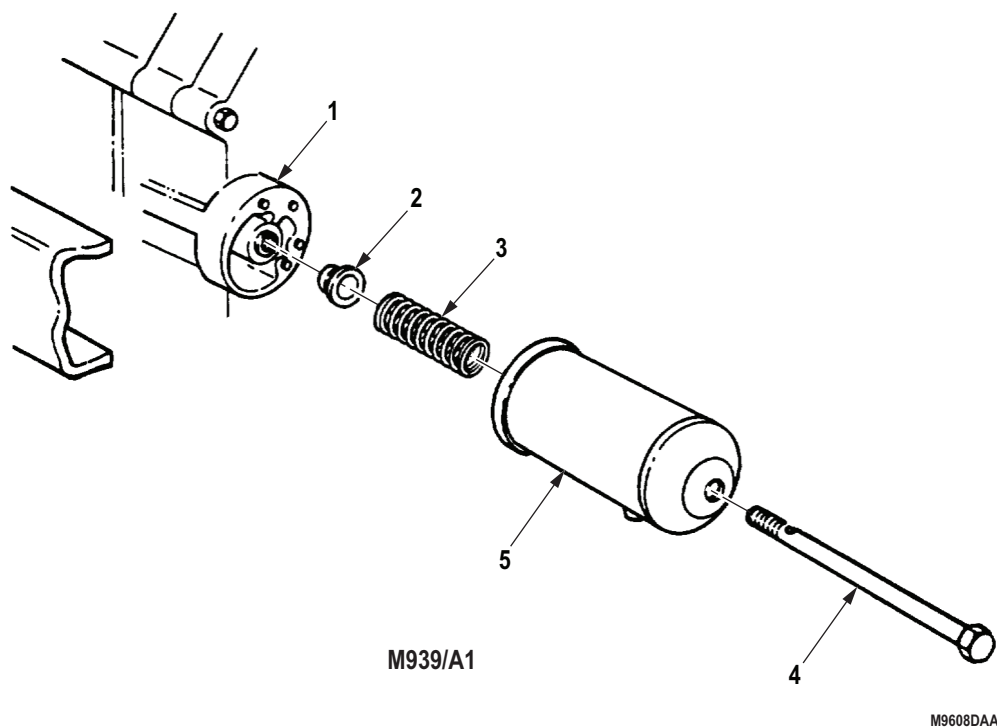

Figure 7. Engine Oil Filter Cleaning and Inspection.

END OF TASK

FILTER SHELL AND BOLT ASSEMBLY (M939/A1)

1. Install center bolt lockwasher (Figure 8, Item 7) and center bolt (Figure 8, Item 6) in oil filter shell (Figure 8, Item 8).
2. Install spring (Figure 8, Item 5), washer (Figure 8, Item 4), gasket (Figure 8, Item 3), filter element support (Figure 8, Item 2), and center bolt retaining pin (Figure 8, Item 1) on center bolt (Figure 8, Item 6) and oil filter shell (Figure 8, Item 8).

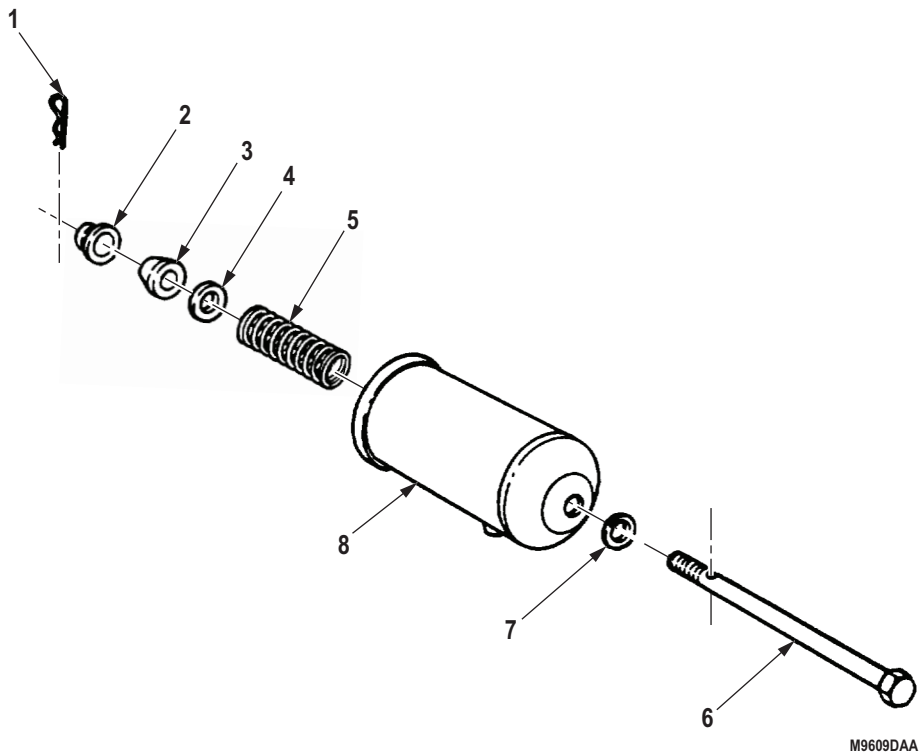
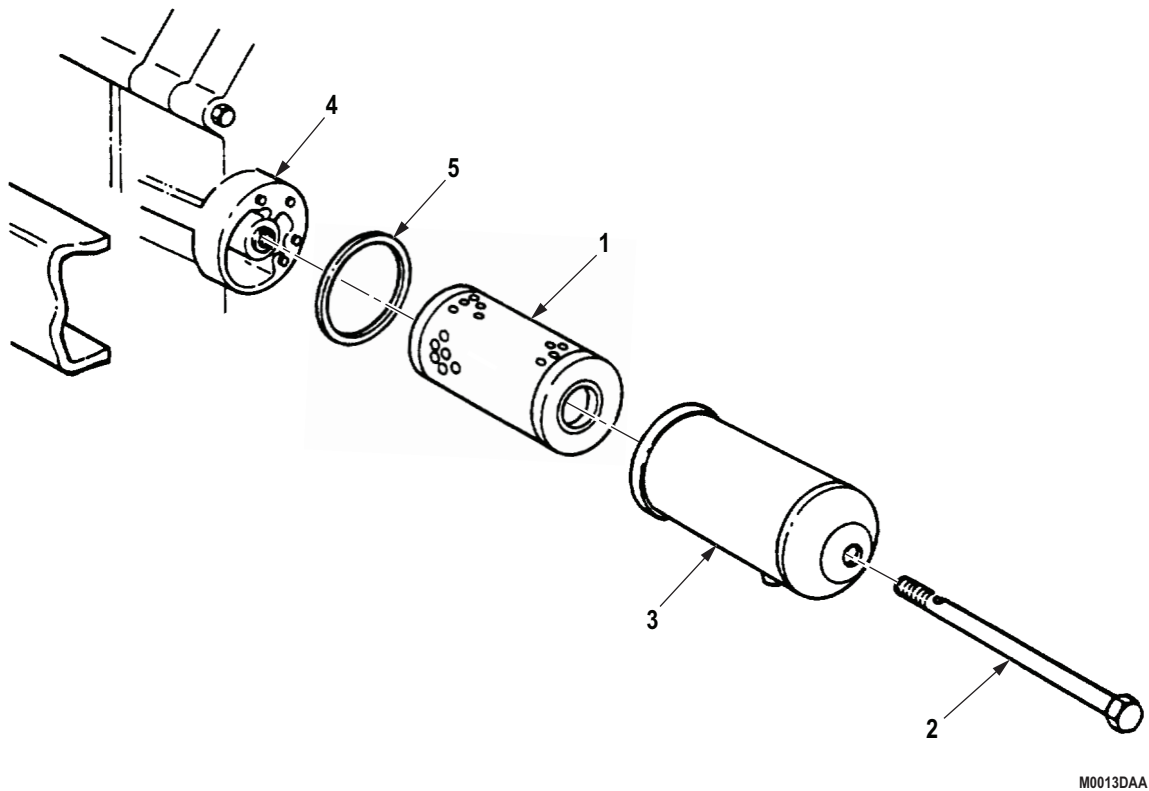

Figure 8. Filter Shell and Bolt Assembly.

END OF TASK

OIL FILTER INSTALLATION**NOTE**

- Perform Steps (1) through (3) for oil filters on M939/A1 series vehicles and Steps (4) and (5) for oil filters on M939A2 series vehicles.
 - Ensure correct filter is used during installation. Filter element and oil filter shell seal used on the M939/A1 series vehicle engines are supplied as a kit. Early and late model engines in M939A2 series vehicles use different filters.
1. Install oil filter element (Figure 9, Item 1) in oil filter shell (Figure 9, Item 3).
 2. Install packing assembly (Figure 9, Item 5) and oil filter shell (Figure 9, Item 3) on filter base (Figure 9, Item 4). Hand-tighten center bolt (Figure 9, Item 2) until oil filter shell seats in filter base.
 3. Tighten center bolt (Figure 9, Item 2) 25 to 35 lb-ft (34 to 47 N·m).



M0013DAA

Figure 9. Engine Oil Filter Installation.

OIL FILTER INSTALLATION - Continued

4. Fill oil filter (Figure 10, Item 2) with clean engine oil and install on adapter (Figure 10, Item 1). Hand tighten.
5. Tighten oil filter (Figure 10, Item 2) an additional 3/4 turn.

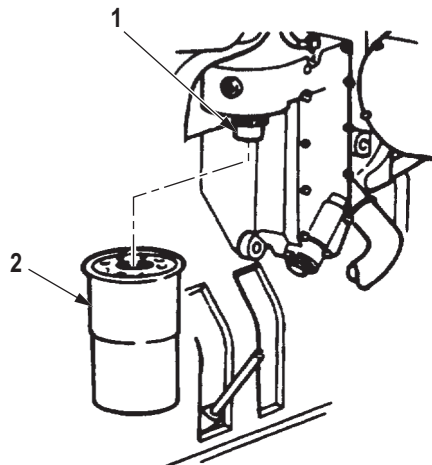

M10243DAA

Figure 10. Engine Oil Filter Installation.

END OF TASK**FOLLOW-ON MAINTENANCE**

1. Fill engine with oil to proper level. (Volume 5, WP 0820)
2. Start engine and check for leaks. (TM 9-2320-272-10)
3. Check oil level and add oil as necessary. (TM 9-2320-272-10)
4. Install right splash shield (M939A2 only). (TM 9-2320-272-10)
5. Install left splash shield (M939/A1 only). (TM 9-2320-272-10)

END OF TASK**END OF WORK PACKAGE**

**FIELD MAINTENANCE
ENGINE OIL COOLER REPAIR (M939/A1)**

INITIAL SETUP:**Tools and Special Tools**

Tool Kit, General Mechanic's: Automotive
(Volume 5, WP 0826, Table 1, Item 56)

Materials/Parts

Cleaning Compound, Solvent
(Volume 5, WP 0825, Table 1, Item 16, 17)
Lubricating Oil, Engine
(Volume 5, WP 0825, Table 1, Item 39, 40, 41,
42)
Tape, Antiseizing
(Volume 5, WP 0825, Table 1, Item 65)
Bushing (Volume 5, WP 0827, Table 1, Item 118)
Qty: 1
Gasket (Volume 5, WP 0827, Table 1, Item 102)
Qty: 1

Materials/Parts (cont.)

Gasket (Volume 5, WP 0827, Table 1, Item 165)
Qty: 1
Lockwasher
(Volume 5, WP 0827, Table 1, Item 186)
Qty: 9
O-ring (Volume 5, WP 0827, Table 1, Item 109)
Qty: 2
Retaining Ring
(Volume 5, WP 0827, Table 1, Item 21)
Qty: 2

Equipment Condition

Parking brake set. (TM 9-2320-272-10)
Right splash shield removed. (TM 9-2320-272-10)
Cooling system drained. (WP 0287)

REMOVAL

1. Loosen hose clamp (Figure 1, Item 15) and disconnect heater hose (Figure 1, Item 14) from shutoff valve (Figure 1, Item 16).
2. Remove shutoff valve (Figure 1, Item 16) and adapter (Figure 1, Item 13) from oil cooler (Figure 1, Item 8).
3. Loosen hose clamp (Figure 1, Item 11) and disconnect surge tank-to-oil cooler hose (Figure 1, Item 12) from oil cooler (Figure 1, Item 8).
4. Loosen hose clamp (Figure 1, Item 10) and disconnect transmission cooler-to-oil hose (Figure 1, Item 9) from oil cooler (Figure 1, Item 8).
5. Disconnect air compressor coolant line (Figure 1, Item 3) and bushing (Figure 1, Item 2) from oil cooler elbow (Figure 1, Item 1). Discard bushing.
6. Remove five screws (Figure 1, Item 7), lockwashers (Figure 1, Item 6), oil cooler (Figure 1, Item 8), and gasket (Figure 1, Item 5) from engine block (Figure 1, Item 4). Discard lockwashers and gasket. Clean gasket remains from engine block and oil cooler mating surfaces.

REMOVAL - Continued

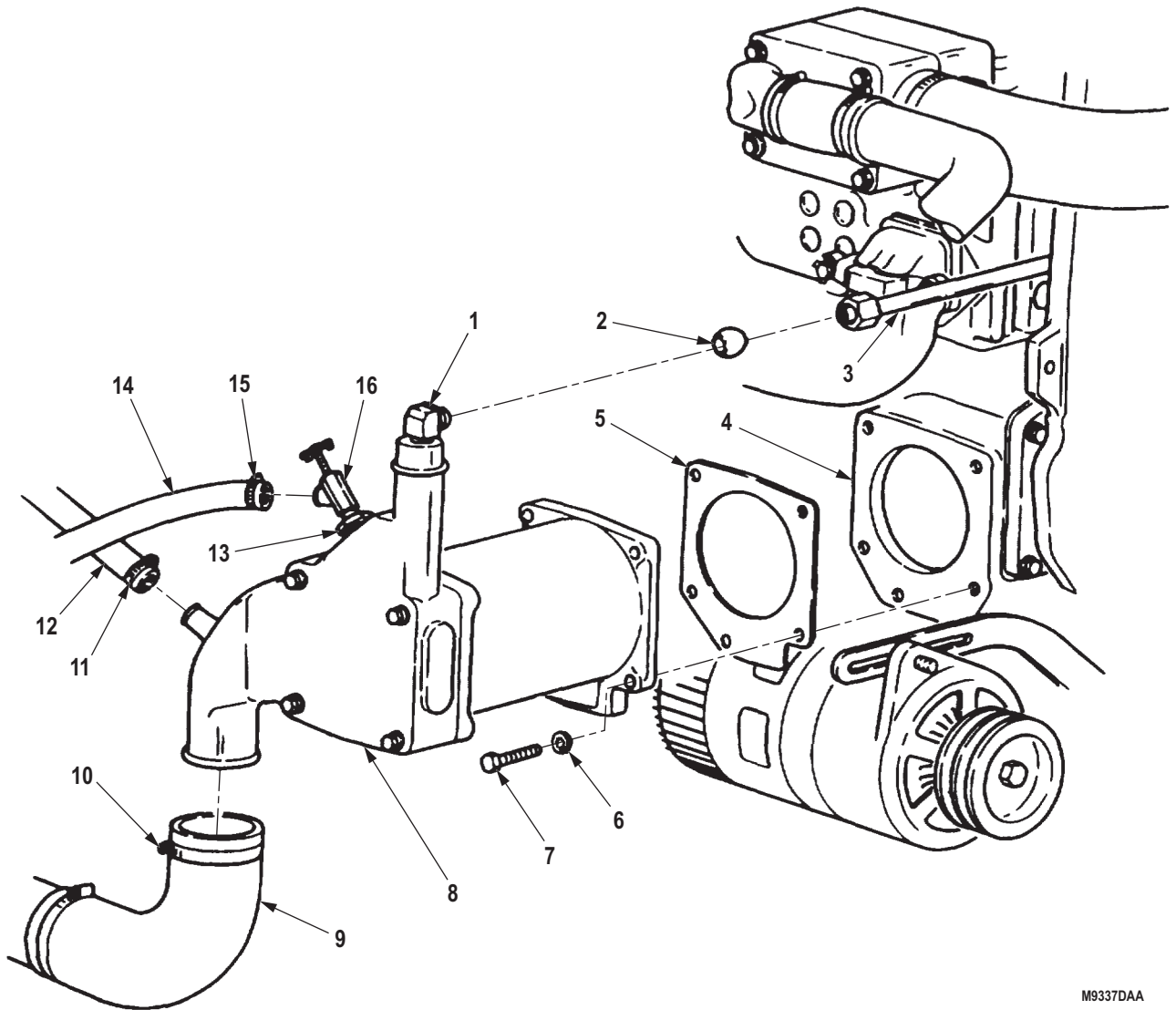

M9337DAA

Figure 1. Engine Oil Cooler Removal.

END OF TASK

DISASSEMBLY

1. Remove four screws (Figure 2, Item 2), lockwashers (Figure 2, Item 3), cooler housing (Figure 2, Item 6), and gasket (Figure 2, Item 9) from oil cooler end cover (Figure 2, Item 10). Discard lockwashers and gasket. Clean gasket remains from mating surfaces of end cover and cooler housing.
2. Remove pipe plug (Figure 2, Item 5), elbow (Figure 2, Item 1), two retaining rings (Figure 2, Item 8), o-rings (Figure 2, Item 7), and oil cooler element (Figure 2, Item 4) from oil cooler end cover (Figure 2, Item 10). Discard retaining rings and o-rings.

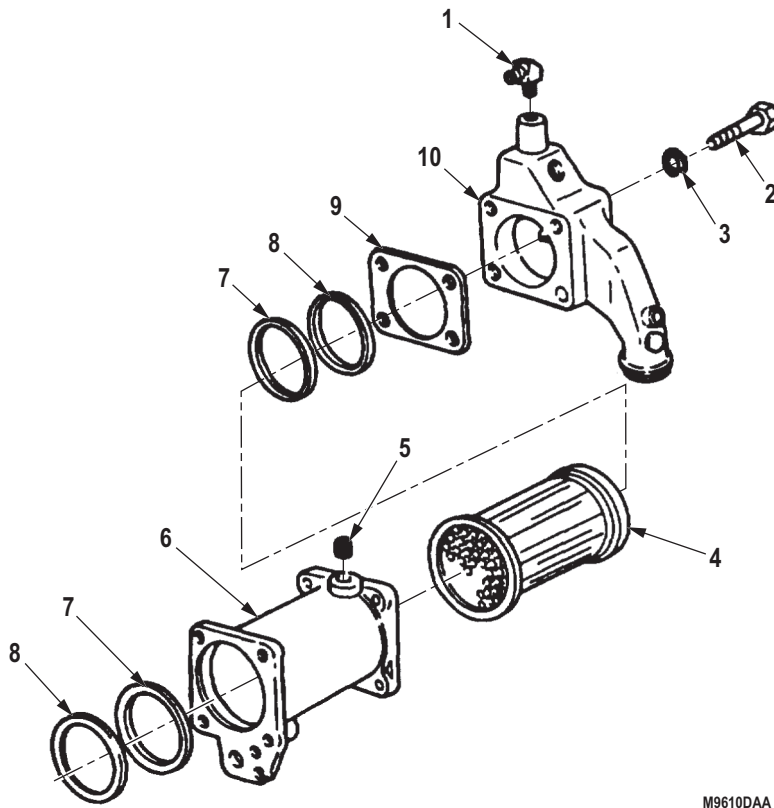

Figure 2. Engine Oil Cooler Disassembly.

END OF TASK

CLEANING AND INSPECTION**WARNING**

Solvent cleaning compound is flammable and toxic. Do not use near an open flame and always have a fire extinguisher nearby when solvents are used. Use only in well-ventilated places, wear protective clothing, and dispose of cleaning rags in approved container. Failure to comply may result in damage to equipment, injury, or death to personnel.

NOTE

To prevent hardening and drying of foreign substances, clean cooler element as soon as possible after removal.

1. Clean cooler housing (Figure 3, Item 1) with solvent cleaning compound and inspect for cracks and stripped threads. Replace cooler housing if cracked or threads are stripped.
2. Soak and flush oil cooler element (Figure 3, Item 2) with solvent cleaning compound and inspect for broken and cracked welds. Replace cooler element if broken or cracked.

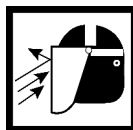
WARNING

Eyeshields must be worn when cleaning with compressed air. Compressed air source will not exceed 30 psi (207 kPa). Failure to comply may result in injury or death to personnel.

3. Immerse oil cooler element (Figure 3, Item 2) in water, apply 30 psi (207 kPa) air pressure, and plug opposite end. Replace oil cooler element if air bubbles are observed.

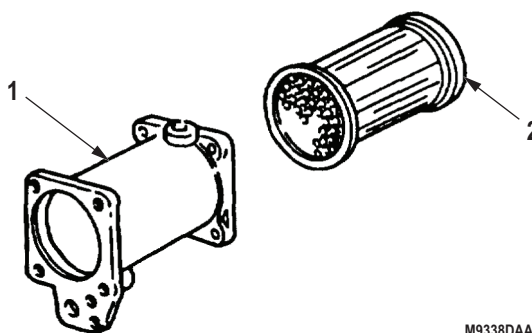

M9338DAA

Figure 3. Engine Oil Cooler Cleaning and Inspection.

END OF TASK

ASSEMBLY

1. Align index marks on oil cooler element (Figure 4, Item 4) and install in cooler housing (Figure 4, Item 6).

NOTE

Apply engine oil to lubricate o-rings before installation.

2. Install two o-rings (Figure 4, Item 7) and retaining rings (Figure 4, Item 8) in each end of cooler housing (Figure 4, Item 6).
3. Wrap end of elbow (Figure 4, Item 1) with antiseize tape and install in end cover (Figure 4, Item 10).
4. Wrap pipe plug (Figure 4, Item 5) with sealing tape and install in cooler housing (Figure 4, Item 6).
5. Install gasket (Figure 4, Item 9) and end cover (Figure 4, Item 10) on cooler housing (Figure 4, Item 6) with four lockwashers (Figure 4, Item 3) and screws (Figure 4, Item 2). Tighten screws 30 to 35 lb-ft (41 to 47 N·m).

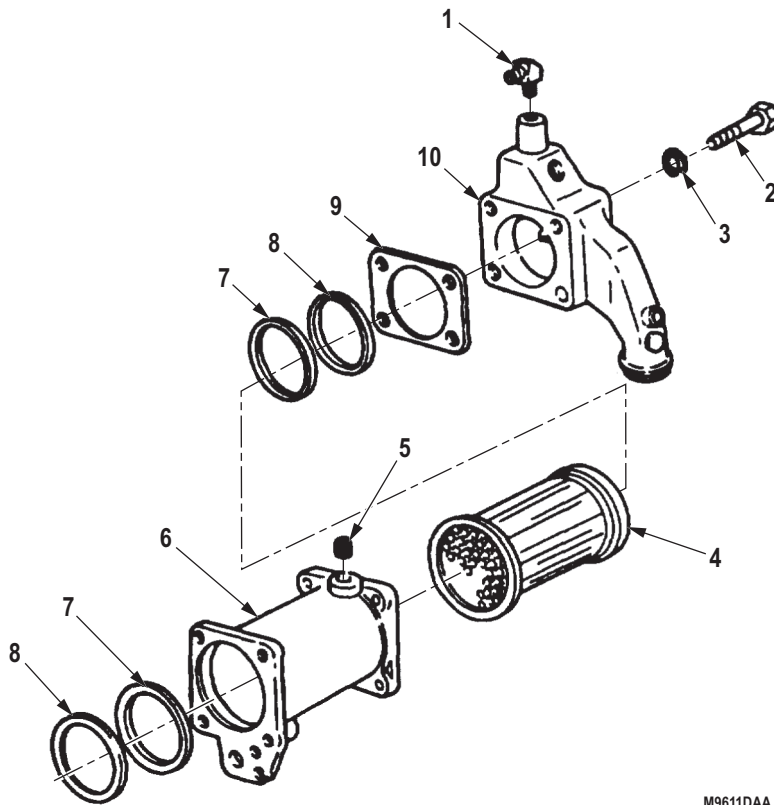

M9611DAA

Figure 4. Engine Oil Cooler Assembly.

END OF TASK**INSTALLATION**

1. Install gasket (Figure 5, Item 5) and oil cooler (Figure 5, Item 8) on engine block (Figure 5, Item 4) with five lockwashers (Figure 5, Item 6) and screws (Figure 5, Item 7). Tighten screws 30 to 35 lb-ft (40 to 47 N·m).
2. Connect bushing (Figure 5, Item 2) and air compressor coolant line (Figure 5, Item 3) to oil cooler elbow (Figure 5, Item 1).

INSTALLATION - Continued

3. Install adapter (Figure 5, Item 13) and shutoff valve (Figure 5, Item 16) on oil cooler (Figure 5, Item 8).
4. Connect surge tank-to-oil cooler hose (Figure 5, Item 12) to oil cooler (Figure 5, Item 8) with clamp (Figure 5, Item 11).
5. Connect transmission cooler-to-oil hose (Figure 5, Item 9) to oil cooler (Figure 5, Item 8) with hose clamp (Figure 5, Item 10).
6. Connect heater hose (Figure 5, Item 14) to shutoff valve (Figure 5, Item 16) with hose clamp (Figure 5, Item 15).

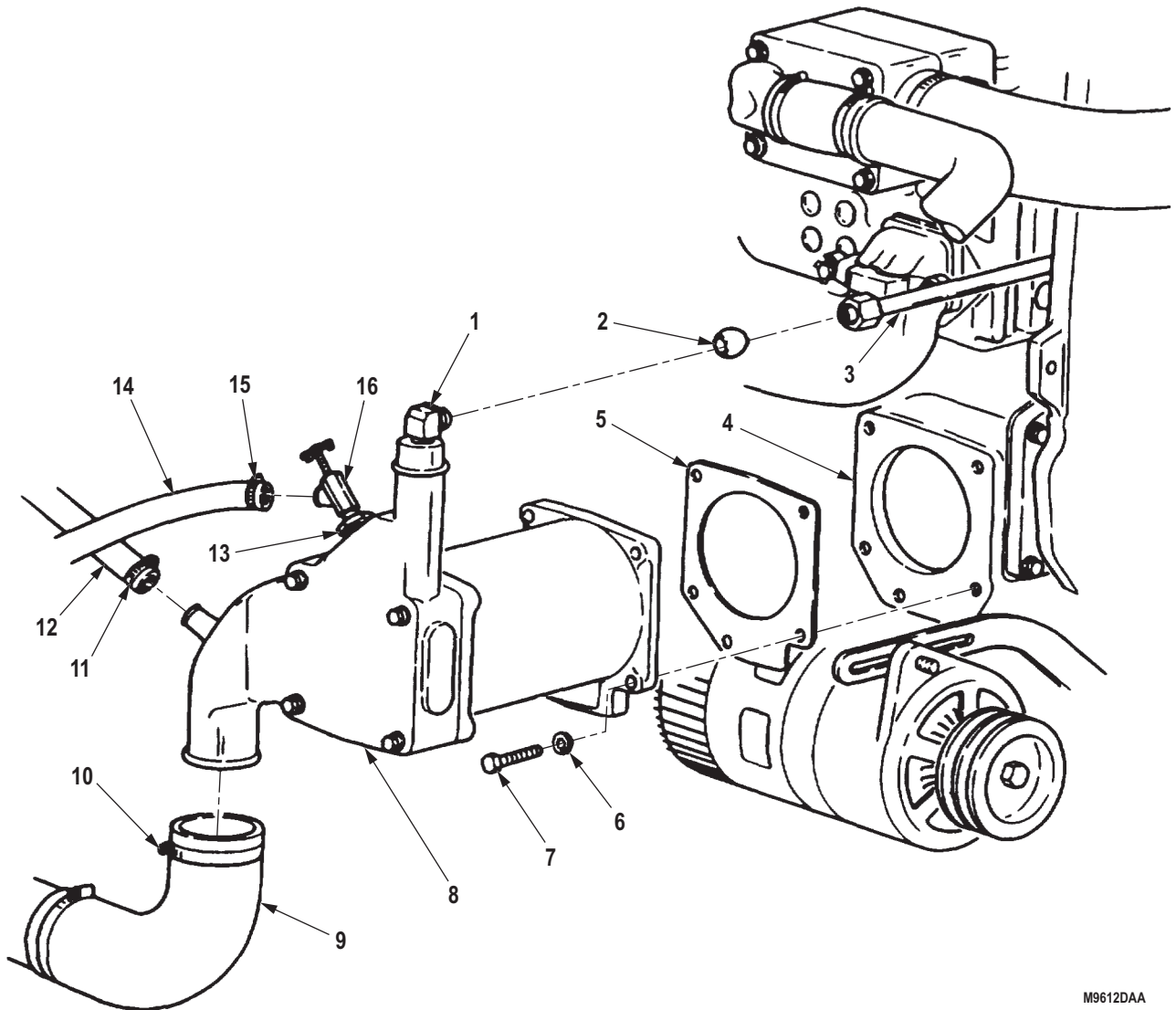

M9612DAA

Figure 5. Engine Oil Cooler Installation.

END OF TASK

FOLLOW-ON MAINTENANCE

1. Fill cooling system to proper level. (WP 0287)
2. Install right splash shield. (TM 9-2320-272-10)

END OF TASK**END OF WORK PACKAGE**

FIELD MAINTENANCE
ENGINE AIR INTAKE MANIFOLD REPLACEMENT (M939/A1)

INITIAL SETUP:**Tools and Special Tools**

Tool Kit, General Mechanic's: Automotive
(Volume 5, WP 0826, Table 1, Item 56)
Wrench, Torque, Click, Ratcheting, 3/8" Drive,
75 Ft-Lb
(Volume 5, WP 0826, Table 1, Item 62)

Materials/Parts

Cap Set, Protective, Dust and Moisture Seal
(Volume 5, WP 0825, Table 1, Item 13)
Tape, Antiseizing
(Volume 5, WP 0825, Table 1, Item 65)
Gasket (Volume 5, WP 0827, Table 1, Item 103)
Qty: 3

Materials/Parts (cont.)

Gasket (Volume 5, WP 0827, Table 1, Item 108)
Qty: 1
Lockwasher
(Volume 5, WP 0827, Table 1, Item 425)
Qty: 1

References

WP 0214

Equipment Condition

Air cleaner intake pipe. (WP 0246)
Air compressor air intake tube removed.
(Volume 3, WP 0470)
Ether atomizer removed. (WP 0265)
Crankcase breather tube removed. (WP 0223)

REMOVAL**CAUTION**

Cover or plug all openings to prevent dirt from entering and damaging engine components.

1. Loosen nut (Figure 1, Item 27) and disconnect air tube (Figure 1, Item 8) from air compressor (Figure 1, Item 28) and elbow (Figure 1, Item 26).
2. Loosen nut (Figure 1, Item 14) and disconnect air tube (Figure 1, Item 8) from air governor (Figure 1, Item 13) and adapter (Figure 1, Item 15).
3. Remove screw (Figure 1, Item 11), washer (Figure 1, Item 10), two clamps (Figure 1, Item 9), and air tube (Figure 1, Item 8) from engine access cover (Figure 1, Item 12).
4. Remove screw (Figure 1, Item 23), wire clamp (Figure 1, Item 24), and wiring harness (Figure 1, Item 25) from lower left side of air intake connector (Figure 1, Item 2) and intake manifold (Figure 1, Item 3).

NOTE

Wire clamp will remain on wiring harness.

5. Disconnect hose (Figure 1, Item 20) from elbow (Figure 1, Item 21).
6. Remove elbow (Figure 1, Item 21) and air cleaner indicator filter (Figure 1, Item 22) from intake manifold (Figure 1, Item 3).

NOTE

Tag cable ground strap for installation.

7. Remove screw (Figure 1, Item 18), washer (Figure 1, Item 17), lockwasher (Figure 1, Item 16), and cable ground strap (Figure 1, Item 19) from intake manifold (Figure 1, Item 3). Discard lockwasher.

NOTE

- Air intake manifold is mounted with screw-assembled washers on late model engines. Screws, lockwashers, and washers from early model engines will be discarded and replaced with screw-assembled washers.
- Perform Step (8) only if clamps are on vehicle.

8. Remove screw (Figure 1, Item 30), two clamps (Figure 1, Item 29), and fuel tubes (Figure 1, Item 31) from intake manifold (Figure 1, Item 3).
9. Remove eight screws (Figure 1, Item 4), lockwashers (Figure 1, Item 5), washers (Figure 1, Item 6), intake manifold (Figure 1, Item 3), and three gaskets (Figure 1, Item 7) from cylinder heads (Figure 1, Item 1). Discard lockwashers and gaskets. Discard screws, lockwashers, and washers from early model engines. Clean gasket remains from intake manifold and cylinder head mating surfaces.

REMOVAL - Continued

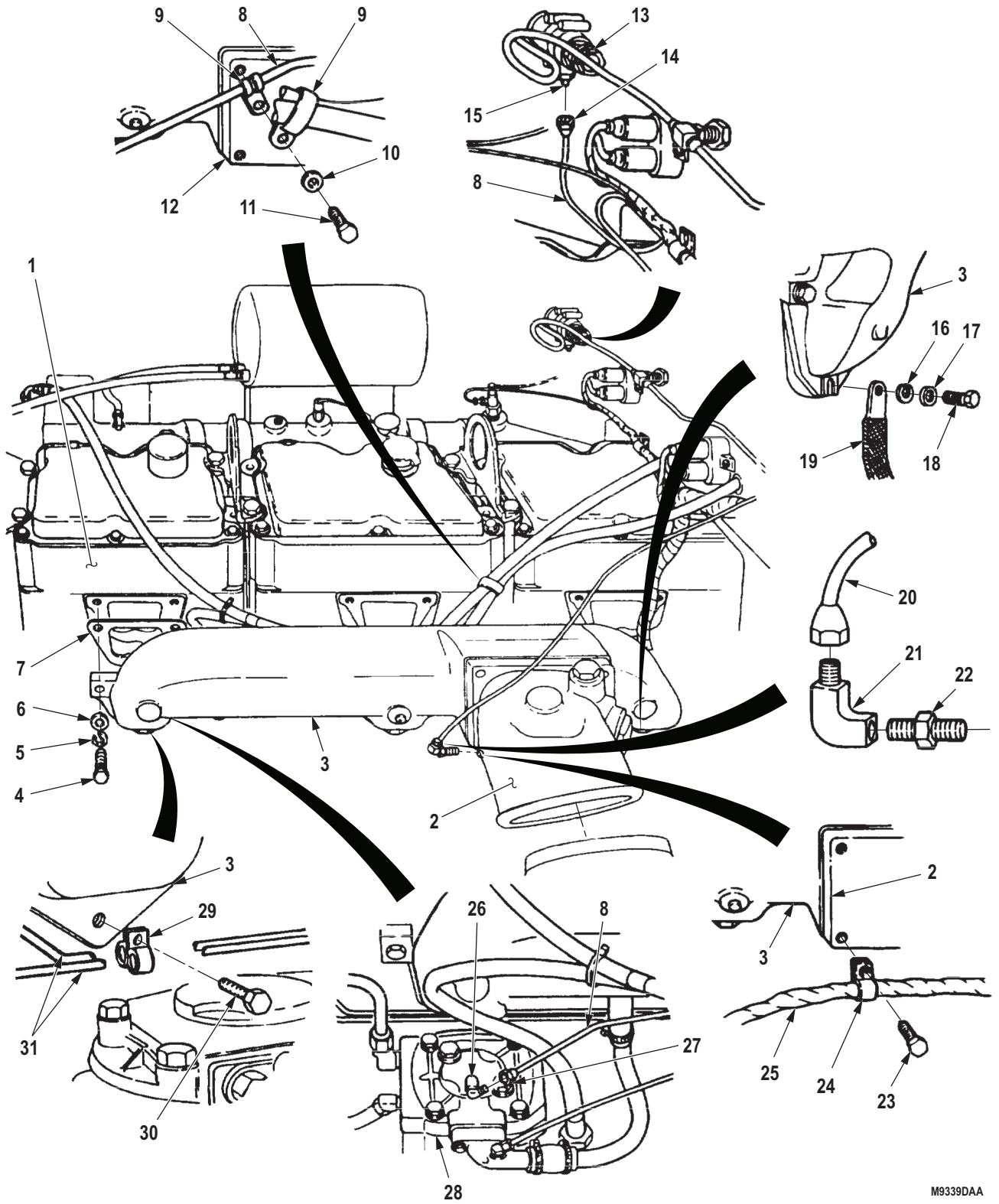

M9339DAA

Figure 1. Engine Air Intake Manifold Removal.

END OF TASK

DISASSEMBLY

1. Remove pipe plug (Figure 2, Item 10) from intake manifold (Figure 2, Item 1).
2. Remove adapter (Figure 2, Item 4) and plug (Figure 2, Item 3) from air intake connector (Figure 2, Item 8).

NOTE

- Air connector is mounted with screw-assembled washers on late model engines. Screws, lockwashers, and washers from early model engines will be discarded and replaced with screw-assembled washers.
 - Perform Step (3) for late model engines.
3. Remove elbow (Figure 2, Item 2) from air intake connector (Figure 2, Item 8).
 4. Remove two screws (Figure 2, Item 6), lockwashers (Figure 2, Item 7), washers (Figure 2, Item 5), air intake connector (Figure 2, Item 8), and gasket (Figure 2, Item 9) from intake manifold (Figure 2, Item 1). Discard lockwashers and gasket. Clean gasket remains from air intake connector and intake manifold mating surfaces.

DISASSEMBLY - Continued

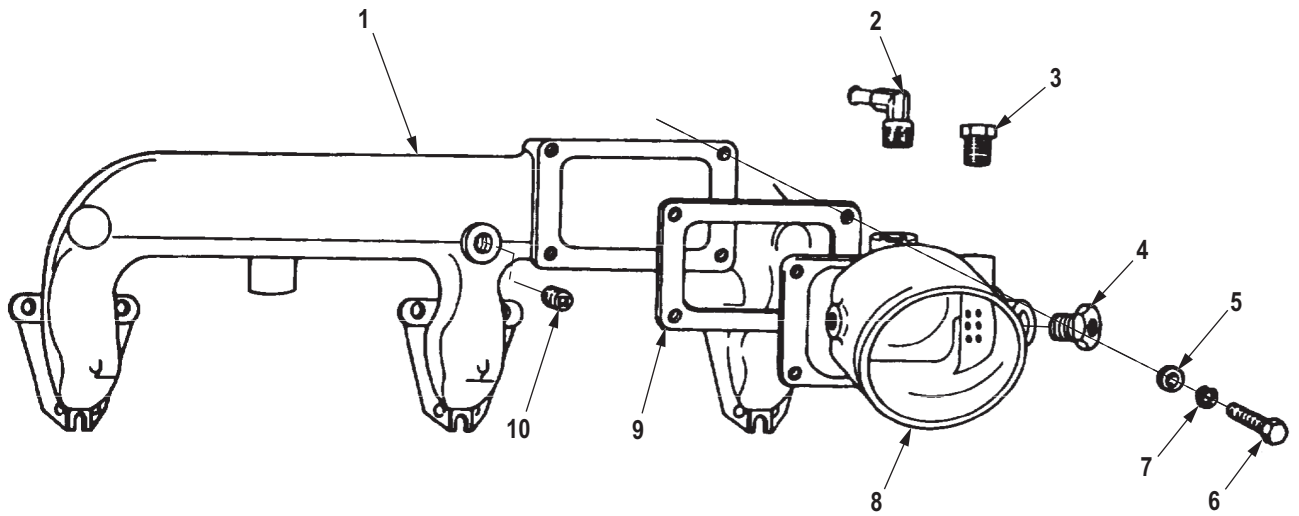

M9340DAA

Figure 2. Engine Air Intake Manifold Disassembly.

END OF TASK

CLEANING AND INSPECTION

1. Brush and clean intake manifold and air intake connector and inspect for breaks, cracks, and elongated holes. Replace if broken, cracked, or if holes are elongated (WP 0214).

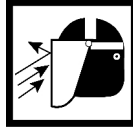
WARNING

Eyeshields must be worn when cleaning with compressed air. Compressed air source will not exceed 30 psi (207 kPa). Failure to comply may result in injury or death to personnel.

2. Clean internal passages of intake manifold and air intake connector with compressed air and inspect threaded holes, screws, pipe plugs, and adapter for stripped or crossed threads. Repair or replace if threaded parts have stripped or crossed threads (WP 0214).

END OF TASK**ASSEMBLY****NOTE**

Male pipe threads must be wrapped with antiseize tape before installation.

1. Install adapter (Figure 3, Item 4) and plug (Figure 3, Item 3) in air intake connector (Figure 3, Item 8).
2. Install pipe plug (Figure 3, Item 10) in intake manifold (Figure 3, Item 1).

NOTE

Perform Step (3) for late model engines.

3. Install elbow (Figure 3, Item 2) on air intake connector (Figure 3, Item 8).
4. Install air intake connector (Figure 3, Item 8) and gasket (Figure 3, Item 9) on intake manifold (Figure 3, Item 1) with two screws (Figure 3, Item 6), lockwashers (Figure 3, Item 7), and washers (Figure 3, Item 5). Tighten screws 25 to 30 lb-ft (34 to 41 N·m).

ASSEMBLY - Continued

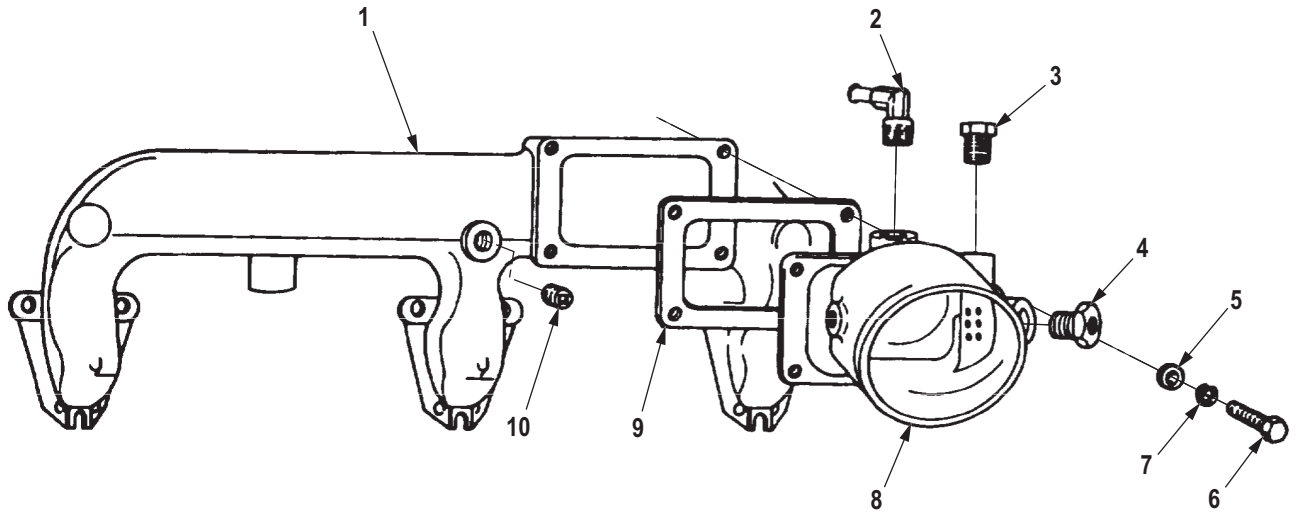

M9501DAA

Figure 3. Engine Air Intake Manifold Assembly.

END OF TASK

INSTALLATION**NOTE**

Wrap male pipe threads with antiseize tape before installation.

1. Install intake manifold (Figure 4, Item 3) and three gaskets (Figure 4, Item 5) on cylinder heads (Figure 4, Item 1) with eight screw-assembled washers (Figure 4, Item 4). Tighten screw-assembled washers 25 to 30 lb-ft (34 to 41 N·m).

NOTE

Perform Step (2) only if clamps were removed previously.

2. Install two clamps (Figure 4, Item 27) and fuel tubes (Figure 4, Item 29) on intake manifold (Figure 4, Item 3) with screw (Figure 4, Item 28). Tighten screw 20 to 25 lb-ft (27 to 34 N·m).
3. Install cable ground strap (Figure 4, Item 17) on intake manifold (Figure 4, Item 3) with washer (Figure 4, Item 14), lockwasher (Figure 4, Item 15), and screw (Figure 4, Item 16). Tighten screw 25 to 30 lb-ft (34 to 41 N·m).
4. Install wire harness (Figure 4, Item 23) and clamp (Figure 4, Item 22) on lower left side of air intake connector (Figure 4, Item 2) with screw (Figure 4, Item 21). Tighten screw 25 to 30 lb-ft (34 to 41 N·m).
5. Install elbow (Figure 4, Item 19) and air cleaner indicator filter (Figure 4, Item 20) on left side of air intake connector (Figure 4, Item 2).
6. Connect hose (Figure 4, Item 18) to elbow (Figure 4, Item 19).
7. Connect air tube (Figure 4, Item 6) and nut (Figure 4, Item 12) to adapter (Figure 4, Item 13) on air governor (Figure 4, Item 11).
8. Connect air tube (Figure 4, Item 6) and nut (Figure 4, Item 25) to elbow (Figure 4, Item 24) on air compressor (Figure 4, Item 26).
9. Position two clamps (Figure 4, Item 7) to screw hole in top left of engine access cover (Figure 4, Item 10) and install air tube (Figure 4, Item 6) and two clamps (Figure 4, Item 7) on air intake connector (Figure 4, Item 2) with washer (Figure 4, Item 8) and screw (Figure 4, Item 9). Tighten screw 25 to 30 lb-ft (34 to 41 N·m).

INSTALLATION - Continued

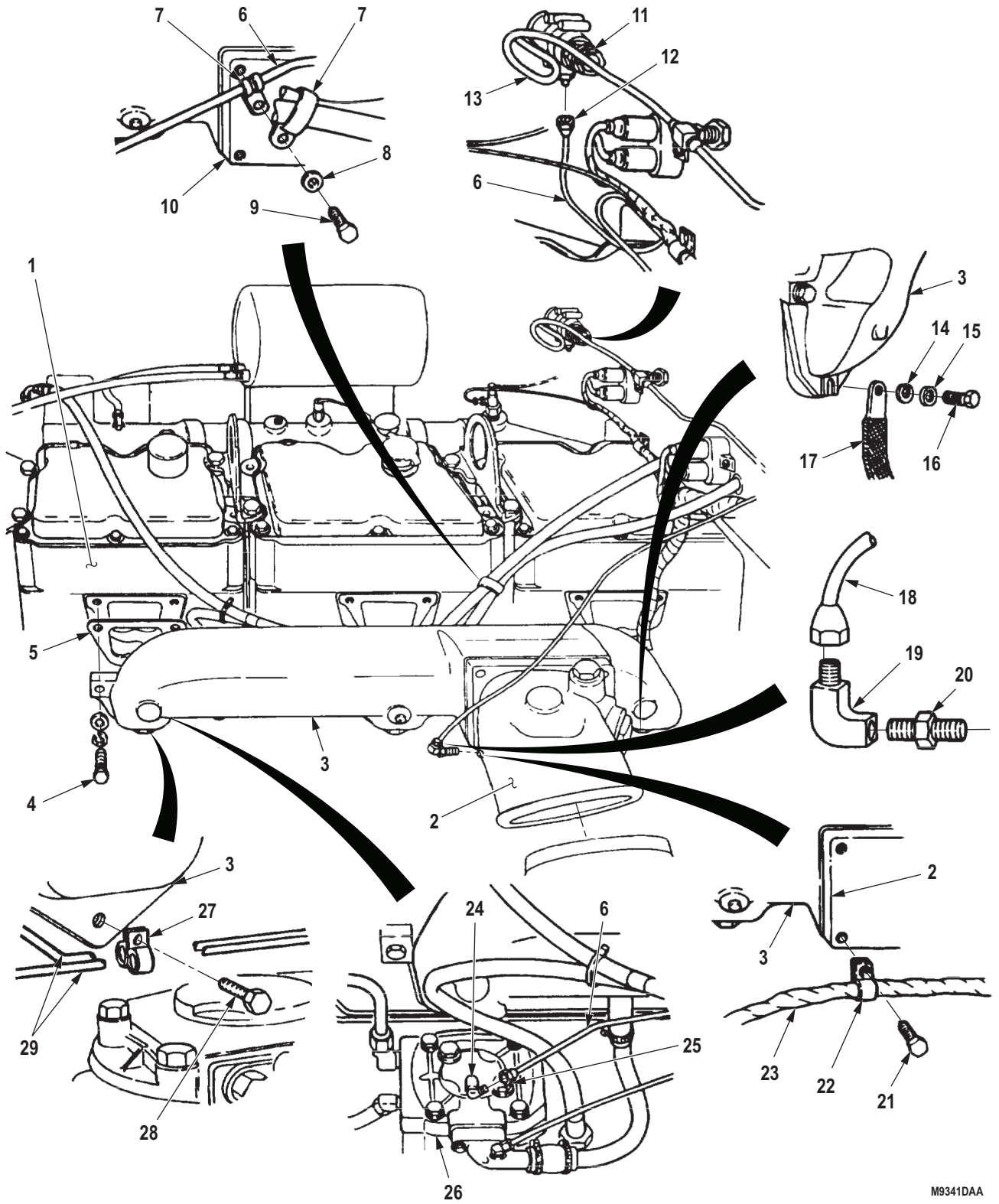

M9341DAA

Figure 4. Engine Air Intake Manifold Installation.

END OF TASK

FOLLOW-ON MAINTENANCE

1. Install ether atomizer. (WP 0265)
2. Install air compressor air intake tube. (Volume 3, WP 0470)
3. Install air intake pipe and hose. (WP 0246)
4. Install crankcase breather tube. (WP 0223)

END OF TASK**END OF WORK PACKAGE**

**FIELD MAINTENANCE
ENGINE EXHAUST MANIFOLD REPLACEMENT (M939/A1)**

INITIAL SETUP:**Tools and Special Tools**

Tool Kit, General Mechanic's: Automotive
(Volume 5, WP 0826, Table 1, Item 56)
Hammer, Soft Face
(Volume 5, WP 0826, Table 1, Item 22)

Materials/Parts

Gasket (Volume 5, WP 0827, Table 1, Item 43)
Qty: 1

Materials/Parts (cont.)

Gasket (Volume 5, WP 0827, Table 1, Item 110)
Qty: 6
Key Washer
(Volume 5, WP 0827, Table 1, Item 22)
Qty: 8

Equipment Condition

Parking brake set. (TM 9-2320-272-10)
Crankcase breather tube and mounting bracket
removed. (WP 0223)
Surge tank removed. (WP 0278)

REMOVAL

1. Remove manifold coupling clamp (Figure 1, Item 4) from front exhaust pipe (Figure 1, Item 5). Using soft-faced hammer, tap clamp.
2. Separate front exhaust pipe (Figure 1, Item 5) from exhaust manifold (Figure 1, Item 2) and remove gasket (Figure 1, Item 3) from front exhaust pipe. Discard gasket.
3. Loosen screw (Figure 1, Item 17) and nut (Figure 1, Item 15) on dipstick tube (Figure 1, Item 16).
4. Loosen clamp (Figure 1, Item 12) and remove heater inlet hose (Figure 1, Item 13) and clamp from shutoff valve (Figure 1, Item 11) on water manifold (Figure 1, Item 1).
5. Unlock eight key washers (Figure 1, Item 7) and remove eight screws (Figure 1, Item 6), key washers, and four clamps (Figure 1, Item 8) from exhaust manifold (Figure 1, Item 2). Discard locktabs.
6. Position oil dipstick bracket (Figure 1, Item 14) out of the way.
7. Remove exhaust manifold (Figure 1, Item 2) and six gaskets (Figure 1, Item 9) from three cylinder head dowels (Figure 1, Item 10). Discard gaskets. Separate manifold sections.

REMOVAL - Continued

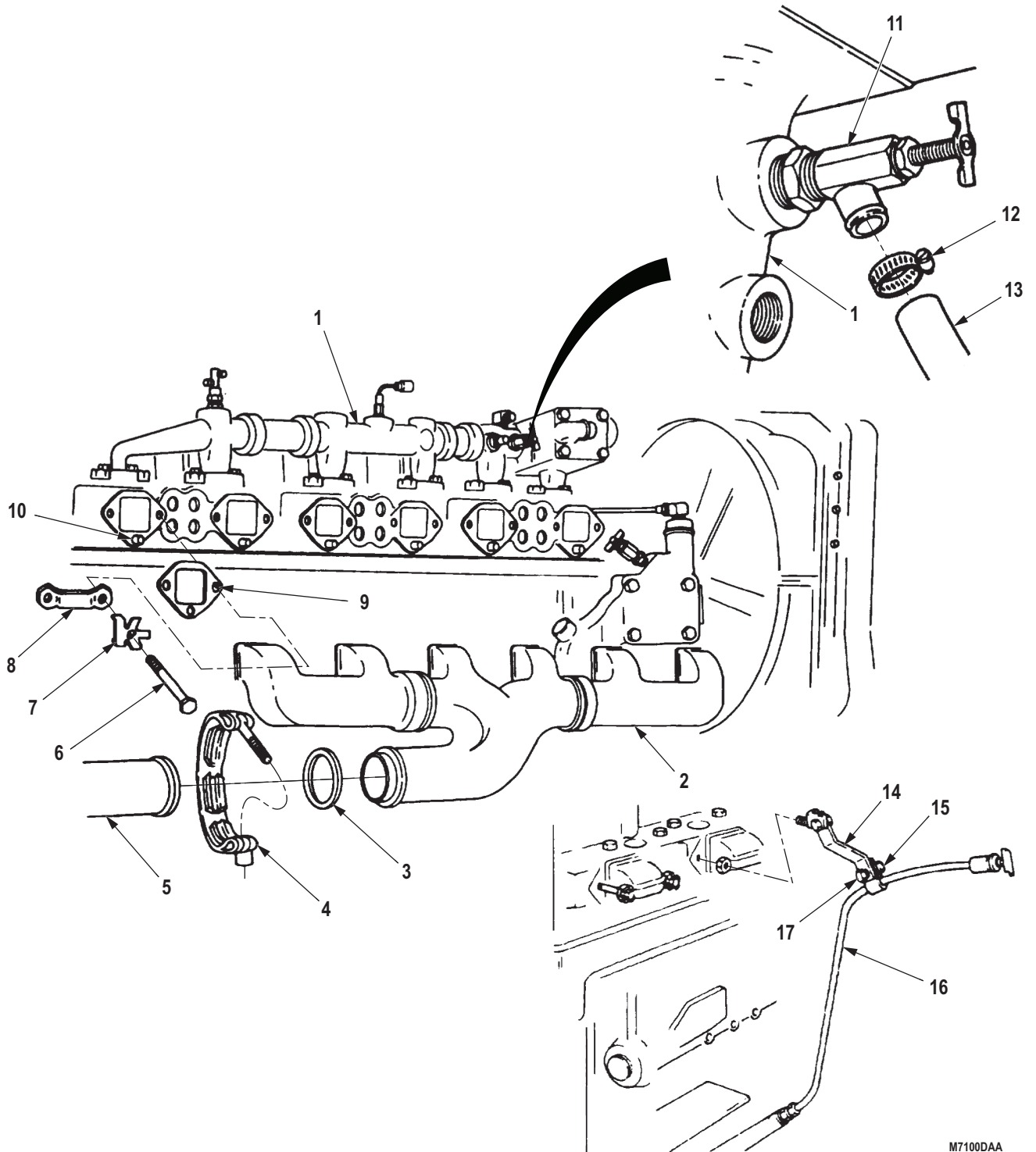

M7100DAA

Figure 1. Engine Exhaust Manifold Removal.

END OF TASK

INSTALLATION

1. Position six gaskets (Figure 2, Item 9) and exhaust manifold (Figure 2, Item 2) on three cylinder head dowels (Figure 2, Item 10) for installation.
2. Install four clamps (Figure 2, Item 8), eight key washers (Figure 2, Item 7), screws (Figure 2, Item 6), and oil dipstick bracket (Figure 2, Item 14) on exhaust manifold (Figure 2, Item 2).
3. Reposition oil dipstick bracket (Figure 2, Item 14) for installation.
4. Connect heater inlet hose (Figure 2, Item 13) to shutoff valve (Figure 2, Item 11) on water manifold (Figure 2, Item 1) and tighten clamp (Figure 2, Item 12).
5. Tighten screw (Figure 2, Item 17) and nut (Figure 2, Item 15) on dipstick tube (Figure 2, Item 16).
6. Install gasket (Figure 2, Item 3) between exhaust manifold (Figure 2, Item 2) and front exhaust pipe (Figure 2, Item 5).
7. Position manifold coupling clamp (Figure 2, Item 4) on front exhaust pipe (Figure 2, Item 5).

INSTALLATION - Continued

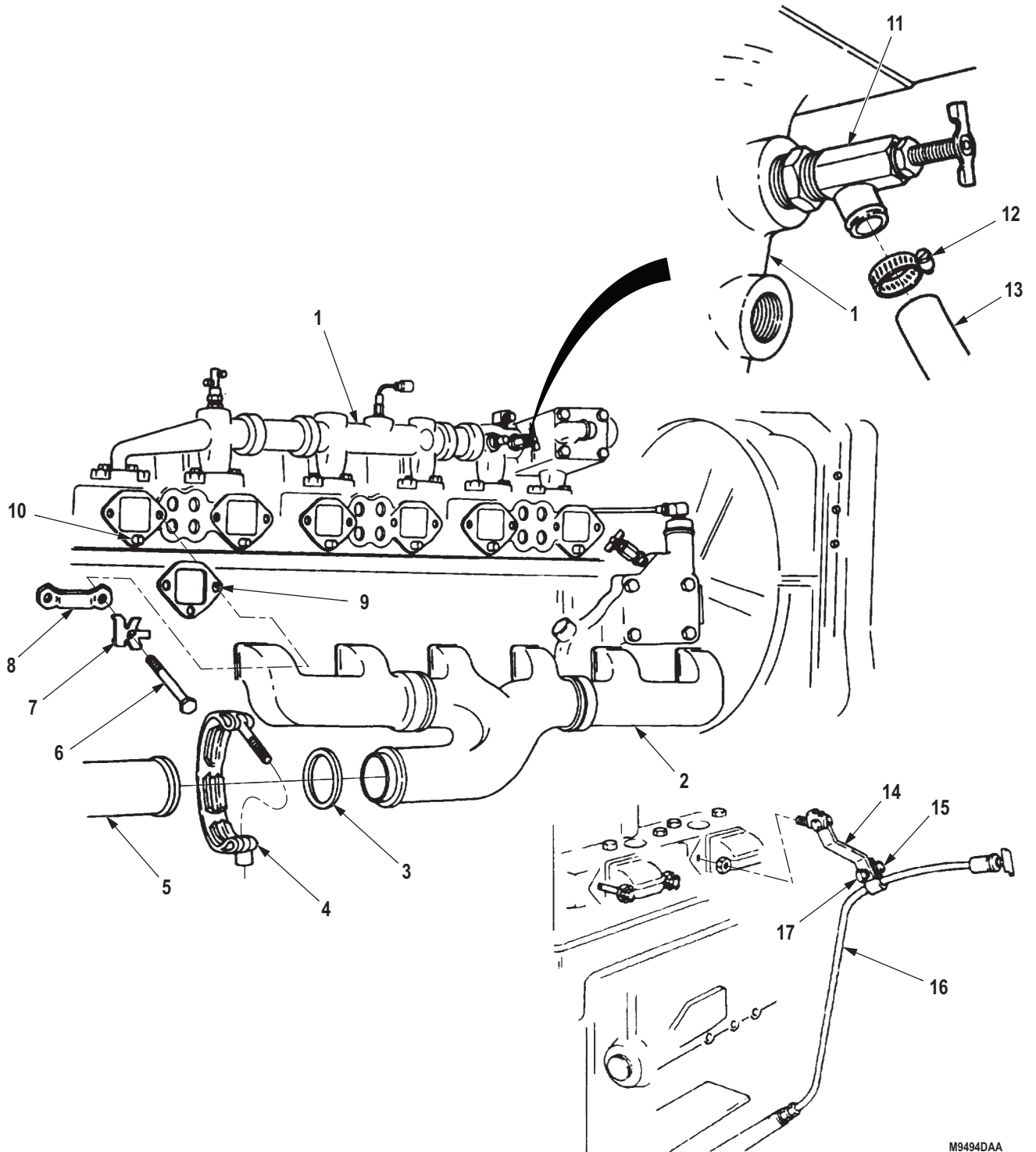

M9494DAA

Figure 2. Engine Exhaust Manifold Installation.

END OF TASK

FOLLOW-ON MAINTENANCE

1. Install surge tank. (WP 0278)
2. Install crankcase breather tube and mounting bracket. (WP 0223)

END OF TASK**END OF WORK PACKAGE**

FIELD MAINTENANCE EXHAUST MANIFOLD REPLACEMENT (M939A2)

INITIAL SETUP:

Tools and Special Tools

Tool Kit, General Mechanic's: Automotive
(Volume 5, WP 0826, Table 1, Item 56)
Wrench, Torque, Click, Ratcheting, 3/8" Drive,
75 Ft-Lb
(Volume 5, WP 0826, Table 1, Item 62)

Materials/Parts (cont.)

Gasket (Volume 5, WP 0827, Table 1, Item 138)
Qty: 6
Washer, Key
(Volume 5, WP 0827, Table 1, Item 148)
Qty: 6

Materials/Parts

Antiseize Compound
(Volume 5, WP 0825, Table 1, Item 9)

Equipment Condition

Turbocharger and coolant lines removed.
(WP 0249)

REMOVAL

1. Remove screw (Figure 1, Item 1) from bracket (Figure 1, Item 2) and exhaust manifold (Figure 1, Item 3).
2. Bend tabs of key washers (Figure 1, Item 5) away from screws (Figure 1, Item 4).
3. Remove 12 screws (Figure 1, Item 4), six key washers (Figure 1, Item 5), exhaust manifold (Figure 1, Item 3), and six gaskets (Figure 1, Item 6) from cylinder head (Figure 1, Item 7). Discard key washers and gaskets.

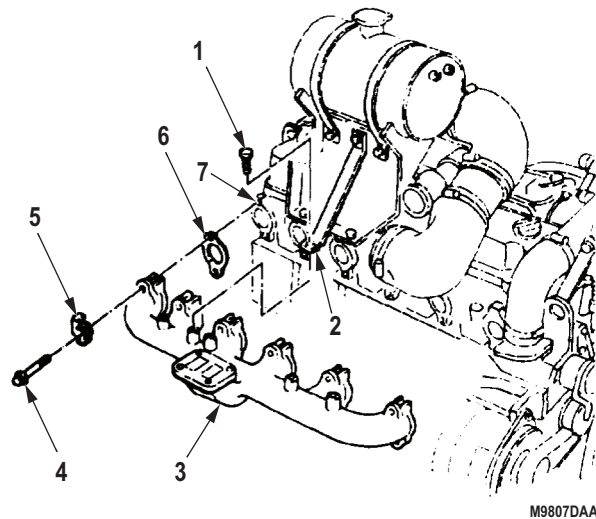

Figure 1. Exhaust Manifold Removal.

END OF TASK

INSTALLATION

1. Position six gaskets (Figure 2, Item 6) and exhaust manifold (Figure 2, Item 3) on cylinder (Figure 2, Item 7) and install with six key washers (Figure 2, Item 5) and 12 screws (Figure 2, Item 4). Tighten screws 30 lb-ft (41 N·m).
2. Bend tabs of lockplates (Figure 2, Item 5) against head of screws (Figure 2, Item 4).
3. Apply antiseize compound to threads of screw (Figure 2, Item 1) and install on bracket (Figure 2, Item 2) and exhaust manifold (Figure 2, Item 3). Tighten screw 30 lb-ft (41 N·m).

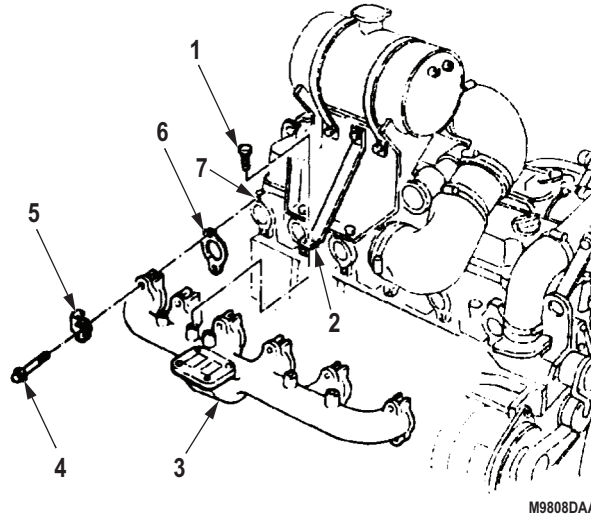

Figure 2. Exhaust Manifold Installation.

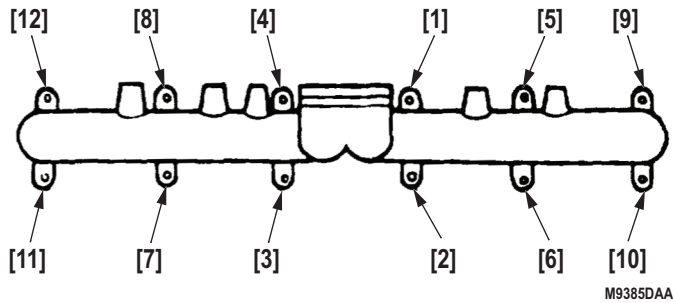

Figure 3. Torque Sequence.

END OF TASK

FOLLOW-ON MAINTENANCE

Install turbocharger and coolant lines. (WP 0249)

END OF TASK

END OF WORK PACKAGE

FIELD MAINTENANCE
ENGINE ACCESSORY DRIVE AND PULLEY REPLACEMENT (M939/A1)

INITIAL SETUP:**Tools and Special Tools**

Tool Kit, General Mechanic's: Automotive
(Volume 5, WP 0826, Table 1, Item 56)
Caliper, Micrometer, Inside
(Volume 5, WP 0826, Table 1, Item 12)
Caliper Set, Micrometer Outside
(Volume 5, WP 0826, Table 1, Item 11)
Hammer, Soft Face
(Volume 5, WP 0826, Table 1, Item 22)
Indicator, Dial
(Volume 5, WP 0826, Table 1, Item 25)
Press, Arbor, Hand Operated
(Volume 5, WP 0826, Table 1, Item 39)
Puller Kit, Mechanical
(Volume 5, WP 0826, Table 1, Item 41)
Wrench, Torque, Click, Ratcheting, 1/2" Drive,
250 Ft-Lb
(Volume 5, WP 0826, Table 1, Item 63)

Materials/Parts

Cleaning Compound, Solvent
(Volume 5, WP 0825, Table 1, Item 16, 17)
Grease, Automotive and Artillery
(Volume 5, WP 0825, Table 1, Item 28)
Tape, Antiseizing

Materials/Parts (cont.)

(Volume 5, WP 0825, Table 1, Item 65)
Cotter Pin
(Volume 5, WP 0827, Table 1, Item 201)
Qty: 1
Gasket (Volume 5, WP 0827, Table 1, Item 116)
Qty: 1
Rubber Strip
(Volume 5, WP 0827, Table 1, Item 104)
Qty: 1
Screw Assembled Lockwasher
(Volume 5, WP 0827, Table 1, Item 105)
Qty: 5

Equipment Condition

Air compressor removed.
(Volume 3, WP 0470)
Power steering drivebelts removed.
(Volume 3, WP 0504)
Radiator removed. (WP 0281)
Water pump drivebelt removed. (WP 0294)

ACCESSORY DRIVE PULLEY REMOVAL

1. Remove nut (Figure 1, Item 4) and washer (Figure 1, Item 3) from accessory drive pulley (Figure 1, Item 6).
2. Using mechanical puller, remove accessory drive pulley (Figure 1, Item 6) from accessory driveshaft (Figure 1, Item 2).
3. Remove gasket (Figure 1, Item 5) from accessory drive pulley (Figure 1, Item 6). Discard gasket.

NOTE

Perform Step (4) only if dowel pin is damaged.

4. Remove cotter pin (Figure 1, Item 1) from accessory driveshaft (Figure 1, Item 2). Discard cotter pin.

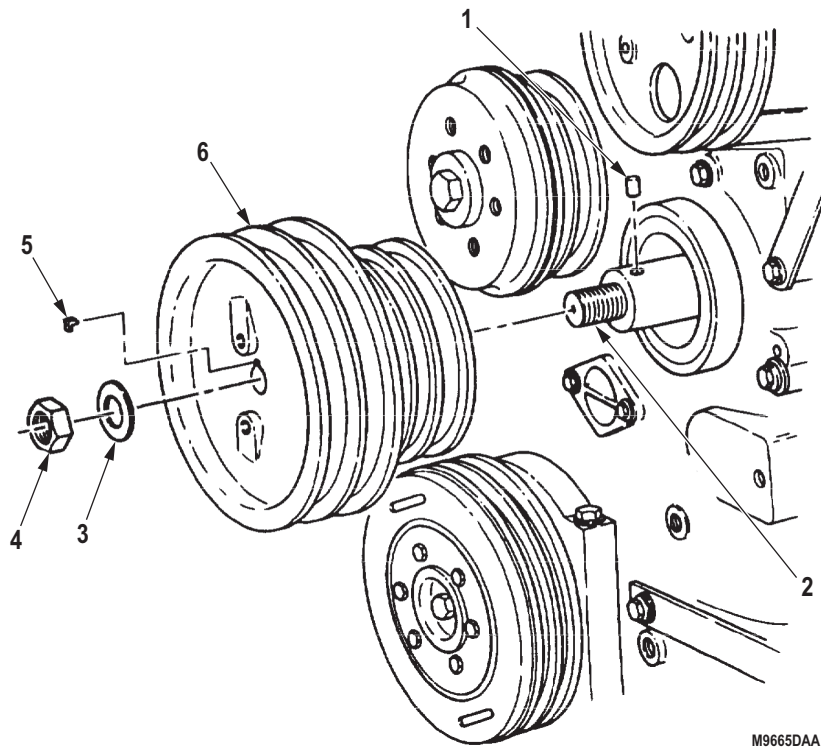
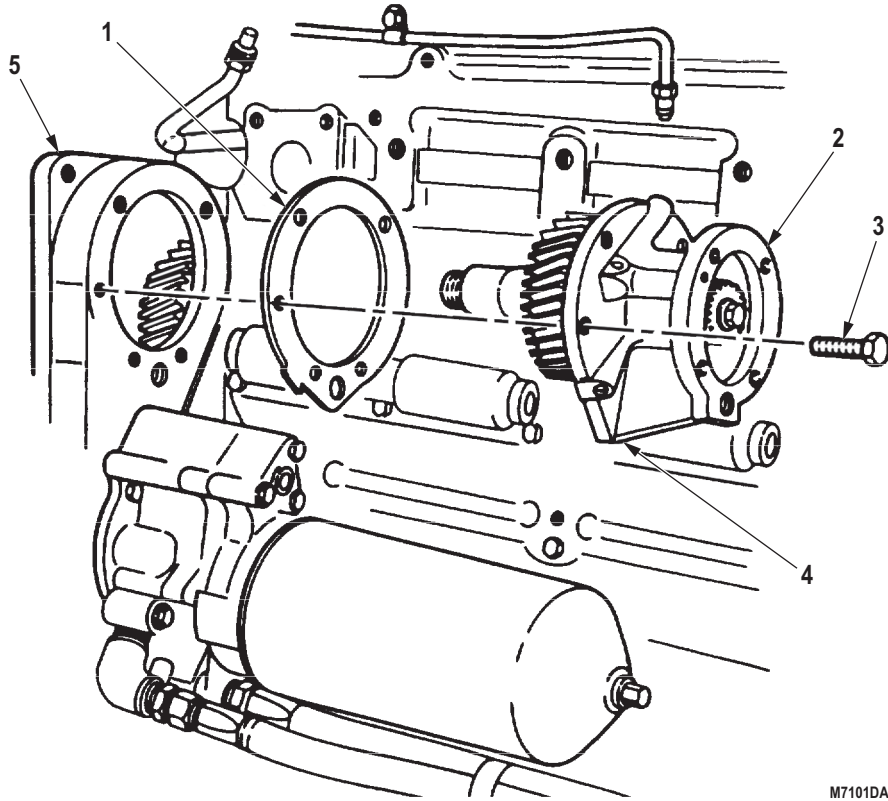

Figure 1. Drive Pulley Removal.

END OF TASK

ACCESSORY DRIVE REMOVAL

1. Remove five screw assembled lockwashers (Figure 2, Item 3) from accessory drive front flange (Figure 2, Item 4). Discard screw assembled lockwashers.
2. Using soft-faced hammer, loosen accessory drive housing (Figure 2, Item 2) and rubber strip (Figure 2, Item 1) from engine block gearcase (Figure 2, Item 5) and remove housing and rubber strip from gearcase. Discard rubber strip and clean rubber strip remains from mating surfaces of accessory drive housing and engine block gearcase.



M7101DAA

Figure 2. Engine Drive Pulley Removal.

END OF TASK

ACCESSORY DRIVE DISASSEMBLY

1. Using dial indicator gauge, measure end play of driveshaft (Figure 3, Item 10). Note end play measurement for reference.
2. Remove screw (Figure 3, Item 6) and washer (Figure 3, Item 7) from driveshaft (Figure 3, Item 10).
3. Using arbor press and mandrel, press driveshaft (Figure 3, Item 10) through coupling halfshaft (Figure 3, Item 5).
4. Remove driveshaft (Figure 3, Item 10), drive gear (Figure 3, Item 8), thrust washers (Figure 3, Items 3 and 12), and washer (Figure 3, Item 4) from accessory drive housing (Figure 3, Item 2) and slide through bushing (Figure 3, Item 1) in accessory drive housing.
5. Using arbor press and mandrel, press driveshaft (Figure 3, Item 10) through drive gear (Figure 3, Item 8).

NOTE

Do not remove dowel pins unless damaged.

6. Remove cotter pins (Figure 3, Items 9 and 11) from driveshaft (Figure 3, Item 10).

ACCESSORY DRIVE DISASSEMBLY - Continued

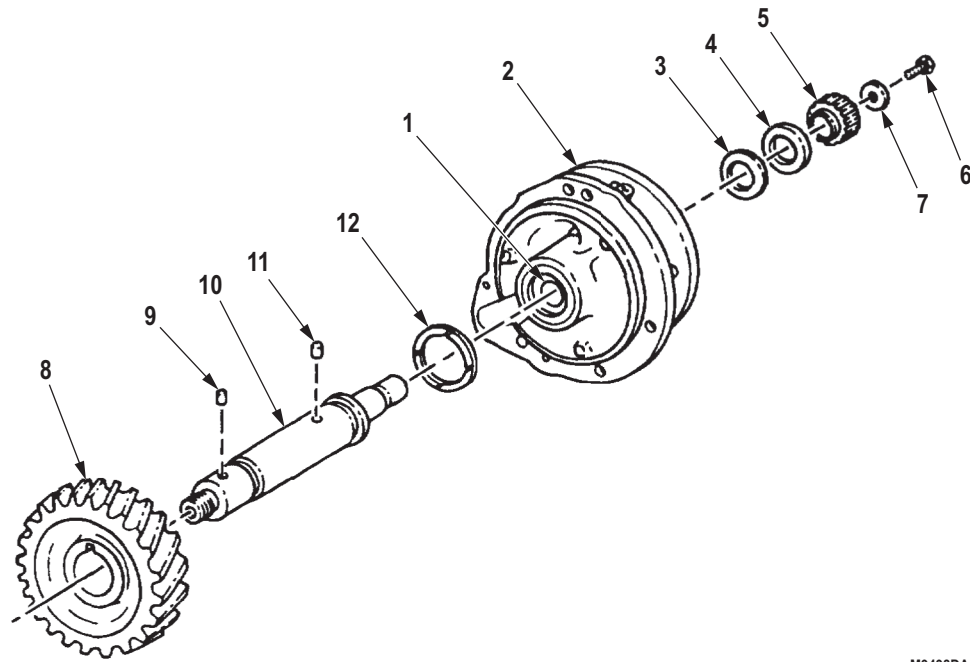

M9498DAA

Figure 3. Drive Disassembly.

END OF TASK

ACCESSORY DRIVE CLEANING AND INSPECTION**WARNING**

- Solvent cleaning compound is flammable and toxic. Do not use near an open flame and always have a fire extinguisher nearby when solvents are used. Use only in well-ventilated places, wear protective clothing, and dispose of cleaning rags in approved container. Failure to comply may result in damage to equipment, injury, or death to personnel.
 - Eyeshields must be worn when cleaning with compressed air. Compressed air source will not exceed 30 psi (207 kPa). Failure to comply may result in injury or death to personnel.
1. Clean accessory drive housing (Figure 4, Item 1) with solvent cleaning compound and blow out passages and bore with compressed air.
 2. Inspect accessory drive housing (Figure 4, Item 1) for breaks and cracks. Replace if broken or cracked.
 3. Inspect bushing (Figure 4, Item 2) on accessory drive housing (Figure 4, Item 1) for pitting, galling, and cracks. Replace bushing if pitted, galled, or cracked.
 4. Check inside diameter of bushing (Figure 4, Item 2) at both ends. Replace bushing if either measurement is greater than 1.321 in. (33.6 mm).

NOTE

Perform Steps (5) and (6) only if bushing must be replaced.

5. Using arbor press and mandrel, press bushing (Figure 4, Item 2) from accessory drive housing (Figure 4, Item 1).
6. Using arbor press and mandrel, install bushing (Figure 4, Item 2) in accessory drive housing (Figure 4, Item 1) flush with face.
7. Clean driveshaft (Figure 4, Item 9) with solvent cleaning compound.
8. Inspect driveshaft (Figure 4, Item 9) for breaks, cracks, and galling. Replace if broken, cracked, or galled.
9. Inspect driveshaft (Figure 4, Item 9) for stripped or crossed threads. Repair or replace driveshaft (Figure 4, Item 9) if threads are stripped or crossed.
10. Check driveshaft (Figure 4, Item 9) outside diameter at bushing (Figure 4, Item 2) location. Replace driveshaft if outside diameter is less than 1.310 in. (33.27 mm).
11. Inspect dowel pin holes (Figure 4, Items 5 and 6) of driveshaft (Figure 4, Item 9). Discard driveshaft if holes are enlarged.
12. Using solvent cleaning compound, clean drive gear (Figure 4, Item 7) and coupling halfshaft (Figure 4, Item 4).
13. Inspect drive gear (Figure 4, Item 7) and coupling halfshaft (Figure 4, Item 4) for breaks, cracks, and galling in bore. Replace if cracked, broken, or bore shows galling.
14. Inspect drive gear (Figure 4, Item 7) and coupling halfshaft (Figure 4, Item 4) for chipped and broken teeth. Replace drive gear and coupling halfshaft if teeth are broken or chipped.
15. Inspect thrust washers (Figure 4, Items 3 and 11) for cracks and scoring. Replace if cracked, broken, or scored.

ACCESSORY DRIVE CLEANING AND INSPECTION - Continued

16. Replace both thrust washers (Figure 4, Items 3 and 11) if end play measured in ACCESSORY DRIVE DISASSEMBLY, Step (1), is greater than 0.012 in. (0.3 mm).
17. Inspect two cotter pins (Figure 4, Items 8 and 10) for burrs or cracks. Replace if cracked or burred.

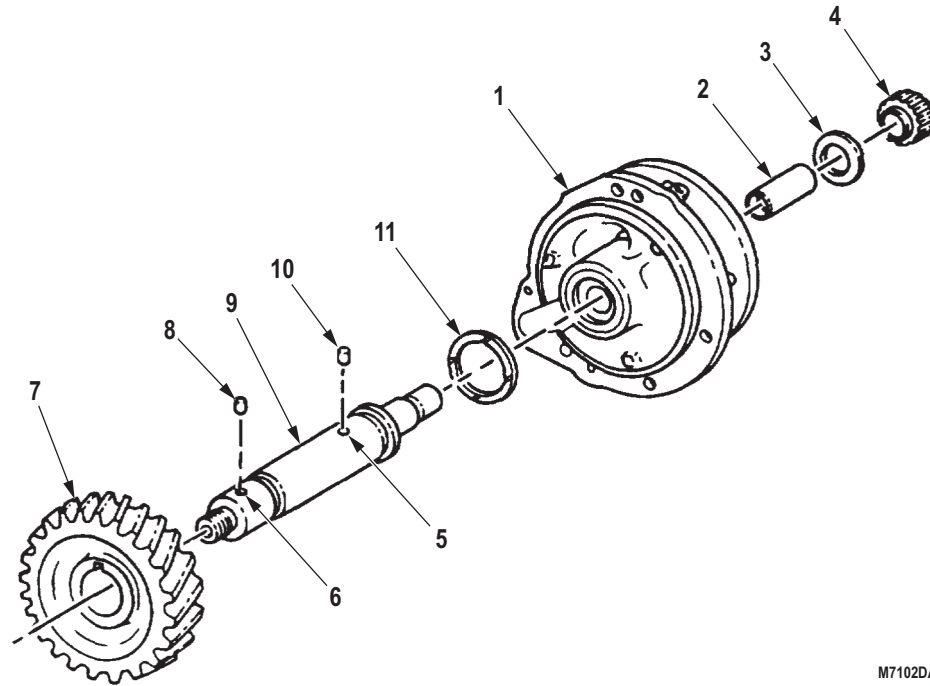

M7102DAA

Figure 4. Engine Accessory Cleaning and Inspection.

END OF TASK

ACCESSORY DRIVE ASSEMBLY

1. Install cotter pin (Figure 5, Item 13) in hole (Figure 5, Item 9) of driveshaft (Figure 5, Item 12).

NOTE

Remaining dowel pin is installed with accessory drive pulley.

2. Align slot (Figure 5, Item 10) in bore of drive gear (Figure 5, Item 11) with cotter pin (Figure 5, Item 13) and press drive gear on driveshaft (Figure 5, Item 12) over cotter pin. Ensure drive gear is seated on shoulder (Figure 5, Item 8).
3. Install large thrust washer (Figure 5, Item 14) on front of accessory drive housing (Figure 5, Item 2).
4. Install driveshaft (Figure 5, Item 12) and drive gear (Figure 5, Item 11) through thrust washer (Figure 5, Item 14) and bushing (Figure 5, Item 1) in accessory drive housing (Figure 5, Item 2).
5. Install thrust washer (Figure 5, Item 3) over driveshaft (Figure 5, Item 12) and position in accessory drive housing (Figure 5, Item 2). Ensure grooved side of thrust washer faces away from accessory drive housing.
6. Install washer (Figure 5, Item 4) on driveshaft (Figure 5, Item 12) against thrust washer (Figure 5, Item 3).

NOTE

Ensure flat end of coupling halfshaft faces away from accessory drive housing.

7. Press coupling halfshaft (Figure 5, Item 5) on driveshaft (Figure 5, Item 12) until flush with end.
8. Measure driveshaft (Figure 5, Item 12) end play. End play should be 0.002 to 0.012 in. (0.05 to 0.26 mm). If end play is not within limits, press driveshaft through coupling halfshaft (Figure 5, Item 5) to obtain proper end play.
9. Install washer (Figure 5, Item 6) and screw (Figure 5, Item 7) on driveshaft (Figure 5, Item 12). Tighten screw 30 to 35 lb-ft (41 to 47 N·m).

ACCESSORY DRIVE ASSEMBLY - Continued

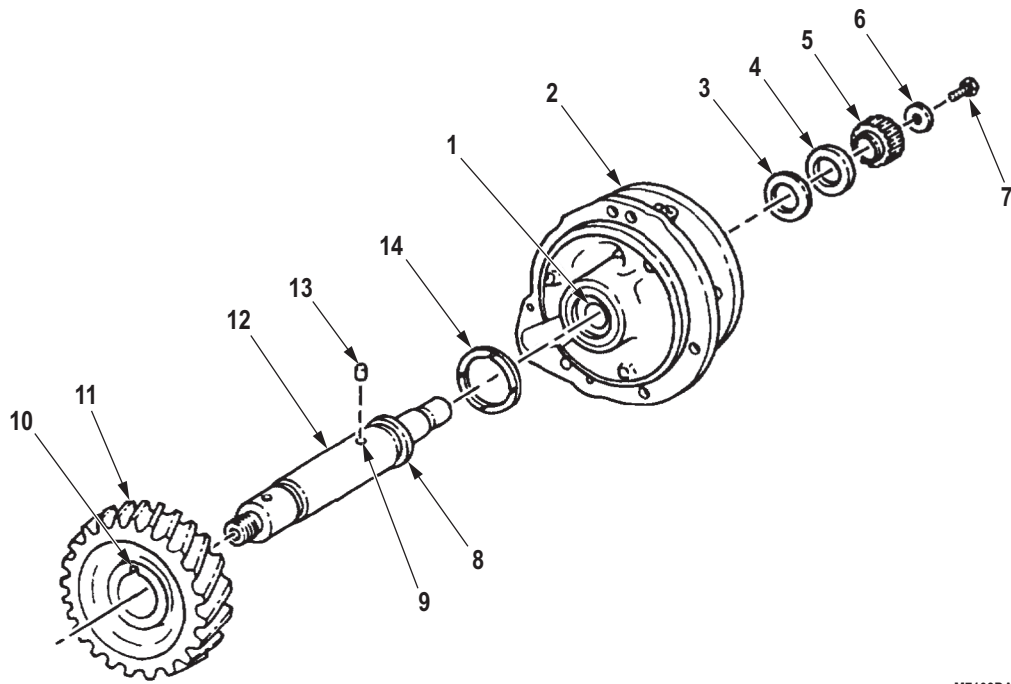

M7103DAA

Figure 5. Drive Assembly.

END OF TASK

ACCESSORY DRIVE INSTALLATION**NOTE**

If accessory drive gear and camshaft gear are not properly aligned, valve, injector, and compressor timing will be incorrect.

1. Remove pipe plug (Figure 6, Item 4) from front gearcase cover (Figure 6, Item 1).

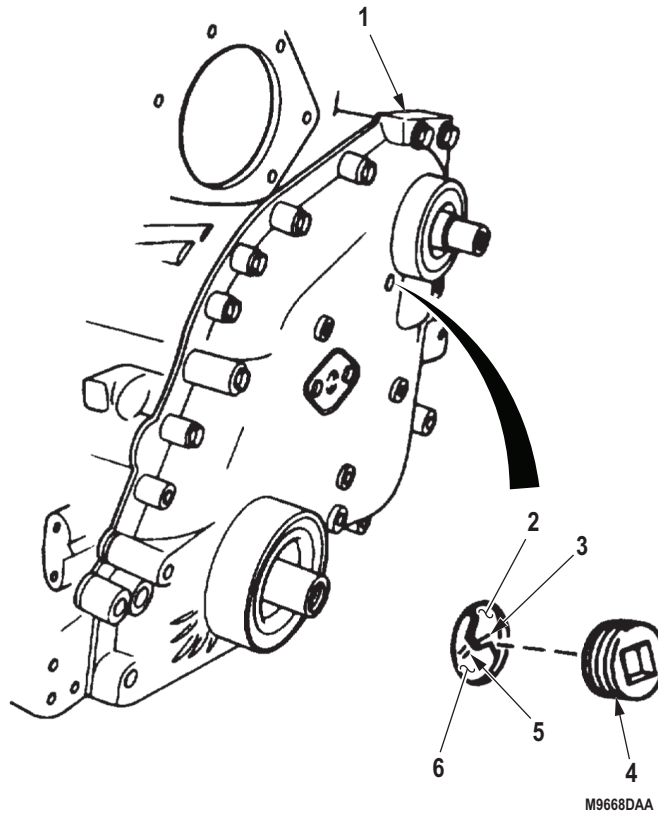
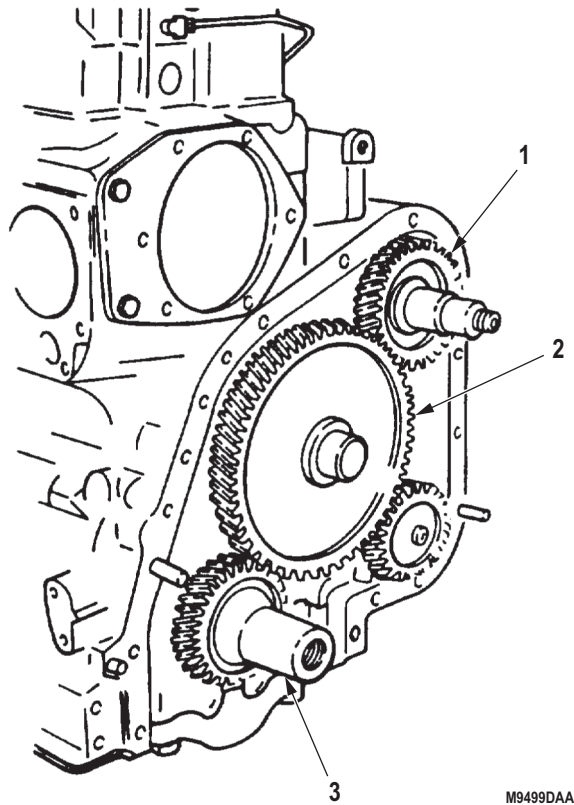

Figure 6. Drive Installation.

ACCESSORY DRIVE INSTALLATION - Continued

2. Rotate crankshaft (Figure 7, Item 3) to No. 1 piston Top Dead Center (TDC) firing stroke.
3. Rotate crankshaft (Figure 7, Item 3) 90 degrees past TDC.



M9499DAA

Figure 7. Drive Installation.

ACCESSORY DRIVE INSTALLATION - Continued

4. Install accessory drive housing (Figure 8, Item 2) and rubber strip (Figure 8, Item 1) on engine block gearcase (Figure 8, Item 5) with five screw assembled lockwashers (Figure 8, Item 3). Ensure timing marks (Figure 6, Item 2) on accessory drive gear (Figure 6, Item 3) and camshaft gear (Figure 6, Item 6) align. Tighten screw assembled lockwashers 40 to 45 lb-ft (54 to 61 N-m).

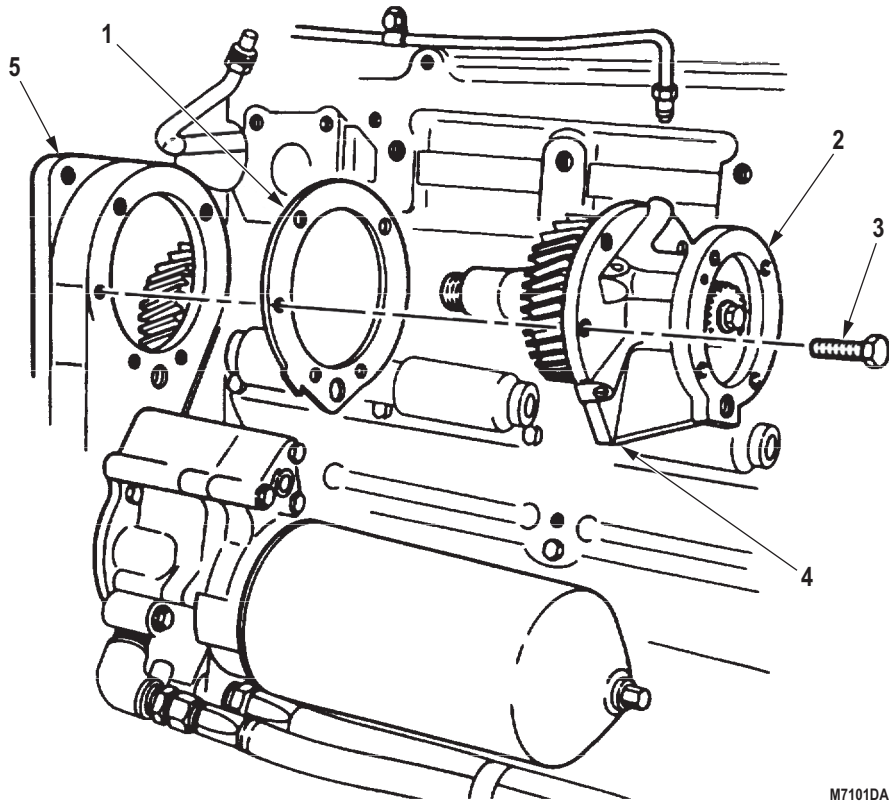

Figure 8. Drive Installation.

5. Wrap pipe plug (Figure 6, Item 4) threads with antiseize tape and install in front gearcase cover (Figure 6, Item 1).

END OF TASK

ACCESSORY DRIVE PULLEY INSTALLATION

1. Apply a light coat of automotive and artillery grease to accessory driveshaft (Figure 9, Item 2).

NOTE

Perform Step (2) if dowel pin was removed.

2. Install cotter pin (Figure 9, Item 1) in accessory driveshaft (Figure 9, Item 2).
3. Install gasket (Figure 9, Item 5) in keyway of accessory drive pulley (Figure 9, Item 6).
4. Install nut (Figure 9, Item 4) and washer (Figure 9, Item 3) in accessory drive pulley (Figure 9, Item 6).

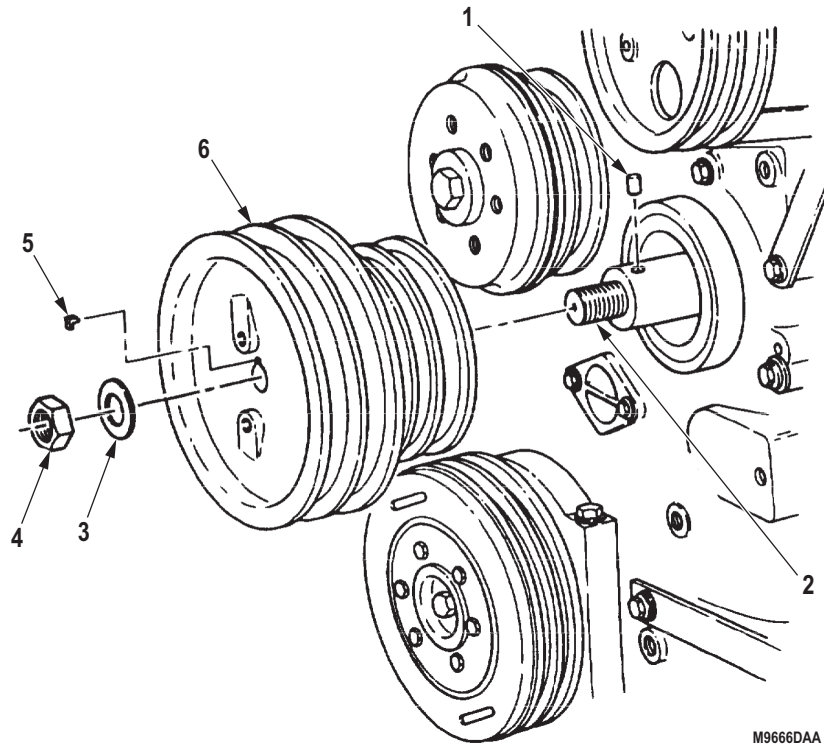

Figure 9. Engine Accessory Drive and Pulley Installation.

END OF TASK**FOLLOW-ON MAINTENANCE**

1. Install air compressor. (Volume 3, WP 0470)
2. Install water pump drivebelt. (WP 0294)
3. Install radiator. (WP 0281)
4. Install power steering drivebelts. (Volume 3, WP 0504)

END OF TASK**END OF WORK PACKAGE**

**FIELD MAINTENANCE
FUEL INJECTOR REPLACEMENT (M939A2)**

INITIAL SETUP:**Tools and Special Tools**

Tool Kit, General Mechanic's: Automotive
(Volume 5, WP 0826, Table 1, Item 56)
Wrench, Torque, Click, Ratcheting, 3/8" Drive,
75 Ft-Lb
(Volume 5, WP 0826, Table 1, Item 62)

Equipment Condition

Fuel injector tubes removed. (WP 0241)

Materials/Parts

Cloth, Cleaning
(Volume 5, WP 0825, Table 1, Item 19)

REMOVAL**WARNING**

Diesel fuel is flammable. Do not perform fuel system procedures near open flame. Failure to comply may result in injury or death to personnel.

1. Remove screw (Figure 1, Item 1), injector clamp (Figure 1, Item 2), and injector (Figure 1, Item 3) from cylinder head (Figure 1, Item 5).
2. Cover injector bore (Figure 1, Item 4) with clean cloth.

REMOVAL - Continued

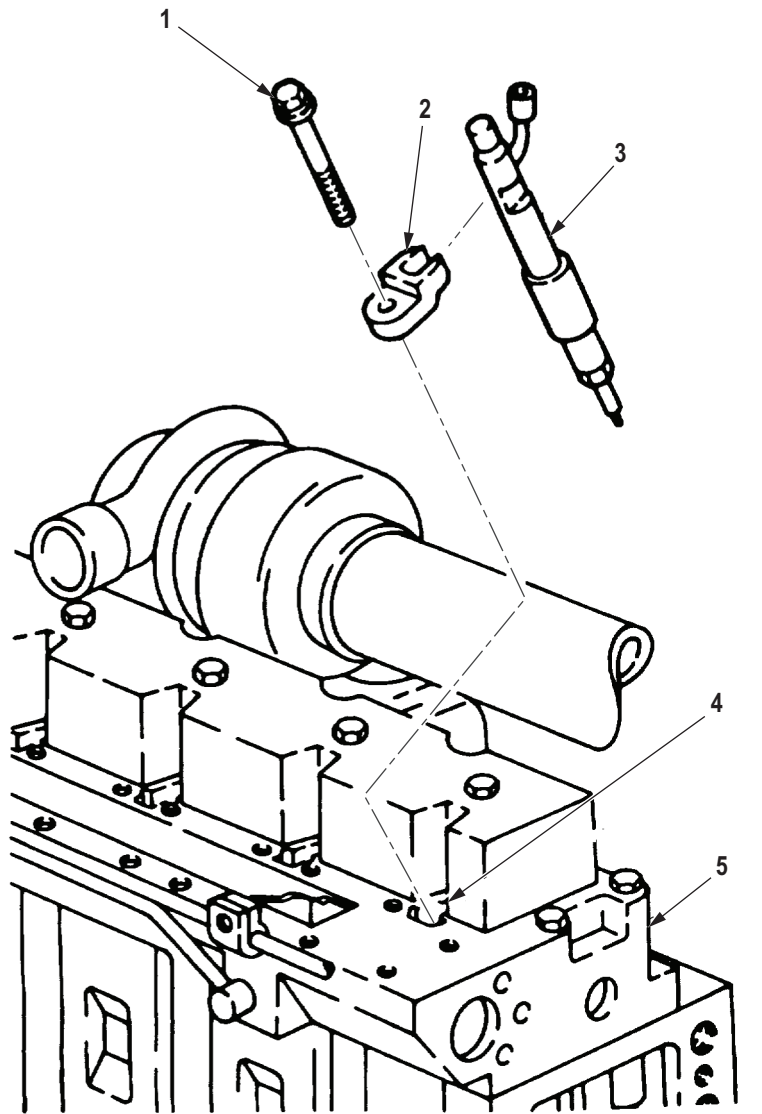

M9032DAA

Figure 1. Fuel Injector Removal.

END OF TASK

INSTALLATION

1. Install washer (Figure 2, Item 3) on injector (Figure 2, Item 2).
2. Remove cleaning cloth from injector bore (Figure 2, Item 4).

NOTE

Coat injector and injector bore with clean diesel fuel.

3. Position injector clamp (Figure 2, Item 6) into injector bore (Figure 2, Item 4) of cylinder head (Figure 2, Item 5).
4. Install injector (Figure 2, Item 2) into injector bore (Figure 2, Item 4) of cylinder head (Figure 2, Item 5).
5. Install injector clamp (Figure 2, Item 6) and injector (Figure 2, Item 2) on cylinder head (Figure 2, Item 5) with screw (Figure 2, Item 1). Tighten screw 20 lb-ft (27 N·m).

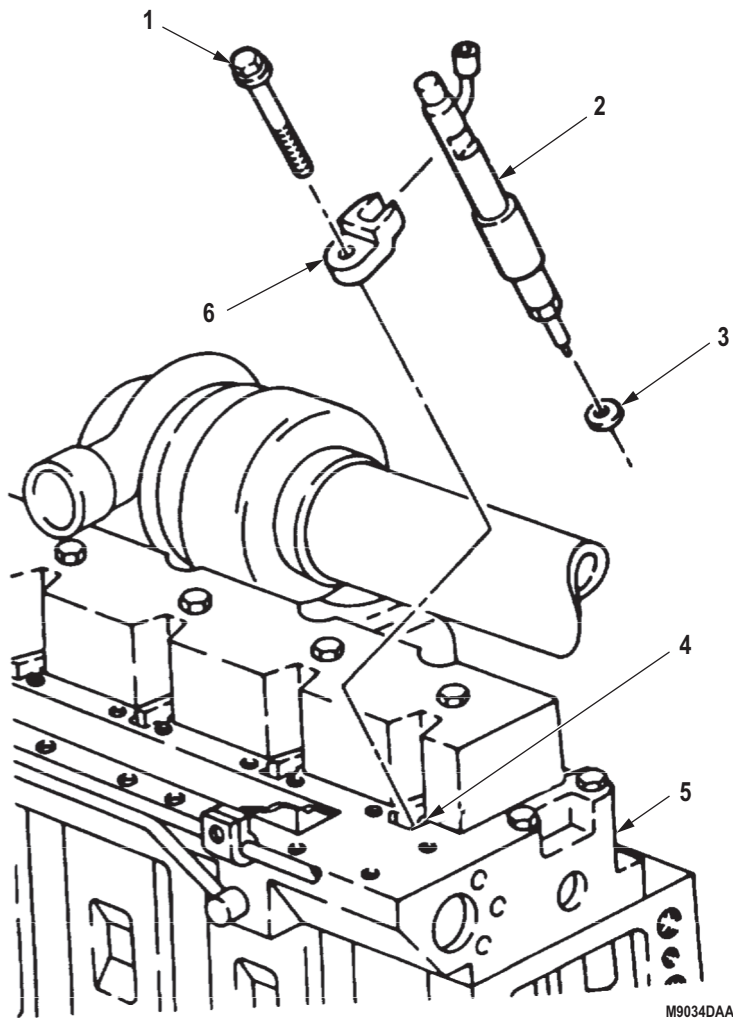

Figure 2. Fuel Injector Installation.

END OF TASK

FOLLOW-ON MAINTENANCE

Install fuel injector tubes. (WP 0241)

END OF TASK

END OF WORK PACKAGE

**FIELD MAINTENANCE
PRIMING FUEL SYSTEM SERVICING (M939A2)**

INITIAL SETUP:**Tools and Special Tools**

Tool Kit, General Mechanic's: Automotive
(Volume 5, WP 0826, Table 1, Item 56)

Personnel Required

(2)

Materials/Parts

Cloth, Cleaning
(Volume 5, WP 0825, Table 1, Item 19)

Equipment Condition

Parking brake set. (TM 9-2320-272-10)
Hood raised and secured. (TM 9-2320-272-10)

PRIMING

1. Loosen adapter (Figure 1, Item 6) and vent screw (Figure 1, Item 7) on fuel pump (Figure 1, Item 5).

NOTE

Perform Step (2) until all air is purged from fuel system.

2. Press plunger (Figure 1, Item 3) on fuel transfer pump (Figure 1, Item 4) until air is purged from fuel system.
3. Tighten vent screw (Figure 1, Item 7) and adapter (Figure 1, Item 6) on fuel pump (Figure 1, Item 5).
4. Start engine (TM 9-2320-272-10).

NOTE

If engine fails to start, or runs rough, perform Steps (5) through (10).

5. Loosen fuel line (Figure 1, Item 2) from fuel injector (Figure 1, Item 1).
6. Place cleaning cloth around fuel line (Figure 1, Item 2) and fuel injector (Figure 1, Item 1).

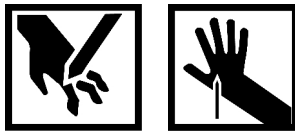
WARNING

- All personnel must stand clear during engine cranking operation. Failure to comply may result in injury or death to personnel.
- Fuel pressure is sufficient to penetrate skin. Wear hand protection and safety goggles at all times when removing injector tubes. Failure to comply may result in injury or death to personnel.

NOTE

Assistant will help with Step (7).

7. Crank engine until all air is vented at fuel injector (Figure 1, Item 1).
8. Tighten fuel line (Figure 1, Item 2) at fuel injector (Figure 1, Item 1).
9. Repeat Steps (5) through (8) until all fuel injectors (Figure 1, Item 1) are purged free of air.

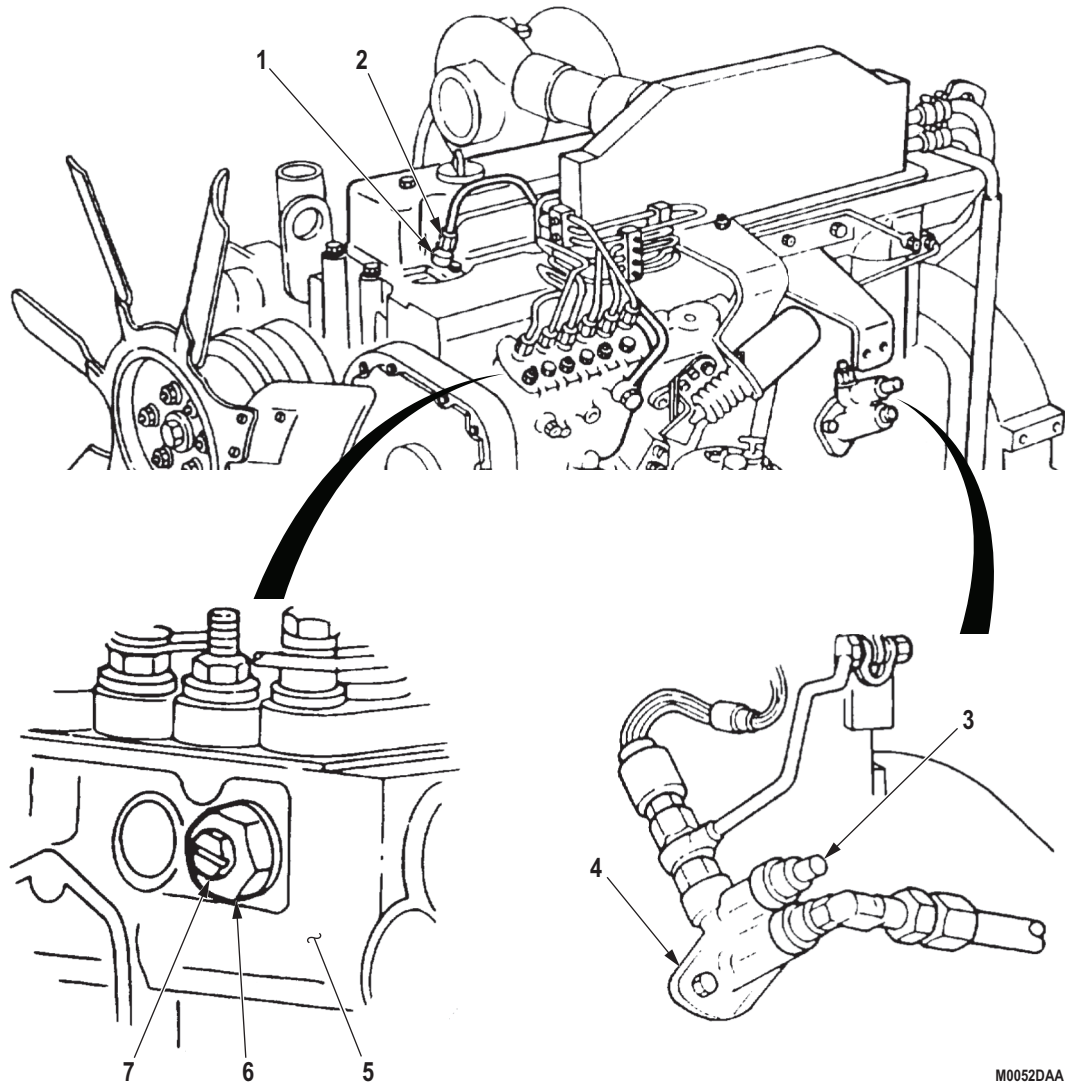
PRIMING - Continued

M0052DAA

Figure 1. Fuel System Priming.

10. Stop engine (TM 9-2320-272-10).

END OF TASK**FOLLOW-ON MAINTENANCE**

1. Install air cleaner hose. (WP 0248)
2. Start engine and check for leaks. (TM 9-2320-272-10)

END OF TASK**END OF WORK PACKAGE**

FIELD MAINTENANCE FUEL PUMP REPLACEMENT (M939/A1)

INITIAL SETUP:

Tools and Special Tools

Tool Kit, General Mechanic's: Automotive
(Volume 5, WP 0826, Table 1, Item 56)

Materials/Parts

Cap Set, Protective, Dust and Moisture Seal
(Volume 5, WP 0825, Table 1, Item 13)
Lubricating Oil, Engine
(Volume 5, WP 0825, Table 1, Item 39, 40, 41,
42)
Tape, Antiseizing
(Volume 5, WP 0825, Table 1, Item 65)
Gasket (Volume 5, WP 0827, Table 1, Item 166)
Qty: 1

Materials/Parts (cont.)

Locknut (Volume 5, WP 0827, Table 1, Item 314)
Qty: 3
Lockwasher
(Volume 5, WP 0827, Table 1, Item 404)
Qty: 1

Equipment Condition

Parking brake set. (TM 9-2320-272-10)
Hood raised and secured. (TM 9-2320-272-10)
Left splash shield removed. (TM 9-2320-272-10)
Air reservoir drained. (TM 9-2320-272-10)

REMOVAL

1. Disconnect lead (Figure 1, Item 11) from fuel pressure transducer (Figure 1, Item 10) and remove fuel pressure transducer from fuel pump (Figure 1, Item 9).
2. Disconnect fuel line (Figure 1, Item 3) from fuel shutoff valve (Figure 1, Item 5).
3. Remove nut (Figure 1, Item 7) and wires (Figure 1, Item 6) from terminal (Figure 1, Item 8).
4. Loosen screw (Figure 1, Item 1) and remove cable (Figure 1, Item 4) from fuel shutoff lever (Figure 1, Item 2).

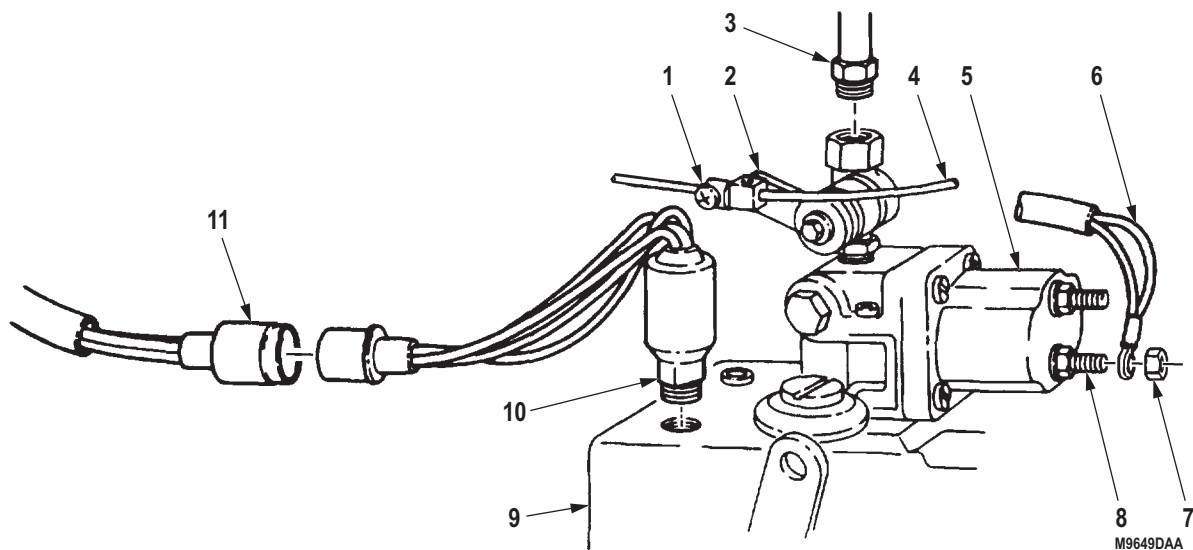

Figure 1. Fuel Pump Removal.

REMOVAL - Continued

5. Remove locknut (Figure 2, Item 1) and screw (Figure 2, Item 10) and disconnect rod clevis (Figure 2, Item 12) from pump throttle lever (Figure 2, Item 11). Discard locknut.
6. Remove return spring (Figure 2, Item 7) from modulator control link (Figure 2, Item 6) and modulator cable clamp bracket (Figure 2, Item 8).
7. Remove locknuts (Figure 2, Items 3 and 13), screws (Figure 2, Items 5 and 9), and rod clevis (Figure 2, Item 4) from pump throttle lever (Figure 2, Item 2). Discard locknuts.

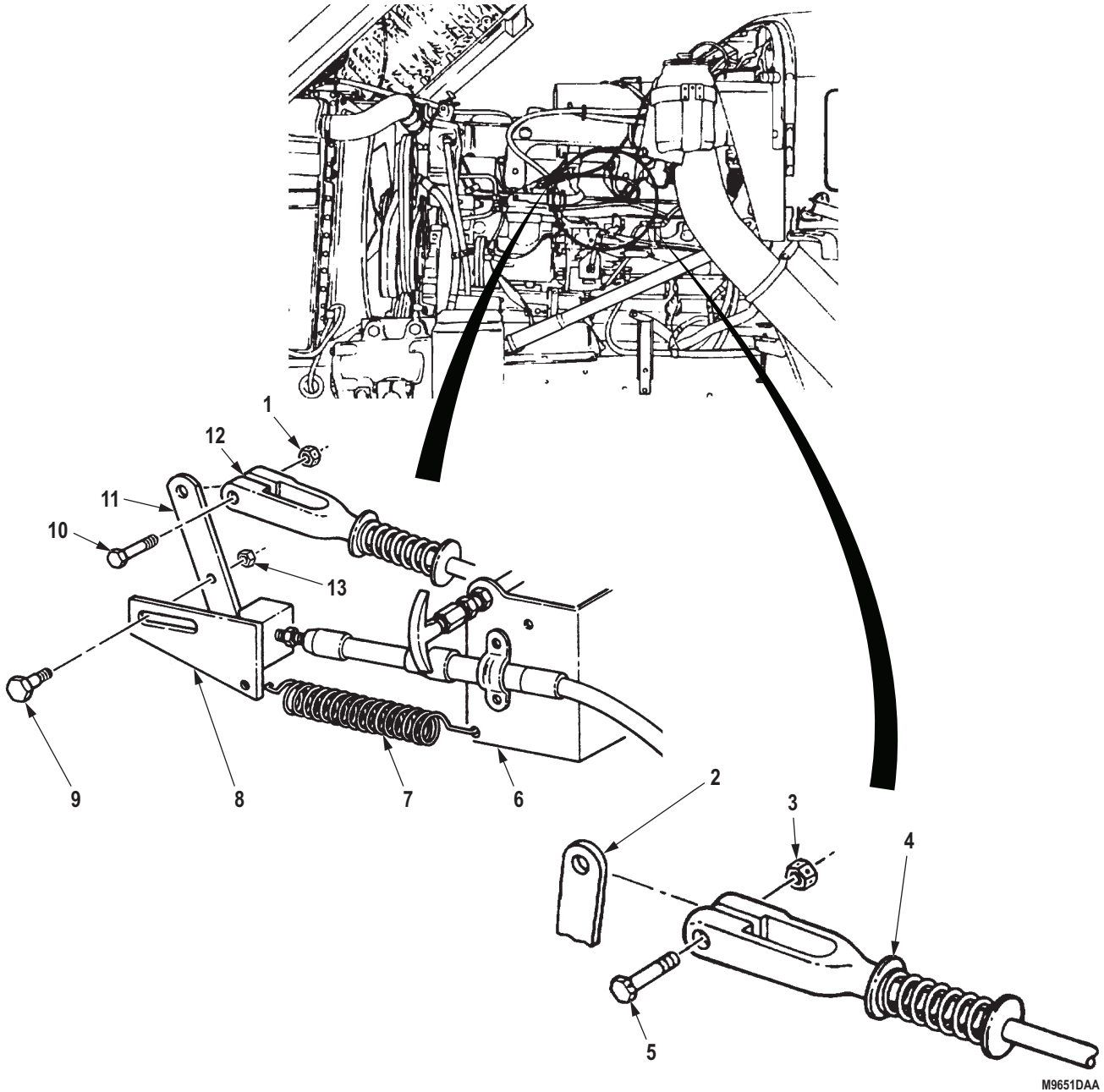

Figure 2. Fuel Pump Removal.

REMOVAL - Continued

8. Disconnect tachometer pulse sender (Figure 3, Item 10) from tachometer drive housing (Figure 3, Item 9).
9. Disconnect primer pump fuel line (Figure 3, Item 4), inlet fuel line (Figure 3, Item 5), and fuel outlet line (Figure 3, Item 3) from inlet adapter elbow (Figure 3, Item 6) and fuel outlet line fitting (Figure 3, Item 2).
10. Disconnect two connectors (Figure 3, Item 7) from ether start fuel pressure switch (Figure 3, Item 8) and remove ether start fuel pressure switch from bottom of fuel pump (Figure 3, Item 1).

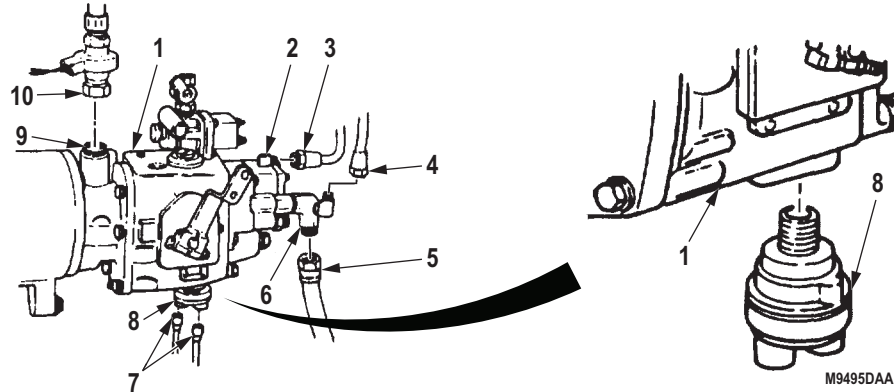
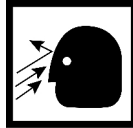

Figure 3. Fuel Pump Removal.

REMOVAL - Continued**NOTE**

Steps (11) through (13) apply to fuel pump with VS governor only.

11. Remove two screws (Figure 4, Item 6) and air cylinder bracket (Figure 4, Item 7) from VS governor (Figure 4, Item 1).

WARNING

Do not disconnect air lines or hoses before draining air reservoirs. Small parts under pressure may shoot out with high velocity. Failure to comply may result in injury or death to personnel.

12. Remove air line (Figure 4, Item 5) and adapter (Figure 4, Item 4) from air cylinder (Figure 4, Item 3).
13. Remove nut (Figure 4, Item 2) and air cylinder (Figure 4, Item 3) from bracket (Figure 4, Item 7).

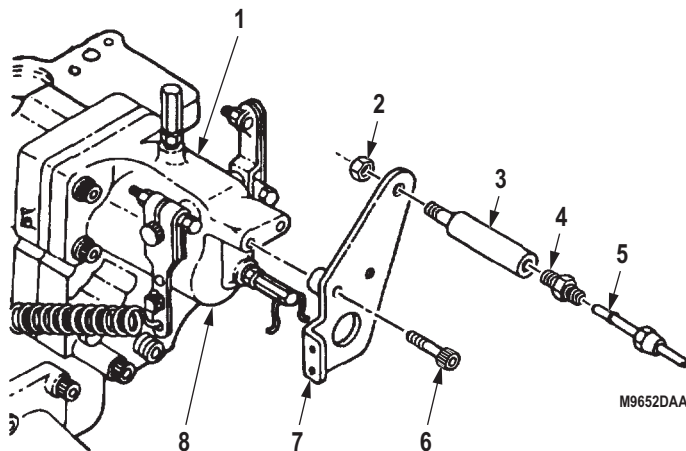

Figure 4. Fuel Pump Removal.

14. Remove three screws (Figure 5, Item 5), washers (Figure 5, Item 6), screw (Figure 5, Item 3), lockwasher (Figure 5, Item 2), washer (Figure 5, Item 1), and fuel pump (Figure 5, Item 4) from air compressor (Figure 5, Item 8). Discard lockwasher.
15. Remove rubber spider coupling (Figure 5, Item 10) and fuel pump gasket (Figure 5, Item 9) from air compressor (Figure 5, Item 8). Discard gasket. Clean gasket remains from mating surfaces of air compressor and rubber spider coupling.

REMOVAL - Continued

Figure 5. Fuel Pump Removal.

END OF TASK**INSTALLATION**

1. Place gasket (Figure 6, Item 9) and rubber spider coupling (Figure 6, Item 10) on air compressor (Figure 6, Item 8).
2. Align fuel pump drive (Figure 6, Item 7) with rubber spider coupling (Figure 6, Item 10) on air compressor (Figure 6, Item 8) and install fuel pump (Figure 6, Item 4) on air compressor with three washers (Figure 6, Item 6), screws (Figure 6, Item 5), washer (Figure 6, Item 1), lockwasher (Figure 6, Item 2), and screw (Figure 6, Item 3).

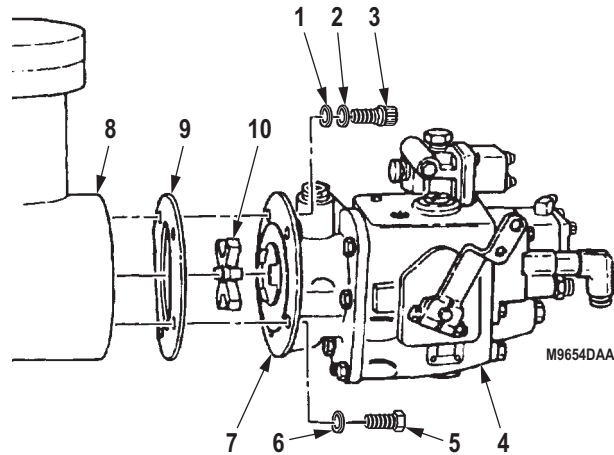
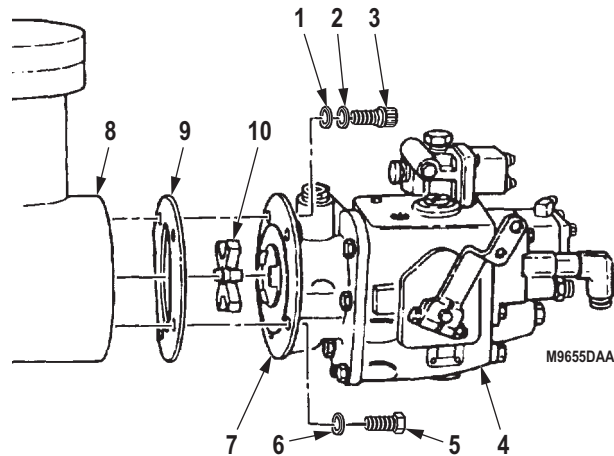

Figure 6. Fuel Pump Installation.

INSTALLATION - Continued**NOTE**

Squirt clean oil into pump through adapter elbow hole. This aids fuel pickup and provides pump lubrication on initial start.

3. Connect tachometer pulse sender (Figure 7, Item 10) to tachometer drive housing (Figure 7, Item 9).
4. Connect primer pump fuel line (Figure 7, Item 4), inlet fuel line (Figure 7, Item 5), and fuel outlet line (Figure 7, Item 3) to inlet adapter elbow (Figure 7, Item 6) and fuel outlet line fitting (Figure 7, Item 2).
5. Install ether start fuel pressure switch (Figure 7, Item 8) on fuel pump (Figure 7, Item 1).
6. Connect two connectors (Figure 7, Item 7) to ether start fuel pressure switch (Figure 7, Item 8).

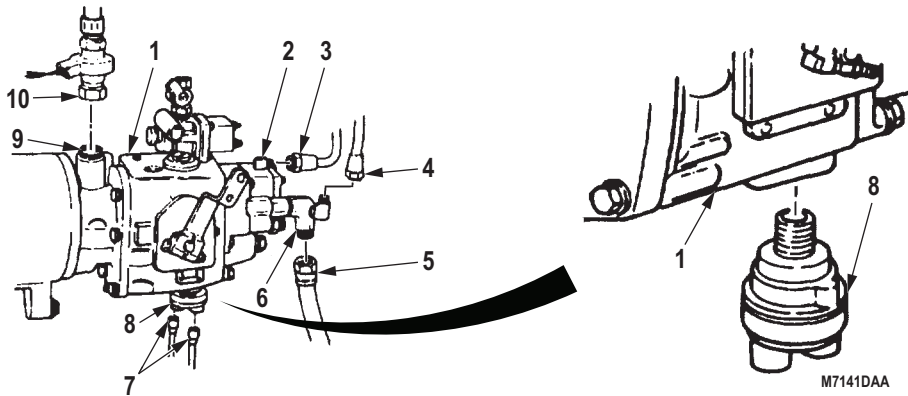

Figure 7. Fuel Pump Installation.

7. Place fuel shutoff control cable (Figure 8, Item 5) through hole in shutoff lever clamp (Figure 8, Item 2). Ensure shutoff lever (Figure 8, Item 3) is in the forward position and tighten screw (Figure 8, Item 1).
8. Connect fuel line (Figure 8, Item 4) to fuel shutoff valve (Figure 8, Item 6).
9. Connect two wires (Figure 8, Item 7) to shutoff valve terminal (Figure 8, Item 9) with nut (Figure 8, Item 8).
10. Install fuel pressure transducer (Figure 8, Item 11) in fuel pump (Figure 8, Item 10) and connect to lead (Figure 8, Item 12).

INSTALLATION - Continued

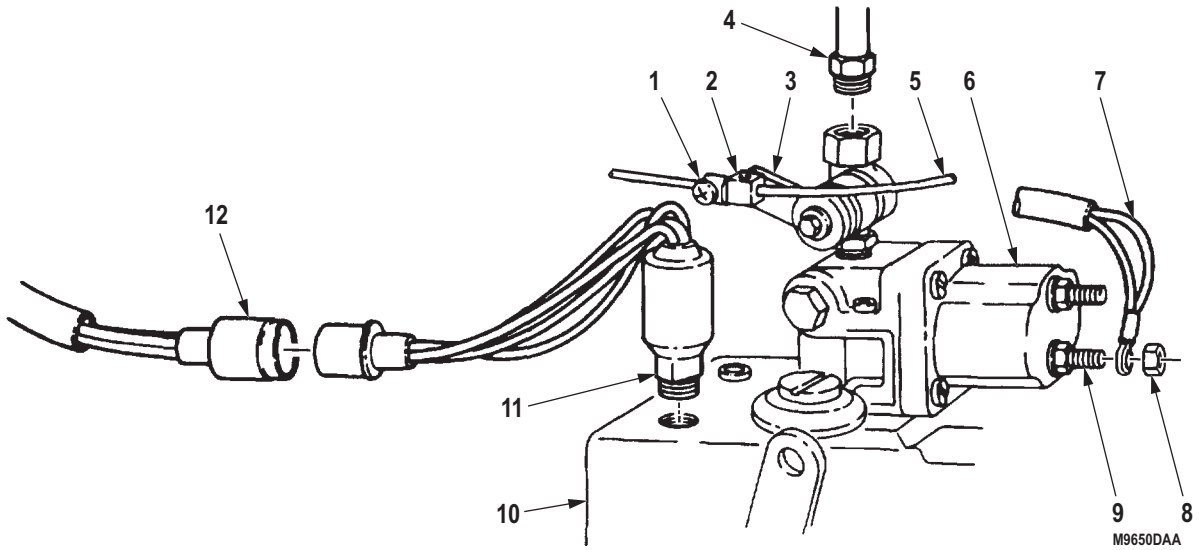

Figure 8. Fuel Pump Installation.

NOTE

Steps (11) through (13) apply to fuel pump with VS governor only.

11. Install air cylinder bracket (Figure 9, Item 7) on VS governor (Figure 9, Item 1) with two screws (Figure 9, Item 6).
12. Install air cylinder (Figure 9, Item 3) on bracket (Figure 9, Item 7) with nut (Figure 9, Item 2).
13. Apply antiseize tape to male threads of adapter (Figure 9, Item 4) and air line (Figure 9, Item 5) and install on air cylinder (Figure 9, Item 3).

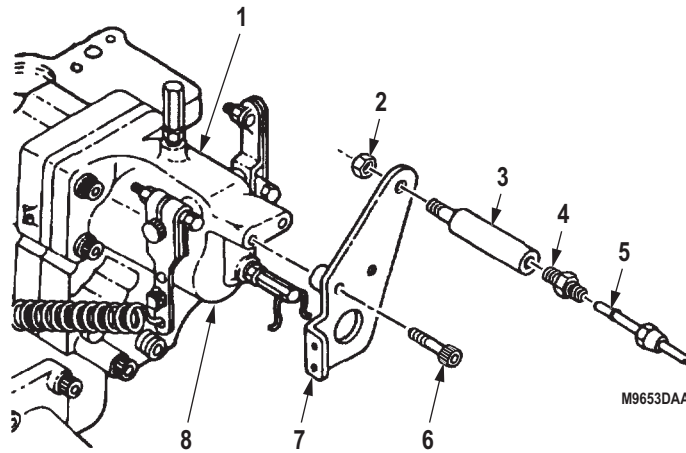

Figure 9. Fuel Pump Installation.

INSTALLATION - Continued

14. Connect rod clevis (Figure 10, Item 12) to throttle lever (Figure 10, Item 11) with screw (Figure 10, Item 10) and locknut (Figure 10, Item 1).
15. Connect modulator link (Figure 10, Item 8) to throttle lever (Figure 10, Item 11) with screw (Figure 10, Item 9) and locknut (Figure 10, Item 13).
16. Connect modulator return spring (Figure 10, Item 7) to modulator link (Figure 10, Item 8) and cable clamp bracket (Figure 10, Item 6).
17. Connect rod clevis (Figure 10, Item 4) to throttle lever (Figure 10, Item 2) with screw (Figure 10, Item 5) and locknut (Figure 10, Item 3).

INSTALLATION - Continued

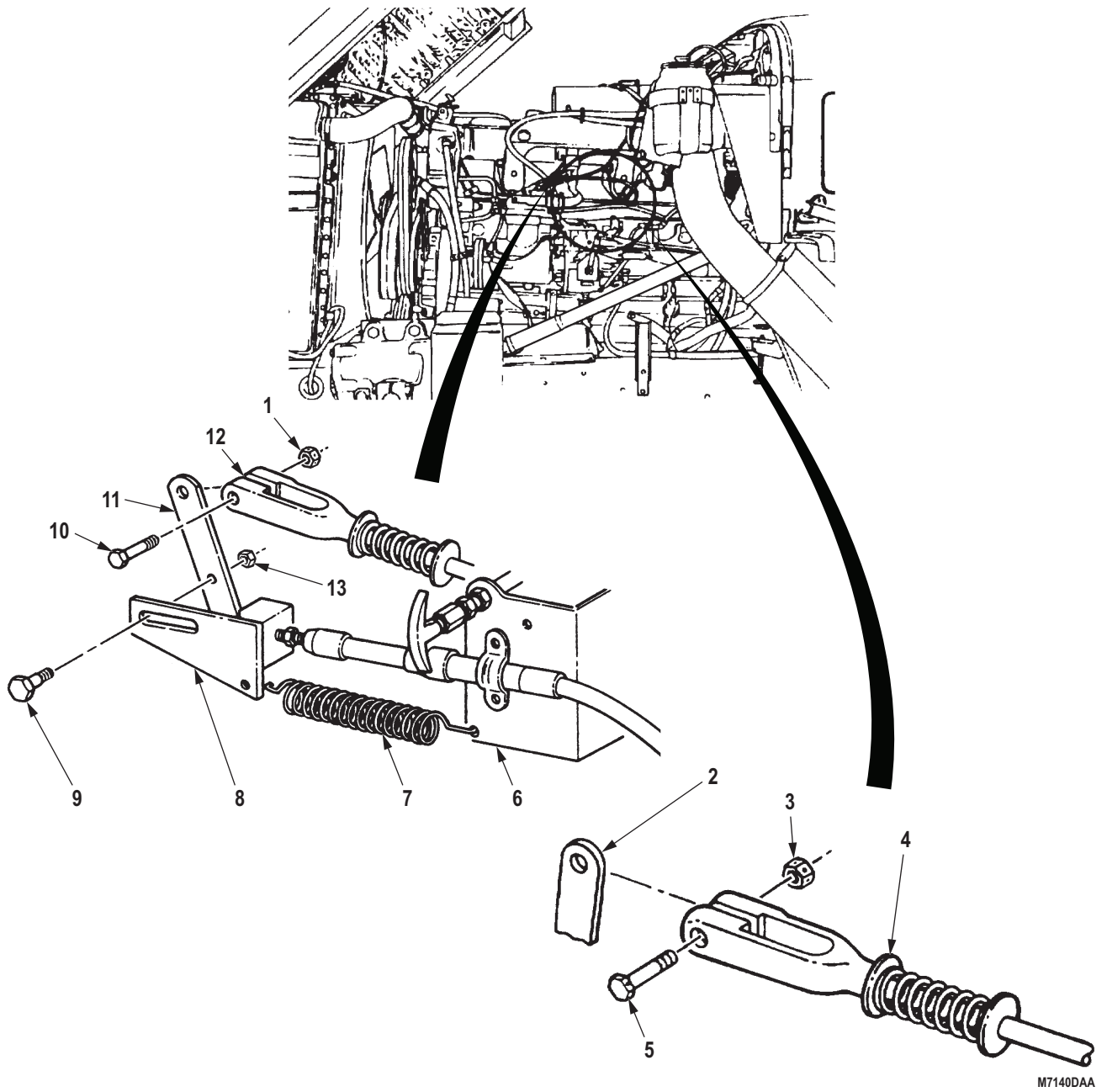

Figure 10. Fuel Pump Installation.

END OF TASK

ON-ENGINE ADJUSTMENTS**CAUTION**

Do not change pump settings made during calibration.

1. Remove nut (Figure 11, Item 4), lockwasher (Figure 11, Item 5), washer (Figure 11, Item 6), and screw (Figure 11, Item 7) from throttle lever (Figure 11, Item 3) and fuel pump (Figure 11, Item 1). Discard lockwasher.
2. Slide throttle lever (Figure 11, Item 3) off splined throttle shaft (Figure 11, Item 8).
3. Turn splined throttle shaft (Figure 11, Item 8) clockwise until resting against idle adjusting screw (Figure 11, Item 2).
4. Slide throttle lever (Figure 11, Item 3) on splined throttle shaft (Figure 11, Item 8) and install with screw (Figure 11, Item 7), washer (Figure 11, Item 6), lockwasher (Figure 11, Item 5), and nut (Figure 11, Item 4). Do not tighten nut.
5. Prime fuel system and allow to warm up to operating temperature (TM 9-2320-272-10).
6. Check idle speed. If idle speed is not 600 to 650 rpm, stop engine and check linkage adjustment.
7. When idle speed is correct, stop engine and tighten nut (Figure 11, Item 4).

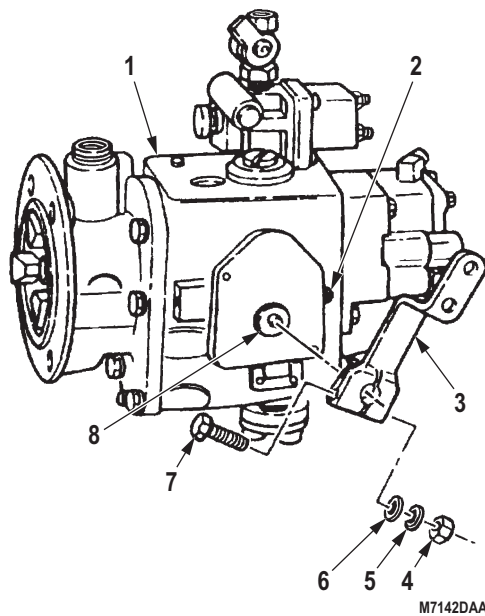

Figure 11. Fuel Pump Adjustments.

ON-ENGINE ADJUSTMENTS - Continued**WARNING**

Hearing protection must be worn by mechanic when engine is running. Noise levels produced by this vehicle exceed 85dB. Failure to comply may result in injury or death to personnel.

NOTE

Steps (8) through (17) apply to fuel pump with VS governor only.

8. Start engine (TM 9-2320-272-10) and allow air system to reach normal operating pressure.
9. Engage crane drive control lever (TM 9-2320-272-10).
10. Engage transfer power takeoff lever (TM 9-2320-272-10).
11. Remove spring (Figure 12, Item 7) from throttle lever (Figure 12, Item 5) and bracket (Figure 12, Item 6).
12. Loosen nut (Figure 12, Item 1) and adjusting screw (Figure 12, Item 2).
13. Place throttle lever (Figure 12, Item 3) forward in full throttle position and hold. Turn adjusting screw (Figure 12, Item 2) until it touches air cylinder piston shaft (Figure 12, Item 4).
14. Release throttle lever (Figure 12, Item 3), hold adjusting screw (Figure 12, Item 2), and tighten nut (Figure 12, Item 1).
15. Install spring (Figure 12, Item 7) on throttle lever (Figure 12, Item 5) and bracket (Figure 12, Item 6).

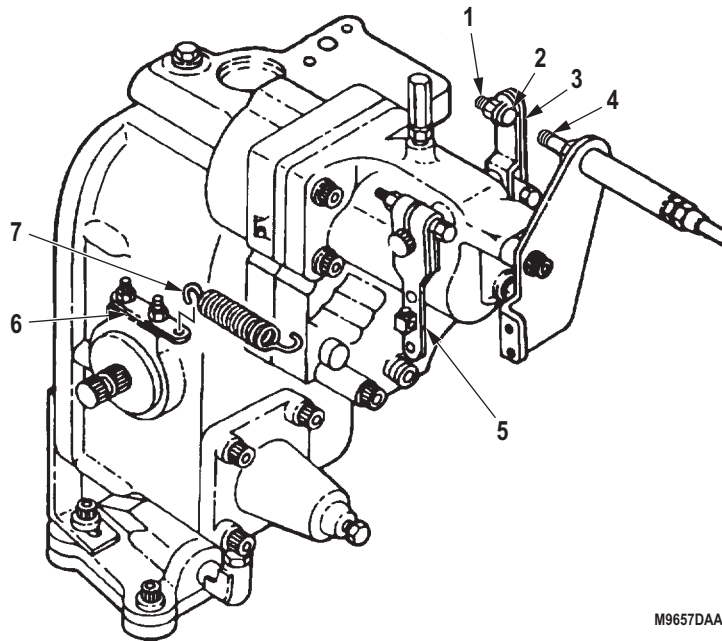

M9657DAA

Figure 12. Fuel Pump Adjustments.

ON-ENGINE ADJUSTMENTS - Continued

16. Disengage transfer PTO lever (TM 9-2320-272-10).
17. Disengage crane drive control lever (TM 9-2320-272-10).

END OF TASK**FOLLOW-ON MAINTENANCE**

Install left splash shield. (TM 9-2320-272-10)

END OF TASK**END OF WORK PACKAGE**

**FIELD MAINTENANCE
FUEL INJECTOR TUBES REPLACEMENT (M939A2)**

INITIAL SETUP:**Tools and Special Tools**

Tool Kit, General Mechanic's: Automotive
(Volume 5, WP 0826, Table 1, Item 56)

References

Volume 5, WP 0819

Materials/Parts

Cap Set, Protective, Dust and Moisture Seal
(Volume 5, WP 0825, Table 1, Item 13)
Banjo Seal
(Volume 5, WP 0827, Table 1, Item 128)
Qty: 7

Equipment Condition

Parking brake set. (TM 9-2320-272-10)
Hood raised and secured. (TM 9-2320-272-10)

REMOVAL**WARNING**

Diesel fuel is highly flammable. Do not perform fuel system procedures near open flame. Failure to comply may result in injury or death to personnel.

CAUTION

Cap or plug all openings immediately after disconnecting fuel lines to prevent contamination. Failure to do so may result in damage to fuel pump.

1. Remove seven screws (Figure 1, Item 3), banjo seals (Figure 1, Item 4), and fuel manifold (Figure 1, Item 5) from six fuel injectors (Figure 1, Item 6) and fuel return tube (Figure 1, Item 7). Discard banjo seals.

NOTE

Tag injector tubes for installation.

2. Loosen six fuel line nuts (Figure 1, Item 10) and disconnect fuel injector tubes (Figure 1, Item 11) from fuel injectors (Figure 1, Item 6).
3. Loosen six fuel line nuts (Figure 1, Item 10) and disconnect fuel injector tubes (Figure 1, Item 11) from fuel injector pump (Figure 1, Item 9).
4. Remove screw (Figure 1, Item 1), washer (Figure 1, Item 2), and fuel injector tubes (Figure 1, Item 11) from cylinder head (Figure 1, Item 8).

NOTE

Tag brace assemblies for installation.

5. Remove two screws (Figure 1, Item 25), washers (Figure 1, Item 28), tube braces (Figure 1, Item 26), and isolators (Figure 1, Item 27) from fuel injector tubes (Figure 1, Item 11).
6. Remove screw (Figure 1, Item 21), washer (Figure 1, Item 24), two tube braces (Figure 1, Item 22), and isolators (Figure 1, Item 23) from fuel injector tubes (Figure 1, Item 11).
7. Remove four screws (Figure 1, Item 12), washers (Figure 1, Item 15), two tube braces (Figure 1, Item 13), and isolators (Figure 1, Item 14) from injector tubes (Figure 1, Item 11).
8. Remove four screws (Figure 1, Item 16), washers (Figure 1, Item 17), two tube braces (Figure 1, Item 18), brace (Figure 1, Item 20), and four isolators (Figure 1, Item 19) from injector tubes (Figure 1, Item 11).

REMOVAL - Continued

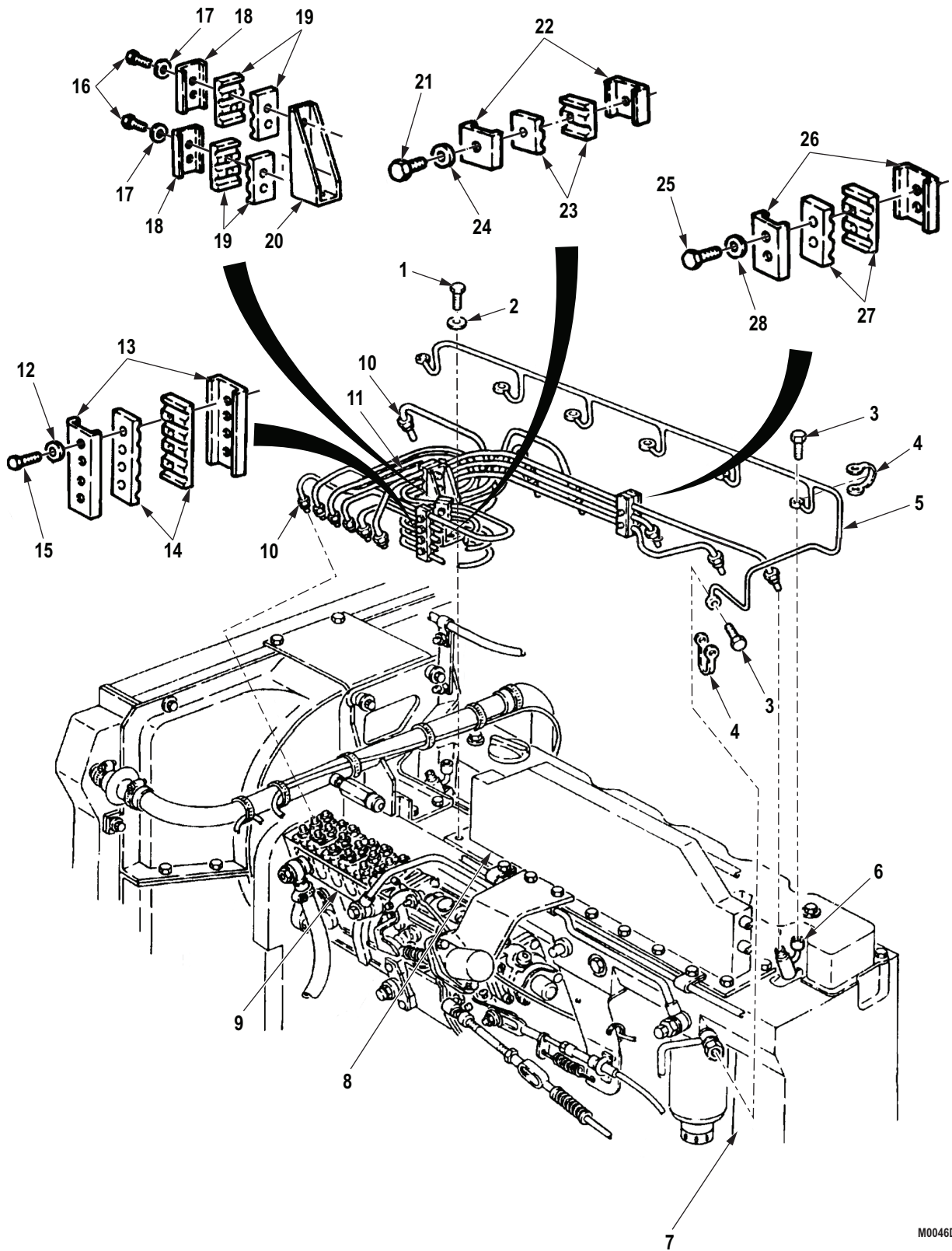

M0046DAA

Figure 1. Fuel Injector Tubes Removal.

END OF TASK

CLEANING AND INSPECTION

1. For General Cleaning Instructions, refer to (Volume 5, WP 0819).
2. For General Inspection Instructions, refer to (Volume 5, WP 0819).
3. Inspect fuel injection tubes for cracks or dents. If cracked or dented, replace fuel injection tubes.
4. Inspect fuel manifold for cracks or dents. If cracked or dented, replace fuel manifold.
5. Replace all parts failing inspection.

END OF TASK

INSTALLATION

CAUTION

- Injector tubes deliver fuel at high pressure causing them to expand and contract. Ensure injector tubes are securely clamped and routed so they do not come in contact with each other or any engine component. Failure to do so may result in premature injector tube failure.
 - Injector tubes must be installed in correct positions as tagged. Failure to do so may result in damage to tubes and engine malfunction.
1. Install four isolators (Figure 2, Item 19), brace (Figure 2, Item 20), and two tube braces (Figure 2, Item 18) on six fuel injector tubes (Figure 2, Item 11) with four washers (Figure 2, Item 17) and screws (Figure 2, Item 16). Finger tighten screws.
 2. Install two isolators (Figure 2, Item 14) and tube braces (Figure 2, Item 13) on fuel injector tubes (Figure 2, Item 11) with four washers (Figure 2, Item 15) and screws (Figure 2, Item 12). Finger tighten screws.
 3. Install two isolators (Figure 2, Item 23) and tube braces (Figure 2, Item 22) on fuel injector tubes (Figure 2, Item 11) with washer (Figure 2, Item 24) and screw (Figure 2, Item 21). Finger tighten screw.
 4. Install two isolators (Figure 2, Item 27) and tube braces (Figure 2, Item 26) on injector tubes (Figure 2, Item 11) with two washers (Figure 2, Item 28) and screws (Figure 2, Item 25). Finger tighten screws.
 5. Install six fuel injector tubes (Figure 2, Item 11) on cylinder head (Figure 2, Item 8) with washer (Figure 2, Item 2) and screw (Figure 2, Item 1).
 6. Position six fuel injector tubes (Figure 2, Item 11) on fuel injection pump (Figure 2, Item 9) and fuel injectors (Figure 2, Item 6).
 7. Connect six fuel tube nuts (Figure 2, Item 10) to fuel injection pump (Figure 2, Item 9).
 8. Connect six fuel tube nuts (Figure 2, Item 10) to fuel injectors (Figure 2, Item 6).
 9. Tighten two screws (Figure 2, Item 25), screw (Figure 2, Item 21), four screws (Figure 2, Item 12) and screws (Figure 2, Item 16).

NOTE

Banjo seals must face toward fuel injectors to allow installation of valve cover.

10. Install fuel manifold (Figure 2, Item 5) and seven banjo seals (Figure 2, Item 4) on six fuel injectors (Figure 2, Item 6) and fuel supply tube (Figure 2, Item 7) with seven screws (Figure 2, Item 3).

INSTALLATION - Continued

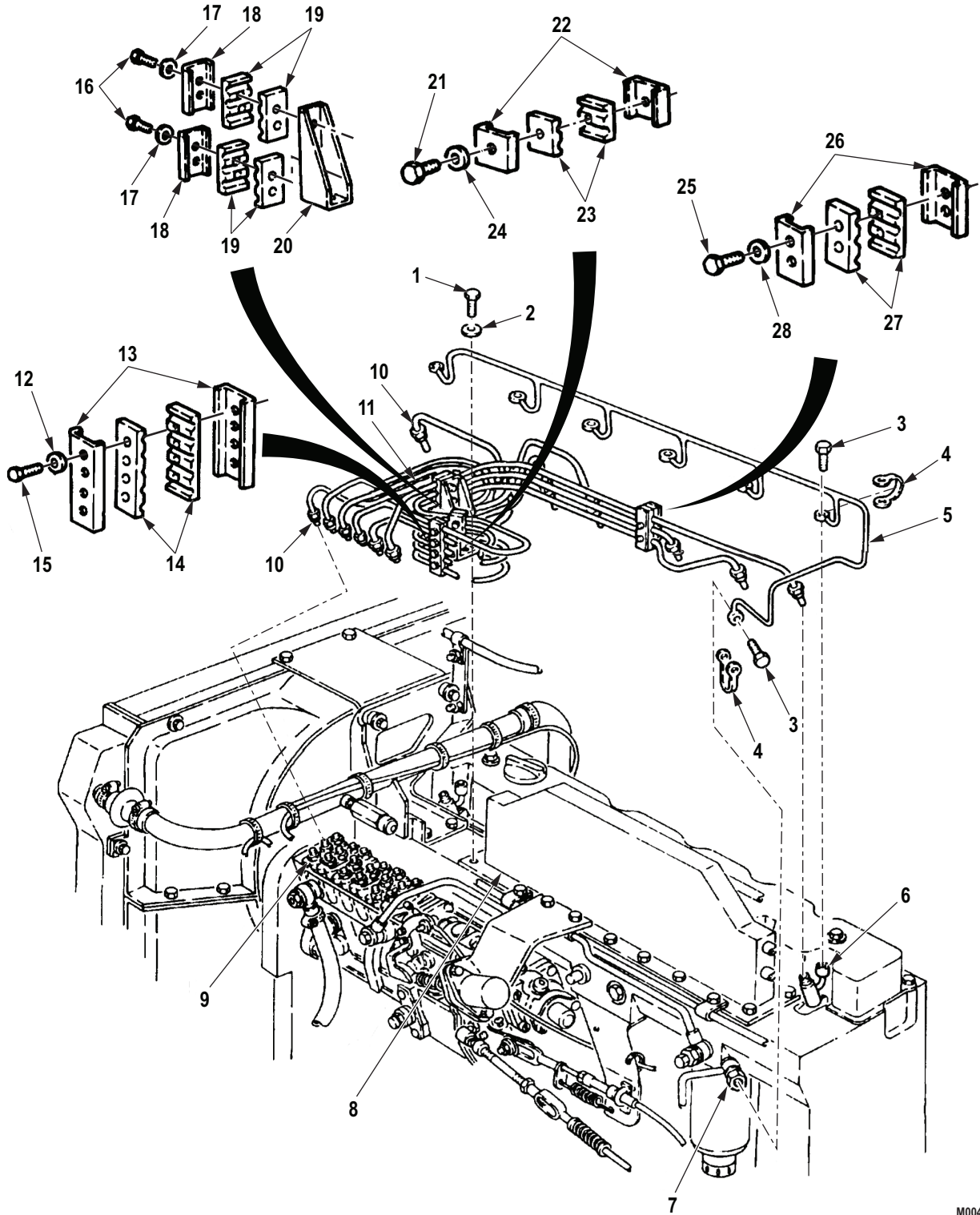

M0047DAA

Figure 2. Fuel Injector Tubes Installation.

END OF TASK

FOLLOW-ON MAINTENANCE

1. Prime fuel system. (WP 0239)
2. Hood lowered and secured. (TM 9-2320-272-10)

END OF TASK**END OF WORK PACKAGE**

**FIELD MAINTENANCE
FUEL INJECTION PUMP REPLACEMENT (M939A2)**

INITIAL SETUP:**Tools and Special Tools**

Tool Kit, General Mechanic's: Automotive
(Volume 5, WP 0826, Table 1, Item 56)
Barring Tool, Gear
(Volume 5, WP 0826, Table 1, Item 8)
Puller Kit, Universal
(Volume 5, WP 0826, Table 1, Item 43)
Wrench, Box
(Volume 5, WP 0826, Table 1, Item 60)
Wrench, Torque, Click, Ratcheting, 1/2" Drive,
250 Ft-Lb
(Volume 5, WP 0826, Table 1, Item 63)

Materials/Parts

Cap Set, Protective, Dust and Moisture Seal
(Volume 5, WP 0825, Table 1, Item 13)
Lubricating Oil, Engine
(Volume 5, WP 0825, Table 1, Item 36, 37,
38) Qty: 10
Wire, Nonelectrical: Safety Wire
(Volume 5, WP 0825, Table 1, Item 69)
Breakoff Screw
(Volume 5, WP 0827, Table 1, Item 86)
Qty: 1
Copper Washer
(Volume 5, WP 0827, Table 1, Item 139)
Qty: 10
Copper Washer
(Volume 5, WP 0827, Table 1, Item 229)
Qty: 2
Cotter Pin
(Volume 5, WP 0827, Table 1, Item 337)
Qty: 2

Materials/Parts (cont.)

Lockwasher
(Volume 5, WP 0827, Table 1, Item 87)
Qty: 2
Lockwasher
(Volume 5, WP 0827, Table 1, Item 163)
Qty: 1
Lockwasher
(Volume 5, WP 0827, Table 1, Item 394)
Qty: 1
O-ring (Volume 5, WP 0827, Table 1, Item 152)
Qty: 1
O-ring (Volume 5, WP 0827, Table 1, Item 160)
Qty: 1
Packing, Preformed
(Volume 5, WP 0827, Table 1, Item 134)
Qty: 1

Personnel Required

(2)

Equipment Condition

Throttle control solenoid removed. (WP 0304)
Air Fuel Control (AFC) tube removed. (WP 0244)
Tachometer drive removed. (Volume 5, WP 0816)

REMOVAL**WARNING**

Diesel fuel is highly flammable. Do not perform fuel system procedures near open flame. Failure to comply may result in injury or death to personnel.

1. Remove cotter pin (Figure 1, Item 8), washer (Figure 1, Item 9) and cable pivot (Figure 1, Item 3) from shutoff valve lever (Figure 1, Item 10). Discard cotter pin.
2. Remove screw (Figure 1, Item 7), clamp (Figure 1, Item 5), and control cable (Figure 1, Item 4) from fuel pump bracket (Figure 1, Item 6).
3. Remove screw (Figure 1, Item 1), throttle connector (Figure 1, Item 8), and control cable (Figure 1, Item 4) from cable pivot (Figure 1, Item 3).
4. Remove cotter pin (Figure 1, Item 11) and washer (Figure 1, Item 12) from link pin (Figure 1, Item 14). Discard cotter pin.
5. Remove modulator control cable (Figure 1, Item 13) from throttle lever (Figure 1, Item 15).
6. Compress socket (Figure 1, Item 18) and remove accelerator linkage (Figure 1, Item 17) from ball joint (Figure 1, Item 16).
7. Remove ball joint (Figure 1, Item 16) and lockwasher (Figure 1, Item 19) from throttle lever (Figure 1, Item 15). Discard lockwasher.

REMOVAL - Continued

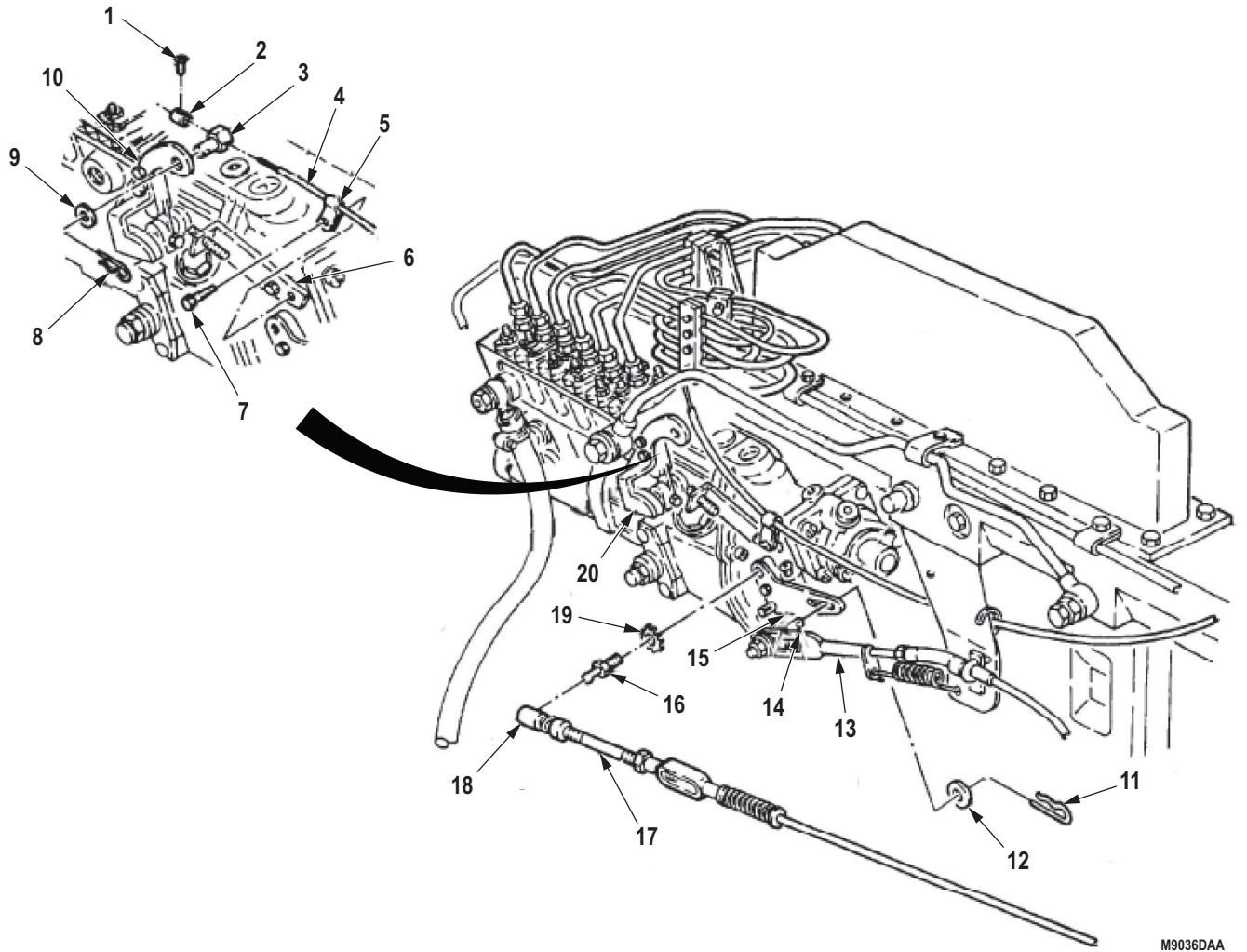

M9036DAA

Figure 1. Fuel Injection Pump Removal.

REMOVAL - Continued**CAUTION**

- Clean area around connections before disconnecting lines and hoses. Failure to do so may result in damage to fuel pump.
- Cap or plug all openings immediately after disconnecting lines and hoses to prevent contamination. Failure to do so may result in damage to fuel pump.

NOTE

- Have drainage container ready to catch excess fuel.
 - Use drain pans to retain leaking/draining fluids. Refer to local procedures and plans for preventing and responding to fluid spills or leaks. Comply with local regulations when disposing of clean up material and leaked and spilled fluids.
8. Loosen clamp (Figure 2, Item 10) and remove fuel return hose (Figure 2, Item 9) from fuel injection pump return nipple (Figure 2, Item 11).
 9. Disconnect six injector fuel lines (Figure 2, Item 12) from fuel injection pump (Figure 2, Item 8).
 10. Remove screw (Figure 2, Item 1), two connection washers (Figure 2, Item 2), and fuel supply tube (Figure 2, Item 3) from fuel injection pump (Figure 2, Item 8).
 11. Remove screw (Figure 2, Item 6), bushing (Figure 2, Item 5), two connector washers (Figure 2, Item 4), and fuel supply tube (Figure 2, Item 3) from cylinder head (Figure 2, Item 7).

REMOVAL - Continued

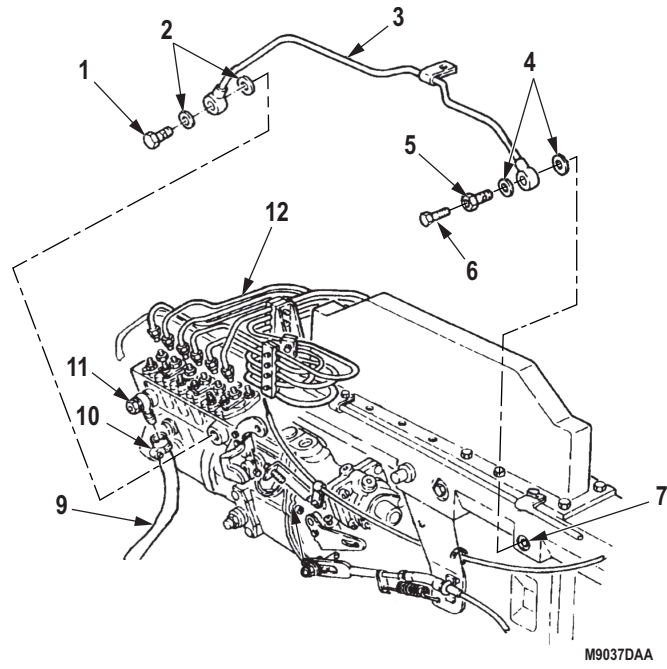

Figure 2. Fuel Injection Pump Removal.

REMOVAL - Continued

12. Remove plug (Figure 3, Item 4) and preformed packing (Figure 3, Item 3) from flywheel housing (Figure 3, Item 2). Discard preformed packing.

NOTE

Assistant will help with Step (13).

13. Using barring tool, secure engine flywheel (Figure 3, Item 1).

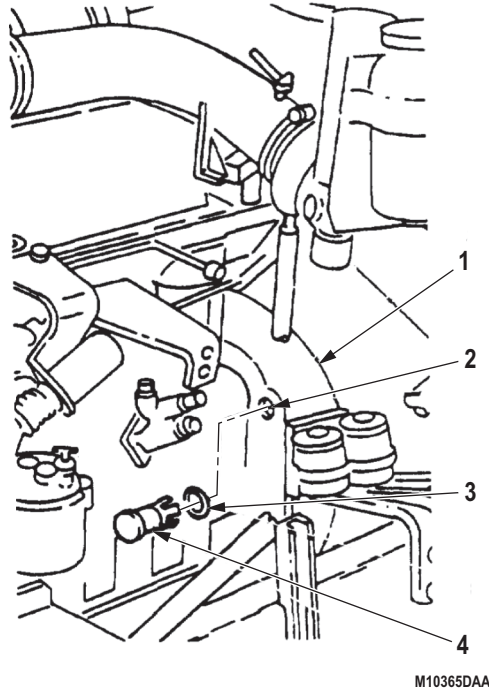

M10365DAA

Figure 3. Fuel Injection Pump Removal.

REMOVAL - Continued

14. Remove nut (Figure 4, Item 1) and lockwasher (Figure 4, Item 9) from fuel pump shaft (Figure 4, Item 5). Discard lockwasher.
15. Using barring tool, rotate engine until timing pin (Figure 4, Item 6) enters hole in camshaft gear (Figure 4, Item 8). Piston No. 1 is now at top dead center.

NOTE

Do not remove fuel injector pump gear from gear housing.

16. Using puller, remove fuel pump gear (Figure 4, Item 8) from fuel pump shaft (Figure 4, Item 5).
17. Remove four nuts (Figure 4, Item 4) and fuel injection pump (Figure 4, Item 3) from gear housing (Figure 4, Item 2).

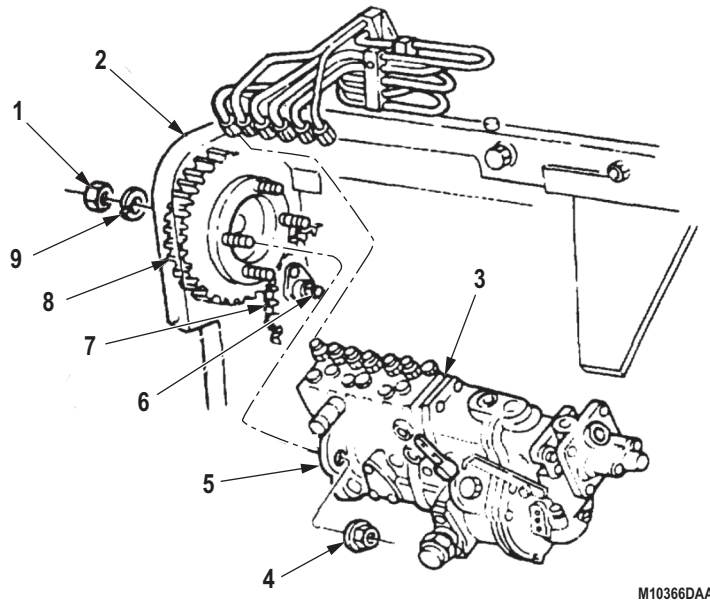

Figure 4. Fuel Injection Pump Removal.

REMOVAL - Continued

18. Remove o-rings (Figure 5, Items 11 and 12) from fuel injection pump (Figure 5, Item 1). Discard o-rings.

NOTE

Perform Steps (19) through (21) if installing fuel injection pump.

19. Remove two screws (Figure 5, Item 5) and fuel shutoff lever (Figure 5, Item 6) from fuel injection pump (Figure 5, Item 1).
20. Remove two screws (Figure 5, Item 4) and throttle lever (Figure 5, Item 3) from shaft (Figure 5, Item 2).
21. Remove plug (Figure 5, Item 8), two copper washers (Figure 5, Item 9), and fitting (Figure 5, Item 7) from fuel injection pump (Figure 5, Item 1). Discard copper washers.

REMOVAL - Continued

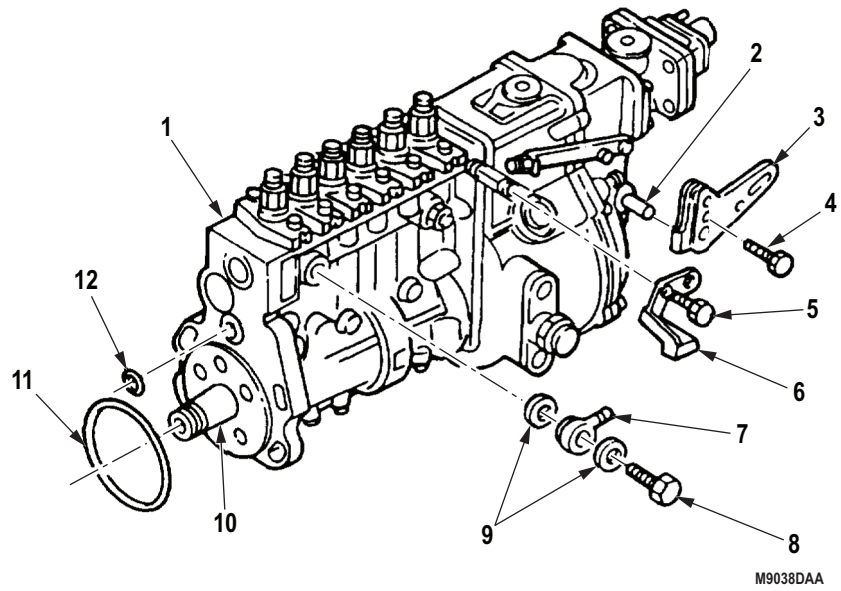

Figure 5. Fuel Injection Pump Removal.

END OF TASK

INSTALLATION**NOTE**

Perform Steps (1) through (4) to ensure fuel injection pump timing is correct.

1. Remove plug (Figure 6, Item 6), copper washer (Figure 6, Item 5), and timing pin (Figure 6, Item 4) from fuel injection pump (Figure 6, Item 3).
2. Install nut (Figure 6, Item 1) on shaft (Figure 6, Item 8).

NOTE

Assistant will help with Step (3).

3. If timing tooth (Figure 6, Item 14) is not aligned with timing pin hole (Figure 6, Item 13), rotate fuel pump shaft (Figure 6, Item 8) until timing tooth aligns with timing pin hole.
4. Remove nut (Figure 6, Item 1) from shaft (Figure 6, Item 8).
5. Reverse timing pin (Figure 6, Item 4) and install slot of timing pin over timing tooth (Figure 6, Item 14).
6. Install copper washer (Figure 6, Item 5) and plug (Figure 6, Item 6) on fuel pump (Figure 6, Item 2).

INSTALLATION - Continued

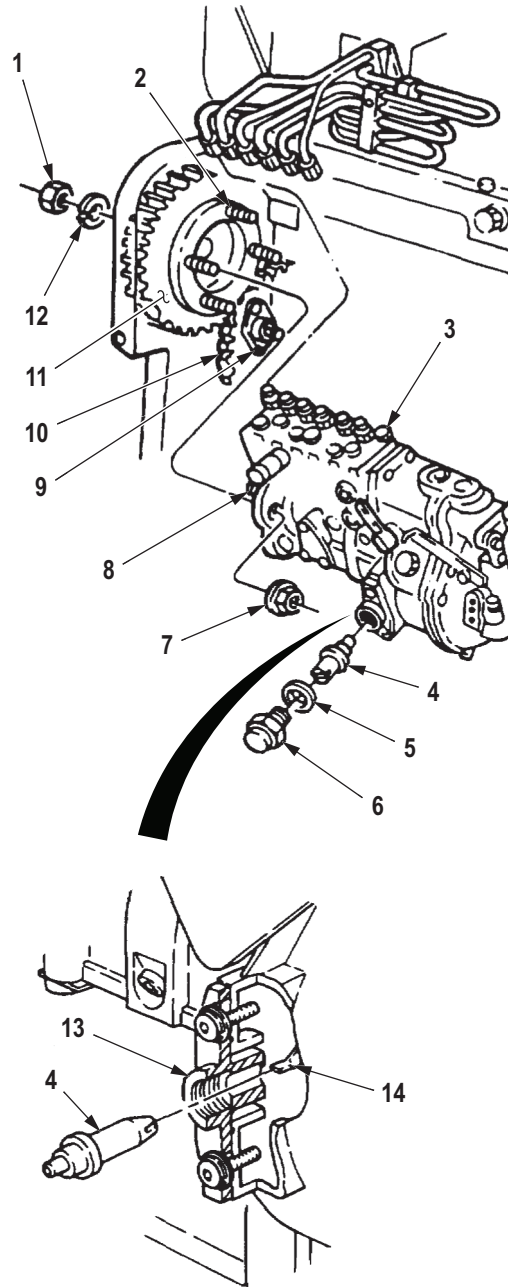

M10364DAA

Figure 6. Fuel Injection Pump Installation.

INSTALLATION - Continued**NOTE**

Perform Steps (7) through (9) if injection pump was installed.

7. Install two copper washers (Figure 7, Item 9) and fitting (Figure 7, Item 7) on fuel pump (Figure 7, Item 1) with screw (Figure 7, Item 8).
8. Install control lever (Figure 7, Item 3) on shaft (Figure 7, Item 2) with two screws (Figure 7, Item 4).
9. Install fuel shutoff lever (Figure 7, Item 6) on fuel injection pump (Figure 7, Item 1) with two screws (Figure 7, Item 5).
10. Install o-rings (Figure 7, Items 10 and 11) on fuel injection pump (Figure 7, Item 1).

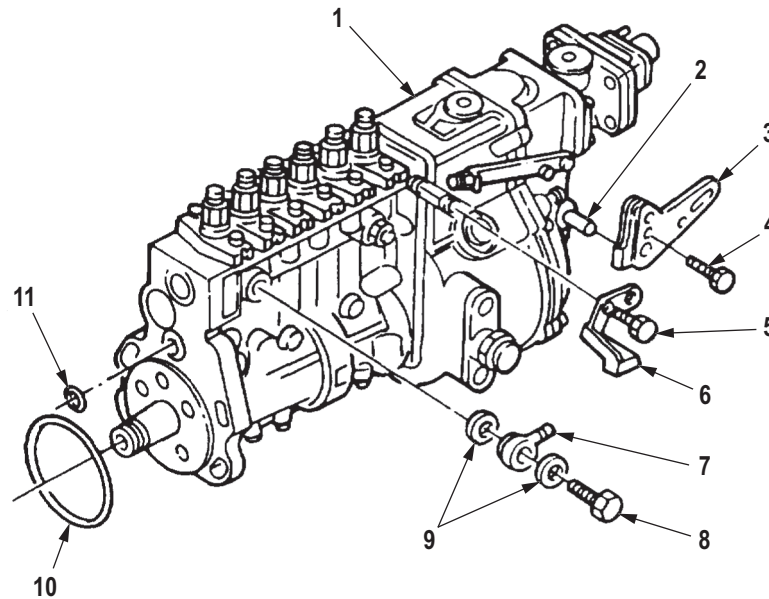

M10363DAA

Figure 7. Fuel Injection Pump Installation.

11. Install fuel injection pump (Figure 6, Item 3) on four mounting studs (Figure 6, Item 2) with nuts (Figure 6, Item 7).
12. Install fuel pump gear (Figure 6, Item 11) on fuel injection pump (Figure 6, Item 3) with lockwasher (Figure 6, Item 12) and nut (Figure 6, Item 1).
13. Disengage engine timing pin (Figure 6, Item 9) from camshaft gear (Figure 6, Item 10).
14. Remove plug (Figure 6, Item 6), copper washer (Figure 6, Item 5), and timing pin (Figure 6, Item 4) from fuel injection pump (Figure 6, Item 3). Discard copper washer.
15. Reverse timing pin (Figure 6, Item 4) so slot of timing pin faces outward from fuel injection pump (Figure 6, Item 3).
16. Install copper washer (Figure 6, Item 5) and plug (Figure 6, Item 6) on fuel injection pump (Figure 6, Item 3).

INSTALLATION - Continued**NOTE**

Assistant will help with Step (17).

17. Using engine barring tool to prevent flywheel (Figure 8, Item 1) from turning, tighten nut (Figure 6, Item 1) 60 lb-ft (81 N-m).
18. Remove engine barring tool and install preformed packing (Figure 8, Item 3) and plug (Figure 8, Item 4) in flywheel housing (Figure 8, Item 2).

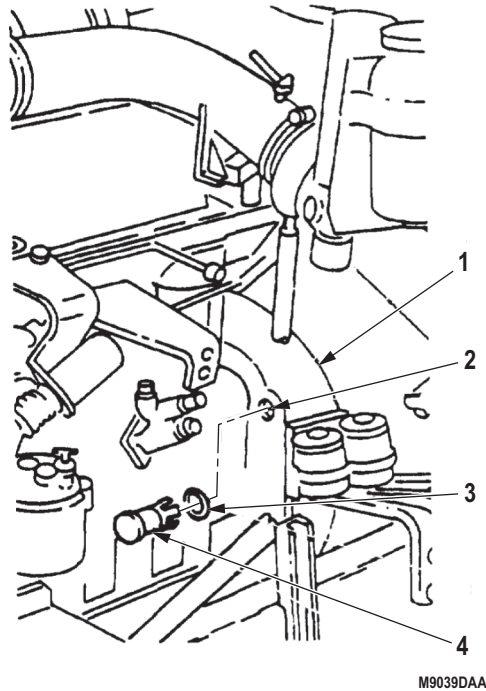
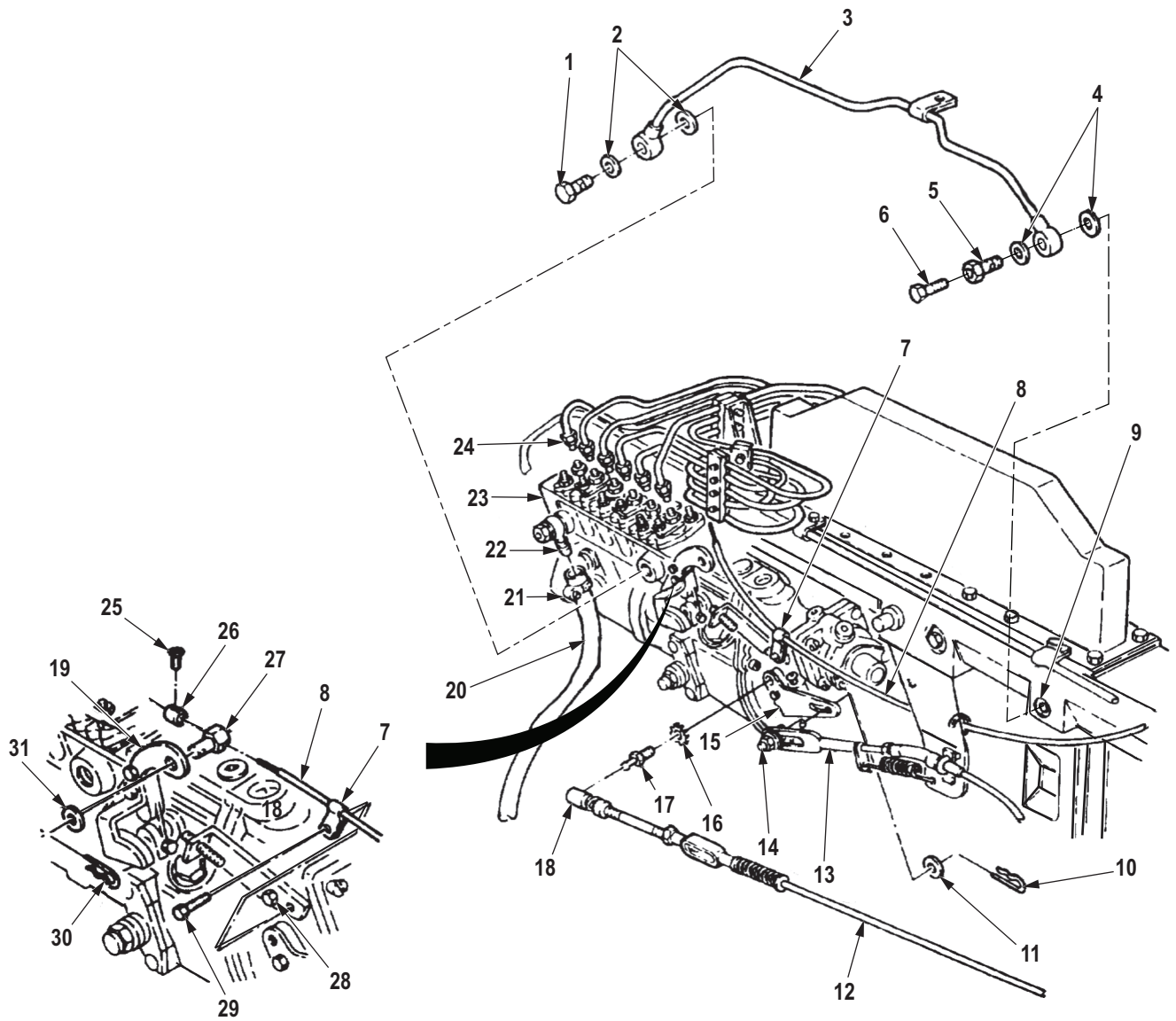

Figure 8. Fuel Injection Pump Installation.

INSTALLATION - Continued

19. Install fuel supply tube (Figure 9, Item 3) on cylinder head (Figure 9, Item 9) with two connector washers (Figure 9, Item 4), bushing (Figure 9, Item 5), and screw (Figure 9, Item 6).
20. Install fuel return tube (Figure 9, Item 3) on fuel injection pump (Figure 9, Item 23) with two connector washers (Figure 9, Item 2) and screw (Figure 9, Item 1).
21. Connect six fuel injector fuel lines (Figure 9, Item 24) to fuel injection pump (Figure 9, Item 23).
22. Install fuel return hose (Figure 9, Item 20) on fuel injection pump fuel return nipple (Figure 9, Item 22) with clamp (Figure 9, Item 21).
23. Install lockwasher (Figure 9, Item 16) and ball joint (Figure 9, Item 17) on throttle lever (Figure 9, Item 15).
24. Compress socket (Figure 9, Item 18) and install accelerator linkage (Figure 9, Item 12) on ball joint (Figure 9, Item 17).
25. Place modulator control cable (Figure 9, Item 13) on throttle lever (Figure 9, Item 15).
26. Install washer (Figure 9, Item 11) and cotter pin (Figure 9, Item 10) on link pin (Figure 9, Item 14).
27. Install throttle connector (Figure 9, Item 26) in cable pivot (Figure 9, Item 27).
28. Install control cable (Figure 9, Item 8) in throttle connector (Figure 9, Item 26) and install screw (Figure 9, Item 25).
29. Install cable pivot (Figure 9, Item 27) on shutoff valve lever (Figure 9, Item 19) with washer (Figure 9, Item 31) and cotter pin (Figure 9, Item 30).
30. Install control cable (Figure 9, Item 8) on fuel pump bracket (Figure 9, Item 28) with clamp (Figure 9, Item 7) and screw (Figure 9, Item 29).

INSTALLATION - Continued



M9040DAA

Figure 9. Fuel Injection Pump Installation.

END OF TASK

ADJUSTMENT**NOTE**

- Perform adjustments procedure for engine models serial number 44629589 and before.
- It may be necessary to cut on break-off screw for removal.

1. Remove safety wire (Figure 10, Item 10) from protective cap (Figure 10, Item 6). Discard safety wire.
2. Remove break-off screw (Figure 10, Item 9), screw (Figure 10, Item 8), two lockwashers (Figure 10, Item 7), and protective cap (Figure 10, Item 6) from manifold pressure compensator (Figure 10, Item 3). Discard lockwashers.
3. Install break-off screw (Figure 10, Item 9) and screw (Figure 10, Item 8) on manifold pressure compensator (Figure 10, Item 3) to hold stop (Figure 10, Item 11) in position during adjustment.

NOTE

Do not turn adjustment screw more than one-half turn.

4. Hold adjusting screw (Figure 10, Item 5) and loosen locknut (Figure 10, Item 4). Turn adjusting screw one-half turn clockwise and tighten locknut.
5. Remove break-off screw (Figure 10, Item 9) and screw (Figure 10, Item 8) from manifold pressure compensator (Figure 10, Item 3). Discard break-off screw.
6. Install protective cap (Figure 10, Item 6) on manifold pressure compensator (Figure 10, Item 3) with two lockwashers (Figure 10, Item 7), break-off screw (Figure 10, Item 9), and screw (Figure 10, Item 8).
7. Install safety wire (Figure 10, Item 10) on protective cap (Figure 10, Item 6).
8. Remove plug (Figure 10, Item 2) from governor housing (Figure 10, Item 1).

NOTE

Do not turn star wheel more than six clicks during adjustment.

9. Using screwdriver, turn star wheel (Figure 10, Item 3) clockwise toward engine (Figure 10, Item 2) until six clicks are heard.
10. Install plug (Figure 10, Item 12) on governor housing (Figure 10, Item 1).
11. Stamp governor housing (Figure 10, Item 1) and engine (Figure 10, Item 12) data plate with field fix FF152 to identify fuel injection pump adjustment.

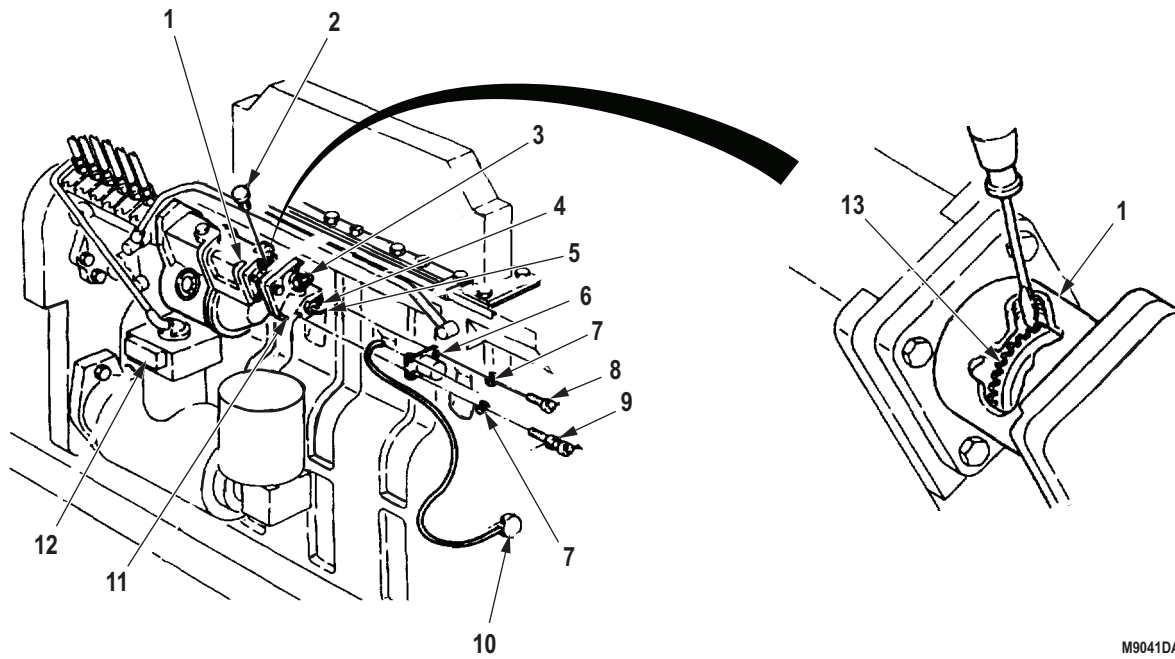
ADJUSTMENT - Continued

M9041DAA

Figure 10. Fuel Injection Pump Adjustment.

END OF TASK**FOLLOW-ON MAINTENANCE**

1. Install tachometer drive. (Volume 5, WP 0816)
2. Install Air Fuel Control (AFC) tube. (WP 0244)
3. Install throttle control solenoid. (WP 0304)
4. Prime fuel system. (WP 0239)

END OF TASK**END OF WORK PACKAGE**

**FIELD MAINTENANCE
FUEL TRANSFER PUMP AND SUPPLY LINES REPLACEMENT (M939A2)**

INITIAL SETUP:**Tools and Special Tools**

Tool Kit, General Mechanic's: Automotive
(Volume 5, WP 0826, Table 1, Item 56)

References

WP 0239
Volume 5, WP 0819

Materials/Parts

Tape, Antiseizing
(Volume 5, WP 0825, Table 1, Item 65)
Banjo Seal
(Volume 5, WP 0827, Table 1, Item 128)
Qty: 1
Flat Washer
(Volume 5, WP 0827, Table 1, Item 149)
Qty: 2
Flat Washer
(Volume 5, WP 0827, Table 1, Item 153)
Qty: 2
Gasket (Volume 5, WP 0827, Table 1, Item 157)
Qty: 1

Equipment Condition

Parking brake set. (TM 9-2320-272-10)
Hood raised and secured. (TM 9-2320-272-10)

REMOVAL**WARNING**

Diesel fuel is highly flammable. Do not perform fuel system procedures near open flame. Failure to comply may result in injury or death to personnel.

1. Disconnect fuel pressure transducer (Figure 1, Item 1) from wiring harness (Figure 1, Item 2).
2. Remove fuel pressure transducer (Figure 1, Item 1) from adapter (Figure 1, Item 10).
3. Remove adapter (Figure 1, Item 10), two seal washers (Figure 1, Item 11), and fuel supply tube (Figure 1, Item 5) from fuel transfer pump (Figure 1, Item 13). Discard seal washers.
4. Remove fuel supply line (Figure 1, Item 16) from elbow (Figure 1, Item 15) on fuel transfer pump (Figure 1, Item 13).
5. Remove two screws (Figure 1, Item 14), transfer pump (Figure 1, Item 13), and gasket (Figure 1, Item 12) from engine block (Figure 1, Item 17). Discard gasket.
6. Remove elbow (Figure 1, Item 15) from fuel transfer pump (Figure 1, Item 13).

NOTE

Perform Steps (7) and (8) if fuel supply tube is damaged.

7. Remove screw (Figure 1, Item 8), banjo seal (Figure 1, Item 9), and fuel drain manifold (Figure 1, Item 7) from adapter (Figure 1, Item 6). Discard banjo seal.
8. Remove adapter (Figure 1, Item 6), two seal washers (Figure 1, Item 4), and fuel supply tube (Figure 1, Item 5) from fuel filter head (Figure 1, Item 3). Discard seal washers.

REMOVAL - Continued

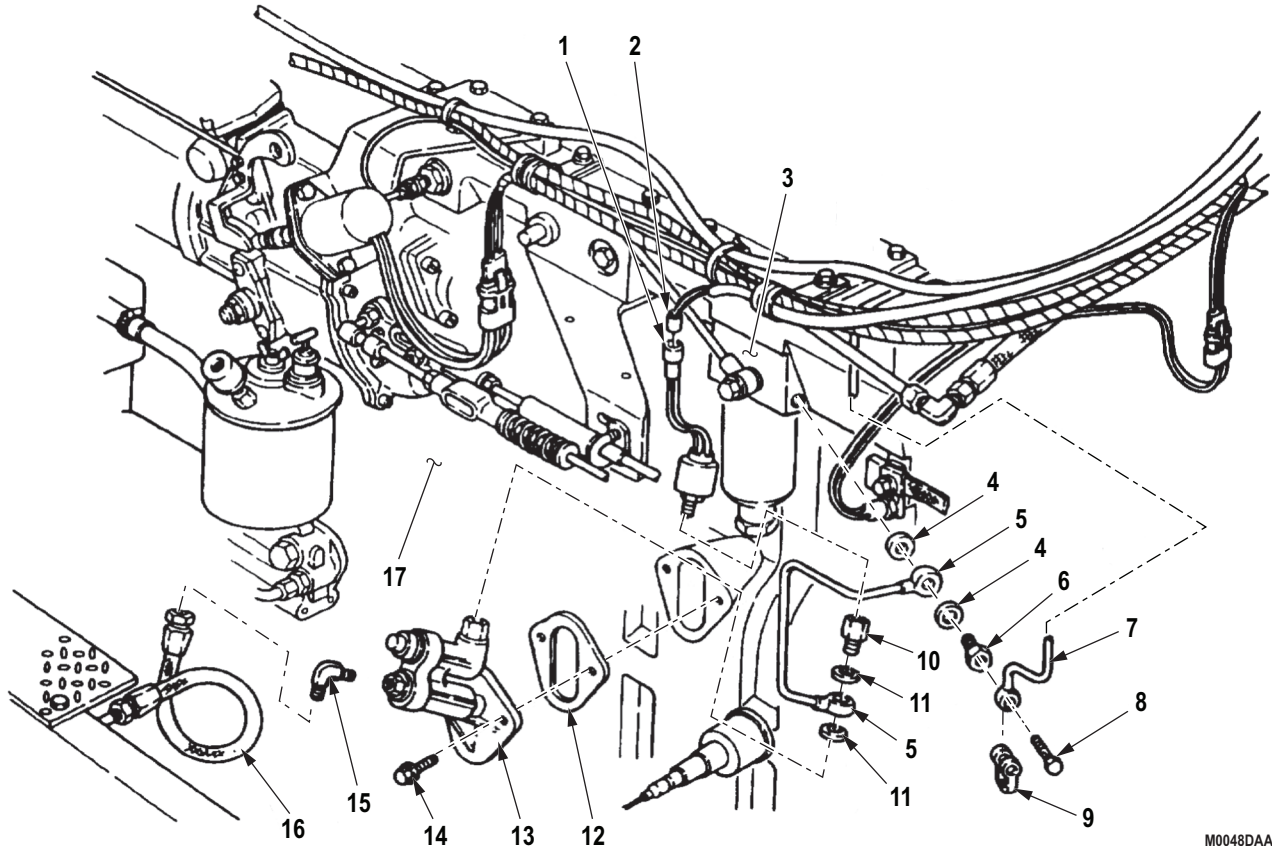

M0048DAA

Figure 1. Fuel Transfer Pump and Supply Lines Removal.

END OF TASK

CLEANING AND INSPECTION

1. For General Cleaning Instructions, refer to (Volume 5, WP 0819).
2. For General Inspection Instructions, refer to (Volume 5, WP 0819).
3. Replace all parts failing inspection.

END OF TASK

INSTALLATION

1. Apply antiseize tape to threads of elbow (Figure 2, Item 15) and install elbow on fuel transfer pump (Figure 2, Item 13).
2. Install gasket (Figure 2, Item 12) and fuel transfer pump (Figure 2, Item 13) on engine block (Figure 2, Item 17) with two screws (Figure 2, Item 14).
3. Connect fuel supply line (Figure 2, Item 16) to elbow (Figure 2, Item 15) on fuel transfer pump (Figure 2, Item 13).
4. Install fuel supply tube (Figure 2, Item 5) on fuel transfer pump (Figure 2, Item 13) with two seal washers (Figure 2, Item 11) and adapter (Figure 2, Item 10). Finger-tighten adapter.

NOTE

Perform Steps (5) through (7) if fuel supply tube was removed.

5. Install fuel supply tube (Figure 2, Item 5) on fuel filter head (Figure 2, Item 3) with two seal washers (Figure 2, Item 4) and adapter (Figure 2, Item 6).
6. Tighten adapter (Figure 2, Item 10).
7. Place banjo seal (Figure 2, Item 9) around fuel drain manifold (Figure 2, Item 7) and install on adapter (Figure 2, Item 6) with screw (Figure 2, Item 8).
8. Apply antiseize tape to threads on fuel pressure transducer (Figure 2, Item 1) and install fuel pressure transducer on adapter (Figure 2, Item 10).
9. Connect wiring harness (Figure 2, Item 2) to fuel pressure transducer (Figure 2, Item 1).

INSTALLATION - Continued

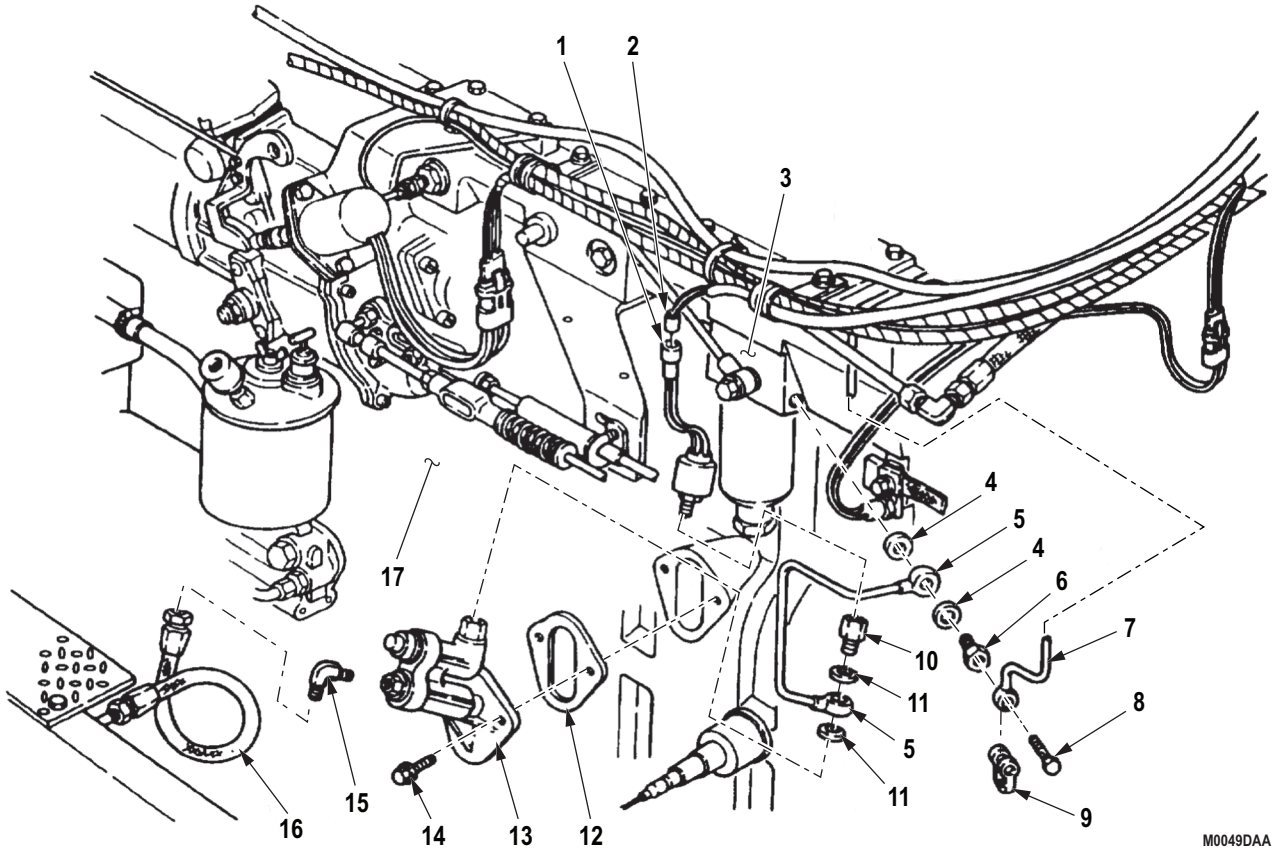

M0049DAA

Figure 2. Fuel Transfer Pump and Supply Lines Installation.

END OF TASK

FOLLOW-ON MAINTENANCE

Prime fuel system. (WP 0239)

END OF TASK

END OF WORK PACKAGE

FIELD MAINTENANCE
AIR FUEL CONTROL (AFC) TUBE REPLACEMENT (M939A2)

INITIAL SETUP:**Tools and Special Tools**

Tool Kit, General Mechanic's: Automotive
(Volume 5, WP 0826, Table 1, Item 56)

References

Volume 5, WP 0819

Materials/Parts

Flat Washer
(Volume 5, WP 0827, Table 1, Item 155)
Qty: 1

Equipment Condition

Parking brake set. (TM 9-2320-272-10)
Hood raised and secured. (TM 9-2320-272-10)

REMOVAL

1. Disconnect AFC tube (Figure 1, Item 2) from adapter (Figure 1, Item 1).
2. Remove screw (Figure 1, Item 3), two seal washers (Figure 1, Item 4), and AFC tube (Figure 1, Item 2) from fuel pump (Figure 1, Item 5). Discard seal washers.

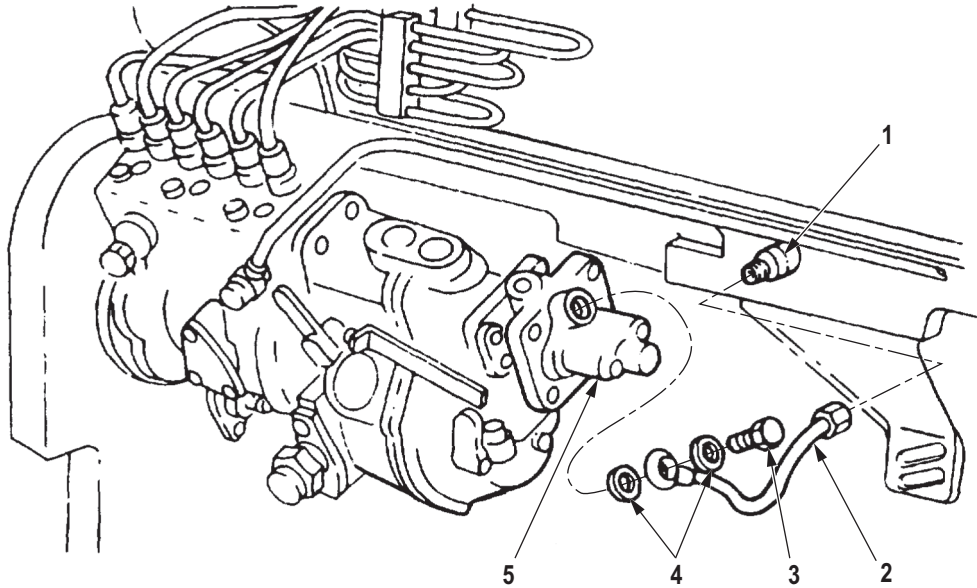

M0044DAA

Figure 1. Air Fuel Control Tube Removal.

END OF TASK**INSPECTION**

1. For General Inspection Instructions, refer to (Volume 5, WP 0819).
2. Replace all parts failing inspection.

END OF TASK**INSTALLATION**

1. Install AFC tube (Figure 2, Item 2) on fuel pump (Figure 2, Item 5) with two seal washers (Figure 2, Item 4) and screw (Figure 2, Item 3).
2. Connect AFC tube (Figure 2, Item 2) to adapter (Figure 2, Item 1).

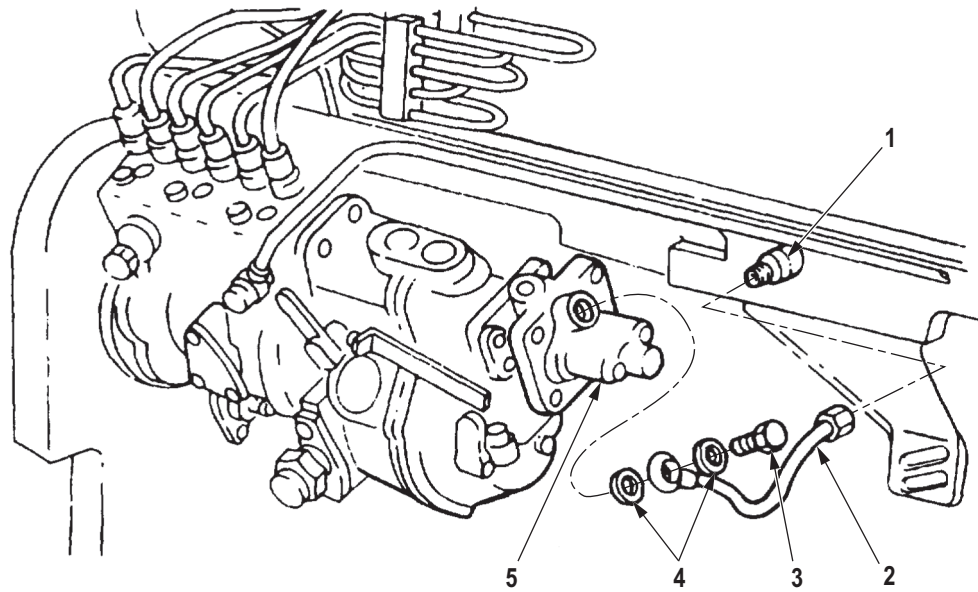
INSTALLATION - Continued

M0045DAA

Figure 2. Air Fuel Control Tube Installation.

END OF TASK**FOLLOW-ON MAINTENANCE**

Start engine and check for leaks. (TM 9-2320-272-10)

END OF TASK**END OF WORK PACKAGE**

FIELD MAINTENANCE
AIR CLEANER ASSEMBLY AND MOUNTING BRACKET REPLACEMENT

INITIAL SETUP:**Tools and Special Tools**

Tool Kit, General Mechanic's: Automotive
(Volume 5, WP 0826, Table 1, Item 56)

Personnel Required

(2)

Materials/Parts

Locknut (Volume 5, WP 0827, Table 1, Item 277)
Qty: 3
Lockwasher
(Volume 5, WP 0827, Table 1, Item 186)
Qty: 5

Equipment Condition

Parking brake set. (TM 9-2320-272-10)

REMOVAL**WARNING**

If NBC exposure is suspected, all air filter media should be handled by personnel wearing protective equipment. Consult your unit NBC officer or NBC NCO for appropriate handling caution or disposal instructions. Failure to comply may result in injury or death to personnel.

1. Loosen hose clamps (Figure 1, Items 6 and 12) on air cleaner tube hose (Figure 1, Item 4) and cleaner-to-intake pipe hose (Figure 1, Item 13).
2. Release support strap latch (Figure 1, Item 8) from mounting bracket (Figure 1, Item 5) and air cleaner assembly (Figure 1, Item 9).
3. Remove two locknuts (Figure 1, Item 1), mounting band (Figure 1, Item 7), and two screws (Figure 1, Item 2) from mounting bracket (Figure 1, Item 3). Discard locknut.

NOTE

Assistant will help with Step (4).

4. Remove air cleaner assembly (Figure 1, Item 9) and hose clamps (Figure 1, Items 6 and 12) from air cleaner tube hose (Figure 1, Item 4) and cleaner-to-intake pipe hose (Figure 1, Item 13).
5. Remove locknut (Figure 1, Item 10), screw (Figure 1, Item 11), mounting band (Figure 1, Item 7), and support strap (Figure 1, Item 8) from air cleaner assembly (Figure 1, Item 9). Discard locknut.

NOTE

Floor mat must be pulled back to gain access to one screw.

6. Remove two screws (Figure 1, Item 17), lockwashers (Figure 1, Item 15), and mounting bracket (Figure 1, Item 3) from mounting bracket (Figure 1, Item 5) and subfloor (Figure 1, Item 18). Discard lockwashers.
7. Remove three screws (Figure 1, Item 14), lockwashers (Figure 1, Item 15), and mounting bracket (Figure 1, Item 5) from cab floor (Figure 1, Item 16). Discard lockwashers.

REMOVAL - Continued

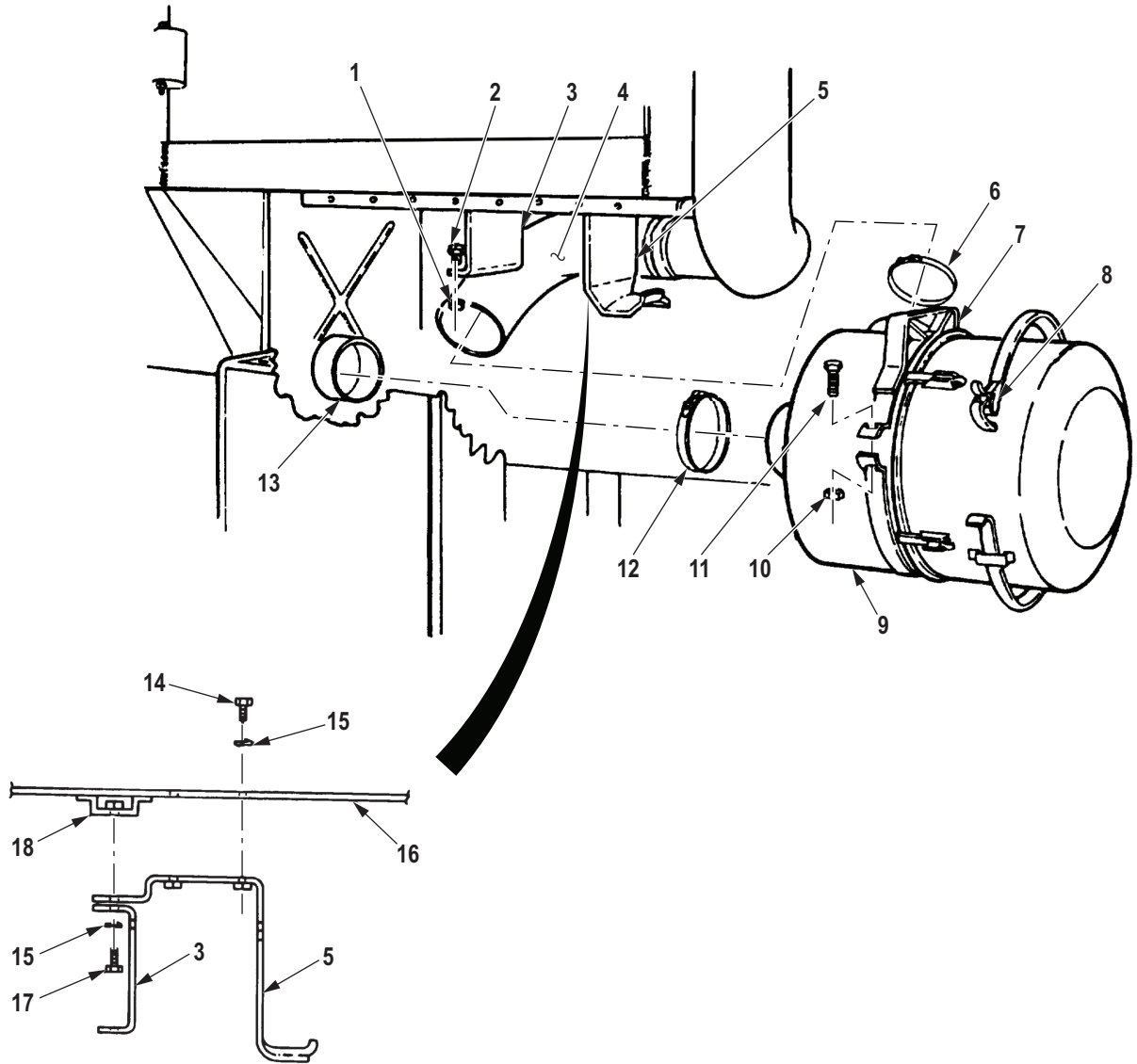

M0038DAA

Figure 1. Air Cleaner Removal.

END OF TASK

DISASSEMBLY

1. Release five latches (Figure 2, Item 1) securing air cleaner body (Figure 2, Item 2) to air cleaner manifold (Figure 2, Item 5).
2. Remove air cleaner body (Figure 2, Item 2) from air cleaner manifold (Figure 2, Item 5).
3. Remove filter element (Figure 2, Item 4) from air cleaner manifold (Figure 2, Item 5).
4. Remove preformed packing (Figure 2, Item 3) from air cleaner body (Figure 2, Item 2). Discard preformed packing.

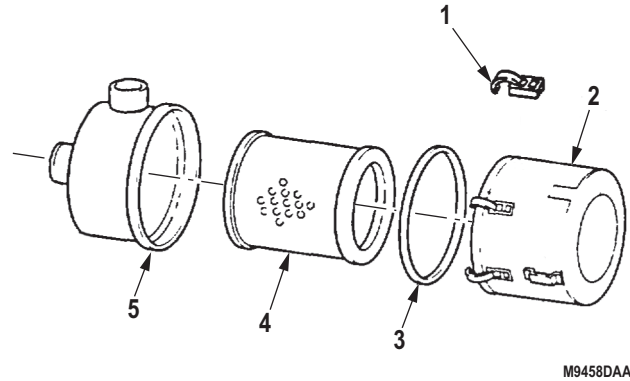

Figure 2. Air Cleaner Disassembly.

END OF TASK**INSPECTION**

1. Inspect air cleaner assembly for cracks and splits that would allow unfiltered air to enter. Replace if cracked or split.
2. Inspect preformed packing for tears, wear, or damage. If damaged, discard preformed packing.
3. Inspect filter element for tears, wear or damage. If damaged, replace filter element. To clean filter element, hold filter element so open end faces ground.

CAUTION

Do not strike ends of filter element on hard surface damage will result.

4. Gently tap completely around element with hand to free tapped dirt.

END OF TASK

ASSEMBLY

1. Install clean filter element (Figure 3, Item 4) in air cleaner manifold (Figure 3, Item 5) with closed end of element facing outward.
2. Install preformed packing (Figure 3, Item 3) in air cleaner body (Figure 3, Item 2).
3. Install air cleaner body (Figure 3, Item 2) over filter element (Figure 3, Item 4) with arrows on end of air cleaner body pointing up.
4. Secure air cleaner body (Figure 3, Item 2) to air cleaner manifold (Figure 3, Item 5) with five latches (Figure 3, Item 1).

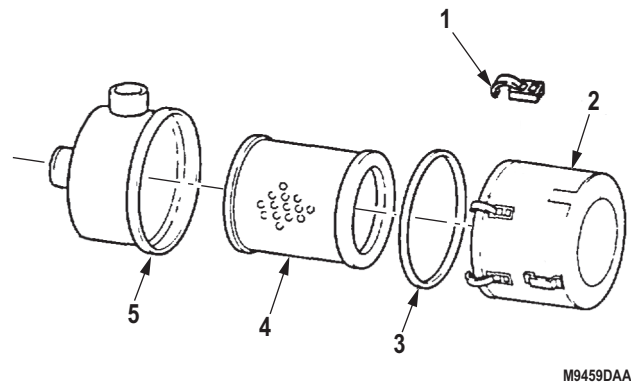

Figure 3. Air Cleaner Assembly.

END OF TASK

INSTALLATION**NOTE**

Floor mat must be pulled back to gain access to one screw hole in Steps (1) and (2).

1. Install mounting bracket (Figure 4, Item 5) on cab floor (Figure 4, Item 16) with three lockwashers (Figure 4, Item 15) and screws (Figure 4, Item 14).
2. Install mounting bracket (Figure 4, Item 3) on mounting bracket (Figure 4, Item 5) and subfloor (Figure 4, Item 18) with two lockwashers (Figure 4, Item 15) and screws (Figure 4, Item 17).
3. Install mounting band (Figure 4, Item 7) on air cleaner assembly (Figure 4, Item 9) with screw (Figure 4, Item 11) and locknut (Figure 4, Item 10).
4. Position support strap (Figure 4, Item 8) on air cleaner assembly (Figure 4, Item 9).

NOTE

Assistant will help with Step (5).

5. Position hose clamps (Figure 4, Items 6 and 12) on air cleaner tube hose (Figure 4, Item 4) and cleaner-to-intake pipe hose (Figure 4, Item 13), and install air cleaner assembly (Figure 4, Item 9) on air cleaner tube hose and cleaner-to-intake pipe hose with hose clamps.
6. Install air cleaner assembly (Figure 4, Item 9) on mounting brackets (Figure 4, Items 3 and 5) with support strap (Figure 4, Item 8), two screws (Figure 4, Item 2), mounting band (Figure 4, Item 7), and two locknuts (Figure 4, Item 1). Fasten support strap (Figure 4, Item 8).
7. Tighten hose clamps (Figure 4, Items 6 and 12).

INSTALLATION - Continued

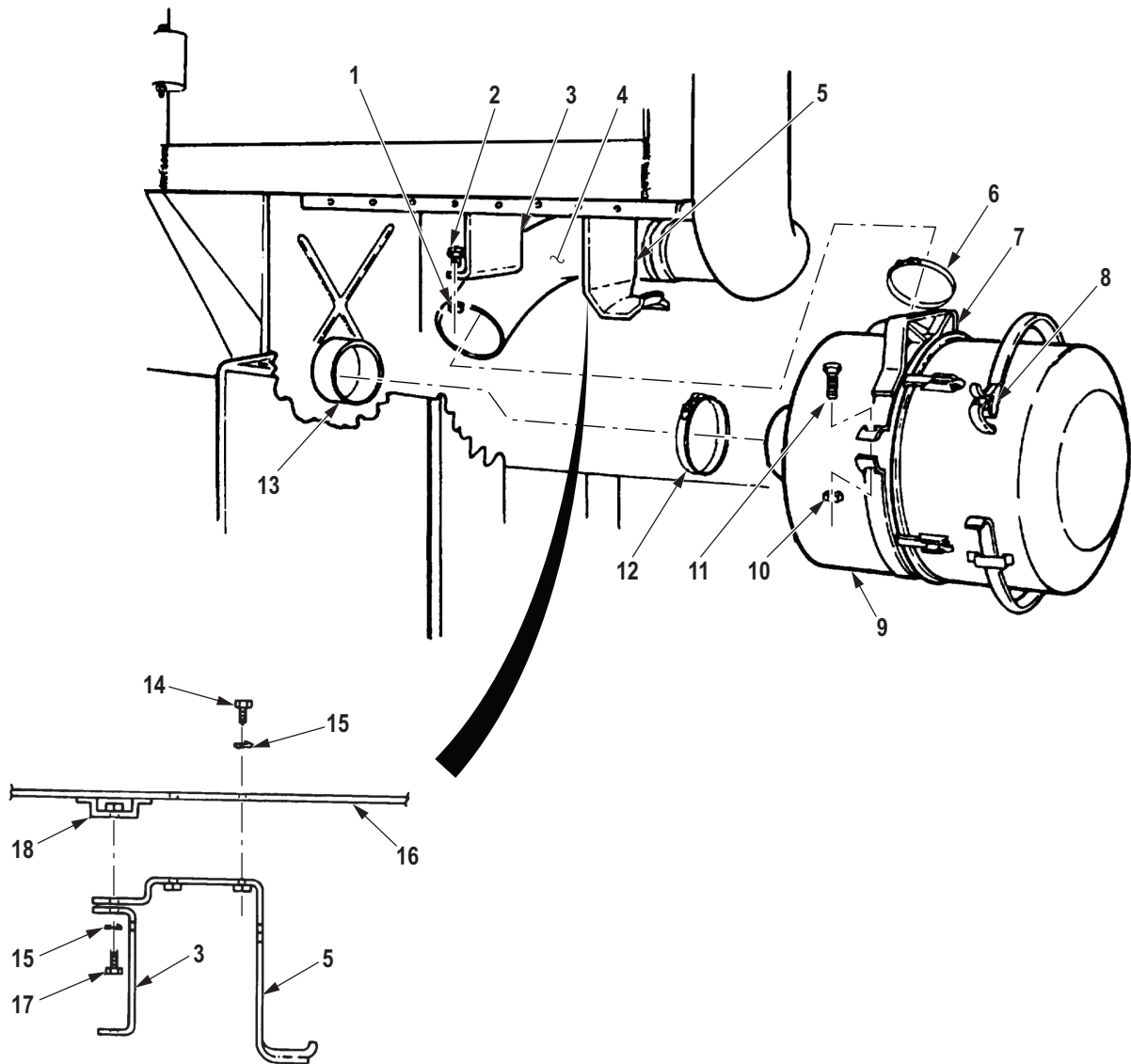

M0039DAA

Figure 4. Air Cleaner Installation.

END OF TASK

FOLLOW-ON MAINTENANCE

1. Start engine and check for air leaks. (TM 9-2320-272-10)
2. Ensure air filter indicator in cab indicates green. (TM 9-2320-272-10)

END OF TASK

END OF WORK PACKAGE

FIELD MAINTENANCE
AIR CLEANER INTAKE PIPE REPLACEMENT (M939/A1)

INITIAL SETUP:**Tools and Special Tools**

Tool Kit, General Mechanic's: Automotive
(Volume 5, WP 0826, Table 1, Item 56)

Equipment Condition (cont.)

Hood raised and secured. (TM 9-2320-272-10)
Left splash shield removed. (TM 9-2320-272-10)
Ether valve and bracket removed. (WP 0263)

Materials/Parts

Locknut (Volume 5, WP 0827, Table 1, Item 277)
Qty: 3

Personnel Required

(2)

Equipment Condition

Parking brake set. (TM 9-2320-272-10)

REMOVAL

1. Remove locknut (Figure 1, Item 18), air intake clamp (Figure 1, Item 23), screw (Figure 1, Item 6), and harness cable clamp (Figure 1, Item 7) from hanger strap (Figure 1, Item 16). Discard locknut.
2. Loosen hose clamps (Figure 1, Items 5 and 21) and remove air intake pipe (Figure 1, Item 22) and hose clamps from lower hose (Figure 1, Item 20) and upper pump hose (Figure 1, Item 4).
3. Loosen hose clamp (Figure 1, Item 3) and remove upper hose (Figure 1, Item 4) and hose clamp from air intake manifold (Figure 1, Item 2).
4. Loosen hose clamp (Figure 1, Item 19) and remove lower hose (Figure 1, Item 20) and hose clamp from air cleaner (Figure 1, Item 17).
5. Remove locknut (Figure 1, Item 10), washer (Figure 1, Item 11), hanger strap (Figure 1, Item 16), and screw (Figure 1, Item 13) from mounting bracket (Figure 1, Item 14). Discard locknut.

NOTE

Assistant will help with Step (6).

6. Pull back floor mat (Figure 1, Item 9) in cab (Figure 1, Item 1), and remove locknut (Figure 1, Item 15), mounting bracket (Figure 1, Item 14), and screw (Figure 1, Item 12) from floor (Figure 1, Item 8). Discard locknut.
7. Remove intake clamp (Figure 1, Item 23) from intake pipe (Figure 1, Item 22).

REMOVAL - Continued

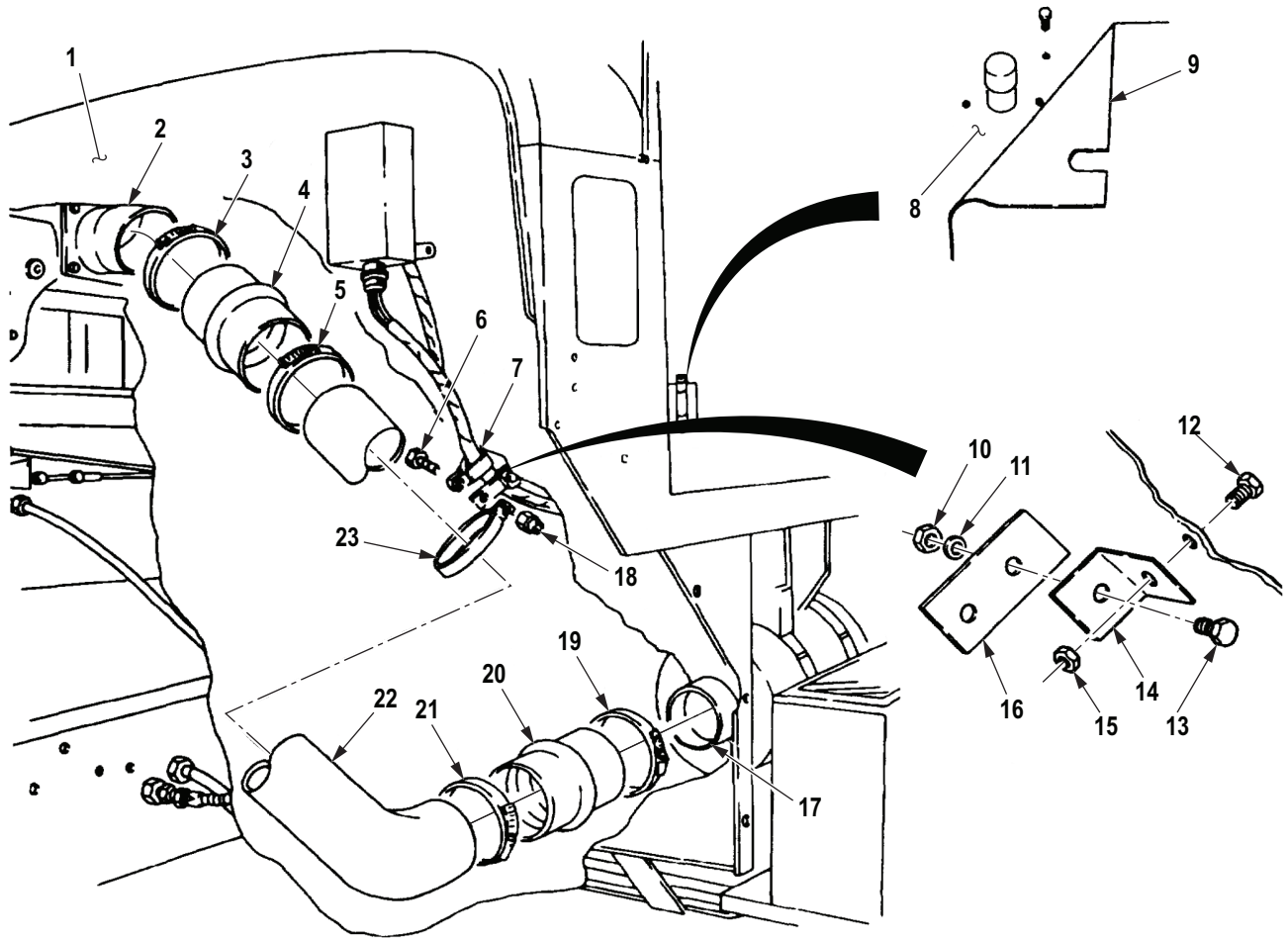

M0036DAA

Figure 1. Air Cleaner Intake Pipe Removal.

END OF TASK

INSPECTION

Inspect hoses and intake pipe for cracks. Replace if cracked.

END OF TASK**INSTALLATION**

1. Install hanger strap (Figure 2, Item 16) on mounting bracket (Figure 2, Item 14) with screw (Figure 2, Item 13), washer (Figure 2, Item 11), and locknut (Figure 2, Item 10).
2. Install mounting bracket (Figure 2, Item 14) on floor (Figure 2, Item 8) in cab (Figure 2, Item 1) with screw (Figure 2, Item 12) and locknut (Figure 2, Item 15). Install floor mat (Figure 2, Item 9).

NOTE

Assistant will help with Step (3).

3. Position hose clamp (Figure 2, Item 19) on lower hose (Figure 2, Item 20), install lower hose on air cleaner (Figure 2, Item 17), and tighten hose clamp.
4. Position hose clamp (Figure 2, Item 3) on upper hose (Figure 2, Item 4), install upper hose on air intake manifold (Figure 2, Item 2) and tighten hose clamp.
5. Position intake pipe clamp (Figure 2, Item 23) over intake pipe (Figure 2, Item 22).

NOTE

Assistant will help with Step (6).

6. Install intake pipe (Figure 2, Item 22) on lower hose (Figure 2, Item 20) and upper hose (Figure 2, Item 4) with hose clamps (Figure 2, Items 5 and 21).
7. Install intake pipe clamp (Figure 2, Item 23) and harness cable clamp (Figure 2, Item 7) on hanger strap (Figure 2, Item 16) with screw (Figure 2, Item 6) and locknut (Figure 2, Item 18).

INSTALLATION - Continued

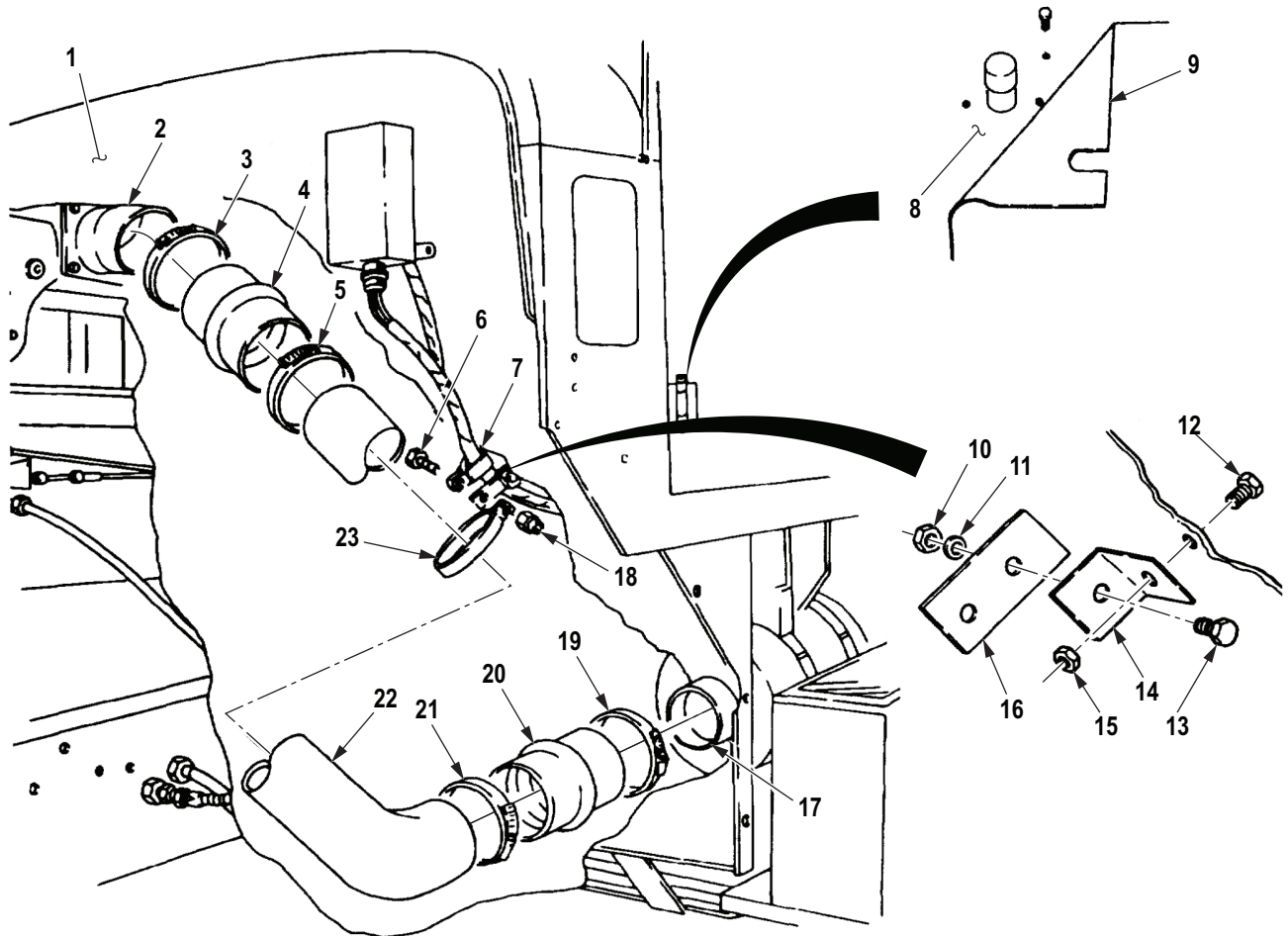

M0037DAA

Figure 2. Air Cleaner Intake Pipe Installation.

END OF TASK

FOLLOW-ON MAINTENANCE

1. Install ether valve and bracket. (WP 0263)
2. Start engine and check for air leaks. (TM 9-2320-272-10)

END OF TASK

END OF WORK PACKAGE

**FIELD MAINTENANCE
AIR CLEANER INDICATOR AND TUBE REPLACEMENT**

INITIAL SETUP:**Tools and Special Tools**

Tool Kit, General Mechanic's: Automotive
(Volume 5, WP 0826, Table 1, Item 56)

Equipment Condition (cont.)

Hood raised and secured. (TM 9-2320-272-10)
Left splash shield removed. (TM 9-2320-272-10)

Materials/Parts

Tape, Antiseizing
(Volume 5, WP 0825, Table 1, Item 65)
Locknut (Volume 5, WP 0827, Table 1, Item 282)
Qty: 2

Equipment Condition

Parking brake set. (TM 9-2320-272-10)

REMOVAL M939A2

1. Remove clamp (Figure 1, Item 2) and air cleaner indicator tube (Figure 1, Item 1) from connector (Figure 1, Item 3).
2. Remove connector (Figure 1, Item 3) and filter (Figure 1, Item 4) from air tube (Figure 1, Item 14).
3. Remove four screws (Figure 1, Item 8) and plate (Figure 1, Item 7) from instrument panel (Figure 1, Item 13).
4. Remove clamp (Figure 1, Item 10) and indicator tube (Figure 1, Item 1) from air cleaner indicator (Figure 1, Item 9).
5. Remove two locknuts (Figure 1, Item 12), screws (Figure 1, Item 11), and air cleaner indicator (Figure 1, Item 9) from plate (Figure 1, Item 7).
6. Remove indicator tube (Figure 1, Item 1) and grommet (Figure 1, Item 5) from firewall (Figure 1, Item 6).
7. Remove grommet (Figure 1, Item 5) from indicator tube (Figure 1, Item 1).

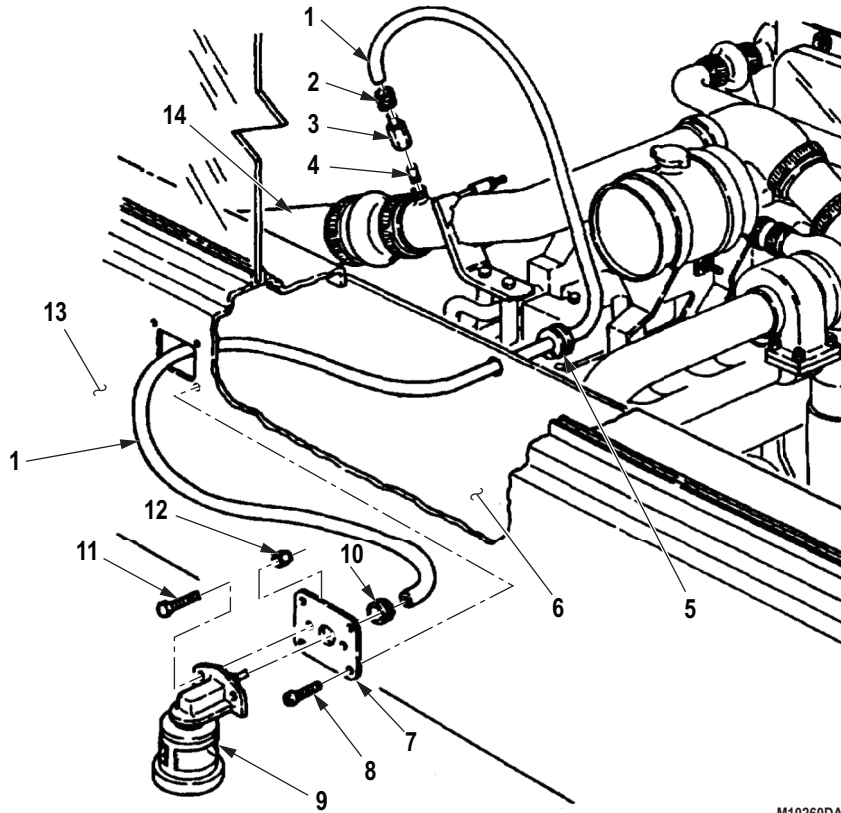

M10260DAA

Figure 1. Air Cleaner Indicator and Tube Removal.

END OF TASK

REMOVAL M939/A1

1. Remove four screws (Figure 2, Item 4), plate (Figure 2, Item 8), and air cleaner indicator (Figure 2, Item 6) from instrument panel (Figure 2, Item 3).
2. Disconnect indicator tube nut (Figure 2, Item 2) from elbow (Figure 2, Item 11).
3. Remove elbow (Figure 2, Item 11) from adapter (Figure 2, Item 9) and adapter from air cleaner indicator (Figure 2, Item 6).
4. Remove two locknuts (Figure 2, Item 10), screws (Figure 2, Item 5), plate (Figure 2, Item 8), and gasket (Figure 2, Item 7) from air cleaner indicator (Figure 2, Item 6). Discard locknuts.
5. Disconnect indicator tube nut (Figure 2, Item 15) from elbow (Figure 2, Item 14).
6. Remove grommet (Figure 2, Item 17) and indicator tube (Figure 2, Item 16) from firewall (Figure 2, Item 1).
7. Remove grommet (Figure 2, Item 17) from indicator tube (Figure 2, Item 16).
8. Remove elbow (Figure 2, Item 14) and filter (Figure 2, Item 13) from intake manifold (Figure 2, Item 12).

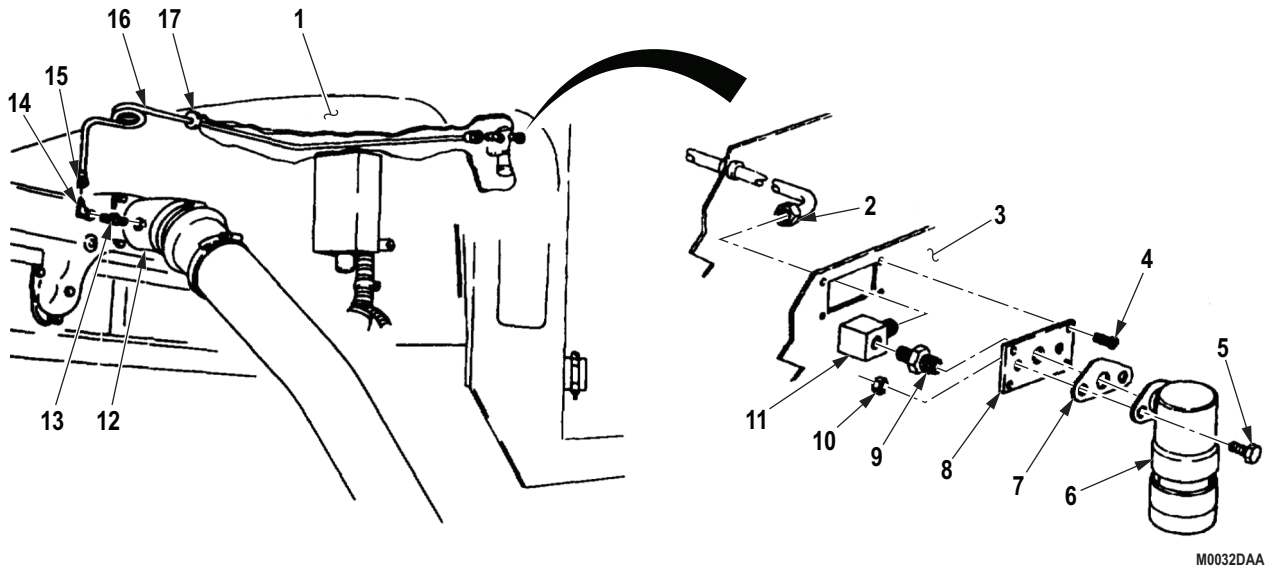

Figure 2. Air Cleaner Indicator and Tube Removal.

END OF TASK

INSTALLATION M939A2

NOTE

Male pipe threads must be wrapped with antiseize tape before installation.

1. Install filter (Figure 3, Item 4) and connector (Figure 3, Item 3) on air tube (Figure 3, Item 14).
2. Install indicator tube (Figure 3, Item 1) on connector (Figure 3, Item 3) with clamp (Figure 3, Item 2).
3. Insert indicator tube (Figure 3, Item 1) through firewall (Figure 3, Item 6).
4. Position grommet (Figure 3, Item 5) on indicator tube (Figure 3, Item 1) and install on firewall (Figure 3, Item 6).
5. Insert indicator tube (Figure 3, Item 1) through instrument panel (Figure 3, Item 13).
6. Install air cleaner indicator (Figure 3, Item 9) on plate (Figure 3, Item 7) with two screws (Figure 3, Item 11) and locknuts (Figure 3, Item 12).
7. Install indicator tube (Figure 3, Item 1) on air cleaner indicator (Figure 3, Item 9) with clamp (Figure 3, Item 10).
8. Install plate (Figure 3, Item 7) and air cleaner indicator (Figure 3, Item 9) on instrument panel (Figure 3, Item 13) with four screws (Figure 3, Item 8).

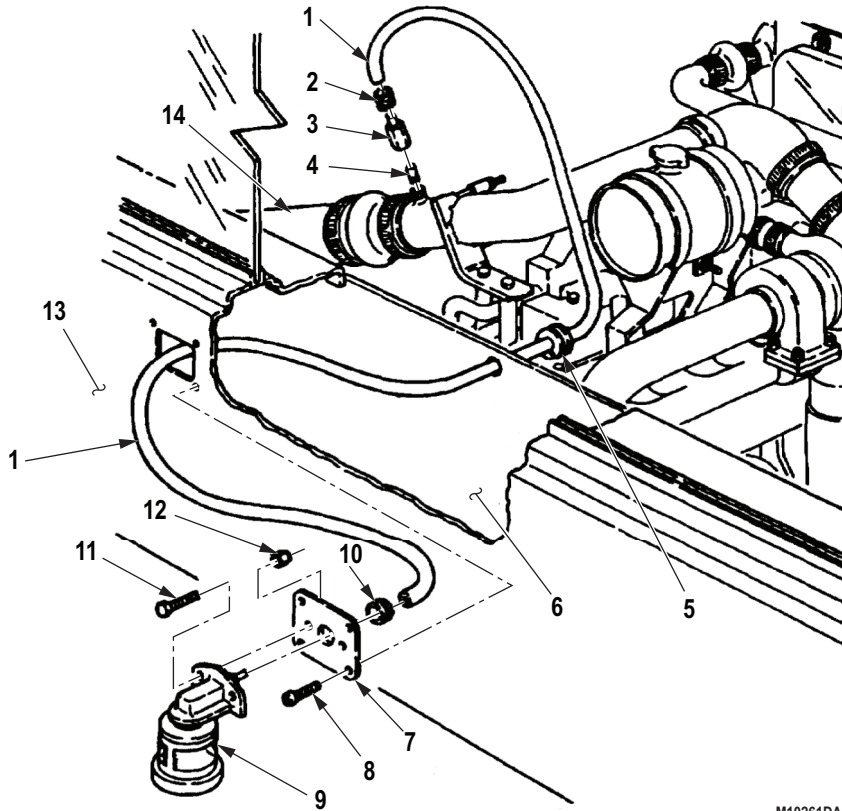

M10261DAA

Figure 3. Air Cleaner Indicator and Tube Installation.

END OF TASK

INSTALLATION M939/A1

1. Install filter (Figure 4, Item 13) and elbow (Figure 4, Item 14) on intake manifold (Figure 4, Item 12).
2. Position grommet (Figure 4, Item 17) on indicator tube (Figure 4, Item 16), and install indicator tube (Figure 4, Item 16) and grommet through firewall (Figure 4, Item 1).
3. Connect indicator tube nut (Figure 4, Item 2) to elbow (Figure 4, Item 11).
4. Install adapter (Figure 4, Item 9) on elbow (Figure 4, Item 11).
5. Install plate (Figure 4, Item 8) and gasket (Figure 4, Item 7) over adapter (Figure 4, Item 9).
6. Install air cleaner indicator (Figure 4, Item 6) on adapter (Figure 4, Item 9).
7. Install air cleaner indicator (Figure 4, Item 6) on gasket (Figure 4, Item 7) and plate (Figure 4, Item 8) with two screws (Figure 4, Item 5) and locknuts (Figure 4, Item 10).
8. Connect indicator tube nut (Figure 4, Item 15) to elbow (Figure 4, Item 14) and install plate (Figure 4, Item 8) on instrument panel (Figure 4, Item 3) with four screws (Figure 4, Item 4).

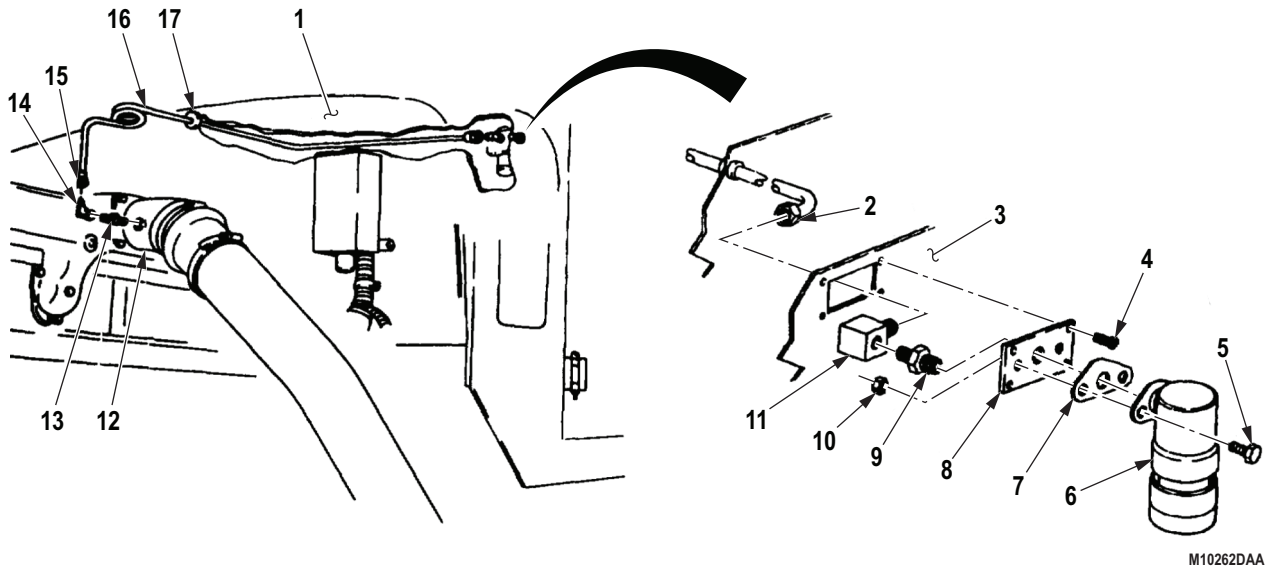

Figure 4. Air Cleaner Indicator and Tube Installation.

END OF TASK

FOLLOW-ON MAINTENANCE

Install left splash shield. (TM 9-2320-272-10)

END OF TASK

END OF WORK PACKAGE

**FIELD MAINTENANCE
AIR CLEANER HOSE MAINTENANCE (M939A2)**

INITIAL SETUP:**Tools and Special Tools**

Tool Kit, General Mechanic's: Automotive
(Volume 5, WP 0826, Table 1, Item 56)

Equipment Condition (cont.)

Hood raised and secured. (TM 9-2320-272-10)

Materials/Parts

Tiedown Strap
(Volume 5, WP 0827, Table 1, Item 378)
Qty: 1

Equipment Condition

Parking brake set. (TM 9-2320-272-10)

REMOVAL

1. Remove clamp (Figure 1, Item 3) and air indicator tube (Figure 1, Item 1) from connector (Figure 1, Item 4).
2. Remove connector (Figure 1, Item 4) from nipple (Figure 1, Item 2).
3. Remove tiedown strap (Figure 1, Item 17) and tachometer drive cable (Figure 1, Item 18) from air intake ducting (Figure 1, Item 7). Discard tiedown strap.
4. Remove two nuts (Figure 1, Item 6), bracket (Figure 1, Item 5), and U-bolt (Figure 1, Item 14) from air intake ducting (Figure 1, Item 7) and support bracket (Figure 1, Item 13).

NOTE

Tag spacers for installation.

5. Remove two screws (Figure 1, Item 15), washers (Figure 1, Item 16), support bracket (Figure 1, Item 13), and two spacers (Figure 1, Item 12) from cylinder head (Figure 1, Item 10).
6. Remove two clamps (Figure 1, Item 8) and air intake ducting (Figure 1, Item 7) from turbocharger (Figure 1, Item 9) and pipe (Figure 1, Item 11).

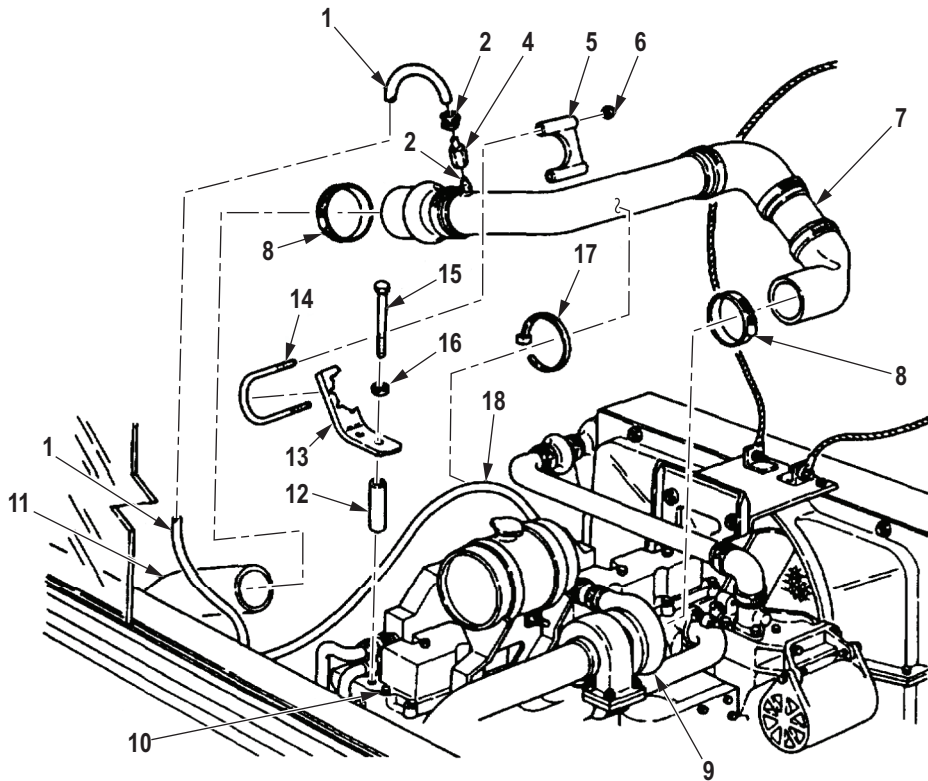

M0034DAA

Figure 1. Air Cleaner Hose Removal.

END OF TASK

DISASSEMBLY

1. Remove clamp (Figure 2, Item 9) and hose (Figure 2, Item 8) from tube (Figure 2, Item 1).
2. Remove clamp (Figure 2, Item 2) and tube (Figure 2, Item 1) from elbow (Figure 2, Item 3).
3. Remove clamp (Figure 2, Item 4) and elbow (Figure 2, Item 3) from tube (Figure 2, Item 5).
4. Remove clamp (Figure 2, Item 6) and tube (Figure 2, Item 5) from elbow (Figure 2, Item 7).

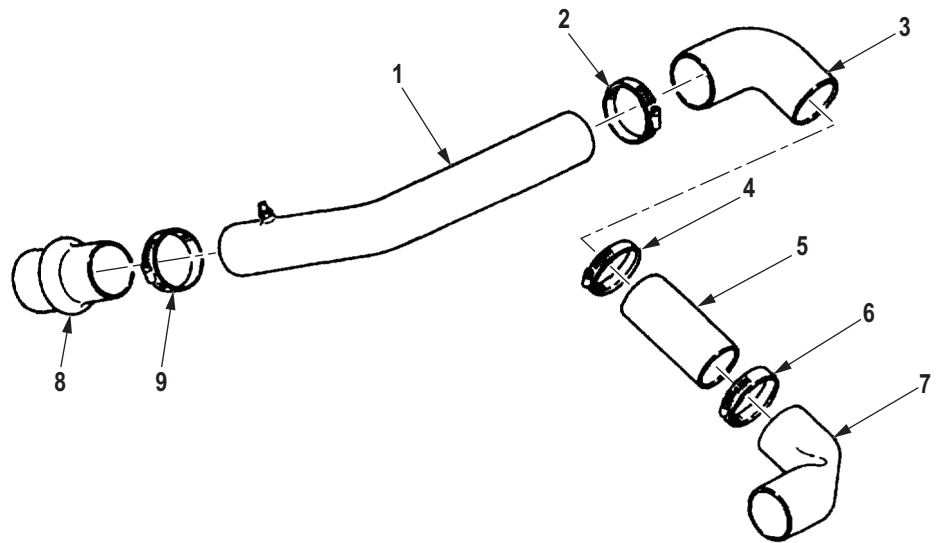

M9460DAA

Figure 2. Air Cleaner Hose Disassembly.

END OF TASK**INSPECTION**

1. Inspect tubes for cracks and dents. Replace tube if cracked or dented.
2. Inspect elbows for cracks and dents. Replace elbow if cracked or dented.

END OF TASK

ASSEMBLY

1. Install tube (Figure 3, Item 5) on elbow (Figure 3, Item 7) with clamp (Figure 3, Item 6). Do not tighten clamp.
2. Install elbow (Figure 3, Item 3) on tube (Figure 3, Item 5) with clamp (Figure 3, Item 4). Do not tighten clamp.
3. Install tube (Figure 3, Item 1) on elbow (Figure 3, Item 3) with clamp (Figure 3, Item 2). Do not tighten clamp.
4. Install hose (Figure 3, Item 8) on tube (Figure 3, Item 1) with clamp (Figure 3, Item 9). Do not tighten clamp.

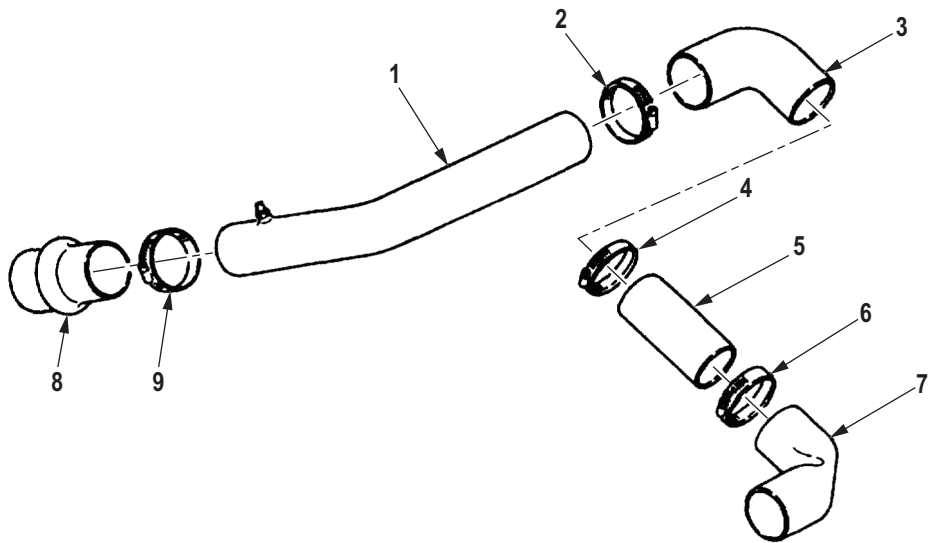

M9461DAA

Figure 3. Air Cleaner Hose Assembly.

END OF TASK

INSTALLATION

1. Install air intake ducting (Figure 4, Item 7) on turbocharger (Figure 4, Item 9) and pipe (Figure 4, Item 11) with two clamps (Figure 4, Item 8).
2. Install two spacers (Figure 4, Item 12) and support bracket (Figure 4, Item 13) on cylinder head (Figure 4, Item 10) with two washers (Figure 4, Item 16) and screws (Figure 4, Item 15).
3. Install air intake ducting (Figure 4, Item 7) on support bracket (Figure 4, Item 13) with U-bolt (Figure 4, Item 14), bracket (Figure 4, Item 5), and two nuts (Figure 4, Item 6).
4. Install tachometer drive cable (Figure 4, Item 18) on air intake ducting (Figure 4, Item 7) with tiedown strap (Figure 4, Item 17).
5. Install connector (Figure 4, Item 4) on nipple (Figure 4, Item 2).
6. Install air indicator tube (Figure 4, Item 1) on connector (Figure 4, Item 4) with clamp (Figure 4, Item 3).

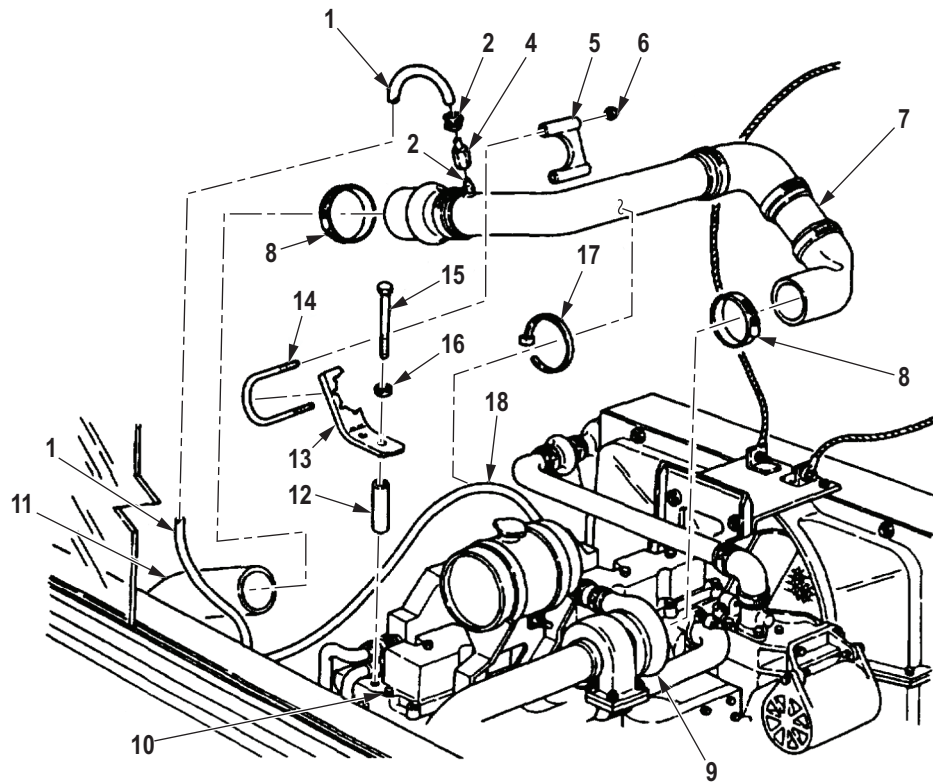

M0035DAA

Figure 4. Air Cleaner Hose Installation.

INSTALLATION - Continued

7. Tighten clamps (Figure 5, Items 1, 2, 3, and 4).

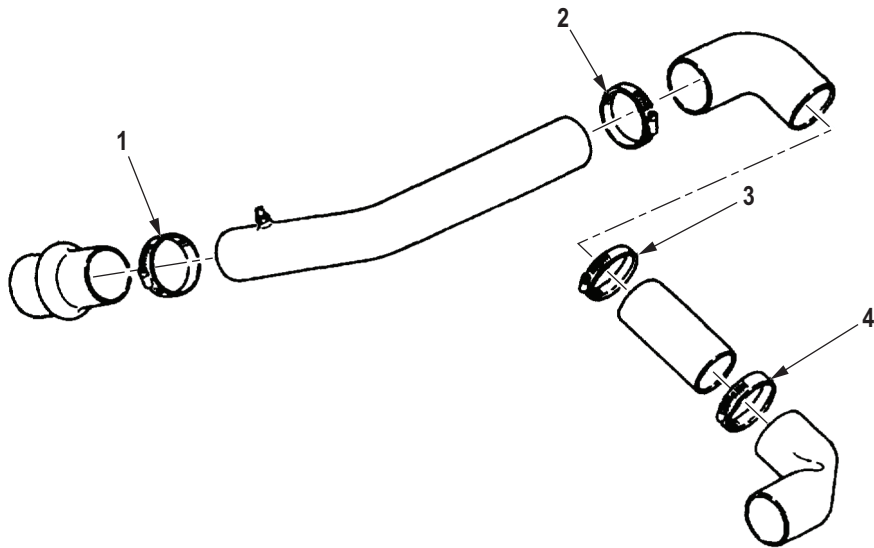

M10032DAA

Figure 5. Air Cleaner Hose Inspection.

END OF TASK

END OF WORK PACKAGE

**FIELD MAINTENANCE
TURBOCHARGER HOSES AND CLAMPS REPLACEMENT (M939A2)**

INITIAL SETUP:**Tools and Special Tools**

Tool Kit, General Mechanic's: Automotive
(Volume 5, WP 0826, Table 1, Item 56)
Wrench, Torque, Click, Ratcheting, 3/8" Drive,
75 Ft-Lb
(Volume 5, WP 0826, Table 1, Item 62)

Materials/Parts

Antiseize Compound
(Volume 5, WP 0825, Table 1, Item 9)
Lubricating Oil, Engine
(Volume 5, WP 0825, Table 1, Item 39, 40, 41,
42)
Tape, Antiseizing
(Volume 5, WP 0825, Table 1, Item 65)

Materials/Parts (cont.)

Gasket (Volume 5, WP 0827, Table 1, Item 137)
Qty: 1
Gasket (Volume 5, WP 0827, Table 1, Item 147)
Qty: 1
O-ring (Volume 5, WP 0827, Table 1, Item 114)
Qty: 1

Equipment Condition

Parking brake set. (TM 9-2320-272-10)
Hood raised and secured. (TM 9-2320-272-10)
Coolant drained. (WP 0287)

REMOVAL

WARNING



Do not touch hot exhaust pipes with bare hands. Severe burns will result. Failure to comply may result in injury or death to personnel.

1. Remove four clamps (Figure 1, Item 1), two hoses (Figure 1, Item 2), and tube (Figure 1, Item 3) from turbocharger (Figure 1, Item 4) and aftercooler (Figure 1, Item 5).

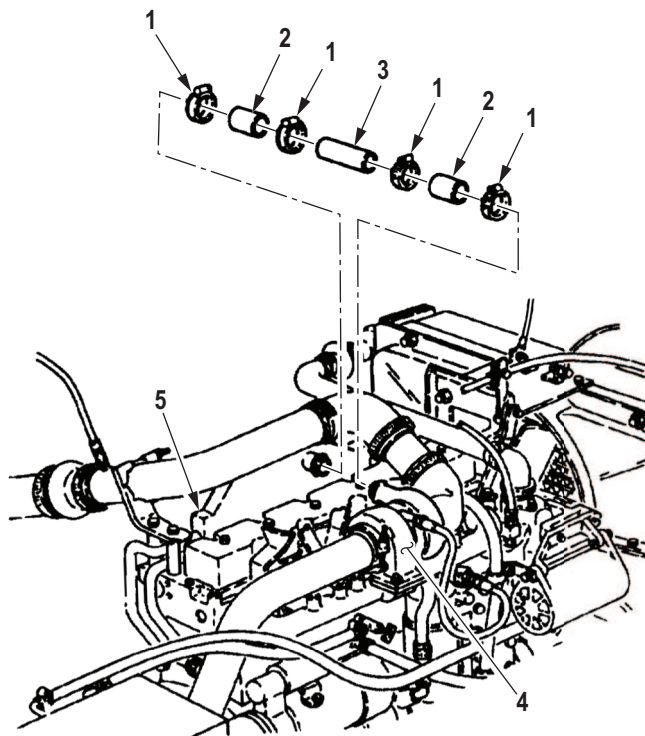

M10244DAA

Figure 1. Turbocharger Hoses and Clamps Removal.

REMOVAL - Continued

2. Remove two screws (Figure 2, Item 2) from oil return tube (Figure 2, Item 3) and turbocharger (Figure 2, Item 8).
3. Remove two clamps (Figure 2, Item 4), oil return tube (Figure 2, Item 3), gasket (Figure 2, Item 1), and hose (Figure 2, Item 5) from tube (Figure 2, Item 6).

NOTE

Perform Step (4) if tube is damaged.

4. Remove tube (Figure 2, Item 6) from engine block (Figure 2, Item 7).

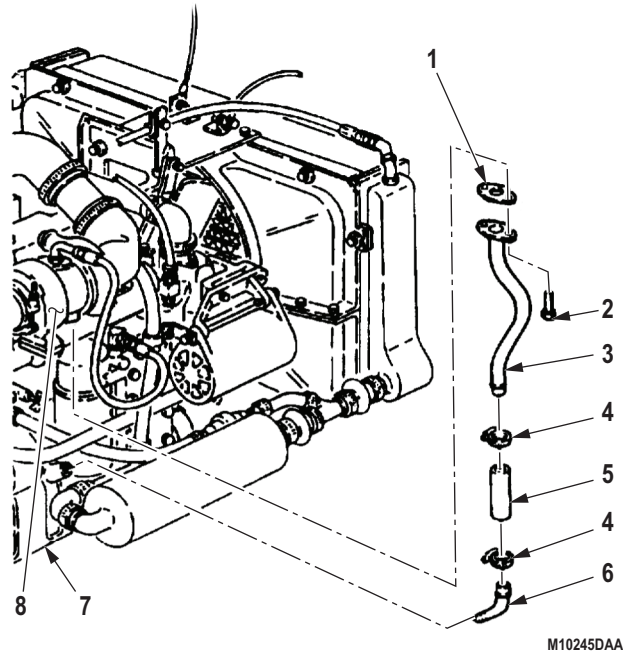
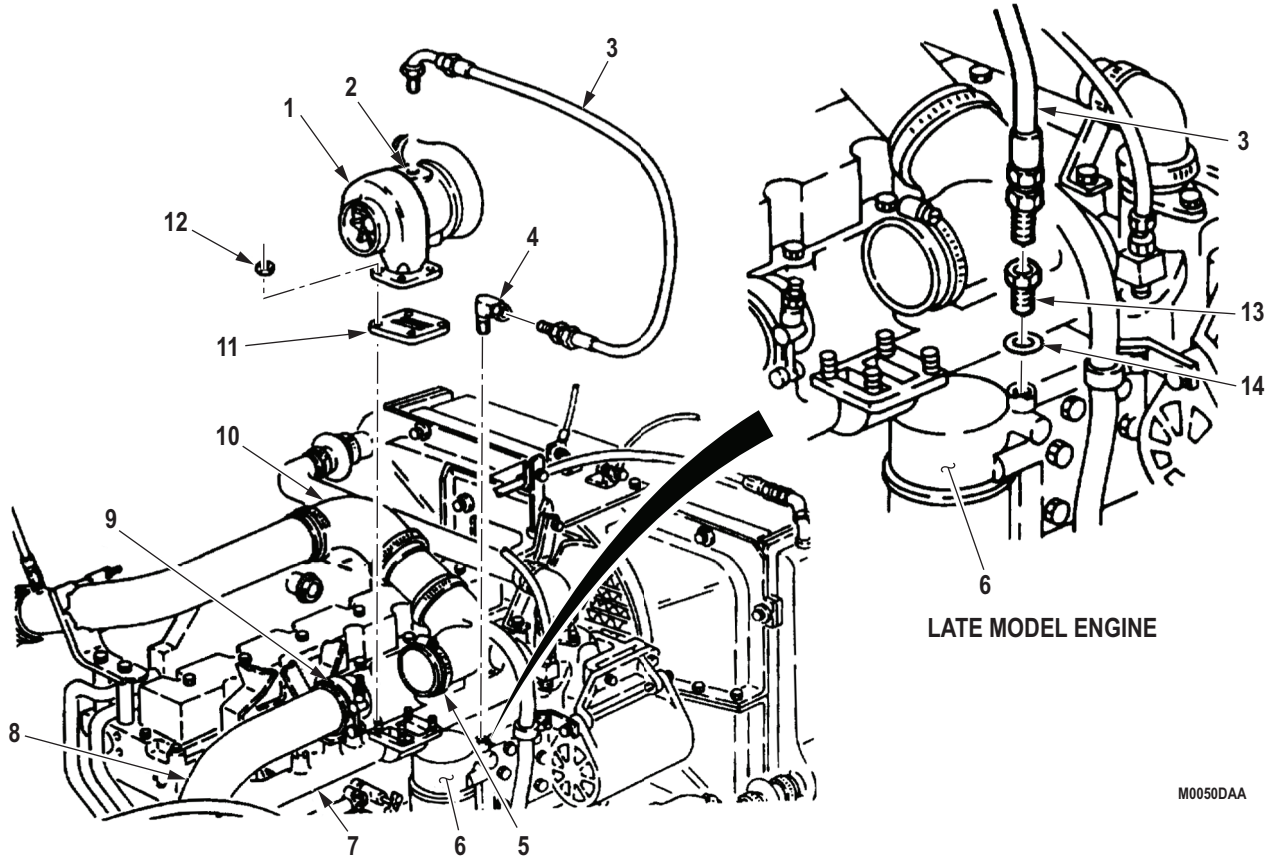

Figure 2. Turbocharger Hoses and Clamps Removal.

REMOVAL - Continued**NOTE**

- Perform Steps (5) and (6) for early model engines.
 - Perform Steps (7) and (8) for late model engines.
5. Remove oil supply hose (Figure 3, Item 3) from turbocharger (Figure 3, Item 1) and connector (Figure 3, Item 4).
 6. Remove connector (Figure 3, Item 4) from oil cooler (Figure 3, Item 6).
 7. Remove oil supply hose (Figure 3, Item 3) from turbocharger oil supply hole (Figure 3, Item 2) and connector (Figure 3, Item 13).
 8. Remove connector (Figure 3, Item 13) and o-ring (Figure 3, Item 14) from oil cooler (Figure 3, Item 6). Discard o-ring.
 9. Loosen clamp (Figure 3, Item 5) and disconnect air intake tube (Figure 3, Item 10) from turbocharger (Figure 3, Item 1).
 10. Loosen clamp (Figure 3, Item 9) and disconnect exhaust pipe (Figure 3, Item 8) from turbocharger (Figure 3, Item 1).
 11. Remove four nuts (Figure 3, Item 12), turbocharger (Figure 3, Item 1), and gasket (Figure 3, Item 11) from exhaust manifold (Figure 3, Item 7). Discard gasket.

REMOVAL - Continued



M0050DAA

Figure 3. Turbocharger Hoses and Clamps Removal.

END OF TASK

INSTALLATION

1. Apply antiseize compound to four mounting studs (Figure 4, Item 6) and install gasket (Figure 4, Item 12) and turbocharger (Figure 4, Item 1) on exhaust manifold (Figure 4, Item 7) with four nuts (Figure 4, Item 13) to 25 lb-ft (34 N·m).

CAUTION

Turbocharger must be lubricated with clean engine oil prior to starting engine, or bearing damage may result.

2. With a small funnel positioned in turbocharger oil supply hole (Figure 4, Item 2), pour 2 to 3 ounces (57 to 85 grams) of clean engine oil into turbocharger (Figure 4, Item 1).
3. Spin impeller/turbine blades (Figure 4, Item 14) by hand to coat bearings with oil.
4. Connect exhaust pipe (Figure 4, Item 8) to turbocharger (Figure 4, Item 1) and tighten clamp (Figure 4, Item 9).
5. Connect air intake tube (Figure 4, Item 11) to turbocharger (Figure 4, Item 1) and tighten clamp (Figure 4, Item 10).

NOTE

- Perform Steps (6) and (7) for early model engines.
 - Perform Steps (8) and (9) for late model engines.
 - Wrap all male pipe threads with antiseize tape before installation.
6. Install connector (Figure 4, Item 4) on oil cooler (Figure 4, Item 5).
 7. Install oil supply hose (Figure 4, Item 3) on turbocharger (Figure 4, Item 1) and connector (Figure 4, Item 4).
 8. Install o-ring (Figure 4, Item 16) and connector (Figure 4, Item 15) on oil cooler (Figure 4, Item 5).
 9. Install oil supply hose (Figure 4, Item 3) on turbocharger (Figure 4, Item 1) and connector (Figure 4, Item 15).

INSTALLATION - Continued

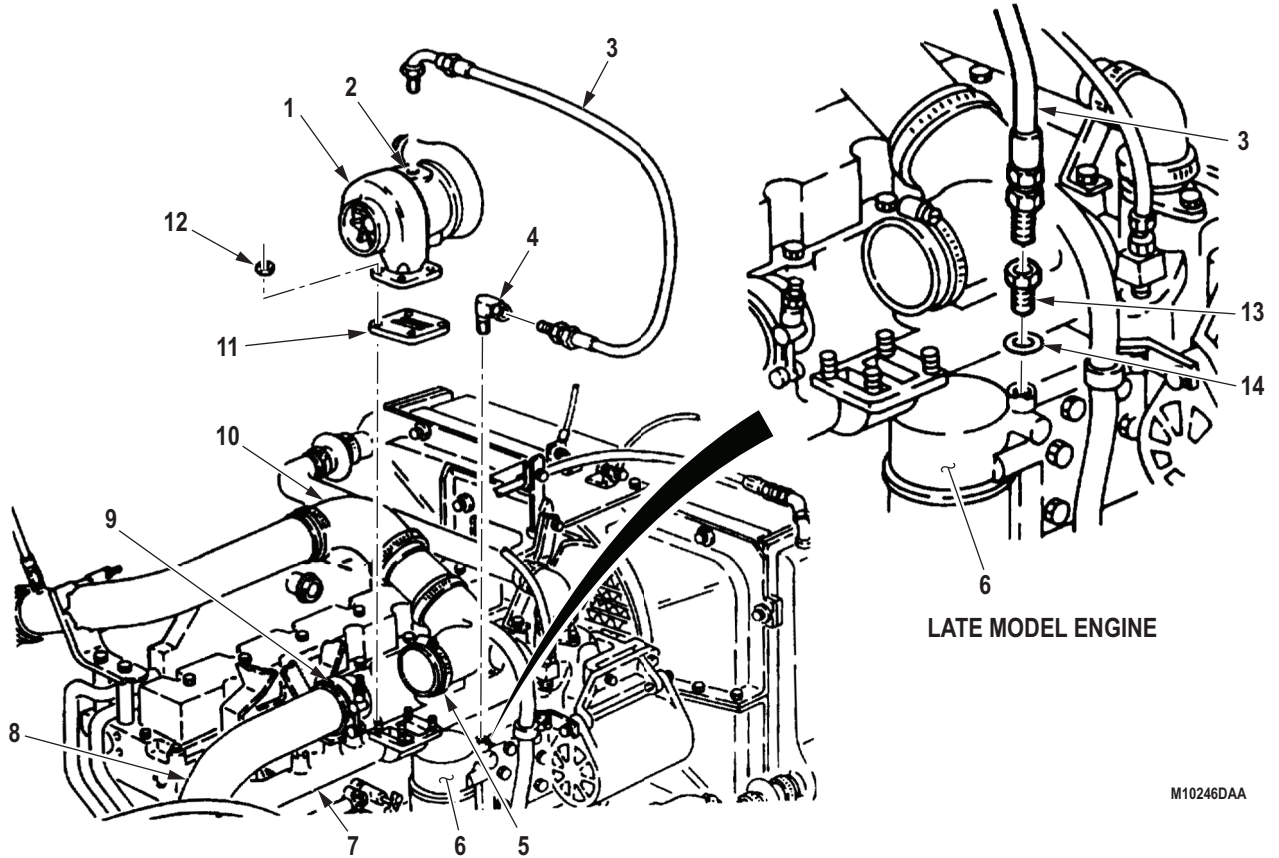

M10246DAA

Figure 4. Turbocharger Hoses and Clamps Installation.

INSTALLATION - Continued**NOTE**

Perform Step (10) if tube was removed.

10. Install tube (Figure 5, Item 6) on engine block (Figure 5, Item 7).
11. Install gasket (Figure 5, Item 1) and oil return tube (Figure 5, Item 3) on turbocharger (Figure 5, Item 8) with two screws (Figure 5, Item 2).
12. Install hose (Figure 5, Item 5) and oil return tube (Figure 5, Item 3) on tube (Figure 5, Item 6) with two clamps (Figure 5, Item 4).

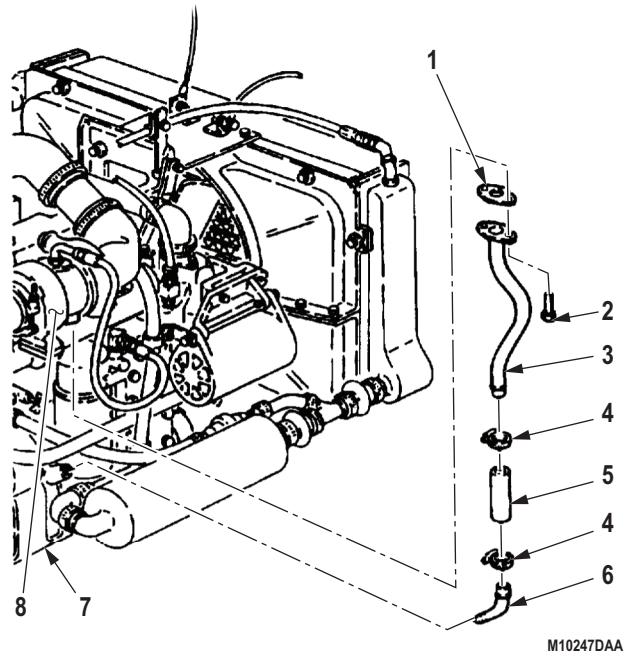
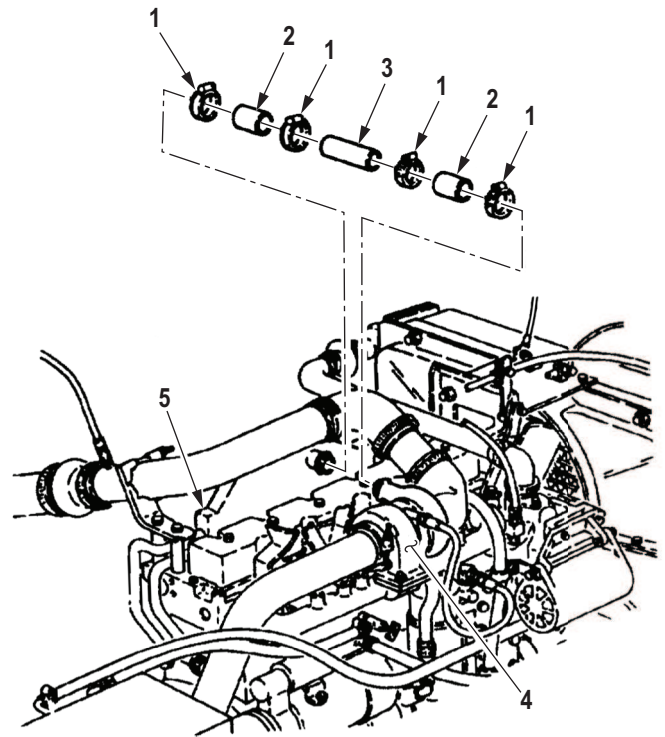

Figure 5. Turbocharger Hoses and Clamps Installation.

INSTALLATION - Continued**CAUTION**

When filling cooling system, ensure drain valve on aftercooler is open. Failure to do so may result in damage to equipment.

13. Install tube (Figure 6, Item 3) and two hoses (Figure 6, Item 2) on aftercooler (Figure 6, Item 5) and turbocharger (Figure 6, Item 4) with four clamps (Figure 6, Item 1).



M0051DAA

Figure 6. Turbocharger Hoses and Clamps Installation.

END OF TASK**FOLLOW-ON MAINTENANCE**

1. Fill coolant system. (WP 0287)
2. Start engine and check turbocharger hoses. (TM 9-2320-272-10)

END OF TASK**END OF WORK PACKAGE**

**FIELD MAINTENANCE
FUEL TANK REPLACEMENT**

INITIAL SETUP:**Tools and Special Tools**

Tool Kit, General Mechanic's: Automotive
(Volume 5, WP 0826, Table 1, Item 56)

References

TC 9-510

Materials/Parts

Tape, Antiseizing
(Volume 5, WP 0825, Table 1, Item 65)
Gasket (Volume 5, WP 0827, Table 1, Item 228)
Qty: 1
Locknut (Volume 5, WP 0827, Table 1, Item 277)
Qty: 4
Washer, Flat
(Volume 5, WP 0827, Table 1, Item 57)
Qty: 1

Equipment Condition

Parking brake set. (TM 9-2320-272-10)
Fuel tank filler cap and spout removed.
(WP 0252)

Personnel Required

(2)

REMOVAL**WARNING**

Diesel fuel is highly flammable. Do not perform fuel system procedures near open flame. Failure to comply may result in injury or death to personnel.

NOTE

- The replacement procedure for right and left single fuel tanks is basically the same. This procedure covers the left fuel tank.
 - Have drainage container ready to catch fuel.
 - Use drain pans to retain leaking/draining fluids. Refer to local procedures and plans for preventing and responding to fluid spills or leaks. Comply with local regulations when disposing of clean up material and leaked and spilled fluids.
1. Remove drain plug (Figure 1, Item 10) and flat washer (Figure 1, Item 9) from bottom of fuel tank (Figure 1, Item 16). Discard flat washer.
 2. After draining is complete, install flat washer (Figure 1, Item 9) and drain plug (Figure 1, Item 10) on bottom of fuel tank (Figure 1, Item 16).

NOTE

Tag lines for installation.

3. Disconnect two vent lines (Figure 1, Item 6) from elbows (Figure 1, Item 7).
4. Disconnect fuel return line (Figure 1, Item 13) from elbow (Figure 1, Item 12).
5. Disconnect fuel supply line (Figure 1, Item 5) from elbow (Figure 1, Item 14).
6. Disconnect fuel transmitter wire (Figure 1, Item 2) from fuel transmitter unit (Figure 1, Item 15).
7. Remove screw (Figure 1, Item 3) and ground wire (Figure 1, Item 4) from fuel tank (Figure 1, Item 16).
8. Remove two locknuts (Figure 1, Item 11) from hanger straps (Figure 1, Item 8). Discard locknuts.
9. Remove two locknuts (Figure 1, Item 22), screws (Figure 1, Item 21), and hanger straps (Figure 1, Item 8) from hangers (Figure 1, Item 1). Discard locknuts.

REMOVAL - Continued

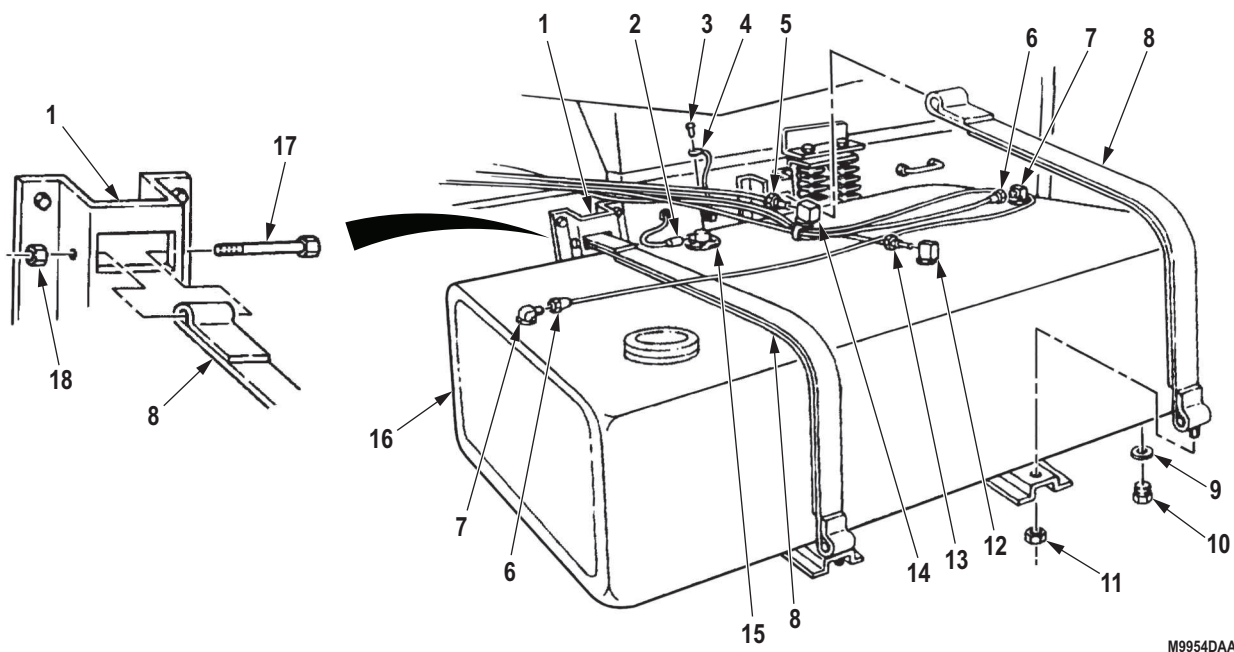

M9954DAA

Figure 1. Fuel Tank Removal.

NOTE

Perform Step (8) for M934/A1/A2 model vehicles.

10. Disconnect personnel heater fuel supply line (Figure 2, Item 1), adapter (Figure 2, Item 3), and fitting (Figure 2, Item 4) from top of fuel tank (Figure 2, Item 2).

NOTE

Assistant will help with Step (9).

11. Remove fuel tank (Figure 2, Item 2) from two hangers (Figure 2, Item 5).

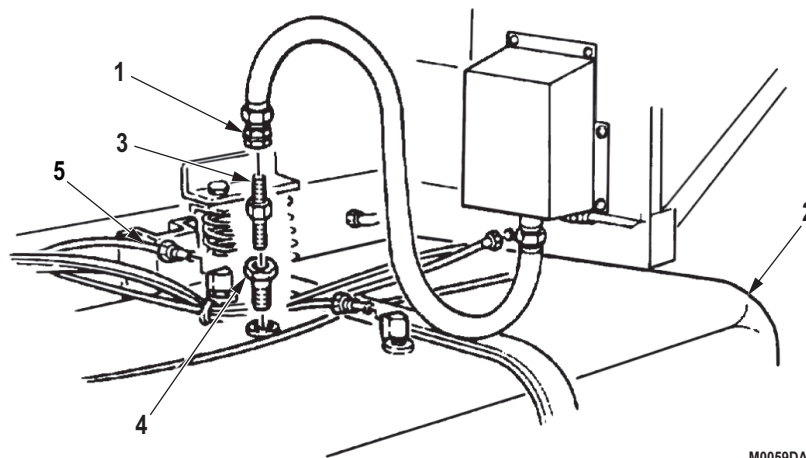

M0059DAA

Figure 2. Fuel Tank Removal.

REMOVAL - Continued**NOTE**

Mark direction of elbows for installation before removing.

12. Remove fuel supply tube and elbow (Figure 3, Item 3) from top of fuel tank (Figure 3, Item 6).
13. Remove two vent line elbows (Figure 3, Item 5) and return line elbow (Figure 3, Item 4) from top of fuel tank (Figure 3, Item 6).
14. Remove four screws (Figure 3, Item 1), fuel transmitter unit (Figure 3, Item 2), and gasket (Figure 3, Item 7) from fuel tank (Figure 3, Item 6). Discard gasket.

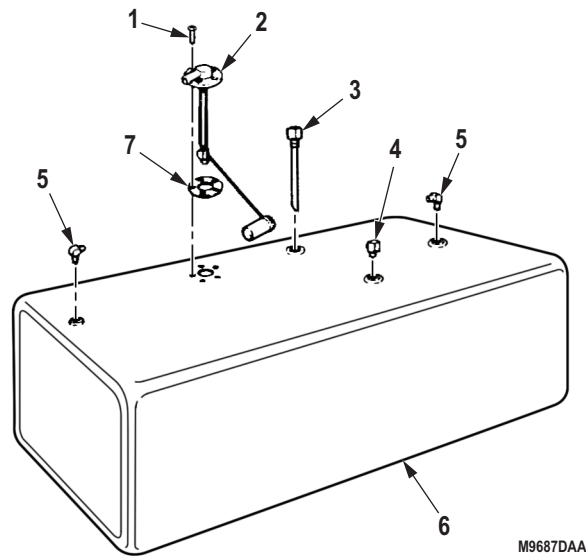

Figure 3. Fuel Tank Fitting Removal.

END OF TASK**INSPECTION**

Inspect fuel tank for cracks, holes, and stripped threads (TC 9-510).

END OF TASK

INSTALLATION**NOTE**

- Male pipe threads must be wrapped with antiseize tape before installation.
 - When installing fuel transmitter unit, do not use screw hole closest to vehicle frame. Ground wire will be installed at that location.
1. Position gasket (Figure 4, Item 7) on fuel transmitter unit (Figure 4, Item 2) and install unit (Figure 4, Item 2) on fuel tank (Figure 4, Item 6) with four screws (Figure 4, Item 1).
 2. Install return line elbow (Figure 4, Item 4) and two vent line elbows (Figure 4, Item 5) on top of fuel tank (Figure 4, Item 6).
 3. Install fuel supply tube with elbow (Figure 4, Item 3) on top of tank (Figure 4, Item 6).

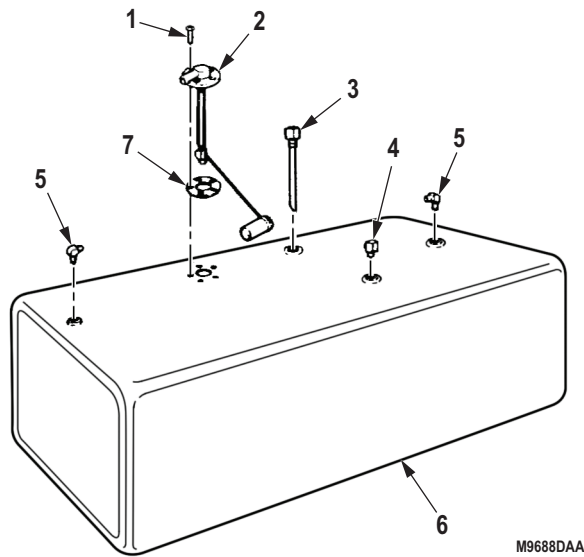

Figure 4. Fuel Tank Installation.

INSTALLATION - Continued**NOTE**

Assistant will help with Step (4).

4. Place fuel tank (Figure 5, Item 16) on two hangers (Figure 5, Item 1).
5. Install two hanger straps (Figure 5, Item 8) on hangers (Figure 5, Item 1) with two screws (Figure 5, Item 21) and locknuts (Figure 5, Item 22).
6. Install outer ends of two hanger straps (Figure 5, Item 8) on hangers (Figure 5, Item 1) with two locknuts (Figure 5, Item 10).
7. Install ground wire (Figure 5, Item 4) on fuel transmitter unit (Figure 5, Item 15) with screw (Figure 5, Item 3).
8. Install fuel transmitter wire (Figure 5, Item 2) to fuel transmitter unit (Figure 5, Item 15).
9. Connect fuel supply line (Figure 5, Item 5) to elbow (Figure 5, Item 14).
10. Connect fuel return line (Figure 5, Item 13) to elbow (Figure 5, Item 12).
11. Connect vent lines (Figure 5, Item 16 and 17) to elbows (Figure 5, Item 7).

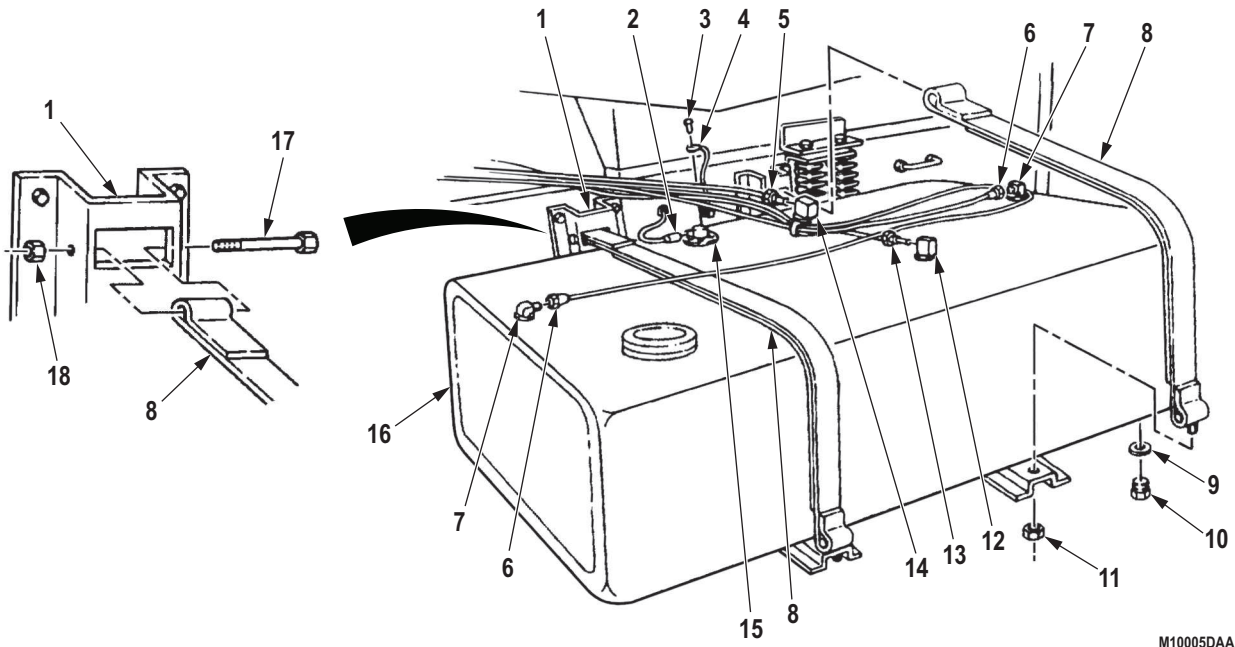

Figure 5. Fuel Tank Installation.

INSTALLATION - Continued**NOTE**

Perform Step (12) for M934/A1/A2 model vehicles.

12. Install fitting (Figure 6, Item 4), adapter (Figure 6, Item 3), and personnel heater fuel supply line (Figure 6, Item 1) on fuel tank (Figure 6, Item 2).

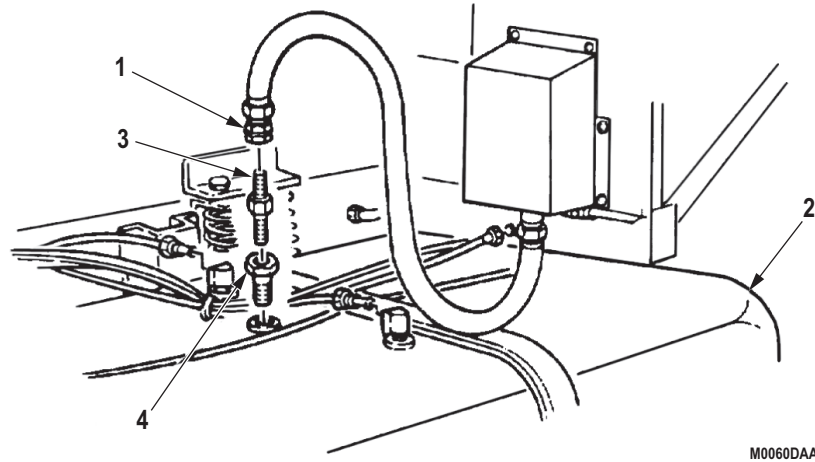

Figure 6. Personnel Heater Fuel Line Installation.

END OF TASK

FOLLOW-ON MAINTENANCE

Install fuel tank spout and filler cap. (WP 0252)

END OF TASK

END OF WORK PACKAGE

**FIELD MAINTENANCE
FUEL TANK REPLACEMENT (M936/A1/A2)**

INITIAL SETUP:**Tools and Special Tools**

Tool Kit, General Mechanic's: Automotive
(Volume 5, WP 0826, Table 1, Item 56)

Materials/Parts

Tape, Antiseizing
(Volume 5, WP 0825, Table 1, Item 65)
Gasket (Volume 5, WP 0827, Table 1, Item 56)
Qty: 1
Gasket (Volume 5, WP 0827, Table 1, Item 228)
Qty: 1
Locknut (Volume 5, WP 0827, Table 1, Item 277)
Qty: 3
Locknut (Volume 5, WP 0827, Table 1, Item 283)
Qty: 1
Lockwasher

Materials/Parts (cont.)

(Volume 5, WP 0827, Table 1, Item 356)
Qty: 2
Lockwasher
(Volume 5, WP 0827, Table 1, Item 425)
Qty: 1
Washer, Flat
(Volume 5, WP 0827, Table 1, Item 57)
Qty: 1

Personnel Required

(2)

References

TM 43-2

Equipment Condition

Parking brake set. (TM 9-2320-272-10)

DRAINING**WARNING**

Diesel fuel is highly flammable. Do not perform fuel system procedures near open flame. Failure to comply may result in injury or death to personnel.

NOTE

The replacement procedure for right and left fuel tanks is basically the same. This procedure covers the left fuel tank.

1. Loosen filler cap (Figure 1, Item 2) at top of fuel tank (Figure 1, Item 1).

NOTE

- Have drainage container ready to catch fuel.
- Use drain pans to retain leaking/draining fluids. Refer to local procedures and plans for preventing and responding to fluid spills or leaks. Comply with local regulations when disposing of clean up material and leaked and spilled fluids.

2. Remove drain plug (Figure 1, Item 4) and flat washer (Figure 1, Item 3) from bottom of fuel tank (Figure 1, Item 1). Discard flat washer.
3. After draining is complete, install flat washer (Figure 1, Item 3) and drain plug (Figure 1, Item 4) in fuel tank (Figure 1, Item 1).
4. Tighten fuel filler cap (Figure 1, Item 2) on fuel tank (Figure 1, Item 1).

END OF TASK**REMOVAL**

1. Loosen two nuts on screws (Figure 1, Item 6) on wrecker body (Figure 1, Item 5) and slide stop plate (Figure 1, Item 7) upward.
2. Remove outrigger (Figure 1, Item 8) from body (Figure 1, Item 5).
3. Remove locknut (Figure 1, Item 14), screw (Figure 1, Item 9), washer (Figure 1, Item 10), ground wire (Figure 1, Item 11), and lockwasher (Figure 1, Item 12) from left side frame (Figure 1, Item 13) and double check valve (Figure 1, Item 15). Discard locknut and lockwasher.

REMOVAL - Continued

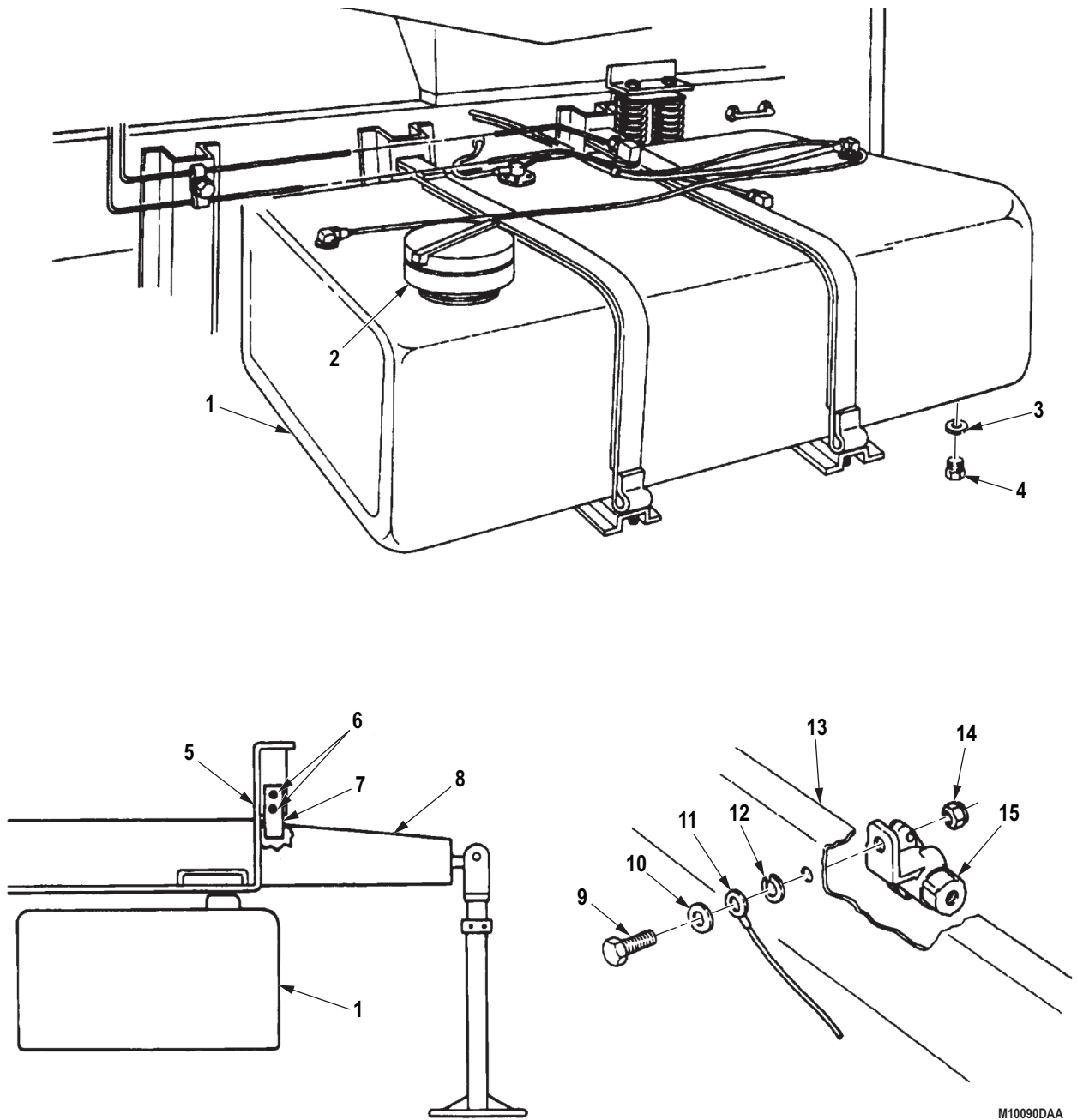

M10090DAA

Figure 1. Fuel Tank Removal (M936/A1/A2).

REMOVAL - Continued

4. Disconnect fuel transmitter wire (Figure 2, Item 24) from fuel transmitter (Figure 2, Item 10).

NOTE

Perform Steps (5), (6), and (7) for left fuel tank only.

5. Disconnect rubber hose adapter (Figure 2, Item 22) from fuel supply line (Figure 2, Item 21).
6. Disconnect rubber hose adapter (Figure 2, Item 19) from fuel return line (Figure 2, Item 20).
7. Remove locknut (Figure 2, Item 18), screw (Figure 2, Item 15), and clamps (Figure 2, Items 16 and 17) from left side of frame (Figure 2, Item 23). Discard locknut.

NOTE

- Perform Steps (8) and (9) for right side fuel tank only.
- Tag lines and fittings for installation.

8. Disconnect fuel supply line (Figure 2, Item 1) from elbow (Figure 2, Item 9).
9. Disconnect fuel return line (Figure 2, Item 8) from elbow (Figure 2, Item 5).
10. Remove vent lines (Figure 2, Items 3 and 13) from elbows (Figure 2, Items 4 and 14).
11. Disconnect wire connector (Figure 2, Item 25) from right side marker light (Figure 2, Item 26).
12. Disconnect wire connector (Figure 2, Item 29) from left side marker light (Figure 2, Item 32).

NOTE

- Assistant will help with Steps (13) through (15).
- Screws for marker light are accessible through storage compartment 1A (TM 9-2320-272-10).

13. Remove two nuts (Figure 2, Item 31), lockwashers (Figure 2, Item 30), screws (Figure 2, Item 27), and left side marker light (Figure 2, Item 32) from body (Figure 2, Item 28). Discard lockwashers.
14. Remove two locknuts (Figure 2, Item 6) from hanger straps (Figure 2, Items 2 and 11) from hangers (Figure 2, Item 7). Discard locknuts.
15. Remove fuel tank (Figure 2, Item 12) from hangers (Figure 2, Item 7).

REMOVAL - Continued

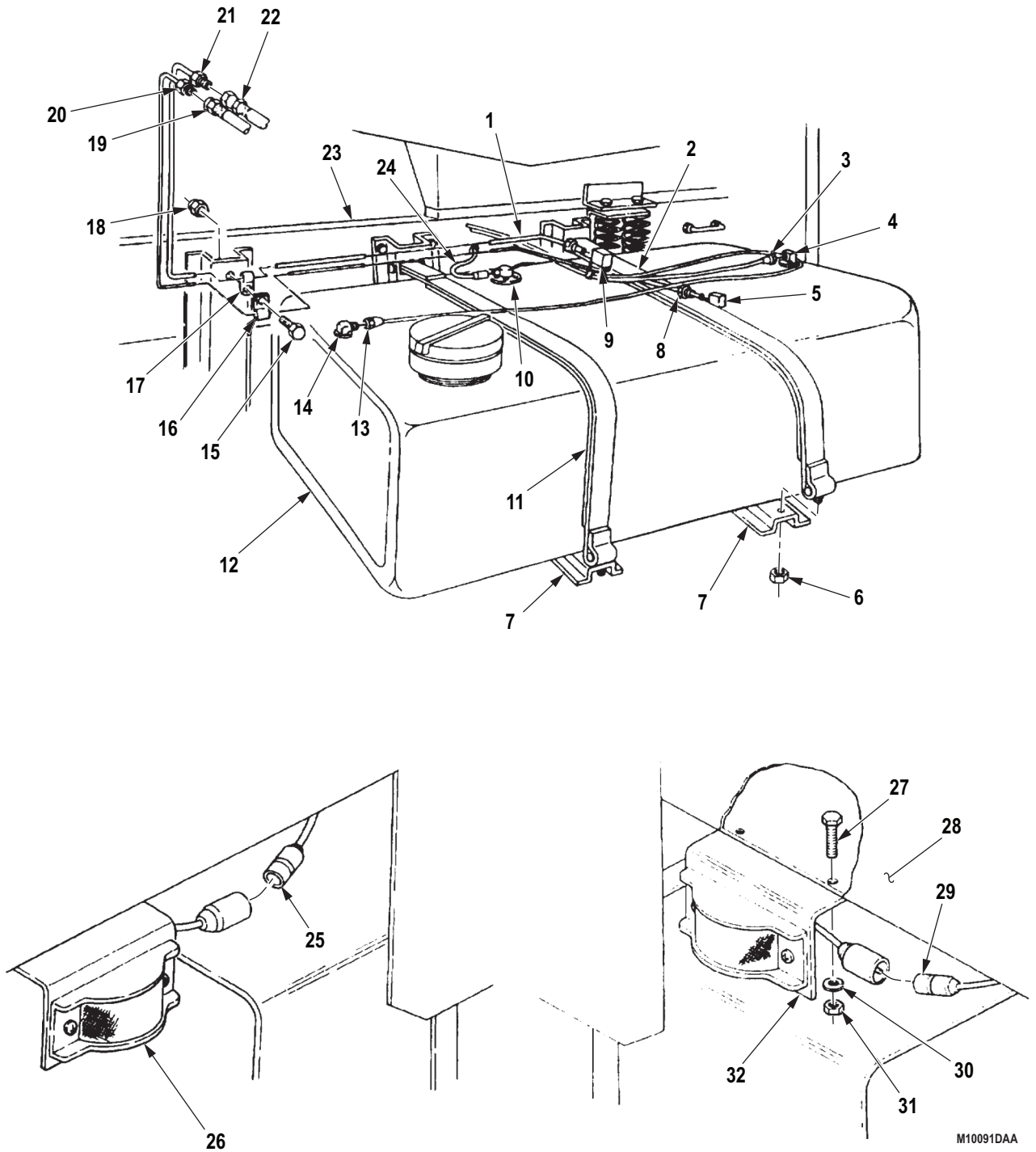

M10091DAA

Figure 2. Fuel Tank Components Removal/Installation.

REMOVAL - Continued**NOTE**

Tag fittings and transmitter unit for direction during installation.

16. Remove fuel supply tube and elbow (Figure 3, Item 5) from top of fuel tank (Figure 3, Item 8).
17. Remove vent line elbows (Figure 3, Items 7 and 9) from top of fuel tank (Figure 3, Item 8).
18. Remove return line elbow (Figure 3, Item 6) from top of fuel tank (Figure 3, Item 8).
19. Remove screw (Figure 3, Item 2) and ground wire (Figure 3, Item 3) from fuel transmitter unit (Figure 3, Item 4).
20. Remove four screws (Figure 3, Item 2), fuel transmitter unit (Figure 3, Item 4), and gasket (Figure 3, Item 11) from fuel tank (Figure 3, Item 8). Discard gasket.
21. Remove filler cap (Figure 3, Item 1) and disconnect S-chain (Figure 3, Item 13) from fuel strainer (Figure 3, Item 12).
22. Remove fuel strainer (Figure 3, Item 12) and gasket (Figure 3, Item 10) from fuel tank (Figure 3, Item 8). Discard gasket.

END OF TASK**INSPECTION**

Inspect fuel tank (Figure 3, Item 8) for cracks, holes, and stripped threads (TM 43-2).

END OF TASK**INSTALLATION****NOTE**

Male pipe threads must be wrapped with antiseize tape before installation.

1. Install gasket (Figure 3, Item 10) and fuel strainer (Figure 3, Item 12) in fuel tank (Figure 3, Item 8).
2. Connect S-chain (Figure 3, Item 13) to fuel strainer (Figure 3, Item 12) and install filler cap (Figure 3, Item 1).

NOTE

Do not use screw hole nearest to vehicle frame.

3. Install gasket (Figure 3, Item 11) and fuel transmitter unit (Figure 3, Item 4) on fuel tank (Figure 3, Item 8) with four screws (Figure 3, Item 2).
4. Install ground wire (Figure 3, Item 3) to fuel transmitter unit (Figure 3, Item 4) with screw (Figure 3, Item 2).
5. Install return line elbow (Figure 3, Item 6) and vent line elbows (Figure 3, Items 7 and 9) on top of fuel tank (Figure 3, Item 8).

INSTALLATION - Continued

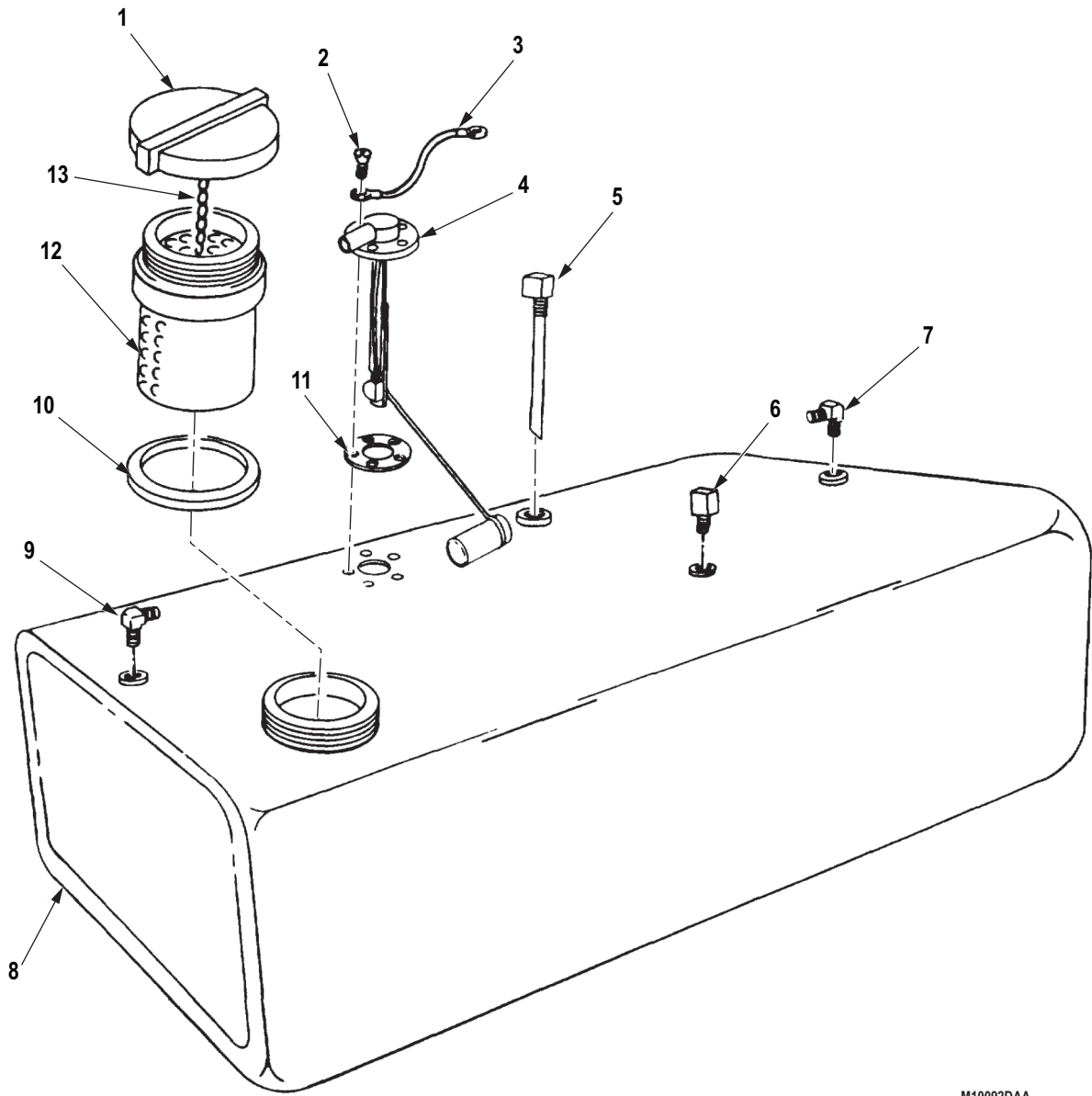

M10092DAA

Figure 3. Fuel Tank Components Installation.

INSTALLATION - Continued**NOTE**

Assistant will help with Steps (6) through (10).

6. Place fuel tank (Figure 4, Item 12) on two hangers (Figure 4, Item 7) far enough to support tank.
7. Connect vent lines (Figure 4, Items 3 and 13) to elbows (Figure 4, Items 4 and 14).
8. Connect fuel supply line (Figure 4, Item 1) to elbow (Figure 4, Item 9).
9. Connect fuel return line (Figure 4, Item 8) to elbow (Figure 4, Item 5).
10. Install hangers straps (Figure 4, Items 2 and 11) on hangers (Figure 4, Item 7) with two locknuts (Figure 4, Item 6).

NOTE

Slide fuel tank all the way in before performing Steps (11) and (12).

11. Install left side marker light (Figure 5, Item 6) on body (Figure 5, Item 2) with two screws (Figure 5, Item 1), lockwashers (Figure 5, Item 4), and nuts (Figure 5, Item 5).
12. Connect left side marker light (Figure 5, Item 6) to harness connector (Figure 5, Item 3).
13. Connect right side marker light (Figure 5, Item 8) to harness connector (Figure 5, Item 7).

NOTE

Perform Steps (14), (15), and (16) for left side tank only.

14. Connect fuel supply line (Figure 4, Item 21) to rubber hose adapter (Figure 4, Item 22).
15. Connect fuel return line (Figure 4, Item 20) to rubber hose adapter (Figure 4, Item 19).
16. Install clamps (Figure 4, Items 16 and 17) on frame (Figure 4, Item 23) with screw (Figure 4, Item 15) and locknut (Figure 4, Item 18).
17. Connect fuel transmitter wire (Figure 4, Item 24) to fuel transmitter unit (Figure 4, Item 10).

INSTALLATION - Continued

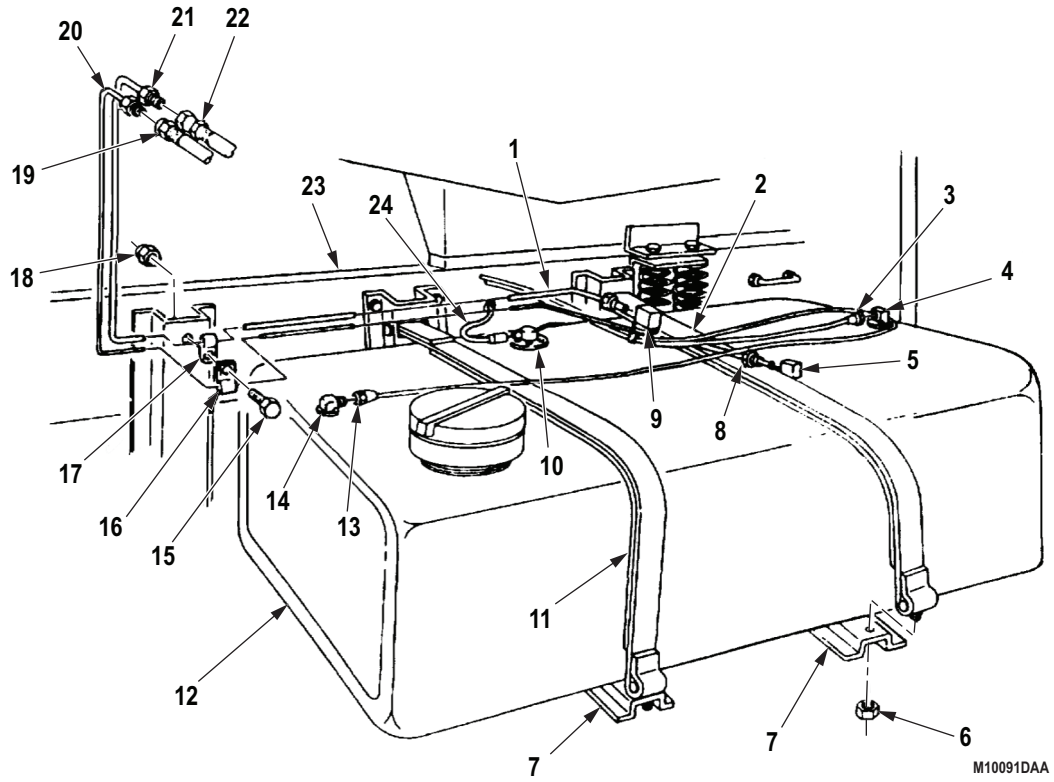

M10091DAA

Figure 4. Fuel Tank Assembly.

INSTALLATION - Continued

18. Install ground wire (Figure 5, Item 11) on frame (Figure 5, Item 13) and double check valve (Figure 5, Item 15) with lockwasher (Figure 5, Item 12), washer (Figure 5, Item 10), screw (Figure 5, Item 9), and locknut (Figure 5, Item 14).
19. Loosen two nuts on screws (Figure 5, Item 17) and slide stop plate (Figure 5, Item 18) upward.
20. Install outrigger (Figure 5, Item 19) in wrecker body (Figure 5, Item 16) and slide stop plate (Figure 5, Item 18) down. Stop plate must contact back of slot in top of outrigger.
21. Tighten two nuts on screws (Figure 5, Item 17).

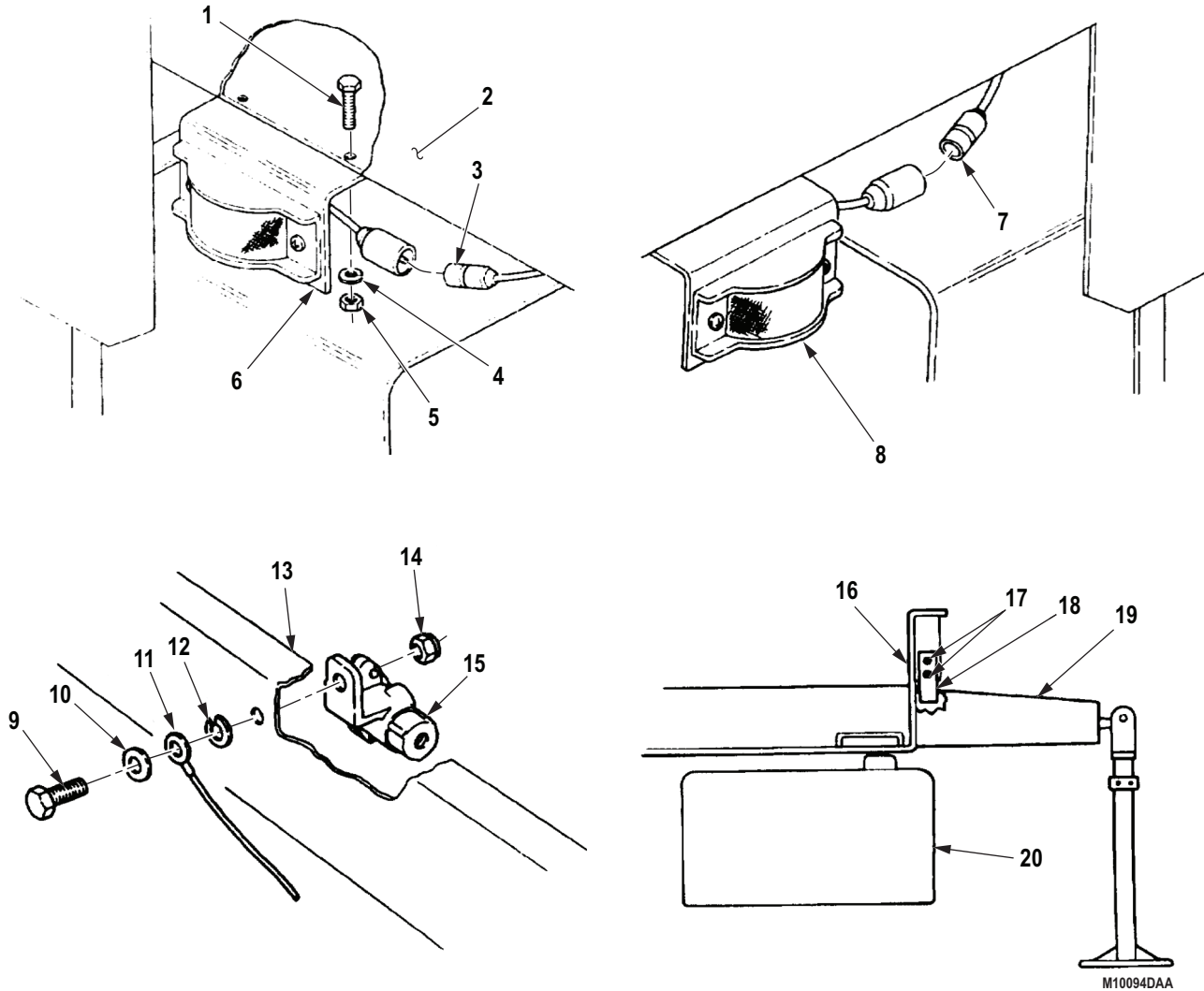

Figure 5. Fuel Tank Installation.

END OF TASK

FOLLOW-ON MAINTENANCE

Start engine and road test vehicle. (TM 9-2320-272-10)

END OF TASK

END OF WORK PACKAGE

**FIELD MAINTENANCE
FUEL TANK FILLER CAP AND SPOUT REPLACEMENT**

INITIAL SETUP:**Tools and Special Tools**

Tool Kit, General Mechanic's: Automotive
(Volume 5, WP 0826, Table 1, Item 56)

Equipment Condition

Parking brake set. (TM 9-2320-272-10)
Filler cap removed. (TM 9-2320-272-10)

Materials/Parts

Gasket (Volume 5, WP 0827, Table 1, Item 56)
Qty: 2

REMOVAL**WARNING**

Diesel fuel is highly flammable. Do not perform fuel system procedures near open flame. Failure to comply may result in injury or death to personnel.

1. Remove gasket (Figure 1, Item 2) from filler cap (Figure 1, Item 1). Discard gasket.
2. Remove filler cap retaining chain (Figure 1, Item 6) from filler spout assembly (Figure 1, Item 3).
3. Turn filler spout assembly (Figure 1, Item 3) counterclockwise and remove it from fuel tank (Figure 1, Item 5).
4. Remove gasket (Figure 1, Item 4) from filler spout assembly (Figure 1, Item 3). Discard gasket.

REMOVAL - Continued

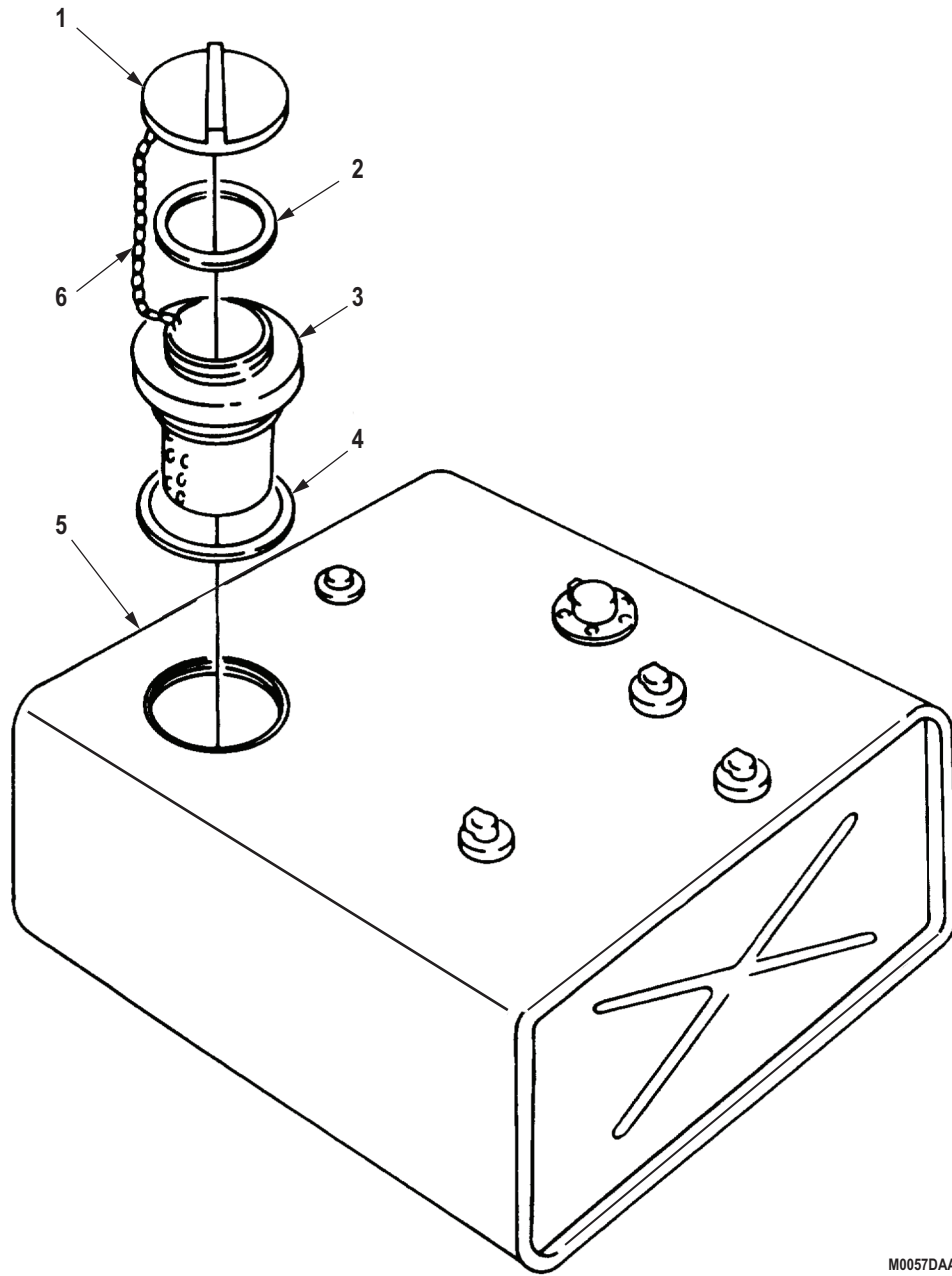

M0057DAA

Figure 1. Fuel Tank Filler Cap and Spout Removal.

END OF TASK

INSTALLATION**NOTE**

- M939/A1 vehicles use same gaskets in Steps (1) and (2).
- M939A2 vehicles use different gaskets for Steps (1) and (2).

1. Install gasket (Figure 2, Item 2) on filler cap (Figure 2, Item 1).
2. Install gasket (Figure 2, Item 4) on filler spout assembly (Figure 2, Item 3).
3. Install filler spout assembly (Figure 2, Item 3) in fuel tank (Figure 2, Item 5).
4. Attach filler cap retaining chain (Figure 2, Item 6) to filler spout assembly (Figure 2, Item 3).

INSTALLATION - Continued

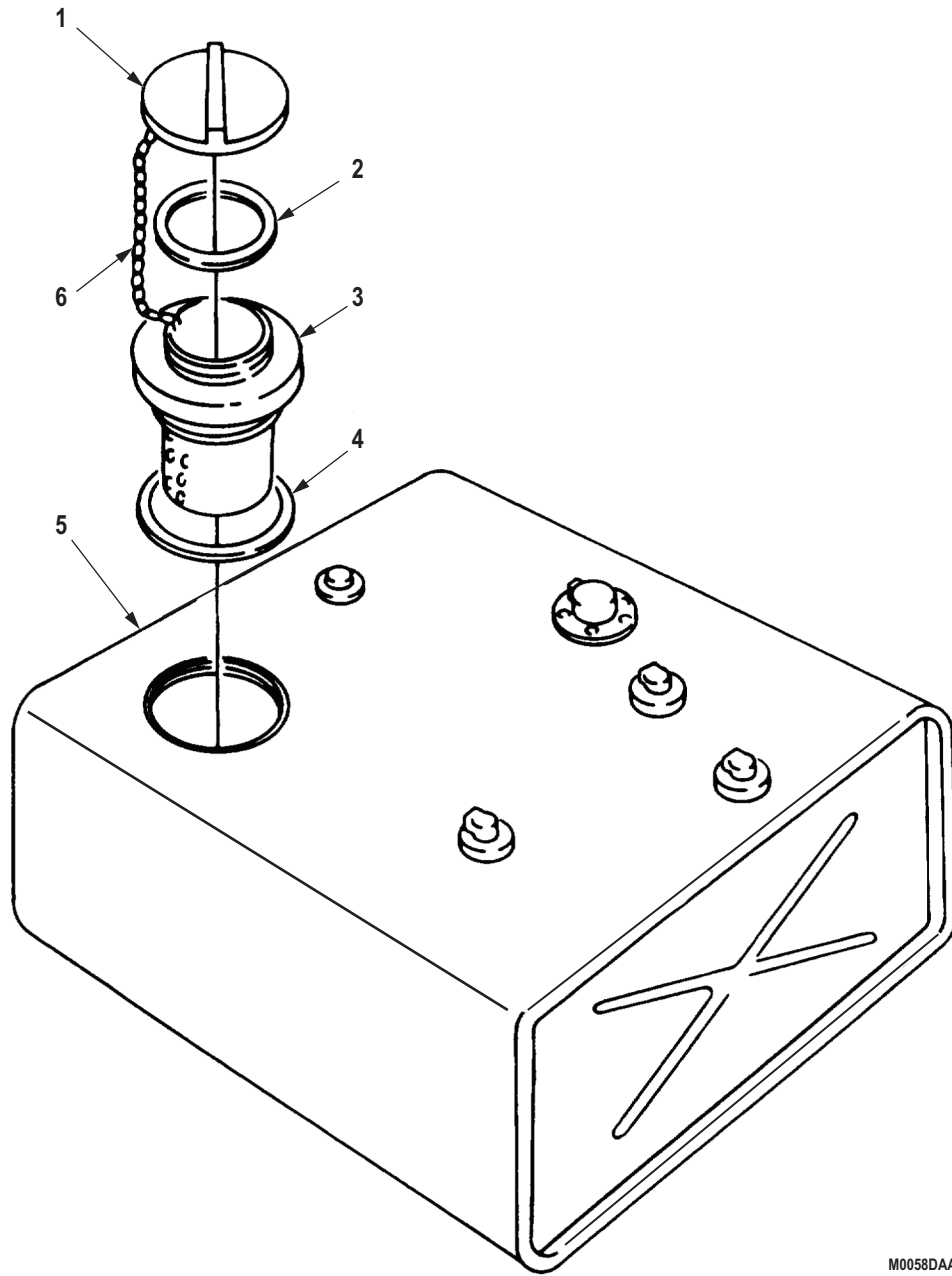

M0058DAA

Figure 2. Fuel Tank Filler Cap and Spout Installation.

END OF TASK

FOLLOW-ON MAINTENANCE

Install filler cap. (TM 9-2320-272-10)

END OF TASK

END OF WORK PACKAGE

**FIELD MAINTENANCE
FUEL TANK HANGERS AND RETAINING STRAPS REPLACEMENT**

INITIAL SETUP:**Tools and Special Tools**

Tool Kit, General Mechanic's: Automotive
(Volume 5, WP 0826, Table 1, Item 56)

Materials/Parts

Adhesive, Silicone Rubber
(Volume 5, WP 0825, Table 1, Item 1)
Locknut (Volume 5, WP 0827, Table 1, Item 277)
Qty: 10
Locknut (Volume 5, WP 0827, Table 1, Item 285)
Qty: 5

Materials/Parts (cont.)

Locknut (Volume 5, WP 0827, Table 1, Item 313)
Qty: 8
Lockwasher
(Volume 5, WP 0827, Table 1, Item 425)
Qty: 2

Personnel Required

(2)

Equipment Condition

Parking brake set. (TM 9-2320-272-10)
Fuel tank(s) removed. (WP 0250)
Dual fuel tank wet air reservoir removed.
(Volume 3, WP 0442)

REMOVAL**NOTE**

- On models with dual fuel tanks (M929/A1/A2, M930/A1/A2, M931/A1/A2, and M932/A1/A2), right side forward fuel tank hanger must be removed and installed at direct support maintenance.
 - The number of locknuts and lockwashers varies between models. Refer to parts list for quantity for particular model.
1. Remove two locknuts (Figure 1, Item 19), screws (Figure 1, Item 8), retaining straps (Figure 1, Item 22), and insulators (Figure 1, Item 1) from two fuel tank hangers (Figure 1, Item 14). Discard locknuts.
 2. Remove eight locknuts (Figure 1, Item 13), screws (Figure 1, Item 15), and two hanger stabilizing straps (Figure 1, Item 12) from hangers (Figure 1, Item 14). Discard locknuts.
 3. Remove four locknuts (Figure 1, Item 9), screws (Figure 1, Item 11), and two support brackets (Figure 1, Item 10) from fuel tank hangers (Figure 1, Item 14). Discard locknuts.
 4. Remove locknut (Figure 1, Item 6), bracket (Figure 1, Item 5), lockwasher (Figure 1, Item 4), washer (Figure 1, Item 3), screw (Figure 1, Item 21), lockwasher (Figure 1, Item 4), washer (Figure 1, Item 3), and ground lead (Figure 1, Item 20) from hanger (Figure 1, Item 14) and frame (Figure 1, Item 7). Discard lockwashers and locknut.

NOTE

Assistant will help with Step (5).

5. Remove eight locknuts (Figure 1, Item 2), screws (Figure 1, Item 18), and two fuel tank hangers (Figure 1, Item 14) from side rail (Figure 1, Item 7). Discard locknuts.
6. Remove two rubber sheets (Figure 1, Item 16) and rubber sheets (Figure 1, Item 17) from two fuel tank hangers (Figure 1, Item 14).

REMOVAL - Continued

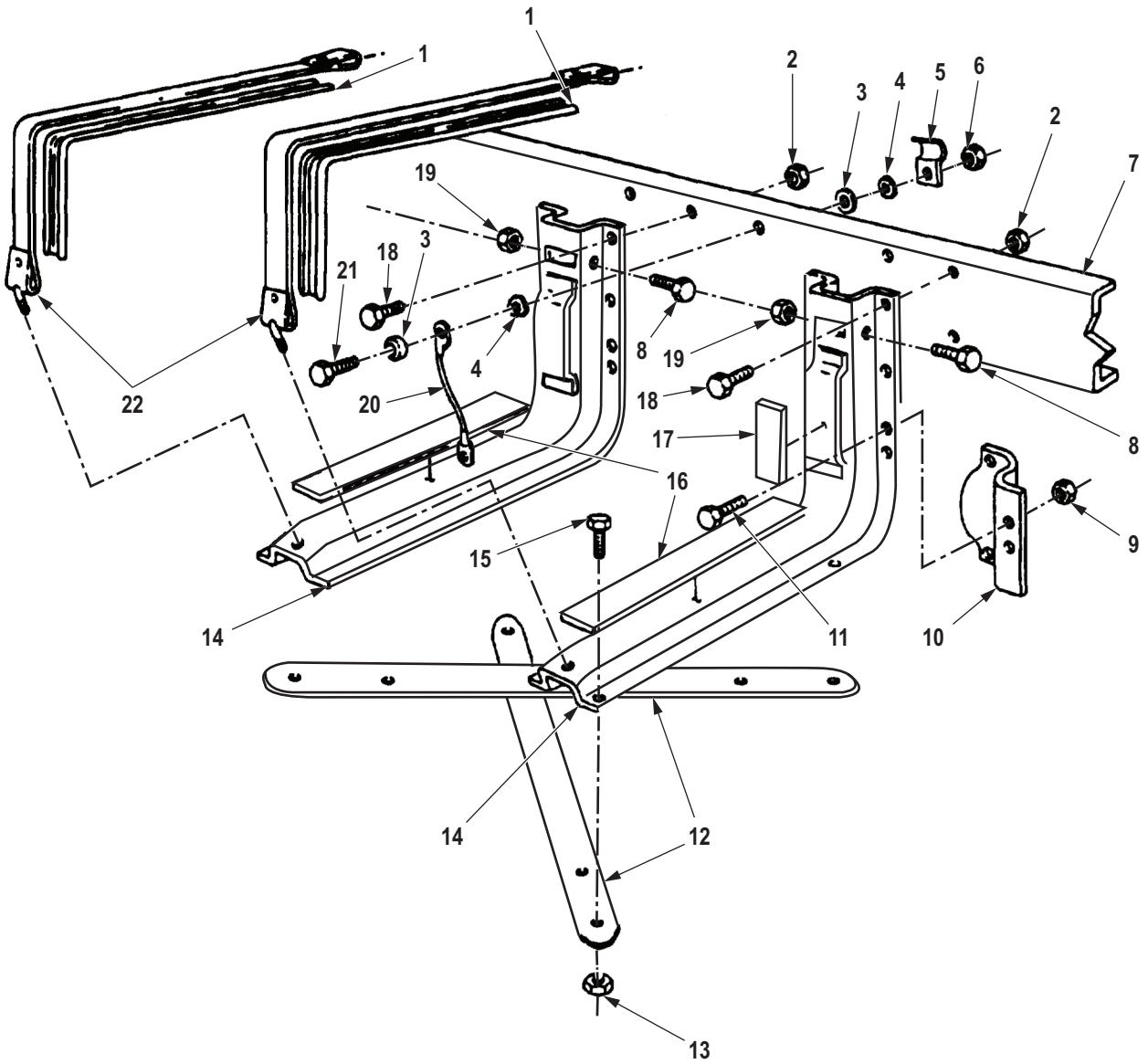

M0066DAA

Figure 1. Fuel Tank Hangers and Retaining Straps Removal.

END OF TASK

INSPECTION

1. Inspect two rubber sheets (Figure 2, Item 16) and (Figure 2, Item 17) for presence and damage. Replace if missing or damaged.
2. Inspect two insulators (Figure 2, Item 1) for deterioration. Replace if missing or damaged.

INSPECTION - Continued

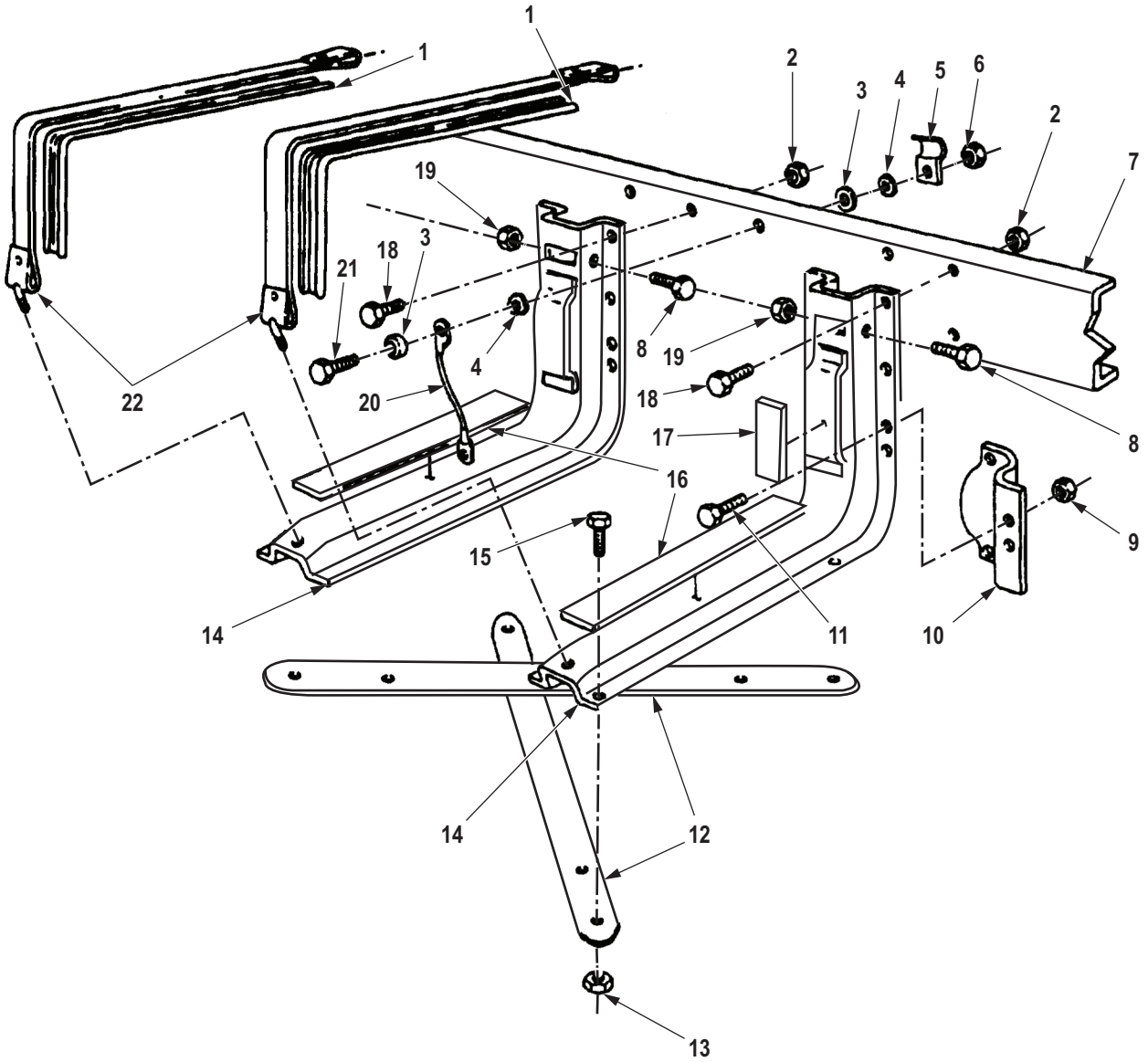

M9620DAA

Figure 2. Fuel Tank Hangers and Retaining Straps Inspection.

END OF TASK

INSTALLATION

1. Apply adhesive sealant to two insulators (Figure 3, Item 1) and install, as needed, on retaining straps (Figure 3, Item 22).
2. Apply adhesive sealant to two rubber sheets (Figure 3, Item 16) and (Figure 3, Item 17) and install, as needed, on hangers.

NOTE

Assistant will help with Step (2).

3. Install fuel tank hangers (Figure 3, Item 14) on frame (Figure 3, Item 7) with eight screws (Figure 3, Item 18) and locknuts (Figure 3, Item 2).
4. Place wiring harness bracket (Figure 3, Item 5) over wiring harness and install lockwasher (Figure 3, Item 4), ground wire (Figure 3, Item 20), washer (Figure 3, Item 3), screw (Figure 3, Item 21), washer (Figure 3, Item 3), lockwasher (Figure 3, Item 4), wiring harness bracket (Figure 3, Item 5), and locknut (Figure 3, Item 6) on frame (Figure 3, Item 7).
5. Install two support brackets (Figure 3, Item 10) on hangers (Figure 3, Item 14) with four screws (Figure 3, Item 11) and locknuts (Figure 3, Item 9).
6. Install two fuel hanger stabilizing straps (Figure 3, Item 12) on hangers (Figure 3, Item 14) with eight screws (Figure 3, Item 15) and locknuts (Figure 3, Item 13).
7. Install two retaining straps (Figure 3, Item 22) and insulators (Figure 3, Item 1) on hangers (Figure 3, Item 14) with two screws (Figure 3, Item 8) and locknuts (Figure 3, Item 19).

INSTALLATION - Continued

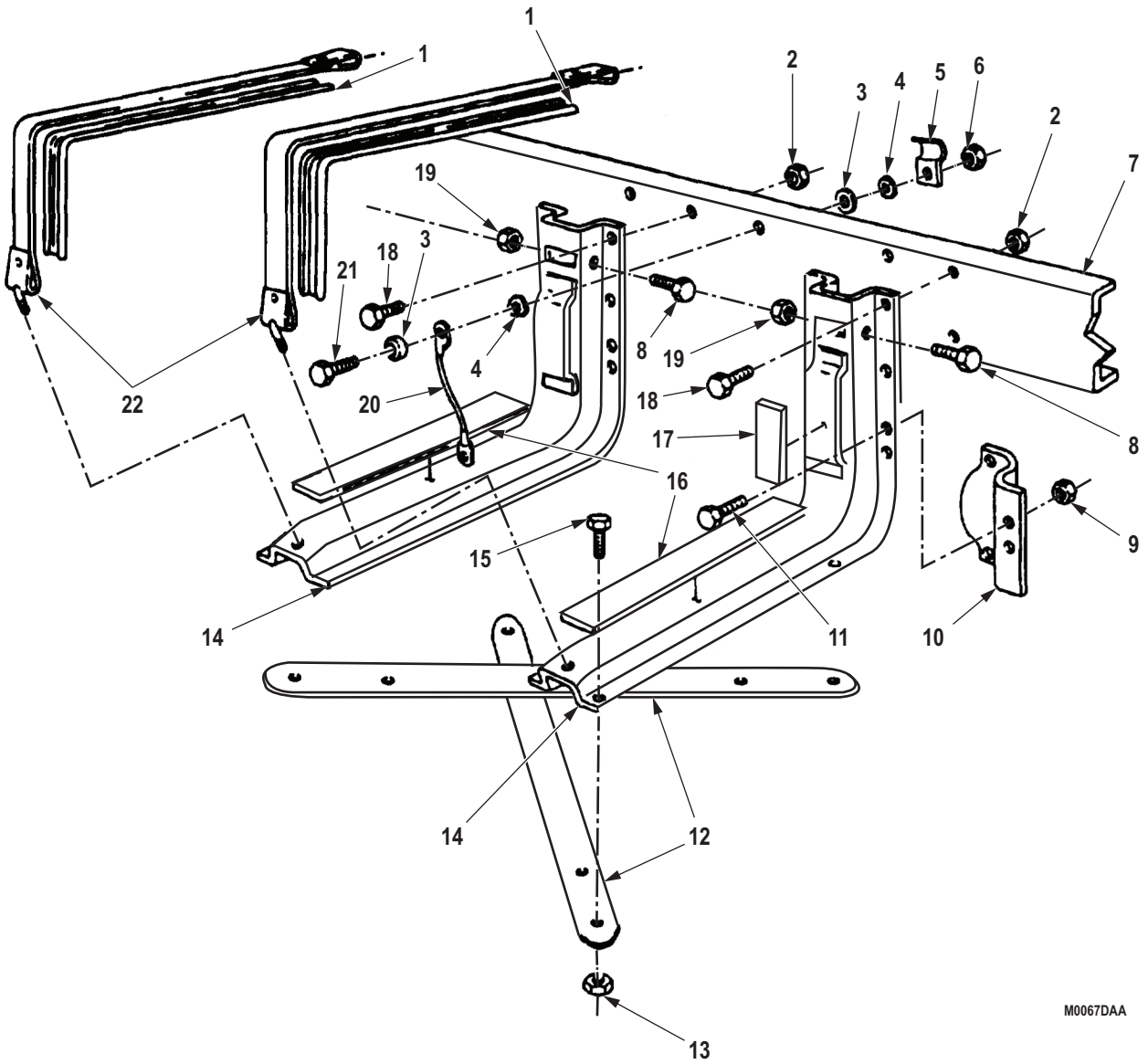

M0067DAA

Figure 3. Fuel Tank Hangers and Retaining Straps Installation.

END OF TASK

FOLLOW-ON MAINTENANCE

1. Install fuel tank(s). (WP 0250)
2. Install dual fuel tank wet air reservoir. (Volume 3, WP 0442)

END OF TASK**END OF WORK PACKAGE**

**FIELD MAINTENANCE
FUEL TANK LINES REPLACEMENT (M939A2)**

INITIAL SETUP:**Tools and Special Tools**

Tool Kit, General Mechanic's: Automotive
(Volume 5, WP 0826, Table 1, Item 56)

Materials/Parts

Cap Set, Protective, Dust and Moisture Seal
(Volume 5, WP 0825, Table 1, Item 13)

Materials/Parts (cont.)

Locknut (Volume 5, WP 0827, Table 1, Item 271)

Qty: 1

Tiedown Strap

(Volume 5, WP 0827, Table 1, Item 379)

Qty: 1

Equipment Condition

Parking brake set. (TM 9-2320-272-10)

Hood raised and secured. (TM 9-2320-272-10)

REMOVAL**WARNING**

Diesel fuel is highly flammable. Do not perform fuel system procedures near open flame. Failure to comply may result in injury or death to personnel.

CAUTION

Cap or plug all openings immediately after disconnecting lines and hoses to prevent contamination. Failure to do so may result in fuel system damage.

NOTE

Remove and discard tiedown straps as required and note locations for installation.

1. Disconnect two tubing nuts (Figure 1, Item 3) and remove fuel supply hose (Figure 1, Item 4) from elbow (Figure 1, Item 2) and fuel supply line (Figure 1, Item 7).

NOTE

- Perform Step (2) if fuel filter is damaged.
 - Note position and direction of arrow for installation.
2. Remove two clamps (Figure 1, Item 5) and fuel filter (Figure 1, Item 6) from fuel supply hose (Figure 1, Item 4).
 3. Remove locknut (Figure 1, Item 12), screw (Figure 1, Item 8), fuel return hose (Figure 1, Item 14), and clamp (Figure 1, Item 13) from bracket (Figure 1, Item 11). Discard locknut.
 4. Loosen two clamps (Figure 1, Item 10) and remove fuel return hose (Figure 1, Item 14) from fitting (Figure 1, Item 1) and fuel return line (Figure 1, Item 9).

REMOVAL - Continued

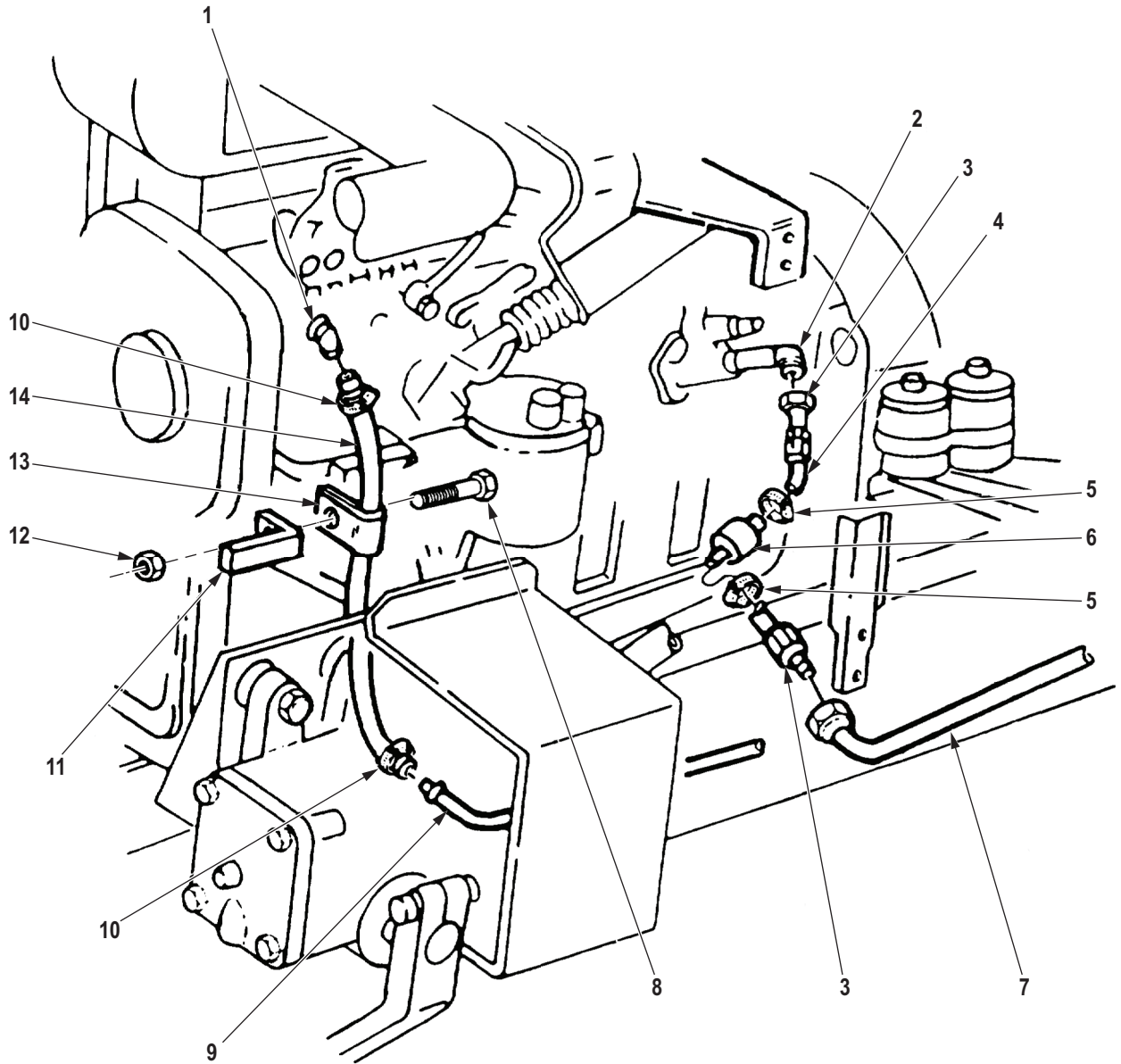

M0068DAA

Figure 1. Fuel Tank Lines Removal.

REMOVAL - Continued

5. Remove nut (Figure 2, Item 4), screw (Figure 2, Item 1), and clamp (Figure 2, Item 3) from fuel return line (Figure 2, Item 2).
6. Remove nut (Figure 2, Item 8), screw (Figure 2, Item 5), and clamp (Figure 2, Item 7) from fuel supply line (Figure 2, Item 6).
7. Remove nut (Figure 2, Item 11) from screw (Figure 2, Item 9).
8. Remove two clamps (Figure 2, Item 10) from fuel supply line (Figure 2, Item 6) and fuel return line (Figure 2, Item 2).
9. Remove nut (Figure 2, Item 17), screw (Figure 2, Item 15), and two clamps (Figure 2, Item 16) from fuel supply line (Figure 2, Item 6) and fuel return line (Figure 2, Item 2).
10. Disconnect two tubing nuts (Figure 2, Item 18) and remove tee fitting (Figure 2, Item 19) and front half of fuel supply line (Figure 2, Item 6) from rear half of fuel supply line (Figure 2, Item 6).
11. Remove nut (Figure 2, Item 14), screw (Figure 2, Item 12), and clamp (Figure 2, Item 13) from fuel return line (Figure 2, Item 2).

REMOVAL - Continued

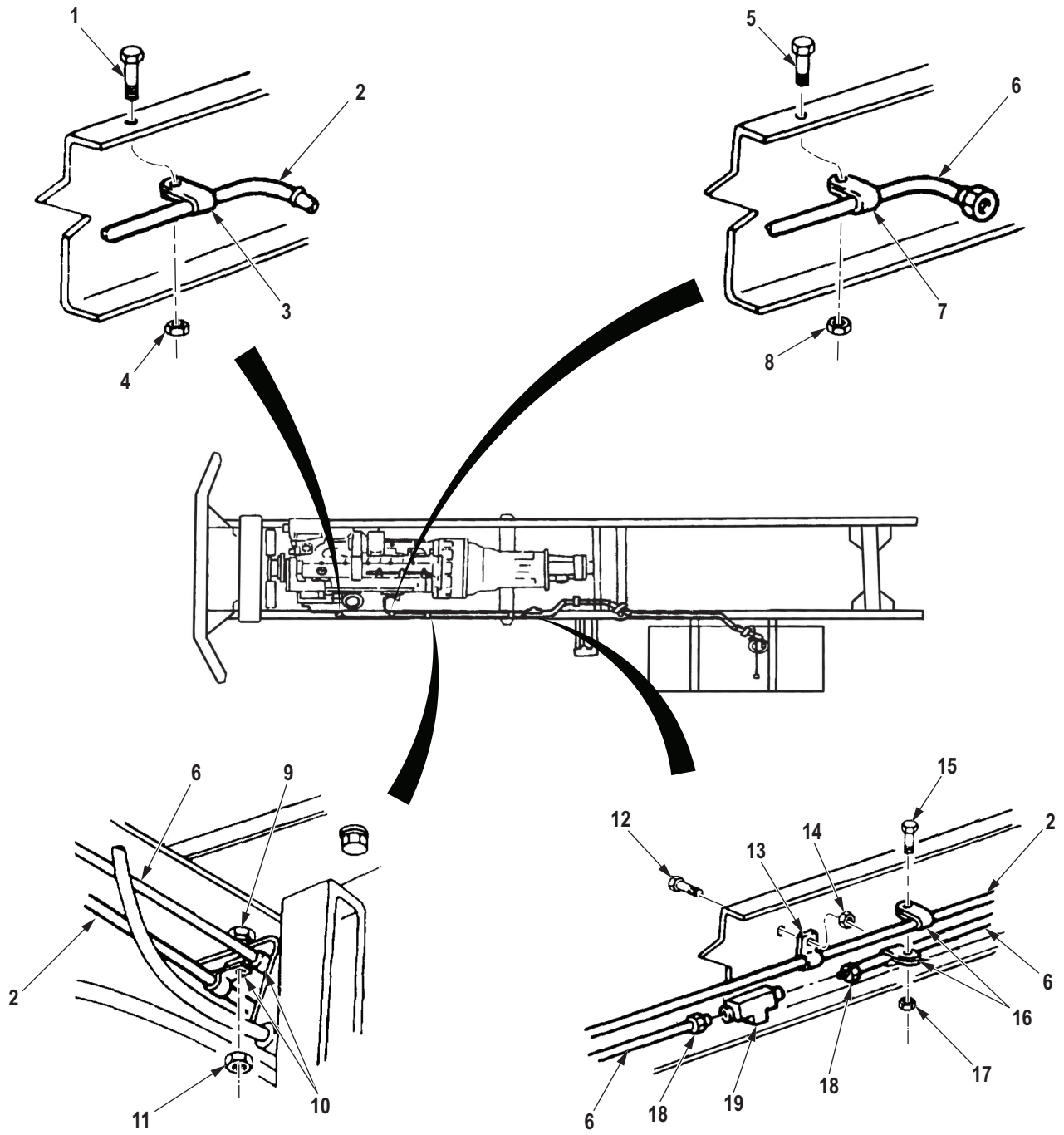

M0069DAA

Figure 2. Fuel Return and Supply Lines Removal.

REMOVAL - Continued

12. Remove nut (Figure 3, Item 5), screw (Figure 3, Item 1), and two clamps (Figure 3, Item 4) from fuel supply line (Figure 3, Item 2) and fuel return line (Figure 3, Item 3).
13. Remove nut (Figure 3, Item 11), screw (Figure 3, Item 8), and two clamps (Figure 3, Item 10) from fuel supply line (Figure 3, Item 2), fuel return line (Figure 3, Item 3), and bracket (Figure 3, Item 7).

NOTE

Perform Step (14) if bracket is damaged.

14. Remove nut (Figure 3, Item 9), screw (Figure 3, Item 6), and bracket (Figure 3, Item 7) from frame rail (Figure 3, Item 12).
15. Remove nut (Figure 3, Item 15), screw (Figure 3, Item 13), and two clamps (Figure 3, Item 14) from fuel supply line (Figure 3, Item 2) and fuel return line (Figure 3, Item 3).
16. Disconnect two tubing nuts (Figure 3, Item 17) from fittings (Figure 3, Item 18) and remove rear half of fuel supply line (Figure 3, Item 2) and fuel return line (Figure 3, Item 3) from fuel tank (Figure 3, Item 16).

NOTE

Perform Steps (17) through (19) for vehicles equipped with dual fuel tanks.

17. Remove nut (Figure 3, Item 22) and screw (Figure 3, Item 24) from two clamps (Figure 3, Item 23).
18. Disconnect two tubing nuts (Figure 3, Item 21) from adapter fittings (Figure 3, Item 20) on selector valve (Figure 3, Item 19).
19. Remove fuel supply line (Figure 3, Item 2) and fuel return line (Figure 3, Item 3) from adapter fittings (Figure 3, Item 20).

REMOVAL - Continued

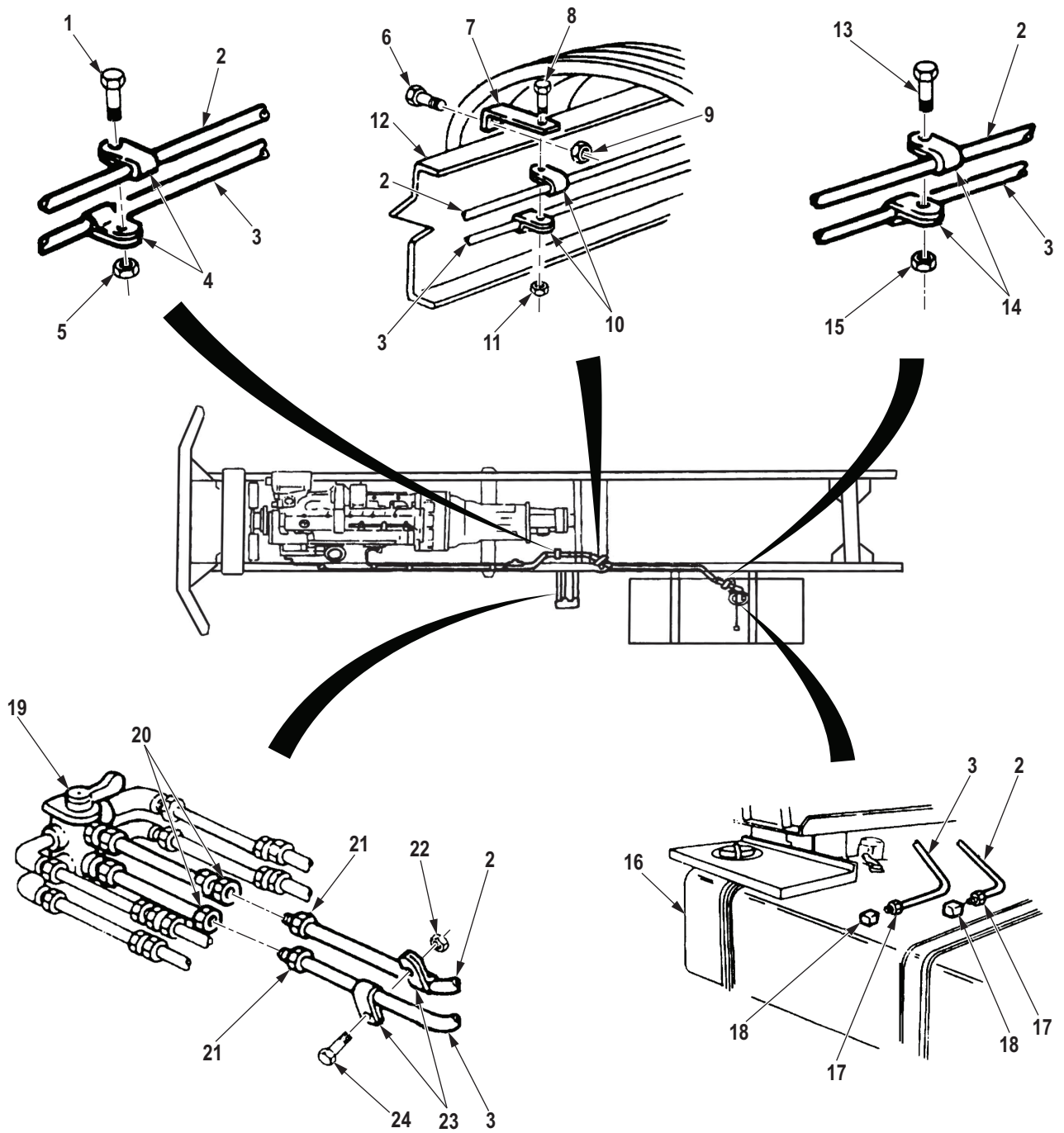

M0070DAA

Figure 3. Fuel Return and Supply Lines Removal.

END OF TASK

INSTALLATION

1. Connect rear half of fuel supply line (Figure 4, Item 2) and fuel return line (Figure 4, Item 3) to two fittings (Figure 4, Item 18) on fuel tank (Figure 4, Item 16) with tubing nuts (Figure 4, Item 17).
2. Install two clamps (Figure 4, Item 14) on fuel supply line (Figure 4, Item 2) and fuel return line (Figure 4, Item 3) with screw (Figure 4, Item 13) and nut (Figure 4, Item 15).

NOTE

Perform Step (3) if bracket was removed.

3. Install bracket (Figure 4, Item 7) on frame rail (Figure 4, Item 12) with screw (Figure 4, Item 6) and nut (Figure 4, Item 9).
4. Install two clamps (Figure 4, Item 10) on fuel supply line (Figure 4, Item 2), fuel return line (Figure 4, Item 3), and bracket (Figure 4, Item 7) with screw (Figure 4, Item 8) and nut (Figure 4, Item 11).
5. Install two clamps (Figure 4, Item 4) on fuel supply line (Figure 4, Item 2) and fuel return line (Figure 4, Item 3) with screw (Figure 4, Item 1) and nut (Figure 4, Item 5).

NOTE

Perform Steps (6) and (7) for vehicles equipped with dual tanks.

6. Install fuel supply line (Figure 4, Item 2) and fuel return line (Figure 4, Item 3) on adapter fittings (Figure 4, Item 20) on selector valve (Figure 4, Item 19) with tubing nuts (Figure 4, Item 21).
7. Install two clamps (Figure 4, Item 23) on fuel supply line (Figure 4, Item 2) and fuel return line (Figure 4, Item 3) with screw (Figure 4, Item 24) and nut (Figure 4, Item 22).

INSTALLATION - Continued

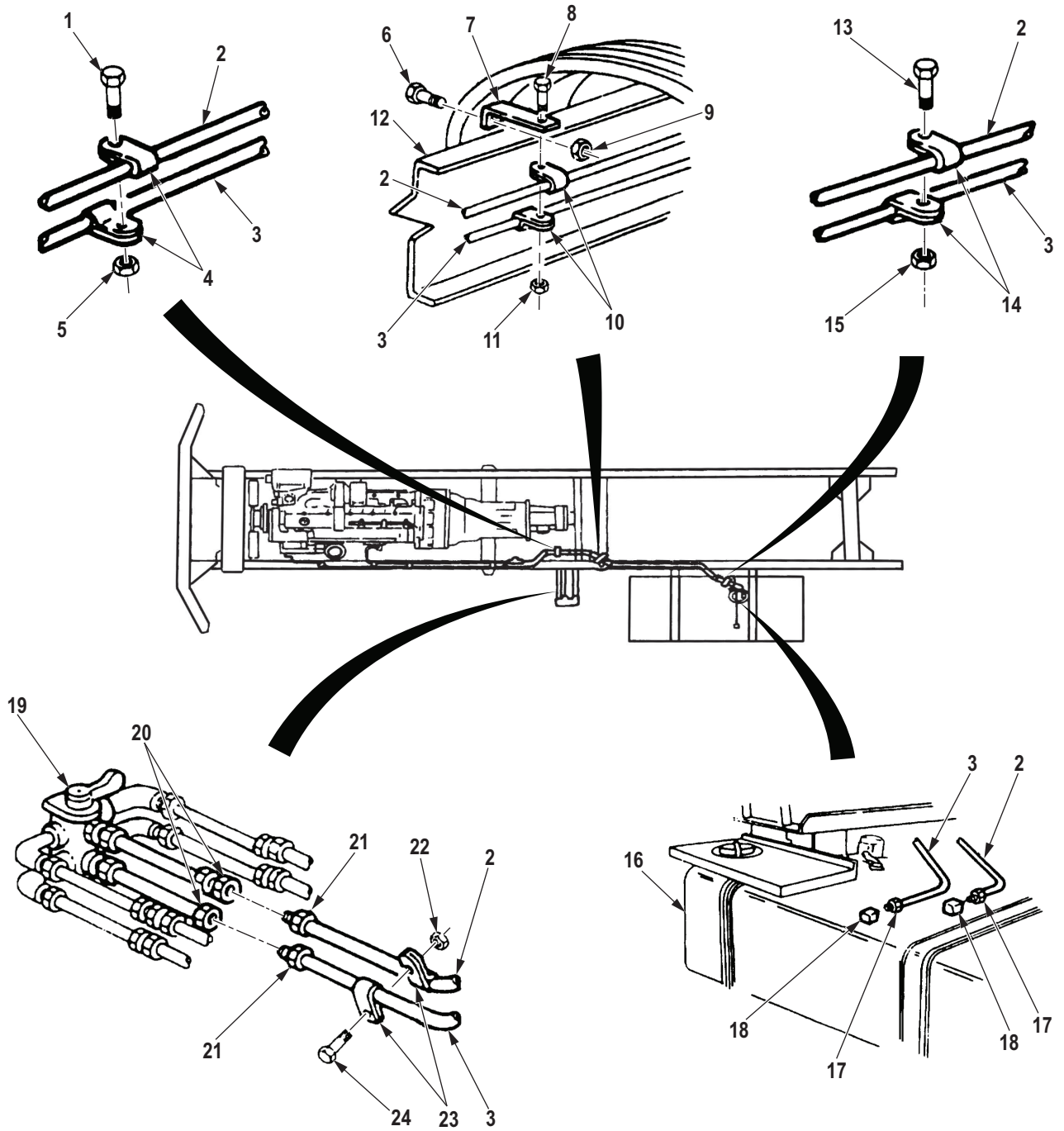

M0071DAA

Figure 4. Fuel Return and Supply Lines Installation.

INSTALLATION - Continued

8. Install clamp (Figure 5, Item 2) on fuel return line (Figure 5, Item 5) with screw (Figure 5, Item 1) and nut (Figure 5, Item 3).
9. Install front half of fuel supply line (Figure 5, Item 6) and rear half of fuel supply line (Figure 5, Item 6) on tee (Figure 5, Item 10) with tubing nuts (Figure 5, Item 9).
10. Install two clamps (Figure 5, Item 7) on fuel supply line (Figure 5, Item 6) and fuel return line (Figure 5, Item 5) with screw (Figure 5, Item 4) and nut (Figure 5, Item 8).
11. Install two clamps (Figure 5, Item 12) on fuel supply line (Figure 5, Item 6) and fuel return line (Figure 5, Item 5) with screw (Figure 5, Item 11) and nut (Figure 5, Item 13).
12. Install clamp (Figure 5, Item 15) on fuel supply line (Figure 5, Item 6) with screw (Figure 5, Item 14) and nut (Figure 5, Item 16).
13. Install clamp (Figure 5, Item 18) on fuel return line (Figure 5, Item 5) with screw (Figure 5, Item 17) and nut (Figure 5, Item 19).

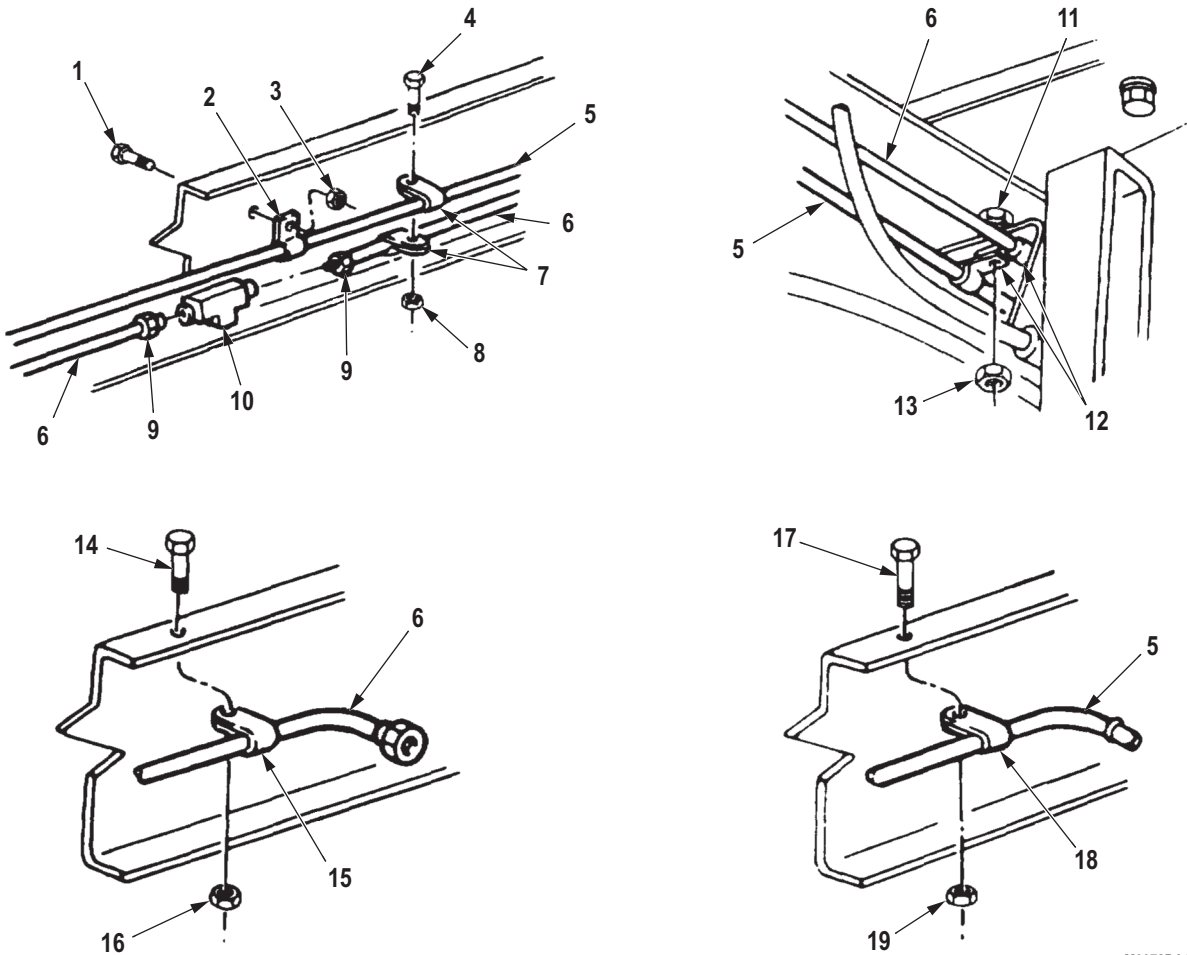

M0072DAA

Figure 5. Fuel Return and Supply Lines Installation.

14. Install fuel return hose (Figure 6, Item 14) on fitting (Figure 6, Item 1) and fuel return line (Figure 6, Item 9) with two hose clamps (Figure 6, Item 10).

INSTALLATION - Continued

15. Install fuel return hose (Figure 6, Item 14) on bracket (Figure 6, Item 11) with clamp (Figure 6, Item 13), screw (Figure 6, Item 8), and locknut (Figure 6, Item 12).

NOTE

Perform Step (16) if fuel filter was removed.

16. Install fuel filter (Figure 6, Item 6) on fuel supply hose (Figure 6, Item 4) with two clamps (Figure 6, Item 5).
17. Install fuel supply hose (Figure 6, Item 4) on fuel supply line (Figure 6, Item 7) and elbow (Figure 6, Item 2) with tubing nuts (Figure 6, Item 3).
18. Install tiedown straps as required.

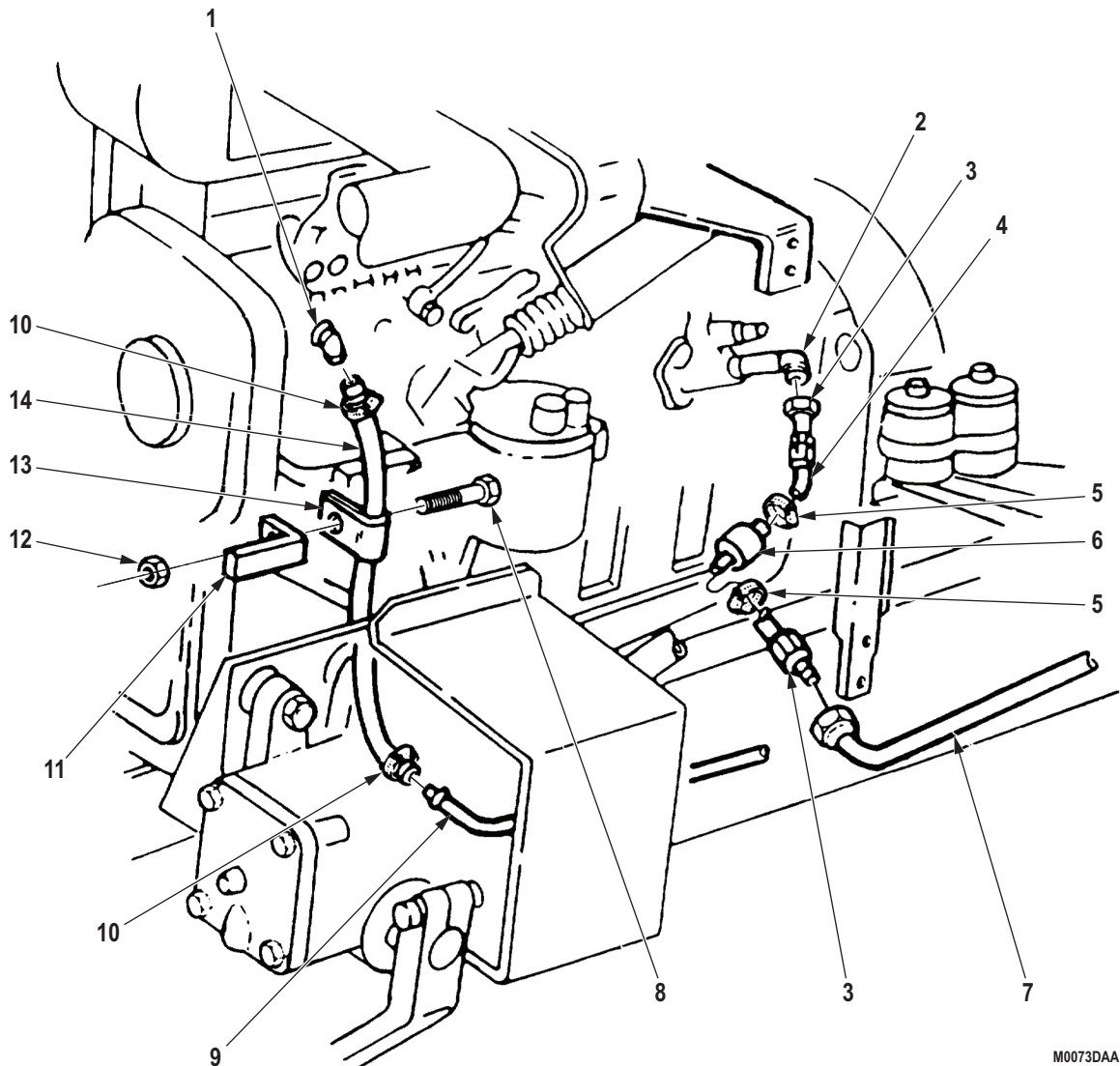

M0073DAA

Figure 6. Fuel Return and Supply Lines Installation.

END OF TASK

FOLLOW-ON MAINTENANCE

1. Prime fuel system. (WP 0239)
2. Hood closed and secured. (TM 9-2320-272-10)
3. Start engine and check for fuel leaks. (TM 9-2320-272-10)

END OF TASK**END OF WORK PACKAGE**

FIELD MAINTENANCE
FUEL SELECTOR VALVE, MOUNTING BRACKET, AND INDICATOR PLATE REPLACEMENT

INITIAL SETUP:**Tools and Special Tools**

Tool Kit, General Mechanic's: Automotive
(Volume 5, WP 0826, Table 1, Item 56)

Materials/Parts

Tape, Antiseizing
(Volume 5, WP 0825, Table 1, Item 65)
Locknut (Volume 5, WP 0827, Table 1, Item 282)
Qty: 2
Lockwasher

Materials/Parts (cont.)

(Volume 5, WP 0827, Table 1, Item 186)
Qty: 2
Lockwasher
(Volume 5, WP 0827, Table 1, Item 402)
Qty: 1

Equipment Condition

Parking brake set. (TM 9-2320-272-10)
Selector valve flex hoses removed. (WP 0257)

REMOVAL**WARNING**

Diesel fuel is highly flammable. Do not perform fuel system procedures near open flame. Failure to comply may result in injury or death to personnel.

1. Remove screw (Figure 1, Item 1), lockwasher (Figure 1, Item 2), and lever (Figure 1, Item 3) from left rear cab floor (Figure 1, Item 5). Discard lockwasher.
2. Remove two screws (Figure 1, Item 12), lockwashers (Figure 1, Item 11), and selector valve (Figure 1, Item 9) from mounting bracket (Figure 1, Item 10). Discard lockwashers.
3. Remove two locknuts (Figure 1, Item 13), screws (Figure 1, Item 15), washers (Figure 1, Item 14), indicator plate (Figure 1, Item 4), and mounting bracket (Figure 1, Item 10) from cab floor (Figure 1, Item 5). Discard locknuts.

NOTE

- Use soft-nosed vise to hold selector valve.
 - Tag fittings for installation.
4. Remove two elbows (Figure 1, Item 7), pipe nipples (Figure 1, Item 6), and elbows (Figure 1, Item 8) from fuel selector valve (Figure 1, Item 9).

END OF TASK**INSPECTION**

1. Install lever (Figure 1, Item 3) on selector valve (Figure 1, Item 9) with screw (Figure 1, Item 1).
2. Turn lever (Figure 1, Item 3) left, then right, while checking inside of selector valve (Figure 1, Item 9) for burrs and nicks. Replace selector valve if nicked or burred.
3. Remove screw (Figure 1, Item 1) and lever (Figure 1, Item 3) from selector valve (Figure 1, Item 9).
4. Inspect two pipe nipples (Figure 1, Item 6) and elbows (Figure 1, Items 7 and 8) for stripped threads. Replace any part if threads are stripped.

INSPECTION - Continued

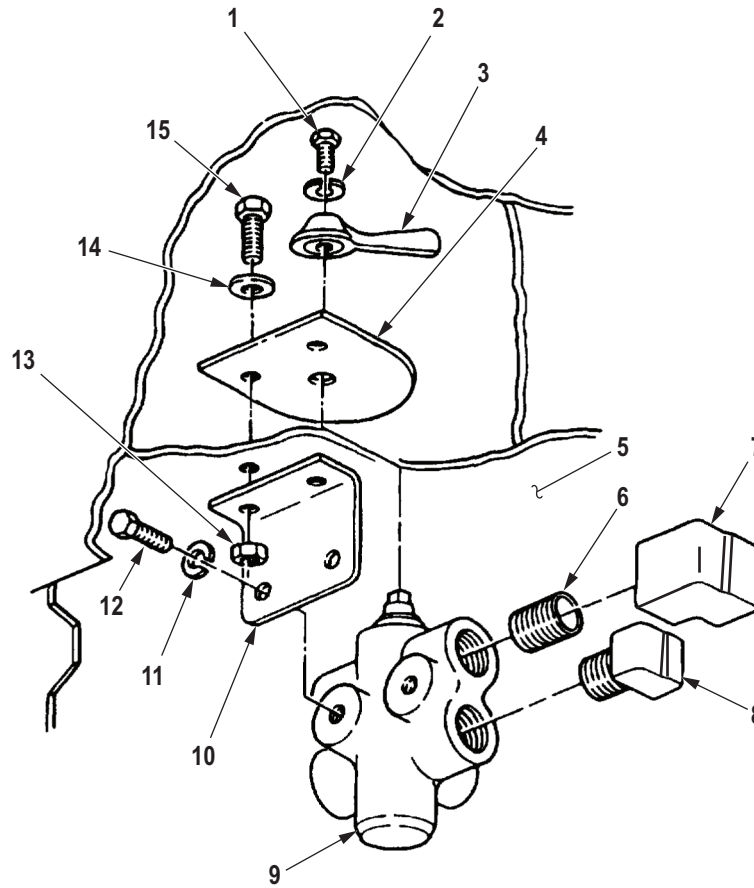

M0055DAA

Figure 1. Fuel Selector Valve Removal.

END OF TASK

INSTALLATION**NOTE**

Locknuts are installed under cab floor.

1. Align indicator plate (Figure 2, Item 4) and mounting bracket (Figure 2, Item 10) with holes in cab floor (Figure 2, Item 5) and install with two washers (Figure 2, Item 14), screws (Figure 2, Item 15), and locknuts (Figure 2, Item 13).

NOTE

Male pipe threads must be wrapped with antiseize tape before installation.

2. Install two elbows (Figure 2, Item 8), pipe nipples (Figure 2, Item 6), and elbows (Figure 2, Item 7) on selector valve (Figure 2, Item 9).
3. Install selector valve (Figure 2, Item 9) on mounting bracket (Figure 2, Item 10) with two lockwashers (Figure 2, Item 11) and screws (Figure 2, Item 12).
4. Install lever (Figure 2, Item 3) on selector valve (Figure 2, Item 9) with lockwasher (Figure 2, Item 2) and screw (Figure 2, Item 1). Ensure lever (Figure 2, Item 3) pointer is positioned opposite notch on stem of selector valve (Figure 2, Item 9).

INSTALLATION - Continued

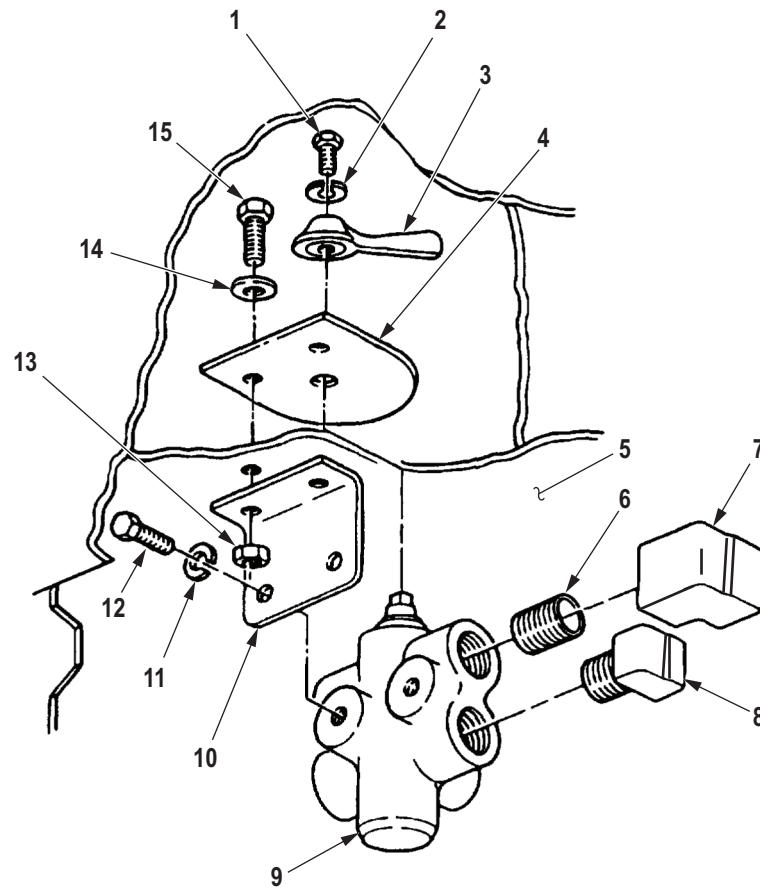

M0056DAA

Figure 2. Fuel Selector Valve Installation.

END OF TASK

FOLLOW-ON MAINTENANCE

1. Connect selector valve flex hoses. (WP 0257)
2. Start engine and check for fuel leaks at valve when switching selector valve to both tanks. (TM 9-2320-272-10)

END OF TASK

END OF WORK PACKAGE

FIELD MAINTENANCE
FUEL DRAIN AND BYPASS TUBING REPLACEMENT (M939/A1)

INITIAL SETUP:**Tools and Special Tools**

Tool Kit, General Mechanic's: Automotive
(Volume 5, WP 0826, Table 1, Item 56)
Wrench, Torque, Click, Ratcheting, 1/2" Drive,
250 Ft-Lb
(Volume 5, WP 0826, Table 1, Item 63)

Equipment Condition (cont.)

Hood raised and secured. (TM 9-2320-272-10)
Water pump removed. (WP 0293)
Air compressor-to-engine coolant return tube
removed. (WP 0284)

Materials/Parts

Tape, Antiseizing
(Volume 5, WP 0825, Table 1, Item 65)
Lockwasher
(Volume 5, WP 0827, Table 1, Item 301)
Qty: 5
Lockwasher
(Volume 5, WP 0827, Table 1, Item 443)
Qty: 1

Equipment Condition

Parking brake set. (TM 9-2320-272-10)

REMOVAL**NOTE**

- Have drainage container ready to catch fuel.
 - Use drain pans to retain leaking/draining fluids. Refer to local procedures and plans for preventing and responding to fluid spills or leaks. Comply with local regulations when disposing of clean up material and leaked and spilled fluids.
1. Disconnect fuel supply tube (Figure 1, Item 9) from fuel pump shutoff valve (Figure 1, Item 10).
 2. Disconnect fuel return tube (Figure 1, Item 18) from fuel pump elbow (Figure 1, Item 21).
 3. Remove screw (Figure 1, Item 17), lockwasher (Figure 1, Item 16), washer (Figure 1, Item 15), clamp (Figure 1, Item 14), and spacer (Figure 1, Item 13) from left side of engine block (Figure 1, Item 3) and bracket (Figure 1, Item 12). Discard lockwasher.
 4. Remove screw (Figure 1, Item 19), lockwasher (Figure 1, Item 20), and bracket (Figure 1, Item 12) from left side of engine block (Figure 1, Item 3). Discard lockwasher.

NOTE

Step (5) may not be required for all vehicles.

5. Remove screw (Figure 1, Item 26), lockwasher (Figure 1, Item 25), washer (Figure 1, Item 24), two clamps (Figure 1, Item 23), fuel supply tube (Figure 1, Item 9), and fuel return tube (Figure 1, Item 4) from intake manifold (Figure 1, Item 22). Discard lockwasher.
6. Remove nut (Figure 1, Item 5), lockwasher (Figure 1, Item 6), screw (Figure 1, Item 8), and clamp (Figure 1, Item 7) from left side of engine block (Figure 1, Item 3). Discard lockwasher.
7. Remove nut (Figure 1, Item 1), lockwasher (Figure 1, Item 2), screw (Figure 1, Item 27), and clamp (Figure 1, Item 28) from tubes (Figure 1, Items 4 and 9) on left side of engine block (Figure 1, Item 3). Discard lockwasher.
8. Disconnect fuel return tubes (Figure 1, Items 4 and 17) from tee (Figure 1, Item 11).

REMOVAL - Continued

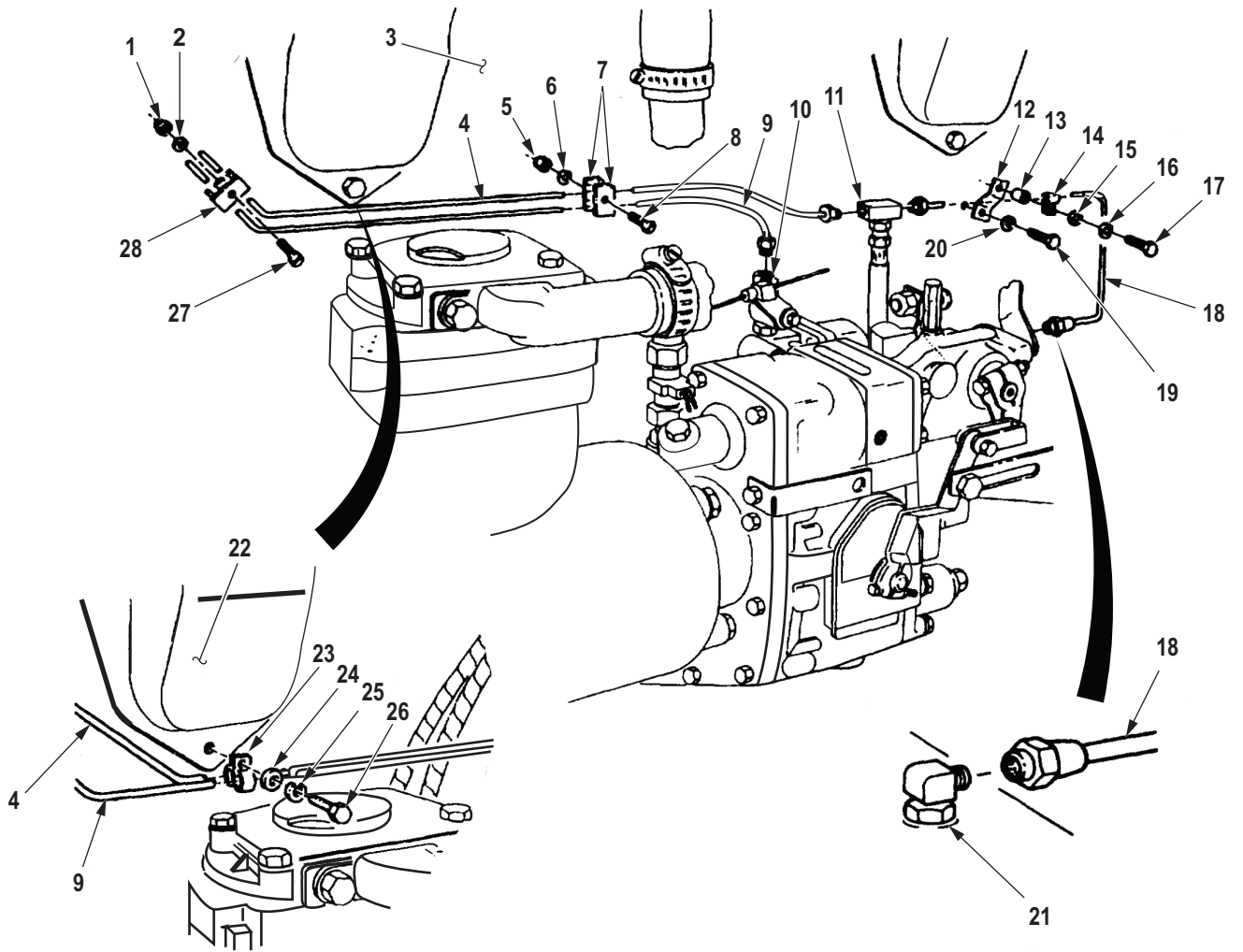

M0040DAA

Figure 1. Fuel Bypass Tubing Removal.

REMOVAL - Continued

9. Remove screw (Figure 2, Item 4), lockwasher (Figure 2, Item 5), washer (Figure 2, Item 6), clamp (Figure 2, Item 7) with fuel supply tube (Figure 2, Item 10), support bracket (Figure 2, Item 8), and spacer (Figure 2, Item 9) from front of cylinder head (Figure 2, Item 3). Discard lockwasher.

NOTE

Perform Step (10) for early model engines or Step (11) for late model engines.

10. Remove fuel supply tube (Figure 2, Item 10) from adapter (Figure 2, Item 15).

NOTE

Perform Step (11) for vehicles equipped with late model engines.

11. Remove fuel supply tube (Figure 2, Item 10) and fuel pressure transducer (Figure 2, Item 14) from tee (Figure 2, Item 11).
12. Remove fuel supply tube (Figure 2, Item 12) from adapter (Figure 2, Item 13).
13. Remove two screws (Figure 2, Item 1) and upper radiator support bracket (Figure 2, Item 2) from front of cylinder head (Figure 2, Item 3).

NOTE

Perform Step (14) for early model engines or Step (15) for late model engines.

14. Remove two adapters (Figure 2, Items 13 and 15) from front of cylinder head (Figure 2, Item 3).
15. Remove tee (Figure 2, Item 11) and adapter (Figure 2, Item 13) from front of cylinder head (Figure 2, Item 3).

REMOVAL - Continued

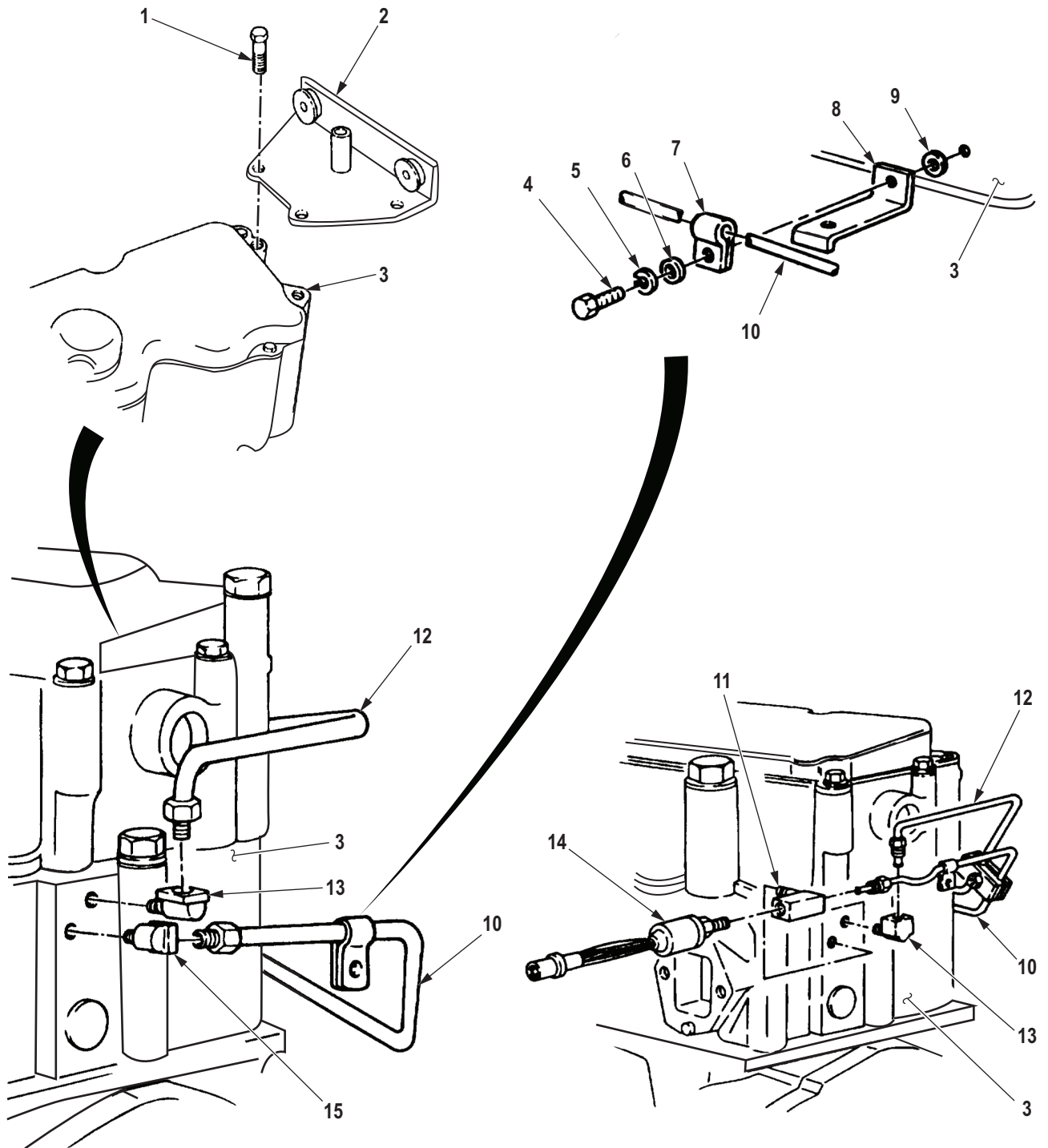

M0041DAA

Figure 2. Fuel Bypass Tubing Removal.

END OF TASK

INSTALLATION**NOTE**

- Wrap all male pipe threads with antiseize tape before installation.
 - Perform Step (1) for early model engines and Step (2) for late model engines.
1. Install adapters (Figure 3, Item 13) and (Figure 3, Item 15) on front of cylinder head (Figure 3, Item 3).
 2. Install tee (Figure 3, Item 11) and adapter (Figure 3, Item 13) on front of cylinder head (Figure 3, Item 3).
 3. Install upper radiator support bracket (Figure 3, Item 2) on front of cylinder head (Figure 3, Item 3) with two screws (Figure 3, Item 1). Tighten screws 55 to 65 lb-ft (75 to 88 N·m).
 4. Connect fuel return tube (Figure 3, Item 12) to adapter (Figure 3, Item 13).

NOTE

Perform Step (5) for early model engines or Step (6) for late model engines.

5. Connect fuel supply tube (Figure 3, Item 10) to adapter (Figure 3, Item 15).

NOTE

Perform Step (6) for vehicles with late model engines.

6. Connect fuel supply tube (Figure 3, Item 10) and fuel pressure transducer (Figure 3, Item 14) to tee (Figure 3, Item 11).
7. Install spacer (Figure 3, Item 9), support bracket (Figure 3, Item 8), and clamp (Figure 3, Item 7) with fuel supply tube (Figure 3, Item 10) on front of cylinder head (Figure 3, Item 3) with washer (Figure 3, Item 6), lockwasher (Figure 3, Item 5), and screw (Figure 3, Item 4).

INSTALLATION - Continued

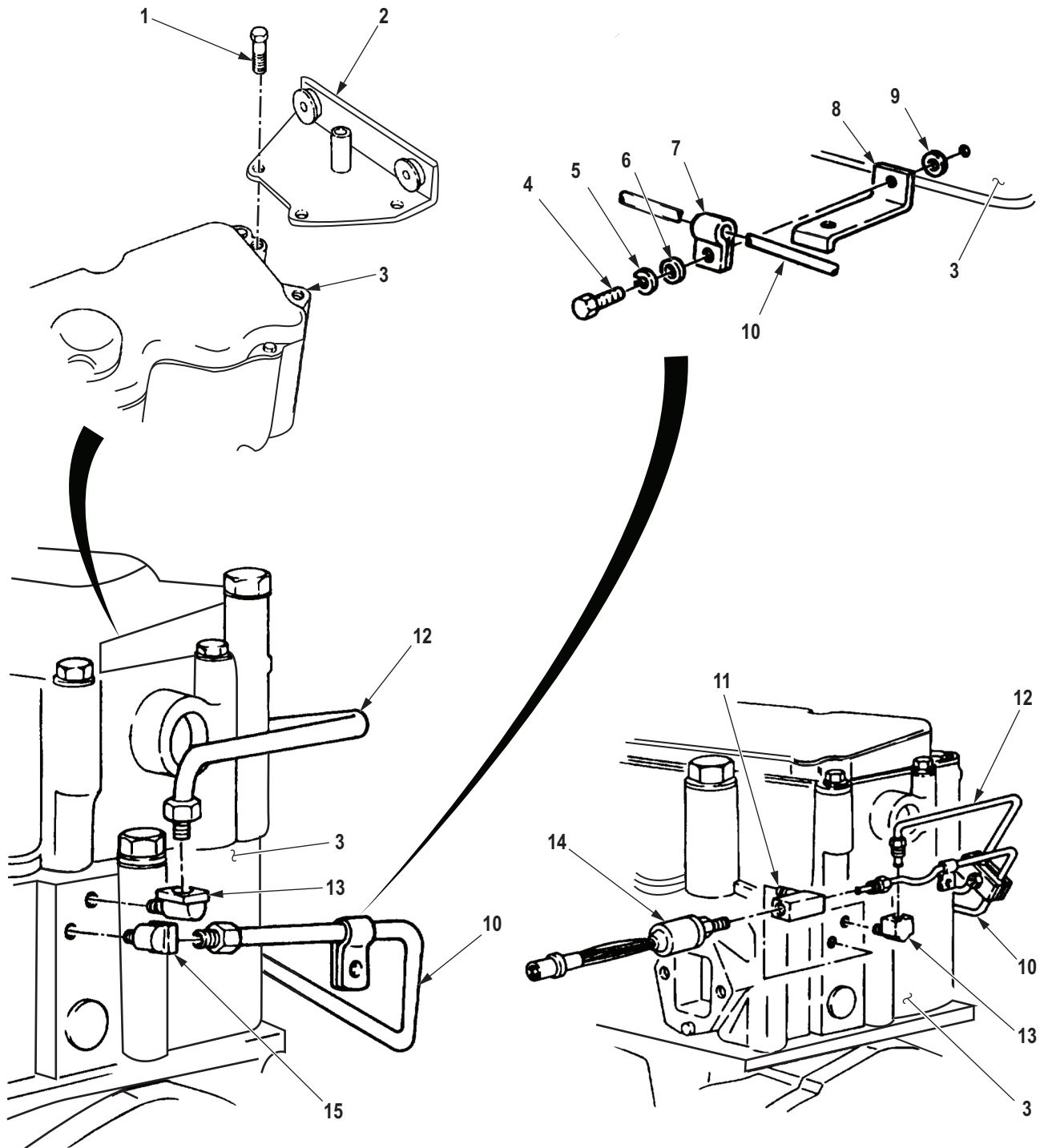

M0042DAA

Figure 3. Fuel Bypass Tubing Installation.

INSTALLATION - Continued

8. Install clamp (Figure 4, Item 28) on fuel return tube (Figure 4, Item 4) and fuel supply tube (Figure 4, Item 9) with screw (Figure 4, Item 27), lockwasher (Figure 4, Item 2), and nut (Figure 4, Item 1).
9. Install clamp (Figure 4, Item 7) on fuel return tube (Figure 4, Item 4) and fuel supply tube (Figure 4, Item 9) with screw (Figure 4, Item 8), lockwasher (Figure 4, Item 6), and nut (Figure 4, Item 5).

NOTE

Step (10) may not be required for all vehicles.

10. Install two clamps (Figure 4, Item 23) and tubes (Figure 4, Items 4 and 9) on manifold (Figure 4, Item 22) with washer (Figure 4, Item 24), lockwasher (Figure 4, Item 25), and screw (Figure 4, Item 26).
11. Install bracket (Figure 4, Item 12) on engine block (Figure 4, Item 3) with lockwasher (Figure 4, Item 20) and screw (Figure 4, Item 19).
12. Install clamp (Figure 4, Item 14) and tube (Figure 4, Item 18) on bracket (Figure 4, Item 12) with spacer (Figure 4, Item 13), washer (Figure 4, Item 15), lockwasher (Figure 4, Item 16), and screw (Figure 4, Item 17).
13. Connect fuel return tube (Figure 4, Item 18) to fuel pump elbow (Figure 4, Item 21).
14. Connect fuel supply tube (Figure 4, Item 9) to fuel pump shutoff valve (Figure 4, Item 10).
15. Connect tubes (Figure 4, Items 4 and 18) to tee (Figure 4, Item 11).

INSTALLATION - Continued

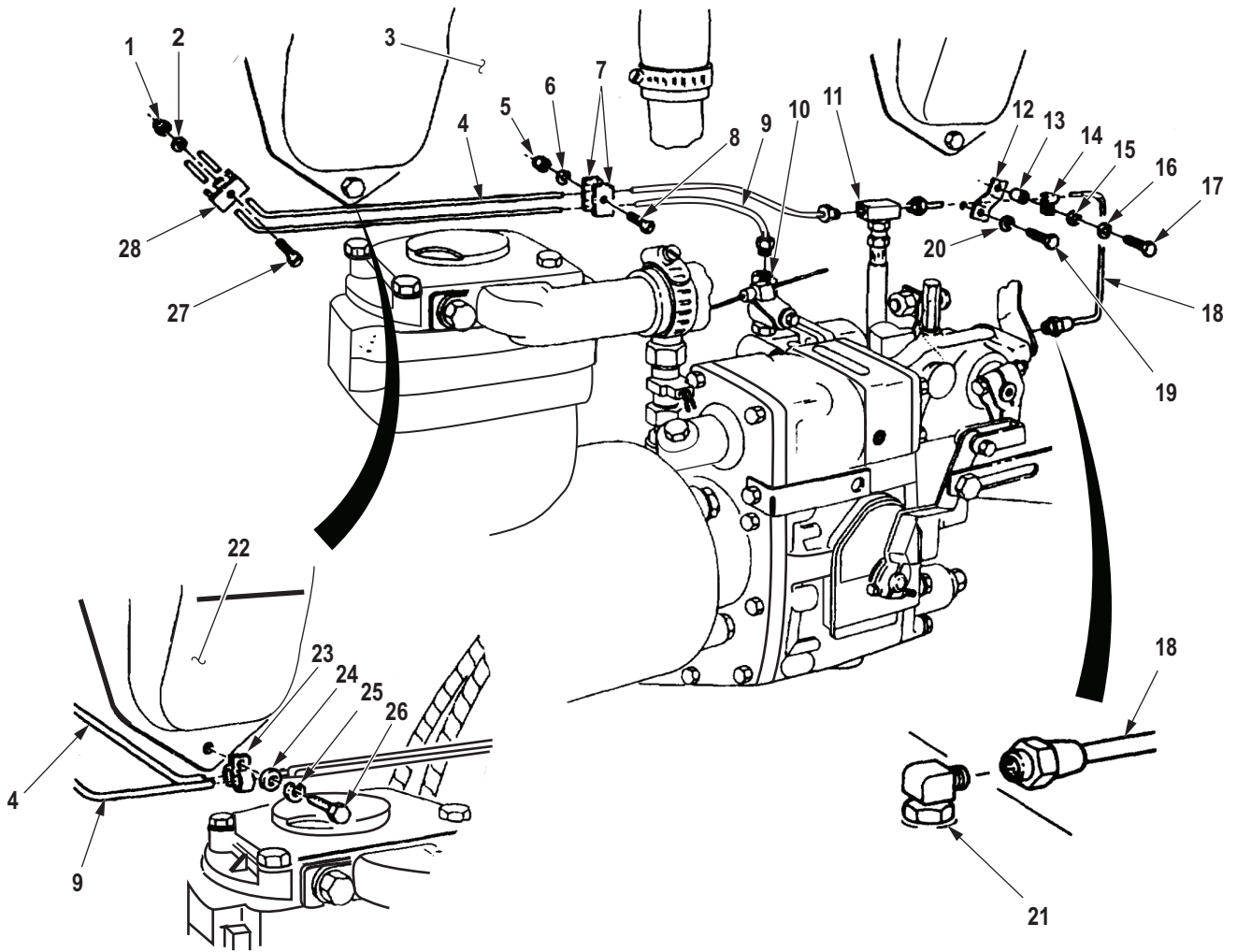

M0043DAA

Figure 4. Fuel Bypass Tubing Installation.

END OF TASK

FOLLOW-ON MAINTENANCE

1. Install air compressor-to-engine coolant return tube. (WP 0284)
2. Install water pump. (WP 0293)
3. Hood closed and secured. (TM 9-2320-272-10)

END OF TASK

END OF WORK PACKAGE

FIELD MAINTENANCE
FUEL SELECTOR VALVE FLEX HOSE REPLACEMENT

INITIAL SETUP:**Tools and Special Tools**

Tool Kit, General Mechanic's: Automotive
(Volume 5, WP 0826, Table 1, Item 56)

Equipment Condition (cont.)

Hood raised and secured. (TM 9-2320-272-10)

Materials/Parts

Cap Set, Protective, Dust and Moisture Seal
(Volume 5, WP 0825, Table 1, Item 13)
Tape, Antiseizing
(Volume 5, WP 0825, Table 1, Item 65)

Equipment Condition

Parking brake set. (TM 9-2320-272-10)

REMOVAL**WARNING**

Diesel fuel is highly flammable. Do not perform fuel system procedures near open flame. Failure to comply may result in injury or death to personnel.

NOTE

- All hoses are disconnected the same.
 - All hoses must be disconnected from fuel lines first.
 - Have drainage container ready to catch fuel.
 - Plug all fuel lines using protective cap plugs.
 - Tag lines and fittings for installation.
 - Use drain pans to retain leaking/draining fluids. Refer to local procedures and plans for preventing and responding to fluid spills or leaks. Comply with local regulations when disposing of clean up material and leaked and spilled fluids.
1. Disconnect six flex hoses (Figure 1, Item 4) from four fuel lines (Figure 1, Item 3) and two fuel line-to-hose adapters (Figure 1, Item 5).
 2. Disconnect six flex hoses (Figure 1, Item 4) from two valve ports (Figure 1, Item 6) and four elbows (Figure 1, Item 2) on selector valve (Figure 1, Item 1).

REMOVAL - Continued

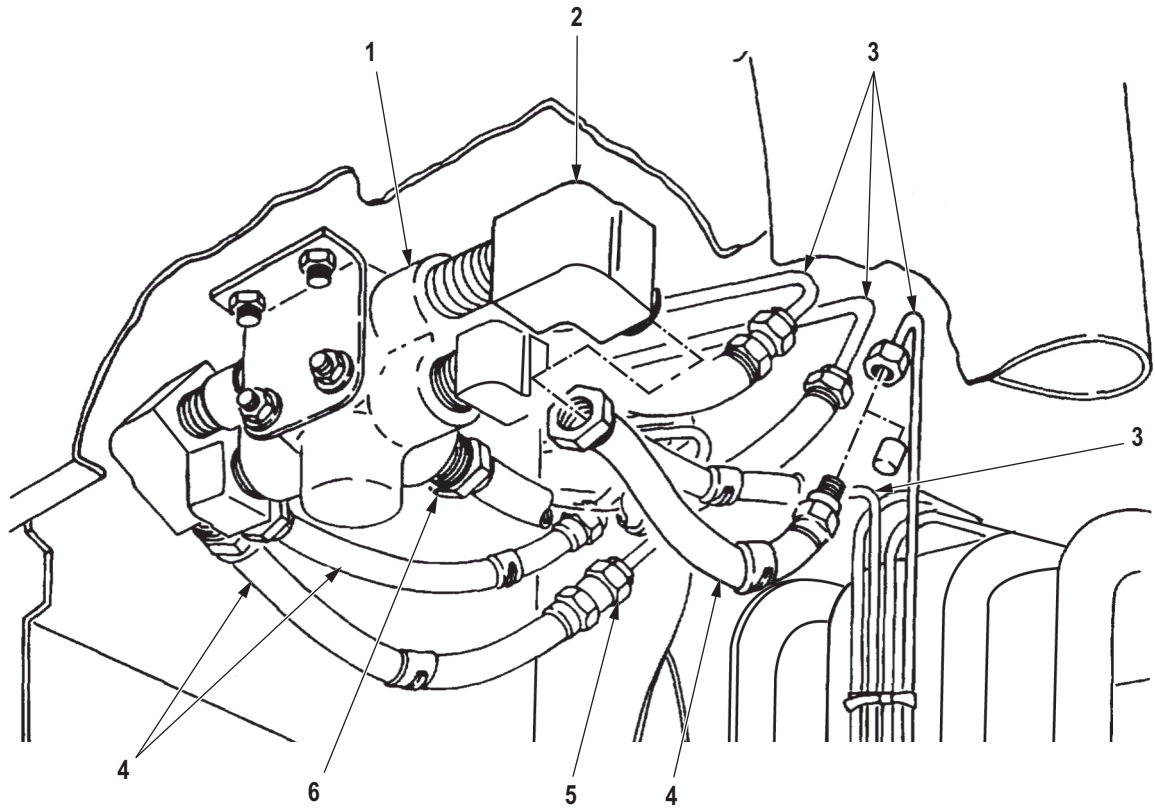

M0053DAA

Figure 1. Fuel Selector Valve Flex Hose Removal.

END OF TASK

INSTALLATION**NOTE**

- Male pipe threads must be wrapped with antiseize tape before installation.
 - Remove protective cap plugs from fuel lines before installation.
1. Connect six flex hoses (Figure 2, Item 4) to two valve ports (Figure 2, Item 6) and four elbows (Figure 2, Item 2) on selector valve (Figure 2, Item 1).
 2. Connect six flex hoses (Figure 2, Item 4) to four fuel line (Figure 2, Item 3) and two fuel line-to-hose adapters (Figure 2, Item 5).

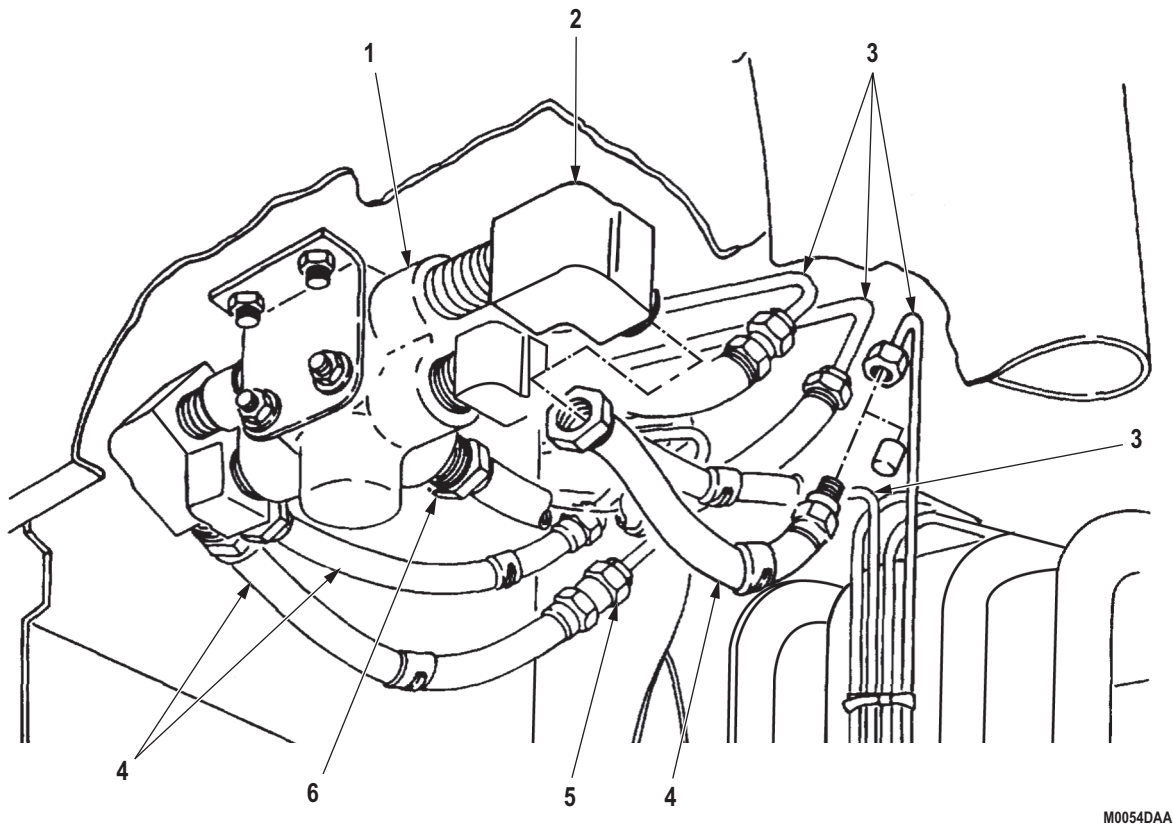

M0054DAA

Figure 2. Fuel Selector Valve Flex Hose Installation.

END OF TASK**FOLLOW-ON MAINTENANCE**

1. Hood closed and secured. (TM 9-2320-272-10)
2. Start engine and test selector valve for fuel leaks and proper operation. (TM 9-2320-272-10)

END OF TASK**END OF WORK PACKAGE**

**FIELD MAINTENANCE
FUEL FILTER AND COVER REPLACEMENT**

INITIAL SETUP:**Tools and Special Tools**

Tool Kit, General Mechanic's: Automotive
(Volume 5, WP 0826, Table 1, Item 56)
Wrench, Torque, Click, Ratcheting, 3/8" Drive,
75 Ft-Lb
(Volume 5, WP 0826, Table 1, Item 62)

Materials/Parts

Cleaning Compound, Solvent
(Volume 5, WP 0825, Table 1, Item 16, 17)
Cloth, Cleaning
(Volume 5, WP 0825, Table 1, Item 19)
Diesel Fuel, DF-2, Regular
(Volume 5, WP 0825, Table 1, Item 21, 22,
23)
Tape, Antiseizing
(Volume 5, WP 0825, Table 1, Item 65)
Fluid Pressure Kit
(Volume 5, WP 0827, Table 1, Item 55)
Fuel Filter
(Volume 5, WP 0827, Table 1, Item 120)
Qty: 1

Materials/Parts (cont.)

Locknut
(Volume 5, WP 0827, Table 1, Item 277)
Qty: 3
Stud, Continuous Thread
(Volume 5, WP 0827, Table 1, Item 158)
Qty: 1

Personnel Required

(2)

Equipment Condition

Parking brake set. (TM 9-2320-272-10)
Hood raised and secured. (TM 9-2320-272-10)

REMOVAL (M939A2)**WARNING**

Diesel fuel is highly flammable. Do not perform fuel system procedures near open flame. Failure to comply may result in injury or death to personnel.

NOTE

- Have drainage container ready to catch fuel.
 - Use drain pans to retain leaking/draining fluids. Refer to local procedures and plans for preventing and responding to fluid spills or leaks. Comply with local regulations when disposing of clean up material and leaked and spilled fluids.
1. Remove fuel filter (Figure 1, Item 3) from fuel filter head (Figure 1, Item 1). Discard fuel filter.

NOTE

Perform Step (2) if stud threads are stripped.

2. Remove stud (Figure 1, Item 2) from fuel filter head (Figure 1, Item 1). Discard stud.

REMOVAL (M939A2) - Continued

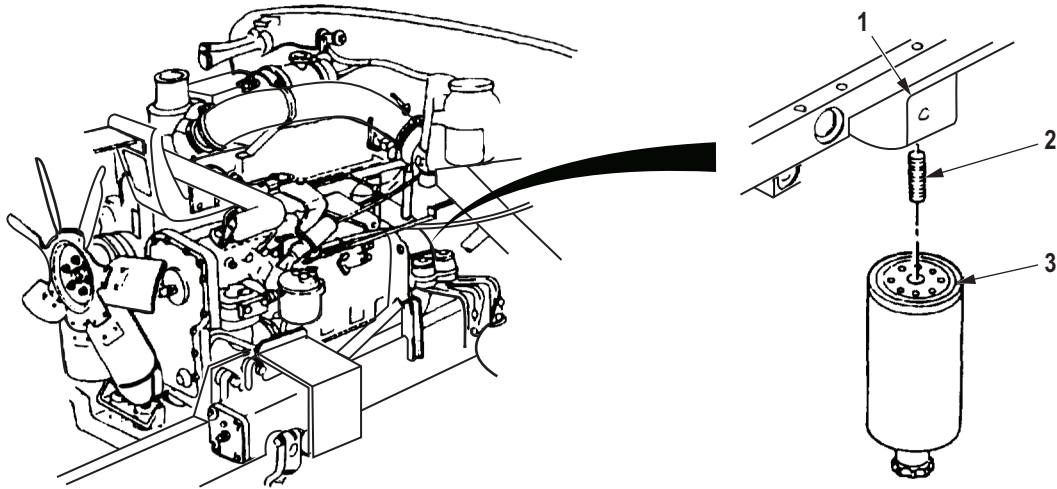

M0074DAA

Figure 1. Fuel Filter Removal.

END OF TASK

REMOVAL (M939/A1)**NOTE**

- Have drainage container ready to catch fuel.
 - Use drain pans to retain leaking/draining fluids. Refer to local procedures and plans for preventing and responding to fluid spills or leaks. Comply with local regulations when disposing of clean up material and leaked and spilled fluids.
1. Open filter drain valve (Figure 2, Item 6) and inlet drain valve (Figure 2, Item 4) located at left front underside of cab.
 2. Close drain valves (Figure 2, Items 4 and 6) when fuel drainage is complete.
 3. Holding filter case (Figure 2, Item 5), remove center bolt (Figure 2, Item 1), square washer (Figure 2, Item 2), and small o-ring (Figure 2, Item 3) from top of filter cover (Figure 2, Item 9). Discard o-ring.
 4. Remove filter case (Figure 2, Item 5), fuel filter element (Figure 2, Item 7), and large gasket (Figure 2, Item 8) from filter cover (Figure 2, Item 9). Discard gasket and fuel filter element.
 5. Remove drain valve (Figure 2, Item 6) from filter case (Figure 2, Item 5).

REMOVAL (M939/A1) - Continued

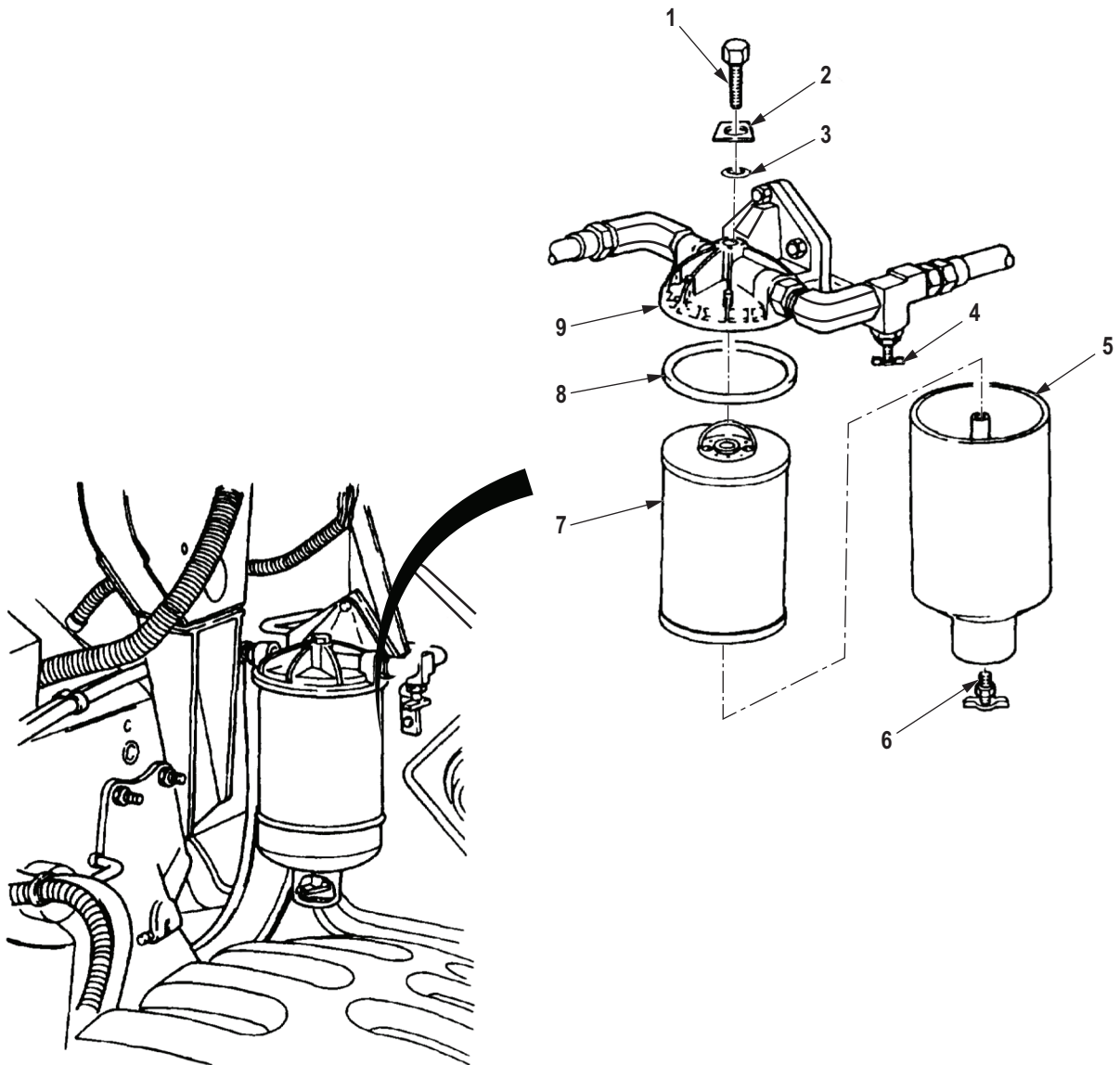

M10227DAA

Figure 2. Fuel Filter Removal.

REMOVAL (M939/A1) - Continued**NOTE**

- If only the filter is to be replaced, perform Cleaning and Inspection, Steps (2) through (5).
- Perform Steps (6) through (11) to repair or replace filter cover or any fittings.

6. Disconnect filter inlet line (Figure 3, Item 3) from stud (Figure 3, Item 4).
7. Disconnect filter outlet line (Figure 3, Item 9) from elbow (Figure 3, Item 10).

NOTE

- Assistant will help with Steps (8) through (10).
- Record the directions of elbow and tee before removal.

8. Remove three locknuts (Figure 3, Item 2), screws (Figure 3, Item 11), and filter cover (Figure 3, Item 8) from mounting bracket (Figure 3, Item 1). Discard locknuts.
9. Remove elbow (Figure 3, Item 10) from filter cover (Figure 3, Item 8).
10. Remove stud (Figure 3, Item 4), tee (Figure 3, Item 3), and elbow (Figure 3, Item 7) from filter cover (Figure 3, Item 8).
11. Remove drain valve (Figure 3, Item 6) from tee (Figure 3, Item 3).

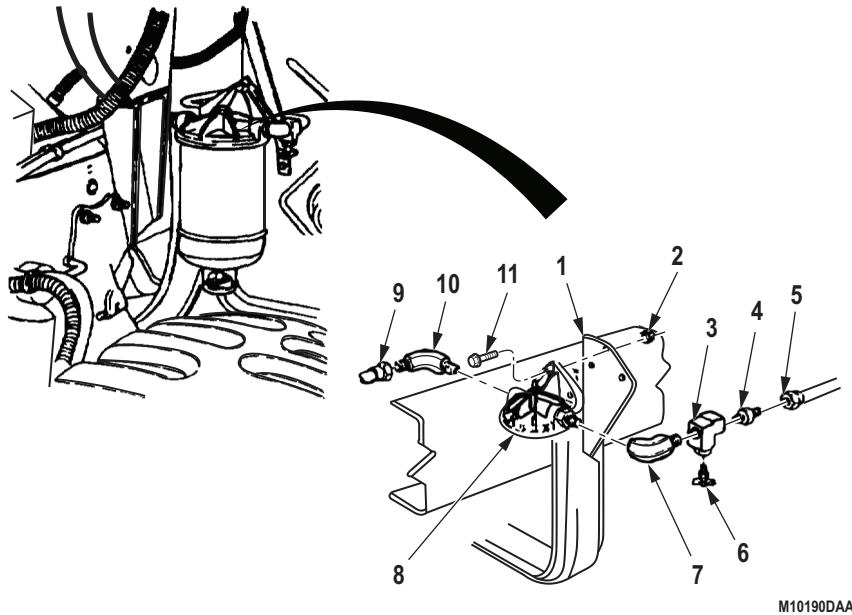

Figure 3. Fuel Filter Removal.

END OF TASK

CLEANING AND INSPECTION**NOTE**

Perform all steps if fuel filter cover was removed from vehicle.

1. Inspect elbows (Figure 4, Items 1 and 5), tee (Figure 4, Item 2), stud (Figure 4, Item 3), and drain valve (Figure 4, Item 4) for stripped threads. Replace any damaged part(s).

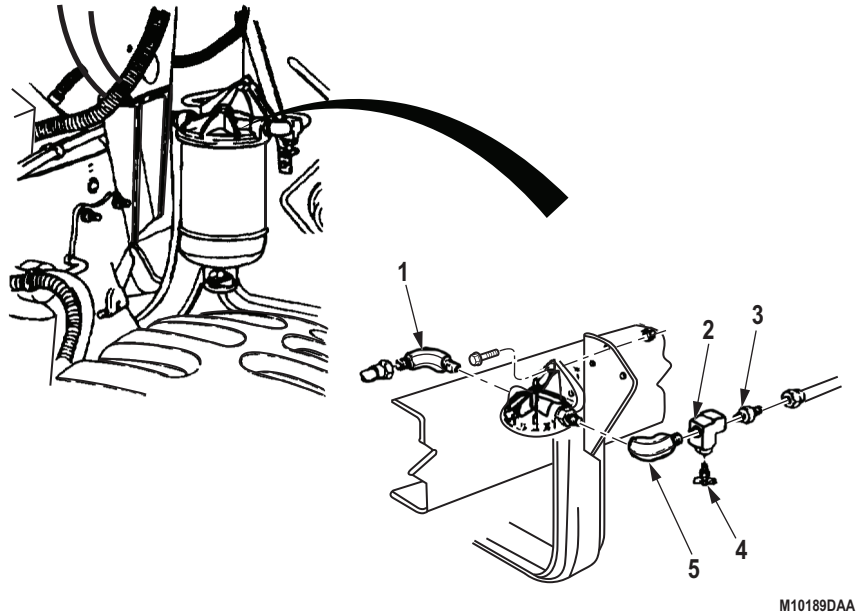
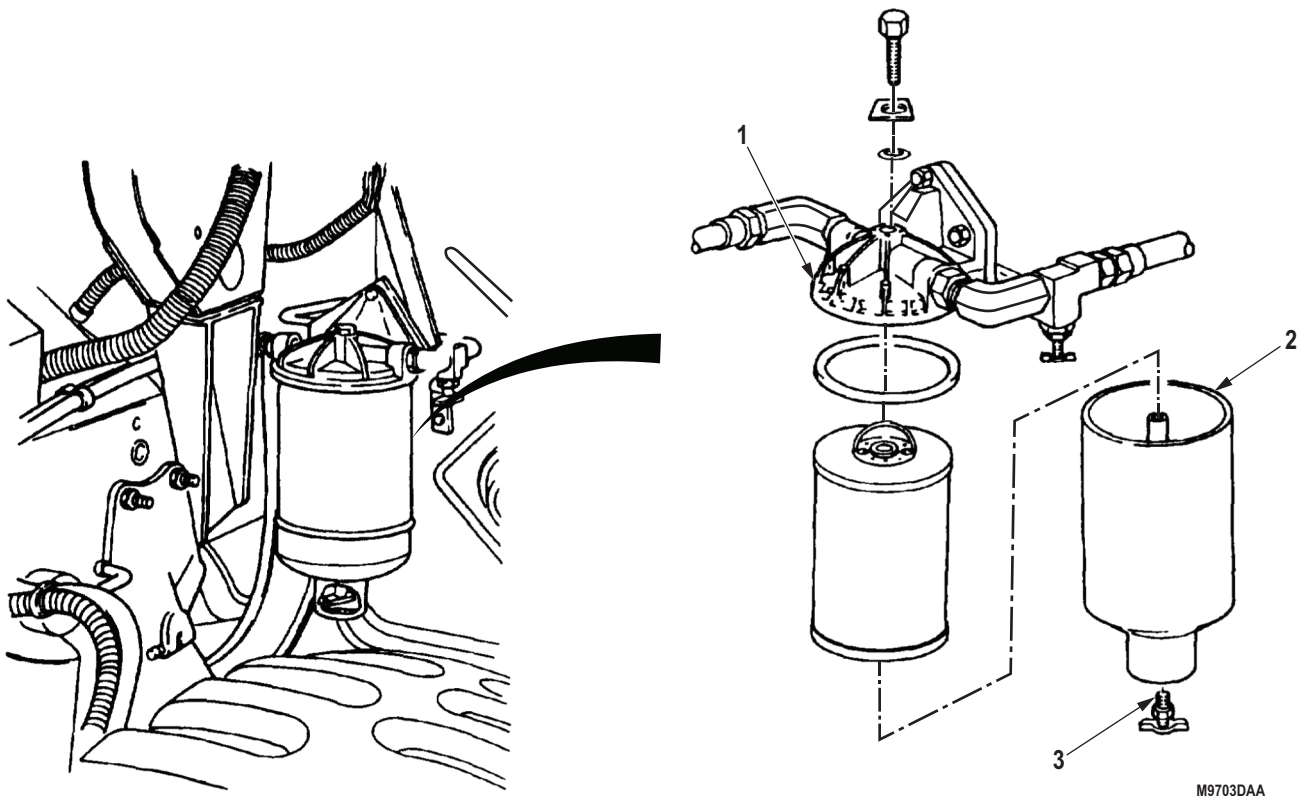

Figure 4. Fuel Filter Removal.

CLEANING AND INSPECTION - Continued**WARNING**

Solvent cleaning compound is flammable and will not be used near an open flame. A fire extinguisher will be kept nearby when solvent is used. Use only in well-ventilated places. Failure to comply may result in damage to equipment, injury, or death to personnel.

2. Clean filter cover (Figure 5, Item 1) and filter case (Figure 5, Item 2) with solvent cleaning compound and dry with lint-free cloth.
3. Inspect fuel filter cover (Figure 5, Item 1) for cracks or damage to gasket seating area. Replace if cracked or seating area is damaged.
4. Inspect fuel filter case (Figure 5, Item 2) for cracks, stripped threads or damage to gasket seating area. Replace if cracked, threads are stripped, or seating area is damaged.
5. Inspect drain valve (Figure 5, Item 3) for stripped threads. Replace if threads are stripped.



M9703DAA

Figure 5. Fuel Filter Cleaning and Inspection.

END OF TASK

INSTALLATION (M939/A1)**NOTE**

All male pipe threads must be wrapped with antiseize tape before installation.
If only the fuel filter element was changed, go to Step (5).

1. Install adapter elbows (Figure 6, Items 7 and 10) on filter cover (Figure 6, Item 8) in directions noted during removal.

NOTE

Ensure drain valve port on tee faces down.

2. Install tee (Figure 6, Item 3) on elbow (Figure 6, Item 7).
3. Install drain valve (Figure 6, Item 6) and stud (Figure 6, Item 4) on tee (Figure 6, Item 3) and connect filter inlet line (Figure 6, Item 5) to stud.
4. Connect filter outlet line (Figure 6, Item 9) to elbow (Figure 6, Item 10) and attach filter cover (Figure 6, Item 8) to mounting bracket (Figure 6, Item 1) with three screws (Figure 6, Item 11) and locknuts (Figure 6, Item 2).

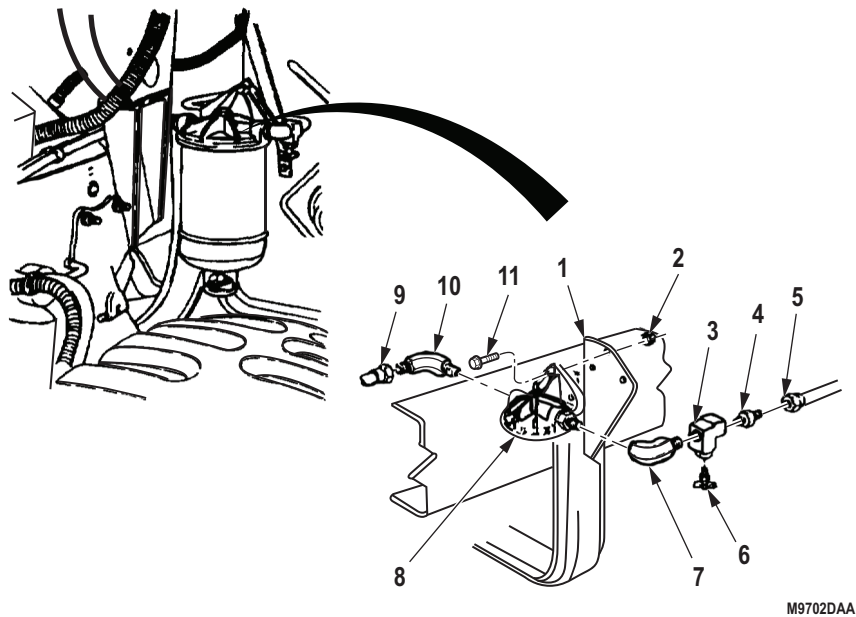

M9702DAA

Figure 6. Fuel Filter Installation.

INSTALLATION (M939/A1) - Continued

5. Install drain valve (Figure 7, Item 5) in fuel filter case (Figure 7, Item 4).
6. Position gasket (Figure 7, Item 8) in fuel filter cover (Figure 7, Item 9).
7. Place filter element (Figure 7, Item 6) in filter case (Figure 7, Item 4) with handle (Figure 7, Item 7) up.
8. Position filter case (Figure 7, Item 4) against cover (Figure 7, Item 9) and install filter case on filter cover with o-ring (Figure 7, Item 3), washer (Figure 7, Item 2), and screw (Figure 7, Item 1). Tighten screw 20 to 25 lb-ft (27 to 34 N·m).

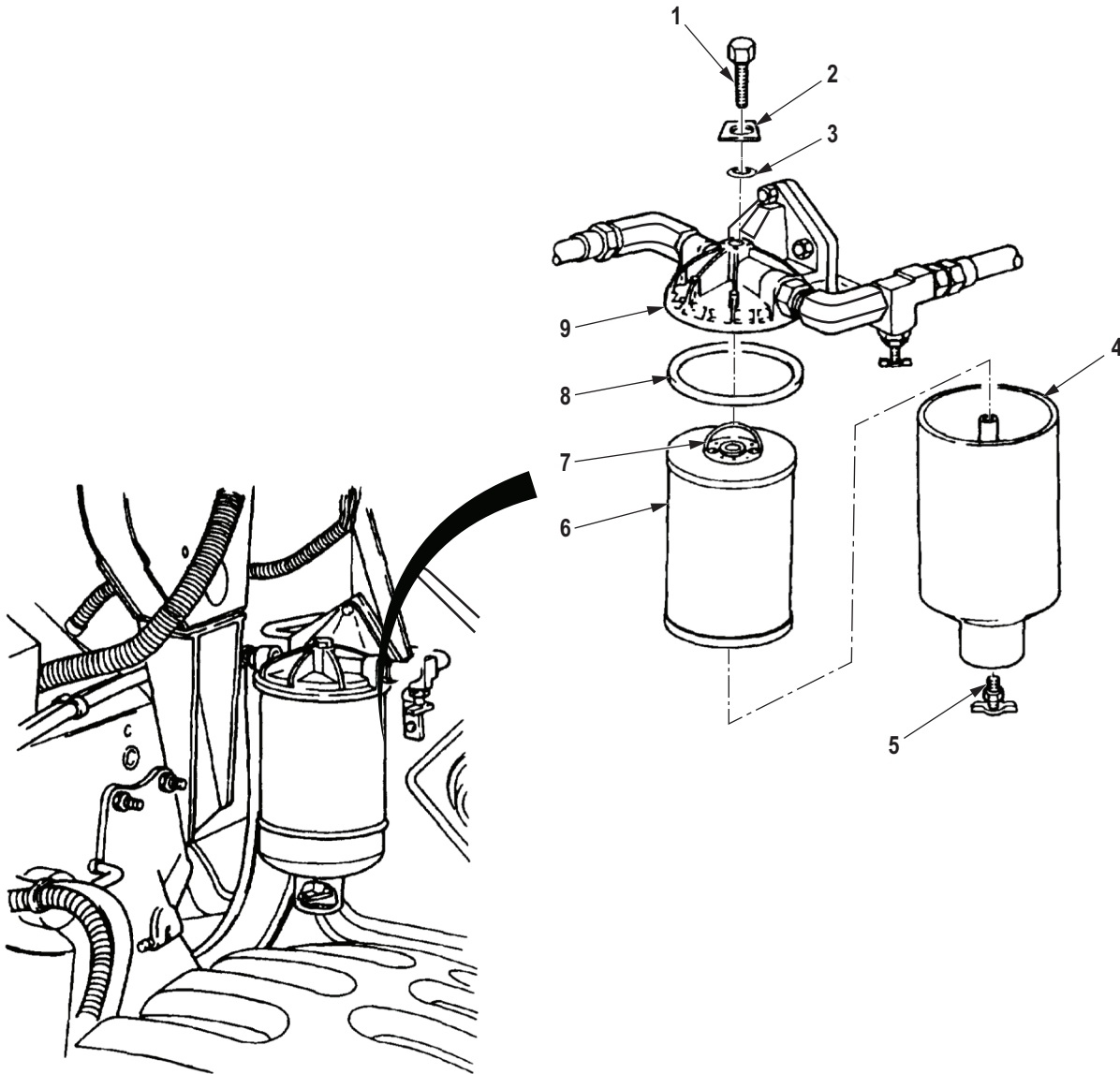

M0075DAA

*Figure 7. Fuel Filter Installation.***END OF TASK**

INSTALLATION (M939A2)**NOTE**

Perform Step (1) if stud was removed.

1. Install stud (Figure 8, Item 4) on fuel filter head (Figure 8, Item 1).
2. Fill fuel filter (Figure 8, Item 3) with clean diesel fuel. Coat seal (Figure 8, Item 2) with diesel fuel.
3. Install fuel filter (Figure 8, Item 3) on fuel filter head (Figure 8, Item 1). Hand-tighten fuel filter, then tighten an additional 3/4 turn.

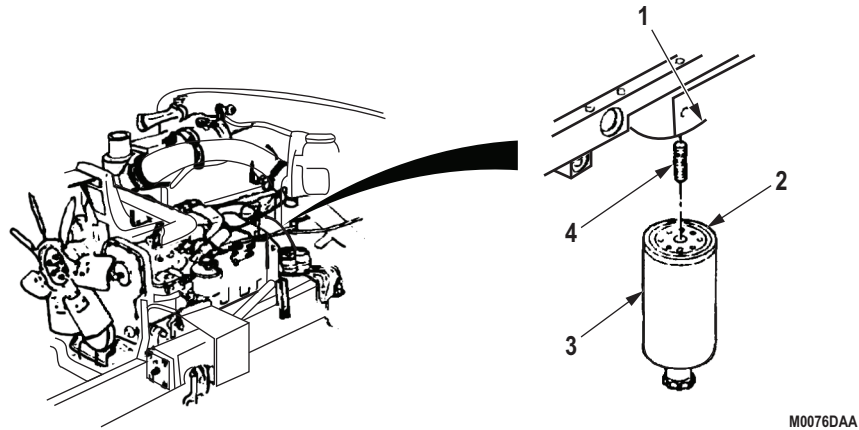

Figure 8. Fuel Filter Installation.

END OF TASK**FOLLOW-ON MAINTENANCE**

1. Prime fuel system (WP 0239) for M939A2; (TM 9-2320-272-10) for M939/A1.
2. Hood closed and secured. (TM 9-2320-272-10)
3. Start engine and check for fuel leaks. (TM 9-2320-272-10)

END OF TASK**END OF WORK PACKAGE**

FIELD MAINTENANCE
AFC FUEL PUMP FILTER REPLACEMENT (M939/A1)

INITIAL SETUP:**Tools and Special Tools**

Tool Kit, General Mechanic's: Automotive
(Volume 5, WP 0826, Table 1, Item 56)
Wrench, Torque, Click, Ratcheting, 3/8" Drive,
75 Ft-Lb
(Volume 5, WP 0826, Table 1, Item 62)

Materials/Parts

Rag, Wiping
(Volume 5, WP 0825, Table 1, Item 53)

Materials/Parts (cont.)

Filter (Volume 5, WP 0827, Table 1, Item 70)
Qty: 1
Gasket (Volume 5, WP 0827, Table 1, Item 74)
Qty: 1

References

WP 0239

Equipment Condition

Parking brake set. (TM 9-2320-272-10)
Left splash shield removed. (TM 9-2320-272-10)

REMOVAL**WARNING**

Diesel fuel is highly flammable. Do not perform fuel system procedures near open flame. Failure to comply may result in injury or death to personnel.

CAUTION

Fuel pump exterior must be cleaned before filter cap is removed to prevent foreign particles from entering fuel pump.

1. Using clean, dry cloth, clean exterior of fuel pump (Figure 1, Item 5) located on left side of engine (Figure 1, Item 6).
2. Remove filter cap (Figure 1, Item 3) and gasket (Figure 1, Item 4) from fuel pump (Figure 1, Item 5). Discard gasket.
3. Remove filter spring (Figure 1, Item 2) and filter (Figure 1, Item 1) from fuel pump (Figure 1, Item 5). Discard filter.

REMOVAL - Continued

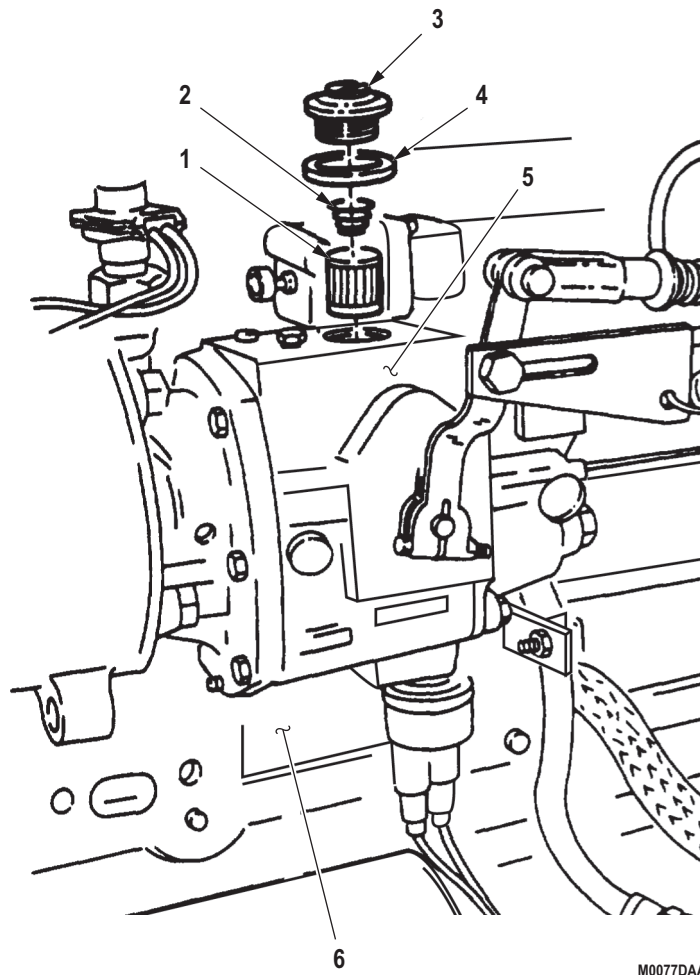

M0077DAA

Figure 1. AFC Fuel Pump Filter Removal.

END OF TASK

INSTALLATION**CAUTION**

Ensure small end of filter spring is against filter to assure proper fuel flow. Failure to do this will result in fuel pump damage.

1. Install filter (Figure 2, Item 1), open end first, in fuel pump (Figure 2, Item 5).
2. Install gasket (Figure 2, Item 4) and filter spring (Figure 2, Item 2) on filter cap (Figure 2, Item 3).
3. Install filter cap (Figure 2, Item 3) on fuel pump (Figure 2, Item 5). Tighten cap to 8 to 12 lb-ft (11 to 16 N·m).

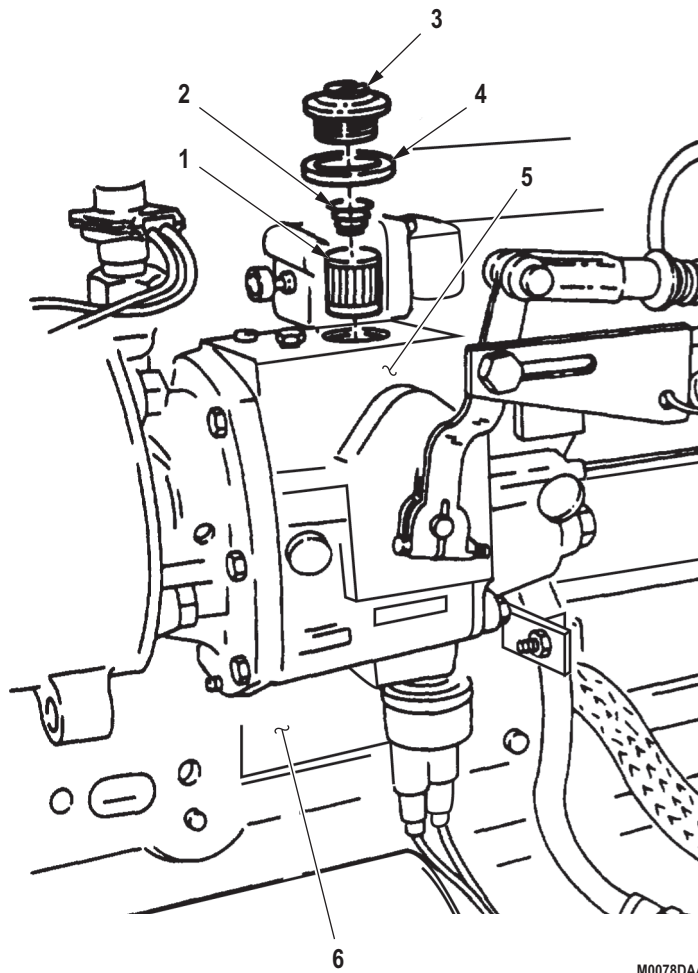

M0078DAA

Figure 2. AFC Fuel Pump Filter Installation.

END OF TASK

FOLLOW-ON MAINTENANCE

1. Prime fuel system for M939A2 (WP 0239); TM 9-2320-272-10 for M939/A1.
2. Install left splash shield. (TM 9-2320-272-10)
3. Start engine and check for fuel leaks. (TM 9-2320-272-10)

END OF TASK**END OF WORK PACKAGE**

FIELD MAINTENANCE
FUEL PUMP WITH VS GOVERNOR FILTER REPLACEMENT (M939/A1)

INITIAL SETUP:**Tools and Special Tools**

Tool Kit, General Mechanic's: Automotive
(Volume 5, WP 0826, Table 1, Item 56)

References

WP 0239

Materials/Parts

Cloth, Cleaning
(Volume 5, WP 0825, Table 1, Item 19)
Filter (Volume 5, WP 0827, Table 1, Item 70)
Qty: 1
Packing, Preformed
(Volume 5, WP 0827, Table 1, Item 68)
Qty: 1

Equipment Condition

Parking brake set. (TM 9-2320-272-10)
Left splash shield removed. (TM 9-2320-272-10)

REMOVAL**WARNING**

Diesel fuel is highly flammable. Do not perform fuel system procedures near open flame. Failure to comply may result in injury or death to personnel.

CAUTION

Fuel pump exterior must be cleaned before filter cap is removed to prevent foreign particles from entering fuel pump.

1. Using a clean, dry cloth, clean fuel pump (Figure 1, Item 7) located on left side of engine (Figure 1, Item 6).

NOTE

Place hand under fuel filter to catch assembly when retaining ring is removed.

2. Remove retaining ring (Figure 1, Item 5), retainer (Figure 1, Item 3), filter spring (Figure 1, Item 2), and filter (Figure 1, Item 1) from fuel pump (Figure 1, Item 7).
3. Remove preformed packing (Figure 1, Item 4) from retainer (Figure 1, Item 3). Discard preformed packing.
4. Inspect filter (Figure 1, Item 1) for holes or embedded metal particles. If holes or metal particles are found, discard filter.

REMOVAL - Continued

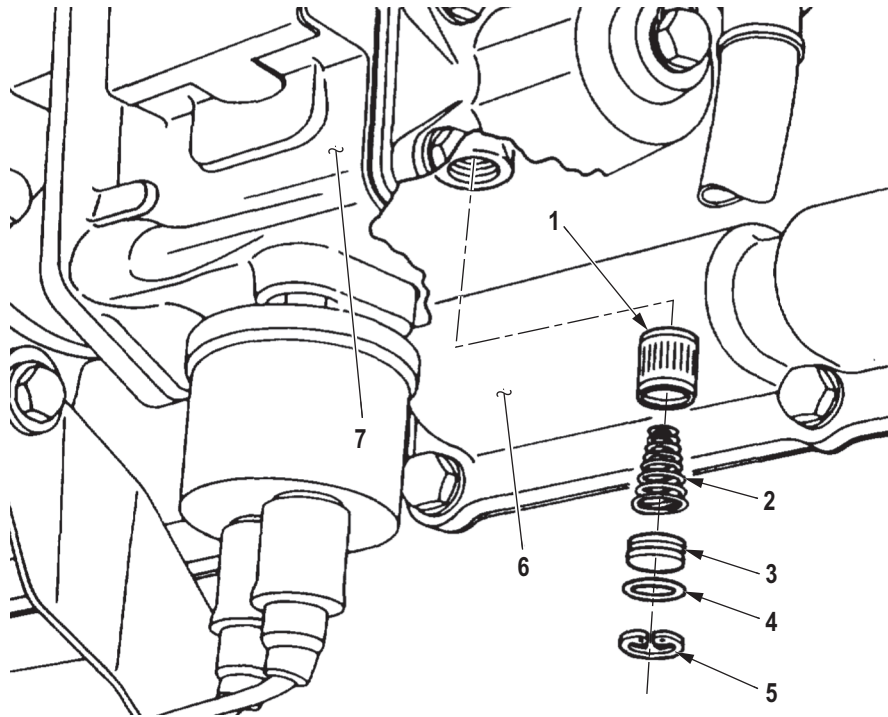

M0079DAA

Figure 1. Fuel Pump with VS Governor Filter Removal.

END OF TASK

INSTALLATION

1. Install preformed packing (Figure 2, Item 4) on retainer (Figure 2, Item 3).

CAUTION

Small end of filter spring and hole in filter screen must be facing up toward pump to allow fuel flow. Failure to do this will result in fuel pump damage.

2. Install filter (Figure 2, Item 1), filter spring (Figure 2, Item 2), and retainer (Figure 2, Item 3) in fuel pump (Figure 2, Item 7) with retaining ring (Figure 2, Item 5).

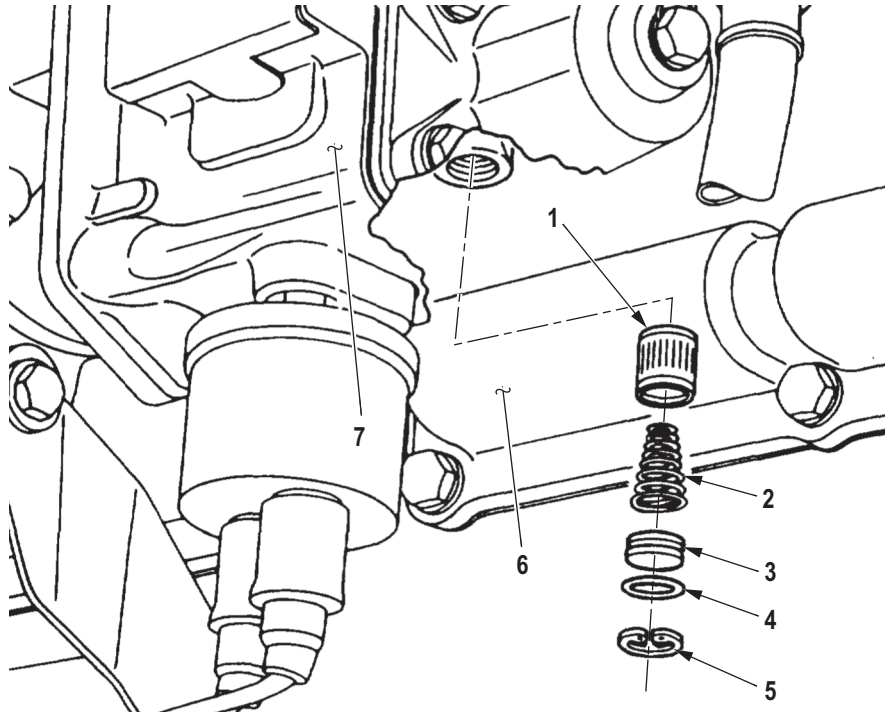

M0080DAA

Figure 2. Fuel Pump with VS Governor Filter Installation.

END OF TASK

FOLLOW-ON MAINTENANCE

1. Prime fuel system (M939A2). (WP 0239)
2. Prime fuel system (M939/A1). (TM 9-2320-272-10)
3. Install left splash shield. (TM 9-2320-272-10)
4. Start engine and check fuel pump for leaks and operation. (TM 9-2320-272-10)

END OF TASK**END OF WORK PACKAGE**

**FIELD MAINTENANCE
FUEL PRIMER PUMP REPLACEMENT (M939/A1)**

INITIAL SETUP:

Tools and Special Tools

Tool Kit, General Mechanic's: Automotive
(Volume 5, WP 0826, Table 1, Item 56)

Equipment Condition

Parking brake set. (TM 9-2320-272-10)
Hood raised and secured. (TM 9-2320-272-10)

References

WP 0239

REMOVAL

1. Open drain valve (Figure 1, Item 6) on primer pump (Figure 1, Item 7).
2. Disconnect fuel primer supply line (Figure 1, Item 9) from fuel primer adapter (Figure 1, Item 8).
3. Loosen plunger retainer locknut (Figure 1, Item 5) from plunger retainer (Figure 1, Item 4).
4. Loosen and remove plunger (Figure 1, Item 3) and retainer (Figure 1, Item 4) from primer pump (Figure 1, Item 7).
5. Remove plunger retainer locknut (Figure 1, Item 5) from primer pump (Figure 1, Item 7).
6. Remove jamnut (Figure 1, Item 2) and primer pump (Figure 1, Item 7) from accelerator bracket (Figure 1, Item 1).
7. Remove drain valve (Figure 1, Item 6) and fuel primer adapter (Figure 1, Item 8) from primer pump (Figure 1, Item 7).

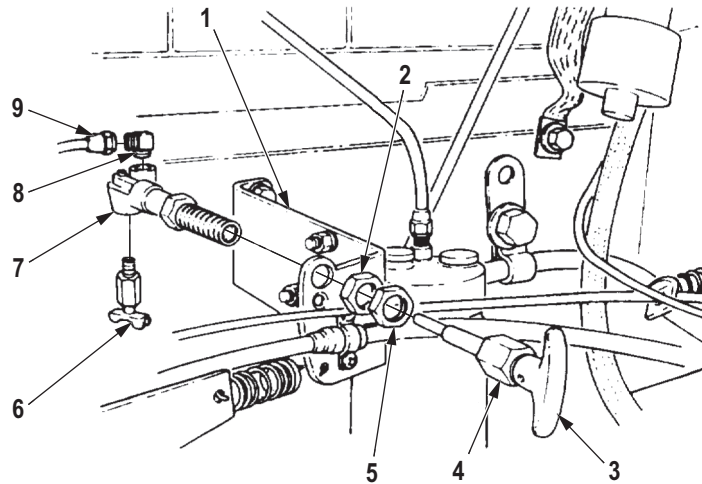

M0096DAA

Figure 1. Fuel Primer Pump Removal.

END OF TASK

INSTALLATION

1. Install drain valve (Figure 2, Item 6) and fuel primer adapter (Figure 2, Item 8) on primer pump (Figure 2, Item 7).
2. Install primer pump (Figure 2, Item 7) on accelerator bracket (Figure 2, Item 1) with jamnut (Figure 2, Item 2). Tighten jamnut against accelerator bracket.
3. Install plunger retainer locknut (Figure 2, Item 5) on primer pump (Figure 2, Item 7).
4. Install plunger (Figure 2, Item 3) and plunger retainer (Figure 2, Item 4) in primer pump (Figure 2, Item 7).
5. Tighten plunger retainer (Figure 2, Item 4) on pump (Figure 2, Item 7).
6. Tighten locknut (Figure 2, Item 5) against plunger retainer (Figure 2, Item 4).
7. Connect fuel primer supply line (Figure 2, Item 9) to fuel primer adapter (Figure 2, Item 8).

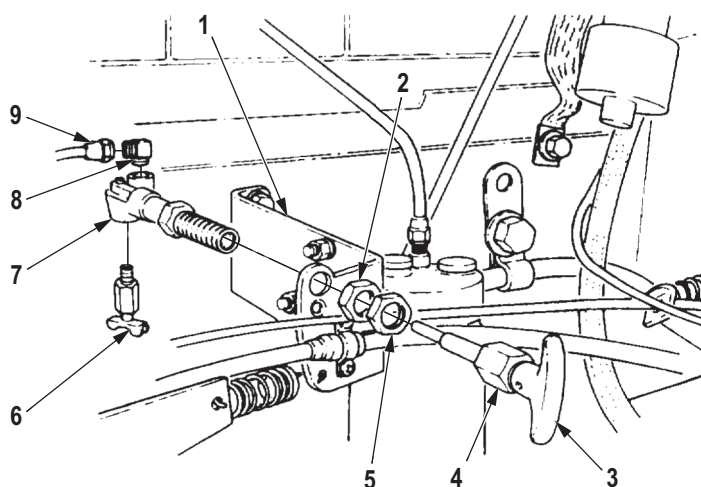

M0095DAA

Figure 2. Fuel Primer Pump Installation.

END OF TASK**FOLLOW-ON MAINTENANCE**

1. Prime fuel system (M939A2). (WP 0239)
2. OR Prime fuel system (M939/A1). (TM 9-2320-272-10)
3. Hood closed and secured. (TM 9-2320-272-10)

END OF TASK**END OF WORK PACKAGE**

**FIELD MAINTENANCE
ETHER START SWITCH REPLACEMENT (M939/A1)**

INITIAL SETUP:

Tools and Special Tools

Tool Kit, General Mechanic's: Automotive
(Volume 5, WP 0826, Table 1, Item 56)

Equipment Condition

Parking brake set. (TM 9-2320-272-10)
Battery ground cables disconnected. (WP 0350)

REMOVAL**NOTE**

Prior to removal, tag wires for installation.

1. Disconnect two ether start switch wires (Figure 1, Item 3) from harness wires (Figure 1, Item 2) under left side of dash (Figure 1, Item 1).
2. Remove nut (Figure 1, Item 5) and ether start switch (Figure 1, Item 4) from left side of dash (Figure 1, Item 1).

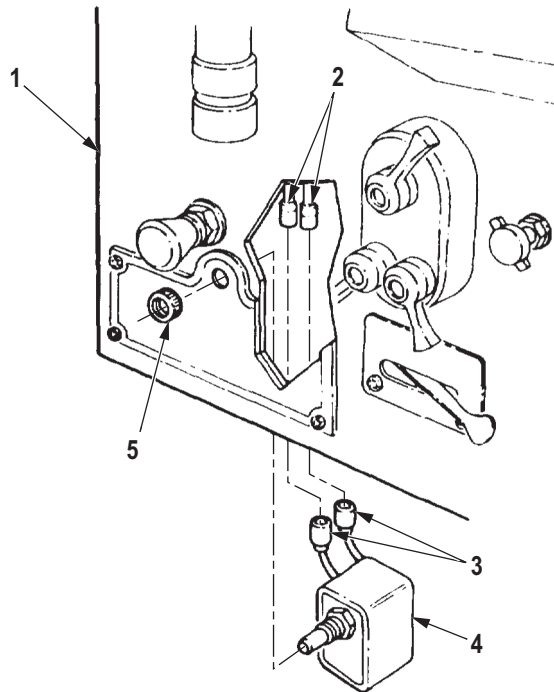

M0081DAA

Figure 1. Ether Start Switch Removal.

END OF TASK

INSTALLATION

1. Install ether start switch (Figure 2, Item 4) on left side of dash (Figure 2, Item 1) with nut (Figure 2, Item 5).
2. Connect two ether start switch wires (Figure 2, Item 3) to wiring harness wires (Figure 2, Item 2) under left side of dash (Figure 2, Item 1).

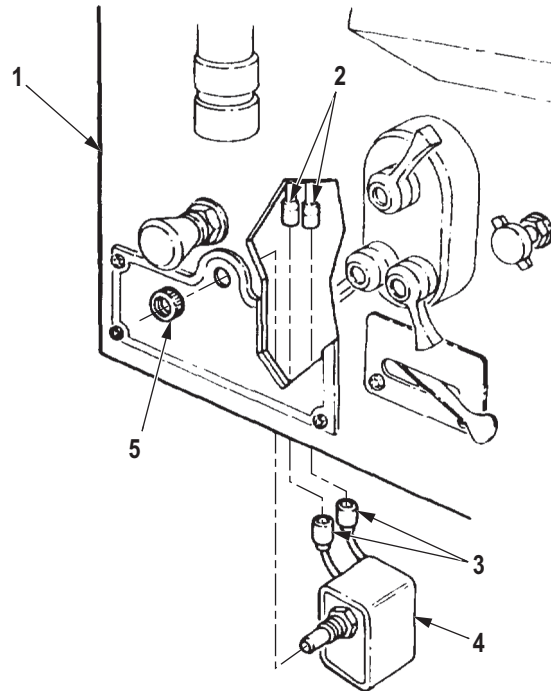

M0082DAA

Figure 2. Ether Start Switch Installation.

END OF TASK**FOLLOW-ON MAINTENANCE**

Connect battery ground cables. (WP 0350)

END OF TASK**END OF WORK PACKAGE**

**FIELD MAINTENANCE
ETHER CYLINDER AND VALVE REPLACEMENT (M939/A1)**

INITIAL SETUP:**Tools and Special Tools**

Tool Kit, General Mechanic's: Automotive
(Volume 5, WP 0826, Table 1, Item 56)

Equipment Condition (cont.)

Hood raised and secured. (TM 9-2320-272-10)
Left splash shield removed. (TM 9-2320-272-10)
Battery ground cables disconnected. (WP 0350)

Materials/Parts

Locknut (Volume 5, WP 0827, Table 1, Item 283)
Qty: 2

Equipment Condition

Parking brake set. (TM 9-2320-272-10)

ETHER CYLINDER REMOVAL**WARNING**

Ether is extremely flammable. Do not perform ether start system testing procedures near fire. Failure to comply may result in injury or death to personnel.

1. Loosen ether cylinder clamp (Figure 1, Item 2) on ether cylinder bracket (Figure 1, Item 3).

NOTE

Ether cylinder must be removed quickly to allow ether cylinder check valve to close and prevent loss of ether.

2. Remove ether cylinder (Figure 1, Item 1) from ether valve (Figure 1, Item 4).

ETHER CYLINDER REMOVAL - Continued

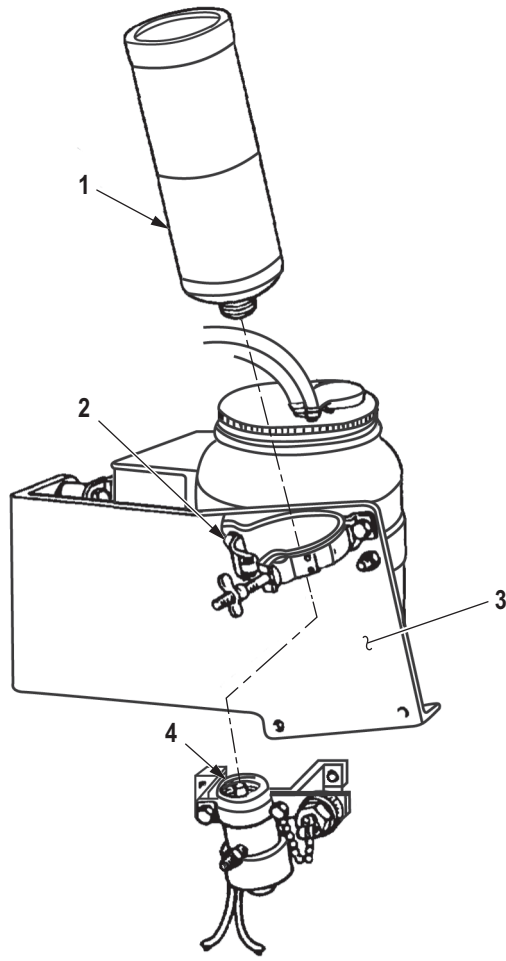

M0085DAA

Figure 1. Ether Cylinder Removal.

END OF TASK

ETHER VALVE REMOVAL**CAUTION**

When ether cylinder is removed, cover must be installed to prevent dust or dirt from entering valve.

NOTE

Tag wires for installation.

1. Disconnect wire (Figure 2, Item 7) from ether valve wire (Figure 2, Item 6).
2. Disconnect ether supply tube (Figure 2, Item 8) from ether valve adapter (Figure 2, Item 9).
3. Remove two locknuts (Figure 2, Item 5), screws (Figure 2, Item 2), ground wire (Figure 2, Item 3), ether valve bracket (Figure 2, Item 4), and ether valve (Figure 2, Item 10) from ether cylinder bracket (Figure 2, Item 1). Discard locknuts.

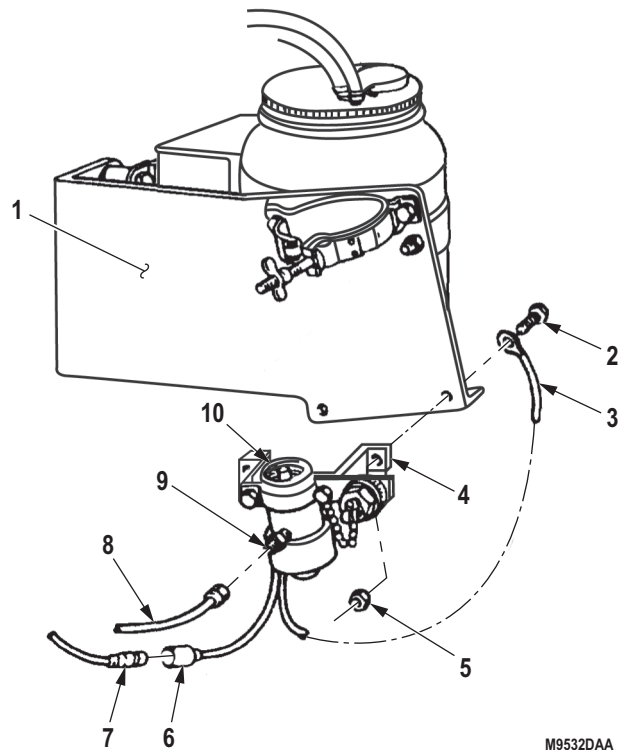

M9532DAA

Figure 2. Ether Valve Removal.

END OF TASK

ETHER VALVE INSTALLATION

1. Install ether valve bracket (Figure 3, Item 4), ether valve (Figure 3, Item 10), and ground wire (Figure 3, Item 3) on ether cylinder bracket (Figure 3, Item 1) with two screws (Figure 3, Item 2) and locknuts (Figure 3, Item 5).
2. Connect wire (Figure 3, Item 7) to ether valve wire (Figure 3, Item 6).
3. Connect ether supply tube (Figure 3, Item 8) to ether valve fitting (Figure 3, Item 9).

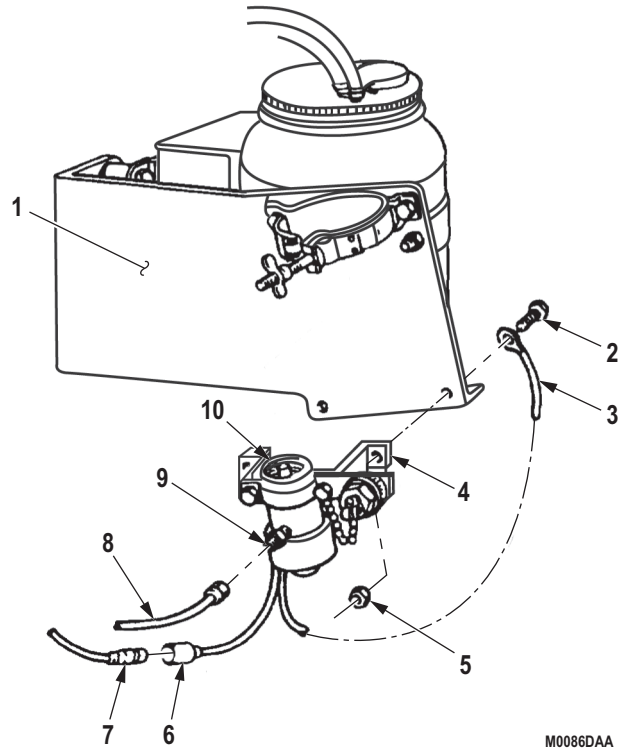
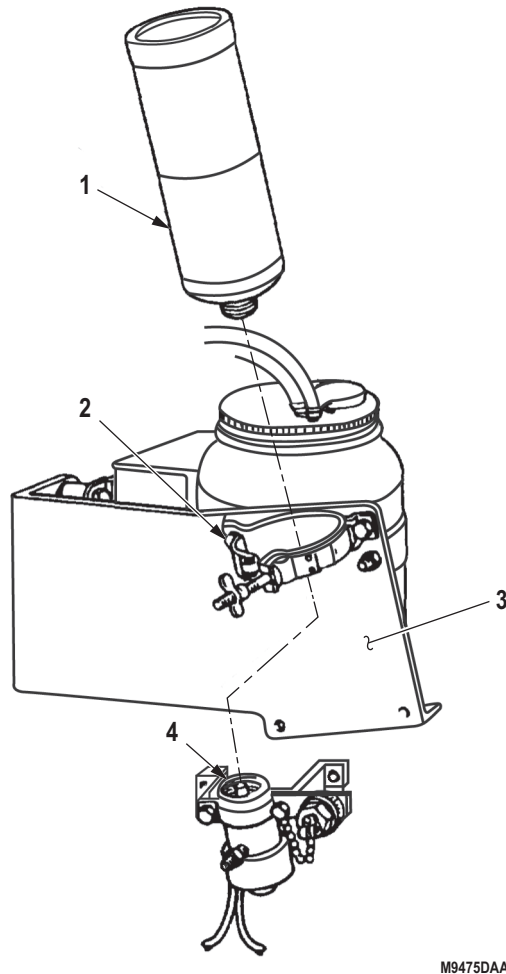

Figure 3. Ether Valve Installation.

END OF TASK

ETHER CYLINDER INSTALLATION

Install ether cylinder (Figure 4, Item 1) on ether valve (Figure 4, Item 4) and ether cylinder bracket (Figure 4, Item 3) and tighten clamp (Figure 4, Item 2).



M9475DAA

Figure 4. Ether Cylinder Installation.

END OF TASK

FOLLOW-ON MAINTENANCE

1. Connect battery ground cables. (WP 0350)
2. Install left splash shield. (TM 9-2320-272-10)
3. Hood closed and secured. (TM 9-2320-272-10)

END OF TASK

END OF WORK PACKAGE

FIELD MAINTENANCE
ETHER THERMAL CLOSE VALVE AND BUSHING REPLACEMENT (M939/A1)

INITIAL SETUP:**Tools and Special Tools**

Tool Kit, General Mechanic's: Automotive
(Volume 5, WP 0826, Table 1, Item 56)

Equipment Condition (cont.)

Hood raised and secured. (TM 9-2320-272-10)

Materials/Parts

Tape, Antiseizing
(Volume 5, WP 0825, Table 1, Item 65)

Equipment Condition

Parking brake set. (TM 9-2320-272-10)

REMOVAL**NOTE**

Tag tubes for installation.

1. Disconnect thermal close ether supply tube (Figure 1, Item 2) and atomizer ether supply tube (Figure 1, Item 6) from adapters (Figure 1, Item 1) on thermal close valve (Figure 1, Item 5).
2. Remove thermal close valve (Figure 1, Item 5) from adapter bushing (Figure 1, Item 4).
3. Remove adapter bushing (Figure 1, Item 4) from water manifold (Figure 1, Item 3).

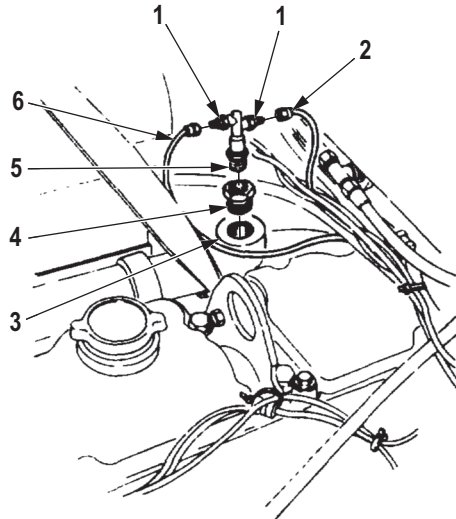

M0087DAA

Figure 1. Ether Thermal Close Valve and Bushing Removal.

END OF TASK

INSTALLATION**NOTE**

Male pipe threads must be wrapped with antiseize tape before installation.

1. Install adapter bushing (Figure 2, Item 4) in water manifold (Figure 2, Item 3).
2. Install thermal close valve (Figure 2, Item 5) in bushing (Figure 2, Item 4).
3. Connect atomizer ether supply tube (Figure 2, Item 6) and thermal close ether supply tube (Figure 2, Item 2) to adapters (Figure 2, Item 1) on thermal close valve (Figure 2, Item 5).

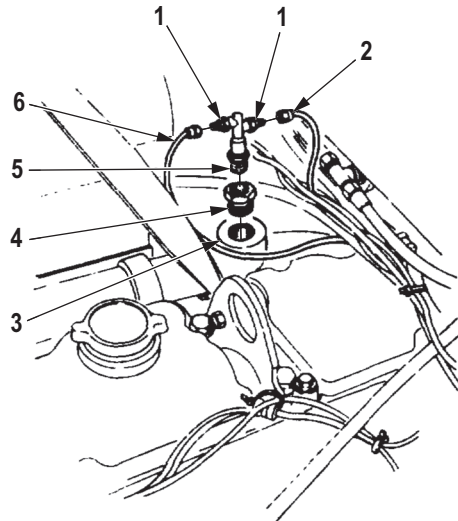

M0088DAA

Figure 2. Ether Thermal Close Valve and Bushing Installation.

END OF TASK**FOLLOW-ON MAINTENANCE**

1. Hood closed and secured. (TM 9-2320-272-10)
2. Start engine and check for coolant leaks around thermal close valve and adapter bushing. (TM 9-2320-272-10)

END OF TASK**END OF WORK PACKAGE**

**FIELD MAINTENANCE
ETHER ATOMIZER REPLACEMENT (M939/A1)**

INITIAL SETUP:**Tools and Special Tools**

Tool Kit, General Mechanic's: Automotive
(Volume 5, WP 0826, Table 1, Item 56)

Equipment Condition (cont.)

Hood raised and secured. (TM 9-2320-272-10)

Materials/Parts

Tape, Antiseizing
(Volume 5, WP 0825, Table 1, Item 65)

Equipment Condition

Parking brake set. (TM 9-2320-272-10)

REMOVAL

1. Disconnect ether atomizer tube (Figure 1, Item 2) from ether atomizer (Figure 1, Item 1).
2. Remove ether atomizer (Figure 1, Item 1) from intake manifold (Figure 1, Item 3).

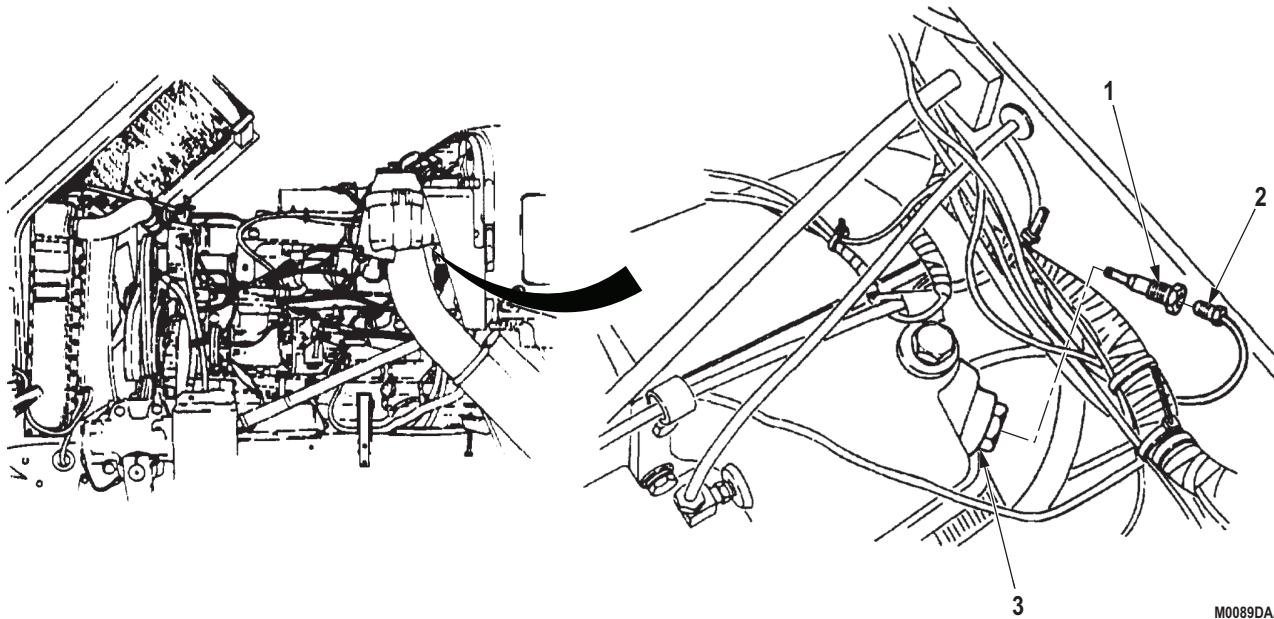

Figure 1. Ether Atomizer Removal.

END OF TASK

INSTALLATION**NOTE**

Male pipe threads must be wrapped with antiseize tape before installation.

1. Install atomizer (Figure 2, Item 1) on intake manifold (Figure 2, Item 3).
2. Connect ether atomizer supply tube (Figure 2, Item 2) to atomizer (Figure 2, Item 1).

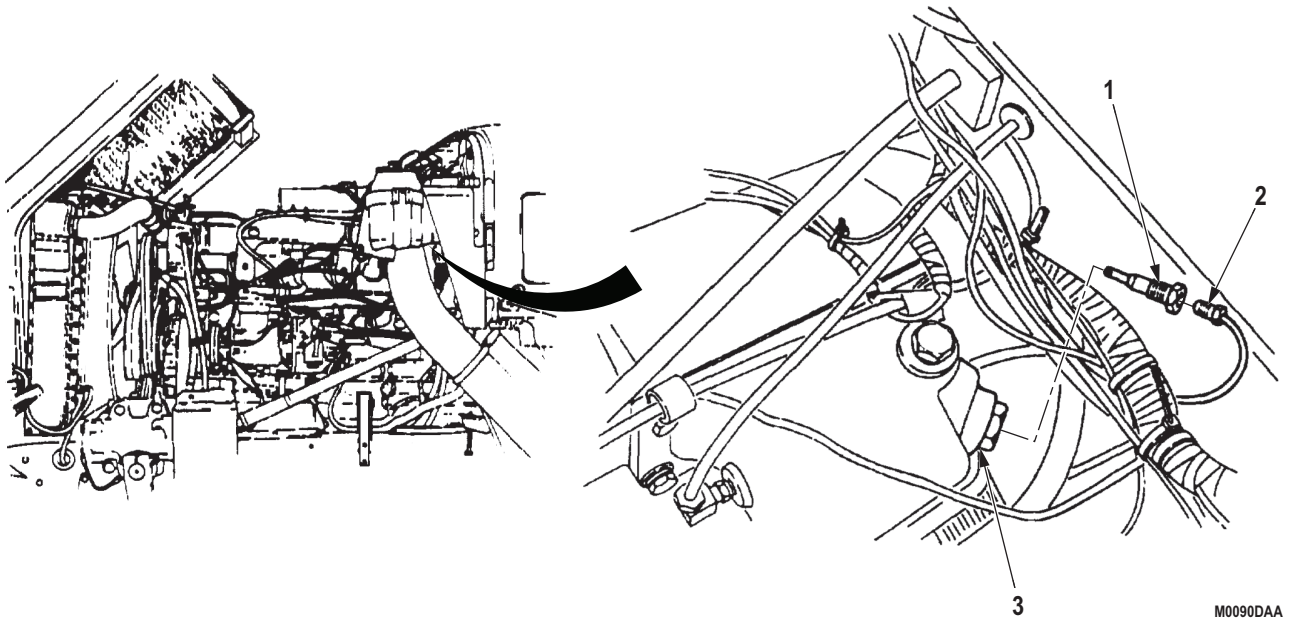

Figure 2. Ether Atomizer Installation.

END OF TASK**FOLLOW-ON MAINTENANCE**

Hood lowered and secured. (TM 9-2320-272-10)

END OF TASK**END OF WORK PACKAGE**

FIELD MAINTENANCE
ETHER ATOMIZER AND TEMPERATURE SENSOR REPLACEMENT (M939A2)

INITIAL SETUP:**Tools and Special Tools**

Tool Kit, General Mechanic's: Automotive
(Volume 5, WP 0826, Table 1, Item 56)

Materials/Parts

Antiseize Compound
(Volume 5, WP 0825, Table 1, Item 9)
Cap Set, Protective, Dust and Moisture Seal
(Volume 5, WP 0825, Table 1, Item 13)
Qty: 1

Materials/Parts (cont.)

Lockwasher
(Volume 5, WP 0827, Table 1, Item 215)
Qty: 1
Tiedown Strap
(Volume 5, WP 0827, Table 1, Item 370)
Qty: 1

Equipment Condition

Parking brake set. (TM 9-2320-272-10)
Hood raised and secured. (TM 9-2320-272-10)

REMOVAL**WARNING**

Ether is extremely flammable. Do not perform ether start system testing procedures near fire. Failure to comply may result in injury or death to personnel.

CAUTION

Cap or plug all openings immediately after disconnecting lines and hoses to prevent contamination. Failure to do so may result in damage to engine.

NOTE

Record locations of tiedown straps.

1. Remove tiedown straps (Figure 1, Item 2) as required. Discard tiedown straps.
2. Disconnect wire connector (Figure 1, Item 4) from wiring harness (Figure 1, Item 3).
3. Remove screw (Figure 1, Item 10), washer (Figure 1, Item 9), ground strap (Figure 1, Item 8), lockwasher (Figure 1, Item 7), and temperature sensor (Figure 1, Item 6) from engine block (Figure 1, Item 5). Discard lockwasher.
4. Disconnect ether supply tube (Figure 1, Item 12) from ether atomizer (Figure 1, Item 1).
5. Remove ether atomizer (Figure 1, Item 1) from adapter (Figure 1, Item 11).

REMOVAL - Continued

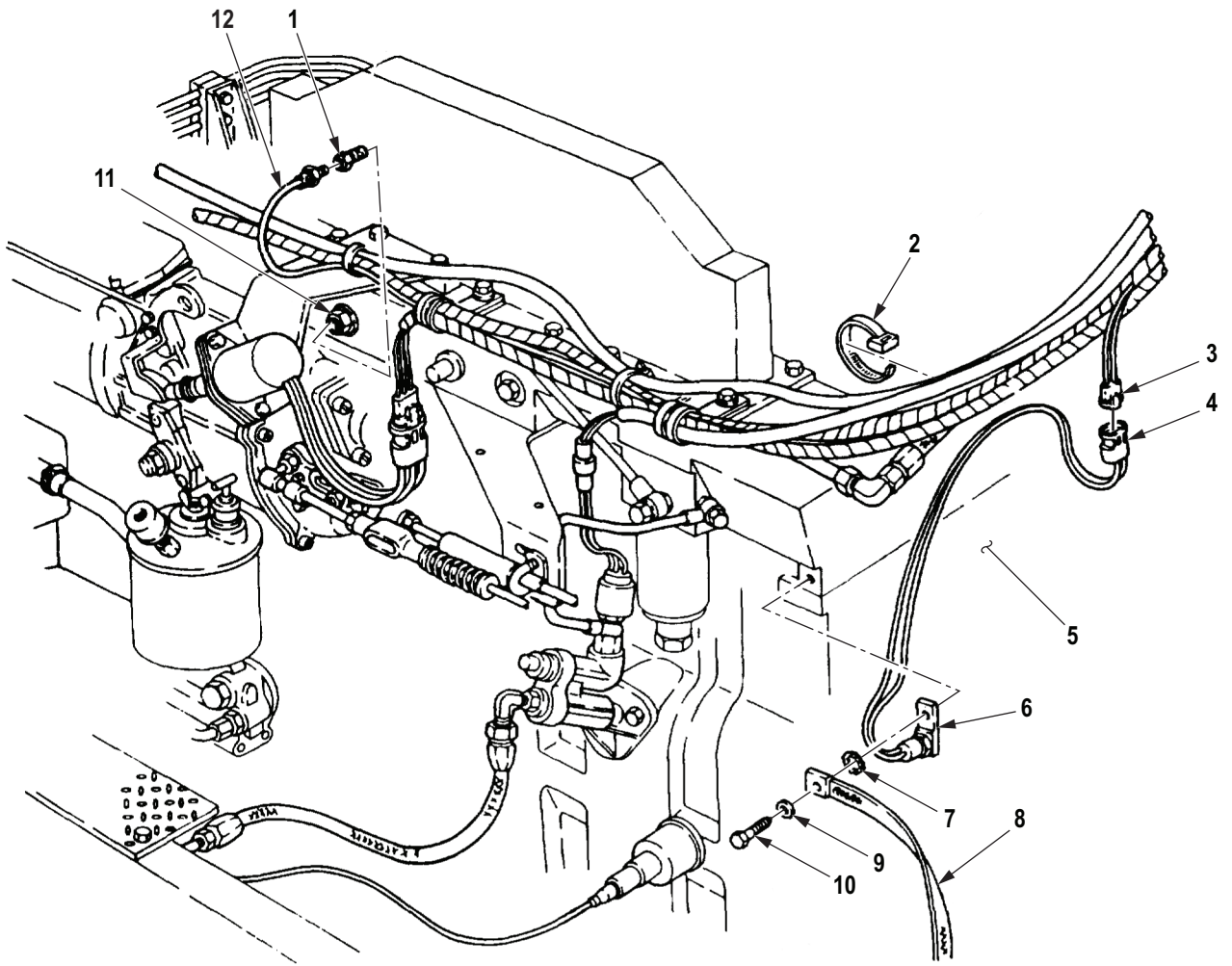

M0091DAA

Figure 1. Ether Atomizer and Temperature Sensor Removal.

END OF TASK

INSTALLATION

1. Coat threads of ether atomizer (Figure 2, Item 1) with antiseize compound and install ether atomizer in adapter (Figure 2, Item 11).
2. Tighten ether atomizer (Figure 2, Item 1) until indicator mark is in three or nine o'clock position.
3. Connect ether supply tube (Figure 2, Item 12) to ether atomizer (Figure 2, Item 1).
4. Install temperature sensor (Figure 2, Item 6) and ground strap (Figure 2, Item 8) on engine block (Figure 2, Item 5) with lockwasher (Figure 2, Item 7), washer (Figure 2, Item 9), and screw (Figure 2, Item 10).
5. Connect wire (Figure 2, Item 4) to wiring harness (Figure 2, Item 3).
6. Install tiedown straps (Figure 2, Item 2) as required.

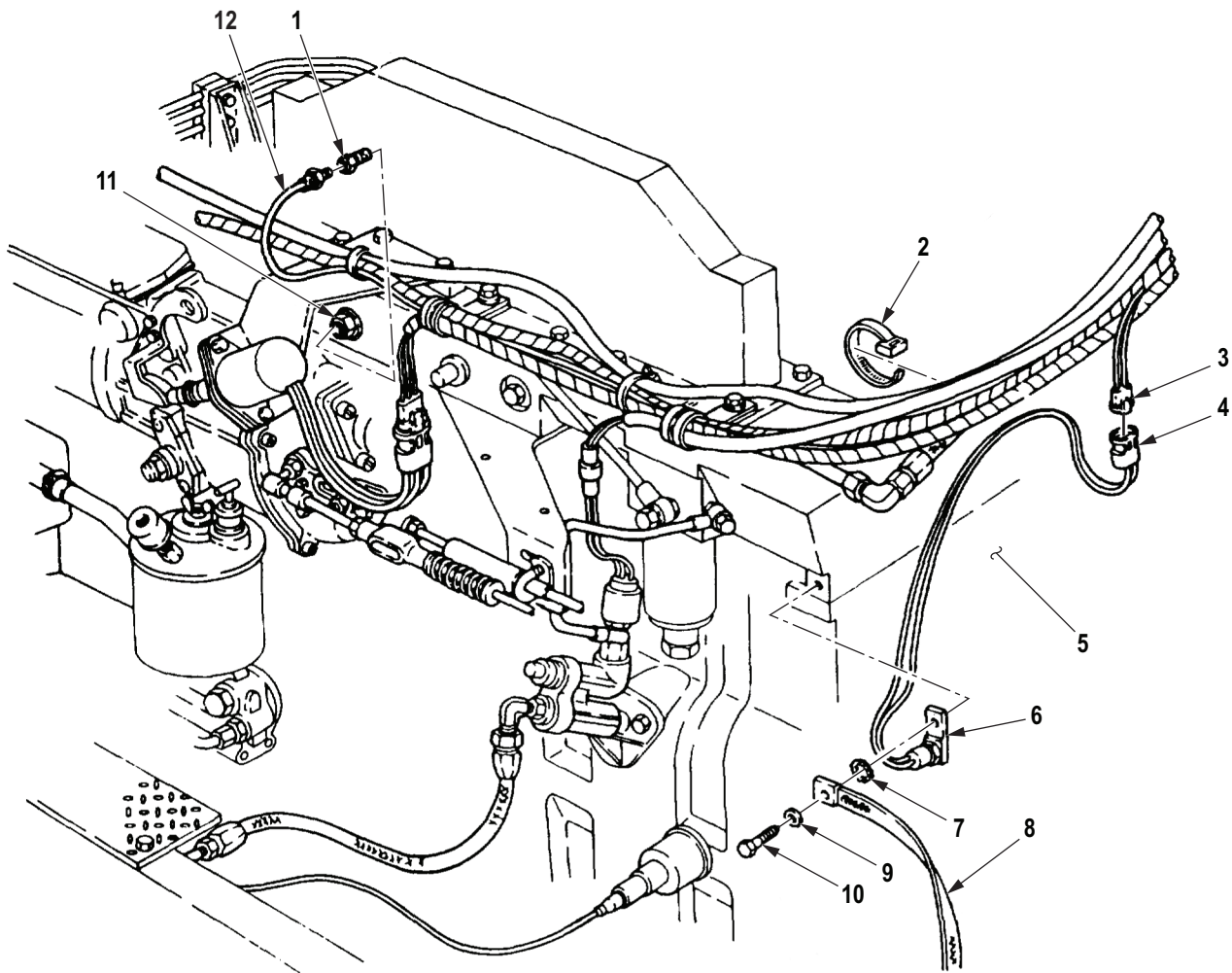

M0092DAA

Figure 2. Ether Atomizer and Temperature Sensor Installation.

END OF TASK

FOLLOW-ON MAINTENANCE

Hood lowered and secured. (TM 9-2320-272-10)

END OF TASK

END OF WORK PACKAGE

**FIELD MAINTENANCE
ETHER TUBING REPLACEMENT (M939/A1)**

INITIAL SETUP:**Tools and Special Tools**

Tool Kit, General Mechanic's: Automotive
(Volume 5, WP 0826, Table 1, Item 56)

Equipment Condition (cont.)

Left splash shield removed. (TM 9-2320-272-10)

Materials/Parts

Tiedown Strap
(Volume 5, WP 0827, Table 1, Item 45)
Qty: 3

Equipment Condition

Parking brake set. (TM 9-2320-272-10)

REMOVAL**WARNING**

Ether is extremely flammable. Do not perform ether start system testing procedures near fire. Failure to comply may result in injury or death to personnel.

1. Remove three tiedown straps (Figure 1, Item 6) from atomizer ether supply tube (Figure 1, Item 7) and thermal close ether supply tube (Figure 1, Item 2). Discard tiedown straps.
2. Disconnect thermal close ether supply tube (Figure 1, Item 2) from thermal close adapter (Figure 1, Item 10) and ether valve adapter (Figure 1, Item 5).

NOTE

Tag tubes for installation.

3. Disconnect atomizer ether supply tube (Figure 1, Item 7) from thermal close adapter (Figure 1, Item 9) and atomizer (Figure 1, Item 8).
4. Disconnect ether cylinder relief tube (Figure 1, Item 4) from ether cylinder relief inlet adapter (Figure 1, Item 3).

REMOVAL - Continued

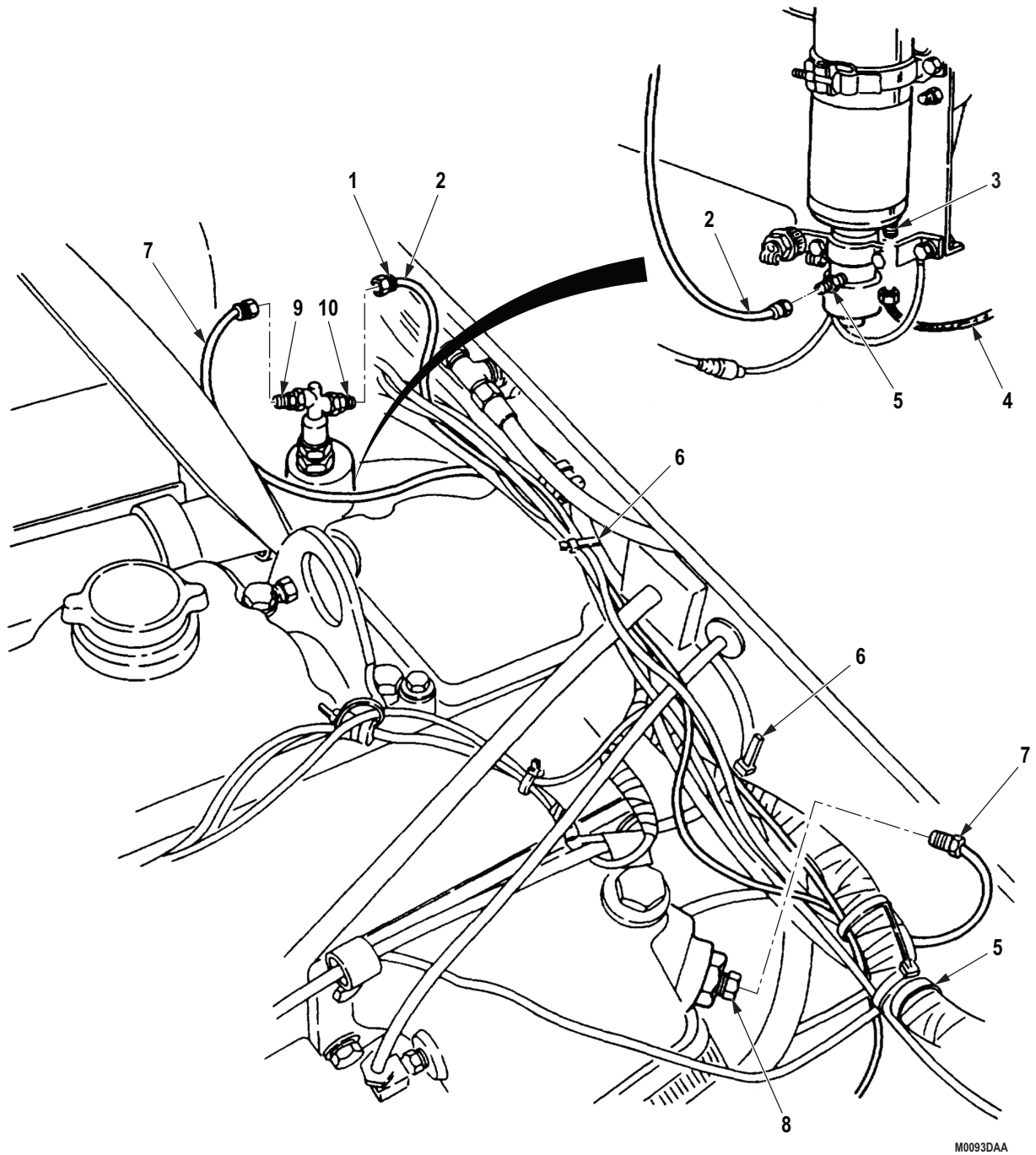

M0093DAA

Figure 1. Ether Tubing Removal.

END OF TASK

INSTALLATION

1. Connect ether cylinder relief tube (Figure 2, Item 4) to ether cylinder relief inlet adapter (Figure 2, Item 3).
2. Connect atomizer ether supply tube (Figure 2, Item 7) to thermal close adapter (Figure 2, Item 9) and atomizer (Figure 2, Item 8).
3. Connect thermal close ether supply tube (Figure 2, Item 2) to thermal close adapter (Figure 2, Item 10) and ether valve adapter (Figure 2, Item 5).
4. Secure atomizer ether supply tube (Figure 2, Item 7) and thermal close ether supply tube (Figure 2, Item 2) with three tiedown straps (Figure 2, Item 6).

INSTALLATION - Continued

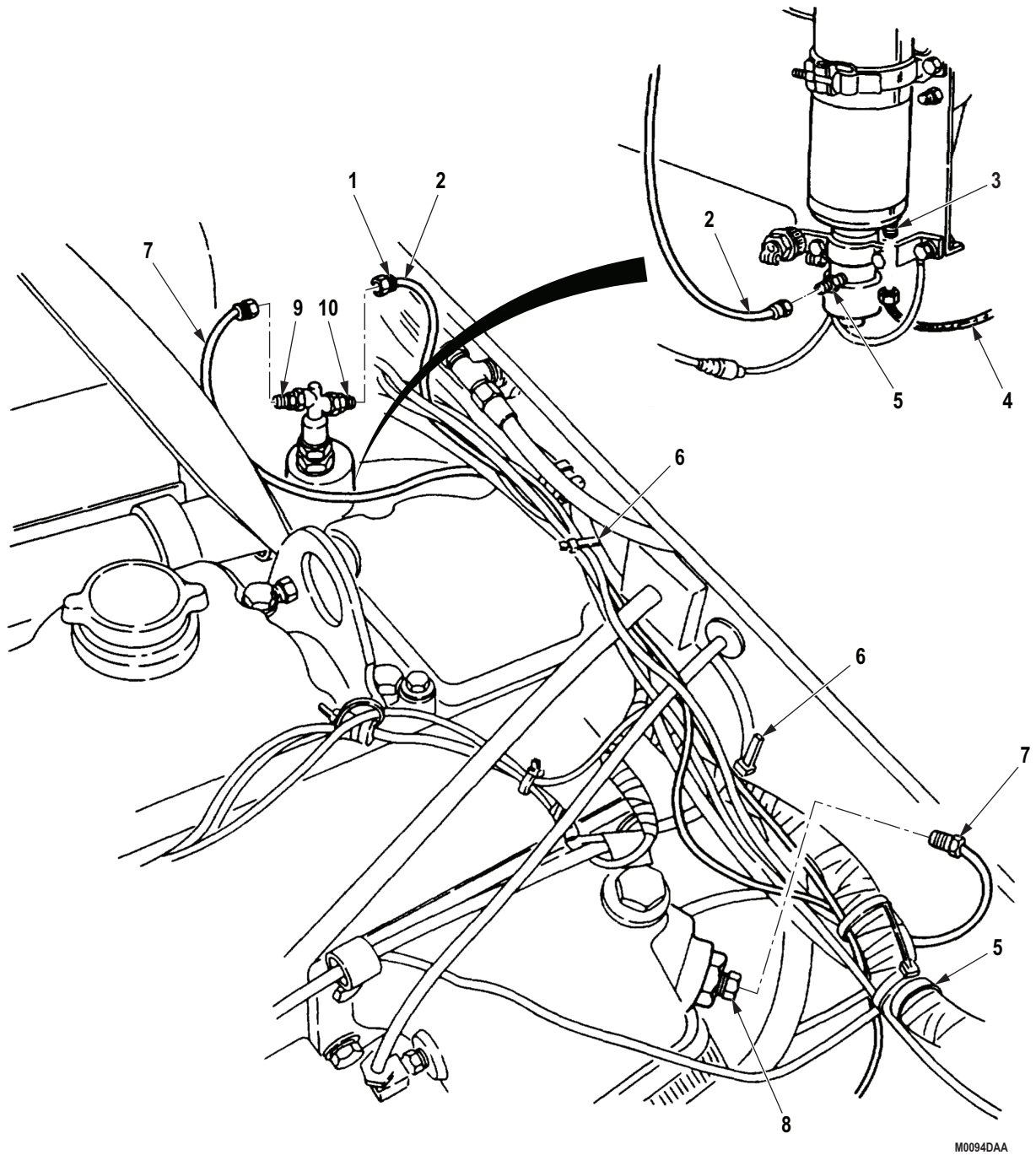

M0094DAA

Figure 2. Ether Tubing Installation.

END OF TASK

FOLLOW-ON MAINTENANCE

Install left splash shield. (TM 9-2320-272-10)

END OF TASK

END OF WORK PACKAGE

**FIELD MAINTENANCE
ACCELERATOR LINKAGE REPLACEMENT (M939/A1)**

INITIAL SETUP:**Tools and Special Tools**

Tool Kit, General Mechanic's: Automotive
(Volume 5, WP 0826, Table 1, Item 56)

Materials/Parts

Locknut (Volume 5, WP 0827, Table 1, Item 274)
Qty: 1
Locknut (Volume 5, WP 0827, Table 1, Item 314)
Qty: 1

Materials/Parts (cont.)

Screw (Volume 5, WP 0827, Table 1, Item 434)
Qty: 1
Spring Pin
(Volume 5, WP 0827, Table 1, Item 302)
Qty: 1

Personnel Required

(2)

Equipment Condition

Parking brake set. (TM 9-2320-272-10)
Hood raised and secured. (TM 9-2320-272-10)
Left splash shield removed. (TM 9-2320-272-10)

REMOVAL

1. Remove locknut (Figure 1, Item 9), screw (Figure 1, Item 12), and clevis rod (Figure 1, Item 8) from throttle lever (Figure 1, Item 13). Discard screw and locknut.
2. Disconnect return spring (Figure 1, Item 2) from accelerator rod (Figure 1, Item 1) and link assembly (Figure 1, Item 6).
3. While holding nut (Figure 1, Item 5), remove locknut (Figure 1, Item 7) and accelerator rod (Figure 1, Item 1) from link assembly (Figure 1, Item 6). Discard locknut.

NOTE

Record position of accelerator rod in ball joint for installation.

4. Loosen jamnut (Figure 1, Item 3) and remove ball joint (Figure 1, Item 4) from accelerator rod (Figure 1, Item 1).
5. Remove spring pin (Figure 1, Item 10), clevis rod (Figure 1, Item 8), and spring (Figure 1, Item 11) from accelerator rod (Figure 1, Item 1). Discard spring pin.

REMOVAL - Continued

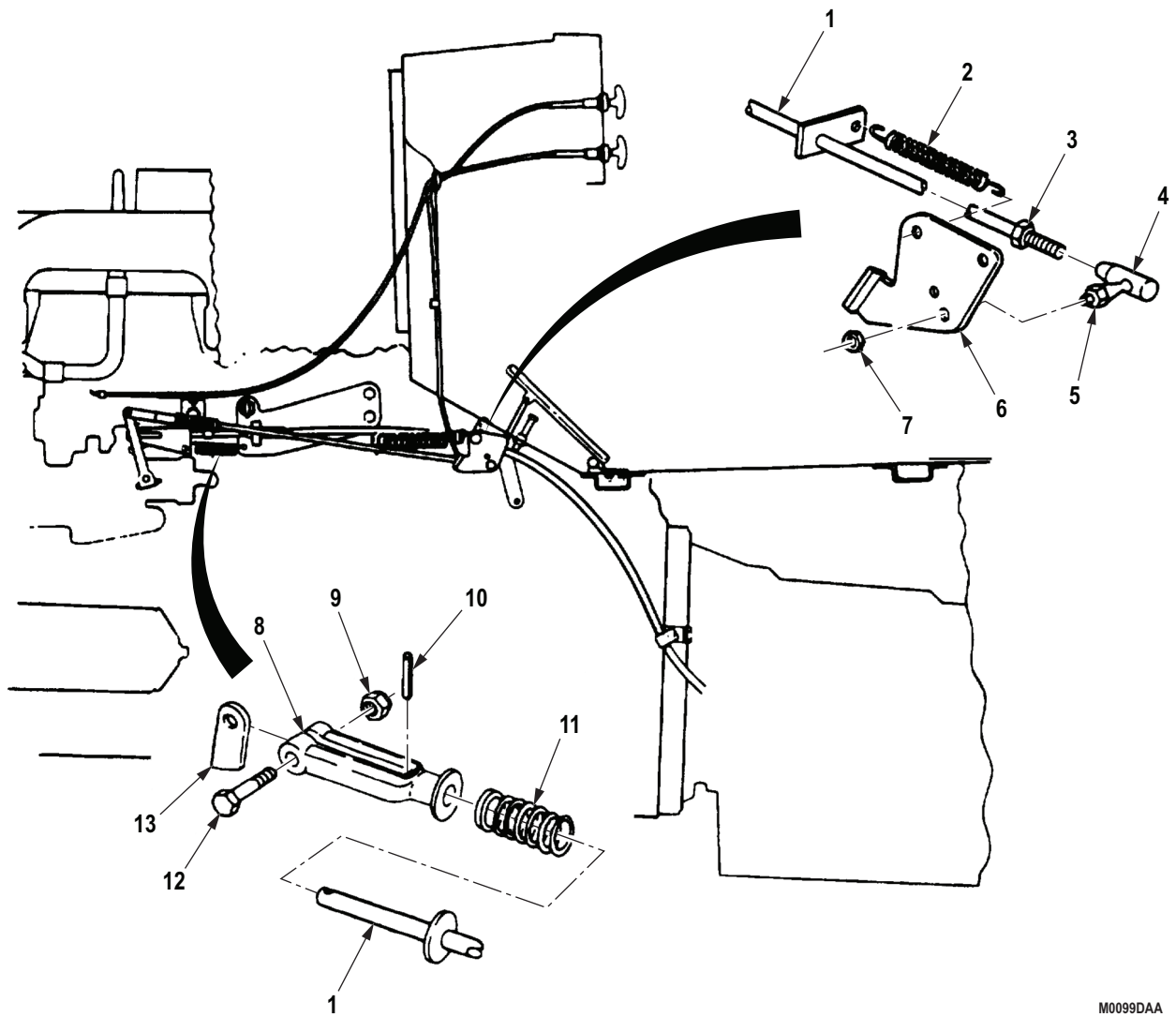

M0099DAA

Figure 1. Accelerator Linkage Removal.

END OF TASK

INSTALLATION

1. Install spring (Figure 2, Item 11) and clevis rod (Figure 2, Item 8) on accelerator rod (Figure 2, Item 1) and secure with spring pin (Figure 2, Item 10).
2. Install ball joint (Figure 2, Item 4) on accelerator rod (Figure 2, Item 1).
3. Position accelerator rod (Figure 2, Item 1) and ball joint (Figure 2, Item 4) on link assembly (Figure 2, Item 6).
4. While holding nut (Figure 2, Item 5), install and tighten locknut (Figure 2, Item 7) on ball joint (Figure 2, Item 4).

NOTE

If holes in clevis and throttle lever do not align, go to adjustment.

5. Connect clevis rod (Figure 2, Item 8) to throttle lever (Figure 2, Item 13) with screw (Figure 2, Item 12) and locknut (Figure 2, Item 9).
6. Connect return spring (Figure 2, Item 2) to accelerator rod (Figure 2, Item 1) and link assembly (Figure 2, Item 6).

INSTALLATION - Continued

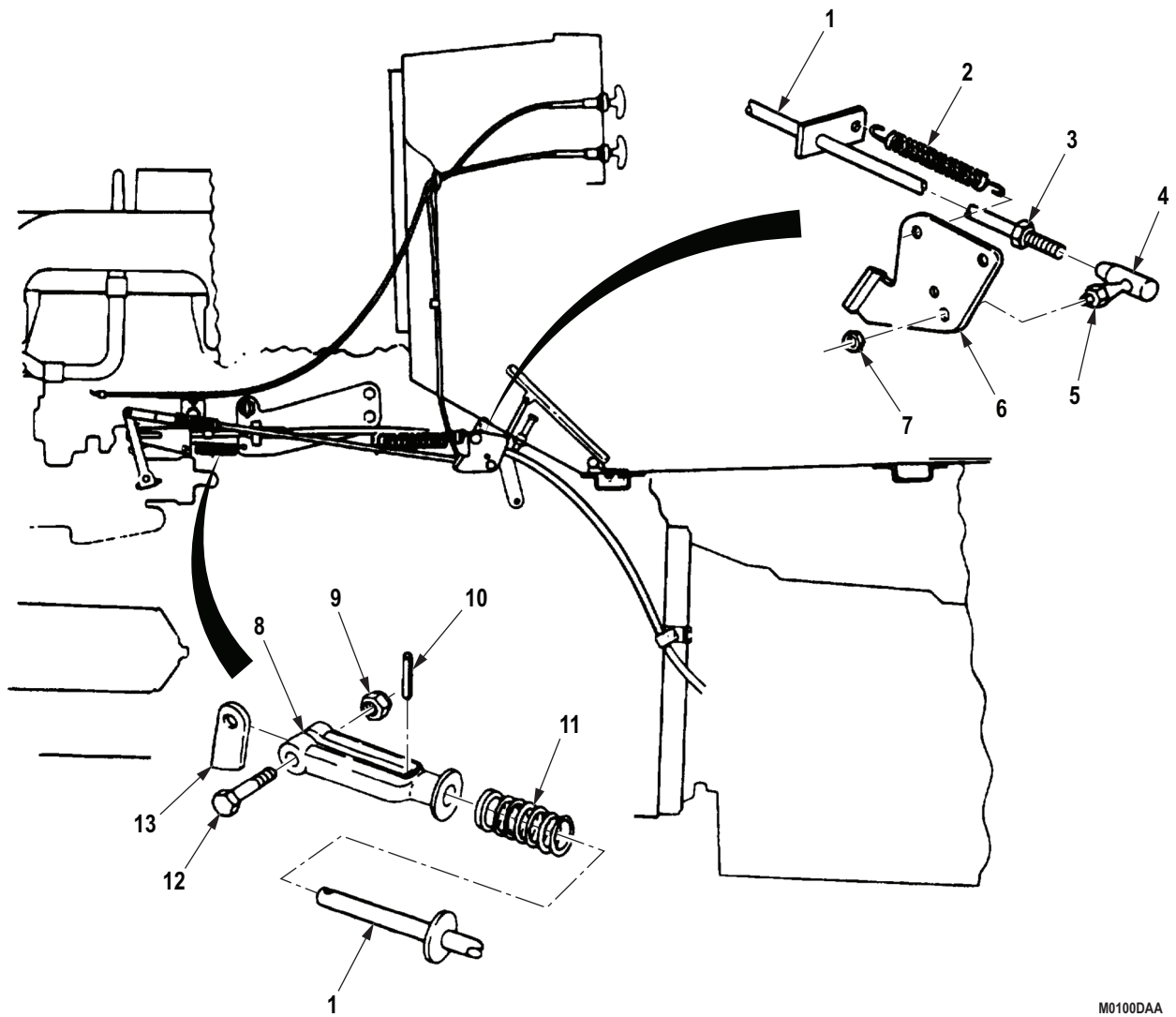

M0100DAA

Figure 2. Accelerator Linkage Installation.

END OF TASK

ADJUSTMENT**NOTE**

Perform Step (1) only if link assembly was removed.

1. Disconnect return spring (Figure 3, Item 2) from link assembly (Figure 3, Item 6) and accelerator rod (Figure 3, Item 1).
2. Remove screw (Figure 3, Item 12) and locknut (Figure 3, Item 9). Discard locknut and screw.

NOTE

Assistant will help with Steps (3) through (8).

3. Push throttle lever (Figure 3, Item 13) forward to FULL THROTTLE position.
4. Pull clevis rod (Figure 3, Item 8) forward as far as possible.
5. Loosen jamnut (Figure 3, Item 3) and hand-turn accelerator rod (Figure 3, Item 1) to shorten or lengthen as needed to align holes in clevis rod (Figure 3, Item 8) and throttle lever (Figure 3, Item 13).
6. Install clevis (Figure 3, Item 8) on throttle lever (Figure 3, Item 13) with screw (Figure 3, Item 12) and locknut (Figure 3, Item 9).
7. Tighten jamnut (Figure 3, Item 3) against ball joint (Figure 3, Item 4).
8. Connect return spring (Figure 3, Item 2) to accelerator rod (Figure 3, Item 1) and link assembly (Figure 3, Item 6).

ADJUSTMENT - Continued

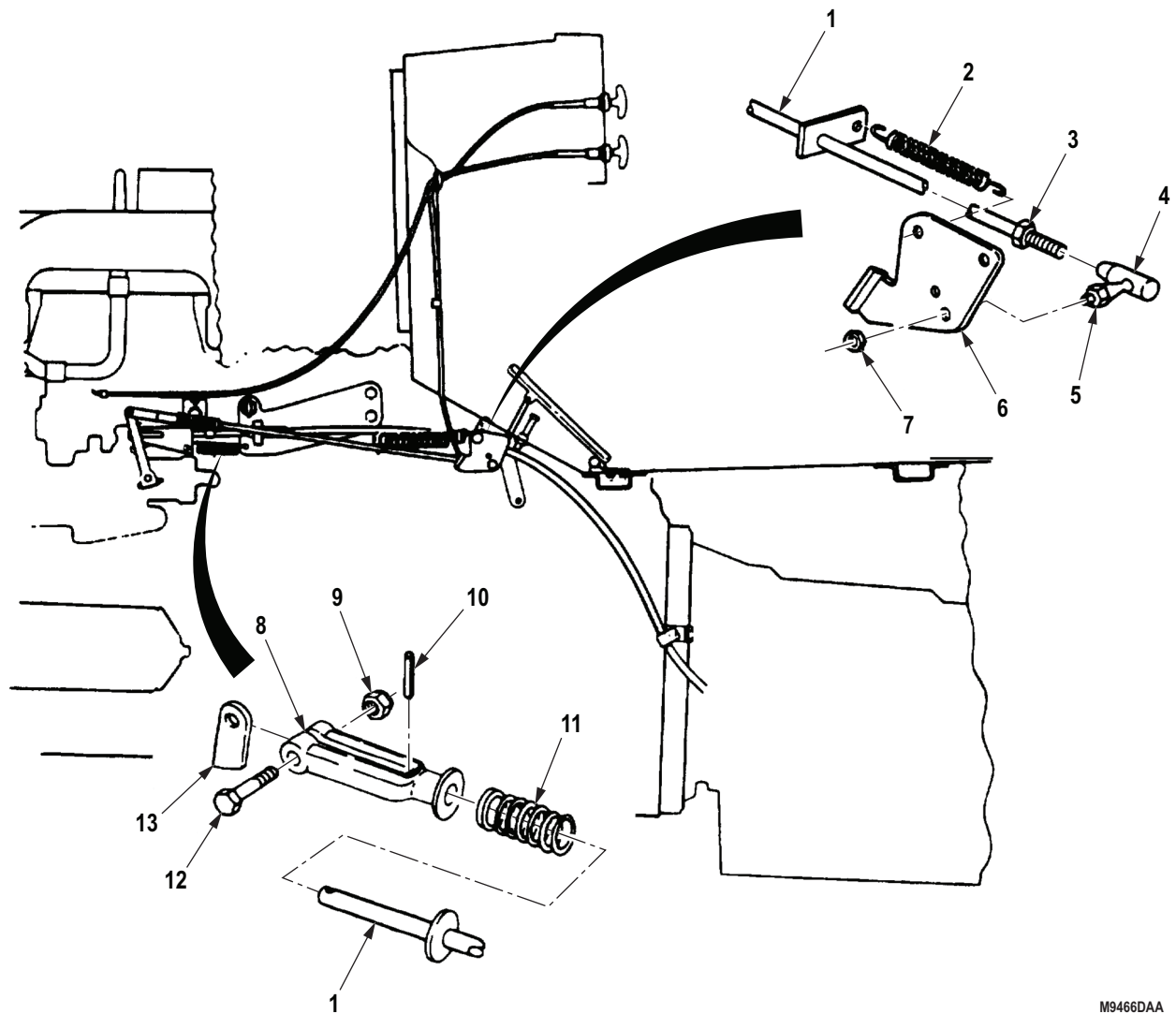

M9466DAA

Figure 3. Accelerator Linkage Adjustment.

END OF TASK

FOLLOW-ON MAINTENANCE

1. Install left splash shield. (TM 9-2320-272-10)
2. Hood lowered and secured. (TM 9-2320-272-10)

END OF TASK

END OF WORK PACKAGE

**FIELD MAINTENANCE
ACCELERATOR LINKAGE REPLACEMENT (M939A2)**

INITIAL SETUP:**Tools and Special Tools**

Tool Kit, General Mechanic's: Automotive
(Volume 5, WP 0826, Table 1, Item 56)

Personnel Required

(2)

Materials/Parts

Cotter Pin
(Volume 5, WP 0827, Table 1, Item 337)
Qty: 2
Locknut (Volume 5, WP 0827, Table 1, Item 274)
Qty: 1

References

Volume 5, WP 0819

Equipment Condition

Parking brake set. (TM 9-2320-272-10)
Hood raised and secured. (TM 9-2320-272-10)

REMOVAL

1. Compress spring-loaded sleeve (Figure 1, Item 22) and remove quick-disconnect socket (Figure 1, Item 21) from ball joint (Figure 1, Item 1) on control lever (Figure 1, Item 2).
2. Remove throttle return spring (Figure 1, Item 14) from accelerator rod (Figure 1, Item 15) and throttle shaft (Figure 1, Item 6).
3. Remove locknut (Figure 1, Item 9) and ball joint (Figure 1, Item 12) from bracket (Figure 1, Item 8). Discard locknut.
4. Loosen screw (Figure 1, Item 11) and remove connector (Figure 1, Item 10) and cable (Figure 1, Item 3) from bracket (Figure 1, Item 8).
5. Remove two cotter pins (Figure 1, Item 5), washers (Figure 1, Item 7), throttle shaft (Figure 1, Item 6), and bracket (Figure 1, Item 8) from bracket (Figure 1, Item 4). Discard cotter pins.

REMOVAL - Continued

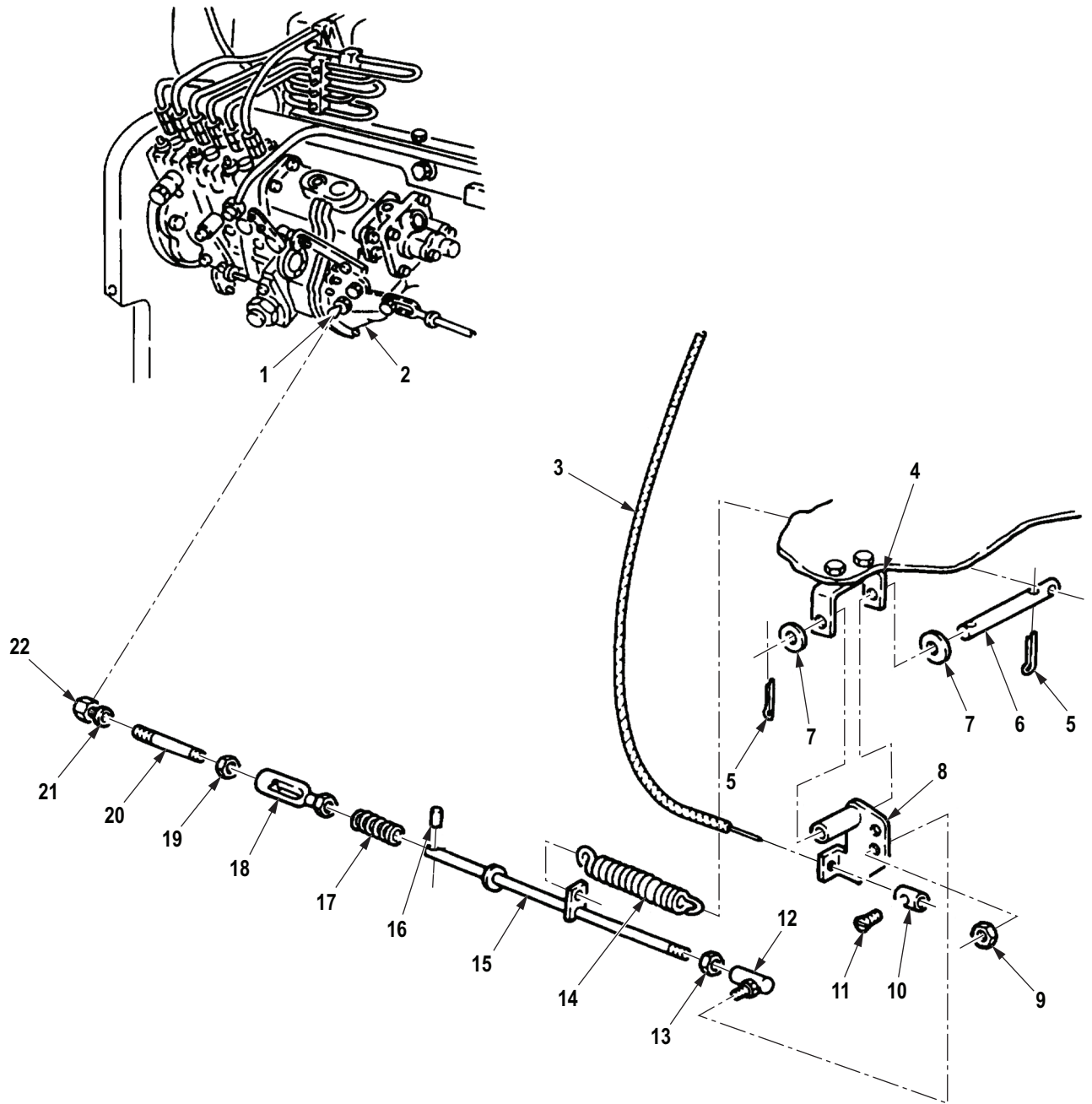

M0101DAA

Figure 1. Accelerator Linkage Removal.

END OF TASK

DISASSEMBLY**NOTE**

Assistant will help with Step (1).

1. Compress spring (Figure 2, Item 17) and remove pin (Figure 2, Item 16), spring, and yoke (Figure 2, Item 18) from accelerator rod (Figure 2, Item 15).
2. Loosen nut (Figure 2, Item 19) and remove yoke (Figure 2, Item 18) from rod (Figure 2, Item 20).
3. Remove nut (Figure 2, Item 19) from rod (Figure 2, Item 20).
4. Remove rod (Figure 2, Item 20) from quick-disconnect socket (Figure 2, Item 21).

NOTE

Mark position of nut on accelerator rod for installation.

5. Loosen nut (Figure 2, Item 13) and remove ball joint (Figure 2, Item 12) from accelerator rod (Figure 2, Item 15).

DISASSEMBLY - Continued

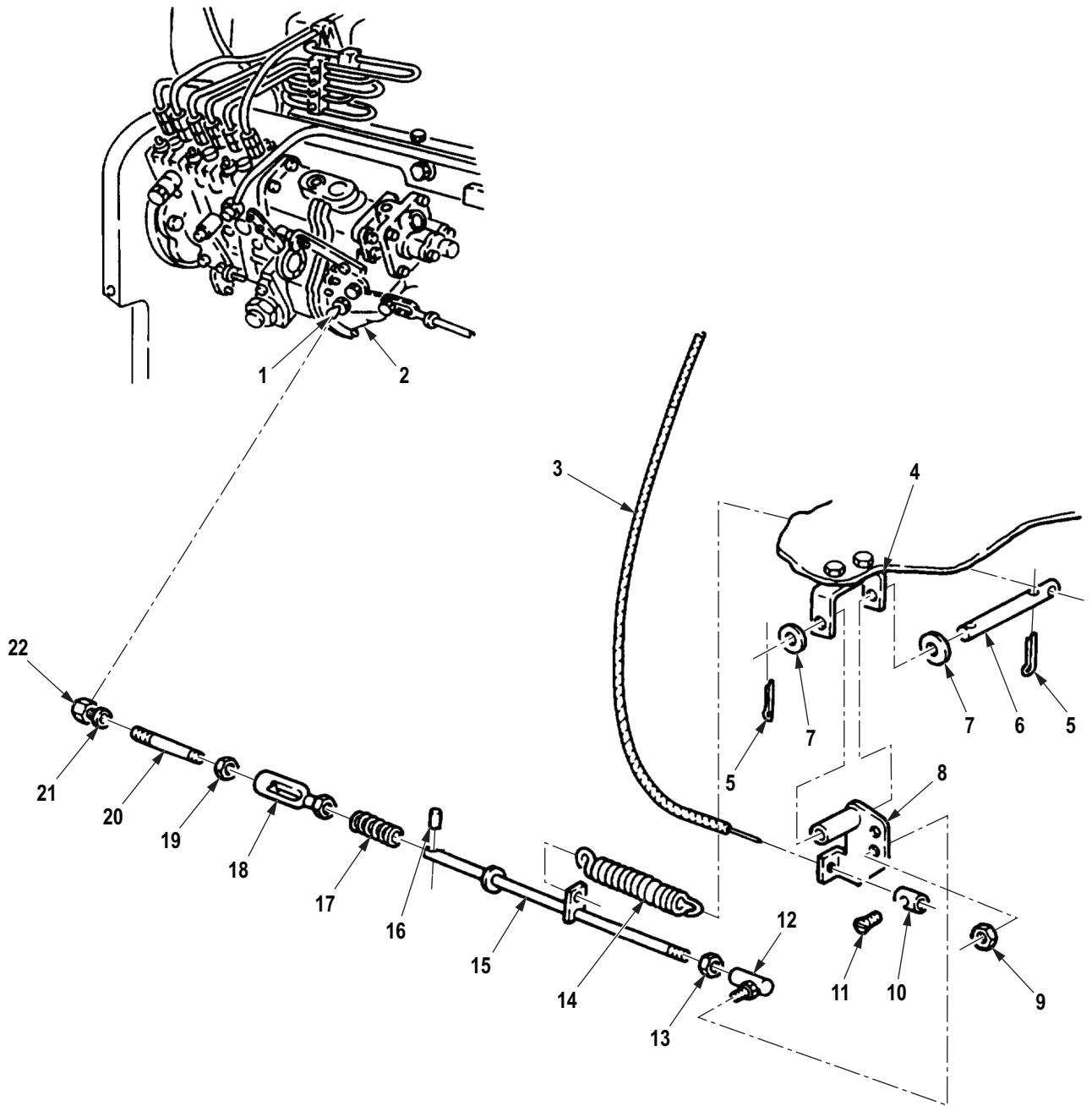

M9467DAA

Figure 2. Accelerator Linkage Disassembly.

END OF TASK

CLEANING AND INSPECTION

1. For General Cleaning Instructions, refer to (Volume 5, WP 0819).
2. For General Inspection Instructions, refer to (Volume 5, WP 0819).
3. Replace all parts failing inspection.

END OF TASK**ASSEMBLY**

1. Position nut (Figure 3, Item 13) to mark on accelerator rod (Figure 3, Item 15).
2. Install ball joint (Figure 3, Item 12) on accelerator rod (Figure 3, Item 15).
3. Install rod (Figure 3, Item 20) on quick disconnect socket (Figure 3, Item 21).
4. Install nut (Figure 3, Item 19) on rod (Figure 3, Item 20). Finger tighten nut (Figure 3, Item 19).
5. Install yoke (Figure 3, Item 18) on rod (Figure 3, Item 20) so several threads are between yoke and nut (Figure 3, Item 19).
6. Install yoke (Figure 3, Item 18) and spring (Figure 3, Item 17) on accelerator rod (Figure 3, Item 15).

NOTE

Assistant will help with Step (7).

7. Compress spring (Figure 3, Item 17) and install pin (Figure 3, Item 16) in accelerator rod (Figure 3, Item 15).

ASSEMBLY - Continued

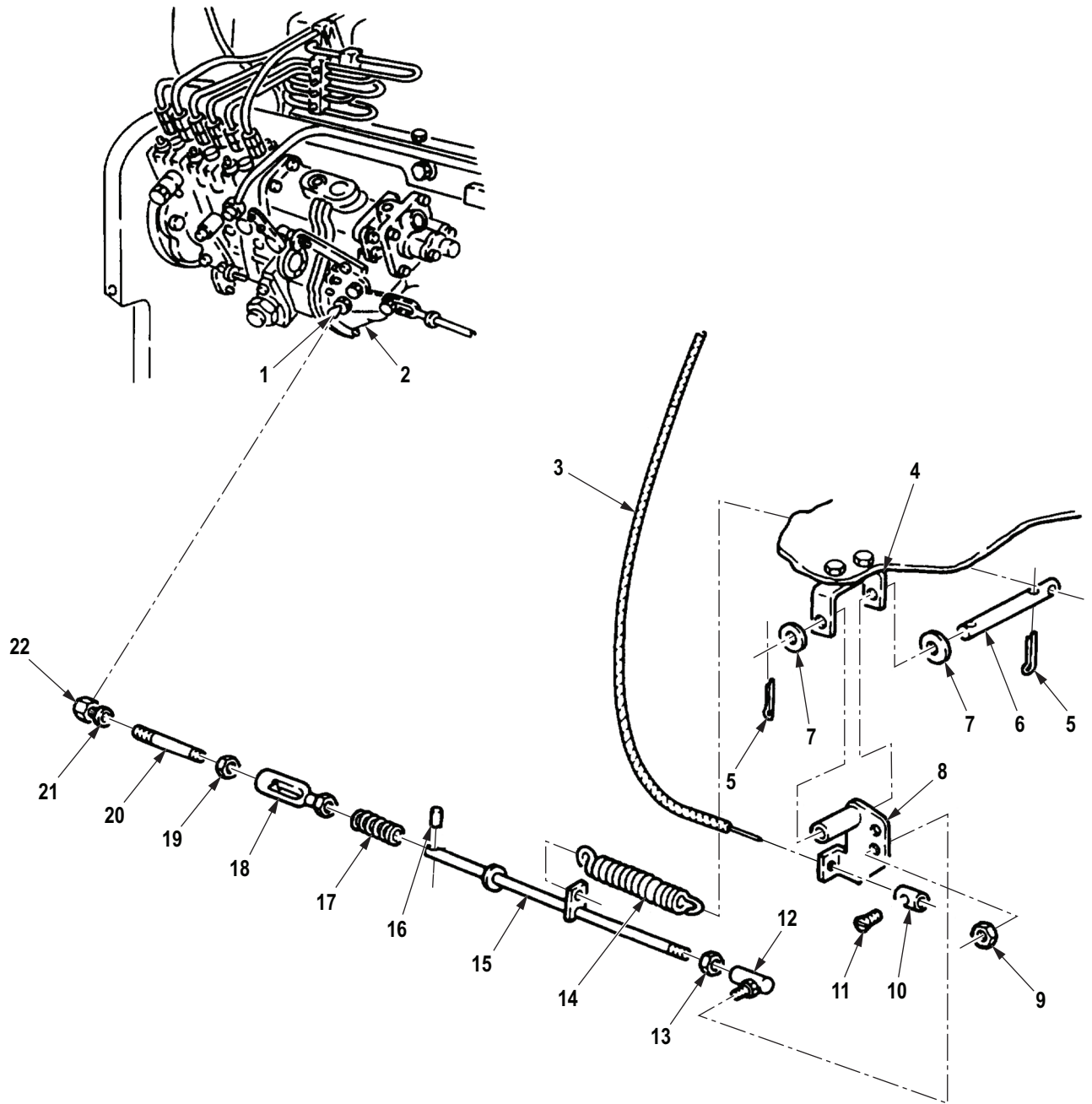

M0102DAA

Figure 3. Accelerator Linkage Assembly.

END OF TASK

INSTALLATION

1. Install bracket (Figure 4, Item 8) on bracket (Figure 4, Item 4) with throttle shaft (Figure 4, Item 6), two washers (Figure 4, Item 7), and two cotter pins (Figure 4, Item 5).
2. Install connector (Figure 4, Item 10) and cable (Figure 4, Item 3) on bracket (Figure 4, Item 8) and tighten screw (Figure 4, Item 11).
3. Install ball joint (Figure 4, Item 12) on bracket (Figure 4, Item 8) with locknut (Figure 4, Item 9).
4. Install throttle return spring (Figure 4, Item 14) on accelerator rod (Figure 4, Item 15) and throttle shaft (Figure 4, Item 6).

INSTALLATION - Continued

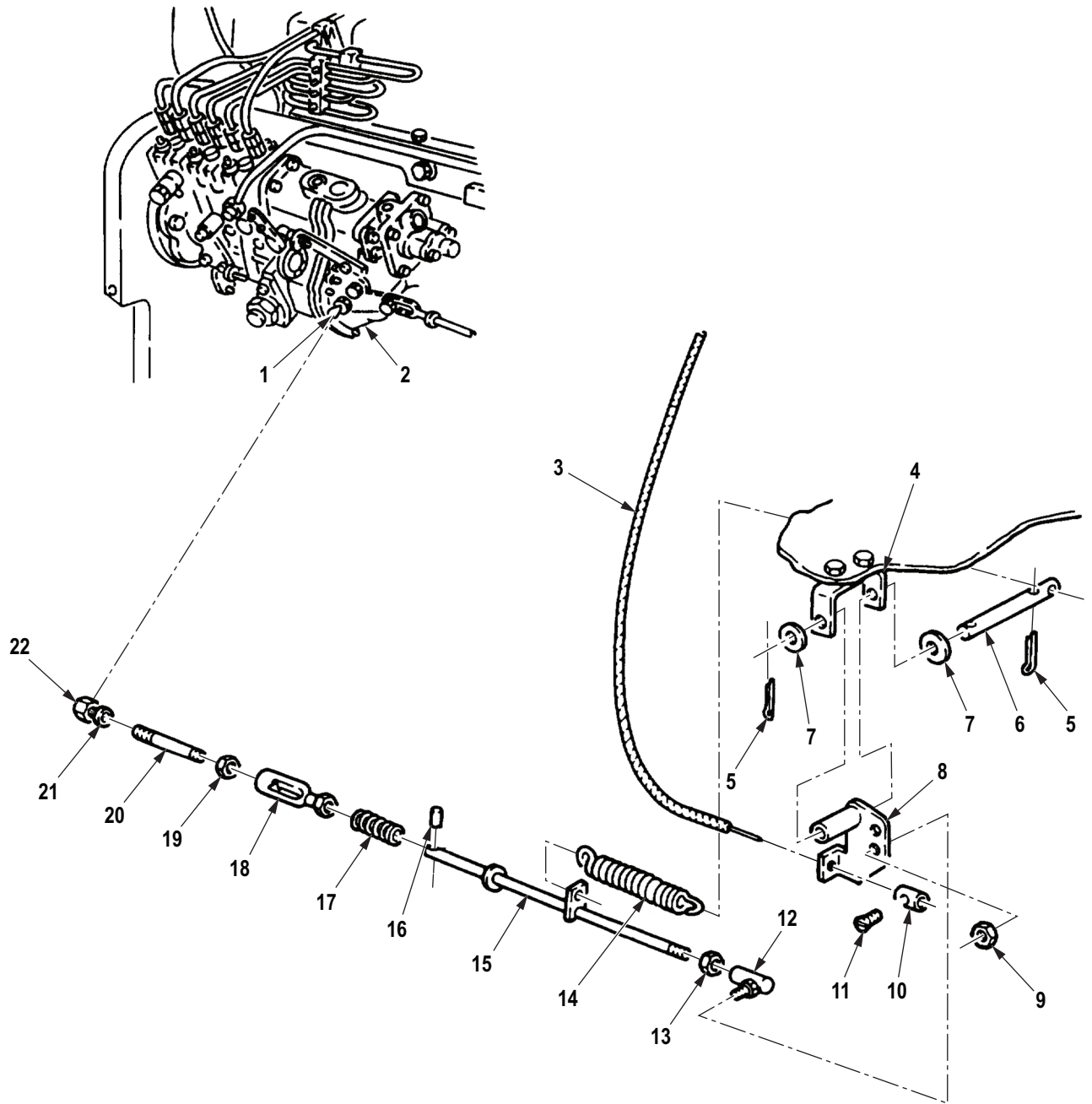

M9468DAA

Figure 4. Accelerator Linkage Installation.

END OF TASK

ADJUSTMENT

1. Position control lever (Figure 5, Item 2) to idle position.
2. Turn rod (Figure 5, Item 20) until control lever (Figure 5, Item 2) moves forward 0.125 in. (3.2 mm).
3. Tighten nut (Figure 5, Item 19) securely.
4. Depress spring-loaded sleeve (Figure 5, Item 22) and install quick-disconnect socket (Figure 5, Item 21) from ball joint (Figure 5, Item 1).
5. Check for engine idle at 550 to 650 rpm.

NOTE

Perform Steps (6), (7), and (8) as necessary to obtain correct idle speed.

6. Compress spring-loaded sleeve (Figure 5, Item 22) and disconnect socket (Figure 5, Item 21) from ball joint (Figure 5, Item 1).
7. Loosen jamnut (Figure 5, Item 19) and lengthen or shorten rod (Figure 5, Item 20) by turning rod into or out of yoke (Figure 5, Item 18) to obtain correct movement for idle speed.
8. Depress spring-loaded sleeve (Figure 5, Item 22) and install quick-disconnect socket (Figure 5, Item 21) on ball joint (Figure 5, Item 1).
9. Tighten jamnut (Figure 5, Item 19) when correct idle speed is obtained.

ADJUSTMENT - Continued

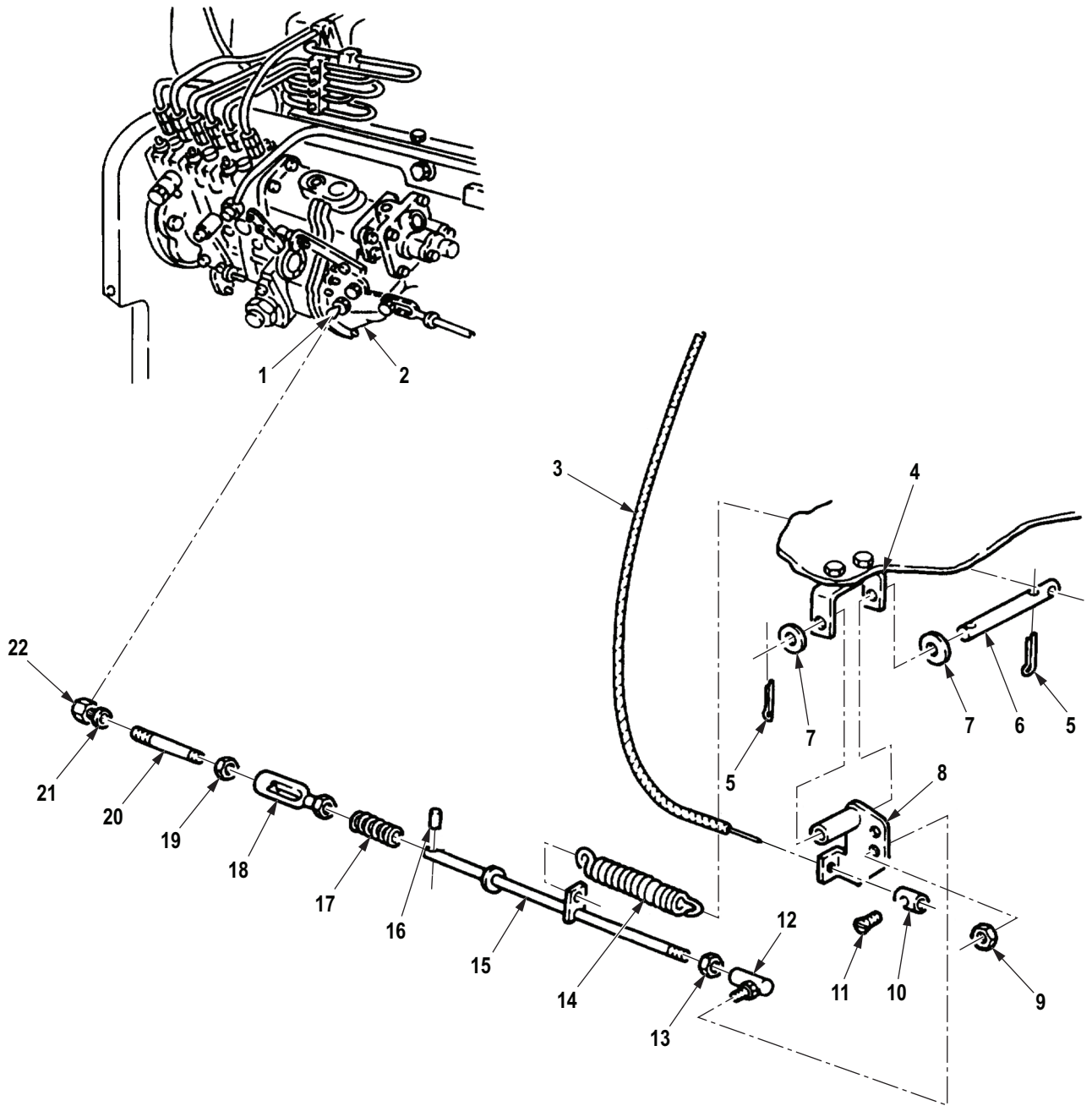

M9469DAA

Figure 5. Accelerator Linkage Adjustment.

END OF TASK

FOLLOW-ON MAINTENANCE

Start engine and check engine idle. (TM 9-2320-272-10)

END OF TASK

END OF WORK PACKAGE

**FIELD MAINTENANCE
THROTTLE CONTROL CABLE REPLACEMENT**

INITIAL SETUP:**Tools and Special Tools**

Tool Kit, General Mechanic's: Automotive
(Volume 5, WP 0826, Table 1, Item 56)

Materials/Parts

Grease, Automotive and Artillery
(Volume 5, WP 0825, Table 1, Item 28)
Locknut (Volume 5, WP 0827, Table 1, Item 274)
Qty: 1
Lockwasher

Materials/Parts (cont.)

(Volume 5, WP 0827, Table 1, Item 407)
Qty: 1
Lockwasher
(Volume 5, WP 0827, Table 1, Item 426)
Qty: 1

Equipment Condition

Parking brake set. (TM 9-2320-272-10)
Hood raised and secured. (TM 9-2320-272-10)
Left splash shield removed. (TM 9-2320-272-10)

REMOVAL**NOTE**

- Throttle control cable maintenance for all vehicles is basically the same. This procedure covers M939/A1 series vehicles.
- Throttle cable end may have to be straightened before performing Step (1).

1. Remove screw (Figure 1, Item 25) and connector (Figure 1, Item 23) from throttle cable (Figure 1, Item 26).
2. Remove throttle cable (Figure 1, Item 26) from throttle rod link (Figure 1, Item 24).

NOTE

Perform Step (3) for unmodified throttle routing (throttle cable on bracket). Perform Step (4) if throttle cable clamp is mounted on firewall.

3. Remove locknut (Figure 1, Item 12), washer (Figure 1, Item 11), conduit clamp (Figure 1, Item 14), and screw (Figure 1, Item 15) from bracket (Figure 1, Item 9) on firewall (Figure 1, Item 10). Discard locknut.
4. Remove screw (Figure 1, Item 16), conduit (Figure 1, Item 13) with clamp (Figure 1, Item 17), wire harness (Figure 1, Item 18) with clamp (Figure 1, Item 19), washer (Figure 1, Item 20), ground strap (Figure 1, Item 21), and lockwasher (Figure 1, Item 22) from firewall (Figure 1, Item 10). Discard lockwasher.
5. Pull conduit (Figure 1, Item 13) and throttle cable (Figure 1, Item 26) through grommet (Figure 1, Item 1) in firewall (Figure 1, Item 10) and into vehicle cab.
6. Remove grommet (Figure 1, Item 1) from firewall (Figure 1, Item 10).
7. Remove four screws (Figure 1, Item 4) from throttle control plate (Figure 1, Item 7) and instrument panel (Figure 1, Item 2).
8. Remove nut (Figure 1, Item 3), lockwasher (Figure 1, Item 8), and plate (Figure 1, Item 7) from throttle control (Figure 1, Item 6). Discard lockwasher.
9. Remove throttle control (Figure 1, Item 6), plate (Figure 1, Item 7), and conduit (Figure 1, Item 13) from instrument panel (Figure 1, Item 2).

NOTE

Perform Step (10) if throttle control is to be replaced.

10. Remove throttle control handle (Figure 1, Item 5) and cable (Figure 1, Item 26) from conduit (Figure 1, Item 13).

REMOVAL - Continued

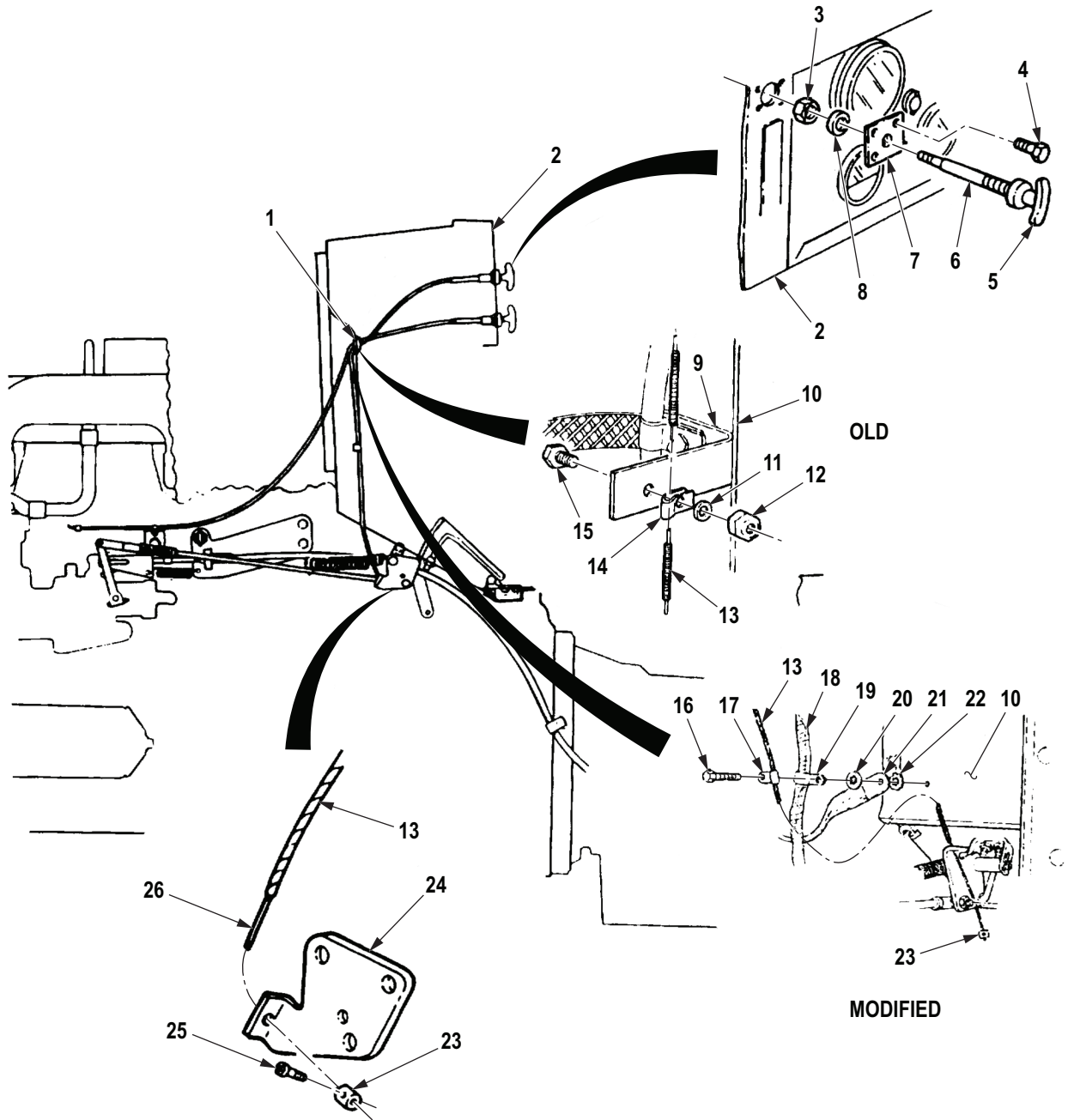

M0105DAA

Figure 1. Throttle Control Cable Removal.

END OF TASK

INSPECTION

1. Inspect throttle cable (Figure 2, Item 13) for bends, breaks, and damage. Replace if bent, broken, or damaged.
2. Inspect conduit (Figure 2, Item 9) for breaks and kinks that could bind on cable (Figure 2, Item 13). Replace conduit (Figure 2, Item 9) if broken or kinked.

END OF TASK**INSTALLATION****NOTE**

- If throttle control cable is being replaced, installed, or if throttle sticks in the DOWN position, follow this installation procedure.
- Perform Step (1) if throttle cable is new or has been removed from conduit.

1. Coat throttle cable (Figure 2, Item 21) with light film of automotive and artillery grease and thread through cable conduit (Figure 2, Item 11).
2. Install plate (Figure 2, Item 7) over conduit (Figure 2, Item 11) and secure to throttle control (Figure 2, Item 6) with lockwasher (Figure 2, Item 8) and nut (Figure 2, Item 3).
3. Coat control cable (Figure 2, Item 21) with light coat of automotive and artillery grease and feed throttle control cable and conduit (Figure 2, Item 11) through instrument panel (Figure 2, Item 2) and secure plate (Figure 2, Item 7) to instrument panel (Figure 2, Item 2) with four screws (Figure 2, Item 4).
4. Install grommet (Figure 2, Item 1) in firewall (Figure 2, Item 17).
5. Thread control cable (Figure 2, Item 21) and conduit (Figure 2, Item 11) through grommet (Figure 2, Item 1) and into engine side of firewall (Figure 2, Item 17).
6. Position conduit clamp (Figure 2, Item 10) over conduit (Figure 2, Item 11) and feed control cable (Figure 2, Item 21) through hole in throttle rod link (Figure 2, Item 18).

NOTE

Throttle rod link and handle on end of control cable must be in closed throttle position before performing Step (8).

7. Ensuring handle (Figure 2, Item 5) is fully seated on control (Figure 2, Item 6), install connector (Figure 2, Item 19) over control cable (Figure 2, Item 21), slide connector up cable (Figure 2, Item 21) into contact with link (Figure 2, Item 18) and install screw (Figure 2, Item 20). Bend projecting end of cable up at connector.
8. Install conduit clamp (Figure 2, Item 10) and wiring harness (Figure 2, Item 12) with clamp (Figure 2, Item 13), washer (Figure 2, Item 14), strap (Figure 2, Item 15), and lockwasher (Figure 2, Item 16) on firewall (Figure 2, Item 17) with screw (Figure 2, Item 9).

INSTALLATION - Continued

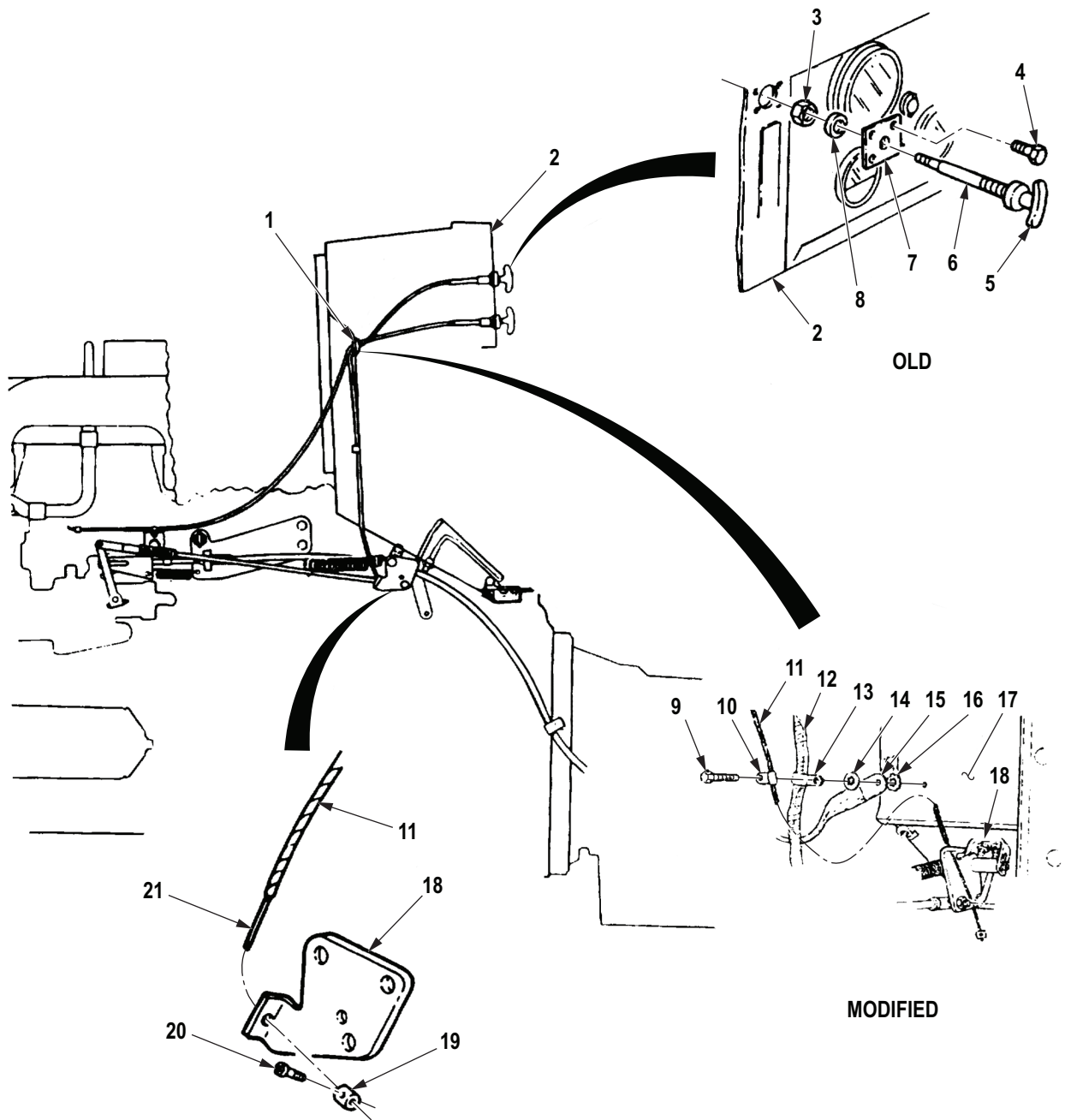

M0106DAA

Figure 2. Throttle Control Cable Installation.

END OF TASK

FOLLOW-ON MAINTENANCE

1. Install left splash shield. (TM 9-2320-272-10)
2. Start engine and test throttle control for proper operation. (TM 9-2320-272-10)

END OF TASK**END OF WORK PACKAGE**

**FIELD MAINTENANCE
EMERGENCY STOP CONTROL CABLE REPLACEMENT**

INITIAL SETUP:**Tools and Special Tools**

Tool Kit, General Mechanic's: Automotive
(Volume 5, WP 0826, Table 1, Item 56)

Materials/Parts

Grease, Automotive and Artillery
(Volume 5, WP 0825, Table 1, Item 65)
Locknut (Volume 5, WP 0827, Table 1, Item 282)
Qty: 1
Lock Pin (Volume 5, WP 0827, Table 1, Item 11)
Qty: 1

Materials/Parts (cont.)

Lockwasher
(Volume 5, WP 0827, Table 1, Item 186)
Qty: 1
Lockwasher
(Volume 5, WP 0827, Table 1, Item 407)
Qty: 1

Equipment Condition

Parking brake set. (TM 9-2320-272-10)
Hood raised and secured. (TM 9-2320-272-10)
Battery ground cables disconnected. (WP 0350)
Left splash shield removed. (TM 9-2320-272-10)

REMOVAL**NOTE**

Steps (1) through (4) are for M939A2 series vehicles.

1. Remove lock pin (Figure 1, Item 10), washer (Figure 1, Item 11), and cable pivot (Figure 1, Item 4) from shutoff valve lever (Figure 1, Item 1). Discard lock pin.
2. Remove screw (Figure 1, Item 2), connector (Figure 1, Item 3), and cable pivot (Figure 1, Item 4) from cable (Figure 1, Item 5).
3. Remove screw (Figure 1, Item 9), clamp (Figure 1, Item 7), and cable conduit (Figure 1, Item 6) from fuel bracket (Figure 1, Item 8).
4. Remove clamp (Figure 1, Item 7) from conduit (Figure 1, Item 6).

NOTE

Steps (5) through (9) are for M939/A1 series vehicles.

5. Remove connector screw (Figure 1, Item 18) and connector (Figure 1, Item 19) from shutoff valve control lever (Figure 1, Item 28) and cable (Figure 1, Item 5).
6. Remove connector (Figure 1, Item 19) from stop control cable (Figure 1, Item 5).
7. Remove locknut (Figure 1, Item 24), washer (Figure 1, Item 25), and screw (Figure 1, Item 21) from clamp (Figure 1, Item 20) on conduit (Figure 1, Item 6) and conduit clamp bracket (Figure 1, Item 26). Discard locknut.
8. Remove screw (Figure 1, Item 23), lockwasher (Figure 1, Item 22), and clamp bracket (Figure 1, Item 26) from engine (Figure 1, Item 27). Discard lockwasher.
9. Remove clamp (Figure 1, Item 20) from conduit (Figure 1, Item 6).

NOTE

Steps (10) through (13) applies to all vehicles.

10. From behind instrument panel (Figure 1, Item 15), remove nut (Figure 1, Item 12) and lockwasher (Figure 1, Item 13) on emergency stop control (Figure 1, Item 14). Discard lockwasher.
11. Pull emergency stop control (Figure 1, Item 14), conduit (Figure 1, Item 6), and cable (Figure 1, Item 5) through firewall (Figure 1, Item 17), grommet (Figure 1, Item 16), and front of instrument panel (Figure 1, Item 15).
12. Remove grommet (Figure 1, Item 16) from firewall (Figure 1, Item 17).

NOTE

Perform Step (13) only if replacing stop control cable.

13. Remove stop control cable (Figure 1, Item 5) and handle of stop control (Figure 1, Item 14) from conduit (Figure 1, Item 6).

REMOVAL - Continued

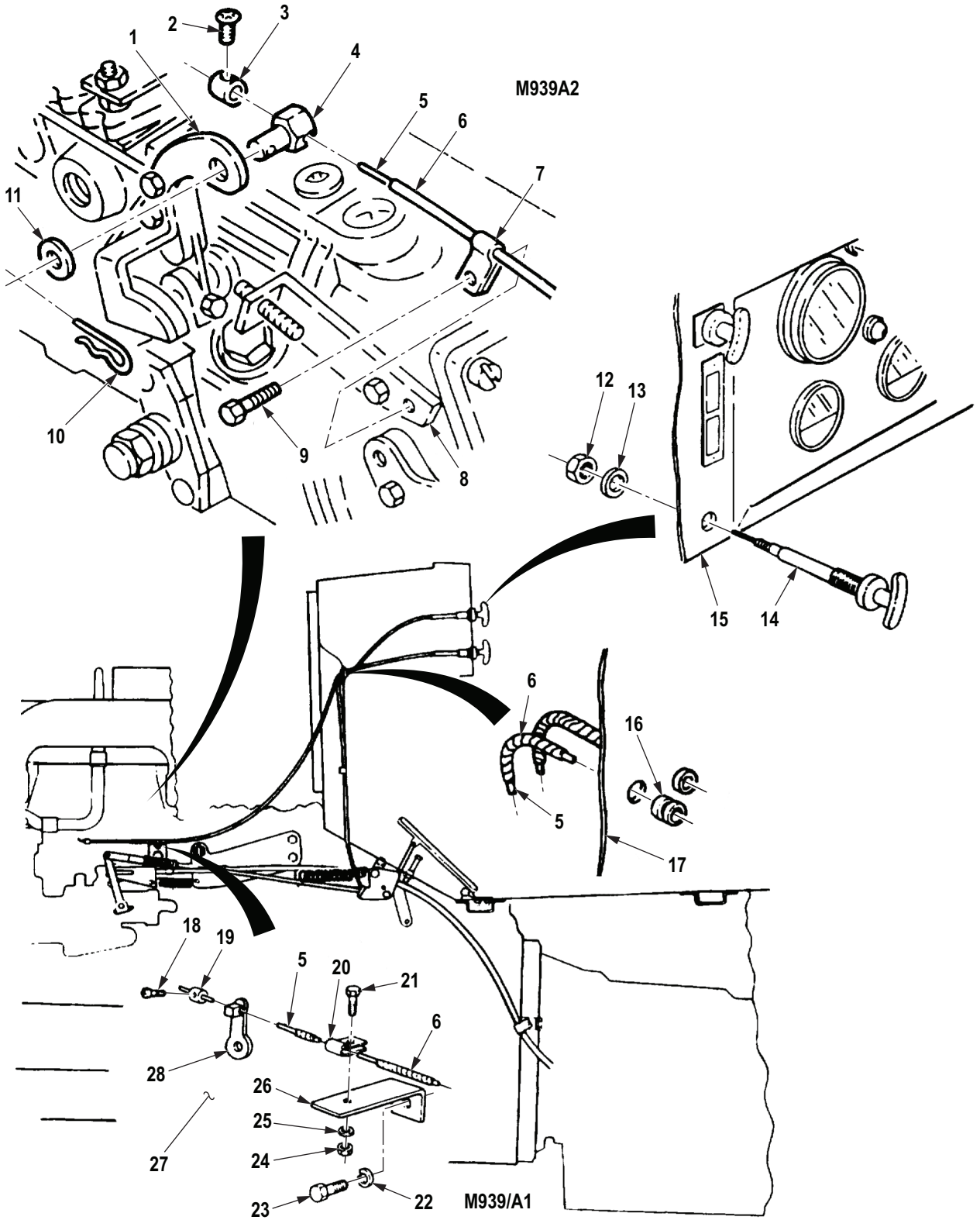

M0103DAA

Figure 1. Emergency Stop Control Cable Removal.

END OF TASK

INSPECTION

1. Inspect stop control cable for binding and breaks. Replace cable if broken, bent, or damaged.
2. Inspect conduit for breaks or kinks that could cause cable to bind. Replace conduit if broken or kinked.

END OF TASK**INSTALLATION****NOTE**

Perform Step (1) only if replacing cable in conduit.

1. Coat stop control cable (Figure 2, Item 8) with light film of GAA grease and thread through cable conduit (Figure 2, Item 5).
2. Thread stop control conduit (Figure 2, Item 5) and cable (Figure 2, Item 8) through front of instrument panel (Figure 2, Item 4) and seat stop control (Figure 2, Item 3) in panel.
3. Place lockwasher (Figure 2, Item 2) and nut (Figure 2, Item 1) over conduit (Figure 2, Item 5) and install on stop control (Figure 2, Item 3). Tighten nut on stop control.
4. Install grommet (Figure 2, Item 6) in firewall (Figure 2, Item 7).
5. Thread cable (Figure 2, Item 8) and conduit (Figure 2, Item 5) through grommet (Figure 2, Item 6) and firewall (Figure 2, Item 7).

NOTE

Steps (6) through (11) apply to M939/A1 series vehicles.

6. Thread cable (Figure 2, Item 8) through hole in shutoff valve control lever (Figure 2, Item 18).
7. Push shutoff valve control lever (Figure 2, Item 18) all the way forward and slide connector (Figure 2, Item 10) over cable (Figure 2, Item 8) and against shutoff lever.
8. Install screw (Figure 2, Item 9) in connector (Figure 2, Item 10) and tighten screw against cable (Figure 2, Item 8).
9. Bend end of cable (Figure 2, Item 8) projecting beyond connector (Figure 2, Item 10) upward at a 90 degree angle.
10. Install clamp bracket (Figure 2, Item 17) on engine (Figure 2, Item 19) with screw (Figure 2, Item 14) and lockwasher (Figure 2, Item 13).
11. Install stop control clamp (Figure 2, Item 11) on conduit (Figure 2, Item 5) and clamp bracket (Figure 2, Item 17) with screw (Figure 2, Item 12), washer (Figure 2, Item 16), and locknut (Figure 2, Item 15).

NOTE

Steps (12) through (16) apply to M939A2 series vehicles.

12. Position clamp (Figure 2, Item 24) over cable conduit (Figure 2, Item 5) and install clamp on fuel bracket (Figure 2, Item 25) with screw (Figure 2, Item 26).
13. Position cable pivot (Figure 2, Item 23) on cable (Figure 2, Item 8), put pivot into shutoff lever (Figure 2, Item 20), and secure with washer (Figure 2, Item 28) and lock pin (Figure 2, Item 27).
14. Place connector (Figure 2, Item 22) over cable (Figure 2, Item 8) and snugged up to cable pivot (Figure 2, Item 23).
15. Install screw (Figure 2, Item 21) in connector (Figure 2, Item 22) to secure connector on cable (Figure 2, Item 8).

INSTALLATION - Continued

16. Bend end of cable (Figure 2, Item 8) projecting beyond connector (Figure 2, Item 22) upward at 90 degree angle.
17. Start engine and check for correct emergency stop operation (TM 9-2320-272-10).
18. For M939A2 series vehicles, loosen screw (Figure 2, Item 21) in connector (Figure 2, Item 22) and adjust as needed to achieve engine cutoff.
19. For M939/A1 series vehicles, loosen screw (Figure 2, Item 9) in connector (Figure 2, Item 10) and adjust as needed to achieve engine cutoff.

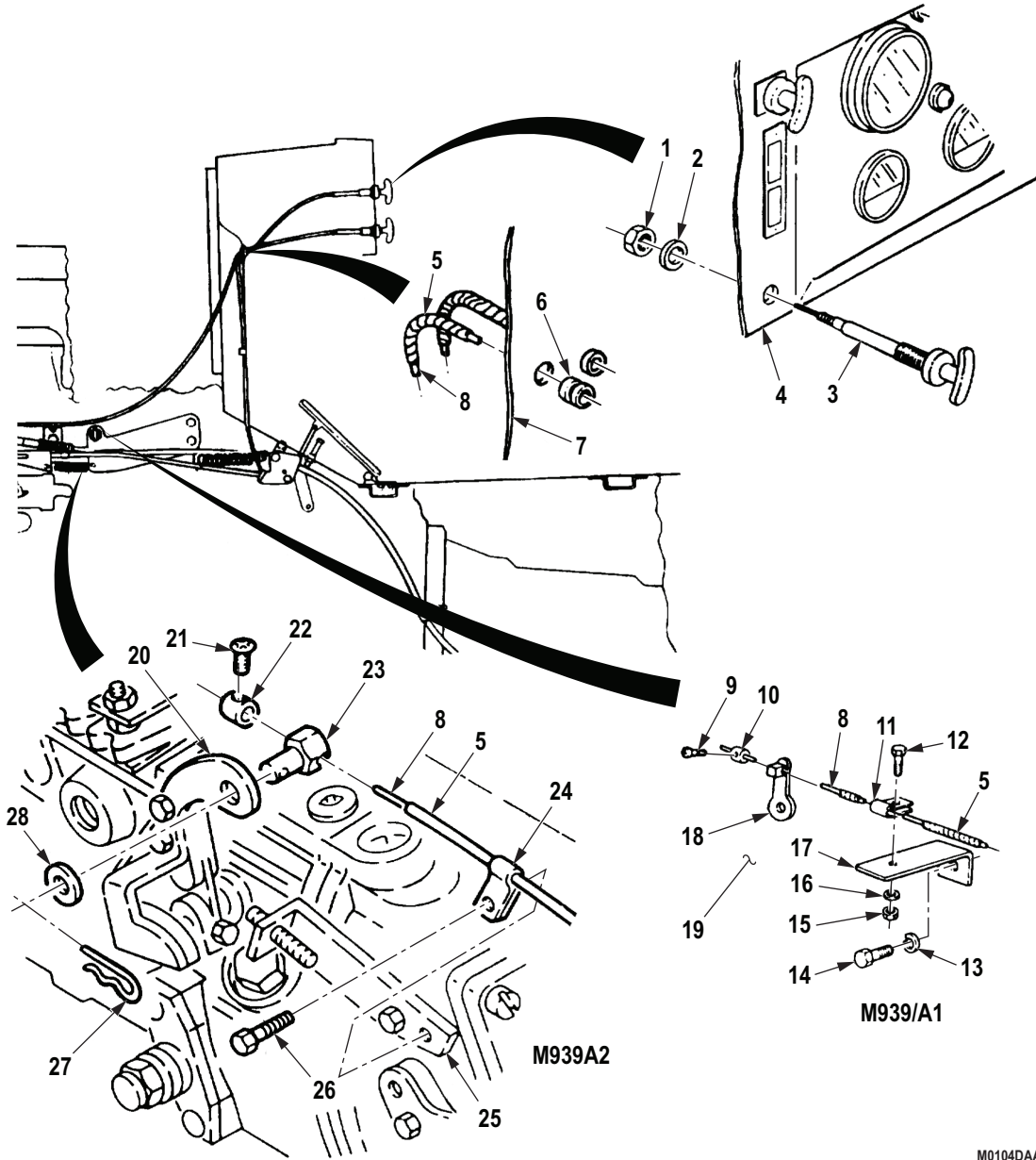

Figure 2. Emergency Stop Control Cable Installation.

END OF TASK

FOLLOW-ON MAINTENANCE

1. Connect battery ground cables. (WP 0350)
2. Install left splash shield. (TM 9-2320-272-10)

END OF TASK**END OF WORK PACKAGE**

FIELD MAINTENANCE
ACCELERATOR PEDAL, BRACKET, ROD, AND STOPSCREW REPLACEMENT

INITIAL SETUP:**Tools and Special Tools**

Tool Kit, General Mechanic's: Automotive
(Volume 5, WP 0826, Table 1, Item 56)

References

WP 0268
WP 0269

Materials/Parts

Cotter Pin
(Volume 5, WP 0827, Table 1, Item 331)
Qty: 2

Equipment Condition

Parking brake set. (TM 9-2320-272-10)
Left splash shield removed. (TM 9-2320-272-10)

REMOVAL

1. Remove cotter pin (Figure 1, Item 1) and washer (Figure 1, Item 2) from accelerator pedal push rod (Figure 1, Item 13). Discard cotter pin.
2. Remove hinge pin (Figure 1, Item 7) and accelerator pedal (Figure 1, Item 3) from accelerator pedal bracket (Figure 1, Item 5).
3. Remove two screws (Figure 1, Item 4) and bracket (Figure 1, Item 5) from cab floor (Figure 1, Item 6).
4. Remove cotter pin (Figure 1, Item 12), washer (Figure 1, Item 10), and accelerator pedal rod (Figure 1, Item 13) from link assembly (Figure 1, Item 11). Discard cotter pin.
5. Loosen jamnut (Figure 1, Item 9) above cab floor (Figure 1, Item 6) and remove accelerator pedal stopscrew (Figure 1, Item 8).
6. Remove jamnut (Figure 1, Item 9) from pedal stopscrew (Figure 1, Item 8).

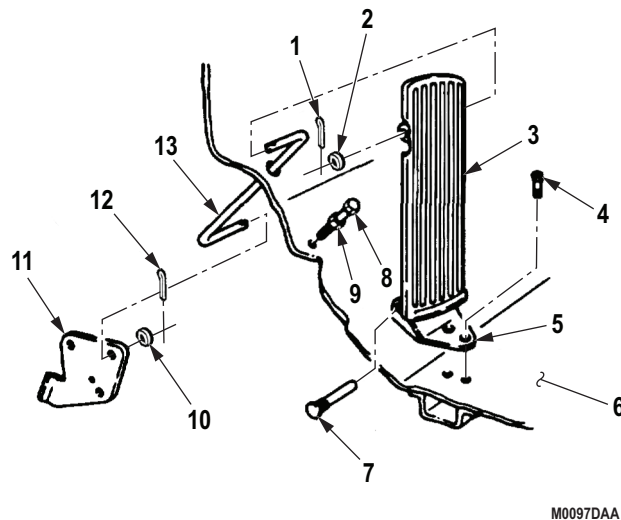

M0097DAA

Figure 1. Accelerator Pedal Removal.

END OF TASK**INSTALLATION**

1. Install jamnut (Figure 2, Item 9) on pedal stopscrew (Figure 2, Item 8) to limit of threads.
2. Install pedal stopscrew (Figure 2, Item 8) on cab floor (Figure 2, Item 6) and tighten jamnut (Figure 2, Item 9) against cab floor.
3. Install accelerator pedal bracket (Figure 2, Item 5) on cab floor (Figure 2, Item 6) with two screws (Figure 2, Item 4).
4. Install accelerator pedal (Figure 2, Item 3) on bracket (Figure 2, Item 5) with hinge pin (Figure 2, Item 7).
5. Install accelerator pedal push rod (Figure 2, Item 13) on accelerator pedal (Figure 2, Item 3) and link assembly (Figure 2, Item 11) with washers (Figure 2, Items 2 and 10) and cotter pins (Figure 2, Items 1 and 12). Spread ends of cotter pins after adjustment.

INSTALLATION - Continued

Figure 2. Accelerator Pedal Installation.

END OF TASK**FOLLOW-ON MAINTENANCE**

1. Adjust accelerator linkage. (WP 0268) or (WP 0269)
2. Install left splash shield. (TM 9-2320-272-10)

END OF TASK**END OF WORK PACKAGE**

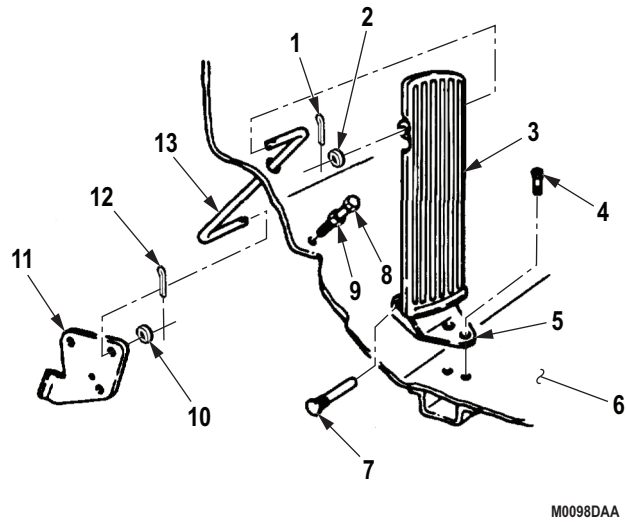
**FIELD MAINTENANCE
EXHAUST STACK REPLACEMENT**

INITIAL SETUP:**Tools and Special Tools**

Tool Kit, General Mechanic's: Automotive
(Volume 5, WP 0826, Table 1, Item 56)

Materials/Parts

Grease, Automotive and Artillery
(Volume 5, WP 0825, Table 1, Item 28)

Materials/Parts (cont.)

Gasket (Volume 5, WP 0827, Table 1, Item 42)
Qty: 1
Locknut (Volume 5, WP 0827, Table 1, Item 27)
Qty: 1

Personnel Required

(2)

Equipment Condition

Parking brake set. (TM 9-2320-272-10)

REMOVAL**WARNING**

Do not touch hot exhaust system components with bare hands. Failure to comply may result in injury or death to personnel.

1. Remove locknut (Figure 1, Item 6) and screw (Figure 1, Item 3) from clamp (Figure 1, Item 2) at right rear of cab (Figure 1, Item 7). Discard locknut.

NOTE

Assistant will help with Step (2).

2. Remove clamp (Figure 1, Item 2) from exhaust stack (Figure 1, Item 1) and muffler (Figure 1, Item 4).
3. Remove exhaust stack (Figure 1, Item 1) and gasket (Figure 1, Item 5) from muffler (Figure 1, Item 4). Discard gasket and clean gasket remains from mating surfaces.

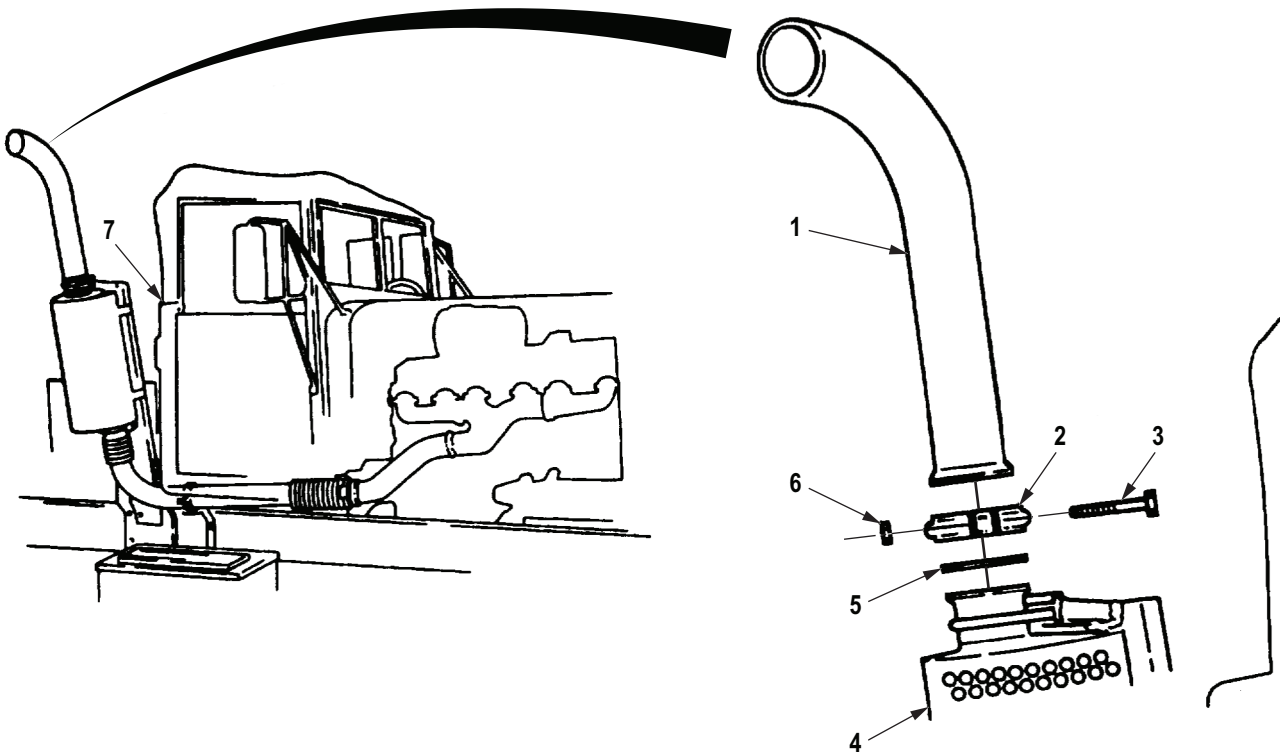

M0109DAA

Figure 1. Exhaust Stack Removal.

END OF TASK

INSTALLATION

1. Apply small amount of automotive and artillery grease on muffler mating surface and position gasket (Figure 2, Item 5) and exhaust stack (Figure 2, Item 1) over muffler (Figure 2, Item 4) so opening of exhaust stack is directly away from cab (Figure 2, Item 7).

NOTE

Assistant will help with Step (2).

2. Secure exhaust stack (Figure 2, Item 1) to muffler (Figure 2, Item 4) with clamp (Figure 2, Item 2), screw, and locknut (Figure 2, Item 6).

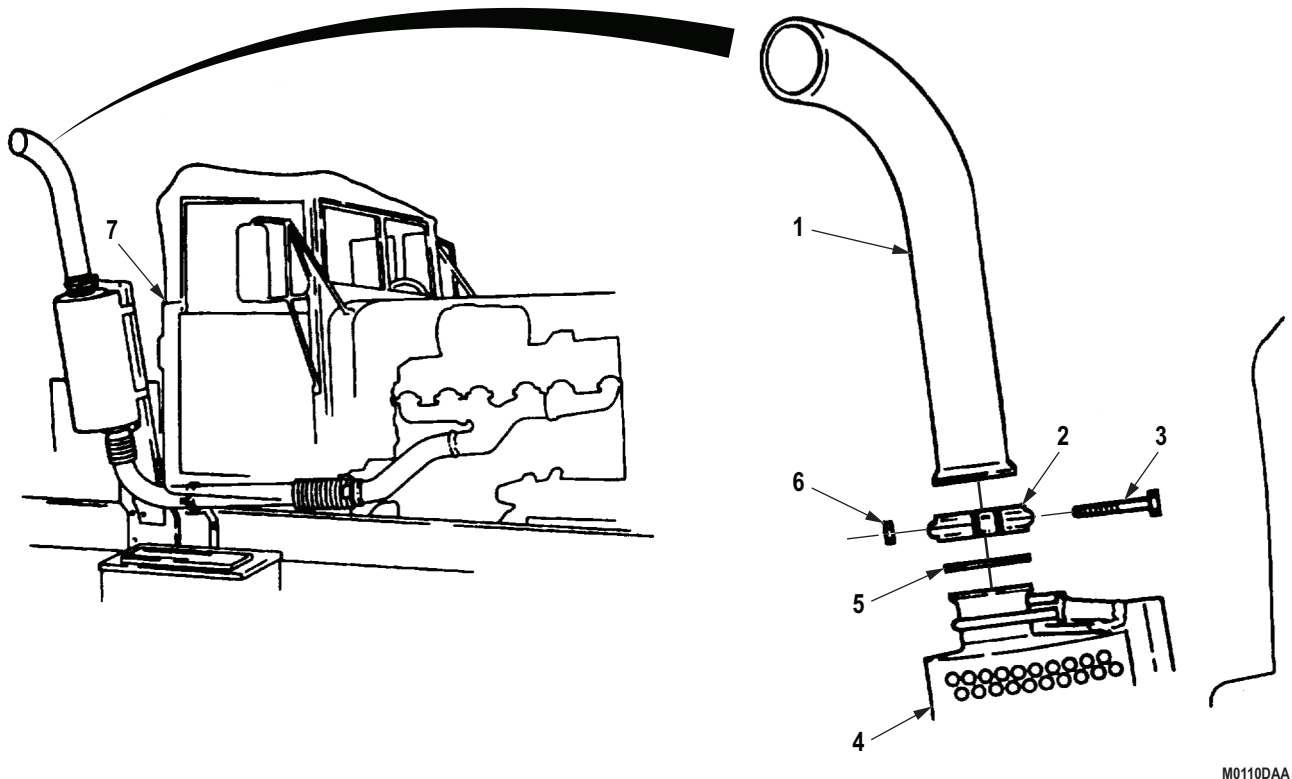

M0110DAA

Figure 2. Exhaust Stack Installation.

END OF TASK**FOLLOW-ON MAINTENANCE**

Start engine and check for exhaust leaks. (TM 9-2320-272-10)

END OF TASK**END OF WORK PACKAGE**

**FIELD MAINTENANCE
MUFFLER AND SHIELD REPLACEMENT**

INITIAL SETUP:**Tools and Special Tools**

Tool Kit, General Mechanic's: Automotive
(Volume 5, WP 0826, Table 1, Item 56)

Materials/Parts

Grease, Automotive and Artillery
(Volume 5, WP 0825, Table 1, Item 28)
Gasket (Volume 5, WP 0827, Table 1, Item 42)
Qty: 1

Materials/Parts (cont.)

Locknut (Volume 5, WP 0827, Table 1, Item 27)
Qty: 1
Locknut (Volume 5, WP 0827, Table 1, Item 285)
Qty: 4

Personnel Required

(2)

Equipment Condition

Parking brake set. (TM 9-2320-272-10)
Exhaust stack removed. (WP 0273)

REMOVAL**WARNING**

Do not touch hot exhaust system components with bare hands. Failure to comply may result in injury or death to personnel.

1. Remove four locknuts (Figure 1, Item 8), screws (Figure 1, Item 14), and muffler shield (Figure 1, Item 1) from muffler shield support (Figure 1, Item 5). Discard locknuts.

NOTE

Assistant will help with Steps (2) and (3).

2. Remove four nuts (Figure 1, Item 7), lockwashers (Figure 1, Item 6), two U-bolts (Figure 1, Item 2), U-clamps (Figure 1, Item 4) and muffler (Figure 1, Item 3) from muffler shield support (Figure 1, Item 5). Discard lockwashers.
3. Remove locknut (Figure 1, Item 13), screw (Figure 1, Item 9), exhaust pipe coupling clamp (Figure 1, Item 12), muffler (Figure 1, Item 3), and exhaust pipe gasket (Figure 1, Item 11) from exhaust pipe (Figure 1, Item 10). Discard locknut and gasket.

REMOVAL - Continued

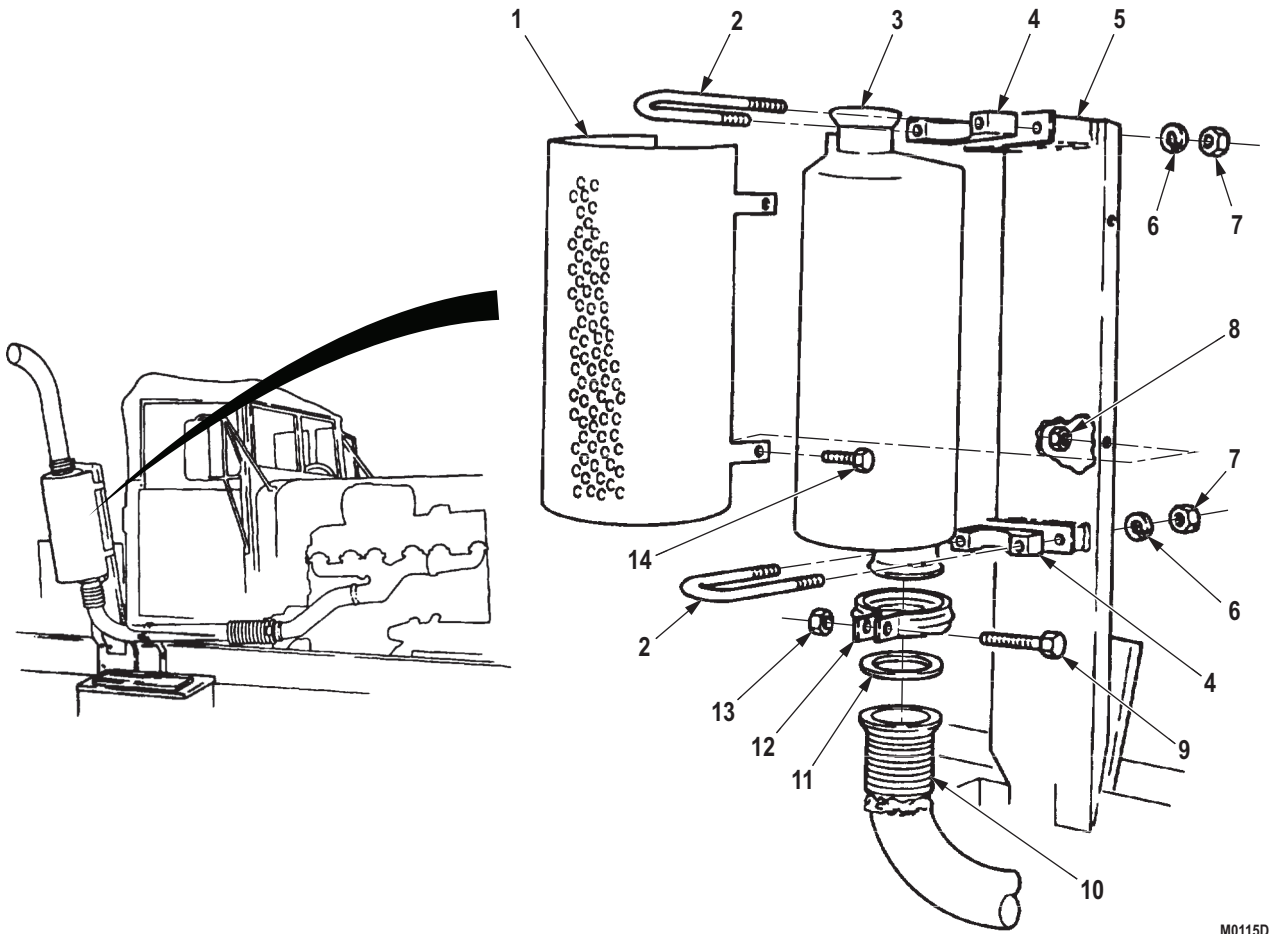

M0115DAA

Figure 1. Muffler and Shield Removal.

END OF TASK

INSPECTION

Inspect muffler (Figure 2, Item 3) for cracks. Replace if cracked.

END OF TASK**INSTALLATION****NOTE**

Assistant will help with Steps (1) and (2).

1. Apply small amount of automotive and artillery grease on flange of exhaust pipe (Figure 2, Item 10), position muffler (Figure 2, Item 3) with narrow side facing away from cab (Figure 2, Item 15) and install gasket (Figure 2, Item 11) and muffler on exhaust pipe with coupling clamp (Figure 2, Item 12), screw (Figure 2, Item 9), and locknut (Figure 2, Item 13).
2. Install muffler (Figure 2, Item 3) on muffler shield support (Figure 2, Item 5) with two U-clamps (Figure 2, Item 4), U-bolts (Figure 2, Item 2), four lockwashers (Figure 2, Item 6), and nuts (Figure 2, Item 7).
3. Install muffler shield (Figure 2, Item 1) on muffler shield support (Figure 2, Item 5) with four screws (Figure 2, Item 14) and locknuts (Figure 2, Item 8).

INSTALLATION - Continued

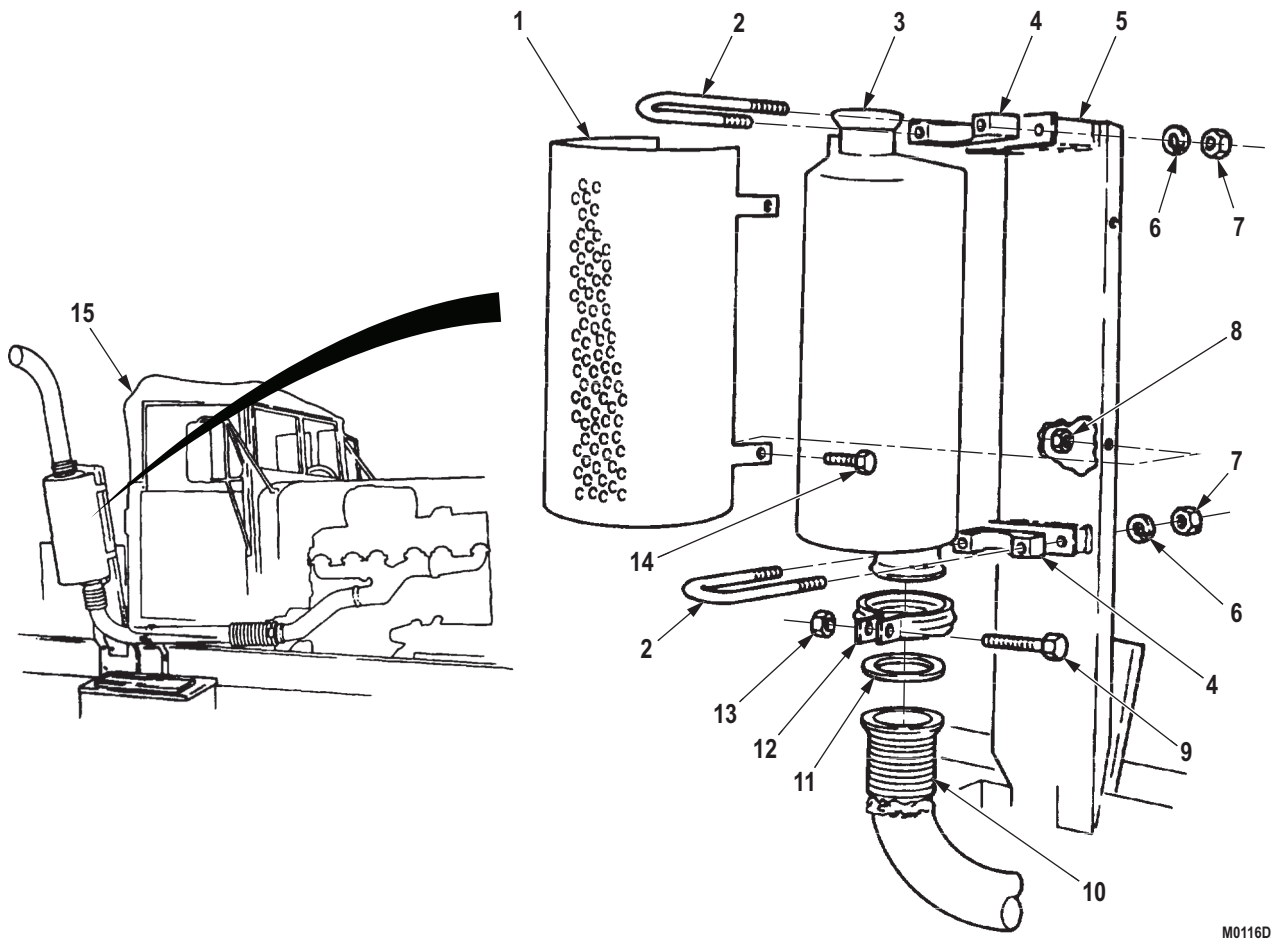

M0116DAA

Figure 2. Muffler and Shield Installation.

END OF TASK

FOLLOW-ON MAINTENANCE

Install exhaust stack. (WP 0273)

END OF TASK

END OF WORK PACKAGE

FIELD MAINTENANCE
REAR EXHAUST PIPE, SUPPORT BRACKET, AND CAB HEAT SHIELD REPLACEMENT

INITIAL SETUP:**Tools and Special Tools**

Tool Kit, General Mechanic's: Automotive
(Volume 5, WP 0826, Table 1, Item 56)

Materials/Parts

Grease, Automotive and Artillery
(Volume 5, WP 0825, Table 1, Item 28)
Gasket (Volume 5, WP 0827, Table 1, Item 42)
Qty: 2
Locknut (Volume 5, WP 0827, Table 1, Item 27)
Qty: 2

Materials/Parts (cont.)

Locknut (Volume 5, WP 0827, Table 1, Item 285)
Qty: 2
Locknut (Volume 5, WP 0827, Table 1, Item 289)
Qty: 2

Equipment Condition

Parking brake set. (TM 9-2320-272-10)

REMOVAL**WARNING**

Do not touch hot exhaust system components with bare hands. Failure to comply may result in injury or death to personnel.

1. Remove two screws (Figure 1, Item 14) and heat shield (Figure 1, Item 13) from cab heat shield brackets (Figure 1, Item 7).
2. Remove locknut (Figure 1, Item 3), screw (Figure 1, Item 20), exhaust pipe coupling clamp (Figure 1, Item 4), and gasket (Figure 1, Item 2) from muffler flange (Figure 1, Item 1). Discard locknut and gasket.
3. Remove locknut (Figure 1, Item 12), screw (Figure 1, Item 8), exhaust pipe coupling clamp (Figure 1, Item 9), and gasket (Figure 1, Item 10) from front exhaust pipe flange (Figure 1, Item 11). Discard locknut and gasket.
4. Remove two locknuts (Figure 1, Item 15), screws (Figure 1, Item 5), top support bracket (Figure 1, Item 6), and rear exhaust pipe (Figure 1, Item 19) from bottom support bracket, muffler flange (Figure 1, Item 1), and front exhaust pipe flange (Figure 1, Item 11). Discard locknuts.
5. Remove two locknuts (Figure 1, Item 17), screws (Figure 1, Item 16), and bottom support bracket (Figure 1, Item 6) from crossmember (Figure 1, Item 18). Discard locknuts.
6. Remove gasket remains from rear exhaust pipe (Figure 1, Item 19) flange, front exhaust pipe flange (Figure 1, Item 11), and muffler flange (Figure 1, Item 1).

REMOVAL - Continued

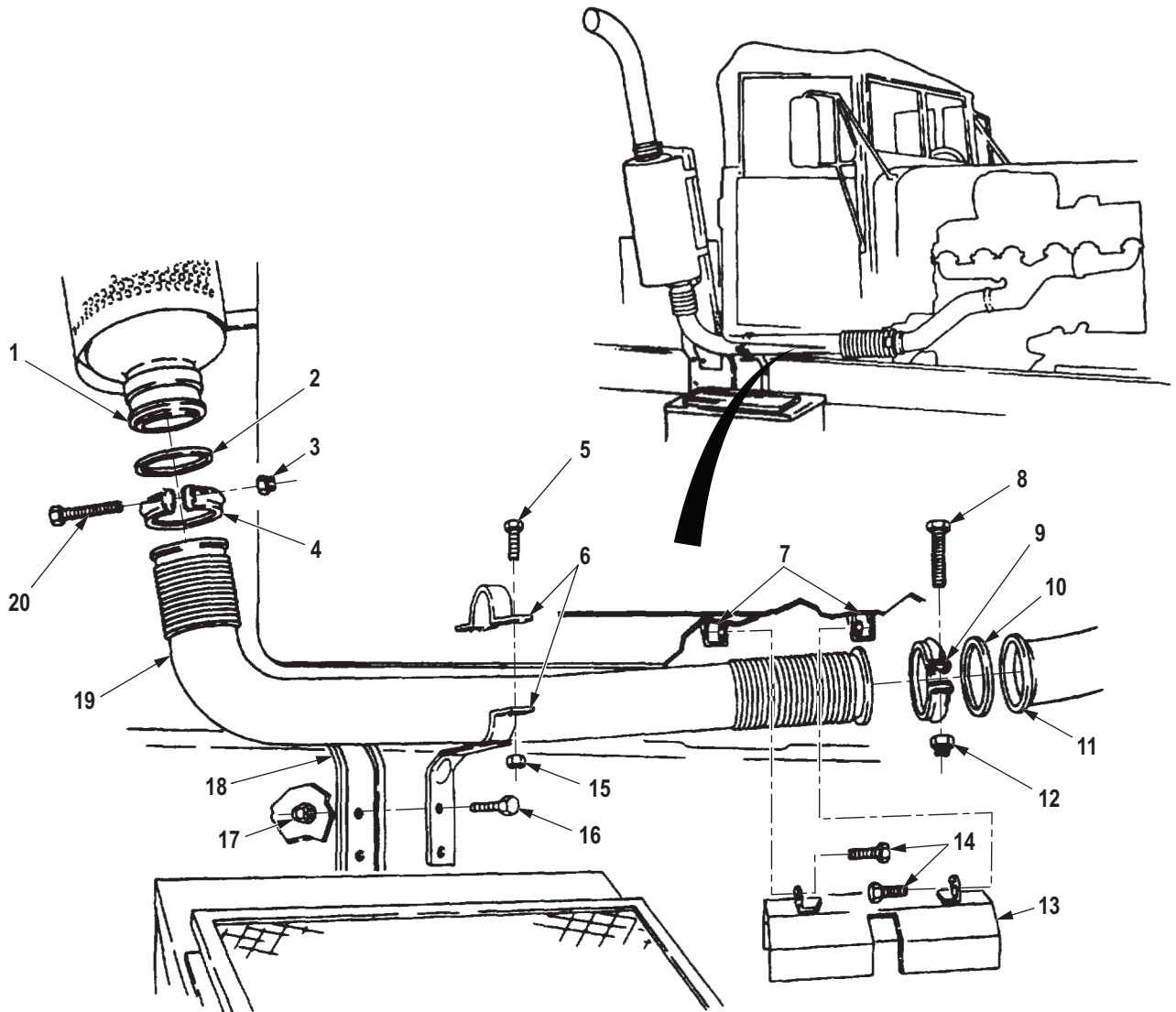

M0111DAA

Figure 1. Rear Exhaust Pipe, Support Bracket, and Cab Heat Shield Removal.

END OF TASK

INSPECTION

Inspect rear exhaust pipe, front exhaust pipe flange, and muffler flange for cracks. Replace if cracked.

END OF TASK

INSTALLATION

1. Install bottom support bracket (Figure 2, Item 6) on crossmember (Figure 2, Item 18) with two screws (Figure 2, Item 16) and locknuts (Figure 2, Item 17).
2. Apply small amount of automotive and artillery grease on gaskets (Figure 2, Items 2 and 10) and position gaskets on muffler flange (Figure 2, Item 1) and front exhaust pipe flange (Figure 2, Item 11).
3. Install rear exhaust pipe (Figure 2, Item 19) on bottom support bracket (Figure 2, Item 6) with top support bracket, two screws (Figure 2, Item 5), and locknuts (Figure 2, Item 15).
4. Install rear exhaust pipe (Figure 2, Item 19) on muffler flange (Figure 2, Item 1) and front exhaust pipe flange (Figure 2, Item 11) with exhaust pipe coupling clamps (Figure 2, Items 4 and 9), screws (Figure 2, Items 8 and 20), and locknuts (Figure 2, Items 3 and 12).
5. Install heat shield (Figure 2, Item 13) on two cab heat shield brackets (Figure 2, Item 7) with screws (Figure 2, Item 14).

INSTALLATION - Continued

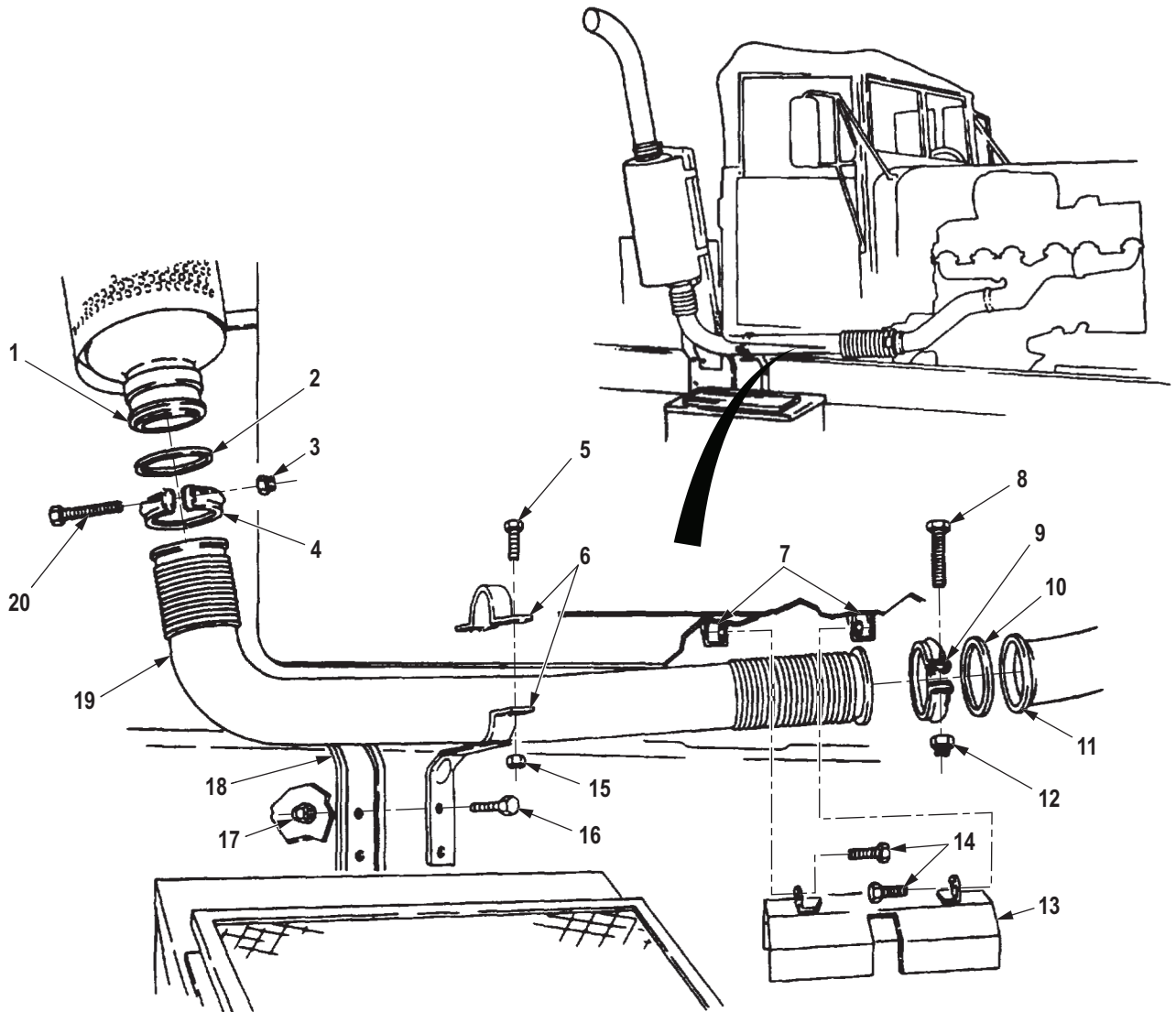

M0112DAA

Figure 2. Rear Exhaust Pipe, Support Bracket, and Cab Heat Shield Installation.

END OF TASK

FOLLOW-ON MAINTENANCE

Start engine and check for exhaust leaks. (TM 9-2320-272-10)

END OF TASK

END OF WORK PACKAGE

**FIELD MAINTENANCE
FRONT EXHAUST PIPE REPLACEMENT**

INITIAL SETUP:**Tools and Special Tools**

Tool Kit, General Mechanic's: Automotive
(Volume 5, WP 0826, Table 1, Item 56)

Materials/Parts

Grease, Automotive and Artillery
(Volume 5, WP 0825, Table 1, Item 28)
Gasket (Volume 5, WP 0827, Table 1, Item 42)
Qty: 1

Materials/Parts (cont.)

Gasket (Volume 5, WP 0827, Table 1, Item 43)
Qty: 1
Locknut (Volume 5, WP 0827, Table 1, Item 27)
Qty: 1

Equipment Condition

Parking brake set. (TM 9-2320-272-10)
Hood raised and secured. (TM 9-2320-272-10)
Right splash shield removed. (TM 9-2320-272-10)

REMOVAL**WARNING**

Do not touch hot exhaust system components with bare hands. Failure to comply may result in injury or death to personnel.

NOTE

Steps (1) through (4) are for M939/A1.

1. Remove two screws (Figure 1, Item 12) and heat shield (Figure 1, Item 13) from cab heat shield brackets (Figure 1, Item 11).
2. Remove locknut (Figure 1, Item 4) and manifold coupling clamp (Figure 1, Item 1) from front exhaust pipe (Figure 1, Item 5) and exhaust manifold (Figure 1, Item 2). Retain locknut (Figure 1, Item 4).
3. Remove front exhaust pipe (Figure 1, Item 5) and gasket (Figure 1, Item 3) from exhaust manifold (Figure 1, Item 2). Discard gasket.
4. Remove locknut (Figure 1, Item 8), screw (Figure 1, Item 10), coupling clamp (Figure 1, Item 7), front exhaust pipe (Figure 1, Item 5), and gasket (Figure 1, Item 6) from rear flex pipe (Figure 1, Item 9). Discard locknut and gasket.

NOTE

Steps (5) and (6) are for M939A2.

5. Remove two screws (Figure 1, Item 10), two locknuts (Figure 1, Item 8), and coupling clamp (Figure 1, Item 7) from rear flex pipe (Figure 1, Item 9). Discard locknut.
6. Loosen turbocharger coupling clamp (Figure 1, Item 4) and remove gasket (Figure 1, Item 3) and front exhaust pipe (Figure 1, Item 5) from turbocharger.

REMOVAL - Continued

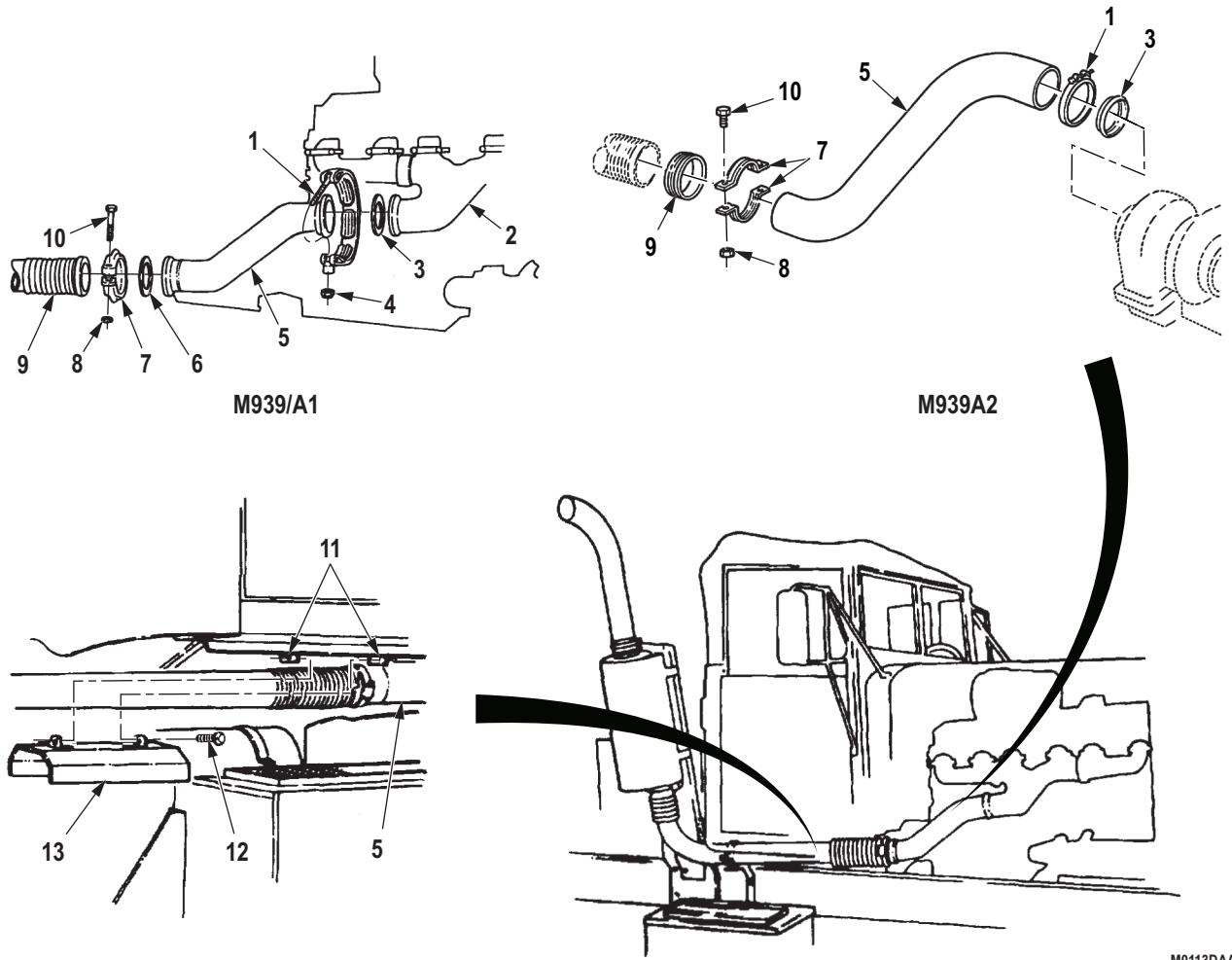

Figure 1. Front Exhaust Pipe Replacement.

END OF TASK

INSTALLATION

1. Apply small amount of automotive and artillery grease on flange of front exhaust pipe (Figure 2, Item 5), position gasket (Figure 2, Item 6) on front exhaust pipe (Figure 2, Item 5), and install pipe (Figure 2, Item 5) on flex pipe (Figure 2, Item 9) with coupling clamp (Figure 2, Item 7), screw (Figure 2, Item 10), and locknut (Figure 2, Item 8).
2. Apply small amount of automotive and artillery grease on flange of exhaust manifold (Figure 2, Item 2), and position gasket (Figure 2, Item 3) and front exhaust pipe (Figure 2, Item 5) on exhaust manifold (Figure 2, Item 2).
3. Install front exhaust pipe (Figure 2, Item 5) on flange of exhaust manifold (Figure 2, Item 2) with manifold coupling clamp (Figure 2, Item 1) and locknut (Figure 2, Item 4).
4. Install heat shield (Figure 2, Item 13) on two cab heat shield brackets (Figure 2, Item 11) with screws (Figure 2, Item 12).

NOTE

Steps (5) through (6) are for M939A2.

5. Apply small amount of automotive and artillery grease on turbocharger flange and install gasket (Figure 2, Item 3), coupling clamp (Figure 2, Item 2), and front exhaust pipe (Figure 2, Item 5) on turbocharger. Tighten coupling clamp.
6. Install two screws (Figure 2, Item 1), two locknuts (Figure 2, Item 8), coupling clamp (Figure 2, Item 7), and front exhaust pipe to rear flex pipe (Figure 2, Item 9). Tighten two locknuts to 45 lb-ft (61 N·m).

INSTALLATION - Continued

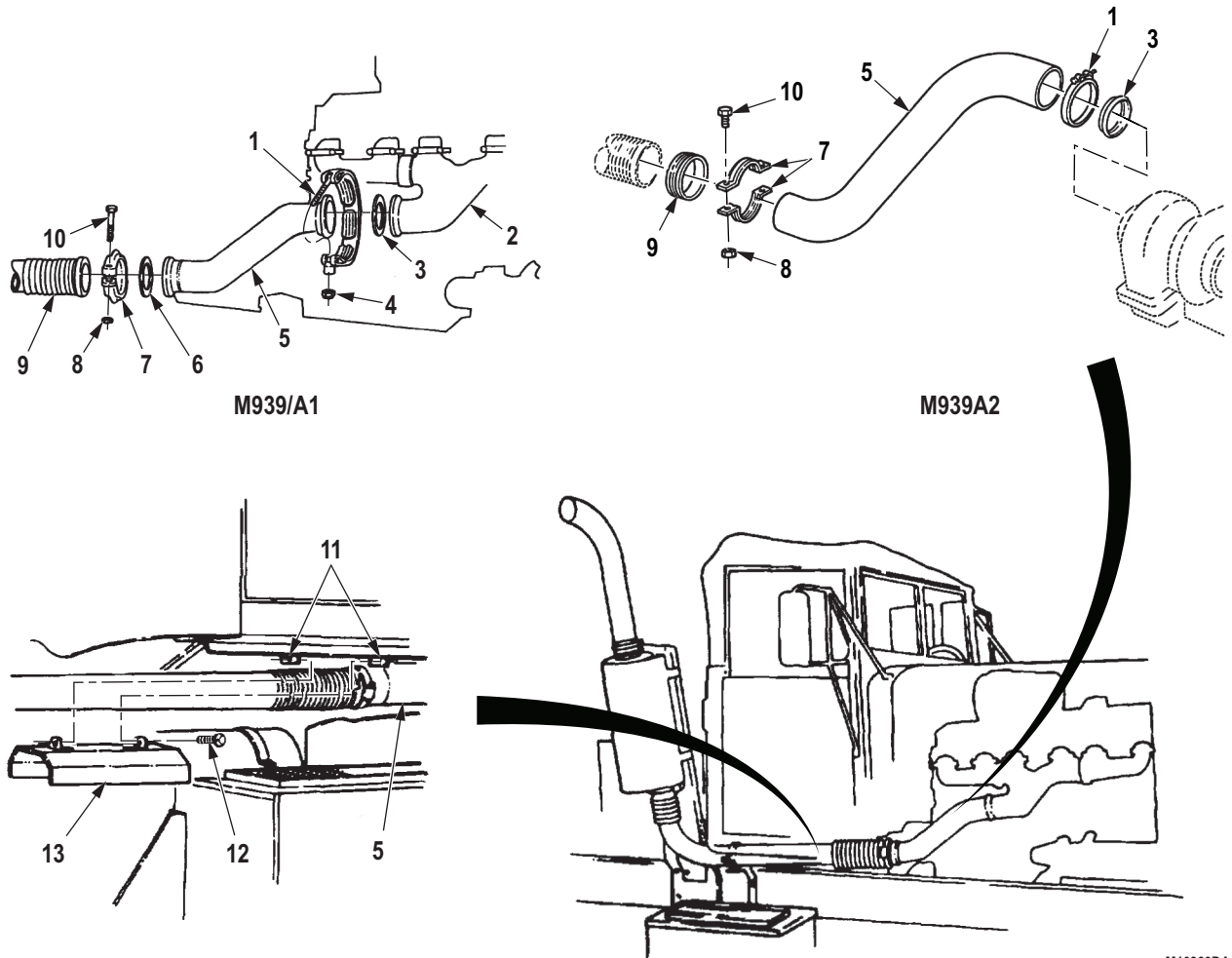

Figure 2. Front Exhaust Pipe Installation.

END OF TASK

FOLLOW-ON MAINTENANCE

1. Start engine and check for exhaust leaks. (TM 9-2320-272-10)
2. Install right splash shield. (TM 9-2320-272-10)

END OF TASK

END OF WORK PACKAGE

**FIELD MAINTENANCE
RADIATOR AND MOUNTING HARDWARE REPLACEMENT (M939A2 ONLY)**

INITIAL SETUP:**Tools and Special Tools**

Tool Kit, General Mechanic's: Automotive
(Volume 5, WP 0826, Table 1, Item 56)
Wrench, Torque, Click, Ratcheting, 3/8" Drive,
75 Ft-Lb
(Volume 5, WP 0826, Table 1, Item 62)

Personnel Required

(2)

References

TM 750-254

Materials/Parts

Tape, Antiseizing
(Volume 5, WP 0825, Table 1, Item 65)
Locknut (Volume 5, WP 0827, Table 1, Item 249)
Qty: 4
Locknut (Volume 5, WP 0827, Table 1, Item 280)
Qty: 1
Locknut (Volume 5, WP 0827, Table 1, Item 289)
Qty: 2
Lockwasher
(Volume 5, WP 0827, Table 1, Item 390)
Qty: 2

Equipment Condition

Parking brake set. (TM 9-2320-272-10)
Right and left splash shields removed.
(TM 9-2320-272-10)
Coolant drained. (WP 0287)
Hood removed. (Volume 4, WP 0565)
Oil cooler removed. (WP 0229)

REMOVAL

1. Straighten tabs of two lockwashers (Figure 1, Item 29) and remove screws (Figure 1, Item 30), lockwashers (Figure 1, Item 29), and washers (Figure 1, Item 28) from bracket (Figure 1, Item 27) and radiator (Figure 1, Item 1). Discard lockwashers.
2. Disconnect hose (Figure 1, Item 5) from adapter (Figure 1, Item 2).
3. Remove adapter (Figure 1, Item 2), elbow (Figure 1, Item 3), and elbow (Figure 1, Item 4) from radiator (Figure 1, Item 1).
4. Loosen clamp (Figure 1, Item 25) and disconnect hump hose (Figure 1, Item 26) from inlet of radiator (Figure 1, Item 1).
5. Loosen clamp (Figure 1, Item 7) and remove lower hump hose (Figure 1, Item 6) from outlet of radiator (Figure 1, Item 1).
6. Remove screws (Figure 1, Items 10 and 11) and washers (Figure 1, Item 9) from radiator (Figure 1, Item 1).

NOTE

Assistant will help with Steps (7) and (8).

7. Remove four screws (Figure 1, Item 21) and washers (Figure 1, Item 20) from mounting bracket (Figure 1, Item 19).
8. Remove radiator (Figure 1, Item 1) from engine compartment (Figure 1, Item 12).

NOTE

- Replace mounting bracket only if damaged.
- Retain attaching hardware, fan shroud, and fittings for installation of radiator.

9. Remove two locknuts (Figure 1, Item 22), screws (Figure 1, Item 18), washers (Figure 1, Item 16), and radiator mounting bracket (Figure 1, Item 19) from control assembly (Figure 1, Item 23). Discard locknuts.
10. Remove locknut (Figure 1, Item 24), screw (Figure 1, Item 15), and control assembly (Figure 1, Item 23) from radiator support (Figure 1, Item 13). Discard locknut.
11. Remove four locknuts (Figure 1, Item 8), screws (Figure 1, Item 17), washers (Figure 1, Item 14), and radiator support (Figure 1, Item 13) from engine compartment (Figure 1, Item 12). Discard locknuts.

REMOVAL - Continued

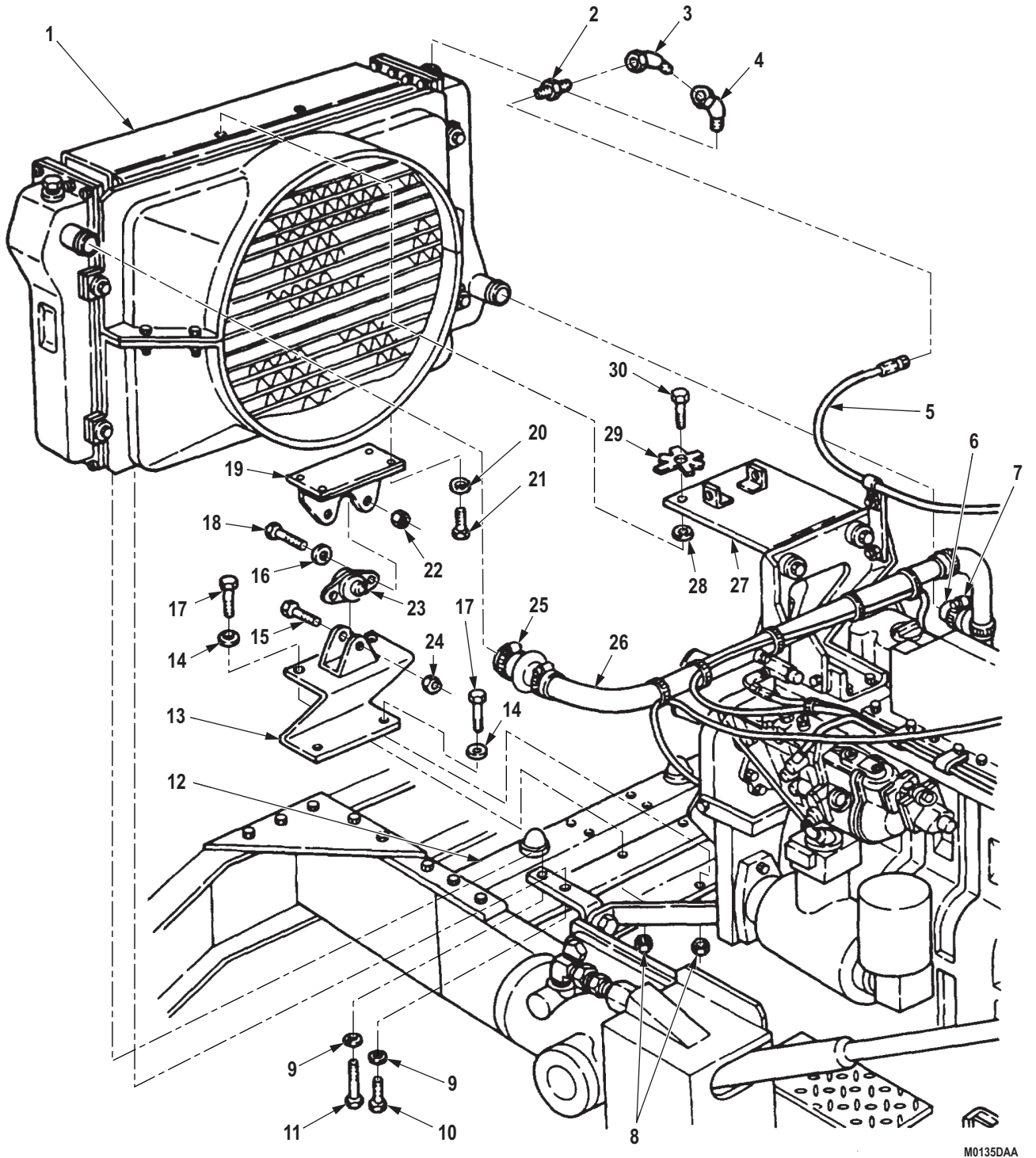

Figure 1. Radiator and Mounting Hardware Removal.

END OF TASK

CLEANING AND INSPECTION

1. Refer to TM 750-254 for radiator cleaning, inspection, and repair instructions.
2. Inspect mounting and fitting parts (Volume 5, WP 0818).
3. Replace all parts failing inspection.

END OF TASK**INSTALLATION****NOTE**

- Refer to (WP 0283) for removing and installing fan and shroud.
 - Perform Steps (1) through (3) only if parts were removed.
1. Install radiator support (Figure 2, Item 13) in engine compartment (Figure 2, Item 12) with four washers (Figure 2, Item 14), screws (Figure 2, Item 17), and locknuts (Figure 2, Item 8).
 2. Install control assembly (Figure 2, Item 23) on radiator support (Figure 2, Item 13) with screw (Figure 2, Item 15) and locknut (Figure 2, Item 24).
 3. Install radiator mounting bracket (Figure 2, Item 19) on control assembly (Figure 2, Item 23) with two screws (Figure 2, Item 18), washers (Figure 2, Item 16), and locknuts (Figure 2, Item 22).

NOTE

Assistant will help with Steps (4) and (5).

4. Position radiator (Figure 2, Item 1) in vehicle.
5. Attach radiator (Figure 2, Item 1) to mounting bracket (Figure 2, Item 19) with four screws (Figure 2, Item 21) and washers (Figure 2, Item 20). Hand tighten screws.
6. Install two washers (Figure 2, Item 9) and screws (Figure 2, Items 10 and 11) through bracket (Figure 2, Item 19) and into bottom of radiator (Figure 2, Item 1). Tighten screws (Figure 2, Items 10, 11, and 21) 40 lb-ft (54 N·m).
7. Connect lower hump hose (Figure 2, Item 6) to outlet of radiator (Figure 2, Item 1) and tighten clamp (Figure 2, Item 7).
8. Connect upper hump hose (Figure 2, Item 26) to inlet of radiator (Figure 2, Item 1) and tighten clamp (Figure 2, Item 25).
9. Wrap male threads of elbows (Figure 2, Items 3 and 4) with antiseize tape and install in radiator (Figure 2, Item 1).
10. Install adapter (Figure 2, Item 2) in elbow (Figure 2, Item 3) and connect hose (Figure 2, Item 5) to adapter.
11. Install two washers (Figure 2, Item 28), lockwashers (Figure 2, Item 29), and screws (Figure 2, Item 30) through bracket (Figure 2, Item 27) and into radiator (Figure 2, Item 1). Tighten screws 40 lb-ft (54 N·m). Bend tabs of two lockwashers over flats of screws.

INSTALLATION - Continued

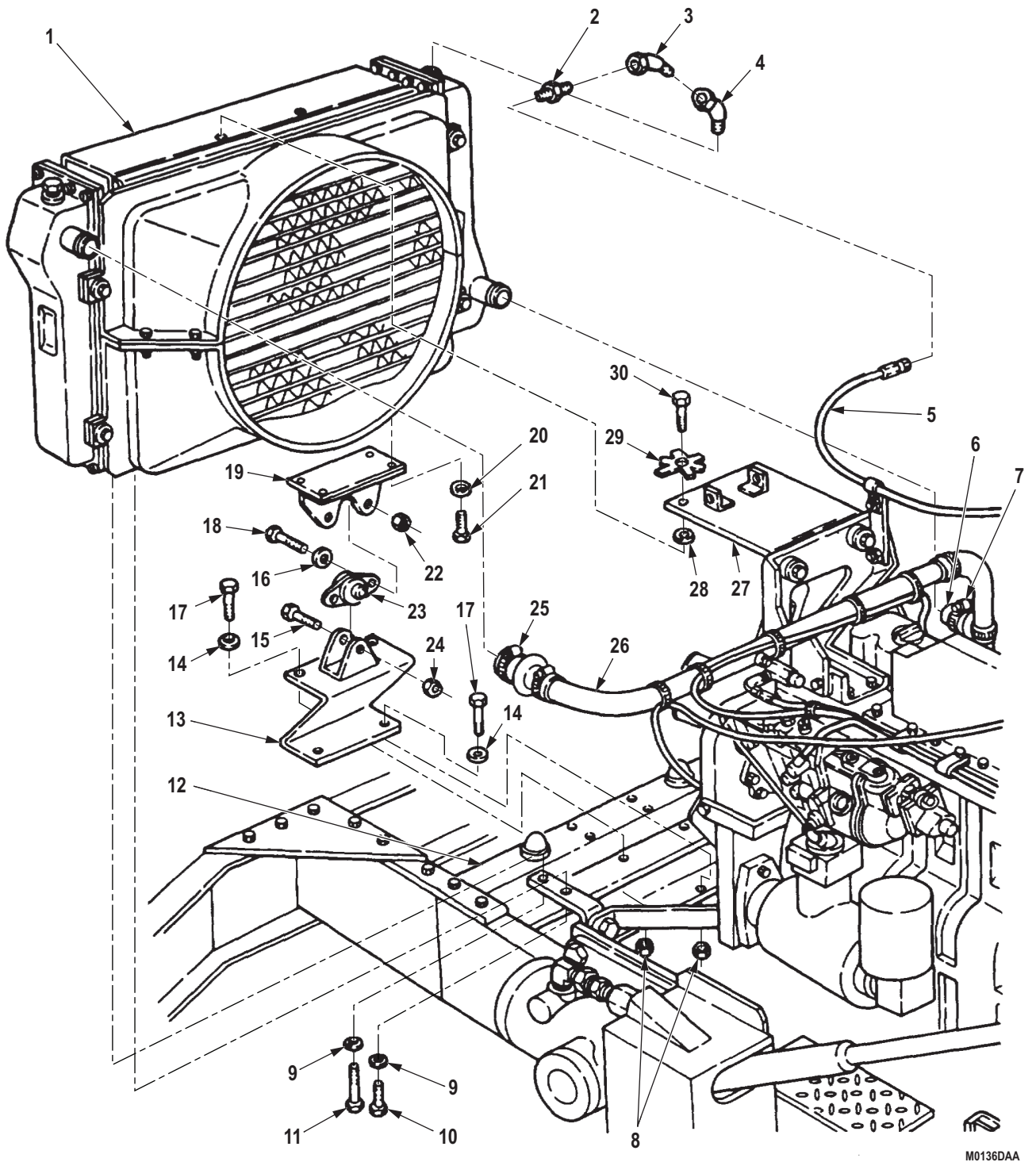

Figure 2. Radiator and Mounting Hardware Installation.

END OF TASK

FOLLOW-ON MAINTENANCE

1. Install oil cooler. (WP 0229)
2. Fill cooling system to proper level. (WP 0287)
3. Start engine and check cooling system for leaks. Tighten fittings and clamps as necessary. (TM 9-2320-272-10)
4. Install right and left splash shields. (TM 9-2320-272-10)
5. Install hood. (Volume 4, WP 0565)

END OF TASK**END OF WORK PACKAGE**

FIELD MAINTENANCE
SURGE TANK, RADIATOR VENT HOSE, AND MANIFOLD RETURN HOSE REPLACEMENT (M939/A1)

INITIAL SETUP:**Tools and Special Tools**

Tool Kit, General Mechanic's: Automotive
(Volume 5, WP 0826, Table 1, Item 56)
Wrench, Torque, Click, Ratcheting, 1/2" Drive,
250 Ft-Lb
(Volume 5, WP 0826, Table 1, Item 63)

Equipment Condition (cont.)

Parking brake set. (TM 9-2320-272-10)
Right splash shield removed. (TM 9-2320-272-10)
Cooling system drained as required. (WP 0287)

Materials/Parts

Tape, Antiseizing
(Volume 5, WP 0825, Table 1, Item 65)
Key Washer
(Volume 5, WP 0827, Table 1, Item 22)
Qty: 4
Locknut (Volume 5, WP 0827, Table 1, Item 277)
Qty: 1

Equipment Condition

Hood raised and secured. (TM 9-2320-272-10)

RADIATOR VENT AND MANIFOLD RETURN HOSES REMOVAL

1. Disconnect radiator vent hose (Figure 1, Item 4) from adapter (Figure 1, Item 10) on radiator (Figure 1, Item 5).
2. Remove adapter (Figure 1, Item 10) and elbows (Figure 1, Items 8 and 9) from radiator (Figure 1, Item 5).
3. Remove screw (Figure 1, Item 2), washer (Figure 1, Item 3), hose clamp (Figure 1, Item 1), and spacer (Figure 1, Item 7) from engine bracket (Figure 1, Item 6).
4. Disconnect manifold return hose (Figure 1, Item 13) from elbow (Figure 1, Item 14) on water manifold (Figure 1, Item 11).
5. Remove manifold return hose (Figure 1, Item 13) and radiator vent hose (Figure 1, Item 4) from surge tank (Figure 1, Item 12).
6. Remove elbow (Figure 1, Item 14) from water manifold (Figure 1, Item 11).

RADIATOR VENT AND MANIFOLD RETURN HOSES REMOVAL - Continued

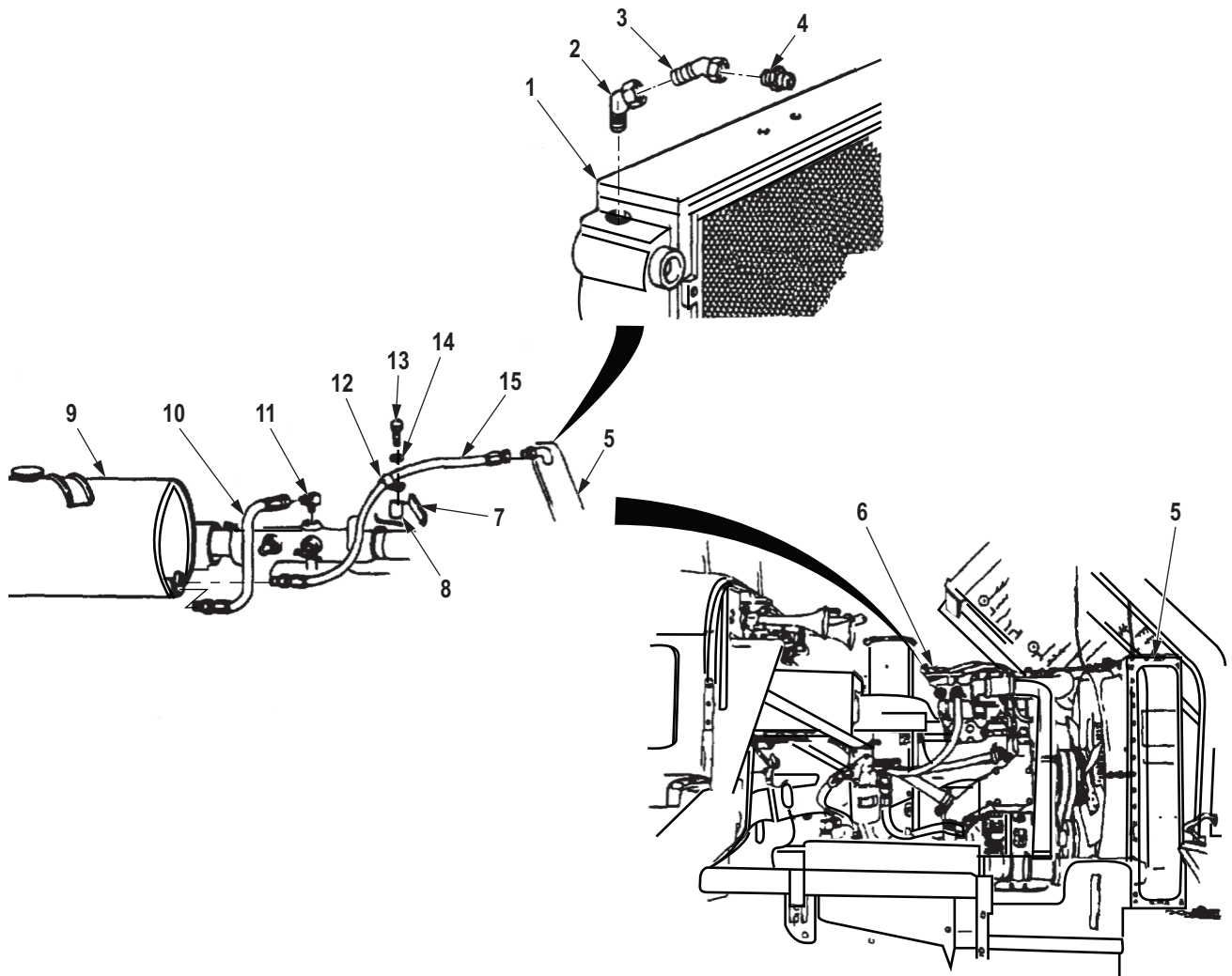

M0137DAA

Figure 1. Radiator Vent and Manifold Return Hoses Removal.

END OF TASK

SURGE TANK REMOVAL

1. Remove cap (Figure 2, Item 17) from surge tank (Figure 2, Item 16) and disconnect cap from retaining pin (Figure 2, Item 18).
2. Remove pin (Figure 2, Item 2) and chain (Figure 2, Item 19) from surge tank support (Figure 2, Item 7).
3. Remove screw (Figure 2, Item 1), washer (Figure 2, Item 4), and surge tank support extension (Figure 2, Item 11) from surge tank (Figure 2, Item 16).
4. Remove locknut (Figure 2, Item 6), screw (Figure 2, Item 3), and surge tank support (Figure 2, Item 7) from lifting eye (Figure 2, Item 5). Discard locknut.
5. Loosen clamp (Figure 2, Item 10) and disconnect engine oil cooler hose (Figure 2, Item 9) from surge tank (Figure 2, Item 16).
6. Unlock four key washers (Figure 2, Item 13) and remove four screws (Figure 2, Item 12), keywashers, washers (Figure 2, Item 14), and two exhaust manifold clamps (Figure 2, Item 15) from cylinder head (Figure 2, Item 8). Discard key washers.
7. Remove surge tank (Figure 2, Item 16) from vehicle.

SURGE TANK REMOVAL - Continued

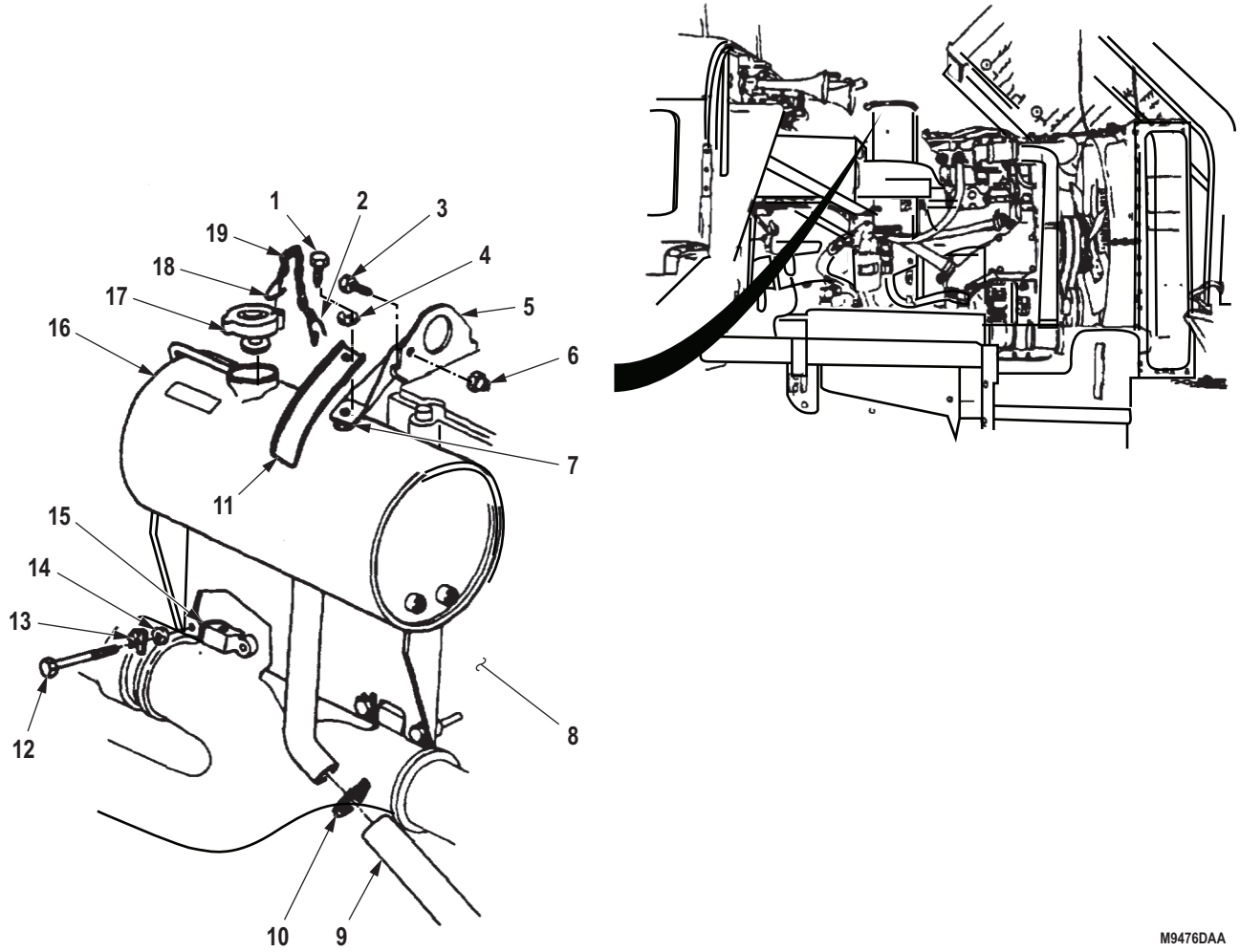

Figure 2. Surge Tank Removal.

END OF TASK

SURGE TANK INSTALLATION

1. Install surge tank (Figure 3, Item 18) on cylinder head (Figure 3, Item 10) with two exhaust manifold clamps (Figure 3, Item 16), four washers (Figure 3, Item 15), keywashers (Figure 3, Item 14), and screws (Figure 3, Item 13). Ensure clamps are parallel to surface of cylinder head. Tighten screws 15 to 20 lb-ft (20 to 27 N·m).
2. Retighten screws (Figure 3, Item 13) 40 to 45 lb-ft (54 to 61 N·m) and bend tabs of key washers (Figure 3, Item 14) against flats of screws.
3. Connect engine oil cooler hose (Figure 3, Item 11) to surge tank (Figure 3, Item 18) and tighten clamp (Figure 3, Item 12).
4. Install surge tank support (Figure 3, Item 9) on lifting eye (Figure 3, Item 7) with screw (Figure 3, Item 5) and locknut (Figure 3, Item 8).
5. Install surge tank support extension (Figure 3, Item 17) on support (Figure 3, Item 9) with washer (Figure 3, Item 6) and screw (Figure 3, Item 3).
6. Connect chain (Figure 3, Item 2) to cap (Figure 3, Item 19) and surge tank support (Figure 3, Item 9) with pin (Figure 3, Item 4).
7. Install cap (Figure 3, Item 19) on surge tank (Figure 3, Item 18) with retaining pin (Figure 3, Item 1).

SURGE TANK INSTALLATION - Continued

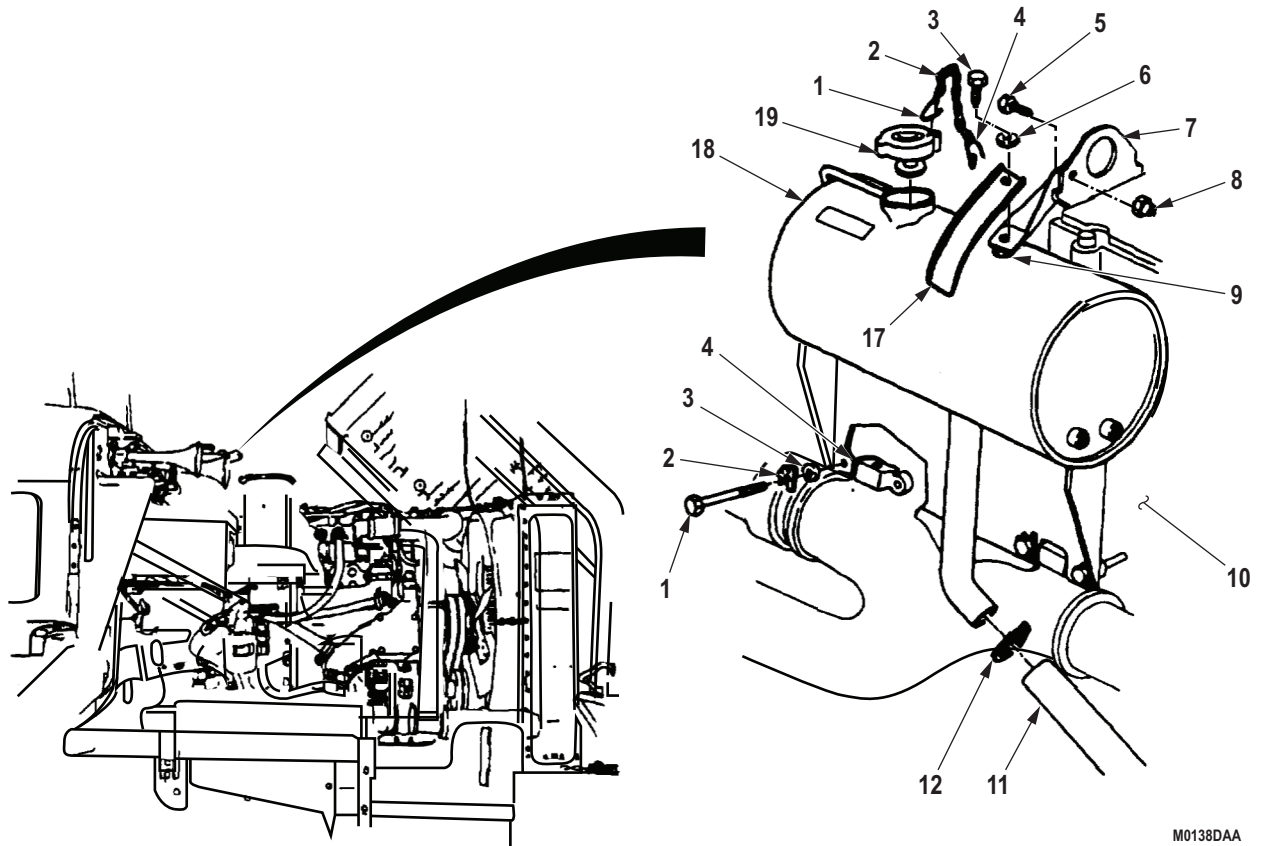
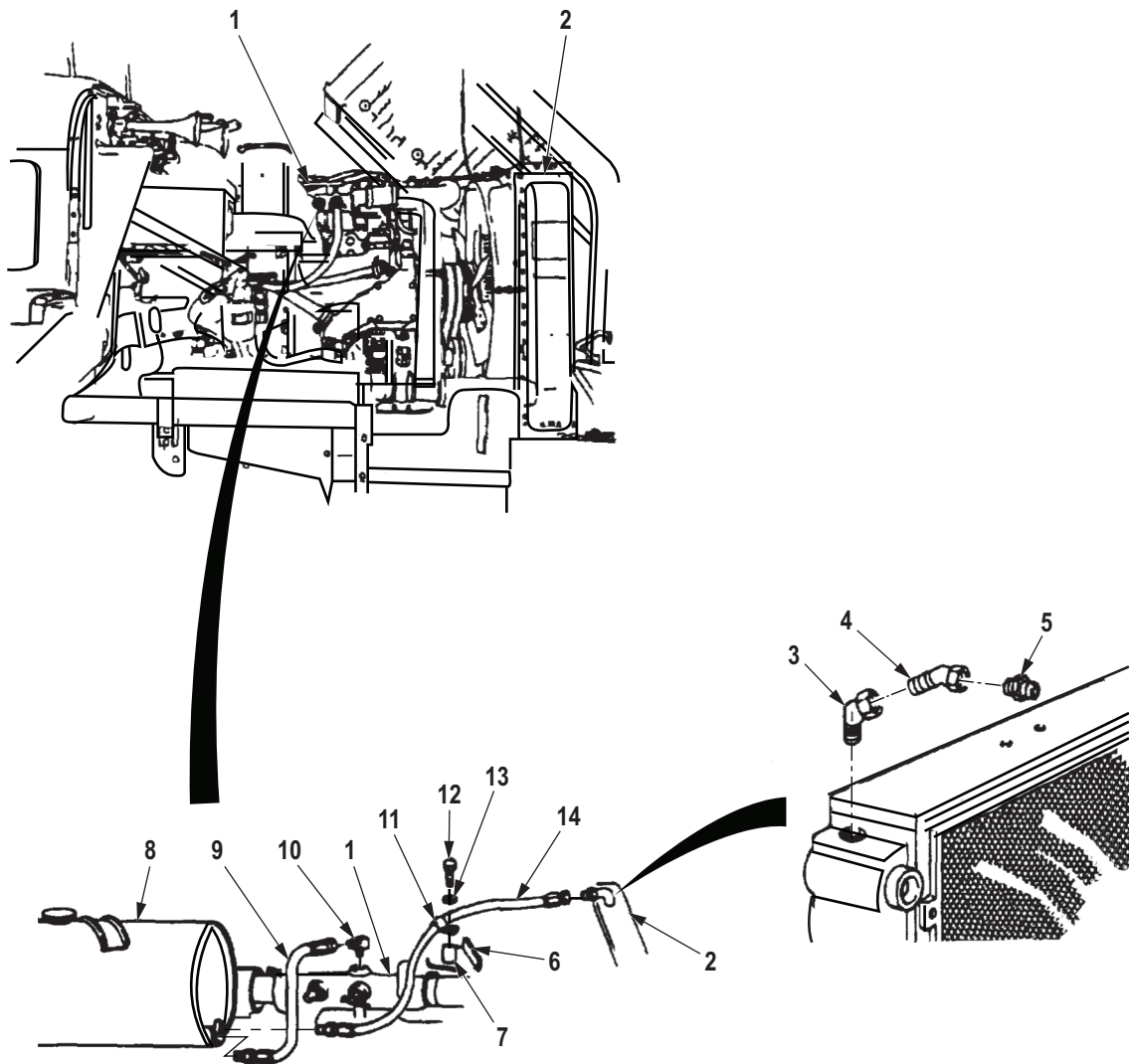

Figure 3. Surge Tank Installation.

END OF TASK

RADIATOR VENT AND MANIFOLD RETURN HOSES INSTALLATION**NOTE**

- Fittings must be cleaned and inspected for cracks and crossed or stripped threads.
 - Male pipe threads must be wrapped with antiseize tape before installation.
1. Install manifold return hose (Figure 4, Item 9) and radiator vent hose (Figure 4, Item 14) on surge tank (Figure 4, Item 8).
 2. Install elbow (Figure 4, Item 10) on water manifold (Figure 4, Item 1).
 3. Install elbows (Figure 4, Items 3 and 4) and adapter (Figure 4, Item 5) on radiator (Figure 4, Item 2).
 4. Connect manifold return hose (Figure 4, Item 9) to elbow (Figure 4, Item 10) on water manifold (Figure 4, Item 1).
 5. Connect radiator vent hose (Figure 4, Item 14) to adapter (Figure 4, Item 3) on radiator (Figure 4, Item 2).
 6. Install spacer (Figure 4, Item 7) and hose clamp (Figure 4, Item 11) on engine bracket (Figure 4, Item 6) with washer (Figure 4, Item 13) and screw (Figure 4, Item 12). Tighten screw 75 to 95 lb-in. (8 to 10 N·m).

RADIATOR VENT AND MANIFOLD RETURN HOSES INSTALLATION - Continued

M9474DAA

Figure 4. Radiator Vent and Manifold Return Hoses Installation.

END OF TASK
FOLLOW-ON MAINTENANCE

1. Install right splash shield. (TM 9-2320-272-10)
2. Fill cooling system. (WP 0287)
3. Start engine and check cooling system for leaks. (TM 9-2320-272-10)

END OF TASK
END OF WORK PACKAGE

**FIELD MAINTENANCE
SURGE TANK AND BRACKET REPLACEMENT (M939A2)**

INITIAL SETUP:**Tools and Special Tools**

Tool Kit, General Mechanic's: Automotive
(Volume 5, WP 0826, Table 1, Item 56)

Materials/Parts

Tape, Antiseizing
(Volume 5, WP 0825, Table 1, Item 65)

Materials/Parts (cont.)

Locknut (Volume 5, WP 0827, Table 1, Item 248)
Qty: 2
Tiedown Strap
(Volume 5, WP 0827, Table 1, Item 375)
Qty: 1

Equipment Condition

Parking brake set. (TM 9-2320-272-10)
Hood raised and secured. (TM 9-2320-272-10)
Cooling system drained as required. (WP 0287)
Exhaust pipe removed. (WP 0276)

REMOVAL

1. Loosen clamp (Figure 1, Item 18) and disconnect hose (Figure 1, Item 17) from surge tank (Figure 1, Item 1).
2. Loosen clamp (Figure 1, Item 16) and disconnect hose (Figure 1, Item 14) from surge tank (Figure 1, Item 1).
3. Loosen clamp (Figure 1, Item 12) and disconnect hose (Figure 1, Item 13) from surge tank (Figure 1, Item 1).
4. Remove fitting (Figure 1, Item 4) from surge tank (Figure 1, Item 1).
5. Disconnect hose (Figure 1, Item 11) from surge tank (Figure 1, Item 1).
6. Remove two locknuts (Figure 1, Item 6), washers (Figure 1, Item 5), screws (Figure 1, Item 2), nuts (Figure 1, Item 7), clamps (Figure 1, Item 3), surge tank (Figure 1, Item 1), and two seats (Figure 1, Item 22) from bracket (Figure 1, Item 20). Discard locknuts.
7. Remove cap (Figure 1, Item 25), chain (Figure 1, Item 24), and S-hook (Figure 1, Item 23) from surge tank (Figure 1, Item 1).
8. Remove two screws (Figure 1, Item 19), screw (Figure 1, Item 10), and bracket (Figure 1, Item 20) from engine (Figure 1, Item 15).
9. Remove nut (Figure 1, Item 9), screw (Figure 1, Item 21), and bracket (Figure 1, Item 8) from bracket (Figure 1, Item 20).

REMOVAL - Continued

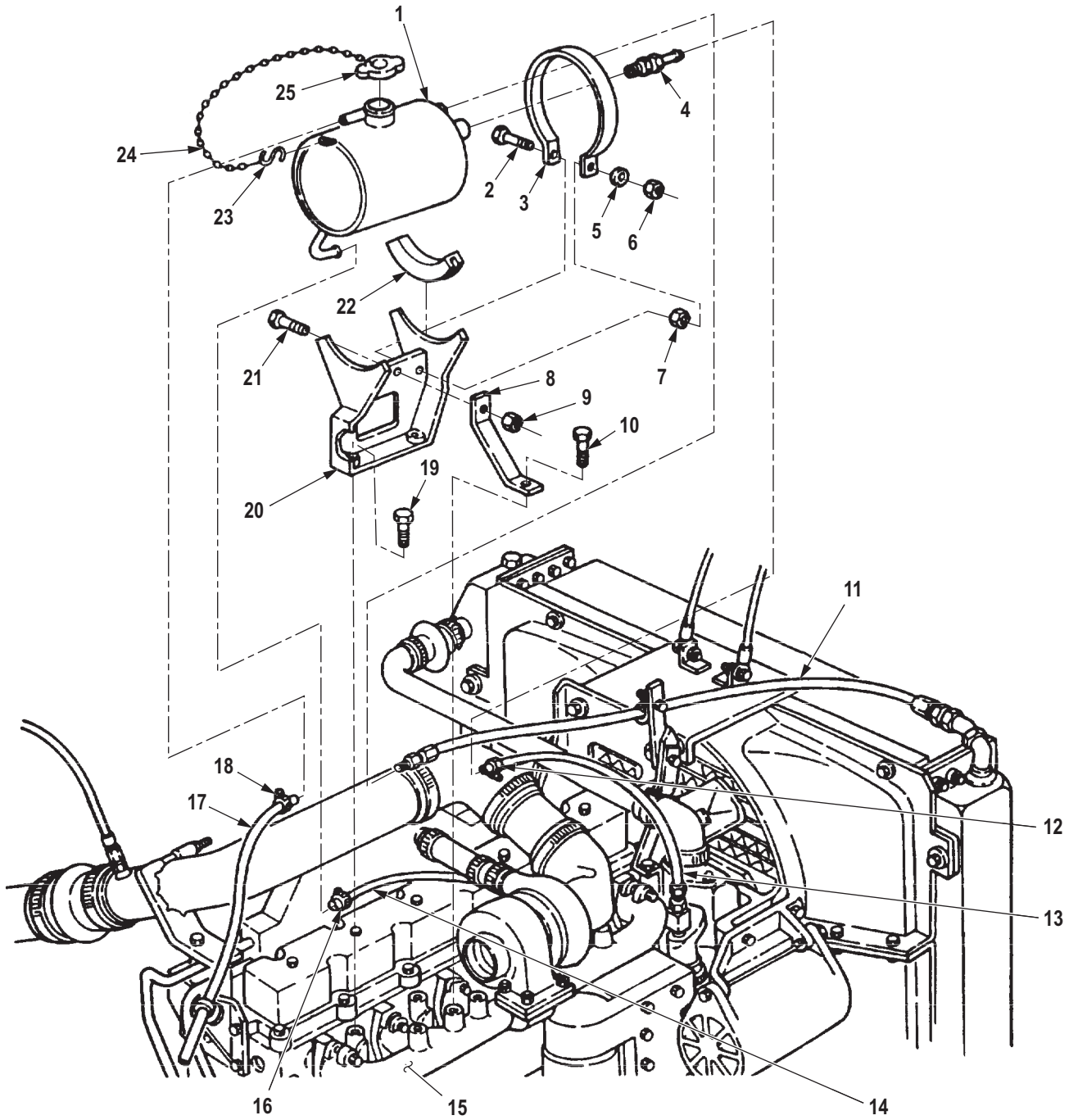

M0139DAA

Figure 1. Surge Tank and Bracket Removal.

END OF TASK

INSTALLATION

1. Install S-hook (Figure 2, Item 23), chain (Figure 2, Item 24), and cap (Figure 2, Item 25) on surge tank (Figure 2, Item 1).
2. Install bracket (Figure 2, Item 8) on bracket (Figure 2, Item 20) with screw (Figure 2, Item 21) and nut (Figure 2, Item 9). Do not tighten nut.
3. Install brackets (Figure 2, Items 8 and 20) on engine (Figure 2, Item 15) with two screws (Figure 2, Item 19) and screw (Figure 2, Item 10).
4. Position two seats (Figure 2, Item 22) on bracket (Figure 2, Item 20).
5. Position two clamps (Figure 2, Item 3) on surge tank (Figure 2, Item 1) and install clamps and surge tank on bracket (Figure 2, Item 20) with two screws (Figure 2, Item 2), nuts (Figure 2, Item 7), washers (Figure 2, Item 5), and locknuts (Figure 2, Item 6).
6. Connect hose (Figure 2, Item 14) on surge tank (Figure 2, Item 1) and tighten clamp (Figure 2, Item 16).
7. Connect hose (Figure 2, Item 17) to surge tank (Figure 2, Item 1) and tighten clamp (Figure 2, Item 18).

NOTE

Male pipe threads must be wrapped with antiseize tape before installation.

8. Install fitting (Figure 2, Item 4) on surge tank (Figure 2, Item 1).
9. Connect hose (Figure 2, Item 13) to fitting (Figure 2, Item 4) and tighten clamp (Figure 2, Item 12).
10. Connect hose (Figure 2, Item 11) to surge tank (Figure 2, Item 1).

INSTALLATION - Continued

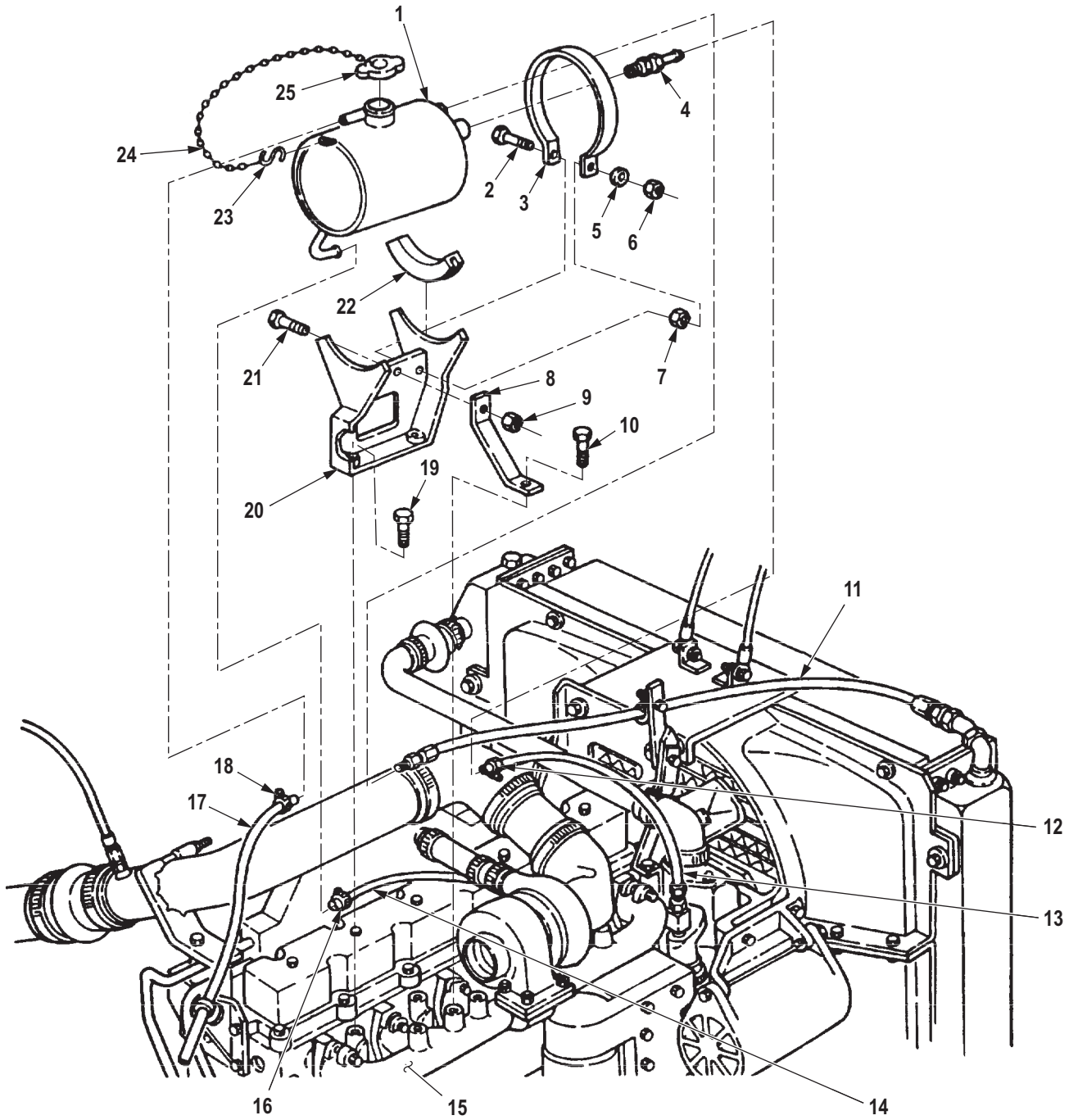

M0140DAA

Figure 2. Surge Tank and Bracket Installation.

END OF TASK

FOLLOW-ON MAINTENANCE

1. Install exhaust pipe. (WP 0276)
2. Fill cooling system to proper level. (WP 0287)
3. Start engine and check for coolant leaks. (TM 9-2320-272-10)

END OF TASK**END OF WORK PACKAGE**

**FIELD MAINTENANCE
COOLANT HOSES AND TUBES REPLACEMENT (M939/A1)**

INITIAL SETUP:**Tools and Special Tools**

Tool Kit, General Mechanic's: Automotive
(Volume 5, WP 0826, Table 1, Item 56)

Equipment Condition (cont.)

Hood raised and secured. (TM 9-2320-272-10)
Right splash shield removed. (TM 9-2320-272-10)
Coolant drained. (WP 0287)

Materials/Parts

Locknut (Volume 5, WP 0827, Table 1, Item 282)
Qty: 2

Equipment Condition

Parking brake set. (TM 9-2320-272-10)

RADIATOR INLET HOSES AND TUBE REMOVAL

1. Loosen two clamps (Figure 1, Item 2) and remove radiator inlet hose (Figure 1, Item 1) from radiator (Figure 1, Item 3) and inlet tube (Figure 1, Item 11).
2. Loosen two clamps (Figure 1, Item 10) and remove hose (Figure 1, Item 8) from thermostat housing (Figure 1, Item 9) and radiator inlet tube (Figure 1, Item 11).
3. Remove two locknuts (Figure 1, Item 5), screws (Figure 1, Item 7), clamps (Figure 1, Item 4), and inlet tube (Figure 1, Item 11) from upper radiator bracket (Figure 1, Item 6). Discard locknuts.

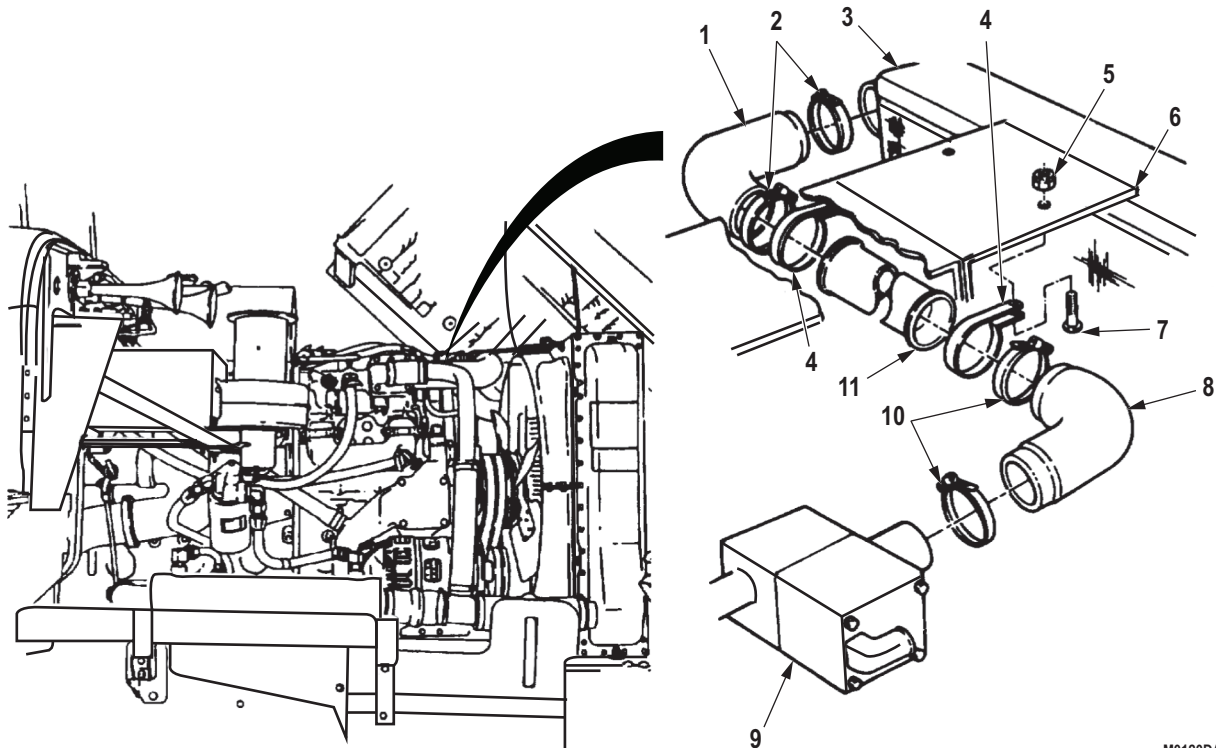

M0120DAA

Figure 1. Radiator Inlet Hoses and Tube Removal.

END OF TASK

THERMOSTAT HOUSING HOSE, RADIATOR BYPASS TUBE, AND HOSE REMOVAL

1. Loosen two clamps (Figure 2, Item 2) and remove thermostat hose (Figure 2, Item 1) from thermostat housing (Figure 2, Item 8) and bypass tube (Figure 2, Item 3).
2. Loosen clamp (Figure 2, Item 4) and remove tube (Figure 2, Item 3) from hose (Figure 2, Item 5).
3. Loosen clamp (Figure 2, Item 6) and remove hose (Figure 2, Item 5) from tee (Figure 2, Item 7).

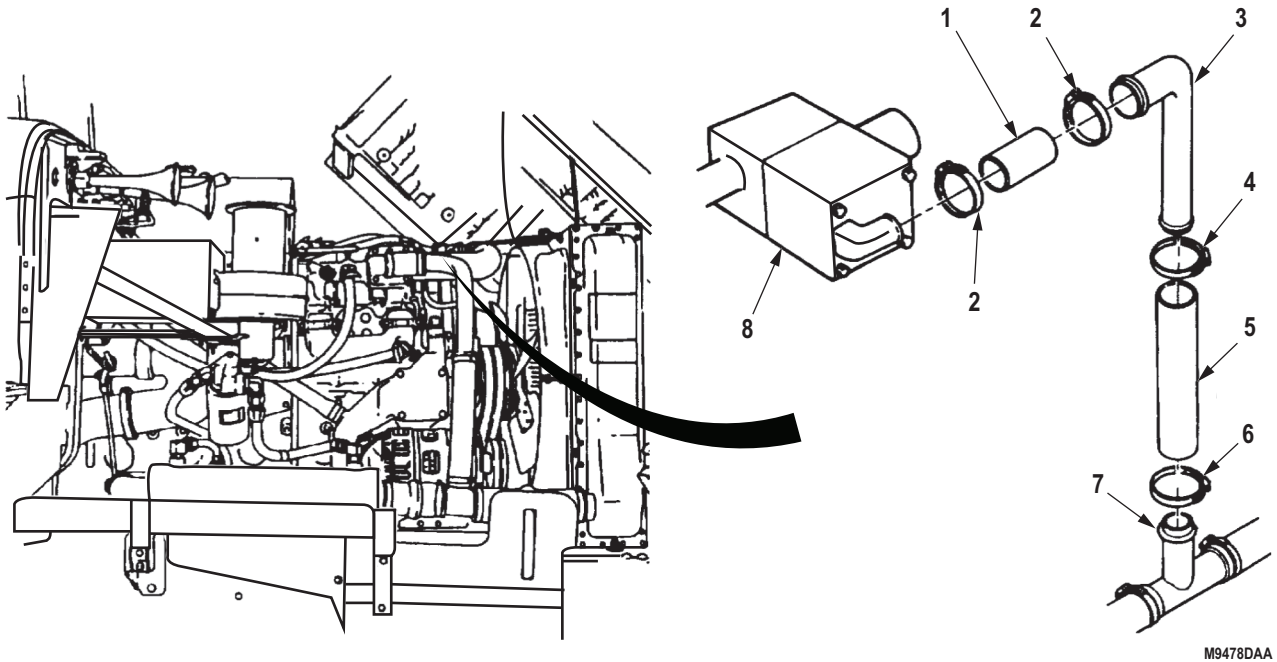
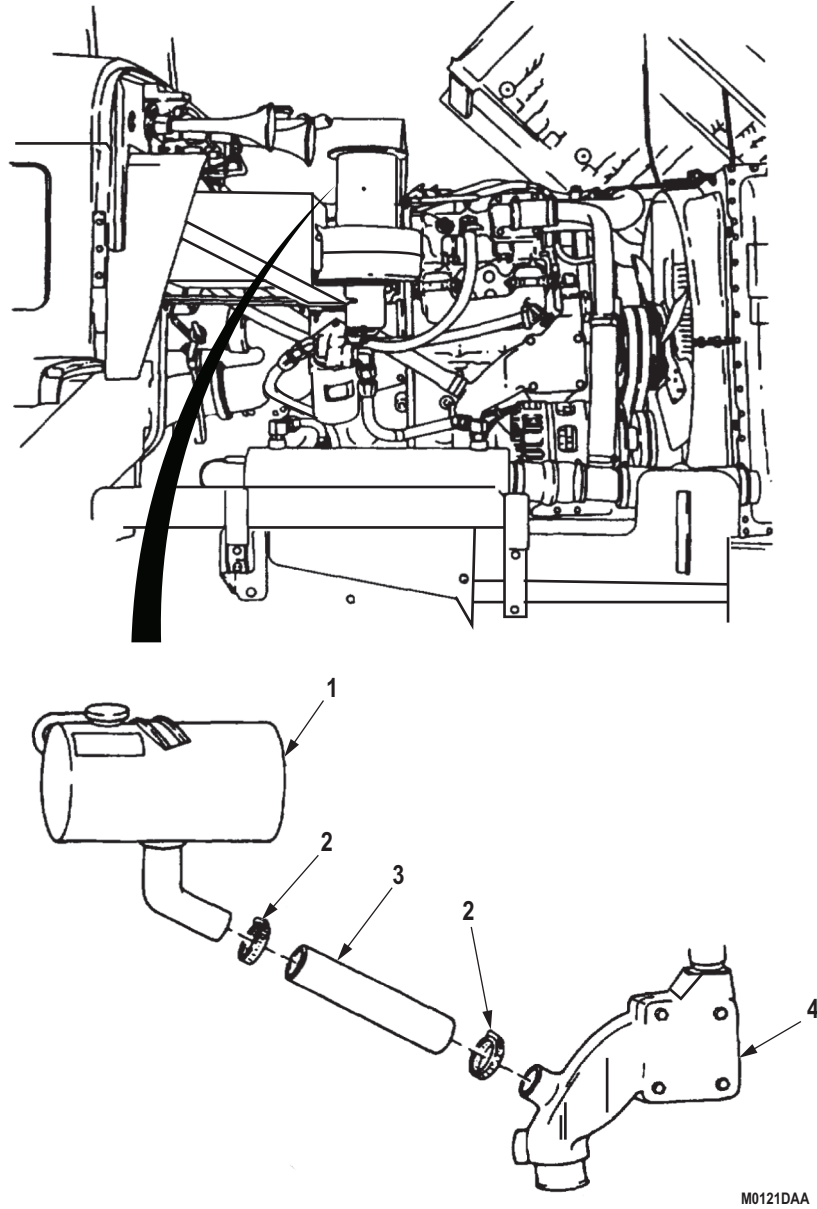

Figure 2. Thermostat Housing Hose, Radiator Bypass Tube, and Hose Removal.

END OF TASK

SURGE TANK HOSE REMOVAL

Loosen two clamps (Figure 3, Item 2) and remove surge tank hose (Figure 3, Item 3) from surge tank (Figure 3, Item 1) and engine oil cooler (Figure 3, Item 4).



M0121DAA

Figure 3. Surge Tank Hose Removal.

END OF TASK

RADIATOR OUTLET HOSES AND TEE REMOVAL

1. Loosen two clamps (Figure 4, Item 3) and remove hose (Figure 4, Item 4) from outlet (Figure 4, Item 5) and tee (Figure 4, Item 2).
2. Loosen clamp (Figure 4, Item 1) and remove tee (Figure 4, Item 2) from hose (Figure 4, Item 6).
3. Loosen clamp (Figure 4, Item 7) and remove hose (Figure 4, Item 6) from transmission oil cooler (Figure 4, Item 8).

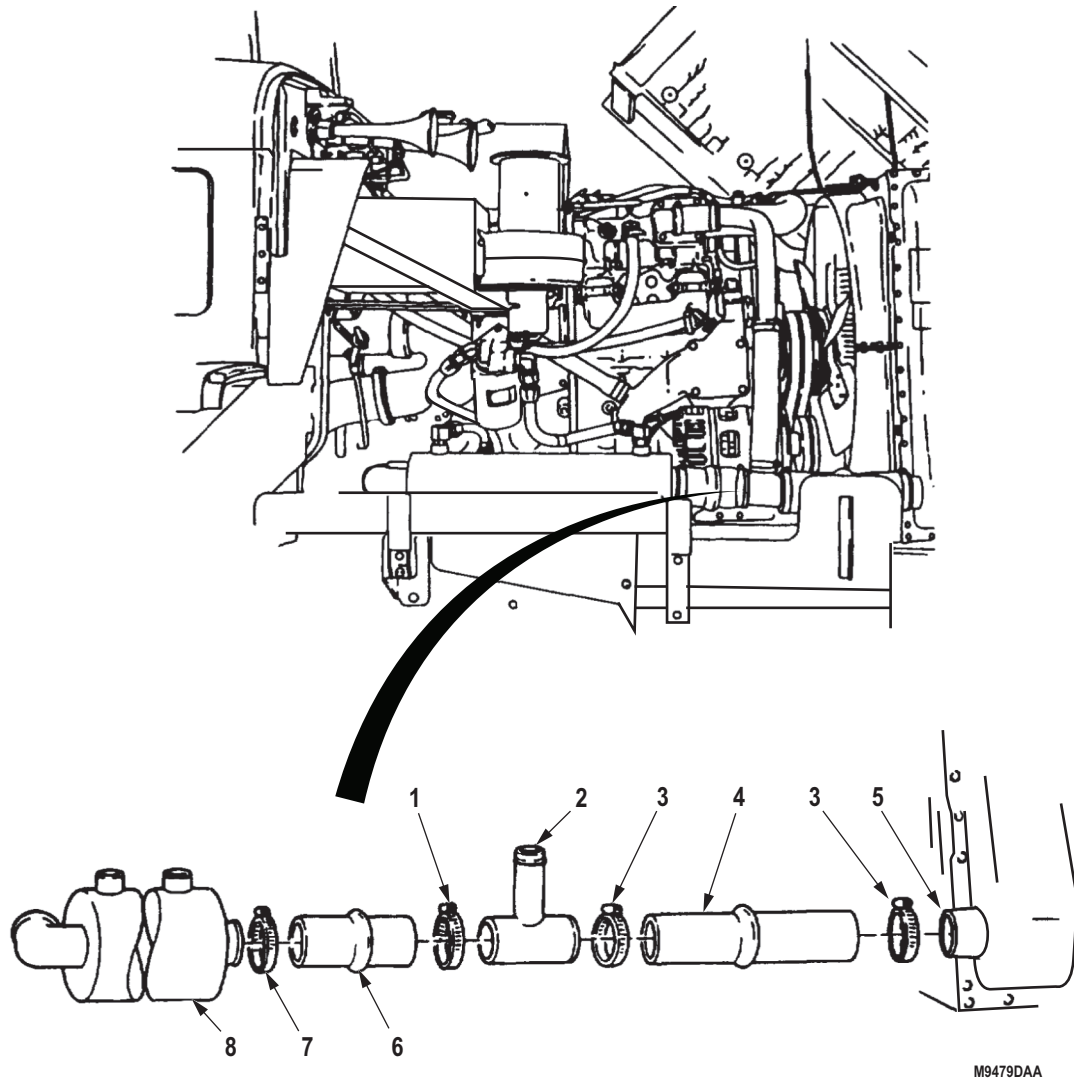

Figure 4. Radiator Outlet Hoses and Tee Removal.

END OF TASK

TRANSMISSION OIL COOLER HOSES AND TUBE REMOVAL

1. Loosen two clamps (Figure 5, Item 3) and remove hose (Figure 5, Item 4) from transmission oil cooler (Figure 5, Item 2) and tube (Figure 5, Item 5).
2. Loosen clamp (Figure 5, Item 6) and remove tube (Figure 5, Item 5) from hose (Figure 5, Item 7).
3. Loosen clamp (Figure 5, Item 8) and remove hose (Figure 5, Item 7) from engine oil cooler (Figure 5, Item 1).

TRANSMISSION OIL COOLER HOSES AND TUBE REMOVAL - Continued

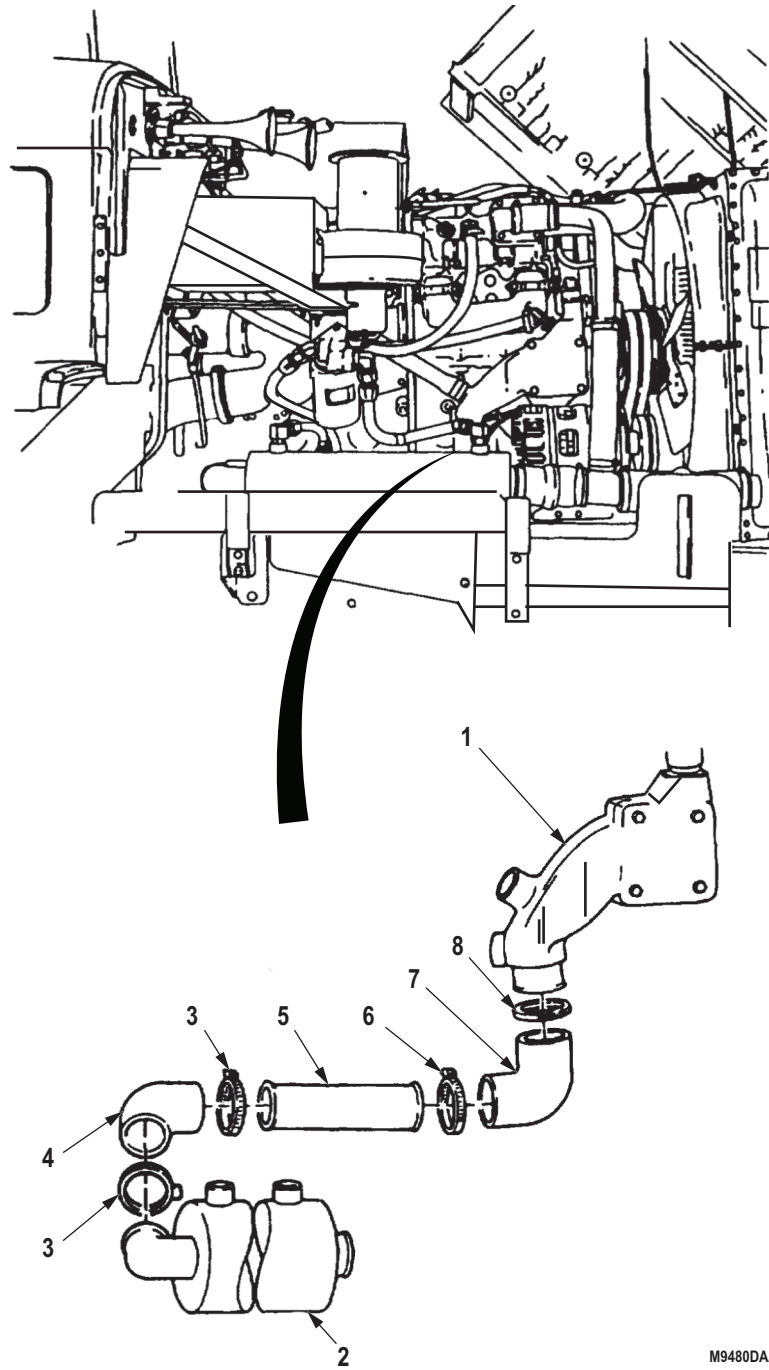

M9480DAA

Figure 5. Transmission Oil Cooler Hoses and Tube Removal.

END OF TASK

TRANSMISSION OIL COOLER HOSES AND TUBE INSTALLATION

1. Install hose (Figure 6, Item 7) and clamp (Figure 6, Item 8) on engine oil cooler (Figure 6, Item 1) and tighten clamp (Figure 6, Item 8).
2. Install tube (Figure 6, Item 5) in hose (Figure 6, Item 7) and tighten clamp (Figure 6, Item 6).
3. Install two clamps (Figure 6, Item 3) and hose (Figure 6, Item 4) on transmission oil cooler (Figure 6, Item 2) and tube (Figure 6, Item 5) and tighten clamps.

TRANSMISSION OIL COOLER HOSES AND TUBE INSTALLATION - Continued

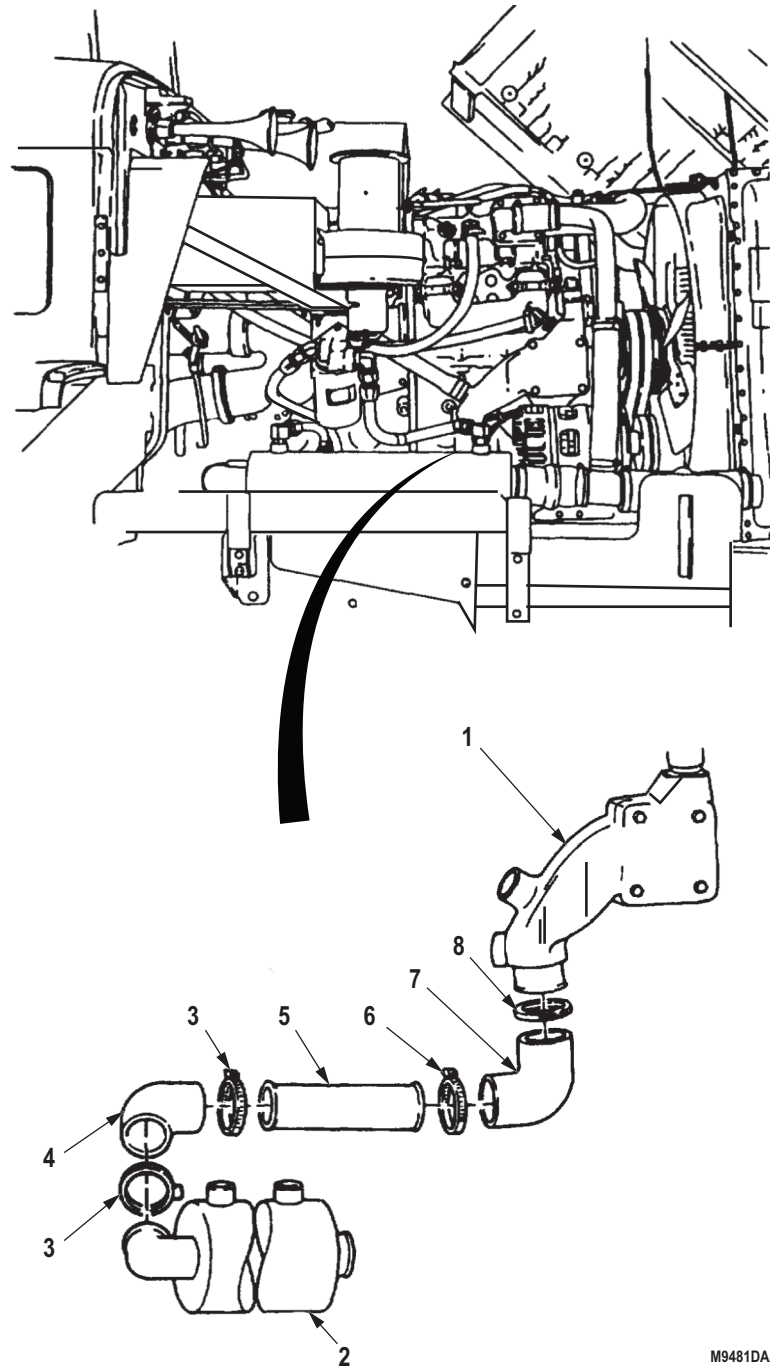

M9481DAA

Figure 6. Transmission Oil Cooler Hoses and Tubes Installation.

END OF TASK

RADIATOR OUTLET HOSES AND TEE INSTALLATION

1. Install clamp (Figure 7, Item 7) and hose (Figure 7, Item 6) on transmission oil cooler (Figure 7, Item 8) and tighten clamp.
2. Install clamp (Figure 7, Item 1) over hose (Figure 7, Item 6) and install tee (Figure 7, Item 2) and tighten clamp.
3. Install two clamps (Figure 7, Item 3) and hose (Figure 7, Item 4) on tee (Figure 7, Item 2) and radiator outlet (Figure 7, Item 5) and tighten clamps.

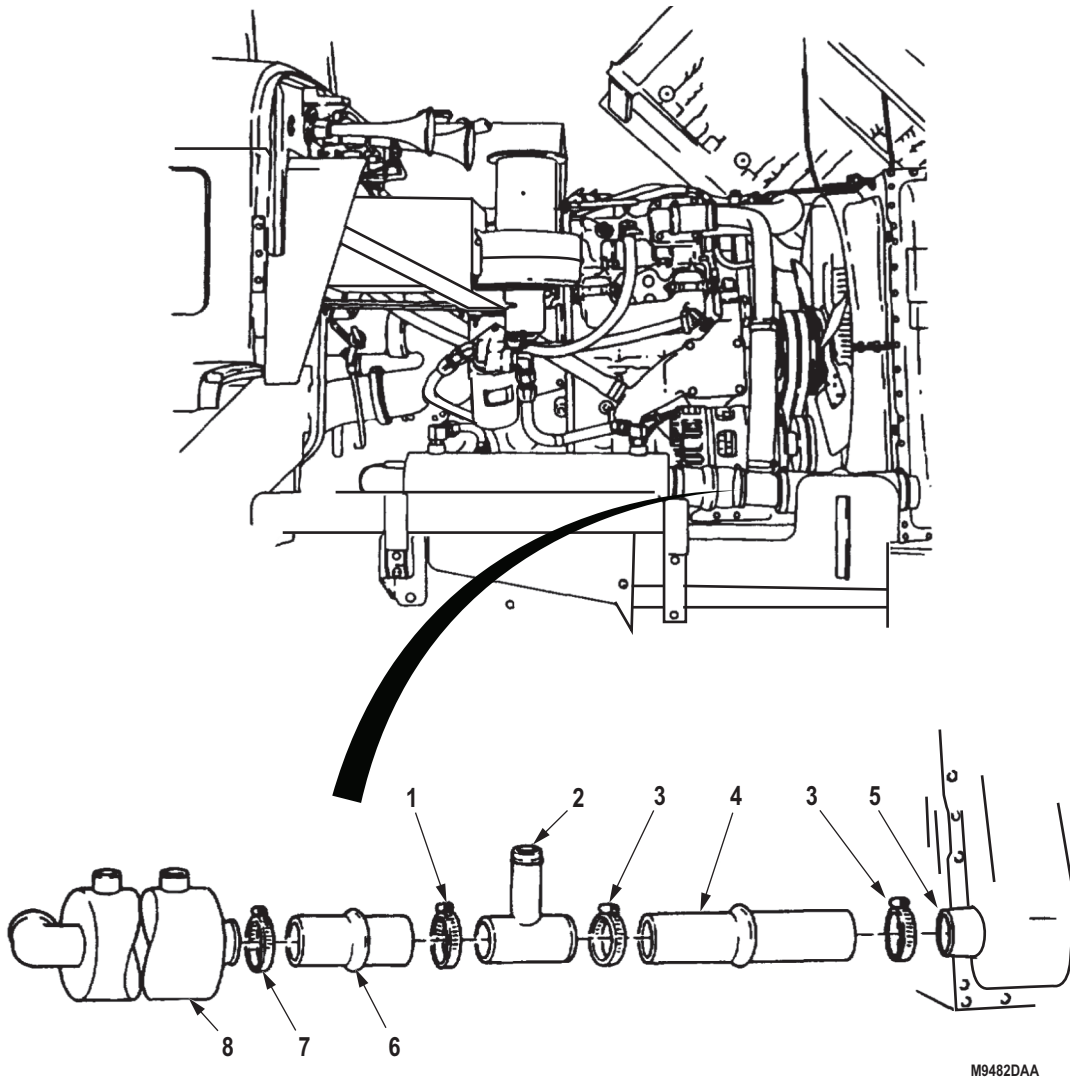

Figure 7. Radiator Outlet Hoses and Tee Installation.

END OF TASK

SURGE TANK HOSE INSTALLATION

Install surge tank hose (Figure 8, Item 3) on surge tank (Figure 8, Item 1) and engine oil cooler (Figure 8, Item 4) and tighten two clamps (Figure 8, Item 2).

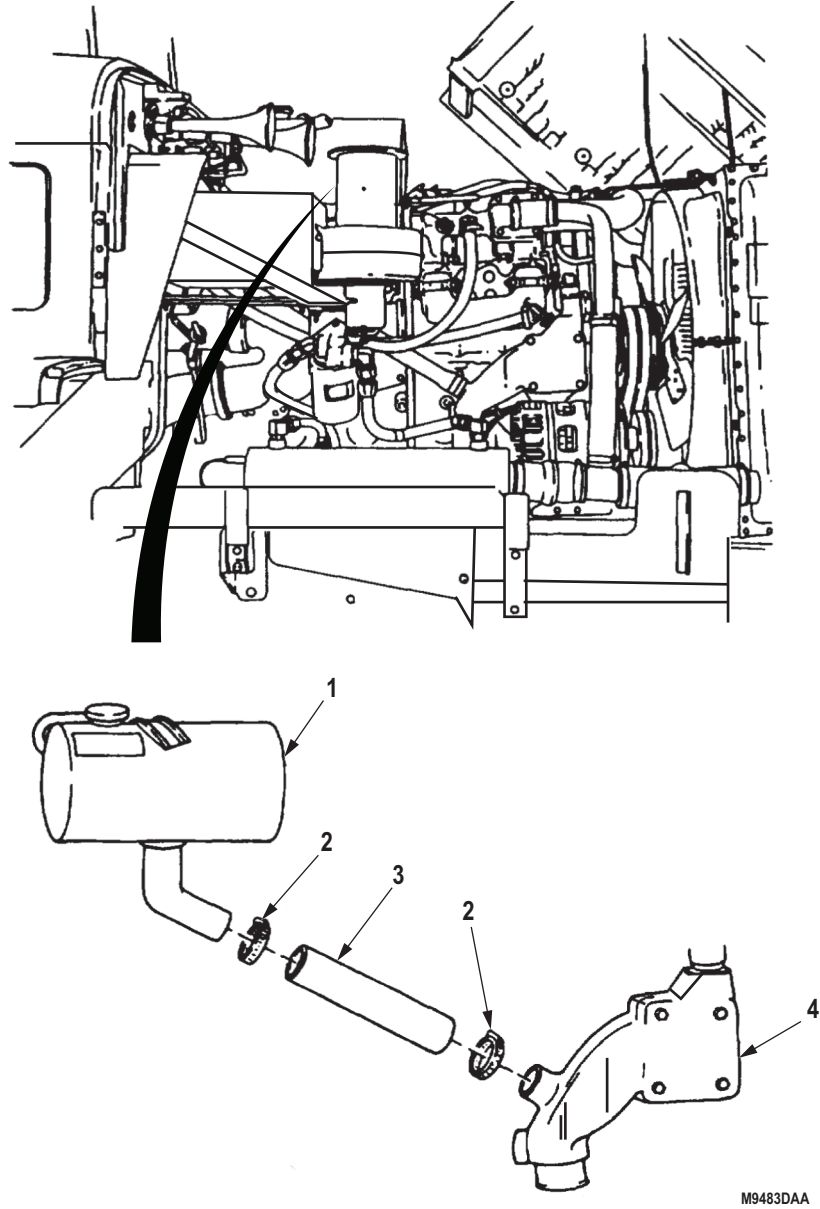

Figure 8. Surge Tank Hose Installation.

END OF TASK

THERMOSTAT HOUSING HOSE, RADIATOR BYPASS TUBE, AND HOSE INSTALLATION

1. Install bypass hose (Figure 9, Item 5) and clamp (Figure 9, Item 6) on tee (Figure 9, Item 7) and tighten clamp.
2. Install tube (Figure 9, Item 3) and clamp (Figure 9, Item 4) on hose (Figure 9, Item 5) and tighten clamp.
3. Install thermostat hose (Figure 9, Item 1) on tube (Figure 9, Item 3) and thermostat housing (Figure 9, Item 8) and tighten two clamps (Figure 9, Item 2).

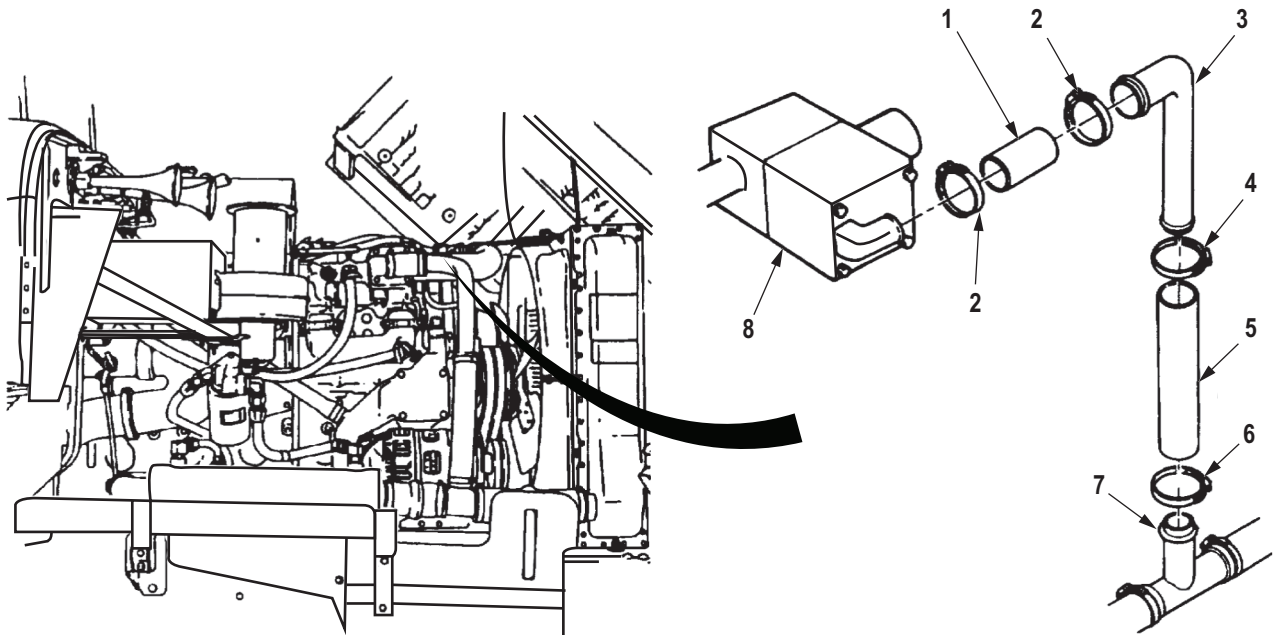
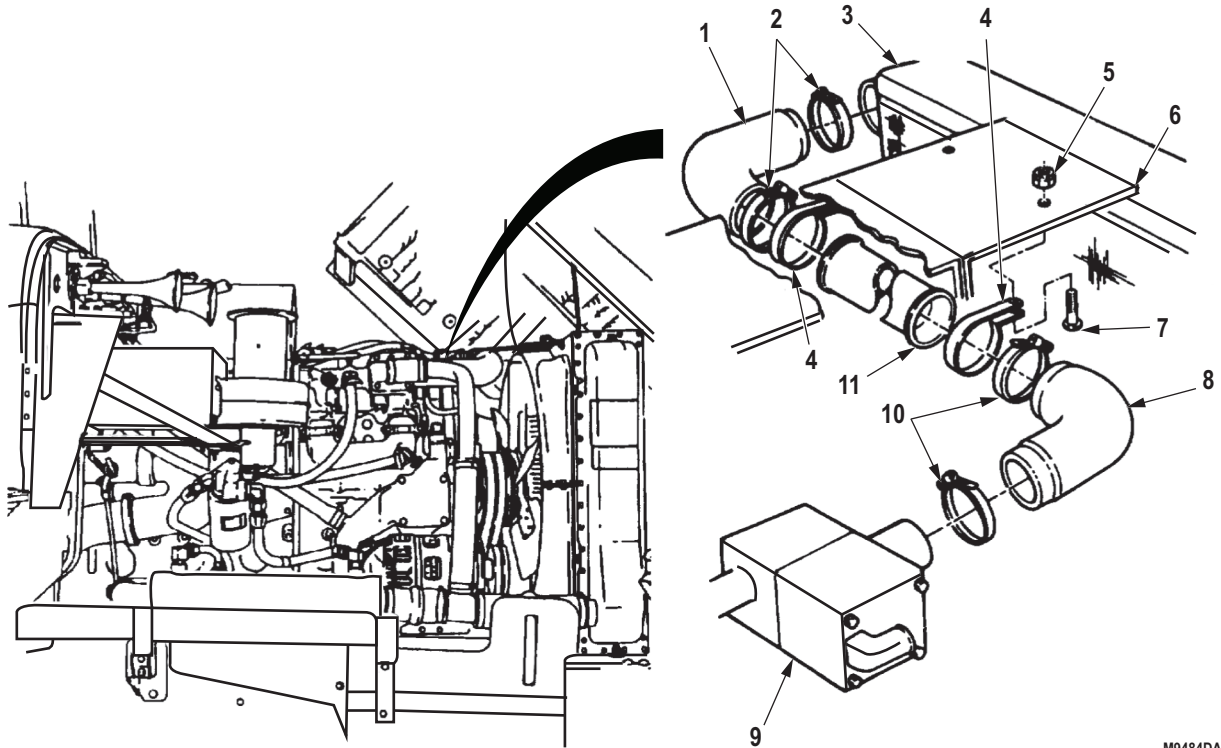

Figure 9. Thermostat Housing Hose, Radiator Bypass Tube, and Hose Installation.

END OF TASK

RADIATOR INLET HOSES AND TUBE INSTALLATION

1. Install two clamps (Figure 10, Item 4) on upper radiator support (Figure 10, Item 6) with two screws (Figure 10, Item 7) and locknuts (Figure 10, Item 5).
2. Install two clamps (Figure 10, Item 10) and hose (Figure 10, Item 8) on thermostat housing (Figure 10, Item 9) and tube (Figure 10, Item 11).
3. Install inlet hose (Figure 10, Item 1) on radiator (Figure 10, Item 3) and tube (Figure 10, Item 11) with two clamps (Figure 10, Item 2).



M9484DAA

Figure 10. Radiator Inlet Hoses and Tube Installation.

END OF TASK

FOLLOW-ON MAINTENANCE

1. Fill cooling system to proper level. (WP 0287)
2. Install right splash shield. (TM 9-2320-272-10)
3. Hood closed and secured. (TM 9-2320-272-10)
4. Start engine. (TM 9-2320-272-10)

END OF TASK

END OF WORK PACKAGE

**FIELD MAINTENANCE
RADIATOR AND MOUNTING HARDWARE REPLACEMENT (M939/A1)**

INITIAL SETUP:**Tools and Special Tools**

Tool Kit, General Mechanic's: Automotive
(Volume 5, WP 0826, Table 1, Item 56)

Materials/Parts

Tape, Antiseizing
(Volume 5, WP 0825, Table 1, Item 65)
Locknut (Volume 5, WP 0827, Table 1, Item 280)
Qty: 1
Locknut (Volume 5, WP 0827, Table 1, Item 282)
Qty: 2
Locknut (Volume 5, WP 0827, Table 1, Item 285)
Qty: 5
Locknut (Volume 5, WP 0827, Table 1, Item 289)
Qty: 6
Lockwasher
(Volume 5, WP 0827, Table 1, Item 390)
Qty: 2
Lockwasher
(Volume 5, WP 0827, Table 1, Item 404)
Qty: 2

Materials/Parts (cont.)

Lockwasher
(Volume 5, WP 0827, Table 1, Item 405)
Qty: 6
Mount, Resident, WS
(Volume 5, WP 0827, Table 1, Item 189)
Qty: 3

Personnel Required

(2)

Equipment Condition

Parking brake set. (TM 9-2320-272-10)
Hood raised and secured. (TM 9-2320-272-10)
Right and left splash shields removed.
(TM 9-2320-272-10)
Cooling system drained. (WP 0287)
Fan shroud removed. (WP 0282)

REMOVAL

1. Disconnect radiator vent hose (Figure 1, Item 16) from radiator (Figure 1, Item 17).
2. Remove two locknuts (Figure 1, Item 4), washers (Figure 1, Item 6), screws (Figure 1, Item 7), and hood stop cables (Figure 1, Item 5) from upper radiator bracket (Figure 1, Item 19). Discard locknuts.
3. Remove two screws (Figure 1, Item 2), lockwashers (Figure 1, Item 1), and washers (Figure 1, Item 20) from upper radiator bracket (Figure 1, Item 19). Discard lockwashers.
4. Remove two locknuts (Figure 1, Item 3), screws (Figure 1, Item 13), and clamps (Figure 1, Item 18) from upper radiator bracket (Figure 1, Item 19). Discard locknuts.
5. Remove two locknuts (Figure 1, Item 9), washers (Figure 1, Item 10), screws (Figure 1, Item 12), and upper radiator bracket (Figure 1, Item 19) from engine bracket (Figure 1, Item 8). Discard locknuts.

NOTE

Perform Step (6) only if rubber mounts are damaged or radiator is being installed.

6. Remove two rubber mounts (Figure 1, Item 11) from engine bracket (Figure 1, Item 8). Discard rubber mounts.
7. Loosen clamp (Figure 1, Item 15) and disconnect radiator hose (Figure 1, Item 14) from radiator (Figure 1, Item 17).

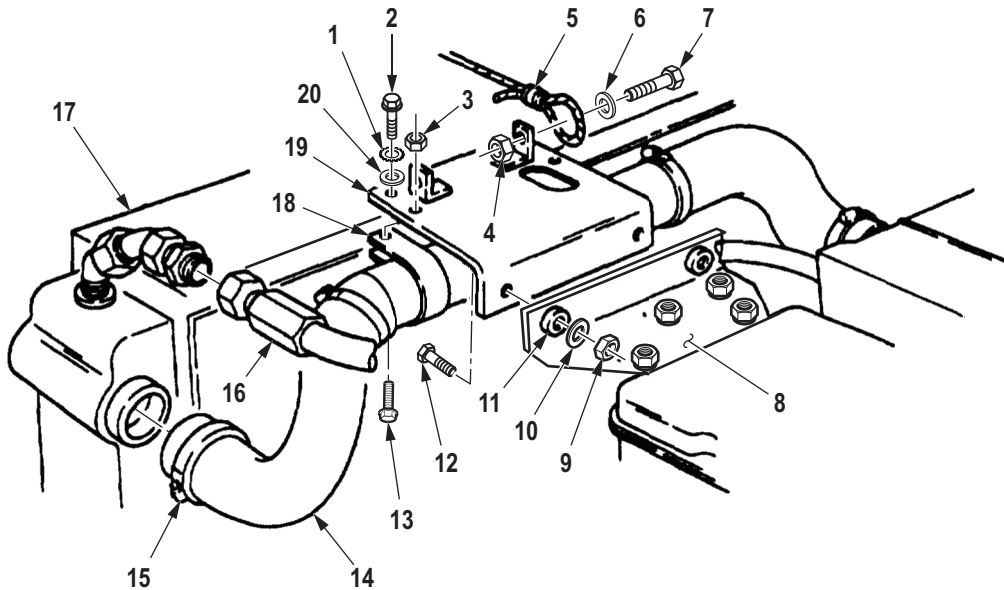

M9718DAA

Figure 1. Radiator (M939/A1) Removal.

8. Remove adapter (Figure 2, Item 1) and two elbows (Figure 2, Item 20) from radiator (Figure 2, Item 3).
9. Remove two plugs (Figure 2, Item 16) and drain valve (Figure 2, Item 6) from radiator (Figure 2, Item 3).
10. Loosen clamp (Figure 2, Item 4) and disconnect radiator outlet hose (Figure 2, Item 5) from radiator (Figure 2, Item 3).
11. Remove locknut (Figure 2, Item 11), screw (Figure 2, Item 18), and washer (Figure 2, Item 17) from brackets (Figure 2, Items 10 and 14). Discard locknut.

REMOVAL - Continued**NOTE**

Assistant will help with Steps (12) and (13).

12. Remove four locknuts (Figure 2, Item 12), two screws (Figure 2, Item 7), and screws (Figure 2, Item 19) from radiator support (Figure 2, Item 14). Discard locknuts.
13. Remove radiator (Figure 2, Item 3) from vehicle.

NOTE

Perform Step (14) only if rubber mount is damaged or a radiator is being installed.

14. Remove and discard rubber mount (Figure 3, Item 8).

NOTE

Perform Step (15) only if bracket is damaged or being replaced.

15. Remove two screws (Figure 2, Item 13), lockwashers (Figure 2, Item 8), washers (Figure 2, Item 9), and radiator support bracket (Figure 2, Item 10) from vehicle. Discard lockwashers.
16. Remove two plugs (Figure 2, Item 16) from radiator (Figure 2, Item 3).

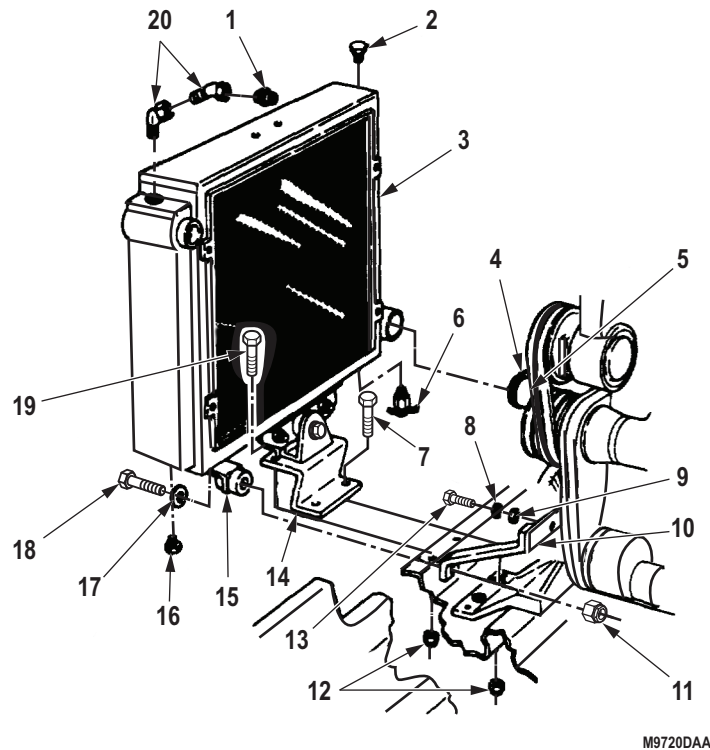

M9720DAA

Figure 2. Radiator (M939/A1) Removal.

REMOVAL - Continued

17. Remove locknut (Figure 3, Item 7), screw (Figure 3, Item 12), and radiator support (Figure 3, Item 6) from radiator (Figure 3, Item 15). Discard locknut.
18. Remove two locknuts (Figure 3, Item 2), screws (Figure 3, Item 14), and control assembly (Figure 3, Item 13) from mounting bracket (Figure 3, Item 1).
19. Remove four screws (Figure 3, Item 5), lockwashers (Figure 3, Item 4), washers (Figure 3, Item 3), and mounting bracket (Figure 3, Item 1) from radiator (Figure 3, Item 15). Discard lockwashers.
20. Remove two screws (Figure 3, Item 9), lockwashers (Figure 3, Item 10), and bracket (Figure 3, Item 11) from radiator (Figure 3, Item 15). Discard lockwashers.
21. Remove rubber mount (Figure 3, Item 8) from bracket (Figure 3, Item 11).

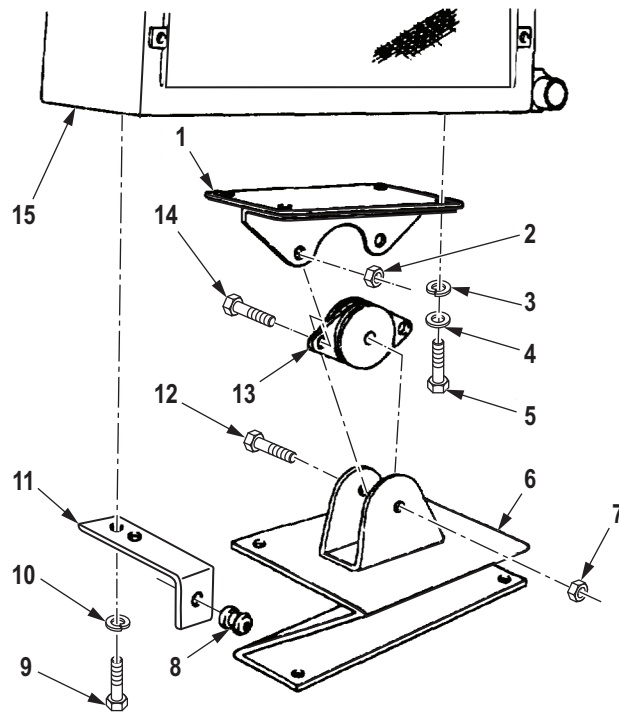

M0133DAA

Figure 3. Radiator (M939/A1) Removal.

END OF TASK

INSTALLATION

NOTE

- If radiator is being installed, use attaching parts and fittings from old radiator.
 - Fittings must be inspected for cracks or stripped threads.
 - Male pipe threads must be wrapped with antiseize tape before installation.
1. Install rubber mount (Figure 4, Item 8) in angle bracket (Figure 4, Item 11).
 2. Install bracket (Figure 4, Item 11) on radiator (Figure 4, Item 14) with two lockwashers (Figure 4, Item 10) and screws (Figure 4, Item 9).
 3. Install mounting bracket (Figure 4, Item 1) on radiator (Figure 4, Item 15) with four washers (Figure 4, Item 4), lockwashers (Figure 4, Item 3), and screws (Figure 4, Item 5).
 4. Install control assembly (Figure 4, Item 13) on bracket (Figure 4, Item 1) with two screws (Figure 4, Item 14) and locknuts (Figure 4, Item 2).
 5. Install radiator support (Figure 4, Item 6) on control assembly (Figure 4, Item 13) with screw (Figure 4, Item 12) and locknut (Figure 4, Item 7).

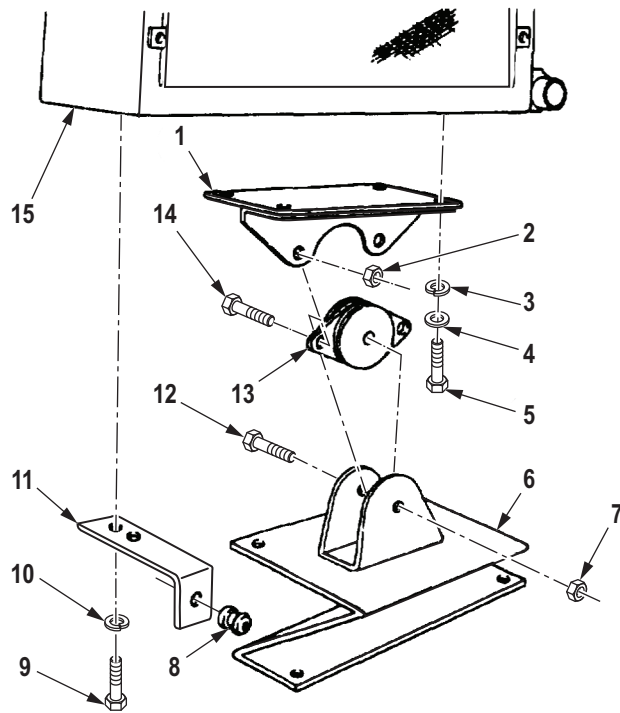

M9721DAA

Figure 4. Radiator (M939/A1) Installation.

INSTALLATION - Continued

NOTE

Perform Step (6) only if bracket was removed.

6. Install radiator support bracket (Figure 5, Item 10) with two washers (Figure 5, Item 9), lockwashers (Figure 5, Item 8), and screws (Figure 5, Item 13).

NOTE

Assistant is needed for Steps (7), (8), and (9).

7. Install radiator (Figure 5, Item 3) on frame.
8. Install radiator support (Figure 5, Item 14) on support bracket (Figure 5, Item 10) with two screws (Figure 5, Item 7), screws (Figure 5, Item 19), and four locknuts (Figure 5, Item 12).
9. Install washer (Figure 5, Item 17), screw (Figure 5, Item 18), and locknut (Figure 5, Item 11) on brackets (Figure 5, Items 10 and 15).
10. Connect radiator outlet hose (Figure 5, Item 5) to radiator (Figure 5, Item 3) and tighten clamp (Figure 5, Item 4).
11. Install two plugs (Figure 5, Item 16) and drain valve (Figure 5, Item 6) on radiator (Figure 5, Item 3).
12. Install two elbows (Figure 5, Item 20) and adapter (Figure 5, Item 1) on radiator (Figure 5, Item 3).
13. Install two plugs (Figure 5, Item 16) to radiator (Figure 5, Item 3).

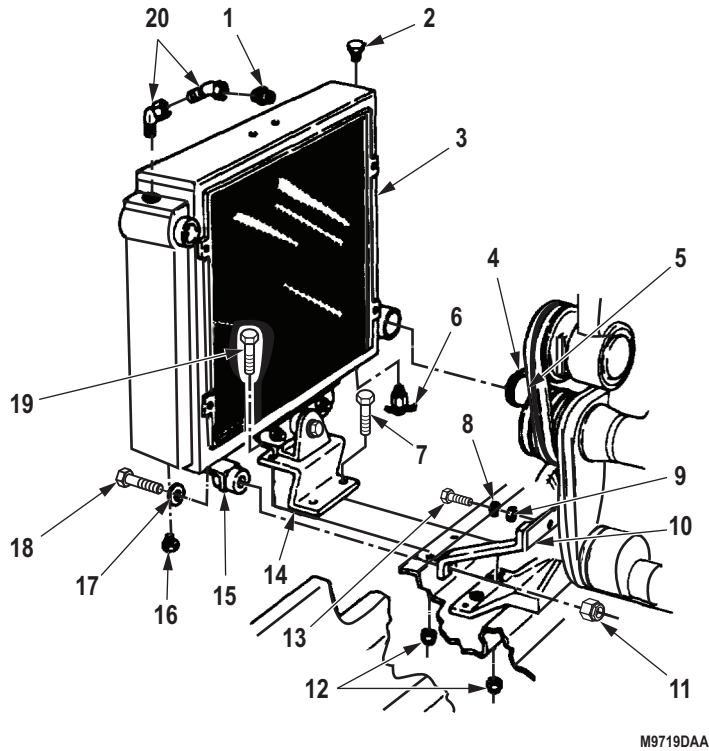

Figure 5. Radiator (M939/A1) Installation.

INSTALLATION - Continued

14. Connect radiator inlet hose (Figure 6, Item 14) to radiator (Figure 6, Item 17) and tighten clamp (Figure 6, Item 15).

NOTE

Perform Step (14) only if rubber mounts were removed.

15. Install two rubber mounts (Figure 6, Item 11) on engine bracket (Figure 6, Item 8).
16. Install upper radiator bracket (Figure 6, Item 19) on engine bracket (Figure 6, Item 8) with two screws (Figure 6, Item 12), washers (Figure 6, Item 10), and locknuts (Figure 6, Item 9).
17. Install upper radiator bracket (Figure 6, Item 19) on radiator (Figure 6, Item 17) with two washers (Figure 6, Item 20), lockwashers (Figure 6, Item 1), and screws (Figure 6, Item 2).
18. Install two hood stop cables (Figure 6, Item 5) on upper radiator bracket (Figure 6, Item 19) with two screws (Figure 6, Item 7), washers (Figure 6, Item 6), and locknuts (Figure 6, Item 4).
19. Install two clamps (Figure 6, Item 18) on upper radiator bracket (Figure 6, Item 19) with two screws (Figure 6, Item 13) and locknuts (Figure 6, Item 3).
20. Connect radiator vent hose (Figure 6, Item 16) on adapter.

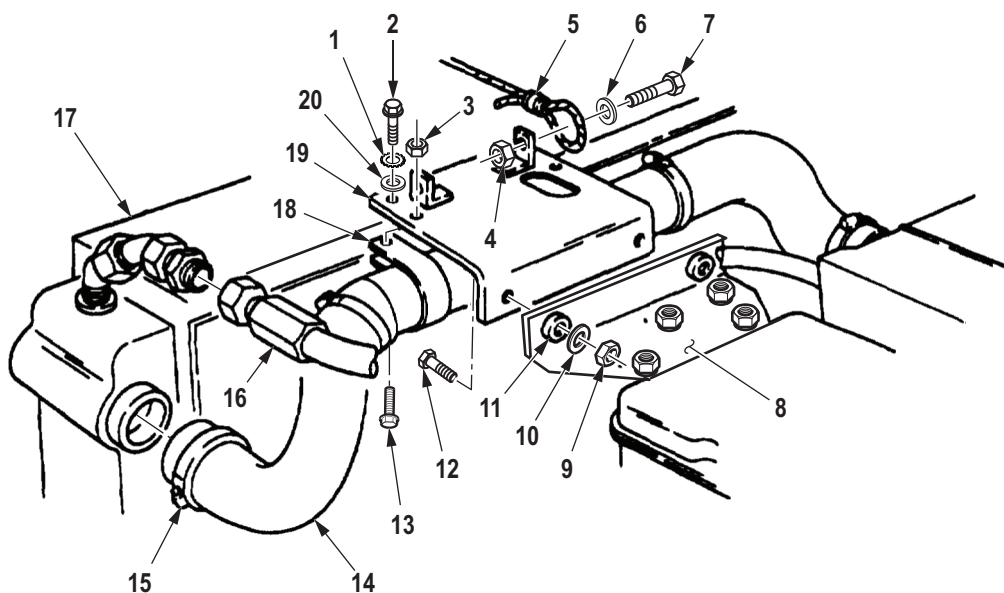

M9717DAA

Figure 6. Radiator (M939/A1) Installation.

END OF TASK

FOLLOW-ON MAINTENANCE

1. Install fan shroud. (WP 0282)
2. Fill cooling system to proper level. (WP 0287)
3. Install left and right splash shields. (TM 9-2320-272-10)
4. Hood closed and secured. (TM 9-2320-272-10)
5. Start engine and check cooling system for leaks. (TM 9-2320-272-10)

END OF TASK**END OF WORK PACKAGE**

**FIELD MAINTENANCE
RADIATOR FAN SHROUD REPLACEMENT (M939/A1)**

INITIAL SETUP:**Tools and Special Tools**

Tool Kit, General Mechanic's: Automotive
(Volume 5, WP 0826, Table 1, Item 56)
Wrench, Torque, Click, Ratcheting, 3/8" Drive,
75 Ft-Lb
(Volume 5, WP 0826, Table 1, Item 62)

Materials/Parts

Locknut (Volume 5, WP 0827, Table 1, Item 282)
Qty: 4
Locknut (Volume 5, WP 0827, Table 1, Item 283)
Qty: 4

Materials/Parts (cont.)

Locknut (Volume 5, WP 0827, Table 1, Item 292)
Qty: 8
Lockwasher
(Volume 5, WP 0827, Table 1, Item 215)
Qty: 6

Equipment Condition

Parking brake set. (TM 9-2320-272-10)
Hood raised and secured. (TM 9-2320-272-10)
Left and right splash shields removed.
(TM 9-2320-272-10)
Cooling system drained as needed. (WP 0287)

REMOVAL**NOTE**

- Have drainage container ready to catch coolant.
 - Use drain pans to retain leaking/draining fluids. Refer to local procedures and plans for preventing and responding to fluid spills or leaks. Comply with local regulations when disposing of clean up material and leaked and spilled fluids.
1. Loosen hose clamp (Figure 1, Item 2) and disconnect radiator inlet hose (Figure 1, Item 1) from radiator pipe (Figure 1, Item 3).
 2. Remove screw (Figure 1, Item 20), lockwasher (Figure 1, Item 21), and washer (Figure 1, Item 22) from corner shroud (Figure 1, Item 23). Discard lockwasher.
 3. Remove locknut (Figure 1, Item 5), screw (Figure 1, Item 18), and washers (Figure 1, Items 6 and 19) from radiator (Figure 1, Item 4) and corner shroud (Figure 1, Item 23). Discard locknut.
 4. Remove four locknuts (Figure 1, Item 10), eight washers (Figure 1, Item 9), four screws (Figure 1, Item 17), and corner shroud (Figure 1, Item 23) from radiator (Figure 1, Item 4). Discard locknuts.
 5. Remove three locknuts (Figure 1, Item 7), washers (Figure 1, Item 8), screws (Figure 1, Item 13), and washers (Figure 1, Item 12) from fan shroud (Figure 1, Item 11) from radiator (Figure 1, Item 4). Discard locknuts.
 6. Remove five screws (Figure 1, Item 16), washers (Figure 1, Item 14), and lockwashers (Figure 1, Item 15) from radiator (Figure 1, Item 4). Discard lockwashers.
 7. Remove fan shroud (Figure 1, Item 11) from radiator (Figure 1, Item 4).
 8. Remove eight locknuts (Figure 1, Item 27), 16 washers (Figure 1, Item 24), eight screws (Figure 1, Item 25), and four brackets (Figure 1, Item 26) from radiator (Figure 1, Item 4). Discard locknuts.

REMOVAL - Continued

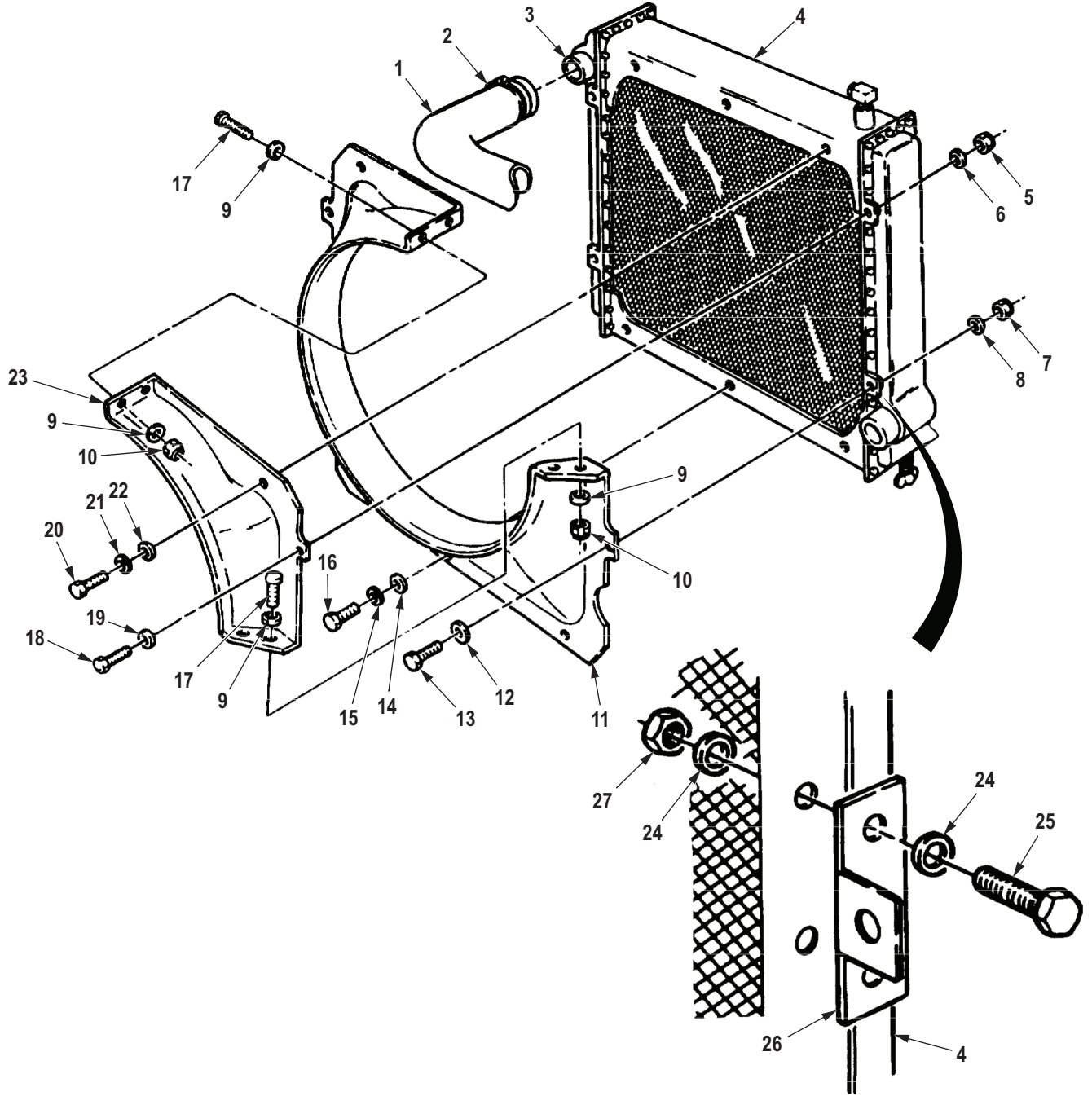

M0141DAA

Figure 1. Radiator Fan Shroud Removal.

END OF TASK

INSTALLATION

1. Install four brackets (Figure 2, Item 26) on radiator (Figure 2, Item 4) with 16 washers (Figure 2, Item 24), eight screws (Figure 2, Item 25), and locknuts (Figure 2, Item 27). Tighten screws 10 to 14 lb-ft (14 to 19 N·m).
2. Install fan shroud (Figure 2, Item 11) on radiator (Figure 2, Item 4) with five washers (Figure 2, Item 14), lockwashers (Figure 2, Item 15), and screws (Figure 2, Item 16). Tighten screws to 10 to 14 lb-ft (14 to 19 N·m).
3. Install fan shroud (Figure 2, Item 11) on radiator (Figure 2, Item 4) with three washers (Figure 2, Item 12), screws (Figure 2, Item 13), washers (Figure 2, Item 8), and locknuts (Figure 2, Item 7).
4. Install corner shroud (Figure 2, Item 23) on radiator (Figure 2, Item 4) with four washers (Figure 2, Item 9), screws (Figure 2, Item 17), washers (Figure 2, Item 9), and locknuts (Figure 2, Item 10). Tighten screws 66 to 86 lb-in. (7 to 10 N·m).
5. Install corner shroud (Figure 2, Item 23) on radiator (Figure 2, Item 4) with washer (Figure 2, Item 19), screw (Figure 2, Item 18), washer (Figure 2, Item 6), and locknut (Figure 2, Item 5). Tighten screw 10 to 14 lb-ft (14 to 19 N·m).
6. Secure corner shroud (Figure 2, Item 23) on radiator (Figure 2, Item 4) with washer (Figure 2, Item 22), lockwasher (Figure 2, Item 21), and screw (Figure 2, Item 20). Tighten screw 10 to 14 lb-ft (14 to 19 N·m).
7. Connect radiator hose (Figure 2, Item 1) to radiator inlet (Figure 2, Item 3) and tighten clamp (Figure 2, Item 2).

INSTALLATION - Continued

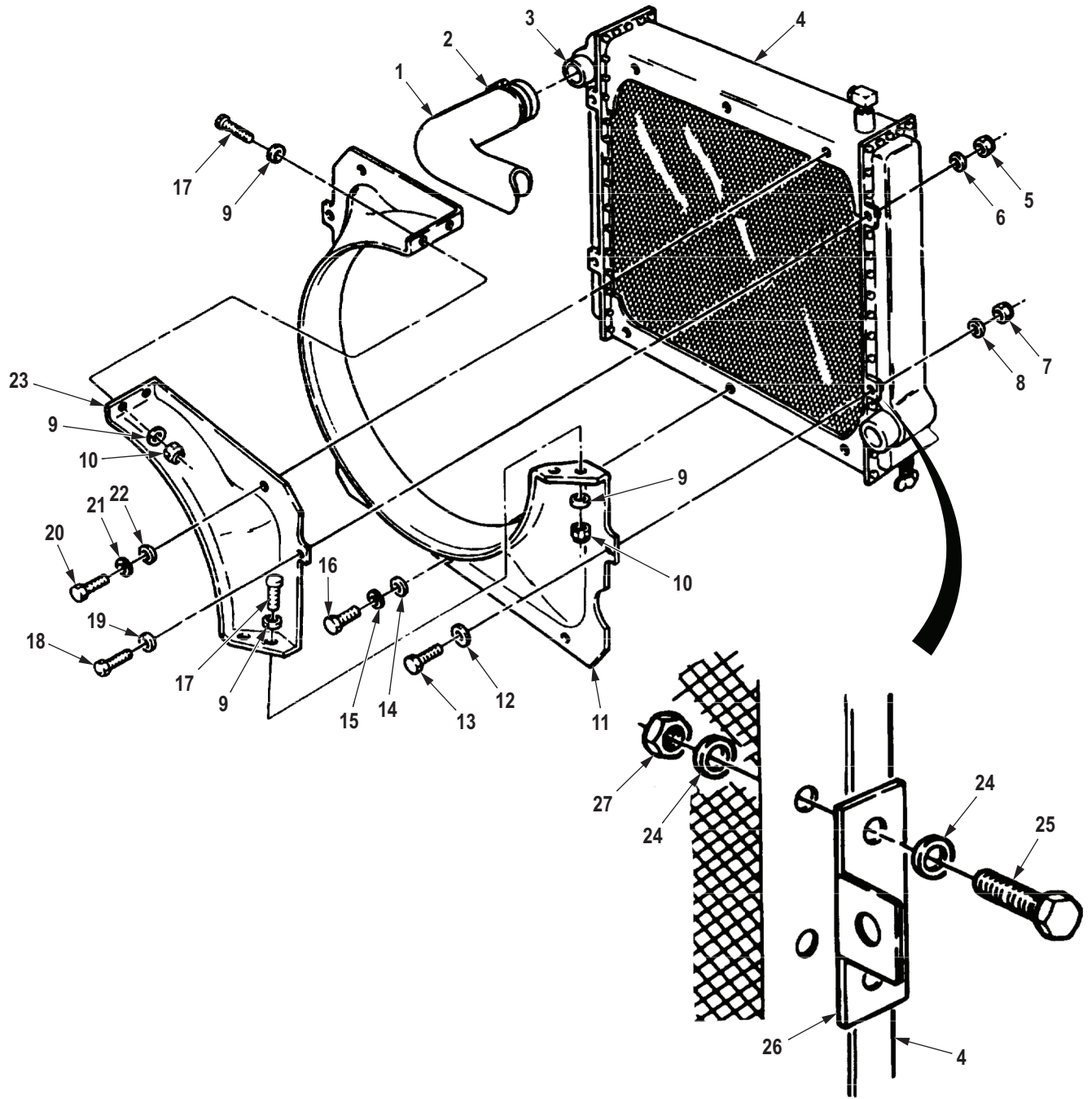

M0142DAA

Figure 2. Radiator Fan Shroud Installation.

END OF TASK

FOLLOW-ON MAINTENANCE

1. Fill cooling system to proper level. (WP 0287)
2. Hood closed and secured. (TM 9-2320-272-10)
3. Start engine and check for coolant leaks. (TM 9-2320-272-10)
4. Install left and right splash shields. (TM 9-2320-272-10)

END OF TASK**END OF WORK PACKAGE**

**FIELD MAINTENANCE
FAN AND FAN SHROUD REPAIR (M939A2)**

INITIAL SETUP:**Tools and Special Tools**

Tool Kit, General Mechanic's: Automotive
(Volume 5, WP 0826, Table 1, Item 56)
Wrench, Torque, Click, Ratcheting, 3/8" Drive,
75 Ft-Lb
(Volume 5, WP 0826, Table 1, Item 62)

Materials/Parts

Antiseize Compound
(Volume 5, WP 0825, Table 1, Item 9)
Locknut
(Volume 5, WP 0827, Table 1, Item 246)
Qty: 2
Locknut (Volume 5, WP 0827, Table 1, Item 282)
Qty: 4
Locknut (Volume 5, WP 0827, Table 1, Item 283)
Qty: 4

Materials/Parts (cont.)

Lockwasher
(Volume 5, WP 0827, Table 1, Item 390)
Qty: 2
Mount, Resident, WS
(Volume 5, WP 0827, Table 1, Item 189)
Qty: 2

References

Volume 5, WP 0819

Equipment Condition

Parking brake set. (TM 9-2320-272-10)
Hood raised and secured. (TM 9-2320-272-10)

REMOVAL

1. Remove two locknuts (Figure 1, Item 24), snubbing washers (Figure 1, Item 25), screws (Figure 1, Item 13), and washers (Figure 1, Item 14) from brackets (Figure 1, Items 18 and 23). Discard locknuts.
2. Remove two sets of resident mounts (Figure 1, Item 12) from brackets (Figure 1, Items 18 and 23). Discard resident mounts.
3. Straighten tabs on two lockwashers (Figure 1, Item 20) and remove screws (Figure 1, Item 21), lockwashers, bracket (Figure 1, Item 23), and spacer (Figure 1, Item 19) from radiator (Figure 1, Item 17). Let bracket hang from attaching cables (Figure 1, Item 22) on vehicle hood (Figure 1, Item 1). Discard lockwashers.
4. Remove four locknuts (Figure 1, Item 5), eight washers (Figure 1, Item 6), and four screws (Figure 1, Item 7) securing top half of shroud (Figure 1, Item 2) to bottom half of shroud (Figure 1, Item 8). Discard locknuts.
5. Remove five screws (Figure 1, Item 4), six washers (Figure 1, Item 3), two locknuts (Figure 1, Item 16), and top half of shroud (Figure 1, Item 2) from radiator (Figure 1, Item 17). Discard locknuts.
6. Remove two screws (Figure 1, Item 27) from fan mounting bracket (Figure 1, Item 26), position fan drive pulley (Figure 1, Item 28) with fan clutch (Figure 1, Item 29) so fan clutch holes (Figure 1, Item 34) are aligned, and install two screws in fan clutch holes (Figure 1, Item 34).
7. Remove six nuts (Figure 1, Item 30), washers (Figure 1, Item 31), and fan blade (Figure 1, Item 32) from fan clutch (Figure 1, Item 29).
8. Remove five screws (Figure 1, Item 10), seven washers (Figure 1, Item 11), two locknuts (Figure 1, Item 15), clip (Figure 1, Item 9), and bottom half of shroud (Figure 1, Item 8) from radiator (Figure 1, Item 17). Discard locknuts.

REMOVAL - Continued

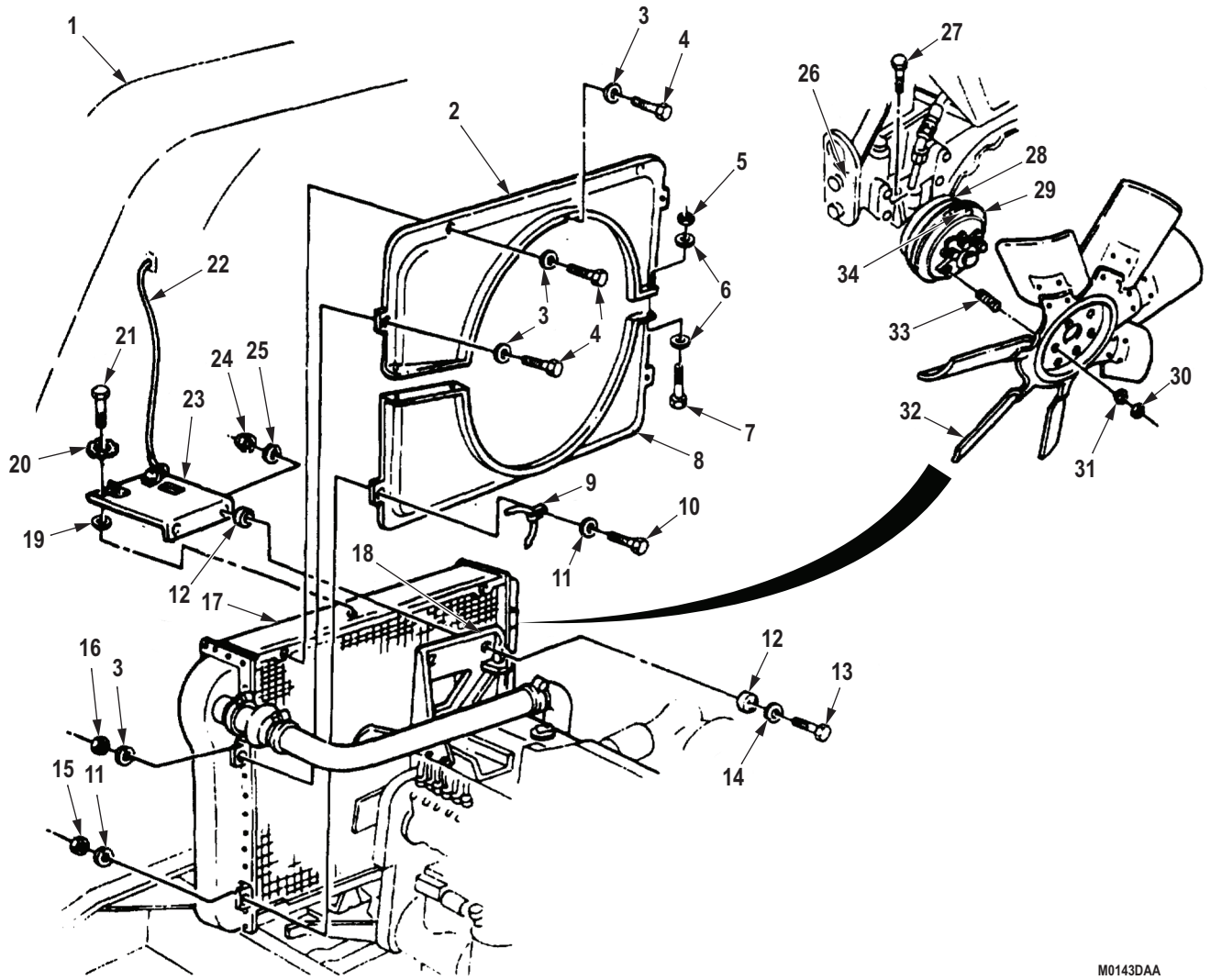

M0143DAA

Figure 1. Fan and Shroud Removal.

END OF TASK

INSPECTION

1. Inspect fan shrouds for cracks and missing pieces.
2. Lay fan on flat surface. Ensure all blades of fan contact the flat surface the same way.
3. Inspect fan for cracks, broken pieces, and loose anchorage and studs for cracks or stripped threads.
4. Inspect all other parts (Volume 5, WP 0819).
5. Replace all parts failing inspection.

END OF TASK**INSTALLATION**

1. Install bottom half of shroud (Figure 2, Item 8) on radiator (Figure 2, Item 17) with clip (Figure 2, Item 9), five screws (Figure 2, Item 10), seven washers (Figure 2, Item 11), and two locknuts (Figure 2, Item 15). Ensure clip is mounted under correct screw.
2. Align fan blade (Figure 2, Item 32) with fan clutch holes (Figure 2, Item 34) and install six washers (Figure 2, Item 31) and nuts (Figure 2, Item 30). Tighten nuts 36 lb-ft (47 N·m).
3. Remove two screws (Figure 2, Item 27) from fan clutch (Figure 2, Item 29).
4. Coat screw (Figure 2, Item 27) threads with antiseize compound and install screws on fan mounting bracket (Figure 2, Item 26).
5. Install top half of shroud (Figure 2, Item 2) on radiator (Figure 2, Item 17) with five screws (Figure 2, Item 4), six washers (Figure 2, Item 3), and two locknuts (Figure 2, Item 16). Finger-tighten screws.
6. Secure halves of shroud (Figure 2, Items 2 and 8) with eight washers (Figure 2, Item 6), four screws (Figure 2, Item 7), and locknuts (Figure 2, Item 5).
7. Tighten five screws (Figure 2, Item 4) and two locknuts (Figure 2, Item 16).
8. Install two sets of resident mounts (Figure 2, Item 12) in brackets (Figure 2, Items 18 and 23).
9. Install spacer (Figure 2, Item 19) and bracket (Figure 2, Item 23) on bracket (Figure 2, Item 18) and radiator (Figure 2, Item 17) with two screws (Figure 2, Item 13), washers (Figure 2, Item 14), snubbing washers (Figure 2, Item 25), and locknuts (Figure 2, Item 24). Finger tighten locknuts.
10. Install two lockwashers (Figure 2, Item 20) and screws (Figure 2, Item 21) on bracket (Figure 2, Item 23) and radiator (Figure 2, Item 17). Tighten screws 40 lb-ft (55 N·m). Bend tabs on lockwashers against flats of screws.
11. Tighten locknuts (Figure 2, Item 24) 35 lb-ft (50 N·m).

INSTALLATION - Continued

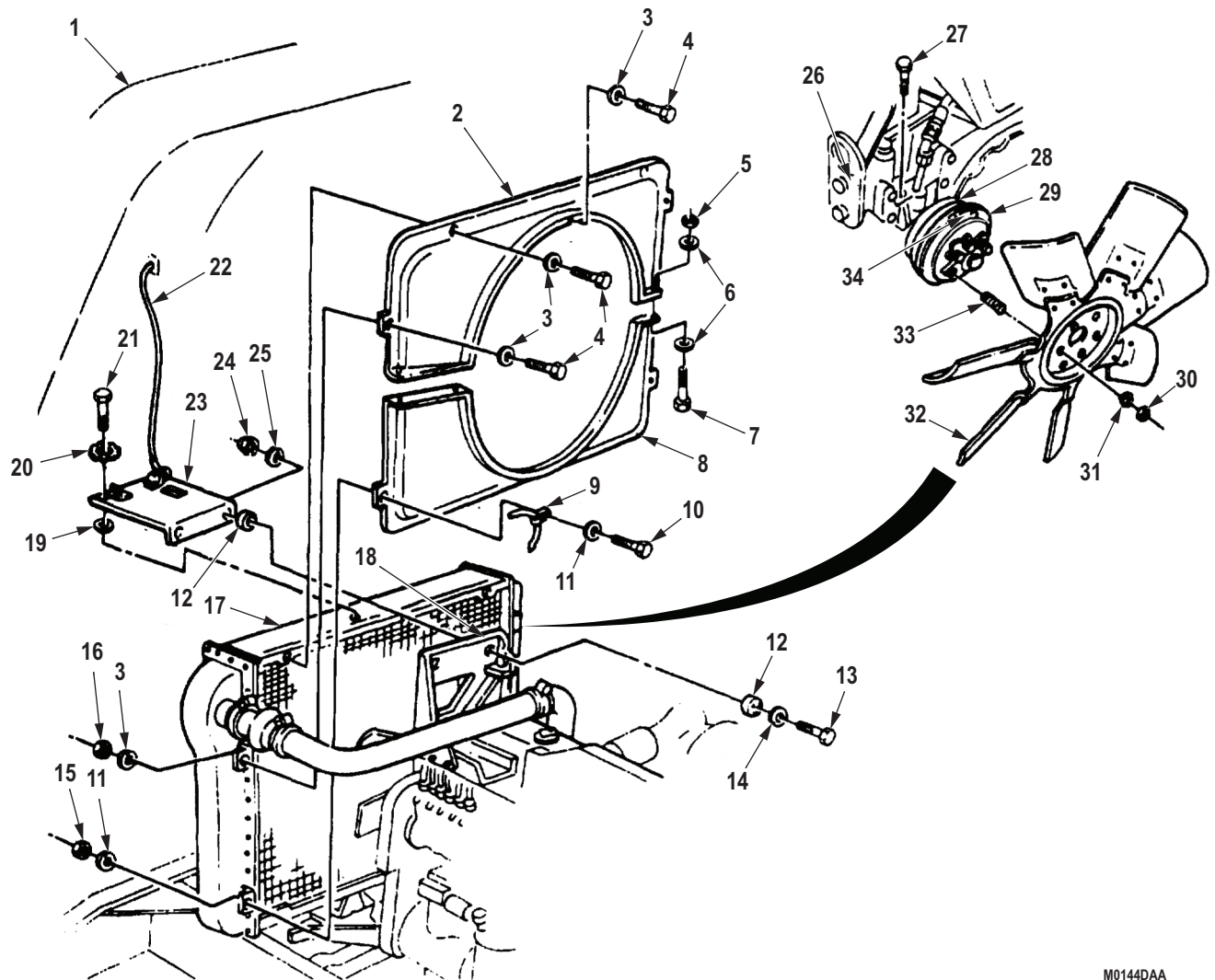

M0144DAA

Figure 2. Fan and Shroud Installation.

END OF TASK**FOLLOW-ON MAINTENANCE**

1. Hood closed and secured. (TM 9-2320-272-10)
2. Start engine and run until fan clutch locks up. Check fan for alignment. (TM 9-2320-272-10)

END OF TASK**END OF WORK PACKAGE**

FIELD MAINTENANCE
AIR COMPRESSOR COOLANT SUPPLY AND RETURN TUBES REPLACEMENT (M939/A1)

INITIAL SETUP:**Tools and Special Tools**

Tool Kit, General Mechanic's: Automotive
(Volume 5, WP 0826, Table 1, Item 56)

References

TM 9-243

Materials/Parts

Tape, Antiseizing
(Volume 5, WP 0825, Table 1, Item 65)
Bushing (Volume 5, WP 0827, Table 1, Item 118)
Qty: 4
Lockwasher
(Volume 5, WP 0827, Table 1, Item 443)
Qty: 1

Equipment Condition

Parking brake set. (TM 9-2320-272-10)
Hood raised and secured. (TM 9-2320-272-10)
Cooling system drained. (WP 0287)

SUPPLY TUBE REMOVAL

1. Loosen two flare nuts (Figure 1, Item 5) and remove coolant supply tube (Figure 1, Item 6) from water pump adapter (Figure 1, Item 7) and air compressor elbow (Figure 1, Item 2), and slide nuts to center of tube.
2. Remove and discard two bushings from tube (Figure 1, Item 6).
3. Remove water pump adapter (Figure 1, Item 7) and air compressor elbow (Figure 1, Item 2) from engine oil cooler (Figure 1, Item 1) and air compressor (Figure 1, Item 3).

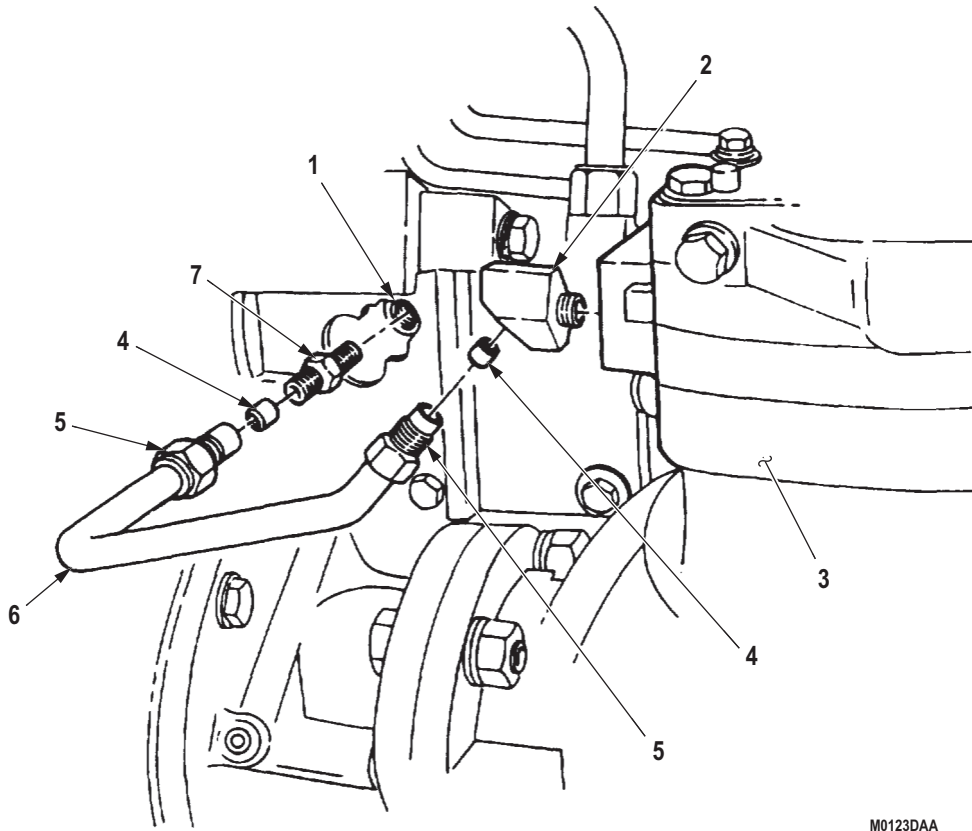

Figure 1. Supply Tube Removal.

END OF TASK

RETURN TUBE REMOVAL

1. Loosen flare nut (Figure 2, Item 9) and disconnect coolant return tube (Figure 2, Item 5) from engine oil cooler elbow (Figure 2, Item 11).
2. Remove nut (Figure 2, Item 6), lockwasher (Figure 2, Item 7), washer (Figure 2, Item 8), screw (Figure 2, Item 1), washer (Figure 2, Item 2), and coolant return tube clamp (Figure 2, Item 3) from bracket (Figure 2, Item 4). Discard lockwasher.
3. Loosen flare nut (Figure 2, Item 13) and remove coolant return tube (Figure 2, Item 5) from elbow (Figure 2, Item 15).
4. Remove bushings (Figure 2, Items 10 and 14) from coolant return tube (Figure 2, Item 5). Discard bushings.

RETURN TUBE REMOVAL - Continued

- Remove elbows (Figure 2, Items 11 and 15) from engine oil cooler (Figure 2, Item 12) and air compressor (Figure 2, Item 16).

END OF TASK**INSPECTION**

- Inspect flare nut (Figure 1, Item 5), adapter (Figure 1, Item 7), elbow (Figure 1, Item 2), and coolant supply tube (Figure 1, Item 6) for cracks and stripped threads. Replace parts if cracked or are damaged threads. Refer to TM 9-243 for fabrication of supply tube.
- Inspect flare nuts (Figure 2, Items 9 and 13), elbows (Figure 2, Items 11 and 15), and tubing (Figure 2, Item 5) for cracks and severe bends. Discard tubing if cracked or badly bent. Refer to TM 9-243 for fabrication of tubing.

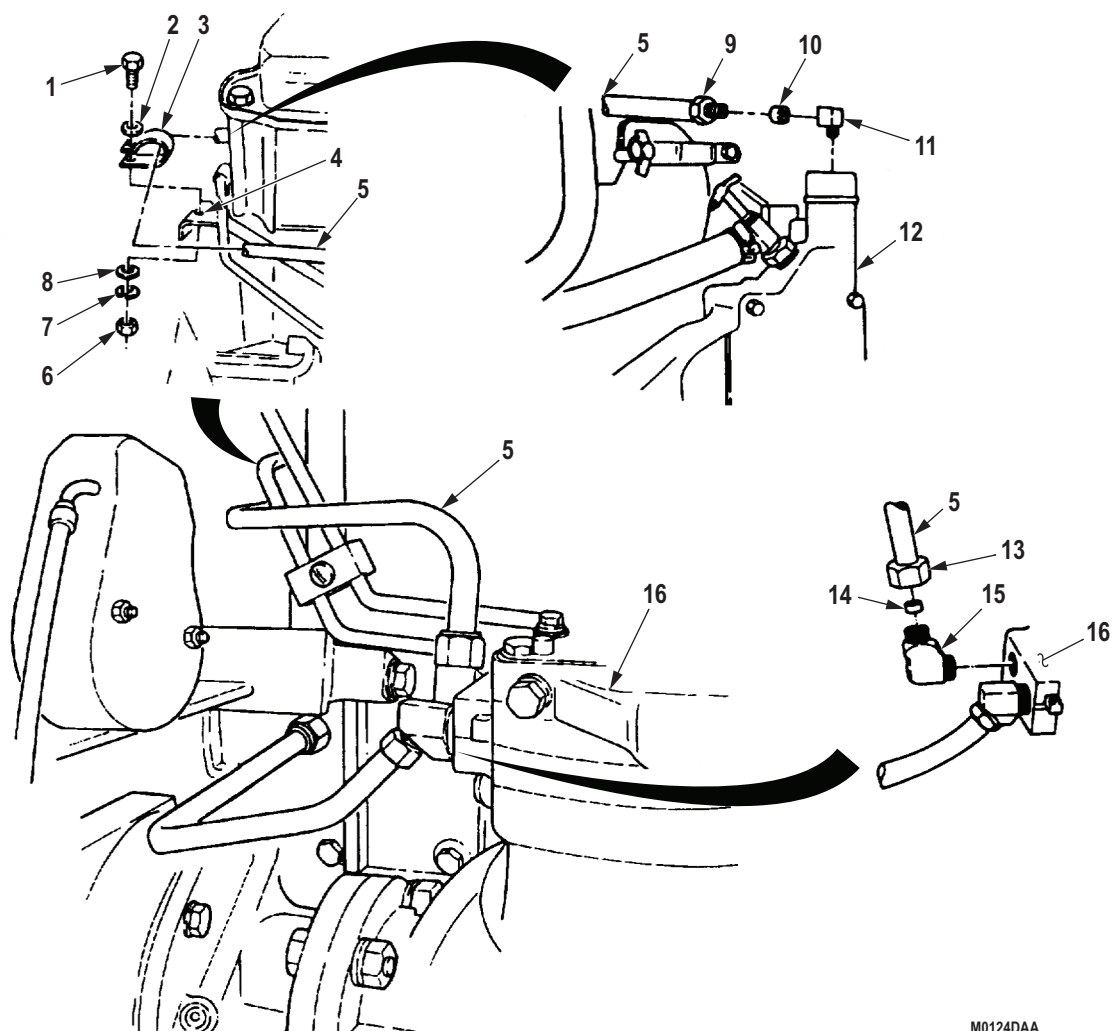

M0124DAA

Figure 2. Return Tube Inspection.

END OF TASK

SUPPLY TUBE INSTALLATION**NOTE**

Male pipe threads must be wrapped with antiseize tape before installation.

1. Install water pump adapter (Figure 3, Item 7) in engine oil cooler (Figure 3, Item 1).
2. Install air compressor elbow (Figure 3, Item 2) on air compressor (Figure 3, Item 3).
3. Install two bushings (Figure 3, Item 4) in coolant supply tube (Figure 3, Item 6).
4. Install coolant supply tube (Figure 3, Item 6) on air compressor elbow (Figure 3, Item 2) and water pump adapter (Figure 3, Item 7).

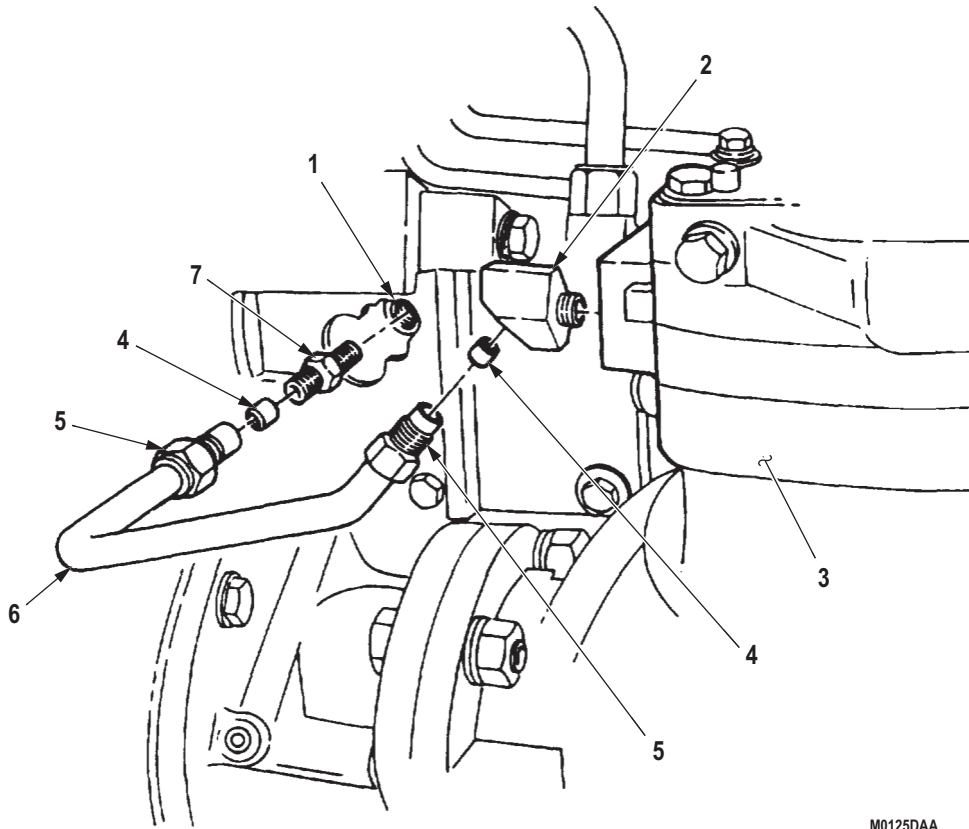

M0125DAA

Figure 3. Supply Tube Installation.

END OF TASK**RETURN TUBE INSTALLATION****NOTE**

Male pipe threads must be wrapped with antiseize tape before installation.

1. Install air compressor elbow (Figure 4, Item 15) on air compressor (Figure 4, Item 16).
2. Install engine oil cooler elbow (Figure 4, Item 11) on engine oil cooler (Figure 4, Item 12).

RETURN TUBE INSTALLATION - Continued

3. Install return tube (Figure 4, Item 5) on compressor elbow (Figure 4, Item 15) with bushing (Figure 4, Item 14) and flare nut (Figure 4, Item 13). Do not tighten flare nut.
4. Connect return tube (Figure 4, Item 5) on engine oil cooler elbow (Figure 4, Item 11) with bushing (Figure 4, Item 10) and flare nut (Figure 4, Item 9). Do not tighten flare nut.
5. Install coolant return tube (Figure 4, Item 5) on support bracket (Figure 4, Item 4) with clamp (Figure 4, Item 3), washers (Figure 4, Items 2 and 8), lockwasher (Figure 4, Item 7), and nut (Figure 4, Item 6). Tighten nut.
6. Tighten flare nuts (Figure 4, Items 9 and 13).

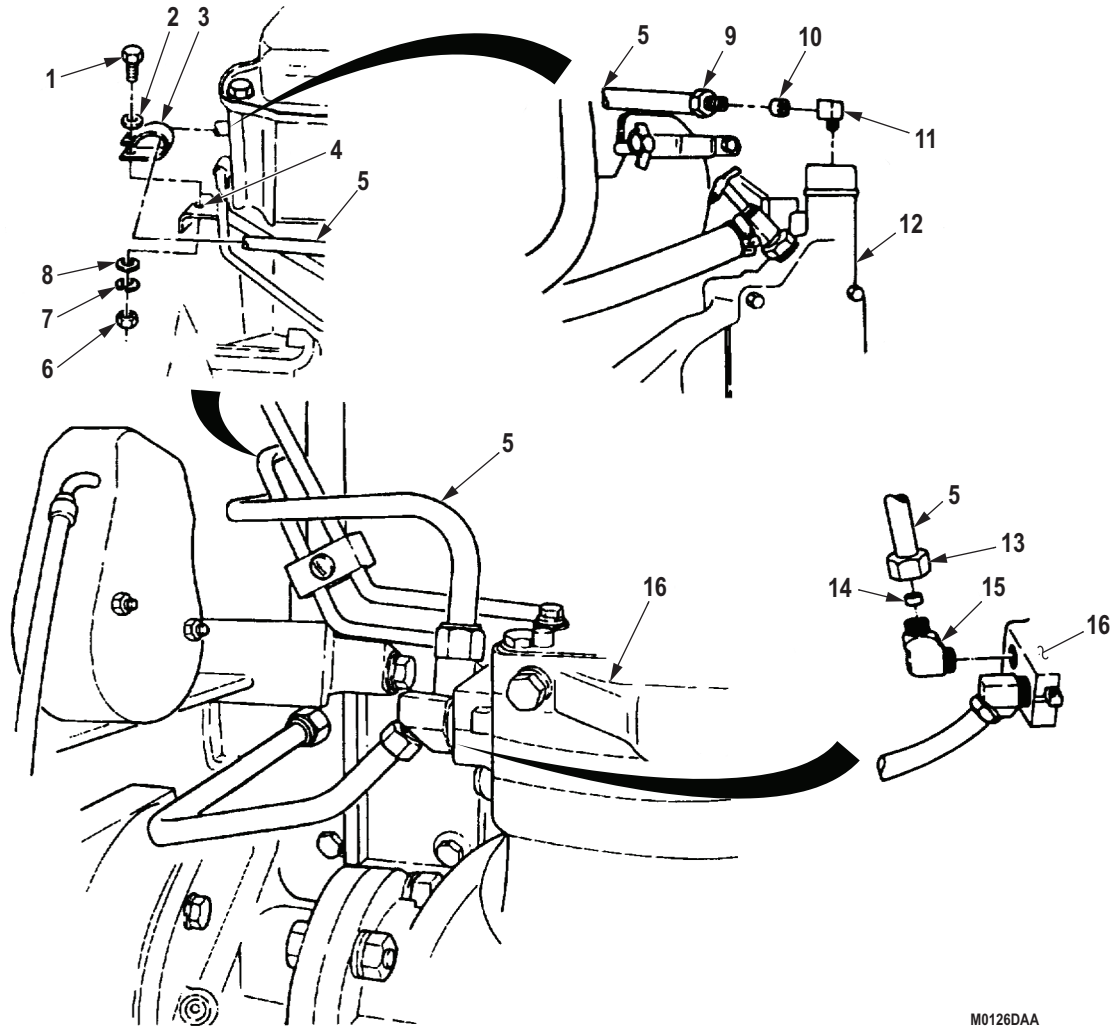

Figure 4. Return Tube Installation.

END OF TASK

FOLLOW-ON MAINTENANCE

1. Fill cooling system to proper level. (WP 0287)
2. Hood closed and secured. (TM 9-2320-272-10)
3. Start engine and check for coolant leaks. (TM 9-2320-272-10)

END OF TASK**END OF WORK PACKAGE**

**FIELD MAINTENANCE
COOLANT HOSES AND LINES REPLACEMENT (M939A2)**

INITIAL SETUP:**Tools and Special Tools**

Tool Kit, General Mechanic's: Automotive
(Volume 5, WP 0826, Table 1, Item 56)

Equipment Condition (cont.)

Right splash shield removed. (TM 9-2320-272-10)
Cooling system drained. (WP 0287)

Materials/Parts

Tape, Antiseizing
(Volume 5, WP 0825, Table 1, Item 65)
Locknut (Volume 5, WP 0827, Table 1, Item 430)
Qty: 1

Equipment Condition

Hood raised and secured. (TM 9-2320-272-10)

REMOVAL**NOTE**

If removal of tiedown straps is necessary, note location for installation.

1. Remove locknut (Figure 1, Item 5), screw (Figure 1, Item 2), clamp (Figure 1, Item 3), and hose (Figure 1, Item 1) from bracket (Figure 1, Item 6). Discard locknut.
2. Disconnect hose (Figure 1, Item 1) from adapter (Figure 1, Item 4) and surge tank (Figure 1, Item 18).
3. Remove two clamps (Figure 1, Item 19) and hose (Figure 1, Item 20) from surge tank (Figure 1, Item 18) and thermostat housing (Figure 1, Item 9).
4. Remove adapter (Figure 1, Item 4) and two elbows (Figure 1, Item 7) from radiator (Figure 1, Item 8).
5. Remove two clamps (Figure 1, Item 12) and remove hose (Figure 1, Item 13) from heater valve (Figure 1, Item 16) and fitting (Figure 1, Item 10).
6. Remove two clamps (Figure 1, Item 11) and remove hose (Figure 1, Item 14) from heater valve (Figure 1, Item 15) and fitting (Figure 1, Item 17).

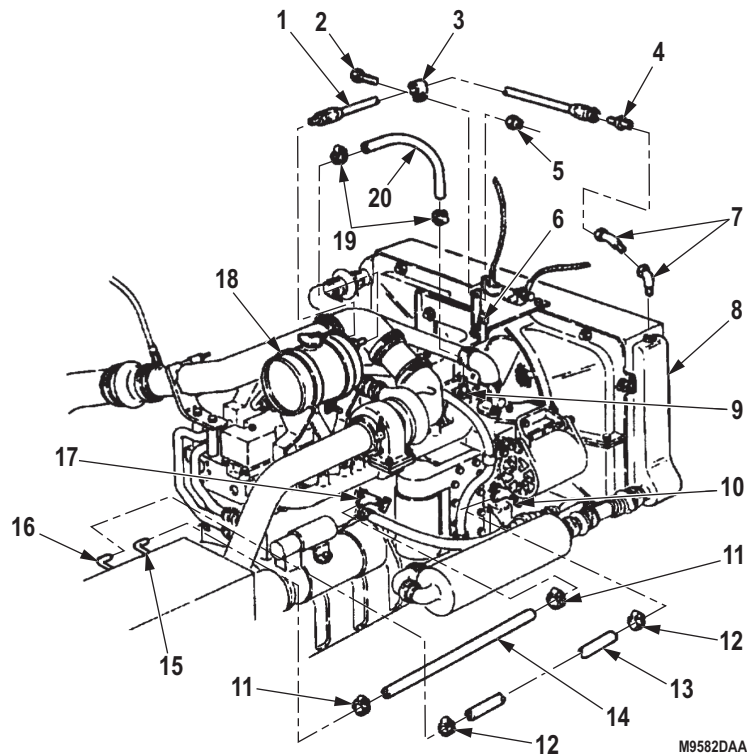

Figure 1. Coolant Hoses and Lines Removal.

REMOVAL - Continued

7. Remove nut (Figure 2, Item 2), screw (Figure 2, Item 6), clamp (Figure 2, Item 5), and hose (Figure 2, Item 4) from bracket (Figure 2, Item 3).
8. Remove clamp (Figure 2, Item 16) and hose (Figure 2, Item 17) from surge tank fitting (Figure 2, Item 1).
9. Remove clamp (Figure 2, Item 7) and hose (Figure 2, Item 4) from tube (Figure 2, Item 14).

NOTE

Perform Steps (10) and (11) for internal bypass systems.

10. Remove two clamps (Figure 2, Item 10) and hose (Figure 2, Item 11) from fitting (Figure 2, Item 15) and thermostat canister (Figure 2, Item 9).
11. Remove two clamps (Figure 2, Item 12), hose (Figure 2, Item 13), and thermostat canister (Figure 2, Item 9) from tube (Figure 2, Item 8).

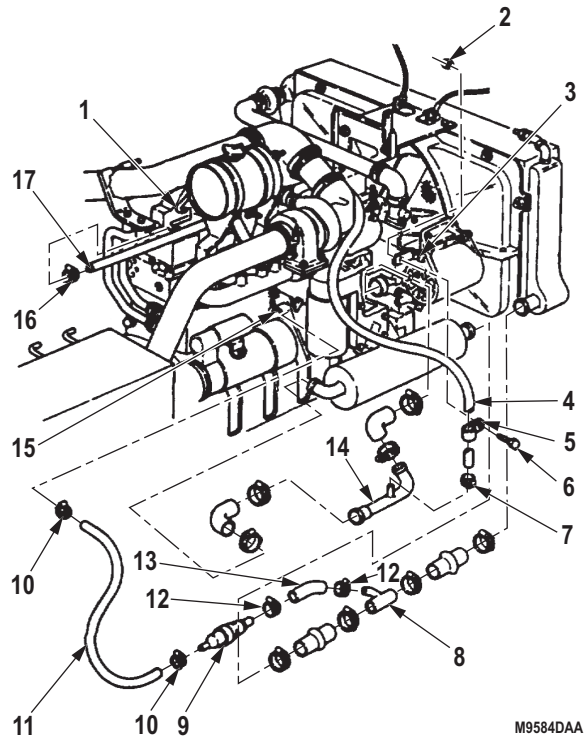

M9584DAA

Figure 2. Coolant Hoses and Lines Removal.

REMOVAL - Continued**NOTE**

Perform Step (12) for external bypass systems.

12. Remove two clamps (Figure 3, Item 4) and hose (Figure 3, Item 3) from fitting (Figure 3, Item 1) and tube (Figure 3, Item 2).

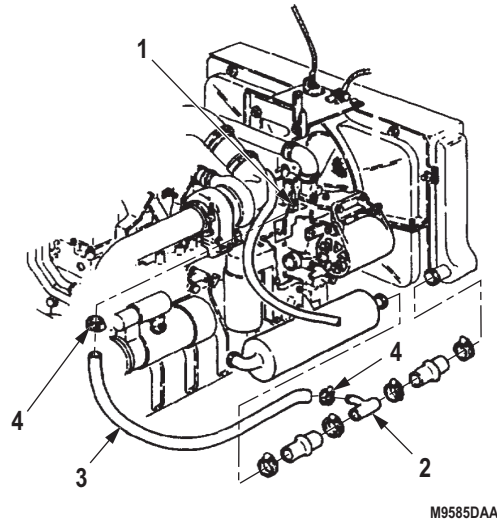

Figure 3. Coolant Hoses and Lines Removal.

REMOVAL - Continued

13. Remove two clamps (Figure 4, Item 3) and hump hose (Figure 4, Item 4) from outlet tube (Figure 4, Item 2) and tube (Figure 4, Item 5).
14. Remove two clamps (Figure 4, Item 6), tube (Figure 4, Item 5), and hump hose (Figure 4, Item 7) from transmission oil cooler (Figure 4, Item 13).
15. Remove two clamps (Figure 4, Item 9) and elbow hose (Figure 4, Item 10) from outlet port (Figure 4, Item 1) and tube (Figure 4, Item 8).
16. Remove two clamps (Figure 4, Item 11), elbow hose (Figure 4, Item 12), and tube (Figure 4, Item 8) from transmission oil cooler (Figure 4, Item 13).

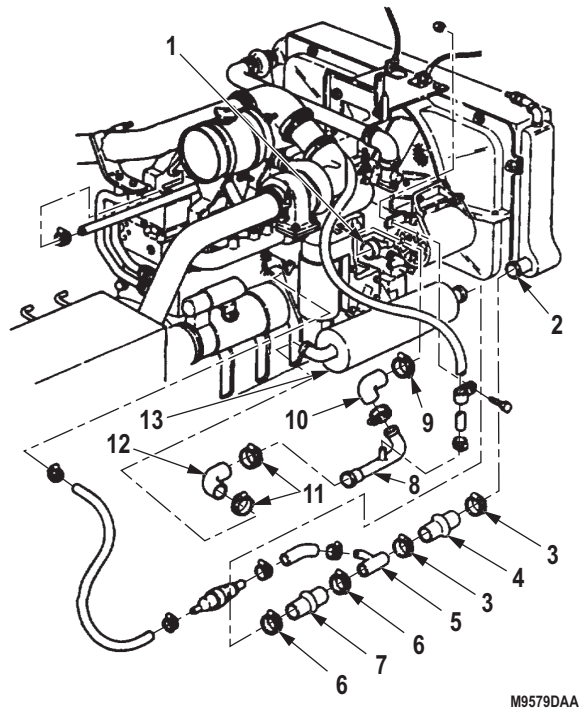

Figure 4. Coolant Hoses and Lines Removal.

END OF TASK

INSTALLATION

1. Install elbow hose (Figure 5, Item 14) on transmission oil cooler (Figure 5, Item 15) with clamp (Figure 5, Item 13).
2. Install tube (Figure 5, Item 10) on elbow (Figure 5, Item 14) with clamp (Figure 5, Item 13).
3. Install elbow hose (Figure 5, Item 12) on outlet port (Figure 5, Item 1) and tube (Figure 5, Item 10) with two clamps (Figure 5, Item 11).
4. Install hump hose (Figure 5, Item 9) on transmission oil cooler (Figure 5, Item 15) with clamp (Figure 5, Item 8).
5. Install tube (Figure 5, Item 7) on hump hose (Figure 5, Item 9) with clamp (Figure 5, Item 8).
6. Install hump hose (Figure 5, Item 6) on tube (Figure 5, Item 7) and outlet tube (Figure 5, Item 4) with two clamps (Figure 5, Item 5).

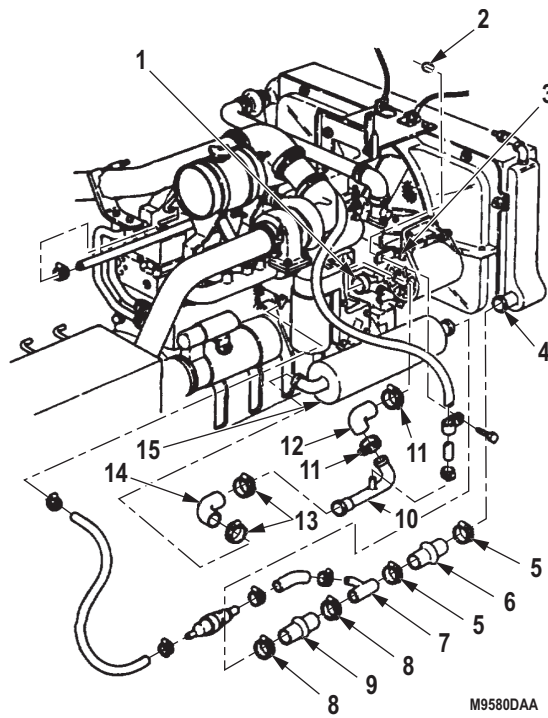

Figure 5. Coolant Hoses and Lines Installation.

INSTALLATION - Continued**NOTE**

Perform Step (7) for external bypass systems.

7. Install hose (Figure 6, Item 3) on fitting (Figure 6, Item 1) and tube (Figure 6, Item 2) with two clamps (Figure 6, Item 4).

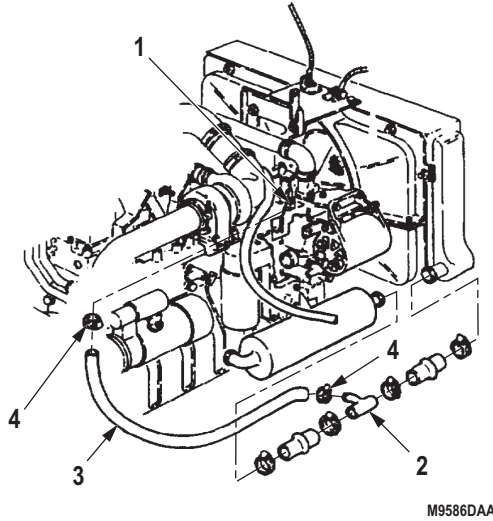
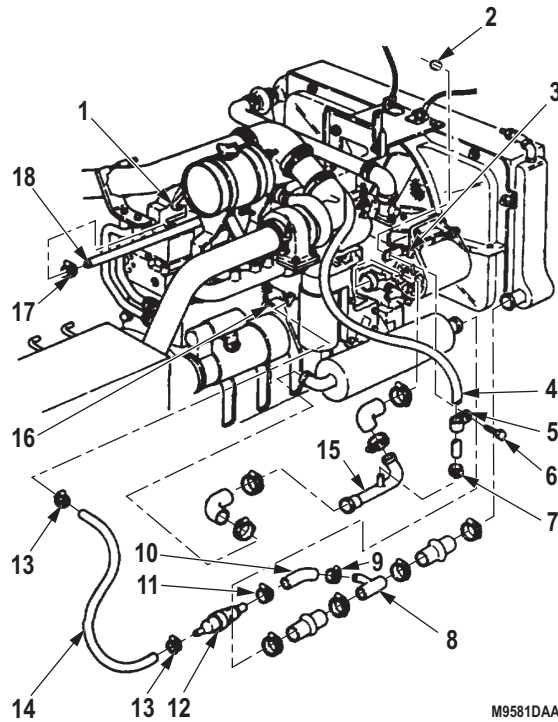

Figure 6. Coolant Hoses and Lines Installation.

INSTALLATION - Continued**NOTE**

Perform Steps (8), (9), and (10) for internal bypass systems.

8. Install hose (Figure 7, Item 10) on tube (Figure 7, Item 8) with clamp (Figure 7, Item 9).
9. Install thermostat canister (Figure 7, Item 12) on hose (Figure 7, Item 10) with clamp (Figure 7, Item 11).
10. Install hose (Figure 7, Item 14) on fitting (Figure 7, Item 16) and thermostat canister (Figure 7, Item 12) with two clamps (Figure 7, Item 13).
11. Install hose (Figure 7, Item 4) on tube (Figure 7, Item 15) with clamp (Figure 7, Item 7).
12. Install hose (Figure 7, Item 18) on surge tank fitting (Figure 7, Item 1) with clamp (Figure 7, Item 17).
13. Install hose (Figure 7, Item 4) and clamp (Figure 7, Item 5) on bracket (Figure 7, Item 3) with screw (Figure 7, Item 6) and nut (Figure 7, Item 2).



M9581DAA

Figure 7. Coolant Hoses and Lines Installation.

INSTALLATION - Continued

14. Install hose (Figure 8, Item 14) on heater valve (Figure 8, Item 15) and fitting (Figure 8, Item 17) with two clamps (Figure 8, Item 11).
15. Install hose (Figure 8, Item 13) on heater valve (Figure 8, Item 16) and fitting (Figure 8, Item 10) with two clamps (Figure 8, Item 12).

NOTE

Wrap male pipe threads with antiseize tape before installation.

16. Install two elbows (Figure 8, Item 7) and adapter (Figure 8, Item 4) on radiator (Figure 8, Item 8).
17. Install hose (Figure 8, Item 20) on surge tank (Figure 8, Item 18) and thermostat housing (Figure 8, Item 9) with two clamps (Figure 8, Item 19).
18. Install hose (Figure 8, Item 1) on adapter (Figure 8, Item 4) and surge tank (Figure 8, Item 18).
19. Install clamp (Figure 8, Item 3) and hose (Figure 8, Item 1) on bracket (Figure 8, Item 6) with screw (Figure 8, Item 2) and locknut (Figure 8, Item 5).

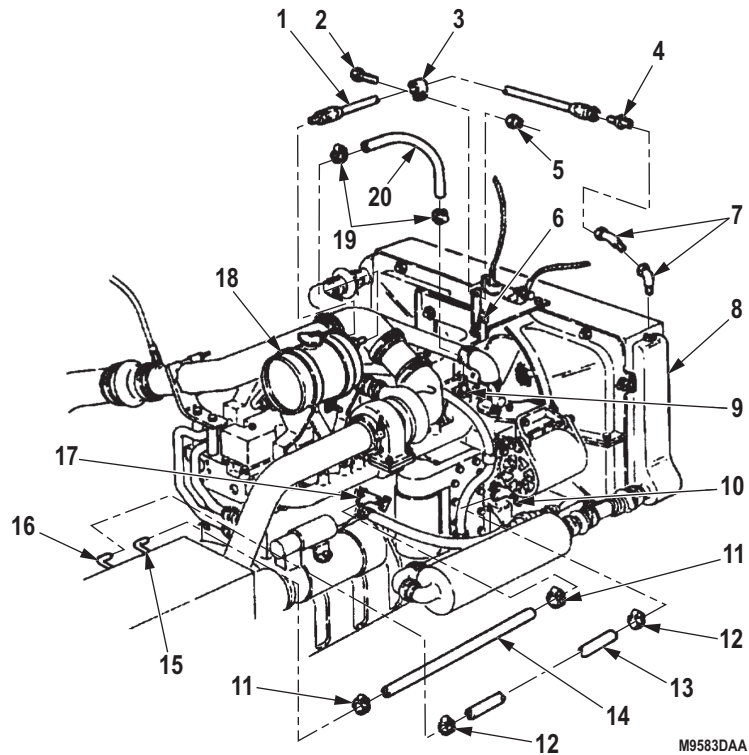

Figure 8. Coolant Hoses and Lines Installation.

END OF TASK

FOLLOW-ON MAINTENANCE

1. Fill cooling system to proper level. (WP 0287)
2. Hood closed and secured. (TM 9-2320-272-10)
3. Install right splash shield. (TM 9-2320-272-10)
4. Start engine and check for coolant leaks. Tighten fittings and clamps as necessary. (TM 9-2320-272-10)

END OF TASK**END OF WORK PACKAGE**

FIELD MAINTENANCE
UPPER RADIATOR HOSES AND BRACKETS REPLACEMENT (M939A2)

INITIAL SETUP:**Tools and Special Tools**

Tool Kit, General Mechanic's: Automotive
(Volume 5, WP 0826, Table 1, Item 56)
Wrench, Torque, Click, Ratcheting, 1/2" Drive,
250 Ft-Lb
(Volume 5, WP 0826, Table 1, Item 63)

Materials/Parts

Locknut (Volume 5, WP 0827, Table 1, Item 246)
Qty: 2
Locknut (Volume 5, WP 0827, Table 1, Item 273)
Qty: 2
Locknut (Volume 5, WP 0827, Table 1, Item 430)
Qty: 1
Lockwasher

Materials/Parts (cont.)

(Volume 5, WP 0827, Table 1, Item 390)
Qty: 2
Mount, Resident, WS
(Volume 5, WP 0827, Table 1, Item 189)
Qty: 4
Tiedown Strap
(Volume 5, WP 0827, Table 1, Item 375)
Qty: 1

Equipment Condition

Hood raised and secured. (TM 9-2320-272-10)
Right splash shield removed. (TM 9-2320-272-10)
Coolant drained as necessary. (WP 0287)
Fan actuator disconnected. (Volume 3, WP 0448)

REMOVAL

1. Remove tiedown straps (Figure 1, Item 12), tachometer drive cable (Figure 1, Item 8), and cable (Figure 1, Item 9) from radiator inlet tube (Figure 1, Item 14). Discard tiedown straps.
2. Remove two locknuts (Figure 1, Item 5), washers (Figure 1, Item 6), screws (Figure 1, Item 1), and washers (Figure 1, Item 2) from radiator inlet tube (Figure 1, Item 14) and bracket (Figure 1, Item 11). Discard locknuts.
3. Remove four clamps (Figure 1, Item 3), hose (Figure 1, Item 13), elbow (Figure 1, Item 4), and radiator inlet tube (Figure 1, Item 14) from radiator (Figure 1, Item 10) and thermostat housing (Figure 1, Item 7).

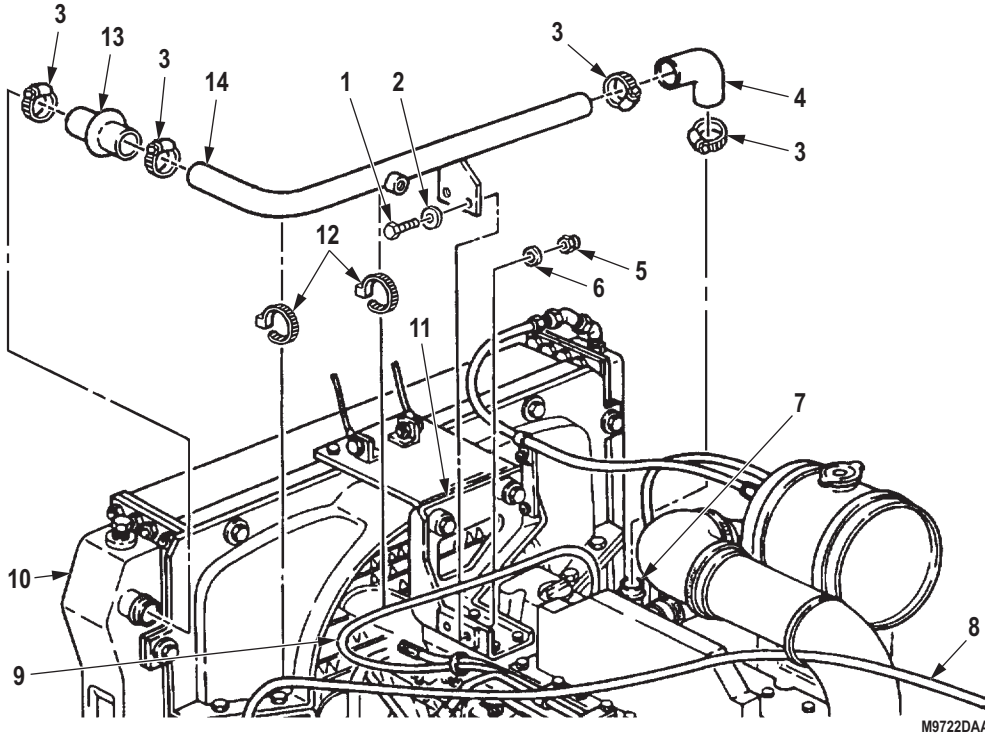

Figure 1. Upper Radiator Hoses and Brackets Removal.

REMOVAL - Continued

4. Remove two nuts (Figure 2, Item 27), screws (Figure 2, Item 3), washers (Figure 2, Item 2), and hood stop cables (Figure 2, Item 1) from bracket (Figure 2, Item 24).
5. Straighten tabs of two lockwashers (Figure 2, Item 25), remove two screws (Figure 2, Item 26), lockwashers, and washers (Figure 2, Item 23) from bracket (Figure 2, Item 24) and radiator (Figure 2, Item 20). Discard lockwashers.
6. Remove two locknuts (Figure 2, Item 22), washers (Figure 2, Item 21), resident mount (Figure 2, Item 28), screws (Figure 2, Item 17), washers (Figure 2, Item 18), and resident mount (Figure 2, Item 19) from bracket (Figure 2, Item 14). Discard locknuts and resident mounts.
7. Remove locknut (Figure 2, Item 5), clamp (Figure 2, Item 6), nut (Figure 2, Item 20), washer (Figure 2, Item 4), screws (Figure 2, Items 7 and 9), and bracket (Figure 2, Item 8) from brackets (Figure 2, Items 10 and 14). Discard locknut.
8. Remove screw (Figure 2, Item 11), washer (Figure 2, Item 12), and bracket (Figure 2, Item 10) from engine (Figure 2, Item 13).
9. Remove four screws (Figure 2, Item 15), washers (Figure 2, Item 16), and bracket (Figure 2, Item 14) from engine (Figure 2, Item 13).

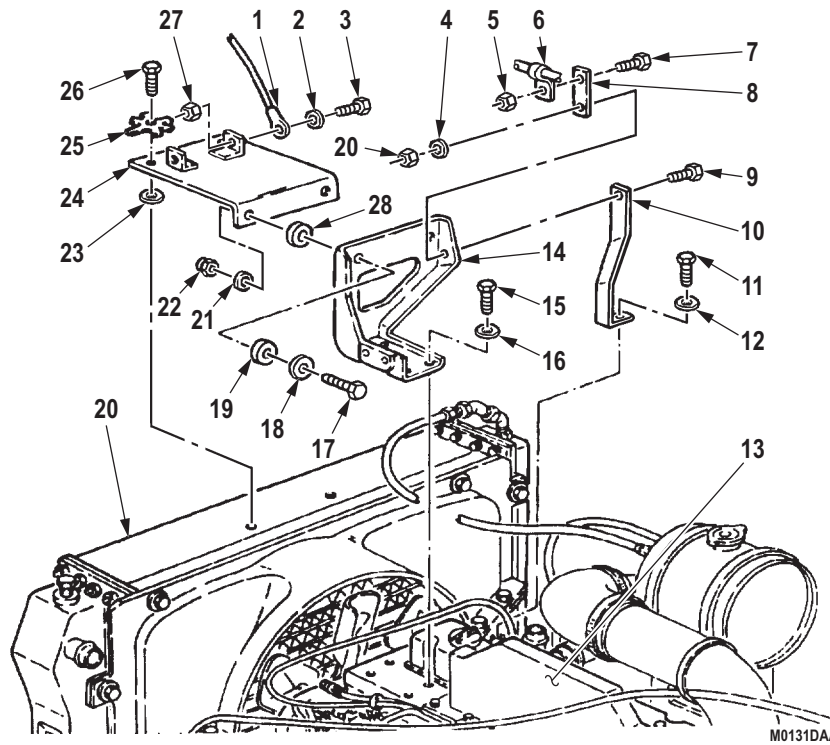

Figure 2. Upper Radiator Hoses and Brackets Removal.

END OF TASK

INSTALLATION

1. Install bracket (Figure 3, Item 14) on engine (Figure 3, Item 13) with four washers (Figure 3, Item 16) and screws (Figure 3, Item 15). Finger tighten screws.
2. Install bracket (Figure 3, Item 10) on engine (Figure 3, Item 13) with washer (Figure 3, Item 12) and screw (Figure 3, Item 11). Finger tighten screw.
3. Install brackets (Figure 3, Items 8 and 10) on bracket (Figure 3, Item 14) with screw (Figure 3, Item 9), washer (Figure 3, Item 4), and nut (Figure 3, Item 20).
4. Install clamp (Figure 3, Item 6) on bracket (Figure 3, Item 8) with screw (Figure 3, Item 7) and locknut (Figure 3, Item 5).
5. Install two resident mounts (Figure 3, Item 28), resident mount (Figure 3, Item 19), and bracket (Figure 3, Item 24) on bracket (Figure 3, Item 14) with two washers (Figure 3, Item 21), screws (Figure 3, Item 17), washers (Figure 3, Item 18), and locknuts (Figure 3, Item 22). Tighten screws 30 lb-ft (41 N-m).
6. Install bracket (Figure 3, Item 24) on radiator (Figure 3, Item 20) with two washers (Figure 3, Item 23), lockwashers (Figure 3, Item 25), and screws (Figure 3, Item 26). Tighten screws (Figure 3, Item 26) 40 lb-ft (54 N-m). Tighten screws (Figure 3, Item 15) 45 lb-ft (61 N-m). Tighten screw (Figure 3, Item 11).
7. Bend tabs of two lockwashers (Figure 3, Item 25) against flats of screws (Figure 3, Item 26).
8. Install two hood stop cables (Figure 3, Item 1) on bracket (Figure 3, Item 24) with two washers (Figure 3, Item 2), screws (Figure 3, Item 3), and nuts (Figure 3, Item 27).

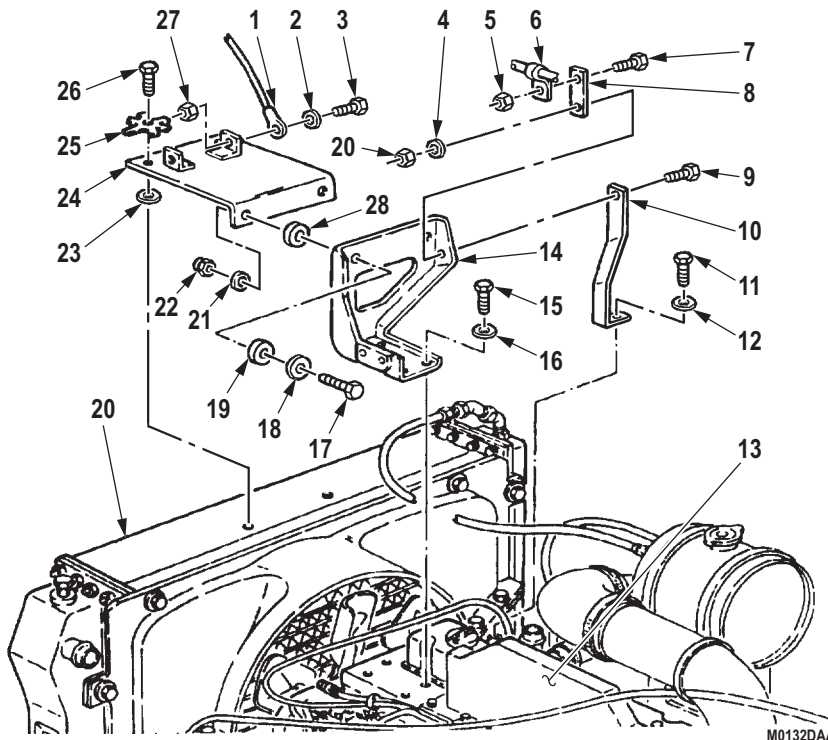

Figure 3. Upper Radiator Hoses and Brackets Installation.

INSTALLATION - Continued

9. Install hose (Figure 4, Item 13), elbow (Figure 4, Item 4), and radiator inlet tube (Figure 4, Item 14) on radiator (Figure 4, Item 10) and thermostat housing (Figure 4, Item 7) with four clamps (Figure 4, Item 3).
10. Install radiator inlet tube (Figure 4, Item 14) on bracket (Figure 4, Item 11) with two washers (Figure 4, Item 2), screws (Figure 4, Item 1), washers (Figure 4, Item 6), and locknuts (Figure 4, Item 5).
11. Secure tachometer drive cable (Figure 4, Item 8) and cable (Figure 4, Item 9) to radiator inlet tube (Figure 4, Item 14) with tiedown straps (Figure 4, Item 12).

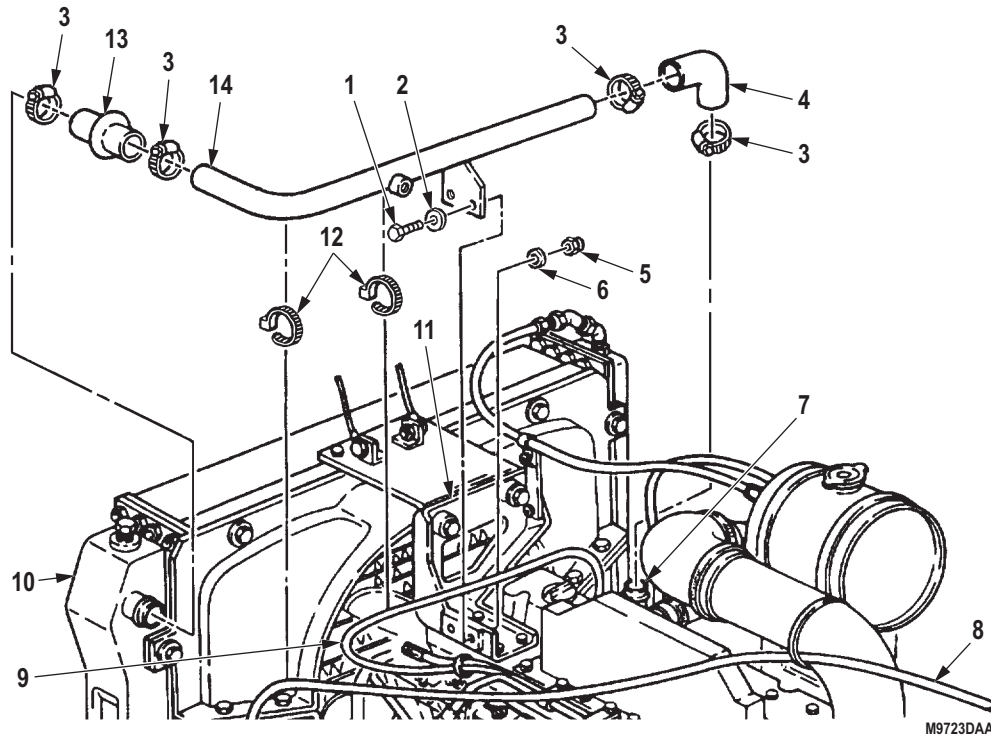

Figure 4. Upper Radiator Hoses and Brackets Installation.

END OF TASK**FOLLOW-ON MAINTENANCE**

1. Connect fan actuator. (Volume 3, WP 0448)
2. Fill cooling system. (WP 0287)
3. Install right splash shield. (TM 9-2320-272-10)
4. Hood closed and secured. (TM 9-2320-272-10)
5. Start engine and check for leaks. (TM 9-2320-272-10)

END OF TASK**END OF WORK PACKAGE**

**FIELD MAINTENANCE
COOLING SYSTEM SERVICE**

INITIAL SETUP:**Tools and Special Tools**

Tool Kit, General Mechanic's: Automotive
(Volume 5, WP 0826, Table 1, Item 56)

Equipment Condition (cont.)

Hood raised and secured. (TM 9-2320-272-10)
Right splash shield removed. (TM 9-2320-272-10)

Materials/Parts

Antifreeze: Arctic Grade
(Volume 5, WP 0825, Table 1, Item 5)
OR Antifreeze: Ethylene Glycol
(Volume 5, WP 0825, Table 1, Item 6, 7, 8)
Cleaning Compound Kit
(Volume 5, WP 0825, Table 1, Item 15)

Equipment Condition

Parking brake set. (TM 9-2320-272-10)

DEPRESSURIZING SYSTEM**WARNING**

Care should be taken when removing surge tank filler cap. Steam or hot coolant under pressure may escape rapidly or cause burns. Failure to comply may result in injury or death to personnel.

If engine is hot, place thick cloth over cap and turn cap to first stop. Wait until pressure has escaped then remove cap from surge tank.

END OF TASK**DRAINING SYSTEM****NOTE**

- Have drainage container ready to catch coolant.
 - Use drain pans to retain leaking/draining fluids. Refer to local procedures and plans for preventing and responding to fluid spills or leaks. Comply with local regulations when disposing of clean up material and leaked and spilled fluids.
1. Remove cap (Figure 1, Item 1) from surge tank (Figure 1, Item 2) and open drain valve on radiator (Figure 1, Item 3) and allow system to drain.

NOTE

Open drain valve on aftercooler to permit cooling system to fully drain.

2. Open aftercooler drain valve (Figure 1, Item 4) on M939A2 series vehicles and allow cooling system to drain.

DRAINING SYSTEM - Continued

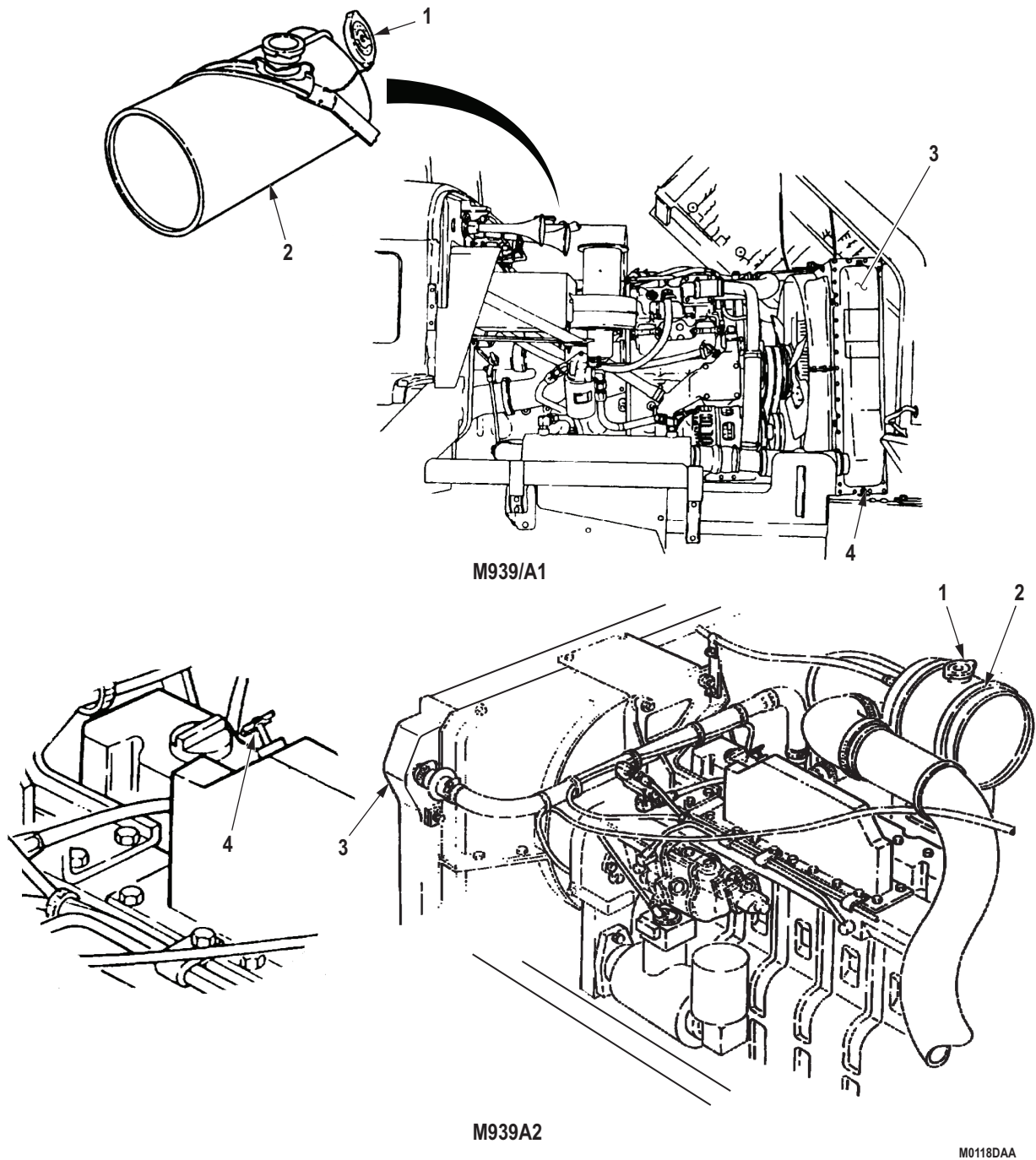

Figure 1. Cooling System.

3. Inspect coolant for rust and foreign particles.
4. If drained coolant is heavily rusted, the partially clogged system must be cleaned and flushed.

END OF TASK

CLEANING AND FLUSHING SYSTEM

Clean and flush radiator (Figure 1, Item 3) and cooling system with cleaning compound kit. Follow instructions provided with kit.

END OF TASK

FILLING SYSTEM

Table 1. Guide for Preparation of Antifreeze Solutions.

ETHYLENE-GLYCOL -60°F (-51°C) INHIBITED ML-A-46153			
LOWEST EXPECTED AMBIENT TEMPERATURE		QUARTS OF ANTIFREEZE REQUIRED	ARCTIC GRADE ANTIFREEZE -90°F (-68°C) ML-A-11755
°F	°C		Freezing point of -90°F (-68°C). Issued ready for use and must not be mixed with any other liquid.
+20	-7	9	
+10	-12	11-3/4	
0	-18	16	
-10	-23	19	
-20	-29	20-1/2	
-30	-34	23-1/3	
-40	-40	25	
-50	-46	22-26-1/2	
-55	-48	28	
Below -60	Below-51	Use arctic grade antifreeze (-90°F)(-68°C)	

CAUTION

When filling cooling system on M939A2 series vehicles, ensure drain valve on aftercooler is open. Failure to do so may result in damage to equipment.

NOTE

The cooling system for the vehicles covered in this manual has a 47 qt (44.5 L) capacity.

1. Fill cooling system with required amount of antifreeze and add water to full mark. Close aftercooler (Figure 2, Item 3) drain valve (Figure 2, Item 4) when coolant starts running out of drain valve on M939A2 vehicles.
2. Install filler cap (Figure 2, Item 1) on surge tank (Figure 2, Item 2).
3. Start engine (TM 9-2320-272-10) and run at fast idle (800 to 1,000 rpm) until engine temperature reaches 185°F (85°C). At this temperature, thermostats should fully open.

FILLING SYSTEM - Continued

NOTE

Follow surge tank filler cap removal procedure in DEPRESSURIZING SYSTEM.

4. Check antifreeze protection level using antifreeze tester.

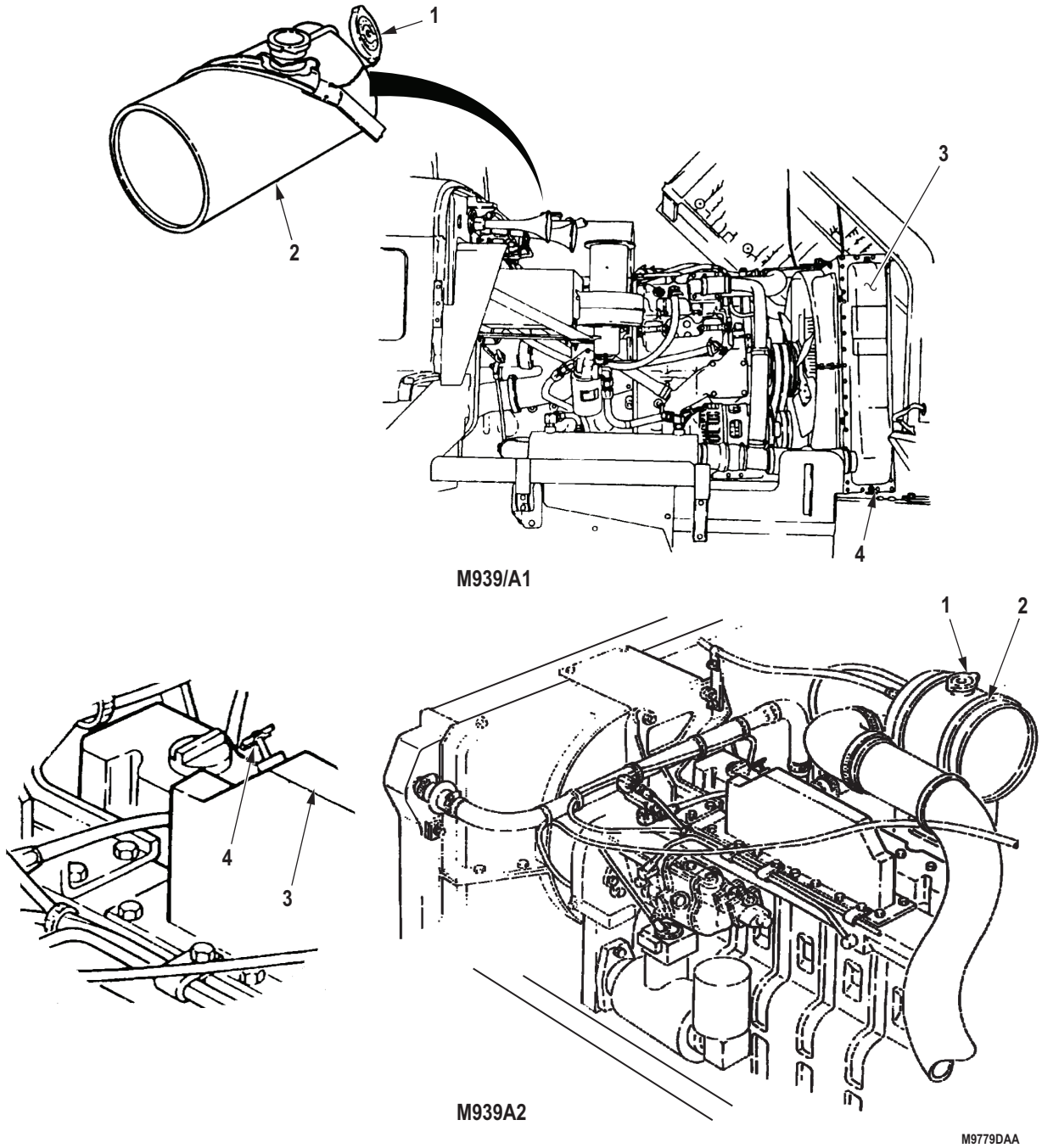

Figure 2. Cooling System.

END OF TASK

FOLLOW-ON MAINTENANCE

1. Install right splash shield. (TM 9-2320-272-10)
2. Hood closed and secured. (TM 9-2320-272-10)
3. Start engine and check for coolant leaks. (TM 9-2320-272-10)

END OF TASK**END OF WORK PACKAGE**

**FIELD MAINTENANCE
THERMOSTAT AND HOUSING REPLACEMENT (M939/A1)**

INITIAL SETUP:**Tools and Special Tools**

Tool Kit, General Mechanic's: Automotive
(Volume 5, WP 0826, Table 1, Item 56)

Materials/Parts

Grease, Automotive and Artillery
(Volume 5, WP 0825, Table 1, Item 28)
Gasket (Volume 5, WP 0827, Table 1, Item 200)
Qty: 1
Screw Assembled Lockwasher

Materials/Parts (cont.)

(Volume 5, WP 0827, Table 1, Item 107)
Qty: 4
Seal (Volume 5, WP 0827, Table 1, Item 82)
Qty: 1

Equipment Condition

Hood raised and secured. (TM 9-2320-272-10)
Parking brake set. (TM 9-2320-272-10)
Right splash shield removed. (TM 9-2320-272-10)
Cooling system drained as necessary. (WP 0287)

REMOVAL

1. Loosen clamp (Figure 1, Item 6) and disconnect radiator inlet hose (Figure 1, Item 7) from thermostat housing (Figure 1, Item 5).
2. Loosen two clamps (Figure 1, Item 9) and remove radiator bypass hose (Figure 1, Item 10) from thermostat housing (Figure 1, Item 5) and radiator bypass tube (Figure 1, Item 8).
3. Remove four screw assembled lockwashers (Figure 1, Item 11) from thermostat housing (Figure 1, Item 5) and water manifold header (Figure 1, Item 1). Discard screw assembled lockwashers.
4. Remove thermostat housing (Figure 1, Item 5) and gasket (Figure 1, Item 2) from water manifold header (Figure 1, Item 1). Discard gasket and clean gasket remains from mating surfaces.
5. Remove thermostat (Figure 1, Item 3) from thermostat housing (Figure 1, Item 5).
6. Remove seal (Figure 1, Item 4) from thermostat housing (Figure 1, Item 5). Discard seal.

REMOVAL - Continued

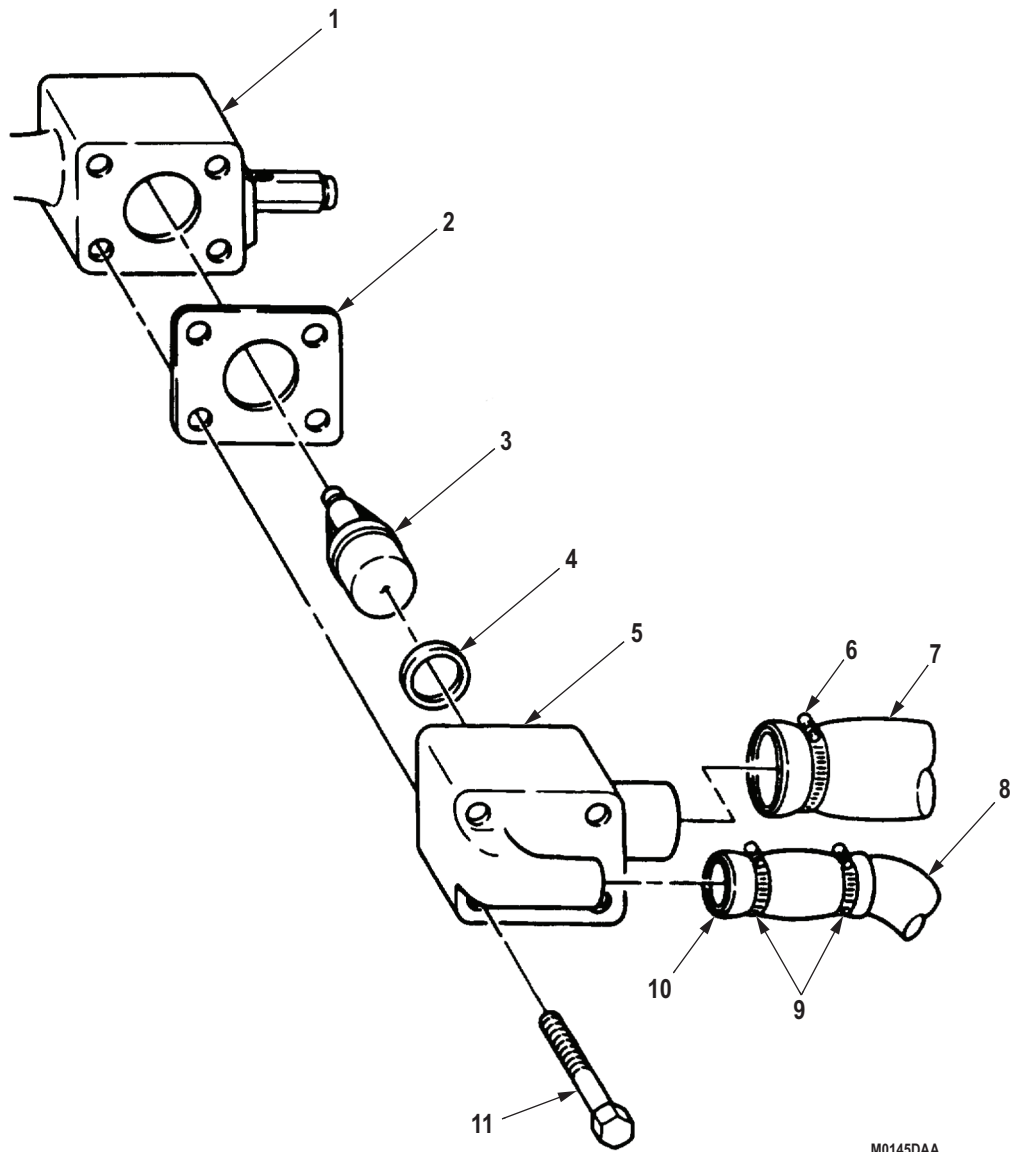

M0145DAA

Figure 1. Thermostat and Housing Removal.

END OF TASK

INSTALLATION

1. Position seal (Figure 2, Item 4) in thermostat housing (Figure 2, Item 5).
2. Install thermostat (Figure 2, Item 3) in thermostat housing (Figure 2, Item 5).
3. Coat one surface of gasket (Figure 2, Item 2) with light coat of automotive and artillery grease and position gasket over four holes on water manifold header (Figure 2, Item 1).
4. Aligning holes in thermostat housing (Figure 2, Item 5) and header (Figure 2, Item 1), install housing with four screw assembled lockwashers (Figure 2, Item 11).
5. Connect radiator bypass hose (Figure 2, Item 10) to thermostat housing (Figure 2, Item 5) and bypass tube (Figure 2, Item 8) and tighten two clamps (Figure 2, Item 9).
6. Connect radiator inlet hose (Figure 2, Item 7) to thermostat housing (Figure 2, Item 5) and tighten clamp (Figure 2, Item 6).

INSTALLATION - Continued

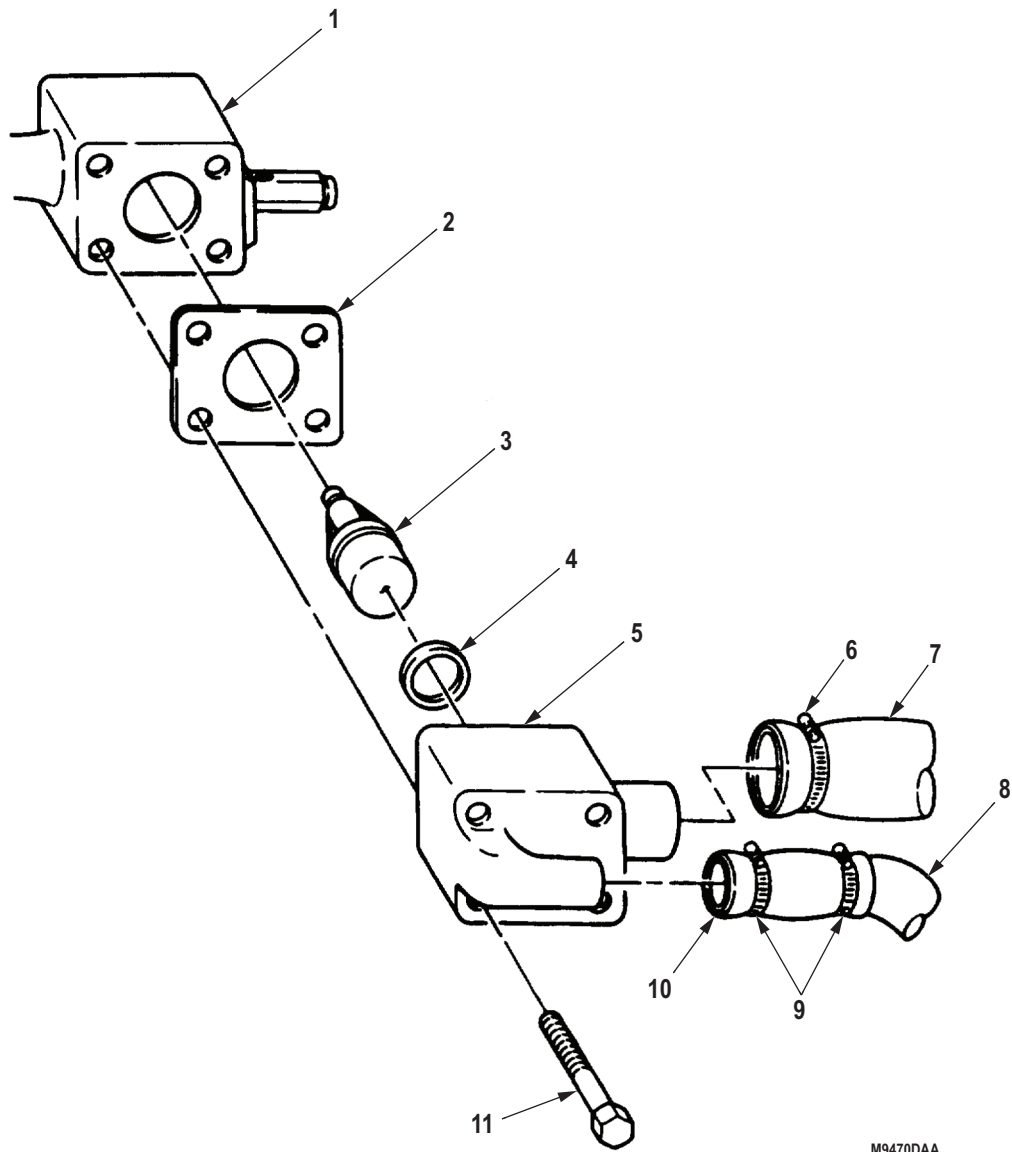

M9470DAA

Figure 2. Thermostat and Housing Installation.

END OF TASK

FOLLOW-ON MAINTENANCE

1. Fill cooling system to proper level. (WP 0287)
2. Hood closed and secured. (TM 9-2320-272-10)
3. Start engine, check for coolant leaks, and check temperature gauge for normal reading of 175°F to 195°F (70°C to 97°C). (TM 9-2320-272-10)
4. Install right splash shield. (TM 9-2320-272-10)

END OF TASK**END OF WORK PACKAGE**

**FIELD MAINTENANCE
THERMOSTATS AND HOUSING REPLACEMENT (M939A2)**

INITIAL SETUP:**Tools and Special Tools**

Tool Kit, General Mechanic's: Automotive
(Volume 5, WP 0826, Table 1, Item 56)
Wrench, Torque, Click, Ratcheting, 3/8" Drive,
75 Ft-Lb
(Volume 5, WP 0826, Table 1, Item 62)

Materials/Parts

Tape, Antiseizing
(Volume 5, WP 0825, Table 1, Item 65)
Gasket (Volume 5, WP 0827, Table 1, Item 115)
Qty: 1
Gasket (Volume 5, WP 0827, Table 1, Item 140)
Qty: 1
Gasket (Volume 5, WP 0827, Table 1, Item 141)
Qty: 1

Materials/Parts (cont.)

Gasket (Volume 5, WP 0827, Table 1, Item 142)
Qty: 1
Gasket (Volume 5, WP 0827, Table 1, Item 146)
Qty: 1
Seal (Volume 5, WP 0827, Table 1, Item 85)
Qty: 1

References

Volume 5, WP 0819

Equipment Condition

Parking brake set. (TM 9-2320-272-10)
Hood raised and secured. (TM 9-2320-272-10)
Drivebelt tensioner removed. (WP 0296)

REMOVAL (INTERNAL BYPASS)**WARNING**

Do not drain coolant when engine is hot. Severe burns may result. Failure to comply may result in injury or death to personnel.

NOTE

There are two different bypass systems used for M939A2 engines. An identifiable difference is the thermostat housing for external bypass and internal bypass engines.

1. Drain three quarts of coolant from oil cooler drain valve (Figure 1, Item 11) into container.
2. Loosen clamp (Figure 1, Item 3) and remove hose (Figure 1, Item 2) from adapter (Figure 1, Item 4).
3. Loosen alternator link screw (Figure 1, Item 12).
4. While supporting alternator (Figure 1, Item 15), remove two screws (Figure 1, Item 13) and washers (Figure 1, Item 14) from bracket (Figure 1, Item 16). Pivot alternator down and move bracket aside.
5. Remove four screws (Figure 1, Item 17) and bracket (Figure 1, Item 18) from thermostat housing (Figure 1, Item 7).

NOTE

Tag screws for identification in installation.

6. Remove two screws (Figure 1, Item 1), adapter (Figure 1, Item 4), and gasket (Figure 1, Item 5) from thermostat housing (Figure 1, Item 7). Discard gasket.
7. Remove two screws (Figure 1, Item 6), thermostat housing (Figure 1, Item 7), and gasket (Figure 1, Item 8) from engine block (Figure 1, Item 10). Discard gasket.

CAUTION

Cover coolant passages. Dirt in cooling system will cause overheating and engine failure.

8. Remove two thermostats (Figure 1, Item 9) from engine block (Figure 1, Item 10).

REMOVAL (INTERNAL BYPASS) - Continued

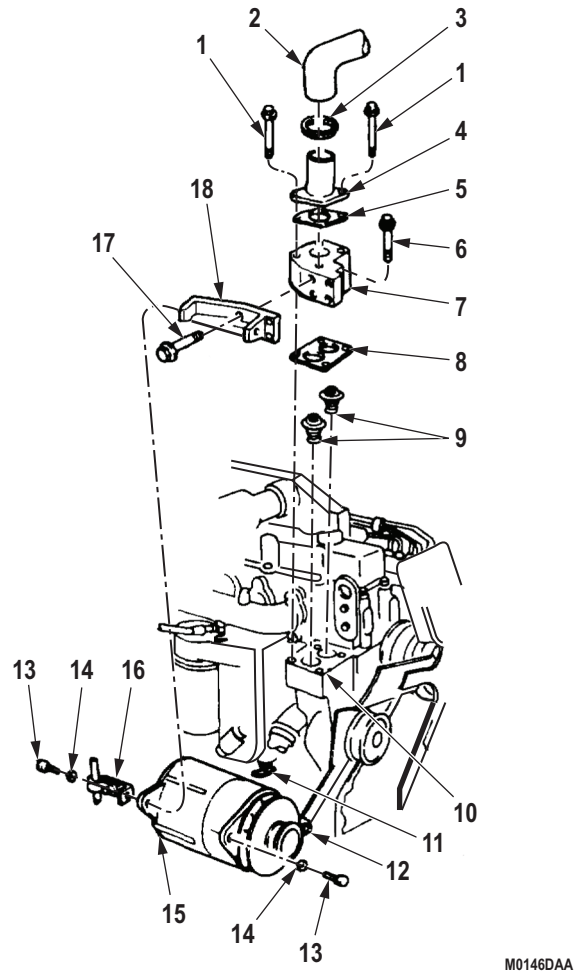

M0146DAA

Figure 1. Thermostat and Housing Removal.

END OF TASK

CLEANING AND INSPECTION (BOTH TYPES)

1. Clean all parts and mating surfaces (Volume 5, WP 0819).
2. Inspect all other parts (Volume 5, WP 0819).
3. Replace all parts failing inspection.

END OF TASK**INSTALLATION (INTERNAL BYPASS)**

1. Install two thermostats (Figure 2, Item 9) in engine block (Figure 2, Item 10).
2. Install gasket (Figure 2, Item 8) on engine block (Figure 2, Item 10).
3. Install thermostat housing (Figure 2, Item 7) on engine block (Figure 2, Item 10) with two screws (Figure 2, Item 6).
4. Install gasket (Figure 2, Item 5) and adapter (Figure 2, Item 4) on thermostat housing (Figure 2, Item 7) with two screws (Figure 2, Item 1). Tighten screws (Figure 2, Items 1 and 6).
5. Install bracket (Figure 2, Item 18) on thermostat housing (Figure 2, Item 7) with four screws (Figure 2, Item 17).
6. Move alternator (Figure 2, Item 15) up with bracket (Figure 2, Item 16), and install two washers (Figure 2, Item 14) and screws (Figure 2, Item 13). Tighten screws 35 lb-ft (45 N-m).
7. Tighten link screw (Figure 2, Item 12).
8. Install hose (Figure 2, Item 2) on adapter (Figure 2, Item 4) with clamp (Figure 2, Item 3).
9. Make sure oil cooler drain valve (Figure 2, Item 11) is closed.

INSTALLATION (INTERNAL BYPASS) - Continued

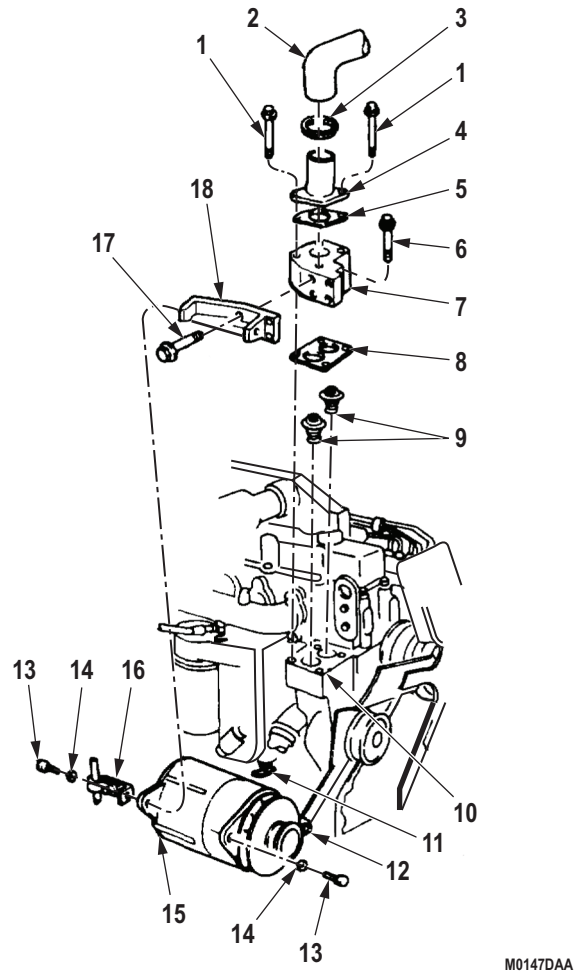

M0147DAA

Figure 2. Thermostat and Housing Installation.

END OF TASK

REMOVAL (EXTERNAL BYPASS)**WARNING**

Do not drain coolant when engine is hot. Severe burns may result. Failure to comply may result in injury or death to personnel.

1. Drain three quarts of coolant from oil cooler valve (Figure 3, Item 17) into container.
2. Loosen clamp (Figure 3, Item 5) and remove hose (Figure 3, Item 4) from adapter (Figure 3, Item 8).
3. Loosen alternator link screw (Figure 3, Item 18).
4. While supporting alternator (Figure 3, Item 21), remove two screws (Figure 3, Item 19) and washers (Figure 3, Item 20) from brackets (Figure 3, Items 22 and 25) and move alternator aside.
5. Remove four screws (Figure 3, Item 23) and bracket (Figure 3, Item 25) from support housing (Figure 3, Item 14).
6. Loosen clamp (Figure 3, Item 33) and remove hose (Figure 3, Item 1) from valve (Figure 3, Item 32).
7. Loosen tube (Figure 3, Item 29) and fittings (Figure 3, Items 2 and 30) from tee (Figure 3, Item 31).
8. Remove tee (Figure 3, Item 31) from thermostat housing (Figure 3, Item 10).
9. Remove valve (Figure 3, Item 32) from tee (Figure 3, Item 31).

NOTE

Note the location of long and short screws.

10. Remove short screw (Figure 3, Item 6), long screw (Figure 3, Item 3), adapter (Figure 3, Item 8), and gasket (Figure 3, Item 9) from thermostat housing (Figure 3, Item 10). Discard gasket.
11. Loosen clamp (Figure 3, Item 28) and remove hose (Figure 3, Item 26) from thermostat housing (Figure 3, Item 10).
12. Remove two screws (Figure 3, Item 7), thermostat housing (Figure 3, Item 10), thermostat (Figure 3, Item 12), and gasket (Figure 3, Item 13) from support housing (Figure 3, Item 14). Discard gasket.
13. Remove seal (Figure 3, Item 11) from thermostat housing (Figure 3, Item 10). Discard seal.
14. Remove two screws (Figure 3, Item 27), support (Figure 3, Item 14), and gasket (Figure 3, Item 15) from engine block (Figure 3, Item 16). Discard gasket.
15. Remove plug (Figure 3, Item 24) from support (Figure 3, Item 14).

REMOVAL (EXTERNAL BYPASS) - Continued

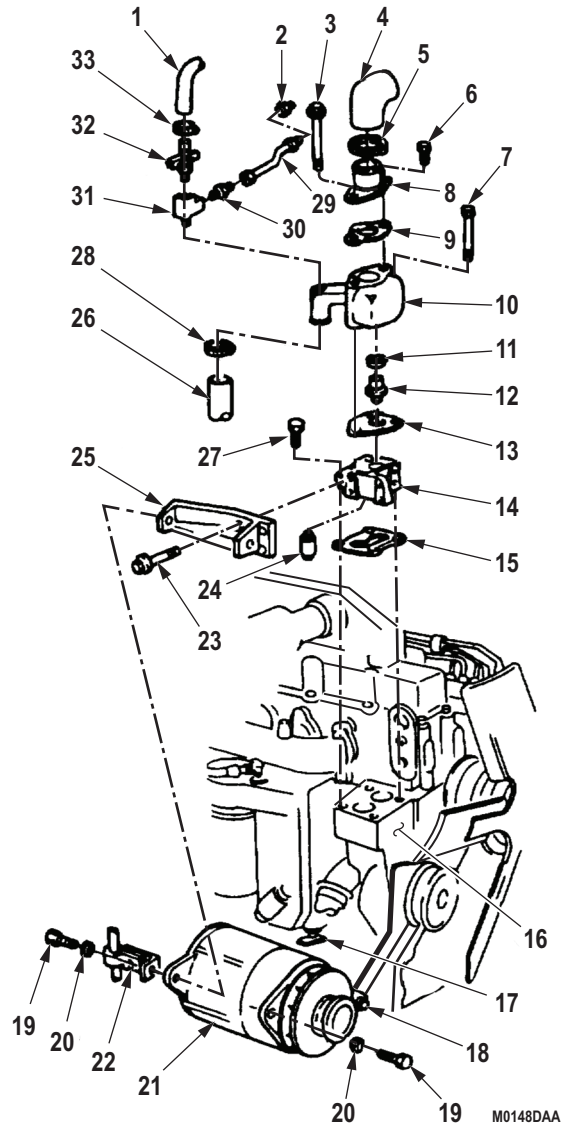

Figure 3. Thermostat and Housing Removal.

END OF TASK

INSTALLATION (EXTERNAL BYPASS)**NOTE**

If support was removed, perform Steps (1) and (2).

1. Install plug (Figure 4, Item 24) in support (Figure 4, Item 14).
2. Install gasket (Figure 4, Item 15) and support (Figure 4, Item 14) on engine block (Figure 4, Item 16) with two screws (Figure 4, Item 27).
3. With housing (Figure 4, Item 10) upside down, install seal (Figure 4, Item 11), with cupped side down, until seal is seated.

CAUTION

If seal is damaged, engine failure may result.

4. Install thermostat (Figure 4, Item 12) into seal (Figure 4, Item 11) until thermostat (Figure 4, Item 12) seats against housing (Figure 4, Item 10).
5. Install gasket (Figure 4, Item 13) and housing (Figure 4, Item 10) on support (Figure 4, Item 14) with two screws (Figure 4, Item 7).
6. Install hose (Figure 4, Item 26) on housing (Figure 4, Item 10) and tighten clamp (Figure 4, Item 28).
7. Install gasket (Figure 4, Item 9) and adapter (Figure 4, Item 8) on thermostat housing (Figure 4, Item 10) with long screw (Figure 4, Item 3) and short screw (Figure 4, Item 6).

CAUTION

Ensure that drain valve on aftercooler is open or cooling system may overheat.

8. Wrap threads of valve (Figure 4, Item 32) with antiseize tape and install in tee (Figure 4, Item 31), and install tee on housing (Figure 4, Item 10).
9. Install tube (Figure 4, Item 29), fitting (Figure 4, Item 2), and fitting (Figure 4, Item 30) on tee (Figure 4, Item 31).
10. Install hose (Figure 4, Item 1) on valve (Figure 4, Item 32) and tighten clamp (Figure 4, Item 33).
11. Install bracket (Figure 4, Item 25) on support (Figure 4, Item 14) with four screws (Figure 4, Item 23).
12. Move alternator (Figure 4, Item 21) up and align bracket (Figure 4, Item 22) to support (Figure 4, Item 14) and install two washers (Figure 4, Item 20) and screws (Figure 4, Item 19). Tighten screws 35 lb-ft (45 N·m).
13. Tighten link screw (Figure 4, Item 18).
14. Install hose (Figure 4, Item 4) on adapter (Figure 4, Item 8) and tighten clamp (Figure 4, Item 5).

INSTALLATION (EXTERNAL BYPASS) - Continued

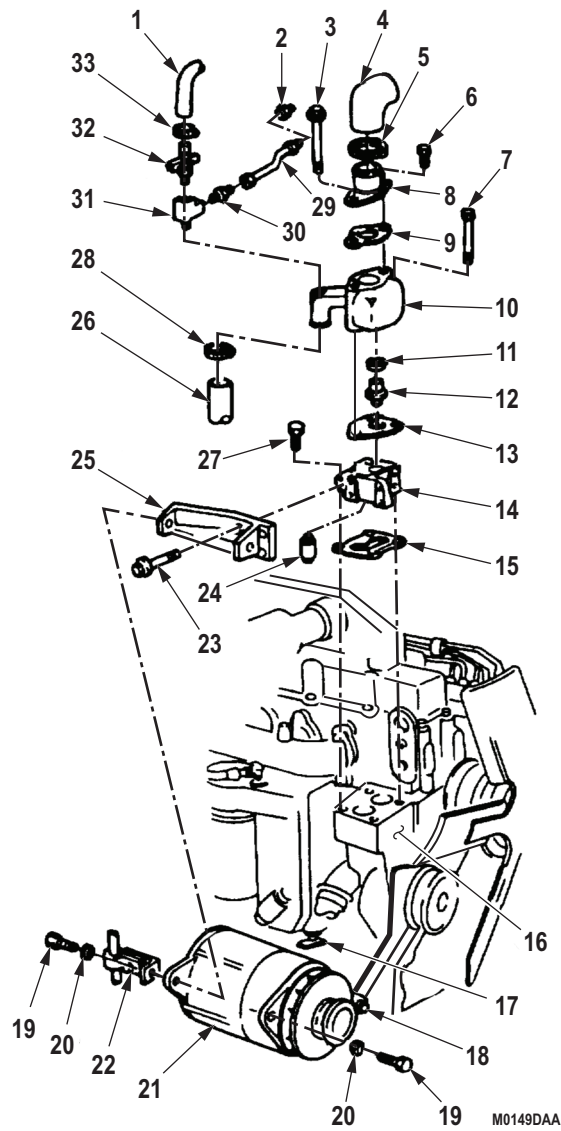

Figure 4. Thermostat and Housing Installation.

END OF TASK

FOLLOW-ON MAINTENANCE

1. Install drivebelt tensioner. (WP 0296)
2. Fill cooling system to proper level. (WP 0287)
3. Hood closed and secured. (TM 9-2320-272-10)
4. Start engine, check for leaks, and check temperature gauge for indication of 180°F to 205°F (82°C to 95°C). (TM 9-2320-272-10)

END OF TASK**END OF WORK PACKAGE**

**FIELD MAINTENANCE
ENGINE WATER MANIFOLD REPLACEMENT (M939/A1)**

INITIAL SETUP:**Tools and Special Tools**

Tool Kit, General Mechanic's: Automotive
(Volume 5, WP 0826, Table 1, Item 56)
Wire Brush

Materials/Parts

Cap Set, Protective, Dust and Moisture Seal
(Volume 5, WP 0825, Table 1, Item 13)
Grease, Automotive and Artillery
(Volume 5, WP 0825, Table 1, Item 28)
Tape, Antiseizing
(Volume 5, WP 0825, Table 1, Item 65)
Gasket (Volume 5, WP 0827, Table 1, Item 112)
Qty: 6

Materials/Parts (cont.)

O-ring (Volume 5, WP 0827, Table 1, Item 203)
Qty: 4
Screw Assembled Lockwasher
(Volume 5, WP 0827, Table 1, Item 106)
Qty: 12

References

Volume 5, WP 0820

Equipment Condition

Surge tank removed. (WP 0278)
Engine crankcase breather draft tube removed.
(Volume 1, WP 0005)
Thermostat and housing removed. (WP 0288)
Fan drive clutch actuator removed.
(Volume 3, WP 0446)

REMOVAL**NOTE**

Have container ready to catch coolant.

1. Loosen hose clamp (Figure 1, Item 7) and disconnect personnel heater inlet hose (Figure 1, Item 8) from water manifold shutoff drain valve (Figure 1, Item 6).
2. Disconnect connector (Figure 1, Item 5) from water temperature sending unit (Figure 1, Item 4) at water manifold (Figure 1, Item 12).
3. Disconnect ether cylinder-to-safety valve line (Figure 1, Item 3) and safety valve-to-atomizer line (Figure 1, Item 1) from ether start safety valve (Figure 1, Item 2).

NOTE

Clean area around water manifold to prevent dirt or debris from entering cylinder head water ports when water manifold is removed.

4. Remove 12 screw assembled lockwashers (Figure 1, Item 13) and manifold (Figure 1, Item 12) from cylinder heads (Figure 1, Item 11). Discard screw assembled lockwashers.
5. Remove six gaskets (Figure 1, Item 9) from cylinder head water ports (Figure 1, Item 10). Discard gaskets.
6. Plug openings on six open cylinder head water ports (Figure 1, Item 10) to prevent dirt from entering water ports.

REMOVAL - Continued

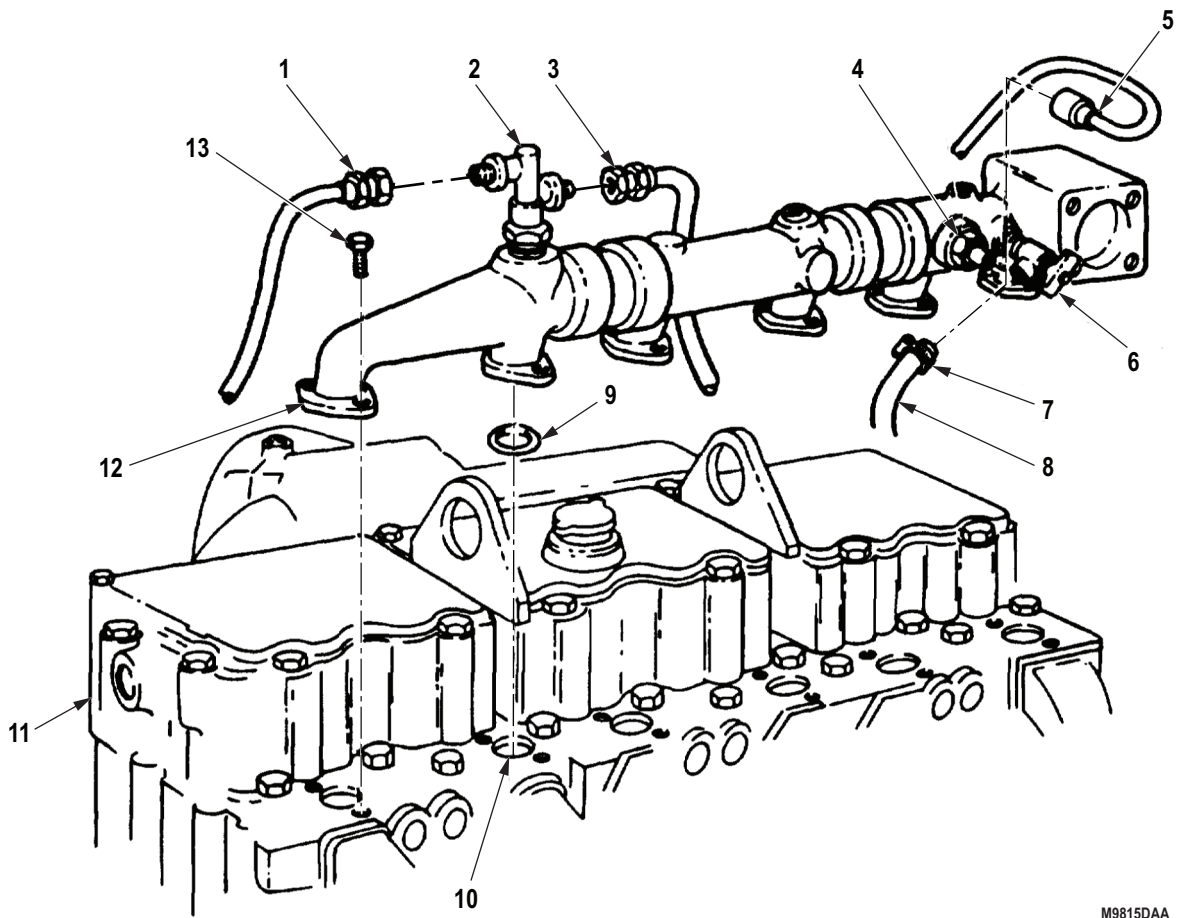

M9815DAA

Figure 1. Engine Water Manifold Removal.

END OF TASK

DISASSEMBLY

1. Remove rear water manifold section (Figure 2, Item 8) and o-ring (Figure 2, Item 10) from rear coupling (Figure 2, Item 11). Discard o-ring.
2. Remove rear coupling (Figure 2, Item 11) and o-ring (Figure 2, Item 12) from center water manifold section (Figure 2, Item 1). Discard o-ring.
3. Remove center water manifold section (Figure 2, Item 1) and o-ring (Figure 2, Item 2) from front coupling (Figure 2, Item 3). Discard o-ring.
4. Remove front coupling (Figure 2, Item 3) and o-ring (Figure 2, Item 4) from front water manifold section (Figure 2, Item 5). Discard o-ring.
5. Remove ether start safety valve (Figure 2, Item 9) from rear water manifold section (Figure 2, Item 8).
6. Remove water temperature sending unit (Figure 2, Item 7) and water manifold shutoff drain valve (Figure 2, Item 6) from front water manifold section (Figure 2, Item 5).

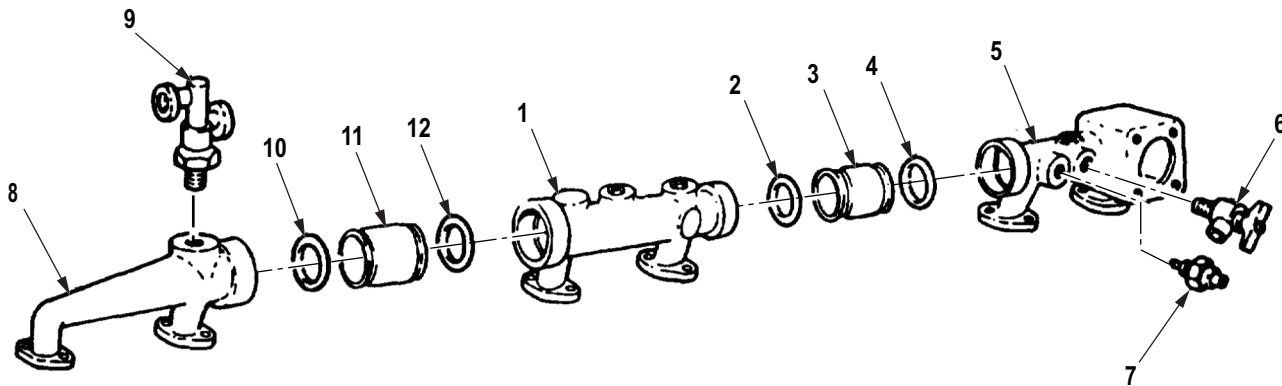

M9492DAA

Figure 2. Engine Water Manifold Disassembly.

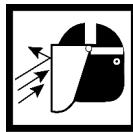
END OF TASK**CLEANING AND INSPECTION****WARNING**

Eyeshields must be worn during cleaning procedure. Failure to comply may result in injury or death to personnel.

1. Clean water manifold sections and couplings with wire brush and inspect (Volume 5, WP 0820). Replace if broken or cracked.
2. Check heater shutoff drain valve for proper opening and closing (Volume 5, WP 0820). Replace if defective.
3. Test water temperature sending unit. Replace if defective.

END OF TASK

ASSEMBLY

1. Wrap male threaded ends of water temperature sending unit (Figure 3, Item 7) and heater shutoff drain valve (Figure 3, Item 6) with antiseize tape and install in front water manifold section (Figure 3, Item 5).
2. Apply light coat of GAA grease to o-ring (Figure 3, Item 4) and install on front coupling (Figure 3, Item 3).
3. Install one end of front coupling (Figure 3, Item 3) in bore of front water manifold section (Figure 3, Item 5) until o-ring (Figure 3, Item 4) is seated.
4. Apply light coat of GAA grease to o-ring (Figure 3, Item 2) and install on front coupling (Figure 3, Item 3).
5. Install bore of center water manifold section (Figure 3, Item 1) over end of front coupling (Figure 3, Item 3) until seated against o-ring (Figure 3, Item 2).
6. Apply light coat of GAA grease to o-ring (Figure 3, Item 12) and install on rear coupling (Figure 3, Item 11).
7. Install one end of rear coupling (Figure 3, Item 11) in bore of center water manifold section (Figure 3, Item 1) until o-ring (Figure 3, Item 12) is seated.
8. Apply sealant to male threaded end of ether start safety valve (Figure 3, Item 9) and install in rear water manifold section (Figure 3, Item 8).
9. Apply light coat of GAA grease to o-ring (Figure 3, Item 10) and install on rear coupling (Figure 3, Item 11).
10. Install rear water manifold section (Figure 3, Item 8) bore over end of rear coupling (Figure 3, Item 11) until seated against o-ring (Figure 3, Item 10).

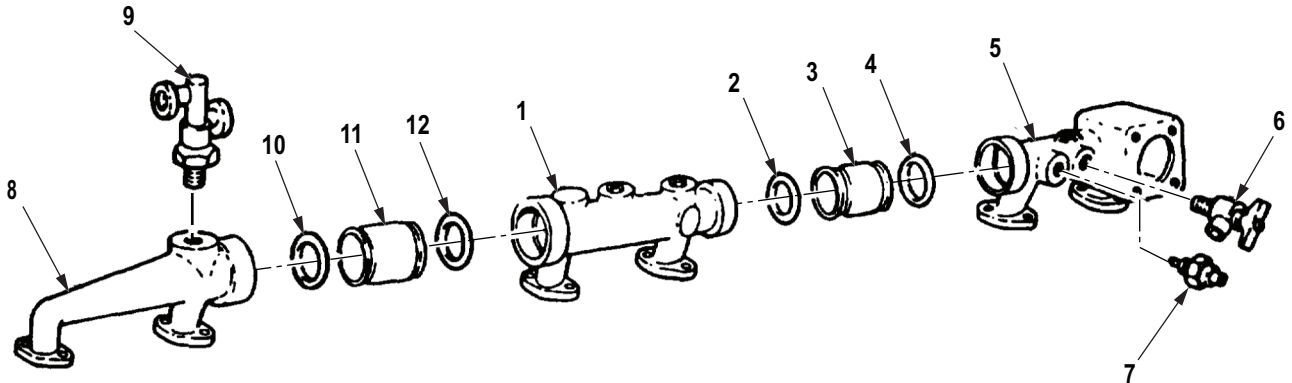

M9817DAA

Figure 3. Engine Water Manifold Assembly.

END OF TASK

INSTALLATION**NOTE**

Ensure all cylinder head water ports are unplugged.

1. Apply light coat of GAA grease to six gaskets (Figure 4, Item 9) and install in each cylinder head water port (Figure 4, Item 10).
2. Install water manifold (Figure 4, Item 12) on cylinder heads (Figure 4, Item 11) with 12 screw assembled lockwashers (Figure 4, Item 13). Alternately tighten screw assembled lockwashers 30 to 35 lb-ft (41 to 47 N·m).
3. Install ether cylinder on safety valve line (Figure 4, Item 3) and safety valve-to-atomizer line (Figure 4, Item 1) on ether start safety valve (Figure 4, Item 2) at same points where disconnected.
4. Connect connector (Figure 4, Item 5) to water temperature sending unit (Figure 4, Item 4).
5. Connect personnel heater inlet hose (Figure 4, Item 8) to heater shutoff drain valve (Figure 4, Item 6) with hose clamp (Figure 4, Item 7).

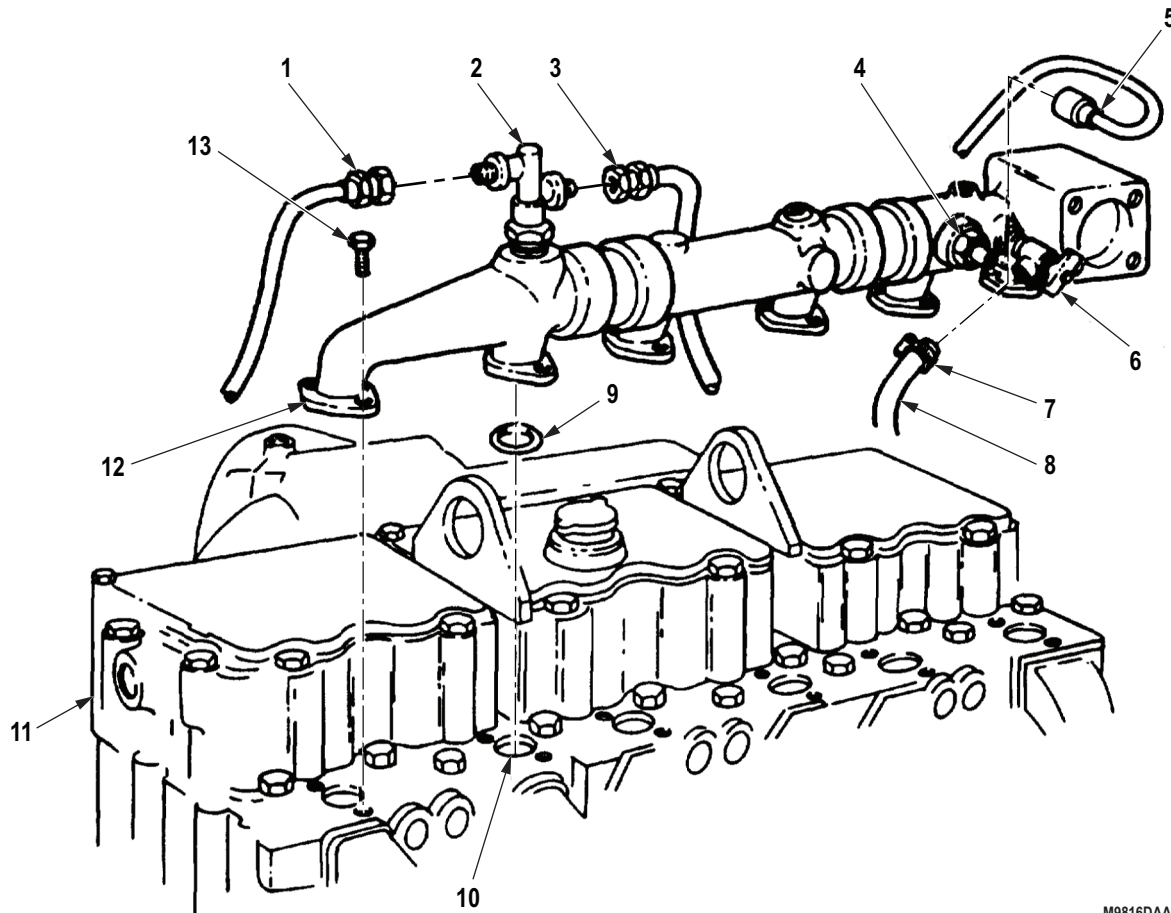

M9816DAA

Figure 4. Engine Water Manifold Installation.

END OF TASK

FOLLOW-ON MAINTENANCE

1. Install fan drive clutch actuator. (Volume 3, WP 0446)
2. Install thermostat and housing. (WP 0288)
3. Install engine crankcase breather draft tube. (Volume 1, WP 0005)
4. Install surge tank. (WP 0278)
5. Fill cooling system to proper level. (WP 0287)
6. Start engine and check for leaks. (TM 9-2320-272-10)

END OF TASK**END OF WORK PACKAGE**

**FIELD MAINTENANCE
WATER HEADER PLATES REPLACEMENT (M939/A1)**

INITIAL SETUP:**Tools and Special Tools**

Tool Kit, General Mechanic's: Automotive
(Volume 5, WP 0826, Table 1, Item 56)

Equipment Condition

Parking brake set. (TM 9-2320-272-10)
Cooling system drained. (WP 0287)

Materials/Parts

Gasket (Volume 5, WP 0827, Table 1, Item 199)
Qty: 2

REMOVAL**NOTE**

Water header plates are mounted with screw assembled lockwashers on late model engines.

1. Remove 12 screws (Figure 1, Item 1), two water header plates (Figure 1, Item 2), and gaskets (Figure 1, Item 3) from cylinder block (Figure 1, Item 4). Discard gaskets.
2. Clean gasket remains from mating surface of cylinder block (Figure 1, Item 4) and water header plate (Figure 1, Item 2).

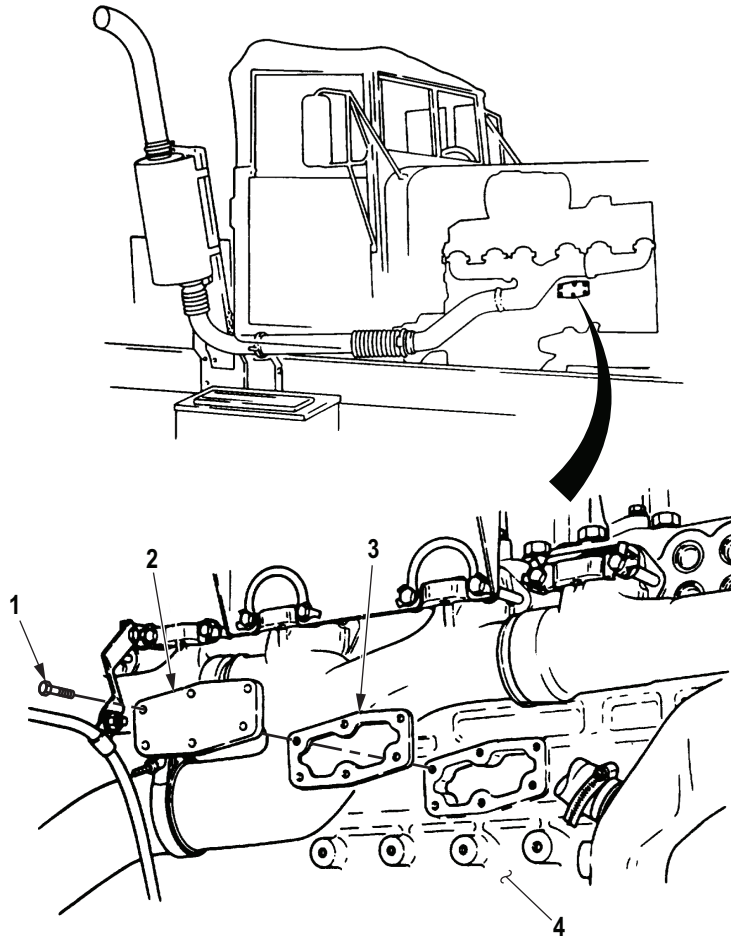

M7107DAA

Figure 1. Water Header Plates Removal.

END OF TASK

INSTALLATION

Install two gaskets (Figure 2, Item 3) and water header plates (Figure 2, Item 2) on cylinder block (Figure 2, Item 4) with 12 screws (Figure 2, Item 1).

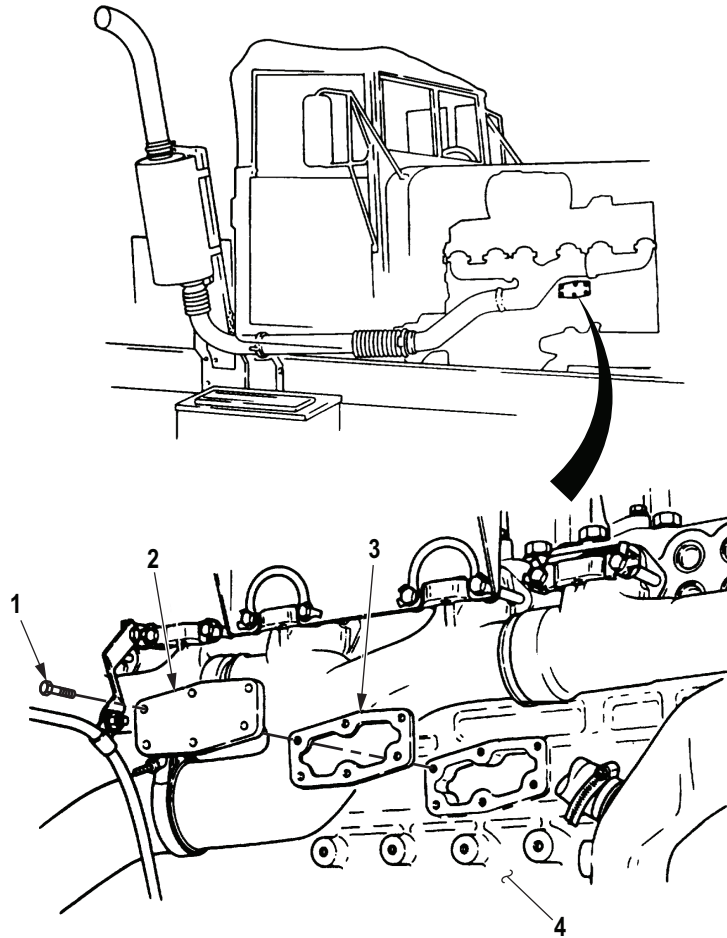

M9462DAA

Figure 2. Water Header Plates Installation.

END OF TASK**FOLLOW-ON MAINTENANCE**

1. Fill cooling system to proper level. (WP 0287)
2. Start engine and check for leaks. (TM 9-2320-272-10)

END OF TASK**END OF WORK PACKAGE**

**FIELD MAINTENANCE
WATER PUMP REPLACEMENT (M939A2)**

INITIAL SETUP:

Tools and Special Tools

Tool Kit, General Mechanic's: Automotive
(Volume 5, WP 0826, Table 1, Item 56)

Equipment Condition (cont.)

Hood raised and secured. (TM 9-2320-272-10)
Engine coolant drained. (WP 0287)
Fan drivebelt removed. (WP 0296)

Materials/Parts

O-ring (Volume 5, WP 0827, Table 1, Item 10)
Qty: 1

Equipment Condition

Parking brake set. (TM 9-2320-272-10)

REMOVAL

1. Loosen alternator link screw (Figure 1, Item 10) and remove long screw (Figure 1, Item 8) and two short screws (Figure 1, Item 2) from water pump (Figure 1, Item 3). Note locations of long and short screws.

CAUTION

Do not strike or pry on water pump pulley or shaft. Coolant leaks may result.

2. Tap edge of water pump flange (Figure 1, Item 4) to release water pump (Figure 1, Item 3) from engine block (Figure 1, Item 1).
3. Remove water pump (Figure 1, Item 3) and o-ring (Figure 1, Item 7) from engine block (Figure 1, Item 1). Discard o-ring.

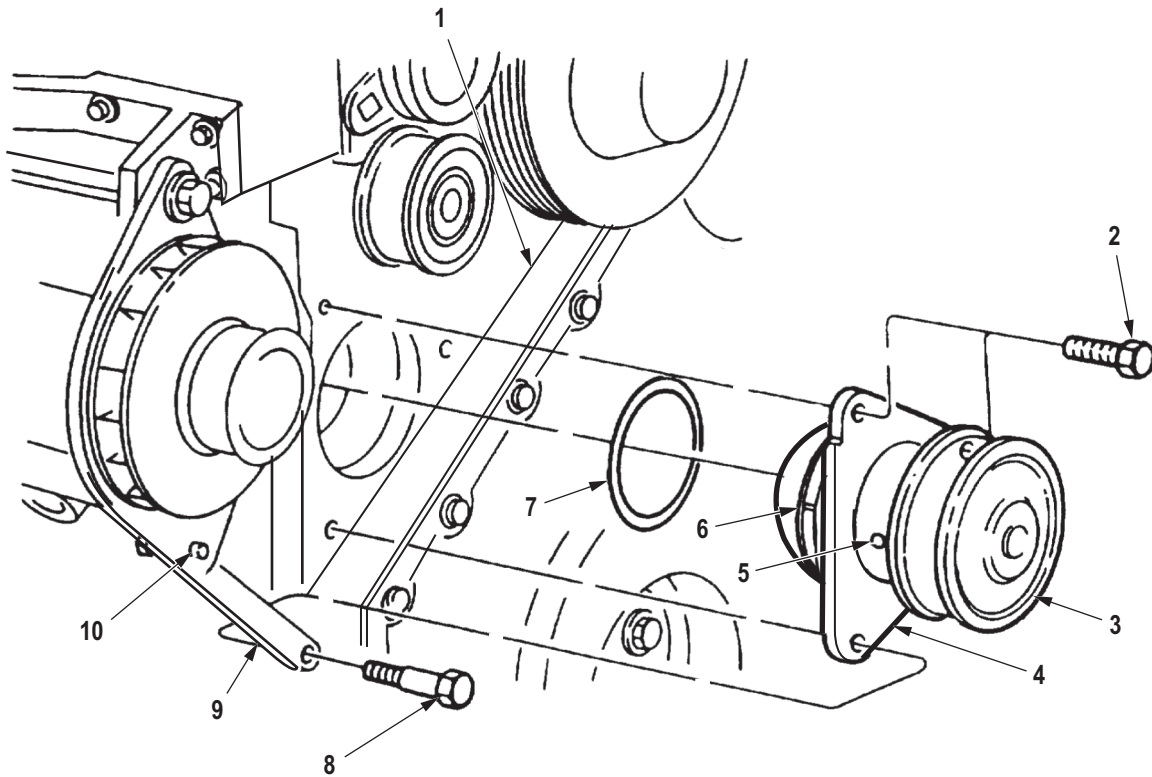

M0155DAA

Figure 1. Water Pump Removal.

END OF TASK**CLEANING AND INSPECTION**

Clean mating surfaces of engine block.

END OF TASK

INSTALLATION**CAUTION**

Do not pinch, cut, or crimp o-ring while performing Steps (1) and (2). Damaged o-ring may result in coolant leak.

1. Install o-ring (Figure 2, Item 7) on water pump (Figure 2, Item 3).
2. Install water pump (Figure 2, Item 3) on engine block (Figure 2, Item 1) with two short screws (Figure 2, Item 2). Hand tighten screws.
3. Align alternator link (Figure 2, Item 9) with water pump flange (Figure 2, Item 4) and install long screw (Figure 2, Item 8). Hand tighten screw.
4. Tighten alternator link screw (Figure 2, Item 10) and short and long screws (Figure 2, Items 2 and 8).

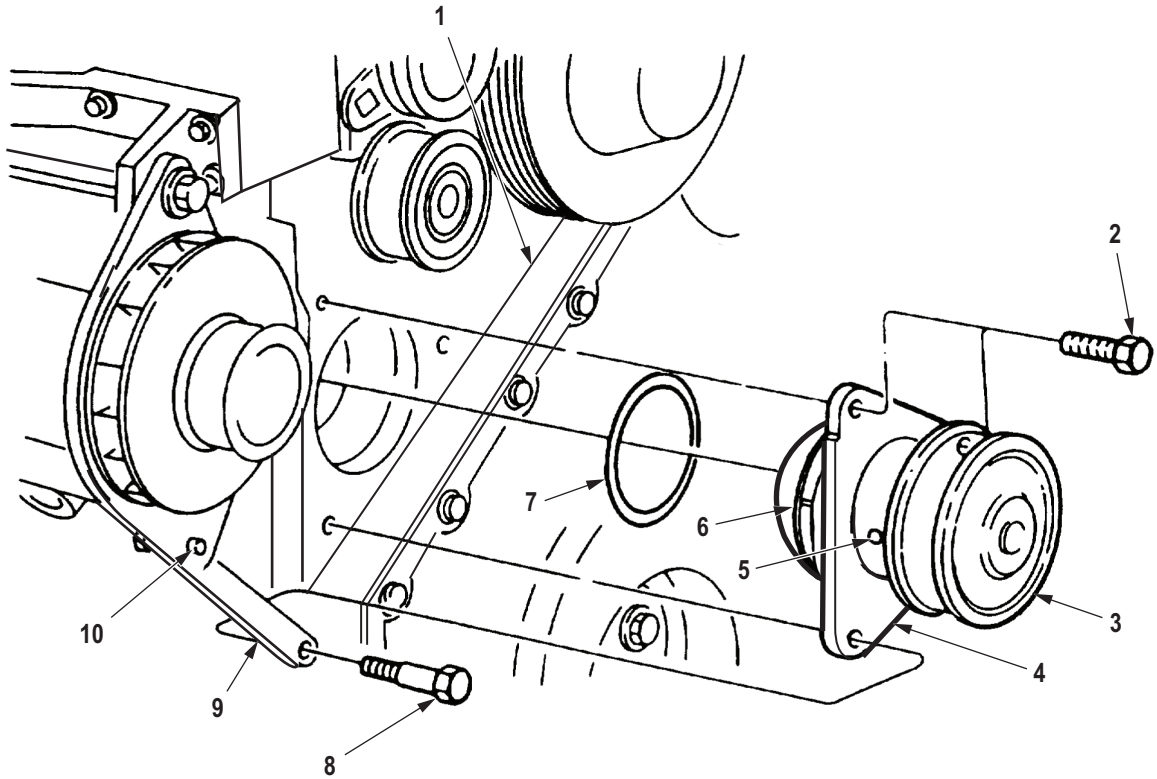

M0156DAA

Figure 2. Water Pump Installation.

END OF TASK

FOLLOW-ON MAINTENANCE

1. Install fan drivebelt. (WP 0296)
2. Fill cooling system to proper level. (WP 0287)
3. Hood closed and secured. (TM 9-2320-272-10)
4. Start engine, idle engine for five minutes, and check for coolant leaks when temperature gauge reads 180°F to 205°F (85°C to 95°C). (TM 9-2320-272-10)

END OF TASK**END OF WORK PACKAGE**

**FIELD MAINTENANCE
WATER PUMP REPLACEMENT (M939/A1)**

INITIAL SETUP:**Tools and Special Tools**

Tool Kit, General Mechanic's: Automotive
(Volume 5, WP 0826, Table 1, Item 56)
Wrench, Torque, Click, Ratcheting, 3/8" Drive,
75 Ft-Lb
(Volume 5, WP 0826, Table 1, Item 62)

Materials/Parts

Grease, Automotive and Artillery
(Volume 5, WP 0825, Table 1, Item 28)
Gasket (Volume 5, WP 0827, Table 1, Item 59)
Qty: 1
Lockwasher
(Volume 5, WP 0827, Table 1, Item 405)
Qty: 2

Materials/Parts (cont.)

Lockwasher
(Volume 5, WP 0827, Table 1, Item 443)
Qty: 8
O-ring (Volume 5, WP 0827, Table 1, Item 60)
Qty: 1

Equipment Condition

Parking brake set. (TM 9-2320-272-10)
Hood raised and secured. (TM 9-2320-272-10)
Cooling system drained. (WP 0287)
Fan drive clutch removed. (WP 0295)
Water pump drivebelt removed. (WP 0294)
Alternator adjusting link removed. (WP 0300)

REMOVAL

1. Remove screw (Figure 1, Item 2), lockwasher (Figure 1, Item 3), hose clamp (Figure 1, Item 4), and spacer (Figure 1, Item 5) from engine bracket (Figure 1, Item 6). Discard lockwasher.
2. Remove screw (Figure 1, Item 1), lockwasher (Figure 1, Item 12), and washer (Figure 1, Item 11) from engine bracket (Figure 1, Item 6). Discard lockwasher.
3. Remove six screws (Figure 1, Item 9), lockwashers (Figure 1, Item 8), and support bracket (Figure 1, Item 7) from engine (Figure 1, Item 10). Discard lockwashers.

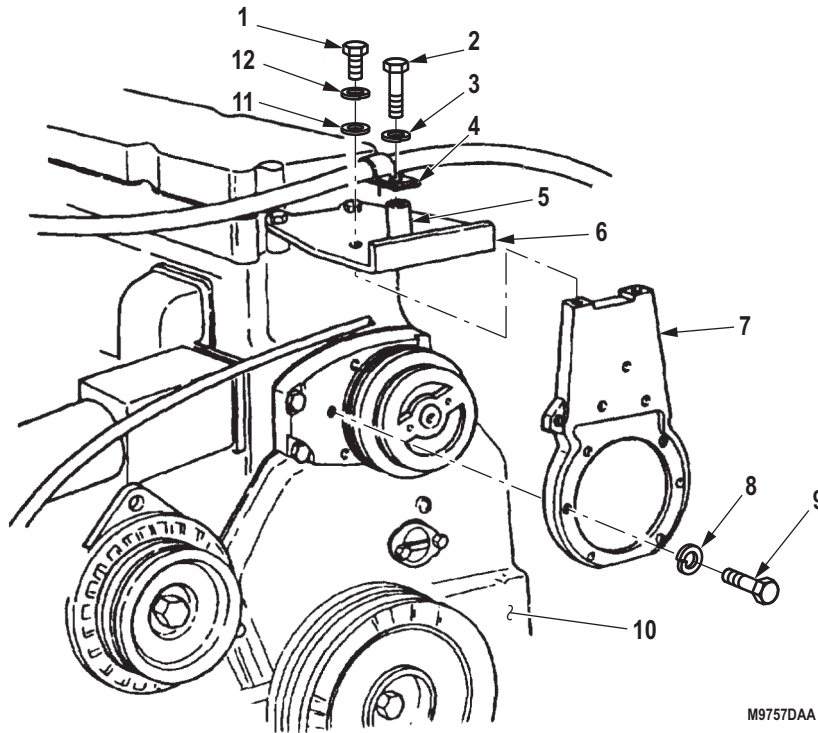

M9757DAA

Figure 1. Water Pump Removal.

REMOVAL - Continued

4. Remove water pump body (Figure 2, Item 5) and o-ring (Figure 2, Item 4) from water pump support (Figure 2, Item 3). Discard o-ring.
5. Remove two screws (Figure 2, Item 6) and lockwashers (Figure 2, Item 7) from water pump support (Figure 2, Item 3) and engine (Figure 2, Item 1). Discard lockwasher.
6. Remove water pump support (Figure 2, Item 3) and gasket (Figure 2, Item 2) from engine (Figure 2, Item 1). Discard gasket.

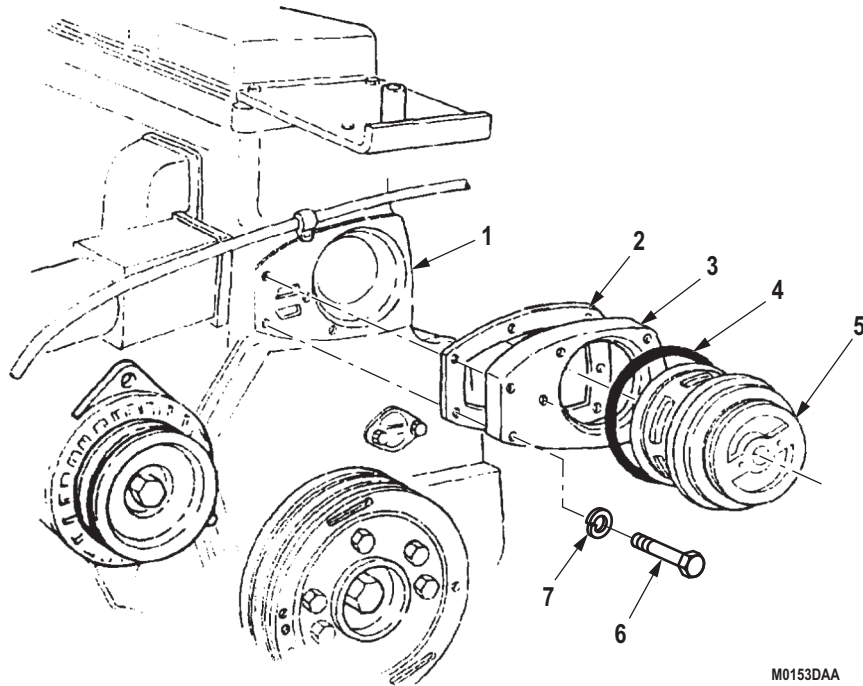

M0153DAA

*Figure 2. Water Pump Removal.***END OF TASK**

INSTALLATION

1. Coat both sides of gasket (Figure 3, Item 2) lightly with clean GAA grease and position on water pump support (Figure 3, Item 3).
2. Position water pump support (Figure 3, Item 3) with gasket (Figure 3, Item 2) on engine (Figure 3, Item 1).
3. Install water pump support (Figure 3, Item 3) on engine (Figure 3, Item 1) with two lockwashers (Figure 3, Item 7) and screws (Figure 3, Item 6).
4. Put light coat of GAA grease on o-ring (Figure 3, Item 4), mount o-ring on water pump body (Figure 3, Item 5), and install water pump body into support (Figure 3, Item 3).

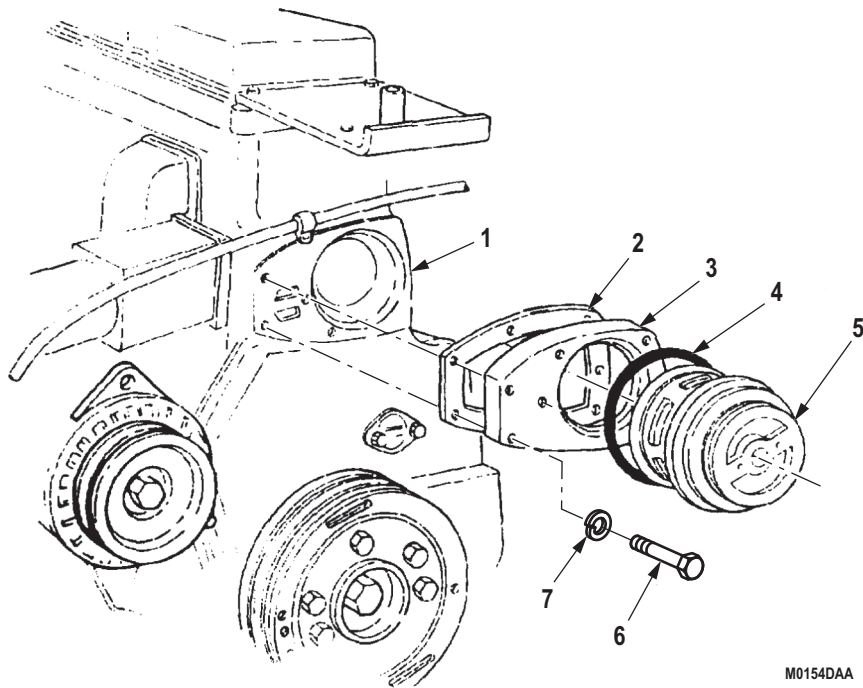

Figure 3. Water Pump Installation.

5. Install support bracket (Figure 4, Item 7) on engine (Figure 4, Item 10) with six lockwashers (Figure 4, Item 8) and screws (Figure 4, Item 9). Tighten screws 30 lb-ft (41 N·m).
6. Install washer (Figure 4, Item 11), lockwasher (Figure 4, Item 12), and screw (Figure 4, Item 1) through engine bracket (Figure 4, Item 6) and into support bracket (Figure 4, Item 7).
7. Install hose clamp (Figure 4, Item 4) and spacer (Figure 4, Item 5) on engine bracket (Figure 4, Item 6) with lockwasher (Figure 4, Item 3) and screw (Figure 4, Item 2).

INSTALLATION - Continued

Figure 4. Water Pump Installation.

END OF TASK**FOLLOW-ON MAINTENANCE**

1. Install and adjust water pump drivebelt. (WP 0294)
2. Install fan drive clutch. (WP 0295)
3. Fill cooling system to proper level. (WP 0287)
4. Install alternator adjusting link. (WP 0300)
5. Hood closed and secured. (TM 9-2320-272-10)
6. Start engine and check for coolant leaks. (TM 9-2320-272-10)

END OF TASK**END OF WORK PACKAGE**

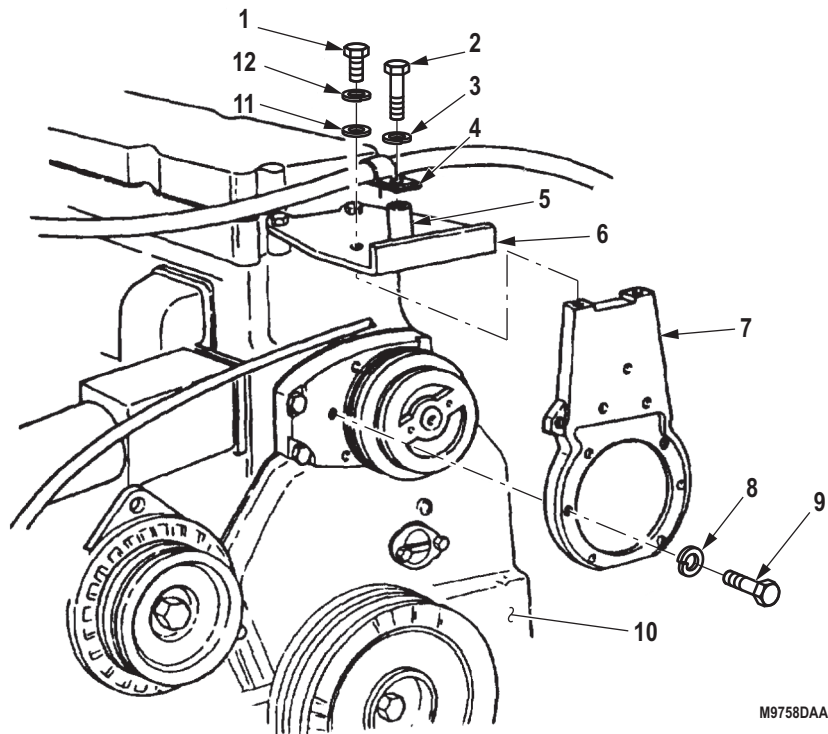
FIELD MAINTENANCE
WATER PUMP DRIVEBELT REPLACEMENT (M939/A1)

INITIAL SETUP:**Tools and Special Tools**

Tool Kit, General Mechanic's: Automotive
(Volume 5, WP 0826, Table 1, Item 56)
Belt, Tension Gauge
(Volume 5, WP 0826, Table 1, Item 9)

Materials/Parts

Lockwasher
(Volume 5, WP 0827, Table 1, Item 405)
Qty: 3

Personnel Required

(2)

Equipment Condition

Parking brake set. (TM 9-2320-272-10)
Hood raised and secured. (TM 9-2320-272-10)
Right splash shield removed. (TM 9-2320-272-10)
Fan drivebelts removed. (WP 0297)
Power steering pump drivebelts removed.
(Volume 3, WP 0504)

ADJUSTMENT

1. Check for proper belt tension by positioning belt tension gauge (Figure 1, Item 1) on drivebelt (Figure 1, Item 2) between pump housing (Figure 1, Item 5) and accessory drive pulley. New belt tension should be 95 to 105 lb-ft (423 to 467 N·m). Used belt tension should be 90 to 95 lb-ft (378 to 422 N·m).
2. Loosen six screws (Figure 1, Item 3) securing support bracket (Figure 1, Item 8) to engine (Figure 1, Item 7).
3. Place brass drift punch (Figure 1, Item 6) against stud (Figure 1, Item 4) on water pump housing (Figure 1, Item 5).
4. Referring to values in Step (1), move stud (Figure 1, Item 4) clockwise facing pump housing (Figure 1, Item 5) to tighten drivebelt (Figure 1, Item 2) tension. Move stud counterclockwise to loosen drivebelt tension.
5. Tighten six screws (Figure 1, Item 3) securing support bracket (Figure 1, Item 8) to engine (Figure 1, Item 7).
6. Recheck drivebelt (Figure 1, Item 2) tension. If drivebelt tension cannot be adjusted, replace drivebelt.

ADJUSTMENT - Continued

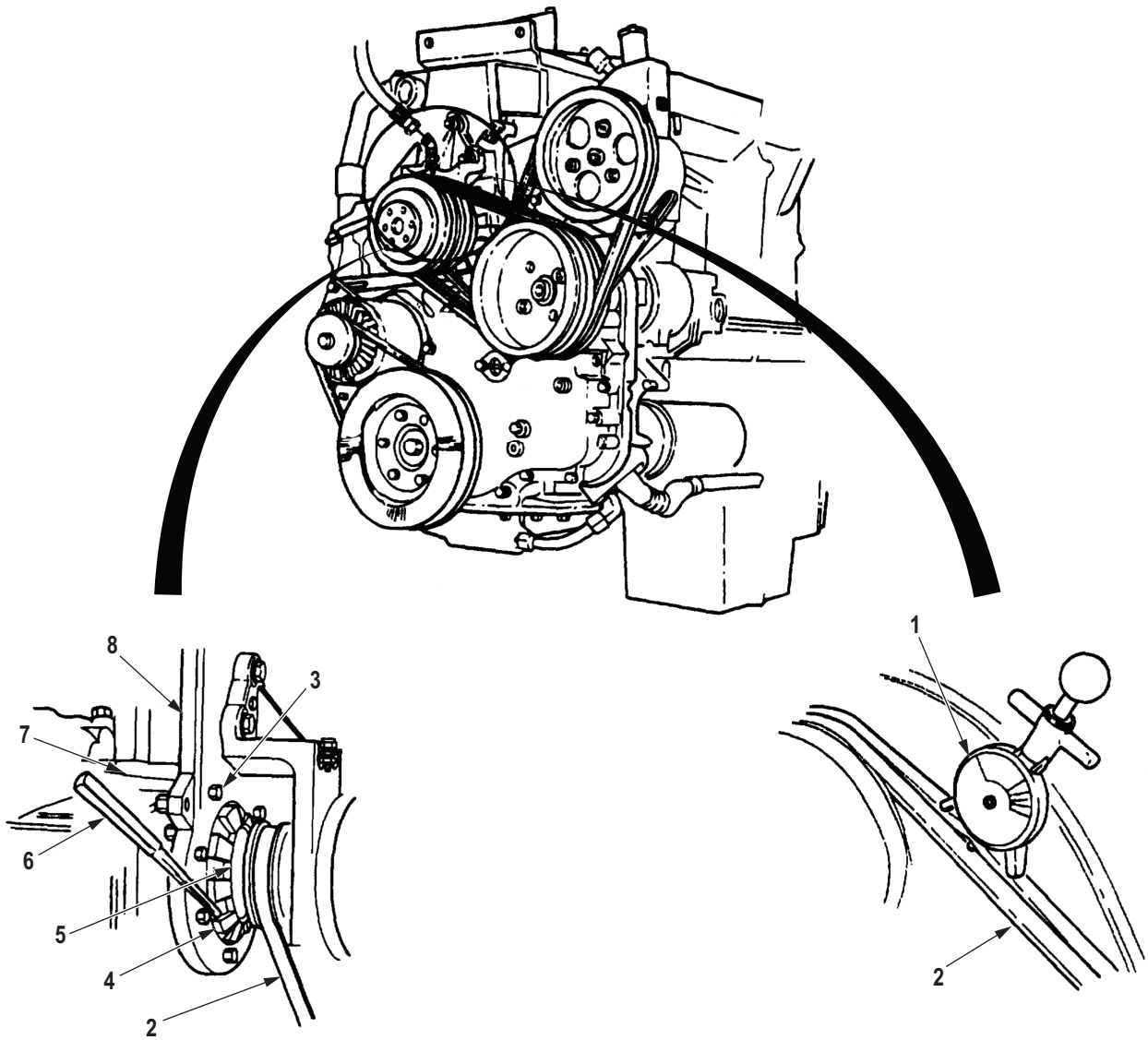

M0150DAA

Figure 1. Water Pump Drivebelt Adjustment.

END OF TASK

REMOVAL**NOTE**

Assistant will help with Step (1).

1. Remove screw (Figure 2, Item 1), lockwasher (Figure 2, Item 2), two screws (Figure 2, Item 16), washers (Figure 2, Item 17), screws (Figure 2, Item 15), lockwashers (Figure 2, Item 14), and washers (Figure 2, Item 13) from fan pulley bracket (Figure 2, Item 3). Discard lockwashers.
2. Lower fan pulley bracket (Figure 2, Item 3).
3. Loosen six screws (Figure 2, Item 6) holding support bracket (Figure 2, Item 4) to engine.
4. Place brass drift punch (Figure 2, Item 11) against stud (Figure 2, Item 9) on water pump housing (Figure 2, Item 10) and turn stud counterclockwise to release drivebelt (Figure 2, Item 8) tension.
5. Remove drivebelt (Figure 2, Item 8) from pump pulley (Figure 2, Item 7) and accessory drive pulley (Figure 2, Item 5).

INSPECTION

Inspect drivebelt for cracks, splits, and breaks. Replace drivebelt if cracked, split, or broken.

END OF TASK**INSTALLATION**

1. Install drivebelt (Figure 3, Item 8) over pump pulley (Figure 3, Item 7) and accessory drive pulley (Figure 3, Item 5).
2. Using brass drift punch (Figure 3, Item 11), turn stud (Figure 3, Item 9) clockwise for preliminary belt (Figure 3, Item 8) tightening.
3. Check drivebelt (Figure 3, Item 8) tension. See ADJUSTMENT.
4. Tighten six screws (Figure 3, Item 6).

NOTE

An assistant will help with Step (5).

5. Raise fan pulley bracket (Figure 3, Item 3) and install lockwasher (Figure 3, Item 2), screw (Figure 3, Item 1), two washers (Figure 3, Item 13), lockwashers (Figure 3, Item 14), screws (Figure 3, Item 15), washers (Figure 3, Item 17), and screws (Figure 3, Item 16). Do not tighten screws.
6. Recheck drivebelt tension. See ADJUSTMENT.
7. If drivebelt (Figure 3, Item 8) tension is satisfactory, tighten screws (Figure 3, Items 1, 15, and 16).

INSTALLATION - Continued

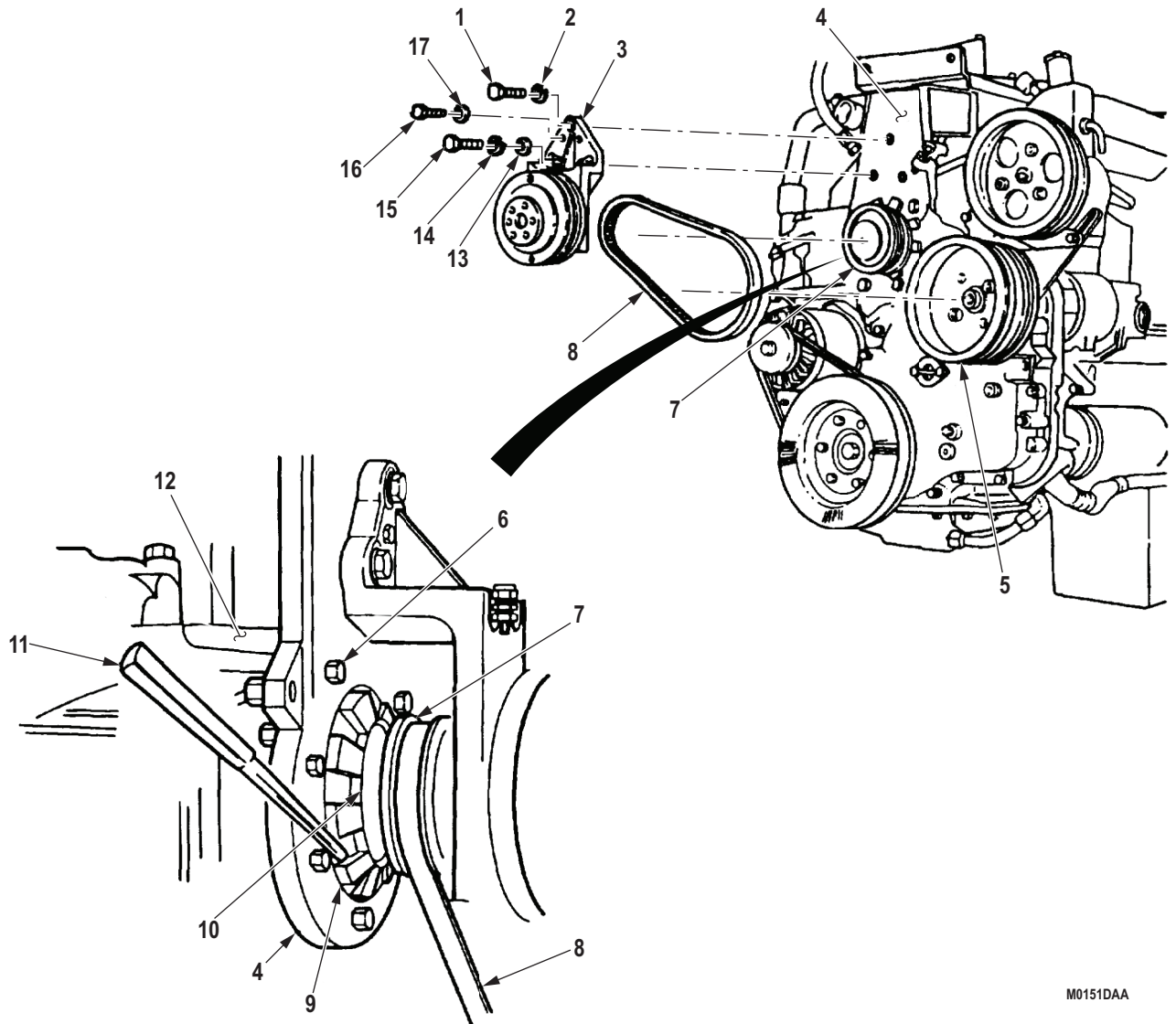

M0151DAA

Figure 3. Water Pump Drivebelt Installation.

END OF TASK

FOLLOW-ON MAINTENANCE

1. Install power steering pump drivebelts. (Volume 3, WP 0504)
2. Install fan drivebelts. (WP 0297)
3. Hood closed and secured. (TM 9-2320-272-10)
4. Start engine, idle engine for five minutes, and stop engine. (TM 9-2320-272-10)
5. Install right splash shield. (TM 9-2320-272-10)

END OF TASK**END OF WORK PACKAGE**

**FIELD MAINTENANCE
FAN DRIVE CLUTCH REPLACEMENT (M939/A1)**

INITIAL SETUP:

Tools and Special Tools

Tool Kit, General Mechanic's: Automotive
(Volume 5, WP 0826, Table 1, Item 56)

Materials/Parts

Cap Set, Protective, Dust and Moisture Seal
(Volume 5, WP 0825, Table 1, Item 13)
Compound, Sealing
(Volume 5, WP 0825, Table 1, Item 58)
Tape, Antiseizing

Materials/Parts (cont.)

(Volume 5, WP 0825, Table 1, Item 65)
Lockwasher
(Volume 5, WP 0827, Table 1, Item 405)
Qty: 3

Equipment Condition

Parking brake set. (TM 9-2320-272-10)
Hood raised and secured. (TM 9-2320-272-10)
Fan drivebelts removed. (WP 0297)
Fan removed. (WP 0298)

REMOVAL

1. Disconnect hose (Figure 1, Item 2) from fan drive actuator (Figure 1, Item 1) and elbow (Figure 1, Item 3) on fan pulley bracket (Figure 1, Item 6).
2. Remove elbow (Figure 1, Item 3) and adapter (Figure 1, Item 4) from union (Figure 1, Item 5).

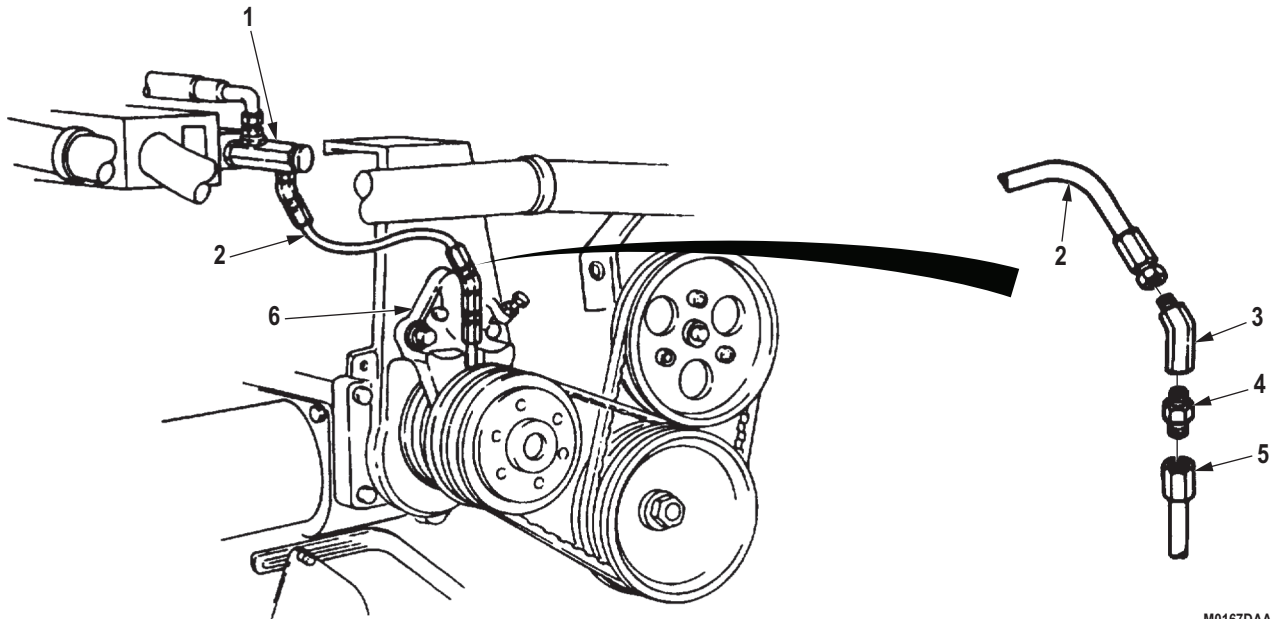

M0167DAA

Figure 1. Fan Drive Clutch Removal.

INSTALLATION

1. Install fan drive clutch (Figure 3, Item 4) and fan pulley bracket (Figure 3, Item 1) on support bracket (Figure 3, Item 2) with lockwasher (Figure 3, Item 11), two lockwashers (Figure 3, Item 6), two washers (Figure 3, Item 5), screws (Figure 3, Item 7), and screw (Figure 3, Item 10). Do not tighten screws until drivebelts are installed.
2. Apply Loctite on threads of screws (Figure 3, Item 8). Install two fan clutch override washers (Figure 3, Item 9) and screws in fan pulley bracket (Figure 3, Item 1).

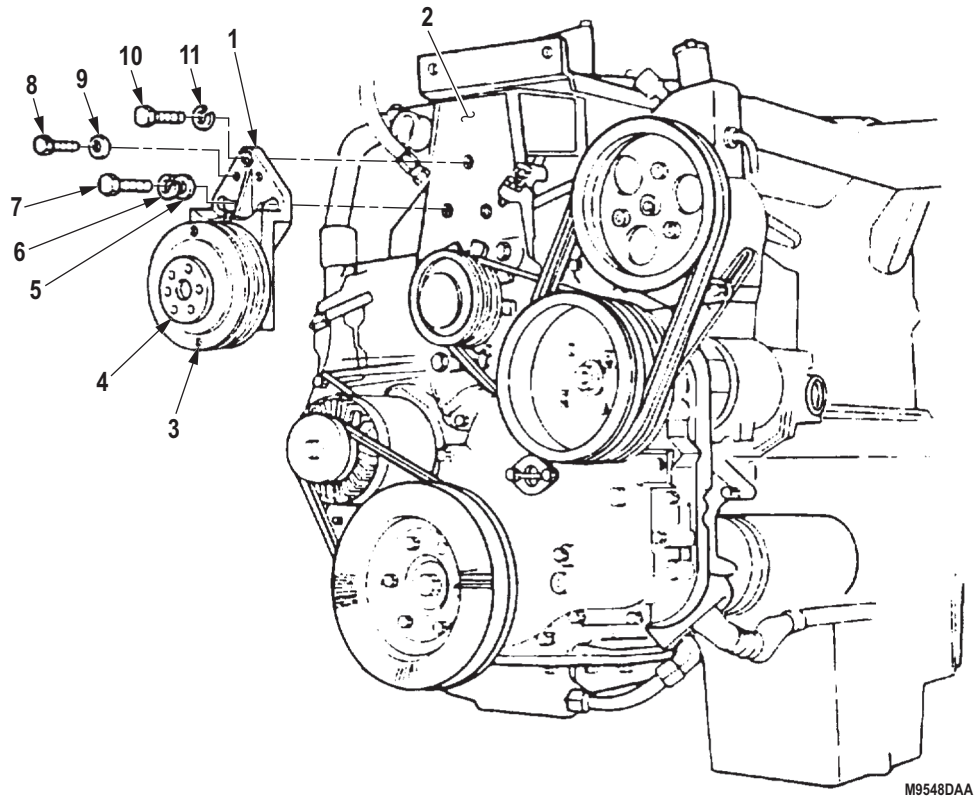
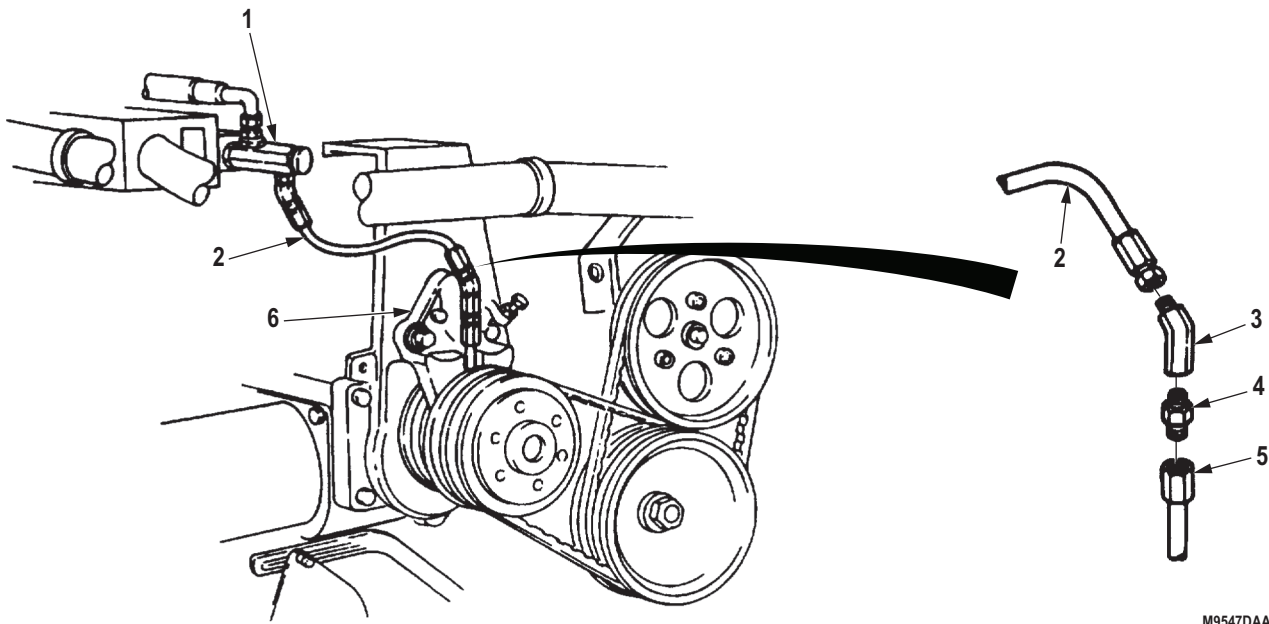

Figure 3. Fan Drive Clutch Installation.

INSTALLATION - Continued**NOTE**

Male pipe threads must be wrapped with antiseize tape before installation.

3. Install adapter (Figure 4, Item 4) and elbow (Figure 4, Item 3) on union (Figure 4, Item 5).
4. Connect hose (Figure 4, Item 2) to elbow (Figure 4, Item 3) and fan drive actuator (Figure 4, Item 1).



M9547DAA

Figure 4. Fan Drive Clutch Installation.

END OF TASK**FOLLOW-ON MAINTENANCE**

1. Install fan. (WP 0298)
2. Install drivebelts. (WP 0297)
3. Hood closed and secured. (TM 9-2320-272-10)

END OF TASK**END OF WORK PACKAGE**

FIELD MAINTENANCE
FAN DRIVEBELT AND DRIVEBELT TENSIONER REPLACEMENT (M939A2)

INITIAL SETUP:**Tools and Special Tools**

Tool Kit, General Mechanic's: Automotive
(Volume 5, WP 0826, Table 1, Item 56)
Wrench, Torque, Click, Ratcheting, 3/8" Drive,
75 Ft-Lb
(Volume 5, WP 0826, Table 1, Item 62)

Equipment Condition (cont.)

Hood raised and secured. (TM 9-2320-272-10)
Right splash shield removed. (TM 9-2320-272-10)

Personnel Required

(2)

Equipment Condition

Parking brake set. (TM 9-2320-272-10)

REMOVAL

1. Using a breaker bar in square drive hole (Figure 1, Item 6) of belt tensioner (Figure 1, Item 3), move belt tensioner up.

NOTE

Assistant will help with Step (2).

2. Remove drivebelt (Figure 1, Item 7) from alternator pulley (Figure 1, Item 10), and release belt tensioner (Figure 1, Item 3).
3. Remove drivebelt (Figure 1, Item 7) from vibration damper pulley (Figure 1, Item 8), water pump pulley (Figure 1, Item 9), and fan pulley (Figure 1, Item 1).
4. Remove two screws (Figure 1, Item 5) and belt tensioner bracket (Figure 1, Item 2) from thermostat housing (Figure 1, Item 11).
5. Remove screw (Figure 1, Item 4) and belt tensioner (Figure 1, Item 3) from bracket (Figure 1, Item 2).

REMOVAL - Continued

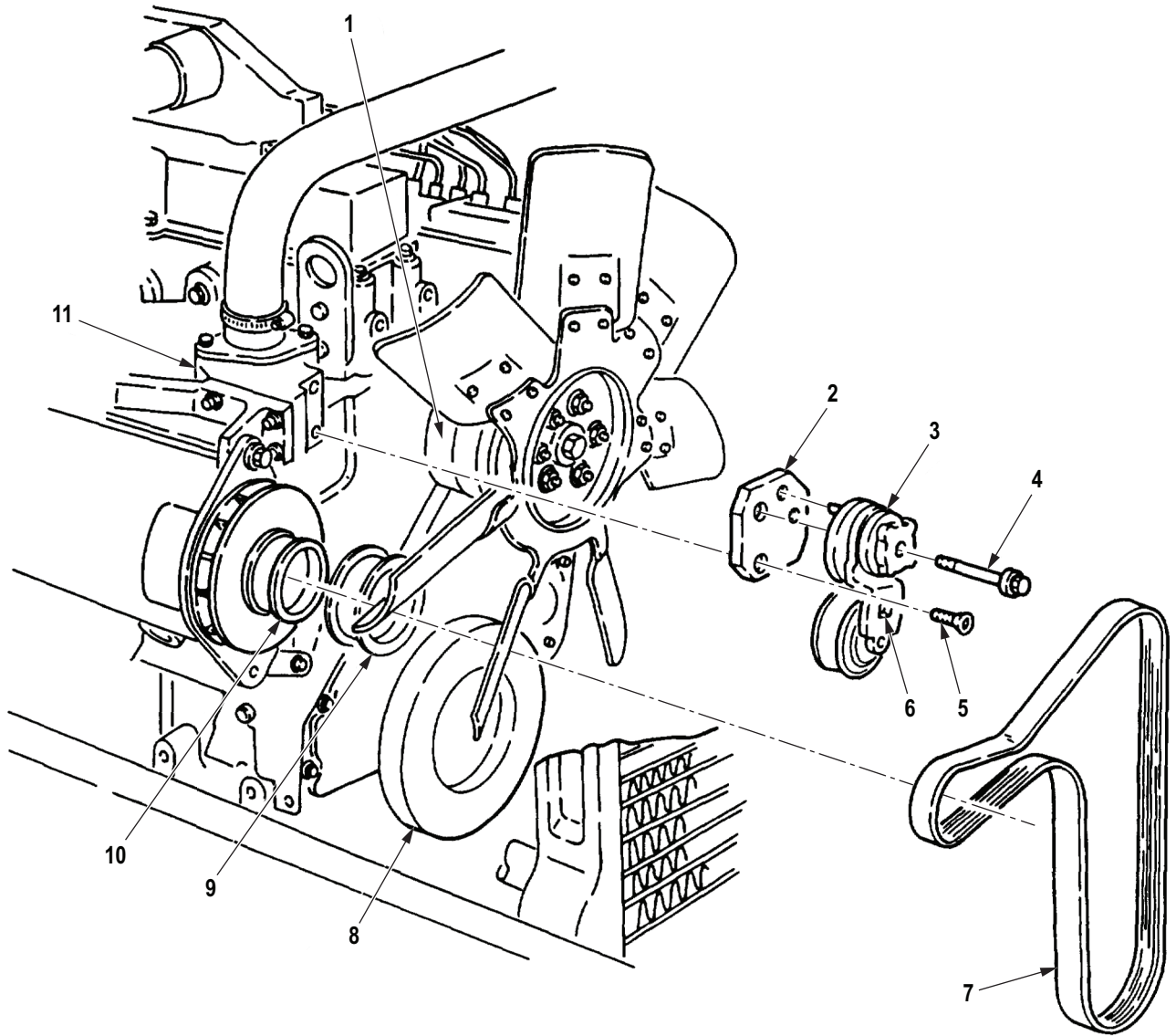

M0159DAA

Figure 1. Fan Drivebelt and Drivebelt Tensioner Removal.

END OF TASK

INSTALLATION

1. Install belt tensioner bracket (Figure 2, Item 2) on thermostat housing (Figure 2, Item 12) with two screws (Figure 2, Item 6).
2. Align locating pin (Figure 2, Item 3) on belt tensioner (Figure 2, Item 4) with belt tensioner bracket (Figure 2, Item 2) and install screw (Figure 2, Item 5). Tighten screw 30 lb-ft (45 N·m).
3. Install drivebelt (Figure 2, Item 8) over fan pulley (Figure 2, Item 1) and under vibration damper pulley (Figure 2, Item 9).
4. Install drivebelt (Figure 2, Item 8) between water pump pulley (Figure 2, Item 10) and belt tensioner (Figure 2, Item 4).

NOTE

Assistant will help with Step (5).

5. Using breaker bar in square drive hole (Figure 2, Item 7) of belt tensioner (Figure 2, Item 4), move belt tensioner up and install drivebelt (Figure 2, Item 8) on alternator pulley (Figure 2, Item 11). Release belt tensioner.

INSTALLATION - Continued

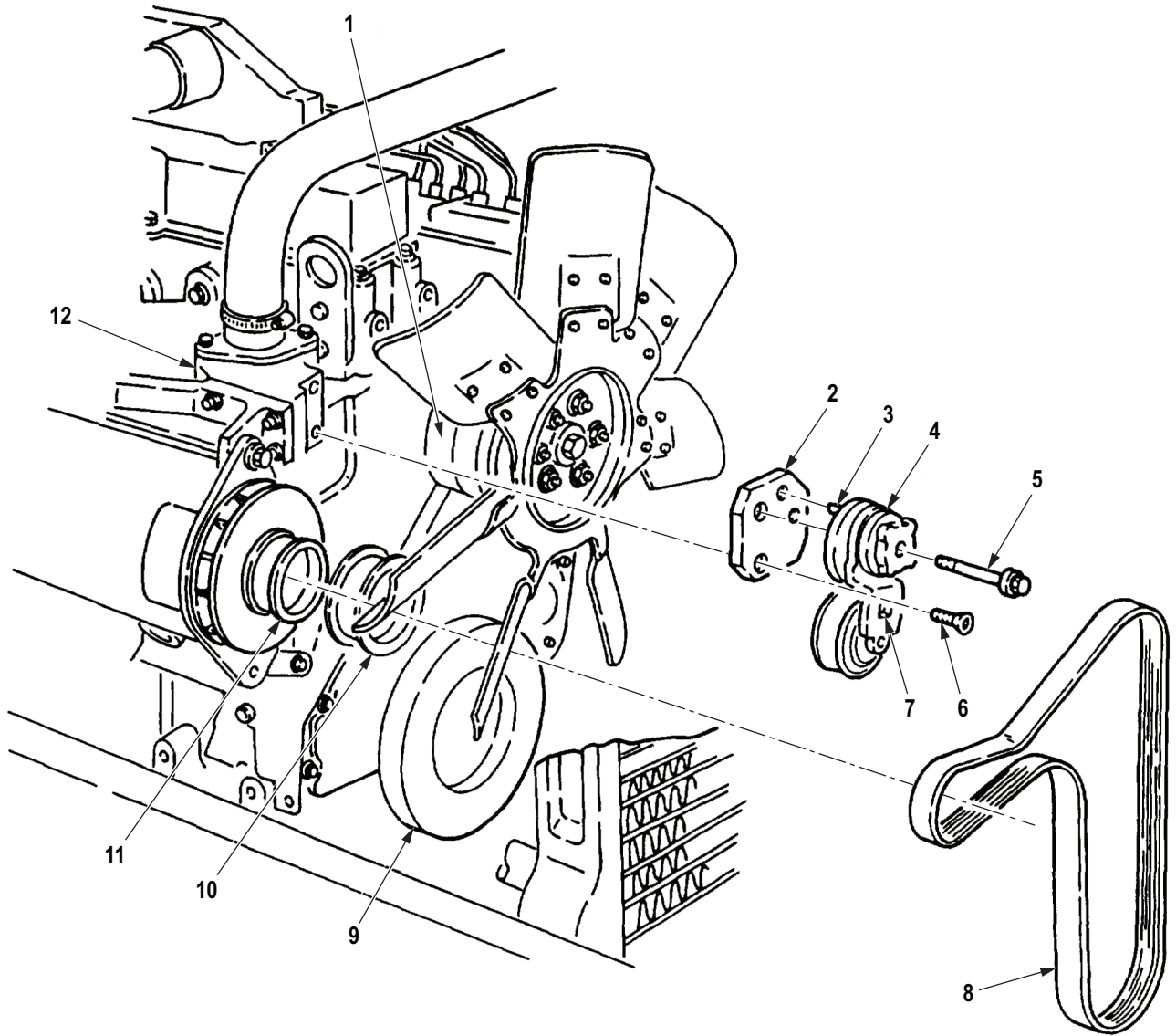

M0160DAA

Figure 2. Fan Drivebelt and Drivebelt Tensioner Installation.

END OF TASK

FOLLOW-ON MAINTENANCE

1. Start engine and check drivebelt. (TM 9-2320-272-10)
2. Hood closed and secured. (TM 9-2320-272-10)
3. Install right splash shield. (TM 9-2320-272-10)

END OF TASK**END OF WORK PACKAGE**

**FIELD MAINTENANCE
FAN DRIVEBELTS MAINTENANCE (M939/A1)**

INITIAL SETUP:**Tools and Special Tools**

Tool Kit, General Mechanic's: Automotive
(Volume 5, WP 0826, Table 1, Item 56)
Belt, Tension Gauge
(Volume 5, WP 0826, Table 1, Item 9)
Wrench, Torque, Click, Ratcheting, 3/8" Drive,
75 Ft-Lb
(Volume 5, WP 0826, Table 1, Item 62)

Equipment Condition (cont.)

Hood raised and secured. (TM 9-2320-272-10)
Air reservoirs drained. (TM 9-2320-272-10)
Right splash shield removed. (TM 9-2320-272-10)

Materials/Parts

Cap Set, Protective, Dust and Moisture Seal
(Volume 5, WP 0825, Table 1, Item 13)
Tape, Antiseizing
(Volume 5, WP 0825, Table 1, Item 65)

Equipment Condition

Parking brake set. (TM 9-2320-272-10)

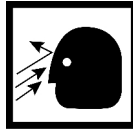
ADJUSTMENT**WARNING**

Do not disconnect air lines or hoses before draining air reservoirs. Small parts under pressure may shoot out with high velocity. Failure to comply may result in injury or death to personnel.

1. Disconnect air line (Figure 1, Item 13) from elbow (Figure 1, Item 10).
2. Remove elbow (Figure 1, Item 10) and adapter (Figure 1, Item 12) from union (Figure 1, Item 11).
3. Loosen three screws (Figure 1, Item 1) on fan pulley bracket (Figure 1, Item 6).
4. Loosen jamnut (Figure 1, Item 2) on adjusting screw (Figure 1, Item 3) on water pump clamp ring (Figure 1, Item 4).
5. Using belt tension gauge (Figure 1, Item 7) on inner belt midway between pulleys, adjust tension of inner belt (Figure 1, Item 5) by turning screw (Figure 1, Item 3). Tension should be 95 to 105 lb-ft (423 to 467 N·m) for a new belt and 85 to 95 lb-ft (378 to 422 N·m) for a used belt.
6. Repeat tension check of Step (5) for outer belt (Figure 1, Item 5). Recheck inner belt.

NOTE

Belts must be replaced as a matched set.

7. If either inner or outer belts (Figure 1, Item 5) cannot be adjusted in proper range, replace both belts.
8. Tighten top screw (Figure 1, Item 1) 25 to 35 lb-ft (34 to 47 N·m). Tighten two side screws 25 to 35 lb-ft (34 to 47 N·m).

NOTE

Male pipe threads must be wrapped with antiseize tape before installation.

9. Install adapter (Figure 1, Item 12) and elbow (Figure 1, Item 10) on union (Figure 1, Item 11).
10. Connect air line (Figure 1, Item 13) to elbow (Figure 1, Item 10).

ADJUSTMENT - Continued

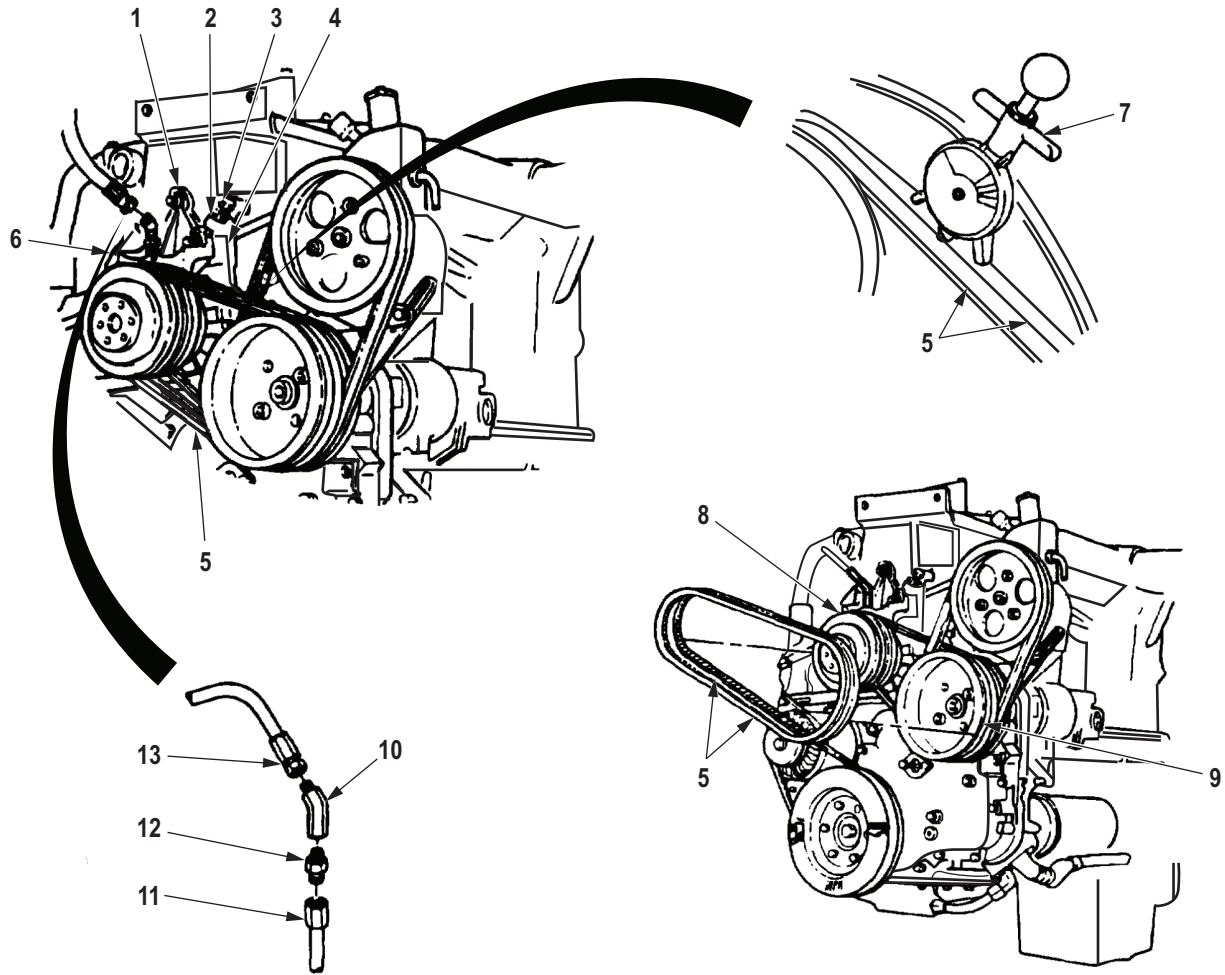

M0157DAA

Figure 1. Fan Drivebelt Adjustment.

END OF TASK

REMOVAL

1. Disconnect air line (Figure 2, Item 10) from elbow (Figure 2, Item 7).
2. Remove elbow (Figure 2, Item 7) and adapter (Figure 2, Item 9) from union (Figure 2, Item 8).
3. Loosen three screws (Figure 2, Item 1) on bracket (Figure 2, Item 5).
4. Loosen jamnut (Figure 2, Item 2) on adjusting screw (Figure 2, Item 3).
5. Push fan pulley bracket (Figure 2, Item 5) toward accessory drive pulley (Figure 2, Item 6) and remove two fan drivebelts (Figure 2, Item 4).

REMOVAL - Continued

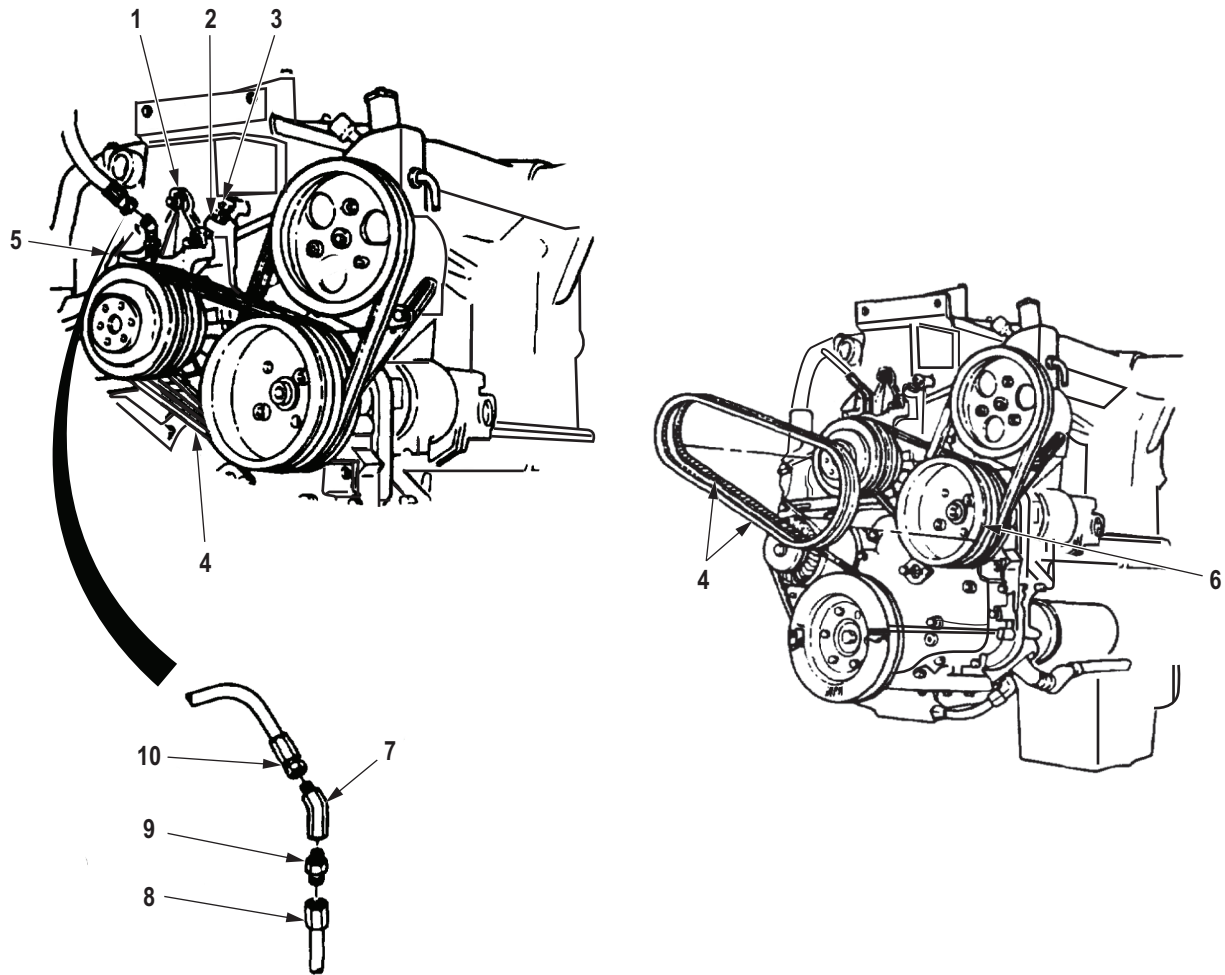

M0158DAA

Figure 2. Fan Drivebelt Removal.

END OF TASK

INSPECTION

Inspect two fan drivebelts (Figure 2, Item 5) for cracks, splits, and breaks. Replace both belts (Figure 2, Item 4) if either one fails inspection.

END OF TASK**INSTALLATION****CAUTION**

Fan drivebelts must be replaced in matched sets. Failure to do so will result in premature belt wear or failure.

1. Position two fan drivebelts (Figure 3, Item 3) over fan clutch pulley (Figure 3, Item 1) and in first and second grooves of accessory drive pulley (Figure 3, Item 2).
2. Complete installation with correct tensioning of drivebelts (Figure 3, Item 3). Refer to adjustment procedure.

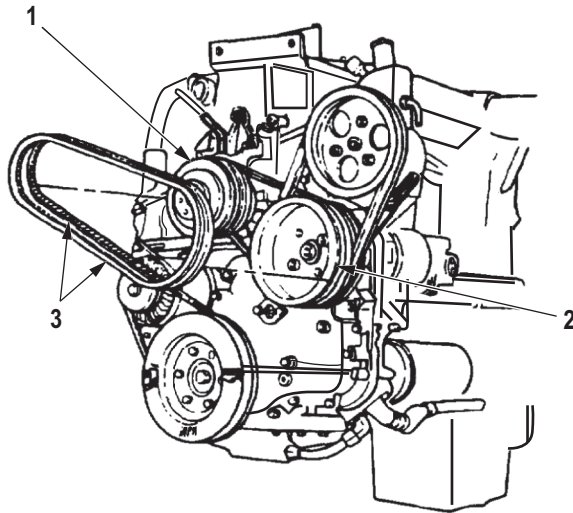

M9617DAA

Figure 3. Fan Drivebelt Installation.

END OF TASK**FOLLOW-ON MAINTENANCE**

1. Hood closed and secured. (TM 9-2320-272-10)
2. Start engine and idle for five minutes. (TM 9-2320-272-10)
3. Install right splash shield. (TM 9-2320-272-10)

END OF TASK**END OF WORK PACKAGE**

FIELD MAINTENANCE
RADIATOR FAN BLADE REPLACEMENT (M939/A1)

INITIAL SETUP:**Tools and Special Tools**

Tool Kit, General Mechanic's: Automotive
(Volume 5, WP 0826, Table 1, Item 56)
Wrench, Torque, Click, Ratcheting, 3/8" Drive,
75 Ft-Lb
(Volume 5, WP 0826, Table 1, Item 62)

Materials/Parts (cont.)

Locknut (Volume 5, WP 0827, Table 1, Item 283)
Qty: 1
Lockwasher
(Volume 5, WP 0827, Table 1, Item 186)
Qty: 6

Materials/Parts

Locknut (Volume 5, WP 0827, Table 1, Item 282)
Qty: 4

Equipment Condition

Parking brake set. (TM 9-2320-272-10)
Hood raised and secured. (TM 9-2320-272-10)
Right splash shield removed. (TM 9-2320-272-10)

REMOVAL

1. Remove four locknuts (Figure 1, Item 1), eight washers (Figure 1, Item 4), and four screws (Figure 1, Item 5) from corner shroud (Figure 1, Item 6). Discard locknuts.
2. Remove screw (Figure 1, Item 2) and washer (Figure 1, Item 3) from corner shroud (Figure 1, Item 6) and radiator (Figure 1, Item 7).
3. Remove locknut (Figure 1, Item 11), washers (Figure 1, Items 9 and 12), screw (Figure 1, Item 8), and corner shroud (Figure 1, Item 6) from bracket (Figure 1, Item 10). Discard locknut.
4. Remove six screws (Figure 1, Item 13), lockwashers (Figure 1, Item 14), and fan (Figure 1, Item 16) from fan hub (Figure 1, Item 15). Discard lockwashers.

REMOVAL - Continued

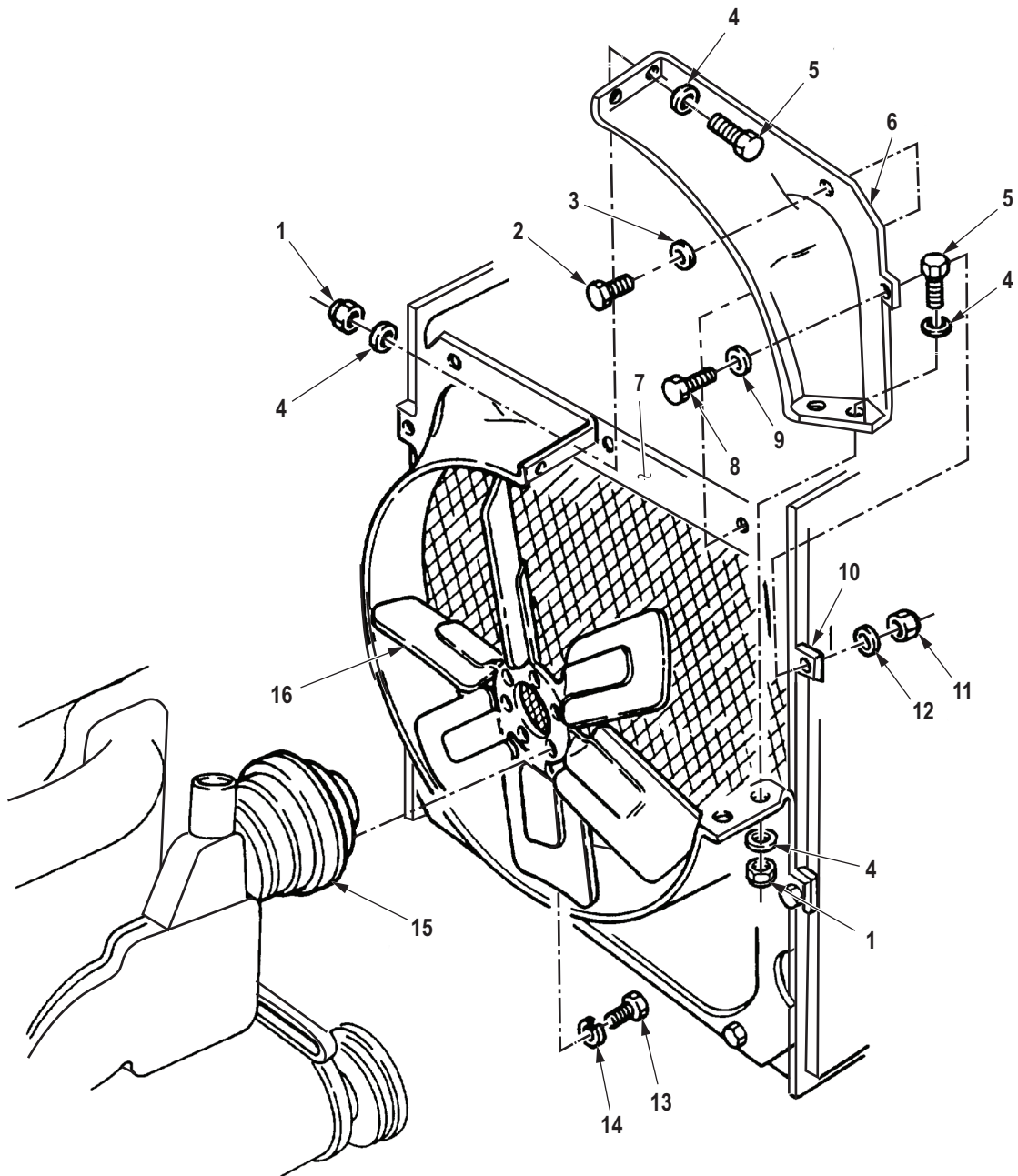

M0161DAA

Figure 1. Radiator Fan Blade Removal.

END OF TASK

INSTALLATION**NOTE**

Ensure fan installation does not block fan drive clutch lockup holes.

1. Install fan blade (Figure 2, Item 16) on fan hub (Figure 2, Item 15) with six lockwashers (Figure 2, Item 14) and screws (Figure 2, Item 13). Tighten screws 25 to 31 lb-ft (34 to 42 N·m).
2. Install corner shroud (Figure 2, Item 6) on bracket (Figure 2, Item 10) with washer (Figure 2, Item 9), screw (Figure 2, Item 8), washer (Figure 2, Item 12), and locknut (Figure 2, Item 11).
3. Install corner shroud (Figure 2, Item 6) on radiator (Figure 2, Item 7) with washer (Figure 2, Item 3) and screw (Figure 2, Item 2).
4. Secure corner shroud (Figure 2, Item 6) on radiator (Figure 2, Item 7) with four washers (Figure 2, Item 4), screws (Figure 2, Item 5), washers, and locknuts (Figure 2, Item 1).

INSTALLATION - Continued

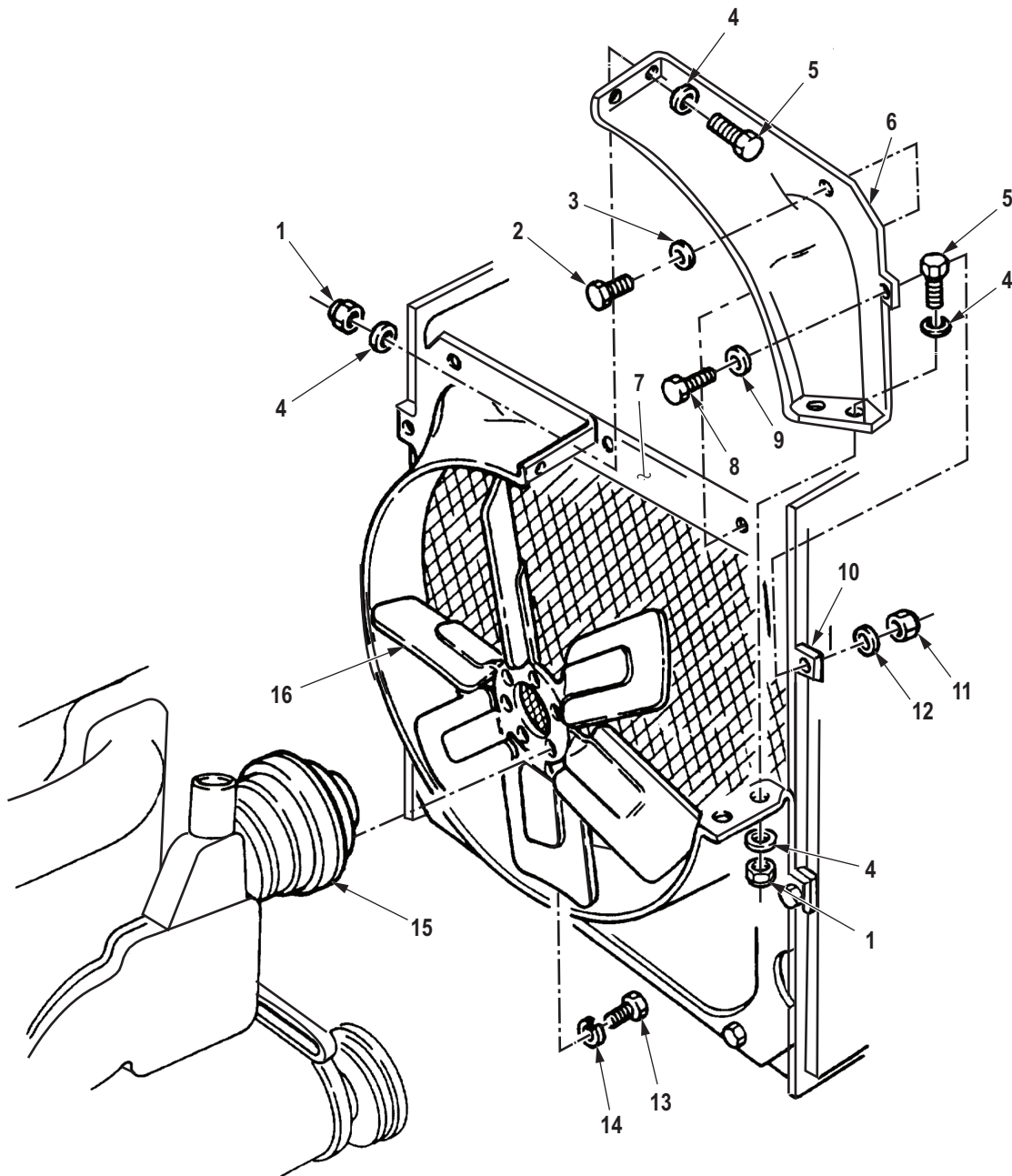

M0162DAA

Figure 2. Radiator Fan Blade Installation.

END OF TASK

FOLLOW-ON MAINTENANCE

1. Install right splash shield. (TM 9-2320-272-10)
2. Hood closed and secured. (TM 9-2320-272-10)

END OF TASK**END OF WORK PACKAGE**

**FIELD MAINTENANCE
AFTERCOOLER AND TUBES REPLACEMENT (M939A2)**

INITIAL SETUP:**Tools and Special Tools**

Tool Kit, General Mechanic's: Automotive
(Volume 5, WP 0826, Table 1, Item 56)
Wrench, Torque, Click, Ratcheting, 3/8" Drive,
75 Ft-Lb
(Volume 5, WP 0826, Table 1, Item 62)

Materials/Parts

Cloth, Cleaning
(Volume 5, WP 0825, Table 1, Item 19)
Tape, Antiseizing
(Volume 5, WP 0825, Table 1, Item 65)

Materials/Parts (cont.)

Gasket (Volume 5, WP 0827, Table 1, Item 161)
Qty: 1
O-ring (Volume 5, WP 0827, Table 1, Item 69)
Qty: 2

Equipment Condition

Parking brake set. (TM 9-2320-272-10)
Hood raised and secured. (TM 9-2320-272-10)
Coolant drained from block. (WP 0287)
Air cleaner hose removed. (WP 0248)
Surge tank and bracket removed. (WP 0279)

REMOVAL

1. Remove screw (Figure 1, Item 5) and tube brace (Figure 1, Item 12) from aftercooler (Figure 1, Item 6).
2. Remove screws (Figure 1, Items 4 and 7) from aftercooler (Figure 1, Item 6) and clamps (Figure 1, Item 8) and rotate clamps (Figure 1, Item 8) away from aftercooler.
3. Disconnect plug (Figure 1, Item 1) from wiring harness plug (Figure 1, Item 13).
4. Remove two screws (Figure 1, Item 3) and throttle control solenoid bracket (Figure 1, Item 2) from aftercooler (Figure 1, Item 6). Move clamp (Figure 1, Item 10) clear of aftercooler.
5. Remove two screws (Figure 1, Item 9) and clamps (Figure 1, Item 11) from aftercooler (Figure 1, Item 6).

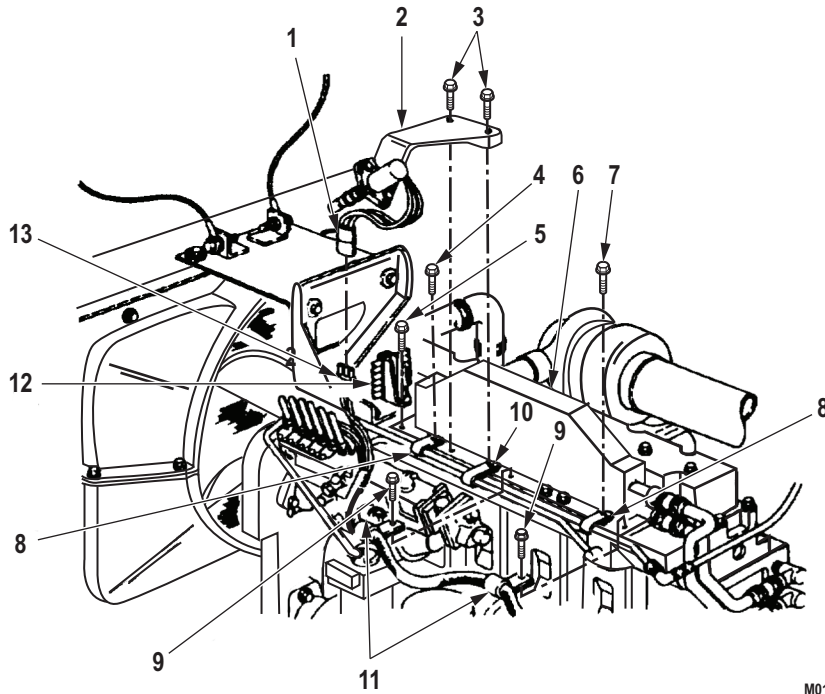

M0169DAA

Figure 1. Aftercooler and Tubes Removal.

6. Loosen two clamps (Figure 2, Item 4) and disconnect crossover tube (Figure 2, Item 13) from aftercooler (Figure 2, Item 1) and turbocharger (Figure 2, Item 17).
7. Remove screw (Figure 2, Item 13) and clamping plate (Figure 2, Item 14) from engine block (Figure 2, Item 15).

REMOVAL - Continued**NOTE**

Tag tubes for installation.

8. Loosen four hose clamps (Figure 2, Item 4) and remove two hoses (Figure 2, Item 6), and water return tube (Figure 2, Item 8) from aftercooler (Figure 2, Item 1) and elbow (Figure 2, Item 9).
9. Loosen four hose clamps (Figure 2, Item 7) and remove two hoses (Figure 2, Item 5), and water supply tube (Figure 2, Item 16) from aftercooler (Figure 2, Item 1) and elbow (Figure 2, Item 9).
10. Remove elbows (Figure 2, Item 4) and (Figure 2, Item 9) and two o-rings (Figure 2, Item 10) from engine block (Figure 2, Item 15). Discard o-rings.

CAUTION

Cover intake manifold with lint-free cloth to prevent contamination from entering engine.
Failure to do so may result in damage to engine.

11. Remove 13 screws (Figure 2, Item 2), aftercooler (Figure 2, Item 1), and gasket (Figure 2, Item 8) from engine block (Figure 2, Item 15). Discard gasket.

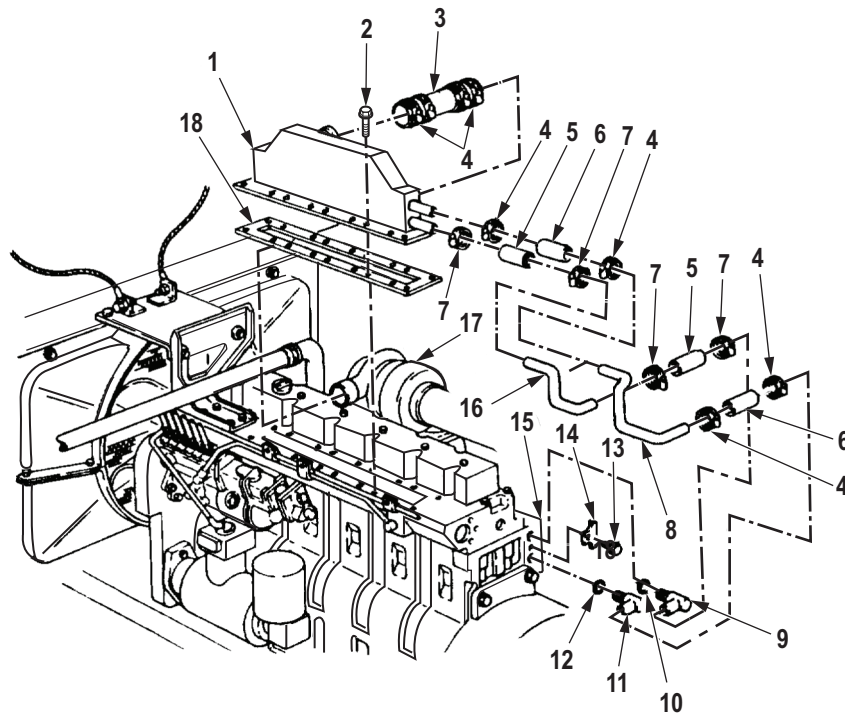

M0170DAA

Figure 2. Aftercooler and Tubes Removal.

END OF TASK

INSTALLATION

NOTE

Male pipe threads must be wrapped with antiseize tape before installation.

1. Install gasket (Figure 3, Item 18) and aftercooler (Figure 3, Item 1) on engine block (Figure 3, Item 15) with 13 screws (Figure 3, Item 2). Tighten screws 28 lb-ft (24 N·m).
2. Install two o-rings (Figure 3, Item 12) and elbows (Figure 3, Items 9 and 11) on engine block (Figure 3, Item 15).
3. Install two hoses (Figure 3, Item 5) and water supply tube (Figure 3, Item 6) on aftercooler (Figure 3, Item 1) and elbow (Figure 3, Item 9) with four hose clamps (Figure 3, Item 7).
4. Install two hoses (Figure 3, Item 6) and water return tube (Figure 3, Item 8) on aftercooler (Figure 3, Item 1) and elbow (Figure 3, Item 11) with four hose clamps (Figure 3, Item 4).
5. Install clamping plate (Figure 3, Item 14) on engine block (Figure 3, Item 15) with screw (Figure 3, Item 13).
6. Install crossover tube (Figure 3, Item 3) on aftercooler (Figure 3, Item 1) and turbocharger (Figure 3, Item 17) with two clamps (Figure 3, Item 4).

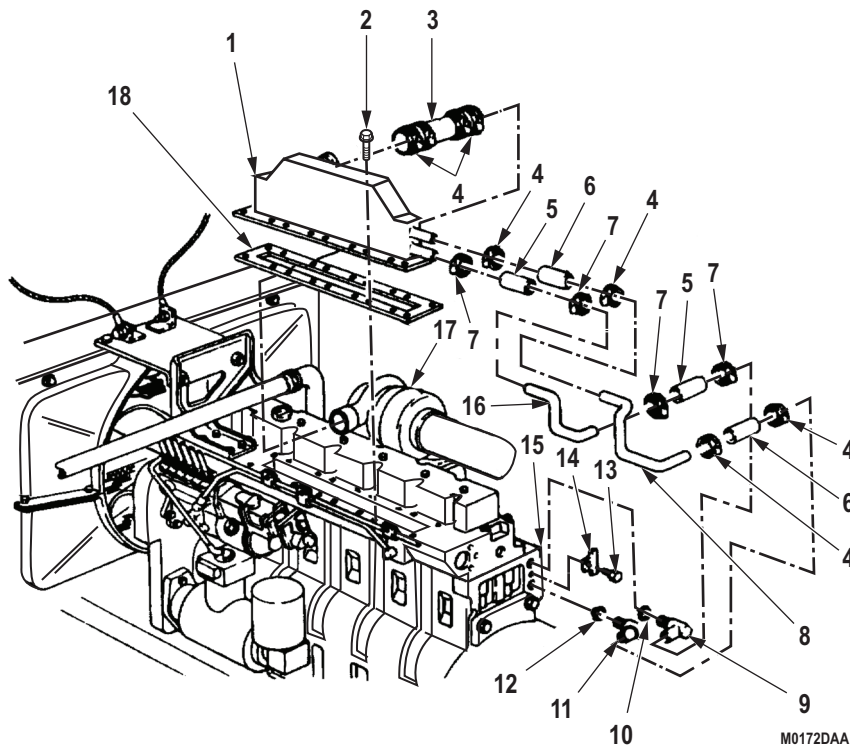

Figure 3. Aftercooler and Tubes Installation.

INSTALLATION - Continued

7. Install two clamps (Figure 4, Item 11) on aftercooler (Figure 4, Item 6) with two screws (Figure 4, Item 9).
8. Install clamp (Figure 4, Item 10) and throttle control solenoid bracket (Figure 4, Item 2) on aftercooler (Figure 4, Item 6) with two screws (Figure 4, Item 3).
9. Connect plug (Figure 4, Item 1) to wiring harness plug (Figure 4, Item 13).
10. Rotate two clamps (Figure 4, Item 8) into position on aftercooler (Figure 4, Item 6) and install with screws (Figure 4, Items 7 and 4).
11. Install tube brace (Figure 4, Item 12) on aftercooler (Figure 4, Item 6) with screw (Figure 4, Item 5).

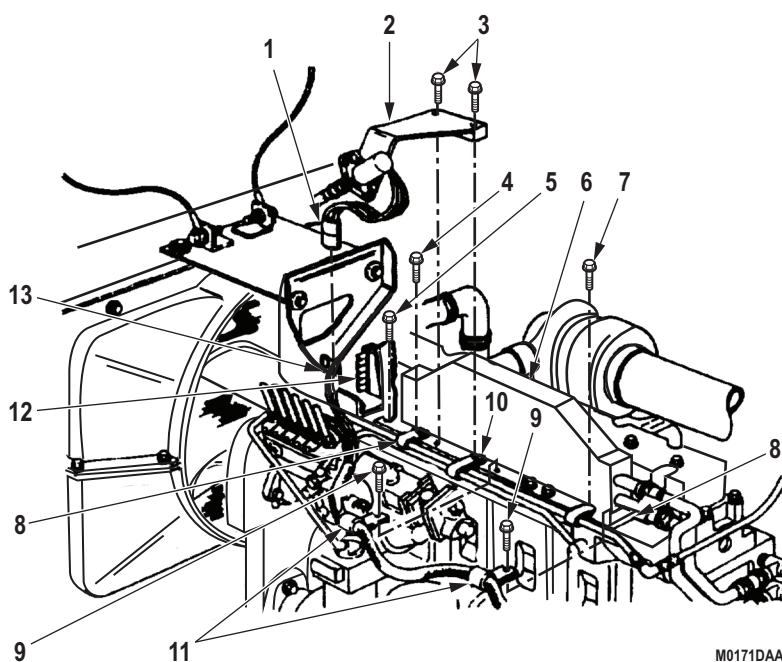

Figure 4. Aftercooler and Tubes Installation.

END OF TASK**FOLLOW-ON MAINTENANCE**

1. Install surge tank and bracket. (WP 0279)
2. Install air cleaner hose. (WP 0248)

END OF TASK**END OF WORK PACKAGE**

**FIELD MAINTENANCE
ALTERNATOR, MOUNTING BRACKET, AND PULLEY REPLACEMENT (M939/A1)**

INITIAL SETUP:**Tools and Special Tools**

Tool Kit, General Mechanic's: Automotive
(Volume 5, WP 0826, Table 1, Item 56)
Puller Kit, Universal
(Volume 5, WP 0826, Table 1, Item 43)
Vise, Machinist's
(Volume 5, WP 0826, Table 1, Item 59)
Wrench, Torque, Click, Ratcheting, 1/2" Drive,
250 Ft-Lb
(Volume 5, WP 0826, Table 1, Item 63)

Materials/Parts

Adhesive, Silicone Rubber
(Volume 5, WP 0825, Table 1, Item 4)
Locknut (Volume 5, WP 0827, Table 1, Item 323)
Qty: 2
Locknut (Volume 5, WP 0827, Table 1, Item 327)
Qty: 1
Lockwasher
(Volume 5, WP 0827, Table 1, Item 62)
Qty: 5
Lockwasher
(Volume 5, WP 0827, Table 1, Item 215)
Qty: 3

Materials/Parts (cont.)

Lockwasher
(Volume 5, WP 0827, Table 1, Item 410)
Qty: 2
Screw Assembled Lockwasher
(Volume 5, WP 0827, Table 1, Item 187)
Qty: 2
Woodruff Key
(Volume 5, WP 0827, Table 1, Item 419)
Qty: 1

Personnel Required

(2)

Equipment Condition

Parking brake set. (TM 9-2320-272-10)
Hood raised and secured. (TM 9-2320-272-10)
Battery ground cables disconnected. (WP 0350)
Alternator drivebelts removed. (WP 0302)

REMOVAL

1. Remove two screw assembled lockwashers (Figure 1, Item 10) and terminal cover (Figure 1, Item 9) from alternator (Figure 1, Item 15). Discard screw assembled lockwashers.
2. Remove two screws (Figure 1, Item 8), lockwashers (Figure 1, Item 7), and wire retaining strap (Figure 1, Item 6) from alternator (Figure 1, Item 15). Discard lockwashers.

NOTE

- Sealant must be removed before removing wires.
- Tag all wires for installation.

3. Remove screw (Figure 1, Item 1), lockwasher (Figure 1, Item 19), and wire (Figure 1, Item 18) from alternator (Figure 1, Item 15). Discard lockwasher.
4. Remove nut (Figure 1, Item 5), lockwasher (Figure 1, Item 4), washer (Figure 1, Item 3), and wire (Figure 1, Item 2) from alternator (Figure 1, Item 15). Discard lockwasher.
5. Remove nut (Figure 1, Item 11), lockwasher (Figure 1, Item 12), washer (Figure 1, Item 13), and wire (Figure 1, Item 14) from alternator (Figure 1, Item 15). Discard lockwasher.
6. Disconnect connector (Figure 1, Item 16) from alternator (Figure 1, Item 15).
7. Remove and discard tiedown strap (Figure 1, Item 17).

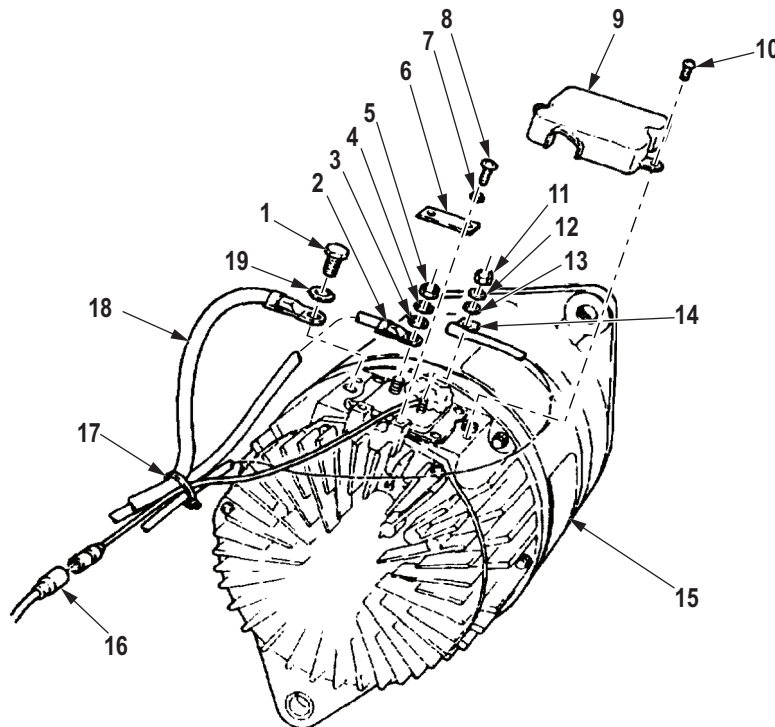

M0175DAA

Figure 1. Alternator and Mounting Bracket Removal.

REMOVAL - Continued

WARNING

Alternator is heavy. Assistant will help with alternator removal. Failure to comply may result in injury or death to personnel.

8. Remove screw (Figure 2, Item 14), lockwasher (Figure 2, Item 1), washers (Figure 2, Items 2 and 3), screw assembled washer (Figure 2, Item 4), and adjusting link (Figure 2, Item 13) from alternator (Figure 2, Item 12). Discard lockwasher.
9. Remove two locknuts (Figure 2, Item 5), washers (Figure 2, Item 6), screws (Figure 2, Item 11), and alternator (Figure 2, Item 12) from mounting bracket (Figure 2, Item 7). Discard locknuts.
10. Remove four screws (Figure 2, Item 10), lockwashers (Figure 2, Item 9), and mounting bracket (Figure 2, Item 7) from engine (Figure 2, Item 8). Discard lockwashers.

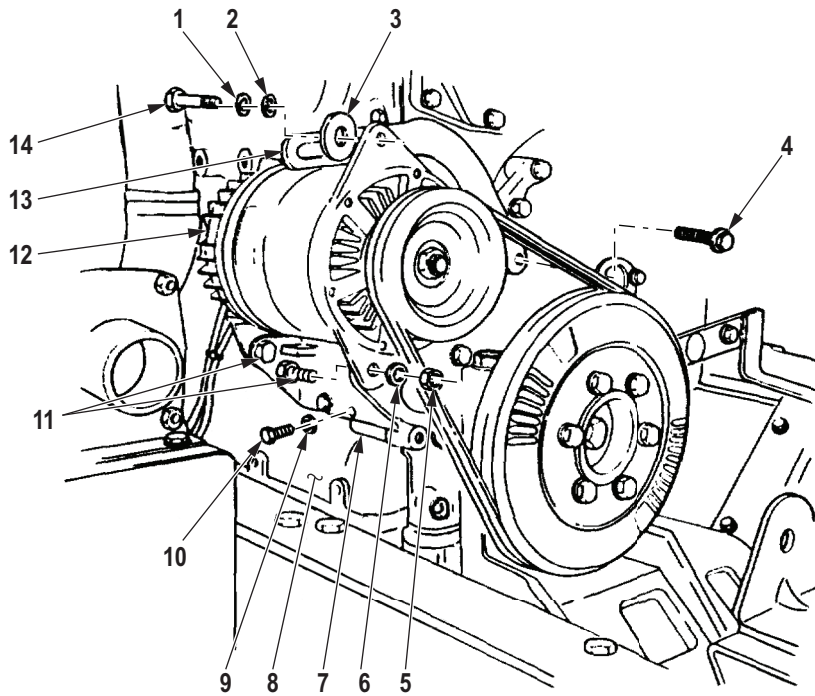

M0176DAA

Figure 2. Alternator and Mounting Bracket Removal.

REMOVAL - Continued

11. Position alternator pulley (Figure 3, Item 1) in vise (Figure 3, Item 2).
12. Remove locknut (Figure 3, Item 4) and washer (Figure 3, Item 3) from pulley shaft (Figure 3, Item 6). Discard locknut.
13. Remove alternator pulley (Figure 3, Item 1) from vise (Figure 3, Item 2).
14. Using universal puller, remove alternator pulley (Figure 3, Item 1) and woodruff key (Figure 3, Item 5) from pulley shaft (Figure 3, Item 6). Discard woodruff key.

REMOVAL - Continued

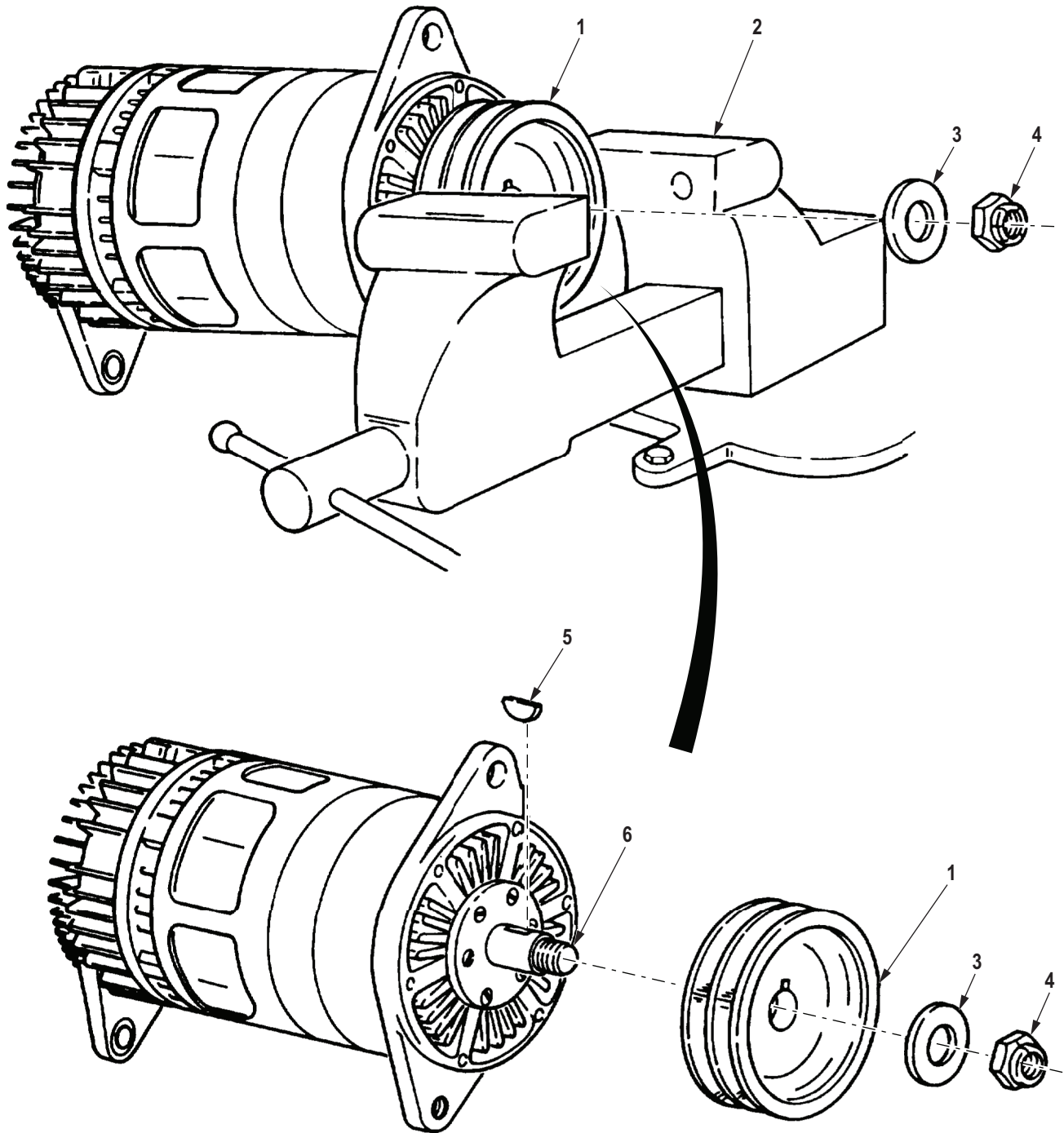

M0177DAA

Figure 3. Alternator Pulley Removal.

END OF TASK

INSTALLATION**WARNING**

Alternator is heavy. Assistant will help with alternator removal. Failure to comply may result in injury or death to personnel.

1. Install woodruff key (Figure 4, Item 5) in groove of pulley shaft (Figure 4, Item 6) with flat edge up.
2. Install pulley (Figure 4, Item 1) on pulley shaft (Figure 4, Item 6) with keyway (Figure 4, Item 7) on woodruff key (Figure 4, Item 5).
3. Place alternator pulley (Figure 4, Item 1) in vise (Figure 4, Item 2).
4. Install washer (Figure 4, Item 3) and locknut (Figure 4, Item 4) on pulley shaft (Figure 4, Item 6). Tighten locknut 90 to 95 lb-ft (122 to 128 N·m).

INSTALLATION - Continued

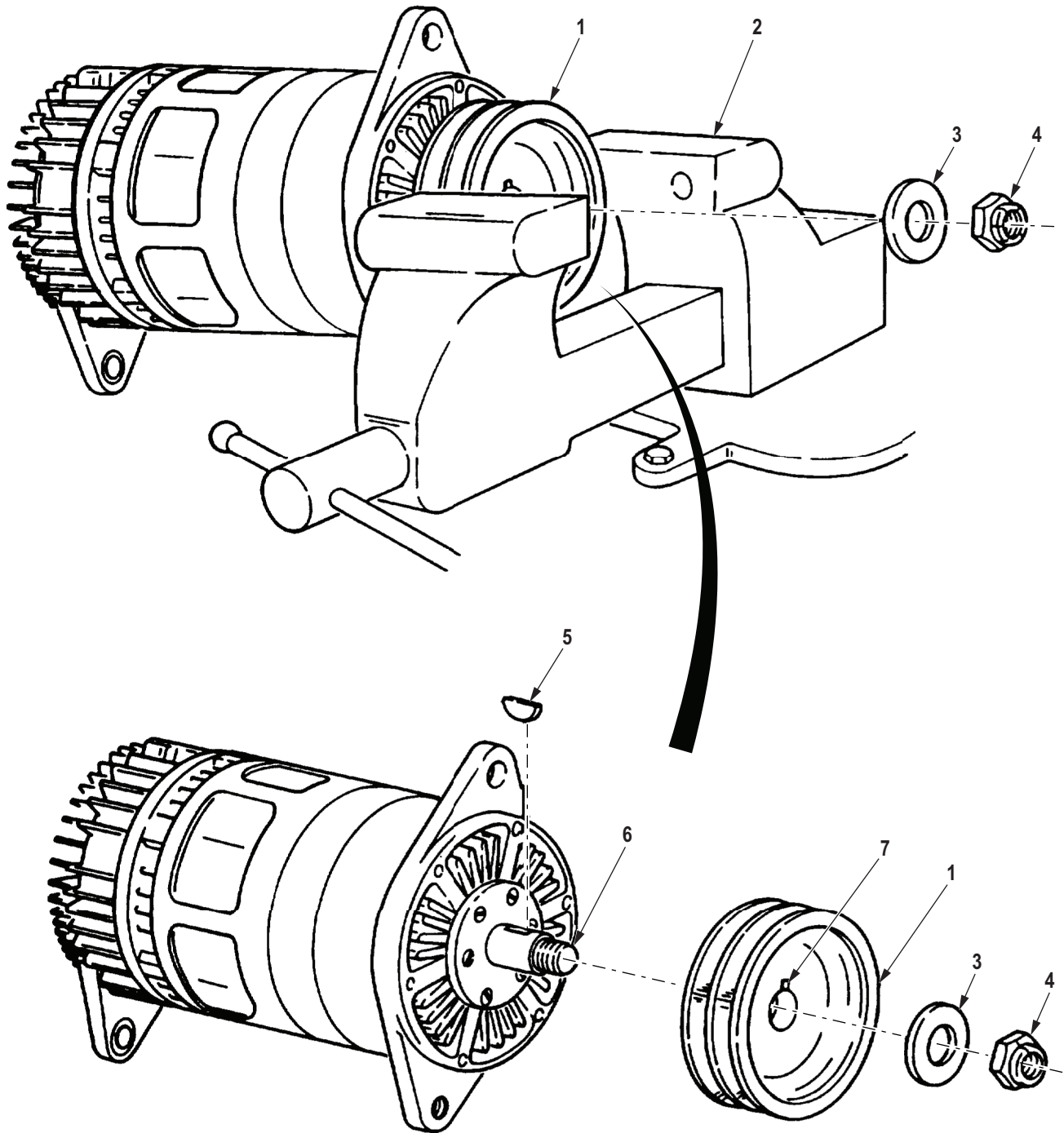

M0178DAA

Figure 4. Alternator Pulley Installation.

INSTALLATION - Continued

5. Install mounting bracket (Figure 5, Item 7) on engine (Figure 5, Item 8) with four lockwashers (Figure 5, Item 9) and screws (Figure 5, Item 10).
6. Install alternator (Figure 5, Item 12) on mounting bracket (Figure 5, Item 7) with two screws (Figure 5, Item 11), washers (Figure 5, Item 6), and locknuts (Figure 5, Item 5). Finger tighten locknuts.
7. Install washer (Figure 5, Item 3) and adjusting link (Figure 5, Item 13) on alternator (Figure 5, Item 12) with screw assembled washer (Figure 5, Item 4), washer (Figure 5, Item 2), lockwasher (Figure 5, Item 1), and screw (Figure 5, Item 14).

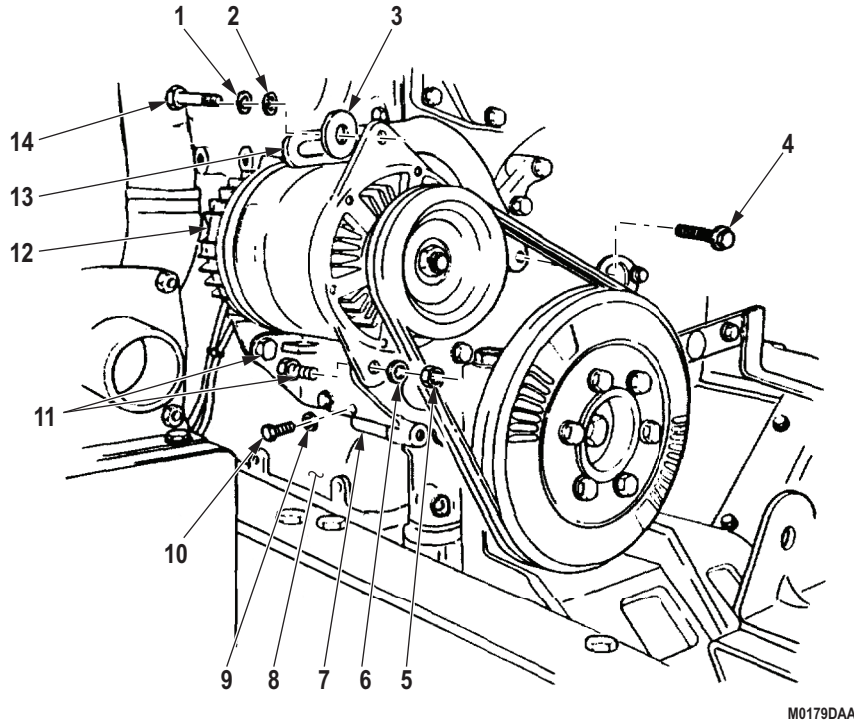

Figure 5. Alternator and Mounting Bracket Installation.

INSTALLATION - Continued**NOTE**

Ensure wire connecting points are thoroughly cleaned before connections are made.

8. Install wire (Figure 6, Item 2) on alternator (Figure 6, Item 15) with washer (Figure 6, Item 3), lockwasher (Figure 6, Item 4), and nut (Figure 6, Item 5). Tighten nut 45 to 55 lb-in. (5 to 6 N·m).
9. Install wire (Figure 6, Item 14) on alternator (Figure 6, Item 15) with washer (Figure 6, Item 13), lockwasher (Figure 6, Item 12), and nut (Figure 6, Item 11). Tighten nut 20 to 25 lb-in. (2 to 3 N·m).
10. Connect connector (Figure 6, Item 16) to alternator (Figure 6, Item 15).
11. Install wire (Figure 6, Item 18) on alternator (Figure 6, Item 15) with lockwasher (Figure 6, Item 19) and screw (Figure 6, Item 1). Tighten screw 82 to 102 lb-in. (9 to 12 N·m).

NOTE

Wires are held in place with strap.

12. Install wire retaining strap (Figure 6, Item 6) on alternator (Figure 6, Item 15) with two lockwashers (Figure 6, Item 7) and screws (Figure 6, Item 8).
13. Seal wires (Figure 6, Items 2 and 14) and connectors with gasket sealant.
14. Install tiedown strap (Figure 6, Item 17) on alternator wires.

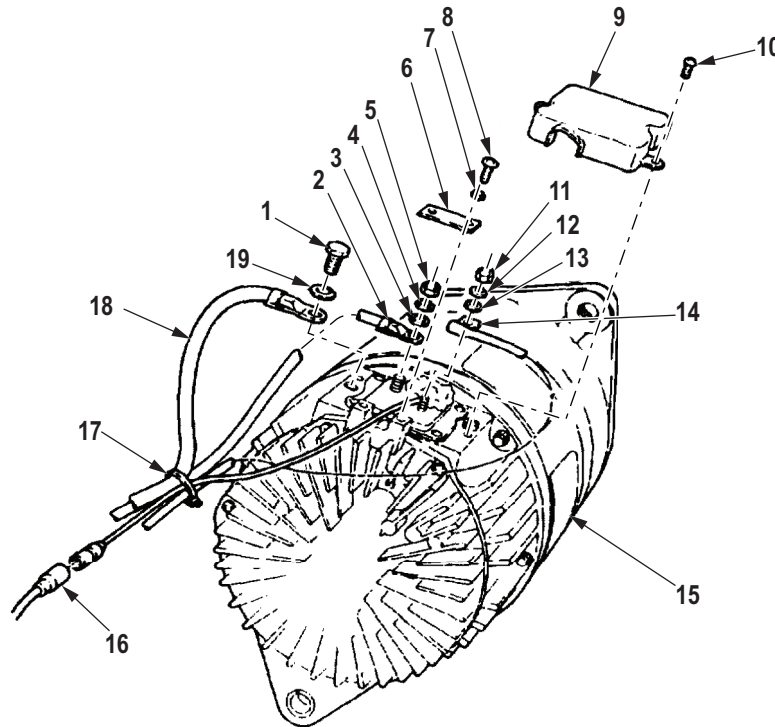

M0180DAA

Figure 6. Alternator and Mounting Bracket Installation.

END OF TASK

FOLLOW-ON MAINTENANCE

1. Install alternator drivebelts. (WP 0302)
2. Connect battery ground cable. (WP 0350)
3. Start engine and check alternator operation. (TM 9-2320-272-10)

END OF TASK**END OF WORK PACKAGE**

**FIELD MAINTENANCE
ALTERNATOR, MOUNTING BRACKET, AND PULLEY REPLACEMENT (M939A2)**

INITIAL SETUP:**Tools and Special Tools**

Tool Kit, General Mechanic's: Automotive
(Volume 5, WP 0826, Table 1, Item 56)
Multimeter
(Volume 5, WP 0826, Table 1, Item 34)
Puller Kit, Universal
(Volume 5, WP 0826, Table 1, Item 43)
Vise, Machinist's
(Volume 5, WP 0826, Table 1, Item 59)
Wrench, Torque, Click, Ratcheting, 3/8 in. Drive,
75 Ft-Lb
(Volume 5, WP 0826, Table 1, Item 62)

Materials/Parts

Adhesive, Silicone Rubber
(Volume 5, WP 0825, Table 1, Item 4)
Locknut (Volume 5, WP 0827, Table 1, Item 327)
Qty: 1
Lockwasher
(Volume 5, WP 0827, Table 1, Item 215)
Qty: 1
Lockwasher
(Volume 5, WP 0827, Table 1, Item 403)
Qty: 1
Lockwasher
(Volume 5, WP 0827, Table 1, Item 420)
Qty: 1

Materials/Parts (cont.)

Screw Assembled Lockwasher
(Volume 5, WP 0827, Table 1, Item 187)
Qty: 2
Woodruff Key
(Volume 5, WP 0827, Table 1, Item 419)
Qty: 1

Personnel Required

(2)

Equipment Condition

Parking brake set. (TM 9-2320-272-10)
Hood raised and secured. (TM 9-2320-272-10)
Right splash shield removed. (TM 9-2320-272-10)
Battery ground cables disconnected. (WP 0350)
Fan drivebelts removed. (WP 0296)

ALTERNATOR AND MOUNTING BRACKET REMOVAL

1. Remove screw (Figure 1, Item 12) and washer (Figure 1, Item 11) from alternator link (Figure 1, Item 10).
2. Loosen two screws (Figure 1, Item 2) and pivot alternator (Figure 1, Item 1) upward to access terminal cover (Figure 1, Item 20).
3. Remove two screw assembled lockwashers (Figure 1, Item 21) and terminal cover (Figure 1, Item 20) from alternator (Figure 1, Item 1). Discard screw assembled lockwashers.

NOTE

- Sealant must be removed before removing wires.
 - Tag all leads for installation.
4. Remove screw (Figure 1, Item 19), lockwasher (Figure 1, Item 18), negative wire (Figure 1, Item 25), and capacitor lead (Figure 1, Item 22) from alternator (Figure 1, Item 1). Discard lockwasher.
 5. Remove nut (Figure 1, Item 17), lockwasher (Figure 1, Item 16), lead wire 566 (Figure 1, Item 24), and capacitor (Figure 1, Item 15) from alternator (Figure 1, Item 1). Discard lockwasher.
 6. Remove locknut (Figure 1, Item 14), lockwasher (Figure 1, Item 13), positive wire (Figure 1, Item 23) from alternator (Figure 1, Item 1). Discard lockwasher.
 7. Disconnect wire (Figure 1, Item 26) from connector (Figure 1, Item 27).

WARNING

Alternator is heavy. Assistant will help with alternator removal. Failure to comply may result in injury or death to personnel.

8. Remove two screws (Figure 1, Item 2), washers (Figure 1, Item 3), and alternator (Figure 1, Item 1) from brackets (Figure 1, Items 4 and 6). Move bracket (Figure 1, Item 4) to one side.
9. Remove four screws (Figure 1, Item 7) and bracket (Figure 1, Item 6) from engine (Figure 1, Item 5).
10. Remove screw (Figure 1, Item 8), washer (Figure 1, Item 9), and alternator link (Figure 1, Item 10) from engine (Figure 1, Item 5).

ALTERNATOR AND MOUNTING BRACKET REMOVAL - Continued

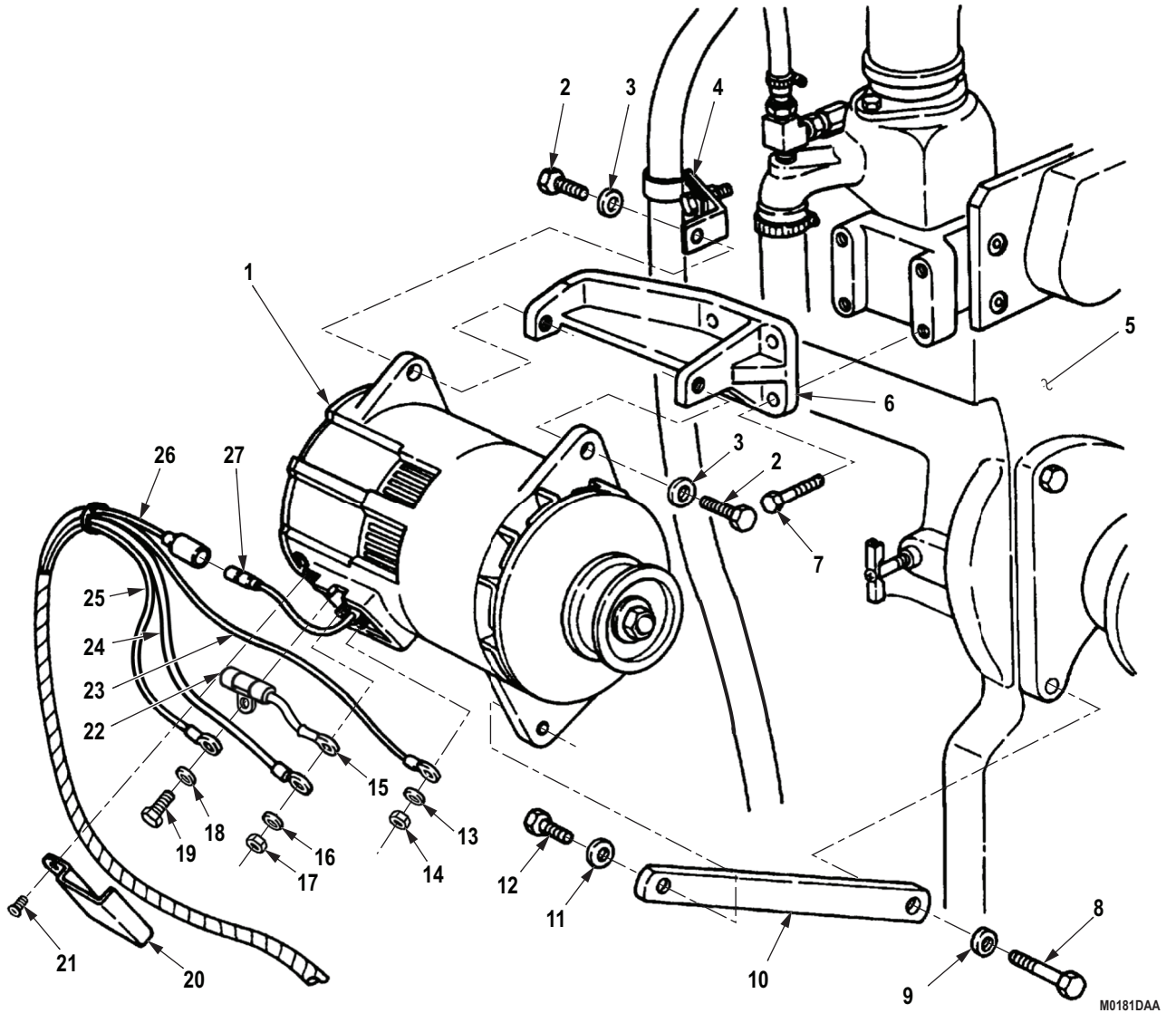

Figure 1. Alternator and Mounting Bracket Removal.

END OF TASK

PULLEY REMOVAL

1. Place alternator pulley (Figure 2, Item 1) in vise (Figure 2, Item 2).
2. Remove locknut (Figure 2, Item 4) and washer (Figure 2, Item 3) from pulley shaft (Figure 2, Item 6). Discard locknut.
3. Remove alternator pulley (Figure 2, Item 1) from vise (Figure 2, Item 2).
4. Using universal puller, remove alternator pulley (Figure 2, Item 1) and woodruff key (Figure 2, Item 5) from pulley shaft (Figure 2, Item 6). Discard woodruff key.

PULLEY REMOVAL - Continued

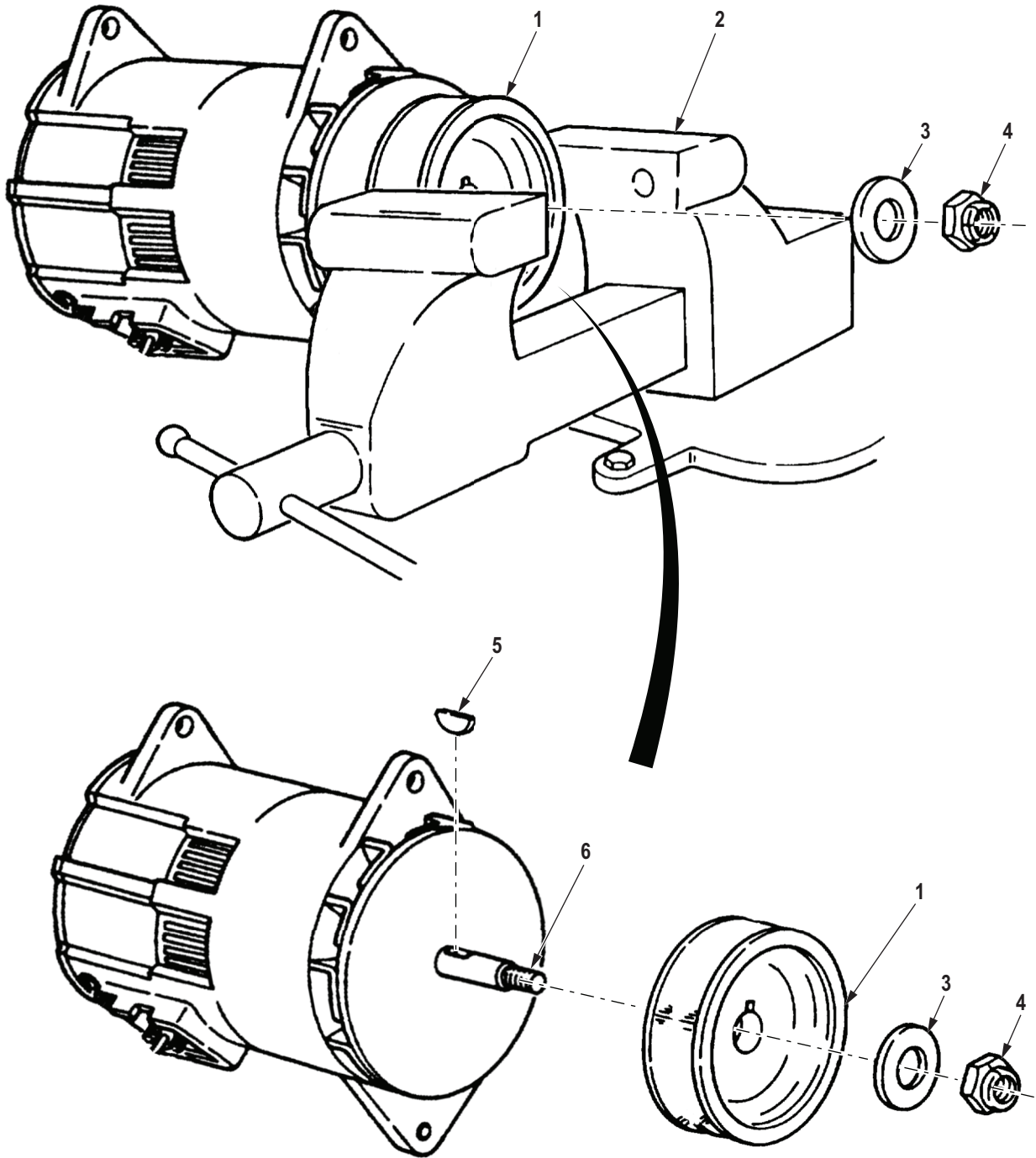

M10383DAA

Figure 2. Pulley Removal.

END OF TASK

PULLEY INSTALLATION

1. Install woodruff key (Figure 3, Item 5) in groove of pulley shaft (Figure 3, Item 6) with flat edge up.
2. Install pulley (Figure 3, Item 1) on pulley shaft (Figure 3, Item 6) with keyway (Figure 3, Item 7) on woodruff key (Figure 3, Item 5).
3. Place alternator pulley (Figure 3, Item 1) in vise (Figure 4, Item 2).
4. Install washer (Figure 3, Item 3) and locknut (Figure 3, Item 4) on pulley shaft (Figure 3, Item 6). Tighten locknut 90 to 100 lb-ft (122 to 136 N·m).

PULLEY INSTALLATION - Continued

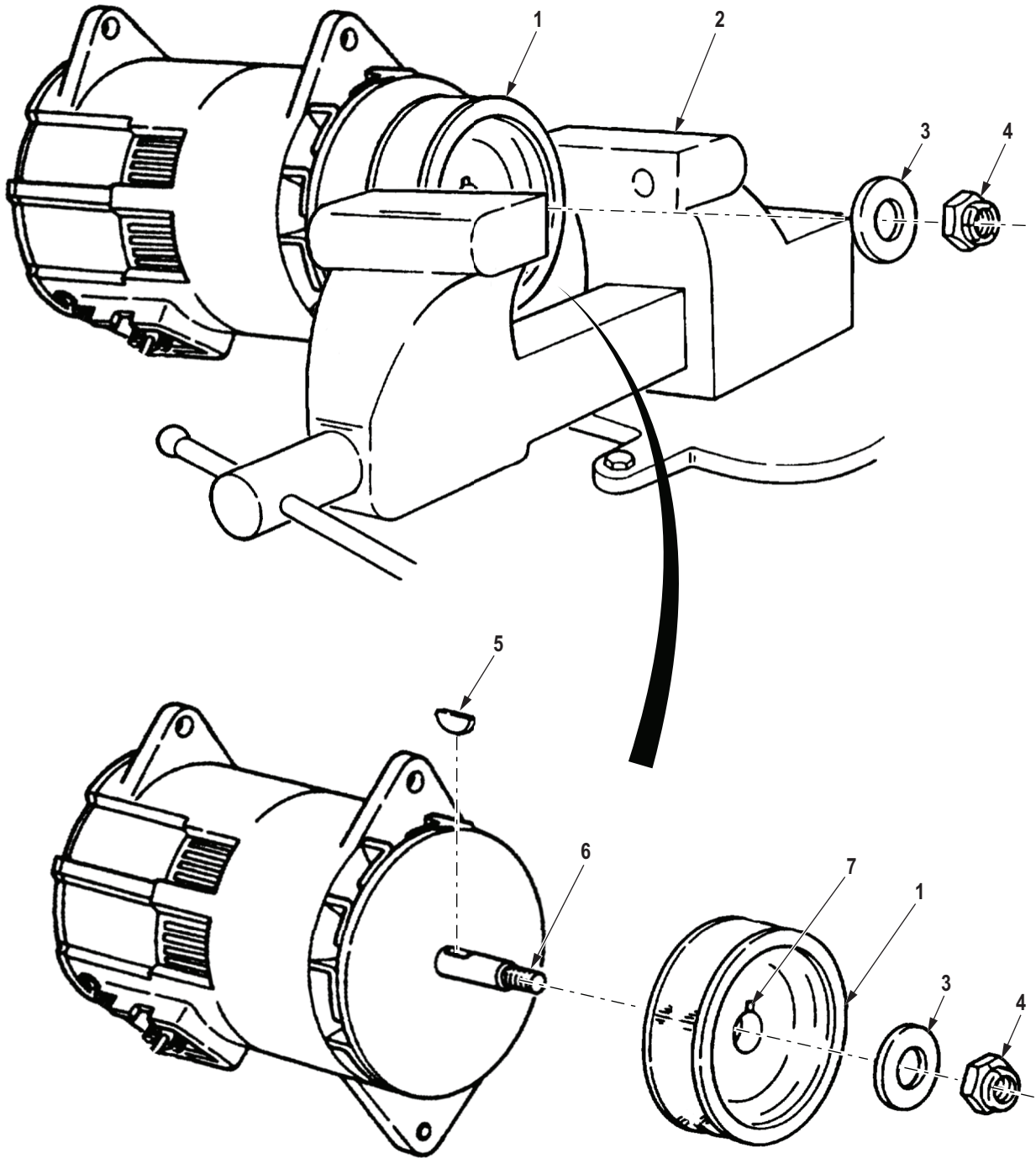

M10384DAA

Figure 3. Pulley Installation.

END OF TASK

ALTERNATOR AND MOUNTING BRACKET INSTALLATION**WARNING**

Alternator is heavy. Assistant will help with alternator removal. Failure to comply may result in injury or death to personnel.

NOTE

Ensure wire connecting points are thoroughly cleaned before connections are made.

1. Install alternator link (Figure 4, Item 10) on engine (Figure 4, Item 5) with washer (Figure 4, Item 9) and screw (Figure 4, Item 8).
2. Install mounting bracket (Figure 4, Item 6) on engine (Figure 4, Item 5) with four screws (Figure 4, Item 7).
3. Install alternator (Figure 4, Item 1) on mounting bracket (Figure 4, Item 6) and bracket (Figure 4, Item 4) with two washers (Figure 4, Item 3) and screws (Figure 4, Item 2). Finger-tighten screws.
4. Connect wire (Figure 4, Item 26) to connector (Figure 4, Item 27).
5. Install positive wire (Figure 4, Item 23) on alternator (Figure 4, Item 1) with lockwasher (Figure 4, Item 13) and nut (Figure 4, Item 14). Tighten nut 45 to 55 lb-in. (5 to 6 N·m).
6. Install lead wire 566 (Figure 4, Item 24) and capacitor lead (Figure 4, Item 15) on alternator (Figure 4, Item 1) with lockwasher (Figure 4, Item 16) and nut (Figure 4, Item 17). Tighten nut 20 to 25 lb-in. (2 to 3 N·m).
7. Install negative wire (Figure 4, Item 25) and capacitor lead (Figure 4, Item 22) on alternator (Figure 4, Item 1) with lockwasher (Figure 4, Item 18) and screw (Figure 4, Item 19). Tighten screw 82 to 102 lb-in. (9 to 12 N·m).
8. Pivot alternator (Figure 4, Item 1) to align with alternator link (Figure 4, Item 10).
9. Install alternator link (Figure 4, Item 10) on alternator (Figure 4, Item 1) with washer (Figure 4, Item 11) and screw (Figure 4, Item 12).
10. Install fan drivebelt (WP 0296).
11. Connect battery ground cables (WP 0350).
12. Adjust alternator (Figure 4, Item 1) as found in the ADJUSTMENT section of this work package.

ALTERNATOR AND MOUNTING BRACKET INSTALLATION - Continued

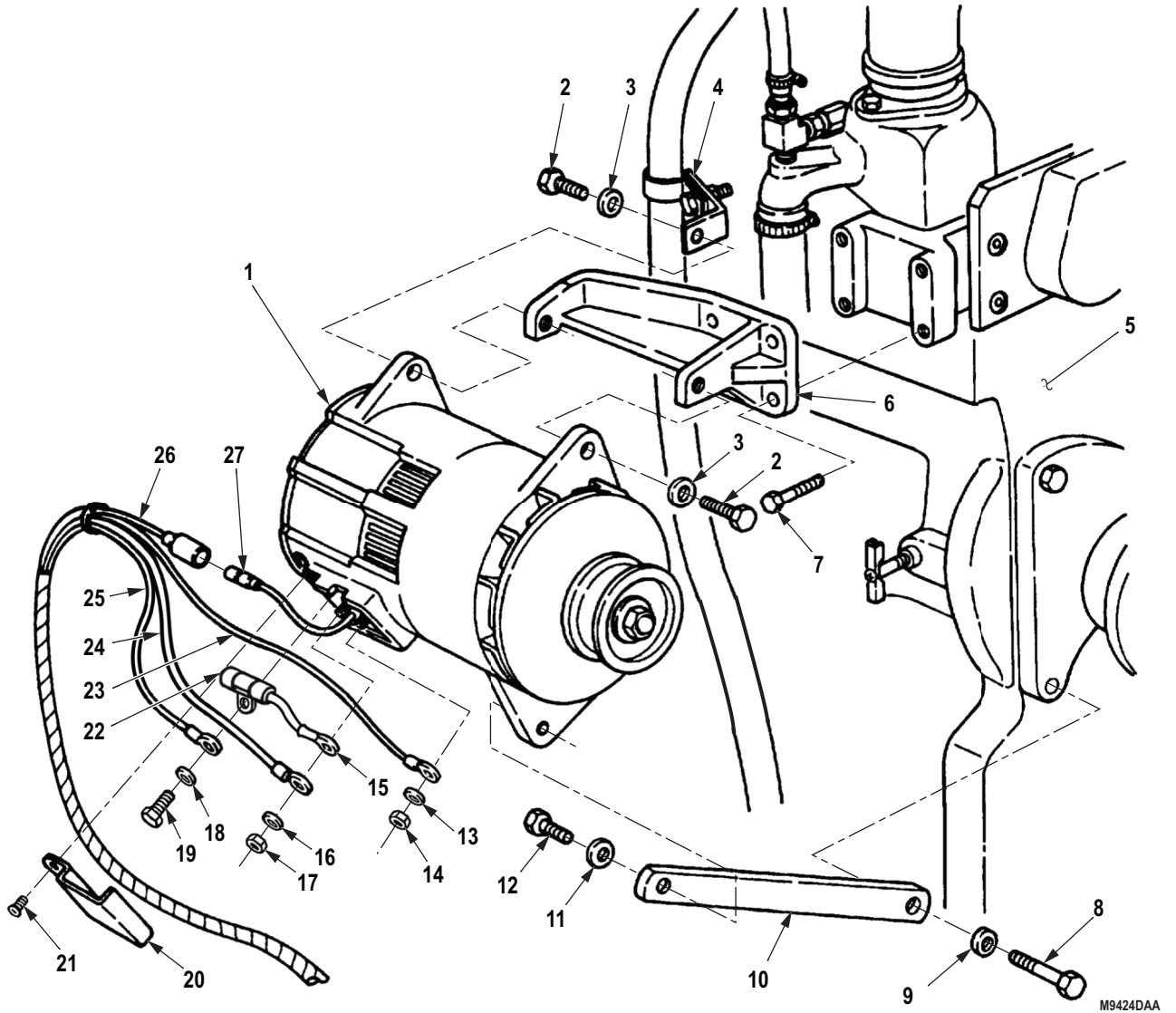

Figure 4. Alternator and Mounting Bracket Installation.

END OF TASK

ADJUSTMENT

1. Start engine (TM 9-2320-272-10).
2. Set engine speed to 1,200 rpm (TM 9-2320-272-10).
3. Turn on headlights (TM 9-2320-272-10) to place load on alternator (Figure 5, Item 1).
4. Using multimeter, check alternator (Figure 5, Item 1) output voltage. Connect black lead to ground cable (Figure 5, Item 27) and touch red lead to wire (Figure 5, Item 28). Output voltage should be 27.8 to 28.2 VDC. If adjustment is required, continue with next step. If no adjustment is required, proceed to Step (8).
5. Using hex-head driver, remove pipe plug (Figure 5, Item 30) from alternator (Figure 5, Item 1).
6. Turn adjusting screw counterclockwise to increase or clockwise to decrease voltage.
7. Apply silicone rubber adhesive to pipe plug (Figure 5, Item 30) threads. Using hex-head driver, install pipe plug (Figure 5, Item 30) and tighten 24 to 36 lb-in. (3 to 4 N·m).
8. Turn off headlights (TM 9-2320-272-10).
9. Stop engine (TM 9-2320-272-10).
10. Seal wires (Figure 5, Items 25, 26, 27, and 28) and connector (Figure 5, Item 29) completely with silicone rubber adhesive.
11. Install terminal cover (Figure 5, Item 23) on alternator (Figure 5, Item 1) with two screw assembly lockwashers (Figure 5, Item 24).

ADJUSTMENT - Continued

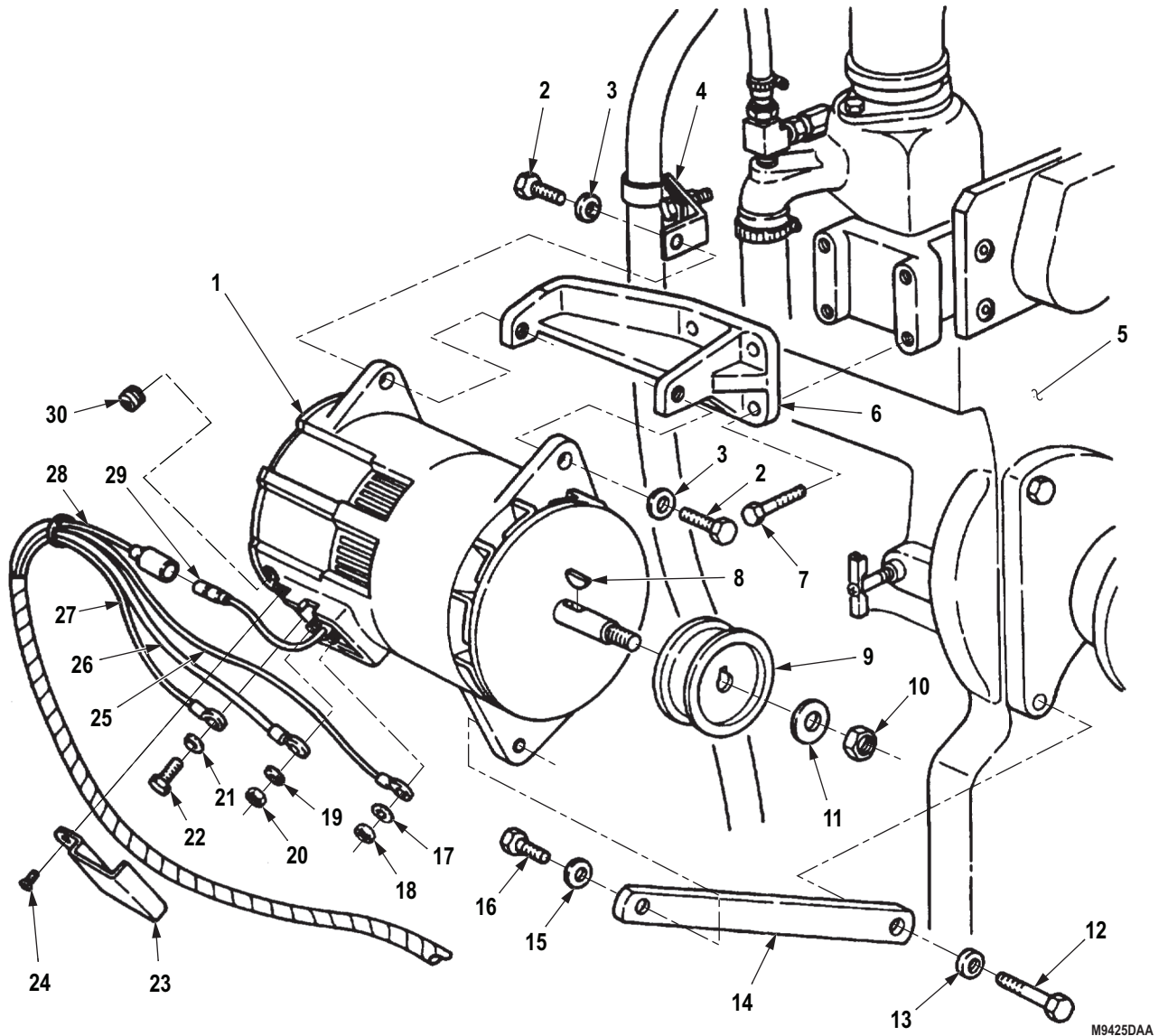

M9425DAA

Figure 5. Alternator, Mounting Bracket, and Pulley Adjustment.

END OF TASK

FOLLOW-ON MAINTENANCE

Install right splash shield. (TM 9-2320-272-10)

END OF TASK

END OF WORK PACKAGE

**FIELD MAINTENANCE
ALTERNATOR DRIVEBELTS REPLACEMENT (M939/A1)**

INITIAL SETUP:**Tools and Special Tools**

Tool Kit, General Mechanic's: Automotive
(Volume 5, WP 0826, Table 1, Item 56)
Belt, Tension Gauge
(Volume 5, WP 0826, Table 1, Item 9)
Wrench, Torque, Click, Ratcheting, 1/2" Drive,
250 Ft-Lb
(Volume 5, WP 0826, Table 1, Item 63)

Equipment Condition (cont.)

Hood raised and secured. (TM 9-2320-272-10)
Right splash shield removed. (TM 9-2320-272-10)

Equipment Condition

Parking brake set. (TM 9-2320-272-10)

REMOVAL

1. Loosen screws (Figure 1, Items 3 and 6) at adjusting link (Figure 1, Item 2). Do not remove screws.
2. Loosen two screws (Figure 1, Item 9) on alternator mounting bracket (Figure 1, Item 10). Do not remove screws.
3. Push alternator (Figure 1, Item 1) toward engine (Figure 1, Item 5) until slack exists in two alternator belts (Figure 1, Item 8). Remove two alternator belts from alternator pulley (Figure 1, Item 4) and vibration damper (Figure 1, Item 7).

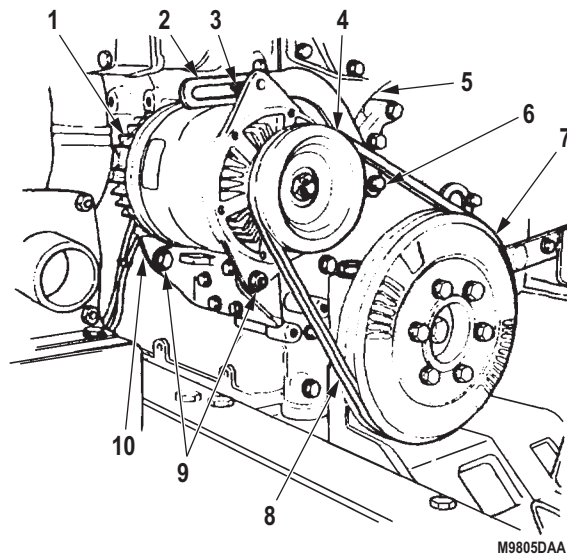

Figure 1. Alternator Drivebelts Removal.

END OF TASK**INSPECTION**

Inspect two alternator belts for breaks, cracks, or splits. Replace if broken, cracked or split.

END OF TASK

INSTALLATION AND ADJUSTMENT**NOTE**

Alternator belts must be replaced as matched sets.

1. Position two alternator belts (Figure 2, Item 8) over vibration damper (Figure 2, Item 7) and alternator pulley (Figure 2, Item 4).

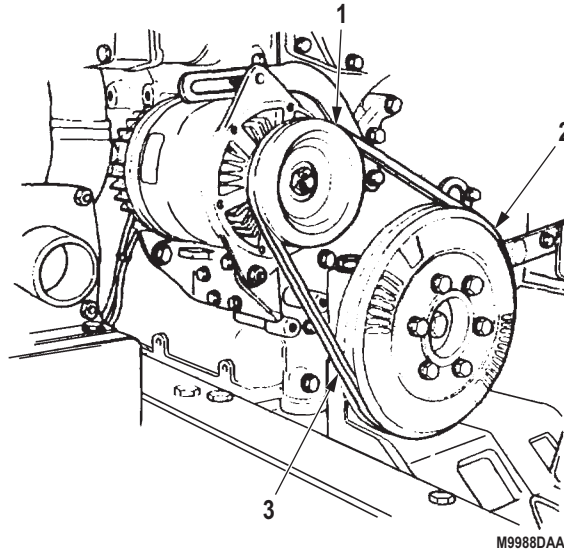

Figure 2. Alternator Drivebelts Installation.

2. Insert prybar (Figure 3, Item 1) between engine (Figure 3, Item 2) and alternator (Figure 3, Item 4) and pull prybar (Figure 3, Item 1) down until belts (Figure 3, Item 3) appear tight.

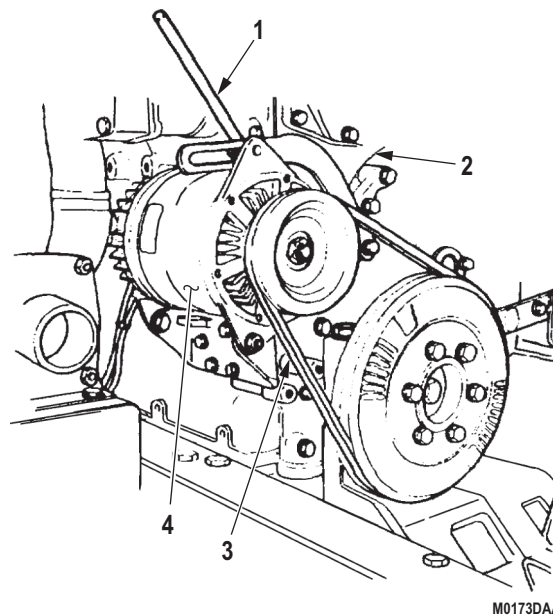

Figure 3. Alternator Drivebelts Installation.

INSTALLATION AND ADJUSTMENT - Continued

3. Tighten screw (Figure 4, Item 2) on adjusting link (Figure 4, Item 1) 15 to 20 lb-ft (20 to 27 N·m).
4. Tighten screw (Figure 4, Item 3) on adjusting link (Figure 4, Item 1) 25 to 31 lb-ft (34 to 42 N·m).

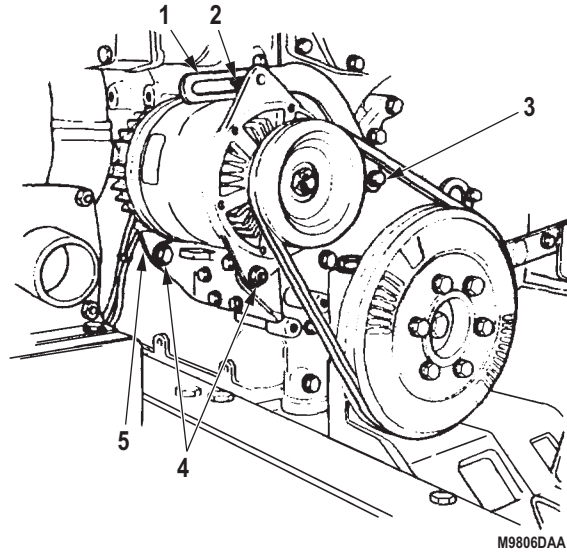

Figure 4. Alternator Drivebelts Installation.

5. Using belt tension gauge (Figure 5, Item 2), check for proper tension. Tension of new belts (Figure 5, Item 1) should be 95 to 105 lb-ft (423 to 467 N·m). Tension of used belts should be 85 to 95 lb-ft (378 to 422 N·m). Replace belts if they cannot be adjusted.

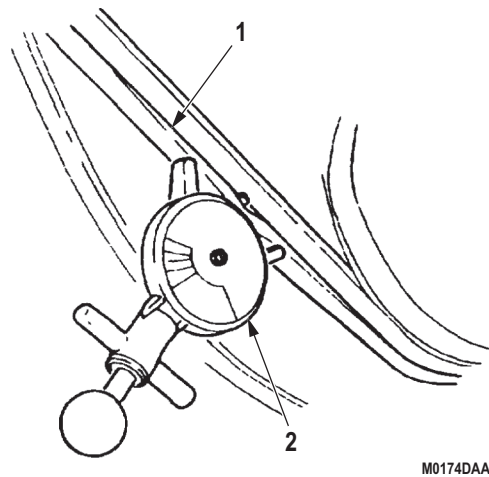

Figure 5. Alternator Drivebelts Installation.

6. Tighten two screws (Figure 4, Item 4) on mounting bracket (Figure 4, Item 5) 39 to 49 lb-ft (53 to 66 N·m).

END OF TASK

FOLLOW-ON MAINTENANCE

1. Start engine and check alternator operation. (TM 9-2320-272-10)
2. Install right splash shield. (TM 9-2320-272-10)

END OF TASK**END OF WORK PACKAGE**

**FIELD MAINTENANCE
STARTER REPLACEMENT**

INITIAL SETUP:**Tools and Special Tools**

Tool Kit, General Mechanic's: Automotive
(Volume 5, WP 0826, Table 1, Item 56)

Materials/Parts

Gasket (M939/A1)
(Volume 5, WP 0827, Table 1, Item 8)
Qty: 1
Gasket (M939/A1)
(Volume 5, WP 0827, Table 1, Item 31)
Qty: 1
Gasket (M939A2)
(Volume 5, WP 0827, Table 1, Item 113)
Qty: 1
Gasket (M939A2)

Materials/Parts (cont.)

(Volume 5, WP 0827, Table 1, Item 119)
Qty: 1
Lockwasher (M939/A1)
(Volume 5, WP 0827, Table 1, Item 406)
Qty: 2
Lockwasher (M939A2)
(Volume 5, WP 0827, Table 1, Item 406)
Qty: 4

Personnel Required

(2)

Equipment Condition

Parking brake set. (TM 9-2320-272-10)
Hood raised and secured. (TM 9-2320-272-10)
Battery ground cables disconnected.
(Volume 3, WP 0426)

REMOVAL**NOTE**

- Tag wires for installation.
 - Step (1) is for M939A2 vehicles only.
1. Remove nut (Figure 1, Item 24), lockwasher (Figure 1, Item 23), and wire (Figure 1, Item 22) from solenoid (Figure 1, Item 2). Discard lockwasher.
 2. Remove nut (Figure 1, Item 16), lockwasher (Figure 1, Item 17), and wires (Figure 1, Items 15 and 18) from solenoid (Figure 1, Item 2). Discard lockwasher.

NOTE

Ground strap will be present on M939/A1 vehicles only.

3. Remove nut (Figure 1, Item 12), lockwasher (Figure 1, Item 13), wires (Figure 1, Items 11 and 14), and ground strap (Figure 1, Item 10) from starter (Figure 1, Item 9). Discard lockwasher.

NOTE

Step (4) is for M939A2 vehicles only.

4. Remove nut (Figure 1, Item 25), lockwasher (Figure 1, Item 26), and wire (Figure 1, Item 27) from starter (Figure 1, Item 9). Discard lockwasher.

NOTE

Step (5) is for M939/A1 vehicles only.

5. Remove screw (Figure 1, Item 21), clip (Figure 1, Item 20), and wire (Figure 1, Item 19) from solenoid (Figure 1, Item 2).

NOTE

- Step (6) and (7) is for M939A2 vehicles only.
 - Assistant will help with Step (6).
6. Remove three screws (Figure 1, Item 8), washers (Figure 1, Item 7), starter (Figure 1, Item 9), gasket (Figure 1, Item 6), spacer (Figure 1, Item 5), and gasket (Figure 1, Item 4) from flywheel housing (Figure 1, Item 3). Discard gaskets.

NOTE

- Step (8) and (9) is for M939/A1 only.
 - Assistant will help with Step (9).
7. Remove three sleeves (Figure 1, Item 28) from starter (Figure 1, Item 9).
 8. Remove screw-assembled washer (Figure 1, Item 1) from starter (Figure 1, Item 9).
 9. Remove two screws (Figure 1, Item 8), washers (Figure 1, Item 7), starter (Figure 1, Item 9), gasket (Figure 1, Item 6), spacer (Figure 1, Item 5), and gasket (Figure 1, Item 4) from flywheel housing (Figure 1, Item 3). Discard gaskets.

REMOVAL - Continued

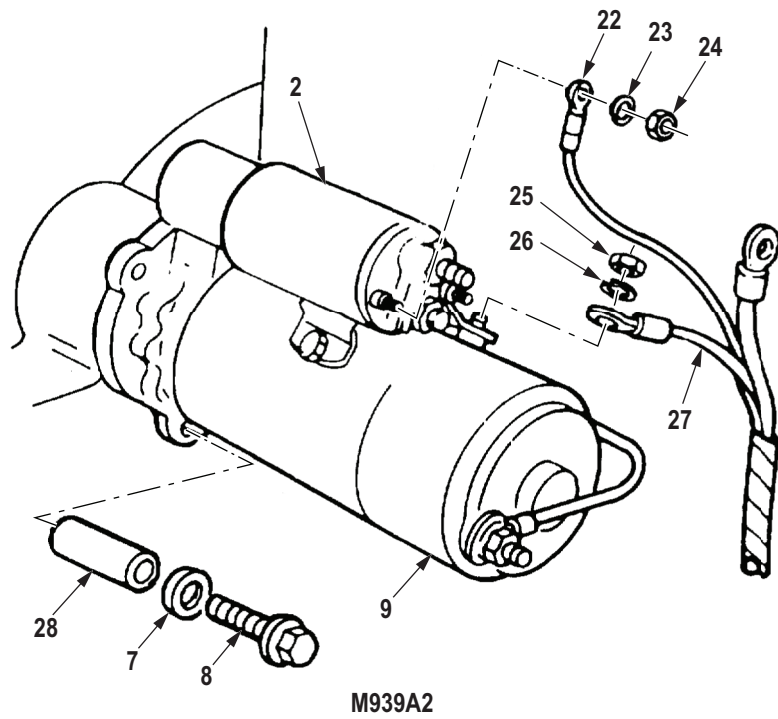
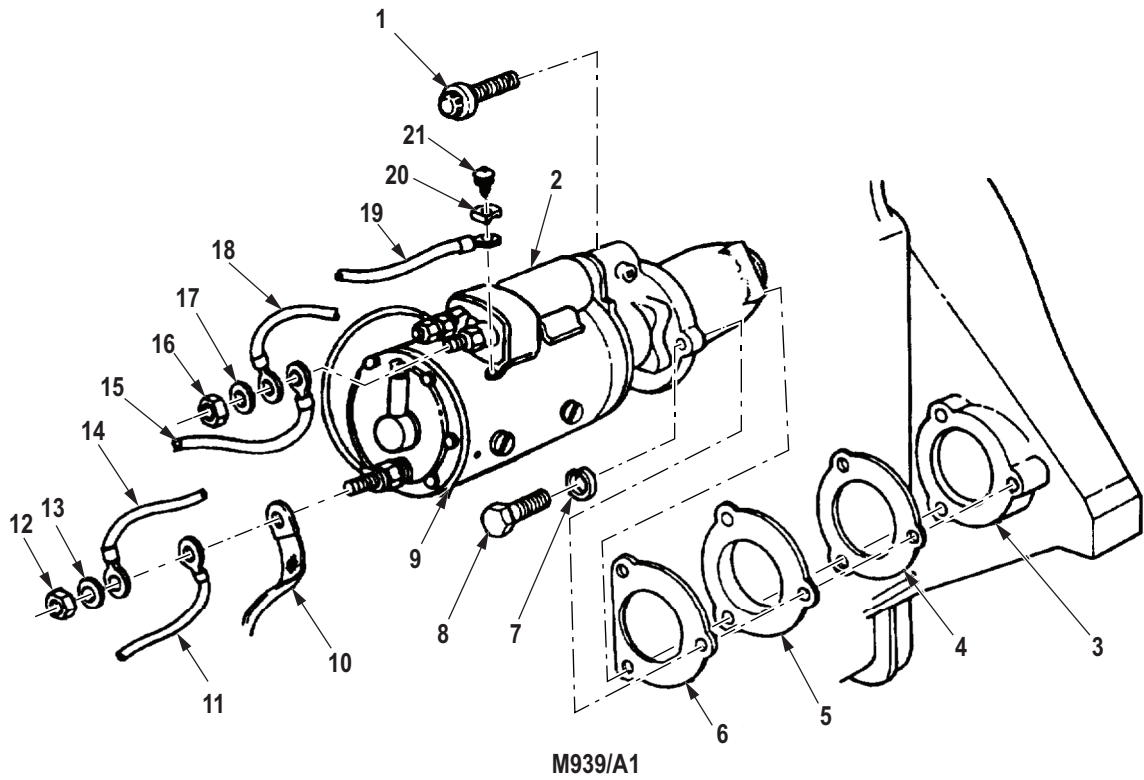

Figure 1. Starter Replacement Removal.

END OF TASK

INSTALLATION**NOTE**

- Steps (1) and (2) are for M939/A1 vehicles only.
 - Assistant will help with Step (1).
1. Install gasket (Figure 2, Item 4), spacer (Figure 2, Item 5), gasket (Figure 2, Item 6), and starter (Figure 2, Item 9) on flywheel housing (Figure 2, Item 3) with two washers (Figure 2, Item 7) and screws (Figure 2, Item 8). Tighten screws 55 lb-ft (75 N·m).
 2. Install screw-assembled washer (Figure 2, Item 1) in starter (Figure 2, Item 9).

NOTE

- Steps (3) and (4) are for M939A2 vehicles only.
 - Assistant will help with Step (4).
3. Install three sleeves (Figure 2, Item 28) on starter (Figure 2, Item 9).
 4. Install gasket (Figure 2, Item 4), spacer (Figure 2, Item 5), gasket (Figure 2, Item 6), and starter (Figure 2, Item 9) on flywheel housing (Figure 2, Item 3) with three washers (Figure 2, Item 7) and screws (Figure 2, Item 8). Tighten screws 55 lb-ft (75 N·m).

NOTE

Step (5) is for M939/A1 vehicles only.

5. Install wire (Figure 2, Item 19) on solenoid (Figure 2, Item 2) with clip (Figure 2, Item 20) and screw (Figure 2, Item 21).

NOTE

Step (6) is for M939A2 vehicles only.

6. Install wire (Figure 2, Item 27) on starter (Figure 2, Item 9) with lockwasher (Figure 2, Item 26) and nut (Figure 2, Item 25).

NOTE

Ground strap will be present on M939/A1 vehicles only.

7. Install ground strap (Figure 2, Item 10) and wires (Figure 2, Items 11 and 14) on starter (Figure 2, Item 9) with lockwasher (Figure 2, Item 13) and nut (Figure 2, Item 12).
8. Install wires (Figure 2, Items 15 and 18) on solenoid (Figure 2, Item 2) with a lockwasher (Figure 2, Item 17) and nut (Figure 2, Item 16).

NOTE

Step (6) is for M939A2 vehicles only.

9. Install wire (Figure 2, Item 22) on solenoid (Figure 2, Item 2) with lockwasher (Figure 2, Item 23) and nut (Figure 2, Item 24).

INSTALLATION - Continued

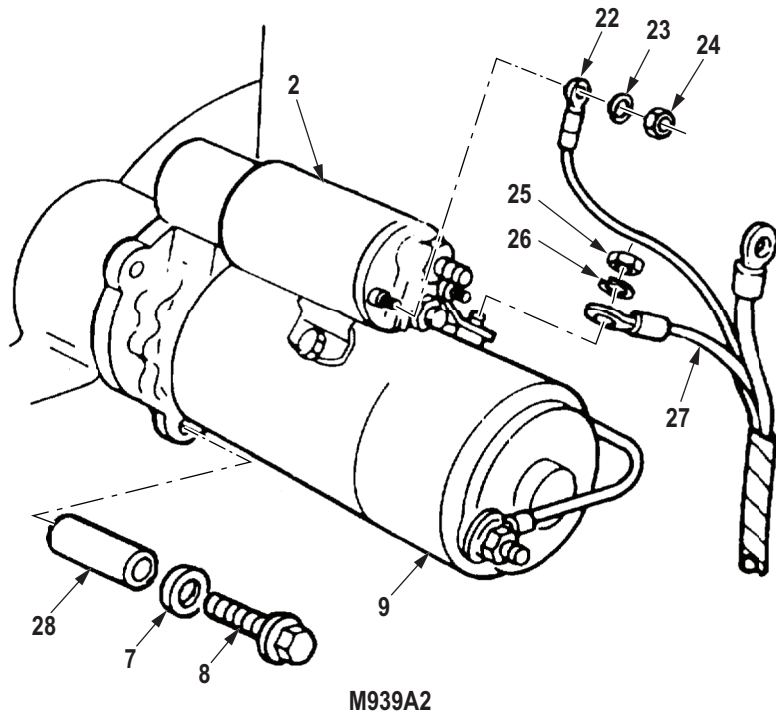
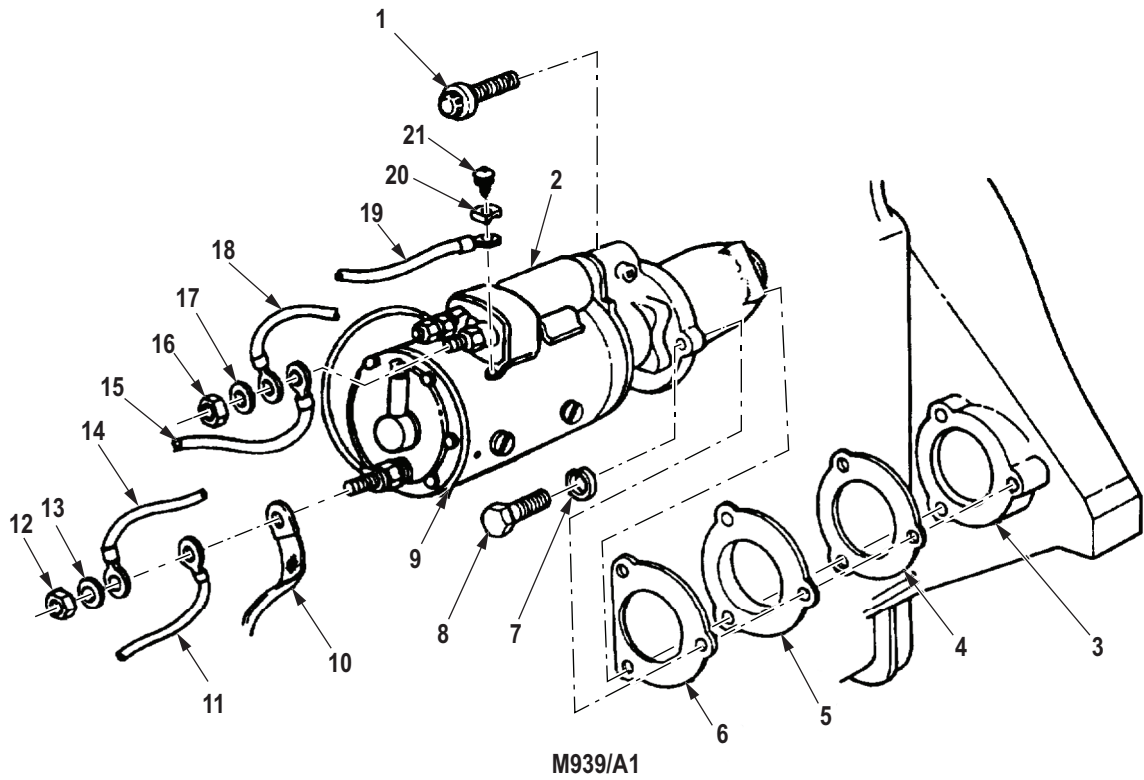

M0184DAA

Figure 2. Starter Installation.

END OF TASK

FOLLOW-ON MAINTENANCE

Connect battery ground cables. (WP 0350)

END OF TASK

END OF WORK PACKAGE

**FIELD MAINTENANCE
THROTTLE CONTROL SOLENOID REPLACEMENT (M939A2)**

INITIAL SETUP:

Tools and Special Tools

Tool Kit, General Mechanic's: Automotive
(Volume 5, WP 0826, Table 1, Item 56)

Equipment Condition (cont.)

Hood raised and secured. (TM 9-2320-272-10)
Battery ground cables disconnected. (WP 0350)

Equipment Condition

Parking brake set. (TM 9-2320-272-10)

REMOVAL

1. Disconnect plug (Figure 1, Item 6) from wiring harness (Figure 1, Item 7).
2. Remove two screws (Figure 1, Item 4) and throttle control solenoid (Figure 1, Item 5) from bracket (Figure 1, Item 3).
3. Remove boot (Figure 1, Item 8) from throttle control solenoid (Figure 1, Item 5).
4. Remove two screws (Figure 1, Item 2) and bracket (Figure 1, Item 3) from engine (Figure 1, Item 1).

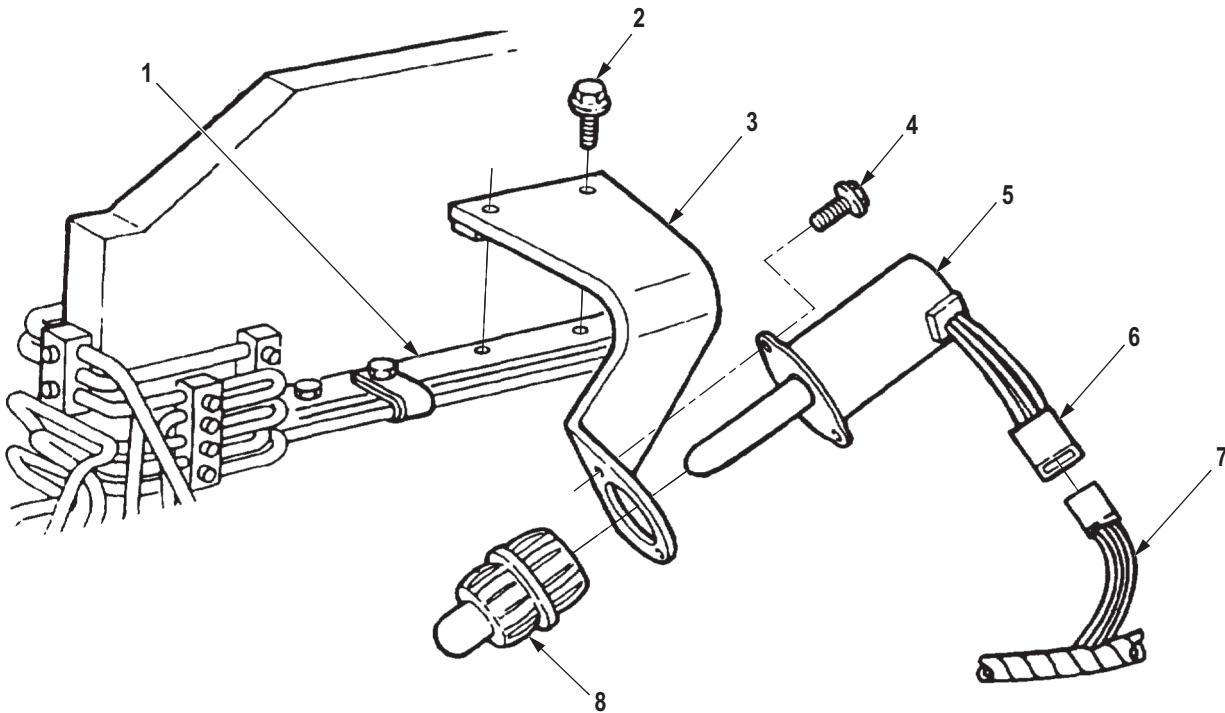

M0107DAA

Figure 1. Throttle Control Solenoid Removal.

END OF TASK

INSTALLATION

1. Install bracket (Figure 2, Item 3) on engine (Figure 2, Item 1) with two screws (Figure 2, Item 2).
2. Install boot (Figure 2, Item 8) on throttle control solenoid (Figure 2, Item 5).
3. Install throttle control solenoid (Figure 2, Item 5) on bracket (Figure 2, Item 3) with two screws (Figure 2, Item 4).
4. Connect plug (Figure 2, Item 6) to wiring harness (Figure 2, Item 7).

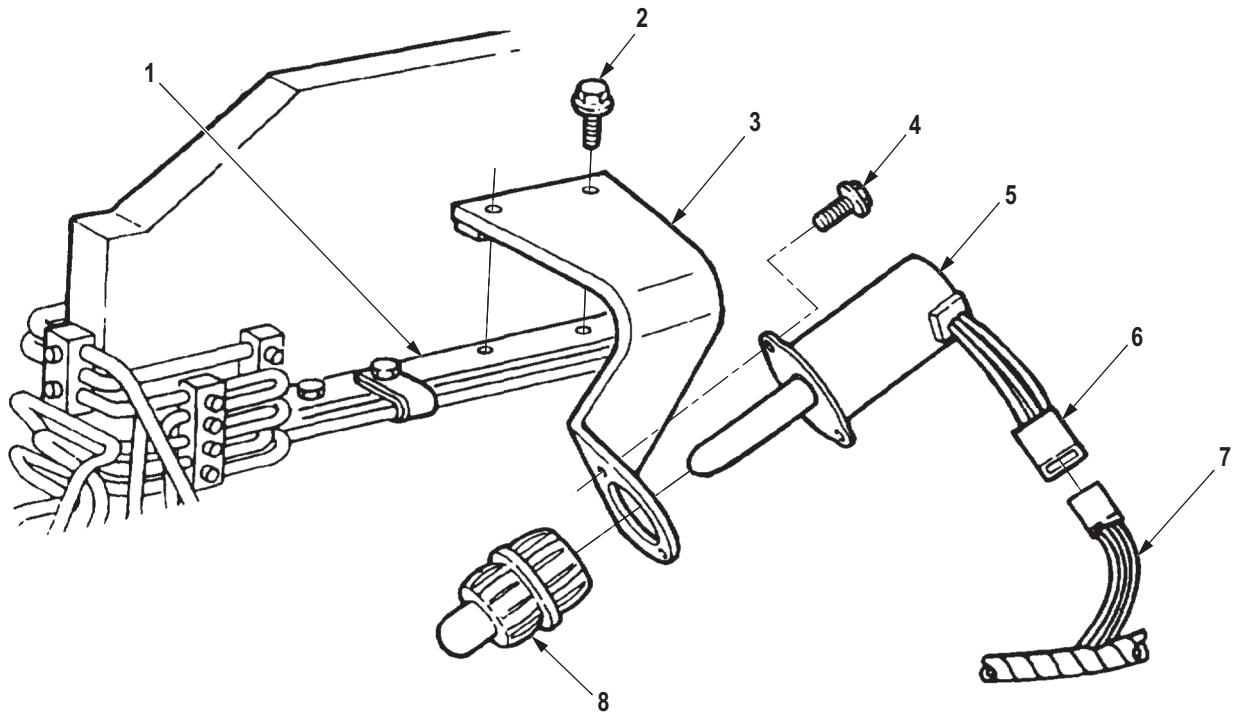

M0108DAA

Figure 2. Throttle Control Solenoid Installation.

END OF TASK**FOLLOW-ON MAINTENANCE**

Connect battery ground cables. (WP 0350)

END OF TASK**END OF WORK PACKAGE**

FIELD MAINTENANCE
FUEL PUMP METERING VALVE REPLACEMENT (M939/A1)

INITIAL SETUP:**Tools and Special Tools**

Tool Kit, General Mechanic's: Automotive
(Volume 5, WP 0826, Table 1, Item 56)

Equipment Condition

Hood raised and secured. (TM 9-2320-272-10)
Left splash shield removed. (TM 9-2320-272-10)

Materials/Parts

Cap Set, Protective, Dust and Moisture Seal
(Volume 5, WP 0825, Table 1, Item 13)
Packing, Preformed
(Volume 5, WP 0827, Table 1, Item 73)
Qty: 1

MANUAL SHUTOFF VALVE REMOVAL

1. Disconnect fuel line (Figure 1, Item 3) from manual fuel shutoff valve (Figure 1, Item 4).
2. Loosen screw (Figure 1, Item 7), remove clip (Figure 1, Item 1), and pull fuel shutoff control cable (Figure 1, Item 5) until free of shutoff lever (Figure 1, Item 2).
3. Remove manual fuel shutoff valve (Figure 1, Item 4) from fuel pump metering valve (Figure 1, Item 6).

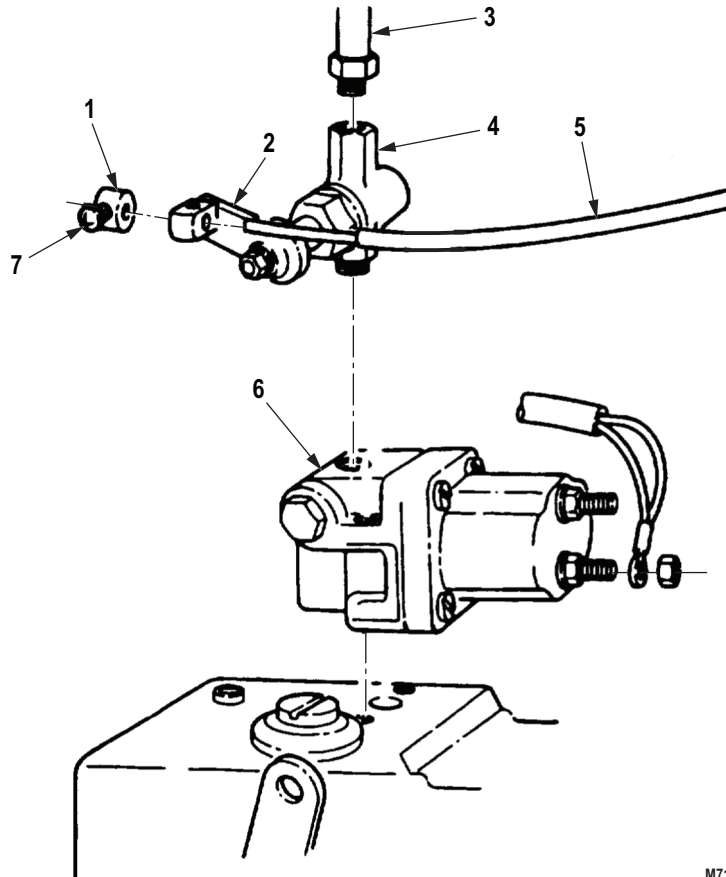

M7143DAA

Figure 1. Manual Shutoff Valve Removal.

END OF TASK

FUEL PUMP METERING VALVE REMOVAL

1. Remove nut (Figure 2, Item 5) and wires (Figure 2, Item 4) from terminal (Figure 2, Item 6).
2. Remove two screws (Figure 2, Item 1), lockwashers (Figure 2, Item 2), and washers (Figure 2, Item 3) from fuel pump metering valve (Figure 2, Item 7). Discard lockwashers.
3. Remove fuel shutoff valve (Figure 2, Item 7) and preformed packing (Figure 2, Item 8) from fuel pump (Figure 2, Item 9). Plug openings in fuel pump. Discard preformed packing.

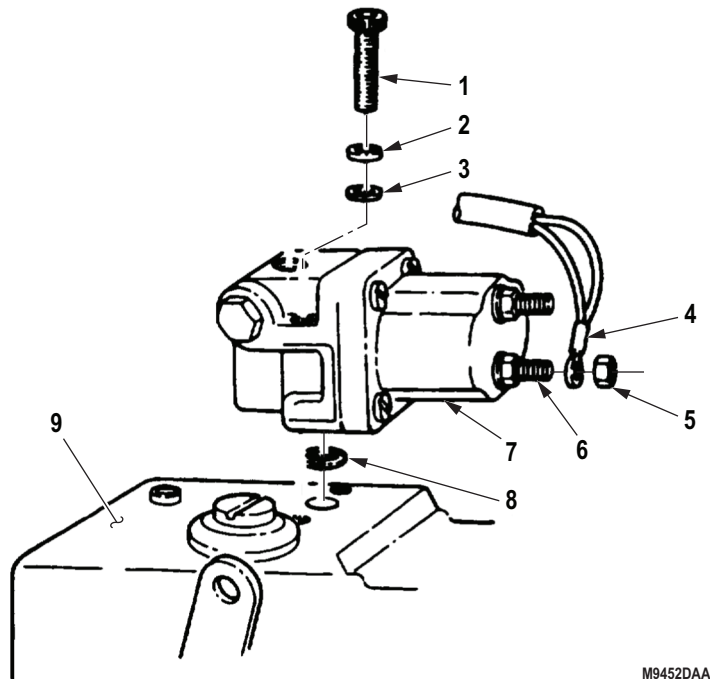

Figure 2. Fuel Pump Metering Valve Removal.

END OF TASK

FUEL PUMP METERING VALVE INSTALLATION

1. Install preformed packing (Figure 3, Item 8) and fuel pump metering valve (Figure 3, Item 7) on fuel pump (Figure 3, Item 9) with two washers (Figure 3, Item 3), lockwashers (Figure 3, Item 2), and screws (Figure 3, Item 1).
2. Install wires (Figure 3, Item 4) on terminal (Figure 3, Item 6) with nut (Figure 3, Item 5).

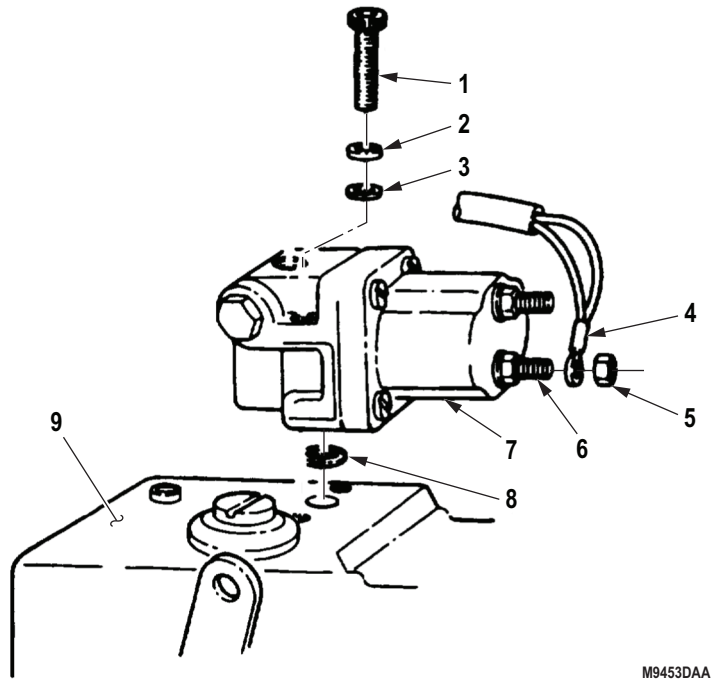
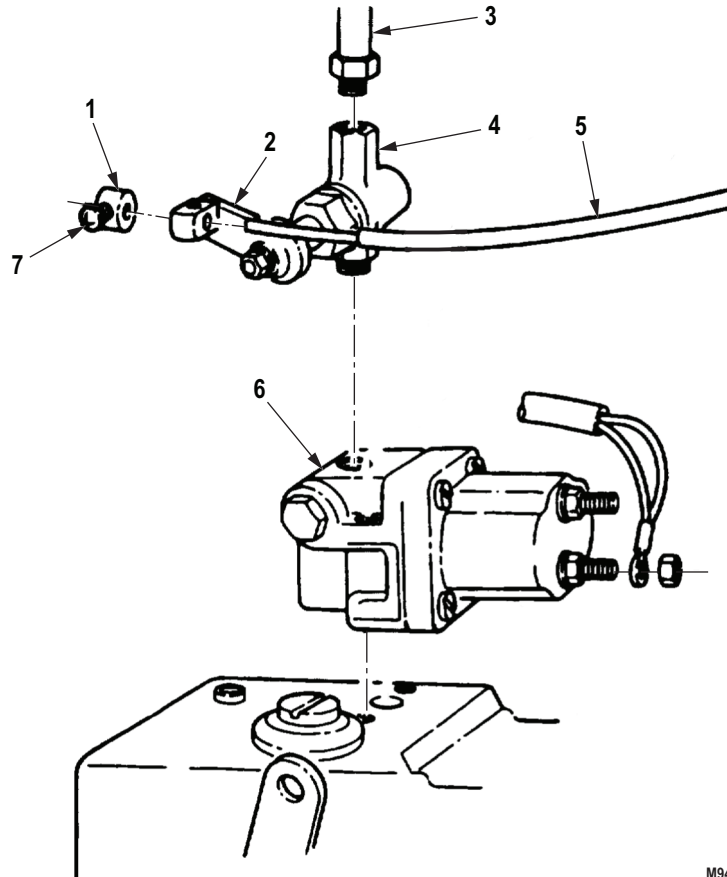

Figure 3. Fuel Pump Metering Valve Installation.

END OF TASK

MANUAL SHUTOFF VALVE INSTALLATION

1. Install manual fuel shutoff valve (Figure 4, Item 4) in fuel shutoff valve (Figure 4, Item 6).
2. Install control cable (Figure 4, Item 5) on shutoff lever (Figure 4, Item 2) with clip (Figure 4, Item 1) and screw (Figure 4, Item 7). Ensure shutoff lever is in forward position.
3. Connect fuel line (Figure 4, Item 3) to manual fuel shutoff valve (Figure 4, Item 4).



M9454DAA

Figure 4. Manual Shutoff Valve Installation.

END OF TASK**FOLLOW-ON MAINTENANCE**

1. Start engine and check fuel pump shutoff valves for proper operation. (TM 9-2320-272-10)
2. Install left splash shield. (TM 9-2320-272-10)

END OF TASK**END OF WORK PACKAGE**

FIELD MAINTENANCE
FUEL PUMP METERING VALVE REPLACEMENT (M936 WRECKER)

INITIAL SETUP:**Tools and Special Tools**

Tool Kit, General Mechanic's: Automotive
(Volume 5, WP 0826, Table 1, Item 56)

Materials/Parts

Cap Set, Protective, Dust and Moisture Seal
(Volume 5, WP 0825, Table 1, Item 13)
Qty: 1
Lockwasher

Materials/Parts (cont.)

(Volume 5, WP 0827, Table 1, Item 79)
Qty: 2
Packing, Preformed
(Volume 5, WP 0827, Table 1, Item 144)
Qty: 1

Equipment Condition

Hood raised and secured. (TM 9-2320-272-10)
Left splash shield removed. (TM 9-2320-272-10)

REMOVAL

1. Disconnect fuel line (Figure 1, Item 2) from manual fuel shutoff valve (Figure 1, Item 1).
2. Remove nut (Figure 1, Item 7) and wires (Figure 1, Item 6) from terminal (Figure 1, Item 8).
3. Loosen screw (Figure 1, Item 5) on clip (Figure 1, Item 3), and remove clip and fuel shutoff control cable (Figure 1, Item 4) from manual fuel shutoff valve (Figure 1, Item 1).
4. Remove manual fuel shutoff valve (Figure 1, Item 1) from fuel pump metering valve (Figure 1, Item 11).
5. Remove two screws (Figure 1, Item 14), lockwashers (Figure 1, Item 13), washers (Figure 1, Item 12), fuel pump metering valve (Figure 1, Item 11), and preformed packing (Figure 1, Item 9) from fuel pump (Figure 1, Item 10). Plug openings in fuel pump and discard preformed packing and lockwashers.

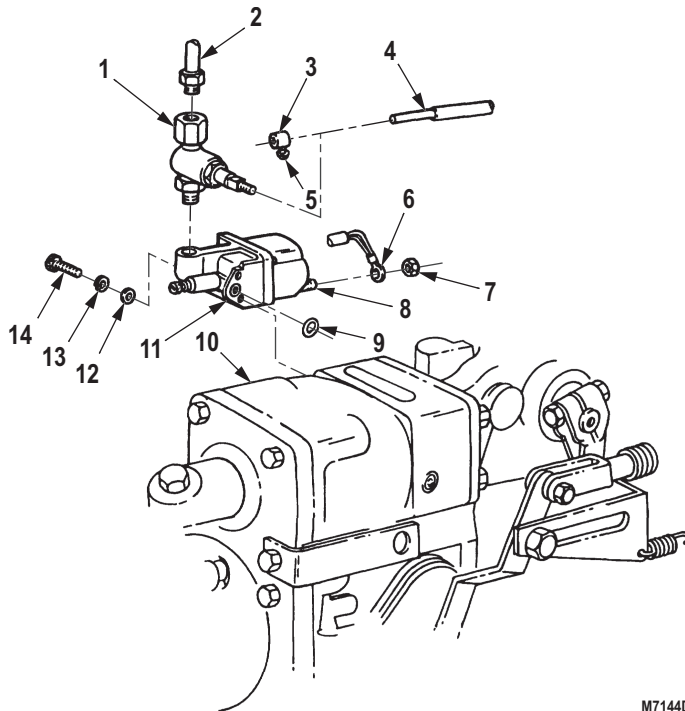

M7144DAA

Figure 1. Fuel Pump Metering Valve Removal.

END OF TASK

FUEL PUMP SHUTOFF VALVE INSTALLATION

1. Unplug openings in fuel pump (Figure 2, Item 10) and install preformed packing (Figure 2, Item 9) and fuel pump metering valve (Figure 2, Item 11) on fuel pump with two lockwashers (Figure 2, Item 13), washers (Figure 2, Item 12), and screws (Figure 2, Item 14).
2. Install manual fuel shutoff valve (Figure 2, Item 1) on fuel pump metering valve (Figure 2, Item 11).
3. Ensuring shutoff lever is in forward position, install fuel shutoff control cable (Figure 2, Item 4) on manual fuel shutoff valve (Figure 2, Item 1) with clip (Figure 2, Item 3) and tighten screws (Figure 2, Item 5).
4. Install wires (Figure 2, Item 6) on terminal (Figure 2, Item 8) with nut (Figure 2, Item 7).
5. Connect fuel line (Figure 2, Item 2) to manual fuel shutoff valve (Figure 2, Item 1).

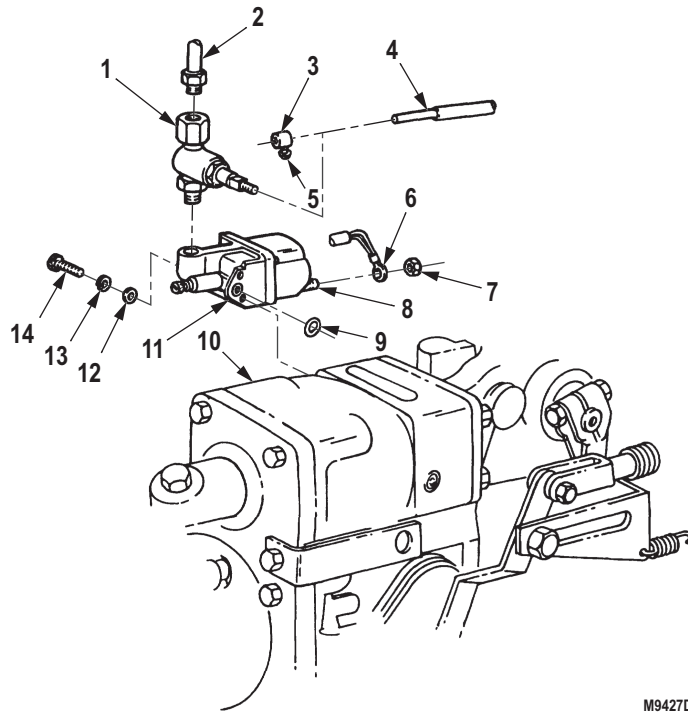

M9427DAA

Figure 2. Fuel Pump Metering Valve Installation.

END OF TASK

FOLLOW-ON MAINTENANCE

1. Start engine and check fuel pump shutoff valve for proper operation. (TM 9-2320-272-10)
2. Install left splash shield. (TM 9-2320-272-10)

END OF TASK**END OF WORK PACKAGE**

FIELD MAINTENANCE ELECTRICAL SWITCHES AND CIRCUIT BREAKER REPLACEMENT

INITIAL SETUP:

Tools and Special Tools

Tool Kit, General Mechanic's: Automotive
(Volume 5, WP 0826, Table 1, Item 56)

Equipment Condition (cont.)

Blower motor in OFF position. (TM 9-2320-272-10)
Hood raised and secured. (TM 9-2320-272-10)
Battery ground cables disconnected. (WP 0350)

Materials/Parts

Lockwasher
(Volume 5, WP 0827, Table 1, Item 387)
Qty: 3

Equipment Condition

Parking brake set. (TM 9-2320-272-10)

BLOWER SWITCH REMOVAL

NOTE

- Blower motor switch, floodlight switch, and warning switches are all replaced the same way.
 - Blower motor switch shown.
1. Remove screw (Figure 1, Item 1) and lever (Figure 1, Item 2) from blower motor switch (Figure 1, Item 5).
 2. Remove nut (Figure 1, Item 3), lockwasher (Figure 1, Item 4), and blower motor switch (Figure 1, Item 5) from instrument panel (Figure 1, Item 6). Discard lockwasher.

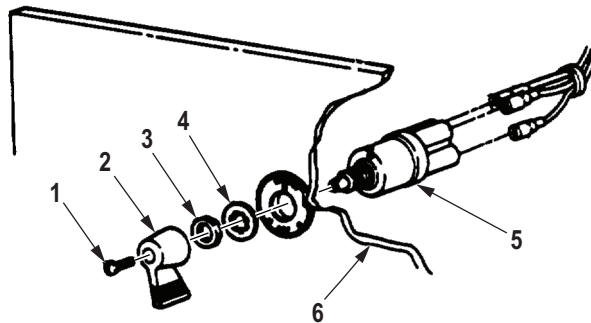

M0241DAA

Figure 1. Switch Removal.

BLOWER SWITCH REMOVAL - Continued**NOTE**

Tag all connectors for installation.

3. Disconnect connectors (Figure 2, Items 1, 3, and 5) from blower motor switch (Figure 2, Item 2).
4. Remove plug (Figure 2, Item 4) from blower motor switch (Figure 2, Item 2).

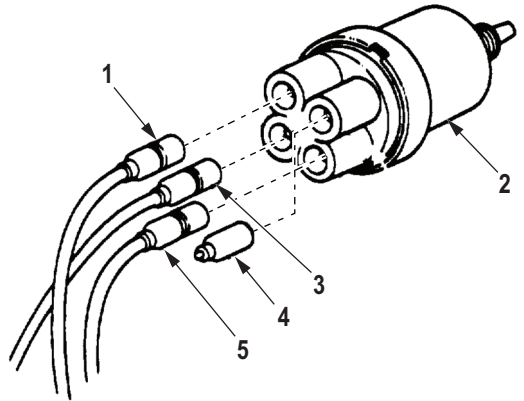

M0242DAA

Figure 2. Wire Removal.

END OF TASK**BLOWER MOTOR SWITCH INSTALLATION****NOTE**

Ensure each connector is inserted into proper terminal end.

1. Install plug (Figure 3, Item 4) to blower motor switch (Figure 3, Item 2).
2. Install connectors (Figure 3, Items 1, 3, and 5) into blower motor switch (Figure 3, Item 2).

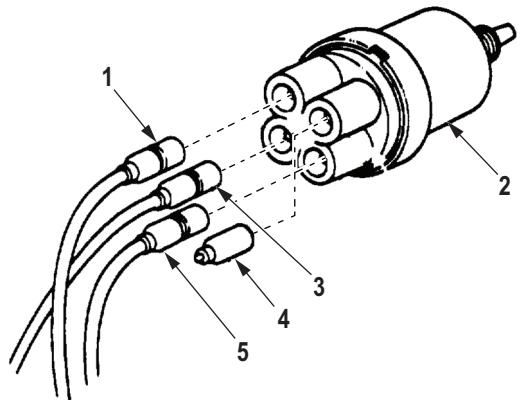

M9428DAA

Figure 3. Wire Connector Installation.

BLOWER MOTOR SWITCH INSTALLATION - Continued

3. Install blower motor switch (Figure 4, Item 2) on instrument panel (Figure 4, Item 6), with lockwasher (Figure 4, Item 4), and nut (Figure 4, Item 3).
4. Position lever (Figure 4, Item 2) on blower motor switch (Figure 4, Item 5) with pointing edge placed in OFF position and install with screw (Figure 4, Item 1).

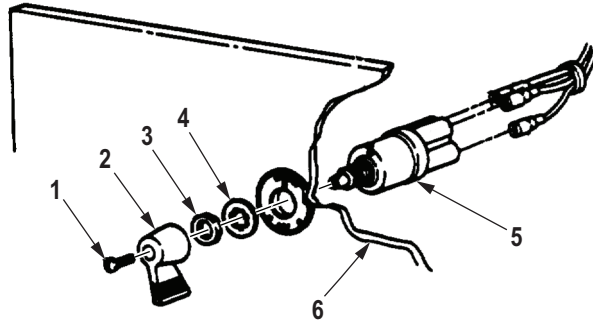

M9429DAA

Figure 4. Blower Motor Switch Installation.

END OF TASK

BATTERY AND STARTER SWITCH REMOVAL

1. Remove screw (Figure 5, Item 9), lockwasher (Figure 5, Item 8), switch lever (Figure 5, Item 1), felt washer (Figure 5, Item 2), and washer (Figure 5, Item 3) from battery switch (Figure 5, Item 5). Discard lockwasher.
2. Remove nut (Figure 5, Item 7) and lockwasher (Figure 5, Item 4) from instrument cluster (Figure 5, Item 6) and pull switch (Figure 5, Item 5) from behind instrument cluster (Figure 5, Item 6). Discard lockwasher.

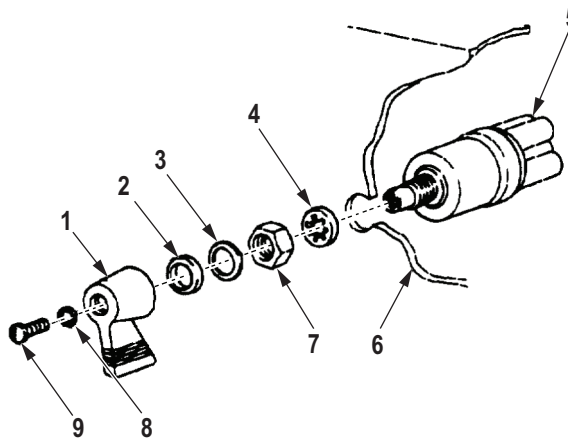

M9514DAA

Figure 5. Battery and Switch Removal.

BATTERY AND STARTER SWITCH REMOVAL - Continued**NOTE**

- Tag all wires for installation.
- There are only three wires on starter switch.

3. Disconnect wires (Figure 6, Items 1, 2, 4, and 5) from battery switch (Figure 6, Item 3).

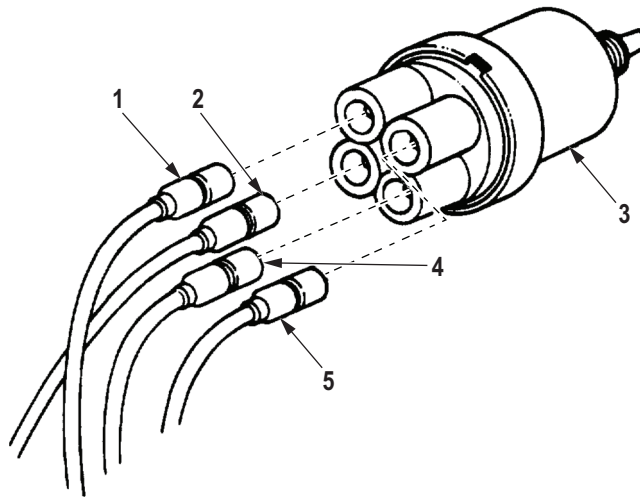

Figure 6. Battery and Starter Switch Removal.

END OF TASK**BATTERY AND STARTER SWITCH INSTALLATION****NOTE**

- If switch is being installed, use mounting hardware supplied with switch.
- Starter switch has only three wires.

1. Connect wires (Figure 7, Items 1, 2, 4, and 5) to battery switch (Figure 7, Item 3).

BATTERY AND STARTER SWITCH INSTALLATION - Continued

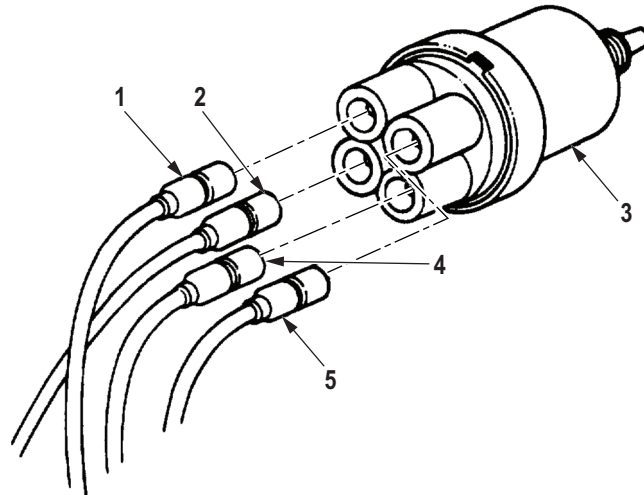

M9516DAA

Figure 7. Battery and Switch Installation.

2. Position battery switch (Figure 8, Item 5) through instrument cluster (Figure 8, Item 6) from the rear and install with lockwasher (Figure 8, Item 4) and nut (Figure 8, Item 7).
3. Position washer (Figure 8, Item 3), felt washer (Figure 8, Item 2), and switch lever (Figure 8, Item 1) on battery switch (Figure 8, Item 5) and install with lockwasher (Figure 8, Item 8) and screw (Figure 8, Item 9).

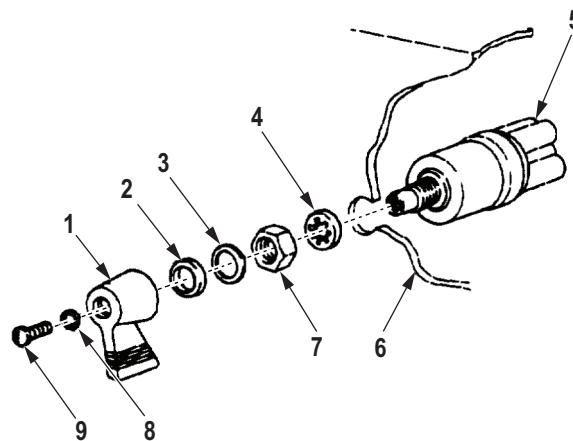

M9517DAA

Figure 8. Battery and Starter Switch Installation.

END OF TASK

CIRCUIT BREAKER REPLACEMENT REMOVAL**NOTE**

- Perform Steps (1) and (2) to remove circuit breakers located on engine firewall.
 - Perform Steps (3) and (4) to remove circuit breakers located behind instrument panel and above steering column.
 - Tag wires for installation.
1. Disconnect wires (Figure 9, Items 3 and 5) from circuit breaker (Figure 9, Item 2).
 2. Remove two screws (Figure 9, Item 4) and circuit breaker (Figure 9, Item 2) from firewall (Figure 9, Item 1).
 3. Disconnect wires (Figure 9, Items 6 and 7) from circuit breaker (Figure 9, Item 9).
 4. Remove two screws (Figure 9, Item 8) and circuit breaker (Figure 9, Item 9) from instrument panel brace (Figure 9, Item 10).

CIRCUIT BREAKER REPLACEMENT REMOVAL - Continued

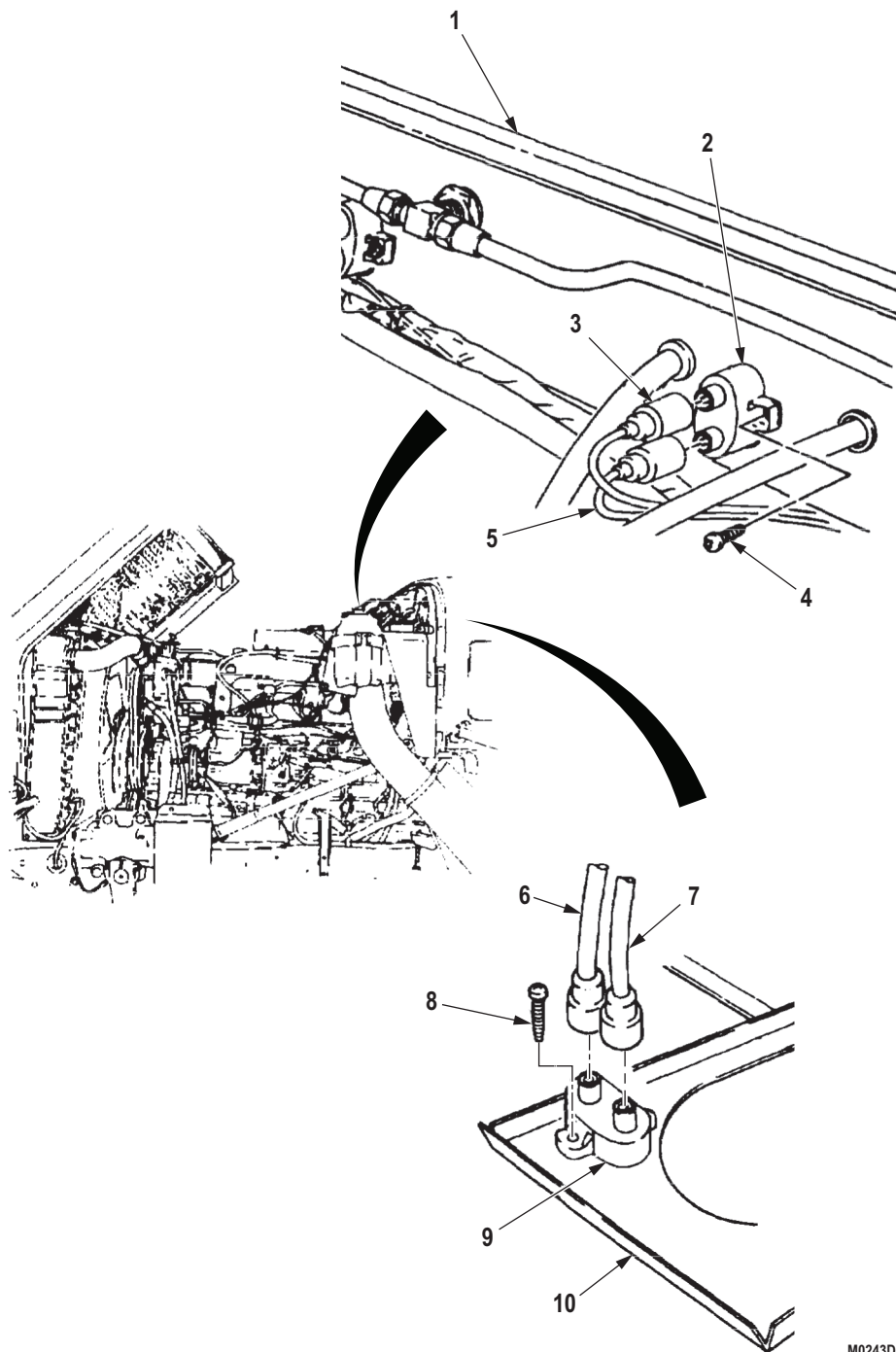

M0243DAA

Figure 9. Circuit Breaker Removal.

END OF TASK

CIRCUIT REAKER REPLACEMENT INSTALLATION**NOTE**

- Perform Steps (1) and (2) to install circuit breakers on engine firewall.
 - Perform Steps (3) and (4) to install circuit breakers behind instrument panel.
1. Install circuit breaker (Figure 10, Item 2) on firewall (Figure 10, Item 1) with two screws (Figure 10, Item 4).
 2. Connect wires (Figure 10, Items 3 and 5) to circuit breaker (Figure 10, Item 2).
 3. Install circuit breaker (Figure 10, Item 9) on instrument panel brace (Figure 10, Item 10) with two screws (Figure 10, Item 8).
 4. Connect wires (Figure 10, Items 6 and 7) to circuit breaker (Figure 10, Item 5).

CIRCUIT REAKER REPLACEMENT INSTALLATION - Continued

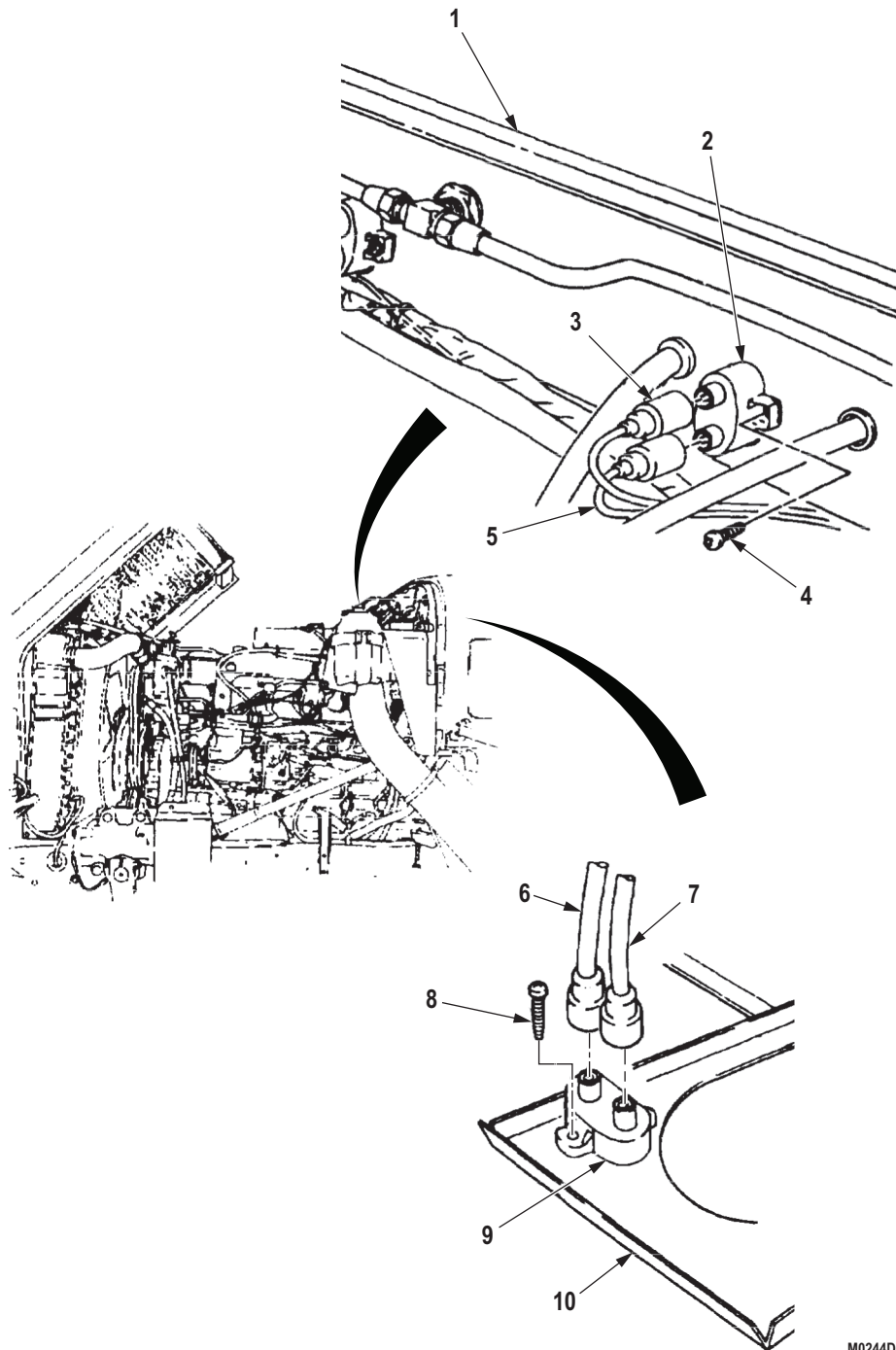

M0244DAA

Figure 10. Circuit Breaker Installation.

END OF TASK

FOLLOW-ON MAINTENANCE

Connect battery ground cables. (WP 0350)

END OF TASK

END OF WORK PACKAGE

FIELD MAINTENANCE
SPRING BRAKE PRESSURE SWITCH REPLACEMENT

INITIAL SETUP:**Tools and Special Tools**

Tool Kit, General Mechanic's: Automotive
(Volume 5, WP 0826, Table 1, Item 56)

Equipment Condition (cont.)

Air reservoirs drained. (TM 9-2320-272-10)
Battery ground cables disconnected. (WP 0350)

Materials/Parts

Tape, Antiseizing
(Volume 5, WP 0825, Table 1, Item 65)

Equipment Condition

Parking brake set. (TM 9-2320-272-10)

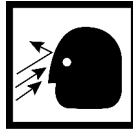
REMOVAL**WARNING**

Do not disconnect air lines or hoses before draining air reservoirs. Small parts under pressure may shoot out with high velocity. Failure to comply may result in injury or death to personnel.

1. Remove eight screws (Figure 1, Item 3) from instrument cluster (Figure 1, Item 2).
2. Pull instrument cluster (Figure 1, Item 2) away from instrument panel (Figure 1, Item 1).
3. Disconnect two wires (Figure 1, Item 8) from spring brake pressure switch (Figure 1, Item 7).
4. Remove spring brake pressure switch (Figure 1, Item 7), fitting (Figure 1, Item 6), and elbow (Figure 1, Item 5) from spring brake release control valve (Figure 1, Item 4).

REMOVAL - Continued

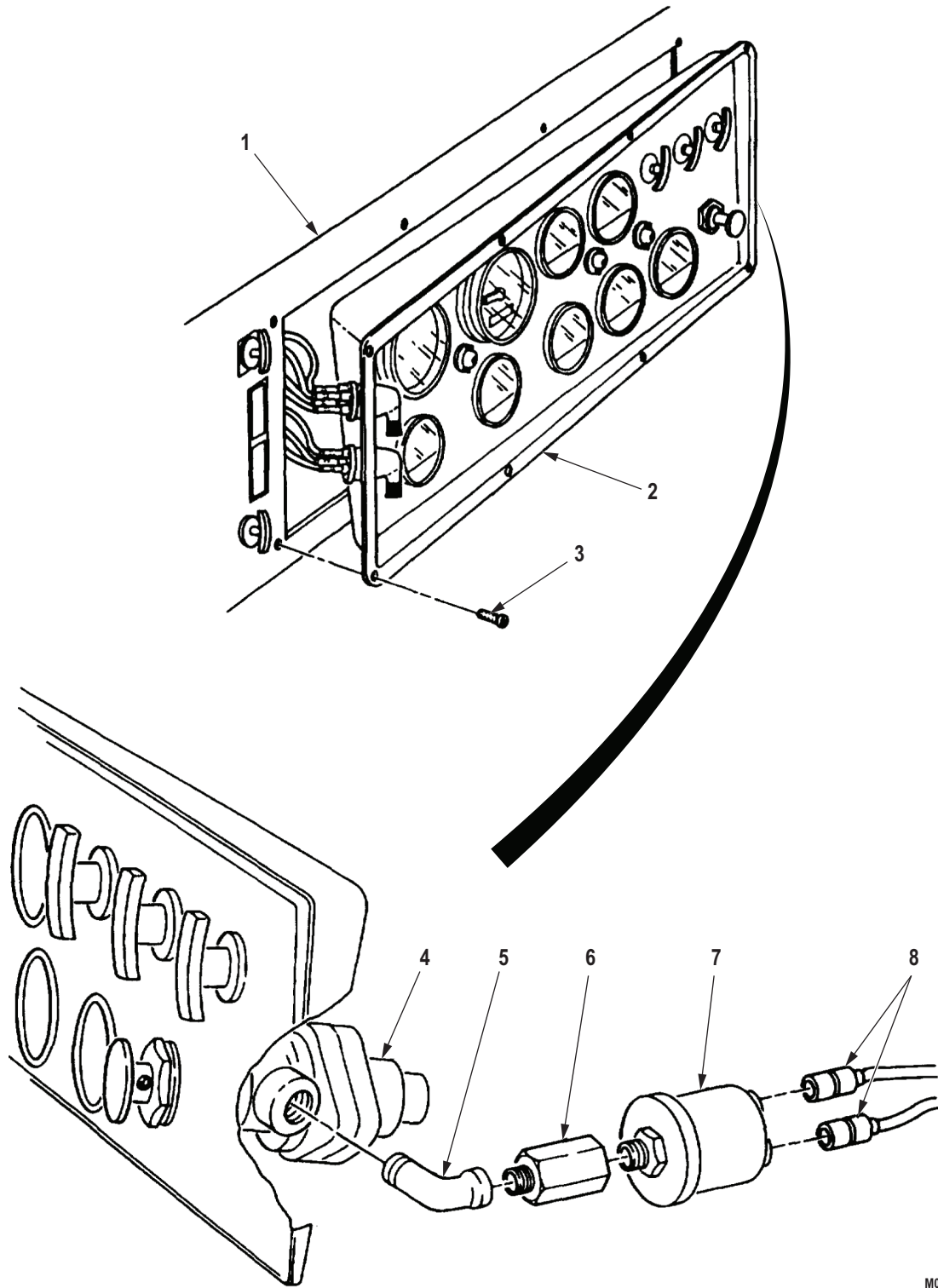

M0229DAA

Figure 1. Spring Brake Pressure Switch Removal.

END OF TASK

INSTALLATION**NOTE**

Male pipe threads must be wrapped with antiseize tape before installation.

1. Install elbow (Figure 2, Item 5), fitting (Figure 2, Item 6), and spring brake pressure switch (Figure 2, Item 7) on spring brake release control valve (Figure 2, Item 4).
2. Connect two wires (Figure 2, Item 8) to spring brake pressure switch (Figure 2, Item 7).
3. Install instrument cluster (Figure 2, Item 2) on instrument panel (Figure 2, Item 1) with eight screws (Figure 2, Item 3).

INSTALLATION - Continued

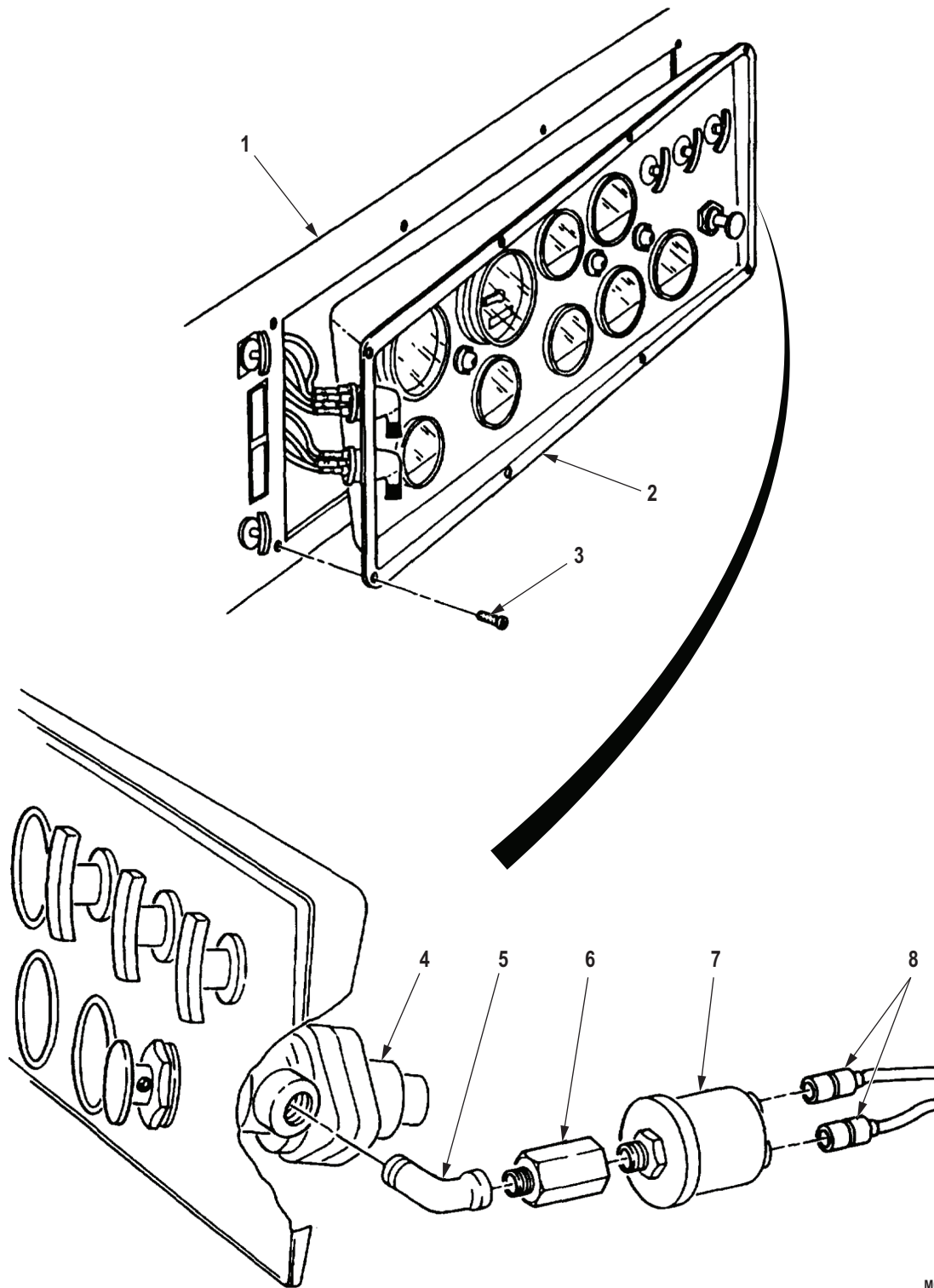

M0230DAA

Figure 2. Spring Brake Pressure Switch Installation.

END OF TASK

FOLLOW-ON MAINTENANCE

1. Connect battery ground cables. (WP 0350)
2. Start engine and allow air pressure to build up to normal operating range. Check for air leaks at point switch is attached to valve. Stop engine and engage spring brakes. Spring brake warning light should glow.
(TM 9-2320-272-10)

END OF TASK**END OF WORK PACKAGE**

**FIELD MAINTENANCE
INSTRUMENT PANEL REPLACEMENT**

INITIAL SETUP:**Tools and Special Tools**

Tool Kit, General Mechanic's: Automotive
(Volume 5, WP 0826, Table 1, Item 56)

Personnel Required

(2)

References

Volume 3, WP 0494

Equipment Condition

Parking brake set. (TM 9-2320-272-10)
Battery ground cables disconnected. (WP 0350)
Instrument cluster removed. (WP 0310)
Electrical switches removed. (WP 0307)
Fuel selector valve switch removed. (WP 0314)
Floodlight control switch removed. (WP 0320)

Equipment Condition (cont.)

Pressure gauge removed. (WP 0312)
Steering wheel removed. (Volume 3, WP 0495)
Cold-start indicator and lamp removed.
(WP 0311)
Engine stop and throttle control cable removed.
(Volume 3, WP 0409)
Turn signal flasher removed. (WP 0318)
Instrument panel circuit breaker removed.
(WP 0307)
Windshield wiper pump removed.
(Volume 4, WP 0737)
Windshield wiper hoses removed.
(Volume 4, WP 0737)
Heater control box removed.
(Volume 4, WP 0742)
Personnel heater control cables removed.
(Volume 4, WP 0745)

REMOVAL**NOTE**

It may be necessary to remove the upper steering column. Refer to (Volume 3, WP 0494).

1. Remove two screws (Figure 1, Item 5) from instrument panel (Figure 1, Item 4) and bracket (Figure 1, Item 7).
2. Remove five screws (Figure 1, Item 3) from instrument panel (Figure 1, Item 4).
3. Remove four screws (Figure 1, Item 2) from instrument panel (Figure 1, Item 4).
4. Remove two screw-assembled washers (Figure 1, Item 1) from instrument panel (Figure 1, Item 4).
5. Remove screw (Figure 1, Item 6) from instrument panel (Figure 1, Item 4).

NOTE

Assistant will help with Step (6).

6. Remove instrument panel (Figure 1, Item 4) from cab (Figure 1, Item 8) and brackets (Figure 1, Items 7 and 9).

REMOVAL - Continued

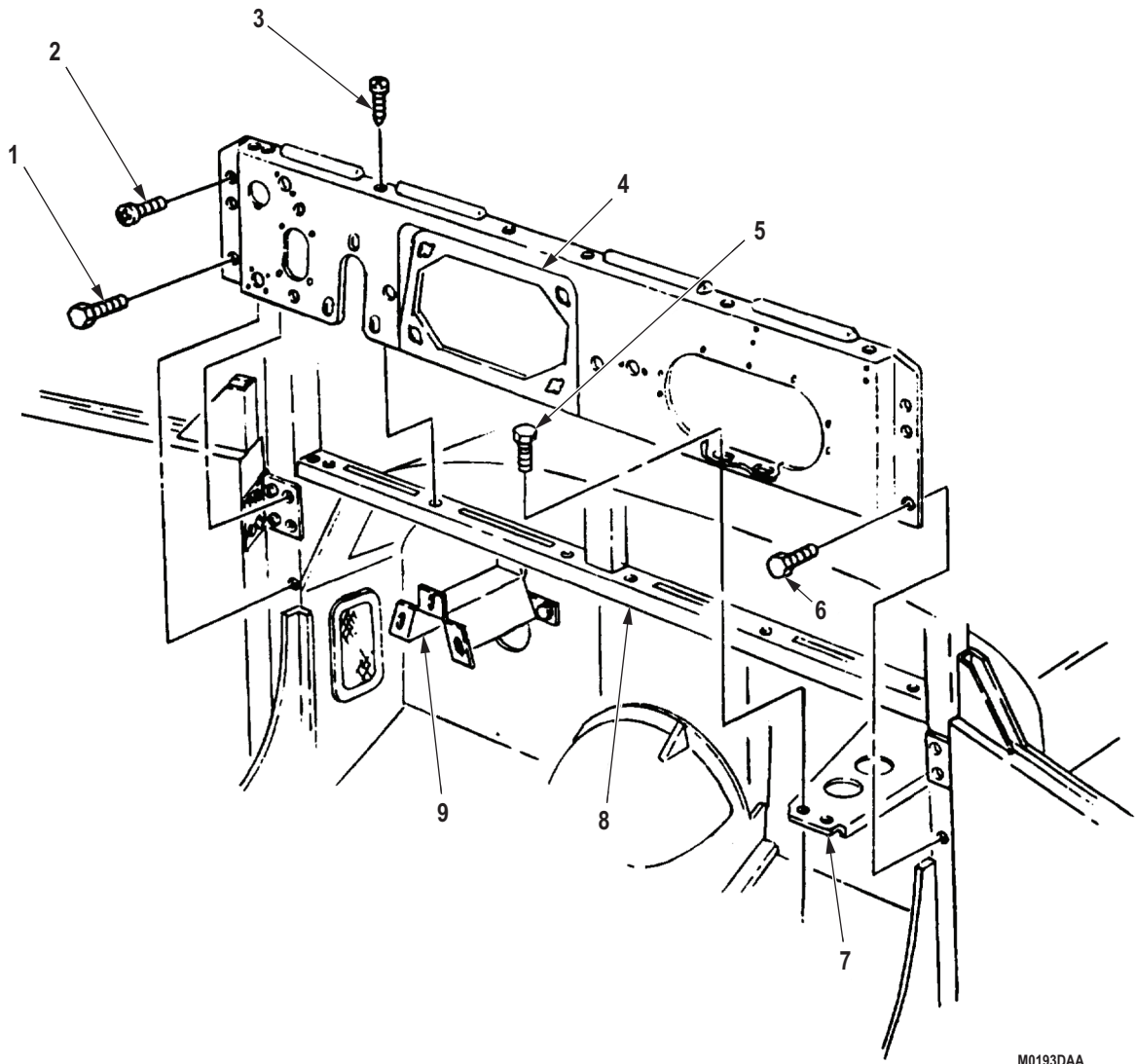

M0193DAA

Figure 1. Instrument Panel Removal.

END OF TASK

INSTALLATION**NOTE**

Assistant will help with Step (1).

1. Position instrument panel (Figure 2, Item 4) on cab (Figure 2, Item 8) and brackets (Figure 2, Items 7 and 9).
2. Install screw (Figure 2, Item 6) on instrument panel (Figure 2, Item 4).
3. Install two screw-assembled washers (Figure 2, Item 1) on instrument panel (Figure 2, Item 4).
4. Install four screws (Figure 2, Item 2) on instrument panel (Figure 2, Item 4).
5. Install five screws (Figure 2, Item 3) on instrument panel (Figure 2, Item 4).
6. Install two screws (Figure 2, Item 5) on instrument panel (Figure 2, Item 4) and bracket (Figure 2, Item 7).

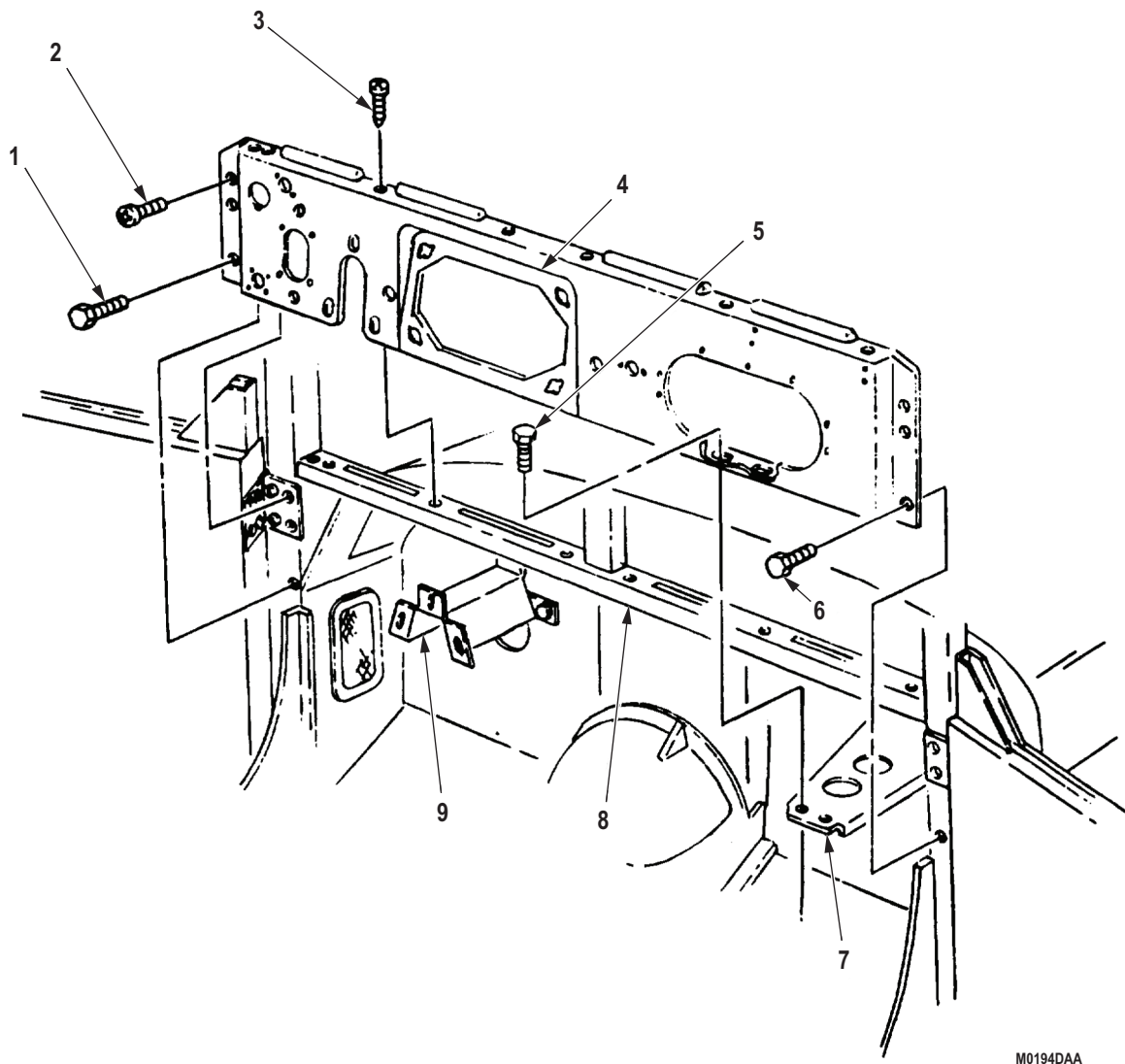

M0194DAA

Figure 2. Instrument Panel Installation.

END OF TASK

FOLLOW-ON MAINTENANCE

1. Install turn signal flasher. (WP 0318)
2. Install instrument cluster. (WP 0310)
3. Install electrical switches. (WP 0307)
4. Install fuel selector valve switch. (WP 0314)
5. Install floodlight control switch. (WP 0320)
6. Install pressure gauge switch. (WP 0312)
7. Install steering wheel. (Volume 3, WP 0494)
8. Install cold-start indicator and lamp. (WP 0311)
9. Install engine stop and throttle control cables. (WP 0270)
10. Install instrument panel circuit breaker. (WP 0307)
11. Install personnel heater control cables. (Volume 4, WP 0745)
12. Install heater control box. (Volume 4, WP 0742)
13. Install windshield wiper hoses. (Volume 4, WP 0737)
14. Install windshield wiper pump. (Volume 4, WP 0737)
15. Connect battery ground cables. (WP 0350)

END OF TASK**END OF WORK PACKAGE**

**FIELD MAINTENANCE
INSTRUMENT CLUSTER REPLACEMENT**

INITIAL SETUP:**Tools and Special Tools**

Tool Kit, General Mechanic's: Automotive
(Volume 5, WP 0826, Table 1, Item 56)

Materials/Parts

Cotter Pin
(Volume 5, WP 0827, Table 1, Item 257)
Qty: 3
Spring Nut
(Volume 5, WP 0827, Table 1, Item 428)
Qty: 3

References

WP 0307
WP 0308
WP 0311

References (cont.)

WP 0312
WP 0324
Volume 4, WP 0741
Volume 4, WP 0745
Volume 5, WP 0815
Volume 5, WP 0818

Equipment Condition

Parking brake set. (TM 9-2320-272-10)
Air reservoirs drained. (TM 9-2320-272-10)
Hood raised and secured. (TM 9-2320-272-10)
Battery ground cables disconnected. (WP 0350)
Disconnect CTIS electrical components (M939A2).
(WP 0322)

REMOVAL

1. Remove screw (Figure 1, Item 15), clamp (Figure 1, Item 3), cable (Figure 1, Item 1), and retaining clip (Figure 1, Item 4) from diverter bracket (Figure 1, Item 6).
2. Remove cotter pin (Figure 1, Item 16) from control rod (Figure 1, Item 5). Discard cotter pin.

NOTE

Tag cables for installation.

3. Remove cable (Figure 1, Item 1) and spring nut (Figure 1, Item 2)
4. Remove screw (Figure 1, Item 14), clamp (Figure 1, Item 10), cable (Figure 1, Item 13), and retaining clip (Figure 1, Item 8) from diverter bracket (Figure 1, Item 7).
5. Remove cotter pin (Figure 1, Item 12) from control rod (Figure 1, Item 9). Discard cotter pin.
6. Remove heat control cable (Figure 1, Item 13) and spring nut (Figure 1, Item 11) from control rod (Figure 1, Item 9). Discard spring nut.

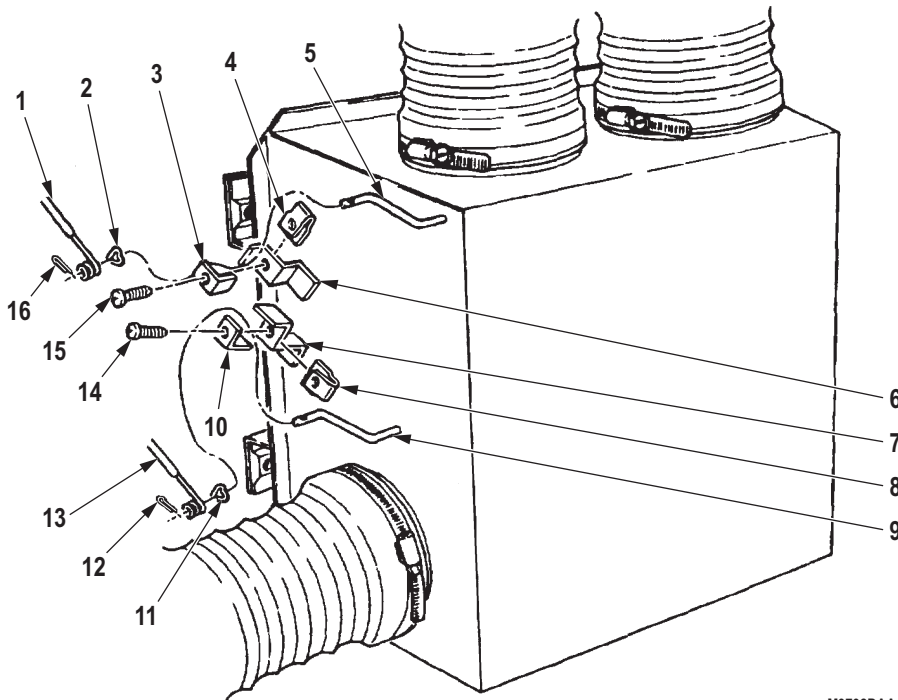

M9798DAA

Figure 1. Cable Removal.

REMOVAL - Continued

7. Remove screw (Figure 2, Item 4), retaining nut (Figure 2, Item 6), and clamp (Figure 2, Item 5) from blower motor (Figure 2, Item 1).
8. Remove cotter pin (Figure 2, Item 7) from heater assembly (Figure 2, Item 1). Discard cotter pin.
9. Remove fresh air control cable (Figure 2, Item 3) and spring nut (Figure 2, Item 2) from heater assembly (Figure 2, Item 1). Discard spring nut.

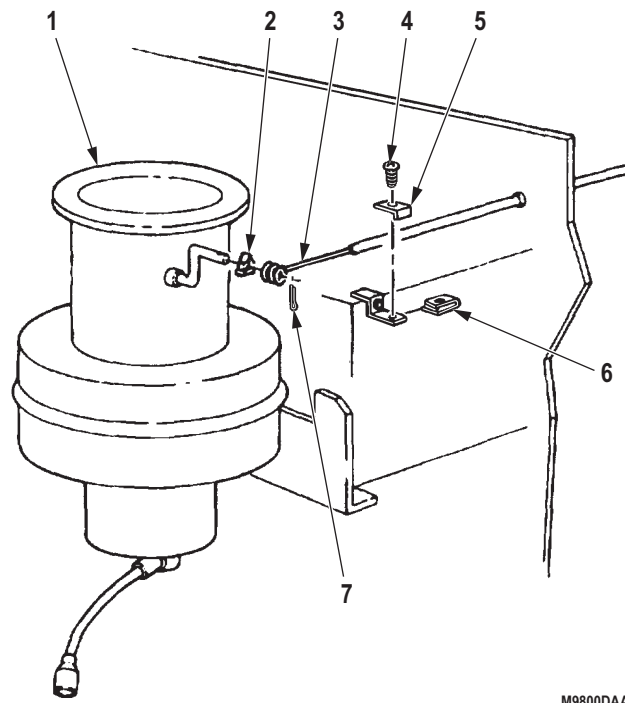

M9800DAA

Figure 2. Cable Removal.

REMOVAL - Continued

10. Remove eight screws (Figure 3, Item 3) from instrument cluster (Figure 3, Item 2).
11. Separate instrument cluster (Figure 3, Item 2) from instrument panel (Figure 3, Item 1).

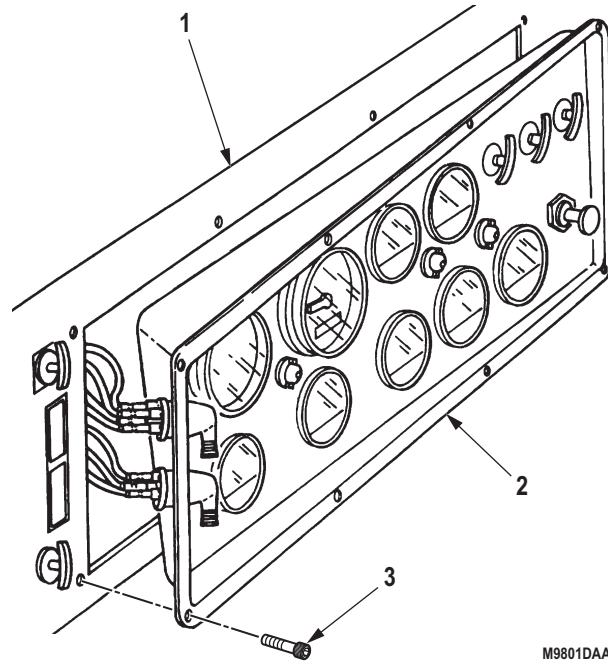

Figure 3. Instrument Cluster Removal.

NOTE

Tag wires and drive shaft for installation.

12. Disconnect tachometer driveshaft (Figure 4, Item 5) from instrument cluster (Figure 4, Item 24).
13. Disconnect speedometer driveshaft (Figure 4, Item 10) from instrument cluster (Figure 4, Item 24).

WARNING

Do not disconnect air lines or hoses before draining air reservoirs. Small parts under pressure may shoot out with high velocity. Failure to comply may result in injury or death to personnel.

14. Disconnect air lines (Figure 4, Items 1, 15, and 17) from instrument cluster (Figure 4, Item 24).
15. Disconnect four wires (Figure 4, Item 6) from instrument cluster (Figure 4, Item 24).
16. Disconnect three wires (Figure 4, Item 7) from instrument cluster (Figure 4, Item 24).
17. Disconnect wire (Figure 4, Item 11) from wire (Figure 4, Item 13).

REMOVAL - Continued

NOTE

Wires in Steps (20) through (28) are located behind instrument cluster.

18. Disconnect five wires (Figure 4, Item 4) from instrument cluster (Figure 4, Item 24).
19. Disconnect wires (Figure 4, Items 8 and 9) from instrument cluster (Figure 4, Item 24).
20. Disconnect wires (Figure 4, Items 12 and 14) from instrument cluster (Figure 4, Item 24).
21. Disconnect wires (Figure 4, Items 18 and 19) from instrument cluster (Figure 4, Item 24).
22. Disconnect wires (Figure 4, Items 2 and 3) from instrument cluster (Figure 4, Item 24).
23. Disconnect wire (Figure 4, Item 16) from instrument cluster (Figure 4, Item 24).
24. Disconnect two wires (Figure 4, Item 20) from instrument cluster (Figure 4, Item 24).
25. Disconnect cables (Figure 4, Items 21, 22, and 23) from instrument cluster (Figure 4, Item 24).

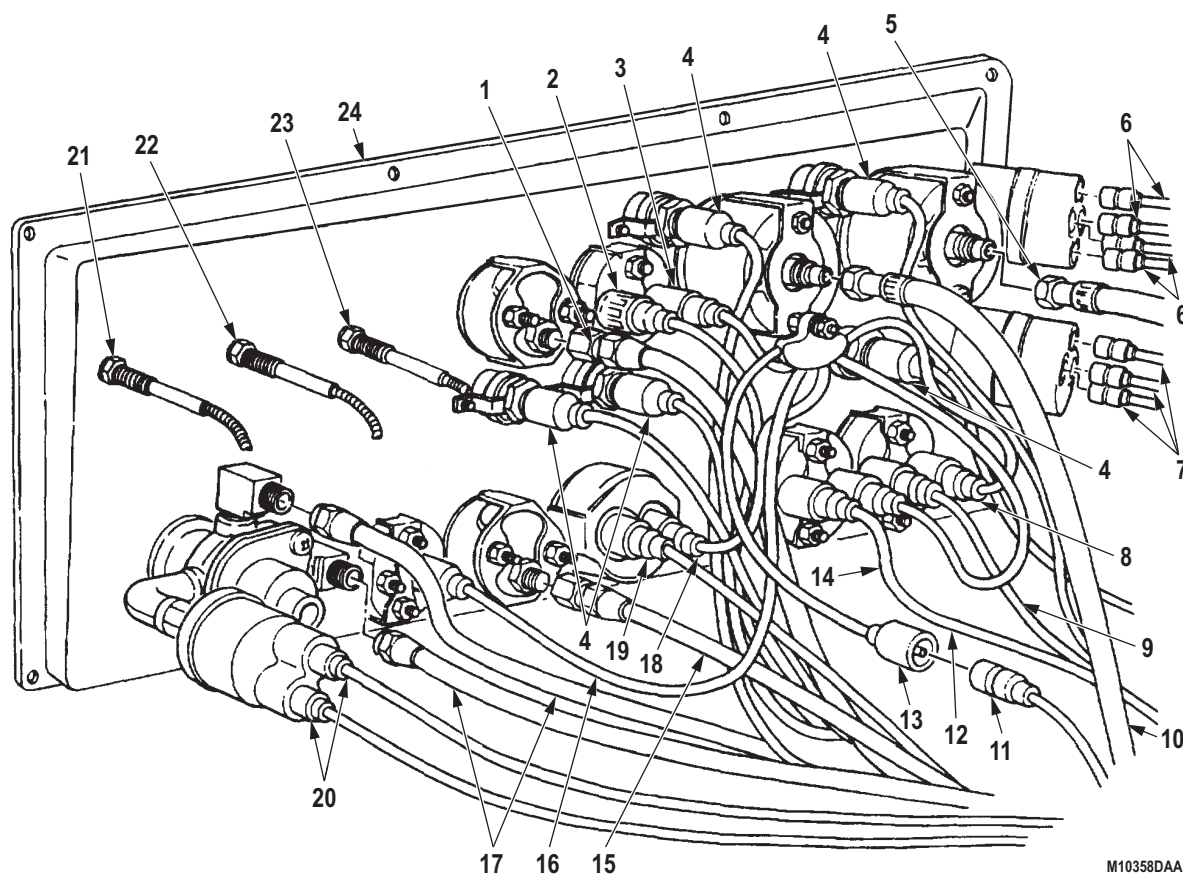

M10358DAA

Figure 4. Instrument Cluster Removal.

END OF TASK

DISASSEMBLY

1. Remove battery switch lever (Figure 5, Item 1) from instrument cluster (Figure 5, Item 13) (WP 0308).
2. Remove starter switch lever (Figure 5, Item 12) from instrument cluster (Figure 5, Item 13) (WP 0307).
3. Remove five indicator panel lights (Figure 5, Item 10) from instrument cluster (Figure 5, Item 13) (WP 0311).
4. Remove tachometer (Figure 5, Item 2) from instrument cluster (Figure 5, Item 13) (Volume 5, WP 0815).
5. Remove speedometer (Figure 5, Item 3) from instrument cluster (Figure 5, Item 13) (Volume 5, WP 0815).
6. Remove five electrical gauges (Figure 5, Item 4) from instrument cluster (Figure 5, Item 13) (WP 0312).
7. Remove primary air gauge (Figure 5, Item 5) from instrument cluster (Figure 5, Item 13) (Volume 5, WP 0818).
8. Remove secondary air gauge (Figure 5, Item 11) from instrument cluster (Figure 5, Item 13) (Volume 5, WP 0818).
9. Remove fresh air vent control (Figure 5, Item 8) from instrument cluster (Figure 5, Item 13) (Volume 4, WP 0741).
10. Remove defroster control (Figure 5, Item 6) from instrument cluster (Figure 5, Item 13) (Volume 4, WP 0745).
11. Remove heater control (Figure 5, Item 7) from instrument cluster (Figure 5, Item 13) (Volume 4, WP 0745).
12. Remove spring brake pressure switch (Figure 5, Item 9) from instrument cluster (Figure 5, Item 13) (WP 0308).

DISASSEMBLY - Continued

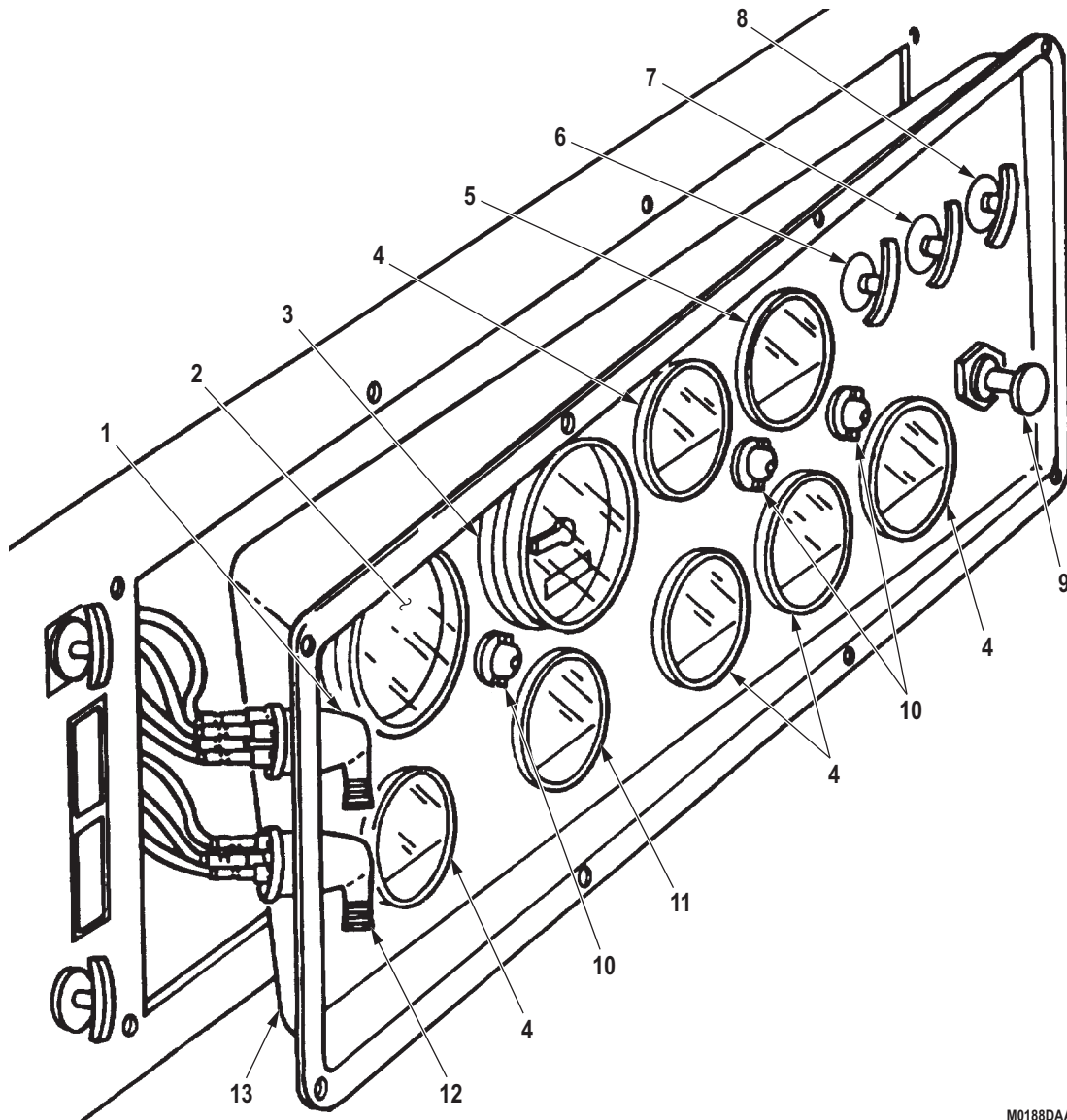

M0188DAA

Figure 5. Instrument Cluster Disassembly.

END OF TASK

ASSEMBLY

1. Install spring brake pressure switch (Figure 6 Item 9) on instrument cluster (Figure 6, Item 13) (WP 0324).
2. Install heater control (Figure 6, Item 7) on instrument cluster (Figure 6, Item 13) (Volume 4, WP 0745).
3. Install defroster control (Figure 6, Item 6) on instrument cluster (Figure 6, Item 13) (Volume 4, WP 0745).
4. Install fresh air vent control (Figure 6, Item 8) on instrument cluster (Figure 6, Item 13) (Volume 4, WP 0741).
5. Install secondary air control (Figure 6, Item 11) on instrument cluster (Figure 6, Item 13) (Volume 5, WP 0818).
6. Install primary air gauge (Figure 6, Item 5) on instrument cluster (Figure 6, Item 13) (Volume 5, WP 0818).
7. Install five electrical gauges (Figure 6, Item 4) on instrument cluster (Figure 6, Item 13) (WP 0312).
8. Install speedometer (Figure 6, Item 3) on instrument cluster (Figure 6, Item 13) (Volume 5, WP 0815).
9. Install tachometer (Figure 6, Item 2) on instrument cluster (Figure 6, Item 13) (Volume 5, WP 0815).
10. Install five indicator panel lights (Figure 6, Item 10) on instrument cluster (Figure 6, Item 13) (WP 0311).
11. Install starter switch lever (Figure 6, Item 12) on instrument cluster (Figure 6, Item 13) (WP 0307).
12. Install battery switch lever (Figure 6, Item 1) on instrument cluster (Figure 6, Item 13) (WP 0307).

ASSEMBLY - Continued

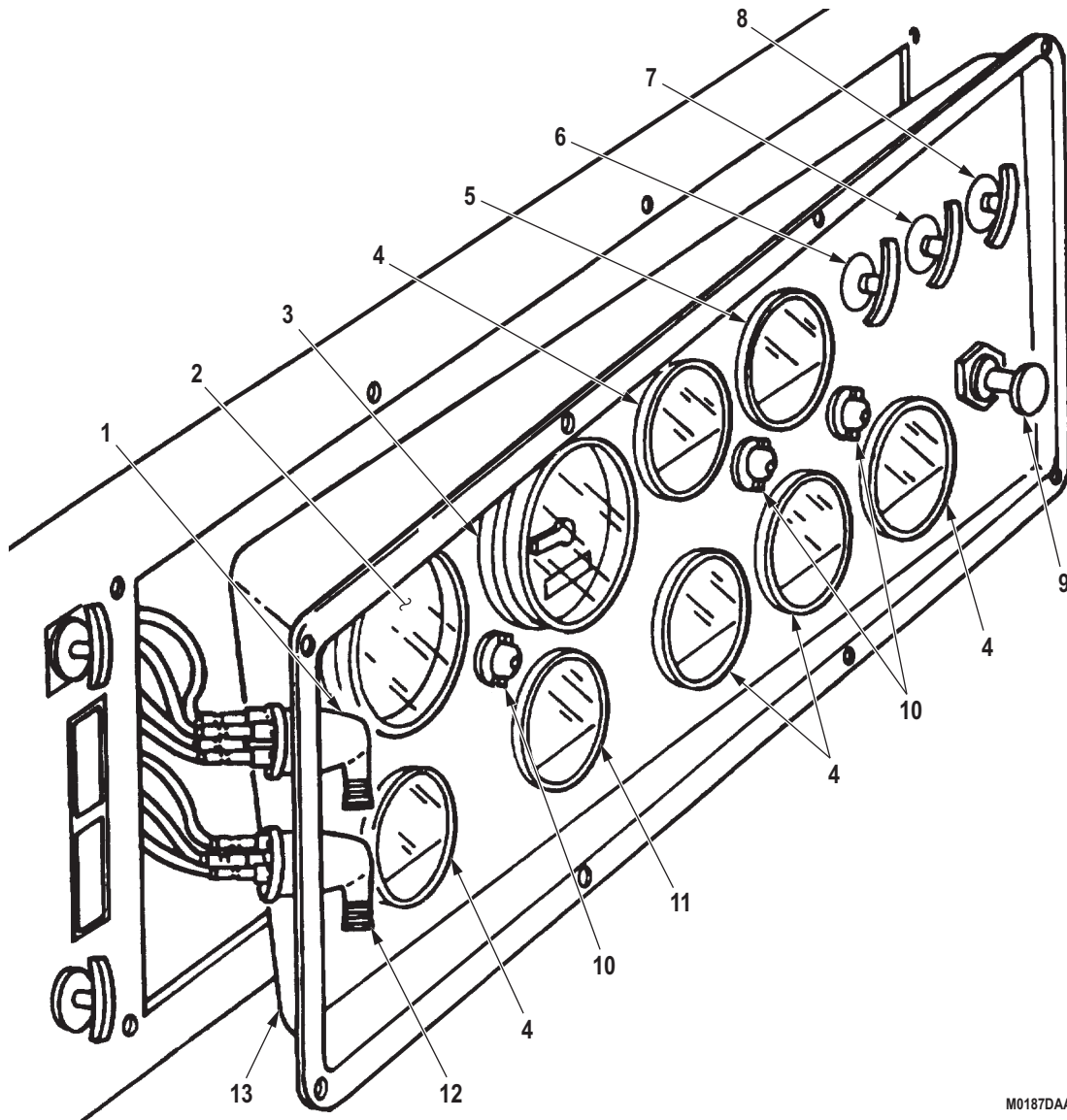

M0187DAA

Figure 6. Instrument Cluster Assembly.

END OF TASK

INSTALLATION

1. Connect cables (Figure 7, Items 21, 22, and 23) to instrument cluster (Figure 7, Item 24).
2. Connect two wires (Figure 7, Item 20) to instrument cluster (Figure 7, Item 24).
3. Connect wire (Figure 7, Item 16) to instrument cluster (Figure 7, Item 24).
4. Connect wires (Figure 7, Items 2 and 3) to instrument cluster (Figure 7, Item 24).
5. Connect wires (Figure 7, Items 18 and 19) to battery instrument cluster (Figure 7, Item 24).
6. Connect wires (Figure 7, Items 12 and 14) to instrument cluster (Figure 7, Item 24).
7. Connect wires (Figure 7, Items 8 and 9) to instrument cluster (Figure 7, Item 24).
8. Connect wires (Figure 7, Item 4) to instrument cluster (Figure 7, Item 24).
9. Connect wire (Figure 7, Item 11) to wire (Figure 7, Item 13).
10. Connect three wires (Figure 7, Item 7) to instrument cluster (Figure 7, Item 24).
11. Connect four wires (Figure 7, Item 6) to instrument cluster (Figure 7, Item 24).
12. Connect air lines (Figure 7, Items 1, 15, and 17) to instrument cluster (Figure 7, Item 24).
13. Connect speedometer driveshaft (Figure 7, Item 10) to instrument cluster (Figure 7, Item 24).
14. Connect tachometer driveshaft (Figure 7, Item 5) to instrument cluster (Figure 7, Item 24).

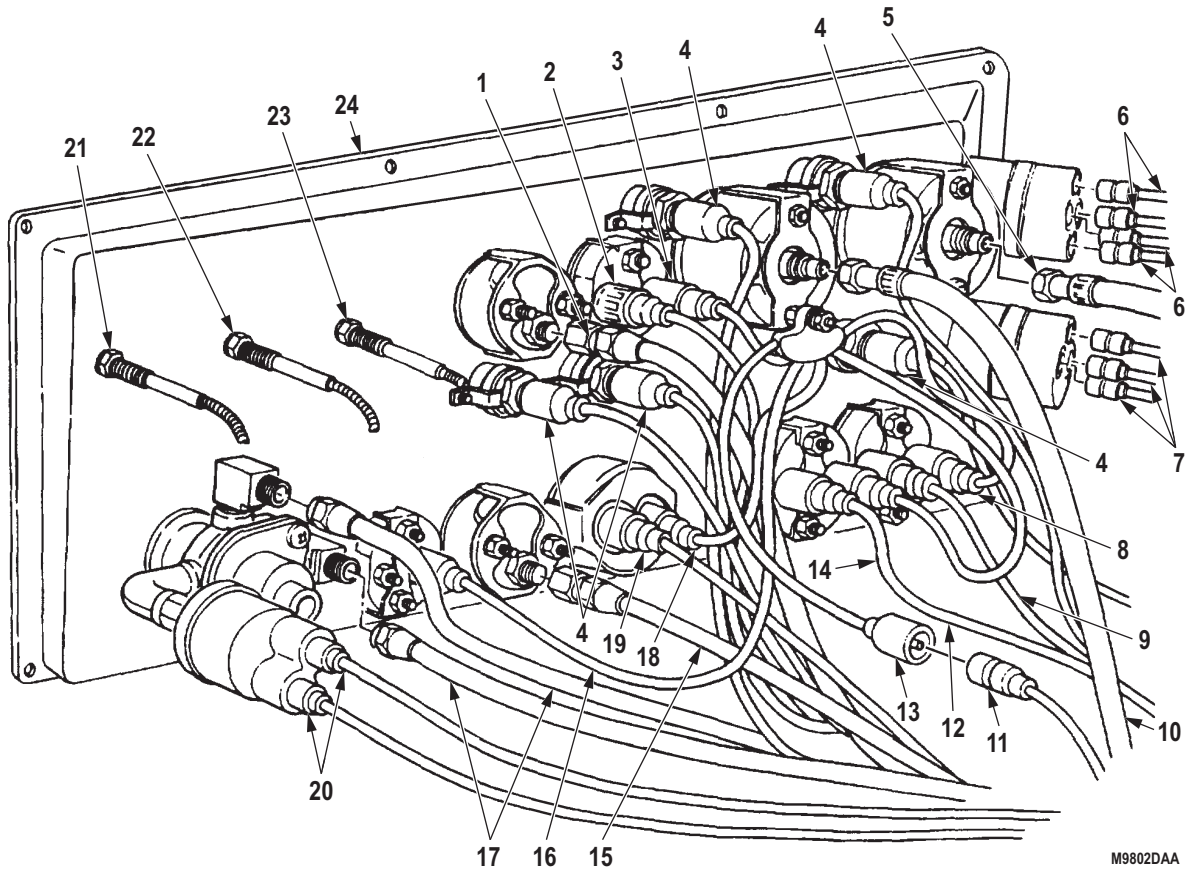
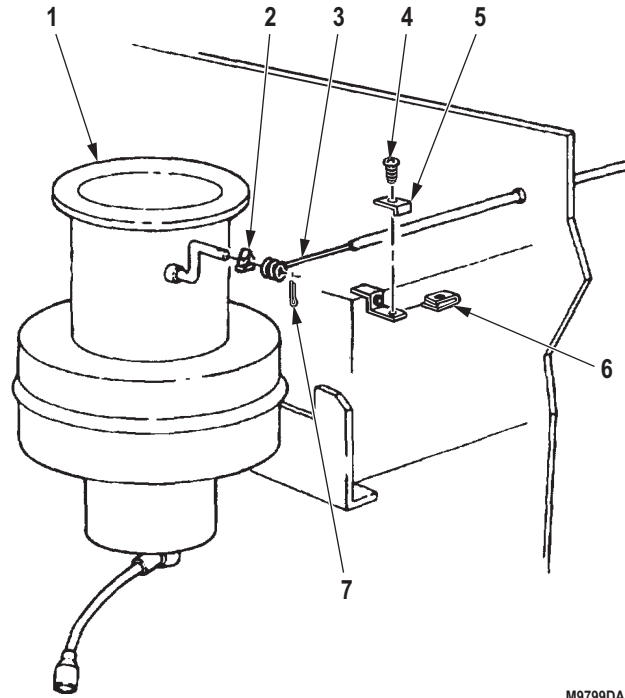

Figure 7. Instrument Cluster Installation.

INSTALLATION - Continued

15. Install fresh air control cable (Figure 8, Item 3) and spring nut (Figure 8, Item 2) on blower motor (Figure 8, Item 1).
16. Install cotter pin (Figure 8, Item 7) on heater assembly (Figure 8, Item 1).
17. Install clamp (Figure 8, Item 5), retaining nut (Figure 8, Item 6), and screw (Figure 8, Item 4) on heater assembly (Figure 8, Item 1).



M9799DAA

Figure 8. Instrument Cluster Installation.

INSTALLATION - Continued

18. Route heat control cable (Figure 9, Item 13) and defroster control cable (Figure 9, Item 1) through diverter brackets (Figure 9, Items 6 and 7).
19. Install heat control cable (Figure 9, Item 13), defroster control cable (Figure 9, Item 1), and spring nuts (Figure 9, Items 2 and 11) on control panel rods (Figure 9, Items 5 and 9).
20. Install cotter pins (Figure 9, Items 12 and 16) on control rods (Figure 9, Items 5 and 9).
21. Install retaining clips (Figure 9, Items 4 and 8), cables (Figure 9, Items 1 and 13), and clamps (Figure 9, Items 3 and 10) on diverter brackets (Figure 9, Items 6 and 7) with screws (Figure 9, Items 14 and 15).

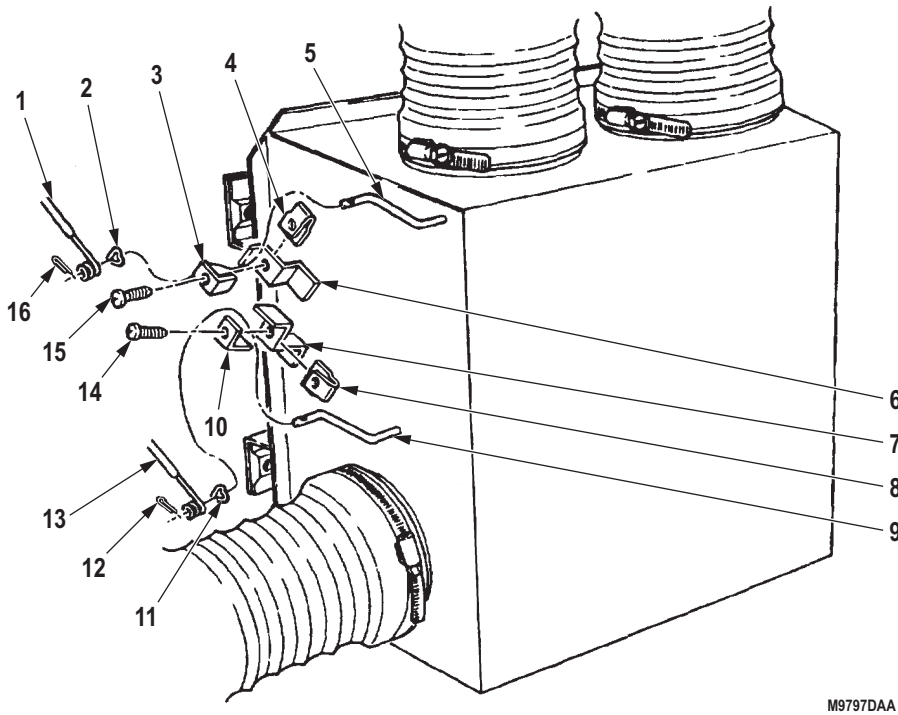

M9797DAA

Figure 9. Instrument Cluster Installation.

INSTALLATION - Continued

22. Install instrument cluster (Figure 10, Item 2) on instrument panel (Figure 10, Item 1) with eight screws (Figure 10, Item 3).

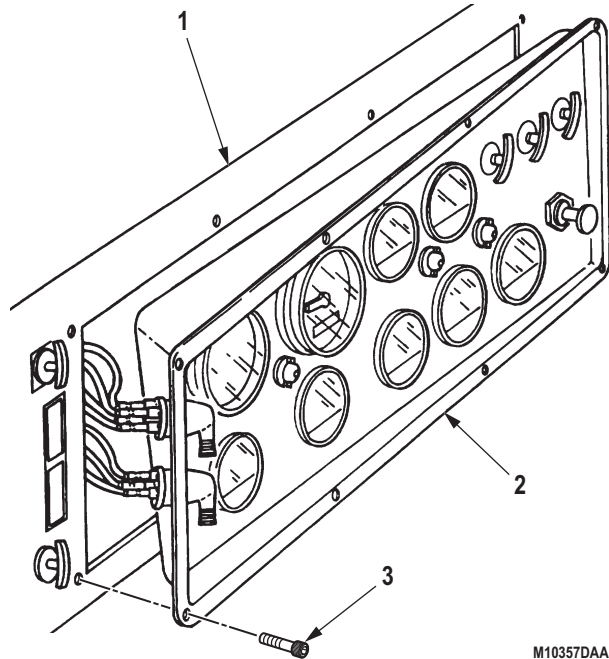

Figure 10. Instrument Cluster Installation.

END OF TASK**FOLLOW-ON MAINTENANCE**

1. Connect CTIS electrical components. (WP 0322)
2. Connect battery ground cables. (WP 0350)
3. Start engine and check gauges for proper operation. Check for air leaks at air gauges. (TM 9-2320-272-10)

END OF TASK**END OF WORK PACKAGE**

**FIELD MAINTENANCE
INDICATOR PANEL LIGHT AND LAMP REPLACEMENT**

INITIAL SETUP:**Tools and Special Tools**

Tool Kit, General Mechanic's: Automotive
(Volume 5, WP 0826, Table 1, Item 56)

Equipment Condition (cont.)

Battery ground cables disconnected. (WP 0350)

Materials/Parts

Lockwasher
(Volume 5, WP 0827, Table 1, Item 401)
Qty: 2

Equipment Condition

Parking brake set. (TM 9-2320-272-10)

LIGHT ASSEMBLY REMOVAL

1. Remove four screws (Figure 1, Item 7) from warning light panel assembly (Figure 1, Item 1) and pull warning light panel away from instrument panel (Figure 1, Item 2).
2. Remove lamp lens (Figure 1, Item 10) from lamp holder (Figure 1, Item 5).
3. Remove two screws (Figure 1, Item 9) and lockwashers (Figure 1, Item 8) from warning light panel assembly (Figure 1, Item 1) and lamp holder bracket (Figure 1, Item 6). Discard lockwashers.

NOTE

Tag all wires for installation.

4. Disconnect wire (Figure 1, Item 3) from of lamp holder connector (Figure 1, Item 4).
5. Remove lamp holder (Figure 1, Item 5) and bracket (Figure 1, Item 6) from warning light panel assembly (Figure 1, Item 1).

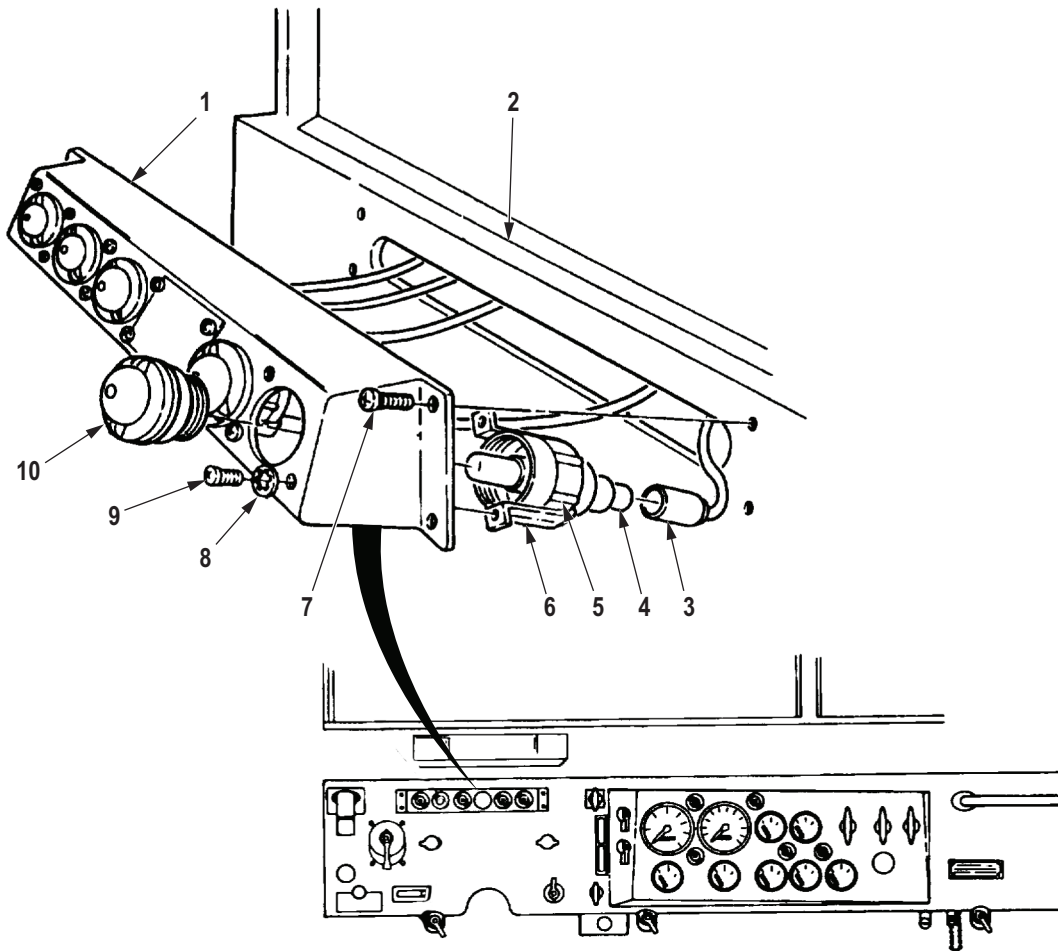

M0191DAA

Figure 1. Indicator Panel Light Removal.

END OF TASK

LIGHT ASSEMBLY INSTALLATION

1. Install lamp holder (Figure 2, Item 5) and bracket (Figure 2, Item 6) on warning light panel (Figure 2, Item 1) with two lockwashers (Figure 2, Item 8) and screws (Figure 2, Item 9).
2. Connect wire (Figure 2, Item 3) to lamp holder connector (Figure 2, Item 4).
3. Install lamp lens (Figure 2, Item 10) on lamp holder (Figure 2, Item 5).
4. Install warning light panel (Figure 2, Item 1) to instrument panel (Figure 2, Item 2) with four screws (Figure 2, Item 7).

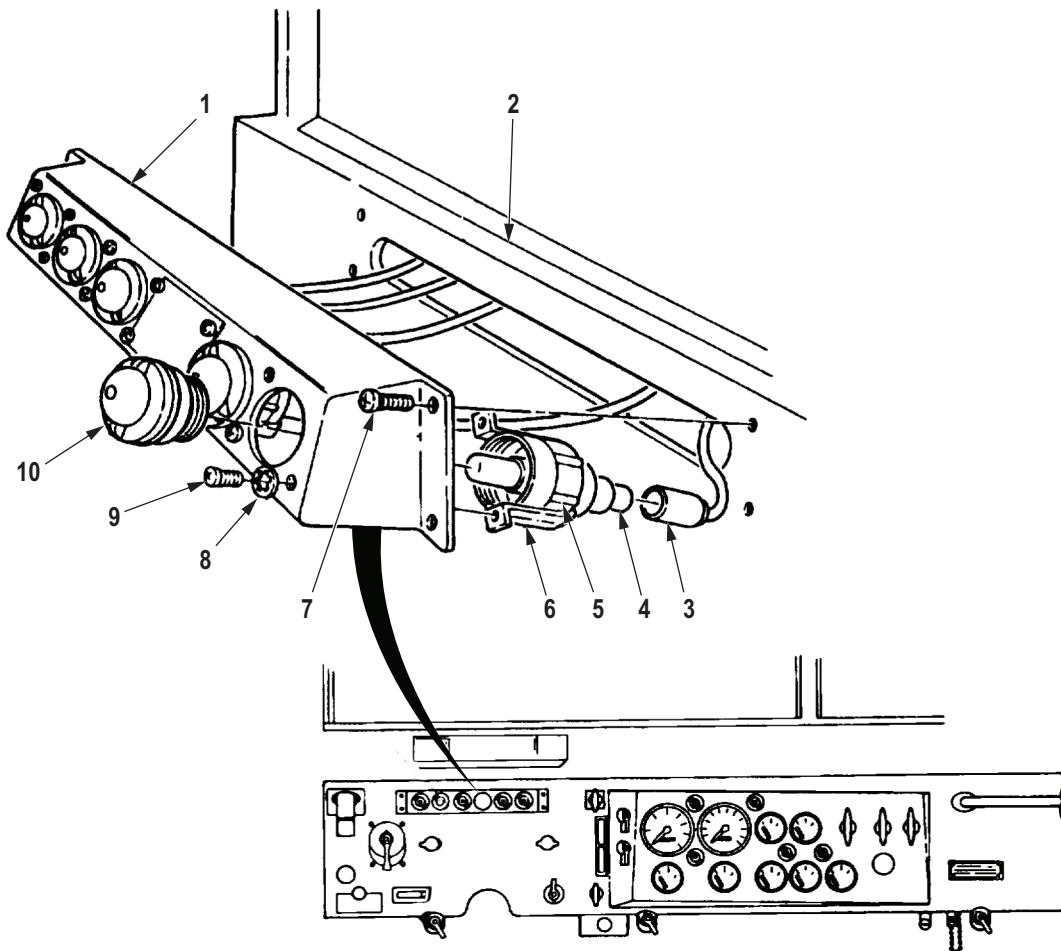

M0192DAA

*Figure 2. Indicator Panel Light Installation.***END OF TASK**

LAMP REMOVAL**NOTE**

All panel light lamps are removed and installed the same.

1. Remove lamp lens (Figure 3, Item 1) from lamp holder (Figure 3, Item 2).
2. Push lamp (Figure 3, Item 3) inward and turn counterclockwise to remove.

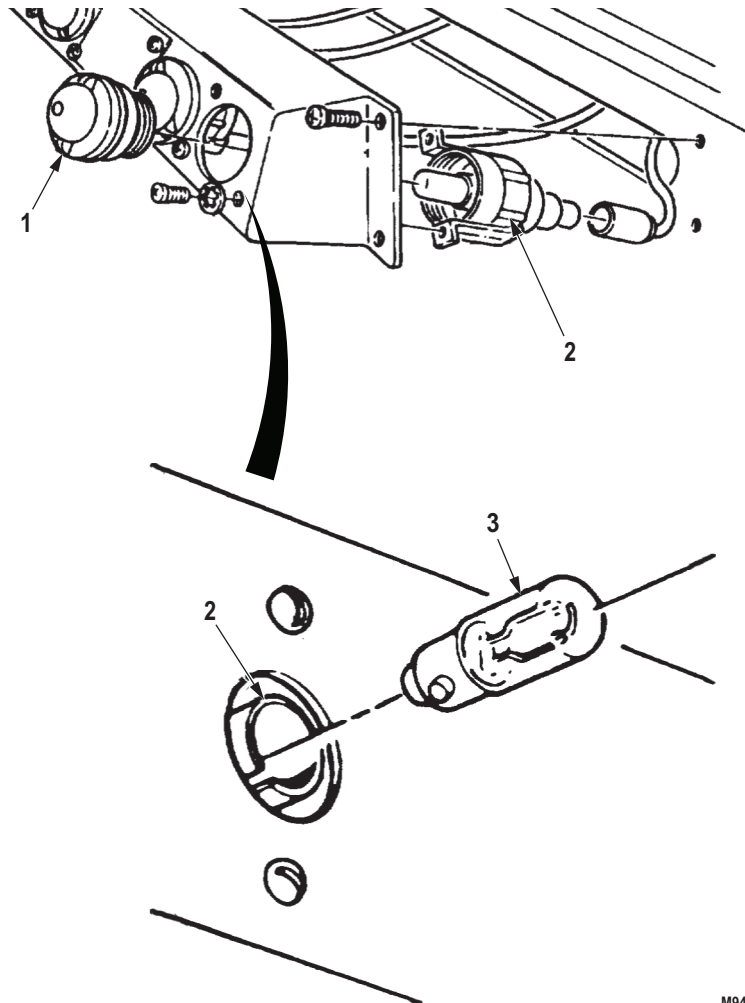

M9490DAA

Figure 3. Lamp Removal.

END OF TASK

LAMP INSTALLATION

1. Push lamp (Figure 4, Item 3) inward and turn clockwise to install.
2. Install lamp lens (Figure 4, Item 1) on lamp holder (Figure 4, Item 2).

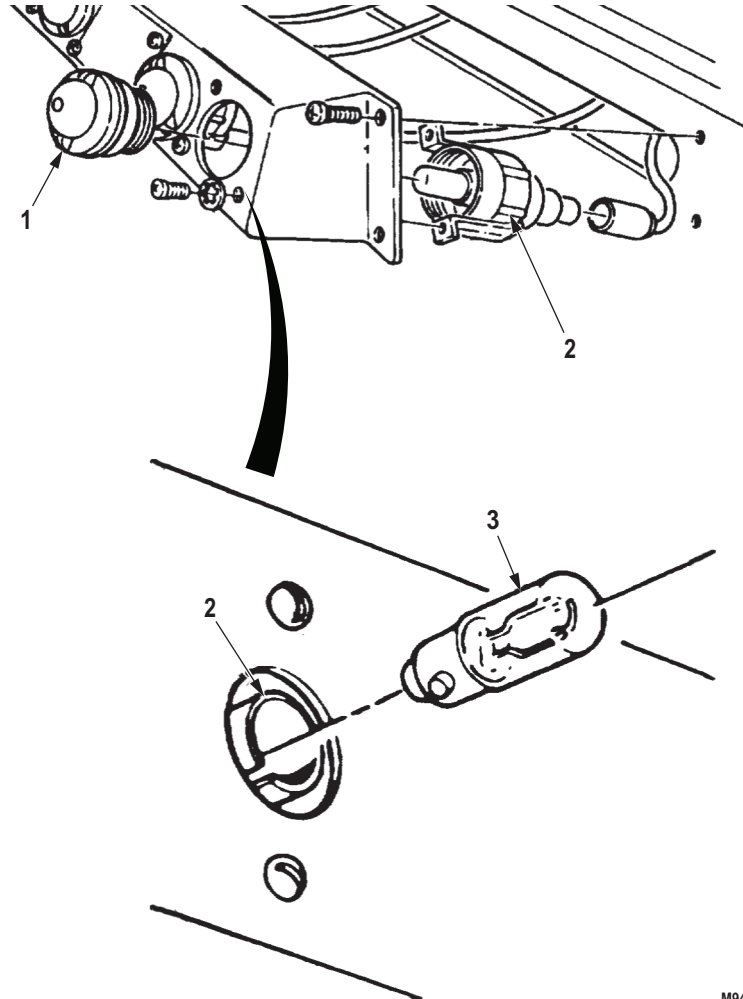

M9491DAA

Figure 4. Lamp Installation.

END OF TASK**FOLLOW-ON MAINTENANCE**

Connect battery ground cables. (WP 0350)

END OF TASK**END OF WORK PACKAGE**

**FIELD MAINTENANCE
ELECTRICAL GAUGES REPLACEMENT**

INITIAL SETUP:**Tools and Special Tools**

Tool Kit, General Mechanic's: Automotive
(Volume 5, WP 0826, Table 1, Item 56)

Equipment Condition (cont.)

Battery ground cables disconnected. (WP 0350)

Materials/Parts

Lockwasher
(Volume 5, WP 0827, Table 1, Item 402)
Qty: 2

Equipment Condition

Parking brake set. (TM 9-2320-272-10)

REMOVAL**NOTE**

Engine coolant temperature, transmission oil temperature, engine oil pressure, battery/alternator, and fuel level gauges are removed and installed the same.

1. Remove eight screws (Figure 1, Item 7) from instrument panel (Figure 1, Item 4).
2. Pull instrument cluster (Figure 1, Item 5) away from instrument panel (Figure 1, Item 4).

NOTE

- Battery indicator gauge has only one wire to disconnect.
- Tag all wires for installation.

3. Disconnect wires (Figure 1, Items 3 and 9) from fuel level gauge (Figure 1, Item 6).
4. Remove two nuts (Figure 1, Item 1), lockwashers (Figure 1, Item 2), and gauge mounting bracket (Figure 1, Item 8) from fuel level gauge (Figure 1, Item 6). Discard lockwashers.
5. Remove fuel level gauge (Figure 1, Item 6) from instrument cluster (Figure 1, Item 5).

REMOVAL - Continued

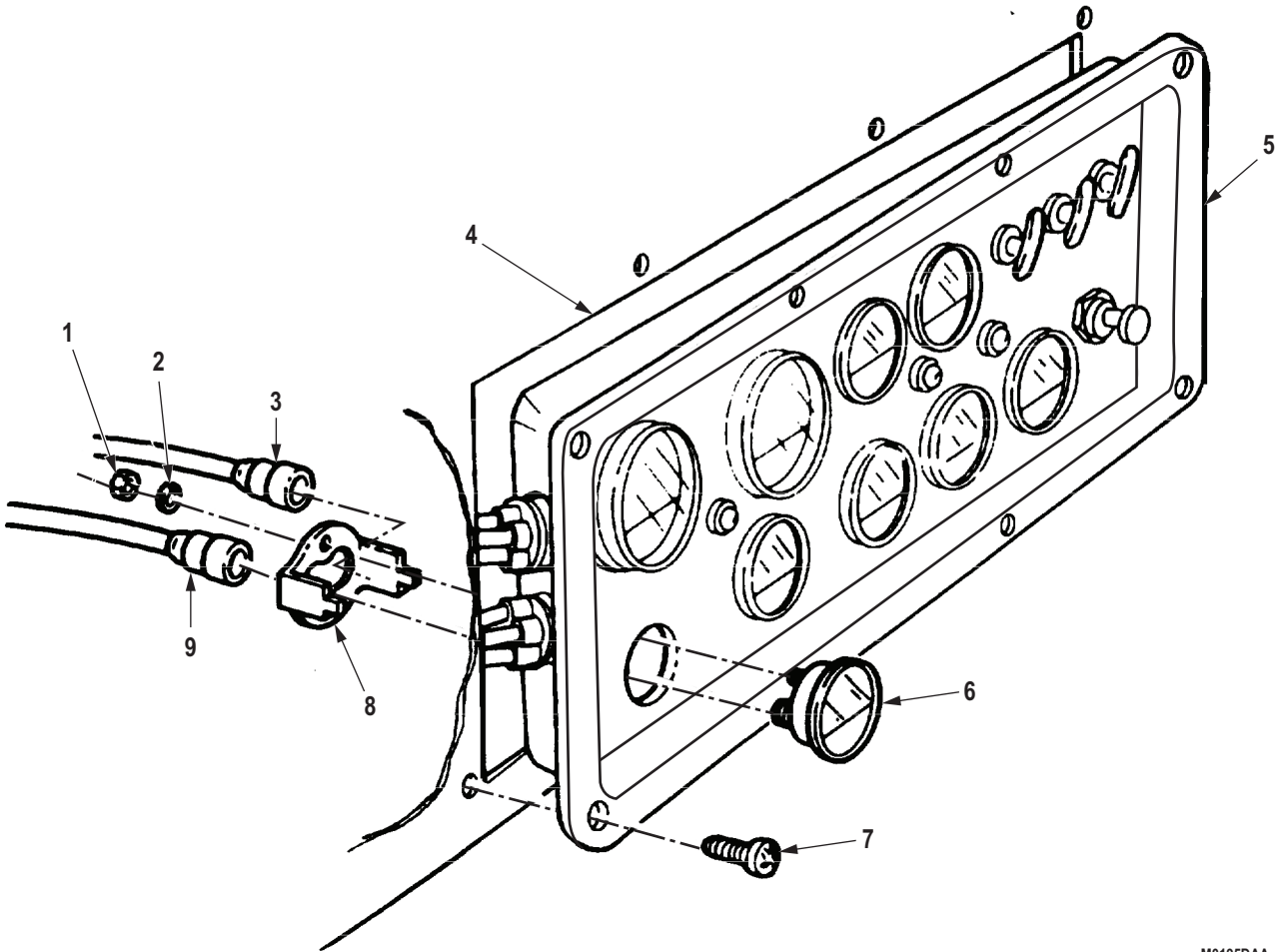

M0195DAA

Figure 1. Gauges Removal.

END OF TASK

INSTALLATION

1. Install fuel level gauge (Figure 2, Item 6) on instrument cluster (Figure 2, Item 5).
2. Install gauge mounting bracket (Figure 2, Item 8) on fuel level gauge (Figure 2, Item 6) with two lockwashers (Figure 2, Item 2) and nuts (Figure 2, Item 1).
3. Connect wires (Figure 2, Items 3 and 9) to fuel level gauge (Figure 2, Item 6).
4. Install instrument cluster (Figure 2, Item 5) on instrument panel (Figure 2, Item 4) with eight screws (Figure 2, Item 7).

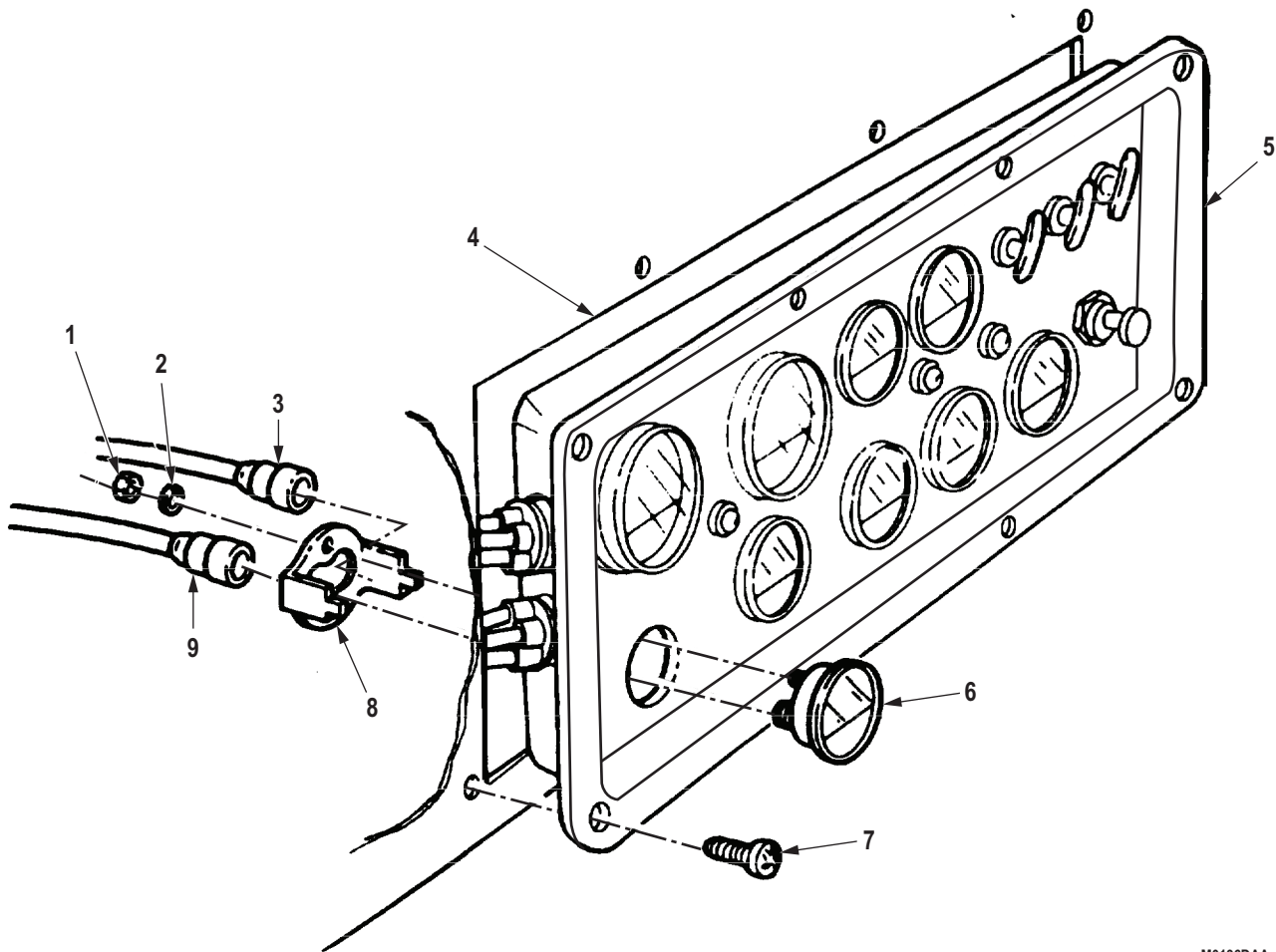

M0196DAA

*Figure 2. Gauges Installation.***END OF TASK**

FOLLOW-ON MAINTENANCE

1. Connect battery ground cables. (WP 0350)
2. Start engine and check gauge for proper operation. (TM 9-2320-272-10)

END OF TASK**END OF WORK PACKAGE**

**FIELD MAINTENANCE
AUXILIARY OUTLET SOCKET AND RECEPTACLE REPLACEMENT**

INITIAL SETUP:

Tools and Special Tools

Tool Kit, General Mechanic's: Automotive
(Volume 5, WP 0826, Table 1, Item 56)

Equipment Condition

Parking brake set. (TM 9-2320-272-10)
Battery ground cables disconnected. (WP 0350)

REMOVAL

1. Remove screw (Figure 1, Item 11) and outlet cable (Figure 1, Item 9) from auxiliary outlet socket (Figure 1, Item 12).
2. Remove screw (Figure 1, Item 8), clamp (Figure 1, Item 14), and auxiliary outlet socket (Figure 1, Item 12) from instrument panel (Figure 1, Item 13).
3. Remove clip (Figure 1, Item 10) from instrument panel (Figure 1, Item 13).
4. Disconnect wire (Figure 1, Item 1) from wire (Figure 1, Item 2).
5. Remove four nuts (Figure 1, Item 7), screws (Figure 1, Item 6), cover (Figure 1, Item 5), and auxiliary outlet receptacle (Figure 1, Item 4) from instrument panel (Figure 1, Item 13).

REMOVAL - Continued

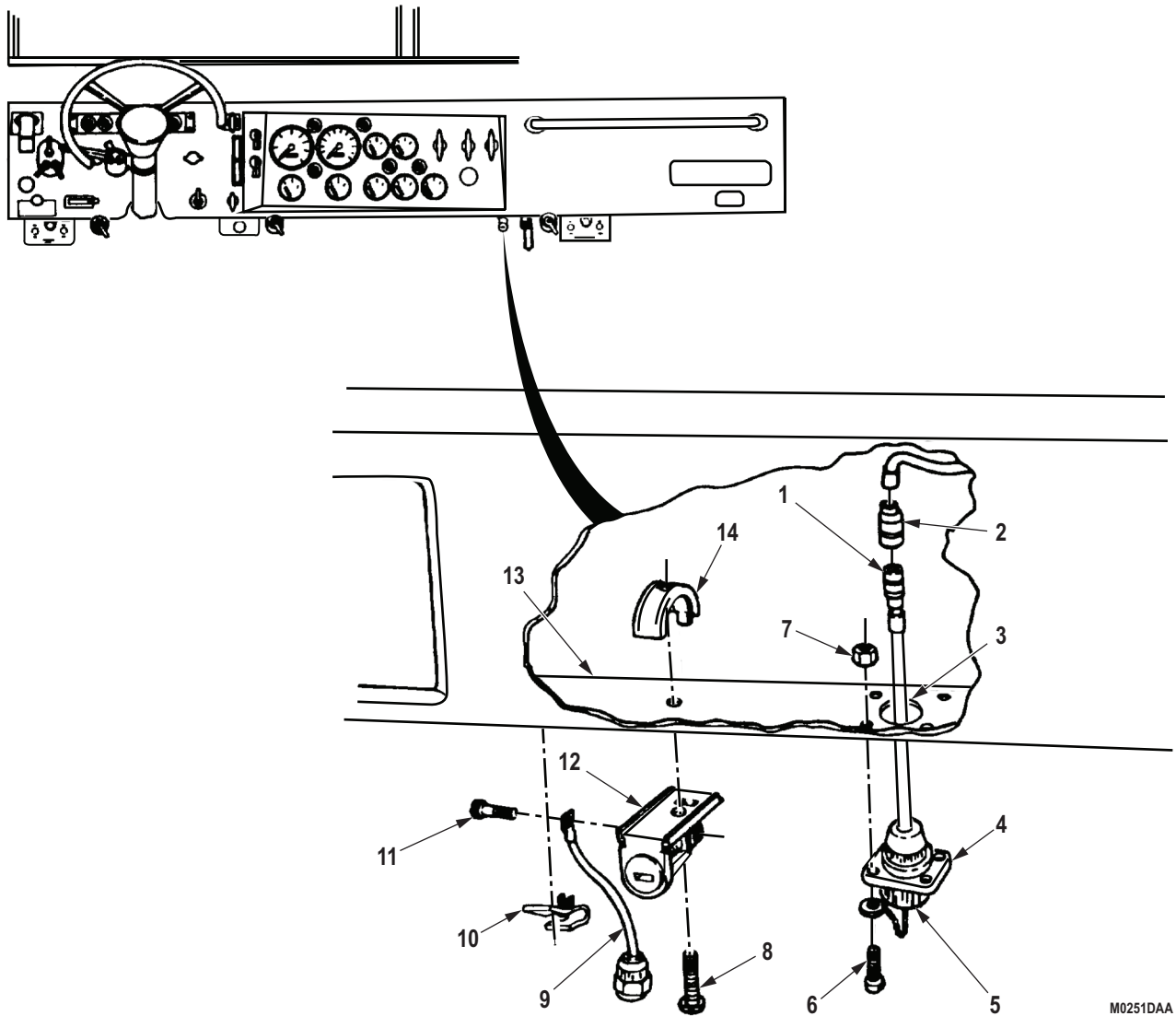

M0251DAA

Figure 1. Auxiliary Outlet Socket and Receptacle Removal.

END OF TASK

INSTALLATION

1. Insert wire (Figure 2, Item 1) through hole (Figure 2, Item 3) on instrument panel (Figure 2, Item 13) and connect to wire (Figure 2, Item 2).
2. Install auxiliary outlet receptacle (Figure 2, Item 4) and cover (Figure 2, Item 5) on instrument panel (Figure 2, Item 13) with four screws (Figure 2, Item 6) and nuts (Figure 2, Item 7).
3. Install clip (Figure 2, Item 10) on instrument panel (Figure 2, Item 13).
4. Install auxiliary outlet socket (Figure 2, Item 12) on instrument panel (Figure 2, Item 13) with clamp (Figure 2, Item 14) and screw (Figure 2, Item 8).
5. Install outlet cable (Figure 2, Item 9) on auxiliary outlet socket (Figure 2, Item 12) with screw (Figure 2, Item 11).
6. Install outlet cable (Figure 2, Item 9) on clip (Figure 2, Item 10).

INSTALLATION - Continued

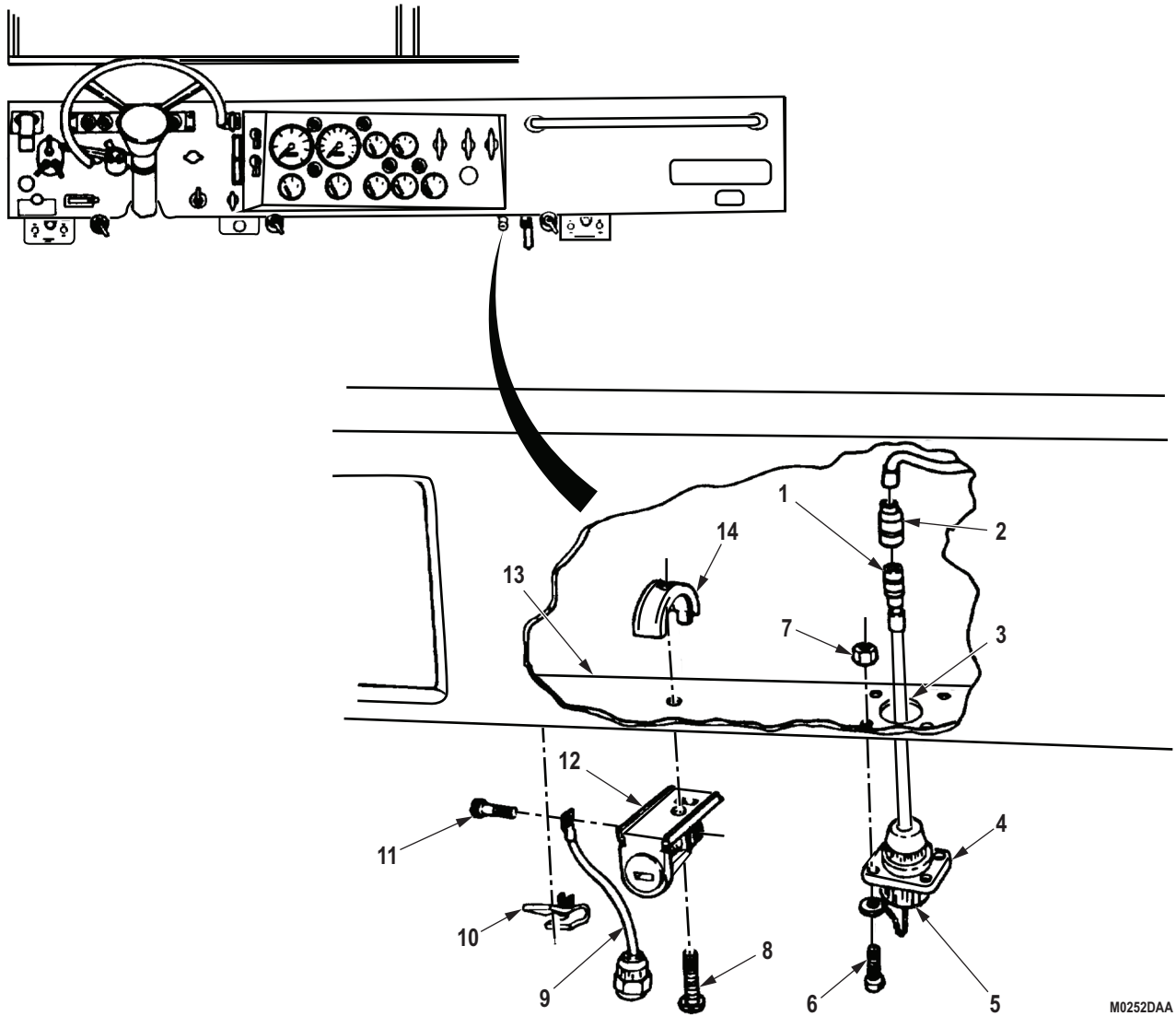

M0252DAA

Figure 2. Auxiliary Outlet Installation.

END OF TASK

FOLLOW-ON MAINTENANCE

Connect battery ground cables. (WP 0350)

END OF TASK

END OF WORK PACKAGE

**FIELD MAINTENANCE
FUEL SELECTOR VALVE SWITCH REPLACEMENT**

INITIAL SETUP:**Tools and Special Tools**

Tool Kit, General Mechanic's: Automotive
(Volume 5, WP 0826, Table 1, Item 56)

Equipment Condition

Parking brake set. (TM 9-2320-272-10)
Battery ground cables disconnected. (WP 0350)

Materials/Parts

Locknut (Volume 5, WP 0827, Table 1, Item 312)
Qty: 2

REMOVAL**NOTE**

Tag wires for installation.

1. Disconnect two wires (Figure 1, Item 2) and wire (Figure 1, Item 14) from fuel selector valve switch (Figure 1, Item 3).
2. Remove screw (Figure 1, Item 9), washer (Figure 1, Item 10), lever (Figure 1, Item 8), felt washer (Figure 1, Item 11), and washer (Figure 1, Item 7) from fuel selector valve switch (Figure 1, Item 3).
3. Remove nut (Figure 1, Item 12), washer (Figure 1, Item 6), and plate (Figure 1, Item 5) from fuel selector switch (Figure 1, Item 3).
4. Remove fuel selector valve switch (Figure 1, Item 3) from bracket (Figure 1, Item 4).
5. Remove two locknuts (Figure 1, Item 1), screws (Figure 1, Item 13), and bracket (Figure 1, Item 4) from instrument panel (Figure 1, Item 15). Discard locknuts.

REMOVAL - Continued

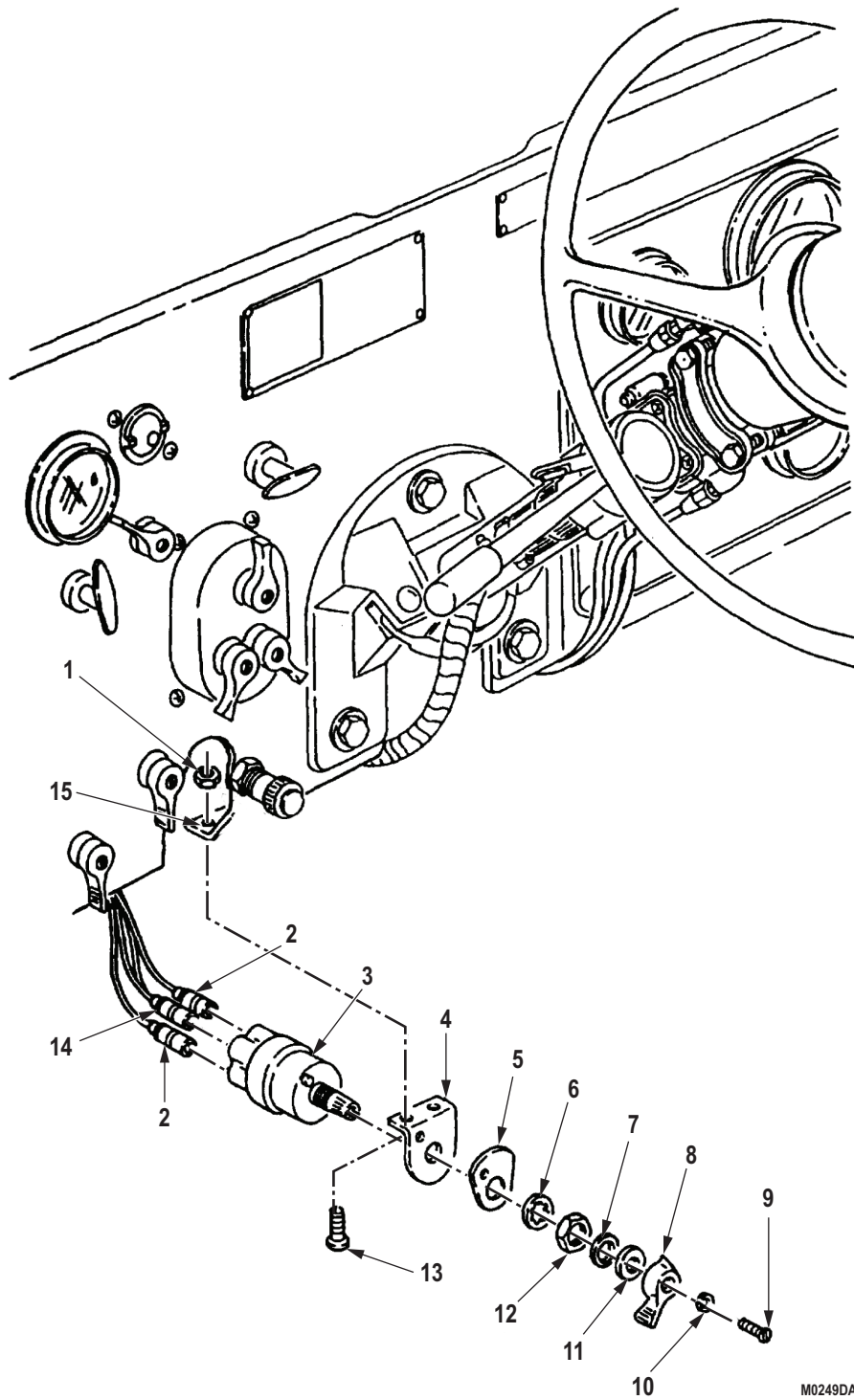

M0249DAA

Figure 1. Fuel Selector Valve Switch Removal.

END OF TASK

INSTALLATION

1. Install bracket (Figure 2, Item 4) on instrument panel (Figure 2, Item 15) with two screws (Figure 2, Item 13) and locknuts (Figure 2, Item 1).
2. Position fuel selector valve switch (Figure 2, Item 3) on bracket (Figure 2, Item 4) and install plate (Figure 2, Item 5), washer (Figure 2, Item 6), and nut (Figure 2, Item 12).
3. Install lever (Figure 2, Item 8) on fuel selector valve switch (Figure 2, Item 3) with washer (Figure 2, Item 7), felt washer (Figure 2, Item 11), washer (Figure 2, Item 10), and screw (Figure 2, Item 9).
4. Connect two wires (Figure 2, Item 2) and wire (Figure 2, Item 14) to fuel selector valve switch (Figure 2, Item 3).

INSTALLATION - Continued

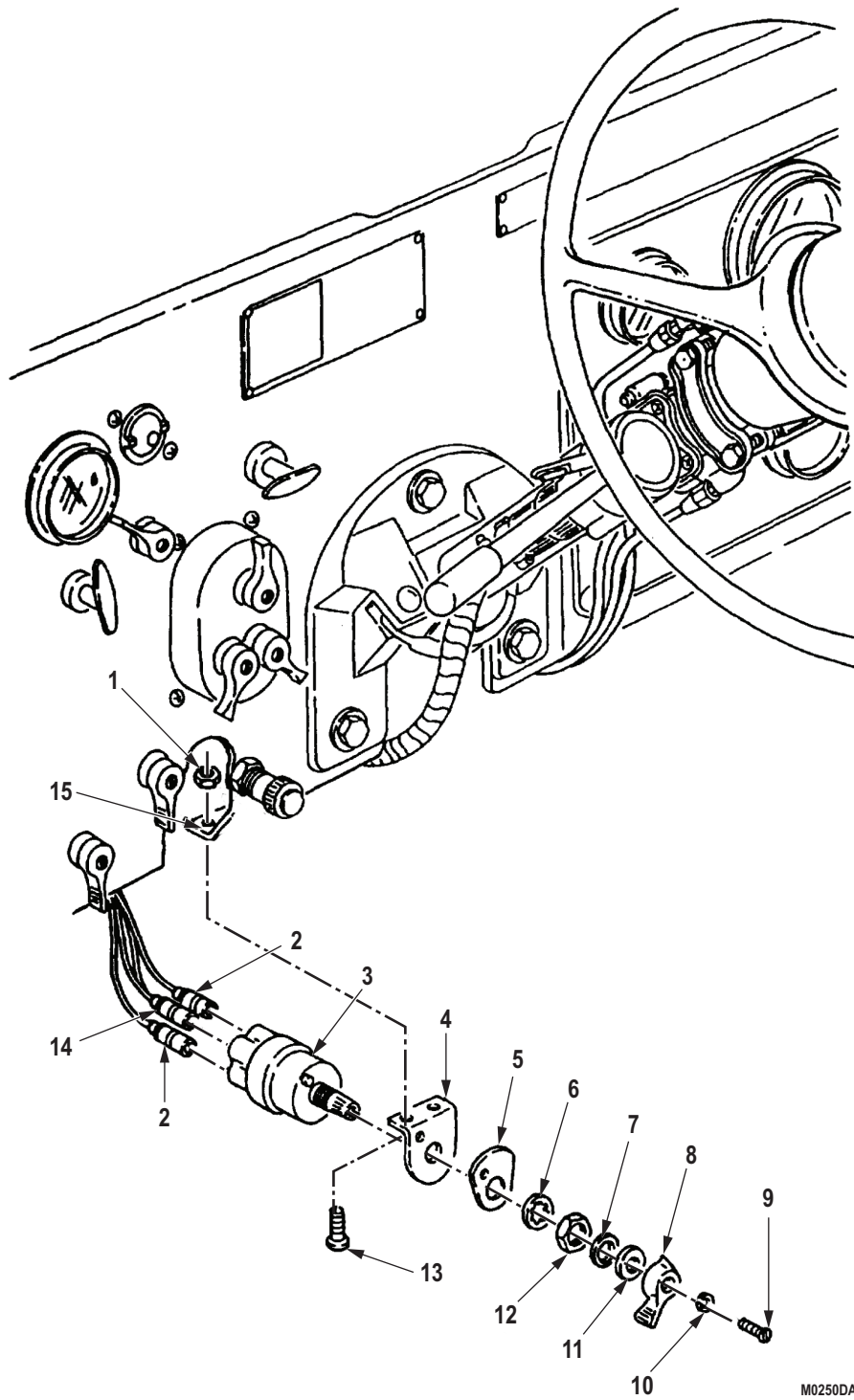

M0250DAA

Figure 2. Fuel Selector Valve Switch Installation.

END OF TASK

FOLLOW-ON MAINTENANCE

1. Connect battery ground cables. (WP 0350)
2. Check fuel selector valve switch for proper operation. (TM 9-2320-272-10)

END OF TASK**END OF WORK PACKAGE**

**FIELD MAINTENANCE
MAIN LIGHT SWITCH REPLACEMENT**

INITIAL SETUP:

Tools and Special Tools

Tool Kit, General Mechanic's: Automotive
(Volume 5, WP 0826, Table 1, Item 56)

Equipment Condition

Parking brake set. (TM 9-2320-272-10)
Battery ground cables disconnected. (WP 0350)

REMOVAL**NOTE**

- Two different types of light switches are used.
 - Step (1) applies to three lever switch.
1. Remove three screws (Figure 1, Item 8), washers (Figure 1, Item 7), switch levers (Figure 1, Item 6), and washers (Figure 1, Item 5) from main light switch (Figure 1, Item 1).

NOTE

- Switch is removed from behind instrument panel.
 - Steps (2) and (3) apply to both switches.
2. Remove four screws (Figure 1, Item 4) and light switch (Figure 1, Item 1) from instrument panel (Figure 1, Item 3).
 3. Disconnect harness connector (Figure 1, Item 2) from main light switch (Figure 1, Item 1).

REMOVAL - Continued

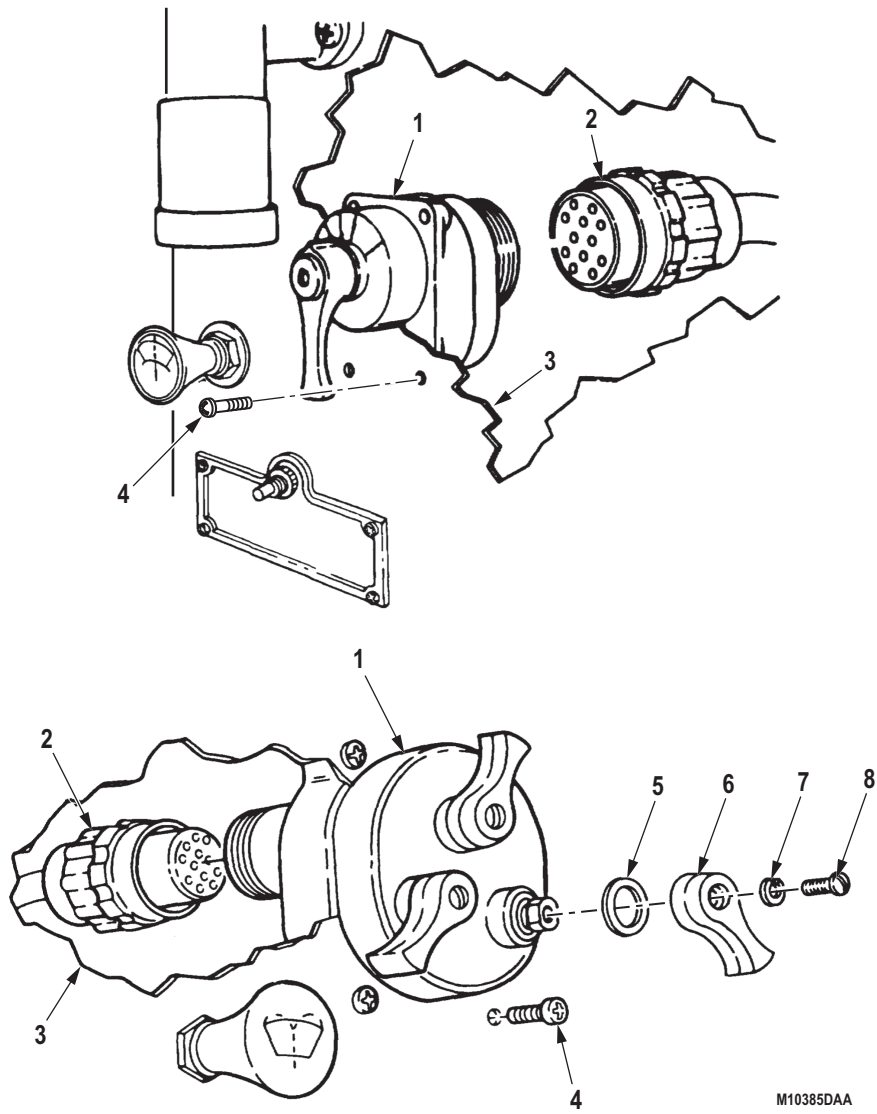

M10385DAA

Figure 1. Main Light Switch Removal.

END OF TASK

INSTALLATION**NOTE**

Steps (1) and (2) apply to both switches.

1. Connect harness connector (Figure 2, Item 2) to main light switch (Figure 2, Item 1).
2. Install main light switch (Figure 2, Item 1) on instrument panel (Figure 2, Item 3) with four screws (Figure 2, Item 4).

NOTE

Step (3) applies to three lever switch.

3. Install three washers (Figure 2, Item 5) and switch levers (Figure 2, Item 6) on main light switch (Figure 2, Item 1) with three washers (Figure 2, Item 7) and screws (Figure 2, Item 8).

INSTALLATION - Continued

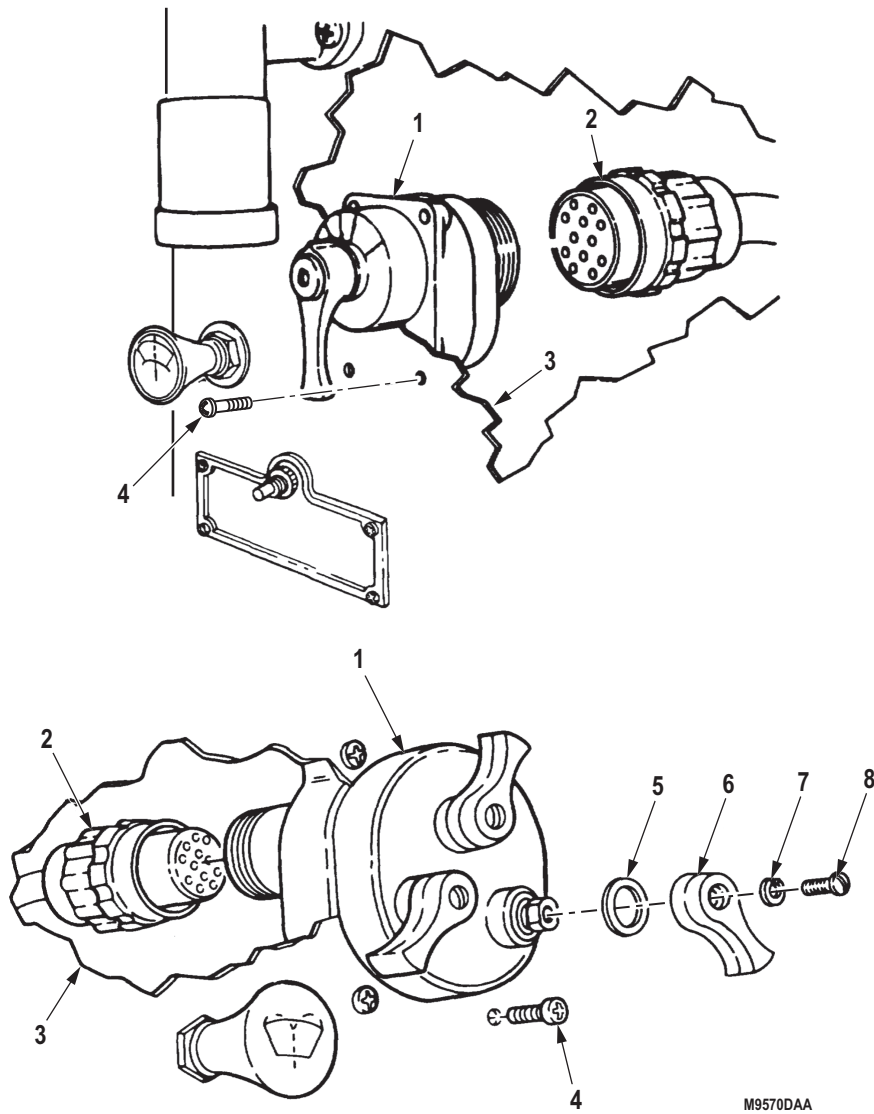

M9570DAA

Figure 2. Main Light Switch Installation.

END OF TASK

FOLLOW-ON MAINTENANCE

1. Connect battery ground cables. (WP 0350)
2. Check lights for proper operation. (TM 9-2320-272-10)

END OF TASK

END OF WORK PACKAGE

**FIELD MAINTENANCE
HIGH BEAM SELECTOR SWITCH REPLACEMENT**

INITIAL SETUP:**Tools and Special Tools**

Tool Kit, General Mechanic's: Automotive
(Volume 5, WP 0826, Table 1, Item 56)

Equipment Condition

Parking brake set. (TM 9-2320-272-10)
Battery ground cables disconnected. (WP 0350)

Personnel Required

(2)

REMOVAL**NOTE**

Tag all wires for installation.

1. Disconnect electrical wires (Figure 1, Items 3, 4, and 5) from selector switch (Figure 1, Item 6) under cab floor (Figure 1, Item 2).

NOTE

Assistant will help with Step (2).

2. Remove two screws (Figure 1, Item 1) and selector switch (Figure 1, Item 6) from cab floor (Figure 1, Item 2).

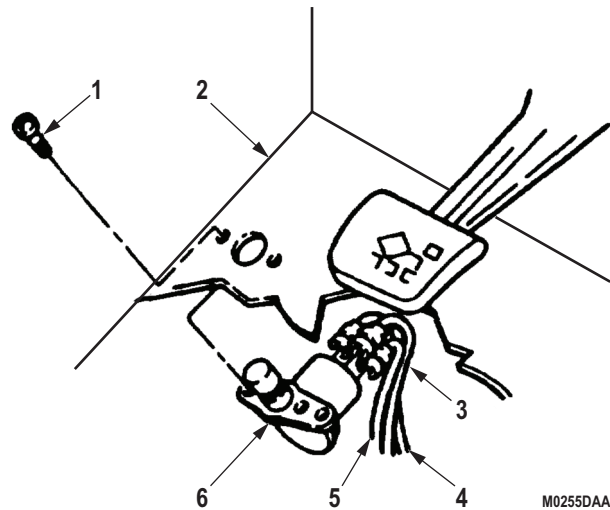

Figure 1. High Beam Selector Switch Removal.

END OF TASK

INSTALLATION**NOTE**

Assistant will help with Step (1).

1. Install selector switch (Figure 2, Item 6) on cab floor (Figure 2, Item 2) with two screws (Figure 2, Item 1).
2. Connect electrical wires (Figure 2, Items 3, 4, and 5) to selector switch (Figure 2, Item 6).

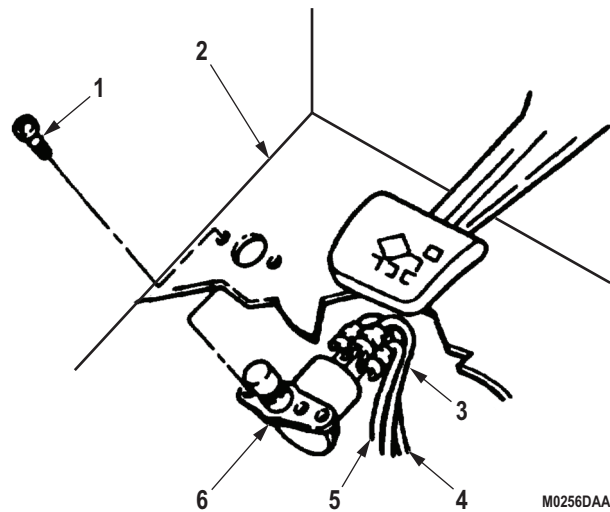

Figure 2. High Beam Selector Switch Installation.

END OF TASK**FOLLOW-ON MAINTENANCE**

1. Connect battery ground cables. (WP 0350)
2. Check headlight beam selector for proper operation. (TM 9-2320-272-10)

END OF TASK**END OF WORK PACKAGE**

FIELD MAINTENANCE
TURN SIGNAL CONTROL AND INDICATOR LAMP REPLACEMENT

INITIAL SETUP:**Tools and Special Tools**

Tool Kit, General Mechanic's: Automotive
(Volume 5, WP 0826, Table 1, Item 56)

Equipment Condition

Parking brake set. (TM 9-2320-272-10)
Battery ground cables disconnected. (WP 0350)

REMOVAL

1. Disconnect connector (Figure 1, Item 7) from signal control (Figure 1, Item 8).
2. Remove clamp (Figure 1, Item 5), signal self-canceller (Figure 1, Item 6), and turn signal control (Figure 1, Item 8) from steering column (Figure 1, Item 4).
3. Remove lamp lens (Figure 1, Item 1) and lamp (Figure 1, Item 9) from lamp socket (Figure 1, Item 2).

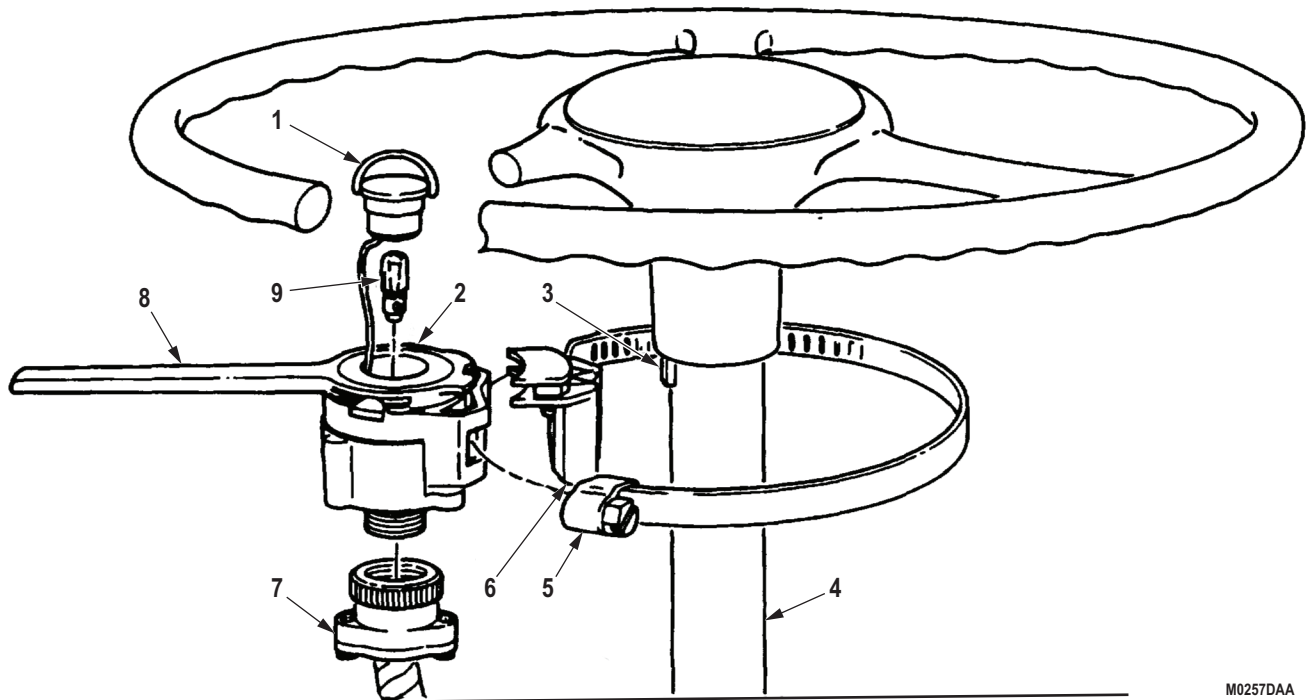

M0257DAA

Figure 1. Turn Signal Removal.

END OF TASK

INSTALLATION

1. Install lamp (Figure 2, Item 9) on lamp socket (Figure 2, Item 2).
2. Install lamp lens (Figure 2, Item 1) on turn signal control (Figure 2, Item 8).
3. Align signal self-canceller (Figure 2, Item 6) with cancelling pin (Figure 2, Item 3), and install turn signal control (Figure 2, Item 8) on steering column (Figure 2, Item 4) with clamp (Figure 2, Item 5).
4. Connect connector (Figure 2, Item 7) to turn signal control (Figure 2, Item 8).

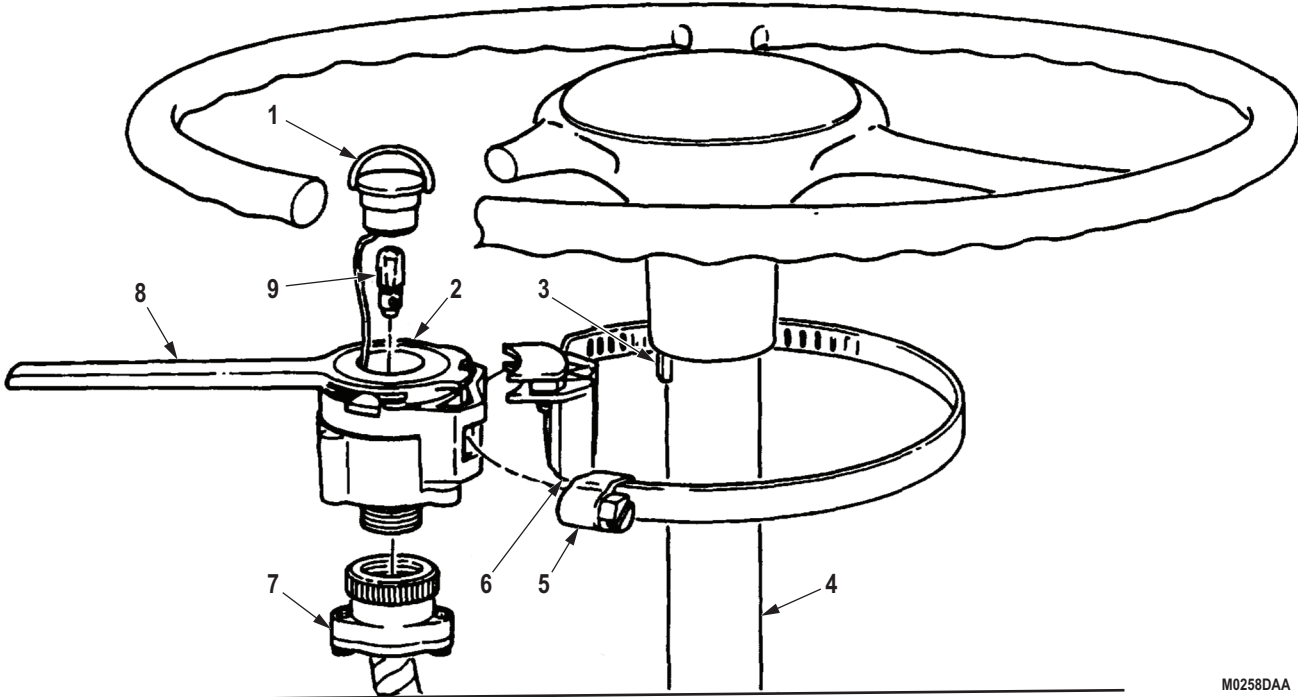

M0258DAA

Figure 2. Turn Signal Installation.

END OF TASK**FOLLOW-ON MAINTENANCE**

1. Connect battery ground cables. (WP 0350)
2. Check turn signal flasher for proper operation. (TM 9-2320-272-10)

END OF TASK**END OF WORK PACKAGE**

**FIELD MAINTENANCE
TURN SIGNAL FLASHER REPLACEMENT**

INITIAL SETUP:**Tools and Special Tools**

Tool Kit, General Mechanic's: Automotive
(Volume 5, WP 0826, Table 1, Item 56)

Equipment Condition

Parking brake set. (TM 9-2320-272-10)
Battery ground cables disconnected. (WP 0350)

REMOVAL

1. Remove screws (Figure 1, Items 7 and 8), washers (Figure 1, Item 6) and (Figure 1, Item 9), wire (Figure 1, Item 5), horn ground wire (Figure 1, Item 4), and flasher (Figure 1, Item 3) from firewall (Figure 1, Item 1).
2. Remove harness connector (Figure 1, Item 2) from flasher (Figure 1, Item 3).

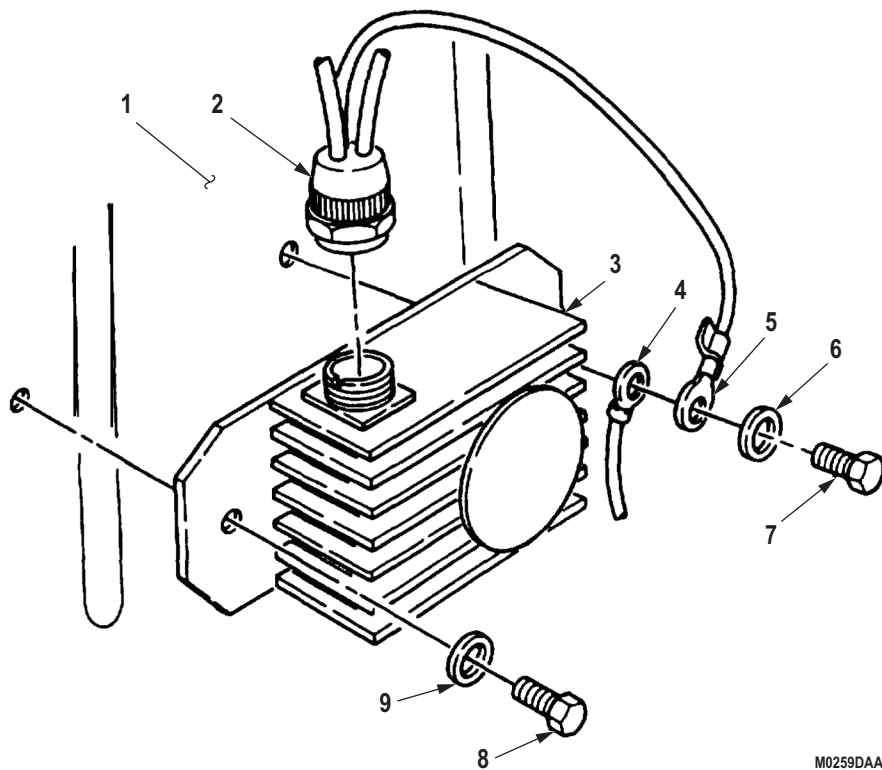

M0259DAA

Figure 1. Turn Signal Removal.

END OF TASK

INSTALLATION

1. Install harness connector (Figure 2, Item 2) on flasher (Figure 2, Item 3).
2. Install flasher (Figure 2, Item 3), horn ground wire (Figure 2, Item 4), and wire (Figure 2, Item 5) on firewall (Figure 2, Item 1) with washers (Figure 2, Items 6 and 9) and screws (Figure 2, Items 7 and 8).

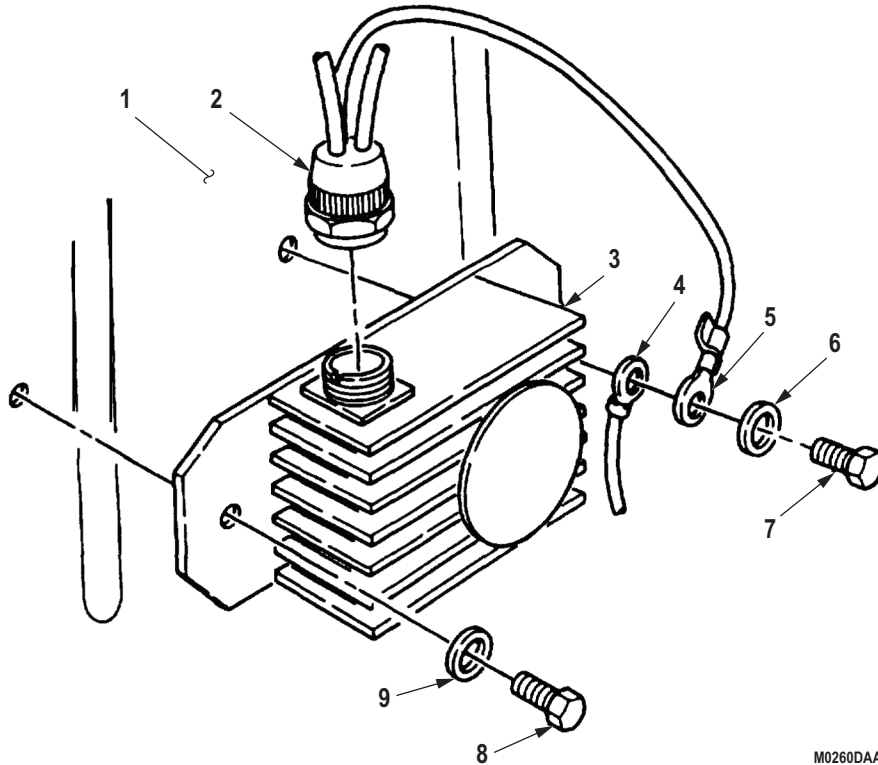

M0260DAA

Figure 2. Turn Signal Installation.

END OF TASK**FOLLOW-ON MAINTENANCE**

1. Connect battery ground cables. (WP 0350)
2. Check turn signal flasher for proper operation. (TM 9-2320-272-10)

END OF TASK**END OF WORK PACKAGE**

**FIELD MAINTENANCE
PROTECTIVE CONTROL BOX REPLACEMENT**

INITIAL SETUP:**Tools and Special Tools**

Tool Kit, General Mechanic's: Automotive
(Volume 5, WP 0826, Table 1, Item 56)
Wrench, Torque, Click, Ratcheting, 1/2" Drive,
250 Ft-Lb
(Volume 5, WP 0826, Table 1, Item 63)

Equipment Condition (cont.)

Battery ground cables disconnected. (WP 0350)
Ether cylinder and valve removed. (WP 0263)

Materials/Parts

Lockwasher
(Volume 5, WP 0827, Table 1, Item 387)
Qty: 6

Equipment Condition

Parking brake set. (TM 9-2320-272-10)

REMOVAL

1. Remove windshield washer bottle lid (Figure 1, Item 2) and washer bottle (Figure 1, Item 3) from windshield washer bottle bracket (Figure 1, Item 4). Do not disconnect windshield washer hoses (Figure 1, Item 1).
2. Disconnect harness connector (Figure 1, Item 12) from protective control box (Figure 1, Item 13).
3. Remove four screws (Figure 1, Item 11), lockwashers (Figure 1, Item 10), ground wire (Figure 1, Item 9), protective control box (Figure 1, Item 13), two lockwashers (Figure 1, Item 8), spacers (Figure 1, Items 5 and 7), and washer bottle bracket (Figure 1, Item 4) from firewall (Figure 1, Item 6). Discard lockwashers.

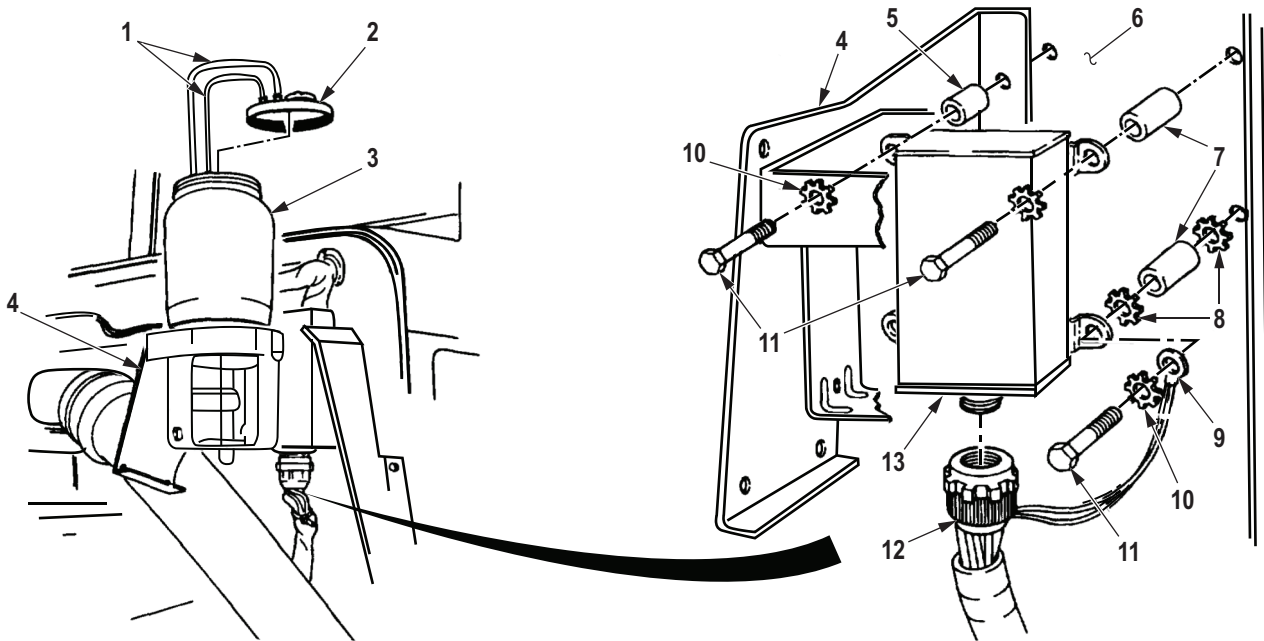

M0261DAA

Figure 1. Protective Control Box Removal.

END OF TASK

INSTALLATION

1. Install washer bottle bracket (Figure 2, Item 4) on firewall (Figure 2, Item 6) with two spacers (Figure 2, Item 5), lockwashers (Figure 2, Item 8), spacers (Figure 2, Item 7), protective control box (Figure 2, Item 13), ground wire (Figure 2, Item 9), four lockwashers (Figure 2, Item 10), and screws (Figure 2, Item 11).
2. Connect harness connector (Figure 2, Item 12) on protective control box (Figure 2, Item 13). Tighten connector to 10 lb-ft (14 N·m).
3. Install windshield washer bottle (Figure 2, Item 3) and windshield washer bottle lid (Figure 2, Item 2) on windshield bottle bracket (Figure 2, Item 4).

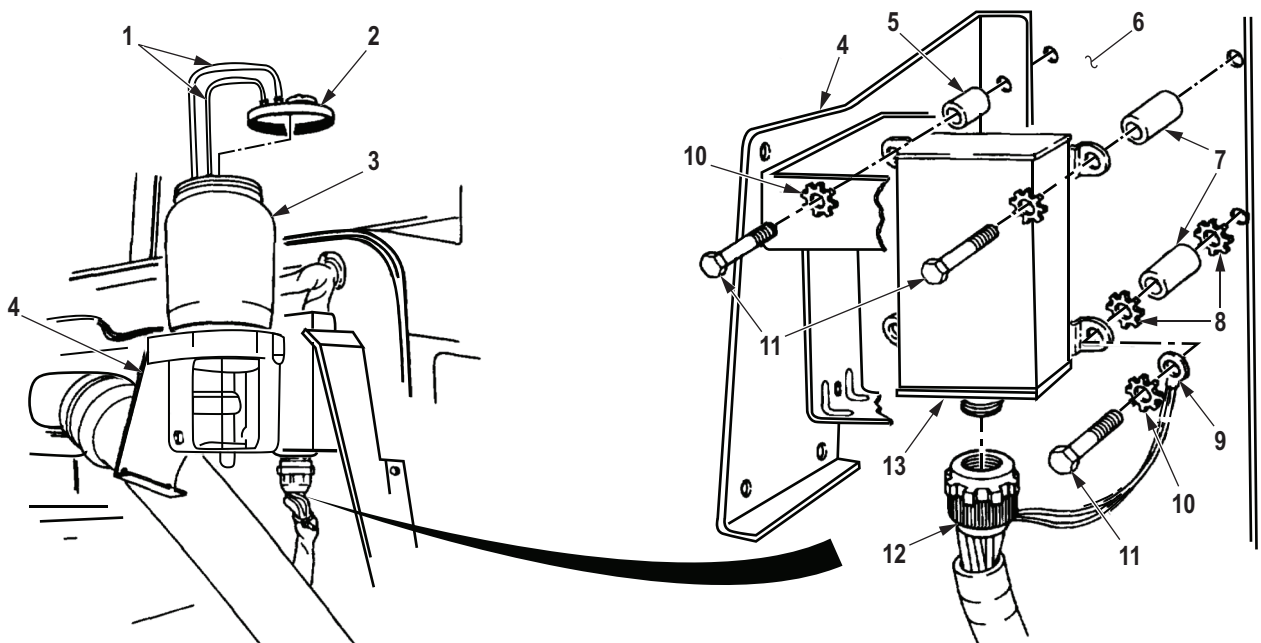

M0262DAA

Figure 2. Protective Control Box Installation.

END OF TASK**FOLLOW-ON MAINTENANCE**

1. Install ether cylinder and valve. (WP 0263)
2. Connect battery ground cables. (WP 0350)

END OF TASK**END OF WORK PACKAGE**

**FIELD MAINTENANCE
FLOODLIGHT CONTROL SWITCH REPLACEMENT**

INITIAL SETUP:**Tools and Special Tools**

Tool Kit, General Mechanic's: Automotive
(Volume 5, WP 0826, Table 1, Item 56)

Materials/Parts

Locknut
(Volume 5, WP 0827, Table 1, Item 312)
Qty: 2
Lockwasher

Materials/Parts (cont.)

(Volume 5, WP 0827, Table 1, Item 387)
Qty: 1
Lockwasher
(Volume 5, WP 0827, Table 1, Item 401)
Qty: 1

Equipment Condition

Parking brake set. (TM 9-2320-272-10)
Battery ground cables disconnected. (WP 0350)

REMOVAL

1. Remove two locknuts (Figure 1, Item 1) and mounting screws (Figure 1, Item 3) from angle bracket (Figure 1, Item 2) and instrument panel (Figure 1, Item 6). Discard locknuts.
2. Lower floodlight control switch (Figure 1, Item 4).

NOTE

Tag connectors for installation.

3. Disconnect four connectors (Figure 1, Item 5) from floodlight control switch (Figure 1, Item 4).

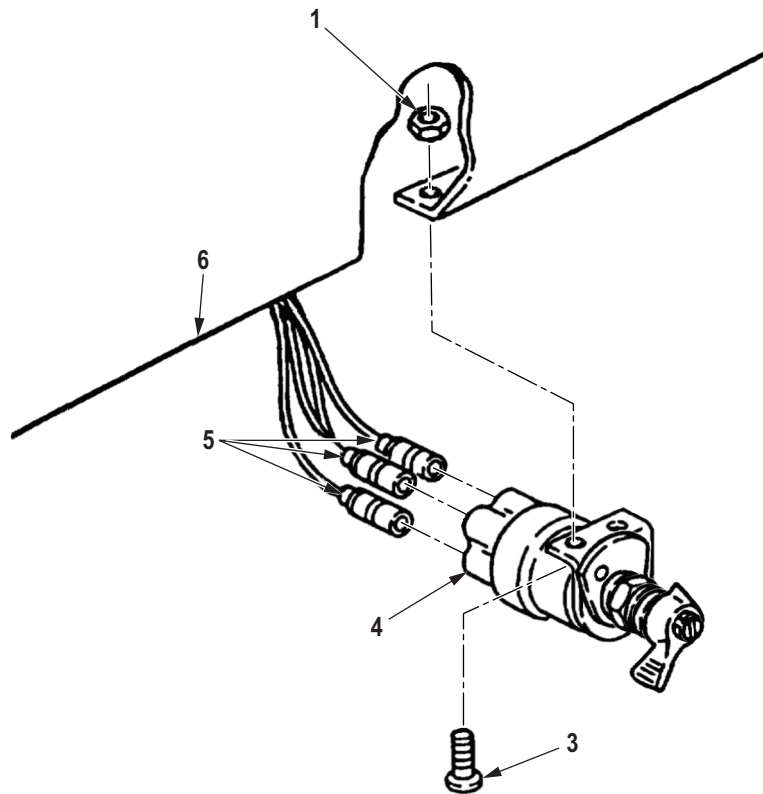

M8021DAA

Figure 1. Floodlight Switch Installation Removal.

END OF TASK

DISASSEMBLY

1. Remove screw (Figure 2, Item 6), lockwasher (Figure 2, Item 5), switch lever (Figure 2, Item 7), washer (Figure 2, Item 4), and felt washer (Figure 2, Item 8) from floodlight control switch (Figure 2, Item 10). Discard lockwasher.
2. Remove nut (Figure 2, Item 3), lockwasher (Figure 2, Item 9), identification plate (Figure 2, Item 4), angle bracket (Figure 2, Item 1), plug (Figure 2, Item 12), and shell (Figure 2, Item 11) from floodlight control switch (Figure 2, Item 10). Discard lockwasher.

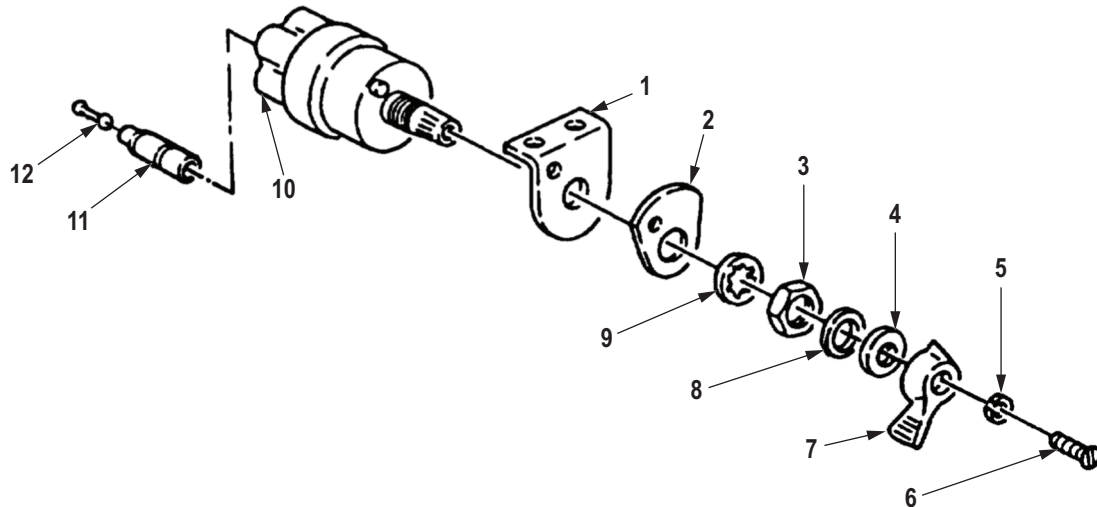

M9568DAA

Figure 2. Floodlight Switch Disassembly.

END OF TASK

INSPECTION

1. Inspect floodlight control switch (Figure 3, Item 2) for breaks and cracks in housing. Replace if housing is broken or cracked.
2. Inspect switch lever (Figure 3, Item 1) for breaks and cracks. Replace if broken or cracked.

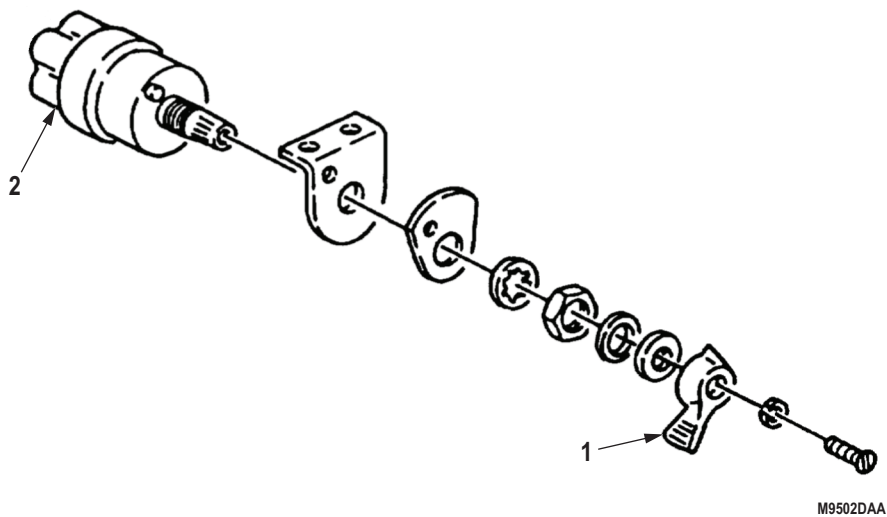
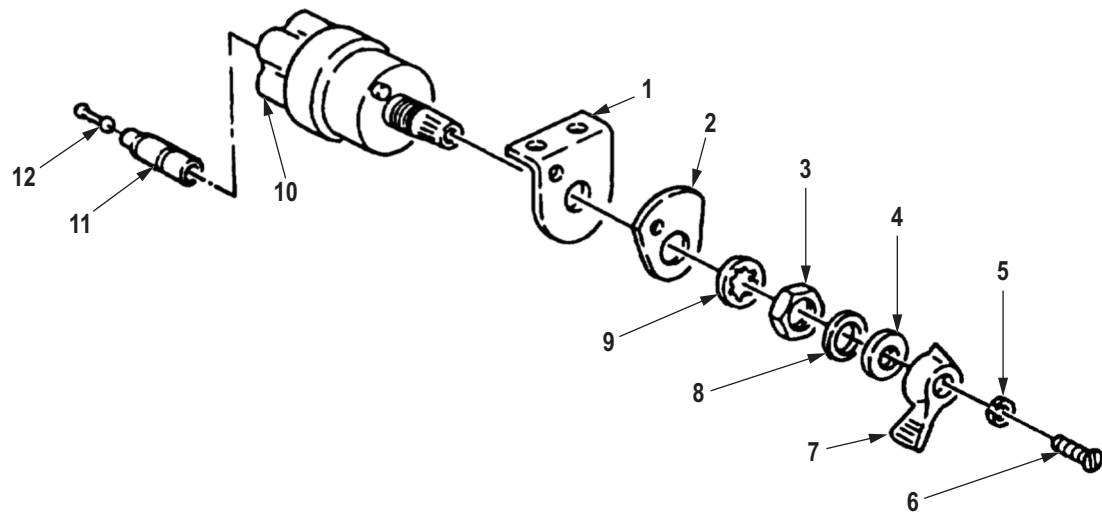

Figure 3. Floodlight Switch Inspection.

END OF TASK

ASSEMBLY

1. Install shell (Figure 4, Item 11), plug (Figure 4, Item 12), angle bracket (Figure 4, Item 1), and identification plate (Figure 4, Item 2) on floodlight control switch (Figure 4, Item 10) with lockwasher (Figure 4, Item 9) and nut (Figure 4, Item 3).
2. Install felt washer (Figure 4, Item 8), washer (Figure 4, Item 4), and switch lever (Figure 4, Item 7) on floodlight control switch (Figure 4, Item 10) with lockwasher (Figure 4, Item 5) and screw (Figure 4, Item 6).



M9503DAA

Figure 4. Floodlight Switch Assembly.

END OF TASK

INSTALLATION

1. Install floodlight control switch (Figure 5, Item 4) and angle bracket (Figure 5, Item 2) on instrument panel (Figure 5, Item 6) with two screws (Figure 5, Item 3) and locknuts (Figure 5, Item 1).
2. Connect four connectors (Figure 5, Item 5) to floodlight control switch (Figure 5, Item 4).

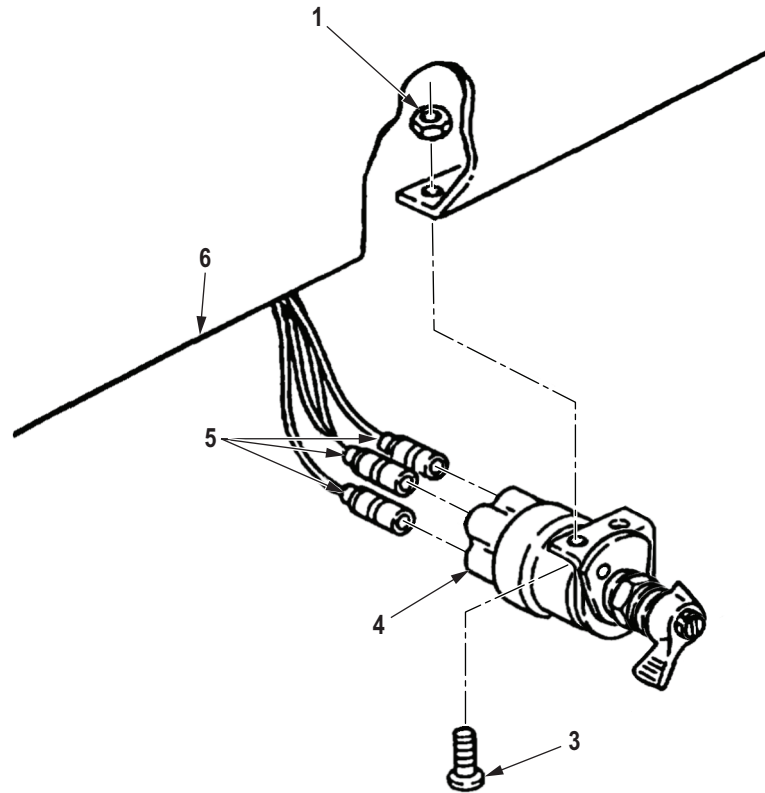

M8022DAA

Figure 5. Floodlight Switch Installation.

END OF TASK

FOLLOW-ON MAINTENANCE

1. Connect battery ground cables. (WP 0350)
2. Check operation of floodlight control switch. (TM 9-2320-272-10)

END OF TASK**END OF WORK PACKAGE**

FIELD MAINTENANCE AMBER WARNING LIGHT REPLACEMENT

INITIAL SETUP:

Tools and Special Tools

Tool Kit, General Mechanic's: Automotive
(Volume 5, WP 0826, Table 1, Item 56)

Equipment Condition (cont.)

Battery ground cables disconnected. (WP 0350)

Materials/Parts

Lockwasher
(Volume 5, WP 0827, Table 1, Item 424)
Qty: 1

Equipment Condition

Parking brake set. (TM 9-2320-272-10)

REMOVAL

1. Disconnect electrical lead (Figure 1, Item 7) from wiring harness (Figure 1, Item 8).
2. Remove screw (Figure 1, Item 6), ground strap (Figure 1, Item 11), lockwasher (Figure 1, Item 5), and J-nut (Figure 1, Item 2) from bracket (Figure 1, Item 4) and instrument cluster (Figure 1, Item 1). Discard lockwasher.
3. Remove two nuts (Figure 1, Item 9), screws (Figure 1, Item 3), and amber warning light (Figure 1, Item 10) from instrument cluster (Figure 1, Item 1).

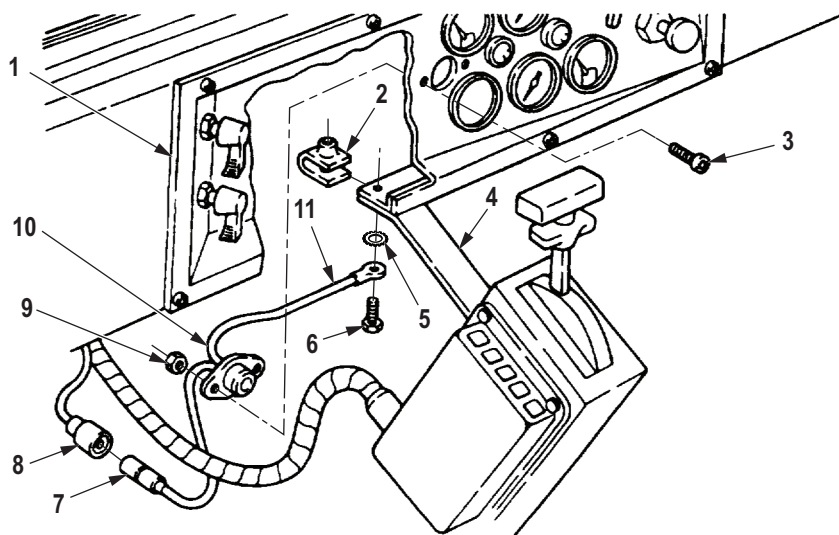

M6365DAA

Figure 1. Amber Warning Light Removal.

END OF TASK

INSTALLATION

1. Install amber warning light (Figure 2, Item 10) on instrument cluster (Figure 2, Item 1) with two screws (Figure 2, Item 3) and nuts (Figure 2, Item 9).
2. Install lockwasher (Figure 2, Item 5) and ground strap (Figure 2, Item 11) on bracket (Figure 2, Item 4) and instrument cluster (Figure 2, Item 1) with J-nut (Figure 2, Item 2) and screw (Figure 2, Item 6).
3. Connect electrical lead (Figure 2, Item 7) to wiring harness (Figure 2, Item 8).

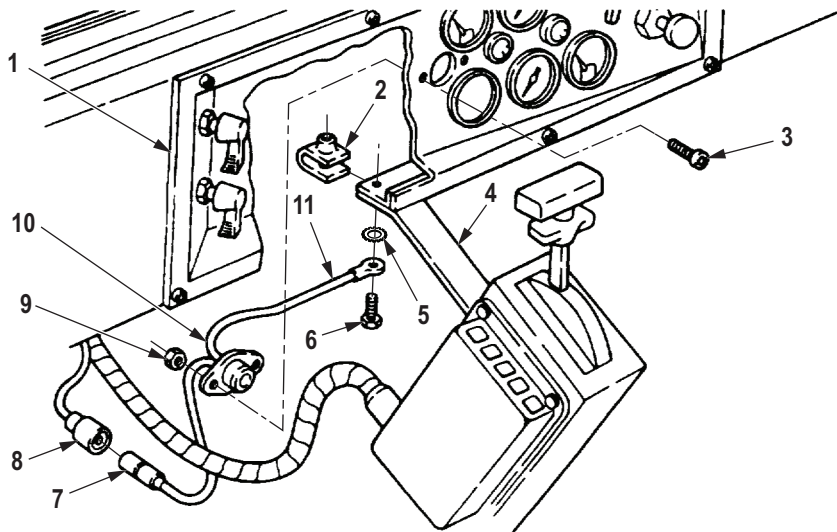

M6366DAA

Figure 2. Amber Warning Light Installation.

END OF TASK**FOLLOW-ON MAINTENANCE**

Connect battery ground cables. (WP 0350)

END OF TASK**END OF WORK PACKAGE**

**FIELD MAINTENANCE
CTIS WIRING HARNESS REPLACEMENT**

INITIAL SETUP:**Tools and Special Tools**

Tool Kit, General Mechanic's: Automotive
(Volume 5, WP 0826, Table 1, Item 56)

Materials/Parts

Grommet

Materials/Parts (cont.)

(Volume 5, WP 0827, Table 1, Item 412)
Qty: 1
Tiedown Strap
(Volume 5, WP 0827, Table 1, Item 379)
Qty: 1

Equipment Condition

Parking brake set. (TM 9-2320-272-10)
Battery ground cables disconnected. (WP 0350)

REMOVAL**NOTE**

- When removing CTIS wiring harness, note location of all tiedown straps and protective covering for installation.
- Tag all wiring harness leads and note routing for installation.

1. Disconnect wiring harness connector (Figure 1, Item 12) from electronic control unit (ECU) receptacle (Figure 1, Item 11).
2. Disconnect wiring harness connector (Figure 1, Item 9) from amber warning light wire (Figure 1, Item 10).
3. Disconnect wiring harness connector (Figure 1, Item 18) from power and ground cable (Figure 1, Item 17).
4. Disconnect wiring harness connector (Figure 1, Item 15) from blackout wire (Figure 1, Item 16).
5. Disconnect wiring harness connector (Figure 1, Item 20) from pressure transducer (Figure 1, Item 19).
6. Disconnect wiring harness connector (Figure 1, Item 22) from pneumatic controller solenoid receptacle (Figure 1, Item 21).
7. Disconnect wiring harness connector (Figure 1, Item 1) from speed signal generator wire (Figure 1, Item 23) on transfer case (Figure 1, Item 5).
8. Disconnect wire (Figure 1, Item 4) from pressure switch wire (Figure 1, Item 24) located on right frame rail (Figure 1, Item 2) above wet tank (Figure 1, Item 3).
9. Remove screw (Figure 1, Item 26), washer (Figure 1, Item 27), and clamp (Figure 1, Item 28) from wiring harness (Figure 1, Item 7) and bracket (Figure 1, Item 25).
10. Remove screw (Figure 1, Item 30), washer (Figure 1, Item 29), and clamp (Figure 1, Item 31) from wiring harness (Figure 1, Item 7) and firewall (Figure 1, Item 13).
11. Remove wiring harness (Figure 1, Item 7) from frame rails (Figure 1, Items 2 and 8) and crossmember (Figure 1, Item 6).
12. Carefully pull wiring harness (Figure 1, Item 7) through grommet (Figure 1, Item 14) on firewall (Figure 1, Item 13).

NOTE

Perform Step (13) if grommet is damaged.

13. Remove grommet (Figure 1, Item 14) from firewall (Figure 1, Item 13). Discard grommet.

REMOVAL - Continued

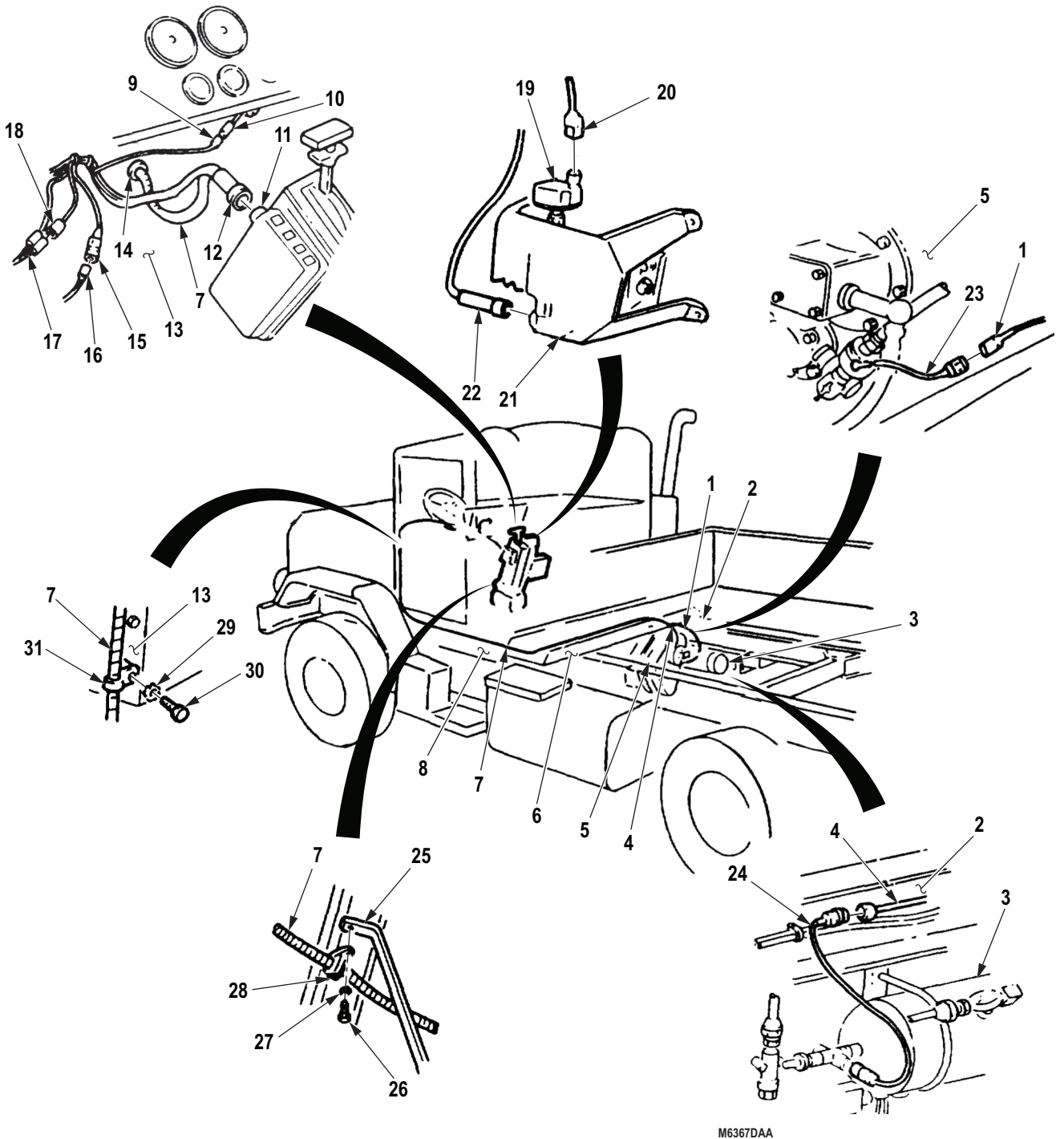

Figure 1. Wiring Harness Removal.

END OF TASK

INSTALLATION**CAUTION**

Use care when routing CTIS wiring harness. Snagging may result, and forceful pulling will cause damage to harness.

NOTE

- Perform Step (1) if grommet was removed.
 - Route CTIS wiring harness and install tiedown straps as noted in removal.
1. Install grommet (Figure 2, Item 14) on firewall (Figure 2, Item 13).
 2. Insert wiring harness (Figure 2, Item 7) through grommet (Figure 2, Item 14) on firewall (Figure 2, Item 13), and pull wiring harness into engine compartment.
 3. Route wiring harness (Figure 2, Item 7) along frame rail (Figure 2, Item 8), crossmember (Figure 2, Item 6), and frame rail (Figure 2, Item 2).
 4. Connect wiring harness connector (Figure 2, Item 1) to speed signal generator wire (Figure 2, Item 23) on transfer case (Figure 2, Item 5).
 5. Connect wiring harness connector (Figure 2, Item 4) to pressure switch wire (Figure 2, Item 24) located above wet tank (Figure 2, Item 3) at right frame rail (Figure 2, Item 2).
 6. Position clamp (Figure 2, Item 28) on wiring harness (Figure 2, Item 7) and install clamp (Figure 2, Item 28) on bracket (Figure 2, Item 25) with washer (Figure 2, Item 27) and screw (Figure 2, Item 26).
 7. Position clamp (Figure 2, Item 31) on wiring harness (Figure 2, Item 7) and install clamp (Figure 2, Item 31) on firewall (Figure 2, Item 13) with washer (Figure 2, Item 29) and screw (Figure 2, Item 30).
 8. Connect wiring harness connector (Figure 2, Item 22) to pneumatic controller solenoid receptacle (Figure 2, Item 21).
 9. Connect wiring harness connector (Figure 2, Item 19) to pressure transducer (Figure 2, Item 20).
 10. Connect wiring harness connector (Figure 2, Item 15) to blackout wire (Figure 2, Item 16).
 11. Connect wiring harness connector (Figure 2, Item 18) to power and ground cable (Figure 2, Item 17).
 12. Connect wiring harness connector (Figure 2, Item 9) to amber warning light wire (Figure 2, Item 10).
 13. Connect wiring harness connector (Figure 2, Item 12) to ECU receptacle (Figure 2, Item 11).

INSTALLATION - Continued

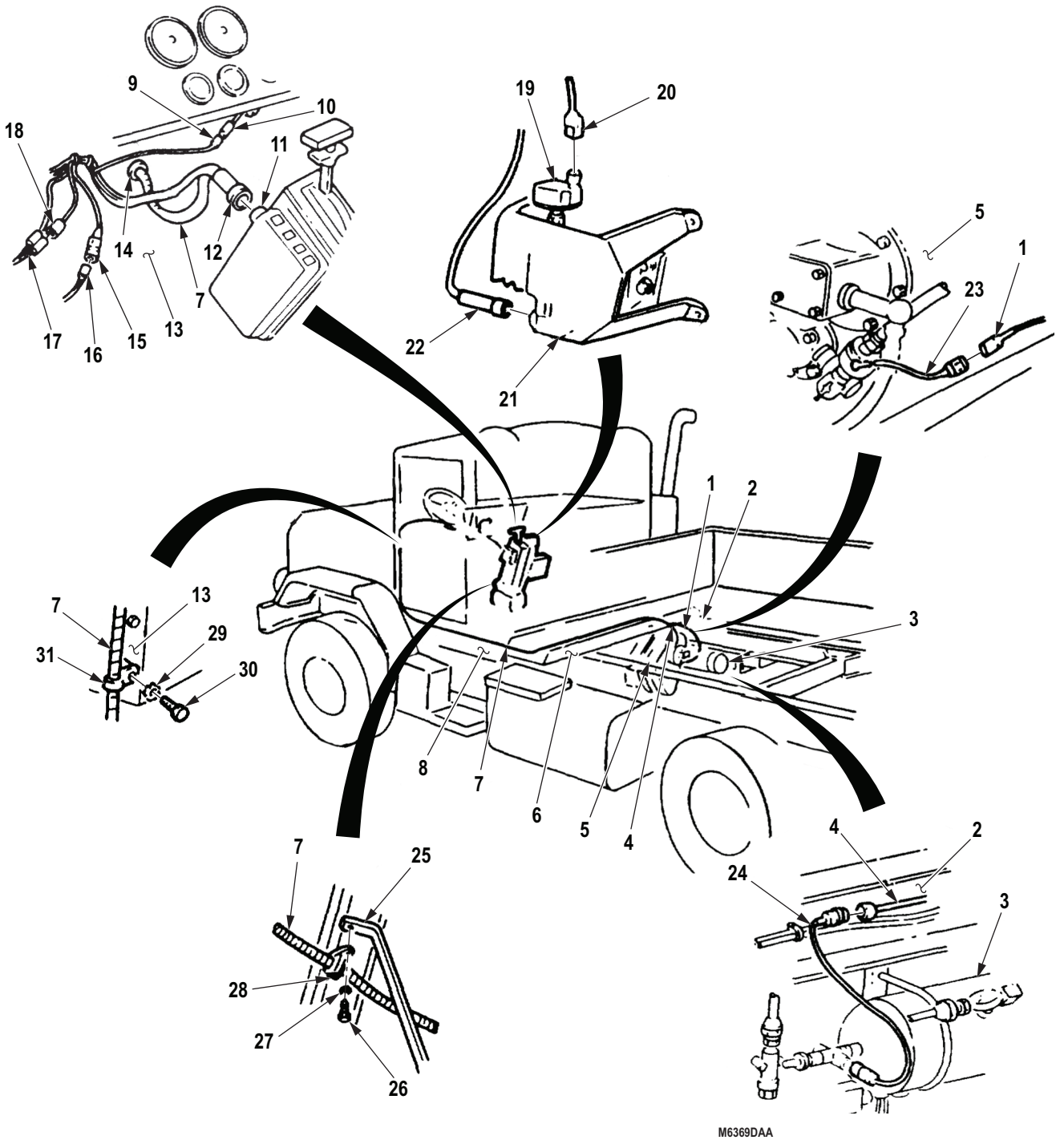

Figure 2. Wiring Harness Installation.

END OF TASK

FOLLOW-ON MAINTENANCE

1. Connect battery ground cables. (WP 0350)
2. Start engine and check CTIS for proper operation. (TM 9-2320-272-10)

END OF TASK**END OF WORK PACKAGE**

**FIELD MAINTENANCE
SPEED SIGNAL GENERATOR REPLACEMENT**

INITIAL SETUP:

Tools and Special Tools

Tool Kit, General Mechanic's: Automotive
(Volume 5, WP 0826, Table 1, Item 56)

Equipment Condition

Parking brake set. (TM 9-2320-272-10)
Battery ground cables disconnected. (WP 0350)

REMOVAL**NOTE**

Gasket and drive pins are provisioned with speedometer drive adapter.

1. Disconnect speed signal generator electrical lead (Figure 1, Item 5) from wiring harness.
2. Disconnect speedometer cable (Figure 1, Item 1) from speed signal generator (Figure 1, Item 3), and remove gasket (Figure 1, Item 2) from speedometer cable.
3. Remove speed signal generator (Figure 1, Item 3) and drive pin (Figure 1, Item 6) from speedometer drive adapter (Figure 1, Item 7).

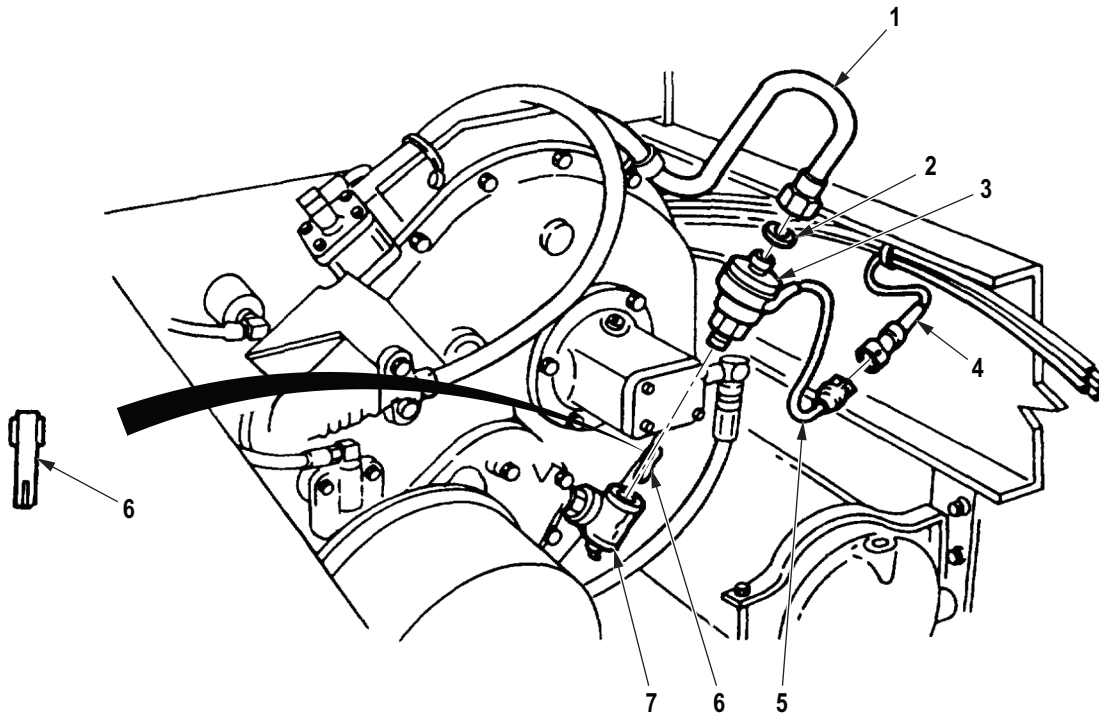

M6370DAA

Figure 1. Speed Signal Generator Removal.

END OF TASK

INSTALLATION**NOTE**

When installing drive pin, ensure end with double tab is facing speed signal generator.

1. Align tab of drive pin (Figure 2, Item 6) with slot of speedometer drive adapter (Figure 2, Item 7) and install drive pin on speedometer drive adapter.
2. Install speed signal generator (Figure 2, Item 3) on drive pin (Figure 2, Item 6) and speedometer drive adapter (Figure 2, Item 7).
3. Install gasket (Figure 2, Item 2) on speedometer cable (Figure 2, Item 1), and connect speedometer cable to speed signal generator (Figure 2, Item 3).
4. Connect speed signal generator electrical lead (Figure 2, Item 5) to wiring harness (Figure 2, Item 4).

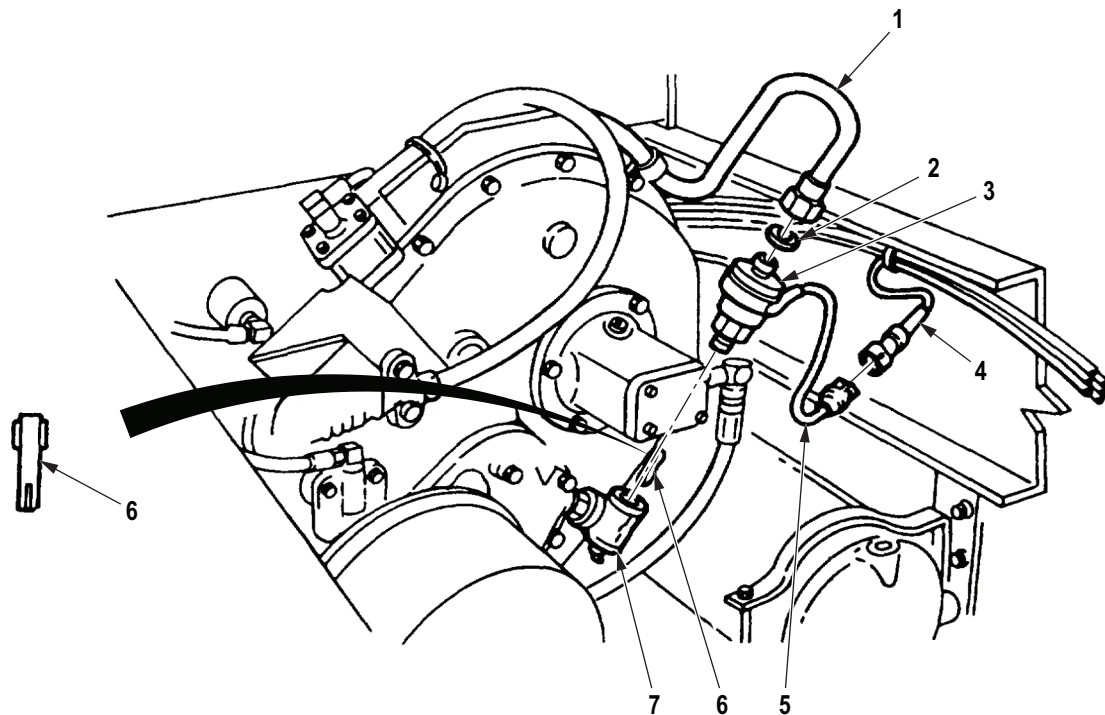

M6371DAA

Figure 2. Speed Signal Generator Installation.

END OF TASK**FOLLOW-ON MAINTENANCE**

1. Connect battery ground cables. (WP 0350)
2. Road test vehicle and check CTIS operation. (TM 9-2320-272-10)

END OF TASK**END OF WORK PACKAGE**

**FIELD MAINTENANCE
PRESSURE SWITCH REPLACEMENT**

INITIAL SETUP:**Tools and Special Tools**

Tool Kit, General Mechanic's: Automotive
(Volume 5, WP 0826, Table 1, Item 56)

Equipment Condition (cont.)

Air reservoirs drained. (TM 9-2320-272-10)
Battery ground cables disconnected. (WP 0350)

Materials/Parts

Tape, Antiseizing
(Volume 5, WP 0825, Table 1, Item 65)
Tiedown Strap
(Volume 5, WP 0827, Table 1, Item 379)
Qty: 1

Equipment Condition

Parking brake set. (TM 9-2320-272-10)

REMOVAL**WARNING**

- Release all air pressure before loosening or removing air system component(s). Failure to comply may result in injury or death to personnel.
- Eyeshields must be worn when releasing compressed air. Failure to comply may result in injury or death to personnel.

1. Remove tiedown straps (Figure 1, Item 3) from pressure switch lead (Figure 1, Item 4). Discard tiedown straps.
2. Disconnect pressure switch (Figure 1, Item 2) from wiring harness (Figure 1, Item 1).
3. Remove pressure switch lead (Figure 1, Item 4) from elbow (Figure 1, Item 5).

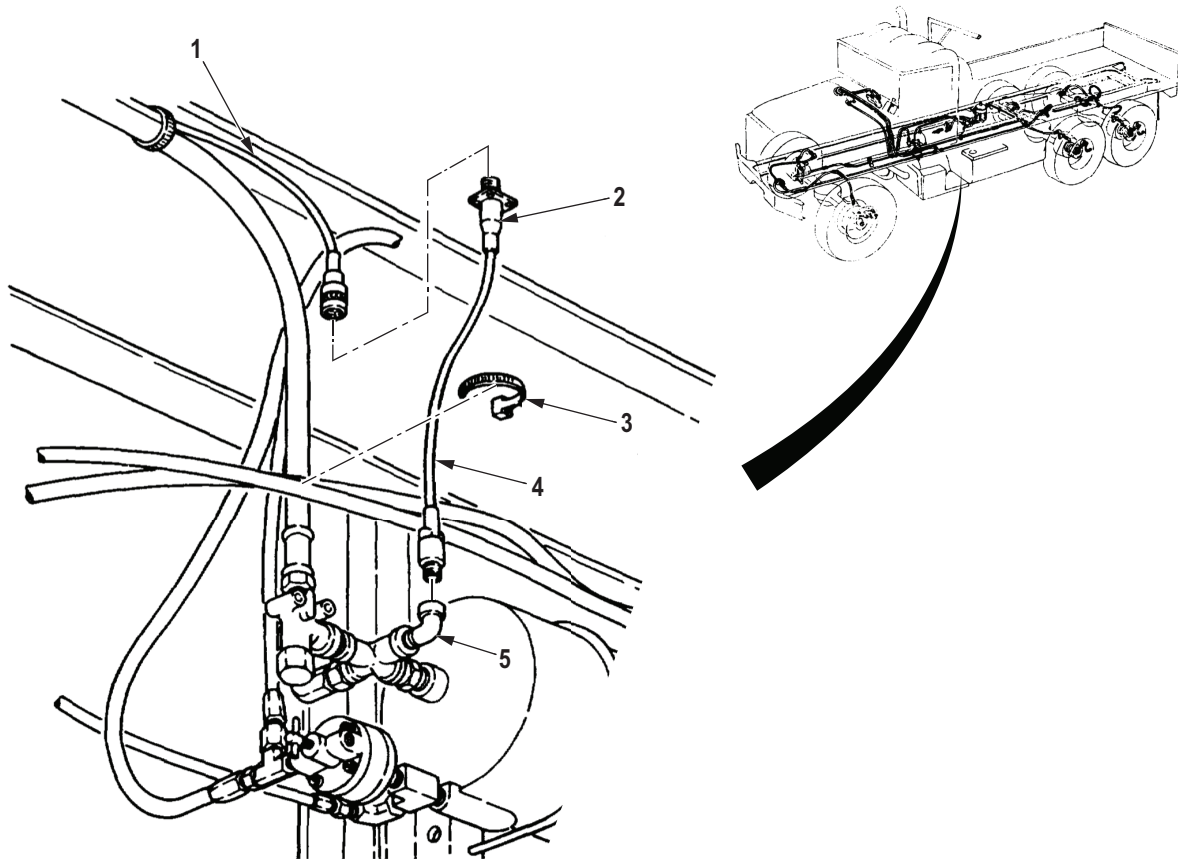

M6360DAA

Figure 1. Pressure Switch Removal.

END OF TASK

INSTALLATION**NOTE**

Wrap male threads with antiseize tape before installation.

1. Install pressure switch lead (Figure 2, Item 4) on elbow (Figure 2, Item 5).
2. Connect pressure switch (Figure 2, Item 2) to wiring harness (Figure 2, Item 1).
3. Install tiedown straps (Figure 2, Item 3) on pressure switch lead (Figure 2, Item 4).

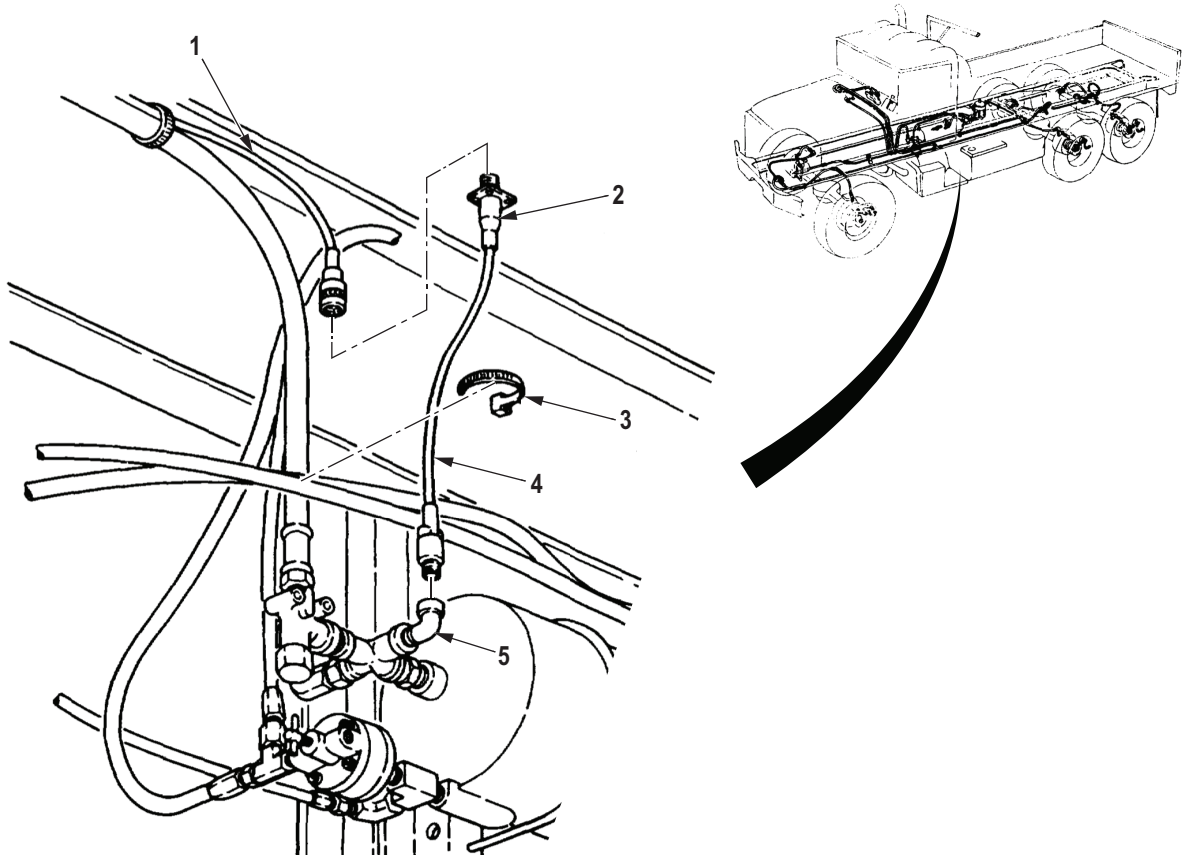

M6361DAA

Figure 2. Pressure Switch Installation.

END OF TASK

FOLLOW-ON MAINTENANCE

1. Connect battery ground cables. (WP 0350)
2. Start engine and check for air leaks. (TM 9-2320-272-10)

END OF TASK**END OF WORK PACKAGE**

**FIELD MAINTENANCE
HEADLIGHT REPAIR**

INITIAL SETUP:**Tools and Special Tools**

Tool Kit, General Mechanic's: Automotive
(Volume 5, WP 0826, Table 1, Item 56)

Equipment Condition (cont.)

Hood raised and secured. (TM 9-2320-272-10)
Battery ground cables disconnected. (WP 0350)

Materials/Parts

Lockwasher
(Volume 5, WP 0827, Table 1, Item 394)
Qty: 3

Equipment Condition

Parking brake set. (TM 9-2320-272-10)

REMOVAL**NOTE**

Tag all connectors for installation.

1. Remove three screws (Figure 1, Item 3) and retaining ring (Figure 1, Item 2) from headlamp housing (Figure 1, Item 1).
2. Pull headlamp (Figure 1, Item 4) out from headlamp housing (Figure 1, Item 1).
3. Disconnect three connectors (Figure 1, Item 5) from headlamp housing (Figure 1, Item 1).

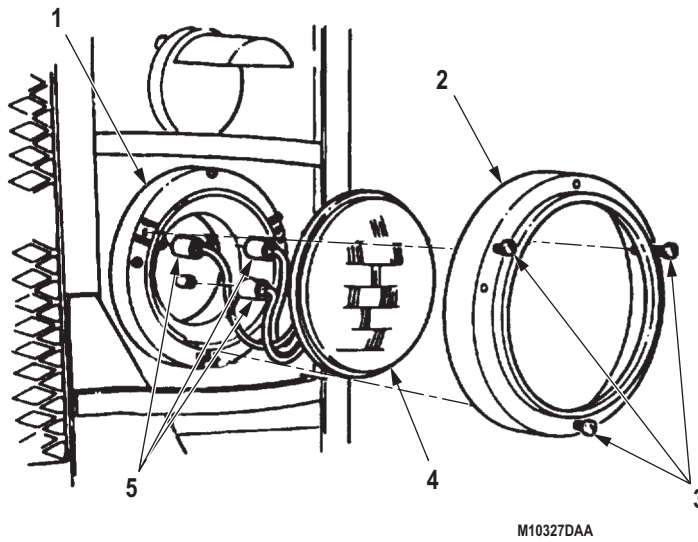
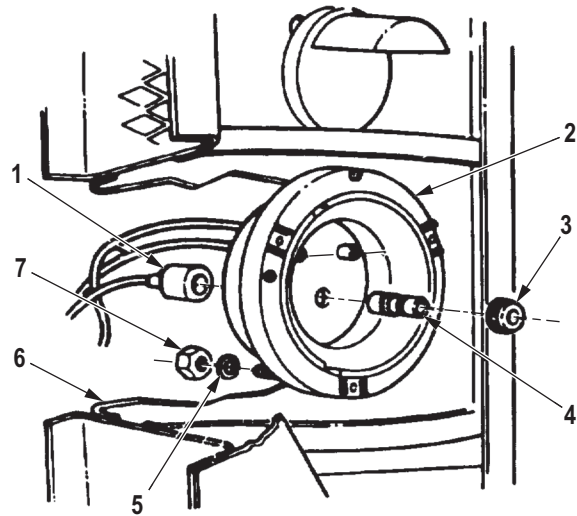

Figure 1. Headlight Removal.

REMOVAL - Continued

4. Remove three nuts (Figure 2, Item 7), lockwashers (Figure 2, Item 5), and headlamp housing (Figure 2, Item 2) from hood (Figure 2, Item 6). Discard lockwashers.
5. Disconnect three connectors (Figure 2, Item 1) from headlamp housing (Figure 2, Item 2).
6. Remove three headlamp connectors (Figure 2, Item 4) and grommets (Figure 2, Item 3) from headlamp housing (Figure 2, Item 2).



M0263DAA

*Figure 2. Headlight Removal.***END OF TASK**

INSTALLATION

1. Install three grommets (Figure 3, Item 3) and headlamp connectors (Figure 3, Item 4) on headlamp housing (Figure 3, Item 2).
2. Connect three connectors (Figure 3, Item 1) to headlamp housing (Figure 3, Item 2).
3. Install headlamp housing (Figure 3, Item 2) on hood (Figure 3, Item 6) with three lockwashers (Figure 3, Item 5) and nuts (Figure 3, Item 7).

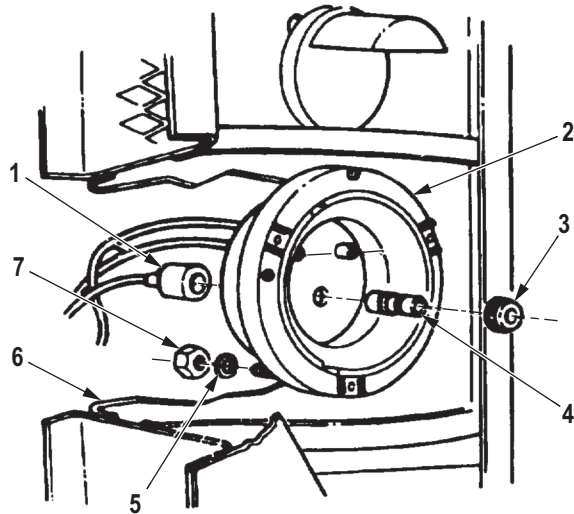

M0246DAA

Figure 3. Headlight Installation.

INSTALLATION - Continued

4. Connect three connectors (Figure 4, Item 5) to headlamp (Figure 4, Item 4).
5. Position headlamp (Figure 4, Item 4) in headlamp housing (Figure 4, Item 1) with the words SEALED BEAM positioned at bottom of headlamp (Figure 4, Item 4).
6. Install retaining ring (Figure 4, Item 2) on headlamp housing (Figure 4, Item 1) with three screws (Figure 4, Item 3).
7. Connect battery ground cables (WP 0350).

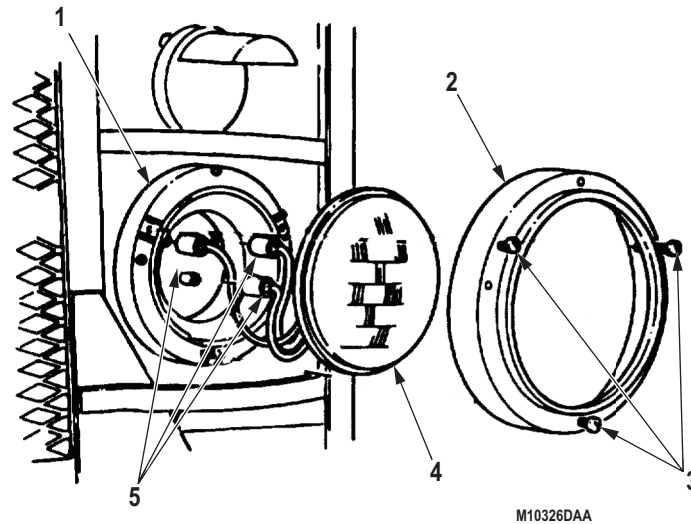
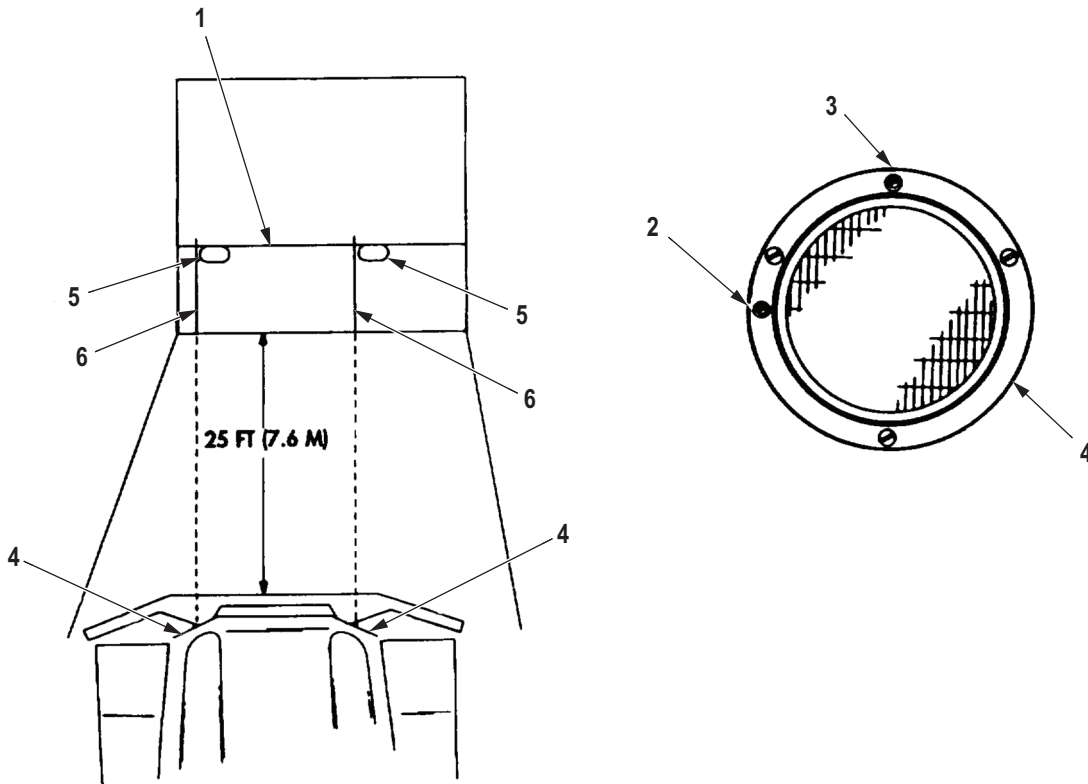

Figure 4. Headlight Installation.

END OF TASK

ALIGNMENT

1. Draw a horizontal line (Figure 5, Item 1) on a wall the height of center of headlights (Figure 5, Item 4).
2. Park truck facing wall so headlights (Figure 5, Item 4) are 25 ft (7.6 m) from wall.
3. Draw a vertical line (Figure 5, Item 6) through horizontal line (Figure 5, Item 1) so it is in line with center of headlight (Figure 5, Item 4).
4. Turn headlights on low beam (TM 9-2320-260-102).
5. Adjust headlight horizontal direction with adjusting screw (Figure 5, Item 2) until left edge of bright light area (Figure 5, Item 5) on wall is 2 to 6 in. (5.08 to 15.24 cm) right of vertical line (Figure 5, Item 6).
6. Adjust headlight vertical direction with adjusting screw (Figure 5, Item 3) until top edge of bright light area (Figure 5, Item 5) on wall is touching lower side of horizontal line (Figure 5, Item 1).
7. Adjust other headlight using same procedure.



M0265DAA

Figure 5. Headlight Alignment.

END OF TASK

FOLLOW-ON MAINTENANCE

Check headlamps for proper operation. (TM 9-2320-272-10)

END OF TASK

END OF WORK PACKAGE

**FIELD MAINTENANCE
BLACKOUT LIGHT REPAIR**

INITIAL SETUP:**Tools and Special Tools**

Tool Kit, General Mechanic's: Automotive
(Volume 5, WP 0826, Table 1, Item 56)

Equipment Condition (cont.)

Hood raised and secured. (TM 9-2320-272-10)
Battery ground cables disconnected. (WP 0350)

Materials/Parts

Locknut (Volume 5, WP 0827, Table 1, Item 282)
Qty: 4
Lockwasher
(Volume 5, WP 0827, Table 1, Item 186)
Qty: 1

Personnel Required

(2)

Equipment Condition

Parking brake set. (TM 9-2320-272-10)

REMOVAL

1. Disconnect wire (Figure 1, Item 8) from blackout light connector (Figure 1, Item 12).
2. Remove nut (Figure 1, Item 7), lockwasher (Figure 1, Item 9), and adjustment washer (Figure 1, Item 10) from mounting bracket (Figure 1, Item 3). Discard lockwasher.

NOTE

Assistant will help with Step (3).

3. Remove four locknuts (Figure 1, Item 2), screws (Figure 1, Items 5 and 6), and mounting bracket (Figure 1, Item 3) from hood (Figure 1, Item 4). Discard locknuts.
4. Remove blackout light (Figure 1, Item 1) and spacer (Figure 1, Item 11) from mounting bracket (Figure 1, Item 3).

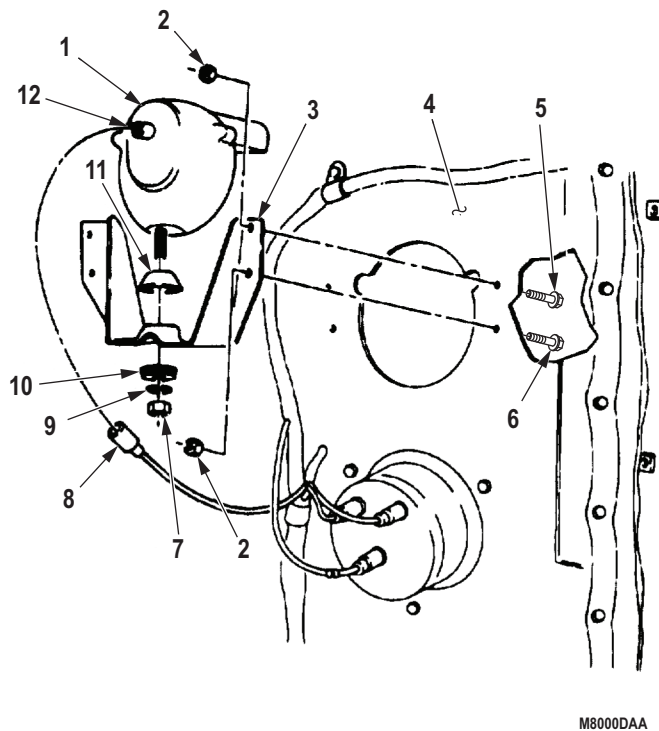
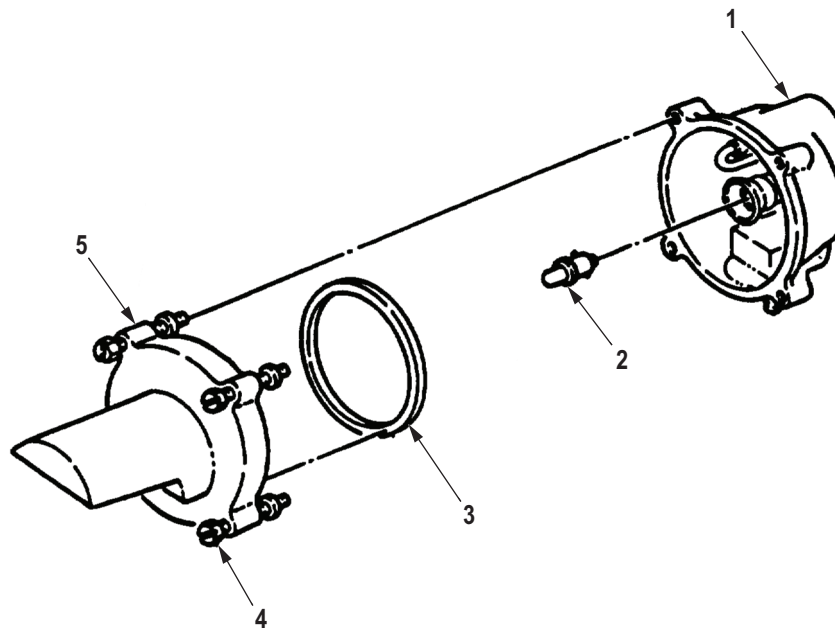

Figure 1. *Blackout Light Removal.*

END OF TASK

DISASSEMBLY

1. Loosen four screws (Figure 2, Item 4) on cover (Figure 2, Item 5).
2. Remove door (Figure 2, Item 5) from light housing (Figure 2, Item 1).
3. Remove gasket (Figure 2, Item 3) from cover (Figure 2, Item 5).
4. Remove lamp (Figure 2, Item 2) from light housing (Figure 2, Item 1).



M8002DAA

*Figure 2. Blackout Light Disassembly.***END OF TASK**

ASSEMBLY

1. Install lamp (Figure 3, Item 2) on light housing (Figure 3, Item 1).
2. Install gasket (Figure 3, Item 3) on cover (Figure 3, Item 5).
3. Install cover (Figure 3, Item 5) on light housing (Figure 3, Item 1) and tighten four screws (Figure 3, Item 4).

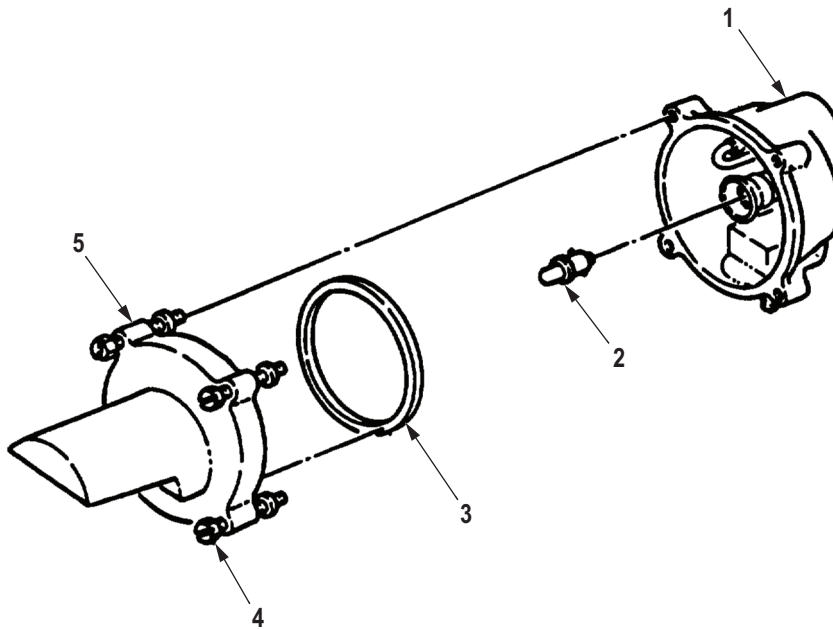

M8003DAA

Figure 3. Blackout Light Assembly.

END OF TASK

INSTALLATION

1. Install blackout light (Figure 4, Item 1) and spacer (Figure 4, Item 11) on mounting bracket (Figure 4, Item 3).

NOTE

Assistant will help with Step (2).

2. Install mounting bracket (Figure 4, Item 3) on hood (Figure 4, Item 4) with four screws (Figure 4, Items 5 and 6) and four locknuts (Figure 4, Item 2).
3. Install adjustment washer (Figure 4, Item 10), lockwasher (Figure 4, Item 9), and nut (Figure 4, Item 7) on mounting bracket (Figure 4, Item 3).
4. Connect wire (Figure 4, Item 8) to blackout light connector (Figure 4, Item 12).

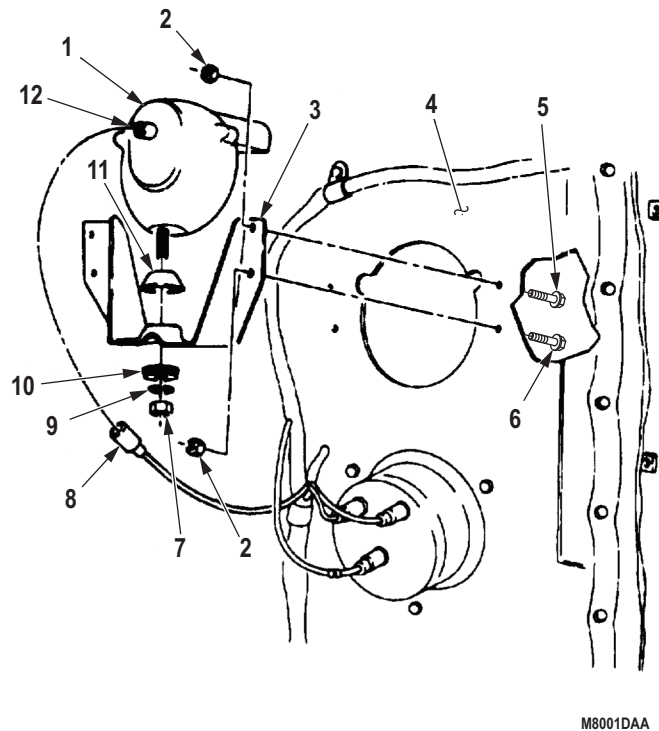

Figure 4. Blackout Light Installation.

END OF TASK**FOLLOW-ON MAINTENANCE**

1. Connect battery ground cables. (WP 0350)
2. Check blackout light for proper operation. (TM 9-2320-272-10)

END OF TASK**END OF WORK PACKAGE**

FIELD MAINTENANCE
FRONT AND REAR COMPOSITE LIGHT AND BRACKET REPLACEMENT

INITIAL SETUP:**Tools and Special Tools**

Tool Kit, General Mechanic's: Automotive
(Volume 5, WP 0826, Table 1, Item 56)

Materials/Parts

Locknut (Volume 5, WP 0827, Table 1, Item 283)
Qty: 4
Locknut (M929/A1/A2)
(Volume 5, WP 0827, Table 1, Item 282)
Qty: 7
Locknut (M931/A1/A2)
(Volume 5, WP 0827, Table 1, Item 277)
Qty: 3
Locknut (M931/A1/A2)
(Volume 5, WP 0827, Table 1, Item 291)
Qty: 2
Locknut (M936/A1/A2)
(Volume 5, WP 0827, Table 1, Item 285)
Qty: 2

Materials/Parts (cont.)

Lockwasher
(Volume 5, WP 0827, Table 1, Item 386)
Qty: 2
Lockwasher (M936/A1/A2)
(Volume 5, WP 0827, Table 1, Item 394)
Qty: 4
Screw Assembled Lockwasher
(Volume 5, WP 0827, Table 1, Item 167)
Qty: 2

Equipment Condition

Parking brake set. (TM 9-2320-272-10)
Battery ground cables disconnected. (WP 0350)

FRONT COMPOSITE LIGHT REMOVAL

1. Remove four locknuts (Figure 1, Item 12) and screws (Figure 1, Item 5) from fender (Figure 1, Item 3). Discard locknuts.
2. Remove wiring cover (Figure 1, Item 10) from cable (Figure 1, Item 11).

NOTE

Tag wires for installation.

3. Disconnect wires (Figure 1, Items 7, 8, 9, and 13) and remove through hole in fender (Figure 1, Item 3).
4. Remove grommet (Figure 1, Item 14) from fender (Figure 1, Item 3).
5. Remove two screws (Figure 1, Item 1), lockwasher (Figure 1, Item 2), and front composite light (Figure 1, Item 6) from fender (Figure 1, Item 3). Discard lockwasher.
6. Remove locknut (Figure 1, Item 18), two washers (Figure 1, Item 15), and lockwashers (Figure 1, Item 16), screw (Figure 1, Item 17), and mounting bracket (Figure 1, Item 4) from fender (Figure 1, Item 3). Discard lockwashers and locknut.

FRONT COMPOSITE LIGHT REMOVAL - Continued

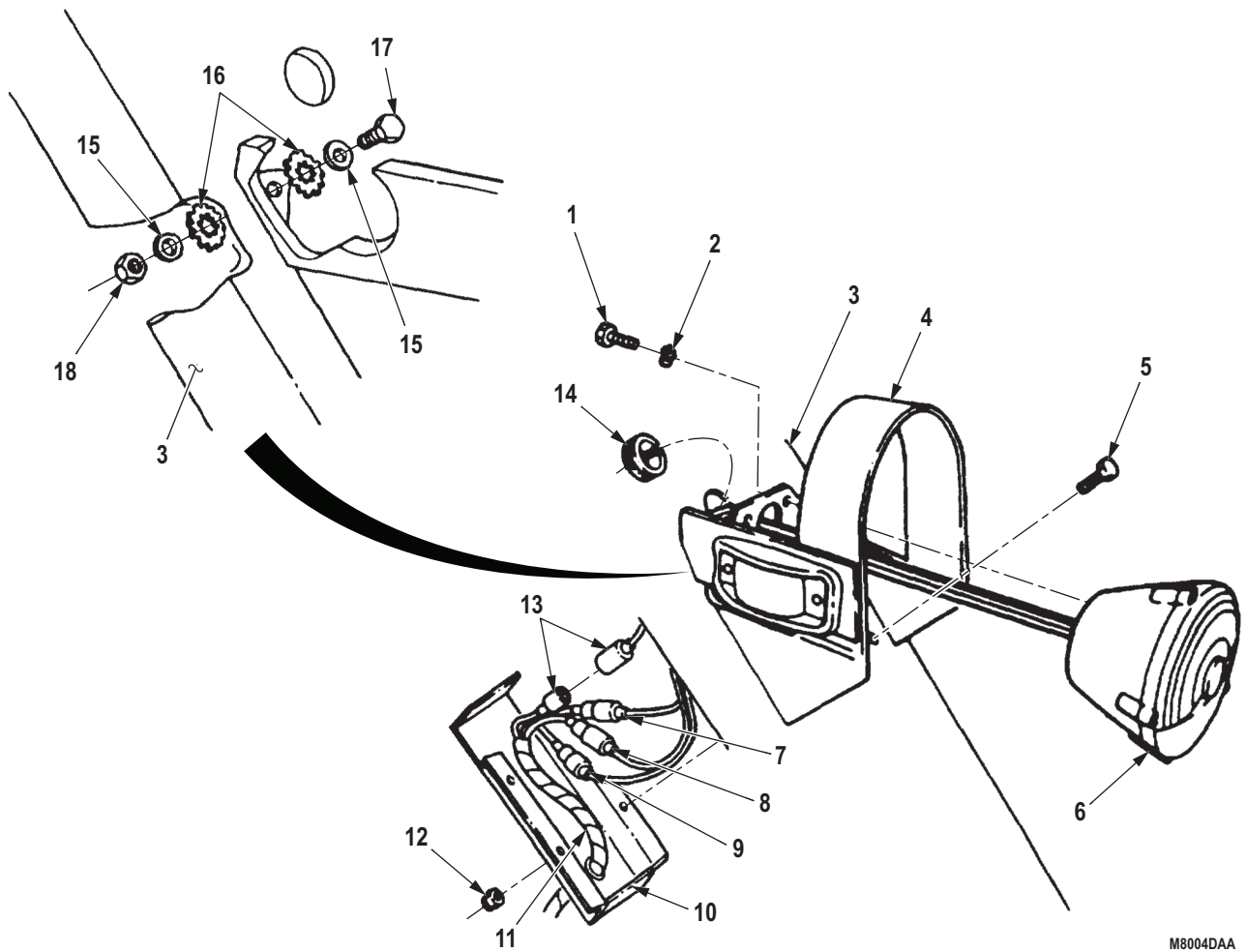

M8004DAA

Figure 1. Front Composite Light Removal.

END OF TASK

FRONT COMPOSITE LIGHT INSTALLATION

1. Install mounting bracket (Figure 2, Item 4) on fender (Figure 2, Item 3) with screw (Figure 2, Item 17), two washers (Figure 2, Item 15), lockwashers (Figure 2, Item 16), and locknut (Figure 2, Item 18).
2. Install grommet (Figure 2, Item 14) on fender (Figure 2, Item 3).
3. Insert wires (Figure 2, Items 7, 8, 9, and 13) through hole in fender (Figure 2, Item 3).
4. Install composite light (Figure 2, Item 6) on fender (Figure 2, Item 3) with lockwasher (Figure 2, Item 2) and two screws (Figure 2, Item 1).
5. Connect wires (Figure 2, Items 7, 8, 9, and 13) with wires in wiring cover (Figure 2, Item 10).
6. Install wiring cover (Figure 2, Item 10) with four screws (Figure 2, Item 5) and locknuts (Figure 2, Item 12).

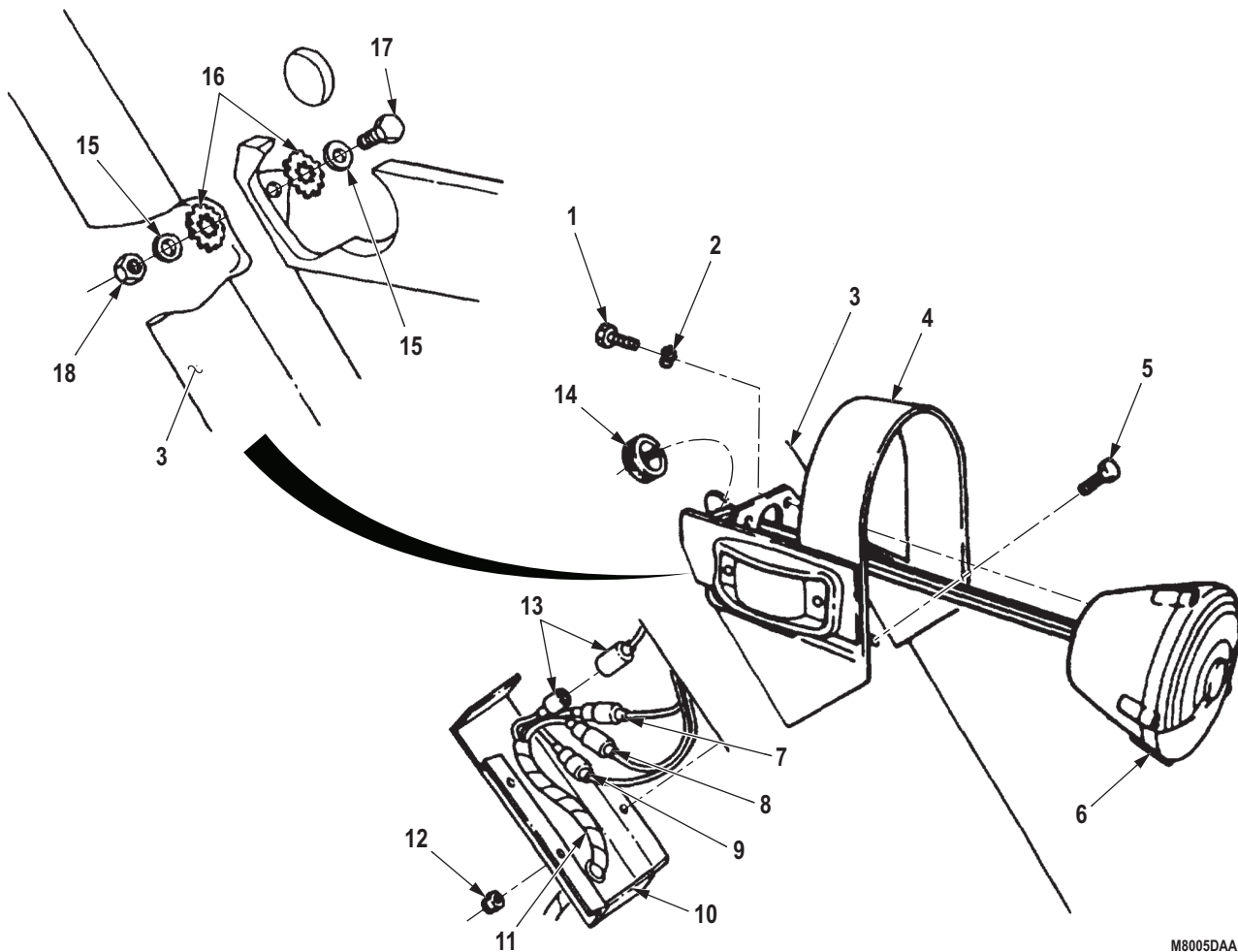

M8005DAA

Figure 2. Front Composite Light Installation.

END OF TASK

REMOVAL (M923/A1/A2)

NOTE

Left and right composite lights are replaced the same way.

1. Remove two screw assembled lockwashers (Figure 3, Item 2), clamp (Figure 3, Item 3), and rear composite light (Figure 3, Item 6) from bracket (Figure 3, Item 1). Discard screw assembled lockwashers.

NOTE

Tag connectors for installation.

2. Disconnect four connectors (Figure 3, Item 4) from wires (Figure 3, Item 5).

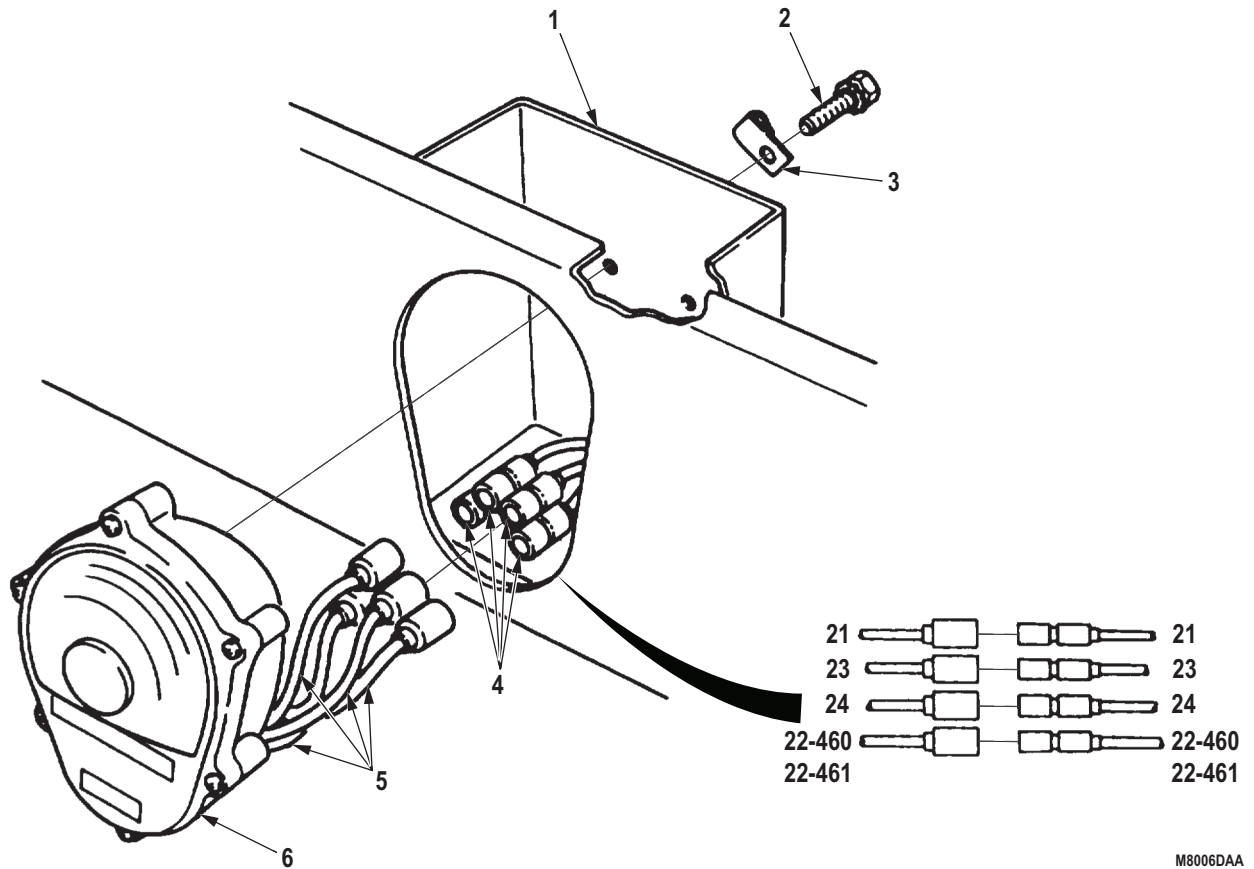

M8006DAA

Figure 3. Rear Composite Light Removal.

END OF TASK

INSTALLATION (M923/A1/A2)

1. Connect four connectors (Figure 4, Item 4) to wires (Figure 4, Item 5).
2. Install rear composite light (Figure 4, Item 6) and clamp (Figure 4, Item 3) on bracket (Figure 4, Item 1) with two screw assembled lockwashers (Figure 4, Item 2).

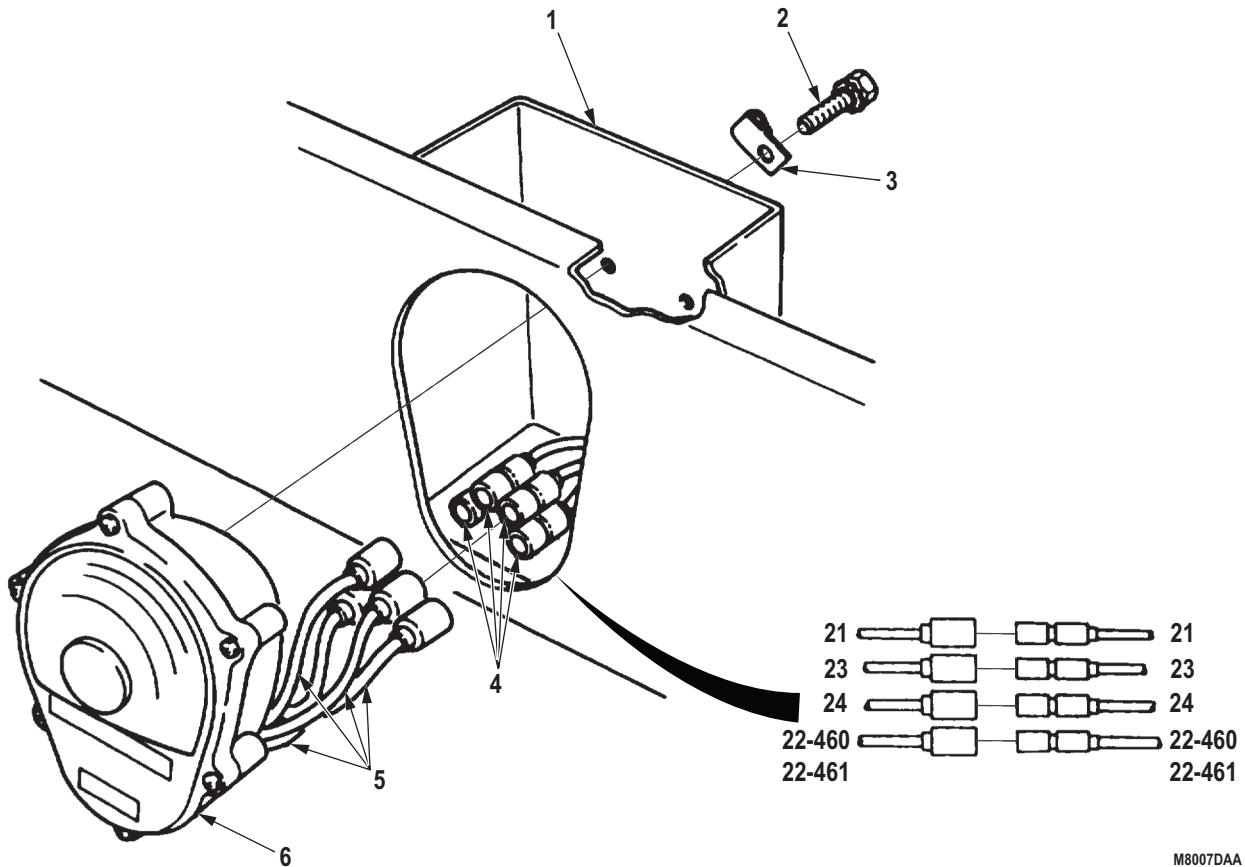

M8007DAA

Figure 4. Rear Composite Light Installation.

END OF TASK

REMOVAL (M936/A1/A2)

NOTE

Left and right composite lights and brackets are replaced the same way.

1. Remove two locknuts (Figure 5, Item 4), screws (Figure 5, Item 6), and reflector (Figure 5, Item 5) from taillight guard (Figure 5, Item 1). Discard locknuts.
2. Remove four screws (Figure 5, Item 3), lockwashers (Figure 5, Item 2), and taillight guard (Figure 5, Item 1) from bracket (Figure 5, Item 12). Discard lockwasher.

NOTE

Tag wires for installation.

3. Disconnect four connectors (Figure 5, Item 7) from wires (Figure 5, Item 8).
4. Remove two screw assembled lockwashers (Figure 5, Item 10) and rear composite light (Figure 5, Item 9) from bracket (Figure 5, Item 12).
5. Remove two locknuts (Figure 5, Item 11), screws (Figure 5, Item 14), and bracket (Figure 5, Item 12) from ladder bracket (Figure 5, Item 13). Discard locknuts.

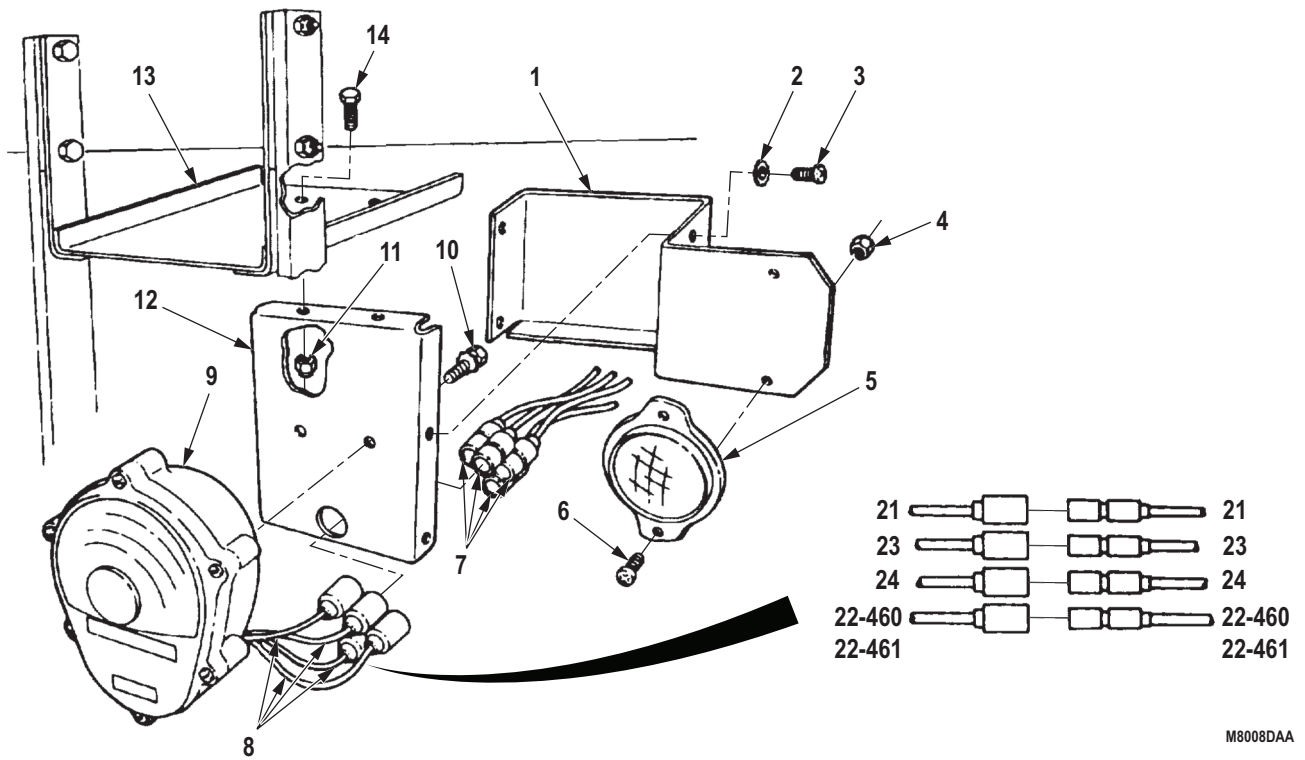

M8008DAA

Figure 5. Rear Composite Light Removal.

END OF TASK

INSTALLATION (M936/A1/A2)

1. Install bracket (Figure 6, Item 12) on ladder bracket (Figure 6, Item 13) with two screws (Figure 6, Item 14), and locknuts (Figure 6, Item 11).
2. Install rear composite light (Figure 6, Item 9) on bracket (Figure 6, Item 12) with two screw assembled lockwashers (Figure 6, Item 10).
3. Connect four connectors (Figure 6, Item 7) to wires (Figure 6, Item 8).
4. Install taillight guard (Figure 6, Item 1) on bracket (Figure 6, Item 12) with four lockwashers (Figure 6, Item 2) and screws (Figure 6, Item 3).
5. Install reflector (Figure 6, Item 5) on taillight guard (Figure 6, Item 1) with two screws (Figure 6, Item 6) and locknuts (Figure 6, Item 4).

INSTALLATION (M936/A1/A2) - Continued

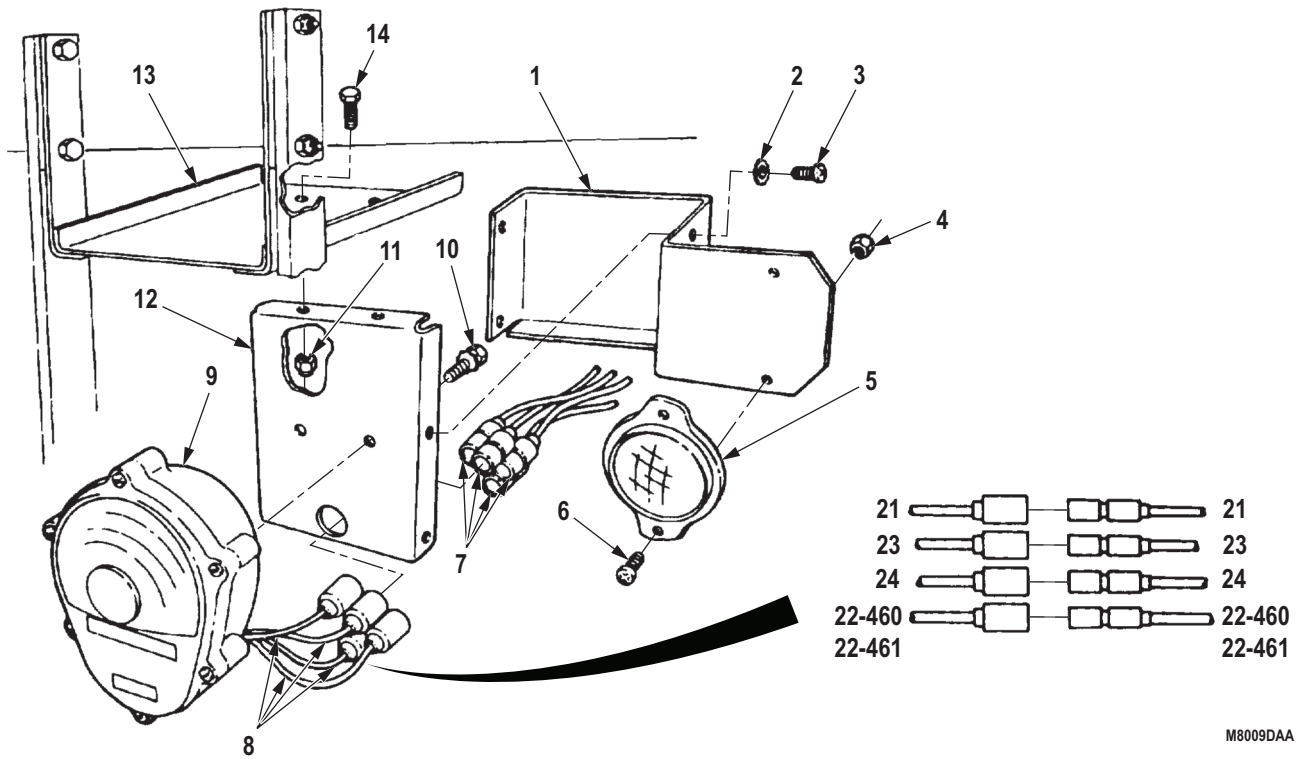

M8009DAA

Figure 6. Rear Composite Light Installation.

END OF TASK

REMOVAL (M929/A1/A2)**NOTE**

Left and right composite lights and covers are replaced the same way.

1. Remove three locknuts (Figure 7, Item 4), screws (Figure 7, Item 6), and cover (Figure 7, Item 3) from dump bed (Figure 7, Item 1). Discard locknuts.

NOTE

Tag wires for installation.

2. Disconnect four connectors (Figure 7, Item 5) from wires (Figure 7, Item 7).
3. Remove two screw assembled lockwashers (Figure 7, Item 2) and rear composite light (Figure 7, Item 8) from dump bed (Figure 7, Item 1). Discard screw assembled lockwashers.

REMOVAL (M929/A1/A2) - Continued

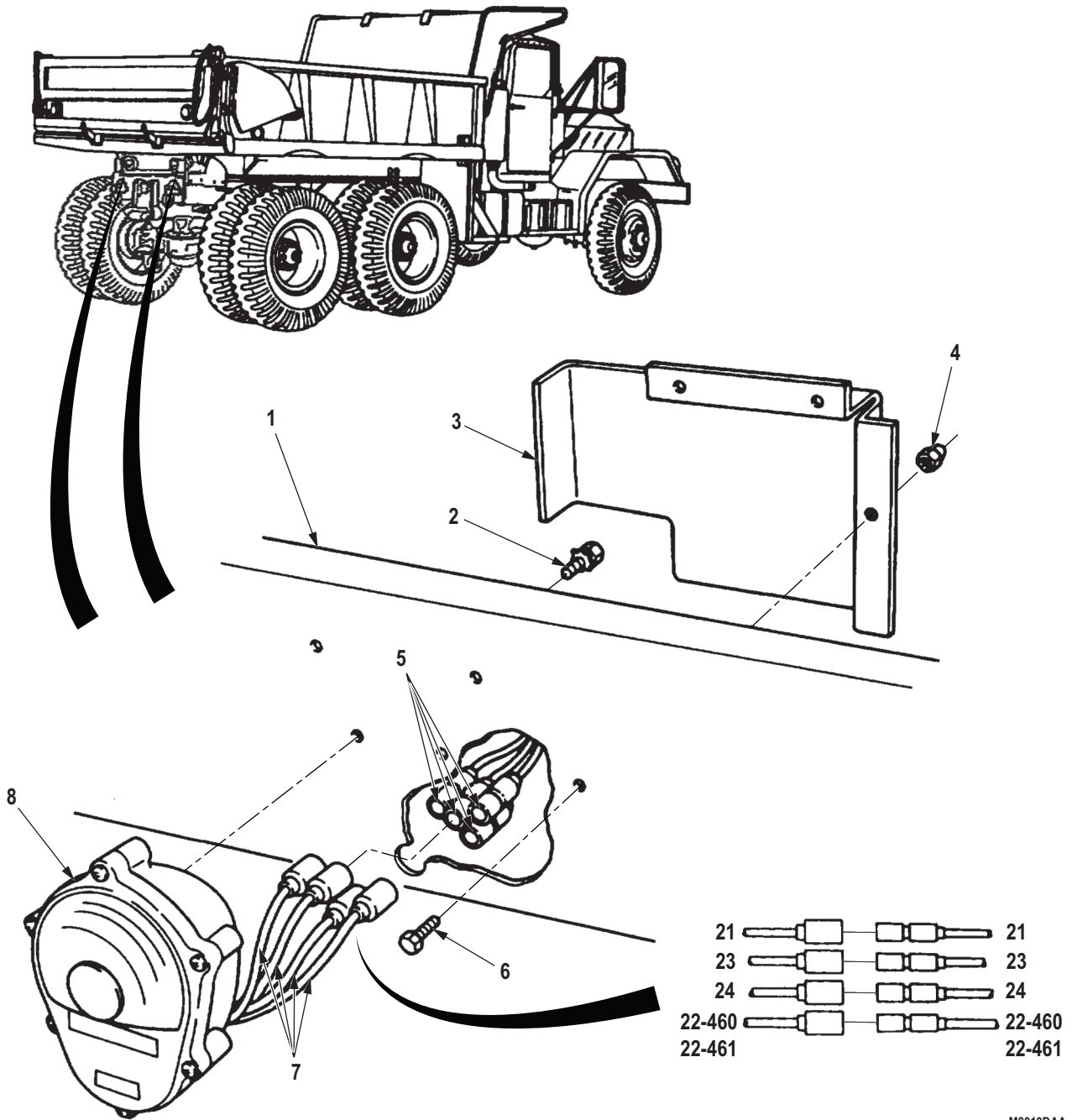

M8010DAA

Figure 7. Rear Composite Light and Bracket Removal.

END OF TASK

INSTALLATION (M929/A1/A2)

1. Install rear composite light (Figure 8, Item 8) on dump bed (Figure 8, Item 1) with two screw assembled lockwashers (Figure 8, Item 2).
2. Connect four connectors (Figure 8, Item 5) to wires (Figure 8, Item 7).
3. Install cover (Figure 8, Item 3) on dump bed (Figure 8, Item 1) with three screws (Figure 8, Item 6) and locknuts (Figure 8, Item 4).

INSTALLATION (M929/A1/A2) - Continued

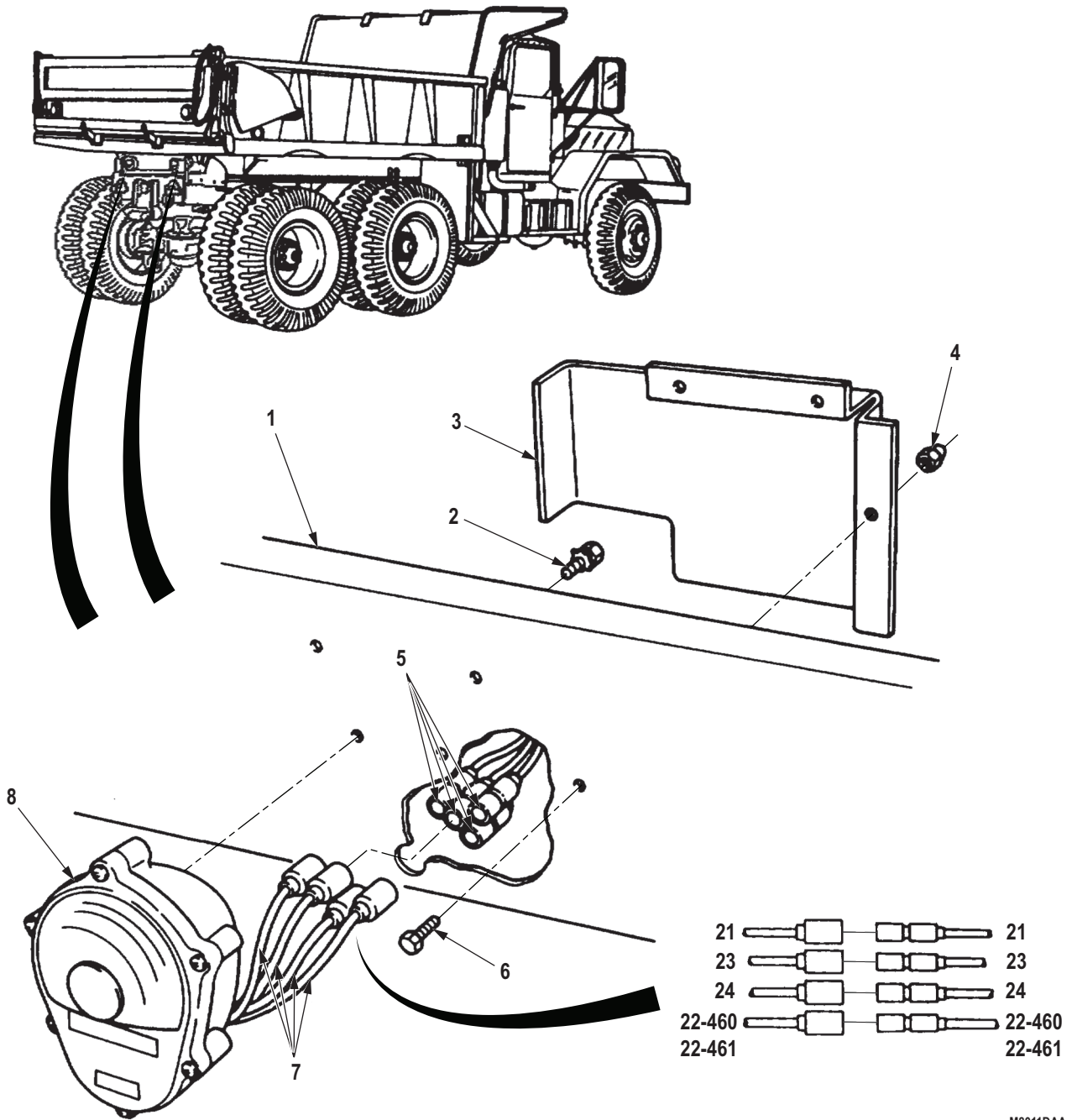

M8011DAA

Figure 8. Rear Composite Light and Bracket Installation.

END OF TASK

REMOVAL (M931/A1/A2)**NOTE**

Left and right composite lights, covers, and brackets are replaced the same way.

1. Remove two locknuts (Figure 9, Item 6), screws (Figure 9, Item 12), and reflector (Figure 9, Item 11) from bracket (Figure 9, Item 5). Discard locknuts.
2. Remove four locknuts (Figure 9, Item 9), screws (Figure 9, Item 13), and cover (Figure 9, Item 8) from bracket (Figure 9, Item 5). Discard locknuts.

NOTE

Tag wires for installation.

3. Disconnect four connectors (Figure 9, Item 10) from wires (Figure 9, Item 14).
4. Remove two screw assembled lockwashers (Figure 9, Item 7) and rear composite light (Figure 9, Item 15) from bracket (Figure 9, Item 5).
5. Remove nut (Figure 9, Item 2), locknut (Figure 9, Item 3), two screws (Figure 9, Item 4), and bracket (Figure 9, Item 5) from frame (Figure 9, Item 1). Discard locknut.

REMOVAL (M931/A1/A2) - Continued

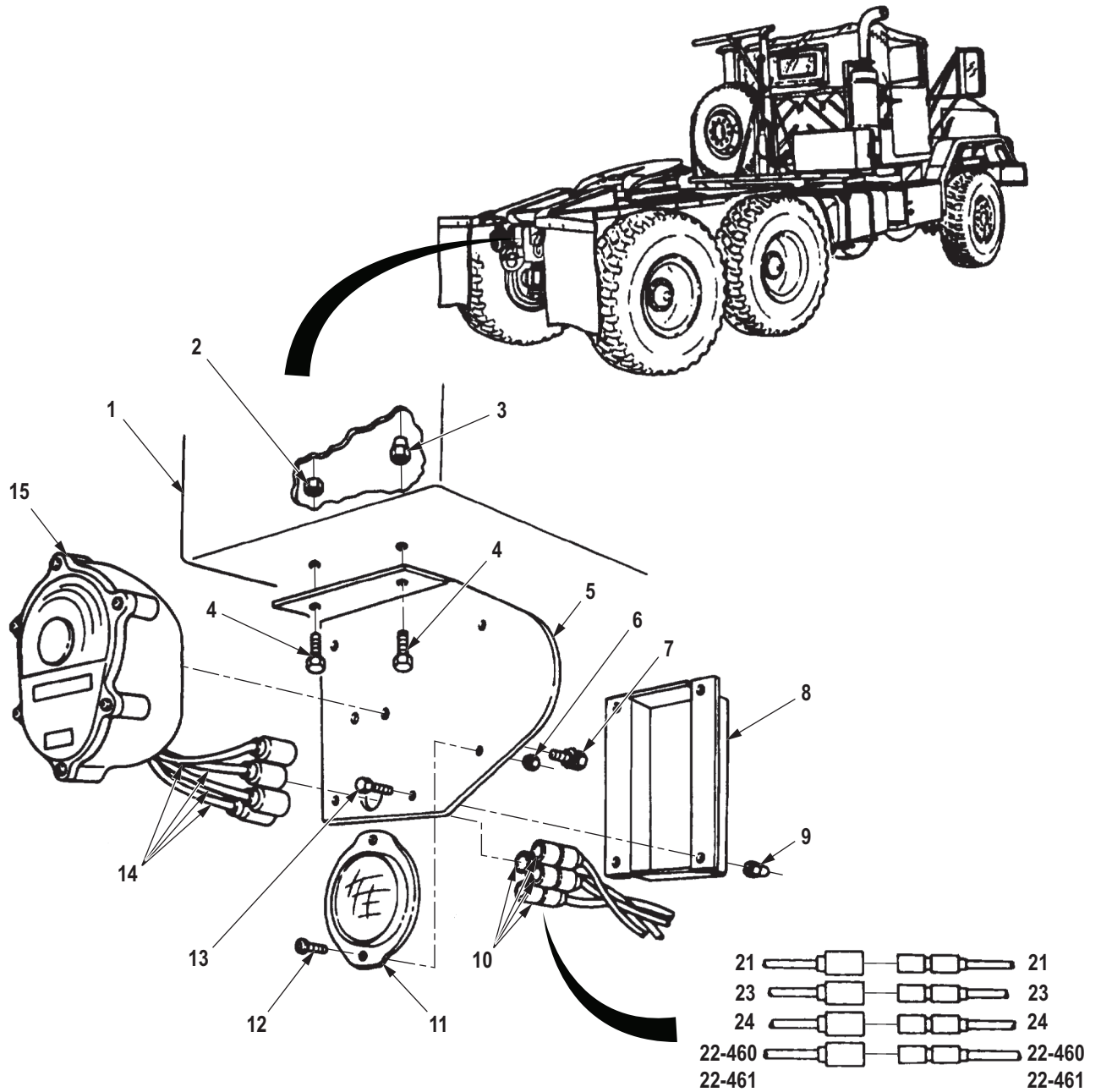

M8012DAA

Figure 9. Rear Composite Light and Bracket Removal.

END OF TASK

INSTALLATION (M931/A1/A2)

1. Install bracket (Figure 10, Item 5) on frame (Figure 10, Item 1) with two screws (Figure 10, Item 4), locknut (Figure 10, Item 3), and nut (Figure 10, Item 2).
2. Install rear composite light (Figure 10, Item 15) on bracket (Figure 10, Item 5) with two screw assembled lockwashers (Figure 10, Item 7).
3. Connect four connectors (Figure 10, Item 10) to wires (Figure 10, Item 14).
4. Install cover (Figure 10, Item 8) on bracket (Figure 10, Item 5) with four screws (Figure 10, Item 13) and locknuts (Figure 10, Item 9).
5. Install reflector (Figure 10, Item 11) on bracket (Figure 10, Item 5) with two screws (Figure 10, Item 12) and locknuts (Figure 10, Item 6).

INSTALLATION (M931/A1/A2) - Continued

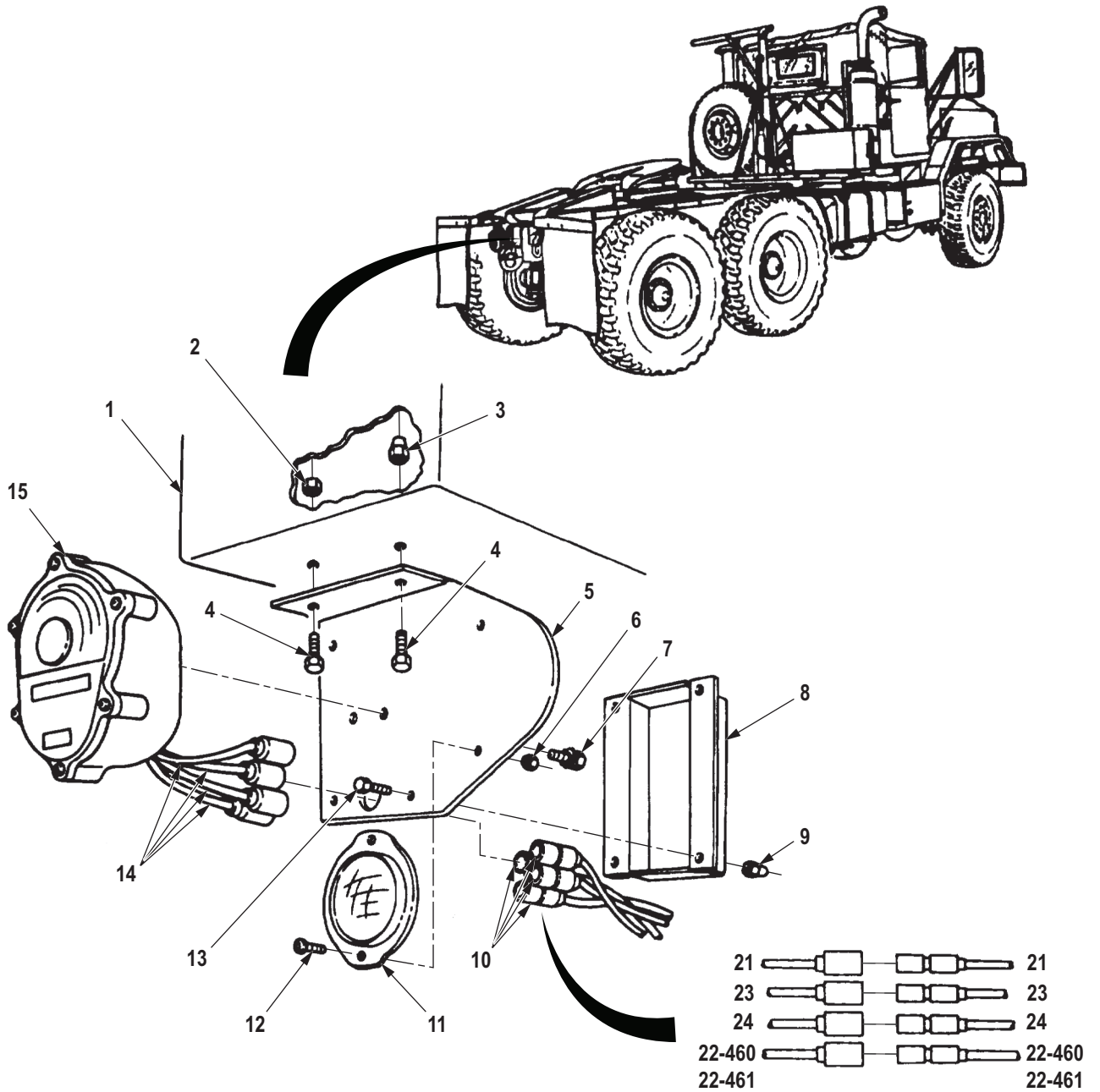

M8013DAA

Figure 10. Rear Composite Light and Bracket Installation.

END OF TASK

REMOVAL (M934/A1/A2)**NOTE**

- Left and right composite lights, brackets, covers, and braces are replaced the same way.
 - Tag wires for installation.
1. Remove four screws (Figure 11, Item 6) and cover (Figure 11, Item 5) from bracket (Figure 11, Item 9).
 2. Disconnect four connectors (Figure 11, Item 8) from wires (Figure 11, Item 10).
 3. Remove two screw assembled lockwashers (Figure 11, Item 4) and rear composite light (Figure 11, Item 11) from bracket (Figure 11, Item 9). Discard screw assembled lockwashers.
 4. Remove locknuts (Figure 11, Items 2 and 7), two screws (Figure 11, Item 3), and bracket (Figure 11, Item 9) from brace (Figure 11, Item 1). Discard locknuts.
 5. Remove two nuts (Figure 11, Item 12), screws (Figure 11, Item 13), and brace (Figure 11, Item 1) from frame rail (Figure 11, Item 14).

REMOVAL (M934/A1/A2) - Continued

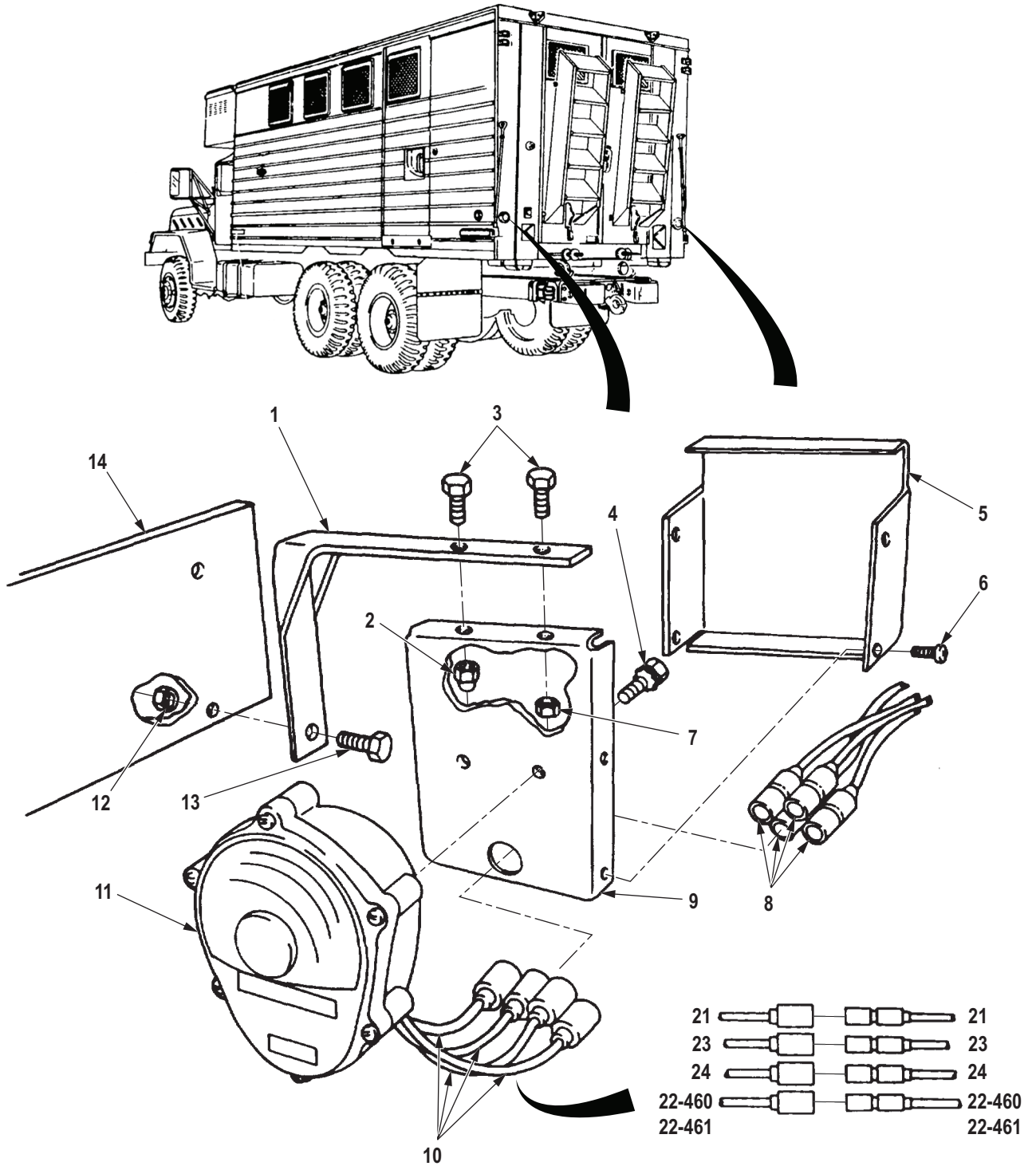

M8014DAA

Figure 11. Rear Composite Light Removal.

END OF TASK

INSTALLATION (M934/A1/A2)

1. Install brace (Figure 12, Item 1) on frame rail (Figure 12, Item 14) with two screws (Figure 12, Item 13) and nuts (Figure 12, Item 12).
2. Install bracket (Figure 12, Item 9) on brace (Figure 12, Item 1) with two screws (Figure 12, Item 3) and locknuts (Figure 12, Items 2 and 7).
3. Install rear composite light (Figure 12, Item 11) on bracket (Figure 12, Item 9) with two screw assembled lockwashers (Figure 12, Item 4).
4. Connect four connectors (Figure 12, Item 8) to wires (Figure 12, Item 10).
5. Install cover (Figure 12, Item 5) on bracket (Figure 12, Item 9) with four screws (Figure 12, Item 6).

INSTALLATION (M934/A1/A2) - Continued

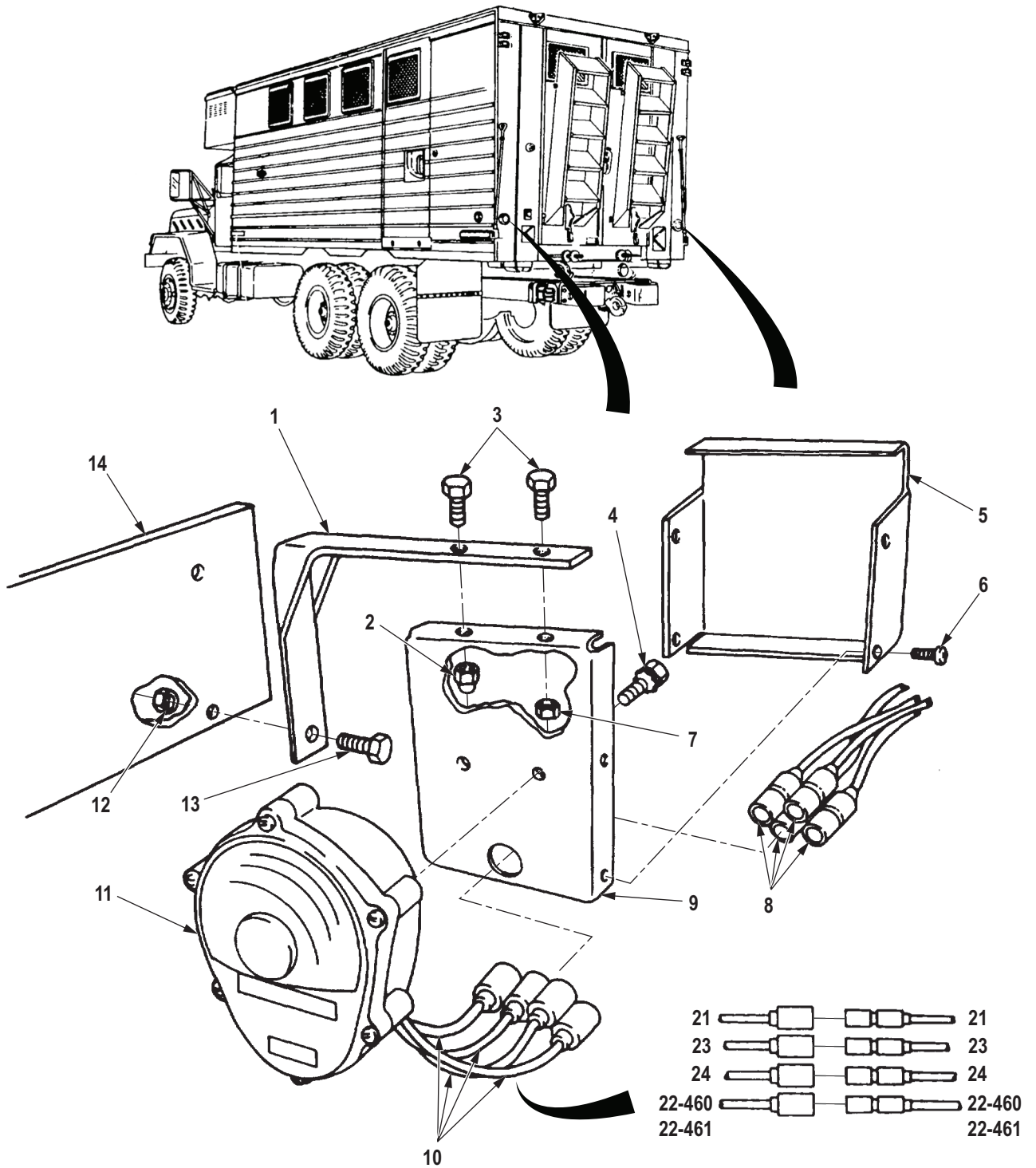

M8015DAA

Figure 12. Rear Composite Light Installation.

END OF TASK

COMPOSITE LIGHT LAMP REMOVAL**NOTE**

Composite light is off vehicle for this task.

1. Loosen six screws (Figure 13, Item 8) on composite light body (Figure 13, Item 4).
2. Remove composite light door (Figure 13, Item 1) and seal (Figure 13, Item 7) from composite light body (Figure 13, Item 4).
3. Remove stoplight lamp (Figure 13, Item 5), blackout marker lamp (Figure 13, Item 6), turn signal lamp (Figure 13, Item 2), and parking lamp (Figure 13, Item 3) from composite light body (Figure 13, Item 4).

NOTE

Perform Step (4) for diode configured rear composite lights only.

4. Remove stoplight lamp (Figure 13, Item 5), blackout marker diode (Figure 13, Item 6), turn signal lamp (Figure 13, Item 2), and parking lamp (Figure 13, Item 3) from composite light body (Figure 13, Item 4).

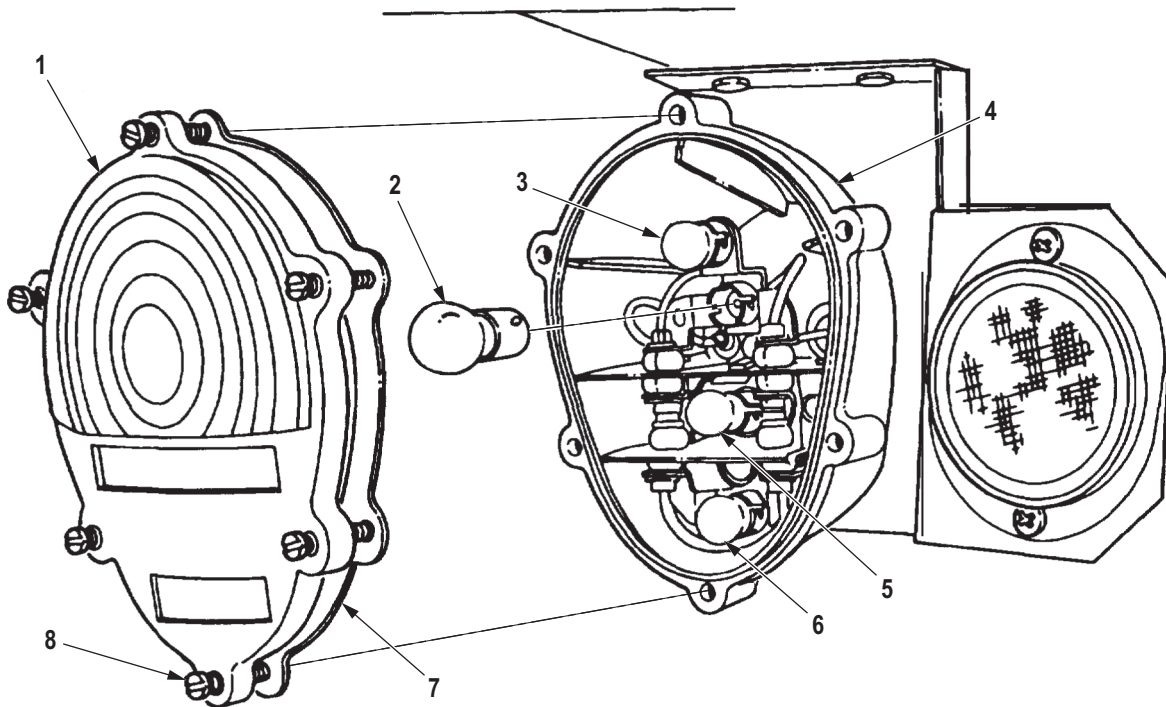

M8016DAA

Figure 13. Rear Composite Bulb Removal.

END OF TASK

COMPOSITE LIGHT LAMP INSTALLATION**NOTE**

Composite light is off vehicle for this task.

1. Install stoplight lamp (Figure 14, Item 5), blackout marker lamp (Figure 14, Item 6), turn signal lamp (Figure 14, Item 2), and parking lamp (Figure 14, Item 3) on composite light body (Figure 14, Item 4).

NOTE

Perform Step (2) for diode configured rear composite lights only.

2. Install stoplight lamp (Figure 14, Item 5), blackout marker diode (Figure 14, Item 6), turn signal lamp (Figure 14, Item 2), and parking lamp (Figure 14, Item 3) on composite light body (Figure 14, Item 4).
3. Install seal (Figure 14, Item 7) and composite light door (Figure 14, Item 1) on composite light body (Figure 14, Item 4) and tighten six screws (Figure 14, Item 8).

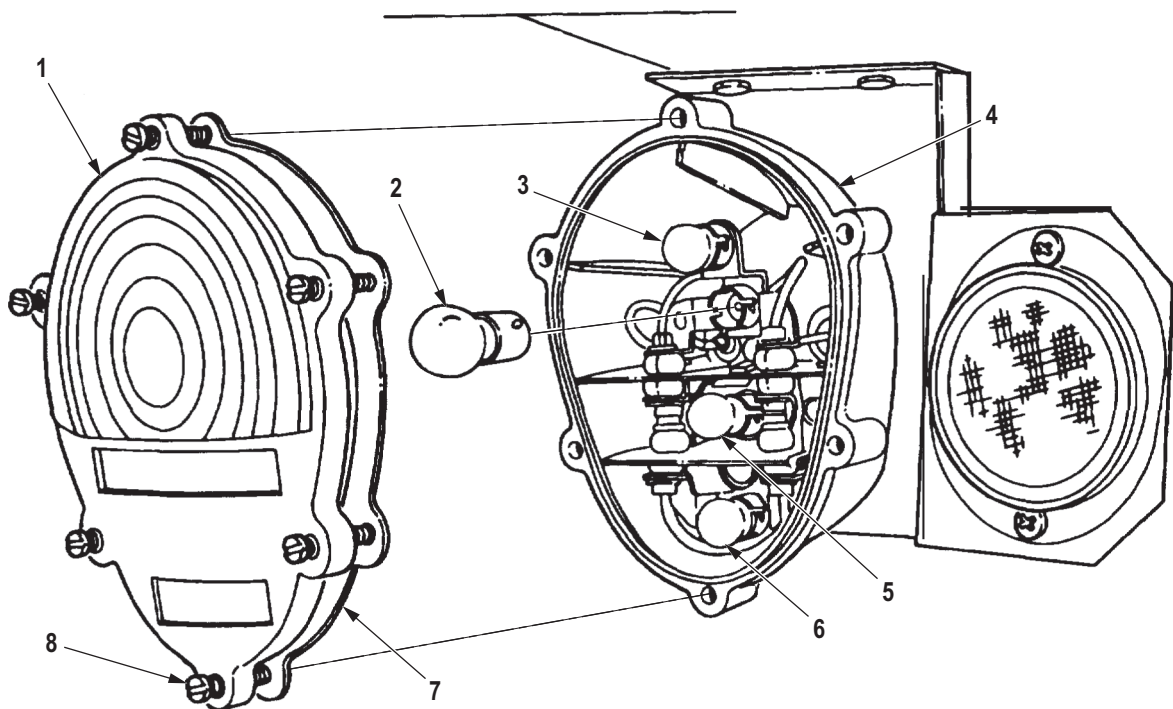

M8017DAA

Figure 14. Rear Composite Bulb Installation.

END OF TASK

FOLLOW-ON MAINTENANCE

1. Connect battery ground cables. (WP 0350)
2. Check composite light for proper operation. (TM 9-2320-272-10)

END OF TASK

END OF WORK PACKAGE

**FIELD MAINTENANCE
FLOODLIGHT SEALED BEAM LAMP AND DOOR REPLACEMENT**

INITIAL SETUP:

Tools and Special Tools

Tool Kit, General Mechanic's: Automotive
(Volume 5, WP 0826, Table 1, Item 56)

Equipment Condition

Battery ground cables disconnected. (WP 0350)

REMOVAL**NOTE**

All floodlight sealed beam lamps and doors are replaced the same way.

1. Remove three screws (Figure 1, Item 7) and retaining rings (Figure 1, Item 8) from lamp door (Figure 1, Item 6).
2. Separate lamp door (Figure 1, Item 6) from lamp housing (Figure 1, Item 4).
3. Remove two screws (Figure 1, Item 3) and wires (Figure 1, Item 5) from sealed beam lamp (Figure 1, Item 2).

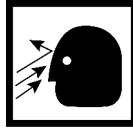
WARNING

Lamp door retaining clips are under tension and must be removed with firm grip. Failure to comply may result in injury or death to personnel.

NOTE

Note position of clips for installation.

4. Remove four retaining clips (Figure 1, Item 1) from lamp door (Figure 1, Item 6).
5. Remove sealed beam lamp (Figure 1, Item 2) from lamp door (Figure 1, Item 6).

REMOVAL - Continued

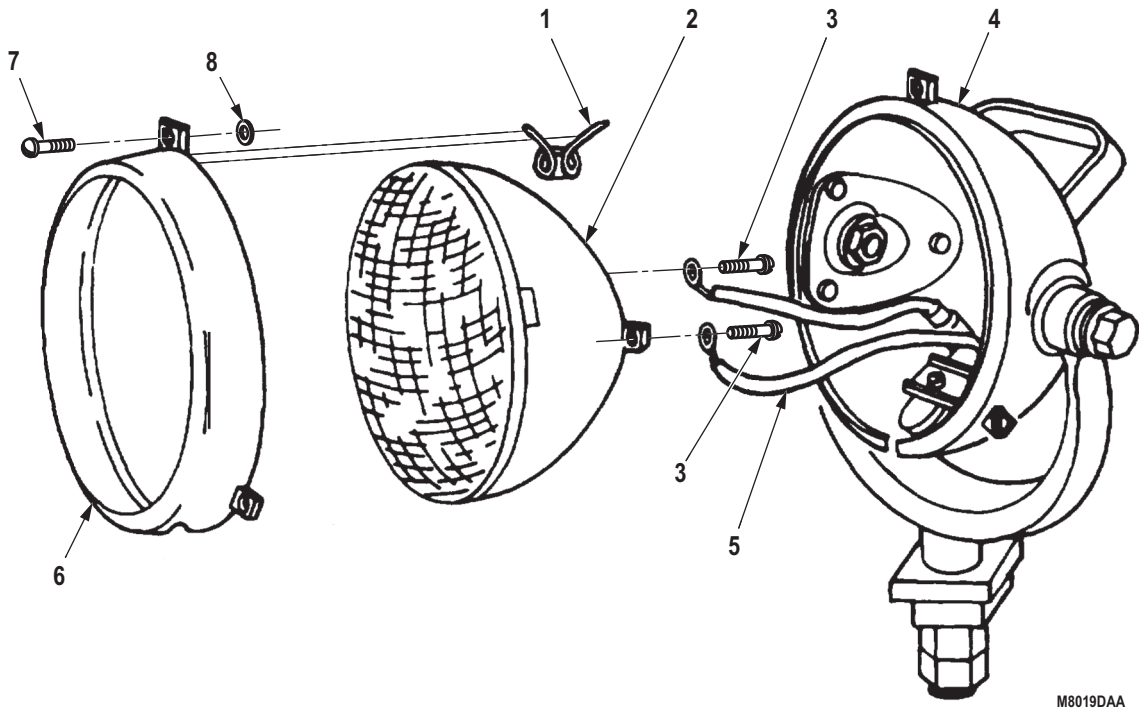

M8019DAA

Figure 1. Floodlight Removal.

END OF TASK

INSTALLATION

1. Install sealed beam lamp (Figure 2, Item 2) on lamp door (Figure 2, Item 9). Align lamp with notch (Figure 2, Item 7) on lamp door.
2. Install four retaining clips (Figure 2, Item 1) on lamp door (Figure 2, Item 9).
3. Install two wires (Figure 2, Item 6) on lamp (Figure 2, Item 2) with two screws (Figure 2, Item 3).
4. Align drain hole (Figure 2, Item 8) in lamp door (Figure 2, Item 9) with notch (Figure 2, Item 5) in lamp housing (Figure 2, Item 4) and install lamp door on lamp housing with three screws (Figure 2, Item 10) and retaining rings (Figure 2, Item 11).

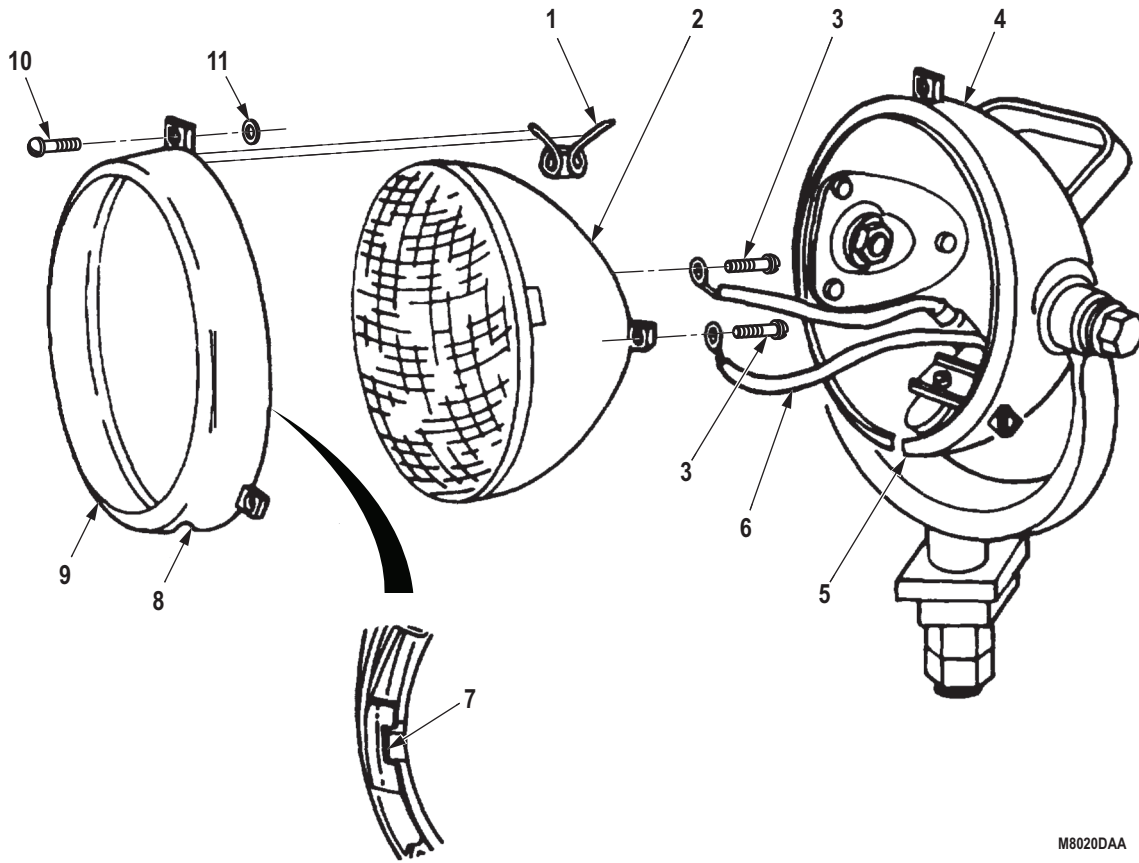

M8020DAA

Figure 2. Floodlight Installation.

END OF TASK

FOLLOW-ON MAINTENANCE

1. Connect battery ground cables. (WP 0350)
2. Check floodlight for proper operation. (TM 9-2320-272-10)

END OF TASK

END OF WORK PACKAGE

**FIELD MAINTENANCE
FLOODLIGHT REPAIR**

INITIAL SETUP:**Tools and Special Tools**

Tool Kit, General Mechanic's: Automotive
(Volume 5, WP 0826, Table 1, Item 56)

Equipment Condition (cont.)

Floodlight sealed beam lamp and door removed.
(WP 0328)

Materials/Parts

Lockwasher
(Volume 5, WP 0827, Table 1, Item 62)

Qty: 2

Lockwasher
(Volume 5, WP 0827, Table 1, Item 401)

Qty: 2

Equipment Condition

Parking brake set. (TM 9-2320-272-10)

REMOVAL**NOTE**

- All floodlights are maintained the same way.
 - Tag all wires for installation.
1. Disconnect two wires (Figure 1, Item 1) from connectors (Figure 1, Item 2).
 2. Remove two nuts (Figure 1, Item 6), washer (Figure 1, Item 4), floodlight housing (Figure 1, Item 3), and washer (Figure 1, Item 4) from floodlight bracket (Figure 1, Item 5).

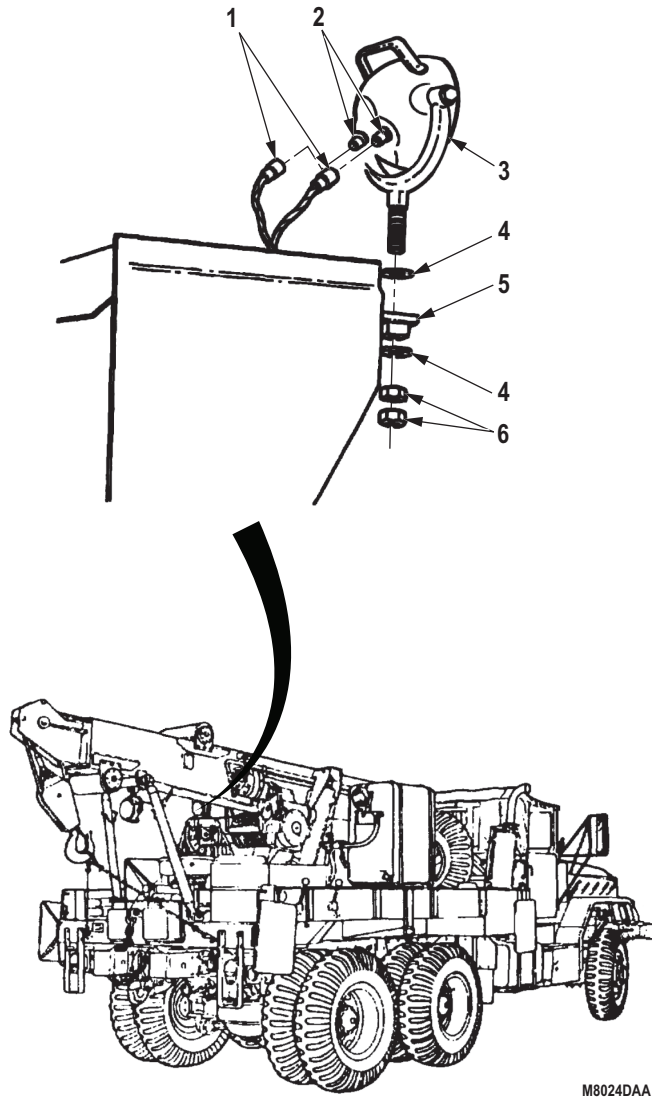

Figure 1. Floodlight Removal.

END OF TASK

DISASSEMBLY**NOTE**

Tag wires for installation.

1. Disconnect switch wire (Figure 2, Item 3) and lamp wire (Figure 2, Item 1) from floodlight housing (Figure 2, Item 2).
2. Remove two connectors (Figure 2, Items 4 and 6) and grommets (Figure 2, Item 5) from floodlight housing (Figure 2, Item 2).

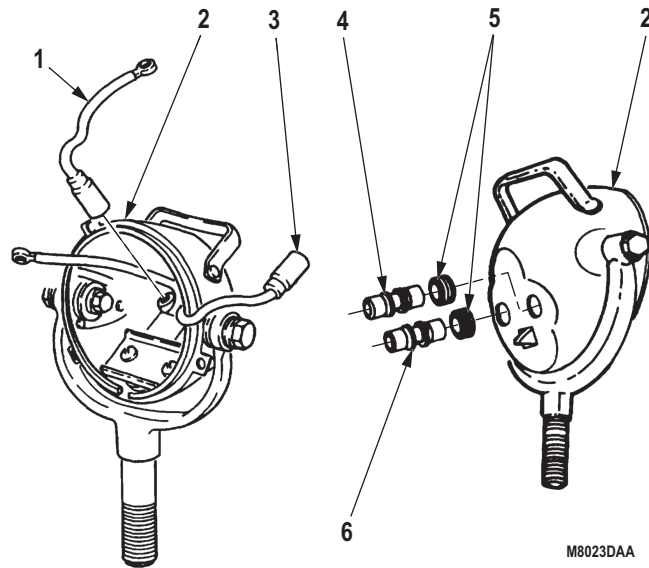
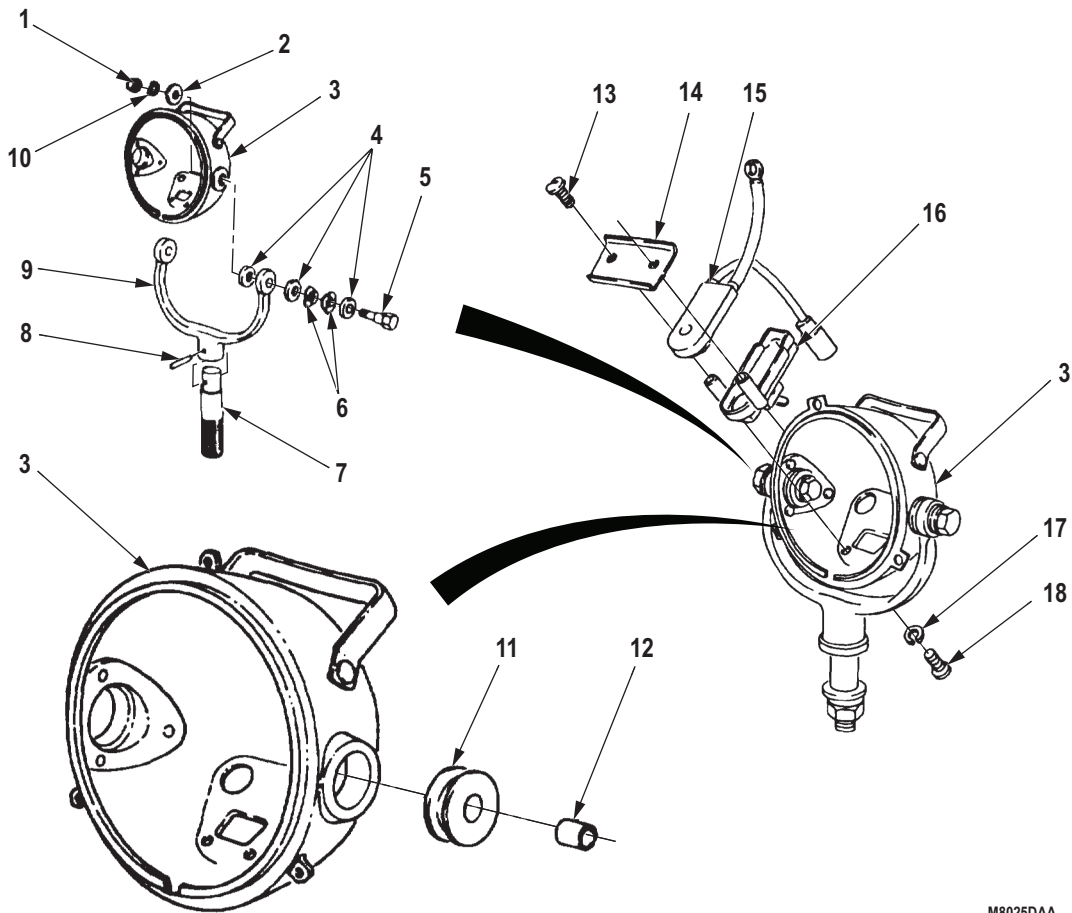

Figure 2. Floodlight Disassembly.

DISASSEMBLY - Continued

3. Remove two screws (Figure 3, Item 13), retainer (Figure 3, Item 14), and pressure switch (Figure 3, Item 15) from floodlight housing (Figure 3, Item 3).
4. Remove two screws (Figure 3, Item 18), lockwashers (Figure 3, Item 17), and switch housing (Figure 3, Item 16) from floodlight housing (Figure 3, Item 3). Discard lockwashers.
5. Remove two nuts (Figure 3, Item 1), lockwashers (Figure 3, Item 10), and washers (Figure 3, Item 2) from floodlight housing (Figure 3, Item 3) and screws (Figure 3, Item 5).
6. Remove two screws (Figure 3, Item 5), washers (Figure 3, Item 4), four spring washers (Figure 3, Item 6), two washers (Figure 3, Item 4), floodlight housing (Figure 3, Item 3), and two washers (Figure 3, Item 4) from mounting bracket (Figure 3, Item 9).
7. Remove pin (Figure 3, Item 8) and stud (Figure 3, Item 7) from mounting bracket (Figure 3, Item 9).
8. Remove two spacers (Figure 3, Item 12) and grommets (Figure 3, Item 11) from floodlight housing (Figure 3, Item 3).



M8025DAA

Figure 3. Floodlight Disassembly.

END OF TASK

ASSEMBLY

1. Install two grommets (Figure 4, Item 11) and spacers (Figure 4, Item 12) on floodlight housing (Figure 4, Item 3).
2. Install stud (Figure 4, Item 7) on mounting bracket (Figure 4, Item 9) with pin (Figure 4, Item 8).
3. Install floodlight housing (Figure 4, Item 3) and two washers (Figure 4, Item 4) on mounting bracket (Figure 4, Item 9) with four spring washers (Figure 4, Item 6), two washers (Figure 4, Item 4), and screws (Figure 4, Item 5).
4. Install two washers (Figure 4, Item 2), lockwashers (Figure 4, Item 10), and nuts (Figure 4, Item 1) on floodlight housing (Figure 3, Item 3) and screws (Figure 3, Item 5).
5. Install switch housing (Figure 4, Item 16) on floodlight housing (Figure 4, Item 3) with two lockwashers (Figure 4, Item 17) and screws (Figure 4, Item 18).
6. Install pressure switch (Figure 4, Item 15) on floodlight housing (Figure 4, Item 3) with retainer (Figure 4, Item 14) and two screws (Figure 4, Item 13).

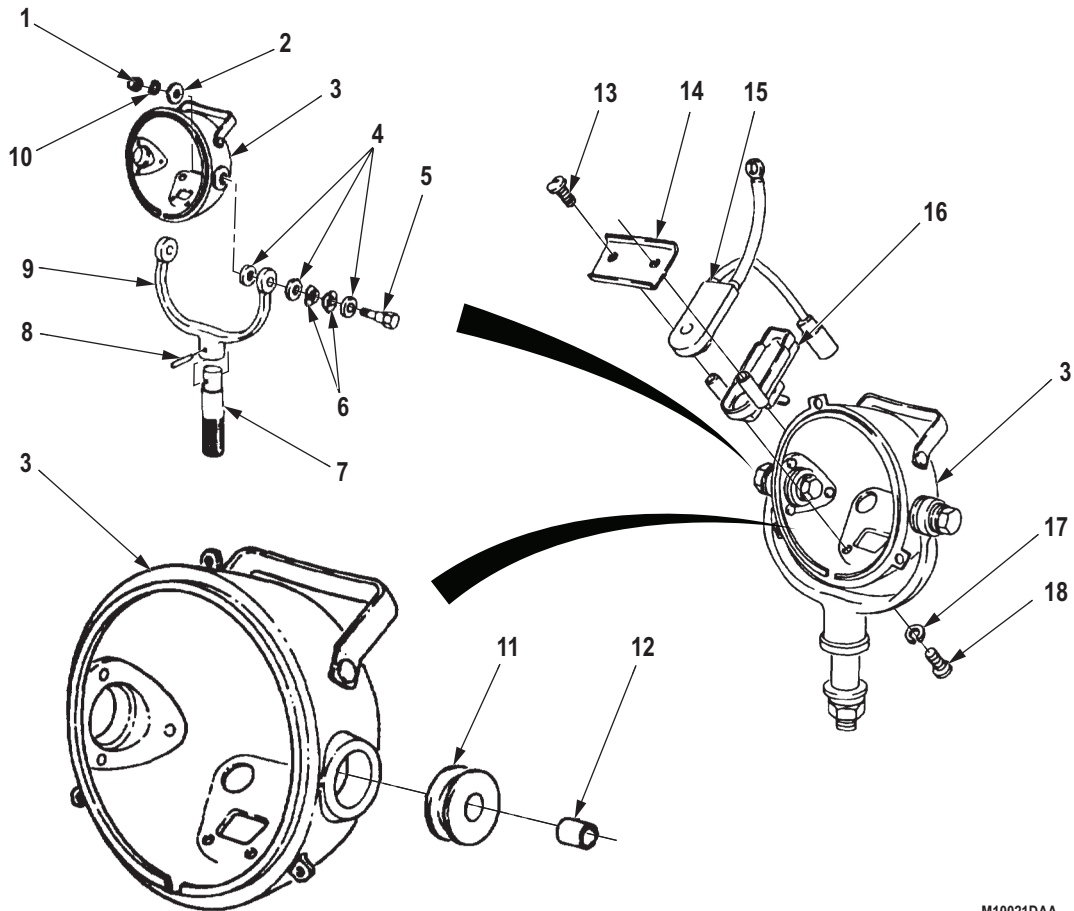

M10021DAA

Figure 4. Floodlight Assembly.

ASSEMBLY - Continued

7. Install two grommets (Figure 5, Item 5) and connectors (Figure 5, Items 4 and 6) on floodlight housing (Figure 5, Item 2).
8. Connect lamp wire (Figure 5, Item 1) and switch wire (Figure 5, Item 3) to floodlight housing (Figure 5, Item 2).

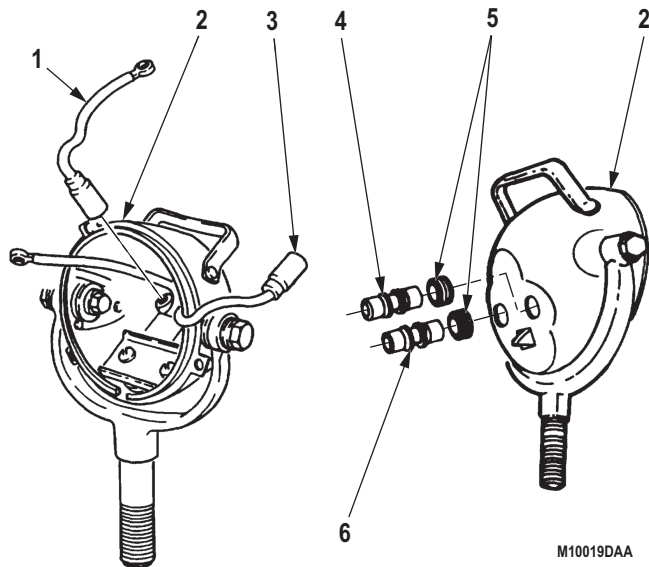
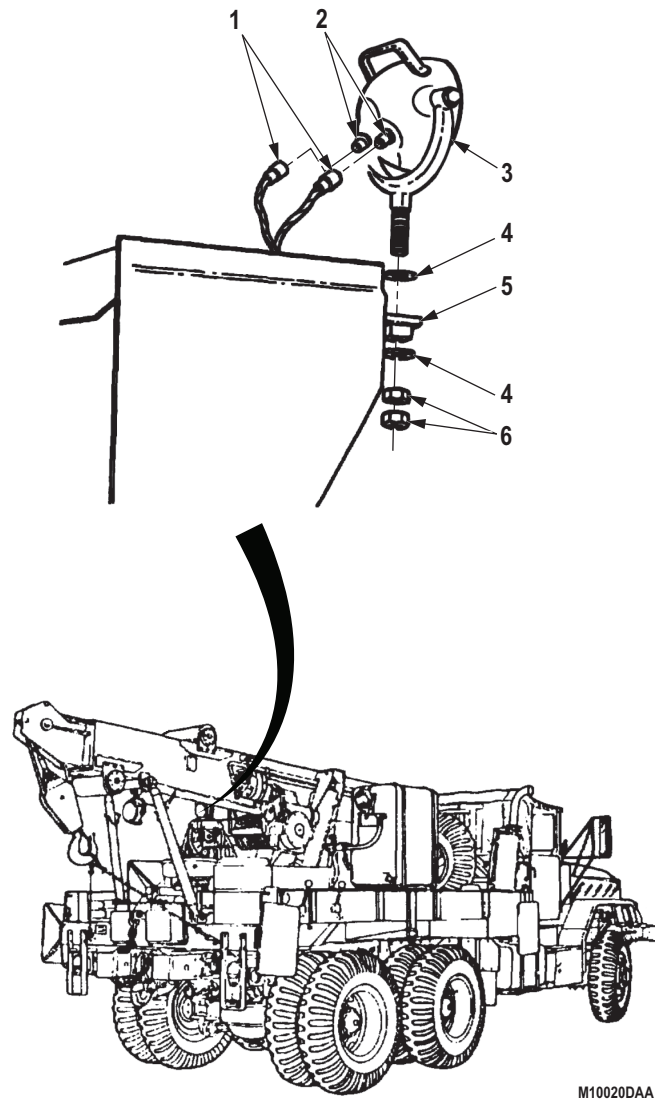

Figure 5. Floodlight Assembly.

END OF TASK**INSTALLATION**

1. Install washer (Figure 6, Item 4) and floodlight housing (Figure 6, Item 3) on floodlight bracket (Figure 6, Item 5) with washer (Figure 6, Item 4) and two nuts (Figure 6, Item 6).
2. Connect two wires (Figure 6, Item 1) to connectors (Figure 6, Item 2).

INSTALLATION - Continued

M10020DAA

*Figure 6. Floodlight Installation.***END OF TASK****FOLLOW-ON MAINTENANCE**

1. Install floodlight sealed beam lamp and door. (WP 0328)
2. Check floodlight for proper operation. (TM 9-2320-272-10)

END OF TASK**END OF WORK PACKAGE**

**FIELD MAINTENANCE
SIDE MARKER LIGHTS AND BRACKET REPLACEMENT**

INITIAL SETUP:**Tools and Special Tools**

Tool Kit, General Mechanic's: Automotive
(Volume 5, WP 0826, Table 1, Item 56)

Equipment Condition (cont.)

Battery ground cables disconnected. (WP 0350)

Materials/Parts

Locknut (Volume 5, WP 0827, Table 1, Item 277)

Qty: 2

Lockwasher

(Volume 5, WP 0827, Table 1, Item 386)

Qty: 4

Lockwasher

(Volume 5, WP 0827, Table 1, Item 393)

Qty: 4

Equipment Condition

Parking brake set. (TM 9-2320-272-10)

LAMP REMOVAL**NOTE**

- Clearance lights have the same design as side marker lights. Only their location on the vehicle is different.
- Front and rear side markers are replaced basically the same. This procedure is for rear side marker light.

1. Remove two screws (Figure 1, Item 4), cover (Figure 1, Item 3), and lens cover (Figure 1, Item 2) from side marker light (Figure 1, Item 5).
2. Remove lamp (Figure 1, Item 1) from side marker light (Figure 1, Item 5).

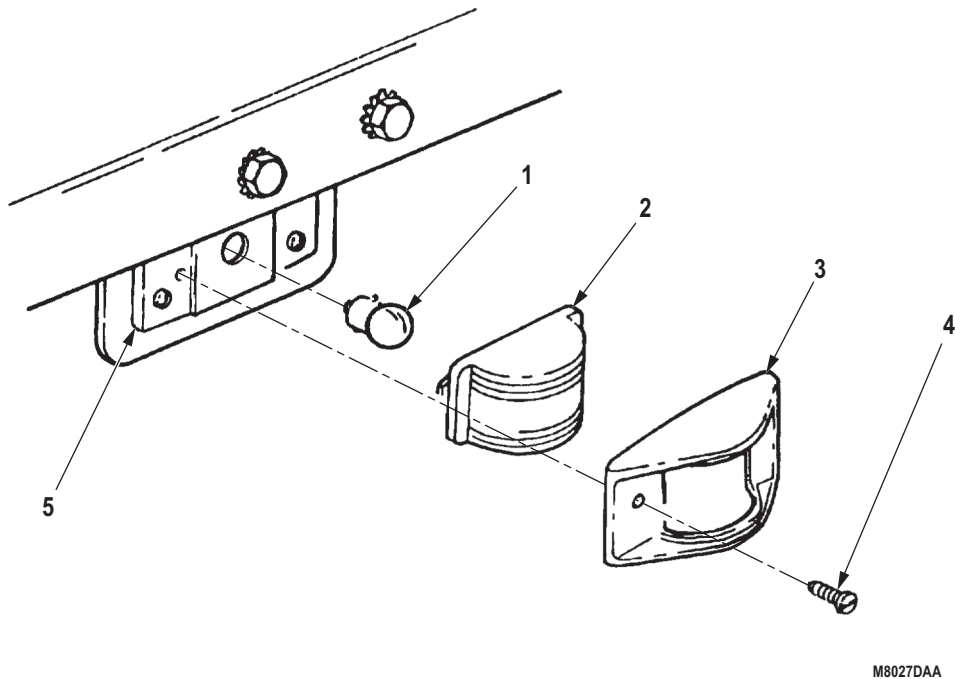

M8027DAA

Figure 1. Side Marker Lamp Removal.

END OF TASK

LIGHT REMOVAL

1. Disconnect side marker light plug (Figure 2, Item 11) from wiring harness lead (Figure 2, Item 12).
2. Remove four nuts (Figure 2, Item 10), lockwashers (Figure 2, Item 9), screws (Figure 2, Item 7), and side marker light (Figure 2, Item 8) from bracket (Figure 2, Item 4). Discard lockwashers.
3. Remove two locknuts (Figure 2, Item 1), screws (Figure 2, Item 6), four lockwashers (Figure 2, Item 2), clamp (Figure 2, Item 3), and bracket (Figure 2, Item 4) from rail (Figure 2, Item 5). Discard locknuts and lockwashers.
4. Remove clamp (Figure 2, Item 3) from wiring harness lead (Figure 2, Item 12).

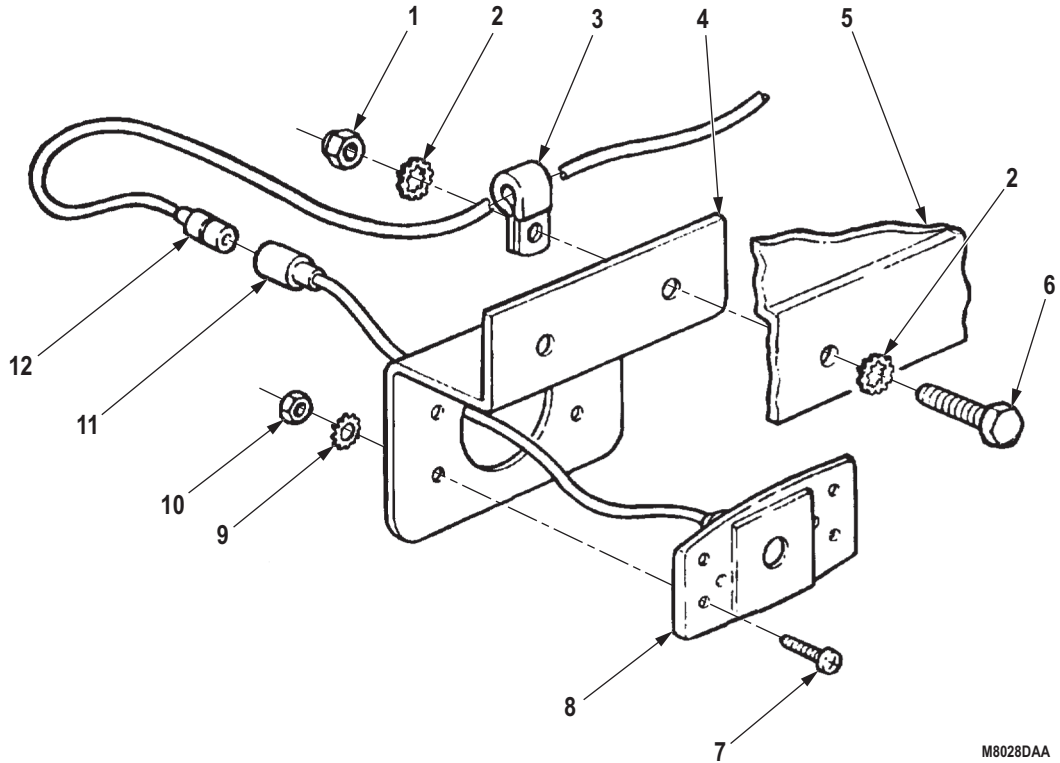

M8028DAA

Figure 2. Side Marker Light Removal.

END OF TASK

LIGHT INSTALLATION

1. Position clamp (Figure 3, Item 3) on wiring harness lead (Figure 3, Item 12).
2. Install bracket (Figure 3, Item 4) on clamp (Figure 3, Item 3) on rail (Figure 3, Item 5) with four lockwashers (Figure 3, Item 2), two screws (Figure 3, Item 6), and locknuts (Figure 3, Item 1).
3. Install side marker light (Figure 3, Item 8) on bracket (Figure 3, Item 4) with four screws (Figure 3, Item 7), lockwashers (Figure 3, Item 9), and nuts (Figure 3, Item 10).
4. Connect side marker light plug (Figure 3, Item 11) to wiring harness lead (Figure 3, Item 12).

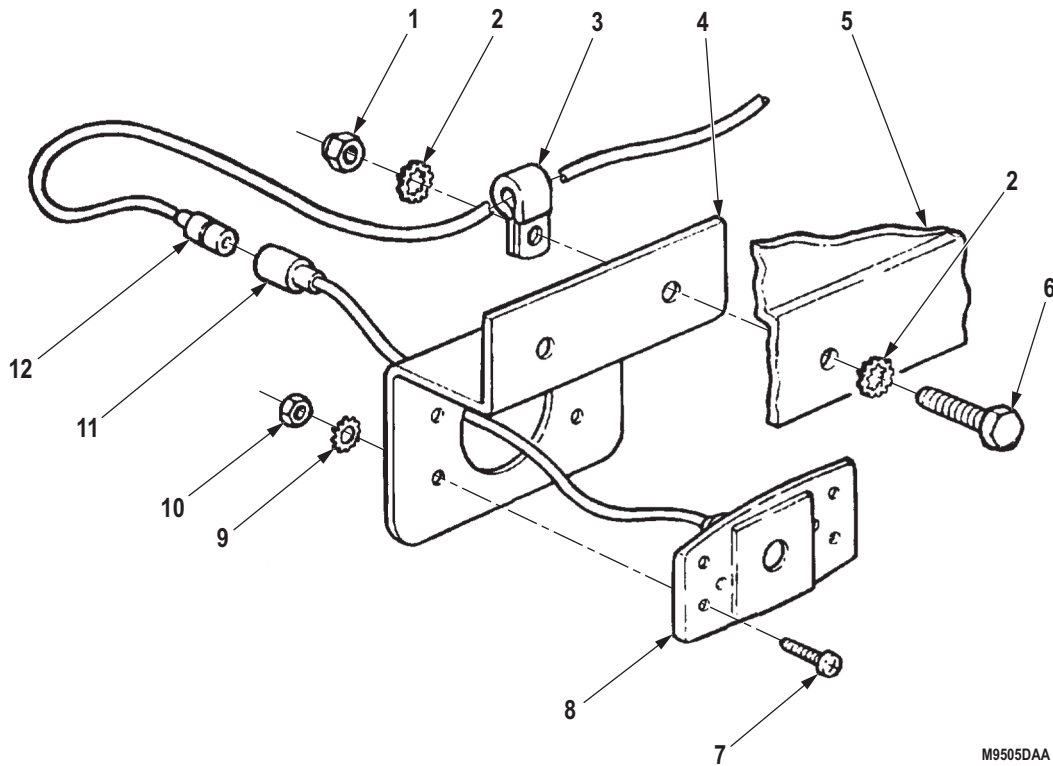
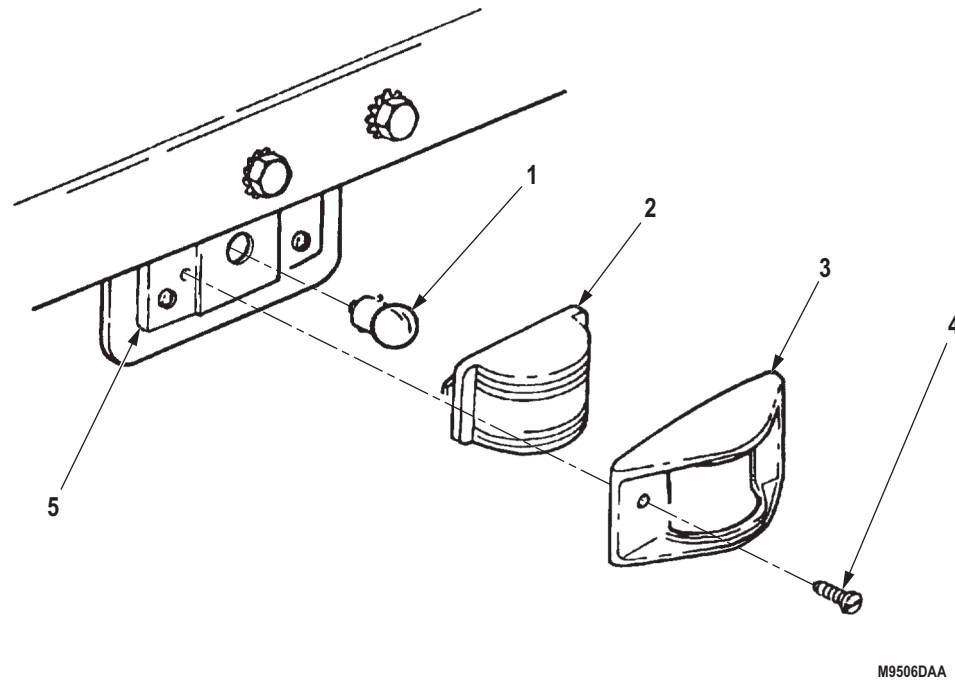

Figure 3. Side Marker Light Installation.

END OF TASK

LAMP INSTALLATION

1. Install lamp (Figure 4, Item 1) on side marker light (Figure 4, Item 5).
2. Install lens cover (Figure 4, Item 2) and cover (Figure 4, Item 3) on side marker light (Figure 4, Item 5) with two screws (Figure 4, Item 4).



M9506DAA

Figure 4. Side Marker Lamp Installation.

END OF TASK**FOLLOW-ON MAINTENANCE**

1. Connect battery ground cables. (WP 0350)
2. Check operation of clearance and side marker lights. (TM 9-2320-272-10)

END OF TASK**END OF WORK PACKAGE**

**FIELD MAINTENANCE
BOOM FLOODLIGHT WIRE REPLACEMENT**

INITIAL SETUP:

Tools and Special Tools

Tool Kit, General Mechanic's: Automotive
(Volume 5, WP 0826, Table 1, Item 56)

Equipment Condition (cont.)

Battery ground cables disconnected. (WP 0350)

Personnel Required

(2)

Equipment Condition

Parking brake set. (TM 9-2320-272-10)

REMOVAL**NOTE**

Tag all leads for installation.

1. Disconnect floodlight wire leads (Figure 1, Item 5) from floodlight (Figure 1, Item 6).
2. Remove seven screws (Figure 1, Item 2), clamps (Figure 1, Item 1), and floodlight wire (Figure 1, Item 3) from boom (Figure 1, Item 4).

WARNING

- Assistant must remain at crane controls until removal operation is completed. Injury to personnel may result if boom control lever is accidentally engaged while work is being done between raised boom and swivel base. Failure to comply may result in injury or death to personnel.
- All personnel must stand clear during hoisting operations. A snapped cable, or swinging or shifting load, may occur. Failure to comply may result in injury or death to personnel.

NOTE

Assistant will operate crane. Mechanic will continue with removal operation after boom has been raised.

3. Raise boom (Figure 1, Item 4) to a 45-degree position (TM 9-2320-272-10).
4. Remove remaining screws (Figure 1, Item 2), clamps (Figure 1, Item 1), and floodlight wire (Figure 1, Item 3) from boom (Figure 1, Item 4).
5. Disconnect floodlight wires leads (Figure 1, Item 7) from crane harness leads (Figure 1, Item 8) and remove floodlight cable (Figure 1, Item 3) from vehicle.

REMOVAL - Continued

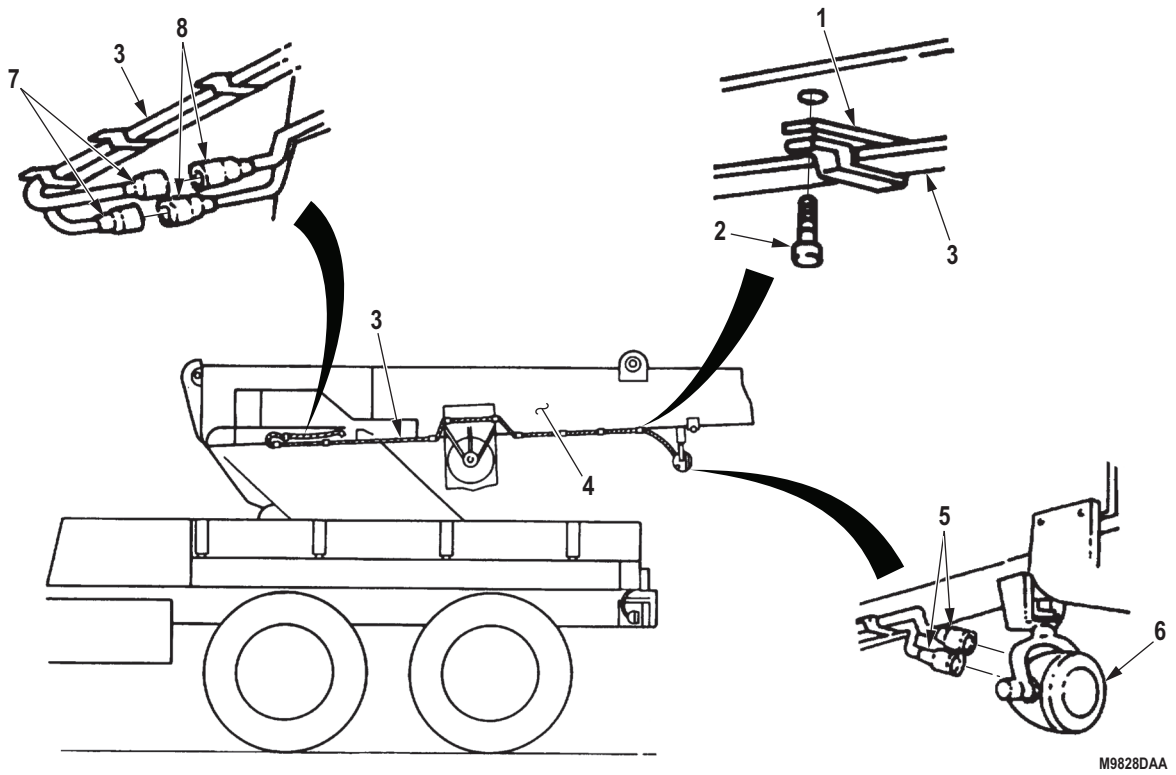

Figure 1. Boom Floodlight Wire Removal.

END OF TASK

INSTALLATION

WARNING



- Assistant must remain at crane controls until removal operation is completed. Injury to personnel may result if boom control lever is accidentally engaged while work is being done between raised boom and swivel base. Failure to comply may result in injury or death to personnel.
- All personnel must stand clear during hoisting operations. A snapped cable, or swinging or shifting load, may occur. Failure to comply may result in injury or death to personnel.

1. Spread out floodlight wire (Figure 2, Item 3) on vehicle along general lines of installation.
2. Connect floodlight wire leads (Figure 2, Item 5) to floodlight (Figure 2, Item 6).
3. Connect floodlight wire leads (Figure 2, Item 7) to crane harness leads (Figure 2, Item 8).
4. Install floodlight wire (Figure 2, Item 3) on boom (Figure 2, Item 4) with ten clamps (Figure 2, Item 1) and screws (Figure 2, Item 2).
5. Lower boom (Figure 2, Item 4) (TM 9-2320-272-10).

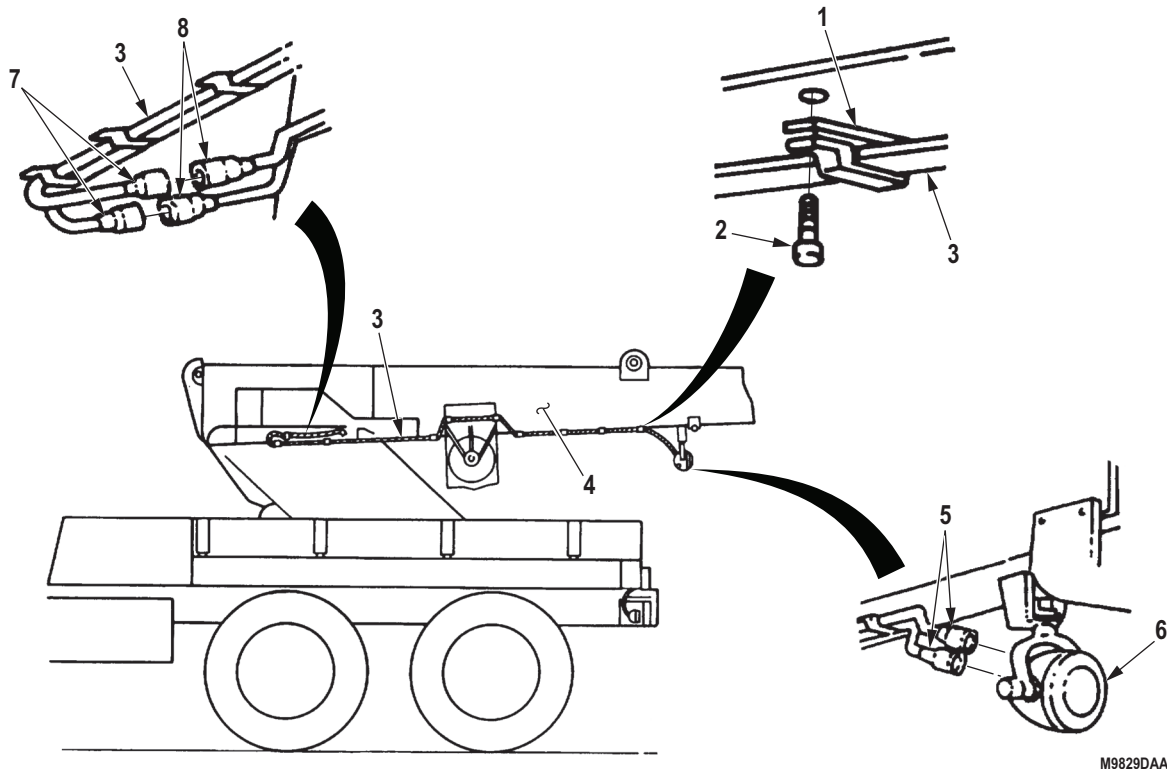

Figure 2. Boom Floodlight Wire Installation.

END OF TASK

FOLLOW-ON MAINTENANCE

Connect battery ground cables. (WP 0350)

END OF TASK

END OF WORK PACKAGE

**FIELD MAINTENANCE
FUEL LEVEL SENDING UNIT REPLACEMENT**

INITIAL SETUP:**Tools and Special Tools**

Tool Kit, General Mechanic's: Automotive
(Volume 5, WP 0826, Table 1, Item 56)

Materials/Parts

Gasket (Volume 5, WP 0827, Table 1, Item 228)
Qty: 1

Equipment Condition (cont.)

Spare tire carrier access step removed
(M931/A1/A2 and M932/A1/A2).
(Volume 3, WP 0529)

Battery ground cables disconnected. (WP 0350)

Equipment Condition

Parking brake set. (TM 9-2320-272-10)

REMOVAL**WARNING**

Diesel fuel is highly flammable. Do not perform fuel system procedures near open flame. Failure to comply may result in injury or death to personnel.

1. Disconnect wire (Figure 1, Item 2) from sending unit (Figure 1, Item 3).
2. Remove five screws (Figure 1, Item 1) and ground wire (Figure 1, Item 6) from sending unit (Figure 1, Item 3) and fuel tank (Figure 1, Item 5).
3. Remove sending unit (Figure 1, Item 3) and gasket (Figure 1, Item 4) from fuel tank (Figure 1, Item 5). Discard gasket.

REMOVAL - Continued

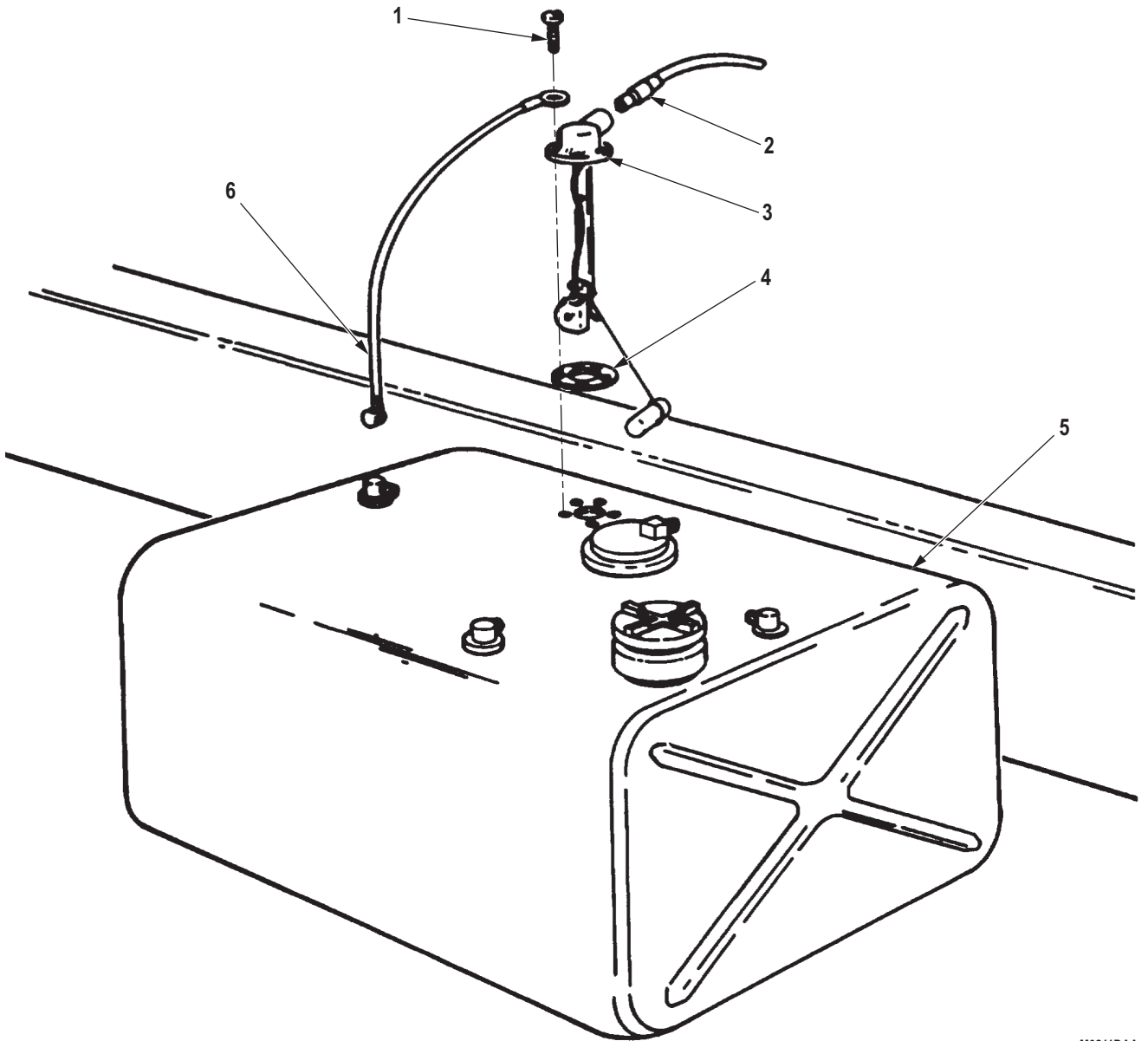

M0211DAA

Figure 1. Fuel Level Sending Unit Removal.

END OF TASK

INSTALLATION

1. Install gasket (Figure 2, Item 4), sending unit (Figure 2, Item 3), and ground wire (Figure 2, Item 6) on fuel tank (Figure 2, Item 5) with five screws (Figure 2, Item 1).
2. Connect wire (Figure 2, Item 2) to sending unit (Figure 2, Item 3).

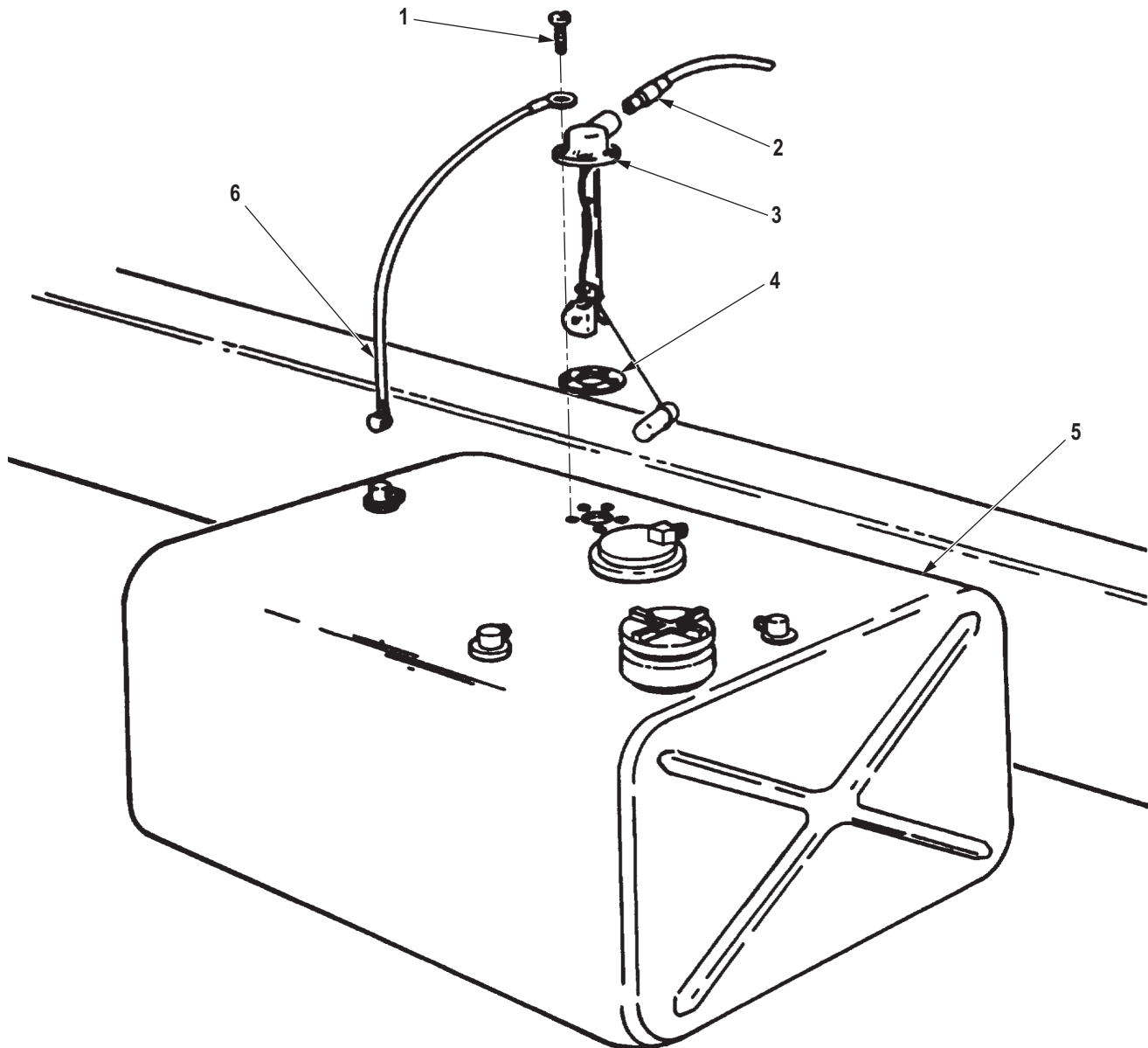

M0212DAA

Figure 2. Fuel Level Sending Unit Installation.

END OF TASK

FOLLOW-ON MAINTENANCE

1. Install spare tire carrier access step (M931/A1/A2 and M932/A1/A2). (Volume 3, WP 0529)
2. Connect battery ground cables. (WP 0350)
3. Start engine and check fuel gage. (TM 9-2320-272-10)

END OF TASK**END OF WORK PACKAGE**

**FIELD MAINTENANCE
OIL PRESSURE SENDING UNIT REPLACEMENT**

INITIAL SETUP:**Tools and Special Tools**

Tool Kit, General Mechanic's: Automotive
(Volume 5, WP 0826, Table 1, Item 56)

Equipment Condition (cont.)

Left splash shield removed. (TM 9-2320-272-10)
Battery ground cables disconnected. (WP 0350)

Materials/Parts

Tape, Antiseizing
(Volume 5, WP 0825, Table 1, Item 65)

Equipment Condition

Parking brake set. (TM 9-2320-272-10)

REMOVAL

1. Disconnect wire (Figure 1, Item 1) from oil pressure sending unit (Figure 1, Item 2).
2. Remove oil pressure sending unit (Figure 1, Item 2) from adapter fitting (Figure 1, Item 5).

NOTE

Step (3) is for M939/A1 models only.

3. Remove adapter fitting (Figure 1, Item 5) and elbow (Figure 1, Item 4) from left side of engine (Figure 1, Item 3).

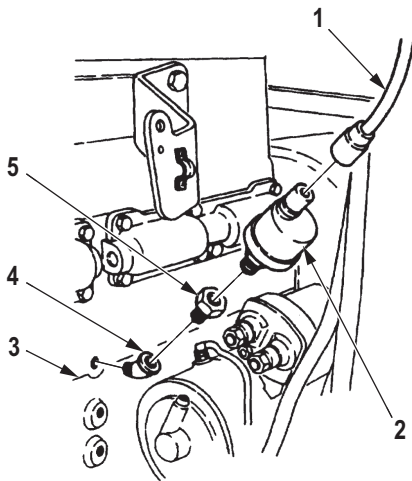

M939/A1 VEHICLES

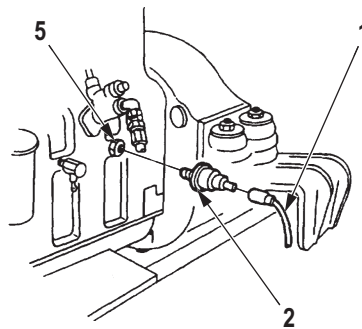

M939/A2 VEHICLES

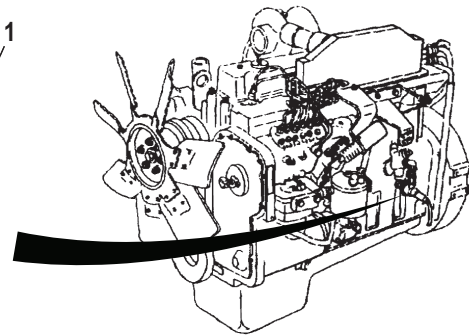

M0209DAA

Figure 1. Oil Pressure Sending Unit Removal.

END OF TASK

INSTALLATION**NOTE**

- Male pipe threads must be wrapped with antiseize tape before installation.
 - Steps (1) and (2) are for M939/A1 models only.
1. Install elbow (Figure 2, Item 4) on left side of engine (Figure 2, Item 3).
 2. Install adapter fitting (Figure 2, Item 5) on elbow (Figure 2, Item 4).
 3. Install oil pressure sending unit (Figure 2, Item 2) on adapter fitting (Figure 2, Item 5).
 4. Connect wire (Figure 2, Item 1) to oil pressure sending unit (Figure 2, Item 2).

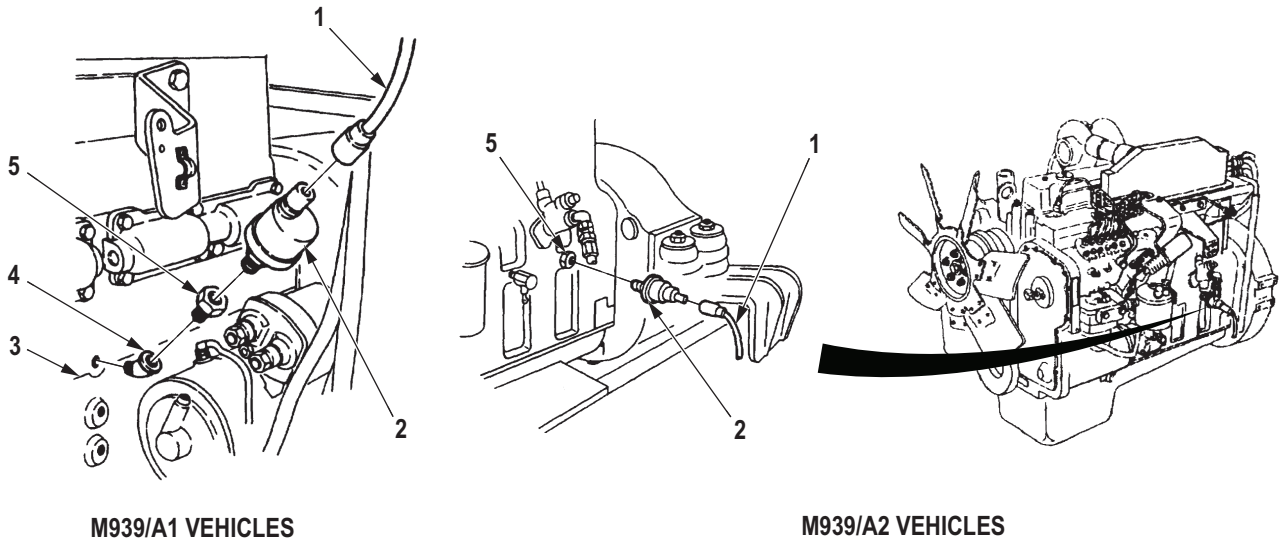

M0210DAA

Figure 2. Oil Pressure Sending Unit Installation.

END OF TASK**FOLLOW-ON MAINTENANCE**

1. Install left splash shield. (TM 9-2320-272-10)
2. Connect battery ground cables. (WP 0350)
3. Start engine and check oil pressure sending unit operation. (TM 9-2320-272-10)

END OF TASK**END OF WORK PACKAGE**

FIELD MAINTENANCE
WATER TEMPERATURE SENDING UNIT REPLACEMENT

INITIAL SETUP:**Tools and Special Tools**

Tool Kit, General Mechanic's: Automotive
(Volume 5, WP 0826, Table 1, Item 56)

Materials/Parts

Tape, Antiseizing
(Volume 5, WP 0825, Table 1, Item 65)

Equipment Condition (cont.)

Battery ground cables disconnected. (WP 0350)
Right splash shield removed. (TM 9-2320-272-10)
Surge tank cap removed. (TM 9-2320-272-10)
Engine coolant drained. (WP 0287)

Equipment Condition

Parking brake set. (TM 9-2320-272-10)

REMOVAL

1. Disconnect wire (Figure 1, Item 3) from water temperature sending unit (Figure 1, Item 2).
2. Remove water temperature sending unit (Figure 1, Item 2) from water manifold (Figure 1, Item 1).

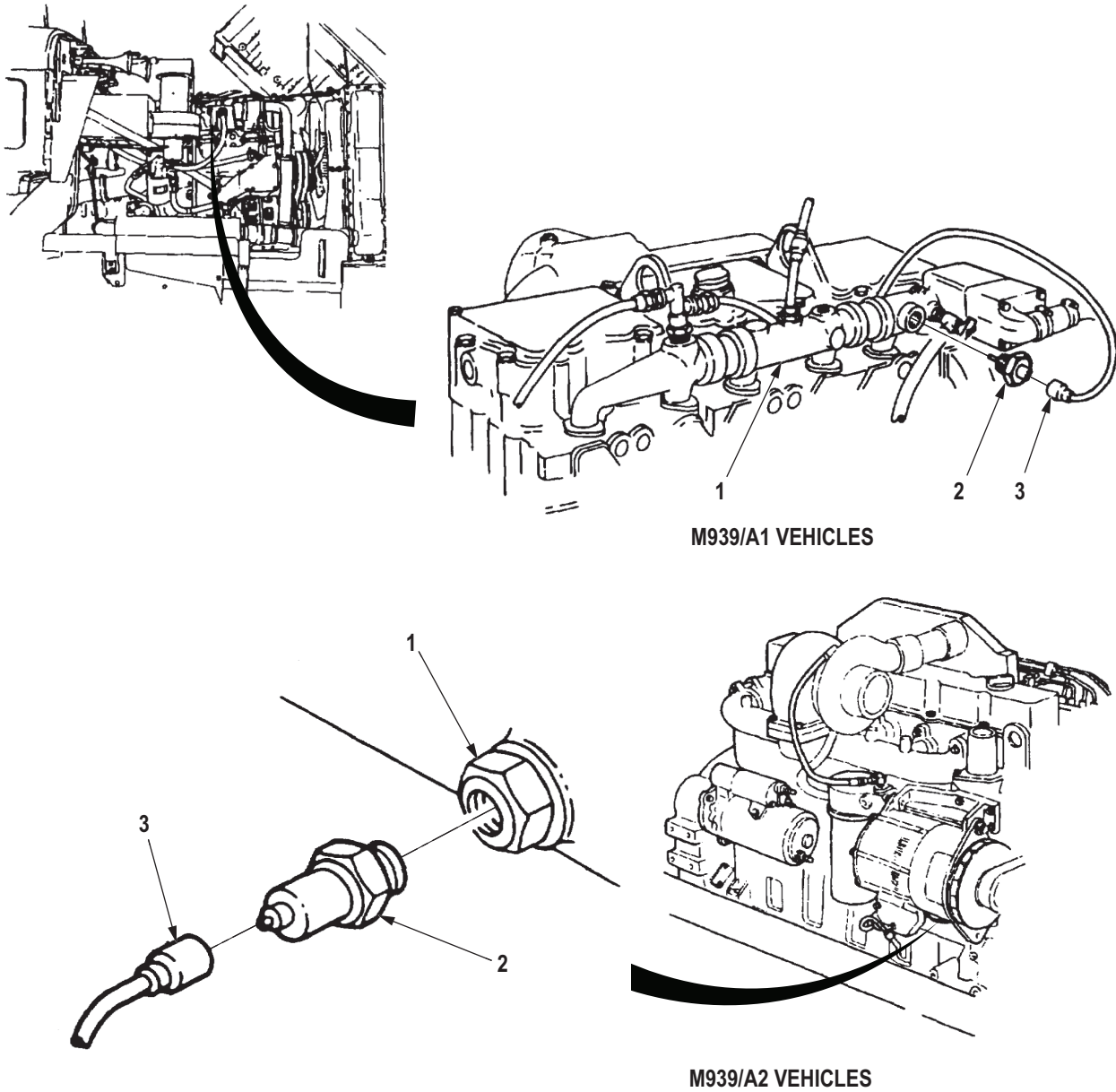

Figure 1. Water Temperature Sending Unit Removal.

END OF TASK

M0213DAA

INSTALLATION**NOTE**

Male pipe thread must be wrapped with antiseize tape before installation.

1. Install water temperature sending unit (Figure 2, Item 2) on water manifold (Figure 2, Item 1).
2. Connect wire (Figure 2, Item 3) to water temperature sending unit (Figure 2, Item 2).

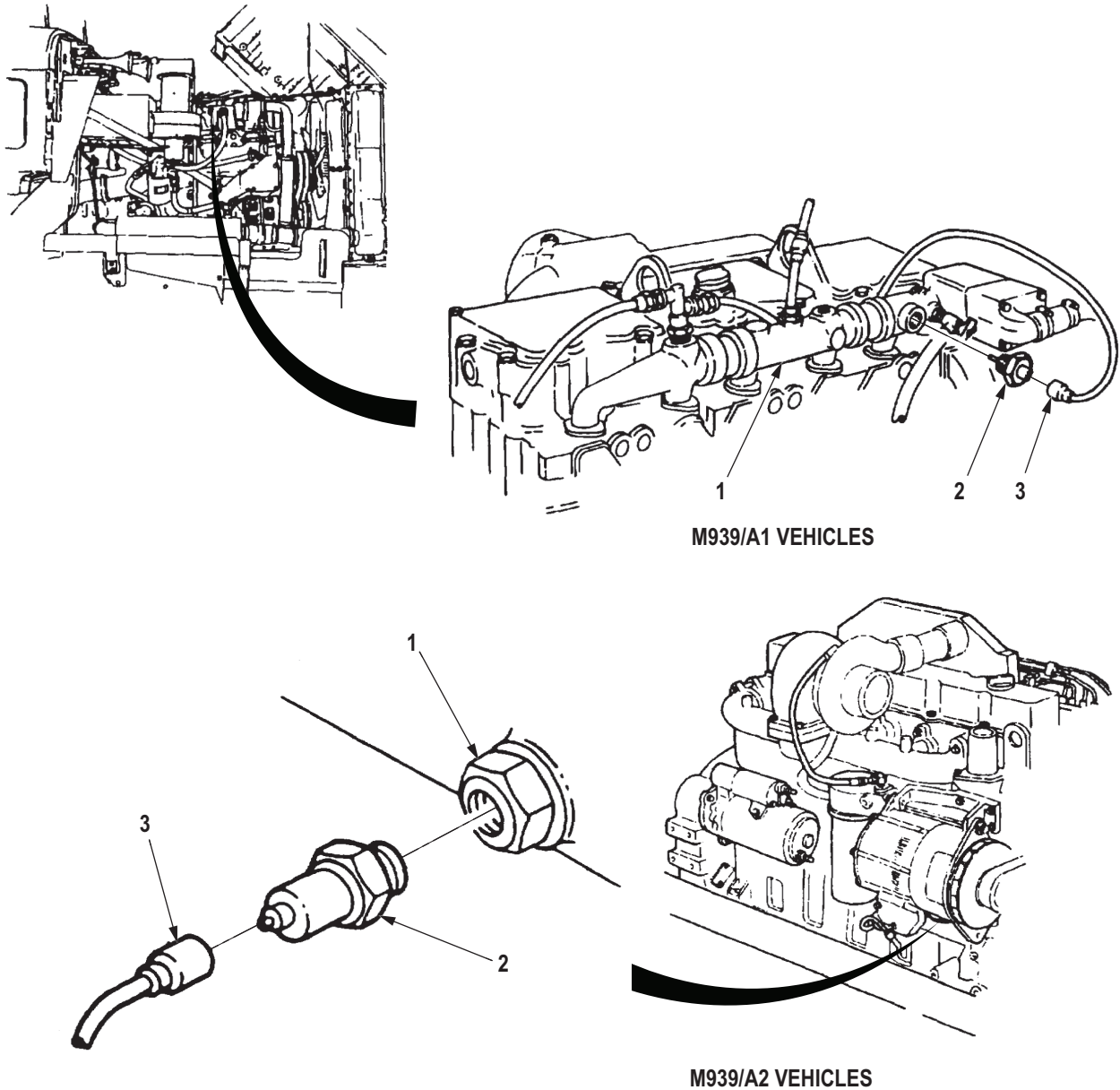

Figure 2. Water Temperature Sending Unit Installation.

END OF TASK

FOLLOW-ON MAINTENANCE

1. Connect battery ground cables. (WP 0350)
2. Fill coolant. (WP 0287)
3. Install surge tank cap. (TM 9-2320-272-10)
4. Start engine and check for leaks at water manifold. Check temperature gauge for proper operation. (TM 9-2320-272-10)
5. Install right splash shield. (TM 9-2320-272-10)

END OF TASK**END OF WORK PACKAGE**

FIELD MAINTENANCE
STOPLIGHT SWITCH REPLACEMENT

INITIAL SETUP:**Tools and Special Tools**

Tool Kit, General Mechanic's: Automotive
(Volume 5, WP 0826, Table 1, Item 56)

Equipment Condition (cont.)

Air reservoirs drained. (TM 9-2320-272-10)
Battery ground cables disconnected. (WP 0350)

Materials/Parts

Tape, Antiseizing
(Volume 5, WP 0825, Table 1, Item 65)

Equipment Condition

Parking brake set. (TM 9-2320-272-10)

REMOVAL**NOTE**

Tag wires for installation.

1. Disconnect two wires (Figure 1, Item 1) from stoplight switch (Figure 1, Item 2).
2. Remove stoplight switch (Figure 1, Item 2) from double check valve (Figure 1, Item 3).

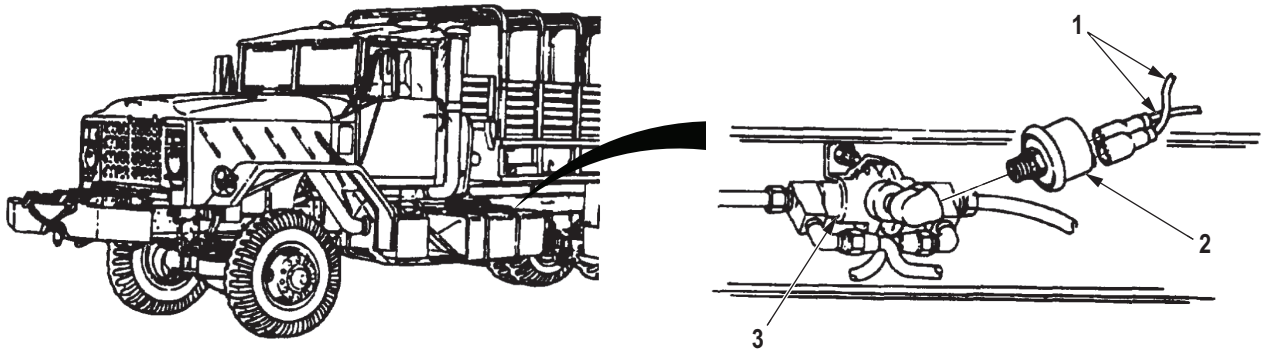

M0253DAA

Figure 1. Stoplight Switch Removal.

END OF TASK

INSTALLATION**NOTE**

Male pipe threads must be wrapped with antiseize tape before installation.

1. Install stoplight switch (Figure 2, Item 2) on double check valve (Figure 2, Item 3).
2. Connect two wires (Figure 2, Item 1) to stoplight switch (Figure 2, Item 2).

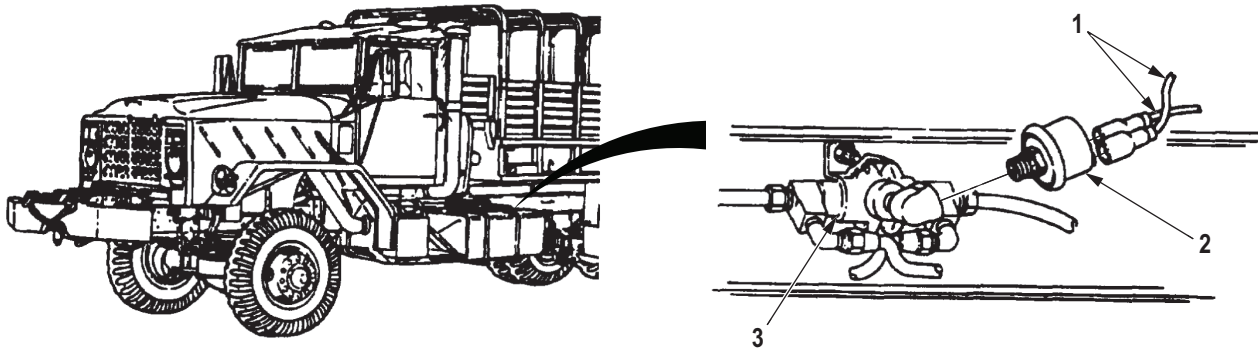

M0254DAA

Figure 2. Stoplight Switch Installation.

END OF TASK**FOLLOW-ON MAINTENANCE**

1. Connect battery ground cables. (WP 0350)
2. Start engine and allow air pressure to build up to normal operating range. Check for air leaks at switch. (TM 9-2320-272-10)
3. Check stoplights for proper operation. (TM 9-2320-272-10)

END OF TASK**END OF WORK PACKAGE**

**FIELD MAINTENANCE
FAILSAFE WARNING MODULE REPLACEMENT**

INITIAL SETUP:**Tools and Special Tools**

Tool Kit, General Mechanic's: Automotive
(Volume 5, WP 0826, Table 1, Item 56)

Equipment Condition

Parking brake set. (TM 9-2320-272-10)
Battery ground cables disconnected. (WP 0350)

REMOVAL

1. Disconnect harness connector (Figure 1, Item 2) from failsafe warning module (Figure 1, Item 6).
2. Remove screw (Figure 1, Item 5), ground wire (Figure 1, Item 4), and washer (Figure 1, Item 3) from right side of failsafe warning module (Figure 1, Item 6).
3. Remove screw (Figure 1, Item 7), washer (Figure 1, Item 8), and failsafe warning module (Figure 1, Item 6) from left side cowl (Figure 1, Item 1).

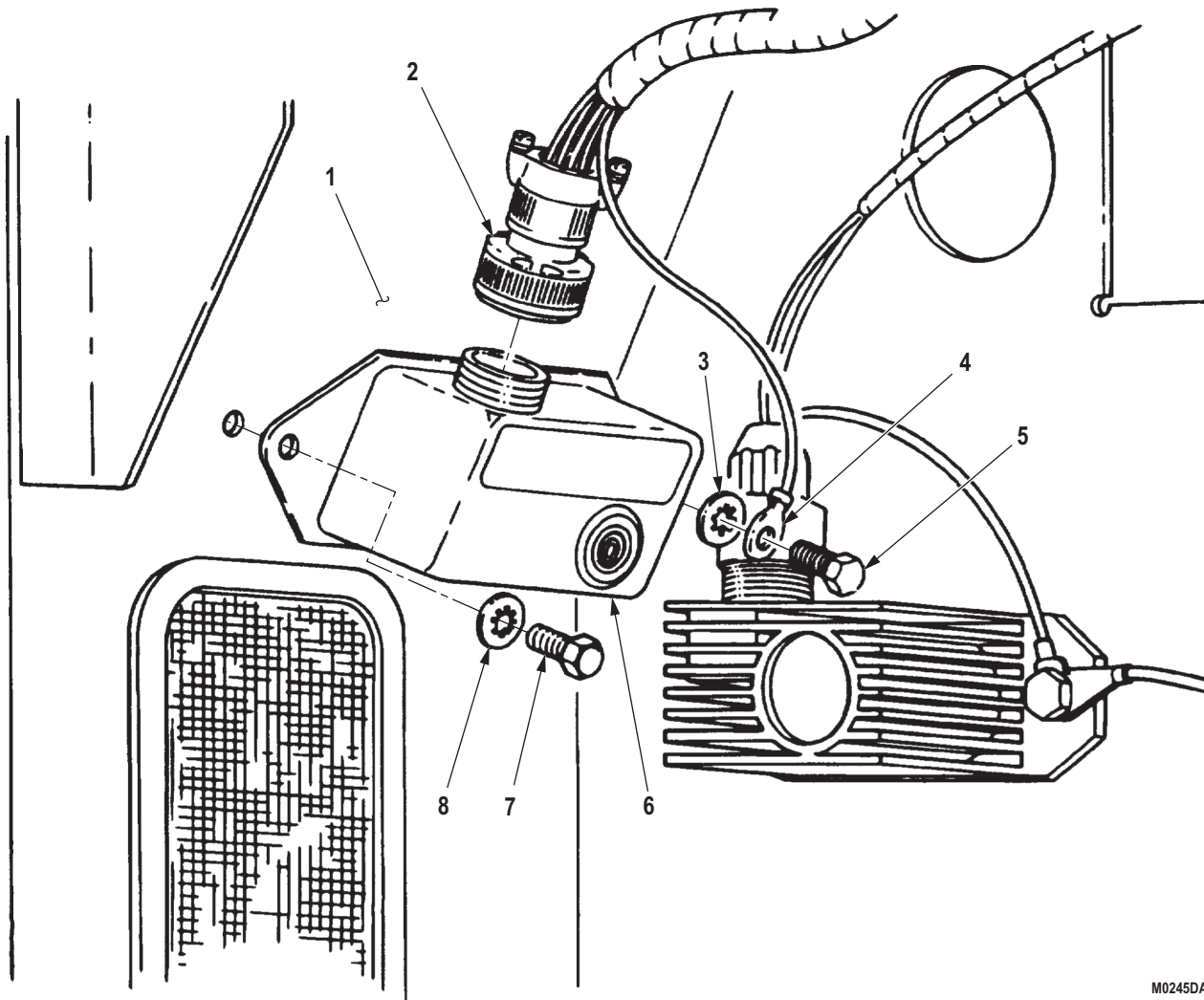

M0245DAA

Figure 1. Failsafe Warning Module Removal.

END OF TASK

INSTALLATION

1. Install failsafe warning module (Figure 2, Item 6) on cowl (Figure 2, Item 1) with washer (Figure 2, Item 8) and screw (Figure 2, Item 7).
2. Install washer (Figure 2, Item 3) and ground wire (Figure 2, Item 4) on failsafe warning module (Figure 2, Item 6) with screw (Figure 2, Item 5).
3. Connect harness connector (Figure 2, Item 2) to failsafe warning module (Figure 2, Item 6).

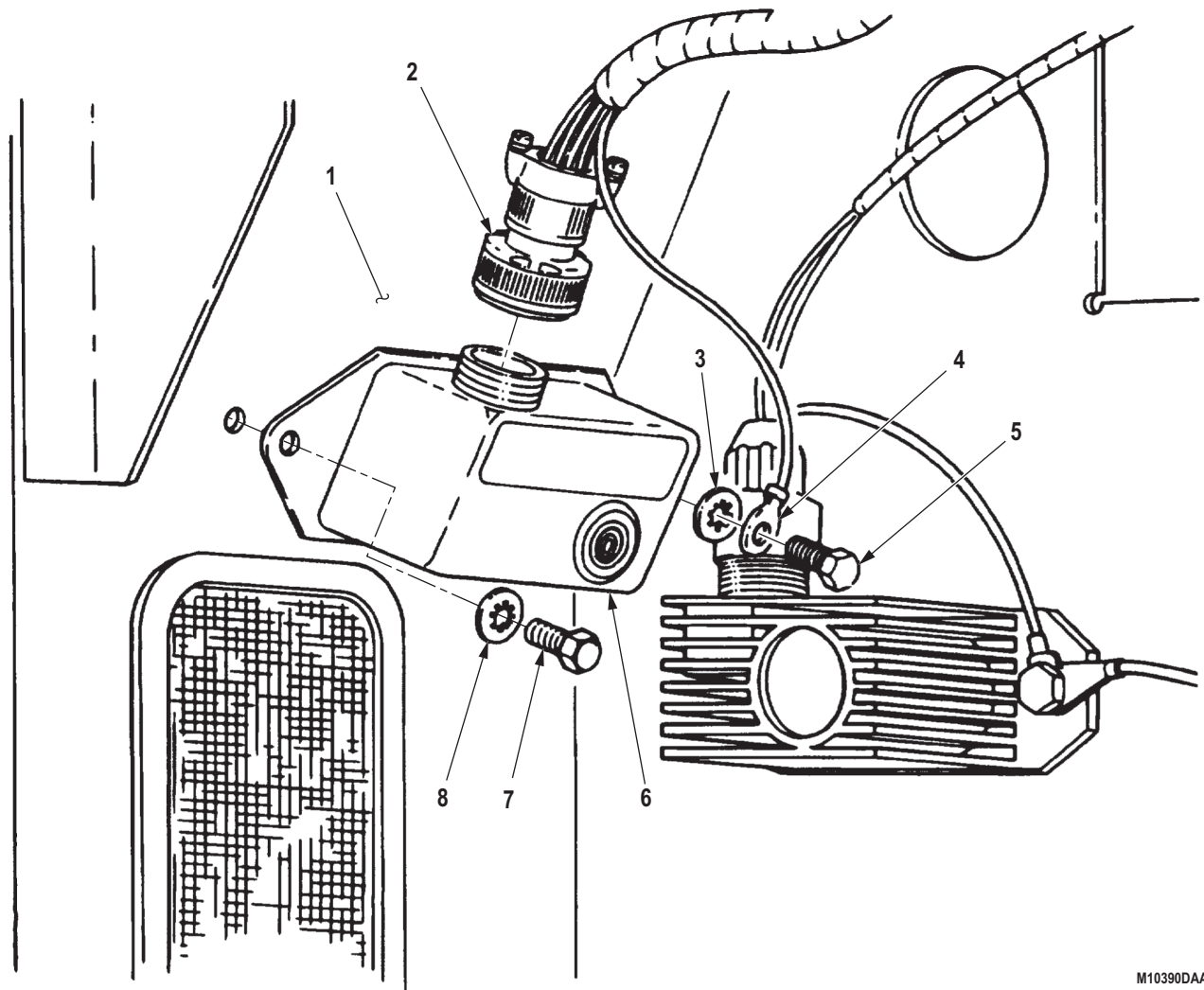

M10390DAA

Figure 2. Failsafe Warning Module Installation.

END OF TASK

FOLLOW-ON MAINTENANCE

1. Connect battery ground cables. (WP 0350)
2. Start engine and check failsafe warning module for proper operation. (TM 9-2320-272-10)

END OF TASK**END OF WORK PACKAGE**

**FIELD MAINTENANCE
ETHER START FUEL PRESSURE SWITCH REPLACEMENT**

INITIAL SETUP:**Tools and Special Tools**

Tool Kit, General Mechanic's: Automotive
(Volume 5, WP 0826, Table 1, Item 56)

Equipment Condition (cont.)

Left splash shield removed. (TM 9-2320-272-10)
Battery ground cables disconnected. (WP 0350)

Equipment Condition

Parking brake set. (TM 9-2320-272-10)

REMOVAL**NOTE**

- Have drainage container ready to catch fuel.
 - Use drain pans to retain leaking/draining fluids. Refer to local procedures and plans for preventing and responding to fluid spills or leaks. Comply with local regulations when disposing of clean up material and leaked and spilled fluids.
1. Disconnect two wires (Figure 1, Item 2) from ether start fuel pressure switch (Figure 1, Item 3).
 2. Remove ether start fuel pressure switch (Figure 1, Item 3) from bottom of fuel pump (Figure 1, Item 1).

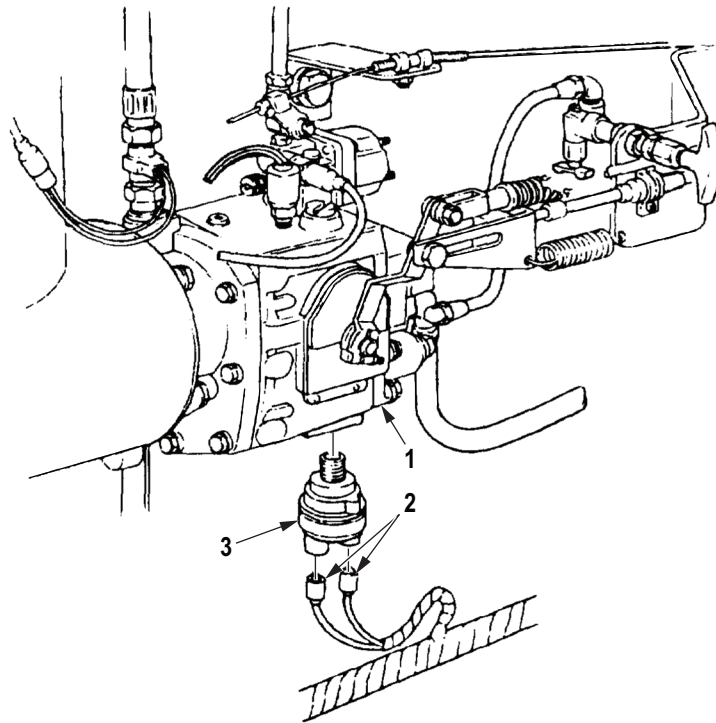
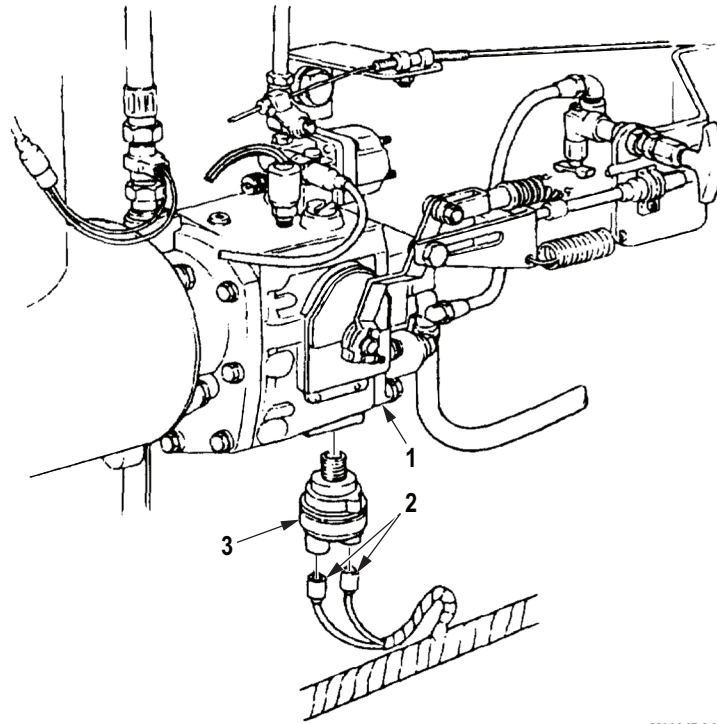

Figure 1. Ether Start Fuel Pressure Switch Removal.

END OF TASK

INSTALLATION

1. Install ether start fuel pressure switch (Figure 2, Item 3) on bottom of fuel pump (Figure 2, Item 1).
2. Connect two wires (Figure 2, Item 2) to ether start fuel pressure switch (Figure 2, Item 3).



M0084DAA

Figure 2. Ether Start Fuel Pressure Switch Installation.

END OF TASK**FOLLOW-ON MAINTENANCE**

1. Connect battery ground cables. (WP 0350)
2. Install left splash shield. (TM 9-2320-272-10)

END OF TASK**END OF WORK PACKAGE**

**FIELD MAINTENANCE
TACHOMETER PULSE SENSOR REPLACEMENT**

INITIAL SETUP:

Tools and Special Tools

Tool Kit, General Mechanic's: Automotive
(Volume 5, WP 0826, Table 1, Item 56)

Equipment Condition

Parking brake set. (TM 9-2320-272-10)
Battery ground cables disconnected. (WP 0350)

REMOVAL

1. Disconnect tachometer pulse sender connector (Figure 1, Item 1) from pulse sender receptacle (Figure 1, Item 6).
2. Remove tachometer cable (Figure 1, Item 2) from tachometer pulse sender (Figure 1, Item 3).
3. Remove tachometer pulse sender (Figure 1, Item 3) from adapter fitting (Figure 1, Item 5).
4. Remove drive tip (Figure 1, Item 4) from adapter fitting (Figure 1, Item 5).

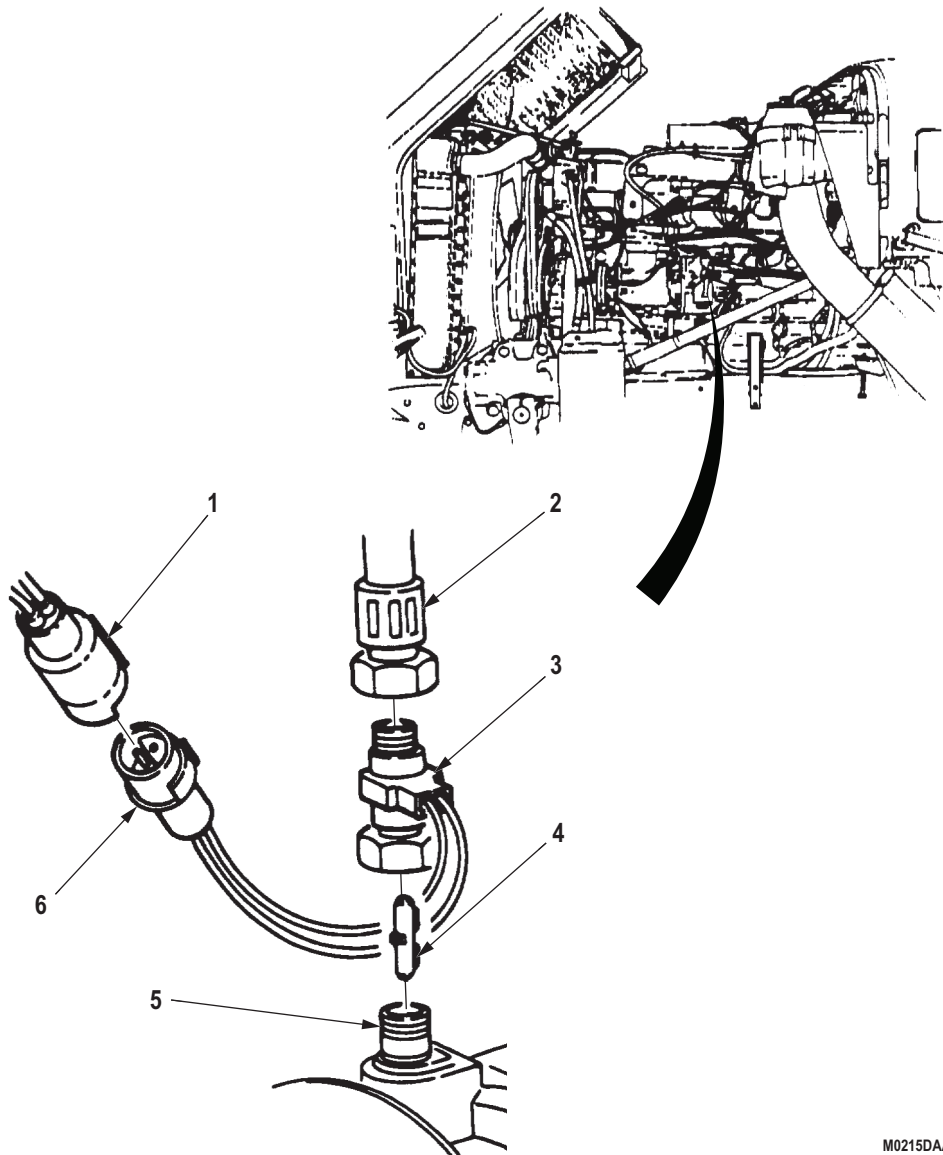
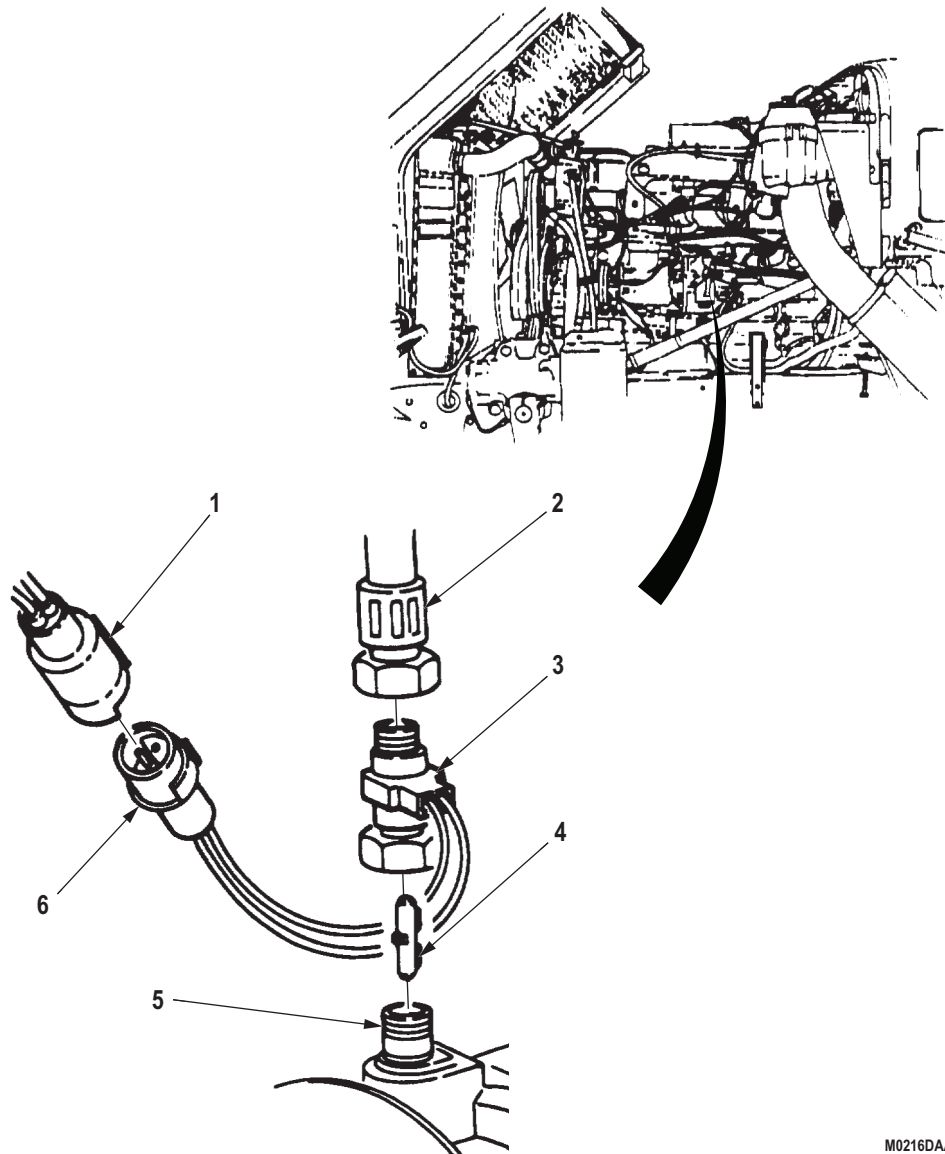

Figure 1. Tachometer Pulse Sender Removal.

END OF TASK

INSTALLATION

1. Install drive tip (Figure 2, Item 4) on adapter fitting (Figure 2, Item 5).
2. Install tachometer pulse sender (Figure 2, Item 3) on adapter fitting (Figure 2, Item 5).
3. Install tachometer cable (Figure 2, Item 2) on tachometer pulse sender (Figure 2, Item 3).
4. Connect tachometer pulse sender connector (Figure 2, Item 1) to pulse sender receptacle (Figure 2, Item 6).



M0216DAA

*Figure 2. Tachometer Pulse Sender Installation.***END OF TASK**

FOLLOW-ON MAINTENANCE

1. Connect battery ground cables. (WP 0350)
2. Start engine and test tachometer for proper operation. (TM 9-2320-272-10)

END OF TASK**END OF WORK PACKAGE**

FIELD MAINTENANCE
TACHOMETER PULSE SENSOR REPLACEMENT (M939A2)

INITIAL SETUP:**Tools and Special Tools**

Tool Kit, General Mechanic's: Automotive
(Volume 5, WP 0826, Table 1, Item 56)

Equipment Condition (cont.)

Hood raised and secured. (TM 9-2320-272-10)
Battery ground cable disconnected. (WP 0350)

Equipment Condition

Parking brake set. (TM 9-2320-272-10)

REMOVAL

1. Remove eight screws (Figure 1, Item 3) and pull instrument cluster (Figure 1, Item 2) from instrument panel (Figure 1, Item 1).
2. Disconnect tachometer drive cable (Figure 1, Item 8) from tachometer pulse sensor (Figure 1, Item 7).
3. Disconnect plug (Figure 1, Item 4) from connector (Figure 1, Item 5).
4. Disconnect tachometer pulse sensor (Figure 1, Item 7) from tachometer gauge (Figure 1, Item 6).

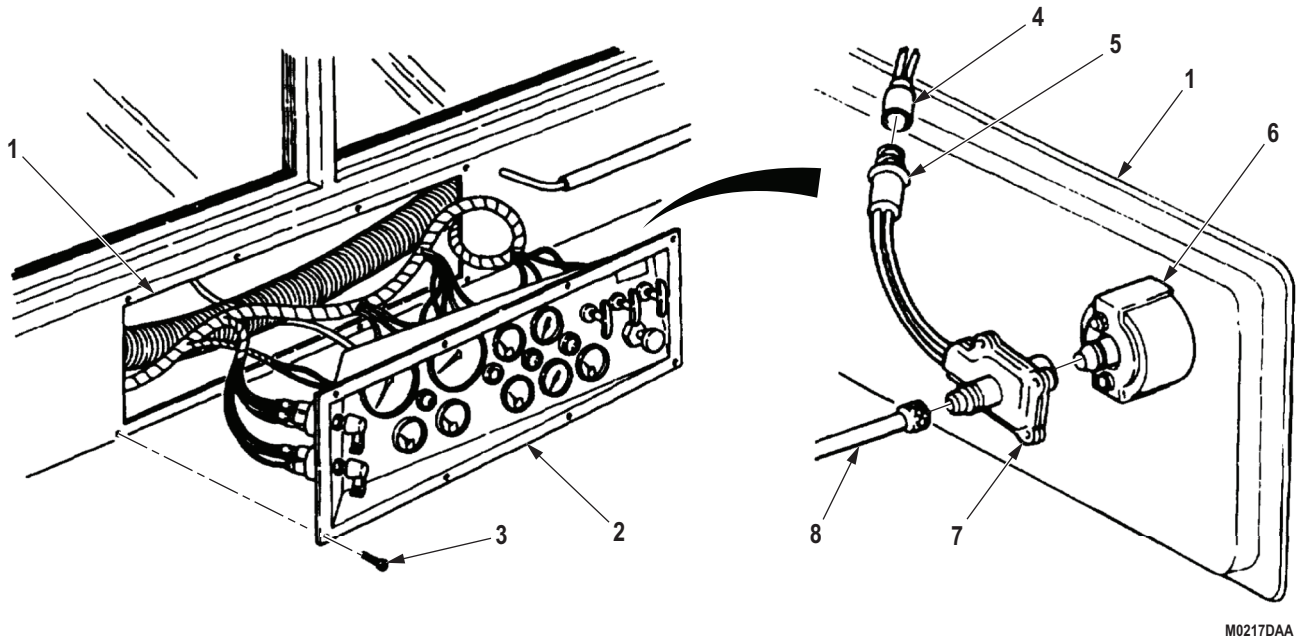

M0217DAA

Figure 1. Tachometer Pulse Sender Removal.

END OF TASK

INSTALLATION

1. Connect tachometer pulse sensor (Figure 2, Item 7) on tachometer gauge (Figure 2, Item 6).
2. Connect plug (Figure 2, Item 4) to connector (Figure 2, Item 5).
3. Connect tachometer drive cable (Figure 2, Item 8) to tachometer pulse sensor (Figure 2, Item 7).
4. Install instrument cluster (Figure 2, Item 2) on instrument panel (Figure 2, Item 1) with eight screws (Figure 2, Item 3).

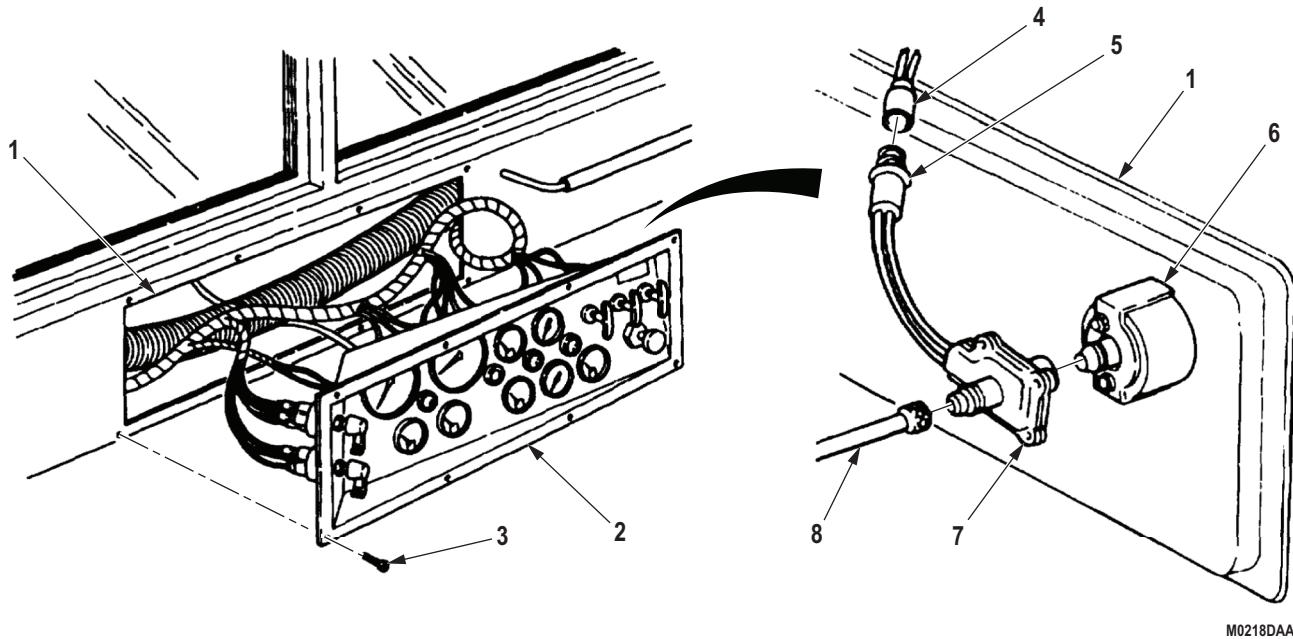

Figure 2. Tachometer Pulse Sender Installation.

END OF TASK**FOLLOW-ON MAINTENANCE**

1. Connect battery ground cables. (WP 0350)
2. Start engine and test tachometer for proper operation. (TM 9-2320-272-10)

END OF TASK**END OF WORK PACKAGE**

**FIELD MAINTENANCE
FUEL PRESSURE TRANSDUCER REPLACEMENT**

INITIAL SETUP:**Tools and Special Tools**

Tool Kit, General Mechanic's: Automotive
(Volume 5, WP 0826, Table 1, Item 56)

Equipment Condition (cont.)

Left splash shield removed. (TM 9-2320-272-10)
Battery ground cables disconnected. (WP 0350)

Materials/Parts

Tape, Antiseizing
(Volume 5, WP 0825, Table 1, Item 65)

Equipment Condition

Parking brake set. (TM 9-2320-272-10)

REMOVAL

1. Disconnect fuel pressure transducer connector (Figure 1, Item 4) from harness wire (Figure 1, Item 1).
2. Remove fuel pressure transducer (Figure 1, Item 2) from fuel pump (Figure 1, Item 3).

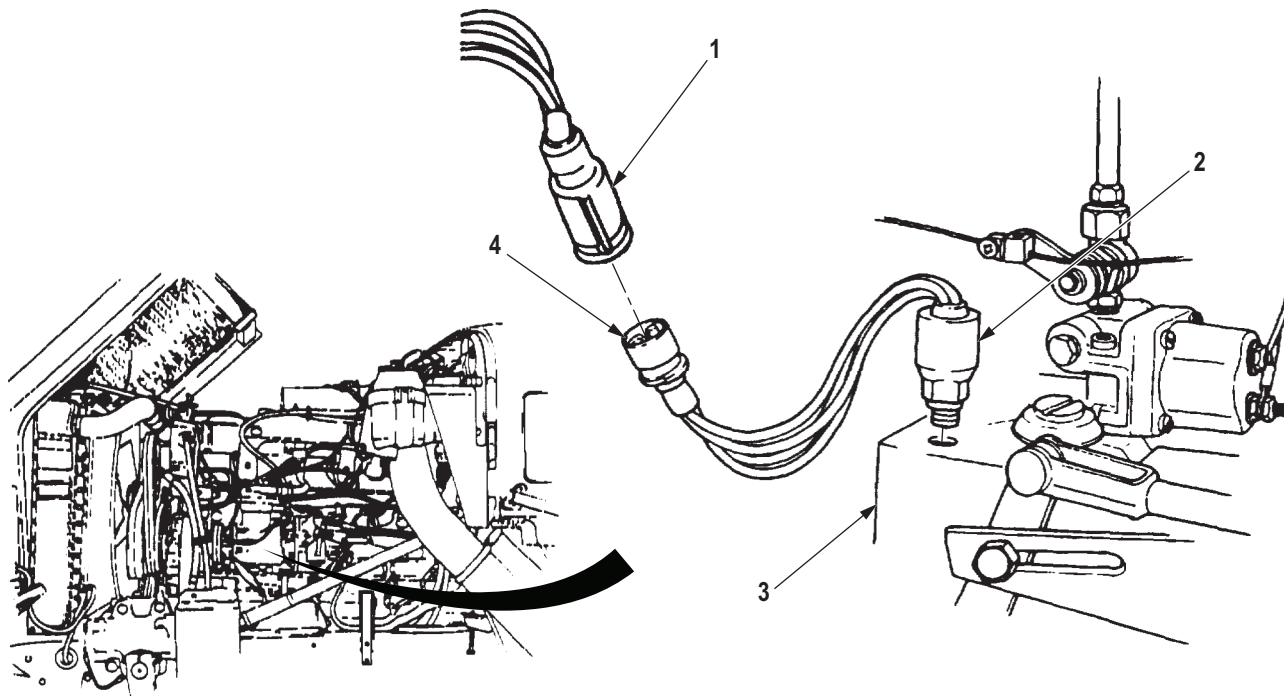

M0219DAA

Figure 1. Fuel Pressure Transducer Removal.

END OF TASK

INSTALLATION**NOTE**

Male pipe threads must be wrapped with antiseize tape before installation.

1. Install fuel pressure transducer (Figure 2, Item 2) on fuel pump (Figure 2, Item 3).
2. Connect fuel pressure transducer connector (Figure 2, Item 4) to harness wire (Figure 2, Item 1).

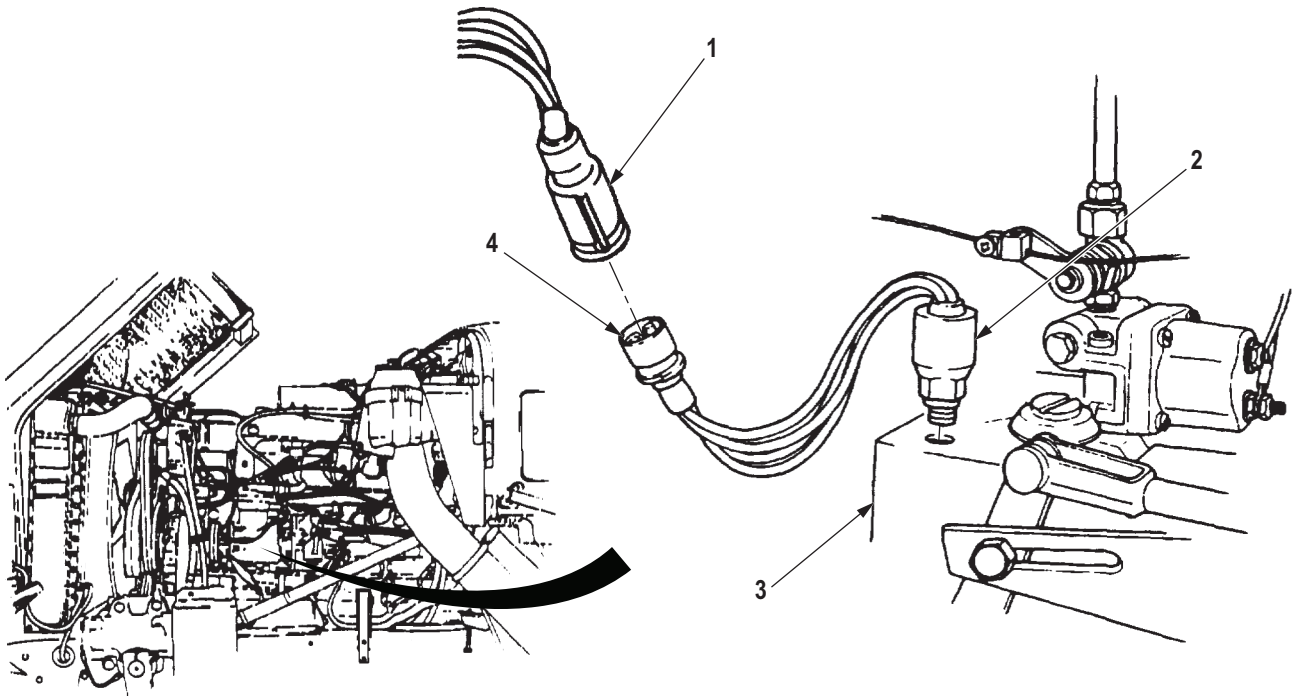

M0220DAA

Figure 2. Fuel Pressure Transducer Installation.

END OF TASK**FOLLOW-ON MAINTENANCE**

1. Connect battery ground cables. (WP 0350)
2. Start engine and check fuel pressure gauge for proper operation. (TM 9-2320-272-10)
3. Install left splash shield. (TM 9-2320-272-10)

END OF TASK**END OF WORK PACKAGE**

FIELD MAINTENANCE
TRANSMISSION TEMPERATURE TRANSMITTER REPLACEMENT

INITIAL SETUP:**Tools and Special Tools**

Tool Kit, General Mechanic's: Automotive
(Volume 5, WP 0826, Table 1, Item 56)

Equipment Condition

Parking brake set. (TM 9-2320-272-10)
Battery ground cables disconnected. (WP 0350)

REMOVAL**NOTE**

Access to transmitter can be gained through access plate on cab floor.

1. Disconnect wire (Figure 1, Item 1) from temperature transmitter (Figure 1, Item 2).
2. Remove temperature transmitter (Figure 1, Item 2) from transmission adapter fitting (Figure 1, Item 3).

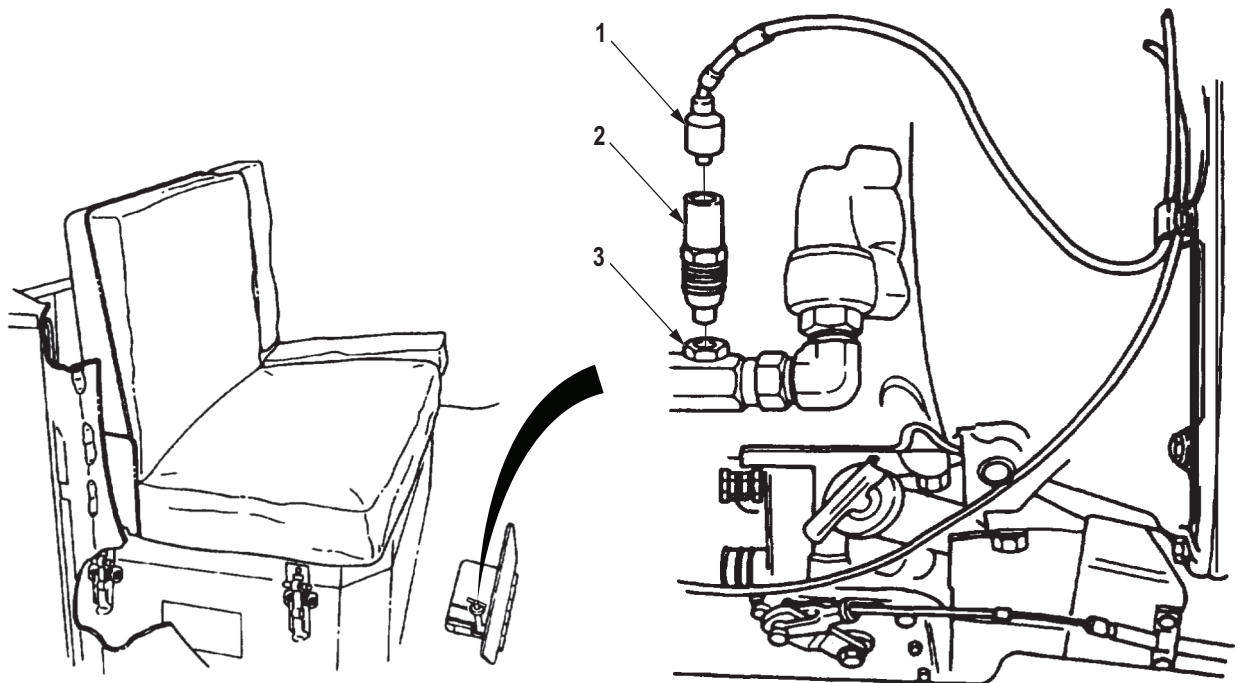

M0221DAA

Figure 1. Transmission Temperature Transmitter Removal.

END OF TASK

INSTALLATION

1. Install temperature transmitter (Figure 2, Item 2) on transmission adapter fitting (Figure 2, Item 3).
2. Connect wire (Figure 2, Item 1) to temperature transmitter (Figure 2, Item 2).

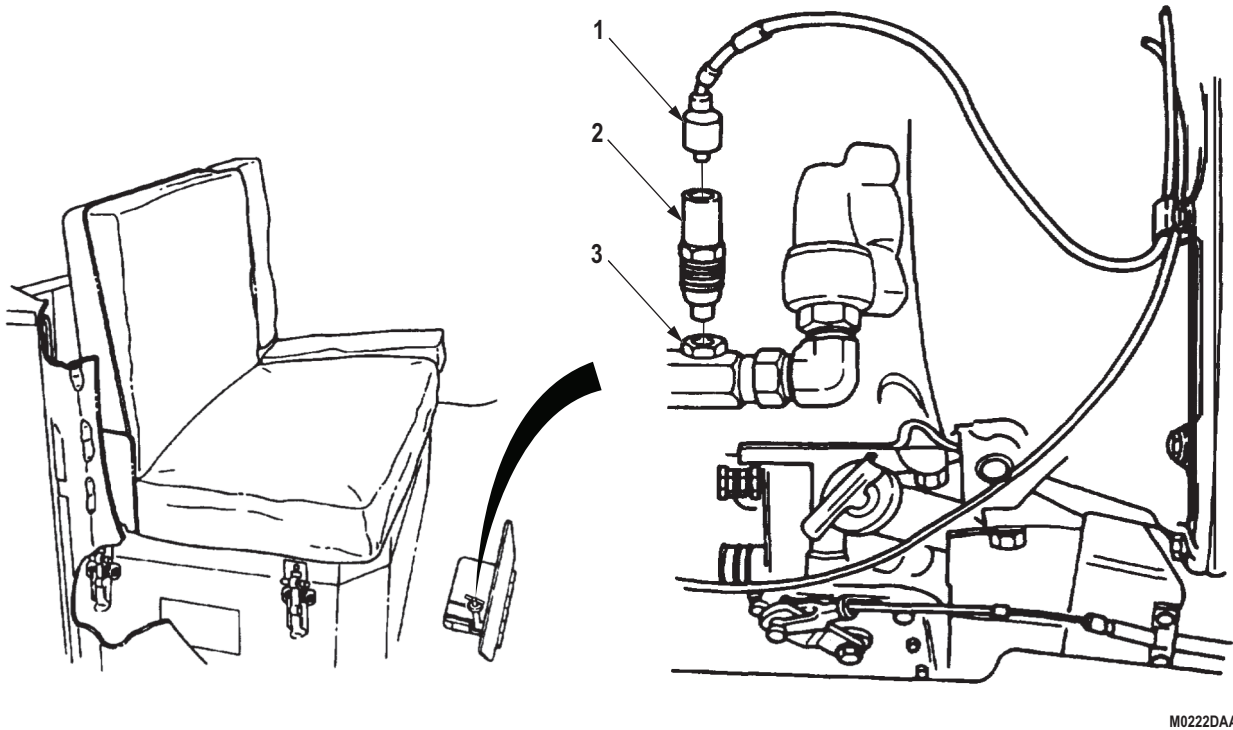

Figure 2. Transmission Temperature Transmitter Installation.

END OF TASK**FOLLOW-ON MAINTENANCE**

1. Connect battery ground cables. (WP 0350)
2. Start engine and check transmission temperature gauge operation. (TM 9-2320-272-10)

END OF TASK**END OF WORK PACKAGE**

**FIELD MAINTENANCE
PRIMARY AND SECONDARY LOW AIR PRESSURE SWITCH REPLACEMENT**

INITIAL SETUP:**Tools and Special Tools**

Tool Kit, General Mechanic's: Automotive
(Volume 5, WP 0826, Table 1, Item 56)

Equipment Condition (cont.)

Air reservoirs drained. (TM 9-2320-272-10)
Battery ground cables disconnected. (WP 0350)

Materials/Parts

Tape, Antiseizing
(Volume 5, WP 0825, Table 1, Item 65)

Personnel Required

(2)

Equipment Condition

Parking brake set. (TM 9-2320-272-10)

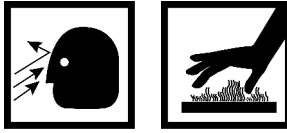
PRIMARY SWITCH REMOVAL**WARNING**

- Do not disconnect air lines before draining air reservoirs. Small parts under pressure may shoot out with high velocity. Failure to comply may result in injury or death to personnel.
- Do not touch hot exhaust system components with bare hands. Failure to comply may result in injury or death to personnel.

NOTE

Tag wires for installation.

1. Disconnect wires (Figure 1, Item 1) and (Figure 1, Item 2) from primary low air pressure switch (Figure 1, Item 5).
2. Remove low air pressure switch (Figure 1, Item 5) and adapter fitting (Figure 1, Item 4) from adapter elbow (Figure 1, Item 3).

PRIMARY SWITCH REMOVAL - Continued

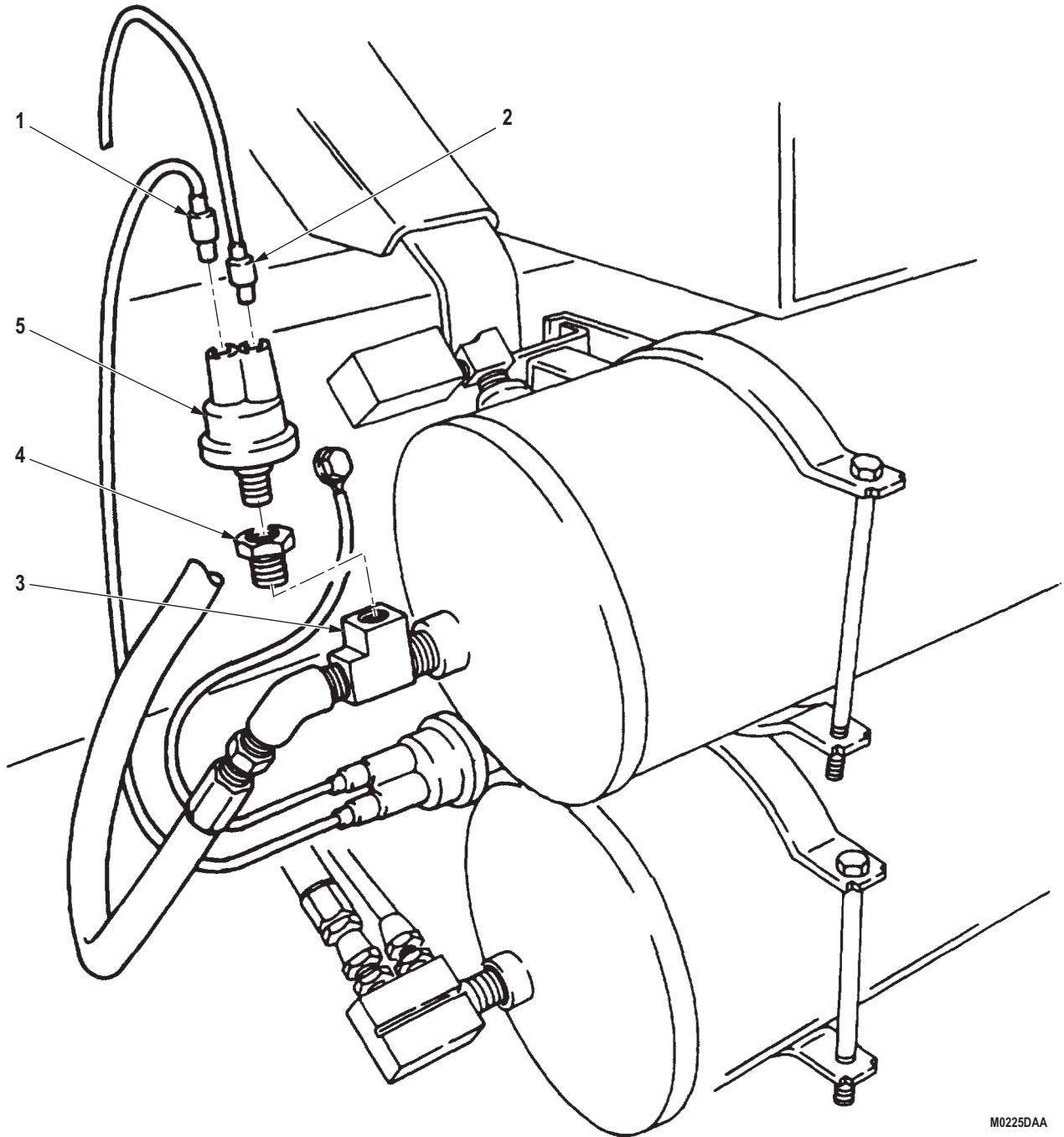

M0225DAA

Figure 1. Primary and Secondary Air Pressure Removal.

END OF TASK

PRIMARY SWITCH INSTALLATION**NOTE**

Male pipe threads must be wrapped with antiseize tape before installation.

1. Install adapter fitting (Figure 2, Item 4) and low air pressure switch (Figure 2, Item 5) on adapter elbow (Figure 2, Item 3).
2. Connect wires (Figure 2, Item 1) and (Figure 2, Item 2) to primary low air pressure switch (Figure 2, Item 5).

PRIMARY SWITCH INSTALLATION - Continued

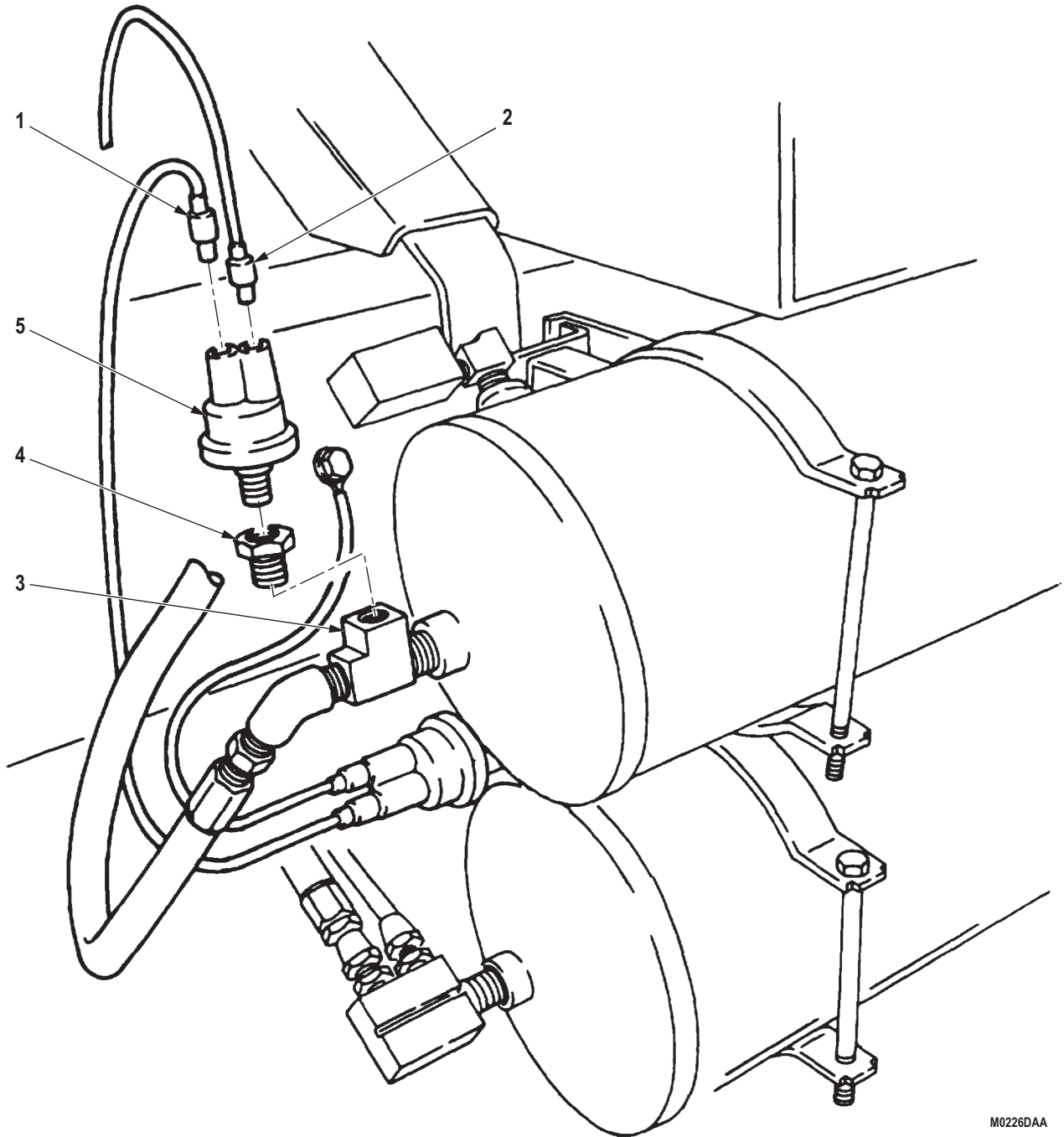

M0226DAA

Figure 2. Primary and Secondary Air Pressure Removal.

END OF TASK

SECONDARY SWITCH REMOVAL**NOTE**

Tag wires for installation.

1. Disconnect wire (Figure 3, Item 8) and ground wire (Figure 3, Item 1) from secondary low air pressure switch (Figure 3, Item 7).

NOTE

Assistant will help with Steps (2) and (3).

2. Remove two nuts (Figure 3, Item 4) and screws (Figure 3, Item 3) from secondary air reservoir (Figure 3, Item 5).
3. Push and rotate secondary air reservoir (Figure 3, Item 5) toward rear of vehicle.
4. Remove secondary low air pressure switch (Figure 3, Item 7) and adapter fitting (Figure 3, Item 6) from adapter elbow (Figure 3, Item 2).

SECONDARY SWITCH REMOVAL - Continued

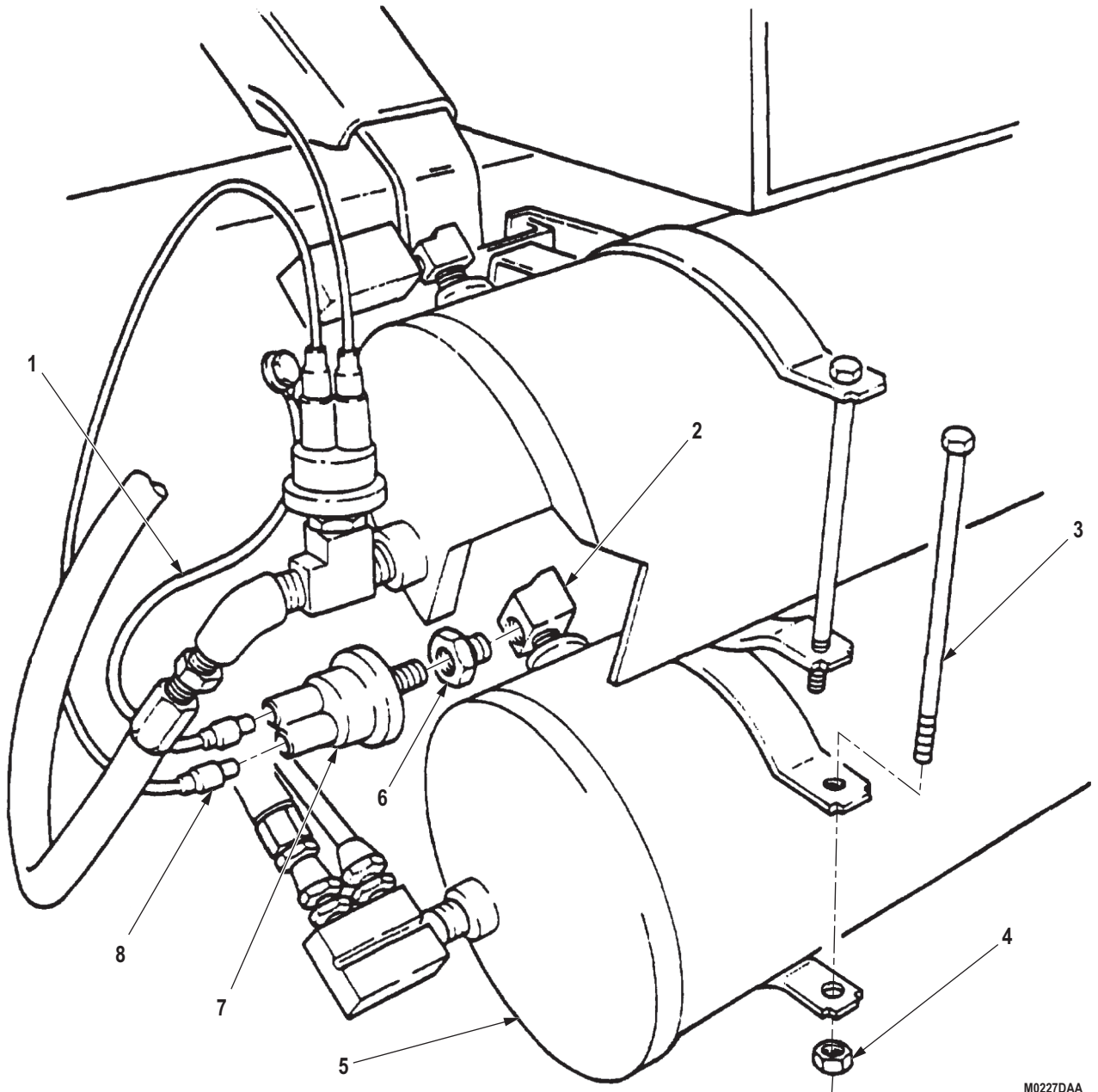

M0227DAA

Figure 3. Primary and Secondary Air Pressure Removal.

END OF TASK

SECONDARY SWITCH INSTALLATION**NOTE**

Male pipe threads must be wrapped with antiseize tape before installation.

1. Install adapter fitting (Figure 4, Item 6) and secondary low air pressure switch (Figure 4, Item 7) on adapter elbow (Figure 4, Item 2).

NOTE

Assistant will help with Step (2).

2. Install two screws (Figure 4, Item 3) and nuts (Figure 4, Item 4) on secondary air reservoir (Figure 4, Item 5).
3. Connect wire (Figure 4, Item 8) and ground wire (Figure 4, Item 1) to secondary low air pressure switch (Figure 4, Item 7).

SECONDARY SWITCH INSTALLATION - Continued

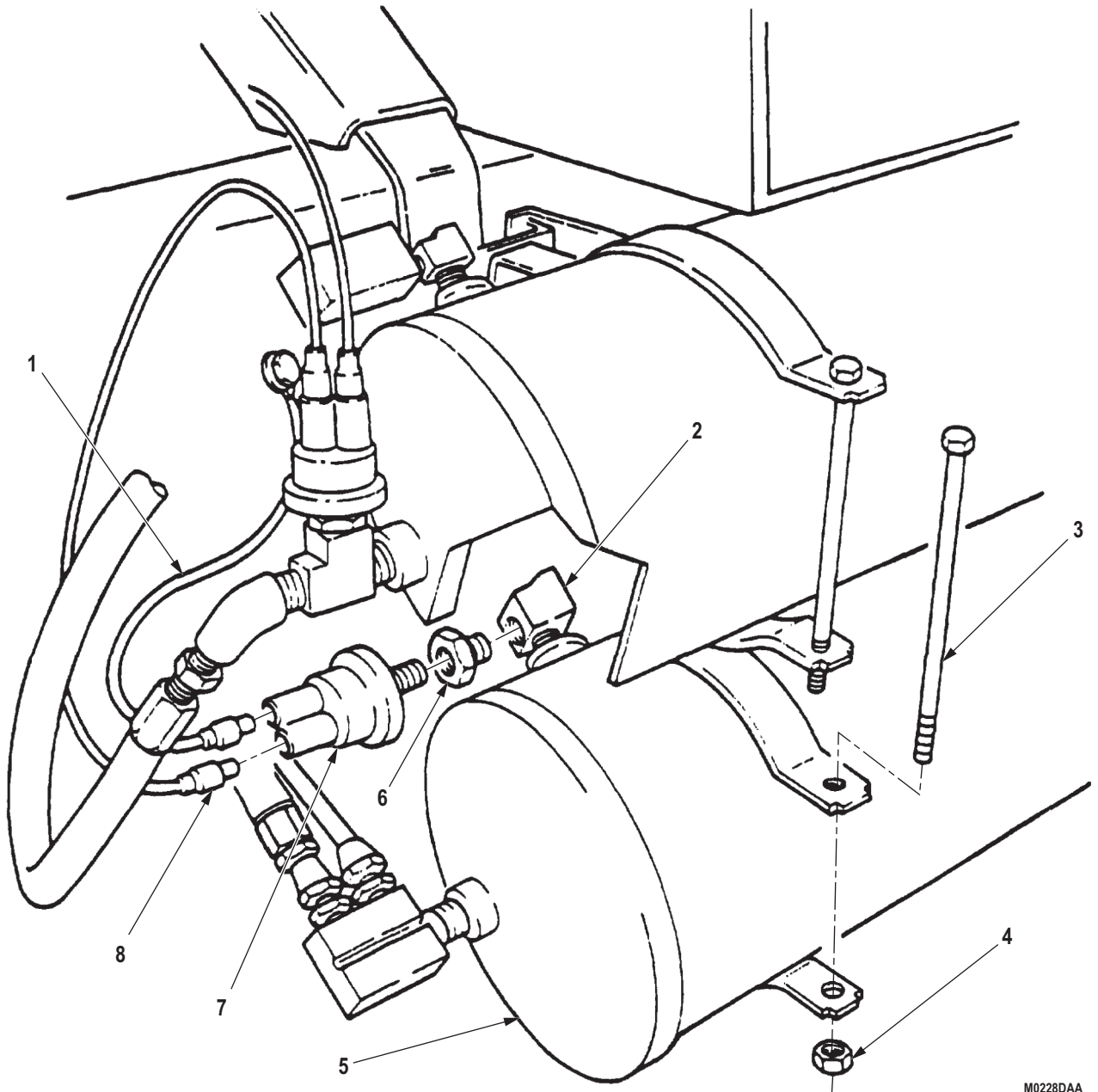

M0228DAA

Figure 4. Primary and Secondary Air Pressure Installation.

END OF TASK

FOLLOW-ON MAINTENANCE

1. Connect battery ground cables. (WP 0350)
2. Start engine and allow air pressure to build up to normal operating range. Check for air leaks at switch. Check if air pressure warning light and buzzer stop operating when air pressure has built up to 60 psi (413 kPa). (TM 9-2320-272-10)

END OF TASK**END OF WORK PACKAGE**

**FIELD MAINTENANCE
HORN, SOLENOID, AND BRACKET REPLACEMENT**

INITIAL SETUP:**Tools and Special Tools**

Tool Kit, General Mechanic's: Automotive
(Volume 5, WP 0826, Table 1, Item 56)

Personnel Required

(2)

Materials/Parts

Tape, Antiseizing
(Volume 5, WP 0825, Table 1, Item 65)
Lockwasher
(Volume 5, WP 0827, Table 1, Item 384)
Qty: 2

Equipment Condition

Parking brake set. (TM 9-2320-272-10)
Air reservoirs drained. (TM 9-2320-272-10)
Hood raised and secured. (TM 9-2320-272-10)
Battery ground cables disconnected. (WP 0350)

REMOVAL

1. Disconnect wires (Figure 1, Items 6 and 7) from horn solenoid (Figure 1, Item 5).

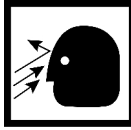
WARNING

Do not disconnect air lines or hoses before draining air reservoirs. Small parts under pressure may shoot out with high velocity. Failure to comply may result in injury or death to personnel.

2. Disconnect air line (Figure 1, Item 4) from elbow (Figure 1, Item 3).
3. Remove elbow (Figure 1, Item 3) from horn solenoid (Figure 1, Item 6).

NOTE

Horn solenoid fitting may become disconnected from horn solenoid during removal. Horn solenoid and fitting are replaced as an assembly.

4. Remove horn solenoid (Figure 1, Item 6) from horn (Figure 1, Item 2).
5. Remove two nuts (Figure 1, Item 10), wire (Figure 1, Item 9), two lockwashers (Figure 1, Item 11), screws (Figure 1, Item 1), and horn (Figure 1, Item 2) from bracket (Figure 1, Item 14). Discard lockwashers.

NOTE

- Assistant will help with Step (6).
 - Pull insulation away from inside cab firewall to allow access to nut.
6. Remove screw-assembled washer (Figure 1, Item 8), nut (Figure 1, Item 15), washer (Figure 1, Item 13), screw (Figure 1, Item 12), and bracket (Figure 1, Item 14) from firewall (Figure 1, Item 16).

REMOVAL - Continued

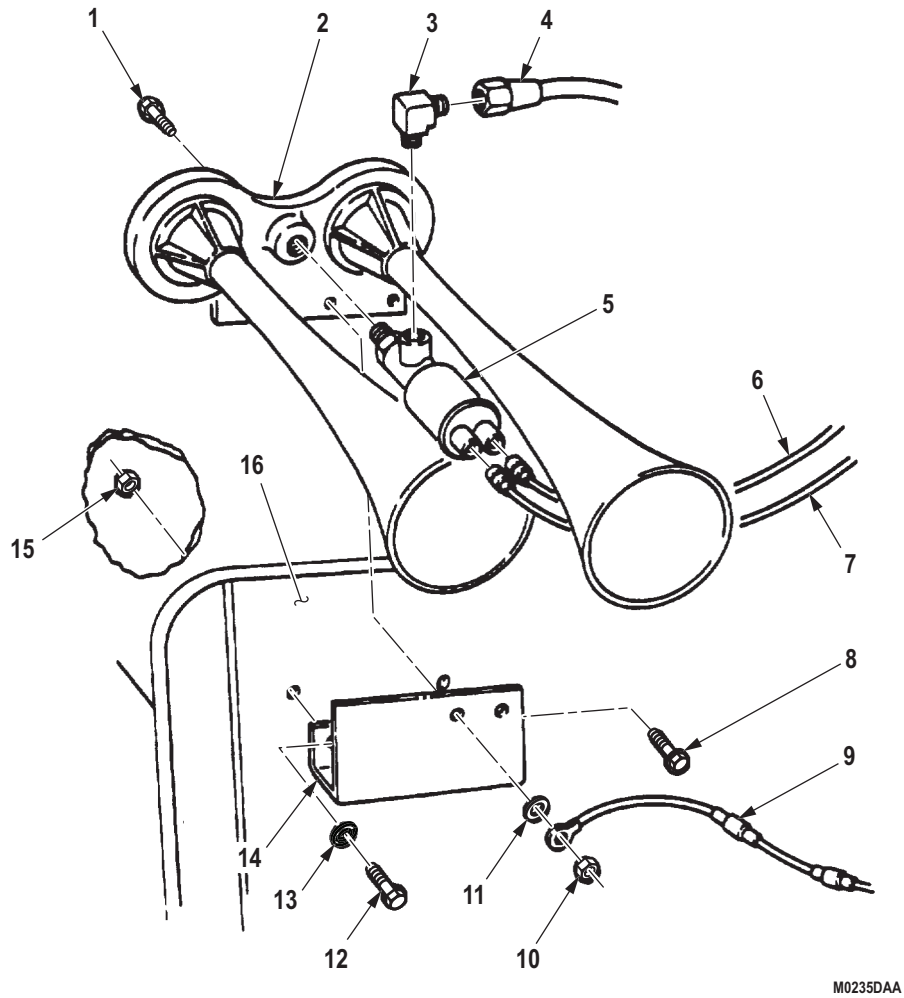

M0235DAA

Figure 1. Horn, Solenoid, and Bracket Removal.

END OF TASK

INSTALLATION**NOTE**

- When new solenoid is installed, fitting from old solenoid may be used. Fitting must be cleaned and inspected for cracks or stripped threads.
 - Male pipe threads must be wrapped with antiseize tape before installation.
 - Assistant will help with Step (1).
1. Install bracket (Figure 2, Item 14) on firewall (Figure 2, Item 16) with washer (Figure 2, Item 13), screw (Figure 2, Item 12), nut (Figure 2, Item 15), and screw-assembled washer (Figure 2, Item 8).
 2. Install horn (Figure 2, Item 2) on bracket (Figure 2, Item 14) with two screws (Figure 2, Item 1), lockwashers (Figure 2, Item 11), wire (Figure 2, Item 9), and two nuts (Figure 2, Item 10).
 3. Install horn solenoid (Figure 2, Item 6) on horn (Figure 2, Item 2).
 4. Install elbow (Figure 2, Item 3) on horn solenoid (Figure 2, Item 6).
 5. Connect air line (Figure 2, Item 4) to elbow (Figure 2, Item 3).
 6. Connect wires (Figure 2, Items 6 and 7) to horn solenoid (Figure 2, Item 5).

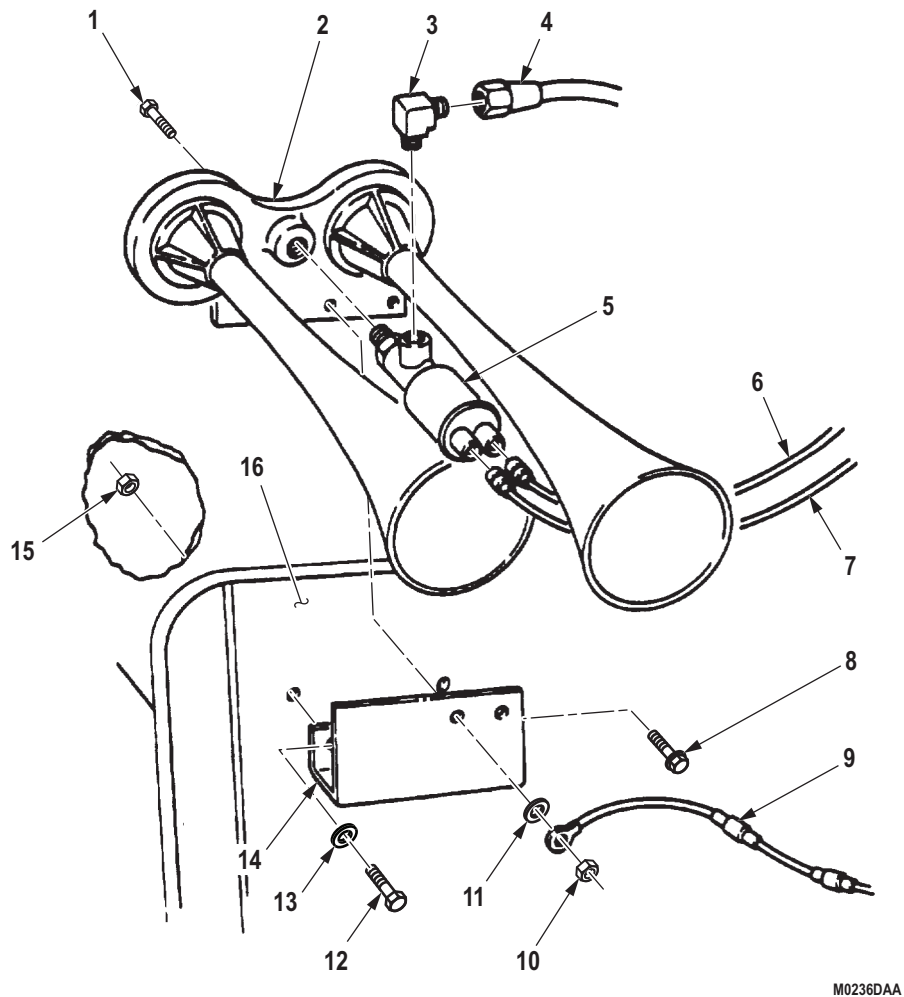
INSTALLATION - Continued

M0236DAA

Figure 2. Horn, Solenoid, and Bracket Installation.

END OF TASK**FOLLOW-ON MAINTENANCE**

1. Connect battery ground cables. (WP 0350)
2. Start engine and allow air pressure to build up to normal operating range. Check for air leaks at horn solenoid. (TM 9-2320-272-10)
3. Check horn for proper operation. (TM 9-2320-272-10)

END OF TASK**END OF WORK PACKAGE**

**FIELD MAINTENANCE
HORN SWITCH REPLACEMENT**

INITIAL SETUP:**Tools and Special Tools**

Tool Kit, General Mechanic's: Automotive
(Volume 5, WP 0826, Table 1, Item 56)

Equipment Condition

Parking brake set. (TM 9-2320-272-10)
Battery ground cables disconnected. (WP 0350)

Materials/Parts

O-ring (Volume 5, WP 0827, Table 1, Item 357)
Qty: 1

REMOVAL

1. Remove three screws (Figure 1, Item 4) and horn switch assembly (Figure 1, Item 2) from steering wheel (Figure 1, Item 9).
2. Disconnect horn switch assembly (Figure 1, Item 2) from electrical lead (Figure 1, Item 8).
3. Remove spring (Figure 1, Item 7) and seat (Figure 1, Item 6) from steering wheel (Figure 1, Item 9).
4. Remove retaining ring (Figure 1, Item 1), horn switch assembly (Figure 1, Item 2), and o-ring (Figure 1, Item 3) from adapter (Figure 1, Item 5). Discard o-ring.

REMOVAL - Continued

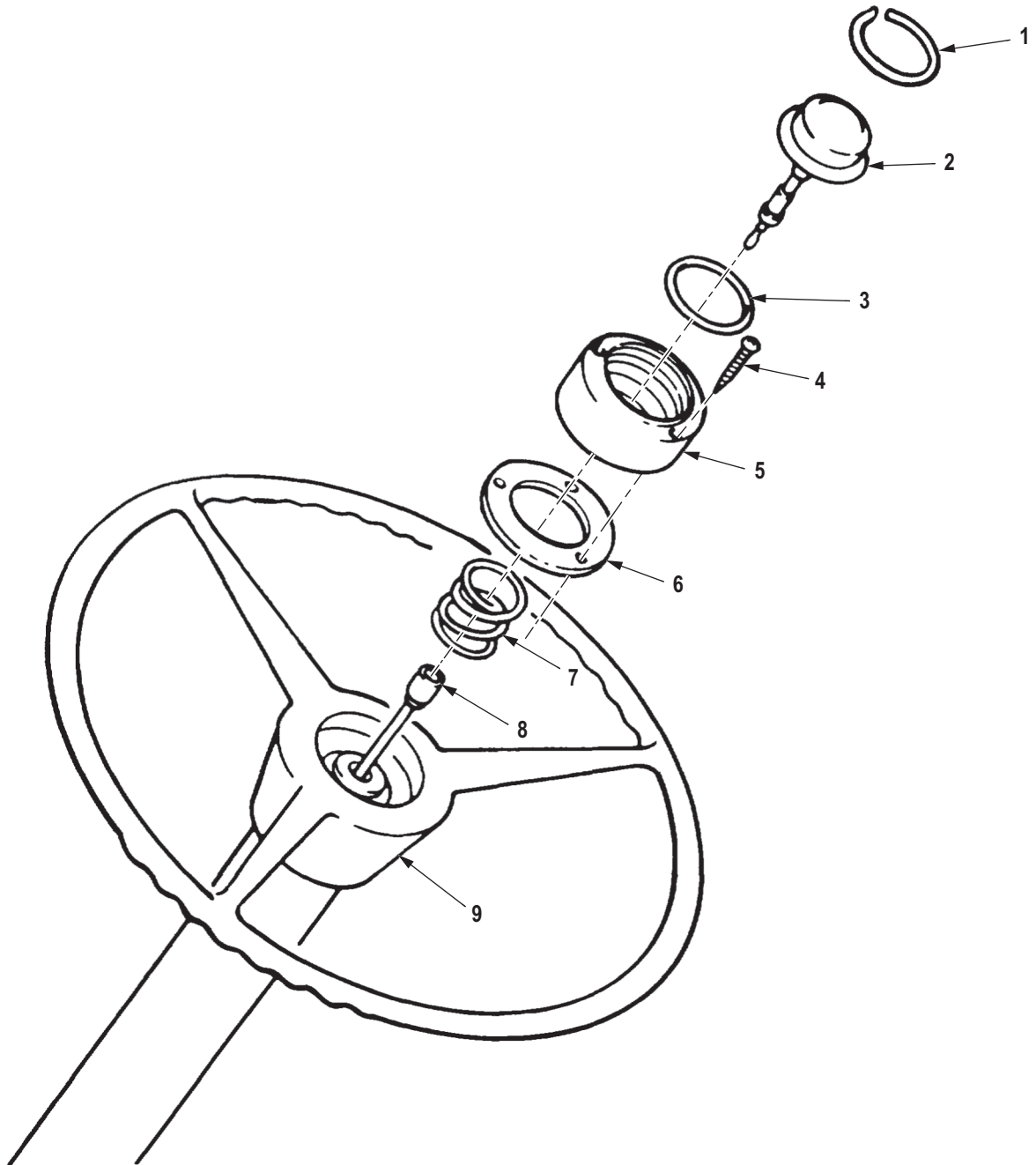

M0237DAA

Figure 1. Horn Switch Removal.

END OF TASK

INSTALLATION

1. Install o-ring (Figure 2, Item 3), horn switch assembly (Figure 2, Item 2), and retaining ring (Figure 2, Item 1) on adapter (Figure 2, Item 5).
2. Install seat (Figure 2, Item 6) and spring (Figure 2, Item 7) in steering wheel (Figure 2, Item 9).
3. Connect horn switch assembly (Figure 2, Item 2) to electrical lead (Figure 2, Item 8).
4. Install horn switch assembly (Figure 2, Item 2) on steering wheel (Figure 2, Item 9) with three screws (Figure 2, Item 4).

INSTALLATION - Continued

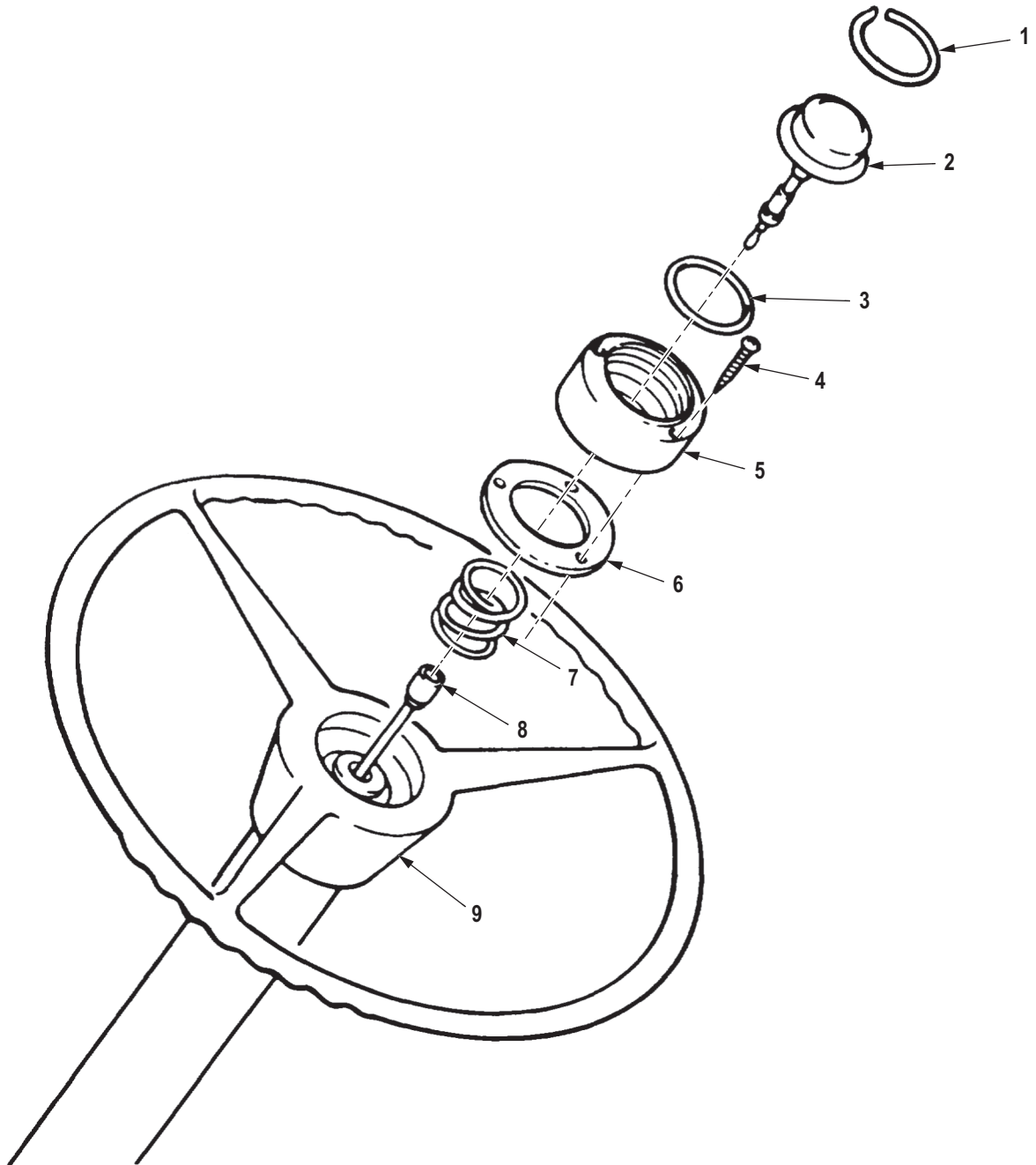

M0238DAA

Figure 2. Horn Switch Installation.

END OF TASK

FOLLOW-ON MAINTENANCE

1. Connect battery ground cables. (WP 0350)
2. Check horn for proper operation. (TM 9-2320-272-10)

END OF TASK**END OF WORK PACKAGE**

**FIELD MAINTENANCE
HORN CONTACT BRUSH REPLACEMENT**

INITIAL SETUP:**Tools and Special Tools**

Tool Kit, General Mechanic's: Automotive
(Volume 5, WP 0826, Table 1, Item 56)

Equipment Condition (cont.)

Left splash shield removed. (TM 9-2320-272-10)
Battery ground cables disconnected. (WP 0350)

Equipment Condition

Parking brake set. (TM 9-2320-272-10)

REMOVAL

1. Loosen two screws (Figure 1, Item 1) and nuts (Figure 1, Item 3) on outer cab firewall (Figure 1, Item 2).

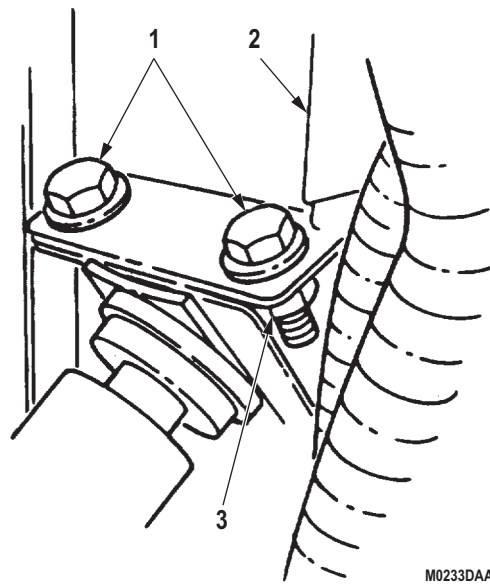

Figure 1. Horn Contact Removal.

REMOVAL - Continued**NOTE**

Step (2) applies to M931 and M932 models only.

2. Loosen two screws (Figure 2, Item 7) on trailer brake control valve bracket (Figure 2, Item 8).
3. Loosen two screws (Figure 2, Item 9) on steering column bracket (Figure 2, Item 10).
4. Turn steering column (Figure 2, Item 18) until contact brush cover (Figure 2, Item 24) is free from firewall (Figure 2, Item 17).
5. Separate floormat (Figure 2, Item 15) from steering column (Figure 2, Item 18) and cab floor (Figure 2, Item 16).
6. Disconnect connector (Figure 2, Item 1) and boot (Figure 2, Item 25) from brush cover (Figure 2, Item 24).
7. Remove four screws (Figure 2, Item 4), wire (Figure 2, Item 5), contact brush cover (Figure 2, Item 24), and gasket (Figure 2, Item 12) from steering column (Figure 2, Item 18).
8. Remove screw (Figure 2, Item 23) and locktab (Figure 2, Item 22) from contact brush (Figure 2, Item 13). Disconnect wire (Figure 2, Item 21) and capacitor (Figure 2, Item 20).
9. Remove two screws (Figure 2, Item 19), capacitor (Figure 2, Item 20), contact brush (Figure 2, Item 13), and pad (Figure 2, Item 14) from steering column (Figure 2, Item 18).
10. Remove nut (Figure 2, Item 2), two washers (Figure 2, Item 3), washer (Figure 2, Item 6), wire (Figure 2, Item 21), screw (Figure 2, Item 11), and boot (Figure 2, Item 25) from contact brush cover (Figure 2, Item 24).

REMOVAL - Continued

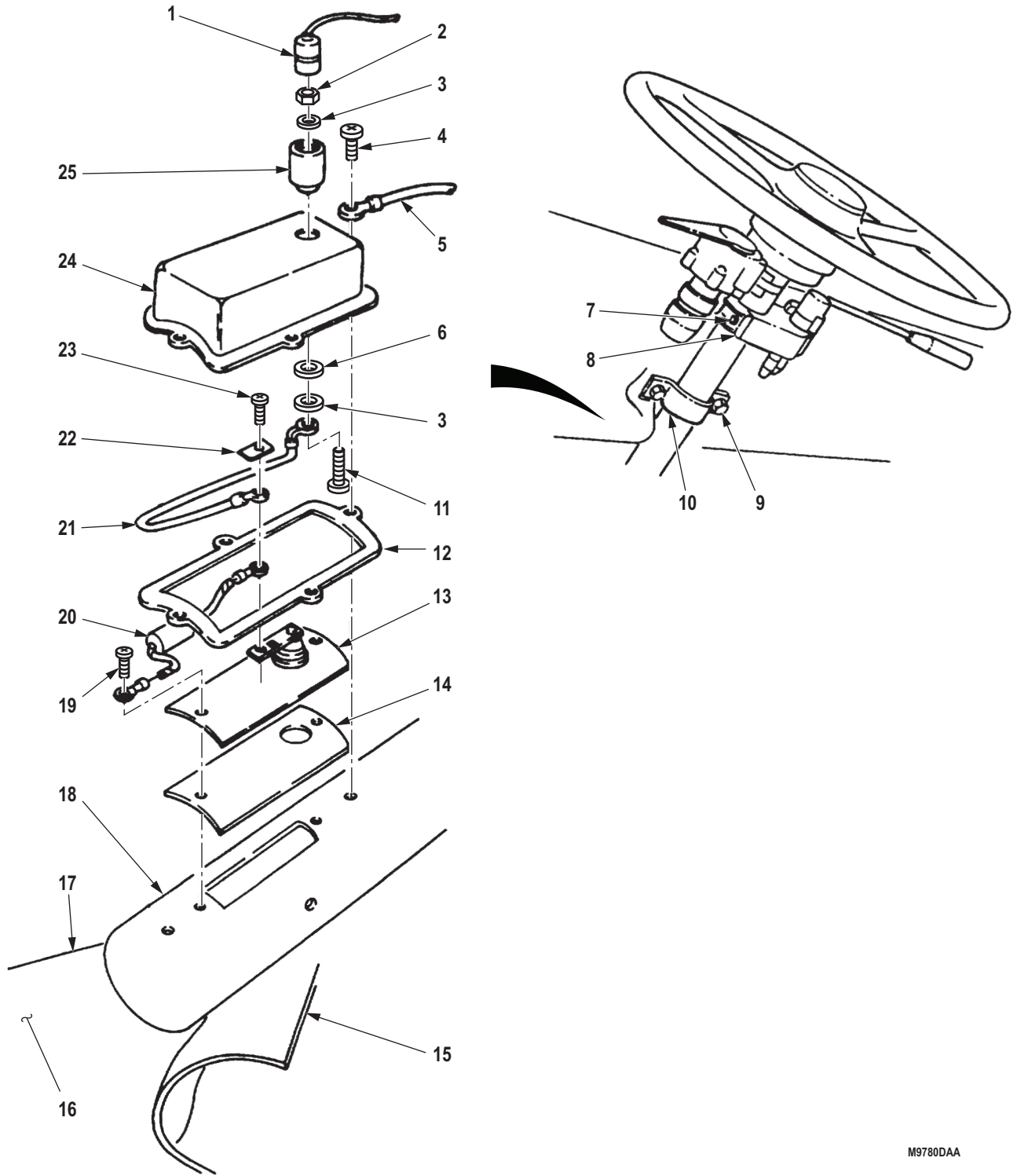

Figure 2. Horn Contact Removal.

END OF TASK

INSTALLATION

1. Install pad (Figure 3, Item 14), contact brush (Figure 3, Item 13), and capacitor (Figure 3, Item 20) on steering column (Figure 3, Item 18) with two screws (Figure 3, Item 19).
2. Install boot (Figure 3, Item 25) and wire (Figure 3, Item 21) on contact brush cover (Figure 3, Item 24) with screw (Figure 3, Item 11), two washers (Figure 3, Item 3), washer (Figure 3, Item 6), and nut (Figure 3, Item 2).
3. Install wire (Figure 3, Item 21) and capacitor (Figure 3, Item 20) on contact brush (Figure 3, Item 13) with locktab (Figure 3, Item 22) and screw (Figure 3, Item 23).
4. Install gasket (Figure 3, Item 12), contact brush cover (Figure 3, Item 24), and ground wire (Figure 3, Item 5) on steering column (Figure 3, Item 18) with four screws (Figure 3, Item 4).
5. Connect connector (Figure 3, Item 1) and boot (Figure 3, Item 25) to brush cover (Figure 3, Item 24).
6. Turn steering column (Figure 3, Item 18) until contact brush cover (Figure 3, Item 24) is toward firewall (Figure 3, Item 17).
7. Position floormat (Figure 3, Item 15) against steering column (Figure 3, Item 18) on cab floor (Figure 3, Item 16).
8. Tighten two screws (Figure 3, Item 9) on steering column bracket (Figure 3, Item 10).

NOTE

Step (9) applies to M931 and M932 vehicles only.

9. Tighten two screws (Figure 3, Item 7) on trailer brake control valve bracket (Figure 3, Item 8).

INSTALLATION - Continued

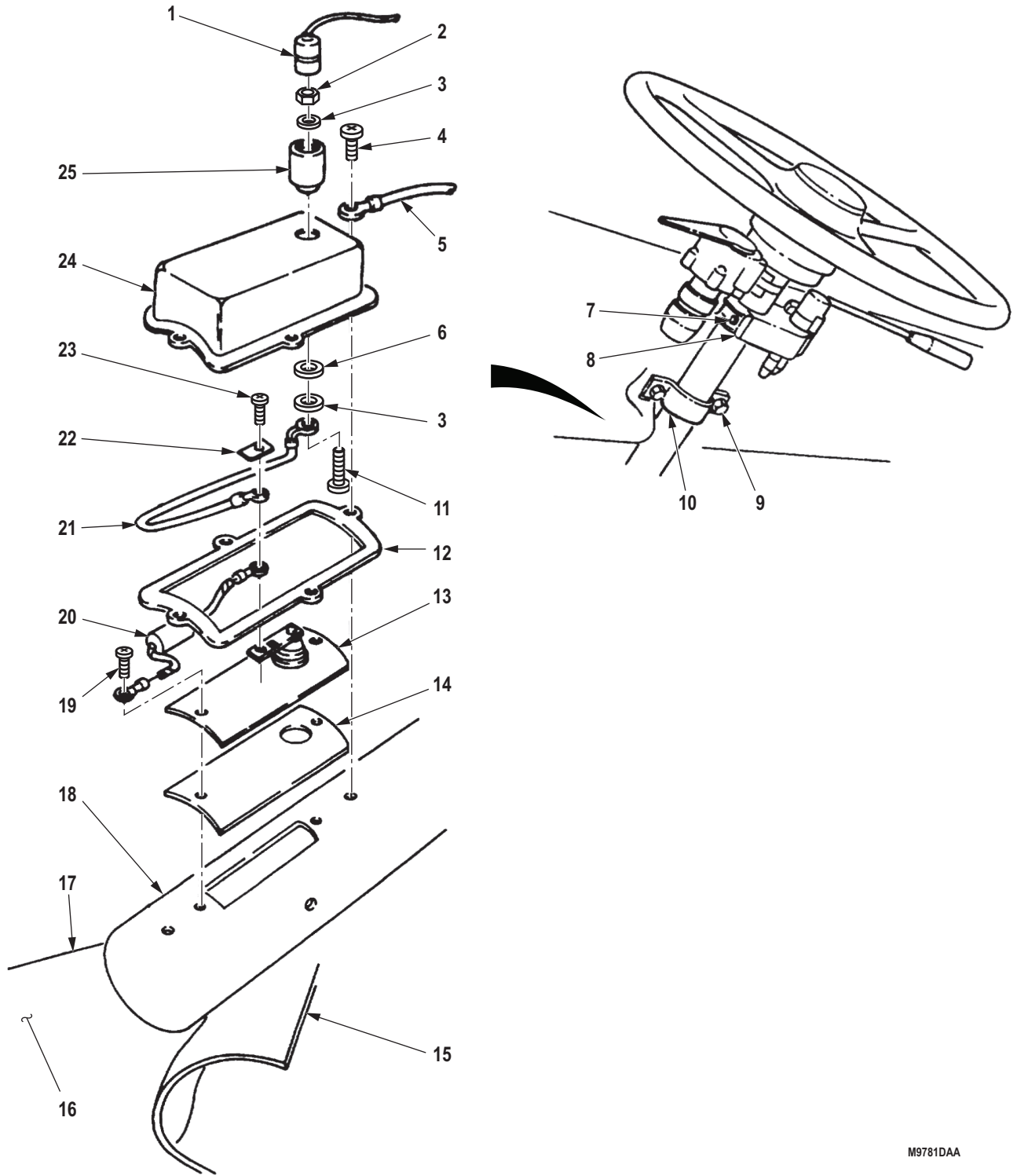

M9781DAA

Figure 3. Horn Contact Installation.

INSTALLATION - Continued

10. Tighten two screws (Figure 4, Item 1) and nuts (Figure 4, Item 3) on outer cab firewall (Figure 4, Item 2).

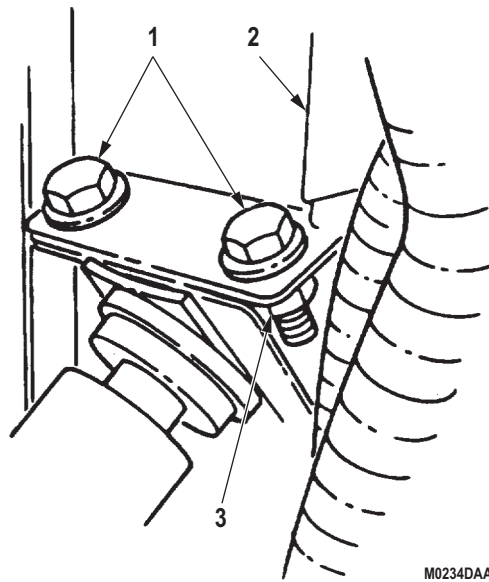

Figure 4. Horn Contact Installation.

END OF TASK**FOLLOW-ON MAINTENANCE**

1. Connect battery ground cables. (WP 0350)
2. Check horn for proper operation. (Volume 5, WP 0822)
3. Install left splash shield. (Volume 5, WP 0822)

END OF TASK**END OF WORK PACKAGE**

**FIELD MAINTENANCE
BATTERY REPLACEMENT**

INITIAL SETUP:**Tools and Special Tools**

Tool Kit, General Mechanic's: Automotive
(Volume 5, WP 0826, Table 1, Item 56)

Materials/Parts

Rag, Wiping
(Volume 5, WP 0825, Table 1, Item 53)
Sodium Bicarbonate
(Volume 5, WP 0825, Table 1, Item 63)
Lockwasher
(Volume 5, WP 0827, Table 1, Item 186)
Qty: 10

Personnel Required

(2)

References

TM 9-6140-200-14

Equipment Condition

Parking brake set. (TM 9-2320-272-10)
Battery ground cables disconnected. (WP 0350)

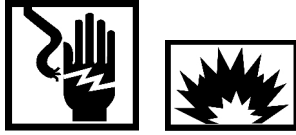
REMOVAL**WARNING**

Remove all jewelry when working on electrical circuits. Jewelry coming in contact with electrical circuits may produce a short circuit, causing extreme heat, explosions, and fling particles of metal. Failure to comply may result in damage to equipment, injury, or death to personnel.

1. Loosen six nuts (Figure 1, Item 9) and screws (Figure 1, Item 10) on terminal adapters (Figure 1, Item 8).

NOTE

Tag all cables for installation.

2. Remove six terminal adapters (Figure 1, Item 8) and eight rubber boots (Figure 1, Item 11) from four batteries (Figure 1, Item 3).
3. Remove ten nuts (Figure 1, Item 7), lockwashers (Figure 1, Item 6), and washers (Figure 1, Item 5) from battery tiedown bolts (Figure 1, Item 4). Discard lockwashers.
4. Remove two battery tiedowns (Figure 1, Item 1) from battery box (Figure 1, Item 2).

NOTE

Assistant will help with Step (5).

5. Remove four batteries (Figure 1, Item 3) from battery box (Figure 1, Item 2).
6. Remove ten battery tiedown bolts (Figure 1, Item 4) from battery box (Figure 1, Item 2).

REMOVAL - Continued

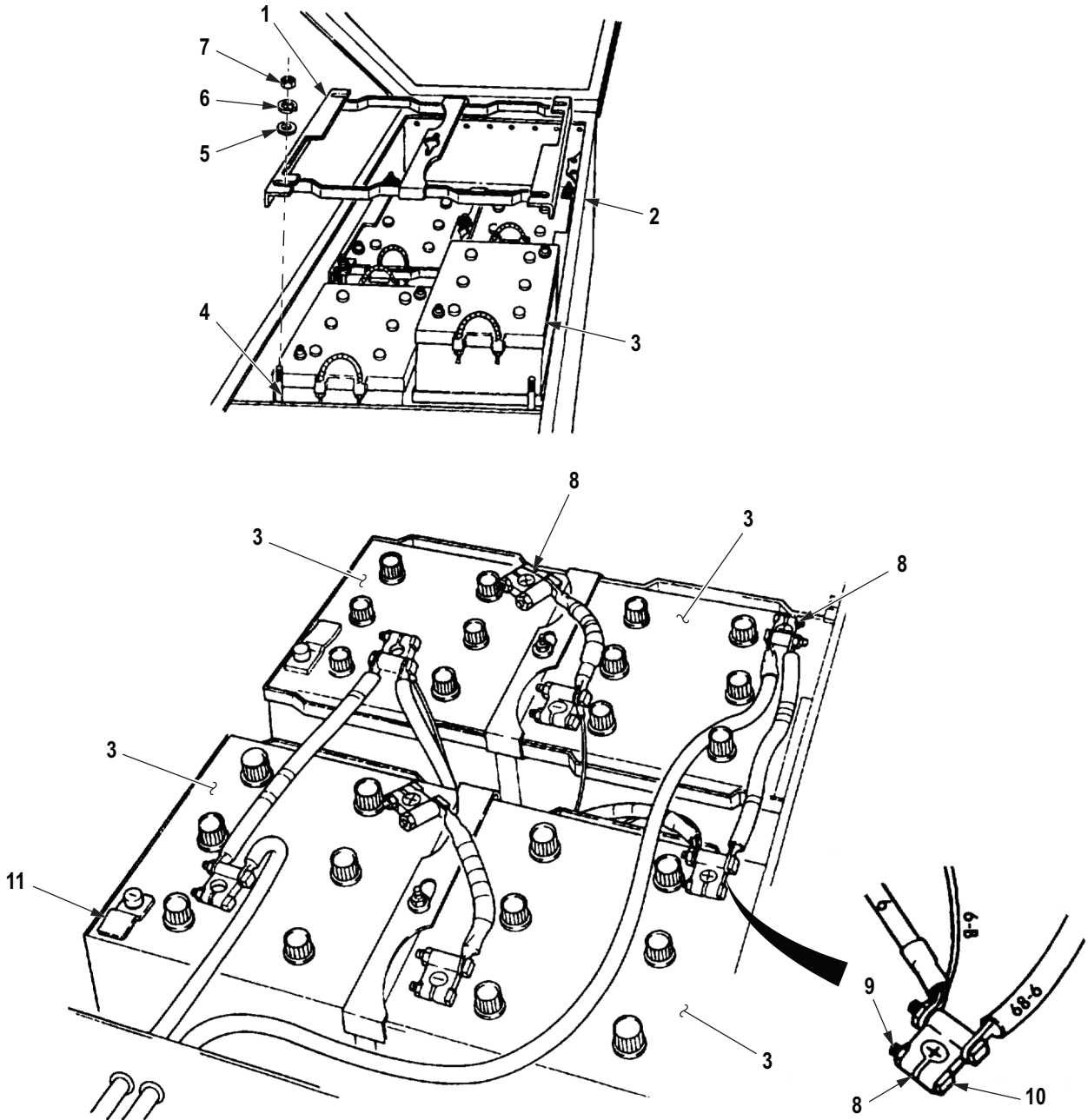

M8033DAA

Figure 1. Battery Removal.

END OF TASK

INSPECTION AND CLEANING**NOTE**

Refer to TM 9-6140-200-14 for battery inspection and service.

Inspect battery box (Figure 2, Item 1) for corrosion and acid deposits. If found:

- a. Apply sodium bicarbonate and water solution to inside of battery box to neutralize acid.
- b. Let solution set for five minutes.
- c. Rinse with clean water.
- d. Wipe dry with clean rag.

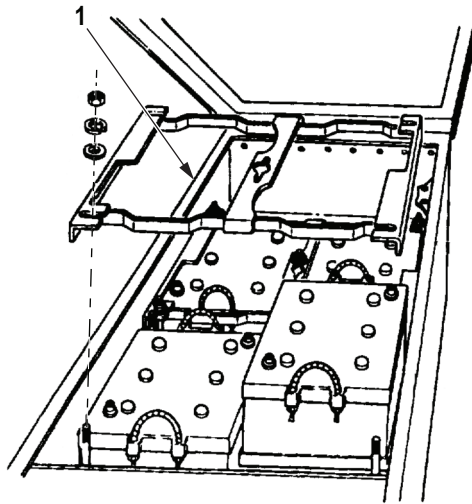

M8034DAA

Figure 2. Battery Inspection and Cleaning.

END OF TASK**INSTALLATION**

1. Install ten battery tiedown bolts (Figure 3, Item 4) in battery box (Figure 3, Item 2).

NOTE

Assistant will help with Step (2).

2. Lower four batteries (Figure 3, Item 3) into battery box (Figure 3, Item 2).
3. Install two battery tiedowns (Figure 3, Item 1) over ten bolts (Figure 3, Item 4) with washers (Figure 3, Item 5), lockwashers (Figure 3, Item 6), and nuts (Figure 3, Item 7).
4. Install eight rubber boots (Figure 3, Item 11) on batteries (Figure 3, Item 3).
5. Install six terminal adapters (Figure 3, Item 8) on batteries (Figure 3, Item 3) and tighten screws (Figure 3, Item 10) and nuts (Figure 3, Item 9).

INSTALLATION - Continued

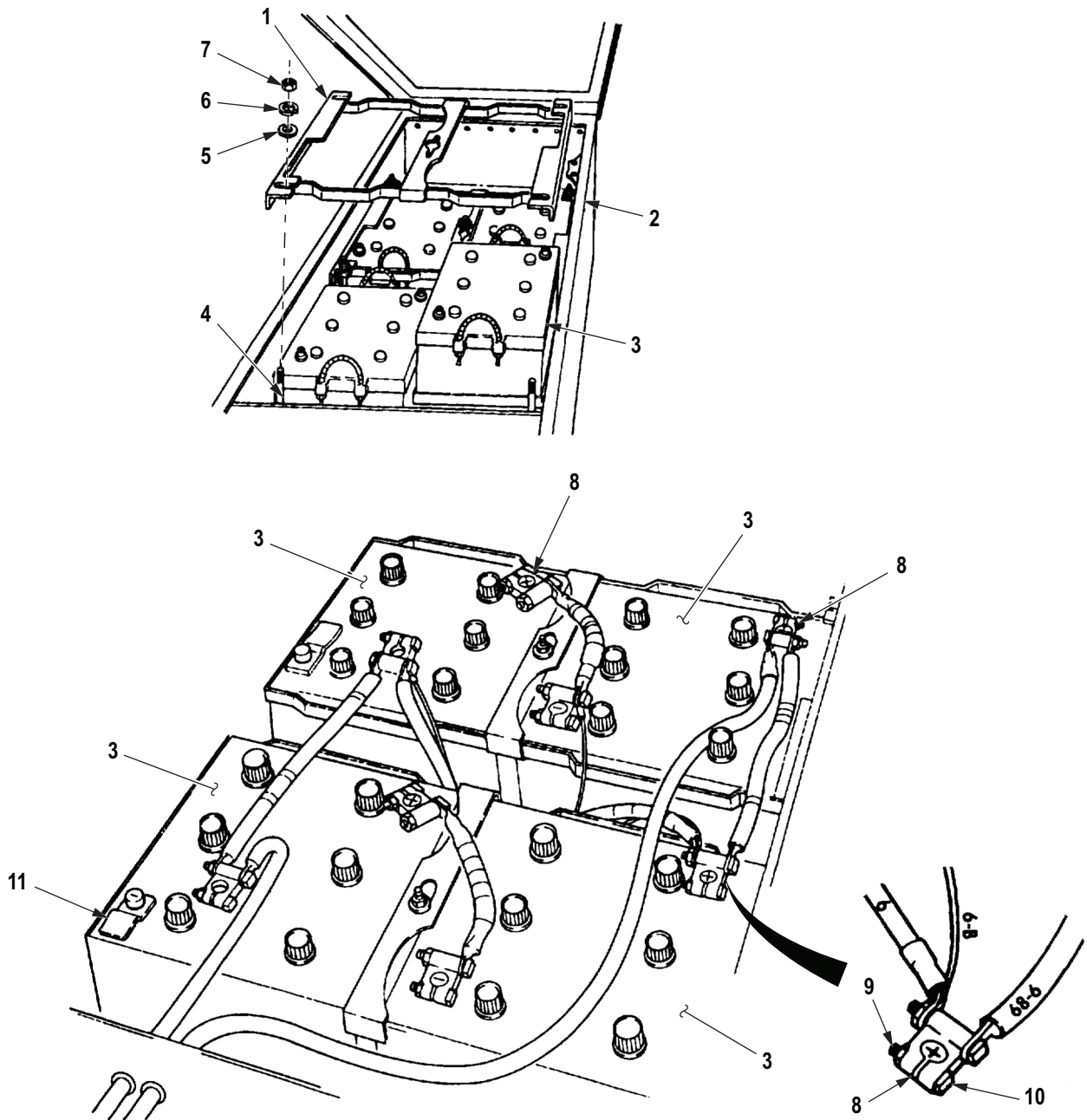

M9422DAA

Figure 3. Battery Installation.

END OF TASK

FOLLOW-ON MAINTENANCE

Connect battery ground cables. (WP 0350)

END OF TASK

END OF WORK PACKAGE

**FIELD MAINTENANCE
BATTERY BOX REPLACEMENT**

INITIAL SETUP:**Tools and Special Tools**

Tool Kit, General Mechanic's: Automotive
(Volume 5, WP 0826, Table 1, Item 56)
Wrench, Torque, Click, Ratcheting, 3/8" Drive,
75 Ft-Lb
(Volume 5, WP 0826, Table 1, Item 62)

Equipment Condition (cont.)

Battery box cover removed. (WP 0348)
Battery cable terminal adapters removed.
(WP 0349)
Batteries removed. (WP 0346)

Materials/Parts

Lockwasher
(Volume 5, WP 0827, Table 1, Item 356)
Qty: 4

Equipment Condition

Parking brake set. (TM 9-2320-272-10)

REMOVAL

1. Pull slave receptacle cables (Figure 1, Item 12) and (Figure 1, Item 13) through grommets (Figure 1, Item 14) on right rear of cab (Figure 1, Item 11).
2. Loosen two clamps (Figure 1, Item 5) on hose (Figure 1, Item 2).
3. Remove hose (Figure 1, Item 2) from battery box (Figure 1, Item 6) and right rear of cab (Figure 1, Item 11).
4. Remove wood battery support blocks (Figure 1, Item 1) from battery box (Figure 1, Item 6).
5. Remove four screws (Figure 1, Item 3) and lockwashers (Figure 1, Item 4) from battery box (Figure 1, Item 6). Discard lockwashers.
6. Push battery cables (Figure 1, Item 7) through grommets (Figure 1, Item 8). Remove battery box (Figure 1, Item 6) from right rear of cab (Figure 1, Item 11) and vent tube (Figure 1, Item 9) comes out of hole in cab floor (Figure 1, Item 10).
7. Remove four grommets (Figure 1, Item 14) and two grommets (Figure 1, Item 8) from battery box (Figure 1, Item 6).

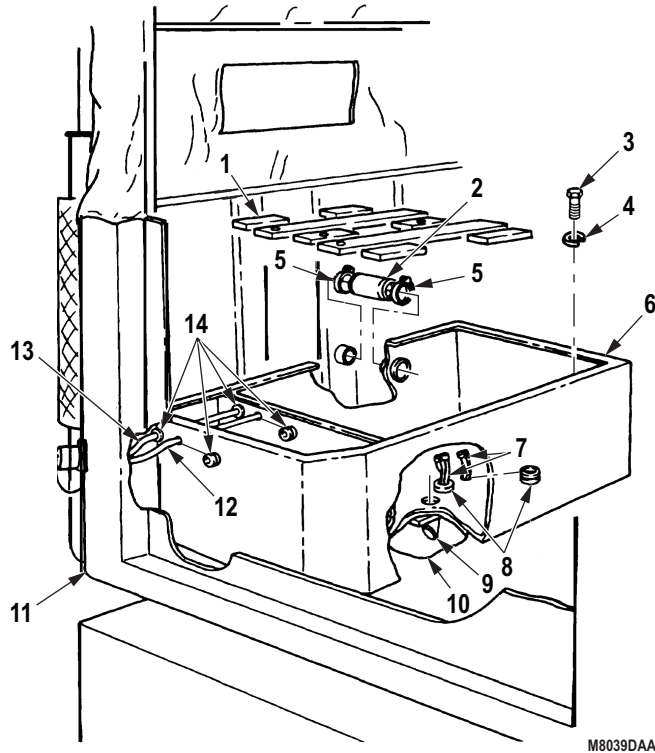

Figure 1. Battery Box Removal.

END OF TASK

INSTALLATION

1. Install four grommets (Figure 2, Item 14) and two grommets (Figure 2, Item 8) on battery box (Figure 2, Item 6).
2. Align vent tube (Figure 2, Item 9) with hole in cab floor (Figure 2, Item 10) and install battery box (Figure 2, Item 6) on cab (Figure 2, Item 11) with cable grommets (Figure 2, Item 8) aligned with cables (Figure 2, Item 7).
3. Pull battery cables (Figure 2, Item 7) through grommets (Figure 2, Item 8).
4. Secure battery box (Figure 2, Item 6) to cab (Figure 2, Item 11) with four lockwashers (Figure 2, Item 4) and screws (Figure 2, Item 3). Tighten screws to 25 lb-ft (34 N·m).
5. Place wood battery support blocks (Figure 2, Item 1) in battery box (Figure 2, Item 6).
6. Install hose (Figure 2, Item 2) on battery box (Figure 2, Item 6) and cab (Figure 2, Item 11) with two clamps (Figure 2, Item 5).
7. Pull slave receptacle cables (Figure 2, Items 12 and 13) through grommets (Figure 2, Item 14).

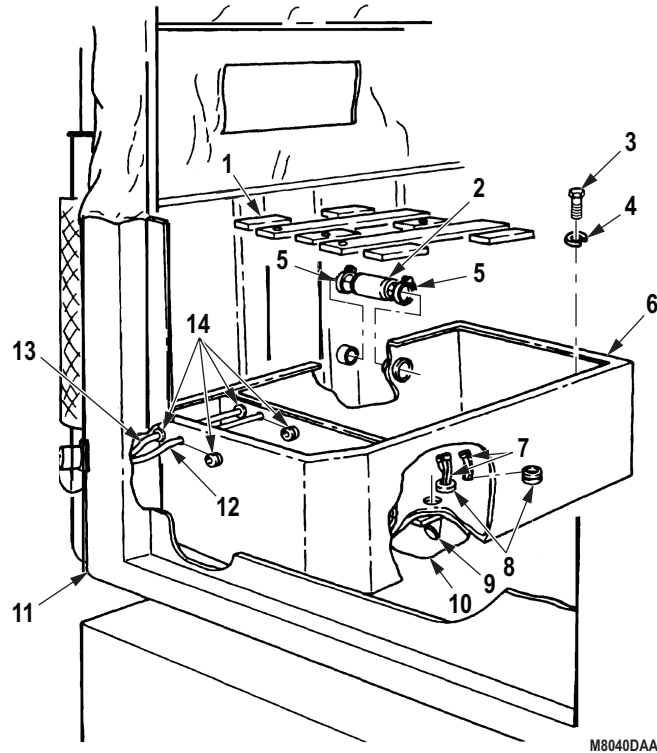

Figure 2. Battery Box Installation.

END OF TASK

FOLLOW-ON MAINTENANCE

1. Install batteries. (WP 0346)
2. Install battery cable terminal adapters. (WP 0349)
3. Install battery box cover. (WP 0348)

END OF TASK**END OF WORK PACKAGE**

**FIELD MAINTENANCE
BATTERY BOX COVER REPLACEMENT**

INITIAL SETUP:**Tools and Special Tools**

Tool Kit, General Mechanic's: Automotive
(Volume 5, WP 0826, Table 1, Item 56)

Personnel Required

(2)

Materials/Parts

Locknut (Volume 5, WP 0827, Table 1, Item 312)
Qty: 6

Equipment Condition

Parking brake set. (TM 9-2320-272-10)
Companion seat cushion removed.
(Volume 4, WP 0581)

REMOVAL

WARNING



- When performing battery maintenance, ensure batteries are seated and clamped down, all rubber boots are installed, clamps are well down on battery posts, and all battery cables lie flat against top of batteries. Failure to comply may result in damage to equipment, injury, or death to personnel.
- Remove all jewelry. If jewelry or disconnected battery ground cable contacts positive battery terminal, a direct short will result. Failure to comply may result in damage to equipment, injury, or death to personnel.

NOTE

Assistant will hold battery box cover open while mechanic removes support rod.

1. Release two latches (Figure 1, Item 5) and raise battery box cover (Figure 1, Item 1).
2. Remove six locknuts (Figure 1, Item 4), screws (Figure 1, Item 2), and battery box cover (Figure 1, Item 1) from battery box cover hinge (Figure 1, Item 3). Discard locknuts.

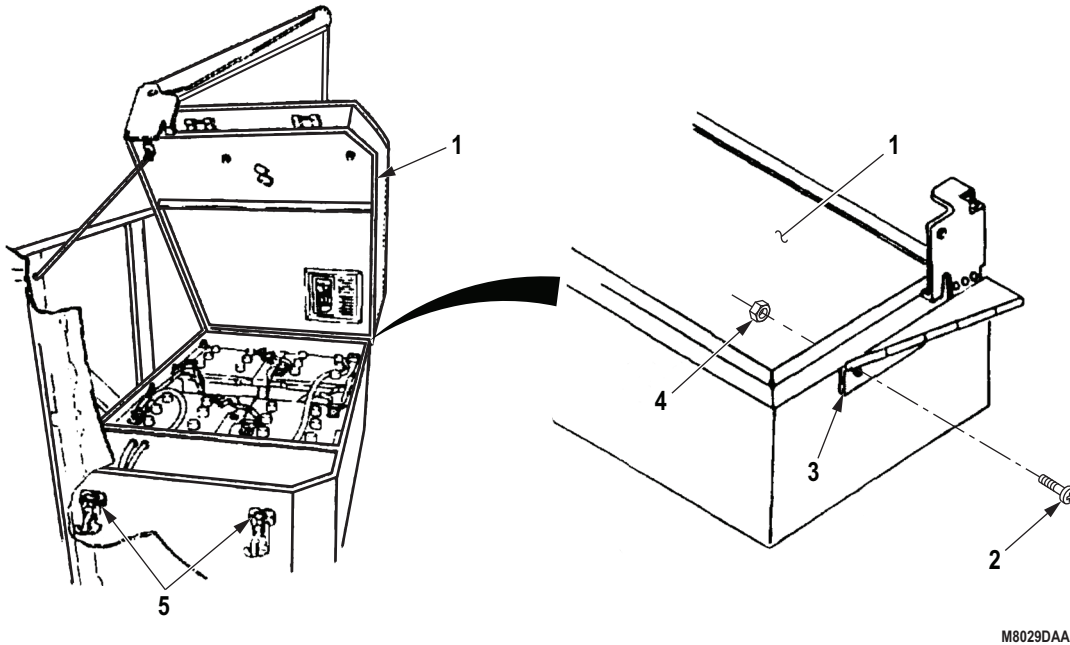

Figure 1. Battery Box Cover Removal.

END OF TASK

INSTALLATION

1. Install battery box cover (Figure 2, Item 1) on battery box cover hinge (Figure 2, Item 3) with six screws (Figure 2, Item 2) and locknuts (Figure 2, Item 4).
2. Lower battery box cover (Figure 2, Item 1) and secure with two latches (Figure 2, Item 5).

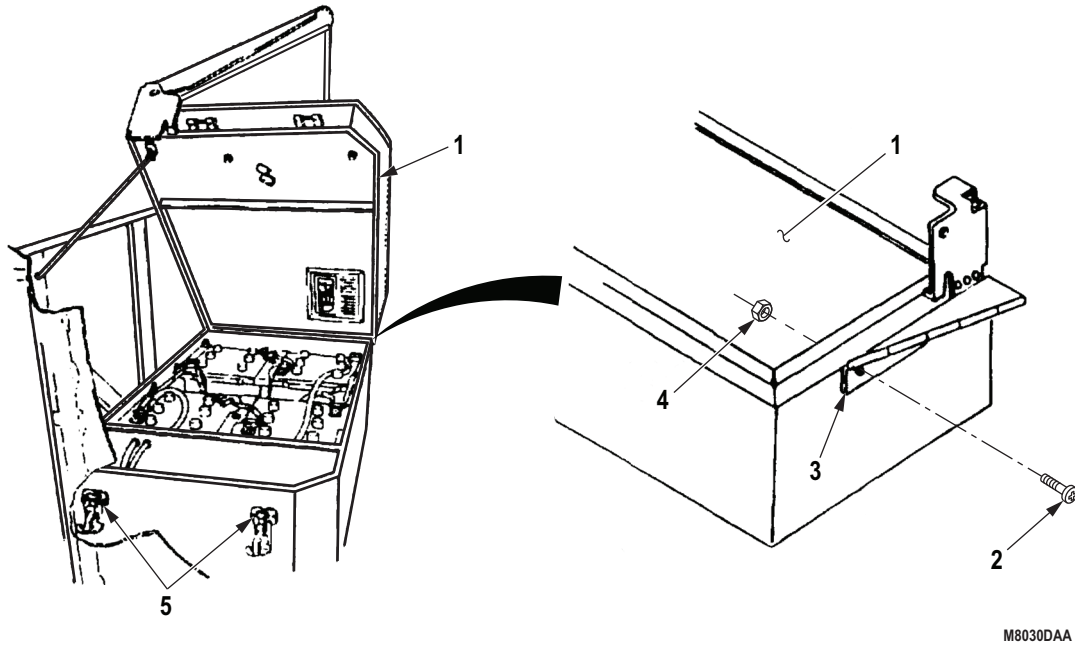

Figure 2. Battery Box Cover Installation.

END OF TASK

FOLLOW-ON MAINTENANCE

Install companion seat cushion. (Volume 4, WP 0581)

END OF TASK

END OF WORK PACKAGE

**FIELD MAINTENANCE
BATTERY CABLE AND TERMINAL ADAPTER REPLACEMENT**

INITIAL SETUP:**Tools and Special Tools**

Tool Kit, General Mechanic's: Automotive
(Volume 5, WP 0826, Table 1, Item 56)

Equipment Condition

Parking brake set. (TM 9-2320-272-10)
Battery ground cables disconnected. (WP 0350)

References

TM 9-6140-200-14

REMOVAL**WARNING**

Remove all jewelry. If jewelry or disconnected battery ground cable contacts positive battery terminal, a direct short will result. Failure to comply may result in damage to equipment, injury, or death to personnel.

NOTE

- All battery cables and terminal adapters are replaced the same way.
 - Tag cables for installation.
 - Refer to TM 9-6140-200-14 for inspection and service of battery cables and adapters.
1. Remove nut (Figure 1, Item 1) and screw (Figure 1, Item 6) from terminal adapter (Figure 1, Item 4).
 2. Remove terminal adapter (Figure 1, Item 4) and rubber boot (Figure 1, Item 8) from battery post (Figure 1, Item 7).
 3. Remove nut (Figure 1, Item 2), screw (Figure 1, Item 5), and two battery cables (Figure 1, Item 3) from terminal adapter (Figure 1, Item 4).

REMOVAL - Continued

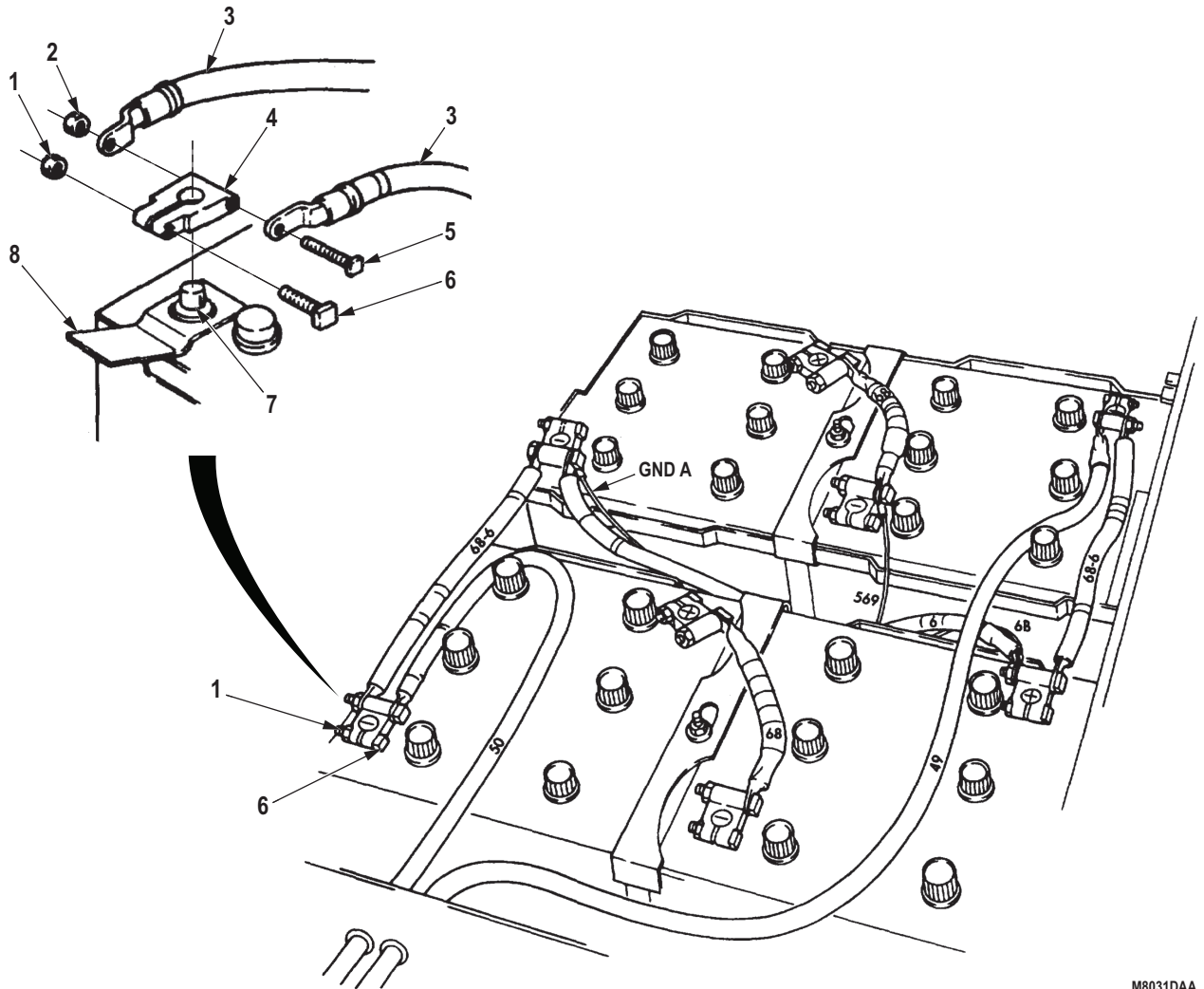

M8031DAA

Figure 1. Battery Cable Removal.

END OF TASK

INSTALLATION**WARNING**

When performing battery maintenance, ensure batteries are seated and clamped down, all rubber boots are installed, clamps are well down on battery posts, and all battery cables lie flat against top of batteries. Failure to comply may result in damage to equipment, injury, or death to personnel.

NOTE

- When installing one cable to a terminal adapter, place the cable under the bolt head.
 - When installing two cables, place one cable on each side of the terminal adapter.
1. Install rubber boot (Figure 2, Item 8) on battery post (Figure 2, Item 7).
 2. Install two cables (Figure 2, Item 3) on terminal adapter (Figure 2, Item 4) with screw (Figure 2, Item 5) and nut (Figure 2, Item 2).
 3. Install terminal adapter (Figure 2, Item 4) on battery post (Figure 2, Item 7) with screw (Figure 2, Item 6) and nut (Figure 2, Item 1).

INSTALLATION - Continued

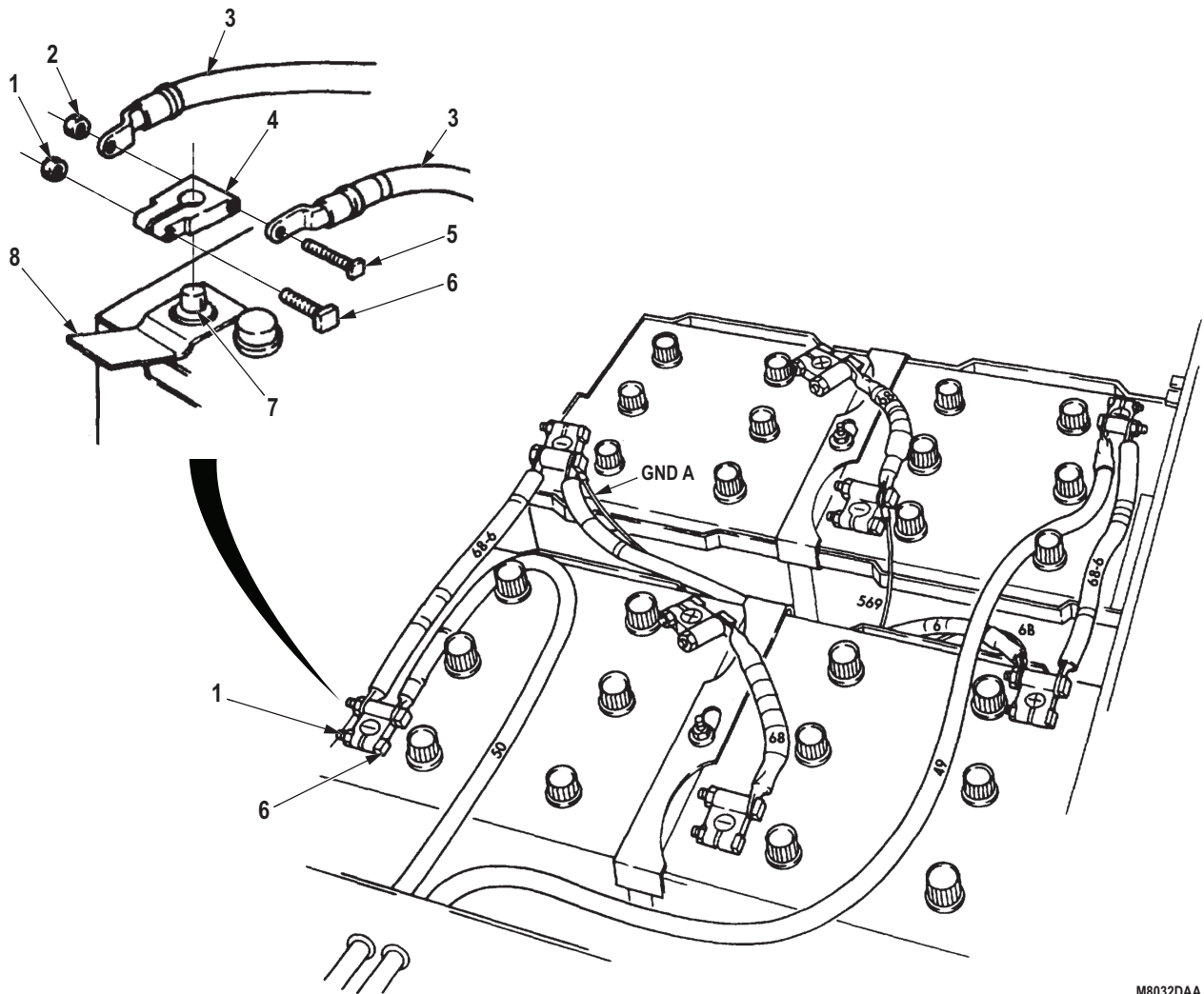

M8032DAA

Figure 2. Battery Cable Installation.

END OF TASK

FOLLOW-ON MAINTENANCE

Connect battery ground cables. (WP 0350)

END OF TASK

END OF WORK PACKAGE

**FIELD MAINTENANCE
BATTERY GROUND CABLE REPLACEMENT**

INITIAL SETUP:

Tools and Special Tools

Tool Kit, General Mechanic's: Automotive
(Volume 5, WP 0826, Table 1, Item 56)

Equipment Condition

Parking brake set. (TM 9-2320-272-10)
Battery box cover raised and secured.
(TM 9-2320-272-10)

DISCONNECTION**WARNING**

- Remove all jewelry. If jewelry or disconnected battery ground cable contacts positive battery terminal, a direct short will result. Failure to comply may result in damage to equipment, injury, or death to personnel.
 - When performing battery maintenance, ensure batteries are seated and clamped down, all rubber boots are installed, clamps are well down on battery posts, and all battery cables lie flat against top of batteries. Failure to comply may result in damage to equipment, injury, or death to personnel.
1. Loosen nut (Figure 1, Item 5) and screw (Figure 1, Item 3) on terminal adapter (Figure 1, Item 6).

NOTE

Tag all terminal adapters and rubber boots for installation.

2. Remove terminal adapter (Figure 1, Item 6) and rubber boot (Figure 1, Item 4) from battery (Figure 1, Item 7).
3. Loosen nut (Figure 1, Item 10) and screw (Figure 1, Item 2) on terminal adapter (Figure 1, Item 1).
4. Remove terminal adapter (Figure 1, Item 1) and rubber boot (Figure 1, Item 9) from battery (Figure 1, Item 8).

DISCONNECTION - Continued

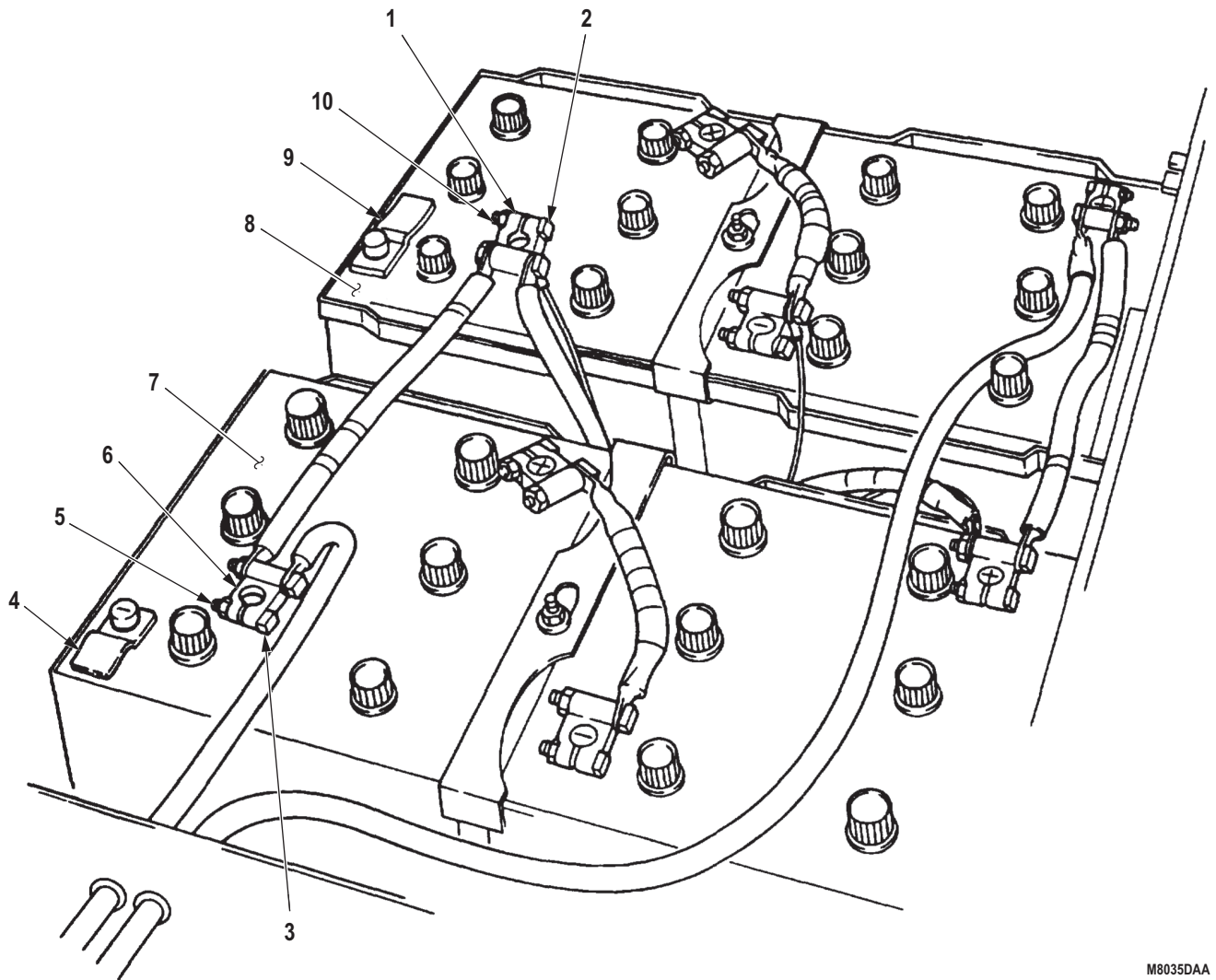

M8035DAA

Figure 1. Battery Ground Cable Disconnection.

END OF TASK

CONNECTION

1. Install rubber boots (Figure 2, Items 4 and 9) on batteries (Figure 2, Items 7 and 8).
2. Install terminal adapter (Figure 2, Item 1) on battery (Figure 2, Item 8) and tighten screw (Figure 2, Item 2) and nut (Figure 2, Item 10).
3. Install terminal adapter (Figure 2, Item 6) on battery (Figure 2, Item 7) and tighten screw (Figure 2, Item 3) and nut (Figure 2, Item 5).

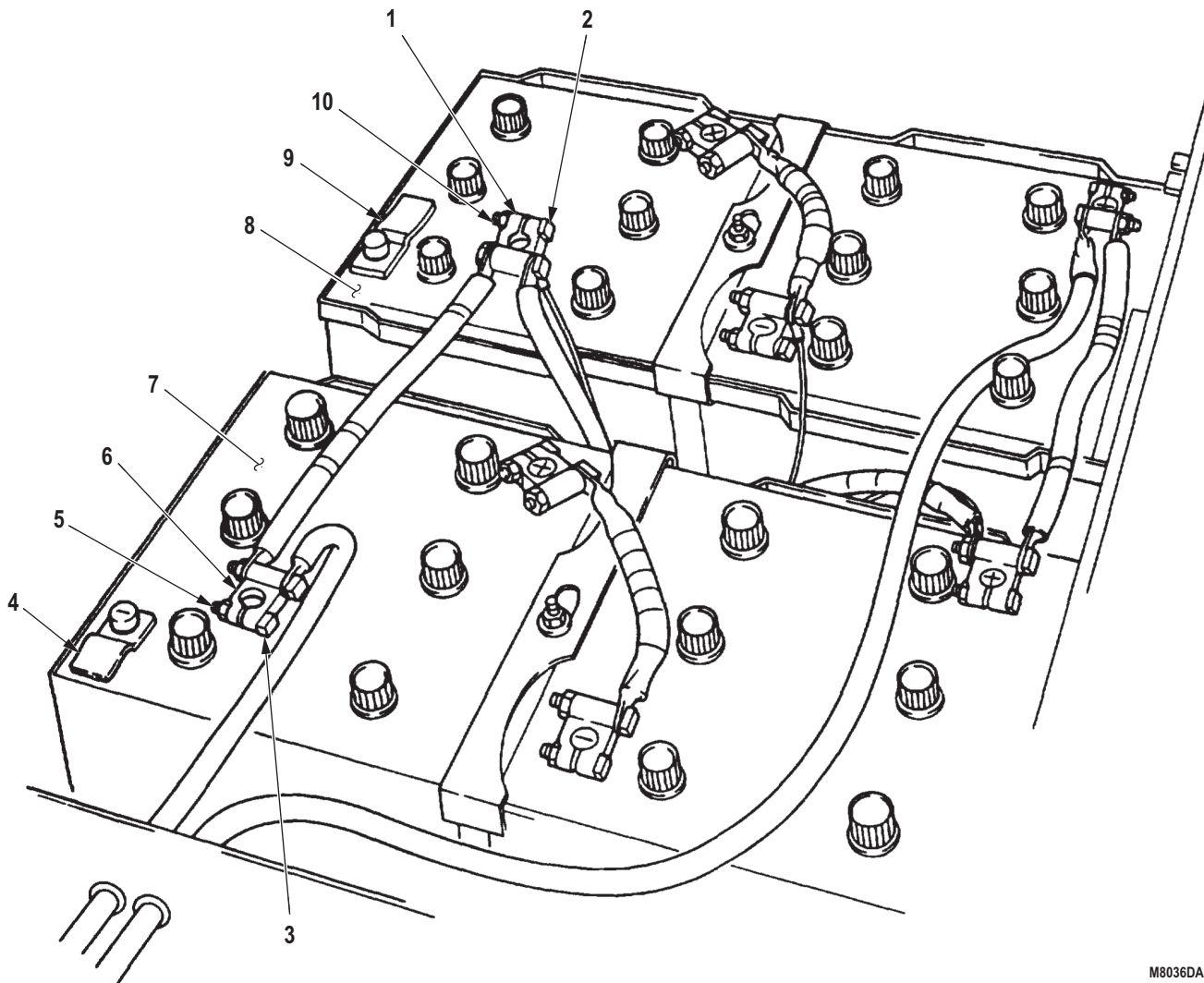

M8036DAA

Figure 2. Battery Ground Cable Connection.

END OF TASK

FOLLOW-ON MAINTENANCE

Lower battery box cover and secure. (TM 9-2320-272-10)

END OF TASK

END OF WORK PACKAGE

INDEX

Subject

WP Sequence No.-Page No.

A

ABS - CLEAR HISTORICAL CODES WITH THE HALDEX INFO CENTER (SCAN TOOL).....	WP 0159-1
ABS - CODE B+HI 92 (ABS VOLTAGE ABOVE 32.0 VOLTS).....	WP 0184-1
ABS - CODE B+LO 90 (ABS VOLTAGE BELOW 21.0 VOLTS).....	WP 0182-1
ABS - CODE BUDU 68 (LEFT SIDE - BLUE CHANNEL).....	WP 0172-1
ABS - CODE BUDU 78 (LEFT SIDE - BLUE CHANNEL).....	WP 0176-1
ABS - CODE BUDU 88 (LEFT SIDE - BLUE CHANNEL).....	WP 0180-1
ABS - CODE BUHd 62 (LEFT SIDE - BLUE CHANNEL).....	WP 0170-1
ABS - CODE BUHd 72 (LEFT SIDE - BLUE CHANNEL).....	WP 0174-1
ABS - CODE BUHd 82 (LEFT SIDE - BLUE CHANNEL).....	WP 0178-1
ABS - CODE EO - E9, EA - EF (ECU FAULT).....	WP 0157-1
ABS - CODE ISO1 91 (ABS VOLTAGE BELOW 8.0 VOLTS).....	WP 0183-1
ABS - CODE S2A 03 (LEFT SIDE - BLUE CHANNEL).....	WP 0162-1
ABS - CODE S2A 13 (LEFT SIDE - BLUE CHANNEL).....	WP 0164-1
ABS - CODE S2A 23 (LEFT SIDE - BLUE CHANNEL).....	WP 0166-1
ABS - CODE S2A 24 (RIGHT SIDE - YELLOW CHANNEL).....	WP 0167-1
ABS - CODE S2B 04 (RIGHT SIDE - YELLOW CHANNEL).....	WP 0163-1
ABS - CODE S2B 14 (RIGHT SIDE - YELLOW CHANNEL).....	WP 0165-1
ABS - CODE SLW 42 (LEFT SIDE - BLUE CHANNEL).....	WP 0168-1
ABS - CODE SLW 43 (RIGHT SIDE - YELLOW CHANNEL).....	WP 0169-1
ABS - CODE SOL 80, ECU 93, OR ECU 99 (ECU FAULT).....	WP 0158-1
ABS - CODE YEDU 69 (RIGHT SIDE - YELLOW CHANNEL).....	WP 0173-1
ABS - CODE YEDU 79 (RIGHT SIDE - YELLOW CHANNEL).....	WP 0177-1
ABS - CODE YEDU 89 (RIGHT SIDE - YELLOW CHANNEL).....	WP 0181-1
ABS - CODE YEHd 63 (RIGHT SIDE - YELLOW CHANNEL).....	WP 0171-1
ABS - CODE YEHd 73 (RIGHT SIDE - YELLOW CHANNEL).....	WP 0175-1
ABS - CODE YEHd 83 (RIGHT SIDE - YELLOW CHANNEL).....	WP 0179-1
ABS - NO DATA (BLANK SCREEN ON HALDEX INFO-CENTER).....	WP 0185-1
ABS - START - RETRIEVING FAULT CODES WITH THE HALDEX INFO CENTER (SCAN TOOL).....	WP 0161-1
ABS TROUBLESHOOTING INDEX.....	WP 0155-1
ACCELERATOR LINKAGE REPLACEMENT (M939/A1).....	WP 0268-1
ACCELERATOR LINKAGE REPLACEMENT (M939A2).....	WP 0269-1
ACCELERATOR PEDAL, BRACKET, ROD, AND STOPSCREW REPLACEMENT.....	WP 0272-1
AFC FUEL PUMP FILTER REPLACEMENT (M939/A1).....	WP 0259-1
AFTERCOOLER AND TUBES REPLACEMENT (M939A2).....	WP 0299-1
AIR CLEANER ASSEMBLY AND MOUNTING BRACKET REPLACEMENT.....	WP 0245-1
AIR CLEANER HOSE MAINTENANCE (M939A2).....	WP 0248-1
AIR CLEANER INDICATOR AND TUBE REPLACEMENT.....	WP 0247-1
AIR CLEANER INTAKE PIPE REPLACEMENT (M939/A1).....	WP 0246-1
AIR COMPRESSOR COOLANT SUPPLY AND RETURN TUBES REPLACEMENT (M939/A1).....	WP 0284-1
AIR FUEL CONTROL (AFC) TUBE REPLACEMENT (M939A2).....	WP 0244-1
ALTERNATOR DRIVEBELTS REPLACEMENT (M939/A1).....	WP 0302-1
ALTERNATOR, MOUNTING BRACKET, AND PULLEY REPLACEMENT (M939/A1)....	WP 0300-1
ALTERNATOR, MOUNTING BRACKET, AND PULLEY REPLACEMENT (M939A2).....	WP 0301-1
AMBER WARNING LIGHT REPLACEMENT.....	WP 0321-1
ANTILOCK BRAKE SYSTEM (ABS) ELECTRONIC DIAGNOSTIC TROUBLESHOOTING.....	WP 0154-1

<u>Subject</u>	<u>WP Sequence No.-Page No.</u>
AUXILIARY OUTLET SOCKET AND RECEPTACLE REPLACEMENT.....	WP 0313-1
B	
BATTERY BOX COVER REPLACEMENT.....	WP 0348-1
BATTERY BOX REPLACEMENT.....	WP 0347-1
BATTERY CABLE AND TERMINAL ADAPTER REPLACEMENT.....	WP 0349-1
BATTERY GROUND CABLE REPLACEMENT.....	WP 0350-1
BATTERY REPLACEMENT.....	WP 0346-1
BLACKOUT LIGHT REPAIR.....	WP 0326-1
BOOM FLOODLIGHT WIRE REPLACEMENT.....	WP 0331-1
C	
COOLANT HOSES AND LINES REPLACEMENT (M939A2).....	WP 0285-1
COOLANT HOSES AND TUBES REPLACEMENT (M939/A1).....	WP 0280-1
COOLING SYSTEM SERVICE.....	WP 0287-1
CRANKCASE BREATHER AND TUBE REPLACEMENT (M939/A1/A2).....	WP 0223-1
CRANKSHAFT VIBRATION DAMPENER REPLACEMENT (M939/A1).....	WP 0218-1
CTIS WIRING HARNESS REPLACEMENT.....	WP 0322-1
D	
DC VOLTAGE TEST.....	WP 0196-1
E	
ELECTRICAL GAUGES REPLACEMENT.....	WP 0312-1
ELECTRICAL SWITCHES AND CIRCUIT BREAKER REPLACEMENT.....	WP 0307-1
EMERGENCY STOP CONTROL CABLE REPLACEMENT.....	WP 0271-1
ENGINE ACCESS COVER REPLACEMENT (M939/A1).....	WP 0217-1
ENGINE ACCESSORY DRIVE AND PULLEY REPLACEMENT (M939/A1).....	WP 0237-1
ENGINE AIR INTAKE MANIFOLD REPLACEMENT (M939/A1).....	WP 0234-1
ENGINE AND CONTAINER REPLACEMENT.....	WP 0212-1
ENGINE EXHAUST MANIFOLD REPLACEMENT (M939/A1).....	WP 0235-1
ENGINE LIFT EYES REPLACEMENT (M939/A1).....	WP 0214-1
ENGINE LIFTING BRACKETS REPLACEMENT (M939A2).....	WP 0215-1
ENGINE MOUNTING BRACKETS AND ISOLATORS REPLACEMENT.....	WP 0216-1
ENGINE OIL COOLER MAINTENANCE (M939A2).....	WP 0229-1
ENGINE OIL COOLER REPAIR (M939/A1).....	WP 0233-1
ENGINE OIL FILTER REPLACEMENT.....	WP 0232-1
ENGINE OIL PAN REPLACEMENT (M939/A1).....	WP 0231-1
ENGINE SAMPLING VALVE REPLACEMENT.....	WP 0227-1
ENGINE WATER MANIFOLD REPLACEMENT (M939/A1).....	WP 0290-1
ETHER ATOMIZER AND TEMPERATURE SENSOR REPLACEMENT (M939A2).....	WP 0266-1
ETHER ATOMIZER REPLACEMENT (M939/A1).....	WP 0265-1
ETHER CYLINDER AND VALVE REPLACEMENT (M939/A1).....	WP 0263-1
ETHER START FUEL PRESSURE SWITCH REPLACEMENT.....	WP 0337-1
ETHER START SWITCH REPLACEMENT (M939/A1).....	WP 0262-1
ETHER THERMAL CLOSE VALVE AND BUSHING REPLACEMENT (M939/A1).....	WP 0264-1
ETHER TUBING REPLACEMENT (M939/A1).....	WP 0267-1
EXHAUST MANIFOLD REPLACEMENT (M939A2).....	WP 0236-1
EXHAUST STACK REPLACEMENT.....	WP 0273-1
F	
FAILSAFE WARNING MODULE REPLACEMENT.....	WP 0336-1

<u>Subject</u>	<u>WP Sequence No.-Page No.</u>
FAN AND FAN SHROUD REPAIR (M939A2).....	WP 0283-1
FAN DRIVE CLUTCH REPLACEMENT (M939/A1).....	WP 0295-1
FAN DRIVEBELT AND DRIVEBELT TENSIONER REPLACEMENT (M939A2).....	WP 0296-1
FAN DRIVEBELTS MAINTENANCE (M939/A1).....	WP 0297-1
FLEXPLATE AND FLYWHEEL ASSEMBLY REPLACEMENT (M939A2).....	WP 0221-1
FLOODLIGHT CONTROL SWITCH REPLACEMENT.....	WP 0320-1
FLOODLIGHT REPAIR.....	WP 0329-1
FLOODLIGHT SEALED BEAM LAMP AND DOOR REPLACEMENT.....	WP 0328-1
FLYWHEEL ASSEMBLY REPLACEMENT (M939/A1).....	WP 0220-1
FRONT AND REAR COMPOSITE LIGHT AND BRACKET REPLACEMENT.....	WP 0327-1
FRONT EXHAUST PIPE REPLACEMENT.....	WP 0276-1
FRONT SUMP TUBE REPLACEMENT (M939/A1).....	WP 0226-1
FUEL DRAIN AND BYPASS TUBING REPLACEMENT (M939/A1).....	WP 0256-1
FUEL FILTER AND COVER REPLACEMENT.....	WP 0258-1
FUEL INJECTION PUMP REPLACEMENT (M939A2).....	WP 0242-1
FUEL INJECTOR REPLACEMENT (M939A2).....	WP 0238-1
FUEL INJECTOR TUBES REPLACEMENT (M939A2).....	WP 0241-1
FUEL LEVEL SENDING UNIT REPLACEMENT.....	WP 0332-1
FUEL PRESSURE TRANSDUCER REPLACEMENT.....	WP 0340-1
FUEL PRIMER PUMP REPLACEMENT (M939/A1).....	WP 0261-1
FUEL PUMP METERING VALVE REPLACEMENT (M936 Wrecker).....	WP 0306-1
FUEL PUMP METERING VALVE REPLACEMENT (M939/A1).....	WP 0305-1
FUEL PUMP REPLACEMENT (M939/A1).....	WP 0240-1
FUEL PUMP WITH VS GOVERNOR FILTER REPLACEMENT (M939/A1).....	WP 0260-1
FUEL SELECTOR VALVE FLEX HOSE REPLACEMENT.....	WP 0257-1
FUEL SELECTOR VALVE SWITCH REPLACEMENT.....	WP 0314-1
FUEL SELECTOR VALVE, MOUNTING BRACKET, AND INDICATOR PLATE REPLACEMENT.....	WP 0255-1
FUEL TANK FILLER CAP AND SPOUT REPLACEMENT.....	WP 0252-1
FUEL TANK HANGERS AND RETAINING STRAPS REPLACEMENT.....	WP 0253-1
FUEL TANK LINES REPLACEMENT (M939A2).....	WP 0254-1
FUEL TANK REPLACEMENT.....	WP 0250-1
FUEL TANK REPLACEMENT (M936/A1/A2).....	WP 0251-1
FUEL TRANSFER PUMP AND SUPPLY LINES REPLACEMENT (M939A2).....	WP 0243-1

G

G01: VTM CONNECTION AND CHECKOUT (PART 1).....	WP 0188-1
G02: FIRST PEAK TEST- STARTER CURRENT.....	WP 0189-1
G03: ENGINE START- LUBRICATION CHECK.....	WP 0190-1
G04: CHARGING CIRCUIT AND BATTERY VOLTAGE TEST.....	WP 0191-1
G05: ENGINE WARMUP/COOLANT CHECK/OIL PRESSURE TEST.....	WP 0192-1
G06: GOVERNOR CHECK/POWER TEST.....	WP 0193-1
G07: IDLE SPEED/GOVERNOR CHECK.....	WP 0194-1
G08: COMPRESSION UNBALANCE TEST.....	WP 0195-1

H

HEADLIGHT REPAIR.....	WP 0325-1
HIGH BEAM SELECTOR SWITCH REPLACEMENT.....	WP 0316-1
HORN CONTACT BRUSH REPLACEMENT.....	WP 0345-1
HORN SWITCH REPLACEMENT.....	WP 0344-1
HORN, SOLENOID, AND BRACKET REPLACEMENT.....	WP 0343-1

Subject

WP Sequence No.-Page No.

I

INDICATOR PANEL LIGHT AND LAMP REPLACEMENT.....	WP 0311-1
INSTRUMENT CLUSTER REPLACEMENT.....	WP 0310-1
INSTRUMENT PANEL REPLACEMENT.....	WP 0309-1

M

MAIN LIGHT SWITCH REPLACEMENT.....	WP 0315-1
MUFFLER AND SHIELD REPLACEMENT.....	WP 0274-1

N

NG05: LOW PRESSURE CHECK.....	WP 0197-1
NG130: ENGINE TIGHTNESS TEST.....	WP 0205-1
NG20: NO CRANK- NO START.....	WP 0198-1
NG30: ENGINE CRANK - NO START.....	WP 0199-1
NG31: GAUGE TEST.....	WP 0200-1
NG50: CHARGING CIRCUIT TESTS.....	WP 0201-1
NG80: STARTER CIRCUIT TESTS.....	WP 0202-1
NG81: BATTERY TESTS.....	WP 0203-1
NG90: GOVERNOR/POWER TEST FAULT ISOLATION.....	WP 0204-1

O

OIL DIPSTICK TUBE REPLACEMENT.....	WP 0228-1
OIL PAN AND OIL SUCTION TUBE (M939A2).....	WP 0230-1
OIL PRESSURE SENDING UNIT REPLACEMENT.....	WP 0333-1
OIL PUMP PICKUP HOSE REPLACEMENT (M939/A1).....	WP 0224-1
OIL PUMP RETURN HOSE REPLACEMENT (M939/A1).....	WP 0225-1

P

POWER PLANT REPLACEMENT (M939/A1).....	WP 0211-1
POWER PLANT REPLACEMENT (M939A2).....	WP 0213-1
PRESSURE SWITCH REPLACEMENT.....	WP 0324-1
PREVENTIVE MAINTENANCE CHECKS AND SERVICES (PMCS) INTRODUCTION.....	WP 0206-1
PREVENTIVE MAINTENANCE CHECKS AND SERVICES FOR MODELS M939/A1/A2 (ANNUAL).....	WP 0208-1
PREVENTIVE MAINTENANCE CHECKS AND SERVICES FOR MODELS M939/A1/A2 (BIENNIAL).....	WP 0209-1
PREVENTIVE MAINTENANCE CHECKS AND SERVICES FOR MODELS M939/A1/A2 (SEMIANNUAL).....	WP 0207-1
PRIMARY AND SECONDARY LOW AIR PRESSURE SWITCH REPLACEMENT.....	WP 0342-1
PRIMING FUEL SYSTEM SERVICING (M939A2).....	WP 0239-1
PROTECTIVE CONTROL BOX REPLACEMENT.....	WP 0319-1

R

RADIATOR AND MOUNTING HARDWARE REPLACEMENT (M939/A1).....	WP 0281-1
RADIATOR AND MOUNTING HARDWARE REPLACEMENT (M939A2 ONLY).....	WP 0277-1
RADIATOR FAN BLADE REPLACEMENT (M939/A1).....	WP 0298-1
RADIATOR FAN SHROUD REPLACEMENT (M939/A1).....	WP 0282-1
REAR EXHAUST PIPE, SUPPORT BRACKET, AND CAB HEAT SHIELD REPLACEMENT.....	WP 0275-1

Subject

WP Sequence No.-Page No.

S

SERVICE UPON RECEIPT.....	WP 0210-1
SIDE MARKER LIGHTS AND BRACKET REPLACEMENT.....	WP 0330-1
SPEED SIGNAL GENERATOR REPLACEMENT.....	WP 0323-1
SPRING BRAKE PRESSURE SWITCH REPLACEMENT.....	WP 0308-1
STARTER REPLACEMENT.....	WP 0303-1
STE/ICE TROUBLESHOOTING.....	WP 0186-1
STE/ICE TROUBLESHOOTING INDEX.....	WP 0187-1
STOPLIGHT SWITCH REPLACEMENT.....	WP 0335-1
SURGE TANK AND BRACKET REPLACEMENT (M939A2).....	WP 0279-1
SURGE TANK, RADIATOR VENT HOSE, AND MANIFOLD RETURN HOSE REPLACEMENT (M939/A1).....	WP 0278-1

T

TACHOMETER PULSE SENSOR REPLACEMENT.....	WP 0338-1
TACHOMETER PULSE SENSOR REPLACEMENT (M939A2).....	WP 0339-1
THERMOSTAT AND HOUSING REPLACEMENT (M939/A1).....	WP 0288-1
THERMOSTATS AND HOUSING REPLACEMENT (M939A2).....	WP 0289-1
THROTTLE CONTROL CABLE REPLACEMENT.....	WP 0270-1
THROTTLE CONTROL SOLENOID REPLACEMENT (M939A2).....	WP 0304-1
TRANSMISSION TEMPERATURE TRANSMITTER REPLACEMENT.....	WP 0341-1
TROUBLESHOOTING ABS WITHOUT DIAGNOSTIC TOOLS.....	WP 0156-1
TURBOCHARGER HOSES AND CLAMPS REPLACEMENT (M939A2).....	WP 0249-1
TURN SIGNAL CONTROL AND INDICATOR LAMP REPLACEMENT.....	WP 0317-1
TURN SIGNAL FLASHER REPLACEMENT.....	WP 0318-1

U

UPPER RADIATOR HOSES AND BRACKETS REPLACEMENT (M939A2).....	WP 0286-1
---	-----------

V

VALVE COVER REPLACEMENT (M939A2).....	WP 0222-1
VIBRATION DAMPENER REPLACEMENT (M939A2).....	WP 0219-1

W

WATER HEADER PLATES REPLACEMENT (M939/A1).....	WP 0291-1
WATER PUMP DRIVEBELT REPLACEMENT (M939/A1).....	WP 0294-1
WATER PUMP REPLACEMENT (M939/A1).....	WP 0293-1
WATER PUMP REPLACEMENT (M939A2).....	WP 0292-1
WATER TEMPERATURE SENDING UNIT REPLACEMENT.....	WP 0334-1
WHEEL SPEED SENSOR OUTPUT TEST.....	WP 0160-1

RECOMMENDED CHANGES TO PUBLICATIONS AND BLANK FORMS						Use Part II (reverse) for Repair Parts and Special Tool Lists (RPSTL) and Supply Catalogs/Supply Manuals (SC/SM).	DATE <i>Date you filled out this form.</i>
For use of this form, see AR 25-30; the proponent agency is OAASA.							
TO (Forward to proponent of publication or form) (Include ZIP Code) U.S. Army TACOM Life Cycle Management Command ATTN: AMSTA-LCL-MPP/TECH PUBS 6501 E. 11 Mile Road, Warren, MI 48397-5000						FROM (Activity and location) (Include ZIP Code) <i>Your mailing address</i>	
PART I – ALL PUBLICATIONS (EXCEPT RPSTL AND SC/SM) AND BLANK FORMS							
PUBLICATION/FORM NUMBER <i>TM Number</i>						DATE <i>Date of the TM</i>	TITLE <i>Title of the TM</i>
ITEM	PAGE	PARA-GRAPH	LINE	FIGURE NO.	TABLE	RECOMMENDED CHANGES AND REASON (Exact wording of recommended change must be given)	
	0007-3					<i>Figure 2, Item 9 should show a lockwasher. Currently shows a flat washer.</i>	
	0018-2					<i>Cleaning and inspection, Step 6, reference to governor support pin (14) is wrong reference. Reference should be change to (12).</i>	
<h1>SAMPLE</h1>							
TYPED NAME, GRADE OR TITLE <i>Your Name</i>						TELEPHONE EXCHANGE/AUTOVON, PLUS EXTENSION <i>Your Phone Number</i>	SIGNATURE <i>Your Signature</i>

TO (Forward direct to addressee listed in publication) U.S. Army TACOM Life Cycle Management Command ATTN: AMSTA-LCL-MPP/TECH PUBS 6501 E. 11 Mile Road, Warren, MI 48397-5000	FROM (Activity and location) (Include ZIP Code) <i>Your Address</i>	DATE <i>Date you filled out this form</i>
--	---	---

PART II – REPAIR PARTS AND SPECIAL TOOL LISTS AND SUPPLY CATALOGS/SUPPLY MANUALS

PUBLICATION NUMBER <i>TM Number</i>	DATE <i>Date of the TM</i>	TITLE <i>Title of the TM</i>
--	-------------------------------	---------------------------------

PAGE NO.	COLM NO.	LINE NO.	NATIONAL STOCK NUMBER	REFERENCE NO.	FIGURE NO.	ITEM NO.	TOTAL NO. OF MAJOR ITEMS SUPPORTED	RECOMMENDED ACTION
<h1>SAMPLE</h1>								

PART III – REMARKS (Any general remarks, or recommendations, or suggestions for improvement of publications and blank forms. Additional blank sheets may be used if more space is needed.)

TYPED NAME, GRADE OR TITLE <i>Your Name</i>	TELEPHONE EXCHANGE/AUTOVON, PLUS EXTENSION <i>Your Phone Number</i>	SIGNATURE <i>Your Signature</i>
--	--	------------------------------------

RECOMMENDED CHANGES TO PUBLICATIONS AND BLANK FORMS						Use Part II (reverse) for Repair Parts and Special Tool Lists (RPSTL) and Supply Catalogs/Supply Manuals (SC/SM).	DATE
For use of this form, see AR 25-30; the proponent agency is OAASA							
TO (Forward to proponent of publication or form) (Include ZIP Code) U.S. Army TACOM Life Cycle Management Command ATTN: AMSTA-LCL-MPP/TECH PUBS 6501 E. 11 Mile Road, Warren, MI 48397-5000						FROM (Activity and location) (Include ZIP Code)	
PART I – ALL PUBLICATIONS (EXCEPT RPSTL AND SC/SM) AND BLANK FORMS							
PUBLICATION/FORM NUMBER TM 9-2320-272-23-2						DATE 10 September 2012	TITLE Truck, 5-Ton, 6X6, M939A1, And M939A2 Series Trucks (Diesel), Field Maintenance Manual
	PAGE	PARA-GRAPH	LINE	FIGURE NO.	TABLE	RECOMMENDED CHANGES AND REASON	
TYPED NAME, GRADE OR TITLE					TELEPHONE EXCHANGE/AUTOVON, PLUS EXTENSION		SIGNATURE

TO <i>(Forward direct to addressee listed in publication)</i> U.S. Army TACOM Life Cycle Management Command ATTN: AMSTA-LCL-MPP/TECH PUBS 6501 E. 11 Mile Road, Warren, MI 48397-5000	FROM <i>(Activity and location) (Include ZIP Code)</i>	DATE
---	---	-------------

PART II – REPAIR PARTS AND SPECIAL TOOL LISTS AND SUPPLY CATALOGS/SUPPLY MANUALS

PUBLICATION/FORM NUMBER TM 9-2320-272-23-2	DATE 10 September 2012	TITLE Truck, 5-Ton, 6X6, M939A1, And M939A2 Series Trucks (Diesel), Field Maintenance Manual
--	----------------------------------	--

PAGE NO.	COLM NO.	LINE NO.	NATIONAL STOCK NUMBER	REFERENCE NO.	FIGURE NO.	ITEM NO.	TOTAL NO. OF MAJOR ITEMS SUPPORTED	RECOMMENDED ACTION

PART III – REMARKS *(Any general remarks, or recommendations, or suggestions for improvement of publications and blank forms. Additional blank sheets may be used if more space is needed.)*

TYPED NAME, GRADE OR TITLE	TELEPHONE EXCHANGE/AUTOVON, PLUS EXTENSION	SIGNATURE
----------------------------	--	-----------

RECOMMENDED CHANGES TO PUBLICATIONS AND BLANK FORMS						Use Part II (reverse) for Repair Parts and Special Tool Lists (RPSTL) and Supply Catalogs/Supply Manuals (SC/SM).	DATE
For use of this form, see AR 25-30; the proponent agency is OAASA							
TO (Forward to proponent of publication or form) (Include ZIP Code) U.S. Army TACOM Life Cycle Management Command ATTN: AMSTA-LCL-MPP/TECH PUBS 6501 E. 11 Mile Road, Warren, MI 48397-5000						FROM (Activity and location) (Include ZIP Code)	
PART I – ALL PUBLICATIONS (EXCEPT RPSTL AND SC/SM) AND BLANK FORMS							
PUBLICATION/FORM NUMBER TM 9-2320-272-23-2						DATE 10 September 2012	TITLE Truck, 5-Ton, 6X6, M939A1, And M939A2 Series Trucks (Diesel), Field Maintenance Manual
ITEM	PAGE	PARA-GRAPH	LINE	FIGURE NO.	TABLE	RECOMMENDED CHANGES AND REASON	
TYPED NAME, GRADE OR TITLE					TELEPHONE EXCHANGE/AUTOVON, PLUS EXTENSION		SIGNATURE

TO <i>(Forward direct to addressee listed in publication)</i> U.S. Army TACOM Life Cycle Management Command ATTN: AMSTA-LCL-MPP/TECH PUBS 6501 E. 11 Mile Road, Warren, MI 48397-5000	FROM <i>(Activity and location) (Include ZIP Code)</i>	DATE
---	---	-------------

PART II – REPAIR PARTS AND SPECIAL TOOL LISTS AND SUPPLY CATALOGS/SUPPLY MANUALS

PUBLICATION/FORM NUMBER TM 9-2320-272-23-2	DATE 10 September 2012	TITLE Truck, 5-Ton, 6X6, M939A1, And M939A2 Series Trucks (Diesel), Field Maintenance Manual
--	----------------------------------	--

PAGE NO.	COLM NO.	LINE NO.	NATIONAL STOCK NUMBER	REFERENCE NO.	FIGURE NO.	ITEM NO.	TOTAL NO. OF MAJOR ITEMS SUPPORTED	RECOMMENDED ACTION

PART III – REMARKS *(Any general remark, or recommendations, or suggestions for improvement of publications and blank forms. Additional blank sheets may be used if more space is needed.)*

TYPED NAME, GRADE OR TITLE	TELEPHONE EXCHANGE/AUTOVON, PLUS EXTENSION	SIGNATURE
----------------------------	--	-----------

RECOMMENDED CHANGES TO PUBLICATIONS AND BLANK FORMS						Use Part II (reverse) for Repair Parts and Special Tool Lists (RPSTL) and Supply Catalogs/Supply Manuals (SC/SM).	DATE
For use of this form, see AR 25-30; the proponent agency is OAASA							
TO (Forward to proponent of publication or form) (Include ZIP Code) U.S. Army TACOM Life Cycle Management Command ATTN: AMSTA-LCL-MPP/TECH PUBS 6501 E. 11 Mile Road, Warren, MI 48397-5000						FROM (Activity and location) (Include ZIP Code)	
PART I – ALL PUBLICATIONS (EXCEPT RPSTL AND SC/SM) AND BLANK FORMS							
PUBLICATION/FORM NUMBER TM 9-2320-272-23-2						DATE 10 September 2012	TITLE Truck, 5-Ton, 6X6, M939A1, And M939A2 Series Trucks (Diesel), Field Maintenance Manual
ITEM	PAGE	PARA-GRAPH	LINE	FIGURE NO.	TABLE	RECOMMENDED CHANGES AND REASON	
TYPED NAME, GRADE OR TITLE					TELEPHONE EXCHANGE/AUTOVON, PLUS EXTENSION		SIGNATURE

TO <i>(Forward direct to addressee listed in publication)</i> U.S. Army TACOM Life Cycle Management Command ATTN: AMSTA-LCL-MPP/TECH PUBS 6501 E. 11 Mile Road, Warren, MI 48397-5000	FROM <i>(Activity and location) (Include ZIP Code)</i>	DATE
---	---	-------------

PART II – REPAIR PARTS AND SPECIAL TOOL LISTS AND SUPPLY CATALOGS/SUPPLY MANUALS

PUBLICATION/FORM NUMBER TM 9-2320-272-23-2	DATE 10 September 2012	TITLE Truck, 5-Ton, 6X6, M939A1, And M939A2 Series Trucks (Diesel), Field Maintenance Manual
--	----------------------------------	--

PAGE NO.	COLM NO.	LINE NO.	NATIONAL STOCK NUMBER	REFERENCE NO.	FIGURE NO.	ITEM NO.	TOTAL NO. OF MAJOR ITEMS SUPPORTED	RECOMMENDED ACTION

PART III – REMARKS *(Any general remarks, recommendations, or suggestions for improvement of publications and blank forms. Additional blank sheets may be used if more space is needed.)*

TYPED NAME, GRADE OR TITLE	TELEPHONE EXCHANGE/AUTOVON, PLUS EXTENSION	SIGNATURE
----------------------------	--	-----------

By Order of the Secretary of the Army:

Official:



JOYCE E. MORROW
*Administrative Assistant to the
Secretary of the Army*

1220208

RAYMOND T. ODIERNO
*General, United States Army
Chief of Staff*

By Order of the Secretary of the Air Force:

DONALD J. HOFFMAN
*General, United States Air Force
Commander, AFMC*

NORTON A. SCHWARTZ
*General, United States Air Force
Chief of Staff*

Distribution:

To be distributed in accordance with the initial distribution number (IDN) 386968
requirements for TM 9-2320-272-23-2 .

THE METRIC SYSTEM AND EQUIVALENTS

LINEAR MEASURE

1 Centimeter=10 Millimeters=0.01 Meters=0.3937 Inches
 1 Meter=100 Centimeters=1000 Millimeters=39.37 Inches
 1 Kilometer=1000 Meters=0.621 Miles

WEIGHTS

1 Gram=0.001 Kilograms=1000 Milligrams=0.035 Ounces
 1 Kilogram=1000 Grams=2.2 Lb
 1 Metric Ton=1000 Kilograms=1 Megagram=1.1 Short Tons

LIQUID MEASURE

1 Milliliter=0.001 Liters=0.0338 Fluid Ounces
 1 Liter=1000 Milliliters=33.82 Fluid Ounces

SQUARE MEASURE

1 Sq Centimeter=100 Sq Millimeters=0.155 Sq Inches
 1 Sq Meter=10,000 Sq Centimeters=10.76 Sq Feet
 1 Sq Kilometer=1,000,000 Sq Meters=0.386 Sq Miles

CUBIC MEASURE

1 Cu Centimeter=1000 Cu Millimeters=0.06 Cu Inches
 1 Cu Meter=1,000,000 Cu Centimeters=35.31 Cu Feet

TEMPERATURE

$5/9 (^{\circ}\text{F} - 32) = ^{\circ}\text{C}$
 212°Fahrenheit is equivalent to 100°Celsius
 90°Fahrenheit is equivalent to 32.2°Celsius
 32°Fahrenheit is equivalent to 0°Celsius
 $9/5 (^{\circ}\text{C} + 32) = ^{\circ}\text{F}$

APPROXIMATE CONVERSION FACTORS

<u>TO CHANGE</u>	<u>TO</u>	<u>MULTIPLY BY</u>
Inches	Centimeters	2.540
Feet	Meters	0.305
Yards	Meters	0.914
Miles	Kilometers	1.609
Square Inches	Square Centimeters	6.451
Square Feet	Square Meters	0.093
Square Yards	Square Meters	0.836
Square Miles	Square Kilometers	2.590
Acres	Square Hectometers	0.405
Cubic Feet	Cubic Meters	0.028
Cubic Yards	Cubic Meters	0.765
Fluid Ounces	Milliliters	29.573
Pints	Liters	0.473
Quarts	Liters	0.946
Gallons	Liters	3.785
Ounces	Grams	28.349
Pounds	Kilograms	0.454
Short Tons	Metric Tons	0.907
Pound-Feet	Newton-Meters	1.356
Pounds/Sq Inch	Kilopascals	6.895
Miles per Gallon	Kilometers per Liter	0.425
Miles per Hour	Kilometers per Hour	1.609

<u>TO CHANGE</u>	<u>TO</u>	<u>MULTIPLY BY</u>
Centimeters	Inches	0.394
Meters	Feet	3.280
Meters	Yards	1.094
Kilometers	Miles	0.621
Sq Centimeters	Square Inches	0.155
Square Meters	Square Feet	10.764
Square Meters	Square Yards	1.196
Square Kilometers	Square Miles	0.386
Sq Hectometers	Acres	2.471
Cubic Meters	Cubic Feet	35.315
Cubic Meters	Cubic Yards	1.308
Milliliters	Fluid Ounces	0.034
Liters	Pints	2.113
Liters	Quarts	1.057
Liters	Gallons	0.264
Grams	Ounces	0.035
Kilograms	Pounds	2.205
Metric Tons	Short Tons	1.102
Newton-Meters	Pound-Feet	0.738
Kilopascals	Pounds per Sq Inch	0.145
Km per Liter	Miles per Gallon	2.354
Km per Hour	Miles per Hour	0.621

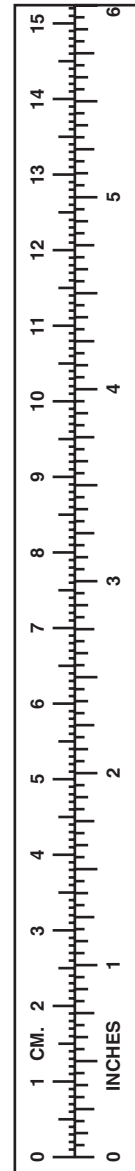

PIN: 087176-000