

- (f) Connect wiring harness ((N), fig. 23) to head light wiring connector ((B), fig. 22) using spanner wrench 41-W-3249-900.
- (4) *Operations at left side of vehicle.*
- (a) Assemble engine mounting cushion ((K), fig. 42), special washer ((L), fig. 42), and  $\frac{3}{8}$ -24 nut on engine mounting bolt ((J), fig. 42) and tighten nut firmly.
- (b) Install  $\frac{1}{2}$ -20 x  $1\frac{3}{8}$  cap screw ((N), fig. 42) with  $\frac{1}{2}$ -inch lock washer ((P), fig. 42) to anchor power plant rear mounting ((E), fig. 21) to rear support cushion ((Q), fig. 42).
- (c) Connect flexible fuel line ((H), fig. 23) to carburetor ((C), fig. 21).
- (d) Connect rod ((G), fig. 23) linking transmission lever and transfer reverse cross shaft by installing yoke pin at transmission end of rod ((F), fig. 21).
- (e) Connect air compressor discharge line ((K), fig. 23) to elbow ((B), fig. 21) on air compressor and secure line to base of air compressor with clip ((J), fig. 21).
- (f) Disconnect brace ((A), fig. 21) from engine cylinder head stud and position in clip on radiator support.

## 69. Installation of Rear Exhaust Pipe

*Note.* Key letters in following text indicate connect points and refer to figure 41.

a. Install exhaust pipe supporting strap (E) and rear exhaust pipe supporting clamp (H) on rear exhaust pipe (J) with  $\frac{3}{8}$ -24 x  $1\frac{5}{8}$  cap screw (G), clamp screw spacer (D), plain washer (F), and  $\frac{3}{8}$ -24 nut (C). Do not tighten nut.

b. Install new exhaust pipe seals (A) at exhaust pipe ends.

c. Position rear exhaust pipe (J) at muffler (N) and front exhaust pipe (K), then secure exhaust pipe connecting clamp (B) at each end of pipe.

d. Attach rear exhaust pipe hanger strap (E) to transmission rear support by installing  $\frac{5}{16}$ -24 x  $1\frac{5}{8}$  cap screw, flat washer, and spacer, with rubber insulator on each side of strap, through transmission rear support and secure with  $\frac{5}{16}$ -24 nut. Tighten nut firmly.

e. Tighten cap screw nut on rear exhaust pipe supporting clamp (H) to torque of 20 to 27 pound-feet.

## 70. Installation of Cab

*Note.* Key letters in following text indicate connect points and refer to figure 43.

a. *General.*

- (1) The cab assembly, which includes instruments, accelerator pedal, engine air cleaner, generator regulator, wiring, batteries, air lines, vent lines, parking brake lever, transfer lever, power take-off lever, muffler tail pipes, hood extension panels, hood props, running boards, tool box, fluid container bracket, gun mount bracket, and "U" bolts, can be installed as an assembly.
- (2) A suitable chain fall must be provided to lift cab onto chassis.
- (3) The sequence of procedures for installing cab on chassis are listed in logical sequence, permitting the use of more than one mechanic; however, the sequence can be changed to meet existing conditions or facilities.

b. *Raise Cab Onto Chassis.*

- (1) Attach hoist to four lifting ring nuts on cab.
- (2) Raise cab high enough to clear steering gear column and move cab to position above mountings on frame.
- (3) Lower cab, taking care to avoid damage to steering column, fuel tank, control linkage, etc. Do not rest cab solidly on supports until rubber cushions (D) at each front support are in place and bolt holes are alined.
- (4) Install steel washer (C) and cushion (D) on each front mounting bolt (B); then from inside of cab, insert bolts through cab, cushion (D), and support bracket.
- (5) Position rubber cushion (K) and steel spacer (G) into place under rear center of cab. Aline with center cap screw hole in cross member.
- (6) Install steel washer (H) and cushion (K) on  $\frac{1}{2}$ -20 x  $4\frac{1}{2}$  cap screw (J); then insert cap screw through cab floor, steel spacer, mounting cushion, and frame cross member.
- (7) Install two  $\frac{7}{16}$ -20 x 1 cap screws (N) and  $\frac{7}{16}$ -20 nuts which attach each cab mounting spring to frame cross member.
- (8) Lower cab and remove hoist.
- (9) Install two lower cushions (D), steel washer (E), and  $\frac{1}{2}$ -20 nut (F) on each front mounting bolt (B). Tighten nut firmly against shoulder on bolt.
- (10) Install cushion (K), steel washer (L), and  $\frac{1}{2}$ -20 nut (M) on rear center cap screw. Tighten nut firmly.

c. *Procedures Underneath Cab.*

- (1) Connect speedometer shaft ((T), fig. 18) to transfer. Tighten connector nut firmly.
- (2) Connect parking brake lever rod ((V), fig. 18) to relay lever ((N), fig. 19 or (G), fig. 36) on frame cross member with yoke pin and cotter pin.



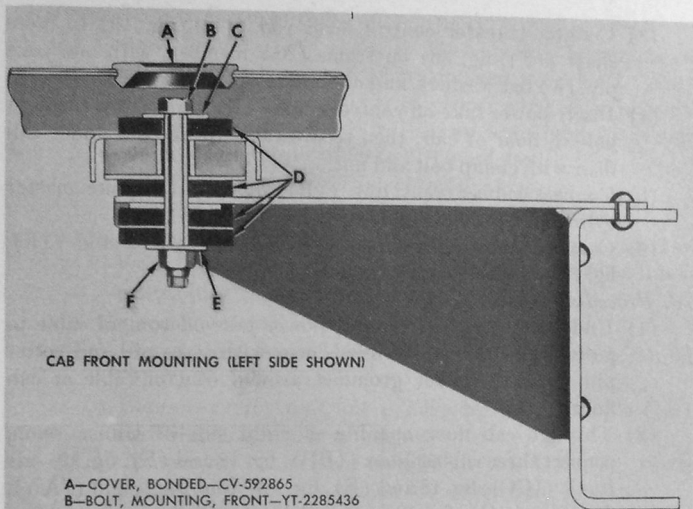

CAB FRONT MOUNTING (LEFT SIDE SHOWN)

- A—COVER, BONDED—CV-592865
- B—BOLT, MOUNTING, FRONT—YT-2285436
- C—WASHER—YT-2202966
- D—CUSHION—YT-2074388
- E—WASHER—YT-2285443
- F—NUT, 1/2-20—442801
- G—SPACER—GM-2073217
- H—WASHER—YT-2202966
- J—SCREW, CAP, 1/2-20x4-1/2—189347
- K—CUSHION—YT-2073216
- L—WASHER—YT-2202966
- M—NUT, 1/2-20—442801
- N—SCREW, CAP, 7/16-20x1—1811666

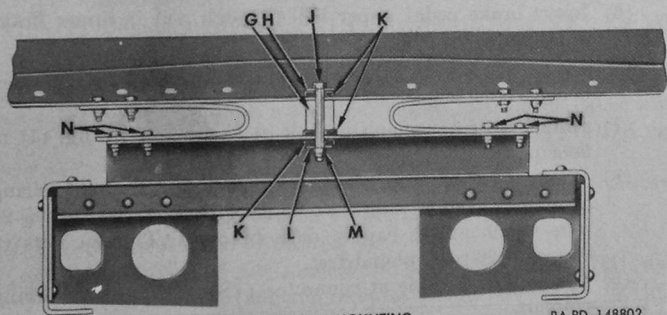

CAB REAR MOUNTING

RA PD 148802

Figure 43. Cab mountings.

- (3) Connect transfer control lever rod ((U), fig. 18) to cross shaft ((F), fig. 36) on frame cross member, with one yoke pin, two flat washers, and one cotter pin.
- (4) Insert power take-off control cable ((P), fig. 19) up through hole in floor of cab; then secure cable to bracket under cab floor with clamp bolt and nut.
- (5) Connect rubber vent line ((R), fig. 18) to brake master cylinder ((R), fig. 19).
- (6) Connect starter ground cable ((H), fig. 18) to stud ((F), fig. 22) on starter. Tighten nut firmly.

*d. Procedures Inside of Cab.*

- (1) Under drivers seat, connect power take-off control cable to power take-off hand control lever with yoke pin and cotter pin. Install rubber grommet around control cable at cab floor.
- (2) Through cab floor opening at right side of transmission, connect three rubber lines ((BB), fig. 18 and (F), fig. 19—air line), ((CC), fig. 18 and (E), fig. 19—vent line), and ((AA), fig. 18 and (G), fig. 19—exhaust line). Tighten connections firmly.
- (3) Install cab front floor pan over transmission control tower and secure to floor with fourteen  $\frac{5}{16}$ -24 x  $\frac{5}{8}$  cap screws.
- (4) Position rubber seal over shift control tower; then lower seal against floor pan.
- (5) Raise rubber seal on steering column; then install upper brake pedal plate and lower brake pedal plate to cowl with seven  $\frac{5}{16}$ -24 x  $\frac{5}{8}$  cap screws. Position steering column seal against top of pedal plates.
- (6) Insert brake pedal upper ball through seal in upper brake pedal plate.

*Note.* Refer to *e*(1) below for attaching brake pedal upper ball to brake pedal lower half.

- (7) Install cab front mounting bolt hole covers ((A), fig. 43) in floor pan.
- (8) Position rubber grommet and bracket cap around steering column at dash. Install two  $\frac{3}{8}$ -24 x 2 cap screws and  $\frac{3}{8}$ -24 nuts which attach cap to dash bracket. Tighten nuts to torque of 20 to 27 pound-feet.
- (9) Connect horn cable at connector ((S), fig. 19) on steering column.
- (10) Install steering wheel on steering gear shaft; then install nut. Tighten nut to torque of 40 to 55 pound-feet.
- (11) Position horn button contact and spring over steering shaft nut, and install horn button and retaining ring; then attach retaining ring to steering wheel with four No. 8 x  $\frac{7}{8}$  screws.

*e. Procedures at Front of Cab.*

- (1) *Connect brake upper pedal to lower pedal.* Insert brake pedal upper half into end of brake pedal lower half. Aline notch in pedal upper half with clamp screw hole in pedal lower half. Install  $\frac{3}{8}$ -24 x  $1\frac{5}{8}$  cap screw and  $\frac{3}{8}$ -24 nut. Tighten nut to torque of 20 to 27 pound-feet.
- (2) *Connect choke and throttle controls.*
  - (a) Connect choke control ((F), fig. 18) at carburetor.
  - (b) Connect throttle rod ((H), fig. 21) linking accelerator lever ((GG), fig. 18) on cowl to accelerator lever on intake manifold with clevis pin and cotter pin.
- (3) *Connect hoses and lines.*
  - (a) Connect air cleaner hose ((G), fig. 18) to elbow ((B), fig. 19) on carburetor.
  - (b) Connect engine vent line ((EE), fig. 18) to nipple ((D), fig. 19) on right side of engine.
  - (c) Connect air compressor-to-cowl air line ((Z), fig. 18) to connector ((A), fig. 19) on air compressor governor.
- (4) *Install batteries.*
  - (a) Position battery on battery support. Install battery retainer over hold-down bolts. Make sure battery lifting handles are positioned in recess of battery to prevent battery retainer from resting on top of battery. Install  $\frac{5}{16}$ -inch lock washer and  $\frac{5}{16}$ -18 nut on each hold-down bolt; then tighten nuts firmly.
  - (b) Install battery cables and terminals on battery posts and tighten clamp bolts. Refer to figure 44 for battery cable identification.
  - (c) Engage starter cable ((K), fig. 19) in clips ((F), fig. 18) on cowl.
- (5) *Connect wiring harness and cables.*
  - (a) Connect engine wiring harness to instrument panel wiring harness at three bayonet type connectors ((DD), fig. 18 and (H), fig. 19).
  - (b) Connect generator wiring cable ((Y), fig. 18) to generator, using spanner wrench 41-W-3249-900.

*f. Procedures at Sides of Cab.*

- (1) At left side of cab, connect two wiring harnesses ((Q), fig. 19) at multiple plug and receptacle connectors ((N), fig. 18) located under cab floor directly above running board, using spanner wrench 41-W-3249-900, then engage harnesses in clips ((Q), fig. 18) on running board rear support.
- (2) At right side of cab, install new seal on tail pipe and connect tail pipe to muffler with clamp.



Figure 44. Battery cables installed.

## 71. Installation of Fender and Skirt Assemblies

*a. General.*—Each fender and skirt assembly, which includes hood catch, fender support, fender brace, and blackout head light on left fender assembly only, can be installed as an assembly.

*b. Installation Procedures.*

- (1) Position fender assembly to vehicle. Install one  $\frac{1}{2}$ -20 x 1 cap screw and plain washer which attach each fender skirt to radiator side baffles ((E), fig. 16).
- (2) Install one  $\frac{1}{2}$ -20 x 1 cap screw, one plain washer, and one lock washer which attach each fender brace to bracket ((L), fig. 18) on cowl.
- (3) Install two  $\frac{5}{16}$ -24 x  $1\frac{3}{8}$  cap screws, one rubber spacer, two washers, and two  $\frac{5}{16}$ -24 nuts which attach each fender to running board ((P), fig. 18).
- (4) Install two  $\frac{1}{2}$ -20 x 1 cap screws, two plain washers, and two lock washers which attach each fender support to brush guard and radiator side baffle ((A), fig. 16).
- (5) At left fender, connect blackout head light wiring cables at two bayonet type connectors.

## 72. Installation of Hood Assembly

*a. General.*—The hood assembly, which includes horn and horn air supply line, can be installed as an assembly.

*b. Installation Procedures.*

- (1) Position hood assembly on vehicle, with hinge cap screw holes alined. Install  $\frac{5}{16}$ -24 x  $2\frac{1}{2}$  cap screw and  $\frac{5}{16}$ -24 nut in each hinge; then, while supporting hood in upright position, connect each prop ((A), fig. 18) to hood with two  $\frac{1}{4}$ -28 x  $\frac{5}{8}$  cap screws.
- (2) Connect horn air supply line to air line fitting ((E), fig. 18) on cowl.
- (3) Connect horn wiring cables at two bayonet type connectors ((J), fig. 18).

### 73. Installation of Winch

a. *General.*—The winch assembly, which includes support brackets and drive shaft universal joint, can be installed as an assembly. A suitable chain fall is required to install winch assembly.

b. *Installation Procedures.*

- (1) Install right and left support brackets ((D) and (A), fig. 45) on which with special bolts ((E), fig. 45) and  $\frac{3}{16}$ -inch lock washers.
- (2) Install front universal joint ((B), fig. 45) on splines of winch shaft and insert shear pin ((C), fig. 45) through joint and shaft. Secure shear pin with two cotter pins.
- (3) Supporting winch with chain fall, guide winch with support brackets attached (fig. 45) between frame side members. As winch is pushed toward rear, guide front universal joint splines onto front drive shaft splines.
- (4) Position support brackets in place in frame. Install eight  $\frac{5}{8}$ -18 x  $1\frac{3}{4}$  bracket-to-frame cap screws ((A), (B), (C), and (F), fig. 17) and eight  $\frac{5}{8}$ -18 nuts. Tighten nuts to torque of 95 to 127 pound-feet.
- (5) Position front drive shaft stop  $\frac{3}{8}$ -inch from winch universal joint yoke. Lock stop to shaft with  $\frac{3}{16}$ -16 x  $\frac{1}{2}$  set screw.

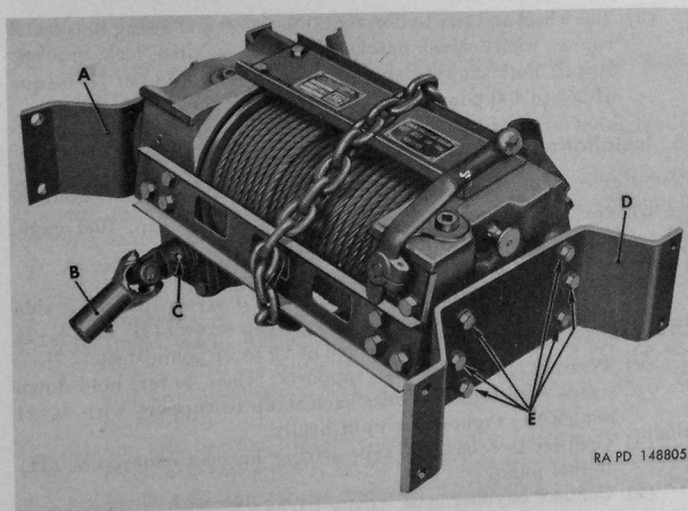

Figure 45. Winch assembly.

## 74. Installation of Front Bumper Assembly

*a. General.*—The front bumper assembly, which includes gussets, can be installed as an assembly.

### *b. Installation Procedures.*

- (1) Position bumper assembly in place on front of frame side members with attaching cap screw holes in alinement.
- (2) Install eight cap screws ((D), fig. 16) and nuts. Tighten nuts firmly.
- (3) Position tow hook ((C), fig. 16) to bracket on bumper and secure with shackle pin ((B), fig. 16); then install cotter pin through hole in shackle pin.

## 75. Installation of Spare Wheel and Carrier

*a. General.*—The spare wheel carrier, less the spare wheel and tire, should be installed first on frame side member; then install spare wheel and tire on carrier.

### *b. Installation Procedures.*

- (1) Position spare wheel carrier and bracket to frame side member. Install four  $\frac{1}{2}$ -20 x  $1\frac{1}{4}$  cap screws and  $\frac{1}{2}$ -20 nuts which attach carrier to side member. Tighten nuts to torque of 48 to 64 pound-feet.
- (2) Position spare wheel and tire on carrier swivel bracket and attach with four  $\frac{3}{4}$ -16 nuts. Tighten nuts to torque of 250 to 300 pound-feet.
- (3) Tip wheel and tire to horizontal position and swing in toward frame, with swivel bracket in place against lock bracket. Install nuts on two attaching studs and tighten to torque of 250 to 300 pound-feet.

## 76. Installation of Fuel Tank and Supports

*Note.* Key letters in following text indicate connect points and refer to figure 24.

*a. General.*—The fuel tank, which includes filler cap, fuel gage, and fuel pump, can be installed as an assembly.

### *b. Installation Procedures.*

- (1) Position each fuel tank support and strap to frame side member and install four  $\frac{3}{8}$ -24 x 1 cap screws (B) and  $\frac{3}{8}$ -24 nuts. Tighten nuts to torque of 20 to 27 pound-feet.
- (2) Position fuel tank on supports; then lower hold-down straps over tank. Secure each strap to support with  $\frac{3}{8}$ -24 nut (K). Tighten each nut firmly.
- (3) Connect two bayonet type wiring harness connectors (H) at fuel pump.
- (4) Connect bayonet type wiring harness connector (G) at fuel gage sending unit.



- (5) Engage wiring harness in clip (D) at fuel gage sending unit.
- (6) Connect fuel line (C) to fuel tank shut-off cock (J).
- (7) Connect vent line (E) to fuel tank elbow (F).
- (8) Engage chassis wiring harness in clip (A) on fuel tank front support.

## 77. Installation of Rear Tow Hooks, Bumpers, Pintle, and Pintle Brackets

*a. Installation of Rear Tow Hooks.*—Position each tow hook at bracket on rear cross member and secure with shackle pin; then install cotter pin through hole in shackle pin.

*b. Installation of Rear Bumpers.*—Position each rear bumper against frame side member and rear cross member with cap screw holes in alinement. Install four  $\frac{1}{2}$ -20 x  $1\frac{5}{8}$  and two  $\frac{1}{2}$ -20 x  $1\frac{1}{2}$  cap screws ((A), fig. 37) and nuts in each bumper. Tighten nuts to torque of 48 to 64 pound-feet.

*c. Installation of Pintle and Pintle Brackets.*

- (1) Install two  $\frac{3}{4}$ -16 x 3 cap screws and two  $\frac{3}{4}$ -16 nuts which attach inner and outer pintle brackets to rear cross member. Tighten nuts to torque of 165 to 220 pound-feet.
- (2) Lubricate pintle shaft and insert shaft through brackets and cross member. Install one  $1\frac{1}{2}$ -12 nut and one plain washer on shaft. Use bar through pintle jaw to prevent turning as nut is tightened. Tighten until pintle binds; then back off nut until cotter pin can be installed and pintle can be turned by hand.

## 78. Installation of Trailer Air Connection and Tail Light Bracket Assemblies

*a. General.* The right bracket assembly, which includes trailer air connection cut-out cock and coupling, and the left bracket assembly, which includes chassis wiring harness trailer connection receptacle, receptacle cover, air cut-out cock, and trailer air supply coupling, can be installed as assemblies.

*b. Installation Procedures.*

- (1) Install cut-out cock and trailer air supply coupling on each bracket.
- (2) Install each bracket assembly to frame side member with two  $\frac{1}{2}$ -20 x  $1\frac{1}{2}$  cap screws ((B), fig. 37 and (A), fig. 38) and two  $\frac{1}{2}$ -20 nuts. Tighten nuts to torque of 48 to 64 pound-feet.
- (3) On left bracket, install chassis wiring harness receptacle, receptacle cover ((C), fig. 38), and ground cable, using four  $\frac{1}{4}$ -28 x  $\frac{7}{8}$  cap screws and four  $\frac{1}{4}$ -28 nuts ((B), fig. 38). Tighten nuts firmly.

- (4) Connect air supply line to coupling ((D), fig. 37 and (D), fig. 38) on each bracket. Tighten line nut firmly.
- (5) Engage chassis wiring harness in clip ((C), fig. 37 and (E), fig. 38) on each bracket.

## 79. Installation of Cargo Body

*Note.* Key letters in following text indicate connect points and refer to figure 46.

*a. General.*—The cargo body, which includes racks, roof bows, top paulin, rear curtain, tail light, marker light, reflectors, and splash shields, can be installed as an assembly. One or more chain falls are required to install body on chassis.

### *b. Installation Procedures.*

- (1) Place a wood body support sill on each frame side member, making sure cut-outs in sills match rivet heads on top of frame to permit sills to seat solidly on side members. Position cargo body on chassis and aline mounting bolt holes.
- (2) At front flexible spring-type mountings, position  $1\frac{1}{16}$ -inch plain washer (E), inner compression spring (F), and outer compression spring (G) on each bolt (A). Position bolt (A) through frame and body brackets. Install  $\frac{5}{8}$ -18 nut (B) and tighten just enough to partly compress springs.
- (3) At each rear rigid-type mounting, position  $\frac{3}{4}$ -16 x  $2\frac{1}{2}$  cap screw (C) up through frame and body bracket, and install  $\frac{3}{4}$ -16 nut (D). Tighten nuts to torque of 165 to 220 pound-feet.
- (4) Connect tail and marker light wiring harness to chassis wiring harness at bayonet type connectors.

## 80. Inspection

Perform a technical inspection as prescribed in AR 700-105, using DA Form 461-5, Limited Technical Inspection, and as outlined in TM 9-819A for the "6,000-mile" organizational maintenance services.

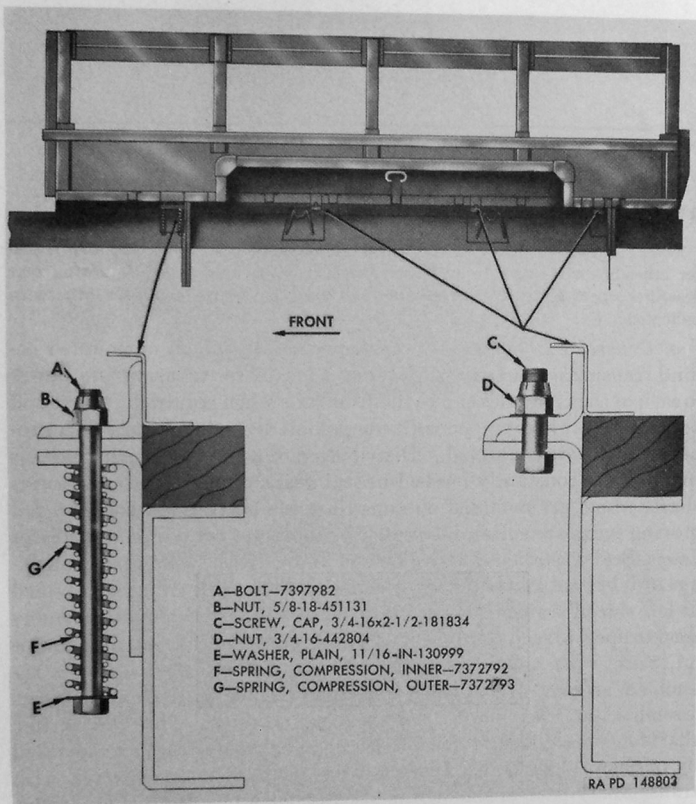

Figure 46. Cargo body mountings.

## CHAPTER 5

### TRANSFER ASSEMBLY

---

#### Section I. DESCRIPTION AND DATA

##### 81. Description

*Note.* Arrows and lines on views in figure 48 show power path through transfer assembly when vehicle is driven forward or backward and following text describes operation. Key letters in text refer to figure 49 unless otherwise indicated.

*a. General Description.*—Transfer assembly, which is mounted behind transmission assembly, provides a means for transmitting power to each of the rear axles and to the front axle when required. Input and output shafts are equipped with companion drive flanges to which propeller shafts are connected. Distribution of power to output shafts is by means of constantly meshed helical gears, supported on respective shafts which are mounted on nonadjustable bearing assemblies. All moving parts are splash-lubricated by lubricant contained in transfer case. Seals installed at drive flanges and shifter shafts prevent leakage of lubricant and entrance of dirt and water. Opening is provided at left side of transfer case to accommodate a power take-off assembly used to operate such equipment as winch, dump body hoist, and pumps on trucks with tank-type bodies. Parking brake mechanism is assembled at rear of transfer, and speedometer is driven by gears assembled at idler shaft front bearing retainer. The two shifter shafts mounted in support at front side of transfer case are operated by mechanical linkage. Lower shifter shaft is interconnected with transmission control and automatically positions front axle output shaft gear for forward and reverse driving. External views of transfer assembly are shown in figure 47.

*b. Operation.*

- (1) *Forward.*—When transmission control is in neutral or any of the forward speeds, the front axle shifter shaft is in rearward position and shifter shaft front spring ((S), fig. 54), which is stronger than shifter shaft rear spring ((H), fig. 54), forces yoke toward rear and holds front axle output shaft gear in contact with clutch teeth on output shaft. Input shaft is driven from transmission, and since sliding gear (B) ex-

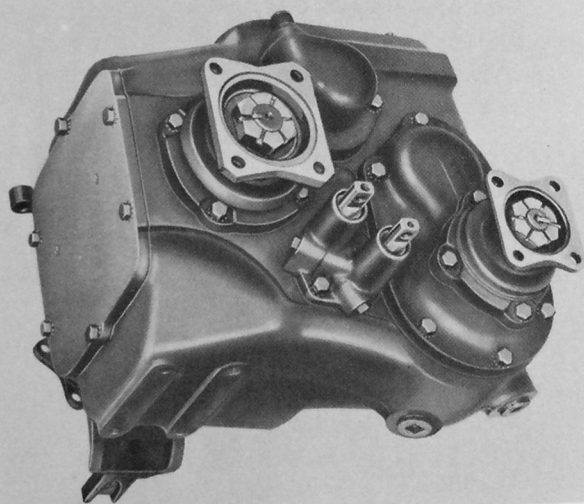

3/4 RIGHT FRONT VIEW

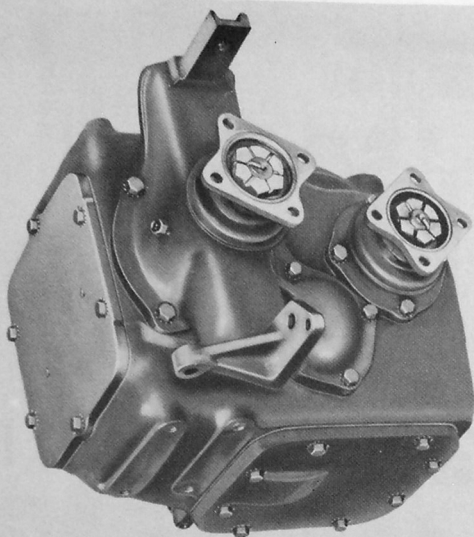

3/4 LEFT REAR VIEW

RA PD 149523

*Figure 47. Front and rear external views of transfer assembly.*

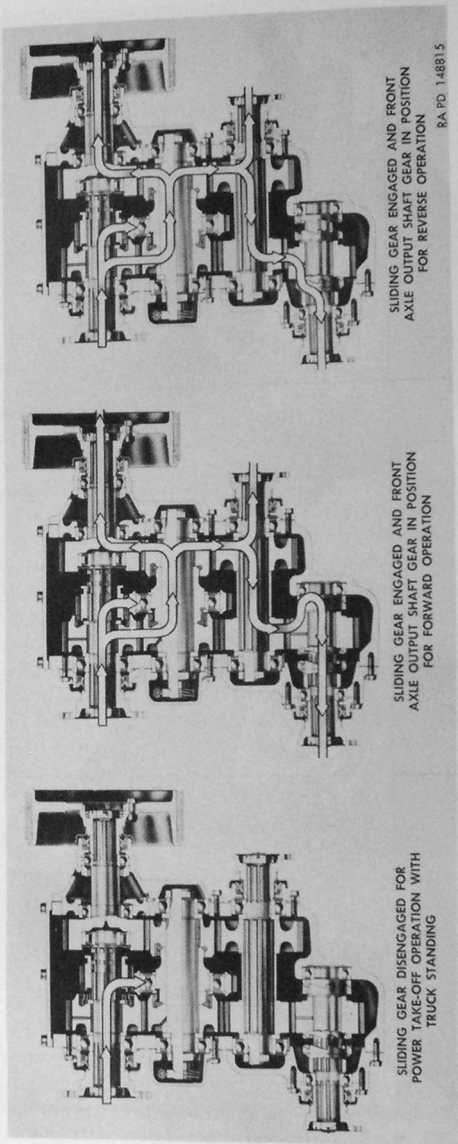

SLIDING GEAR ENGAGED AND FRONT  
AXLE OUTPUT SHAFT GEAR IN POSITION  
FOR REVERSE OPERATION

BA PD 1.4881.5

SLIDING GEAR ENGAGED AND FRONT  
AXLE OUTPUT SHAFT GEAR IN POSITION  
FOR FORWARD OPERATION

SLIDING GEAR DISENGAGED FOR  
POWER TAKE-OFF OPERATION WITH  
TRUCK STANDING

*Figure 48. Power flow through transfer.*



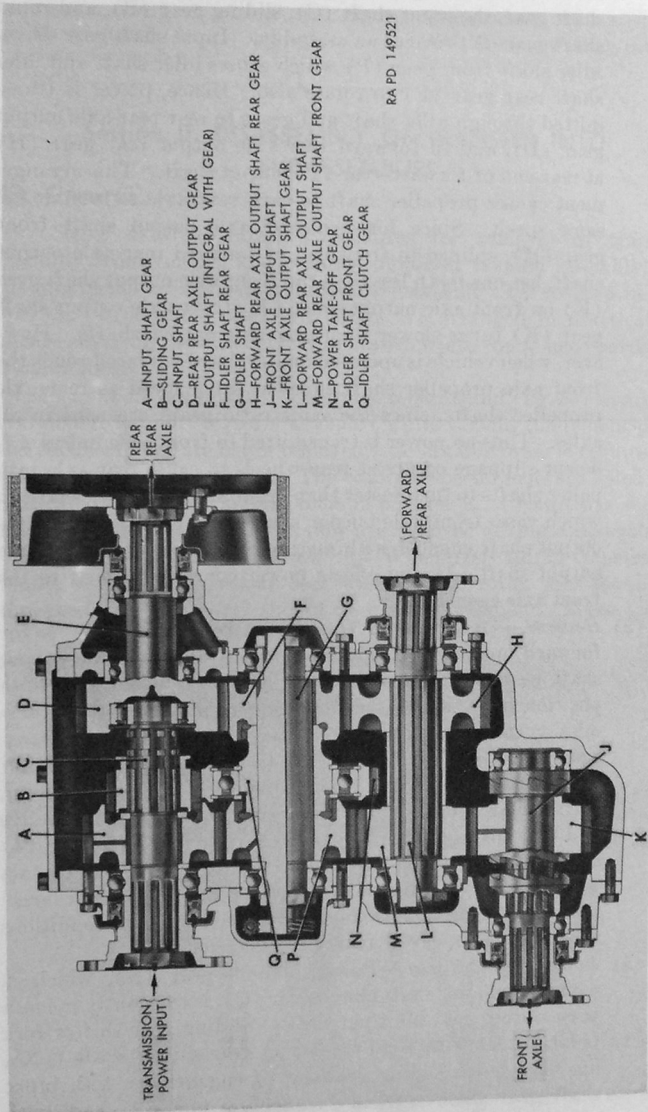

Figure 49. Identification of transfer gears and shafts.

ternal teeth are engaged with internal teeth at rear of input shaft gear, the input shaft (C), sliding gear (B), and input shaft gear (A) turn as an assembly. Input shaft gear drives idler shaft front gear (P) which causes idler shaft and idler shaft rear gear (F) to rotate also. Hence, power is transmitted through idler shaft and gears to rear rear axle output gear (D), and to forward rear axle output rear gear (H) at rear end of forward rear axle output shaft. This arrangement causes propeller shaft to each rear axle to turn at the same speed. Since forward rear axle output shaft front gear (M), splined to front end of forward rear axle output shaft, has one tooth less than the front axle output shaft gear (K) on front axle output shaft (J), front axle output shaft gear (K) turns slower than rear axle output shafts. However, when vehicle is operated on dry, hard-surfaced roads the front axle propeller shaft turns at same speed as rear axle propeller shafts, since the same ratio gears are used in all axles. Thus no power is transmitted to front axle unless sufficient slippage occurs at rear wheels to cause rear axle propeller shafts to turn faster than front axle propeller shaft, in which case, front axle output shaft gear (K) on front axle output shaft engages with mating clutch teeth on front axle output shaft (J) and effects power connection to drive the front axle assembly.

- (2) *Reverse.*—Operation of transfer in reverse is same as for forward operation except for position of front axle output shaft gear, which is automatically moved ahead to reverse position by action of shifter mechanism linked with transmission control which moves shifter shaft ahead as transmission is shifted into reverse. With front axle shifter shaft ((V), fig. 54) in reverse position (toward front of transfer), shifter shaft front spring ((S), fig. 54) is rendered ineffective and rear spring moves front axle shifter fork ((R), fig. 54) and front axle output shaft gear (K) forward and in contact with clutch ((L), fig. 54). In this position, power connection for driving front axle will be effected should conditions arise when slippage at rear wheels occurs.
- (3) *Power take-off gear.*—Power take-off gear (N), which is mounted on idler shaft clutch gear (Q), is constantly in mesh with sliding gear on input shaft. Sliding gear shifter fork ((E), fig. 54), installed on sliding gear shifter shaft ((X), fig. 54), moves sliding gear out of engagement with input shaft gear when necessary to operate power take-off with vehicle standing. Refer to TM 9-819A for arrangement of power take-off controls and for control operating instructions.

## 82. Data

Type.....	Single-speed
Manufacturer.....	GMC Truck and Coach Div
Ordinance number.....	7411327
Ratio.....	1.16 to 1

## Section II. DISASSEMBLY OF TRANSFER INTO SUBASSEMBLIES

### 83. General

*a. Scope of Procedures.*—Procedures for removal of transfer assembly from vehicle, and removal of power take-off assembly and parking brake mechanism from transfer assembly are covered in TM 9-819A. Procedures described herein are arranged in practical sequence covering the disassembly of transfer into component parts and subassemblies.

*b. Tools and Equipment.*—A suitable repair stand (fig. 50) should be available to support transfer assembly while various component parts and subassemblies are being removed. A suitable press is required to remove bearing from shafts. The required special tools are listed and illustrated with other special tools in chapter 2. Clean trays should be available to receive parts as they are removed during disassembly.

*c. Inspection During Disassembly.*—When overhauling transfer assembly, all oil seals, gaskets, lock washers, and cotter pins should be discarded and new parts should be used at assembly. Make visual

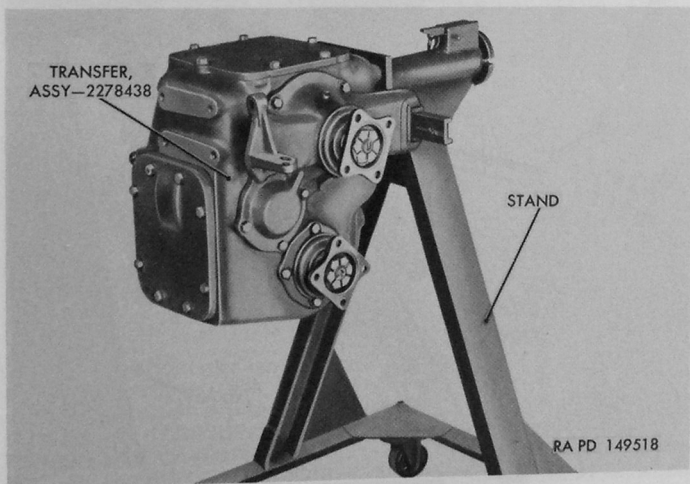

Figure 50. Transfer assembly mounted in repair stand.

inspection of parts as they are removed or disassembled. Discard all damaged or broken parts.

#### 84. Removal of Covers, Plugs, and Flanges

a. Remove six cap screws and lock washers attaching cover to top of transfer case. Remove drain plug and filler plug and drain lubricant from case. If case is equipped with a cover at power take-off opening, remove eight cap screws and lock washers and remove power take-off opening cover from left side of transfer. Remove and discard gaskets.

b. Remove cotter pins used to lock retaining nuts at each of the four flanges to which propeller shafts are attached. Attach tool 41-T-3215-910 to companion flange on rear axle output gear as shown in figure 51. Remove flange nuts from input shaft and output shafts.

*Note.* From axle shifter shaft ((V), fig. 54) must be in forward position to lock input shaft to front gear to prevent shafts from turning while flange nuts are loosened.

c. Using soft metal hammer, drive flanges off input shaft, rear rear axle output shaft, and front axle output shaft. Flange should remain on forward rear axle output shaft until after lock nuts on

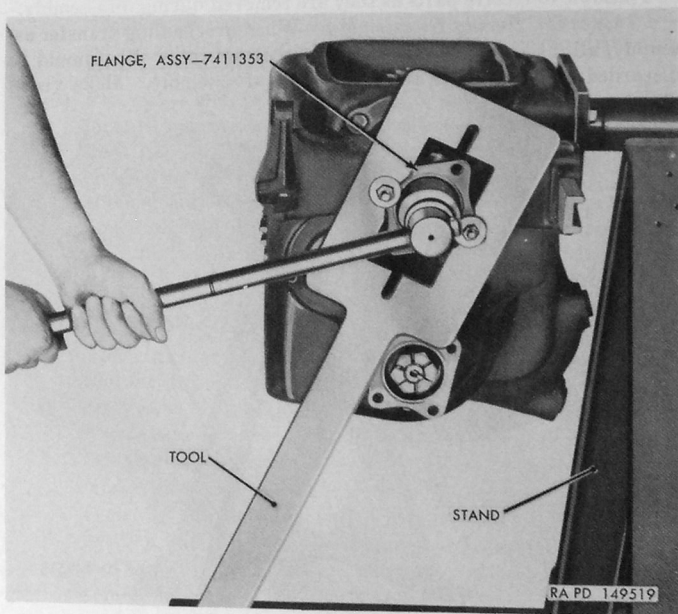

Figure 51. Use of companion flange holding tool 41-T-3215-910.

idler shaft and front end of forward rear axle output shaft have been loosened.

## 85. Removal of Output Gear Components

*Note.* Key letters in text refer to figure 52.

a. Remove seven cap screws and lock washers attaching output gear bearing retainer (K) transfer to case (ZZ).

b. Strike output gear bearing retainer (K) with lead hammer to free retainer from transfer case (ZZ); then withdraw output gear

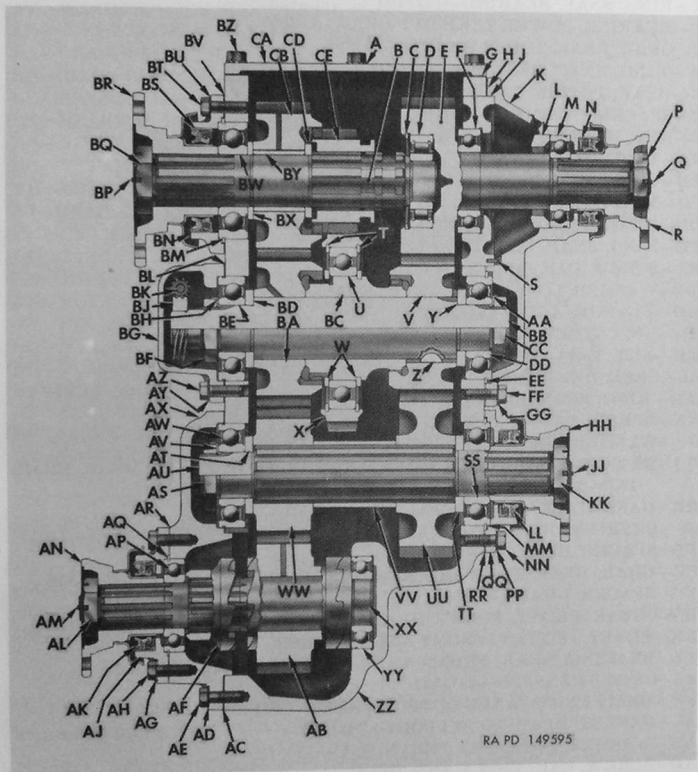

- A—WASHER, LOCK, EXT-TEETH,  $\frac{3}{8}$ -IN.—138489
- B—SHAFT, INPUT—7412876
- C—RING, LOCKING—7411340
- D—BEARING, REAR, INPUT SHAFT—707655
- E—GEAR, OUTPUT—7411356
- F—BEARING, FRONT, OUTPUT GEAR—700539

Figure 52. Sectional view of transfer assembly.

G—GASKET, COVER—7411491  
 H—GASKET, RETAINER—7411398  
 J—RETAINER, BEARING, FRONT, ASSY—7002111  
 K—RETAINER, OUTPUT GEAR BEARING—7411361  
 L—SLEEVE, LOCK, REAR BEARING—7411409  
 M—BEARING, REAR, OUTPUT GEAR—7411351  
 N—SEAL, OIL—7411263  
 P—NUT,  $\frac{7}{8}$ -14—7411259  
 Q—PIN, COTTER,  $\frac{1}{8}$  X  $1\frac{3}{4}$ —103388  
 R—FLANGE, ASSY—7411353  
 S—PIN, DOWEL,  $\frac{1}{8}$  X  $\frac{3}{8}$ —141107  
 T—RING, SNAP, BEARING—7411400  
 U—BEARING, POWER TAKE-OFF GEAR—712866  
 V—GEAR, REAR, IDLER SHAFT—7411395  
 W—RING, SNAP, BEARING—7411401  
 X—GEAR, POWER TAKE-OFF—7411396  
 Y—SPACER, BEARING—7374703  
 Z—KEY, WOODRUFF,  $\frac{1}{4}$  X  $\frac{3}{4}$ —127559  
 AA—LOCK, NUT—6245933  
 BB—SHAFT, IDLER—7411402  
 CC—NUT, LOCK, BEARING,  $1\frac{1}{2}$  X 16—6245935  
 DD—BEARING, REAR, IDLER SHAFT—710145  
 EE—RING, SNAP, BEARING—7411407  
 FF—SCREW, CAP,  $\frac{3}{8}$ -16 X  $1\frac{1}{8}$ —180123  
 GG—WASHER, LOCK, EXT-TEETH,  $\frac{3}{8}$ -IN.—138489  
 HH—FLANGE, ASSY—7411353  
 JJ—PIN, COTTER,  $\frac{1}{8}$  X  $1\frac{3}{4}$ —103388  
 KK—NUT,  $\frac{7}{8}$ -14—7411259  
 LL—SEAL, OIL—7411263  
 MM—RING, SNAP, BEARING—7411407  
 NN—SCREW, CAP,  $\frac{3}{8}$ -16 X  $1\frac{1}{8}$ —180123  
 PP—WASHER, LOCK, EXT-TEETH,  $\frac{3}{8}$ -IN.—138489  
 QQ—RETAINER FORWARD REAR AXLE OUTPUT SHAFT BEARING—7411260  
 RR—GASKET, BEARING RETAINER—6244507  
 SS—BEARING, REAR, FORWARD REAR AXLE OUTPUT SHAFT—710145  
 TT—SPACER, BEARING—7374703  
 UU—GEAR, REAR, FORWARD REAR AXLE OUTPUT SHAFT—7411359  
 VV—SPACER, GEAR—7411389  
 WW—GEAR, FRONT, FORWARD REAR AXLE OUTPUT SHAFT—7411358  
 XX—SHAFT, OUTPUT, FRONT AXLE—7411388  
 YY—BEARING, REAR, FRONT AXLE OUTPUT SHAFT—6244507  
 ZZ—CASE, TRANSFER—7411331  
 AB—GEAR, FRONT AXLE OUTPUT SHAFT—7411360  
 AC—GASKET, BEARING SUPPORT—7411355  
 AD—WASHER, LOCK, EXT-TEETH,  $\frac{3}{8}$ -IN.—138489  
 AE—SCREW, CAP,  $\frac{3}{8}$ -16 X  $1\frac{1}{8}$ —180123  
 AF—CLUTCH—7412879  
 AG—WASHER, LOCK, EXT-TEETH,  $\frac{3}{8}$ -IN.—138489  
 AH—SCREW, CAP,  $\frac{3}{8}$ -16 X  $1\frac{1}{8}$ —180123  
 AJ—RETAINER, FRONT AXLE OUTPUT SHAFT FRONT BEARING—7411384  
 AK—SEAL, OIL—7411263  
 AL—NUT,  $\frac{7}{8}$ -14—7411259

Figure 52.—Continued.



AM—PIN, COTTER,  $\frac{1}{8}$  X  $1\frac{3}{4}$ —103388  
 AN—FLANGE, ASSY—7411353  
 AP—BEARING, FRONT, FRONT AXLE OUTPUT SHAFT—6244507  
 AQ—RING, SNAP, BEARING—7411408  
 AR—GASKET, RETAINER—7411404  
 AS—NUT, LOCK, BEARING,  $1\frac{1}{2}$ —16—6245935  
 AT—SPACER, BEARING—7374703  
 AU—SHAFT, OUTPUT, FORWARD REAR AXLE—7411386  
 AV—LOCK, NUT—6245933  
 AW—BEARING, FRONT, FORWARD REAR AXLE OUTPUT SHAFT—710145  
 AX—SUPPORT, BEARING—7411391  
 AY—WASHER, LOCK, EXT-TEETH,  $\frac{3}{8}$ -IN.—138489  
 AZ—SCREW, CAP,  $\frac{3}{8}$ -16 X  $1\frac{1}{8}$ —180123  
 BA—GEAR, FRONT, IDLER SHAFT—6245934  
 BC—GEAR, CLUTCH, IDLER SHAFT—7411397  
 BD—SPACER, BEARING—7374703  
 BE—BEARING, FRONT, IDLER SHAFT—710145  
 BF—NUT, LOCK, BEARING,  $1\frac{1}{2}$ —16—6245935  
 BG—RETAINER, IDLER SHAFT FRONT BEARING—7411399  
 BH—LOCK, NUT—6245933  
 BJ—GEAR, DRIVE, SPEEDOMETER—7412877  
 BK—GEAR, DRIVEN, SPEEDOMETER, ASSY—7412878  
 BL—GASKET, RETAINER—7411394  
 BM—RING, SNAP, BEARING—7411328  
 BN—RETAINER, INPUT SHAFT FRONT BEARING—7411329  
 BP—PIN, COTTER,  $\frac{1}{8}$  X 2—103389  
 BQ—NUT,  $1\frac{1}{8}$ —12—7411336  
 BR—FLANGE, ASSY—7411324  
 BS—SEAL, OIL—7411330  
 BT—SCREW, CAP,  $\frac{3}{8}$ -16 X  $1\frac{1}{8}$ —180123  
 BU—WASHER, LOCK, EXT-TEETH,  $\frac{3}{8}$ -IN.—138489  
 BV—GASKET, RETAINER—7411325  
 BW—BEARING, FRONT, INPUT SHAFT—700773  
 BX—SPACER, BEARING—7411339  
 BY—BEARING, BUSHING TYPE—7411230  
 BZ—SCREW, CAP,  $\frac{3}{8}$ -16 X  $1\frac{1}{8}$ —180123  
 CA—COVER, CASE, ASSY—7342349  
 CB—GEAR, INPUT SHAFT—6245938  
 CD—SPACER, SLIDING GEAR—7411339  
 CE—GEAR, SLIDING—7412875

Figure 52.—Continued.

(E) and retainer with output gear front and rear bearings (F and M) as an assembly.

*Note.* Inner race of input shaft rear bearing (D) is press fit and remains on input shaft (B) while rollers and outer race are removed with output gear (E).

c. Strike rear end of output gear shaft with soft metal hammer to force output gear (E) with output gear front bearing (F) out of output gear rear bearing (M) and front bearing retainer assembly (J). Remove front bearing retainer assembly (J).

d. Refer to paragraphs 95 through 98 for procedure covering further disassembly of these two subassemblies.

## 86. Removal of Shifting Mechanism

*Note.* Key letters noted in parentheses are in figure 54 unless otherwise indicated.

a. Clean exposed portion of shifter shafts (fig. 53). Remove poppet ball plugs from shifter shaft support.

b. Remove two bolts ((J), fig. 53) and lock washers ((K), fig. 53) holding shifter shaft support assembly (Z) on front of transfer case. While holding front axle shifter fork (R) and shifter shaft rear spring (H) inside transfer case, remove front axle shifter shaft (V), shifter shaft front spring (S), and support from front of case. Remove fork and rear spring from inside case. Remove support gasket.

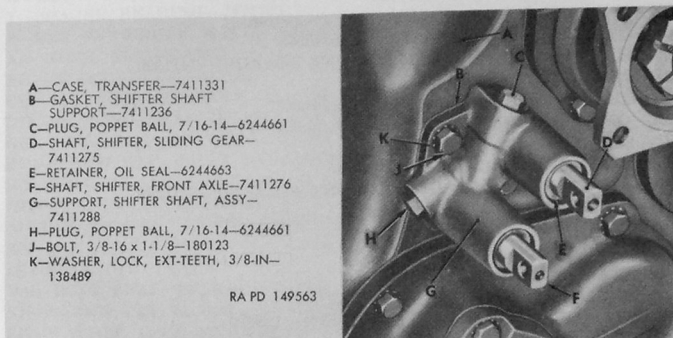

Figure 53. Transfer shifter shafts installed.

c. Allow poppet ball springs (U) and poppet balls (T) to fall out of shifter shaft support assembly (Z). Remove oil seals (W) and oil seal retainers (Y).

d. Through opening in rear of case, use wrench to remove  $\frac{5}{16}$ -24 x  $1\frac{1}{2}$  bolt (F) from sliding gear shifter fork (E). Withdraw sliding gear shifter shaft (X) from sliding gear shifter fork (E) and pull out through front of case. Remove sliding gear shifter fork (E) from inside case.

e. Refer to paragraph 111 for inspection of shifter components and procedure for replacing front axle shifter shaft spacer (Q) on front axle shifter shaft (V), and shifter shaft support pilot (N) which is pressed into support.

## 87. Removal of Input Shaft and Gear Assembly

*Note.* Key letters noted in parentheses are in figure 52 unless otherwise indicated.

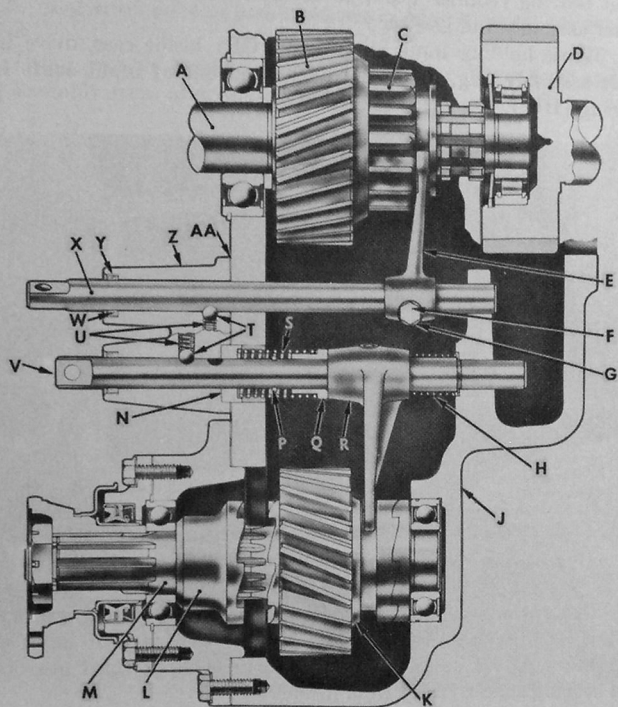

- A—SHAFT, INPUT—7412876
- B—GEAR, INPUT SHAFT—6245938
- C—GEAR, SLIDING—7412875
- D—GEAR, OUTPUT—7411342
- E—FORK, SHIFTER, SLIDING GEAR—7411342
- F—BOLT, 5/16-24x1-1/2—181614
- G—WASHER, LOCK, 5/16-IN—120638
- H—SPRING, SHIFTER SHAFT, REAR—7412874
- J—CASE, TRANSFER—7411331
- K—GEAR, FRONT AXLE OUTPUT SHAFT—7411360
- L—CLUTCH—7412879
- M—SHAFT, OUTPUT, FRONT AXLE—7411388
- N—PILOT, SHIFTER SHAFT SUPPORT—7412857

- P—RING, SNAP—7412858
- Q—SPACER, FRONT AXLE SHIFTER SHAFT—7412859
- R—FORK, SHIFTER, FRONT AXLE—YT-2290942
- S—SPRING, SHIFTER SHAFT, FRONT—7412500
- T—BALL, POPPET, 5/16-IN—147489
- U—SPRING, POPPET BALL—7411347
- V—SHAFT, SHIFTER, FRONT AXLE—7411276
- W—SEAL, OIL—6244662
- X—SHAFT, SHIFTER, SLIDING GEAR—7411275
- Y—RETAINER, OIL SEAL—6244663
- Z—SUPPORT, SHIFTER SHAFT, ASSY—7411288
- AA—GASKET, SHIFTER SHAFT SUPPORT—7411236

RA PD 148790

Figure 54. Sectional view of transfer shifting mechanism.

a. Remove four cap screws and lock washers attaching input shaft front bearing retainer (BN) to transfer case (ZZ) and remove retainer assembly and gasket.

b. While holding input shaft gear (CB) inside case, drive input shaft assembly (fig. 55) toward rear and out of input shaft front bearing (BW).

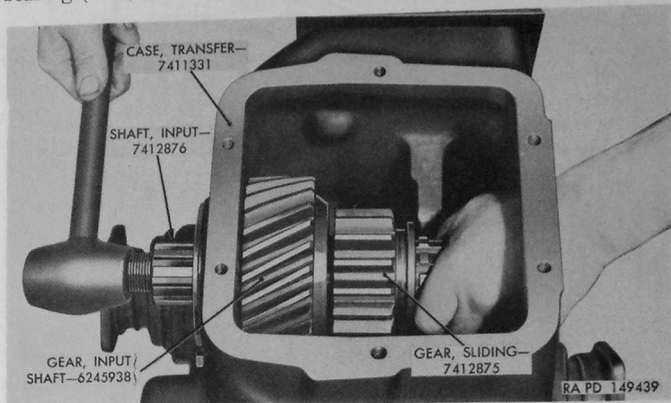

Figure 55. Removing input shaft and sliding gear assembly.

c. Remove input shaft with sliding gear (CE), sliding gear spacer (CD), bushing type bearing (BY), and inner race of input shaft rear bearing (D) as an assembly. Remove input shaft gear (CB) and bearing spacer (BX) from inside case.

d. Paragraph 92 gives instructions for further disassembly of components remaining on input shaft.

e. Remove input shaft front bearing (BW) from bore in front of transfer case.

f. Remove oil seal (BS) from input shaft front bearing retainer (BN).

## 88. Removal of Front Axle Output Shaft Components

Note. Key letters noted in parentheses are in figure 52.

a. Remove seven cap screws and lock washers which attach bearing support (AX) to front of transfer case.

b. Pull front axle output shaft with bearing support, gears, and front and rear bearings out of transfer case as an assembly. Remove bearing support gasket (AC).

c. Refer to paragraph 101 for instructions covering disassembly of front axle output shaft components.

## 89. Removal of Speedometer Gears

*Note.* Key letters noted in parentheses are in figure 52 unless otherwise indicated.

a. Using suitable wrench, remove speedometer driven gear and fitting assembly from idler shaft front bearing retainer (BG).

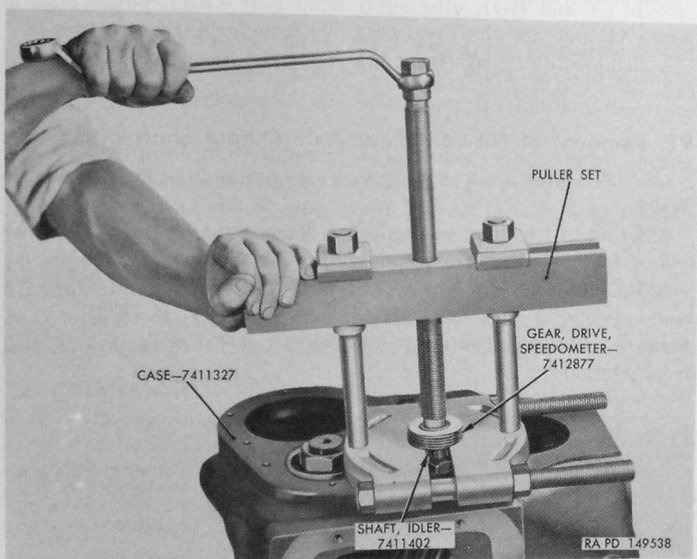

Figure 56.—Removing speedometer drive gear using puller set 41-P-2905-60.

b. Remove three bolts and lock washers which attach idler shaft front bearing retainer (BG) to transfer case; then remove retainer and retainer gasket (BL).

c. Remove speedometer drive gear (BJ) from idler shaft as shown in figure 56. Turn puller screw to remove gear from idler shaft.

## 90. Removal of Idler Shaft, Gears, and Bearings

*Note.* Key letters noted in parentheses are in figure 52 unless otherwise indicated.

a. Attach tool 41-T-3215-910 to flange on rear end of forward rear axle output shaft to hold shafts while loosening nuts as directed in b below. Use holding tool in manner illustrated in figure 51.

b. Bend nut locks (AA and BH) away from lock nut at each end of idler shaft (BB) and bend nut lock (AV) away from lock nut at front end of forward rear axle output shaft (AU). Remove three bearing lock nuts and nut locks.

c. Using soft metal hammer, drive on front end of idler shaft to force idler shaft rearward. As idler shaft is moved rearward, idler shaft rear bearing (DD) is forced out of bore in case and Woodruff key (Z), which fits into keyway in idler shaft rear gear (V), is removed with idler shaft (BB).

d. As idler shaft is pulled out of transfer case, remove bearing spacers (Y and BD), idler shaft front gear (BA), power take-off gear (X), and idler shaft rear gear (V) from inside transfer case.

e. Remove idler shaft front bearing (BE) from bore in front of case.

## 91. Removal of Forward Rear Axle Output Shaft and Gears

*Note.* Key letters noted in parentheses are in figure 52 unless otherwise indicated.

a. Using soft metal hammer, drive flange assembly (HH) off rear end of forward rear axle output shaft (AU).

b. Remove four cap screws and lock washers attaching forward rear axle output shaft rear bearing retainer (QQ) to transfer case. Remove retainer and oil seal (LL) from case; then remove oil seal from retainer.

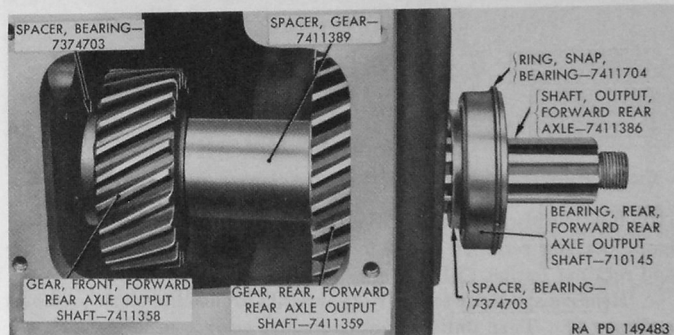

Figure 57. Removing forward rear axle output shaft and gears.

c. Drive forward rear axle output shaft (AU) rearward with soft metal hammer. As shaft moves out of case, rear bearing assembly and spacer (fig. 57) will be carried with shaft. When rear bearing assembly is free from bore in case, support gears and pull shaft out of gears. Remove gears and spacers (fig. 57) from inside transfer case.

d. Remove forward rear axle output shaft front bearing (AW) from bore in case.



### Section III. REBUILD OF INPUT SHAFT AND COMPONENTS

#### 92. Disassembly of Input Shaft Components

*Note.* Key letters noted in parentheses are in figure 52 unless otherwise indicated.

a. Place input shaft with sliding gear in arbor press supported on attachment 41-A-345-328 (part of puller set 41-P-2905-60) as shown in figure 59.

b. Using suitable driver under press ram, apply pressure at input shaft (M) to remove bearing inner race (N) from rear end of shaft.

*Note.* The preceding operation may be deferred until after inspection (par. 93b).

c. Change position of input shaft assembly in press with sliding gear spacer (K) supported on attachment (fig. 59).

d. Press on front end of input shaft to force bushing type bearing (J) and sliding gear spacer (K) off input shaft.

#### 93. Cleaning, Inspection, and Repair of Input Shaft Components

*Note.* Key letters noted in parentheses are in figure 52 unless otherwise indicated.

a. *Cleaning.*—Wash all input shaft components shown in figure 58 in dry-cleaning solvent or volatile mineral spirits and wipe or blow dry. Handle parts with care to prevent damage to ground surfaces and to prevent damage to splines.

b. *Inspection.*

*Note.* Refer to paragraph 343 for dimensions and fits.

- (1) Examine surface of bearing inner race (N) for evidence of pitting, grooving, and roughness. If race is not in good condition, replace input shaft rear bearing ((D), fig. 52), including inner race.
- (2) Note condition of splines at input shaft (M) and sliding gear (L). Also inspect teeth at sliding gear. If teeth are broken, chipped, or otherwise damaged, discard gear and use new part when assembling.
- (3) Measure outside diameter of bushing type bearing (J) over bearing area. If diameter is less than shown in paragraph 343a, install new bearing.
- (4) Inspect bearing spacer (G) and sliding gear spacer (K) for wear and other damage; discard if outer edge is worn.
- (5) Inspect teeth on input shaft gear (H). Measure diameter of bore through gear (par. 343a). Replace gear if damaged or excessively worn.
- (6) Examine input shaft front bearing (F). Rotate bearing races by hand to detect roughness. If wear, roughness, or

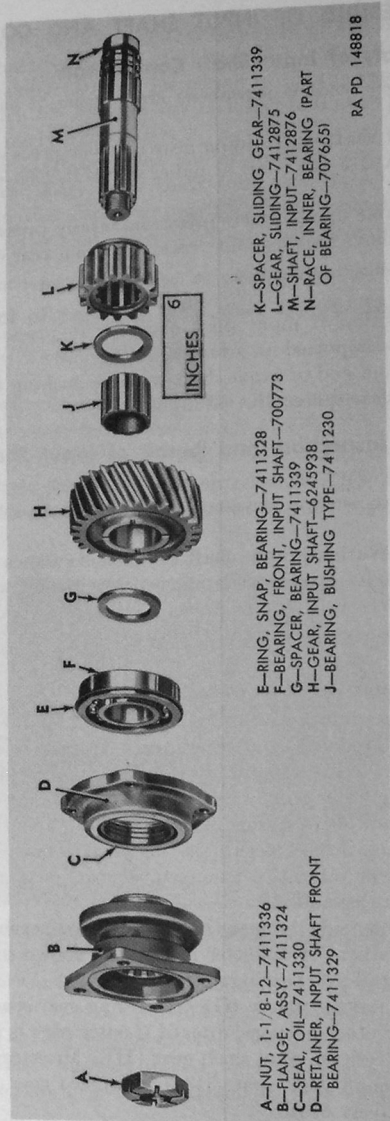

Figure 58. Transfer input shaft, sliding gear, and related components.

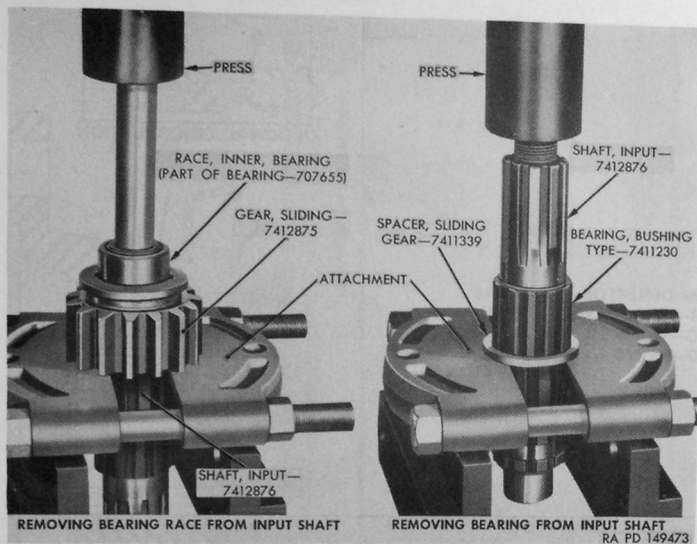

Figure 59. Removing bearing race and input shaft gear bearing from input shaft with attachment 41-A-345-328 (part of puller set 41-P-2905-60).

damage is evident, replace bearing. Bearing snap ring (E) should be checked for distortion and for fit in groove in bearing.

(7) Examine input shaft front bearing retainer (D). If evidence of excessive wear appears at surfaces contacted by bearing and snap ring, or if retainer is distorted or otherwise damaged, the retainer should be replaced.

(8) Inspect deflector and oil seal sleeve on input shaft flange assembly (fig. 60). If surface of sleeve is scored or grooved at point of contact with oil seal lip, or if deflector is bent or otherwise damaged, these parts should be replaced. Refer to *c* below for procedure necessary to replace sleeve and deflector.

(9) Check width of fork groove on sliding gear (L). Replace gear if groove is worn (par. 343a).

*c. Repair of Input shaft Components.*

(1) *Replacing input shaft flange deflector.*

(a) Using a hack saw, make a diagonal cut through outer edge of deflector, then with a sharp cold chisel, cut through remaining portion of deflector. If deflector is welded to flange, use suitable chisel to break the weld and remove deflector.

A—DEFLECTOR—YT-2278618  
 B—FLANGE, ASSY—7411324  
 C—ARC WELD  
 D—SLEEVE—7411338

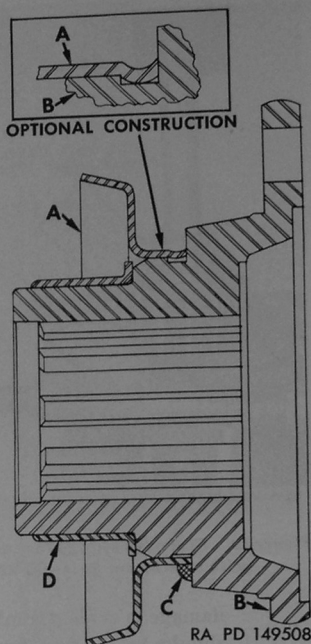

Figure 60. Sectional view of input shaft flange assembly.

- (b) File off any weld metal at flange shoulder which would prevent new deflector from seating against shoulder; then locate new deflector on flange as shown in figure 60.
- (c) Either of the methods shown in figure 60 may be used to attach new deflector to flange. When peening deflector into groove as shown in inset (fig. 60), use peening tool and peen in four equally spaced places. If welding is employed, tack weld deflector to flange in three places.
- (2) *Replacing oil seal sleeve on input shaft flange assembly.*
  - (a) Using a light-weight hammer, tap sleeve (fig. 60) over entire exposed area to stretch metal and loosen sleeve on flange; then use chisel to cut through sleeve flange. Pry sleeve off flange assembly.
  - (b) Inspect surface of flange assembly for burrs or roughness and smooth with file if necessary.
  - (c) Install new oil seal sleeve on flange, using replacer 41-R-2395-535 as illustrated in figure 61 to drive sleeve flange firmly against shoulder at input shaft flange assembly.

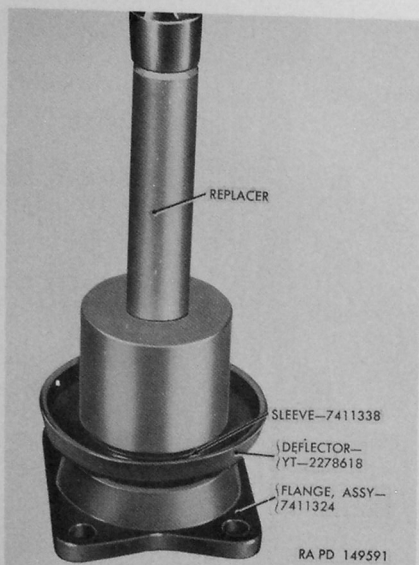

Figure 61. Use of replacer 41-R-2395-535 to install oil seal sleeve on input shaft flange.

## 94. Assembly of Input Shaft Components

*Note.* Key letters noted in parentheses are in figure 58.

a. Place sliding gear spacer (K) against shoulder on input shaft (M); then install bushing type bearing (J) on shaft and press or drive bearing firmly against sliding gear spacer (K).

*Note.* If bearing inner race (N) is on shaft, place sliding gear (L) on shaft before bushing type bearing (J) is installed.

b. If bearing inner race (N) has been removed from input shaft (M), install sliding gear (L) on shaft with shifter fork groove toward rear end of input shaft; then support bearing inner race on press plate and press input shaft into inner bearing race (fig. 62). Figure 63 shows input shaft and components assembled and ready for installation in transfer case.

## Section IV. REBUILD OF OUTPUT GEAR AND COMPONENTS

### 95. Disassembly of Rear Rear Axle Output Gear Components

*Note.* Key letters noted in parentheses are in figure 52.

a. Pry locking ring (C) out of groove at front of output gear (E). Using suitable puller, remove input shaft rear bearing (D) from output gear (E).

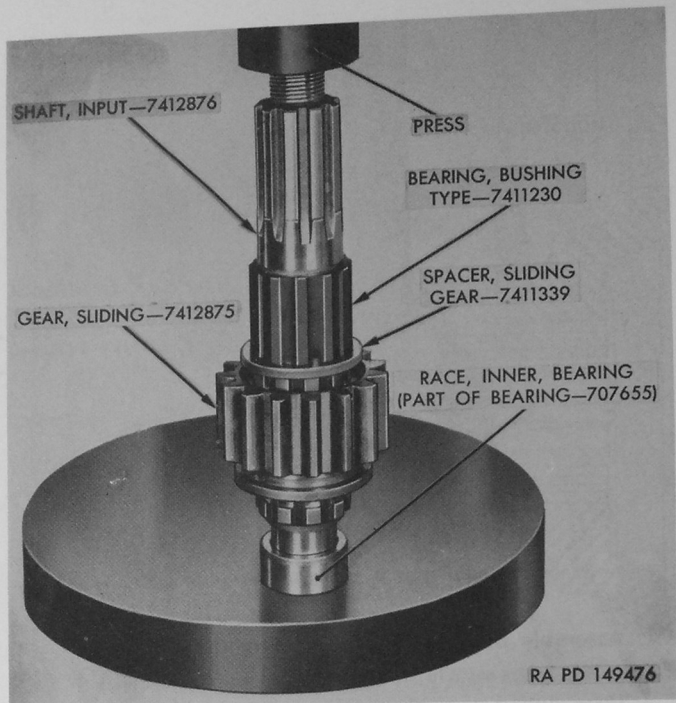

Figure 62. Use of arbor press to install input shaft bearing inner race.

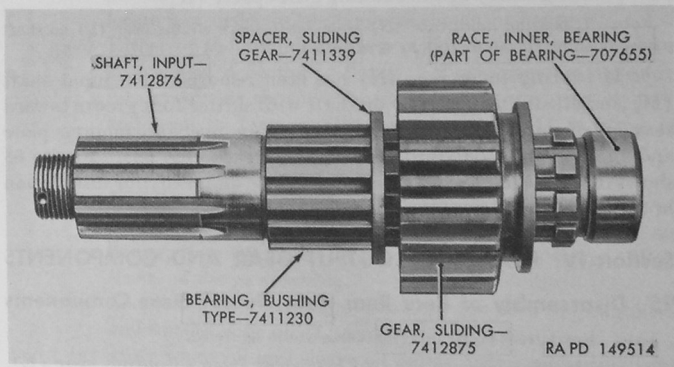

Figure 63. Input shaft and components assembled for installation in transfer case.



b. Assemble attachment 41-A-345-328 (part of puller set 41-P-2905-60) at output gear front bearing (F). Position output gear and bearing assembly with attachment in arbor press as shown in figure 64 and remove bearing from gear.

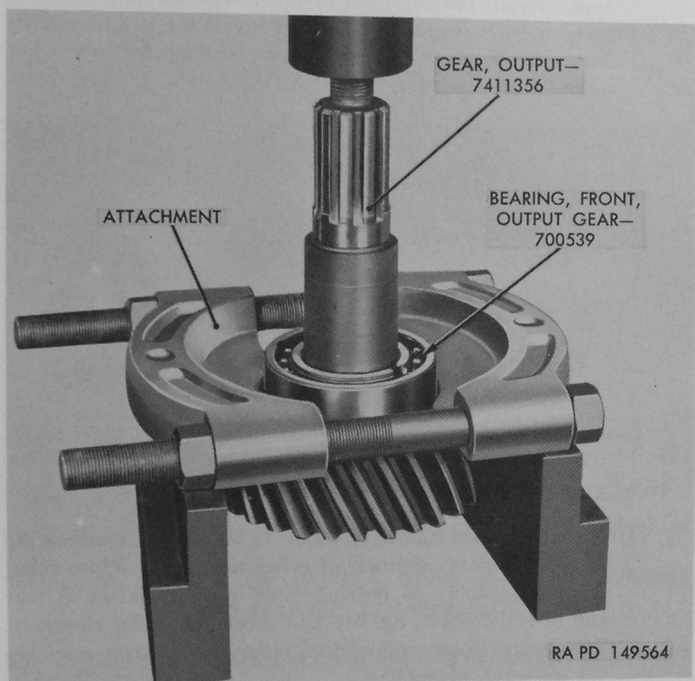

Figure 64. Using arbor press and attachment 41-A-345-328 (part of puller set 41-P-2905-60) to remove output gear front bearing.

## 96. Cleaning and Inspection of Output Gear Components.

a. *Cleaning.* Wash all output gear components shown in figure 65 in dry-cleaning solvent or volatile mineral spirits, and wipe or blow dry.

**Caution:** Do not spin bearings with air as damage may result.

b. *Inspection.*

- (1) Examine gear teeth on output gear for wear, nicks, and chipped or broken teeth. Also inspect splines and threads at rear end of shaft which is forged integral with output gear. If any damage is found, discard gear as no repair is recommended on this part.

- (2) Inspect front bearing retainer assembly (fig. 65) for damage and check  $\frac{1}{8} \times \frac{3}{8}$  dowel pin ((S), fig. 52) which should be tight in hole in retainer.
- (3) Examine output gear front bearing, which is single-row ball type. Rotate bearing races by hand to detect roughness. If races or balls are rough or if excessive wear is indicated by looseness of parts, obtain a new bearing for use when assembling.

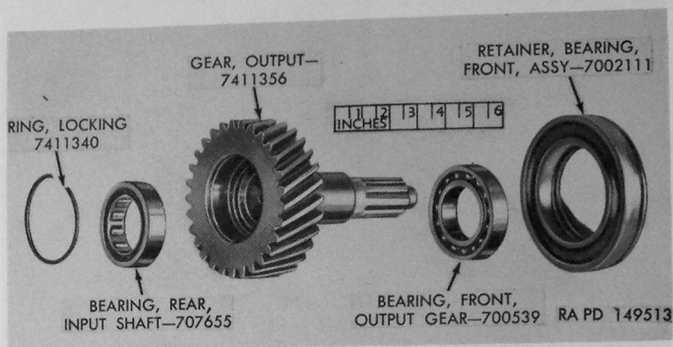

Figure 65. Output gear, bearings, and related components.

- (4) Visually inspect surface of rollers in input shaft rear bearing (fig. 65). Note condition of roller separator. Place roller bearing assembly on bearing inner race (installed at rear end of input shaft, fig. 63) and check for radial clearance. If excessive looseness is evident, obtain new bearing assembly for use when assembling.
- (5) Check bearing locking ring for distortion.

## 97. Assembly of Output Gear Components

*Note.* Key letters noted in parentheses are in figure 52 unless otherwise indicated.

a. Set output gear (E) on flat solid support; then use replacer 41-R-2390-415 to drive output gear front bearing (F) into place at shoulder on output gear (fig. 66).

b. Install input shaft rear bearing (D) (except inner race) in recess at front side of output gear. Drive bearing outer race squarely into place. Install locking ring (C) to retain bearing.

*Note.* Inner race of input shaft rear bearing (D) must be installed on rear end of input shaft (B). Refer to paragraphs 92a and b, and 94b for instructions covering replacement of input shaft rear bearing inner race on input shaft.

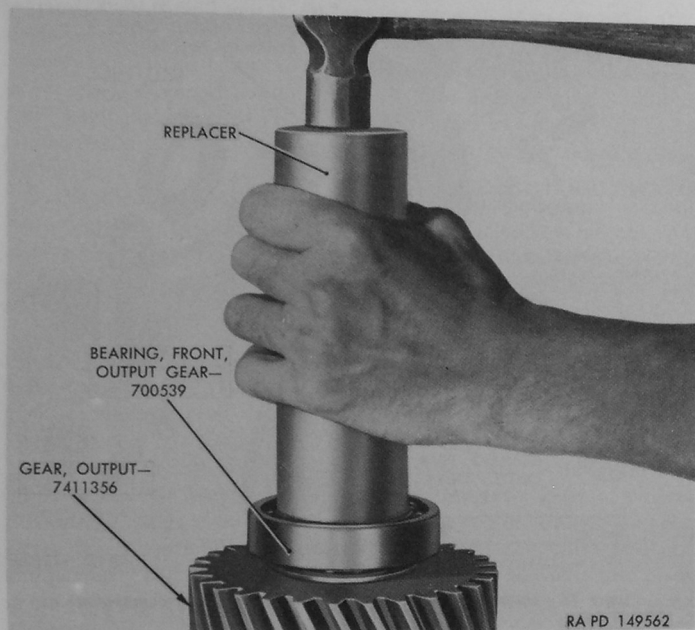

Figure 66. Installing front bearing on output gear with replacer 41-R-2390-415.

## Section V. REBUILD OF OUTPUT GEAR BEARING RETAINER AND RELATED COMPONENTS

### 98. Disassembly of Output Gear Bearing Retainer Components

*Note.* Key letters noted in parentheses are in figure 52 unless otherwise indicated.

*a.* Loosen jam nuts on  $\frac{1}{2}$ -20 x  $1\frac{7}{32}$  special screws (fig. 67); then remove two special screws which hold rear bearing lock sleeve (L) in contact with output gear rear bearing (M). Remove rear bearing lock sleeve (L) from output gear bearing retainer (K).

*b.* Remove and discard oil seal (N) installed at rear of output gear bearing retainer; then using a suitable driver and light-weight hammer, remove output gear rear bearing (M), driving bearing out toward front side of retainer.

### 99. Cleaning, Inspection, and Repair of Output Gear Bearing Retainer Components

*a. Cleaning.*—Wash all components (fig. 67) in dry-cleaning solvent or volatile mineral spirits. Wipe parts or dry with air.

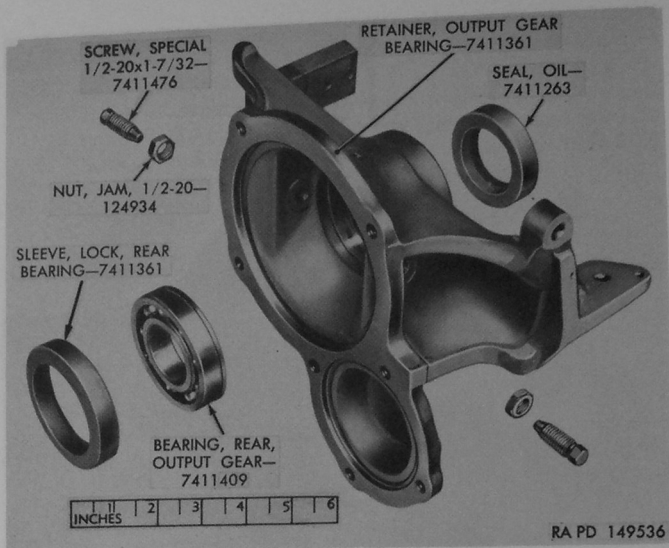

Figure 67. Output gear bearing retainer and related components.

*b. Inspection* (fig. 67).

- (1) Visually inspect output gear bearing retainer for damage, cracks, and warpage. Front machined surface which contacts gasket must be flat. Inspect threads in tapped holes.
- (2) Check threads on special screws and jam nuts, and replace any damaged parts.
- (3) Rotate races of output gear rear bearing by hand to detect roughness. Examine bearing races for cracks. If bearing is damaged or excessively worn, replace with new bearing.
- (4) Examine rear bearing lock sleeve. Obtain new sleeve if old sleeve is broken or distorted.

*c. Repair.* Sleeve and deflector on flange assembly ((R), fig. 52) must be replaced if inspection shows parts to be grooved or worn. Flange assembly is identical with flange assembly used at pillow block. Refer to paragraph 224 for inspection and repair procedure for flange assembly.

## 100. Assembly of Output Gear Bearing Retainer Components

*Note.* Key letters noted in parentheses are in figure 52 unless otherwise indicated.

- a.* Install output gear rear bearing (M) in recess in output gear bearing retainer (K). Place rear bearing lock sleeve (L) against

bearing; then thread one  $\frac{1}{2}$ -20 jam nut on each of two  $\frac{1}{2}$ -20 x  $1\frac{7}{32}$  special screws (fig. 67), coat screw threads with plastic type gasket cement, and install screws in tapped holes in output gear bearing retainer (K). Conical points on screws must engage tapered side of rear bearing lock sleeve (L). Tighten screws to torque of 20 to 25 pound-feet to force sleeve firmly against outer race of bearing, then tighten jam nuts.

b. Place output gear bearing retainer on flat surface and coat oil seal recess with plastic type gasket cement. Drive new oil seal (N) into recess with spring-loaded lip pointing inward. Use wood block or suitable driver to apply pressure at outer circumference of seal assembly.

c. Locate front bearing retainer assembly (J) with  $\frac{1}{8}$  x  $\frac{3}{8}$  dowel pin (S) aligned with notch in output gear bearing retainer (K); then drive front bearing retainer assembly (J) into counterbore in output gear bearing retainer. Insert splined end of output gear and bearing assembly shown in figure 65 through front bearing retainer assembly (J) and out through output gear rear bearing (M). Coat surface of oil seal sleeve on flange assembly (R) with universal gear lubricant; then install flange assembly on splines at rear end of output gear (E). Drive flange assembly onto splines far enough to install  $\frac{7}{8}$ -14 nut and partially tighten nut to pull gear and bearing assembly into place in output gear bearing retainer (K). Final tightening of nut is done

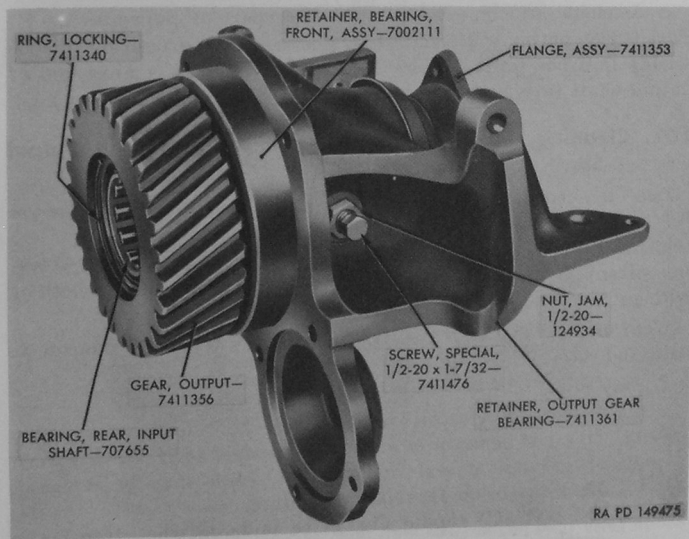

Figure 68. Output gear and bearing retainer assembled.

after subassemblies are installed in transfer case (par. 119). Figure 68 shows output gear and bearing retainer components assembled prior to installation.

## Section VI. REBUILD OF FRONT AXLE OUTPUT SHAFT COMPONENTS

### 101. Disassembly of Front Axle Output Shaft Components

*Note.* Key letters noted in parentheses are in figure 52 unless otherwise indicated.

a. Remove four  $\frac{3}{8}$ -18 x  $1\frac{1}{8}$  cap screws (AH) and  $\frac{3}{8}$ -inch external-teeth lock washers (AG) which attach front axle output shaft front bearing retainer (AJ) to bearing support (AX); then remove retainer assembly and retainer gasket (AR) from bearing support.

b. Remove oil seal (AK) from bearing retainer.

*Note.* Discard oil seal, as new seals should be installed when assembling transfer.

c. Position output shaft and bearing support assembly in arbor press and press front axle output shaft assembly out of front bearing (fig. 69).

d. Remove clutch (AF) from front axle output shaft; then remove clutch snap ring ((J), fig. 71) from groove in front axle output shaft. Remove front axle output shaft gear (AB) from output shaft.

e. Assemble attachment 41-A-345-328 (part of puller set 41-P-2905-60) on output shaft and bearing assembly, and position this assembly in arbor press as shown in figure 70. Press against end of output shaft to remove front axle output shaft rear bearing (YY).

### 102. Cleaning, Inspection, and Repair of Front Axle Output Shaft Components

*Note.* Key letters noted in parentheses are in figure 71 unless otherwise indicated.

a. *Cleaning.*—Wash all components shown in figure 71 in dry-cleaning solvent or volatile mineral spirits. Dry parts with clean cloth or with air.

**Caution:** Do not spin ball-type bearings with air as damage to balls and races will result.

b. *Inspection.*

- (1) Inspect deflector, oil seal sleeve, and splines on flange assembly (B). If deflector or sleeve are damaged or if sleeve is worn or grooved at seal surface, these parts may be replaced. Refer to *c* below for repair procedure.
- (2) Oil seal (C) should always be replaced when transfer is overhauled.



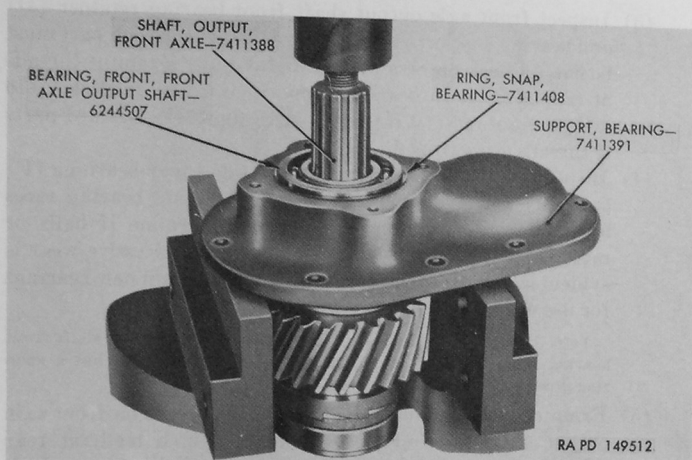

Figure 69. Pressing front axle output shaft out of front bearing.

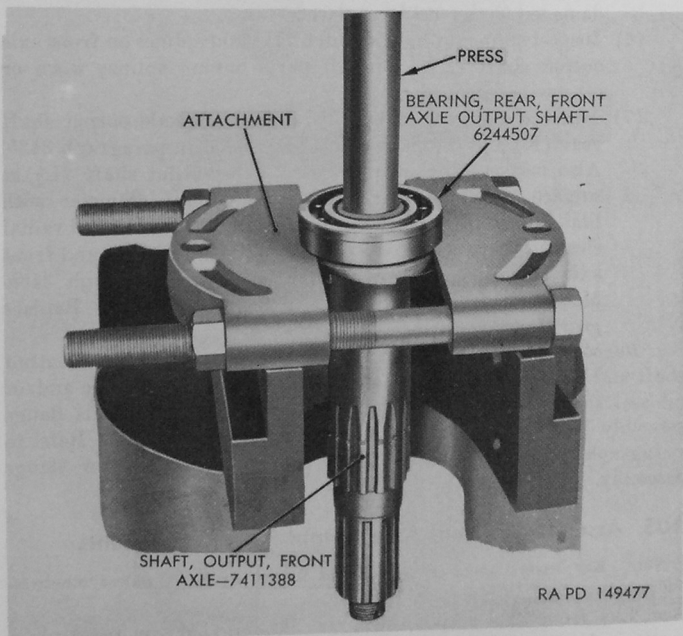

Figure 70. Removing rear bearing from front axle output shaft using attachment 41-A-345-328 (part of puller set 41-P-2905-60) and arbor press.

- (3) Inspect front axle output shaft front bearing retainer (D) and bearing support (G). Gasket surfaces on each part must be flat. Check flatness with straightedge. Examine threads at tapped holes in bearing support (G), also inspect  $\frac{3}{8}$ -16 x  $\frac{1}{8}$  cap screws ((AH), and (AE), fig. 52). Discard parts if threads are stripped.
- (4) Inspect front axle output shaft front and rear bearings (F) and (M) for wear and for damage. Rotate bearing races by hand while exerting pressure to determine if balls or races are rough. If roughness is felt or if excessive wear is evident as indicated by looseness of balls, obtain new bearings for use when assembling.

*Note.* Bearing snap ring (E) is used at front axle output shaft front bearing (F). Front axle output shaft rear bearing (M) has a snap ring groove, but no snap ring is used.

- (5) Examine teeth on clutch (H) and mating teeth on front axle output shaft gear (K). Also check clutch teeth at rear side of gear and mating teeth on front axle output shaft (L). If any of the teeth are chipped or broken, parts having damaged teeth must be replaced.
- (6) Inspect splines at hub of clutch (H) and splines on front axle output shaft (L). Discard parts having splines worn or otherwise damaged.
- (7) Measure diameter of bore through front axle output shaft gear (K) and compare with limits listed in paragraph 343*b*. Also measure diameter of front axle output shaft (L) at surface on which gear operates. Compare diameter with limits listed for this part in paragraph 343*b*. Desired radial clearance between front axle output shaft gear (K) and front axle output shaft (L) is also listed in paragraph 343*b*. Measure width of fork groove in gear (par. 343*b*). Replace gear if groove is worn.

*c. Repair.*—The only repair recommended at front axle output shaft and related components is the replacement of deflector and/or oil seal sleeve on output shaft flange assembly (B). This flange assembly is identical to flange assembly used at pillow block. Refer to paragraph 224 for inspection and repair procedures for flange assembly.

### 103. Assembly of Front Axle Output Shaft Components

*Note.* Key letters noted in parentheses are in figure 71 unless otherwise indicated.

*a.* Lay front axle output shaft rear bearing (M) on press plate, position front axle output shaft (L) on bearing inner race and press shaft squarely into bearing. Inner race must seat solidly on shaft.

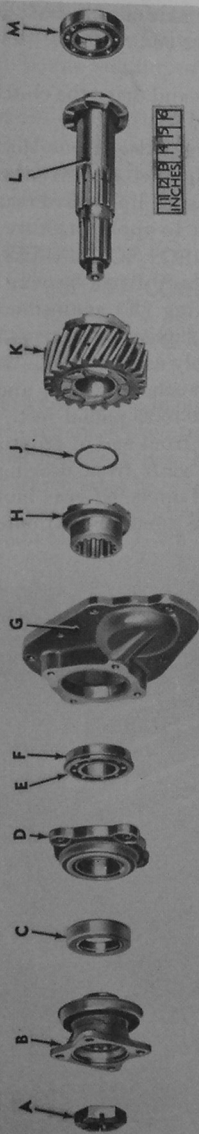

A—NUT, 7/8-14-7411259  
 B—FLANGE, ASSY-7411353  
 C—SEAL, OIL-7411263  
 D—RETAINER, FRONT AXLE OUTPUT  
 SHAFT FRONT BEARING-7411384

E—RING, SNAP, BEARING-7411408  
 F—BEARING, FRONT, FRONT AXLE  
 OUTPUT SHAFT-6244507  
 G—SUPPORT, BEARING-7411391  
 H—CLUTCH-7412879  
 J—RING, SNAP, CLUTCH-7412880

K—GEAR, FRONT AXLE OUTPUT  
 SHAFT-7411360  
 L—SHAFT, OUTPUT, FRONT AXLE-7411388  
 M—BEARING, REAR, FRONT AXLE  
 OUTPUT SHAFT-6244507

RA PD 148628

Figure 71. Front axle output shaft and related components.

b. Coat surface of front axle output shaft with universal gear lubricant (GO), then install front axle output shaft gear (K) on shaft with shift fork groove toward rear end of shaft. Install clutch snap ring (J) in groove in output shaft.

c. Install clutch (H) on splines and drive the clutch tightly against snap ring (J).

d. Coat oil seal recess in front axle output shaft front bearing retainer (D) with plastic type gasket cement; then drive new oil seal (C) into recess with spring-loaded lip toward rear side of retainer. Use wood block or suitable driver to apply pressure at outer circumference of seal assembly.

e. Install front axle output shaft front bearing (F) in bearing support (G), with bearing snap ring (E) against surface of support. Place new retainer gasket ((AR), fig. 52) at bearing support (G) and install retainer and oil seal assembly using four  $\frac{3}{8}$ -16 x  $1\frac{1}{8}$  cap screws with  $\frac{3}{8}$ -inch external-teeth lock washers ((AH) and (AG), fig. 52). Tighten cap screws to torque of 20 to 25 pound-feet.

f. Place support assembly over front end of front axle output shaft (L) and push front axle output shaft front bearing (F) onto shaft as far as possible. Apply coat of universal gear lubricant on surface of oil seal sleeve; then start flange assembly (B) onto splines at front

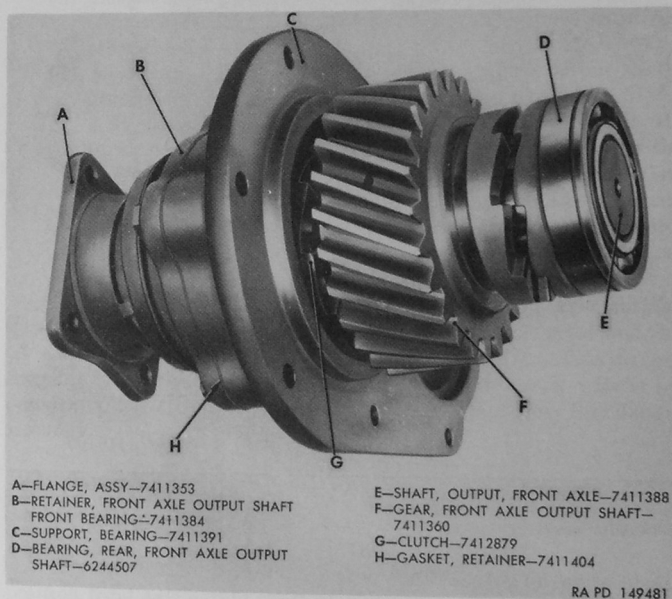

Figure 72. Front axle output shaft components assembled.

axle output shaft and through oil seal in front axle output shaft front bearing retainer (D). Drive flange assembly onto shaft with lead hammer until flange hub forces inner race of bearing into contact with clutch (H).

*g.* Install  $\frac{7}{8}$ -14 nut (A) on shaft threads and tighten lightly. Final tightening is done after subassembly is installed in transfer case (par. 115). Front axle output shaft components appear as shown in figure 72 when properly assembled.

## Section VII. REBUILD OF FORWARD REAR AXLE OUTPUT SHAFT COMPONENTS

### 104. Disassembly of Forward Rear Axle Output Shaft Components

*a. General.*—Forward rear axle output shaft components are disassembled as they are removed from transfer case (par. 91), except forward rear axle output shaft rear boring (K, fig. 74) and bearing spacer (J, fig. 74) which must be removed as directed in *b* below.

*b. Removal of Forward Rear Axle Output Shaft Rear Bearing.*—Assemble attachment 41-A-345-328 (part of puller set 41-P-2905-60)

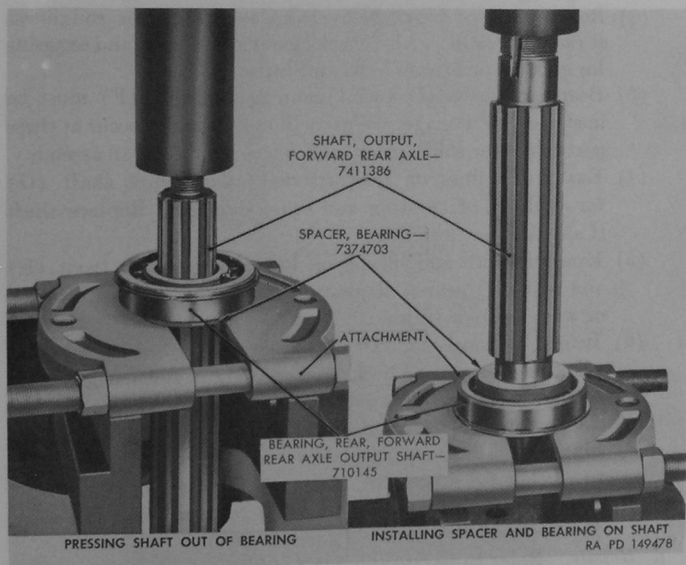

Figure 73. Use of attachment 41-A-345-328 (part of puller set 41-P-2905-60) for removing and installing rear bearing on forward rear axle output shaft.

on output shaft and support shaft and bearing assembly in arbor press as shown in figure 73. Press shaft out of bearing and remove spacer from shaft.

## 105. Cleaning, Inspection, and Repair of Forward Rear Axle Output Shaft Components

*Note.* Key letters noted in parentheses are in figure 74.

*a. General.*—Gaskets, oil seal, and bearing nut lock should be discarded and new parts obtained for use when assembling. The only one of this group of components which may be repaired is the flange assembly (P).

*b. Cleaning.*—Wash all forward rear axle output shaft components in dry-cleaning solvent or volatile mineral spirits and wipe or blow dry.

**Caution:** Do not spin ball bearing assemblies with air as damage to bearings may result.

*c. Inspection.*

- (1) Inspect threads in bearing lock nut (A) and  $\frac{7}{8}$ -14 nut (Q) and threads on each end of forward rear axle output shaft (G). Obtain new parts for assembly if threads are stripped or damaged.
- (2) Rotate races of bearings by hand and check for roughness at races and balls. Also check bearings for wear and examine for cracked or broken balls and races.
- (3) Bearing spacers (D and J) and gear spacer (F) must be inspected for damage. Wear will not normally occur at these parts since the shaft, gears, and spacers rotate as an assembly.
- (4) Examine splines on forward rear axle output shaft (G) for evidence of twisting and other damage. Replace shaft if any damage is evident.
- (5) Examine teeth and splines on forward rear axle front (E) and rear (H) gears. Replace gears having chipped, broken, or worn teeth or splines.
- (6) Inspect forward rear axle output shaft rear bearing retainer (N) for damage. Check gasket surface for flatness with straightedge. Replace retainer if damaged.
- (7) Inspect splines, deflector, and oil seal sleeve on flange assembly (P). If deflector or sleeve require replacement, refer to *d* below for procedure.
- (8) Inspect rear bearing snap ring (L) for distortion and wear. Replace snap ring if not in good condition.

*d. Repair.* Refer to paragraph 224 for instructions for replacing deflector and sleeve on flange assembly (P).



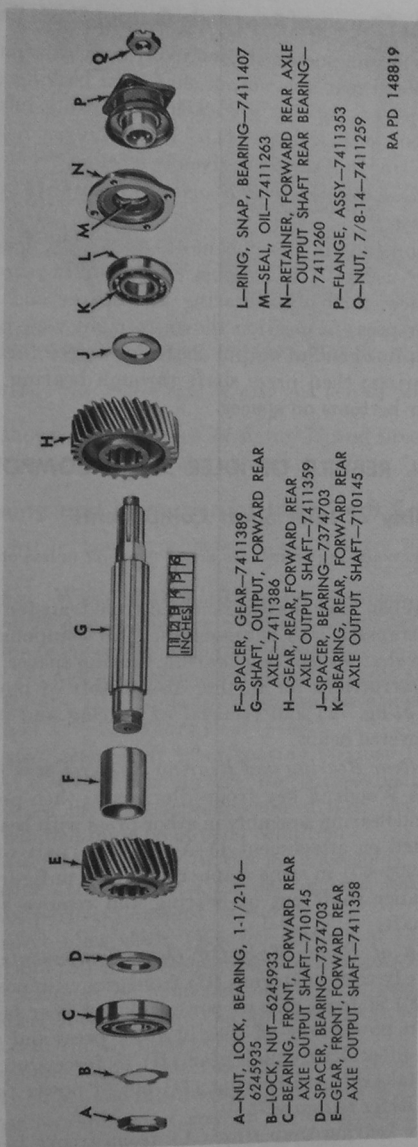

Figure 74. Forward rear axle output shaft components.

## 106. Assembly of Forward Rear Axle Output Shaft Components

*a. General.*—All components of forward rear axle output shaft and gears except forward rear axle output shaft rear bearing (K, fig. 74) and bearing spacer (J, fig. 74) are assembled during installation of components in transfer case (par. 114). Procedure for installing output shaft rear bearing and spacer is given in *b* below.

*b. Installing Rear Bearing and Bearing Spacer on Forward Rear Axle Output Shaft.*

- (1) Adjust opening in attachment 41-A-345-328 (part of puller set 41-P-2905-60) to support output shaft rear bearing at inner race; then place bearing and spacer and attachment on arbor press in position shown in right view of figure 73.
- (2) Insert splined end of output shaft downward through spacer and bearing; then press shaft through bearing until shaft shoulder bottoms on spacer.

## Section VIII. REBUILD OF IDLER SHAFT COMPONENTS

### 107. Disassembly of Idler Shaft Components

*Note.* Key letters noted in parentheses are in figure 77 unless otherwise indicated.

*a. General.* When idler shaft is removed from transfer case during disassembly of transfer into subassemblies, all components are removed from idler shaft except rear bearing, bearing spacer, and Woodruff key. The instructions for further disassembly of power take-off gear assembly (J, fig. 76) and removal of bearing and spacer from idler shaft are covered below.

*b. Removing Rear Bearing and Bearing Spacer From Idler Shaft.*

- (1) Remove Woodruff key from idler shaft; then position idler shaft and bearing assembly in arbor press with bearing spacer supported on attachment 41-A-345-328 (part of puller set 41-P-2905-60) in same manner as shown in figure 73.
- (2) Press idler shaft out of bearing and remove spacer from idler shaft.

*c. Disassembly of Power Take-Off Gear Components.*

- (1) Remove bearing snap ring (C) from groove in power take-off gear (E) at front side of power take-off gear bearing (D).
- (2) Support power take-off gear in arbor press and apply pressure at idler shaft clutch gear (B) to force clutch gear and power take-off gear bearing (D) out of power take-off gear (E). Refer to figure 75.
- (3) Remove bearing snap ring (A) from groove in idler shaft clutch gear (B) at front side of power take-off gear bearing (D). Place clutch gear and bearing assembly in arbor press

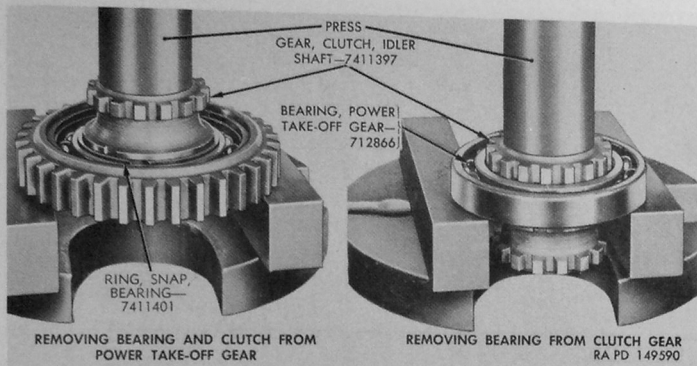

Figure 75. Power take-off gear and bearing removal.

as shown in right view of figure 75 and press on clutch gear to separate clutch gear from bearing.

## 108. Cleaning and Inspection of Idler Shaft Components

*Note.* Key letters noted in parentheses are in figure 76 unless otherwise indicated.

*a. Cleaning.* Wash idler shaft, gears, bearings, and other components (figs. 77 and 76) in dry-cleaning solvent or volatile mineral spirits. Wipe parts or dry with compressed air.

**Caution:** Do not spin bearings with air as balls and races may be damaged. Be sure all oil holes through gears are open.

*b. Inspection of Idler Shaft Components.*

- (1) Inspect idler shaft front bearing retainer (A) for damage. Also check gasket surface for flatness using straightedge. Threads in which speedometer driven gear assembly (B) is installed must be in good condition.
- (2) Inspect speedometer driven gear assembly (B) and speedometer drive gear (C) for damage and wear at teeth. Replace parts if damaged or worn.
- (3) Inspect idler shaft (K) for damage at threads on either end and inspect threads in bearing lock nuts (D). If threads are stripped or damaged, obtain new parts for assembly. Inspect Woodruff key (L) and keyway in idler shaft. Key must fit tightly in keyway.
- (4) Examine helical teeth on idler shaft front and rear gears (H and M) and the internal clutch teeth on each gear. Gears must be replaced if any of the teeth are found broken or chipped, or if drive surfaces are pitted.
- (5) Inspect bearing spacers (G) which must be flat and have no evidence of wear.

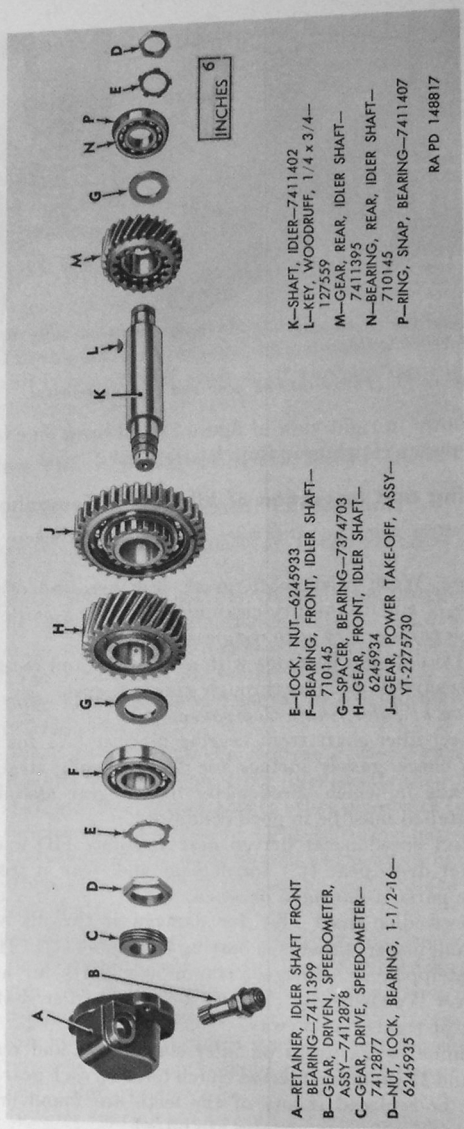

Figure 76. Transfer idler shaft and related components.

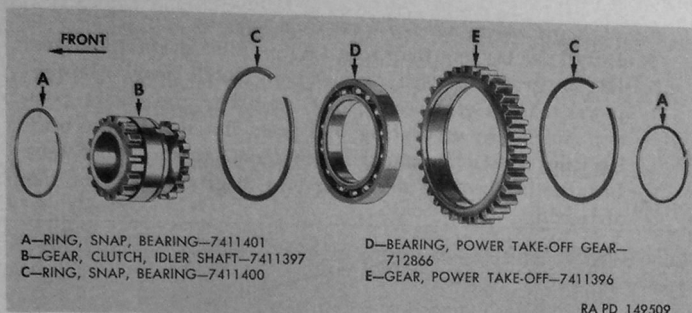

Figure 77. Power take-off gear and related components.

- (6) Power take-off gear assembly (J) is composed of the components shown in figure 77. Refer to *c* below for inspection procedure for these components.

*c. Inspection of Power Take-Off Gear Components.*

- (1) Inspect bearing snap rings (A and C, fig. 77) for distortion and for wear. Rings must be flat and round. Discard rings if not in good condition.
- (2) Inspect idler shaft clutch gear (B, fig. 77) which has clutch teeth at both ends. If any of the teeth are chipped, broken, or worn, clutch gear must be replaced with new part.
- (3) Inspect power take-off gear bearing (D, fig. 77) for roughness of races and balls by turning bearing races by hand. If rough spots are felt or if races are cracked or broken, replace bearing. Excessive looseness of balls allowing radial movement of inner race indicates worn bearing which must be replaced.
- (4) Examine teeth on power take-off gear (E, fig. 77). If any teeth are found to be broken, chipped, or pitted, the gear must be replaced.

## 109. Assembly of Idler Shaft Components

*Note.* Key letters noted in parentheses are in figure 77 unless otherwise indicated.

*a. General.*—Components of power take-off gear (fig. 77) must be assembled into a subassembly before installing idler shaft in transfer case. Power take-off gear assembly (J, fig. 76) and balance of idler shaft components except Woodruff key (L, fig. 76), bearing spacer (G, fig. 76), idler shaft rear bearing (N, fig. 76), nut lock (E, fig. 76), and bearing lock nut (D, fig. 76) are assembled in transfer case as described in procedure for installing idler shaft (par. 116). Refer to *b* and *c* below for procedure for assembling power take-off gear assembly and for installing idler shaft rear bearing and bearing spacer.

*b. Assembling Power Take-Off Gear Components.*

- (1) Install one bearing snap ring (A) on idler shaft clutch gear (B) in groove toward rear end of clutch gear. Support power take-off gear bearing (D) on arbor press plate, position clutch gear on bearing, and press clutch gear into bearing (fig. 78) until snap ring contacts bearing inner race. Install other bearing snap ring (A) in groove at front side of bearing.

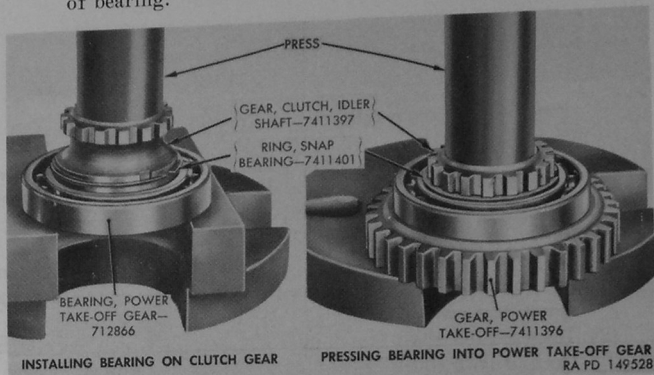

Figure 78. Installing power take-off gear and bearing on clutch gear.

- (2) Install one bearing snap ring (C) in groove in power take-off gear (E); then lay gear on press plate with clearance below for clutch gear hub. Position clutch gear and bearing assembly on power take-off gear; then press on clutch gear to force bearing outer race into power take-off gear (fig. 78) until bearing outer race contacts large bearing snap ring (C). Install remaining large bearing snap ring (C) in groove in power take-off gear (E).

*c. Installing Idler Shaft Rear Bearing and Spacer on Idler Shaft.*

- (1) Support idler shaft rear bearing (N, fig. 76) on attachment 41-A-345-328 (part of puller set 41-P-2905-60) in arbor press. Lay bearing spacer (G, fig. 76) on bearing and insert rear end of idler shaft (K, fig. 76) through spacer and into bearing in same manner as illustrated in right view of figure 73.
- (2) Press idler shaft into bearing until shoulder on shaft contacts bearing spacer (G, fig. 76).
- (3) Remove idler shaft (K, fig. 76) from press and drive  $\frac{1}{4} \times \frac{3}{4}$  Woodruff key (L, fig. 76) into place in keyway in idler shaft.
- (4) Grip idler shaft (K, fig. 76) in vise equipped with soft jaws.



Install new bearing nut lock (E, fig. 76) and bearing lock nut (D, fig. 76) on rear end of idler shaft. Final tightening of nut is deferred until idler shaft has been installed in transfer case (par. 116).

## Section IX. REBUILD OF SHIFTING MECHANISM

### 110. General

*Note.* Key letters noted in parentheses are in figure 79 unless otherwise indicated.

Shifting mechanism, consisting of the components shown in figure 79, is disassembled to the extent shown. Front axle shifter shaft

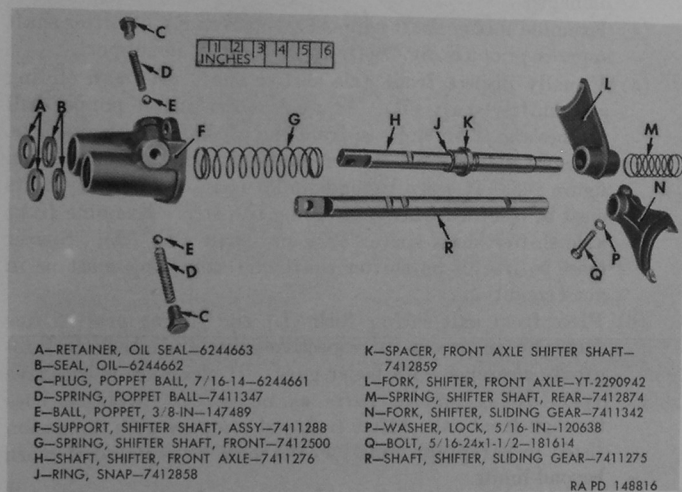

Figure 79. Transfer shifting mechanism components.

spacer (K) need not be removed from front axle shifter shaft (H) unless inspection indicates necessity for replacement of parts. Shifter shaft support pilot (N, fig. 54) is pressed into shifter shaft support assembly (F) and is replaceable. Specifications for various parts are given in paragraph 343c.

### 111. Cleaning, Inspection, and Repair of Shifting Mechanism

*Note.* Key letters noted in parentheses are in figure 79 unless otherwise indicated.

*a. Cleaning.*—Wash all parts of shifting mechanism in dry-cleaning solvent or volatile mineral spirits. Be sure all paint or other deposits

are removed from portion of shifter shafts which extend on outside of support. When parts are clean, wipe dry or blow dry with air.

*b. Inspection.*

- (1) Inspect two poppet ball springs (D) for distortion. If springs appear in good condition, test for pressure and free length (par. 343c).
- (2) Inspect shifter shaft front and rear springs (G and M) for distortion and if springs appear to be in good condition, measure free length and test spring pressure (par. 343c).
- (3) Inspect poppet ball plugs (C) and note condition of threads. Also inspect mating threads in shifter shaft support assembly (F). Replace parts if threads are stripped or otherwise damaged.
- (4) Examine shifter shaft support assembly (F). Shifter shaft support pilot (N, fig. 54) must be tight fit in support.
- (5) Visually inspect front axle shifter shaft (H) and sliding gear shifter shaft (R). If wear is evident at poppet ball notches and at pin holes in front end of shafts, replace shafts. Measure diameter of shifter shafts at points indicated on figure 243. If worn beyond limits (par. 343c), new shafts must be installed when assembling transfer. Examine front axle shifter shaft spacer (K) and snap ring (J). Spacer must be free fit on shifter shaft and snap ring must be in good condition.
- (6) Place front axle shifter fork (L) and sliding gear shifter fork (N) in groove in respective gears and check fork-to-groove clearance with feeler gage. If clearance is excessive (par. 343c), replace parts as necessary. Measure bore through front axle shifter fork and compare with dimension listed in paragraph 343c. Forks must be replaced if worn beyond limits.

*c. Repair.*

- (1) *Shifter shaft spacer.*—If inspection indicates necessity for replacing front axle shifter shaft spacer (K, fig. 79), remove snap ring (J, fig. 79) with snap ring pliers and slide spacer off front end of front axle shifter shaft (H, fig. 79). Slide new spacer on shifter shaft with flange toward rear end of shifter shaft. Install new snap ring (J, fig. 79) in groove in shifter shaft.
- (2) *Shifter shaft support pilot.*—If inspection indicates that shifter shaft support pilot (N, fig. 54) requires replacement, remove pilot from shifter shaft support assembly (F, fig. 79) and press new pilot into recess, with counterbore in pilot facing outward.

## Section X. CLEANING AND INSPECTION OF TRANSFER CASE AND COVERS

### 112. Cleaning

*Note.* Key letters noted in parentheses are in figure 80.

a. Thoroughly wash transfer case (K), both inside and out, using dry-cleaning solvent or volatile mineral spirits. If necessary, use a stiff brush or other cleaning tool to dislodge accumulations of dirt.

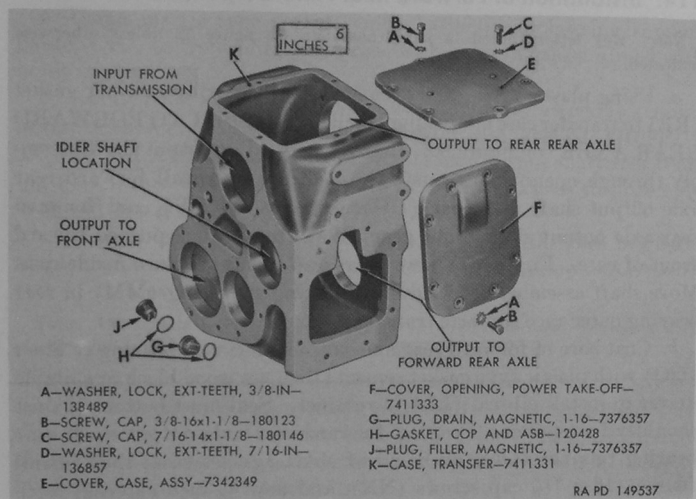

Figure 80. Transfer case and covers.

b. Remove metal particles from magnetic drain and filler plugs (G and J).

c. Clean case cover assembly (E) and power take-off opening cover (F), using same method described in a above.

d. Blow out dirt from tapped holes in case. Dry parts by wiping or with compressed air.

### 113. Inspection

*Note.* Key letters noted in parentheses are in figure 80.

a. Examine transfer case (K) carefully for evidence of cracks, using approved method for locating defects in iron castings. If case is cracked or broken, obtain new case for use when assembling.

b. Inspect case cover assembly (E) and note condition of oil trough riveted to under side of cover. Also inspect power take-off opening

cover (F) (if used). If covers are broken or otherwise damaged, obtain new parts to be used when assembling transfer.

c. Inspect threads on magnetic drain and filler plugs (G and J). If plug threads are damaged, use new plugs when assembling.

## Section XI. ASSEMBLY OF TRANSFER FROM SUBASSEMBLIES AND COMPONENTS

### 114. Installation of Forward Rear Axle Output Shaft and Gears

*Note.* Key letters noted in parentheses are in figure 52 unless otherwise indicated.

a. Using plastic type gasket cement, attach bearing retainer gasket (RR) to transfer case at opening labelled "OUTPUT TO FORWARD REAR AXLE" on figure 80. Insert front end of output shaft assembly through opening in transfer case (ZZ) and install forward rear axle output shaft rear gear (UU), gear spacer (VV), and forward rear axle output shaft front gear (WW) as shaft is pushed toward front of case. Figure 57 shows gears and spacer in place inside case. Move shaft assembly forward until bearing snap ring (MM) in rear bearing outer race contacts transfer case.

b. Coat bore in forward rear axle output shaft rear bearing retainer (QQ) with plastic type gasket cement; then use wood block or suitable driver to install oil seal (LL) in retainer. Seal must bottom against shoulder in retainer. Position forward rear axle output shaft rear bearing retainer (QQ) over end of shaft against case; then install four  $\frac{3}{8}$ -16 x  $1\frac{1}{8}$  cap screws (NN), and new  $\frac{3}{8}$ -inch external teeth lock washers (PP) to attach bearing retainer to case. Tighten cap screws to torque of 20 to 25 pound-feet.

c. Place bearing spacer (AT) on front end of forward rear axle output shaft (AU); then install forward rear axle output shaft front bearing (AW) on shaft, using replacer 41-R-2390-415 in manner illustrated in figure 82. Bearing inner race must seat firmly against bearing spacer (AT).

*Note.* Outer race of forward rear axle output shaft front bearing (AW) has a snap ring groove but no snap ring is used.

d. Place a new nut lock (AV) on front end of forward rear axle output shaft (AU) and install bearing lock nut (AS) loosely.

e. Install flange assembly (HH) on forward rear axle output shaft (AU) and retain with  $\frac{7}{8}$ -14 nut (KK).

f. Assemble companion flange holding tool 41-T-3215-910 on forward rear axle output shaft flange in manner shown in figure 51; then tighten bearing lock nut (AS) to minimum torque of 100 pound-feet.

Bend nut lock (AV) against flat on nut. Tighten  $\frac{7}{8}$ -14 nut (KK) to minimum torque of 130 pound-feet and install  $\frac{1}{8}$  x  $1\frac{3}{4}$  cotter pin (JJ).

*Note.* Leave holding tool attached to flange until balance of bearing lock nuts and flange retaining nuts have been tightened.

## 115. Installation of Front Axle Output Shaft Components

*Note.* Key letters noted in parentheses are in figure 52 unless otherwise indicated.

a. Using plastic type gasket cement, attach new bearing support gasket (AC) to front of transfer case with holes in gasket aligned with holes in case.

b. Install front axle output shaft and components assembly (shown in figure 72) in opening in front of transfer case labelled "OUTPUT TO FRONT AXLE" on figure 80. Front axle output shaft rear bearing (YY) must be guided into recess in transfer case as the assembly is moved into position.

c. Aline holes through front bearing support with holes in gasket and transfer case and install eight  $\frac{3}{8}$ -16 x  $1\frac{1}{8}$  cap screws (AE) with new  $\frac{3}{8}$ -inch external-teeth lock washers (AD).

*Note.* Bolts installed in five holes tapped through case must be coated with plastic type gasket cement.

Tighten cap screws to torque of 20 to 25 pound-feet.

d. Move front axle output shaft gear (AB) into engagement with clutch teeth at rear end of front axle output shaft (XX); then hold shaft from turning with holding tool and tighten  $\frac{7}{8}$ -14 nut (AL) to minimum torque of 130 pound-feet.

## 116. Installation of Idler Shaft, Gears, and Bearings

*Note.* Key letters noted in parentheses are in figure 52 unless otherwise indicated.

a. Make up an assembly composed of idler shaft rear gear (V) and idler shaft front gear (BA) mated with power take-off gear assembly ((J), fig. 76) and hold these parts in position inside transfer case.

*Note.* Sectional view of transfer (fig. 52) shows correct position of parts. Larger (27-tooth) gear is located at front.

b. Insert front end of idler shaft assembly through opening at rear of transfer case and through idler shaft rear gear (V), idler shaft clutch gear (BC), and idler shaft front gear (BA). Aline  $\frac{1}{4}$  x  $\frac{3}{4}$  Woodruff key (Z) in idler shaft with keyway in rear gear as idler shaft (fig. 81) is moved forward. Use lead hammer to drive on rear end of idler shaft to force idler shaft into place with bearing snap ring (EE) against rear face of transfer case.

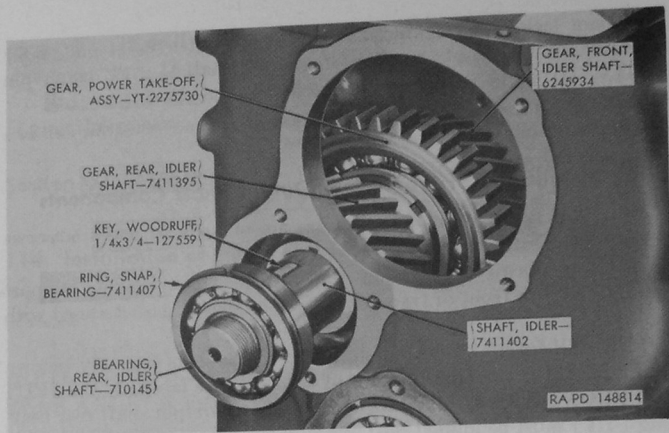

Figure 81. Installing idler shaft and gears.

c. Place bearing spacer (BD) on front end of idler shaft, then install idler shaft front bearing (BE), using replacer 41-R-2390-415 as shown in figure 82 to drive bearing onto idler shaft.

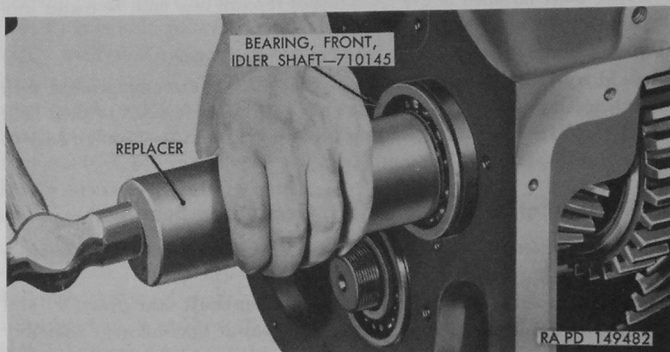

Figure 82. Use of replacer 41-R-2390-415 for installing idler shaft front bearing.

d. Install nut lock (BH); then install bearing lock nut (BF). Tighten bearing lock nuts (BF and CC) to minimum torque of 100 pound-feet, using holding tool 41-T-3215-910 on forward rear axle output shaft flange to prevent idler shaft from turning. Bend nut locks (AA and BH) against nuts to prevent loosening.

e. Install speedometer drive gear (BJ) on front end of idler shaft, using replacer 41-R-2390-415 shown in figure 82 to drive gear into place on idler shaft.



f. Place a new retainer gasket (BL) at transfer case; then install idler shaft front bearing retainer (BG), using three  $\frac{3}{8}$ -16 x  $1\frac{1}{8}$  cap screws (AZ), with new  $\frac{3}{8}$ -inch external-teeth lock washers; coat cap screw threads with plastic type gasket cement to prevent leaks. Tighten cap screws to torque of 20 to 25 pound-feet.

g. Coat threads with plastic type gasket cement; then install speedometer driven gear assembly (BK) in idler shaft front bearing retainer (BG). Tighten gear assembly into retainer with torque wrench to torque 30 to 35 pound-feet.

## 117. Installation of Input Shaft and Gear Assembly

*Note.* Key letters noted in parentheses are in figure 52 unless otherwise indicated.

a. Coat bearing surface of bushing type bearing (BY) and surface of splines on input shaft (B) with universal gear lubricant (GO). Also apply same lubricant on surface of oil seal sleeve on flange assembly.

b. While holding input shaft gear (CB) inside transfer case, insert input shaft (B) through opening in rear of case, through input shaft gear (CB), and out front of case through opening marked "INPUT FROM TRANSMISSION" on figure 80.

c. Place bearing spacer (BX) on input shaft; then install input shaft front bearing (BW), driving bearing into place until bearing snap ring (BM) contacts transfer case.

d. Coat bore in input shaft front bearing retainer (BN) with plastic type gasket cement; then use wood block or suitable driver to install oil seal (BS) in retainer. Front face of seal assembly must be flush with front of retainer.

e. Place retainer gasket (BV) around opening at front of transfer case. Install bearing retainer and oil seal assembly on transfer case, using four  $\frac{3}{8}$ -16 x  $1\frac{1}{8}$  cap screws (BT) and new  $\frac{3}{8}$ -inch external-teeth lock washers (BU). Tighten cap screws to torque of 20 to 25 pound-feet.

f. Install flange assembly (BR) on front end of input shaft and retain with  $1\frac{1}{8}$ -12 nut (BQ). Tighten  $1\frac{1}{8}$ -12 nut (BQ) to minimum torque of 130 pound-feet. Install  $\frac{1}{8}$  x 2 cotter pin (BP) to secure nut.

## 118. Installation of Shifting Mechanism

*Note.* Key letters noted in parentheses are in figure 54 unless otherwise indicated.

a. Hold sliding gear shifter fork (E) in groove at sliding gear (C) with threaded side of fork upward. Insert sliding gear shifter shaft (X) through hole in front of transfer case and move shaft through fork to a point where notch in shifter shaft is aligned with bolt hole

in fork. Install one  $\frac{5}{16}$ -24 x  $1\frac{1}{2}$  bolt (F) with new  $\frac{5}{16}$ -inch lock washer (G) and tighten bolt to torque of 15 to 20 pound-feet.

b. Locate front axle shifter fork (R) in groove in front axle output shaft gear (K). Insert front axle shifter shaft (V) through hole in front of transfer case. Pass shifter shaft through front axle shifter fork (R), then hold shifter shaft rear spring (H) between fork and boss in transfer case. Push shifter shaft through spring and into boss in case.

c. Place shifter shaft front spring (S) on front axle shifter shaft (V). Using plastic type gasket cement, attach shifter shaft support gasket (AA) to front of transfer case.

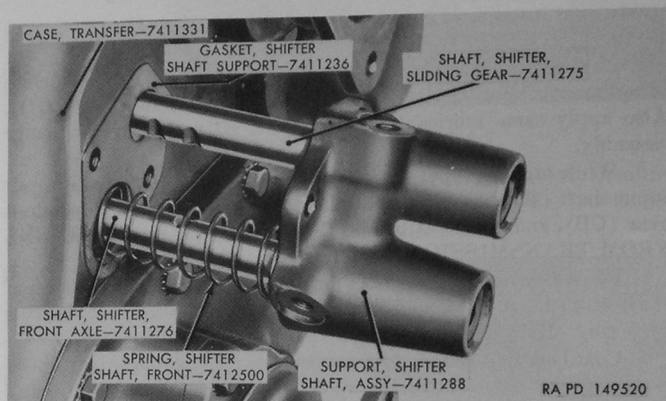

Figure 83. Installing shifter shaft support.

d. Slide shifter shaft support assembly (Z) onto shifter shafts as shown in figure 83. Push support into place at case. Coat threads of two  $\frac{3}{8}$ -16 x  $1\frac{1}{8}$  bolts with plastic type gasket cement, and attach support to transfer case with bolts and new lock washers. Tighten bolts to torque of 20 to 25 pound-feet.

e. Install oil seals (W) and oil seal retainers (Y) in recesses in shifter shaft support assembly (Z). Use shifter shaft oil seal replacer 41-R-2394-115 as shown in figure 84 to drive oil seal retainers into place.

f. Insert one  $\frac{5}{16}$ -inch poppet ball (T) and poppet ball spring (U) in each poppet well in shifter shaft support assembly (Z). Apply plastic type gasket cement on threads of  $\frac{7}{16}$ -14 poppet ball plugs (C and H, fig. 53); then install plugs in shifter shaft support and tighten plugs firmly.

Note. If necessary, turn front axle shifter shaft so that poppet ball engages detent in shaft.

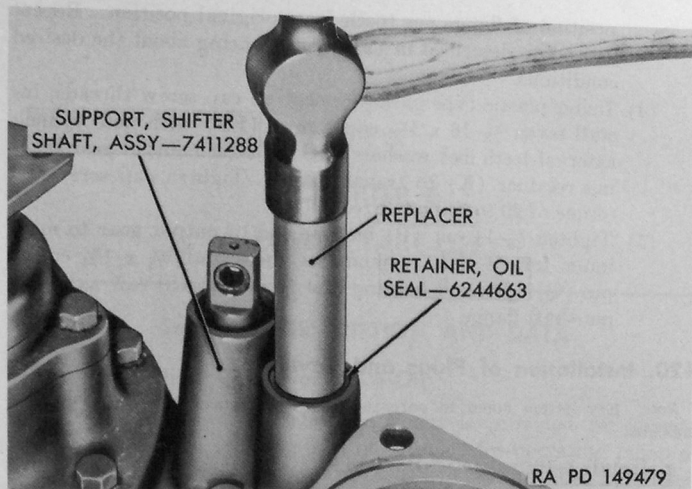

Figure 84. Use of shifter shaft oil seal replacer 41-R-2394-115 to install oil seal retainers.

## 119. Installation of Output Gear Components

*Note.* Key letters noted in parenthesis are in figure 52 unless otherwise indicated.

*a. General.*—Figure 68 shows output gear, bearing retainer, and related components assembled preparatory to installation. Prior to installation of assembly shown in figure 68, forward rear axle output shaft must be rotated so that a line drawn through flange upper mounting bolt holes is parallel to top surface of transfer case.

### *b. Installation.*

- (1) Using plastic type gasket cement sparingly, attach retainer gasket (H) to output gear bearing retainer (K), with holes in gasket and retainer alined.
- (2) Hold output gear assembly at opening in transfer case, and before engaging output gear (E) with idler shaft rear gear (V), turn flange assembly (R) so that a line through flange upper mounting holes is parallel with top of transfer case. Move output gear and retainer assembly toward transfer case.
- (3) Before installing  $\frac{3}{8}$ -16 x  $1\frac{1}{8}$  cap screws (FF), check relationship of flange assemblies (R and HH) with top of transfer case (ZZ). With holes in flange assembly (HH) parallel with top of case, corresponding holes in flange assembly (R) must also be parallel within six degrees. If flanges are not alined within six degrees, remove one of the flanges and shift

position of flange one tooth from original position. Repeat procedure described in (2) above to bring about the desired conditions.

- (4) Using plastic type gasket cement on cap screw threads, install seven  $\frac{3}{8}$ -16 x  $1\frac{1}{8}$  cap screws (FF) with new  $\frac{3}{8}$ -inch external-teeth lock washers (GG) to attach output gear bearing retainer (K) to transfer case. Tighten cap screws to torque of 20 to 25 pound-feet.
- (5) Tighten  $\frac{7}{8}$ -14 nut (P) on rear end of output gear to minimum torque of 100 pound-feet and install  $\frac{1}{8}$  x  $1\frac{3}{4}$  cotter pin (Q). Remove holding tool from forward rear axle output shaft flange.

## 120. Installation of Plugs and Covers

*Note.* Key letters noted in parentheses are in figure 80 unless otherwise indicated.

a. Install 1-16 magnetic drain plug (G) and 1-16 magnetic filler plug (J) using new copper and asbestos gaskets (H).

b. Using eight  $\frac{3}{8}$ -16 x  $1\frac{1}{8}$  cap screws (B) and new  $\frac{3}{8}$ -inch external-teeth lock washers (A), install power take-off opening cover (F) with new gasket. Cap screws used at holes tapped through case must be coated with plastic type gasket cement to prevent leaks. Tighten all cap screws to torque of 20 to 25 pound-feet.

c. Place a new cover gasket (G, fig. 52) on top of transfer case (K) with holes alined in transfer case. Place case cover assembly (E) on case and install one  $\frac{7}{16}$ -14 x  $1\frac{1}{8}$  cap screw (C) with new  $\frac{7}{16}$ -inch external-teeth lock washer through largest hole in cover. Install  $\frac{3}{8}$ -16 x  $1\frac{1}{8}$  cap screws (B) with new  $\frac{3}{8}$ -inch external-teeth lock washers in five remaining holes. Cap screws used in holes tapped through case must be coated with plastic type gasket cement before installation. Tighten transfer case cover cap screws to torque of 20 to 25 pound-feet.

d. Test Transfer Case for Leaks as Follows.—

- (1) Connect air supply with gage and shut-off valve to vent line fitting in output gear bearing retainer (K, fig. 52).
- (2) Fill transfer case with air at 15 psi and close shut-off valve.
- (3) Air pressure must not drop at a rate in excess of 5 pounds in 45 seconds.
- (4) If leakage is excessive, cause must be determined and corrected.

## CHAPTER 6

### POWER TAKE-OFF

---

#### Section I. DESCRIPTION AND DATA

#### 121. Description of Power Take-Off

*a. General.*—Power take-off equipment is provided for driving winch only, winch and dump body hoist, or for operating pump on tank type trucks. The power take-off assembly is installed at left side of transfer and is driven by power take-off gear in transfer. Power take-off can be operated either with truck standing or in motion. Power take-off receives lubrication from the transfer assembly.

*b. Power Take-Off for Operating Winch Only.*—The power take-off used on vehicles equipped with winch only is shown in figure 85. This power take-off has single output shaft which can be operated in either forward or reverse direction. Winch drive shaft and control cable both connect at forward side of power take-off.

*c. Power Take-Off for Operating Winch and Dump Body Hoist.*—Trucks with dump bodies are equipped with a power take-off on which is installed an accessory drive unit (fig. 86). On this installation the winch (when used) is driven in same manner as described in *b* above. The accessory drive unit has an output shaft toward rear and a shifter shaft at the rear to which accessory control linkage is attached. The separate controls permit independent operation of winch and dump body. Figure 98 shows arrangement of accessory drive components for above installation. Refer to paragraph 142*b* for detailed description of accessory drive unit.

*d. Power Take-Off for Operating Pump On Tank Trucks.*—Trucks with tank bodies do not have winch but a drive is provided for operating pump. On these vehicles the installation is similar to that described under *c* above except that winch drive shaft and control parts are omitted from the power take-off. A plain cap is installed to close winch drive shaft opening in front of housing and plug (fig. 87) with washer and seal is installed in winch control cable opening. Front and rear views of power take-off used to operate pump are shown in figure 87. Figure 97 shows arrangement of accessory drive unit com-



RA PD 149567

3/4 LEFT REAR VIEW

3/4 LEFT FRONT VIEW

*Figure 85. Front and rear views of power take-off used to drive winch only.*



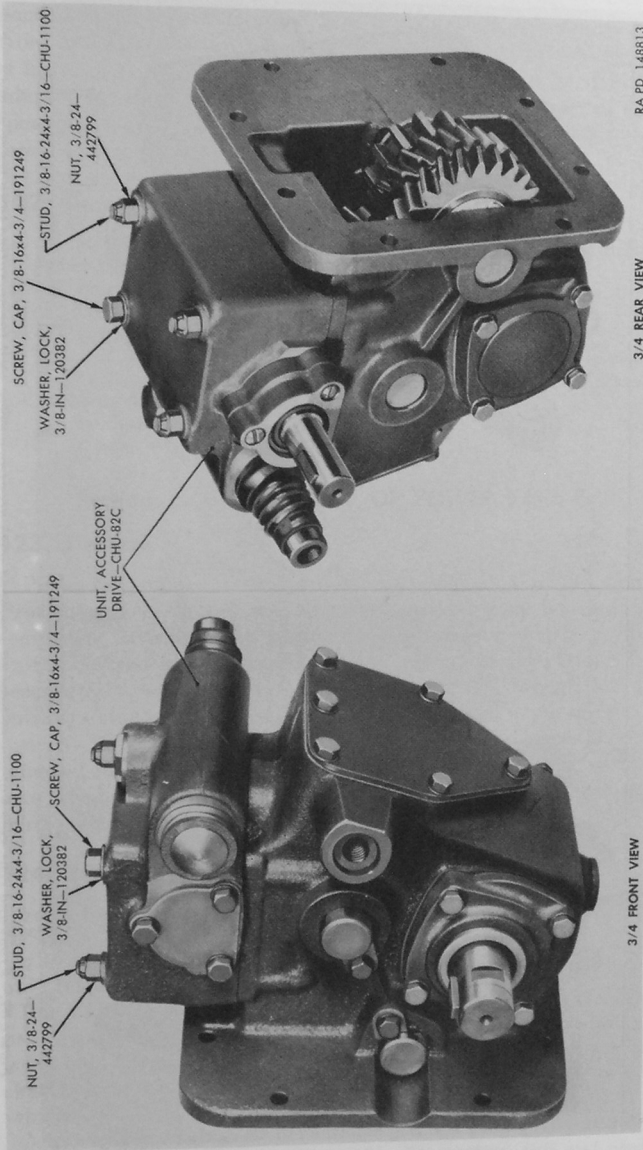

Figure 86. Front and rear views of power take-off used to operate winch and dump body hoist.

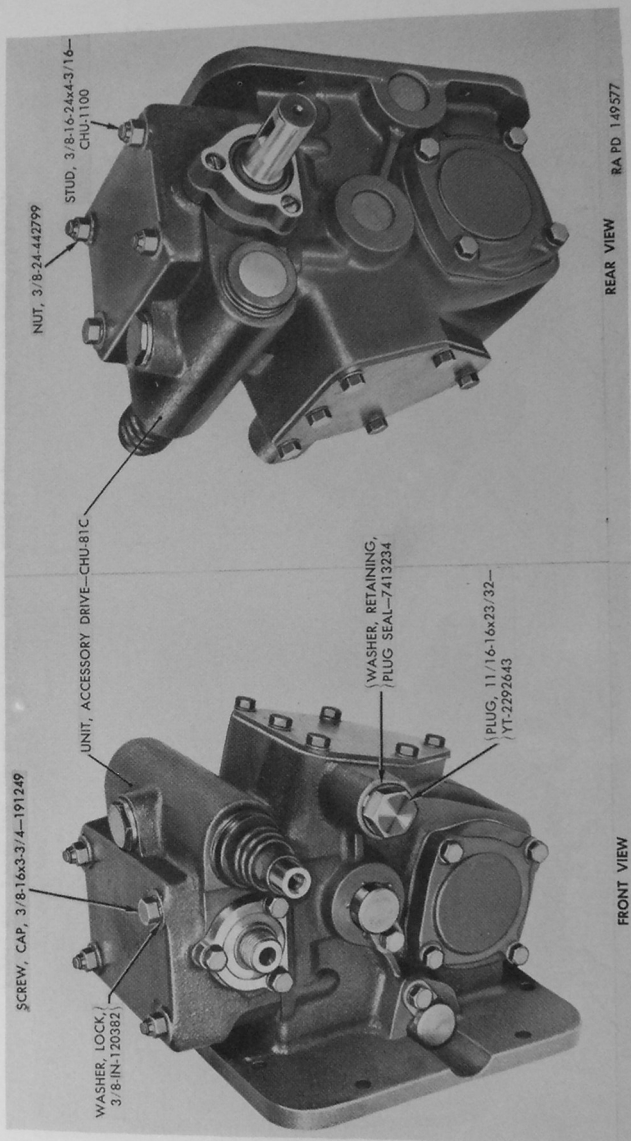

Figure 87. Front and rear views of power take-off equipped with accessory drive unit for operating tank truck pump.

ponents for above installation. Note that shifter shaft extends toward front and a special cap (drive shaft front bearing cap (A, fig. 97)) is installed on accessory drive housing. Special cap serves as an adapter for connecting drive cable used to govern the truck engine speed while operating tank pump. Refer to paragraph 142a for detailed description of accessory drive unit.

## 122. Data

Manufacturer-----	Chelsea Products
Power take-off model:	
Trucks w/winch only-----	87C1
Trucks w/winch and dump body-----	85C
Trucks w/winch and tank body-----	85C
Type-----	reversible
Speed-----	single
Accessory drive model:	
Trucks w/dump body-----	82C
Trucks w/tank body-----	81C

## Section II. DISASSEMBLY OF POWER TAKE-OFF

### 123. General

Power take-off can be disassembled without the use of special tools. Procedure given in this section covers removal from housing of all component parts in logical sequence. Replacement of accessory drive unit is covered in paragraphs 143 and 144. Rebuild of tank truck accessory drive unit is covered in paragraphs 145 through 148. Rebuild of dump truck accessory drive unit is covered in paragraphs 149 through 152. During disassembly, all gaskets and oil seals should be removed and discarded as these parts should be replaced with new ones when overhauling power take-off. Arrangement of component parts is shown in sectional view of power take-off (fig. 88).

### 124. Removal of Plugs and Covers

*Note.* Key letters noted in parentheses are in figure 89 unless otherwise indicated.

*a. General.*—If power take-off is equipped with an accessory drive unit, remove (par. 143) and disassemble unit as instructed in sections VI or VII of this chapter. All power take-off housings have a magnetic-type drain plug and if power take-off is the type used on tank truck (fig. 87), a plug is installed in front of housing and serves to close hole at which shifter control is installed when used on other vehicles.

*b. Removing Plugs.*—Remove housing drain plug (BB) and drain plug gasket (AA). Remove plug (fig 87), washer, and seal used to close shifter hole in power take-off used on tank trucks.

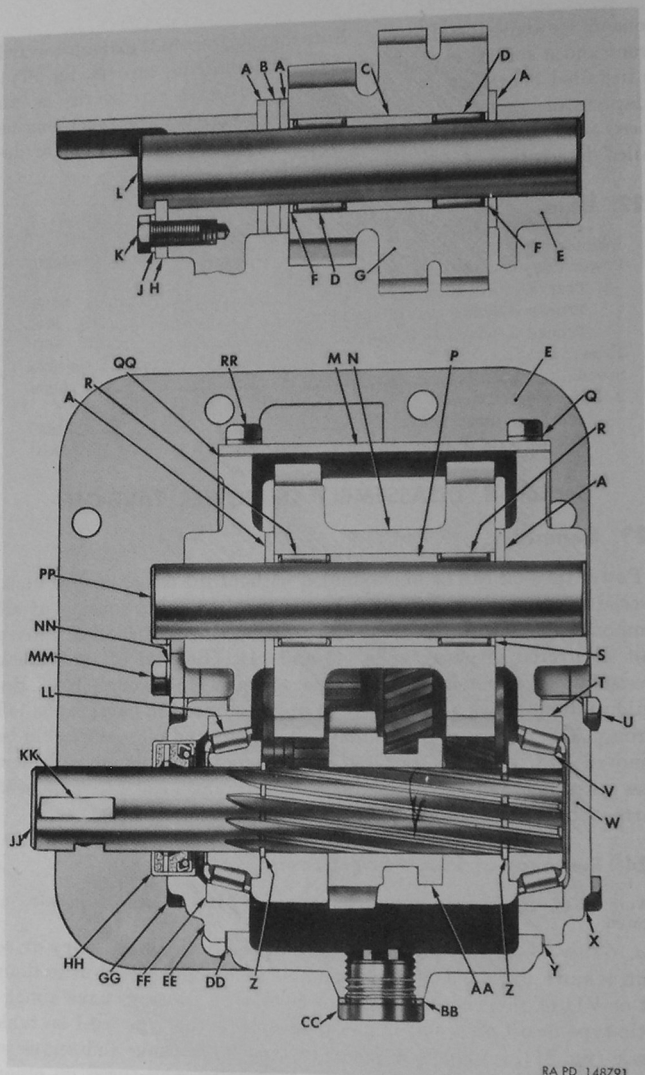

RA PD 148791

Figure 88. Sectional view of winch power take-off.

A—WASHER, THRUST, IDLER GEAR—7412905  
 B—SPACER, IDLER GEAR—7412902  
 C—SPACER, BEARING—7412903  
 D—BEARING, ROLLER, IDLER GEAR—7412832  
 E—HOUSING—7412891  
 F—WASHER, THRUST, IDLER GEAR BEARING—CHU-1415  
 G—GEAR, IDLER—7412889  
 H—PLATE, RETAINING, IDLER SHAFT—7412829  
 J—WASHER, LOCK,  $\frac{5}{16}$ -IN.—120214  
 K—SCREW, CAP,  $\frac{5}{16}$ -18 X  $\frac{3}{4}$ —180077  
 L—SHAFT, IDLER—7412901  
 M—PLATE, COVER, TOP—7412893  
 N—GEAR, REVERSE—7412890  
 P—SPACER, BEARING, REVERSE GEAR—7412904  
 Q—GASKET—105451  
 R—BEARING, ROLLER, REVERSE GEAR—7412832  
 S—WASHER, THRUST, REVERSE GEAR BEARING—CHU-1415  
 T—CUP, BEARING, REAR—706820  
 U—SCREW, CAP,  $\frac{5}{16}$ -18 X 1—180079  
 V—CONE, BEARING, REAR—705804  
 W— $\left\{ \begin{array}{l} \text{CAP, DRIVE SHAFT REAR BEARING—7412882} \\ \text{CAP, FRONT (WITHOUT WINCH DRIVE)—7412882} \end{array} \right.$   
 X—WASHER, COP—7412883  
 Y— $\left\{ \begin{array}{l} \text{GASKET, CAP, REAR BEARING 0.010-IN.—7412886} \\ \text{GASKET, CAP, REAR BEARING 0.020-IN.—7412887} \end{array} \right.$   
 Z—RING, LOCKING, REAR BEARING—7735382  
 AA—GEAR, SLIDING—7412888  
 BB—GASKET, DRAIN PLUG—120428  
 CC—PLUG, DRAIN, HOUSING—7376357  
 DD— $\left\{ \begin{array}{l} \text{GASKET, CAP, FRONT BEARING 0.010-IN.—7412886} \\ \text{GASKET, CAP, FRONT BEARING 0.020-IN.—7412887} \end{array} \right.$   
 EE—CAP, FRONT BEARING—7412881  
 FF—CUP, BEARING, FRONT—706820  
 GG—SCREW, CAP,  $\frac{5}{16}$ -18 X 1—180079  
 HH—SEAL, OIL, DRIVE SHAFT—7412899  
 JJ—SHAFT, DRIVE—7412900  
 KK—KEY, WOODRUFF,  $\frac{5}{16}$  X  $1\frac{1}{8}$ —117979  
 LL—CONE, BEARING, FRONT—705395  
 MM—SCREW, CAP,  $\frac{5}{16}$ -18 X  $\frac{3}{4}$ —180077  
 NN—WASHER, LOCK,  $\frac{5}{16}$ -IN.—120214  
 PP—SHAFT, REVERSE GEAR—7412901  
 QQ—GASKET, TOP COVER PLATE—7412884  
 RR—SCREW, CAP,  $\frac{3}{8}$ -16 X  $\frac{7}{8}$ —180121

Figure 88.—Continued.

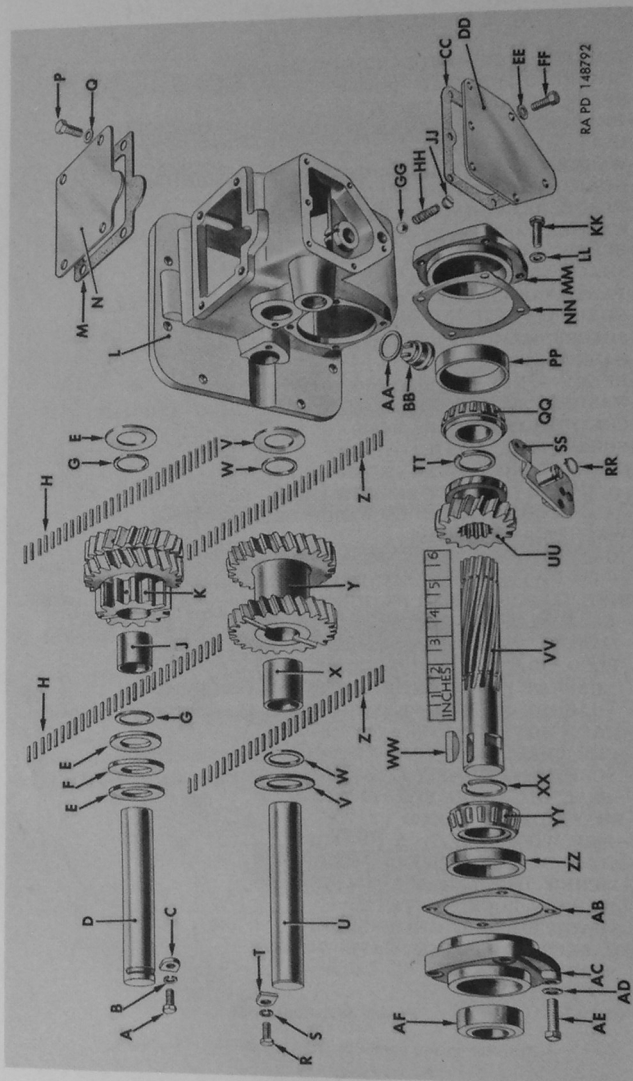



- A—SCREW, CAP,  $\frac{5}{16}$ -18 X  $\frac{3}{4}$ —180077  
 B—WASHER, LOCK,  $\frac{5}{16}$ -IN.—120214  
 C—PLATE, RETAINING, IDLER SHAFT—7412829  
 D—SHAFT, IDLER—7412901  
 E—WASHER, THRUST, IDLER GEAR—7412905  
 F—SPACER, IDLER GEAR—7412902  
 G—WASHER, THRUST, IDLER GEAR BEARING—CHU-1415  
 H—BEARING, ROLLER, IDLER GEAR—7412832  
 J—SPACER, BEARING—7412903  
 K—GEAR, IDLER—7412889  
 L—HOUSING—7412891  
 M—GASKET, TOP COVER PLATE—7412884  
 N—PLATE, COVER, TOP—7412893  
 P—SCREW, CAP,  $\frac{3}{8}$ -16 X  $\frac{7}{8}$ —180121  
 Q—GASKET—105451  
 R—SCREW, CAP,  $\frac{5}{16}$ -18 X  $\frac{3}{4}$ —180077  
 S—WASHER, LOCK,  $\frac{5}{16}$ -IN.—120214  
 T—PLATE, RETAINING, REVERSE SHAFT—7412829  
 U—SHAFT, REVERSE GEAR—7412901  
 V—WASHER, THRUST, REVERSE GEAR—7412905  
 W—WASHER, THRUST, REVERSE GEAR BEARING—CHU-1415  
 X—SPACER, BEARING, REVERSE GEAR—7412904  
 Y—GEAR, REVERSE—7412890  
 Z—BEARING, ROLLER, REVERSE GEAR—7412832  
 AA—GASKET, DRAIN PLUG—120428  
 BB—PLUG, DRAIN, HOUSING—7376357  
 CC—GASKET, SIDE COVER PLATE—7412885  
 DD—PLATE, COVER, SIDE—7412894  
 EE—WASHER, 7412883  
 FF—SCREW, CAP,  $\frac{5}{16}$ -18 X  $\frac{3}{4}$ —180077  
 GG—BALL, DETENT,  $\frac{7}{16}$ -IN.—104921  
 HH—SPRING, DETENT BALL—7412895  
 JJ—PLUG, DETENT BALL SPRING—7412830  
 KK—SCREW, CAP,  $\frac{5}{16}$ -18 X 1—180079  
 LL—WASHER, COPPER—7412883  
 MM—{ CAP, DRIVE SHAFT REAR BEARING—7412882  
       { CAP, FRONT (WITHOUT WINCH DRIVE)—7412882  
 NN—{ GASKET, CAP, REAR BEARING, 0.010-IN.—7412886  
       { GASKET, CAP, REAR BEARING, 0.020-IN.—7412887  
 PP—CUP, BEARING, REAR—706820  
 QQ—CONE, BEARING, REAR—705804  
 RR—RING, LOCKING, SHIFTER PLATE—7412831  
 SS—PLATE, SHIFTER, ASSY—7412892  
 TT—RING, LOCKING, REAR BEARING—735382  
 UU—GEAR, SLIDING—7412888  
 VV—SHAFT, DRIVE—7412900  
 WW—KEY, WOODRUFF,  $\frac{5}{16}$  X 1  $\frac{1}{8}$ —117979  
 XX—RING, LOCKING, FRONT BEARING—7735382  
 YY—CONE, BEARING, FRONT—705395  
 ZZ—CUP, BEARING, FRONT—706820  
 AB—{ GASKET, CAP, FRONT BEARING, 0.010-IN.—7412886  
       { GASKET, CAP, FRONT BEARING, 0.020-IN.—7412887  
 AC—CAP, FRONT BEARING—7412881  
 AD—WASHER, COPPER—7412883  
 AE—SCREW, CAP,  $\frac{5}{16}$ -18 X 1—180079  
 AF—SEAL, OIL, DRIVE SHAFT—7412899

Figure 89. Power take-off components with winch drive.

*c. Removing Covers.*—Remove four top cover plate  $\frac{3}{8}$ -16 x  $\frac{7}{8}$  cap screws (P) and gaskets (Q); then remove top cover plate (N) and top cover plate gasket (M). Remove five cap screws and gaskets used to attach side cover plate (DD) and remove side cover plate and side cover plate gasket (CC).

*d. Removing Caps (Power Take-Off Without Winch Drive Shaft Only).*—Remove four  $\frac{5}{16}$ -18 x 1 cap screws (KK) and copper washers (LL) used at each end of power take-off housing to attach caps which cover winch drive shaft and bearing openings. Remove caps and gaskets.

## 125. Removal of Idler Gear, Shaft, and Bearings

*Note.* Key letters noted in parentheses are in figure 89 unless otherwise indicated.

*a.* Remove  $\frac{5}{16}$ -18 x  $\frac{3}{4}$  cap screw (A) and  $\frac{5}{16}$ -inch lock washer (B) attaching idler shaft retaining plate (C). Remove plate from power take-off housing; then, using hammer and brass drift, drive idler shaft (D) forward and remove from housing.

*b.* Remove parts shown in figure 96 together with idler gear roller bearings (H), idler gear bearing thrust washers (G), and bearing spacer (J). Remove bearings, washers, and spacer from idler gear.

## 126. Removal of Reverse Gear, Shaft, and Bearings

*Note.* Key letters noted in parentheses are in figure 89 unless otherwise indicated.

*a.* Remove reverse shaft retaining plate (T) attached to power take-off housing with cap screw and lock washer.

*b.* Using hammer and brass drift, drive reverse gear shaft (U) forward, and remove from housing. Remove reverse gear and reverse gear thrust washers (fig. 95) together with reverse gear roller bearings (Z), reverse gear bearing thrust washers (W), and reverse gear bearing spacer (X).

## 127. Removal and Disassembly of Drive Shaft and Bearing Components

*Note.* Key letters noted in parentheses are in figure 89.

*a. General.*—If power take-off is for use on truck equipped with tank body, winch drive shaft, bearings, and related components are not installed in power take-off housing and the instructions in this paragraph do not apply; however, the operations described in *b* and *c* below will apply to power take-off used on all other types of trucks.

*b. Removal of Drive Shaft and Bearings.*

- (1) If  $\frac{5}{16}$  x  $1\frac{1}{8}$  Woodruff key (WW) has not been removed from drive shaft, remove key; then remove four  $\frac{5}{16}$ -18 x 1

cap screws (AE) and copper washers (AD) which attach drive shaft front bearing cap (AC) to power take-off housing. Remove front bearing cap (AC) with drive shaft oil seal (AF) and front bearing cup (ZZ). Remove front bearing gasket cap. Remove oil seal from cap. Remove front bearing cup from cap.

- (2) Remove four  $\frac{5}{16}$ -18 x 1 cap screws (KK) and copper washers (LL) attaching drive shaft rear bearing cap (MM) to power take-off housing. Strike front end of drive shaft lightly with lead hammer to remove rear bearing cap (MM). Remove rear bearing gasket cap (NN). Remove rear bearing cup (PP) from cap.
  - (3) Remove drive shaft (VV) with sliding gear (UU) and drive shaft front and rear bearing cones (YY and QQ) as an assembly.
- c. *Removal of Sliding Gear and Bearings From Drive Shaft.*
- (1) Using arbor press, remove front and rear bearing cones from drive shaft.
  - (2) Remove front and rear bearing locking rings (XX and TT), using snap ring pliers. Remove sliding gear (UU) from rear end of drive shaft.

## 128. Removal of Shifter Plate and Shifter Detent Components

a. *General.*—If power take-off is used on truck equipped with a tank body, no shifter mechanism is used since these power take-offs do not have a drive shaft for operating winch. The procedure given in *b* below is applicable to all trucks equipped with winch.

b. *Removing Shifting Mechanism.*

- (1) Remove detent ball spring plug, detent ball spring, and detent ball (fig. 90).
- (2) Using needle-nose snap ring pliers, remove shifter plate locking ring, then remove shifter plate assembly from inside housing.

## Section III. REBUILD OF POWER TAKE-OFF COMPONENTS

### 129. General

The procedures described in this section cover all the component parts of power take-off. On some applications, some of the parts mentioned are not used. Gaskets and drive shaft oil seal should be discarded and new parts obtained for use at assembly.

### 130. Cleaning

Wash all components in dry-cleaning solvent or volatile mineral spirits, using a stiff brush if necessary to dislodge accumulations of

grease and dirt. Scrape off all portions of gaskets and sealing compound. Use a wire to clean out oil holes through gears. Immerse roller bearing assemblies in cleaning solution until all lubricant is dissolved and bearings are clean. Use necessary care to remove all metallic particles from magnetic drain plug.

### 131. Inspection of Gears

*Note.* Key letters noted in parentheses are in figure 89.

*a.* Inspect all gear teeth for evidence of wear. Also look for chipped or broken teeth. If any of the teeth are damaged, discard gear and obtain new part. Compare diameter of bore of idler gear (K) with dimensions given in paragraph 344. If bore is worn beyond limits, new gear must be used when assembling power take-off. Make same inspection of bore of through reverse gear (Y).

*b.* Inspect sliding gear (UU) for wear at splines which mate with helical splines on drive shaft (VV). If excessive wear is evident select new parts for use when assembling. Refer to paragraph 135 for instructions covering inspection of groove in sliding gear and clearance of shifter plate assembly in groove.

### 132. Inspection of Shafts

*Note.* Key letters noted in parentheses are in figure 89.

*a.* Idler shaft (D) and reverse gear shaft (U) are identical and should be inspected for wear at surfaces contacted by bearing rollers. Diameter of new shafts is given in paragraph 344.

*b.* Inspect drive shaft (VV) for condition at splines and at keyway. If drive shaft is not in good condition, it must be replaced by new drive shaft when assembling power take-off.

### 133. Inspection of Bearings and Thrust Washers

*Note.* Key letters noted in parentheses are in figure 89.

*a.* Inspect idler gear and reverse gear roller bearings (H and Z). If any of the rollers are broken or worn excessively, obtain a complete set of 60 rollers for use in each gear at assembly. Also note condition of bearing spacer (J) and reverse gear bearing spacer (X). Spacers must not show evidence of excessive wear and must be free fit in respective gears and slide freely over idler shaft (D) and reverse gear shaft (U).

*b.* Check condition of idler gear bearing thrust washers (G) and reverse gear bearing thrust washers (W). Replace thrust washers if worn or damaged.

*c.* Examine each roller in front bearing cone (YY) and rear bearing cone (QQ) for chipping, pitting, or other damage. Also inspect

rear bearing cup (PP) and front bearing cup (ZZ) for damage and wear at surface contacted by rollers. Replace cups if damaged.

d. Measure thickness of three idler gear thrust washers (E) and two reverse gear thrust washers (V). Thickness must be within limits listed in paragraph 344. Inspect idler gear spacer (F) for scoring and for wear. If any of the thrust washers or the spacer is worn, the damaged parts must be replaced.

### 134. Inspection of Power Take-Off Housing and Covers

*Note.* Key letters noted in parentheses are in figure 89.

a. Inspect power take-off housing (L) for cracked or broken condition. Also examine threads in tapped holes. If housing is damaged, replace with new housing when assembling.

b. Examine top cover plate (N) and side cover plate (DD). If covers are bent or otherwise damaged, replace with new parts.

c. Inspect drive shaft rear bearing cap (MM) for cracks and for distortion. Replace cap if damaged.

### 135. Inspection of Miscellaneous Parts

*Note.* Key letters noted in parentheses are in figure 89.

a. Inspect front bearing locking ring (XX) and rear bearing locking ring (TT) for bent condition. If rings are bent or broken, obtain new rings for installation at assembly.

b. Inspect threads on housing drain plug (BB). Replace plug if threads are not in good condition.

c. Inspect  $\frac{5}{16} \times 1\frac{1}{8}$  Woodruff key (WW), and idler shaft and reverse shaft retaining plates (C) and (T). Replace if these parts are not in good condition.

d. Examine shifter plate assembly (SS) for fit in housing and position shifter shoe (part of plate assembly) in groove in sliding gear (UU) and check fit of shoe in groove. If clearance exceeds maximum clearance listed in paragraph 344, replace worn parts.

e. Check shifter detent ball spring for free length. If spring is not within specifications (par. 344), obtain new spring for use at assembly.

## Section IV. ASSEMBLY OF POWER TAKE-OFF

### 136. General

Procedures for assembling power take-off differ, depending on the type of vehicle on which power take-off is installed. On trucks with tank type bodies, no drive shaft is used in power take-off, since these vehicles have no winch. Shifting mechanism is also omitted from

power take-off used on these vehicles. When an accessory drive unit is used, the top cover plate ((N), fig. 89) is omitted and studs with self-locking nuts are used to mount the accessory drive unit. Refer to figures 85, 86, and 87 for external views of various power take-off assemblies used. Refer to paragraphs 142 through 152 for procedures for removing, rebuilding, and installing accessory drive units.

### 137. Installation of Shifter Plate Assembly and Components

*Note.* Information in this paragraph is not applicable to power take-off used on vehicles without winch. Key letters noted in parentheses are in figure 89 unless otherwise indicated.

a. From inside housing (L), position shifter plate assembly (SS) with plate shaft through hole in housing. Using snap ring pliers, install shifter plate locking ring (RR) in groove in shaft (fig. 90)

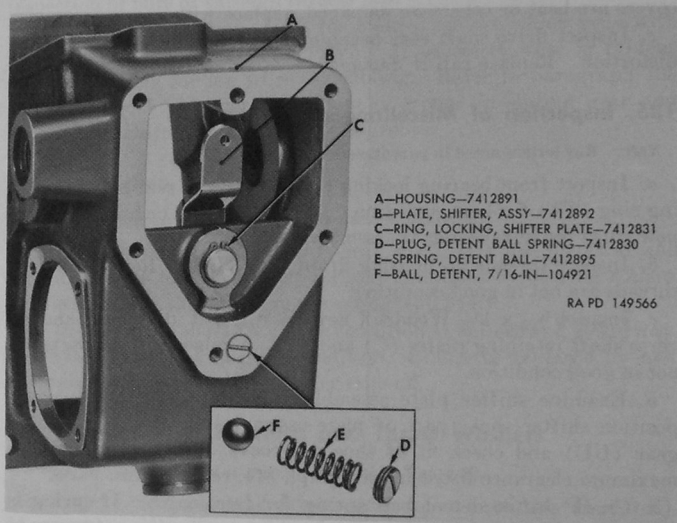

Figure 90. Shifter plate assembly installed in housing.

b. Assemble  $\frac{7}{16}$ -inch detent ball (fig. 90) detent ball spring, and detent ball spring plug in poppet well in housing. Tighten plug firmly with screwdriver.

### 138. Assembly and Installation of Drive Shaft and Related Components

*Note.* Key letters noted in parentheses are in figure 89 unless otherwise indicated.



a. Using snap ring pliers, install front bearing locking ring (XX) in groove at front end of splines in drive shaft (VV). Support front side of front bearing cone (YY) on arbor press; then press drive shaft through bearing until locking ring seats firmly against rear of front bearing cone.

b. Install sliding gear (UU) on drive shaft splines with shifter groove toward rear end of drive shaft. Install rear bearing locking ring (TT) in groove near rear end of drive shaft; then press rear bearing cone (QQ) on drive shaft with locking ring contacting bearing cone.

c. Apply universal gear lubricant (GO) on front and rear bearing cones and on surface of drive shaft which is contacted by oil seal.

d. Press front bearing cup (ZZ) into place in front bearing cap (AC). Coat bore in front bearing cap (AC) with light coat of plastic type gasket cement; then press drive shaft oil seal into bore with spring-loaded lip pointing inward. Press oil seal in until inner edge is just flush with inner edge of bore. Refer to sectional view of winch power take-off (fig. 88). Wipe off any excess cement after oil seal is installed.

e. Wrap shim stock around front end of drive shaft (VV) to protect oil seal from damage during installation; then install front bearing cap on front end of drive shaft. Figure 91 shows drive shaft components assembled, ready for installation in housing.

f. Using light coat of plastic type gasket cement, mount two front bearing cap gaskets (AB) at housing; then place drive shaft assembly through bore in front of housing and move into place with bearing

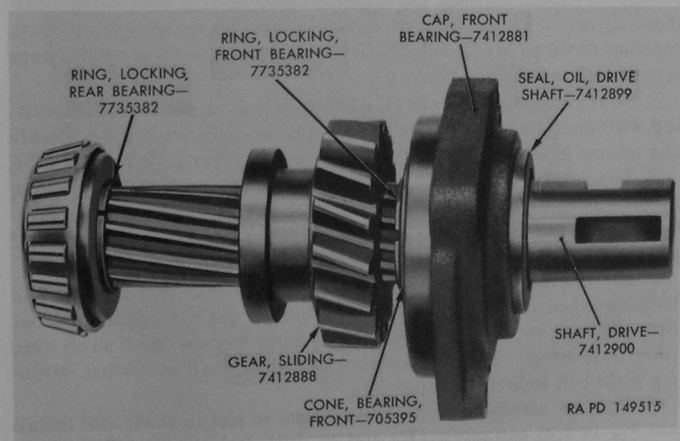

Figure 91. Drive shaft, sliding gear, and bearings assembled.

cap alined with holes in housing and shoe on shifter plate assembly engaged in groove in sliding gear (UU). Install four  $\frac{5}{16}$ -18 x 1 cap screws (AE) and four copper washers (AD) to attach cap to housing. Tighten cap screws firmly.

*g.* Press rear bearing cup (PP) into drive shaft rear bearing cap (MM); then, using two rear bearing cap gaskets (NN), install drive shaft rear bearing cap on housing and retain with four  $\frac{5}{16}$ -18 x 1 cap screws (KK) and copper washers (LL). Tighten cap screws gradually, meanwhile turning drive shaft by hand to detect any tightness at bearings. If tightening cap screws causes tightness in bearings, remove rear cap and use thicker gaskets or add one 0.010-inch gasket. When sufficient gaskets have been selected to prevent tightness at bearings, tighten rear bearing cap attaching cap screws firmly.

*Note.* Shoe on shifter plate assembly (SS) must engage groove in sliding gear. Figure 92 shows drive shaft and sliding gear installed.

*h.* Check bearing adjustment with dial indicator mounted as shown in figure 93. Adjustment is correct when there is 0.005-inch end play in drive shaft (VV).

### 139. Installation of Reverse Gear, Shaft, and Bearings

*Note.* Key letters noted in parentheses are in figure 89.

*a.* Coat reverse gear thrust washers and bore of reverse gear (Y) with universal gear lubricant (GO).

*b.* Set reverse gear (Y) on end on work bench. Using a tool made of metal or wood approximately 1.100-inch in diameter and long enough to extend through gear, assemble 30 reverse gear roller bearings (Z) around tool. Use reverse gear bearing spacer (X) to push bearings down to lower side of gear; then assemble 30 more bearings around tool as shown in figure 94.

*c.* Start reverse gear shaft (U) through boss at front side of housing with end of shaft slightly beyond inside surface of case. Locate one reverse gear thrust washer (V) on end of reverse gear shaft (U).

*d.* Lay reverse gear (Y) on side and place one reverse gear bearing thrust washer (W) against rollers at each end of reverse gear. Position reverse gear in housing as shown in figure 95. Note that end of gear with rounded teeth must be toward front of housing.

*e.* Hold reverse gear thrust washer between rear end of gear and housing; then drive lightly on reverse gear shaft to push tool out through bore in rear of housing and force reverse gear shaft into place in housing. Be sure slot in reverse gear shaft is toward retaining plate bolt hole in housing.

*f.* Position reverse shaft retaining plate in slot in shaft and install one  $\frac{5}{16}$ -18 x  $\frac{3}{4}$  cap screw (R) and  $\frac{5}{16}$ -inch lock washer (S) to hold retaining plate in place.

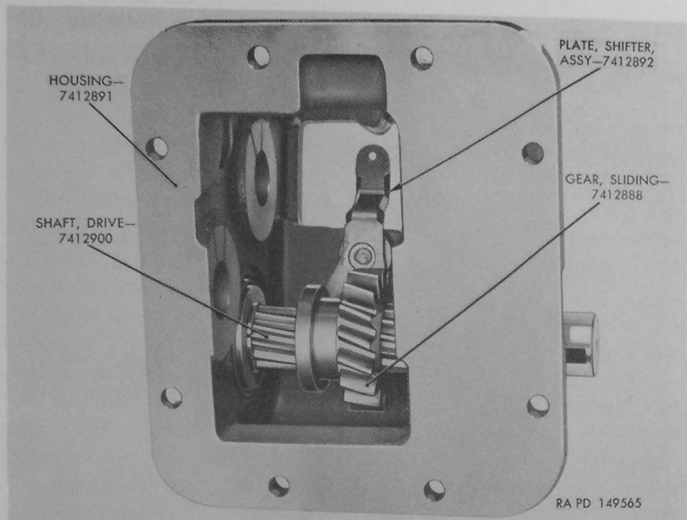

Figure 92. Power take-off drive shaft and sliding gear installed.

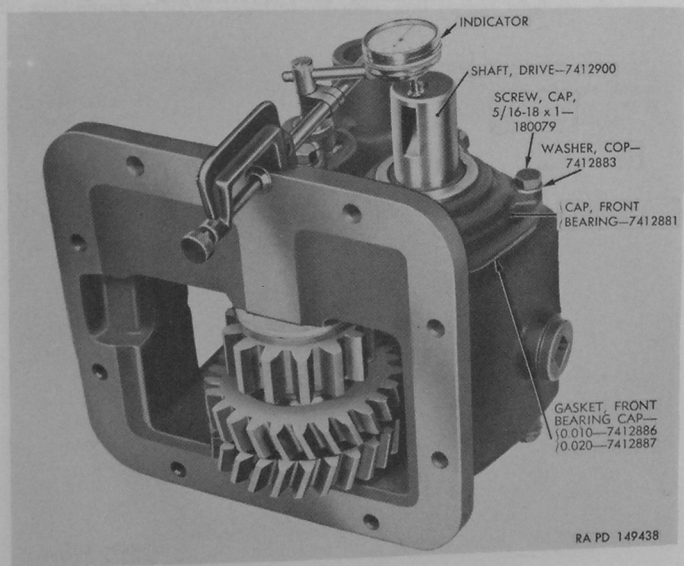

Figure 93. Checking drive shaft bearing adjustment.

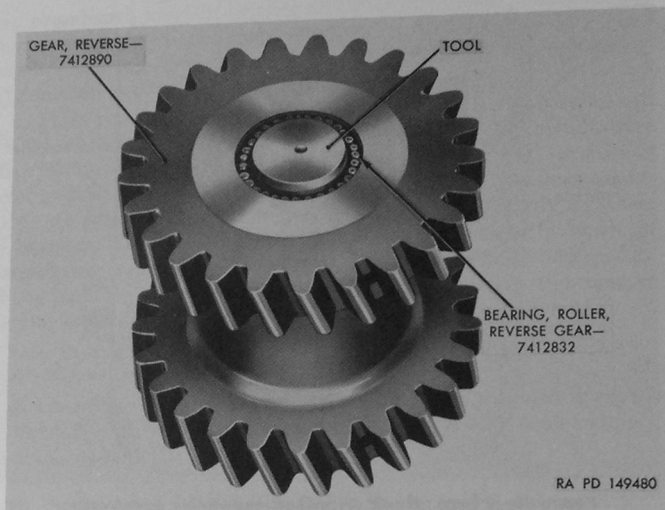

Figure 94. Assembling rollers in reverse gear.

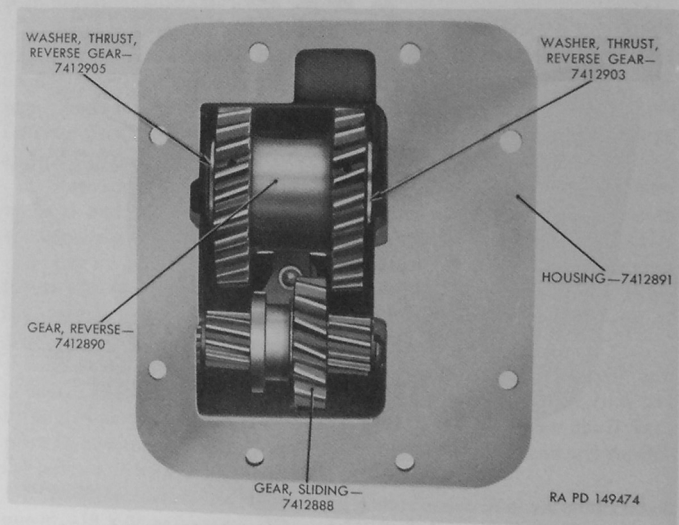

Figure 95. Power take-off reverse gear installed.

## 140. Installation of Idler Gear, Shaft, and Bearings

*Note.* Key letters noted in parentheses are in figure 89 unless otherwise indicated.

a. Coat three idler gear thrust washers (E) and idler gear spacer (F) with universal gear lubricant (GO). Also apply same lubricant on bore of idler gear (K).

b. Set idler gear on work bench and assemble 30 idler gear roller bearings in each end of bore with bearing spacer (J) between sets of bearings. Use tool in same manner as described in paragraph 139b to hold bearings in place while assembling.

c. Start idler shaft (D) through boss at front side of housing (L) with end of shaft extending slightly beyond inside of case. Place one idler gear thrust washer (E) on end of idler shaft.

d. Lay idler gear on side and place one idler gear bearing thrust washer (G) against bearings at each end of idler gear. Place one thrust washer (E) and idler gear spacer (F) at front side of idler gear; then locate idler gear (fig. 96) and bearings in housing. Place idler gear rear thrust washer between gear and housing; then drive lightly on front end of idler shaft to push out assembly tool through rear of housing and force idler shaft into place in housing. Refer to figure 96 and check relative position of gear and thrust washers.

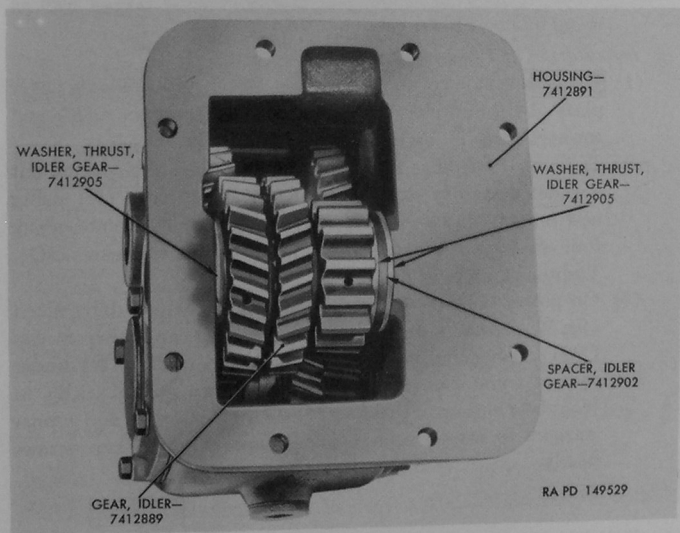

Figure 96. Power take-off idler gear installed.

e. Locate idler shaft retaining plate (C) in slot in idler shaft and attach plate with  $\frac{5}{16}$ -18 x  $\frac{3}{4}$  cap screw (A) and  $\frac{5}{16}$ -inch lock washer (B).

## 141. Installation of Plugs and Covers on Power Take-Off Housing

*Note.* Key letters noted in parentheses are in figure 89 unless otherwise indicated.

a. *General.* If power take-off is used on truck which requires an accessory drive unit, no top cover plate (N) is used; however, a side cover plate (DD) must be installed, and housing drain plug (BB) is always used. The hex-head plug shown in figure 87 is installed in tapped hole at front side of housing on power take-off used on tank-type trucks. Refer to paragraphs 143 and 144 for procedure for installation of accessory drive units on power take-off housing.

### b. Installation of Plugs.

- (1) Install housing drain plug (BB), using new drain plug gasket (AA).
- (2) Using a new plug seal (same as item (J), fig. 104) install  $\frac{11}{16}$ -16 x  $\frac{23}{32}$  plug (fig. 87, front view) and new seal retaining washer in threaded hole at front of housing.

*Note.* Installation of this plug applies to power take-off used on trucks with tank bodies only.

### c. Installation of Covers.

- (1) Using new side cover plate gasket (CC), position side cover plate (DD) and install six  $\frac{5}{16}$ -18 x  $\frac{3}{4}$  cap screws (FF) and washers (EE). Tighten cap screws firmly.
- (2) If power take-off is used on truck equipped with winch but without accessory drive, install top cover plate (N) using new top cover plate gasket (M). Attach cover plate, using four  $\frac{3}{8}$ -16 x  $\frac{7}{8}$  cap screws (P) and new gaskets (Q). Tighten cap screws firmly.
- (3) On power take-off which does not have a winch drive shaft (fig. 87), install a drive shaft rear bearing cap and front cap (MM), using one new rear bearing cap gasket (N) under rear cap and one new front bearing cap gasket (AB) at front bearing cap. Use four  $\frac{5}{16}$ -18 x 1 cap screws and copper washers to attach each bearing cap. Tighten cap screws firmly.



## Section V. DESCRIPTION AND REPLACEMENT OF ACCESSORY DRIVE UNIT

### 142. Description

*Note.* Key letters noted in parentheses are in figure 97 unless otherwise indicated.

*a. Tank Truck Accessory Drive.*—The accessory drive unit (fig. 97) used with water and gasoline tank trucks is mounted on power take-off as illustrated in figure 87. The assembly consists of a drive shaft (H) upon which a sliding gear (G) operates on spiral spline on shaft. A shifter fork (U), mounted on shifter shaft (Z), positions sliding gear (G) to engage power take-off reverse gear when shifter shaft (Z) is manually positioned through linkage. The governor drive engages front end of drive shaft to operate limiting speed auxiliary governor.

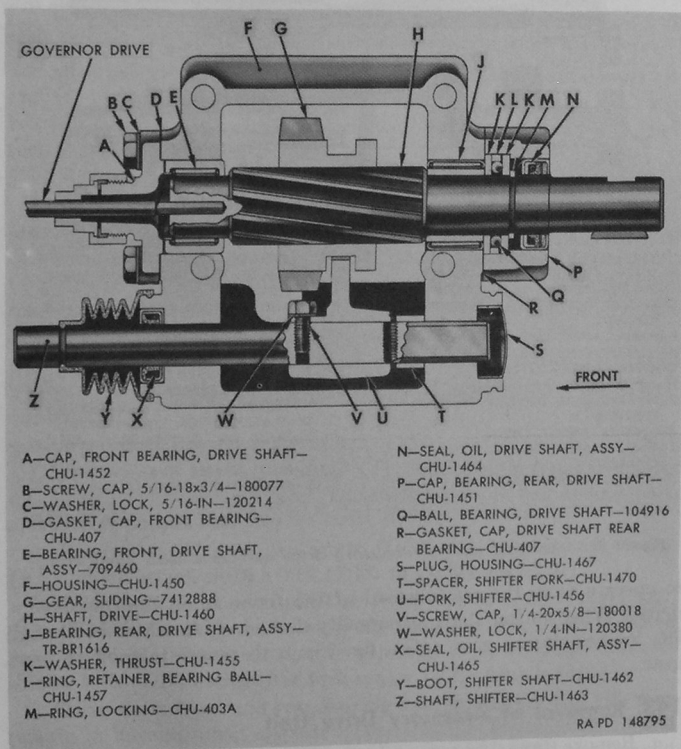

Figure 97. Sectional view of accessory drive unit used with tank truck.



b. Lift accessory drive assembly straight up from power take-off assembly. Remove accessory drive-to-power-take-off gasket (CC), fig. 99 or (JJ), fig. 104).

#### 144. Installation of Accessory Drive Unit

a. Position accessory drive-to-power-take-off gasket on power take-off.

b. Position accessory drive unit over the three studs. Install one  $\frac{3}{8}$ -16 x  $\frac{3}{4}$  cap screw and three  $\frac{3}{8}$ -24 stud nuts. Tighten nuts and cap screw firmly.

### Section VI. REBUILD OF TANK TRUCK ACCESSORY DRIVE UNIT

#### 145. Disassembly of Tank Truck Accessory Drive

*Note.* Key letters in text refer to figure 99 unless otherwise indicated. The sectional view (fig. 97) shows the various components in their correct positions.

a. Remove three cross-recess  $\frac{5}{16}$ -18 x  $1\frac{1}{2}$  fillister head screws (Z) and  $\frac{5}{16}$ -inch special lock washers (AA) which attach drive shaft rear bearing cap (X) to housing. Remove bearing cap and drive shaft rear bearing cap gasket (W).

b. Remove  $\frac{5}{16}$ -18 x  $\frac{3}{4}$  cap screws (C) and  $\frac{5}{16}$ -inch lock washers (D) which attach drive shaft front bearing cap (E) to housing (H).

c. With brass drift applied to front end of drive shaft (Q), force drive shaft through housing. Drive shaft front bearing assembly (G) will remain in housing. The inner race (R) of the drive shaft rear bearing assembly (P) will remain on drive shaft. Remove sliding gear (H) from housing.

d. Remove locking ring (V) from drive shaft. Remove two thrust washers (S), bearing ball retainer ring (U), and 21 drive shaft bearing balls (T).

e. Remove shifter shaft boot (A).

f. Remove ball spring retainer (J), ball spring retainer washer (K), ball spring retainer seal (L), shifter poppet ball spring (M), and shifter poppet ball (N).

g. Remove  $\frac{1}{4}$ -20 x  $\frac{5}{8}$  cap screw (GG) and  $\frac{1}{4}$ -inch lock washer (FF) which attach shifter fork (DD) to shifter shaft (B).

h. With soft hammer applied at front end of shifter shaft (B), drive shaft toward rear of housing until housing plug (BB) is forced from housing. Shaft can then be removed from housing. Remove shifter fork (DD) and shifter fork spacer (EE) from housing.

i. Drive shaft front and rear bearing assemblies (G) and (P) may remain in housing until inspected (par. 146b). Drive shaft oil seal assembly (Y) and shifter shaft oil seal assembly (JJ) may remain in place until after inspection (par. 146b).

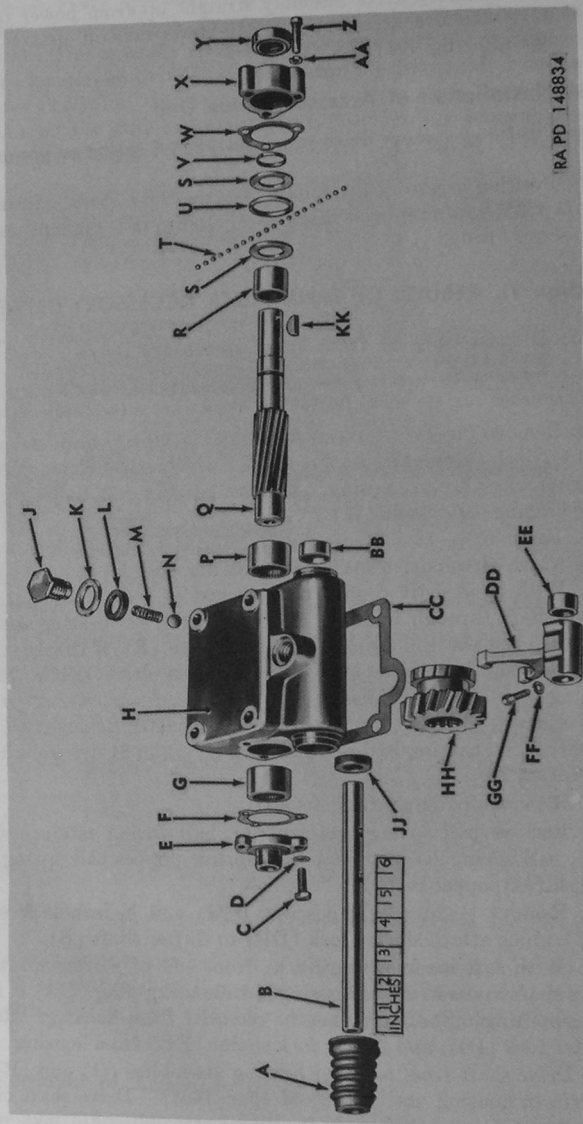

RA PD 148834

A—BOOT, SHIFTER SHAFT—CHU-1462  
 B—SHAFT, SHIFTER—CHU-1463  
 C—SCREW, CAP,  $\frac{5}{16}$ -18 X  $\frac{3}{4}$ —180077  
 D—WASHER, LOCK,  $\frac{5}{16}$ -IN.—120214  
 E—CAP, FRONT BEARING, DRIVE SHAFT—CHU-1458  
 F—GASKET, CAP, FRONT BEARING—CHU-407  
 G—BEARING, FRONT, DRIVE SHAFT, ASSY—709460  
 H—HOUSING—CHU-1450  
 J—RETAINER, SPRING, BALL—CHU-1468  
 K—WASHER, BALL SPRING RETAINER—7413234  
 L—SEAL, RETAINER, BALL SPRING—7413233  
 M—SPRING, BALL, SHIFTER POPPET—7378128  
 N—BALL, SHIFTER POPPET—104921  
 P—BEARING, REAR, DRIVE SHAFT, ASSY—TR-BR1616  
 Q—SHAFT, DRIVE—CHU-1460  
 R—RACE, INNER (PART OF REAR BEARING  
 ASSY—TR-BR1616)  
 S—WASHER, THRUST—CHU-1455  
 T—BALL, BEARING, DRIVE SHAFT—104916  
 U—RING, RETAINER, BEARING BALL—CHU-1457  
 V—RING, LOCKING—CHU-408A  
 W—GASKET, CAP, DRIVE SHAFT REAR BEARING—CHU-407  
 X—CAP, BEARING, REAR, DRIVE SHAFT—CHU-1451  
 Y—SEAL, OIL, DRIVE SHAFT, ASSY—CHU-1464  
 Z—SCREW, FIL-ED, CROSS-RECESS,  $\frac{5}{16}$ -18 X  $1\frac{1}{2}$ —154000  
 AA—WASHER, LOCK, SPECIAL,  $\frac{5}{16}$ -IN.—CHU-1087  
 BB—PLUG, HOUSING—CHU-1467  
 CC—GASKET, ACCESSORY DRIVE-TO-POWER TAKE-  
 OFF—7412884  
 DD—FORK, SHIFTER—CHU-1456  
 EE—SPACER, SHIFTER FORK—CHU-1470  
 FF—WASHER, LOCK,  $\frac{3}{4}$ -IN.—120380  
 GG—SCREW, CAP,  $\frac{1}{4}$ -20 X  $\frac{5}{8}$ —180018  
 HH—GEAR, SLIDING—7412888  
 JJ—SEAL, OIL, SHIFTER SHAFT, ASSY—CHU-1465  
 KK—KEY, WOODRUFF—112139

Figure 99. Components of accessory drive unit for tank trucks.

## 146. Cleaning and Inspection of Tank Truck Accessory Drive

*Note.* Key letters in text refer to figure 99 unless otherwise indicated.

*a. Cleaning.*—Clean all parts thoroughly with dry-cleaning solvent or volatile mineral spirits. Thoroughly scrub drive shaft front bearing assembly (G) and drive shaft rear bearing assembly (P) so that needle bearings can be inspected. Do not clean shifter shaft boot (A) with solvent.

### *b. Inspection.*

- (1) *Housing.*—Thoroughly inspect housing (H) for cracks and damaged threads. Examine mounting surface for scores or roughness. Small nicks may be honed out. Check clearance of shifter shaft (B) in passages in housing. Replace shifter shaft or housing if clearance is excessive (par. 345).
- (2) *Drive shaft front and rear bearings.*—Examine needle bearings in drive shaft front bearing assembly (G) and drive shaft rear bearing assembly (P). If needle bearings are checked, bent, or otherwise damaged, replace with new parts (par. 147). The inner race (R) which is a part of drive shaft rear bearing assembly is pressed on drive shaft (Q). Examine outer surface of race for roughness or scores. If race is damaged, the rear bearing assembly (with inner race) must be replaced (par. 147).
- (3) *Oil seals.*—Examine shifter shaft oil seal assembly (JJ) for damage or looseness in housing. Examine drive shaft oil seal assembly (Y) in drive shaft rear bearing cap (X) for similar damage. Replace if necessary as described in paragraph 147.
- (4) *Shifter shaft.*—Inspect shifter shaft (B) for damage. Check outside diameter and clearance as described in (1) above. Refer to paragraph 345 for dimensions. Inspect shifter shaft boot (A) for stretched or damaged condition. The boot must fit tightly in shifter shaft groove and groove on housing (refer to fig. 97). Replace boot if damaged.
- (5) *Sliding gear.*—Check inner splines of sliding gear (HH) for roughness or damage. Check teeth for chipped, rough, or damaged condition. Small nicks or burrs on teeth may be honed out. Check condition of shifter fork groove on sliding gear. Check clearance of shifter fork pads to groove ((6) below). If groove in gear is excessively worn (par. 345), replace gear.
- (6) *Shifter fork.*—Inspect shifter fork (DD) for damaged or sprung fork legs and worn fork pads. Check clearance of fork pads in sliding gear groove ((5) above). If clearance is excessive (par. 345), check width of pads for excessive wear (par. 345).