

**DEPOT MAINTENANCE
WORK REQUIREMENT**

for

FRONT WINCH ASSEMBLIES

NSN 2590-00-641-6405	P/N 7412382
NSN 2590-01-082-2644	P/N 7412382-1
NSN 2590-00-741-1122	P/N 7411122
NSN 2590-01-082-9050	P/N 7411122-1

AND

REAR WINCH ASSEMBLIES

NSN 2540-00-740-9980	P/N 7409980
-----------------------------	--------------------

This DMWR supersedes DMWR 9-3830-501 dated 28 February 1973.

NOTICE: Reproduction for non-military use of the information or illustrations contained in this publication is not permitted without specific approval of U.S. ARMY TANK-AUTOMOTIVE COMMAND (TACOM).

This DMWR is required for official use or administrative or operational purposes only. Distribution is limited to U.S. Government Agencies. Other requests for this document must be referred to: U.S. Army Tank-Automotive Command, Warren, Michigan 48397-5000.

THIS PUBLICATION IS NOT AVAILABLE THROUGH THE AG PUBLICATION CENTERS.

**U.S. ARMY TANK-AUTOMOTIVE COMMAND
WARREN, MICHIGAN 48397-5000**

WARNING SUMMARY

WARNING

FIRE HAZARD

- Drycleaning solvent is flammable and will not be used near open flame. A fire extinguisher will be kept nearby when drycleaning solvent is used. Use only in well-ventilated places. Failure to do this may result in injury to personnel.

COMPRESSED AIR

- Compressed air source will not exceed 30 psi (207 kPa). When cleaning with compressed air, eyeshields must be worn. Failure to wear eyeshields may result in injury to personnel.

ASBESTOS DUST

- Do not use a dry brush or compressed air to clean brake housing and lining. There may be asbestos dust on brake lining and in brake housing which can be dangerous to your health if you breathe it. (Housing and lining must be wet, and a soft bristle brush must be used.)

U.S. ARMY TANK-AUTOMOTIVE
COMMAND
WARREN, MICHIGAN 48397-5000

DEPOT MAINTENANCE
WORK REQUIREMENT
NO. 9-3830-501

FRONT WINCH ASSEMBLIES

NSN 2590-00-641-6405	P/N 7412382
NSN 2590-01-082-2644	P/N 7412382-1
NSN 2590-00-741-1122	P/N 7411122
NSN 2590-01-082-9050	P/N 7411122-1

AND

REAR WINCH ASSEMBLIES

NSN 2540-00-740-9980	P/N 7409980
----------------------	-------------

M39, M809, M939, AND M939A1 SERIES VEHICLES

REPORTING ERRORS AND RECOMMENDING IMPROVEMENTS

You can help improve this manual. If you find any mistakes or if you know of a way to improve the procedures, please let us know. Mail your letter, DA Form 2028, Recommended Changes to Publications and Blank Forms, or DA Form 2028-2 located in back of this manual direct to: U.S. Army Tank-Automotive Command, ATTN: AMSTA-QRT, Warren, Michigan 48397-5000. A reply will be furnished to you.

TABLE OF CONTENTS

	Page
CHAPTER 1. INTRODUCTION	
Section I. General	1-1
II. Description, Data Plates, and Tabulated Data	1-1
CHAPTER 2. REQUIREMENTS	
Section I. General	2-1
II. Standards	2-8
CHAPTER 3. MAINTENANCE, OVERHAUL, AND REPAIR	
Section I. General	3-1
II. Safety	3-2
III. Preshop Analysis	3-2
IV. In-Process Inspection	3-16
V. Removal of Major Assemblies	3-17
VI. Disassembly	3-17
VII. Repair	3-93
VIII. Assembly of Winches	3-94
CHAPTER 4. FINAL ASSEMBLY AND TESTING	
Section I. General	4-1
II. Final Performance Check	4-10
CHAPTER 5. QUALITY ASSURANCE/QUALITY CONTROL (QA/QC) PROVISIONS	
Section I. General Requirements	5-1
II. Inspection Requirements	5-3

CHAPTER 6.	PRESERVATION, PACKING, AND MARKING	
Section I.	General Requirements	6-1
II.	Storage and Marking	6-1
APPENDIX A.	REFERENCES	A-1
APPENDIX B.	REPAIR PARTS AND SPECIAL TOOLS LIST	B-1
APPENDIX C.	OVERHAUL INSPECTION PROCEDURES	C-1
APPENDIX D.	FITS AND TOLERANCES	D-1
APPENDIX E.	FABRICATED TOOLS AND EQUIPMENT	E-1
APPENDIX F.	EXPENDABLE/DURABLE SUPPLIES AND MATERIALS LIST	F-1
GLOSSARY	Glossary 1
INDEX	Index 1

LIST OF ILLUSTRATIONS

Number	Title	Page
1-1	Front Winch Assembly (Without Level Wind and Cable Tensioner) (M39 and M809 Series Vehicles)	1-2
1-2	Front Winch Assembly (Without Level Wind and Cable Tensioner) (M939 Series Vehicles)	1-2
1-3	Front Winch Assembly (With Level Wind and Cable Tensioner) (M39, M809, and M939 Series Vehicles)	1-3
1-4	Rear Winch Assembly (M39, M809, and M939 Series Vehicles)	1-4
1-5	Data Plates, Front Winch (Without Level Wind) (M39, M809, and M939 Series Vehicles)	1-5
1-6	Data Plates, Front Winch (With Level Wind and Cable Tensioner) (M39, M809, and M939 Series Vehicles)	1-6
1-7	Data Plates, Rear Winch (With Level Wind and Cable Tensioner) (M39, M809, and M939 Series Vehicles)	1-7
3-1	Front Winch Assembly With Level Wind and Cable Tensioner	3-11
3-2	Front Winch Assembly Without Level Wind or Cable Tensioner	3-12
3-3	Rear Winch With Level Wind and Cable Tensioner	3-13
4-1	Front Winch Assembly With Level Wind and Cable Tensioner	4-7
4-2	Front Winch Assembly Without Level Wind or Cable Tensioner	4-8
4-3	Rear Winch Assembly With Level Wind and Cable Tensioner	4-9
4-4	Final Inspection Record (F.I.R.)	4-10
D-1	Repair and Replacement Standards; Points of Measurement for Front Winch Components	D-2
D-2	Repair and Replacement Standards; Points of Measurement for Front Winch Tensioner and Front Winch Level Wind	D-3
D-3	Repair and Replacement Standards; Points of Measurement for Front Winch Roller	D-4
D-4	Repair and Replacement Standards; Points of Measurement for Rear Winch Components	D-5
D-5	Repair and Replacement Standards; Points of Measurement for Rear Winch Tensioner and Rear Winch Level Wind	D-6
D-6	Repair and Replacement Standards; Points of Measurement for Rear Winch Level Wind (Contd)	D-7
E-1	Front Winch Roller Brackets Spacer Gage	E-2

LIST OF TABLES

Number	Title	Page
2-1	Inspection and Test Equipment	2-2
2-2	Mandatory Replacement Parts - Front Winch	2-2
2-3	Mandatory Replacement Parts - Rear Winch	2-5
2-4	Estimated Man-Hour Standards	2-8
4-1	Test Sequences for Front and Rear Winches	4-4
C-1	List of Overhaul Inspection Procedures	C-1
D-1	Repair and Replacement Standards	D-2
D-2	Standard Capscrew Markings and Torque Specifications	D-8

CHAPTER 1 INTRODUCTION

Section I. GENERAL

1-1. SCOPE.

a. These instructions are for use by contractor/depot personnel. They apply to the front and rear winches used on the M39, M809, M939, and M939A1 series, 5-ton vehicles and, in case of conflict, take precedence over all other documents pertinent to overhaul and inspection. There are no differences in procedures or parts for winches used with M939A1 vehicles.

b. Tolerances and wear limits established herein are the minimum acceptable. Parts, components, assemblies, or subassemblies not meeting these requirements shall be condemned and disposition made in accordance with the appropriate directive.

1-2. MAINTENANCE FORMS AND RECORDS.

Maintenance forms, records, and reports which are to be used by depot maintenance personnel are listed in and prescribed by DA Pam 738-750, The Army Maintenance Management System (TAMMS).

1-3. REPORTING EQUIPMENT IMPROVEMENT RECOMMENDATIONS (EIR's).

You can help improve this equipment by recommending design improvements and/or better service and repair procedures. EIR's will be prepared using SF 368, Quality Deficiency Report. Instructions for preparing EIR's are provided in DA Pam 738-750. Mail directly to: Commander, U.S. Army Tank-Automotive Command, ATTN: AMSTA-QRT, Warren, Michigan 48397-5000. A reply will be furnished to you.

Section II. DESCRIPTION, DATA PLATES, AND TABULATED DATA

1-4. DESCRIPTION.

a. Front Winch (Without Level Wind).

(1) The front winch (figs. 1-1 and 1-2) is a worm gear, jaw clutch, horizontal drum type with an internal automatic brake and drum drag brake.

(2) The automatic brake, which is attached to the front end of the drive (worm gear) shaft, sustains winch load whenever delivery of power to winch is interrupted.

(3) The internally-mounted drag brake is in constant contact with the left end of winch drum. It prevents the drum from spinning when unwinding the cable.

(4) Power for the M39 and M809 front winch (fig. 1-1) is supplied by the vehicle engine through a transmission power takeoff turning a drive shaft connected directly to the winch.

(5) Power for the M939 front winch (fig. 1-2) is supplied by the vehicle engine through a transmission power takeoff that drives a hydraulic pump. Hydraulic pressure drives a hydraulic motor mounted on the rear of the winch.

(6) The front winch is mounted on extensions bolted to the left and right frame side rails.

1-4. DESCRIPTION (Contd).

a. Front Winch (Without Level Wind) (Contd).

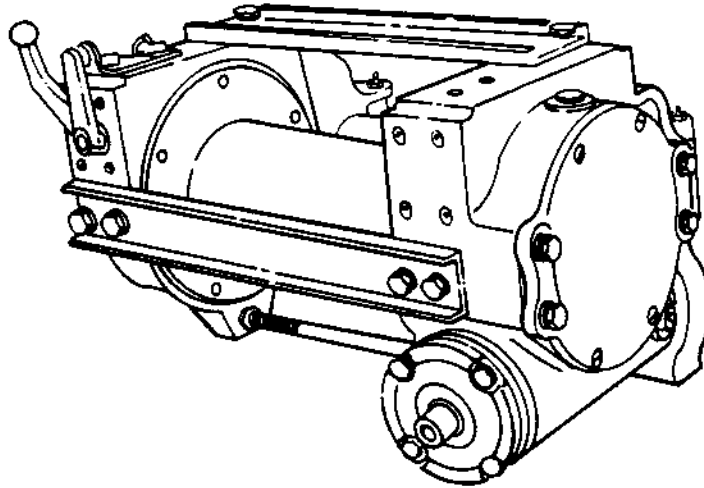

*Figure 1-1. Front Winch Assembly (Without Level Wind and Cable Tensioner)
(M39 and M809 Series Vehicles).*

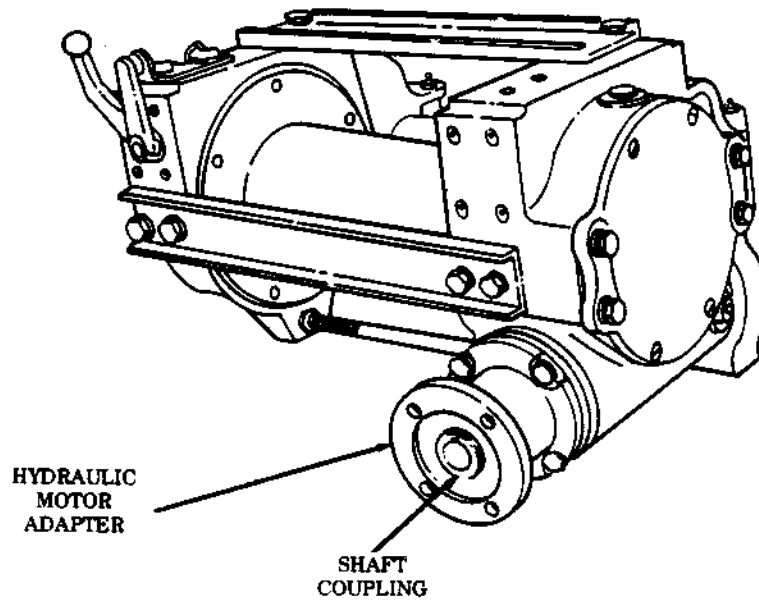

*Figure 1-2. Front Winch Assembly (Without Level Wind and Cable Tensioner)
(M939 Series Vehicles).*

TA 51141

1-4. DESCRIPTION (Contd).

b. Front Winch (With Level Wind and Cable Tensioner).

(1) The front winch (fig. 1-3) is equipped with a level wind device bolted to the top of the end frame (left end of winch) and the gearcase (right end of winch). When winding the cable, cable tension on swivel sheave causes swivel sheave frame to travel on its wheels from side to side on the trolley track and wind the cable in tight, even coils and layers on the drum.

(2) The winch is also equipped with a manually-operated cable tensioner mounted on the front of the winch. The cable tensioner places a drag on the cable during winding on the drum without a load.

(3) Power for the M39 and M809 front winch is supplied by the vehicle engine through transmission power takeoff turning a drive shaft connected directly to the winch. Power for the M939 front winch is supplied by the vehicle engine through a transmission power takeoff that drives a hydraulic pump. Hydraulic pressure drives a hydraulic motor mounted on the rear of the winch.

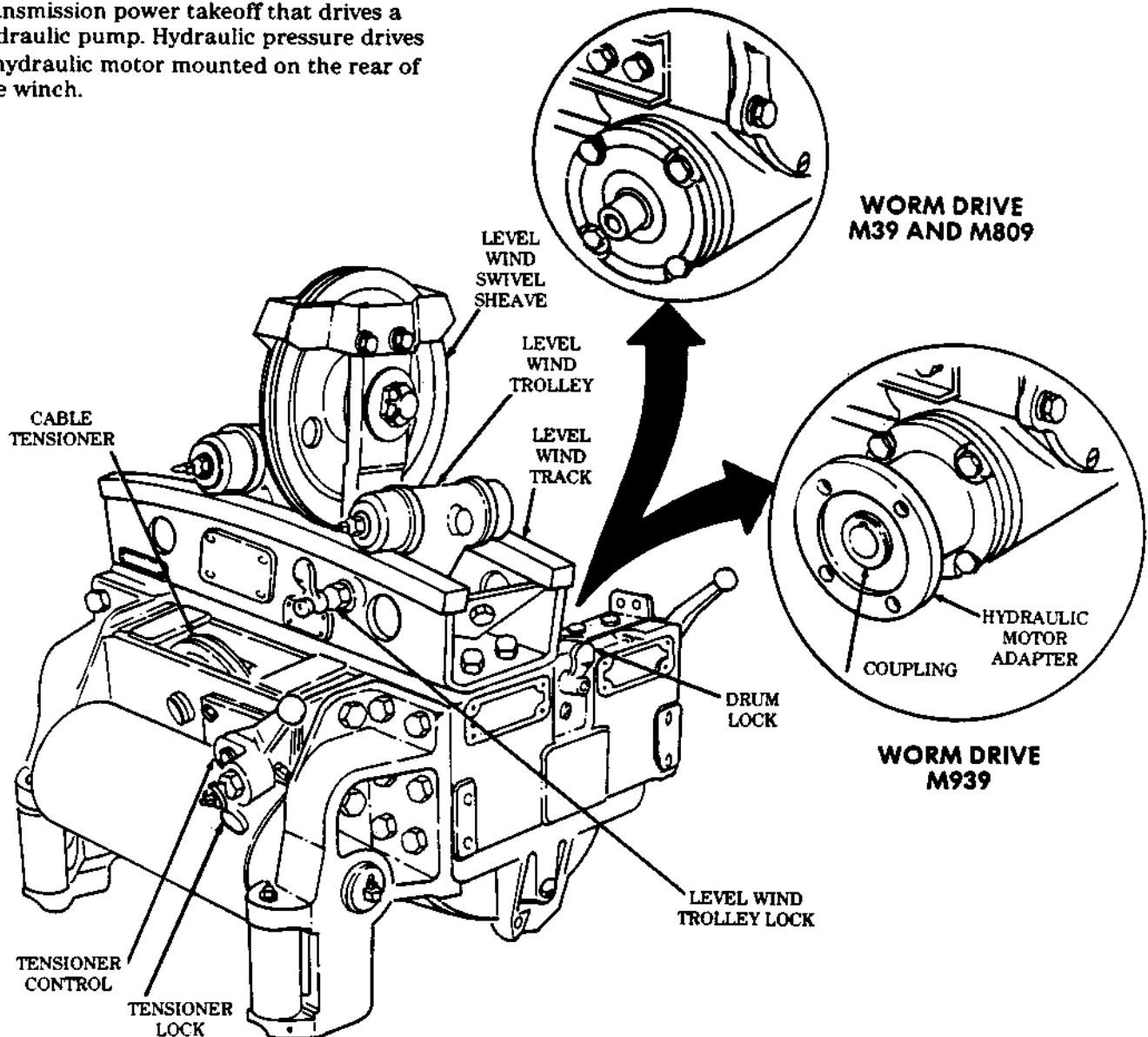

Figure 1-3. Front Winch Assembly (With Level Wind and Cable Tensioner)
(M39, M809, and M939 Series Vehicles).

TA 51142

1-4. DESCRIPTION (Contd).

c. Rear Winch.

- (1) The rear winch (fig. 1-4) is a worm gear, horizontal drum type with an internal automatic brake.
- (2) The automatic brake, attached to the rear end of the drive (worm) shaft, sustains winch load whenever delivery of power to winch is interrupted.
- (3) The rear winch is equipped with a level wind device that winds cable in tight, even coils and layers.
- (4) The rear winch is equipped with manually-controlled, pneumatically-operated cable tensioner. The cable tensioner places tension-drag on the cable being wound on the drum without a load.
- (5) Power for the M939 rear winch is supplied from the crane hydraulic system. Hydraulic pressure drives a hydraulic motor attached through a coupling to the front of the winch.
- (6) Power for the M39 and M809 rear winch is supplied by the vehicle engine through a transfer-mounted power takeoff. The drive shaft, chain drive, and power divider constitute drivetrain components for the rear winch.
- (7) The rear winch assembly is mounted on the wrecker body at the rear of the crane.

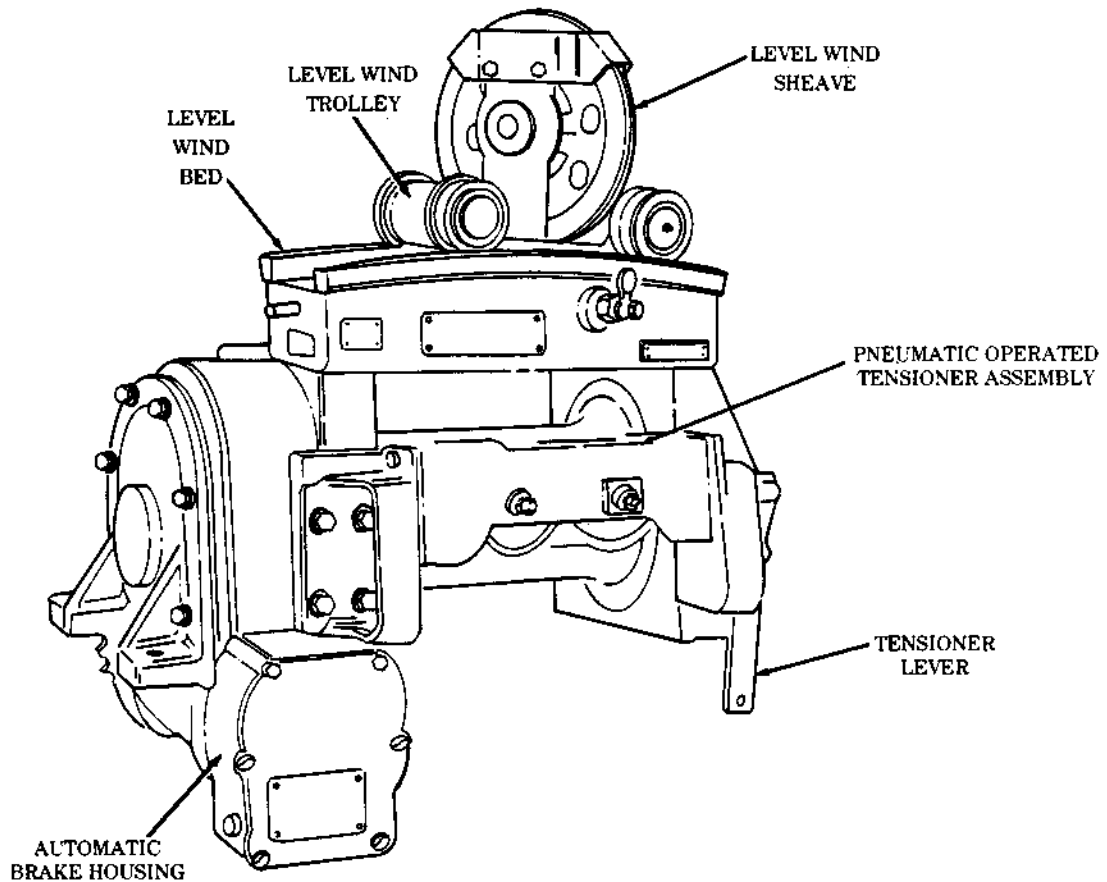

Figure 1-4. Rear Winch Assembly (M39, M809, and M939 Series Vehicles).

TA 51143

1-5. DATA PLATES.

a. **Equipment Data Plates.** Each winch shall display an equipment data plate listing the vendor's name, serial number, Ordnance part number, model number, and type of winch. This plate shall be placed on the top tension channel on Ordnance Numbers 7412382 and 7412382-1 (2, fig. 1-5); on the front of the cable level wind track assembly on Ordnance Numbers 7411122 and 7411122-1 (2, fig. 1-6); and on the front of the cable level wind track assembly on Ordnance Number 7409980 (1, fig. 1-7). For information on caution and warning plates, refer to TM 9-2320-211-20-1 (M39), TM 9-2320-260-20-1 (M809), and TM 9-2320-272-20-1 (M939).

b. **Overhaul Data Plates.**

CAUTION

Stamping of overhaul data plate shall be accomplished prior to placing on winch to reduce chance of error, ensure clarity, and prevent damage to winch.

(1) An overhaul data plate (1, fig. 1-5; 4, fig. 1-6; and 3, fig. 1-7) shall be furnished to provide a convenient record of overhaul of the winch assembly. Refer to TB Ord 1030, Army Vehicles: Installation and Use of Overhaul/MWO Data Plates.

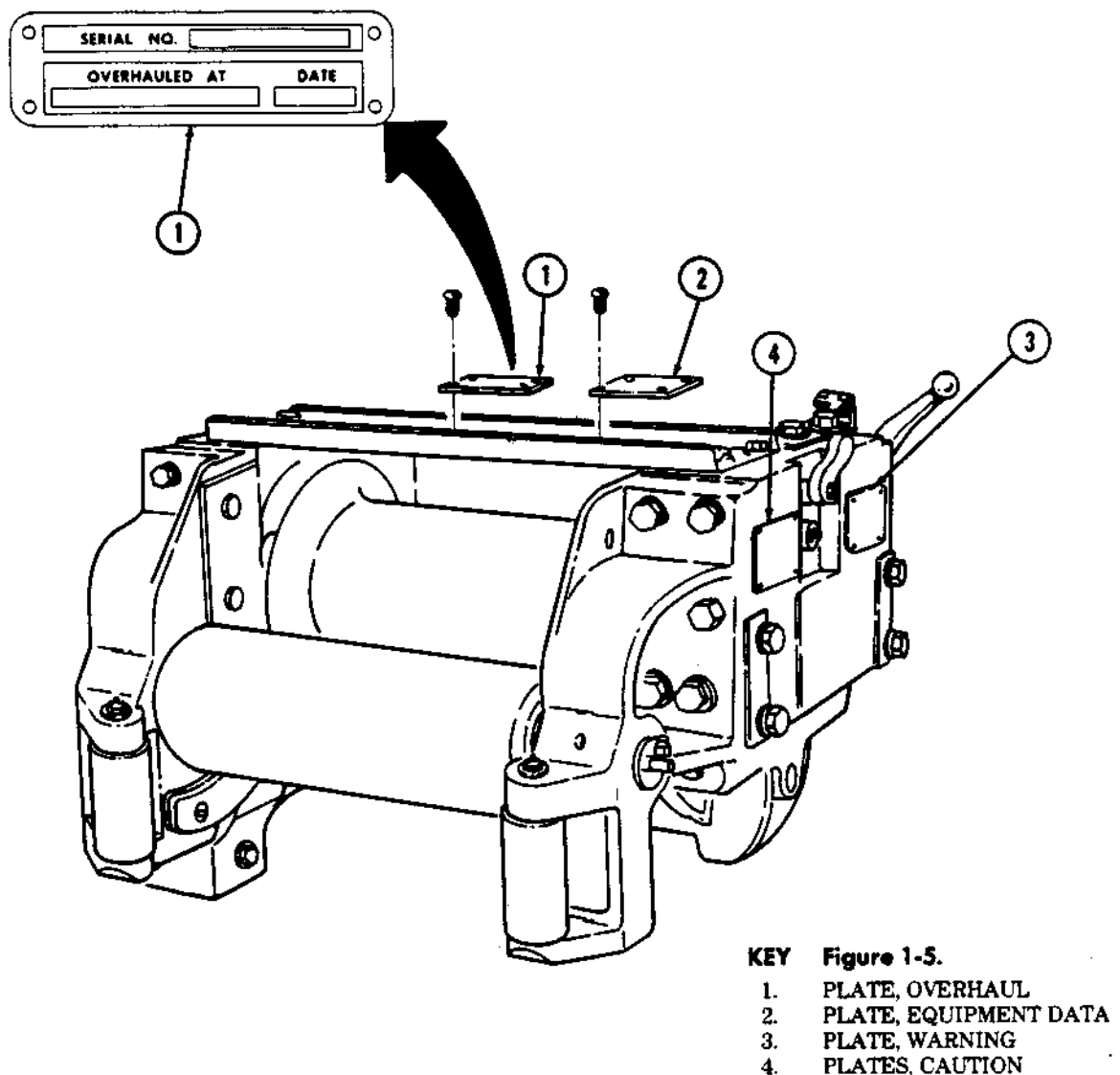
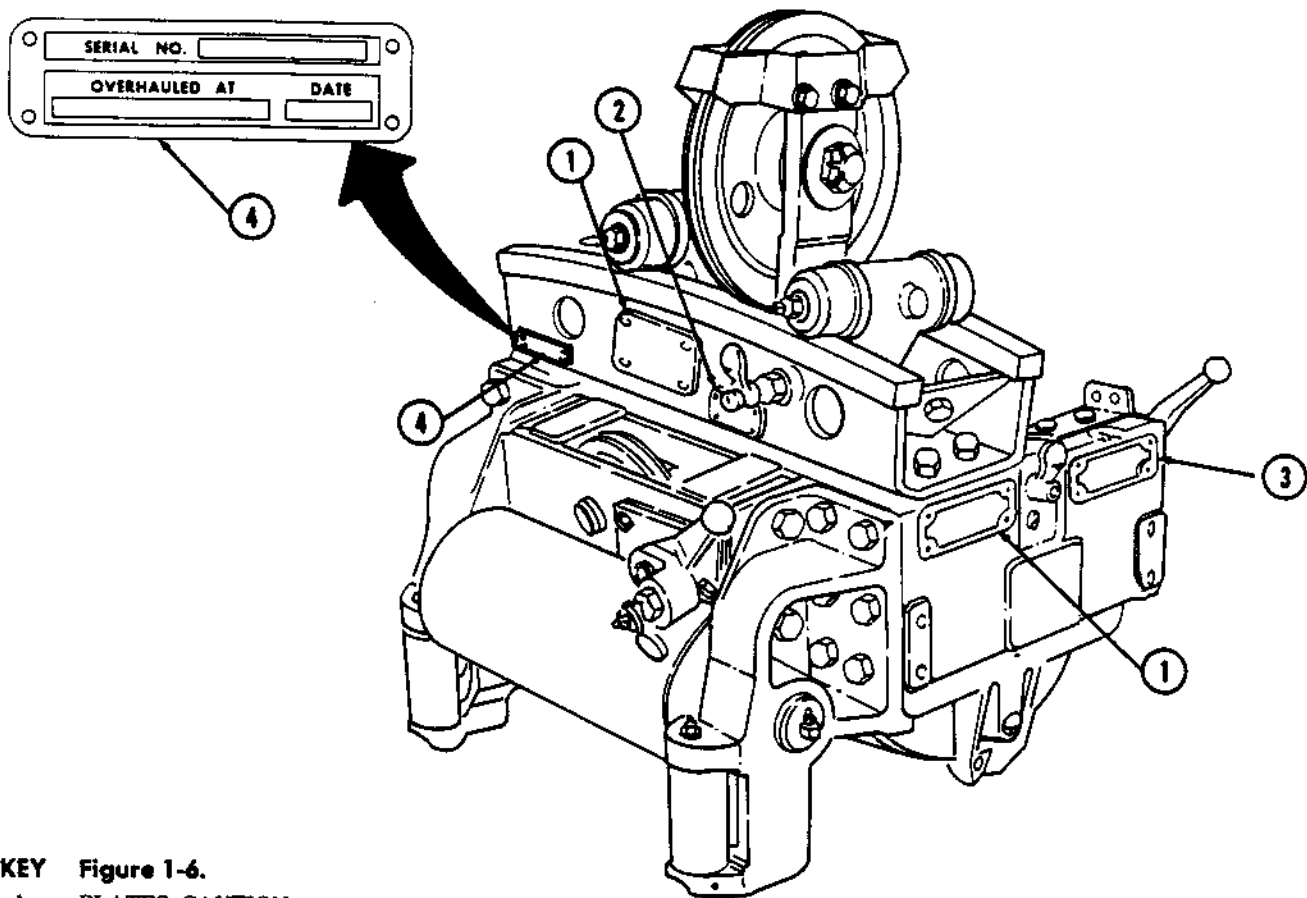

Figure 1-5. Data Plates, Front Winch (Without Level Wind)
(M39, M809, and M939 Series Vehicles).

TA 51144

1-5. DATA PLATES (Contd).

b. Overhaul Data Plates (Contd).



- KEY Figure 1-6.**
- 1. PLATES, CAUTION
 - 2. PLATE, EQUIPMENT DATA
 - 3. PLATE, WARNING
 - 4. PLATE, OVERHAUL

Figure 1-6. Data Plates, Front Winch (With Level Wind and Cable Tensioner)
(M39, M809, and M939 Series Vehicles).

TA 51145

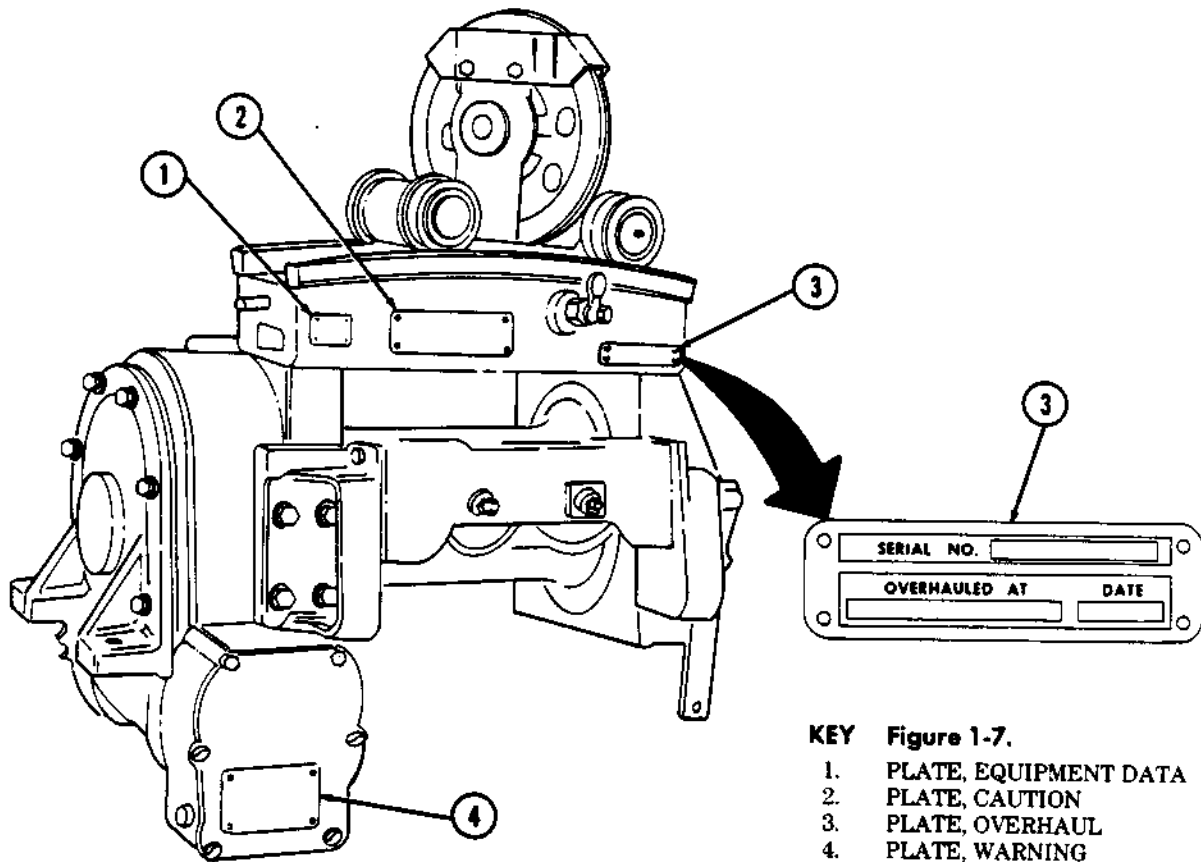
1-5. DATA PLATES (Contd).**b. Overhaul Data Plates (Contd).****KEY Figure 1-7.**

1. PLATE, EQUIPMENT DATA
2. PLATE, CAUTION
3. PLATE, OVERHAUL
4. PLATE, WARNING

*Figure 1-7. Data Plates, Rear Winch (With Level Wind and Cable Tensioner)
(M39, M809, and M939 Series Vehicles).*

TA 51146

(2) A 1-3/16 x 3-23/32 in. (27 x 94 mm) overhaul data plate will be attached to each winch upon completion of overhaul.

(3) Information on the overhaul data plate will show the designation of the overhauling activity and the date (month and year) when the overhaul was accomplished. Lettering shall be 1/16 in. (1.6 mm) high.

(4) The overhaul data plate shall be mounted on the top tension channel on Ordnance Numbers 7412382 and 7412382-1 (1, fig. 1-5); on the left front of the cable level wind track assembly on Ordnance Numbers 7411122 and 7411122-1 (4, fig. 1-6); and on the right front of the cable level wind track assembly on Ordnance Number 7409980 (3, fig. 1-7).

(5) When sufficient space is not available on the existing overhaul data plate to add information, the plate shall be replaced and all pertinent data transferred to the new plate. Data shall not be stamped directly on any part, assembly, or item of equipment.

c. Material.**CAUTION**

When drilling holes to mount data plates, do not drill through housing, lubricant leakage will result.

The overhaul data plate shall be fabricated by the photo-sensitive anodized aluminum process conforming to composition "C" of MIL-P-514, Plate, Identification, Instruction, and Marking Blank. Refer to TB Ord 1024, Army Equipment: Manufacture of Data Plates, color as specified. Install as required by TB Ord 1030.

1-6. TABULATED DATA (M39, M809, AND M939 SERIES VEHICLES).

Models:

M39, M809 series vehicles:

Front winch (without level wind)	ORD NO. 7412382
Front winch (with level wind and cable tensioner)	ORD NO. 7411122
Rear winch (with level wind and cable tensioner)	ORD NO. 7409980

M939 series vehicles:

Front winch (without level wind)	ORD NO. 7412382-1
Front winch (with level wind and cable tensioner)	ORD NO. 7411122-1
Rear winch (with level wind and cable tensioner)	ORD NO. 7409980

Type Worm gear, horizontal drum

Capacity:

Front winch	9,500 lb (4,313 kg) at winding speed of 15 ft (4.51 m) per minute, first layer of cable on bare drum
Rear winch	14,500 lb (6,583 kg) at winding speed of 15 ft (4.51 m) per minute, first layer of cable on bare drum

Cable diameter:

Front winch	5/8 in. (15.8 mm)
Rear winch	3/4 in. (19.0 mm)

Cable length:

Front winch (without level wind)	200 ft (61.0 M)
Front winch (with level wind and cable tensioner)	280 ft (85.4 M)
Rear winch (with level wind and cable tensioner)	350 ft (106.8 M)

Lubricant capacity:

Front winch (without level wind)	2.6 qt (2.5 L)
Front winch (with level wind and cable tensioner)	2.6 qt (2.5 L)
Rear winch (with level wind and cable tensioner)	3.0 qt (2.8 L)

Overall dimensions:

Front Winch (without level wind)

Ordinance numbers 7412382 and 7412382-1

Length	33 in. (83.8 cm)
Height	18 in. (45.7 cm)
Width	24 in. (61.0 cm)

Weight:

Winch only	397 lb (180 kg)
Shipping crate and winch	480 lb (218 kg)

Front winch (with level wind and cable tensioner)

Ordinance numbers 7411122 and 7411122-1

Length	33 in. (83.8 cm)
Height	30 in. (76.2 cm)
Width	24 in. (61.0 cm)

Weight:

Winch only	490 lb (222 kg)
Shipping crate and winch	617 lb (280 kg)

Rear Winch (with level wind and cable tensioner)

Ordinance number 7409980

Length	40.5 in. (102.9 cm)
Height	25.5 in. (64.8 cm)
Width	34 in. (86.4 cm)

Weight:

Winch only	776 lb (352 kg)
Shipping crate and winch	981 lb (445 kg)

1-6. TABULATED DATA (M39, M809, AND M939 SERIES VEHICLES) (Contd).**Winch Drive**

- | | |
|-----------------------------|---------------------|
| (1) Front winch — M39, M809 | |
| Drive | Shaft/power takeoff |
| Location | Transmission |
| (2) Rear winch — M39, M809 | |
| Drive | Shaft/power takeoff |
| Location | Transfer case |
| (3) Front winch — M939 | |
| Drive | Hydraulic motor |
| Location | Rear of winch |
| (4) Rear winch — M939 | |
| Drive | Hydraulic motor |
| Location | Front of winch |

1-7. DIFFERENCES BETWEEN MODELS (M39, M809, AND M939).

a. Basic differences between M39 and M809 shaft-driven front winch assemblies are that a manual cable tensioner and cable level wind is added on P/N 7412382 winch assembly to convert to P/N 7411122 winch assembly. Shaft-driven winch assemblies P/N 7412382 and P/N 7411122 are converted to hydraulically-driven winch assemblies P/N 7412382-1 and 7411122-1 by adding an input shaft housing extension and a shaft adapter for M939 and M939A1 series vehicle application.

b. Basic differences between front winch assemblies and rear winch assembly P/N 7409980 are as follows:

(1) Front winch controls for drum locking, drum engagement, and cable tensioner are located directly at the winch.

(2) Rear winch controls for cable tensioner and drum engagement are external to the winch. Rear winch is not equipped with drag brake or direct drum locking system.

CHAPTER 2

REQUIREMENTS

Section 1. GENERAL

2-1. FACILITIES.

The overhaul activity requires equipment to perform all operations contained in this DMWR. These operations include: handling, disassembly and assembly, quality and tolerance checking, identification and marking, cleaning, painting, processing, and the use of machine shop equipment.

2-2. SUPPORT ITEMS.

a. **Tools.** There are no additional tools required for this overhaul.

b. **Inspection and Test Equipment.** Inspection and test equipment listed in table 2-1 are considered necessary to ensure a uniform level of quality control in accordance with overhaul procedures contained in this DMWR.

c. **Mandatory Replacement Parts.** Mandatory replacement parts will be replaced if the assembly or subassembly in which they are found is overhauled; refer to table 2-2, Mandatory Replacement Parts - Front Winch and table 2-3, Mandatory Replacement Parts - Rear Winch.

d. **Repair Parts.** Refer to:

(1) TM 9-2320-211-34P, Direct Support and General Support Maintenance Repair Parts and Special Tools List for Truck: 5-Ton, 6x6, M39 Series Vehicles.

(2) TM 9-2320-260-34P/2, Direct Support and General Support Maintenance Repair Parts and Special Tools List for Truck: 5-Ton, 6x6, M809 Series Vehicles.

(3) TM 9-2320-272-34P-2, Direct Support and General Support Maintenance Repair Parts and Special Tools List for Truck: 5-Ton, 6x6, M939 Series Vehicles.

e. **Modifications.** Refer to DA Pamphlet 310-1, Consolidated Index of Army Publications and Blank Forms.

f. **Deviations and Exceptions (Contractor).**

(1) All departures from drawings, specifications, and the quality assurance overhaul standards will be considered nonconforming material. Nonconforming material involving major defects will not be accepted without TACOM approval.

(2) When any work segment as set forth in this Depot Maintenance Work Requirement cannot be accomplished, or can only be accomplished in a manner other than specified, prior approval of the procuring activity shall be obtained by immediately submitting to the contracting officer a written notice containing the following information:

(a) Serial number (if applicable), part number, and NSN of affected equipment.

(b) Work elements which will not be completed or which will not be accomplished exactly as specified herein.

(c) Reason for nonaccomplishment or deviation.

(d) Action taken to correct condition causing nonaccomplishment or need for deviation.

(e) Data relative to availability of parts required, if applicable.

(f) Estimated man-hours.

(g) Instructions and inspection required to maintain the integrity of the end item because of such omission or deviation.

g. **Deviations and Exceptions (Depot).** Depots will follow the procedures in DESCOM-R 702-1, Quality Control System.

Table 2-1. Inspection and Test Equipment.

NOMENCLATURE	NSN OR PART NO.	REFERENCE PARA. OF USE
Specified Pins for Measurement of Gear and Spline Tooth Wear 0.50000 in. (12.7000 mm) diameter 0.62500 in. (15.8750 mm) diameter 0.68750 in. (17.4625 mm) diameter 0.75000 in. (19.0500 mm) diameter:	No NSN OR P/N	3-19b. Inspection requirements and procedures.
Surface Plate	No NSN or P/N	3-19b. Inspection requirements and procedures.
Test Stand	No NSN or P/N	4-4. Testing.

Table 2-2. Mandatory Replacement Parts — Front Winch.

PART NO.	NSN	NOMENCLATURE	QTY.
		GROUP 2001 HOIST, CRANE, OR WINCH ASSEMBLY TENSIONER AND ROLLER ASSEMBLY	
MS15003-1 (96906)	4730-00-050-4208	FITTING, LUBRICATION	2
7417093 (19207)	5330-00-741-7093	PACKING ASSEMBLY	4
MS15003-6 (96906)	4730-00-172-0034	FITTING, LUBRICATION	2
MS35756-1 (96906)	5315-00-616-5519	KEY, WOODRUFF	1
7538706 (19207)	5360-00-753-8706	SPRING, HELICAL	1
MS35338-46 (96906)	5310-00-637-9541	WASHER, LOCK	4
MS16624-1100 (96906)	5365-00-530-7968	RING, RETAINING	1
MS35671-42 (96906)	5315-00-014-2972	PIN, GROOVED	1
		WINCH ASSEMBLY	
MS24665-283 (96906)	5315-00-842-3044	PIN, COTTER (WINCH P/N 7411122-1 AND 7412382-1 ONLY)	1
MS24665-283 (96906)	5315-00-842-3044	PIN, COTTER (WINCH P/N 7411122 AND 7412382 ONLY)	2

Table 2-2. Mandatory Replacement Parts — Front Winch (Contd).

PART NO.	NSN	NOMENCLATURE	QTY.
12276678 (19207)	5315-01-109-6846	PIN, STRAIGHT HEADED (WINCH P/N 7411122-1 AND 7412382-1 ONLY)	1
7409348 (19207)	5315-00-209-7979	PIN, STRAIGHT (WINCH P/N 7411122 AND 7412382 ONLY)	1
MS35336-39 (96906)	5310-00-194-9213	WASHER, LOCK (WINCH P/N 7412382 AND 7412382-1 ONLY)	6
MS35338-46 (96906)	5310-00-637-9541	WASHER, LOCK (WINCH P/N 7411122 AND 7411122-1 ONLY)	4
23MS35338-50 (80045)	5310-00-820-6653	WASHER, LOCK	12
304677 (61465)	5360-00-740-9727	SPRING, HELICAL COMPRESSION (WINCH P/N 7411122 AND 7411122-1 ONLY)	1
MS35338-48 (96906)	5310-00-584-5272	WASHER, LOCK (WINCH P/N 7411122 AND 7411122-1 ONLY)	8
MS35338-51 (96906)	5310-00-584-7888	WASHER, LOCK	4
7538706 (19207)	5360-00-753-8706	SPRING, HELICAL (WINCH P/N 7411122 AND 7411122-1 ONLY)	1
7409822 (19207)	5330-00-057-3823	GASKET	1
MS35336-39 (96906)	5310-00-194-9213	WASHER, LOCK (WINCH P/N 7412382 AND 7412382-1 ONLY)	6
		BASIC WINCH, DRUM, AND RELATED PARTS	
7538726 (19207)	2540-00-753-8726	BRAKESHOE, DRAG	1
MS35338-51 (96906)	5310-00-584-7888	WASHER, LOCK	4
MS35756-13 (96906)	5315-00-616-5521	KEY, WOODRUFF	1
7418774 (19207)	5330-00-866-6236	SEAL, PLAIN, ENCASED	1
23MS35338-50 (80045)	5310-00-820-6653	WASHER, LOCK	2
7538706 (19207)	5360-00-753-8706	SPRING, HELICAL	1
7409684 (19207)	5340-00-740-9684	PLUG, EXPANSION	1
451081 (21450)	5310-00-045-1081	NUT, SELF-LOCKING	1

Table 2-2. Mandatory Replacement Parts — Front Winch (Contd).

PART NO.	NSN	NOMENCLATURE	QTY.
		BASIC WINCH, DRUM, AND RELATED PARTS (Contd)	
7409697 (19207)	5330-00-740-9697	SEAL, PLAIN, ENCASED	1
10875107-7 (19207)	5330-01-119-5801	SEAL, PLAIN, ENCASED	1
7538712 (19207)	5360-01-042-9532	SPRING, HELICAL	1
		BASIC WINCH, GEARCASE	
MS35338-48 (96906)	5310-00-584-5272	WASHER, LOCK	9
7409822 (19207)	5330-00-057-3823	GASKET	2
5196397 (19207)	4820-00-726-4719	VALVE, AIR PRESSURE	1
8327444 (19207)	5315-00-281-7652	KEY, MACHINE	2
8327443 (19207)	5315-00-281-7650	KEY, MACHINE	2
5277992 (19207)	5360-00-664-4374	SPRING, HELICAL	1
187527 (21450)	5306-00-018-7527	BOLT, ASSEMBLED WASHER	6
7973339 (19207)	5330-00-895-3424	GASKET	1
7409565 (19207)	2590-00-740-9565	BRAKE AND LINING	1
17657/ 55-542465 (80201)	5330-01-150-9691	SEAL, PLAIN, ENCASED	2
7409821 (19207)	5330-00-740-9821	GASKET	1
23MS35338-50 (80045)	5310-00-820-6653	WASHER, LOCK	8
MS20067-270 (96906)	5315-00-042-3293	KEY, MACHINE	1
MS35648-3 (96906)	5340-00-050-1589	PLUG, EXPANSION	1

Table 2-2. Mandatory Replacement Parts — Front Winch (Contd).

PART NO.	NSN	NOMENCLATURE	QTY.
MS35338-46 (96906)	5310-00-637-9541	FRONT WINCH SHEAVE AND TROLLEY ASSEMBLIES WASHER, LOCK	4
23MS35338-50 (80045)	5310-00-820-6653	WASHER, LOCK	4
MS24665-362 (96906)	5315-00-298-1498	PIN, COTTER	1
7411156 (19207)	3120-00-741-1156	BEARING, SLEEVE	1
7409929 (19207)	5330-00-740-9929	PACKING WITH RETAINER	8
7411159 (19207)	5330-00-741-1159	FELT	1
MS15003-1 (96906)	4730-00-172-0010	FITTING, LUBRICATION	3
MS15003-6 (96906)	4730-00-172-0034	FITTING, LUBRICATION	1
7411154 (19207)	5330-00-741-1154	FELT, SHEAVE	2
7411160 (19207)	5330-00-741-1160	FELT	1

Table 2-3. Mandatory Replacement Parts — Rear Winch.

PART NO.	NSN	NOMENCLATURE	QTY.
MS35338-51 (96906)	5310-00-584-7888	GROUP 2001 HOIST, CRANE, OR WINCH ASSEMBLY REAR WINCH ASSEMBLY, BASIC	20
7409940 (19207)	5330-00-292-1600	SEAL, PLAIN, ENCASED	1
7409931 (19207)	5330-00-166-4333	GASKET, GEARCASE	2

Table 2-3. Mandatory Replacement Parts — Rear Winch (Contd).

PART NO.	NSN	NOMENCLATURE	QTY.
		REAR WINCH ASSEMBLY, BASIC (Contd)	
MS20067-305 (96906)	5315-00-042-4950	KEY, MACHINE	1
500207 (21450)	5330-00-585-3210	SEAL, PLAIN, ENCASED	2
MS15003-1 (96906)	4730-00-050-4208	FITTING, LUBRICATION	1
187527 (21450)	5306-00-018-7527	BOLT, ASSEMBLED WASHER	6
7409932 (19207)	5330-00-740-9932	GASKET, BRAKE COVER	1
7409663 (19207)	2590-00-740-9663	BRAKE, BAND AND LINING	1
MS35338-48 (96906)	5310-00-584-5272	WASHER, LOCK	1
501514 (21450)	5340-01-136-8387	PLUG, EXPANSION	1
5416501 (19207)	5360-00-541-6501	SPRING, BRAKE BAND	1
MS28775-113 (96906)	5330-00-582-2855	PACKING, PREFORMED	1
MS35338-50 (96906)	5310-00-820-6653	WASHER, LOCK	6
7409933 (19207)	5330-00-740-9933	GASKET	1
MS20067-493 (96906)	5315-01-119-5239	KEY, MACHINE	4
MS24665-5 (96906)	5315-00-236-8345	PIN, COTTER	1
8330478 (19207)	5315-00-282-2583	PIN, GROOVED, HEADED	1
		REAR WINCH CABLE TENSIONER AND MOUNTING	
MS35338-51 (96906)	5310-00-584-7888	WASHER, LOCK	8
7409929 (19207)	5330-00-740-9929	PACKING WITH RETAINER	4

Table 2-3. Mandatory Replacement Parts — Rear Winch (Contd).

PART NO.	NSN	NOMENCLATURE	QTY.
		REAR WINCH CABLE TENSIONER AND MOUNTING (Contd)	
MS24665-502 (96906)	5315-00-849-5582	PIN, COTTER	2
MS24665-351 (96906)	5315-00-839-5821	PIN, COTTER	4
MS15003-2 (96906)	4730-00-172-0022	FITTING, LUBRICATION	2
MS35338-48 (96906)	5310-00-584-5272	WASHER, LOCK	4
		REAR WINCH SHEAVE SWIVEL, TROLLEY, MOUNTING, AND TRACK	
MS35338-50 (96906)	5310-00-820-6653	WASHER, LOCK	4
7538706 (19207)	5360-00-753-8706	SPRING, HELICAL COMPRESSION	1
MS35338-46 (96906)	5310-00-637-9541	WASHER, LOCK	4
MS15003-1 (96906)	4730-00-050-4208	FITTING, LUBRICATION	7
7409889 (19207)	5330-00-740-9889	FELT, MECHANICAL	1
MS16624-1275 (96906)	5365-00-200-7234	RING, RETAINING	2
7409959 (19207)	5330-00-740-9959	FELT, MECHANICAL	8
MS16624-1200 (96906)	5365-00-252-4758	RING, RETAINING	4
MS15003-6 (96906)	4730-00-172-0034	FITTING, LUBRICATION	1
MS21245-18 (96906)	5310-00-449-2378	NUT, SELF-LOCKING	1
22NA797-82 (72962)	5310-00-596-7753	NUT, SELF-LOCKING	1
MS51943-16 (96906)	5310-00-045-1031	NUT, SELF-LOCKING	1

Section II. STANDARDS

2-3. QUALITY OF MATERIAL.

Unless otherwise specified, parts and material used for replacement or modification will comply with applicable drawings and specifications.

2-4. MAN-HOUR STANDARDS.

See estimated man-hour standards in table 2-4.

Table 2-4. Estimated Man-Hour Standards.

OPERATION	MAN-HOURS
Front Winch:	
Initial Inspection and Test (Preshop)	4.0
Disassemble	3.0
Cleaning	3.5
Inspection	5.0
Repair	6.5
Assemble	5.5
Test, Paint, and Prepare for Shipment	3.5
Total	31.0
Rear Winch:	
Initial Inspection and Test (Preshop)	4.0
Disassemble	3.5
Cleaning	4.0
Inspection	4.0
Repair	6.0
Assemble	6.0
Test, Paint, and Prepare for Shipment	3.5
Total	31.0

CHAPTER 3 MAINTENANCE, OVERHAUL, AND REPAIR

Section I. GENERAL

3-1. SCOPE.

a. This chapter contains specific instructions including disassembly, cleaning, inspection, repair, and assembly of winch components.

b. Maximum repair and renovation of parts is mandatory. Parts, components, subassemblies, or assemblies found to be worn or defective beyond repairable limits established by this DMWR will be condemned and disposed of as directed by appropriate directives, or in case of commercial contracts, as specified in provisions of the contract. Tolerances and wear limits set forth herein are the minimum acceptable standards.

3-2. REFERENCES (FRONT AND REAR WINCH ASSEMBLIES — M39, M809, AND M939 SERIES VEHICLES).

a. M39 Series Vehicles.

(1) Disassemble and assemble using the procedures provided in the following publications:

(a) TM 9-2320-211-20-3-2, Organizational Maintenance Manual for Truck: 5-Ton, 6x6, M39 Series Vehicles, chapter 18.

(b) TM 9-2320-211-34-2-3, Direct Support and General Support Maintenance Manual for Truck: 5-Ton, 6x6, M39 Series Vehicles, chapter 17.

(2) Refer to TM 9-2320-211-34P for parts identification.

(3) Refer to LO 9-2320-211-12, Lubrication Order for Truck, Chassis: 5-Ton, 6x6, M39 Series Vehicles, for lubrication instructions.

b. M809 Series Vehicles.

(1) Disassemble and assemble using the procedures contained in the following publications:

(a) TM 9-2320-260-20-3-4, Organizational Maintenance Manual for Truck: 5-Ton, 6x6, M809 Series Vehicles, chapter 18.

(b) TM 9-2320-260-34-2-4, Direct Support and General Support Maintenance Manual for Truck: 5-Ton, 6x6, M809 Series Vehicles, chapter 17.

(2) Refer to TM 9-2320-260-34P/2 for parts identification.

(3) Refer to LO 9-2320-260-12, Lubrication Order for Truck, Chassis: 5-Ton, 6x6, M809 Series Vehicles, for lubrication instructions.

c. M939 Series Vehicles.

(1) Disassemble and assemble using the procedures contained in the following publications:

(a) TM 9-2320-272-20-2, Organizational Maintenance Manual for Truck: 5-Ton, 6x6, M939 Series Vehicles, chapter 10.

(b) TM 9-2320-272-34-2, Direct Support and General Support Maintenance Manual for Truck: 5-Ton, 6x6, M939 Series Vehicles, chapter 19.

(2) Refer to TM 9-2320-272-34P-2 for parts identification.

(3) Refer to LO 9-2320-272-12, Lubrication Order for Truck: 5-Ton, 6x6, M939 Series Vehicles, for lubrication instructions.

Section II. SAFETY

3-3. PRECAUTIONS.

- a. All material handling equipment shall be adequate to ensure safe shop working conditions for personnel and efficient processing of items.
- b. Winches will be properly mounted on a fixture or stabilized with wood blocking on bench or table for disassembly and assembly to ensure safe working conditions.

Section III. PRESHOP ANALYSIS

3-4. PURPOSE.

- a. The purpose of preshop analysis is to determine, prior to beginning overhaul activities, the extent of overhaul required to return the winch assembly to a serviceable condition as specified herein.
- b. The receiving agency or shop will physically check all tags and forms attached to the equipment to determine the reason for its removal from service. Do not remove any tags or forms from the winch assembly.
- c. Where it has been previously determined that a 100 percent teardown will be accomplished, a preshop analysis is not mandatory.
- d. The preshop analysis testing (table 3-1), and preshop analysis checklist (table 3-2) will be used to evaluate the items to determine the extent of cleaning, repair, modification, or replacement needed to make the item completely serviceable.
- e. Tags and forms (paragraph b above) may be removed after preshop analysis has been completed and the extent of required overhaul has been determined. All tags and forms will become part of record file with Final Inspection Record.

3-5. UNPACKING INSTRUCTIONS.

Unpack winch assemblies following standard depot procedures.

3-6. CLEANING.

WARNING

Drycleaning solvent is flammable and will not be used near open flame. A fire extinguisher will be kept nearby when drycleaning solvent is used. Use only in well-ventilated places. Failure to do this may result in injury to personnel.

- a. Cleaning will be accomplished following standard depot cleaning procedures.
- b. Record on preshop analysis checklist (table 3-2) any evidence of lubricant leakage points.

Table 3-1. Preshop Analysis Testing.

PRESHOP ANALYSIS TESTING

NOM _____ NSN _____

SERIAL # _____ INSPECTOR _____ DATE _____

PARA. NO.	TEST/INSPECTION POINT	CONDITION	PERFORMANCE DATA	REMARKS
1.	Shipping and maintenance records check	<p>RECORDS CHECK</p> <p>Check accompanying maintenance and shipping documents to determine reason for withdrawal of winch from service. Attempt to confirm reason for withdrawal. Determine if any additional damage occurred to winch during shipping.</p>		
2.		<p>GENERAL EXTERNAL INSPECTION</p>		Refer to figs. 3-1, 3-2, or 3-3.
a.	Winch assembly	<p>Evidence of improper or incomplete assembly:</p> <p>(1) Loose or missing screws.</p> <p>(2) Torn or missing gaskets.</p> <p>(3) Missing fill plugs or drain-plugs.</p>		Record. Contaminated oil or corroded parts.
b.	Winch assembly	<p>Examine for cracked, bent, broken, or otherwise damaged parts:</p> <p>(1) Drum and drum lock assembly.</p> <p>(2) Gearcase housing.</p> <p>(3) End case housing.</p> <p>(4) Tie rod and channels.</p> <p>(5) Input shaft adapter and housing (hydraulic motor operated winches).</p>		Disassemble and inspect. Repair or replace defective parts.
c.	Roller assembly (if equipped)	<p>Examine for cracked, broken, or damaged:</p> <p>(1) Brackets.*</p> <p>(2) Rollers and bearings.</p> <p>(3) Lubrication fittings.</p>		Repair or replace defective parts.

*Refer to paragraph 3-18b for automatic replacement of roller brackets.

Table 3-1. Preshop Analysis Testing (Contd).

PARA. NO.	TEST/INSPECTION POINT	CONDITION	PERFORMANCE DATA	REMARKS
2.		GENERAL EXTERNAL INSPECTION (Contd)		
d.	Tensioner assembly (if equipped)	Examine for cracked, bent, broken or damaged: (1) Sheaves (2), pins, and bearings. (2) Lock handle and poppet assembly (front winches only). (3) Frame (and adjustable frame on rear winch). (4) Lubrication fittings.		Repair or replace defective parts.
e.	Level wind assembly (if equipped)	Examine for cracked, bent, broken, or damaged: (1) Track. (2) Wheels (4) and bearings. (3) Sheave and bearings. (4) Swivel assembly. (5) Lubrication fittings.		Repair or replace defective parts.
f.	Lubricant leakage	Examine for evidence of lubricant leakage.		Record locations.
3.	Winch assembly	MANUAL OPERATIONAL TEST		
a.	Input shaft and bearings	Turn input shaft and examine for: (1) Radial freeplay: None. Noticeable. (2) Axial freeplay.	0.006-0.010 in. (0.15-0.25 mm)	Normal. Ball bearings damaged. Replace. Normal. If less, out of adjustment. If greater, housing and/or shaft worn. Adjust or replace.

Table 3-1. Preshop Analysis Testing (Contd).

PARA. NO.	TEST/INSPECTION POINT	CONDITION	PERFORMANCE DATA	REMARKS
3.	Winch assembly	MANUAL OPERATIONAL TEST (Contd)		
b.	Drum clutch, drum lock, and drum	<p>Turn input shaft and examine for:</p> <p>(1) Proper drum engagement (front winches only).</p> <p>Operate manual clutch control lever and ensure drum engages and disengages crisply.</p> <p>(2) Manual control lever (front winches only):</p> <p>(a) Detent seats.</p> <p>(b) Lock works.</p> <p>(c) Lever operates smoothly over range of movement.</p> <p>(3) Drum lock poppet (front winches only):</p> <p>(a) Locks and unlocks drum without binding.</p> <p>(b) Seats in poppet nut in both lock and unlock position.</p> <p>(4) Noisy or binding drum bushings.</p> <p>(5) Using a pry bar, examine drum radial and axial movement.</p> <p>(a) Radial freeplay:</p> <p>None.</p> <p>Noticeable.</p> <p>(b) Axial freeplay.</p>	<p>0.05-0.015 in. (0.13-0.31 mm)</p>	<p>Drum does not engage and disengage properly, repair or replace defective parts.</p> <p>Manual control lever does not operate properly, repair or replace defective parts.</p> <p>Drum lock poppet does not operate properly, replace defective parts.</p> <p>Repair or replace defective parts.</p> <p>Normal.</p> <p>Bushings or shaft worn. Replace.</p> <p>If less, out of adjustment. If greater, worn parts. Adjust or replace.</p>

Table 3-1. Preshop Analysis Testing (Contd).

PARA. NO.	TEST/INSPECTION POINT	CONDITION	PERFORMANCE DATA	REMARKS
3.	Winch assembly	MANUAL OPERATIONAL TEST (Contd)		
c.	Tensioner (front winch)	<p>Tensioner assembly operation (without cable).</p> <p>Examine for:</p> <p>(1) Sheave (2) rotation binding or noisy.</p> <p>(2) Sheave radial or axial freeplay noticeable.</p> <p>(3) Adjustment handle and poppet lock (front winches only). Operates smoothly over range.</p> <p>(4) Tensioner adjustment handle operates smoothly over adjustment range and seats crisply in detent holes.</p> <p>(5) Tensioner lock poppet seats in both lock and unlock positions without binding.</p>		<p>Replace defective roller bearings or inner race.</p> <p>Replace defective roller bearing, race, or thrust washers.</p> <p>Adjustment handle and poppet lock does not operate properly, disassemble and inspect camshaft and bearings.</p> <p>Tensioner adjustment handle does not operate properly, replace defective parts.</p> <p>Binding indicates bent or damaged parts. Replace.</p>
d.	Level wind and track (if equipped)	<p>Level wind and track assembly operation (without cable).</p> <p>Examine for:</p> <p>(1) Trolley wheels (4) operation:</p> <p>(a) Rotate easily.</p> <p>(b) Bind or noisy.</p> <p>(c) Radial or axial freeplay noticeable.</p>		<p>Normal.</p> <p>Replace defective roller bearings.</p> <p>Replace worn parts.</p>

Table 3-1. Preshop Analysis Testing (Contd).

PARA. NO.	TEST/INSPECTION POINT	CONDITION	PERFORMANCE DATA	REMARKS
3.	Winch assembly	<p>MANUAL OPERATIONAL TEST (Contd)</p> <p>(2) Trolley frame moves over range from stop to stop:</p> <p>(a) Moves smoothly.</p> <p>(b) Binds.</p> <p>(c) Drags on track or frame.</p> <p>(3) Swivel frame operation:</p> <p>(a) Rotates easily.</p> <p>(b) Binds or noisy.</p> <p>(c) Radial or axial freeplay noticeable.</p> <p>(4) Sheave operation:</p> <p>(a) Rotates easily.</p> <p>(b) Binds or noisy.</p> <p>(c) Radial or axial freeplay noticeable.</p>		<p>Normal.</p> <p>Inspect track and axles/alinement.</p> <p>Check retaining bolts positions.</p> <p>Normal.</p> <p>Replace defective bearings and/or race.</p> <p>Replace worn parts.</p> <p>Normal.</p> <p>Replace worn parts.</p> <p>Replace worn parts.</p>
e.	Side and horizontal rollers (front winch)	<p>Brackets and rollers assembly. Examine for:</p> <p>(1) Rollers rotate easily.</p> <p>(2) Binds or noisy.</p> <p>(3) Radial and axial freeplay.</p> <p>(a) Side rollers, noticeable radial freeplay.</p> <p>(b) Side rollers axial freeplay.</p> <p>(c) Horizontal roller. Noticeable axial or radial freeplay (either end).</p>	<p>0-0.078 in. (0-2.38 mm)</p>	<p>Normal.</p> <p>Replace damaged or worn parts.</p> <p>Replace worn bushings.</p> <p>Normal.</p> <p>If greater, replace thrust washers.</p> <p>Replace worn bushings or thrust washers.</p>

Table 3-1. Preshop Analysis Testing (Contd).

PARA. NO.	TEST/INSPECTION POINT	CONDITION	PERFORMANCE DATA	REMARKS
3.	Winch assembly	MANUAL OPERATIONAL TEST (Contd)		
f.	Input shaft and automatic brake	Automatic brake operation. Turn input shaft in both directions. (1) Turns in one direction only. (2) Turns in both directions.		Normal. Automatic brake problems. Replace defective parts.
g.	Tensioner (rear winch)	Tensioner assembly operation. Examine for: (1) Sheave (2) rotation binding or noisy. (2) Sheave axial or radial freeplay noticeable. (3) Movable sheave operates smoothly over range.		Replace defective roller bearings or inner race. Replace defective roller bearing, race, or thrust washers. Sheave does not operate properly, disassemble and inspect bearings.
4.	Lubricant (oil)	Drain lubricant and examine for:		
a.		Evidence of overheating (odor and color).		Disassemble and inspect.
b.		Evidence of metal flakes, chips, or metal powder in oil or housing(s).		Disassemble and inspect.
5.	Functional winch assembly	POWER TEST CAUTION Do not power test winch if any malfunctions or deficiencies listed below exist. Additional damage to winch could result.		
a.		Input shaft (worm) radial freeplay.		

Table 3-1. Preshop Analysis Testing (Contd).

PARA. NO.	TEST/INSPECTION POINT	CONDITION	PERFORMANCE DATA	REMARKS
5.	Functional winch assembly	POWER TEST (Contd)		
b.		Drum (and/or drum shaft) radial freeplay.		
c.		Drum lock (front winches only) does not unlock, or poppet does not seat into unlock position on poppet nut.		
d.		Manual clutch control (front winches only) does not engage and disengage drum properly.		
e.		Mount winch on test stand.		
f.		Replace drainplug(s).		
		NOTE		
		Front winches have oil reservoirs in two housings, rear winches have only one reservoir.		
g.		Fill with gear oil.		
		2.6 qt (2.5 L) front winches. 3.0 qt (2.8 L) rear winches.		
h.		Lube winch per LO 9-2320-211-12, LO 9-2320-260-12, or LO 9-2320-272-12.		
i.		Perform power test as described in para. 4-4c(3) for front and rear winches.		
		NOTE		
		If winch passes preshop analysis testing, go to acceptance (final) test. If the winch passes acceptance testing, ship as a serviceable unit.		

KEY Figure 3-1.

1. RIGHT SIDE ROLLER
2. RIGHT ROLLER BRACKET
3. TENSIONER FRAME
4. TENSIONER HANDLE
5. TENSIONER SHEAVE (2)
6. TROLLEY LOCK
7. TROLLEY WHEEL (4)
8. SWIVEL FRAME
9. LEVEL WIND SHEAVE
10. TROLLEY FRAME
11. TROLLEY TRACK (2)
12. TROLLEY STOPSCREW (2)
13. MANUAL CLUTCH HANDLE
14. END FRAME HOUSING
15. END FRAME OIL FILLER PLUG
(REAR OF END FRAME)
16. DRUM LOCK
17. DRAG BRAKE ADJUSTMENT
(UNDER PIPE PLUG)
18. DRAINPLUG (UNDERSIDE OF
END FRAME HOUSING)
19. LEFT ROLLER BRACKET
20. LEFT SIDE ROLLER
21. TENSIONER LOCK
22. HORIZONTAL ROLLER
23. GEARCASE OIL FILLER PLUG
24. AUTOMATIC BRAKE ADJUSTMENT
(INNER SIDE OF HOUSING)
25. AUTOMATIC BRAKE HOUSING
26. GEARCASE HOUSING
27. DRUM
28. DRAINPLUG (UNDERSIDE OF
GEARCASE HOUSING)
29. WORMSHAFT (INPUT)
30. TIE ROD
31. REAR CHANNEL

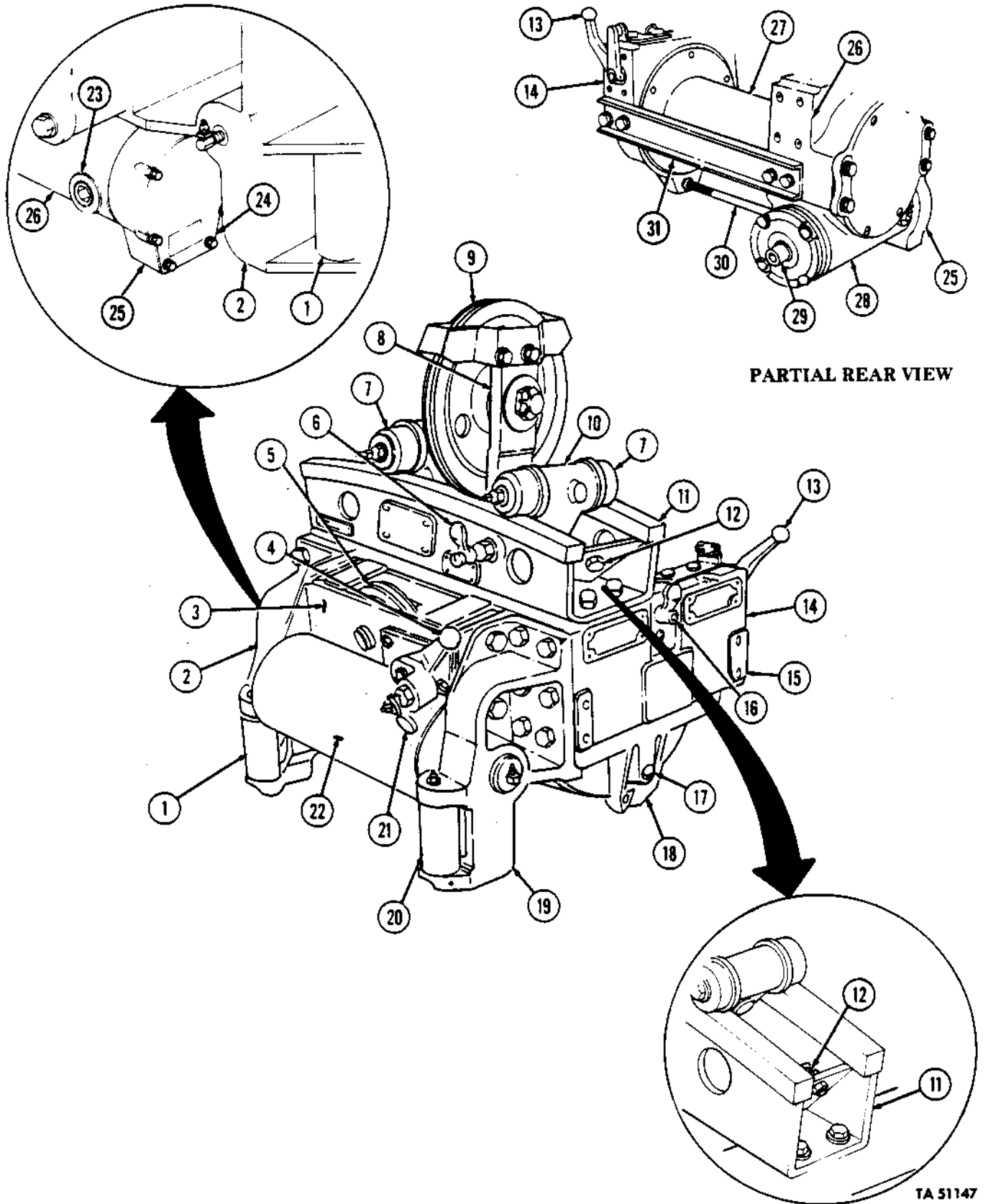

PARTIAL REAR VIEW

TA 51147

Figure 3-1. Front Winch Assembly With Level Wind and Cable Tensioner.

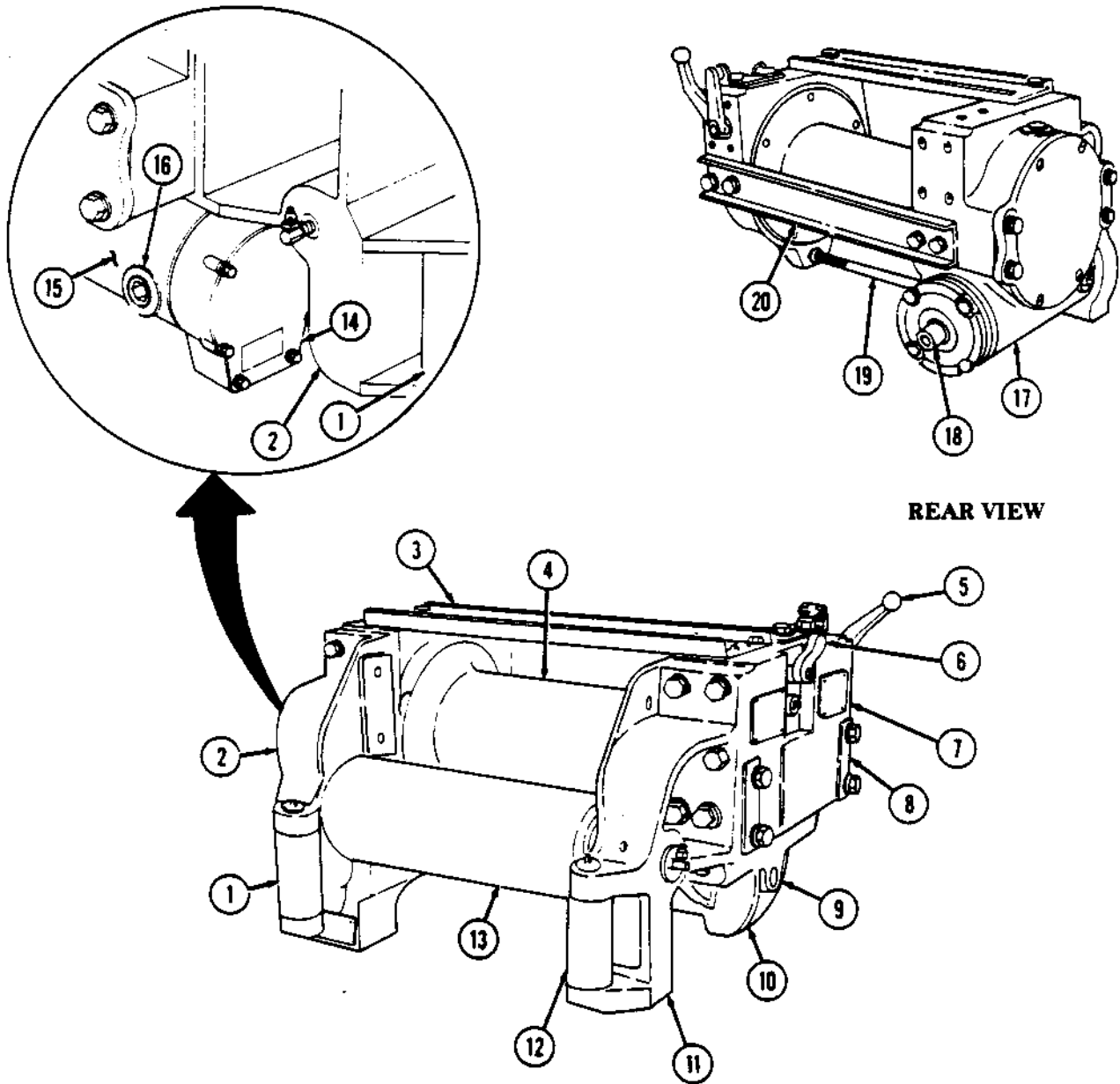

REAR VIEW

KEY Figure 3-2.

- | | |
|---|---|
| <ul style="list-style-type: none"> 1. RIGHT SIDE ROLLER 2. RIGHT ROLLER BRACKET 3. TOP CHANNEL 4. DRUM 5. MANUAL CLUTCH HANDLE 6. DRUM LOCK 7. END FRAME HOUSING 8. END FRAME OIL FILLER PLUG (REAR OF END FRAME) 9. DRAG BRAKE ADJUSTMENT (UNDER PIPE PLUG) 10. DRAINPLUG (UNDERSIDE OF END FRAME) | <ul style="list-style-type: none"> 11. LEFT ROLLER BRACKET 12. LEFT SIDE ROLLER 13. HORIZONTAL ROLLER 14. AUTOMATIC BRAKE ADJUSTMENT (INNER SIDE OF HOUSING) 15. GEARCASE HOUSING 16. GEARCASE OIL FILLER PLUG 17. DRAINPLUG (UNDERSIDE OF GEARCASE HOUSING) 18. WORMSHAFT (INPUT) 19. TIE ROD 20. REAR CHANNEL |
|---|---|

TA 51148

Figure 3-2. Front Winch Assembly Without Level Wind or Cable Tensioner.

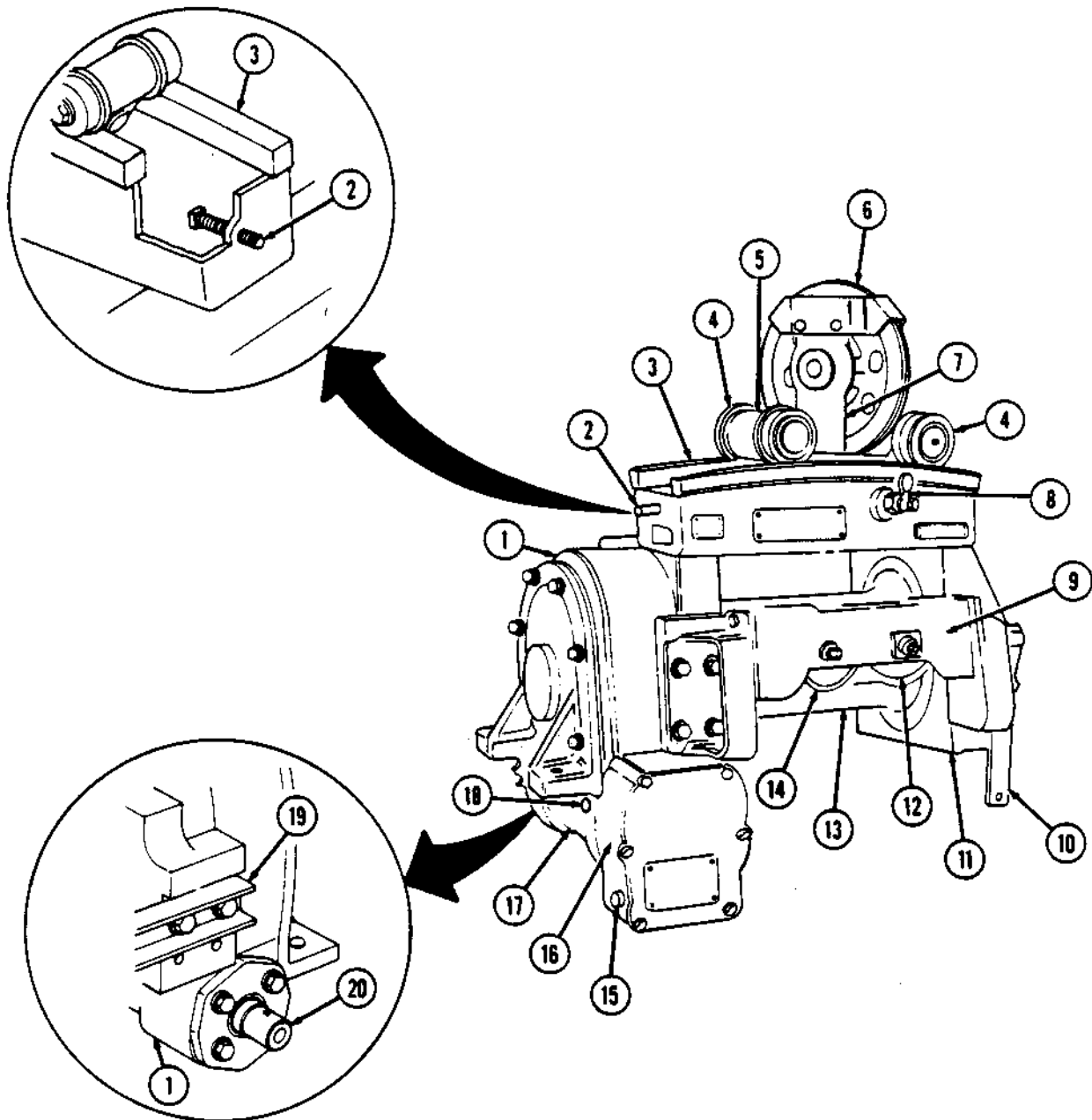
**KEY Figure 3-3.**

- | | | | |
|-----|-----------------------|-----|----------------------------------|
| 1. | GEARCASE HOUSING | 12. | TENSIONER SHEAVE (MOVABLE) |
| 2. | TROLLEY STOPSCREW (2) | 13. | DRUM |
| 3. | TROLLEY TRACK | 14. | TENSIONER SHEAVE (FIXED) |
| 4. | TROLLEY WHEEL (4) | 15. | AUTOMATIC BRAKE ADJUSTMENT |
| 5. | TROLLEY FRAME | 16. | AUTOMATIC BRAKE HOUSING |
| 6. | LEVEL WIND SHEAVE | 17. | DRAINPLUG (UNDERSIDE OF HOUSING) |
| 7. | SWIVEL FRAME | 18. | GEARCASE OIL FILLER PLUG |
| 8. | TROLLEY LOCK | 19. | REAR CHANNEL |
| 9. | TENSIONER FRAME | 20. | WORMSHAFT (INPUT) |
| 10. | TENSIONER LEVER | | |
| 11. | END FRAME | | |

TA 51149

Figure 3-3. Rear Winch Assembly With Level Wind and Cable Tensioner.

Table 3-2. Preshop Analysis Checklist.

PRESHOP ANALYSIS CHECKLIST

NOM _____ NSN _____

SERIAL # _____ INSPECTOR _____ DATE _____

PARA. NO.	TEST/INSPECTION POINT	CONDITION/DIMENSIONS FOUND	RECOMMENDED MAINTENANCE ACTION	SIGNATURE AND DATE OF PERSON PERFORMING ANALYSIS
1.	Shipping and maintenance records check			
2.	General external inspection			
a.	Winch assembly			
b.	Winch assembly			
c.	Roller assembly (if equipped)			
d.	Tensioner assembly (if equipped)			
e.	Level wind assembly (if equipped)			
f.	Lubricant leakage			

*Refer to table 3-1 for description of test.

Table 3-2. Preshop Analysis Checklist (Contd).

PARA. NO.	TEST/INSPECTION POINT	CONDITION/DIMENSIONS FOUND	RECOMMENDED MAINTENANCE ACTION	SIGNATURE AND DATE OF PERSON PERFORMING ANALYSIS
3.	Winch assembly manual operational test			
a.	Input shaft and bearings			
b.	Drum clutch, drum lock, and drum			
c.	Tensioner (front winch)			
d.	Level wind and track (if equipped)			
e.	Side and horizontal rollers (front winch)			
f.	Input shaft and automatic brake			
g.	Tensioner (rear winch)			
4.	Lubricant (oil)			
5.	Power test functional winch assembly			

*Refer to table 3-1 for description of test.

3-7. TEMPORARY PRESERVATION AND STORAGE.

Temporary preservation and storage will be accomplished following standard depot procedures.

Section IV. IN-PROCESS INSPECTION

NOTE

- All components subjected to magnetic particle inspection shall be demagnetized prior to assembly.
- All components subjected to dye penetrant inspection shall be cleaned after inspection. Coat part with preservative oil as required.

3-8. GENERAL COMPONENT INSPECTION.

Measurements are used to confirm the serviceability of items after a visual inspection. Measurements will be performed as required by depot quality assurance, in-process inspection, overhaul inspection procedures, and Final Inspection Record (F.I.R.). For further details, refer to chapter 5.

3-9. NEW COMPONENT INSPECTION.

Measurements are used to confirm the serviceability of items after a visual inspection. Measurements will be performed as required by depot quality assurance, in-process inspection, overhaul inspection procedures, and Final Inspection Record (F.I.R.). For further details, refer to chapter 5.

3-10. USED COMPONENT INSPECTION.

a. Used components and refinished parts recovered as products of disassembly will be examined 100 percent to determine serviceability.

b. An Overhaul Inspection Procedure (OIP) has been prepared for each part or component with specified wear limits, performance requirements, or fatigue characteristics which may cause part failure. Every part for which an OIP has been written will be subjected to the serviceability inspection standard (item 1 on every OIP).

c. Requirement to perform measurements listed in the OIP's will be based on results of visual inspection in instances where interference fits are involved, such as next higher assembly components where the fit of mating parts is obviously satisfactory.

d. Except as noted in some OIP's, visual inspection for cracks is authorized as an alternative to magnetic particle or dye penetrant inspection. If, as a result of visual inspection, there is doubt as to part serviceability, the technical inspection will be performed.

e. Bearings mounted on shafts or gear hubs and bearing races mounted in gear or hub bores, with interference fits that can be visually inspected to determine serviceability, will not be removed to obtain particular measurements listed in the OIP's.

3-10. USED COMPONENT INSPECTION (Contd).

f. Bushing-type bearings mounted in component parts that can be visually inspected and the inside diameter measurement made, will not be removed for outside diameter measurement of bushings or inside diameter measurement of bushing bores.

g. Gear and spline teeth may have minor nicks, burrs, and scoring removed using a fine mill file or fine emery cloth. Welding, grinding, machining, plating, etc. of gear and spline teeth to correct defects is not authorized.

h. Parts showing evidence of overheating are unreparable by any process. These parts will be discarded.

i. Repaired components will be inspected to OIP's and/or drawings, as applicable.

j. Surface corrosion may be removed using crocus cloth. Rust and corrosion resulting in pitting of sealing, bushing, bearing, or polished contact surfaces will be carefully inspected to serviceability standards of OIP's.

3-11. REPAIRED COMPONENT INSPECTION.

a. Methods of repair/rework shall be inspected to ensure that they are in accordance with specifications and this DMWR.

b. Repaired/reworked components will be inspected to OIP's and/or drawings, as applicable.

3-12. TOLERANCES, WEAR LIMITS, CORROSION LIMITS, TORQUE VALUES, AND ADJUSTMENTS.

a. Torque Specifications.

(1) Special torque specifications are given in text, as applicable.

(2) Standard capscrew markings and torque specifications are found in appendix D.

NOTE

Metric equivalents will be in parenthesis following the U.S. Customary System (example, "Tighten oil pump mounting bolts 33-40 lb-ft (45-54 N·m)").

b. Fits and Tolerances. Tolerances, torque values, and adjustments are provided in the text for each task to which they apply and appendix D.

Section V. REMOVAL OF MAJOR ASSEMBLIES

3-13. GENERAL.

For removal of major assemblies from front and rear winches, refer to paragraph 3-2.

Section VI. DISASSEMBLY

3-14. GENERAL.

a. This section contains instructions for preliminary steps prior to disassembly of the winches. Proper equipment, as listed in chapter 2, table 2-1, must be available before starting disassembly.

b. Take care in handling parts during disassembly. Nicks, scratches, or other damage caused by careless handling may cause subsequent failure of equipment.

c. Matched, married, and mated items (examples: bearings and races, covers and housings, and some gear sets) should be fastened together or otherwise identified as being parts that must be processed together. If one part fails inspection, both parts must be replaced as a set.

3-15. SPECIAL TOOLS AND EQUIPMENT.

- a. There are no additional tools required for this overhaul.
- b. Inspection and test equipment required to overhaul the winches are listed in table 2-1.

3-16. SPECIAL PROCESSES.

a. Special processes and equipment required for overhaul operations, as specified in this DMWR, are defined or referenced at the point of their application. When any of the special processes listed are required, the overhaul activity (when requested) shall provide evidence of compliance with controlling specifications.

b. **Phosphate Coating.** TT-C-490, Cleaning Methods for Ferrous Surfaces and Pretreatment for Organic Coatings, type I, describes a process for applying a light phosphate coating on ferrous metal to provide corrosion protection when paint will not be applied.

c. **Chemical Conversion Films for Aluminum and Aluminum Alloys.** The process described in MIL-C-5541, Chemical Conversion Coatings on Aluminum and Aluminum Alloys, type I, is used as a touch-up for damaged anodized coating. MIL-A-8625, Anodic Coating for Aluminum and Aluminum Alloys, is used for aluminum and aluminum alloys, or as a paint base. MIL-C-5541 is not suitable for interiors of oil-filled castings.

d. **Cadmium Plating.** The process described in QQ-P-416, Plating, Cadmium (Electrodeposited), is used in plating nuts, bolts, etc.

e. **Anodized Coating for Aluminum and Aluminum Alloys.** The process described in MIL-A-8625 is used as specified by part drawings.

f. **Liquid Penetrant Inspection.** The process described in MIL-STD-6866, Inspection, Penetrant, Method of, is followed when using fluorescent or visible dye, to detect cracks, flaws, etc., open to the surface of any nonporous metal.

g. **Magnetic Particle Inspection.** The process described in MIL-STD-1949, Inspection Process, Magnetic Particle, is used to detect cracks, etc., at or below the surface of ferrous (ferromagnetic) metals.

h. **Other Special Processes.** Parts beyond wear limit tolerances, broken, cracked, or otherwise damaged, may be considered for repair by special processes listed below and by requesting approval from Research and Engineering, TACOM. In requesting approval, the overhaul activity will furnish:

- (1) Written repair procedure.
- (2) Specifications covering the procedure.
- (3) Referenced drawing.
- (4) Samples (when requested) of parts repaired by the applicable process listed.

(a) Chrome plate, class 2, per QQ-C-320, Chrome Plating (Electrodeposited). A film 0.002 to 0.015 in. (0.05-0.38 mm) thick after finish-machining to print dimensions and surface finish specified, may be used to repair damaged surfaces.

(b) Electroless nickel plating, per MIL-C-26074, Coatings, Electroless Nickel, Requirements for, may be used to correct undersize or oversize condition. After plating, parts must meet print dimensions and surface finish specified.

(c) It is permissible to impregnate structurally sound castings (that contain some porosity, including microporosity) that weep or sweat during hydrostatic or pneumatic pressure testing by utilizing one of the impregnation methods specified in MIL-I-13857, type I, Impregnation of Metal Casting and MIL-STD-276, Impregnation of Porous Nonferrous Metal Castings.

(d) Cast aluminum parts may be welded in approved areas before machining to add sufficient finish stock to repair cracks, fill sand holes, etc. Weld in accordance with MIL-W-8604, Welding, Fusion: Aluminum Alloys; Process and Performance of.

(e) Steel parts may be welded in approved areas before machining to add sufficient finish stock to repair cracks, flaws, etc. Weld in accordance with MIL-W-13773, Welding, Repair of Steel Castings (Other than Armor) Metal Arc, Manual. Use welding rod in accordance with MIL-STD-1261, Arc Welding Procedures for Constructional Steels, Class 1.

3-16. SPECIAL PROCESSES (Contd).

h. Other Special Processes (Contd).

(f) For static applications, spray metalizing, per MIL-W-6712, Wire Metalizing, may be used to repair steel or aluminum parts.

(g) Damaged internal threads may be repaired by installing threaded inserts, per MS33537, Insert, Screw Thread, Helical Coil, Coarse and Fine Thread, Standard Dimensions for, as stated in salvage rework drawings. Refer to section VII for restrictions.

(h) Peening, rolling, etc. may be used in accordance with salvage rework drawings.

3-17. DIAGNOSTIC, INSPECTION, AND TEST EQUIPMENT.

Diagnostic, inspection, and test equipment necessary for overhaul of the winch assemblies are listed in table 2-1.

3-18. DISASSEMBLY OF FRONT AND REAR WINCHES.

a. Disassemble front and rear winches. Refer to paragraph 3-2.

b. On front winches P/N 7411122 and 7411122-1, aluminum roller brackets, P/N 7409804 and 7409805, will be removed from equipment, inspected and, if serviceable, returned to stock. The cast aluminum roller brackets will be replaced with steel roller brackets P/N 7409804-1 and 7409805-1.

c. On front winches P/N 7412382 and 7412382-1, the plate P/N 11608776 (used on both left and right sides of winch), if defective, must be replaced with new J-shaped plate (P/N 1230666-1 and 1230666-2). New plates are installed with J-shaped brackets P/N 12300665-1 and 12300655-2 which replace brackets P/N 11608821-1 and 11608821-2. Old parts will be discarded.

3-19. CLEANING AND INSPECTION.

a. Cleaning.

WARNING

Drycleaning solvent is flammable and will not be used near open flame. A fire extinguisher will be kept nearby when drycleaning solvent is used. Use only in well-ventilated places. Failure to do this may result in injury to personnel.

(1) Refer to TM 9-247, Materials Used for Cleaning, Preserving, Abrading, and Cementing Ordnance Material and Related Materials Including Chemicals, for authorized cleaning materials.

NOTE

Do not separate or intermix matched, married, or mated, parts during cleaning operations. Refer to paragraph 3-14c.

(2) Remove all rust and surface scale using a wire brush, sand blast, grit blast, or other effective methods. Block all ports and mask machined surfaces of aluminum castings before using these cleaning methods in accordance with depot procedures.

(3) Clean all bearings in accordance with TM 9-214, Inspection, Care, and Maintenance of Antifriction Bearings.

3-19. CLEANING AND INSPECTION (Contd).

b. Inspection.

WARNING

Compressed air source will not exceed 30 psi (207 kPa). When cleaning with compressed air, eyeshields must be worn. Failure to wear eyeshields may result in injury to personnel.

- (1) Examine all oil and lubrication passages for obstruction. Remove all obstructions with compressed air or by working a wire back and forth through the passage and flushing it with drycleaning solvent.
- (2) Examine for damaged threads. Repair threads as required. Refer to paragraph 3-20d.
- (3) Examine machined surfaces for damage that could cause oil leakage or malfunction of the part. Remove small burrs and scratches with a fine mill file, fine grit emery cloth, or crocus cloth. Discard parts that are broken, burred, or damaged beyond repair.
- (4) Examine all antifriction bearings in accordance with TM 9-214. Replace all bearings and matching cones or races that do not meet inspection requirements.
- (5) Some parts may not look exactly like illustrations. Manufacturing methods may change part appearance, but parts are functionally the same.
- (6) Visual type inspection may be utilized in place of magnetic particle or dye penetrant as an initial inspection (unless otherwise indicated). Technical inspection is performed as a followup to visual inspection if serviceability of the part is in doubt.

OVERHAUL INSPECTION PROCEDURE

OIP - 7954482

ITEM: Frame, End

M39, M809, M939

NO.	REF LTR	CHARACTERISTIC	INSP METHOD	REQUISITE
1		Serviceability	Visual	Examine for nicks, burrs, scoring on machined surfaces, and damaged threads. None allowed after repair. Refer to section VII.
2	A	Inside diameter	Measure	3.253 in. (82.63 mm) diameter maximum.
3		Cracks, entire part	Visual/ Dye penetrant	None allowed. If cracks are suspect, perform dye penetrant inspection. Refer to para. 3-16f.

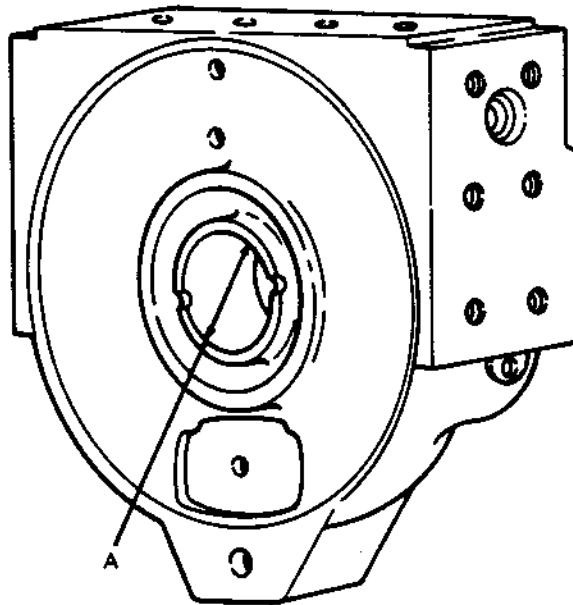
TA 51150
SHEET 1 OF 1

OVERHAUL INSPECTION PROCEDURE

OIP - 7409150

ITEM: Latch, Lock

M39, M809, M939

NO.	REF LTR	CHARACTERISTIC	INSP METHOD	REQUISITE
1		Serviceability	Visual	Examine for cracks and damaged lugs. None allowed.

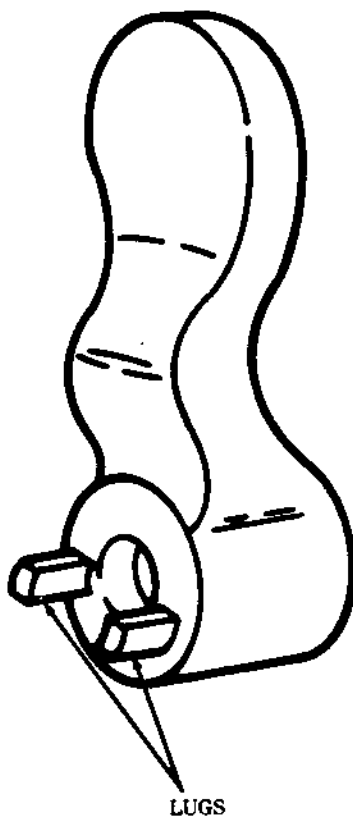

OVERHAUL INSPECTION PROCEDURE

OIP - 7538725/8344240

ITEM: Nut, Lock Poppet, Drum

M39, M809, M939

NO.	REF LTR	CHARACTERISTIC	INSP METHOD	REQUISITE
1		Serviceability	Visual	Examine for cracks and rounded hex and slots. None allowed. Examine for damaged threads. None allowed after repair. Refer to section VII.

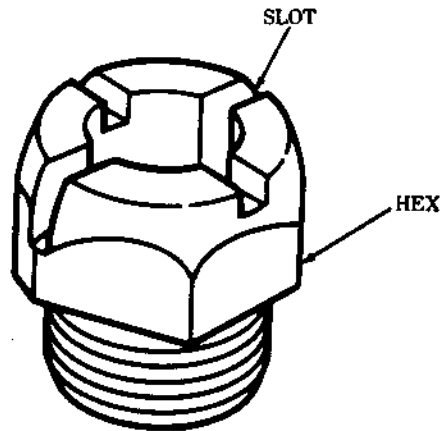

OVERHAUL INSPECTION PROCEDURE

OIP - 8723828

ITEM: Poppet, Drum Lock

M39, M809, M939

NO.	REF LTR	CHARACTERISTIC	INSP METHOD	REQUISITE
1		Serviceability	Visual	Examine for bends and cracks. None allowed. Examine for burrs, nicks, and damaged threads. None allowed after repair. Refer to section VII.

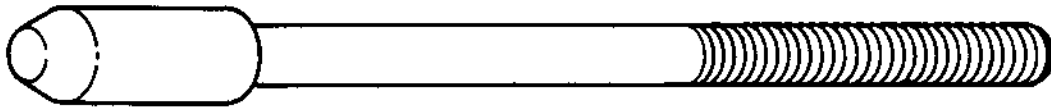

OVERHAUL INSPECTION PROCEDURE

OIP - 7017190

ITEM: Shaft, Shifter

M39, M809, M939

NO.	REF LTR	CHARACTERISTIC	INSP METHOD	REQUISITE
1		Serviceability	Visual	Examine for damaged keyways and bent and twisted shaft. None allowed. Examine for nicks, burrs, and scoring. None allowed after repair. Refer to section VII.
2	A	Outside diameter	Measure	0.748 in. (19.00 mm) diameter minimum.
3		Cracks, entire part	Visual/ Magnetic particle	None allowed. If cracks are suspect, perform magnetic particle inspection. Refer to para. 3-16g.

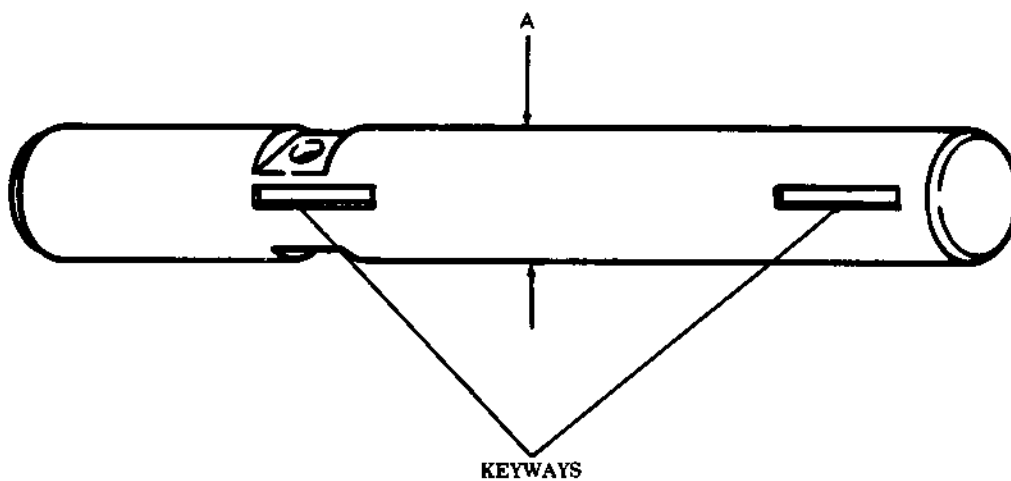
TA 51154
SHEET 1 OF 1

OVERHAUL INSPECTION PROCEDURE

OIP - 7017195

ITEM: Yoke, Clutch Shifter

M39, M809, M939

NO.	REF LTR	CHARACTERISTIC	INSP METHOD	REQUISITE
1		Serviceability	Visual	Examine for damaged keyway. None allowed. Examine for nicks, burrs, scoring on machined surfaces, and damaged threads. None allowed after repair. Refer to section VII.
2	A	Pin diameter	Measure	0.468 in. (11.89 mm) diameter minimum.
3	B	Distance between pins	Measure	2.968-3.032 in. (75.39-77.01 mm).
4		Cracks, entire part	Visual/ Magnetic particle	None allowed. If cracks are suspect, perform magnetic particle inspection. Refer to para. 3-16g.

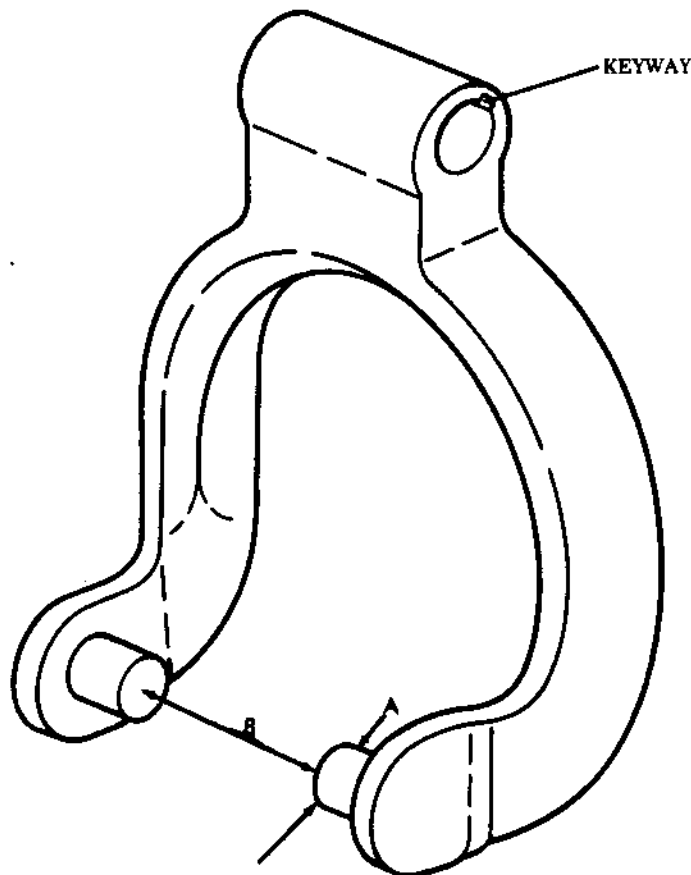

TA 51155
SHEET 1 OF 1

OVERHAUL INSPECTION PROCEDURE

OIP - 7409814

ITEM: Clutch, Sliding

M39, M809, M939

NO.	REF LTR	CHARACTERISTIC	INSP METHOD	REQUISITE
1		Serviceability	Visual	Examine for damaged lugs. None allowed. Examine for nicks, burrs, and scoring on machined surfaces. None allowed after repair. Refer to section VII.
2		Thrust bearing surface	Visual	No metal transfer or evidence of overheating.
3		Cracks, entire part	Visual/ Magnetic particle	None allowed. If cracks are suspect, perform magnetic particle inspection. Refer to para. 3-16g.

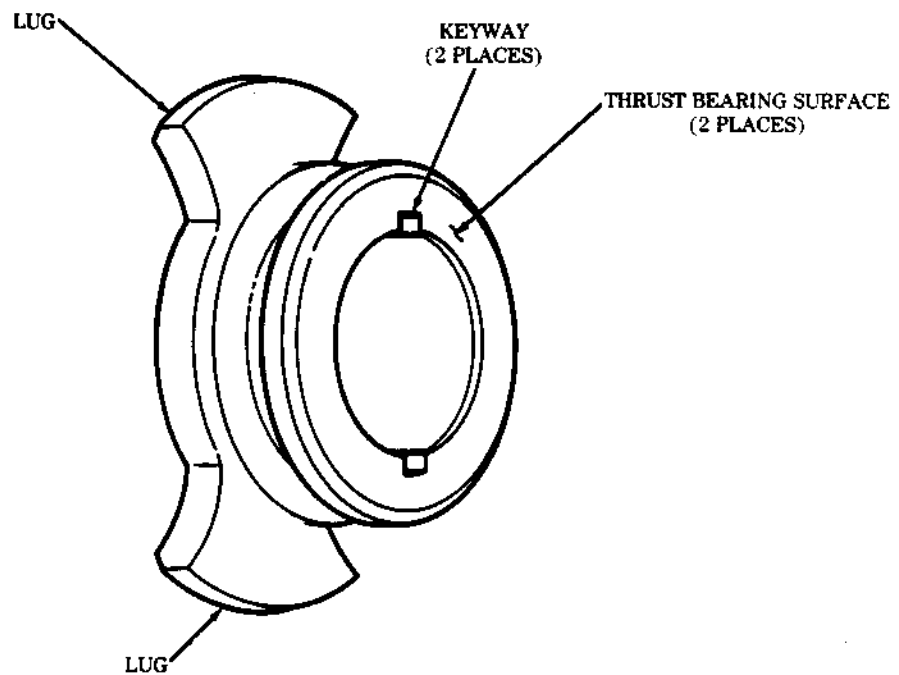
TA 51156
SHEET 1 OF 1

OVERHAUL INSPECTION PROCEDURE

OIP - 7954477/7409800

ITEM: Drum with Bushings

M39, M809, M939

NO.	REF LTR	CHARACTERISTIC	INSP METHOD	REQUISITE
1		Serviceability	Visual	Examine for nicks, burrs, scoring on machined surfaces and clutch engaging surfaces, broken welds, and damaged threads. None allowed after repair. Refer to section VII.
2		Bushing bore and thrust washer surfaces (both ends)	Visual	No metal transfer or evidence of overheating.
3	A	Inside diameter (bushings installed) (both ends)	Measure	2.131 in. (54.13 mm) diameter maximum.
4	B	Inside diameter (inspect only if bushings are rejected) (both ends)	Measure	2.376 in. (60.35 mm) diameter maximum.
5	C	Outside diameter (seal area)	Measure	5.872 in. (149.15 mm) diameter minimum.
6	D	Inside diameter (seal area)	Measure	4.377 in. (111.18 mm) diameter maximum.
7	E	Thrust face dimension	Measure	0.879 in. (22.30 mm) maximum.
8	F	Thrust face dimension	Measure	2.754 in. (69.95 mm) maximum.
9		Cracks, entire part	Visual/ Magnetic particle	None allowed. If cracks are suspect, perform magnetic particle inspection. Refer to para. 3-16g.

SHEET 1 OF 2

OVERHAUL INSPECTION PROCEDURE

OIP - 7954477/7409800

ITEM: Drum with Bushings

M39, M809, M939

THRUST WASHER SURFACE
(BOTH ENDS)

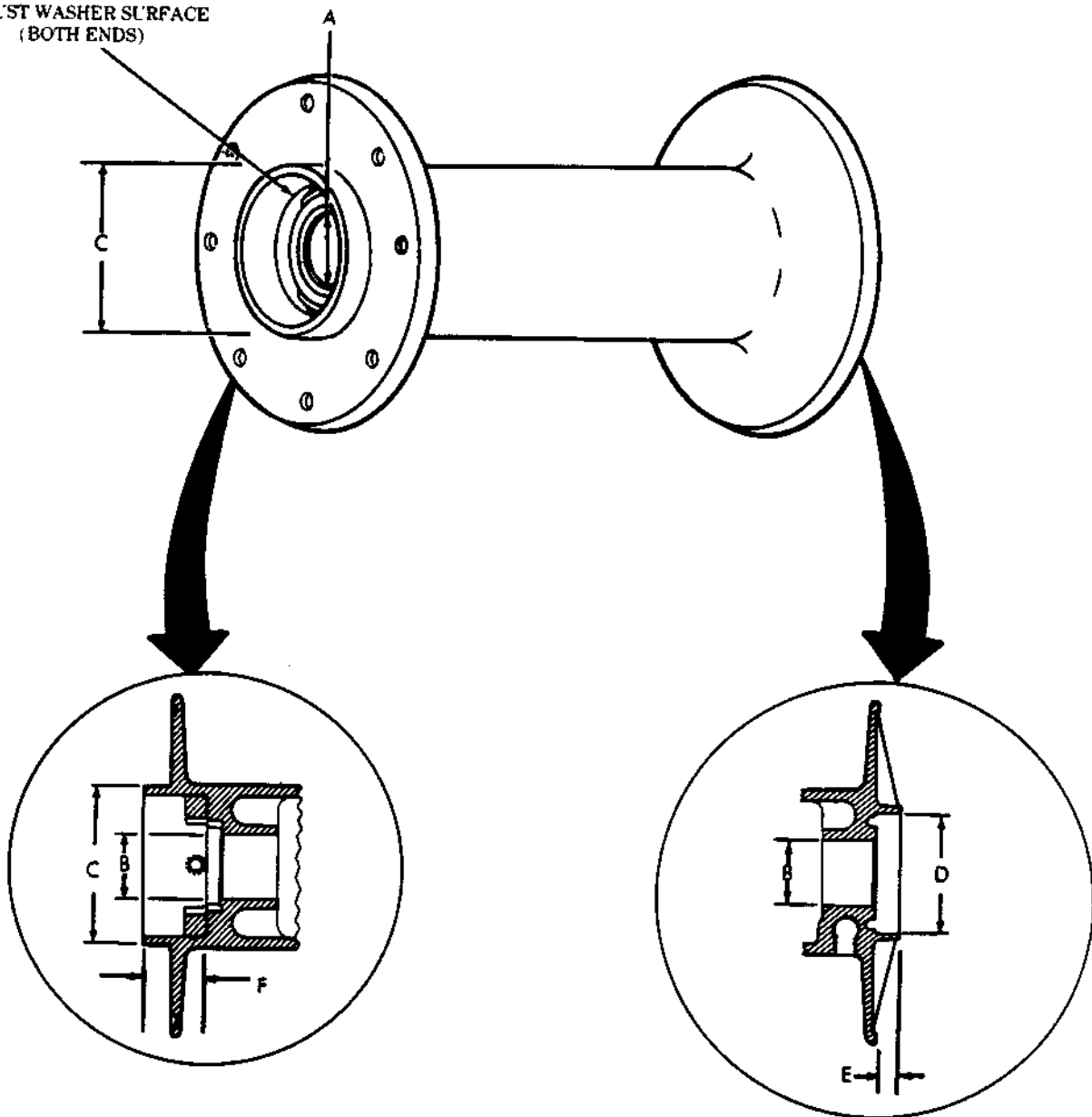

OVERHAUL INSPECTION PROCEDURE

OIP - 7954454/7409800

ITEM: Sleeve, End Bearing with Bushing

M39, M809, M939

NO.	REF LTR	CHARACTERISTIC	INSP METHOD	REQUISITE
1		Serviceability	Visual	Examine for cracks and damaged slot. None allowed. Examine for nicks, burrs, scoring on machined surfaces, and debris in oil passages. None allowed after repair. Refer to section VII.
2		Bushing	Visual	No metal transfer or evidence of overheating.
3	A	Inside diameter (bushing installed)	Measure	2.131 in. (54.13 mm) diameter maximum.
4	B	Inside diameter (inspect only if bushing is rejected)	Measure	2.376 in. (60.35 mm) diameter maximum.

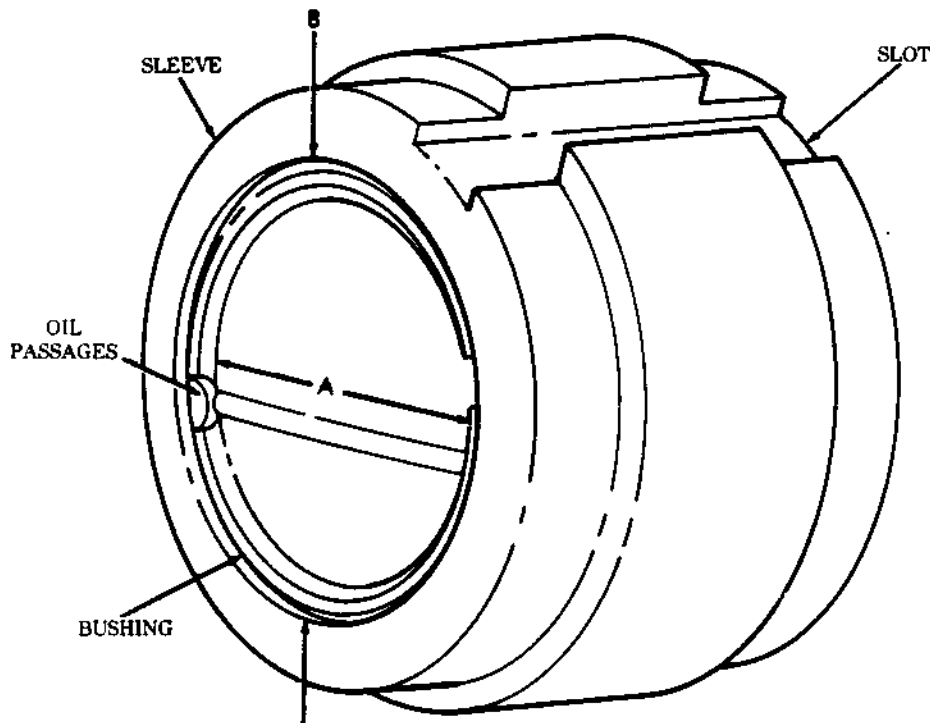

TA 51158
SHEET 1 OF 1

OVERHAUL INSPECTION PROCEDURE

OIP - 7954476/7409800

ITEM: Cover with Bushing, Gearcase

M39, M809, M939

NO.	REF LTR	CHARACTERISTIC	INSP METHOD	REQUISITE
1		Serviceability	Visual	Examine for nicks, burrs, scoring on machined surfaces, and debris in oil passage. None allowed after repair. Refer to section VII.
2		Bushing	Visual	No metal transfer or evidence of overheating.
3	A	Inside diameter (bushing installed)	Measure	2.131 in. (54.13 mm) diameter maximum.
4	B	Inside diameter (inspect only if bushing is rejected)	Measure	2.376 in. (60.35 mm) diameter maximum.
5		Cracks, entire part	Visual/ Dye penetrant	None allowed. If cracks are suspect, perform dye penetrant inspection. Refer to para. 3-16f.

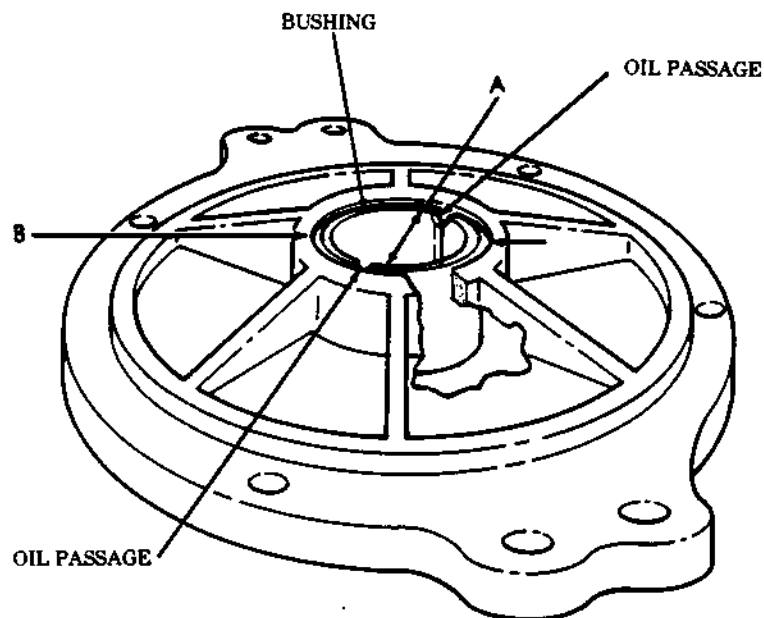

TA 51159
SHEET 1 OF 1

OVERHAUL INSPECTION PROCEDURE

OIP - 7409823

ITEM: Gear, Worm

M39, M809, M939

NO.	REF LTR	CHARACTERISTIC	INSP METHOD	REQUISITE
1		Serviceability	Visual	Examine for embedded particles, broken and chipped gear teeth, and damaged keyways. None allowed. Examine for nicks, burrs, pitting, and scoring. None allowed after repair. Refer to section VII.
2		Cracks, entire part	Visual/ Dye penetrant	None allowed. If cracks are suspect, perform dye penetrant inspection. Refer to para. 3-16f.

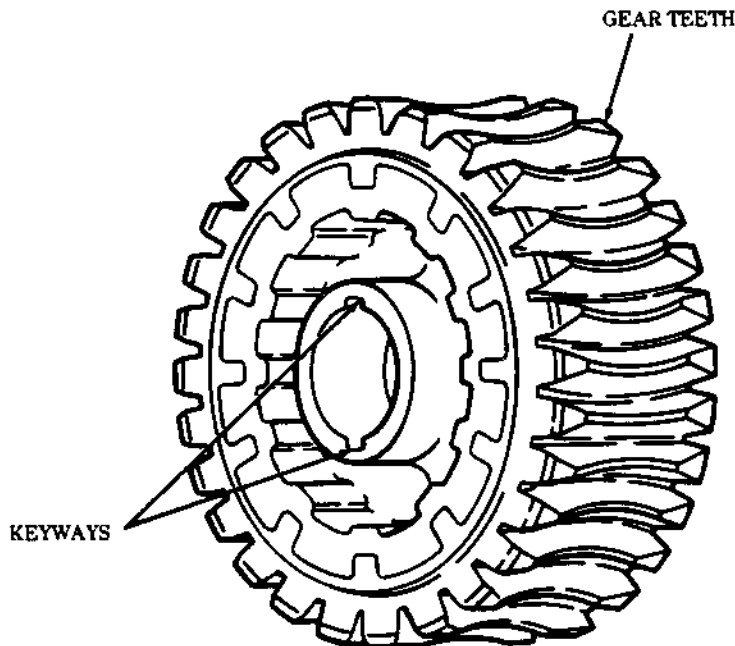

OVERHAUL INSPECTION PROCEDURE

OIP - 7954473

ITEM: Shaft, Drum

M39, M809, M939

NO.	REF LTR	CHARACTERISTIC	INSP METHOD	REQUISITE
1		Serviceability	Visual	Examine for bent or twisted shaft and damaged keyways. None allowed. Examine for nicks, burrs, and scoring. None allowed after repair. Refer to section VII.
2		Bushing surfaces (4 places)	Visual	No metal transfer or evidence of overheating.
3	A	Outside diameter (4 places)	Measure	2.123 in. (53.92 mm) diameter minimum.
4	B	Runout	Measure	0.003 in. (0.08 mm) maximum.
5		Cracks, entire part	Visual/ Magnetic particle	None allowed. If cracks are suspect, perform magnetic particle inspection. Refer to para. 3-16g.

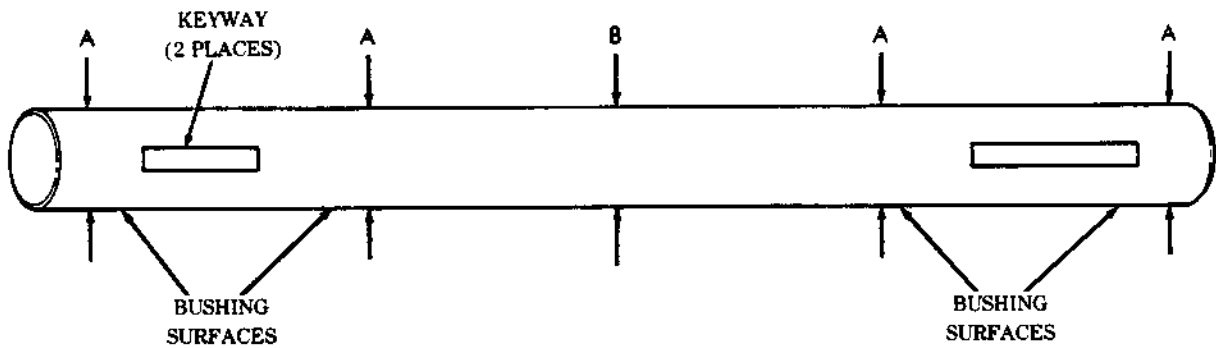

OVERHAUL INSPECTION PROCEDURE

OIP - 7954478

ITEM: Worm

M39, M809, M939

NO.	REF LTR	CHARACTERISTIC	INSP METHOD	REQUISITE
1		Serviceability	Visual	Examine for broken, burred, and chipped gear teeth and damaged keyway. None allowed. Examine for nicks, burrs, scoring, and pitting on machined surfaces, and damaged threads. None allowed after repair. Refer to section VII.
2		Bearing and sealing surfaces	Visual	No metal transfer or evidence of overheating.
3	A	Outside diameter (2 places)	Measure	1.765 in. (44.83 mm) diameter minimum.
4	B	Outside diameter (2 places)	Measure	1.7710 in. (44.983 mm) diameter minimum.
5	C	Diameter of worm (over three 0.5000 in. (12.7000 mm) diameter pins)	Measure	3.959 in. (100.56 mm) diameter minimum.
6		Cracks, entire part	Visual/ Magnetic particle	None allowed. If cracks are suspect, perform magnetic particle inspection. Refer to para. 3-16g.

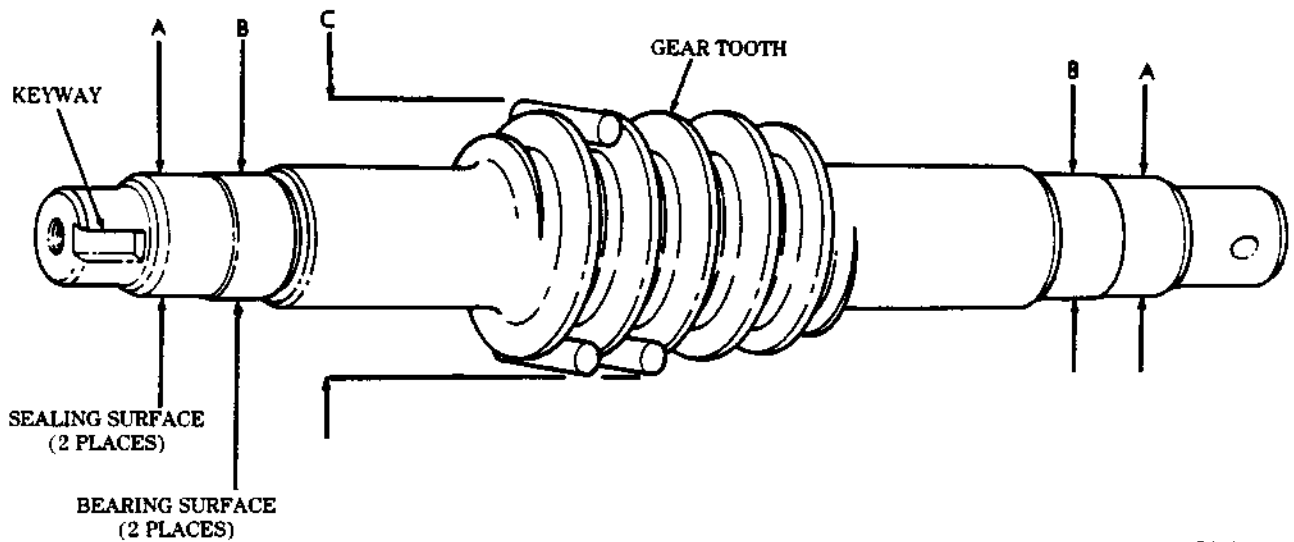

TA 51162
SHEET 1 OF 1

OVERHAUL INSPECTION PROCEDURE

OIP - 8331202

ITEM: Lock Assembly, Shifter

M39, M809, M939

NO.	REF LTR	CHARACTERISTIC	INSP METHOD	REQUISITE
1		Serviceability	Visual	Examine for breaks, bends, twists, and broken weld. None allowed.

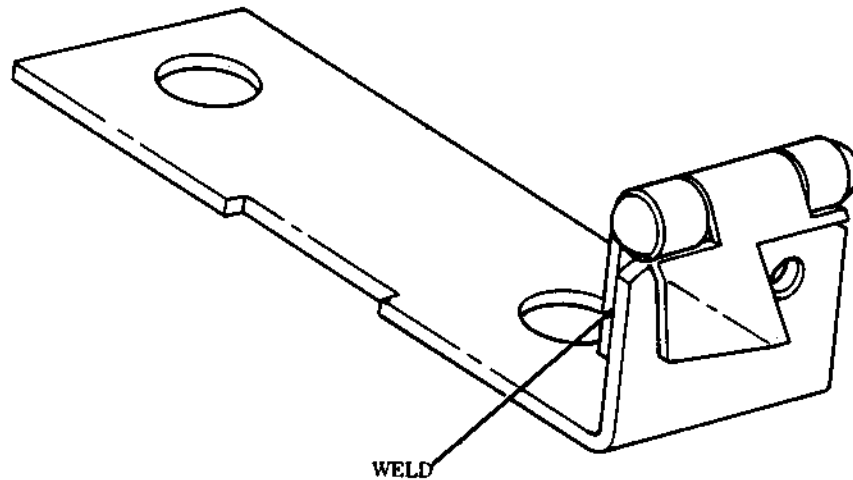
TA 51163
SHEET 1 OF 1

OVERHAUL INSPECTION PROCEDURE

OIP - 7954484/7409800

ITEM: Gearcase with Bushing

M39, M809, M939

NO.	REF LTR	CHARACTERISTIC	INSP METHOD	REQUISITE
1		Serviceability	Visual	Examine for nicks, burrs, scoring on machined surfaces, and damaged threads. None allowed after repair. Refer to section VII.
2		Bushing	Visual	No metal transfer or evidence of overheating.
3	A	Inside diameter (bushing installed)	Measure	2.131 in. (54.13 mm) diameter maximum.
4	B	Inside diameter (inspect only if bushing is rejected)	Measure	2.376 in. (60.35 mm) diameter maximum.
5	C	Inside diameter (both ends)	Measure	3.9370 in. (100.000 mm) diameter minimum.
6	D	Outside diameter (seal surface)	Measure	3.373 in. (85.67 mm) diameter minimum.
7		Cracks, entire part	Visual/ Dye penetrant	None allowed. If cracks are suspect, perform dye penetrant inspection. Refer to para. 3-16f.

OVERHAUL INSPECTION PROCEDURE

OIP - 7954484/7409800

ITEM: Gearcase with Bushing

M39, M809, M939

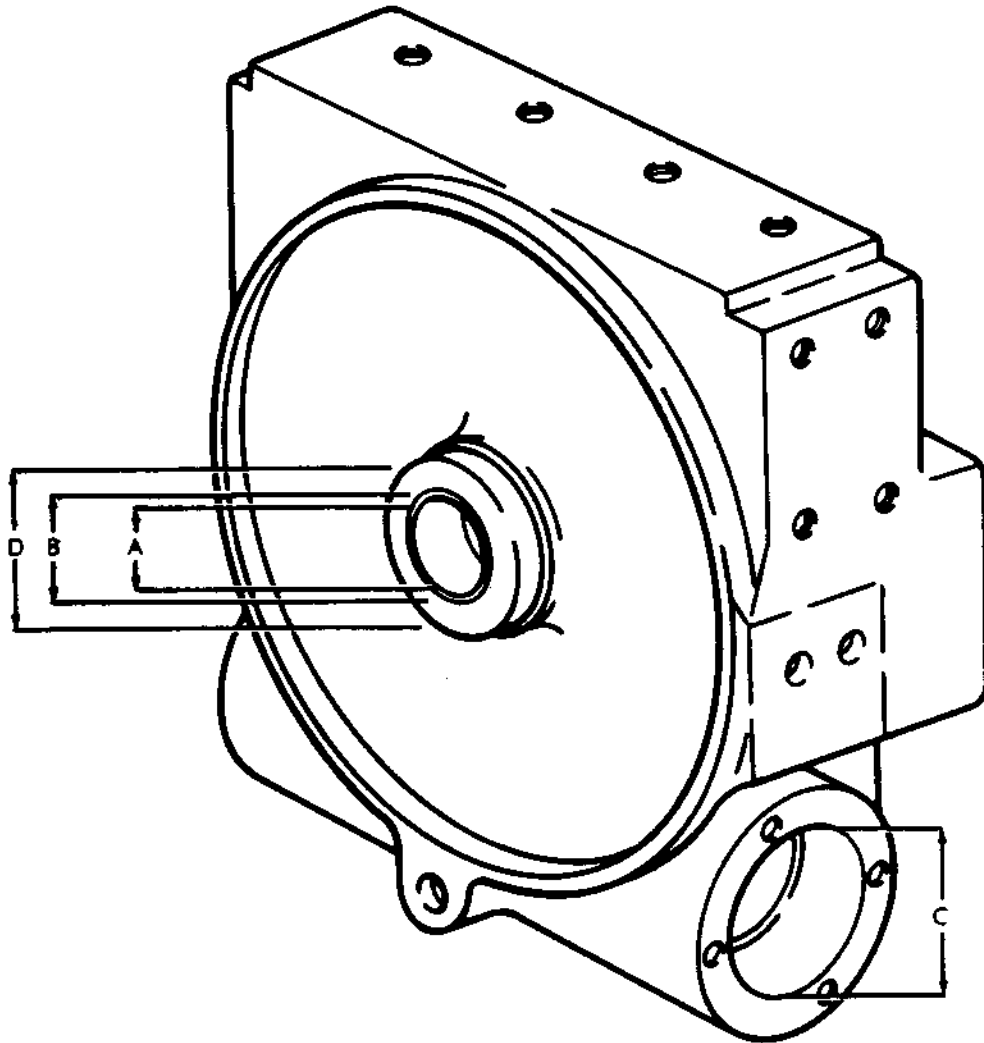

OVERHAUL INSPECTION PROCEDURE

OIP - 7409817

ITEM: Drum, Automatic Brake

M39, M809, M939

NO.	REF LTR	CHARACTERISTIC	INSP METHOD	REQUISITE
1		Serviceability	Visual	Examine for damaged keyway and scores in excess of 0.010 in. (0.25 mm) deep by 0.125 in. (3.18 mm) wide on brake band-to-drum contact surface; scoring in excess of 10% of contact surface area of drum. None allowed. Examine for pitting, nicks, burrs, and scoring on machined surfaces. None allowed after repair. Refer to section VII.
2	A	Outside diameter	Measure	4.992 in. (126.80 mm) diameter minimum.
3		Cracks, entire part	Visual/ Magnetic particle	None allowed. If cracks are suspect, perform magnetic particle inspection. Refer to para. 3-16g.

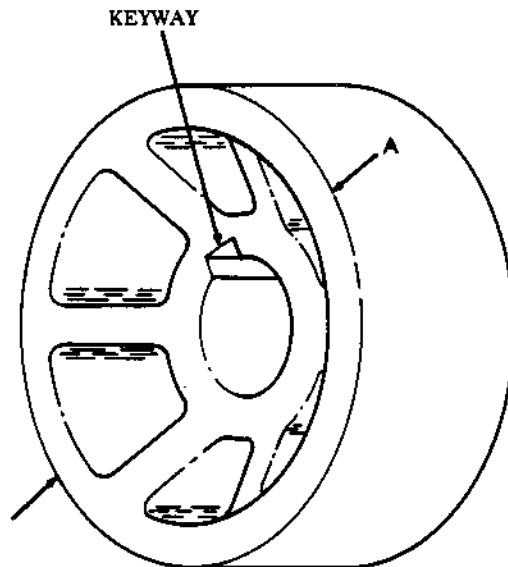

OVERHAUL INSPECTION PROCEDURE

ITEM: Case, Automatic Brake

OIP - 7954475

M39, M809, M939

NO.	REF LTR	CHARACTERISTIC	INSP METHOD	REQUISITE
1		Serviceability	Visual	Examine for breaks and cracks. None allowed. Examine for damaged threads. None allowed after repair. Refer to section VII.

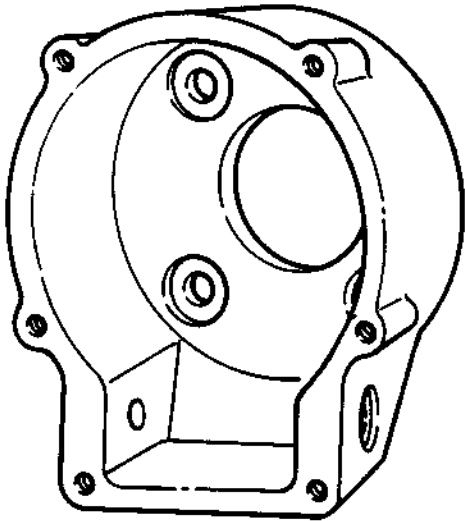

OVERHAUL INSPECTION PROCEDURE

OIP - 8344251

ITEM: Lever, Tensioner

M39, M809, M939

NO.	REF LTR	CHARACTERISTIC	INSP METHOD	REQUISITE
1		Serviceability	Visual	Examine for cracks and damaged keyway. None allowed. Examine for nicks, burrs, and damaged threads. None allowed after repair. Refer to section VII.

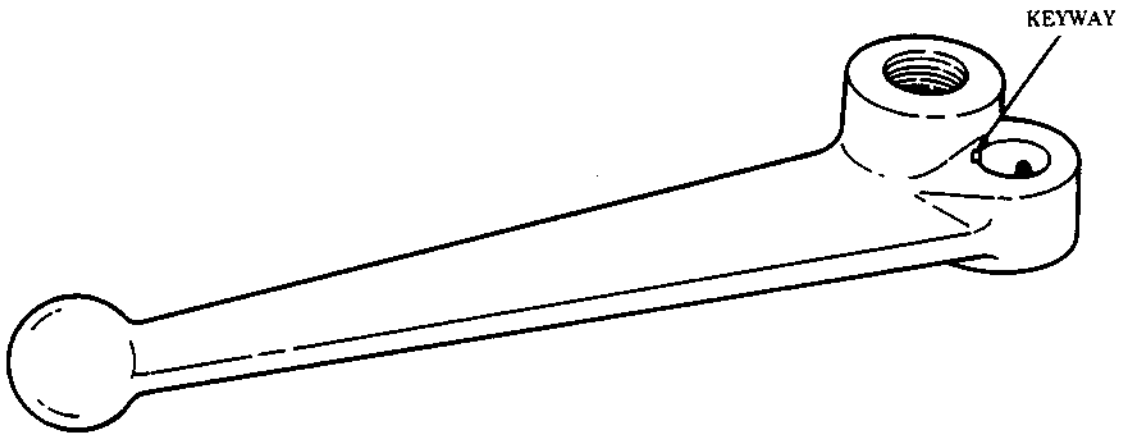

OVERHAUL INSPECTION PROCEDURE

OIP - 7411166

ITEM: Poppet, Tensioner

M39, M809, M939

NO.	REF LTR	CHARACTERISTIC	INSP METHOD	REQUISITE
1		Serviceability	Visual	Examine for bends and cracks. None allowed. Examine for burrs, nicks, and damaged threads. None allowed after repair. Refer to section VII.

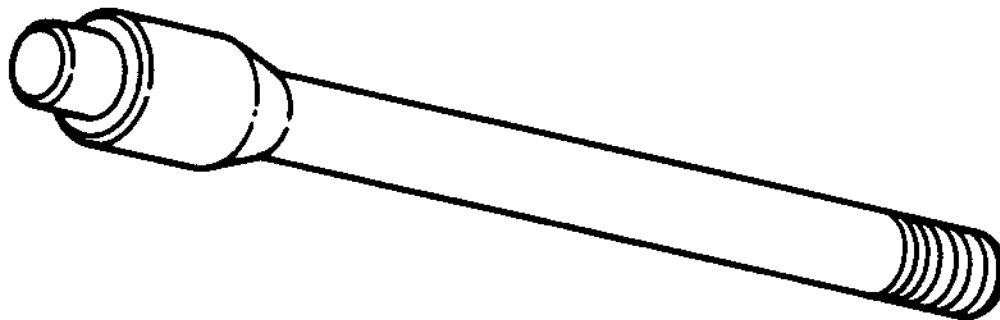

OVERHAUL INSPECTION PROCEDURE

OIP - 8344506/7411163

ITEM: Block Assembly, Bearing with Bushing

M39, M809, M939

NO.	REF LTR	CHARACTERISTIC	INSP METHOD	REQUISITE
1		Serviceability	Visual	Examine for cracks and distortion. None allowed. Examine for nicks and burrs. None allowed after repair. Refer to section VII.
2		Bushing	Visual	No metal transfer or evidence of overheating.
3	A	Inside diameter (bushing installed)	Measure	0.755 in. (19.18 mm) diameter maximum.
4	B	Inside diameter (inspect only if bushing is rejected)	Measure	1.0005 in. (25.413 mm) diameter maximum.

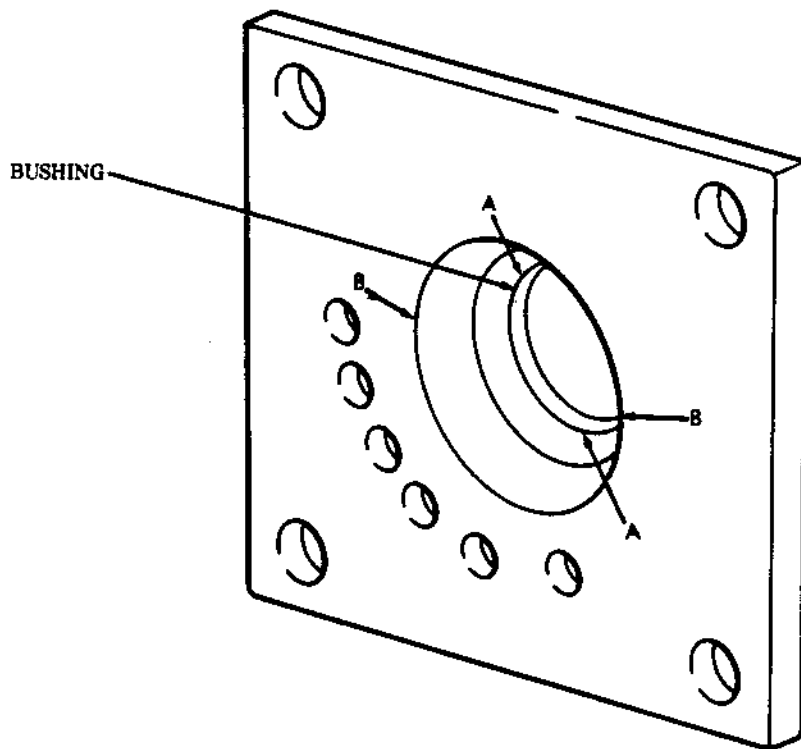

OVERHAUL INSPECTION PROCEDURE

OIP - 7994965

ITEM: Camshaft, Tensioner

M39, M809, M939

NO.	REF LTR	CHARACTERISTIC	INSP METHOD	REQUISITE
1		Serviceability	Visual	Examine for damaged keyway and corrosion. None allowed. Examine for nicks, burrs, scoring, rust, damaged threads, and debris in lubrication passage. None allowed after repair. Refer to section VII.
2	A	Outside diameter	Measure	0.9995 in. (25.387 mm) diameter minimum.
3	B	Outside diameter (2 places)	Measure	0.748 in. (19.00 mm) diameter minimum.
4		Cracks, entire part	Visual/ Magnetic particle	None allowed. If cracks are suspect, perform magnetic particle inspection. Refer to para. 3-16g.

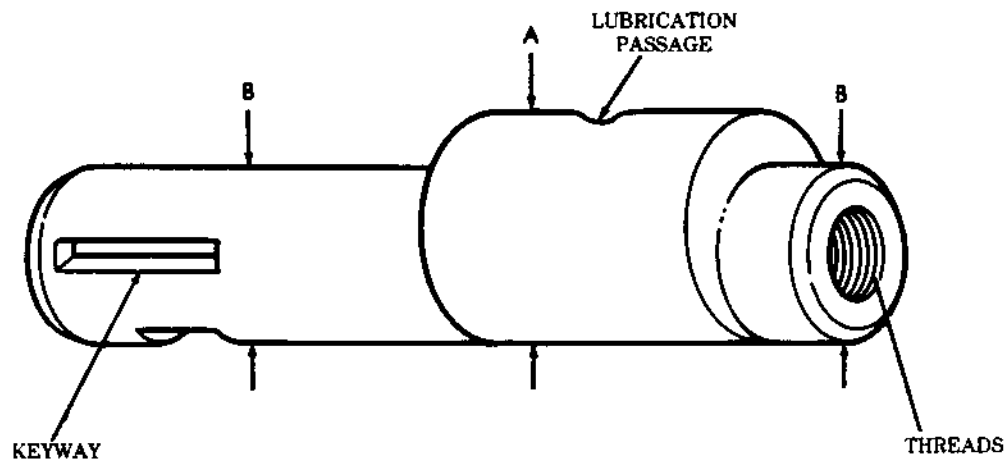
TA 51170
SHEET 1 OF 1

OVERHAUL INSPECTION PROCEDURE

OIP - 8344248/7411164

ITEM: Frame, Tensioner with Bushing

M39, M809, M939

NO.	REF LTR	CHARACTERISTIC	INSP METHOD	REQUISITE
1		Serviceability	Visual	Examine for nicks, burrs, damaged threads, and damaged and twisted areas. None allowed after repair. Refer to section VII.
2		Bushing	Visual	No metal transfer or evidence of overheating.
3	A	Inside diameter (bushing installed)	Measure	0.755 in. (19.18 mm) diameter maximum.
4	B	Inside diameter (inspect only if bushing is rejected)	Measure	1.0005 in. (25.413 mm) diameter maximum.
5		Cracks, entire part	Visual/ Magnetic particle	None allowed. If cracks are suspect, perform magnetic particle inspection. Refer to para. 3-16g.

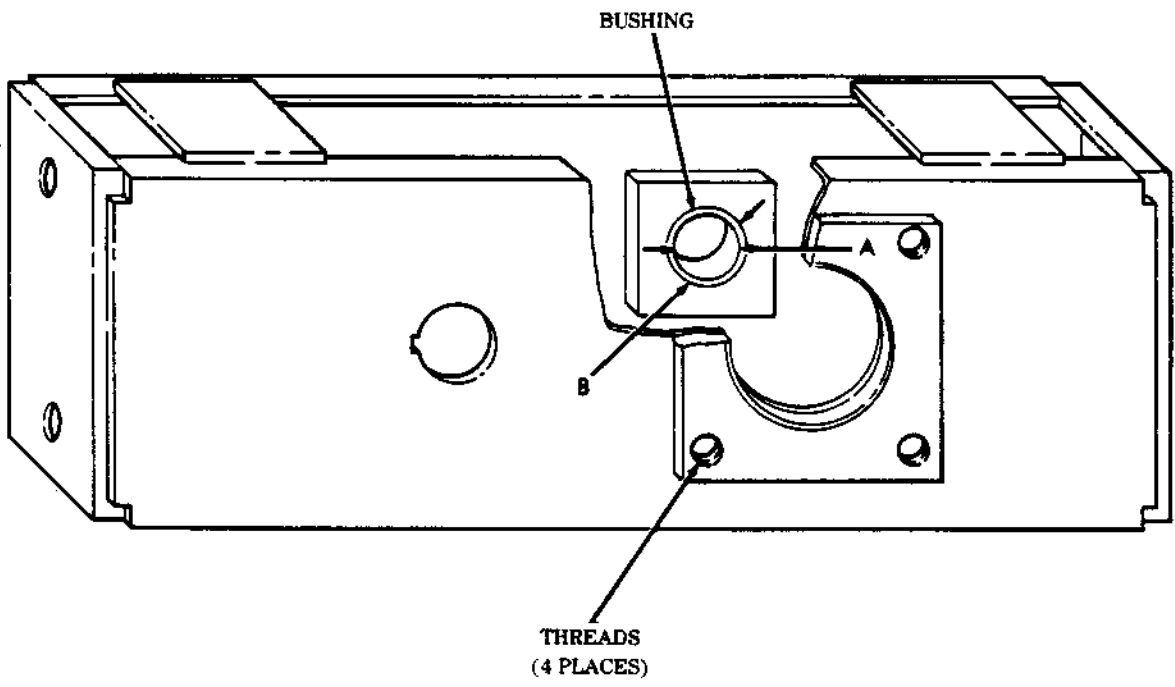

OVERHAUL INSPECTION PROCEDURE

OIP - 8344250

ITEM: Sheave, Tensioner (2)

M39, M809, M939

NO.	REF LTR	CHARACTERISTIC	INSP METHOD	REQUISITE
1		Serviceability	Visual	Examine for nicks, burrs, and scoring on machined surfaces. None allowed after repair. Refer to section VII.
2		Bearing and thrust washer surfaces	Visual	No metal transfer or evidence of overheating.
3	A	Inside diameter (inspect only if bearing is rejected)	Measure	1.4997 in. (38.092 mm) diameter maximum.
4	B	Groove diameter (over two 0.6250 in. (15.8750 mm) diameter pins)	Measure	5.630 in. (127.79 mm) diameter minimum.
5	C	Thickness	Measure	1.230 in. (31.24 mm) minimum.
6		Cracks, entire part	Visual/ Magnetic particle	None allowed. If cracks are suspect, perform magnetic particle inspection. Refer to para. 3-16g.

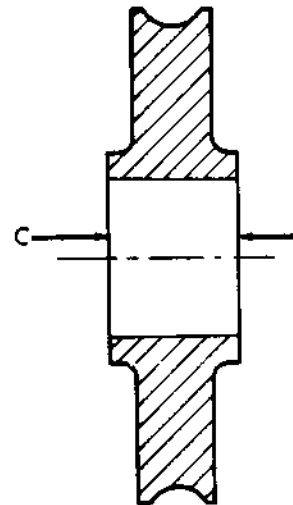
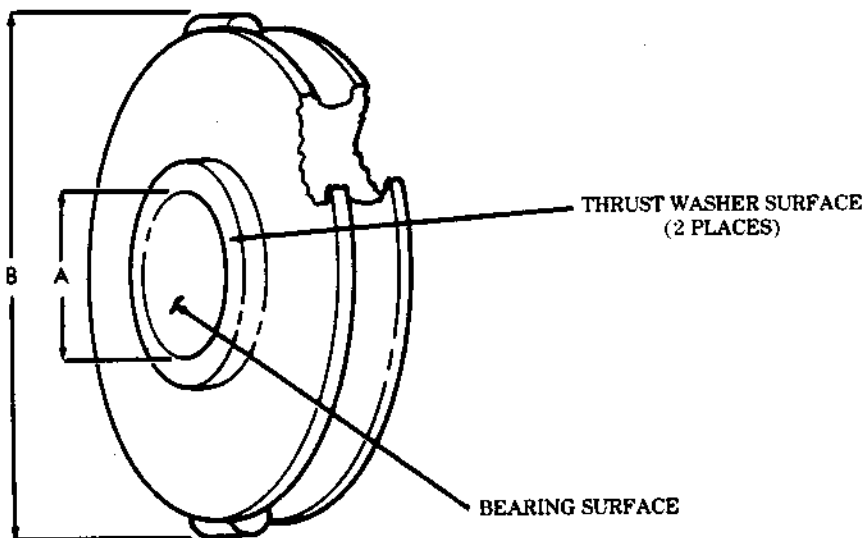

OVERHAUL INSPECTION PROCEDURE

OIP - 7411161/MS51838-147

ITEM: Pin, Tensioner, Roller Sheave
with Straight Pin

M39, M809, M939

NO.	REF LTR	CHARACTERISTIC	INSP METHOD	REQUISITE
1		Serviceability	Visual	Examine for distortion of straight pin and corrosion. None allowed. Examine for nicks, burrs, scoring, rust, and damaged threads. None allowed after repair. Refer to section VII.
2		Bearing surface	Visual	No metal transfer.
3	A	Outside diameter	Measure	0.9995 in. (25.387 mm) diameter minimum.
4		Cracks, entire part	Visual/ Magnetic particle	None allowed. If cracks are suspect, perform magnetic particle inspection. Refer to para. 3-16g.

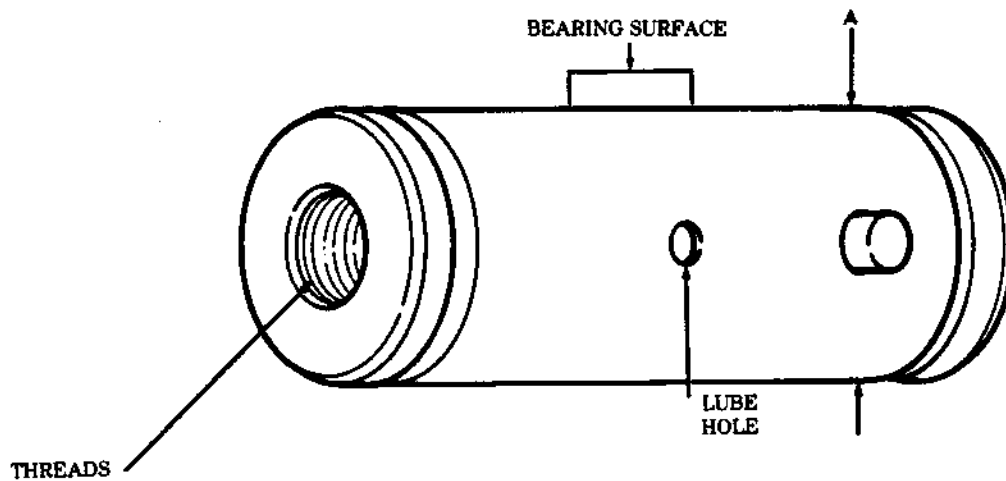

OVERHAUL INSPECTION PROCEDURE

OIP - 8741768

ITEM: Poppet, Trolley, Lock

M39, M809, M939

NO.	REF LTR	CHARACTERISTIC	INSP METHOD	REQUISITE
1		Serviceability	Visual	Examine for bends and cracks. None allowed. Examine for burrs, nicks, and damaged threads. None allowed after repair. Refer to section VII.

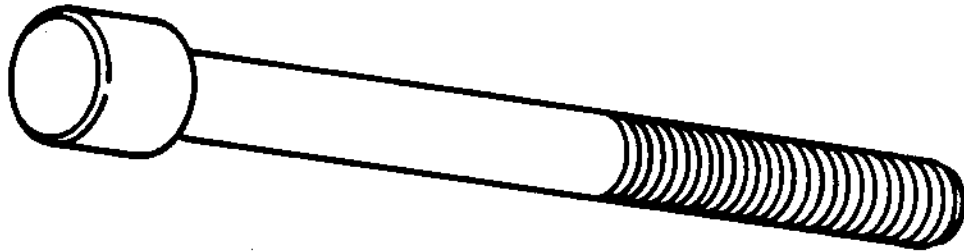

OVERHAUL INSPECTION PROCEDURE

OIP - 8344234

ITEM: Track Assembly, Trolley, Front

M39, M809, M939

NO.	REF LTR	CHARACTERISTIC	INSP METHOD	REQUISITE
1		Serviceability	Visual	Examine for cracks. None allowed. Examine for nicks and burrs on tracks, broken welds, and damaged threads. None allowed after repair. Refer to section VII.

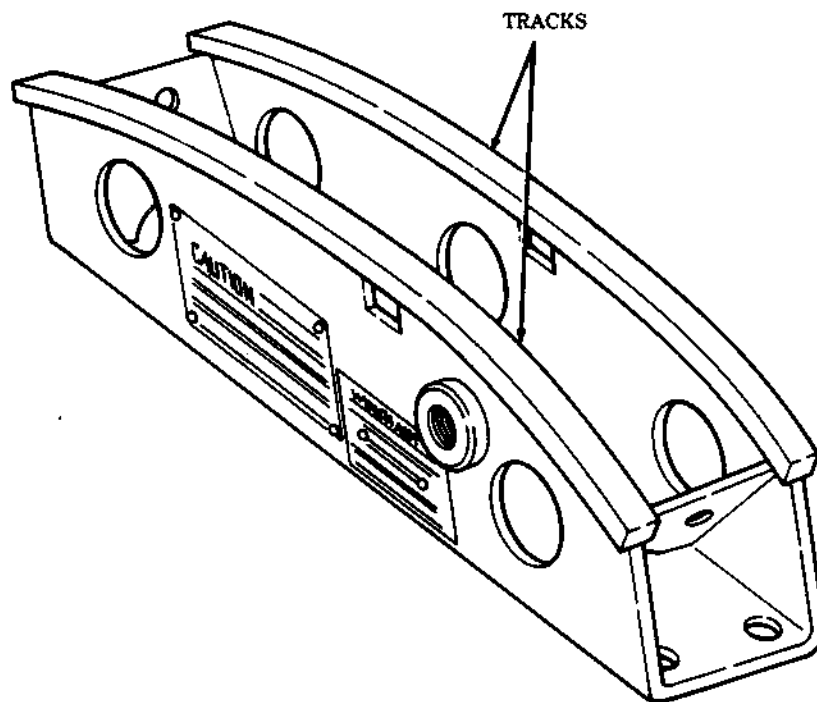

OVERHAUL INSPECTION PROCEDURE

OIP - 8344243

ITEM: Wheel, Trolley (4)

M39, M809, M939

NO.	REF LTR	CHARACTERISTIC	INSP METHOD	REQUISITE
1		Serviceability	Visual	Examine for cracks. None allowed. Examine for scoring on bearing bore, nicks, burrs, and flat spots on wheel to track surface. None allowed after repair. Refer to section VII.
2	A	Inside diameter	Measure	1.7497 in. (44.442 mm) diameter maximum.
3	B	Outside diameter	Measure	2.995 in. (76.07 mm) diameter minimum.

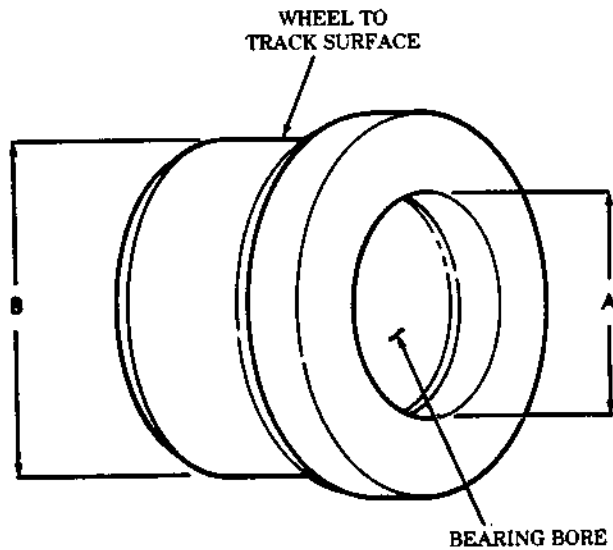

OVERHAUL INSPECTION PROCEDURE

M39, M809, M939

ITEM: Frame, Trolley with Axles

NO.	REF LTR	CHARACTERISTIC	INSP METHOD	REQUISITE
1		Serviceability	Visual	Examine for corrosion and loose shafts in bores. None allowed. Examine for nicks, burrs, scoring on machined surfaces, rust, damaged threads, and debris in lubrication passages. None allowed after repair. Refer to section VII.
2		Thrust washer and bearing contact surfaces		No metal transfer or evidence of overheating.
3	A	Inside diameter	Measure	1.2505 in. (31.763 mm) diameter maximum.
4	B	Outside diameter (4 places)	Measure	1.2495 in. (31.738 mm) diameter minimum.
5	C	Inside diameter	Measure	3.251 in. (82.58 mm) diameter maximum.
6		Cracks, entire part	Visual/ Magnetic particle	None allowed. If cracks are suspect, perform magnetic particle inspection. Refer to para. 3-16g.

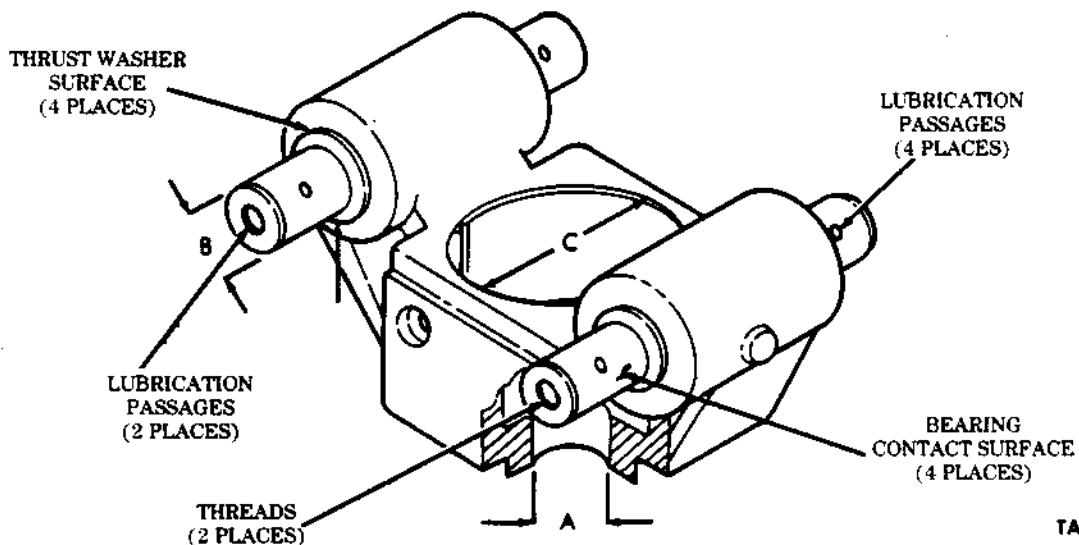

TA 51177

SHEET 1 OF 1

OVERHAUL INSPECTION PROCEDURE

OIP - 7994976/ 8344246

ITEM: Frame, Swivel Sheave with Extension

M39, M809, M939

NO.	REF LTR	CHARACTERISTIC	INSP METHOD	REQUISITE
1		Serviceability	Visual	Examine for corrosion. None allowed. Examine for nicks, burrs, scoring on machined surfaces, rust, damaged threads, and debris in lubrication passages. None allowed after repair. Refer to section VII.
2	A	Inside diameter (2 places)	Measure	1.502 in. (38.15 mm) diameter maximum.
3	B	Outside diameter	Measure	1.000 in. (25.40 mm) diameter minimum.
4	C	Outside diameter	Measure	2.987 in. (75.87 mm) diameter minimum.
5		Cracks, entire part	Visual/ Magnetic particle	None allowed. If cracks are suspect, perform magnetic particle inspection. Refer to para. 3-16g.

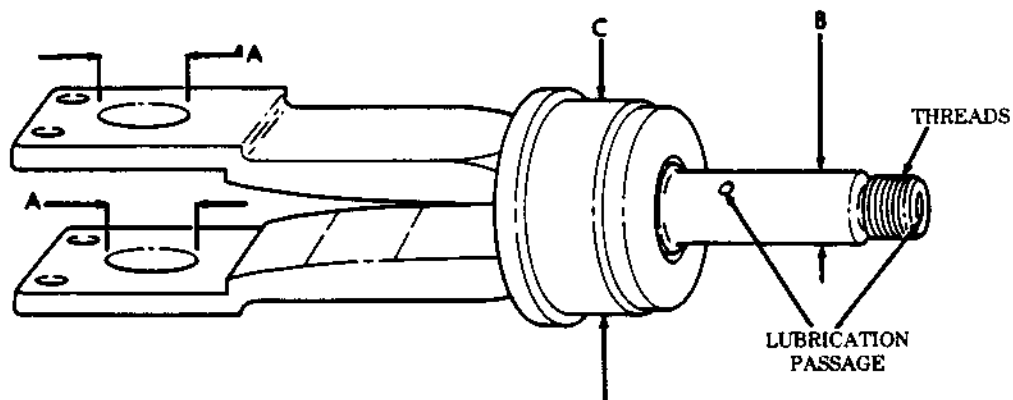

TA 51178
SHEET 1 OF 1

OVERHAUL INSPECTION PROCEDURE

OIP - 7411123

ITEM: Race, Ball Thrust, Inner (Upper)

M39, M809, M939

NO.	REF LTR	CHARACTERISTIC	INSP METHOD	REQUISITE
1		Serviceability	Visual	Examine for corrosion. None allowed. Examine for nicks, burrs, scoring, and rust. None allowed after repair. Refer to section VII.
2		Extension bore	Visual	No metal transfer.
3	A	Inside diameter	Measure	0.999 in. (25.37 mm) diameter maximum.
4	B	Groove depth (2 places)	Measure	0.310 in. (7.87 mm) minimum.
5		Cracks, entire part	Visual/ Magnetic particle	None allowed. If cracks are suspect, perform magnetic particle inspection. Refer to para. 3-16g.

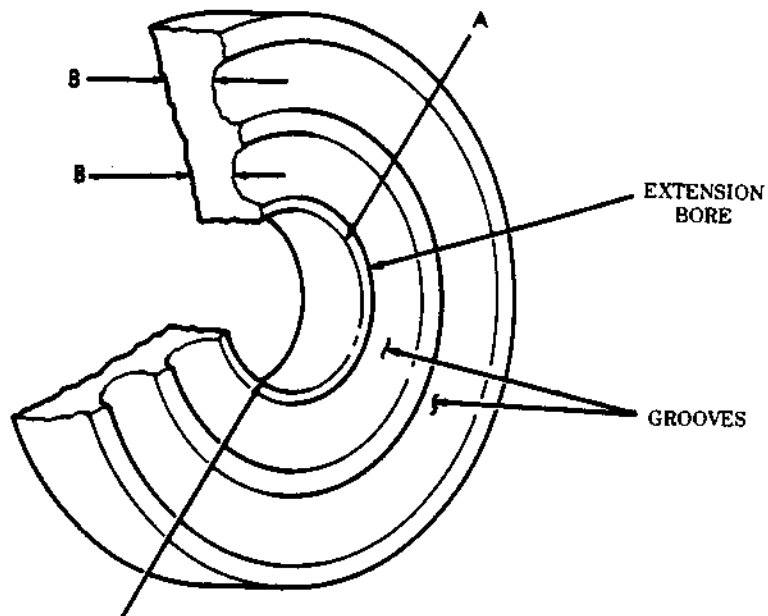

OVERHAUL INSPECTION PROCEDURE

OIP - MS19059-2422

ITEM: Ball, Bearing (26)

M39, M809, M939

NO.	REF LTR	CHARACTERISTIC	INSP METHOD	REQUISITE
1		Serviceability	Visual	Examine for cracks, nicks, burrs, galling, scoring, rust, and corrosion. None allowed.
2	A	Diameter	Measure	0.4995-0.5000 in. (12.687-12.700 mm) diameter minimum.

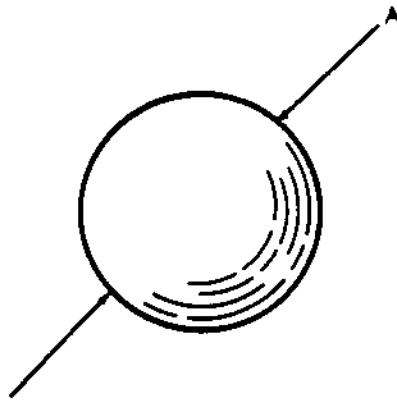
TA 51180
SHEET 1 OF 1

OVERHAUL INSPECTION PROCEDURE

OIP - 7411124

ITEM: Race, Ball Thrust, Outer (Lower)

M39, M809, M939

NO.	REF LTR	CHARACTERISTIC	INSP METHOD	REQUISITE
1		Serviceability	Visual	Examine for corrosion. None allowed. Examine for nicks, burrs, scoring, and rust. None allowed after repair.
2		Extension bore	Visual	No metal transfer.
3	A	Inside diameter	Measure	1.025 in. (26.04 mm) diameter maximum.
4	B	Groove depth (2 places)	Measure	0.310 in. (7.87 mm) minimum.
5		Cracks, entire part	Visual/ Magnetic particle	None allowed. If cracks are suspect, perform magnetic particle inspection. Refer to para. 3-16g.

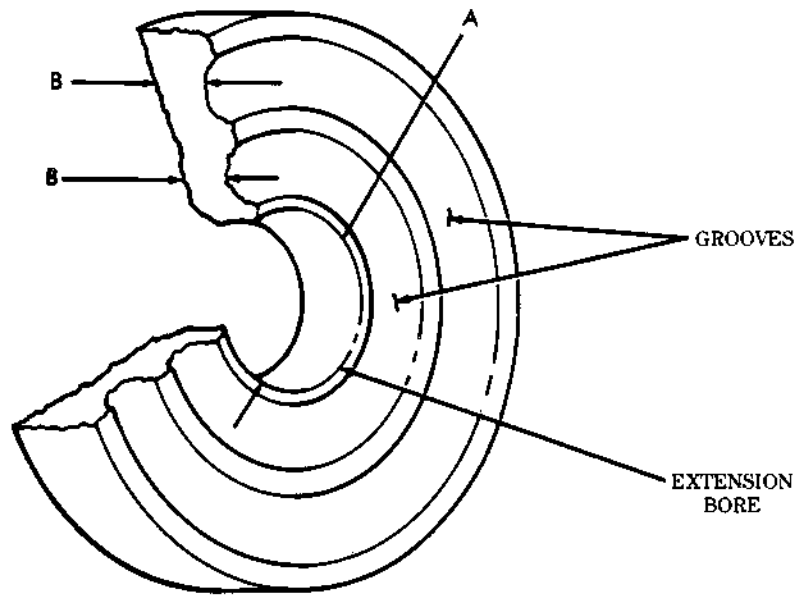

OVERHAUL INSPECTION PROCEDURE

OIP - 8344244

ITEM: Bolt, Swivel Sheave

M39, M809, M939

NO.	REF LTR	CHARACTERISTIC	INSP METHOD	REQUISITE
1		Serviceability	Visual	Examine for nicks, burrs, scoring, damaged threads, and debris in lubrication passages. None allowed after repair. Refer to section VII.
2		Bearing surface	Visual	No metal transfer or evidence of overheating.
3	A	Outside diameter	Measure	1.498 in. (38.05 mm) diameter minimum.
4		Cracks, entire part	Visual/ Magnetic particle	None allowed. If cracks are suspect, perform magnetic particle inspection. Refer to para. 3-16g.

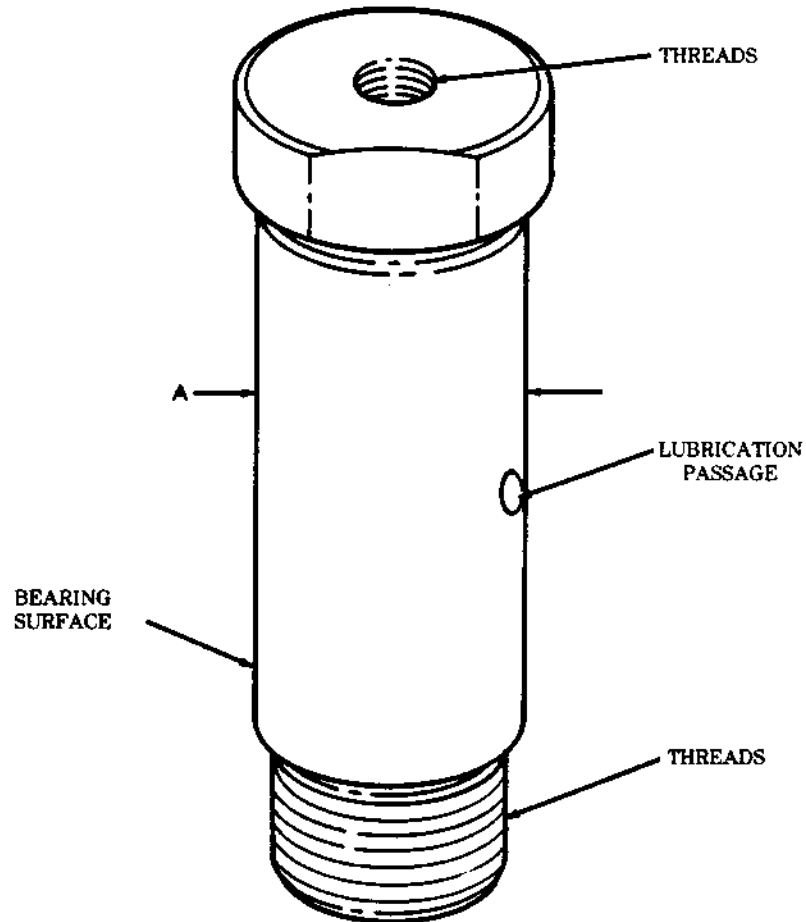

TA 51182
SHEET 1 OF 1

OVERHAUL INSPECTION PROCEDURE

OIP - 7411121

ITEM: Sheave, Swivel

M39, M809, M939

NO.	REF LTR	CHARACTERISTIC	INSP METHOD	REQUISITE
1		Serviceability	Visual	Examine for nicks, burrs, and scoring on machined surfaces. None allowed after repair. Refer to section VII.
2		Bearing and thrust washer surfaces	Visual	No metal transfer or evidence of overheating.
3	A	Inside diameter (inspect only if bearing is rejected)	Measure	2.5005 in. (63.513 mm) diameter maximum.
4	B	Groove diameter (over two 0.62500 in. (15.8750 mm) diameter pins)	Measure	7.980 in. (202.70 mm) diameter minimum.
5	C	Thickness	Measure	1.885 in. (47.88 mm) minimum.
6		Cracks, entire part	Visual/ Magnetic particle	None allowed. If cracks are suspect, perform magnetic particle inspection. Refer to para. 3-16g.

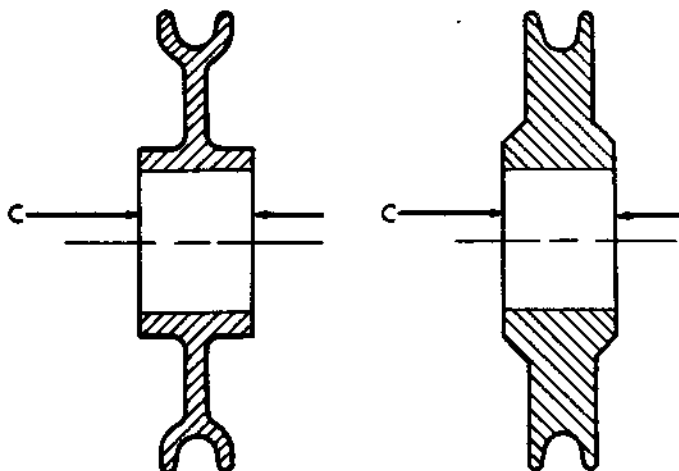
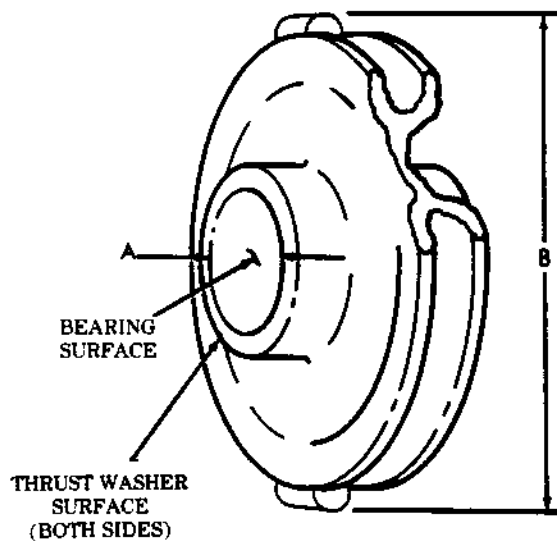

OVERHAUL INSPECTION PROCEDURE

OIP - 7954470

ITEM: Roller Assembly

M39, M809, M939

NO.	REF LTR	CHARACTERISTIC	INSP METHOD	REQUISITE
1		Serviceability	Visual	Examine for nicks, burrs, scoring on bearing bores, and broken welds. None allowed after repair. Refer to section VII.
2		Bearing bores (inspect only if bearings are rejected)	Visual	No metal transfer.
3	A	Inside diameter (inspect only if bearings are rejected)	Measure	2.0629 in. (52.398 mm) diameter maximum.
4		Cracks, entire part	Visual/ Magnetic particle	None allowed. If cracks are suspect, perform magnetic particle inspection. Refer to para. 3-16g.

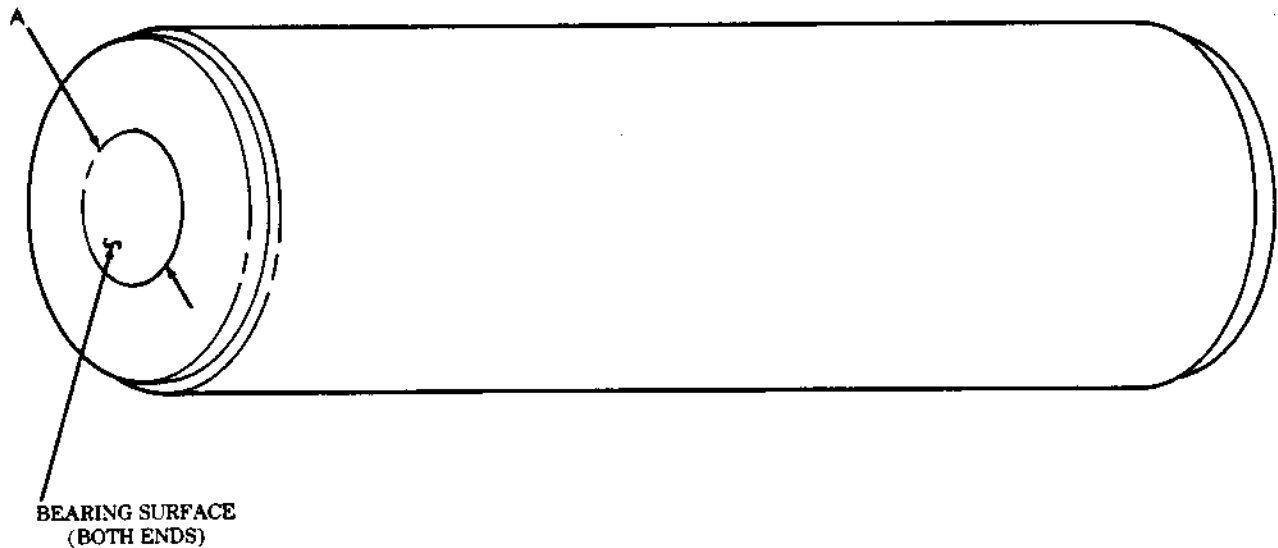
TA 51184
SHEET 1 OF 1

OVERHAUL INSPECTION PROCEDURE

OIP - 7409725

ITEM: Shaft, Roller

M39, M809, M939

NO.	REF LTR	CHARACTERISTIC	INSP METHOD	REQUISITE
1		Serviceability	Visual	Examine for nicks, burrs, scoring on machined surfaces, damaged threads, and debris in lubrication passages. None allowed after repair. Refer to section VII.
2	A	Outside diameter	Measure	1.4995 in. (38.087 mm) diameter minimum.
3		Cracks, entire part	Magnetic particle	None allowed. If cracks are suspect, perform magnetic particle inspection. Refer to para. 3-16g.

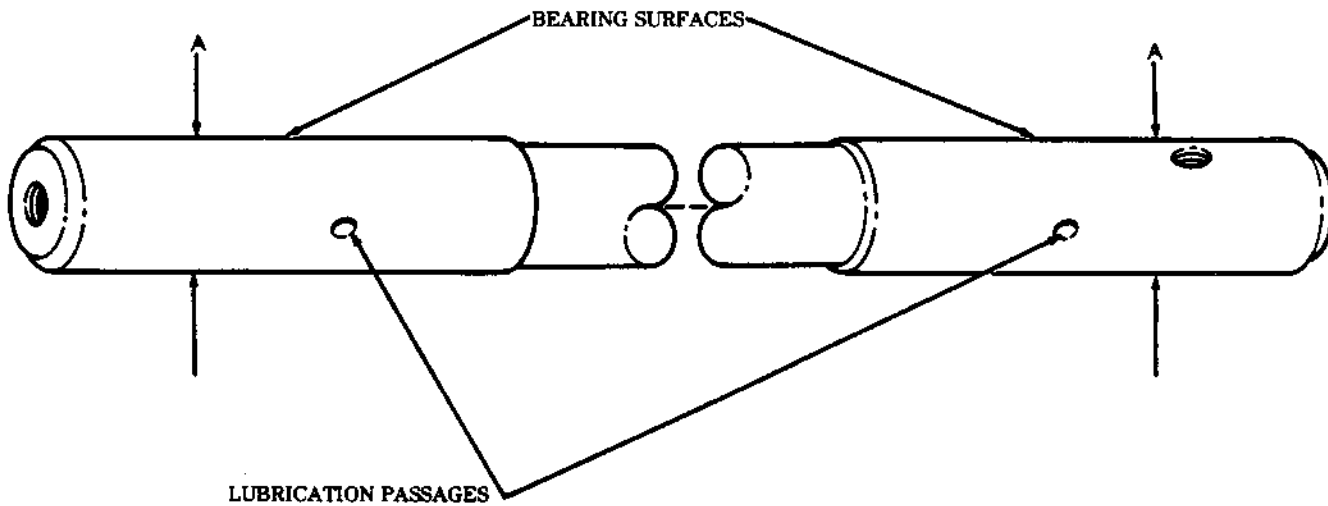

OVERHAUL INSPECTION PROCEDURE

OIP - 7409804/7409804-1,
7409805/7409805-1,
7409695/7409609

ITEM: Bracket and Side Roller Assembly, Left and Right

M39, M809, M939

NO.	REF LTR	CHARACTERISTIC	INSP METHOD	REQUISITE
1		Serviceability	Visual	Examine for cracked or broken bracket, elongated shaft bore, loose roller pin, frozen side roller, and elongated roller pin holes. None allowed. Examine for nicks and burrs; free rotation of side roller. debris in lubrication passage, tight roll pin, and damaged threads. None after repair. Refer to section VII.
2		Side roller end play	Measure	0.006-0.010 in. (0.15-0.25 mm) maximum end play.
3		Shaft bore (both sides of each bracket)	Measure	1.518 in. (38.56 mm) maximum diameter.
4		Cracks, bracket	Visual/ Dye Penetrant/ Magnetic particle	None allowed. If cracks are suspect, perform dye penetrant inspection on aluminum parts. Refer to para. 3-16f. For steel parts, perform magnetic particle inspection. Refer to para. 3-16g.

ROLLER BRACKETS

LEFT: P/N 7409805
ALUMINUM
P/N 7409805-1
STEEL

RIGHT: P/N 7409804
ALUMINUM
P/N 7409804-1
STEEL

REFER TO PARA. 3-18b.

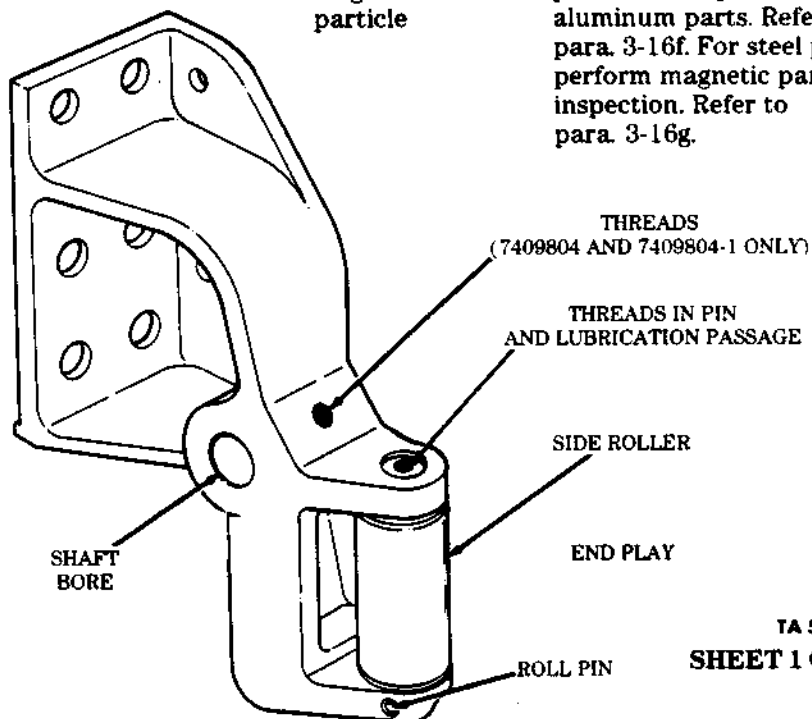

TA 51186
SHEET 1 OF 1

OVERHAUL INSPECTION PROCEDURE

OIP - 12300666-1/12300666-2

ITEM: Plate, Cable Guide, Left and Right

M39, M809, M939

NO.	REF LTR	CHARACTERISTIC	INSP METHOD	REQUISITE
1		Serviceability	Visual	Examine for breaks, cracks, and wear grooves. None allowed.

P/N 11608776



OLD PART

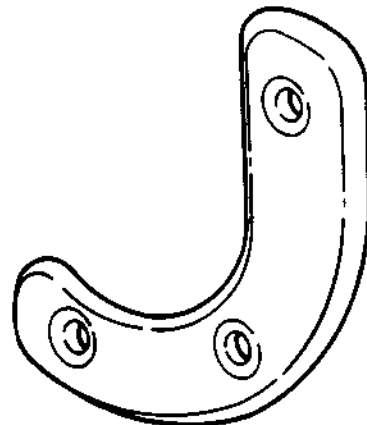

NEW PART

RIGHT SIDE P/N 12300666-1

LEFT SIDE P/N 12300666-2

NOTE

USE OF THESE NEW PARTS TO REPLACE P/N 11608776 REQUIRES NEW MOUNTING BRACKETS P/N 12300665-1 AND 12600665-2 ON WINCH P/N 7412382 AND 7412382-1.

OVERHAUL INSPECTION PROCEDURE

OIP - 7409695/7409807

ITEM: Roller, Side, with Bushings

M39, M809, M939

NO.	REF LTR	CHARACTERISTIC	INSP METHOD	REQUISITE
1		Serviceability	Visual	Examine for cracks and grooves. None allowed. Examine for nicks, burrs, and scoring on bushing surfaces. None allowed after repair. Refer to section VII.
2		Bushing	Visual	No metal transfer.
3	A	Inside diameter (bushing installed)	Measure	1.006 in. (25.59 mm) diameter maximum for bronze bushing. 1.004 in. (25.50 mm) diameter maximum for steel backed bushing.
4	B	Inside diameter (inspect only if bushings are rejected)	Measure	1.2505 in. (31.763 mm) diameter maximum.

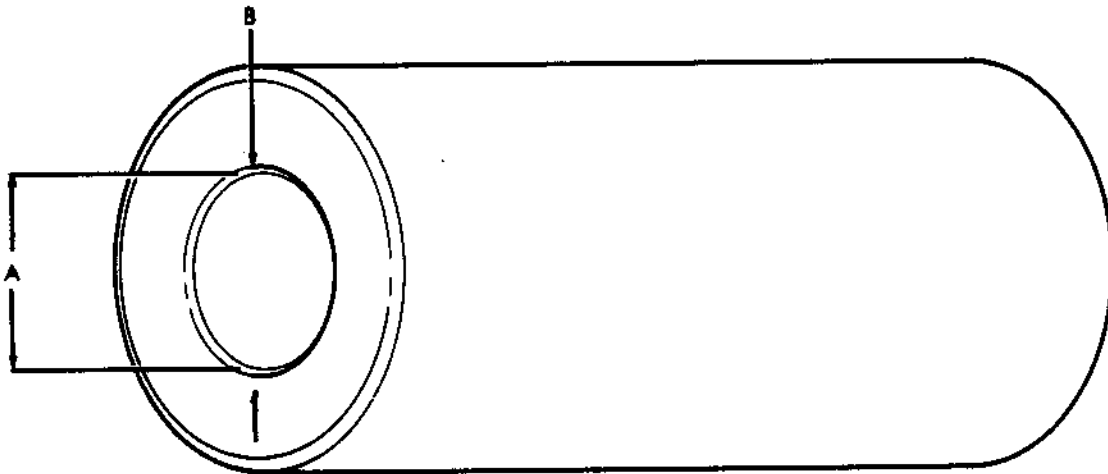
TA 51188
SHEET 1 OF 1

OVERHAUL INSPECTION PROCEDURE

OIP - 7409609

ITEM: Pin, Side Roller

M39, M809, M939

NO.	REF LTR	CHARACTERISTIC	INSP METHOD	REQUISITE
1		Serviceability	Visual	Examine for cracks. None allowed. Examine for damaged threads and debris in lubrication passage. None allowed after repair. Refer to section VII.
2		Bushing surfaces	Visual	No metal transfer.
3	A	Outside diameter	Measure	0.995 in. (25.29 mm) diameter minimum.

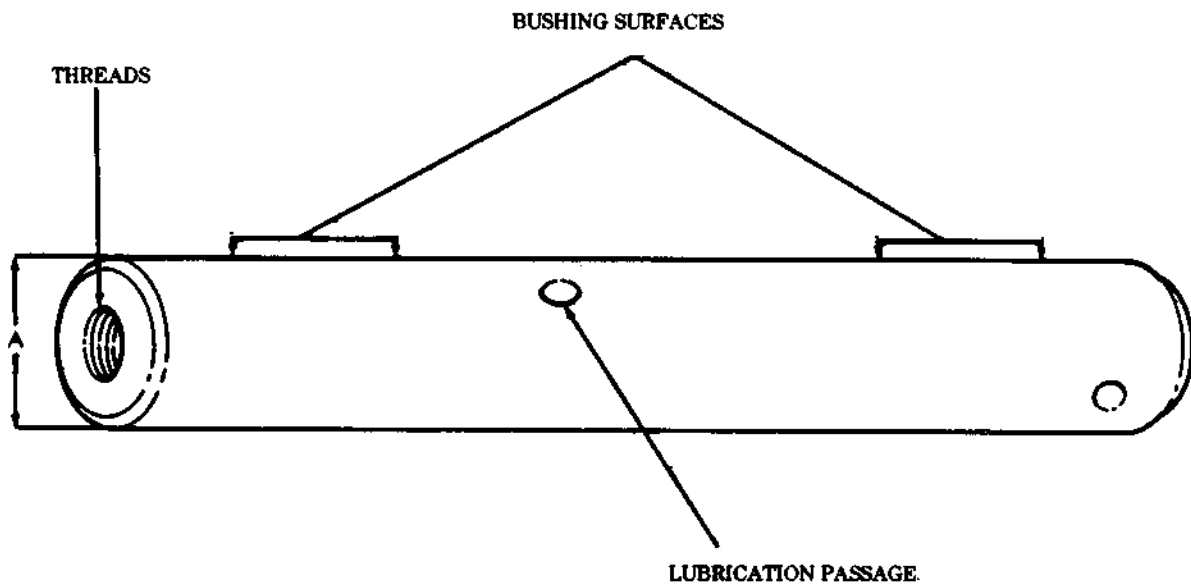

OVERHAUL INSPECTION PROCEDURE

OIP - 7954585

ITEM: Frame, End

M39, M809, M939

NO.	REF LTR	CHARACTERISTIC	INSP METHOD	REQUISITE
1		Serviceability	Visual	Examine for nicks, burrs, scoring on machined surfaces, and damaged threads. None allowed after repair. Refer to section VII.
2	A	Inside diameter	Measure	4.253 in. (108.03 mm) diameter maximum.
3		Cracks, entire part	Visual/ Dye penetrant	None allowed. If cracks are suspect, perform dye penetrant inspection. Refer to para. 3-16f.

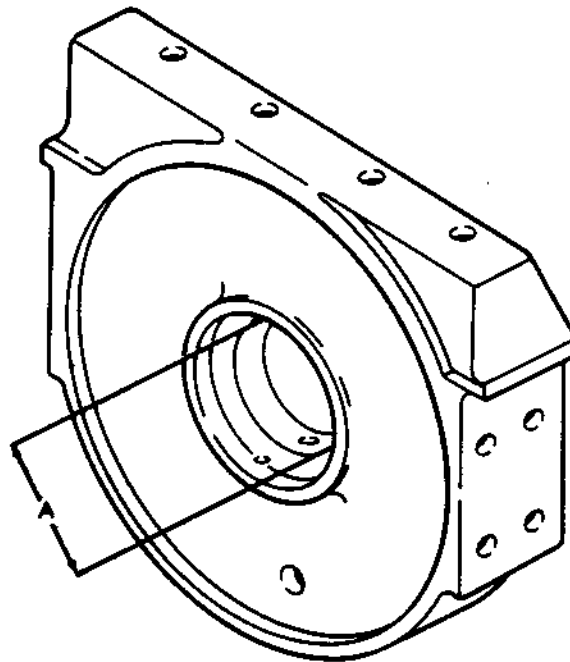

TA 51190
SHEET 1 OF 1

OVERHAUL INSPECTION PROCEDURE

OIP - 7954586

ITEM: Drum Assembly

M39, M809, M939

NO.	REF LTR	CHARACTERISTIC	INSP METHOD	REQUISITE
1		Serviceability	Visual	Examine for damaged keyways. None allowed. Examine for nicks, burrs, scoring on machined surfaces, and damaged threads. None allowed after repair. Refer to section VII.
2		Thrust washer surfaces	Visual	No metal transfer or evidence of overheating.
3	A	Outside diameter (seal area)	Measure	4.999 in. (126.97 mm) diameter minimum.
4	B	Thrust face dimension	Measure	0.687 in. (17.45 mm) minimum.
5	C	Thrust face dimension	Measure	1.406 in. (35.71 mm) maximum.
6		Cracks, entire part	Visual/ Magnetic particle	None allowed. If cracks are suspect, perform magnetic particle inspection. Refer to para. 3-16g.

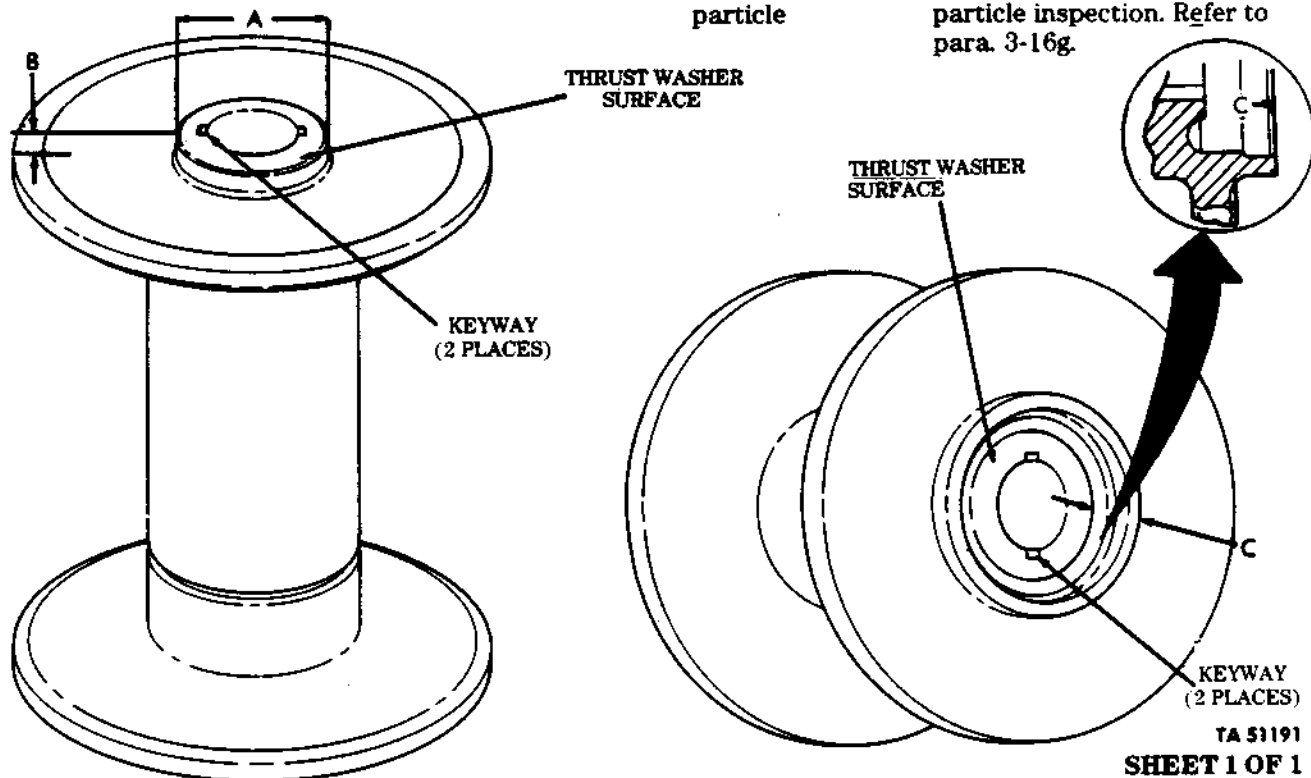

OVERHAUL INSPECTION PROCEDURE

OIP - 7954534/7409666

ITEM: Sleeve, End Bearing with Bushing

M39, M809, M939

NO.	REF LTR	CHARACTERISTIC	INSP METHOD	REQUISITE
1		Serviceability	Visual	Examine for cracks and damaged slot. None allowed. Examine for nicks, burrs, scoring on machined surfaces, and debris in oil passages. None allowed after repair. Refer to section VII.
2		Bushing	Visual	No metal transfer or evidence of overheating.
3	A	Inside diameter (bushing installed)	Measure	3.005 in. (76.33 mm) diameter maximum.
4	B	Inside diameter (inspect only if bushing is rejected)	Measure	3.251 in. (82.58 mm) diameter maximum.

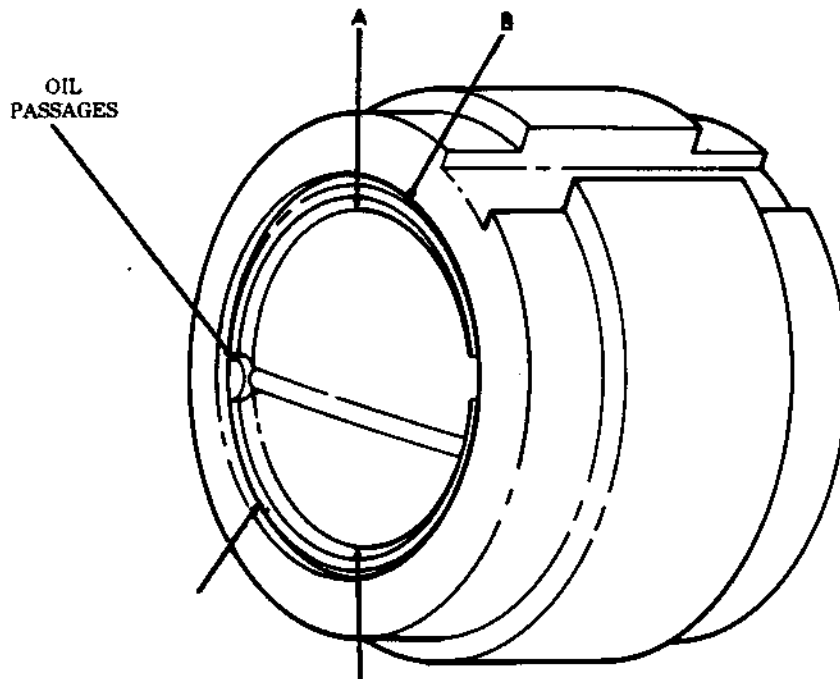

OVERHAUL INSPECTION PROCEDURE

OIP - 7954563

ITEM: Shaft

M39, M809, M939

NO.	REF LTR	CHARACTERISTIC	INSP METHOD	REQUISITE
1		Serviceability	Visual	Examine for damaged keyways. None allowed. Examine for nicks, burrs, and scoring. None allowed after repair. Refer to section VII.
2		Bushing surfaces (3 places)	Visual	No metal transfer or evidence of overheating.
3	A	Outside diameter (3 places)	Measure	2.998 in. (76.15 mm) diameter minimum.
4	B	Runout	Measure	0.006 in. (0.15 mm) maximum.
5		Cracks, entire part	Visual/ Magnetic particle	None allowed. If cracks are suspect, perform magnetic particle inspection. Refer to para. 3-16g.

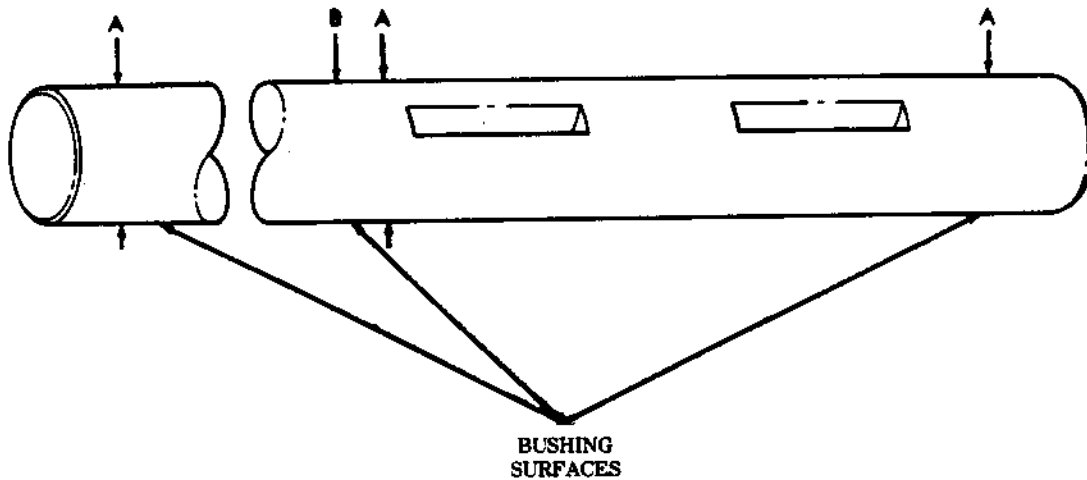

OVERHAUL INSPECTION PROCEDURE

OIP - 7409934

ITEM: Gear, Worm

M39, M809, M939

NO.	REF LTR	CHARACTERISTIC	INSP METHOD	REQUISITE
1		Serviceability	Visual	Examine for embedded particles, broken, burred, and chipped gear teeth, and damaged keyways. None allowed. Examine for nicks, burrs, scoring, and pitting. None allowed after repair. Refer to section VII.
2		Cracks, entire part	Visual/ Dye penetrant	None allowed. If cracks are suspect, perform dye penetrant inspection. Refer to para. 3-16f.

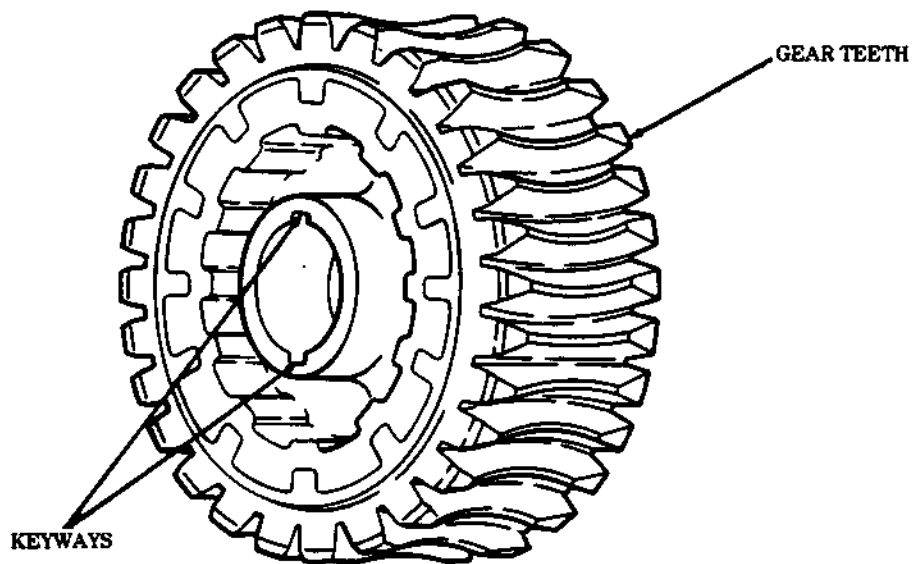

OVERHAUL INSPECTION PROCEDURE

OIP - 7954562

ITEM: Worm

M39, M809, M939

NO.	REF LTR	CHARACTERISTIC	INSP METHOD	REQUISITE
1		Serviceability	Visual	Examine for broken, burred, and chipped gear teeth and damaged keyway. None allowed. Examine for nicks, burrs, scoring, and pitting on machined surfaces, and damaged threads. None allowed after repair. Refer to section VII.
2		Bearing and sealing surfaces	Visual	No metal transfer or evidence of overheating.
3	A	Outside diameter (2 places)	Measure	2.124 in. (53.95 mm) diameter minimum.
4	B	Outside diameter (2 places)	Measure	2.3615 in. (59.982 mm) diameter minimum.
5	C	Diameter of worm (over three 0.68750 in. (17.4625 mm) diameter pins)	Measure	4.8756 in. (123.840 mm) diameter minimum.
6		Cracks, entire part	Visual/ Magnetic particle	None allowed. If cracks are suspect, perform magnetic particle inspection. Refer to para. 3-16g.

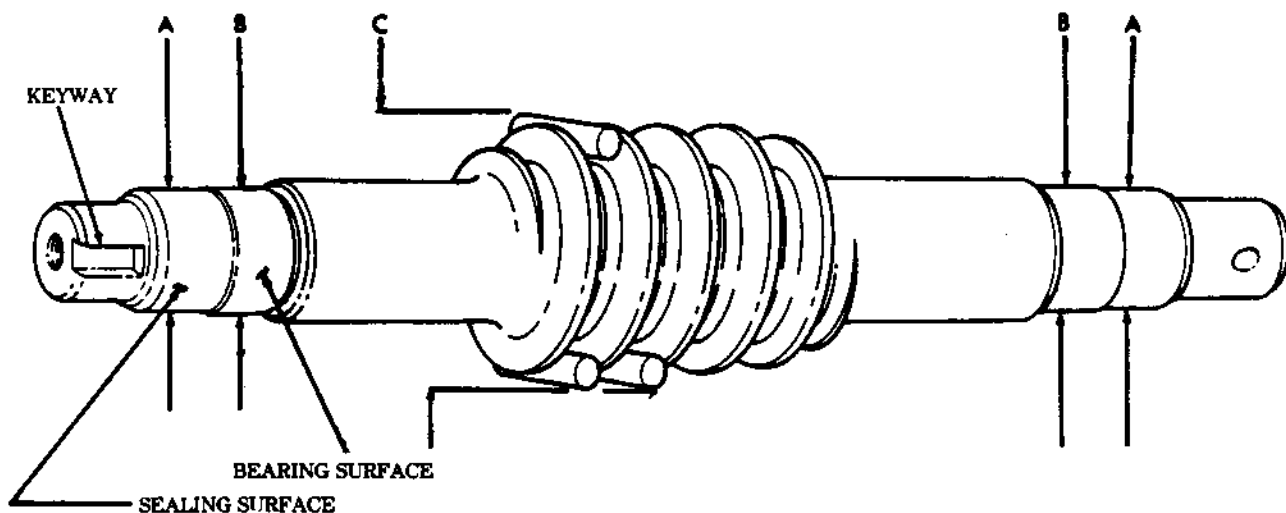

TA 51195
SHEET 1 OF 1

OVERHAUL INSPECTION PROCEDURE

OIP - 7954587/7409666

ITEM: Cover, Gearcase with Bushing

M39, M809, M939

NO.	REF LTR	CHARACTERISTIC	INSP METHOD	REQUISITE
1		Serviceability	Visual	Examine for nicks, burrs, and scoring on machined surfaces. None allowed after repair. Refer to section VII.
2		Bushing	Visual	No metal transfer or evidence of overheating.
3	A	Inside diameter (bushing installed)	Measure	3.005 in. (76.33 mm) diameter maximum.
4	B	Inside diameter (inspect only if bushing is rejected)	Measure	3.251 in. (82.58 mm) diameter maximum.
5		Cracks, entire part	Visual/ Dye penetrant	None allowed. If cracks are suspect, perform dye penetrant inspection. Refer to para. 3-16f.

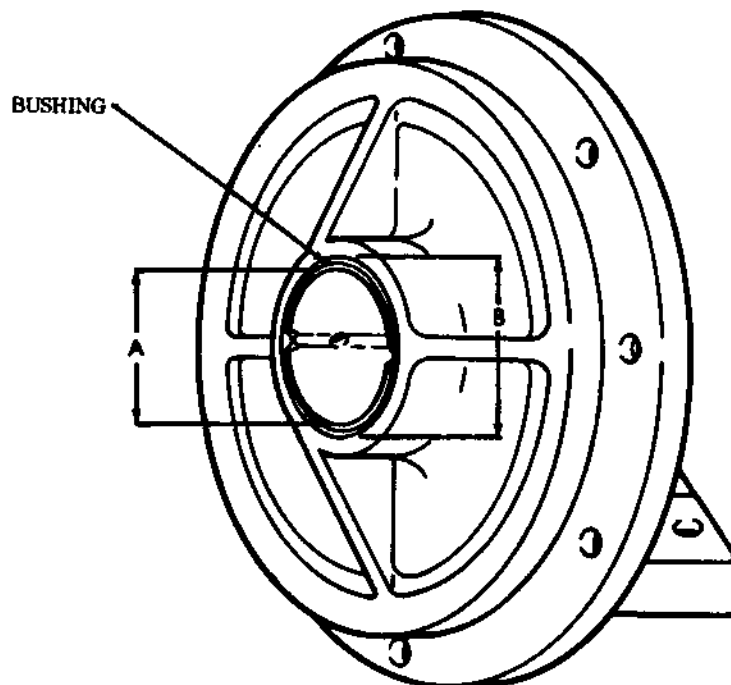

TA 51198
SHEET 1 OF 1

OVERHAUL INSPECTION PROCEDURE

OIP - 7409669/7409666

ITEM: Gearcase with Bushing

M39, M809, M939

NO.	REF LTR	CHARACTERISTIC	INSP METHOD	REQUISITE
1		Serviceability	Visual	Examine for nicks, burrs, scoring on machined surfaces, and damaged threads. None allowed after repair. Refer to section VII.
2		Bushing	Visual	No metal transfer or evidence of overheating.
3	A	Inside diameter (bushing installed)	Measure	3.005 in. (76.33 mm) diameter maximum.
4	B	Inside diameter (inspect only if bushing is rejected)	Measure	3.251 in. (82.58 mm) diameter maximum.
5	C	Inside diameter (both ends)	Measure	5.1191 in. (130.125 mm) diameter maximum.
6	D	Outside diameter (seal surface)	Measure	4.999 in. (126.97 mm) diameter minimum.
7		Cracks, entire part	Visual/ Dye penetrant	None allowed. If cracks are suspect, perform dye penetrant inspection. Refer to para. 3-16f.

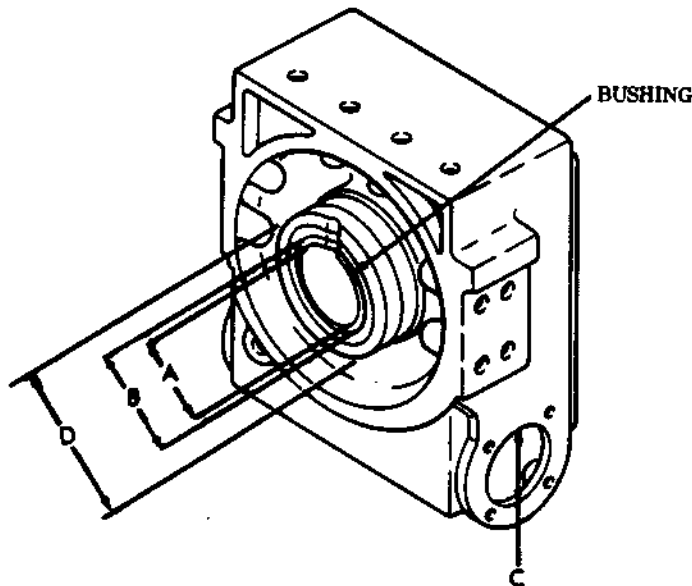

TA 51199
SHEET 1 OF 1

OVERHAUL INSPECTION PROCEDURE

OIP - 7409935

ITEM: Lever, Rocker

M39, M809, M939

NO.	REF LTR	CHARACTERISTIC	INSP METHOD	REQUISITE
1		Serviceability	Visual	Examine for cracks, breaks, and elongated holes. None allowed. Examine for bends. None allowed after repair.

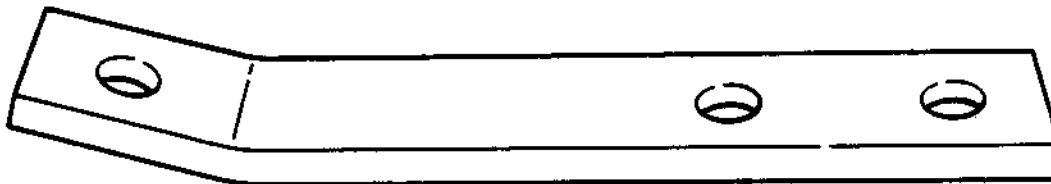

OVERHAUL INSPECTION PROCEDURE

OIP - 7409665

ITEM: Bracket, Tensioner, Right-Hand

M39, M809, M939

NO.	REF. LTR	CHARACTERISTIC	INSP METHOD	REQUISITE
1		Serviceability	Visual	Examine for elongated holes. None allowed. Examine for nicks, burrs, and scoring on machined surfaces. None allowed after repair. Refer to section VII.
2		Cracks, entire part	Visual/ Dye penetrant	None allowed. If cracks are suspect, perform dye penetrant inspection. Refer to para. 3-16f.

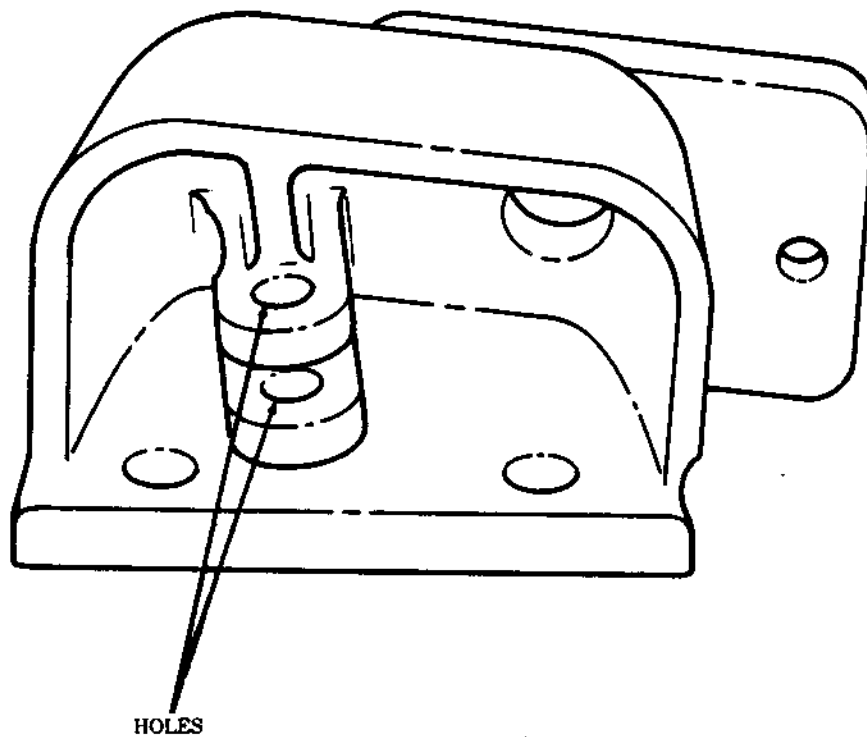

OVERHAUL INSPECTION PROCEDURE

OIP - 7409668

ITEM: Bracket, Tensioner, Left-Hand

M39, M809, M939

NO.	REF LTR	CHARACTERISTIC	INSP METHOD	REQUISITE
1		Serviceability	Visual	Examine for nicks, burrs, and scoring on machined surfaces. None allowed after repair. Refer to section VII.

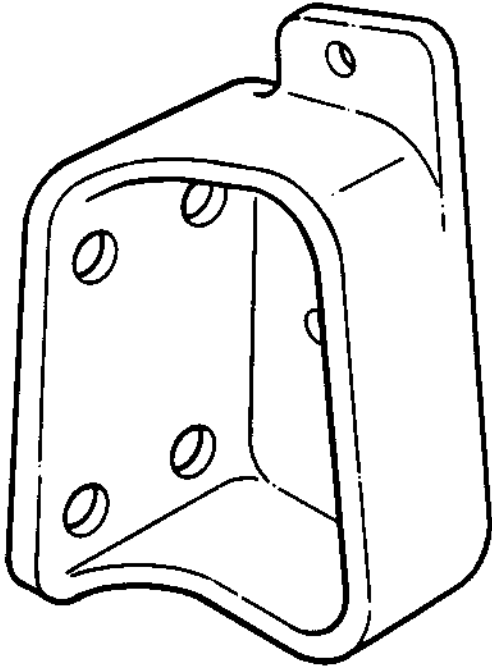

OVERHAUL INSPECTION PROCEDURE

OIP - 7409945

ITEM: Pin, Tensioner Sheave

M39, M809, M939

NO.	REF LTR	CHARACTERISTIC	INSP METHOD	REQUISITE
1		Serviceability	Visual	Examine for corrosion. None allowed. Examine for nicks, burrs, scoring, rust, damaged threads, and debris in lubrication passages. None allowed after repair. Refer to section VII.
2		Bearing surface	Visual	No metal transfer.
3	A	Outside diameter	Measure	1.2495 in. (31.737 mm) diameter minimum.
4		Cracks, entire part	Visual/ Magnetic particle	None allowed. If cracks are suspect, perform magnetic particle inspection. Refer to para. 3-16g.

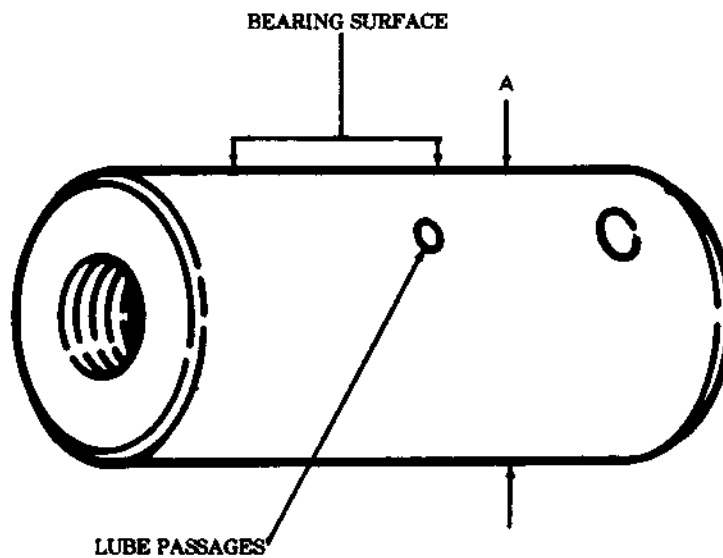

OVERHAUL INSPECTION PROCEDURE

OIP - 7409930

ITEM: Frame Assembly, Adjustable Sheave

M39, M809, M939

NO.	REF LTR	CHARACTERISTIC	INSP METHOD	REQUISITE
1		Serviceability	Visual	Examine for elongated holes. None allowed. Examine for bends, damaged welds, nicks, and burrs. None allowed after repair. Refer to section VII.
2		Cracks, entire part	Visual/ Magnetic particle	None allowed. If cracks are suspect, perform magnetic particle inspection. Refer to para. 3-16g.

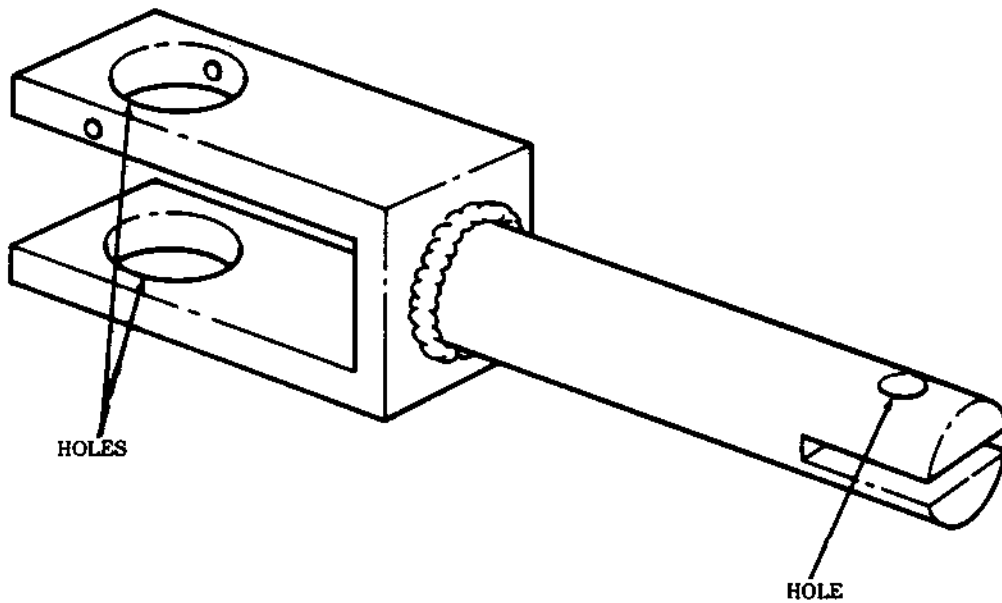
TA 51204
SHEET 1 OF 1

OVERHAUL INSPECTION PROCEDURE

OIP - 7409948

ITEM: Sheave, Tensioner (2)

M39, M809, M939

NO.	REF LTR	CHARACTERISTIC	INSP METHOD	REQUISITE
1		Serviceability	Visual	Examine for nicks, burrs, and scoring on machined surfaces. None allowed after repair. Refer to section VII.
2		Bearing and thrust washer surfaces	Visual	No metal transfer or evidence of overheating.
3	A	Inside diameter (inspect only if bearing rejected)	Measure	1.7497 in. (44.442 mm) diameter maximum.
4	B	Groove diameter (over two 0.75000 in. (19.0500 mm) diameter pins)	Measure	6.500 in. (165.10 mm) diameter minimum.
5	C	Thickness	Measure	1.480 in. (37.59 mm) minimum.
6		Cracks, entire part	Visual/ Magnetic particle	None allowed. If cracks are suspect, perform magnetic particle inspection. Refer to para. 3-16g.

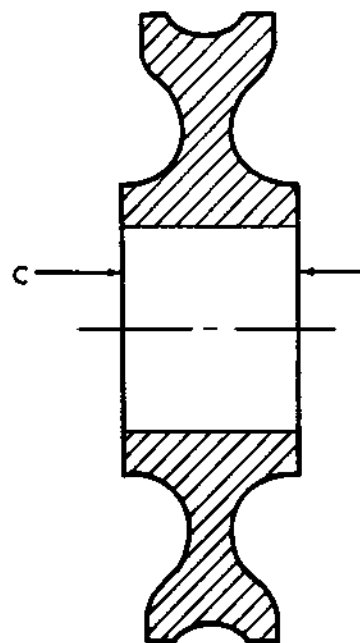
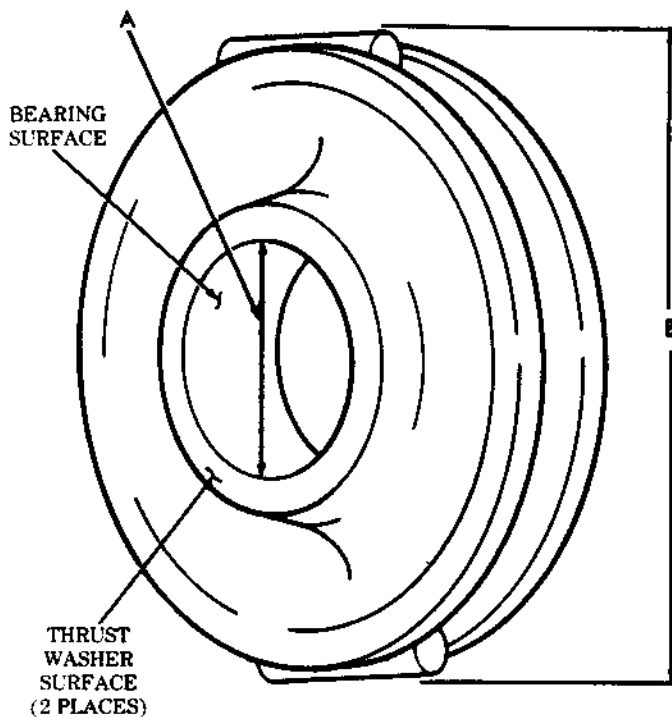

TA 51205
SHEET 1 OF 1

OVERHAUL INSPECTION PROCEDURE

OIP - 7954584

ITEM: Frame Assembly, Tensioner

M39, M809, M939

NO.	REF LTR	CHARACTERISTIC	INSP METHOD	REQUISITE
1		Serviceability	Visual	Examine for damaged and twisted areas. None allowed after repair. Refer to section VII.
2		Cracks, entire part	Visual/ Magnetic particle	None allowed. If cracks are suspect, perform magnetic particle inspection. Refer to para. 3-16g.

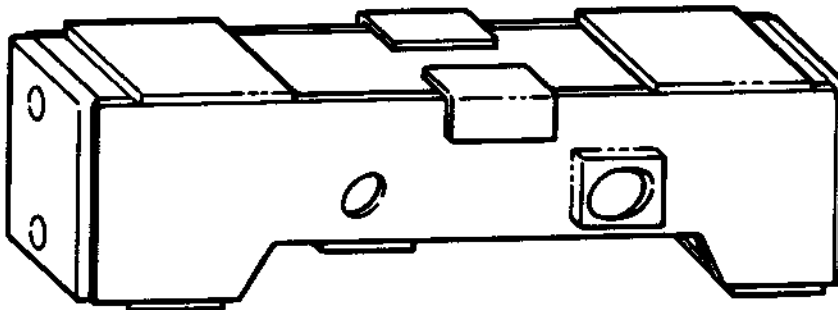

OVERHAUL INSPECTION PROCEDURE

OIP - 7409150

ITEM: Latch, Trolley Lock

M39, M809, M939

NO.	REF LTR	CHARACTERISTIC	INSP METHOD	REQUISITE
1		Serviceability	Visual	Examine for cracks and damaged lugs. None allowed.

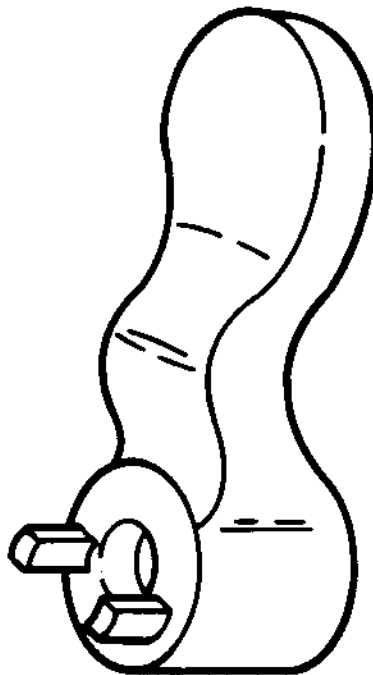

OVERHAUL INSPECTION PROCEDURE

OIP - 8344240

ITEM: Nut, Poppet, Trolley

M39, M809, M939

NO.	REF LTR	CHARACTERISTIC	INSP METHOD	REQUISITE
1		Serviceability	Visual	Examine for cracks, rounded hex, and slots. None allowed. Examine for damaged threads. None allowed after repair. Refer to section VII.

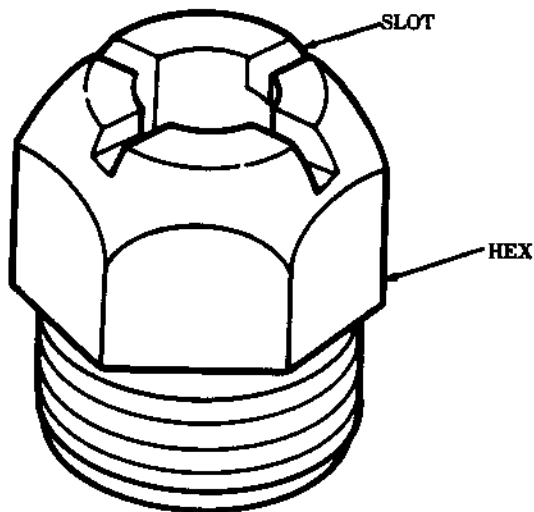

OVERHAUL INSPECTION PROCEDURE

OIP - 8741768

ITEM: Poppet, Trolley Lock

M39, M809, M939

NO.	REF LTR	CHARACTERISTIC	INSP METHOD	REQUISITE
1		Serviceability	Visual	Examine for bends and cracks. None allowed. Examine for burrs, nicks, and damaged threads. None allowed after repair. Refer to section VII.

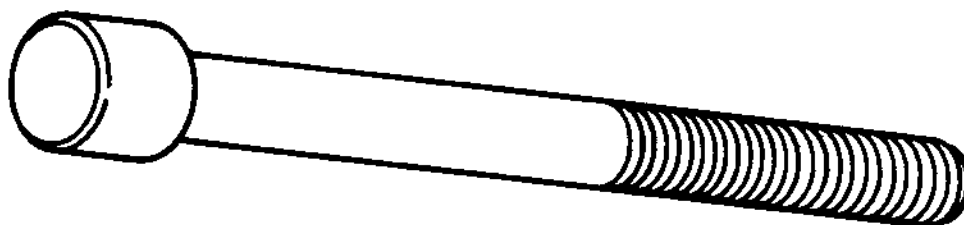

OVERHAUL INSPECTION PROCEDURE

OIP - 7954574

ITEM: Track Assembly, Trolley, Rear

M39, M809, M939

NO.	REF LTR	CHARACTERISTIC	INSP METHOD	REQUISITE
1		Serviceability	Visual	Examine for cracks. None allowed. Examine for nicks and burrs on track, broken welds and damaged threads. None allowed after repair. Refer to section VII.

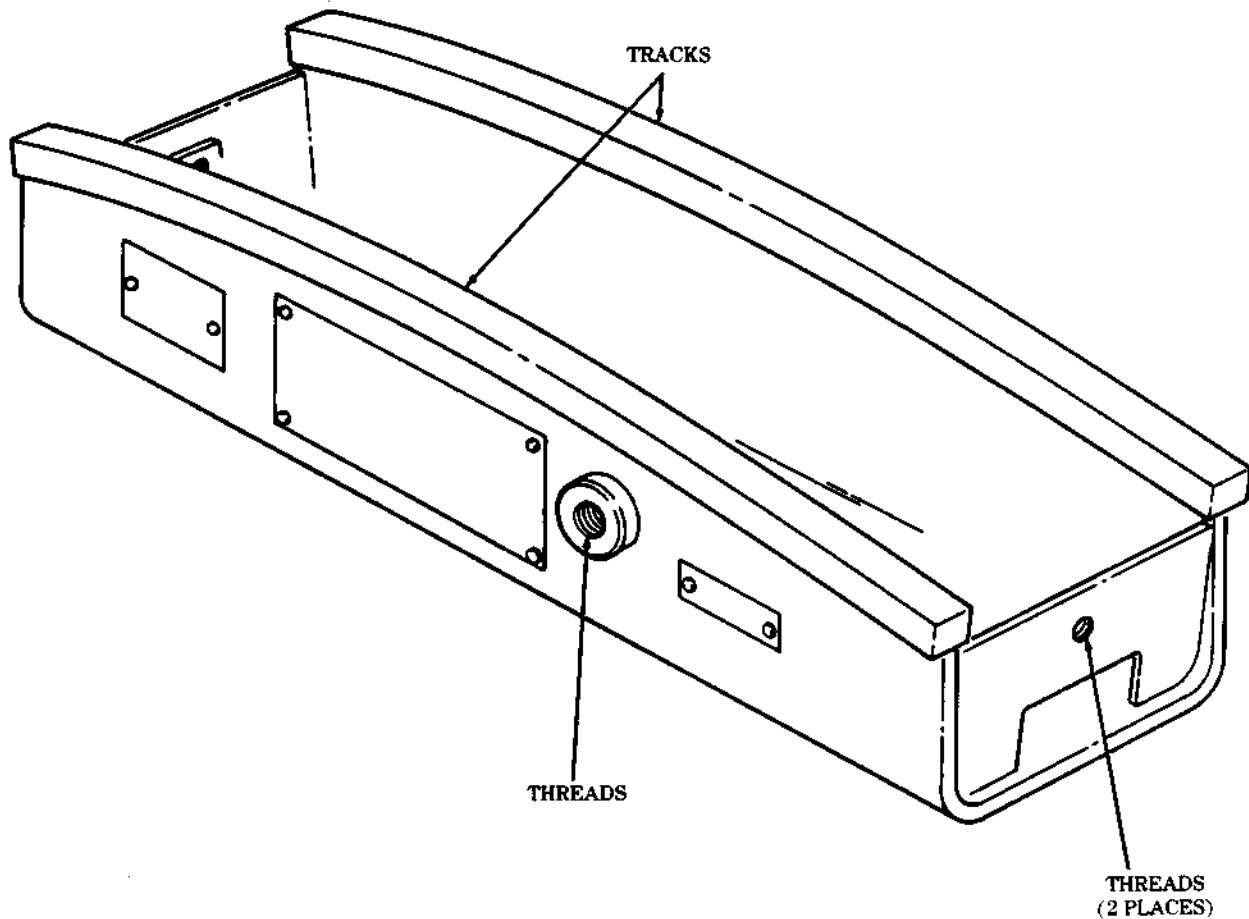

TA 51210
SHEET 1 OF 1

OVERHAUL INSPECTION PROCEDURE

OIP - 8690894/7409950/
7409982

ITEM: Frame Assembly, Trolley

M39, M809, M939

NO.	REF LTR	CHARACTERISTIC	INSP METHOD	REQUISITE
1		Serviceability	Visual	Examine for corrosion and loose shaft and axles in bores. None allowed. Examine for nicks, burrs, scoring on machined surfaces, rust, debris in lubrication passages, and damaged threads. None allowed after repair. Refer to section VII.
2		Thrust washer and bearing contact surfaces	Visual	No metal transfer or evidence of overheating.
3	A	Outside diameter (4 places)	Measure	1.9995 in. (50.787 mm) diameter minimum.
4	B	Outside diameter	Measure	0.8745 in. (22.212 mm) diameter minimum.
5	C	Inside diameter (inspect only if shaft is rejected)	Measure	0.750 in. (19.05 mm) diameter maximum.
6		Cracks, entire part	Visual/ Magnetic particle	None allowed. If cracks are suspect, perform magnetic particle inspection. Refer to para. 3-16g.

SHEET 1 OF 2

OVERHAUL INSPECTION PROCEDURE

OIP - 8690894/7409950

ITEM: Frame Assembly, Trolley

M39, M809, M939

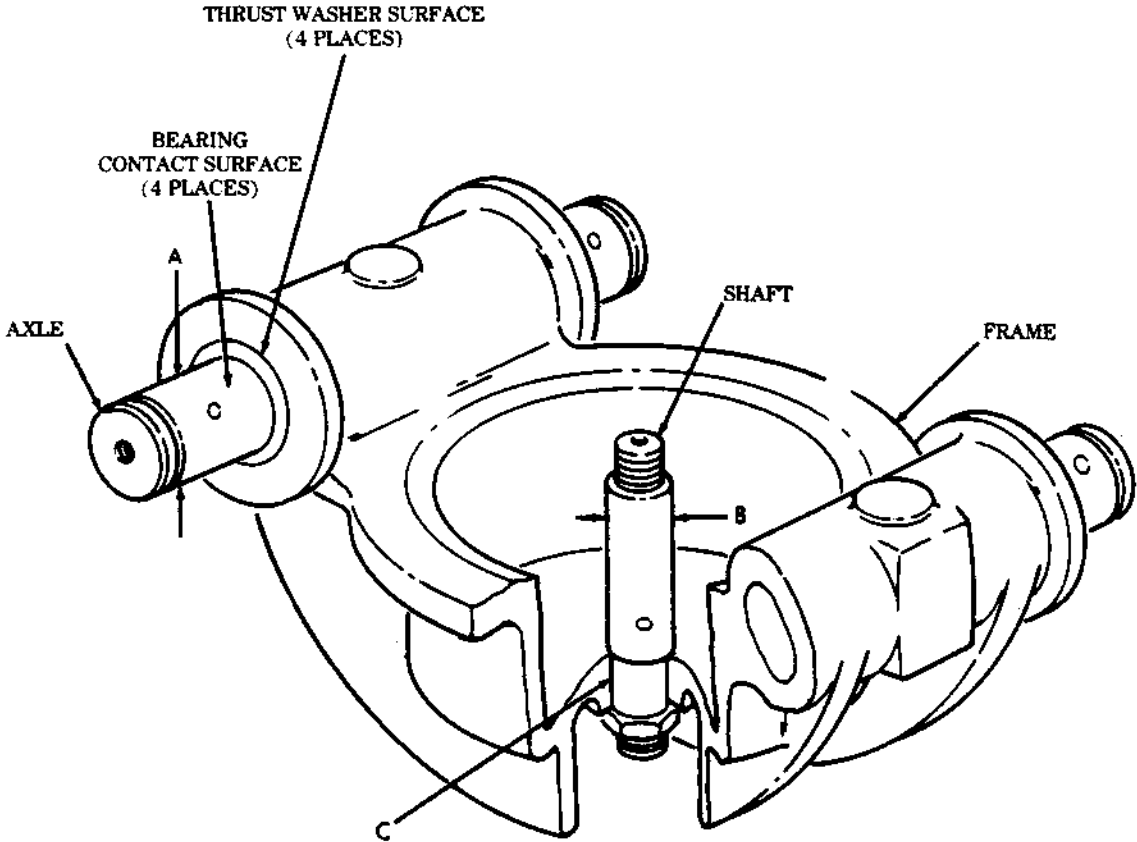

OVERHAUL INSPECTION PROCEDURE

OIP - 7409960

ITEM: Wheel, Trolley (4)

M39, M809, M939

NO.	REF LTR	CHARACTERISTIC	INSP METHOD	REQUISITE
1		Serviceability	Visual	Examine for cracks. None allowed. Examine for scoring on bearing bore and nicks, burrs, and flat spots on wheel to track surface. None allowed after repair. Refer to section VII.
2	A	Inside diameter	Measure	2.5622 in. (65.080 mm) diameter maximum.
3	B	Outside diameter	Measure	3.745 in. (95.12 mm) diameter minimum.

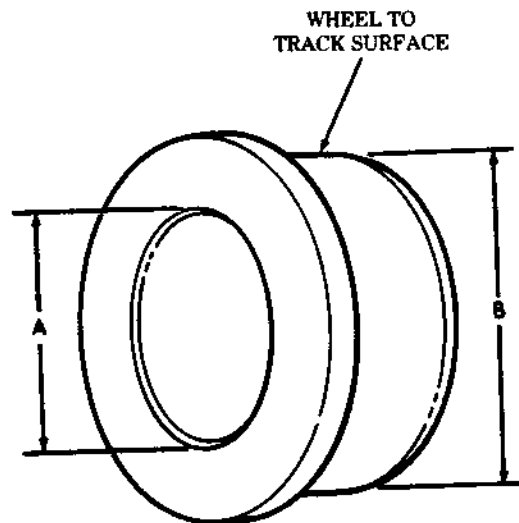

OVERHAUL INSPECTION PROCEDURE

OIP - 7409892

ITEM: Frame, Swivel

M39, M809, M939

NO.	REF LTR	CHARACTERISTIC	INSP METHOD	REQUISITE
1		Serviceability	Visual	Examine for nicks, burrs, scoring on machined surfaces, and damaged threads. None allowed after repair. Refer to section VII.
2		Shaft bores and thrust washer surfaces	Visual	No metal transfer or evidence of overheating.
3	A	Inside diameter	Measure	1.3747 in. (34.917 mm) diameter maximum.
4		Cracks, entire part	Visual/ Magnetic particle	None allowed. If cracks are suspect, perform magnetic particle inspection. Refer to para. 3-16g.

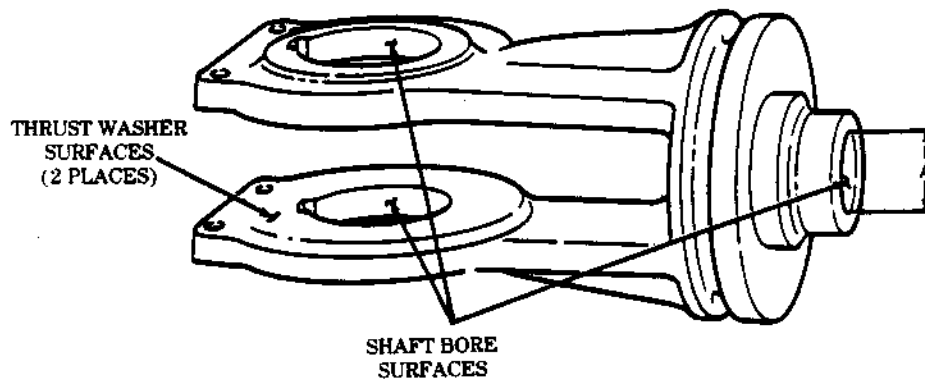
TA 51213
SHEET 1 OF 1

OVERHAUL INSPECTION PROCEDURE

OIP - 8690893

ITEM: Shaft Assembly, Swivel Sheave

M39, M809, M939

NO.	REF LTR	CHARACTERISTIC	INSP METHOD	REQUISITE
1		Serviceability	Visual	Examine for distortion of straight pin and corrosion. None allowed. Examine for nicks, burrs, scoring, and rust. None allowed after repair. Refer to section VII.
2		Bearing surface	Visual	No metal transfer.
3	A	Outside diameter	Measure	2.7490 in. (69.825 mm) diameter minimum.
4		Cracks, entire part	Visual/ Magnetic particle	None allowed. If cracks are suspect, perform magnetic particle inspection. Refer to para. 3-16g.

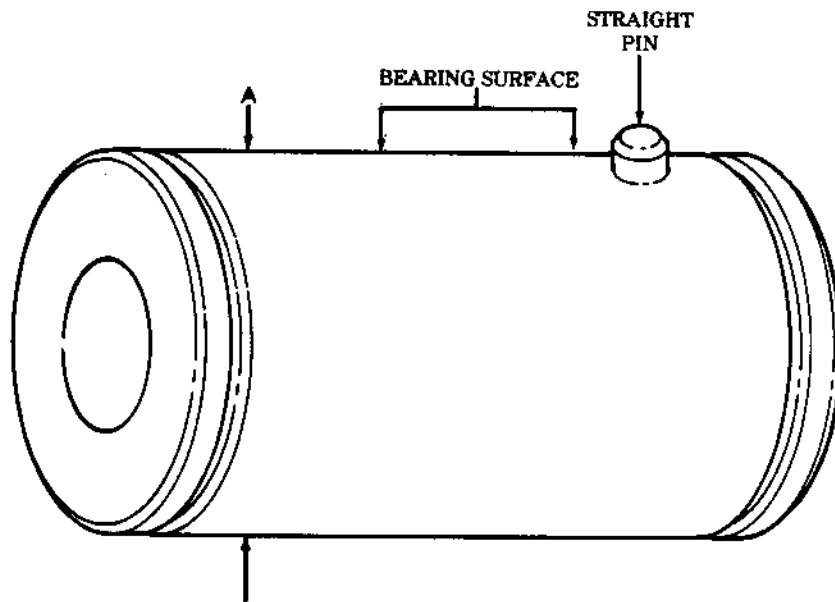

OVERHAUL INSPECTION PROCEDURE

OIP - 7954539-1

ITEM: Spacer, Bearing (2)

M39, M809, M939

NO.	REF. LTR	CHARACTERISTIC	INSP METHOD	REQUISITE
1		Serviceability	Visual	Examine for cracks. None allowed. Examine for nicks, burrs, and scoring. None allowed after repair. Refer to section VII.
2		Thrust washer and bearing contact surfaces	Visual	No metal transfer or evidence of overheating.
3	A	Thickness	Measure	0.178 in. (4.52 mm) minimum.
4	B	Thickness	Measure	0.087 in. (2.21 mm) minimum.

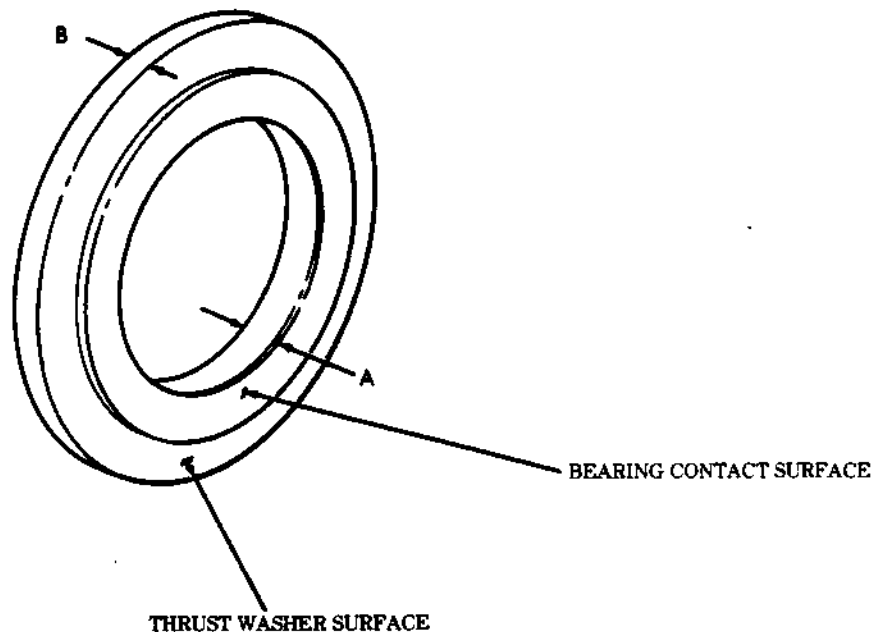

TA 51215
SHEET 1 OF 1

OVERHAUL INSPECTION PROCEDURE

OIP - 7409952

ITEM: Sheave, Swivel

M39, M809, M939

NO.	REF LTR	CHARACTERISTIC	INSP METHOD	REQUISITE
1		Serviceability	Visual	Examine for nicks, burrs, and scoring on machined surfaces. None allowed after repair. Refer to section VII.
2		Bearing and thrust washer surfaces	Visual	No metal transfer or evidence of overheating.
3	A	Inside diameter (inspect only if bearing rejected)	Measure	4.2496 in. (107.940 mm) diameter maximum.
4	B	Groove diameter (over two 0.75000 in. (19.0500 mm) diameter pins)	Measure	11.968 in. (303.98 mm) diameter minimum.
5	C	Thickness	Measure	2.235 in. (56.77 mm) minimum.
6		Cracks, entire part	Visual/ Magnetic particle	None allowed. If cracks are suspect, perform magnetic particle inspection. Refer to para. 3-16g.

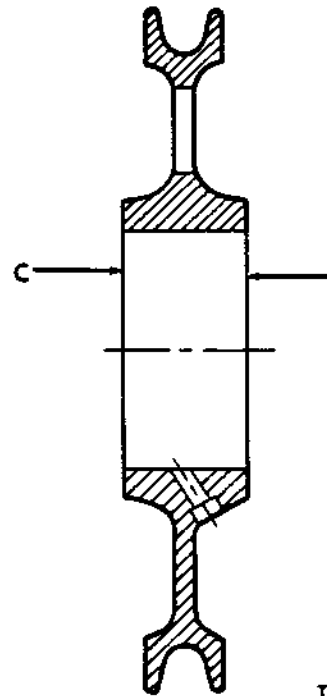
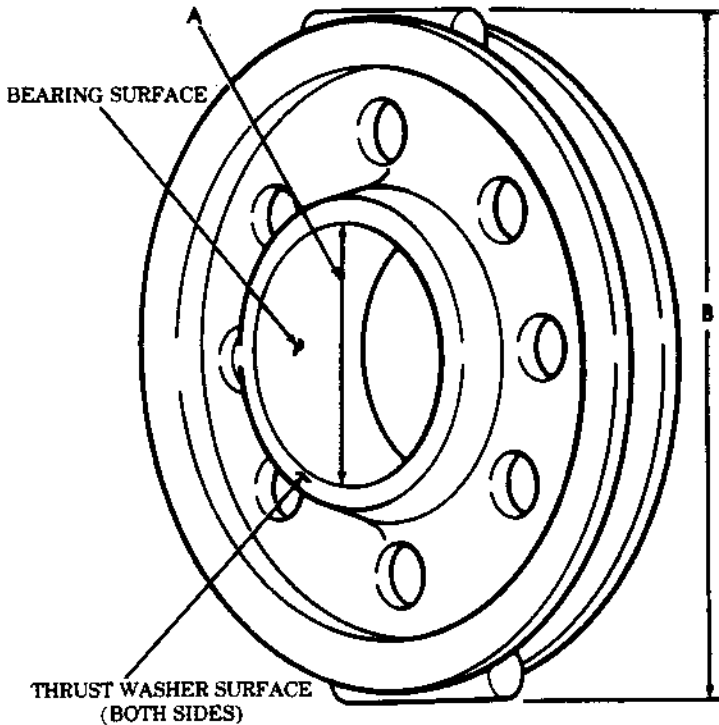

TA 51216
SHEET 1 OF 1

OVERHAUL INSPECTION PROCEDURE

OIP - MS19059-2424

ITEM: Ball, Bearing (45)

M39, M809, M939

NO.	REF LTR	CHARACTERISTIC	INSP METHOD	REQUISITE
1		Serviceability	Visual	Examine for nicks, burrs, cracks, galling, and scoring, rust, and corrosion. None allowed.
2	A	Diameter	Measure	0.5620-0.5625 in. (14.275-14.288 mm) diameter.

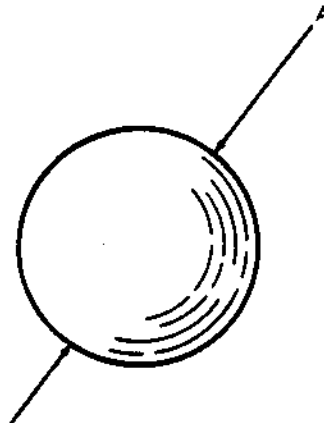
TA 51217
SHEET 1 OF 1

OVERHAUL INSPECTION PROCEDURE

OIP - 7409896

ITEM: Race, Ball Thrust, Inner and Outer (2)

M39, M809, M939

NO.	REF LTR	CHARACTERISTIC	INSP METHOD	REQUISITE
1		Serviceability	Visual	Examine for corrosion. None allowed. Examine for nicks, burrs, rust, and scoring. None allowed after repair. Refer to section VII.
2		Frame bore	Visual	No metal transfer.
3	A	Inside diameter	Measure	2.811 in. (71.40 mm) diameter maximum.
4	B	Groove depth (2 places)	Measure	0.404 in. (10.26 mm) minimum.
5		Cracks, entire part	Visual/ Magnetic particle	None allowed. If cracks are suspect, perform magnetic particle inspection. Refer to para. 3-16g.

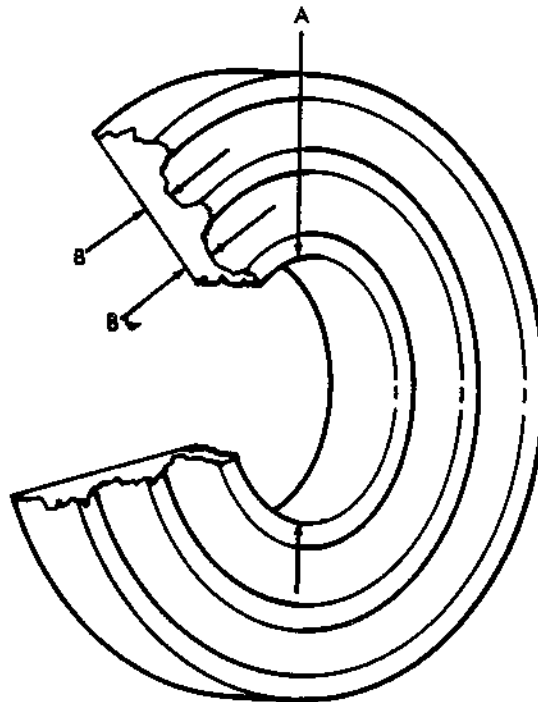

Section VII. REPAIR

3-20. GENERAL.

a. **Special Process Approval.** Parts beyond wear limit tolerances may be considered for repair by special processes by requesting approval of the Contracting Officer. In requesting approval, the contractor will furnish:

- (1) Written repair procedure.
- (2) Specifications covering the procedure.
- (3) Samples of parts repaired in accordance with the special processes are as follows:
 - (a) One sample of plated or metallurgical parts.
 - (b) Two samples of welded parts:
 1. One for metallurgical examination.
 2. One for quality sample.

b. **Repairable Defects.** The special processes will include one of the following:

REPAIR AREA	PROCESSES
Shaft journals	Chrome plate
Shaft load surfaces	Spray metalize
Brakedrum braking surfaces	Spray metalize
Flat surfaces	Hard facing arc weld
Casting build-up of bores	Weld
Casting crack	Weld

c. **Unrepairable Defects.** Do not repair any of the following:

- (1) Casting cracks at throughbores, threaded holes, or high stress areas.
- (2) Cracked, chipped, ridged, or pitted spline or gear teeth. Cracked or split keyways.

d. **Damaged Threads.**

(1) Repair external threads having slight irregularities. Remove burrs with a soft stone, fine mill file, or emery cloth. Clean up slight irregularities by running a thread die of correct size over thread. Otherwise, replace the part.

(2) Repair internal threads in tapped holes with minor irregularities by retapping with correct size hole tap. Drill out tapped holes with badly damaged threads and install a threaded insert. Follow kit manufacturer's and MS33537 instructions. When drilling, the land width (space between holes or between edge of hole and edge of material) must measure at least three-fourths of the hole diameter. Discard components not repairable.

e. **Housings, Castings, Brakedrums, and Shaped or Machined Surfaces.** Unless otherwise indicated, minor nicks, burrs, scoring, and surface corrosion can be repaired using fine emery cloth, crocus cloth, or a soft stone. Front brakedrum may be cut to 4.992 in. (126.80 mm) diameter to remove scoring or pitting. Rear brakedrum may be cut to 4.997 in. (126.92 mm) diameter to remove scoring or pitting. Minor surface irregularities on noncontact surfaces do not need repair.

f. **Gears, Splines, and Shafts.** Remove minor nicks, burrs, and scoring using crocus cloth, soft stone, or a fine mill file. Pitted or grooved gear teeth and splines, unless otherwise indicated on OIP, are unrepairable and parts will be discarded.

g. **Surface Rust and Corrosion.** Remove surface rust and corrosion from all internal parts and surfaces. Mechanical and/or chemical methods may be used. Minor surface rust and corrosion can be removed using fine mill file, fine emery cloth, crocus cloth, or soft stone. Refer to OIP if pitting or scoring is uncovered when corrosion is removed.

h. **Special Process Repair.** Refer to para. 3-16 for special process repair references.

Section VIII. ASSEMBLY OF WINCHES

3-21. GENERAL.

a. Preliminary Instructions.

(1) Replace all parts furnished in Mandatory Replacement Parts List, tables 2-2 and 2-3, regardless of the condition of the disassembled parts.

(2) Replace only those components or subassemblies that do not conform to the tolerances in appendix D or fail OIP criteria.

(3) Utilize the same handling equipment for assembly as used for disassembly.

(4) Adhere to the following basic rules:

(a) Keep all parts clean during assembly. Protect subassemblies from dust, as even the smallest particles of dust and dirt are abrasive.

(b) Apply gear oil to all gears, shafts, and bearings during assembly.

(c) Saturate oil seals with warm engine oil before installing. Handle seals carefully to avoid damage during installation. Lubricate the sealing element of all oil seals with GAA grease, MIL-G-10924, Grease, Automotive and Artillery.

(d) Apply sealing compound conforming to MIL-S-45180, Sealing Compound, Gasket Hydrocarbon Fluid and Water Resistant, type 2, to all external capscrews, threads of plugs, mounting surfaces, and outside diameter of oil seal retainers.

(e) Lubricate bearings in accordance with TM 9-214.

(f) Refer to TM 9-214 for bearing installation.

(g) After assembly, coat outside edges of all gasket surfaces, weld seams, and openings of lockwashers with sealing compound, MIL-S-45180, type 1, or equivalent.

(h) Tighten all bolts and nuts to specified torque.

b. Assembly. Assemble and adjust front and rear winches in accordance with the following series vehicles and their respective manuals:

(1) M39 Series Vehicles.

(a) TM 9-2320-211-20-3-2, chapter 18.

(b) TM 9-2320-211-34-2-3, chapter 17.

Refer to TM 9-2320-211-34P for parts identification.

(2) M809 Series Vehicles.

(a) TM 9-2320-260-20-3-4, chapter 18.

(b) TM 9-2320-260-34-2-4, chapter 17.

Refer to TM 9-2320-260-34P/2 for parts identification.

(3) M939 Series Vehicles.

(a) TM 9-2320-272-20-2, chapter 10.

(b) TM 9-2320-272-34-2, chapter 19.

Refer to TM 9-2320-272-34P-2 for parts identification.

3-22. LUBRICATION.

a. Refer to LO 9-2320-211-12 (M39).

b. Refer to LO 9-2320-260-12 (M809).

c. Refer to LO 9-2320-272-12 (M939).

d. Refer to chapter 4 of this DMWR for additional instructions.

CHAPTER 4 FINAL ASSEMBLY AND TESTING

Section I. GENERAL

4-1. ASSEMBLY OF FRONT AND REAR WINCHES.

Refer to paragraph 3-21b.

4-2. PRELIMINARY MEASUREMENTS AND ADJUSTMENTS.

General. Certain measurements and adjustments are done during inspection or assembly operations for the winch assembly. Actual values are to be recorded on the Final Inspection Record (F.I.R.) at the time adjustment or inspection is accomplished. These measurements and adjustments are:

- (1) Wormshaft end freeplay — 0.005-0.015 in. (0.13-0.38 mm).
- (2) Worm gear shaft end play — 0.005-0.015 in. (0.13-0.38 mm).
- (3) Roller bracket spacing — 15.5 ± 0.060 -0.0 in. (393.7 ± 1.59 -0.0 mm). Measure at top and bottom.
- (4) Poppet clearance over poppet nut — 0.015-0.060 in. (0.38-1.52 mm).
- (5) Wormshaft and worm gear backlash (all winches) — 0.006-0.010 in. (0.16-0.25 mm).

4-3. TEST FACILITY.

Test Stand. The test stand must meet these minimum requirements:

- (1) A rotating power source capable of 50 lb-ft (69 N-m) of input torque at 500-1200 rpm, driveable in either direction.
- (2) A quick disconnect coupling to fit the input shaft to mechanically drive all winches. Adapters will be needed for power test of front winches P/N 7411122-1 and 7412382-1, which are driven by hydraulic motors.
- (3) Instrumentation to measure input shaft speed and front winch end case and gearcase (gearcase only on rear winch) oil temperature.

4-4. TESTING (ACCEPTANCE TEST).

a. Preparation (Refer to Figs. 4-1, 4-2, and 4-3).

- (1) Mount winch on test stand bed, but do not make connections to winch input shaft.
- (2) Make sure oil level is correct (two places on front winches and one place on rear winch) and winch is lubricated per LO 9-2320-211-12, LO 9-2320-260-12, or LO 9-2320-272-12.
- (3) Loosen front winch drag brake to allow drum to rotate freely.
- (4) Loosen automatic brake to remove drag on wormshaft.

4-4. TESTING (ACCEPTANCE TEST) (Contd).

b. Free Running Test.

NOTE

During free running test, check for the following malfunctions. Record discrepancies on Final Inspection Record (F.I.R.). Make corrections and record corrections on F.I.R.

(1) Malfunctions:

- (a) Winch controls do not operate properly.
- (b) Binding or noise during drum rotation.
- (c) Freeplay during roller rotation.
- (d) Binding, noise, or freeplay during level wind operation.
- (e) Tensioner sheaves do not rotate freely and tensioner controls do not operate properly.

(2) Front Winch (Refer to Figs. 4-1 and 4-2).

(a) Winch Controls.

1. Operate manual control (clutch) lever and ensure drum engages and disengages (may have to rotate drum by hand to engage). Detent and lock holds manual control lever in engaged or disengaged position.

2. Drum lock holds and releases drum. In unlocked position, poppet must clear drum. No noise when drum free wheeled.

(b) Drum. Drum must rotate with no binding or noise. Rotate in both wind and unwind directions. Engage manual control and turn input shaft 15 revolutions. Drum must rotate approximately 1/2 revolution.

(c) Rollers.

1. Side rollers must rotate with no radial freeplay. Axial freeplay of 0-0.078 in. (0-2.38 mm) is allowed.

2. Horizontal roller must have no noticeable radial or axial freeplay at either end.

(d) Level Wind (Front Winches P/N 7411122 and 7411122-1 only).

1. Trolley wheels must roll with no binding, noise, or noticeable radial or axial freeplay.

2. Unlock trolley and tip at all four corners. Trolley freeplay is allowed, but must not separate from track when screw heads contact inside lip of track. Trolley must move over track (from stop to stop) with no interference.

3. Sheave must rotate in swivel with no binding, noise, wobble, or noticeable radial or axial freeplay.

4. Swivel must rotate in trolley over range permitted by sheave with no noticeable radial or axial freeplay.

5. Trolley lock poppet must lock and unlock trolley. In lock position, ears of lock handle must fully seat in poppet nut. When unlocked, poppet must not interfere with movement of trolley. Jamnut must be tight.

(e) Tensioner (Front Winches P/N 7411122 and 7411122-1 Only).

1. Sheaves must rotate with no binding, noise, wobble, or radial or axial freeplay. When moveable sheave is at closest position to fixed sheave, lips of sheaves must aline.

2. Tensioner poppet must fully seat in each adjustment position and ears of latch must fully seat in poppet nut. Jamnut must be tight.

3. Adjustment lever must move without interference when poppet is in unlocked position.

(f) If no discrepancies were observed during free running test, proceed to paragraph 4-4c.

4-4. TESTING (ACCEPTANCE TEST) (Contd).

b. Free Running Test (Contd).

(3) Rear Winch (Refer to Fig. 4-3).

(a) **Drum and Winch Controls.** Rear winch drum is keyed to the worm gear shaft and there is no manual clutch or drum lock. Drum is rotated only when input shaft is rotated. Drum must rotate with no binding or noise.

(b) Level Wind.

1. Trolley wheels must roll with no binding, noise, or noticeable radial or axial freeplay.
2. Unlock trolley and tip at all four corners. Trolley freeplay is allowed, but must not separate from track when setscrews contact inside lip of track. Trolley must move over track (from stop to stop) with no interference.
3. Sheave must rotate in swivel with no binding, noise, wobble, or noticeable radial or axial freeplay.
4. Swivel must rotate in trolley over range permitted by sheave with no noticeable radial or axial freeplay.
5. Trolley lock poppet must lock and unlock trolley. In lock position, ears of latch must fully seat in poppet nut. When unlocked, poppet must not interfere with movement of trolley. Jamnut must be tight.

(c) Tensioner.

1. Sheaves must rotate with no binding, noise, wobble, or radial or axial freeplay. When moveable sheave is at closest position to fixed sheave, lips of sheaves must align.
2. Actuating lever must move without interference over range of travel.

(d) If no discrepancies were observed during free running test, proceed to paragraph 4-4c.

c. Power Test.

CAUTION

- Do not perform power test on a unit while any malfunctions or discrepancies exist.
- Stop test immediately if gearcase (or end case on front winches) temperature rises above 250°F (121°C). Correct malfunction before proceeding with test.

NOTE

- Record on Final Inspection Record (F.I.R.) any malfunctions that occur. Also record corrections made.
- Record lubricant temperature at time of malfunction.

(1) Check for the Following Malfunctions:

- (a) Excessive noise or changes in gear noise.
- (b) Excessive bearing noise (ball or roller bearings) or scraping or binding (sleeve bearings).
- (c) Drum does not rotate properly.
- (d) Lubricant leaks.

(2) Preliminary Test Operations (Refer to Figs. 4-1, 4-2, and 4-3).

- (a) Mount winch on test stand.
- (b) Connect input power and instrumentation to winch undergoing test.
- (c) Adjust automatic brake. Refer to TM 9-2320-211-20-3-2, chapter 18; TM 9-2320-260-20-3-4, chapter 18; or TM 9-2320-272-20-2, chapter 10. Do not tighten brake housing cover screws.

4-4. TESTING (ACCEPTANCE TEST) (Contd).

c. Power Test (Contd).

(2) Preliminary Test Operations (Contd).

(d) Burnishing Automatic Brake Lining.

1. Release front winch drum lock, turn handle, and secure in unlocked position.
2. Engage front winch manual clutch (turn drum by hand if necessary).
3. Apply sufficient input power to maintain speed of 1100-1200 rpm for five minutes.
4. Monitor gearcase oil temperature. Temperature should stabilize at 145°F (63°C) or less.
5. Allow oil temperature to drop to 65-85°F (18-29°C).
6. Adjust automatic brake as in (2) (c).
7. Install brake housing cover (and gasket, if removed) and tighten screws.

(e) Adjust front winch drag brake. Refer to (2) (c), which also includes drag brake adjustment for front winches.

(3) Power Test Front and Rear Winches.

Perform power tests sequences shown in table 4-1 for particular winch undergoing power test.

Table 4-1. Test Sequences for Front and Rear Winches.

TIME DURATION FOR EACH TEST IS FIVE MINUTES.		
INPUT TO WINCH		CLUTCH ENGAGEMENT
RPM	DIRECTION	
Front Winch:		
500	Forward	Not Engaged.
500	Reverse	Not Engaged.
1000	Forward	Not Engaged.
1000	Reverse	Not Engaged.
<u>CAUTION</u>		
Do not shift clutch while winch is power driven. Disconnect input power to shift clutch.		
500	Forward	Engaged.
500	Reverse	Engaged.
1000	Forward	Engaged.
1000	Reverse	Engaged.
Rear Winch:		
500	Forward	
500	Reverse	
1000	Forward	
1000	Reverse	

4-4. TESTING (ACCEPTANCE TEST) (Contd).

c. Power Test (Contd).

(4) **Oil Inspection.** Drain oil and examine oil for evidence of overheating (color and odor) and evidence of metal chips, flakes, or powder. If these conditions are present, note on F.I.R., determine source, correct cause, and retest as necessary. Install oil drainplug(s).

(5) Remove instrumentation and input power connections from winch. Remove winch from test stand.

4-5. DURABILITY TESTS.

a. **General.** These tests are performed as follow-on tests to the final performance test (acceptance test) described in paragraph 4-4. Refer to chapter 5, paragraphs 5-9 and 5-11.

(1) The durability tests can be run in a regular work shift schedule. This schedule provides sufficient warmup and cool down intervals.

(2) A log based on comparable sections of the Final Inspection Record (F.I.R.), paragraph 4-8, will be kept for the identified durability test.

(3) The test stand and installed winch assembly will be manned at all times while equipment is under power.

(4) All cautions, notes, and malfunctions listed in paragraphs 4-2 through 4-4, will be strictly observed.

(5) Test winch assembly will be filled with 2.6 qt (2.5 L) (2 places) for front winches and 3.0 qt (2.8 L) for rear winches of gear oil prior to commencement of durability test. Lubricate with GAA grease per LO 9-2320-211-12, LO 9-2320-260-12, and LO 9-2320-272-12.

(6) Recheck that automatic brake (all winches) and drag brake (front winches only) are adjusted to specifications. Refer to paragraph 4-4c(2)(d and e).

(7) Operator performing durability type testing must be familiar with procedures for final (acceptance) test.

b. Test Operation.

(1) Test winch and test equipment are set up the same as in Final Test (Acceptance Test) (paragraph 4-4).

CAUTION

Stop test if oil temperature exceeds 250°F (121°C). Find cause and correct before proceeding with test. Retest if necessary.

NOTE

- Stop test immediately if malfunction occurs, repair as required.
- Record lubricant temperature at time of malfunction.

(2) Check for the following malfunctions:

- (a) Excessive noise or changes in gear noise.
- (b) Excessive bearing noise (ball and roller bearings) or scraping or binding (sleeve bearings).
- (c) Drum does not rotate properly.
- (d) Lubricant leaks.

(3) Perform test sequences of table 4-1. Repeat sequences to meet time conditions of durability test being performed.

(4) At conclusion of durability test, drain oil and examine for evidence of overheating (color and odor) and evidence of metal chips, flakes, or powder. If these conditions are present, determine source, correct cause, and retest as necessary. Install and tighten drain plug(s).

(5) Remove instrumentation and input power connections from winch. Remove winch from test stand.

(6) If winch successfully passes durability test, it may be processed for shipment as an accepted unit.

c. **Initial Reconditioning Test (IRT).** This is a 16 hour durability test performed after Final Test (Acceptance Test). Refer to chapter 5, paragraph 5-9. Perform this test under conditions of paragraphs a. and b. above.

d. **Control Test (CT).** This is an 8 hour durability test performed after Final Test (Acceptance Test). Refer to chapter 5, paragraph 5-11. Perform this test under conditions of paragraphs a. and b. above.

4-6. LUBRICATION.

- a. No additional oil is added after testing. Only oil remaining in unit is drain down oil.
- b. Winch assembly will be tagged, indicating incomplete lubrication. Lubrication will be completed at installation in accordance with lubrication order for the series vehicle.

4-7. PAINTING, REFINISHING, AND MARKING.

- a. At completion of assembly and testing, protect the external surfaces of the winch assembly by applying primer and finish coats of paint. This pertains to all external surfaces except tapped holes, shaft, and lubrication fittings.
- b. Prepare and pretreat surfaces prior to painting as follows:
 - (1) Remove all loose scale, weld spatter, and weld slag from bright metal, welds, and adjacent areas.
 - (2) Remove all rust and surface scale using a wire brush, sand blast, grit blast, or other effective methods.
 - (3) Remove all dirt, grease, and other contaminants with clean cloth saturated with a cleaner before applying each coat of paint. For additional information, see TT-C-490, Cleaning Methods for Ferrous Surfaces and Pretreatment for Organic Coatings and MIL-C-10578, Corrosion Removing and Metal Conditioning Compound (Phosphoric Acid Base).

NOTE

Painting shall be performed in a well-ventilated and protected area that is clean and dry.

- c. Prime and paint according to the following:
 - (1) Use materials given below.

TREATMENT	SPEC. NO.	TITLE
Primer coating	TT-P-636	Primer Coating, Alkyd, Wood and Ferrous Metal
	TT-P-664	Primer Coating, Synthetic, Rust-Inhibiting, Laquer Resisting
External surfaces coating	MIL-P-53030	Primer Coating, Epoxy, Water Reducible, Lead and Chromate Free
	MIL-C-46168D	Coating, Aliphatic Polyurethane, Chemical Agent Resistant, Green 383, type II
Brakedrum brake lining contact surface only	MIL-P-46093	Primer Coating, Synthetic (for Brakedrums)
Tapped holes and exposed shaft.	VV-L-800	Lubricating Oil, General Purpose, Preservative (Water Displacing, Low Temperature)

- (2) Follow painting procedures in TM 43-0139, Painting Instructions for Field Use.

- d. Paint will be inspected to determine quality of workmanship and proper coverage to applicable specifications.
- e. The finish on metal surfaces will be inspected to OIP's, reclamation procedures, or engineering drawings, as applicable. Minor surface defects affecting appearance but not interfering with fit or function are acceptable. Surface defects affecting fit or function must be reworked.
- f. Markings shall be accomplished by use of labels, plates, stamping, stenciling, printing, or tagging in accordance with MIL-STD-129, Marking for Shipment and Storage, and MIL-STD-130, Identification Marking of U.S. Military Property. Hand lettering or writing shall not be used.

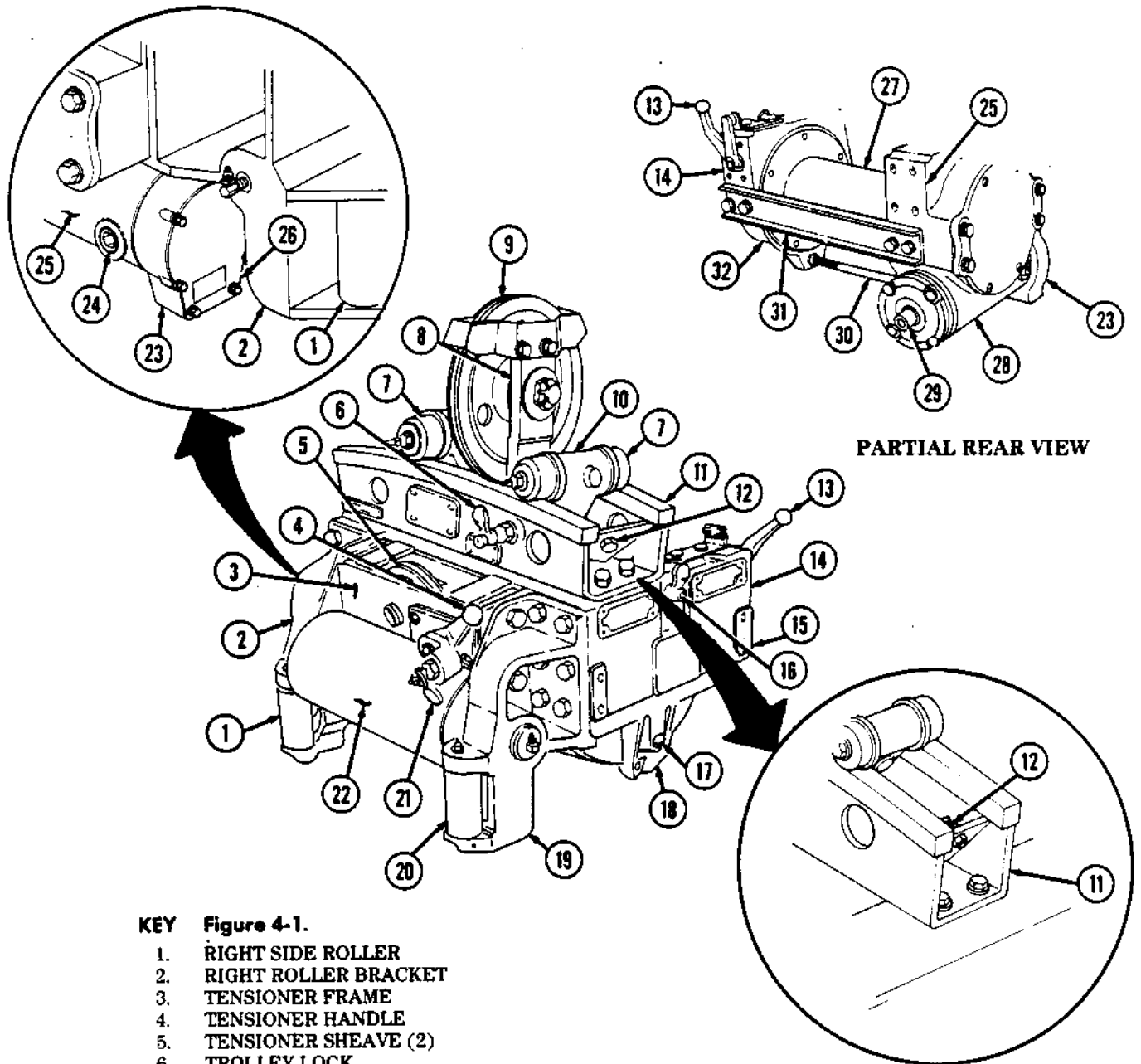

KEY Figure 4-1.

- | | | | |
|-----|--|-----|---|
| 1. | RIGHT SIDE ROLLER | 20. | LEFT SIDE ROLLER |
| 2. | RIGHT ROLLER BRACKET | 21. | TENSIONER LOCK |
| 3. | TENSIONER FRAME | 22. | HORIZONTAL ROLLER |
| 4. | TENSIONER HANDLE | 23. | AUTOMATIC BRAKE HOUSING |
| 5. | TENSIONER SHEAVE (2) | 24. | GEARCASE OIL FILLER PLUG |
| 6. | TROLLEY LOCK | 25. | GEARCASE HOUSING |
| 7. | TROLLEY WHEEL (4) | 26. | AUTOMATIC BRAKE ADJUSTMENT
(INNER SIDE OF HOUSING) |
| 8. | SWIVEL FRAME | 27. | DRUM |
| 9. | LEVEL WIND SHEAVE | 28. | DRAINPLUG (UNDERSIDE OF
GEARCASE HOUSING) |
| 10. | TROLLEY FRAME | 29. | WORMSHAFT (INPUT) |
| 11. | TROLLEY TRACK (2) | 30. | TIE ROD |
| 12. | TROLLEY STOPSCREW (2) | 31. | REAR CHANNEL |
| 13. | MANUAL CLUTCH LEVER | 32. | END FRAME DRAINPLUG
(UNDERSIDE OF END FRAME) |
| 14. | END FRAME HOUSING | | |
| 15. | END FRAME OIL FILLER PLUG
(REAR OF END FRAME) | | |
| 16. | DRUM LOCK | | |
| 17. | DRAG BRAKE ADJUSTMENT
(UNDER PIPE PLUG) | | |
| 18. | DRAINPLUG (UNDERSIDE OF
END FRAME HOUSING) | | |
| 19. | LEFT ROLLER BRACKET | | |

Figure 4-1. Front Winch Assembly With Level Wind and Cable Tensioner.

TA 51219

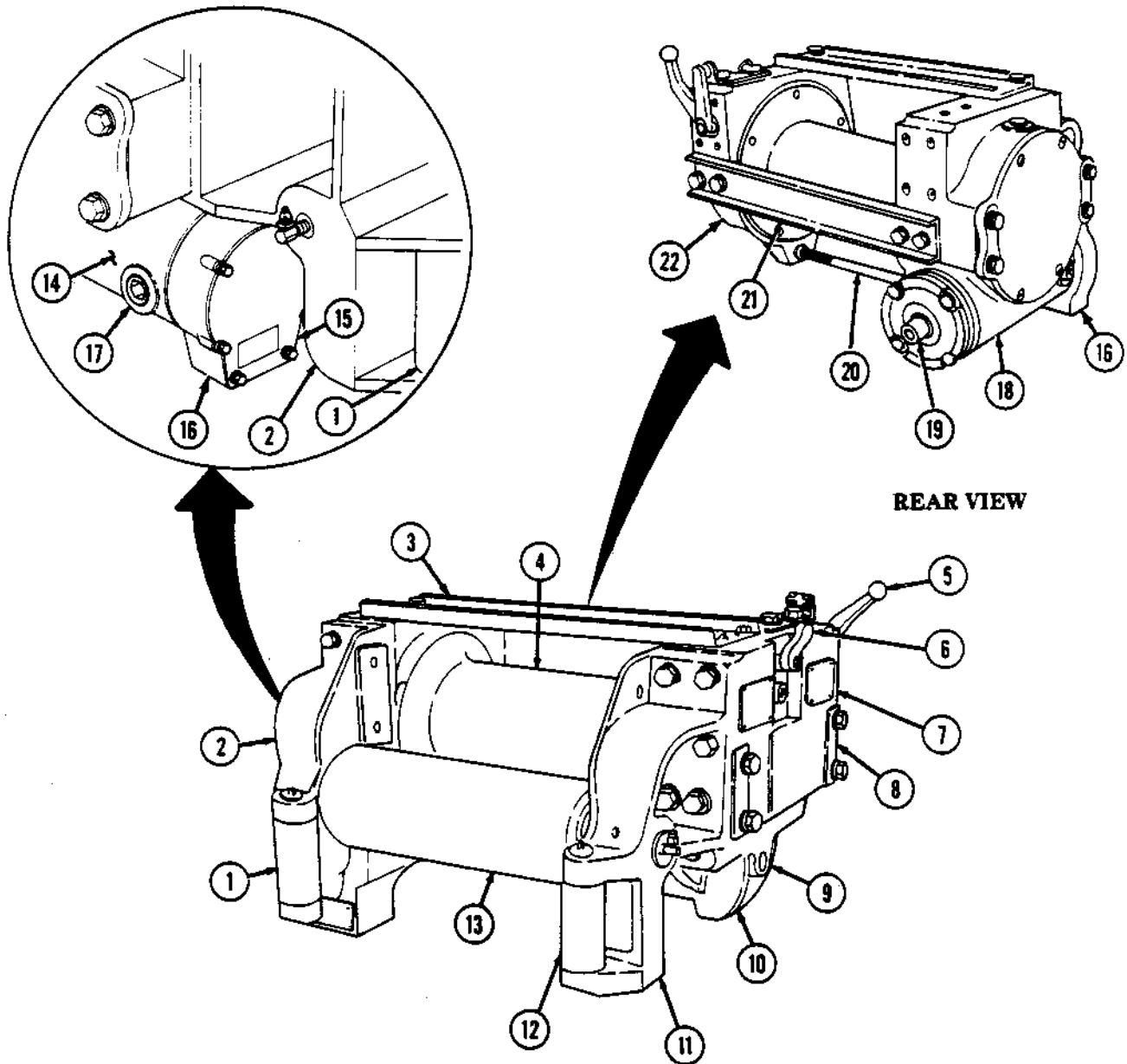

KEY Figure 4-2.

- | | |
|---|--|
| <ul style="list-style-type: none"> 1. RIGHT SIDE ROLLER 2. RIGHT ROLLER BRACKET 3. TOP CHANNEL 4. DRUM 5. MANUAL CLUTCH HANDLE 6. DRUM LOCK 7. END FRAME HOUSING 8. END FRAME OIL FILLER PLUG (REAR OF END FRAME) 9. DRAG BRAKE ADJUSTMENT (UNDER PIPE PLUG) 10. DRAINPLUG (UNDERSIDE OF END FRAME) | <ul style="list-style-type: none"> 11. LEFT ROLLER BRACKET 12. LEFT SIDE ROLLER 13. HORIZONTAL ROLLER 14. GEARCASE HOUSING 15. AUTOMATIC BRAKE ADJUSTMENT (INNER SIDE OF HOUSING) 16. AUTOMATIC BRAKE HOUSING 17. GEARCASE OIL FILLER PLUG 18. DRAINPLUG (UNDERSIDE OF GEARCASE HOUSING) 19. INPUT SHAFT 20. TIE ROD 21. REAR CHANNEL 22. END FRAME DRAINPLUG (UNDERSIDE OF END FRAME) |
|---|--|

Figure 4-2. Front Winch Assembly Without Level Wind or Cable Tensioner.

TA 51220

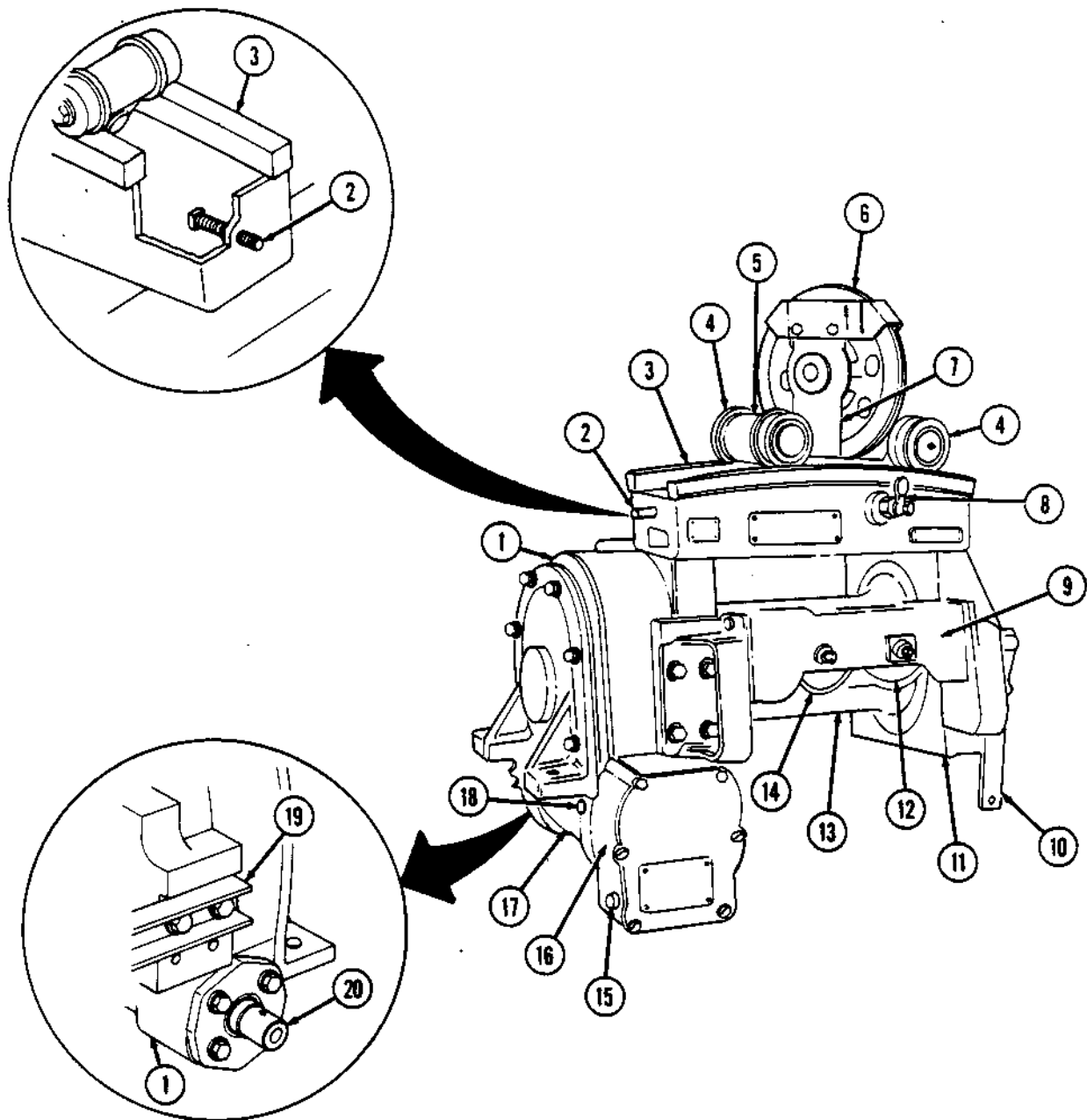
**KEY Figure 4-3.**

- | | |
|--------------------------|--------------------------------------|
| 1. GEARCASE HOUSING | 12. TENSIONER SHEAVE (MOVABLE) |
| 2. TROLLEY STOPSCREW (2) | 13. DRUM |
| 3. TROLLEY TRACK | 14. TENSIONER SHEAVE (FIXED) |
| 4. TROLLEY WHEEL (4) | 15. AUTOMATIC BRAKE ADJUSTMENT |
| 5. TROLLEY FRAME | 16. AUTOMATIC BRAKE HOUSING |
| 6. LEVEL WIND SHEAVE | 17. DRAINPLUG (UNDERSIDE OF HOUSING) |
| 7. SWIVEL FRAME | 18. GEARCASE OIL FILLER PLUG |
| 8. TROLLEY LOCK | 19. REAR CHANNEL |
| 9. TENSIONER FRAME | 20. WORMSHAFT (INPUT) |
| 10. TENSIONER LEVER | |
| 11. END FRAME | |

Figure 4-3. Rear Winch Assembly With LevelWind and Cable Tensioner.

TA 51221

Section II. FINAL PERFORMANCE CHECK

4-8. FINAL INSPECTION RECORD.

**FINAL INSPECTION RECORD
FOR
FRONT AND REAR WINCH ASSEMBLIES
M39, M809, AND M939, 5-TON, 6X6, SERIES VEHICLES**

Part No. _____ Serial No. _____ Model No. _____
Date _____ Inspector _____

Item No.	Characteristic and Type of Inspection	Method of Inspection	Inspector's Initials
1.	<p>COMPLETENESS OF ASSEMBLY:</p> <p>Satisfactory.</p> <p>Unsatisfactory. Describe _____</p> <p>_____</p>	<p>Manual Visual</p>	<p>_____</p> <p>_____</p>
2.	<p>ADJUSTMENTS:</p>	<p>Manual Measure</p>	<p>_____</p> <p>_____</p>
a.	<p>Wormshaft end freeplay. 0.015 in. (0.13-0.38 mm)</p> <p>Satisfactory. Actual _____</p> <p>Unsatisfactory. _____</p>	<p>Manual Measure</p>	<p>_____</p> <p>_____</p>
b.	<p>Worm gear shaft end play. 0.005-0.015 in. (0.13-0.38 mm)</p> <p>Satisfactory. Actual _____</p> <p>Unsatisfactory. _____</p>	<p>Manual Measure</p>	<p>_____</p> <p>_____</p>
c.	<p>Roller brackets spacing (front winches only). 15.5 ± 0.060-0.0 in. (393.7 ± 1.59-0.0 mm)</p> <p>Satisfactory.</p> <p>Unsatisfactory. Describe _____</p> <p>_____</p>	<p>Manual Measure</p>	<p>_____</p> <p>_____</p>

Figure 4-4. Final Inspection Record (F.I.R.) (Sheet 1 of 6).

4-8. FINAL INSPECTION RECORD (Contd).

Item No.	Characteristic and Type of Inspection	Method of Inspection	Inspector's Initials
2.	<p>ADJUSTMENTS (Contd).</p> <p>d. Poppet clearance over poppet nut. 0.015-0.060 in. (0.38-1.52 mm)</p> <p>Front winches:</p> <p>P/N 7412382 and 7412382-1 (1 place)</p> <p>P/N 7411122 and 7411122-1 (3 places)</p> <p>Rear winch:</p> <p>P/N 7409980 (1 place)</p> <p>e. Wormshaft and worm gear backlash (all winches). 0.006-0.010 in. (0.16-0.25 mm)</p> <p>Satisfactory.</p> <p>Unsatisfactory.</p>	<p>Manual Measure</p> <p>Manual Measure</p>	<p>_____</p> <p>_____</p> <p>_____</p> <p>_____</p>
3.	<p>FREE RUNNING TEST. (Refer to para. 4-4b.).</p> <p>FRONT WINCHES.</p> <p>a. Winch controls.</p> <p>Satisfactory.</p> <p>Unsatisfactory. Describe _____</p> <p>_____</p> <p>b. Drum.</p> <p>Satisfactory.</p> <p>Unsatisfactory. Describe _____</p> <p>_____</p> <p>c. Rollers.</p> <p>Satisfactory.</p> <p>Unsatisfactory. Describe _____</p> <p>_____</p>	<p>Manual Visual</p> <p>Manual Visual</p> <p>Manual Visual</p>	<p>_____</p> <p>_____</p> <p>_____</p> <p>_____</p> <p>_____</p>

Figure 4-4. Final Inspection Record (F.I.R.) (Sheet 2 of 6).

4-8. FINAL INSPECTION RECORD (Contd).

Item No.	Characteristic and Type of Inspection	Method of Inspection	Inspector's Initials
3.	<p>FREE RUNNING TEST (Contd). FRONT WINCHES (Contd).</p>		
d.	<p>Level wind.</p> <p>Satisfactory.</p> <p>Unsatisfactory. Describe _____</p> <p>_____</p>	<p>Manual Visual</p>	<p>_____</p> <p>_____</p>
e.	<p>Tensioner.</p> <p>Satisfactory.</p> <p>Unsatisfactory. Describe _____</p> <p>_____</p>	<p>Manual Visual</p>	<p>_____</p> <p>_____</p>
	<p>REAR WINCHES.</p>		
f.	<p>Drum and winch controls.</p> <p>Satisfactory.</p> <p>Unsatisfactory. Describe _____</p> <p>_____</p>	<p>Manual Visual</p>	<p>_____</p> <p>_____</p>
g.	<p>Level wind.</p> <p>Satisfactory.</p> <p>Unsatisfactory. Describe _____</p> <p>_____</p>	<p>Manual Visual</p>	<p>_____</p> <p>_____</p>
h.	<p>Tensioner.</p> <p>Satisfactory.</p> <p>Unsatisfactory. Describe _____</p> <p>_____</p>	<p>Manual Visual</p>	<p>_____</p> <p>_____</p>

Figure 4-4. Final Inspection Record (F.I.R.) (Sheet 3 of 6).

4-8. FINAL INSPECTION RECORD (Contd).

Item No.	Characteristic and Type of Inspection	Method of Inspection	Inspector's Initials
4.	<p>POWER TEST. (Refer to para. 4-4c.)</p> <p>All winches.</p> <p>Satisfactory.</p> <p>Unsatisfactory. Describe _____</p> <p>_____</p>	<p>Manual Visual Audible</p>	<p>_____</p> <p>_____</p>
5.	<p>OIL EXAMINATION.</p> <p>Drain oil from winch undergoing test.</p> <p>Examine oil for evidence of overheating, metal chips, flakes, or powder.</p> <p>Evidence of overheating, metal chips, flakes, or powder present.</p> <p>Yes. _____</p> <p>No. _____</p> <p>Retest necessary?</p>	<p>Manual Visual</p>	<p>_____</p> <p>_____</p> <p>_____</p>
6.	<p>LUBRICATION. (Refer to para. 4-6.)</p>	<p>Visual</p>	<p>_____</p>
7.	<p>PAINTING.</p> <p>Coverage (including subassemblies), runs, overspray, etc.</p> <p>Satisfactory.</p> <p>Unsatisfactory. Describe _____</p> <p>_____</p>	<p>Visual</p>	<p>_____</p> <p>_____</p>

Figure 4-4. Final Inspection Record (F.I.R.) (Sheet 4 of 6).

4-8. FINAL INSPECTION RECORD (Contd).

Item No.	Characteristic and Type of Inspection	Method of Inspection	Inspector's Initials
8.	<p>MARKINGS.</p> <p>Data and caution plates secure, properly marked, etc.</p> <p>Satisfactory.</p> <p>Unsatisfactory. Describe _____</p> <p>_____</p>	Visual	<p>_____</p> <p>_____</p>
9.	<p>Prepared for shipment (internal corrosion protection, properly plugged, etc.).</p> <p>Satisfactory.</p> <p>Unsatisfactory. Describe _____</p> <p>_____</p>	Visual	<p>_____</p> <p>_____</p>

Figure 4-4. Final Inspection Record (F.I.R.) (Sheet 5 of 6).

4-8. FINAL INSPECTION RECORD (Contd).

FINAL INSPECTION RECORD
DEFICIENCY SHEET

Part No. _____ Serial No. _____ Model No. _____
Date _____ Inspected by _____

THE INSPECTOR SHALL COMPLETE THIS FORM BY DESCRIPTION OF THE DEFICIENCIES NOTED ON THE FINAL INSPECTION RECORD (F.I.R.). APPROVAL OF CORRECTIVE ACTION TAKEN SHALL BE REQUIRED PRIOR TO ACCEPTANCE.

Item No.	Description of Deficiency	Corrective Action	Inspector's Initials

Figure 4-4. Final Inspection Record (F.I.R.) (Sheet 6 of 6).

CHAPTER 5

QUALITY ASSURANCE/QUALITY CONTROL (QA/QC) PROVISIONS

Section I. GENERAL REQUIREMENTS

5-1. INTRODUCTION. This chapter contains quality assurance/quality control requirements of the contractor/depot for overhaul requirements specified herein.

5-2. PURPOSE. Instructions specified herein, along with referenced specifications, establish guidelines for quality control of contractor/depot services during preshop analysis, disassembly, cleaning, component inspection, repair, assembly, final inspection and testing, preservation, and packing of winch assembly.

5-3. RESPONSIBILITY FOR INSPECTION.

a. Contractor/depot quality assurance activity is responsible for performance of inspections specified herein. The contractor/depot may utilize its own facilities or any other commercial laboratory acceptable to the procuring activity/commodity manager (PA/CM). The PA/CM reserves the right to perform any inspections specified herein when such inspections are necessary to ensure that supplies or services conform to prescribed requirements.

b. Contractor shall develop, administer, and maintain a quality assurance program fulfilling the requirements of MIL-Q-9858, Quality Program Requirements. Depots shall use DESCOM-R 702-1, Depot Quality System, for their purpose.

c. Contractor/depot shall notify the Contracting Officer/National Maintenance Point (NMP) in writing 30 days in advance of date the first end item overhauled will be subjected to complete examinations and tests to assure item possesses the 90 percent of new service life expectancy. At this time the commodity command's quality assurance activity will advise the contractor/depot of his participation in the first overhauled end item inspections.

5-4. QUALITY ASSURANCE TERMS AND DEFINITIONS.

a. **Source of Terms and Definitions.** Refer to MIL-STD-105, Sampling Procedures and Tables for Inspection by Attributes; MIL-STD-109, Quality Assurance Terms and Definitions; and AR 310-25, Dictionary of U.S. Army Terms, for the quality assurance terms and definitions used herein.

b. **Included Terms and Definitions.** Leakage shall be defined by the following classifications:

- (1) **Class I.** Leakage indicated by wetness or discoloration not great enough to form drops.
- (2) **Class II.** Leakage great enough to form drops but not enough to cause drops to drip from item being checked/inspected.
- (3) **Class III.** Leakage great enough to form drops that fall from the item being checked/inspected.

5-5. INSPECTION AND TEST EQUIPMENT.

- a. Contractor shall ensure that all test and measurement equipment is properly maintained and in current calibration status. Unless otherwise specified, contractor shall be responsible for maintenance, calibration, surveillance, and disposition of acceptance inspection and test equipment prescribed herein. All inspection and test equipment used in conjunction with program shall be controlled in accordance with requirements of MIL-STD-120, Gage Inspection; MIL-I-45607, Inspection Equipment, Acquisition, Maintenance, and Distribution of; and MIL-STD-45662, Calibration System Requirements. All inspection and test equipment shall be made available to representative from procuring activity when required for verification purposes.
- b. Depot shall ensure that all inspection and test equipment used in conjunction with the program is maintained and controlled in accordance with DESCOM-R 702-1.
- c. Inspection and test equipment required to overhaul the winch assemblies are listed in table 2-1.

5-6. CERTIFICATION OF PERSONNEL, MATERIALS, AND PROCESSES.

- a. Contractor/depot QA activity shall be responsible for ascertaining and certifying that personnel skills, equipment, and material meet the requirements of work to be accomplished. Unless otherwise specified by the contract or PA/CM representative, the contractor/depot QA activity shall provide the PA/CM with statements or other evidence that specifications for such special processes as welding, radiography, plating, etc. have been complied with.
- b. Personnel and processes shall be certified in accordance with items listed below:

OPERATION/INSPECTION	QUALIFICATION STANDARD/SPECIFICATION	PROCESS STANDARD/SPECIFICATION
Magnetic particle inspection	MIL-STD-410*	MIL-STD-1949
Penetrant inspection	MIL-STD-410	MIL-STD-6866
Radiographic inspection	MIL-R-11470	MIL-STD-1264
	MIL-STD-453	MIL-R-11470
Welding, resistance	MIL-STD-248	MIL-STD-1265
Welding, metal arc and gas	MIL-STD-248	MIL-W-6858
Welding, repair, metal arc	MIL-STD-248	MIL-W-8611
* Refer to Appendix A for full title of military specifications and standards.		

5-7. VISUAL INSPECTION.

- a. **Standards.** The contractor/depot shall develop comparison standards as the need arises to support prescribed inspection characteristics such as burrs, gouges, cracks, bends, mutilations, protective finish, color, etc. Sample standards are to assist in determining acceptance or rejection. Visual comparison standards shall be concurred with by PA quality element.
- b. **Nondestructive Testing (NDT).** Nondestructive testing such as dye penetrant, magnetic particle, radiography, and ultrasonics shall be used when simple visual inspection cannot determine the existence of suspected defects or the extent of known defects.

5-8. QUALITY ASSURANCE PLAN.

- a. Contractors shall prepare a quality assurance plan reflecting complete implementation of MIL-Q-9858, Quality Program Requirements.
- b. Depots shall prepare a quality assurance plan in accordance with DESCOM-R 702-1.
- c. Contractor/depot quality assurance plan shall be submitted to the PA/CM quality element for approval 30 days prior to start of work and must be available for review by the PA/CM at any time during the program.
- d. Contractor/depot shall notify the PA quality element in writing of any change to the quality assurance plan. All changes are subject to approval by the PA/CM throughout the life of the contract/work directive. Plan changes are subject to change through PA.
- e. Records of all inspections by the contractor/depot shall be kept complete and available to the Government during the performance of the contract/work directive.

Section II. INSPECTION REQUIREMENTS**5-9. INITIAL RECONDITIONING TEST (IRT).**

- a. Contractor/depot shall perform an initial reconditioning test when specified by PA. On-site Government quality assurance representative (QAR) shall select one sample assembly representative of contractor/depot overhaul production. Overhaul facility shall notify product manager 30 days in advance of scheduled IRT so test may be witnessed. At the time of notification, the overhaul facility shall provide a test plan for review.
- b. IRT shall verify the DMWR performance requirements, special processes, final acceptance, control test, processing for storage and shipment, and any additional inspection requirements specified by PA. Test and inspection records and reports of corrective action shall be available for examination.
- c. The winch assembly shall be run in accordance with durability tests paragraph 4-5 except the duration shall be 16 hours. If there are no discrepancies, the test unit may be shipped as an accepted unit.

5-10. COMPARISON TEST.

Comparison testing of the winch assembly is not required unless specified by the contract/work directive.

5-11. CONTROL TEST.**a. General.**

- (1) The control test shall be performed on an overhauled, tested, and accepted winch assembly.
- (2) Control test failure may result in discontinuance of acceptance of winch assemblies by the PA until the contractor/depot has demonstrated to the Government that corrective action has been taken to eliminate causes.
- (3) All failures shall be reported to the PA product quality manager within 48 working hours. After correction of all discrepancies found during control test, the winch shall be assembled, subjected to acceptance inspection requirements, and shipped as a serviceable overhauled winch assembly.

b. Testing.

- (1) The PA quality manager or the delegated representative shall select an overhauled winch assembly for control testing and inspection at the rate of one for each 45 or fraction thereof, not to exceed three in a 90-day period.
- (2) The selected winch assembly shall be identified as to the production overhaul period and run in accordance with durability tests, paragraph 4-5, and duration will be 8 hours.
- (3) Winch assemblies subjected to control test may be shipped as regular units of production, if final test and inspection requirements are met.

5-12. IN-PROCESS INSPECTION.

a. General.

(1) Contractor/depot shall establish and perform inspections throughout the overhaul process as necessary to determine conforming or nonconforming material.

(2) Government sampling inspections for OIP characteristics shall be conducted in accordance with MIL-STD-105. Implementing Acceptable Quality Levels (AQL's) of 2.5 for physical/NDT inspection methods and 4.0 AQL for visual/measure inspection methods using single sampling, general level II.

(3) When any work segment as set forth in this DMWR cannot be accomplished, or can only be accomplished in a manner other than specified for whatever reason, prior approval of the procuring activity shall be obtained. Refer to paragraphs 2-2f and g for Deviations and Exceptions.

b. Component Inspection.

(1) **New Components.** Components that replace mandatory replacement parts and unserviceable parts shall be inspected as follows:

(a) Inspection of new or locally manufactured parts will be accomplished by the contractor/depot using applicable drawings, supplementary quality assurance provisions (SQAP's), quality assurance requirements (QAR's), and quality assurance provisions (QAP's).

(b) The contractor/depot inspection system shall utilize Government furnished inspection equipment or designs, when specified in the contract/work directive.

(2) Used Components.

(a) Used components shall be examined 100% by the contractor/depot to determine serviceability in accordance with the limits, fits, and tolerances established in this DMWR. When a noncorrectable defect is noted, no further inspection need be performed on the defective part. In case of assemblies, the defective item shall be removed and inspection continued on the remaining subassemblies or components.

(b) The OIP's in this DMWR have been prepared for parts and components with specified wear limits, specified performance requirements, or fatigue characteristics which may cause part failure. Refer to paragraph 3-19 for additional OIP information. A complete list of the OIP's is provided in appendix C of this DMWR.

(c) Dye penetrant, fluorescent penetrant, and magnetic particle inspection shall be performed as required by the OIP's or when simple visual inspection cannot determine the existence of a suspected defect or to determine the extent of a known defect.

(d) Bearings mounted on shafts or gear hubs and bearing races mounted in gear or hub bores with interference fits that can be visually inspected to determine serviceability should not be removed to obtain particular measurements listed in the OIP's.

(e) Bushing-type bearings mounted in component parts that can be visually inspected and the inside bushing diameter measurements made should not be removed for outside diameter measurement of bushings or inside diameter measurement of bushing bores.

(3) Repaired Components.

Parts repaired shall be inspected in accordance with the following:

(a) Methods of repair/rework shall be inspected to ensure that they are in accordance with specifications and this DMWR.

(b) Repaired/reworked components will be inspected to OIP's and/or drawings, as applicable.

c. Assembly Inspection. The contractor/depot shall:

(1) Continue surveillance over the torquing activity to ensure that torque values are properly maintained. The frequency of torque checks shall be determined by the contractor/depot and approved by the PA/CM.

(2) Monitor that required mandatory replacement parts prescribed in this DMWR are installed.

d. Painting and Metal Finish Inspection.

(1) Painting of the winch assembly shall be monitored to meet the requirements of this DMWR.

(2) The finish on metal surfaces will be inspected to OIP's, reclamation procedures, or engineering drawings as applicable.

5-13. ACCEPTANCE INSPECTION.

a. Contractor/depot QA activity will inspect each winch assembly in accordance with the requirements of this DMWR, utilizing the Final Inspection Record (F.I.R.), paragraph 4-8. Failure to meet the requirements of F.I.R. shall be cause for rejection. Contractor shall submit a completed copy of F.I.R. to the Government for each winch assembly offered for acceptance to the Government. Depots shall maintain an acceptance system in accordance with DESCOM-R 702-1. Final acceptance shall not be considered until there is conformance with all specified requirements.

b. Additional inspection requirements may be established by the contractor/depot as necessary to enhance final inspection.

5-14. RELIABILITY, AVAILABILITY, MAINTAINABILITY, AND DURABILITY (RAM-D) REQUIREMENTS.

a. The winch assembly shall demonstrate 100% DMWR performance, with reduced durability of 90% of new production requirements.

b. RAM-D testing shall be conducted when and as specified by the PA contract/work directive.

CHAPTER 6 PRESERVATION, PACKING, AND MARKING

Section I. GENERAL REQUIREMENTS

6-1. PRESERVATION AND PACKAGING.

a. **General.** Refer to the Army Central Logistics Data Bank (ACLDB) for detailed packaging instructions. If detailed packaging instructions are not provided in the ACLDB, the DARCOM Packaging, Storage, and Containerization (Tobyhanna Army Depot, ATTN: SDSTO-TP-P, Tobyhanna, PA 18466) should be contacted by the performing depot. If work is being performed by a contractor, the contracting officer should be contacted for detailed packaging instructions.

b. **Methods and Materials.** The methods and materials used in the cleaning, preservation, and packaging, unless otherwise specified, shall be in accordance with material specifications, standard packing provisions, and detailed packaging data sheets, MIL-P-116, Preservation, Methods of, and MIL-P-14232, Equipment and Tools for Army Material.

6-2. SHIPMENT.

Equipment shall be prepared for shipment per instructions in the packaging sheets. Shipments shall be accomplished in accordance with terms of the contract.

Section II. STORAGE AND MARKING

6-3. STORAGE.

a. **Preparation of Equipment.** Equipment shall be prepared for storage per instruction in the applicable packaging data sheets. Storage shall be accomplished in accordance with applicable U.S. Army storage and serviceability standards.

b. **Preservation During Interim Storage.** During interim storage, parts which are subject to deterioration or corrosion shall be preserved in accordance with MIL-P-116.

6-4. MARKING FOR STORAGE AND SHIPMENT.

Marking of equipment for storage and shipment shall be in accordance with MIL-STD-129, Marking for Shipment and Storage and MIL-STD-130, Identification Marking of U.S. Military Property.

APPENDIX A REFERENCES

Publications and forms referenced in this DMWR are listed below by publication number and title.

PUBLICATION	TITLE
Quality Control/Quality Assurance:	
DESCOM-R 702-1	Depot Quality System
DA Pamphlets:	
DA PAM 310-1	Consolidated Index of Army Publications and Blank Forms
DA PAM 738-750	The Army Maintenance Management System (TAMMS)
Forms:	
DA Form 2028	Recommended Changes to DA Publications and Blank Forms
DA Form 2407	Maintenance Request
SF Form 368	Quality Deficiency Report (Category II)
Federal Specifications:	
ANSI-A5.1	Covered Carbon Steel AIC Welding Electrodes, Specifications for
QQ-C-320	Chromium Plating (Electrodeposited)
QQ-P-416	Plating, Cadmium (Electrodeposited)
TT-C-490	Cleaning Methods for Ferrous Surfaces and Pretreatment for Organic Coatings
TT-P-636	Primer Coating, Alkyd, Wood and Ferrous Metal
TT-P-664	Primer Coating, Synthetic, Rust-Inhibiting, Lacquer-Resisting
VV-L-800	Lubricating Oil, General Purpose, Preservative (Water Displacing, Low Temperature)
Military Specifications:	
DOD-P-16232	Phosphate Coating, Heavy, Manganese or Zinc Base (for Ferrous Metals)
MIL-A-8625	Anodic Coating for Aluminum and Aluminum Alloys
MIL-C-5541	Chemical Conversion Coatings on Aluminum and Aluminum Alloys
MIL-C-10578	Corrosion Removing and Metal Conditioning Compound (Phosphoric Acid Base)
MIL-C-16173	Corrosion Preventive Compound, Solvent Cutback, Cold Application
MIL-C-26074	Coatings, Electroless Nickel, Requirements for
MIL-C-46168D	Coating, Aliphatic Polyurethane, Chemical Agent Resistant, Green 383, Type II
MIL-G-10924	Grease, Automotive and Artillery

PUBLICATION	TITLE
Military Specifications (Contd):	
MIL-I-23310	Inhibitors, Corrosion, Volatile Oil Type
MIL-I-8846	Inserts, Screw-Thread, Helical Coil
MIL-I-13857	Impregnation of Metal Castings
MIL-I-45208	Inspection System Requirements
MIL-I-45607	Inspection Equipment, Acquisition, Maintenance and Distribution of
MIL-L-46002	Preservative Oil, Contact and Volatile Corrosion — Inhibited
MIL-P-116	Preservation, Methods of
MIL-P-514	Plate, Identification, Instruction, and Marking Blank
MIL-P-14232	Parts, Equipment and Tools for Army Material
MIL-P-46093	Primer Coating, Synthetic (for Brakedrums)
MIL-P-53030	Primer Coating, Epoxy, Water Reducible, Lead and Chromate Free
MIL-Q-9858	Quality Program Requirements
MIL-R-11470	Radiographic Inspection; Qualification of Equipment, Operators, and Procedures
MIL-S-45180	Sealing Compound, Gasket, Hydrocarbon Fluid and Water Resistant
MIL-W-6712	Wire, Metalizing
MIL-W-6858 (REVD)	Welding, Resistance: Spot and Seam, VSMF
MIL-W-8604	Welding, Fusion: Aluminum Alloys; Process and Performance of
MIL-W-8611	Welding, Metal Arc and Gas, Steels, and Corrosion, and Heat Resistant Alloys; Process for VSMF
MIL-W-13773	Welding, Repair of Steel Castings (Other than Armor) Metal Arc, Manual
Military Standards:	
MIL-STD-105	Sampling Procedures and Tables for Inspection by Attributes
MIL-STD-109	Quality Assurance Terms and Definitions
MIL-STD-120	Gage Inspection
MIL-STD-129	Marking for Shipment and Storage
MIL-STD-130	Identification Marking of U.S. Military Property
MIL-STD-248	Welding and Brazing Procedures, and Performance Qualifications
MIL-STD-276	Impregnation of Porous Nonferrous Metal Castings
MIL-STD-410	Nondestructive Testing Personnel Qualification and Certification (Eddy Current, Liquid Penetrant, Magnetic Particle, Radiographic, and Ultrasonic)
MIL-STD-453	Inspection, Radiographic
MIL-STD-1261	Arc Welding Procedures for Constructional Steels
MIL-STD-1264	Radiographic Inspection for Soundness of Welds in Steel by Comparison to Graded ASTM E390 Reference Radiographs
MIL-STD-1265	Radiographic Inspection, Classification and Soundness Requirements for Steel Castings

PUBLICATION	TITLE
Military Standards (Contd):	
MIL-STD-1943	Welding Repair of Steel Casting (Other than Armor)
MIL-STD-1949	Inspection Process, Magnetic Particle
MIL-STD-6866	Inspection, Penetrant, Method of
MIL-STD-45662	Calibration System Requirements
MIL-STD-MS33537	Insert, Screw Thread, Helical Coil, Coarse and Fine Thread, Standard Dimensions for
Technical Bulletins:	
TB ORD 1024	Army Equipment: Manufacture of Data Plates
TB ORD 1030	Army Vehicles: Installation and Use of Overhaul/MWO Data Plates
Technical Manuals:	
TM 9-214	Inspection, Care, and Maintenance of Antifriction Bearings
TM 9-237	Welding Theory and Application
TM 9-247	Materials Used for Cleaning, Preserving, Abrading, and Cementing Ordnance Material and Related Materials Including Chemicals
TM 9-2320-211-34P	Direct Support and General Support Maintenance Repair Parts and Special Tools List for Truck: 5-Ton, 6x6, M39 Series Vehicles
TM 9-2320-211-20-3-2	Organizational Maintenance Manual for Truck: 5-Ton, 6x6, M939 Series Vehicles
TM 9-2320-211-34-2-3	Direct Support and General Support Maintenance Manual for Truck: 5-Ton, 6x6, M39 Series Vehicles
TM 9-2320-260-34P/2	Direct Support and General Support Maintenance Repair Parts and Special Tools List for Truck: 5-Ton, 6x6, M809 Series Vehicles
TM 9-2320-260-20-3-4	Organizational Maintenance Manual for Truck: 5-Ton, 6x6, M809 Series Vehicles
TM 9-2320-260-34-2-4	Direct Support and General Support Maintenance Manual for Truck: 5-Ton, 6x6, M809 Series Vehicles
TM 9-2320-272-34P-2	Direct Support and General Support Maintenance Repair Parts and Special Tools List for Truck: 5-Ton, 6x6, M939 Series Vehicles
TM 9-2320-272-20-2	Organizational Maintenance Manual for Truck: 5-Ton, 6x6, M939 Series Vehicles
TM 9-2320-272-34-2	Direct Support and General Support Maintenance for Truck: 5-Ton, 6x6, M939 Series Vehicles
TM 43-0139	Painting Instructions for Field Use
Lubrication Orders:	
LO 9-2320-211-12	Lubrication Order for Chassis, Truck: 5-Ton, 6x6, M39 Series Vehicles
LO 9-2320-260-12	Lubrication Order for Chassis, Truck: 5-Ton, 6x6, M809 Series Vehicles
LO 9-2320-272-12	Lubrication Order for Truck: 5-Ton, 6x6, M939 Series Vehicles
Army Regulations:	
AR 310-25	Dictionary of U.S. Army Terms

APPENDIX B REPAIR PARTS AND SPECIAL TOOLS LIST

Refer to TM 9-2320-211-34P (M39), TM 9-2320-260-34P/2 (M809), and TM 9-2320-272-34P-2 (M939) for repair parts.

There are no additional tools required for this overhaul. Refer to appendix E for fabricated tools.

APPENDIX C OVERHAUL INSPECTION PROCEDURES

List of Overhaul Inspection Procedures (table C-1) is provided as a means of ready reference to actual OIPs included in the inspection portion of this DMWR. Overhaul Inspection Procedures (OIPs) included in this DMWR are inspection documents that provide inspection data to the contractor and the Government Quality Assurance representative. Also included are nomenclature and Acceptable Quality Level (AQL) of the wear limit. Sampling inspection to determine the overhaul compliance to OIP-required AQL is for Government inspection only. Contractor is required to provide 100% inspection assurance to wear limit requirements.

Table C-1. List of Overhaul Inspection Procedures.

PART NO.	NOMENCLATURE	PAGES
	FRONT WINCH.	
7954482	Frame, End	3-21
7409150	Latch, Lock	3-22
7538725/8344240	Nut, Lock Poppet	3-23
8723828	Poppet, Drum Lock	3-24
7017190	Shaft, Shifter	3-25
7017195	Yoke, Clutch Shifter	3-26
7409814	Clutch, Sliding	3-27
7954477/7409800	Drum with Bushings	3-28
7954454/7409800	Sleeve, End Bearing with Bushing	3-30
7954476/7409800	Cover with Bushing, Gearcase	3-31
7409823	Gear, Worm	3-32
7954473	Shaft, Drum	3-33
7954478	Worm	3-34
8331202	Lock Assembly, Shifter	3-35
7954484/7409800	Gearcase with Bushing	3-36
7409817	Drum, Automatic Brake	3-38
7954475	Case, Automatic Brake	3-39
8344251	Lever, Tensioner	3-40
7411166	Poppet, Tensioner	3-41
8344506/7411163	Block Assembly, Bearing with Bushing	3-42
7994965	Camshaft, Tensioner	3-43
8344248/7411164	Frame, Tensioner with Bushing	3-44
8344250	Sheave, Tensioner (2)	3-45
7411161/MS51838-147	Pin, Tensioner, Roller Sheave with Straight Pin	3-46

Table C-1. List of Overhaul Inspection Procedures (Contd).

PART NO.	NOMENCLATURE	PAGES
FRONT WINCH (Contd).		
8741768	Poppet, Trolley Lock	3-47
8344234	Track Assembly, Trolley, Front	3-48
8344243	Wheel, Trolley (4)	3-49
8344245/7994954	Frame, Trolley with Axles	3-50
7994976/8344246	Frame, Swivel Sheave with Extension	3-51
7411123	Race, Ball Thrust, Inner (Upper)	3-52
MS19059-2422	Ball, Bearing (26)	3-53
7411124	Race, Ball Thrust, Outer (Lower)	3-54
8344244	Bolt, Swivel Sheave	3-55
7411121	Sheave, Swivel	3-56
7954470	Roller Assembly	3-57
7409725	Shaft, Roller	3-58
7409804/7409804-1, 7409805/7409805-1, 7409695/7409609	Bracket and Side Roller Assembly, Left and Right	3-59
12300666-1/12300666-2	Plate, Cable Guide, Left and Right	3-60
7409695/7409807	Roller, Side, with Bushings	3-61
7409609	Pin, Side Roller	3-62
REAR WINCH.		
7954585	Frame, End	3-63
7954586	Drum Assembly	3-64
7954534/7409666	Sleeve, End Bearing with Bushing	3-65
7954563	Shaft	3-66
7409934	Gear, Worm	3-67
7954562	Worm	3-68
7409925	Drum, Automatic Brake	3-69
7954500	Case, Automatic Brake	3-70
7954587/7409666	Cover, Gearcase with Bushing	3-71
7409669/7409666	Gearcase with Bushing	3-72
7409935	Lever, Rocker	3-73
7409665	Bracket, Tensioner, Right-Hand	3-74
7409668	Bracket, Tensioner, Left-Hand	3-75
7409945	Pin, Tensioner Sheave	3-76
7409930	Frame Assembly, Adjustable Sheave	3-77
7409948	Sheave, Tensioner (2)	3-78
7954584	Frame Assembly, Tensioner	3-79

Table C-1. List of Overhaul Inspection Procedures (Contd).

PART NO.	NOMENCLATURE	PAGES
REAR WINCH (Contd).		
7409150	Latch, Trolley Lock	3-80
8344240	Nut, Poppet, Trolley	3-81
8741768	Poppet, Trolley Lock	3-82
7954574	Track Assembly, Trolley, Rear	3-83
8690894/7409950	Frame Assembly, Trolley	3-84
7409960	Wheel, Trolley (4)	3-86
7409892	Frame, Swivel	3-87
8690893	Shaft Assembly, Swivel Sheave	3-88
7954539-1	Spacer, Bearing (2)	3-89
7409952	Sheave, Swivel	3-90
MS19059-2424	Ball, Bearing (45)	3-91
7409896	Race, Ball Thrust, Inner and Outer (2)	3-92

APPENDIX D FITS AND TOLERANCES

Repair and replacement standards (table D-1) give the minimum, maximum, and key clearances of new or overhauled parts. Normally, all parts which have not worn beyond the dimensions shown in the tolerances column (if not otherwise damaged) are acceptable for service.

Table D-1. Repair and Replacement Standards.

INDEX NUMBER	ITEM/POINT OF MEASUREMENT	WEAR LIMIT
FRONT WINCH		
1	Thrust ring thickness (P/N 7409591)	0.492 - 0.508 in. (12.50 - 12.90 mm)
2	Thrust ring thickness (P/N 7409685)	0.486 - 0.490 in. (12.34 - 12.45 mm)
3	Drum shaft bearing inside diameter (4) (P/N 7409800)	2.127 - 2.130 in. (54.04 - 54.10 mm)
4	Drum shaft outside diameter (4 places) (P/N 7954473)	2.123 - 2.125 in. (53.92 - 53.98 mm)
5	Worm and worm gear backlash	0.006 - 0.010 in. (0.15 - 0.25 mm)
6	Worm shaft end play (assembly)	0.005 - 0.015 in. (0.13 - 0.38 mm)
7	Drum shaft end play (assembly)	0.005 - 0.015 in. (0.13 - 0.38 mm)

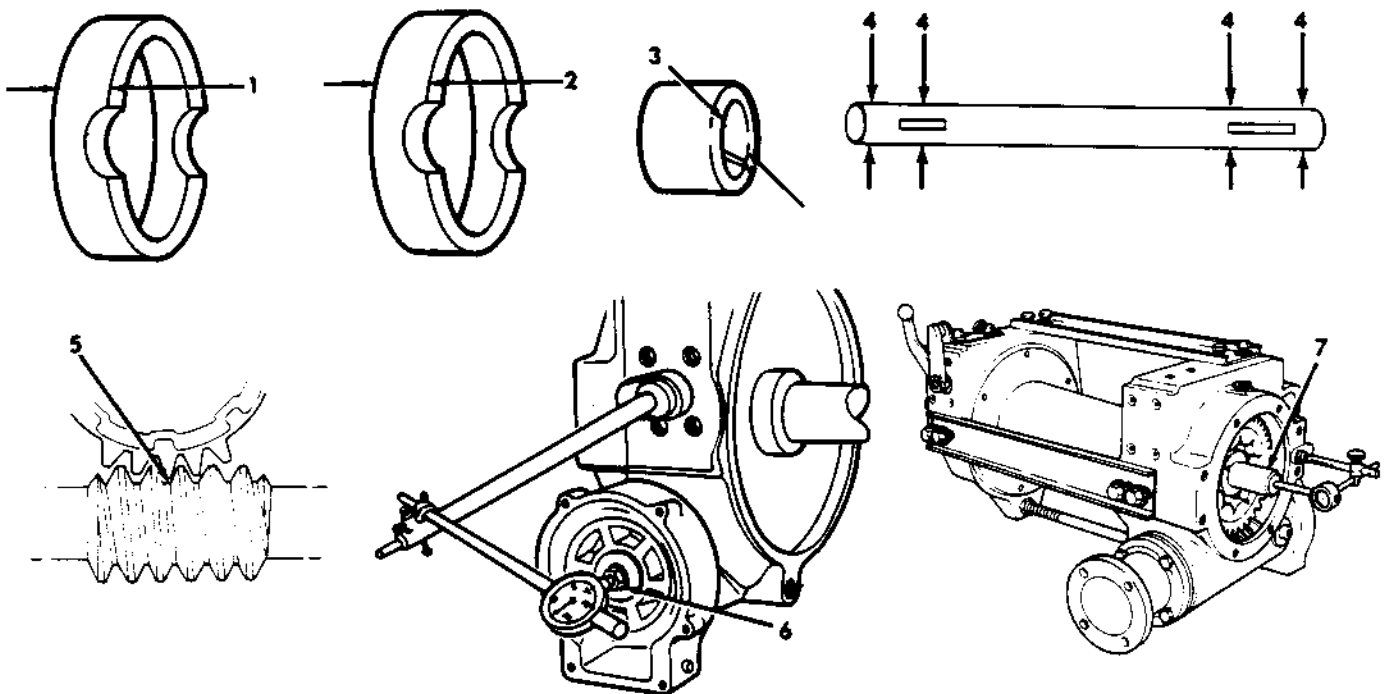

TA 51222

Figure D-1. Repair and Replacement Standards; Points of Measurement for Front Winch and Components.

Table D-1. Repair and Replacement Standards (Contd).

INDEX NUMBER	ITEM/POINT OF MEASUREMENT	TOLERANCES
FRONT WINCH TENSIONER		
1	Tensioner roller pin outside diameter (P/N 7411161)	0.9995 - 1.0000 in. (25.273 - 25.4000 mm)
2	Tensioner thrust washer thickness (4) (P/N 7411170)	0.0615 - 0.0635 in. (1.562 - 1.6091 mm)
3	Tensioner roller shaft cam bearing surface outside diameter (2 places) (P/N 7994965)	0.748 - 0.750 in. (19.00 - 19.05 mm)
4	Tensioner roller shaft cam outside diameter (P/N 7954965)	0.9995 - 1.0000 in. (25.387 - 25.40 mm)
5	Tensioner roller shaft bushing inside diameter (P/N 7411164 and 7411163)	0.751 - 0.754 in. (19.07 - 19.15 mm)
6	Tensioner sheave thickness (2) (P/N 8344250)	1.230 - 1.240 in. (31.24 - 31.50 mm)
FRONT WINCH LEVEL WIND		
7	Level wind sheave thrust washer thickness (2) (P/N 8344242)	0.0615 - 0.0635 in. (1.562 - 1.609 mm)
8	Level wind sheave thickness (P/N 7411121)	1.985 - 1.990 in. (50.42 - 50.55 mm)
9	Level wind axle thrust washer thickness (4) (P/N 7411152)	0.0615 - 0.0635 in. (1.562 - 1.609 mm)

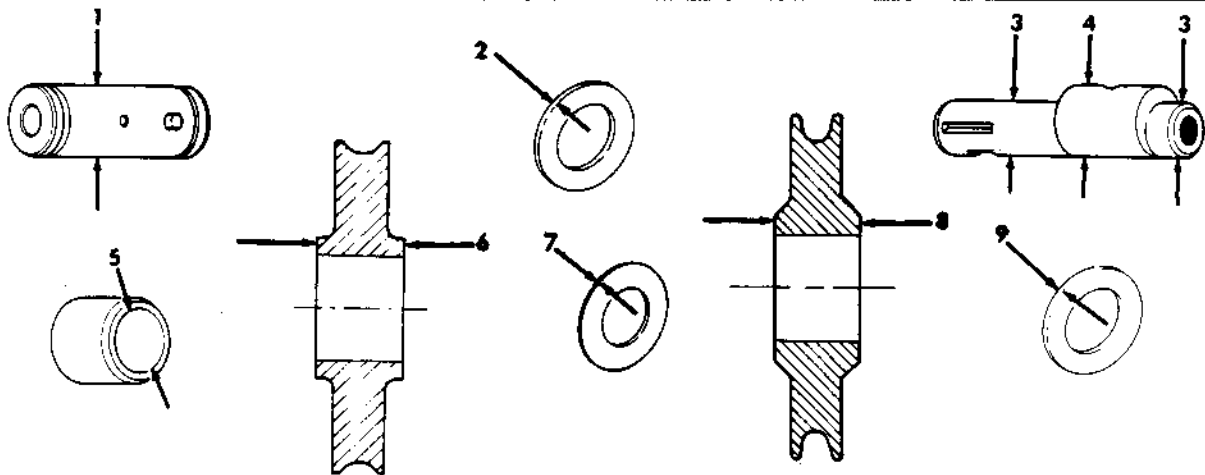

Figure D-2. Repair and Replacement Standards; Points of Measurement for Front Winch Tensioner and Front Winch Level Wind.

TA 51223

Table D-1. Repair and Replacement Standards (Contd).

INDEX NUMBER	ITEM/POINT OF MEASUREMENT	TOLERANCES
FRONT WINCH ROLLER		
1	Side roller pin outside diameter (2) (P/N 7409609)	0.995 - 1.000 in. (25.27 - 25.40 mm)
2	Side roller bushing inside diameter (4) (P/N 7409807)	1.001 - 1.004 in. (25.43 - 25.50 mm)
3	Side roller thrust washer thickness (4) (P/N 7409728)	0.059 - 0.060 in. (1.49 - 1.52 mm)
4	Roller shaft outside diameter (2 places) (P/N 7409725)	1.4995 - 1.5000 in. (38.087 - 38.100 mm)
5	Roller shaft thrust washer thickness (2) (P/N 7409729) (may have notch on outer edge)	0.0615 - 0.0655 in. (1.562 - 1.664 mm)

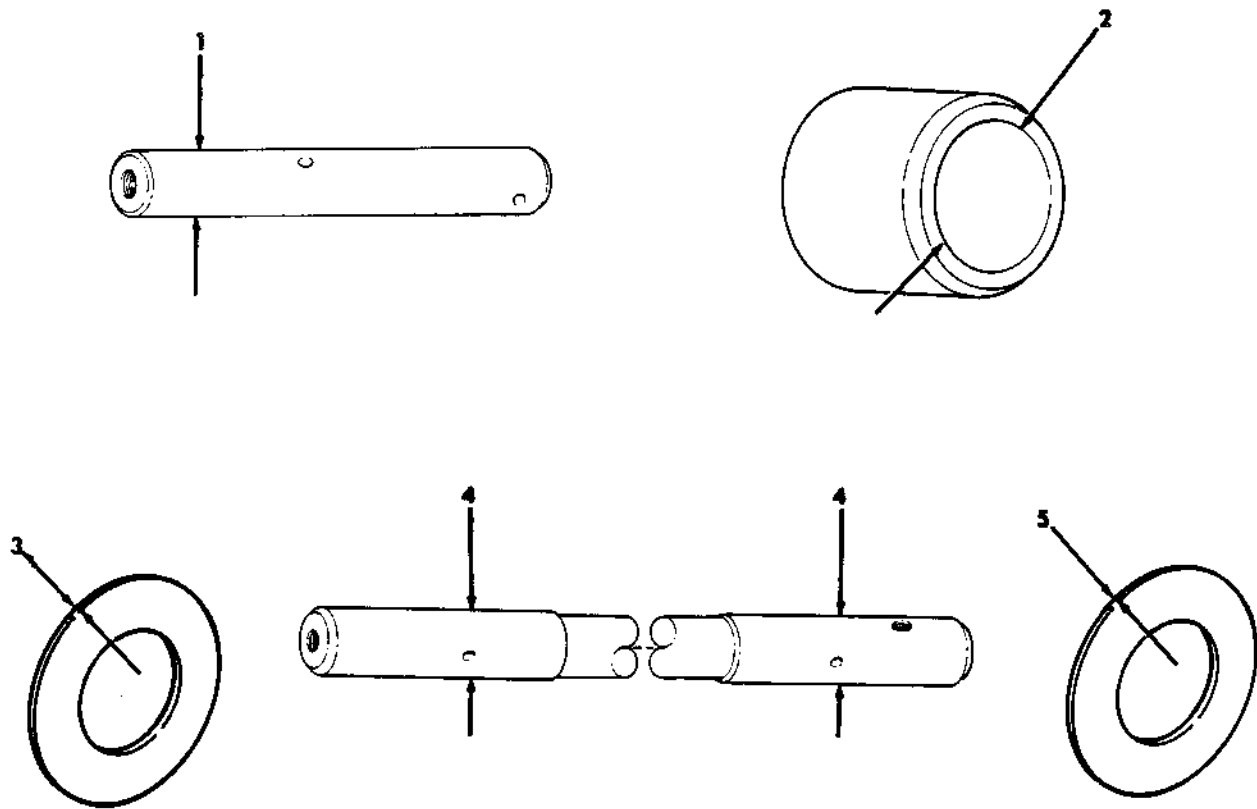

Figure D-3. Repair and Replacement Standards; Points of Measurement for Front Winch Roller.

TA 51224

Table D-1. Repair and Replacement Standards (Contd).

INDEX NUMBER	ITEM/POINT OF MEASUREMENT	TOLERANCES
REAR WINCH		
1	Keyed thrust washer thickness (4) (P/N 7409977 and 7409979)	0.0615 - 0.0655 in. (1.562 - 1.664 mm)
2	Drum shaft outside diameter (3 places) (P/N 7954563)	2.998 - 3.000 in. (76.15 - 76.20 mm)
3	Drum shaft bushing inside diameter (3) (P/N 7409666)	3.005 - 3.007 in. (76.33 - 76.38 mm)
4	Drum shaft end play (assembly)	0.005 - 0.015 in. (0.13 - 0.38 mm)
5	Worm shaft end play (assembly)	0.005 - 0.015 in. (0.13 - 0.38 mm)
6	Worm and worm gear backlash (installed)	0.006 - 0.010 in. (0.15 - 0.25 mm)

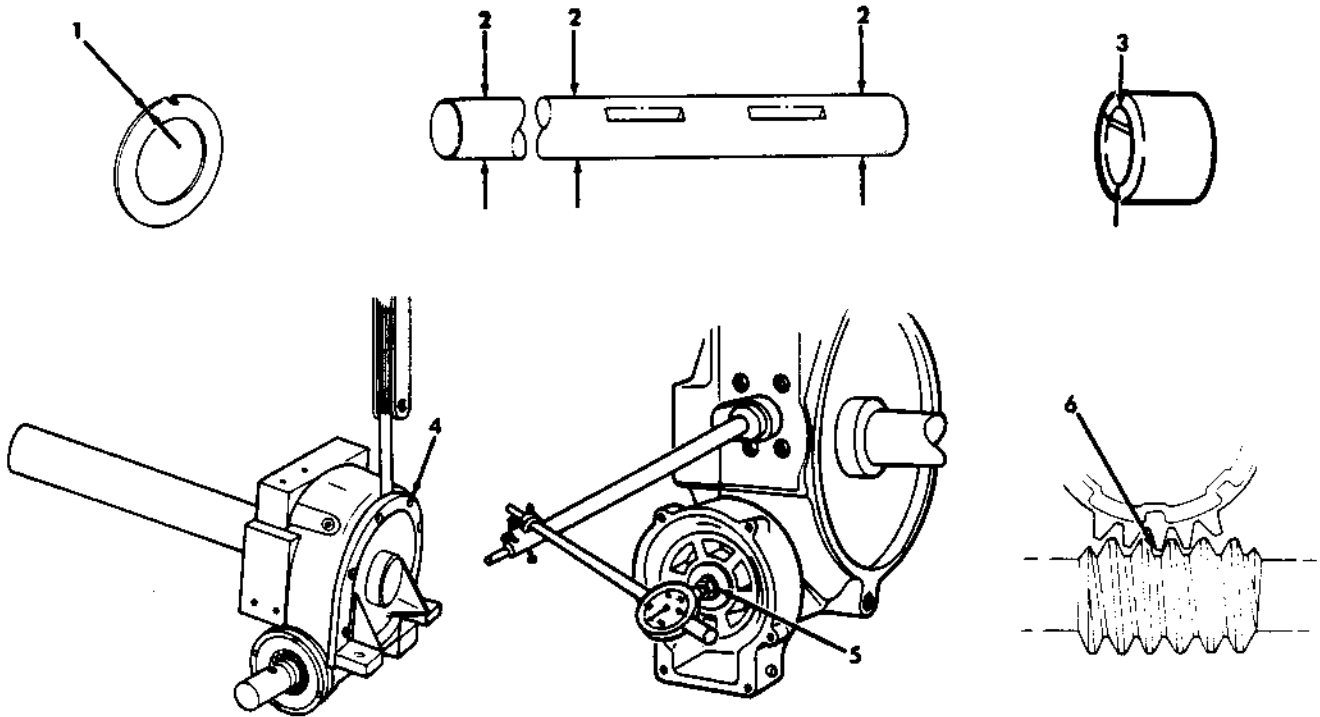

Figure D-4. Repair and Replacement Standards; Points of Measurement for Rear Winch Components.

TA 51225

Table D-1. Repair and Replacement Standards (Contd).

INDEX NUMBER	ITEM/POINT OF MEASUREMENT	TOLERANCES
REAR WINCH TENSIONER		
1	Tensioner sheave thrust washer thickness (4) (P/N 7409975)	0.0615 - 0.0655 in. (1.562 - 1.664 mm)
2	Tensioner roller pin outside diameter (2) (P/N 7409945)	1.2495 - 1.2500 in. (31.737 - 31.750 mm)
3	Tensioner sheave thickness (2) (P/N 7409948)	1.480 - 1.490 in. (37.50 - 37.85 mm)
REAR WINCH LEVEL WIND		
4	Level wind axle outside diameter (4) (P/N 7409891)	1.9995 - 2.0000 in. (50.787 - 50.800 mm)
5	Level wind shaft outside diameter (P/N 7409950)	0.8745 - 0.8750 in. (22.212 - 22.225 mm)
6	Level wind axle thrust washer thickness (4) (P/N 7409953)	0.0615 - 0.0655 in. (1.562 - 1.664 mm)
7	Level wind sheave pin outside diameter (P/N 8690893)	2.7490 - 2.7496 in. (69.825 - 69.840 mm)
8	Level wind sheave thrust washer thickness (2) (P/N 7409958)	0.0615 - 0.0655 in. (1.562 - 1.664 mm)

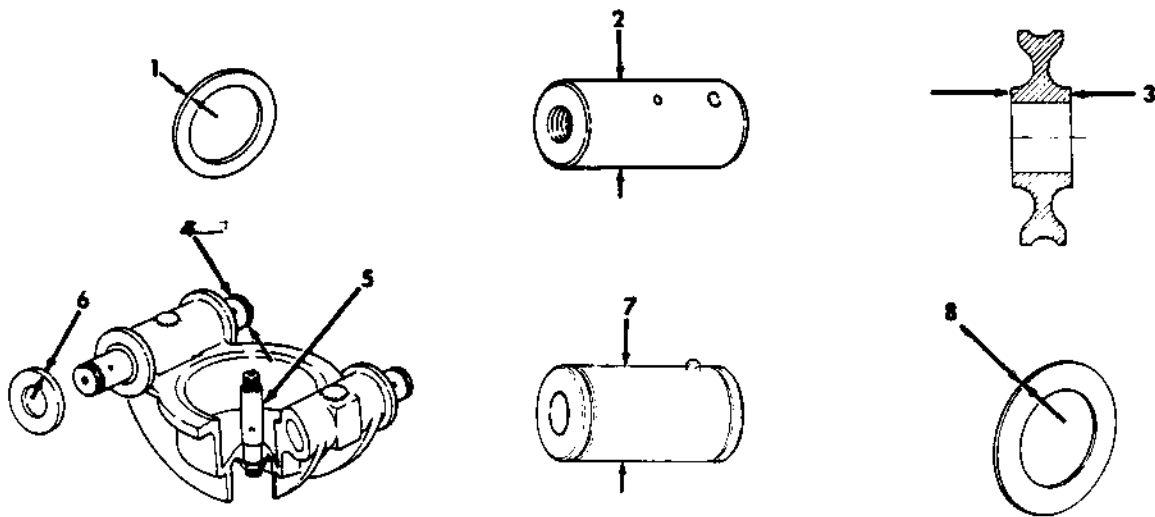

Figure D-5. Repair and Replacement Standards; Points of Measurement for Rear Winch Tensioner and Rear Winch Level Wind.

TA 51226

Table D-1. Repair and Replacement Standards (Contd).

INDEX NUMBER	ITEM/POINT OF MEASUREMENT	TOLERANCES
REAR WINCH LEVEL WIND (Contd)		
1	Sheave spacer thickness (P/N 7954539)	0.087 - 0.091 in. (2.21 - 2.31 mm)
2	Sheave spacer thickness (P/N 7954539)	0.178 - 0.182 in. (4.52 - 4.62 mm)
3	Level wind sheave thickness (P/N 7409952)	2.235 - 2.240 in. (56.77 - 56.90 mm)

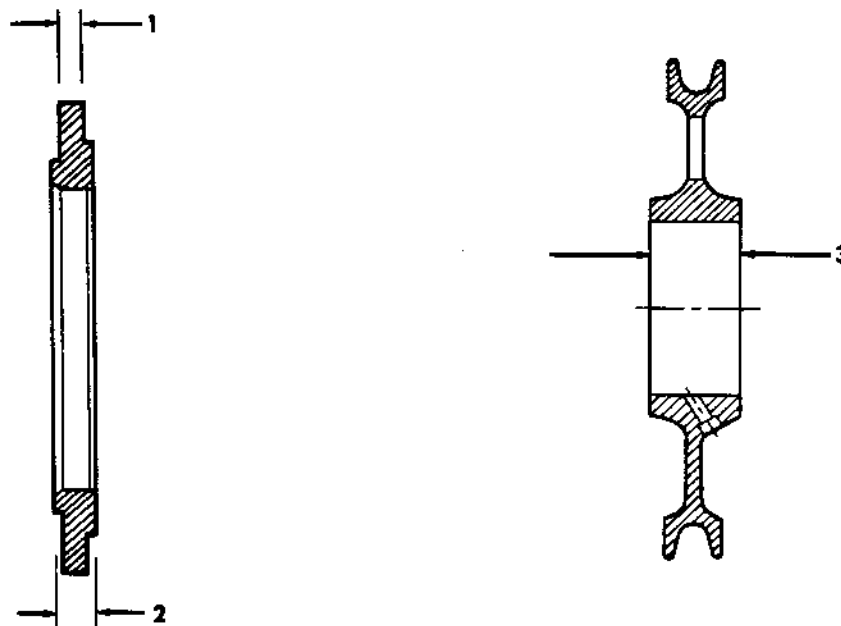

Figure D-6. Repair and Replacement Standards; Points of Measurement for Rear Winch Level Wind (Contd).

TA 51227

Table D-2. Standard Capscrew Markings and Torque Specifications.





Quality of Material	Intermediate	Minimum Commercial	Medium Commercial	Best Commercial
SAE Grade Number	1 or 2	5	6 or 7	8
Capscrew Head Markings:				
Manufacturer's marks may vary. Below are all SAE Grade 5 (3-line)				
				

Table D-2. Standard Capscrew Markings and Torque Specifications (Contd).

Quality of Material		Intermediate		Minimum Commercial		Medium Commercial		Best Commercial	
SAE Grade Number		1 or 2		5		6 or 7		8	
Capscrew Body Size (Inches)	Thread	Torque (lb-ft (N-m))		Torque (lb-ft (N-m))		Torque (lb-ft (N-m))		Torque (lb-ft (N-m))	
		1/4	20	5	7	8	11	10	14
	28	6	8	10	14	--	--	14	19
5/16	18	11	15	17	23	19	26	24	33
	24	13	18	19	26	--	--	27	37
3/8	16	18	24	31	42	34	46	44	60
	24	20	27	35	48	--	--	49	66
7/16	14	28	38	49	66	55	75	70	95
	20	30	41	55	75	--	--	78	106
1/2	13	39	53	75	102	85	115	105	142
	20	41	56	85	115	--	--	120	163
9/16	12	51	69	110	149	120	163	155	210
	18	55	75	120	163	--	--	170	231
5/8	11	83	113	150	203	167	227	210	285
	18	95	129	170	231	--	--	240	325
3/4	10	106	142	270	366	280	380	375	509
	16	115	156	295	400	--	--	420	570
7/8	9	160	217	395	536	440	597	605	820
	14	175	237	435	591	--	--	675	915
1	8	235	319	590	800	660	895	910	1234
	14	250	339	660	895	--	--	990	1342

1. Always use torque values listed above when specifications are not available.
2. The above is based on use of clean and dry threads.
3. Reduce torque by 10% if engine oil is used as a lubricant.
4. Reduce torque by 20% if new plated capscrews are used.

CAUTION: Capscrews threaded into aluminum may require reductions in torque of 30% or more unless inserts are used.

TA 51228

APPENDIX E FABRICATED TOOLS AND EQUIPMENT

Section I. INTRODUCTION

This appendix includes complete instructions for making items authorized to be manufactured or fabricated at depot level maintenance.

Section II. ILLUSTRATED MANUFACTURING INSTRUCTIONS

NOMENCLATURE	MATERIAL REQUIRED
Front Winch Roller Brackets Spacer Gage	1 ea. — 15-5/8 x 3-1/2 x 1/4 in. (approx. metric 39.7 x 8.8 x 0.64 cm) medium carbon steel plate 2 ea. — 12 x 1/2 x 1/4 in. (approx. metric 30.5 x 1.27 x 0.64 cm) medium carbon steel bar 4 ea. — no. 8 x 3/4 in. NF grade 8 flat head screws
FABRICATION INSTRUCTIONS: <ol style="list-style-type: none"> 1. Rough body plate of gage to longest dimension. 2. Drill, tap, and mount two stiffener bars on drilled body plate as shown. Screw spacing not critical. Follow general proportions in sketch. 3. Machine end faces to final tolerances after stiffeners assembled on body. 4. Break all final assembly sharp edges to 0.010-0.020 in. (0.25-0.051 mm). 5. Tolerances, unless otherwise stated, are: <ol style="list-style-type: none"> a. Linear 0.030 in. (0.76 mm). b. Radius (internal or external) 0.060 in. (1.5 mm). 6. Etch markings on one end on each side of gage. 7. Finished surfaces 60-80 micro-inches on end faces of gage body. 8. Lightly grind or stone off any burrs or sharp edges of screw heads or tips. 9. Final finish: <ol style="list-style-type: none"> a. Phosphate treat all surfaces except end faces. (Refer to DOD-P-16232.) b. Optional. Prime, per specification TT-P-636 or TT-P-664, and paint, per MIL-C-46168D, except both end faces. 	

Figure E-1. Front Winch Roller Brackets Spacer Gage.

Section II. ILLUSTRATED MANUFACTURING INSTRUCTIONS (Contd).

SKETCH OR DIAGRAM:

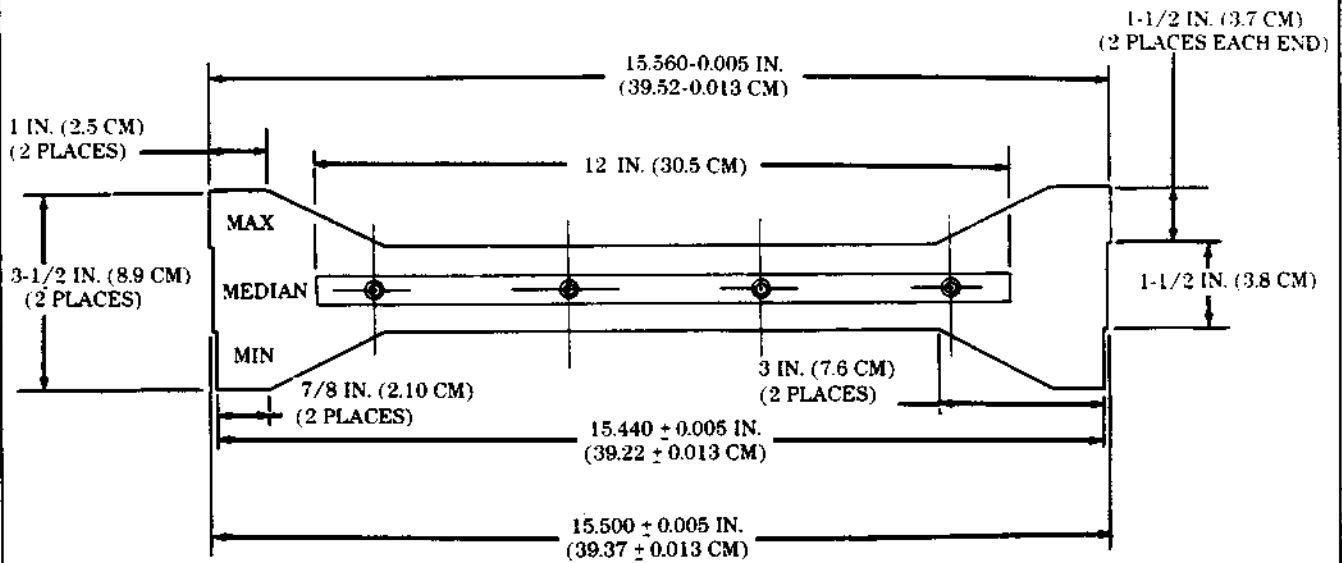

GAGE BODY PLATE

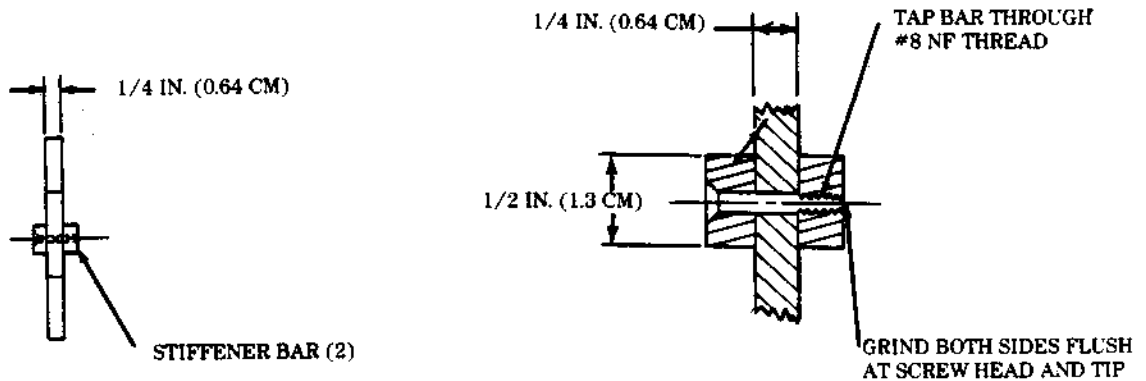

USE: Gage is used to set roller bracket spacing after drum shaft free play is set, channel, trolley track, and threaded rod are all tightened. Tensioner assembly is to be installed after bracket spacing is correct. Check spacing at top and bottom of machined pads on roller brackets. DO NOT FORCE GAGE WHEN CHECKING SPACING. Recheck spacing after brackets-to-housings screws are torqued.

Figure E-1. Front Winch Roller Brackets Spacer Gage (Contd).

TA 51229

APPENDIX F EXPENDABLE/DURABLE SUPPLIES AND MATERIALS LIST

Section I. INTRODUCTION

F-1. SCOPE.

This appendix lists expendable/durable supplies required to perform overhaul service at depot level for the front and rear winches.

F-2. EXPLANATION OF COLUMNS.

- a. **Column (1) — Item Number.** This number is assigned to the entry in the listing.
- b. **Column (2) — National Stock Number.** This is the National Stock Number used to request or requisition the item.
- c. **Column (3) — Description.** Indicates the Federal item name and, if required, a description to identify the item. The last line for each item indicates the Federal Supply Code for Manufacturer (FSCM) in parentheses, followed by the part number.
- d. **Column (4) — Unit of Measure (U/M).** Indicates the measure used in performing the actual maintenance function. This measure is expressed by a two character alphabetical abbreviation (e.g., ea, in., pr, gl, etc). If the unit of measure differs from unit of issue, requisition the lowest unit of issue that will satisfy requirements based on number of units processed for a requisition period.

Section II. EXPENDABLE/DURABLE SUPPLIES AND MATERIALS LIST

(1) ITEM NO.	(2) NATIONAL STOCK NO.	(3) DESCRIPTION	(4) U/M
1		CLOTH: abrasive, crocus (58536) A-A-1206	
	5350-00-221-0872	9 in. x 11 in. Sheets, 50 Sheets/Package	SH
	5350-00-221-0871	250 Sheet/Package	SH
	5350-00-268-3116	50 Yard Roll	YD
2		CLOTH: Cleaning, lint-free, general purpose, white (81349) MIL-C-85043	
	7920-00-044-9281	10 Pound Box	LB
3		COATING: aliphatic polyurethane, chemical agent resistant, green 383, MIL-C-46168D, type II (19207) 5584154	
	8010-01-160-6741	1 Gallon Can	GL
	8010-01-160-6747	55 Gallon Drum	GL
4		COATING: primer, alkyd, wood and ferrous metal (81348) TT-P-636	
	8010-01-140-0959	1 Gallon Can	GL

Section II. EXPENDABLE/DURABLE SUPPLIES AND MATERIALS LIST (Contd).

(1) ITEM NO.	(2) NATIONAL STOCK NO.	(3) DESCRIPTION	(4) U/M
5	8010-01-161-7275	COATING: primer, synthetic rust-inhibiting (81348) TT-P-664 1 Gallon Can	GL
6	6850-00-110-4498	DRYCLEANING SOLVENT (81348) P-D-680, Type II 1 Pint Can	PT
	6850-00-274-5421	5 Gallon Drum	GL
	6850-00-285-8011	55 Gallon Drum	GL
7	9150-00-190-0905	GAA GREASE: automotive and artillery, (MIL-G-10924), (98308) BRAYCO TE610 6-1/2 Pound Can	LB
	9150-00-190-0907	35 Pound Can	LB
8	9150-00-231-6689	INHIBITOR: corrosion, volatile oil type (02847) MIL-I-23310 1 Quart Can	QT
9	9150-06-231-9062	OIL: lubricating, general purpose, preservative (water displacing, low temperature) (81348) VV-L-800 5 Gallon Drum	GL
10	9150-00-189-6727	OIL: lubricating, internal combustion engine, tactical service, OE/HDO 30 (81349) MIL-L-2104 1 Quart Can	QT
	9150-00-188-9858	5 Gallon Drum	GL
11	9150-01-035-5392	OIL: lubricating, gear, multi-purpose GO 80/90 (81349) MIL-L-2105 1 Quart Can	QT
	9150-01-035-5393	5 Gallon Drum	GL
	9150-01-035-5394	55 Gallon Drum	GL
12	8030-00-903-0931	OIL: preservative, contact and volatile corrosion-inhibited (02847) MIL-L-46002 1 Quart Can	QT
13	9150-00-250-0926	PETROLATUM: technical (81348) VV-P-236 1-3/4 Pound Can	LB
	9150-00-250-0933	7-1/2 Pound Can	LB

Section II. EXPENDABLE/DURABLE SUPPLIES AND MATERIALS LIST (Contd).

(1) ITEM NO.	(2) NATIONAL STOCK NO.	(3) DESCRIPTION	(4) U/M
14	8030-00-247-2525	SEALING COMPOUND: hardening, MIL-S-45180, type I (77247) FORMAGASKET 1 11 Ounce Tube	OZ
15	8030-00-252-3391	SEALING COMPOUND: non-hardening, MIL-S-45180, type II, Permatex no. 2 (77247) FORMAGASKET 2 11 Ounce Tube	OZ

GLOSSARY

A

ACCEPTANCE INSPECTION — The examination and/or testing of material to determine acceptance to specified requirements set forth in purchase descriptions, contracts, and/or other criteria.

ACCEPTANCE QUALITY LEVEL (AQL) — The maximum percent defective or the maximum number of defects per 100 units that can be considered satisfactory for the purpose of sampling inspection.

ALLOY — A metallic substance composed of two or more elements which possesses properties different from those of its constituents.

ATTRIBUTE — A characteristic or property which is appraised in terms of whether it does or does not exist with respect to a given requirement.

B

BEND — A forced change in part configuration due to stress, wear, mutilation, or deterioration.

BLACK LIGHT — Light in the near-ultraviolet range, used in the inspection of fluorescent liquid penetrant or magnetic particles.

BLOW HOLES — Voids caused by gases; these gases may be either entrapped or liberated in the metal (castings) as it solidifies.

BURR — A protrusion of the part material from the surface or edge of a part. Usually a burr is caused by mishandling of part, extreme wear, or failure of another part.

C

CHIPPED — Having visual evidence of small pieces of material having been removed due to extensive use or abuse.

COMPARISON TEST — A test of one unit paralleled with another unit, this second unit used as an operational standard. Test may be of time duration to a fault or other defined attributes.

COMPONENT — Any part or group of parts that, when together, form a subassembly or assembly.

CONTROL TEST — A test in which a representative unit of a defined set is tested for selected additional attributes not determined in routine testing. Usually these attributes are concerned with longer testing times and additional or repeated manipulation of controls.

CORROSION — Removal of material (metal) by chemical attack: i.e., rusting of ferrous metal.

CRACK — A break, fissure, or rupture, usually V-shaped and relatively narrow and deep. Visual evidence shows a fine irregular line.

CRITICAL DEFECT — A defect that judgment and experience indicate is likely to result in hazardous or unsafe conditions for individuals using, maintaining, or depending upon the product or is likely to prevent performance of the tactical function of the major end item.

D

DEFECT — Any nonconformance of a characteristic with specified requirements.

DEVIATION — Written authorization, granted prior to the manufacture of an item, to depart from a particular performance or design requirement of a contract, specification, or referenced document, for a specific number of units or specific period of time.

DIAGNOSTIC — Pertaining to the act of examining, observing, and analyzing systems to determine the condition of that being inspected.

DMWR — Depot maintenance work requirement.

E

EVIDENCE OF OVERHEATING - This condition appears as deformation of part or parts, discoloration, galling of adjacent parts, etc.

F

FERROMAGNETIC — Materials which are strongly attracted by a magnetic field.

FINAL INSPECTION RECORD (F.I.R.) — A checklist and record of inspections and verification of results obtained during assembly or final tests and adjustments.

FIT — The term "fit" as used in this DMWR refers to the mating of associated parts and/or components.

a. A loose fit is the condition where sufficient tolerance is provided between the associated parts to allow free movement.

b. A tight, interference, or press fit is when one part with a given outer diameter is pressed into a part with equal or smaller inner diameter to prevent associated parts from moving in relation to each other.

c. A shrink fit is provided when one part with a given outer diameter (i.e., the inner part) is chilled and the other part with a given inner diameter (i.e., the outer part) is heated to permit mating. A shrink fit is accomplished when the associated parts return to normal temperature.

FLUORESCENCE — The property of certain materials to emit visible light when exposed to near-ultraviolet or black light.

G

GALL — A scratch or groove caused by rubbing. Often this is a result of overheating or lubrication failure.

GROOVE — A channel, rut, or slit caused by wear, mutilation, deterioration, or machining.

I

INITIAL RECONDITIONING TEST — A functional test of an overhauled assembly to ensure the assembly performs as designed. This test is usually a time duration and control manipulation test following the first standard acceptance test.

IN-PROCESS INSPECTION — Inspection which is performed during the manufacture or repair cycle in an effort to prevent defects from occurring and to inspect the characteristics and attributes which are not capable of being inspected at final inspection.

INSPECTION — The examination and testing of supplies and services to determine whether they conform to specified requirements.

M

MAGNETIC PARTICLE INSPECTION — A nondestructive inspection method for locating discontinuities at or below the surface in ferromagnetic materials. It utilizes broken magnetic fields to attract finely divided magnetic particles which mark the defect.

MALFUNCTION — Failure to perform properly as designed.

MATCHED, MARRIED, AND MATED PARTS —

a. **MATCHED PARTS** — These are two or more parts that are selected to meet specific assembly working tolerances or dimensions. The individual new part manufacturing tolerances are selected to complement each other to meet the assembly tolerance. One defective part requires the set to be replaced. Example: some pinion gears and ring gears.

b. **MARRIED PARTS** — These are parts that "wear in" usually as a pair. Individual parts can be interchanged when new, but after use must be used as a pair. One defective part requires set replacement. Example: Many roller and ball bearings and one or more of the associated races.

c. **MATED PARTS** — These are parts that are processed during some stage of manufacture as a pair. From that point on, these parts cannot be intermixed for use with other individual parts. One defective part requires replacement of the whole set. Example: certain housings that are bolted together and bearing journals line bored.

MEASURING AND TEST EQUIPMENT — All devices used to measure, gage, test, inspect, diagnose, or otherwise examine materials, supplies, and equipment to determine compliance with technical requirements.

N

NICK — A small cut, notch, slit, chip, or indentation cut into or existing in a part.

NONCONFORMANCE — The failure of a unit or product to conform to specified requirements for any quality characteristics.

O

ONE-HUNDRED PERCENT INSPECTION — Inspection in which specified characteristics of each unit of product are examined or tested to determine conformance with requirements.

OVERHAUL — That maintenance effort/service/action necessary to restore an item to a completely serviceable/operational condition as prescribed by maintenance standards in appropriate technical publications.

P

PENETRANT INSPECTION (LIQUID) — A process to detect discontinuities open to the surface, such as cracks, cold shuts, laps, porosity, etc. A penetrating liquid (fluorescent or visible dye) is applied to the surface and is drawn into the discontinuity to indicate the flaw when a developer is applied.

POUND FOOT — Unit of force equal to the amount of force required to raise a weight of 1 pound to a height of 1 foot.

Q

QUALITY — The composite of all attributes or characteristics, including the performance of an item or product.

QUALITY ASSURANCE — A planned and systematic pattern of all actions necessary to provide adequate confidence that the item or product conforms to established technical requirements.

QUALITY CONTROL — A management function whereby control of quality of raw or produced material is exercised for the purpose of preventing production of defective material.

QUALITY PROGRAM REQUIREMENT — The requirement for the establishment and maintenance of a quality program that shall assure adequate quality throughout all areas of contract performance; i.e., design, development, fabrication, processing, assembly, inspection, test, maintenance, packaging, shipping, storage, and site installation.

R

RANDOM SAMPLE — A sample selected in such a way that each unit of the population has an equal chance of being selected.

RELIABILITY — The probability that an item will perform its intended function for a specified interval under stated conditions.

S

SAMPLE — One or more units of product drawn from a lot or batch; the units of the sample being selected at random without regard to their quality.

SCORING — A wear pattern produced between parts, at least one of which is normally in motion relative to another part. Wear pattern is oriented in direction of motion. Wear is caused by contaminated lubricant, abnormal pressure between parts, or a surface degradation of one or more of the parts.

SPECIFICATION — A document intended primarily for use in procurement, which clearly and accurately describes the essential and technical requirements for items, materials, or services, including the procedures by which it will be determined that the requirements have been met. They may also contain preservation, packaging, packing, and marking requirements.

T

TESTING — An element of inspection; generally denotes the determination by technical means of the properties or elements of supplies, or components thereof, including functional operation, and involves the application of established scientific principles and procedures.

TOLERANCE — Permissible deviation or variation from exact dimensions or standards.

TORQUE — A force or combination of forces that produces or tends to produce a twisting or rotating motion. The amount of force applied to fasteners as prescribed by tightening instructions.

U

UNSERVICABLE — Parts, components, assemblies, etc., that are worn, damaged, mutilated, etc., to the extent that they cannot be used for their intended purpose.

V

VISUAL INSPECTION — Examination by a technician using sense of sight to detect flaws in a part. Sight may be aided or unaided. Most often used as a preliminary examination and suspected flaw points then subjected to technical examination to confirm or deny existence of a flaw in part.

W

WAIVER — A written authorization to accept a configuration item or other designated items which, during production or after having been submitted for inspection, are found to depart from specified requirements but are nevertheless considered suitable for use "as is" or after rework by an approved method.

WEAR LIMITS — An indication of the point to which a part may be worn before replacement is necessary.

INDEX

	Paragraph	Page
A		
Appendix A. References		A-1
Appendix B. Repair parts and tools list		B-1
Appendix C. Overhaul inspection procedures		C-1
Appendix D. Fits and tolerances		D-1
Appendix E. Fabricated tools and equipment		E-1
Appendix F. Expendable/durable supplies and materials list		F-1
Assembly:		
General	3-21	3-94
Lubrication	3-22	3-94
D		
Description, data plates, and tabulated data:		
Data plates	1-5	1-5
Description	1-4	1-1
Tabulated data	1-6	1-8
Disassembly:		
Cleaning and inspection	3-19	3-19
Diagnostic and test equipment	3-17	3-19
Disassembly	3-18	3-19
General	3-14	3-17
Special processes	3-16	3-18
Tools and equipment	3-15	3-18
Durability tests	4-5	4-5
F		
Final assembly and testing:		
Assembly of front and rear winches	4-1	4-1
Durability tests	4-5	4-5
Lubrication	4-6	4-6
Painting, refinishing, and marking	4-7	4-6
Preliminary measurements and adjustments	4-2	4-1
Test facility	4-3	4-1
Testing (acceptance test)	4-4	4-1
Final performance check:		
Final inspection record	4-8	4-10
Fits and tolerances	Appx D	D-1
G		
Glossary		Glossary 1
I		
In-process inspection:		
General component inspection	3-8	3-16
New component inspection	3-9	3-16
Repaired component inspection	3-11	3-17
Tolerances, wear limits, corrosion limits, torque values, and adjustments	3-12	3-17
Used component inspection	3-10	3-16
Inspection requirements:		
Acceptance inspection	5-13	5-5
Comparison test	5-10	5-3
Control test	5-11	5-3
Initial reconditioning test (IRT)	5-9	5-3
In-process inspection	5-12	5-4
Reliability, availability, maintainability, and durability (RAM-D) requirements	5-14	5-5
Introduction:		
Maintenance forms and records	1-2	1-1
Reporting equipment improvement recommendations (EIR's)	1-3	1-1
Scope	1-1	1-1

INDEX (Contd)

	Paragraph	Page
L		
List of illustrations		iii
List of tables		iv
Lubrication	3-22, 4-6	3-94, 4-6
M		
Maintenance, overhaul, and repair:		
References	3-2	3-1
Scope	3-1	3-1
O		
Overhaul inspection procedures (OIPs)	Appx C	C-1
P		
Preservation, packing, and marking:		
General requirements:		
Preservation and packaging	6-1	6-1
Shipment	6-2	6-1
Storage and marking:		
Marking for storage and shipment	6-4	6-1
Storage	6-3	6-1
Preshop analysis:		
Cleaning	3-6	3-2
Purpose	3-4	3-2
Temporary preservation and storage after preshop analysis	3-7	3-16
Unpacking instructions	3-5	3-2
Q		
Quality assurance/quality control (QA/QC) provisions:		
General requirements:		
Certification of personnel, materials, and processes	5-6	5-2
Inspection and test equipment	5-5	5-2
Introduction	5-1	5-1
Purpose	5-2	5-1
Quality assurance plan	5-8	5-3
Quality assurance terms and definitions	5-4	5-1
Responsibility for inspection	5-3	5-1
Visual inspection	5-7	5-2
Inspection requirements:		
Acceptance inspection	5-13	5-5
Comparison test	5-10	5-3
Control test	5-11	5-3
Initial reconditioning test (IRT)	5-9	5-3
In-process inspection	5-12	5-4
Reliability, availability, maintainability, and durability (RAM-D) requirements	5-14	5-5
R		
References	3-2, Appx A	3-1, A-1
Removal of major assemblies:		
General	3-13	3-17
Repair:		
General	3-20	3-93
Repair parts	Appx B	B-1
Reporting errors and recommending improvements		i
Requirements:		
Facilities	2-1	2-1
Support items	2-2	2-1

INDEX (Contd)

	S	Paragraph	Page
Safety:			
Precautions		3-3	3-2
Standards:			
Man-hour standards		2-4	2-8
Quality of material		2-3	2-8
	T		
Testing		4-4,	4-1,
		4-5	4-5
	V		
Visual inspection		5-7	5-2
	W		
Warning summary			Warning a



SOMETHING WRONG WITH THIS PUBLICATION?

THEN... JOT DOWN THE DOPE ABOUT IT ON THIS FORM. CAREFULLY TEAR IT OUT. FOLD IT AND DROP IT IN THE MAIL!

FROM: (PRINT YOUR UNIT'S COMPLETE ADDRESS)

Your mailing address

DATE SENT

Date you filled out form

PUBLICATION NUMBER

TACOM DMWR 9-2520-501

PUBLICATION DATE

PUBLICATION TITLE

DEPOT MAINTENANCE WORK REQUIREMENT FOR FRONT AND REAR WINCHES

BE EXACT... PIN-POINT WHERE IT IS

IN THIS SPACE TELL WHAT IS WRONG AND WHAT SHOULD BE DONE ABOUT IT:

PAGE NO.	PARA-GRAPH	FIGURE NO.	TABLE NO.
3-56		OIP	
3-60		OIP	
D-2		D-1	D-1

Pulley in art doesn't look like one we took off front winch

The cable guide plates (P/N 12300666-1 and 12300666-2) don't fit on mounting bracket on winch P/N 7412382.

Are parts 1 and 2 (P/N 7409541 and 7409685) interchangeable

SAMPLE

PRINTED NAME, GRADE OR TITLE, AND TELEPHONE NUMBERS

Your name, branch or grade and phone

SIGN HERE:

Tech T-8 John A. Doe.

SAMPLE

FILL IN YOUR
UNIT'S ADDRESS



FOLD BACK

TEAR ALONG PERFORATED LINE

DEPARTMENT OF THE ARMY

POSTAGE AND FEES PAID
DEPARTMENT OF THE ARMY
DOD 314



OFFICIAL BUSINESS
PENALTY FOR PRIVATE USE \$300

COMMANDER
U.S. ARMY TANK-AUTOMOTIVE COMMAND
ATTN: AMSTA-MB
WARREN, MI 48397-5000



SOMETHING WRONG

WITH THIS PUBLICATION?

THEN... JOT DOWN THE DOPE ABOUT IT ON THIS FORM. CAREFULLY TEAR IT OUT. FOLD IT AND DROP IT IN THE MAIL!

FROM: (PRINT YOUR UNIT'S COMPLETE ADDRESS)

DATE SENT

PUBLICATION NUMBER

TACOM DMWR 9-2520-501

PUBLICATION DATE

PUBLICATION TITLE

DEPOT MAINTENANCE WORK REQUIREMENT FOR FRONT AND REAR WINCHES

BE EXACT... PIN-POINT WHERE IT IS

IN THIS SPACE TELL WHAT IS WRONG AND WHAT SHOULD BE DONE ABOUT IT:

PAGE NO.

PARA-GRAPH

FIGURE NO.

TABLE NO.

PRINTED NAME, GRADE OR TITLE, AND TELEPHONE NUMBERS

SIGN HERE:

FILL IN YOUR
UNIT'S ADDRESS



FOLD BACK

DEPARTMENT OF THE ARMY

OFFICIAL BUSINESS
PENALTY FOR PRIVATE USE \$300

POSTAGE AND FEES PAID
DEPARTMENT OF THE ARMY
DOD 314



COMMANDER
U.S. ARMY TANK-AUTOMOTIVE COMMAND
ATTN: AMSTA-MB
WARREN, MI 48397-5000

TEAR ALONG PERFORATED LINE



SOMETHING WRONG WITH THIS PUBLICATION?

THEN... JOT DOWN THE DOPE ABOUT IT ON THIS FORM. CAREFULLY TEAR IT OUT. FOLD IT AND DROP IT IN THE MAIL!

FROM: (PRINT YOUR UNIT'S COMPLETE ADDRESS)

DATE SENT

PUBLICATION NUMBER

TACOM DMWR 9-2520-501

PUBLICATION DATE

PUBLICATION TITLE

DEPOT MAINTENANCE WORK REQUIREMENT FOR FRONT AND REAR WINCHES

BE EXACT... PIN-POINT WHERE IT IS

IN THIS SPACE TELL WHAT IS WRONG AND WHAT SHOULD BE DONE ABOUT IT:

PAGE NO.	PARA-GRAPH	FIGURE NO.	TABLE NO.

PRINTED NAME, GRADE OR TITLE, AND TELEPHONE NUMBERS

SIGN HERE:

FILL IN YOUR
UNIT'S ADDRESS



FOLD BACK

DEPARTMENT OF THE ARMY

OFFICIAL BUSINESS
PENALTY FOR PRIVATE USE \$300

POSTAGE AND FEES PAID
DEPARTMENT OF THE ARMY
DOD 314



COMMANDER
U.S. ARMY TANK-AUTOMOTIVE COMMAND
ATTN: AMSTA-MB
WARREN, MI 48397-5000

TEAR ALONG PERFORATED LINE

FILL IN YOUR
UNIT'S ADDRESS



FOLD BACK

DEPARTMENT OF THE ARMY

OFFICIAL BUSINESS
PENALTY FOR PRIVATE USE \$300

POSTAGE AND FEES PAID
DEPARTMENT OF THE ARMY
DOD 314



COMMANDER
U.S. ARMY TANK-AUTOMOTIVE COMMAND
ATTN: AMSTA-MB
WARREN, MI 48397-5000

TEAR ALONG PERFORATED LINE

HEADQUARTERS
U.S. ARMY TANK-AUTOMOTIVE COMMAND
WARREN, MICHIGAN 48397-5000

This Depot Maintenance Work Requirement (DMWR) has been prepared under the supervision and control of the Commander, U.S. Army Tank-Automotive Command, Warren, Michigan, by the Maintenance Directorate, National Maintenance Point (NMP) and is published for the information and guidance of all concerned.

FOR THE COMMANDER:

OFFICIAL:

JAMES G. EDGE
Colonel, GS
Chief of Staff

BRENDA M. STENERSON
1LT, GS
Adjutant

DISTRIBUTION:
Special

THE METRIC SYSTEM AND EQUIVALENTS

LINEAR MEASURE

1 Centimeter = 10 Millimeters = 0.01 Meters = 0.3937 Inches
 1 Meter = 100 Centimeters = 1,000 Millimeters = 39.37 Inches
 1 Kilometer = 1,000 Meters = 0.621 Miles

WEIGHTS

1 Gram = 0.001 Kilograms = 1,000 Milligrams = 0.035 Ounces
 1 Kilogram = 1,000 Grams = 2.2 Lb
 1 Metric Ton = 1,000 Kilograms = 1 Megagram = 1.1 Short Tons

LIQUID MEASURE

1 Milliliter = 0.001 Liters = 0.0338 Fluid Ounces
 1 Liter = 1,000 Milliliters = 33.82 Fluid Ounces

SQUARE MEASURE

1 Sq Centimeter = 100 Sq Millimeters = 0.155 Sq Inches
 1 Sq Meter = 10,000 Sq Centimeters = 10.76 Sq Feet
 1 Sq Kilometer = 1,000,000 Sq Meters = 0.386 Sq Miles

CUBIC MEASURE

1 Cu Centimeter = 1,000 Cu Millimeters = 0.06 Cu Inches
 1 Cu Meter = 1,000,000 Cu Centimeters = 35.31 Cu Feet

TEMPERATURE

$5/9 (F - 32) = C$
 212° Fahrenheit is equivalent to 100° Celsius
 90° Fahrenheit is equivalent to 32.2° Celsius
 32° Fahrenheit is equivalent to 0° Celsius
 $9/5 C + 32 = F$

APPROXIMATE CONVERSION FACTORS

TO CHANGE	TO	MULTIPLY BY
Inches	Centimeters	2.540
Feet	Meters	0.305
Yards	Meters	0.914
Miles	Kilometers	1.609
Square Inches	Square Centimeters	6.451
Square Feet	Square Meters	0.093
Square Yards	Square Meters	0.836
Square Miles	Square Kilometers	2.590
Acres	Square Hectometers	0.405
Cubic Feet	Cubic Meters	0.028
Cubic Yards	Cubic Meters	0.765
Fluid Ounces	Milliliters	29.573
Pints	Liters	0.473
Quarts	Liters	0.946
Gallons	Liters	3.785
Ounces	Grams	28.349
Pounds	Kilograms	0.454
Short Tons	Metric Tons	0.907
Pound-Feet	Newton-Meters	1.356
Pounds Per Square Inch	Kilopascals	6.895
Miles Per Gallon	Kilometers Per Liter	0.425
Miles Per Hour	Kilometers Per Hour	1.609
TO CHANGE	TO	MULTIPLY BY
Centimeters	Inches	0.394
Meters	Feet	3.280
Meters	Yards	1.094
Kilometers	Miles	0.621
Square Centimeters	Square Inches	0.155
Square Meters	Square Feet	10.764
Square Meters	Square Yards	1.196
Square Kilometers	Square Miles	0.386
Square Hectometers	Acres	2.471
Cubic Meters	Cubic Feet	35.315
Cubic Meters	Cubic Yards	1.308
Milliliters	Fluid Ounces	0.034
Liters	Pints	2.113
Liters	Quarts	1.057
Liters	Gallons	0.264
Grams	Ounces	0.035
Kilograms	Pounds	2.205
Metric Tons	Short Tons	1.102
Newton-Meters	Pound-Feet	0.738
Kilopascals	Pounds Per Square Inch	0.145
Kilometers Per Liter	Miles Per Gallon	2.354
Kilometers Per Hour	Miles Per Hour	0.621

