

# ARMY \*TM 9-2320-272-24P-1 AIR FORCE \*TO 36A12-1C-1155-4-1

## TECHNICAL MANUAL REPAIR PARTS AND SPECIAL TOOLS LIST (RPSTL) FOR

### TRUCK, 5-TON, 6X6, M939, M939A1, AND M939A2 SERIES TRUCKS (DIESEL)

TRUCK, CARGO: 5-TON, 6X6 DROPSIDE M923 NSN 2320-01-050-2084 (EIC BRY) M923A1 NSN 2320-01-206-4087 (EIC BSS) M923A2 NSN 2320-01-230-0307 (EIC BS7) M925 NSN 2320-01-047-8769 (EIC BRT) M925A1 NSN 2320-01-206-4088 (EIC BST) M925A2 NSN 2320-01-230-0308 (EIC BS8)	TRUCK, DUMP: 5-TON, 6X6 M929 NSN 2320-01-047-8756 (EIC BTH) M929A1 NSN 2320-01-206-4079 (EIC BSY) M929A2 NSN 2320-01-230-0305 (EIC BSN) M930 NSN 2320-01-047-8755 (EIC BTG) M930A1 NSN 2320-01-206-4080 (EIC BSZ) M930A2 NSN 2320-01-230-0306 (EIC BT7)	TRUCK, VAN, EXPANSIBLE: 5-TON, 6X6 M934 NSN 2320-01-047-8750 (EIC BTB) M934A1 NSN 2320-01-205-2682 (EIC BS4) M934A2 NSN 2320-01-230-0300 (EIC BTR)
TRUCK, CARGO: 5-TON, 6X6 XLWB M927 NSN 2320-01-047-8771 (EIC BRV) M927A1 NSN 2320-01-206-4089 (EIC BSW) M927A2 NSN 2320-01-230-0309 (EIC BS9) M928 NSN 2320-01-047-8770 (EIC BRU) M928A1 NSN 2320-01-206-4090 (EIC BSX) M928A2 NSN 2320-01-230-0310 (EIC BTM)	TRUCK, TRACTOR: 5-TON, 6X6 M931 NSN 2320-01-047-8753 (EIC BTE) M931A1 NSN 2320-01-206-4077 (EIC BS2) M931A2 NSN 2320-01-230-0302 (EIC BTP) M932 NSN 2320-01-047-8752 (EIC BTD) M932A1 NSN 2320-01-205-2684 (EIC BSZ) M932A2 NSN 2320-01-230-0303 (EIC BTQ)	TRUCK, MEDIUM WRECKER: 5-TON, 6X6 M936 NSN 2320-01-047-8754 (EIC BTF) M936A1 NSN 2320-01-206-4078 (EIC BS6) M936A2 NSN 2320-01-230-0304 (EIC BTT)

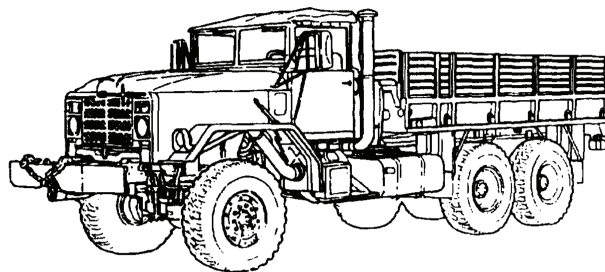

**\*SUPERSEDURE NOTICE** - This manual supersedes TM 9-2320-272-24P-1, TM 9-2320-272-24P-2, and TO 36A12-1C-1155-4-1, TO 36A12-1C-1155-4-2, dated 1 February 1999, including all changes

**DISTRIBUTION STATEMENT A** - Approved for public release; distribution is unlimited.

HEADQUARTERS, DEPARTMENTS OF THE ARMY AND THE AIR FORCE  
27 AUGUST 2012





## LIST OF EFFECTIVE PAGES/WORK PACKAGES

NOTE: \*Supersedes TM 9-2320-272-24P-1, TM 9-2320-272-24P-2, TO 36A12-1C-1155-4-1, and TO 36A12-1C-1155-4-2, dated 1 February 1999. Zero in the Change No. column indicates an original page or work package.

Date of issue for the original manual is:

Original 27 August 2012

TOTAL NUMBER OF VOLUMES IS 3, TOTAL NUMBER OF PAGES FOR FRONT AND REAR MATTER IS 148 AND TOTAL NUMBER OF WORK PACKAGES IS 675 CONSISTING OF THE FOLLOWING:

Page/WP No.	Change No.	Page/WP No.	Change No.
VOLUME 1		WP 0037 (4 pages)	0
Front Cover (2 pages)	0	WP 0038 (6 pages)	0
i-iv (54 pages)	0	WP 0039 (4 pages)	0
Chapter 1 Title Page (2 pages)	0	WP 0040 (4 pages)	0
WP 0001 (8 pages)	0	WP 0041 (4 pages)	0
WP 0002 (4 pages)	0	WP 0042 (4 pages)	0
WP 0003 (4 pages)	0	WP 0043 (4 pages)	0
WP 0004 (4 pages)	0	WP 0044 (4 pages)	0
WP 0005 (4 pages)	0	WP 0045 (6 pages)	0
WP 0006 (4 pages)	0	WP 0046 (4 pages)	0
WP 0007 (6 pages)	0	WP 0047 (6 pages)	0
WP 0008 (6 pages)	0	WP 0048 (6 pages)	0
WP 0009 (6 pages)	0	WP 0049 (4 pages)	0
WP 0010 (4 pages)	0	WP 0050 (4 pages)	0
WP 0011 (4 pages)	0	WP 0051 (6 pages)	0
WP 0012 (4 pages)	0	WP 0052 (4 pages)	0
WP 0013 (8 pages)	0	WP 0053 (4 pages)	0
WP 0014 (4 pages)	0	WP 0054 (4 pages)	0
WP 0015 (4 pages)	0	WP 0055 (4 pages)	0
WP 0016 (4 pages)	0	WP 0056 (4 pages)	0
WP 0017 (4 pages)	0	WP 0057 (4 pages)	0
WP 0018 (4 pages)	0	WP 0058 (4 pages)	0
WP 0019 (4 pages)	0	WP 0059 (6 pages)	0
WP 0020 (4 pages)	0	WP 0060 (8 pages)	0
WP 0021 (4 pages)	0	WP 0061 (4 pages)	0
WP 0022 (4 pages)	0	WP 0062 (4 pages)	0
WP 0023 (4 pages)	0	WP 0063 (8 pages)	0
WP 0024 (6 pages)	0	WP 0064 (4 pages)	0
WP 0025 (4 pages)	0	WP 0065 (4 pages)	0
WP 0026 (4 pages)	0	WP 0066 (6 pages)	0
WP 0027 (4 pages)	0	WP 0067 (6 pages)	0
WP 0028 (4 pages)	0	WP 0068 (4 pages)	0
WP 0029 (4 pages)	0	WP 0069 (4 pages)	0
WP 0030 (4 pages)	0	WP 0070 (4 pages)	0
WP 0031 (4 pages)	0	WP 0071 (4 pages)	0
WP 0032 (4 pages)	0	WP 0072 (6 pages)	0
WP 0033 (4 pages)	0	WP 0073 (4 pages)	0
WP 0034 (6 pages)	0	WP 0074 (4 pages)	0
WP 0035 (4 pages)	0	WP 0075 (4 pages)	0
WP 0036 (4 pages)	0	WP 0076 (4 pages)	0

**LIST OF EFFECTIVE PAGES/WORK PACKAGES - Continued**

<b>Page/WP No.</b>	<b>Change No.</b>	<b>Page/WP No.</b>	<b>Change No.</b>
WP 0077 (4 pages)	0	WP 0128 (4 pages)	0
WP 0078 (6 pages)	0	WP 0129 (4 pages)	0
WP 0079 (4 pages)	0	WP 0130 (4 pages)	0
WP 0080 (4 pages)	0	WP 0131 (4 pages)	0
WP 0081 (4 pages)	0	WP 0132 (8 pages)	0
WP 0082 (4 pages)	0	WP 0133 (8 pages)	0
WP 0083 (6 pages)	0	WP 0134 (4 pages)	0
WP 0084 (4 pages)	0	WP 0135 (8 pages)	0
WP 0085 (4 pages)	0	WP 0136 (4 pages)	0
WP 0086 (4 pages)	0	WP 0137 (4 pages)	0
WP 0087 (4 pages)	0	WP 0138 (4 pages)	0
WP 0088 (4 pages)	0	WP 0139 (4 pages)	0
WP 0089 (4 pages)	0	WP 0140 (4 pages)	0
WP 0090 (4 pages)	0	WP 0141 (6 pages)	0
WP 0091 (6 pages)	0	WP 0142 (6 pages)	0
WP 0092 (6 pages)	0	WP 0143 (4 pages)	0
WP 0093 (4 pages)	0	WP 0144 (6 pages)	0
WP 0094 (4 pages)	0	WP 0145 (4 pages)	0
WP 0095 (4 pages)	0	WP 0146 (4 pages)	0
WP 0096 (4 pages)	0	WP 0147 (4 pages)	0
WP 0097 (4 pages)	0	WP 0148 (4 pages)	0
WP 0098 (6 pages)	0	WP 0149 (4 pages)	0
WP 0099 (4 pages)	0	WP 0150 (4 pages)	0
WP 0100 (4 pages)	0	WP 0151 (6 pages)	0
WP 0101 (8 pages)	0	WP 0152 (6 pages)	0
WP 0102 (6 pages)	0	WP 0153 (4 pages)	0
WP 0103 (6 pages)	0	WP 0154 (8 pages)	0
WP 0104 (4 pages)	0	WP 0155 (6 pages)	0
WP 0105 (4 pages)	0	WP 0156 (4 pages)	0
WP 0106 (4 pages)	0	WP 0157 (4 pages)	0
WP 0107 (4 pages)	0	WP 0158 (6 pages)	0
WP 0108 (6 pages)	0	WP 0159 (4 pages)	0
WP 0109 (4 pages)	0	WP 0160 (12 pages)	0
WP 0110 (4 pages)	0	WP 0161 (4 pages)	0
WP 0111 (4 pages)	0	WP 0162 (6 pages)	0
WP 0112 (6 pages)	0	WP 0163 (4 pages)	0
WP 0113 (4 pages)	0	WP 0164 (4 pages)	0
WP 0114 (4 pages)	0	WP 0165 (6 pages)	0
WP 0115 (4 pages)	0	WP 0166 (4 pages)	0
WP 0116 (6 pages)	0	WP 0167 (4 pages)	0
WP 0117 (4 pages)	0	WP 0168 (4 pages)	0
WP 0118 (4 pages)	0	WP 0169 (4 pages)	0
WP 0119 (4 pages)	0	WP 0170 (6 pages)	0
WP 0120 (4 pages)	0	WP 0171 (6 pages)	0
WP 0121 (6 pages)	0	WP 0172 (4 pages)	0
WP 0122 (4 pages)	0	WP 0173 (4 pages)	0
WP 0123 (6 pages)	0	WP 0174 (4 pages)	0
WP 0124 (4 pages)	0	WP 0175 (4 pages)	0
WP 0125 (4 pages)	0	WP 0176 (4 pages)	0
WP 0126 (6 pages)	0	WP 0177 (4 pages)	0
WP 0127 (4 pages)	0	WP 0178 (4 pages)	0

**LIST OF EFFECTIVE PAGES/WORK PACKAGES - Continued**

Page/WP No.	Change No.	Page/WP No.	Change No.
WP 0179 (4 pages)	0	WP 0230 (4 pages)	0
WP 0180 (4 pages)	0	WP 0231 (4 pages)	0
WP 0181 (6 pages)	0	WP 0232 (4 pages)	0
WP 0182 (4 pages)	0	WP 0233 (6 pages)	0
WP 0183 (4 pages)	0	WP 0234 (6 pages)	0
WP 0184 (4 pages)	0	WP 0235 (10 pages)	0
WP 0185 (4 pages)	0	WP 0236 (6 pages)	0
WP 0186 (8 pages)	0	WP 0237 (10 pages)	0
WP 0187 (4 pages)	0	WP 0238 (4 pages)	0
WP 0188 (6 pages)	0	WP 0239 (4 pages)	0
WP 0189 (6 pages)	0	WP 0240 (6 pages)	0
WP 0190 (8 pages)	0	WP 0241 (6 pages)	0
WP 0191 (6 pages)	0	WP 0242 (10 pages)	0
WP 0192 (4 pages)	0	WP 0243 (6 pages)	0
WP 0193 (6 pages)	0	WP 0244 (6 pages)	0
WP 0194 (6 pages)	0	WP 0245 (6 pages)	0
WP 0195 (4 pages)	0	WP 0246 (6 pages)	0
WP 0196 (4 pages)	0	WP 0247 (6 pages)	0
WP 0197 (4 pages)	0	WP 0248 (4 pages)	0
WP 0198 (6 pages)	0	WP 0249 (6 pages)	0
WP 0199 (6 pages)	0	WP 0250 (6 pages)	0
WP 0200 (4 pages)	0	WP 0251 (6 pages)	0
WP 0201 (8 pages)	0	WP 0252 (6 pages)	0
WP 0202 (6 pages)	0	WP 0253 (6 pages)	0
WP 0203 (4 pages)	0	WP 0254 (8 pages)	0
WP 0204 (4 pages)	0	WP 0255 (4 pages)	0
WP 0205 (6 pages)	0	WP 0256 (4 pages)	0
WP 0206 (4 pages)	0	WP 0257 (4 pages)	0
WP 0207 (4 pages)	0	WP 0258 (6 pages)	0
WP 0208 (10 pages)	0	WP 0259 (6 pages)	0
WP 0209 (4 pages)	0	WP 0260 (4 pages)	0
WP 0210 (6 pages)	0	WP 0261 (4 pages)	0
WP 0211 (4 pages)	0	WP 0262 (4 pages)	0
WP 0212 (10 pages)	0	WP 0263 (6 pages)	0
WP 0213 (6 pages)	0	WP 0264 (4 pages)	0
WP 0214 (8 pages)	0	WP 0265 (4 pages)	0
WP 0215 (6 pages)	0	WP 0266 (4 pages)	0
WP 0216 (6 pages)	0	WP 0267 (8 pages)	0
WP 0217 (4 pages)	0	WP 0268 (6 pages)	0
WP 0218 (4 pages)	0	WP 0269 (6 pages)	0
WP 0219 (4 pages)	0	WP 0270 (4 pages)	0
WP 0220 (4 pages)	0	WP 0271 (8 pages)	0
WP 0221 (4 pages)	0	WP 0272 (4 pages)	0
WP 0222 (4 pages)	0	WP 0273 (8 pages)	0
WP 0223 (4 pages)	0	WP 0274 (6 pages)	0
WP 0224 (4 pages)	0	WP 0275 (4 pages)	0
WP 0225 (4 pages)	0	WP 0276 (8 pages)	0
WP 0226 (4 pages)	0	WP 0277 (4 pages)	0
WP 0227 (4 pages)	0	WP 0278 (6 pages)	0
WP 0228 (4 pages)	0	WP 0279 (4 pages)	0
WP 0229 (4 pages)	0	WP 0280 (8 pages)	0

**LIST OF EFFECTIVE PAGES/WORK PACKAGES - Continued**

<b>Page/WP No.</b>	<b>Change No.</b>	<b>Page/WP No.</b>	<b>Change No.</b>
WP 0281 (4 pages)	0	WP 0326 (6 pages)	0
WP 0282 (4 pages)	0	WP 0327 (4 pages)	0
WP 0283 (4 pages)	0	WP 0328 (6 pages)	0
WP 0284 (4 pages)	0	WP 0329 (6 pages)	0
WP 0285 (4 pages)	0	WP 0330 (4 pages)	0
WP 0286 (4 pages)	0	WP 0331 (4 pages)	0
WP 0287 (4 pages)	0	WP 0332 (4 pages)	0
Inside Back Cover	0	WP 0333 (4 pages)	0
Back Cover	0	WP 0334 (4 pages)	0
		WP 0335 (8 pages)	0
VOLUME 2		WP 0336 (4 pages)	0
Front Cover (2 pages)	0	WP 0337 (4 pages)	0
i-xxviii blank (28 pages)	0	WP 0338 (4 pages)	0
WP 0288 (4 pages)	0	WP 0339 (6 pages)	0
WP 0289 (4 pages)	0	WP 0340 (6 pages)	0
WP 0290 (4 pages)	0	WP 0341 (6 pages)	0
WP 0291 (4 pages)	0	WP 0342 (6 pages)	0
WP 0292 (4 pages)	0	WP 0343 (6 pages)	0
WP 0293 (4 pages)	0	WP 0344 (6 pages)	0
WP 0294 (4 pages)	0	WP 0345 (6 pages)	0
WP 0295 (4 pages)	0	WP 0346 (6 pages)	0
WP 0296 (4 pages)	0	WP 0347 (6 pages)	0
WP 0297 (4 pages)	0	WP 0348 (4 pages)	0
WP 0298 (4 pages)	0	WP 0349 (4 pages)	0
WP 0299 (4 pages)	0	WP 0350 (6 pages)	0
WP 0300 (4 pages)	0	WP 0351 (4 pages)	0
WP 0301 (4 pages)	0	WP 0352 (4 pages)	0
WP 0302 (4 pages)	0	WP 0353 (6 pages)	0
WP 0303 (4 pages)	0	WP 0354 (4 pages)	0
WP 0304 (4 pages)	0	WP 0355 (4 pages)	0
WP 0305 (10 pages)	0	WP 0356 (4 pages)	0
WP 0306 (6 pages)	0	WP 0357 (4 pages)	0
WP 0307 (6 pages)	0	WP 0358 (4 pages)	0
WP 0308 (4 pages)	0	WP 0359 (4 pages)	0
WP 0309 (4 pages)	0	WP 0360 (4 pages)	0
WP 0310 (4 pages)	0	WP 0361 (4 pages)	0
WP 0311 (4 pages)	0	WP 0362 (4 pages)	0
WP 0312 (4 pages)	0	WP 0363 (4 pages)	0
WP 0313 (4 pages)	0	WP 0364 (4 pages)	0
WP 0314 (6 pages)	0	WP 0365 (4 pages)	0
WP 0315 (4 pages)	0	WP 0366 (4 pages)	0
WP 0316 (6 pages)	0	WP 0367 (4 pages)	0
WP 0317 (4 pages)	0	WP 0368 (4 pages)	0
WP 0318 (4 pages)	0	WP 0369 (6 pages)	0
WP 0319 (4 pages)	0	WP 0370 (6 pages)	0
WP 0320 (4 pages)	0	WP 0371 (4 pages)	0
WP 0321 (4 pages)	0	WP 0372 (8 pages)	0
WP 0322 (4 pages)	0	WP 0373 (4 pages)	0
WP 0323 (4 pages)	0	WP 0374 (4 pages)	0
WP 0324 (6 pages)	0	WP 0375 (6 pages)	0
WP 0325 (4 pages)	0	WP 0376 (4 pages)	0

**LIST OF EFFECTIVE PAGES/WORK PACKAGES - Continued**

<b>Page/WP No.</b>	<b>Change No.</b>	<b>Page/WP No.</b>	<b>Change No.</b>
WP 0377 (4 pages)	0	WP 0428 (4 pages)	0
WP 0378 (4 pages)	0	WP 0429 (6 pages)	0
WP 0379 (6 pages)	0	WP 0430 (6 pages)	0
WP 0380 (6 pages)	0	WP 0431 (4 pages)	0
WP 0381 (4 pages)	0	WP 0432 (4 pages)	0
WP 0382 (4 pages)	0	WP 0433 (4 pages)	0
WP 0383 (6 pages)	0	WP 0434 (4 pages)	0
WP 0384 (4 pages)	0	WP 0435 (4 pages)	0
WP 0385 (4 pages)	0	WP 0436 (4 pages)	0
WP 0386 (8 pages)	0	WP 0437 (6 pages)	0
WP 0387 (4 pages)	0	WP 0438 (4 pages)	0
WP 0388 (6 pages)	0	WP 0439 (4 pages)	0
WP 0389 (4 pages)	0	WP 0440 (6 pages)	0
WP 0390 (6 pages)	0	WP 0441 (4 pages)	0
WP 0391 (10 pages)	0	WP 0442 (4 pages)	0
WP 0392 (6 pages)	0	WP 0443 (6 pages)	0
WP 0393 (4 pages)	0	WP 0444 (4 pages)	0
WP 0394 (10 pages)	0	WP 0445 (4 pages)	0
WP 0395 (6 pages)	0	WP 0446 (4 pages)	0
WP 0396 (4 pages)	0	WP 0447 (4 pages)	0
WP 0397 (4 pages)	0	WP 0448 (4 pages)	0
WP 0398 (6 pages)	0	WP 0449 (4 pages)	0
WP 0399 (4 pages)	0	WP 0450 (4 pages)	0
WP 0400 (4 pages)	0	WP 0451 (4 pages)	0
WP 0401 (4 pages)	0	WP 0452 (4 pages)	0
WP 0402 (4 pages)	0	WP 0453 (4 pages)	0
WP 0403 (4 pages)	0	WP 0454 (4 pages)	0
WP 0404 (4 pages)	0	WP 0455 (4 pages)	0
WP 0405 (4 pages)	0	WP 0456 (4 pages)	0
WP 0406 (6 pages)	0	WP 0457 (4 pages)	0
WP 0407 (6 pages)	0	WP 0458 (4 pages)	0
WP 0408 (4 pages)	0	WP 0459 (4 pages)	0
WP 0409 (6 pages)	0	WP 0460 (4 pages)	0
WP 0410 (4 pages)	0	WP 0461 (4 pages)	0
WP 0411 (6 pages)	0	WP 0462 (4 pages)	0
WP 0412 (4 pages)	0	WP 0463 (4 pages)	0
WP 0413 (4 pages)	0	WP 0464 (4 pages)	0
WP 0414 (4 pages)	0	WP 0465 (4 pages)	0
WP 0415 (4 pages)	0	WP 0466 (4 pages)	0
WP 0416 (4 pages)	0	WP 0467 (4 pages)	0
WP 0417 (4 pages)	0	WP 0068 (4 pages)	0
WP 0418 (4 pages)	0	WP 0469 (4 pages)	0
WP 0419 (4 pages)	0	WP 0470 (4 pages)	0
WP 0420 (4 pages)	0	WP 0471 (4 pages)	0
WP 0421 (4 pages)	0	WP 0472 (4 pages)	0
WP 0422 (4 pages)	0	WP 0473 (4 pages)	0
WP 0423 (4 pages)	0	WP 0474 (4 pages)	0
WP 0424 (4 pages)	0	WP 0475 (4 pages)	0
WP 0425 (4 pages)	0	WP 0476 (4 pages)	0
WP 0426 (4 pages)	0	WP 0477 (4 pages)	0
WP 0427 (4 pages)	0	WP 0478 (4 pages)	0

**LIST OF EFFECTIVE PAGES/WORK PACKAGES - Continued**

<b>Page/WP No.</b>	<b>Change No.</b>	<b>Page/WP No.</b>	<b>Change No.</b>
WP 0479 (4 pages)	0	WP 0530 (4 pages)	0
WP 0480 (6 pages)	0	WP 0531 (6 pages)	0
WP 0481 (4 pages)	0	WP 0532 (4 pages)	0
WP 0482 (4 pages)	0	WP 0533 (4 pages)	0
WP 0483 (4 pages)	0	WP 0534 (4 pages)	0
WP 0484 (4 pages)	0	WP 0535 (4 pages)	0
WP 0485 (4 pages)	0	WP 0536 (4 pages)	0
WP 0486 (4 pages)	0	WP 0537 (4 pages)	0
WP 0487 (4 pages)	0	WP 0538 (4 pages)	0
WP 0488 (4 pages)	0	WP 0539 (4 pages)	0
WP 0489 (4 pages)	0	WP 0540 (4 pages)	0
WP 0490 (4 pages)	0	WP 0541 (6 pages)	0
WP 0491 (4 pages)	0	WP 0542 (4 pages)	0
WP 0492 (4 pages)	0	WP 0543 (6 pages)	0
WP 0493 (4 pages)	0	WP 0544 (4 pages)	0
WP 0494 (6 pages)	0	WP 0545 (6 pages)	0
WP 0495 (4 pages)	0	WP 0546 (6 pages)	0
WP 0496 (6 pages)	0	WP 0547 (6 pages)	0
WP 0497 (6 pages)	0	WP 0548 (4 pages)	0
WP 0498 (6 pages)	0	WP 0549 (4 pages)	0
WP 0499 (4 pages)	0	WP 0550 (4 pages)	0
WP 0500 (4 pages)	0	WP 0551 (6 pages)	0
WP 0501 (4 pages)	0	WP 0552 (6 pages)	0
WP 0502 (4 pages)	0	WP 0553 (6 pages)	0
WP 0503 (4 pages)	0	WP 0554 (6 pages)	0
WP 0504 (4 pages)	0	WP 0555 (4 pages)	0
WP 0505 (4 pages)	0	WP 0556 (6 pages)	0
WP 0506 (4 pages)	0	WP 0557 (4 pages)	0
WP 0507 (4 pages)	0	WP 0558 (4 pages)	0
WP 0508 (4 pages)	0	WP 0559 (4 pages)	0
WP 0509 (4 pages)	0	WP 0560 (4 pages)	0
WP 0510 (4 pages)	0	WP 0561 (4 pages)	0
WP 0511 (4 pages)	0	WP 0562 (10 pages)	0
WP 0512 (4 pages)	0	WP 0563 (4 pages)	0
WP 0513 (6 pages)	0	WP 0564 (6 pages)	0
WP 0514 (4 pages)	0	WP 0565 (6 pages)	0
WP 0515 (4 pages)	0	WP 0566 (4 pages)	0
WP 0516 (4 pages)	0	WP 0567 (4 pages)	0
WP 0517 (4 pages)	0	WP 0568 (4 pages)	0
WP 0518 (4 pages)	0	WP 0569 (4 pages)	0
WP 0519 (4 pages)	0	WP 0570 (4 pages)	0
WP 0520 (4 pages)	0	WP 0571 (4 pages)	0
WP 0521 (4 pages)	0	WP 0572 (4 pages)	0
WP 0522 (4 pages)	0	WP 0573 (4 pages)	0
WP 0523 (4 pages)	0	WP 0574 (4 pages)	0
WP 0524 (4 pages)	0	WP 0575 (4 pages)	0
WP 0525 (4 pages)	0	WP 0576 (4 pages)	0
WP 0526 (6 pages)	0	WP 0577 (4 pages)	0
WP 0527 (6 pages)	0	WP 0578 (4 pages)	0
WP 0528 (4 pages)	0	WP 0579 (4 pages)	0
WP 0529 (6 pages)	0	WP 0580 (4 pages)	0

**LIST OF EFFECTIVE PAGES/WORK PACKAGES - Continued**

<b>Page/WP No.</b>	<b>Change No.</b>	<b>Page/WP No.</b>	<b>Change No.</b>
WP 0581 (4 pages)	0	WP 0625 (4 pages)	0
WP 0582 (4 pages)	0	WP 0626 (4 pages)	0
WP 0583 (4 pages)	0	WP 0627 (4 pages)	0
WP 0584 (4 pages)	0	WP 0628 (4 pages)	0
WP 0585 (4 pages)	0	WP 0629 (4 pages)	0
WP 0586 (4 pages)	0	WP 0630 (4 pages)	0
WP 0587 (4 pages)	0	WP 0631 (4 pages)	0
WP 0588 (4 pages)	0	WP 0632 (6 pages)	0
WP 0589 (4 pages)	0	WP 0633 (6 pages)	0
WP 0590 (4 pages)	0	WP 0634 (6 pages)	0
WP 0591 (6 pages)	0	WP 0635 (4 pages)	0
WP 0592 (6 pages)	0	WP 0636 (4 pages)	0
WP 0593 (4 pages)	0	WP 0637 (4 pages)	0
WP 0594 (6 pages)	0	WP 0638 (4 pages)	0
WP 0595 (6 pages)	0	WP 0639 (8 pages)	0
WP 0596 (6 pages)	0	WP 0640 (4 pages)	0
WP 0597 (6 pages)	0	WP 0641 (6 pages)	0
WP 0598 (6 pages)	0	WP 0642 (4 pages)	0
WP 0599 (6 pages)	0	WP 0643 (4 pages)	0
WP 0600 (6 pages)	0	WP 0644 (6 pages)	0
WP 0601 (4 pages)	0	WP 0645 (6 pages)	0
WP 0602 (8 pages)	0	WP 0646 (4 pages)	0
Inside Back Cover	0	WP 0647 (4 pages)	0
Back Cover	0	WP 0648 (4 pages)	0
		WP 0649 (8 pages)	0
VOLUME 3		WP 0650 (4 pages)	0
Front Cover (2 pages)	0	WP 0651 (4 pages)	0
i-viii (8 pages)	0	WP 0652 (4 pages)	0
Chapter 3 Title Page (2 pages)	0	WP 0653 (4 pages)	0
WP 0603 (4 pages)	0	WP 0654 (4 pages)	0
WP 0604 (4 pages)	0	WP 0655 (4 pages)	0
WP 0605 (4 pages)	0	WP 0656 (4 pages)	0
WP 0606 (4 pages)	0	WP 0657 (4 pages)	0
WP 0607 (4 pages)	0	WP 0658 (4 pages)	0
WP 0608 (4 pages)	0	WP 0659 (4 pages)	0
WP 0609 (4 pages)	0	WP 0660 (6 pages)	0
WP 0610 (12 pages)	0	WP 0661 (4 pages)	0
WP 0611 (4 pages)	0	WP 0662 (4 pages)	0
WP 0612 (6 pages)	0	WP 0663 (4 pages)	0
WP 0613 (4 pages)	0	WP 0664 (4 pages)	0
WP 0614 (6 pages)	0	WP 0665 (4 pages)	0
WP 0615 (4 pages)	0	WP 0666 (4 pages)	0
WP 0616 (4 pages)	0	WP 0667 (4 pages)	0
WP 0617 (4 pages)	0	WP 0668 (4 pages)	0
WP 0618 (6 pages)	0	WP 0669 (16 pages)	0
WP 0619 (4 pages)	0	WP 0670 (8 pages)	0
WP 0620 (6 pages)	0	WP 0671 (4 pages)	0
WP 0621 (4 pages)	0	WP 0672 (4 pages)	0
WP 0622 (6 pages)	0	WP 0673 (4 pages)	0
WP 0623 (4 pages)	0	WP 0674 (112 pages)	0
WP 0624 (4 pages)	0	WP 0675 (122 pages)	0

## LIST OF EFFECTIVE PAGES/WORK PACKAGES - Continued

Page/WP No.	Change No.	Page/WP No.	Change No.
Inside Back Cover	0	Back Cover	0



HEADQUARTERS  
DEPARTMENTS OF THE ARMY AND THE AIR FORCE  
WASHINGTON, D.C., 27 AUGUST 2012

REPAIR PARTS AND SPECIAL TOOLS LIST (RPSTL)  
FOR  
TRUCK, 5-TON, 6X6, M939, M939A1, AND M939A2 SERIES TRUCKS (DIESEL)

TRUCK, CARGO: 5-TON, 6X6 DROPSIDE M923 NSN 2320-01-050-2084 (EIC BRY) M923A1 NSN 2320-01-206-4087 (EIC BSS) M923A2 NSN 2320-01-230-0307 (EIC BS7) M925 NSN 2320-01-047-8769 (EIC BRT) M925A1 NSN 2320-01-206-4088 (EIC BST) M925A2 NSN 2320-01-230-0308 (EIC BS8)	TRUCK, DUMP: 5-TON, 6X6 M929 NSN 2320-01-047-8756 (EIC BTH) M929A1 NSN 2320-01-206-4079 (EIC BSY) M929A2 NSN 2320-01-230-0305 (EIC BTN) M930 NSN 2320-01-047-8755 (EIC BTG) M930A1 NSN 2320-01-206-4080 (EIC BSZ) M930A2 NSN 2320-01-230-0306 (EIC BT7)	TRUCK, VAN, EXPANSIBLE: 5-TON, 6X6 M934 NSN 2320-01-047-8750 (EIC BTB) M934A1 NSN 2320-01-205-2682 (EIC BS4) M934A2 NSN 2320-01-230-0300 (EIC BTR)
TRUCK, CARGO: 5-TON, 6X6 XLWB M927 NSN 2320-01-047-8771 (EIC BRV) M927A1 NSN 2320-01-206-4089 (EIC BSW) M927A2 NSN 2320-01-230-0309 (EIC BS9) M928 NSN 2320-01-047-8770 (EIC BRU) M928A1 NSN 2320-01-206-4090 (EIC BSX) M928A2 NSN 2320-01-230-0310 (EIC BTM)	TRUCK, TRACTOR: 5-TON, 6X6 M931 NSN 2320-01-047-8753 (EIC BTE) M931A1 NSN 2320-01-206-4077 (EIC BS2) M931A2 NSN 2320-01-230-0302 (EIC BTP) M932 NSN 2320-01-047-8752 (EIC BTD) M932A1 NSN 2320-01-205-2684 (EIC BSZ) M932A2 NSN 2320-01-230-0303 (EIC BTQ)	TRUCK, MEDIUM WRECKER: 5-TON, 6X6 M936 NSN 2320-01-047-8754 (EIC BTF) M936A1 NSN 2320-01-206-4078 (EIC BS6) M936A2 NSN 2320-01-230-0304 (EIC BTT)

**REPORTING ERRORS AND RECOMMENDING IMPROVEMENTS**

You can help improve this publication. If you find any mistakes, or if you know of a way to improve the procedures, please let us know: Reports, as applicable by the requiring service, should be submitted as follows:

(A) Army - Mail your letter or DA Form 2028 (Recommended Changes to Publications and Blank Forms), located in the back of this manual directly to: U.S. Army TACOM Life Cycle Management Command, ATTN: AMSTA-LCL-MPP/ TECH PUBS, MS 727, 6501 E. 11 Mile Road, Warren, MI 48397-5000. You may also send in your recommended changes via electronic mail or by fax. Our fax number is DSN 786-1856 or Commercial (586) 282-1856. Our email address is [tacomlcmc.daform2028@us.army.mil](mailto:tacomlcmc.daform2028@us.army.mil).

(F) Air Force - By Air Force AFTO Form 22 directly to WR/ALC/GRVEB, Robins GA. You may also send in your recommended changes electronically via email. Email AFTO form 22 to [robins.ce.afto22@robins.af.mil](mailto:robins.ce.afto22@robins.af.mil). A reply will be furnished to you.

**\*SUPERSEDURE NOTICE** - This manual supersedes TM 9-2320-272-24P-1, TM 9-2320-272-24P-2, and TO 36A12-1C-1155-4-1 and TO 36A12-1C-1155-4-2, dated 1 February 1999, including all changes.

**DISTRIBUTION STATEMENT A** - Approved for public release; distribution is unlimited.



# TABLE OF CONTENTS

**Page No.**  
**WP Sequence No.**

**Volume 1**

**Chapter 1 - REPAIR PARTS AND SPECIAL TOOLS LIST (RPSTL)**

INTRODUCTION.....	WP 0001
Table 1. SMR Code Explanation.....	0001-1
GROUP 0100 ENGINE ASSEMBLY.....	WP 0002
Figure 1 Engine and Container Assembly (M939, M939A1).....	0002-2
GROUP 0100 ENGINE ASSEMBLY.....	WP 0003
Figure 2 Engine and Container Assembly (M939A2).....	0003-2
GROUP 0100 ENGINE ASSEMBLY.....	WP 0004
Figure 3 Engine Lifting Brackets (M939, M939A1).....	0004-2
GROUP 0100 ENGINE ASSEMBLY.....	WP 0005
Figure 4 Engine Lifting Brackets (M939A2).....	0005-2
GROUP 0100 ENGINE ASSEMBLY.....	WP 0006
Figure 5 Engine Mounts (M939, M939A1).....	0006-2
GROUP 0100 ENGINE ASSEMBLY.....	WP 0007
Figure 6 Engine Mounts (M939A2).....	0007-2
GROUP 0101 CRANKCASE, BLOCK, CYLINDER HEAD.....	WP 0008
Figure 7 Cylinder Block Assembly (M939, M939A1).....	0008-2
GROUP 0101 CRANKCASE, BLOCK, CYLINDER HEAD.....	WP 0009
Figure 8 Cylinder Block Assembly (M939A2).....	0009-2
GROUP 0101 CRANKCASE, BLOCK, CYLINDER HEAD.....	WP 0010
Figure 9 Cylinder Head Assembly, Gasket, and Mounting Hardware (M939, M939A1).....	0010-2
GROUP 0101 CRANKCASE, BLOCK, CYLINDER HEAD.....	WP 0011
Figure 10 Cylinder Head Assembly, Gasket, and Mounting Hardware (M939A2).....	0011-2
GROUP 0101 CRANKCASE, BLOCK, CYLINDER HEAD.....	WP 0012
Figure 11 Engine Access Cover (M939, M939A1).....	0012-2
GROUP 0102 CRANKSHAFT.....	WP 0013

**TABLE OF CONTENTS - Continued**

	<b>Page No.</b>
	<b><u>WP Sequence No.</u></b>
Figure 12 Crankshaft Assembly (M939, M939A1).....	0013-2
GROUP 0102 CRANKSHAFT.....	WP 0014
Figure 13 Crankshaft Assembly (M939A2).....	0014-2
GROUP 0103 FLYWHELL ASSEMBLY.....	WP 0015
Figure 14 Flywheel Gear Assembly and Housing (M939, M939A1).....	0015-2
GROUP 0103 FLYWHELL ASSEMBLY.....	WP 0016
Figure 15 Flywheel Housing and Flexplate (M939A2).....	0016-2
GROUP 0103 FLYWHELL ASSEMBLY.....	WP 0017
Figure 16 Crankshaft Rear Cover (M939, M939A1).....	0017-2
GROUP 0104 PISTONS, CONNECTING RODS.....	WP 0018
Figure 17 Piston and Rod Assembly (M939, M939A1).....	0018-2
GROUP 0104 PISTONS, CONNECTING RODS.....	WP 0019
Figure 18 Piston and Rod Assembly (M939A2).....	0019-2
GROUP 0105 VALVES, CAMSHAFTS, AND TIMING SYSTEM.....	WP 0020
Figure 19 Front Gear Cover (M939, M939A1).....	0020-2
GROUP 0105 VALVES, CAMSHAFTS, AND TIMING SYSTEM.....	WP 0021
Figure 20 Front Gear Cover (M939A2).....	0021-2
GROUP 0105 VALVES, CAMSHAFTS, AND TIMING SYSTEM.....	WP 0022
Figure 21 Camshaft, Gear, and Related Parts (M939, M939A1).....	0022-2
GROUP 0105 VALVES, CAMSHAFTS, AND TIMING SYSTEM.....	WP 0023
Figure 22 Camshaft, Gear, and Related Parts (M939A2).....	0023-2
GROUP 0105 VALVES, CAMSHAFTS, AND TIMING SYSTEM.....	WP 0024
Figure 23 Cam Follower, Housing and Push Rods (M939, M939A1).....	0024-2
GROUP 0105 VALVES, CAMSHAFTS, AND TIMING SYSTEM.....	WP 0025
Figure 24 Valves, Springs, Guides, and Miscellaneous Parts (M939, M939A1).....	0025-2
GROUP 0105 VALVES, CAMSHAFTS, AND TIMING SYSTEM.....	WP 0026
Figure 25 Valves, Springs, Guides, and Miscellaneous Parts (M939A2).....	0026-2

## TABLE OF CONTENTS - Continued

	<b>Page No.</b>
	<b><u>WP Sequence No.</u></b>
GROUP 0105 VALVES, CAMSHAFTS, AND TIMING SYSTEM.....	WP 0027
Figure 26 Rocker Arms and Miscellaneous Hardware (M939, M939A1).....	0027-2
GROUP 0105 VALVES, CAMSHAFTS, AND TIMING SYSTEM.....	WP 0028
Figure 27 Rocker Arms and Miscellaneous Hardware (M939A2).....	0028-2
GROUP 0105 VALVES, CAMSHAFTS, AND TIMING SYSTEM.....	WP 0029
Figure 28 Valve Cover and Gasket (M939, M939A1).....	0029-2
GROUP 0105 VALVES, CAMSHAFTS, AND TIMING SYSTEM.....	WP 0030
Figure 29 Valve Cover and Gasket (M939A2).....	0030-2
GROUP 0106 ENGINE LUBRICATION SYSTEM.....	WP 0031
Figure 30 Engine Oil Filter (M939, M939A1).....	0031-2
GROUP 0106 ENGINE LUBRICATION SYSTEM.....	WP 0032
Figure 31 Engine Oil Cooler Assembly (M939, M939A1).....	0032-2
GROUP 0106 ENGINE LUBRICATION SYSTEM.....	WP 0033
Figure 32 Engine Oil Cooler and Filter (M939A2).....	0033-2
GROUP 0106 ENGINE LUBRICATION SYSTEM.....	WP 0034
Figure 33 Engine Oil Pump (M939, M939A1).....	0034-2
GROUP 0106 ENGINE LUBRICATION SYSTEM.....	WP 0035
Figure 34 Engine Oil Dipstick and Tube (M939, M939A1).....	0035-2
GROUP 0106 ENGINE LUBRICATION SYSTEM.....	WP 0036
Figure 35 Engine Oil Pump and Dipstick (M939A2).....	0036-2
GROUP 0106 ENGINE LUBRICATION SYSTEM.....	WP 0037
Figure 36 Engine Oil Pump Lines and Fittings (M939, M939A1).....	0037-2
GROUP 0106 ENGINE LUBRICATION SYSTEM.....	WP 0038
Figure 37 Engine Oil Pan and Related Parts (M939, M939A1).....	0038-2
GROUP 0106 ENGINE LUBRICATION SYSTEM.....	WP 0039
Figure 38 Engine Oil Pan and Related Parts (M939A2).....	0039-2
GROUP 0106 ENGINE LUBRICATION SYSTEM.....	WP 0040

## TABLE OF CONTENTS

	<b>Page No.</b>
	<b><u>WP Sequence No.</u></b>
Figure 39 Engine Oil Draft Tube (M939, M939A1).....	0040-2
GROUP 0106 ENGINE LUBRICATION SYSTEM.....	WP 0041
Figure 40 Crankshaft Breather Tube (M939A2).....	0041-2
GROUP 0108 MANIFOLDS.....	WP 0042
Figure 41 Air Intake Manifold (M939, M939A1).....	0042-2
GROUP 0108 MANIFOLDS.....	WP 0043
Figure 42 Exhaust Manifold (M939, M939A1).....	0043-2
GROUP 0108 MANIFOLDS.....	WP 0044
Figure 43 Exhaust Manifold (M939A2).....	0044-2
GROUP 0109 ACCESSORY DRIVING MECHANISMS.....	WP 0045
Figure 44 Accessory Drive, Pulley, and Related Parts (M939, M939A1).....	0045-2
GROUP 0109 ACCESSORY DRIVING MECHANISMS.....	WP 0046
Figure 45 Tachometer Access Cover (M939A2).....	0046-2
GROUP 0301 CARBURETOR, FUEL INJECTOR.....	WP 0047
Figure 46 Fuel Injector Assembly and Related Parts (M939, M939A1).....	0047-2
GROUP 0301 CARBURETOR, FUEL INJECTOR.....	WP 0048
Figure 47 Fuel Injector Assembly and Related Parts (M939A2).....	0048-2
GROUP 0302 FUEL PUMP.....	WP 0049
Figure 48 Fuel Injector Supply Tubes (M939A2).....	0049-2
GROUP 0302 FUEL PUMP.....	WP 0050
Figure 49 Fuel Pump Assembly, AFC (M939, M939A1).....	0050-2
GROUP 0302 FUEL PUMP.....	WP 0051
Figure 50 Fuel Pump Governor and Tachometer Drive Assembly, AFC (M939, M939A1).....	0051-2
GROUP 0302 FUEL PUMP.....	WP 0052
Figure 51 Fuel Pump Housing, AFC (M939, M939A1).....	0052-2
GROUP 0302 FUEL PUMP.....	WP 0053
Figure 52 Fuel Pump Damper (M939, M939A1).....	0053-2

## TABLE OF CONTENTS

	<b>Page No.</b>
	<b><u>WP Sequence No.</u></b>
GROUP 0302 FUEL PUMP.....	WP 0054
Figure 53 Fuel Gear Pump Assembly and Mounting Hardware (M939, M939A1).....	0054-2
GROUP 0302 FUEL PUMP.....	WP 0055
Figure 54 Fuel Pump Assembly with VS Governor (M939, M939A1).....	0055-2
GROUP 0302 FUEL PUMP.....	WP 0056
Figure 55 Fuel Pump Governor and Tachometer Drive Assembly, VS (M939, M939A1).....	0056-2
GROUP 0302 FUEL PUMP.....	WP 0057
Figure 56 Fuel Pump Housing, VS (M939, M939A1).....	0057-2
GROUP 0302 FUEL PUMP.....	WP 0058
Figure 57 Fuel Injector Pump (M939A2).....	0058-2
GROUP 0302 FUEL PUMP.....	WP 0059
Figure 58 Fuel Injector Pump, Camshaft, and Related Parts (M939A2).....	0059-2
GROUP 0302 FUEL PUMP.....	WP 0060
Figure 59 Fuel Injector Pump Plunger and Control Rack (M939A2).....	0060-2
GROUP 0302 FUEL PUMP.....	WP 0061
Figure 60 Fuel Transfer Pump (M939A2).....	0061-2
GROUP 0304 AIR CLEANER.....	WP 0062
Figure 61 Air Cleaner Indicator and Related Parts.....	0062-2
GROUP 0304 AIR CLEANER.....	WP 0063
Figure 62 Air Intake System.....	0063-2
GROUP 0304 AIR CLEANER.....	WP 0064
Figure 63 Air Intake System (M939A2).....	0064-2
GROUP 0305 SUPERCHARGER, BLOWER, TURBOCHARGER OR ALTITUDE COMPENSATOR.....	WP 0065
Figure 64 Turbocharger Hoses and Clamps (M939A2).....	0065-2
GROUP 0305 SUPERCHARGER, BLOWER, TURBOCHARGER OR ALTITUDE COMPENSATOR.....	WP 0066
Figure 65 Turbocharger Assembly (M939A2).....	0066-2

## TABLE OF CONTENTS

	<b>Page No.</b>
	<b><u>WP Sequence No.</u></b>
GROUP 0306 TANKS, LINES, FITTINGS, HEADERS.....	WP 0067
Figure 66 Fuel Crossover, Drain, and Bypass Tubing.....	0067-2
GROUP 0306 TANKS, LINES, FITTINGS, HEADERS.....	WP 0068
Figure 67 Fuel Tank Mounting, Single Tank, LH.....	0068-2
GROUP 0306 TANKS, LINES, FITTINGS, HEADERS.....	WP 0069
Figure 68 Fuel Tank Mounting, Single Tank, RH.....	0069-2
GROUP 0306 TANKS, LINES, FITTINGS, HEADERS.....	WP 0070
Figure 69 Fuel Tank Mounting, Dual Tank.....	0070-2
GROUP 0306 TANKS, LINES, FITTINGS, HEADERS.....	WP 0071
Figure 70 Fuel Tank Vent Lines, Single, LH.....	0071-2
GROUP 0306 TANKS, LINES, FITTINGS, HEADERS.....	WP 0072
Figure 71 Fuel Tank Supply and Return Lines, Single, LH (M939, M939A1).....	0072-2
GROUP 0306 TANKS, LINES, FITTINGS, HEADERS.....	WP 0073
Figure 72 Fuel Tank Supply and Return Lines, Single, LH (M939A2).....	0073-2
GROUP 0306 TANKS, LINES, FITTINGS, HEADERS.....	WP 0074
Figure 73 Fuel Tank Vent Lines, Single, RH.....	0074-2
GROUP 0306 TANKS, LINES, FITTINGS, HEADERS.....	WP 0075
Figure 74 Fuel Tank Supply and Return Lines, Single, RH.....	0075-2
GROUP 0306 TANKS, LINES, FITTINGS, HEADERS.....	WP 0076
Figure 75 Fuel Tank Supply and Return Lines, Dual.....	0076-2
GROUP 0306 TANKS, LINES, FITTINGS, HEADERS.....	WP 0077
Figure 76 Fuel Tank Lines, Dual LH.....	0077-2
GROUP 0306 TANKS, LINES, FITTINGS, HEADERS.....	WP 0078
Figure 77 Fuel Tank Selector Valve to RH Fuel Tank Lines, Dual.....	0078-2
GROUP 0306 TANKS, LINES, FITTINGS, HEADERS.....	WP 0079
Figure 78 Dual Fuel Tank Supply and Return Lines (M939A2).....	0079-2
GROUP 0306 TANKS, LINES, FITTINGS, HEADERS.....	WP 0080



## TABLE OF CONTENTS

	<b>Page No.</b>
	<b><u>WP Sequence No.</u></b>
Figure 79 Fuel Tank Fuel Lines to LH Tank, Wrecker.....	0080-2
GROUP 0306 TANKS, LINES, FITTINGS, HEADERS.....	WP 0081
Figure 80 Dual Fuel Tank Fuel Lines to RH Tank, Wrecker.....	0081-2
GROUP 0306 TANKS, LINES, FITTINGS, HEADERS.....	WP 0082
Figure 81 Fuel Tank Selector Valve Assembly and Related Parts.....	0082-2
GROUP 0306 TANKS, LINES, FITTINGS, HEADERS.....	WP 0083
Figure 82 Fuel Tank Assembly.....	0083-2
GROUP 0306 TANKS, LINES, FITTINGS, HEADERS.....	WP 0084
Figure 83 Fuel Tank Protector Plate and Mounting Hardware.....	0084-2
GROUP 0308 ENGINE SPEED GOVERNOR AND CONTROLS.....	WP 0085
Figure 84 Fuel Pump Governor, AFC (M939, M939A1).....	0085-2
GROUP 0308 ENGINE SPEED GOVERNOR AND CONTROLS.....	WP 0086
Figure 85 Fuel Pump Spring Pack, AFC (M939, M939A1).....	0086-2
GROUP 0308 ENGINE SPEED GOVERNOR AND CONTROLS.....	WP 0087
Figure 86 Fuel Pump Governor, VS (M939, M939A1).....	0087-2
GROUP 0308 ENGINE SPEED GOVERNOR AND CONTROLS.....	WP 0088
Figure 87 Fuel Pump Lower Spring Pack, VS (M939, M939A1).....	0088-2
GROUP 0308 ENGINE SPEED GOVERNOR AND CONTROLS.....	WP 0089
Figure 88 Fuel Pump Upper Spring Pack, VS (M939I, M939A1).....	0089-2
GROUP 0308 ENGINE SPEED GOVERNOR AND CONTROLS.....	WP 0090
Figure 89 Manifold Pressure Compensator Assembly and Related Parts (M939A2).....	0090-2
GROUP 0308 ENGINE SPEED GOVERNOR AND CONTROLS.....	WP 0091
Figure 90 Governor Cover and Related Parts (M939A2).....	0091-2
GROUP 0308 ENGINE SPEED GOVERNOR AND CONTROLS.....	WP 0092
Figure 91 Flyweight Assembly (M939A2).....	0092-2
GROUP 0308 ENGINE SPEED GOVERNOR AND CONTROLS.....	WP 0093
Figure 92 Governor Housing (M939A2).....	0093-2

## TABLE OF CONTENTS

	<b>Page No.</b>
	<b><u>WP Sequence No.</u></b>
GROUP 0309 FUEL FILTERS.....	WP 0094
Figure 93 Fuel Filter, Water Separator, and Mounting Hardware (M939, M939A1, M939A2).....	0094-2
GROUP 0309 FUEL FILTERS.....	WP 0095
Figure 94 Fuel Filter/Water Separator (M939A2).....	0095-2
GROUP 0309 FUEL FILTERS.....	WP 0096
Figure 95 Fuel Pump Filter, AFC (M939, M939A1).....	0096-2
GROUP 0309 FUEL FILTERS.....	WP 0097
Figure 96 Fuel Pump Filter, VS.....	0097-2
GROUP 0311 ENGINE STARTING AIDS.....	WP 0098
Figure 97 Ether Start Cylinder, Switch, and Relate Lines and Fittings.....	0098-2
GROUP 0311 ENGINE STARTING AIDS.....	WP 0099
Figure 98 Atomizer Nozzle (M939A2).....	0099-2
GROUP 0311 ENGINE STARTING AIDS.....	WP 0100
Figure 99 Fuel Primer Pump.....	0100-2
GROUP 0312 ACCELERATOR, THROTTLE OR CHOKE CONTROLS.....	WP 0101
Figure 100 Accelerator Controls and Linkage (M939, M939A1).....	0101-2
GROUP 0312 ACCELERATOR, THROTTLE OR CHOKE CONTROLS.....	WP 0102
Figure 101 Accelerator and Throttle Linkage (M939A2).....	0102-2
GROUP 0401 MUFFLER AND PIPES.....	WP 0103
Figure 102 Muffler, Exhaust Pipes, and Related Parts.....	0103-2
GROUP 0401 MUFFLER AND PIPES.....	WP 0104
Figure 103 Exhaust System (M939A2).....	0104-2
GROUP 0501 RADIATOR, EVAPORATIVE COOLER, OR HEAT EXCHANGER.....	WP 0105
Figure 104 Radiator Hoses and Mounting Hardware (M939, M939A1).....	0105-2
GROUP 0501 RADIATOR, EVAPORATIVE COOLER, OR HEAT EXCHANGER.....	WP 0106
Figure 105 Upper Radiator Mounting Hardware and Hoses (M939, M939A1).....	0106-2
GROUP 0501 RADIATOR, EVAPORATIVE COOLER, OR HEAT EXCHANGER.....	WP 0107

## TABLE OF CONTENTS

	<b>Page No.</b>
	<b><u>WP Sequence No.</u></b>
Figure 106 Lower Radiator Mounting Hardware (M939, M939A1).....	0107-2
GROUP 0501 RADIATOR, EVAPORATIVE COOLER, OR HEAT EXCHANGER.....	WP 0108
Figure 107 Radiator Assembly and Mounting Hardware (M939A2).....	0108-2
GROUP 0501 RADIATOR, EVAPORATIVE COOLER, OR HEAT EXCHANGER.....	WP 0109
Figure 108 Radiator Assembly.....	0109-2
GROUP 0501 RADIATOR, EVAPORATIVE COOLER, OR HEAT EXCHANGER.....	WP 0110
Figure 109 Surge Tank Assembly, Hoses, and Mounting Hardware (M939, M939A1).....	0110-2
GROUP 0501 RADIATOR, EVAPORATIVE COOLER, OR HEAT EXCHANGER.....	WP 0111
Figure 110 Surge Tank Assembly (M939A2).....	0111-2
GROUP 0501 RADIATOR, EVAPORATIVE COOLER, OR HEAT EXCHANGER.....	WP 0112
Figure 111 Surge Tank Lines and Clamps (M939A2).....	0112-2
GROUP 0502 COWLING, DEFLECTORS, AIR DUCTS, SHROUDS, ETC.....	WP 0113
Figure 112 Shroud Assembly and Mounting Hardware (M939, M939A1).....	0113-2
GROUP 0502 COWLING, DEFLECTORS, AIR DUCTS, SHROUDS, ETC.....	WP 0114
Figure 113 Radiator Fan Shroud (M939A2).....	0114-2
GROUP 0503 WATER MANIFOLD, HEADERS, THERMOSTATS AND HOUSING GASKET.....	WP 0115
Figure 114 Thermostat, Housing, Seal and Mounting Hardware (M939, M939A1).....	0115-2
GROUP 0503 WATER MANIFOLD, HEADERS, THERMOSTATS AND HOUSING GASKET.....	WP 0116
Figure 115 Thermostat and Housing Assembly (M939A2).....	0116-2
GROUP 0503 WATER MANIFOLD, HEADERS, THERMOSTATS AND HOUSING GASKET.....	WP 0117
Figure 116 Water Manifold, Cover, and Mounting Hardware (M939, M939A1).....	0117-2
GROUP 0503 WATER MANIFOLD, HEADERS, THERMOSTATS AND HOUSING GASKET.....	WP 0118
Figure 117 Air Compressor Coolant Lines and Related Parts (M939, M939A1).....	0118-2
GROUP 0504 WATER PUMP.....	WP 0119
Figure 118 Water Pump Assembly, Seals, and Mounting Hardware (M939, M939A1).....	0119-2
GROUP 0504 WATER PUMP.....	WP 0120
Figure 119 Water Pump (M939A2).....	0120-2

## TABLE OF CONTENTS

	<b>Page No.</b>
	<b><u>WP Sequence No.</u></b>
GROUP 0505 FAN ASSEMBLY.....	WP 0121
Figure 120 Fan Clutch Assembly, Fan, and Belts (M939, M939A1).....	0121-2
GROUP 0505 FAN ASSEMBLY.....	WP 0122
Figure 121 Fan Assembly (M939A2).....	0122-2
GROUP 0505 FAN ASSEMBLY.....	WP 0123
Figure 122 Fan Drive Clutch Assembly (M939A2).....	0123-2
GROUP 0505 FAN ASSEMBLY.....	WP 0124
Figure 123 Belt Tensioner Pulley (M939A2).....	0124-2
GROUP 0507 AUXILIARY COOLING.....	WP 0125
Figure 124 Engine Aftercooler (M939A2).....	0125-2
GROUP 0601 GENERATOR, ALTERNATOR.....	WP 0126
Figure 125 Alternator Assembly, Mounting Hardware, Belts, and Pulley (M939, M939A1).....	0126-2
GROUP 0601 GENERATOR, ALTERNATOR.....	WP 0127
Figure 126 Alternator Mounting (M939A2).....	0127-2
GROUP 0603 STARTING MOTOR.....	WP 0128
Figure 127 Starting Motor Assembly and Mounting Hardware (M939, M939A1).....	0128-2
GROUP 0603 STARTING MOTOR.....	WP 0129
Figure 128 Starter Assembly (M939A2).....	0129-2
GROUP 0606 ENGINE SAFETY CONTROLS.....	WP 0130
Figure 129 Shutdown Valve and Mounting Hardware (M939, M939A1).....	0130-2
GROUP 0606 ENGINE SAFETY CONTROLS.....	WP 0131
Figure 130 Throttle Control Solenoid (M939A2).....	0131-2
GROUP 0607 INSTRUMENT OR ENGINE CONTROL PANEL.....	WP 0132
Figure 131 Control Panel, Light Switch, and Fuel Tank Selector Switch.....	0132-2
GROUP 0607 INSTRUMENT OR ENGINE CONTROL PANEL.....	WP 0133
Figure 132 Instrument Cluster Assembly.....	0133-2
GROUP 0607 INSTRUMENT OR ENGINE CONTROL PANEL.....	WP 0134

## TABLE OF CONTENTS

	<b>Page No.</b>
	<b><u>WP Sequence No.</u></b>
Figure 133 Instrument Cluster Assembly (M939A2).....	0134-2
GROUP 0607 INSTRUMENT OR ENGINE CONTROL PANEL.....	WP 0135
Figure 134 Instrument Panel, Floodlight, Heater, Warning Switches, Lamp Holder, and Auxiliary Receptacle. (Sheet 1 of 2) .....	0135-1
Figure 134 Instrument Panel, Floodlight, Heater, Warning Switches, Lamp Holder, and Auxiliary Receptacle. (Sheet 2 of 2) .....	0135-2
GROUP 0607 INSTRUMENT OR ENGINE CONTROL PANEL.....	WP 0136
Figure 135 Circuit Breakers.....	0136-2
GROUP 0607 INSTRUMENT OR ENGINE CONTROL PANEL.....	WP 0137
Figure 136 Control Unit and Directional Flasher.....	0137-2
GROUP 0607 INSTRUMENT OR ENGINE CONTROL PANEL.....	WP 0138
Figure 137 Protective Control Box, High Beam Switch, and Mounting Hardware.....	0138-2
GROUP 0608 MISCELLANEOUS ITEMS.....	WP 0139
Figure 138 CTIS Electrical Wiring Harness (M939A2).....	0139-2
GROUP 0609 LIGHTS.....	WP 0140
Figure 139 Taillight Assembly and Mounting Hardware.....	0140-2
GROUP 0609 LIGHTS.....	WP 0141
Figure 140 Front Composite Light and Mounting Hardware.....	0141-2
GROUP 0609 LIGHTS.....	WP 0142
Figure 141 Blackout Lamp and Headlight.....	0142-2
GROUP 0609 LIGHTS.....	WP 0143
Figure 142 Taillight and Blackout Light Brackets and Mounting Hardware.....	0143-2
GROUP 0609 LIGHTS.....	WP 0144
Figure 143 Side Marker Lights, Brackets, and Mounting Hardware.....	0144-2
GROUP 0609 LIGHTS.....	WP 0145
Figure 144 Floodlight Assembly.....	0145-2
GROUP 0610 SENDING UNITS AND WARNING SWITCHES.....	WP 0146

## TABLE OF CONTENTS

	<b>Page No.</b>
	<b><u>WP Sequence No.</u></b>
Figure 145 Fuel Pressure Transducer and Support, Fuel Level Transmitter, Parking Brake, and Warning Control Device.....	0146-2
GROUP 0610 SENDING UNITS AND WARNING SWITCHES.....	WP 0147
Figure 146 Low Air Warning Switch, Mechanical Tachometer, Transmission Temperature Transmitter, Oil Pressure Transmitter, and Stoplight Switch.....	0147-2
GROUP 0610 SENDING UNITS AND WARNING SWITCHES.....	WP 0148
Figure 147 Temperature Transmitter and Tachometer Pulse Sender (M939A2).....	0148-2
GROUP 0611 HORN, SIREN.....	WP 0149
Figure 148 Horn Assembly, Related Tubing, and Mounting Bracket.....	0149-2
GROUP 0611 HORN, SIREN.....	WP 0150
Figure 149 Horn Button and Diode Coupling Assembly.....	0150-2
GROUP 0611 HORN, SIREN.....	WP 0151
Figure 150 Horn Cover, Brush, and Capacitor Assembly.....	0151-2
GROUP 0612 BATTERIES, STORAGE (WET OR DRY).....	WP 0152
Figure 151 Batteries, Cables, and Related Parts.....	0152-2
GROUP 0612 BATTERIES, STORAGE (WET OR DRY).....	WP 0153
Figure 152 Battery Cables (M939A2).....	0153-2
GROUP 0612 BATTERIES, STORAGE (WET OR DRY).....	WP 0154
Figure 153 Battery Box Assembly, Cover, and Mounting Hardware.....	0154-2
GROUP 0612 BATTERIES, STORAGE (WET OR DRY).....	WP 0155
Figure 154 Slave Receptacle, Cable Assemblies, and Mounting Hardware.....	0155-2
GROUP 0613 HULL OR CHASSIS WIRING HARNESS.....	WP 0156
Figure 155 Electrical Ground Straps (M939, M939A1).....	0156-2
GROUP 0613 HULL OR CHASSIS WIRING HARNESS.....	WP 0157
Figure 156 Electrical Ground Straps (M939A2).....	0157-2
GROUP 0613 HULL OR CHASSIS WIRING HARNESS.....	WP 0158
Figure 157 Harness Assembly, Front Vehicle Lights. (Sheet 1 of 2) .....	0158-1
Figure 157 Harness Assembly, Front Vehicle Lights. (Sheet 2 of 2) .....	0158-2

## TABLE OF CONTENTS

	<b>Page No.</b>
	<b><u>WP Sequence No.</u></b>
GROUP 0613 HULL OR CHASSIS WIRING HARNESS.....	WP 0159
Figure 158 Front Wiring Harness Assembly.....	0159-2
GROUP 0613 HULL OR CHASSIS WIRING HARNESS.....	WP 0160
Figure 159 Front Wiring Harness, Partial View. (Sheet 1 of 3) .....	0160-2
Figure 159 Front Wiring Harness, Partial View. (Sheet 2 of 3) .....	0160-3
Figure 159 Front Wiring Harness, Partial View. (Sheet 3 of 3) .....	0160-4
GROUP 0613 HULL OR CHASSIS WIRING HARNESS.....	WP 0161
Figure 160 Front Wiring Harness, Partial View (M939A2). (Sheet 1 of 2) .....	0161-1
Figure 160 Front Wiring Harness, Partial View (M939A2). (Sheet 2 of 2) .....	0161-2
GROUP 0613 HULL OR CHASSIS WIRING HARNESS.....	WP 0162
Figure 161 Front Wiring Harness Clamps and Hardware.....	0162-2
GROUP 0613 HULL OR CHASSIS WIRING HARNESS.....	WP 0163
Figure 162 Front Wiring Harness Clamps and Hardware.....	0163-2
GROUP 0613 HULL OR CHASSIS WIRING HARNESS.....	WP 0164
Figure 163 Front Wiring Harness Bracket and Hardware.....	0164-2
GROUP 0613 HULL OR CHASSIS WIRING HARNESS.....	WP 0165
Figure 164 Rear Wiring Harness Assembly, Cargo. (Sheet 1 of 2) .....	0165-1
Figure 164 Rear Wiring Harness Assembly, Cargo. (Sheet 2 of 2) .....	0165-2
GROUP 0613 HULL OR CHASSIS WIRING HARNESS.....	WP 0166
Figure 165 Rear Wiring Harness Assembly, Wrecker. (Sheet 1 of 2) .....	0166-1
Figure 165 Rear Wiring Harness Assembly, Wrecker. (Sheet 2 of 2) .....	0166-2
GROUP 0613 HULL OR CHASSIS WIRING HARNESS.....	WP 0167
Figure 166 Rear Wiring Harness Assembly, Dump. (Sheet 1 of 2) .....	0167-1
Figure 166 Rear Wiring Harness Assembly, Dump. (Sheet 2 of 2) .....	0167-2
GROUP 0613 HULL OR CHASSIS WIRING HARNESS.....	WP 0168
Figure 167 Rear Wiring Harness Assembly, Tractor. (Sheet 1 of 2) .....	0168-1
Figure 167 Rear Wiring Harness Assembly, Tractor. (Sheet 2 of 2) .....	0168-2

## TABLE OF CONTENTS

	<b>Page No.</b>
	<b><u>WP Sequence No.</u></b>
GROUP 0613 HULL OR CHASSIS WIRING HARNESS.....	WP 0169
Figure 168 Rear Wiring Harness Assembly, Van. (Sheet 1 of 2) .....	0169-1
Figure 168 Rear Wiring Harness Assembly, Van. (Sheet 2 of 2) .....	0169-2
GROUP 0613 HULL OR CHASSIS WIRING HARNESS.....	WP 0170
Figure 169 Rear Wiring Harness Assembly, Chassis. (Sheet 1 of 2) .....	0170-1
Figure 169 Rear Wiring Harness Assembly, Chassis. (Sheet 2 of 2) .....	0170-2
GROUP 0613 HULL OR CHASSIS WIRING HARNESS.....	WP 0171
Figure 170 Crane Wiring Leads. (Sheet 1 of 2) .....	0171-1
Figure 170 Crane Wiring Leads. (Sheet 2 of 2) .....	0171-2
GROUP 0613 HULL OR CHASSIS WIRING HARNESS.....	WP 0172
Figure 171 Wrecker Crane Boom Wiring Harness.....	0172-2
GROUP 0613 HULL OR CHASSIS WIRING HARNESS.....	WP 0173
Figure 172 Side Marker Light Leads.....	0173-2
GROUP 0613 HULL OR CHASSIS WIRING HARNESS.....	WP 0174
Figure 173 Side Marker Light Leads.....	0174-2
GROUP 0613 HULL OR CHASSIS WIRING HARNESS.....	WP 0175
Figure 174 Instrument Cluster Harness.....	0175-2
GROUP 0613 HULL OR CHASSIS WIRING HARNESS.....	WP 0176
Figure 175 Ground and Jumper Cable Assemblies.....	0176-2
GROUP 0700 TRANSMISSION ASSEMBLY.....	WP 0177
Figure 176 Transmission Assembly and Shipping Container.....	0177-2
GROUP 0700 TRANSMISSION ASSEMBLY.....	WP 0178
Figure 177 Transmission Mounting Hardware, Fluid Dipstick, and Tube Assembly (M939, M939A1).....	0178-2
GROUP 0700 TRANSMISSION ASSEMBLY.....	WP 0179
Figure 178 Transmission Mounting Bracket (M939A2).....	0179-2
GROUP 0700 TRANSMISSION ASSEMBLY.....	WP 0180
Figure 179 Transmission Dipstick Tube (M939A2).....	0180-2



## TABLE OF CONTENTS

	<b>Page No.</b>
	<b><u>WP Sequence No.</u></b>
GROUP 0705 TRANSMISSION SHIFTING COMPONENTS.....	WP 0181
Figure 180 Transmission Shift Quadrant Control Cable and Neutral Safety Switch (M939, M939A1).....	0181-2
GROUP 0705 TRANSMISSION SHIFTING COMPONENTS.....	WP 0182
Figure 181 Transmission Shift Control Cable and Related Parts (M939A2).....	0182-2
GROUP 0705 TRANSMISSION SHIFTING COMPONENTS.....	WP 0183
Figure 182 Wrecker Governor Piping and Capacitor Assembly.....	0183-2
GROUP 0705 TRANSMISSION SHIFTING COMPONENTS.....	WP 0184
Figure 183 Transmission Modulator and Cable Assembly (M939, M939A1).....	0184-2
GROUP 0705 TRANSMISSION SHIFTING COMPONENTS.....	WP 0185
Figure 184 Transmission Modulator and Cable Assembly (M939A2).....	0185-2
GROUP 0708 TORQUE CONVERTER OR FLUID COUPLING.....	WP 0186
Figure 185 Torque Converter and Lockup Clutch.....	0186-2
GROUP 0710 TRANSMISSION ASSEMBLY AND ASSOCIATED PARTS.....	WP 0187
Figure 186 Adapter Housing and Low Planetary Carrier Assembly.....	0187-2
GROUP 0710 TRANSMISSION ASSEMBLY AND ASSOCIATED PARTS.....	WP 0188
Figure 187 Housing Assembly and Forward Clutch.....	0188-2
GROUP 0710 TRANSMISSION ASSEMBLY AND ASSOCIATED PARTS.....	WP 0189
Figure 188 Main Shaft and Carrier Assembly.....	0189-2
GROUP 0710 TRANSMISSION ASSEMBLY AND ASSOCIATED PARTS.....	WP 0190
Figure 189 Transmission Housing, Oil Filter, Oil Pan, and Mounting Hardware.....	0190-2
GROUP 0710 TRANSMISSION ASSEMBLY AND ASSOCIATED PARTS.....	WP 0191
Figure 190 Rear Cover Assembly and Related Parts.....	0191-2
GROUP 0713 INTERMEDIATE CLUTCH.....	WP 0192
Figure 191 First Clutch.....	0192-2
GROUP 0713 INTERMEDIATE CLUTCH.....	WP 0193
Figure 192 Second, Third, and Fourth Clutch Assembly, and Center Support (Transmission P/N 6885292).....	0193-2

## TABLE OF CONTENTS

	<b>Page No.</b>
	<b><u>WP Sequence No.</u></b>
GROUP 0713 INTERMEDIATE CLUTCH.....	WP 0194
Figure 193 Fourth Clutch Assembly.....	0194-2
GROUP 0713 INTERMEDIATE CLUTCH.....	WP 0195
Figure 194 Low Clutch.....	0195-2
GROUP 0714 SERVO UNIT.....	WP 0196
Figure 195 Control Valve Assembly and Mounting Hardware.....	0196-2
GROUP 0714 SERVO UNIT.....	WP 0197
Figure 196 Modulated Lockup Valve and Mounting Hardware.....	0197-2
GROUP 0714 SERVO UNIT.....	WP 0198
Figure 197 Low Shift Signal Valve, Low Trimmer Valve, and Mounting Hardware.....	0198-2
GROUP 0714 SERVO UNIT.....	WP 0199
Figure 198 Transmission Tubing, Governor, and Filter Assembly.....	0199-2
GROUP 0721 COOLERS, PUMPS, MOTORS.....	WP 0200
Figure 199 Transmission Vent Line.....	0200-2
GROUP 0721 COOLERS, PUMPS, MOTORS.....	WP 0201
Figure 200 Oil Pump and Front Support Assembly (Transmission P/N 6885292).....	0201-2
GROUP 0721 COOLERS, PUMPS, MOTORS.....	WP 0202
Figure 201 Oil Pump and Front Support Assembly (Transmission P/N 23040127).....	0202-2
GROUP 0721 COOLERS, PUMPS, MOTORS.....	WP 0203
Figure 202 Transmission Oil Cooler and Mounting Hardware.....	0203-2
GROUP 0721 COOLERS, PUMPS, MOTORS.....	WP 0204
Figure 203 Transmission Oil Cooler and Fittings.....	0204-2
GROUP 0721 COOLERS, PUMPS, MOTORS.....	WP 0205
Figure 204 Oil Hoses, Filter, and Mounting Hardware (M939, M939A1).....	0205-2
GROUP 0721 COOLERS, PUMPS, MOTORS.....	WP 0206
Figure 205 Oil Hoses (M939A2).....	0206-2
GROUP 0800 TRANSFER AND FINAL DRIVE ASSEMBLIES.....	WP 0207

## TABLE OF CONTENTS

	<b>Page No.</b>
	<b><u>WP Sequence No.</u></b>
Figure 206 Transfer Case and Shipping Container.....	0207-2
GROUP 0801 POWER TRANSFER, FINAL DRIVE, PLANETARY OR DROP GEAR BOX ASSEMBLIES.....	WP 0208
Figure 207 Transfer Case Mounting Hardware, Housing, Flanges, and Speedometer Drive.....	0208-2
GROUP 0801 POWER TRANSFER, FINAL DRIVE, PLANETARY OR DROP GEAR BOX ASSEMBLIES.....	WP 0209
Figure 208 Transfer Case Housing, Output Shaft, and Cover.....	0209-2
GROUP 0801 POWER TRANSFER, FINAL DRIVE, PLANETARY OR DROP GEAR BOX ASSEMBLIES.....	WP 0210
Figure 209 Transfer Housing Input and Intermediate Drive Shafts.....	0210-2
GROUP 0802 CLUTCH AND CLUTCH CONTROLS.....	WP 0211
Figure 210 Transfer Clutch Assembly and Synchronizer Assembly.....	0211-2
GROUP 0803 GEARSHIFT, VACUUM BOOSTER AND CONTROLS.....	WP 0212
Figure 211 Transfer Controls.....	0212-2
GROUP 0803 GEARSHIFT, VACUUM BOOSTER AND CONTROLS.....	WP 0213
Figure 212 Transfer Air Control Lines.....	0213-2
GROUP 0803 GEARSHIFT, VACUUM BOOSTER AND CONTROLS.....	WP 0214
Figure 213 Transfer Air-Actuated Controls and Interlock Valve.....	0214-2
GROUP 0803 GEARSHIFT, VACUUM BOOSTER AND CONTROLS.....	WP 0215
Figure 214 Transfer Air-Actuated Controls and Manifold Fittings.....	0215-2
GROUP 0803 GEARSHIFT, VACUUM BOOSTER AND CONTROLS.....	WP 0216
Figure 215 Transfer Air-Actuated Controls.....	0216-2
GROUP 0803 GEARSHIFT, VACUUM BOOSTER AND CONTROLS.....	WP 0217
Figure 216 Transfer Shift Mechanisms.....	0217-2
GROUP 0804 LUBRICATION, COOLING, OR HYDRAULIC COMPONENTS.....	WP 0218
Figure 217 Transfer Oil Pump and Related Parts.....	0218-2
GROUP 0900 PROPELLER SHAFTS.....	WP 0219
Figure 218 Propeller Shaft Assembly, Front Axle to Transfer Shaft (Dana) (M939, M939A1).....	0219-2

## TABLE OF CONTENTS

	<b>Page No.</b>
	<b><u>WP Sequence No.</u></b>
GROUP 0900 PROPELLER SHAFTS.....	WP 0220
Figure 219 Propeller Shaft Assembly, Front Axle to Transfer Shaft (Rockwell) (M939, M939A1).....	0220-2
GROUP 0900 PROPELLER SHAFTS.....	WP 0221
Figure 220 Propeller Shaft Assembly, Transfer to Front Axle Shaft (Dana) (M939, M939A1).....	0221-2
GROUP 0900 PROPELLER SHAFTS.....	WP 0222
Figure 221 Propeller Shaft Assembly, Transfer to Front Axle Shaft (Rockwell) (M939, M939A1).....	0222-2
GROUP 0900 PROPELLER SHAFTS.....	WP 0223
Figure 222 Propeller Shaft Assembly, Transfer to Front Axle Shaft (M939A2).....	0223-2
GROUP 0900 PROPELLER SHAFTS.....	WP 0224
Figure 223 Propeller Shaft Assembly, Transmission to Transfer (M939, M939A1).....	0224-2
GROUP 0900 PROPELLER SHAFTS.....	WP 0225
Figure 224 Propeller Shaft Assembly, Transmission to Transfer (M939A2).....	0225-2
GROUP 0900 PROPELLER SHAFTS.....	WP 0226
Figure 225 Propeller Shaft Assembly, Transfer to Forward Rear Axle (Long Wheelbase).....	0226-2
GROUP 0900 PROPELLER SHAFTS.....	WP 0227
Figure 226 Propeller Shaft Assembly, Forward Rear Axle to Rear Rear Axle (Short Wheelbase).....	0227-2
GROUP 0900 PROPELLER SHAFTS.....	WP 0228
Figure 227 Propeller Shaft Assembly, Transfer to Forward Rear Axle (X-Long Wheelbase).....	0228-2
GROUP 0900 PROPELLER SHAFTS.....	WP 0229
Figure 228 Propeller Shaft Assembly, Forward Rear Axle to Rear Rear Axle (Dana).....	0229-2
GROUP 0900 PROPELLER SHAFTS.....	WP 0230
Figure 229 Propeller Shaft Assembly, Forward Rear Axle to Rear Rear Axle (Rockwell).....	0230-2
GROUP 1000 FRONT AXLE ASSEMBLY.....	WP 0231
Figure 230 Front Axle and Housing Assembly (M939, M939A1).....	0231-2
GROUP 1000 FRONT AXLE ASSEMBLY.....	WP 0232

## TABLE OF CONTENTS

	<b>Page No.</b>
	<b><u>WP Sequence No.</u></b>
Figure 231 Front Axle and Housing Assembly (M939A2).....	0232-2
GROUP 1002 DIFFERENTIAL.....	WP 0233
Figure 232 Front Axle Differential Assembly.....	0233-2
GROUP 1002 DIFFERENTIAL.....	WP 0234
Figure 233 Front Axle Differential Carrier Assembly, Access Covers, and Related Parts.....	0234-2
GROUP 1002 DIFFERENTIAL.....	WP 0235
Figure 234 Front Axle Differential Through Shaft, Gears, and Flange Assemblies.....	0235-2
GROUP 1002 DIFFERENTIAL.....	WP 0236
Figure 235 Front Axle Differential Helical Drive Pinion and Related Parts.....	0236-2
GROUP 1004 STEERING AND LEANING WHEEL MECHANISM.....	WP 0237
Figure 236 Spindle Shaft Assembly, Universal Shaft, and Knuckle Assembly.....	0237-2
GROUP 1100 REAR AXLE ASSEMBLY.....	WP 0238
Figure 237 Forward Rear and Rear Rear Axle Assemblies (M939, M939A1).....	0238-2
GROUP 1100 REAR AXLE ASSEMBLY.....	WP 0239
Figure 238 Forward Rear and Rear Rear Axle Assemblies (M939A2).....	0239-2
GROUP 1102 DIFFERENTIAL.....	WP 0240
Figure 239 Rear Axle Differential Assembly and Mounting Hardware.....	0240-2
GROUP 1102 DIFFERENTIAL.....	WP 0241
Figure 240 Rear Axle Differential Carrier Assembly, Access Cover, and Related Parts.....	0241-2
GROUP 1102 DIFFERENTIAL.....	WP 0242
Figure 241 Rear Axle Differential Through Shaft, Gears, and Flange Assemblies.....	0242-2
GROUP 1102 DIFFERENTIAL.....	WP 0243
Figure 242 Rear Axle Differential Helical Drive Pinion and Related Parts.....	0243-2
GROUP 1201 HAND BRAKES.....	WP 0244
Figure 243 Parking Brake Lever Assembly, Cable, and Mounting Hardware.....	0244-2
GROUP 1201 HAND BRAKES.....	WP 0245
Figure 244 Parking Brake Shoe Assembly, Drum, Dust Shield, and Related Parts.....	0245-2

## TABLE OF CONTENTS

	<b>Page No.</b>
	<b><u>WP Sequence No.</u></b>
GROUP 1202 SERVICE BRAKES.....	WP 0246
Figure 245 Front Axle Brake and Spider Assembly.....	0246-2
GROUP 1202 SERVICE BRAKES.....	WP 0247
Figure 246 Rear Axle Brake and Spider Assembly.....	0247-2
GROUP 1202 SERVICE BRAKES.....	WP 0248
Figure 247 Service Brake Mounting Plate (M939A2).....	0248-2
GROUP 1206 MECHANICAL BRAKE SYSTEM.....	WP 0249
Figure 248 Treadle Valve Assembly.....	0249-2
GROUP 1208 AIR BRAKE SYSTEM.....	WP 0250
Figure 249 Air Chambers, Front and Rear Brakes.....	0250-2
GROUP 1208 AIR BRAKE SYSTEM.....	WP 0251
Figure 250 Rear Axle Fail-Safe Brake Chamber Assembly.....	0251-2
GROUP 1208 AIR BRAKE SYSTEM.....	WP 0252
Figure 251 Front Service Half Coupling, Air Brake Valve, and Related Parts.....	0252-2
GROUP 1208 AIR BRAKE SYSTEM.....	WP 0253
Figure 252 Air Control Lines, Front Service Check Valve to Brake Chambers.....	0253-2
GROUP 1208 AIR BRAKE SYSTEM.....	WP 0254
Figure 253 Dash Control Air Supply Lines, Spring Brake Control Valve to Primary and Secondary Air Reservoirs.....	0254-2
GROUP 1208 AIR BRAKE SYSTEM.....	WP 0255
Figure 254 Doublecheck Valve No. 5 (ABS).....	0255-2
GROUP 1208 AIR BRAKE SYSTEM.....	WP 0256
Figure 255 Doublecheck Valve No. 6 (ABS).....	0256-2
GROUP 1208 AIR BRAKE SYSTEM.....	WP 0257
Figure 256 Doublecheck Valve No. 7 (ABS).....	0257-2
GROUP 1208 AIR BRAKE SYSTEM.....	WP 0258
Figure 257 Rear Service Half Coupling and Mounting Hardware.....	0258-2
GROUP 1208 AIR BRAKE SYSTEM.....	WP 0259

## TABLE OF CONTENTS

	<b>Page No.</b>
	<b><u>WP Sequence No.</u></b>
Figure 258 Quick Release Valve, Air Brake Valves, and Related Lines.....	0259-2
GROUP 1208 AIR BRAKE SYSTEM.....	WP 0260
Figure 259 Brake LQ-2 Valve (ABS).....	0260-2
GROUP 1208 AIR BRAKE SYSTEM.....	WP 0261
Figure 260 Inversion Valve (ABS).....	0261-2
GROUP 1208 AIR BRAKE SYSTEM.....	WP 0262
Figure 261 Air Line Cross Fitting (ABS).....	0262-2
GROUP 1208 AIR BRAKE SYSTEM.....	WP 0263
Figure 262 Treadle Valve to Secondary Relay Valve and Primary Relay Valve to Half Coupling Lines.....	0263-2
GROUP 1208 AIR BRAKE SYSTEM.....	WP 0264
Figure 263 Primary and Secondary Relay Valve, Mounting Hardware, and Related Lines.....	0264-2
GROUP 1208 AIR BRAKE SYSTEM.....	WP 0265
Figure 264 Forward Rear Axle Air Brake Chamber Control Lines and Mounting Hardware.....	0265-2
GROUP 1208 AIR BRAKE SYSTEM.....	WP 0266
Figure 265 Rear Rear Axle Air Brake Chamber Control Lines and Mounting Hardware.....	0266-2
GROUP 1208 AIR BRAKE SYSTEM.....	WP 0267
Figure 266 Front Emergency Half Coupling and Related Lines.....	0267-2
GROUP 1208 AIR BRAKE SYSTEM.....	WP 0268
Figure 267 Rear Emergency Half Couplings and Mounting Hardware.....	0268-2
GROUP 1208 AIR BRAKE SYSTEM.....	WP 0269
Figure 268 Air Compressor to Wet Reservoir Air Supply Lines.....	0269-2
GROUP 1208 AIR BRAKE SYSTEM.....	WP 0270
Figure 269 Air Supply Line Safety Valve (ABS).....	0270-2
GROUP 1208 AIR BRAKE SYSTEM.....	WP 0271
Figure 270 Primary, Secondary, Wet Reservoirs, and Related Lines. (Sheet 1 of 2) .....	0271-1
Figure 270 Primary, Secondary, Wet Reservoirs, and Related Lines. (Sheet 2 of 2) .....	0271-2
GROUP 1208 AIR BRAKE SYSTEM.....	WP 0272

## TABLE OF CONTENTS

	<b>Page No.</b>
	<b><u>WP Sequence No.</u></b>
Figure 271 Air Tank Reservoirs, Drainvalves, and Relate Lines.....	0272-2
GROUP 1208 AIR BRAKE SYSTEM.....	WP 0273
Figure 272 Spring Brake Reservoir, Mounting Hardware, Spring Brake Release Valve, and Related Air Supply Lines.....	0273-2
GROUP 1208 AIR BRAKE SYSTEM.....	WP 0274
Figure 273 Air Supply Lines, Double-Check Valve to Coupling to Push-Pull Valve, and Supply Line Quick Release Valve to Tee to Fail-Safe Tee.....	0274-2
GROUP 1208 AIR BRAKE SYSTEM.....	WP 0275
Figure 274 Fail-Safe Air Brake Chamber Lines.....	0275-2
GROUP 1208 AIR BRAKE SYSTEM.....	WP 0276
Figure 275 Air Supply Lines, Treadle Valve to Primary and Secondary Air Tanks, and Relay Valves.....	0276-2
GROUP 1208 AIR BRAKE SYSTEM.....	WP 0277
Figure 276 Dash Control Air Supply Lines, Spring Brake Control Valve to Primary and Secondary Air Reservoirs.....	0277-2
GROUP 1208 AIR BRAKE SYSTEM.....	WP 0278
Figure 277 Treadle Valve to Quick Release Valve and Air Intake Tubing.....	0278-2
GROUP 1208 AIR BRAKE SYSTEM.....	WP 0279
Figure 278 Front Brake Chamber Vent Lines and Limiting Valve.....	0279-2
GROUP 1208 AIR BRAKE SYSTEM.....	WP 0280
Figure 279 Vent Lines, Air Intake Manifold to Primary and Secondary Relay Valves, and Rear Axle Vent Lines.....	0280-2
GROUP 1208 AIR BRAKE SYSTEM.....	WP 0281
Figure 280 Secondary Vent Lines, Rear Axle Brake Chambers to Fail-Safe Brake Chamber.....	0281-2
GROUP 1208 AIR BRAKE SYSTEM.....	WP 0282
Figure 281 Primary Vent Lines, Rear Axle Air Brake.....	0282-2
GROUP 1208 AIR BRAKE SYSTEM.....	WP 0283
Figure 282 Alcohol Evaporator and Air Compressor to Air Governor Lines.....	0283-2
GROUP 1208 AIR BRAKE SYSTEM.....	WP 0284



## TABLE OF CONTENTS

	<b>Page No.</b>
	<b><u>WP Sequence No.</u></b>
Figure 283 Governor Control Air Line (ABS).....	0284-2
GROUP 1208 AIR BRAKE SYSTEM.....	WP 0285
Figure 284 Clutch Fan Actuator and Related Air Lines.....	0285-2
GROUP 1208 AIR BRAKE SYSTEM.....	WP 0286
Figure 285 Pressure Regulator, Double-Check Valves, and Air Lines.....	0286-2
GROUP 1208 AIR BRAKE SYSTEM.....	WP 0287
Figure 286 Brake Lock Valve and Air Lines.....	0287-2
 <b>Volume 2</b>	
GROUP 1208 AIR BRAKE SYSTEM.....	WP 0288
Figure 287 Front Air Brake Chamber Valve Assembly.....	0288-2
GROUP 1208 AIR BRAKE SYSTEM.....	WP 0289
Figure 288 Rear Brake Relay Valve Assembly.....	0289-2
GROUP 1208 AIR BRAKE SYSTEM.....	WP 0290
Figure 289 Air Brake Governor Assembly and Mounting Hardware.....	0290-2
GROUP 1208 AIR BRAKE SYSTEM.....	WP 0291
Figure 290 Spring Brake Release Control Valve Assembly.....	0291-2
GROUP 1208 AIR BRAKE SYSTEM.....	WP 0292
Figure 291 Rear ABS Relay Valve.....	0292-2
GROUP 1208 AIR BRAKE SYSTEM.....	WP 0293
Figure 292 Forward ABS Relay Valve with (ECU).....	0293-2
GROUP 1208 AIR BRAKE SYSTEM.....	WP 0294
Figure 293 ABS Electronic Control Unit (ECU).....	0294-2
GROUP 1208 AIR BRAKE SYSTEM.....	WP 0295
Figure 294 Air Dryer Filter.....	0295-2
GROUP 1208 AIR BRAKE SYSTEM.....	WP 0296
Figure 295 Air Dryer Heater.....	0296-2
GROUP 1208 AIR BRAKE SYSTEM.....	WP 0297

## TABLE OF CONTENTS

	<b>Page No.</b>
	<b><u>WP Sequence No.</u></b>
Figure 296 ABS 3-AMP Fuse and Y-Connector Lead.....	0297-2
GROUP 1208 AIR BRAKE SYSTEM.....	WP 0298
Figure 297 ABS 15-AMP Fuse and Jumper Lead.....	0298-2
GROUP 1208 AIR BRAKE SYSTEM.....	WP 0299
Figure 298 ABS Ground Jumper Lead.....	0299-2
GROUP 1208 AIR BRAKE SYSTEM.....	WP 0300
Figure 299 ABS Indicator Lamp.....	0300-2
GROUP 1208 AIR BRAKE SYSTEM.....	WP 0301
Figure 300 ABS ECU Main Wiring Harness and Diagnostic Mounting Bracket.....	0301-2
GROUP 1208 AIR BRAKE SYSTEM.....	WP 0302
Figure 301 ABS Wheel Sensor and Bracket.....	0302-2
GROUP 1208 AIR BRAKE SYSTEM.....	WP 0303
Figure 302 Wheel Brakedrum Dustcover (ABS).....	0303-2
GROUP 1208 AIR BRAKE SYSTEM.....	WP 0304
Figure 303 Rear Hub and Drum Exciter Ring.....	0304-2
GROUP 1209 AIR COMPRESSOR ASSEMBLY.....	WP 0305
Figure 304 Air Compressor Assembly (M939, M939A1).....	0305-2
GROUP 1209 AIR COMPRESSOR ASSEMBLY.....	WP 0306
Figure 305 Air Compressor Mounting and Lines (M939A2).....	0306-2
GROUP 1209 AIR COMPRESSOR ASSEMBLY.....	WP 0307
Figure 306 Air Compressor Assembly (M939A2).....	0307-2
GROUP 1209 AIR COMPRESSOR ASSEMBLY.....	WP 0308
Figure 307 Air Compressor Lines (M939A2).....	0308-2
GROUP 1211 TRAILER BRAKE CONNECTIONS AND CONTROLS.....	WP 0309
Figure 308 Trailer Brake Control Valve, Hand Valve, and Related Lines.....	0309-2
GROUP 1211 TRAILER BRAKE CONNECTIONS AND CONTROLS.....	WP 0310
Figure 309 Trailer Air Supply Valve Assembly.....	0310-2

## TABLE OF CONTENTS

	<b>Page No.</b>
	<b><u>WP Sequence No.</u></b>
GROUP 1211 TRAILER BRAKE CONNECTIONS AND CONTROLS.....	WP 0311
Figure 310 Tractor Protection Valve, Double-Check Valve, and Trailer Service Air Lines.....	0311-2
GROUP 1211 TRAILER BRAKE CONNECTIONS AND CONTROLS.....	WP 0312
Figure 311 Trailer Brake Lines, Emergency and Service Couplings, and Related Lines.....	0312-2
GROUP 1311 WHEEL ASSEMBLY.....	WP 0313
Figure 312 Wheel Assembly (M939A1, M939A2).....	0313-2
GROUP 1311 WHEEL ASSEMBLY.....	WP 0314
Figure 313 Front Wheel Hub and Drum Assembly (M939, M939A1).....	0314-2
GROUP 1311 WHEEL ASSEMBLY.....	WP 0315
Figure 314 Front Wheel Hub and Drum Assembly (M939A2).....	0315-2
GROUP 1311 WHEEL ASSEMBLY.....	WP 0316
Figure 315 Rear Wheel Hub and Drum Assembly (M939, M939A1).....	0316-2
GROUP 1311 WHEEL ASSEMBLY.....	WP 0317
Figure 316 Rear Wheel Hub and Drum Assembly (M939A2).....	0317-2
GROUP 1311 WHEEL ASSEMBLY.....	WP 0318
Figure 317 Front Axle Wheel Valve Installation (M939A2).....	0318-2
GROUP 1311 WHEEL ASSEMBLY.....	WP 0319
Figure 318 Front Wheel Valve Kit (90 PSI).....	0319-2
GROUP 1311 WHEEL ASSEMBLY.....	WP 0320
Figure 319 Wheel Valve Assembly (M939A2) (70 PSI Only).....	0320-2
GROUP 1311 WHEEL ASSEMBLY.....	WP 0321
Figure 320 Rear Axle Wheel Valve Assembly (M939A2) (70 PSI Only).....	0321-2
GROUP 1311 WHEEL ASSEMBLY.....	WP 0322
Figure 321 Rear Wheel Valve Kit (90 PSI).....	0322-2
GROUP 1313 TIRES, TUBES, TIRE CHAINS.....	WP 0323
Figure 322 Tire Assembly (M939 Basic).....	0323-2
GROUP 1401 MECHANICAL STEERING GEAR ASSEMBLY.....	WP 0324

## TABLE OF CONTENTS

	<b>Page No.</b>
	<b><u>WP Sequence No.</u></b>
Figure 323 Steering Column, Wheel, and Propeller Shaft.....	0324-2
GROUP 1401 MECHANICAL STEERING GEAR ASSEMBLY.....	WP 0325
Figure 324 Stone Shield and Pitman Arm.....	0325-2
GROUP 1401 MECHANICAL STEERING GEAR ASSEMBLY.....	WP 0326
Figure 325 Tie Rod Assemblies.....	0326-2
GROUP 1407 POWER STEERING GEAR ASSEMBLY.....	WP 0327
Figure 326 Steering Gear Assembly and Mounting Hardware.....	0327-2
GROUP 1407 POWER STEERING GEAR ASSEMBLY.....	WP 0328
Figure 327 Steering Gear Sector Shaft and Housing Assembly (M939, M939A1).....	0328-2
GROUP 1407 POWER STEERING GEAR ASSEMBLY.....	WP 0329
Figure 328 Steering Gear, Worm, and Valve (M939, M939A1).....	0329-2
GROUP 1407 POWER STEERING GEAR ASSEMBLY.....	WP 0330
Figure 329 Sheppard Steering Gear Assembly and Mounting Hardware.....	0330-2
GROUP 1407 POWER STEERING GEAR ASSEMBLY.....	WP 0331
Figure 330 Steering Gear Sector Shaft and Housing Assembly.....	0331-2
GROUP 1407 POWER STEERING GEAR ASSEMBLY.....	WP 0332
Figure 331 Steering Gear, Worm, and, Valve (M939A2).....	0332-2
GROUP 1410 HYDRAULIC PUMP OR FLUID MOTOR ASSEMBLY.....	WP 0333
Figure 332 Power Steering Pump Assembly, Pulley Assembly, Mounting Hardware, and Belts.....	0333-2
GROUP 1410 HYDRAULIC PUMP OR FLUID MOTOR ASSEMBLY.....	WP 0334
Figure 333 Power Steering Pump Assembly (M939, M939A1).....	0334-2
GROUP 1410 HYDRAULIC PUMP OR FLUID MOTOR ASSEMBLY.....	WP 0335
Figure 334 Power Steering Pump Assembly (M939A2).....	0335-2
GROUP 1411 HOSES, LINES, FITTINGS.....	WP 0336
Figure 335 Power Steering Hydraulic Lines and Fittings.....	0336-2
GROUP 1411 HOSES, LINES, FITTINGS.....	WP 0337
Figure 336 Power Steering Hydraulic Lines and Fittings.....	0337-2

## TABLE OF CONTENTS

	<b>Page No.</b>
	<b><u>WP Sequence No.</u></b>
GROUP 1411 HOSES, LINES, FITTINGS.....	WP 0338
Figure 337 Power Steering Oil Cooler, Hydraulic Lines, and Fittings (M939A2).....	0338-2
GROUP 1412 HYDRAULIC OR AIR CYLINDERS.....	WP 0339
Figure 338 Tie Rod End, Steering Cylinder Assembly, and Booster Shield.....	0339-2
GROUP 1412 HYDRAULIC OR AIR CYLINDERS.....	WP 0340
Figure 339 Power Steering Cylinder Assembly.....	0340-2
GROUP 1501 FRAME ASSEMBLY.....	WP 0341
Figure 340 Frame Assembly, Standard Cargo, and Droptop Cargo.....	0341-2
GROUP 1501 FRAME ASSEMBLY.....	WP 0342
Figure 341 Frame Assembly, Dump.....	0342-2
GROUP 1501 FRAME ASSEMBLY.....	WP 0343
Figure 342 Frame Assembly, Wrecker.....	0343-2
GROUP 1501 FRAME ASSEMBLY.....	WP 0344
Figure 343 Frame Assembly, Van.....	0344-2
GROUP 1501 FRAME ASSEMBLY.....	WP 0345
Figure 344 Frame Assembly, Tractor.....	0345-2
GROUP 1501 FRAME ASSEMBLY.....	WP 0346
Figure 345 Frame Assembly, Long Wheel Base Cargo.....	0346-2
GROUP 1501 FRAME ASSEMBLY.....	WP 0347
Figure 346 Frame Assembly, Chassis (M939).....	0347-2
GROUP 1501 FRAME ASSEMBLY.....	WP 0348
Figure 347 Frame Assembly (M939A2).....	0348-2
GROUP 1501 FRAME ASSEMBLY.....	WP 0349
Figure 348 Rear Cab Improved Crossmember Assembly.....	0349-2
GROUP 1501 FRAME ASSEMBLY.....	WP 0350
Figure 349 Front Bumper, Lifting Shackle, Hood Latch, and Mounting Hardware.....	0350-2
GROUP 1501 FRAME ASSEMBLY.....	WP 0351

## TABLE OF CONTENTS

	<b>Page No.</b>
	<b><u>WP Sequence No.</u></b>
Figure 350 Rear Bumperette and Shackle Assembly.....	0351-2
GROUP 1501 FRAME ASSEMBLY.....	WP 0352
Figure 351 Front and Rear Field Chock Anchors (M936, M936A1).....	0352-2
GROUP 1503 PINTLES AND TOWING ATTACHMENTS.....	WP 0353
Figure 352 Pintle Hook Assembly.....	0353-2
GROUP 1503 PINTLES AND TOWING ATTACHMENTS.....	WP 0354
Figure 353 Towing Pintle Mounting Brackets, Tractor.....	0354-2
GROUP 1503 PINTLES AND TOWING ATTACHMENTS.....	WP 0355
Figure 354 Towing Pintle Mounting Brackets, Dump.....	0355-2
GROUP 1503 PINTLES AND TOWING ATTACHMENTS.....	WP 0356
Figure 355 Towing Pintle Mounting Brackets.....	0356-2
GROUP 1504 SPARE WHEEL CARRIER AND TIRE LOCK.....	WP 0357
Figure 356 Spare Wheel Carrier, Dump (M939).....	0357-2
GROUP 1504 SPARE WHEEL CARRIER AND TIRE LOCK.....	WP 0358
Figure 357 Spare Wheel Carrier, Dump (M939A1, M939A2).....	0358-2
GROUP 1504 SPARE WHEEL CARRIER AND TIRE LOCK.....	WP 0359
Figure 358 Spare Wheel Carrier, Cargo and Van (M939).....	0359-2
GROUP 1504 SPARE WHEEL CARRIER AND TIRE LOCK.....	WP 0360
Figure 359 Spare Wheel Carrier, Cargo and Van (M939A1, M939A2).....	0360-2
GROUP 1504 SPARE WHEEL CARRIER AND TIRE LOCK.....	WP 0361
Figure 360 Spare Wheel Carrier, Tractor (M939).....	0361-2
GROUP 1504 SPARE WHEEL CARRIER AND TIRE LOCK.....	WP 0362
Figure 361 Spare Wheel Carrier, Tractor (M939A1, M939A2).....	0362-2
GROUP 1504 SPARE WHEEL CARRIER AND TIRE LOCK.....	WP 0363
Figure 362 Lifting Device and Davit Assemblies (M939, M939A1).....	0363-2
GROUP 1504 SPARE WHEEL CARRIER AND TIRE LOCK.....	WP 0364
Figure 363 Davit Assembly, Spare Wheel Carrier (M939A1, M939A2).....	0364-2

## TABLE OF CONTENTS

	<b>Page No.</b>
	<b><u>WP Sequence No.</u></b>
GROUP 1504 SPARE WHEEL CARRIER AND TIRE LOCK.....	WP 0365
Figure 364 Spare Wheel Davit and Winch Assembly, Van (M939, M939A1).....	0365-2
GROUP 1504 SPARE WHEEL CARRIER AND TIRE LOCK.....	WP 0366
Figure 365 Spare Wheel Carrier, Wrecker (M939).....	0366-2
GROUP 1506 FIFTH WHEEL.....	WP 0367
Figure 366 Fifth Wheel Assembly and Mounting Plates (M939, M939A1).....	0367-2
GROUP 1506 FIFTH WHEEL.....	WP 0368
Figure 367 Fifth Wheel Assembly, Basic Leveling Wedge, and Subbase.....	0368-2
GROUP 1506 FIFTH WHEEL.....	WP 0369
Figure 368 Fifth Wheel Assembly.....	0369-2
GROUP 1601 SPRINGS.....	WP 0370
Figure 369 Front Leaf Spring Assembly and Related Parts.....	0370-2
GROUP 1601 SPRINGS.....	WP 0371
Figure 370 Rear Leaf Spring Mounting Hardware.....	0371-2
GROUP 1601 SPRINGS.....	WP 0372
Figure 371 Rear Leaf Spring and Seat Assemblies.....	0372-2
GROUP 1604 SHOCK ABSORBER EQUIPMENT.....	WP 0373
Figure 372 Shock Absorber and Mounting Hardware.....	0373-2
GROUP 1605 TORQUE, RADIUS, AND STABILIZER RODS.....	WP 0374
Figure 373 Torque Rod and Mounting Hardware.....	0374-2
GROUP 1801 BODY, CAB, HOOD, AND HULL ASSEMBLIES.....	WP 0375
Figure 374 Front Guard Assembly and Hood Mounting Hardware.....	0375-2
GROUP 1801 BODY, CAB, HOOD, AND HULL ASSEMBLIES.....	WP 0376
Figure 375 Radiator Baffle Assemblies and Mounting Hardware.....	0376-2
GROUP 1801 BODY, CAB, HOOD, AND HULL ASSEMBLIES.....	WP 0377
Figure 376 Hood and Related Parts.....	0377-2
GROUP 1801 BODY, CAB, HOOD, AND HULL ASSEMBLIES.....	WP 0378

## TABLE OF CONTENTS

	<b>Page No.</b>
	<b><u>WP Sequence No.</u></b>
Figure 377 Hood Support and Stop Cables.....	0378-2
GROUP 1801 BODY, CAB, HOOD, AND HULL ASSEMBLIES.....	WP 0379
Figure 378 Splash Guard Assembly and Related Parts, LH.....	0379-2
GROUP 1801 BODY, CAB, HOOD, AND HULL ASSEMBLIES.....	WP 0380
Figure 379 Splash Guard Assembly and Related Parts, RH.....	0380-2
GROUP 1801 BODY, CAB, HOOD, AND HULL ASSEMBLIES.....	WP 0381
Figure 380 Splash Panel Extension. (M939A2).....	0381-2
GROUP 1801 BODY, CAB, HOOD, AND HULL ASSEMBLIES.....	WP 0382
Figure 381 Cab Assembly Mounting Hardware.....	0382-2
GROUP 1801 BODY, CAB, HOOD, AND HULL ASSEMBLIES.....	WP 0383
Figure 382 Cab Body Assembly and Related Parts.....	0383-2
GROUP 1801 BODY, CAB, HOOD, AND HULL ASSEMBLIES.....	WP 0384
Figure 383 Basic Cab Assembly and Engine Cover (M939A2).....	0384-2
GROUP 1801 BODY, CAB, HOOD, AND HULL ASSEMBLIES.....	WP 0385
Figure 384 Door Assemblies, Machine Gun Mounting Bracket, and Related Parts.....	0385-2
GROUP 1801 BODY, CAB, HOOD, AND HULL ASSEMBLIES.....	WP 0386
Figure 385 Door, Cab Assembly.....	0386-2
GROUP 1801 BODY, CAB, HOOD, AND HULL ASSEMBLIES.....	WP 0387
Figure 386 Window Frame Assembly, Cab Door.....	0387-2
GROUP 1802 FENDERS, RUNNING BOARDS WITH MOUNTING AND ATTACHING PARTS, OUTRIGGERS, WIND-SHIELD, GLASS, ETC.....	WP 0388
Figure 387 Fender, Fender Extension, and Splash Panel Assemblies.....	0388-2
GROUP 1802 FENDERS, RUNNING BOARDS WITH MOUNTING AND ATTACHING PARTS, OUTRIGGERS, WIND-SHIELD, GLASS, ETC.....	WP 0389
Figure 388 Splash Guards, Dump.....	0389-2
GROUP 1802 FENDERS, RUNNING BOARDS WITH MOUNTING AND ATTACHING PARTS, OUTRIGGERS, WIND-SHIELD, GLASS, ETC.....	WP 0390
Figure 389 Windshield Assembly and Mounting Hardware.....	0390-2



## TABLE OF CONTENTS

	<b>Page No.</b>
	<b><u>WP Sequence No.</u></b>
GROUP 1802 FENDERS, RUNNING BOARDS WITH MOUNTING AND ATTACHING PARTS, OUTRIGGERS, WIND-SHIELD, GLASS, ETC.....	WP 0391
Figure 390 Windshield and Frame Assemblies.....	0391-2
GROUP 1802 FENDERS, RUNNING BOARDS WITH MOUNTING AND ATTACHING PARTS, OUTRIGGERS, WIND-SHIELD, GLASS, ETC.....	WP 0392
Figure 391 Running Board, Step, and Mounting Hardware.....	0392-2
GROUP 1805 FLOORS, SUBFLOORS, AND RELATED COMPONENTS.....	WP 0393
Figure 392 Transmission Access Door and Spring Brake Plate.....	0393-2
GROUP 1806 UPHOLSTERY SEATS AND CARPETS.....	WP 0394
Figure 393 Operator's Seat Assembly.....	0394-2
GROUP 1806 UPHOLSTERY SEATS AND CARPETS.....	WP 0395
Figure 394 Companion Seat Assembly.....	0395-2
GROUP 1806 UPHOLSTERY SEATS AND CARPETS.....	WP 0396
Figure 395 Cab and Hood Insulation.....	0396-2
GROUP 1806 UPHOLSTERY SEATS AND CARPETS.....	WP 0397
Figure 396 Cab Insulation (M939A2).....	0397-2
GROUP 1808 STOWAGE RACKS, BOXES, STRAPS, CARRYING CASES, CABLE REELS, HOSE REELS, ETC.....	WP 0398
Figure 397 Toolbox, Step Assembly, and Mounting Hardware.....	0398-2
GROUP 1808 STOWAGE RACKS, BOXES, STRAPS, CARRYING CASES, CABLE REELS, HOSE REELS, ETC.....	WP 0399
Figure 398 Map Compartment and Mounting Hardware.....	0399-2
GROUP 1808 STOWAGE RACKS, BOXES, STRAPS, CARRYING CASES, CABLE REELS, HOSE REELS, ETC.....	WP 0400
Figure 399 Toolbox Fuel Can Bracket and Mounting Hardware.....	0400-2
GROUP 1808 STOWAGE RACKS, BOXES, STRAPS, CARRYING CASES, CABLE REELS, HOSE REELS, ETC.....	WP 0401
Figure 400 Toolbox and Mounting Hardware, Tractor.....	0401-2
GROUP 1808 STOWAGE RACKS, BOXES, STRAPS, CARRYING CASES, CABLE REELS, HOSE REELS, ETC.....	WP 0402

## TABLE OF CONTENTS

	<b>Page No.</b>
	<b><u>WP Sequence No.</u></b>
Figure 401 Tool Frame Assembly, Pioneer.....	0402-2
GROUP 1808 STOWAGE RACKS, BOXES, STRAPS, CARRYING CASES, CABLE REELS, HOSE REELS, ETC.....	WP 0403
Figure 402 Van Cable Reel, Cable, and Mounting Hardware.....	0403-2
GROUP 1810 CARGO BODY.....	WP 0404
Figure 403 Standard Cargo, Dropside Cargo, and Mounting Hardware.....	0404-2
GROUP 1810 CARGO BODY.....	WP 0405
Figure 404 Cargo Body, Long Wheel Base Mounting Hardware.....	0405-2
GROUP 1810 CARGO BODY.....	WP 0406
Figure 405 Cargo Body Side Rack and Gate Assemblies, and Troop Seats.....	0406-2
GROUP 1810 CARGO BODY.....	WP 0407
Figure 406 Cargo Body Side Gates, Tailgate, and Related Parts, Basic and Dropside.....	0407-2
GROUP 1810 CARGO BODY.....	WP 0408
Figure 407 Cargo Body, Tailgate and Side Rack Assemblies, Long Wheel Base.....	0408-2
GROUP 1810 CARGO BODY.....	WP 0409
Figure 408 Cargo Body Personnel Seat Assembly, Side Rack and Gate Assemblies, Dropside.....	0409-2
GROUP 1810 CARGO BODY.....	WP 0410
Figure 409 Cargo Body Assembly, Basic, Side Racks, Tailgate Assembly, and Related Parts.....	0410-2
GROUP 1810 CARGO BODY.....	WP 0411
Figure 410 Cargo Body Rack Assemblies, Troop Seats, Long Wheel Base.....	0411-2
GROUP 1810 CARGO BODY.....	WP 0412
Figure 411 Cargo Body Splash Guard Assembly and Related Parts.....	0412-2
GROUP 1810 CARGO BODY.....	WP 0413
Figure 412 Dump Body and Hoist Assembly, Cab Shield, and Mounting Hardware.....	0413-2
GROUP 1810 CARGO BODY.....	WP 0414
Figure 413 Dump Body, Basic, Tailgate, and Related Parts.....	0414-2

## TABLE OF CONTENTS

	<b>Page No.</b>
	<b><u>WP Sequence No.</u></b>
GROUP 1810 CARGO BODY.....	WP 0415
Figure 414 Dump Tailgate Controls, Safety Catch, and Related Parts.....	0415-2
GROUP 1812 SPECIAL PURPOSE BODIES.....	WP 0416
Figure 415 Wrecker Crane and Body Assembly.....	0416-2
GROUP 1812 SPECIAL PURPOSE BODIES.....	WP 0417
Figure 416 Wrecker Crane and Body Mounting Hardware.....	0417-2
GROUP 1812 SPECIAL PURPOSE BODIES.....	WP 0418
Figure 417 Wrecker Crane and Body Floor Plate, Cover, and Housing Assembly.....	0418-2
GROUP 1812 SPECIAL PURPOSE BODIES.....	WP 0419
Figure 418 Wrecker Body Assembly.....	0419-2
GROUP 1812 SPECIAL PURPOSE BODIES.....	WP 0420
Figure 419 Wrecker Strap and Welding Tank Straps.....	0420-2
GROUP 1812 SPECIAL PURPOSE BODIES.....	WP 0421
Figure 420 Wrecker Splash Guards.....	0421-2
GROUP 1812 SPECIAL PURPOSE BODIES.....	WP 0422
Figure 421 Wrecker Outrigger Jack Assembly and Related Parts.....	0422-2
GROUP 1812 SPECIAL PURPOSE BODIES.....	WP 0423
Figure 422 Wrecker Fuel Can Bracket and Fire Extinguisher Bracket.....	0423-2
GROUP 1812 SPECIAL PURPOSE BODIES.....	WP 0424
Figure 423 Van Body Assembly and Mounting Hardware.....	0424-2
GROUP 1812 SPECIAL PURPOSE BODIES.....	WP 0425
Figure 424 Van Body Splash Guard Assemblies.....	0425-2
GROUP 1812 SPECIAL PURPOSE BODIES.....	WP 0426
Figure 425 Van Side Lock Handle, Lifting Brackets, Rod Retainer, and Related Parts.....	0426-2
GROUP 1812 SPECIAL PURPOSE BODIES.....	WP 0427
Figure 426 Van Rear Wall Panels and Mounting Hardware.....	0427-2
GROUP 1812 SPECIAL PURPOSE BODIES.....	WP 0428

## TABLE OF CONTENTS

	<b>Page No.</b>
	<b><u>WP Sequence No.</u></b>
Figure 427 Van Hinged End Panel Assemblies.....	0428-2
GROUP 1812 SPECIAL PURPOSE BODIES.....	WP 0429
Figure 428 Van Body Door Assembly, Left Rear.....	0429-2
GROUP 1812 SPECIAL PURPOSE BODIES.....	WP 0430
Figure 429 Van Body Door Assembly, Right Rear.....	0430-2
GROUP 1812 SPECIAL PURPOSE BODIES.....	WP 0431
Figure 430 Van Sash Assembly, Rear Doors.....	0431-2
GROUP 1812 SPECIAL PURPOSE BODIES.....	WP 0432
Figure 431 Van Underframe Assembly.....	0432-2
GROUP 1812 SPECIAL PURPOSE BODIES.....	WP 0433
Figure 432 Van Retractable Beams, Ratchet Shaft, and Rollers.....	0433-2
GROUP 1812 SPECIAL PURPOSE BODIES.....	WP 0434
Figure 433 Van Hinged Floor Assembly.....	0434-2
GROUP 1812 SPECIAL PURPOSE BODIES.....	WP 0435
Figure 434 Van Body Counterbalance Assembly and Mounting Hardware.....	0435-2
GROUP 1812 SPECIAL PURPOSE BODIES.....	WP 0436
Figure 435 Van Side Assemblies, Right and Left Side.....	0436-2
GROUP 1812 SPECIAL PURPOSE BODIES.....	WP 0437
Figure 436 Van Interior Side Panels, Right and Left Side.....	0437-2
GROUP 1812 SPECIAL PURPOSE BODIES.....	WP 0438
Figure 437 Van Side Panel Door Checks, Interior Latch Assemblies, and Related Parts, Right and Left Side.....	0438-2
GROUP 1812 SPECIAL PURPOSE BODIES.....	WP 0439
Figure 438 Van Retractable Window Sash Assembly and Related Parts, Right and Left Side.....	0439-2
GROUP 1812 SPECIAL PURPOSE BODIES.....	WP 0440
Figure 439 Van Body Door Assemblies, Right and Left Side.....	0440-2
GROUP 1812 SPECIAL PURPOSE BODIES.....	WP 0441

## TABLE OF CONTENTS

	<b>Page No.</b>
	<b><u>WP Sequence No.</u></b>
Figure 440 Van Interior and Exterior Ceiling, Frame, and Related Parts.....	0441-2
GROUP 1812 SPECIAL PURPOSE BODIES.....	WP 0442
Figure 441 Van Air Conditioning Duct and Related Parts.....	0442-2
GROUP 1812 SPECIAL PURPOSE BODIES.....	WP 0443
Figure 442 Van Hinged Roof Assembly, Latch, and Related Parts, Right and Left Side.....	0443-2
GROUP 1812 SPECIAL PURPOSE BODIES.....	WP 0444
Figure 443 Van Hinged Roof Assembly, Holder Assemblies, Panels, and Related Parts.....	0444-2
GROUP 1812 SPECIAL PURPOSE BODIES.....	WP 0445
Figure 444 Van Front Wall and Fire Extinguisher Bracket.....	0445-2
GROUP 1812 SPECIAL PURPOSE BODIES.....	WP 0446
Figure 445 Van Heater Fuel Pump, Cover, Lines, and Fittings.....	0446-2
GROUP 1812 SPECIAL PURPOSE BODIES.....	WP 0447
Figure 446 Van Heater Fuel Pump, Lines, and Fittings.....	0447-2
GROUP 1812 SPECIAL PURPOSE BODIES.....	WP 0448
Figure 447 Van Bonnet Frame and Related Parts.....	0448-2
GROUP 1812 SPECIAL PURPOSE BODIES.....	WP 0449
Figure 448 Van Heater, Exhaust, and Vent Door Controls.....	0449-2
GROUP 1812 SPECIAL PURPOSE BODIES.....	WP 0450
Figure 449 Van Air Conditioner, Drain Tube, and Mounting Hardware.....	0450-2
GROUP 1812 SPECIAL PURPOSE BODIES.....	WP 0451
Figure 450 Van Bonnet Access Door Assembly.....	0451-2
GROUP 1812 SPECIAL PURPOSE BODIES.....	WP 0452
Figure 451 Van Bonnet Door Assembly, Right and Left Side.....	0452-2
GROUP 1812 SPECIAL PURPOSE BODIES.....	WP 0453
Figure 452 Van Main Wiring Harness Mounting Hardware.....	0453-2
GROUP 1812 SPECIAL PURPOSE BODIES.....	WP 0454
Figure 453 Van Main Wiring Harness, Right and Left Side.....	0454-2

## TABLE OF CONTENTS

	<b>Page No.</b>
	<b><u>WP Sequence No.</u></b>
GROUP 1812 SPECIAL PURPOSE BODIES.....	WP 0455
Figure 454 Van Air Conditioning and Heater Wiring Harnesses.....	0455-2
GROUP 1812 SPECIAL PURPOSE BODIES.....	WP 0456
Figure 455 Van Heater Fuel Pump and Circuit Breaker Harnesses.....	0456-2
GROUP 1812 SPECIAL PURPOSE BODIES.....	WP 0457
Figure 456 Van Blackout By-Pass and 10IKW Electric Heater Wiring Harnesses.....	0457-2
GROUP 1812 SPECIAL PURPOSE BODIES.....	WP 0458
Figure 457 Van Blackout and Clearance Light Wiring Harness.....	0458-2
GROUP 1812 SPECIAL PURPOSE BODIES.....	WP 0459
Figure 458 Van Blackout Wiring Harness, Right and Left Side.....	0459-2
GROUP 1812 SPECIAL PURPOSE BODIES.....	WP 0460
Figure 459 Van Emergency Lamp Wiring Harness, Right and Left Side.....	0460-2
GROUP 1812 SPECIAL PURPOSE BODIES.....	WP 0461
Figure 460 Van Auxiliary Hydraulic Pump and 400Hz Converter Wiring Harnesses.....	0461-2
GROUP 1812 SPECIAL PURPOSE BODIES.....	WP 0462
Figure 461 Van Auxiliary Hydraulic Pump and 400Hz Converter Wiring Harnesses.....	0462-2
GROUP 1812 SPECIAL PURPOSE BODIES.....	WP 0463
Figure 462 Van 400Hz Wiring Harness.....	0463-2
GROUP 1812 SPECIAL PURPOSE BODIES.....	WP 0464
Figure 463 Van Telephone Jack and 3-Phase Receptacle Harness.....	0464-2
GROUP 1812 SPECIAL PURPOSE BODIES.....	WP 0465
Figure 464 Van Electrical Load Center and Mounting Hardware.....	0465-2
GROUP 1812 SPECIAL PURPOSE BODIES.....	WP 0466
Figure 465 Van Electrical Junction Box and Related Parts.....	0466-2
GROUP 1812 SPECIAL PURPOSE BODIES.....	WP 0467
Figure 466 Van 400Hz Converter Junction Box, Auxiliary Hydraulic Pump, Electrical Connector Box, and Related Parts.....	0467-2
GROUP 1812 SPECIAL PURPOSE BODIES.....	WP 0468

## TABLE OF CONTENTS

	<b>Page No.</b>
	<b><u>WP Sequence No.</u></b>
Figure 467 Van Circuit Breakers, Control Box, and Related Parts.....	0468-2
GROUP 1812 SPECIAL PURPOSE BODIES.....	WP 0469
Figure 468 Van 400Hz Converter, Circuit Breaker, and Mounting Hardware.....	0469-2
GROUP 1812 SPECIAL PURPOSE BODIES.....	WP 0470
Figure 469 Van Heater Thermostatic Switch and Fluorescent Starter.....	0470-2
GROUP 1812 SPECIAL PURPOSE BODIES.....	WP 0471
Figure 470 Van Telephone Jack and Related Parts, Interior and Exterior.....	0471-2
GROUP 1812 SPECIAL PURPOSE BODIES.....	WP 0472
Figure 471 Van Hinged Roof Plunger and Blackout Light Switch.....	0472-2
GROUP 1812 SPECIAL PURPOSE BODIES.....	WP 0473
Figure 472 Van 3-Phase and 400Hz Receptacles.....	0473-2
GROUP 1812 SPECIAL PURPOSE BODIES.....	WP 0474
Figure 473 Van Ceiling Switch, Front Wall Switch, Receptacle Assembly, and Related Parts.....	0474-2
GROUP 1812 SPECIAL PURPOSE BODIES.....	WP 0475
Figure 474 Van Blackout and Emergency Switches.....	0475-2
GROUP 1812 SPECIAL PURPOSE BODIES.....	WP 0476
Figure 475 Van Blackout and Emergency Lamps.....	0476-2
GROUP 1812 SPECIAL PURPOSE BODIES.....	WP 0477
Figure 476 Van Ceiling Lamp Fixtures and Bulb.....	0477-2
GROUP 2001 HOIST, CAPSTAN, WINDLASS, CRANE OR WINCH ASSEMBLY.....	WP 0478
Figure 477 Front Winch Controls and Mounting Hardware (M939 and M939A1).....	0478-2
GROUP 2001 HOIST, CAPSTAN, WINDLASS, CRANE OR WINCH ASSEMBLY.....	WP 0479
Figure 478 PTO and Winch Controls.....	0479-2
GROUP 2001 HOIST, CAPSTAN, WINDLASS, CRANE OR WINCH ASSEMBLY.....	WP 0480
Figure 479 Front Winch Pump, Linear Valve, and Related Hoses.....	0480-2
GROUP 2001 HOIST, CAPSTAN, WINDLASS, CRANE OR WINCH ASSEMBLY.....	WP 0481
Figure 480 Front Winch Filter and Reservoir Assembly (M939).....	0481-2

## TABLE OF CONTENTS

	<b>Page No.</b>
	<b><u>WP Sequence No.</u></b>
GROUP 2001 HOIST, CAPSTAN, WINDLASS, CRANE OR WINCH ASSEMBLY.....	WP 0482
Figure 481 Front Winch Reservoir Assembly and Mounting Hardware (M939 A1/A2).....	0482-2
GROUP 2001 HOIST, CAPSTAN, WINDLASS, CRANE OR WINCH ASSEMBLY.....	WP 0483
Figure 482 Front Winch Hydraulic Reservoir Assembly and Mounting Hardware - Non AoA Vehicles.....	0483-2
GROUP 2001 HOIST, CAPSTAN, WINDLASS, CRANE OR WINCH ASSEMBLY.....	WP 0484
Figure 483 Front Winch Hydraulic Reservoir Assembly and Mounting Hardware - After AoA Armor Removed (M939 A1/A2).....	0484-2
GROUP 2001 HOIST, CAPSTAN, WINDLASS, CRANE OR WINCH ASSEMBLY.....	WP 0485
Figure 484 Winch Pump Drive, Hydraulic Tubing (M939A2).....	0485-2
GROUP 2001 HOIST, CAPSTAN, WINDLASS, CRANE OR WINCH ASSEMBLY.....	WP 0486
Figure 485 Front Winch Pump, Linear Valve, Related Hoses and Fittings, Wrecker.....	0486-2
GROUP 2001 HOIST, CAPSTAN, WINDLASS, CRANE OR WINCH ASSEMBLY.....	WP 0487
Figure 486 Front Winch Pump, Linear Valve, Related Hoses and Fittings, Dump.....	0487-2
GROUP 2001 HOIST, CAPSTAN, WINDLASS, CRANE OR WINCH ASSEMBLY.....	WP 0488
Figure 487 Front Winch Pump Assembly.....	0488-2
GROUP 2001 HOIST, CAPSTAN, WINDLASS, CRANE OR WINCH ASSEMBLY.....	WP 0489
Figure 488 Front Winch Propeller Driveshaft Assembly (M939, M939A1).....	0489-2
GROUP 2001 HOIST, CAPSTAN, WINDLASS, CRANE OR WINCH ASSEMBLY.....	WP 0490
Figure 489 Propeller Drive Shaft, Front Winch (M939A2).....	0490-2
GROUP 2001 HOIST, CAPSTAN, WINDLASS, CRANE OR WINCH ASSEMBLY.....	WP 0491
Figure 490 Front Winch Motor and Mounting Hardware.....	0491-2
GROUP 2001 HOIST, CAPSTAN, WINDLASS, CRANE OR WINCH ASSEMBLY.....	WP 0492
Figure 491 Front Winch Brackets and Mounting Hardware.....	0492-2
GROUP 2001 HOIST, CAPSTAN, WINDLASS, CRANE OR WINCH ASSEMBLY.....	WP 0493
Figure 492 Front Winch Assembly Complete and Wire Rope Assembly, Wrecker.....	0493-2
GROUP 2001 HOIST, CAPSTAN, WINDLASS, CRANE OR WINCH ASSEMBLY.....	WP 0494
Figure 493 Front Winch Assembly Complete and Wire Rope Assembly.....	0494-2



## TABLE OF CONTENTS

	<b>Page No.</b>
	<b><u>WP Sequence No.</u></b>
GROUP 2001 HOIST, CAPSTAN, WINDLASS, CRANE OR WINCH ASSEMBLY.....	WP 0495
Figure 494 Front Winch Sheave Assembly, Wrecker.....	0495-2
GROUP 2001 HOIST, CAPSTAN, WINDLASS, CRANE OR WINCH ASSEMBLY.....	WP 0496
Figure 495 Front Winch Tensioner Assembly, Roller Assembly, and Related Parts.....	0496-2
GROUP 2001 HOIST, CAPSTAN, WINDLASS, CRANE OR WINCH ASSEMBLY.....	WP 0497
Figure 496 Front Winch Basic, Drum and Related Parts.....	0497-2
GROUP 2001 HOIST, CAPSTAN, WINDLASS, CRANE OR WINCH ASSEMBLY.....	WP 0498
Figure 497 Front Winch Basic, Gear Case and Related Parts.....	0498-2
GROUP 2001 HOIST, CAPSTAN, WINDLASS, CRANE OR WINCH ASSEMBLY.....	WP 0499
Figure 498 Wrecker Tackle Block and Wire Rope Assembly.....	0499-2
GROUP 2001 HOIST, CAPSTAN, WINDLASS, CRANE OR WINCH ASSEMBLY.....	WP 0500
Figure 499 Wrecker Rear Winch Vertical Roller and Mounting Hardware.....	0500-2
GROUP 2001 HOIST, CAPSTAN, WINDLASS, CRANE OR WINCH ASSEMBLY.....	WP 0501
Figure 500 Wrecker Rear Winch Horizontal Roller and Mounting Hardware.....	0501-2
GROUP 2001 HOIST, CAPSTAN, WINDLASS, CRANE OR WINCH ASSEMBLY.....	WP 0502
Figure 501 Wrecker Hydraulic Oil Tank Assembly and Mounting Hardware.....	0502-2
GROUP 2001 HOIST, CAPSTAN, WINDLASS, CRANE OR WINCH ASSEMBLY.....	WP 0503
Figure 502 Wrecker Hydraulic Fluid Filter Assembly.....	0503-2
GROUP 2001 HOIST, CAPSTAN, WINDLASS, CRANE OR WINCH ASSEMBLY.....	WP 0504
Figure 503 Wrecker Hydraulic Tubing, Swivel to Extension Cylinder and Control Valve.....	0504-2
GROUP 2001 HOIST, CAPSTAN, WINDLASS, CRANE OR WINCH ASSEMBLY.....	WP 0505
Figure 504 Wrecker Hydraulic Tubing, Control Valve to Hoist Motor.....	0505-2
GROUP 2001 HOIST, CAPSTAN, WINDLASS, CRANE OR WINCH ASSEMBLY.....	WP 0506
Figure 505 Wrecker Hydraulic Tubing, Control Valve to Elevating Cylinder and Filter to Elevating Cylinder.....	0506-2
GROUP 2001 HOIST, CAPSTAN, WINDLASS, CRANE OR WINCH ASSEMBLY.....	WP 0507
Figure 506 Wrecker Hoist Hydraulic Winch Motor and Crane Motor Assembly.....	0507-2
GROUP 2001 HOIST, CAPSTAN, WINDLASS, CRANE OR WINCH ASSEMBLY.....	WP 0508

## TABLE OF CONTENTS

	<b>Page No.</b>
	<b><u>WP Sequence No.</u></b>
Figure 507 Wrecker Crane Gearcase Assembly and Mounting Hardware.....	0508-2
GROUP 2001 HOIST, CAPSTAN, WINDLASS, CRANE OR WINCH ASSEMBLY.....	WP 0509
Figure 508 Wrecker Crane Boom Elevating Cylinder Assembly.....	0509-2
GROUP 2001 HOIST, CAPSTAN, WINDLASS, CRANE OR WINCH ASSEMBLY.....	WP 0510
Figure 509 Wrecker Sheave and Operator Guard.....	0510-2
GROUP 2001 HOIST, CAPSTAN, WINDLASS, CRANE OR WINCH ASSEMBLY.....	WP 0511
Figure 510 Wrecker Boom Assembly.....	0511-2
GROUP 2001 HOIST, CAPSTAN, WINDLASS, CRANE OR WINCH ASSEMBLY.....	WP 0512
Figure 511 Crane Hoist Winch and Mounting Hardware.....	0512-2
GROUP 2001 HOIST, CAPSTAN, WINDLASS, CRANE OR WINCH ASSEMBLY.....	WP 0513
Figure 512 Wrecker Boom Hoist Winch Housing, Worm Gear, and Brake.....	0513-2
GROUP 2001 HOIST, CAPSTAN, WINDLASS, CRANE OR WINCH ASSEMBLY.....	WP 0514
Figure 513 Wrecker Inner Boom Extension Assembly.....	0514-2
GROUP 2001 HOIST, CAPSTAN, WINDLASS, CRANE OR WINCH ASSEMBLY.....	WP 0515
Figure 514 Wrecker Inner Boom Extension Cylinder Assembly.....	0515-2
GROUP 2001 HOIST, CAPSTAN, WINDLASS, CRANE OR WINCH ASSEMBLY.....	WP 0516
Figure 515 Crane Gondola Assembly, Warning Light and Instruction Plate.....	0516-2
GROUP 2001 HOIST, CAPSTAN, WINDLASS, CRANE OR WINCH ASSEMBLY.....	WP 0517
Figure 516 Gondola Hoist Control Valve Assembly.....	0517-2
GROUP 2001 HOIST, CAPSTAN, WINDLASS, CRANE OR WINCH ASSEMBLY.....	WP 0518
Figure 517 Crane Gondola Control Valve Assembly, Basic.....	0518-2
GROUP 2001 HOIST, CAPSTAN, WINDLASS, CRANE OR WINCH ASSEMBLY.....	WP 0519
Figure 518 Wrecker Turntable Assembly.....	0519-2
GROUP 2001 HOIST, CAPSTAN, WINDLASS, CRANE OR WINCH ASSEMBLY.....	WP 0520
Figure 519 Crane Hydraulic Swivel Assembly.....	0520-2
GROUP 2001 HOIST, CAPSTAN, WINDLASS, CRANE OR WINCH ASSEMBLY.....	WP 0521
Figure 520 Crane Support, Turntable, and Bearing Guard.....	0521-2

## TABLE OF CONTENTS

	<b>Page No.</b>
	<b><u>WP Sequence No.</u></b>
GROUP 2001 HOIST, CAPSTAN, WINDLASS, CRANE OR WINCH ASSEMBLY.....	WP 0522
Figure 521 Wrecker Rear Winch Tensioner Chamber Assembly.....	0522-2
GROUP 2001 HOIST, CAPSTAN, WINDLASS, CRANE OR WINCH ASSEMBLY.....	WP 0523
Figure 522 Wrecker Rear Winch Assembly Complete and Wire Rope Assembly.....	0523-2
GROUP 2001 HOIST, CAPSTAN, WINDLASS, CRANE OR WINCH ASSEMBLY.....	WP 0524
Figure 523 Wrecker Rear Winch Sheave Swivel and Trolley.....	0524-2
GROUP 2001 HOIST, CAPSTAN, WINDLASS, CRANE OR WINCH ASSEMBLY.....	WP 0525
Figure 524 Wrecker Rear Winch Cable Tensioner.....	0525-2
GROUP 2001 HOIST, CAPSTAN, WINDLASS, CRANE OR WINCH ASSEMBLY.....	WP 0526
Figure 525 Wrecker Rear Winch Assembly, Basic.....	0526-2
GROUP 2001 HOIST, CAPSTAN, WINDLASS, CRANE OR WINCH ASSEMBLY.....	WP 0527
Figure 526 Wrecker Rear Winch Hydraulic Tubing and Control Valves.....	0527-2
GROUP 2001 HOIST, CAPSTAN, WINDLASS, CRANE OR WINCH ASSEMBLY.....	WP 0528
Figure 527 Wrecker Rear Winch Hydraulic Tubing, Control Valves, and Motor.....	0528-2
GROUP 2001 HOIST, CAPSTAN, WINDLASS, CRANE OR WINCH ASSEMBLY.....	WP 0529
Figure 528 Wrecker Rear Winch Hydraulic Tubing and Controls.....	0529-2
GROUP 2001 HOIST, CAPSTAN, WINDLASS, CRANE OR WINCH ASSEMBLY.....	WP 0530
Figure 529 Wrecker Hydraulic Pump and Drive Shaft.....	0530-2
GROUP 2001 HOIST, CAPSTAN, WINDLASS, CRANE OR WINCH ASSEMBLY.....	WP 0531
Figure 530 Dump Hydraulic Hoist Assembly.....	0531-2
GROUP 2001 HOIST, CAPSTAN, WINDLASS, CRANE OR WINCH ASSEMBLY.....	WP 0532
Figure 531 Dump Hoist Safety Latch Assembly, Hoses, and Filter.....	0532-2
GROUP 2001 HOIST, CAPSTAN, WINDLASS, CRANE OR WINCH ASSEMBLY.....	WP 0533
Figure 532 Dump Control Pump, Valve, and Related Parts.....	0533-2
GROUP 2001 HOIST, CAPSTAN, WINDLASS, CRANE OR WINCH ASSEMBLY.....	WP 0534
Figure 533 Dump Control Pump Assembly.....	0534-2
GROUP 2001 HOIST, CAPSTAN, WINDLASS, CRANE OR WINCH ASSEMBLY.....	WP 0535

## TABLE OF CONTENTS

	<b>Page No.</b>
	<b><u>WP Sequence No.</u></b>
Figure 534 Dump Control Valve Assembly.....	0535-2
GROUP 2001 HOIST, CAPSTAN, WINDLASS, CRANE OR WINCH ASSEMBLY.....	WP 0536
Figure 535 Dump Control Propeller Drive Shaft Assembly.....	0536-2
GROUP 2001 HOIST, CAPSTAN, WINDLASS, CRANE OR WINCH ASSEMBLY.....	WP 0537
Figure 536 Dump Controls, Lever Assembly, Cable, and Mounting Hardware.....	0537-2
GROUP 2004 POWER TAKE-OFF ASSEMBLY.....	WP 0538
Figure 537 Power Takeoff Controls, Lever Assembly, Cable Mounting Hardware.....	0538-2
GROUP 2004 POWER TAKE-OFF ASSEMBLY.....	WP 0539
Figure 538 Transfer Power Takeoff Assembly and Related Parts.....	0539-2
GROUP 2004 POWER TAKE-OFF ASSEMBLY.....	WP 0540
Figure 539 Transfer Power Takeoff Main Shaft and Drive Couplings.....	0540-2
GROUP 2004 POWER TAKE-OFF ASSEMBLY.....	WP 0541
Figure 540 Transmission Power Takeoff Shift Controls (M939/M939A1).....	0541-2
GROUP 2004 POWER TAKE-OFF ASSEMBLY.....	WP 0542
Figure 541 Transmission PTO Assembly (M939A2).....	0542-2
GROUP 2004 POWER TAKE-OFF ASSEMBLY.....	WP 0543
Figure 542 Transmission Power Takeoff Assembly.....	0543-2
GROUP 2201 CANVAS, RUBBER, OR PLASTIC ITEMS.....	WP 0544
Figure 543 Wrecker Gondola Canopy and Seat.....	0544-2
GROUP 2201 CANVAS, RUBBER, OR PLASTIC ITEMS.....	WP 0545
Figure 544 Cargo Bow and Stake Assembly and Related Parts.....	0545-2
GROUP 2201 CANVAS, RUBBER, OR PLASTIC ITEMS.....	WP 0546
Figure 545 Soft Top Assembly and Related Parts.....	0546-2
GROUP 2201 CANVAS, RUBBER, OR PLASTIC ITEMS.....	WP 0547
Figure 546 Soft Top Post Assembly.....	0547-2
GROUP 2201 CANVAS, RUBBER, OR PLASTIC ITEMS.....	WP 0548
Figure 547 Tarpaulin Extension Kit, LWB Cargo.....	0548-2

## TABLE OF CONTENTS

	<b>Page No.</b>
	<b><u>WP Sequence No.</u></b>
GROUP 2201 CANVAS, RUBBER, OR PLASTIC ITEMS.....	WP 0549
Figure 548 Splash Guard Assemblies.....	0549-2
GROUP 2201 CANVAS, RUBBER, OR PLASTIC ITEMS.....	WP 0550
Figure 549 Adjustable Safety Strap and Bow Stowage Strap.....	0550-2
GROUP 2202 ACCESSORY ITEMS.....	WP 0551
Figure 550 Windshield Wiper Air Lines and Control Assembly.....	0551-2
GROUP 2202 ACCESSORY ITEMS.....	WP 0552
Figure 551 Windshield Wiper Arm, Blade, and Motor Assembly (Old Style).....	0552-2
GROUP 2202 ACCESSORY ITEMS.....	WP 0553
Figure 552 Windshield Wiper Arm, Blade, and Motor Assembly (New Style).....	0553-2
GROUP 2202 ACCESSORY ITEMS.....	WP 0554
Figure 553 Washer Bottle, Jet, and Control Assembly.....	0554-2
GROUP 2202 ACCESSORY ITEMS.....	WP 0555
Figure 554 Washer Bottle, Jet, and Control Assembly.....	0555-2
GROUP 2202 ACCESSORY ITEMS.....	WP 0556
Figure 555 Rearview Mirrors.....	0556-2
GROUP 2202 ACCESSORY ITEMS.....	WP 0557
Figure 556 Cargo Body Reflectors and Mounting Hardware.....	0557-2
GROUP 2202 ACCESSORY ITEMS.....	WP 0558
Figure 557 Dump Body Reflectors and Mounting Hardware.....	0558-2
GROUP 2202 ACCESSORY ITEMS.....	WP 0559
Figure 558 Wrecker Body Reflectors and Mounting Hardware.....	0559-2
GROUP 2202 ACCESSORY ITEMS.....	WP 0560
Figure 559 Tractor Reflectors and Mounting Hardware.....	0560-2
GROUP 2202 ACCESSORY ITEMS.....	WP 0561
Figure 560 Van Body Reflectors and Mounting Hardware.....	0561-2
GROUP 2207 WINTERIZATION EQUIPMENT.....	WP 0562

## TABLE OF CONTENTS

	<b>Page No.</b>
	<b><u>WP Sequence No.</u></b>
Figure 561 Hot Water Heater, Hoses, Control Assembly, and Mounting Hardware.....	0562-2
GROUP 2207 WINTERIZATION EQUIPMENT.....	WP 0563
Figure 562 Hot Water Heater Valve (M939A2).....	0563-2
GROUP 2207 WINTERIZATION EQUIPMENT.....	WP 0564
Figure 563 Hot Water Heater, Diverter, Air Ducts, and Controls.....	0564-2
GROUP 2210 DATA PLATES AND INSTRUCTION HOLDERS.....	WP 0565
Figure 564 Data Plates, Instrument Panel.....	0565-2
GROUP 2210 DATA PLATES AND INSTRUCTION HOLDERS.....	WP 0566
Figure 565 Data Plates, Engine.....	0566-2
GROUP 2210 DATA PLATES AND INSTRUCTION HOLDERS.....	WP 0567
Figure 566 Data Plates, Transmission.....	0567-2
GROUP 2210 DATA PLATES AND INSTRUCTION HOLDERS.....	WP 0568
Figure 567 Data Plates, Fuel Pump and Transfer.....	0568-2
GROUP 2210 DATA PLATES AND INSTRUCTION HOLDERS.....	WP 0569
Figure 568 Engine Data Plates.....	0569-2
GROUP 2210 DATA PLATES AND INSTRUCTION HOLDERS.....	WP 0570
Figure 569 Data Plates, Air Cleaner, Radiator, Air Cleaner Indicator, Surge Tank, and Fuel Water Selector Surge Tank, and Fuel Water Selector.....	0570-2
GROUP 2210 DATA PLATES AND INSTRUCTION HOLDERS.....	WP 0571
Figure 570 Data Plates, Battery Box, and Generator.....	0571-2
GROUP 2210 DATA PLATES AND INSTRUCTION HOLDERS.....	WP 0572
Figure 571 Data Plates, Service and Emergency Couplings.....	0572-2
GROUP 2210 DATA PLATES AND INSTRUCTION HOLDERS.....	WP 0573
Figure 572 Data Plates, Hardtop.....	0573-2
GROUP 2210 DATA PLATES AND INSTRUCTION HOLDERS.....	WP 0574
Figure 573 Data Plates, Cab, Dump Cab Protector, and Cab Door.....	0574-2
GROUP 2210 DATA PLATES AND INSTRUCTION HOLDERS.....	WP 0575
Figure 574 Data Plates, Cargo Body Side Gate and Tailgate.....	0575-2

## TABLE OF CONTENTS

	<b>Page No.</b>
	<b><u>WP Sequence No.</u></b>
GROUP 2210 DATA PLATES AND INSTRUCTION HOLDERS.....	WP 0576
Figure 575 Data Plates, Front and Rear Winches.....	0576-2
GROUP 2210 DATA PLATES AND INSTRUCTION HOLDERS.....	WP 0577
Figure 576 Data Plates, Hydraulic Reservoir Tank.....	0577-2
GROUP 2210 DATA PLATES AND INSTRUCTION HOLDERS.....	WP 0578
Figure 577 Data Plates, Power Takeoff.....	0578-2
GROUP 2210 DATA PLATES AND INSTRUCTION HOLDERS.....	WP 0579
Figure 578 Data Plates, Wrecker Body and Gondola.....	0579-2
GROUP 2210 DATA PLATES AND INSTRUCTION HOLDERS.....	WP 0580
Figure 579 Data Plates, Hydraulic Control Valves and Towbar.....	0580-2
GROUP 2210 DATA PLATES AND INSTRUCTION HOLDERS.....	WP 0581
Figure 580 Data Plates, Control Box Harness.....	0581-2
GROUP 2210 DATA PLATES AND INSTRUCTION HOLDERS.....	WP 0582
Figure 581 Data Plates, Transfer, Transmission and Engine Container.....	0582-2
GROUP 2210 DATA PLATES AND INSTRUCTION HOLDERS.....	WP 0583
Figure 582 Data Plates, Van Body.....	0583-2
GROUP 2210 DATA PLATES AND INSTRUCTION HOLDERS.....	WP 0584
Figure 583 Data Plates, Van Body Interior, Front Wall.....	0584-2
GROUP 2210 DATA PLATES AND INSTRUCTION HOLDERS.....	WP 0585
Figure 584 Data Plates, Van Body Interior, Rear Wall.....	0585-2
GROUP 2210 DATA PLATES AND INSTRUCTION HOLDERS.....	WP 0586
Figure 585 Data Plates, Van Body Ceiling, Left Side.....	0586-2
GROUP 2210 DATA PLATES AND INSTRUCTION HOLDERS.....	WP 0587
Figure 586 Data Plates, Van Body Ceiling, Right Side.....	0587-2
GROUP 3303 WINTERIZATION KITS.....	WP 0588
Figure 587 Radiator and Hood Cover Kit.....	0588-2
GROUP 3303 WINTERIZATION KITS.....	WP 0589

## TABLE OF CONTENTS

	<b>Page No.</b>
	<b><u>WP Sequence No.</u></b>
Figure 588 Hardtop Kit.....	0589-2
GROUP 3303 WINTERIZATION KITS.....	WP 0590
Figure 589 Engine Coolant Heater Kit, Heater Control Box, and Wiring Harness.....	0590-2
GROUP 3303 WINTERIZATION KITS.....	WP 0591
Figure 590 Engine Coolant Heater Kit, Heater Assembly, Pump, and Related Parts.....	0591-2
GROUP 3303 WINTERIZATION KITS.....	WP 0592
Figure 591 Engine Coolant Heater Kit, Hoses, Fittings, and Pad Assembly.....	0592-2
GROUP 3303 WINTERIZATION KITS.....	WP 0593
Figure 592 Engine Coolant Heater Kit, Oil Pan Shroud, and Related Parts.....	0593-2
GROUP 3303 WINTERIZATION KITS.....	WP 0594
Figure 593 Engine Coolant Heater Kit, Control Box, and Related Parts.....	0594-2
GROUP 3303 WINTERIZATION KITS.....	WP 0595
Figure 594 Engine Coolant Heater Kit, Heater Assembly, Pump Assembly, and Related Parts.....	0595-2
GROUP 3303 WINTERIZATION KITS.....	WP 0596
Figure 595 Fuel Burning Personnel Heater Kit, Control Box, Heater, and Wiring Harness.....	0596-2
GROUP 3303 WINTERIZATION KITS.....	WP 0597
Figure 596 Fuel Burning Personnel Heater Kit.....	0597-2
GROUP 3303 WINTERIZATION KITS.....	WP 0598
Figure 597 Fuel Burning Personnel Heater Kit, Control Box, Heater, and Wiring Harness.....	0598-2
GROUP 3303 WINTERIZATION KITS.....	WP 0599
Figure 598 Fuel Burning Personnel Heater Kit, Pump, Filter, and Related Parts.....	0599-2
GROUP 3305 DEEP WATER FORDING KITS.....	WP 0600
Figure 599 Deep Water Fording Kit, Valve Assembly, and Related Parts.....	0600-2
GROUP 3305 DEEP WATER FORDING KITS.....	WP 0601
Figure 600 Deep Water Fording Kit Air Hoses and Cover Plate.....	0601-2
GROUP 3305 DEEP WATER FORDING KITS.....	WP 0602
Figure 601 Deep Water Fording Kit, Regulator, Selector, and Related Parts.....	0602-2



## TABLE OF CONTENTS

**Page No.**  
**WP Sequence No.**

**Volume 3**

**Chapter 3 - REPAIR PARTS AND SPECIAL TOOLS LIST (RPSTL)**

GROUP 3305 DEEP WATER FORDING KITS.....	WP 0603
Figure 602 Deep Water Fording Kit, Connectors, and Related Parts.....	0603-2
GROUP 3307 SPECIAL PURPOSE KITS.....	WP 0604
Figure 603 Pioneer Tool Bracket Kit.....	0604-2
GROUP 3307 SPECIAL PURPOSE KITS.....	WP 0605
Figure 604 Automatic Throttle Kit, Air Cylinder and Mounting Hardware.....	0605-2
GROUP 3307 SPECIAL PURPOSE KITS.....	WP 0606
Figure 605 Automatic Throttle Kit, Bell Crank Link and Throttle Lever Assembly.....	0606-2
GROUP 3307 SPECIAL PURPOSE KITS.....	WP 0607
Figure 606 Automatic Throttle Kit, Tee Connector.....	0607-2
GROUP 3307 SPECIAL PURPOSE KITS.....	WP 0608
Figure 607 Automatic Throttle Kit, Operation Data Plate.....	0608-2
GROUP 3307 SPECIAL PURPOSE KITS.....	WP 0609
Figure 608 Rifle Mounting Kit.....	0609-2
GROUP 3307 SPECIAL PURPOSE KITS.....	WP 0610
Figure 609 Lightweight Weapon Station Kit. (Sheet 1 of 3) .....	0610-2
Figure 609 Lightweight Weapon Station Kit. (Sheet 2 of 3) .....	0610-3
Figure 609 Lightweight Weapon Station Kit. (Sheet 3 of 3) .....	0610-4
GROUP 3307 SPECIAL PURPOSE KITS.....	WP 0611
Figure 610 Air Brake Kit, Control Valves, and Lines.....	0611-2
GROUP 3307 SPECIAL PURPOSE KITS.....	WP 0612
Figure 611 Air Brake Kit, Air Lines, and Double-check Valves.....	0612-2
GROUP 3307 SPECIAL PURPOSE KITS.....	WP 0613
Figure 612 Air Brake Kit, Air Lines, and Tractor Protection Valve.....	0613-2
GROUP 3307 SPECIAL PURPOSE KITS.....	WP 0614

## TABLE OF CONTENTS

	<b>Page No.</b>
	<b><u>WP Sequence No.</u></b>
Figure 613 Air Dryer Accessory Kit, Air Dryer, Attaching Hoses and Adapters.....	0614-2
GROUP 3307 SPECIAL PURPOSE KITS.....	WP 0615
Figure 614 Air Dryer Accessory Kit, Electrical and Air Tubing Connections.....	0615-2
GROUP 3307 SPECIAL PURPOSE KITS.....	WP 0616
Figure 615 Air Dryer Accessory Kit, Air Tubing and Connectors.....	0616-2
GROUP 3307 SPECIAL PURPOSE KITS.....	WP 0617
Figure 616 Air Dryer Accessory Kit, Copper Air Tubing and Wire Harness (M939A2).....	0617-2
GROUP 3307 SPECIAL PURPOSE KITS.....	WP 0618
Figure 617 Air Dryer Accessory Kit, Wire Harness and Tubing.....	0618-2
GROUP 3307 SPECIAL PURPOSE KITS.....	WP 0619
Figure 618 Air Dryer Accessory Kit, Air Line Adapter.....	0619-2
GROUP 3307 SPECIAL PURPOSE KITS.....	WP 0620
Figure 619 Air Dryer Accessory Kit, Wire Harness and Tubing.....	0620-2
GROUP 3307 SPECIAL PURPOSE KITS.....	WP 0621
Figure 620 Air Dryer Accessory Kit, Air Dryer, Attaching Hoses and Adapters.....	0621-2
GROUP 3307 SPECIAL PURPOSE KITS.....	WP 0622
Figure 621 Chemical Agent Alarm Mounting Kit.....	0622-2
GROUP 3307 SPECIAL PURPOSE KITS.....	WP 0623
Figure 622 Atmospheric Fuel Tank Vent System Kit, Check Valve and Mounting Hardware.....	0623-2
GROUP 3307 SPECIAL PURPOSE KITS.....	WP 0624
Figure 623 Atmospheric Fuel Tank Vent System Kit, Tee Connector and Adapters.....	0624-2
GROUP 3307 SPECIAL PURPOSE KITS.....	WP 0625
Figure 624 Atmospheric Fuel Tank Vent System Kit, Tube Assembly and Mounting Hardware.....	0625-2
GROUP 3307 SPECIAL PURPOSE KITS.....	WP 0626
Figure 625 Atmospheric Fuel Tank Vent System Kit, Double Elbow Plug.....	0626-2
GROUP 3307 SPECIAL PURPOSE KITS.....	WP 0627

## TABLE OF CONTENTS

	<b>Page No.</b>
	<b><u>WP Sequence No.</u></b>
Figure 626 Atmospheric Fuel Tank Vent System Kit, Tube Assemblies and Mounting Hardware.....	0627-2
GROUP 3307 SPECIAL PURPOSE KITS.....	WP 0628
Figure 627 Atmospheric Fuel Tank Vent System Kit, Tube Assemblies and Mounting Hardware.....	0628-2
GROUP 3307 SPECIAL PURPOSE KITS.....	WP 0629
Figure 628 A-Frame Components Kit.....	0629-2
GROUP 3307 SPECIAL PURPOSE KITS.....	WP 0630
Figure 629 Portable DecontaminationApparatus Kit - M13, Splash Shield Reinforcement and Support Bracket.....	0630-2
GROUP 3307 SPECIAL PURPOSE KITS.....	WP 0631
Figure 630 Portable DecontaminationApparatus Kit - M13, Mounting Hardware.....	0631-2
GROUP 3307 SPECIAL PURPOSE KITS.....	WP 0632
Figure 631 Alternator Kit, 60 to 100 AMP.....	0632-2
GROUP 3307 SPECIAL PURPOSE KITS.....	WP 0633
Figure 632 Alternator Kit, 60 to 100 AMP (M939A2).....	0633-2
GROUP 3307 SPECIAL PURPOSE KITS.....	WP 0634
Figure 633 Dump Body Troop Seat and Tarpaulin Kit. (Sheet 1 of 2) .....	0634-1
Figure 633 Dump Body Troop Seat and Tarpaulin Kit. (Sheet 2 of 2) .....	0634-2
GROUP 3307 SPECIAL PURPOSE KITS.....	WP 0635
Figure 634 Hydraulic Hose Chafe Guard, Fittings and Hose.....	0635-2
GROUP 3307 SPECIAL PURPOSE KITS.....	WP 0636
Figure 635 Hydraulic Hose Chafe Guard, Tiedown Strap.....	0636-2
GROUP 3307 SPECIAL PURPOSE KITS.....	WP 0637
Figure 636 Fire Extinguisher Kit.....	0637-2
GROUP 3307 SPECIAL PURPOSE KITS.....	WP 0638
Figure 637 Exhaust Heatshield Kit.....	0638-2
GROUP 3307 SPECIAL PURPOSE KITS.....	WP 0639

## TABLE OF CONTENTS

	<b>Page No.</b>
	<b><u>WP Sequence No.</u></b>
Figure 638 Convoy Warning Light Kit.....	0639-2
GROUP 3307 SPECIAL PURPOSE KITS.....	WP 0640
Figure 639 Portable Decontamination Apparatus Kit-M13, Support Brackets.....	0640-2
GROUP 3307 SPECIAL PURPOSE KITS.....	WP 0641
Figure 640 Convoy Warning Light Kit, Dump.....	0641-2
GROUP 3307 SPECIAL PURPOSE KITS.....	WP 0642
Figure 641 Portable Decontamination Apparatus Kit, Mounting Brackets and Hardware.....	0642-2
GROUP 3307 SPECIAL PURPOSE KITS.....	WP 0643
Figure 642 Portable Decontamination Apparatus Kit-M13.....	0643-2
GROUP 3307 SPECIAL PURPOSE KITS.....	WP 0644
Figure 643 Convoy Warning Light Kit, Van.....	0644-2
GROUP 3307 SPECIAL PURPOSE KITS.....	WP 0645
Figure 644 European Light Kit.....	0645-2
GROUP 3307 SPECIAL PURPOSE KITS.....	WP 0646
Figure 645 Battery Relocation Kit, Mounting Brackets and Retaining Straps.....	0646-2
GROUP 3307 SPECIAL PURPOSE KITS.....	WP 0647
Figure 646 Battery Relocation Kit, Battery Box.....	0647-2
GROUP 3307 SPECIAL PURPOSE KITS.....	WP 0648
Figure 647 Battery Relocation Kit, Battery Box and Cable.....	0648-2
GROUP 3307 SPECIAL PURPOSE KITS.....	WP 0649
Figure 648 Seat Belt Kit.....	0649-2
GROUP 3307 SPECIAL PURPOSE KITS.....	WP 0650
Figure 649 Van Fixed Handle Kit, Mounting Brackets, and Strap.....	0650-2
GROUP 3307 SPECIAL PURPOSE KITS.....	WP 0651
Figure 650 Van Handrail Kit and Double Angle Bracket.....	0651-2
GROUP 3307 SPECIAL PURPOSE KITS.....	WP 0652
Figure 651 Van Swivel Handle Kit and Mounting Brackets.....	0652-2

## TABLE OF CONTENTS

	<b>Page No.</b>
	<b><u>WP Sequence No.</u></b>
GROUP 3307 SPECIAL PURPOSE KITS.....	WP 0653
Figure 652 Wrecker Front Counterweight Kit.....	0653-2
GROUP 3307 SPECIAL PURPOSE KITS.....	WP 0654
Figure 653 Mudflap Stowage Kit. (Sheet 1 of 2) .....	0654-1
Figure 653 Mudflap Stowage Kit. (Sheet 2 of 2) .....	0654-2
GROUP 4316 ASSEMBLED HOSE, FITTING, LINES, BREATHERS, FILTERS AND TRAPS.....	WP 0655
Figure 654 Exhaust Valve Lines and Fittings, Front.....	0655-2
GROUP 4316 ASSEMBLED HOSE, FITTING, LINES, BREATHERS, FILTERS AND TRAPS.....	WP 0656
Figure 655 Exhaust Valve Lines and Fittings, Rear.....	0656-2
GROUP 4317 MANIFOLD AND/OR CONTROL VALVES.....	WP 0657
Figure 656 Air Dryer Lines and Fittings.....	0657-2
GROUP 4317 MANIFOLD AND/OR CONTROL VALVES.....	WP 0658
Figure 657 Air Dryer Lines and Fittings, Water Separator, and Governor.....	0658-2
GROUP 4317 MANIFOLD AND/OR CONTROL VALVES.....	WP 0659
Figure 658 Relief Safety Valve Assembly.....	0659-2
GROUP 4317 MANIFOLD AND/OR CONTROL VALVES.....	WP 0660
Figure 659 Electronic Control Unit and Pneumatic Controller.....	0660-2
GROUP 4701 INSTRUMENTS.....	WP 0661
Figure 660 Speedometer Drive Adapter, Cable, and Gauge Assembly.....	0661-2
GROUP 4701 INSTRUMENTS.....	WP 0662
Figure 661 Tachometer Cable and Gauge Assembly.....	0662-2
GROUP 4701 INSTRUMENTS.....	WP 0663
Figure 662 Speedometer Drive Cable Clamp (M939A2).....	0663-2
GROUP 4701 INSTRUMENTS.....	WP 0664
Figure 663 Tachometer Drive (M939A2).....	0664-2
GROUP 4701 INSTRUMENTS.....	WP 0665
Figure 664 Primary and Secondary Air Pressure Gauges.....	0665-2

## TABLE OF CONTENTS

	<b>Page No.</b>
	<b><u>WP Sequence No.</u></b>
GROUP 2604 SPECIAL TOOLS.....	WP 0666
Figure 665 Peculiar End Item Special Tools.....	0666-2
GROUP 2604 SPECIAL TOOLS.....	WP 0667
Figure 666 Special Tools.....	0667-2
GROUP 2604 SPECIAL TOOLS.....	WP 0668
Figure 667 Special Tools.....	0668-2
GROUP 9401 REPAIR KITS.....	WP 0669
Figure KITS Repair Kits.....	0669-2
GROUP 9501 HARDWARE SUPPLIES AND BULK MATERIALS, COMMON.....	WP 0670
Figure BULK Bulk Items.....	0670-2
GROUP 2604 SPECIAL TOOLS.....	WP 0671
Figure 668 Special Tools.....	0671-2
GROUP 2604 SPECIAL TOOLS.....	WP 0672
Figure 669 Special Tools.....	0672-2
GROUP 2604 SPECIAL TOOLS.....	WP 0673
Figure 670 Special Tools.....	0673-2
NATIONAL STOCK NUMBER INDEX.....	WP 0674
PART NUMBER INDEX.....	WP 0675

## **CHAPTER 1**

### **REPAIR PARTS AND SPECIAL TOOLS LIST (RPSTL)**





**FIELD MAINTENANCE  
INTRODUCTION**

**SCOPE**

This RPSTL lists and authorizes spares and repair parts; special tools; special test, measurement, and diagnostic equipment (TMDE); and other special support equipment required for performance of field and sustainment maintenance of the M939. It authorizes the requisitioning, issue, and disposition of spares, repair parts, and special tools as indicated by the source, maintenance, and recoverability (SMR) codes.

**GENERAL**

In addition to the Introduction work package, this RPSTL is divided into the following work packages.

1. Repair Parts List Work Packages. Work packages containing lists of spares and repair parts authorized by this RPSTL for use in the performance of maintenance. These work packages also include parts which must be removed for replacement of the authorized parts. Parts lists are composed of functional groups in ascending alphanumeric sequence, with the parts in each group listed in ascending figure and item number sequence. Sending units, brackets, filters, and bolts are listed with the component they mount on. Bulk materials are listed by item name in FIG. BULK at the end of the work packages. *Repair parts kits are listed separately in their own functional group and work package.* Repair parts for reparable special tools are also listed in a separate work package. Items listed are shown on the associated illustrations.
2. Special Tools List Work Packages. Work packages containing lists of special tools, Special TMDE, and special support equipment authorized by this RPSTL (as indicated by Basis of Issue (BOI) information in the DESCRIPTION AND USABLE ON CODE (UOC) column). Tools that are components of common tool sets and/or Class VII are not listed.
3. Cross-Reference Indexes Work Packages. There are two cross-reference indexes work packages in this RPSTL: the National Stock Number (NSN) Index work package, *and* the Part Number (P/N) Index work package. The National Stock Number Index work package refers you to the figure and item number. The Part Number Index work package refers you to the figure and item number.

**EXPLANATION OF COLUMNS IN THE REPAIR PARTS LIST AND SPECIAL TOOLS LIST WORK PACKAGES**

ITEM NO. (Column (1)). Indicates the number used to identify items called out in the illustration.

SMR CODE (Column (2)). The SMR code containing supply/requisitioning information, maintenance level authorization criteria, and disposition instruction, as shown in the following breakout. This entry may be subdivided into 4 subentries, one for each service.

**Table 1. SMR Code Explanation.**

<b>Source Code <u>XX</u></b>	<b>Maintenance Code <u>XX</u></b>		<b>Recoverability Code <u>X</u></b>
1st two positions: How to get an item.	3rd position: Who can install, replace, or use the item.	4th position: Who can do complete repair* on the item.	5th position: Who determines disposition action on unserviceable items.

Complete Repair: Maintenance capacity, capability, and authority to perform all corrective maintenance tasks of the "Repair" function in a use/user environment in order to restore serviceability to a failed item.

## EXPLANATION OF COLUMNS IN THE REPAIR PARTS LIST AND SPECIAL TOOLS LIST WORK PACKAGES - Continued

Source Code. The source code tells you how you get an item needed for maintenance, repair, or overhaul of an end item/equipment. Explanations of source codes follow:

<u>Source Code</u>	<u>Application/Explanation</u>
PA  PB PC PD PE PF PG PH PR PZ	<p style="text-align: center;"><b>NOTE</b></p> <p style="text-align: center;">Items coded PC are subject to deterioration.</p> <p>Stock Items; use the applicable NSN to requisition/request items with these source codes. They are authorized to the level indicated by the code entered in the third position of the SMR code.</p>
KD  KF KB	<p>Items with these codes are not to be requested/requisitioned individually. They are part of a kit which is authorized to the maintenance level indicated in the third position of the SMR code. The complete kit must be requisitioned and applied.</p>
MF-Made at field  MH-Made at below depot / sustainment level ML-Made at SRA MD-Made at depot MG-Navy only	<p>Items with these codes are not to be requisitioned/requested individually. They must be made from bulk material which is identified by the part number in the DESCRIPTION AND USABLE ON CODE (UOC) column and listed in the bulk material group work package of the RPSTL. If the item is authorized to you by the third position code of the SMR code, but the source code indicates it is made at higher level, order the item from the higher level of maintenance.</p>
AF-Assembled by field  AH-Assembled by below depot sustainment level AL-Assembled by SRA AD-Assembled by depot AG-Navy only	<p>Items with these codes are not to be requested/requisitioned individually. The parts that make up the assembled item must be requisitioned or fabricated and assembled at the level of maintenance indicated by the source code. If the third position of the SMR code authorizes you to replace the item, but the source code indicates the item is assembled at a higher level, order the item from the higher level of maintenance.</p>
XA	<p>Do not requisition an "XA" coded item. Order the next higher assembly. (Refer to NOTE below.)</p>
XB	<p>If an item is not available from salvage, order it using the CAGEC and part number.</p>
XC	<p>Installation drawings, diagrams, instruction sheets, field service drawings; identified by manufacturer's part number.</p>
XD	<p>Item is not stocked. Order an XD-coded item through local purchase or normal supply channels using the CAGEC and part number given, if no NSN is available.</p>

**EXPLANATION OF COLUMNS IN THE REPAIR PARTS LIST AND SPECIAL TOOLS LIST WORK PACKAGES - Continued**

**NOTE**

Cannibalization or controlled exchange, when authorized, may be used as a source of supply for items with the above source codes except for those items source coded "XA" or those aircraft support items restricted by requirements of AR 750-1.

Maintenance Code. Maintenance codes tell you the level(s) of maintenance authorized to use and repair support items. The maintenance codes are entered in the third and fourth positions of the SMR code as follows:

Third Position. The maintenance code entered in the third position tells you the lowest maintenance level authorized to remove, replace, and use an item. The maintenance code entered in the third position will indicate authorization to the following levels of maintenance:

<b><u>Maintenance Code</u></b>	<b><u>Application/Explanation</u></b>
F-	Field maintenance can remove, replace, and use the item.
H-	Below Depot Sustainment maintenance can remove, replace, and use the item.
L-	Specialized repair activity can remove, replace, and use the item.
G-	Afloat and ashore intermediate maintenance can remove, replace, and use the item. (Navy only)
K-	Contractor facility can remove, replace, and use the item.
Z-	Item is not authorized to be removed, replaced, or used at any maintenance level.
D-	Depot can remove, replace, and use the item.

NOTE - Army use C in the third position. However, for joint service publications, Army will use O.

Fourth Position. The maintenance code entered in the fourth position tells you whether or not the item is to be repaired and identifies the lowest maintenance level with the capability to do complete repair (perform all authorized repair functions).

**EXPLANATION OF COLUMNS IN THE REPAIR PARTS LIST AND SPECIAL TOOLS LIST WORK PACKAGES - Continued**

**NOTE**

Some limited repair may be done on the item at a lower level of maintenance, if authorized by the Maintenance Allocation Chart (MAC) and SMR codes.

<u>Maintenance Code</u>	<u>Application/Explanation</u>
F-	Field is the lowest level that can do complete repair of the item.
H-	Below Depot Sustainment is the lowest level that can do complete repair of the item.
L-	Specialized repair activity is the lowest level that can do complete repair of the item.
D-	Depot is the lowest level that can do complete repair of the item.
G-	Both afloat and ashore intermediate levels are capable of complete repair of item. (Navy only)
K-	Complete repair is done at contractor facility.
Z-	Nonreparable. No repair is authorized.
B-	No repair is authorized. No parts or special tools are authorized for maintenance of "B" coded item. However, the item may be reconditioned by adjusting, lubricating, etc., at the user level.

Recoverability Code. Recoverability codes are assigned to items to indicate the disposition action on unserviceable items. The recoverability code is shown in the fifth position of the SMR code as follows:

<u>Recoverability Code</u>	<u>Application/Explanation</u>
Z-	Nonreparable item. When unserviceable, condemn and dispose of the item at the level of maintenance shown in the third position of the SMR code.
F-	Reparable item. When uneconomically repairable, condemn and dispose of the item at the field level.
H-	Reparable item. When uneconomically repairable, condemn and dispose of the item at the below depot sustainment level.
D-	Reparable item. When beyond lower level repair capability, return to depot. Condemnation and disposal of item are not authorized below depot level.
L-	Reparable item. Condemnation and disposal not authorized below Specialized Repair Activity (SRA).
A-	Item requires special handling or condemnation procedures because of specific reasons (such as precious metal content, high dollar value, critical material, or hazardous material). Refer to appropriate manuals/directives for specific instructions.

## EXPLANATION OF COLUMNS IN THE REPAIR PARTS LIST AND SPECIAL TOOLS LIST WORK PACKAGES - Continued

NSN (Column (3)). The NSN for the item is listed in this column.

CAGEC (Column (4)). The Commercial and Government Entity Code (CAGEC) is a five-digit code which is used to identify the manufacturer, distributor, or Government agency/activity that supplies the item.

PART NUMBER (Column (5)). Indicates the primary number used by the manufacturer individual, company, firm, corporation, or Government activity), which controls the design and characteristics of the item by means of its engineering drawings, specifications, standards, and inspection requires to identify an item or range of items.

### NOTE

When you use an NSN to requisition an item, the item you receive may have a different part number from the number listed.

DESCRIPTION AND USABLE ON CODE (UOC) (Column (6)). This column includes the following information:

1. The federal item name, and when required, a minimum description to identify the item.
2. Part numbers of bulk materials are referenced in this column in the line entry to be manufactured or fabricated.
3. Hardness Critical Item (HCI). A support item that provides the equipment with special protection from electromagnetic pulse (EMP) damage during a nuclear attack.
4. The statement END OF FIGURE appears just below the last item description in column (6) for a given figure in both the repair parts list and special tools list work packages.

QTY (Column (7)). The QTY (quantity per figure) column indicates the quantity of the item used in the breakout shown on the illustration/figure, which is prepared for a functional group, subfunctional group, or an assembly. A "V" appearing in this column instead of a quantity indicates that the quantity is variable and quantity may change from application to application.

## EXPLANATION OF CROSS-REFERENCE INDEXES WORK PACKAGES FORMAT AND COLUMNS

1. National Stock Number (NSN) Index Work Package. NSN's in this index are listed in National Item Identification Number (NIIN) sequence.

STOCK NUMBER Column. This column lists the NSN in NIIN sequence. The NIIN consists of the last nine digits of the NSN. When using this column to locate an item, ignore the first four digits of the NSN. However, the complete NSN should be used when ordering items by stock number.

For example, if the NSN is 5385-01-547-1476, the NIIN is 01-574-1476.

FIG. Column. This column lists the number of the figure where the item is identified/located. The figures are in numerical order in the repair parts list and special tools list work packages.

ITEM Column. The item number identifies the item associated with the figure listed in the adjacent FIG. column. This item is also identified by the NSN listed on the same line.

2. Part Number (P/N) Index Work Package. Part numbers in this index are listed in ascending alphanumeric sequence (vertical arrangement of letter and number combinations which places the first letter or digit of each group in order A through Z, followed by the numbers 0 through 9 and each following letter or digit in like order).

PART NUMBER Column. Indicates the part number assigned to the item.

FIG. Column. This column lists the number of the figure where the item is identified/located in the repair parts list and special tools list work packages.

ITEM Column. The item number is the number assigned to the item as it appears in the figure referenced in the adjacent figure number column.

**EXPLANATION OF CROSS-REFERENCE INDEXES WORK PACKAGES  
FORMAT AND COLUMNS - Continued**

**SPECIAL INFORMATION**

UOC. The UOC appears in the lower left corner of the Description Column heading. Usable on codes are shown as "UOC:..." in the Description Column (justified left) on the first line under the applicable item/nomenclature. Uncoded items are applicable to all models. Identification of the UOCs used in the RPSTL are:

<b>Code</b>	<b>Used On</b>	<b>Code</b>	<b>Used On</b>	<b>Code</b>	<b>Used On</b>
DAC	M927A1 WO/W	V14	M925 W/W	ZAA	M923A2 WO/W
DAD	M928A1 W/W	V15	M923 WO/W	ZAB	M925A2 W/W
DAE	M929A1 WO/W	V16	M928 W/W	ZAC	M927A2 WO/W
DAF	M930A1 W/W	V17	M927 WO/W	ZAD	M928A2 W/W
DAG	M931A1 WO/W	V18	M936 W/W	ZAE	M929A2 WO/W
DAH	M932A1 W/W	V19	M930 W/W	ZAF	M930A2 W/W
DAJ	M934A1 WO/W	V20	M929 WO/W	ZAG	M931A2 WO/W
DAL	M936A1 W/W	V21	M932 W/W	ZAH	M932A2 W/W
DAW	M923A1 WO/W	V22	M931 WO/W	ZAJ	M934A2 WO/W
DAX	M925A1 W/W	V24	M934 WO/W	ZAL	M936A2 W/W

Fabrication Instructions. Bulk materials required to manufacture items are listed in the bulk material functional group of this RPSTL. Part numbers for bulk material are also referenced in the Description Column of the line item entry for the item to be manufactured/fabricated.

Index Numbers. Items which have the word BULK in the figure column will have an index number shown in the item number column. This index number is a cross-reference between the NSN / Part Number (P/N) Index work packages and the bulk material list in the repair parts list work package.

**HOW TO LOCATE REPAIR PARTS**

1. When NSNs or Part Numbers Are Not Known.

First. Using the table of contents, determine the assembly group to which the item belongs. This is necessary since figures are prepared for assembly groups and subassembly groups, and lists are divided into the same groups.

Second. Find the figure covering the functional group or the subfunctional group to which the item belongs.

Third. Identify the item no the figure and note the number(s).

Fourth. Look in the repair parts list work packages for the figure and item numbers. The NSNs and part numbers are on the same line as the associated item numbers.

---

**HOW TO LOCATE REPAIR PARTS - Continued****2. When NSN Is Known.**

First. If you have the NSN, look in the STOCK NUMBER column of the NSN index work package. The NSN is arranged in NIIN sequence. Note the figure and item number next to the NSN.

Second. Turn to the figure and locate the item number. Verify that the item is the one you are looking for.

**3. When Part Number Is Known.**

First. If you have the part number and not the NSN, look in the PART NUMBER column of the part number index work package. Identify the figure and item number.

Second. Look up the item on the figure in the applicable repair parts list work package.

**END OF WORK PACKAGE**





**FIELD MAINTENANCE  
ENGINE AND CONTAINER ASSEMBLY (M939, M939A1)**

---

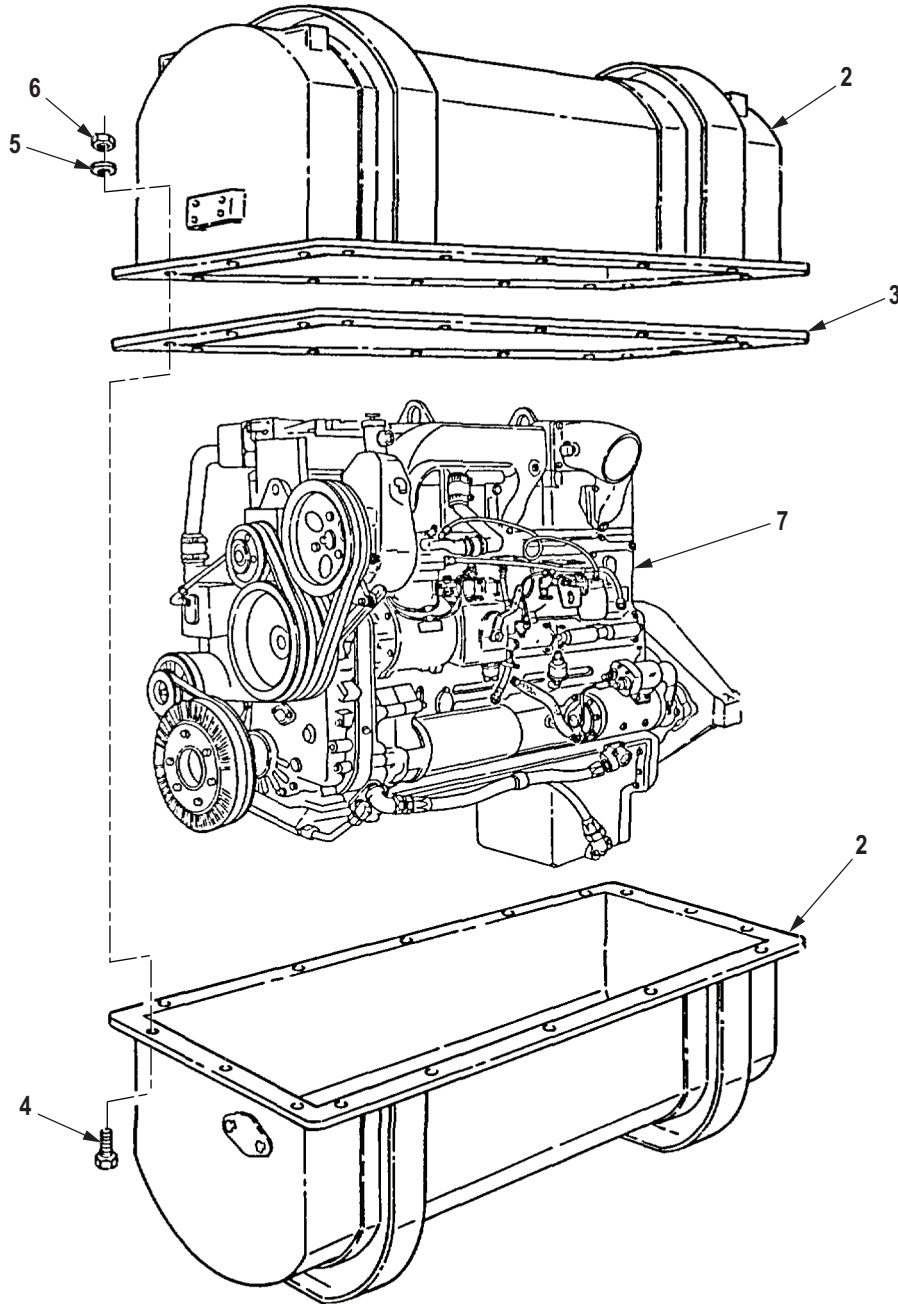
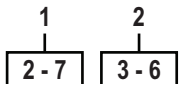

R0001DAA

Figure 1. Engine and Container Assembly (M939, M939A1).

(1) ITEM NO.	(2) SMR CODE	(3) NSN	(4) CAGEC	(5) PART NUMBER	(6) DESCRIPTION AND USABLE ON CODE (UOC)	(7) QTY
<b>GROUP 0100 ENGINE ASSEMBLY.</b>						
<b>FIG. 1. ENGINE AND CONTAINER ASSEMBLY (M939, M939A1).</b>						
1	PBFHH	2815-01-111-2262	19207	5704507	ENGINE,DIESEL ASSEMBLY W/ CONTAINER UOC: DAC,DAD,DAE,DAF,DAG,DA H,DAJ,DAL,DAW,DAX,V14,V15,V16, V17,V18,V19,V20,V21,V22,V24 .....	1
2	PBFHH	8145-00-134-3691	19207	11664574	. SHIPPING AND STORAG UOC: DAC,DAD,DAE,DAF,DAG,DA H,DAJ,DAL,DAW,DAX,V14,V15,V16, V17,V18,V19,V20,V21,V22,V24 .....	1
3	PAFZZ	5330-01-137-7090	19207	11648657	. . SEAL,NONMETALLIC RO UOC: DAC,DAD,DAE,DAF,DAG,DA H,DAJ,DAL,DAW,DAX,V14,V15,V16, V17,V18,V19,V20,V21,V22,V24 .....	1
4	PAFZZ	5305-00-724-7222	80204	B1821BH063C200N	. . SCREW,CAP,HEXAGON H UOC: DAC,DAD,DAE,DAF,DAG,DA H,DAJ,DAL,DAW,DAX,V14,V15,V16, V17,V18,V19,V20,V21,V22,V24 .....	42
5	PAFZZ	5310-00-820-6653	80205	MS35338-50	. . WASHER,LOCK UOC: DAC,DAD,DAE,DAF,DAG,DA H,DAJ,DAL,DAW,DAX,V14,V15,V16, V17,V18,V19,V20,V21,V22,V24 .....	42
6	PAFZZ	5310-00-763-8920	96906	MS51967-20	. . NUT,PLAIN,HEXAGON UOC: DAC,DAD,DAE,DAF,DAG,DA H,DAJ,DAL,DAW,DAX,V14,V15,V16, V17,V18,V19,V20,V21,V22,V24 .....	42
7	XAFHH		19207	5704507XA	. ENGINE,DIESEL ASSY UOC: DAC,DAD,DAE,DAF,DAG,DA H,DAJ,DAL,DAW,DAX,V14,V15,V16, V17,V18,V19,V20,V21,V22,V24 .....	1

END OF FIGURE



**FIELD MAINTENANCE  
ENGINE AND CONTAINER ASSEMBLY (M939A2)**

---

1  
2-6

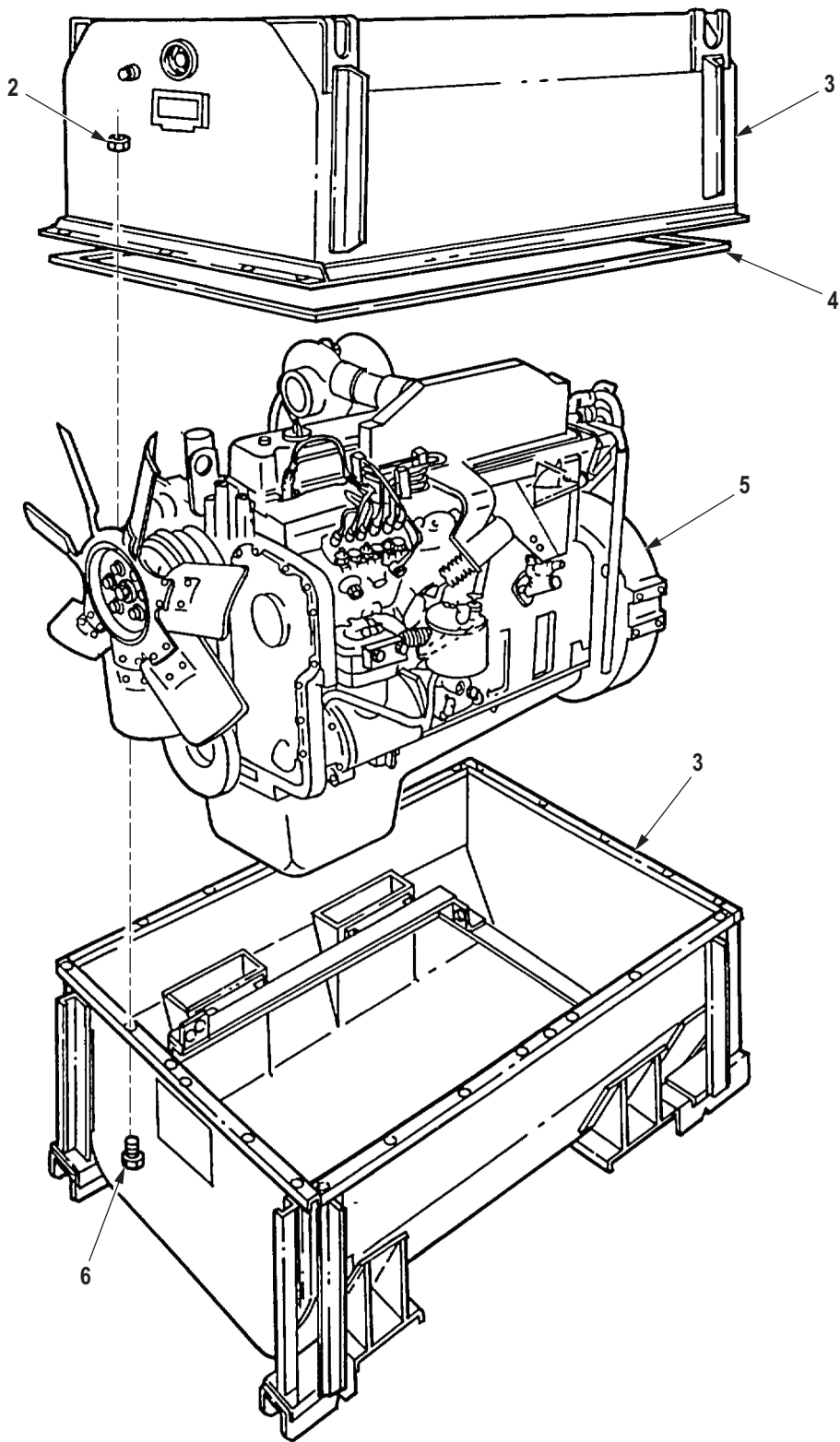

R0002DAA

Figure 2. Engine and Container Assembly (M939A2).

(1) ITEM NO.	(2) SMR CODE	(3) NSN	(4) CAGEC	(5) PART NUMBER	(6) DESCRIPTION AND USABLE ON CODE (UOC)	(7) QTY
<b>GROUP 0100 ENGINE ASSEMBLY.</b>						
<b>FIG. 2. ENGINE AND CONTAINER ASSEMBLY (M939A2).</b>						
1	PBFHH	2815-01-374-7539	19207	57K3194	ENGINE W/CONTAINER ASSEMBLY W/CONTAINER UOC: ZAA,ZAB,ZAC,ZAD,ZAE,ZAF, ZAG,ZAH,ZAJ,ZAL .....	1
2	PAFZZ	5310-00-768-0318	96906	MS51967-14	. NUT,PLAIN,HEXAGON UOC: ZAA,ZAB,ZAC,ZAD,ZAE,ZAF, ZAG,ZAH,ZAJ,ZAL .....	24
3	PRFHH	8145-01-317-3498	19207	12363644	. SHIPPING AND STORAG UOC: ZAA,ZAB,ZAC,ZAD,ZAE,ZAF, ZAG,ZAH,ZAJ,ZAL .....	1
4	PAFZZ	5330-01-350-6119	19207	12363654	. GASKET FOR STORAGE CONTAINER UOC: ZAA,ZAB,ZAC,ZAD,ZAE,ZAF, ZAG,ZAH,ZAJ,ZAL .....	1
5	XAFHH		19207	12363270XA	. ENGINE,DIESEL UOC: ZAA,ZAB,ZAC,ZAD,ZAE,ZAF, ZAG,ZAH,ZAJ,ZAL .....	1
6	PAFZZ	5305-00-071-2067	80204	B1821BH050C125N	. SCREW,CAP,HEXAGON H UOC: ZAA,ZAB,ZAC,ZAD,ZAE,ZAF, ZAG,ZAH,ZAJ,ZAL .....	24

**END OF FIGURE**





**FIELD MAINTENANCE  
ENGINE LIFTING BRACKETS (M939, M939A1)**

---

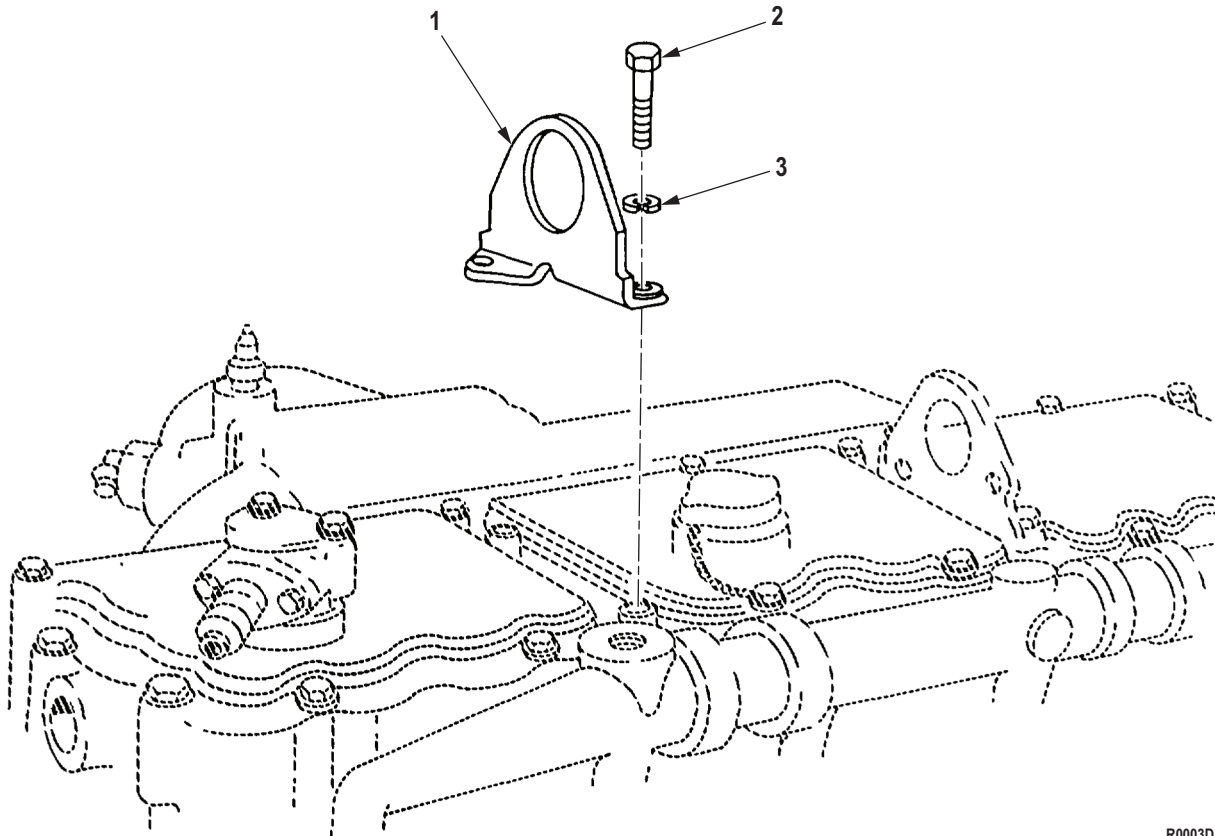

R0003DAA

Figure 3. Engine Lifting Brackets (M939, M939A1).

(1) ITEM NO.	(2) SMR CODE	(3) NSN	(4) CAGEC	(5) PART NUMBER	(6) DESCRIPTION AND USABLE ON CODE (UOC)	(7) QTY
<b>GROUP 0100 ENGINE ASSEMBLY.</b>						
<b>FIG. 3. ENGINE LIFTING BRACKETS (M939, M939A1).</b>						
1	PAFZZ	5342-00-404-2946	15434	170226	BRACKET,ENGINE LIFT UOC: DAC,DAD,DAE,DAF,DAG,DA H,DAJ,DAL,DAW,DAX,V14,V15,V16, V17,V18,V19,V20,V21,V22,V24 .....	2
2	PAFZZ	5305-00-795-9343	15434	S-176	SCREW,CAP,HEXAGON H UOC: DAC,DAD,DAE,DAF,DAG,DA H,DAJ,DAL,DAW,DAX,V14,V15,V16, V17,V18,V19,V20,V21,V22,V24 .....	4
3	PAFZZ	5310-01-200-1318	15434	S608	WASHER,LOCK UOC: DAC,DAD,DAE,DAF,DAG,DA H,DAJ,DAL,DAW,DAX,V14,V15,V16, V17,V18,V19,V20,V21,V22,V24 .....	4
<b>END OF FIGURE</b>						



**FIELD MAINTENANCE  
ENGINE LIFTING BRACKETS (M939A2)**

---

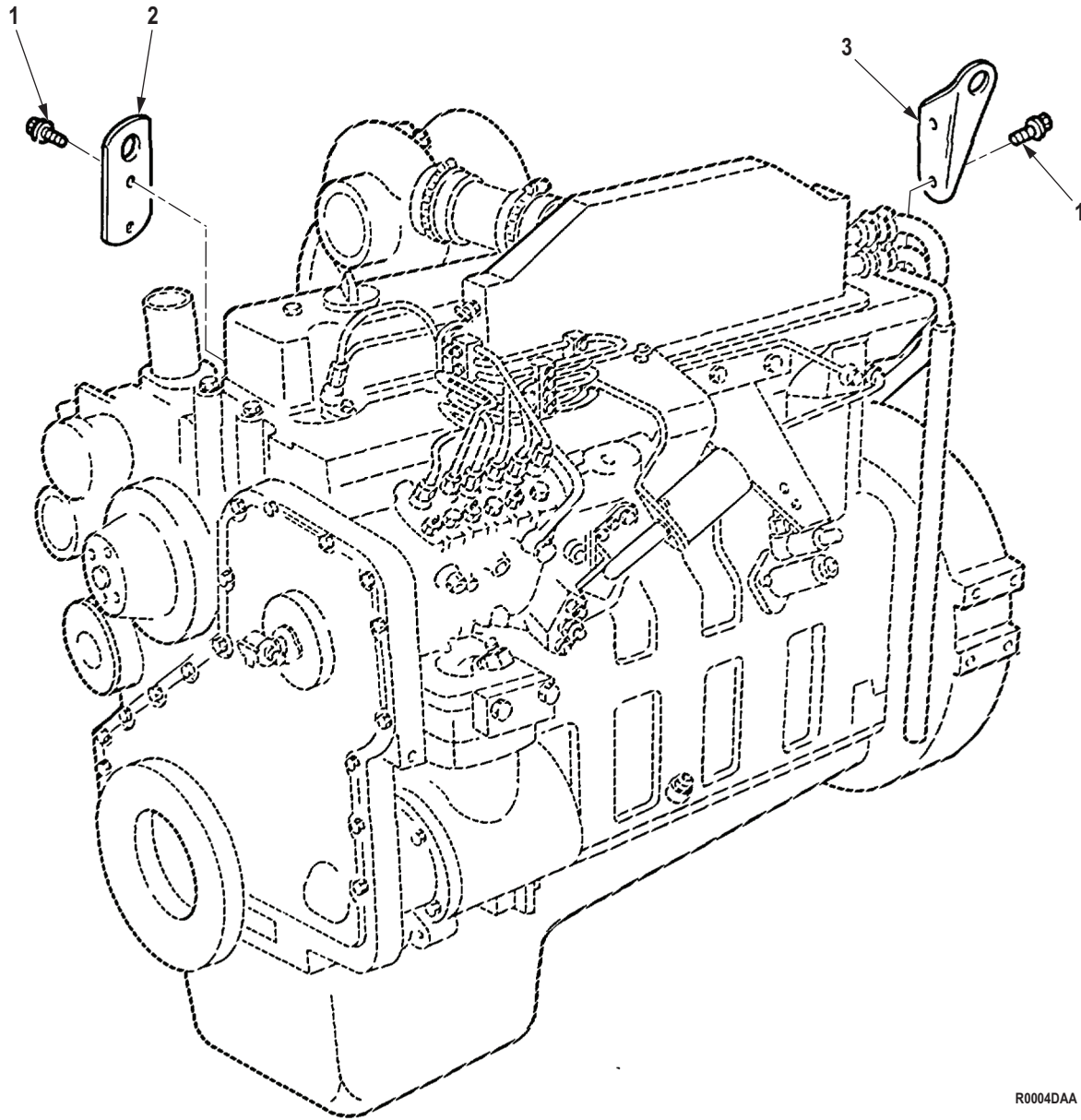

R0004DAA

Figure 4. Engine Lifting Brackets (M939A2).

(1) ITEM NO.	(2) SMR CODE	(3) NSN	(4) CAGEC	(5) PART NUMBER	(6) DESCRIPTION AND USABLE ON CODE (UOC)	(7) QTY
<b>GROUP 0100 ENGINE ASSEMBLY.</b>						
<b>FIG. 4. ENGINE LIFTING BRACKETS (M939A2).</b>						
1	PAFZZ	5305-01-268-5558	15434	3903200	SCREW,CAP,HEXAGON H UOC: ZAA,ZAB,ZAC,ZAD,ZAE,ZAF, ZAG,ZAH,ZAJ,ZAL .....	4
2	PAFZZ	5342-01-272-6725	15434	3907861	BRACKET,ENGINE ACCE UOC: ZAA,ZAB,ZAC,ZAD,ZAE,ZAF, ZAG,ZAH,ZAJ,ZAL .....	1
3	PAFZZ	5342-01-272-6724	15434	3906440	BRACKET,ENGINE ACCE UOC: ZAA,ZAB,ZAC,ZAD,ZAE,ZAF, ZAG,ZAH,ZAJ,ZAL .....	1

**END OF FIGURE**





**FIELD MAINTENANCE  
ENGINE MOUNTS (M939, M939A1)**

---

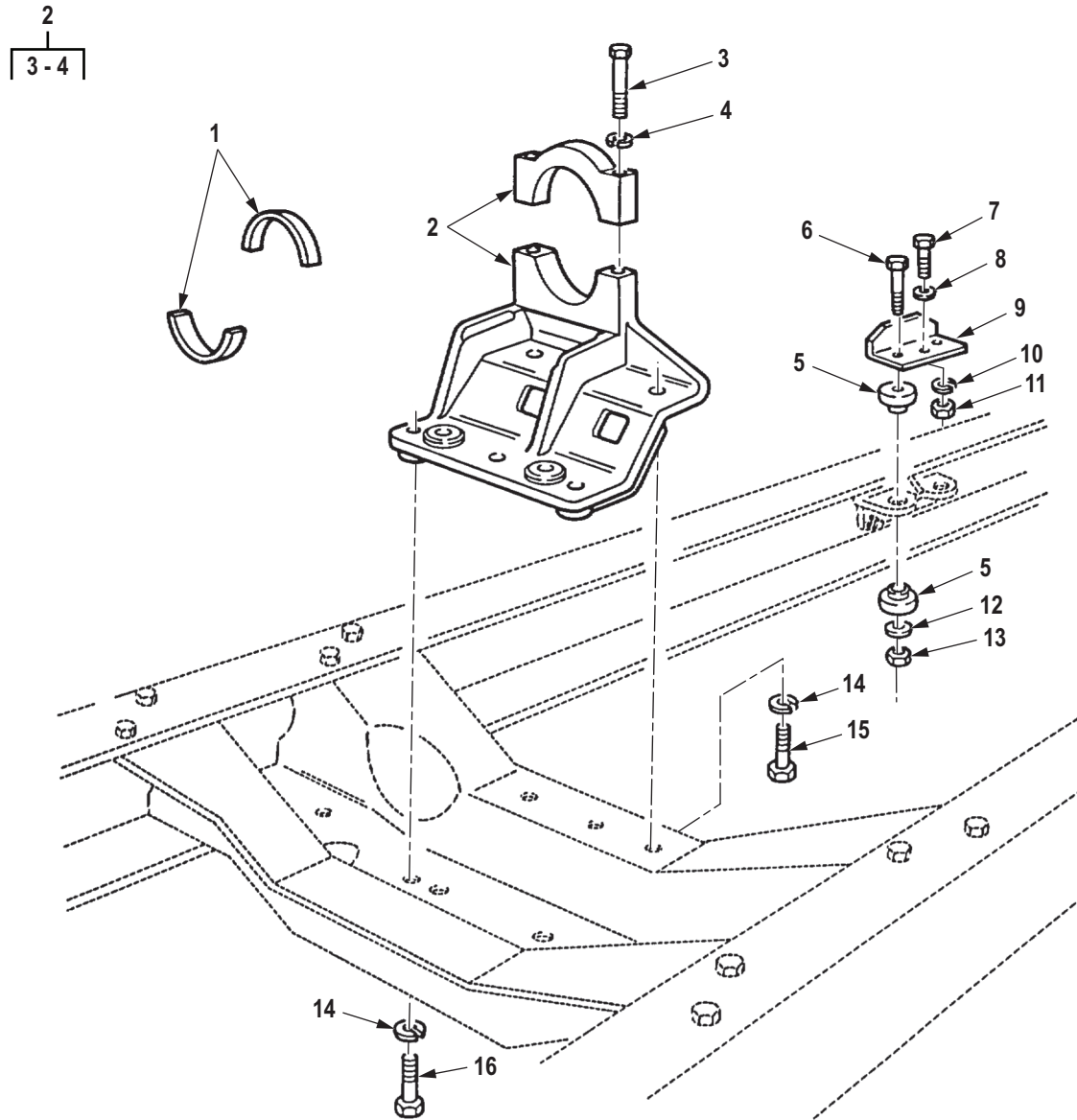

R0005DAA

Figure 5. Engine Mounts (M939, M939A1).

(1) ITEM NO.	(2) SMR CODE	(3) NSN	(4) CAGEC	(5) PART NUMBER	(6) DESCRIPTION AND USABLE ON CODE (UOC)	(7) QTY
<b>GROUP 0100 ENGINE ASSEMBLY.</b>						
<b>FIG. 5. ENGINE MOUNTS (M939, M939A1).</b>						
1	PAFZZ	2815-00-134-4665	76005	J9813-4	INSERT,MOUNT ENGINE UOC: DAC,DAD,DAE,DAF,DAG,DA H,DAJ,DAL,DAW,DAX,V14,V15,V16, V17,V18,V19,V20,V21,V22,V24 .....	2
2	PAFZZ	2510-00-134-4663	19207	11664493	BRACKET,ENGINE MOUN UOC: DAC,DAD,DAE,DAF,DAG,DA H,DAJ,DAL,DAW,DAX,V14,V15,V16, V17,V18,V19,V20,V21,V22,V24 .....	1
3	PAFZZ	5305-00-724-5939	80205	MS90725-173	. SCREW,CAP,HEXAGON H UOC: DAC,DAD,DAE,DAF,DAG,DA H,DAJ,DAL,DAW,DAX,V14,V15,V16, V17,V18,V19,V20,V21,V22,V24 .....	2
4	PAFZZ	5310-00-820-6653	80205	MS35338-50	. WASHER,LOCK UOC: DAC,DAD,DAE,DAF,DAG,DA H,DAJ,DAL,DAW,DAX,V14,V15,V16, V17,V18,V19,V20,V21,V22,V24 .....	2
5	PAFZZ	5342-00-484-8588	19207	11648643	MOUNT,RESILIENT,WEA UOC: DAC,DAD,DAE,DAF,DAG,DA H,DAJ,DAL,DAW,DAX,V14,V15,V16, V17,V18,V19,V20,V21,V22,V24 .....	8
6	PAFZZ	5305-00-719-5270	80204	B1821BH050F400N	SCREW,CAP,HEXAGON H UOC: DAC,DAD,DAE,DAF,DAG,DA H,DAJ,DAL,DAW,DAX,V14,V15,V16, V17,V18,V19,V20,V21,V22,V24 .....	4
7	PAFZZ	5305-00-726-2561	80204	B1821BH063F450N	SCREW,CAP,HEXAGON H UOC: DAC,DAD,DAE,DAF,DAG,DA H,DAJ,DAL,DAW,DAX,V14,V15,V16, V17,V18,V19,V20,V21,V22,V24 .....	2
8	PAFZZ	5310-00-149-9126	80205	MS20002-10	WASHER,FLAT UOC: DAC,DAD,DAE,DAF,DAG,DA H,DAJ,DAL,DAW,DAX,V14,V15,V16, V17,V18,V19,V20,V21,V22,V24 .....	2
9	PAFZZ	5340-00-040-2314	19207	8330333	BRACKET,ANGLE UOC: DAC,DAD,DAE,DAF,DAG,DA H,DAJ,DAL,DAW,DAX,V14,V15,V16, V17,V18,V19,V20,V21,V22,V24 .....	2
10	PAFZZ	5310-00-820-6653	80205	MS35338-50	WASHER,LOCK UOC: DAC,DAD,DAE,DAF,DAG,DA H,DAJ,DAL,DAW,DAX,V14,V15,V16, V17,V18,V19,V20,V21,V22,V24 .....	2
11	PAFZZ	5310-00-241-6664	96906	M45913/3-10FG8C	NUT,SELF-LOCKING,HE UOC: DAC,DAD,DAE,DAF,DAG,DA H,DAJ,DAL,DAW,DAX,V14,V15,V16, V17,V18,V19,V20,V21,V22,V24 .....	2

(1) ITEM NO.	(2) SMR CODE	(3) NSN	(4) CAGEC	(5) PART NUMBER	(6) DESCRIPTION AND USABLE ON CODE (UOC)	(7) QTY
12	PAFZZ	5310-00-470-4271	19207	11664571	WASHER,FLAT UOC: DAC,DAD,DAE,DAF,DAG,DA H,DAJ,DAL,DAW,DAX,V14,V15,V16, V17,V18,V19,V20,V21,V22,V24 .....	4
13	PAFZZ	5310-00-488-3888	81349	M45913/3-8FG8C	NUT,SELF-LOCKING,HE UOC: DAC,DAD,DAE,DAF,DAG,DA H,DAJ,DAL,DAW,DAX,V14,V15,V16, V17,V18,V19,V20,V21,V22,V24 .....	4
14	PAFZZ	5310-00-003-4094	80205	MS35338-48	WASHER,LOCK UOC: DAC,DAD,DAE,DAF,DAG,DA H,DAJ,DAL,DAW,DAX,V14,V15,V16, V17,V18,V19,V20,V21,V22,V24 .....	5
15	PAFZZ	5305-00-071-2068	80204	B1821BH050C138N	SCREW,CAP,HEXAGON H UOC: DAC,DAD,DAE,DAF,DAG,DA H,DAJ,DAL,DAW,DAX,V14,V15,V16, V17,V18,V19,V20,V21,V22,V24 .....	2
16	PAFZZ	5305-00-071-2069	80204	B1821BH050C150N	SCREW,CAP,HEXAGON H UOC: DAC,DAD,DAE,DAF,DAG,DA H,DAJ,DAL,DAW,DAX,V14,V15,V16, V17,V18,V19,V20,V21,V22,V24 .....	2

END OF FIGURE

**FIELD MAINTENANCE  
ENGINE MOUNTS (M939A2)**

---

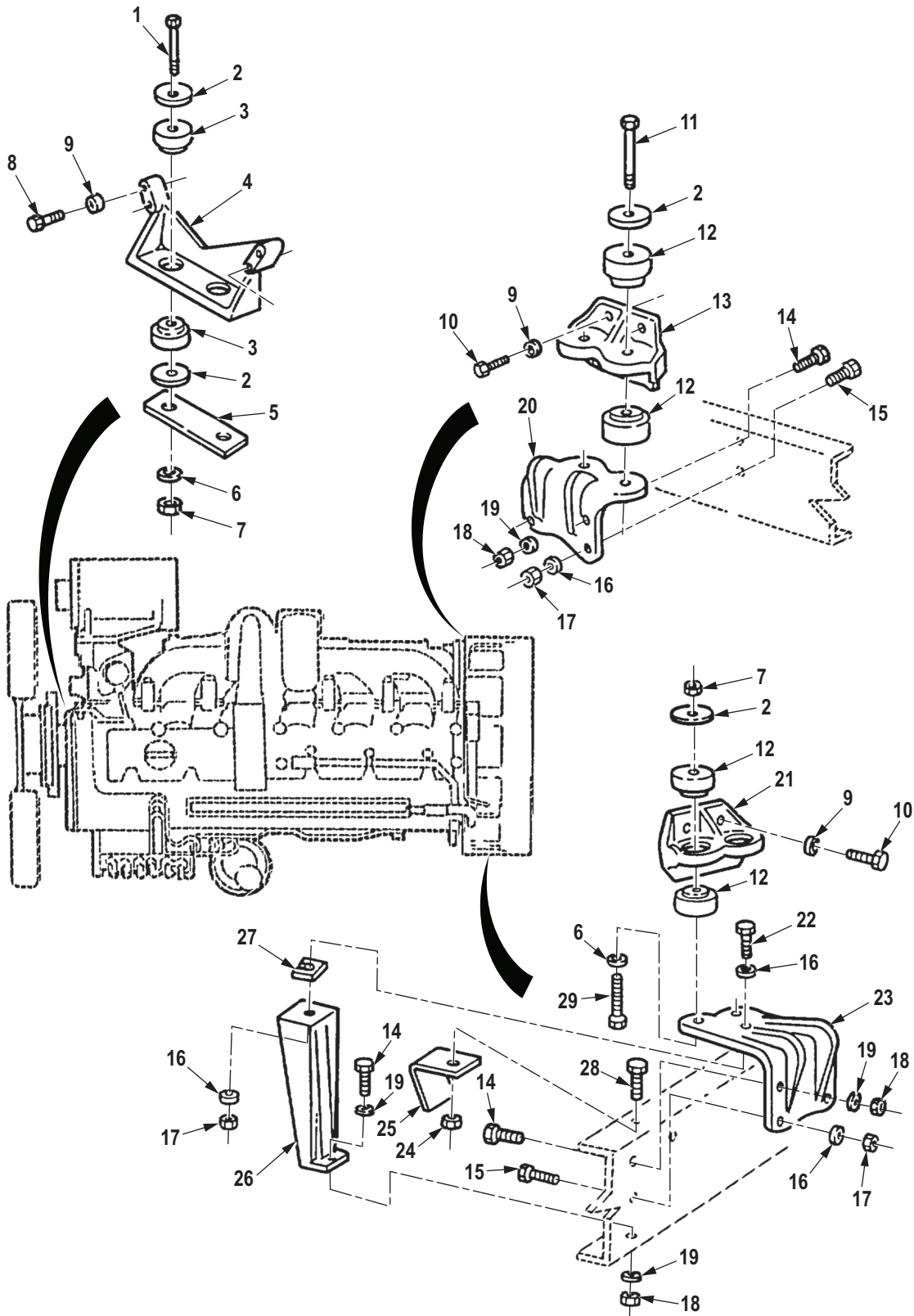

R0006DAA

Figure 6. Engine Mounts (M939A2).

(1) ITEM NO.	(2) SMR CODE	(3) NSN	(4) CAGEC	(5) PART NUMBER	(6) DESCRIPTION AND USABLE ON CODE (UOC)	(7) QTY
<b>GROUP 0100 ENGINE ASSEMBLY.</b>						
<b>FIG. 6. ENGINE MOUNTS (M939A2).</b>						
1	PAFZZ	5305-00-724-7264	80204	B1821BH063C450N	SCREW,CAP,HEXAGON H UOC: ZAA,ZAB,ZAC,ZAD,ZAE,ZAF, ZAG,ZAH,ZAJ,ZAL .....	2
2	PAFZZ	5310-01-309-8575	19207	20510400	WASHER,FLAT UOC: ZAA,ZAB,ZAC,ZAD,ZAE,ZAF, ZAG,ZAH,ZAJ,ZAL .....	8
3	PAFZZ	5342-01-185-3561	81860	22003-14/07	MOUNT,RESILIENT,WEA UOC: ZAA,ZAB,ZAC,ZAD,ZAE,ZAF, ZAG,ZAH,ZAJ,ZAL .....	2
4	PAFZZ	2510-01-279-3089	05MG0	20510296	BRACKET,ENGINE MOUN UOC: ZAA,ZAB,ZAC,ZAD,ZAE,ZAF, ZAG,ZAH,ZAJ,ZAL .....	1
5	PAFZZ	2510-01-286-3329	16567	587-12	BRACKET,ENGINE MOUN UOC: ZAA,ZAB,ZAC,ZAD,ZAE,ZAF, ZAG,ZAH,ZAJ,ZAL .....	1
6	PAFZZ	5310-01-292-9504	3T063	20510370	WASHER,FLAT UOC: ZAA,ZAB,ZAC,ZAD,ZAE,ZAF, ZAG,ZAH,ZAJ,ZAL .....	8
7	PAFZZ	5310-01-130-4274	24617	9422305	NUT,SELF-LOCKING,HE UOC: ZAA,ZAB,ZAC,ZAD,ZAE,ZAF, ZAG,ZAH,ZAJ,ZAL .....	4
8	PAFZZ	5305-01-291-0156	73342	11500899	SCREW,CAP,HEXAGON H UOC: ZAA,ZAB,ZAC,ZAD,ZAE,ZAF, ZAG,ZAH,ZAJ,ZAL .....	4
9	PAFZZ	5310-01-286-6075	24617	11511516	WASHER,FLAT UOC: ZAA,ZAB,ZAC,ZAD,ZAE,ZAF, ZAG,ZAH,ZAJ,ZAL .....	12
10	PAFZZ	5305-01-251-1626	7X677	12337902	SCREW,CAP,HEXAGON H UOC: ZAA,ZAB,ZAC,ZAD,ZAE,ZAF, ZAG,ZAH,ZAJ,ZAL .....	8
11	PAFZZ	5305-00-724-7265	80204	B1821BH063C475N	SCREW,CAP,HEXAGON H UOC: ZAA,ZAB,ZAC,ZAD,ZAE,ZAF, ZAG,ZAH,ZAJ,ZAL .....	2
12	PAFZZ	5342-01-331-7985	19207	12363275	MOUNT,RESILIENT,WEA UOC: ZAA,ZAB,ZAC,ZAD,ZAE,ZAF, ZAG,ZAH,ZAJ,ZAL .....	4
13	PAFZZ	2510-01-286-3328	05MG0	20510132	BRACKET,ENGINE MOUN R.H. UOC: ZAA,ZAB,ZAC,ZAD,ZAE,ZAF, ZAG,ZAH,ZAJ,ZAL .....	1
14	PAFZZ	5305-01-024-4775	72582	179827	SCREW,CAP,HEXAGON H UOC: ZAA,ZAB,ZAC,ZAD,ZAE,ZAF, ZAG,ZAH,ZAJ,ZAL .....	5

(1) ITEM NO.	(2) SMR CODE	(3) NSN	(4) CAGEC	(5) PART NUMBER	(6) DESCRIPTION AND USABLE ON CODE (UOC)	(7) QTY
15	PAFZZ	5305-00-071-2070	80204	B1821BH050C175N	SCREW,CAP,HEXAGON H UOC: ZAA,ZAB,ZAC,ZAD,ZAE,ZAF, ZAG,ZAH,ZAJ,ZAL .....	8
16	PAFZZ	5310-00-799-4910	73342	6752556	WASHER,SPRING TENSI UOC: ZAA,ZAB,ZAC,ZAD,ZAE,ZAF, ZAG,ZAH,ZAJ,ZAL .....	10
17	PAFZZ	5310-01-149-4407	24617	9442939	NUT,SELF-LOCKING,HE UOC: ZAA,ZAB,ZAC,ZAD,ZAE,ZAF, ZAG,ZAH,ZAJ,ZAL .....	9
18	PAFZZ	5310-00-044-3342	19204	8712289-5	NUT,SELF-LOCKING,HE UOC: ZAA,ZAB,ZAC,ZAD,ZAE,ZAF, ZAG,ZAH,ZAJ,ZAL .....	5
19	PAFZZ	5310-01-301-7863	24617	9422849	WASHER,FLAT UOC: ZAA,ZAB,ZAC,ZAD,ZAE,ZAF, ZAG,ZAH,ZAJ,ZAL .....	6
20	PAFZZ	2510-01-280-4244	05MG0	20510134	BRACKET,ENGINE MOUN R.H. UOC: ZAA,ZAB,ZAC,ZAD,ZAE,ZAF, ZAG,ZAH,ZAJ,ZAL .....	1
21	PAFZZ	2510-01-282-2526	05MG0	20510131	BRACKET,ENGINE MOUN L.H. UOC: ZAA,ZAB,ZAC,ZAD,ZAE,ZAF, ZAG,ZAH,ZAJ,ZAL .....	1
22	PAFZZ	5305-00-071-2074	80204	B1821BH050C275N	SCREW,CAP,HEXAGON H UOC: ZAA,ZAB,ZAC,ZAD,ZAE,ZAF, ZAG,ZAH,ZAJ,ZAL .....	1
23	PAFZZ	2510-01-280-4246	89346	20510133	BRACKET,ENGINE MOUN L.H. UOC: ZAA,ZAB,ZAC,ZAD,ZAE,ZAF, ZAG,ZAH,ZAJ,ZAL .....	1
24	PAFZZ	5310-00-814-0672	96906	M45913/3-6FG8C	NUT,SELF-LOCKING,HE UOC: ZAA,ZAB,ZAC,ZAD,ZAE,ZAF, ZAG,ZAH,ZAJ,ZAL .....	1
25	PAFZZ	5340-01-288-0607	05MG0	20511113	BRACKET,ANGLE UOC: ZAA,ZAB,ZAC,ZAD,ZAE,ZAF, ZAG,ZAH,ZAJ,ZAL .....	1
26	PAFZZ	2510-01-280-4245	89346	20510006	BRACKET,ENGINE MOUN UOC: ZAA,ZAB,ZAC,ZAD,ZAE,ZAF, ZAG,ZAH,ZAJ,ZAL .....	1
27	PAFZZ	5365-01-302-9485	05MG0	20511224-3	SPACER,PLATE UOC: ZAA,ZAB,ZAC,ZAD,ZAE,ZAF, ZAG,ZAH,ZAJ,ZAL .....	1
27	PAFZZ	5365-01-304-0652	47457	20511225-1	SPACER,PLATE UOC: ZAA,ZAB,ZAC,ZAD,ZAE,ZAF, ZAG,ZAH,ZAJ,ZAL .....	1
27	PAFZZ	5365-01-301-7872	05MG0	20511224-2	SPACER,PLATE UOC: ZAA,ZAB,ZAC,ZAD,ZAE,ZAF, ZAG,ZAH,ZAJ,ZAL .....	1



(1) ITEM NO.	(2) SMR CODE	(3) NSN	(4) CAGEC	(5) PART NUMBER	(6) DESCRIPTION AND USABLE ON CODE (UOC)	(7) QTY
27	PAFZZ	5365-01-301-7871	05MG0	20511224-1	SPACER,PLATE UOC: ZAA,ZAB,ZAC,ZAD,ZAE,ZAF, ZAG,ZAH,ZAJ,ZAL .....	1
28	PAFZZ	5305-00-269-2804	80205	MS90726-61	SCREW,CAP,HEXAGON H UOC: ZAA,ZAB,ZAC,ZAD,ZAE,ZAF, ZAG,ZAH,ZAJ,ZAL .....	1
29	PAFZZ	5305-00-724-7266	80204	B1821BH063C500N	SCREW,CAP,HEXAGON H UOC: ZAA,ZAB,ZAC,ZAD,ZAE,ZAF, ZAG,ZAH,ZAJ,ZAL .....	2

END OF FIGURE



**FIELD MAINTENANCE  
CYLINDER BLOCK ASSEMBLY (M939, M939A1)**

---

5  
6 - 29

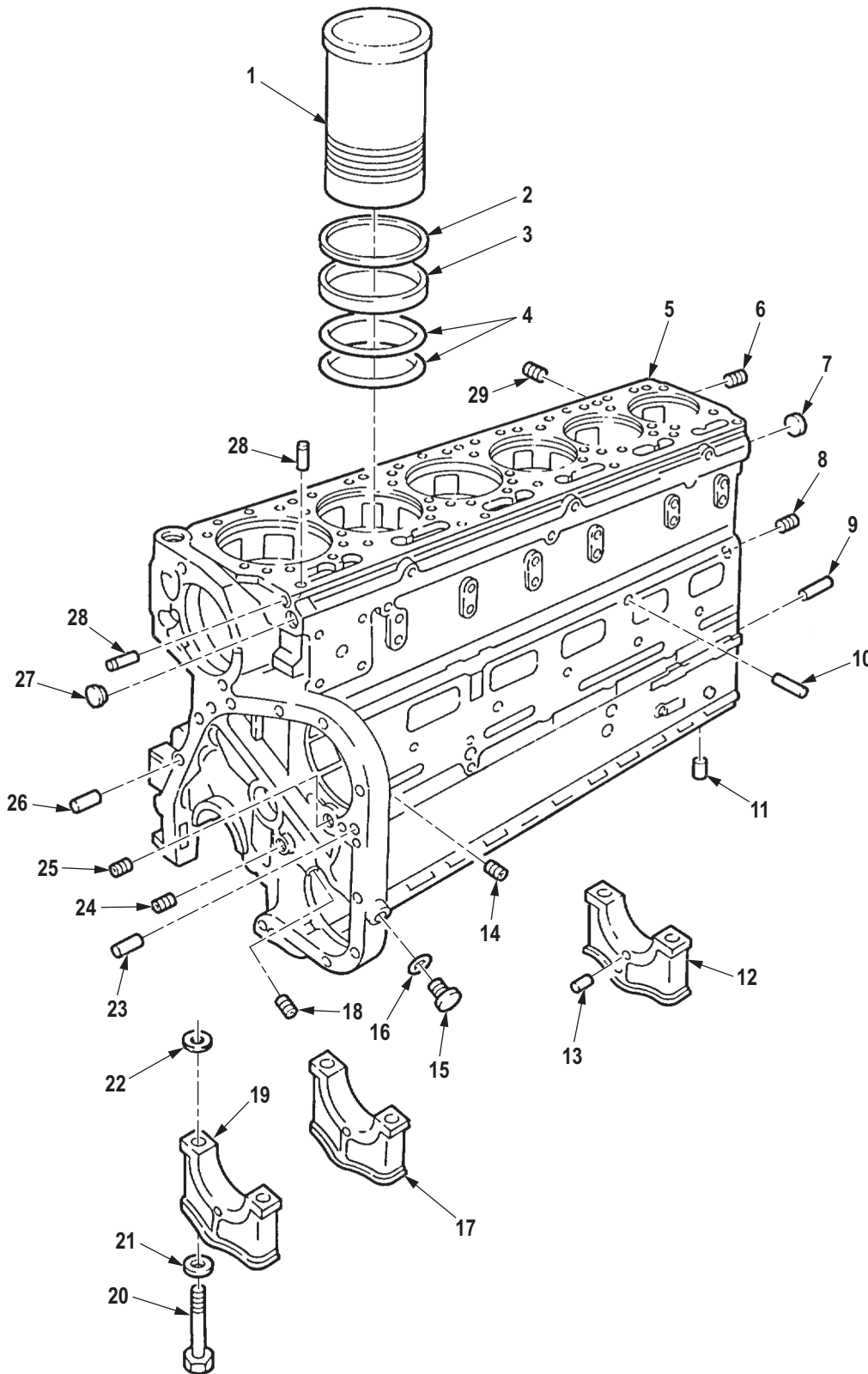

Figure 7. Cylinder Block Assembly (M939, M939A1).

R0007DAA

(1) ITEM NO.	(2) SMR CODE	(3) NSN	(4) CAGEC	(5) PART NUMBER	(6) DESCRIPTION AND USABLE ON CODE (UOC)	(7) QTY
<b>GROUP 0101 CRANKCASE, BLOCK, CYLINDER HEAD</b>						
<b>FIG. 7. CYLINDER BLOCK ASSEMBLY (M939, M939A1).</b>						
1	KBHZZ		15434	3042763	CYLINDER SLEEVE USED AFTER SERIAL NUMBER 11246663 PART OF KIT P/N 3804438, PART OF KIT P/ N 3801826 UOC: DAC,DAD,DAE,DAF,DAG,DA H,DAJ,DAL,DAW,DAX,V14,V15,V16, V17,V18,V19,V20,V21,V22,V24 .....	6
2	PAHZZ	5365-01-147-2495	15434	3019960	SHIM .062,CYLINDER UOC: DAC,DAD,DAE,DAF,DAG,DA H,DAJ,DAL,DAW,DAX,V14,V15,V16, V17,V18,V19,V20,V21,V22,V24 .....	1
2	PAHZZ	5365-01-148-8353	15434	3019959	SHIM .031 CYLINDER UOC: DAC,DAD,DAE,DAF,DAG,DA H,DAJ,DAL,DAW,DAX,V14,V15,V16, V17,V18,V19,V20,V21,V22,V24 .....	1
2	PAHZZ	5365-01-147-2497	15434	305494800	SPACER,RING .020 CYLINDER UOC: DAC,DAD,DAE,DAF,DAG,DA H,DAJ,DAL,DAW,DAX,V14,V15,V16, V17,V18,V19,V20,V21,V22,V24 .....	1
2	PAHZZ	5365-01-147-2496	15434	3019957	SHIM .009 CYLINDER UOC: DAC,DAD,DAE,DAF,DAG,DA H,DAJ,DAL,DAW,DAX,V14,V15,V16, V17,V18,V19,V20,V21,V22,V24 .....	1
2	PAHZZ	5365-00-488-0799	15434	3019956	SPACER,RING .008,CYLINDER UOC: DAC,DAD,DAE,DAF,DAG,DA H,DAJ,DAL,DAW,DAX,V14,V15,V16, V17,V18,V19,V20,V21,V22,V24 .....	1
2	PAHZZ	5365-01-147-9802	15434	3019955	SHIM .007,CYLINDER UOC: DAC,DAD,DAE,DAF,DAG,DA H,DAJ,DAL,DAW,DAX,V14,V15,V16, V17,V18,V19,V20,V21,V22,V24 .....	1
3	KBHZZ	5330-00-064-4399	15434	215090	GASKET PART OF KIT P/N 3011472, PART OF KIT P/N 3804438, PART OF KIT P/N 3801826 UOC: DAC,DAD,DAE,DAF,DAG,DA H,DAJ,DAL,DAW,DAX,V14,V15,V16, V17,V18,V19,V20,V21,V22,V24 .....	6
4	PAHZZ	5331-01-220-2389	15434	3032874	O-RING PART OF KIT P/N 3011472, PART OF KIT P/N 3804438 UOC: DAC,DAD,DAE,DAF,DAG,DA H,DAJ,DAL,DAW,DAX,V14,V15,V16, V17,V18,V19,V20,V21,V22,V24 .....	12

(1) ITEM NO.	(2) SMR CODE	(3) NSN	(4) CAGEC	(5) PART NUMBER	(6) DESCRIPTION AND USABLE ON CODE (UOC)	(7) QTY
5	XAHHH		15434	3801314	ENGINE BLOCK ASSEMB UOC: DAC,DAD,DAE,DAF,DAG,DA H,DAJ,DAL,DAW,DAX,V14,V15,V16, V17,V18,V19,V20,V21,V22,V24 .....	1
6	PAHZZ	4730-00-203-0549	81348	WW-P-471ACBBUH	. PLUG,PIPE UOC: DAC,DAD,DAE,DAF,DAG,DA H,DAJ,DAL,DAW,DAX,V14,V15,V16, V17,V18,V19,V20,V21,V22,V24 .....	1
7	PAHZZ	5340-00-276-5847	15434	S719	. PLUG,EXPANSION UOC: DAC,DAD,DAE,DAF,DAG,DA H,DAJ,DAL,DAW,DAX,V14,V15,V16, V17,V18,V19,V20,V21,V22,V24 .....	1
8	PAHZZ	4730-00-081-9618	01276	C3159X2	. PLUG,PIPE UOC: DAC,DAD,DAE,DAF,DAG,DA H,DAJ,DAL,DAW,DAX,V14,V15,V16, V17,V18,V19,V20,V21,V22,V24 .....	8
9	PAHZZ	5315-00-014-1284	24617	141284	. PIN,STRAIGHT,HEADLE UOC: DAC,DAD,DAE,DAF,DAG,DA H,DAJ,DAL,DAW,DAX,V14,V15,V16, V17,V18,V19,V20,V21,V22,V24 .....	2
10	PAHZZ	5315-00-014-1195	15434	68585	. PIN,STRAIGHT,HEADLE UOC: DAC,DAD,DAE,DAF,DAG,DA H,DAJ,DAL,DAW,DAX,V14,V15,V16, V17,V18,V19,V20,V21,V22,V24 .....	6
11	PAHZZ	5315-00-532-9388	23382	1AB2568	. PIN,STRAIGHT,HEADLE UOC: DAC,DAD,DAE,DAF,DAG,DA H,DAJ,DAL,DAW,DAX,V14,V15,V16, V17,V18,V19,V20,V21,V22,V24 .....	2
12	PAHZZ	3130-01-146-1228	15434	3008049	. CAP,PILLOW BLOCK UOC: DAC,DAD,DAE,DAF,DAG,DA H,DAJ,DAL,DAW,DAX,V14,V15,V16, V17,V18,V19,V20,V21,V22,V24 .....	1
13	PAHZZ	5315-01-058-4551	15434	202903	. PIN STRAIGHT HEXAGO UOC: DAC,DAD,DAE,DAF,DAG,DA H,DAJ,DAL,DAW,DAX,V14,V15,V16, V17,V18,V19,V20,V21,V22,V24 .....	2
14	PAHZZ	4730-00-018-9566	58536	A-A-59616ACABCA	. PLUG,PIPE UOC: DAC,DAD,DAE,DAF,DAG,DA H,DAJ,DAL,DAW,DAX,V14,V15,V16, V17,V18,V19,V20,V21,V22,V24 .....	1
15	PAHZZ	5365-01-150-6257	15434	210884	. PLUG,MACHINE THREAD UOC: DAC,DAD,DAE,DAF,DAG,DA H,DAJ,DAL,DAW,DAX,V14,V15,V16, V17,V18,V19,V20,V21,V22,V24 .....	1
16	PAHZZ	5310-00-197-5304	10001	225334PC7	. WASHER,FLAT UOC: DAC,DAD,DAE,DAF,DAG,DA H,DAJ,DAL,DAW,DAX,V14,V15,V16, V17,V18,V19,V20,V21,V22,V24 .....	1

(1) ITEM NO.	(2) SMR CODE	(3) NSN	(4) CAGEC	(5) PART NUMBER	(6) DESCRIPTION AND USABLE ON CODE (UOC)	(7) QTY
17	PAHZZ	3130-01-146-4504	15434	3008048	. CAP, BEARING UOC: DAC, DAD, DAE, DAF, DAG, DA H, DAJ, DAL, DAW, DAX, V14, V15, V16, V17, V18, V19, V20, V21, V22, V24 .....	3
18	PAHZZ	4730-01-214-7081	15434	3008469	. PLUG, PIPE UOC: DAC, DAD, DAE, DAF, DAG, DA H, DAJ, DAL, DAW, DAX, V14, V15, V16, V17, V18, V19, V20, V21, V22, V24 .....	1
19	PAHZZ	3130-01-146-1150	15434	3008047	. CAP, PILLOW BLOCK UOC: DAC, DAD, DAE, DAF, DAG, DA H, DAJ, DAL, DAW, DAX, V14, V15, V16, V17, V18, V19, V20, V21, V22, V24 .....	3
20	PAHZZ	5306-00-804-2468	15434	105953	. BOLT, MACHINE 1 INCH, USE WITH BLOCK ASSY AR-09883 ONLY UOC: DAC, DAD, DAE, DAF, DAG, DA H, DAJ, DAL, DAW, DAX, V14, V15, V16, V17, V18, V19, V20, V21, V22, V24 .....	14
20	PAHZZ	5305-01-179-2380	15434	208346	. SCREW, CAP, HEXAGON H 3/4 INCH, USE WITH BLOCK ASSY 3801314 ONLY UOC: DAC, DAD, DAE, DAF, DAG, DA H, DAJ, DAL, DAW, DAX, V14, V15, V16, V17, V18, V19, V20, V21, V22, V24 .....	14
21	PAHZZ	5310-00-082-1882	15434	140218	. WASHER, FLAT USE WITH BLOCK ASSY 3801314 ONLY UOC: DAC, DAD, DAE, DAF, DAG, DA H, DAJ, DAL, DAW, DAX, V14, V15, V16, V17, V18, V19, V20, V21, V22, V24 .....	14
21	PAHZZ	5310-00-356-1447	15434	3009213	. WASHER, LOCK USE WITH BLOCK ASSY AR-09883 ONLY UOC: DAC, DAD, DAE, DAF, DAG, DA H, DAJ, DAL, DAW, DAX, V14, V15, V16, V17, V18, V19, V20, V21, V22, V24 .....	14
22	PAHZZ	5325-01-241-3888	15434	3037045	. RING, RETAINING USE WITH BLOCK ASSY 3801314 ONLY UOC: DAC, DAD, DAE, DAF, DAG, DA H, DAJ, DAL, DAW, DAX, V14, V15, V16, V17, V18, V19, V20, V21, V22, V24 .....	7
22	PAHZZ	5365-00-428-6201	15434	60575	. SPACER, RING USE WITH BLOCK ASSY AR-09883 ONLY UOC: V14, V15, V16, V17, V18, V19, V2 0, V21, V22, V24 .....	7
23	PAHZZ	2815-00-772-9434	15434	70653	. DOWEL, METALLIC UOC: DAC, DAD, DAE, DAF, DAG, DA H, DAJ, DAL, DAW, DAX, V14, V15, V16, V17, V18, V19, V20, V21, V22, V24 .....	1

(1) ITEM NO.	(2) SMR CODE	(3) NSN	(4) CAGEC	(5) PART NUMBER	(6) DESCRIPTION AND USABLE ON CODE (UOC)	(7) QTY
24	PAHZZ	4730-01-161-5115	15434	3013786	. PLUG,PIPE UOC: DAC,DAD,DAE,DAF,DAG,DA H,DAJ,DAL,DAW,DAX,V14,V15,V16, V17,V18,V19,V20,V21,V22,V24 .....	5
25	PAHZZ	4730-01-214-7081	15434	3008469	. PLUG,PIPE UOC: DAC,DAD,DAE,DAF,DAG,DA H,DAJ,DAL,DAW,DAX,V14,V15,V16, V17,V18,V19,V20,V21,V22,V24 .....	1
26	PAHZZ	5315-00-238-0882	15434	60408	. PIN,STRAIGHT,HEADLE UOC: DAC,DAD,DAE,DAF,DAG,DA H,DAJ,DAL,DAW,DAX,V14,V15,V16, V17,V18,V19,V20,V21,V22,V24 .....	1
27	PAHZZ	5340-00-050-1600	58536	A-A-52420-08	. PLUG,EXPANSION UOC: DAC,DAD,DAE,DAF,DAG,DA H,DAJ,DAL,DAW,DAX,V14,V15,V16, V17,V18,V19,V20,V21,V22,V24 .....	1
28	PAHZZ	5315-00-281-7610	15434	68445	. PIN,GROOVED,HEADLES UOC: DAC,DAD,DAE,DAF,DAG,DA H,DAJ,DAL,DAW,DAX,V14,V15,V16, V17,V18,V19,V20,V21,V22,V24 .....	6
29	PAHZZ	4730-00-954-1281	58536	AA59616ACACBCB	. PLUG,PIPE UOC: DAC,DAD,DAE,DAF,DAG,DA H,DAJ,DAL,DAW,DAX,V14,V15,V16, V17,V18,V19,V20,V21,V22,V24 .....	1

END OF FIGURE



**FIELD MAINTENANCE  
CYLINDER BLOCK ASSEMBLY (M939A2)**

---

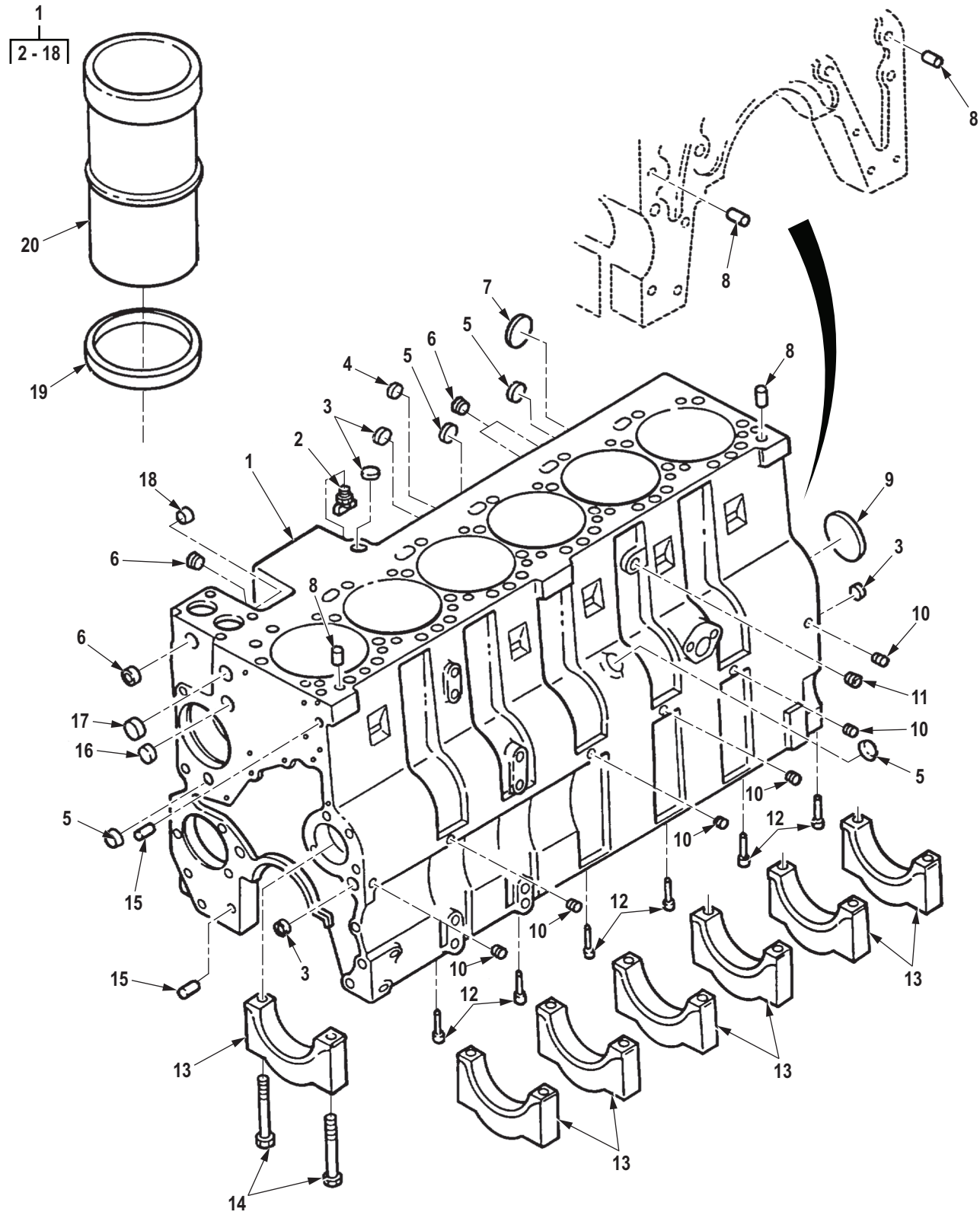

R0008DAA

Figure 8. Cylinder Block Assembly (M939A2).

(1) ITEM NO.	(2) SMR CODE	(3) NSN	(4) CAGEC	(5) PART NUMBER	(6) DESCRIPTION AND USABLE ON CODE (UOC)	(7) QTY
<b>GROUP 0101 CRANKCASE, BLOCK, CYLINDER HEAD</b>						
<b>FIG. 8. CYLINDER BLOCK ASSEMBLY (M939A2).</b>						
1	PFHHH	2815-01-330-8069	15434	3968733	ENGINE BLOCK ASSEMB UOC: ZAA,ZAB,ZAC,ZAD,ZAE,ZAF, ZAG,ZAH,ZAJ,ZAL .....	1
2	PAHZZ	4730-00-246-9217	96906	MS39230-4B	. ELBOW,PIPE PART OF KIT P/N 3802367, PART OF KIT P/N 3909415 UOC: ZAA,ZAB,ZAC,ZAD,ZAE,ZAF, ZAG,ZAH,ZAJ,ZAL .....	1
3	PAHZZ	5340-01-271-2416	15434	3004258	. PLUG,EXPANSION UOC: ZAA,ZAB,ZAC,ZAD,ZAE,ZAF, ZAG,ZAH,ZAJ,ZAL .....	4
4	PAHZZ	5340-01-239-8606	10988	A77439	. PLUG,EXPANSION PART OF KIT P/N 3802367, PART OF KIT P/N 3909415 UOC: ZAA,ZAB,ZAC,ZAD,ZAE,ZAF, ZAG,ZAH,ZAJ,ZAL .....	2
5	PAHZZ	5340-01-271-2417	15434	3905401	. PLUG,EXPANSION UOC: ZAA,ZAB,ZAC,ZAD,ZAE,ZAF, ZAG,ZAH,ZAJ,ZAL .....	4
6	PAHZZ	4730-01-214-7081	15434	3008469	. PLUG,PIPE PART OF KIT P/N 3802367, PART OF KIT P/N 3909415 UOC: ZAA,ZAB,ZAC,ZAD,ZAE,ZAF, ZAG,ZAH,ZAJ,ZAL .....	4
7	PAHZZ	5340-01-431-8753	15434	3922072	. PLUG,EXPANSION UOC: ZAA,ZAB,ZAC,ZAD,ZAE,ZAF, ZAG,ZAH,ZAJ,ZAL .....	1
8	PAHZZ	5315-01-270-8284	15434	3901846	. PIN,STRAIGHT,HEADLE PART OF KIT P/N 3802367, PART OF KIT P/ N 3909415 UOC: ZAA,ZAB,ZAC,ZAD,ZAE,ZAF, ZAG,ZAH,ZAJ,ZAL .....	4
9	PAHZZ	5340-01-271-2418	15434	3901969	. PLUG,EXPANSION PART OF KIT P/N 3802367, PART OF KIT P/N 3909415 UOC: ZAA,ZAB,ZAC,ZAD,ZAE,ZAF, ZAG,ZAH,ZAJ,ZAL .....	1
10	PAHZZ	4730-01-292-4386	15434	3906619	. PLUG,PIPE PART OF KIT P/N 3802367, PART OF KIT P/N 3909415 UOC: ZAA,ZAB,ZAC,ZAD,ZAE,ZAF, ZAG,ZAH,ZAJ,ZAL .....	6
11	PAHZZ	4730-01-214-7081	15434	3008469	. PLUG,PIPE PART OF KIT P/N 3802367, PART OF KIT P/N 3909415 UOC: ZAA,ZAB,ZAC,ZAD,ZAE,ZAF, ZAG,ZAH,ZAJ,ZAL .....	1

(1) ITEM NO.	(2) SMR CODE	(3) NSN	(4) CAGEC	(5) PART NUMBER	(6) DESCRIPTION AND USABLE ON CODE (UOC)	(7) QTY
12	PAHZZ	4730-01-331-2670	15434	3928031	. RESTRICTOR,FLUID FL ENGINE S/N 4448730 AND ABOVE PART OF KIT P/N 380055800, PART OF KIT P/ N 3802367 UOC: ZAA,ZAB,ZAC,ZAD,ZAE,ZAF, ZAG,ZAH,ZAJ,ZAL .....	12
12	PAHZZ	4730-01-271-7181	15434	3905928	. RESTRICTOR,FLUID FL UP TO ENGINE S/N 44487829 PART OF KIT P/N 380055800, PART OF KIT P/N 3909415 UOC: ZAA,ZAB,ZAC,ZAD,ZAE,ZAF, ZAG,ZAH,ZAJ,ZAL .....	6
13	PAHZZ	3130-01-281-9164	15434	3917313	. CAP,PILLOW BLOCK UP TO ENGINE S/N 44487829 UOC: ZAA,ZAB,ZAC,ZAD,ZAE,ZAF, ZAG,ZAH,ZAJ,ZAL .....	7
14	PAHZZ	5305-01-333-5382	15434	3916369	. SCREW,CAP,HEXAGON H ENGINE S/N 44487830 AND ABOVE UOC: ZAA,ZAB,ZAC,ZAD,ZAE,ZAF, ZAG,ZAH,ZAJ,ZAL .....	14
14	PAHZZ	5305-01-271-5848	15434	3906655	. SCREW,CAP,HEXAGON H UP TO ENGINE S/N 44487829 UOC: ZAA,ZAB,ZAC,ZAD,ZAE,ZAF, ZAG,ZAH,ZAJ,ZAL .....	14
15	PAHZZ	5315-01-188-0761	15434	3900257	. PIN,STRAIGHT,HEADLE PART OF KIT P/N 3802367, PART OF KIT P/ N 3909415 UOC: ZAA,ZAB,ZAC,ZAD,ZAE,ZAF, ZAG,ZAH,ZAJ,ZAL .....	2
16	PAHZZ	5340-01-271-2415	15434	143066	. PLUG,EXPANSION UOC: ZAA,ZAB,ZAC,ZAD,ZAE,ZAF, ZAG,ZAH,ZAJ,ZAL .....	1
17	PAHZZ	5342-01-143-6045	15434	3008470	. PLUG PART OF KIT P/N 3802367, PART OF KIT P/N 3909415 UOC: ZAA,ZAB,ZAC,ZAD,ZAE,ZAF, ZAG,ZAH,ZAJ,ZAL .....	1
18	PAHZZ	5340-01-271-2419	15434	156075	. PLUG,EXPANSION PART OF KIT P/N 3802367, PART OF KIT P/N 3909415 UOC: ZAA,ZAB,ZAC,ZAD,ZAE,ZAF, ZAG,ZAH,ZAJ,ZAL .....	2
19	PAHZZ	5330-01-272-1282	15434	390717700	SEAL,NONMETALLIC RO PART OF KIT P/N 2DR671, PART OF KIT P/ N 3802370 UOC: ZAA,ZAB,ZAC,ZAD,ZAE,ZAF, ZAG,ZAH,ZAJ,ZAL .....	6
20	PFHZZ	2815-01-508-8606	0B8S3	3800328	KIT,LINER CYLINDER WITH SEAL UOC: ZAA,ZAB,ZAC,ZAD,ZAE,ZAF, ZAG,ZAH,ZAJ,ZAL .....	6

(1) ITEM NO.	(2) SMR CODE	(3) NSN	(4) CAGEC	(5) PART NUMBER	(6) DESCRIPTION AND USABLE ON CODE (UOC)	(7) QTY
20	PFHZZ	2815-01-492-8963	15434	3948095	CYLINDER SLEEVE PART OF KIT P/N 2DR671, PART OF KIT P/N 3802370 UOC: ZAA,ZAB,ZAC,ZAD,ZAE,ZAF, ZAG,ZAH,ZAJ,ZAL .....	6

END OF FIGURE



**FIELD MAINTENANCE**  
**CYLINDER HEAD ASSEMBLY, GASKET, AND MOUNTING HARDWARE (M939, M939A1)**

---

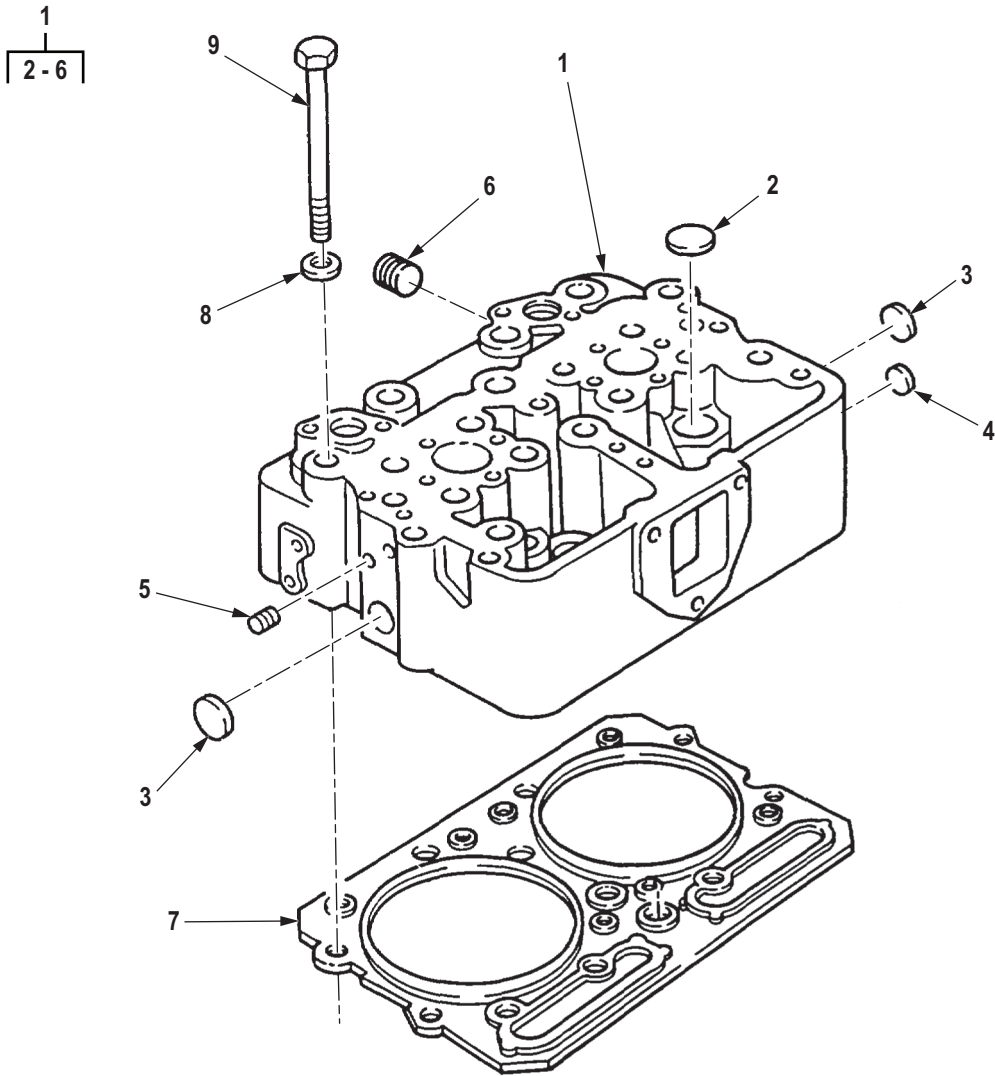

R0009DAA

Figure 9. Cylinder Head Assembly, Gasket, and Mounting Hardware (M939, M939A1).



(1) ITEM NO.	(2) SMR CODE	(3) NSN	(4) CAGEC	(5) PART NUMBER	(6) DESCRIPTION AND USABLE ON CODE (UOC)	(7) QTY
<b>GROUP 0101 CRANKCASE, BLOCK, CYLINDER HEAD</b>						
<b>FIG. 9. CYLINDER HEAD ASSEMBLY, GASKET, AND MOUNTING HARDWARE (M939, M939A1).</b>						
1	PFHHH	2815-01-146-4182	15434	3007835	CYLINDER HEAD, DIESE UOC: DAC,DAD,DAE,DAF,DAG,DA H,DAJ,DAL,DAW,DAX,V14,V15,V16, V17,V18,V19,V20,V21,V22,V24 .....	3
2	PAHZZ	5340-01-087-0681	15434	213395	. PLUG, EXPANSION UOC: DAC,DAD,DAE,DAF,DAG,DA H,DAJ,DAL,DAW,DAX,V14,V15,V16, V17,V18,V19,V20,V21,V22,V24 .....	6
3	PAHZZ	5340-01-086-6193	15434	216524	. PLUG, EXPANSION UOC: DAC,DAD,DAE,DAF,DAG,DA H,DAJ,DAL,DAW,DAX,V14,V15,V16, V17,V18,V19,V20,V21,V22,V24 .....	2
4	PAHZZ	5340-01-087-0682	15434	213394	. PLUG, EXPANSION UOC: DAC,DAD,DAE,DAF,DAG,DA H,DAJ,DAL,DAW,DAX,V14,V15,V16, V17,V18,V19,V20,V21,V22,V24 .....	1
5	PAHZZ	4730-00-018-9566	58536	A-A-59616ACABCA	. PLUG, PIPE UOC: DAC,DAD,DAE,DAF,DAG,DA H,DAJ,DAL,DAW,DAX,V14,V15,V16, V17,V18,V19,V20,V21,V22,V24 .....	10
6	PAHZZ	4730-00-044-4715	15434	S962	. PLUG, PIPE UOC: DAC,DAD,DAE,DAF,DAG,DA H,DAJ,DAL,DAW,DAX,V14,V15,V16, V17,V18,V19,V20,V21,V22,V24 .....	4
7	PAHZZ	5330-01-080-5021	15434	3349819	GASKET PART OF KIT P/N 4024955 UOC: DAC,DAD,DAE,DAF,DAG,DA H,DAJ,DAL,DAW,DAX,V14,V15,V16, V17,V18,V19,V20,V21,V22,V24 .....	3
8	PAHZZ	5310-00-285-8833	17576	538174	WASHER, FLAT UOC: DAC,DAD,DAE,DAF,DAG,DA H,DAJ,DAL,DAW,DAX,V14,V15,V16, V17,V18,V19,V20,V21,V22,V24 .....	36
9	PAHZZ	5305-01-072-4270	15434	177734	SCREW UOC: DAC,DAD,DAE,DAF,DAG,DA H,DAJ,DAL,DAW,DAX,V14,V15,V16, V17,V18,V19,V20,V21,V22,V24 .....	36

END OF FIGURE



**FIELD MAINTENANCE  
CYLINDER HEAD ASSEMBLY, GASKET, AND MOUNTING HARDWARE (M939A2)**

---

1  
2-8

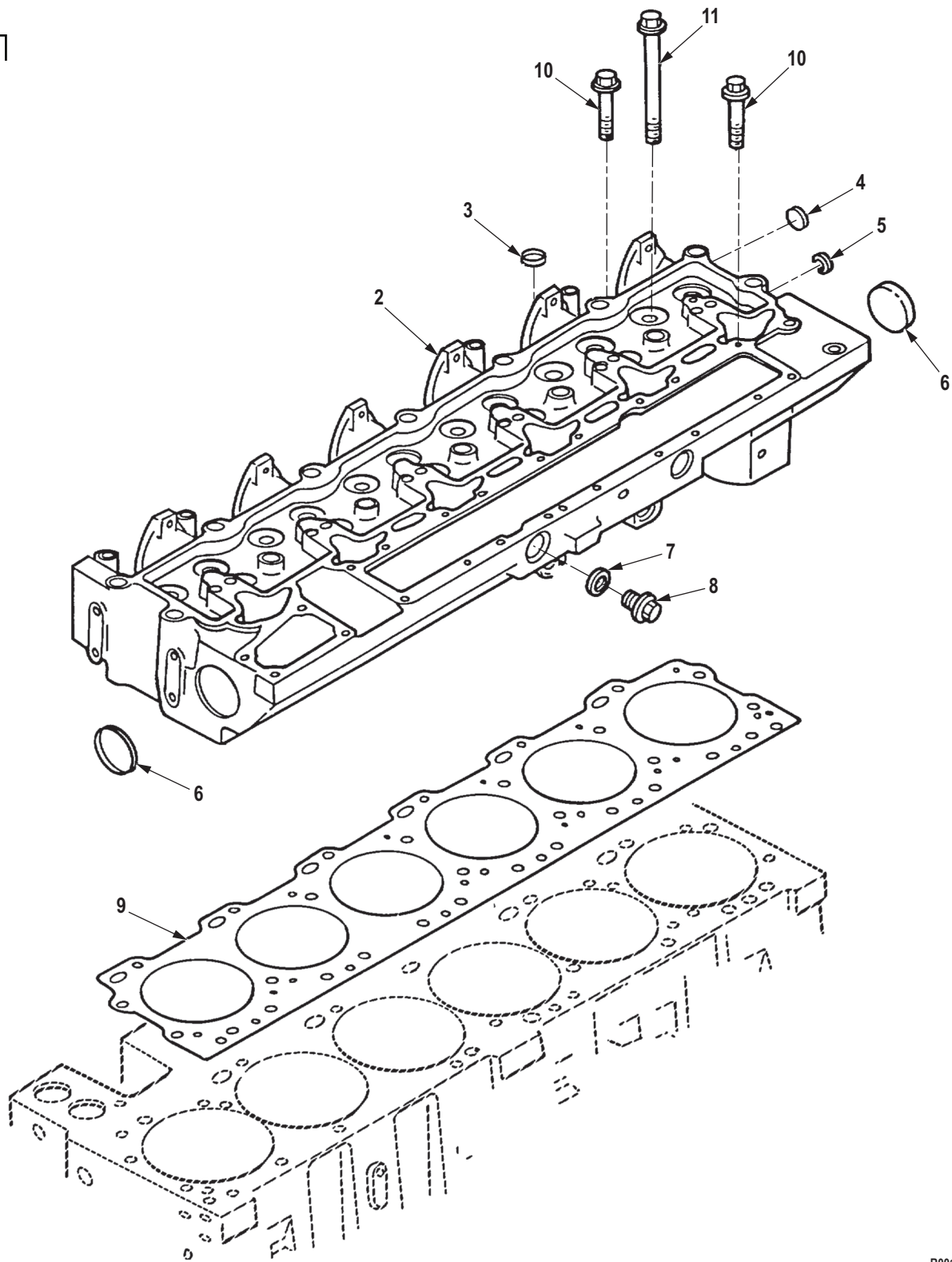

R0010DAA

Figure 10. Cylinder Head Assembly, Gasket, and Mounting Hardware (M939A2).

(1) ITEM NO.	(2) SMR CODE	(3) NSN	(4) CAGEC	(5) PART NUMBER	(6) DESCRIPTION AND USABLE ON CODE (UOC)	(7) QTY
<b>GROUP 0101 CRANKCASE, BLOCK, CYLINDER HEAD</b>						
<b>FIG. 10. CYLINDER HEAD ASSEMBLY, GASKET, AND MOUNTING HARDWARE (M939A2).</b>						
1	PAHHH	2815-01-330-3036	19207	57K4756	CYLINDER HEAD,DIESE ENGINE S/N 44487830 AND ABOVE UOC: ZAA,ZAB,ZAC,ZAD,ZAE,ZAF, ZAG,ZAH,ZAJ,ZAL .....	1
2	XAHZZ	2815-01-330-3036	19207	57K4756	. CYLINDER HEAD,DIESE UP TO ENGINE S/N 44487829 UOC: ZAA,ZAB,ZAC,ZAD,ZAE,ZAF, ZAG,ZAH,ZAJ,ZAL .....	1
3	PAHZZ	5340-01-271-2420	15434	3032693	. PLUG,EXPANSION UOC: ZAA,ZAB,ZAC,ZAD,ZAE,ZAF, ZAG,ZAH,ZAJ,ZAL .....	5
4	PAHZZ	5340-01-271-2419	15434	156075	. PLUG,EXPANSION PART OF KIT P/N 3909415 UOC: ZAA,ZAB,ZAC,ZAD,ZAE,ZAF, ZAG,ZAH,ZAJ,ZAL .....	1
5	PAHZZ	5365-01-112-1524	15434	3008464	. PLUG,MACHINE THREAD UOC: ZAA,ZAB,ZAC,ZAD,ZAE,ZAF, ZAG,ZAH,ZAJ,ZAL .....	1
6	PAHZZ	5340-01-431-8753	15434	3922072	. PLUG,EXPANSION UOC: ZAA,ZAB,ZAC,ZAD,ZAE,ZAF, ZAG,ZAH,ZAJ,ZAL .....	2
7	PAHZZ	5310-01-209-0508	15434	3902425	. WASHER,FLAT PART OF KIT P/ N 3802622, PART OF KIT P/N 3800748, PART OF KIT P/N 402527100 UOC: ZAA,ZAB,ZAC,ZAD,ZAE,ZAF, ZAG,ZAH,ZAJ,ZAL .....	2
8	PAHZZ	5365-01-217-1995	15434	3904386	. PLUG,MACHINE THREAD UOC: ZAA,ZAB,ZAC,ZAD,ZAE,ZAF, ZAG,ZAH,ZAJ,ZAL .....	2
9	PAHZZ	5330-01-272-1144	15434	393558600	GASKET (.15MM O/ S)REFERENCE AGAINST MACHINE BLOCK PART OF KIT P/N 3802622 UOC: ZAA,ZAB,ZAC,ZAD,ZAE,ZAF, ZAG,ZAH,ZAJ,ZAL .....	1
9	PAHZZ	5330-01-271-4311	15434	3938267	GASKET (STANDARD)REFERENCE AGAINST MACHINE BLOCK PART OF KIT P/N 402527100 UOC: ZAA,ZAB,ZAC,ZAD,ZAE,ZAF, ZAG,ZAH,ZAJ,ZAL .....	1

(1) ITEM NO.	(2) SMR CODE	(3) NSN	(4) CAGEC	(5) PART NUMBER	(6) DESCRIPTION AND USABLE ON CODE (UOC)	(7) QTY
9	PAHZZ	5330-01-272-1145	15434	393558700	GASKET (.50MM O/ S)REFERENCE AGAINST MACHINE BLOCK PART OF KIT P/N 3802622 UOC: ZAA,ZAB,ZAC,ZAD,ZAE,ZAF, ZAG,ZAH,ZAJ,ZAL .....	1
10	PAHZZ	5305-01-271-5852	15434	3907234	SCREW,CAP,HEXAGON H UP TO ENGINE S/N 44487829 UOC: ZAA,ZAB,ZAC,ZAD,ZAE,ZAF, ZAG,ZAH,ZAJ,ZAL .....	12
10	PAHZZ	5305-01-331-9479	15434	3917729	SCREW,CAP,HEXAGON H AFTER ENGINE S/N 44487830 UOC: ZAA,ZAB,ZAC,ZAD,ZAE,ZAF, ZAG,ZAH,ZAJ,ZAL .....	12
11	PAHZZ	5305-01-331-9480	15434	3960043	SCREW,CAP,HEXAGON H AFTER ENGINE S/N 44487830 UOC: ZAA,ZAB,ZAC,ZAD,ZAE,ZAF, ZAG,ZAH,ZAJ,ZAL .....	14
11	PAHZZ	5305-01-274-4407	15434	3907233	SCREW,CAP,HEXAGON H UP TO ENGINE S/N 44487829 UOC: ZAA,ZAB,ZAC,ZAD,ZAE,ZAF, ZAG,ZAH,ZAJ,ZAL .....	14

END OF FIGURE

**FIELD MAINTENANCE  
ENGINE ACCESS COVER (M939, M939A1)**

---

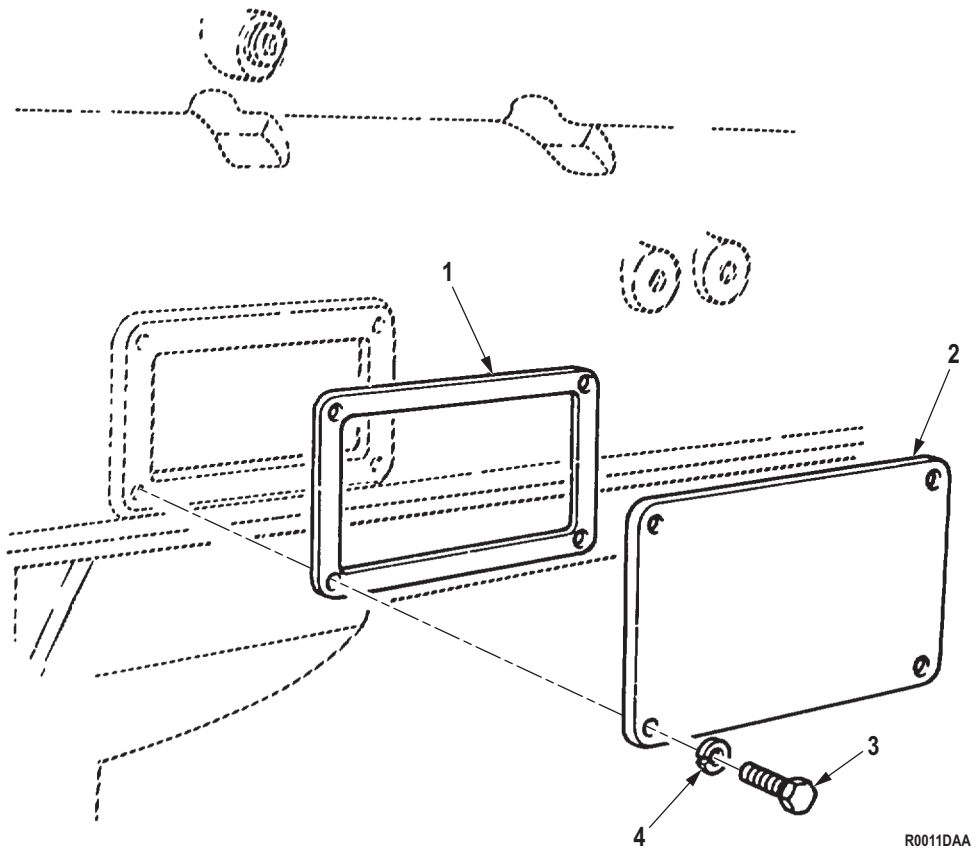

Figure 11. Engine Access Cover (M939, M939A1).



(1) ITEM NO.	(2) SMR CODE	(3) NSN	(4) CAGEC	(5) PART NUMBER	(6) DESCRIPTION AND USABLE ON CODE (UOC)	(7) QTY
<b>GROUP 0101 CRANKCASE, BLOCK, CYLINDER HEAD</b>						
<b>FIG. 11. ENGINE ACCESS COVER (M939, M939A1).</b>						
1	PAFZZ	5330-00-246-0309	79343	00265-0014	GASKET PART OF KIT P/N 3011472 UOC: DAC,DAD,DAE,DAF,DAG,DA H,DAJ,DAL,DAW,DAX,V14,V15,V16, V17,V18,V19,V20,V21,V22,V24 .....	1
2	PAFZZ	5340-00-404-2947	15434	158145	COVER,ACCESS UOC: DAC,DAD,DAE,DAF,DAG,DA H,DAJ,DAL,DAW,DAX,V14,V15,V16, V17,V18,V19,V20,V21,V22,V24 .....	1
3	PAFZZ	5305-01-085-8197	15434	3010595	SCREW,MACHINE UOC: DAC,DAD,DAE,DAF,DAG,DA H,DAJ,DAL,DAW,DAX,V14,V15,V16, V17,V18,V19,V20,V21,V22,V24 .....	4
4	PAFZZ	5310-00-080-6004	96906	MS27183-14	WASHER,FLAT UOC: DAC,DAD,DAE,DAF,DAG,DA H,DAJ,DAL,DAW,DAX,V14,V15,V16, V17,V18,V19,V20,V21,V22,V24 .....	4

**END OF FIGURE**



**FIELD MAINTENANCE  
CRANKSHAFT ASSEMBLY (M939, M939A1)**

---



(1) ITEM NO.	(2) SMR CODE	(3) NSN	(4) CAGEC	(5) PART NUMBER	(6) DESCRIPTION AND USABLE ON CODE (UOC)	(7) QTY
<b>GROUP 0102 CRANKSHAFT.</b>						
<b>FIG. 12. CRANKSHAFT ASSEMBLY (M939, M939A1).</b>						
1	KBHZZ	3120-01-241-6516	15434	3019186	BEARING HALF,SLEEVE STD PART OF KIT P/N 3801260 UOC: DAC,DAD,DAE,DAF,DAG,DA H,DAJ,DAL,DAW,DAX,V14,V15,V16, V17,V18,V19,V20,V21,V22,V24 .....	3
1	KBHZZ		15434	3019190	BEARING HALF .040 PART OF KIT P/N FP3801264 UOC: DAC,DAD,DAE,DAF,DAG,DA H,DAJ,DAL,DAW,DAX,V14,V15,V16, V17,V18,V19,V20,V21,V22,V24 .....	3
1	KBHZZ		15434	3019188	BEARING HALF .020 PART OF KIT P/N 3801262 UOC: DAC,DAD,DAE,DAF,DAG,DA H,DAJ,DAL,DAW,DAX,V14,V15,V16, V17,V18,V19,V20,V21,V22,V24 .....	3
1	KBHZZ		15434	3019187	BEARING HALF .010 PART OF KIT P/N 3801261 UOC: DAC,DAD,DAE,DAF,DAG,DA H,DAJ,DAL,DAW,DAX,V14,V15,V16, V17,V18,V19,V20,V21,V22,V24 .....	3
1	KBHZZ		15434	3019189	BEARING HALF .030 PART OF KIT P/N 3801263 UOC: DAC,DAD,DAE,DAF,DAG,DA H,DAJ,DAL,DAW,DAX,V14,V15,V16, V17,V18,V19,V20,V21,V22,V24 .....	3
2	KBHZZ	3120-01-214-7779	15434	306756800	BEARING,WASHER,THRU PART OF KIT P/N 3801263, PART OF KIT P/ N FP3801264, PART OF KIT P/N 3801260, PART OF KIT P/N 3801261, PART OF KIT P/N 3801262 UOC: DAC,DAD,DAE,DAF,DAG,DA H,DAJ,DAL,DAW,DAX,V14,V15,V16, V17,V18,V19,V20,V21,V22,V24 .....	4
3	KBHZZ	3120-01-241-5166	15434	3019198	BEARING HALF,SLEEVE STD PART OF KIT P/N 3801260 UOC: DAC,DAD,DAE,DAF,DAG,DA H,DAJ,DAL,DAW,DAX,V14,V15,V16, V17,V18,V19,V20,V21,V22,V24 .....	1
3	KBHZZ		15434	3019200	BEARING HALF .020 PART OF KIT P/N 3801262 UOC: DAC,DAD,DAE,DAF,DAG,DA H,DAJ,DAL,DAW,DAX,V14,V15,V16, V17,V18,V19,V20,V21,V22,V24 .....	1

(1) ITEM NO.	(2) SMR CODE	(3) NSN	(4) CAGEC	(5) PART NUMBER	(6) DESCRIPTION AND USABLE ON CODE (UOC)	(7) QTY
3	KBHZZ		15434	3019199	BEARING HALF .010 PART OF KIT P/N 3801261 UOC: DAC,DAD,DAE,DAF,DAG,DA H,DAJ,DAL,DAW,DAX,V14,V15,V16, V17,V18,V19,V20,V21,V22,V24 .....	1
3	KBHZZ		15434	3019201	BEARING HALF .030 PART OF KIT P/N 3801263 UOC: DAC,DAD,DAE,DAF,DAG,DA H,DAJ,DAL,DAW,DAX,V14,V15,V16, V17,V18,V19,V20,V21,V22,V24 .....	1
3	KBHZZ		15434	3019202	BEARING HALF .040 PART OF KIT P/N FP3801264 UOC: DAC,DAD,DAE,DAF,DAG,DA H,DAJ,DAL,DAW,DAX,V14,V15,V16, V17,V18,V19,V20,V21,V22,V24 .....	1
4	PBHHH	2815-00-457-6311	15434	3029340	CRANKSHAFT ASSEMBLY UOC: DAC,DAD,DAE,DAF,DAG,DA H,DAJ,DAL,DAW,DAX,V14,V15,V16, V17,V18,V19,V20,V21,V22,V24 .....	1
5	PBHHH	2815-00-453-8994	15434	208460	. CRANKSHAFT,ENGINE UOC: DAC,DAD,DAE,DAF,DAG,DA H,DAJ,DAL,DAW,DAX,V14,V15,V16, V17,V18,V19,V20,V21,V22,V24 .....	1
6	PAHZZ	5315-00-781-2026	80205	MS20068-271	. KEY,MACHINE UOC: DAC,DAD,DAE,DAF,DAG,DA H,DAJ,DAL,DAW,DAX,V14,V15,V16, V17,V18,V19,V20,V21,V22,V24 .....	1
7	KBHZZ	3020-00-404-2949	15434	142804	. GEAR,HELICAL PART OF KIT P/ N 5704533 UOC: DAC,DAD,DAE,DAF,DAG,DA H,DAJ,DAL,DAW,DAX,V14,V15,V16, V17,V18,V19,V20,V21,V22,V24 .....	1
8	PAFZZ	5310-00-829-5238	15434	140411	. WASHER,FLAT UOC: DAC,DAD,DAE,DAF,DAG,DA H,DAJ,DAL,DAW,DAX,V14,V15,V16, V17,V18,V19,V20,V21,V22,V24 .....	1
9	PAFZZ	5306-00-420-1691	26233	M4DS1216-28B	. BOLT,MACHINE UOC: DAC,DAD,DAE,DAF,DAG,DA H,DAJ,DAL,DAW,DAX,V14,V15,V16, V17,V18,V19,V20,V21,V22,V24 .....	1
10	KBHZZ		15434	3019208	BEARING HALF .040 PART OF KIT P/N FP3801264 UOC: DAC,DAD,DAE,DAF,DAG,DA H,DAJ,DAL,DAW,DAX,V14,V15,V16, V17,V18,V19,V20,V21,V22,V24 .....	1

(1) ITEM NO.	(2) SMR CODE	(3) NSN	(4) CAGEC	(5) PART NUMBER	(6) DESCRIPTION AND USABLE ON CODE (UOC)	(7) QTY
10	KBHZZ		15434	3019207	BEARING HALF .030 PART OF KIT P/N 3801263 UOC: DAC,DAD,DAE,DAF,DAG,DA H,DAJ,DAL,DAW,DAX,V14,V15,V16, V17,V18,V19,V20,V21,V22,V24 .....	1
10	KBHZZ		15434	3019205	BEARING HALF .010 PART OF KIT P/N 3801261 UOC: DAC,DAD,DAE,DAF,DAG,DA H,DAJ,DAL,DAW,DAX,V14,V15,V16, V17,V18,V19,V20,V21,V22,V24 .....	1
10	KBHZZ		15434	3019206	BEARING HALF .020 PART OF KIT P/N 3801262 UOC: DAC,DAD,DAE,DAF,DAG,DA H,DAJ,DAL,DAW,DAX,V14,V15,V16, V17,V18,V19,V20,V21,V22,V24 .....	1
10	KBHZZ	3120-00-593-1507	15434	44388	BEARING HALF,SLEEVE STD PART OF KIT P/N 3801260 UOC: DAC,DAD,DAE,DAF,DAG,DA H,DAJ,DAL,DAW,DAX,V14,V15,V16, V17,V18,V19,V20,V21,V22,V24 .....	1
11	KBHZZ		15434	3019193	BEARING HALF .010 PART OF KIT P/N 3801261 UOC: DAC,DAD,DAE,DAF,DAG,DA H,DAJ,DAL,DAW,DAX,V14,V15,V16, V17,V18,V19,V20,V21,V22,V24 .....	3
11	KBHZZ	3120-01-490-0417	15434	3019192	BEARING HALF STD PART OF KIT P/N 3801260 UOC: DAC,DAD,DAE,DAF,DAG,DA H,DAJ,DAL,DAW,DAX,V14,V15,V16, V17,V18,V19,V20,V21,V22,V24 .....	3
11	KBHZZ		15434	3019195	BEARING HALF .030 .030 PART OF KIT P/N 3801263 UOC: DAC,DAD,DAE,DAF,DAG,DA H,DAJ,DAL,DAW,DAX,V14,V15,V16, V17,V18,V19,V20,V21,V22,V24 .....	3
11	KBHZZ		15434	3019196	BEARING HALF .040 .040 PART OF KIT P/N FP3801264 UOC: DAC,DAD,DAE,DAF,DAG,DA H,DAJ,DAL,DAW,DAX,V14,V15,V16, V17,V18,V19,V20,V21,V22,V24 .....	3
11	KBHZZ		15434	3019194	BEARING HALF .020 PART OF KIT P/N 3801262 UOC: DAC,DAD,DAE,DAF,DAG,DA H,DAJ,DAL,DAW,DAX,V14,V15,V16, V17,V18,V19,V20,V21,V22,V24 .....	3

(1) ITEM NO.	(2) SMR CODE	(3) NSN	(4) CAGEC	(5) PART NUMBER	(6) DESCRIPTION AND USABLE ON CODE (UOC)	(7) QTY
12	KBHZZ		15434	3019181	BEARING HALF .010 PART OF KIT P/N 3801261 UOC: DAC,DAD,DAE,DAF,DAG,DA H,DAJ,DAL,DAW,DAX,V14,V15,V16, V17,V18,V19,V20,V21,V22,V24 .....	3
12	KBHZZ		15434	3019183	BEARING HALF .030 .030 PART OF KIT P/N 3801263 UOC: DAC,DAD,DAE,DAF,DAG,DA H,DAJ,DAL,DAW,DAX,V14,V15,V16, V17,V18,V19,V20,V21,V22,V24 .....	3
12	KBHZZ		15434	3019184	BEARING HALF .040 PART OF KIT P/N FP3801264 UOC: DAC,DAD,DAE,DAF,DAG,DA H,DAJ,DAL,DAW,DAX,V14,V15,V16, V17,V18,V19,V20,V21,V22,V24 .....	3
12	KBHZZ		15434	3019182	BEARING,HALF .020 PART OF KIT P/N 3801262 UOC: DAC,DAD,DAE,DAF,DAG,DA H,DAJ,DAL,DAW,DAX,V14,V15,V16, V17,V18,V19,V20,V21,V22,V24 .....	3
12	KBHZZ	3120-00-695-1232	15434	3019180	BEARING HALF,SLEEVE STD PART OF KIT P/N 3801260 UOC: DAC,DAD,DAE,DAF,DAG,DA H,DAJ,DAL,DAW,DAX,V14,V15,V16, V17,V18,V19,V20,V21,V22,V24 .....	3
13	PAFZZ	2815-00-472-2626	15434	202891	DAMPENER,VIBRATION, UOC: DAC,DAD,DAE,DAF,DAG,DA H,DAJ,DAL,DAW,DAX,V14,V15,V16, V17,V18,V19,V20,V21,V22,V24 .....	1
14	PAFZZ	2815-01-202-9715	15434	4919864	DAMPENER,VIBRATION, UOC: DAC,DAD,DAE,DAF,DAG,DA H,DAJ,DAL,DAW,DAX,V14,V15,V16, V17,V18,V19,V20,V21,V22,V24 .....	1
15	PAFZZ	5310-00-003-4094	80205	MS35338-48	WASHER,LOCK UOC: DAC,DAD,DAE,DAF,DAG,DA H,DAJ,DAL,DAW,DAX,V14,V15,V16, V17,V18,V19,V20,V21,V22,V24 .....	6
16	PAFZZ	5305-01-114-0895	15434	S112A	SCREW,CAP,HEXAGON H UOC: DAC,DAD,DAE,DAF,DAG,DA H,DAJ,DAL,DAW,DAX,V14,V15,V16, V17,V18,V19,V20,V21,V22,V24 .....	6
17	KBHZZ		15434	3019177	BEARING HALF .030 .030 PART OF KIT P/N 3801263 UOC: DAC,DAD,DAE,DAF,DAG,DA H,DAJ,DAL,DAW,DAX,V14,V15,V16, V17,V18,V19,V20,V21,V22,V24 .....	3



(1) ITEM NO.	(2) SMR CODE	(3) NSN	(4) CAGEC	(5) PART NUMBER	(6) DESCRIPTION AND USABLE ON CODE (UOC)	(7) QTY
17	KBHZZ		15434	3019178	BEARING HALF .040 PART OF KIT P/N FP3801264 UOC: DAC,DAD,DAE,DAF,DAG,DA H,DAJ,DAL,DAW,DAX,V14,V15,V16, V17,V18,V19,V20,V21,V22,V24 .....	3
17	KBHZZ		15434	3019175	BEARING HALF .010 PART OF KIT P/N 3801261 UOC: DAC,DAD,DAE,DAF,DAG,DA H,DAJ,DAL,DAW,DAX,V14,V15,V16, V17,V18,V19,V20,V21,V22,V24 .....	3
17	KBHZZ	3120-01-241-4098	15434	3019174	BEARING HALF,SLEEVE STD PART OF KIT P/N 3801260 UOC: DAC,DAD,DAE,DAF,DAG,DA H,DAJ,DAL,DAW,DAX,V14,V15,V16, V17,V18,V19,V20,V21,V22,V24 .....	3
17	KBHZZ		15434	3019176	BEARING HALF .020 PART OF KIT P/N 3801262 UOC: DAC,DAD,DAE,DAF,DAG,DA H,DAJ,DAL,DAW,DAX,V14,V15,V16, V17,V18,V19,V20,V21,V22,V24 .....	3

END OF FIGURE



**FIELD MAINTENANCE  
CRANKSHAFT ASSEMBLY (M939A2)**

---

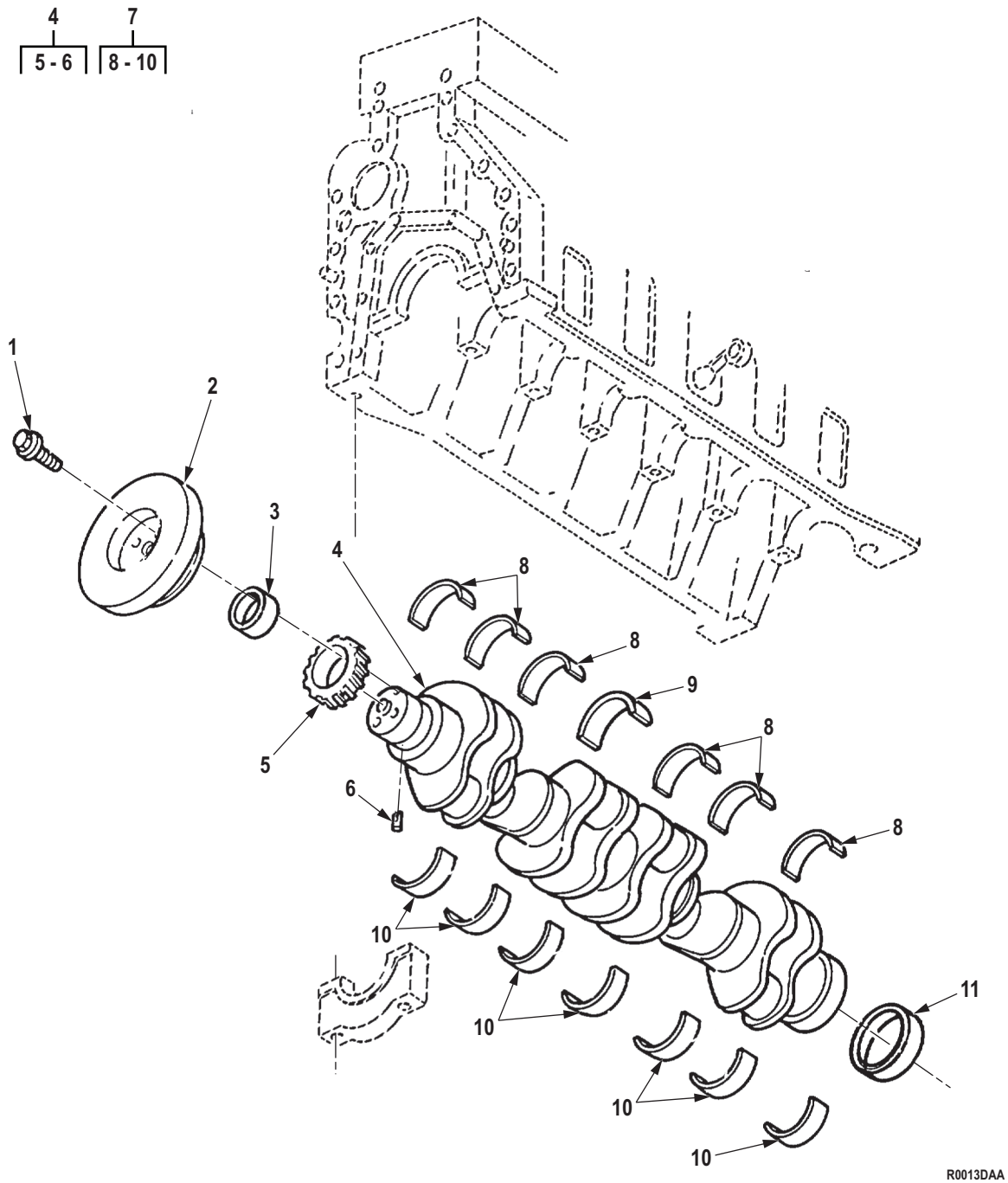

R0013DAA

Figure 13. Crankshaft Assembly (M939A2).

(1) ITEM NO.	(2) SMR CODE	(3) NSN	(4) CAGEC	(5) PART NUMBER	(6) DESCRIPTION AND USABLE ON CODE (UOC)	(7) QTY
<b>GROUP 0102 CRANKSHAFT.</b>						
<b>FIG. 13. CRANKSHAFT ASSEMBLY (M939A2).</b>						
1	PAFZZ	5305-01-274-5655	15434	3906733	SCREW,CAP,HEXAGON H UOC: ZAA,ZAB,ZAC,ZAD,ZAE,ZAF, ZAG,ZAH,ZAJ,ZAL .....	4
2	PAFZZ	2815-01-271-7076	45152	2DR686	DAMPENER,VIBRATION, UOC: ZAA,ZAB,ZAC,ZAD,ZAE,ZAF, ZAG,ZAH,ZAJ,ZAL .....	1
3	PAHZZ	3120-01-280-6566	15434	3925626	BEARING,SLEEVE UOC: ZAA,ZAB,ZAC,ZAD,ZAE,ZAF, ZAG,ZAH,ZAJ,ZAL .....	1
4	PBHHH	2815-01-271-5096	15434	3918986	CRANKSHAFT,ENGINE UOC: ZAA,ZAB,ZAC,ZAD,ZAE,ZAF, ZAG,ZAH,ZAJ,ZAL .....	1
5	PAHZZ	3020-01-271-3812	15434	3918776	. GEAR,HELICAL UOC: ZAA,ZAB,ZAC,ZAD,ZAE,ZAF, ZAG,ZAH,ZAJ,ZAL .....	1
6	PAHZZ	5315-01-270-8285	15434	3904483	. PIN,STRAIGHT,HEADLE UOC: ZAA,ZAB,ZAC,ZAD,ZAE,ZAF, ZAG,ZAH,ZAJ,ZAL .....	1
7	PAHZZ	3120-01-513-6934	0B8S3	3945917	BEARING SET,SLEEVE UOC: ZAA,ZAB,ZAC,ZAD,ZAE,ZAF, ZAG,ZAH,ZAJ,ZAL .....	1
7	PAHZZ	3120-01-273-4654	0B8S3	394591800	BEARING SET,SLEEVE UNDERSIZE, .25MM UOC: ZAA,ZAB,ZAC,ZAD,ZAE,ZAF, ZAG,ZAH,ZAJ,ZAL .....	1
7	PAHZZ	3120-01-274-3377	0B8S3	3945921	BEARING SET,SLEEVE UNDERSIZE, 1.00MM UOC: ZAA,ZAB,ZAC,ZAD,ZAE,ZAF, ZAG,ZAH,ZAJ,ZAL .....	1
7	PAHZZ	3120-01-273-4655	15434	3945919	BEARING SET,SLEEVE UNDERSIZE, .50MM UOC: ZAA,ZAB,ZAC,ZAD,ZAE,ZAF, ZAG,ZAH,ZAJ,ZAL .....	1
7	PAHZZ	3120-01-273-4656	15434	3945920	BEARING SET,SLEEVE UNDERSIZE, .75MM UOC: ZAA,ZAB,ZAC,ZAD,ZAE,ZAF, ZAG,ZAH,ZAJ,ZAL .....	1
8	PAHZZ	3120-01-457-3501	15434	3916840	. BEARING,SLEEVE UOC: ZAA,ZAB,ZAC,ZAD,ZAE,ZAF, ZAG,ZAH,ZAJ,ZAL .....	6
9	XAHZZ		15434	3916830	. BEARING, FLANGE THRUST UOC: ZAA,ZAB,ZAC,ZAD,ZAE,ZAF, ZAG,ZAH,ZAJ,ZAL .....	1

(1) ITEM NO.	(2) SMR CODE	(3) NSN	(4) CAGEC	(5) PART NUMBER	(6) DESCRIPTION AND USABLE ON CODE (UOC)	(7) QTY
10	PAHZZ	3120-01-428-8850	15434	3901590	. BEARING SET,SLEEVE UOC: ZAA,ZAB,ZAC,ZAD,ZAE,ZAF, ZAG,ZAH,ZAJ,ZAL .....	7
11	PAHZZ	3120-01-266-1530	15434	3926126	BEARING,SLEEVE UOC: ZAA,ZAB,ZAC,ZAD,ZAE,ZAF, ZAG,ZAH,ZAJ,ZAL .....	1

END OF FIGURE

**FIELD MAINTENANCE  
FLYWHEEL GEAR ASSEMBLY AND HOUSING (M939, M939A1)**

---

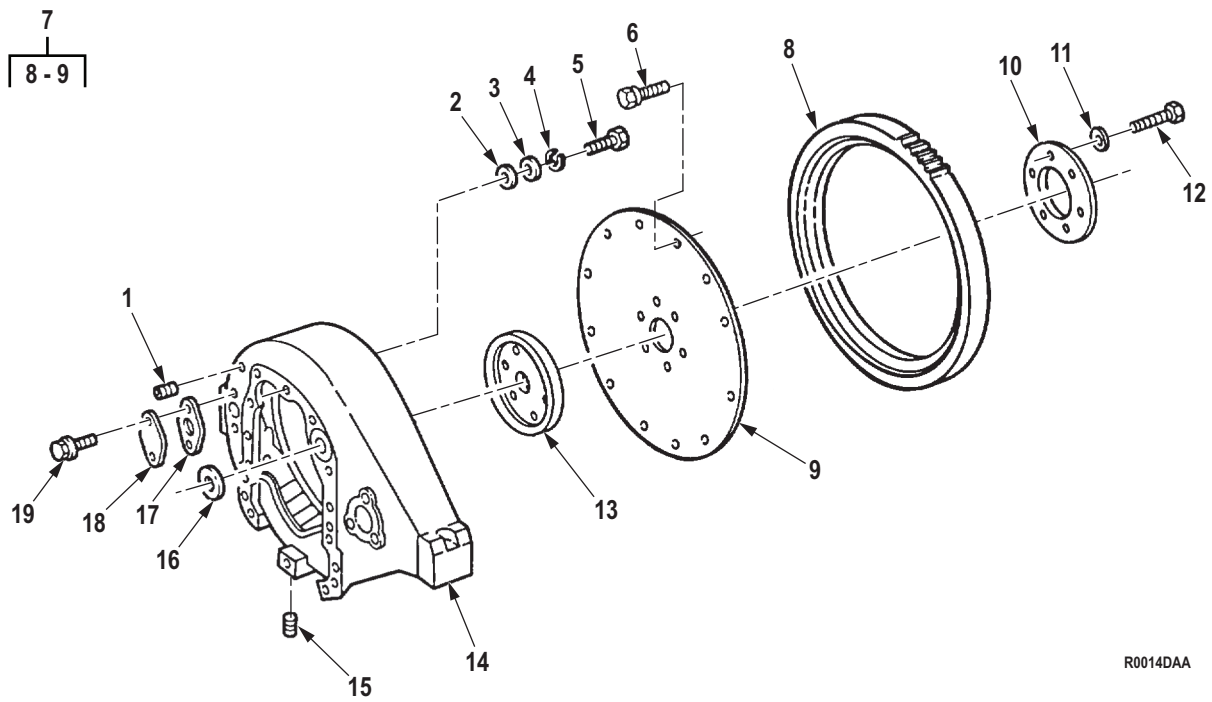

R0014DAA

Figure 14. Flywheel Gear Assembly and Housing (M939, M939A1).



(1) ITEM NO.	(2) SMR CODE	(3) NSN	(4) CAGEC	(5) PART NUMBER	(6) DESCRIPTION AND USABLE ON CODE (UOC)	(7) QTY
<b>GROUP 0103 FLYWHELL ASSEMBLY.</b>						
<b>FIG. 14. FLYWHEEL GEAR ASSEMBLY AND HOUSING (M939, M939A1).</b>						
1	PAFZZ	4730-01-165-9491	86403	4746 644	PLUG,PIPE UOC: DAC,DAD,DAE,DAF,DAG,DA H,DAJ,DAL,DAW,DAX,V14,V15,V16, V17,V18,V19,V20,V21,V22,V24 .....	1
2	PAFZZ	5330-00-404-2920	15434	172648	PACKING,PREFORMED PART OF KIT P/N 3011472 UOC: DAC,DAD,DAE,DAF,DAG,DA H,DAJ,DAL,DAW,DAX,V14,V15,V16, V17,V18,V19,V20,V21,V22,V24 .....	9
3	PAFZZ	5310-00-081-8500	15434	127316	WASHER,RECESSED UOC: DAC,DAD,DAE,DAF,DAG,DA H,DAJ,DAL,DAW,DAX,V14,V15,V16, V17,V18,V19,V20,V21,V22,V24 .....	9
4	PAFZZ	5310-00-820-6653	80205	MS35338-50	WASHER,LOCK UOC: DAC,DAD,DAE,DAF,DAG,DA H,DAJ,DAL,DAW,DAX,V14,V15,V16, V17,V18,V19,V20,V21,V22,V24 .....	9
5	PAFZZ	5305-01-205-3407	15434	138042	SCREW,MACHINE UOC: DAC,DAD,DAE,DAF,DAG,DA H,DAJ,DAL,DAW,DAX,V14,V15,V16, V17,V18,V19,V20,V21,V22,V24 .....	9
6	PAFZZ	5306-01-203-6299	15434	3011315	BOLT UOC: DAC,DAD,DAE,DAF,DAG,DA H,DAJ,DAL,DAW,DAX,V14,V15,V16, V17,V18,V19,V20,V21,V22,V24 .....	12
7	PAFZZ	2815-01-114-7397	15434	3007279	FLYWHEEL ASSEMBLY UOC: DAC,DAD,DAE,DAF,DAG,DA H,DAJ,DAL,DAW,DAX,V14,V15,V16, V17,V18,V19,V20,V21,V22,V24 .....	1
8	XAFZZ		15434	217381	. GEAR,STARTER RING UOC: DAC,DAD,DAE,DAF,DAG,DA H,DAJ,DAL,DAW,DAX,V14,V15,V16, V17,V18,V19,V20,V21,V22,V24 .....	3
9	XAFZZ		15434	3019077	. FLEXPLATE UOC: DAC,DAD,DAE,DAF,DAG,DA H,DAJ,DAL,DAW,DAX,V14,V15,V16, V17,V18,V19,V20,V21,V22,V24 .....	1
10	PAFZZ	2520-01-127-6254	15434	217385	DISK,CLUTCH UOC: DAC,DAD,DAE,DAF,DAG,DA H,DAJ,DAL,DAW,DAX,V14,V15,V16, V17,V18,V19,V20,V21,V22,V24 .....	1

(1) ITEM NO.	(2) SMR CODE	(3) NSN	(4) CAGEC	(5) PART NUMBER	(6) DESCRIPTION AND USABLE ON CODE (UOC)	(7) QTY
11	PAFZZ	5310-00-134-4171	15434	200861	WASHER,FLAT UOC: DAC,DAD,DAE,DAF,DAG,DA H,DAJ,DAL,DAW,DAX,V14,V15,V16, V17,V18,V19,V20,V21,V22,V24 .....	6
12	PAFZZ	5305-01-112-9698	15434	180175	SCREW,CAP,HEXAGON H UOC: DAC,DAD,DAE,DAF,DAG,DA H,DAJ,DAL,DAW,DAX,V14,V15,V16, V17,V18,V19,V20,V21,V22,V24 .....	6
13	PAFZZ	2815-01-126-7404	15434	3007148	ADAPTER,CRANKSHAFT UOC: DAC,DAD,DAE,DAF,DAG,DA H,DAJ,DAL,DAW,DAX,V14,V15,V16, V17,V18,V19,V20,V21,V22,V24 .....	1
14	PFHZZ	2805-00-404-2917	15434	3014979	HOUSING,FLYWHEEL UOC: DAC,DAD,DAE,DAF,DAG,DA H,DAJ,DAL,DAW,DAX,V14,V15,V16, V17,V18,V19,V20,V21,V22,V24 .....	1
15	PAFZZ	4730-01-214-7081	15434	3008469	PLUG,PIPE UOC: DAC,DAD,DAE,DAF,DAG,DA H,DAJ,DAL,DAW,DAX,V14,V15,V16, V17,V18,V19,V20,V21,V22,V24 .....	1
16	PAFZZ	5330-00-729-4427	79150	34834	GASKET PART OF KIT P/N 3011472 UOC: DAC,DAD,DAE,DAF,DAG,DA H,DAJ,DAL,DAW,DAX,V14,V15,V16, V17,V18,V19,V20,V21,V22,V24 .....	1
17	PAFZZ	5330-01-082-6985	15434	3021735	GASKET UOC: DAC,DAD,DAE,DAF,DAG,DA H,DAJ,DAL,DAW,DAX,V14,V15,V16, V17,V18,V19,V20,V21,V22,V24 .....	1
18	PFFZZ	5340-01-122-8002	15434	70657	COVER,ACCESS UOC: DAC,DAD,DAE,DAF,DAG,DA H,DAJ,DAL,DAW,DAX,V14,V15,V16, V17,V18,V19,V20,V21,V22,V24 .....	1
19	PAFZZ	5305-01-135-5344	15434	3011342	SCREW UOC: DAC,DAD,DAE,DAF,DAG,DA H,DAJ,DAL,DAW,DAX,V14,V15,V16, V17,V18,V19,V20,V21,V22,V24 .....	2

END OF FIGURE

**FIELD MAINTENANCE  
FLYWHEEL HOUSING AND FLEXPLATE (M939A2)**

---

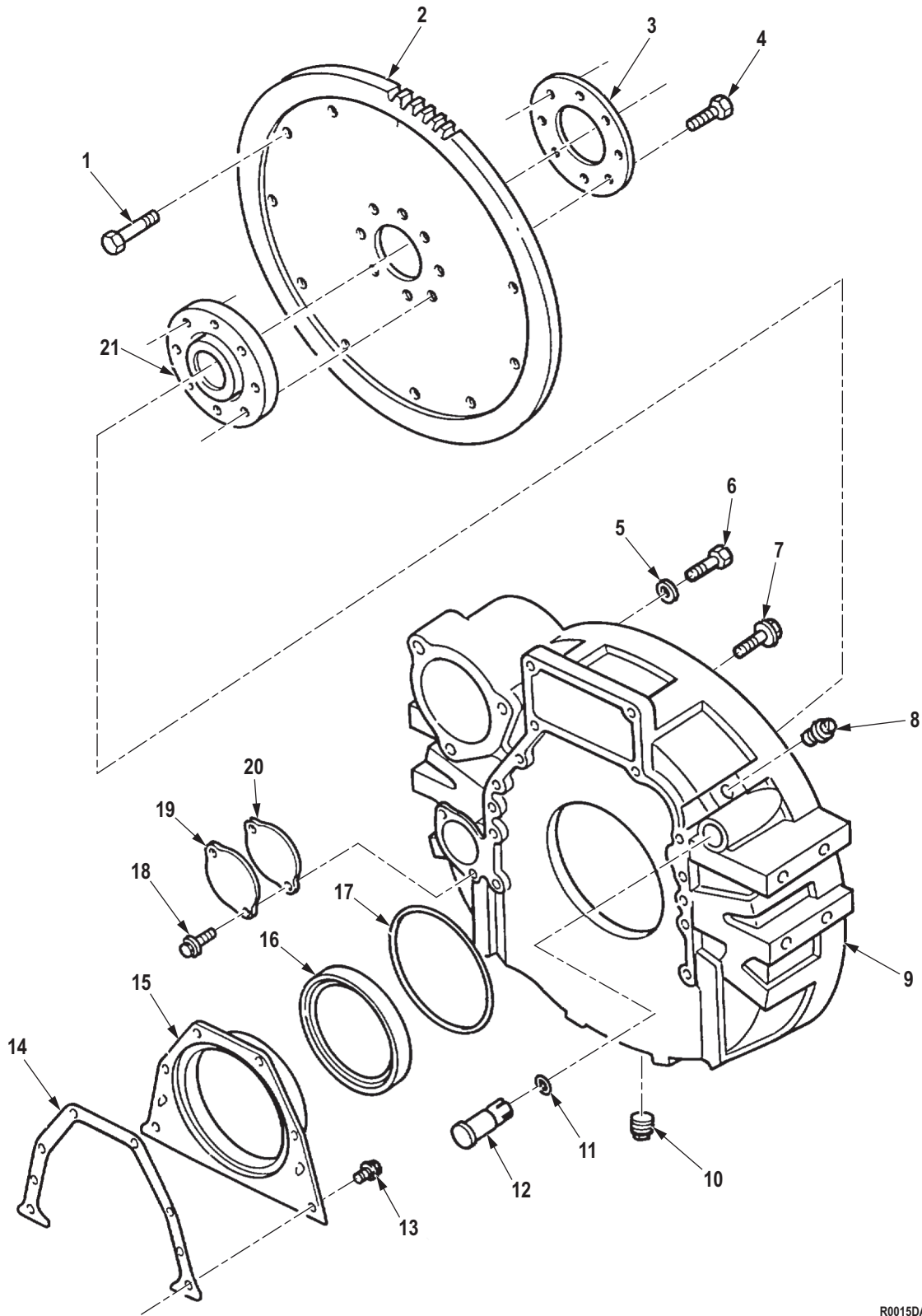

Figure 15. Flywheel Housing and Flexplate (M939A2).

R0015DAA

(1) ITEM NO.	(2) SMR CODE	(3) NSN	(4) CAGEC	(5) PART NUMBER	(6) DESCRIPTION AND USABLE ON CODE (UOC)	(7) QTY
<b>GROUP 0103 FLYWHEEL ASSEMBLY.</b>						
<b>FIG. 15. FLYWHEEL HOUSING AND FLEXPLATE (M939A2).</b>						
1	PAFZZ	5306-01-281-3387	3T063	20510312	BOLT,MACHINE UOC: ZAA,ZAB,ZAC,ZAD,ZAE,ZAF, ZAG,ZAH,ZAJ,ZAL .....	12
2	PAFZZ	3020-01-271-7114	15434	391126000	GEAR,SPUR UOC: ZAA,ZAB,ZAC,ZAD,ZAE,ZAF, ZAG,ZAH,ZAJ,ZAL .....	1
3	PAFZZ	3040-01-271-7165	15434	3923049	PLATE,RETAINING,SHA UOC: ZAA,ZAB,ZAC,ZAD,ZAE,ZAF, ZAG,ZAH,ZAJ,ZAL .....	1
4	PAFZZ	5305-01-192-5677	10988	J901395	SCREW,CAP,HEXAGON H UOC: ZAA,ZAB,ZAC,ZAD,ZAE,ZAF, ZAG,ZAH,ZAJ,ZAL .....	8
5	PAFZZ	5310-01-282-2807	19207	20510912	WASHER,FLAT UOC: ZAA,ZAB,ZAC,ZAD,ZAE,ZAF, ZAG,ZAH,ZAJ,ZAL .....	12
6	PAFZZ	5306-01-283-4199	05MG0	20510498	BOLT,MACHINE UOC: ZAA,ZAB,ZAC,ZAD,ZAE,ZAF, ZAG,ZAH,ZAJ,ZAL .....	12
7	PAFZZ	5305-01-340-8395	15434	3920447	SCREW,CAP,HEXAGON H UOC: ZAA,ZAB,ZAC,ZAD,ZAE,ZAF, ZAG,ZAH,ZAJ,ZAL .....	12
8	PAFZZ	4730-01-237-6950	15434	3904181	PLUG,PIPE UOC: ZAA,ZAB,ZAC,ZAD,ZAE,ZAF, ZAG,ZAH,ZAJ,ZAL .....	1
9	PAFZZ	2815-01-272-6719	15434	3911604	HOUSING,FLYWHEEL UOC: ZAA,ZAB,ZAC,ZAD,ZAE,ZAF, ZAG,ZAH,ZAJ,ZAL .....	1
10	PAFZZ	4730-01-214-7081	15434	3008469	PLUG,PIPE PART OF KIT P/N 3909415 UOC: ZAA,ZAB,ZAC,ZAD,ZAE,ZAF, ZAG,ZAH,ZAJ,ZAL .....	1
11	PAFZZ	5330-01-272-1124	15434	3910260	PACKING,PREFORMED UOC: ZAA,ZAB,ZAC,ZAD,ZAE,ZAF, ZAG,ZAH,ZAJ,ZAL .....	1
12	PAFZZ	2815-01-273-0571	15434	3903450	PLUG,FLYWHEEL HOUSI UOC: ZAA,ZAB,ZAC,ZAD,ZAE,ZAF, ZAG,ZAH,ZAJ,ZAL .....	1
13	PAFZZ	5305-01-271-5851	15434	3913638	SCREW,CAP,HEXAGON H UOC: ZAA,ZAB,ZAC,ZAD,ZAE,ZAF, ZAG,ZAH,ZAJ,ZAL .....	8
14	PAFZZ	5330-01-271-4308	15434	393595300	GASKET PART OF KIT P/N 380055800 UOC: ZAA,ZAB,ZAC,ZAD,ZAE,ZAF, ZAG,ZAH,ZAJ,ZAL .....	1

(1) ITEM NO.	(2) SMR CODE	(3) NSN	(4) CAGEC	(5) PART NUMBER	(6) DESCRIPTION AND USABLE ON CODE (UOC)	(7) QTY
15	PAFZZ	5340-01-271-2497	15434	3921042	COVER,ACCESS UOC: ZAA,ZAB,ZAC,ZAD,ZAE,ZAF, ZAG,ZAH,ZAJ,ZAL .....	1
16	PAFZZ	5330-01-192-2037	10988	J934486	SEAL,SPECIAL PART OF KIT P/N 380055800 UOC: ZAA,ZAB,ZAC,ZAD,ZAE,ZAF, ZAG,ZAH,ZAJ,ZAL .....	1
17	PAFZZ	5330-01-271-9375	15434	3912473	PACKING,PREFORMED PART OF KIT P/N 380055800 UOC: ZAA,ZAB,ZAC,ZAD,ZAE,ZAF, ZAG,ZAH,ZAJ,ZAL .....	1
18	PAFZZ	5305-01-192-2036	15434	3912072	SCREW UOC: ZAA,ZAB,ZAC,ZAD,ZAE,ZAF, ZAG,ZAH,ZAJ,ZAL .....	2
19	PAFZZ	5340-01-271-2496	10988	J925234	COVER,ACCESS UOC: ZAA,ZAB,ZAC,ZAD,ZAE,ZAF, ZAG,ZAH,ZAJ,ZAL .....	1
20	PAFZZ	5330-01-266-3294	15434	3908096	GASKET UOC: ZAA,ZAB,ZAC,ZAD,ZAE,ZAF, ZAG,ZAH,ZAJ,ZAL .....	1
21	PAFZZ	2990-01-271-7086	15434	3911258	ADAPTER,FLYWHEEL HO UOC: ZAA,ZAB,ZAC,ZAD,ZAE,ZAF, ZAG,ZAH,ZAJ,ZAL .....	1

END OF FIGURE

**FIELD MAINTENANCE  
CRANKSHAFT REAR COVER (M939, M939A1)**

---

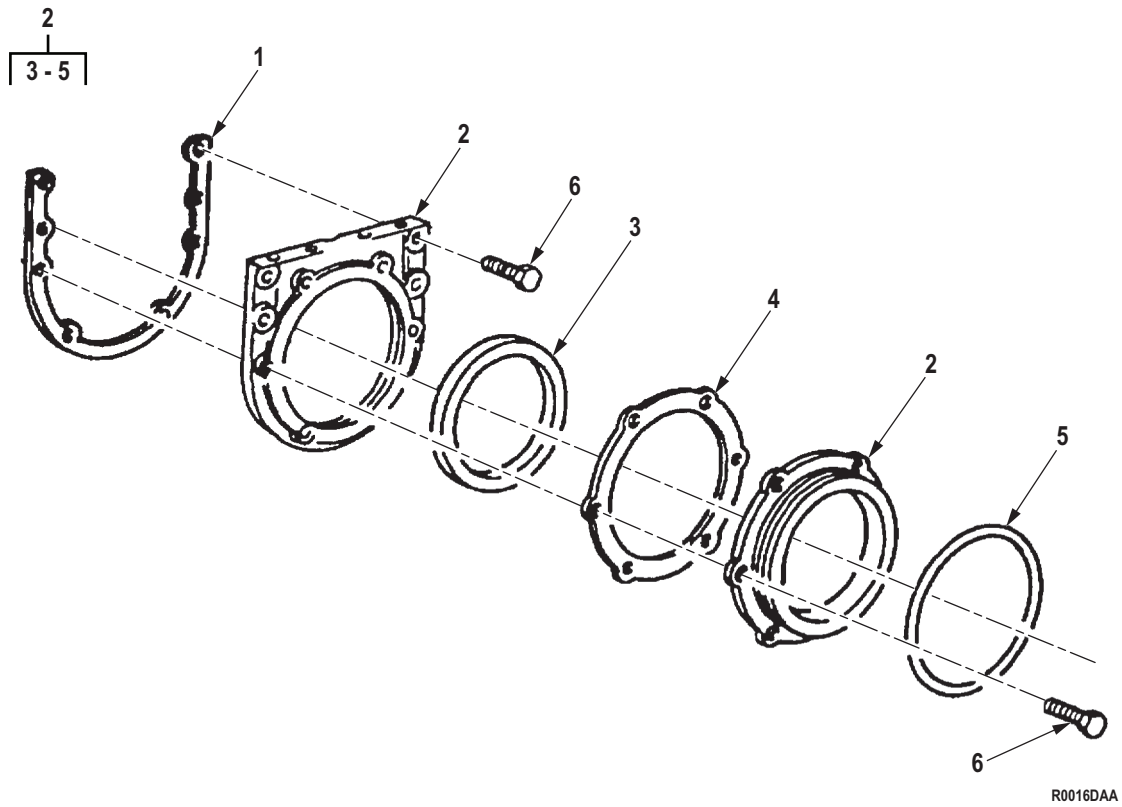

Figure 16. Crankshaft Rear Cover (M939, M939A1).



(1) ITEM NO.	(2) SMR CODE	(3) NSN	(4) CAGEC	(5) PART NUMBER	(6) DESCRIPTION AND USABLE ON CODE (UOC)	(7) QTY
<b>GROUP 0103 FLYWHELL ASSEMBLY.</b>						
<b>FIG. 16. CRANKSHAFT REAR COVER (M939, M939A1).</b>						
1	PAHZZ	5330-00-361-2955	15434	3067616	GASKET UOC: DAC,DAD,DAE,DAF,DAG,DA H,DAJ,DAL,DAW,DAX,V14,V15,V16, V17,V18,V19,V20,V21,V22,V24 .....	1
2	PAHZZ	2990-01-120-2883	15434	216165	COVER,REAR UOC: DAC,DAD,DAE,DAF,DAG,DA H,DAJ,DAL,DAW,DAX,V14,V15,V16, V17,V18,V19,V20,V21,V22,V24 .....	1
3	PAHZZ	5330-00-005-0858	01212	M39807	. SEAL REAR COVER PART OF KIT P/N 3011472 UOC: DAC,DAD,DAE,DAF,DAG,DA H,DAJ,DAL,DAW,DAX,V14,V15,V16, V17,V18,V19,V20,V21,V22,V24 .....	1
4	PAHZZ	5330-01-082-1906	15434	151623	. GASKET PART OF KIT P/N 3011472 UOC: DAC,DAD,DAE,DAF,DAG,DA H,DAJ,DAL,DAW,DAX,V14,V15,V16, V17,V18,V19,V20,V21,V22,V24 .....	1
5	PAHZZ	5331-00-420-9624	81343	AS568-438	. O-RING PART OF KIT P/N 3011472 UOC: DAC,DAD,DAE,DAF,DAG,DA H,DAJ,DAL,DAW,DAX,V14,V15,V16, V17,V18,V19,V20,V21,V22,V24 .....	1
6	PAHZZ	5305-01-130-6100	15434	3010594	SCREW,CAP,HEXAGON H UOC: DAC,DAD,DAE,DAF,DAG,DA H,DAJ,DAL,DAW,DAX,V14,V15,V16, V17,V18,V19,V20,V21,V22,V24 .....	8
<b>END OF FIGURE</b>						



**FIELD MAINTENANCE  
PISTON AND ROD ASSEMBLY (M939, M939A1)**

---

4	8
5-7	9-11

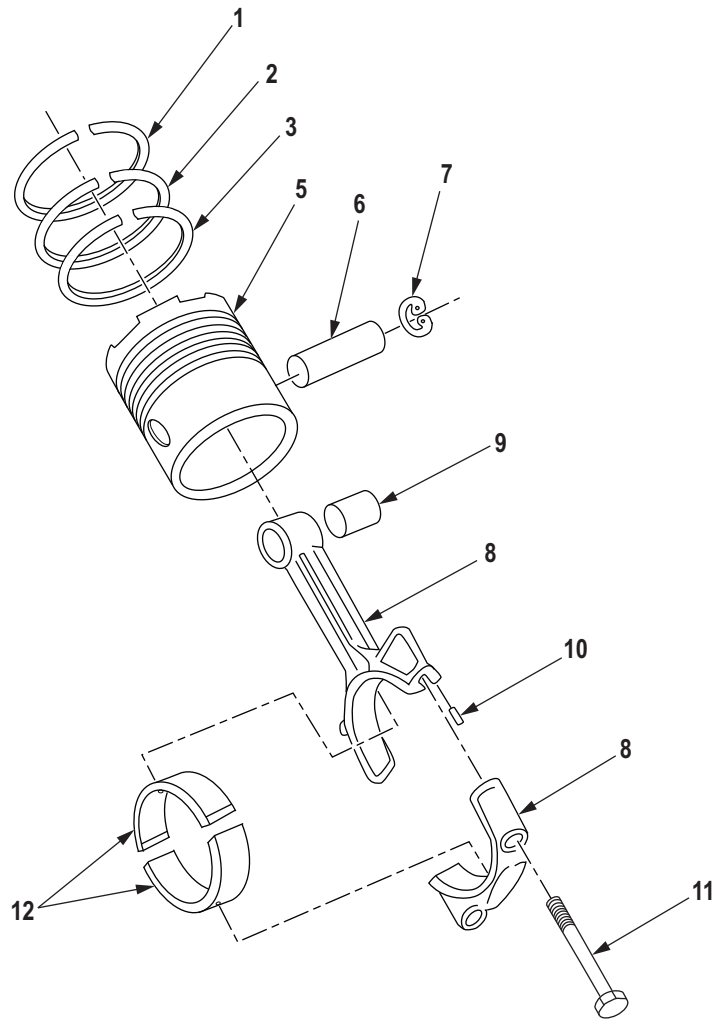

R0017DAA

Figure 17. Piston and Rod Assembly (M939, M939A1).

(1) ITEM NO.	(2) SMR CODE	(3) NSN	(4) CAGEC	(5) PART NUMBER	(6) DESCRIPTION AND USABLE ON CODE (UOC)	(7) QTY
<b>GROUP 0104 PISTONS, CONNECTING RODS.</b>						
<b>FIG. 17. PISTON AND ROD ASSEMBLY (M939, M939A1).</b>						
1	PAHZZ	2815-01-143-4140	15434	218025	RING,PISTON PART OF KIT P/N 3804438, PART OF KIT P/N 3804439, PART OF KIT P/N 4089810 UOC: DAC,DAD,DAE,DAF,DAG,DA H,DAJ,DAL,DAW,DAX,V14,V15,V16, V17,V18,V19,V20,V21,V22,V24 ..... 1	1
2	KBHZZ		15434	216983	RING,PISTON PART OF KIT P/N 4089810 UOC: DAC,DAD,DAE,DAF,DAG,DA H,DAJ,DAL,DAW,DAX,V14,V15,V16, V17,V18,V19,V20,V21,V22,V24 ..... 1	1
3	KFHZZ		15434	214730	RING,PISTON PART OF KIT P/N 3804438 UOC: DAC,DAD,DAE,DAF,DAG,DA H,DAJ,DAL,DAW,DAX,V14,V15,V16, V17,V18,V19,V20,V21,V22,V24 ..... 6	6
4	PAHZZ	2815-00-008-1741	01212	FP-PK5516WP	PISTON,INTERNAL COM PART OF KIT P/N 226-1747 UOC: DAC,DAD,DAE,DAF,DAG,DA H,DAJ,DAL,DAW,DAX,V14,V15,V16, V17,V18,V19,V20,V21,V22,V24 ..... 6	6
5	KFHZZ	2815-01-242-1455	15434	3804409	. PISTON,INTERNAL COM USE PRIOR TO SERIAL NUMBER 11246663 PART OF KIT P/N 3804438, PART OF KIT P/N 3801535 UOC: V14,V15,V16,V17,V18,V19,V2 0,V21,V22,V24 ..... 1	1
5	KFHZZ	2815-01-278-1093	15434	3801535	. PISTON,INTERNAL COM USE AFTER SERIAL NUMBER 11246663 PART OF KIT P/N 3801535 UOC: DAC,DAD,DAE,DAF,DAG,DA H,DAJ,DAL,DAW,DAX,V14,V15,V16, V17,V18,V19,V20,V21,V22,V24 ..... 1	1
6	KFHZZ	2815-00-480-4347	15434	191970	. PIN,PISTON PART OF KIT P/N 3801535 UOC: DAC,DAD,DAE,DAF,DAG,DA H,DAJ,DAL,DAW,DAX,V14,V15,V16, V17,V18,V19,V20,V21,V22,V24 ..... 1	1
7	PAHZZ	5325-00-804-2784	96906	MS16625-1200	. RING,RETAINING PART OF KIT P/N 3801535 UOC: DAC,DAD,DAE,DAF,DAG,DA H,DAJ,DAL,DAW,DAX,V14,V15,V16, V17,V18,V19,V20,V21,V22,V24 ..... 2	2
8	PAHZZ	2815-01-086-4508	15434	3013930	CONNECTING ROD,PIST UOC: DAC,DAD,DAE,DAF,DAG,DA H,DAJ,DAL,DAW,DAX,V14,V15,V16, V17,V18,V19,V20,V21,V22,V24 ..... 1	1

(1) ITEM NO.	(2) SMR CODE	(3) NSN	(4) CAGEC	(5) PART NUMBER	(6) DESCRIPTION AND USABLE ON CODE (UOC)	(7) QTY
9	PAHZZ	5365-00-132-0273	15434	187420	. BUSHING,PISTON PIN UOC: DAC,DAD,DAE,DAF,DAG,DA H,DAJ,DAL,DAW,DAX,V14,V15,V16, V17,V18,V19,V20,V21,V22,V24 .....	1
10	PAHZZ	2815-01-124-0232	15434	70550	. PIN,PISTON UOC: DAC,DAD,DAE,DAF,DAG,DA H,DAJ,DAL,DAW,DAX,V14,V15,V16, V17,V18,V19,V20,V21,V22,V24 .....	2
11	PAHZZ	5306-01-079-7027	15434	219153	. BOLT,MACHINE UOC: DAC,DAD,DAE,DAF,DAG,DA H,DAJ,DAL,DAW,DAX,V14,V15,V16, V17,V18,V19,V20,V21,V22,V24 .....	2
12	PAHZZ	3120-01-087-3004	0B0B1	CB1226P	BEARING UOC: DAC,DAD,DAE,DAF,DAG,DA H,DAJ,DAL,DAW,DAX,V14,V15,V16, V17,V18,V19,V20,V21,V22,V24 .....	12
12	PAHZZ	3120-01-155-4442	15434	214951	BEARING,SLEEVE .010 UNDERSIZE UOC: DAC,DAD,DAE,DAF,DAG,DA H,DAJ,DAL,DAW,DAX,V14,V15,V16, V17,V18,V19,V20,V21,V22,V24 .....	12
12	PAHZZ	3120-01-155-8707	15434	214953	BEARING,SLEEVE .030 UNDERSIZE UOC: DAC,DAD,DAE,DAF,DAG,DA H,DAJ,DAL,DAW,DAX,V14,V15,V16, V17,V18,V19,V20,V21,V22,V24 .....	12
12	PAHZZ	3120-01-157-3316	15434	214952	BEARING,SLEEVE .020 UNDERSIZE UOC: DAC,DAD,DAE,DAF,DAG,DA H,DAJ,DAL,DAW,DAX,V14,V15,V16, V17,V18,V19,V20,V21,V22,V24 .....	12

END OF FIGURE

**FIELD MAINTENANCE  
PISTON AND ROD ASSEMBLY (M939A2)**

---

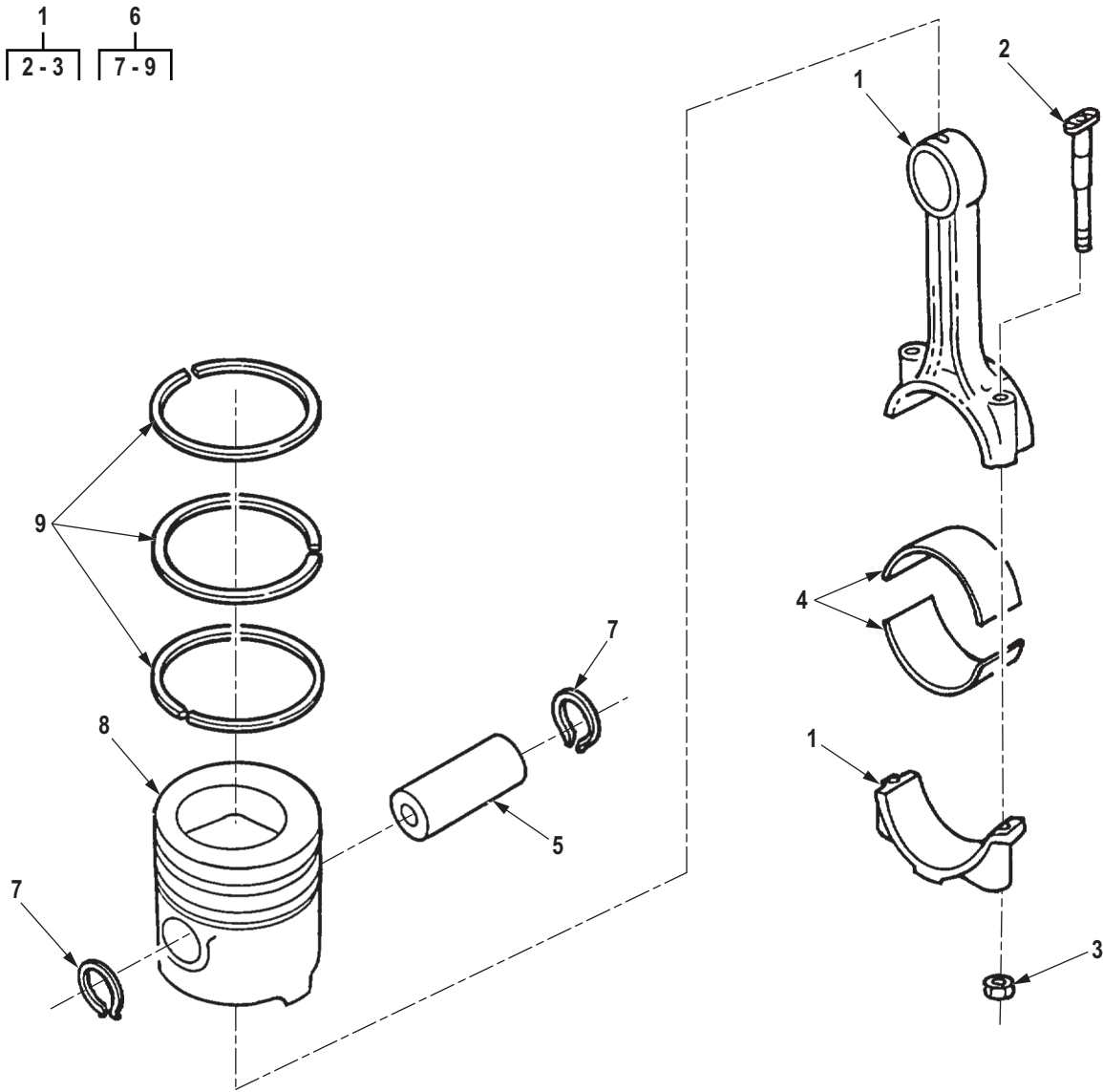

R0018DAA

Figure 18. Piston and Rod Assembly (M939A2).



(1) ITEM NO.	(2) SMR CODE	(3) NSN	(4) CAGEC	(5) PART NUMBER	(6) DESCRIPTION AND USABLE ON CODE (UOC)	(7) QTY
<b>GROUP 0104 PISTONS, CONNECTING RODS.</b>						
<b>FIG. 18. PISTON AND ROD ASSEMBLY (M939A2).</b>						
1	PAHZZ	2815-01-271-5119	45152	2DR678	CONNECTING ROD,PIST UOC: ZAA,ZAB,ZAC,ZAD,ZAE,ZAF, ZAG,ZAH,ZAJ,ZAL .....	6
2	PAHZZ	5306-01-271-6362	15434	392887000	. BOLT,MACHINE UOC: ZAA,ZAB,ZAC,ZAD,ZAE,ZAF, ZAG,ZAH,ZAJ,ZAL .....	2
3	PAHZZ	5310-01-270-8246	15434	3901381	. NUT,PLAIN,HEXAGON UOC: ZAA,ZAB,ZAC,ZAD,ZAE,ZAF, ZAG,ZAH,ZAJ,ZAL .....	2
4	PAHZZ	3120-01-272-3273	15434	3901432	BEARING,SLEEVE ROD, (.50MM O/S), USE AS REQUIRED UOC: ZAA,ZAB,ZAC,ZAD,ZAE,ZAF, ZAG,ZAH,ZAJ,ZAL .....	12
4	PAHZZ	3120-01-272-3272	15434	3901431	BEARING,SLEEVE ROD, (.25MM O/S), USE AS REQUIRED UOC: ZAA,ZAB,ZAC,ZAD,ZAE,ZAF, ZAG,ZAH,ZAJ,ZAL .....	12
4	PAHZZ	3120-01-275-7665	15434	3901434	BEARING,SLEEVE ROD, (1.00MM O/S), USE AS REQUIRED UOC: ZAA,ZAB,ZAC,ZAD,ZAE,ZAF, ZAG,ZAH,ZAJ,ZAL .....	12
4	PAHZZ	3120-01-275-7664	15434	3901433	BEARING,SLEEVE ROD, (.75MM O/S), USE AS REQUIRED UOC: ZAA,ZAB,ZAC,ZAD,ZAE,ZAF, ZAG,ZAH,ZAJ,ZAL .....	12
4	PAHZZ	3120-01-274-3378	15434	3950661	BEARING,SLEEVE ROD UOC: ZAA,ZAB,ZAC,ZAD,ZAE,ZAF, ZAG,ZAH,ZAJ,ZAL .....	12
5	PFHZZ	2815-01-287-4502	15434	3934046	PIN,PISTON PART OF KIT P/N 2DR671 UOC: ZAA,ZAB,ZAC,ZAD,ZAE,ZAF, ZAG,ZAH,ZAJ,ZAL .....	6
6	PAHZZ	2815-01-465-1960	15434	3802398	PARTS KIT,PISTON AS PART OF KIT P/N 2DR671 UOC: ZAA,ZAB,ZAC,ZAD,ZAE,ZAF, ZAG,ZAH,ZAJ,ZAL .....	6
7	PFHZZ	5325-01-280-5592	15434	3901996	. RING,RETAINING PART OF KIT P/N 2DR671 UOC: ZAA,ZAB,ZAC,ZAD,ZAE,ZAF, ZAG,ZAH,ZAJ,ZAL .....	2
8	XBHZZ		15434	3908750	. PISTON UOC: ZAA,ZAB,ZAC,ZAD,ZAE,ZAF, ZAG,ZAH,ZAJ,ZAL .....	1

(1) ITEM NO.	(2) SMR CODE	(3) NSN	(4) CAGEC	(5) PART NUMBER	(6) DESCRIPTION AND USABLE ON CODE (UOC)	(7) QTY
9	PAHZZ	2815-01-271-9792	45152	2DR674	. RING SET,PISTON UOC: ZAA,ZAB,ZAC,ZAD,ZAE,ZAF, ZAG,ZAH,ZAJ,ZAL .....	1

END OF FIGURE

**FIELD MAINTENANCE  
FRONT GEAR COVER (M939, M939A1)**

---

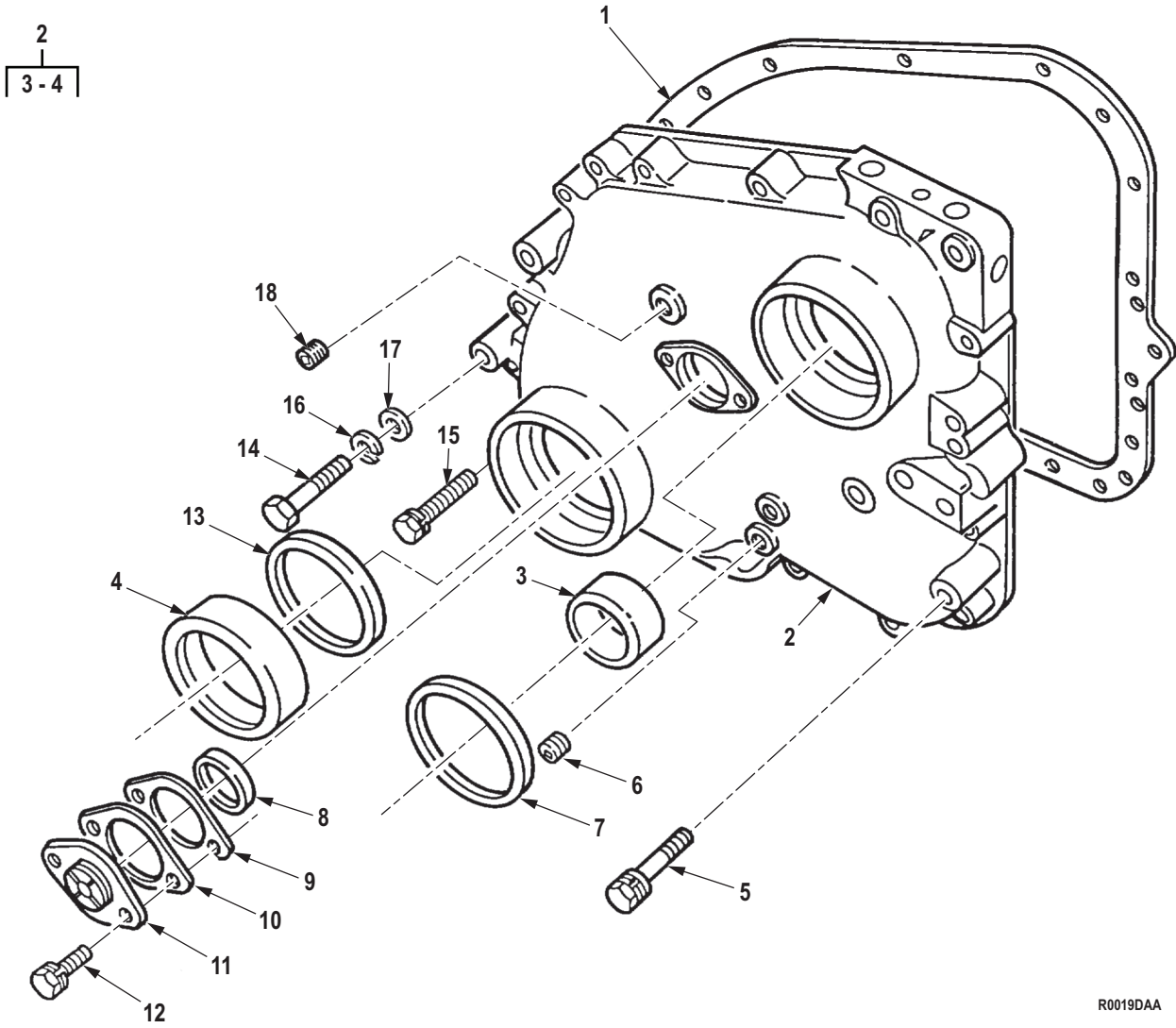

R0019DAA

Figure 19. Front Gear Cover (M939, M939A1).

(1) ITEM NO.	(2) SMR CODE	(3) NSN	(4) CAGEC	(5) PART NUMBER	(6) DESCRIPTION AND USABLE ON CODE (UOC)	(7) QTY
<b>GROUP 0105 VALVES, CAMSHAFTS, AND TIMING SYSTEM.</b>						
<b>FIG. 19. FRONT GEAR COVER (M939, M939A1).</b>						
1	PAHZZ	5330-00-193-7652	15434	3874038	GASKET PART OF KIT P/N 3011472 UOC: DAC,DAD,DAE,DAF,DAG,DA H,DAJ,DAL,DAW,DAX,V14,V15,V16, V17,V18,V19,V20,V21,V22,V24 .....	1
2	PFHZZ	2815-00-404-2915	15434	3024416	COVER,TIMING GEAR,I FRONT UOC: DAC,DAD,DAE,DAF,DAG,DA H,DAJ,DAL,DAW,DAX,V14,V15,V16, V17,V18,V19,V20,V21,V22,V24 .....	1
3	PAHZZ	3120-00-877-2213	15434	132770	. BEARING,SLEEVE UOC: DAC,DAD,DAE,DAF,DAG,DA H,DAJ,DAL,DAW,DAX,V14,V15,V16, V17,V18,V19,V20,V21,V22,V24 .....	1
4	PAHZZ	3120-00-882-7960	0B8S3	68226-1	. BUSHING,SLEEVE UOC: DAC,DAD,DAE,DAF,DAG,DA H,DAJ,DAL,DAW,DAX,V14,V15,V16, V17,V18,V19,V20,V21,V22,V24 .....	1
5	PAHZZ	5305-01-147-4033	15434	3011711	SCREW,CAP,HEXAGON H UOC: DAC,DAD,DAE,DAF,DAG,DA H,DAJ,DAL,DAW,DAX,V14,V15,V16, V17,V18,V19,V20,V21,V22,V24 .....	15
6	PAHZZ	4730-01-161-5115	15434	3013786	PLUG,PIPE UOC: DAC,DAD,DAE,DAF,DAG,DA H,DAJ,DAL,DAW,DAX,V14,V15,V16, V17,V18,V19,V20,V21,V22,V24 .....	1
7	PAFZZ	5330-00-135-6382	15434	211255	SEAL,PLAIN ENCASED PART OF KIT P/N 3011472 UOC: DAC,DAD,DAE,DAF,DAG,DA H,DAJ,DAL,DAW,DAX,V14,V15,V16, V17,V18,V19,V20,V21,V22,V24 .....	1
8	PAHZZ	5331-00-171-3879	15434	67270	O-RING PART OF KIT P/N 3011472 UOC: DAC,DAD,DAE,DAF,DAG,DA H,DAJ,DAL,DAW,DAX,V14,V15,V16, V17,V18,V19,V20,V21,V22,V24 .....	1
9	KBHZZ	5365-00-378-2885	15434	68192A	SHIM 0.010 PART OF KIT P/N BM56657 UOC: DAC,DAD,DAE,DAF,DAG,DA H,DAJ,DAL,DAW,DAX,V14,V15,V16, V17,V18,V19,V20,V21,V22,V24 .....	1
9	KBHZZ	5365-00-378-2886	15434	68192B	SHIM 0.005 PART OF KIT P/N BM56657 UOC: DAC,DAD,DAE,DAF,DAG,DA H,DAJ,DAL,DAW,DAX,V14,V15,V16, V17,V18,V19,V20,V21,V22,V24 .....	1

(1) ITEM NO.	(2) SMR CODE	(3) NSN	(4) CAGEC	(5) PART NUMBER	(6) DESCRIPTION AND USABLE ON CODE (UOC)	(7) QTY
9	KBHZZ	5365-00-378-2887	15434	68192C	SHIM 0.002 PART OF KIT P/N BM56657 UOC: DAC,DAD,DAE,DAF,DAG,DA H,DAJ,DAL,DAW,DAX,V14,V15,V16, V17,V18,V19,V20,V21,V22,V24 .....	1
10	PAHZZ	5365-01-121-3068	15434	185574	SPACER,PLATE UOC: DAC,DAD,DAE,DAF,DAG,DA H,DAJ,DAL,DAW,DAX,V14,V15,V16, V17,V18,V19,V20,V21,V22,V24 .....	1
11	PFHZZ	2815-00-033-9392	15434	138988	COVER PLATE,CAMSHAF UOC: DAC,DAD,DAE,DAF,DAG,DA H,DAJ,DAL,DAW,DAX,V14,V15,V16, V17,V18,V19,V20,V21,V22,V24 .....	1
12	PAHZZ	5305-01-165-3892	15434	3011714	SCREW UOC: DAC,DAD,DAE,DAF,DAG,DA H,DAJ,DAL,DAW,DAX,V14,V15,V16, V17,V18,V19,V20,V21,V22,V24 .....	2
13	PAFZZ	5330-00-006-2529	15434	208069	SEAL PART OF KIT P/N 3011472 UOC: DAC,DAD,DAE,DAF,DAG,DA H,DAJ,DAL,DAW,DAX,V14,V15,V16, V17,V18,V19,V20,V21,V22,V24 .....	1
14	PAHZZ	5305-00-942-2196	80204	B1821BH038C100D	SCREW,CAP,HEXAGON H UOC: DAC,DAD,DAE,DAF,DAG,DA H,DAJ,DAL,DAW,DAX,V14,V15,V16, V17,V18,V19,V20,V21,V22,V24 .....	2
15	PAHZZ	5305-01-145-8381	15434	3011713	SCREW,CAP,HEXAGON H UOC: DAC,DAD,DAE,DAF,DAG,DA H,DAJ,DAL,DAW,DAX,V14,V15,V16, V17,V18,V19,V20,V21,V22,V24 .....	1
16	PAHZZ	5310-00-637-9541	00198	132661	WASHER,LOCK UOC: DAC,DAD,DAE,DAF,DAG,DA H,DAJ,DAL,DAW,DAX,V14,V15,V16, V17,V18,V19,V20,V21,V22,V24 .....	2
17	PAHZZ	5310-00-080-6004	96906	MS27183-14	WASHER,FLAT UOC: DAC,DAD,DAE,DAF,DAG,DA H,DAJ,DAL,DAW,DAX,V14,V15,V16, V17,V18,V19,V20,V21,V22,V24 .....	2
18	PAHZZ	4730-01-030-4950	58536	AA59616ACABDA	PLUG,PIPE UOC: DAC,DAD,DAE,DAF,DAG,DA H,DAJ,DAL,DAW,DAX,V14,V15,V16, V17,V18,V19,V20,V21,V22,V24 .....	1

END OF FIGURE

**FIELD MAINTENANCE  
FRONT GEAR COVER (M939A2)**

---

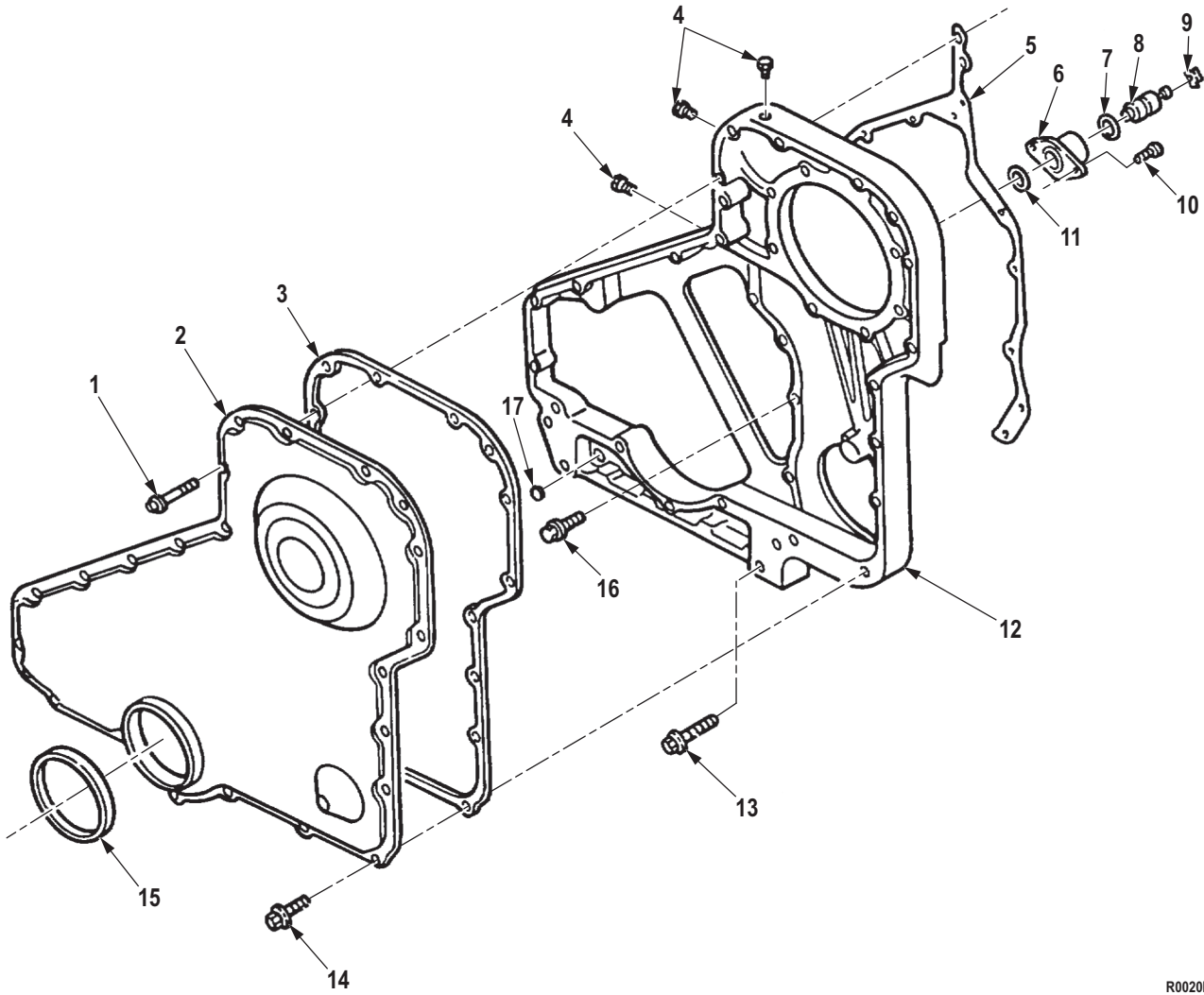

R0020DAA

Figure 20. Front Gear Cover (M939A2).



(1) ITEM NO.	(2) SMR CODE	(3) NSN	(4) CAGEC	(5) PART NUMBER	(6) DESCRIPTION AND USABLE ON CODE (UOC)	(7) QTY
<b>GROUP 0105 VALVES, CAMSHAFTS, AND TIMING SYSTEM.</b>						
<b>FIG. 20. FRONT GEAR COVER (M939A2).</b>						
1	PAHZZ	5306-01-237-1166	15434	3900633	BOLT,MACHINE UOC: ZAA,ZAB,ZAC,ZAD,ZAE,ZAF, ZAG,ZAH,ZAJ,ZAL .....	6
2	PAHZZ	2815-01-424-2581	15434	3916193	COVER,TIMING GEAR,I PART OF KIT P/N 5704533 UOC: ZAA,ZAB,ZAC,ZAD,ZAE,ZAF, ZAG,ZAH,ZAJ,ZAL .....	1
3	PAHZZ	5330-01-321-2053	0B8S3	3917780	GASKET PART OF KIT P/N 380055800 UOC: ZAA,ZAB,ZAC,ZAD,ZAE,ZAF, ZAG,ZAH,ZAJ,ZAL .....	1
4	PAHZZ	4730-01-292-4386	10988	J906619	PLUG,PIPE PART OF KIT P/N 3909415 UOC: ZAA,ZAB,ZAC,ZAD,ZAE,ZAF, ZAG,ZAH,ZAJ,ZAL .....	3
5	PAHZZ	5330-01-317-3213	0B8S3	397934900	GASKET PART OF KIT P/N 380055800 UOC: ZAA,ZAB,ZAC,ZAD,ZAE,ZAF, ZAG,ZAH,ZAJ,ZAL .....	1
6	PAHZZ	5342-01-275-0384	15434	3919683	HOUSNG,TIMING PIN UOC: ZAA,ZAB,ZAC,ZAD,ZAE,ZAF, ZAG,ZAH,ZAJ,ZAL .....	1
7	PAHZZ	5330-01-291-6537	15434	3913994	PACKING,PREFORMED PART OF KIT P/N 380055800 UOC: ZAA,ZAB,ZAC,ZAD,ZAE,ZAF, ZAG,ZAH,ZAJ,ZAL .....	1
8	PAHZZ	3040-01-189-1760	15434	3903924	SHAFT,SHOULDERED UOC: ZAA,ZAB,ZAC,ZAD,ZAE,ZAF, ZAG,ZAH,ZAJ,ZAL .....	1
9	PAHZZ	5325-00-598-1297	15434	3904849	RING,RETAINING UOC: ZAA,ZAB,ZAC,ZAD,ZAE,ZAF, ZAG,ZAH,ZAJ,ZAL .....	1
10	PAHZZ	5305-01-263-2708	15434	3907998	SCREW,MACHINE UOC: ZAA,ZAB,ZAC,ZAD,ZAE,ZAF, ZAG,ZAH,ZAJ,ZAL .....	2
11	PAHZZ	5330-01-263-6179	15434	391577200	GASKET PART OF KIT P/N 380055800 UOC: ZAA,ZAB,ZAC,ZAD,ZAE,ZAF, ZAG,ZAH,ZAJ,ZAL .....	1
12	PAHZZ	2815-01-424-3110	0B8S3	3926721	HOUSING,GEARBOX,TUR UOC: ZAA,ZAB,ZAC,ZAD,ZAE,ZAF, ZAG,ZAH,ZAJ,ZAL .....	1
13	PAHZZ	5305-01-274-4404	15434	3902116	SCREW,CAP,HEXAGON H UOC: ZAA,ZAB,ZAC,ZAD,ZAE,ZAF, ZAG,ZAH,ZAJ,ZAL .....	4

(1) ITEM NO.	(2) SMR CODE	(3) NSN	(4) CAGEC	(5) PART NUMBER	(6) DESCRIPTION AND USABLE ON CODE (UOC)	(7) QTY
14	PAHZZ	5305-01-237-4915	15434	3900629	SCREW,CAP,HEXAGON H UOC: ZAA,ZAB,ZAC,ZAD,ZAE,ZAF, ZAG,ZAH,ZAJ,ZAL .....	17
15	PAHZZ	5330-01-272-1108	15434	3908139	SEAL,PLAIN PART OF KIT P/N 380055800 UOC: ZAA,ZAB,ZAC,ZAD,ZAE,ZAF, ZAG,ZAH,ZAJ,ZAL .....	1
16	PAHZZ	5305-01-234-3755	15434	3900630	SCREW,CAP,HEXAGON H UOC: ZAA,ZAB,ZAC,ZAD,ZAE,ZAF, ZAG,ZAH,ZAJ,ZAL .....	5
17	PAHZZ	5340-01-112-4280	15434	210036	PLUG,EXPANSION UOC: ZAA,ZAB,ZAC,ZAD,ZAE,ZAF, ZAG,ZAH,ZAJ,ZAL .....	1

END OF FIGURE

**FIELD MAINTENANCE  
CAMSHAFT, GEAR, AND RELATED PARTS (M939, M939A1)**

---

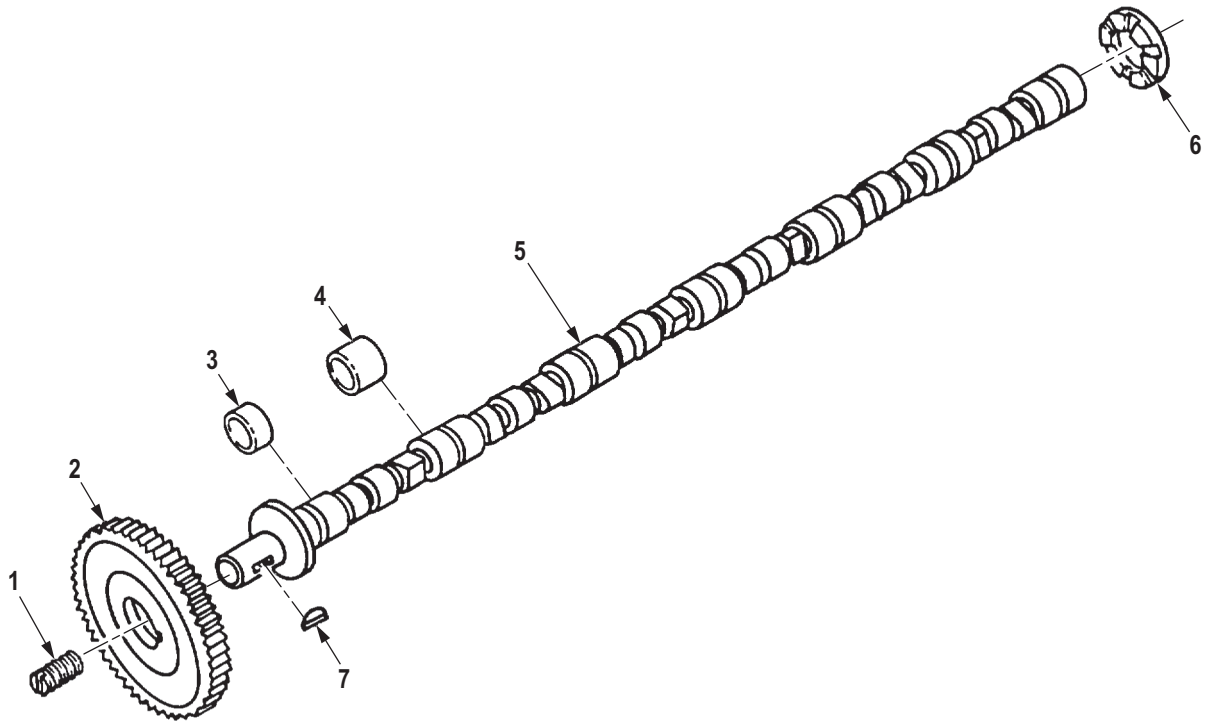

R0021DAA

Figure 21. Camshaft, Gear, and Related Parts (M939, M939A1).

(1) ITEM NO.	(2) SMR CODE	(3) NSN	(4) CAGEC	(5) PART NUMBER	(6) DESCRIPTION AND USABLE ON CODE (UOC)	(7) QTY
<b>GROUP 0105 VALVES, CAMSHAFTS, AND TIMING SYSTEM.</b>						
<b>FIG. 21. CAMSHAFT, GEAR, AND RELATED PARTS (M939, M939A1).</b>						
1	PAHZZ	5340-00-404-2944	15434	68193	PLUG, VENT UOC: DAC, DAD, DAE, DAF, DAG, DA H, DAJ, DAL, DAW, DAX, V14, V15, V16, V17, V18, V19, V20, V21, V22, V24 .....	1
2	KBHZZ		15434	3035194	GEAR, CAMSHAFT PART OF KIT P/N 5704533 UOC: DAC, DAD, DAE, DAF, DAG, DA H, DAJ, DAL, DAW, DAX, V14, V15, V16, V17, V18, V19, V20, V21, V22, V24 .....	1
3	KBHZZ	3120-00-573-0391	15434	100670	BEARING, SLEEVE PART OF KIT P/N BM27253 UOC: DAC, DAD, DAE, DAF, DAG, DA H, DAJ, DAL, DAW, DAX, V14, V15, V16, V17, V18, V19, V20, V21, V22, V24 .....	1
4	KBHZZ	3120-00-906-6657	15434	157870	BEARING, SLEEVE PART OF KIT P/N BM27253 UOC: DAC, DAD, DAE, DAF, DAG, DA H, DAJ, DAL, DAW, DAX, V14, V15, V16, V17, V18, V19, V20, V21, V22, V24 .....	6
5	PAHZZ	2815-00-791-1448	15434	3801030	CAMSHAFT, ENGINE UOC: DAC, DAD, DAE, DAF, DAG, DA H, DAJ, DAL, DAW, DAX, V14, V15, V16, V17, V18, V19, V20, V21, V22, V24 .....	1
6	PAHZZ	3120-00-374-4342	15434	9235-1	BEARING, WASHER, THRU UOC: DAC, DAD, DAE, DAF, DAG, DA H, DAJ, DAL, DAW, DAX, V14, V15, V16, V17, V18, V19, V20, V21, V22, V24 .....	1
7	PAHZZ	5315-00-616-5527	80205	MS35756-18	KEY, WOODRUFF UOC: DAC, DAD, DAE, DAF, DAG, DA H, DAJ, DAL, DAW, DAX, V14, V15, V16, V17, V18, V19, V20, V21, V22, V24 .....	1

**END OF FIGURE**



**FIELD MAINTENANCE  
CAMSHAFT, GEAR, AND RELATED PARTS (M939A2)**

---

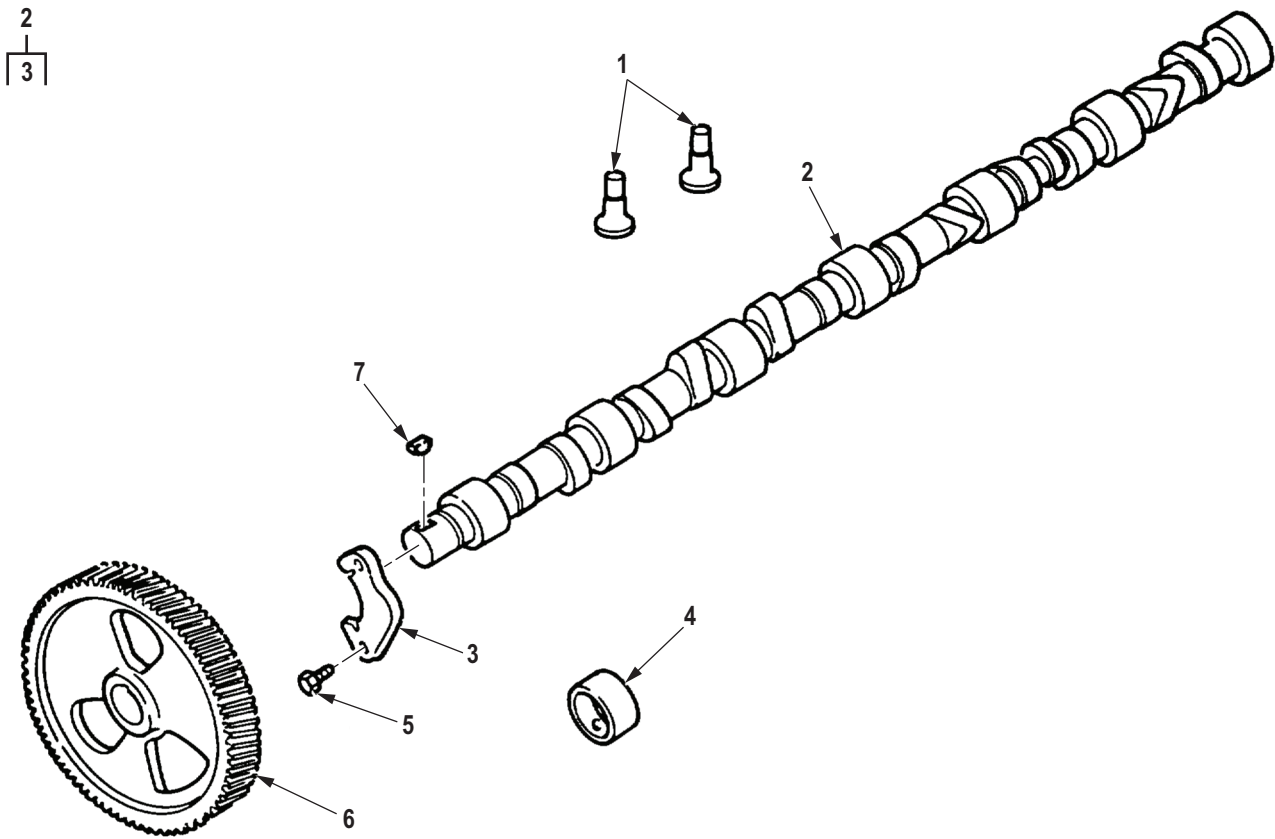

R002DAA

Figure 22. Camshaft, Gear, and Related Parts (M939A2).



(1) ITEM NO.	(2) SMR CODE	(3) NSN	(4) CAGEC	(5) PART NUMBER	(6) DESCRIPTION AND USABLE ON CODE (UOC)	(7) QTY
<b>GROUP 0105 VALVES, CAMSHAFTS, AND TIMING SYSTEM.</b>						
<b>FIG. 22. CAMSHAFT, GEAR, AND RELATED PARTS (M939A2).</b>						
1	PAHZZ	2815-01-440-9762	15434	3931623	TAPPET,ENGINE POPPE UOC: ZAA,ZAB,ZAC,ZAD,ZAE,ZAF, ZAG,ZAH,ZAJ,ZAL .....	12
2	PAHZZ	2805-01-486-6296	15434	3923478	CAMSHAFT,ENGINE UOC: ZAA,ZAB,ZAC,ZAD,ZAE,ZAF, ZAG,ZAH,ZAJ,ZAL .....	1
3	PAHZZ	2815-01-424-4736	15434	3927155	. SUPPORT,CAMSHAFT TH UOC: ZAA,ZAB,ZAC,ZAD,ZAE,ZAF, ZAG,ZAH,ZAJ,ZAL .....	1
4	PAHZZ	5365-01-271-1852	0B8S3	3945329	BUSHING BLANK UOC: ZAA,ZAB,ZAC,ZAD,ZAE,ZAF, ZAG,ZAH,ZAJ,ZAL .....	7
5	PAHZZ	5305-12-168-9310	D8286	DIN933M8X20-8-8B 2C	SCREW,CAP,HEXAGON H UOC: ZAA,ZAB,ZAC,ZAD,ZAE,ZAF, ZAG,ZAH,ZAJ,ZAL .....	2
6	PAHZZ	3020-01-414-8008	15434	3918777	GEAR,HELICAL UOC: ZAA,ZAB,ZAC,ZAD,ZAE,ZAF, ZAG,ZAH,ZAJ,ZAL .....	1
7	PAHZZ	5315-01-235-4688	15434	3902332	KEY,WOODRUFF UOC: ZAA,ZAB,ZAC,ZAD,ZAE,ZAF, ZAG,ZAH,ZAJ,ZAL .....	1

**END OF FIGURE**



**FIELD MAINTENANCE  
CAM FOLLOWER, HOUSING AND PUSH RODS (M939, M939A1)**

---



(1) ITEM NO.	(2) SMR CODE	(3) NSN	(4) CAGEC	(5) PART NUMBER	(6) DESCRIPTION AND USABLE ON CODE (UOC)	(7) QTY
<b>GROUP 0105 VALVES, CAMSHAFTS, AND TIMING SYSTEM.</b>						
<b>FIG. 23. CAM FOLLOWER, HOUSING AND PUSH RODS (M939, M939A1).</b>						
1	PAHZZ	2815-01-136-1987	15434	3046418	PUSH ROD,ENGINE POP UOC: DAC,DAD,DAE,DAF,DAG,DA H,DAJ,DAL,DAW,DAX,V14,V15,V16, V17,V18,V19,V20,V21,V22,V24 .....	12
2	PAHZZ	2815-01-136-1986	15434	3046431	PUSH ROD,ENGINE POP INTAKE UOC: DAC,DAD,DAE,DAF,DAG,DA H,DAJ,DAL,DAW,DAX,V14,V15,V16, V17,V18,V19,V20,V21,V22,V24 .....	6
3	PAHZZ	2815-01-114-7398	15434	3018051	HOUSING ASSEMBLY,CA UOC: DAC,DAD,DAE,DAF,DAG,DA H,DAJ,DAL,DAW,DAX,V14,V15,V16, V17,V18,V19,V20,V21,V22,V24 .....	3
4	PAHZZ	2815-00-505-5116	15434	4072124	. LEVER ASSEMBLY,CAM UOC: DAC,DAD,DAE,DAF,DAG,DA H,DAJ,DAL,DAW,DAX,V14,V15,V16, V17,V18,V19,V20,V21,V22,V24 .....	4
5	PFHZZ	5315-00-041-0916	15434	68513	. . PIN,STRAIGHT,HEADLE UOC: DAC,DAD,DAE,DAF,DAG,DA H,DAJ,DAL,DAW,DAX,V14,V15,V16, V17,V18,V19,V20,V21,V22,V24 .....	1
6	PFHZZ	2815-00-311-2521	15434	9260-1	. . ROLLER,VALVE CAM UOC: DAC,DAD,DAE,DAF,DAG,DA H,DAJ,DAL,DAW,DAX,V14,V15,V16, V17,V18,V19,V20,V21,V22,V24 .....	1
7	PAHZZ	5315-00-777-3544	15434	118939	. . PIN,STRAIGHT,HEADLE UOC: DAC,DAD,DAE,DAF,DAG,DA H,DAJ,DAL,DAW,DAX,V14,V15,V16, V17,V18,V19,V20,V21,V22,V24 .....	1
8	PFHZZ	2815-00-505-5119	15434	107738	. . SOCKET,CAM FOLLOWER UOC: DAC,DAD,DAE,DAF,DAG,DA H,DAJ,DAL,DAW,DAX,V14,V15,V16, V17,V18,V19,V20,V21,V22,V24 .....	1
9	PFHZZ	3120-00-659-7808	15434	3877037	. . BEARING,SLEEVE UOC: DAC,DAD,DAE,DAF,DAG,DA H,DAJ,DAL,DAW,DAX,V14,V15,V16, V17,V18,V19,V20,V21,V22,V24 .....	1
10	PAHZZ	2815-00-705-2851	15434	3018049	. LEVER ASSEMBLY,INJE UOC: DAC,DAD,DAE,DAF,DAG,DA H,DAJ,DAL,DAW,DAX,V14,V15,V16, V17,V18,V19,V20,V21,V22,V24 .....	3

(1) ITEM NO.	(2) SMR CODE	(3) NSN	(4) CAGEC	(5) PART NUMBER	(6) DESCRIPTION AND USABLE ON CODE (UOC)	(7) QTY
11	PFHZZ	5315-01-126-0601	15434	3017544	. . PIN,STRAIGHT,HEADLE UOC: DAC,DAD,DAE,DAF,DAG,DA H,DAJ,DAL,DAW,DAX,V14,V15,V16, V17,V18,V19,V20,V21,V22,V24 .....	1
12	PFHZZ	2815-00-362-1780	15434	3062096	. . ROLLER,INJECTOR CAM UOC: DAC,DAD,DAE,DAF,DAG,DA H,DAJ,DAL,DAW,DAX,V14,V15,V16, V17,V18,V19,V20,V21,V22,V24 .....	1
13	PFHZZ	5315-00-777-3544	15434	118939	. . PIN,STRAIGHT,HEADLE UOC: DAC,DAD,DAE,DAF,DAG,DA H,DAJ,DAL,DAW,DAX,V14,V15,V16, V17,V18,V19,V20,V21,V22,V24 .....	1
14	PFHZZ	2815-01-048-6702	15434	213559	. . SOCKET,CAM FOLLOWER UOC: DAC,DAD,DAE,DAF,DAG,DA H,DAJ,DAL,DAW,DAX,V14,V15,V16, V17,V18,V19,V20,V21,V22,V24 .....	1
15	PFHZZ	3120-00-791-1440	15434	118377	. . BEARING,SLEEVE UOC: DAC,DAD,DAE,DAF,DAG,DA H,DAJ,DAL,DAW,DAX,V14,V15,V16, V17,V18,V19,V20,V21,V22,V24 .....	1
16	PAHZZ	5305-00-339-1415	15434	69736	. SCREW,MACHINE UOC: DAC,DAD,DAE,DAF,DAG,DA H,DAJ,DAL,DAW,DAX,V14,V15,V16, V17,V18,V19,V20,V21,V22,V24 .....	2
17	PAHZZ	3040-00-388-3126	15434	3065125	. SHAFT,STRAIGHT UOC: DAC,DAD,DAE,DAF,DAG,DA H,DAJ,DAL,DAW,DAX,V14,V15,V16, V17,V18,V19,V20,V21,V22,V24 .....	2
18	PAHZZ	5340-00-485-0945	15434	175831	. PLUG,EXPANSION UOC: DAC,DAD,DAE,DAF,DAG,DA H,DAJ,DAL,DAW,DAX,V14,V15,V16, V17,V18,V19,V20,V21,V22,V24 .....	2
19	PAHZZ	2815-00-375-9892	15434	44035	. HOUSING,CAM FOLLOWE CAM FOLLOWER UOC: DAC,DAD,DAE,DAF,DAG,DA H,DAJ,DAL,DAW,DAX,V14,V15,V16, V17,V18,V19,V20,V21,V22,V24 .....	1
20	KBHZZ	5330-00-349-1219	15434	9266A	GASKET .007 PART OF KIT P/N 3011472, PART OF KIT P/N AR51482 UOC: DAC,DAD,DAE,DAF,DAG,DA H,DAJ,DAL,DAW,DAX,V14,V15,V16, V17,V18,V19,V20,V21,V22,V24 .....	1
20	KBHZZ	5330-01-266-1047	15434	3011272	GASKET .020-.024 PART OF KIT P/N 3011472, PART OF KIT P/N AR51482 UOC: DAC,DAD,DAE,DAF,DAG,DA H,DAJ,DAL,DAW,DAX,V14,V15,V16, V17,V18,V19,V20,V21,V22,V24 .....	1

(1) ITEM NO.	(2) SMR CODE	(3) NSN	(4) CAGEC	(5) PART NUMBER	(6) DESCRIPTION AND USABLE ON CODE (UOC)	(7) QTY
20	KBHZZ	5330-00-175-6585	79150	18646MC4	GASKET .014-0.020 PART OF KIT P/N 3011472, PART OF KIT P/N AR51482 UOC: DAC,DAD,DAE,DAF,DAG,DA H,DAJ,DAL,DAW,DAX,V14,V15,V16, V17,V18,V19,V20,V21,V22,V24 .....	1
20	KBHZZ	5330-01-267-6189	15434	3011273	GASKET .037-.041 PART OF KIT P/N 3011472, PART OF KIT P/N AR51482 UOC: DAC,DAD,DAE,DAF,DAG,DA H,DAJ,DAL,DAW,DAX,V14,V15,V16, V17,V18,V19,V20,V21,V22,V24 .....	1
20	KBHZZ	5330-00-777-3545	15434	120819	GASKET .027-.033 PART OF KIT P/N 3011472, PART OF KIT P/N AR51482 UOC: DAC,DAD,DAE,DAF,DAG,DA H,DAJ,DAL,DAW,DAX,V14,V15,V16, V17,V18,V19,V20,V21,V22,V24 .....	1
21	PAHZZ	5305-01-197-3449	15434	3010593	SCREW,CAP,HEXAGON H UOC: DAC,DAD,DAE,DAF,DAG,DA H,DAJ,DAL,DAW,DAX,V14,V15,V16, V17,V18,V19,V20,V21,V22,V24 .....	18

END OF FIGURE





**FIELD MAINTENANCE  
VALVES, SPRINGS, GUIDES, AND MISCELLANEOUS PARTS (M939, M939A1)**

---

6  
7-9

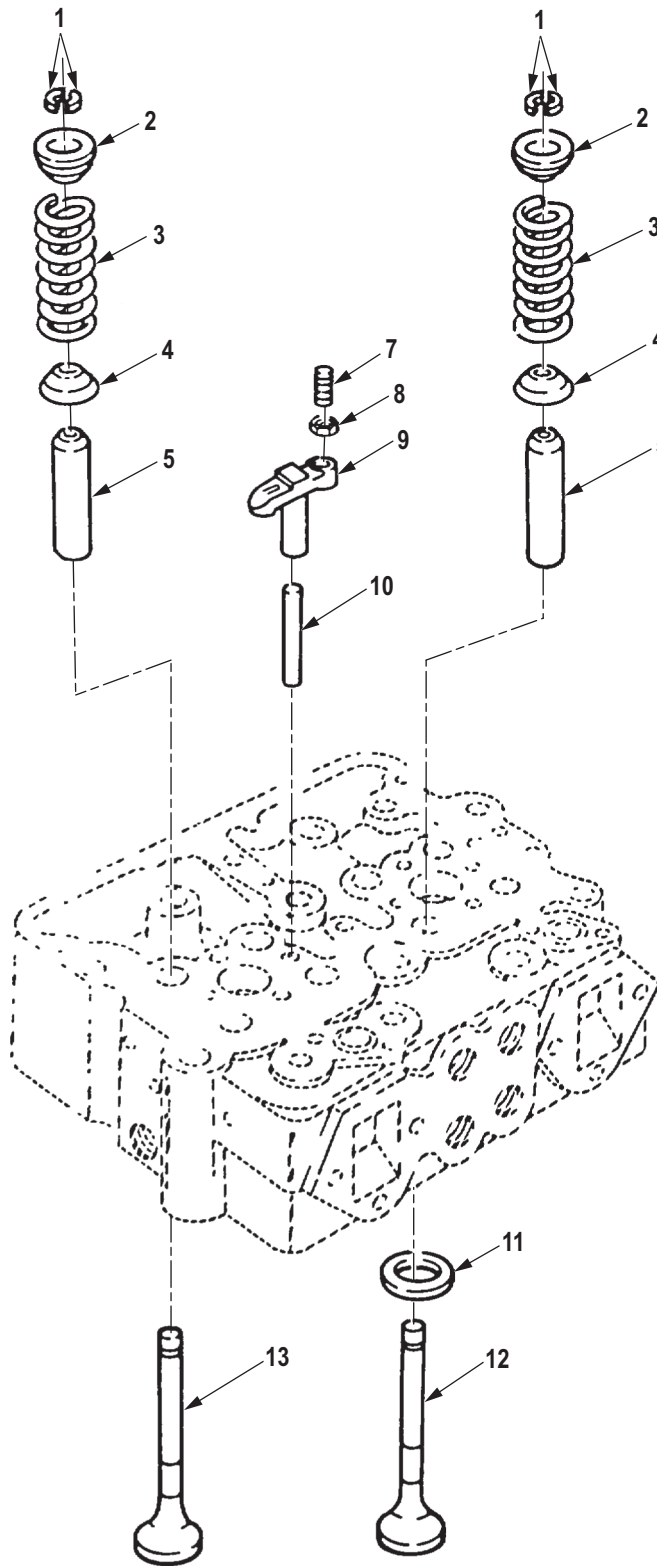

R0024DAA

Figure 24. Valves, Springs, Guides, and Miscellaneous Parts (M939, M939A1).

(1) ITEM NO.	(2) SMR CODE	(3) NSN	(4) CAGEC	(5) PART NUMBER	(6) DESCRIPTION AND USABLE ON CODE (UOC)	(7) QTY
<b>GROUP 0105 VALVES, CAMSHAFTS, AND TIMING SYSTEM.</b>						
<b>FIG. 24. VALVES, SPRINGS, GUIDES, AND MISCELLANEOUS PARTS (M939, M939A1).</b>						
1	PAHZZ	5342-01-143-6048	15434	127554	HALF-COLLET UOC: DAC,DAD,DAE,DAF,DAG,DA H,DAJ,DAL,DAW,DAX,V14,V15,V16, V17,V18,V19,V20,V21,V22,V24 .....	48
2	PAHZZ	5340-00-933-3009	15434	170296	SEAT,HELICAL COMPRE UOC: DAC,DAD,DAE,DAF,DAG,DA H,DAJ,DAL,DAW,DAX,V14,V15,V16, V17,V18,V19,V20,V21,V22,V24 .....	24
3	PAHZZ	5360-00-009-9270	15434	211999	SPRING,HELICAL,COMP EXHAUST UOC: DAC,DAD,DAE,DAF,DAG,DA H,DAJ,DAL,DAW,DAX,V14,V15,V16, V17,V18,V19,V20,V21,V22,V24 .....	24
4	PAHZZ	5340-00-632-6239	15434	172034	SEAT,HELICAL COMPRE SPRING,VALVE UOC: DAC,DAD,DAE,DAF,DAG,DA H,DAJ,DAL,DAW,DAX,V14,V15,V16, V17,V18,V19,V20,V21,V22,V24 .....	24
5	PAHZZ	2815-01-085-2618	15434	3006456	GUIDE,VALVE STEM UOC: DAC,DAD,DAE,DAF,DAG,DA H,DAJ,DAL,DAW,DAX,V14,V15,V16, V17,V18,V19,V20,V21,V22,V24 .....	24
6	PAHZZ	2815-01-159-1789	15434	3030038	VALVE,CROSSHEAD ASS UOC: DAC,DAD,DAE,DAF,DAG,DA H,DAJ,DAL,DAW,DAX,V14,V15,V16, V17,V18,V19,V20,V21,V22,V24 .....	12
7	PAHZZ	5305-00-062-4378	15434	147389	. SETSCREW UOC: DAC,DAD,DAE,DAF,DAG,DA H,DAJ,DAL,DAW,DAX,V14,V15,V16, V17,V18,V19,V20,V21,V22,V24 .....	1
8	PAHZZ	5310-00-426-3990	15434	203131	. NUT,CROSS HD UOC: DAC,DAD,DAE,DAF,DAG,DA H,DAJ,DAL,DAW,DAX,V14,V15,V16, V17,V18,V19,V20,V21,V22,V24 .....	1
9	XAHZZ		15434	3030038XA	. VALVE,CROSSHEAD UOC: DAC,DAD,DAE,DAF,DAG,DA H,DAJ,DAL,DAW,DAX,V14,V15,V16, V17,V18,V19,V20,V21,V22,V24 .....	1
10	PAHZZ	5315-00-866-5015	15434	123558	PIN,STRAIGHT,HEADLE UOC: DAC,DAD,DAE,DAF,DAG,DA H,DAJ,DAL,DAW,DAX,V14,V15,V16, V17,V18,V19,V20,V21,V22,V24 .....	12

(1) ITEM NO.	(2) SMR CODE	(3) NSN	(4) CAGEC	(5) PART NUMBER	(6) DESCRIPTION AND USABLE ON CODE (UOC)	(7) QTY
11	PAHZZ	2815-01-127-3597	15434	4058033	INSERT,ENGINE VALVE .030 UOC: DAC,DAD,DAE,DAF,DAG,DA H,DAJ,DAL,DAW,DAX,V14,V15,V16, V17,V18,V19,V20,V21,V22,V24 .....	12
11	PAHZZ	2815-01-127-3598	15434	127934	INSERT,VALVE SEAT .040 UOC: DAC,DAD,DAE,DAF,DAG,DA H,DAJ,DAL,DAW,DAX,V14,V15,V16, V17,V18,V19,V20,V21,V22,V24 .....	12
11	PAHZZ	2815-01-127-1060	15434	4058032	INSERT,VALVE SEAT .020 UOC: DAC,DAD,DAE,DAF,DAG,DA H,DAJ,DAL,DAW,DAX,V14,V15,V16, V17,V18,V19,V20,V21,V22,V24 .....	12
11	PAHZZ	4820-01-300-2759	15434	127935	SEAT,VALVE .005 UOC: DAC,DAD,DAE,DAF,DAG,DA H,DAJ,DAL,DAW,DAX,V14,V15,V16, V17,V18,V19,V20,V21,V22,V24 .....	12
11	PAHZZ	2815-00-132-0240	15434	4058031	INSERT,ENGINE VALVE .010 UOC: DAC,DAD,DAE,DAF,DAG,DA H,DAJ,DAL,DAW,DAX,V14,V15,V16, V17,V18,V19,V20,V21,V22,V24 .....	12
12	PAHZZ	2815-01-354-2702	15434	3803512	VALVE,POPPET,ENGINE INTAKE UOC: DAC,DAD,DAE,DAF,DAG,DA H,DAJ,DAL,DAW,DAX,V14,V15,V16, V17,V18,V19,V20,V21,V22,V24 .....	12
13	PAHZZ	2815-00-962-5623	15434	3803524	VALVE,POPPET,ENGINE EXHAUST UOC: DAC,DAD,DAE,DAF,DAG,DA H,DAJ,DAL,DAW,DAX,V14,V15,V16, V17,V18,V19,V20,V21,V22,V24 .....	12

END OF FIGURE

**FIELD MAINTENANCE  
VALVES, SPRINGS, GUIDES, AND MISCELLANEOUS PARTS (M939A2)**

---

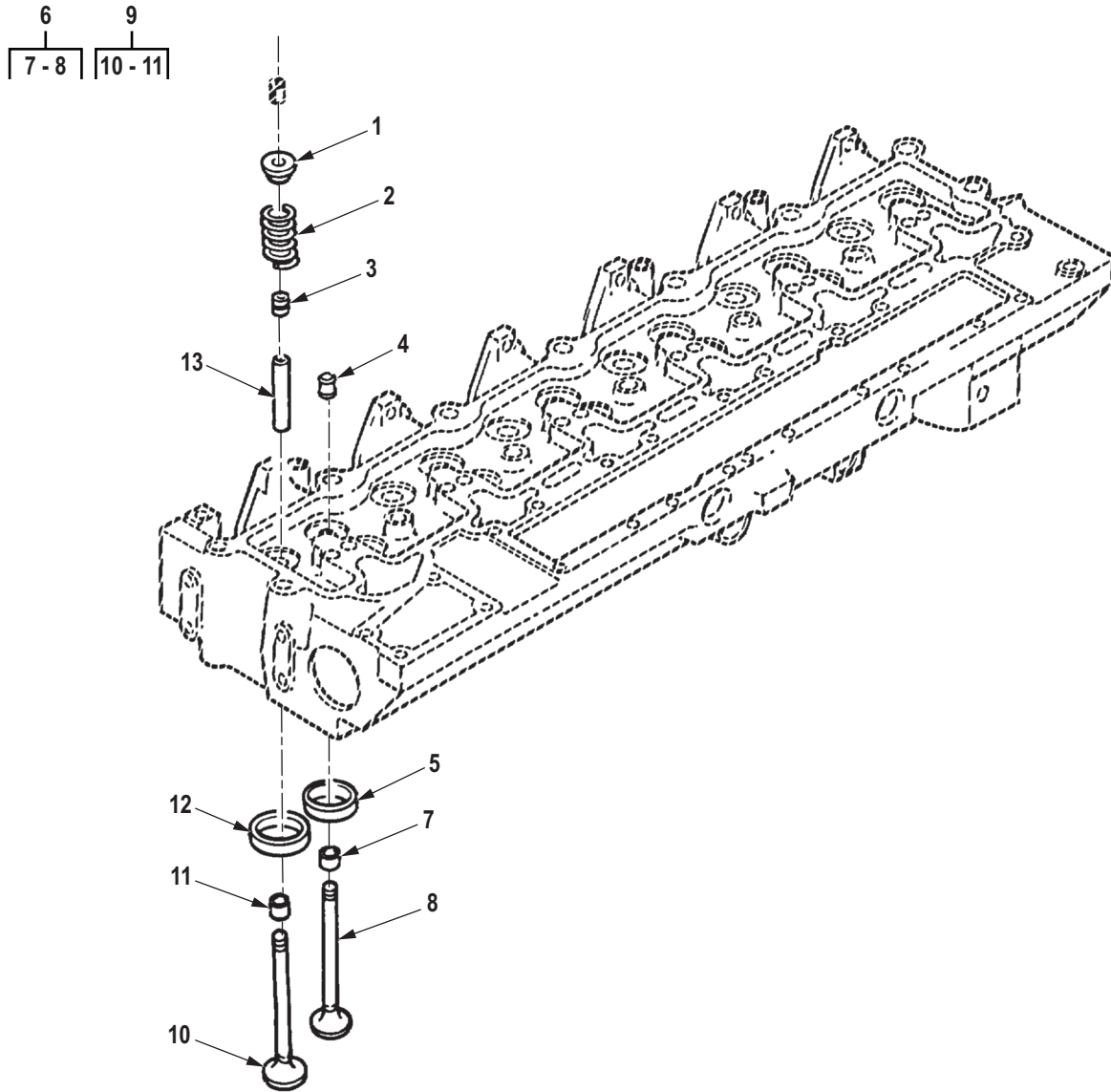

R0025DAA

Figure 25. Valves, Springs, Guides, and Miscellaneous Parts (M939A2).

(1) ITEM NO.	(2) SMR CODE	(3) NSN	(4) CAGEC	(5) PART NUMBER	(6) DESCRIPTION AND USABLE ON CODE (UOC)	(7) QTY
<b>GROUP 0105 VALVES, CAMSHAFTS, AND TIMING SYSTEM.</b>						
<b>FIG. 25. VALVES, SPRINGS, GUIDES, AND MISCELLANEOUS PARTS (M939A2).</b>						
1	PAHZZ	5340-01-271-2485	15434	3972757	SEAT,HELICAL COMPRE UOC: ZAA,ZAB,ZAC,ZAD,ZAE,ZAF, ZAG,ZAH,ZAJ,ZAL .....	12
2	PAHZZ	5360-01-271-8282	15434	3906412	SPRING,HELICAL,COMP UOC: ZAA,ZAB,ZAC,ZAD,ZAE,ZAF, ZAG,ZAH,ZAJ,ZAL .....	12
3	PAHZZ	5340-01-281-7792	15434	392764200	RETAINER,HELICAL CO PART OF KIT P/N 3802622, PART OF KIT P/N 3800748, PART OF KIT P/N 3802367 UOC: ZAA,ZAB,ZAC,ZAD,ZAE,ZAF, ZAG,ZAH,ZAJ,ZAL .....	12
4	KBHZZ		15434	3919038	SEAL,PLAIN EXHAUST PART OF KIT P/N 3802622, PART OF KIT P/N 3800748, PART OF KIT P/N 3802367 UOC: ZAA,ZAB,ZAC,ZAD,ZAE,ZAF, ZAG,ZAH,ZAJ,ZAL .....	12
5	PAHZZ	2815-01-272-5538	15434	3929005	INSERT,ENGINE VALVE EXHAUST UOC: ZAA,ZAB,ZAC,ZAD,ZAE,ZAF, ZAG,ZAH,ZAJ,ZAL .....	6
6	PAHZZ	2815-01-271-9794	15434	3802085	VALVE,POPPET,ENGINE EXHAUST ASSEMBLY UOC: ZAA,ZAB,ZAC,ZAD,ZAE,ZAF, ZAG,ZAH,ZAJ,ZAL .....	6
7	PAHZZ	2815-01-271-7171	15434	3901177	. LOCK,VALVE SPRING R INTAKE COLLET UOC: ZAA,ZAB,ZAC,ZAD,ZAE,ZAF, ZAG,ZAH,ZAJ,ZAL .....	2
8	PAHZZ	1543-01-486-6292	15434	3921444	. VALVE,POPPET,ENGINE EXHAUST UOC: ZAA,ZAB,ZAC,ZAD,ZAE,ZAF, ZAG,ZAH,ZAJ,ZAL .....	1
9	PAHZZ	2815-01-272-6679	15434	3802463	VALVE,POPPET,ENGINE INTAKE ASSEMBLY UOC: ZAA,ZAB,ZAC,ZAD,ZAE,ZAF, ZAG,ZAH,ZAJ,ZAL .....	6
10	PAHZZ	1543-01-457-3762	15434	3924492	. VALVE,POPPET,ENGINE INTAKE UOC: ZAA,ZAB,ZAC,ZAD,ZAE,ZAF, ZAG,ZAH,ZAJ,ZAL .....	1
11	PAHZZ	2815-01-271-7171	15434	3901177	. LOCK,VALVE SPRING R EXHAUST COLLETT UOC: ZAA,ZAB,ZAC,ZAD,ZAE,ZAF, ZAG,ZAH,ZAJ,ZAL .....	2

(1) ITEM NO.	(2) SMR CODE	(3) NSN	(4) CAGEC	(5) PART NUMBER	(6) DESCRIPTION AND USABLE ON CODE (UOC)	(7) QTY
12	PAHZZ	2815-01-272-5539	15434	3908830	INSERT,ENGINE VALVE INTAKE UOC: ZAA,ZAB,ZAC,ZAD,ZAE,ZAF, ZAG,ZAH,ZAJ,ZAL .....	6
13	PFHZZ	2815-01-272-3980	45152	2DR636	GUIDE,VALVE STEM UOC: ZAA,ZAB,ZAC,ZAD,ZAE,ZAF, ZAG,ZAH,ZAJ,ZAL .....	12

END OF FIGURE



**FIELD MAINTENANCE  
ROCKER ARMS AND MISCELLANEOUS HARDWARE (M939, M939A1)**

---

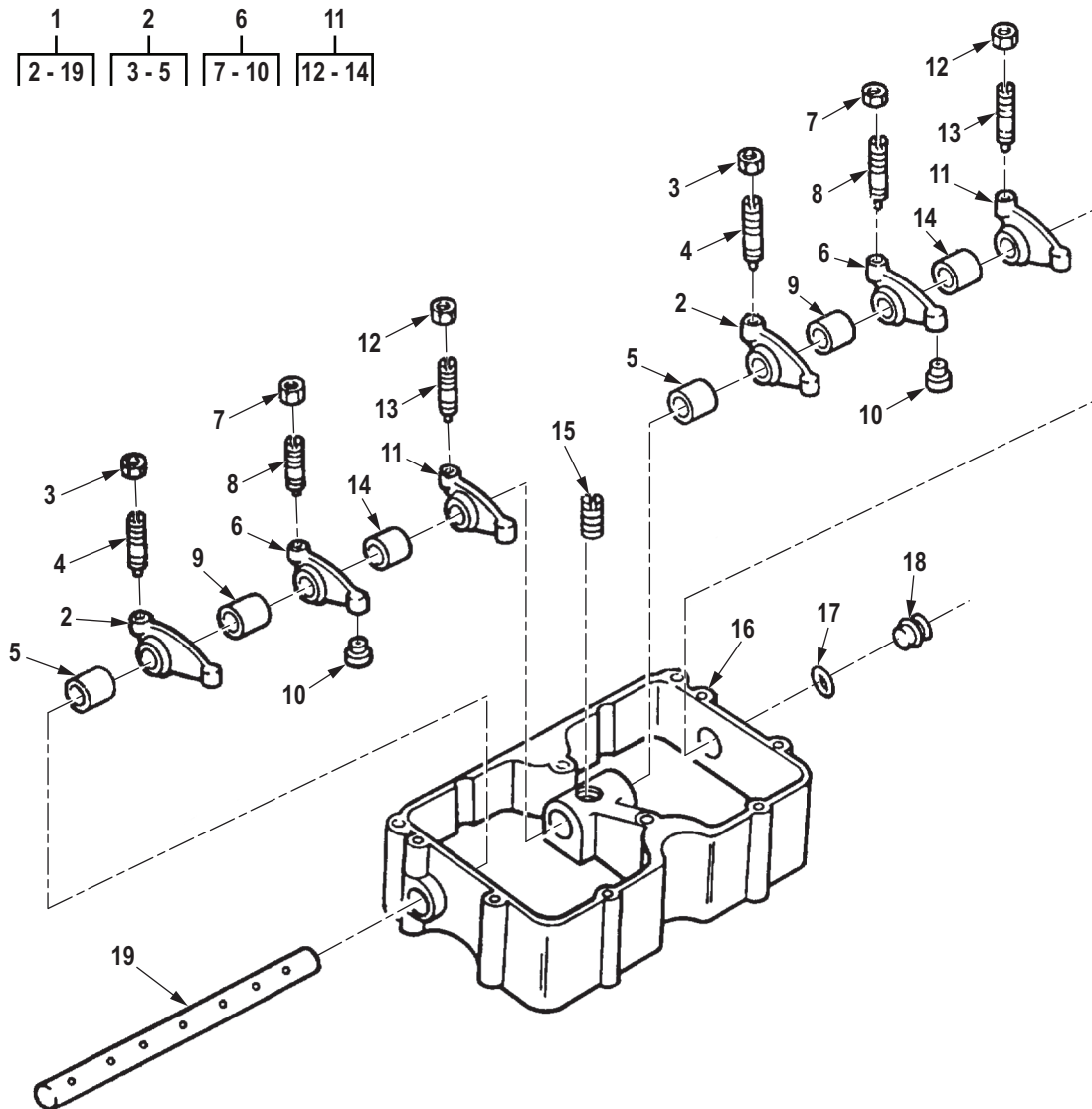

R0026DAA

Figure 26. Rocker Arms and Miscellaneous Hardware (M939, M939A1).

(1) ITEM NO.	(2) SMR CODE	(3) NSN	(4) CAGEC	(5) PART NUMBER	(6) DESCRIPTION AND USABLE ON CODE (UOC)	(7) QTY
<b>GROUP 0105 VALVES, CAMSHAFTS, AND TIMING SYSTEM.</b>						
<b>FIG. 26. ROCKER ARMS AND MISCELLANEOUS HARDWARE (M939, M939A1).</b>						
1	PFHHH	2815-01-085-2569	15434	3035961	HOUSING AND ROCKER UOC: DAC,DAD,DAE,DAF,DAG,DA H,DAJ,DAL,DAW,DAX,V14,V15,V16, V17,V18,V19,V20,V21,V22,V24 .....	3
2	PAHZZ	2815-01-096-9198	0B8S3	BM95161	. ROCKER ARM,ENGINE P UOC: DAC,DAD,DAE,DAF,DAG,DA H,DAJ,DAL,DAW,DAX,V14,V15,V16, V17,V18,V19,V20,V21,V22,V24 .....	2
3	PAHZZ	5310-00-732-0560	96906	MS51968-14	. . NUT,PLAIN,HEXAGON UOC: DAC,DAD,DAE,DAF,DAG,DA H,DAJ,DAL,DAW,DAX,V14,V15,V16, V17,V18,V19,V20,V21,V22,V24 .....	1
4	PAHZZ	5305-00-947-3437	15434	168306	. . SETSCREW ROCKER ARM ADJUSTING UOC: DAC,DAD,DAE,DAF,DAG,DA H,DAJ,DAL,DAW,DAX,V14,V15,V16, V17,V18,V19,V20,V21,V22,V24 .....	1
5	PAHZZ	3120-00-589-3537	15434	140330	. . BUSHING,SLEEVE UOC: DAC,DAD,DAE,DAF,DAG,DA H,DAJ,DAL,DAW,DAX,V14,V15,V16, V17,V18,V19,V20,V21,V22,V24 .....	1
6	PAHZZ	2815-00-005-7431	15434	AR-2308	. LEVER,INJECTOR,FUEL UOC: DAC,DAD,DAE,DAF,DAG,DA H,DAJ,DAL,DAW,DAX,V14,V15,V16, V17,V18,V19,V20,V21,V22,V24 .....	2
7	PAHZZ	5310-00-732-0560	96906	MS51968-14	. . NUT,PLAIN,HEXAGON UOC: DAC,DAD,DAE,DAF,DAG,DA H,DAJ,DAL,DAW,DAX,V14,V15,V16, V17,V18,V19,V20,V21,V22,V24 .....	1
8	PAHZZ	5305-00-947-3437	15434	168306	. . SETSCREW UOC: DAC,DAD,DAE,DAF,DAG,DA H,DAJ,DAL,DAW,DAX,V14,V15,V16, V17,V18,V19,V20,V21,V22,V24 .....	1
9	PAHZZ	3120-01-079-5208	15434	218153	. . BUSHING,SLEEVE UOC: DAC,DAD,DAE,DAF,DAG,DA H,DAJ,DAL,DAW,DAX,V14,V15,V16, V17,V18,V19,V20,V21,V22,V24 .....	1
10	PAHZZ	5340-00-404-2940	15434	194037	. . SEAT,BALL SOCKET UOC: DAC,DAD,DAE,DAF,DAG,DA H,DAJ,DAL,DAW,DAX,V14,V15,V16, V17,V18,V19,V20,V21,V22,V24 .....	1

(1) ITEM NO.	(2) SMR CODE	(3) NSN	(4) CAGEC	(5) PART NUMBER	(6) DESCRIPTION AND USABLE ON CODE (UOC)	(7) QTY
11	PAHZZ	2815-00-851-7637	0B8S3	BM95162	. ROCKER ARM,ENGINE P UOC: DAC,DAD,DAE,DAF,DAG,DA H,DAJ,DAL,DAW,DAX,V14,V15,V16, V17,V18,V19,V20,V21,V22,V24 .....	2
12	PAHZZ	5310-00-732-0560	96906	MS51968-14	. . NUT,PLAIN,HEXAGON UOC: DAC,DAD,DAE,DAF,DAG,DA H,DAJ,DAL,DAW,DAX,V14,V15,V16, V17,V18,V19,V20,V21,V22,V24 .....	1
13	PAHZZ	5305-00-947-3437	15434	168306	. . SETSCREW UOC: DAC,DAD,DAE,DAF,DAG,DA H,DAJ,DAL,DAW,DAX,V14,V15,V16, V17,V18,V19,V20,V21,V22,V24 .....	1
14	PAHZZ	3120-00-589-3537	15434	140330	. . BUSHING,SLEEVE UOC: DAC,DAD,DAE,DAF,DAG,DA H,DAJ,DAL,DAW,DAX,V14,V15,V16, V17,V18,V19,V20,V21,V22,V24 .....	1
15	PAHZZ	5305-00-297-4022	15434	168319	. SETSCREW UOC: DAC,DAD,DAE,DAF,DAG,DA H,DAJ,DAL,DAW,DAX,V14,V15,V16, V17,V18,V19,V20,V21,V22,V24 .....	1
16	PFHZZ	2815-01-210-6947	15434	3036285	. HOUSING,ROCKER ARM UOC: DAC,DAD,DAE,DAF,DAG,DA H,DAJ,DAL,DAW,DAX,V14,V15,V16, V17,V18,V19,V20,V21,V22,V24 .....	1
17	PAHZZ	5331-00-984-3756	02697	2-212 N0674-70	. O-RING UOC: DAC,DAD,DAE,DAF,DAG,DA H,DAJ,DAL,DAW,DAX,V14,V15,V16, V17,V18,V19,V20,V21,V22,V24 .....	1
18	PAHZZ	4730-01-124-0293	15434	218736	. PLUG,QUICK DISCONNE UOC: DAC,DAD,DAE,DAF,DAG,DA H,DAJ,DAL,DAW,DAX,V14,V15,V16, V17,V18,V19,V20,V21,V22,V24 .....	1
19	PAHZZ	3040-01-079-1799	15434	3801433	. SHAFT,STRAIGHT UOC: DAC,DAD,DAE,DAF,DAG,DA H,DAJ,DAL,DAW,DAX,V14,V15,V16, V17,V18,V19,V20,V21,V22,V24 .....	1

END OF FIGURE

**FIELD MAINTENANCE  
ROCKER ARMS AND MISCELLANEOUS HARDWARE (M939A2)**

---

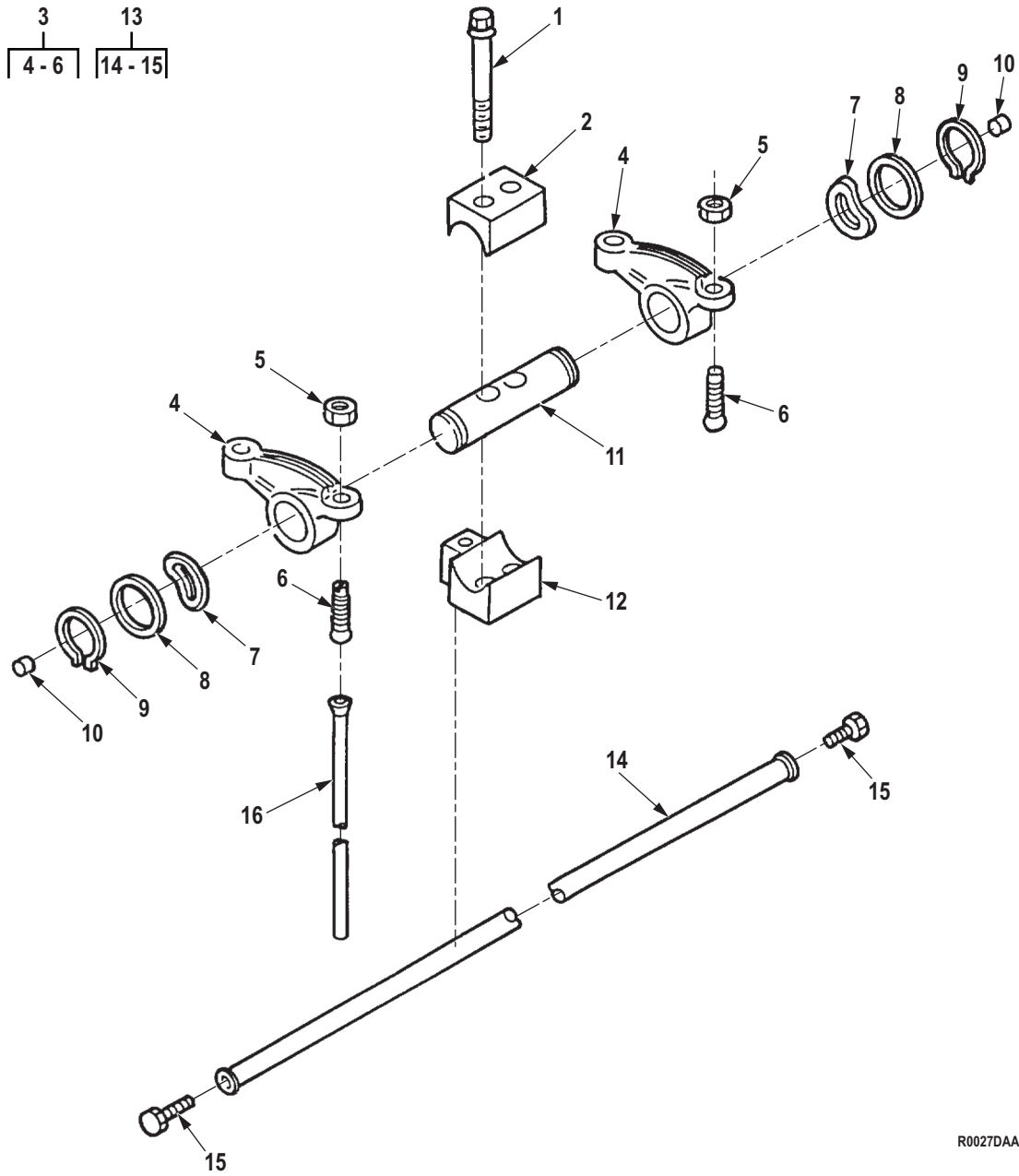

Figure 27. Rocker Arms and Miscellaneous Hardware (M939A2).

(1) ITEM NO.	(2) SMR CODE	(3) NSN	(4) CAGEC	(5) PART NUMBER	(6) DESCRIPTION AND USABLE ON CODE (UOC)	(7) QTY
<b>GROUP 0105 VALVES, CAMSHAFTS, AND TIMING SYSTEM.</b>						
<b>FIG. 27. ROCKER ARMS AND MISCELLANEOUS HARDWARE (M939A2).</b>						
1	PAHZZ	5305-01-271-4326	15434	3901617	SCREW,CAP, SOCKET HE UOC: ZAA,ZAB,ZAC,ZAD,ZAE,ZAF, ZAG,ZAH,ZAJ,ZAL .....	12
2	PAHZZ	5342-01-271-5704	15434	3901693	CLAMP,RETAINING UOC: ZAA,ZAB,ZAC,ZAD,ZAE,ZAF, ZAG,ZAH,ZAJ,ZAL .....	6
3	PAHHH	2815-01-271-5098	15434	390171700	ROCKER ARM,ENGINE P UOC: ZAA,ZAB,ZAC,ZAD,ZAE,ZAF, ZAG,ZAH,ZAJ,ZAL .....	12
4	XAHZZ		45152	2DR625	. ROCKER ARM,ENGINE P UOC: ZAA,ZAB,ZAC,ZAD,ZAE,ZAF, ZAG,ZAH,ZAJ,ZAL .....	2
5	PAHZZ	5310-01-165-2184	15434	S-205	. NUT UOC: ZAA,ZAB,ZAC,ZAD,ZAE,ZAF, ZAG,ZAH,ZAJ,ZAL .....	2
6	PAHZZ	5305-01-197-1663	15434	3900706	. SCREW,MACHINE UOC: ZAA,ZAB,ZAC,ZAD,ZAE,ZAF, ZAG,ZAH,ZAJ,ZAL .....	2
7	PAHZZ	5310-01-270-8422	15434	3906100	WASHER,SPRING TENS UOC: ZAA,ZAB,ZAC,ZAD,ZAE,ZAF, ZAG,ZAH,ZAJ,ZAL .....	12
8	PAHZZ	5310-01-270-8386	15434	3907206	WASHER,FLAT UOC: ZAA,ZAB,ZAC,ZAD,ZAE,ZAF, ZAG,ZAH,ZAJ,ZAL .....	12
9	PAHZZ	5325-01-270-8360	15434	3901764	RING,RETAINING UOC: ZAA,ZAB,ZAC,ZAD,ZAE,ZAF, ZAG,ZAH,ZAJ,ZAL .....	12
10	PAHZZ	5340-01-239-7078	15434	203933	PLUG,EXPANSION UOC: ZAA,ZAB,ZAC,ZAD,ZAE,ZAF, ZAG,ZAH,ZAJ,ZAL .....	12
11	PAHZZ	2815-01-271-3763	15434	3915416	SHAFT,ROCKER ARM,EN UOC: ZAA,ZAB,ZAC,ZAD,ZAE,ZAF, ZAG,ZAH,ZAJ,ZAL .....	6
12	PAHZZ	2815-01-271-5074	15434	3905870	SUPPORT,ROCKER LEVE UOC: ZAA,ZAB,ZAC,ZAD,ZAE,ZAF, ZAG,ZAH,ZAJ,ZAL .....	6
13	PAHZZ	4710-01-271-7921	15434	3910911	TUBE,METALLIC UOC: ZAA,ZAB,ZAC,ZAD,ZAE,ZAF, ZAG,ZAH,ZAJ,ZAL .....	1
14	XAHZZ		15434	3910911XA	. TUBE,METALLIC UOC: ZAA,ZAB,ZAC,ZAD,ZAE,ZAF, ZAG,ZAH,ZAJ,ZAL .....	1

(1) ITEM NO.	(2) SMR CODE	(3) NSN	(4) CAGEC	(5) PART NUMBER	(6) DESCRIPTION AND USABLE ON CODE (UOC)	(7) QTY
15	PAHZZ	5305-01-272-4809	15434	3910981	. SCREW,CAP,HEXAGON H UOC: ZAA,ZAB,ZAC,ZAD,ZAE,ZAF, ZAG,ZAH,ZAJ,ZAL .....	2
16	PAHZZ	2815-01-271-5120	15434	3905194	PUSH ROD,ENGINE POP UOC: ZAA,ZAB,ZAC,ZAD,ZAE,ZAF, ZAG,ZAH,ZAJ,ZAL .....	12

END OF FIGURE



**FIELD MAINTENANCE  
VALVE COVER AND GASKET (M939, M939A1)**

---

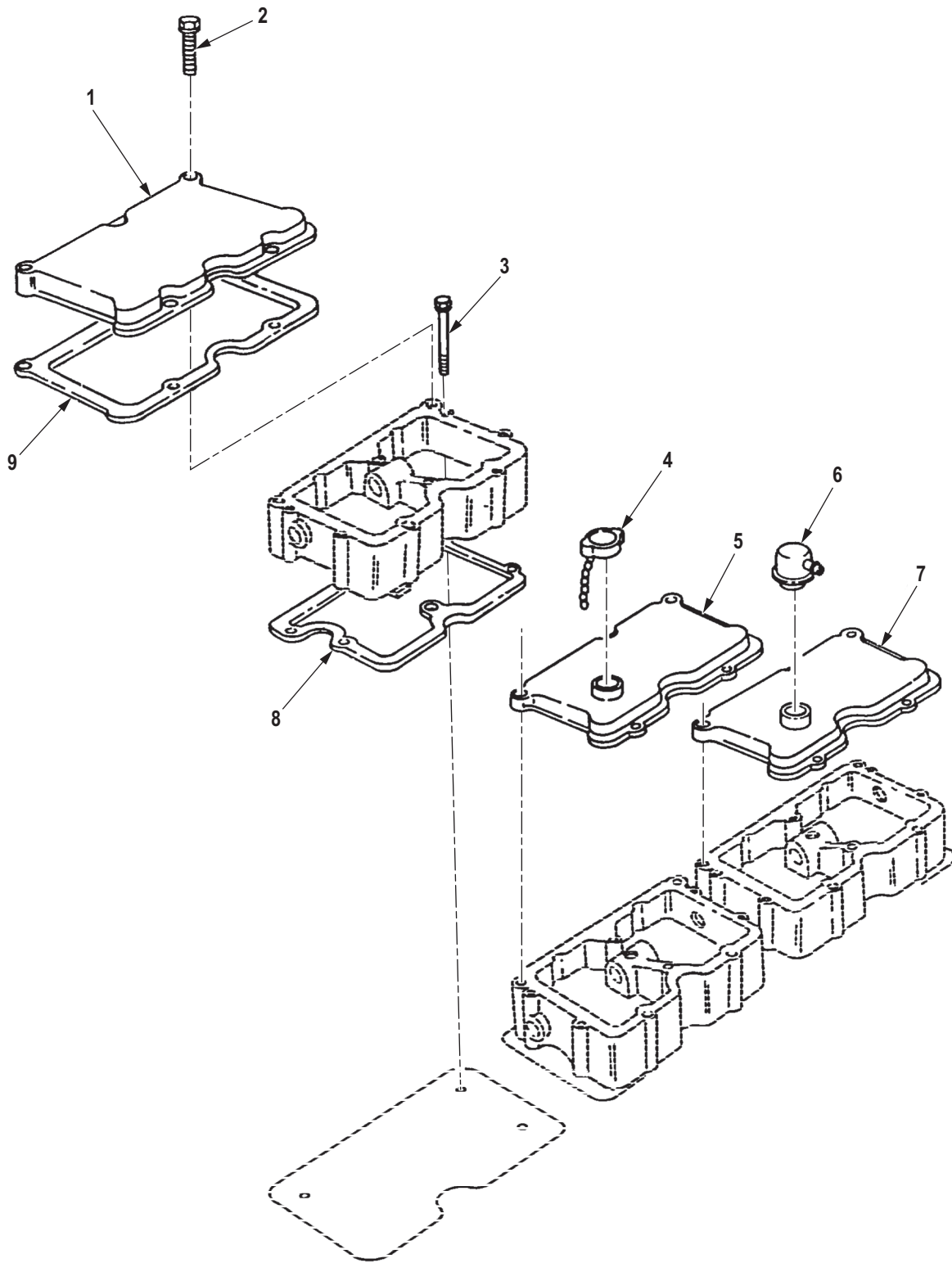

R0028DAA

Figure 28. Valve Cover and Gasket (M939, M939A1).

(1) ITEM NO.	(2) SMR CODE	(3) NSN	(4) CAGEC	(5) PART NUMBER	(6) DESCRIPTION AND USABLE ON CODE (UOC)	(7) QTY
<b>GROUP 0105 VALVES, CAMSHAFTS, AND TIMING SYSTEM.</b>						
<b>FIG. 28. VALVE COVER AND GASKET (M939, M939A1).</b>						
1	PFZZ	2815-01-146-1024	15434	3006358	COVER,ENGINE POPPET UOC: DAC,DAD,DAE,DAF,DAG,DA H,DAJ,DAL,DAW,DAX,V14,V15,V16, V17,V18,V19,V20,V21,V22,V24 .....	1
2	PAFZZ	5305-01-118-8826	15434	3006182	SCREW,CAP,HEXAGON H UOC: DAC,DAD,DAE,DAF,DAG,DA H,DAJ,DAL,DAW,DAX,V14,V15,V16, V17,V18,V19,V20,V21,V22,V24 .....	15
3	PAHZZ	5305-01-129-6901	15434	3010589	SCREW,ASSEMBLED WAS UOC: DAC,DAD,DAE,DAF,DAG,DA H,DAJ,DAL,DAW,DAX,V14,V15,V16, V17,V18,V19,V20,V21,V22,V24 .....	18
4	PAFZZ	2590-00-421-9524	15434	208045	CAP,FILLER OPENING UOC: DAC,DAD,DAE,DAF,DAG,DA H,DAJ,DAL,DAW,DAX,V14,V15,V16, V17,V18,V19,V20,V21,V22,V24 .....	1
5	PFZZ	2815-01-215-1705	15434	3012297	COVER,ENGINE POPPET UOC: DAC,DAD,DAE,DAF,DAG,DA H,DAJ,DAL,DAW,DAX,V14,V15,V16, V17,V18,V19,V20,V21,V22,V24 .....	1
6	PAFZZ	2815-01-146-1092	15434	3008595	BREATHER UOC: DAC,DAD,DAE,DAF,DAG,DA H,DAJ,DAL,DAW,DAX,V14,V15,V16, V17,V18,V19,V20,V21,V22,V24 .....	1
7	PFZZ	2815-01-142-1732	15434	3006183	COVER,ENGINE POPPET UOC: DAC,DAD,DAE,DAF,DAG,DA H,DAJ,DAL,DAW,DAX,V14,V15,V16, V17,V18,V19,V20,V21,V22,V24 .....	1
8	PAHZZ	5330-00-861-8592	15434	3017750	GASKET PART OF KIT P/N 3011472, PART OF KIT P/N 4024955 UOC: DAC,DAD,DAE,DAF,DAG,DA H,DAJ,DAL,DAW,DAX,V14,V15,V16, V17,V18,V19,V20,V21,V22,V24 .....	3
9	PAFZZ	5330-01-285-4827	15434	3054841	GASKET PART OF KIT P/N 3011472, PART OF KIT P/N 4024955 UOC: DAC,DAD,DAE,DAF,DAG,DA H,DAJ,DAL,DAW,DAX,V14,V15,V16, V17,V18,V19,V20,V21,V22,V24 .....	3

END OF FIGURE



**FIELD MAINTENANCE  
VALVE COVER AND GASKET (M939A2)**

---

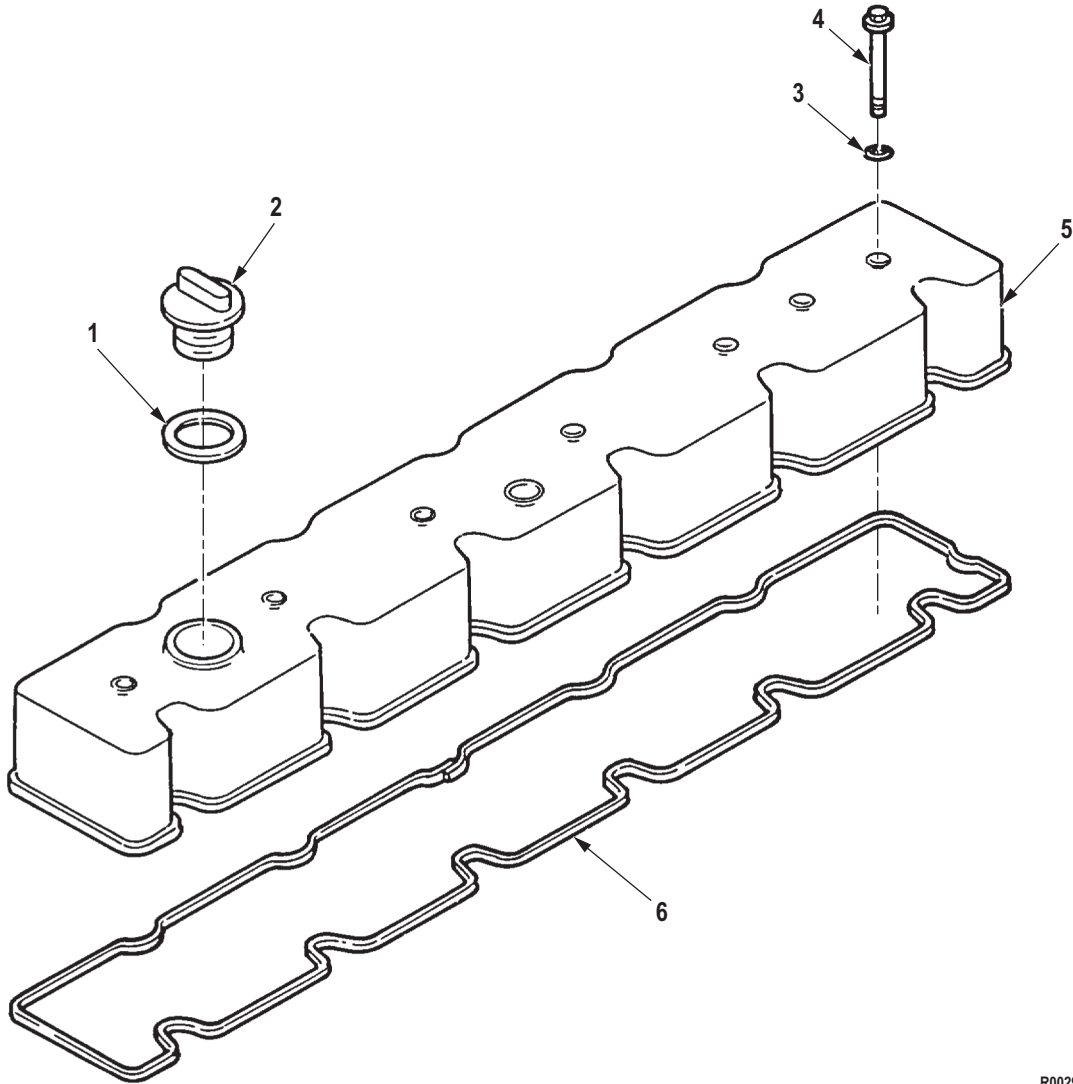

R0029DAA

Figure 29. Valve Cover and Gasket (M939A2).

(1) ITEM NO.	(2) SMR CODE	(3) NSN	(4) CAGEC	(5) PART NUMBER	(6) DESCRIPTION AND USABLE ON CODE (UOC)	(7) QTY
<b>GROUP 0105 VALVES, CAMSHAFTS, AND TIMING SYSTEM.</b>						
<b>FIG. 29. VALVE COVER AND GASKET (M939A2).</b>						
1	PAFZZ	5330-01-272-1246	15434	3902466	CAP,SEAL,NONMETALLI PART OF KIT P/N 3802622, PART OF KIT P/ N 3800748, PART OF KIT P/N 402527100 UOC: ZAA,ZAB,ZAC,ZAD,ZAE,ZAF, ZAG,ZAH,ZAJ,ZAL .....	1
2	PAFZZ	2590-01-273-3321	15434	3902468	CAP,FILLER OPENING UOC: ZAA,ZAB,ZAC,ZAD,ZAE,ZAF, ZAG,ZAH,ZAJ,ZAL .....	1
3	PAFZZ	5331-01-281-8997	15434	3910824	O-RING PART OF KIT P/N 3802622, PART OF KIT P/N 3800748, PART OF KIT P/N 402527100 UOC: ZAA,ZAB,ZAC,ZAD,ZAE,ZAF, ZAG,ZAH,ZAJ,ZAL .....	6
4	PAFZZ	5305-01-273-1594	15434	3916585	SCREW,CAP,HEXAGON H UOC: ZAA,ZAB,ZAC,ZAD,ZAE,ZAF, ZAG,ZAH,ZAJ,ZAL .....	6
5	PAFZZ	2815-01-272-3954	15434	393090300	COVER,ENGINE POPPET UOC: ZAA,ZAB,ZAC,ZAD,ZAE,ZAF, ZAG,ZAH,ZAJ,ZAL .....	1
6	PAFZZ	5330-01-271-8307	15434	3905449	GASKET PART OF KIT P/N 3802622, PART OF KIT P/N 3800748, PART OF KIT P/N 402527100 UOC: ZAA,ZAB,ZAC,ZAD,ZAE,ZAF, ZAG,ZAH,ZAJ,ZAL .....	1
<b>END OF FIGURE</b>						





**FIELD MAINTENANCE  
ENGINE OIL FILTER (M939, M939A1)**

---

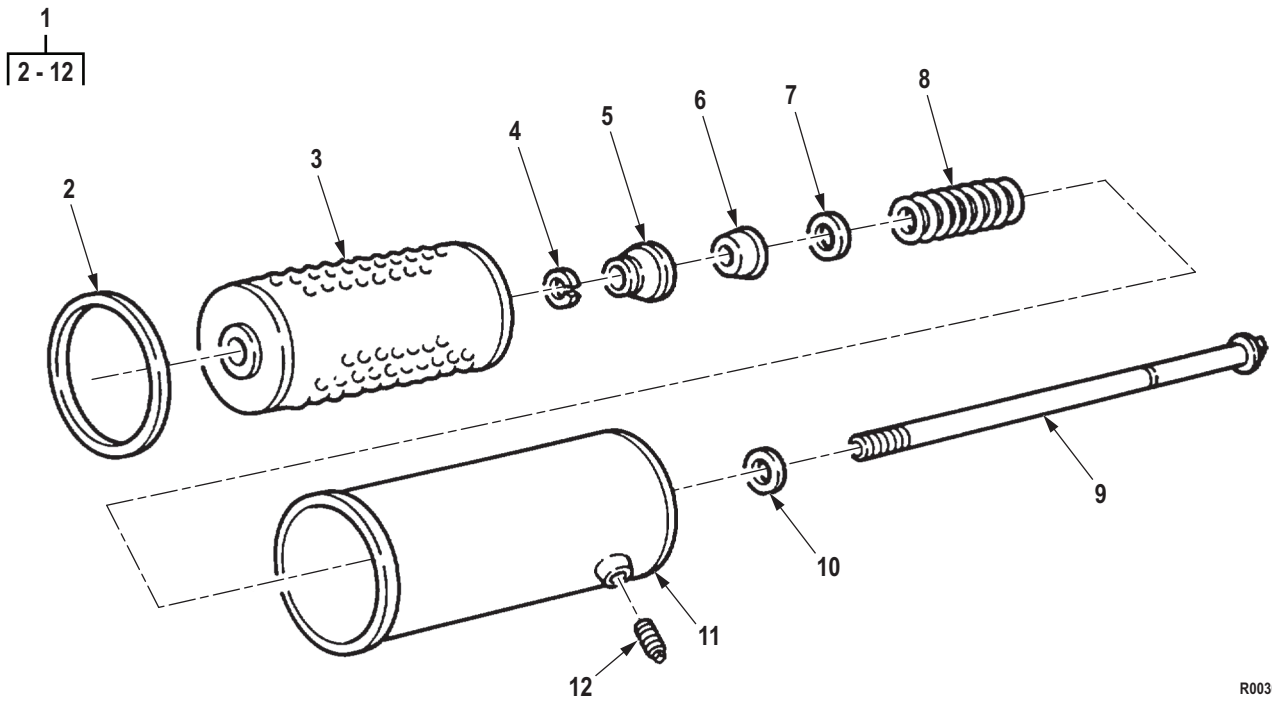

R0030DAA

Figure 30. Engine Oil Filter (M939, M939A1).

(1) ITEM NO.	(2) SMR CODE	(3) NSN	(4) CAGEC	(5) PART NUMBER	(6) DESCRIPTION AND USABLE ON CODE (UOC)	(7) QTY
<b>GROUP 0106 ENGINE LUBRICATION SYSTEM.</b>						
<b>FIG. 30. ENGINE OIL FILTER (M939, M939A1).</b>						
1	PFFZZ	2940-00-552-3842	33457	252916S	FILTER,FLUID UOC: DAC,DAD,DAE,DAF,DAG,DAH,DAJ,DAL,DAW,DAX,V14,V15,V16,V17,V18,V19,V20,V21,V22,V24 .....	1
2	KFFZZ	5330-00-927-4373	15434	153528	. PACKING ASSEMBLY PART OF KIT P/N 3011472, PART OF KIT P/N LF516/W 3836855 UOC: DAC,DAD,DAE,DAF,DAG,DAH,DAJ,DAL,DAW,DAX,V14,V15,V16,V17,V18,V19,V20,V21,V22,V24 .....	1
3	KFFZZ	2940-00-073-3316	15434	158139	. FILTER ELEMENT,FLUI PART OF KIT P/N LF516/W 3836855 UOC: DAC,DAD,DAE,DAF,DAG,DAH,DAJ,DAL,DAW,DAX,V14,V15,V16,V17,V18,V19,V20,V21,V22,V24 .....	1
4	PAFZZ	5325-01-209-7625	33457	3301956	. RING,RETAINING UOC: DAC,DAD,DAE,DAF,DAG,DAH,DAJ,DAL,DAW,DAX,V14,V15,V16,V17,V18,V19,V20,V21,V22,V24 .....	1
5	PAFZZ	1680-01-100-5608	15434	153521	. SUPPORT,CARTRIDGE UOC: DAC,DAD,DAE,DAF,DAG,DAH,DAJ,DAL,DAW,DAX,V14,V15,V16,V17,V18,V19,V20,V21,V22,V24 .....	1
6	PAFZZ	5330-01-044-2096	33457	153518	. GASKET UOC: DAC,DAD,DAE,DAF,DAG,DAH,DAJ,DAL,DAW,DAX,V14,V15,V16,V17,V18,V19,V20,V21,V22,V24 .....	1
7	PAFZZ	5310-00-249-6540	15434	153520	. WASHER,FLAT UOC: DAC,DAD,DAE,DAF,DAG,DAH,DAJ,DAL,DAW,DAX,V14,V15,V16,V17,V18,V19,V20,V21,V22,V24 .....	1
8	PAFZZ	5360-01-118-5596	15434	153519-S	. SPRING,HELICAL,COMP UOC: DAC,DAD,DAE,DAF,DAG,DAH,DAJ,DAL,DAW,DAX,V14,V15,V16,V17,V18,V19,V20,V21,V22,V24 .....	1
9	XAFZZ		15434	3301954	. BOLT,MACHINE UOC: DAC,DAD,DAE,DAF,DAG,DAH,DAJ,DAL,DAW,DAX,V14,V15,V16,V17,V18,V19,V20,V21,V22,V24 .....	1
10	PAFZZ	5310-00-246-0221	15434	8265	. WASHER,FLAT UOC: DAC,DAD,DAE,DAF,DAG,DAH,DAJ,DAL,DAW,DAX,V14,V15,V16,V17,V18,V19,V20,V21,V22,V24 .....	1

(1) ITEM NO.	(2) SMR CODE	(3) NSN	(4) CAGEC	(5) PART NUMBER	(6) DESCRIPTION AND USABLE ON CODE (UOC)	(7) QTY
11	PAFZZ	4930-01-124-3523	15434	153516	. FILTER BODY,FLUID UOC: DAC,DAD,DAE,DAF,DAG,DA H,DAJ,DAL,DAW,DAX,V14,V15,V16, V17,V18,V19,V20,V21,V22,V24 .....	1
12	PAFZZ	4730-00-924-7886	11083	5M6214	. PLUG,PIPE UOC: DAC,DAD,DAE,DAF,DAG,DA H,DAJ,DAL,DAW,DAX,V14,V15,V16, V17,V18,V19,V20,V21,V22,V24 .....	1

END OF FIGURE

**FIELD MAINTENANCE  
ENGINE OIL COOLER ASSEMBLY (M939, M939A1)**

---

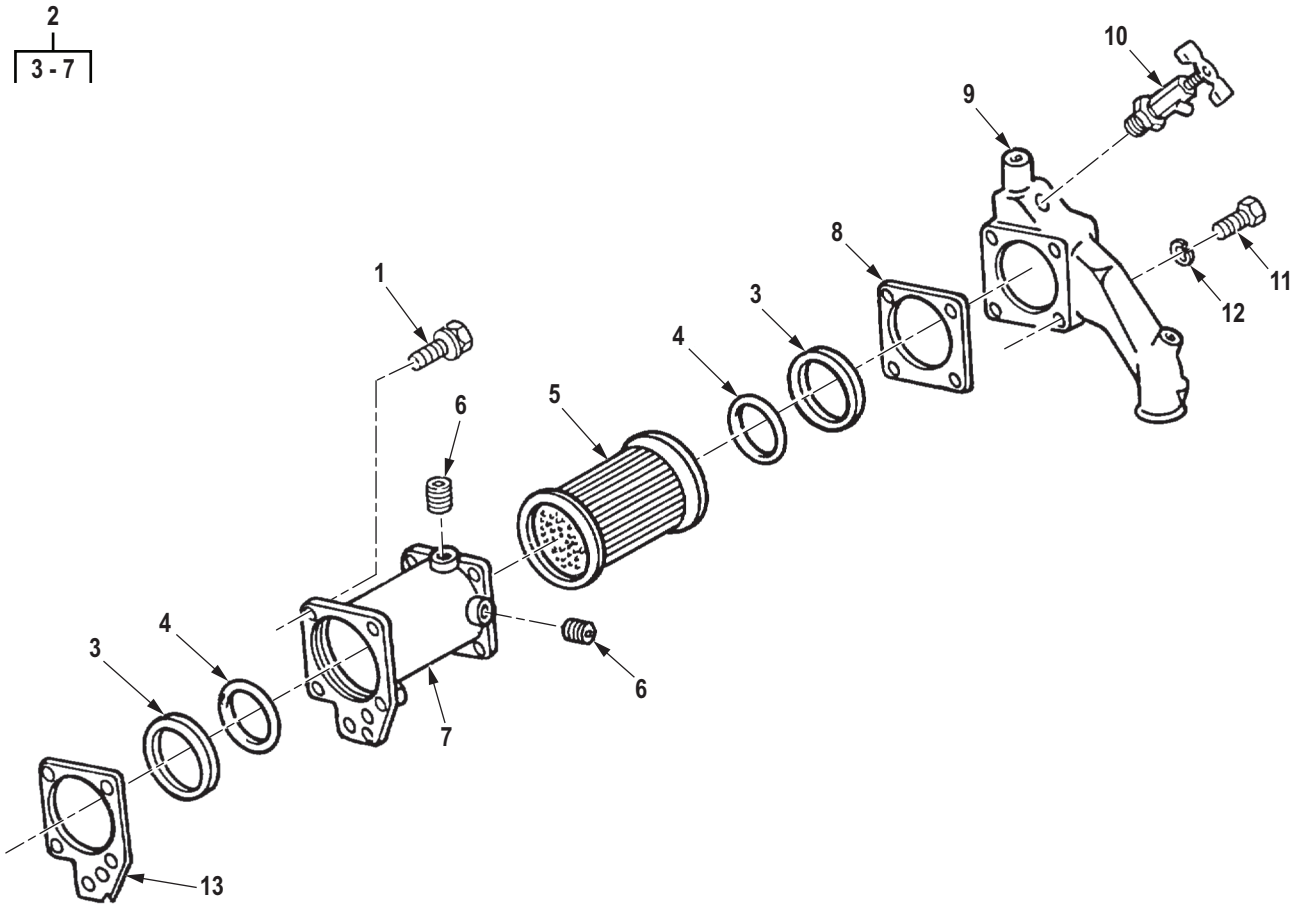

R0031DAA

Figure 31. Engine Oil Cooler Assembly (M939, M939A1).

(1) ITEM NO.	(2) SMR CODE	(3) NSN	(4) CAGEC	(5) PART NUMBER	(6) DESCRIPTION AND USABLE ON CODE (UOC)	(7) QTY
<b>GROUP 0106 ENGINE LUBRICATION SYSTEM.</b>						
<b>FIG. 31. ENGINE OIL COOLER ASSEMBLY (M939, M939A1).</b>						
1	PAFZZ	5305-01-088-6019	15434	3010596	SCREW,ASSEMBLED WAS UOC: DAC,DAD,DAE,DAF,DAG,DAH,DAJ,DAL,DAW,DAX,V14,V15,V16,V17,V18,V19,V20,V21,V22,V24 .....	5
2	PAFFF	2930-01-117-5238	15434	AR5128800	COOLER,LUBRICATING UOC: DAC,DAD,DAE,DAF,DAG,DAH,DAJ,DAL,DAW,DAX,V14,V15,V16,V17,V18,V19,V20,V21,V22,V24 .....	1
3	PAFZZ	5330-00-785-7894	15434	110827	. RETAINER,PACKING PART OF KIT P/N 3011472 UOC: DAC,DAD,DAE,DAF,DAG,DAH,DAJ,DAL,DAW,DAX,V14,V15,V16,V17,V18,V19,V20,V21,V22,V24 .....	2
4	PAFZZ	5331-01-160-7458	15434	3019116	. O-RING PART OF KIT P/N 3011472, PART OF KIT P/N AR51481 UOC: DAC,DAD,DAE,DAF,DAG,DAH,DAJ,DAL,DAW,DAX,V14,V15,V16,V17,V18,V19,V20,V21,V22,V24 .....	2
5	PAFZZ	2930-00-701-2091	15434	110848	. ELEMENT,OIL COOLER UOC: DAC,DAD,DAE,DAF,DAG,DAH,DAJ,DAL,DAW,DAX,V14,V15,V16,V17,V18,V19,V20,V21,V22,V24 .....	1
6	PAFZZ	4730-00-954-1281	58536	AA59616ACABCB	. PLUG,PIPE UOC: DAC,DAD,DAE,DAF,DAG,DAH,DAJ,DAL,DAW,DAX,V14,V15,V16,V17,V18,V19,V20,V21,V22,V24 .....	2
7	PAFZZ	2815-00-430-2090	15434	127863	. HOUSING,LUBE OIL CO UOC: DAC,DAD,DAE,DAF,DAG,DAH,DAJ,DAL,DAW,DAX,V14,V15,V16,V17,V18,V19,V20,V21,V22,V24 .....	1
8	PAFZZ	5330-00-328-8656	15434	68210	GASKET PART OF KIT P/N 3011472, PART OF KIT P/N AR51481 UOC: DAC,DAD,DAE,DAF,DAG,DAH,DAJ,DAL,DAW,DAX,V14,V15,V16,V17,V18,V19,V20,V21,V22,V24 .....	1
9	PAFZZ	5340-01-157-9898	15434	3030464	COVER,ACCESS UOC: DAC,DAD,DAE,DAF,DAG,DAH,DAJ,DAL,DAW,DAX,V14,V15,V16,V17,V18,V19,V20,V21,V22,V24 .....	1
10	PAFZZ	4820-00-845-1096	58536	AA59440/2-010	COCK,DRAIN UOC: DAC,DAD,DAE,DAF,DAG,DAH,DAJ,DAL,DAW,DAX,V14,V15,V16,V17,V18,V19,V20,V21,V22,V24 .....	1

(1) ITEM NO.	(2) SMR CODE	(3) NSN	(4) CAGEC	(5) PART NUMBER	(6) DESCRIPTION AND USABLE ON CODE (UOC)	(7) QTY
11	PAFZZ	5305-00-177-5552	15434	S126	SCREW,CAP,HEXAGON H UOC: DAC,DAD,DAE,DAF,DAG,DA H,DAJ,DAL,DAW,DAX,V14,V15,V16, V17,V18,V19,V20,V21,V22,V24 .....	4
12	PAFZZ	5310-00-637-9541	00198	132661	WASHER,LOCK UOC: DAC,DAD,DAE,DAF,DAG,DA H,DAJ,DAL,DAW,DAX,V14,V15,V16, V17,V18,V19,V20,V21,V22,V24 .....	4
13	PAFZZ	5330-01-079-6514	15434	3008017	GASKET PART OF KIT P/N 3011472, PART OF KIT P/N AR51481 UOC: DAC,DAD,DAE,DAF,DAG,DA H,DAJ,DAL,DAW,DAX,V14,V15,V16, V17,V18,V19,V20,V21,V22,V24 .....	1

END OF FIGURE



**FIELD MAINTENANCE  
ENGINE OIL COOLER AND FILTER (M939A2)**

---

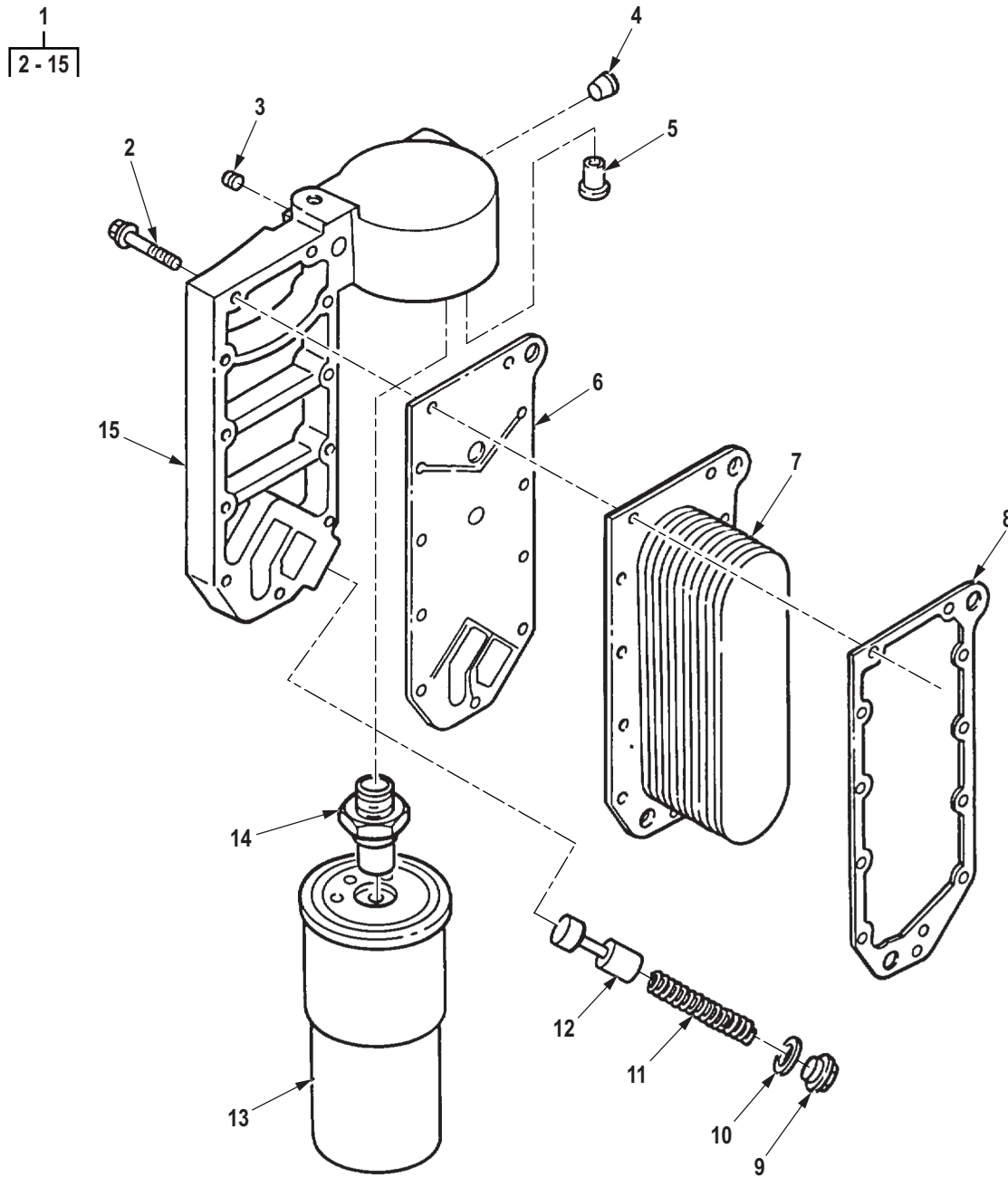

R0032DAA

Figure 32. Engine Oil Cooler and Filter (M939A2).

(1) ITEM NO.	(2) SMR CODE	(3) NSN	(4) CAGEC	(5) PART NUMBER	(6) DESCRIPTION AND USABLE ON CODE (UOC)	(7) QTY
<b>GROUP 0106 ENGINE LUBRICATION SYSTEM.</b>						
<b>FIG. 32. ENGINE OIL COOLER AND FILTER (M939A2).</b>						
1	AFFFF		15434	3918175-1	OIL COOLER,ENGINE UOC: ZAA,ZAB,ZAC,ZAD,ZAE,ZAF, ZAG,ZAH,ZAJ,ZAL .....	1
2	PAFZZ	5305-01-271-5850	15434	3901445	. SCREW,CAP,HEXAGON H UOC: ZAA,ZAB,ZAC,ZAD,ZAE,ZAF, ZAG,ZAH,ZAJ,ZAL .....	11
3	PAFZZ	4730-01-165-9491	15434	3008465	. PLUG,PIPE UOC: ZAA,ZAB,ZAC,ZAD,ZAE,ZAF, ZAG,ZAH,ZAJ,ZAL .....	1
4	PAFZZ	4730-01-214-7081	15434	3008469	. PLUG,PIPE PART OF KIT P/N 3909415 UOC: ZAA,ZAB,ZAC,ZAD,ZAE,ZAF, ZAG,ZAH,ZAJ,ZAL .....	1
5	PAFZZ	2815-01-211-5270	15434	3902338	. VALVE PRESSURE RELI UOC: ZAA,ZAB,ZAC,ZAD,ZAE,ZAF, ZAG,ZAH,ZAJ,ZAL .....	1
6	PAFZZ	5330-01-271-6404	15434	3914308	. GASKET PART OF KIT P/N 380055800 UOC: ZAA,ZAB,ZAC,ZAD,ZAE,ZAF, ZAG,ZAH,ZAJ,ZAL .....	1
7	PAFZZ	2930-01-271-5102	15434	3974815	. CORE ASSEMBLY,FLUID UOC: ZAA,ZAB,ZAC,ZAD,ZAE,ZAF, ZAG,ZAH,ZAJ,ZAL .....	1
8	PAFZZ	5330-01-271-5791	15434	3918174	. GASKET PART OF KIT P/N 380055800 UOC: ZAA,ZAB,ZAC,ZAD,ZAE,ZAF, ZAG,ZAH,ZAJ,ZAL .....	1
9	PAFZZ	5365-01-270-8290	15434	3906299	. PLUG,MACHINE THREAD UOC: ZAA,ZAB,ZAC,ZAD,ZAE,ZAF, ZAG,ZAH,ZAJ,ZAL .....	1
10	PAFZZ	5310-01-270-8388	15434	3901798	. WASHER,FLAT PART OF KIT P/ N 380055800 UOC: ZAA,ZAB,ZAC,ZAD,ZAE,ZAF, ZAG,ZAH,ZAJ,ZAL .....	1
11	PAFZZ	5360-00-664-5343	15434	68274	. SPRING,HELICAL,COMP UOC: ZAA,ZAB,ZAC,ZAD,ZAE,ZAF, ZAG,ZAH,ZAJ,ZAL .....	1
12	PAFZZ	5340-01-331-9625	15434	394596700	. PLUNGER,DETENT UOC: ZAA,ZAB,ZAC,ZAD,ZAE,ZAF, ZAG,ZAH,ZAJ,ZAL .....	1
13	PAFZZ	2940-01-157-6309	45152	2DR513	. FILTER ELEMENT,FLUI UOC: ZAA,ZAB,ZAC,ZAD,ZAE,ZAF, ZAG,ZAH,ZAJ,ZAL .....	1

(1) ITEM NO.	(2) SMR CODE	(3) NSN	(4) CAGEC	(5) PART NUMBER	(6) DESCRIPTION AND USABLE ON CODE (UOC)	(7) QTY
14	PAFZZ	2940-01-145-9398	15434	303457800	. ADAPTER, FILTER HEAD UOC: ZAA, ZAB, ZAC, ZAD, ZAE, ZAF, ZAG, ZAH, ZAJ, ZAL .....	1
15	PAFZZ	2940-01-271-7203	15434	3918290	. HEAD, FLUID FILTER UOC: ZAA, ZAB, ZAC, ZAD, ZAE, ZAF, ZAG, ZAH, ZAJ, ZAL .....	1

END OF FIGURE

**FIELD MAINTENANCE  
ENGINE OIL PUMP (M939, M939A1)**

---

2	20
3 - 33	21 - 32

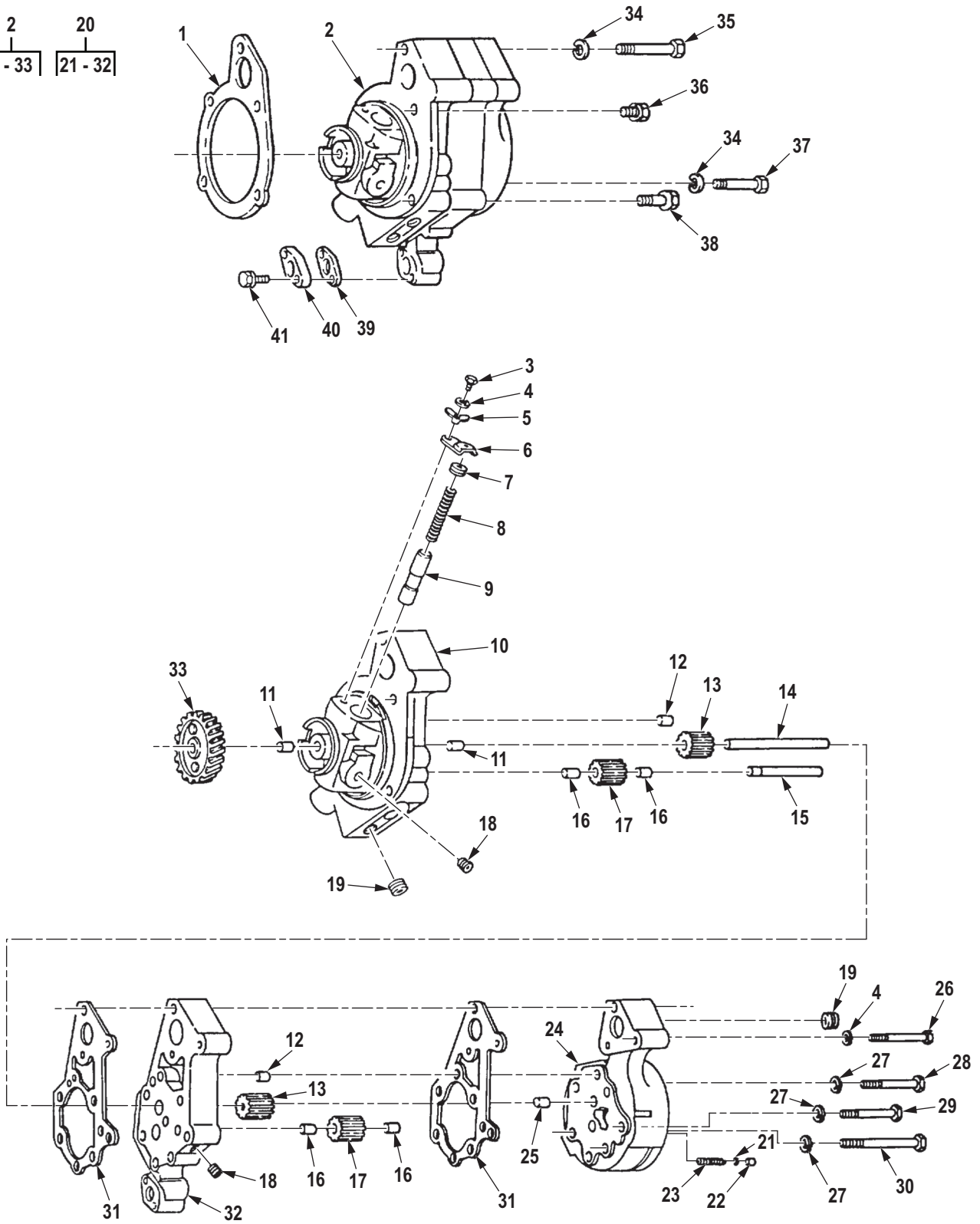

R0033DAA

Figure 33. Engine Oil Pump (M939, M939A1).

(1) ITEM NO.	(2) SMR CODE	(3) NSN	(4) CAGEC	(5) PART NUMBER	(6) DESCRIPTION AND USABLE ON CODE (UOC)	(7) QTY
<b>GROUP 0106 ENGINE LUBRICATION SYSTEM.</b>						
<b>FIG. 33. ENGINE OIL PUMP (M939, M939A1).</b>						
1	PAFZZ	5330-01-147-4071	15434	3067613	GASKET PART OF KIT P/N 3011472 UOC: DAC,DAD,DAE,DAF,DAG,DAH,DAJ,DAL,DAW,DAX,V14,V15,V16,V17,V18,V19,V20,V21,V22,V24 .....	1
2	PAHHH	2815-00-404-2954	15434	BM94082	OIL PUMP ASSEMBLY,E UOC: DAC,DAD,DAE,DAF,DAG,DAH,DAJ,DAL,DAW,DAX,V14,V15,V16,V17,V18,V19,V20,V21,V22,V24 .....	1
3	PAHZZ	5305-00-543-4372	80204	B1821BH038C075N	. SCREW,CAP,HEXAGON H UOC: DAC,DAD,DAE,DAF,DAG,DAH,DAJ,DAL,DAW,DAX,V14,V15,V16,V17,V18,V19,V20,V21,V22,V24 .....	1
4	PAHZZ	5310-00-407-9566	80205	MS35338-45	. WASHER,LOCK UOC: DAC,DAD,DAE,DAF,DAG,DAH,DAJ,DAL,DAW,DAX,V14,V15,V16,V17,V18,V19,V20,V21,V22,V24 .....	2
5	PAHZZ	2815-00-406-8936	15434	109319	. LOCK PLATE UOC: DAC,DAD,DAE,DAF,DAG,DAH,DAJ,DAL,DAW,DAX,V14,V15,V16,V17,V18,V19,V20,V21,V22,V24 .....	1
6	PAHZZ	2815-00-828-7013	15434	126304	. YOKE,CAP RETAINING UOC: DAC,DAD,DAE,DAF,DAG,DAH,DAJ,DAL,DAW,DAX,V14,V15,V16,V17,V18,V19,V20,V21,V22,V24 .....	1
7	PAHZZ	5340-00-833-7966	15434	134596	. PLUG,VENT UOC: DAC,DAD,DAE,DAF,DAG,DAH,DAJ,DAL,DAW,DAX,V14,V15,V16,V17,V18,V19,V20,V21,V22,V24 .....	1
8	PAHZZ	5360-00-664-5343	15434	68274	. SPRING,HELICAL,COMP UOC: DAC,DAD,DAE,DAF,DAG,DAH,DAJ,DAL,DAW,DAX,V14,V15,V16,V17,V18,V19,V20,V21,V22,V24 .....	1
9	PAHZZ	2815-00-791-1453	15434	127558	. PLUNGER,OIL PUMP RE UOC: DAC,DAD,DAE,DAF,DAG,DAH,DAJ,DAL,DAW,DAX,V14,V15,V16,V17,V18,V19,V20,V21,V22,V24 .....	1
10	PAHZZ	2990-01-123-3454	15434	BM66076	. HOUSING,OIL PUMP AS UOC: DAC,DAD,DAE,DAF,DAG,DAH,DAJ,DAL,DAW,DAX,V14,V15,V16,V17,V18,V19,V20,V21,V22,V24 .....	1

(1) ITEM NO.	(2) SMR CODE	(3) NSN	(4) CAGEC	(5) PART NUMBER	(6) DESCRIPTION AND USABLE ON CODE (UOC)	(7) QTY
11	PAHZZ	3120-00-661-6646	15434	68586	. BEARING,SLEEVE UOC: DAC,DAD,DAE,DAF,DAG,DA H,DAJ,DAL,DAW,DAX,V14,V15,V16, V17,V18,V19,V20,V21,V22,V24 .....	2
12	PAHZZ	5315-00-475-2574	15434	69519	. PIN,STRAIGHT,HEADLE UOC: DAC,DAD,DAE,DAF,DAG,DA H,DAJ,DAL,DAW,DAX,V14,V15,V16, V17,V18,V19,V20,V21,V22,V24 .....	2
13	PAHZZ	3020-00-353-9384	15434	68588	. GEAR,SPUR UOC: DAC,DAD,DAE,DAF,DAG,DA H,DAJ,DAL,DAW,DAX,V14,V15,V16, V17,V18,V19,V20,V21,V22,V24 .....	2
14	PAHZZ	5315-00-425-0118	15434	164164	. PIN,STRAIGHT,HEADLE UOC: DAC,DAD,DAE,DAF,DAG,DA H,DAJ,DAL,DAW,DAX,V14,V15,V16, V17,V18,V19,V20,V21,V22,V24 .....	1
15	PAHZZ	3040-00-485-9224	15434	13384800	. SHAFT,SHOULDERED UOC: DAC,DAD,DAE,DAF,DAG,DA H,DAJ,DAL,DAW,DAX,V14,V15,V16, V17,V18,V19,V20,V21,V22,V24 .....	1
16	PAHZZ	3120-00-661-6646	15434	68586	. BEARING,SLEEVE UOC: DAC,DAD,DAE,DAF,DAG,DA H,DAJ,DAL,DAW,DAX,V14,V15,V16, V17,V18,V19,V20,V21,V22,V24 .....	2
17	PAHZZ	3020-00-331-7672	15434	3017065	. GEAR,SPUR UOC: DAC,DAD,DAE,DAF,DAG,DA H,DAJ,DAL,DAW,DAX,V14,V15,V16, V17,V18,V19,V20,V21,V22,V24 .....	2
18	PAHZZ	4730-00-057-5555	81343	6 130109NC	. PLUG,PIPE UOC: DAC,DAD,DAE,DAF,DAG,DA H,DAJ,DAL,DAW,DAX,V14,V15,V16, V17,V18,V19,V20,V21,V22,V24 .....	2
19	PAHZZ	4730-01-214-7081	15434	3008469	. PLUG,PIPE UOC: DAC,DAD,DAE,DAF,DAG,DA H,DAJ,DAL,DAW,DAX,V14,V15,V16, V17,V18,V19,V20,V21,V22,V24 .....	2
20	PAHZZ	2940-01-123-4875	15434	BM94081	. HEAD,FILTER,OIL PUM UOC: DAC,DAD,DAE,DAF,DAG,DA H,DAJ,DAL,DAW,DAX,V14,V15,V16, V17,V18,V19,V20,V21,V22,V24 .....	1
21	PAHZZ	2815-00-131-1700	15434	153526	. . SEAT,LUBRICATION FI UOC: DAC,DAD,DAE,DAF,DAG,DA H,DAJ,DAL,DAW,DAX,V14,V15,V16, V17,V18,V19,V20,V21,V22,V24 .....	1
22	PAHZZ	4820-00-400-5189	15434	200819	. . DISK,VALVE UOC: DAC,DAD,DAE,DAF,DAG,DA H,DAJ,DAL,DAW,DAX,V14,V15,V16, V17,V18,V19,V20,V21,V22,V24 .....	1



(1) ITEM NO.	(2) SMR CODE	(3) NSN	(4) CAGEC	(5) PART NUMBER	(6) DESCRIPTION AND USABLE ON CODE (UOC)	(7) QTY
23	PAHZZ	5360-00-932-7452	15434	251152	. . SPRING,HELICAL,COMP UOC: DAC,DAD,DAE,DAF,DAG,DA H,DAJ,DAL,DAW,DAX,V14,V15,V16, V17,V18,V19,V20,V21,V22,V24 .....	1
24	XDHZZ		15434	BM94080	. . HEAD,FLUID FILTER UOC: DAC,DAD,DAE,DAF,DAG,DA H,DAJ,DAL,DAW,DAX,V14,V15,V16, V17,V18,V19,V20,V21,V22,V24 .....	1
25	PAHZZ	3120-00-661-6646	15434	68586	. . BEARING,SLEEVE UOC: DAC,DAD,DAE,DAF,DAG,DA H,DAJ,DAL,DAW,DAX,V14,V15,V16, V17,V18,V19,V20,V21,V22,V24 .....	1
26	PAHZZ	2815-00-327-6439	15434	101662	. . SCREW UOC: DAC,DAD,DAE,DAF,DAG,DA H,DAJ,DAL,DAW,DAX,V14,V15,V16, V17,V18,V19,V20,V21,V22,V24 .....	2
27	PAHZZ	5310-00-637-9541	00198	132661	. . WASHER,LOCK UOC: DAC,DAD,DAE,DAF,DAG,DA H,DAJ,DAL,DAW,DAX,V14,V15,V16, V17,V18,V19,V20,V21,V22,V24 .....	7
28	PAHZZ	5305-00-964-0565	96906	MS51095-374	. . SCREW,CAP,HEXAGON H UOC: DAC,DAD,DAE,DAF,DAG,DA H,DAJ,DAL,DAW,DAX,V14,V15,V16, V17,V18,V19,V20,V21,V22,V24 .....	2
29	PAHZZ	5305-01-126-8811	15434	S-199-A	. . SCREW,CAP,HEXAGON H UOC: DAC,DAD,DAE,DAF,DAG,DA H,DAJ,DAL,DAW,DAX,V14,V15,V16, V17,V18,V19,V20,V21,V22,V24 .....	1
30	PAHZZ	5305-00-206-4527	15434	S130A	. . SCREW,CAP,HEXAGON H UOC: DAC,DAD,DAE,DAF,DAG,DA H,DAJ,DAL,DAW,DAX,V14,V15,V16, V17,V18,V19,V20,V21,V22,V24 .....	3
31	PAHZZ	5330-00-961-6314	15434	151911	. . GASKET PART OF KIT P/N 3011472 UOC: DAC,DAD,DAE,DAF,DAG,DA H,DAJ,DAL,DAW,DAX,V14,V15,V16, V17,V18,V19,V20,V21,V22,V24 .....	2
32	PAHZZ	2815-01-126-9367	15434	151917	. . BODY,INNER LUBRICAT UOC: DAC,DAD,DAE,DAF,DAG,DA H,DAJ,DAL,DAW,DAX,V14,V15,V16, V17,V18,V19,V20,V21,V22,V24 .....	1
33	PAHZZ	3020-00-820-7915	15434	302519800	. GEAR,HELICAL UOC: DAC,DAD,DAE,DAF,DAG,DA H,DAJ,DAL,DAW,DAX,V14,V15,V16, V17,V18,V19,V20,V21,V22,V24 .....	1
34	PAFZZ	5310-00-209-0965	80205	MS35338-47	WASHER,LOCK UOC: DAC,DAD,DAE,DAF,DAG,DA H,DAJ,DAL,DAW,DAX,V14,V15,V16, V17,V18,V19,V20,V21,V22,V24 .....	2

(1) ITEM NO.	(2) SMR CODE	(3) NSN	(4) CAGEC	(5) PART NUMBER	(6) DESCRIPTION AND USABLE ON CODE (UOC)	(7) QTY
35	PAFZZ	5305-00-795-9341	15434	69960	SCREW,CAP UOC: DAC,DAD,DAE,DAF,DAG,DA H,DAJ,DAL,DAW,DAX,V14,V15,V16, V17,V18,V19,V20,V21,V22,V24 .....	1
36	PAFZZ	5305-00-795-9352	15434	S196A	SCREW,CAP,HEXAGON H UOC: DAC,DAD,DAE,DAF,DAG,DA H,DAJ,DAL,DAW,DAX,V14,V15,V16, V17,V18,V19,V20,V21,V22,V24 .....	2
37	PAFZZ	5305-00-795-9308	15434	169657	SCREW,CAP UOC: DAC,DAD,DAE,DAF,DAG,DA H,DAJ,DAL,DAW,DAX,V14,V15,V16, V17,V18,V19,V20,V21,V22,V24 .....	1
38	PAFZZ	5305-01-227-6249	15434	3012480	SCREW,ASSEMBLED WAS UOC: DAC,DAD,DAE,DAF,DAG,DA H,DAJ,DAL,DAW,DAX,V14,V15,V16, V17,V18,V19,V20,V21,V22,V24 .....	1
39	PAFZZ	5330-00-465-5818	15434	134285	GASKET PART OF KIT P/N 3011472 UOC: DAC,DAD,DAE,DAF,DAG,DA H,DAJ,DAL,DAW,DAX,V14,V15,V16, V17,V18,V19,V20,V21,V22,V24 .....	1
40	PAFZZ	2815-01-114-7399	15434	20350200	FLANGE,BODY,PUMP UOC: DAC,DAD,DAE,DAF,DAG,DA H,DAJ,DAL,DAW,DAX,V14,V15,V16, V17,V18,V19,V20,V21,V22,V24 .....	1
41	PAFZZ	5305-01-088-6019	15434	3010596	SCREW,ASSEMBLED WAS UOC: DAC,DAD,DAE,DAF,DAG,DA H,DAJ,DAL,DAW,DAX,V14,V15,V16, V17,V18,V19,V20,V21,V22,V24 .....	2

END OF FIGURE

**FIELD MAINTENANCE  
ENGINE OIL DIPSTICK AND TUBE (M939, M939A1)**

---

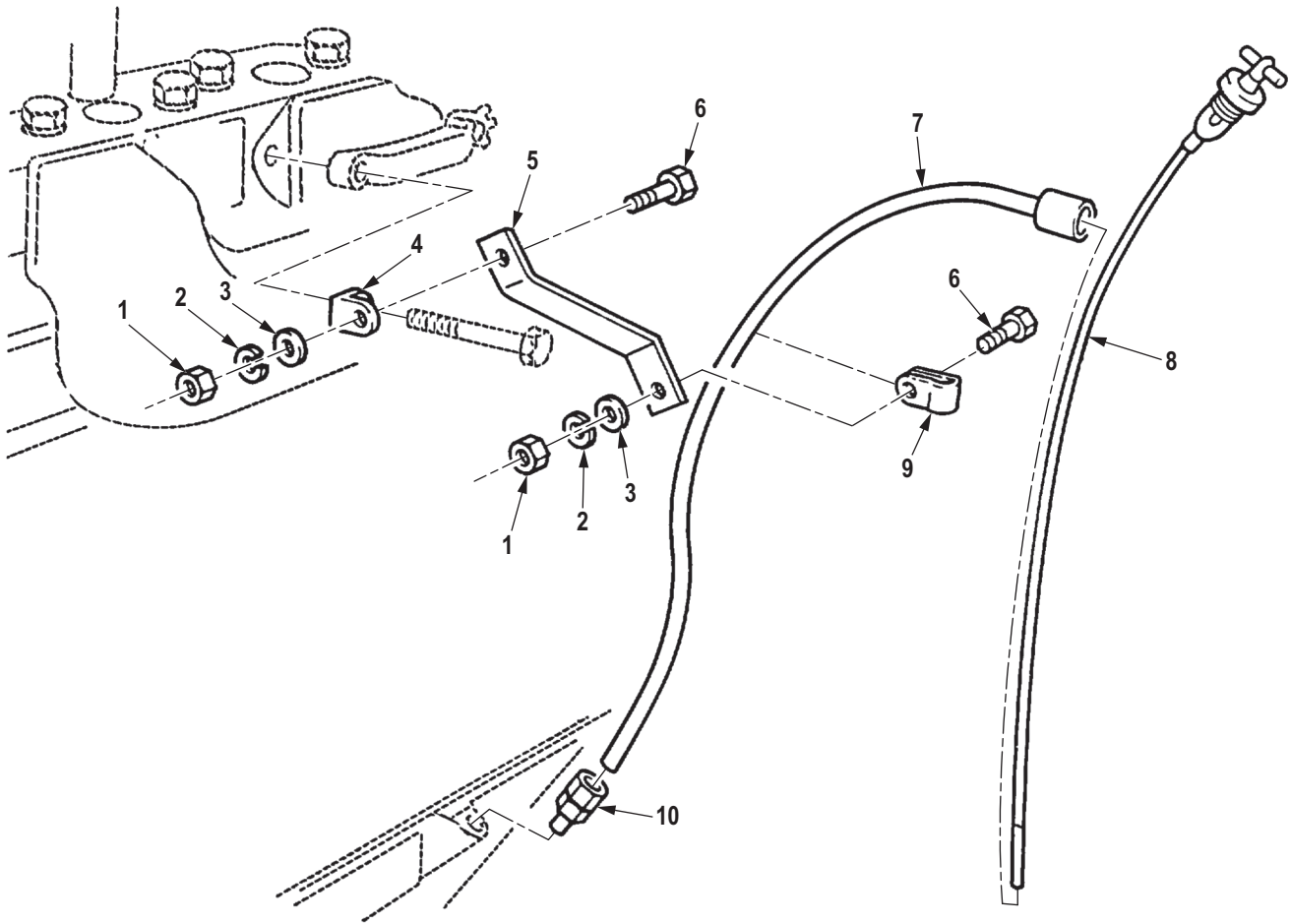

R0034DAA

Figure 34. Engine Oil Dipstick and Tube (M939, M939A1).

(1) ITEM NO.	(2) SMR CODE	(3) NSN	(4) CAGEC	(5) PART NUMBER	(6) DESCRIPTION AND USABLE ON CODE (UOC)	(7) QTY
<b>GROUP 0106 ENGINE LUBRICATION SYSTEM.</b>						
<b>FIG. 34. ENGINE OIL DIPSTICK AND TUBE (M939, M939A1).</b>						
1	PAFZZ	5310-00-521-8595	15434	S223	NUT, HEXAGON UOC: DAC, DAD, DAE, DAF, DAG, DA H, DAJ, DAL, DAW, DAX, V14, V15, V16, V17, V18, V19, V20, V21, V22, V24 .....	2
2	PAFZZ	5310-00-637-9541	00198	132661	WASHER, LOCK UOC: DAC, DAD, DAE, DAF, DAG, DA H, DAJ, DAL, DAW, DAX, V14, V15, V16, V17, V18, V19, V20, V21, V22, V24 .....	2
3	PAFZZ	5310-00-080-6004	96906	MS27183-14	WASHER, FLAT UOC: DAC, DAD, DAE, DAF, DAG, DA H, DAJ, DAL, DAW, DAX, V14, V15, V16, V17, V18, V19, V20, V21, V22, V24 .....	2
4	PFFZZ	5340-00-243-7145	34623	139395	BRACKET, ANGLE UOC: DAC, DAD, DAE, DAF, DAG, DA H, DAJ, DAL, DAW, DAX, V14, V15, V16, V17, V18, V19, V20, V21, V22, V24 .....	1
5	PFFZZ	5340-00-821-2364	15434	204966	BRACKET, DOUBLE ANGL DIPSTICK TUBE UOC: DAC, DAD, DAE, DAF, DAG, DA H, DAJ, DAL, DAW, DAX, V14, V15, V16, V17, V18, V19, V20, V21, V22, V24 .....	1
6	PAFZZ	5305-00-269-3236	80204	B1821BH038F100N	SCREW, CAP, HEXAGON H UOC: DAC, DAD, DAE, DAF, DAG, DA H, DAJ, DAL, DAW, DAX, V14, V15, V16, V17, V18, V19, V20, V21, V22, V24 .....	2
7	PAFZZ	4710-01-133-6947	15434	204587	TUBE, DIPSTICK UOC: DAC, DAD, DAE, DAF, DAG, DA H, DAJ, DAL, DAW, DAX, V14, V15, V16, V17, V18, V19, V20, V21, V22, V24 .....	1
8	PAFZZ	6680-00-159-1732	55683	851-204993	GAGE ROD, LIQUID LEV UOC: DAC, DAD, DAE, DAF, DAG, DA H, DAJ, DAL, DAW, DAX, V14, V15, V16, V17, V18, V19, V20, V21, V22, V24 .....	1
9	PAFZZ	5340-00-417-5800	15434	200064	CLAMP, LOOP UOC: DAC, DAD, DAE, DAF, DAG, DA H, DAJ, DAL, DAW, DAX, V14, V15, V16, V17, V18, V19, V20, V21, V22, V24 .....	1
10	PAFZZ	4730-00-492-6040	96906	MS51843-6PA	ADAPTER, STRAIGHT, TU UOC: DAC, DAD, DAE, DAF, DAG, DA H, DAJ, DAL, DAW, DAX, V14, V15, V16, V17, V18, V19, V20, V21, V22, V24 .....	1

END OF FIGURE



**FIELD MAINTENANCE  
ENGINE OIL PUMP AND DIPSTICK (M939A2)**

---

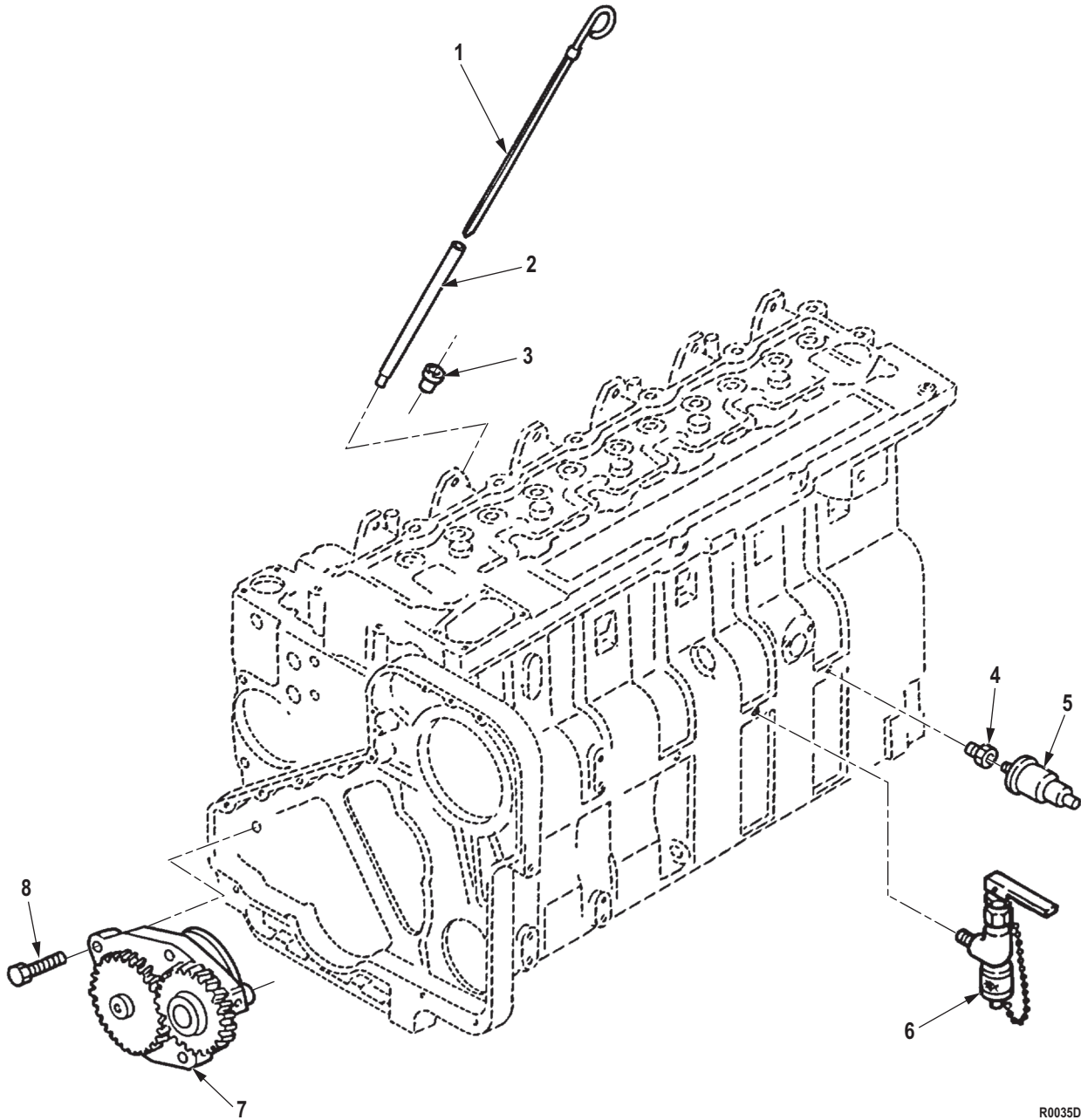

R0035DAA

Figure 35. Engine Oil Pump and Dipstick (M939A2).



(1) ITEM NO.	(2) SMR CODE	(3) NSN	(4) CAGEC	(5) PART NUMBER	(6) DESCRIPTION AND USABLE ON CODE (UOC)	(7) QTY
<b>GROUP 0106 ENGINE LUBRICATION SYSTEM.</b>						
<b>FIG. 35. ENGINE OIL PUMP AND DIPSTICK (M939A2).</b>						
1	PAFZZ	6680-01-272-1867	15434	3911630	GAGE ROD, LIQUID LEV UOC: ZAA,ZAB,ZAC,ZAD,ZAE,ZAF, ZAG,ZAH,ZAJ,ZAL .....	1
2	PAFZZ	2590-01-281-9716	15434	328089300	FILLER NECK, VEHICUL UOC: ZAA,ZAB,ZAC,ZAD,ZAE,ZAF, ZAG,ZAH,ZAJ,ZAL .....	1
3	PAFZZ	5340-01-239-8607	15434	3900955	PLUG, EXPANSION UOC: ZAA,ZAB,ZAC,ZAD,ZAE,ZAF, ZAG,ZAH,ZAJ,ZAL .....	1
4	PAFZZ	4730-00-226-8874	19207	12325823	REDUCER, PIPE UOC: ZAA,ZAB,ZAC,ZAD,ZAE,ZAF, ZAG,ZAH,ZAJ,ZAL .....	1
5	PAFZZ	6620-00-993-5546	96906	MS24539	TRANSMITTER, PRESSUR UOC: ZAA,ZAB,ZAC,ZAD,ZAE,ZAF, ZAG,ZAH,ZAJ,ZAL .....	1
6	PAFZZ	4820-01-281-5847	91816	HV22-20	VALVE, ANGLE UOC: ZAA,ZAB,ZAC,ZAD,ZAE,ZAF, ZAG,ZAH,ZAJ,ZAL .....	1
7	PAHZZ	2815-01-268-8753	15434	3800828	OIL PUMP ASSEMBLY, E UOC: ZAA,ZAB,ZAC,ZAD,ZAE,ZAF, ZAG,ZAH,ZAJ,ZAL .....	1
8	PAHZZ	5305-01-207-7447	15434	3900677	SCREW, CAP, HEXAGON H UOC: ZAA,ZAB,ZAC,ZAD,ZAE,ZAF, ZAG,ZAH,ZAJ,ZAL .....	4

**END OF FIGURE**



**FIELD MAINTENANCE  
ENGINE OIL PUMP LINES AND FITTINGS (M939, M939A1)**

---

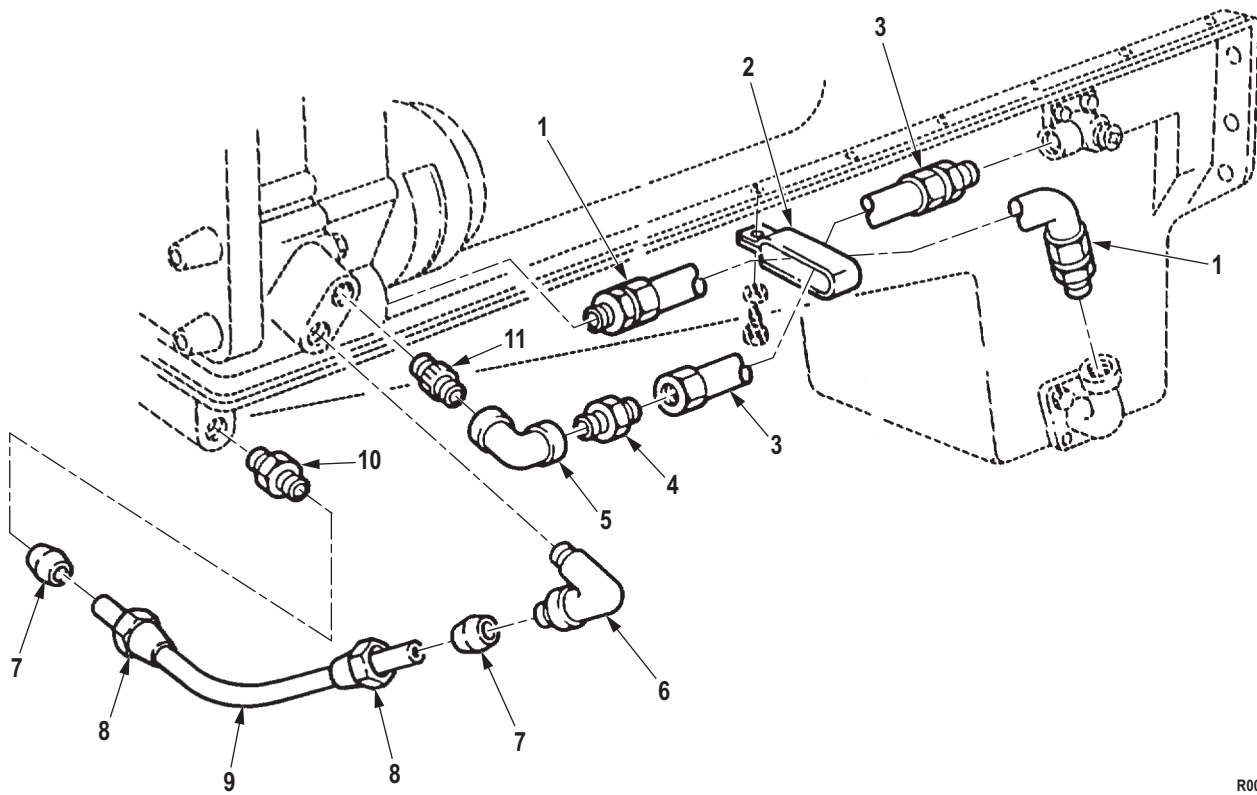

R0036DAA

Figure 36. Engine Oil Pump Lines and Fittings (M939, M939A1).

(1) ITEM NO.	(2) SMR CODE	(3) NSN	(4) CAGEC	(5) PART NUMBER	(6) DESCRIPTION AND USABLE ON CODE (UOC)	(7) QTY
<b>GROUP 0106 ENGINE LUBRICATION SYSTEM.</b>						
<b>FIG. 36. ENGINE OIL PUMP LINES AND FITTINGS (M939, M939A1).</b>						
1	PAFZZ	4720-01-128-0331	61125	AIG-213R16AS16PMHOSE N12-35	HOSE ASSEMBLY, NONME UOC: DAC, DAD, DAE, DAF, DAG, DAH, DAJ, DAL, DAW, DAX, V14, V15, V16, V17, V18, V19, V20, V21, V22, V24 .....	1
2	PAFZZ	5340-00-409-9978	15434	114421	CLAMP, LOOP UOC: DAC, DAD, DAE, DAF, DAG, DAH, DAJ, DAL, DAW, DAX, V14, V15, V16, V17, V18, V19, V20, V21, V22, V24 .....	1
3	PAFZZ	4720-00-607-7645	15434	AS1602906MS	HOSE ASSEMBLY, NONME UOC: DAC, DAD, DAE, DAF, DAG, DAH, DAJ, DAL, DAW, DAX, V14, V15, V16, V17, V18, V19, V20, V21, V22, V24 .....	1
4	PAFZZ	4730-00-097-4236	15434	6794400	ADAPTER, STRAIGHT, PI UOC: DAC, DAD, DAE, DAF, DAG, DAH, DAJ, DAL, DAW, DAX, V14, V15, V16, V17, V18, V19, V20, V21, V22, V24 .....	1
5	PAFZZ	4730-00-193-7080	15434	S-987	ELBOW, PIPE UOC: DAC, DAD, DAE, DAF, DAG, DAH, DAJ, DAL, DAW, DAX, V14, V15, V16, V17, V18, V19, V20, V21, V22, V24 .....	1
6	PAFZZ	4730-00-428-5631	15434	5-1075	ELBOW, PIPE TO TUBE UOC: DAC, DAD, DAE, DAF, DAG, DAH, DAJ, DAL, DAW, DAX, V14, V15, V16, V17, V18, V19, V20, V21, V22, V24 .....	1
7	PAFZZ	5365-00-362-1880	15434	S1077	BUSHING, NONMETALLIC UOC: DAC, DAD, DAE, DAF, DAG, DAH, DAJ, DAL, DAW, DAX, V14, V15, V16, V17, V18, V19, V20, V21, V22, V24 .....	2
8	PAFZZ	4730-00-430-4385	15434	S-1076	NUT, TUBE COUPLING UOC: DAC, DAD, DAE, DAF, DAG, DAH, DAJ, DAL, DAW, DAX, V14, V15, V16, V17, V18, V19, V20, V21, V24 .....	2
9	PAFZZ	4710-00-425-5921	15434	202603	TUBE ASSEMBLY, METAL UOC: DAC, DAD, DAE, DAF, DAG, DAH, DAJ, DAL, DAW, DAX, V14, V15, V16, V17, V18, V19, V20, V21, V22, V24 .....	1
10	PAFZZ	4730-01-130-8766	93061	68CA-12-12	ADAPTER, STRAIGHT, PI UOC: DAC, DAD, DAE, DAF, DAG, DAH, DAJ, DAL, DAW, DAX, V14, V15, V16, V17, V18, V19, V20, V21, V22, V24 .....	1

(1) ITEM NO.	(2) SMR CODE	(3) NSN	(4) CAGEC	(5) PART NUMBER	(6) DESCRIPTION AND USABLE ON CODE (UOC)	(7) QTY
11	PAFZZ	4730-00-196-1468	81343	A733S-97CFG	NIPPLE,PIPE UOC: DAC,DAD,DAE,DAF,DAG,DA H,DAJ,DAL,DAW,DAX,V14,V15,V16, V17,V18,V19,V20,V21,V22,V24 .....	1

END OF FIGURE

**FIELD MAINTENANCE  
ENGINE OIL PAN AND RELATED PARTS (M939, M939A1)**

---

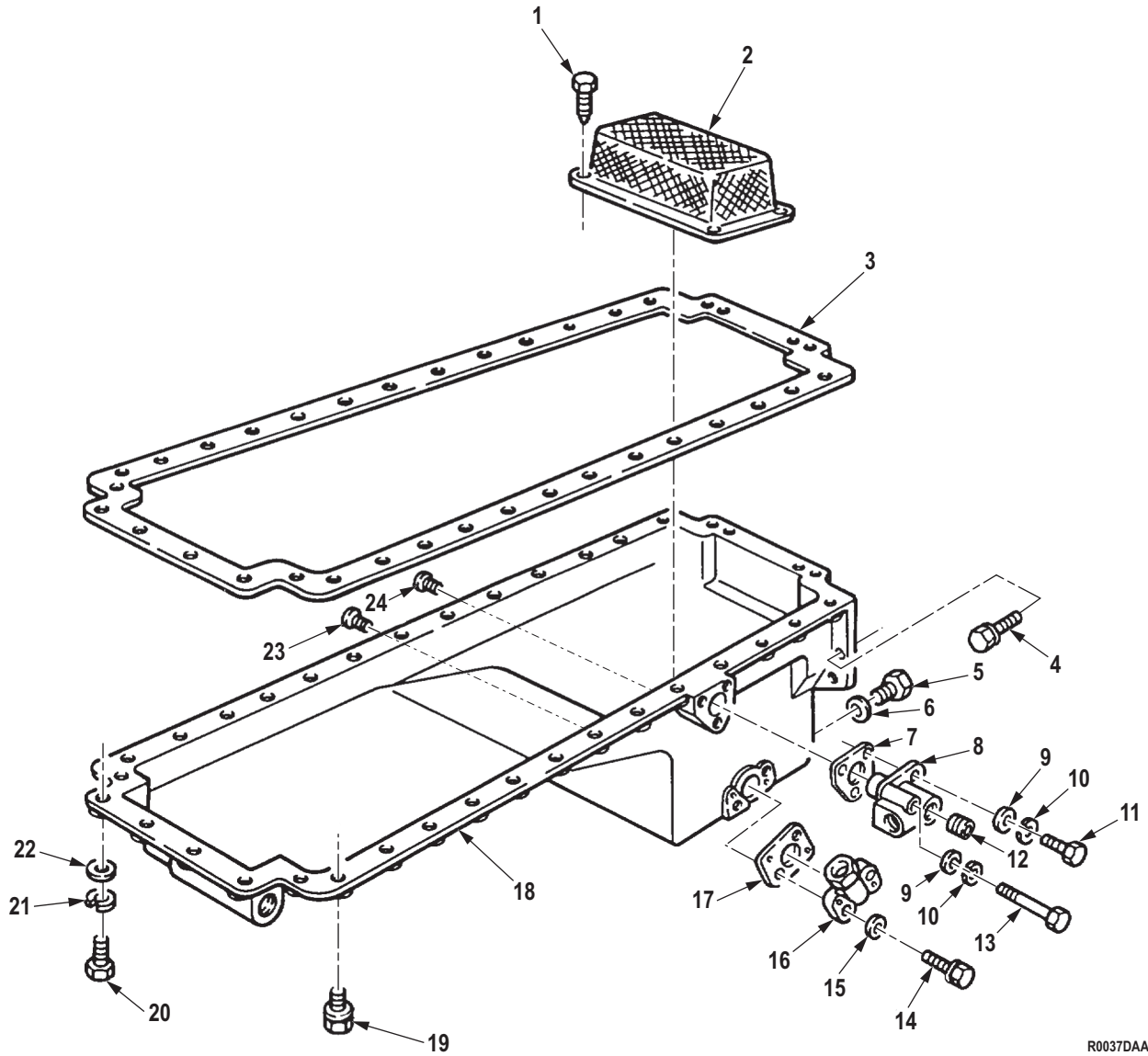

R0037DAA

Figure 37. Engine Oil Pan and Related Parts (M939, M939A1).



(1) ITEM NO.	(2) SMR CODE	(3) NSN	(4) CAGEC	(5) PART NUMBER	(6) DESCRIPTION AND USABLE ON CODE (UOC)	(7) QTY
<b>GROUP 0106 ENGINE LUBRICATION SYSTEM.</b>						
<b>FIG. 37. ENGINE OIL PAN AND RELATED PARTS (M939, M939A1).</b>						
1	PAFZZ	5305-00-068-0523	96906	MS24621-42	SCREW,TAPPING UOC: DAC,DAD,DAE,DAF,DAG,DAH,DAJ,DAL,DAW,DAX,V14,V15,V16,V17,V18,V19,V20,V21,V22,V24 .....	4
2	PAFZZ	4730-00-338-6839	15434	2062200	STRAINER ELEMENT,SE UOC: DAC,DAD,DAE,DAF,DAG,DAH,DAJ,DAL,DAW,DAX,V14,V15,V16,V17,V18,V19,V20,V21,V22,V24 .....	1
3	PAFZZ	5330-01-147-0748	0B8S3	3099083	GASKET PART OF KIT P/N 3011472 UOC: DAC,DAD,DAE,DAF,DAG,DAH,DAJ,DAL,DAW,DAX,V14,V15,V16,V17,V18,V19,V20,V21,V22,V24 .....	1
4	PAFZZ	5305-00-463-0429	15434	105574	SCREW,CAP,HEXAGON H UOC: DAC,DAD,DAE,DAF,DAG,DAH,DAJ,DAL,DAW,DAX,V14,V15,V16,V17,V18,V19,V20,V21,V22,V24 .....	4
5	PAFZZ	5365-00-695-1247	0B8S3	3055069	PLUG,MACHINE THREAD UOC: DAC,DAD,DAE,DAF,DAG,DAH,DAJ,DAL,DAW,DAX,V14,V15,V16,V17,V18,V19,V20,V21,V22,V24 .....	1
6	PAFZZ	5365-00-197-9327	15434	67946	SPACER,RING PART OF KIT P/N 3011472 UOC: DAC,DAD,DAE,DAF,DAG,DAH,DAJ,DAL,DAW,DAX,V14,V15,V16,V17,V18,V19,V20,V21,V22,V24 .....	1
7	PAFZZ	5330-00-143-8371	15434	110453	GASKET PART OF KIT P/N 3011472 UOC: DAC,DAD,DAE,DAF,DAG,DAH,DAJ,DAL,DAW,DAX,V14,V15,V16,V17,V18,V19,V20,V21,V22,V24 .....	1
8	PAFZZ	2815-00-138-8280	15434	204531	AERATOR,OIL PAN UOC: DAC,DAD,DAE,DAF,DAG,DAH,DAJ,DAL,DAW,DAX,V14,V15,V16,V17,V18,V19,V20,V21,V22,V24 .....	1
9	PAFZZ	5310-00-562-6558	15434	S626	WASHER,FLAT UOC: DAC,DAD,DAE,DAF,DAG,DAH,DAJ,DAL,DAW,DAX,V14,V15,V16,V17,V18,V19,V20,V21,V22,V24 .....	3
10	PAFZZ	5310-00-407-9566	80205	MS35338-45	WASHER,LOCK UOC: DAC,DAD,DAE,DAF,DAG,DAH,DAJ,DAL,DAW,DAX,V14,V15,V16,V17,V18,V19,V20,V21,V22,V24 .....	3

(1) ITEM NO.	(2) SMR CODE	(3) NSN	(4) CAGEC	(5) PART NUMBER	(6) DESCRIPTION AND USABLE ON CODE (UOC)	(7) QTY
11	PAFZZ	5306-01-075-8519	80205	MS90725-36	BOLT,MACHINE UOC: DAC,DAD,DAE,DAF,DAG,DA H,DAJ,DAL,DAW,DAX,V14,V15,V16, V17,V18,V19,V20,V21,V22,V24 .....	2
12	PAFZZ	4730-01-214-7081	15434	3008469	PLUG,PIPE UOC: DAC,DAD,DAE,DAF,DAG,DA H,DAJ,DAL,DAW,DAX,V14,V15,V16, V17,V18,V19,V20,V21,V22,V24 .....	2
13	PAFZZ	5306-00-136-9751	15434	S-147-B	BOLT,MACHINE UOC: DAC,DAD,DAE,DAF,DAG,DA H,DAJ,DAL,DAW,DAX,V14,V15,V16, V17,V18,V19,V20,V21,V22,V24 .....	1
14	PAFZZ	5305-01-137-6706	15434	3012473	SCREW UOC: DAC,DAD,DAE,DAF,DAG,DA H,DAJ,DAL,DAW,DAX,V14,V15,V16, V17,V18,V19,V20,V21,V22,V24 .....	2
15	PAFZZ	5310-00-080-6004	96906	MS27183-14	WASHER,FLAT UOC: DAC,DAD,DAE,DAF,DAG,DA H,DAJ,DAL,DAW,DAX,V14,V15,V16, V17,V18,V19,V20,V21,V22,V24 .....	2
16	PAFZZ	2815-00-404-2957	15434	17968800	FLANGE,SUCTION UOC: DAC,DAD,DAE,DAF,DAG,DA H,DAJ,DAL,DAW,DAX,V14,V15,V16, V17,V18,V19,V20,V21,V22,V24 .....	1
17	PAFZZ	5330-00-143-8376	15434	157551	GASKET UOC: DAC,DAD,DAE,DAF,DAG,DA H,DAJ,DAL,DAW,DAX,V14,V15,V16, V17,V18,V19,V20,V21,V22,V24 .....	1
18	PAFZZ	2815-00-404-2956	15434	AR45247	OIL PAN UOC: DAC,DAD,DAE,DAF,DAG,DA H,DAJ,DAL,DAW,DAX,V14,V15,V16, V17,V18,V19,V20,V21,V22,V24 .....	1
19	PAFZZ	5305-01-212-5210	15434	3008069	SCREW,CAP,HEXAGON H UOC: DAC,DAD,DAE,DAF,DAG,DA H,DAJ,DAL,DAW,DAX,V14,V15,V16, V17,V18,V19,V20,V21,V22,V24 .....	32
20	PAFZZ	5305-00-463-0428	15434	185804	SCREW,CAP,HEXAGON H UOC: DAC,DAD,DAE,DAF,DAG,DA H,DAJ,DAL,DAW,DAX,V14,V15,V16, V17,V18,V19,V20,V21,V22,V24 .....	4
21	PAFZZ	5310-00-209-0965	80205	MS35338-47	WASHER,LOCK UOC: DAC,DAD,DAE,DAF,DAG,DA H,DAJ,DAL,DAW,DAX,V14,V15,V16, V17,V18,V19,V20,V21,V22,V24 .....	4
22	PAFZZ	5310-00-562-6557	15434	S622	WASHER,FLAT UOC: DAC,DAD,DAE,DAF,DAG,DA H,DAJ,DAL,DAW,DAX,V14,V15,V16, V17,V18,V19,V20,V21,V22,V24 .....	4

(1) ITEM NO.	(2) SMR CODE	(3) NSN	(4) CAGEC	(5) PART NUMBER	(6) DESCRIPTION AND USABLE ON CODE (UOC)	(7) QTY
23	PAFZZ	4730-01-160-3579	15434	S00091000B	PLUG,PIPE UOC: DAC,DAD,DAE,DAF,DAG,DA H,DAJ,DAL,DAW,DAX,V14,V15,V16, V17,V18,V19,V20,V21,V22,V24 .....	1
24	PAFZZ	4730-00-801-8186	15434	S-915-A	PLUG,PIPE UOC: DAC,DAD,DAE,DAF,DAG,DA H,DAJ,DAL,DAW,DAX,V14,V15,V16, V17,V18,V19,V20,V21,V22,V24 .....	1

END OF FIGURE



**FIELD MAINTENANCE  
ENGINE OIL PAN AND RELATED PARTS (M939A2)**

---

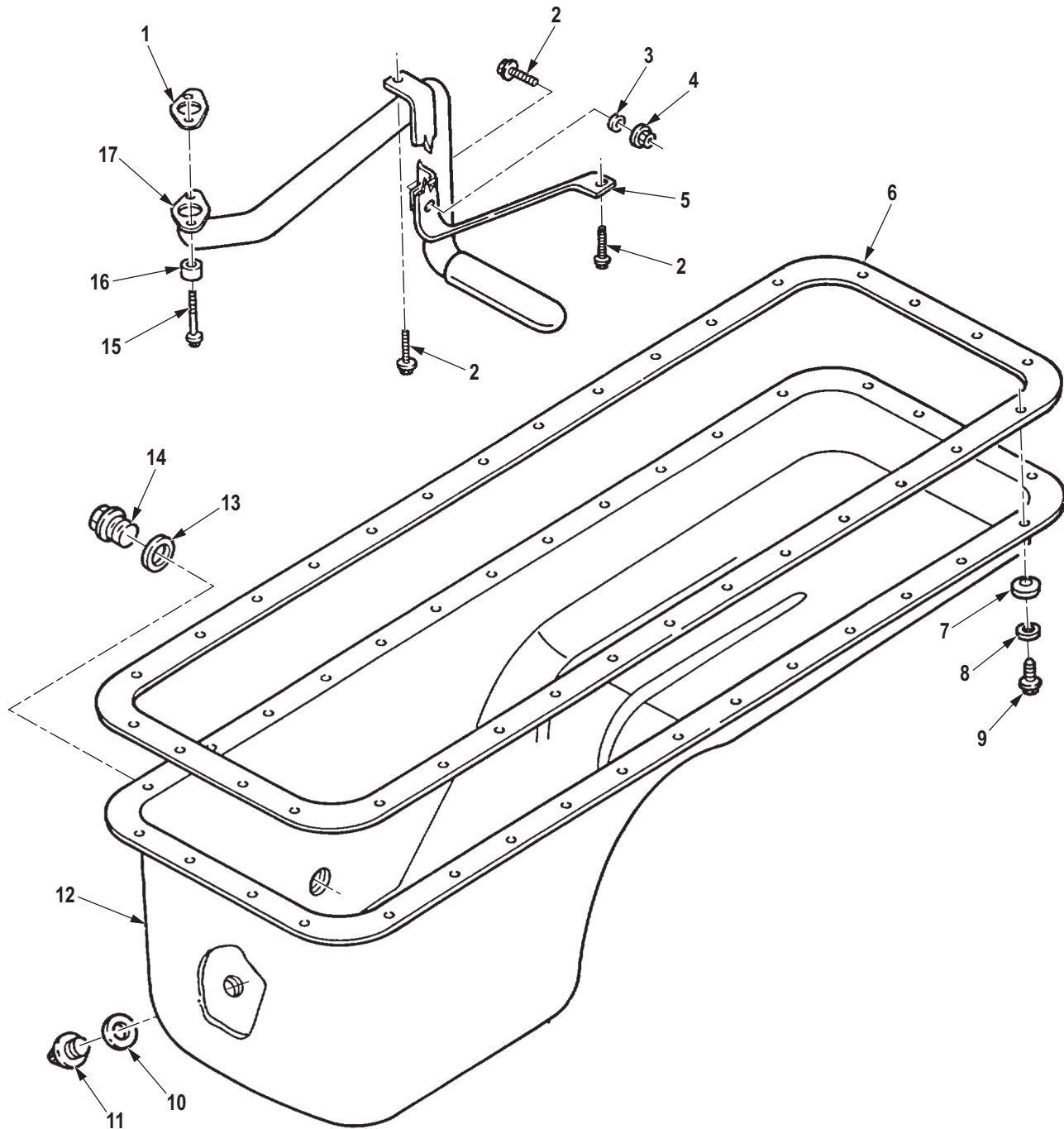

R0038DAA

Figure 38. Engine Oil Pan and Related Parts (M939A2).

(1) ITEM NO.	(2) SMR CODE	(3) NSN	(4) CAGEC	(5) PART NUMBER	(6) DESCRIPTION AND USABLE ON CODE (UOC)	(7) QTY
<b>GROUP 0106 ENGINE LUBRICATION SYSTEM.</b>						
<b>FIG. 38. ENGINE OIL PAN AND RELATED PARTS (M939A2).</b>						
1	PAFZZ	5330-01-272-1143	15434	393935200	GASKET PART OF KIT P/N 380055800 UOC: ZAA,ZAB,ZAC,ZAD,ZAE,ZAF, ZAG,ZAH,ZAJ,ZAL .....	1
2	PAFZZ	5305-01-193-6839	15434	3900627	SCREW,CAP,HEXAGON H UOC: ZAA,ZAB,ZAC,ZAD,ZAE,ZAF, ZAG,ZAH,ZAJ,ZAL .....	3
3	PAFZZ	5310-01-270-8391	15434	3910960	WASHER,FLAT UOC: ZAA,ZAB,ZAC,ZAD,ZAE,ZAF, ZAG,ZAH,ZAJ,ZAL .....	1
4	PAFZZ	5310-01-270-8251	15434	3906216	NUT,PLAIN,PLATE UOC: ZAA,ZAB,ZAC,ZAD,ZAE,ZAF, ZAG,ZAH,ZAJ,ZAL .....	1
5	PAFZZ	5340-01-287-0751	7U263	3927611	STRAP,RETAINING UOC: ZAA,ZAB,ZAC,ZAD,ZAE,ZAF, ZAG,ZAH,ZAJ,ZAL .....	1
6	PAFZZ	5330-01-289-3135	7U263	3938160	GASKET PART OF KIT P/N 380055800 UOC: ZAA,ZAB,ZAC,ZAD,ZAE,ZAF, ZAG,ZAH,ZAJ,ZAL .....	1
7	PAFZZ	5310-01-270-8423	15434	3910266	WASHER,SPRING TENS UOC: ZAA,ZAB,ZAC,ZAD,ZAE,ZAF, ZAG,ZAH,ZAJ,ZAL .....	32
8	PAFZZ	5310-01-270-8390	15434	3908316	WASHER,FLAT UOC: ZAA,ZAB,ZAC,ZAD,ZAE,ZAF, ZAG,ZAH,ZAJ,ZAL .....	32
9	PAFZZ	5305-01-266-8568	15434	3907860	SETSCREW UOC: ZAA,ZAB,ZAC,ZAD,ZAE,ZAF, ZAG,ZAH,ZAJ,ZAL .....	32
10	PAFZZ	5310-01-381-5774	15434	3920773	WASHER,FLAT PART OF KIT P/N 380055800 UOC: ZAA,ZAB,ZAC,ZAD,ZAE,ZAF, ZAG,ZAH,ZAJ,ZAL .....	1
11	PAFZZ	4730-01-331-2913	15434	391163800	PLUG,PIPE UOC: ZAA,ZAB,ZAC,ZAD,ZAE,ZAF, ZAG,ZAH,ZAJ,ZAL .....	1
12	PAFZZ	2815-01-272-6714	15434	3914011	OIL PAN UOC: ZAA,ZAB,ZAC,ZAD,ZAE,ZAF, ZAG,ZAH,ZAJ,ZAL .....	1
13	PAFZZ	5310-01-209-0508	15434	3902425	WASHER,FLAT PART OF KIT P/N 380055800 UOC: ZAA,ZAB,ZAC,ZAD,ZAE,ZAF, ZAG,ZAH,ZAJ,ZAL .....	1

(1) ITEM NO.	(2) SMR CODE	(3) NSN	(4) CAGEC	(5) PART NUMBER	(6) DESCRIPTION AND USABLE ON CODE (UOC)	(7) QTY
14	PAFZZ	5365-01-217-1995	15434	3904386	PLUG,MACHINE THREAD UOC: ZAA,ZAB,ZAC,ZAD,ZAE,ZAF, ZAG,ZAH,ZAJ,ZAL .....	1
15	PAFZZ	5305-01-272-4812	15434	3900628	SCREW,CAP,HEXAGON H FLANGED UOC: ZAA,ZAB,ZAC,ZAD,ZAE,ZAF, ZAG,ZAH,ZAJ,ZAL .....	2
16	PAFZZ	5365-01-270-8482	15434	39268650	SPACER,PLATE UOC: ZAA,ZAB,ZAC,ZAD,ZAE,ZAF, ZAG,ZAH,ZAJ,ZAL .....	2
17	PAFZZ	4710-01-271-7943	15434	3911617	TUBE,BENT,METALLIC UOC: ZAA,ZAB,ZAC,ZAD,ZAE,ZAF, ZAG,ZAH,ZAJ,ZAL .....	1

END OF FIGURE



**FIELD MAINTENANCE  
ENGINE OIL DRAFT TUBE (M939, M939A1)**

---

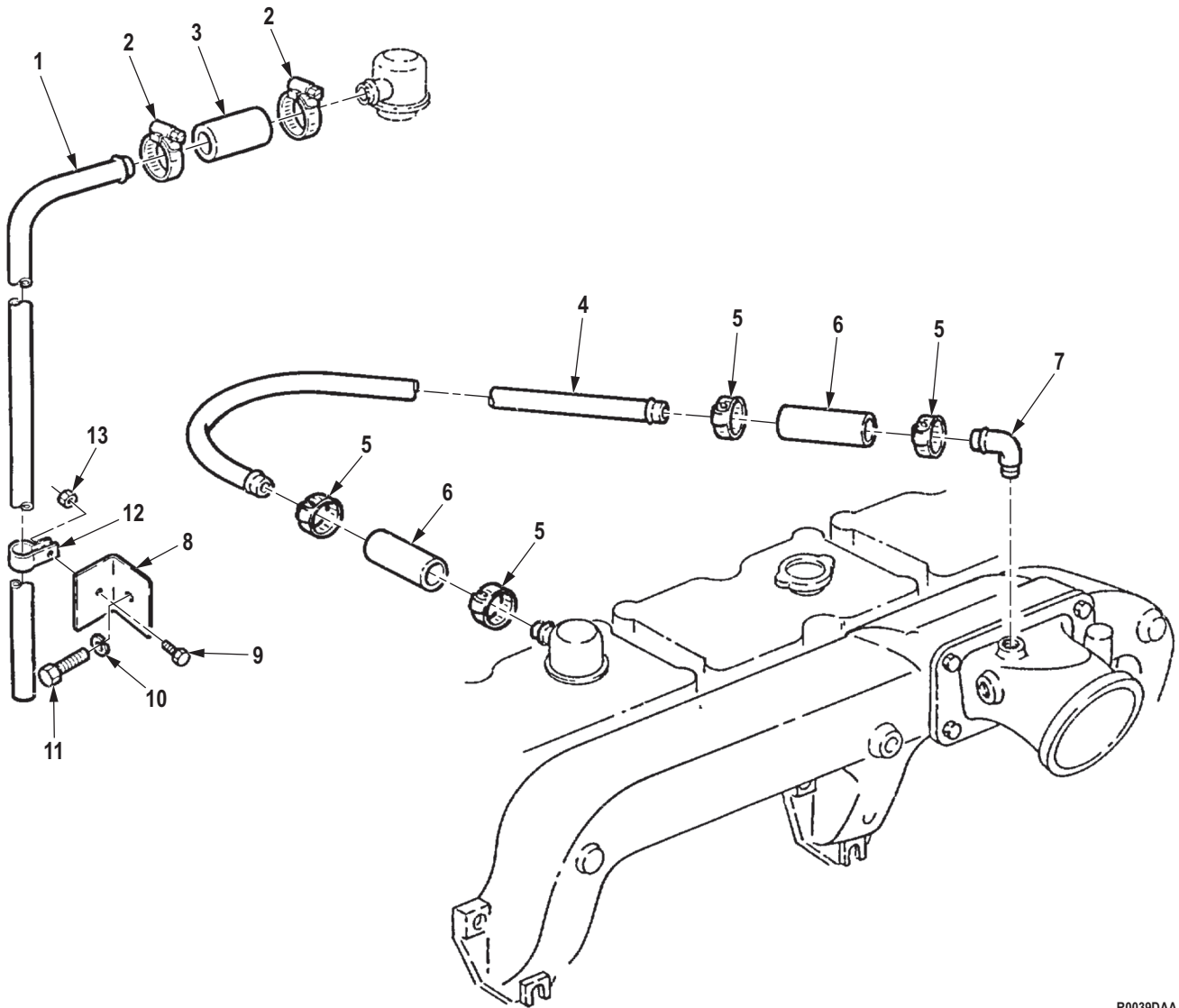

R0039DAA

Figure 39. Engine Oil Draft Tube (M939, M939A1).

(1) ITEM NO.	(2) SMR CODE	(3) NSN	(4) CAGEC	(5) PART NUMBER	(6) DESCRIPTION AND USABLE ON CODE (UOC)	(7) QTY
<b>GROUP 0106 ENGINE LUBRICATION SYSTEM.</b>						
<b>FIG. 39. ENGINE OIL DRAFT TUBE (M939, M939A1).</b>						
1	PAFZZ	4710-00-493-8899	19207	11648495	TUBE,BENT,METALLIC ENGINE DRAFT UOC: V14,V15,V16,V17,V18,V19,V2 0,V21,V22,V24 .....	1
2	PAFZZ	4730-00-908-3194	58536	A-A-52506-F-12	CLAMP,HOSE USE PRIOR TO SERIAL NUMBER 11246663 UOC: V14,V15,V16,V17,V18,V19,V2 0,V21,V22,V24 .....	2
3	MFFZZ		19207	11648497	HOSE USE PRIOR TO SERIAL NUMBER 11246663, MAKE FROM HOSE, P/N MS521303A203R, AS REQUIRED UOC: V14,V15,V16,V17,V18,V19,V2 0,V21,V22,V24 .....	1
4	PAFZZ	4710-01-257-2193	15434	3044873	TUBE,BENT,METALLIC USE AFTER SERIAL NUMBER 11246663 UOC: DAC,DAD,DAE,DAF,DAG,DA H,DAJ,DAL,DAW,DAX,V14,V15,V16, V17,V18,V19,V20,V21,V22,V24 .....	1
5	PAFZZ	4730-00-908-3194	58536	A-A-52506-F-12	CLAMP,HOSE USE AFTER SERIAL NUMBER 11246663 UOC: DAC,DAD,DAE,DAF,DAG,DA H,DAJ,DAL,DAW,DAX,V14,V15,V16, V17,V18,V19,V20,V21,V22,V24 .....	4
6	MFFZZ		19207	11648497-1	HOSE USE AFTER SERIAL NUMBER 11246663, MAKE FROM HOSE, P/N MS521303A203R, AS REQUIRED UOC: DAC,DAD,DAE,DAF,DAG,DA H,DAJ,DAL,DAW,DAX,V14,V15,V16, V17,V18,V19,V20,V21,V22,V24 .....	2
7	PAFZZ	4730-01-257-3328	15434	13652100	ELBOW,PIPE TO HOSE USE AFTER SERIAL NUMBER 11246663 UOC: DAC,DAD,DAE,DAF,DAG,DA H,DAJ,DAL,DAW,DAX,V14,V15,V16, V17,V18,V19,V20,V21,V22,V24 .....	1
8	PAFZZ	5340-00-007-9442	19207	11648729	BRACKET,ANGLE USE PRIOR TO SERIAL NUMBER 11246663 UOC: V14,V15,V16,V17,V18,V19,V2 0,V21,V22,V24 .....	1
9	PAFZZ	5306-00-068-0513	80204	B1821BH025F075N	BOLT,MACHINE USE PRIOR TO SERIAL NUMBER 11246663 UOC: V14,V15,V16,V17,V18,V19,V2 0,V21,V22,V24 .....	1

(1) ITEM NO.	(2) SMR CODE	(3) NSN	(4) CAGEC	(5) PART NUMBER	(6) DESCRIPTION AND USABLE ON CODE (UOC)	(7) QTY
10	PAFZZ	5310-00-637-9541	00198	132661	WASHER,LOCK USE PRIOR TO SERIAL NUMBER 11246663 UOC: V14,V15,V16,V17,V18,V19,V2 0,V21,V22,V24 .....	1
11	PAFZZ	5305-00-543-4372	80204	B1821BH038C075N	SCREW,CAP,HEXAGON H USE PRIOR TO SERIAL NUMBER 11246663 UOC: V14,V15,V16,V17,V18,V19,V2 0,V21,V22,V24 .....	1
12	PAFZZ	5340-00-282-7521	80205	MS21333-40	CLAMP,LOOP USE PRIOR TO SERIAL NUMBER 11246663 UOC: V14,V15,V16,V17,V18,V19,V2 0,V21,V22,V24 .....	1
13	PAFZZ	5310-00-061-7325	80205	MS21045-4	NUT,SELF-LOCKING,HE USE PRIOR TO SERIAL NUMBER 11246663 UOC: V14,V15,V16,V17,V18,V19,V2 0,V21,V22,V24 .....	1

END OF FIGURE

**FIELD MAINTENANCE  
CRANKSHAFT BREATHER TUBE (M939A2)**

---

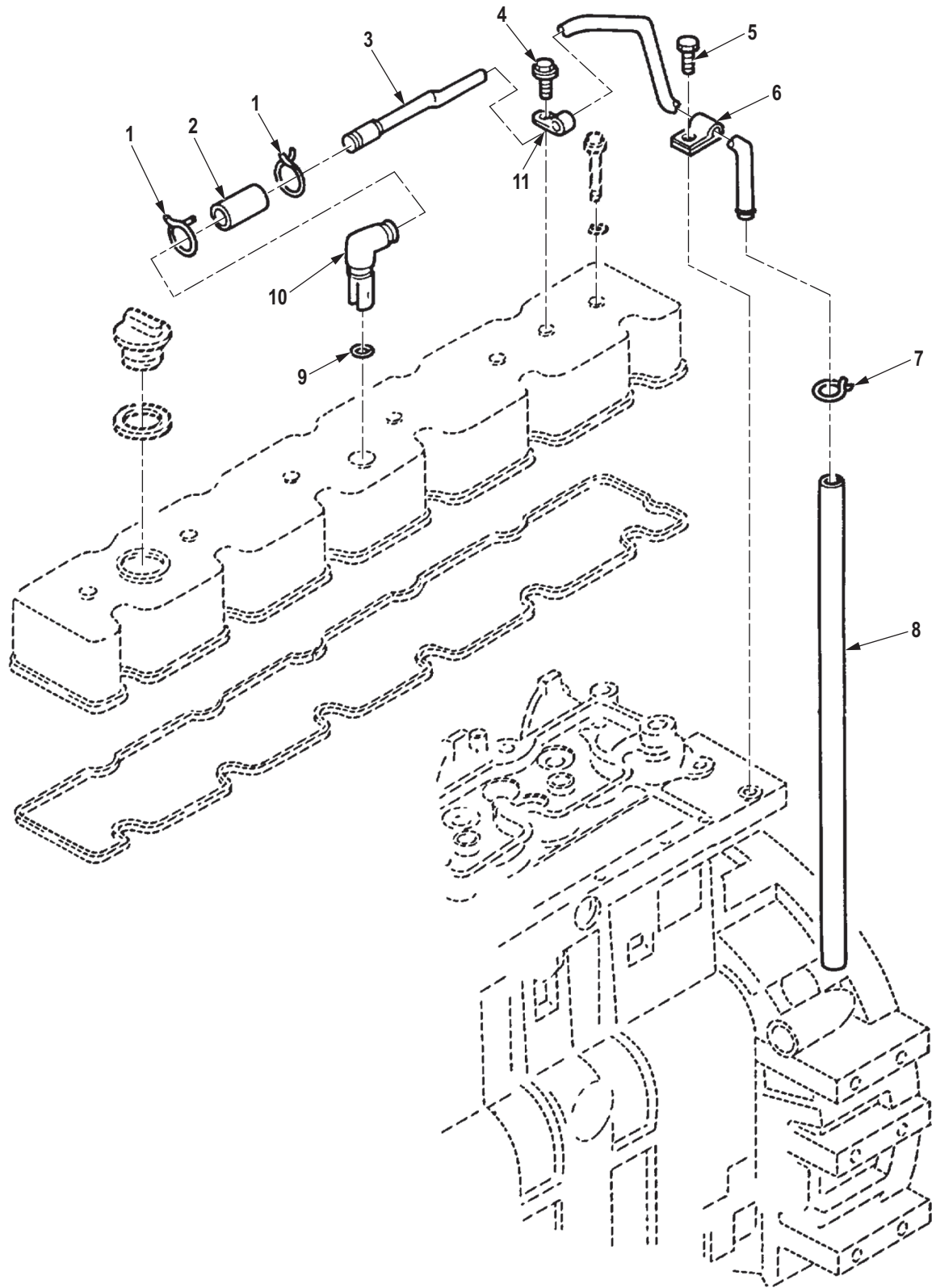

R0040DAA

Figure 40. Crankshaft Breather Tube (M939A2).

(1) ITEM NO.	(2) SMR CODE	(3) NSN	(4) CAGEC	(5) PART NUMBER	(6) DESCRIPTION AND USABLE ON CODE (UOC)	(7) QTY
<b>GROUP 0106 ENGINE LUBRICATION SYSTEM.</b>						
<b>FIG. 40. CRANKSHAFT BREATHER TUBE (M939A2).</b>						
1	PAFZZ	4730-01-291-8401	15434	3918163	CLAMP,HOSE UOC: ZAA,ZAB,ZAC,ZAD,ZAE,ZAF, ZAG,ZAH,ZAJ,ZAL .....	2
2	PAFZZ	4720-01-373-5652	15434	3918611	HOSE,NONMETALLIC UOC: ZAA,ZAB,ZAC,ZAD,ZAE,ZAF, ZAG,ZAH,ZAJ,ZAL .....	1
3	PAFZZ	4710-01-271-7922	15434	3909669	TUBE,BENT,METALLIC UOC: ZAA,ZAB,ZAC,ZAD,ZAE,ZAF, ZAG,ZAH,ZAJ,ZAL .....	1
4	PAFZZ	5305-01-192-2036	15434	3912072	SCREW UOC: ZAA,ZAB,ZAC,ZAD,ZAE,ZAF, ZAG,ZAH,ZAJ,ZAL .....	1
5	PAFZZ	5305-01-245-3817	15434	3901249	SCREW,CAP,HEXAGON H UOC: ZAA,ZAB,ZAC,ZAD,ZAE,ZAF, ZAG,ZAH,ZAJ,ZAL .....	1
6	PAFZZ	5340-01-271-2470	15434	70622	CLAMP,LOOP UOC: ZAA,ZAB,ZAC,ZAD,ZAE,ZAF, ZAG,ZAH,ZAJ,ZAL .....	1
7	PAFZZ	4730-01-271-3739	15434	3907740	CLAMP,HOSE UOC: ZAA,ZAB,ZAC,ZAD,ZAE,ZAF, ZAG,ZAH,ZAJ,ZAL .....	1
8	PAFZZ	4720-01-271-6950	15434	3918616	HOSE,NONMETALLIC UOC: ZAA,ZAB,ZAC,ZAD,ZAE,ZAF, ZAG,ZAH,ZAJ,ZAL .....	1
9	PAFZZ	5331-01-272-1120	15434	3909397	O-RING PART OF KIT P/N 3802622, PART OF KIT P/N 3800748, PART OF KIT P/N 402527100 UOC: ZAA,ZAB,ZAC,ZAD,ZAE,ZAF, ZAG,ZAH,ZAJ,ZAL .....	1
10	PAFZZ	4730-01-271-7955	15434	392049700	ELBOW,PIPE TO HOSE UOC: ZAA,ZAB,ZAC,ZAD,ZAE,ZAF, ZAG,ZAH,ZAJ,ZAL .....	1
11	PAFZZ	5340-01-275-0487	15434	3907741	CLAMP,LOOP UOC: ZAA,ZAB,ZAC,ZAD,ZAE,ZAF, ZAG,ZAH,ZAJ,ZAL .....	1

**END OF FIGURE**





**FIELD MAINTENANCE  
AIR INTAKE MANIFOLD (M939, M939A1)**

---

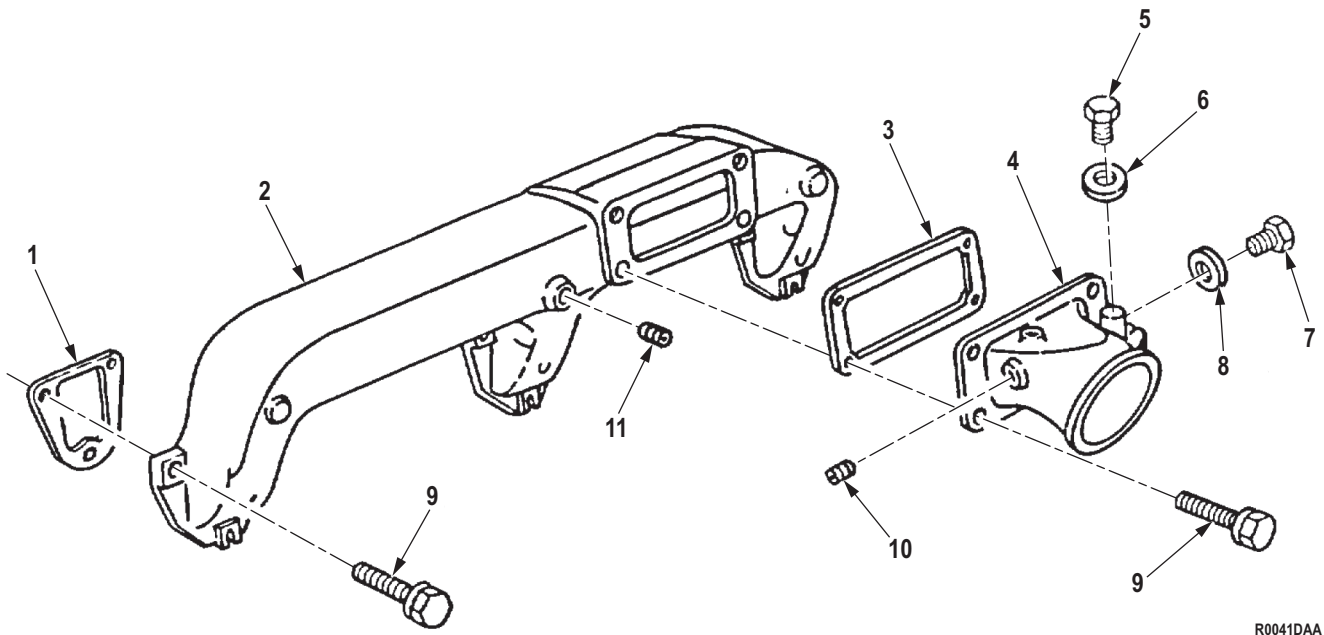

R0041DAA

Figure 41. Air Intake Manifold (M939, M939A1).

(1) ITEM NO.	(2) SMR CODE	(3) NSN	(4) CAGEC	(5) PART NUMBER	(6) DESCRIPTION AND USABLE ON CODE (UOC)	(7) QTY
<b>GROUP 0108 MANIFOLDS.</b>						
<b>FIG. 41. AIR INTAKE MANIFOLD (M939, M939A1).</b>						
1	PAFZZ	5330-01-086-3523	15434	3008591	GASKET PART OF KIT P/N 3011472, PART OF KIT P/N 4024955 UOC: DAC,DAD,DAE,DAF,DAG,DA H,DAJ,DAL,DAW,DAX,V14,V15,V16, V17,V18,V19,V20,V21,V22,V24 .....	3
2	PAFZZ	2815-00-404-2921	15434	202890	MANIFOLD,INTAKE UOC: DAC,DAD,DAE,DAF,DAG,DA H,DAJ,DAL,DAW,DAX,V14,V15,V16, V17,V18,V19,V20,V21,V22,V24 .....	1
3	PAFZZ	5330-01-520-3471	15434	3012972 NON- ASBESTOS	GASKET PART OF KIT P/N 3011472, PART OF KIT P/N 4024955 UOC: DAC,DAD,DAE,DAF,DAG,DA H,DAJ,DAL,DAW,DAX,V14,V15,V16, V17,V18,V19,V20,V21,V22,V24 .....	1
4	PFFZZ	2815-01-257-0853	15434	3044876	CONNECTION,AIR INTA UOC: DAC,DAD,DAE,DAF,DAG,DA H,DAJ,DAL,DAW,DAX,V14,V15,V16, V17,V18,V19,V20,V21,V22,V24 .....	1
5	PAFZZ	5365-00-974-9851	15434	138608	PLUG,MACHINE THREAD UOC: DAC,DAD,DAE,DAF,DAG,DA H,DAJ,DAL,DAW,DAX,V14,V15,V16, V17,V18,V19,V20,V21,V22,V24 .....	1
6	PAFZZ	5330-00-599-4517	77237	852050	GASKET UOC: DAC,DAD,DAE,DAF,DAG,DA H,DAJ,DAL,DAW,DAX,V14,V15,V16, V17,V18,V19,V20,V21,V22,V24 .....	1
7	PAFZZ	5365-01-197-3179	15434	108392	PLUG,MACHINE THREAD UOC: DAC,DAD,DAE,DAF,DAG,DA H,DAJ,DAL,DAW,DAX,V14,V15,V16, V17,V18,V19,V20,V21,V22,V24 .....	1
8	PAFZZ	5365-00-197-9327	15434	67946	SPACER,RING UOC: DAC,DAD,DAE,DAF,DAG,DA H,DAJ,DAL,DAW,DAX,V14,V15,V16, V17,V18,V19,V20,V21,V22,V24 .....	1
9	PAFZZ	5305-01-072-8816	15434	3011715	SCREW UOC: DAC,DAD,DAE,DAF,DAG,DA H,DAJ,DAL,DAW,DAX,V14,V15,V16, V17,V18,V19,V20,V21,V22,V24 .....	13
10	PAFZZ	4730-00-954-1281	58536	AA59616ACACBCB	PLUG,PIPE UOC: DAC,DAD,DAE,DAF,DAG,DA H,DAJ,DAL,DAW,DAX,V14,V15,V16, V17,V18,V19,V20,V21,V22,V24 .....	2

(1) ITEM NO.	(2) SMR CODE	(3) NSN	(4) CAGEC	(5) PART NUMBER	(6) DESCRIPTION AND USABLE ON CODE (UOC)	(7) QTY
11	PAFZZ	4730-00-018-9566	58536	A-A-59616ACABCA	PLUG,PIPE UOC: DAC,DAD,DAE,DAF,DAG,DA H,DAJ,DAL,DAW,DAX,V14,V15,V16, V17,V18,V19,V20,V21,V22,V24 .....	1

END OF FIGURE

**FIELD MAINTENANCE  
EXHAUST MANIFOLD (M939, M939A1)**

---

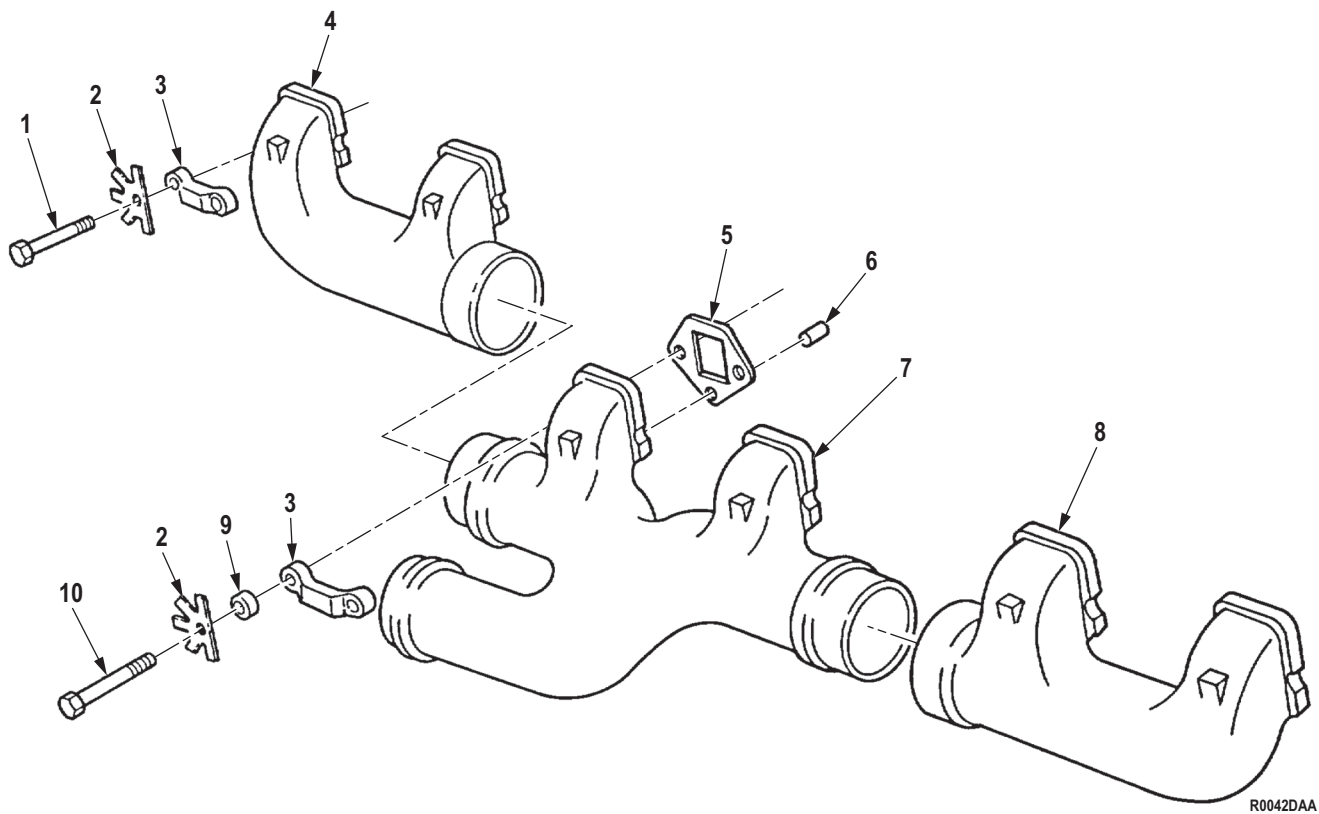

R0042DAA

Figure 42. Exhaust Manifold (M939, M939A1).

(1) ITEM NO.	(2) SMR CODE	(3) NSN	(4) CAGEC	(5) PART NUMBER	(6) DESCRIPTION AND USABLE ON CODE (UOC)	(7) QTY
<b>GROUP 0108 MANIFOLDS.</b>						
<b>FIG. 42. EXHAUST MANIFOLD (M939, M939A1).</b>						
1	PAFZZ	5305-00-005-0666	15434	200908	SCREW,CAP,HEXAGON H UOC: DAC,DAD,DAE,DAF,DAG,DA H,DAJ,DAL,DAW,DAX,V14,V15,V16, V17,V18,V19,V20,V21,V22,V24 .....	8
2	PAFZZ	5310-00-887-8325	15434	114638	WASHER,KEY PART OF KIT P/N 3011472, PART OF KIT P/N 4024955 UOC: DAC,DAD,DAE,DAF,DAG,DA H,DAJ,DAL,DAW,DAX,V14,V15,V16, V17,V18,V19,V20,V21,V22,V24 .....	12
3	PAFZZ	5340-00-132-3203	15434	200919	STRAP,RETAINING UOC: DAC,DAD,DAE,DAF,DAG,DA H,DAJ,DAL,DAW,DAX,V14,V15,V16, V17,V18,V19,V20,V21,V22,V24 .....	6
4	PFFZZ	2815-00-404-2926	15434	194921	MANIFOLD,EXHAUST UOC: DAC,DAD,DAE,DAF,DAG,DA H,DAJ,DAL,DAW,DAX,V14,V15,V16, V17,V18,V19,V20,V21,V22,V24 .....	1
5	PAFZZ	5330-00-659-3178	15434	3020943	GASKET PART OF KIT P/N 3011472, PART OF KIT P/N 4024955 UOC: DAC,DAD,DAE,DAF,DAG,DA H,DAJ,DAL,DAW,DAX,V14,V15,V16, V17,V18,V19,V20,V21,V22,V24 .....	6
6	PAFZZ	2815-00-829-5227	34623	MA243 21 011	DOWEL,MANIFOLD UOC: DAC,DAD,DAE,DAF,DAG,DA H,DAJ,DAL,DAW,DAX,V14,V15,V16, V17,V18,V19,V20,V21,V22,V24 .....	6
7	PFFZZ	2815-01-137-9707	15434	210879	MANIFOLD,EXHAUST UOC: DAC,DAD,DAE,DAF,DAG,DA H,DAJ,DAL,DAW,DAX,V14,V15,V16, V17,V18,V19,V20,V21,V22,V24 .....	1
8	PFFZZ	2815-00-404-2931	15434	19492300	MANIFOLD,EXHAUST UOC: DAC,DAD,DAE,DAF,DAG,DA H,DAJ,DAL,DAW,DAX,V14,V15,V16, V17,V18,V19,V20,V21,V22,V24 .....	1
9	PAFZZ	5310-00-562-6557	15434	S622	WASHER,FLAT UOC: DAC,DAD,DAE,DAF,DAG,DA H,DAJ,DAL,DAW,DAX,V14,V15,V16, V17,V18,V19,V20,V21,V22,V24 .....	6
10	PAFZZ	5305-00-340-3492	15434	S152	SCREW,CAP,HEXAGON H UOC: DAC,DAD,DAE,DAF,DAG,DA H,DAJ,DAL,DAW,DAX,V14,V15,V16, V17,V18,V19,V20,V21,V22,V24 .....	4

END OF FIGURE





**FIELD MAINTENANCE  
EXHAUST MANIFOLD (M939A2)**

---

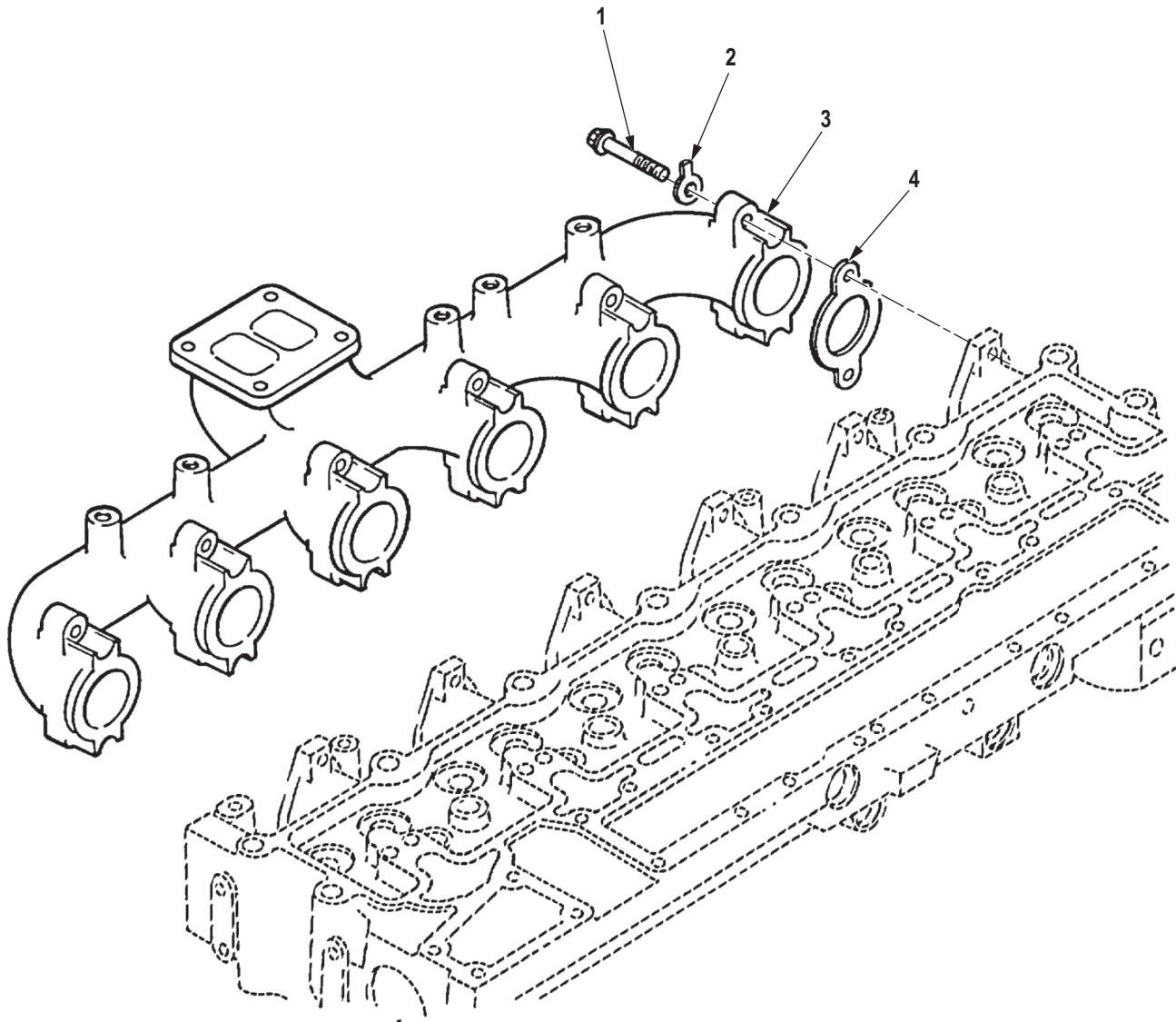

R0043DAA

Figure 43. Exhaust Manifold (M939A2).

(1) ITEM NO.	(2) SMR CODE	(3) NSN	(4) CAGEC	(5) PART NUMBER	(6) DESCRIPTION AND USABLE ON CODE (UOC)	(7) QTY
<b>GROUP 0108 MANIFOLDS.</b>						
<b>FIG. 43. EXHAUST MANIFOLD (M939A2).</b>						
1	PAFZZ	5305-01-271-6448	15434	3081346	SCREW,CAP,HEXAGON H UOC: ZAA,ZAB,ZAC,ZAD,ZAE,ZAF, ZAG,ZAH,ZAJ,ZAL .....	12
2	PAFZZ	5310-01-330-8313	15434	3914708	WASHER,KEY PART OF KIT P/N 3800748, PART OF KIT P/N 402527100 UOC: ZAA,ZAB,ZAC,ZAD,ZAE,ZAF, ZAG,ZAH,ZAJ,ZAL .....	12
3	PAFZZ	2815-01-272-0547	15434	3932183	MANIFOLD,EXHAUST UOC: ZAA,ZAB,ZAC,ZAD,ZAE,ZAF, ZAG,ZAH,ZAJ,ZAL .....	1
4	PAFZZ	5330-01-272-1139	15434	3929012	GASKET PART OF KIT P/N 3802622, PART OF KIT P/N 3800748, PART OF KIT P/N 402527100 UOC: ZAA,ZAB,ZAC,ZAD,ZAE,ZAF, ZAG,ZAH,ZAJ,ZAL .....	6

**END OF FIGURE**



**FIELD MAINTENANCE  
ACCESSORY DRIVE, PULLEY, AND RELATED PARTS (M939, M939A1)**

---

1	6	18
2-11	7-8	19

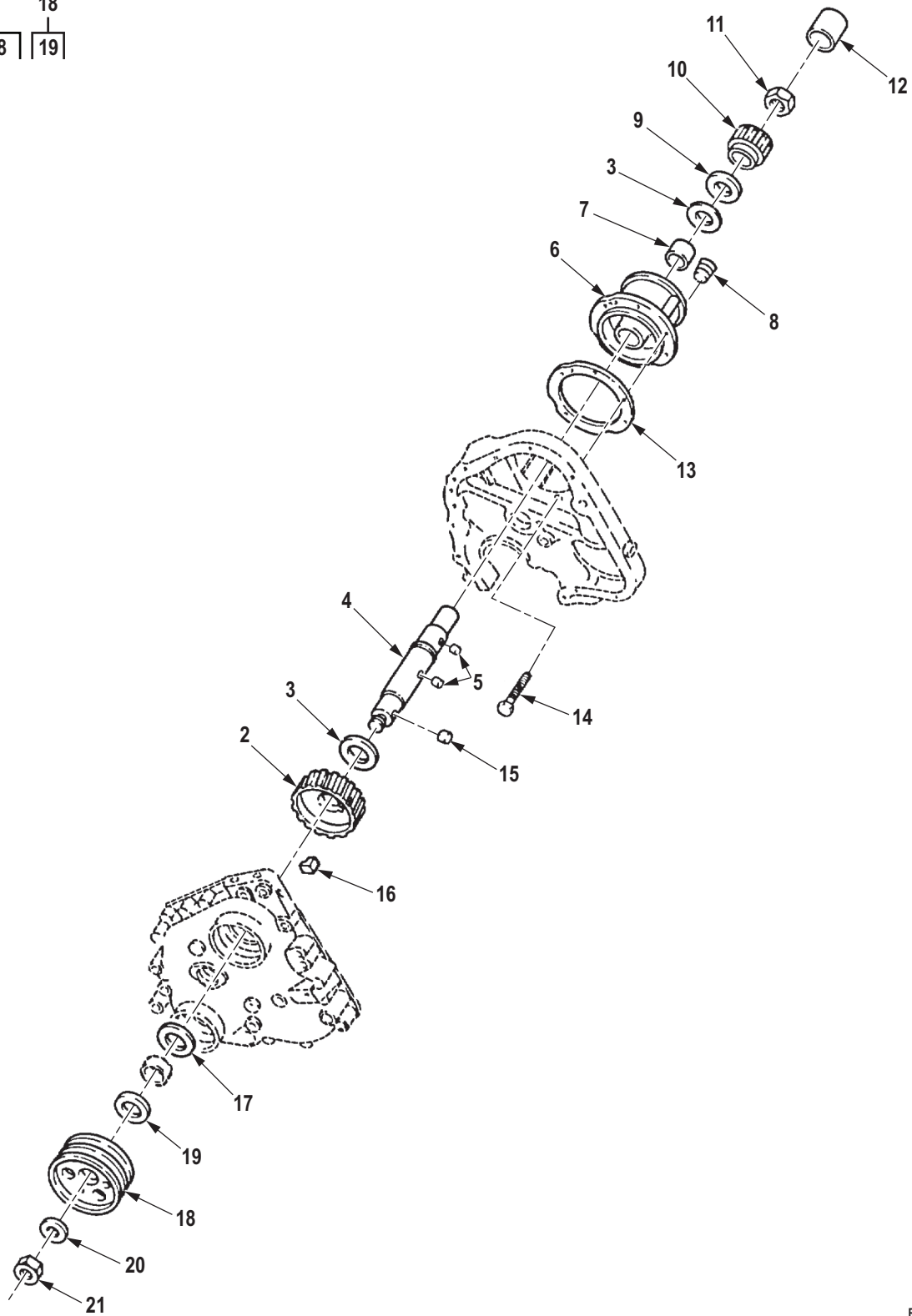

R0044DAA

Figure 44. Accessory Drive, Pulley, and Related Parts (M939, M939A1).

(1) ITEM NO.	(2) SMR CODE	(3) NSN	(4) CAGEC	(5) PART NUMBER	(6) DESCRIPTION AND USABLE ON CODE (UOC)	(7) QTY
<b>GROUP 0109 ACCESSORY DRIVING MECHANISMS.</b>						
<b>FIG. 44. ACCESSORY DRIVE, PULLEY, AND RELATED PARTS (M939, M939A1).</b>						
1	PAHHH	4310-01-092-9815	15434	3005133	DRIVE ACCESSORY,COM UOC: DAC,DAD,DAE,DAF,DAG,DAH,DAJ,DAL,DAW,DAX,V14,V15,V16,V17,V18,V19,V20,V21,V22,V24 .....	1
2	PAHZZ	3020-00-820-7914	15434	12193300	. GEAR,HELICAL USE PRIOR TO SERIAL NUMBER 11246663 PART OF KIT P/N 5704533 UOC: V14,V15,V16,V17,V18,V19,V20,V21,V22,V24 .....	1
2	KBHZZ	3020-00-160-9092	15434	142689	. GEAR,HELICAL USED AFTER SERIAL NUMBER 11246663 PART OF KIT P/N 5704533 UOC: DAC,DAD,DAE,DAF,DAG,DAH,DAJ,DAL,DAW,DAX,V14,V15,V16,V17,V18,V19,V20,V21,V22,V24 .....	1
3	PAHZZ	3120-01-144-7368	15434	3026557	. BEARING,WASHER,THRU UOC: DAC,DAD,DAE,DAF,DAG,DAH,DAJ,DAL,DAW,DAX,V14,V15,V16,V17,V18,V19,V20,V21,V22,V24 .....	2
4	PAHZZ	4310-01-092-9816	15434	3000171	. SHAFT,AIR COMPRESSO UOC: DAC,DAD,DAE,DAF,DAG,DAH,DAJ,DAL,DAW,DAX,V14,V15,V16,V17,V18,V19,V20,V21,V22,V24 .....	1
5	PAHZZ	5315-01-177-7507	15434	3034438	. PIN,STRAIGHT,HEADLE UOC: DAC,DAD,DAE,DAF,DAG,DAH,DAJ,DAL,DAW,DAX,V14,V15,V16,V17,V18,V19,V20,V21,V22,V24 .....	2
6	PAHZZ	3040-01-129-4302	15434	AR4572400	. HOUSING,MECHANICAL UOC: DAC,DAD,DAE,DAF,DAG,DAH,DAJ,DAL,DAW,DAX,V14,V15,V16,V17,V18,V19,V20,V21,V22,V24 .....	1
7	PAHZZ	3120-00-792-9834	15434	116391	. . BEARING,SLEEVE UOC: DAC,DAD,DAE,DAF,DAG,DAH,DAJ,DAL,DAW,DAX,V14,V15,V16,V17,V18,V19,V20,V21,V22,V24 .....	1
8	PAHZZ	4730-00-018-9566	58536	A-A-59616ACABCA	. . PLUG,PIPE UOC: DAC,DAD,DAE,DAF,DAG,DAH,DAJ,DAL,DAW,DAX,V14,V15,V16,V17,V18,V19,V20,V21,V22,V24 .....	2
9	PAHZZ	5310-00-081-9292	15434	3014103	. WASHER,FLAT UOC: DAC,DAD,DAE,DAF,DAG,DAH,DAJ,DAL,DAW,DAX,V14,V15,V16,V17,V18,V19,V20,V21,V22,V24 .....	1

(1) ITEM NO.	(2) SMR CODE	(3) NSN	(4) CAGEC	(5) PART NUMBER	(6) DESCRIPTION AND USABLE ON CODE (UOC)	(7) QTY
10	PAHZZ	3010-01-085-2732	15434	3000174	. COUPLING HALF,SHAFT UOC: DAC,DAD,DAE,DAF,DAG,DA H,DAJ,DAL,DAW,DAX,V14,V15,V16, V17,V18,V19,V20,V21,V22,V24 .....	1
11	PAHZZ	5310-00-442-6899	15434	191517	. NUT,SELF-LOCKING,HE UOC: DAC,DAD,DAE,DAF,DAG,DA H,DAJ,DAL,DAW,DAX,V14,V15,V16, V17,V18,V19,V20,V21,V22,V24 .....	1
12	PAHZZ	3010-01-079-3461	15434	199349	COUPLING,SHAFT,RIGI UOC: DAC,DAD,DAE,DAF,DAG,DA H,DAJ,DAL,DAW,DAX,V14,V15,V16, V17,V18,V19,V20,V21,V22,V24 .....	1
13	PAHZZ	5330-00-026-2931	15434	3069101	GASKET PART OF KIT P/N 3011472 UOC: DAC,DAD,DAE,DAF,DAG,DA H,DAJ,DAL,DAW,DAX,V14,V15,V16, V17,V18,V19,V20,V21,V22,V24 .....	1
14	PAHZZ	5305-01-119-8621	15434	3010590	SCREW UOC: DAC,DAD,DAE,DAF,DAG,DA H,DAJ,DAL,DAW,DAX,V14,V15,V16, V17,V18,V19,V20,V21,V22,V24 .....	5
15	PAHZZ	2815-01-124-0232	15434	70550	PIN,PISTON UOC: DAC,DAD,DAE,DAF,DAG,DA H,DAJ,DAL,DAW,DAX,V14,V15,V16, V17,V18,V19,V20,V21,V22,V24 .....	3
16	PAFZZ	5330-01-129-6541	15434	3008947	RUBBER STRIP PART OF KIT P/ N 3011472 UOC: DAC,DAD,DAE,DAF,DAG,DA H,DAJ,DAL,DAW,DAX,V14,V15,V16, V17,V18,V19,V20,V21,V22,V24 .....	1
17	PAFZZ	5330-00-135-6382	15434	211255	SEAL,PLAIN ENCASED PART OF KIT P/N 3011472 UOC: DAC,DAD,DAE,DAF,DAG,DA H,DAJ,DAL,DAW,DAX,V14,V15,V16, V17,V18,V19,V20,V21,V22,V24 .....	1
18	PAFFF	3020-01-195-6990	15434	303050600	PULLEY,GROOVE UOC: DAC,DAD,DAE,DAF,DAG,DA H,DAJ,DAL,DAW,DAX,V14,V15,V16, V17,V18,V19,V20,V21,V22,V24 .....	1
19	PAFZZ	2930-00-401-9531	15434	190397	. SLEEVE,PULLEY,PUMP UOC: DAC,DAD,DAE,DAF,DAG,DA H,DAJ,DAL,DAW,DAX,V14,V15,V16, V17,V18,V19,V20,V21,V22,V24 .....	1
20	PAFZZ	5310-01-124-6463	15434	193136	WASHER,FLAT UOC: DAC,DAD,DAE,DAF,DAG,DA H,DAJ,DAL,DAW,DAX,V14,V15,V16, V17,V18,V19,V20,V21,V22,V24 .....	1



(1) ITEM NO.	(2) SMR CODE	(3) NSN	(4) CAGEC	(5) PART NUMBER	(6) DESCRIPTION AND USABLE ON CODE (UOC)	(7) QTY
21	PAFZZ	5310-01-126-1045	15434	3012526	NUT,SELF-LOCKING,HE UOC: DAC,DAD,DAE,DAF,DAG,DA H,DAJ,DAL,DAW,DAX,V14,V15,V16, V17,V18,V19,V20,V21,V22,V24 .....	1

END OF FIGURE



**FIELD MAINTENANCE  
TACHOMETER ACCESS COVER (M939A2)**

---

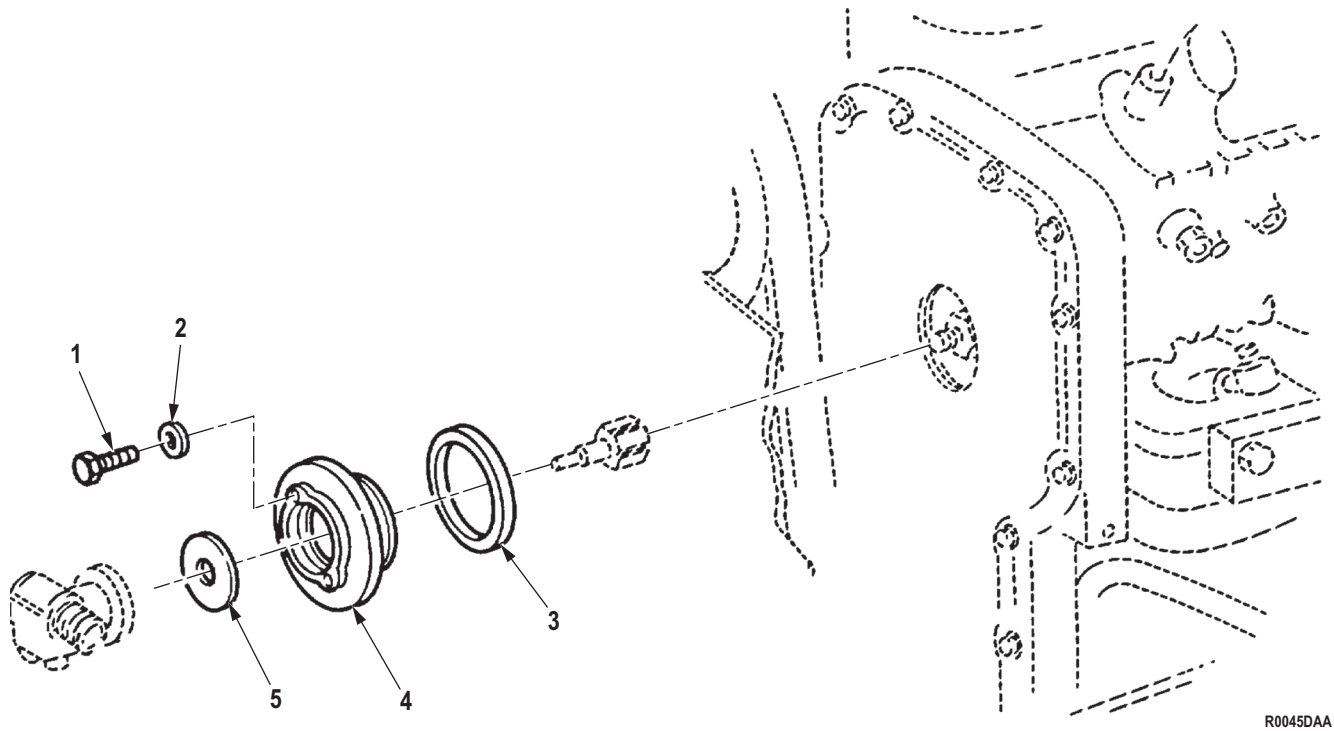

R0045DAA

Figure 45. Tachometer Access Cover (M939A2).

(1) ITEM NO.	(2) SMR CODE	(3) NSN	(4) CAGEC	(5) PART NUMBER	(6) DESCRIPTION AND USABLE ON CODE (UOC)	(7) QTY
<b>GROUP 0109 ACCESSORY DRIVING MECHANISMS.</b>						
<b>FIG. 45. TACHOMETER ACCESS COVER (M939A2).</b>						
1	PAFZZ	5305-01-263-2733	15434	3027685	SCREW,CAP,HEXAGON H UOC: ZAA,ZAB,ZAC,ZAD,ZAE,ZAF, ZAG,ZAH,ZAJ,ZAL .....	2
2	PAFZZ	5310-01-265-7014	15434	62392	WASHER,FLAT UOC: ZAA,ZAB,ZAC,ZAD,ZAE,ZAF, ZAG,ZAH,ZAJ,ZAL .....	2
3	PAFZZ	5330-01-191-8047	15434	3903475	GASKET UOC: ZAA,ZAB,ZAC,ZAD,ZAE,ZAF, ZAG,ZAH,ZAJ,ZAL .....	1
4	PAFZZ	5340-01-266-3023	15434	391821500	COVER,ACCESS UOC: ZAA,ZAB,ZAC,ZAD,ZAE,ZAF, ZAG,ZAH,ZAJ,ZAL .....	1
5	PAFZZ	5330-01-270-8144	15434	3915800	GASKET TACHOMETER DRIVE UOC: ZAA,ZAB,ZAC,ZAD,ZAE,ZAF, ZAG,ZAH,ZAJ,ZAL .....	1

**END OF FIGURE**



**FIELD MAINTENANCE  
FUEL INJECTOR ASSEMBLY AND RELATED PARTS (M939, M939A1)**

---

1  
2 - 16

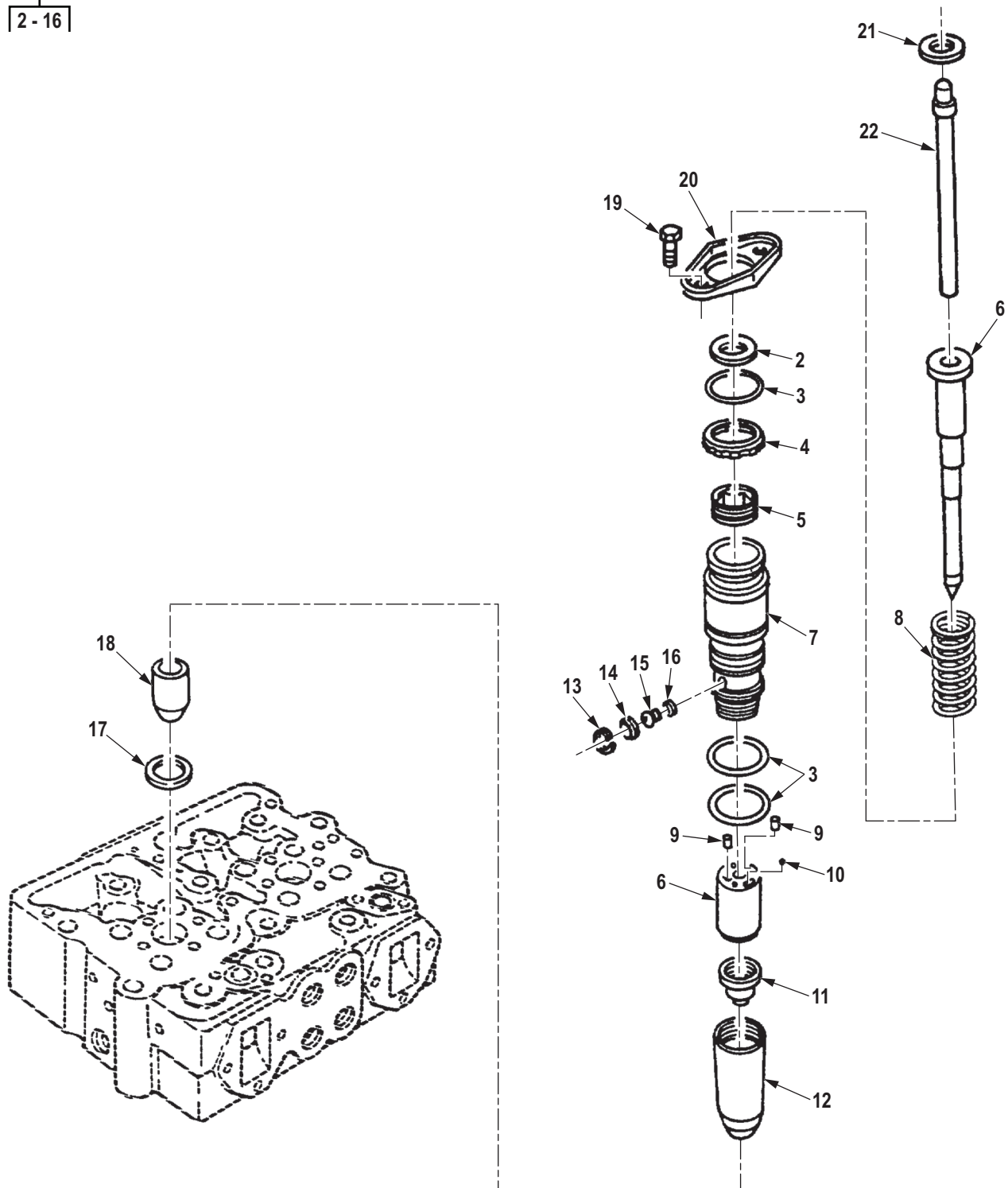

R0046DAA

Figure 46. Fuel Injector Assembly and Related Parts (M939, M939A1).



(1) ITEM NO.	(2) SMR CODE	(3) NSN	(4) CAGEC	(5) PART NUMBER	(6) DESCRIPTION AND USABLE ON CODE (UOC)	(7) QTY
<p><b>GROUP 0301 CARBURETOR, FUEL INJECTOR.</b></p> <p><b>FIG. 46. FUEL INJECTOR ASSEMBLY AND RELATED PARTS (M939, M939A1).</b></p>						
1	PAHHH	2910-00-404-3054	15434	3054250	INJECTOR ASSEMBLY, F USE PRIOR TO SERIAL NUMBER 11246663 UOC: V14,V15,V16,V17,V18,V19,V20,V21,V22,V24 .....	6
1	PAHHH	2910-01-218-5155	15434	3046281	NOZZLE, FUEL INJECTOR USE AFTER SERIAL NUMBER 11246663 UOC: DAC,DAD,DAE,DAF,DAG,DAH,DAJ,DAL,DAW,DAX,V14,V15,V16,V17,V18,V19,V20,V21,V22,V24 .....	6
2	PAHZZ	5310-01-145-1114	15434	3015469	. WASHER USE AFTER SERIAL NUMBER 11246663 UOC: DAC,DAD,DAE,DAF,DAG,DAH,DAJ,DAL,DAW,DAX,V14,V15,V16,V17,V18,V19,V20,V21,V22,V24 .....	1
3	KBHZZ	5330-00-132-0276	15434	193736	. GASKET PART OF KIT P/N 3011472, PART OF KIT P/N 4024955, PART OF KIT P/N AR51483 UOC: DAC,DAD,DAE,DAF,DAG,DAH,DAJ,DAL,DAW,DAX,V14,V15,V16,V17,V18,V19,V20,V21,V22,V24 .....	3
4	PAHZZ	5310-01-079-6708	15434	3000465	. NUT, PLAIN, DODECAGON UOC: DAC,DAD,DAE,DAF,DAG,DAH,DAJ,DAL,DAW,DAX,V14,V15,V16,V17,V18,V19,V20,V21,V22,V24 .....	1
5	PAHZZ	5305-01-079-7028	15434	212954	. SCREW UOC: DAC,DAD,DAE,DAF,DAG,DAH,DAJ,DAL,DAW,DAX,V14,V15,V16,V17,V18,V19,V20,V21,V22,V24 .....	1
6	PAHZZ	2910-01-191-8470	15434	3054532	. BARREL AND PLUNGER USE PRIOR TO SERIAL NUMBER 11246663 PART OF KIT P/N 4024955 UOC: V14,V15,V16,V17,V18,V19,V20,V21,V22,V24 .....	1
6	PAHZZ	2910-01-219-2086	15434	3054533	. PARTS KIT, FUEL INJECTOR USE AFTER SERIAL NUMBER 11246663 UOC: DAC,DAD,DAE,DAF,DAG,DAH,DAJ,DAL,DAW,DAX,V14,V15,V16,V17,V18,V19,V20,V21,V22,V24 .....	1
7	PAHZZ	2910-01-105-6457	15434	185139	. ADAPTER, INJECTOR USE PRIOR TO SERIAL NUMBER 11246663 UOC: V14,V15,V16,V17,V18,V19,V20,V21,V22,V24 .....	1

(1) ITEM NO.	(2) SMR CODE	(3) NSN	(4) CAGEC	(5) PART NUMBER	(6) DESCRIPTION AND USABLE ON CODE (UOC)	(7) QTY
7	PAHZZ	2910-01-076-8632	15434	3000464	. ADAPTER,INJECTOR USE AFTER SERIAL NUMBER 11246663 UOC: DAC,DAD,DAE,DAF,DAG,DA H,DAJ,DAL,DAW,DAX,V14,V15,V16, V17,V18,V19,V20,V21,V22,V24 .....	1
8	PAHZZ	5360-00-132-0245	15434	166009	. SPRING,HELICAL,COMP UOC: DAC,DAD,DAE,DAF,DAG,DA H,DAJ,DAL,DAW,DAX,V14,V15,V16, V17,V18,V19,V20,V21,V22,V24 .....	1
9	PAHZZ	5315-01-079-6506	15434	203426	. PIN,SPRING UOC: DAC,DAD,DAE,DAF,DAG,DA H,DAJ,DAL,DAW,DAX,V14,V15,V16, V17,V18,V19,V20,V21,V22,V24 .....	2
10	KBHZZ	4820-01-070-9710	15434	167157	. BALL,CHECK PART OF KIT P/N AR51522 UOC: DAC,DAD,DAE,DAF,DAG,DA H,DAJ,DAL,DAW,DAX,V14,V15,V16, V17,V18,V19,V20,V21,V22,V24 .....	1
11	KBHZZ	2910-01-152-8531	15434	3012537	. CUP,INJECTOR PART OF KIT P/ N 4024955 UOC: DAC,DAD,DAE,DAF,DAG,DA H,DAJ,DAL,DAW,DAX,V14,V15,V16, V17,V18,V19,V20,V21,V22,V24 .....	1
12	PAHZZ	5342-01-079-4678	15434	185138	. RETAINER,CUP UOC: DAC,DAD,DAE,DAF,DAG,DA H,DAJ,DAL,DAW,DAX,V14,V15,V16, V17,V18,V19,V20,V21,V22,V24 .....	1
13	KBHZZ	5325-00-815-1137	15434	174299	. RING,RETAINING PART OF KIT P/N AR51522 UOC: DAC,DAD,DAE,DAF,DAG,DA H,DAJ,DAL,DAW,DAX,V14,V15,V16, V17,V18,V19,V20,V21,V22,V24 .....	1
14	KBHZZ	4730-01-077-2016	15434	3008706	. STRAINER ELEMENT,SE PART OF KIT P/N AR51522 UOC: DAC,DAD,DAE,DAF,DAG,DA H,DAJ,DAL,DAW,DAX,V14,V15,V16, V17,V18,V19,V20,V21,V22,V24 .....	1
15	KBHZZ		15434	3044992	. PLUG,ORIFICE .017 PART OF KIT P/N AR51522 UOC: DAC,DAD,DAE,DAF,DAG,DA H,DAJ,DAL,DAW,DAX,V14,V15,V16, V17,V18,V19,V20,V21,V22,V24 .....	1
15	KBHZZ	4730-01-199-7720	15434	3044995	. PLUG,ORIFICE .020 PART OF KIT P/N AR51522 UOC: DAC,DAD,DAE,DAF,DAG,DA H,DAJ,DAL,DAW,DAX,V14,V15,V16, V17,V18,V19,V20,V21,V22,V24 .....	1

(1) ITEM NO.	(2) SMR CODE	(3) NSN	(4) CAGEC	(5) PART NUMBER	(6) DESCRIPTION AND USABLE ON CODE (UOC)	(7) QTY
15	KBHZZ	4730-01-089-4269	15434	3044994	. PLUG,ORIFICE .019 PART OF KIT P/N AR51522 UOC: DAC,DAD,DAE,DAF,DAG,DA H,DAJ,DAL,DAW,DAX,V14,V15,V16, V17,V18,V19,V20,V21,V22,V24 .....	1
15	KBHZZ	4730-01-496-4411	15434	3044993	. PLUG,ORIFICE .018 PART OF KIT P/N AR51522 UOC: DAC,DAD,DAE,DAF,DAG,DA H,DAJ,DAL,DAW,DAX,V14,V15,V16, V17,V18,V19,V20,V21,V22,V24 .....	1
16	KBHZZ	5330-00-132-0247	15434	173086	. GASKET PART OF KIT P/N 3011472, PART OF KIT P/N 4024955, PART OF KIT P/N AR51522 UOC: DAC,DAD,DAE,DAF,DAG,DA H,DAJ,DAL,DAW,DAX,V14,V15,V16, V17,V18,V19,V20,V21,V22,V24 .....	1
17	PAHZZ	5331-01-072-4436	15434	3007759	O-RING PART OF KIT P/N 3011472, PART OF KIT P/N 4024955 UOC: DAC,DAD,DAE,DAF,DAG,DA H,DAJ,DAL,DAW,DAX,V14,V15,V16, V17,V18,V19,V20,V21,V22,V24 .....	6
18	PAHZZ	2910-01-146-0048	15434	3011934	SLEEVE,COOLING,FUEL UOC: DAC,DAD,DAE,DAF,DAG,DA H,DAJ,DAL,DAW,DAX,V14,V15,V16, V17,V18,V19,V20,V21,V22,V24 .....	6
19	PAHZZ	5305-01-145-0777	15434	3028279	SCREW,CAP,HEXAGON H UOC: DAC,DAD,DAE,DAF,DAG,DA H,DAJ,DAL,DAW,DAX,V14,V15,V16, V17,V18,V19,V20,V21,V22,V24 .....	12
20	PAHZZ	2910-01-150-4925	15434	303113700	CLAMP,INJECTOR MOUN (NON TOP STOP) UOC: DAC,DAD,DAE,DAF,DAG,DA H,DAJ,DAL,DAW,DAX,V14,V15,V16, V17,V18,V19,V20,V21,V22,V24 .....	6
20	PAHZZ	5342-01-145-0646	15434	2028171	CLAMP,INJECTOR MOUN (TOP STOP) UOC: DAC,DAD,DAE,DAF,DAG,DA H,DAJ,DAL,DAW,DAX,V14,V15,V16, V17,V18,V19,V20,V21,V22,V24 .....	6
21	PAHZZ	5310-01-066-2942	15434	180626	. WASHER,LOCK UOC: DAC,DAD,DAE,DAF,DAG,DA H,DAJ,DAL,DAW,DAX,V14,V15,V16, V17,V18,V19,V20,V21,V22,V24 .....	6
22	PAHZZ	5340-00-238-5435	15434	191916	PLUNGER,DETENT UOC: DAC,DAD,DAE,DAF,DAG,DA H,DAJ,DAL,DAW,DAX,V14,V15,V16, V17,V18,V19,V20,V21,V22,V24 .....	6

END OF FIGURE



**FIELD MAINTENANCE  
FUEL INJECTOR ASSEMBLY AND RELATED PARTS (M939A2)**

---

1  
2-6

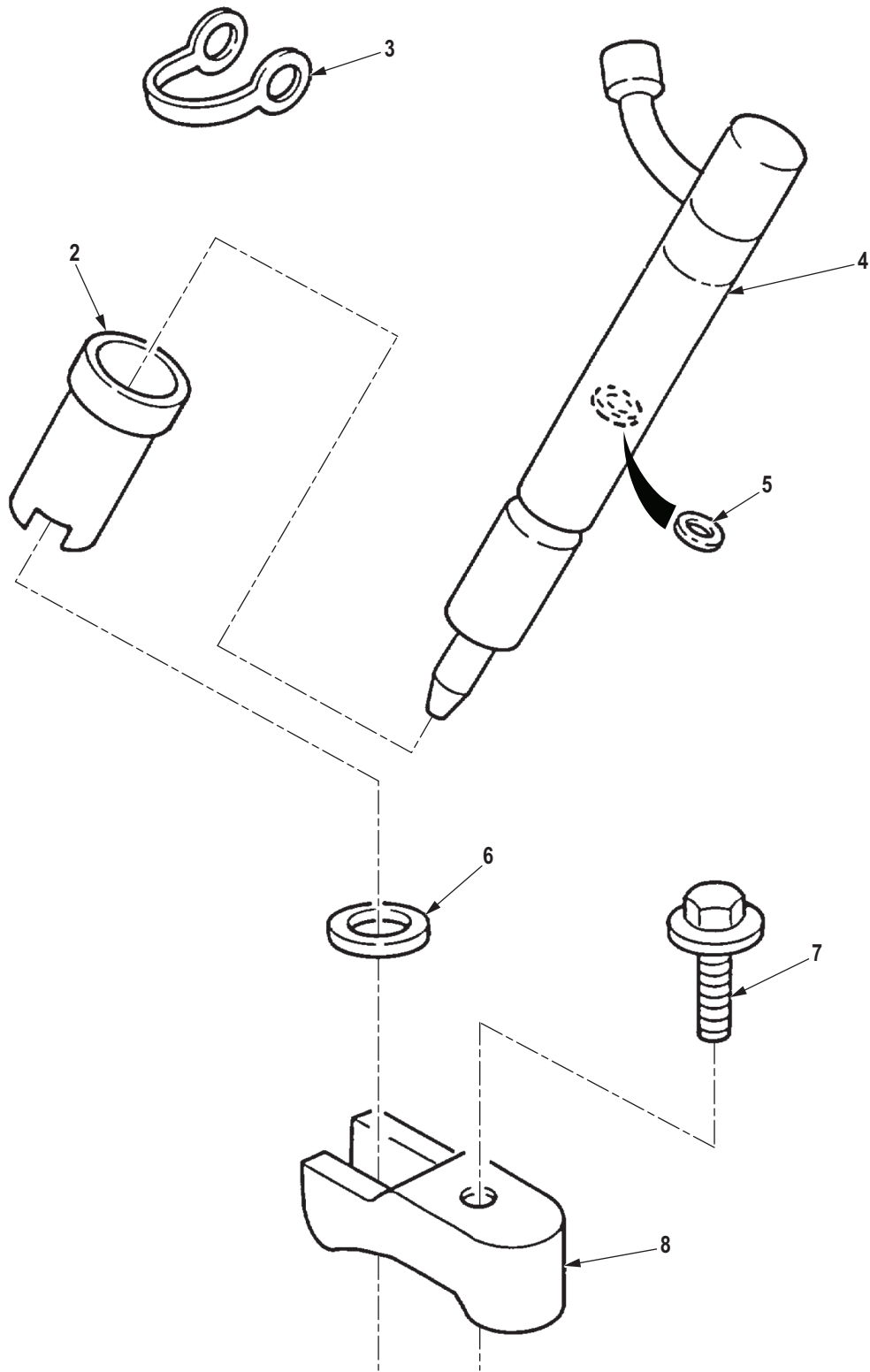

R0047DAA

Figure 47. Fuel Injector Assembly and Related Parts (M939A2).

(1) ITEM NO.	(2) SMR CODE	(3) NSN	(4) CAGEC	(5) PART NUMBER	(6) DESCRIPTION AND USABLE ON CODE (UOC)	(7) QTY
<b>GROUP 0301 CARBURETOR, FUEL INJECTOR.</b>						
<b>FIG. 47. FUEL INJECTOR ASSEMBLY AND RELATED PARTS (M939A2).</b>						
1	PAFHH	2910-01-292-5663	15434	3802091	PARTS KIT,FUEL INJE UOC: ZAA,ZAB,ZAC,ZAD,ZAE,ZAF, ZAG,ZAH,ZAJ,ZAL .....	6
2	PAHZZ	2910-01-271-9826	15434	3909886	. SLEEVE,COOLING,FUEL UOC: ZAA,ZAB,ZAC,ZAD,ZAE,ZAF, ZAG,ZAH,ZAJ,ZAL .....	1
3	PAHZZ	5330-01-195-5268	15434	3903380	. SEAL,BANJO CONNECT PART OF KIT P/N 3802622, PART OF KIT P/ N 3800748, PART OF KIT P/N 402527100 UOC: ZAA,ZAB,ZAC,ZAD,ZAE,ZAF, ZAG,ZAH,ZAJ,ZAL .....	1
4	XAHZZ		15434	3908513	. INJECTOR UOC: ZAA,ZAB,ZAC,ZAD,ZAE,ZAF, ZAG,ZAH,ZAJ,ZAL .....	1
5	PAHZZ	5310-01-189-5409	15434	3905181	. WASHER,FLAT 1.80MM UOC: ZAA,ZAB,ZAC,ZAD,ZAE,ZAF, ZAG,ZAH,ZAJ,ZAL .....	1
5	PAHZZ	5310-01-189-5413	15434	3905186	. WASHER,FLAT INJECTOR,1.98MM UOC: ZAA,ZAB,ZAC,ZAD,ZAE,ZAF, ZAG,ZAH,ZAJ,ZAL .....	1
5	PAHZZ	5310-01-189-5412	15434	3905185	. WASHER,FLAT 1.94MM UOC: ZAA,ZAB,ZAC,ZAD,ZAE,ZAF, ZAG,ZAH,ZAJ,ZAL .....	1
5	PAHZZ	5310-01-189-5410	15434	3905182	. WASHER,FLAT 1.84MM UOC: ZAA,ZAB,ZAC,ZAD,ZAE,ZAF, ZAG,ZAH,ZAJ,ZAL .....	1
5	PAHZZ	5365-01-191-3533	15434	3905161	. SHIM 1.18MM UOC: ZAA,ZAB,ZAC,ZAD,ZAE,ZAF, ZAG,ZAH,ZAJ,ZAL .....	1
5	PAHZZ	5365-01-189-9028	15434	3905172	. SPACER,PLATE 1.54 UOC: ZAA,ZAB,ZAC,ZAD,ZAE,ZAF, ZAG,ZAH,ZAJ,ZAL .....	1
5	PAHZZ	5310-01-189-7499	15434	3905183	. WASHER,FLAT 1.88MM UOC: ZAA,ZAB,ZAC,ZAD,ZAE,ZAF, ZAG,ZAH,ZAJ,ZAL .....	1
5	PAHZZ	5310-01-189-5411	15434	3905184	. WASHER,FLAT 1.90MM UOC: ZAA,ZAB,ZAC,ZAD,ZAE,ZAF, ZAG,ZAH,ZAJ,ZAL .....	1
5	PAHZZ	5365-01-191-3535	15434	3905178	. SPACER,PLATE 1.70MM UOC: ZAA,ZAB,ZAC,ZAD,ZAE,ZAF, ZAG,ZAH,ZAJ,ZAL .....	1

(1) ITEM NO.	(2) SMR CODE	(3) NSN	(4) CAGEC	(5) PART NUMBER	(6) DESCRIPTION AND USABLE ON CODE (UOC)	(7) QTY
5	PAHZZ	5365-01-191-0776	15434	3905177	. SPACER,PLATE 1.70MM UOC: ZAA,ZAB,ZAC,ZAD,ZAE,ZAF, ZAG,ZAH,ZAJ,ZAL .....	1
5	PAHZZ	5310-01-189-5408	15434	3905176	. WASHER,FLAT 1.68MM UOC: ZAA,ZAB,ZAC,ZAD,ZAE,ZAF, ZAG,ZAH,ZAJ,ZAL .....	1
5	PAHZZ	5365-01-189-9029	15434	3905173	. SPACER,PLATE 1.58 UOC: ZAA,ZAB,ZAC,ZAD,ZAE,ZAF, ZAG,ZAH,ZAJ,ZAL .....	1
5	PAHZZ	5365-01-191-2411	15434	3905180	. SHIM 1.78MM UOC: ZAA,ZAB,ZAC,ZAD,ZAE,ZAF, ZAG,ZAH,ZAJ,ZAL .....	1
5	PAHZZ	5365-01-188-1056	15434	3905175	. SHIM 1.64MM UOC: ZAA,ZAB,ZAC,ZAD,ZAE,ZAF, ZAG,ZAH,ZAJ,ZAL .....	1
5	PAHZZ	5365-01-189-9030	15434	3905174	. SPACER,PLATE 1.60 UOC: ZAA,ZAB,ZAC,ZAD,ZAE,ZAF, ZAG,ZAH,ZAJ,ZAL .....	1
5	PAHZZ	5310-01-191-6333	15434	3905170	. WASHER,FLAT 1.48MM UOC: ZAA,ZAB,ZAC,ZAD,ZAE,ZAF, ZAG,ZAH,ZAJ,ZAL .....	1
5	PAHZZ	5365-01-189-9027	15434	3905171	. SPACER,PLATE 1.50MM UOC: ZAA,ZAB,ZAC,ZAD,ZAE,ZAF, ZAG,ZAH,ZAJ,ZAL .....	1
5	PAHZZ	5365-01-191-0775	15434	3905168	. SPACER,PLATE 1.40MM UOC: ZAA,ZAB,ZAC,ZAD,ZAE,ZAF, ZAG,ZAH,ZAJ,ZAL .....	1
5	PAHZZ	5310-01-189-5407	15434	3905165	. WASHER,FLAT 1.30MM UOC: ZAA,ZAB,ZAC,ZAD,ZAE,ZAF, ZAG,ZAH,ZAJ,ZAL .....	1
5	PAHZZ	5310-01-191-2494	15434	3905166	. WASHER,FLAT INJECTOR,1.34MM UOC: ZAA,ZAB,ZAC,ZAD,ZAE,ZAF, ZAG,ZAH,ZAJ,ZAL .....	1
5	PAHZZ	5365-01-189-9026	15434	3905167	. SPACER,PLATE 1.38MM UOC: ZAA,ZAB,ZAC,ZAD,ZAE,ZAF, ZAG,ZAH,ZAJ,ZAL .....	1
5	PAHZZ	5365-01-191-3534	15434	3905164	. SHIM 1.28MM UOC: ZAA,ZAB,ZAC,ZAD,ZAE,ZAF, ZAG,ZAH,ZAJ,ZAL .....	1
5	PAHZZ	5310-01-191-7512	15434	3905169	. WASHER,FLAT 1.44MM UOC: ZAA,ZAB,ZAC,ZAD,ZAE,ZAF, ZAG,ZAH,ZAJ,ZAL .....	1
5	PAHZZ	5365-01-191-0774	15434	3905162	. SPACER,PLATE 1.20MM UOC: ZAA,ZAB,ZAC,ZAD,ZAE,ZAF, ZAG,ZAH,ZAJ,ZAL .....	1



(1) ITEM NO.	(2) SMR CODE	(3) NSN	(4) CAGEC	(5) PART NUMBER	(6) DESCRIPTION AND USABLE ON CODE (UOC)	(7) QTY
5	PAHZZ	5365-01-189-7804	15434	3905163	. SPACER,PLATE 1.24MM UOC: ZAA,ZAB,ZAC,ZAD,ZAE,ZAF, ZAG,ZAH,ZAJ,ZAL .....	1
5	PAHZZ	5365-01-191-2413	15434	3905160	. SHIM 1.14MM UOC: ZAA,ZAB,ZAC,ZAD,ZAE,ZAF, ZAG,ZAH,ZAJ,ZAL .....	1
5	PAHZZ	5365-01-190-2131	15434	3905157	. SHIM 1.04MM UOC: ZAA,ZAB,ZAC,ZAD,ZAE,ZAF, ZAG,ZAH,ZAJ,ZAL .....	1
5	PAHZZ	5365-01-188-1055	15434	3905158	. SHIM 1.08MM UOC: ZAA,ZAB,ZAC,ZAD,ZAE,ZAF, ZAG,ZAH,ZAJ,ZAL .....	1
5	PAHZZ	5365-01-191-3532	15434	3905159	. SHIM 1.10MM UOC: ZAA,ZAB,ZAC,ZAD,ZAE,ZAF, ZAG,ZAH,ZAJ,ZAL .....	1
5	PAHZZ	5365-01-188-1054	15434	3905156	. SHIM 1.00MM UOC: ZAA,ZAB,ZAC,ZAD,ZAE,ZAF, ZAG,ZAH,ZAJ,ZAL .....	1
6	PAFZZ	5310-01-270-8417	15434	3906659	. WASHER,SADDLE PART OF KIT P/N 3802622, PART OF KIT P/N 3800748, PART OF KIT P/N 402527100 UOC: ZAA,ZAB,ZAC,ZAD,ZAE,ZAF, ZAG,ZAH,ZAJ,ZAL .....	1
7	PAFZZ	5305-01-272-4811	15434	3902112	SCREW,CAP,HEXAGON H UOC: ZAA,ZAB,ZAC,ZAD,ZAE,ZAF, ZAG,ZAH,ZAJ,ZAL .....	6
8	PAFZZ	5342-01-271-2349	15434	3910279	CLAMP,INJECTOR UOC: ZAA,ZAB,ZAC,ZAD,ZAE,ZAF, ZAG,ZAH,ZAJ,ZAL .....	6

END OF FIGURE



**FIELD MAINTENANCE  
FUEL INJECTOR SUPPLY TUBES (M939A2)**

---

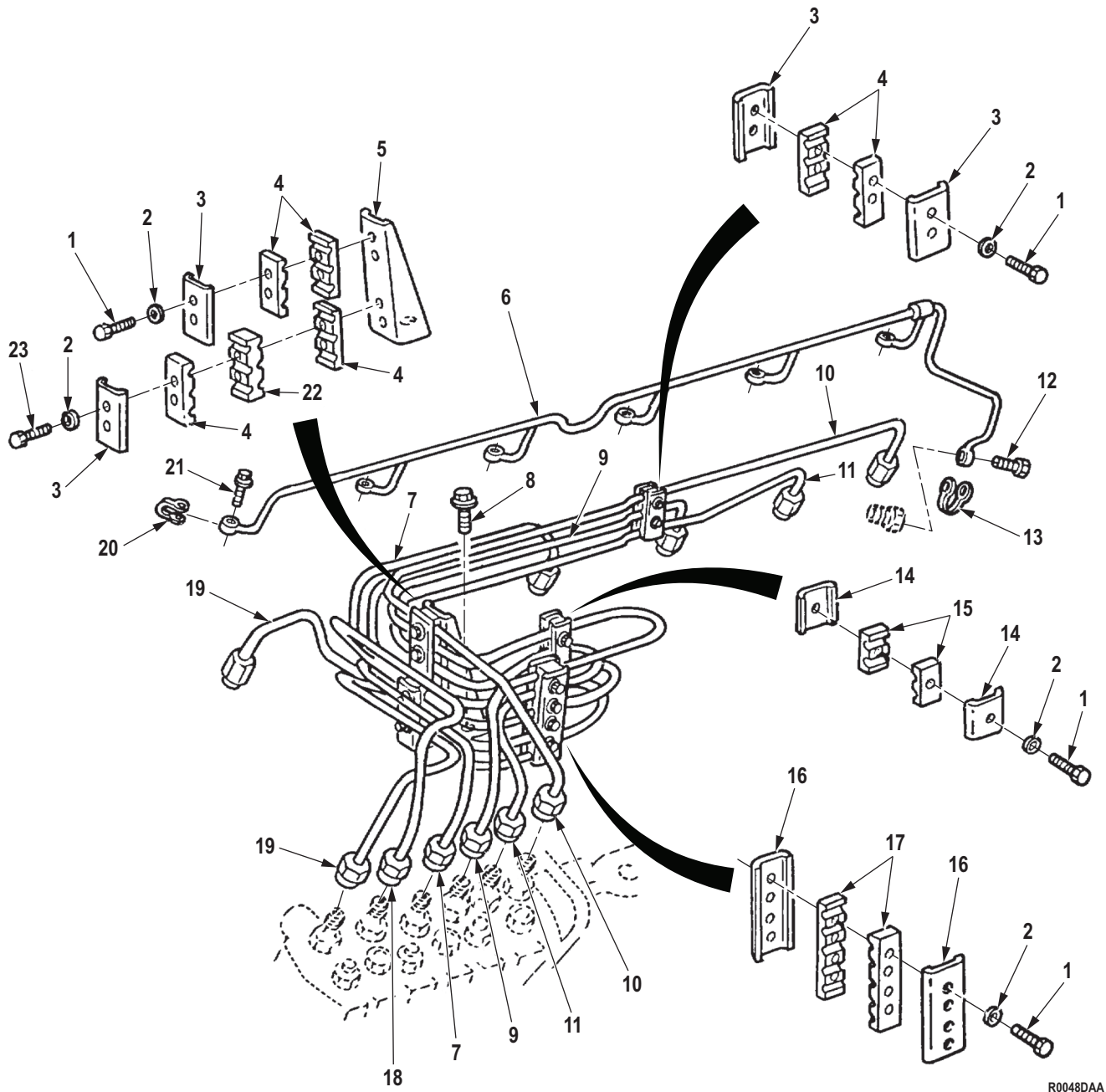

R0048DAA

Figure 48. Fuel Injector Supply Tubes (M939A2).

(1) ITEM NO.	(2) SMR CODE	(3) NSN	(4) CAGEC	(5) PART NUMBER	(6) DESCRIPTION AND USABLE ON CODE (UOC)	(7) QTY
<b>GROUP 0302 FUEL PUMP.</b>						
<b>FIG. 48. FUEL INJECTOR SUPPLY TUBES (M939A2).</b>						
1	PAFZZ	5305-01-234-3756	15434	3903609	SCREW,CAP,HEXAGON H UOC: ZAA,ZAB,ZAC,ZAD,ZAE,ZAF, ZAG,ZAH,ZAJ,ZAL .....	9
2	PAFZZ	5310-01-234-1411	15434	3903723	WASHER,FLAT UOC: ZAA,ZAB,ZAC,ZAD,ZAE,ZAF, ZAG,ZAH,ZAJ,ZAL .....	11
3	PAFZZ	5340-01-196-3680	15434	3904519	BRACKET,DOUBLE ANGL UOC: ZAA,ZAB,ZAC,ZAD,ZAE,ZAF, ZAG,ZAH,ZAJ,ZAL .....	4
4	PAFZZ	5342-01-341-2973	15434	3917747	MOUNT,RESILIENT,WEA UOC: ZAA,ZAB,ZAC,ZAD,ZAE,ZAF, ZAG,ZAH,ZAJ,ZAL .....	6
5	PAFZZ	5340-01-275-3403	15434	3917776	BRACKET,DOUBLE ANGL UOC: ZAA,ZAB,ZAC,ZAD,ZAE,ZAF, ZAG,ZAH,ZAJ,ZAL .....	1
6	PAFZZ	4710-01-339-0584	15434	3922117	TUBE ASSEMBLY,METAL UOC: ZAA,ZAB,ZAC,ZAD,ZAE,ZAF, ZAG,ZAH,ZAJ,ZAL .....	1
7	PAFZZ	4710-01-271-3838	15434	3910751	TUBE ASSEMBLY,METAL UOC: ZAA,ZAB,ZAC,ZAD,ZAE,ZAF, ZAG,ZAH,ZAJ,ZAL .....	1
8	PAFZZ	5305-01-245-3192	15434	3918109	SCREW,CAP,HEXAGON H UOC: ZAA,ZAB,ZAC,ZAD,ZAE,ZAF, ZAG,ZAH,ZAJ,ZAL .....	1
9	PAFZZ	4710-01-271-3843	15434	3910752	TUBE ASSEMBLY,METAL SUPPLY UOC: ZAA,ZAB,ZAC,ZAD,ZAE,ZAF, ZAG,ZAH,ZAJ,ZAL .....	1
10	PAFZZ	4710-01-271-3840	15434	3910754	TUBE ASSEMBLY,METAL SUPPLY UOC: ZAA,ZAB,ZAC,ZAD,ZAE,ZAF, ZAG,ZAH,ZAJ,ZAL .....	1
11	PAFZZ	4710-01-271-3839	15434	3910753	TUBE ASSEMBLY,METAL SUPPLY UOC: ZAA,ZAB,ZAC,ZAD,ZAE,ZAF, ZAG,ZAH,ZAJ,ZAL .....	1
12	PAFZZ	4730-01-195-0825	15434	3905307	BOLT,FLUID PASSAGE (USE WITH ORIGINAL FUEL INJECTOR MANIFOLD) UOC: ZAA,ZAB,ZAC,ZAD,ZAE,ZAF, ZAG,ZAH,ZAJ,ZAL .....	1
12	PAFZZ	4820-01-383-5527	15434	3924726	VALVE,CHECK (USE WITH REPLACEMENT FUEL INJECTOR MANIFOLD) UOC: ZAA,ZAB,ZAC,ZAD,ZAE,ZAF, ZAG,ZAH,ZAJ,ZAL .....	1

(1) ITEM NO.	(2) SMR CODE	(3) NSN	(4) CAGEC	(5) PART NUMBER	(6) DESCRIPTION AND USABLE ON CODE (UOC)	(7) QTY
13	PAFZZ	5330-01-195-5268	15434	3903380	SEAL,BANJO CONNECT (USE WITH ORIGINAL FUEL INJECTOR MANIFOLD) PART OF KIT P/N 3802622, PART OF KIT P/N 3800748, PART OF KIT P/N 402527100 UOC: ZAA,ZAB,ZAC,ZAD,ZAE,ZAF, ZAG,ZAH,ZAJ,ZAL .....	1
13	PAFZZ	5310-01-381-5769	15434	3918188	WASHER,FLAT (USE WITH REPLACEMENT FUEL INJECTOR MANIFOLD) UOC: ZAA,ZAB,ZAC,ZAD,ZAE,ZAF, ZAG,ZAH,ZAJ,ZAL .....	2
14	PAFZZ	5340-01-271-5705	15434	3907546	BRACKET,DOUBLE ANGL UOC: ZAA,ZAB,ZAC,ZAD,ZAE,ZAF, ZAG,ZAH,ZAJ,ZAL .....	2
15	PAFZZ	5342-01-239-7140	15434	3914338	FAIRLEAD,BLOCK UOC: ZAA,ZAB,ZAC,ZAD,ZAE,ZAF, ZAG,ZAH,ZAJ,ZAL .....	2
16	PAFZZ	5342-01-271-7081	15434	3910687	BRACKET,ENGINE ACCE UOC: ZAA,ZAB,ZAC,ZAD,ZAE,ZAF, ZAG,ZAH,ZAJ,ZAL .....	2
17	PAFZZ	5342-01-280-6639	15434	3917749	MOUNT,RESILIENT,WEA UOC: ZAA,ZAB,ZAC,ZAD,ZAE,ZAF, ZAG,ZAH,ZAJ,ZAL .....	1
18	PAFZZ	4710-01-271-7198	15434	3910750	TUBE ASSEMBLY,METAL SUPPLY UOC: ZAA,ZAB,ZAC,ZAD,ZAE,ZAF, ZAG,ZAH,ZAJ,ZAL .....	1
19	PAFZZ	4710-01-271-3837	15434	3910749	TUBE ASSEMBLY,METAL SUPPLY UOC: ZAA,ZAB,ZAC,ZAD,ZAE,ZAF, ZAG,ZAH,ZAJ,ZAL .....	1
20	PAFZZ	5330-01-195-5268	15434	3903380	SEAL,BANJO CONNECT PART OF KIT P/N 3802622, PART OF KIT P/N 3800748, PART OF KIT P/N 402527100 UOC: ZAA,ZAB,ZAC,ZAD,ZAE,ZAF, ZAG,ZAH,ZAJ,ZAL .....	6
21	PAFZZ	4730-01-195-0825	15434	3905307	BOLT,FLUID PASSAGE (USE WITH ORIGINAL FUEL INJECTOR MANIFOLD) UOC: ZAA,ZAB,ZAC,ZAD,ZAE,ZAF, ZAG,ZAH,ZAJ,ZAL .....	6
22	PAFZZ	5342-01-271-5862	15434	3917748	MOUNT,RESILIENT,WEA UOC: ZAA,ZAB,ZAC,ZAD,ZAE,ZAF, ZAG,ZAH,ZAJ,ZAL .....	1
23	PAFZZ	5305-01-272-1334	15434	3910037	SCREW,CAP,HEXAGON H UOC: ZAA,ZAB,ZAC,ZAD,ZAE,ZAF, ZAG,ZAH,ZAJ,ZAL .....	2

END OF FIGURE

**FIELD MAINTENANCE  
FUEL PUMP ASSEMBLY, AFC (M939, M939A1)**

---

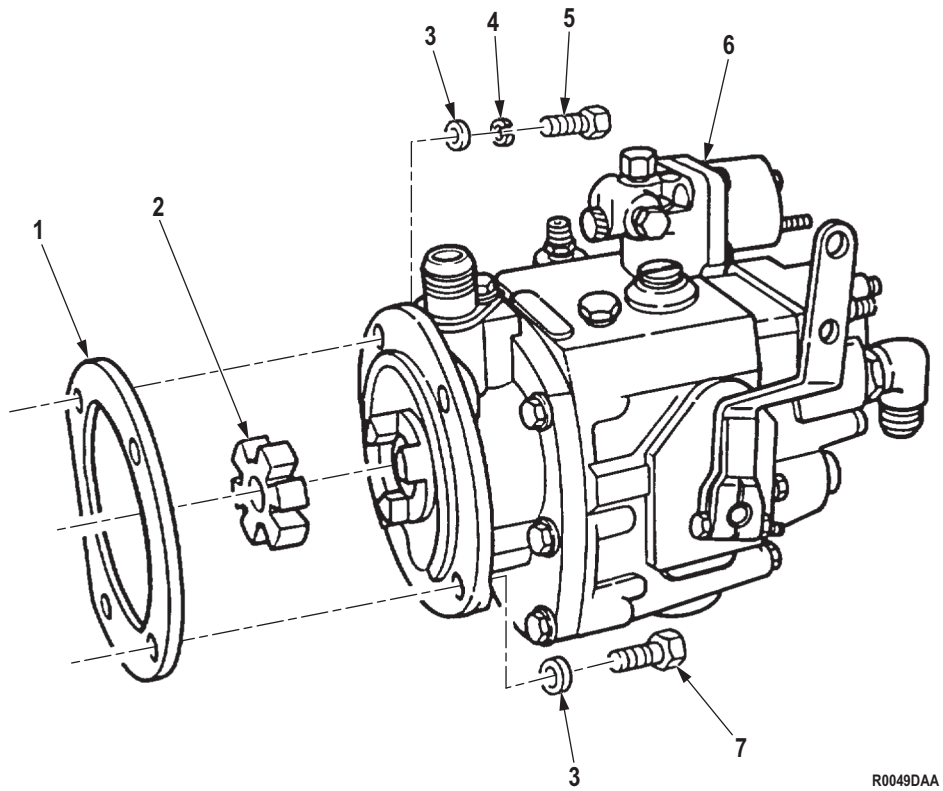

R0049DAA

Figure 49. Fuel Pump Assembly, AFC (M939, M939A1).



(1) ITEM NO.	(2) SMR CODE	(3) NSN	(4) CAGEC	(5) PART NUMBER	(6) DESCRIPTION AND USABLE ON CODE (UOC)	(7) QTY
<b>GROUP 0302 FUEL PUMP.</b>						
<b>FIG. 49. FUEL PUMP ASSEMBLY, AFC (M939, M939A1).</b>						
1	PAFZZ	5330-01-338-4829	15434	4026171	GASKET PART OF KIT P/N 3011472, PART OF KIT P/N 3010240, PART OF KIT P/N 5704519 UOC: DAC,DAD,DAE,DAF,DAG,DA H,DAJ,DAW,DAX,V14,V15,V16,V17, V19,V20,V21,V22,V24 .....	1
2	PAFZZ	3010-00-447-9799	15434	162426	INSERT,FLEXIBLE COU PART OF KIT P/N 3011472 UOC: DAC,DAD,DAE,DAF,DAG,DA H,DAJ,DAW,DAX,V14,V15,V16,V17, V19,V20,V21,V22,V24 .....	1
3	PAFZZ	5310-01-112-4307	15434	69324	WASHER,FLAT UOC: DAC,DAD,DAE,DAF,DAG,DA H,DAJ,DAW,DAX,V14,V15,V16,V17, V19,V20,V21,V22,V24 .....	4
4	PAFZZ	5310-00-209-0965	80205	MS35338-47	WASHER,LOCK UOC: DAC,DAD,DAE,DAF,DAG,DA H,DAJ,DAW,DAX,V14,V15,V16,V17, V19,V20,V21,V22,V24 .....	1
5	PAFZZ	5305-01-113-1179	15434	206326	SCREW,CAP,HEXAGON H UOC: DAC,DAD,DAE,DAF,DAG,DA H,DAJ,DAW,DAX,V14,V15,V16,V17, V19,V20,V21,V22,V24 .....	1
6	PAFHH	2910-01-225-1031	15434	3060766	PUMP,FUEL,METERING UOC: DAC,DAD,DAE,DAF,DAG,DA H,DAJ,DAL,DAW,DAX,V14,V15,V16, V17,V18,V19,V20,V21,V22,V24 .....	1
7	PAFZZ	5305-01-129-4384	15434	3015282	SCREW,CAP,HEXAGON H UOC: DAC,DAD,DAE,DAF,DAG,DA H,DAJ,DAW,DAX,V14,V15,V16,V17, V19,V20,V21,V22,V24 .....	3

**END OF FIGURE**



**FIELD MAINTENANCE**  
**FUEL PUMP GOVERNOR AND TACHOMETER DRIVE ASSEMBLY, AFC (M939, M939A1)**

---

1	8
2 - 21	9 - 10

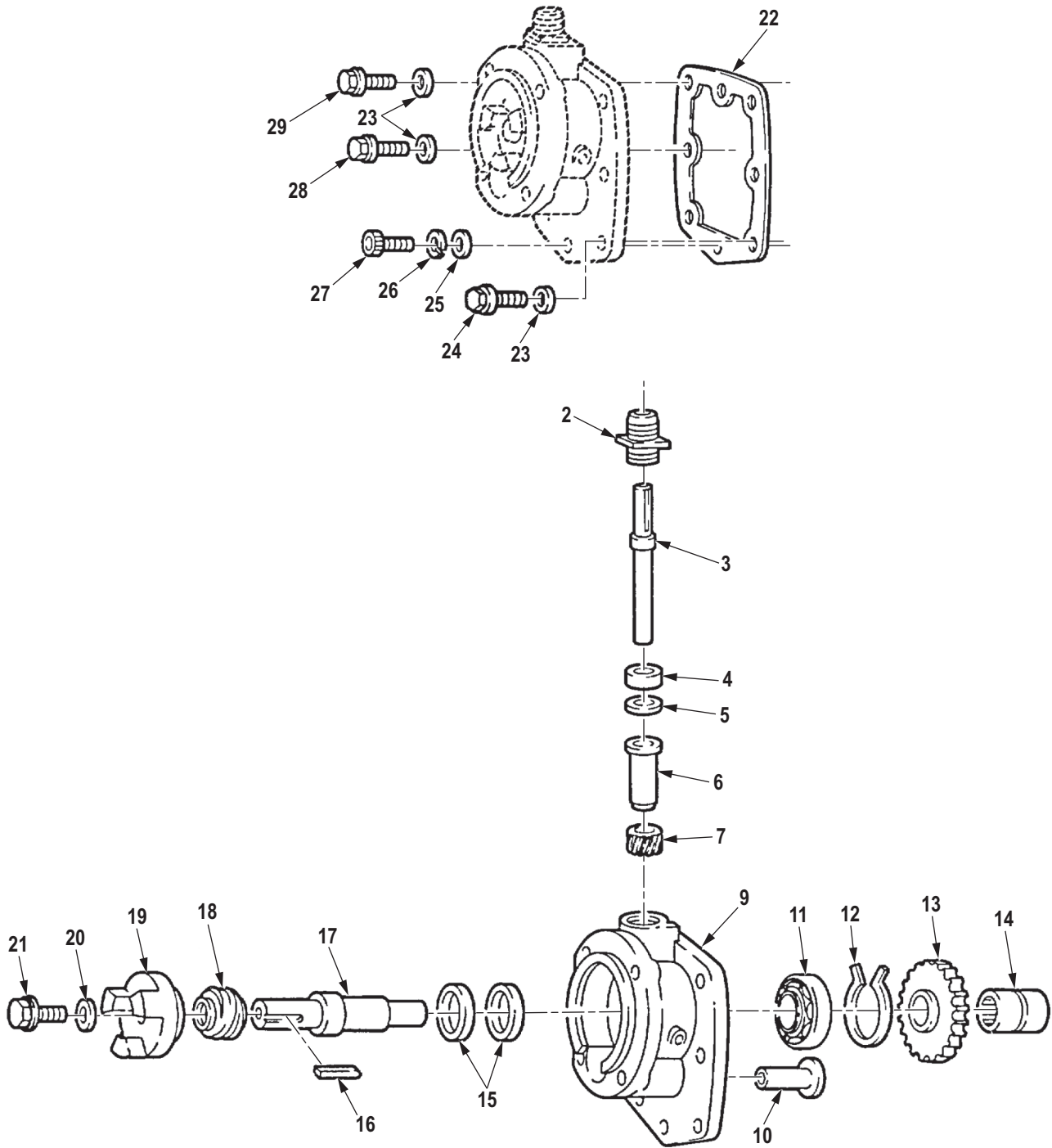

R0050DAA

Figure 50. Fuel Pump Governor and Tachometer Drive Assembly, AFC (M939, M939A1).

(1) ITEM NO.	(2) SMR CODE	(3) NSN	(4) CAGEC	(5) PART NUMBER	(6) DESCRIPTION AND USABLE ON CODE (UOC)	(7) QTY
<b>GROUP 0302 FUEL PUMP.</b>						
<b>FIG. 50. FUEL PUMP GOVERNOR AND TACHOMETER DRIVE ASSEMBLY, AFC (M939, M939A1).</b>						
1	PFHHH	2910-01-146-1999	15434	3030269	COVER ASSEMBLY,FRON UOC: DAC,DAD,DAE,DAF,DAG,DA H,DAJ,DAW,DAX,V14,V15,V16,V17, V19,V20,V21,V22,V24 .....	1
2	PAHZZ	2910-01-086-7715	15434	3002110	. HOUSING,DRIVE ASSEM UOC: DAC,DAD,DAE,DAF,DAG,DA H,DAJ,DAW,DAX,V14,V15,V16,V17, V19,V20,V21,V22,V24 .....	1
3	XAHZZ	3040-01-151-9348	15434	21690800	. SHAFT,TACHOMETER DR UOC: DAC,DAD,DAE,DAF,DAG,DA H,DAJ,DAW,DAX,V14,V15,V16,V17, V19,V20,V21,V22,V24 .....	1
4	PAHZZ	5330-01-072-8828	15434	212603	. SEAL UOC: DAC,DAD,DAE,DAF,DAG,DA H,DAJ,DAW,DAX,V14,V15,V16,V17, V19,V20,V21,V22,V24 .....	1
5	PAHZZ	5365-01-126-3334	15434	3004724	. SPACER UOC: DAC,DAD,DAE,DAF,DAG,DA H,DAJ,DAW,DAX,V14,V15,V16,V17, V19,V20,V21,V22,V24 .....	1
6	PAHZZ	3120-01-087-2539	15434	212609	. BEARING,SLEEVE UOC: DAC,DAD,DAE,DAF,DAG,DA H,DAJ,DAW,DAX,V14,V15,V16,V17, V19,V20,V21,V22,V24 .....	1
7	PFHZZ	3020-01-086-8780	15434	212610	. GEAR,HELICAL UOC: DAC,DAD,DAE,DAF,DAG,DA H,DAJ,DAW,DAX,V14,V15,V16,V17, V19,V20,V21,V22,V24 .....	1
8	PAHZZ	2910-01-141-4337	15434	AR41006	. HOUSING,FUEL PUMP UOC: DAC,DAD,DAE,DAF,DAG,DA H,DAJ,DAW,DAX,V14,V15,V16,V17, V19,V20,V21,V22,V24 .....	1
9	XAHZZ	2990-01-147-4177	15434	3028302	. . HOUSING,GOVERNOR AN UOC: DAC,DAD,DAE,DAF,DAG,DA H,DAJ,DAW,DAX,V14,V15,V16,V17, V19,V20,V21,V22,V24 .....	1
10	PAHZZ	3120-00-904-9595	15434	163944	. . BUSHING,SLEEVE UOC: DAC,DAD,DAE,DAF,DAG,DA H,DAJ,DAW,DAX,V14,V15,V16,V17, V19,V20,V21,V22,V24 .....	1

(1) ITEM NO.	(2) SMR CODE	(3) NSN	(4) CAGEC	(5) PART NUMBER	(6) DESCRIPTION AND USABLE ON CODE (UOC)	(7) QTY
11	PAHZZ	3110-00-516-5289	52676	6203	. ADAPTER,STRAIGHT,PI UOC: DAC,DAD,DAE,DAF,DAG,DA H,DAJ,DAW,DAX,V14,V15,V16,V17, V19,V20,V21,V22,V24 .....	1
12	PAHZZ	5325-01-081-0662	15434	212604	. RING,RETAINING UOC: DAC,DAD,DAE,DAF,DAG,DA H,DAJ,DAW,DAX,V14,V15,V16,V17, V19,V20,V21,V22,V24 .....	1
13	PAHZZ	3020-01-070-9003	15434	21260500	. GEAR,SPUR UOC: DAC,DAD,DAE,DAF,DAG,DA H,DAJ,DAW,DAX,V14,V15,V16,V17, V19,V20,V21,V22,V24 .....	1
14	PBHZZ	3010-01-088-5727	15434	212639	. COUPLING,SHAFT,RIGI GEAR PUMP DRIVE UOC: DAC,DAD,DAE,DAF,DAG,DA H,DAJ,DAW,DAX,V14,V15,V16,V17, V19,V20,V21,V22,V24 .....	1
15	PAHZZ	5330-01-072-8829	15434	3045173	. SEAL,OIL PART OF KIT P/N 3010240 UOC: DAC,DAD,DAE,DAF,DAG,DA H,DAJ,DAW,DAX,V14,V15,V16,V17, V19,V20,V21,V22,V24 .....	2
16	PAHZZ	5315-01-087-0534	15434	212668	. KEY,MACHINE UOC: DAC,DAD,DAE,DAF,DAG,DA H,DAJ,DAW,DAX,V14,V15,V16,V17, V19,V20,V21,V22,V24 .....	1
17	PBHZZ	3040-01-070-9004	15434	212601	. SHAFT,SHOULDERED UOC: DAC,DAD,DAE,DAF,DAG,DA H,DAJ,DAW,DAX,V14,V15,V16,V17, V19,V20,V21,V22,V24 .....	1
18	PBHZZ	3020-01-086-4158	15434	212602	. GEAR,HELICAL UOC: DAC,DAD,DAE,DAF,DAG,DA H,DAJ,DAW,DAX,V14,V15,V16,V17, V19,V20,V21,V22,V24 .....	1
19	PBHZZ	3010-01-080-1529	15434	212613	. COUPLING HALF,SHAFT UOC: DAC,DAD,DAE,DAF,DAG,DA H,DAJ,DAW,DAX,V14,V15,V16,V17, V19,V20,V21,V22,V24 .....	1
20	PAHZZ	5301-01-234-9415	96906	MS51412-5	. WASHER,FLAT UOC: DAC,DAD,DAE,DAF,DAG,DA H,DAJ,DAW,DAX,V14,V15,V16,V17, V19,V20,V21,V22,V24 .....	1
21	PAHZZ	5306-01-119-8870	15434	3022589	. BOLT,MACHINE UOC: DAC,DAD,DAE,DAF,DAG,DA H,DAJ,DAW,DAX,V14,V15,V16,V17, V19,V20,V21,V22,V24 .....	1

(1) ITEM NO.	(2) SMR CODE	(3) NSN	(4) CAGEC	(5) PART NUMBER	(6) DESCRIPTION AND USABLE ON CODE (UOC)	(7) QTY
22	PAHZZ	5330-00-506-4866	15434	100764	GASKET PART OF KIT P/N 5704519 UOC: DAC,DAD,DAE,DAF,DAG,DA H,DAJ,DAW,DAX,V14,V15,V16,V17, V19,V20,V21,V22,V24 .....	1
23	PAHZZ	5310-00-141-1795	80205	NAS1149F0463P	WASHER,FLAT UOC: DAC,DAD,DAE,DAF,DAG,DA H,DAJ,DAW,DAX,V14,V15,V16,V17, V19,V20,V21,V22,V24 .....	6
24	PAHZZ	5305-01-112-9110	15434	3017051	SCREW,CAP,HEXAGON H UOC: DAC,DAD,DAE,DAF,DAG,DA H,DAJ,DAW,DAX,V14,V15,V16,V17, V19,V20,V21,V22,V24 .....	4
25	PAHZZ	5310-00-014-5850	96906	MS27183-42	WASHER,FLAT UOC: DAC,DAD,DAE,DAF,DAG,DA H,DAJ,DAW,DAX,V14,V15,V16,V17, V19,V20,V21,V22,V24 .....	1
26	PAHZZ	5310-00-484-1718	15434	181466	WASHER,LOCK UOC: DAC,DAD,DAE,DAF,DAG,DA H,DAJ,DAW,DAX,V14,V15,V16,V17, V19,V20,V21,V22,V24 .....	1
27	PAHZZ	5305-00-161-0902	15434	118226	SCREW UOC: DAC,DAD,DAE,DAF,DAG,DA H,DAJ,DAW,DAX,V14,V15,V16,V17, V19,V20,V21,V22,V24 .....	1
28	PAHZZ	5305-01-126-1128	15434	3017052	SCREW,CAP,HEXAGON H UOC: DAC,DAD,DAE,DAF,DAG,DA H,DAJ,DAW,DAX,V14,V15,V16,V17, V19,V20,V21,V22,V24 .....	1
29	PAHZZ	5305-01-325-5854	15434	3067897	SCREW,ASSEMBLED WAS UOC: DAC,DAD,DAE,DAF,DAG,DA H,DAJ,DAW,DAX,V14,V15,V16,V17, V19,V20,V21,V22,V24 .....	1

END OF FIGURE





**FIELD MAINTENANCE  
FUEL PUMP HOUSING, AFC (M939, M939A1)**

---

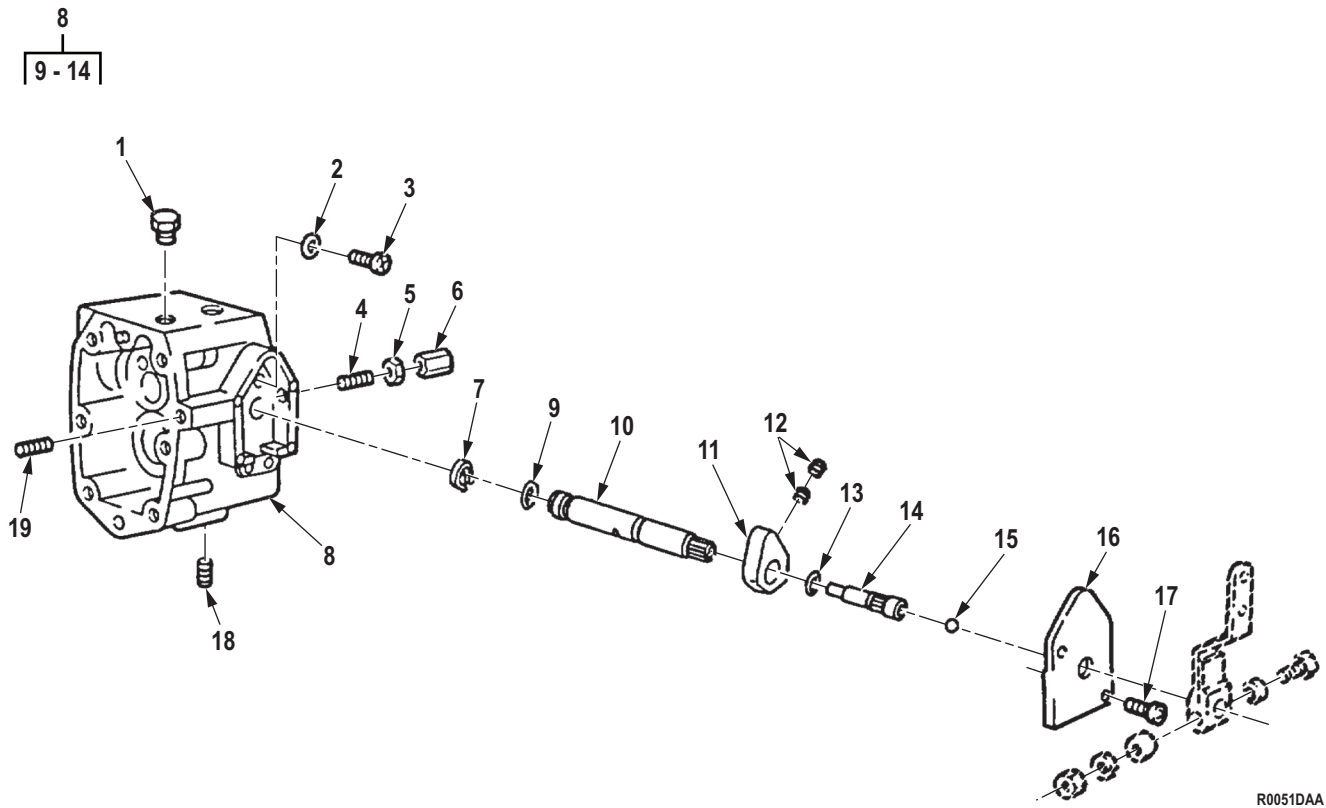

Figure 51. Fuel Pump Housing, AFC (M939, M939A1).

(1) ITEM NO.	(2) SMR CODE	(3) NSN	(4) CAGEC	(5) PART NUMBER	(6) DESCRIPTION AND USABLE ON CODE (UOC)	(7) QTY
<b>GROUP 0302 FUEL PUMP.</b>						
<b>FIG. 51. FUEL PUMP HOUSING, AFC (M939, M939A1).</b>						
1	PAHZZ	5365-01-160-1832	15434	112076	PLUG,FUEL OUTLET UOC: DAC,DAD,DAE,DAF,DAG,DA H,DAJ,DAW,DAX,V14,V15,V16,V17, V19,V20,V21,V22,V24 .....	1
2	PAHZZ	5331-00-970-3461	15434	68061A	O-RING PART OF KIT P/N 3011472 UOC: DAC,DAD,DAE,DAF,DAG,DA H,DAJ,DAW,DAX,V14,V15,V16,V17, V19,V20,V21,V22,V24 .....	1
3	PAHZZ	4730-01-078-4703	15434	3004293	PLUG,TUBE FITTING,T UOC: DAC,DAD,DAE,DAF,DAG,DA H,DAJ,DAW,DAX,V14,V15,V16,V17, V19,V20,V21,V22,V24 .....	1
4	PAHZZ	5305-01-109-9307	15434	195755	SCREW UOC: DAC,DAD,DAE,DAF,DAG,DA H,DAJ,DAW,DAX,V14,V15,V16,V17, V19,V20,V21,V22,V24 .....	1
5	PAHZZ	5310-00-971-7989	96906	MS35691-5	NUT,PLAIN,HEXAGON UOC: DAC,DAD,DAE,DAF,DAG,DA H,DAJ,DAW,DAX,V14,V15,V16,V17, V19,V20,V21,V22,V24 .....	2
6	PAHZZ	5340-00-716-4975	15434	110058	POST,ELECTRICAL-MEC UOC: DAC,DAD,DAE,DAF,DAG,DA H,DAJ,DAW,DAX,V14,V15,V16,V17, V19,V20,V21,V22,V24 .....	1
7	PAHZZ	5325-00-256-2846	96906	MS16632-1050	RING,RETAINING UOC: DAC,DAD,DAE,DAF,DAG,DA H,DAJ,DAW,DAX,V14,V15,V16,V17, V19,V20,V21,V22,V24 .....	1
8	PBHHH	2910-01-303-1195	15434	3043254	HOUSING,FUEL PUMP UOC: DAC,DAD,DAE,DAF,DAG,DA H,DAJ,DAW,DAX,V14,V15,V16,V17, V19,V20,V21,V22,V24 .....	1
9	PAHZZ	5331-00-081-9289	15434	100478	. O-RING PART OF KIT P/N 3010240 UOC: DAC,DAD,DAE,DAF,DAG,DA H,DAJ,DAW,DAX,V14,V15,V16,V17, V19,V20,V21,V22,V24 .....	1
10	PAHZZ	3040-01-241-4696	15434	3046680	. SHAFT,SHOULDERED UOC: DAC,DAD,DAE,DAF,DAG,DA H,DAJ,DAW,DAX,V14,V15,V16,V17, V19,V20,V21,V22,V24 .....	1

(1) ITEM NO.	(2) SMR CODE	(3) NSN	(4) CAGEC	(5) PART NUMBER	(6) DESCRIPTION AND USABLE ON CODE (UOC)	(7) QTY
11	PBHZZ	3040-01-086-1449	15434	3006343	. COLLAR,SHAFT THROTTLE SHAFT STOP UOC: DAC,DAD,DAE,DAF,DAG,DA H,DAJ,DAW,DAX,V14,V15,V16,V17, V19,V20,V21,V22,V24 .....	1
12	PAHZZ	5305-01-135-5446	15434	3006344	. SETSCREW UOC: DAC,DAD,DAE,DAF,DAG,DA H,DAJ,DAW,DAX,V14,V15,V16,V17, V19,V20,V21,V22,V24 .....	2
13	PAHZZ	5331-01-072-8983	15434	213768	. O-RING UOC: DAC,DAD,DAE,DAF,DAG,DA H,DAJ,DAW,DAX,V14,V15,V16,V17, V19,V20,V21,V22,V24 .....	1
14	PAHZZ	5305-01-072-8826	15434	3076040	. SCREW UOC: DAC,DAD,DAE,DAF,DAG,DA H,DAJ,DAW,DAX,V14,V15,V16,V17, V19,V20,V21,V22,V24 .....	1
15	PAHZZ	3110-01-079-8190	15434	213769	BALL,BEARING PART OF KIT P/N 5704519 UOC: DAC,DAD,DAE,DAF,DAG,DA H,DAJ,DAW,DAX,V14,V15,V16,V17, V19,V20,V21,V22,V24 .....	1
16	PAHZZ	4320-01-098-5115	15434	3000446	COVER,HYDRAULIC,PUM UOC: DAC,DAD,DAE,DAF,DAG,DA H,DAJ,DAW,DAX,V14,V15,V16,V17, V19,V20,V21,V22,V24 .....	1
17	PAHZZ	5305-00-804-6318	15434	S2286	SCREW PART OF KIT P/N 5704519 UOC: DAC,DAD,DAE,DAF,DAG,DA H,DAJ,DAW,DAX,V14,V15,V16,V17, V19,V20,V21,V22,V24 .....	2
18	PAHZZ	4730-01-124-3762	15434	3025460	PLUG,PIPE UOC: DAC,DAD,DAE,DAF,DAG,DA H,DAJ,DAW,DAX,V14,V15,V16,V17, V19,V20,V21,V22,V24 .....	3
19	PAHZZ	5305-00-063-5043	88044	AN565F428H24	SETSCREW UOC: DAC,DAD,DAE,DAF,DAG,DA H,DAJ,DAW,DAX,V14,V15,V16,V17, V19,V20,V21,V22,V24 .....	1

END OF FIGURE

**FIELD MAINTENANCE  
FUEL PUMP DAMPER (M939, M939A1)**

---

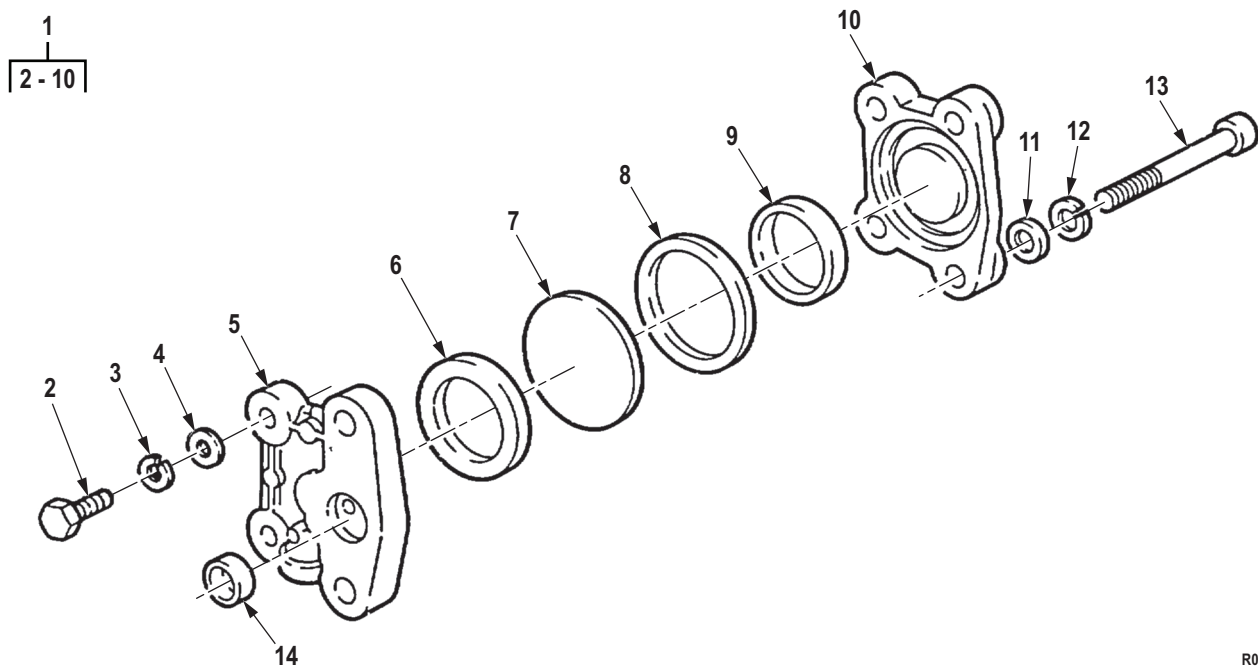

R0052DAA

Figure 52. Fuel Pump Damper (M939, M939A1).

(1) ITEM NO.	(2) SMR CODE	(3) NSN	(4) CAGEC	(5) PART NUMBER	(6) DESCRIPTION AND USABLE ON CODE (UOC)	(7) QTY
<b>GROUP 0302 FUEL PUMP.</b>						
<b>FIG. 52. FUEL PUMP DAMPER (M939, M939A1).</b>						
1	PBFFF	6685-00-828-7126	15434	BM76340	DAMPENER,FLUID PRES UOC: DAC,DAD,DAE,DAF,DAG,DAH,DAJ,DAW,DAX,V14,V15,V16,V17,V19,V20,V21,V22,V24 .....	1
2	PAFZZ	5305-00-068-0509	80204	B1821BH025C125N	. SCREW,CAP,HEXAGON H UOC: DAC,DAD,DAE,DAF,DAG,DAH,DAJ,DAW,DAX,V14,V15,V16,V17,V19,V20,V21,V22,V24 .....	2
3	PAFZZ	5310-00-159-6209	96906	MS122032	. WASHER,LOCK UOC: DAC,DAD,DAE,DAF,DAG,DAH,DAJ,DAW,DAX,V14,V15,V16,V17,V19,V20,V21,V22,V24 .....	2
4	PAFZZ	5310-00-141-1795	80205	NAS1149F0463P	. WASHER,FLAT UOC: DAC,DAD,DAE,DAF,DAG,DAH,DAJ,DAW,DAX,V14,V15,V16,V17,V19,V20,V21,V22,V24 .....	2
5	PFFZZ	2910-00-829-5616	15434	153336	. HOUSING,FUEL PUMP UOC: DAC,DAD,DAE,DAF,DAG,DAH,DAJ,DAW,DAX,V14,V15,V16,V17,V19,V20,V21,V22,V24 .....	1
6	PAFZZ	5331-00-809-2667	15434	100099	. O-RING PART OF KIT P/N 3010240 UOC: DAC,DAD,DAE,DAF,DAG,DAH,DAJ,DAW,DAX,V14,V15,V16,V17,V19,V20,V21,V22,V24 .....	1
7	PAFZZ	5340-00-951-3536	15434	202897	. DISK,SOLID,PLAIN UOC: DAC,DAD,DAE,DAF,DAG,DAH,DAJ,DAW,DAX,V14,V15,V16,V17,V19,V20,V21,V22,V24 .....	1
8	PAFZZ	5331-00-809-3276	15434	139988	. O-RING PART OF KIT P/N 3010240 UOC: DAC,DAD,DAE,DAF,DAG,DAH,DAJ,DAW,DAX,V14,V15,V16,V17,V19,V20,V21,V22,V24 .....	1
9	PAFZZ	5365-00-965-0870	15434	160514	. SPACER,RING PART OF KIT P/N 3010240 UOC: DAC,DAD,DAE,DAF,DAG,DAH,DAJ,DAW,DAX,V14,V15,V16,V17,V19,V20,V21,V22,V24 .....	1
10	PFFZZ	5340-00-829-5617	15434	153338	. COVER,ACCESS UOC: DAC,DAD,DAE,DAF,DAG,DAH,DAJ,DAW,DAX,V14,V15,V16,V17,V19,V20,V21,V22,V24 .....	1

(1) ITEM NO.	(2) SMR CODE	(3) NSN	(4) CAGEC	(5) PART NUMBER	(6) DESCRIPTION AND USABLE ON CODE (UOC)	(7) QTY
11	PAFZZ	5310-00-141-1795	80205	NAS1149F0463P	WASHER,FLAT UOC: DAC,DAD,DAE,DAF,DAG,DA H,DAJ,DAW,DAX,V14,V15,V16,V17, V19,V20,V21,V22,V24 .....	2
12	PAFZZ	5310-00-484-1718	15434	181466	WASHER,LOCK UOC: DAC,DAD,DAE,DAF,DAG,DA H,DAJ,DAW,DAX,V14,V15,V16,V17, V19,V20,V21,V22,V24 .....	2
13	PAFZZ	5305-01-133-2060	15434	133538	SCREW,CAP,SOCKET HE UOC: DAC,DAD,DAE,DAF,DAG,DA H,DAJ,DAW,DAX,V14,V15,V16,V17, V19,V20,V21,V22,V24 .....	2
14	PAFZZ	5330-00-252-8888	9F512	691-10014	GASKET PART OF KIT P/N 3010240 UOC: DAC,DAD,DAE,DAF,DAG,DA H,DAJ,DAW,DAX,V14,V15,V16,V17, V19,V20,V21,V22,V24 .....	1

END OF FIGURE



**FIELD MAINTENANCE  
FUEL GEAR PUMP ASSEMBLY AND MOUNTING HARDWARE (M939, M939A1)**

---

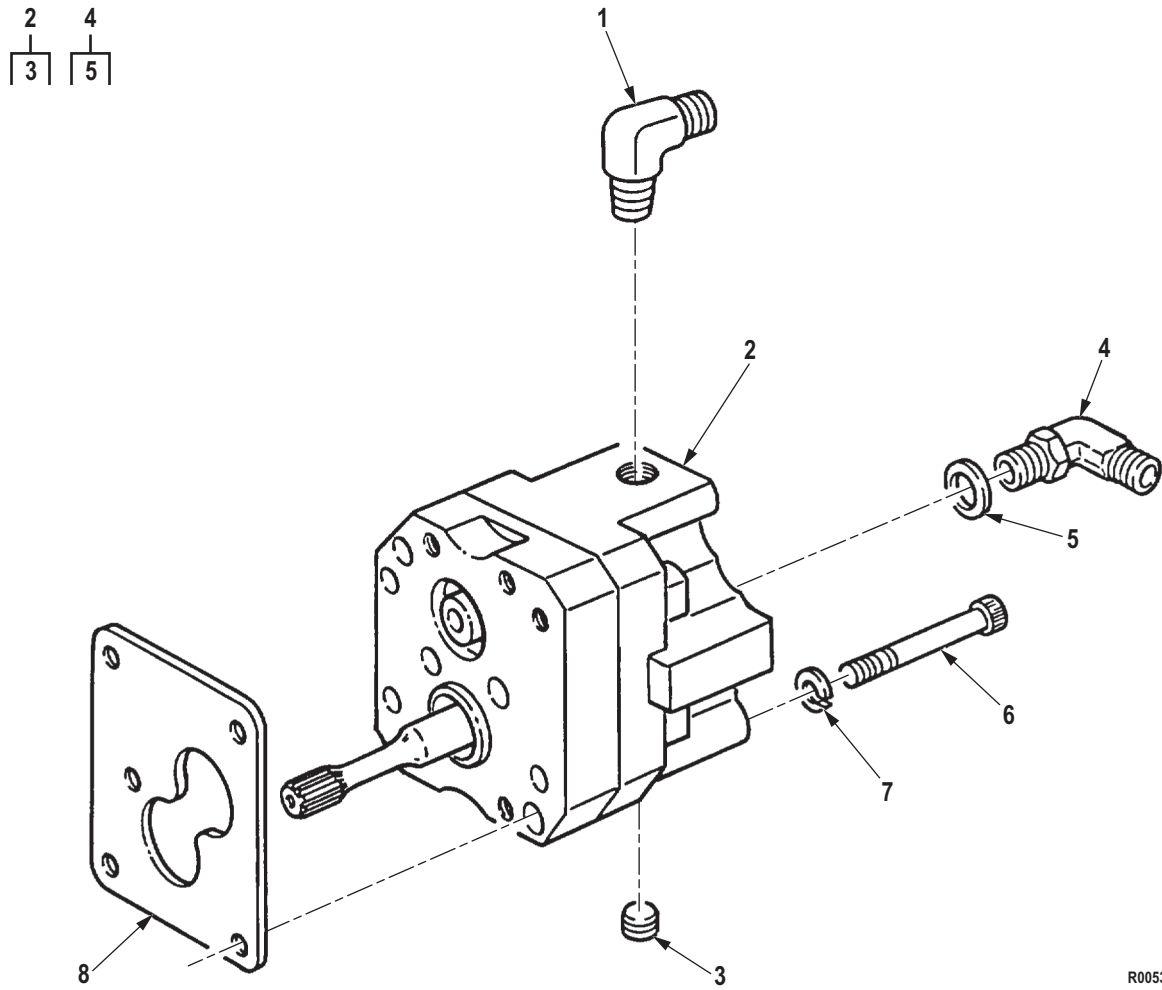

R0053DAA

Figure 53. Fuel Gear Pump Assembly and Mounting Hardware (M939, M939A1).

(1) ITEM NO.	(2) SMR CODE	(3) NSN	(4) CAGEC	(5) PART NUMBER	(6) DESCRIPTION AND USABLE ON CODE (UOC)	(7) QTY
<b>GROUP 0302 FUEL PUMP.</b>						
<b>FIG. 53. FUEL GEAR PUMP ASSEMBLY AND MOUNTING HARDWARE (M939, M939A1).</b>						
1	PAFZZ	4820-01-164-7002	15434	3033740	VALVE,CHECK UOC: DAC,DAD,DAE,DAF,DAG,DA H,DAJ,DAW,DAX,V14,V15,V16,V17, V19,V20,V21,V22,V24 .....	1
2	PAFFF	3020-01-166-5647	15434	3034217	GEAR,PUMP ASSEMBLY UOC: DAC,DAD,DAE,DAF,DAG,DA H,DAJ,DAL,DAW,DAX,V14,V15,V16, V17,V18,V19,V20,V21,V22,V24 .....	1
3	PAFZZ	4730-00-050-0718	15434	3026624	. PLUG,PIPE UOC: DAC,DAD,DAE,DAF,DAG,DA H,DAJ,DAW,DAX,V14,V15,V16,V17, V19,V20,V21,V22,V24 .....	1
4	PAFZZ	4730-01-078-9859	15434	20384900	ELBOW,TUBE TO BOSS UOC: DAC,DAD,DAE,DAF,DAG,DA H,DAJ,DAW,DAX,V14,V15,V16,V17, V19,V20,V21,V22,V24 .....	1
5	PAFZZ	5331-01-072-8984	15434	3046201	. O-RING UOC: DAC,DAD,DAE,DAF,DAG,DA H,DAJ,DAW,DAX,V14,V15,V16,V17, V19,V20,V21,V22,V24 .....	1
6	PAFZZ	5306-00-485-0790	15434	70790	BOLT,MACHINE USE AFTER SERIAL NUMBER 11246663 UOC: DAC,DAD,DAE,DAF,DAG,DA H,DAJ,DAW,DAX,V14,V15,V16,V17, V19,V20,V21,V22,V24 .....	4
7	PAFZZ	5310-00-484-1718	15434	181466	WASHER,LOCK UOC: DAC,DAD,DAE,DAF,DAG,DA H,DAJ,DAW,DAX,V14,V15,V16,V17, V19,V20,V21,V22,V24 .....	4
8	PAFZZ	5330-01-136-8569	15434	309607700	GASKET PART OF KIT P/N 3010240 UOC: DAC,DAD,DAE,DAF,DAG,DA H,DAJ,DAW,DAX,V14,V15,V16,V17, V19,V20,V21,V22,V24 .....	1

**END OF FIGURE**



**FIELD MAINTENANCE  
FUEL PUMP ASSEMBLY WITH VS GOVERNOR (M939, M939A1)**

---

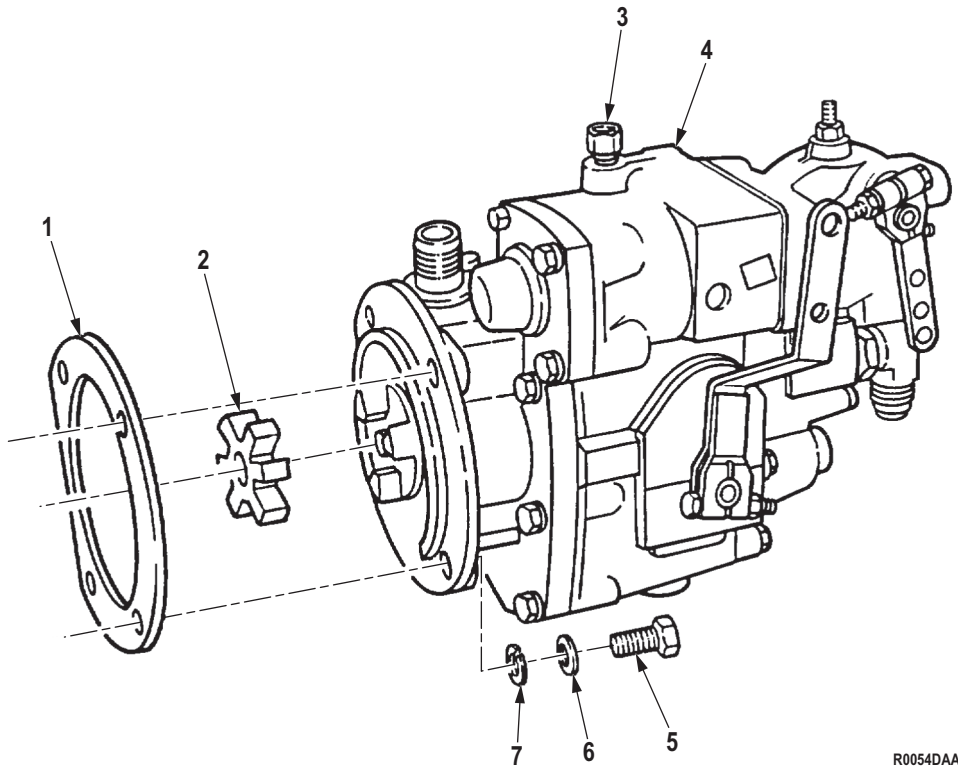

R0054DAA

Figure 54. Fuel Pump Assembly with VS Governor (M939, M939A1).

(1) ITEM NO.	(2) SMR CODE	(3) NSN	(4) CAGEC	(5) PART NUMBER	(6) DESCRIPTION AND USABLE ON CODE (UOC)	(7) QTY
<b>GROUP 0302 FUEL PUMP.</b>						
<b>FIG. 54. FUEL PUMP ASSEMBLY WITH VS GOVERNOR (M939, M939A1).</b>						
1	PAFZZ	5330-01-160-7460	15434	3035053	GASKET PART OF KIT P/N 3011472, PART OF KIT P/N 3010240 UOC: DAL,V18 .....	1
2	PAFZZ	3010-00-447-9799	15434	162426	INSERT,FLEXIBLE COU PART OF KIT P/N 3011472 UOC: DAL,V18 .....	1
3	PAFZZ	4730-01-303-1160	15434	187368	ADAPTER,STRAIGHT,TU UOC: DAL,V18 .....	1
4	PBFHH	2910-01-135-0104	15434	3028790-9093	PUMP,FUEL,METERING UOC: DAL,V18 .....	1
5	PAFZZ	5305-00-071-2056	80204	B1821BH044C175N	SCREW,CAP,HEXAGON H UOC: DAL,V18 .....	4
6	PAFZZ	5310-00-562-6557	15434	S622	WASHER,FLAT UOC: DAL,V18 .....	4
7	PAFZZ	5310-00-209-0965	80205	MS35338-47	WASHER,LOCK UOC: DAL,V18 .....	1

**END OF FIGURE**





**FIELD MAINTENANCE**  
**FUEL PUMP GOVERNOR AND TACHOMETER DRIVE ASSEMBLY, VS (M939, M939A1)**

---

1	8
2 - 21	9 - 10

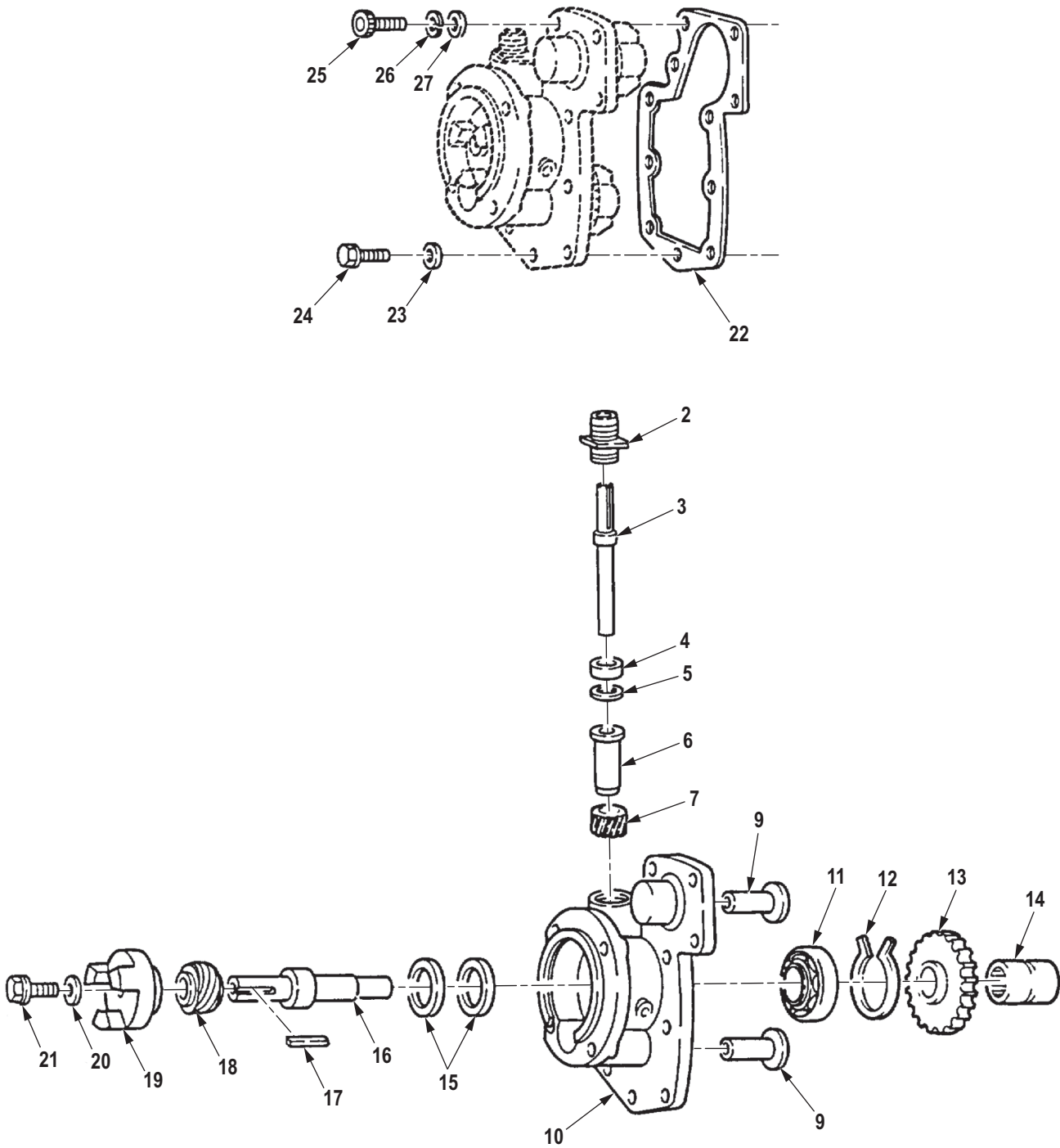

R0055DAA

Figure 55. Fuel Pump Governor and Tachometer Drive Assembly, VS (M939, M939A1).

(1) ITEM NO.	(2) SMR CODE	(3) NSN	(4) CAGEC	(5) PART NUMBER	(6) DESCRIPTION AND USABLE ON CODE (UOC)	(7) QTY
<b>GROUP 0302 FUEL PUMP.</b>						
<b>FIG. 55. FUEL PUMP GOVERNOR AND TACHOMETER DRIVE ASSEMBLY, VS (M939, M939A1).</b>						
1	PFHHH	2910-01-090-9345	15434	3030276	SHAFT ASSEMBLY UOC: DAL,V18 .....	1
2	PAHZZ	2910-01-086-7715	15434	3002110	. HOUSING,DRIVE ASSEM UOC: DAL,V18 .....	1
3	XAHZZ	3040-01-151-9348	15434	21690800	. SHAFT,TACHOMETER DR UOC: DAL,V18 .....	1
4	PAHZZ	5330-01-072-8828	15434	212603	. SEAL UOC: DAL,V18 .....	1
5	PAHZZ	5365-01-126-3334	15434	3004724	. SPACER UOC: DAL,V18 .....	1
6	PAHZZ	3120-01-087-2539	15434	212609	. BEARING,SLEEVE UOC: DAL,V18 .....	1
7	PFHZZ	3020-01-086-8780	15434	212610	. GEAR,HELICAL UOC: DAL,V18 .....	1
8	PAHZZ	2910-01-183-2403	15434	30283770	. COVER,FUEL PUMP UOC: DAL,V18 .....	1
9	PAHZZ	3120-00-904-9595	15434	163944	. . BUSHING,SLEEVE UOC: DAL,V18 .....	2
10	PAHZZ	2990-01-159-8738	15434	307552500	. . COVER,MAINSHAFT,GOV UOC: DAL,V18 .....	1
11	PAHZZ	3110-00-156-5453	21335	5207WD	. BEARING,BALL,ANNULA UOC: DAL,V18 .....	1
12	PAHZZ	5325-01-081-0662	15434	212604	. RING,RETAINING UOC: DAL,V18 .....	1
13	PAHZZ	3020-01-070-9003	15434	21260500	. GEAR,SPUR UOC: DAL,V18 .....	1
14	PBHZZ	3010-01-088-5727	15434	212639	. COUPLING,SHAFT,RIGI UOC: DAL,V18 .....	1
15	PAHZZ	5330-01-072-8829	15434	3045173	. SEAL,OIL PART OF KIT P/N 3010240 UOC: DAL,V18 .....	2
16	PBHZZ	3040-01-070-9004	15434	212601	. SHAFT,SHOULDERED UOC: DAL,V18 .....	1
17	PAHZZ	5315-01-087-0534	15434	212668	. KEY,MACHINE UOC: DAL,V18 .....	1
18	PAHZZ	3020-01-086-4158	15434	212602	. GEAR,HELICAL UOC: DAL,V18 .....	1
19	PBHZZ	3010-01-080-1529	15434	212613	. COUPLING HALF,SHAFT UOC: DAL,V18 .....	1
20	PAHZZ	5301-01-234-9415	96906	MS51412-5	. WASHER,FLAT UOC: DAL,V18 .....	1

(1) ITEM NO.	(2) SMR CODE	(3) NSN	(4) CAGEC	(5) PART NUMBER	(6) DESCRIPTION AND USABLE ON CODE (UOC)	(7) QTY
21	PAHZZ	5306-01-119-8870	15434	3022589	. BOLT,MACHINE UOC: DAL,V18 .....	1
22	PAHZZ	5330-01-051-1053	15434	200998	GASKET FUEL PUMP COVER UOC: DAL,V18 .....	1
23	PAHZZ	5310-00-141-1795	80205	NAS1149F0463P	WASHER,FLAT UOC: DAL,V18 .....	8
24	PAHZZ	5305-01-112-9110	15434	3017051	SCREW,CAP,HEXAGON H UOC: DAL,V18 .....	8
25	PAHZZ	5305-00-161-0902	15434	118226	SCREW UOC: DAL,V18 .....	2
26	PAHZZ	5310-00-410-6756	15434	S606	WASHER,LOCK UOC: DAL,V18 .....	2
27	PAHZZ	5310-00-014-5850	96906	MS27183-42	WASHER,FLAT UOC: DAL,V18 .....	2

END OF FIGURE

**FIELD MAINTENANCE  
FUEL PUMP HOUSING, VS (M939, M939A1)**

---

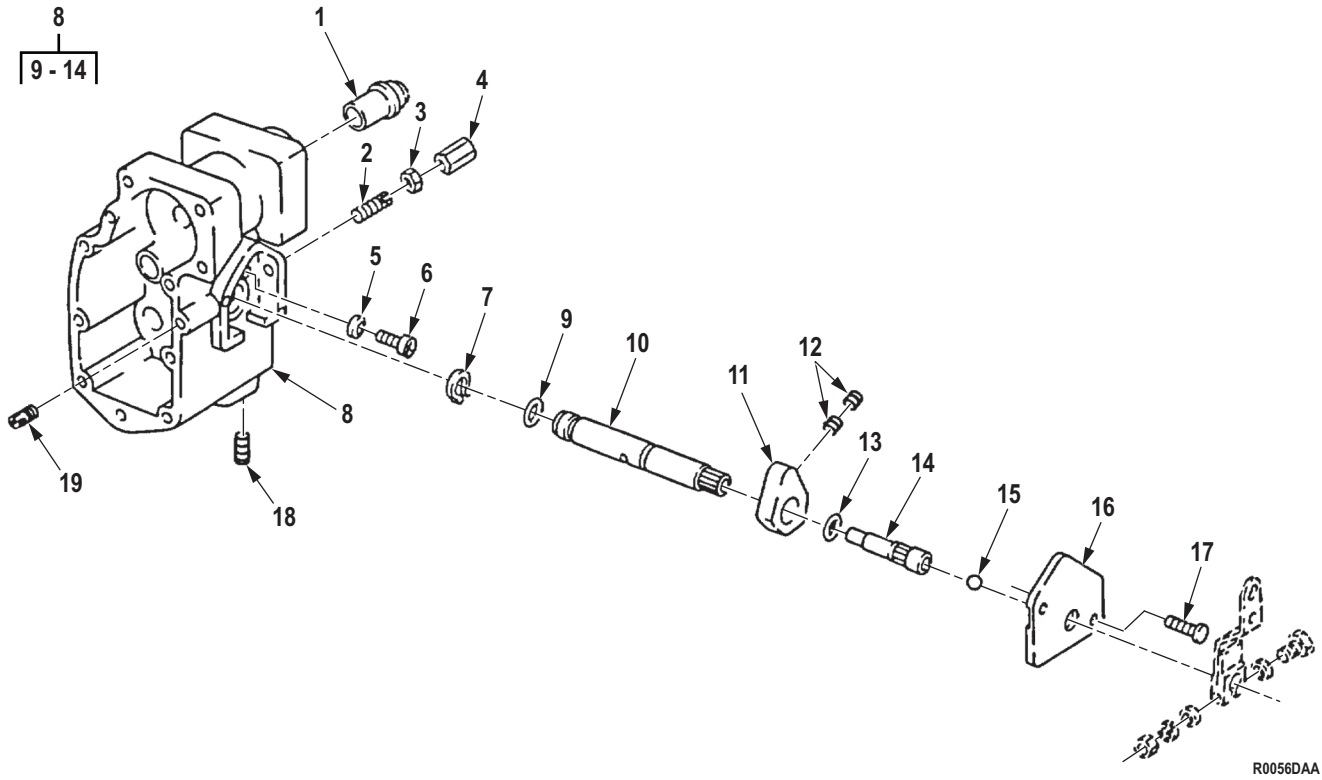

R0056DAA

Figure 56. Fuel Pump Housing, VS (M939, M939A1).

(1) ITEM NO.	(2) SMR CODE	(3) NSN	(4) CAGEC	(5) PART NUMBER	(6) DESCRIPTION AND USABLE ON CODE (UOC)	(7) QTY
<b>GROUP 0302 FUEL PUMP.</b>						
<b>FIG. 56. FUEL PUMP HOUSING, VS (M939, M939A1).</b>						
1	PAHZZ	4820-01-106-1760	15434	201806	VALVE,DUAL BALL UOC: DAL,V18 .....	1
2	PAHZZ	5305-01-109-9307	15434	195755	SCREW UOC: DAL,V18 .....	1
3	PAHZZ	5310-00-971-7989	96906	MS35691-5	NUT,PLAIN,HEXAGON UOC: DAL,V18 .....	2
4	PAHZZ	5340-00-716-4975	15434	110058	POST,ELECTRICAL-MEC UOC: DAL,V18 .....	1
5	PAHZZ	5330-00-171-6600	83259	600-001 1-4	PACKING WITH RETAIN PART OF KIT P/N 3011472, PART OF KIT P/N 3010240 UOC: DAL,V18 .....	1
6	PFHZZ	4730-01-078-4703	15434	3004293	PLUG,TUBE FITTING,T UOC: DAL,V18 .....	1
7	PAHZZ	5325-00-256-2846	96906	MS16632-1050	RING,RETAINING UOC: DAL,V18 .....	1
8	PBHHH	3040-01-219-5697	15434	3038668	HOUSING,MECHANICAL USE AFTER SERIAL NUMBER 11246663 UOC: DAL,V18 .....	1
9	PAHZZ	5331-00-081-9289	15434	100478	. O-RING PART OF KIT P/N 3010240 UOC: DAL,V18 .....	1
10	PAHZZ	3040-01-241-4696	15434	3046680	. SHAFT,SHOULDERED UOC: DAL,V18 .....	1
11	PBHZZ	3040-01-086-1449	15434	3006343	. COLLAR,SHAFT UOC: DAL,V18 .....	1
12	PAHZZ	5305-01-135-5446	15434	3006344	. SETSCREW UOC: DAL,V18 .....	2
13	PAHZZ	5331-01-072-8983	15434	213768	. O-RING UOC: DAL,V18 .....	1
14	PAHZZ	5305-01-072-8826	15434	3076040	. SCREW UOC: DAL,V18 .....	1
15	PAHZZ	3110-01-079-8190	15434	213769	BALL,BEARING UOC: DAL,V18 .....	1
16	PAHZZ	4320-01-098-5115	15434	3000446	COVER,HYDRAULIC,PUM UOC: DAL,V18 .....	1
17	PAHZZ	5305-00-804-6318	15434	S2286	SCREW UOC: DAL,V18 .....	2
18	PAHZZ	4730-01-124-3762	15434	3025460	PLUG,PIPE UOC: DAL,V18 .....	1
19	PAHZZ	5305-00-063-5043	88044	AN565F428H24	SETSCREW UOC: DAL,V18 .....	1

END OF FIGURE





**FIELD MAINTENANCE  
FUEL INJECTOR PUMP (M939A2)**

---

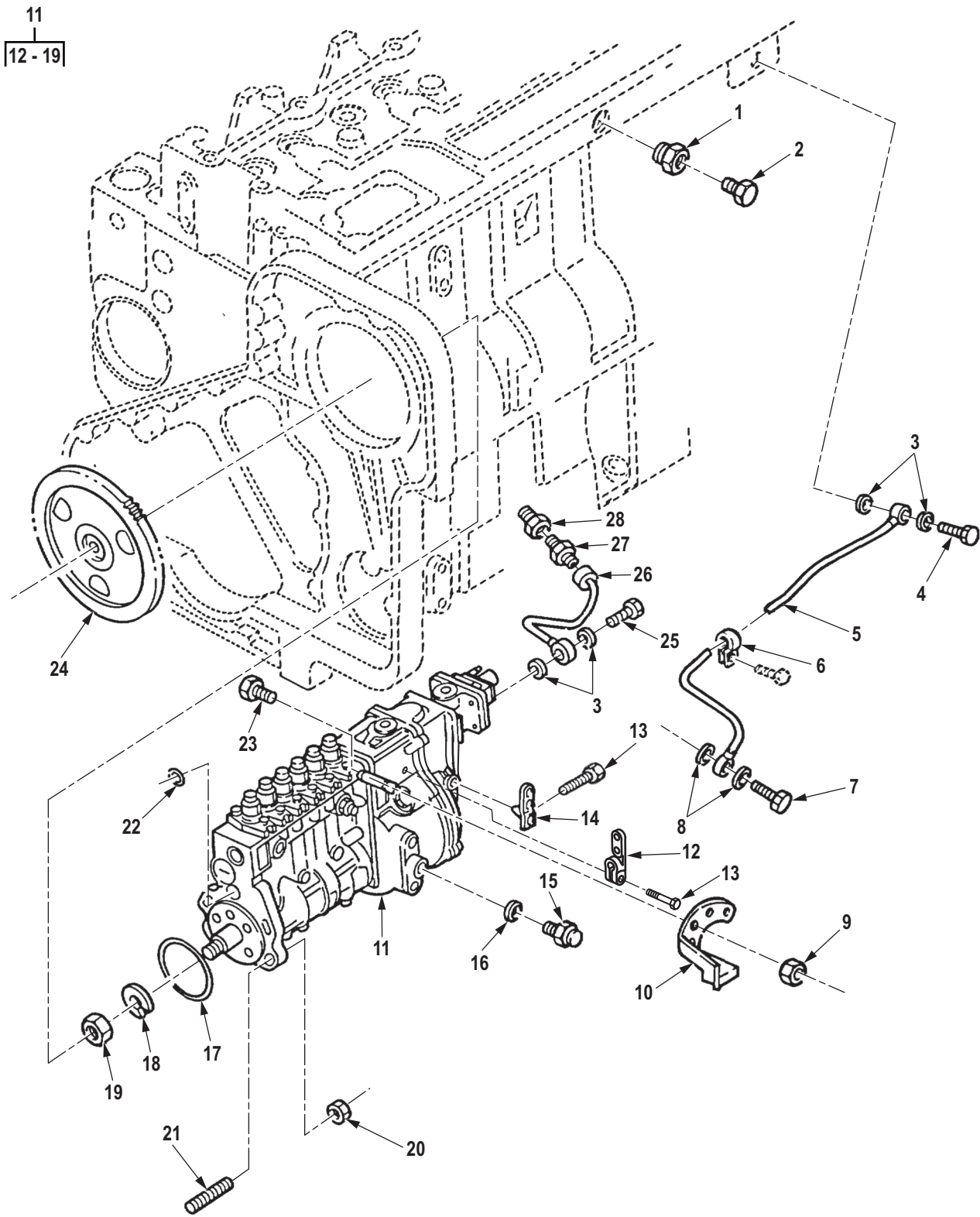

R0057DAA

Figure 57. Fuel Injector Pump (M939A2).

(1) ITEM NO.	(2) SMR CODE	(3) NSN	(4) CAGEC	(5) PART NUMBER	(6) DESCRIPTION AND USABLE ON CODE (UOC)	(7) QTY
<b>GROUP 0302 FUEL PUMP.</b>						
<b>FIG. 57. FUEL INJECTOR PUMP (M939A2).</b>						
1	PAFZZ	3120-01-272-3276	15434	3908110	BUSHING,SLEEVE UOC: ZAA,ZAB,ZAC,ZAD,ZAE,ZAF, ZAG,ZAH,ZAJ,ZAL .....	1
2	PAFZZ	4730-01-165-9491	86403	4746 644	PLUG,PIPE UOC: ZAA,ZAB,ZAC,ZAD,ZAE,ZAF, ZAG,ZAH,ZAJ,ZAL .....	1
3	PAFZZ	5310-01-195-1441	15434	3963983	WASHER,FLAT PART OF KIT P/N 3802622, PART OF KIT P/N 402527100 UOC: ZAA,ZAB,ZAC,ZAD,ZAE,ZAF, ZAG,ZAH,ZAJ,ZAL .....	4
4	PAFZZ	5305-01-272-1333	15434	3911446	SCREW,CAP,HEXAGON H UOC: ZAA,ZAB,ZAC,ZAD,ZAE,ZAF, ZAG,ZAH,ZAJ,ZAL .....	2
5	PAFZZ	4710-01-505-8850	15434	3936709	TUBE ASSEMBLY,METAL UOC: ZAA,ZAB,ZAC,ZAD,ZAE,ZAF, ZAG,ZAH,ZAJ,ZAL .....	1
6	PAFZZ	5340-00-843-7825	80205	MS21333-68	CLAMP,LOOP UOC: ZAA,ZAB,ZAC,ZAD,ZAE,ZAF, ZAG,ZAH,ZAJ,ZAL .....	1
7	PAFZZ	4730-01-281-0840	15434	392472500	BOLT,FLUID PASSAGE UOC: ZAA,ZAB,ZAC,ZAD,ZAE,ZAF, ZAG,ZAH,ZAJ,ZAL .....	1
8	KFFZZ	5310-01-335-4861	15434	3918192	WASHER,FLAT PART OF KIT P/N 3802622, PART OF KIT P/N 3800748, PART OF KIT P/N 402527100 UOC: ZAA,ZAB,ZAC,ZAD,ZAE,ZAF, ZAG,ZAH,ZAJ,ZAL .....	2
9	PAFZZ	5310-01-270-8341	15434	3910959	NUT,SELF-LOCKING,HE UOC: ZAA,ZAB,ZAC,ZAD,ZAE,ZAF, ZAG,ZAH,ZAJ,ZAL .....	2
10	PAFZZ	3040-01-271-3821	15434	3912484	LEVER,REMOTE CONTRO UOC: ZAA,ZAB,ZAC,ZAD,ZAE,ZAF, ZAG,ZAH,ZAJ,ZAL .....	1
11	PAFHH	2910-01-268-8757	53867	0 403 436 109	PUMP,FUEL,METERING UOC: ZAA,ZAB,ZAC,ZAD,ZAE,ZAF, ZAG,ZAH,ZAJ,ZAL .....	1
12	PAFZZ	3040-01-338-2546	15434	3912635	. LEVER,REMOTE CONTRO UOC: ZAA,ZAB,ZAC,ZAD,ZAE,ZAF, ZAG,ZAH,ZAJ,ZAL .....	1
13	PFHZZ	5305-01-248-3222	64678	000933005057	. SCREW,CAP,HEXAGON H UOC: ZAA,ZAB,ZAC,ZAD,ZAE,ZAF, ZAG,ZAH,ZAJ,ZAL .....	1

(1) ITEM NO.	(2) SMR CODE	(3) NSN	(4) CAGEC	(5) PART NUMBER	(6) DESCRIPTION AND USABLE ON CODE (UOC)	(7) QTY
14	PAFZZ	3040-01-271-3820	15434	3913326	. LEVER,REMOTE CONTRO UOC: ZAA,ZAB,ZAC,ZAD,ZAE,ZAF, ZAG,ZAH,ZAJ,ZAL .....	1
15	PAFZZ	5342-01-271-2340	15434	3912888	. PLUG,TIMING UOC: ZAA,ZAB,ZAC,ZAD,ZAE,ZAF, ZAG,ZAH,ZAJ,ZAL .....	1
16	PAFZZ	5310-01-271-5706	15434	3912889	. WASHER,SEALING UOC: ZAA,ZAB,ZAC,ZAD,ZAE,ZAF, ZAG,ZAH,ZAJ,ZAL .....	1
17	PAFZZ	5331-01-272-1121	15434	3935032	. O-RING PART OF KIT P/N 380055800 UOC: ZAA,ZAB,ZAC,ZAD,ZAE,ZAF, ZAG,ZAH,ZAJ,ZAL .....	1
18	PAFZZ	5310-01-270-8405	15434	3977395	. WASHER,LOCK UOC: ZAA,ZAB,ZAC,ZAD,ZAE,ZAF, ZAG,ZAH,ZAJ,ZAL .....	1
19	PAFZZ	5310-01-270-8229	15434	3912896	. NUT RETAINING UOC: ZAA,ZAB,ZAC,ZAD,ZAE,ZAF, ZAG,ZAH,ZAJ,ZAL .....	1
20	PAFZZ	5310-01-270-8343	15434	3902662	NUT,SELF-LOCKING,HE UOC: ZAA,ZAB,ZAC,ZAD,ZAE,ZAF, ZAG,ZAH,ZAJ,ZAL .....	4
21	PAFZZ	5307-01-271-9511	15434	393712300	STUD,PLAIN UOC: ZAA,ZAB,ZAC,ZAD,ZAE,ZAF, ZAG,ZAH,ZAJ,ZAL .....	4
22	PAFZZ	5331-01-272-1122	15434	3916284	O-RING PART OF KIT P/N 380055800 UOC: ZAA,ZAB,ZAC,ZAD,ZAE,ZAF, ZAG,ZAH,ZAJ,ZAL .....	1
23	PAFZZ	5305-01-271-5851	15434	3913638	SCREW,CAP,HEXAGON H UOC: ZAA,ZAB,ZAC,ZAD,ZAE,ZAF, ZAG,ZAH,ZAJ,ZAL .....	2
24	PAFZZ	3020-01-280-9024	15434	393137900	GEAR,SPUR UOC: ZAA,ZAB,ZAC,ZAD,ZAE,ZAF, ZAG,ZAH,ZAJ,ZAL .....	1
25	PAFZZ	5305-01-207-7243	15434	3903035	SCREW UOC: ZAA,ZAB,ZAC,ZAD,ZAE,ZAF, ZAG,ZAH,ZAJ,ZAL .....	1
26	PAFZZ	4710-01-271-3841	15434	3909556	TUBE ASSEMBLY,METAL UOC: ZAA,ZAB,ZAC,ZAD,ZAE,ZAF, ZAG,ZAH,ZAJ,ZAL .....	2
27	PAFZZ	4730-01-272-2827	15434	3909552	ADAPTER,STRAIGHT,PI UOC: ZAA,ZAB,ZAC,ZAD,ZAE,ZAF, ZAG,ZAH,ZAJ,ZAL .....	1
28	PAFZZ	4730-01-287-9100	7U263	3909557	REDUCER,PIPE UOC: ZAA,ZAB,ZAC,ZAD,ZAE,ZAF, ZAG,ZAH,ZAJ,ZAL .....	1

END OF FIGURE

**FIELD MAINTENANCE  
FUEL INJECTOR PUMP, CAMSHAFT, AND RELATED PARTS (M939A2)**

---

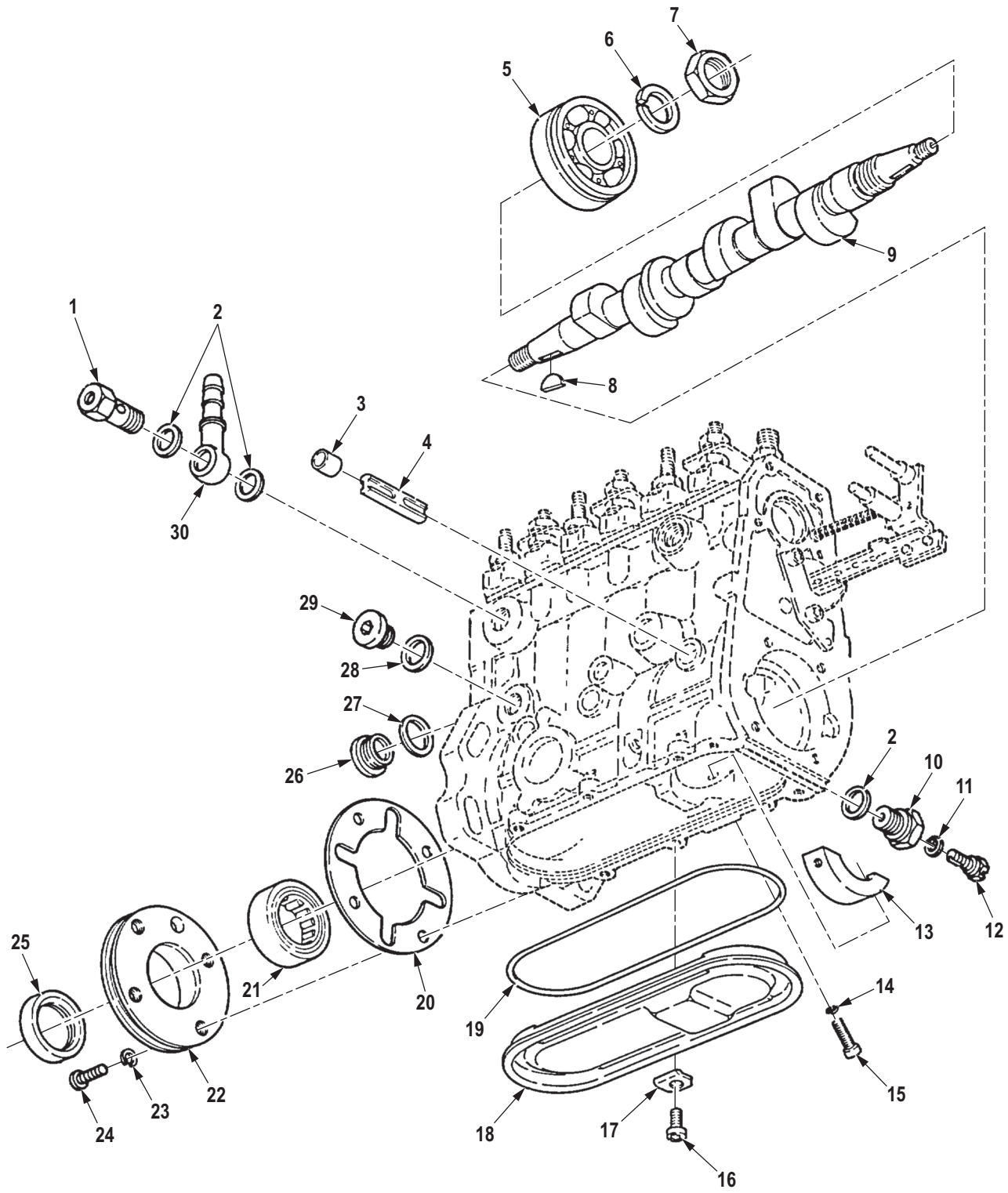

R0058DAA

Figure 58. Fuel Injector Pump, Camshaft, and Related Parts (M939A2).

(1) ITEM NO.	(2) SMR CODE	(3) NSN	(4) CAGEC	(5) PART NUMBER	(6) DESCRIPTION AND USABLE ON CODE (UOC)	(7) QTY
<b>GROUP 0302 FUEL PUMP.</b>						
<b>FIG. 58. FUEL INJECTOR PUMP, CAMSHAFT, AND RELATED PARTS (M939A2).</b>						
1	PFHZZ	4820-01-300-4051	53867	1 417 413 047	VALVE,CHECK UOC: ZAA,ZAB,ZAC,ZAD,ZAE,ZAF, ZAG,ZAH,ZAJ,ZAL .....	1
2	PFHZZ	5330-12-156-4523	D8046	007603014106	GASKET PART OF KIT P/N 1 417 010 008 UOC: ZAA,ZAB,ZAC,ZAD,ZAE,ZAF, ZAG,ZAH,ZAJ,ZAL .....	3
3	PFHZZ	5365-01-300-6885	53867	2410505004	PLUG,MACHINE THREAD PART OF KIT P/N 1 417 010 008 UOC: ZAA,ZAB,ZAC,ZAD,ZAE,ZAF, ZAG,ZAH,ZAJ,ZAL .....	3
4	PFHZZ	5315-01-301-3892	53867	1 413 106 002	PIN,STRAIGHT,HEADLE UOC: ZAA,ZAB,ZAC,ZAD,ZAE,ZAF, ZAG,ZAH,ZAJ,ZAL .....	3
5	PFHZZ	3110-01-300-6796	53867	1 410 900 015	BEARING,BALL,ANNULA UOC: ZAA,ZAB,ZAC,ZAD,ZAE,ZAF, ZAG,ZAH,ZAJ,ZAL .....	1
6	PFHZZ	5310-01-300-7037	53867	2 916 699 092	WASHER,LOCK 22-FST PART OF KIT P/N 57K0144 UOC: ZAA,ZAB,ZAC,ZAD,ZAE,ZAF, ZAG,ZAH,ZAJ,ZAL .....	1
7	PFHZZ	5310-01-301-1798	53867	1 413 300 014	NUT,PLAIN,HEXAGON 18 X 1.5 DIN 934-M-8 UOC: ZAA,ZAB,ZAC,ZAD,ZAE,ZAF, ZAG,ZAH,ZAJ,ZAL .....	1
8	PFHZZ	5315-01-301-7912	53867	1 900 023 011	KEY,WOODRUFF 5 X 7.5DIN68888 ST60-2K UOC: ZAA,ZAB,ZAC,ZAD,ZAE,ZAF, ZAG,ZAH,ZAJ,ZAL .....	1
9	PAHZZ	3040-01-337-4145	53867	1 416 116 342	CAM,CONTROL UOC: ZAA,ZAB,ZAC,ZAD,ZAE,ZAF, ZAG,ZAH,ZAJ,ZAL .....	1
10	PFHZZ	4730-01-300-8819	53867	1 413 457 001	BOLT,FLUID PASSAGE UOC: ZAA,ZAB,ZAC,ZAD,ZAE,ZAF, ZAG,ZAH,ZAJ,ZAL .....	1
11	PFHZZ	5331-01-238-8316	53867	1410107005	O-RING PART OF KIT P/N 57K0144 UOC: ZAA,ZAB,ZAC,ZAD,ZAE,ZAF, ZAG,ZAH,ZAJ,ZAL .....	1
12	PFHZZ	5305-01-238-8438	53867	1413453025	SCREW,CAP,HEXAGON H UOC: ZAA,ZAB,ZAC,ZAD,ZAE,ZAF, ZAG,ZAH,ZAJ,ZAL .....	1

(1) ITEM NO.	(2) SMR CODE	(3) NSN	(4) CAGEC	(5) PART NUMBER	(6) DESCRIPTION AND USABLE ON CODE (UOC)	(7) QTY
13	PFHZZ	3120-01-300-7135	53867	1 415 800 014	BEARING HALF,SLEEVE UOC: ZAA,ZAB,ZAC,ZAD,ZAE,ZAF, ZAG,ZAH,ZAJ,ZAL .....	1
14	PFHZZ	5331-01-300-6907	53867	2 410 113 004	O-RING PART OF KIT P/N 1 417 010 008 UOC: ZAA,ZAB,ZAC,ZAD,ZAE,ZAF, ZAG,ZAH,ZAJ,ZAL .....	2
15	PAHZZ	5305-01-301-7817	53867	2 914 552 158	SCREW,CAP,HEXAGON H UOC: ZAA,ZAB,ZAC,ZAD,ZAE,ZAF, ZAG,ZAH,ZAJ,ZAL .....	2
16	PFHZZ	5305-01-301-0533	53867	2 912 732 191	SCREW,CAP,HEXAGON H UOC: ZAA,ZAB,ZAC,ZAD,ZAE,ZAF, ZAG,ZAH,ZAJ,ZAL .....	6
17	PFHZZ	5340-01-300-7295	53867	1413335001	CLAMP,RIM CLENCHING UOC: ZAA,ZAB,ZAC,ZAD,ZAE,ZAF, ZAG,ZAH,ZAJ,ZAL .....	6
18	PFHZZ	5340-01-300-7203	53867	1 415 616 005	COVER,ACCESS UOC: ZAA,ZAB,ZAC,ZAD,ZAE,ZAF, ZAG,ZAH,ZAJ,ZAL .....	1
19	PFHZZ	5330-01-302-5738	53867	1 410 210 054	GASKET PART OF KIT P/N 1 417 010 008 UOC: ZAA,ZAB,ZAC,ZAD,ZAE,ZAF, ZAG,ZAH,ZAJ,ZAL .....	1
20	PAHZZ	5330-01-301-5995	53867	1-410-137-021	GASKET PART OF KIT P/N 1 417 010 008 UOC: ZAA,ZAB,ZAC,ZAD,ZAE,ZAF, ZAG,ZAH,ZAJ,ZAL .....	1
21	PFHZZ	3110-01-300-6804	53867	1 410 910 005	BEARING,ROLLER,NEED UOC: ZAA,ZAB,ZAC,ZAD,ZAE,ZAF, ZAG,ZAH,ZAJ,ZAL .....	1
22	PFHZZ	3110-01-300-7136	53867	1 415 511 047	PLATE,RETAINING,BEA UOC: ZAA,ZAB,ZAC,ZAD,ZAE,ZAF, ZAG,ZAH,ZAJ,ZAL .....	1
23	PAHZZ	5310-01-167-1964	D8265	001720	WASHER,LOCK UOC: ZAA,ZAB,ZAC,ZAD,ZAE,ZAF, ZAG,ZAH,ZAJ,ZAL .....	4
24	PAHZZ	5305-01-301-7818	53867	2 912 742 196	SCREW,CAP,HEXAGON H UOC: ZAA,ZAB,ZAC,ZAD,ZAE,ZAF, ZAG,ZAH,ZAJ,ZAL .....	4
25	PFHZZ	5330-01-300-6898	53867	1 410 283 005	SEAL,PLAIN PART OF KIT P/N 1 417 010 008 UOC: ZAA,ZAB,ZAC,ZAD,ZAE,ZAF, ZAG,ZAH,ZAJ,ZAL .....	1
26	PFHZZ	5365-01-336-5187	5T151	1 423 463 007	PLUG,MACHINE THREAD 3.00MM UOC: ZAA,ZAB,ZAC,ZAD,ZAE,ZAF, ZAG,ZAH,ZAJ,ZAL .....	1



(1) ITEM NO.	(2) SMR CODE	(3) NSN	(4) CAGEC	(5) PART NUMBER	(6) DESCRIPTION AND USABLE ON CODE (UOC)	(7) QTY
27	PAHZZ	5330-01-301-1763	53867	2 916 710 619	SEAL RING DIM 7603-A26 X 31-E-CU UOC: ZAA,ZAB,ZAC,ZAD,ZAE,ZAF, ZAG,ZAH,ZAJ,ZAL .....	1
28	PFHZZ	5325-01-276-8488	53867	2916710613	RING,RETAINING PART OF KIT P/ N 1 417 010 008 UOC: ZAA,ZAB,ZAC,ZAD,ZAE,ZAF, ZAG,ZAH,ZAJ,ZAL .....	1
29	PFHZZ	5365-12-305-0652	D8015	1413462898	PLUG,MACHINE THREAD UOC: ZAA,ZAB,ZAC,ZAD,ZAE,ZAF, ZAG,ZAH,ZAJ,ZAL .....	1
30	PFHZZ	4730-01-349-2436	87373	34982-14-6	CONNECTOR,MULTIPLE, UOC: ZAA,ZAB,ZAC,ZAD,ZAE,ZAF, ZAG,ZAH,ZAJ,ZAL .....	1

END OF FIGURE



**FIELD MAINTENANCE  
FUEL INJECTOR PUMP PLUNGER AND CONTROL RACK (M939A2)**

---



(1) ITEM NO.	(2) SMR CODE	(3) NSN	(4) CAGEC	(5) PART NUMBER	(6) DESCRIPTION AND USABLE ON CODE (UOC)	(7) QTY
<b>GROUP 0302 FUEL PUMP.</b>						
<b>FIG. 59. FUEL INJECTOR PUMP PLUNGER AND CONTROL RACK (M939A2).</b>						
1	PFHZZ	4820-01-300-4257	53867	1 413 356 040	RETAINER,DISK,VALVE UOC: ZAA,ZAB,ZAC,ZAD,ZAE,ZAF, ZAG,ZAH,ZAJ,ZAL .....	6
2	PFHZZ	5310-01-336-8721	5T151	1 413 300 023	NUT,PLAIN,HEXAGON PART OF KIT P/N 57K0144 UOC: ZAA,ZAB,ZAC,ZAD,ZAE,ZAF, ZAG,ZAH,ZAJ,ZAL .....	12
3	PFHZZ	5310-01-301-1875	53867	2916699109	WASHER,LOCK PART OF KIT P/ N 57K0144 UOC: ZAA,ZAB,ZAC,ZAD,ZAE,ZAF, ZAG,ZAH,ZAJ,ZAL .....	12
4	PFHZZ	5365-01-303-1612	53867	1 410 200 019	SPACER,RING PART OF KIT P/N 57K0144 UOC: ZAA,ZAB,ZAC,ZAD,ZAE,ZAF, ZAG,ZAH,ZAJ,ZAL .....	12
5	PFHZZ	5310-01-301-1802	53867	1 410 149 001	WASHER,KEY UOC: ZAA,ZAB,ZAC,ZAD,ZAE,ZAF, ZAG,ZAH,ZAJ,ZAL .....	6
6	PFHZZ	5307-01-301-7815	53867	1 413 500 006	STUD,PLAIN UOC: ZAA,ZAB,ZAC,ZAD,ZAE,ZAF, ZAG,ZAH,ZAJ,ZAL .....	6
7	PFHZZ	5315-01-335-9941	53867	1 413 105 008	PIN,GROOVED,HEADLES UOC: ZAA,ZAB,ZAC,ZAD,ZAE,ZAF, ZAG,ZAH,ZAJ,ZAL .....	1
8	PFHZZ	5310-01-336-6748	5T151	2 916 021 010	WASHER,FLAT UOC: ZAA,ZAB,ZAC,ZAD,ZAE,ZAF, ZAG,ZAH,ZAJ,ZAL .....	1
9	PFHZZ	5360-01-335-9947	5T151	1 424 610 053	SPRING,HELICAL,COMP UOC: ZAA,ZAB,ZAC,ZAD,ZAE,ZAF, ZAG,ZAH,ZAJ,ZAL .....	1
10	PFHZZ	5340-01-339-0839	5T151	1 420 505 062	SEAT,HELICAL COMPRE UOC: ZAA,ZAB,ZAC,ZAD,ZAE,ZAF, ZAG,ZAH,ZAJ,ZAL .....	1
11	PFHZZ	5340-01-336-3889	5T151	1 416 016 013	BRACKET,LEVER UOC: ZAA,ZAB,ZAC,ZAD,ZAE,ZAF, ZAG,ZAH,ZAJ,ZAL .....	1
12	PAHZZ	5305-01-301-7817	53867	2 914 552 158	SCREW,CAP,HEXAGON H UOC: ZAA,ZAB,ZAC,ZAD,ZAE,ZAF, ZAG,ZAH,ZAJ,ZAL .....	2
13	XBHZZ		5T151	1 411 032 004	STOP PLATE UOC: ZAA,ZAB,ZAC,ZAD,ZAE,ZAF, ZAG,ZAH,ZAJ,ZAL .....	1

(1) ITEM NO.	(2) SMR CODE	(3) NSN	(4) CAGEC	(5) PART NUMBER	(6) DESCRIPTION AND USABLE ON CODE (UOC)	(7) QTY
14	PFHZZ	2910-01-301-9936	53867	1418-710-025	TAPPET,ROLLER,FUEL UOC: ZAA,ZAB,ZAC,ZAD,ZAE,ZAF, ZAG,ZAH,ZAJ,ZAL .....	6
15	PFHZZ	5340-01-300-7154	53867	1 410 520 007	SEAT,HELICAL COMPRE UOC: ZAA,ZAB,ZAC,ZAD,ZAE,ZAF, ZAG,ZAH,ZAJ,ZAL .....	6
16	PFHZZ	2910-01-338-2335	5T151	1 418 415 082	PLUNGER ASSEMBLY,FU UOC: ZAA,ZAB,ZAC,ZAD,ZAE,ZAF, ZAG,ZAH,ZAJ,ZAL .....	6
17	PFHZZ	5360-01-300-6888	53867	1 414 618 030	SPRING,HELICAL,COMP UOC: ZAA,ZAB,ZAC,ZAD,ZAE,ZAF, ZAG,ZAH,ZAJ,ZAL .....	6
18	PFHZZ	5340-01-300-7153	53867	1 410 505 015	SEAT,HELICAL COMPRE UOC: ZAA,ZAB,ZAC,ZAD,ZAE,ZAF, ZAG,ZAH,ZAJ,ZAL .....	6
19	PFHZZ	2910-01-300-4271	53867	1 410 422 031	SLEEVE,GOVERNOR,FUE UOC: ZAA,ZAB,ZAC,ZAD,ZAE,ZAF, ZAG,ZAH,ZAJ,ZAL .....	6
20	PFHZZ	5331-01-301-5992	53867	1410210503	O-RING 16 X 3MM PART OF KIT P/ N 1 417 010 008 UOC: ZAA,ZAB,ZAC,ZAD,ZAE,ZAF, ZAG,ZAH,ZAJ,ZAL .....	6
21	PFHZZ	5365-01-300-7149	53867	1 410 290 005	SPACER,RING PART OF KIT P/N 1 417 010 008 UOC: ZAA,ZAB,ZAC,ZAD,ZAE,ZAF, ZAG,ZAH,ZAJ,ZAL .....	6
22	KBHZZ		5T151	1 414 601 004	RETAINER RING PART OF KIT P/ N 1 417 010 008 UOC: ZAA,ZAB,ZAC,ZAD,ZAE,ZAF, ZAG,ZAH,ZAJ,ZAL .....	6
23	PFHZZ	5365-01-300-7021	53867	1 410 505 023	SPACER,SLEEVE UOC: ZAA,ZAB,ZAC,ZAD,ZAE,ZAF, ZAG,ZAH,ZAJ,ZAL .....	6
24	PFHZZ	5331-01-301-7867	53867	1 410 210 501	O-RING 19 X 2MM PART OF KIT P/ N 1 417 010 008 UOC: ZAA,ZAB,ZAC,ZAD,ZAE,ZAF, ZAG,ZAH,ZAJ,ZAL .....	6
25	PFHZZ	5365-01-300-7160	53867	1 411 030 136	SPACER,PLATE 1.10MM THICK UOC: ZAA,ZAB,ZAC,ZAD,ZAE,ZAF, ZAG,ZAH,ZAJ,ZAL .....	1
25	PFHZZ	5365-01-300-7158	53867	1 411 030 134	SPACER,PLATE 1.00 MM THICK UOC: ZAA,ZAB,ZAC,ZAD,ZAE,ZAF, ZAG,ZAH,ZAJ,ZAL .....	1
25	PFHZZ	5365-01-300-7161	53867	1 411 030 138	SPACER,PLATE 1.20MM THICK UOC: ZAA,ZAB,ZAC,ZAD,ZAE,ZAF, ZAG,ZAH,ZAJ,ZAL .....	1

(1) ITEM NO.	(2) SMR CODE	(3) NSN	(4) CAGEC	(5) PART NUMBER	(6) DESCRIPTION AND USABLE ON CODE (UOC)	(7) QTY
25	PFHZZ	5365-01-300-7167	53867	1 411 030 144	SPACER,PLATE 1.50MM THICK UOC: ZAA,ZAB,ZAC,ZAD,ZAE,ZAF, ZAG,ZAH,ZAJ,ZAL .....	1
25	PFHZZ	5365-01-301-0554	53867	1 411 030 137	SPACER,PLATE 1.15MM THICK UOC: ZAA,ZAB,ZAC,ZAD,ZAE,ZAF, ZAG,ZAH,ZAJ,ZAL .....	1
25	PFHZZ	5365-01-300-7164	53867	1 411 030 141	SPACER,PLATE 1.35MM THICK UOC: ZAA,ZAB,ZAC,ZAD,ZAE,ZAF, ZAG,ZAH,ZAJ,ZAL .....	1
25	PFHZZ	5365-01-300-7162	53867	1 411 030 139	SPACER,PLATE 1.25MM THICK UOC: ZAA,ZAB,ZAC,ZAD,ZAE,ZAF, ZAG,ZAH,ZAJ,ZAL .....	1
25	PFHZZ	5365-01-300-7166	53867	1 411 030 143	SPACER,PLATE 1.45MM THICK UOC: ZAA,ZAB,ZAC,ZAD,ZAE,ZAF, ZAG,ZAH,ZAJ,ZAL .....	1
25	PFHZZ	5365-01-300-7159	53867	1 411 030 135	SPACER,PLATE 1.05MM THICK UOC: ZAA,ZAB,ZAC,ZAD,ZAE,ZAF, ZAG,ZAH,ZAJ,ZAL .....	1
25	PFHZZ	5365-01-300-7165	53867	1 411 030 142	SPACER,PLATE 1.40MM THICK UOC: ZAA,ZAB,ZAC,ZAD,ZAE,ZAF, ZAG,ZAH,ZAJ,ZAL .....	1
25	PFHZZ	5365-01-300-7168	53867	1 411 030 145	SPACER,PLATE 1.55MM THICK UOC: ZAA,ZAB,ZAC,ZAD,ZAE,ZAF, ZAG,ZAH,ZAJ,ZAL .....	1
25	PFHZZ	5365-01-300-7169	53867	1 411 030 146	SPACER,PLATE 1.60MM THICK UOC: ZAA,ZAB,ZAC,ZAD,ZAE,ZAF, ZAG,ZAH,ZAJ,ZAL .....	1
25	PFHZZ	5365-01-303-0937	53867	1 411 030 147	SPACER,PLATE 1.65MM THICK UOC: ZAA,ZAB,ZAC,ZAD,ZAE,ZAF, ZAG,ZAH,ZAJ,ZAL .....	1
25	PFHZZ	5365-01-304-9530	53867	1 411 030 148	SPACER,PLATE 1.70MM THICK UOC: ZAA,ZAB,ZAC,ZAD,ZAE,ZAF, ZAG,ZAH,ZAJ,ZAL .....	1
25	PFHZZ	5365-01-302-9953	53867	1 411 030 149	SPACER,PLATE 1.75MM THICK UOC: ZAA,ZAB,ZAC,ZAD,ZAE,ZAF, ZAG,ZAH,ZAJ,ZAL .....	1
25	PFHZZ	5365-01-303-0938	53867	1 411 030 150	SPACER,PLATE 1.80MM THICK UOC: ZAA,ZAB,ZAC,ZAD,ZAE,ZAF, ZAG,ZAH,ZAJ,ZAL .....	1
25	PFHZZ	5365-01-304-1802	53867	1 411 030 151	SPACER,PLATE 1.85MM THICK UOC: ZAA,ZAB,ZAC,ZAD,ZAE,ZAF, ZAG,ZAH,ZAJ,ZAL .....	1
25	PFHZZ	5365-01-300-7170	53867	1 411 030 152	SPACER,PLATE 1.90MM THICK UOC: ZAA,ZAB,ZAC,ZAD,ZAE,ZAF, ZAG,ZAH,ZAJ,ZAL .....	1

(1) ITEM NO.	(2) SMR CODE	(3) NSN	(4) CAGEC	(5) PART NUMBER	(6) DESCRIPTION AND USABLE ON CODE (UOC)	(7) QTY
25	PFHZZ	5365-01-300-7172	53867	1 411 030 154	SPACER,PLATE 2.00MM THICK UOC: ZAA,ZAB,ZAC,ZAD,ZAE,ZAF, ZAG,ZAH,ZAJ,ZAL .....	1
25	PFHZZ	5365-01-300-7171	53867	1 411 030 153	SPACER,PLATE 1.95MM THICK UOC: ZAA,ZAB,ZAC,ZAD,ZAE,ZAF, ZAG,ZAH,ZAJ,ZAL .....	1
25	PFHZZ	5365-01-300-7173	53867	1 411 030 155	SPACER,PLATE 2.05MM THICK UOC: ZAA,ZAB,ZAC,ZAD,ZAE,ZAF, ZAG,ZAH,ZAJ,ZAL .....	1
25	PFHZZ	5365-01-300-7174	53867	1 411 030 156	SPACER,PLATE 2.10MM THICK UOC: ZAA,ZAB,ZAC,ZAD,ZAE,ZAF, ZAG,ZAH,ZAJ,ZAL .....	1
25	PFHZZ	5365-01-300-7176	53867	1 411 030 158	SPACER,PLATE 2.20MM THICK UOC: ZAA,ZAB,ZAC,ZAD,ZAE,ZAF, ZAG,ZAH,ZAJ,ZAL .....	1
25	PFHZZ	5365-01-300-7182	53867	1 411 030 164	SPACER,PLATE 2.50MM THICK UOC: ZAA,ZAB,ZAC,ZAD,ZAE,ZAF, ZAG,ZAH,ZAJ,ZAL .....	1
25	PFHZZ	5365-01-300-7175	53867	1 411 030 157	SPACER,PLATE 2.15MM THICK UOC: ZAA,ZAB,ZAC,ZAD,ZAE,ZAF, ZAG,ZAH,ZAJ,ZAL .....	1
25	PFHZZ	5365-01-300-7178	53867	1 411 030 160	SPACER,PLATE 2.30MM THICK UOC: ZAA,ZAB,ZAC,ZAD,ZAE,ZAF, ZAG,ZAH,ZAJ,ZAL .....	1
25	PFHZZ	5365-01-300-7179	53867	1 411 030 161	SPACER,PLATE 2.35MM THICK UOC: ZAA,ZAB,ZAC,ZAD,ZAE,ZAF, ZAG,ZAH,ZAJ,ZAL .....	1
25	PFHZZ	5365-01-300-7180	53867	1 411 030 162	SPACER,PLATE 2.40MM THICK UOC: ZAA,ZAB,ZAC,ZAD,ZAE,ZAF, ZAG,ZAH,ZAJ,ZAL .....	1
25	PFHZZ	5365-01-300-7177	53867	1 411 030 159	SPACER,PLATE 2.25MM THICK UOC: ZAA,ZAB,ZAC,ZAD,ZAE,ZAF, ZAG,ZAH,ZAJ,ZAL .....	1
25	PFHZZ	5365-01-300-7181	53867	1 411 030 163	SPACER,PLATE 2.45MM THICK UOC: ZAA,ZAB,ZAC,ZAD,ZAE,ZAF, ZAG,ZAH,ZAJ,ZAL .....	1
25	PFHZZ	5365-01-302-5848	53867	1 411 030 165	SPACER,PLATE 2.55MM THICK UOC: ZAA,ZAB,ZAC,ZAD,ZAE,ZAF, ZAG,ZAH,ZAJ,ZAL .....	1
25	PFHZZ	5365-01-300-7183	53867	1 411 030 166	SPACER,PLATE 2.60MM THICK UOC: ZAA,ZAB,ZAC,ZAD,ZAE,ZAF, ZAG,ZAH,ZAJ,ZAL .....	1
25	PFHZZ	5365-01-300-7185	53867	1 411 030 168	SPACER,PLATE 2.70MM THICK UOC: ZAA,ZAB,ZAC,ZAD,ZAE,ZAF, ZAG,ZAH,ZAJ,ZAL .....	1



(1) ITEM NO.	(2) SMR CODE	(3) NSN	(4) CAGEC	(5) PART NUMBER	(6) DESCRIPTION AND USABLE ON CODE (UOC)	(7) QTY
25	PFHZZ	5365-01-300-7163	53867	1 411 030 140	SPACER,PLATE 1.30MM THICK UOC: ZAA,ZAB,ZAC,ZAD,ZAE,ZAF, ZAG,ZAH,ZAJ,ZAL .....	1
25	PFHZZ	5365-01-300-7184	53867	1 411 030 167	SPACER,PLATE 2.65MM THICK UOC: ZAA,ZAB,ZAC,ZAD,ZAE,ZAF, ZAG,ZAH,ZAJ,ZAL .....	1
25	PFHZZ	5365-01-300-7187	53867	1 411 030 170	SPACER,PLATE 2.80MM THICK UOC: ZAA,ZAB,ZAC,ZAD,ZAE,ZAF, ZAG,ZAH,ZAJ,ZAL .....	1
25	PFHZZ	5365-01-301-4006	53867	1 411 030 171	SPACER,PLATE 2.85MM THICK UOC: ZAA,ZAB,ZAC,ZAD,ZAE,ZAF, ZAG,ZAH,ZAJ,ZAL .....	1
25	PFHZZ	5365-01-300-7188	53867	1 411 030 172	SPACER,PLATE UOC: ZAA,ZAB,ZAC,ZAD,ZAE,ZAF, ZAG,ZAH,ZAJ,ZAL .....	1
25	PFHZZ	5365-01-300-7186	53867	1 411 030 169	SPACER,PLATE 2.75MM THICK UOC: ZAA,ZAB,ZAC,ZAD,ZAE,ZAF, ZAG,ZAH,ZAJ,ZAL .....	1
25	PFHZZ	5365-01-301-4007	53867	1 411 030 173	SPACER,PLATE 2.95MM THICK UOC: ZAA,ZAB,ZAC,ZAD,ZAE,ZAF, ZAG,ZAH,ZAJ,ZAL .....	1
26	PFHZZ	2910-01-339-8598	53867	1 418 512 225	VALVE,FUEL SYSTEM UOC: ZAA,ZAB,ZAC,ZAD,ZAE,ZAF, ZAG,ZAH,ZAJ,ZAL .....	6
27	PFHZZ	5360-01-300-6889	53867	1 414 613 002	SPRING,HELICAL,COMP PART OF KIT P/N 57K0144 UOC: ZAA,ZAB,ZAC,ZAD,ZAE,ZAF, ZAG,ZAH,ZAJ,ZAL .....	6
28	PFHZZ	5310-01-301-7807	53867	1 410 100 002	WASHER,FLAT PART OF KIT P/N 57K0144 UOC: ZAA,ZAB,ZAC,ZAD,ZAE,ZAF, ZAG,ZAH,ZAJ,ZAL .....	6
29	PFHZZ	5331-01-303-1635	53867	1 410 210 041	O-RING 13 X 2.5MM PART OF KIT P/N 1 417 010 008 UOC: ZAA,ZAB,ZAC,ZAD,ZAE,ZAF, ZAG,ZAH,ZAJ,ZAL .....	6

END OF FIGURE



**FIELD MAINTENANCE  
FUEL TRANSFER PUMP (M939A2)**

---

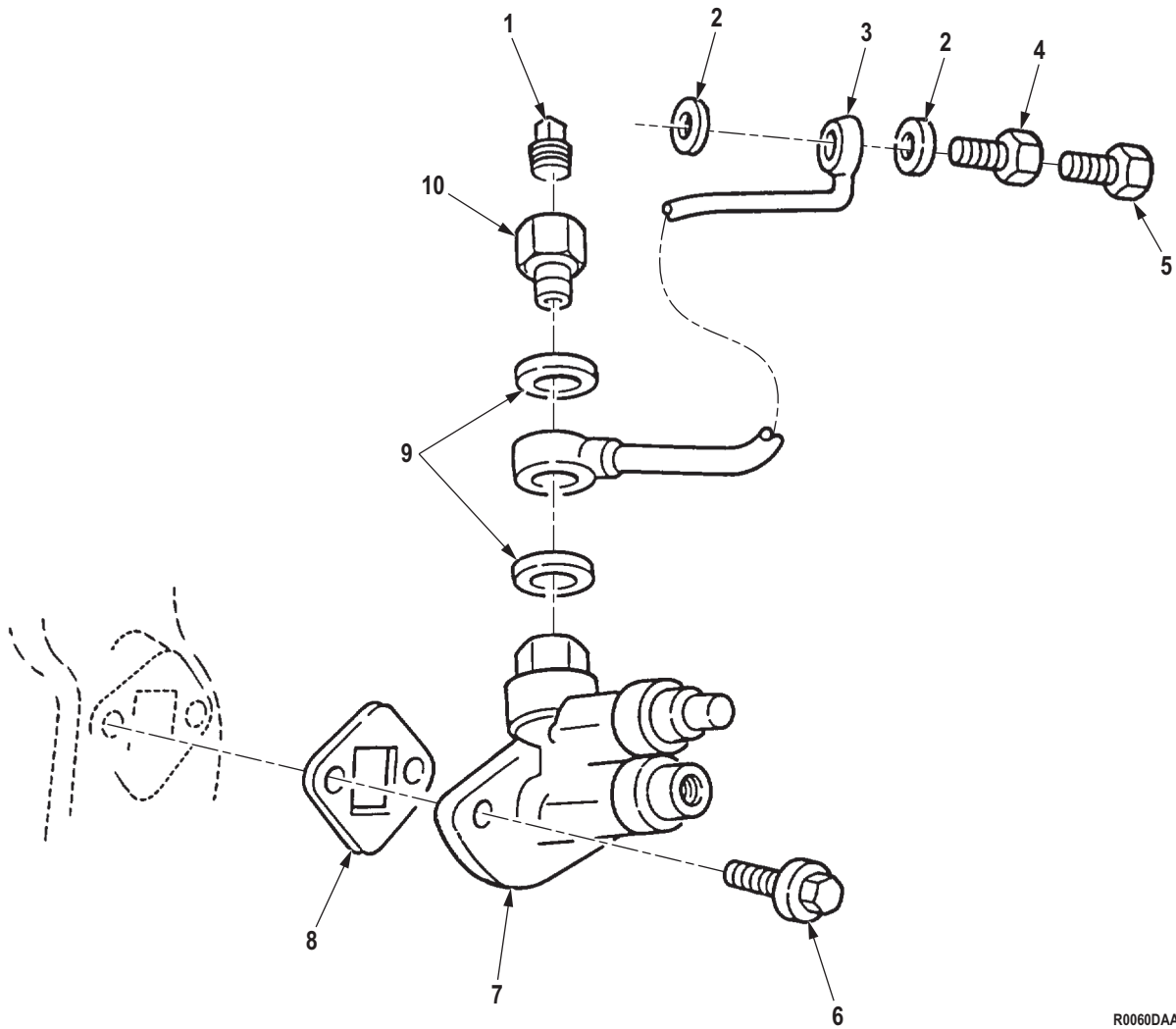

R0060DAA

Figure 60. Fuel Transfer Pump (M939A2).

(1) ITEM NO.	(2) SMR CODE	(3) NSN	(4) CAGEC	(5) PART NUMBER	(6) DESCRIPTION AND USABLE ON CODE (UOC)	(7) QTY
<b>GROUP 0302 FUEL PUMP.</b>						
<b>FIG. 60. FUEL TRANSFER PUMP (M939A2).</b>						
1	PAFZZ	4730-00-011-2578	96906	MS14314-2X	PLUG,PIPE UOC: ZAA,ZAB,ZAC,ZAD,ZAE,ZAF, ZAG,ZAH,ZAJ,ZAL .....	1
2	PAFZZ	5310-01-195-1441	15434	3963983	WASHER,FLAT UOC: ZAA,ZAB,ZAC,ZAD,ZAE,ZAF, ZAG,ZAH,ZAJ,ZAL .....	2
3	PAFZZ	4710-01-271-7199	15434	3914036	TUBE ASSEMBLY,METAL UOC: ZAA,ZAB,ZAC,ZAD,ZAE,ZAF, ZAG,ZAH,ZAJ,ZAL .....	1
4	PAFZZ	5305-01-272-1333	15434	3911446	SCREW,CAP,HEXAGON H FLUID PASSAGE UOC: ZAA,ZAB,ZAC,ZAD,ZAE,ZAF, ZAG,ZAH,ZAJ,ZAL .....	1
5	PAFZZ	5306-01-507-0906	15434	3939570	BOLT,ASSEMBLED WASH UOC: DAC,DAD,DAE,DAF,DAG,DA H,DAJ,DAL,DAW,DAX,V14,V15,V16, V17,V18,V19,V20,V21,V22,V24,ZAA, ZAB,ZAC,ZAD,ZAE,ZAF,ZAG,ZAH,Z AJ,ZAL .....	1
6	PAFZZ	5305-01-234-3755	15434	3900630	SCREW,CAP,HEXAGON H UOC: ZAA,ZAB,ZAC,ZAD,ZAE,ZAF, ZAG,ZAH,ZAJ,ZAL .....	2
7	PAFZZ	2910-01-268-8736	0B8S3	4988749	PUMP,FUEL TRANSFER UOC: ZAA,ZAB,ZAC,ZAD,ZAE,ZAF, ZAG,ZAH,ZAJ,ZAL .....	1
8	PAFZZ	5330-01-467-2130	15434	393925800	GASKET PUMP PART OF KIT P/N 380055800 UOC: ZAA,ZAB,ZAC,ZAD,ZAE,ZAF, ZAG,ZAH,ZAJ,ZAL .....	1
9	PAFZZ	5310-01-335-4861	15434	3918192	WASHER,FLAT UOC: ZAA,ZAB,ZAC,ZAD,ZAE,ZAF, ZAG,ZAH,ZAJ,ZAL .....	2
10	PAFZZ	4730-01-301-4286	15434	3914037	BOLT,FLUID PASSAGE UOC: ZAA,ZAB,ZAC,ZAD,ZAE,ZAF, ZAG,ZAH,ZAJ,ZAL .....	1

**END OF FIGURE**



**FIELD MAINTENANCE  
AIR CLEANER INDICATOR AND RELATED PARTS**

---

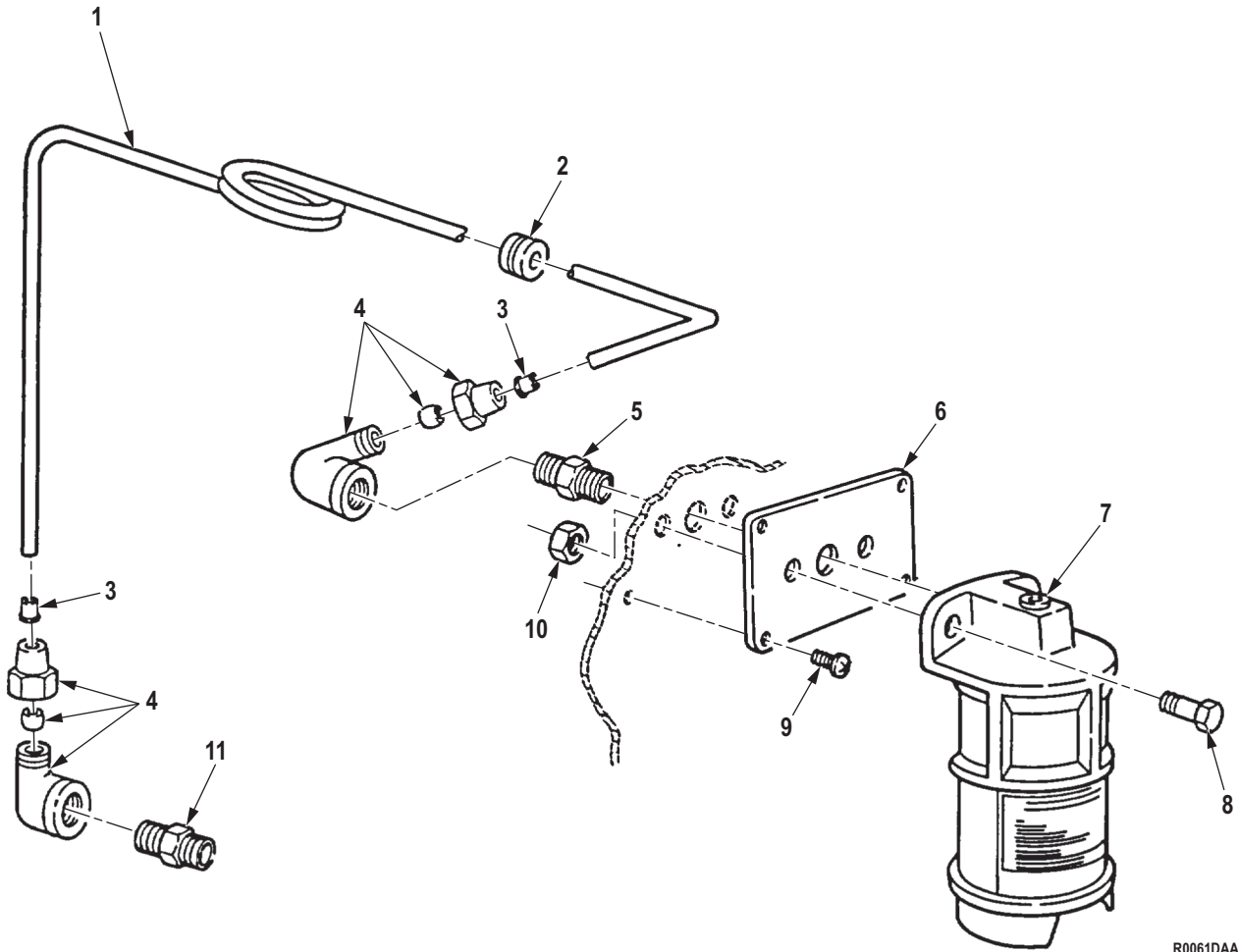

R0061DAA

Figure 61. Air Cleaner Indicator and Related Parts.



(1) ITEM NO.	(2) SMR CODE	(3) NSN	(4) CAGEC	(5) PART NUMBER	(6) DESCRIPTION AND USABLE ON CODE (UOC)	(7) QTY
<b>GROUP 0304 AIR CLEANER.</b>						
<b>FIG. 61. AIR CLEANER INDICATOR AND RELATED PARTS.</b>						
1	MFFZZ		19207	8675779-32	TUBE,METALLIC MAKE FROM TUBING, P/N 8675779 (19207), 32IN.LONG UOC: DAC,DAD,DAE,DAF,DAG,DAH,DAJ,DAL,DAW,DAX,V14,V15,V16,V17,V18,V19,V20,V21,V22,V24,ZAA,ZAB,ZAC,ZAD,ZAE,ZAF,ZAG,ZAH,ZAJ,ZAL .....	1
2	PAFZZ	5325-00-164-2087	96906	MS35489-39	GROMMET,NONMETALLIC UOC: DAC,DAD,DAE,DAF,DAG,DAH,DAJ,DAL,DAW,DAX,V14,V15,V16,V17,V18,V19,V20,V21,V22,V24,ZAA,ZAB,ZAC,ZAD,ZAE,ZAF,ZAG,ZAH,ZAJ,ZAL .....	1
3	PAFZZ	4730-00-132-4588	19207	11648703	INSERT,TUBE FITTING UOC: DAC,DAD,DAE,DAF,DAG,DAH,DAJ,DAL,DAW,DAX,V14,V15,V16,V17,V18,V19,V20,V21,V22,V24,ZAA,ZAB,ZAC,ZAD,ZAE,ZAF,ZAG,ZAH,ZAJ,ZAL .....	2
4	PAFZZ	4730-00-912-9114	81343	4-2 120203BA	ELBOW,PIPE TO TUBE UOC: DAC,DAD,DAE,DAF,DAG,DAH,DAJ,DAL,DAW,DAX,V14,V15,V16,V17,V18,V19,V20,V21,V22,V24,ZAA,ZAB,ZAC,ZAD,ZAE,ZAF,ZAG,ZAH,ZAJ,ZAL .....	2
5	PAFZZ	4730-00-196-1481	96906	MS51953-9	NIPPLE,PIPE UOC: DAC,DAD,DAE,DAF,DAG,DAH,DAJ,DAL,DAW,DAX,V14,V15,V16,V17,V18,V19,V20,V21,V22,V24,ZAA,ZAB,ZAC,ZAD,ZAE,ZAF,ZAG,ZAH,ZAJ,ZAL .....	1
6	PBFZZ	4330-01-108-5109	19207	12277150	BRACKET,FILTER MOUN UOC: DAC,DAD,DAE,DAF,DAG,DAH,DAJ,DAL,DAW,DAX,V14,V15,V16,V17,V18,V19,V20,V21,V22,V24,ZAA,ZAB,ZAC,ZAD,ZAE,ZAF,ZAG,ZAH,ZAJ,ZAL .....	1
7	PAFZZ	2940-01-386-8281	59150	A35501-01825	INDICATOR,FILTER WA UOC: DAC,DAD,DAE,DAF,DAG,DAH,DAJ,DAL,DAW,DAX,V14,V15,V16,V17,V18,V19,V20,V21,V22,V24,ZAA,ZAB,ZAC,ZAD,ZAE,ZAF,ZAG,ZAH,ZAJ,ZAL .....	1

(1) ITEM NO.	(2) SMR CODE	(3) NSN	(4) CAGEC	(5) PART NUMBER	(6) DESCRIPTION AND USABLE ON CODE (UOC)	(7) QTY
8	PAFZZ	5305-00-267-8953	80204	B1821BH025F063N	SCREW,CAP,HEXAGON H UOC: DAC,DAD,DAE,DAF,DAG,DA H,DAJ,DAL,DAW,DAX,V14,V15,V16, V17,V18,V19,V20,V21,V22,V24,ZAA, ZAB,ZAC,ZAD,ZAE,ZAF,ZAG,ZAH,Z AJ,ZAL .....	2
9	PAFZZ	5305-00-989-7435	80205	MS35207-264	SCREW,MACHINE UOC: DAC,DAD,DAE,DAF,DAG,DA H,DAJ,DAL,DAW,DAX,V14,V15,V16, V17,V18,V19,V20,V21,V22,V24,ZAA, ZAB,ZAC,ZAD,ZAE,ZAF,ZAG,ZAH,Z AJ,ZAL .....	4
10	PAFZZ	5310-00-935-9022	81349	M45913/3-4FG8C	NUT,SELF-LOCKING,HE UOC: DAC,DAD,DAE,DAF,DAG,DA H,DAJ,DAL,DAW,DAX,V14,V15,V16, V17,V18,V19,V20,V21,V22,V24,ZAA, ZAB,ZAC,ZAD,ZAE,ZAF,ZAG,ZAH,Z AJ,ZAL .....	2
11	PAFZZ	2910-00-911-5635	19207	8712058	FILTER,FLUID UOC: DAC,DAD,DAE,DAF,DAG,DA H,DAJ,DAL,DAW,DAX,V14,V15,V16, V17,V18,V19,V20,V21,V22,V24,ZAA, ZAB,ZAC,ZAD,ZAE,ZAF,ZAG,ZAH,Z AJ,ZAL .....	1

END OF FIGURE

**FIELD MAINTENANCE  
AIR INTAKE SYSTEM**

---

11	12	22	23	29
12	13 - 14	23 - 27	24	30 - 31

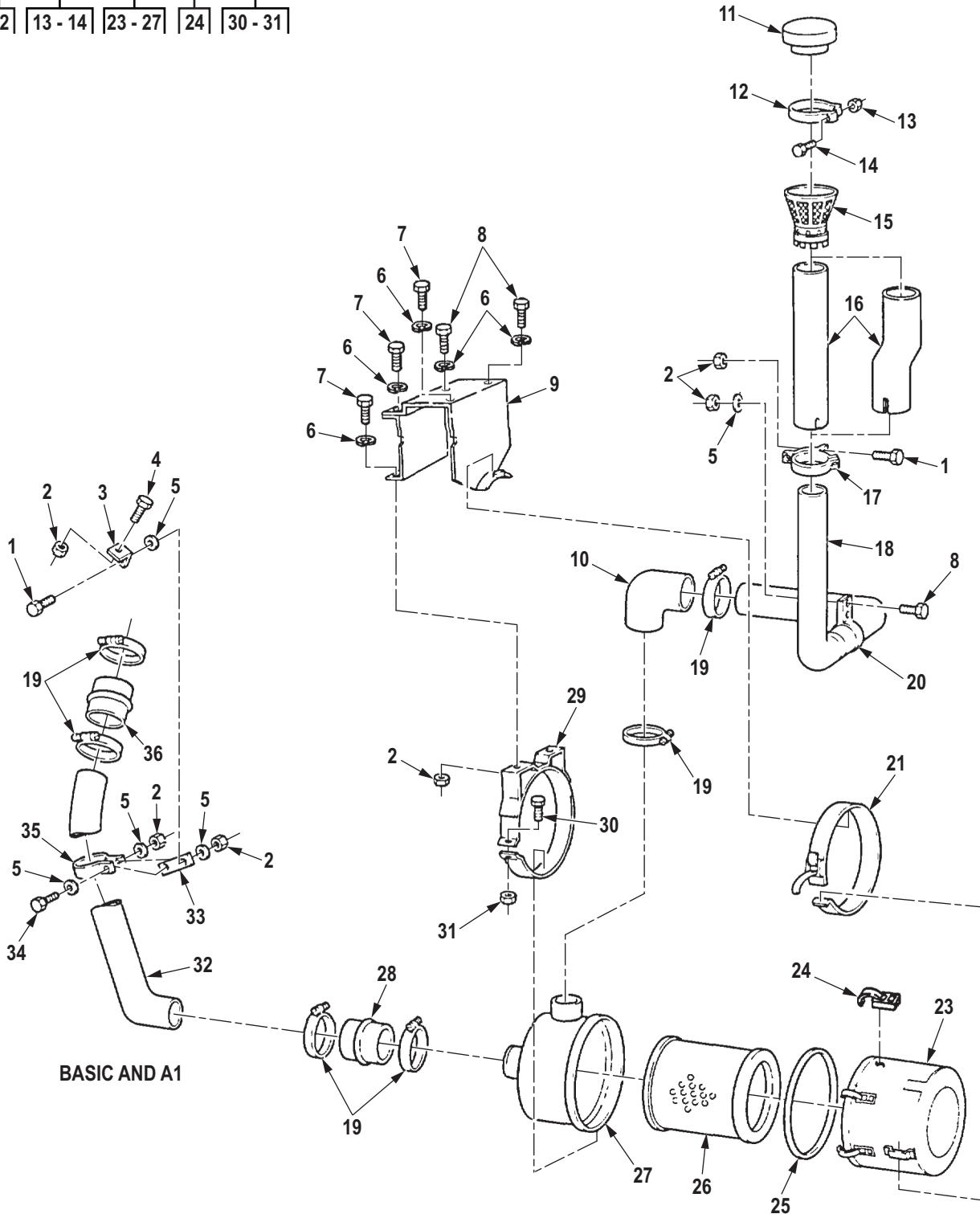

R0062DAA

Figure 62. Air Intake System.

(1) ITEM NO.	(2) SMR CODE	(3) NSN	(4) CAGEC	(5) PART NUMBER	(6) DESCRIPTION AND USABLE ON CODE (UOC)	(7) QTY
<b>GROUP 0304 AIR CLEANER.</b>						
<b>FIG. 62. AIR INTAKE SYSTEM.</b>						
1	PAFZZ	5305-00-269-2804	80205	MS90726-61	SCREW,CAP,HEXAGON H UOC: DAC,DAD,DAE,DAF,DAG,DA H,DAJ,DAL,DAW,DAX,V14,V15,V16, V17,V18,V19,V20,V21,V22,V24,ZAA, ZAB,ZAC,ZAD,ZAE,ZAF,ZAG,ZAH,Z AJ,ZAL .....	1
2	PAFZZ	5310-00-959-1488	81349	M45913/2-6FG5C	NUT,SELF-LOCKING,HE UOC: DAC,DAD,DAE,DAF,DAG,DA H,DAJ,DAL,DAW,DAX,V14,V15,V16, V17,V18,V19,V20,V21,V22,V24,ZAA, ZAB,ZAC,ZAD,ZAE,ZAF,ZAG,ZAH,Z AJ,ZAL .....	10
3	PFFZZ	5340-01-090-7627	19207	12256040	BRACKET,ANGLE UOC: DAC,DAD,DAE,DAF,DAG,DA H,DAJ,DAL,DAW,DAX .....	1
4	PAFZZ	5305-00-269-3235	80204	B1821BH038F088N	SCREW,CAP,HEXAGON H UOC: DAC,DAD,DAE,DAF,DAG,DA H,DAJ,DAL,DAW,DAX .....	1
5	PAFZZ	5310-00-087-7493	96906	MS27183-13	WASHER,FLAT UOC: DAC,DAD,DAE,DAF,DAG,DA H,DAJ,DAL,DAW,DAX,V14,V15,V16, V17,V18,V19,V20,V21,V22,V24,ZAA, ZAB,ZAC,ZAD,ZAE,ZAF,ZAG,ZAH,Z AJ,ZAL .....	2
6	PAFZZ	5310-00-637-9541	00198	132661	WASHER,LOCK UOC: DAC,DAD,DAE,DAF,DAG,DA H,DAJ,DAL,DAW,DAX,V14,V15,V16, V17,V18,V19,V20,V21,V22,V24,ZAA, ZAB,ZAC,ZAD,ZAE,ZAF,ZAG,ZAH,Z AJ,ZAL .....	5
7	PAFZZ	5305-00-269-2803	80205	MS90726-60	SCREW,CAP,HEXAGON H UOC: DAC,DAD,DAE,DAF,DAG,DA H,DAJ,DAL,DAW,DAX,V14,V15,V16, V17,V18,V19,V20,V21,V22,V24,ZAA, ZAB,ZAC,ZAD,ZAE,ZAF,ZAG,ZAH,Z AJ,ZAL .....	11
8	PAFZZ	5305-00-269-3238	80204	B1821BH038F125N	SCREW,CAP,HEXAGON H UOC: DAC,DAD,DAE,DAF,DAG,DA H,DAJ,DAL,DAW,DAX,V14,V15,V16, V17,V18,V19,V20,V21,V22,V24,ZAA, ZAB,ZAC,ZAD,ZAE,ZAF,ZAG,ZAH,Z AJ,ZAL .....	2

(1) ITEM NO.	(2) SMR CODE	(3) NSN	(4) CAGEC	(5) PART NUMBER	(6) DESCRIPTION AND USABLE ON CODE (UOC)	(7) QTY
9	PFZZ	5340-01-090-7628	19207	12256307	BRACKET,MOUNTING UOC: DAC,DAD,DAE,DAF,DAG,DA H,DAJ,DAL,DAW,DAX,V14,V15,V16, V17,V18,V19,V20,V21,V22,V24,ZAA, ZAB,ZAC,ZAD,ZAE,ZAF,ZAG,ZAH,Z AJ,ZAL .....	1
10	PAFZZ	4720-00-134-4655	19207	11664545	HOSE,PREFORMED UOC: DAC,DAD,DAE,DAF,DAG,DA H,DAJ,DAL,DAW,DAX,V14,V15,V16, V17,V18,V19,V20,V21,V22,V24,ZAA, ZAB,ZAC,ZAD,ZAE,ZAF,ZAG,ZAH,Z AJ,ZAL .....	1
11	PAFZZ	2940-01-129-0261	19207	11648582	CAP,AIR CLEANER INT UOC: DAC,DAD,DAE,DAF,DAG,DA H,DAJ,DAL,DAW,DAX,V14,V15,V16, V17,V18,V19,V20,V21,V22,V24,ZAA, ZAB,ZAC,ZAD,ZAE,ZAF,ZAG,ZAH,Z AJ,ZAL .....	1
12	PAFZZ	5340-01-107-9688	19207	11663037	. CLAMP,LOOP UOC: DAC,DAD,DAE,DAF,DAG,DA H,DAJ,DAL,DAW,DAX,V14,V15,V16, V17,V18,V19,V20,V21,V22,V24,ZAA, ZAB,ZAC,ZAD,ZAE,ZAF,ZAG,ZAH,Z AJ,ZAL .....	1
13	PAFZZ	5310-00-829-9981	96906	MS35649-2312	. . NUT,PLAIN,HEXAGON UOC: DAC,DAD,DAE,DAF,DAG,DA H,DAJ,DAL,DAW,DAX,V14,V15,V16, V17,V18,V19,V20,V21,V22,V24,ZAA, ZAB,ZAC,ZAD,ZAE,ZAF,ZAG,ZAH,Z AJ,ZAL .....	1
14	PAFZZ	5306-01-370-6947	96906	MS16207-26	. . BOLT,SQUARE NECK UOC: DAC,DAD,DAE,DAF,DAG,DA H,DAJ,DAL,DAW,DAX,V14,V15,V16, V17,V18,V19,V20,V21,V22,V24,ZAA, ZAB,ZAC,ZAD,ZAE,ZAF,ZAG,ZAH,Z AJ,ZAL .....	1
15	PAFZZ	2510-01-112-2170	19207	12277111	GRILLE,METAL UOC: DAG,DAH,V21,V22,ZAG,ZAH .....	1
16	PAFZZ	4710-01-090-4487	19207	12256314	TUBE,METALLIC BENT UOC: DAE,DAF,DAJ,V19,V20,V24,Z AE,ZAF,ZAJ .....	1
16	PAFZZ	4710-01-090-4584	19207	12256315	TUBE,METALLIC STRAIGHT UOC: DAC,DAD,DAL,DAW,DAX,V14 ,V15,V16,V17,V18,ZAA,ZAB,ZAC,ZA D,ZAG,ZAH,ZAL .....	1

(1) ITEM NO.	(2) SMR CODE	(3) NSN	(4) CAGEC	(5) PART NUMBER	(6) DESCRIPTION AND USABLE ON CODE (UOC)	(7) QTY
17	PAFZZ	5340-01-090-7650	19207	12255981	CLAMP,LOOP UOC: DAC,DAD,DAE,DAF,DAG,DA H,DAJ,DAL,DAW,DAX,V14,V15,V16, V17,V18,V19,V20,V21,V22,V24,ZAA, ZAB,ZAC,ZAD,ZAE,ZAF,ZAG,ZAH,Z AJ,ZAL .....	1
18	PAFZZ	4710-01-090-4486	19207	12256096	TUBE ASSEMBLY UOC: DAC,DAD,DAE,DAF,DAG,DA H,DAJ,DAL,DAW,DAX,V14,V15,V16, V17,V18,V19,V20,V21,V22,V24,ZAA, ZAB,ZAC,ZAD,ZAE,ZAF,ZAG,ZAH,Z AJ,ZAL .....	1
19	PAFZZ	4730-00-908-6294	58536	A-A-52506-F-104	CLAMP,HOSE UOC: DAC,DAD,DAE,DAF,DAG,DA H,DAJ,DAL,DAW,DAX,V14,V15,V16, V17,V18,V19,V20,V21,V22,V24,ZAA, ZAB,ZAC,ZAD,ZAE,ZAF,ZAG,ZAH,Z AJ,ZAL .....	6
20	PAFZZ	5340-01-090-7622	19207	12255862	CLAMP,LOOP UOC: DAC,DAD,DAE,DAF,DAG,DA H,DAJ,DAL,DAW,DAX,V14,V15,V16, V17,V18,V19,V20,V21,V22,V24,ZAA, ZAB,ZAC,ZAD,ZAE,ZAF,ZAG,ZAH,Z AJ,ZAL .....	1
21	PAFZZ	5340-01-090-7629	19207	12256312	BAND,RETAINING UOC: DAC,DAD,DAE,DAF,DAG,DA H,DAJ,DAL,DAW,DAX,V14,V15,V16, V17,V18,V19,V20,V21,V22,V24,ZAA, ZAB,ZAC,ZAD,ZAE,ZAF,ZAG,ZAH,Z AJ,ZAL .....	1
22	PFFZZ	2940-00-197-5364	19207	11604557	AIR CLEANER,INTAKE UOC: DAC,DAD,DAE,DAF,DAG,DA H,DAJ,DAL,DAW,DAX,V14,V15,V16, V17,V18,V19,V20,V21,V22,V24,ZAA, ZAB,ZAC,ZAD,ZAE,ZAF,ZAG,ZAH,Z AJ,ZAL .....	1
23	PFFZZ	2940-00-134-8326	19207	11648617	. AIR CLEANER,INTAKE UOC: DAC,DAD,DAE,DAF,DAG,DA H,DAJ,DAL,DAW,DAX,V14,V15,V16, V17,V18,V19,V20,V21,V22,V24,ZAA, ZAB,ZAC,ZAD,ZAE,ZAF,ZAG,ZAH,Z AJ,ZAL .....	1
24	PAFZZ	5342-00-833-1236	19207	11602023	. . LATCH,INTAKE AIR CL UOC: DAC,DAD,DAE,DAF,DAG,DA H,DAJ,DAL,DAW,DAX,V14,V15,V16, V17,V18,V19,V20,V21,V22,V24,ZAA, ZAB,ZAC,ZAD,ZAE,ZAF,ZAG,ZAH,Z AJ,ZAL .....	5

(1) ITEM NO.	(2) SMR CODE	(3) NSN	(4) CAGEC	(5) PART NUMBER	(6) DESCRIPTION AND USABLE ON CODE (UOC)	(7) QTY
25	PAFZZ	5330-00-432-2142	19207	11604520-5	. PACKING,PREFORMED PART OF KIT P/N 5702838 UOC: DAC,DAD,DAE,DAF,DAG,DA H,DAJ,DAL,DAW,DAX,V14,V15,V16, V17,V18,V19,V20,V21,V22,V24,ZAA, ZAB,ZAC,ZAD,ZAE,ZAF,ZAG,ZAH,Z AJ,ZAL .....	1
26	PAFZZ	2940-00-134-4657	19207	11604545	. FILTER ELEMENT,INTA PART OF KIT P/N 5702838 UOC: DAC,DAD,DAE,DAF,DAG,DA H,DAJ,DAL,DAW,DAX,V14,V15,V16, V17,V18,V19,V20,V21,V22,V24,ZAA, ZAB,ZAC,ZAD,ZAE,ZAF,ZAG,ZAH,Z AJ,ZAL .....	1
27	XDFZZ		19207	11664491	. AIR CLEANER,INTAKE UOC: DAC,DAD,DAE,DAF,DAG,DA H,DAJ,DAL,DAW,DAX,V14,V15,V16, V17,V18,V19,V20,V21,V22,V24,ZAA, ZAB,ZAC,ZAD,ZAE,ZAF,ZAG,ZAH,Z AJ,ZAL .....	1
28	PAFZZ	4720-00-477-8933	19207	11664544	HOSE,PREFORMED UOC: DAC,DAD,DAE,DAF,DAG,DA H,DAJ,DAL,DAW,DAX,V14,V15,V16, V17,V18,V19,V20,V21,V22,V24,ZAA, ZAB,ZAC,ZAD,ZAE,ZAF,ZAG,ZAH,Z AJ,ZAL .....	1
29	PAFZZ	2940-01-090-4480	19207	11664234-3	MOUNTING BAND UOC: DAC,DAD,DAE,DAF,DAG,DA H,DAJ,DAL,DAW,DAX,V14,V15,V16, V17,V18,V19,V20,V21,V22,V24,ZAA, ZAB,ZAC,ZAD,ZAE,ZAF,ZAG,ZAH,Z AJ,ZAL .....	1
30	PAFZZ	5305-00-225-9092	80205	MS90726-37	. SCREW,CAP,HEXAGON H UOC: DAC,DAD,DAE,DAF,DAG,DA H,DAJ,DAL,DAW,DAX,V14,V15,V16, V17,V18,V19,V20,V21,V22,V24,ZAA, ZAB,ZAC,ZAD,ZAE,ZAF,ZAG,ZAH,Z AJ,ZAL .....	1
31	PAFZZ	5310-00-982-4912	96906	MS21045-5	. NUT,SELF-LOCKING,HE UOC: DAC,DAD,DAE,DAF,DAG,DA H,DAJ,DAL,DAW,DAX,V14,V15,V16, V17,V18,V19,V20,V21,V22,V24,ZAA, ZAB,ZAC,ZAD,ZAE,ZAF,ZAG,ZAH,Z AJ,ZAL .....	1
32	PAFZZ	4710-01-090-7620	19207	12256045	PIPE,AIR CLEANER OU UOC: DAC,DAD,DAE,DAF,DAG,DA H,DAJ,DAL,DAW,DAX,V14,V15,V16, V17,V18,V19,V20,V21,V22,V24 .....	1



(1) ITEM NO.	(2) SMR CODE	(3) NSN	(4) CAGEC	(5) PART NUMBER	(6) DESCRIPTION AND USABLE ON CODE (UOC)	(7) QTY
33	PAFZZ	5340-01-112-2292	19207	12256042	BAND,RETAINING UOC: DAC,DAD,DAE,DAF,DAG,DA H,DAJ,DAL,DAW,DAX,V14,V15,V16, V17,V18,V19,V20,V21,V22,V24 .....	1
34	PAFZZ	5305-00-269-3239	80204	B1821BH038F138N	SCREW,CAP,HEXAGON H UOC: DAC,DAD,DAE,DAF,DAG,DA H,DAJ,DAL,DAW,DAX,V14,V15,V16, V17,V18,V19,V20,V21,V22,V24 .....	1
35	PAFZZ	5340-01-090-7619	19207	12256031-2	CLAMP,LOOP UOC: DAC,DAD,DAE,DAF,DAG,DA H,DAJ,DAL,DAW,DAX,V14,V15,V16, V17,V18,V19,V20,V21,V22,V24 .....	1
36	PAFZZ	4720-01-090-7617	19207	12256068	HOSE,PREFORMED UOC: DAC,DAD,DAE,DAF,DAG,DA H,DAJ,DAL,DAW,DAX,V14,V15,V16, V17,V18,V19,V20,V21,V22,V24 .....	1

END OF FIGURE



**FIELD MAINTENANCE  
AIR INTAKE SYSTEM (M939A2)**

---

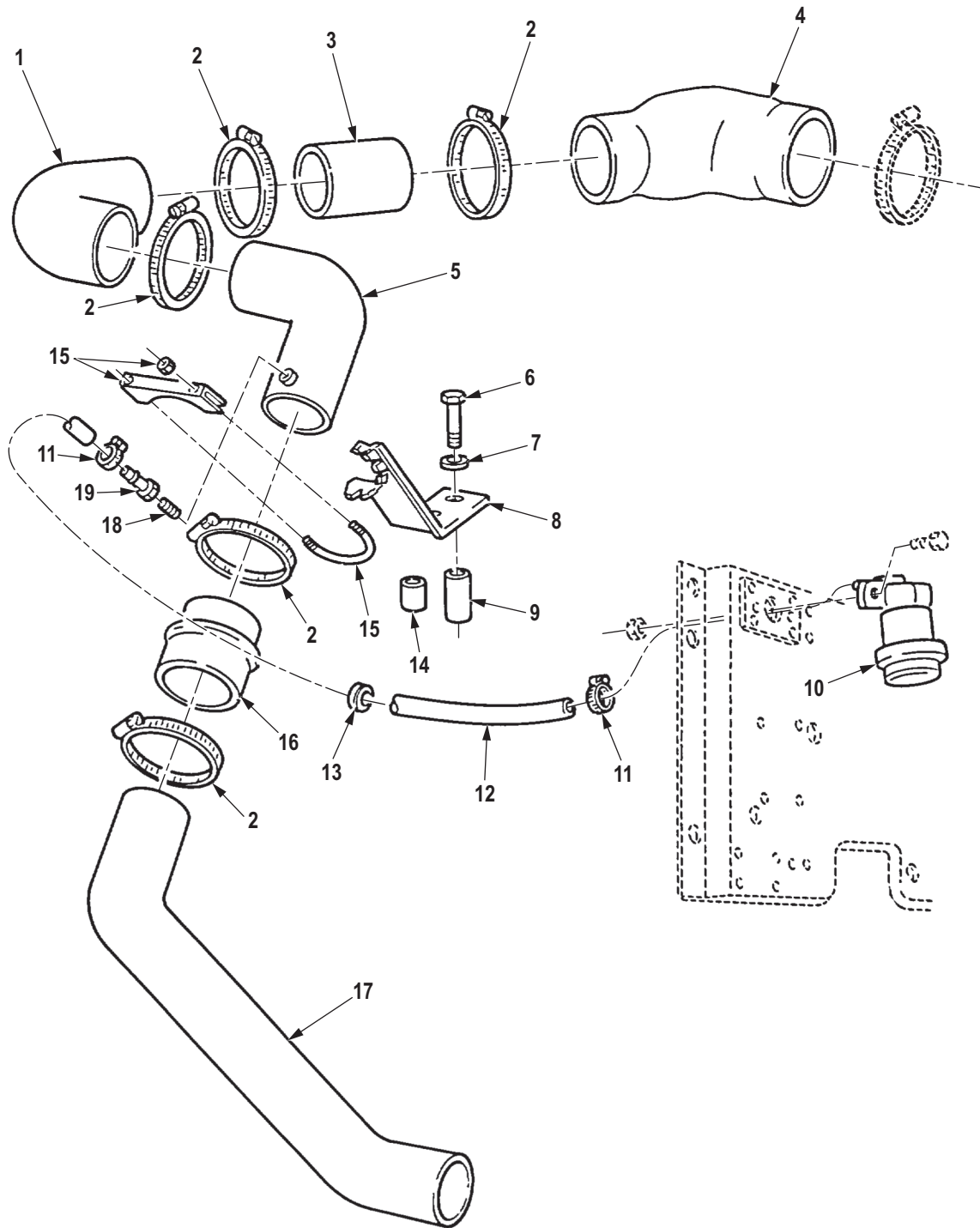

R0063DAA

Figure 63. Air Intake System (M939A2).

(1) ITEM NO.	(2) SMR CODE	(3) NSN	(4) CAGEC	(5) PART NUMBER	(6) DESCRIPTION AND USABLE ON CODE (UOC)	(7) QTY
<b>GROUP 0304 AIR CLEANER.</b>						
<b>FIG. 63. AIR INTAKE SYSTEM (M939A2).</b>						
1	PAFZZ	4720-01-279-3171	98441	38221-64-01-RN	HOSE,PREFORMED UOC: ZAA,ZAB,ZAC,ZAD,ZAE,ZAF, ZAG,ZAH,ZAJ,ZAL .....	1
2	PAFZZ	4730-00-908-6294	58536	A-A-52506-F-104	CLAMP,HOSE UOC: ZAA,ZAB,ZAC,ZAD,ZAE,ZAF, ZAG,ZAH,ZAJ,ZAL .....	5
3	PAFZZ	4710-01-279-1490	1HT81	Q46545	TUBE,METALLIC UOC: ZAA,ZAB,ZAC,ZAD,ZAE,ZAF, ZAG,ZAH,ZAJ,ZAL .....	1
4	PAFZZ	4720-01-285-6312	15434	3037625	HOSE,PREFORMED UOC: ZAA,ZAB,ZAC,ZAD,ZAE,ZAF, ZAG,ZAH,ZAJ,ZAL .....	1
5	PAFZZ	4710-01-279-1493	05MG0	20510090	TUBE,BENT,METALLIC UOC: ZAA,ZAB,ZAC,ZAD,ZAE,ZAF, ZAG,ZAH,ZAJ,ZAL .....	1
6	PAFZZ	5305-01-271-8381	24617	11501092	SCREW,CAP,HEXAGON H HEAD M12X130.0 MM. LG UOC: ZAA,ZAB,ZAC,ZAD,ZAE,ZAF, ZAG,ZAH,ZAJ,ZAL .....	2
7	PAFZZ	5310-01-286-6075	24617	11511516	WASHER,FLAT UOC: ZAA,ZAB,ZAC,ZAD,ZAE,ZAF, ZAG,ZAH,ZAJ,ZAL .....	2
8	PAFZZ	5340-01-280-7098	05MG0	20510807	BRACKET,MOUNTING UOC: ZAA,ZAB,ZAC,ZAD,ZAE,ZAF, ZAG,ZAH,ZAJ,ZAL .....	1
9	PAFZZ	5365-01-280-3668	05MG0	20510492-1	SPACER,SLEEVE UOC: ZAA,ZAB,ZAC,ZAD,ZAE,ZAF, ZAG,ZAH,ZAJ,ZAL .....	1
10	PAFZZ	5220-01-317-1436	59150	AD35501-00825	MINDER,FILTER UOC: ZAA,ZAB,ZAC,ZAD,ZAE,ZAF, ZAG,ZAH,ZAJ,ZAL .....	1
11	PAFZZ	4730-00-374-2045	70494	A6S	CLAMP,HOSE UOC: ZAA,ZAB,ZAC,ZAD,ZAE,ZAF, ZAG,ZAH,ZAJ,ZAL .....	2
12	MFFZZ		19207	12277246 X 40 IN	TUBING MAKE FROM TUBING, P/ N 1448 (99227), 40 IN.LONG UOC: ZAA,ZAB,ZAC,ZAD,ZAE,ZAF, ZAG,ZAH,ZAJ,ZAL .....	1
13	PAFZZ	5325-00-174-5315	96906	MS35489-7	GROMMET,NONMETALLIC UOC: ZAA,ZAB,ZAC,ZAD,ZAE,ZAF, ZAG,ZAH,ZAJ,ZAL .....	1
14	PAFZZ	5365-01-280-9432	05MG0	20510492-2	SPACER,SLEEVE UOC: ZAA,ZAB,ZAC,ZAD,ZAE,ZAF, ZAG,ZAH,ZAJ,ZAL .....	1

(1) ITEM NO.	(2) SMR CODE	(3) NSN	(4) CAGEC	(5) PART NUMBER	(6) DESCRIPTION AND USABLE ON CODE (UOC)	(7) QTY
15	PAFZZ	5340-01-272-1471	96906	MS52150-37HE	CLAMP, LOOP UOC: ZAA, ZAB, ZAC, ZAD, ZAE, ZAF, ZAG, ZAH, ZAJ, ZAL .....	1
16	PAFZZ	4720-01-305-2440	05MG0	20510087	HOSE, PREFORMED UOC: ZAA, ZAB, ZAC, ZAD, ZAE, ZAF, ZAG, ZAH, ZAJ, ZAL .....	1
17	PAFZZ	2805-01-279-4630	1HT81	Q45405	PIPE, INTAKE UOC: ZAA, ZAB, ZAC, ZAD, ZAE, ZAF, ZAG, ZAH, ZAJ, ZAL .....	1
18	PAFZZ	2910-00-911-5635	19207	8712058	FILTER, FLUID UOC: ZAA, ZAB, ZAC, ZAD, ZAE, ZAF, ZAG, ZAH, ZAJ, ZAL .....	1
19	PAFZZ	4730-01-443-2888	05MG0	12363593	ADAPTER, STRAIGHT, PI UOC: ZAA, ZAB, ZAC, ZAD, ZAE, ZAF, ZAG, ZAH, ZAJ, ZAL .....	1

END OF FIGURE

**FIELD MAINTENANCE  
TURBOCHARGER HOSES AND CLAMPS (M939A2)**

---

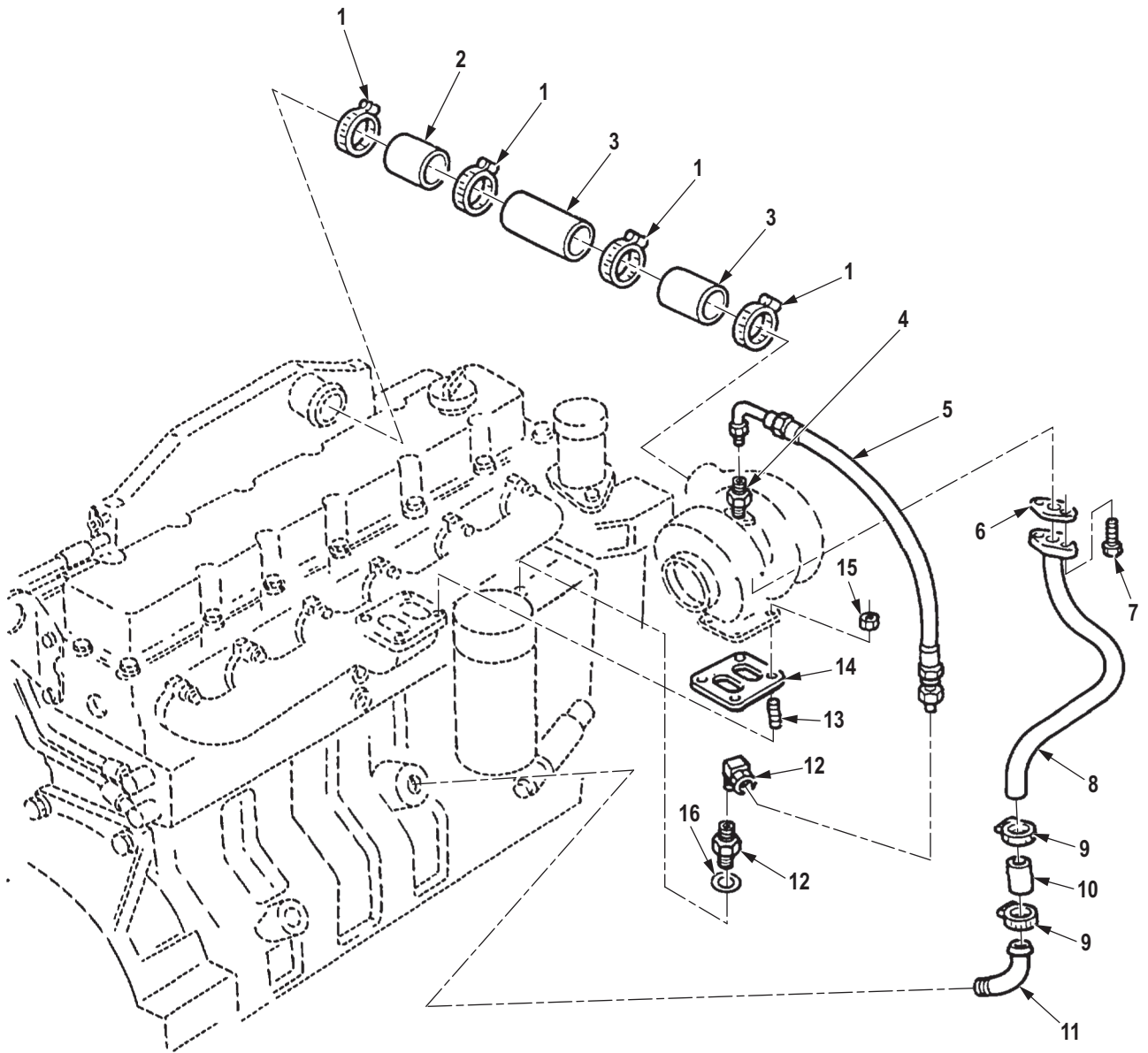

R0064DAA

Figure 64. Turbocharger Hoses and Clamps (M939A2).



(1) ITEM NO.	(2) SMR CODE	(3) NSN	(4) CAGEC	(5) PART NUMBER	(6) DESCRIPTION AND USABLE ON CODE (UOC)	(7) QTY
					<b>GROUP 0305 SUPERCHARGER, BLOWER, TURBOCHARGER OR ALTITUDE COMPENSATOR.</b>	
					<b>FIG. 64. TURBOCHARGER HOSES AND CLAMPS (M939A2).</b>	
1	PAFZZ	4730-01-110-0342	15434	3026396	CLAMP,HOSE UOC: ZAA,ZAB,ZAC,ZAD,ZAE,ZAF, ZAG,ZAH,ZAJ,ZAL .....	4
2	PAFZZ	4710-01-271-7938	15434	3914943	TUBE,METALLIC UOC: ZAA,ZAB,ZAC,ZAD,ZAE,ZAF, ZAG,ZAH,ZAJ,ZAL .....	1
3	PAFZZ	4720-01-271-6951	15434	397040300	HOSE,NONMETALLIC UOC: ZAA,ZAB,ZAC,ZAD,ZAE,ZAF, ZAG,ZAH,ZAJ,ZAL .....	2
4	PAFZZ	4730-00-289-1254	81343	SAE J512 6-4 040102B	ADAPTER,STRAIGHT,PI UOC: ZAA,ZAB,ZAC,ZAD,ZAE,ZAF, ZAG,ZAH,ZAJ,ZAL .....	1
5	PAFZZ	4720-01-331-8717	15434	392153000	HOSE ASSEMBLY,NONME AFTER ENGINE S/N 44487830 UOC: ZAA,ZAB,ZAC,ZAD,ZAE,ZAF, ZAG,ZAH,ZAJ,ZAL .....	1
5	PAFZZ	4720-01-271-6945	15434	3909545	HOSE ASSEMBLY,NONME UP TO ENGINE S/N 44487829 UOC: ZAA,ZAB,ZAC,ZAD,ZAE,ZAF, ZAG,ZAH,ZAJ,ZAL .....	1
6	PAFZZ	5330-01-190-1905	15434	3914388	GASKET PART OF KIT P/N 3802622, PART OF KIT P/N 3800748, PART OF KIT P/N 402527100 UOC: ZAA,ZAB,ZAC,ZAD,ZAE,ZAF, ZAG,ZAH,ZAJ,ZAL .....	1
7	PAFZZ	5305-01-237-4915	15434	3900629	SCREW,CAP,HEXAGON H UOC: ZAA,ZAB,ZAC,ZAD,ZAE,ZAF, ZAG,ZAH,ZAJ,ZAL .....	2
8	PAFZZ	4710-01-193-7944	86403	4429 744	TUBE,BENT,METALLIC UOC: ZAA,ZAB,ZAC,ZAD,ZAE,ZAF, ZAG,ZAH,ZAJ,ZAL .....	1
9	PAFZZ	4730-00-555-8263	53496	556-1-1-2A	CLAMP,HOSE UOC: ZAA,ZAB,ZAC,ZAD,ZAE,ZAF, ZAG,ZAH,ZAJ,ZAL .....	2
10	PAFZZ	4720-01-271-6946	15434	3286499	HOSE,NONMETALLIC UOC: ZAA,ZAB,ZAC,ZAD,ZAE,ZAF, ZAG,ZAH,ZAJ,ZAL .....	1
11	PAFZZ	4710-01-271-7941	15434	3917417	TUBE,BENT,METALLIC UOC: ZAA,ZAB,ZAC,ZAD,ZAE,ZAF, ZAG,ZAH,ZAJ,ZAL .....	1

(1) ITEM NO.	(2) SMR CODE	(3) NSN	(4) CAGEC	(5) PART NUMBER	(6) DESCRIPTION AND USABLE ON CODE (UOC)	(7) QTY
12	PAFZZ	4730-00-277-8274	12204	137423	ELBOW,PIPE TO TUBE UP TO ENGINE S/N 44487829,USE WITH HOSE P/N 3909545 UOC: ZAA,ZAB,ZAC,ZAD,ZAE,ZAF, ZAG,ZAH,ZAJ,ZAL .....	1
12	XDFZZ	4730-01-333-0133	U5612	CBU1730	ADAPTER,STRAIGHT,TU AFTER ENGINE S/N 44487830,USE WITH HOSE P/N 3918556 UOC: ZAA,ZAB,ZAC,ZAD,ZAE,ZAF, ZAG,ZAH,ZAJ,ZAL .....	1
13	PAFZZ	5307-01-287-0854	7U263	3818823	STUD,PLAIN UOC: ZAA,ZAB,ZAC,ZAD,ZAE,ZAF, ZAG,ZAH,ZAJ,ZAL .....	4
14	PAFZZ	5330-01-272-1146	15434	3911941	GASKET PART OF KIT P/N 3802622, PART OF KIT P/N 3800748, PART OF KIT P/N 402527100, PART OF KIT P/N 3802149 UOC: ZAA,ZAB,ZAC,ZAD,ZAE,ZAF, ZAG,ZAH,ZAJ,ZAL .....	1
15	PAFZZ	5310-01-270-8244	15434	380188800	NUT,PLAIN,HEXAGON UOC: ZAA,ZAB,ZAC,ZAD,ZAE,ZAF, ZAG,ZAH,ZAJ,ZAL .....	4
16	PAFZZ	5331-01-331-9293	15434	3037236	O-RING AFTER ENGINE S/N 44487830,USE WITH HOSE P/N 3918556 UOC: ZAA,ZAB,ZAC,ZAD,ZAE,ZAF, ZAG,ZAH,ZAJ,ZAL .....	1

END OF FIGURE

**FIELD MAINTENANCE  
TURBOCHARGER ASSEMBLY (M939A2)**

---

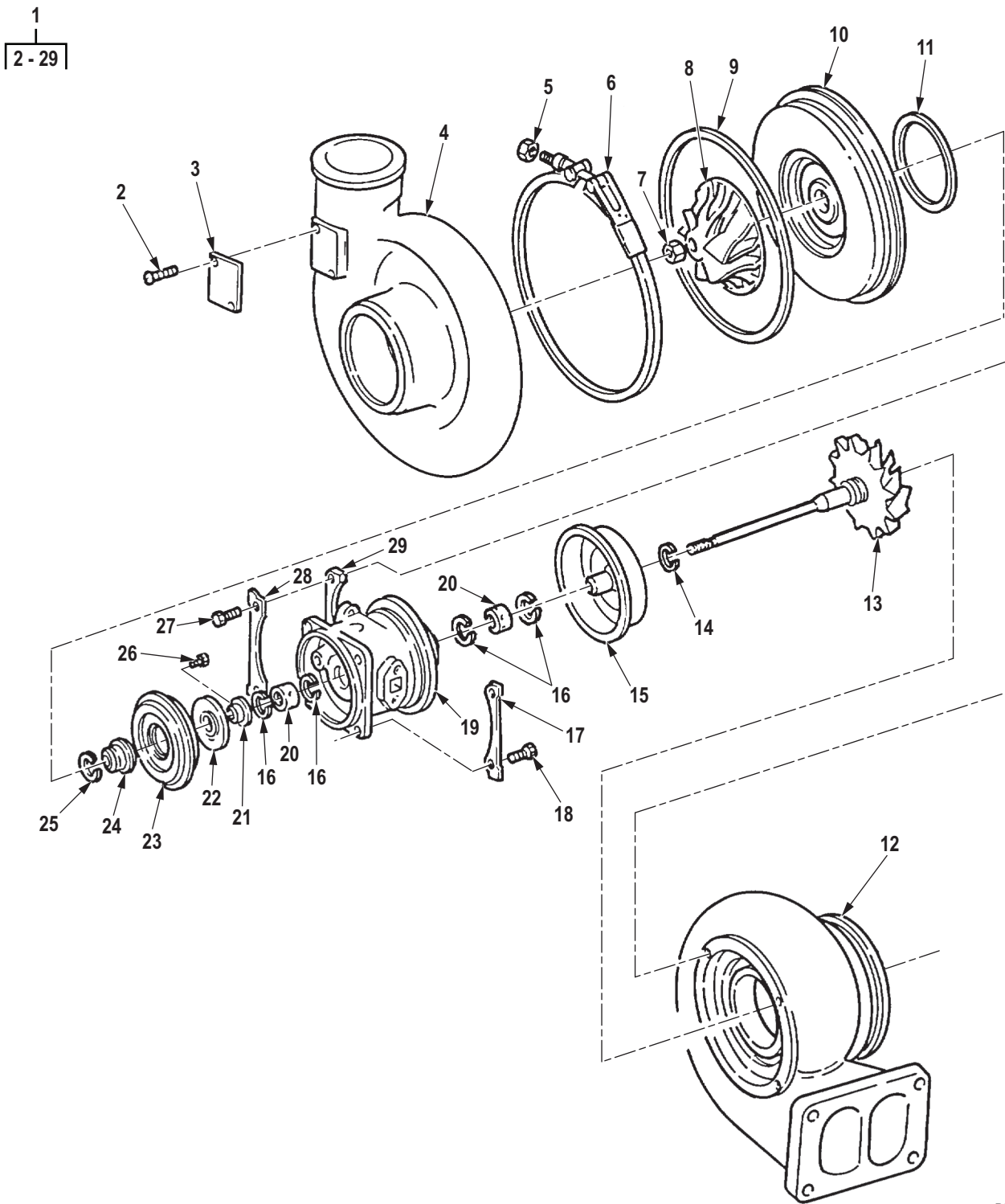

R0065DAA

Figure 65. Turbocharger Assembly (M939A2).

(1) ITEM NO.	(2) SMR CODE	(3) NSN	(4) CAGEC	(5) PART NUMBER	(6) DESCRIPTION AND USABLE ON CODE (UOC)	(7) QTY
					<b>GROUP 0305 SUPERCHARGER, BLOWER, TURBOCHARGER OR ALTITUDE COMPENSATOR.</b>	
					<b>FIG. 65. TURBOCHARGER ASSEMBLY (M939A2).</b>	
1	PAFHH	2990-01-446-5359	15434	3802257	TURBOCHARGER,ENGINE AFTER ENGINE S/N 44487830 UOC: ZAA,ZAB,ZAC,ZAD,ZAE,ZAF, ZAG,ZAH,ZAJ,ZAL .....	1
2	PAFZZ	5305-01-271-8375	15434	3519163	. SCREW,DRIVE UOC: ZAA,ZAB,ZAC,ZAD,ZAE,ZAF, ZAG,ZAH,ZAJ,ZAL .....	2
3	PAFZZ	9905-01-279-4690	15434	3519905	. PLATE,MARKING,BLANK UOC: ZAA,ZAB,ZAC,ZAD,ZAE,ZAF, ZAG,ZAH,ZAJ,ZAL .....	1
4	PAHZZ	2950-01-271-2341	0B853	3525359	. HOUSING,COMPRESSOR UOC: ZAA,ZAB,ZAC,ZAD,ZAE,ZAF, ZAG,ZAH,ZAJ,ZAL .....	1
5	PAHZZ	5310-01-270-8245	15434	3529372	. NUT,PLAIN,HEXAGON UOC: ZAA,ZAB,ZAC,ZAD,ZAE,ZAF, ZAG,ZAH,ZAJ,ZAL .....	1
6	PAHZZ	5340-01-271-2471	15434	3521832	. BAND,RETAINING UOC: ZAA,ZAB,ZAC,ZAD,ZAE,ZAF, ZAG,ZAH,ZAJ,ZAL .....	1
7	PAHZZ	5310-01-288-5690	15434	3503562	. NUT,SELF-LOCKING,HE PART OF KIT P/N 3545528, PART OF KIT P/ N 3545745, PART OF KIT P/N 3802149 UOC: ZAA,ZAB,ZAC,ZAD,ZAE,ZAF, ZAG,ZAH,ZAJ,ZAL .....	1
8	KBHZZ	2930-01-287-4444	45152	3525358	. IMPELLER, TURBO PART OF KIT P/N 3545528, PART OF KIT P/N 3545745 UOC: ZAA,ZAB,ZAC,ZAD,ZAE,ZAF, ZAG,ZAH,ZAJ,ZAL .....	1
9	PAHZZ	5331-01-272-1125	15434	3523958	. O-RING UOC: ZAA,ZAB,ZAC,ZAD,ZAE,ZAF, ZAG,ZAH,ZAJ,ZAL .....	1
10	PAHZZ	2950-01-271-2342	15434	3522801	. DIFFUSER,SPECIAL UOC: ZAA,ZAB,ZAC,ZAD,ZAE,ZAF, ZAG,ZAH,ZAJ,ZAL .....	1
11	PAHZZ	5330-01-272-1250	15434	3502449	. SEAL RING,METAL PART OF KIT P/N 3802149 UOC: ZAA,ZAB,ZAC,ZAD,ZAE,ZAF, ZAG,ZAH,ZAJ,ZAL .....	1
12	PAHZZ	2815-01-272-5422	15434	3525130	. HOUSING,SUPERCHARGE UP TO ENGINE S/N 44487829 UOC: ZAA,ZAB,ZAC,ZAD,ZAE,ZAF, ZAG,ZAH,ZAJ,ZAL .....	1

(1) ITEM NO.	(2) SMR CODE	(3) NSN	(4) CAGEC	(5) PART NUMBER	(6) DESCRIPTION AND USABLE ON CODE (UOC)	(7) QTY
12	PAHZZ	2815-01-332-5462	15434	3527122	. HOUSING,SUPERCHARGE AFTER ENGINE S/N 44487830 UOC: ZAA,ZAB,ZAC,ZAD,ZAE,ZAF, ZAG,ZAH,ZAJ,ZAL .....	1
13	KBHZZ		15434	3522879	. SHAFT & WHEEL ASSY. AFTER ENGINE S/N 44487830 PART OF KIT P/N 3545745 UOC: ZAA,ZAB,ZAC,ZAD,ZAE,ZAF, ZAG,ZAH,ZAJ,ZAL .....	1
13	KBHZZ		15434	3522880	. SHAFT & WHEEL ASSY. UP TO ENGINE S/N 44487829 PART OF KIT P/N 3545528 UOC: ZAA,ZAB,ZAC,ZAD,ZAE,ZAF, ZAG,ZAH,ZAJ,ZAL .....	1
14	PAHZZ	5330-01-203-3612	15434	3756754	. SEAL PART OF KIT P/N 3802149 UOC: ZAA,ZAB,ZAC,ZAD,ZAE,ZAF, ZAG,ZAH,ZAJ,ZAL .....	1
15	PAHZZ	2950-01-271-2511	15434	3519302	. SHIELD,HEAT,TURBINE UOC: ZAA,ZAB,ZAC,ZAD,ZAE,ZAF, ZAG,ZAH,ZAJ,ZAL .....	1
16	PAHZZ	5325-01-270-8361	15434	3762259	. RING,RETAINING PART OF KIT P/N 3802149 UOC: ZAA,ZAB,ZAC,ZAD,ZAE,ZAF, ZAG,ZAH,ZAJ,ZAL .....	4
17	PAHZZ	5340-01-271-2504	15434	3502066	. PLATE,RETAINING,SEA PART OF KIT P/N 3802149 UOC: ZAA,ZAB,ZAC,ZAD,ZAE,ZAF, ZAG,ZAH,ZAJ,ZAL .....	2
18	PAHZZ	5305-01-271-8379	15434	3522827	. SCREW,CAP,HEXAGON H UOC: ZAA,ZAB,ZAC,ZAD,ZAE,ZAF, ZAG,ZAH,ZAJ,ZAL .....	4
19	PAHZZ	3130-01-372-3522	15434	3530591	. HOUSING,BEARING UNI UP TO ENGINE S/N 44487829 UOC: ZAA,ZAB,ZAC,ZAD,ZAE,ZAF, ZAG,ZAH,ZAJ,ZAL .....	1
19	PAHZZ	3130-01-331-7182	15434	353059200	. HOUSING,BEARING UNI AFTER ENGINE S/N 44487830 UOC: ZAA,ZAB,ZAC,ZAD,ZAE,ZAF, ZAG,ZAH,ZAJ,ZAL .....	1
20	PAHZZ	3120-01-272-3270	15434	3503100	. BEARING,SLEEVE PART OF KIT P/N 3802149 UOC: ZAA,ZAB,ZAC,ZAD,ZAE,ZAF, ZAG,ZAH,ZAJ,ZAL .....	2
21	KBHZZ	3040-01-289-1636	7U263	3518980	. COLLAR, THRUST PART OF KIT P/N 3545528, PART OF KIT P/N 3545745 UOC: ZAA,ZAB,ZAC,ZAD,ZAE,ZAF, ZAG,ZAH,ZAJ,ZAL .....	1

(1) ITEM NO.	(2) SMR CODE	(3) NSN	(4) CAGEC	(5) PART NUMBER	(6) DESCRIPTION AND USABLE ON CODE (UOC)	(7) QTY
22	PAHZZ	3120-01-272-3269	15434	3525739	. BEARING,SLEEVE UOC: ZAA,ZAB,ZAC,ZAD,ZAE,ZAF, ZAG,ZAH,ZAJ,ZAL .....	1
23	PAHZZ	2950-01-211-0163	0B8S3	3503668	. BAFFLE,OIL UOC: ZAA,ZAB,ZAC,ZAD,ZAE,ZAF, ZAG,ZAH,ZAJ,ZAL .....	1
24	KBHZZ	2950-01-465-2646	15434	3503662	. SLINGER, OIL PART OF KIT P/ N 3545528, PART OF KIT P/N 3545745 UOC: ZAA,ZAB,ZAC,ZAD,ZAE,ZAF, ZAG,ZAH,ZAJ,ZAL .....	1
25	PAHZZ	5330-01-213-1258	15434	3758848	. SEAL PART OF KIT P/N 3802149 UOC: ZAA,ZAB,ZAC,ZAD,ZAE,ZAF, ZAG,ZAH,ZAJ,ZAL .....	1
26	PAHZZ	5305-01-292-3182	15434	3503347	. SCREW,MACHINE PART OF KIT P/N 3802149 UOC: ZAA,ZAB,ZAC,ZAD,ZAE,ZAF, ZAG,ZAH,ZAJ,ZAL .....	3
27	PAHZZ	5305-01-272-3305	15434	3759917	. SETSCREW PART OF KIT P/N 3802149 UOC: ZAA,ZAB,ZAC,ZAD,ZAE,ZAF, ZAG,ZAH,ZAJ,ZAL .....	4
28	PAHZZ	5340-01-271-2505	15434	3501102	. PLATE,RETAINING,SEA PART OF KIT P/N 3802149 UOC: ZAA,ZAB,ZAC,ZAD,ZAE,ZAF, ZAG,ZAH,ZAJ,ZAL .....	2
29	PAHZZ	5342-01-271-2343	15434	3501188	. PLATE,CLAMPING UOC: ZAA,ZAB,ZAC,ZAD,ZAE,ZAF, ZAG,ZAH,ZAJ,ZAL .....	2

END OF FIGURE





**FIELD MAINTENANCE  
FUEL CROSSOVER, DRAIN, AND BYPASS TUBING**

---

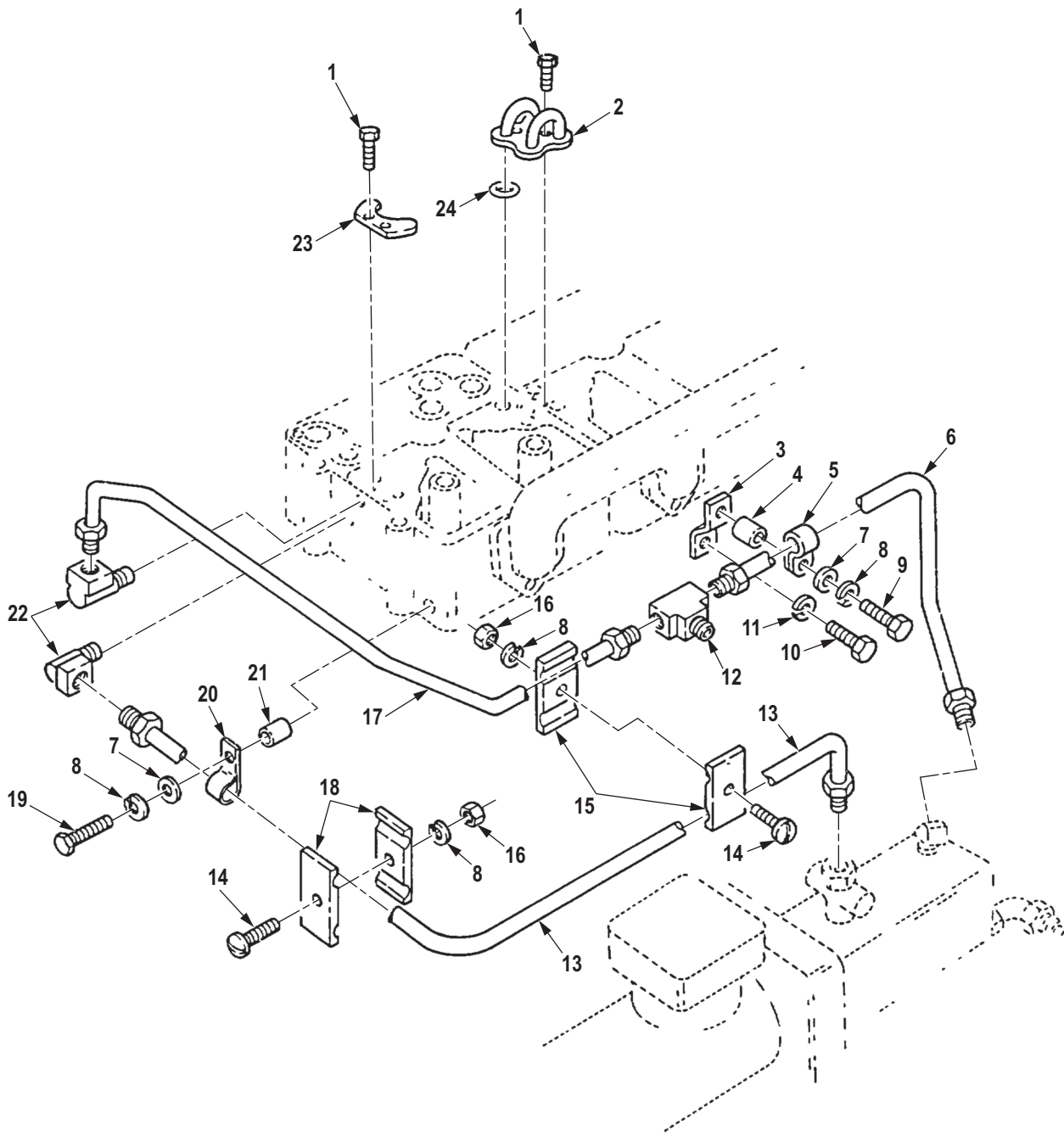

R0066DAA

Figure 66. Fuel Crossover, Drain, and Bypass Tubing.

(1) ITEM NO.	(2) SMR CODE	(3) NSN	(4) CAGEC	(5) PART NUMBER	(6) DESCRIPTION AND USABLE ON CODE (UOC)	(7) QTY
<b>GROUP 0306 TANKS, LINES, FITTINGS, HEADERS.</b>						
<b>FIG. 66. FUEL CROSSOVER, DRAIN, AND BYPASS TUBING.</b>						
1	PAFZZ	5305-00-477-6769	15434	70772	SCREW,ASSEMBLED WAS UOC: DAC,DAD,DAE,DAF,DAG,DA H,DAJ,DAL,DAW,DAX,V14,V15,V16, V17,V18,V19,V20,V21,V22,V24 .....	12
2	PAFZZ	2910-00-928-3505	15434	147100	CROSSOVER,FUEL UOC: DAC,DAD,DAE,DAF,DAG,DA H,DAJ,DAL,DAW,DAX,V14,V15,V16, V17,V18,V19,V20,V21,V22,V24 .....	2
3	PAFZZ	5340-01-203-9261	15434	3033098	BRACKET,DOUBLE ANGL UOC: DAC,DAD,DAE,DAF,DAG,DA H,DAJ,DAL,DAW,DAX,V14,V15,V16, V17,V18,V19,V20,V21,V22,V24 .....	1
4	PAFZZ	5365-01-221-8749	15434	3019301	SPACER,SLEEVE UOC: DAC,DAD,DAE,DAF,DAG,DA H,DAJ,DAL,DAW,DAX,V14,V15,V16, V17,V18,V19,V20,V21,V22,V24 .....	1
5	PAFZZ	5340-00-719-4601	15434	180372	CLAMP,LOOP UOC: DAC,DAD,DAE,DAF,DAG,DA H,DAJ,DAL,DAW,DAX,V14,V15,V16, V17,V18,V19,V20,V21,V22,V24 .....	1
6	PAFZZ	4710-01-218-6950	15434	3009846	TUBE ASSEMBLY,METAL UOC: DAC,DAD,DAE,DAF,DAG,DA H,DAJ,DAL,DAW,DAX,V14,V15,V16, V17,V18,V19,V20,V21,V22,V24 .....	1
7	PAFZZ	5310-00-562-6560	15434	S631	WASHER,FLAT UOC: DAC,DAD,DAE,DAF,DAG,DA H,DAJ,DAL,DAW,DAX,V14,V15,V16, V17,V18,V19,V20,V21,V22,V24 .....	2
8	PAFZZ	5310-00-159-6209	96906	MS122032	WASHER,LOCK UOC: DAC,DAD,DAE,DAF,DAG,DA H,DAJ,DAL,DAW,DAX,V14,V15,V16, V17,V18,V19,V20,V21,V22,V24 .....	4
9	PAFZZ	5305-00-068-0509	80204	B1821BH025C125N	SCREW,CAP,HEXAGON H UOC: DAC,DAD,DAE,DAF,DAG,DA H,DAJ,DAL,DAW,DAX,V14,V15,V16, V17,V18,V19,V20,V21,V22,V24 .....	1
10	PAFZZ	5305-00-795-9345	15434	S190C	SCREW,CAP,HEXAGON H UOC: DAC,DAD,DAE,DAF,DAG,DA H,DAJ,DAL,DAW,DAX,V14,V15,V16, V17,V18,V19,V20,V21,V22,V24 .....	1

(1) ITEM NO.	(2) SMR CODE	(3) NSN	(4) CAGEC	(5) PART NUMBER	(6) DESCRIPTION AND USABLE ON CODE (UOC)	(7) QTY
11	PAFZZ	5310-00-261-7340	18876	103221	WASHER,LOCK UOC: DAC,DAD,DAE,DAF,DAG,DA H,DAJ,DAL,DAW,DAX,V14,V15,V16, V17,V18,V19,V20,V21,V22,V24 .....	1
12	PAFZZ	4730-01-078-2731	15434	20972600	TEE,TUBE UOC: DAC,DAD,DAE,DAF,DAG,DA H,DAJ,DAL,DAW,DAX,V14,V15,V16, V17,V18,V19,V20,V21,V22,V24 .....	1
13	PAFZZ	4710-01-218-6952	15434	3035616	TUBE ASSEMBLY,METAL UOC: DAC,DAD,DAE,DAF,DAG,DA H,DAJ,DAW,DAX,V14,V15,V16,V17, V19,V20,V21,V22,V24 .....	1
13	PAFZZ	4710-01-218-6951	15434	3035612	TUBE ASSEMBLY,METAL UOC: DAL,V18 .....	1
14	PAFZZ	5305-00-757-6567	15434	S1315	SCREW,MACHINE UOC: DAC,DAD,DAE,DAF,DAG,DA H,DAJ,DAL,DAW,DAX,V14,V15,V16, V17,V18,V19,V20,V21,V22,V24 .....	2
15	PAFZZ	5340-01-246-6172	15434	3007025	STRAP,RETAINING UOC: DAC,DAD,DAE,DAF,DAG,DA H,DAJ,DAL,DAW,DAX,V14,V15,V16, V17,V18,V19,V20,V21,V22,V24 .....	2
16	PAFZZ	5310-00-971-7989	96906	MS35691-5	NUT,PLAIN,HEXAGON UOC: DAC,DAD,DAE,DAF,DAG,DA H,DAJ,DAL,DAW,DAX,V14,V15,V16, V17,V18,V19,V20,V21,V22,V24 .....	2
17	PAFZZ	4710-01-218-6949	15434	3035614	TUBE ASSEMBLY,METAL UOC: DAC,DAD,DAE,DAF,DAG,DA H,DAJ,DAL,DAW,DAX,V14,V15,V16, V17,V18,V19,V20,V21,V22,V24 .....	1
18	PAFZZ	4730-01-070-6667	15434	3007024	CLAMP HALF,DOUBLE,H UOC: DAC,DAD,DAE,DAF,DAG,DA H,DAJ,DAL,DAW,DAX,V14,V15,V16, V17,V18,V19,V20,V21,V22,V24 .....	2
19	PAFZZ	5305-00-071-2505	80204	B1821BH025C088N	SCREW,CAP,HEXAGON H UOC: DAC,DAD,DAE,DAF,DAG,DA H,DAJ,DAL,DAW,DAX,V14,V15,V16, V17,V18,V19,V20,V21,V22,V24 .....	1
20	PAFZZ	5340-01-079-8097	15434	180371	CLAMP,LOOP UOC: DAC,DAD,DAE,DAF,DAG,DA H,DAJ,DAL,DAW,DAX,V14,V15,V16, V17,V18,V19,V20,V21,V22,V24 .....	1
21	PAFZZ	5365-00-203-1281	15434	114850	SPACER,SPECIAL UOC: DAC,DAD,DAE,DAF,DAG,DA H,DAJ,DAL,DAW,DAX,V14,V15,V16, V17,V18,V19,V20,V21,V22,V24 .....	1

(1) ITEM NO.	(2) SMR CODE	(3) NSN	(4) CAGEC	(5) PART NUMBER	(6) DESCRIPTION AND USABLE ON CODE (UOC)	(7) QTY
22	PAFZZ	4730-00-444-1710	15434	181213	ELBOW,PIPE TO TUBE UOC: DAC,DAD,DAE,DAF,DAG,DA H,DAJ,DAL,DAW,DAX,V14,V15,V16, V17,V18,V19,V20,V21,V22,V24 .....	2
23	PAFZZ	2815-01-146-4164	15434	135308	PLATE,FUEL CROSSOVE UOC: DAC,DAD,DAE,DAF,DAG,DA H,DAJ,DAL,DAW,DAX,V14,V15,V16, V17,V18,V19,V20,V21,V22,V24 .....	2
24	PAFZZ	5331-00-143-8485	15434	131026	O-RING PART OF KIT P/N 3011472 UOC: DAC,DAD,DAE,DAF,DAG,DA H,DAJ,DAL,DAW,DAX,V14,V15,V16, V17,V18,V19,V20,V21,V22,V24 .....	12

END OF FIGURE



**FIELD MAINTENANCE  
FUEL TANK MOUNTING, SINGLE TANK, LH**

---

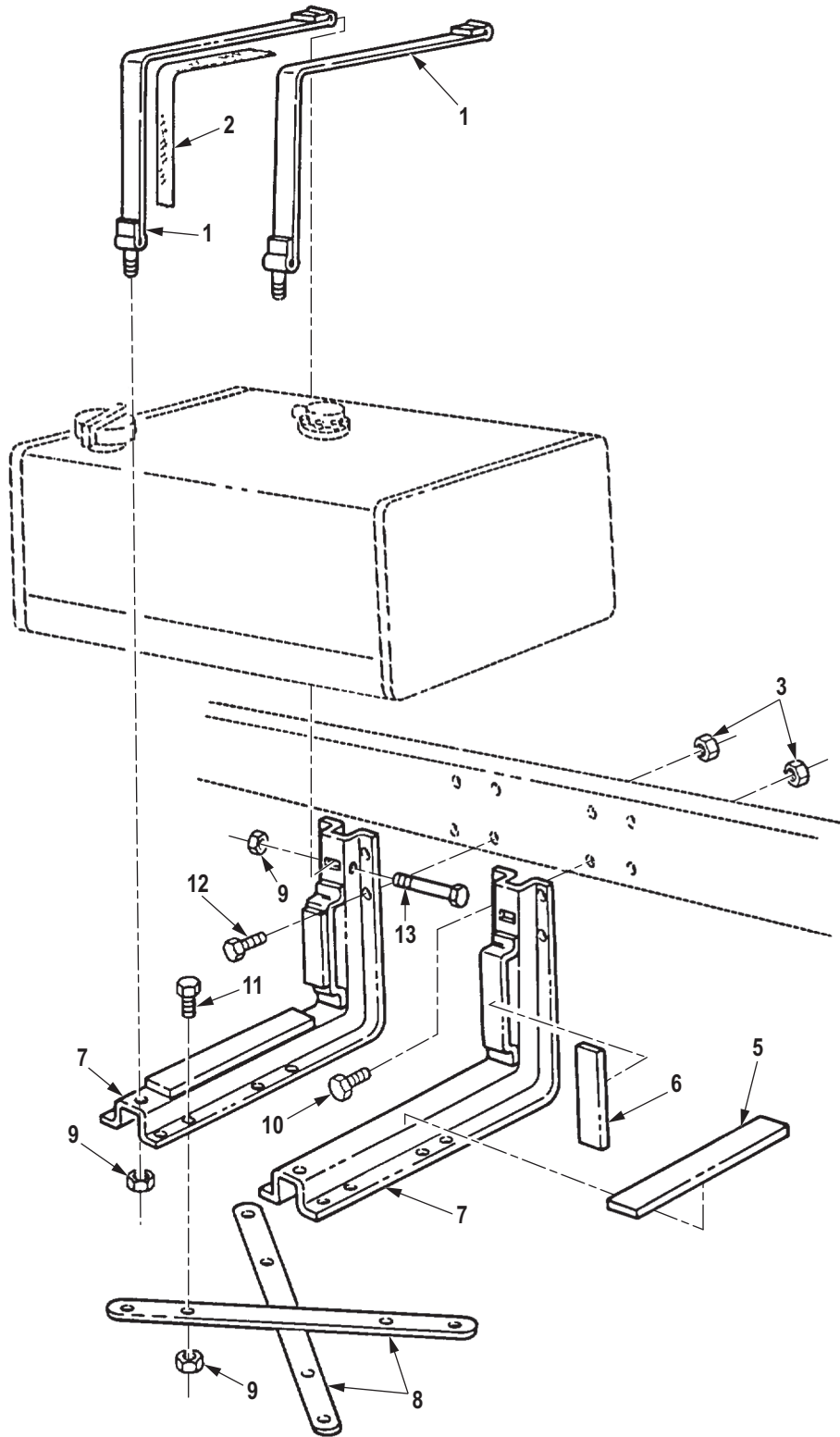
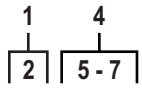

R0067DAA

Figure 67. Fuel Tank Mounting, Single Tank, LH.



(1) ITEM NO.	(2) SMR CODE	(3) NSN	(4) CAGEC	(5) PART NUMBER	(6) DESCRIPTION AND USABLE ON CODE (UOC)	(7) QTY
<b>GROUP 0306 TANKS, LINES, FITTINGS, HEADERS.</b>						
<b>FIG. 67. FUEL TANK MOUNTING, SINGLE TANK, LH.</b>						
1	PAFZZ	5340-01-090-7657	19207	12276998-2	BAND,RETAINING UOC: DAC,DAD,DAJ,DAW,DAX,V14 ,V15,V16,V17,V24,ZAA,ZAB,ZAC,ZAD,ZAJ	2
2	PAFZZ	9390-01-192-1610	19207	12277027-2	. NONMETALLIC CHANNEL UOC: DAC,DAD,DAJ,DAW,DAX,V14 ,V15,V16,V17,V24,ZAA,ZAB,ZAC,ZAD,ZAJ	1
3	PAFZZ	5310-00-877-5795	80205	MS21044-N8	NUT,SELF-LOCKING,HE UOC: DAC,DAD,DAJ,DAW,DAX,V14 ,V15,V16,V17,V24,ZAA,ZAB,ZAC,ZAD,ZAJ	8
4	PAFZZ	5340-01-112-2169	19207	12277030	BRACKET,ANGLE UOC: DAC,DAD,DAJ,DAW,DAX,V14 ,V15,V16,V17,V24,ZAA,ZAB,ZAC,ZAD,ZAJ	2
5	PAFZZ	5330-01-117-0608	19207	12277026-1	. RUBBER SHEET,SOLID UOC: DAC,DAD,DAJ,DAW,DAX,V14 ,V15,V16,V17,V24,ZAA,ZAB,ZAC,ZAD,ZAJ	1
6	PAFZZ	5330-01-117-0609	19207	12277026-2	. RUBBER SHEET,SOLID UOC: DAC,DAD,DAJ,DAW,DAX,V14 ,V15,V16,V17,V24,ZAA,ZAB,ZAC,ZAD,ZAJ	1
7	XAFZZ		19207	7017087-1	. HANGER UOC: DAC,DAD,DAJ,DAW,DAX,V14 ,V15,V16,V17,V24,ZAA,ZAB,ZAC,ZAD,ZAJ	1
8	PAFZZ	5340-01-090-7649	19207	12256176-2	BRACKET,MOUNTING UOC: DAC,DAD,DAJ,DAW,DAX,V14 ,V15,V16,V17,V24,ZAA,ZAB,ZAC,ZAD,ZAJ	2
9	PAFZZ	5310-00-959-1488	81349	M45913/2-6FG5C	NUT,SELF-LOCKING,HE UOC: DAC,DAD,DAJ,DAW,DAX,V14 ,V15,V16,V17,V24,ZAA,ZAB,ZAC,ZA D,ZAJ .....	12
10	PAFZZ	5305-00-719-5235	80204	B1821BH050F175N	SCREW,CAP,HEXAGON H UOC: DAC,DAD,DAJ,V16,V17,V24,Z AA,ZAB,ZAC,ZAD,ZAJ .....	8
10	PAFZZ	5305-00-719-5219	80204	B1821BH050F125N	SCREW,CAP,HEXAGON H UOC: DAW,DAX,V14,V15,ZAA,ZAB .....	8
11	PAFZZ	5305-00-269-2803	80205	MS90726-60	SCREW,CAP,HEXAGON H UOC: DAC,DAD,DAJ,DAW,DAX,V14 ,V15,V16,V17,V24,ZAA,ZAB,ZAC,ZAD,ZAJ	8
12	PAFZZ	5305-00-725-4183	80205	MS90726-113	SCREW,CAP,HEXAGON H UOC: DAW,DAX,V14,V15,V16,V17,V 24,ZAA,ZAB,ZAC,ZAD,ZAJ .....	4

(1) ITEM NO.	(2) SMR CODE	(3) NSN	(4) CAGEC	(5) PART NUMBER	(6) DESCRIPTION AND USABLE ON CODE (UOC)	(7) QTY
13	PAFZZ	5305-00-269-3247	80204	B1821BH038F325N	SCREW,CAP,HEXAGON H UOC: DAC,DAD,DAJ,DAW,DAX,V14 ,V15,V16,V17,V24,ZAA,ZAB,ZAC,ZAD,ZAJ	2

END OF FIGURE

**FIELD MAINTENANCE  
FUEL TANK MOUNTING, SINGLE TANK, RH**

---

1	6
2	7-9

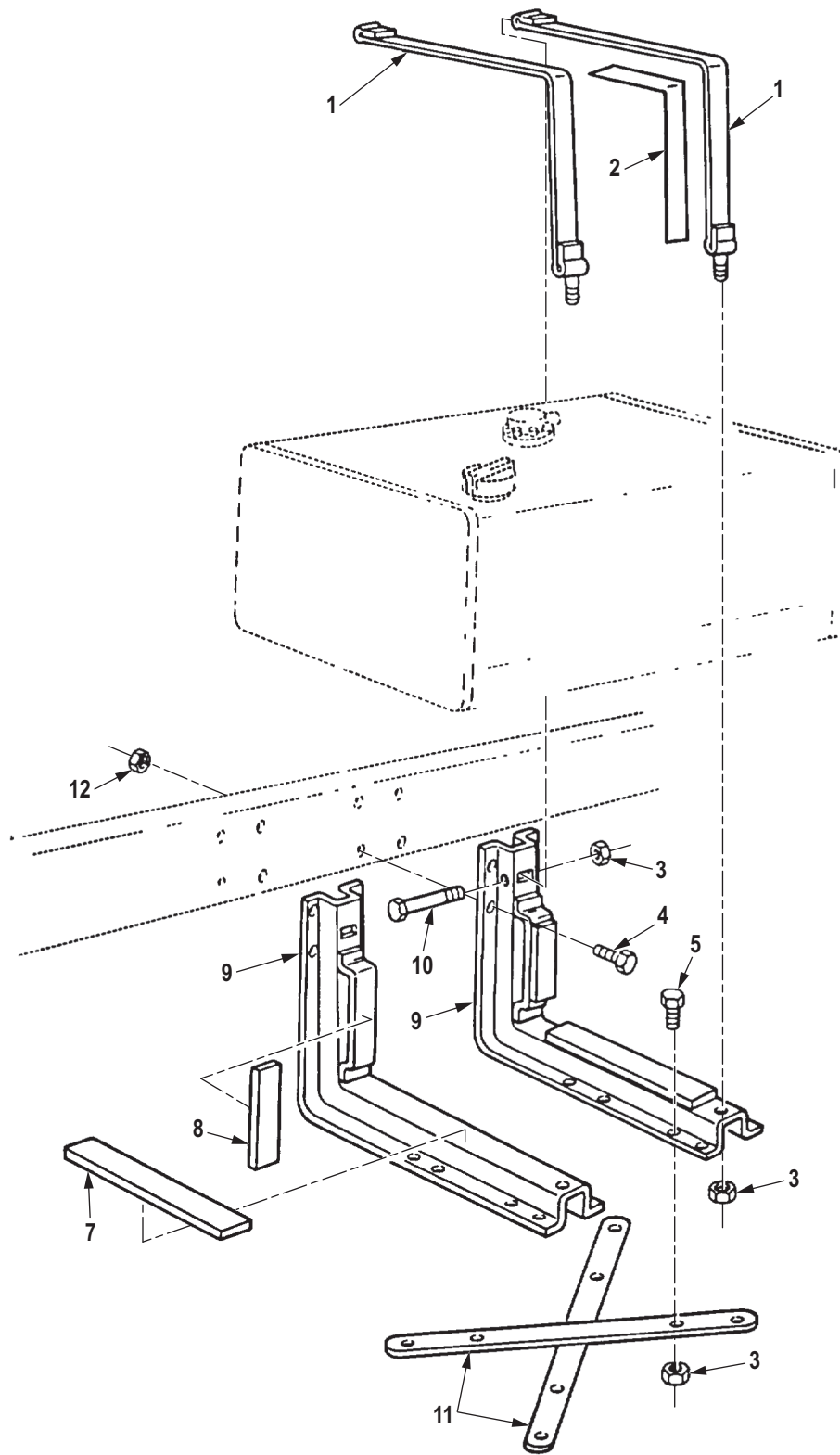

Figure 68. Fuel Tank Mounting, Single Tank, RH.

R0068DAA

(1) ITEM NO.	(2) SMR CODE	(3) NSN	(4) CAGEC	(5) PART NUMBER	(6) DESCRIPTION AND USABLE ON CODE (UOC)	(7) QTY
<b>GROUP 0306 TANKS, LINES, FITTINGS, HEADERS.</b>						
<b>FIG. 68. FUEL TANK MOUNTING, SINGLE TANK, RH.</b>						
1	PAFZZ	5340-01-117-0606	19207	12276998-1	STRAP,RETAINING UOC: V39 .....	2
2	PAFZZ	9390-01-207-8125	19207	12277027-1	. NONMETALLIC CHANNEL UOC: V39 .....	1
3	PAFZZ	5310-00-959-1488	81349	M45913/2-6FG5C	NUT,SELF-LOCKING,HE UOC: V39 .....	12
4	PAFZZ	5305-00-719-5235	80204	B1821BH050F175N	SCREW,CAP,HEXAGON H UOC: V39 .....	5
5	PAFZZ	5305-00-269-2803	80205	MS90726-60	SCREW,CAP,HEXAGON H UOC: V39 .....	8
6	PAFZZ	5340-01-112-2169	19207	12277030	BRACKET,ANGLE UOC: V39 .....	2
7	PAFZZ	5330-01-117-0608	19207	12277026-1	. RUBBER SHEET,SOLID UOC: V39 .....	1
8	PAFZZ	5330-01-117-0609	19207	12277026-2	. RUBBER SHEET,SOLID UOC: V39 .....	1
9	XAFZZ		19207	7017087-1	. HANGER UOC: V39 .....	1
10	PAFZZ	5305-00-269-3247	80204	B1821BH038F325N	SCREW,CAP,HEXAGON H UOC: V39 .....	2
11	PAFZZ	5340-01-090-7649	19207	12256176-2	BRACKET,MOUNTING UOC: V39 .....	2
12	PAFZZ	5310-00-877-5795	80205	MS21044-N8	NUT,SELF-LOCKING,HE UOC: V39 .....	5

**END OF FIGURE**



**FIELD MAINTENANCE  
FUEL TANK MOUNTING, DUAL TANK**

---

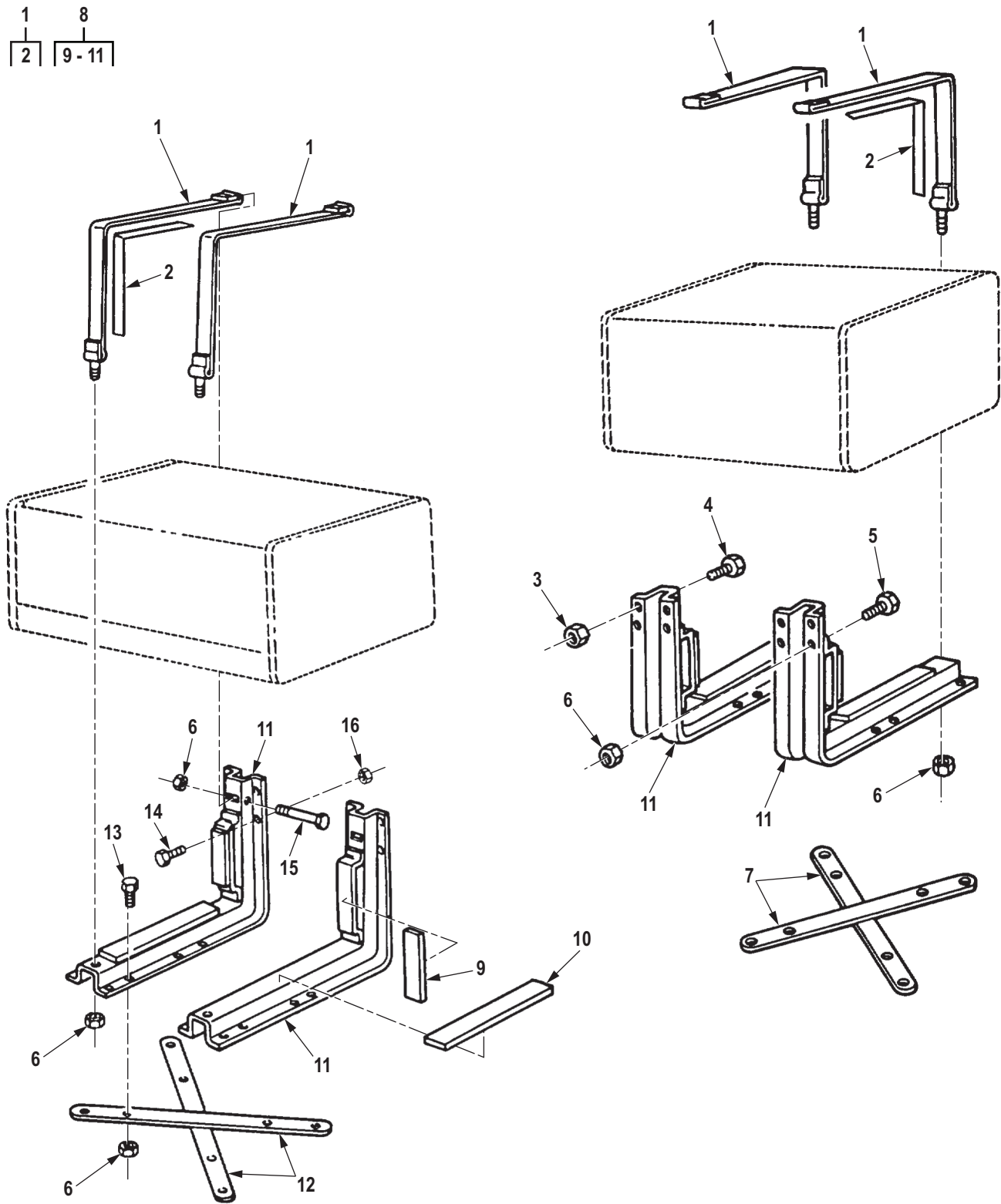

R0069DAA

Figure 69. Fuel Tank Mounting, Dual Tank.



(1) ITEM NO.	(2) SMR CODE	(3) NSN	(4) CAGEC	(5) PART NUMBER	(6) DESCRIPTION AND USABLE ON CODE (UOC)	(7) QTY
<b>GROUP 0306 TANKS, LINES, FITTINGS, HEADERS.</b>						
<b>FIG. 69. FUEL TANK MOUNTING, DUAL TANK.</b>						
1	PAFZZ	5340-01-090-7657	19207	12276998-2	BAND,RETAINING UOC: DAE,DAF,DAG,DAH,DAL,V18, V19,V20,V21,V22,ZAE,ZAF,ZAG,ZAH,ZAL	4
2	PAFZZ	9390-01-192-1610	19207	12277027-2	. NONMETALLIC CHANNEL UOC: DAE,DAF,DAG,DAH,DAL,V18, V19,V20,V21,V22,ZAE,ZAF,ZAG,ZAH,ZAL	1
3	PAFZZ	5310-00-488-3888	81349	M45913/3-8FG8C	NUT,SELF-LOCKING,HE UOC: DAE,DAF,DAG,DAH,DAL,V18, V19,V20,V21,V22,ZAE,ZAF,ZAG,ZAH,ZAL	5
4	PAFZZ	5305-00-725-4183	80205	MS90726-113	SCREW,CAP,HEXAGON H UOC: DAE,DAF,DAG,DAH,DAL,V18, V19,V20,V21,V22,ZAE,ZAF,ZAG,ZAH,ZAL	1
5	PAFZZ	5305-00-719-5221	80204	B1821BH050F150N	SCREW,CAP,HEXAGON H UOC: DAE,DAF,DAG,DAH,DAL,V18, V19,V20,V21,V22,ZAE,ZAF,ZAG,ZAH,ZAL	4
6	PAFZZ	5310-00-959-1488	81349	M45913/2-6FG5C	NUT,SELF-LOCKING,HE UOC: DAE,DAF,DAG,DAH,DAL,V18, V19,V20,V21,V22 .....	24
7	PFFZZ	5340-01-090-7645	19207	12256176-1	PLATE,MENDING UOC: DAE,DAF,DAG,DAH,DAL,V18, V19,V20,V21,V22,ZAE,ZAF,ZAG,ZAH,ZAL	2
8	PAFZZ	5340-01-112-2169	19207	12277030	BRACKET,ANGLE UOC: DAE,DAF,DAG,DAH,DAL,V18, V19,V20,V21,V22,ZAE,ZAF,ZAG,ZAH,ZAL	4
9	PAFZZ	5330-01-117-0609	19207	12277026-2	. RUBBER SHEET,SOLID UOC: DAE,DAF,DAG,DAH,DAL,V18, V19,V20,V21,V22,ZAE,ZAF,ZAG,ZAH,ZAL	1
10	PAFZZ	5330-01-117-0608	19207	12277026-1	. RUBBER SHEET,SOLID UOC: DAE,DAF,DAG,DAH,DAL,V18, V19,V20,V21,V22,ZAE,ZAF,ZAG,ZAH,ZAL	1
11	XAFZZ		19207	7017087-1	. HANGER UOC: DAE,DAF,DAG,DAH,DAL,V18, V19,V20,V21,V22,ZAE,ZAF,ZAG,ZAH,ZAL	1
12	PAFZZ	5340-01-090-7649	19207	12256176-2	BRACKET,MOUNTING UOC: DAL,V18,ZAL .....	2
13	PAFZZ	5305-00-269-2803	80205	MS90726-60	SCREW,CAP,HEXAGON H UOC: DAE,DAF,DAG,DAH,DAJ,DAL, V18,V19,V20,V21,V22,ZAE,ZAF,ZAG ,ZAH,ZAL .....	16
14	PAFZZ	5305-00-719-5219	80204	B1821BH050F125N	SCREW,CAP,HEXAGON H UOC: DAE,DAF,DAG,DAH,V19,V20, V21,V22,ZAE,ZAF,ZAG,ZAH .....	8

(1) ITEM NO.	(2) SMR CODE	(3) NSN	(4) CAGEC	(5) PART NUMBER	(6) DESCRIPTION AND USABLE ON CODE (UOC)	(7) QTY
14	PAFZZ	5305-00-719-5235	80204	B1821BH050F175N	SCREW,CAP,HEXAGON H UOC: DAL,V18,ZAL .....	8
15	PAFZZ	5305-00-269-3247	80204	B1821BH038F325N	SCREW,CAP,HEXAGON H UOC: DAE,DAF,DAG,DAH,V19,V20, V21,V22,ZAE,ZAF,ZAG,ZAH .....	4
16	PAFZZ	5310-00-877-5795	80205	MS21044-N8	NUT,SELF-LOCKING,HE UOC: DAE,DAF,DAG,DAH,DAL,V18, V19,V20,V21,V22,ZAE,ZAF,ZAG,ZAH,ZAL	8

END OF FIGURE

**FIELD MAINTENANCE  
FUEL TANK VENT LINES, SINGLE, LH**

---

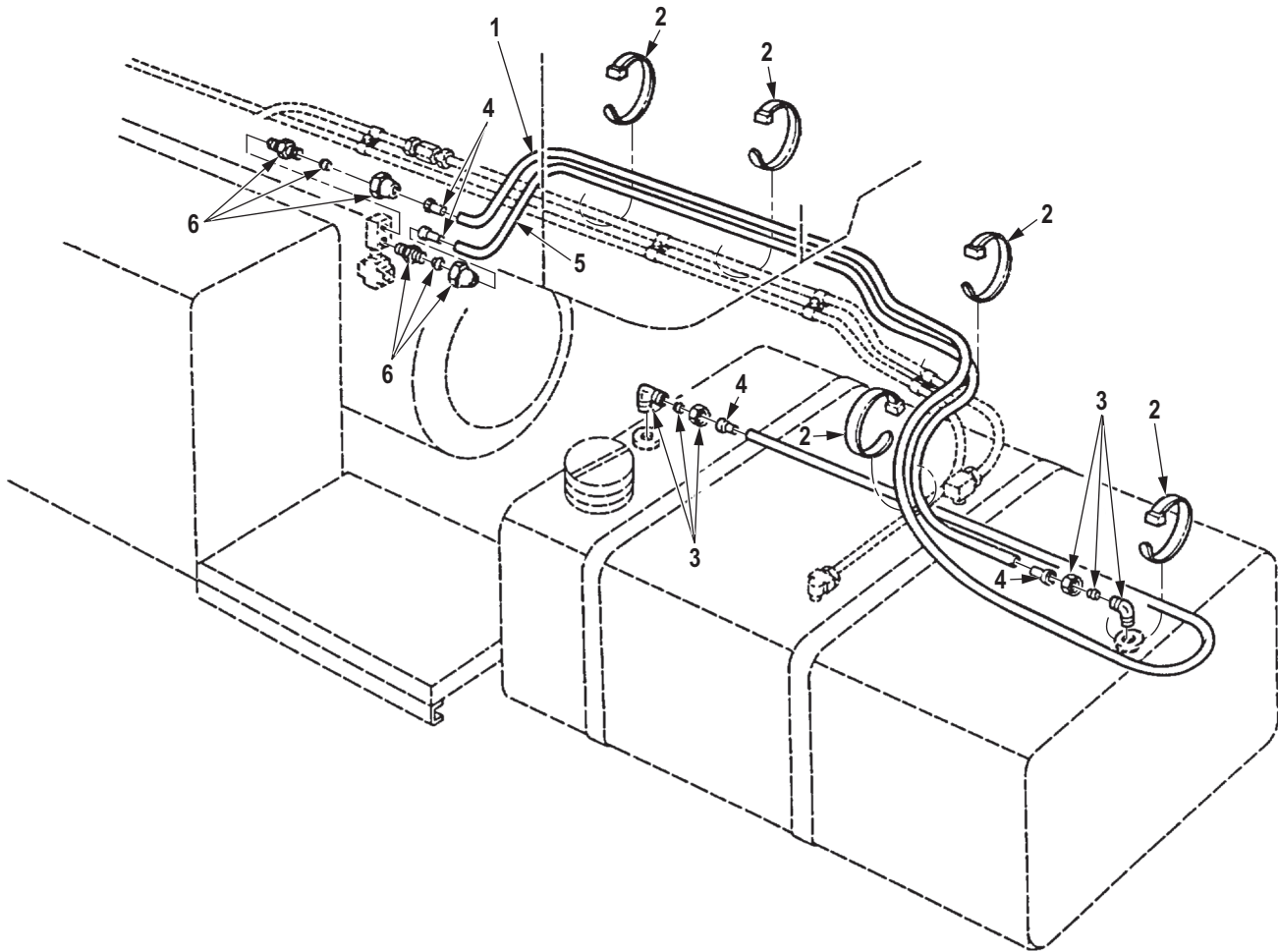

R0070DAA

Figure 70. Fuel Tank Vent Lines, Single, LH.

(1) ITEM NO.	(2) SMR CODE	(3) NSN	(4) CAGEC	(5) PART NUMBER	(6) DESCRIPTION AND USABLE ON CODE (UOC)	(7) QTY
<b>GROUP 0306 TANKS, LINES, FITTINGS, HEADERS.</b>						
<b>FIG. 70. FUEL TANK VENT LINES, SINGLE, LH.</b>						
1	MFFZZ		19207	CPR104420-1-144	TUBING,NYLON MAKE FROM TUBING,P/N CPR104420-1,144 IN. LONG UOC: DAC,DAD,DAJ,DAW,DAX,V14 ,V15,V16,V17,V24,ZAA,ZAB,ZAC,ZAD,ZAJ	1
2	PAFZZ	5975-00-984-6582	96906	MS3367-1-0	STRAP,TIEDOWN,ELECT UOC: DAC,DAD,DAJ,DAW,DAX,V14 ,V15,V16,V17,V24,ZAA,ZAB,ZAC,ZAD,ZAJ	5
3	PAFZZ	4730-00-921-3240	81343	4-2 120202BA	ELBOW,PIPE TO TUBE UOC: DAC,DAD,DAJ,DAW,DAX,V14 ,V15,V16,V17,V24,ZAA,ZAB,ZAC,ZAD,ZAJ	2
4	PAFZZ	4730-00-132-4588	19207	11648703	INSERT,TUBE FITTING UOC: DAC,DAD,DAJ,DAW,DAX,V14 ,V15,V16,V17,V24,ZAA,ZAB,ZAC,ZAD,ZAJ	4
5	MFFZZ		19207	CPR104420-1-108	TUBING,NYLON MAKE FROM TUBING,P/N CPR104420-1, 108 IN.LONG UOC: DAC,DAD,DAJ,DAW,DAX,V14 ,V15,V16,V17,V24,ZAA,ZAB,ZAC,ZAD,ZAJ	1
6	PAFZZ	4730-00-270-4580	81343	SAE J246 4-4 120102BA	ADAPTER,STRAIGHT,PI UOC: DAC,DAD,DAJ,DAW,DAX,V14 ,V15,V16,V17,V24,ZAA,ZAB,ZAC,ZAD,ZAJ	2

**END OF FIGURE**



**FIELD MAINTENANCE  
FUEL TANK SUPPLY AND RETURN LINES, SINGLE, LH (M939, M939A1)**

---

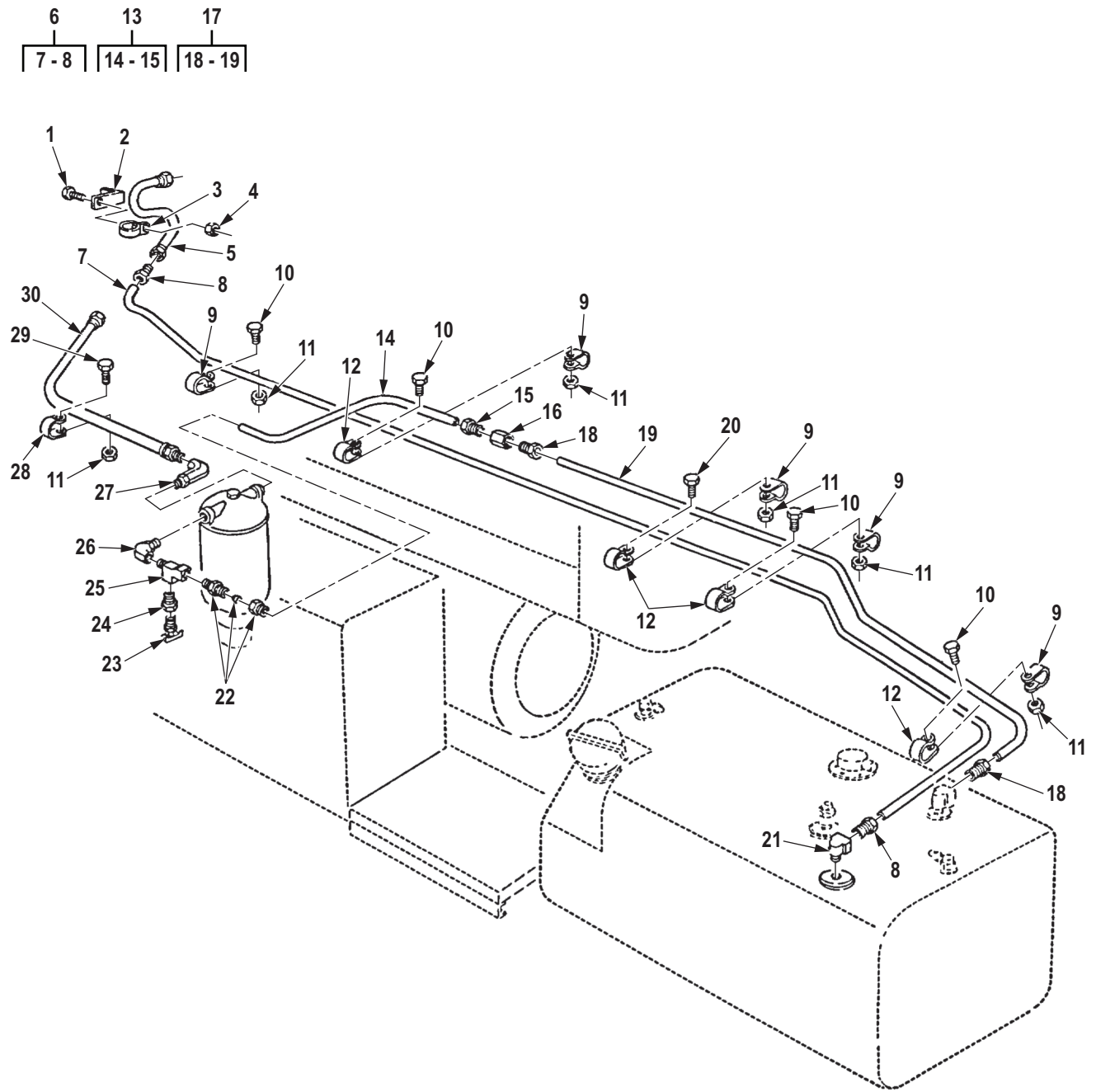

R0071DAA

Figure 71. Fuel Tank Supply and Return Lines, Single, LH (M939, M939A1).



(1) ITEM NO.	(2) SMR CODE	(3) NSN	(4) CAGEC	(5) PART NUMBER	(6) DESCRIPTION AND USABLE ON CODE (UOC)	(7) QTY
<p><b>GROUP 0306 TANKS, LINES, FITTINGS, HEADERS.</b></p> <p><b>FIG. 71. FUEL TANK SUPPLY AND RETURN LINES, SINGLE, LH (M939, M939A1).</b></p>						
1	PAFZZ	5305-00-267-8953	80204	B1821BH025F063N	SCREW,CAP,HEXAGON H UOC: DAC,DAD,DAJ,DAW,DAX,V14 ,V15,V16,V17,V24 .....	1
2	PFFZZ	5342-01-090-7658	19207	12256187	BRACKET,SUPPORT FUE UOC: DAC,DAD,DAJ,DAW,DAX,V14 ,V15,V16,V17,V24 .....	1
3	PAFZZ	5340-00-088-1254	80205	MS21333-104	CLAMP,LOOP UOC: DAC,DAD,DAJ,DAW,DAX,V14 ,V15,V16,V17,V24 .....	1
4	PAFZZ	5310-00-143-6102	81349	M45913/1-4FS3	NUT,SELF-LOCKING,HE UOC: DAC,DAD,DAJ,DAW,DAX,V14 ,V15,V16,V17,V24 .....	1
5	PAFZZ	4720-01-091-5169	19207	12256185	HOSE ASSEMBLY,METAL UOC: DAC,DAD,DAJ,DAW,DAX,V14 ,V15,V16,V17,V24 .....	1
6	AFFFF		19207	12256160	TUBE ASSY UOC: DAC,DAD,DAJ,DAW,DAX,V14 ,V15,V16,V17,V24 .....	1
7	MFFZZ		19207	12256160-AR	. TUBE,METALLIC FUEL BY- PASS;MAKE FROM TUBE, P/N 5174K5, AS REQUIRED UOC: DAC,DAD,DAE,DAF,DAG,DA H,DAJ,DAW,DAX,V14,V15,V16,V17,V24 ...	1
8	PAFZZ	4730-00-014-2433	13174	41-WB-06	. INVERTED NUT,TUBE C UOC: DAC,DAD,DAJ,DAW,DAX,V14 ,V15,V16,V17,V24 .....	2
9	PAFZZ	5340-00-954-6014	80205	MS21333-121	CLAMP,LOOP UOC: DAC,DAD,DAJ,DAW,DAX,V14 ,V15,V16,V17,V24 .....	5
10	PAFZZ	5305-00-269-3233	80204	B1821BH038F063N	SCREW,CAP,HEXAGON H UOC: DAC,DAD,DAJ,DAW,DAX,V14 ,V15,V16,V17,V24 .....	5
11	PAFZZ	5310-00-959-1488	81349	M45913/2-6FG5C	NUT,SELF-LOCKING,HE UOC: DAC,DAD,DAJ,DAW,DAX,V14 ,V15,V16,V17,V24 .....	6
12	PAFZZ	5340-00-989-1771	80205	MS21333-123	CLAMP,LOOP UOC: DAC,DAD,DAJ,DAW,DAX,V14 ,V15,V16,V17,V24 .....	4
13	AFFFF		19207	12256159	TUBE ASSEMBLY UOC: DAC,DAD,DAJ,DAW,DAX,V14 ,V15,V16,V17,V24 .....	1

(1) ITEM NO.	(2) SMR CODE	(3) NSN	(4) CAGEC	(5) PART NUMBER	(6) DESCRIPTION AND USABLE ON CODE (UOC)	(7) QTY
14	MFFZZ		19207	12256159-AR	. TUBE,METALLIC MAKE FROM TUBE, P/N ASTM B280, LENGTH AS REQUIRED UOC: DAC,DAD,DAE,DAF,DAG,DA H,DAJ,DAW,DAX,V14,V15,V16,V17,V24 ...	1
15	PAFZZ	4730-00-014-2435	81343	8-040110B	. INVERTED NUT,TUBE C UOC: DAC,DAD,DAJ,DAW,DAX,V14 ,V15,V16,V17,V24 .....	1
16	PAFZZ	4730-01-148-7397	81343	SAE J512 8 040101B	COUPLING,TUBE UOC: DAC,DAD,DAJ,DAW,DAX,V14 ,V15,V16,V17,V24 .....	1
17	AFFFF		19207	12256158	TUBE ASSY UOC: DAC,DAD,DAJ,DAW,DAX,V14 ,V15,V16,V17,V24 .....	1
18	PAFZZ	4730-00-014-2435	81343	8-040110B	. INVERTED NUT,TUBE C UOC: DAC,DAD,DAJ,DAW,DAX,V14 ,V15,V16,V17,V24 .....	2
19	MFFZZ		19207	12256158-AR	. TUBE,METALLIC MAKE FROM TUBE, P/N 5174K5, AS REQUIRED UOC: DAC,DAD,DAE,DAF,DAG,DA H,DAJ,DAW,DAX,V14,V15,V16,V17,V24 ...	1
20	PAFZZ	5305-00-269-3235	80204	B1821BH038F088N	SCREW,CAP,HEXAGON H UOC: DAC,DAD,DAJ,DAW,DAX,V14 ,V15,V16,V17,V24 .....	1
21	PAFZZ	4730-00-277-8274	12204	137423	ELBOW,PIPE TO TUBE UOC: DAC,DAD,DAJ,DAW,DAX,V14 ,V15,V16,V17,V24 .....	1
22	PAFZZ	4730-00-202-9036	81343	SAE J246 8-8 120102BA	ADAPTER,STRAIGHT,PI UOC: DAC,DAD,DAJ,DAW,DAX,V14 ,V15,V16,V17,V24 .....	1
23	PAFZZ	4820-00-752-9040	58536	AA59440/1-004	COCK,DRAIN UOC: DAC,DAD,DAJ,DAW,DAX,V14 ,V15,V16,V17,V24 .....	1
24	PAFZZ	4730-01-133-6209	96906	MS14315-6X	BUSHING,PIPE UOC: DAC,DAD,DAJ,DAW,DAX,V14 ,V15,V16,V17,V24 .....	1
25	PAFZZ	4730-01-095-2034	81343	SAE J530 8-8-8 130424BA	TEE,PIPE UOC: DAC,DAD,DAJ,DAW,DAX,V14 ,V15,V16,V17,V24 .....	1
26	PAFZZ	4730-01-090-6468	30780	10-1/2 AOEG-SS	ELBOW,PIPE TO TUBE UOC: DAC,DAD,DAJ,DAW,DAX,V14 ,V15,V16,V17,V24 .....	1
27	PAFZZ	4730-01-104-4314	30780	10-1/2 AOE4G-B	ELBOW,PIPE TO TUBE UOC: DAC,DAD,DAJ,DAW,DAX,V14 ,V15,V16,V17,V24 .....	1

(1) ITEM NO.	(2) SMR CODE	(3) NSN	(4) CAGEC	(5) PART NUMBER	(6) DESCRIPTION AND USABLE ON CODE (UOC)	(7) QTY
28	PAFZZ	5340-00-053-8994	80205	MS21333-126	CLAMP,LOOP UOC: DAC,DAD,DAJ,DAW,DAX,V14 ,V15,V16,V17,V24 .....	1
29	PAFZZ	5305-00-269-2804	80205	MS90726-61	SCREW,CAP,HEXAGON H UOC: DAC,DAD,DAJ,DAW,DAX,V14 ,V15,V16,V17,V24 .....	1
30	PAFZZ	4720-01-090-7618	19207	12256186	HOSE ASSEMBLY,NONME UOC: DAC,DAD,DAH,DAJ,DAW,DA X,V14,V15,V16,V17,V24 .....	1

END OF FIGURE



**FIELD MAINTENANCE  
FUEL TANK SUPPLY AND RETURN LINES, SINGLE, LH (M939A2)**

---

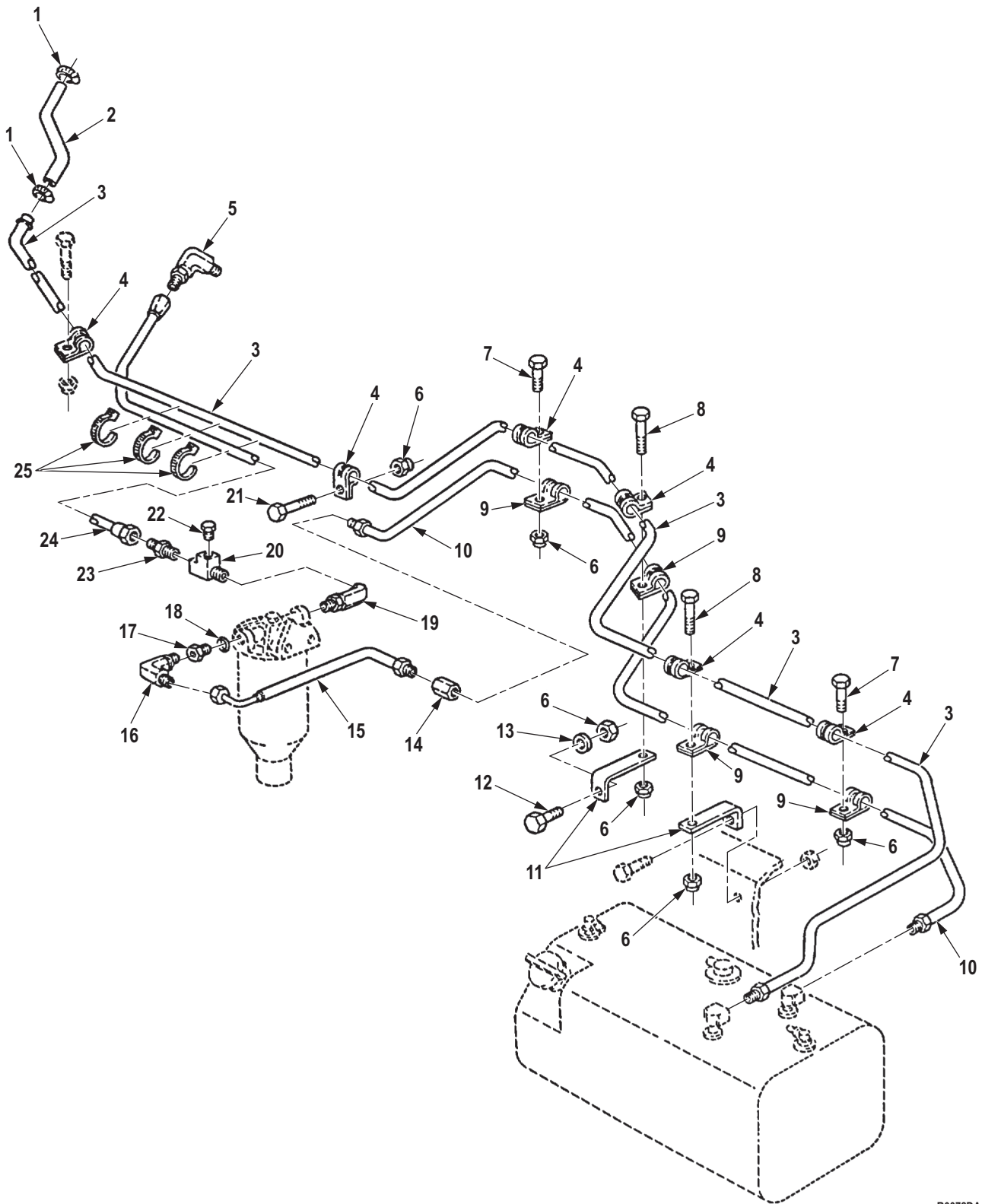

R0072DAA

Figure 72. Fuel Tank Supply and Return Lines, Single, LH (M939A2).

(1) ITEM NO.	(2) SMR CODE	(3) NSN	(4) CAGEC	(5) PART NUMBER	(6) DESCRIPTION AND USABLE ON CODE (UOC)	(7) QTY
<b>GROUP 0306 TANKS, LINES, FITTINGS, HEADERS.</b>						
<b>FIG. 72. FUEL TANK SUPPLY AND RETURN LINES, SINGLE, LH (M939A2).</b>						
1	PAFZZ	4730-01-109-8001	81343	J1508 TYPE M, SIZE 04	CLAMP,HOSE UOC: ZAA,ZAB,ZAC,ZAD,ZAJ .....	2
2	MFFZZ		98441	A2697 X 15 1/2IN	RETURN HOSE, FUEL MAKE FROM HOSE, P/N 1525-6, 15.5 IN.LONG UOC: ZAA,ZAB,ZAC,ZAD,ZAJ .....	1
3	PAFZZ	4710-01-279-3163	4F744	20511273	TUBE ASSEMBLY,METAL UOC: ZAA,ZAB,ZAC,ZAD,ZAJ .....	1
4	PAFZZ	5340-00-954-6014	80205	MS21333-121	CLAMP,LOOP UOC: ZAA,ZAB,ZAC,ZAD,ZAJ .....	6
5	PAFZZ	4730-00-235-1483	72915	8040341	ELBOW,PIPE TO TUBE UOC: ZAA,ZAB,ZAC,ZAD,ZAJ .....	1
6	PAFZZ	5310-00-959-1488	81349	M45913/2-6FG5C	NUT,SELF-LOCKING,HE UOC: ZAA,ZAB,ZAC,ZAD,ZAJ .....	9
7	PAFZZ	5305-00-269-3234	80204	B1821BH038F075N	SCREW,CAP,HEXAGON H UOC: ZAA,ZAB,ZAC,ZAD,ZAJ .....	6
8	PAFZZ	5305-00-269-3235	80204	B1821BH038F088N	SCREW,CAP,HEXAGON H UOC: ZAA,ZAB,ZAC,ZAD,ZAJ .....	2
9	PAFZZ	5340-00-989-1771	80205	MS21333-123	CLAMP,LOOP UOC: ZAA,ZAB,ZAC,ZAD,ZAJ .....	4
10	PAFZZ	4710-01-279-3164	05MG0	20511274	TUBE ASSEMBLY,METAL FUEL UOC: ZAA,ZAB,ZAC,ZAD,ZAJ .....	1
11	PFFZZ	5340-01-298-4861	05MG0	20510460	BRACKET,ANGLE STANDOFF UOC: ZAA,ZAB,ZAC,ZAD,ZAJ .....	2
12	PAFZZ	5305-00-269-2803	80205	MS90726-60	SCREW,CAP,HEXAGON H UOC: ZAA,ZAB,ZAC,ZAD,ZAJ .....	1
13	PAFZZ	5310-00-080-6004	96906	MS27183-14	WASHER,FLAT UOC: ZAA,ZAB,ZAC,ZAD,ZAJ .....	1
14	PAFZZ	4730-00-203-3179	81343	8-8 010103B	ADAPTER,STRAIGHT,PI UOC: ZAA,ZAB,ZAC,ZAD,ZAJ .....	1
15	PAFZZ	4720-01-442-2533	19207	12432371	HOSE ASSEMBLY,NONME PART OF KIT P/N 57K0251 UOC: ZAA,ZAB,ZAC,ZAD,ZAJ .....	1
16	PAFZZ	4730-00-254-6229	81343	8-8 010202B	ELBOW,PIPE TO TUBE UOC: ZAA,ZAB,ZAC,ZAD,ZAJ .....	1
17	PAFZZ	4730-01-123-0254	30780	0502-10-8	ADAPTER,STRAIGHT,PI UOC: ZAA,ZAB,ZAC,ZAD,ZAJ .....	1
18	PAFZZ	5330-01-220-5498	24617	274250	PACKING,PREFORMED UOC: ZAA,ZAB,ZAC,ZAD,ZAJ .....	1
19	PAFZZ	4730-01-104-4314	30780	10-1/2 AOE4G-B	ELBOW,PIPE TO TUBE PART OF KIT P/N 57K0251 UOC: ZAA,ZAB,ZAC,ZAD,ZAJ .....	1

(1) ITEM NO.	(2) SMR CODE	(3) NSN	(4) CAGEC	(5) PART NUMBER	(6) DESCRIPTION AND USABLE ON CODE (UOC)	(7) QTY
20	PAFZZ	4730-01-095-2034	81343	SAE J530 8-8-8 130424BA	TEE,PIPE UOC: ZAA,ZAB,ZAC,ZAD,ZAJ .....	1
21	PAFZZ	5305-00-269-3239	80204	B1821BH038F138N	SCREW,CAP,HEXAGON H UOC: ZAC,ZAD,ZAJ .....	1
21	PAFZZ	5305-00-269-2803	80205	MS90726-60	SCREW,CAP,HEXAGON H UOC: ZAA,ZAB .....	1
22	PAFZZ	4730-00-014-4027	51900	8W8X543	PLUG,PIPE PART OF KIT P/N 57K0251 UOC: ZAA,ZAB,ZAC,ZAD,ZAJ .....	1
23	PAFZZ	4730-00-809-9427	81343	MS51500A8-8	ADAPTER,STRAIGHT,PI UOC: ZAA,ZAB,ZAC,ZAD,ZAJ .....	1
24	PAFZZ	4720-01-441-2922	96906	MS52104C8-0270	HOSE ASSEMBLY,NONME PART OF KIT P/N 57K0251 UOC: ZAA,ZAB,ZAC,ZAD,ZAJ .....	1
25	PAFZZ	5975-00-985-6630	96906	MS3367-3-0	STRAP,TIEDOWN,ELECT PART OF KIT P/N 57K0251 UOC: ZAA,ZAB,ZAC,ZAD,ZAJ .....	3

END OF FIGURE



**FIELD MAINTENANCE  
FUEL TANK VENT LINES, SINGLE, RH**

---

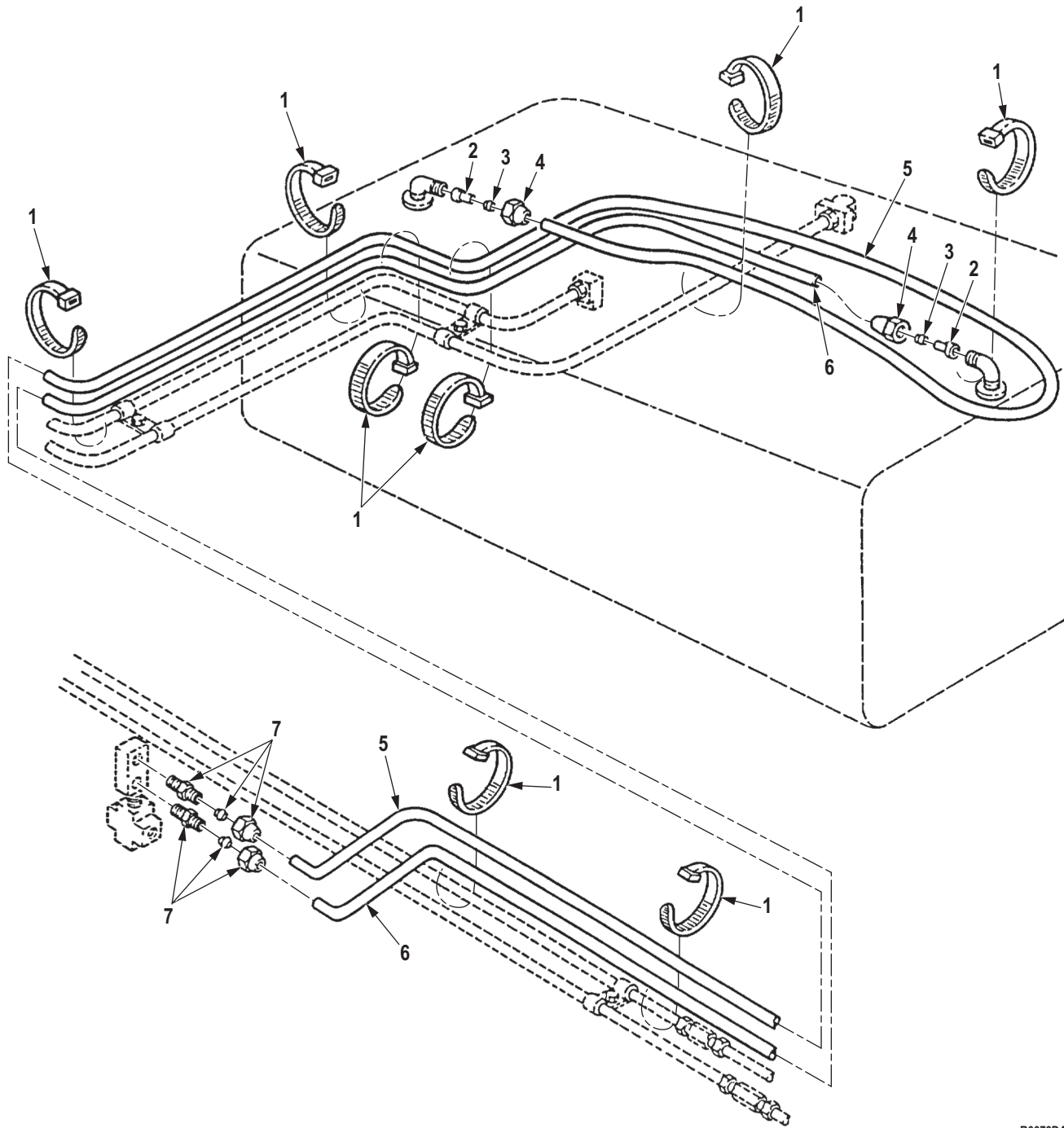

R0073DAA

Figure 73. Fuel Tank Vent Lines, Single, RH.

(1) ITEM NO.	(2) SMR CODE	(3) NSN	(4) CAGEC	(5) PART NUMBER	(6) DESCRIPTION AND USABLE ON CODE (UOC)	(7) QTY
<b>GROUP 0306 TANKS, LINES, FITTINGS, HEADERS.</b>						
<b>FIG. 73. FUEL TANK VENT LINES, SINGLE, RH.</b>						
1	PAFZZ	5975-00-984-6582	96906	MS3367-1-0	STRAP,TIEDOWN,ELECT UOC: ZAP .....	8
2	PAFZZ	4730-00-132-4588	19207	11648703	INSERT,TUBE FITTING UOC: ZAP .....	2
3	PAFZZ	4730-00-122-0477	81343	4 120115B	SLEEVE,COMPRESSION, UOC: ZAP .....	1
4	PAFZZ	4730-00-278-8824	06853	200455	NUT,TUBE COUPLING UOC: ZAP .....	2
5	MFFZZ		19207	CPR104420-1-160	TUBING,NONMETALIC REAR LEFT HAND VENT,MAKE FROM TUBING,P/N CPR104420-1, 160 IN.LONG UOC: ZAP .....	1
6	MFFZZ		19207	CPR104420-1-122	TUBING,NONMETALIC REAR LEFT HAND VENT,MAKE FROM TUBING,P/N CPR104420-1, 122 IN.LONG UOC: ZAP .....	1
7	PAFZZ	4730-00-270-4580	81343	SAE J246 4-4 120102BA	ADAPTER,STRAIGHT,PI UOC: ZAP .....	2

**END OF FIGURE**



**FIELD MAINTENANCE  
FUEL TANK SUPPLY AND RETURN LINES, SINGLE, RH**

---

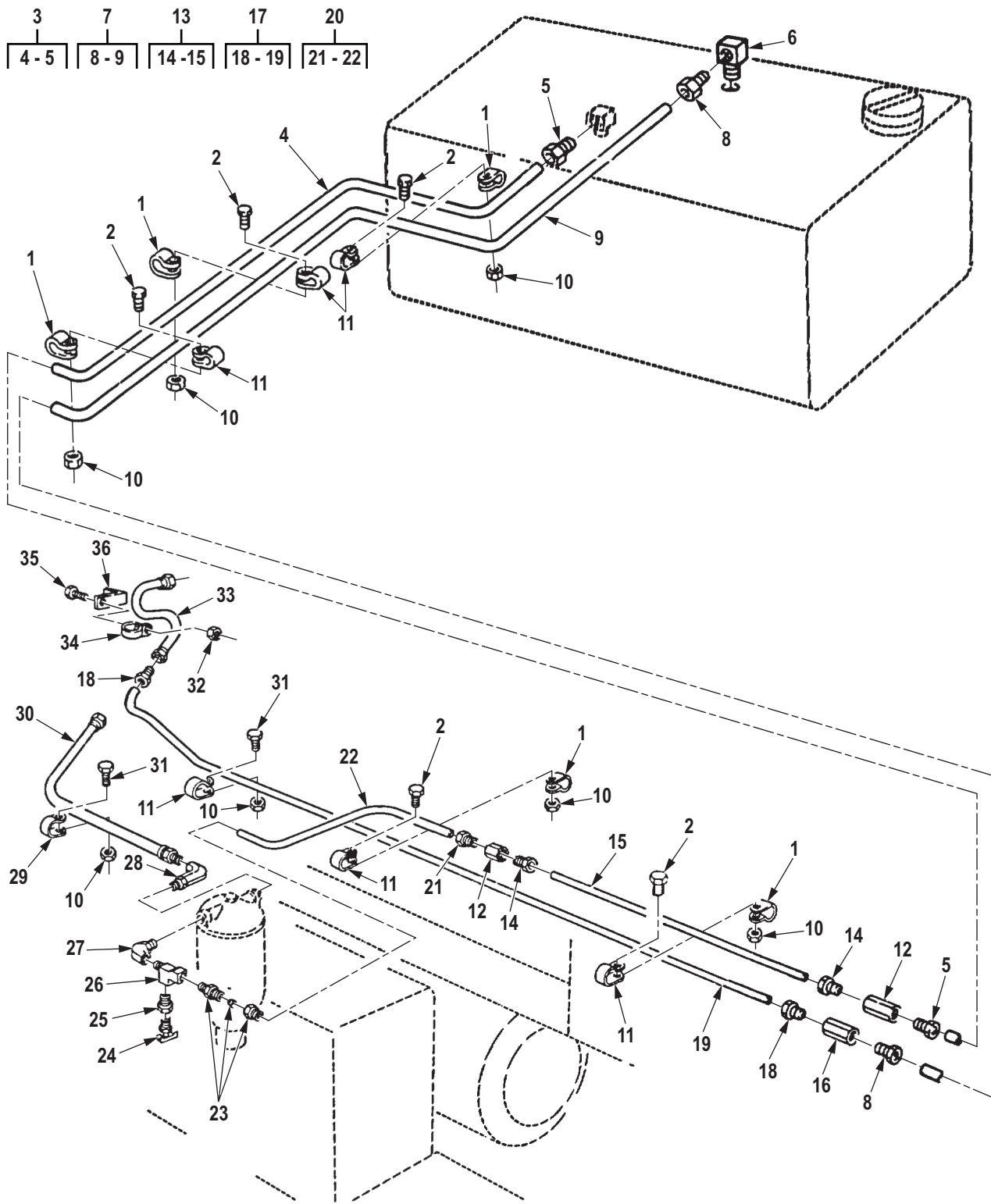

R0074DAA

Figure 74. Fuel Tank Supply and Return Lines, Single, RH.

(1) ITEM NO.	(2) SMR CODE	(3) NSN	(4) CAGEC	(5) PART NUMBER	(6) DESCRIPTION AND USABLE ON CODE (UOC)	(7) QTY
<b>GROUP 0306 TANKS, LINES, FITTINGS, HEADERS.</b>						
<b>FIG. 74. FUEL TANK SUPPLY AND RETURN LINES, SINGLE, RH.</b>						
1	PAFZZ	5340-00-989-1771	80205	MS21333-123	CLAMP,LOOP UOC: V39 .....	5
2	PAFZZ	5305-00-269-3234	80204	B1821BH038F075N	SCREW,CAP,HEXAGON H UOC: V39 .....	5
3	AFFFF		19207	12257058	TUBE ASSY UOC: V39 .....	1
4	MFFZZ		19207	12257058-AR	. TUBE,METALLIC MAKE FROM TUBE, P/N 5174K5, AS REQUIRED UOC: V39 .....	1
5	PAFZZ	4730-00-014-2433	13174	41-WB-06	. INVERTED NUT,TUBE C UOC: V39 .....	2
6	PAFZZ	4730-00-277-8274	12204	137423	ELBOW,PIPE TO TUBE UOC: V39 .....	1
7	AFFFF		19207	12257057	TUBE ASSY FUEL RETURN UOC: V39 .....	1
8	PAFZZ	4730-00-014-2435	81343	8-040110B	. INVERTED NUT,TUBE C UOC: V39 .....	2
9	MFFZZ		19207	12257057-AR	. TUBE,METALLIC MAKE FROM TUBE, P/N ASTM B280, LENGTH AS REQUIRED UOC: V39 .....	1
10	PAFZZ	5310-00-959-1488	81349	M45913/2-6FG5C	NUT,SELF-LOCKING,HE UOC: V39 .....	7
11	PAFZZ	5340-00-954-6014	80205	MS21333-121	CLAMP,LOOP UOC: V39 .....	6
12	PAFZZ	4730-00-278-8889	21450	137417	COUPLING,TUBE UOC: V39 .....	2
13	AFFFF		19207	12257055	TUBE ASSY FUEL TANK SUPPLY LINE UOC: V39 .....	1
14	PAFZZ	4730-00-014-2435	81343	8-040110B	. INVERTED NUT,TUBE C UOC: V39 .....	2
15	MFFZZ		19207	12257055-AR	. TUBE,METALLIC MAKE FROM TUBE, P/N ASTM B280, LENGTH AS REQUIRED UOC: V39 .....	1
16	PAFZZ	4730-00-278-8888	21450	137415	COUPLING,TUBE UOC: V39 .....	1
17	AFFFF		19207	12257059	TUBE ASSY UOC: V39 .....	1
18	PAFZZ	4730-00-014-2433	13174	41-WB-06	. INVERTED NUT,TUBE C UOC: V39 .....	2

(1) ITEM NO.	(2) SMR CODE	(3) NSN	(4) CAGEC	(5) PART NUMBER	(6) DESCRIPTION AND USABLE ON CODE (UOC)	(7) QTY
19	MFFZZ		19207	12257059-AR	. TUBE,METALLIC MAKE FROM TUBE, P/N 5174K5, AS REQUIRED UOC: V39 .....	1
20	AFFFF		19207	12256159	TUBE ASSEMBLY FUEL SUPPLY LINE UOC: V39 .....	1
21	PAFZZ	4730-00-014-2435	81343	8-040110B	. INVERTED NUT,TUBE C UOC: V39 .....	1
22	MFFZZ		19207	12256159-AR	. TUBE,METALLIC MAKE FROM TUBE, P/N ASTM B280, LENGTH AS REQUIRED UOC: V39 .....	1
23	PAFZZ	4730-00-202-9036	81343	SAE J246 8-8 120102BA	ADAPTER,STRAIGHT,PI UOC: V39 .....	1
24	PAFZZ	4820-00-752-9040	58536	AA59440/1-004	COCK,DRAIN UOC: V39 .....	1
25	PAFZZ	4730-01-133-6209	96906	MS14315-6X	BUSHING,PIPE UOC: V39 .....	1
26	PAFZZ	4730-01-095-2034	81343	SAE J530 8-8-8 130424BA	TEE,PIPE UOC: V39 .....	1
27	PAFZZ	4730-01-090-6468	30780	10-1/2 AOEG-SS	ELBOW,PIPE TO TUBE UOC: V39 .....	1
28	PAFZZ	4730-01-104-4314	30780	10-1/2 AOE4G-B	ELBOW,PIPE TO TUBE UOC: V39 .....	1
29	PAFZZ	5340-00-053-8994	80205	MS21333-126	CLAMP,LOOP UOC: V39 .....	1
30	PAFZZ	4720-01-090-7618	19207	12256186	HOSE ASSEMBLY,NONME UOC: V39 .....	1
31	PAFZZ	5305-00-269-2804	80205	MS90726-61	SCREW,CAP,HEXAGON H UOC: V39 .....	2
32	PAFZZ	5310-00-143-6102	81349	M45913/1-4FS3	NUT,SELF-LOCKING,HE UOC: V39 .....	1
33	PAFZZ	4720-01-091-5169	19207	12256185	HOSE ASSEMBLY,METAL UOC: V39 .....	1
34	PAFZZ	5340-00-088-1254	80205	MS21333-104	CLAMP,LOOP UOC: V39 .....	1
35	PAFZZ	5305-00-267-8953	80204	B1821BH025F063N	SCREW,CAP,HEXAGON H UOC: V39 .....	1
36	PFFZZ	5342-01-090-7658	19207	12256187	BRACKET,SUPPORT FUE UOC: V39 .....	1

END OF FIGURE



**FIELD MAINTENANCE  
FUEL TANK SUPPLY AND RETURN LINES, DUAL**

---

6	13
7-8	14-15

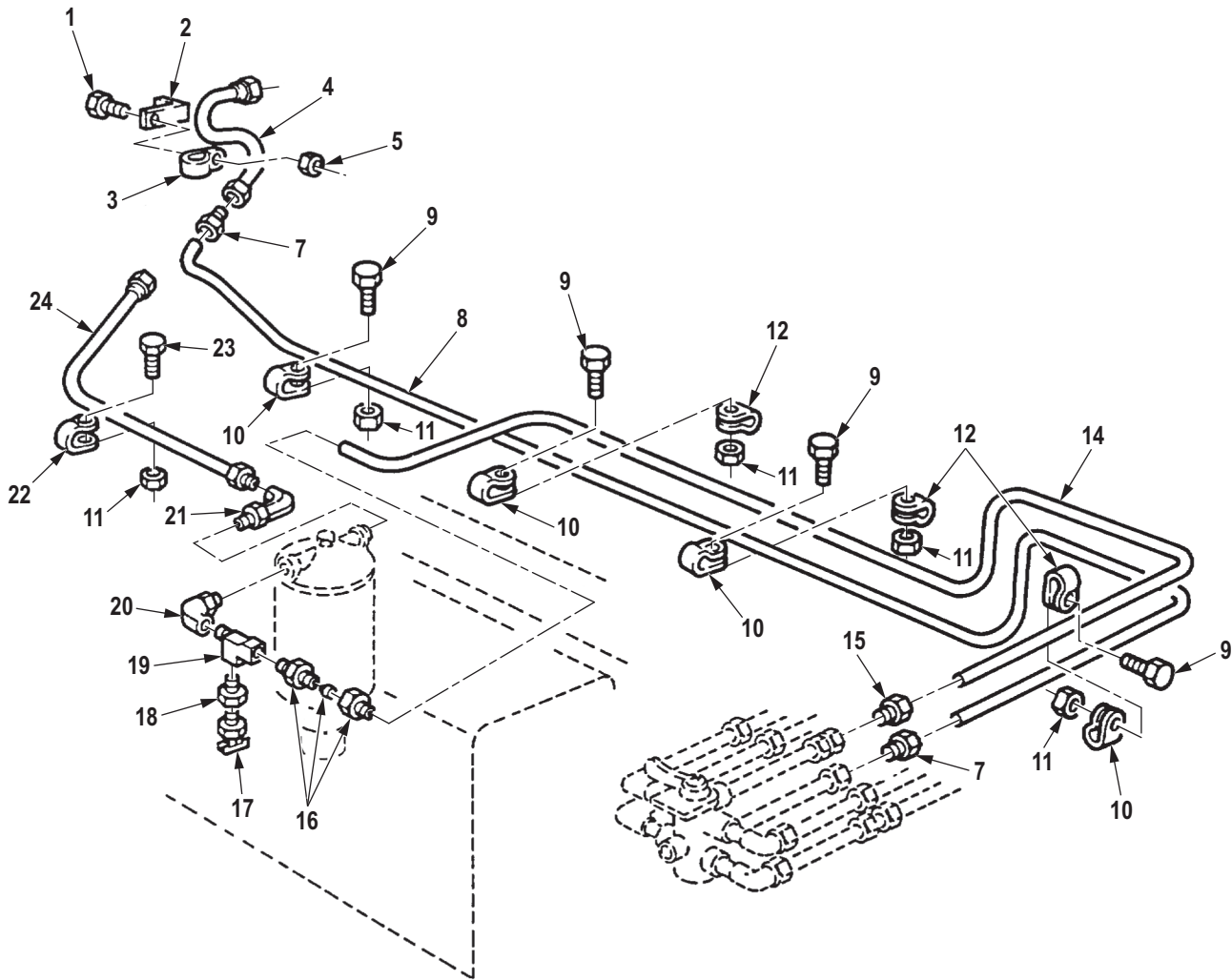

R0075DAA

Figure 75. Fuel Tank Supply and Return Lines, Dual.

(1) ITEM NO.	(2) SMR CODE	(3) NSN	(4) CAGEC	(5) PART NUMBER	(6) DESCRIPTION AND USABLE ON CODE (UOC)	(7) QTY
<b>GROUP 0306 TANKS, LINES, FITTINGS, HEADERS.</b>						
<b>FIG. 75. FUEL TANK SUPPLY AND RETURN LINES, DUAL.</b>						
1	PAFZZ	5305-00-267-8953	80204	B1821BH025F063N	SCREW,CAP,HEXAGON H UOC: DAE,DAF,DAG,DAH,DAL,V18, V19,V20,V21,V22 .....	1
2	PFFZZ	5342-01-090-7658	19207	12256187	BRACKET,SUPPORT FUE UOC: DAE,DAF,DAG,DAH,DAL,V18, V19,V20,V21,V22 .....	1
3	PAFZZ	5340-00-088-1254	80205	MS21333-104	CLAMP,LOOP UOC: DAE,DAF,DAG,DAH,DAL,V18, V19,V20,V21,V22 .....	1
4	PAFZZ	4720-01-091-5169	19207	12256185	HOSE ASSEMBLY,METAL UOC: DAE,DAF,DAG,DAH,DAL,V18, V19,V20,V21,V22 .....	1
5	PAFZZ	5310-00-143-6102	81349	M45913/1-4FS3	NUT,SELF-LOCKING,HE UOC: DAE,DAF,DAG,DAH,DAL,V18, V19,V20,V21,V22 .....	1
6	AFFFF		19207	12256180	TUBE ASSEMBLY UOC: DAE,DAF,DAG,DAH,DAL,V18, V19,V20,V21,V22 .....	1
7	PAFZZ	4730-00-014-2433	13174	41-WB-06	. INVERTED NUT,TUBE C UOC: DAE,DAF,DAG,DAH,DAL,V18, V19,V20,V21,V22 .....	2
8	MFFZZ		19207	12256180-AR	. TUBE,METALLIC MAKE FROM TUBE, P/N 5174K5, AS REQUIRED UOC: DAE,DAF,DAG,DAH,DAL,V18, V19,V20,V21,V22 .....	1
9	PAFZZ	5305-00-269-3233	80204	B1821BH038F063N	SCREW,CAP,HEXAGON H UOC: DAE,DAF,DAG,DAH,DAL,V18, V19,V20,V21,V22 .....	4
10	PAFZZ	5340-00-954-6014	80205	MS21333-121	CLAMP,LOOP UOC: DAE,DAF,DAG,DAH,DAL,V18, V19,V20,V21,V22 .....	4
11	PAFZZ	5310-00-959-1488	81349	M45913/2-6FG5C	NUT,SELF-LOCKING,HE UOC: DAE,DAF,DAG,DAH,DAL,V18, V19,V20,V21,V22 .....	5
12	PAFZZ	5340-00-989-1771	80205	MS21333-123	CLAMP,LOOP UOC: DAE,DAF,DAG,DAH,DAL,V18, V19,V20,V21,V22 .....	3
13	AFFFF		19207	12256177	TUBE ASSEMBLY FUEL INLET UOC: DAE,DAF,DAG,DAH,DAL,V18, V19,V20,V21,V22 .....	1

(1) ITEM NO.	(2) SMR CODE	(3) NSN	(4) CAGEC	(5) PART NUMBER	(6) DESCRIPTION AND USABLE ON CODE (UOC)	(7) QTY
14	MFFZZ		19207	12256177-AR	. TUBE,METALLIC MAKE FROM TUBE, P/N ASTM B280, LENGTH AS REQUIRED UOC: DAE,DAF,DAG,DAH,DAL,V18, V19,V20,V21,V22 .....	1
15	PAFZZ	4730-00-014-2435	81343	8-040110B	. INVERTED NUT,TUBE C UOC: DAE,DAF,DAG,DAH,DAL,V18, V19,V20,V21,V22 .....	1
16	PAFZZ	4730-00-202-9036	81343	SAE J246 8-8 120102BA	ADAPTER,STRAIGHT,PI UOC: DAE,DAF,DAG,DAH,DAL,V18, V19,V20,V21,V22 .....	1
17	PAFZZ	4820-00-752-9040	58536	AA59440/1-004	COCK,DRAIN UOC: DAE,DAF,DAG,DAH,DAL,V18, V19,V20,V21,V22 .....	1
18	PAFZZ	4730-01-133-6209	96906	MS14315-6X	BUSHING,PIPE UOC: DAE,DAF,DAG,DAH,DAL,V18, V19,V20,V21,V22 .....	1
19	PAFZZ	4730-01-095-2034	81343	SAE J530 8-8-8 130424BA	TEE,PIPE UOC: DAE,DAF,DAG,DAH,DAL,V18, V19,V20,V21,V22 .....	1
20	PAFZZ	4730-01-090-6468	30780	10-1/2 AOEG-SS	ELBOW,PIPE TO TUBE UOC: DAE,DAF,DAG,DAH,DAL,V18, V19,V20,V21,V22 .....	1
21	PAFZZ	4730-01-104-4314	30780	10-1/2 AOE4G-B	ELBOW,PIPE TO TUBE UOC: DAE,DAF,DAG,DAH,DAL,V18, V19,V20,V21,V22 .....	1
22	PAFZZ	5340-00-053-8994	80205	MS21333-126	CLAMP,LOOP UOC: DAE,DAF,DAG,DAH,DAL,V18, V19,V20,V21,V22 .....	1
23	PAFZZ	5305-00-269-2804	80205	MS90726-61	SCREW,CAP,HEXAGON H UOC: DAE,DAF,DAG,DAH,DAL,V18, V19,V20,V21,V22 .....	1
24	PAFZZ	4720-01-090-7618	19207	12256186	HOSE ASSEMBLY,NONME UOC: DAE,DAF,DAG,DAH,DAL,V18, V19,V20,V21,V22 .....	1

END OF FIGURE

**FIELD MAINTENANCE  
FUEL TANK LINES, DUAL LH**

---

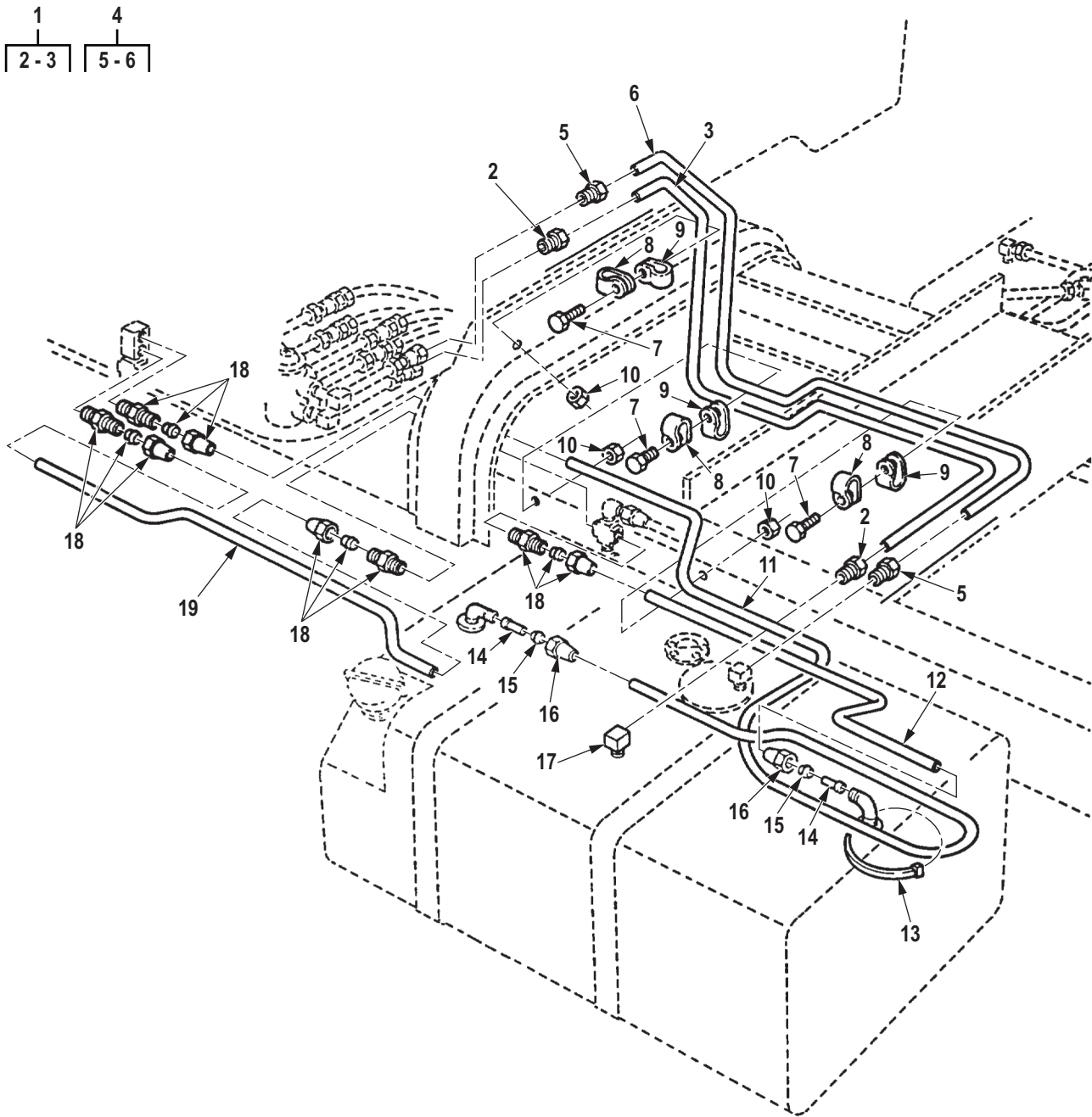

R0076DAA

Figure 76. Fuel Tank Lines, Dual LH.

(1) ITEM NO.	(2) SMR CODE	(3) NSN	(4) CAGEC	(5) PART NUMBER	(6) DESCRIPTION AND USABLE ON CODE (UOC)	(7) QTY
<b>GROUP 0306 TANKS, LINES, FITTINGS, HEADERS.</b>						
<b>FIG. 76. FUEL TANK LINES, DUAL LH.</b>						
1	AFFFF		19207	12256183	TUBE ASSY FUEL,L.H. RETURN UOC: DAE,DAF,DAG,DAH,V19,V20, V21,V22,ZAE,ZAF,ZAG,ZAH .....	1
2	PAFZZ	4730-00-014-2433	13174	41-WB-06	. INVERTED NUT,TUBE C UOC: DAE,DAF,DAG,DAH,V19,V20, V21,V22,ZAE,ZAF,ZAG,ZAH .....	2
3	MFFZZ		19207	12256183-AR	. TUBE,METALLIC MAKE FROM TUBE, P/N 5174K5, AS REQUIRED UOC: DAE,DAF,DAG,DAH,V19,V20, V21,V22,ZAE,ZAF,ZAG,ZAH .....	1
4	AFFFF		19207	12256184	TUBE ASSY FUEL,L.H. INLET UOC: DAE,DAF,DAG,DAH,V19,V20, V21,V22,ZAE,ZAF,ZAG,ZAH .....	1
5	PAFZZ	4730-00-014-2435	81343	8-040110B	. INVERTED NUT,TUBE C UOC: DAE,DAF,DAG,DAH,V19,V20, V21,V22,ZAE,ZAF,ZAG,ZAH .....	2
6	MFFZZ		19207	12256184-AR	. TUBE,METALLIC MAKE FROM TUBE, P/N ASTM B280, LENGTH AS REQUIRED UOC: DAE,DAF,DAG,DAH,V19,V20, V21,V22,ZAE,ZAF,ZAG,ZAH .....	1
7	PAFZZ	5305-00-269-3233	80204	B1821BH038F063N	SCREW,CAP,HEXAGON H UOC: DAE,DAF,DAG,DAH,V19,V20, V21,V22,ZAE,ZAF,ZAG,ZAH .....	3
8	PAFZZ	5340-00-954-6014	80205	MS21333-121	CLAMP,LOOP UOC: DAE,DAF,DAG,DAH,V19,V20, V21,V22,ZAE,ZAF,ZAG,ZAH .....	3
9	PAFZZ	5340-00-989-1771	80205	MS21333-123	CLAMP,LOOP UOC: DAE,DAF,DAG,DAH,V19,V20, V21,V22,ZAE,ZAF,ZAG,ZAH .....	3
10	PAFZZ	5310-00-959-1488	81349	M45913/2-6FG5C	NUT,SELF-LOCKING,HE UOC: DAE,DAF,DAG,DAH,V19,V20, V21,V22,ZAE,ZAF,ZAG,ZAH .....	3
11	MFFZZ		19207	CPR104420-1-105	TUBING,NYLON MAKE FROM TUBING,P/N CPR104420-1, 105 IN.LONG UOC: DAE,DAF,DAG,DAH,V19,V20, V21,V22,ZAE,ZAF,ZAG,ZAH .....	1
12	MFFZZ		19207	CPR104420-1-37	TUBING,NYLON MAKE FROM TUBING,P/N CPR104420-1, 37 IN.LONG UOC: DAE,DAF,DAG,DAH,V19,V20, V21,V22,ZAE,ZAF,ZAG,ZAH .....	1
13	PAFZZ	5975-00-984-6582	96906	MS3367-1-0	STRAP,TIEDOWN,ELECT UOC: DAE,DAF,DAG,DAH,V19,V20, V21,V22,ZAE,ZAF,ZAG,ZAH .....	3

(1) ITEM NO.	(2) SMR CODE	(3) NSN	(4) CAGEC	(5) PART NUMBER	(6) DESCRIPTION AND USABLE ON CODE (UOC)	(7) QTY
14	PAFZZ	4730-00-132-4588	19207	11648703	INSERT,TUBE FITTING UOC: DAE,DAF,DAG,DAH,V19,V20, V21,V22,ZAE,ZAF,ZAG,ZAH .....	4
15	PAFZZ	4730-00-122-0477	81343	4 120115B	SLEEVE,COMPRESSION, UOC: DAE,DAF,DAG,DAH,V19,V20, V21,V22,ZAE,ZAF,ZAG,ZAH .....	2
16	PAFZZ	4730-00-278-8824	06853	200455	NUT,TUBE COUPLING UOC: DAE,DAF,DAG,DAH,V19,V20, V21,V22,ZAE,ZAF,ZAG,ZAH .....	2
17	PAFZZ	4730-00-277-8274	12204	137423	ELBOW,PIPE TO TUBE UOC: DAE,DAF,DAG,DAH,V19,V20, V21,V22,ZAE,ZAF,ZAG,ZAH .....	1
18	PAFZZ	4730-00-270-4580	81343	SAE J246 4-4 120102BA	ADAPTER,STRAIGHT,PI UOC: DAE,DAF,DAG,DAH,V19,V20, V21,V22,ZAE,ZAF,ZAG,ZAH .....	4
19	MFFZZ		19207	CPR104420-1-36	TUBING,NONMETALIC MAKE FROM TUBING,P/N CPR104420-1, 36 IN.LONG UOC: DAE,DAF,DAG,DAH,V19,V20, V21,V22,ZAE,ZAF,ZAG,ZAH .....	1

END OF FIGURE



**FIELD MAINTENANCE  
FUEL TANK SELECTOR VALVE TO RH FUEL TANK LINES, DUAL**

---

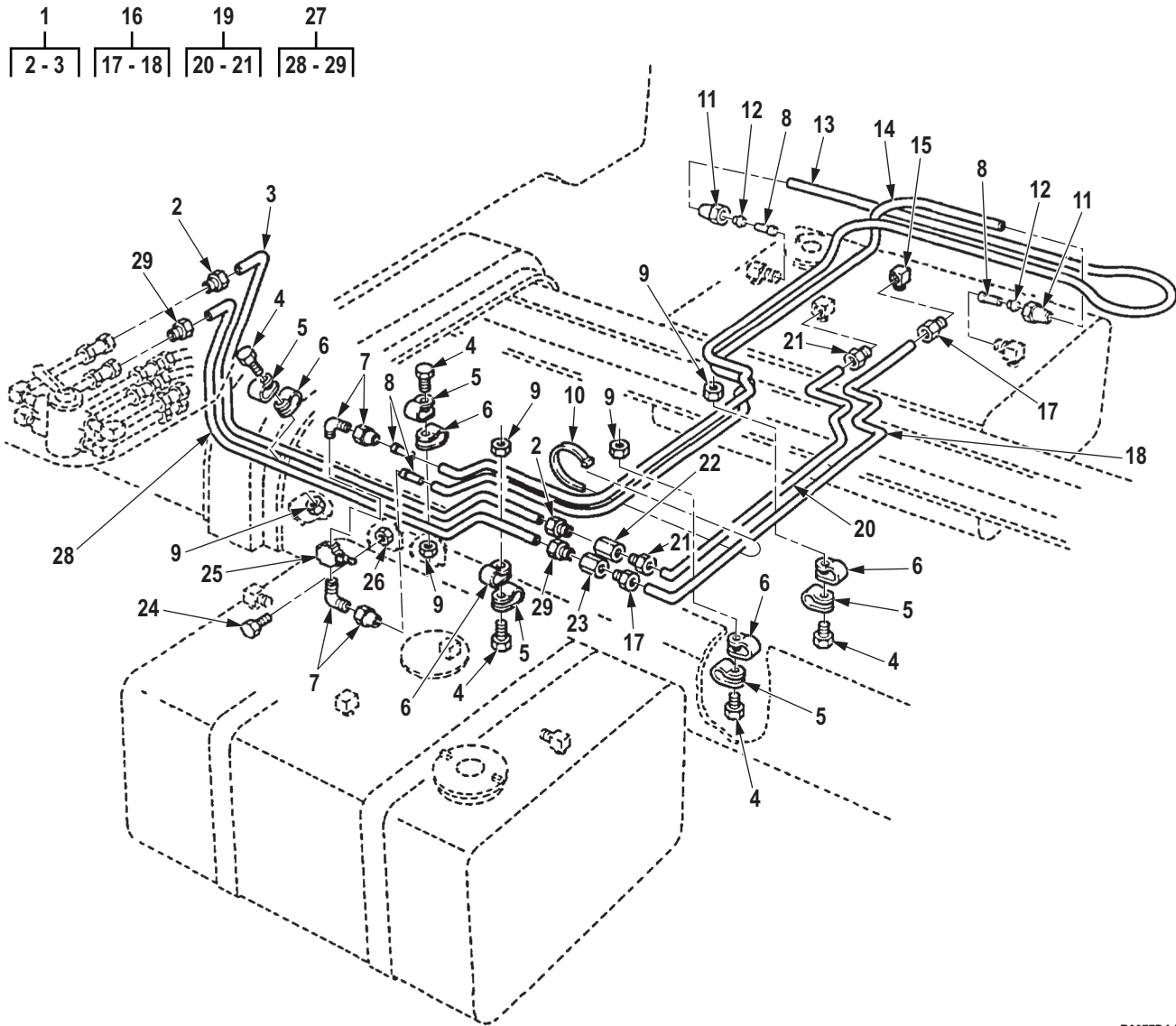

R0077DAA

Figure 77. Fuel Tank Selector Valve to RH Fuel Tank Lines, Dual.

(1) ITEM NO.	(2) SMR CODE	(3) NSN	(4) CAGEC	(5) PART NUMBER	(6) DESCRIPTION AND USABLE ON CODE (UOC)	(7) QTY
<p><b>GROUP 0306 TANKS, LINES, FITTINGS, HEADERS.</b></p> <p><b>FIG. 77. FUEL TANK SELECTOR VALVE TO RH FUEL TANK LINES, DUAL.</b></p>						
1	AFFFF		19207	12256181	TUBE ASSY R.H. SUPPLY,FRONT UOC: DAE,DAF,DAG,DAH,V19,V20, V21,V22,ZAE,ZAF,ZAG,ZAH .....	1
2	PAFZZ	4730-00-014-2435	81343	8-040110B	. INVERTED NUT,TUBE C UOC: DAE,DAF,DAG,DAH,V19,V20, V21,V22,ZAE,ZAF,ZAG,ZAH .....	2
3	MFFZZ		19207	12256181-AR	. TUBE,METALLIC TUBE R.H. SUPPLY,FRONT MAKE FROM TUBING,P/N ASTM B280,LENGTH AS REQUIRED UOC: DAE,DAF,DAG,DAH,V19,V20, V21,V22,ZAE,ZAF,ZAG,ZAH .....	1
4	PAFZZ	5305-00-269-3233	80204	B1821BH038F063N	SCREW,CAP,HEXAGON H UOC: DAE,DAF,DAG,DAH,V19,V20, V21,V22,ZAE,ZAF,ZAG,ZAH .....	5
5	PAFZZ	5340-00-954-6014	80205	MS21333-121	CLAMP,LOOP UOC: DAE,DAF,DAG,DAH,V19,V20, V21,V22,ZAE,ZAF,ZAG,ZAH .....	5
6	PAFZZ	5340-00-989-1771	80205	MS21333-123	CLAMP,LOOP UOC: DAE,DAF,DAG,DAH,V19,V20, V21,V22,ZAE,ZAF,ZAG,ZAH .....	5
7	PAFZZ	4730-01-208-5859	19207	8328777	ELBOW,PIPE TO TUBE UOC: DAE,DAF,DAG,DAH,V19,V20, V21,V22,ZAE,ZAF,ZAG,ZAH .....	2
8	PAFZZ	4730-00-278-8824	06853	200455	NUT,TUBE COUPLING UOC: DAE,DAF,DAG,DAH,V19,V20, V21,V22,ZAE,ZAF,ZAG,ZAH .....	2
9	PAFZZ	5310-00-959-1488	81349	M45913/2-6FG5C	NUT,SELF-LOCKING,HE UOC: DAE,DAF,DAG,DAH,V19,V20, V21,V22,ZAE,ZAF,ZAG,ZAH .....	5
10	PAFZZ	5975-00-984-6582	96906	MS3367-1-0	STRAP,TIEDOWN,ELECT UOC: DAE,DAF,DAG,DAH,V19,V20, V21,V22,ZAE,ZAF,ZAG,ZAH .....	10
11	PAFZZ	4730-00-132-4588	19207	11648703	INSERT,TUBE FITTING UOC: DAE,DAF,DAG,DAH,V19,V20, V21,V22,ZAE,ZAF,ZAG,ZAH .....	2
12	PAFZZ	4730-00-122-0477	81343	4 120115B	SLEEVE,COMPRESSION, UOC: DAE,DAF,DAG,DAH,V19,V20, V21,V22,ZAE,ZAF,ZAG,ZAH .....	2

(1) ITEM NO.	(2) SMR CODE	(3) NSN	(4) CAGEC	(5) PART NUMBER	(6) DESCRIPTION AND USABLE ON CODE (UOC)	(7) QTY
13	MFFZZ		19207	CPR104420-1-123	TUBING,NYLON VENT RIGHT REAR, MAKE FROM TUBING,P/N CPR104420-1,123 IN.LONG UOC: DAE,DAF,DAG,DAH,V19,V20, V21,V22,ZAE,ZAF,ZAG,ZAH .....	1
14	MFFZZ		19207	CPR104420-1-92	TUBING,NYLON VENT,R.H. REAR, MAKE FROM TUBING, P/N CPR104420-1, 92 IN.LONG UOC: DAE,DAF,DAG,DAH,V19,V20, V21,V22,ZAE,ZAF,ZAG,ZAH .....	1
15	PAFZZ	4730-00-277-8274	12204	137423	ELBOW,PIPE TO TUBE UOC: DAE,DAF,DAG,DAH,V19,V20, V21,V22,ZAE,ZAF,ZAG,ZAH .....	1
16	AFFFF		19207	12256179	TUBE ASSY FUEL R.H. RETURN UOC: DAE,DAF,DAG,DAH,V19,V20, V21,V22,ZAE,ZAF,ZAG,ZAH .....	1
17	PAFZZ	4730-00-014-2433	13174	41-WB-06	. INVERTED NUT,TUBE C UOC: DAE,DAF,DAG,DAH,V19,V20, V21,V22,ZAE,ZAF,ZAG,ZAH .....	2
18	MFFZZ		19207	12256179-AR	. TUBE,METALLIC TUBE FUEL R.H. RETURN,MAKE FROM TUBING,P/N ASTM B280 UOC: DAE,DAF,DAG,DAH,V19,V20, V21,V22,ZAE,ZAF,ZAG,ZAH .....	1
19	AFFFF		19207	12256182	TUBE ASSY R.H. SUPPLY,REAR UOC: DAE,DAF,DAG,DAH,V19,V20, V21,V22,ZAE,ZAF,ZAG,ZAH .....	1
20	MFFZZ		19207	12256182-AR	. TUBE,METALLIC TUBE R.H. SUPPLY,REAR,MAKE FROM TUBING,P/N ASTM B280 UOC: DAE,DAF,DAG,DAH,V19,V20, V21,V22,ZAE,ZAF,ZAG,ZAH .....	1
21	PAFZZ	4730-00-014-2435	81343	8-040110B	. INVERTED NUT,TUBE C UOC: DAE,DAF,DAG,DAH,V19,V20, V21,V22,ZAE,ZAF,ZAG,ZAH .....	2
22	PAFZZ	4730-01-148-7397	81343	SAE J512 8 040101B	COUPLING,TUBE UOC: DAE,DAF,DAG,DAH,V19,V20, V21,V22,ZAE,ZAF,ZAG,ZAH .....	1
23	PAFZZ	4730-00-278-8888	21450	137415	COUPLING,TUBE UOC: DAE,DAF,DAG,DAH,V19,V20, V21,V22,ZAE,ZAF,ZAG,ZAH .....	1
24	PAFZZ	5306-00-225-9088	80205	MS90726-33	BOLT,MACHINE UOC: DAE,DAF,DAG,DAH,V19,V20, V21,V22,ZAE,ZAF,ZAG,ZAH .....	1
25	PAFZZ	4730-01-112-6561	9S775	11669082	CROSS,PIPE UOC: DAE,DAF,DAG,DAH,V19,V20, V21,V22,ZAE,ZAF,ZAG,ZAH .....	1

(1) ITEM NO.	(2) SMR CODE	(3) NSN	(4) CAGEC	(5) PART NUMBER	(6) DESCRIPTION AND USABLE ON CODE (UOC)	(7) QTY
26	PAFZZ	5310-00-241-6658	81349	M45913/3-5FG8C	NUT,SELF-LOCKING,HE UOC: DAE,DAF,DAG,DAH,V19,V20, V21,V22,ZAE,ZAF,ZAG,ZAH .....	1
27	AFFFF		19207	12256178	TUBE ASSY FUEL R.H. RETURN UOC: DAE,DAF,DAG,DAH,V19,V20, V21,V22,ZAE,ZAF,ZAG,ZAH .....	1
28	MFFZZ		19207	12256178-AR	. TUBE,METALLIC TUBE FUEL R.H. RETURN,MAKE FROM TUBING,P/N ASTM B280 UOC: DAE,DAF,DAG,DAH,V19,V20, V21,V22,ZAE,ZAF,ZAG,ZAH .....	1
29	PAFZZ	4730-00-014-2433	13174	41-WB-06	. INVERTED NUT,TUBE C UOC: DAE,DAF,DAG,DAH,V19,V20, V21,V22,ZAE,ZAF,ZAG,ZAH .....	2

END OF FIGURE



**FIELD MAINTENANCE  
DUAL FUEL TANK SUPPLY AND RETURN LINES (M939A2)**

---

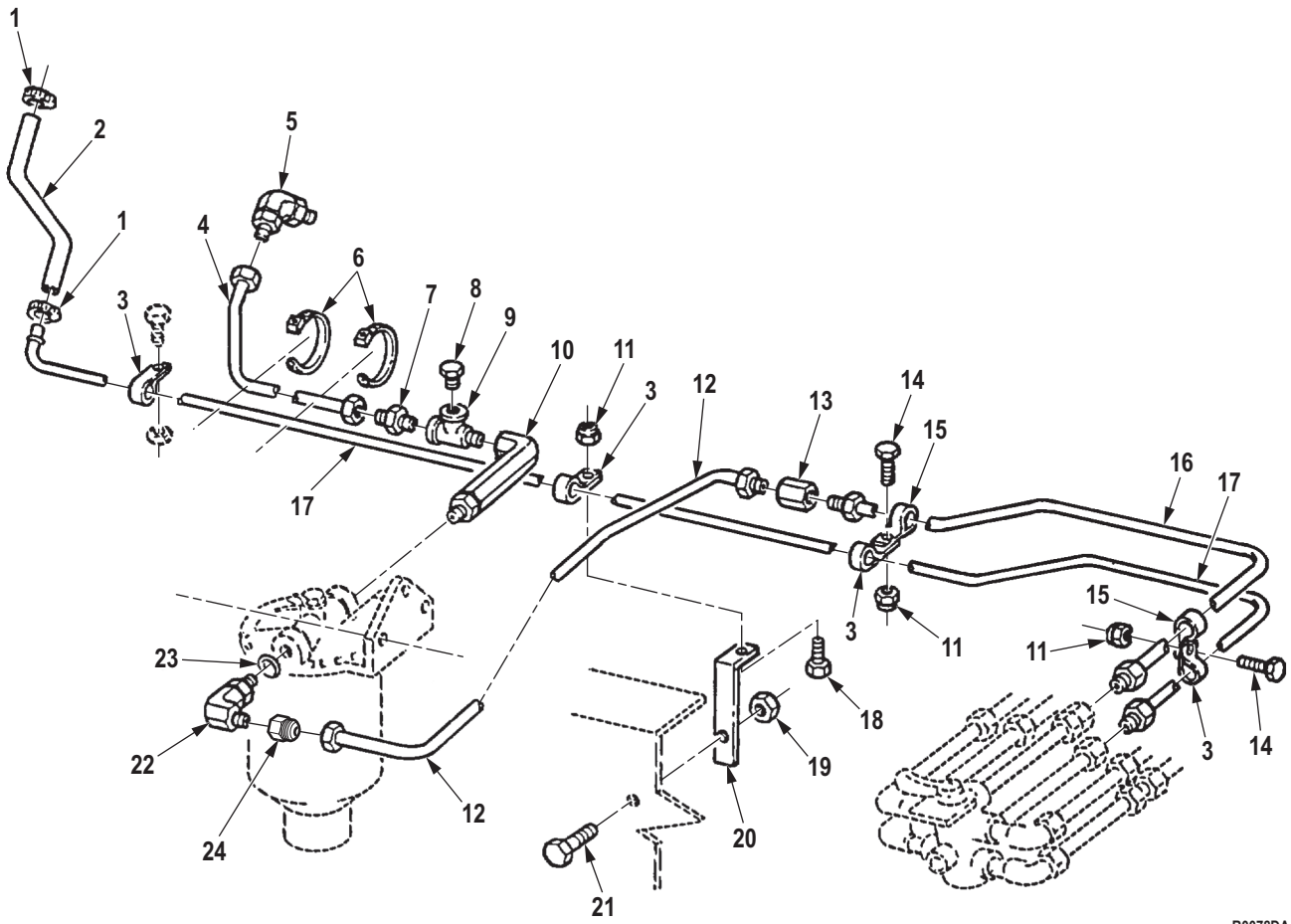

R0078DAA

Figure 78. Dual Fuel Tank Supply and Return Lines (M939A2).



(1) ITEM NO.	(2) SMR CODE	(3) NSN	(4) CAGEC	(5) PART NUMBER	(6) DESCRIPTION AND USABLE ON CODE (UOC)	(7) QTY
<b>GROUP 0306 TANKS, LINES, FITTINGS, HEADERS.</b>						
<b>FIG. 78. DUAL FUEL TANK SUPPLY AND RETURN LINES (M939A2).</b>						
1	PAFZZ	4730-01-109-8001	81343	J1508 TYPE M, SIZE 04	CLAMP,HOSE UOC: ZAE,ZAF,ZAG,ZAH,ZAL .....	2
2	MFFZZ		98441	A2697 X 15-1/2IN	RETURN HOSE,FUEL MAKE FROM HOSE,P/N 1525-6,15.5 IN.LONG UOC: ZAE,ZAF,ZAG,ZAH,ZAL .....	1
3	PAFZZ	5340-00-954-6014	80205	MS21333-121	CLAMP,LOOP UOC: ZAE,ZAF,ZAG,ZAH,ZAL .....	4
4	PAFZZ	4720-01-441-2922	96906	MS52104C8-0270	HOSE ASSEMBLY,NONME UOC: ZAE,ZAF,ZAG,ZAH,ZAL .....	1
5	PAFZZ	4730-00-235-1483	72915	8040341	ELBOW,PIPE TO TUBE UOC: ZAE,ZAF,ZAG,ZAH,ZAL .....	1
6	PAFZZ	5975-00-985-6630	96906	MS3367-3-0	STRAP,TIEDOWN,ELECT UOC: ZAE,ZAF,ZAG,ZAH,ZAL .....	2
7	PAFZZ	4730-00-809-9427	81343	MS51500A8-8	ADAPTER,STRAIGHT,PI UOC: ZAE,ZAF,ZAG,ZAH,ZAL .....	1
8	PAFZZ	4730-00-014-4027	51900	8W8X543	PLUG,PIPE UOC: ZAE,ZAF,ZAG,ZAH,ZAL .....	1
9	PAFZZ	4730-01-095-2034	81343	SAE J530 8-8-8 130424BA	TEE,PIPE UOC: ZAE,ZAF,ZAG,ZAH,ZAL .....	1
10	PAFZZ	4730-01-104-4314	30780	10-1/2 AOE4G-B	ELBOW,PIPE TO TUBE UOC: ZAE,ZAF,ZAG,ZAH,ZAL .....	3
11	PAFZZ	5310-00-959-1488	81349	M45913/2-6FG5C	NUT,SELF-LOCKING,HE UOC: ZAE,ZAF,ZAG,ZAH,ZAL .....	3
12	PAFZZ	4720-01-442-2533	19207	12432371	HOSE ASSEMBLY,NONME UOC: ZAE,ZAF,ZAG,ZAH,ZAL .....	1
13	PAFZZ	4730-00-203-3179	81343	8-8 010103B	ADAPTER,STRAIGHT,PI UOC: ZAE,ZAF,ZAG,ZAH,ZAL .....	1
14	PAFZZ	5305-00-269-3233	80204	B1821BH038F063N	SCREW,CAP,HEXAGON H UOC: ZAE,ZAF,ZAG,ZAH,ZAL .....	1
15	PAFZZ	4730-01-280-6402	08627	3545	CLAMP,HOSE,SPECIAL- UOC: ZAE,ZAF,ZAG,ZAH,ZAL .....	1
16	PAFZZ	4710-01-282-2586	05MG0	12256177A	TUBE ASSEMBLY,METAL UOC: ZAE,ZAF,ZAG,ZAH,ZAL .....	1
17	PAFZZ	4710-01-282-2585	05MG0	12256180A	TUBE ASSEMBLY,METAL UOC: ZAE,ZAF,ZAG,ZAH,ZAL .....	1
18	PAFZZ	5305-00-269-3234	80204	B1821BH038F075N	SCREW,CAP,HEXAGON H UOC: ZAE,ZAF,ZAG,ZAH,ZAL .....	1
19	PAFZZ	5310-00-225-6408	81349	M45913/1-10FG5C	NUT,SELF-LOCKING,HE UOC: ZAE,ZAF,ZAG,ZAH,ZAL .....	1
20	PAFZZ	5340-01-285-7762	05MG0	20510933	BRACKET,ANGLE UOC: ZAE,ZAF,ZAG,ZAH,ZAL .....	1

(1) ITEM NO.	(2) SMR CODE	(3) NSN	(4) CAGEC	(5) PART NUMBER	(6) DESCRIPTION AND USABLE ON CODE (UOC)	(7) QTY
21	PAFZZ	5305-00-726-2543	80204	B1821BH063F125N	SCREW,CAP,HEXAGON H UOC: ZAE,ZAF,ZAG,ZAH,ZAL .....	1
22	PAFZZ	4730-00-254-6229	81343	8-8 010202B	ELBOW,PIPE TO TUBE UOC: ZAE,ZAF,ZAG,ZAH,ZAL .....	1
23	PAFZZ	5330-01-220-5498	24617	274250	PACKING,PREFORMED UOC: ZAE,ZAF,ZAG,ZAH,ZAL .....	1
24	PAFZZ	4730-01-123-0254	30780	0502-10-8	ADAPTER,STRAIGHT,PI UOC: ZAE,ZAF,ZAG,ZAH,ZAL .....	1

END OF FIGURE

**FIELD MAINTENANCE  
FUEL TANK FUEL LINES TO LH TANK, WRECKER**

---

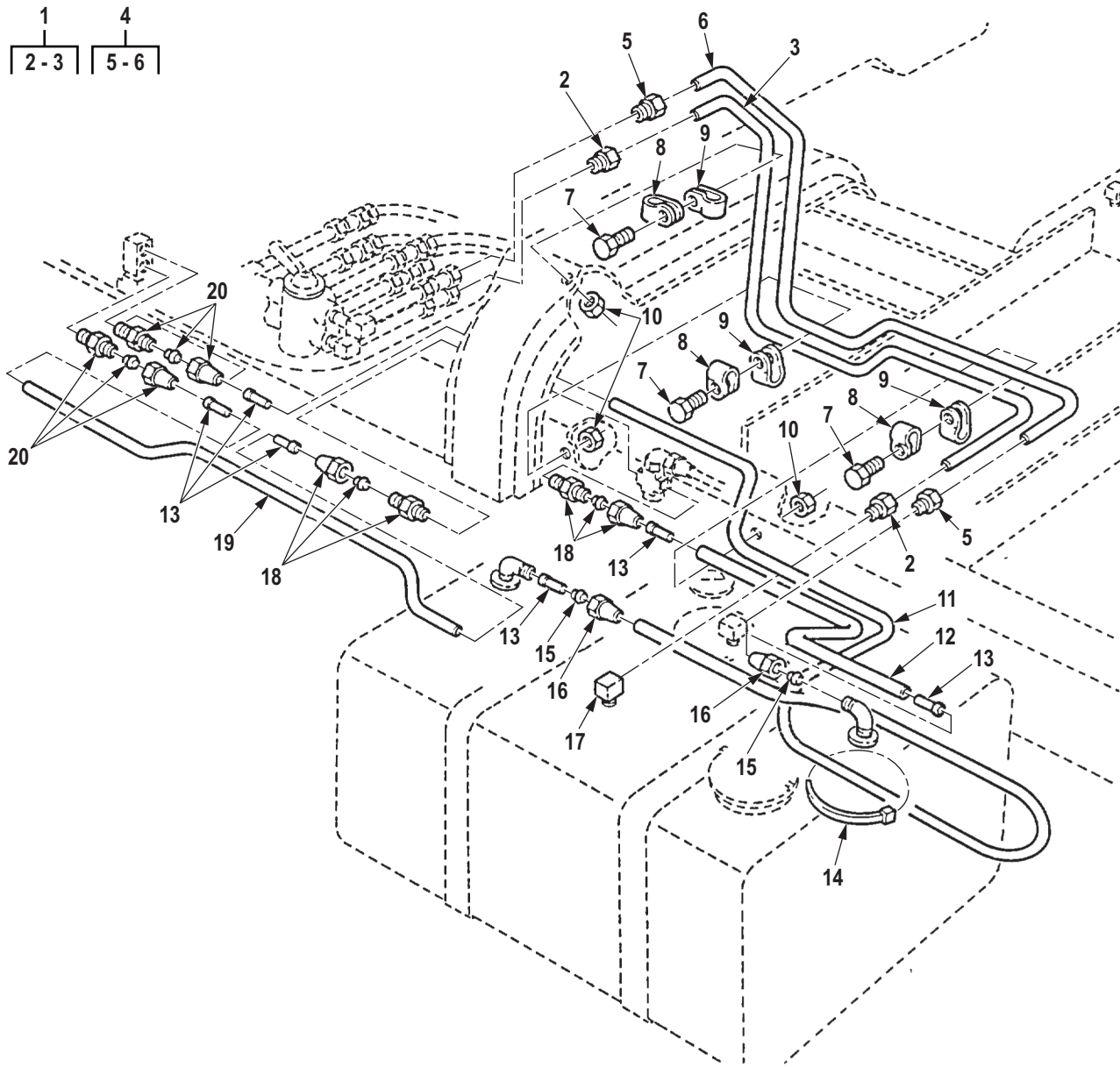

R0079DAA

Figure 79. Fuel Tank Fuel Lines to LH Tank, Wrecker.

(1) ITEM NO.	(2) SMR CODE	(3) NSN	(4) CAGEC	(5) PART NUMBER	(6) DESCRIPTION AND USABLE ON CODE (UOC)	(7) QTY
<b>GROUP 0306 TANKS, LINES, FITTINGS, HEADERS.</b>						
<b>FIG. 79. FUEL TANK FUEL LINES TO LH TANK, WRECKER.</b>						
1	AFFFF		19207	12256596	TUBE ASSEMBLY FUEL,RETURN,L.H. UOC: DAL,V18,ZAL .....	1
2	PAFZZ	4730-00-014-2433	13174	41-WB-06	. INVERTED NUT,TUBE C UOC: DAL,V18,ZAL .....	2
3	MFFZZ		19207	12256596-AR	. TUBE,METALLIC FUEL RETURN,L.H.,MAKE FROM TUBE, P/ N 5174K5, LENGTH AS REQUIRED UOC: DAL,V18,ZAL .....	1
4	AFFFF		19207	12256595	TUBE ASSEMBLY FUEL INLET,L.H.,AND TWO INVERTED NUTS UOC: DAL,V18,ZAL .....	1
5	PAFZZ	4730-00-014-2435	81343	8-040110B	. INVERTED NUT,TUBE C UOC: DAL,V18,ZAL .....	2
6	MFFZZ		19207	12256595-AR	. TUBE,METALLIC FUEL INLET,L.H.,MAKE FROM TUBE, P/N ASTM B280, LENGTH AS REQUIRED UOC: DAL,V18,ZAL .....	1
7	PAFZZ	5305-00-269-3233	80204	B1821BH038F063N	SCREW,CAP,HEXAGON H UOC: DAL,V18,ZAL .....	3
8	PAFZZ	5340-00-954-6014	80205	MS21333-121	CLAMP,LOOP UOC: DAL,V18,ZAL .....	3
9	PAFZZ	5340-00-989-1771	80205	MS21333-123	CLAMP,LOOP UOC: DAL,V18,ZAL .....	3
10	PAFZZ	5310-00-959-1488	81349	M45913/2-6FG5C	NUT,SELF-LOCKING,HE UOC: DAL,V18,ZAL .....	3
11	MFFZZ		19207	CPR104420-1-150	TUBING,NYLON L.H.,MAKE FROM TUBING,P/N CPR104420-1 (19207), 150 IN.LONG UOC: DAL,V18,ZAL .....	1
12	MFFZZ		19207	CPR104420-1-60	TUBING,NYLON L.H.,MAKE FROM TUBING,P/N CPR104420-1 (19207), 60 IN.LONG UOC: DAL,V18,ZAL .....	1
13	PAFZZ	4730-00-132-4588	19207	11648703	INSERT,TUBE FITTING UOC: DAL,V18,ZAL .....	4
14	PAFZZ	5975-00-984-6582	96906	MS3367-1-0	STRAP,TIEDOWN,ELECT UOC: DAL,V18,ZAL .....	5
15	PAFZZ	4730-00-122-0477	81343	4 120115B	SLEEVE,COMPRESSION, UOC: DAL,V18,ZAL .....	2
16	PAFZZ	4730-00-278-8824	06853	200455	NUT,TUBE COUPLING UOC: DAL,V18,ZAL .....	2

(1) ITEM NO.	(2) SMR CODE	(3) NSN	(4) CAGEC	(5) PART NUMBER	(6) DESCRIPTION AND USABLE ON CODE (UOC)	(7) QTY
17	PAFZZ	4730-00-277-8274	12204	137423	ELBOW,PIPE TO TUBE UOC: DAL,V18,ZAL .....	1
18	PAFZZ	4730-00-270-4580	81343	SAE J246 4-4 120102BA	ADAPTER,STRAIGHT,PI UOC: DAL,V18,ZAL .....	3
19	MFFZZ		19207	CPR104420-1-36	TUBING,NONMETALIC MAKE FROM TUBING,P/N CPR104420-1, 36 IN.LONG UOC: DAL,V18,ZAL .....	1
20	PAFZZ	4730-01-208-5859	19207	8328777	ELBOW,PIPE TO TUBE UOC: DAL,V18,ZAL .....	1

END OF FIGURE

**FIELD MAINTENANCE  
DUAL FUEL TANK FUEL LINES TO RH TANK, WRECKER**

---

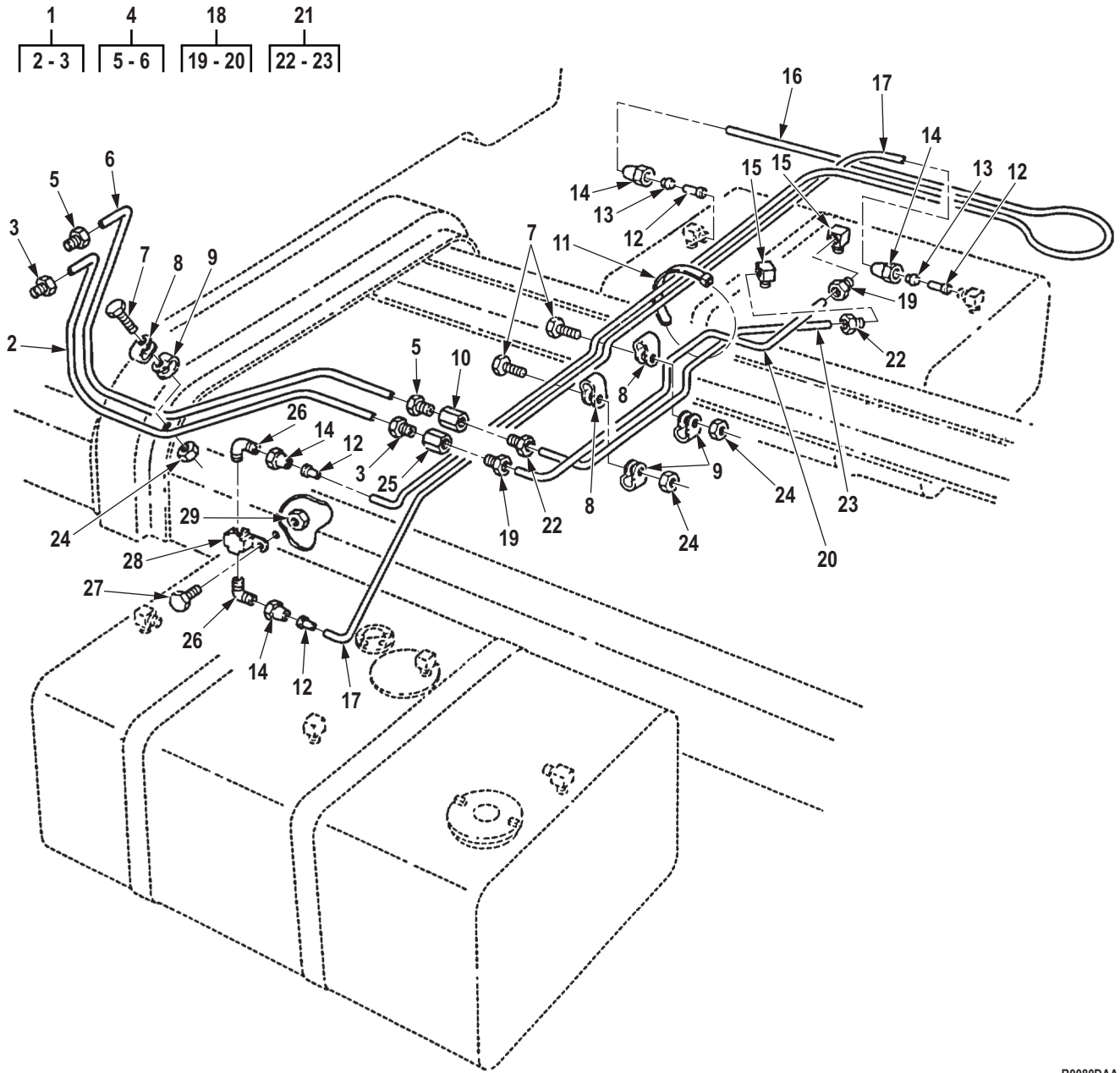

R0080DAA

Figure 80. Dual Fuel Tank Fuel Lines to RH Tank, Wrecker.



(1) ITEM NO.	(2) SMR CODE	(3) NSN	(4) CAGEC	(5) PART NUMBER	(6) DESCRIPTION AND USABLE ON CODE (UOC)	(7) QTY
<b>GROUP 0306 TANKS, LINES, FITTINGS, HEADERS.</b>						
<b>FIG. 80. DUAL FUEL TANK FUEL LINES TO RH TANK, WRECKER.</b>						
1	AFFFF		19207	12256597	TUBE ASSEMBLY FUEL R.H. INLET REAR, AND TWO INVERTED NUTS UOC: DAL,V18,ZAL .....	1
2	MFFZZ		19207	12256597-AR	. TUBE,METALLIC FUEL R.H. INLET REAR,MAKE FROM TUBE,P/ N 5174K5, AS REQUIRED UOC: DAL,V18,ZAL .....	1
3	PAFZZ	4730-00-014-2433	13174	41-WB-06	. INVERTED NUT,TUBE C UOC: DAL,V18,ZAL .....	2
4	AFFFF		19207	12256600	TUBE ASSEMBLY FUEL,R.H.INLET,AND TWO INVERTED NUTS UOC: DAL,V18,ZAL .....	1
5	PAFZZ	4730-00-014-2435	81343	8-040110B	. INVERTED NUT,TUBE C UOC: DAL,V18,ZAL .....	2
6	MFFZZ		19207	12256600-AR	. TUBE,METALLIC FUEL,R.H.INLET,MAKE FROM TUBE, P/N ASTM B280, LENGTH AS REQUIRED UOC: DAL,V18,ZAL .....	1
7	PAFZZ	5305-00-269-3233	80204	B1821BH038F063N	SCREW,CAP,HEXAGON H UOC: DAL,V18,ZAL .....	5
8	PAFZZ	5340-00-954-6014	80205	MS21333-121	CLAMP,LOOP UOC: DAL,V18,ZAL .....	5
9	PAFZZ	5340-00-989-1771	80205	MS21333-123	CLAMP,LOOP UOC: DAL,V18,ZAL .....	5
10	PAFZZ	4730-00-278-8889	21450	137417	COUPLING,TUBE UOC: DAL,V18,ZAL .....	1
11	PAFZZ	5975-00-984-6582	96906	MS3367-1-0	STRAP,TIEDOWN,ELECT UOC: DAL,V18,ZAL .....	3
12	PAFZZ	4730-00-132-4588	19207	11648703	INSERT,TUBE FITTING UOC: DAL,V18,ZAL .....	2
13	PAFZZ	4730-00-122-0477	81343	4 120115B	SLEEVE,COMPRESSION, UOC: DAL,V18,ZAL .....	2
14	PAFZZ	4730-00-278-8824	06853	200455	NUT,TUBE COUPLING UOC: DAL,V18,ZAL .....	2
15	PAFZZ	4730-00-277-8274	12204	137423	ELBOW,PIPE TO TUBE UOC: DAL,V18,ZAL .....	2
16	MFFZZ		19207	CPR104420-1-142	TUBING,NYLON MAKE FROM TUBING,P/N CPR104420-1,142 IN.LONG UOC: DAL,V18,ZAL .....	1

(1) ITEM NO.	(2) SMR CODE	(3) NSN	(4) CAGEC	(5) PART NUMBER	(6) DESCRIPTION AND USABLE ON CODE (UOC)	(7) QTY
17	MFFZZ		19207	CPR104420-1-128	TUBING,NYLON MAKE FROM TUBING,P/N CPR104420-1,128 IN.LONG UOC: DAL,V18,ZAL .....	1
18	AFFFF		19207	12256598	TUBE ASSEMBLY FUEL R.H. RETURN, AND TWO INVERTED NUTS UOC: DAL,V18,ZAL .....	1
19	PAFZZ	4730-00-014-2433	13174	41-WB-06	. INVERTED NUT,TUBE C UOC: DAL,V18,ZAL .....	2
20	MFFZZ		19207	12256598-AR	. TUBE,METALLIC FUEL R.H. RETURN,MAKE FROM TUBE, P/N 5174K5, AS REQUIRED UOC: DAL,V18,ZAL .....	1
21	AFFFF		19207	12256599	TUBE ASSEMBLY FUEL R.H. INLET,REAR,AND TWO INVERTED NUTS UOC: DAL,V18,ZAL .....	1
22	PAFZZ	4730-00-014-2435	81343	8-040110B	. INVERTED NUT,TUBE C UOC: DAL,V18,ZAL .....	2
23	MFFZZ		19207	12256599-AR	. TUBE,METALLIC FUEL R.H. INLET,REAR,MAKE FROM TUBE, P/ N ASTM B280, LENGTH AS REQUIRED UOC: DAL,V18,ZAL .....	1
24	PAFZZ	5310-00-959-1488	81349	M45913/2-6FG5C	NUT,SELF-LOCKING,HE UOC: DAL,V18,ZAL .....	5
25	PAFZZ	4730-00-278-8888	21450	137415	COUPLING,TUBE UOC: DAL,V18,ZAL .....	1
26	PAFZZ	4730-01-208-5859	19207	8328777	ELBOW,PIPE TO TUBE UOC: DAL,V18,ZAL .....	2
27	PAFZZ	5306-00-225-9088	80205	MS90726-33	BOLT,MACHINE UOC: DAL,V18,ZAL .....	1
28	PAFZZ	4730-01-112-6561	9S775	11669082	CROSS,PIPE UOC: DAL,V18,ZAL .....	1
29	PAFZZ	5310-00-241-6658	81349	M45913/3-5FG8C	NUT,SELF-LOCKING,HE UOC: DAL,V18,ZAL .....	1

END OF FIGURE

**FIELD MAINTENANCE  
FUEL TANK SELECTOR VALVE ASSEMBLY AND RELATED PARTS**

---

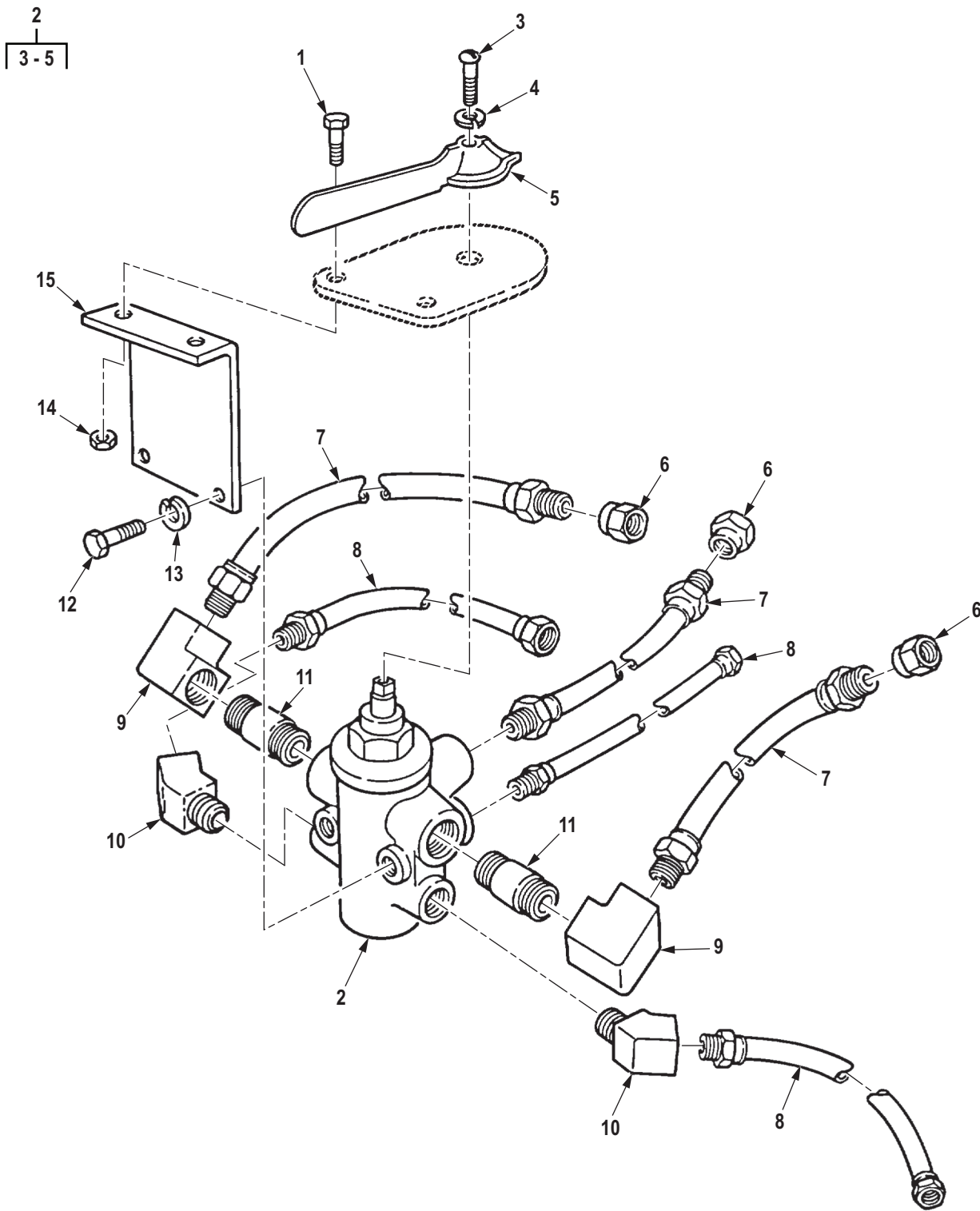

R0081DAA

Figure 81. Fuel Tank Selector Valve Assembly and Related Parts.

(1) ITEM NO.	(2) SMR CODE	(3) NSN	(4) CAGEC	(5) PART NUMBER	(6) DESCRIPTION AND USABLE ON CODE (UOC)	(7) QTY
<b>GROUP 0306 TANKS, LINES, FITTINGS, HEADERS.</b>						
<b>FIG. 81. FUEL TANK SELECTOR VALVE ASSEMBLY AND RELATED PARTS.</b>						
1	PAFZZ	5306-00-068-0514	80204	B1821BH025F088N	BOLT,MACHINE UOC: DAE,DAF,DAG,DAH,DAL,V18, V19,V20,V21,V22,ZAE,ZAF,ZAG,ZAH,ZAL	2
2	PAFZZ	4820-01-117-7949	70411	SP2483-CM, REV E	VALVE,FUEL,6 PORT UOC: DAE,DAF,DAG,DAH,DAL,V18, V19,V20,V21,V22,ZAE,ZAF,ZAG,ZAH,ZAL	1
3	PAFZZ	5305-00-984-6208	95105	343-0586-000	. SCREW,MACHINE UOC: DAE,DAF,DAG,DAH,DAL,V18, V19,V20,V21,V22,ZAE,ZAF,ZAG,ZAH,ZAL	1
4	PAFZZ	5310-00-045-3296	80205	MS35338-43	. WASHER,LOCK UOC: DAE,DAF,DAG,DAH,DAL,V18, V19,V20,V21,V22,ZAE,ZAF,ZAG,ZAH,ZAL	1
5	PAFZZ	5340-01-569-5467	70411	8X61	. HANDLE,LEVER UOC: DAE,DAF,DAG,DAH,DAL,V18, V19,V20,V21,V22,ZAE,ZAF,ZAG,ZAH,ZAL	1
6	PAFZZ	4730-00-278-4594	81343	J512 8-6 040103BA	ADAPTER,STRAIGHT,PI UOC: DAE,DAF,DAG,DAH,DAL,V18, V19,V20,V21,V22,ZAE,ZAF,ZAG,ZAH,ZAL	3
7	PAFZZ	4720-00-001-7854	19207	11664614	HOSE ASSEMBLY,NONME UOC: DAE,DAF,DAG,DAH,DAL,V18, V19,V20,V21,V22,ZAE,ZAF,ZAG,ZAH,ZAL	3
8	PAFZZ	4720-00-096-9648	19207	11664615	HOSE ASSEMBLY,NONME UOC: DAE,DAF,DAG,DAH,DAL,V18, V19,V20,V21,V22,ZAE,ZAF,ZAG,ZAH,ZAL	3
9	PAFZZ	4730-00-253-5794	96906	MS14311-3P	ELBOW,PIPE UOC: DAJ,V24,ZAJ .....	2
10	PAFZZ	4730-00-278-4822	19207	7364214	ELBOW,PIPE UOC: DAE,DAF,DAG,DAH,DAL,V18, V19,V20,V21,V22,ZAE,ZAF,ZAG,ZAH,ZAL	2
11	PAFZZ	4730-00-196-1504	81346	A733S-75CFG	NIPPLE,PIPE UOC: DAE,DAF,DAG,DAH,DAL,V18, V19,V20,V21,V22,ZAE,ZAF,ZAG,ZAH,ZAL	2
12	PAFZZ	5305-00-721-5492	80204	B1821BH038C063N	SCREW,CAP,HEXAGON H UOC: DAE,DAF,DAG,DAH,DAL,V18, V19,V20,V21,V22,ZAE,ZAF,ZAG,ZAH,ZAL	2
13	PAFZZ	5310-00-637-9541	00198	132661	WASHER,LOCK UOC: DAE,DAF,DAG,DAH,DAL,V18, V19,V20,V21,V22,ZAE,ZAF,ZAG,ZAH,ZAL	2
14	PAFZZ	5310-00-935-9022	81349	M45913/3-4FG8C	NUT,SELF-LOCKING,HE UOC: DAE,DAF,DAG,DAH,DAL,V18, V19,V20,V21,V22,ZAE,ZAF,ZAG,ZAH,ZAL	2

(1) ITEM NO.	(2) SMR CODE	(3) NSN	(4) CAGEC	(5) PART NUMBER	(6) DESCRIPTION AND USABLE ON CODE (UOC)	(7) QTY
15	PAFZZ	5340-00-036-0236	19207	10931962	BRACKET,ANGLE UOC: DAE,DAF,DAG,DAH,DAL,V18, V19,V20,V21,V22,ZAE,ZAF,ZAG,ZAH,ZAL	1

END OF FIGURE

**FIELD MAINTENANCE  
FUEL TANK ASSEMBLY**

---

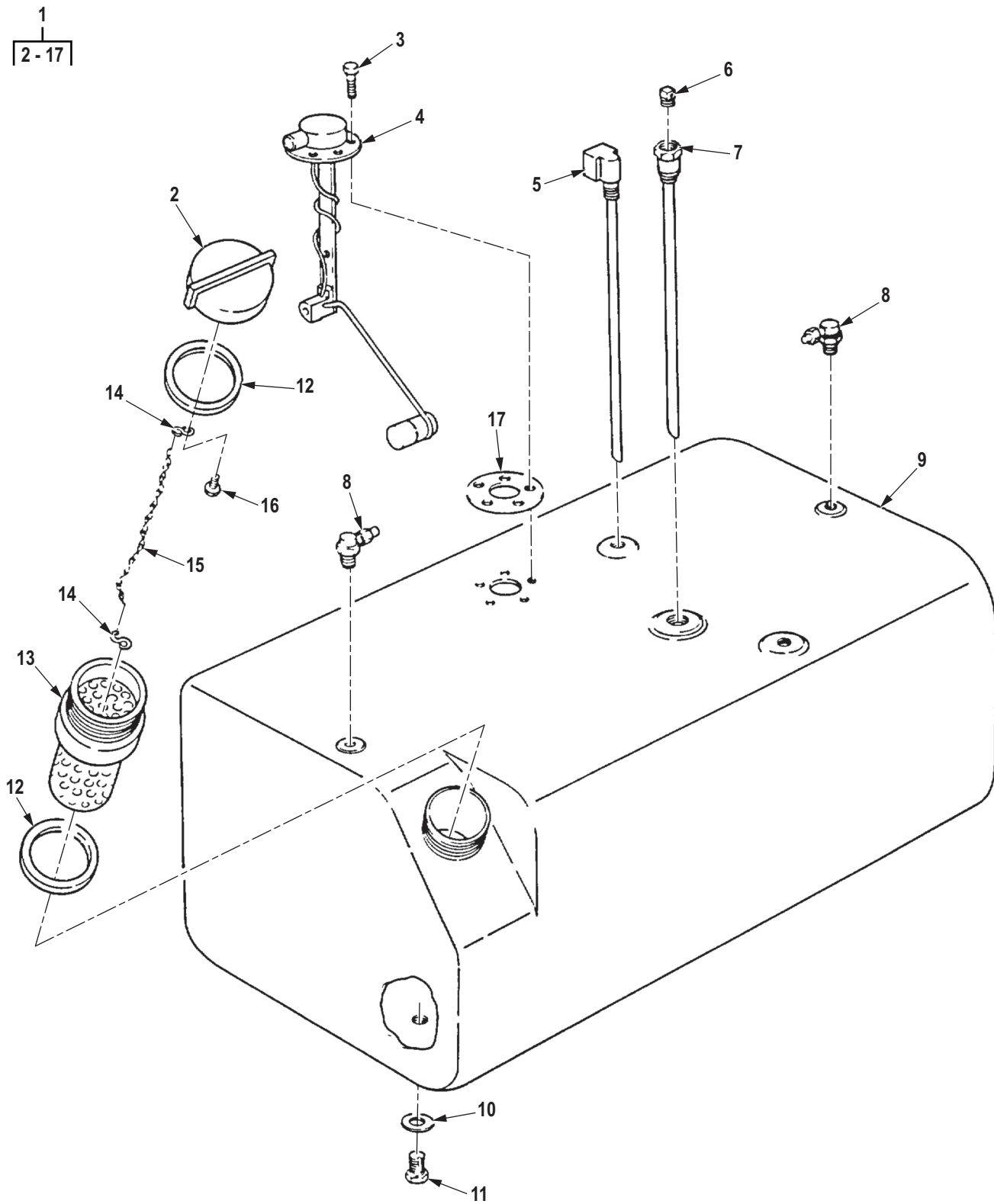

R0082DAA

Figure 82. Fuel Tank Assembly.



(1) ITEM NO.	(2) SMR CODE	(3) NSN	(4) CAGEC	(5) PART NUMBER	(6) DESCRIPTION AND USABLE ON CODE (UOC)	(7) QTY
<b>GROUP 0306 TANKS, LINES, FITTINGS, HEADERS.</b>						
<b>FIG. 82. FUEL TANK ASSEMBLY.</b>						
1	PAFZZ	2910-01-287-9120	19207	12301298-3	TANK,FUEL,ENGINE 58 GALLONS UOC: DAE,DAF,DAG,DAH,DAL,V18, V19,V20,V21,V22,ZAE,ZAF,ZAG,ZAH,ZAL	2
1	PAFZZ	2910-01-287-9120	19207	12301298-3	TANK,FUEL,ENGINE 58 GALLONS UOC: DAL,V18,ZAL .....	1
1	PAFZZ	2910-01-287-9119	19207	12301297-5	TANK,FUEL,ENGINE 81 GALLONS UOC: DAC,DAD,DAE,DAF,DAG,DA H,DAJ,DAL,DAW,DAX,V14,V15,V16, V17,V18,V19,V20,V21,V22,V24,ZAA, ZAB,ZAC,ZAD,ZAE,ZAF,ZAG,ZAH,Z AJ,ZAL .....	1
1	PAFZZ	2910-01-285-9850	19207	12301297-6	TANK,FUEL,ENGINE 81 GALLONS UOC: DAJ,V24,ZAJ .....	1
2	PAFZZ	2590-01-310-1166	19207	12356774	. CAP,FILLER OPENING UOC: DAC,DAD,DAE,DAF,DAG,DA H,DAJ,DAL,V14,V15,V16,V17,V18,V 19,V20,V21,V22,V24,ZAA,ZAB,ZAC, ZAD,ZAE,ZAF,ZAG,ZAH,ZAJ,ZAL .....	1
3	PAFZZ	5305-01-031-5094	80205	MS3213-35	. SCREW,MACHINE UOC: DAC,DAD,DAE,DAF,DAG,DA H,DAJ,DAL,V14,V15,V16,V17,V18,V 19,V20,V21,V22,V24,ZAA,ZAB,ZAC, ZAD,ZAE,ZAF,ZAG,ZAH,ZAJ,ZAL .....	5
4	PAFZZ	6680-00-226-4574	96906	MS500040-6	. TRANSMITTER,LIQUID UOC: DAC,DAD,DAE,DAF,DAG,DA H,DAJ,DAL,V14,V15,V16,V17,V18,V 19,V20,V21,V22,V24,ZAA,ZAB,ZAC, ZAD,ZAE,ZAF,ZAG,ZAH,ZAJ,ZAL .....	1
5	PAFZZ	4710-01-149-5078	19207	12302605	. TUBE ASSEMBLY,METAL UOC: DAC,DAD,DAE,DAF,DAG,DA H,DAJ,DAL,V14,V15,V16,V17,V18,V 19,V20,V21,V22,V24,ZAA,ZAB,ZAC, ZAD,ZAE,ZAF,ZAG,ZAH,ZAJ,ZAL .....	1
6	PAFZZ	4730-00-221-2137	81343	AS4863SIZE02 MOD.	PLUG,PIPE UOC: DAJ,V24,ZAJ .....	1
7	PAFZZ	4710-01-149-5079	19207	12302606	. TUBE ASSEMBLY,METAL UOC: DAJ,V24,ZAA,ZAJ .....	1
8	PAFZZ	4820-01-309-3799	78528	261-3	. VALVE,CHECK ROLLOVER PROTECTION UOC: DAC,DAD,DAE,DAF,DAG,DA H,DAJ,DAL,V14,V15,V16,V17,V18,V 19,V20,V21,V22,V24,ZAA,ZAB,ZAC, ZAD,ZAE,ZAF,ZAG,ZAH,ZAJ,ZAL .....	2

(1) ITEM NO.	(2) SMR CODE	(3) NSN	(4) CAGEC	(5) PART NUMBER	(6) DESCRIPTION AND USABLE ON CODE (UOC)	(7) QTY
9	XAFZZ		19207	12301297-4	. TANK,FUEL 81 GALLON UOC: DAC,V14,V15,V16,V17,V18,V19,V20,V21,V22,ZAA,ZAB,ZAC,ZAD,ZAJ,ZAL .....	1
9	XAFZZ		19207	12301298-1	. TANK,FUEL 58 GALLON UOC: DAE,DAF,DAG,DAH,DAL,V18,V19,V20,V21,V22,ZAE,ZAF,ZAG,ZAH,ZAL .....	1
10	PAFZZ	5310-01-133-5847	19207	12356773	. WASHER,FLAT UOC: DAC,DAD,DAE,DAF,DAG,DAH,DAJ,DAL,V14,V15,V16,V17,V18,V19,V20,V21,V22,V24,ZAA,ZAB,ZAC,ZAD,ZAE,ZAF,ZAG,ZAH,ZAJ,ZAL .....	1
11	PAFZZ	5365-01-298-4877	19207	12356772	. PLUG,MACHINE THREAD UOC: DAC,DAD,DAE,DAF,DAG,DAH,DAJ,DAL,V14,V15,V16,V17,V18,V19,V20,V21,V22,V24,ZAA,ZAB,ZAC,ZAD,ZAE,ZAF,ZAG,ZAH,ZAJ,ZAL .....	1
12	PAFZZ	5330-01-299-6616	19207	12356775	. GASKET UOC: DAC,DAD,DAE,DAF,DAG,DAH,DAJ,DAL,V14,V15,V16,V17,V18,V19,V20,V21,V22,V24,ZAA,ZAB,ZAC,ZAD,ZAE,ZAF,ZAG,ZAH,ZAJ,ZAL .....	2
13	PAFZZ	4730-01-079-6847	34623	5932881	. STRAINER ELEMENT,SE UOC: DAC,DAD,DAE,DAF,DAG,DAH,DAJ,DAL,V14,V15,V16,V17,V18,V19,V20,V21,V22,V24,ZAA,ZAB,ZAC,ZAD,ZAE,ZAF,ZAG,ZAH,ZAJ,ZAL .....	1
14	PAFZZ	4030-00-270-5436	96906	MS87006-3	. HOOK,CHAIN,S UOC: DAC,DAD,DAE,DAF,DAG,DAH,DAJ,DAL,V14,V15,V16,V17,V18,V19,V20,V21,V22,V24,ZAA,ZAB,ZAC,ZAD,ZAE,ZAF,ZAG,ZAH,ZAJ,ZAL .....	2
15	MFFZZ		16004	C43974 X 15 LG	. CHAIN,WELDLESS MAKE FROM CHAIN, P/N C43974, 15 IN.LONG UOC: DAC,DAD,DAE,DAF,DAG,DAH,DAJ,DAL,DAW,DAX,V14,V15,V16,V17,V18,V19,V20,V21,V22,V24,ZAA,ZAB,ZAC,ZAD,ZAE,ZAF,ZAG,ZAH,ZAJ,ZAL .....	1
16	PAFZZ	5305-00-855-0958	80205	MS24629-45	. SCREW,TAPPING UOC: DAC,DAD,DAE,DAF,DAG,DAH,DAJ,DAL,V14,V15,V16,V17,V18,V19,V20,V21,V22,V24,ZAA,ZAB,ZAC,ZAD,ZAE,ZAF,ZAG,ZAH,ZAJ,ZAL .....	1

(1) ITEM NO.	(2) SMR CODE	(3) NSN	(4) CAGEC	(5) PART NUMBER	(6) DESCRIPTION AND USABLE ON CODE (UOC)	(7) QTY
17	PAFZZ	5330-00-753-9072	19207	7539072	. GASKET UOC: DAC,DAD,DAE,DAF,DAG,DA H,DAJ,DAL,V14,V15,V16,V17,V18,V 19,V20,V21,V22,V24,ZAA,ZAB,ZAC, ZAD,ZAE,ZAF,ZAG,ZAH,ZAJ,ZAL .....	1

END OF FIGURE



**FIELD MAINTENANCE  
FUEL TANK PROTECTOR PLATE AND MOUNTING HARDWARE**

---

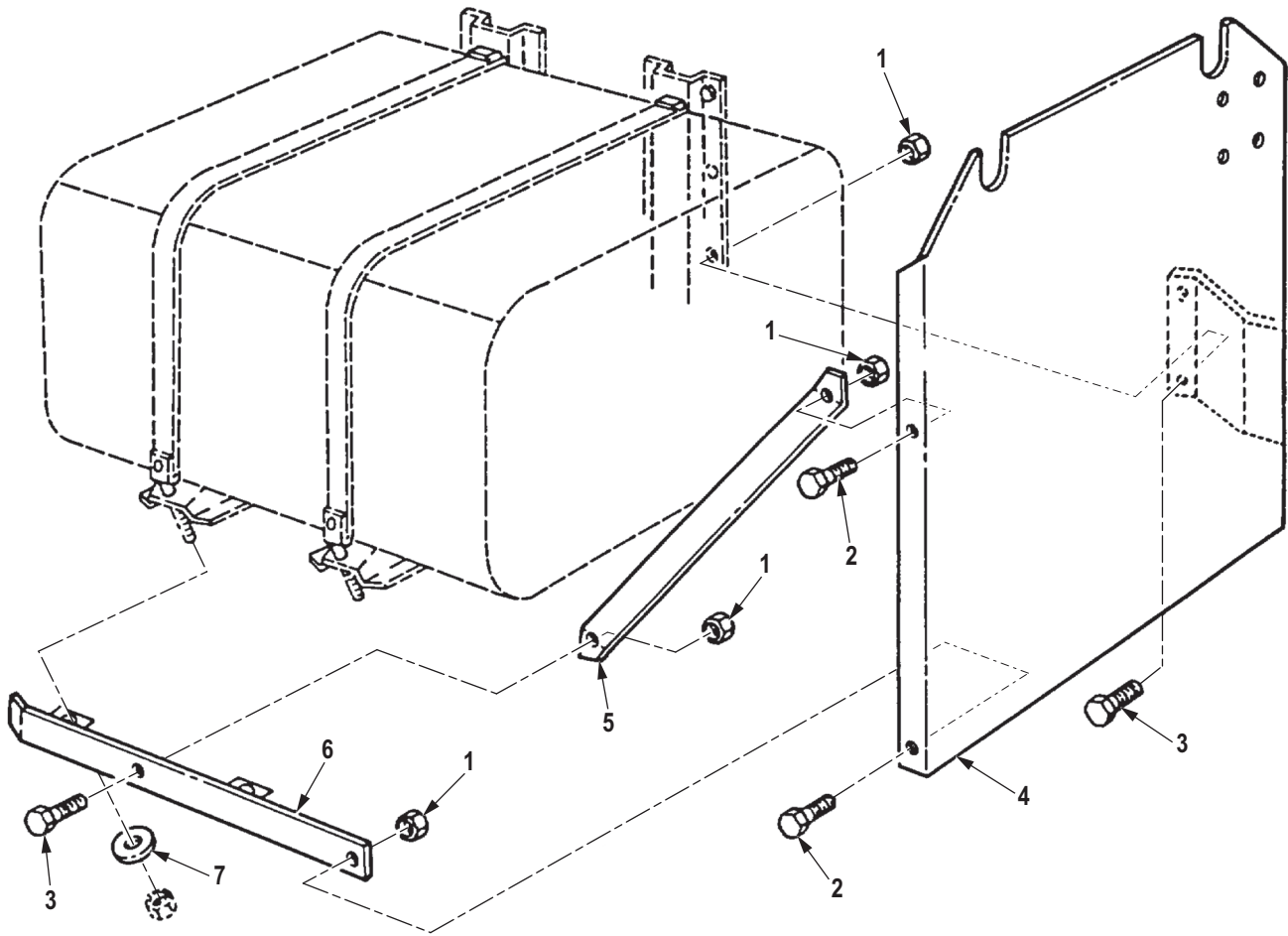

R0083DAA

Figure 83. Fuel Tank Protector Plate and Mounting Hardware.

(1) ITEM NO.	(2) SMR CODE	(3) NSN	(4) CAGEC	(5) PART NUMBER	(6) DESCRIPTION AND USABLE ON CODE (UOC)	(7) QTY
<b>GROUP 0306 TANKS, LINES, FITTINGS, HEADERS.</b>						
<b>FIG. 83. FUEL TANK PROTECTOR PLATE AND MOUNTING HARDWARE.</b>						
1	PAFZZ	5310-00-814-0672	96906	M45913/3-6FG8C	NUT, SELF-LOCKING, HE UOC: DAE, DAF, V19, V20, ZAE, ZAF .....	8
2	PAFZZ	5305-00-912-5113	80205	MS51096-359	SCREW, CAP, HEXAGON H UOC: DAE, DAF, V19, V20, ZAE, ZAF .....	4
3	PAFZZ	5305-00-269-2803	80205	MS90726-60	SCREW, CAP, HEXAGON H UOC: DAE, DAF, V19, V20, ZAE, ZAF .....	4
4	PFFZZ	2510-00-407-6768	19207	10899256	PROTECTOR PLATE, FUE L.H. TANK UOC: DAE, DAF, V19, V20, ZAE, ZAF .....	1
4	PFFZZ	2510-00-417-2713	19207	10899372	PLATE, TANK, PROTECTO R.H. TANK UOC: DAE, DAF, V19, V20, ZAE, ZAF .....	1
5	PFFZZ	5340-00-407-6767	19207	10899255	PLATE, MENDING UOC: DAE, DAF, V19, V20, ZAE, ZAF .....	2
6	PFFZZ	2510-00-408-4631	19207	10899258	BRACKET, PROTECTOR L.H. PLATE UOC: DAE, DAF, V19, V20, ZAE, ZAF .....	1
6	PFFZZ	2510-00-408-4632	19207	10899259	BRACKET, PROTECTOR R.H. PLATE UOC: DAE, DAF, V19, V20, ZAE, ZAF .....	1
7	PAFZZ	5310-00-080-6004	96906	MS27183-14	WASHER, FLAT UOC: DAE, DAF, V19, V20, ZAE, ZAF .....	4

**END OF FIGURE**





**FIELD MAINTENANCE  
FUEL PUMP GOVERNOR, AFC (M939, M939A1)**

---

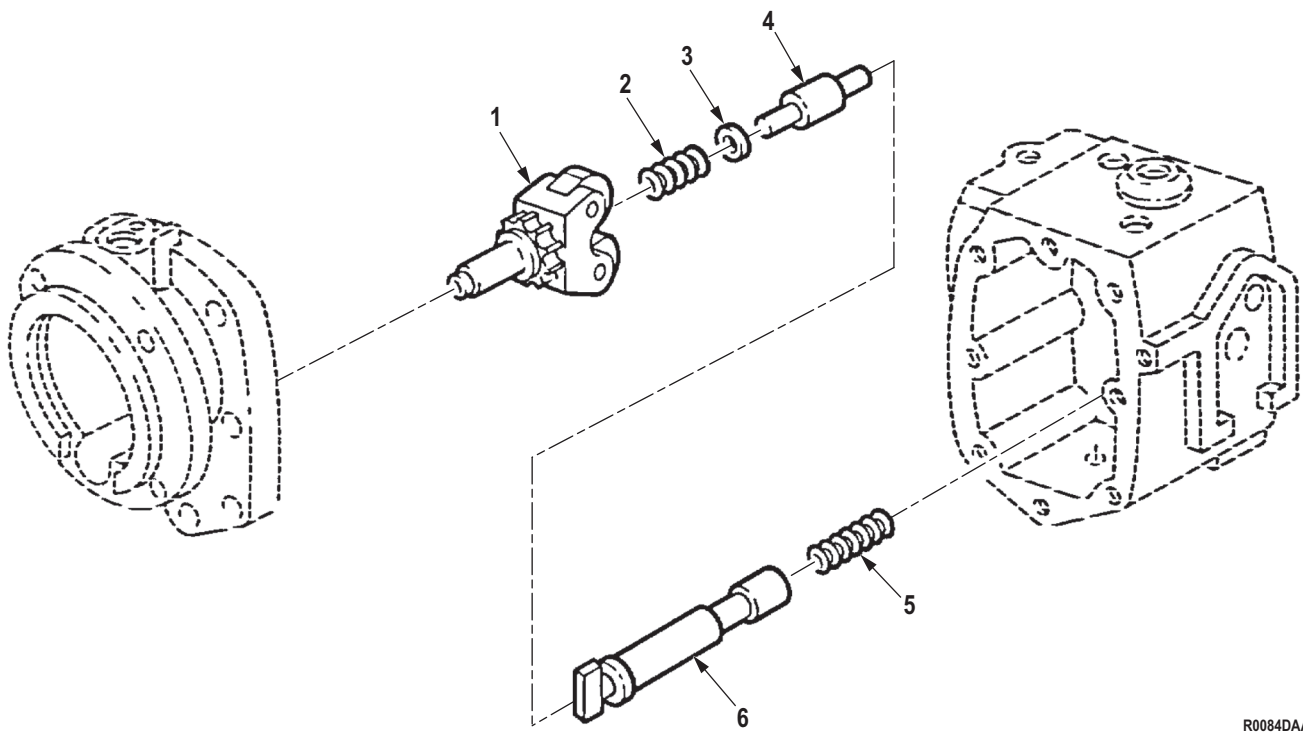

R0084DAA

Figure 84. Fuel Pump Governor, AFC (M939, M939A1).

(1) ITEM NO.	(2) SMR CODE	(3) NSN	(4) CAGEC	(5) PART NUMBER	(6) DESCRIPTION AND USABLE ON CODE (UOC)	(7) QTY
<b>GROUP 0308 ENGINE SPEED GOVERNOR AND CONTROLS.</b>						
<b>FIG. 84. FUEL PUMP GOVERNOR, AFC (M939, M939A1).</b>						
1	PBHZZ	2990-01-143-5489	15434	3024989	WEIGHT AND CARRIER FUEL PUMP UOC: DAC,DAD,DAE,DAF,DAG,DAH,DAJ,DAW,DAX,V14,V15,V16,V17,V19,V20,V21,V22,V24 .....	1
2	PAHZZ	5360-01-095-3661	15434	143848	SPRING,HELICAL,COMP UOC: DAC,DAD,DAE,DAF,DAG,DAH,DAJ,DAW,DAX,V14,V15,V16,V17,V19,V20,V21,V22,V24 .....	1
3	PAHZZ	5310-00-727-8353	96906	MS27183-43	WASHER,FLAT GOVERNOR WEIGHT ASSEMBLY UOC: DAC,DAD,DAE,DAF,DAG,DAH,DAJ,DAW,DAX,V14,V15,V16,V17,V19,V20,V21,V22,V24 .....	1
4	PAHZZ	5315-00-082-0448	15434	144178	PIN,SHOULDER,HEADLE UOC: DAC,DAD,DAE,DAF,DAG,DAH,DAJ,DAW,DAX,V14,V15,V16,V17,V19,V20,V21,V22,V24 .....	1
5	PAHZZ	5360-01-137-6707	15434	138999	SPRING USE AFTER SERIAL NUMBER 11246664 UOC: DAC,DAD,DAE,DAF,DAG,DAH,DAJ,DAW,DAX,V14,V15,V16,V17,V19,V20,V21,V22,V24 .....	1
5	PAHZZ	5360-01-215-5766	15434	138795	SPRING,HELICAL,COMP USE PRIOR TO SERIAL NUMBER 11246663 UOC: DAC,DAD,DAE,DAF,DAG,DAH,DAJ,DAW,DAX,V14,V15,V16,V17,V19,V20,V21,V22,V24 .....	1
6	PBHZZ	2910-01-230-1919	15434	304076000	PLUNGER,GOVERNOR USE AFTER SERIAL NUMBER 11246664 UOC: DAC,DAD,DAE,DAF,DAG,DAH,DAJ,DAW,DAX,V14,V15,V16,V17,V19,V20,V21,V22,V24 .....	1
6	PBHZZ	5342-01-145-1549	15434	3010810	PLUNGER USE PRIOR TO SERIAL NUMBER 11246663 UOC: DAC,DAD,DAE,DAF,DAG,DAH,DAJ,DAW,DAX,V14,V15,V16,V17,V19,V20,V21,V22,V24 .....	1

END OF FIGURE



**FIELD MAINTENANCE  
FUEL PUMP SPRING PACK, AFC (M939, M939A1)**

---

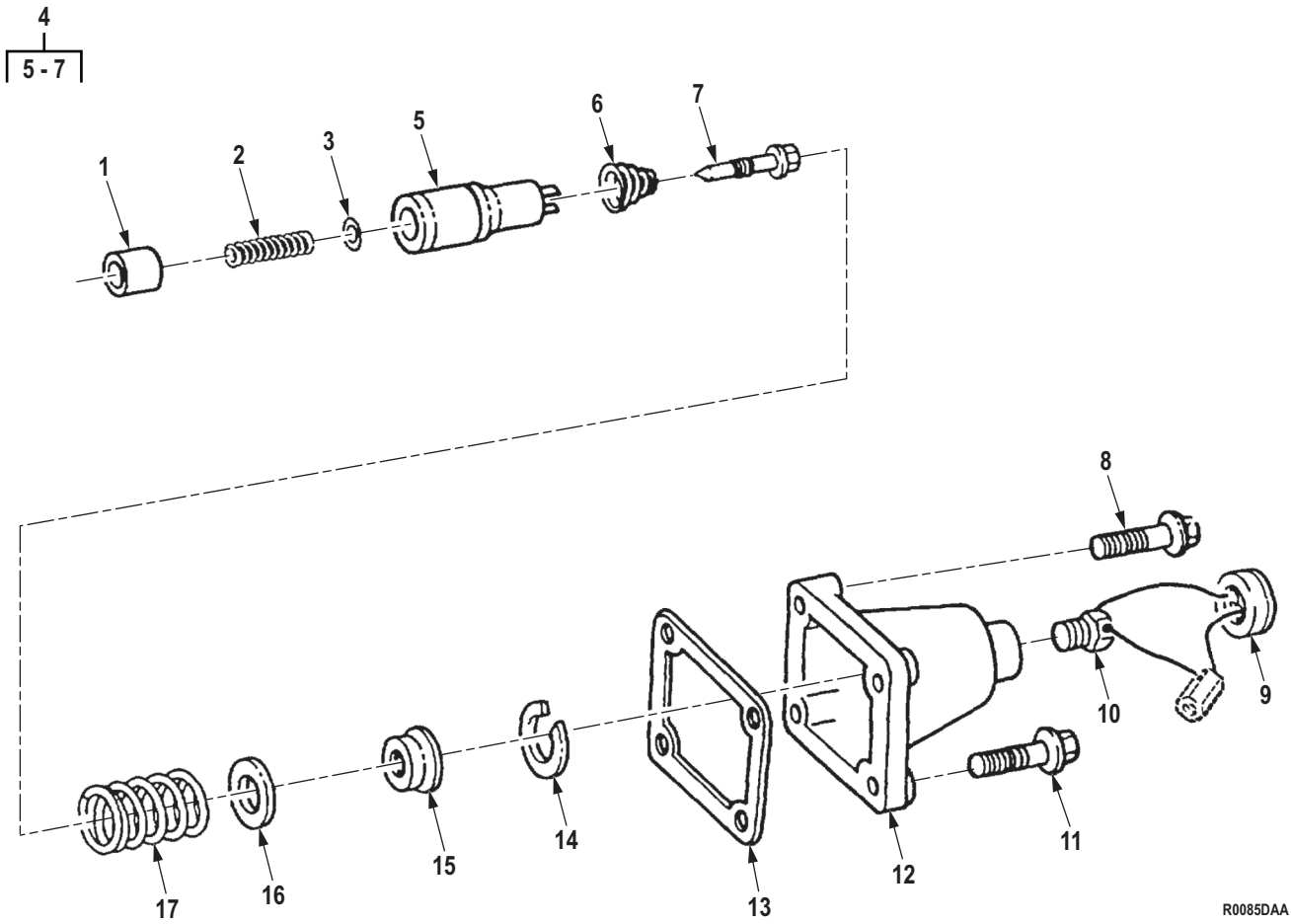

R0085DAA

Figure 85. Fuel Pump Spring Pack, AFC (M939, M939A1).

(1) ITEM NO.	(2) SMR CODE	(3) NSN	(4) CAGEC	(5) PART NUMBER	(6) DESCRIPTION AND USABLE ON CODE (UOC)	(7) QTY
<b>GROUP 0308 ENGINE SPEED GOVERNOR AND CONTROLS.</b>						
<b>FIG. 85. FUEL PUMP SPRING PACK, AFC (M939, M939A1).</b>						
1	PAHZZ	2910-00-238-5434	15434	138862	PLUNGER, IDLE SPRING USE PRIOR TO SERIAL NUMBER 11246663 UOC: DAC, DAD, DAE, DAF, DAG, DA H, DAJ, DAW, DAX, V14, V15, V16, V17, V19, V20, V21, V22, V24 .....	1
1	PAHZZ	2910-01-189-0901	15434	14163400	PLUNGER, GOVERNOR USE AFTER SERIAL NUMBER 11246663 UOC: DAC, DAD, DAE, DAF, DAG, DA H, DAJ, DAW, DAX, V14, V15, V16, V17, V19, V20, V21, V22, V24 .....	1
2	PAHZZ	5360-00-082-0124	15434	144195	. SPRING, HELICAL, COMP UOC: DAC, DAD, DAE, DAF, DAG, DA H, DAJ, DAW, DAX, V14, V15, V16, V17, V19, V20, V21, V22, V24 .....	1
3	PAHZZ	5310-00-507-3259	15434	70715	WASHER, FLAT UOC: DAC, DAD, DAE, DAF, DAG, DA H, DAJ, DAW, DAX, V14, V15, V16, V17, V19, V20, V21, V22, V24 .....	1
4	PBHZZ	2910-00-803-2631	15434	BM69889	SPRING GUIDE, ASSEMB UOC: DAC, DAD, DAE, DAF, DAG, DA H, DAJ, DAW, DAX, V14, V15, V16, V17, V19, V20, V21, V22, V24 .....	1
5	PAHZZ	2990-01-218-6935	15434	303647300	. RETAINER, HELICAL CO UOC: DAC, DAD, DAE, DAF, DAG, DA H, DAJ, DAW, DAX, V14, V15, V16, V17, V19, V20, V21, V22, V24 .....	1
6	PAHZZ	5360-01-240-1626	15434	3032014	. SPRING, HELICAL, COMP UOC: DAC, DAD, DAE, DAF, DAG, DA H, DAJ, DAW, DAX, V14, V15, V16, V17, V19, V20, V21, V22, V24 .....	1
7	PAHZZ	5305-00-506-5722	15434	70716	. SETSCREW UOC: DAC, DAD, DAE, DAF, DAG, DA H, DAJ, DAW, DAX, V14, V15, V16, V17, V19, V20, V21, V22, V24 .....	1
8	PAHZZ	5305-01-112-9110	15434	3017051	SCREW, CAP, HEXAGON H UOC: DAC, DAD, DAE, DAF, DAG, DA H, DAJ, DAW, DAX, V14, V15, V16, V17, V19, V20, V21, V22, V24 .....	3
9	PAHZZ	5330-01-072-8830	15434	3003156	SEAL, SPECIAL PART OF KIT P/N 5704519 UOC: DAC, DAD, DAE, DAF, DAG, DA H, DAJ, DAW, DAX, V14, V15, V16, V17, V19, V20, V21, V22, V24 .....	1

(1) ITEM NO.	(2) SMR CODE	(3) NSN	(4) CAGEC	(5) PART NUMBER	(6) DESCRIPTION AND USABLE ON CODE (UOC)	(7) QTY
10	PAHZZ	5342-01-143-6046	15434	3025459	PLUG,COVER UOC: DAC,DAD,DAE,DAF,DAG,DA H,DAJ,DAW,DAX,V14,V15,V16,V17, V19,V20,V21,V22,V24 .....	1
11	PAHZZ	5305-01-126-1128	15434	3017052	SCREW,CAP,HEXAGON H UOC: DAC,DAD,DAE,DAF,DAG,DA H,DAJ,DAW,DAX,V14,V15,V16,V17, V19,V20,V21,V22,V24 .....	2
12	PBHZZ	2910-00-858-3522	15434	44678	COVER,SPRING PACK UOC: DAC,DAD,DAE,DAF,DAG,DA H,DAJ,DAW,DAX,V14,V15,V16,V17, V19,V20,V21,V22,V24 .....	1
13	PAHZZ	5330-00-562-1176	15434	70705	GASKET PART OF KIT P/N 3010240, PART OF KIT P/N 5704519 UOC: DAC,DAD,DAE,DAF,DAG,DA H,DAJ,DAW,DAX,V14,V15,V16,V17, V19,V20,V21,V22,V24 .....	1
14	PAHZZ	5325-00-807-2636	96906	MS16625-1100	RING,RETAINING UOC: DAC,DAD,DAE,DAF,DAG,DA H,DAJ,DAW,DAX,V14,V15,V16,V17, V19,V20,V21,V22,V24 .....	1
15	PAHZZ	5365-01-119-4954	15434	203346	SPACER,SLEEVE UOC: DAC,DAD,DAE,DAF,DAG,DA H,DAJ,DAW,DAX,V14,V15,V16,V17, V19,V20,V21,V22,V24 .....	1
16	PAHZZ	5365-00-507-3261	15434	70717A	SHIM PART OF KIT P/N 5704519 UOC: DAC,DAD,DAE,DAF,DAG,DA H,DAJ,DAW,DAX,V14,V15,V16,V17, V19,V20,V21,V22,V24 .....	1
16	PAHZZ	5365-00-507-3262	15434	70717B	SHIM PART OF KIT P/N 5704519 UOC: DAC,DAD,DAE,DAF,DAG,DA H,DAJ,DAW,DAX,V14,V15,V16,V17, V19,V20,V21,V22,V24 .....	1
16	PAHZZ	5365-00-462-4504	15434	189800	SHIM PART OF KIT P/N 5704519 UOC: DAC,DAD,DAE,DAF,DAG,DA H,DAJ,DAW,DAX,V14,V15,V16,V17, V19,V20,V21,V22,V24 .....	1
16	PAHZZ	5365-00-507-3260	15434	70717	SPACER,RING PART OF KIT P/N 5704519 UOC: DAC,DAD,DAE,DAF,DAG,DA H,DAJ,DAW,DAX,V14,V15,V16,V17, V19,V20,V21,V22,V24 .....	1
17	PAHZZ	5360-01-222-6879	15434	3000940	SPRING,HELICAL,COMP UOC: DAC,DAD,DAE,DAF,DAG,DA H,DAJ,DAW,DAX,V14,V15,V16,V17, V19,V20,V21,V22,V24 .....	1

END OF FIGURE



**FIELD MAINTENANCE  
FUEL PUMP GOVERNOR, VS (M939, M939A1)**

---

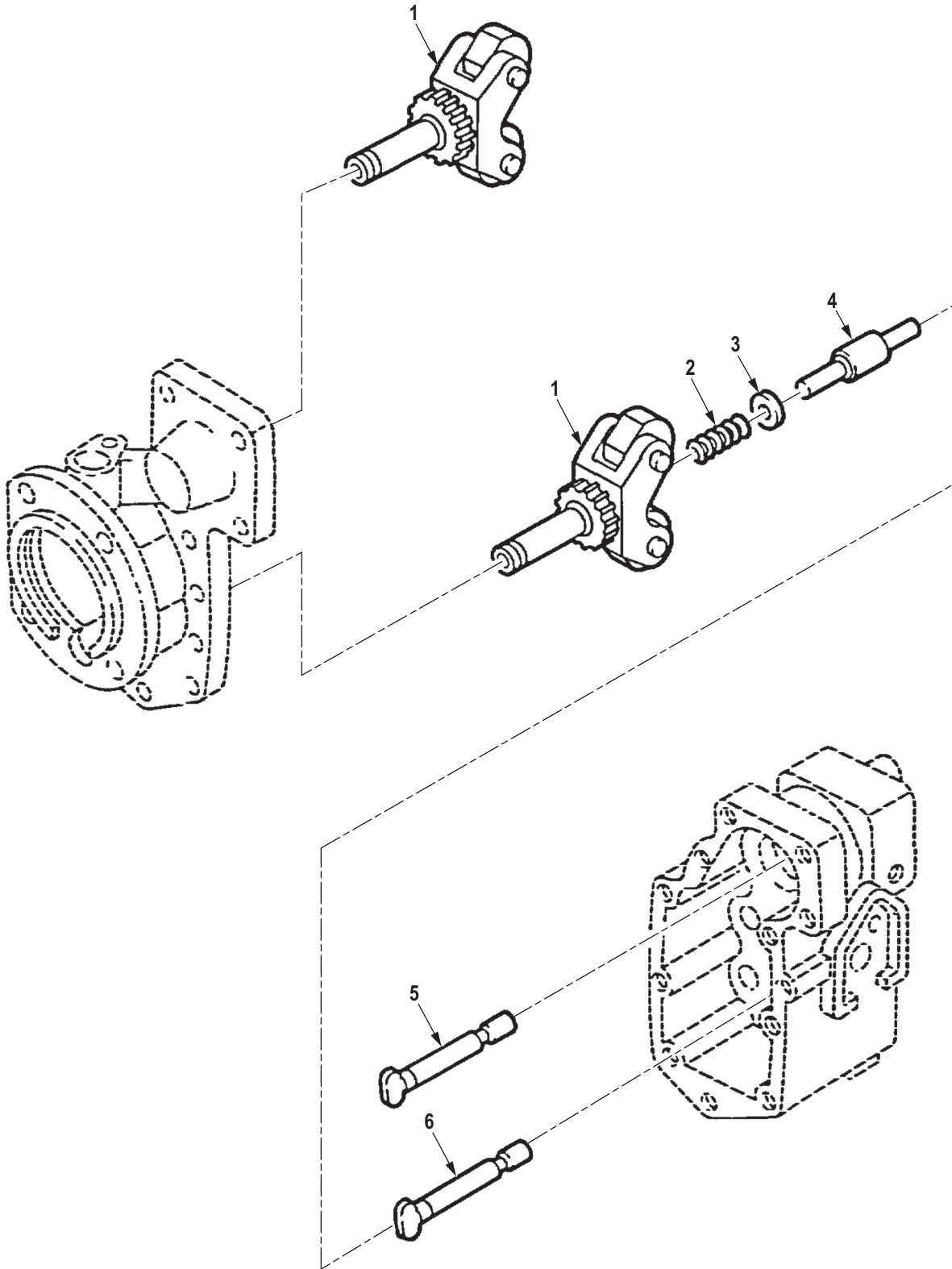

R0086DAA

Figure 86. Fuel Pump Governor, VS (M939, M939A1).

(1) ITEM NO.	(2) SMR CODE	(3) NSN	(4) CAGEC	(5) PART NUMBER	(6) DESCRIPTION AND USABLE ON CODE (UOC)	(7) QTY
<p><b>GROUP 0308 ENGINE SPEED GOVERNOR AND CONTROLS.</b></p> <p><b>FIG. 86. FUEL PUMP GOVERNOR, VS (M939, M939A1).</b></p>						
1	PBHZZ	2990-01-143-5489	15434	3024989	WEIGHT AND CARRIER UOC: DAL,V18,V19,V24 .....	2
2	PAHZZ	5360-01-191-2949	15434	143854	SPRING,HELICAL,COMP GOVERNOR WEIGHT ASSEMBLY UOC: DAL,V18,V24 .....	1
3	PAHZZ	5310-00-727-8353	96906	MS27183-43	WASHER,FLAT LOWER CARRIER ASSEMBLY UOC: DAL,V18 .....	3
4	PAHZZ	5315-00-082-0448	15434	144178	PIN,SHOULDER,HEADLE UOC: DAL,V18 .....	1
5	PFHZZ	5342-01-160-7381	15434	AR-40230	PLUNGER UOC: DAL,V18 .....	1
6	PBHZZ	5342-01-145-1549	15434	3010810	PLUNGER USE PRIOR TO SERIAL NUMBER 11246663 UOC: DAL,V18 .....	1

**END OF FIGURE**



**FIELD MAINTENANCE  
FUEL PUMP LOWER SPRING PACK, VS (M939, M939A1)**

---

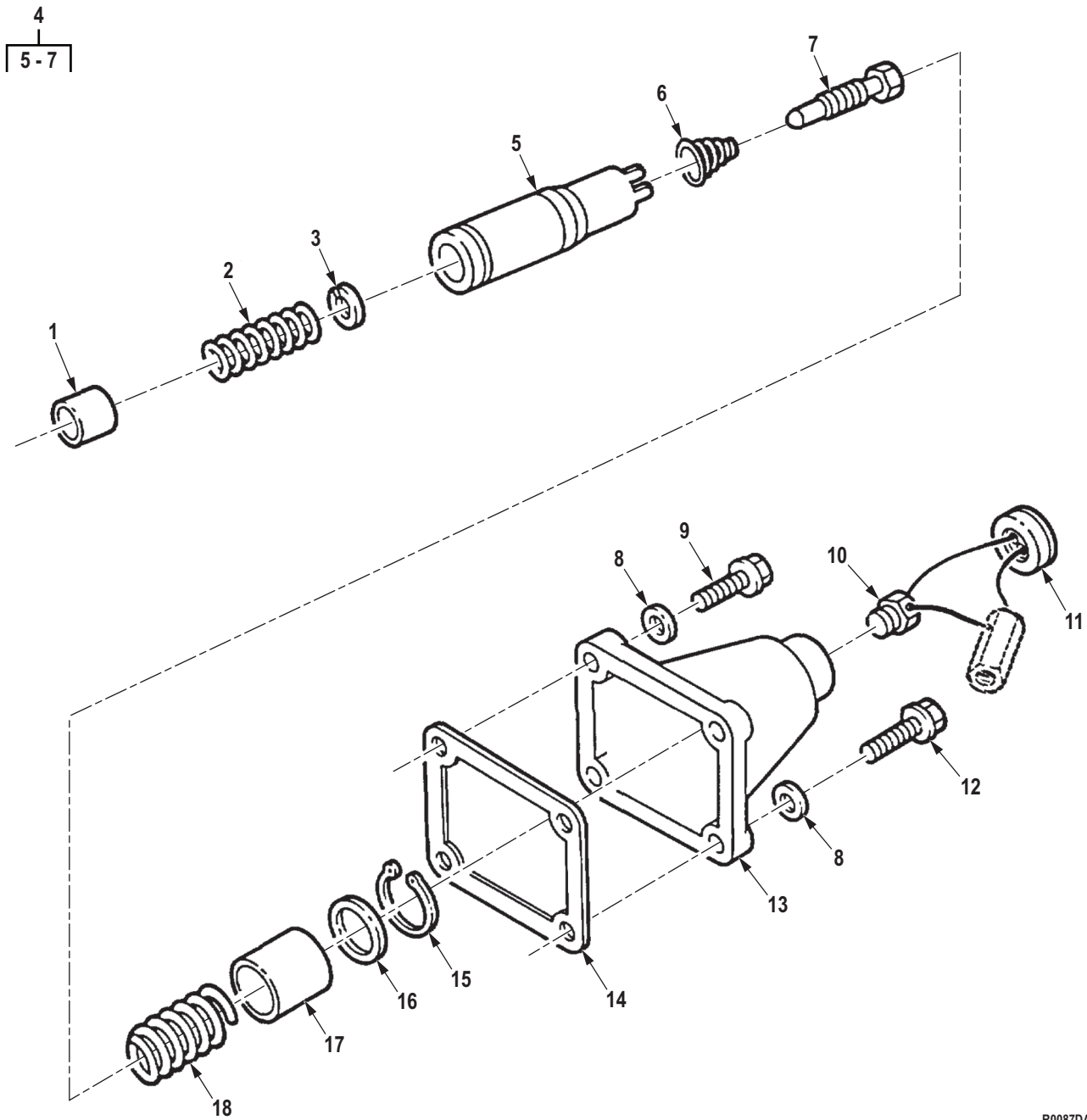

R0087DAA

Figure 87. Fuel Pump Lower Spring Pack, VS (M939, M939A1).

(1) ITEM NO.	(2) SMR CODE	(3) NSN	(4) CAGEC	(5) PART NUMBER	(6) DESCRIPTION AND USABLE ON CODE (UOC)	(7) QTY
<b>GROUP 0308 ENGINE SPEED GOVERNOR AND CONTROLS.</b>						
<b>FIG. 87. FUEL PUMP LOWER SPRING PACK, VS (M939, M939A1).</b>						
1	PAHZZ	2910-01-189-0901	15434	14163400	PLUNGER,GOVERNOR USE AFTER SERIAL NUMBER 11246663 UOC: DAL,V18 .....	1
1	PAHZZ	2910-00-238-5434	15434	138862	PLUNGER,IDLE SPRING USE PRIOR TO SERIAL NUMBER 11246663 UOC: DAL,V18 .....	1
2	PAHZZ	5360-00-082-0124	15434	144195	SPRING,HELICAL,COMP UOC: DAL,V18 .....	1
3	PAHZZ	5310-00-507-3259	15434	70715	WASHER,FLAT UOC: DAL,V18 .....	1
4	PBHZZ	5360-01-228-0747	15434	3038216	SPRING ASSORTMENT UOC: DAL,V18 .....	1
5	PAHZZ	5340-01-241-6939	15434	3036474	. SEAT,HELICAL COMPRE UOC: DAL,V18 .....	1
6	PAHZZ	5360-01-240-1626	15434	3032014	. SPRING,HELICAL,COMP UOC: DAL,V18 .....	1
7	PAHZZ	5305-00-506-5722	15434	70716	. SETSCREW UOC: DAL,V18 .....	1
8	PAHZZ	5310-00-141-1795	80205	NAS1149F0463P	WASHER,FLAT UOC: DAL,V18 .....	4
9	PAHZZ	5305-01-126-1128	15434	3017052	SCREW,CAP,HEXAGON H UOC: DAL,V18 .....	1
10	PAHZZ	5342-01-143-6046	15434	3025459	PLUG,COVER UOC: DAL,V18 .....	1
11	PAHZZ	5330-01-072-8830	15434	3003156	SEAL,SPECIAL UOC: DAL,V18 .....	1
12	PAHZZ	5305-01-112-9110	15434	3017051	SCREW,CAP,HEXAGON H UOC: DAL,V18 .....	2
13	PAHZZ	2910-00-858-3522	15434	44678	COVER,SPRING PACK UOC: DAL,V18 .....	1
14	PAHZZ	5330-00-562-1176	15434	70705	GASKET PART OF KIT P/N 3010240 UOC: DAL,V18 .....	1
15	PAHZZ	5325-00-807-2636	96906	MS16625-1100	RING,RETAINING UOC: DAL,V18 .....	1
16	PAHZZ	5365-00-507-3260	15434	70717	SPACER,RING UOC: DAL,V18 .....	1
16	PAHZZ	5365-00-507-3262	15434	70717B	SHIM UOC: DAL,V18 .....	1
16	PAHZZ	5365-00-462-4504	15434	189800	SHIM UOC: DAL,V18 .....	1

(1) ITEM NO.	(2) SMR CODE	(3) NSN	(4) CAGEC	(5) PART NUMBER	(6) DESCRIPTION AND USABLE ON CODE (UOC)	(7) QTY
16	PAHZZ	5365-00-507-3261	15434	70717A	SHIM UOC: DAL,V18 .....	1
17	PAHZZ	5365-01-119-4954	15434	203346	SPACER,SLEEVE UOC: DAL,V18 .....	1
18	PAHZZ	5360-01-191-2950	15434	3001155	SPRING,HELICAL,COMP UOC: DAL,V18 .....	1

END OF FIGURE



**FIELD MAINTENANCE  
FUEL PUMP UPPER SPRING PACK, VS (M939L, M939A1)**

---

5	10	29
6 - 16	11	30 - 33

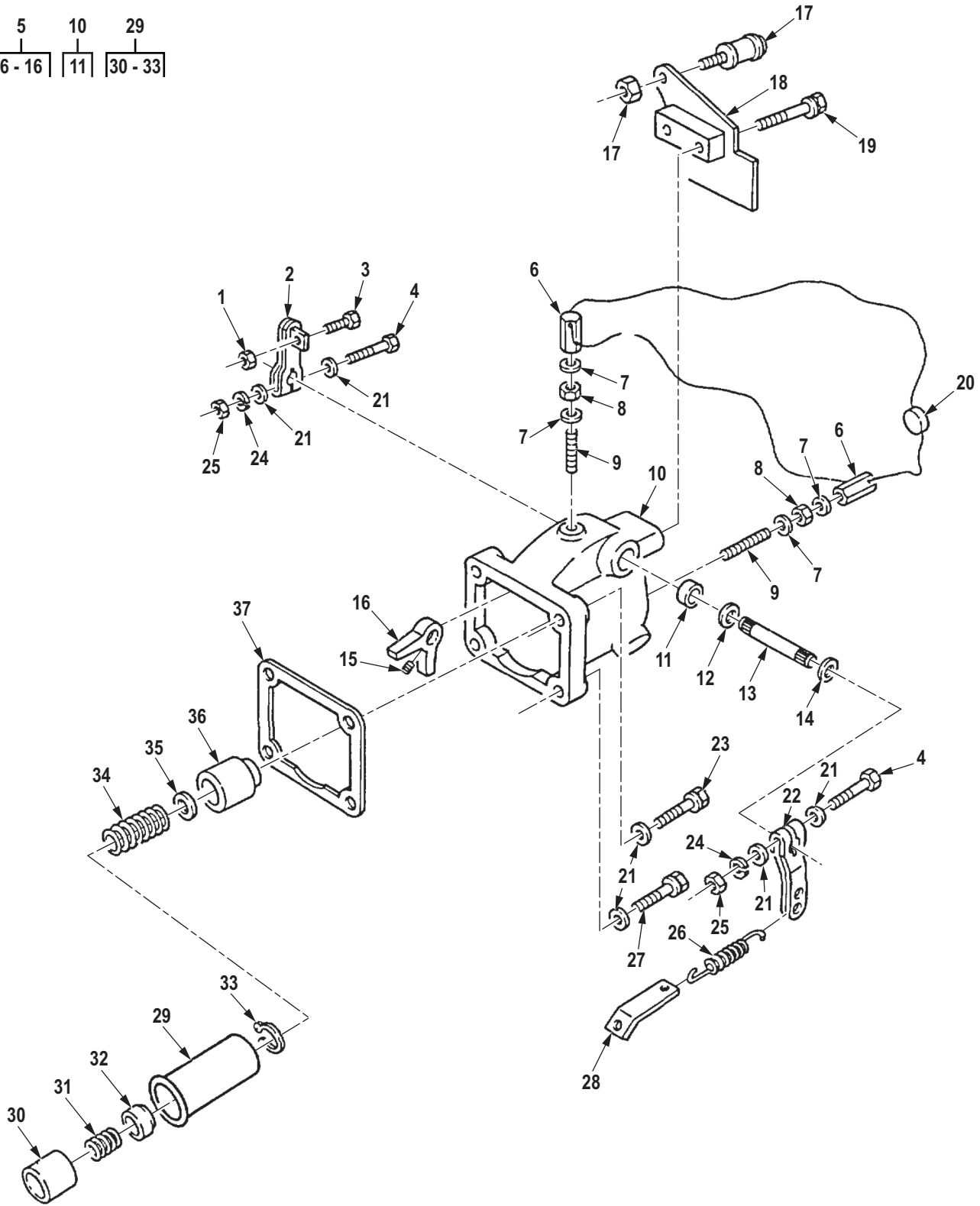

R0088DAA

Figure 88. Fuel Pump Upper Spring Pack, VS (M939I, M939A1).

(1) ITEM NO.	(2) SMR CODE	(3) NSN	(4) CAGEC	(5) PART NUMBER	(6) DESCRIPTION AND USABLE ON CODE (UOC)	(7) QTY
<b>GROUP 0308 ENGINE SPEED GOVERNOR AND CONTROLS.</b>						
<b>FIG. 88. FUEL PUMP UPPER SPRING PACK, VS (M939L, M939A1).</b>						
1	PAHZZ	5310-00-521-8595	15434	S223	NUT,HEXAGON UOC: DAL,V18 .....	1
2	PAHZZ	2910-01-098-6741	15434	187126	LEVER,THROTTLE UOC: DAL,V18 .....	1
3	PAHZZ	5306-00-461-6070	15434	187127	BOLT,CARRIAGE UOC: DAL,V18 .....	1
4	PAHZZ	5305-00-493-3959	15434	S159B	SCREW,CAP,HEXAGON H UOC: DAL,V18 .....	2
5	PBHZZ	5340-01-173-0133	15434	3020523	HOLDER,SPRING UOC: DAL,V18,ZAL .....	1
6	PAHZZ	5340-00-716-4975	15434	110058	. POST,ELECTRICAL-MEC UOC: DAL,V18 .....	2
7	PAHZZ	5310-00-735-7460	15434	112408	. WASHER,FLAT UOC: DAL,V18 .....	4
8	PAHZZ	5310-00-971-7989	96906	MS35691-5	. NUT,PLAIN,HEXAGON UOC: DAL,V18 .....	2
9	PAHZZ	5305-01-109-1292	15434	109917	. SETSCREW UOC: DAL,V18 .....	2
10	PBHZZ	2910-01-177-8816	15434	3016021	. HOUSING,FUEL PUMP UOC: DAL,V18 .....	1
11	PAHZZ	3120-01-160-1891	15434	3010941	. . BUSHING,SLEEVE UOC: DAL,V18 .....	2
12	PAHZZ	5331-00-514-4804	79500	1JH4350REVCPC	. O-RING UOC: DAL,V18 .....	2
13	PAHZZ	3040-01-181-9509	15434	3010942	. SHAFT,STRAIGHT UOC: DAL,V18 .....	1
14	PAHZZ	5330-01-161-0289	15434	3010945	. SEAL UOC: DAL,V18 .....	2
15	PAHZZ	5305-00-899-8054	15434	70813	. SETSCREW UOC: DAL,V18 .....	1
16	PAHZZ	2910-00-773-2108	15434	70834	. STOP,THROTTLE LEVER UOC: DAL,V18 .....	1
17	PAHZZ	3040-00-484-8546	15434	185012	CYLINDER ASSEMBLY,A UOC: DAL,V18 .....	1
18	PBHZZ	5342-01-110-1505	15434	211305	BRACKET UOC: DAL,V18 .....	1
19	PAHZZ	5305-01-112-9021	15434	3013904	SCREW UOC: DAL,V18 .....	2
20	PAHZZ	5330-01-072-8830	15434	3003156	SEAL,SPECIAL UOC: DAL,V18 .....	1

(1) ITEM NO.	(2) SMR CODE	(3) NSN	(4) CAGEC	(5) PART NUMBER	(6) DESCRIPTION AND USABLE ON CODE (UOC)	(7) QTY
21	PAHZZ	5310-00-141-1795	80205	NAS1149F0463P	WASHER,FLAT UOC: DAL,V18 .....	8
22	PAHZZ	2910-01-098-5093	15434	3012497	LEVER,THROTTLE UOC: DAL,V18 .....	1
23	PAHZZ	5305-01-126-1128	15434	3017052	SCREW,CAP,HEXAGON H UOC: DAL,V18 .....	1
24	PAHZZ	5310-00-159-6209	96906	MS122032	WASHER,LOCK UOC: DAL,V18 .....	2
25	PAHZZ	5310-00-971-7989	96906	MS35691-5	NUT,PLAIN,HEXAGON UOC: DAL,V18 .....	2
26	PAHZZ	5360-00-140-2078	15434	203762	SPRING,HELICAL,EXTE UOC: DAL,V18 .....	1
27	PAHZZ	5305-01-112-9110	15434	3017051	SCREW,CAP,HEXAGON H UOC: DAL,V18 .....	3
28	PAHZZ	5342-01-109-4013	15434	3005543	LINK,SPRING UOC: DAL,V18 .....	1
29	PAHZZ	5360-00-194-5920	15434	BM30245	SPRING,GOVERNOR MAX UOC: DAL,V18 .....	1
30	PAHZZ	2990-00-567-4367	15434	70820	. PLUNGER,GOVERNOR SP UOC: DAL,V18 .....	1
31	PAHZZ	5360-00-698-7100	15434	70778	. SPRING,HELICAL,COMP UOC: DAL,V18 .....	1
32	PAHZZ	5340-00-572-8042	15434	70798	. SEAT,HELICAL COMPRE UOC: DAL,V18 .....	1
33	PAHZZ	5325-00-846-1637	96906	MS16627-1093	. RING,RETAINING UOC: DAL,V18 .....	1
34	PAHZZ	5360-01-222-6880	15434	109686	SPRING,HELICAL,COMP UOC: DAL,V18 .....	1
35	PAHZZ	5310-00-550-8124	15434	70811	WASHER,FLAT .020 UOC: DAL,V18 .....	1
35	PAHZZ	5365-00-550-8127	15434	70811B	SHIM .005 UOC: DAL,V18 .....	1
35	PAHZZ	5365-00-550-8125	15434	70811A	SHIM .020 UOC: DAL,V18 .....	1
36	PAHZZ	5340-00-711-5372	15434	70836	PLUNGER,DETENT UOC: DAL,V18 .....	1
37	PAHZZ	5330-00-562-1176	15434	70705	GASKET UOC: DAL,V18 .....	1

END OF FIGURE

**FIELD MAINTENANCE  
MANIFOLD PRESSURE COMPENSATOR ASSEMBLY AND RELATED PARTS (M939A2)**

---

1  
2 - 18

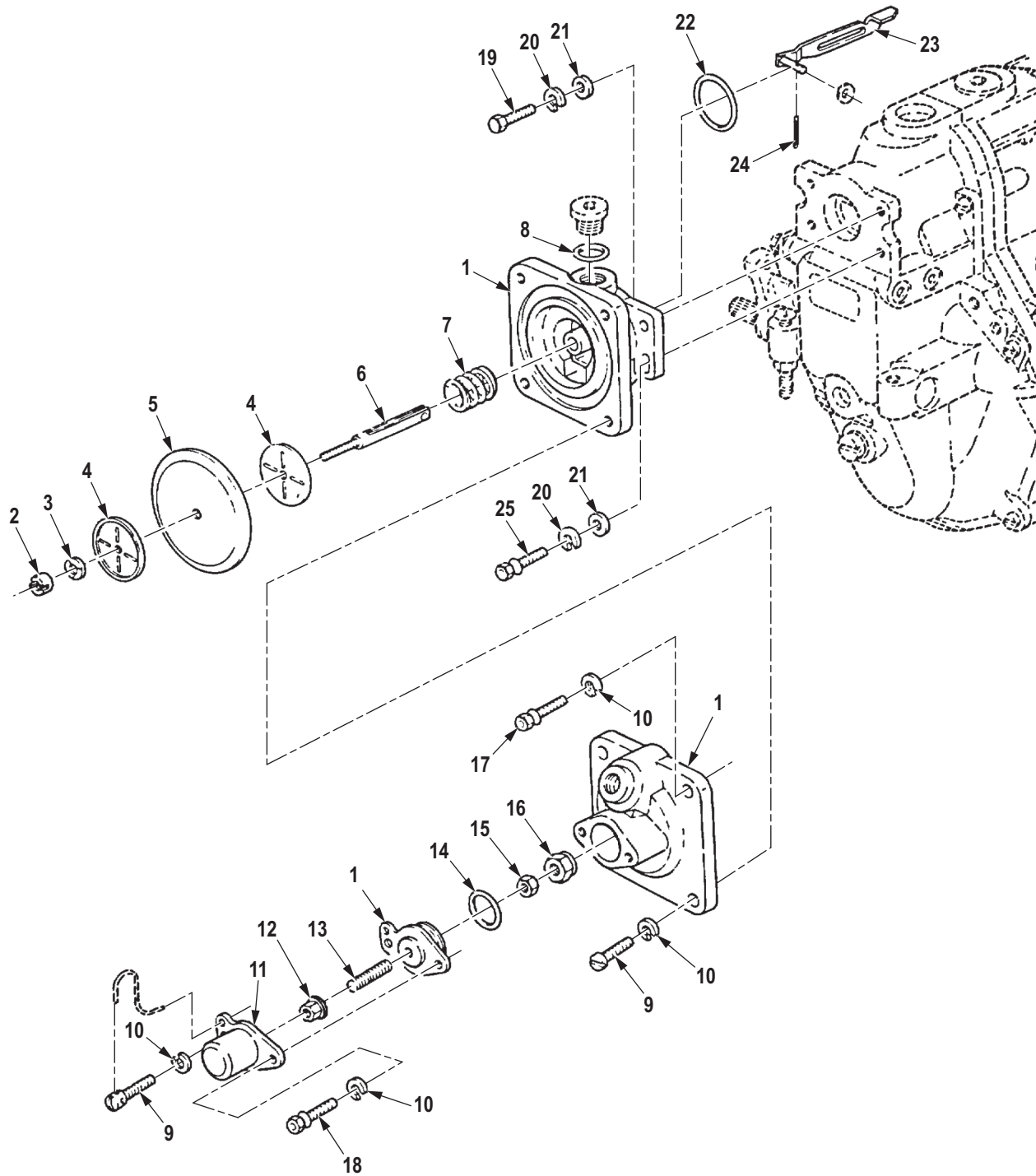

R0089DAA

Figure 89. Manifold Pressure Compensator Assembly and Related Parts (M939A2).

(1) ITEM NO.	(2) SMR CODE	(3) NSN	(4) CAGEC	(5) PART NUMBER	(6) DESCRIPTION AND USABLE ON CODE (UOC)	(7) QTY
<b>GROUP 0308 ENGINE SPEED GOVERNOR AND CONTROLS.</b>						
<b>FIG. 89. MANIFOLD PRESSURE COMPENSATOR ASSEMBLY AND RELATED PARTS (M939A2).</b>						
1	PFHHH	5365-01-336-8895	53867	1 427 133 313	MANIFOLD ASSEMBLY UOC: ZAA,ZAB,ZAC,ZAD,ZAE,ZAF, ZAG,ZAH,ZAJ,ZAL .....	1
2	XAHZZ		5T151	2 420 360 004	. SLOTTED ROUND NUT UOC: ZAA,ZAB,ZAC,ZAD,ZAE,ZAF, ZAG,ZAH,ZAJ,ZAL .....	1
3	PAHZZ	5310-01-341-8953	5T151	2 916 069 083	. WASHER,SPRING TENSI UOC: ZAA,ZAB,ZAC,ZAD,ZAE,ZAF, ZAG,ZAH,ZAJ,ZAL .....	1
4	XAHZZ		5T151	2 420 551 005	. PLATE WASHER UOC: ZAA,ZAB,ZAC,ZAD,ZAE,ZAF, ZAG,ZAH,ZAJ,ZAL .....	2
5	PFHZZ	4820-01-338-4642	5T151	2 420 503 013	. DIAPHRAGM,ACTUATOR PART OF KIT P/N 57K0143 UOC: ZAA,ZAB,ZAC,ZAD,ZAE,ZAF, ZAG,ZAH,ZAJ,ZAL .....	1
6	XAHZZ		5T151	2 423 050 056	. LIFTING ROD UOC: ZAA,ZAB,ZAC,ZAD,ZAE,ZAF, ZAG,ZAH,ZAJ,ZAL .....	1
7	PFHZZ	5360-01-339-0684	5T151	1 424 619 179	. SPRING,HELICAL,COMP UOC: ZAA,ZAB,ZAC,ZAD,ZAE,ZAF, ZAG,ZAH,ZAJ,ZAL .....	1
8	PFHZZ	5325-01-276-8488	53867	2916710613	. RING,RETAINING UOC: ZAA,ZAB,ZAC,ZAD,ZAE,ZAF, ZAG,ZAH,ZAJ,ZAL .....	1
9	PAHZZ	5305-01-336-0006	5T151	2 423 450 005	. SCREW,CAP,HEXAGON H UOC: ZAA,ZAB,ZAC,ZAD,ZAE,ZAF, ZAG,ZAH,ZAJ,ZAL .....	4
10	PFHZZ	5310-01-301-7811	53867	2916699132	. WASHER,LOCK 6.00MM PART OF KIT P/N 57K0143 UOC: ZAA,ZAB,ZAC,ZAD,ZAE,ZAF, ZAG,ZAH,ZAJ,ZAL .....	6
11	PFHZZ	5340-01-335-9996	5T151	1 420 505 036	. PLUG,PROTECTIVE,DUS UOC: ZAA,ZAB,ZAC,ZAD,ZAE,ZAF, ZAG,ZAH,ZAJ,ZAL .....	1
12	PAHZZ	5310-01-351-7542	5T151	1 423 314 003	NUT,PLAIN,HEXAGON UOC: ZAA,ZAB,ZAC,ZAD,ZAE,ZAF, ZAG,ZAH,ZAJ,ZAL .....	1
13	XAHZZ		5T151	2 423 400 034	. HEADLESS SETSCREW UOC: ZAA,ZAB,ZAC,ZAD,ZAE,ZAF, ZAG,ZAH,ZAJ,ZAL .....	1

(1) ITEM NO.	(2) SMR CODE	(3) NSN	(4) CAGEC	(5) PART NUMBER	(6) DESCRIPTION AND USABLE ON CODE (UOC)	(7) QTY
14	PFHZZ	5331-01-336-9559	5T151	1 410 210 014	. O-RING 12 X 2MM. PART OF KIT P/N 57K0143 UOC: ZAA,ZAB,ZAC,ZAD,ZAE,ZAF, ZAG,ZAH,ZAJ,ZAL .....	1
15	PFHZZ	5310-01-301-3885	53867	2 915 012 007	. NUT,PLAIN,HEXAGON DIM 934-M6-M8 UOC: ZAA,ZAB,ZAC,ZAD,ZAE,ZAF, ZAG,ZAH,ZAJ,ZAL .....	1
16	XAHZZ		5T151	2 423 315 004	. ROUND-NECK NUT UOC: ZAA,ZAB,ZAC,ZAD,ZAE,ZAF, ZAG,ZAH,ZAJ,ZAL .....	1
17	PFHZZ	5305-01-335-9965	53867	2 910 172 197	. SCREW,MACHINE DIM 404-M6 X 16-5.8 UOC: ZAA,ZAB,ZAC,ZAD,ZAE,ZAF, ZAG,ZAH,ZAJ,ZAL .....	1
18	PFHZZ	5305-01-342-5171	5T151	2 910 022 197	. SCREW,MACHINE PART OF KIT P/N 57K0143 UOC: ZAA,ZAB,ZAC,ZAD,ZAE,ZAF, ZAG,ZAH,ZAJ,ZAL .....	1
19	PAHZZ	5305-01-264-5886	21760	1206LT-1B1	SCREW,CAP,HEXAGON H DIM 84-AM6 X 16-8.8 UOC: ZAA,ZAB,ZAC,ZAD,ZAE,ZAF, ZAG,ZAH,ZAJ,ZAL .....	3
20	PFHZZ	5310-01-301-7811	53867	2916699132	WASHER,LOCK PART OF KIT P/ N 57K0143 UOC: ZAA,ZAB,ZAC,ZAD,ZAE,ZAF, ZAG,ZAH,ZAJ,ZAL .....	2
21	PAHZZ	5310-01-151-0113	18876	13142983-2/48	WASHER,LOCK UOC: ZAA,ZAB,ZAC,ZAD,ZAE,ZAF, ZAG,ZAH,ZAJ,ZAL .....	4
22	KBHZZ		5T151	1 420 210 022	O-RING PART OF KIT P/N 57K0143 UOC: ZAA,ZAB,ZAC,ZAD,ZAE,ZAF, ZAG,ZAH,ZAJ,ZAL .....	1
23	XAHZZ		5T151	2 421 335 025	STRAP UOC: ZAA,ZAB,ZAC,ZAD,ZAE,ZAF, ZAG,ZAH,ZAJ,ZAL .....	1
24	KBHZZ		5T151	2 424 680 003	RETAINING SPRING PART OF KIT P/N 57K0143 UOC: ZAA,ZAB,ZAC,ZAD,ZAE,ZAF, ZAG,ZAH,ZAJ,ZAL .....	1
25	PAHZZ	5305-01-336-0007	53867	2 423 450 002	SCREW,CAP,HEXAGON H PART OF KIT P/N 57K0143 UOC: ZAA,ZAB,ZAC,ZAD,ZAE,ZAF, ZAG,ZAH,ZAJ,ZAL .....	1

END OF FIGURE



**FIELD MAINTENANCE  
GOVERNOR COVER AND RELATED PARTS (M939A2)**

---



(1) ITEM NO.	(2) SMR CODE	(3) NSN	(4) CAGEC	(5) PART NUMBER	(6) DESCRIPTION AND USABLE ON CODE (UOC)	(7) QTY
<b>GROUP 0308 ENGINE SPEED GOVERNOR AND CONTROLS.</b>						
<b>FIG. 90. GOVERNOR COVER AND RELATED PARTS (M939A2).</b>						
1	PFHZZ	5305-12-142-0188	D8286	M6X22DIN933-8-8A 2P	SCREW,CAP,HEXAGON H UOC: ZAA,ZAB,ZAC,ZAD,ZAE,ZAF, ZAG,ZAH,ZAJ,ZAL .....	1
2	PFHZZ	5310-01-301-1885	53867	2 916 690 005	WASHER,SPRING TENS OF KIT P/N 57K0142 UOC: ZAA,ZAB,ZAC,ZAD,ZAE,ZAF, ZAG,ZAH,ZAJ,ZAL .....	1
3	PFHZZ	5310-01-336-6747	5T151	2 421 321 009	WASHER,FLAT UOC: ZAA,ZAB,ZAC,ZAD,ZAE,ZAF, ZAG,ZAH,ZAJ,ZAL .....	1
4	PFHZZ	3040-01-336-8168	53867	1 423 103 016	SHAFT,STRAIGHT UOC: ZAA,ZAB,ZAC,ZAD,ZAE,ZAF, ZAG,ZAH,ZAJ,ZAL .....	1
5	PFHZZ	5365-01-336-8916	5T151	1 421 036 010	SPACER,PLATE 0.20MM UOC: ZAA,ZAB,ZAC,ZAD,ZAE,ZAF, ZAG,ZAH,ZAJ,ZAL .....	1
5	PFHZZ	5340-01-339-0868	53867	1 421 036 012	BRACKET,MOUNTING 0.80 MM UOC: ZAA,ZAB,ZAC,ZAD,ZAE,ZAF, ZAG,ZAH,ZAJ,ZAL .....	1
5	PFHZZ	5340-01-341-6655	5T151	1 421 036 013	PLATE,MOUNTING 0.50 MM UOC: ZAA,ZAB,ZAC,ZAD,ZAE,ZAF, ZAG,ZAH,ZAJ,ZAL .....	1
6	PFHZZ	5315-01-336-5185	53867	2 423 202 001	PIN,STRAIGHT,HEADLE OF KIT P/N 57K0142 UOC: ZAA,ZAB,ZAC,ZAD,ZAE,ZAF, ZAG,ZAH,ZAJ,ZAL .....	2
7	PFHZZ	5365-01-336-5224	5T151	1 411 030 000	SPACER,PLATE UOC: ZAA,ZAB,ZAC,ZAD,ZAE,ZAF, ZAG,ZAH,ZAJ,ZAL .....	2
8	PFHZZ	5310-01-301-7811	53867	2916699132	WASHER,LOCK PART OF KIT P/ N 57K0142 UOC: ZAA,ZAB,ZAC,ZAD,ZAE,ZAF, ZAG,ZAH,ZAJ,ZAL .....	2
9	PFHZZ	5305-01-264-5886	21760	1206LT-1B1	SCREW,CAP,HEXAGON H UOC: ZAA,ZAB,ZAC,ZAD,ZAE,ZAF, ZAG,ZAH,ZAJ,ZAL .....	2
10	PFHZZ	5340-01-336-2292	5T151	2 421 332 022	BRACKET,ANGLE UOC: ZAA,ZAB,ZAC,ZAD,ZAE,ZAF, ZAG,ZAH,ZAJ,ZAL .....	1
11	PFHZZ	5305-01-336-9380	5T151	2 423 400 031	SETSCREW UOC: ZAA,ZAB,ZAC,ZAD,ZAE,ZAF, ZAG,ZAH,ZAJ,ZAL .....	1

(1) ITEM NO.	(2) SMR CODE	(3) NSN	(4) CAGEC	(5) PART NUMBER	(6) DESCRIPTION AND USABLE ON CODE (UOC)	(7) QTY
12	PFHZZ	5310-01-301-3885	53867	2 915 012 007	NUT,PLAIN,HEXAGON UOC: ZAA,ZAB,ZAC,ZAD,ZAE,ZAF, ZAG,ZAH,ZAJ,ZAL .....	1
13	PFHZZ	5365-01-336-8908	5T151	1 190 200 000	SPACER,RING UOC: ZAA,ZAB,ZAC,ZAD,ZAE,ZAF, ZAG,ZAH,ZAJ,ZAL .....	2
14	PFHZZ	5340-01-337-3760	5T151	2 425 650 759	COVER,ACCESS UOC: ZAA,ZAB,ZAC,ZAD,ZAE,ZAF, ZAG,ZAH,ZAJ,ZAL .....	1
15	PFHZZ	5310-01-336-6683	5T151	2 423 300 008	NUT,PLAIN,HEXAGON UOC: ZAA,ZAB,ZAC,ZAD,ZAE,ZAF, ZAG,ZAH,ZAJ,ZAL .....	1
16	PFHZZ	5305-01-335-9966	5T151	2 423 410 026	SCREW,MACHINE UOC: ZAA,ZAB,ZAC,ZAD,ZAE,ZAF, ZAG,ZAH,ZAJ,ZAL .....	1
17	PFHZZ	5305-01-335-9968	5T151	1 423 414 031	SCREW,MACHINE UOC: ZAA,ZAB,ZAC,ZAD,ZAE,ZAF, ZAG,ZAH,ZAJ,ZAL .....	1
18	PFHZZ	5305-01-336-0026	5T151	1 423 412 025	SCREW,CLOSE TOLERAN UOC: ZAA,ZAB,ZAC,ZAD,ZAE,ZAF, ZAG,ZAH,ZAJ,ZAL .....	1
19	PFHZZ	5330-00-503-5789	53867	2-916-710-605	GASKET PART OF KIT P/N 57K0142 UOC: ZAA,ZAB,ZAC,ZAD,ZAE,ZAF, ZAG,ZAH,ZAJ,ZAL .....	1
20	PFHZZ	5305-01-335-9967	5T151	1 423 415 003	SCREW,MACHINE UOC: ZAA,ZAB,ZAC,ZAD,ZAE,ZAF, ZAG,ZAH,ZAJ,ZAL .....	1
21	PFHZZ	5310-01-264-9401	04627	136687	NUT,PLAIN,HEXAGON UOC: ZAA,ZAB,ZAC,ZAD,ZAE,ZAF, ZAG,ZAH,ZAJ,ZAL .....	1
22	PFHZZ	5305-01-336-0015	5T151	2 912 732 203	SCREW,SHOULDER UOC: ZAA,ZAB,ZAC,ZAD,ZAE,ZAF, ZAG,ZAH,ZAJ,ZAL .....	5
23	PFHZZ	3120-12-198-1758	D8015	1420301002	BUSHING,SLEEVE UOC: ZAA,ZAB,ZAC,ZAD,ZAE,ZAF, ZAG,ZAH,ZAJ,ZAL .....	2
24	PFHZZ	5340-01-336-6704	5T151	1 420 555 000	PLUG,EXPANSION UOC: ZAA,ZAB,ZAC,ZAD,ZAE,ZAF, ZAG,ZAH,ZAJ,ZAL .....	1
25	PFHZZ	3040-01-339-8572	53867	2 423 061 006	SHAFT,STRAIGHT UOC: ZAA,ZAB,ZAC,ZAD,ZAE,ZAF, ZAG,ZAH,ZAJ,ZAL .....	1
26	PFHZZ	5315-12-156-4502	D8286	DIN6888-3X5	KEY,WOODRUFF UOC: ZAA,ZAB,ZAC,ZAD,ZAE,ZAF, ZAG,ZAH,ZAJ,ZAL .....	1

(1) ITEM NO.	(2) SMR CODE	(3) NSN	(4) CAGEC	(5) PART NUMBER	(6) DESCRIPTION AND USABLE ON CODE (UOC)	(7) QTY
27	PFHZZ	5330-01-188-0908	5T151	2 421 015 066	GASKET PART OF KIT P/N 57K0142 UOC: ZAA,ZAB,ZAC,ZAD,ZAE,ZAF, ZAG,ZAH,ZAJ,ZAL .....	1
28	PFHZZ	5360-01-335-9948	5T151	2 424 611 024	SPRING,HELICAL,COMP UOC: ZAA,ZAB,ZAC,ZAD,ZAE,ZAF, ZAG,ZAH,ZAJ,ZAL .....	1
29	PFHZZ	2815-01-336-2199	5T151	2 422 060 021	ROCKER ARM,ENGINE P UOC: ZAA,ZAB,ZAC,ZAD,ZAE,ZAF, ZAG,ZAH,ZAJ,ZAL .....	1
30	PFHZZ	3040-01-338-2545	53867	1 422 120 023	LEVER,REMOTE CONTRO UOC: ZAA,ZAB,ZAC,ZAD,ZAE,ZAF, ZAG,ZAH,ZAJ,ZAL .....	1

END OF FIGURE



**FIELD MAINTENANCE  
FLYWEIGHT ASSEMBLY (M939A2)**

---

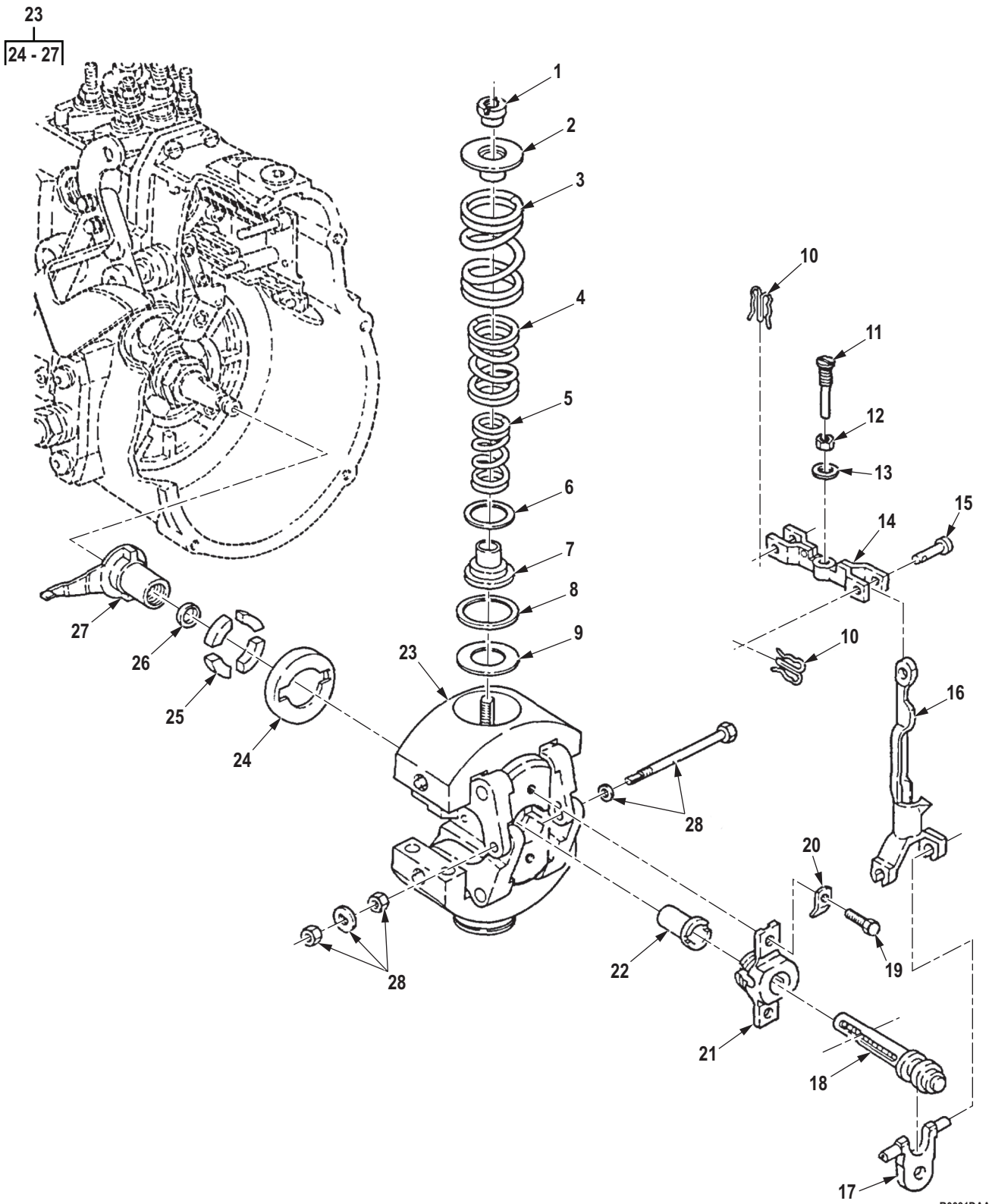

R0091DAA

Figure 91. Flyweight Assembly (M939A2).



(1) ITEM NO.	(2) SMR CODE	(3) NSN	(4) CAGEC	(5) PART NUMBER	(6) DESCRIPTION AND USABLE ON CODE (UOC)	(7) QTY
<b>GROUP 0308 ENGINE SPEED GOVERNOR AND CONTROLS.</b>						
<b>FIG. 91. FLYWEIGHT ASSEMBLY (M939A2).</b>						
1	PFHZZ	5310-01-336-8722	5T151	2 423 345 006	NUT,PLAIN,HEXAGON UOC: ZAA,ZAB,ZAC,ZAD,ZAE,ZAF, ZAG,ZAH,ZAJ,ZAL .....	2
2	PFHZZ	5340-01-336-0021	5T151	2 420 520 005	SEAT,HELICAL COMPRE UOC: ZAA,ZAB,ZAC,ZAD,ZAE,ZAF, ZAG,ZAH,ZAJ,ZAL .....	2
3	PFHZZ	5360-01-335-9951	5T151	1 424 618 035	SPRING,HELICAL,COMP UOC: ZAA,ZAB,ZAC,ZAD,ZAE,ZAF, ZAG,ZAH,ZAJ,ZAL .....	2
4	PFHZZ	5360-01-335-9950	5T151	9 428 270 053	SPRING,HELICAL,COMP UOC: ZAA,ZAB,ZAC,ZAD,ZAE,ZAF, ZAG,ZAH,ZAJ,ZAL .....	2
5	PFHZZ	5360-01-335-9949	5T151	2 424 619 172	SPRING,HELICAL,COMP UOC: ZAA,ZAB,ZAC,ZAD,ZAE,ZAF, ZAG,ZAH,ZAJ,ZAL .....	2
6	PFHZZ	5365-01-336-5221	5T151	1 420 101 023	SPACER,RING 0.50MM UOC: ZAA,ZAB,ZAC,ZAD,ZAE,ZAF, ZAG,ZAH,ZAJ,ZAL .....	2
7	PFHZZ	5340-01-336-0020	5T151	2 420 328 034	SEAT,HELICAL COMPRE UOC: ZAA,ZAB,ZAC,ZAD,ZAE,ZAF, ZAG,ZAH,ZAJ,ZAL .....	2
8	PFHZZ	5365-01-336-5912	5T151	2 420 101 027	SPACER,RING 0.50MM UOC: ZAA,ZAB,ZAC,ZAD,ZAE,ZAF, ZAG,ZAH,ZAJ,ZAL .....	2
9	PFHZZ	5365-01-336-5220	53867	1 200 102 624	SPACER,RING 0.50MM UOC: ZAA,ZAB,ZAC,ZAD,ZAE,ZAF, ZAG,ZAH,ZAJ,ZAL .....	2
10	KBHZZ		5T151	2 424 680 003	RETAINING SPRING PART OF KIT P/N 57K0141 UOC: ZAA,ZAB,ZAC,ZAD,ZAE,ZAF, ZAG,ZAH,ZAJ,ZAL .....	2
11	PFHZZ	5305-01-335-9969	5T151	2 423 412 003	SCREW,MACHINE UOC: ZAA,ZAB,ZAC,ZAD,ZAE,ZAF, ZAG,ZAH,ZAJ,ZAL .....	1
12	PFHZZ	5310-01-301-0455	53867	1 423 300 045	NUT,PLAIN,HEXAGON UOC: ZAA,ZAB,ZAC,ZAD,ZAE,ZAF, ZAG,ZAH,ZAJ,ZAL .....	1
13	PAHZZ	5310-01-336-7368	5T151	2 916 069 007	WASHER,SPRING TENS UOC: ZAA,ZAB,ZAC,ZAD,ZAE,ZAF, ZAG,ZAH,ZAJ,ZAL .....	1
14	PFHZZ	3040-01-336-8293	53867	1 421 933 132	CONNECTING LINK,RIG UOC: ZAA,ZAB,ZAC,ZAD,ZAE,ZAF, ZAG,ZAH,ZAJ,ZAL .....	1

(1) ITEM NO.	(2) SMR CODE	(3) NSN	(4) CAGEC	(5) PART NUMBER	(6) DESCRIPTION AND USABLE ON CODE (UOC)	(7) QTY
15	PFHZZ	5315-01-352-8225	5T151	2 423 121 021	PIN,STRAIGHT,HEADLE UOC: ZAA,ZAB,ZAC,ZAD,ZAE,ZAF, ZAG,ZAH,ZAJ,ZAL .....	1
16	PFHZZ	5340-01-336-0016	5T151	1 422 033 068	LEVER,LOCK-RELEASE UOC: ZAA,ZAB,ZAC,ZAD,ZAE,ZAF, ZAG,ZAH,ZAJ,ZAL .....	1
17	PFHZZ	3040-01-337-4368	53867	1 422 130 011	BRACKET,EYE,NONROTA UOC: ZAA,ZAB,ZAC,ZAD,ZAE,ZAF, ZAG,ZAH,ZAJ,ZAL .....	1
18	PFHZZ	5315-01-335-9940	53867	1 423 521 014	PIN,STRAIGHT,THREAD UOC: ZAA,ZAB,ZAC,ZAD,ZAE,ZAF, ZAG,ZAH,ZAJ,ZAL .....	1
19	PFHZZ	5305-01-187-0531	53867	2911061196	SCREW,CAP,HEXAGON H UOC: ZAA,ZAB,ZAC,ZAD,ZAE,ZAF, ZAG,ZAH,ZAJ,ZAL .....	2
20	PFHZZ	5310-01-336-6687	5T151	1 421 331 009	WASHER,KEY UOC: ZAA,ZAB,ZAC,ZAD,ZAE,ZAF, ZAG,ZAH,ZAJ,ZAL .....	2
21	PFHZZ	3120-01-351-7779	5T151	2 425 703 005	BUSHING,SLEEVE UOC: ZAA,ZAB,ZAC,ZAD,ZAE,ZAF, ZAG,ZAH,ZAJ,ZAL .....	1
22	PFHZZ	5310-01-336-6684	5T151	2 423 345 015	NUT,PLAIN,HEXAGON UOC: ZAA,ZAB,ZAC,ZAD,ZAE,ZAF, ZAG,ZAH,ZAJ,ZAL .....	1
23	PFHZZ	2910-01-337-2984	53867	1 428 199 009	FLYWEIGHT ASSEMBLY, UOC: ZAA,ZAB,ZAC,ZAD,ZAE,ZAF, ZAG,ZAH,ZAJ,ZAL .....	1
24	PFHZZ	3010-01-337-8937	53867	1 420 500 025	. INSERT,FLEXIBLE COU UOC: ZAA,ZAB,ZAC,ZAD,ZAE,ZAF, ZAG,ZAH,ZAJ,ZAL .....	1
25	KBHZZ		5T151	1 420 026 004	. RUBBER BUFFER PART OF KIT P/N 57K0141 UOC: ZAA,ZAB,ZAC,ZAD,ZAE,ZAF, ZAG,ZAH,ZAJ,ZAL .....	4
26	PFHZZ	5365-01-336-5219	5T151	2 420 101 074	. SPACER,RING 2.14MM THICK UOC: ZAA,ZAB,ZAC,ZAD,ZAE,ZAF, ZAG,ZAH,ZAJ,ZAL .....	1
26	PFHZZ	5365-01-336-8911	53867	2 420 101 073	. SPACER,RING 2.11MM THICK UOC: ZAA,ZAB,ZAC,ZAD,ZAE,ZAF, ZAG,ZAH,ZAJ,ZAL .....	1
26	PFHZZ	5365-01-336-8910	53867	2 420 101 072	. SPACER,RING 2.08MM THICK UOC: ZAA,ZAB,ZAC,ZAD,ZAE,ZAF, ZAG,ZAH,ZAJ,ZAL .....	1
26	PFHZZ	5365-01-336-8909	53867	2 420 101 071	. SPACER,RING 2.05MM THICK UOC: ZAA,ZAB,ZAC,ZAD,ZAE,ZAF, ZAG,ZAH,ZAJ,ZAL .....	1

(1) ITEM NO.	(2) SMR CODE	(3) NSN	(4) CAGEC	(5) PART NUMBER	(6) DESCRIPTION AND USABLE ON CODE (UOC)	(7) QTY
26	PFHZZ	5365-01-339-3838	5T151	2 420 101 070	. SHIM 2.02MM THICK UOC: ZAA,ZAB,ZAC,ZAD,ZAE,ZAF, ZAG,ZAH,ZAJ,ZAL .....	1
26	PFHZZ	5365-01-336-5218	5T151	2 420 101 069	. SPACER,RING 1.99MM THICK UOC: ZAA,ZAB,ZAC,ZAD,ZAE,ZAF, ZAG,ZAH,ZAJ,ZAL .....	1
26	PFHZZ	5365-01-336-5217	5T151	2 420 101 068	. SPACER,RING 1.96MM THICK UOC: ZAA,ZAB,ZAC,ZAD,ZAE,ZAF, ZAG,ZAH,ZAJ,ZAL .....	1
26	PFHZZ	5365-01-336-5216	5T151	2 420 101 067	. SPACER,RING 1.93MM THICK UOC: ZAA,ZAB,ZAC,ZAD,ZAE,ZAF, ZAG,ZAH,ZAJ,ZAL .....	1
26	PFHZZ	5365-01-336-5215	53867	2 420 101 066	. SPACER,RING 1.90MM THICK UOC: ZAA,ZAB,ZAC,ZAD,ZAE,ZAF, ZAG,ZAH,ZAJ,ZAL .....	1
26	PFHZZ	5365-01-339-3837	5T151	2 420 101 065	. SHIM 1.87MM THICK UOC: ZAA,ZAB,ZAC,ZAD,ZAE,ZAF, ZAG,ZAH,ZAJ,ZAL .....	1
26	PFHZZ	5365-01-336-5214	53867	2 420 101 064	. SPACER,RING 1.84MM THICK UOC: ZAA,ZAB,ZAC,ZAD,ZAE,ZAF, ZAG,ZAH,ZAJ,ZAL .....	1
26	PFHZZ	5365-01-336-5911	5T151	2 420 101 063	. SPACER,RING 1.81MM THICK UOC: ZAA,ZAB,ZAC,ZAD,ZAE,ZAF, ZAG,ZAH,ZAJ,ZAL .....	1
26	PFHZZ	5365-01-336-5910	53867	2 420 101 062	. SPACER,RING 1.78MM THICK UOC: ZAA,ZAB,ZAC,ZAD,ZAE,ZAF, ZAG,ZAH,ZAJ,ZAL .....	1
26	PFHZZ	5365-01-336-5213	53867	2 420 101 061	. SPACER,RING 1.75MM THICK UOC: ZAA,ZAB,ZAC,ZAD,ZAE,ZAF, ZAG,ZAH,ZAJ,ZAL .....	1
26	PFHZZ	5365-01-336-5212	5T151	2 420 101 059	. SPACER,RING 1.69MM THICK UOC: ZAA,ZAB,ZAC,ZAD,ZAE,ZAF, ZAG,ZAH,ZAJ,ZAL .....	1
26	PFHZZ	5340-01-336-6783	5T151	2 420 101 058	. RETAINER,HELICAL CO 1.66MM THICK UOC: ZAA,ZAB,ZAC,ZAD,ZAE,ZAF, ZAG,ZAH,ZAJ,ZAL .....	1
26	PFHZZ	5365-01-339-3836	5T151	2 420 101 057	. SHIM 1.63MM THICK UOC: ZAA,ZAB,ZAC,ZAD,ZAE,ZAF, ZAG,ZAH,ZAJ,ZAL .....	1
26	PFHZZ	5365-01-339-3835	5T151	2 420 101 056	. SHIM 1.60MM THICK UOC: ZAA,ZAB,ZAC,ZAD,ZAE,ZAF, ZAG,ZAH,ZAJ,ZAL .....	1
26	PFHZZ	5365-01-336-6782	53867	2 420 101 060	. SPACER,RING 1.72MM THICK UOC: ZAA,ZAB,ZAC,ZAD,ZAE,ZAF, ZAG,ZAH,ZAJ,ZAL .....	1

(1) ITEM NO.	(2) SMR CODE	(3) NSN	(4) CAGEC	(5) PART NUMBER	(6) DESCRIPTION AND USABLE ON CODE (UOC)	(7) QTY
27	PFHZZ	2910-01-337-2983	53867	2 426 449 018	. DRIVER,MECHANICAL G UOC: ZAA,ZAB,ZAC,ZAD,ZAE,ZAF, ZAG,ZAH,ZAJ,ZAL .....	1
28	KBHZZ		5T151	1 423 450 900	PARTS SET, SCREW PART OF KIT P/N 57K0141 UOC: ZAA,ZAB,ZAC,ZAD,ZAE,ZAF, ZAG,ZAH,ZAJ,ZAL .....	1

END OF FIGURE

**FIELD MAINTENANCE  
GOVERNOR HOUSING (M939A2)**

---

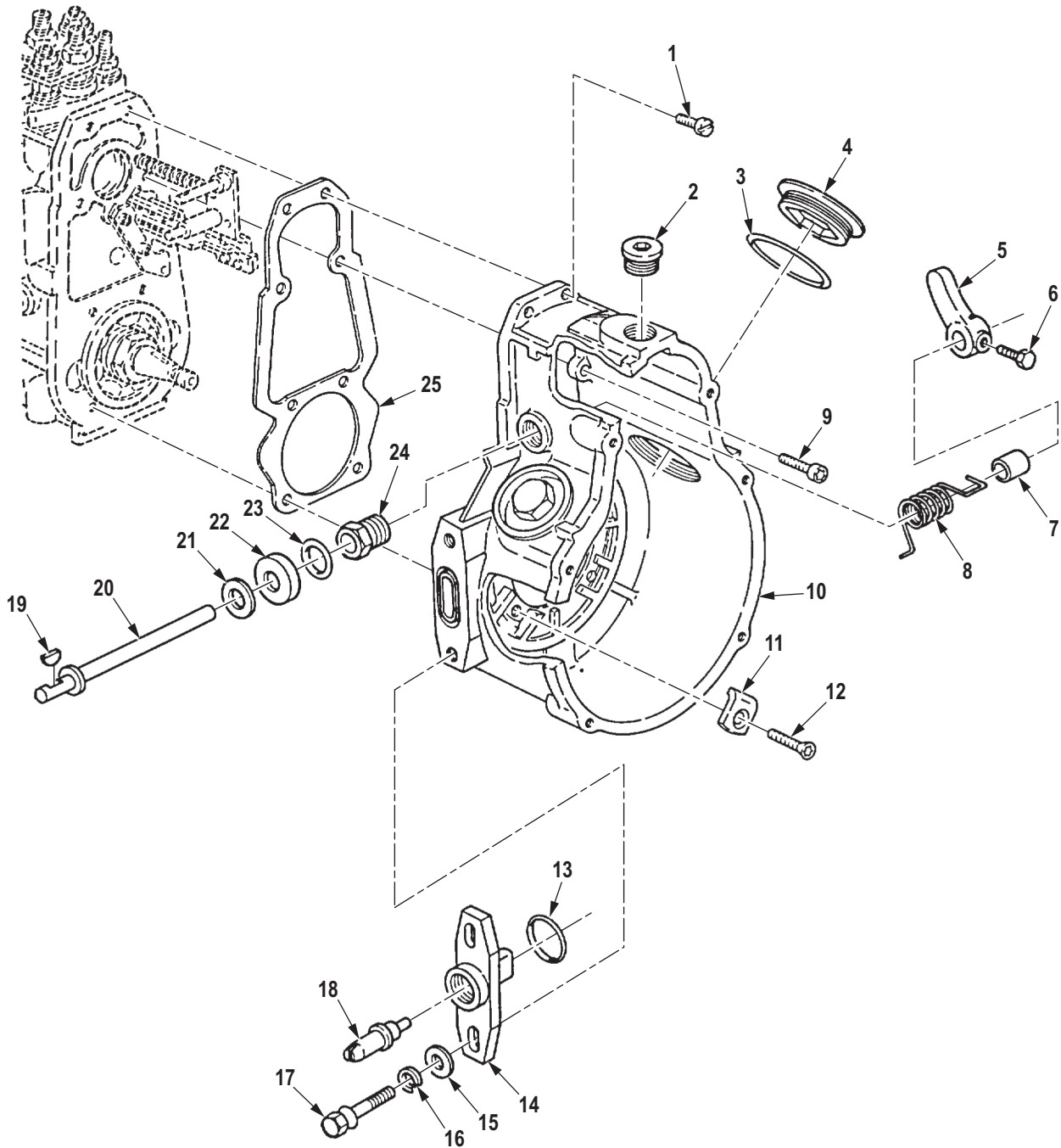

R0092DAA

Figure 92. Governor Housing (M939A2).

(1) ITEM NO.	(2) SMR CODE	(3) NSN	(4) CAGEC	(5) PART NUMBER	(6) DESCRIPTION AND USABLE ON CODE (UOC)	(7) QTY
<b>GROUP 0308 ENGINE SPEED GOVERNOR AND CONTROLS.</b>						
<b>FIG. 92. GOVERNOR HOUSING (M939A2).</b>						
1	PFHZZ	5305-01-301-5034	53867	1 423 414 021	SCREW,MACHINE UOC: ZAA,ZAB,ZAC,ZAD,ZAE,ZAF, ZAG,ZAH,ZAJ,ZAL .....	2
2	PFHZZ	5365-12-173-6488	D8015	1423462099	PLUG,MACHINE THREAD UOC: ZAA,ZAB,ZAC,ZAD,ZAE,ZAF, ZAG,ZAH,ZAJ,ZAL .....	1
3	PFHZZ	5330-01-336-3150	5T151	1 420 113 004	GASKET PART OF KIT P/N 57K0141 UOC: ZAA,ZAB,ZAC,ZAD,ZAE,ZAF, ZAG,ZAH,ZAJ,ZAL .....	2
4	PFHZZ	5340-01-336-2588	5T151	1 420 560 004	PLUG,PROTECTIVE,DUS UOC: ZAA,ZAB,ZAC,ZAD,ZAE,ZAF, ZAG,ZAH,ZAJ,ZAL .....	2
5	PFHZZ	5340-01-336-0046	53867	1-422-010-015	LEVER,MANUAL CONTRO UOC: ZAA,ZAB,ZAC,ZAD,ZAE,ZAF, ZAG,ZAH,ZAJ,ZAL .....	1
6	PFHZZ	5305-01-336-0008	5T151	1 423 452 000	SCREW,CAP,HEXAGON H UOC: ZAA,ZAB,ZAC,ZAD,ZAE,ZAF, ZAG,ZAH,ZAJ,ZAL .....	1
7	PFHZZ	5365-01-336-5913	5T151	2 420 200 009	SPACER,RING UOC: ZAA,ZAB,ZAC,ZAD,ZAE,ZAF, ZAG,ZAH,ZAJ,ZAL .....	1
8	PFHZZ	5360-01-336-9366	5T151	1-424-651-075	SPRING,HELICAL,COMP UOC: ZAA,ZAB,ZAC,ZAD,ZAE,ZAF, ZAG,ZAH,ZAJ,ZAL .....	1
9	PFHZZ	5305-01-301-7817	53867	2 914 552 158	SCREW,CAP,HEXAGON H UOC: ZAA,ZAB,ZAC,ZAD,ZAE,ZAF, ZAG,ZAH,ZAJ,ZAL .....	2
10	PFHZZ	2910-01-337-4142	53867	1 425 100 323	HOUSING,GOVERNOR,DI UOC: ZAA,ZAB,ZAC,ZAD,ZAE,ZAF, ZAG,ZAH,ZAJ,ZAL .....	1
11	PFHZZ	5340-01-336-6761	5T151	1 421 389 008	BRACKET,ANGLE UOC: ZAA,ZAB,ZAC,ZAD,ZAE,ZAF, ZAG,ZAH,ZAJ,ZAL .....	4
12	KBHZZ		5T151	1 423 421 007	FLAT-HEAD SCREW PART OF KIT P/N 57K0141 UOC: ZAA,ZAB,ZAC,ZAD,ZAE,ZAF, ZAG,ZAH,ZAJ,ZAL .....	4
13	PFHZZ	5331-01-301-1825	53867	2420210034	O-RING PART OF KIT P/N 57K0141 UOC: ZAA,ZAB,ZAC,ZAD,ZAE,ZAF, ZAG,ZAH,ZAJ,ZAL .....	1
14	PFHZZ	3040-01-300-5309	53867	1 425 703 013	PLATE,RETAINING,SHA 13.50MM UOC: ZAA,ZAB,ZAC,ZAD,ZAE,ZAF, ZAG,ZAH,ZAJ,ZAL .....	1

(1) ITEM NO.	(2) SMR CODE	(3) NSN	(4) CAGEC	(5) PART NUMBER	(6) DESCRIPTION AND USABLE ON CODE (UOC)	(7) QTY
15	PAHZZ	5310-01-237-5224	64678	000125 008413	WASHER,FLAT UOC: ZAA,ZAB,ZAC,ZAD,ZAE,ZAF, ZAG,ZAH,ZAJ,ZAL .....	2
16	PAHZZ	5310-01-301-1875	53867	2916699109	WASHER,LOCK UOC: ZAA,ZAB,ZAC,ZAD,ZAE,ZAF, ZAG,ZAH,ZAJ,ZAL .....	2
17	PAHZZ	5305-01-301-5112	53867	1 423 450 056	SCREW,CAP,HEXAGON H UOC: ZAA,ZAB,ZAC,ZAD,ZAE,ZAF, ZAG,ZAH,ZAJ,ZAL .....	2
18	PAHZZ	5306-01-301-4881	53867	1 423 124 108	BOLT,SPECIAL TIMING PIN UOC: ZAA,ZAB,ZAC,ZAD,ZAE,ZAF, ZAG,ZAH,ZAJ,ZAL .....	1
19	PFHZZ	5315-01-336-6689	5T151	1 900 023 002	KEY,WOODRUFF DIM 6888-2 X 3.7S160-2A UOC: ZAA,ZAB,ZAC,ZAD,ZAE,ZAF, ZAG,ZAH,ZAJ,ZAL .....	1
20	PAHZZ	3040-01-337-4368	53867	1 422 130 011	BRACKET,EYE,NONROTA UOC: ZAA,ZAB,ZAC,ZAD,ZAE,ZAF, ZAG,ZAH,ZAJ,ZAL .....	1
21	PFHZZ	5365-01-339-3839	5T151	1 420 100 602	SHIM 0.30MM THICK UOC: ZAA,ZAB,ZAC,ZAD,ZAE,ZAF, ZAG,ZAH,ZAJ,ZAL .....	1
22	PFHZZ	5340-01-336-6784	5T151	1 420 505 057	RETAINER,HELICAL CO UOC: ZAA,ZAB,ZAC,ZAD,ZAE,ZAF, ZAG,ZAH,ZAJ,ZAL .....	1
23	PFHZZ	5331-01-336-6717	5T151	1 810 210 147	O-RING UOC: ZAA,ZAB,ZAC,ZAD,ZAE,ZAF, ZAG,ZAH,ZAJ,ZAL .....	1
24	PFHZZ	5325-01-336-6738	5T151	2 423 457 003	INSERT,SCREW THREAD UOC: ZAA,ZAB,ZAC,ZAD,ZAE,ZAF, ZAG,ZAH,ZAJ,ZAL .....	1
25	KBHZZ		5T151	1 421 015 082	GASKET PART OF KIT P/N 57K0141 UOC: ZAA,ZAB,ZAC,ZAD,ZAE,ZAF, ZAG,ZAH,ZAJ,ZAL .....	1

END OF FIGURE



**FIELD MAINTENANCE  
FUEL FILTER, WATER SEPARATOR, AND MOUNTING HARDWARE (M939, M939A1, M939A2)**

---

2  
3-9

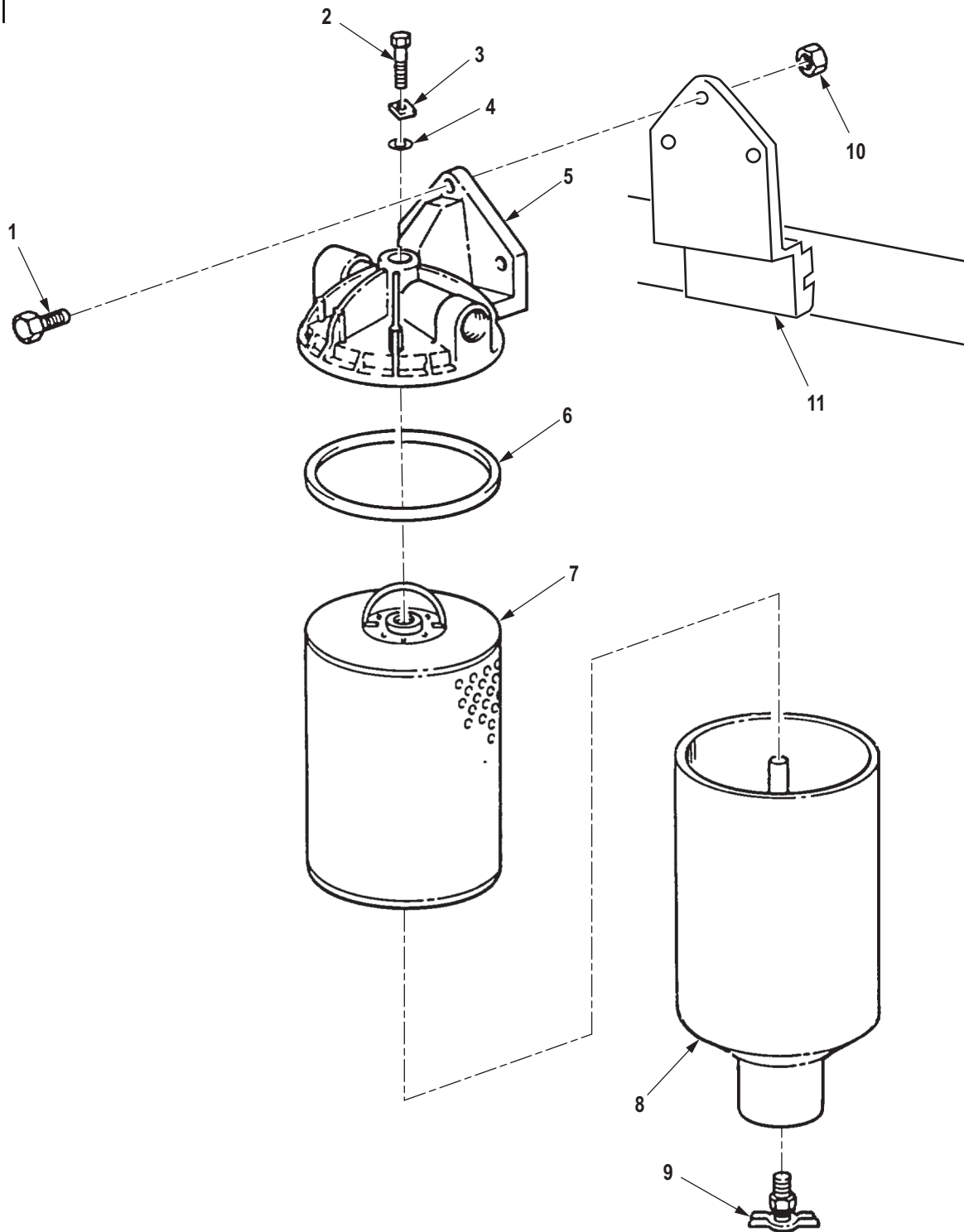

R0093DAA

Figure 93. Fuel Filter, Water Separator, and Mounting Hardware (M939, M939A1, M939A2).

(1) ITEM NO.	(2) SMR CODE	(3) NSN	(4) CAGEC	(5) PART NUMBER	(6) DESCRIPTION AND USABLE ON CODE (UOC)	(7) QTY
<b>GROUP 0309 FUEL FILTERS.</b>						
<b>FIG. 93. FUEL FILTER, WATER SEPARATOR, AND MOUNTING HARDWARE (M939, M939A1).</b>						
1	PAFZZ	5305-00-269-3239	80204	B1821BH038F138N	SCREW,CAP,HEXAGON H PART OF KIT P/N 57K0251 UOC: DAC,DAD,DAE,DAF,DAG,DAH,DAJ,DAL,DAW,DAX,V14,V15,V16,V17,V18,V19,V20,V21,V22,V24,ZAA,ZAB,ZAC,ZAD,ZAE,ZAF,ZAG,ZAH,ZAJ,ZAL .....	3
2	PAFZZ	4930-00-477-8276	15434	256172	SEPARATOR,WATER,LIQ PART OF KIT P/N 57K0251 UOC: DAC,DAD,DAE,DAF,DAG,DAH,DAJ,DAL,DAW,DAX,V14,V15,V16,V17,V18,V19,V20,V21,V22,V24,ZAA,ZAB,ZAC,ZAD,ZAE,ZAF,ZAG,ZAH,ZAJ,ZAL .....	1
3	XDFZZ		15434	251081	. WASHER,FLAT UOC: DAC,DAD,DAE,DAF,DAG,DAH,DAJ,DAL,DAW,DAX,V14,V15,V16,V17,V18,V19,V20,V21,V22,V24,ZAA,ZAB,ZAC,ZAD,ZAE,ZAF,ZAG,ZAH,ZAJ,ZAL .....	1
4	KFFZZ	5331-01-160-7457	15434	3010937	. O-RING PART OF KIT P/N LFF1201 UOC: DAC,DAD,DAE,DAF,DAG,DAH,DAJ,DAL,DAW,DAX,V14,V15,V16,V17,V18,V19,V20,V21,V22,V24,ZAA,ZAB,ZAC,ZAD,ZAE,ZAF,ZAG,ZAH,ZAJ,ZAL .....	1
5	PAFZZ	2910-01-097-8591	15434	257548	. HEAD,FLUID FILTER UOC: DAC,DAD,DAE,DAF,DAG,DAH,DAJ,DAL,DAW,DAX,V14,V15,V16,V17,V18,V19,V20,V21,V22,V24,ZAA,ZAB,ZAC,ZAD,ZAE,ZAF,ZAG,ZAH,ZAJ,ZAL .....	1
6	KFFZZ	5330-01-039-9514	33457	25139000	. GASKET PART OF KIT P/N LFF1201 UOC: DAC,DAD,DAE,DAF,DAG,DAH,DAJ,DAL,DAW,DAX,V14,V15,V16,V17,V18,V19,V20,V21,V22,V24,ZAA,ZAB,ZAC,ZAD,ZAE,ZAF,ZAG,ZAH,ZAJ,ZAL .....	1

(1) ITEM NO.	(2) SMR CODE	(3) NSN	(4) CAGEC	(5) PART NUMBER	(6) DESCRIPTION AND USABLE ON CODE (UOC)	(7) QTY
7	KFFZZ		15434	256416	. ELEMENT ASSY PART OF KIT P/N LFF1201 UOC: DAC,DAD,DAE,DAF,DAG,DA H,DAJ,DAL,DAW,DAX,V14,V15,V16, V17,V18,V19,V20,V21,V22,V24,ZAA, ZAB,ZAC,ZAD,ZAE,ZAF,ZAG,ZAH,Z AJ,ZAL .....	1
8	PAFZZ	4330-01-110-9054	33457	025642400 S	. FILTER BODY,FLUID UOC: DAC,DAD,DAE,DAF,DAG,DA H,DAJ,DAL,DAW,DAX,V14,V15,V16, V17,V18,V19,V20,V21,V22,V24,ZAA, ZAB,ZAC,ZAD,ZAE,ZAF,ZAG,ZAH,Z AJ,ZAL .....	1
9	PAFZZ	4820-01-263-6410	01276	145	. COCK,DRAIN UOC: DAC,DAD,DAE,DAF,DAG,DA H,DAJ,DAL,DAW,DAX,V14,V15,V16, V17,V18,V19,V20,V21,V22,V24,ZAA, ZAB,ZAC,ZAD,ZAE,ZAF,ZAG,ZAH,Z AJ,ZAL .....	1
10	PAFZZ	5310-00-959-1488	81349	M45913/2-6FG5C	NUT,SELF-LOCKING,HE PART OF KIT P/N 57K0251 UOC: DAC,DAD,DAE,DAF,DAG,DA H,DAJ,DAL,DAW,DAX,V14,V15,V16, V17,V18,V19,V20,V21,V22,V24,ZAA, ZAB,ZAC,ZAD,ZAE,ZAF,ZAG,ZAH,Z AJ,ZAL .....	3
11	PAFZZ	4330-01-440-7637	19207	12256078	BRACKET,FILTER MOUN PART OF KIT P/N 57K0251 UOC: ZAA,ZAB,ZAC,ZAD,ZAE,ZAF, ZAG,ZAH,ZAJ,ZAL .....	1

END OF FIGURE

**FIELD MAINTENANCE  
FUEL FILTER/WATER SEPARATOR (M939A2)**

---

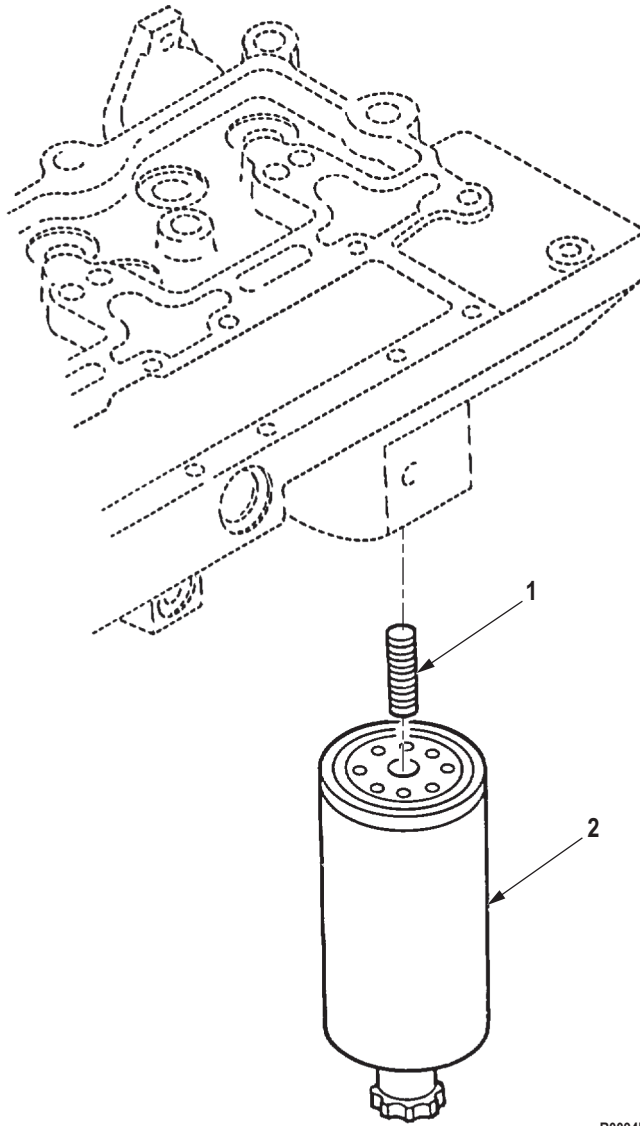

R0094DAA

Figure 94. Fuel Filter/Water Separator (M939A2).

(1) ITEM NO.	(2) SMR CODE	(3) NSN	(4) CAGEC	(5) PART NUMBER	(6) DESCRIPTION AND USABLE ON CODE (UOC)	(7) QTY
<b>GROUP 0309 FUEL FILTERS.</b>						
<b>FIG. 94. FUEL FILTER/WATER SEPARATOR (M939A2).</b>						
1	PAFZZ	5307-01-196-4246	15434	3925955	STUD, CONTINUOUS THR UOC: ZAA,ZAB,ZAC,ZAD,ZAE,ZAF, ZAG,ZAH,ZAJ,ZAL .....	1
2	PAFZZ	2910-01-201-7719	79396	33472	FILTER ELEMENT, FLUI UOC: ZAA,ZAB,ZAC,ZAD,ZAE,ZAF, ZAG,ZAH,ZAJ,ZAL .....	1

**END OF FIGURE**





**FIELD MAINTENANCE  
FUEL PUMP FILTER, AFC (M939, M939A1)**

---

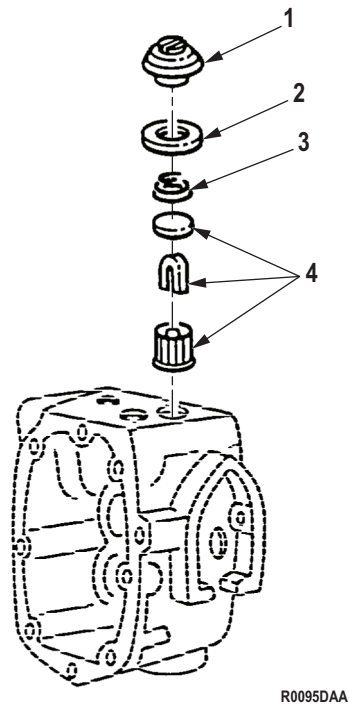

R0095DAA

Figure 95. Fuel Pump Filter, AFC (M939, M939A1).

(1) ITEM NO.	(2) SMR CODE	(3) NSN	(4) CAGEC	(5) PART NUMBER	(6) DESCRIPTION AND USABLE ON CODE (UOC)	(7) QTY
<b>GROUP 0309 FUEL FILTERS.</b>						
<b>FIG. 95. FUEL PUMP FILTER, AFC (M939, M939A1).</b>						
1	PAFZZ	5365-00-507-3271	0B8S3	157088	PLUG,MACHINE THREAD UOC: DAC,DAD,DAE,DAF,DAG,DAH,DAJ,DAW,DAX,V14,V15,V16,V17,V19,V20,V21,V22,V24 .....	1
2	PAFZZ	5330-00-961-9470	15434	154088	GASKET PART OF KIT P/N 3010240, PART OF KIT P/N 5704519 UOC: DAC,DAD,DAE,DAF,DAG,DAH,DAJ,DAW,DAX,V14,V15,V16,V17,V19,V20,V21,V22,V24 .....	1
3	PAFZZ	5360-00-597-4570	15434	70700	SPRING,HELICAL,COMP UOC: DAC,DAD,DAE,DAF,DAG,DAH,DAJ,DAW,DAX,V14,V15,V16,V17,V19,V20,V21,V22,V24 .....	1
4	PAFZZ	2910-00-790-8736	15434	14648300	FILTER ELEMENT,FLUI UOC: DAC,DAD,DAE,DAF,DAG,DAH,DAJ,DAW,DAX,V14,V15,V16,V17,V19,V20,V21,V22,V24 .....	1

**END OF FIGURE**



**FIELD MAINTENANCE  
FUEL PUMP FILTER, VS**

---

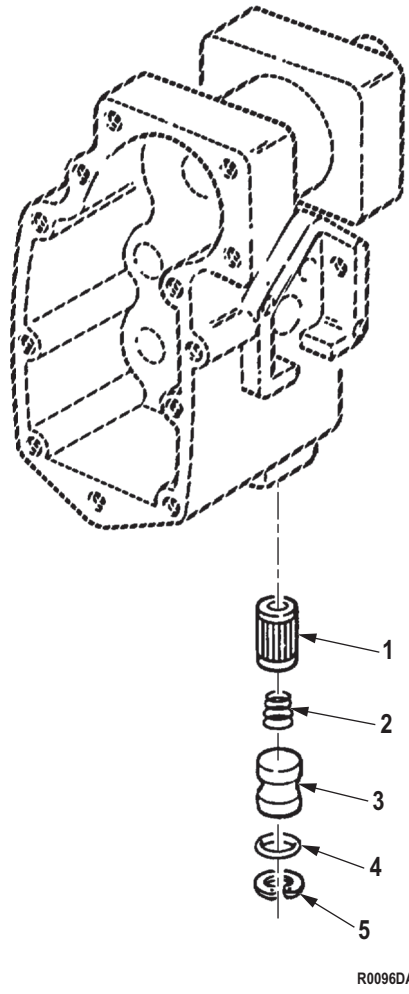

Figure 96. Fuel Pump Filter, VS.

(1) ITEM NO.	(2) SMR CODE	(3) NSN	(4) CAGEC	(5) PART NUMBER	(6) DESCRIPTION AND USABLE ON CODE (UOC)	(7) QTY
<b>GROUP 0309 FUEL FILTERS.</b>						
<b>FIG. 96. FUEL PUMP FILTER, VS.</b>						
1	PAFZZ	2910-00-790-8736	15434	14648300	FILTER ELEMENT,FLUI UOC: DAL,V18 .....	1
2	PAFZZ	5360-00-597-4570	15434	70700	SPRING,HELICAL,COMP UOC: DAL,V18 .....	1
3	PAFZZ	2910-01-051-4292	15434	201007	COVER,FLUID FILTER UOC: DAL,V18 .....	1
4	PAFZZ	5330-01-051-4243	15434	145504	PACKING,PREFORMED UOC: DAL,V18 .....	1
5	PAFZZ	5325-00-823-6002	15434	128807	RING,RETAINING UOC: DAL,V18 .....	1

**END OF FIGURE**





**FIELD MAINTENANCE  
ETHER START CYLINDER, SWITCH, AND RELATE LINES AND FITTINGS**

---

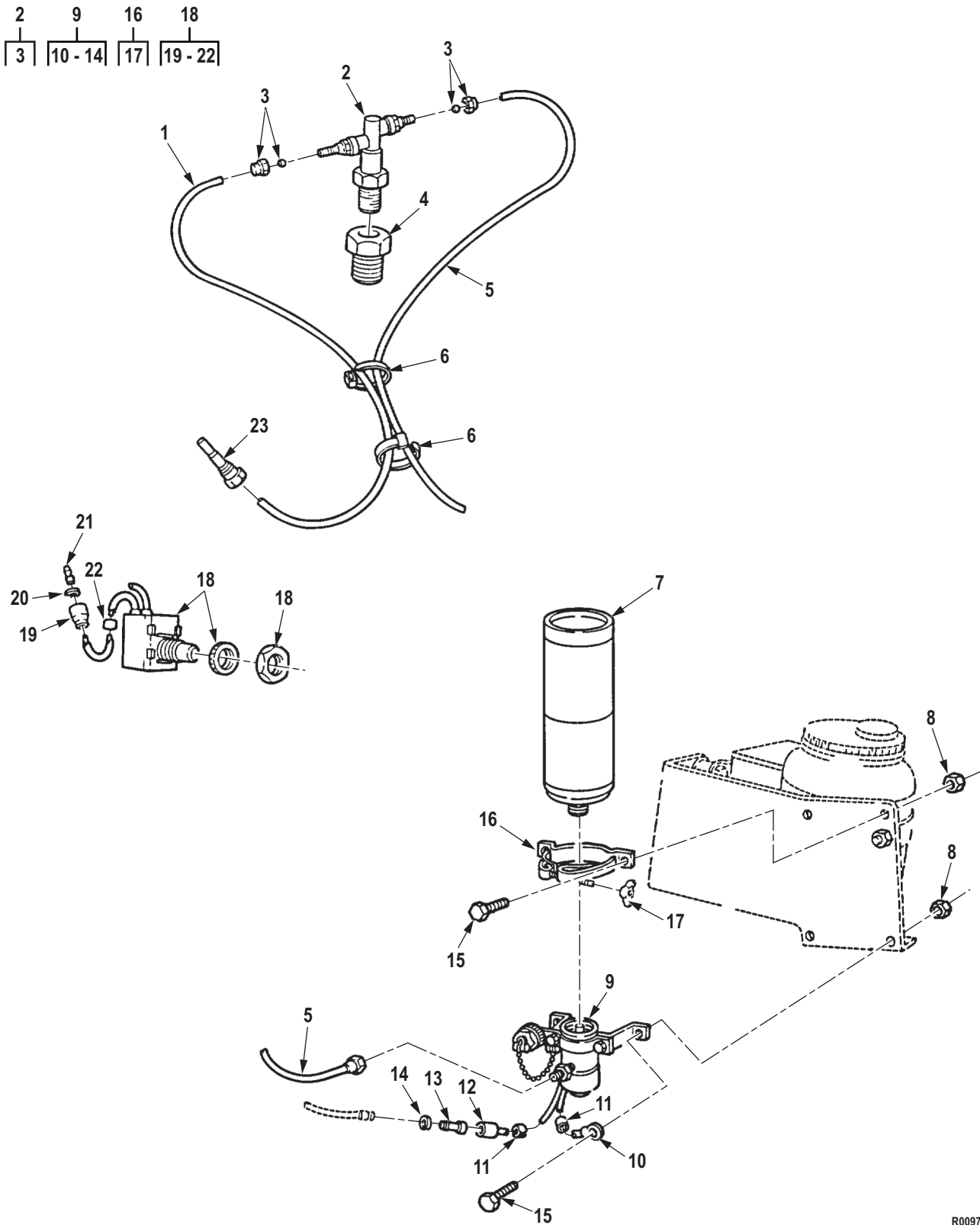

Figure 97. Ether Start Cylinder, Switch, and Related Lines and Fittings.

R0097DAA

(1) ITEM NO.	(2) SMR CODE	(3) NSN	(4) CAGEC	(5) PART NUMBER	(6) DESCRIPTION AND USABLE ON CODE (UOC)	(7) QTY
<b>GROUP 0311 ENGINE STARTING AIDS.</b>						
<b>FIG. 97. ETHER START CYLINDER, SWITCH, AND RELATE LINES AND FITTINGS.</b>						
1	MFFZZ		19207	CPR104420-6-20	TUBING, NONMETALLIC MAKE FROM HOSE, P/N CPR104420-6, 20 IN. LONG UOC: DAC, DAD, DAE, DAF, DAG, DA H, DAJ, DAL, DAW, DAX, V14, V15, V16, V17, V18, V19, V20, V21, V22, V24, ZAA, ZAB, ZAC, ZAD, ZAE, ZAF, ZAG, ZAH, Z AJ, ZAL .....	1
2	PAFZZ	5930-01-069-2776	78280	QS-4577	SWITCH, THERMOSTATIC UOC: DAC, DAD, DAE, DAF, DAG, DA H, DAJ, DAL, DAW, DAX, V14, V15, V16, V17, V18, V19, V20, V21, V22, V24, ZAA, ZAB, ZAC, ZAD, ZAE, ZAF, ZAG, ZAH, Z AJ, ZAL .....	1
3	PAFZZ	4730-00-057-0650	78280	LP-5146-10	. SLEEVE, CLINCH, TUBE UOC: DAC, DAD, DAE, DAF, DAG, DA H, DAJ, DAL, DAW, DAX, V14, V15, V16, V17, V18, V19, V20, V21, V22, V24, ZAA, ZAB, ZAC, ZAD, ZAE, ZAF, ZAG, ZAH, Z AJ, ZAL .....	2
4	PAFZZ	4730-00-817-6578	80204	ANSI/ASME B16.15 1/2 X 3/8 MPT	BUSHING, PIPE UOC: DAC, DAD, DAE, DAF, DAG, DA H, DAJ, DAL, DAW, DAX, V14, V15, V16, V17, V18, V19, V20, V21, V22, V24, ZAA, ZAB, ZAC, ZAD, ZAE, ZAF, ZAG, ZAH, Z AJ, ZAL .....	1
5	MFFZZ		19207	CPR104420-6-30	TUBING, NONMETALLIC MAKE FROM HOSE, P/N CPR104420-6, 30 IN. LONG UOC: DAC, DAD, DAE, DAF, DAG, DA H, DAJ, DAL, DAW, DAX, V14, V15, V16, V17, V18, V19, V20, V21, V22, V24, ZAA, ZAB, ZAC, ZAD, ZAE, ZAF, ZAG, ZAH, Z AJ, ZAL .....	1
6	PAFZZ	5975-00-984-6582	96906	MS3367-1-0	STRAP, TIEDOWN, ELECT UOC: DAC, DAD, DAE, DAF, DAG, DA H, DAJ, DAL, DAW, DAX, V14, V15, V16, V17, V18, V19, V20, V21, V22, V24, ZAA, ZAB, ZAC, ZAD, ZAE, ZAF, ZAG, ZAH, Z AJ, ZAL .....	2

(1) ITEM NO.	(2) SMR CODE	(3) NSN	(4) CAGEC	(5) PART NUMBER	(6) DESCRIPTION AND USABLE ON CODE (UOC)	(7) QTY
7	PAFZZ	2910-00-646-9727	78280	LP-535	CYLINDER,ENGINE STA UOC: DAC,DAD,DAE,DAF,DAG,DA H,DAJ,DAL,DAW,DAX,V14,V15,V16, V17,V18,V19,V20,V21,V22,V24,ZAA, ZAB,ZAC,ZAD,ZAE,ZAF,ZAG,ZAH,Z AJ,ZAL .....	1
8	PAFZZ	5310-00-241-6658	81349	M45913/3-5FG8C	NUT,SELF-LOCKING,HE UOC: DAC,DAD,DAE,DAF,DAG,DA H,DAJ,DAL,DAW,DAX,V14,V15,V16, V17,V18,V19,V20,V21,V22,V24,ZAA, ZAB,ZAC,ZAD,ZAE,ZAF,ZAG,ZAH,Z AJ,ZAL .....	4
9	PAFZZ	4810-01-124-5056	19207	12277380	VALVE,SOLENOID UOC: DAC,DAD,DAE,DAF,DAG,DA H,DAJ,DAL,DAW,DAX,V14,V15,V16, V17,V18,V19,V20,V21,V22,V24,ZAA, ZAB,ZAC,ZAD,ZAE,ZAF,ZAG,ZAH,Z AJ,ZAL .....	1
10	PAFZZ	5940-00-283-5281	81343	MS25036-109	. TERMINAL,LUG UOC: DAC,DAD,DAE,DAF,DAG,DA H,DAJ,DAL,DAW,DAX,V14,V15,V16, V17,V18,V19,V20,V21,V22,V24,ZAA, ZAB,ZAC,ZAD,ZAE,ZAF,ZAG,ZAH,Z AJ,ZAL .....	1
11	PAFZZ	9905-00-752-4649	24617	5939707	. BAND MRKER BLNK-ALU UOC: DAC,DAD,DAE,DAF,DAG,DA H,DAJ,DAL,DAW,DAX,V14,V15,V16, V17,V18,V19,V20,V21,V22,V24,ZAA, ZAB,ZAC,ZAD,ZAE,ZAF,ZAG,ZAH,Z AJ,ZAL .....	2
12	PAFZZ	5935-00-691-5591	97403	13207E6498-2	. SHELL,ELECTRICAL CO UOC: DAC,DAD,DAE,DAF,DAG,DA H,DAJ,DAL,DAW,DAX,V14,V15,V16, V17,V18,V19,V20,V21,V22,V24,ZAA, ZAB,ZAC,ZAD,ZAE,ZAF,ZAG,ZAH,Z AJ,ZAL .....	1
13	PAFZZ	5999-00-926-3144	58536	AA52536-3	. CONTACT,ELECTRICAL UOC: DAC,DAD,DAE,DAF,DAG,DA H,DAJ,DAL,DAW,DAX,V14,V15,V16, V17,V18,V19,V20,V21,V22,V24,ZAA, ZAB,ZAC,ZAD,ZAE,ZAF,ZAG,ZAH,Z AJ,ZAL .....	1
14	PAFZZ	5310-00-656-0067	19207	8724497	. WASHER,SLOTTED UOC: DAC,DAD,DAE,DAF,DAG,DA H,DAJ,DAL,DAW,DAX,V14,V15,V16, V17,V18,V19,V20,V21,V22,V24,ZAA, ZAB,ZAC,ZAD,ZAE,ZAF,ZAG,ZAH,Z AJ,ZAL .....	1

(1) ITEM NO.	(2) SMR CODE	(3) NSN	(4) CAGEC	(5) PART NUMBER	(6) DESCRIPTION AND USABLE ON CODE (UOC)	(7) QTY
15	PAFZZ	5306-00-050-1238	80204	B1821BH031F075N	BOLT,MACHINE UOC: DAC,DAD,DAE,DAF,DAG,DA H,DAJ,DAL,DAW,DAX,V14,V15,V16, V17,V18,V19,V20,V21,V22,V24,ZAA, ZAB,ZAC,ZAD,ZAE,ZAF,ZAG,ZAH,Z AJ,ZAL .....	4
16	PAFZZ	5340-01-128-9558	19207	12277381	CLAMP,LOOP UOC: DAC,DAD,DAE,DAF,DAG,DA H,DAJ,DAL,DAW,DAX,V14,V15,V16, V17,V18,V19,V20,V21,V22,V24,ZAA, ZAB,ZAC,ZAD,ZAE,ZAF,ZAG,ZAH,Z AJ,ZAL .....	1
17	PAFZZ	5310-01-100-5199	96906	MS35426-27	. NUT,PLAIN,WING UOC: DAC,DAD,DAE,DAF,DAG,DA H,DAJ,DAL,DAW,DAX,V14,V15,V16, V17,V18,V19,V20,V21,V22,V24,ZAA, ZAB,ZAC,ZAD,ZAE,ZAF,ZAG,ZAH,Z AJ,ZAL .....	1
18	PAFZZ	5930-01-132-3247	19207	11669772	SWITCH,PUSH UOC: DAC,DAD,DAE,DAF,DAG,DA H,DAJ,DAL,DAW,DAX,V14,V15,V16, V17,V18,V19,V20,V21,V22,V24,ZAA, ZAB,ZAC,ZAD,ZAE,ZAF,ZAG,ZAH,Z AJ,ZAL .....	1
19	PAFZZ	5935-00-691-5591	97403	13207E6498-2	. SHELL,ELECTRICAL CO UOC: DAC,DAD,DAE,DAF,DAG,DA H,DAJ,DAL,DAW,DAX,V14,V15,V16, V17,V18,V19,V20,V21,V22,V24,ZAA, ZAB,ZAC,ZAD,ZAE,ZAF,ZAG,ZAH,Z AJ,ZAL .....	2
20	PAFZZ	5310-00-656-0067	19207	8724497	. WASHER,SLOTTED UOC: DAC,DAD,DAE,DAF,DAG,DA H,DAJ,DAL,DAW,DAX,V14,V15,V16, V17,V18,V19,V20,V21,V22,V24,ZAA, ZAB,ZAC,ZAD,ZAE,ZAF,ZAG,ZAH,Z AJ,ZAL .....	2
21	PAFZZ	5999-00-926-3144	58536	AA52536-3	. CONTACT,ELECTRICAL UOC: DAC,DAD,DAE,DAF,DAG,DA H,DAJ,DAL,DAW,DAX,V14,V15,V16, V17,V18,V19,V20,V21,V22,V24,ZAA, ZAB,ZAC,ZAD,ZAE,ZAF,ZAG,ZAH,Z AJ,ZAL .....	2
22	PAFZZ	9905-00-752-4649	24617	5939707	. BAND MRKER BLNK-ALU UOC: DAC,DAD,DAE,DAF,DAG,DA H,DAJ,DAL,DAW,DAX,V14,V15,V16, V17,V18,V19,V20,V21,V22,V24,ZAA, ZAB,ZAC,ZAD,ZAE,ZAF,ZAG,ZAH,Z AJ,ZAL .....	2

(1) ITEM NO.	(2) SMR CODE	(3) NSN	(4) CAGEC	(5) PART NUMBER	(6) DESCRIPTION AND USABLE ON CODE (UOC)	(7) QTY
23	PAFZZ	2910-01-130-1535	55683	12277379	NOZZLE,FUEL INJECTI UOC: DAC,DAD,DAE,DAF,DAG,DA H,DAJ,DAL,DAW,DAX,V14,V15,V16, V17,V18,V19,V20,V21,V22,V24,ZAA, ZAB,ZAC,ZAD,ZAE,ZAF,ZAG,ZAH,Z AJ,ZAL .....	1

END OF FIGURE

**FIELD MAINTENANCE  
ATOMIZER NOZZLE (M939A2)**

---

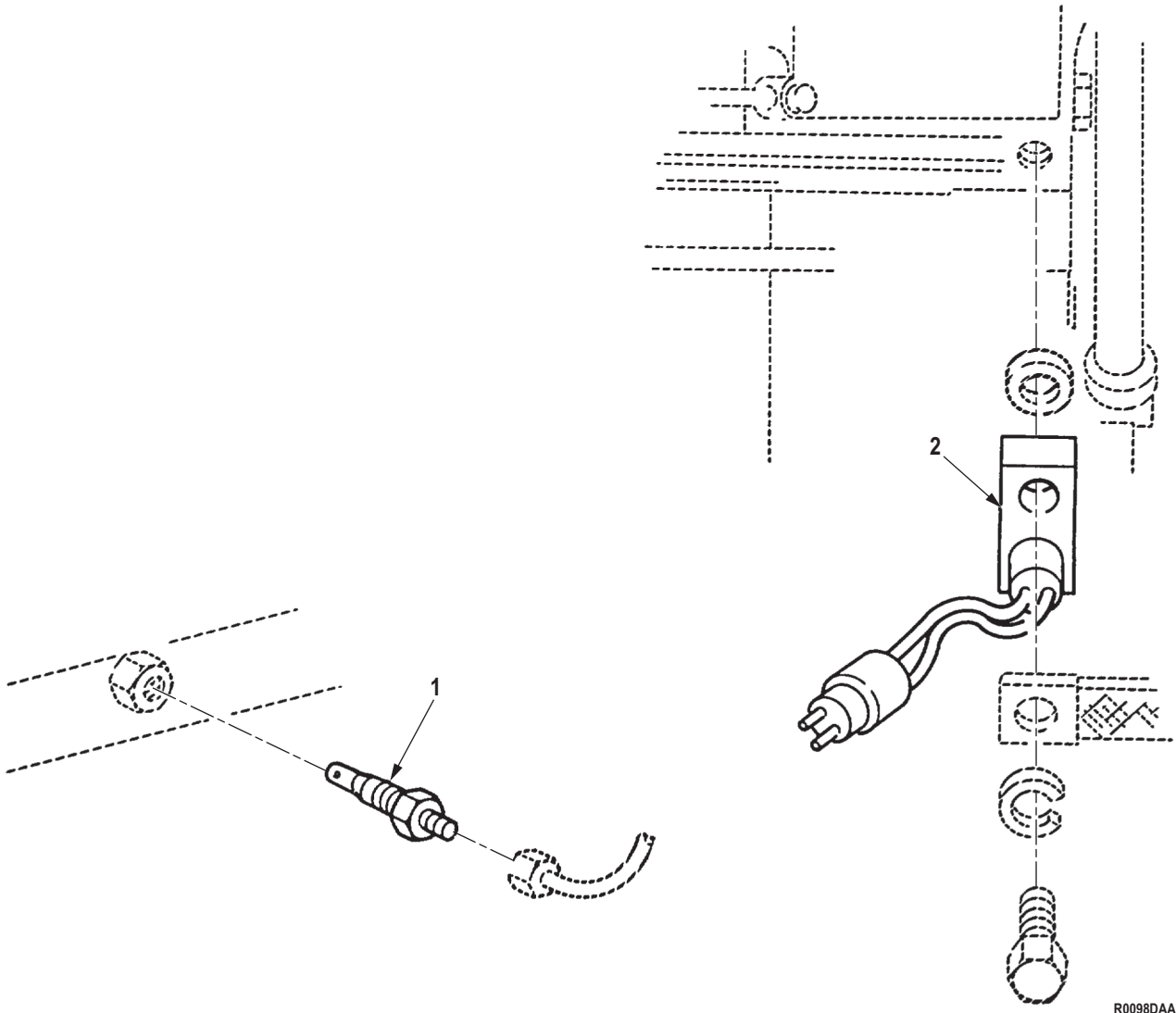

R0098DAA

Figure 98. Atomizer Nozzle (M939A2).



(1) ITEM NO.	(2) SMR CODE	(3) NSN	(4) CAGEC	(5) PART NUMBER	(6) DESCRIPTION AND USABLE ON CODE (UOC)	(7) QTY
<b>GROUP 0311 ENGINE STARTING AIDS.</b>						
<b>FIG. 98. ATOMIZER NOZZLE (M939A2).</b>						
1	PAFZZ	2910-01-305-7983	33457	331641000	ATOMIZER, STARTING F UOC: ZAA,ZAB,ZAC,ZAD,ZAE,ZAF, ZAG,ZAH,ZAJ,ZAL .....	1
2	PAFZZ	5905-01-280-3388	6Y402	829-5220	SENSOR, TEMPERATURE ETHER START UOC: ZAA,ZAB,ZAC,ZAD,ZAE,ZAF, ZAG,ZAH,ZAJ,ZAL .....	1
<b>END OF FIGURE</b>						



**FIELD MAINTENANCE  
FUEL PRIMER PUMP**

---

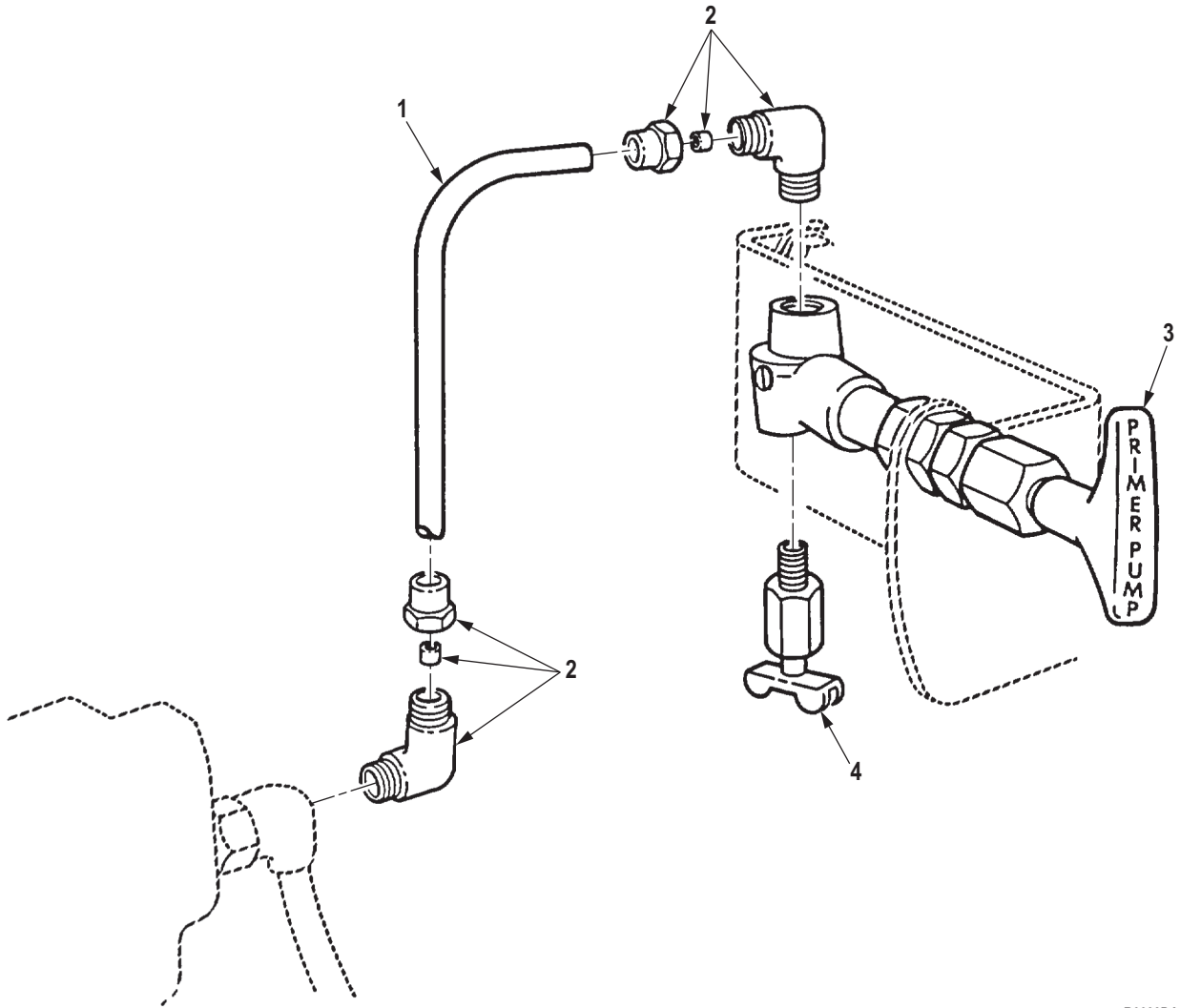

R0099DAA

Figure 99. Fuel Primer Pump.

(1) ITEM NO.	(2) SMR CODE	(3) NSN	(4) CAGEC	(5) PART NUMBER	(6) DESCRIPTION AND USABLE ON CODE (UOC)	(7) QTY
<b>GROUP 0311 ENGINE STARTING AIDS.</b>						
<b>FIG. 99. FUEL PRIMER PUMP.</b>						
1	MFFZZ		19207	8675779-28	TUBING, NONMETALLIC MAKE FROM TUBING, P/N 8675779, 28 IN. LONG UOC: DAC, DAD, DAE, DAF, DAG, DA H, DAJ, DAL, DAW, DAX, V14, V15, V16, V17, V18, V19, V20, V21, V22, V24, ZAA, ZAB, ZAC, ZAD, ZAE, ZAF, ZAG, ZAH, Z AJ, ZAL .....	1
2	PAFZZ	4730-00-921-3240	81343	4-2 120202BA	ELBOW, PIPE TO TUBE UOC: DAC, DAD, DAE, DAF, DAG, DA H, DAJ, DAL, DAW, DAX, V14, V15, V16, V17, V18, V19, V20, V21, V22, V24, ZAA, ZAB, ZAC, ZAD, ZAE, ZAF, ZAG, ZAH, Z AJ, ZAL .....	2
3	PAFZZ	2910-00-421-3967	50496	PP93372	PUMP, ENGINE PRIMING UOC: DAC, DAD, DAE, DAF, DAG, DA H, DAJ, DAL, DAW, DAX, V14, V15, V16, V17, V18, V19, V20, V21, V22, V24, ZAA, ZAB, ZAC, ZAD, ZAE, ZAF, ZAG, ZAH, Z AJ, ZAL .....	1
4	PAFZZ	4820-00-684-0880	58536	AA59440/1-001	COCK, DRAIN UOC: DAC, DAD, DAE, DAF, DAG, DA H, DAJ, DAL, DAW, DAX, V14, V15, V16, V17, V18, V19, V20, V21, V22, V24, ZAA, ZAB, ZAC, ZAD, ZAE, ZAF, ZAG, ZAH, Z AJ, ZAL .....	1

**END OF FIGURE**



**FIELD MAINTENANCE  
ACCELERATOR CONTROLS AND LINKAGE (M939, M939A1)**

---

10  
|  
11-13

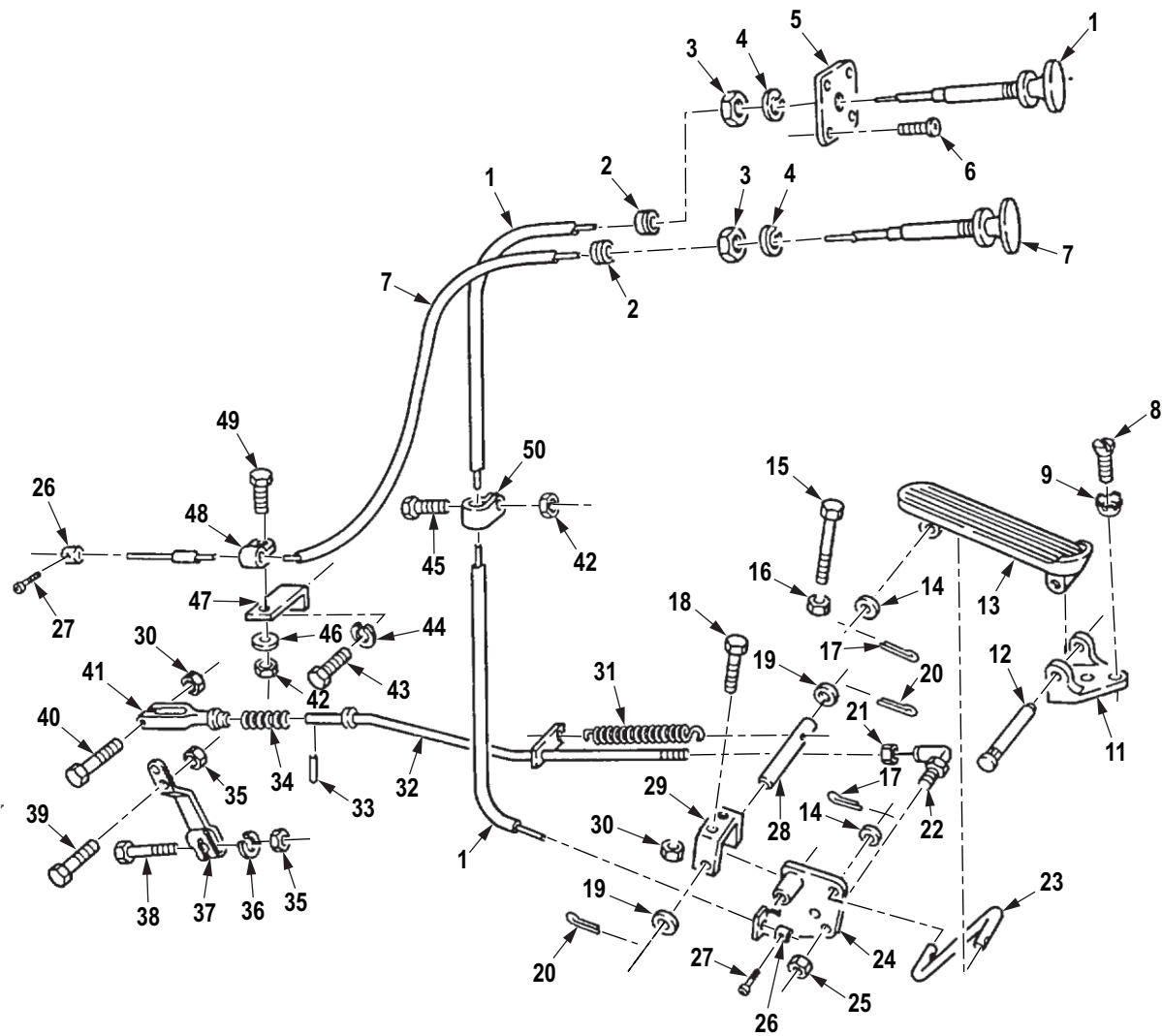

R0100DAA

Figure 100. Accelerator Controls and Linkage (M939, M939A1).



(1) ITEM NO.	(2) SMR CODE	(3) NSN	(4) CAGEC	(5) PART NUMBER	(6) DESCRIPTION AND USABLE ON CODE (UOC)	(7) QTY
<b>GROUP 0312 ACCELERATOR, THROTTLE OR CHOKE CONTROLS.</b>						
<b>FIG. 100. ACCELERATOR CONTROLS AND LINKAGE (M939, M939A1).</b>						
1	PAFZZ	2590-01-107-9917	19207	11664388-3	CONTROL ASSEMBLY,PU THROTTLE 39" UOC: DAC,DAD,DAE,DAF,DAG,DA H,DAJ,DAL,DAW,DAX,V14,V15,V16, V17,V18,V19,V20,V21,V22,V24 .....	1
2	PAFZZ	5325-00-174-5316	96906	MS35489-2	GROMMET,NONMETALLIC UOC: DAC,DAD,DAE,DAF,DAG,DA H,DAJ,DAL,DAW,DAX,V14,V15,V16, V17,V18,V19,V20,V21,V22,V24 .....	2
3	PAFZZ	5310-00-058-1626	80205	MS35650-3382	NUT,PLAIN,HEXAGON UOC: DAC,DAD,DAE,DAF,DAG,DA H,DAJ,DAL,DAW,DAX,V14,V15,V16, V17,V18,V19,V20,V21,V22,V24 .....	2
4	PAFZZ	5310-00-637-9541	00198	132661	WASHER,LOCK UOC: DAC,DAD,DAE,DAF,DAG,DA H,DAJ,DAL,DAW,DAX,V14,V15,V16, V17,V18,V19,V20,V21,V22,V24 .....	2
5	PFFZZ	3040-01-130-7931	19207	12277149	PLATE,RETAINING,SHA UOC: DAC,DAD,DAE,DAF,DAG,DA H,DAJ,DAL,DAW,DAX,V14,V15,V16, V17,V18,V19,V20,V21,V22,V24 .....	1
6	PAFZZ	5305-00-989-7435	80205	MS35207-264	SCREW,MACHINE UOC: DAC,DAD,DAE,DAF,DAG,DA H,DAJ,DAL,DAW,DAX,V14,V15,V16, V17,V18,V19,V20,V21,V22,V24 .....	4
7	PAFZZ	2590-00-197-1739	19207	11664388	CONTROL ASSEMBLY,PU EMERGENCY ENGINE STOP 45" UOC: DAC,DAD,DAE,DAF,DAG,DA H,DAJ,DAL,DAW,DAX,V14,V15,V16, V17,V18,V19,V20,V21,V22,V24 .....	1
8	PAFZZ	5305-00-984-7342	96906	MS35191-274	SCREW,MACHINE UOC: DAC,DAD,DAE,DAF,DAG,DA H,DAJ,DAL,DAW,DAX,V14,V15,V16, V17,V18,V19,V20,V21,V22,V24,ZAA, ZAB,ZAC,ZAD,ZAE,ZAF,ZAG,ZAH,Z AJ,ZAL .....	2
9	PAFZZ	5310-00-194-9209	96906	MS35336-21	WASHER,LOCK UOC: DAC,DAD,DAE,DAF,DAG,DA H,DAJ,DAL,DAW,DAX,V14,V15,V16, V17,V18,V19,V20,V21,V22,V24,ZAA, ZAB,ZAC,ZAD,ZAE,ZAF,ZAG,ZAH,Z AJ,ZAL .....	2

(1) ITEM NO.	(2) SMR CODE	(3) NSN	(4) CAGEC	(5) PART NUMBER	(6) DESCRIPTION AND USABLE ON CODE (UOC)	(7) QTY
10	PFFZZ	2540-00-115-2565	19207	7397798	PEDAL,CONTROL THROTTLE PEDAL UOC: DAC,DAD,DAE,DAF,DAG,DA H,DAJ,DAL,DAW,DAX,V14,V15,V16, V17,V18,V19,V20,V21,V22,V24,ZAA, ZAB,ZAC,ZAD,ZAE,ZAF,ZAG,ZAH,Z AJ,ZAL .....	1
11	PAFZZ	3040-00-753-9130	19207	7539130	. BRACKET,EYE,ROTATIN UOC: DAC,DAD,DAE,DAF,DAG,DA H,DAJ,DAL,DAW,DAX,V14,V15,V16, V17,V18,V19,V20,V21,V22,V24,ZAA, ZAB,ZAC,ZAD,ZAE,ZAF,ZAG,ZAH,Z AJ,ZAL .....	1
12	PAFZZ	5315-00-338-1621	19207	7539131	. PIN,STRAIGHT,HEADED UOC: DAC,DAD,DAE,DAF,DAG,DA H,DAJ,DAL,DAW,DAX,V14,V15,V16, V17,V18,V19,V20,V21,V22,V24,ZAA, ZAB,ZAC,ZAD,ZAE,ZAF,ZAG,ZAH,Z AJ,ZAL .....	1
13	PAFZZ	2540-00-753-9114	19207	7539114	. PEDAL,CONTROL UOC: DAC,DAD,DAE,DAF,DAG,DA H,DAJ,DAL,DAW,DAX,V14,V15,V16, V17,V18,V19,V20,V21,V22,V24,ZAA, ZAB,ZAC,ZAD,ZAE,ZAF,ZAG,ZAH,Z AJ,ZAL .....	1
14	PAFZZ	5310-00-515-7449	88044	AN960C416L	WASHER,FLAT UOC: DAC,DAD,DAE,DAF,DAG,DA H,DAJ,DAL,DAW,DAX,V14,V15,V16, V17,V18,V19,V20,V21,V22,V24,ZAA, ZAB,ZAC,ZAD,ZAE,ZAF,ZAG,ZAH,Z AJ,ZAL .....	2
15	PAFZZ	5305-00-914-6131	80204	B1821BH038F175D	SCREW,CAP,HEXAGON H UOC: DAC,DAD,DAE,DAF,DAG,DA H,DAJ,DAL,DAW,DAX,V14,V15,V16, V17,V18,V19,V20,V21,V22,V24,ZAA, ZAB,ZAC,ZAD,ZAE,ZAF,ZAG,ZAH,Z AJ,ZAL .....	1
16	PAFZZ	5310-00-891-1751	96906	MS35691-22	NUT,PLAIN,HEXAGON UOC: DAC,DAD,DAE,DAF,DAG,DA H,DAJ,DAL,DAW,DAX,V14,V15,V16, V17,V18,V19,V20,V21,V22,V24,ZAA, ZAB,ZAC,ZAD,ZAE,ZAF,ZAG,ZAH,Z AJ,ZAL .....	1
17	PAFZZ	5315-00-839-2325	06848	P6666	PIN,COTTER UOC: DAC,DAD,DAE,DAF,DAG,DA H,DAJ,DAL,DAW,DAX,V14,V15,V16, V17,V18,V19,V20,V21,V22,V24,ZAA, ZAB,ZAC,ZAD,ZAE,ZAF,ZAG,ZAH,Z AJ,ZAL .....	2

(1) ITEM NO.	(2) SMR CODE	(3) NSN	(4) CAGEC	(5) PART NUMBER	(6) DESCRIPTION AND USABLE ON CODE (UOC)	(7) QTY
18	PAFZZ	5306-00-050-1238	80204	B1821BH031F075N	BOLT,MACHINE UOC: DAC,DAD,DAE,DAF,DAG,DA H,DAJ,DAL,DAW,DAX,V14,V15,V16, V17,V18,V19,V20,V21,V22,V24,ZAA, ZAB,ZAC,ZAD,ZAE,ZAF,ZAG,ZAH,Z AJ,ZAL .....	2
19	PAFZZ	5310-00-080-6004	96906	MS27183-14	WASHER,FLAT UOC: DAC,DAD,DAE,DAF,DAG,DA H,DAJ,DAL,DAW,DAX,V14,V15,V16, V17,V18,V19,V20,V21,V22,V24,ZAA, ZAB,ZAC,ZAD,ZAE,ZAF,ZAG,ZAH,Z AJ,ZAL .....	2
20	PAFZZ	5315-00-842-3044	80205	MS24665-283	PIN,COTTER UOC: DAC,DAD,DAE,DAF,DAG,DA H,DAJ,DAL,DAW,DAX,V14,V15,V16, V17,V18,V19,V20,V21,V22,V24,ZAA, ZAB,ZAC,ZAD,ZAE,ZAF,ZAG,ZAH,Z AJ,ZAL .....	2
21	PAFZZ	5310-00-880-7746	96906	MS51968-5	NUT,PLAIN,HEXAGON UOC: DAC,DAD,DAE,DAF,DAG,DA H,DAJ,DAL,DAW,DAX,V14,V15,V16, V17,V18,V19,V20,V21,V22,V24,ZAA, ZAB,ZAC,ZAD,ZAE,ZAF,ZAG,ZAH,Z AJ,ZAL .....	1
22	PAFZZ	3040-00-965-0143	72582	5118951	BALL JOINT UOC: DAC,DAD,DAE,DAF,DAG,DA H,DAJ,DAL,DAW,DAX,V14,V15,V16, V17,V18,V19,V20,V21,V22,V24,ZAA, ZAB,ZAC,ZAD,ZAE,ZAF,ZAG,ZAH,Z AJ,ZAL .....	1
23	PAFZZ	3040-01-090-9341	19207	12255972	CONNECTING LINK,RIG UOC: DAC,DAD,DAE,DAF,DAG,DA H,DAJ,DAL,DAW,DAX,V14,V15,V16, V17,V18,V19,V20,V21,V22,V24,ZAA, ZAB,ZAC,ZAD,ZAE,ZAF,ZAG,ZAH,Z AJ,ZAL .....	1
24	PAFZZ	3040-01-090-4482	19207	12255965-1	BELL CRANK UOC: DAC,DAD,DAE,DAF,DAG,DA H,DAJ,DAL,DAW,DAX,V14,V15,V16, V17,V18,V19,V20,V21,V22,V24,ZAA, ZAB,ZAC,ZAD,ZAE,ZAF,ZAG,ZAH,Z AJ,ZAL .....	1
25	PAFZZ	5310-00-984-3807	81349	M45913/1-5FG5C	NUT,SELF-LOCKING,HE UOC: DAC,DAD,DAE,DAF,DAG,DA H,DAJ,DAL,DAW,DAX,V14,V15,V16, V17,V18,V19,V20,V21,V22,V24,ZAA, ZAB,ZAC,ZAD,ZAE,ZAF,ZAG,ZAH,Z AJ,ZAL .....	1

(1) ITEM NO.	(2) SMR CODE	(3) NSN	(4) CAGEC	(5) PART NUMBER	(6) DESCRIPTION AND USABLE ON CODE (UOC)	(7) QTY
26	PAFZZ	2910-00-753-9184	19207	7539184	CONNECTOR, THROTTLE UOC: DAC,DAD,DAE,DAF,DAG,DA H,DAJ,DAL,DAW,DAX,V14,V15,V16, V17,V18,V19,V20,V21,V22,V24,ZAA, ZAB,ZAC,ZAD,ZAE,ZAF,ZAG,ZAH,Z AJ,ZAL .....	2
27	PAFZZ	5305-00-889-3002	96906	MS35206-242	SCREW, MACHINE UOC: DAC,DAD,DAE,DAF,DAG,DA H,DAJ,DAL,DAW,DAX,V14,V15,V16, V17,V18,V19,V20,V21,V22,V24,ZAA, ZAB,ZAC,ZAD,ZAE,ZAF,ZAG,ZAH,Z AJ,ZAL .....	2
28	PAFZZ	3040-01-090-9342	19207	12256352	SHAFT, STRAIGHT UOC: DAC,DAD,DAE,DAF,DAG,DA H,DAJ,DAL,DAW,DAX,V14,V15,V16, V17,V18,V19,V20,V21,V22,V24,ZAA, ZAB,ZAC,ZAD,ZAE,ZAF,ZAG,ZAH,Z AJ,ZAL .....	1
29	PAFZZ	2590-00-421-1595	19207	10896277	BRACKET, THROTTLE LI UOC: DAC,DAD,DAE,DAF,DAG,DA H,DAJ,DAL,DAW,DAX,V14,V15,V16, V17,V18,V19,V20,V21,V22,V24,ZAA, ZAB,ZAC,ZAD,ZAE,ZAF,ZAG,ZAH,Z AJ,ZAL .....	1
30	PAFZZ	5310-00-241-6658	81349	M45913/3-5FG8C	NUT, SELF-LOCKING, HE UOC: DAC,DAD,DAE,DAF,DAG,DA H,DAJ,DAL,DAW,DAX,V14,V15,V16, V17,V18,V19,V20,V21,V22,V24,ZAA, ZAB,ZAC,ZAD,ZAE,ZAF,ZAG,ZAH,Z AJ,ZAL .....	2
31	PAFZZ	5360-00-941-8684	19207	10938295	SPRING, HELICAL, EXTE UOC: DAC,DAD,DAE,DAF,DAG,DA H,DAJ,DAL,DAW,DAX,V14,V15,V16, V17,V18,V19,V20,V21,V22,V24 .....	1
32	PAFZZ	5306-01-090-9344	19207	12256353	ROD, THREADED END UOC: DAC,DAD,DAE,DAF,DAG,DA H,DAJ,DAL,DAW,DAX,V14,V15,V16, V17,V18,V19,V20,V21,V22,V24 .....	1
33	PAFZZ	5315-00-814-3530	80205	MS16562-35	PIN, SPRING UOC: DAC,DAD,DAE,DAF,DAG,DA H,DAJ,DAL,DAW,DAX,V14,V15,V16, V17,V18,V19,V20,V21,V22,V24 .....	1
34	PAFZZ	5360-01-090-9333	19207	12256429	SPRING, HELICAL, EXTE UOC: DAC,DAD,DAE,DAF,DAG,DA H,DAJ,DAL,DAW,DAX,V14,V15,V16, V17,V18,V19,V20,V21,V22,V24 .....	1

(1) ITEM NO.	(2) SMR CODE	(3) NSN	(4) CAGEC	(5) PART NUMBER	(6) DESCRIPTION AND USABLE ON CODE (UOC)	(7) QTY
35	PAFZZ	5310-00-877-5796	80205	MS21044N4	NUT,SELF-LOCKING,HE 1/4-28 UNF-3B R.H. UOC: DAC,DAD,DAE,DAF,DAG,DA H,DAJ,DAL,DAW,DAX,V14,V15,V16, V17,V18,V19,V20,V21,V22,V24 .....	2
36	PAFZZ	5310-00-582-5965	80205	MS35338-44	WASHER,LOCK UOC: DAC,DAD,DAE,DAF,DAG,DA H,DAJ,DAL,DAW,DAX,V14,V15,V16, V17,V18,V19,V20,V21,V22,V24 .....	1
37	PAFZZ	3040-01-189-6406	19207	12302679-1	LEVER,REMOTE CONTRO UOC: DAC,DAD,DAE,DAF,DAG,DA H,DAJ,DAL,DAW,DAX,V14,V15,V16, V17,V18,V19,V20,V21,V22,V24 .....	1
38	PAFZZ	5305-00-267-8955	80204	B1821BH025F138N	SCREW,CAP,HEXAGON H UOC: DAC,DAD,DAE,DAF,DAG,DA H,DAJ,DAL,DAW,DAX,V14,V15,V16, V17,V18,V19,V20,V21,V22,V24 .....	1
39	PAFZZ	5305-01-090-7625	19207	12256366	SCREW,SHOULDER UOC: DAC,DAD,DAE,DAF,DAG,DA H,DAJ,DAL,DAW,DAX,V14,V15,V16, V17,V18,V19,V20,V21,V22,V24 .....	1
40	PAFZZ	5305-00-225-9092	80205	MS90726-37	SCREW,CAP,HEXAGON H UOC: DAC,DAD,DAE,DAF,DAG,DA H,DAJ,DAL,DAW,DAX,V14,V15,V16, V17,V18,V19,V20,V21,V22,V24 .....	1
41	PAFZZ	5340-01-090-9332	19207	12256357	CLEVIS,ROD END UOC: DAC,DAD,DAE,DAF,DAG,DA H,DAJ,DAL,DAW,DAX,V14,V15,V16, V17,V18,V19,V20,V21,V22,V24 .....	1
42	PAFZZ	5310-00-935-9022	81349	M45913/3-4FG8C	NUT,SELF-LOCKING,HE UOC: DAC,DAD,DAE,DAF,DAG,DA H,DAJ,DAL,DAW,DAX,V14,V15,V16, V17,V18,V19,V20,V21,V22,V24 .....	2
43	PAFZZ	5305-01-277-0423	80204	B1821BH056F075N	SCREW,CAP,HEXAGON H UOC: DAC,DAD,DAE,DAF,DAG,DA H,DAJ,DAL,DAW,DAX,V14,V15,V16, V17,V18,V19,V20,V21,V22,V24 .....	1
44	PAFZZ	5310-00-167-0680	80205	MS35338-49	WASHER,LOCK UOC: DAC,DAD,DAE,DAF,DAG,DA H,DAJ,DAL,DAW,DAX,V14,V15,V16, V17,V18,V19,V20,V21,V22,V24 .....	1
45	PAFZZ	5305-00-267-8952	80204	B1821BH025F050N	SCREW,CAP,HEXAGON H UOC: DAC,DAD,DAE,DAF,DAG,DA H,DAJ,DAL,DAW,DAX,V14,V15,V16, V17,V18,V19,V20,V21,V22,V24 .....	1

(1) ITEM NO.	(2) SMR CODE	(3) NSN	(4) CAGEC	(5) PART NUMBER	(6) DESCRIPTION AND USABLE ON CODE (UOC)	(7) QTY
46	PAFZZ	5310-00-809-4058	96906	MS27183-10	WASHER,FLAT UOC: DAC,DAD,DAE,DAF,DAG,DA H,DAJ,DAL,DAW,DAX,V14,V15,V16, V17,V18,V19,V20,V21,V22,V24 .....	1
47	PFFZZ	5340-00-472-1953	19207	11664613	BRACKET,ANGLE UOC: DAC,DAD,DAE,DAF,DAG,DA H,DAJ,DAL,DAW,DAX,V14,V15,V16, V17,V18,V19,V20,V21,V22,V24 .....	1
48	PAFZZ	5340-00-088-1255	96906	MS21333-96	CLAMP,LOOP UOC: DAC,DAD,DAE,DAF,DAG,DA H,DAJ,DAL,DAW,DAX,V14,V15,V16, V17,V18,V19,V20,V21,V22,V24 .....	1
49	PAFZZ	5306-00-068-0513	80204	B1821BH025F075N	BOLT,MACHINE UOC: DAC,DAD,DAE,DAF,DAG,DA H,DAJ,DAL,DAW,DAX,V14,V15,V16, V17,V18,V19,V20,V21,V22,V24 .....	1
50	PAFZZ	5340-00-827-8314	96906	MS21333-33	CLAMP,LOOP UOC: DAC,DAD,DAE,DAF,DAG,DA H,DAJ,DAL,DAW,DAX,V14,V15,V16, V17,V18,V19,V20,V21,V22,V24 .....	1

END OF FIGURE

**FIELD MAINTENANCE  
ACCELERATOR AND THROTTLE LINKAGE (M939A2)**

---

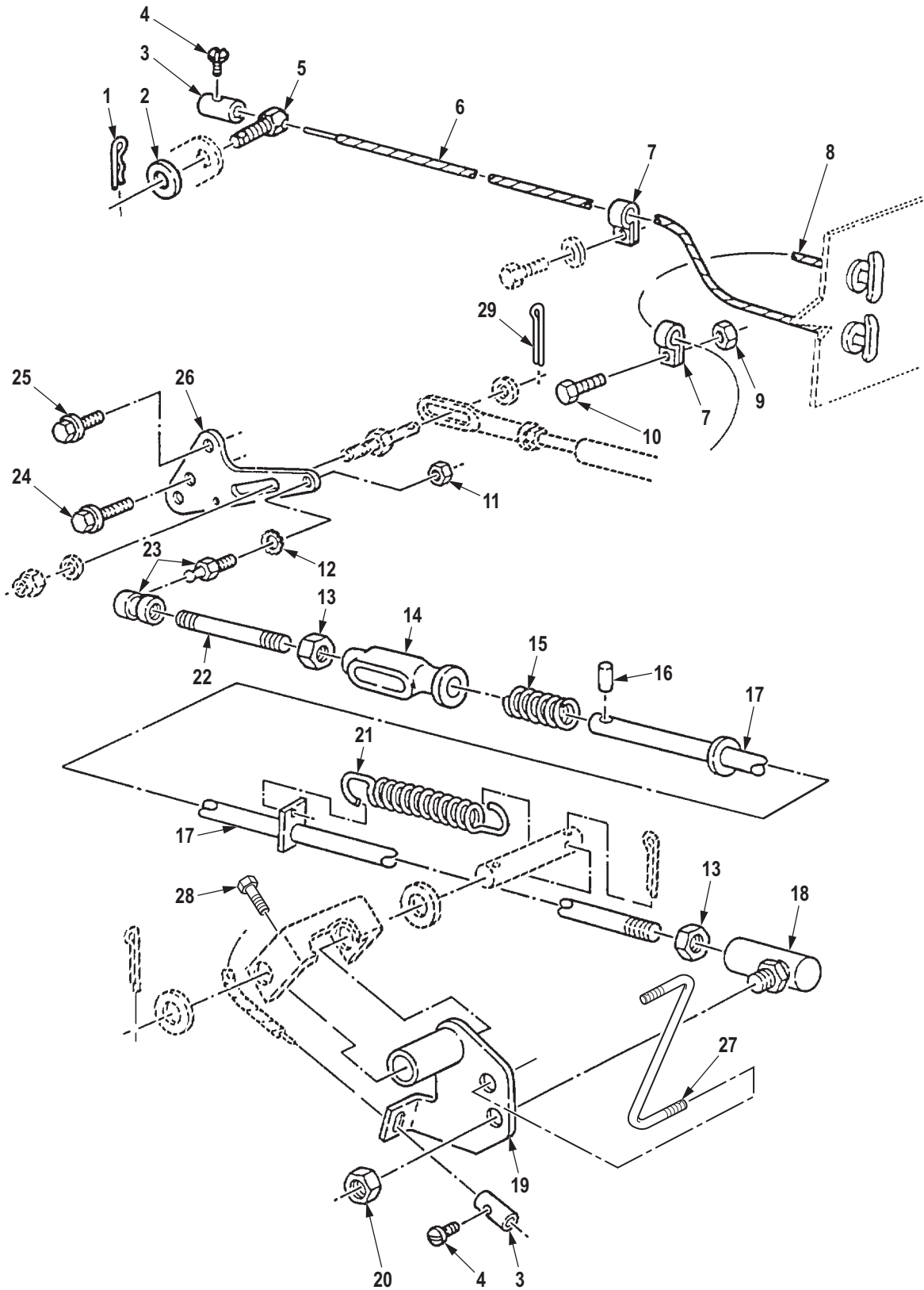

Figure 101. Accelerator and Throttle Linkage (M939A2).

R0101DAA



(1) ITEM NO.	(2) SMR CODE	(3) NSN	(4) CAGEC	(5) PART NUMBER	(6) DESCRIPTION AND USABLE ON CODE (UOC)	(7) QTY
<b>GROUP 0312 ACCELERATOR, THROTTLE OR CHOKE CONTROLS.</b>						
<b>FIG. 101. ACCELERATOR AND THROTTLE LINKAGE (M939A2).</b>						
1	PAFZZ	5315-01-284-9812	60602	10166	PIN,LOCK PART OF KIT P/N 57K0281 UOC: ZAA,ZAB,ZAC,ZAD,ZAE,ZAF, ZAG,ZAH,ZAJ,ZAL .....	1
2	PAFZZ	5310-00-236-3694	11083	8H9620	WASHER,FLAT UOC: ZAA,ZAB,ZAC,ZAD,ZAE,ZAF, ZAG,ZAH,ZAJ,ZAL .....	1
3	PAFZZ	2910-00-753-9184	19207	7539184	CONNECTOR,THROTTLE UOC: ZAA,ZAB,ZAC,ZAD,ZAE,ZAF, ZAG,ZAH,ZAJ,ZAL .....	2
4	PAFZZ	5305-00-889-3002	96906	MS35206-242	SCREW,MACHINE UOC: ZAA,ZAB,ZAC,ZAD,ZAE,ZAF, ZAG,ZAH,ZAJ,ZAL .....	2
5	PAFZZ	5315-01-284-9583	60602	30223-3	PIN,SHOULDER,HEADLE UOC: ZAA,ZAB,ZAC,ZAD,ZAE,ZAF, ZAG,ZAH,ZAJ,ZAL .....	1
6	PAFZZ	2590-01-443-8097	19207	11664388-4	CONTROL ASSEMBLY,PU EMERGENCY ENGINE STOP 51.5" UOC: ZAA,ZAB,ZAC,ZAD,ZAE,ZAF, ZAG,ZAH,ZAJ,ZAL .....	1
7	PAFZZ	5340-00-827-8314	96906	MS21333-33	CLAMP,LOOP UOC: ZAA,ZAB,ZAC,ZAD,ZAE,ZAF, ZAG,ZAH,ZAJ,ZAL .....	2
8	PAFZZ	2590-01-107-9917	19207	11664388-3	CONTROL ASSEMBLY,PU UOC: ZAA,ZAB,ZAC,ZAD,ZAE,ZAF, ZAG,ZAH,ZAJ,ZAL .....	1
9	PAFZZ	5310-00-935-9022	81349	M45913/3-4FG8C	NUT,SELF-LOCKING,HE PART OF KIT P/N 57K0281 UOC: ZAA,ZAB,ZAC,ZAD,ZAE,ZAF, ZAG,ZAH,ZAJ,ZAL .....	1
10	PAFZZ	5305-00-267-8952	80204	B1821BH025F050N	SCREW,CAP,HEXAGON H UOC: ZAA,ZAB,ZAC,ZAD,ZAE,ZAF, ZAG,ZAH,ZAJ,ZAL .....	1
11	PAFZZ	5310-01-437-8728	80204	B18244B06	NUT,PLAIN,EXTENDED PART OF KIT P/N 57K0281 UOC: ZAA,ZAB,ZAC,ZAD,ZAE,ZAF, ZAG,ZAH,ZAJ,ZAL .....	1
12	PAFZZ	5310-00-527-3634	96906	MS35335-61	WASHER,LOCK PART OF KIT P/ N 57K0281 UOC: ZAA,ZAB,ZAC,ZAD,ZAE,ZAF, ZAG,ZAH,ZAJ,ZAL .....	1
13	PAFZZ	5310-00-880-7746	96906	MS51968-5	NUT,PLAIN,HEXAGON UOC: ZAA,ZAB,ZAC,ZAD,ZAE,ZAF, ZAG,ZAH,ZAJ,ZAL .....	2

(1) ITEM NO.	(2) SMR CODE	(3) NSN	(4) CAGEC	(5) PART NUMBER	(6) DESCRIPTION AND USABLE ON CODE (UOC)	(7) QTY
14	PAFZZ	3040-01-280-4153	05MG0	20510914	SLIP UNION,THROTTLE THROTTLE ROD UOC: ZAA,ZAB,ZAC,ZAD,ZAE,ZAF, ZAG,ZAH,ZAJ,ZAL ..... 1	1
15	PAFZZ	5360-01-285-6010	18028	161	SPRING,HELICAL,COMP UOC: ZAA,ZAB,ZAC,ZAD,ZAE,ZAF, ZAG,ZAH,ZAJ,ZAL ..... 1	1
16	PAFZZ	5315-00-826-3251	80205	MS16562-223	PIN,SPRING PART OF KIT P/N 57K0281 UOC: ZAA,ZAB,ZAC,ZAD,ZAE,ZAF, ZAG,ZAH,ZAJ,ZAL ..... 1	1
17	PAFZZ	5340-01-444-1016	19207	12363294-2	ROD END,THREADED PART OF KIT P/N 57K0281 UOC: ZAA,ZAB,ZAC,ZAD,ZAE,ZAF, ZAG,ZAH,ZAJ,ZAL ..... 1	1
18	PAFZZ	3040-00-965-0143	72582	5118951	BALL JOINT UOC: ZAA,ZAB,ZAC,ZAD,ZAE,ZAF, ZAG,ZAH,ZAJ,ZAL ..... 1	1
19	PAFZZ	3040-01-279-4658	33477	20510540	BELL CRANK UOC: ZAA,ZAB,ZAC,ZAD,ZAE,ZAF, ZAG,ZAH,ZAJ,ZAL ..... 1	1
20	PAFZZ	5310-00-984-3807	81349	M45913/1-5FG5C	NUT,SELF-LOCKING,HE UOC: ZAA,ZAB,ZAC,ZAD,ZAE,ZAF, ZAG,ZAH,ZAJ,ZAL ..... 1	1
21	PAFZZ	5360-00-941-8684	19207	10938295	SPRING,HELICAL,EXTE UOC: ZAA,ZAB,ZAC,ZAD,ZAE,ZAF, ZAG,ZAH,ZAJ,ZAL ..... 1	1
22	PAFZZ	5306-01-281-6560	05MG0	20510383	ROD,THREADED END UOC: ZAA,ZAB,ZAC,ZAD,ZAE,ZAF, ZAG,ZAH,ZAJ,ZAL ..... 1	1
23	PAFZZ	3040-01-284-6230	19207	12363293	BALL JOINT THROTTLE ROD UOC: ZAA,ZAB,ZAC,ZAD,ZAE,ZAF, ZAG,ZAH,ZAJ,ZAL ..... 1	1
24	PAFZZ	5305-01-287-1585	05MG0	20511190	SCREW,CAP,HEXAGON H UOC: ZAA,ZAB,ZAC,ZAD,ZAE,ZAF, ZAG,ZAH,ZAJ,ZAL ..... 1	1
25	PAFZZ	5306-01-435-3269	80204	B18234B06016N	BOLT,MACHINE PART OF KIT P/ N 57K0281 UOC: ZAA,ZAB,ZAC,ZAD,ZAE,ZAF, ZAG,ZAH,ZAJ,ZAL ..... 1	1
26	PAFZZ	3040-01-444-7878	19207	12363633-1	LEVER,REMOTE CONTRO PART OF KIT P/N 57K0281 UOC: ZAA,ZAB,ZAC,ZAD,ZAE,ZAF, ZAG,ZAH,ZAJ ..... 1	1
27	PAFZZ	3040-01-445-1651	34623	12255972-2	CONNECTING LINK,RIG PART OF KIT P/N 57K0281 UOC: ZAA,ZAB,ZAC,ZAD,ZAE,ZAF, ZAG,ZAH,ZAJ,ZAL ..... 1	1

(1) ITEM NO.	(2) SMR CODE	(3) NSN	(4) CAGEC	(5) PART NUMBER	(6) DESCRIPTION AND USABLE ON CODE (UOC)	(7) QTY
28	PAFZZ	5305-00-269-3243	80204	B1821BH038F225N	SCREW,CAP,HEXAGON H 3/8 IN X2-1/4 UNF-2A RH PART OF KIT P/N 57K0281 UOC: ZAA,ZAB,ZAC,ZAD,ZAE,ZAF, ZAG,ZAH,ZAJ,ZAL .....	1
29	PAFZZ	5315-00-815-1405	80205	MS24665-151	PIN,COTTER PART OF KIT P/N 57K0281 UOC: ZAA,ZAB,ZAC,ZAD,ZAE,ZAF, ZAG,ZAH,ZAJ,ZAL .....	2

END OF FIGURE



**FIELD MAINTENANCE  
MUFFLER, EXHAUST PIPES, AND RELATED PARTS**

---

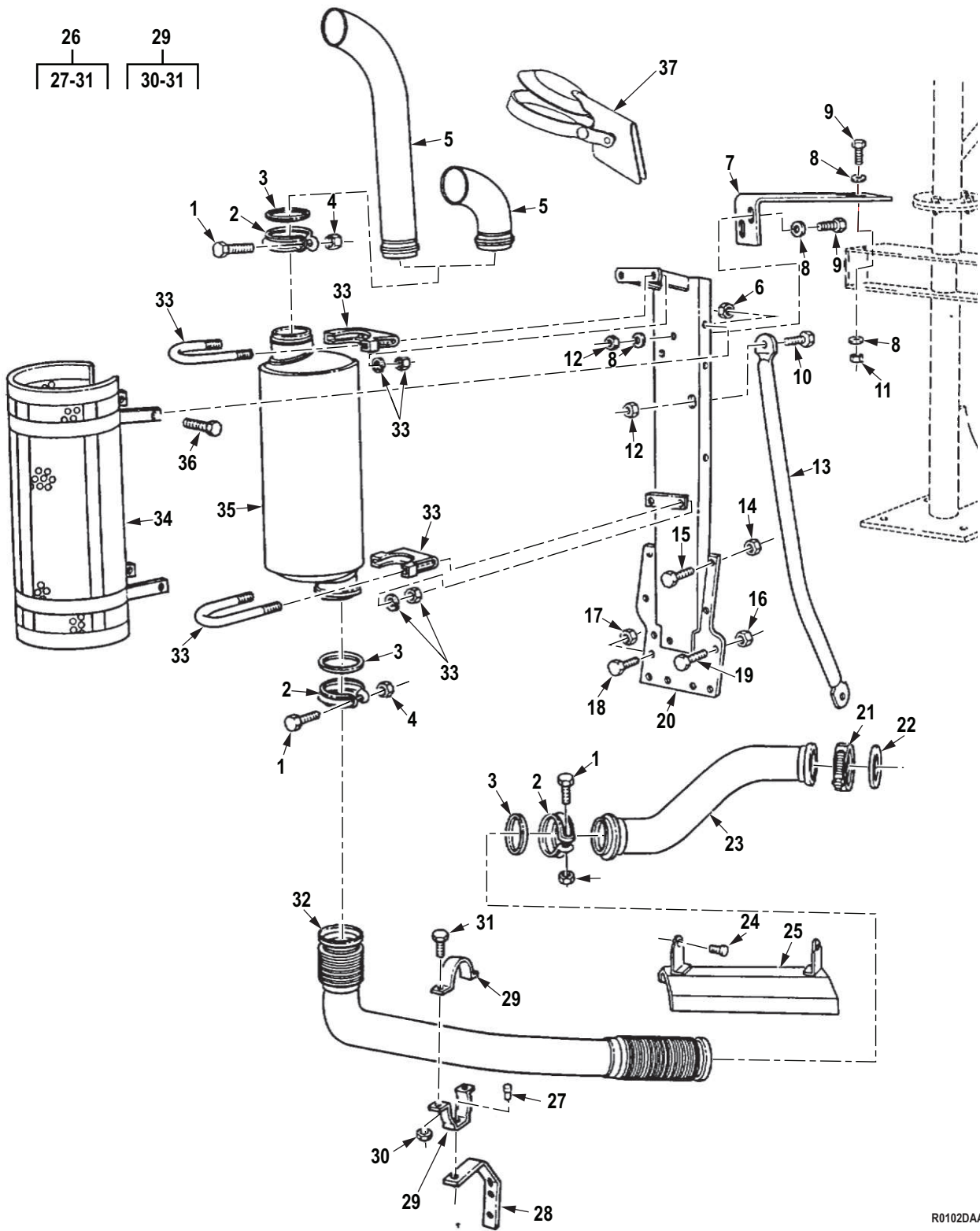

R0102DAA

Figure 102. Muffler, Exhaust Pipes, and Related Parts.

(1) ITEM NO.	(2) SMR CODE	(3) NSN	(4) CAGEC	(5) PART NUMBER	(6) DESCRIPTION AND USABLE ON CODE (UOC)	(7) QTY
<b>GROUP 0401 MUFFLER AND PIPES.</b>						
<b>FIG. 102. MUFFLER, EXHAUST PIPES, AND RELATED PARTS.</b>						
1	PAFZZ	5306-00-225-9095	80205	MS90726-40	BOLT,MACHINE UOC: DAC,DAD,DAE,DAF,DAG,DA H,DAJ,DAL,DAW,DAX,V14,V15,V16, V17,V18,V19,V20,V21,V22,V24 .....	3
2	PAFZZ	5342-01-106-5488	19207	11609348-11	COUPLING,CLAMP,GROO UOC: DAC,DAD,DAE,DAF,DAG,DA H,DAJ,DAL,DAW,DAX,V14,V15,V16, V17,V18,V19,V20,V21,V22,V24 .....	3
3	PAFZZ	5330-01-379-4345	19207	12255817 NON- ASBESTOS	GASKET NON-ASBESTOS UOC: DAC,DAD,DAE,DAF,DAG,DA H,DAJ,DAL,DAW,DAX,V14,V15,V16, V17,V18,V19,V20,V21,V22,V24 .....	3
4	PAFZZ	5310-00-176-6690	19207	11609727-2	NUT,SELF-LOCKING,HE UOC: DAC,DAD,DAE,DAF,DAG,DA H,DAJ,DAL,DAW,DAX,V14,V15,V16, V17,V18,V19,V20,V21,V22,V24 .....	3
5	PAFZZ	2990-01-083-5715	19207	12255920	PIPE,EXHAUST UOC: DAC,DAD,DAG,DAH,DAL,DA W,DAX,V14,V15,V16,V17,V18,V21,V 22,ZAA,ZAB,ZAC,ZAD,ZAG,ZAH,ZAL .....	1
5	PAFZZ	2990-01-085-3833	19207	12256298	CONNECTOR,EXHAUST P UOC: DAE,DAF,DAJ,V19,V20,V24,Z AE,ZAF,ZAJ .....	1
6	PAFZZ	5310-00-814-0672	96906	M45913/3-6FG8C	NUT,SELF-LOCKING,HE UOC: DAC,DAD,DAE,DAF,DAG,DA H,DAJ,DAL,DAW,DAX,V14,V15,V16, V17,V18,V19,V20,V21,V22,V24 .....	4
7	PAFZZ	5340-01-210-2158	19207	12301092	BRACKET,ANGLE UOC: DAC,DAD,DAJ,DAW,DAX,V14 ,V15,V16,V19,V24,ZAA,ZAB,ZAD,ZAF,ZAJ	1
8	PAFZZ	5310-00-080-6004	96906	MS27183-14	WASHER,FLAT UOC: DAC,DAD,DAJ,DAW,DAX,V14 ,V15,V16,V17,V19,V24,ZAA,ZAB,ZA C,ZAD,ZAJ .....	8
9	PAFZZ	5305-00-269-3238	80204	B1821BH038F125N	SCREW,CAP,HEXAGON H UOC: DAC,DAD,DAJ,DAW,DAX,V14 ,V15,V16,V17,V19,V24,ZAA,ZAB,ZA C,ZAD,ZAJ .....	4
10	PAFZZ	5305-00-719-5219	80204	B1821BH050F125N	SCREW,CAP,HEXAGON H UOC: DAE,DAF,DAG,DAH,V19,V20, V21,V22,ZAE,ZAF,ZAG,ZAH .....	2
11	PAFZZ	5310-00-814-0672	96906	M45913/3-6FG8C	NUT,SELF-LOCKING,HE UOC: DAC,DAD,DAJ,DAW,DAX,V14 ,V15,V16,V19,V24,ZAA,ZAB,ZAD,ZAF,ZAJ	4

(1) ITEM NO.	(2) SMR CODE	(3) NSN	(4) CAGEC	(5) PART NUMBER	(6) DESCRIPTION AND USABLE ON CODE (UOC)	(7) QTY
12	PAFZZ	5310-00-488-3888	81349	M45913/3-8FG8C	NUT,SELF-LOCKING,HE UOC: DAE,DAF,DAG,DAH,V19,V20, V21,V22,ZAE,ZAF,ZAG,ZAH .....	2
13	PAFZZ	5340-01-083-1117	19207	12256650	BRACKET,ANGLE UOC: DAE,DAF,DAG,DAH,V19,V20, V21,V22,ZAE,ZAF,ZAG,ZAH .....	1
14	PAFZZ	5310-00-488-3888	81349	M45913/3-8FG8C	NUT,SELF-LOCKING,HE UOC: DAC,DAD,DAJ,DAL,DAW,DAX ,V14,V15,V16,V17,V18,V24,ZAA,ZAB ,ZAC,ZAD,ZAJ,ZAL .....	4
15	PAFZZ	5305-00-719-5235	80204	B1821BH050F175N	SCREW,CAP,HEXAGON H UOC: DAE,DAF,DAG,DAH,V19,V20, V21,V22,ZAE,ZAF,ZAG,ZAH .....	4
16	PAFZZ	5310-00-488-3888	81349	M45913/3-8FG8C	NUT,SELF-LOCKING,HE UOC: DAE,DAF,DAG,DAH,DAL,V18, V19,V20,V21,V22,ZAE,ZAF,ZAG,ZAH,ZAL	1
17	PAFZZ	5310-00-488-3888	81349	M45913/3-8FG8C	NUT,SELF-LOCKING,HE UOC: DAC,DAD,DAE,DAF,DAG,DA H,DAJ,DAL,DAW,DAX,V14,V15,V16, V17,V18,V19,V20,V21,V22,V24 .....	6
18	PAFZZ	5305-00-719-5238	80204	B1821BH050F200N	SCREW,CAP,HEXAGON H UOC: DAC,DAD,DAE,DAF,DAG,DA H,DAJ,DAL,DAW,DAX,V14,V15,V16, V17,V18,V19,V20,V21,V22,V24 .....	6
19	PAFZZ	5305-00-719-5238	80204	B1821BH050F200N	SCREW,CAP,HEXAGON H UOC: DAE,DAF,DAG,DAH,V19,V20, V21,V22,ZAE,ZAF,ZAG,ZAH .....	1
20	PAFZZ	2990-01-218-2100	19207	12302949-2	BRACKET ASSEMBLY,MU UOC: DAE,DAF,DAG,DAH,DAL,ZAE, ZAF,ZAG,ZAH,ZAL .....	1
20	PAFZZ	2990-01-085-5350	19207	12256632-2	HANGER,ENGINE EXHAU UOC: V18,V19,V20,V21,V22 .....	1
20	PAFZZ	2990-01-210-4650	19207	12302949-1	BRACKET ASSEMBLY,MU UOC: DAC,DAD,DAJ,DAW,DAX,ZAA ,ZAB,ZAC,ZAD,ZAJ .....	1
20	PAFZZ	2990-01-085-5349	19207	12256632-1	HANGER,ENGINE EXHAU UOC: V14,V15,V16,V17,V24 .....	1
21	PAFZZ	5340-01-151-6145	19207	10949040-4	COUPLING,CLAMP,GROO UOC: DAC,DAD,DAE,DAF,DAG,DA H,DAJ,DAL,DAW,DAX,V14,V15,V16, V17,V18,V19,V20,V21,V22,V24 .....	1
22	PAFZZ	5330-01-374-0400	19207	12256082-1 NON- ASBESTOS	GASKET UOC: DAC,DAD,DAE,DAF,DAG,DA H,DAJ,DAL,DAW,DAX,V14,V15,V16, V17,V18,V19,V20,V21,V22,V24 .....	1



(1) ITEM NO.	(2) SMR CODE	(3) NSN	(4) CAGEC	(5) PART NUMBER	(6) DESCRIPTION AND USABLE ON CODE (UOC)	(7) QTY
23	PAFZZ	2990-01-082-9009	19207	12255964	PIPE,EXHAUST UOC: DAC,DAD,DAE,DAF,DAG,DA H,DAJ,DAL,DAW,DAX,V14,V15,V16, V17,V18,V19,V20,V21,V22,V24 .....	1
24	PAFZZ	5305-00-267-8953	80204	B1821BH025F063N	SCREW,CAP,HEXAGON H UOC: DAC,DAD,DAE,DAF,DAG,DA H,DAJ,DAL,DAW,DAX,V14,V15,V16, V17,V18,V19,V20,V21,V22,V24,ZAA, ZAB,ZAC,ZAD,ZAE,ZAF,ZAG,ZAH,Z AJ,ZAL .....	2
25	PAFZZ	2990-01-082-2511	19207	12256292-1	GUARD,MUFFLER-EXHAU UOC: DAC,DAD,DAE,DAF,DAG,DA H,DAJ,DAL,DAW,DAX,V14,V15,V16, V17,V18,V19,V20,V21,V22,V24,ZAA, ZAB,ZAC,ZAD,ZAE,ZAF,ZAG,ZAH,Z AJ,ZAL .....	1
26	PFFZZ	5342-01-103-7589	19207	12256802	CLAMP AND BRACKET A UOC: DAC,DAD,DAE,DAF,DAG,DA H,DAJ,DAL,DAW,DAX,V14,V15,V16, V17,V18,V19,V20,V21,V22,V24,ZAA, ZAB,ZAC,ZAD,ZAE,ZAF,ZAG,ZAH,Z AJ,ZAL .....	1
27	PFFZZ	5320-01-145-3183	96906	MS35743-73	. RIVET,SOLID UOC: DAC,DAD,DAE,DAF,DAG,DA H,DAJ,DAL,DAW,DAX,V14,V15,V16, V17,V18,V19,V20,V21,V22,V24,ZAA, ZAB,ZAC,ZAD,ZAE,ZAF,ZAG,ZAH,Z AJ,ZAL .....	1
28	PFFZZ	5340-01-130-7932	19207	12256801	. BRACKET,PIPE UOC: DAC,DAD,DAE,DAF,DAG,DA H,DAJ,DAL,DAW,DAX,V14,V15,V16, V17,V18,V19,V20,V21,V22,V24,ZAA, ZAB,ZAC,ZAD,ZAE,ZAF,ZAG,ZAH,Z AJ,ZAL .....	1
29	PFFZZ	5340-01-160-2299	19207	12256800	. CLAMP,LOOP UOC: DAC,DAD,DAE,DAF,DAG,DA H,DAJ,DAL,DAW,DAX,V14,V15,V16, V17,V18,V19,V20,V21,V22,V24,ZAA, ZAB,ZAC,ZAD,ZAE,ZAF,ZAG,ZAH,Z AJ,ZAL .....	1
30	PAFZZ	5310-00-814-0672	96906	M45913/3-6FG8C	. . NUT,SELF-LOCKING,HE UOC: DAC,DAD,DAE,DAF,DAG,DA H,DAJ,DAL,DAW,DAX,V14,V15,V16, V17,V18,V19,V20,V21,V22,V24,ZAA, ZAB,ZAC,ZAD,ZAE,ZAF,ZAG,ZAH,Z AJ,ZAL .....	2

(1) ITEM NO.	(2) SMR CODE	(3) NSN	(4) CAGEC	(5) PART NUMBER	(6) DESCRIPTION AND USABLE ON CODE (UOC)	(7) QTY
31	PAFZZ	5305-00-269-2803	80205	MS90726-60	. . SCREW,CAP,HEXAGON H UOC: DAC,DAD,DAE,DAF,DAG,DA H,DAJ,DAL,DAW,DAX,V14,V15,V16, V17,V18,V19,V20,V21,V22,V24,ZAA, ZAB,ZAC,ZAD,ZAE,ZAF,ZAG,ZAH,Z AJ,ZAL .....	2
32	PAFZZ	2990-01-083-1142	19207	12256075	PIPE,EXHAUST UOC: DAC,DAD,DAE,DAF,DAG,DA H,DAJ,DAL,DAW,DAX,V14,V15,V16, V17,V18,V19,V20,V21,V22,V24,ZAA, ZAB,ZAC,ZAD,ZAE,ZAF,ZAG,ZAH,Z AJ,ZAL .....	1
33	PAFZZ	5340-00-532-9231	93742	B52-1111-2	CLAMP,LOOP UOC: DAC,DAD,DAE,DAF,DAG,DA H,DAJ,DAL,DAW,DAX,V14,V15,V16, V17,V18,V19,V20,V21,V22,V24,ZAA, ZAB,ZAC,ZAD,ZAE,ZAF,ZAG,ZAH,Z AJ,ZAL .....	2
34	PAFZZ	2990-01-083-1123	19207	12255868	GUARD,MUFFLER-EXHAU UOC: DAC,DAD,DAE,DAF,DAG,DA H,DAJ,DAL,DAW,DAX,V14,V15,V16, V17,V18,V19,V20,V21,V22,V24,ZAA, ZAB,ZAC,ZAD,ZAE,ZAF,ZAG,ZAH,Z AJ,ZAL .....	1
35	PAFZZ	2990-01-085-3786	19207	11669108	MUFFLER,EXHAUST UOC: DAC,DAD,DAE,DAF,DAG,DA H,DAJ,DAL,DAW,DAX,V14,V15,V16, V17,V18,V19,V20,V21,V22,V24,ZAA, ZAB,ZAC,ZAD,ZAE,ZAF,ZAG,ZAH,Z AJ,ZAL .....	1
36	PAFZZ	5305-00-269-2803	80205	MS90726-60	SCREW,CAP,HEXAGON H UOC: DAC,DAD,DAE,DAF,DAG,DA H,DAJ,DAL,DAW,DAX,V14,V15,V16, V17,V18,V19,V20,V21,V22,V24 .....	4
37	PAFZZ	2990-01-204-1161	17284	FB0037	CAP ASSEMBLY,PROTEC UOC: DAC,DAD,DAG,DAH,DAL,DA W,DAX,V14,V15,V16,V17,V18,V21,V 22,ZAA,ZAB,ZAC,ZAD,ZAG,ZAH,ZAL .....	1

END OF FIGURE

**FIELD MAINTENANCE  
EXHAUST SYSTEM (M939A2)**

---

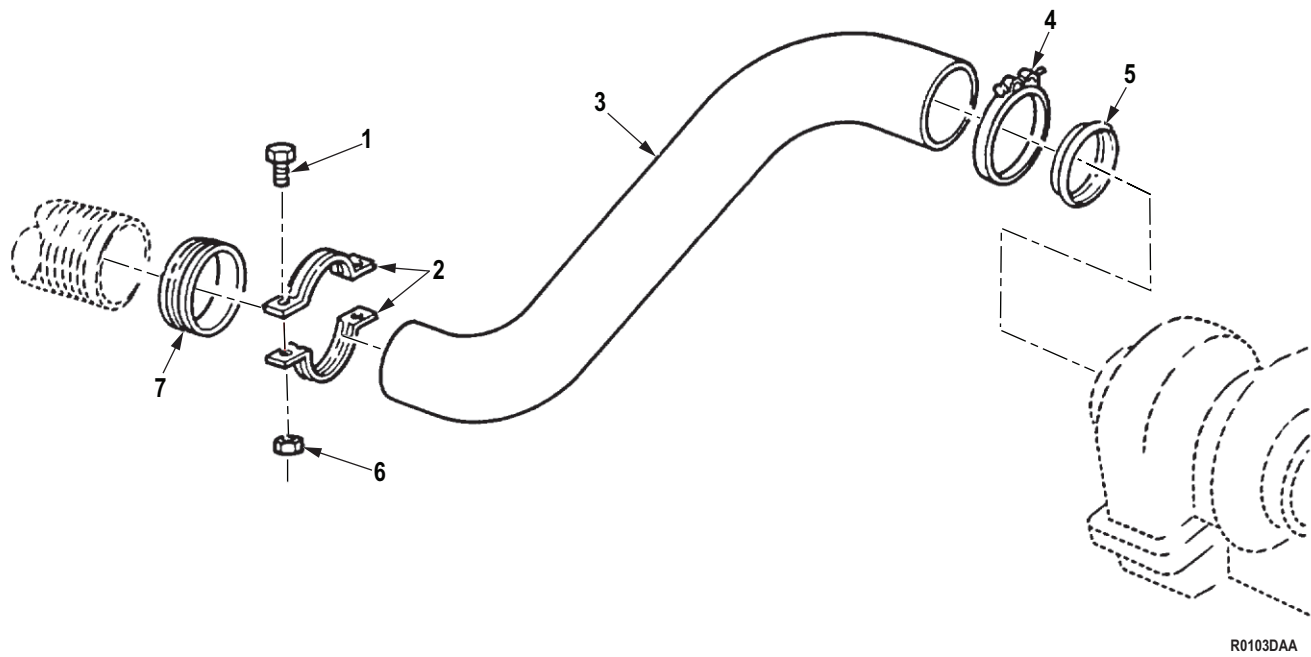

Figure 103. Exhaust System (M939A2).

(1) ITEM NO.	(2) SMR CODE	(3) NSN	(4) CAGEC	(5) PART NUMBER	(6) DESCRIPTION AND USABLE ON CODE (UOC)	(7) QTY
<b>GROUP 0401 MUFFLER AND PIPES.</b>						
<b>FIG. 103. EXHAUST SYSTEM (M939A2).</b>						
1	PAFZZ	5306-00-225-9095	80205	MS90726-40	BOLT,MACHINE UOC: ZAA,ZAB,ZAC,ZAD,ZAE,ZAF, ZAG,ZAH,ZAJ,ZAL .....	2
2	PAFZZ	5342-01-106-5488	19207	11609348-11	COUPLING,CLAMP,GROO UOC: ZAA,ZAB,ZAC,ZAD,ZAE,ZAF, ZAG,ZAH,ZAJ,ZAL .....	1
3	PAFZZ	2990-01-280-4284	05MG0	20510347	PIPE,EXHAUST UOC: ZAA,ZAB,ZAC,ZAD,ZAE,ZAF, ZAG,ZAH,ZAJ,ZAL .....	2
4	PAFZZ	5340-01-297-1187	0B8S3	3903652	CLAMP,LOOP UOC: ZAA,ZAB,ZAC,ZAD,ZAE,ZAF, ZAG,ZAH,ZAJ,ZAL .....	2
5	PAFZZ	5330-01-361-5600	0UBK6	20511420	GASKET UOC: ZAA,ZAB,ZAC,ZAD,ZAE,ZAF, ZAG,ZAH,ZAJ,ZAL .....	1
6	PAFZZ	5310-00-176-6690	19207	11609727-2	NUT,SELF-LOCKING,HE UOC: ZAA,ZAB,ZAC,ZAD,ZAE,ZAF, ZAG,ZAH,ZAJ,ZAL .....	2
7	PAFZZ	5330-01-379-4345	19207	12255817 NON- ASBESTOS	GASKET NON-ASBESTOS UOC: ZAA,ZAB,ZAC,ZAD,ZAE,ZAF, ZAG,ZAH,ZAJ,ZAL .....	1

**END OF FIGURE**



**FIELD MAINTENANCE  
RADIATOR HOSES AND MOUNTING HARDWARE (M939, M939A1)**

---

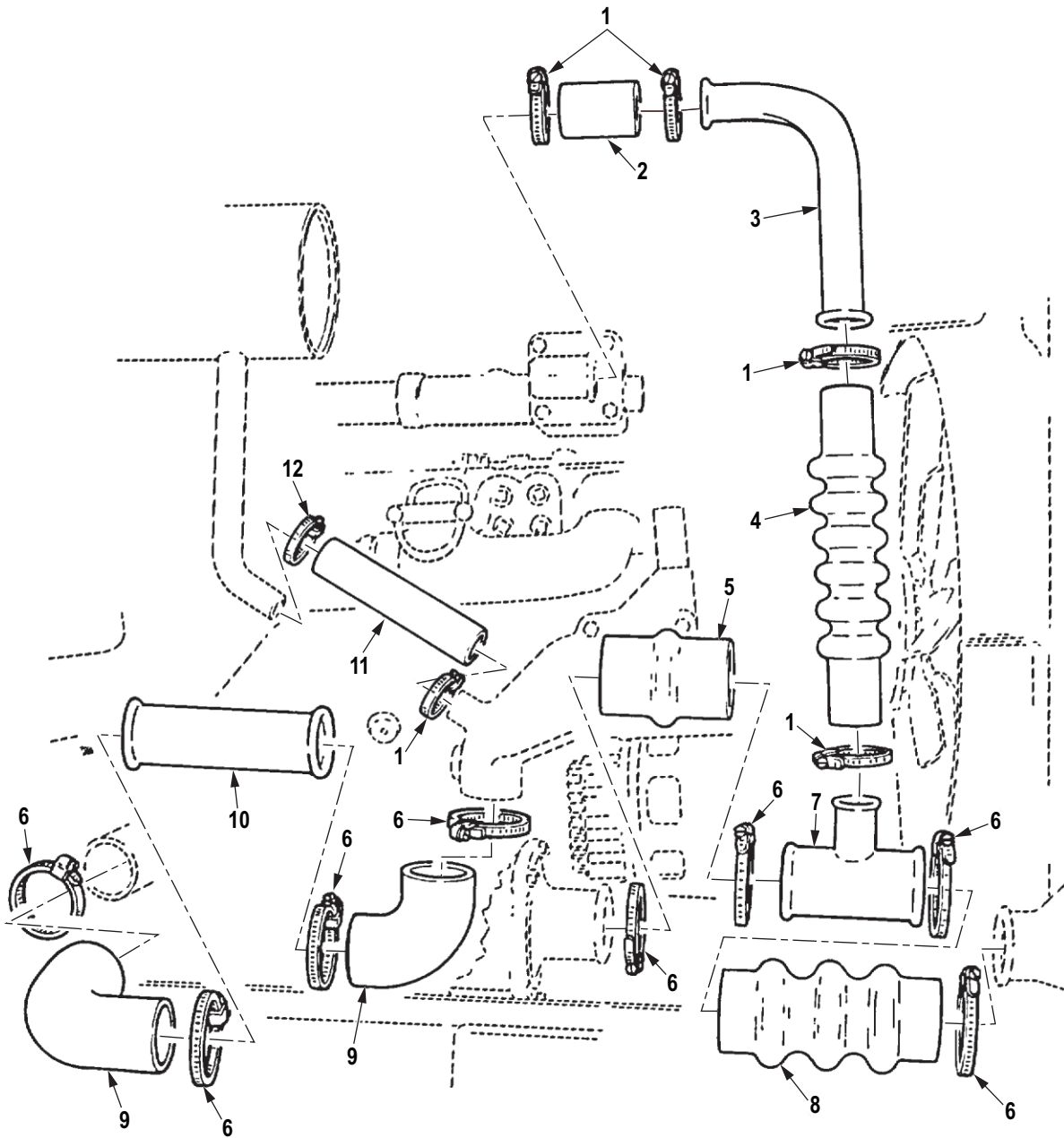

R0104DAA

Figure 104. Radiator Hoses and Mounting Hardware (M939, M939A1).



(1) ITEM NO.	(2) SMR CODE	(3) NSN	(4) CAGEC	(5) PART NUMBER	(6) DESCRIPTION AND USABLE ON CODE (UOC)	(7) QTY
					<b>GROUP 0501 RADIATOR, EVAPORATIVE COOLER, OR HEAT EXCHANGER.</b>	
					<b>FIG. 104. RADIATOR HOSES AND MOUNTING HARDWARE (M939, M939A1).</b>	
1	PAFZZ	4730-01-089-4596	19207	11669079-1	CLAMP,HOSE UOC: DAC,DAD,DAE,DAF,DAG,DA H,DAJ,DAL,DAW,DAX,V14,V15,V16, V17,V18,V19,V20,V21,V22,V24 .....	5
2	PAFZZ	4720-01-121-7749	19207	12277172-1	HOSE,NONMETALLIC UOC: DAC,DAD,DAE,DAF,DAG,DA H,DAJ,DAL,DAW,DAX,V14,V15,V16, V17,V18,V19,V20,V21,V22,V24 .....	1
3	PAFZZ	4710-01-114-7759	19207	12277170	TUBE,BENT,METALLIC UOC: DAC,DAD,DAE,DAF,DAG,DA H,DAJ,DAL,DAW,DAX,V14,V15,V16, V17,V18,V19,V20,V21,V22,V24 .....	1
4	PAFZZ	4720-01-108-5346	19207	12277172-3	HOSE,NONMETALLIC UOC: DAC,DAD,DAE,DAF,DAG,DA H,DAJ,DAL,DAW,DAX,V14,V15,V16, V17,V18,V19,V20,V21,V22,V24 .....	1
5	PAFZZ	4720-01-108-5347	19207	12277173	HOSE,NONMETALLIC UOC: DAC,DAD,DAE,DAF,DAG,DA H,DAJ,DAL,DAW,DAX,V14,V15,V16, V17,V18,V19,V20,V21,V22,V24 .....	1
6	PRFZZ	4730-01-331-6630	9C234	11669079-5	CLAMP,HOSE UOC: DAC,DAD,DAE,DAF,DAG,DA H,DAJ,DAL,DAW,DAX,V14,V15,V16, V17,V18,V19,V20,V21,V22,V24 .....	8
7	PAFZZ	4730-01-117-0602	19207	12277168	TEE,TUBE UOC: DAC,DAD,DAE,DAF,DAG,DA H,DAJ,DAL,DAW,DAX,V14,V15,V16, V17,V18,V19,V20,V21,V22,V24 .....	1
8	PAFZZ	4720-01-089-9049	19207	12255978	HOSE,PREFORMED UOC: DAC,DAD,DAE,DAF,DAG,DA H,DAJ,DAL,DAW,DAX,V14,V15,V16, V17,V18,V19,V20,V21,V22,V24 .....	1
9	PAFZZ	4720-01-108-9118	19207	12255963	HOSE,PREFORMED UOC: DAC,DAD,DAE,DAF,DAG,DA H,DAJ,DAL,DAW,DAX,V14,V15,V16, V17,V18,V19,V20,V21,V22,V24 .....	2
10	PAFZZ	4710-01-121-7600	19207	12277171	TUBE,METALLIC UOC: DAC,DAD,DAE,DAF,DAG,DA H,DAJ,DAL,DAW,DAX,V14,V15,V16, V17,V18,V19,V20,V21,V22,V24 .....	1

(1) ITEM NO.	(2) SMR CODE	(3) NSN	(4) CAGEC	(5) PART NUMBER	(6) DESCRIPTION AND USABLE ON CODE (UOC)	(7) QTY
11	PAFZZ	4720-01-089-1108	19207	12256468	HOSE,PREFORMED UOC: DAC,DAD,DAE,DAF,DAG,DA H,DAJ,DAL,DAW,DAX,V14,V15,V16, V17,V18,V19,V20,V21,V22,V24 .....	1
12	PAFZZ	4730-01-225-9003	19207	11669079-4	CLAMP,HOSE UOC: DAC,DAD,DAE,DAF,DAG,DA H,DAJ,DAL,DAW,DAX,V14,V15,V16, V17,V18,V19,V20,V21,V22,V24 .....	1

END OF FIGURE

**FIELD MAINTENANCE**  
**UPPER RADIATOR MOUNTING HARDWARE AND HOSES (M939, M939A1)**

---

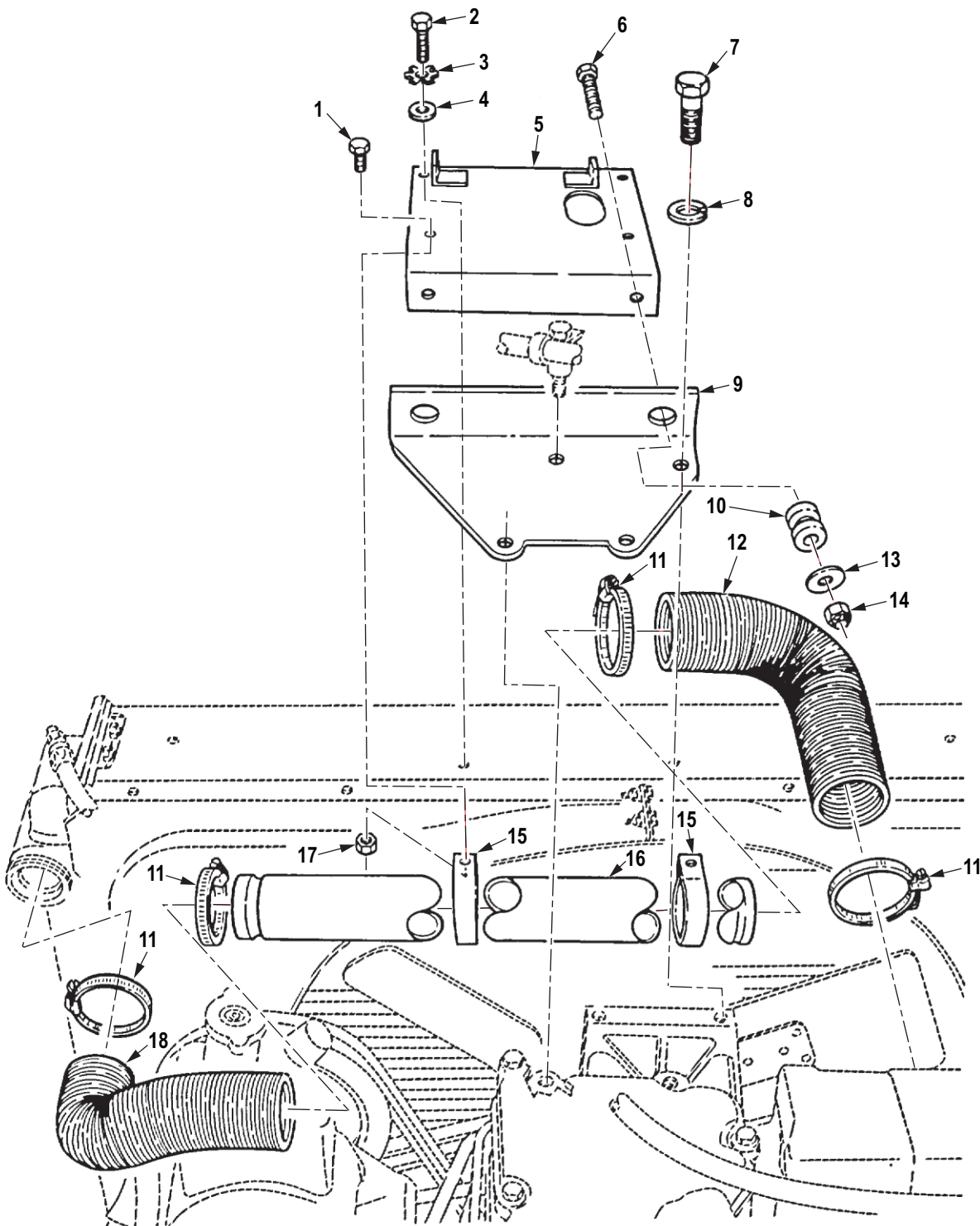

R0105DAA

Figure 105. Upper Radiator Mounting Hardware and Hoses (M939, M939A1).

(1) ITEM NO.	(2) SMR CODE	(3) NSN	(4) CAGEC	(5) PART NUMBER	(6) DESCRIPTION AND USABLE ON CODE (UOC)	(7) QTY
					<b>GROUP 0501 RADIATOR, EVAPORATIVE COOLER, OR HEAT EXCHANGER.</b>	
					<b>FIG. 105. UPPER RADIATOR MOUNTING HARDWARE AND HOSES (M939, M939A1).</b>	
1	PAFZZ	5306-00-068-0514	80204	B1821BH025F088N	BOLT,MACHINE UOC: DAC,DAD,DAE,DAF,DAG,DA H,DAJ,DAL,DAW,DAX,V14,V15,V16, V17,V18,V19,V20,V21,V22,V24 .....	2
2	PAFZZ	5305-00-269-2804	80205	MS90726-61	SCREW,CAP,HEXAGON H UOC: DAC,DAD,DAE,DAF,DAG,DA H,DAJ,DAL,DAW,DAX,V14,V15,V16, V17,V18,V19,V20,V21,V22,V24 .....	2
3	PAFZZ	5310-00-627-6128	96906	MS35335-35	WASHER,LOCK UOC: DAC,DAD,DAE,DAF,DAG,DA H,DAJ,DAL,DAW,DAX,V14,V15,V16, V17,V18,V19,V20,V21,V22,V24 .....	2
4	PAFZZ	5310-01-120-8507	19207	12277033	WASHER,FLAT UOC: DAC,DAD,DAE,DAF,DAG,DA H,DAJ,DAL,DAW,DAX,V14,V15,V16, V17,V18,V19,V20,V21,V22,V24 .....	2
5	PFFZZ	2930-01-130-7934	19207	12277035	RETAINER,RADIATOR UOC: DAC,DAD,DAE,DAF,DAG,DA H,DAJ,DAL,DAW,DAX,V14,V15,V16, V17,V18,V19,V20,V21,V22,V24 .....	1
6	PAFZZ	5305-00-269-3244	80204	B1821BH038F250N	SCREW,CAP,HEXAGON H UOC: DAC,DAD,DAE,DAF,DAG,DA H,DAJ,DAL,DAW,DAX,V14,V15,V16, V17,V18,V19,V20,V21,V22,V24 .....	2
7	PAFZZ	5305-00-071-2068	80204	B1821BH050C138N	SCREW,CAP,HEXAGON H UOC: DAC,DAD,DAE,DAF,DAG,DA H,DAJ,DAL,DAW,DAX,V14,V15,V16, V17,V18,V19,V20,V21,V22,V24 .....	1
8	PAFZZ	5310-00-003-4094	80205	MS35338-48	WASHER,LOCK UOC: DAC,DAD,DAE,DAF,DAG,DA H,DAJ,DAL,DAW,DAX,V14,V15,V16, V17,V18,V19,V20,V21,V22,V24 .....	1
9	PFFZZ	5340-01-130-7933	19207	12277034	BRACKET,ANGLE UOC: DAC,DAD,DAE,DAF,DAG,DA H,DAJ,DAL,DAW,DAX,V14,V15,V16, V17,V18,V19,V20,V21,V22,V24 .....	1
10	PAFZZ	5342-01-101-0005	19207	11669109	MOUNT,RESILIENT,WEA UOC: DAC,DAD,DAE,DAF,DAG,DA H,DAJ,DAL,DAW,DAX,V14,V15,V16, V17,V18,V19,V20,V21,V22,V24 .....	2

(1) ITEM NO.	(2) SMR CODE	(3) NSN	(4) CAGEC	(5) PART NUMBER	(6) DESCRIPTION AND USABLE ON CODE (UOC)	(7) QTY
11	PAFZZ	4730-01-117-3837	19207	11669079-2	CLAMP,HOSE UOC: DAC,DAD,DAE,DAF,DAG,DA H,DAJ,DAL,DAW,DAX,V14,V15,V16, V17,V18,V19,V20,V21,V22,V24 .....	4
12	PAFZZ	4720-01-089-2061	19207	12256611	HOSE,PREFORMED UOC: DAC,DAD,DAE,DAF,DAG,DA H,DAJ,DAL,DAW,DAX,V14,V15,V16, V17,V18,V19,V20,V21,V22,V24 .....	1
13	PAFZZ	5365-01-108-4811	19207	12256205	SHIM UOC: DAC,DAD,DAE,DAF,DAG,DA H,DAJ,DAL,DAW,DAX,V14,V15,V16, V17,V18,V19,V20,V21,V22,V24 .....	2
14	PAFZZ	5310-00-814-0672	96906	M45913/3-6FG8C	NUT,SELF-LOCKING,HE UOC: DAC,DAD,DAE,DAF,DAG,DA H,DAJ,DAL,DAW,DAX,V14,V15,V16, V17,V18,V19,V20,V21,V22,V24 .....	2
15	PAFZZ	5340-01-105-0993	19207	12276945	CLAMP,LOOP UOC: DAC,DAD,DAE,DAF,DAG,DA H,DAJ,DAL,DAW,DAX,V14,V15,V16, V17,V18,V19,V20,V21,V22,V24 .....	2
16	PAFZZ	4710-01-130-3437	19207	12255959	TUBE,METALLIC UOC: DAC,DAD,DAE,DAF,DAG,DA H,DAJ,DAL,DAW,DAX,V14,V15,V16, V17,V18,V19,V20,V21,V22,V24 .....	1
17	PAFZZ	5310-00-935-9022	81349	M45913/3-4FG8C	NUT,SELF-LOCKING,HE UOC: DAC,DAD,DAE,DAF,DAG,DA H,DAJ,DAL,DAW,DAX,V14,V15,V16, V17,V18,V19,V20,V21,V22,V24 .....	2
18	PAFZZ	4720-01-089-4595	19207	12256446	HOSE,PREFORMED UOC: DAC,DAD,DAE,DAF,DAG,DA H,DAJ,DAL,DAW,DAX,V14,V15,V16, V17,V18,V19,V20,V21,V22,V24 .....	1

END OF FIGURE

**FIELD MAINTENANCE**  
**LOWER RADIATOR MOUNTING HARDWARE (M939, M939A1)**

---

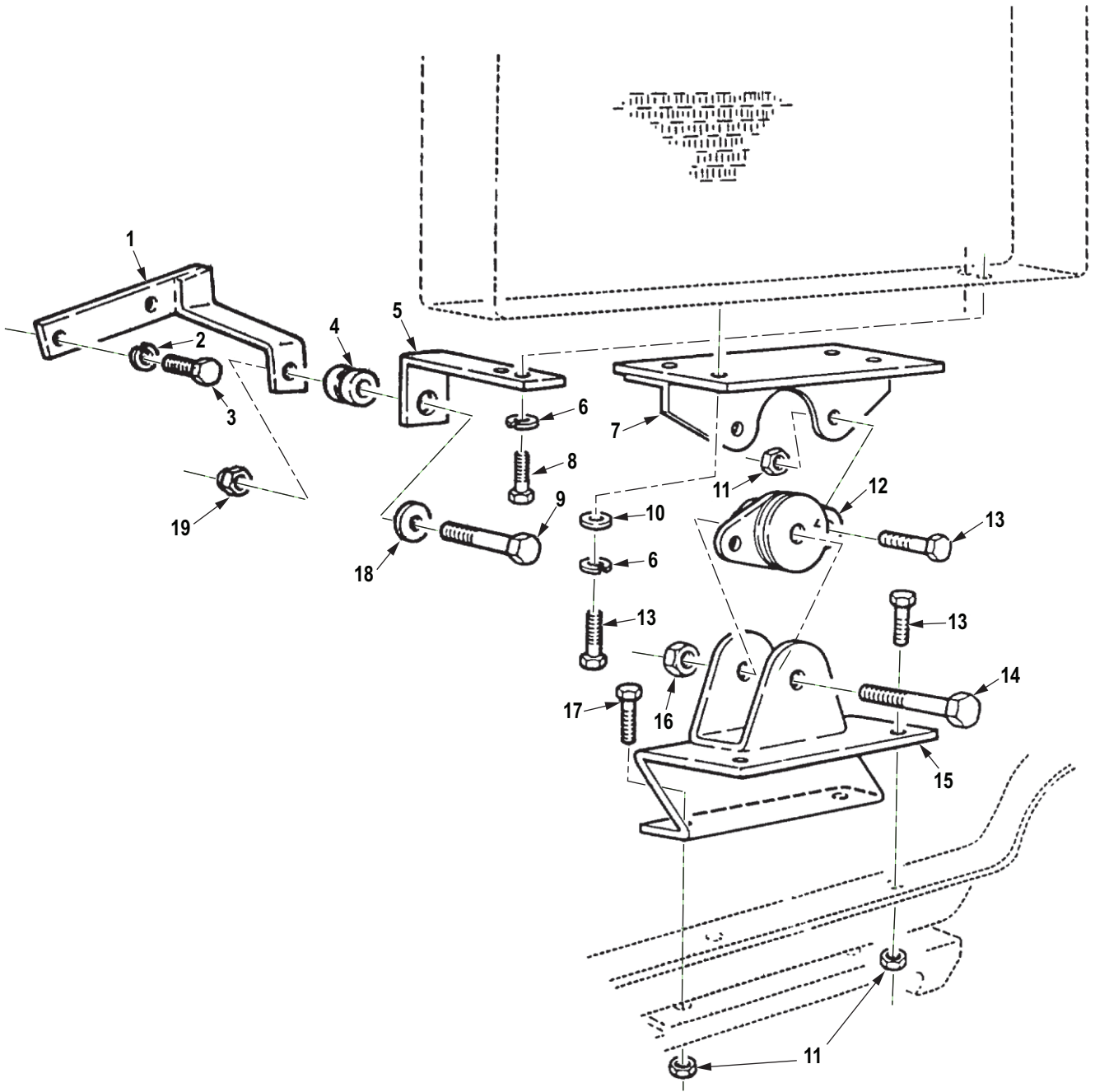

R0106DAA

Figure 106. Lower Radiator Mounting Hardware (M939, M939A1).



(1) ITEM NO.	(2) SMR CODE	(3) NSN	(4) CAGEC	(5) PART NUMBER	(6) DESCRIPTION AND USABLE ON CODE (UOC)	(7) QTY
					<b>GROUP 0501 RADIATOR, EVAPORATIVE COOLER, OR HEAT EXCHANGER.</b>	
					<b>FIG. 106. LOWER RADIATOR MOUNTING HARDWARE (M939, M939A1).</b>	
1	PFZZ	2930-01-131-0107	19207	12255852	RETAINER,RADIATOR UOC: DAC,DAD,DAE,DAF,DAG,DA H,DAJ,DAL,DAW,DAX,V14,V15,V16, V17,V18,V19,V20,V21,V22,V24 .....	1
2	PAFZZ	5310-00-209-0965	80205	MS35338-47	WASHER,LOCK UOC: DAC,DAD,DAE,DAF,DAG,DA H,DAJ,DAL,DAW,DAX,V14,V15,V16, V17,V18,V19,V20,V21,V22,V24 .....	2
3	PAFZZ	5305-00-071-1788	80204	B1821BH044C125N	SCREW,CAP,HEXAGON H UOC: DAC,DAD,DAE,DAF,DAG,DA H,DAJ,DAL,DAW,DAX,V14,V15,V16, V17,V18,V19,V20,V21,V22,V24 .....	2
4	PAFZZ	5342-01-101-0005	19207	11669109	MOUNT,RESILIENT,WEA UOC: DAC,DAD,DAE,DAF,DAG,DA H,DAJ,DAL,DAW,DAX,V14,V15,V16, V17,V18,V19,V20,V21,V22,V24 .....	1
5	PFZZ	5340-01-105-0992	19207	12255844	BRACKET,ANGLE UOC: DAC,DAD,DAE,DAF,DAG,DA H,DAJ,DAL,DAW,DAX,V14,V15,V16, V17,V18,V19,V20,V21,V22,V24 .....	1
6	PAFZZ	5310-00-003-4094	80205	MS35338-48	WASHER,LOCK UOC: DAC,DAD,DAE,DAF,DAG,DA H,DAJ,DAL,DAW,DAX,V14,V15,V16, V17,V18,V19,V20,V21,V22,V24 .....	6
7	PFZZ	5340-01-104-8944	19207	12255837	BRACKET,MOUNTING UOC: DAC,DAD,DAE,DAF,DAG,DA H,DAJ,DAL,DAW,DAX,V14,V15,V16, V17,V18,V19,V20,V21,V22,V24 .....	1
8	PAFZZ	5305-00-226-7767	H0001	0251588	SCREW,CAP,HEXAGON H UOC: DAC,DAD,DAE,DAF,DAG,DA H,DAJ,DAL,DAW,DAX,V14,V15,V16, V17,V18,V19,V20,V21,V22,V24 .....	2
9	PAFZZ	5305-00-269-3244	80204	B1821BH038F250N	SCREW,CAP,HEXAGON H UOC: DAC,DAD,DAE,DAF,DAG,DA H,DAJ,DAL,DAW,DAX,V14,V15,V16, V17,V18,V19,V20,V21,V22,V24 .....	1
10	PAFZZ	5310-00-809-5998	96906	MS27183-18	WASHER,FLAT UOC: DAC,DAD,DAE,DAF,DAG,DA H,DAJ,DAL,DAW,DAX,V14,V15,V16, V17,V18,V19,V20,V21,V22,V24 .....	4

(1) ITEM NO.	(2) SMR CODE	(3) NSN	(4) CAGEC	(5) PART NUMBER	(6) DESCRIPTION AND USABLE ON CODE (UOC)	(7) QTY
11	PAFZZ	5310-00-488-3888	81349	M45913/3-8FG8C	NUT,SELF-LOCKING,HE UOC: DAC,DAD,DAE,DAF,DAG,DA H,DAJ,DAL,DAW,DAX,V14,V15,V16, V17,V18,V19,V20,V21,V22,V24 .....	6
12	PAFZZ	5342-01-101-0075	81860	22696-5/06	MOUNT,RESILIENT,WEA UOC: DAC,DAD,DAE,DAF,DAG,DA H,DAJ,DAL,DAW,DAX,V14,V15,V16, V17,V18,V19,V20,V21,V22,V24 .....	1
13	PAFZZ	5305-00-719-5219	80204	B1821BH050F125N	SCREW,CAP,HEXAGON H UOC: DAC,DAD,DAE,DAF,DAG,DA H,DAJ,DAL,DAW,DAX,V14,V15,V16, V17,V18,V19,V20,V21,V22,V24 .....	8
14	PAFZZ	5305-00-947-4360	80204	B1821BH075C450N	SCREW,CAP,HEXAGON H UOC: DAC,DAD,DAE,DAF,DAG,DA H,DAJ,DAL,DAW,DAX,V14,V15,V16, V17,V18,V19,V20,V21,V22,V24 .....	1
15	PAFZZ	5340-01-066-6086	19207	12255855	BRACKET,MOUNTING UOC: DAC,DAD,DAE,DAF,DAG,DA H,DAJ,DAL,DAW,DAX,V14,V15,V16, V17,V18,V19,V20,V21,V22,V24 .....	1
16	PAFZZ	5310-00-935-3569	81349	M45913/3-12FG8C	NUT,SELF-LOCKING,HE UOC: DAC,DAD,DAE,DAF,DAG,DA H,DAJ,DAL,DAW,DAX,V14,V15,V16, V17,V18,V19,V20,V21,V22,V24 .....	1
17	PAFZZ	5305-00-719-5235	80204	B1821BH050F175N	SCREW,CAP,HEXAGON H UOC: DAC,DAD,DAE,DAF,DAG,DA H,DAJ,DAL,DAW,DAX,V14,V15,V16, V17,V18,V19,V20,V21,V22,V24 .....	2
18	PAFZZ	5365-01-108-4811	19207	12256205	SHIM UOC: DAC,DAD,DAE,DAF,DAG,DA H,DAJ,DAL,DAW,DAX,V14,V15,V16, V17,V18,V19,V20,V21,V22,V24 .....	1
19	PAFZZ	5310-00-814-0672	96906	M45913/3-6FG8C	NUT,SELF-LOCKING,HE UOC: DAC,DAD,DAE,DAF,DAG,DA H,DAJ,DAL,DAW,DAX,V14,V15,V16, V17,V18,V19,V20,V21,V22,V24 .....	1

END OF FIGURE

**FIELD MAINTENANCE  
RADIATOR ASSEMBLY AND MOUNTING HARDWARE (M939A2)**

---

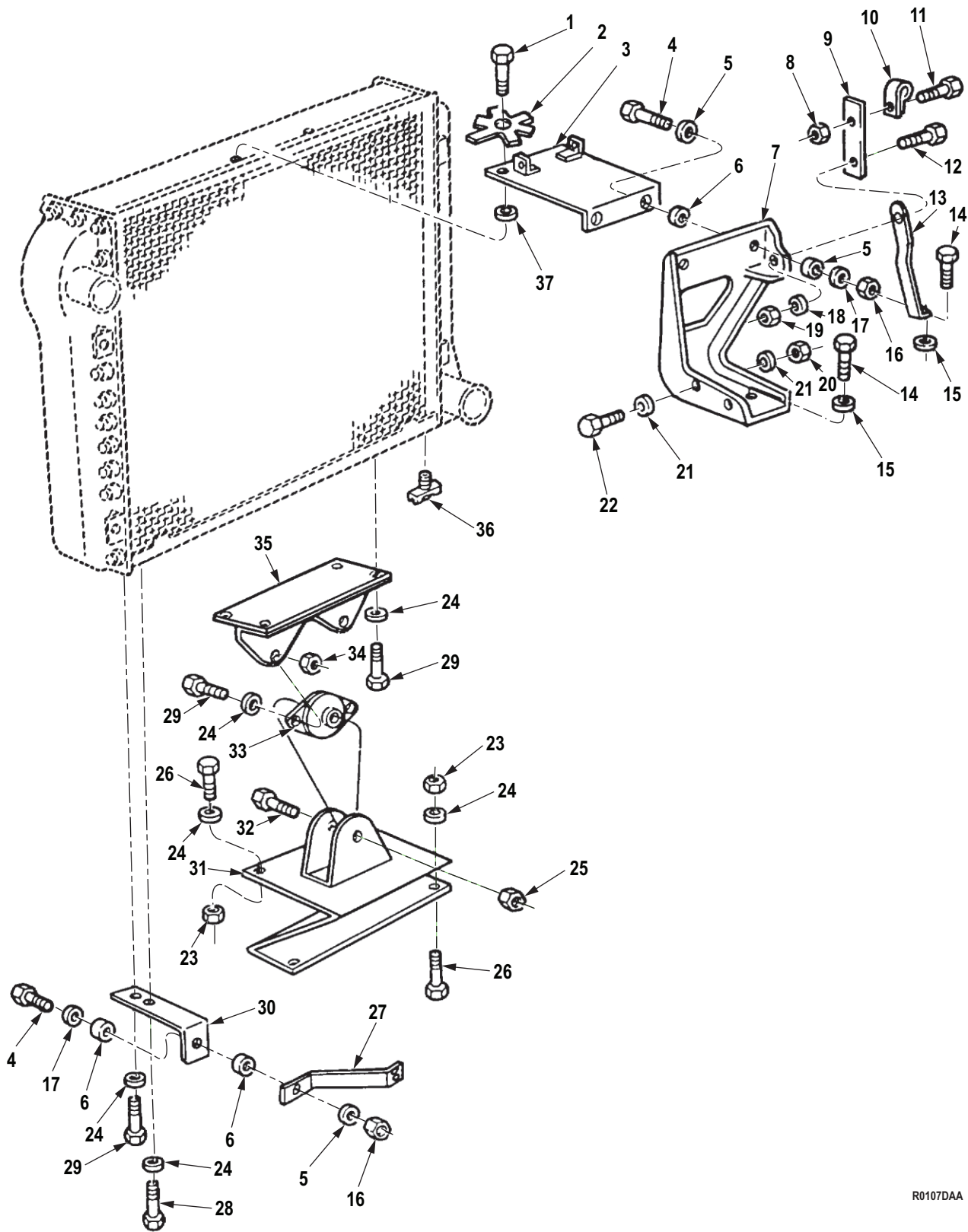

R0107DAA

Figure 107. Radiator Assembly and Mounting Hardware (M939A2).

(1) ITEM NO.	(2) SMR CODE	(3) NSN	(4) CAGEC	(5) PART NUMBER	(6) DESCRIPTION AND USABLE ON CODE (UOC)	(7) QTY
					<b>GROUP 0501 RADIATOR, EVAPORATIVE COOLER, OR HEAT EXCHANGER.</b>	
					<b>FIG. 107. RADIATOR ASSEMBLY AND MOUNTING HARDWARE (M939A2).</b>	
1	PAFZZ	5305-00-269-3237	80204	B1821BH038F113N	SCREW,CAP,HEXAGON H UOC: ZAA,ZAB,ZAC,ZAD,ZAE,ZAF, ZAG,ZAH,ZAJ,ZAL .....	2
2	PAFZZ	5310-00-627-6128	96906	MS35335-35	WASHER,LOCK UOC: ZAA,ZAB,ZAC,ZAD,ZAE,ZAF, ZAG,ZAH,ZAJ,ZAL .....	2
3	PAFZZ	5340-01-317-8144	05MG0	20510270	BRACKET,MOUNTING UOC: ZAA,ZAB,ZAC,ZAD,ZAE,ZAF, ZAG,ZAH,ZAJ,ZAL .....	1
4	PAFZZ	5305-00-638-8920	80204	B1821BH038C225N	SCREW,CAP,HEXAGON H UOC: DAC,DAD,DAE,DAF,DAG,DA H,DAJ,DAL,DAW,DAX,ZAA,ZAB,ZAC ,ZAD,ZAE,ZAF,ZAG,ZAH,ZAJ,ZAL .....	3
5	PAFZZ	5310-00-274-8041	06853	204235	WASHER,FLAT UOC: ZAA,ZAB,ZAC,ZAD,ZAE,ZAF, ZAG,ZAH,ZAJ,ZAL .....	3
6	PAFZZ	5342-01-101-0005	19207	11669109	MOUNT,RESILIENT,WEA SET OF 2 UOC: ZAA,ZAB,ZAC,ZAD,ZAE,ZAF, ZAG,ZAH,ZAJ,ZAL .....	2
7	PAFZZ	5340-01-280-7101	05MG0	20510480-1	BRACKET,MOUNTING UOC: ZAA,ZAB,ZAC,ZAD,ZAE,ZAF, ZAG,ZAH,ZAJ,ZAL .....	1
8	PAFZZ	5310-00-935-9021	96906	MS51943-35	NUT,SELF-LOCKING,HE UOC: ZAA,ZAB,ZAC,ZAD,ZAE,ZAF, ZAG,ZAH,ZAJ,ZAL .....	1
9	PAFZZ	5340-01-287-6660	05MG0	20511172	PLATE,MENDING UOC: ZAA,ZAB,ZAC,ZAD,ZAE,ZAF, ZAG,ZAH,ZAJ,ZAL .....	1
10	PAFZZ	5340-00-053-8994	80205	MS21333-126	CLAMP,LOOP UOC: ZAA,ZAB,ZAC,ZAD,ZAE,ZAF, ZAG,ZAH,ZAJ,ZAL .....	1
11	PAFZZ	5305-00-721-5492	80204	B1821BH038C063N	SCREW,CAP,HEXAGON H UOC: ZAA,ZAB,ZAC,ZAD,ZAE,ZAF, ZAG,ZAH,ZAJ,ZAL .....	1
12	PAFZZ	5305-00-071-2055	80204	B1821BH044C150N	SCREW,CAP,HEXAGON H UOC: ZAA,ZAB,ZAC,ZAD,ZAE,ZAF, ZAG,ZAH,ZAJ,ZAL .....	1
13	PAFZZ	5340-01-280-7100	05MG0	20510429	BRACKET,MOUNTING UOC: ZAA,ZAB,ZAC,ZAD,ZAE,ZAF, ZAG,ZAH,ZAJ,ZAL .....	1

(1) ITEM NO.	(2) SMR CODE	(3) NSN	(4) CAGEC	(5) PART NUMBER	(6) DESCRIPTION AND USABLE ON CODE (UOC)	(7) QTY
14	PAFZZ	5306-01-243-4650	7X677	11504596	BOLT,MACHINE UOC: ZAA,ZAB,ZAC,ZAD,ZAE,ZAF, ZAG,ZAH,ZAJ,ZAL .....	6
15	PAFZZ	5310-01-270-8392	24617	11511515	WASHER,FLAT UOC: ZAA,ZAB,ZAC,ZAD,ZAE,ZAF, ZAG,ZAH,ZAJ,ZAL .....	6
16	PAFZZ	5310-01-126-9404	7X677	9422297	NUT,SELF-LOCKING,HE UOC: ZAA,ZAB,ZAC,ZAD,ZAE,ZAF, ZAG,ZAH,ZAJ,ZAL .....	3
17	PAFZZ	5310-01-292-7251	47457	20510333	WASHER,FLAT UOC: ZAA,ZAB,ZAC,ZAD,ZAE,ZAF, ZAG,ZAH,ZAJ,ZAL .....	3
18	PAFZZ	5310-01-092-5495	19207	8356625-4	WASHER,FLAT UOC: ZAA,ZAB,ZAC,ZAD,ZAE,ZAF, ZAG,ZAH,ZAJ,ZAL .....	1
19	PAFZZ	5310-01-150-4003	24617	9422299	NUT,SELF-LOCKING,HE UOC: ZAA,ZAB,ZAC,ZAD,ZAE,ZAF, ZAG,ZAH,ZAJ,ZAL .....	1
20	PAFZZ	5310-00-984-3806	81349	M45913/1-5CG5C	NUT,SELF-LOCKING,HE UOC: ZAA,ZAB,ZAC,ZAD,ZAE,ZAF, ZAG,ZAH,ZAJ,ZAL .....	2
21	PAFZZ	5310-01-084-1197	19207	8356625-2	WASHER,FLAT UOC: ZAA,ZAB,ZAC,ZAD,ZAE,ZAF, ZAG,ZAH,ZAJ,ZAL .....	4
22	PAFZZ	5306-00-226-4827	80204	B1821BH031C100N	BOLT,MACHINE UOC: ZAA,ZAB,ZAC,ZAD,ZAE,ZAF, ZAG,ZAH,ZAJ,ZAL .....	2
23	PAFZZ	5310-01-149-4407	24617	9442939	NUT,SELF-LOCKING,HE UOC: ZAA,ZAB,ZAC,ZAD,ZAE,ZAF, ZAG,ZAH,ZAJ,ZAL .....	4
24	PAFZZ	5310-00-799-4910	73342	6752556	WASHER,SPRING TENS UOC: ZAA,ZAB,ZAC,ZAD,ZAE,ZAF, ZAG,ZAH,ZAJ,ZAL .....	13
25	PAFZZ	5310-00-935-3569	81349	M45913/3-12FG8C	NUT,SELF-LOCKING,HE UOC: ZAA,ZAB,ZAC,ZAD,ZAE,ZAF, ZAG,ZAH,ZAJ,ZAL .....	1
26	PAFZZ	5305-00-071-2069	80204	B1821BH050C150N	SCREW,CAP,HEXAGON H UOC: ZAA,ZAB,ZAC,ZAD,ZAE,ZAF, ZAG,ZAH,ZAJ,ZAL .....	4
27	PAFZZ	5340-01-285-3239	05MG0	20510277	BRACKET,DOUBLE ANGL STABILIZER UOC: ZAA,ZAB,ZAC,ZAD,ZAE,ZAF, ZAG,ZAH,ZAJ,ZAL .....	1
28	PAFZZ	5305-00-719-5184	80204	B1821BH050F100N	SCREW,CAP,HEXAGON H UOC: ZAA,ZAB,ZAC,ZAD,ZAE,ZAF, ZAG,ZAH,ZAJ,ZAL .....	2

(1) ITEM NO.	(2) SMR CODE	(3) NSN	(4) CAGEC	(5) PART NUMBER	(6) DESCRIPTION AND USABLE ON CODE (UOC)	(7) QTY
29	PAFZZ	5305-00-719-5219	80204	B1821BH050F125N	SCREW,CAP,HEXAGON H UOC: ZAA,ZAB,ZAC,ZAD,ZAE,ZAF, ZAG,ZAH,ZAJ,ZAL .....	7
30	PAFZZ	5340-01-281-7205	05MG0	20510341	BRACKET,ANGLE LOWER RADIATOR UOC: ZAA,ZAB,ZAC,ZAD,ZAE,ZAF, ZAG,ZAH,ZAJ,ZAL .....	1
31	PAFZZ	5340-01-481-3179	19207	12363315	BRACKET,MOUNTING UOC: ZAA,ZAB,ZAC,ZAD,ZAE,ZAF, ZAG,ZAH,ZAJ,ZAL .....	1
32	PAFZZ	5305-00-940-8069	80204	B1821BH075F450N	SCREW,CAP,HEXAGON H UOC: ZAA,ZAB,ZAC,ZAD,ZAE,ZAF, ZAG,ZAH,ZAJ,ZAL .....	1
33	PAFZZ	5342-01-101-0075	81860	22696-5/06	MOUNT,RESILIENT,WEA UOC: ZAA,ZAB,ZAC,ZAD,ZAE,ZAF, ZAG,ZAH,ZAJ,ZAL .....	1
34	PAFZZ	5310-00-488-3888	81349	M45913/3-8FG8C	NUT,SELF-LOCKING,HE UOC: ZAA,ZAB,ZAC,ZAD,ZAE,ZAF, ZAG,ZAH,ZAJ,ZAL .....	3
35	PFFZZ	5340-01-104-8944	19207	12255837	BRACKET,MOUNTING UOC: ZAA,ZAB,ZAC,ZAD,ZAE,ZAF, ZAG,ZAH,ZAJ,ZAL .....	1
36	PAFZZ	4820-00-849-1220	58536	A-A-59440/1-005	COCK,DRAIN UOC: ZAA,ZAB,ZAC,ZAD,ZAE,ZAF, ZAG,ZAH,ZAJ,ZAL .....	1
37	PAFZZ	5310-01-257-7590	96906	MS51412-7	WASHER,FLAT UOC: ZAA,ZAB,ZAC,ZAD,ZAE,ZAF, ZAG,ZAH,ZAJ,ZAL .....	1

END OF FIGURE





**FIELD MAINTENANCE  
RADIATOR ASSEMBLY**

---

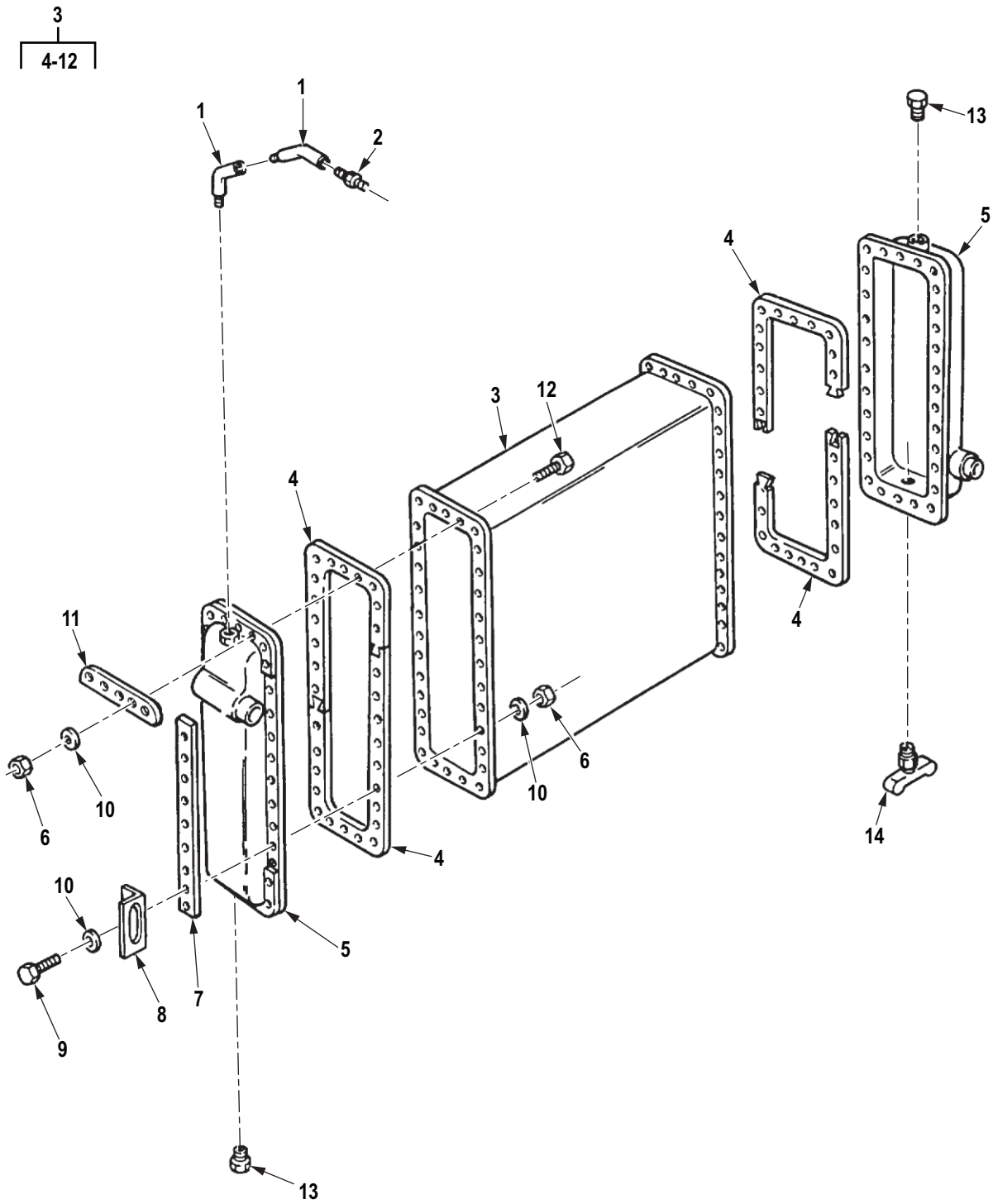

R0108DAA

Figure 108. Radiator Assembly.

(1) ITEM NO.	(2) SMR CODE	(3) NSN	(4) CAGEC	(5) PART NUMBER	(6) DESCRIPTION AND USABLE ON CODE (UOC)	(7) QTY
<b>GROUP 0501 RADIATOR, EVAPORATIVE COOLER, OR HEAT EXCHANGER.</b>						
<b>FIG. 108. RADIATOR ASSEMBLY.</b>						
1	PAFZZ	4730-00-277-5684	96906	MS14307-2	ELBOW,PIPE UOC: DAC,DAD,DAE,DAF,DAG,DA H,DAJ,DAL,DAW,DAX,V14,V15,V16, V17,V18,V19,V20,V21,V22,V24 .....	2
2	PAFZZ	4730-00-266-0538	81343	SAE J513 6-4 010102BA	ADAPTER,STRAIGHT,PI UOC: DAC,DAD,DAE,DAF,DAG,DA H,DAJ,DAL,DAW,DAX,V14,V15,V16, V17,V18,V19,V20,V21,V22,V24 .....	1
3	PAFHH	2930-01-133-2143	50022	DG-781900-D	RADIATOR,ENGINE COO UOC: DAC,DAD,DAE,DAF,DAG,DA H,DAJ,DAL,DAW,DAX,V14,V15,V16, V17,V18,V19,V20,V21,V22,V24 .....	1
4	PAHZZ	5330-01-232-1487	19207	12302621	. GASKET PART OF KIT P/N D-781964-A UOC: DAC,DAD,DAE,DAF,DAG,DA H,DAJ,DAL,DAW,DAX,V14,V15,V16, V17,V18,V19,V20,V21,V22,V24 .....	4
5	PAHZZ	5430-01-235-5442	19207	12302618	. TANK SECTION,FLUID UOC: DAC,DAD,DAE,DAF,DAG,DA H,DAJ,DAL,DAW,DAX,V14,V15,V16, V17,V18,V19,V20,V21,V22,V24 .....	2
6	PAHZZ	5310-00-814-0673	81349	M45913/3-5CG8C	. NUT,SELF-LOCKING,HE PART OF KIT P/N D-781964-A UOC: DAC,DAD,DAE,DAF,DAG,DA H,DAJ,DAL,DAW,DAX,V14,V15,V16, V17,V18,V19,V20,V21,V22,V24 .....	80
7	PAHZZ	5340-01-131-7443	19207	12302624	. PLATE,MENDING PART OF KIT P/N D-781964-A UOC: DAC,DAD,DAE,DAF,DAG,DA H,DAJ,DAL,DAW,DAX,V14,V15,V16, V17,V18,V19,V20,V21,V22,V24 .....	4
8	PAHZZ	5340-01-444-6658	19207	12301081	. BRACKET,MOUNTING PART OF KIT P/N D-781964-A UOC: DAC,DAD,DAE,DAF,DAG,DA H,DAJ,DAL,DAW,DAX,V14,V15,V16, V17,V18,V19,V20,V21,V22,V24 .....	4
9	PAHZZ	5306-01-447-2565	96906	MS35356-33	. BOLT,MACHINE PART OF KIT P/N D-781964-A UOC: DAC,DAD,DAE,DAF,DAG,DA H,DAJ,DAL,DAW,DAX,V14,V15,V16, V17,V18,V19,V20,V21,V22,V24 .....	8

(1) ITEM NO.	(2) SMR CODE	(3) NSN	(4) CAGEC	(5) PART NUMBER	(6) DESCRIPTION AND USABLE ON CODE (UOC)	(7) QTY
10	PAHZZ	5310-00-081-4219	96906	MS27183-12	. WASHER,FLAT PART OF KIT P/ N D-781964-A UOC: DAC,DAD,DAE,DAF,DAG,DA H,DAJ,DAL,DAW,DAX,V14,V15,V16, V17,V18,V19,V20,V21,V22,V24 .....	80
11	PAHZZ	5340-01-131-7444	19207	12302623	. PLATE,MENDING PART OF KIT P/N D-781964-A UOC: DAC,DAD,DAE,DAF,DAG,DA H,DAJ,DAL,DAW,DAX,V14,V15,V16, V17,V18,V19,V20,V21,V22,V24 .....	4
12	PAHZZ	5306-00-225-8499	80205	MS90725-34	. BOLT,MACHINE PART OF KIT P/N D-781964-A UOC: DAC,DAD,DAE,DAF,DAG,DA H,DAJ,DAL,DAW,DAX,V14,V15,V16, V17,V18,V19,V20,V21,V22,V24 .....	72
13	PAFZZ	4730-00-012-7951	01276	2082-4B	PLUG,PIPE UOC: DAC,DAD,DAE,DAF,DAG,DA H,DAJ,DAL,DAW,DAX,V14,V15,V16, V17,V18,V19,V20,V21,V22,V24 .....	2
14	PAFZZ	4820-00-720-4488	58536	AA59440/1-002	COCK,DRAIN UOC: DAC,DAD,DAE,DAF,DAG,DA H,DAJ,DAL,DAW,DAX,V14,V15,V16, V17,V18,V19,V20,V21,V22,V24 .....	1

END OF FIGURE

**FIELD MAINTENANCE**  
**SURGE TANK ASSEMBLY, HOSES, AND MOUNTING HARDWARE (M939, M939A1)**

---

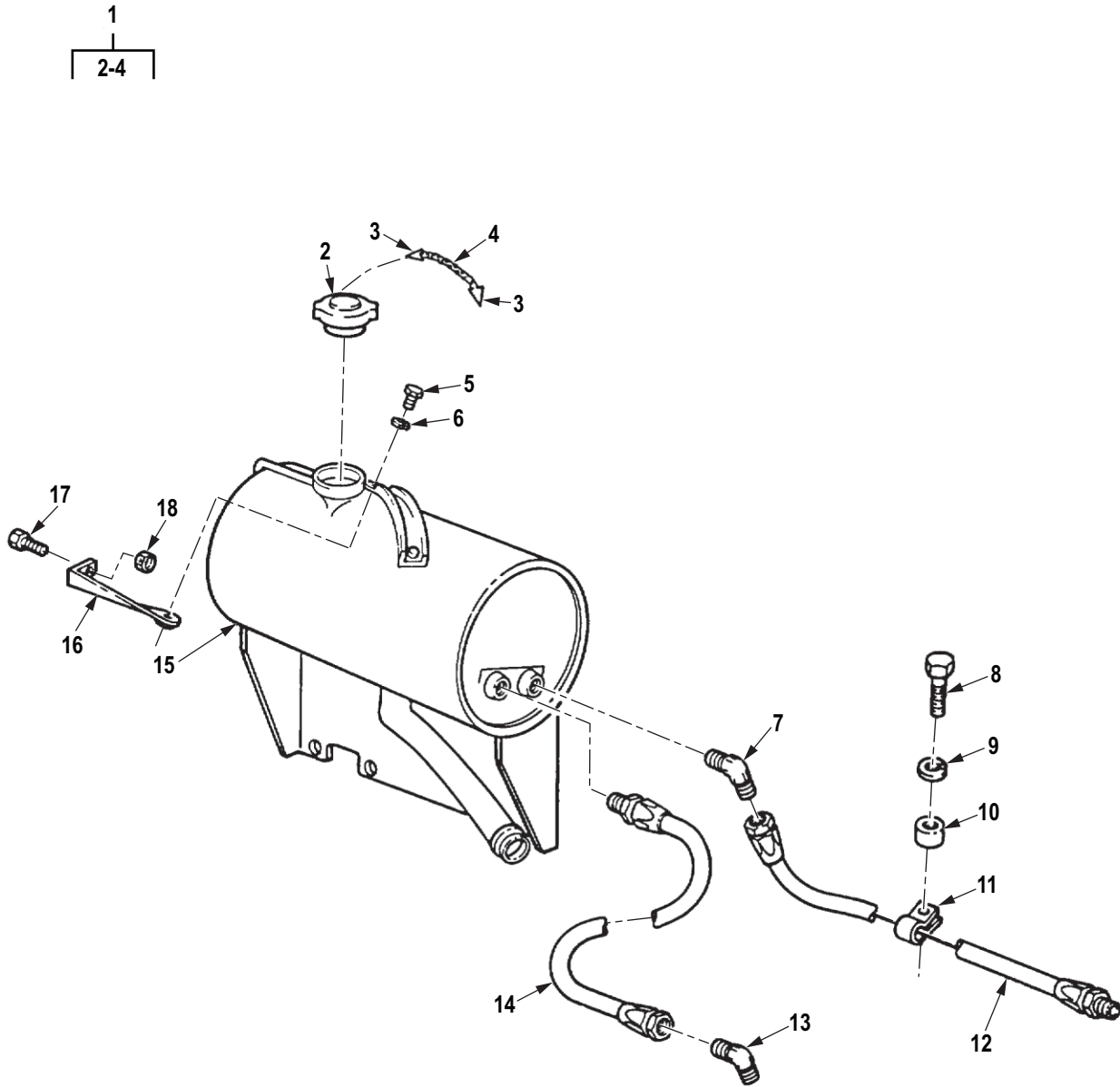

R0109DAA

Figure 109. Surge Tank Assembly, Hoses, and Mounting Hardware (M939, M939A1).

(1) ITEM NO.	(2) SMR CODE	(3) NSN	(4) CAGEC	(5) PART NUMBER	(6) DESCRIPTION AND USABLE ON CODE (UOC)	(7) QTY
					<b>GROUP 0501 RADIATOR, EVAPORATIVE COOLER, OR HEAT EXCHANGER.</b>	
					<b>FIG. 109. SURGE TANK ASSEMBLY, HOSES, AND MOUNTING HARDWARE (M939, M939A1).</b>	
1	PAFZZ	2930-00-147-5202	19207	11648745	CAP,FILLER OPENING UOC: DAC,DAD,DAE,DAF,DAG,DA H,DAJ,DAL,DAW,DAX,V14,V15,V16, V17,V18,V19,V20,V21,V22,V24 .....	1
2	XAFZZ		19207	11648745-1	. CAP,FILLER OPENING UOC: DAC,DAD,DAE,DAF,DAG,DA H,DAJ,DAL,DAW,DAX,V14,V15,V16, V17,V18,V19,V20,V21,V22,V24 .....	1
3	PAFZZ	5315-00-514-2660	81343	AS29523-1	. PIN,RETAINING UOC: DAC,DAD,DAE,DAF,DAG,DA H,DAJ,DAL,DAW,DAX,V14,V15,V16, V17,V18,V19,V20,V21,V22,V24 .....	2
4	MFFZZ		80244	42-C-16560-9	. CHAIN,SASH MAKE FROM CHAIN,P/N 42-C-16560, 9 IN.LONG UOC: DAC,DAD,DAE,DAF,DAG,DA H,DAJ,DAL,DAW,DAX,V14,V15,V16, V17,V18,V19,V20,V21,V22,V24 .....	1
5	PAFZZ	5306-00-225-8496	80205	MS90725-31	BOLT,MACHINE UOC: DAC,DAD,DAE,DAF,DAG,DA H,DAJ,DAL,DAW,DAX,V14,V15,V16, V17,V18,V19,V20,V21,V22,V24 .....	1
6	PAFZZ	5310-00-809-3078	96906	MS27183-11	WASHER,FLAT UOC: DAC,DAD,DAE,DAF,DAG,DA H,DAJ,DAL,DAW,DAX,V14,V15,V16, V17,V18,V19,V20,V21,V22,V24 .....	1
7	PAFZZ	4730-00-231-3906	81343	AS4855-3	ELBOW,PIPE UOC: DAC,DAD,DAE,DAF,DAG,DA H,DAJ,DAL,DAW,DAX,V14,V15,V16, V17,V18,V19,V20,V21,V22,V24 .....	1
8	PAFZZ	5305-00-071-2077	80204	B1821BH050C350N	SCREW,CAP,HEXAGON H UOC: DAC,DAD,DAE,DAF,DAG,DA H,DAJ,DAL,DAW,DAX,V14,V15,V16, V17,V18,V19,V20,V21,V22,V24 .....	1
9	PAFZZ	5310-00-003-4094	80205	MS35338-48	WASHER,LOCK UOC: DAC,DAD,DAE,DAF,DAG,DA H,DAJ,DAL,DAW,DAX,V14,V15,V16, V17,V18,V19,V20,V21,V22,V24 .....	1
10	PAFZZ	5365-01-104-7846	19207	12256491	SPACER,SLEEVE UOC: DAC,DAD,DAE,DAF,DAG,DA H,DAJ,DAL,DAW,DAX,V14,V15,V16, V17,V18,V19,V20,V21,V22,V24 .....	1

(1) ITEM NO.	(2) SMR CODE	(3) NSN	(4) CAGEC	(5) PART NUMBER	(6) DESCRIPTION AND USABLE ON CODE (UOC)	(7) QTY
11	PAFZZ	5340-00-421-7254	19207	8352679	CLAMP,LOOP UOC: DAC,DAD,DAE,DAF,DAG,DA H,DAJ,DAL,DAW,DAX,V14,V15,V16, V17,V18,V19,V20,V21,V22,V24 .....	1
12	PAFZZ	4720-01-088-9650	19207	11664472-1	HOSE ASSEMBLY,NONME UOC: DAC,DAD,DAE,DAF,DAG,DA H,DAJ,DAL,DAW,DAX,V14,V15,V16, V17,V18,V19,V20,V21,V22,V24 .....	1
13	PAFZZ	4730-00-254-6211	81343	J5124-2010202B	ELBOW,PIPE TO TUBE UOC: DAC,DAD,DAE,DAF,DAG,DA H,DAJ,DAL,DAW,DAX,V14,V15,V16, V17,V18,V19,V20,V21,V22,V24 .....	1
14	PAFZZ	4720-00-177-6184	19207	11664473	HOSE ASSEMBLY,NONME UOC: DAC,DAD,DAE,DAF,DAG,DA H,DAJ,DAL,DAW,DAX,V14,V15,V16, V17,V18,V19,V20,V21,V22,V24 .....	1
15	PAFZZ	2930-01-083-1122	19207	12256019	TANK,RADIATOR,OVERF UOC: DAC,DAD,DAE,DAF,DAG,DA H,DAJ,DAL,DAW,DAX,V14,V15,V16, V17,V18,V19,V20,V21,V22,V24 .....	1
16	PFFZZ	5340-01-082-2512	19207	12256284	BRACKET,MOUNTING UOC: DAC,DAD,DAE,DAF,DAG,DA H,DAJ,DAL,DAW,DAX,V14,V15,V16, V17,V18,V19,V20,V21,V22,V24 .....	1
17	PAFZZ	5305-00-269-2803	80205	MS90726-60	SCREW,CAP,HEXAGON H UOC: DAC,DAD,DAE,DAF,DAG,DA H,DAJ,DAL,DAW,DAX,V14,V15,V16, V17,V18,V19,V20,V21,V22,V24 .....	1
18	PAFZZ	5310-00-959-1488	81349	M45913/2-6FG5C	NUT,SELF-LOCKING,HE UOC: DAC,DAD,DAE,DAF,DAG,DA H,DAJ,DAL,DAW,DAX,V14,V15,V16, V17,V18,V19,V20,V21,V22,V24 .....	1

END OF FIGURE



**FIELD MAINTENANCE  
SURGE TANK ASSEMBLY (M939A2)**

---

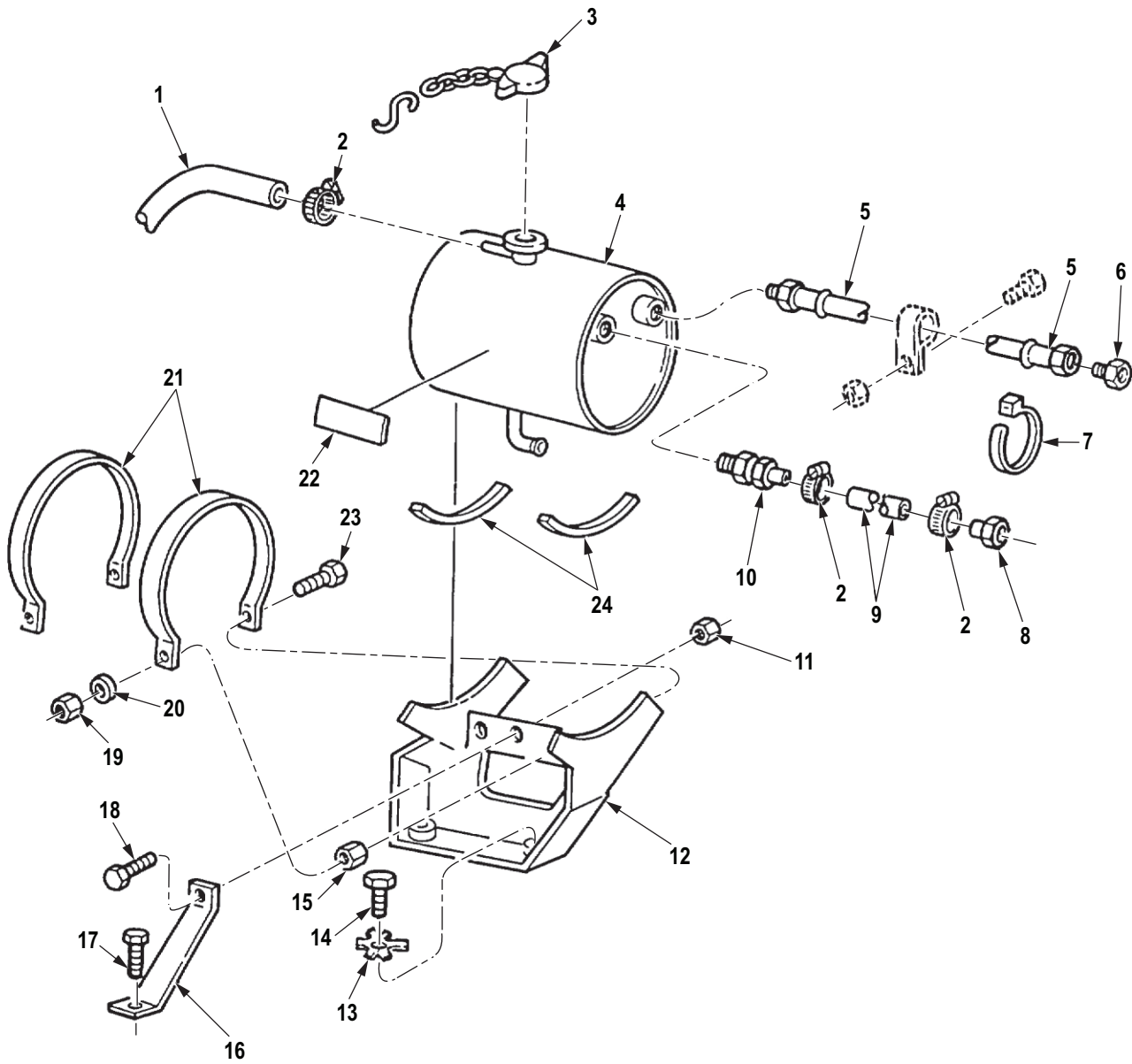

R0110DAA

Figure 110. Surge Tank Assembly (M939A2).

(1) ITEM NO.	(2) SMR CODE	(3) NSN	(4) CAGEC	(5) PART NUMBER	(6) DESCRIPTION AND USABLE ON CODE (UOC)	(7) QTY
<b>GROUP 0501 RADIATOR, EVAPORATIVE COOLER, OR HEAT EXCHANGER.</b>						
<b>FIG. 110. SURGE TANK ASSEMBLY (M939A2).</b>						
1	MFFZZ		47457	20511258 X 25IN	HOSE, NONMETALLIC MAKE FROM HOSE, P/N MIL- DTL-13444TY1SZ4, 25 IN. LONG UOC: ZAA, ZAB, ZAC, ZAD, ZAE, ZAF, ZAG, ZAH, ZAJ, ZAL .....	1
2	PAFZZ	4730-01-109-8001	81343	J1508 TYPE M, SIZE 04	CLAMP, HOSE UOC: ZAA, ZAB, ZAC, ZAD, ZAE, ZAF, ZAG, ZAH, ZAJ, ZAL .....	3
3	PAFZZ	2930-00-147-5202	19207	11648745	CAP, FILLER OPENING UOC: ZAA, ZAB, ZAC, ZAD, ZAE, ZAF, ZAG, ZAH, ZAJ, ZAL .....	1
4	PAFZZ	2590-01-291-4598	47457	20510923	TANK, SURGE, TRUCK UOC: ZAA, ZAB, ZAC, ZAD, ZAE, ZAF, ZAG, ZAH, ZAJ, ZAL .....	1
5	PAFZZ	4720-01-088-9650	19207	11664472-1	HOSE ASSEMBLY, NONME UOC: ZAA, ZAB, ZAC, ZAD, ZAE, ZAF, ZAG, ZAH, ZAJ, ZAL .....	1
6	PAFZZ	4730-01-283-8148	98441	40483-4-6S25	ELBOW, PIPE TO TUBE UOC: ZAA, ZAB, ZAC, ZAD, ZAE, ZAF, ZAG, ZAH, ZAJ, ZAL .....	1
7	PAFZZ	5975-00-451-5001	81343	MS3367-3-9	STRAP, TIEDOWN, ELECT UOC: ZAA, ZAB, ZAC, ZAD, ZAE, ZAF, ZAG, ZAH, ZAJ, ZAL .....	2
8	PAFZZ	4730-01-284-9071	1GF04	31R82-2-4B	ADAPTER, STRAIGHT, PI UOC: ZAA, ZAB, ZAC, ZAD, ZAE, ZAF, ZAG, ZAH, ZAJ, ZAL .....	1
9	MFFZZ		47457	20511258 X 22IN	HOSE, NONMETALLIC MAKE FROM HOSE, P/N MIL- DTL-13444TY1SZ4, 22 IN. LONG UOC: ZAA, ZAB, ZAC, ZAD, ZAE, ZAF, ZAG, ZAH, ZAJ, ZAL .....	1
10	PAFZZ	4730-00-028-7021	72582	5189292	ADAPTER, STRAIGHT, PI UOC: ZAA, ZAB, ZAC, ZAD, ZAE, ZAF, ZAG, ZAH, ZAJ, ZAL .....	1
11	PAFZZ	5310-01-184-5784	7X677	9422302	NUT, PLAIN, HEXAGON UOC: ZAA, ZAB, ZAC, ZAD, ZAE, ZAF, ZAG, ZAH, ZAJ, ZAL .....	1
12	PAFZZ	5340-01-280-3716	05MG0	20511166	BRACKET, MOUNTING UOC: ZAA, ZAB, ZAC, ZAD, ZAE, ZAF, ZAG, ZAH, ZAJ, ZAL .....	1

(1) ITEM NO.	(2) SMR CODE	(3) NSN	(4) CAGEC	(5) PART NUMBER	(6) DESCRIPTION AND USABLE ON CODE (UOC)	(7) QTY
13	PAFZZ	5310-00-824-5474	96906	MS15820-1	WASHER,KEY UOC: ZAA,ZAB,ZAC,ZAD,ZAE,ZAF, ZAG,ZAH,ZAJ,ZAL .....	2
14	PAFZZ	5306-01-284-9663	24617	11503669	BOLT,MACHINE UOC: ZAA,ZAB,ZAC,ZAD,ZAE,ZAF, ZAG,ZAH,ZAJ,ZAL .....	2
15	PAFZZ	5310-01-107-3570	24617	9424985	NUT,PLAIN,HEXAGON UOC: ZAA,ZAB,ZAC,ZAD,ZAE,ZAF, ZAG,ZAH,ZAJ,ZAL .....	1
16	PAFZZ	5340-01-281-5150	05MG0	20511162	BRACKET,DOUBLE ANGL UOC: ZAA,ZAB,ZAC,ZAD,ZAE,ZAF, ZAG,ZAH,ZAJ,ZAL .....	1
17	PAFZZ	5306-01-197-1513	24617	11502788	BOLT,SHOULDER UOC: ZAA,ZAB,ZAC,ZAD,ZAE,ZAF, ZAG,ZAH,ZAJ,ZAL .....	1
18	PAFZZ	5305-00-719-5221	80204	B1821BH050F150N	SCREW,CAP,HEXAGON H UOC: ZAA,ZAB,ZAC,ZAD,ZAE,ZAF, ZAG,ZAH,ZAJ,ZAL .....	1
19	PAFZZ	5310-01-150-4003	24617	9422299	NUT,SELF-LOCKING,HE UOC: ZAA,ZAB,ZAC,ZAD,ZAE,ZAF, ZAG,ZAH,ZAJ,ZAL .....	2
20	PAFZZ	5310-01-092-5495	19207	8356625-4	WASHER,FLAT UOC: ZAA,ZAB,ZAC,ZAD,ZAE,ZAF, ZAG,ZAH,ZAJ,ZAL .....	2
21	PAFZZ	5340-01-280-6996	05MG0	20510929	CLAMP,LOOP UOC: ZAA,ZAB,ZAC,ZAD,ZAE,ZAF, ZAG,ZAH,ZAJ,ZAL .....	2
22	PAFZZ	7690-01-196-6355	19207	12302869	MARKER,IDENTIFICATI UOC: ZAA,ZAB,ZAC,ZAD,ZAE,ZAF, ZAG,ZAH,ZAJ,ZAL .....	1
23	PAFZZ	5305-01-280-9367	6N171	1039234	SCREW,CAP,HEXAGON H UOC: ZAA,ZAB,ZAC,ZAD,ZAE,ZAF, ZAG,ZAH,ZAJ,ZAL .....	2
24	PAFZZ	9390-01-280-3408	57643	20511185	NONMETALLIC CHANNEL UOC: ZAA,ZAB,ZAC,ZAD,ZAE,ZAF, ZAG,ZAH,ZAJ,ZAL .....	2

END OF FIGURE

**FIELD MAINTENANCE  
SURGE TANK LINES AND CLAMPS (M939A2)**

---

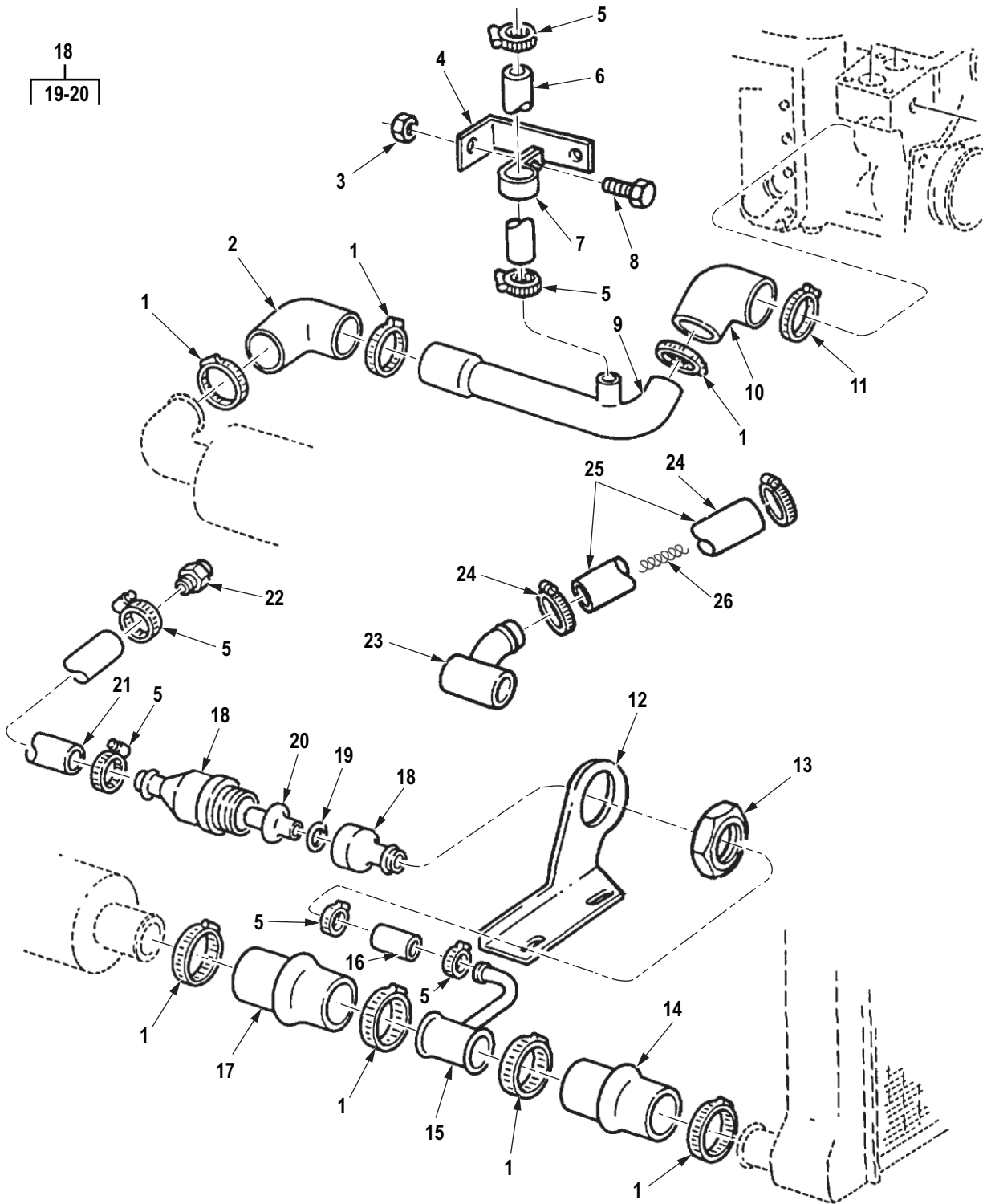

18  
|  
19-20

R0111DAA

Figure 111. Surge Tank Lines and Clamps (M939A2).

(1) ITEM NO.	(2) SMR CODE	(3) NSN	(4) CAGEC	(5) PART NUMBER	(6) DESCRIPTION AND USABLE ON CODE (UOC)	(7) QTY
					<b>GROUP 0501 RADIATOR, EVAPORATIVE COOLER, OR HEAT EXCHANGER.</b>	
					<b>FIG. 111. SURGE TANK LINES AND CLAMPS (M939A2).</b>	
1	PAFZZ	4730-01-331-6630	9C234	11669079-5	CLAMP,HOSE UOC: ZAA,ZAB,ZAC,ZAD,ZAE,ZAF, ZAG,ZAH,ZAJ,ZAL .....	7
2	PAFZZ	4720-01-279-3170	05MG0	20510329	HOSE,PREFORMED UOC: ZAA,ZAB,ZAC,ZAD,ZAE,ZAF, ZAG,ZAH,ZAJ,ZAL .....	1
3	PAFZZ	5310-00-208-1918	88044	AN365-1024A	NUT,SELF-LOCKING,HE UOC: ZAA,ZAB,ZAC,ZAD,ZAE,ZAF, ZAG,ZAH,ZAJ,ZAL .....	1
4	PAFZZ	5340-01-280-6875	05MG0	20510993	BRACKET,ANGLE UOC: ZAA,ZAB,ZAC,ZAD,ZAE,ZAF, ZAG,ZAH,ZAJ,ZAL .....	1
5	PAFZZ	4730-00-908-3194	58536	A-A-52506-F-12	CLAMP,HOSE UOC: ZAA,ZAB,ZAC,ZAD,ZAE,ZAF, ZAG,ZAH,ZAJ,ZAL .....	6
6	MFFZZ		19207	8710557 X 44IN	HOSE MAKE FROM HOSE, P/N 8710557, 44 IN.LONG UOC: ZAA,ZAB,ZAC,ZAD,ZAE,ZAF, ZAG,ZAH,ZAJ,ZAL .....	1
7	PAFZZ	5340-00-922-6300	80205	MS21333-77	CLAMP,LOOP UOC: ZAA,ZAB,ZAC,ZAD,ZAE,ZAF, ZAG,ZAH,ZAJ,ZAL .....	1
8	PAFZZ	5306-00-044-0502	21450	440502	BOLT,MACHINE UOC: ZAA,ZAB,ZAC,ZAD,ZAE,ZAF, ZAG,ZAH,ZAJ,ZAL .....	1
9	PAFZZ	4710-01-284-9029	05MG0	20510409	TUBE,BENT,METALLIC UOC: ZAA,ZAB,ZAC,ZAD,ZAE,ZAF, ZAG,ZAH,ZAJ,ZAL .....	1
10	PAFZZ	4720-01-271-7202	15434	3920762	HOSE,PREFORMED UOC: ZAA,ZAB,ZAC,ZAD,ZAE,ZAF, ZAG,ZAH,ZAJ,ZAL .....	1
11	PAFZZ	4730-01-348-9510	7Z588	CT 9444 B	CLAMP,HOSE UOC: ZAA,ZAB,ZAC,ZAD,ZAE,ZAF, ZAG,ZAH,ZAJ,ZAL .....	1
12	PAFZZ	5340-01-280-6869	05MG0	20510980	BRACKET,ANGLE CANISTER UOC: ZAA,ZAB,ZAC,ZAD,ZAE,ZAF, ZAG,ZAH,ZAJ,ZAL .....	1
13	PAFZZ	5310-01-287-8812	05MG0	20510996	NUT,PLAIN,ROUND UOC: ZAA,ZAB,ZAC,ZAD,ZAE,ZAF, ZAG,ZAH,ZAJ,ZAL .....	1

(1) ITEM NO.	(2) SMR CODE	(3) NSN	(4) CAGEC	(5) PART NUMBER	(6) DESCRIPTION AND USABLE ON CODE (UOC)	(7) QTY
14	PAFZZ	4720-01-279-3168	05MG0	12255978A	HOSE,PREFORMED UOC: ZAA,ZAB,ZAC,ZAD,ZAE,ZAF, ZAG,ZAH,ZAJ,ZAL .....	1
15	PAFZZ	4730-01-279-1510	4F744	20510924	TEE,HOSE USE WITH INTERNAL BYPASS SYSTEM ONLY UOC: ZAA,ZAB,ZAC,ZAD,ZAE,ZAF, ZAG,ZAH,ZAJ,ZAL .....	1
16	MFFZZ		19207	8710557 X 3 IN	HOSE, BYPASS MAKE FROM HOSE, P,N 8710557, 3 IN.LONG, USE WITH INTERNAL BYPASS SYSTEM ONLY UOC: ZAA,ZAB,ZAC,ZAD,ZAE,ZAF, ZAG,ZAH,ZAJ,ZAL .....	1
17	PAFZZ	4720-01-285-3008	05MG0	20510979	HOSE,PREFORMED USE WITH INTERNAL BYPASS SYSTEM ONLY UOC: ZAA,ZAB,ZAC,ZAD,ZAE,ZAF, ZAG,ZAH,ZAJ,ZAL .....	1
18	PAFZZ	2910-01-285-6253	79343	20510922	CANISTER,CARBON,EMI THERMOSTAT,USE WITH INTERNAL BYPASS SYSTEM ONLY UOC: ZAA,ZAB,ZAC,ZAD,ZAE,ZAF, ZAG,ZAH,ZAJ,ZAL .....	1
19	PAFZZ	5330-01-359-2316	59342	CT2900-02	. GASKET UOC: ZAA,ZAB,ZAC,ZAD,ZAE,ZAF, ZAG,ZAH,ZAJ,ZAL .....	1
20	PAFZZ	6685-01-361-7552	05MG0	20510922-5	. THERMOSTAT,FLOW CON UOC: ZAA,ZAB,ZAC,ZAD,ZAE,ZAF, ZAG,ZAH,ZAJ,ZAL .....	1
21	MFFZZ		19207	8710557 X 25IN	HOSE, CANISTER, MAKE FROM HOSE, P/N 8710557, 25 IN.LONG, USE WITH INTERNAL BYPASS SYSTEM ONLY UOC: ZAA,ZAB,ZAC,ZAD,ZAE,ZAF, ZAG,ZAH,ZAJ,ZAL .....	1
22	PAFZZ	4730-01-105-9466	93061	68HB-10-8	ADAPTER,STRAIGHT,PI USE WITH INTERNAL BYPASS SYSTEM ONLY UOC: ZAA,ZAB,ZAC,ZAD,ZAE,ZAF, ZAG,ZAH,ZAJ,ZAL .....	1
23	PAFZZ	4730-01-300-4112	47457	20511285	TEE,HOSE USE WITH EXTERNAL BYPASS SYSTEM ONLY UOC: ZAA,ZAB,ZAC,ZAD,ZAE,ZAF, ZAG,ZAH,ZAJ,ZAL .....	1
24	PAFZZ	4730-00-909-8627	58536	AA52506-F-36	CLAMP,HOSE USE WITH EXTERNAL BYPASS SYSTEM ONLY UOC: ZAA,ZAB,ZAC,ZAD,ZAE,ZAF, ZAG,ZAH,ZAJ,ZAL .....	2



(1) ITEM NO.	(2) SMR CODE	(3) NSN	(4) CAGEC	(5) PART NUMBER	(6) DESCRIPTION AND USABLE ON CODE (UOC)	(7) QTY
25	PAFZZ	4720-01-300-4146	98441	4244-24	HOSE, NONMETALLIC USE WITH EXTERNAL BYPASS SYSTEM ONLY UOC: ZAA, ZAB, ZAC, ZAD, ZAE, ZAF, ZAG, ZAH, ZAJ, ZAL .....	1
26	MFFZZ		01276	222005-17C-AR	SPRING, REINFORCING MAKE FROM SPRING, P/N 222005-17C, AS REQUIRED UOC: ZAA, ZAB, ZAC, ZAD, ZAE, ZAF, ZAG, ZAH, ZAJ, ZAL .....	1

END OF FIGURE



**FIELD MAINTENANCE  
SHROUD ASSEMBLY AND MOUNTING HARDWARE (M939, M939A1)**

---

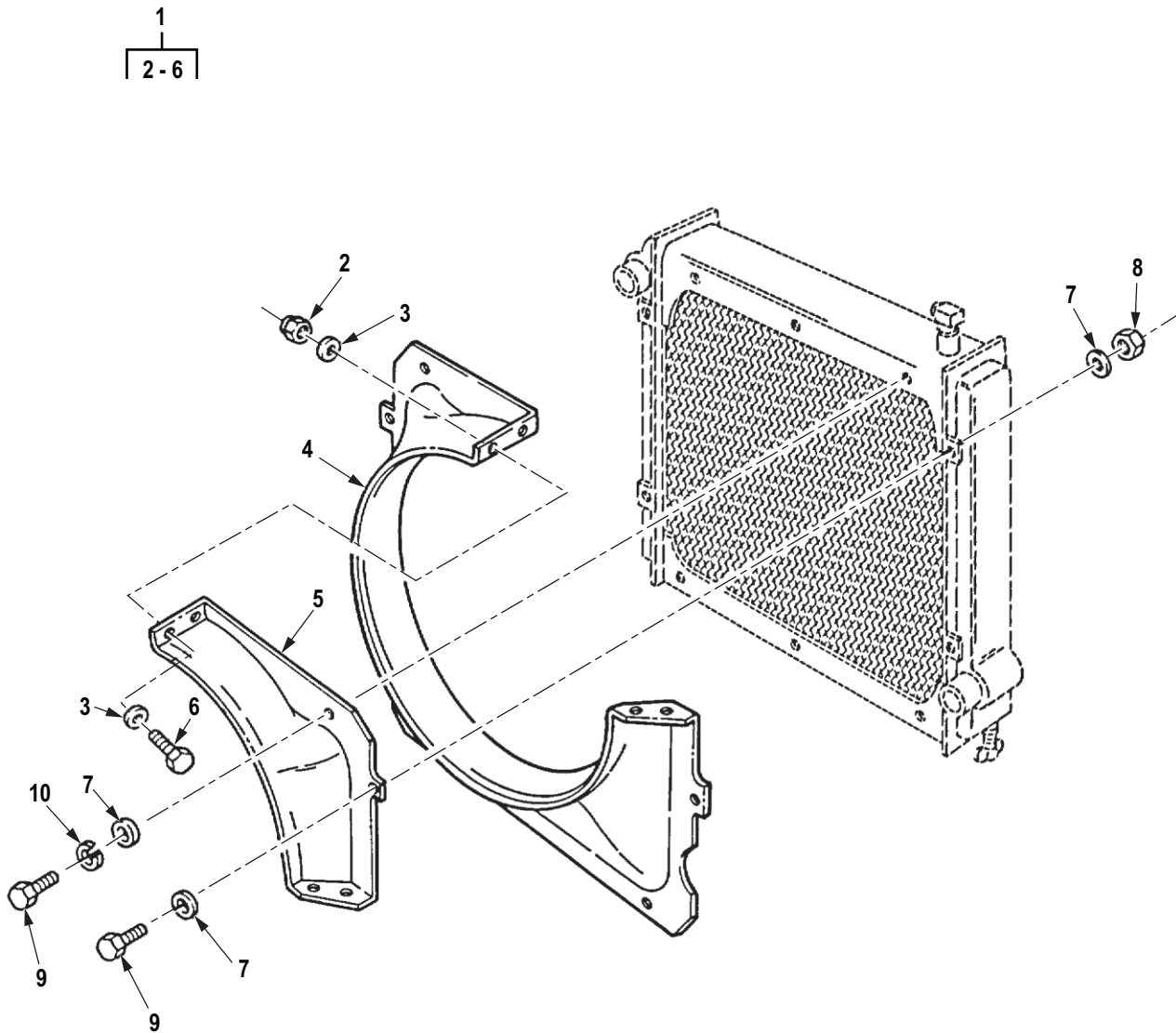

R0112DAA

Figure 112. Shroud Assembly and Mounting Hardware (M939, M939A1).

(1) ITEM NO.	(2) SMR CODE	(3) NSN	(4) CAGEC	(5) PART NUMBER	(6) DESCRIPTION AND USABLE ON CODE (UOC)	(7) QTY
<b>GROUP 0502 COWLING, DEFLECTORS, AIR DUCTS, SHROUDS, ETC.</b>						
<b>FIG. 112. SHROUD ASSEMBLY AND MOUNTING HARDWARE (M939, M939A1).</b>						
1	PAFFF	2930-01-082-2514	19207	12256280	SHROUD,FAN,RADIATOR UOC: DAC,DAD,DAE,DAF,DAG,DA H,DAJ,DAL,DAW,DAX,V14,V15,V16, V17,V18,V19,V20,V21,V22,V24 .....	1
2	PAFZZ	5310-00-935-9022	81349	M45913/3-4FG8C	. NUT,SELF-LOCKING,HE UOC: DAC,DAD,DAE,DAF,DAG,DA H,DAJ,DAL,DAW,DAX,V14,V15,V16, V17,V18,V19,V20,V21,V22,V24 .....	4
3	PAFZZ	5310-00-823-8804	96906	MS27183-9	. WASHER,FLAT UOC: DAC,DAD,DAE,DAF,DAG,DA H,DAJ,DAL,DAW,DAX,V14,V15,V16, V17,V18,V19,V20,V21,V22,V24 .....	8
4	PAFZZ	2930-01-082-3631	19207	12256280-1	. SHROUD,FAN,RADIATOR UOC: DAC,DAD,DAE,DAF,DAG,DA H,DAJ,DAL,DAW,DAX,V14,V15,V16, V17,V18,V19,V20,V21,V22,V24 .....	1
5	PAFZZ	2930-01-082-2513	19207	12256280-2	. SHROUD,FAN,RADIATOR UOC: DAC,DAD,DAE,DAF,DAG,DA H,DAJ,DAL,DAW,DAX,V14,V15,V16, V17,V18,V19,V20,V21,V22,V24 .....	1
6	PAFZZ	5305-00-068-0515	80204	B1821BH025F100N	. SCREW,CAP,HEXAGON H SHROUD ASSEMBLY,RADIATOR UOC: DAC,DAD,DAE,DAF,DAG,DA H,DAJ,DAL,DAW,DAX,V14,V15,V16, V17,V18,V19,V20,V21,V22,V24 .....	4
7	PAFZZ	5310-01-132-8275	24617	9418924	WASHER,FLAT UOC: DAC,DAD,DAE,DAF,DAG,DA H,DAJ,DAL,DAW,DAX,V14,V15,V16, V17,V18,V19,V20,V21,V22,V24 .....	14
8	PAFZZ	5310-00-241-6658	81349	M45913/3-5FG8C	NUT,SELF-LOCKING,HE UOC: DAC,DAD,DAE,DAF,DAG,DA H,DAJ,DAL,DAW,DAX,V14,V15,V16, V17,V18,V19,V20,V21,V22,V24 .....	4
9	PAFZZ	5306-00-050-1238	80204	B1821BH031F075N	BOLT,MACHINE UOC: DAC,DAD,DAE,DAF,DAG,DA H,DAJ,DAL,DAW,DAX,V14,V15,V16, V17,V18,V19,V20,V21,V22,V24 .....	10

(1) ITEM NO.	(2) SMR CODE	(3) NSN	(4) CAGEC	(5) PART NUMBER	(6) DESCRIPTION AND USABLE ON CODE (UOC)	(7) QTY
10	PAFZZ	5310-00-407-9566	80205	MS35338-45	WASHER,LOCK UOC: DAC,DAD,DAE,DAF,DAG,DA H,DAJ,DAL,DAW,DAX,V14,V15,V16, V17,V18,V19,V20,V21,V22,V24 .....	6

END OF FIGURE

**FIELD MAINTENANCE  
RADIATOR FAN SHROUD (M939A2)**

---

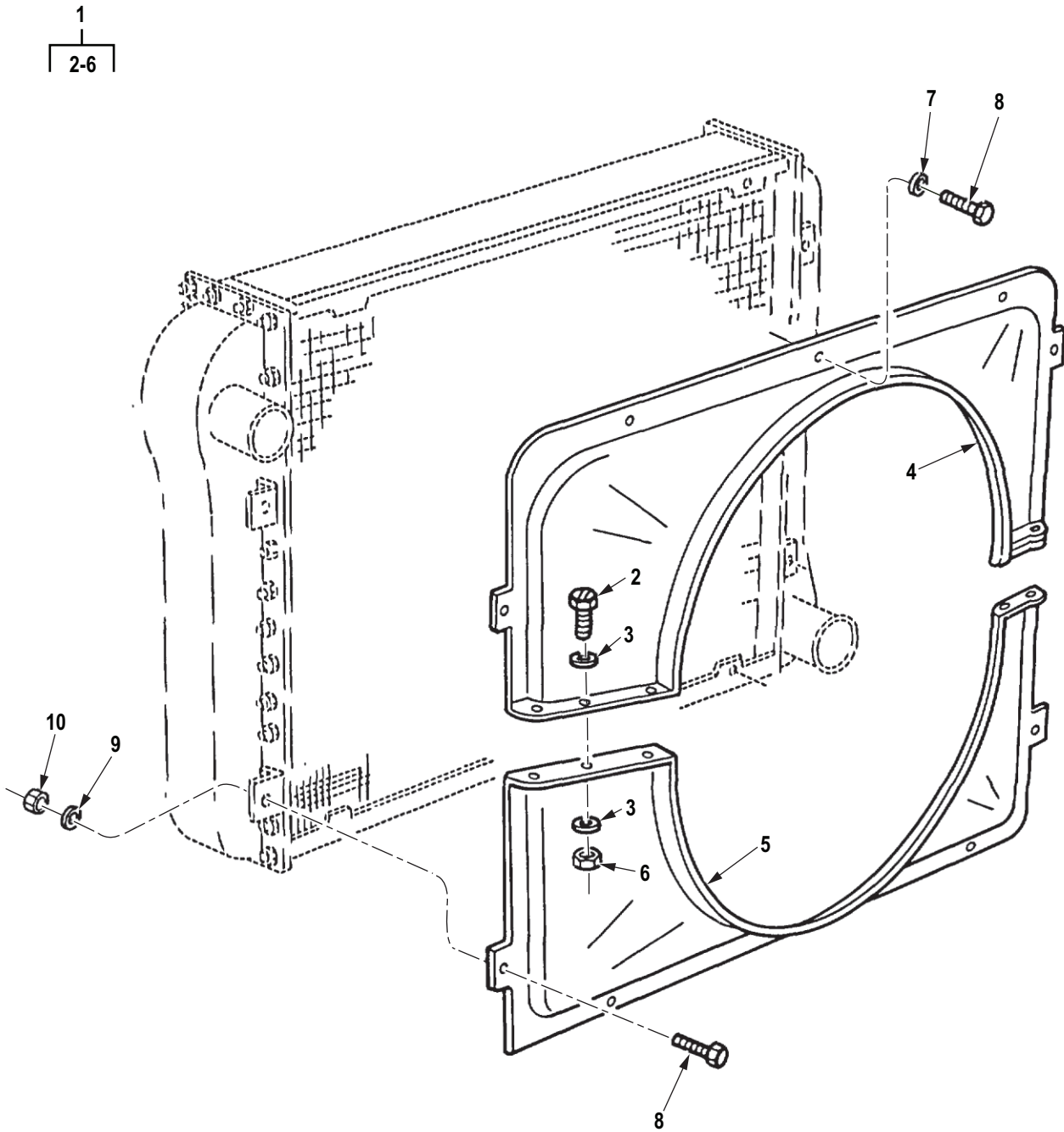

R0113DAA

Figure 113. Radiator Fan Shroud (M939A2).



(1) ITEM NO.	(2) SMR CODE	(3) NSN	(4) CAGEC	(5) PART NUMBER	(6) DESCRIPTION AND USABLE ON CODE (UOC)	(7) QTY
					<b>GROUP 0502 COWLING, DEFLECTORS, AIR DUCTS, SHROUDS, ETC.</b>	
					<b>FIG. 113. RADIATOR FAN SHROUD (M939A2).</b>	
1	PAFFF	2930-01-540-5716	19207	12363316	SHROUD,FAN,RADIATOR UOC: ZAA,ZAB,ZAC,ZAD,ZAE,ZAF, ZAG,ZAH,ZAJ,ZAL .....	1
2	PAFZZ	5305-00-068-0515	80204	B1821BH025F100N	. SCREW,CAP,HEXAGON H UOC: ZAA,ZAB,ZAC,ZAD,ZAE,ZAF, ZAG,ZAH,ZAJ,ZAL .....	4
3	PAFZZ	5310-00-823-8804	96906	MS27183-9	. WASHER,FLAT UOC: ZAA,ZAB,ZAC,ZAD,ZAE,ZAF, ZAG,ZAH,ZAJ,ZAL .....	8
4	PAFZZ	2930-01-287-3180	19207	12363316-1	. SHROUD,FAN,RADIATOR UOC: ZAA,ZAB,ZAC,ZAD,ZAE,ZAF, ZAG,ZAH,ZAJ,ZAL .....	1
5	PAFZZ	2930-01-287-4545	19207	12363316-2	. SHROUD,FAN,RADIATOR UOC: ZAA,ZAB,ZAC,ZAD,ZAE,ZAF, ZAG,ZAH,ZAJ,ZAL .....	1
6	PAFZZ	5310-00-935-9022	81349	M45913/3-4FG8C	. NUT,SELF-LOCKING,HE UOC: ZAA,ZAB,ZAC,ZAD,ZAE,ZAF, ZAG,ZAH,ZAJ,ZAL .....	4
7	PAFZZ	5310-01-259-0296	96906	MS51412-6	WASHER,FLAT UOC: ZAA,ZAB,ZAC,ZAD,ZAE,ZAF, ZAG,ZAH,ZAJ,ZAL .....	1
8	XDFZZ	5306-00-225-9087	80205	MS90726-32	BOLT,MACHINE UOC: ZAA,ZAB,ZAC,ZAD,ZAE,ZAF, ZAG,ZAH,ZAJ,ZAL .....	10
9	PAFZZ	5310-01-132-8275	24617	9418924	WASHER,FLAT UOC: ZAA,ZAB,ZAC,ZAD,ZAE,ZAF, ZAG,ZAH,ZAJ,ZAL .....	13
10	PAFZZ	5310-00-241-6658	81349	M45913/3-5FG8C	NUT,SELF-LOCKING,HE UOC: ZAA,ZAB,ZAC,ZAD,ZAE,ZAF, ZAG,ZAH,ZAJ,ZAL .....	4

**END OF FIGURE**



**FIELD MAINTENANCE  
THERMOSTAT, HOUSING, SEAL AND MOUNTING HARDWARE (M939, M939A1)**

---

2  
| 3-4 |

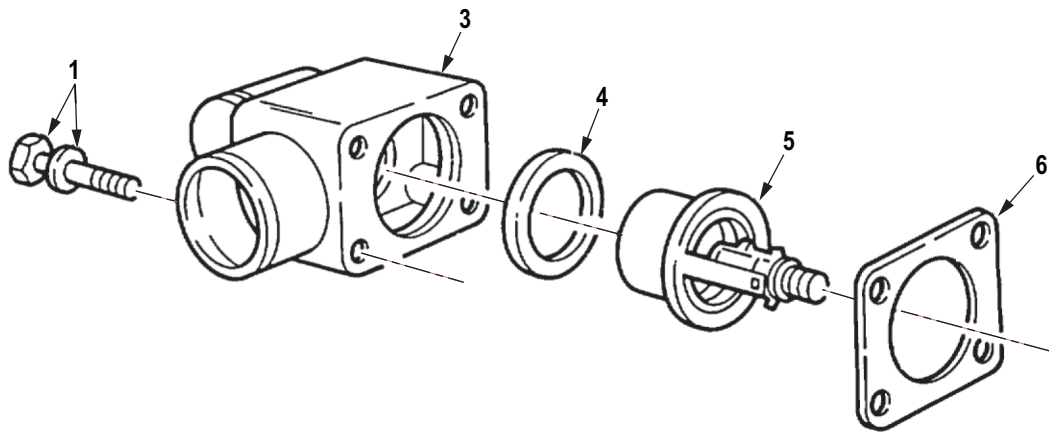

R0114DAA

Figure 114. Thermostat, Housing, Seal and Mounting Hardware (M939, M939A1).

(1) ITEM NO.	(2) SMR CODE	(3) NSN	(4) CAGEC	(5) PART NUMBER	(6) DESCRIPTION AND USABLE ON CODE (UOC)	(7) QTY
					<b>GROUP 0503 WATER MANIFOLD, HEADERS, THERMOSTATS AND HOUSING GASKET.</b>	
					<b>FIG. 114. THERMOSTAT, HOUSING, SEAL AND MOUNTING HARDWARE (M939, M939A1).</b>	
1	PAFZZ	5305-01-086-7036	15434	3010597	SCREW UOC: DAC,DAD,DAE,DAF,DAG,DA H,DAJ,DAL,DAW,DAX,V14,V15,V16, V17,V18,V19,V20,V21,V22,V24 .....	4
2	PBFZZ	2930-00-404-3053	55683	851-AR51264	WATER OUTLET,ENGINE UOC: DAC,DAD,DAE,DAF,DAG,DA H,DAJ,DAL,DAW,DAX,V14,V15,V16, V17,V18,V19,V20,V21,V22,V24 .....	1
3	PAFZZ	6620-01-158-3125	15434	3013607	. HOUSING,THERMOSTAT UOC: DAC,DAD,DAE,DAF,DAG,DA H,DAJ,DAL,DAW,DAX,V14,V15,V16, V17,V18,V19,V20,V21,V22,V24 .....	1
4	PAFZZ	5330-00-864-5422	15434	186780	. SEAL,THERMO PART OF KIT P/ N 3011472, PART OF KIT P/N 4024955 UOC: DAC,DAD,DAE,DAF,DAG,DA H,DAJ,DAL,DAW,DAX,V14,V15,V16, V17,V18,V19,V20,V21,V22,V24 .....	1
5	PAFZZ	6685-01-391-8587	0B8S3	307648900	THERMOSTAT,FLOW CON UOC: DAC,DAD,DAE,DAF,DAG,DA H,DAJ,DAL,DAW,DAX,V14,V15,V16, V17,V18,V19,V20,V21,V22,V24 .....	1
6	PAFZZ	5330-01-354-7651	15434	70441	GASKET THERMOSTAT HOUSING PART OF KIT P/N 3011472, PART OF KIT P/N 4024955 UOC: DAC,DAD,DAE,DAF,DAG,DA H,DAJ,DAL,DAW,DAX,V14,V15,V16, V17,V18,V19,V20,V21,V22,V24 .....	1

**END OF FIGURE**



**FIELD MAINTENANCE  
THERMOSTAT AND HOUSING ASSEMBLY (M939A2)**

---

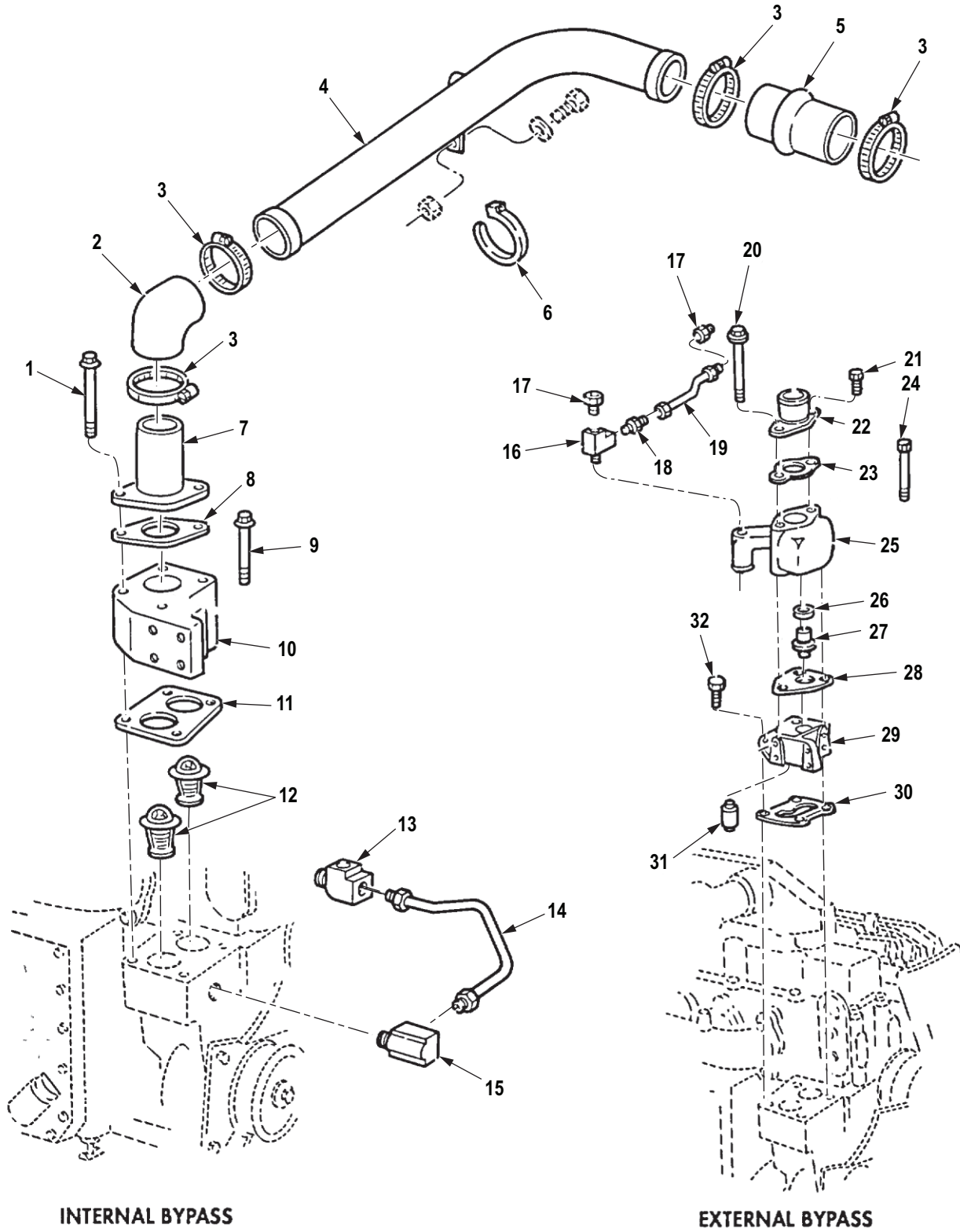

**INTERNAL BYPASS**

**EXTERNAL BYPASS**

R0115DAA

Figure 115. Thermostat and Housing Assembly (M939A2).



(1) ITEM NO.	(2) SMR CODE	(3) NSN	(4) CAGEC	(5) PART NUMBER	(6) DESCRIPTION AND USABLE ON CODE (UOC)	(7) QTY
					<b>GROUP 0503 WATER MANIFOLD, HEADERS, THERMOSTATS AND HOUSING GASKET.</b>	
					<b>FIG. 115. THERMOSTAT AND HOUSING ASSEMBLY (M939A2).</b>	
1	PAFZZ	5305-01-272-4810	15434	3906715	SCREW,CAP,HEXAGON H USED WITH INTERNAL BYPASS SYSTEM ONLY UOC: ZAA,ZAB,ZAC,ZAD,ZAE,ZAF, ZAG,ZAH,ZAJ,ZAL .....	2
2	PAFZZ	4720-01-302-6687	05MG0	20510473	HOSE,PREFORMED UOC: ZAA,ZAB,ZAC,ZAD,ZAE,ZAF, ZAG,ZAH,ZAJ,ZAL .....	1
3	PAFZZ	4730-01-331-6630	9C234	11669079-5	CLAMP,HOSE UOC: ZAA,ZAB,ZAC,ZAD,ZAE,ZAF, ZAG,ZAH,ZAJ,ZAL .....	4
4	PAFZZ	4710-01-284-9032	05MG0	20510518	TUBE,BENT,METALLIC RADIATOR UOC: ZAA,ZAB,ZAC,ZAD,ZAE,ZAF, ZAG,ZAH,ZAJ,ZAL .....	1
5	PAFZZ	4720-01-279-3169	05MG0	2051 0481	HOSE,PREFORMED RADIATOR UOC: ZAA,ZAB,ZAC,ZAD,ZAE,ZAF, ZAG,ZAH,ZAJ,ZAL .....	1
6	PAFZZ	5975-00-451-5001	81343	MS3367-3-9	STRAP,TIEDOWN,ELECT UOC: ZAA,ZAB,ZAC,ZAD,ZAE,ZAF, ZAG,ZAH,ZAJ,ZAL .....	1
7	PAFZZ	2930-01-272-6716	15434	3912800	WATER OUTLET,ENGINE OUTLET, USED WITH INTERNAL BYPASS SYSTEM ONLY UOC: ZAA,ZAB,ZAC,ZAD,ZAE,ZAF, ZAG,ZAH,ZAJ,ZAL .....	1
8	PAFZZ	5330-01-272-1142	15434	306091200	GASKET USED WITH INTERNAL BYPASS SYSTEM ONLY PART OF KIT P/N 3802622, PART OF KIT P/N 3800748, PART OF KIT P/N 402527100 UOC: ZAA,ZAB,ZAC,ZAD,ZAE,ZAF, ZAG,ZAH,ZAJ,ZAL .....	1
9	PAFZZ	5305-01-272-4811	15434	3902112	SCREW,CAP,HEXAGON H UOC: ZAA,ZAB,ZAC,ZAD,ZAE,ZAF, ZAG,ZAH,ZAJ,ZAL .....	2
10	PAFZZ	2930-01-291-5867	15434	392653400	WATER OUTLET,ENGINE USED WITH INTERNAL BYPASS SYSTEM ONLY UOC: ZAA,ZAB,ZAC,ZAD,ZAE,ZAF, ZAG,ZAH,ZAJ,ZAL .....	1

(1) ITEM NO.	(2) SMR CODE	(3) NSN	(4) CAGEC	(5) PART NUMBER	(6) DESCRIPTION AND USABLE ON CODE (UOC)	(7) QTY
11	PAFZZ	5330-01-287-8656	7U263	3914310	GASKET USED WITH INTERNAL BYPASS SYSTEM ONLY PART OF KIT P/N 3802622, PART OF KIT P/N 3800748, PART OF KIT P/N 402527100 UOC: ZAA,ZAB,ZAC,ZAD,ZAE,ZAF, ZAG,ZAH,ZAJ,ZAL .....	1
12	PAFZZ	6685-01-425-7336	15434	3928639	THERMOSTAT,FLOW CON USED WITH INTERNAL BYPASS SYSTEM ONLY UOC: ZAA,ZAB,ZAC,ZAD,ZAE,ZAF, ZAG,ZAH,ZAJ,ZAL .....	2
13	PAFZZ	4730-01-271-7977	15434	390876300	TEE,TUBE USED WITH INTERNAL BYPASS SYSTEM ONLY UOC: ZAA,ZAB,ZAC,ZAD,ZAE,ZAF, ZAG,ZAH,ZAJ,ZAL .....	1
14	PAFZZ	4710-01-271-8033	15434	3926545	TUBE ASSEMBLY,METAL USED WITH INTERNAL BYPASS SYSTEM ONLY UOC: ZAA,ZAB,ZAC,ZAD,ZAE,ZAF, ZAG,ZAH,ZAJ,ZAL .....	1
15	PAFZZ	4730-01-151-6316	15434	S1004-1	ELBOW,TUBE USED WITH INTERNAL BYPASS SYSTEM ONLY UOC: ZAA,ZAB,ZAC,ZAD,ZAE,ZAF, ZAG,ZAH,ZAJ,ZAL .....	1
16	PAFZZ	4730-01-300-9030	15434	3023198	TEE,PIPE TO TUBE USED WITH EXTERNAL BYPASS SYSTEM ONLY UOC: ZAA,ZAB,ZAC,ZAD,ZAE,ZAF, ZAG,ZAH,ZAJ,ZAL .....	1
17	PAFZZ	4730-01-300-9024	15434	3018888	ADAPTER,STRAIGHT,PI USED WITH EXTERNAL BYPASS SYSTEM ONLY UOC: ZAA,ZAB,ZAC,ZAD,ZAE,ZAF, ZAG,ZAH,ZAJ,ZAL .....	2
18	PAFZZ	4730-01-131-4884	15434	S00109700	ADAPTER,STRAIGHT,PI USED WITH EXTERNAL BYPASS SYSTEM ONLY UOC: ZAA,ZAB,ZAC,ZAD,ZAE,ZAF, ZAG,ZAH,ZAJ,ZAL .....	1
19	PAFZZ	4710-01-301-4358	15434	3913033	TUBE ASSEMBLY,METAL USED WITH EXTERNAL BYPASS SYSTEM ONLY UOC: ZAA,ZAB,ZAC,ZAD,ZAE,ZAF, ZAG,ZAH,ZAJ,ZAL .....	1
20	PAFZZ	5305-01-301-9756	15434	3903118	SCREW,CAP,HEXAGON H USED WITH EXTERNAL BYPASS SYSTEM ONLY UOC: ZAA,ZAB,ZAC,ZAD,ZAE,ZAF, ZAG,ZAH,ZAJ,ZAL .....	1
21	PAFZZ	5305-01-234-3755	15434	3900630	SCREW,CAP,HEXAGON H USED WITH EXTERNAL BYPASS SYSTEM ONLY UOC: ZAA,ZAB,ZAC,ZAD,ZAE,ZAF, ZAG,ZAH,ZAJ,ZAL .....	1

(1) ITEM NO.	(2) SMR CODE	(3) NSN	(4) CAGEC	(5) PART NUMBER	(6) DESCRIPTION AND USABLE ON CODE (UOC)	(7) QTY
22	PAFZZ	2930-01-305-3303	15434	3913030	WATER OUTLET,ENGINE USED WITH EXTERNAL BYPASS SYSTEM ONLY UOC: ZAA,ZAB,ZAC,ZAD,ZAE,ZAF, ZAG,ZAH,ZAJ,ZAL .....	1
23	PAFZZ	5330-01-301-1828	15434	3913032	GASKET USED WITH EXTERNAL BYPASS SYSTEM ONLY UOC: ZAA,ZAB,ZAC,ZAD,ZAE,ZAF, ZAG,ZAH,ZAJ,ZAL .....	1
24	PAFZZ	5305-01-301-9757	15434	3913034	SCREW,CAP,HEXAGON H USED WITH EXTERNAL BYPASS SYSTEM ONLY UOC: ZAA,ZAB,ZAC,ZAD,ZAE,ZAF, ZAG,ZAH,ZAJ,ZAL .....	2
25	PAFZZ	2930-01-300-5943	15434	3913024	WATER OUTLET,ENGINE USED WITH EXTERNAL BYPASS SYSTEM ONLY UOC: ZAA,ZAB,ZAC,ZAD,ZAE,ZAF, ZAG,ZAH,ZAJ,ZAL .....	1
26	PAFZZ	5330-01-301-1761	15434	188318	SEAL,SPECIAL USED WITH EXTERNAL BYPASS SYSTEM ONLY UOC: ZAA,ZAB,ZAC,ZAD,ZAE,ZAF, ZAG,ZAH,ZAJ,ZAL .....	1
27	PAFZZ	6620-01-302-0045	15434	3913028	THERMOSTAT,FLOW CON USED WITH EXTERNAL BYPASS SYSTEM ONLY UOC: ZAA,ZAB,ZAC,ZAD,ZAE,ZAF, ZAG,ZAH,ZAJ,ZAL .....	1
28	PAFZZ	5330-01-302-0780	15434	3913025	GASKET USED WITH EXTERNAL BYPASS SYSTEM ONLY UOC: ZAA,ZAB,ZAC,ZAD,ZAE,ZAF, ZAG,ZAH,ZAJ,ZAL .....	1
29	PAFZZ	2930-01-300-5944	15434	3926094	WATER OUTLET,ENGINE USED WITH EXTERNAL BYPASS SYSTEM ONLY UOC: ZAA,ZAB,ZAC,ZAD,ZAE,ZAF, ZAG,ZAH,ZAJ,ZAL .....	1
30	PAFZZ	5330-01-301-1829	15434	3913027	GASKET USED WITH EXTERNAL BYPASS SYSTEM ONLY UOC: ZAA,ZAB,ZAC,ZAD,ZAE,ZAF, ZAG,ZAH,ZAJ,ZAL .....	1
31	PAFZZ	5365-01-302-6555	15434	3935234	PLUG,MACHINE THREAD USED WITH EXTERNAL BYPASS SYSTEM ONLY UOC: ZAA,ZAB,ZAC,ZAD,ZAE,ZAF, ZAG,ZAH,ZAJ,ZAL .....	1
32	PAFZZ	5305-01-269-6274	15434	3902114	SCREW,CAP,HEXAGON H USED WITH EXTERNAL BYPASS SYSTEM ONLY UOC: ZAA,ZAB,ZAC,ZAD,ZAE,ZAF, ZAG,ZAH,ZAJ,ZAL .....	2

END OF FIGURE



**FIELD MAINTENANCE  
WATER MANIFOLD, COVER, AND MOUNTING HARDWARE (M939, M939A1)**

---

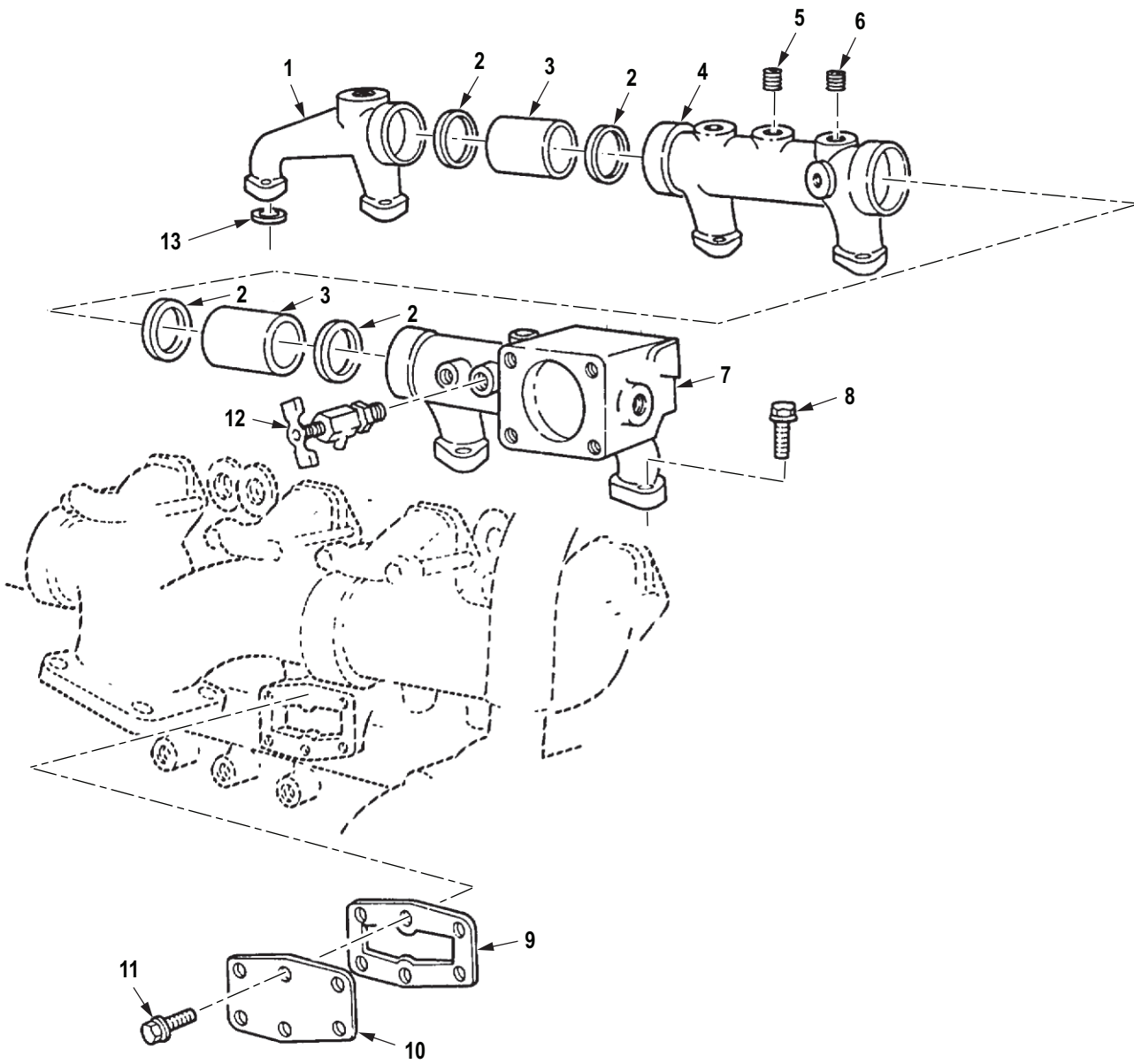

R0116DAA

Figure 116. Water Manifold, Cover, and Mounting Hardware (M939, M939A1).

(1) ITEM NO.	(2) SMR CODE	(3) NSN	(4) CAGEC	(5) PART NUMBER	(6) DESCRIPTION AND USABLE ON CODE (UOC)	(7) QTY
<p><b>GROUP 0503 WATER MANIFOLD, HEADERS, THERMOSTATS AND HOUSING GASKET.</b></p> <p><b>FIG. 116. WATER MANIFOLD, COVER, AND MOUNTING HARDWARE (M939, M939A1).</b></p>						
1	PAFZZ	2930-01-134-2238	15434	3013001	MANIFOLD,FLUID COOL REAR UOC: DAC,DAD,DAE,DAF,DAG,DAH,DAJ,DAL,DAW,DAX,V14,V15,V16,V17,V18,V19,V20,V21,V22,V24 .....	1
2	PAFZZ	5331-00-506-4874	15434	70624	O-RING PART OF KIT P/N 3011472, PART OF KIT P/N 4024955 UOC: DAC,DAD,DAE,DAF,DAG,DAH,DAJ,DAL,DAW,DAX,V14,V15,V16,V17,V18,V19,V20,V21,V22,V24 .....	4
3	PAFZZ	4730-00-404-2906	15434	130394	COUPLING,TUBE UOC: DAC,DAD,DAE,DAF,DAG,DAH,DAJ,DAL,DAW,DAX,V14,V15,V16,V17,V18,V19,V20,V21,V22,V24 .....	2
4	PAFZZ	2930-01-204-4475	15434	3030866	MANIFOLD,FLUID COOL CENTER UOC: DAC,DAD,DAE,DAF,DAG,DAH,DAJ,DAL,DAW,DAX,V14,V15,V16,V17,V18,V19,V20,V21,V22,V24 .....	1
5	PAFZZ	4730-01-085-7328	15434	217632	PLUG,PIPE UOC: DAC,DAD,DAE,DAF,DAG,DAH,DAJ,DAL,DAW,DAX,V14,V15,V16,V17,V18,V19,V20,V21,V22,V24 .....	1
6	PAFZZ	4730-01-161-5115	15434	3013786	PLUG,PIPE UOC: DAC,DAD,DAE,DAF,DAG,DAH,DAJ,DAL,DAW,DAX,V14,V15,V16,V17,V18,V19,V20,V21,V22,V24 .....	1
7	PAFZZ	2930-00-404-3050	15434	202334	MANIFOLD,FLUID COOL UOC: DAC,DAD,DAE,DAF,DAG,DAH,DAJ,DAL,DAW,DAX,V14,V15,V16,V17,V18,V19,V20,V21,V22,V24 .....	1
8	PAFZZ	5305-01-088-6019	15434	3010596	SCREW,ASSEMBLED WAS UOC: DAC,DAD,DAE,DAF,DAG,DAH,DAJ,DAL,DAW,DAX,V14,V15,V16,V17,V18,V19,V20,V21,V22,V24 .....	12
9	PAFZZ	5330-00-537-2382	15434	70089-1	GASKET PART OF KIT P/N 3011472 UOC: DAC,DAD,DAE,DAF,DAG,DAH,DAJ,DAL,DAW,DAX,V14,V15,V16,V17,V18,V19,V20,V21,V22,V24 .....	2
10	PBFZZ	5340-00-799-0843	15434	132019	COVER,ACCESS UOC: DAC,DAD,DAE,DAF,DAG,DAH,DAJ,DAL,DAW,DAX,V14,V15,V16,V17,V18,V19,V20,V21,V22,V24 .....	2

(1) ITEM NO.	(2) SMR CODE	(3) NSN	(4) CAGEC	(5) PART NUMBER	(6) DESCRIPTION AND USABLE ON CODE (UOC)	(7) QTY
11	PAFZZ	5305-01-112-9021	15434	3013904	SCREW UOC: DAC,DAD,DAE,DAF,DAG,DA H,DAJ,DAL,DAW,DAX,V14,V15,V16, V17,V18,V19,V20,V21,V22,V24 .....	12
12	PAFZZ	4820-00-752-9040	58536	AA59440/1-004	COCK,DRAIN UOC: DAC,DAD,DAE,DAF,DAG,DA H,DAJ,DAL,DAW,DAX,V14,V15,V16, V17,V18,V19,V20,V21,V22,V24 .....	1
13	PAFZZ	5330-01-145-5381	15434	3024709	GASKET PART OF KIT P/N 3011472, PART OF KIT P/N 4024955 UOC: DAC,DAD,DAE,DAF,DAG,DA H,DAJ,DAL,DAW,DAX,V14,V15,V16, V17,V18,V19,V20,V21,V22,V24 .....	6

END OF FIGURE



**FIELD MAINTENANCE**  
**AIR COMPRESSOR COOLANT LINES AND RELATED PARTS (M939, M939A1)**

---

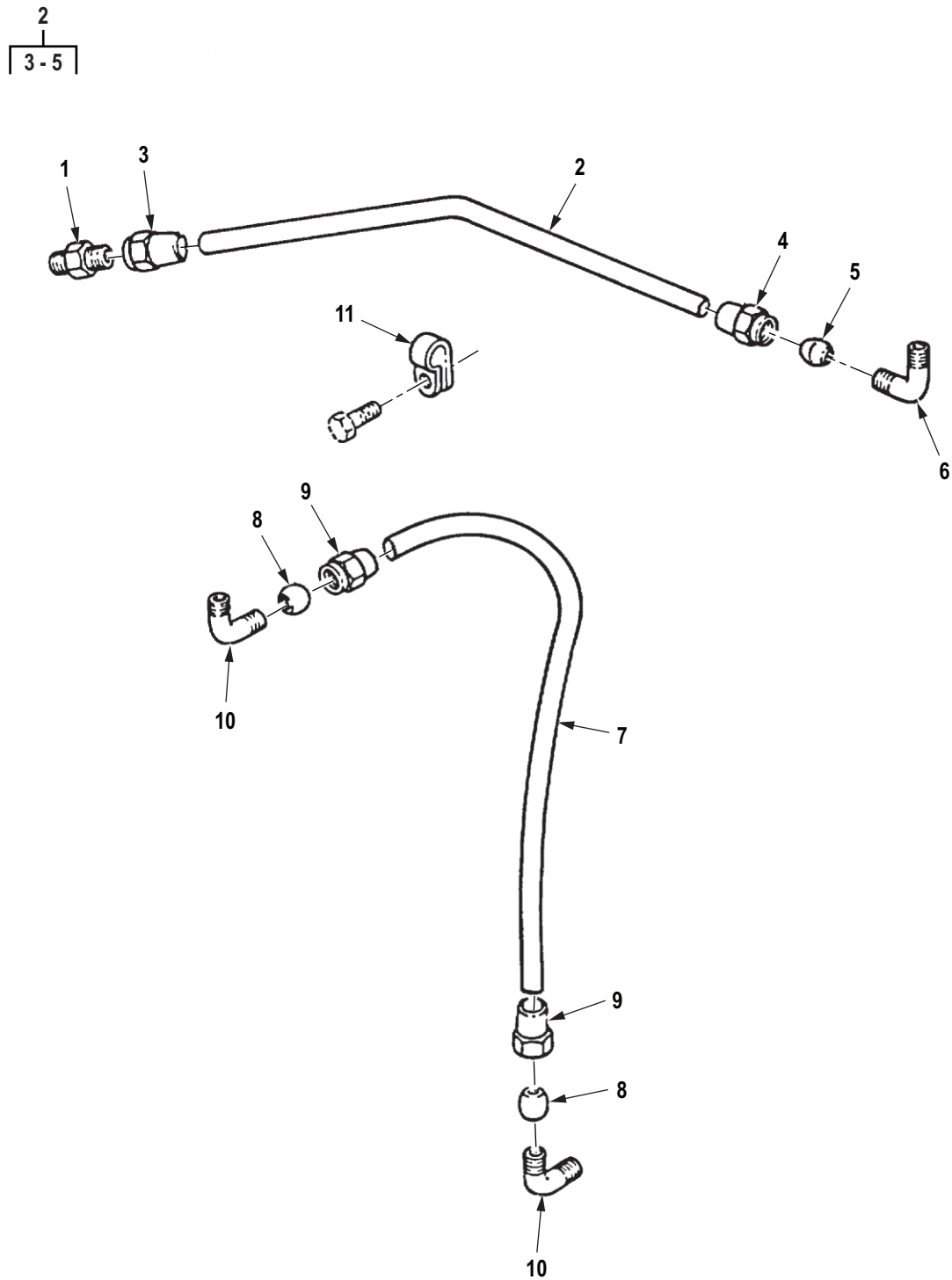

R0117DAA

Figure 117. Air Compressor Coolant Lines and Related Parts (M939, M939A1).

(1) ITEM NO.	(2) SMR CODE	(3) NSN	(4) CAGEC	(5) PART NUMBER	(6) DESCRIPTION AND USABLE ON CODE (UOC)	(7) QTY
					<b>GROUP 0503 WATER MANIFOLD, HEADERS, THERMOSTATS AND HOUSING GASKET.</b>	
					<b>FIG. 117. AIR COMPRESSOR COOLANT LINES AND RELATED PARTS (M939, M939A1).</b>	
1	PAFZZ	4730-00-365-2690	15434	S-1002-A	ADAPTER, STRAIGHT, TU UOC: DAC, DAD, DAE, DAF, DAG, DA H, DAJ, DAL, DAW, DAX, V14, V15, V16, V17, V18, V19, V20, V21, V22, V24 .....	1
2	MFFZZ		15434	204898	TUBING, NONMETALLIC MAKE FROM TUBING, P/N 8689210 UOC: DAC, DAD, DAE, DAF, DAG, DA H, DAJ, DAL, DAW, DAX, V14, V15, V16, V17, V18, V19, V20, V21, V22, V24 .....	1
3	PAFZZ	4730-00-013-7401	72582	137401	. INVERTED NUT, TUBE C UOC: DAC, DAD, DAE, DAF, DAG, DA H, DAJ, DAL, DAW, DAX, V14, V15, V16, V17, V18, V19, V20, V21, V22, V24 .....	1
4	PAFZZ	4730-00-289-5179	15434	S-1004-A	. NUT, TUBE COUPLING UOC: DAC, DAD, DAE, DAF, DAG, DA H, DAJ, DAL, DAW, DAX, V14, V15, V16, V17, V18, V19, V20, V21, V22, V24 .....	1
5	PAFZZ	5365-00-598-5255	0B853	3103015	. BUSHING, NONMETALLIC UOC: DAC, DAD, DAE, DAF, DAG, DA H, DAJ, DAL, DAW, DAX, V14, V15, V16, V17, V18, V19, V20, V21, V22, V24 .....	1
6	PAFZZ	4730-01-201-0717	15434	S0010900	ELBOW, PIPE TO TUBE UOC: DAC, DAD, DAE, DAF, DAG, DA H, DAJ, DAL, DAW, DAX, V14, V15, V16, V17, V18, V19, V20, V21, V22, V24 .....	1
7	MFFFF		15434	3031619	TUBE MAKE FROM TUBE, P/N ASTM B280 UOC: DAC, DAD, DAE, DAF, DAG, DA H, DAJ, DAL, DAW, DAX, V14, V15, V16, V17, V18, V19, V20, V21, V22, V24 .....	1
8	PAFZZ	5365-00-598-5255	0B853	3103015	BUSHING, NONMETALLIC AIR COMPRESSOR TUBE UOC: DAC, DAD, DAE, DAF, DAG, DA H, DAJ, DAL, DAW, DAX, V14, V15, V16, V17, V18, V19, V20, V21, V22, V24 .....	2
9	PAFZZ	4730-00-289-5179	15434	S-1004-A	NUT, TUBE COUPLING AIR COMPRESSOR TUBE UOC: DAC, DAD, DAE, DAF, DAG, DA H, DAJ, DAL, DAW, DAX, V14, V15, V16, V17, V18, V19, V20, V21, V22, V24 .....	2

(1) ITEM NO.	(2) SMR CODE	(3) NSN	(4) CAGEC	(5) PART NUMBER	(6) DESCRIPTION AND USABLE ON CODE (UOC)	(7) QTY
10	PAFZZ	4730-00-374-4282	15434	S00100500A	ELBOW,PIPE TO TUBE UOC: DAC,DAD,DAE,DAF,DAG,DA H,DAJ,DAL,DAW,DAX,V14,V15,V16, V17,V18,V19,V20,V21,V22,V24 .....	2
11	PAFZZ	5340-00-286-1868	15434	68152	CLAMP,LOOP UOC: DAC,DAD,DAE,DAF,DAG,DA H,DAJ,DAL,DAW,DAX,V14,V15,V16, V17,V18,V19,V20,V21,V22,V24 .....	1

END OF FIGURE

**FIELD MAINTENANCE  
WATER PUMP ASSEMBLY, SEALS, AND MOUNTING HARDWARE (M939, M939A1)**

---

1  
2-3

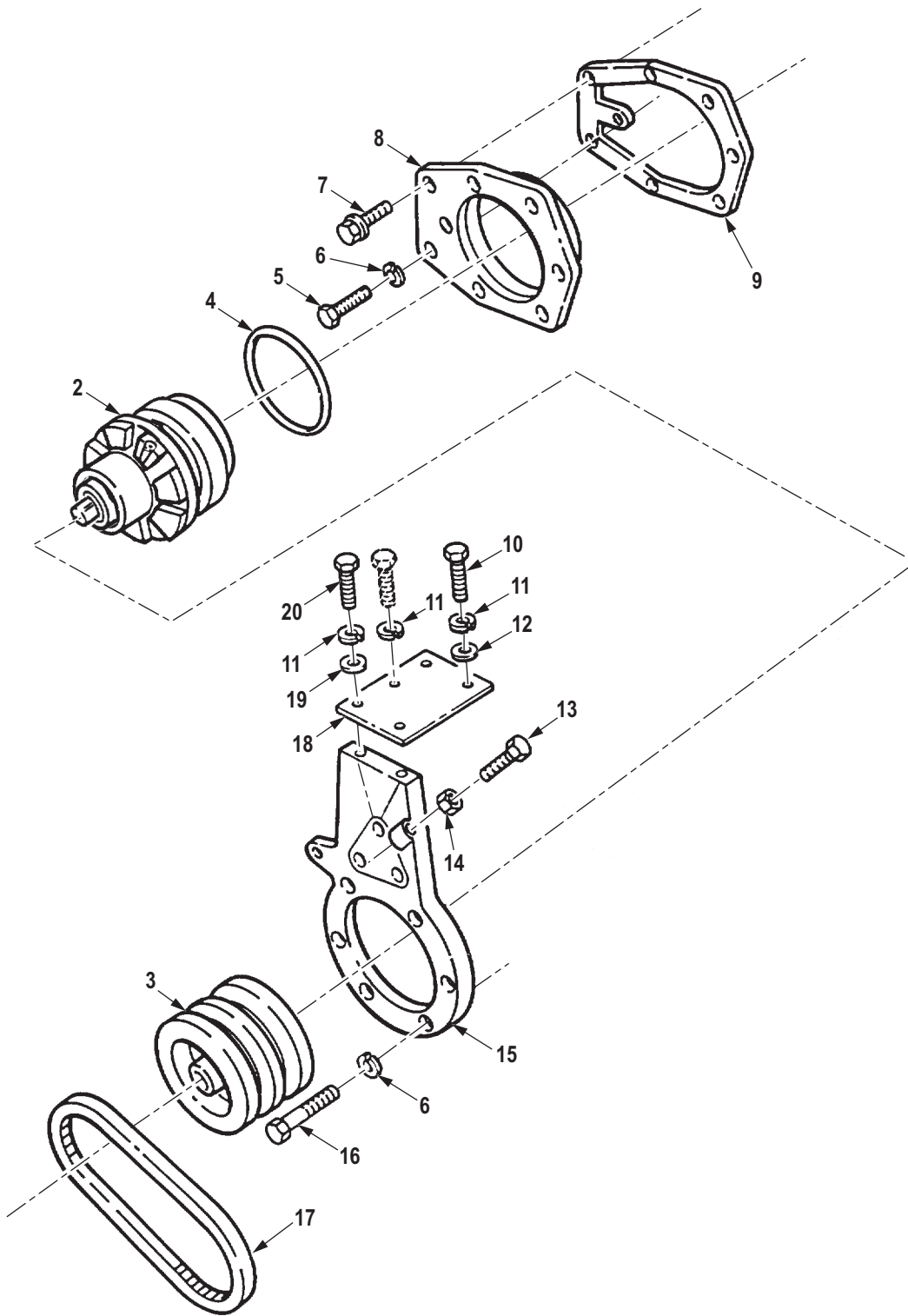

R0118DAA

Figure 118. Water Pump Assembly, Seals, and Mounting Hardware (M939, M939A1).

(1) ITEM NO.	(2) SMR CODE	(3) NSN	(4) CAGEC	(5) PART NUMBER	(6) DESCRIPTION AND USABLE ON CODE (UOC)	(7) QTY
<b>GROUP 0504 WATER PUMP.</b>						
<b>FIG. 118. WATER PUMP ASSEMBLY, SEALS, AND MOUNTING HARDWARE (M939, M939A1).</b>						
1	PAFZZ	2930-00-890-2440	15434	AR4284	PUMP, COOLING SYSTEM UOC: DAC, DAD, DAE, DAF, DAG, DA H, DAJ, DAL, DAW, DAX, V14, V15, V16, V17, V18, V19, V20, V21, V22, V24 .....	1
2	PAFZZ	2930-00-004-8420	15434	AR04283	. PUMP, WATER, ENGINE C UOC: DAC, DAD, DAE, DAF, DAG, DA H, DAJ, DAL, DAW, DAX, V14, V15, V16, V17, V18, V19, V20, V21, V22, V24 .....	1
3	PAFZZ	3020-00-929-0713	15434	15496600	. PULLEY, GROOVE WATER PUMP UOC: DAC, DAD, DAE, DAF, DAG, DA H, DAJ, DAL, DAW, DAX, V14, V15, V16, V17, V18, V19, V20, V21, V22, V24 .....	1
4	PAFZZ	5330-00-106-6369	15434	130240	GASKET PART OF KIT P/N 3011472 UOC: DAC, DAD, DAE, DAF, DAG, DA H, DAJ, DAL, DAW, DAX, V14, V15, V16, V17, V18, V19, V20, V21, V22, V24 .....	1
5	PAFZZ	5305-01-210-1608	15434	106549	SCREW, CAP, HEXAGON H UOC: DAC, DAD, DAE, DAF, DAG, DA H, DAJ, DAL, DAW, DAX, V14, V15, V16, V17, V18, V19, V20, V21, V22, V24 .....	1
6	PAFZZ	5310-00-261-7340	01276	202983	WASHER, LOCK UOC: DAC, DAD, DAE, DAF, DAG, DA H, DAJ, DAL, DAW, DAX, V14, V15, V16, V17, V18, V19, V20, V21, V22, V24 .....	1
7	PAFZZ	5305-01-130-6100	15434	3010594	SCREW, CAP, HEXAGON H UOC: DAC, DAD, DAE, DAF, DAG, DA H, DAJ, DAL, DAW, DAX, V14, V15, V16, V17, V18, V19, V20, V21, V22, V24 .....	1
8	PBFZZ	2930-00-408-9404	15434	130227	SUPPORT, PUMP, WATER UOC: DAC, DAD, DAE, DAF, DAG, DA H, DAJ, DAL, DAW, DAX, V14, V15, V16, V17, V18, V19, V20, V21, V22, V24 .....	1
9	PAFZZ	5330-00-106-6370	15434	130226	GASKET WATER PUMP SUPPORT PART OF KIT P/N 3011472 UOC: DAC, DAD, DAE, DAF, DAG, DA H, DAJ, DAL, DAW, DAX, V14, V15, V16, V17, V18, V19, V20, V21, V22, V24 .....	1
10	PAFZZ	5305-00-795-9343	15434	S-176	SCREW, CAP, HEXAGON H UOC: DAC, DAD, DAE, DAF, DAG, DA H, DAJ, DAL, DAW, DAX, V14, V15, V16, V17, V18, V19, V20, V21, V22, V24 .....	2

(1) ITEM NO.	(2) SMR CODE	(3) NSN	(4) CAGEC	(5) PART NUMBER	(6) DESCRIPTION AND USABLE ON CODE (UOC)	(7) QTY
11	PAFZZ	5310-00-003-4094	80205	MS35338-48	WASHER,LOCK UOC: DAC,DAD,DAE,DAF,DAG,DA H,DAJ,DAL,DAW,DAX,V14,V15,V16, V17,V18,V19,V20,V21,V22,V24 .....	7
12	PAFZZ	5310-00-930-7013	11083	4B4280	WASHER,FLAT UOC: DAC,DAD,DAE,DAF,DAG,DA H,DAJ,DAL,DAW,DAX,V14,V15,V16, V17,V18,V19,V20,V21,V22,V24 .....	2
13	PAFZZ	5305-01-091-2498	15434	166777	SCREW UOC: DAC,DAD,DAE,DAF,DAG,DA H,DAJ,DAL,DAW,DAX,V14,V15,V16, V17,V18,V19,V20,V21,V22,V24 .....	1
14	PAFZZ	5310-00-470-6154	15434	S285	NUT,PLAIN,HEXAGON UOC: DAC,DAD,DAE,DAF,DAG,DA H,DAJ,DAL,DAW,DAX,V14,V15,V16, V17,V18,V19,V20,V21,V22,V24 .....	1
15	PBFZZ	5342-01-134-3860	15434	147588	BRACKET,FAN SUPPORT UOC: DAC,DAD,DAE,DAF,DAG,DA H,DAJ,DAL,DAW,DAX,V14,V15,V16, V17,V18,V19,V20,V21,V22,V24 .....	1
16	PAFZZ	5305-00-914-6131	80204	B1821BH038F175D	SCREW,CAP,HEXAGON H UOC: DAC,DAD,DAE,DAF,DAG,DA H,DAJ,DAL,DAW,DAX,V14,V15,V16, V17,V18,V19,V20,V21,V22,V24 .....	6
17	PAFZZ	3030-01-200-6004	15434	3019061	BELT,V UOC: DAC,DAD,DAE,DAF,DAG,DA H,DAJ,DAL,DAW,DAX,V14,V15,V16, V17,V18,V19,V20,V21,V22,V24 .....	1
18	PAFZZ	2930-01-196-7521	15434	131622	BRACE,FAN SUPPORT UOC: DAC,DAD,DAE,DAF,DAG,DA H,DAJ,DAL,DAW,DAX,V14,V15,V16, V17,V18,V19,V20,V21,V22,V24 .....	1
19	PAFZZ	5310-00-595-6153	11083	1F7960	WASHER,FLAT UOC: DAC,DAD,DAE,DAF,DAG,DA H,DAJ,DAL,DAW,DAX,V14,V15,V16, V17,V18,V19,V20,V21,V22,V24 .....	2
20	PAFZZ	5305-01-209-7068	15434	69952	SCREW,CAP,HEXAGON H UOC: DAC,DAD,DAE,DAF,DAG,DA H,DAJ,DAL,DAW,DAX,V14,V15,V16, V17,V18,V19,V20,V21,V22,V24 .....	2

END OF FIGURE



**FIELD MAINTENANCE  
WATER PUMP (M939A2)**

---

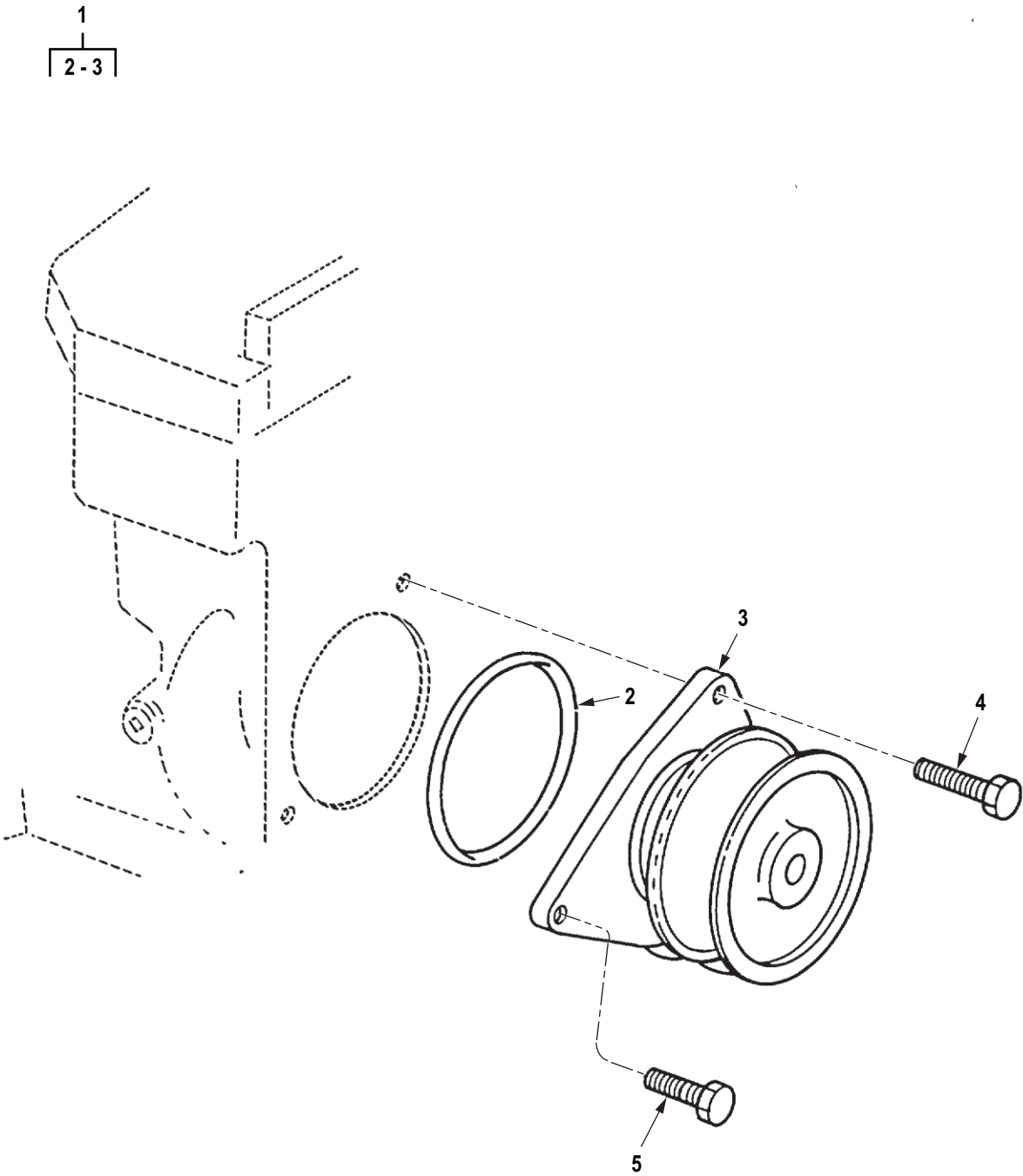

R0119DAA

Figure 119. Water Pump (M939A2).

(1) ITEM NO.	(2) SMR CODE	(3) NSN	(4) CAGEC	(5) PART NUMBER	(6) DESCRIPTION AND USABLE ON CODE (UOC)	(7) QTY
<b>GROUP 0504 WATER PUMP.</b>						
<b>FIG. 119. WATER PUMP (M939A2).</b>						
1	PAFFF	2930-01-268-8751	15434	3806180	PUMP,COOLING SYSTEM UOC: ZAA,ZAB,ZAC,ZAD,ZAE,ZAF, ZAG,ZAH,ZAJ,ZAL .....	1
2	PAFZZ	5331-01-272-1123	15434	3902089	. O-RING PART OF KIT P/N 380055800 UOC: ZAA,ZAB,ZAC,ZAD,ZAE,ZAF, ZAG,ZAH,ZAJ,ZAL .....	1
3	XAFZZ		15434	3806180-1	. PUMP,COOLING SYSTEM UOC: ZAA,ZAB,ZAC,ZAD,ZAE,ZAF, ZAG,ZAH,ZAJ,ZAL .....	1
4	PAFZZ	5305-01-207-7447	15434	3900677	SCREW,CAP,HEXAGON H UOC: ZAA,ZAB,ZAC,ZAD,ZAE,ZAF, ZAG,ZAH,ZAJ,ZAL .....	1
5	PAFZZ	5305-01-245-3193	15434	3900621	SCREW,CAP,HEXAGON H UOC: ZAA,ZAB,ZAC,ZAD,ZAE,ZAF, ZAG,ZAH,ZAJ,ZAL .....	4

**END OF FIGURE**



**FIELD MAINTENANCE  
FAN CLUTCH ASSEMBLY, FAN, AND BELTS (M939, M939A1)**

---

7  
|  
8-31

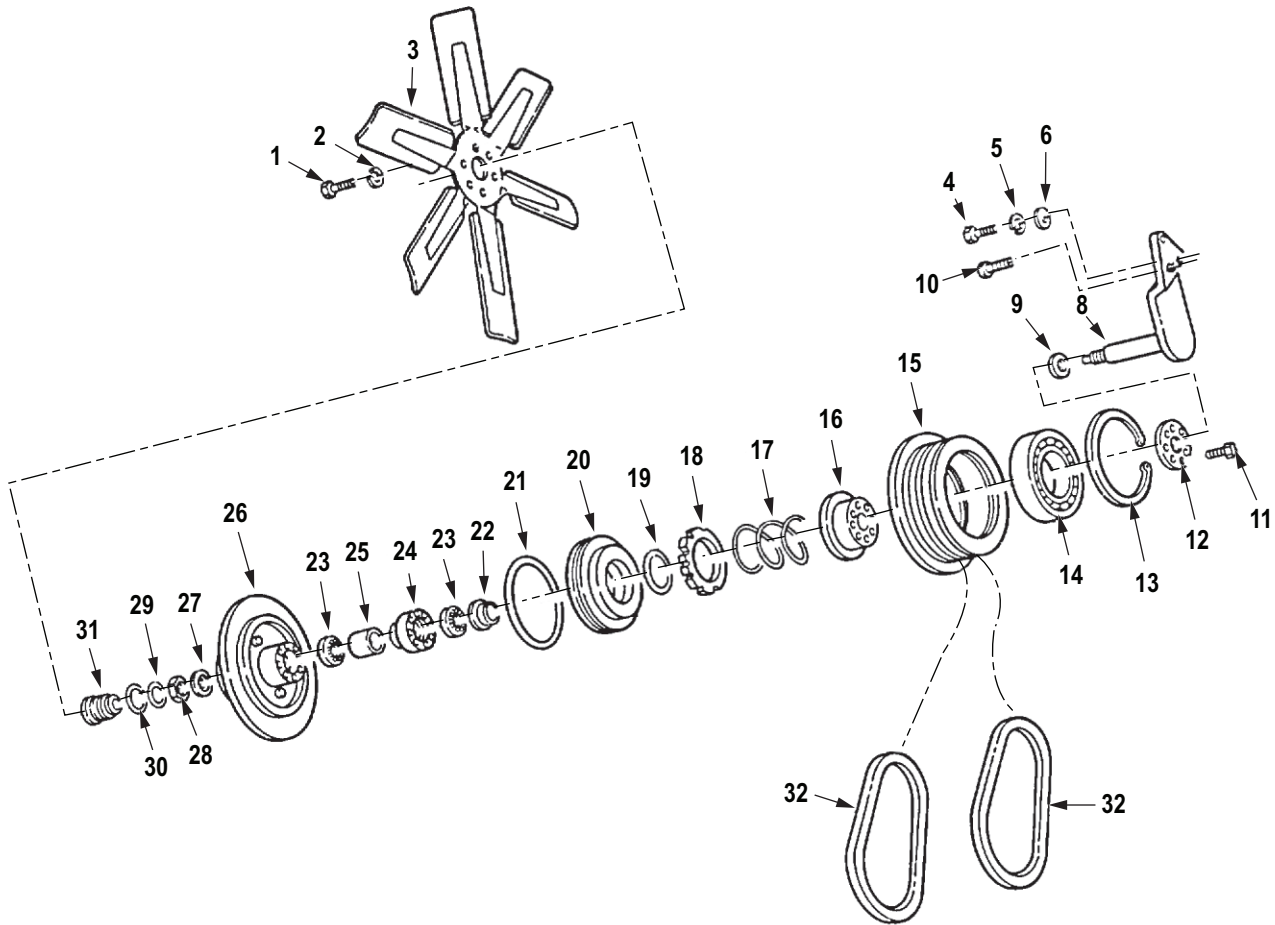

R0120DAA

Figure 120. Fan Clutch Assembly, Fan, and Belts (M939, M939A1).

(1) ITEM NO.	(2) SMR CODE	(3) NSN	(4) CAGEC	(5) PART NUMBER	(6) DESCRIPTION AND USABLE ON CODE (UOC)	(7) QTY
<b>GROUP 0505 FAN ASSEMBLY.</b>						
<b>FIG. 120. FAN CLUTCH ASSEMBLY, FAN, AND BELTS (M939, M939A1).</b>						
1	PAFZZ	5305-01-210-4595	97403	13222E0109	SCREW,ROLLER ASSEMB UOC: DAC,DAD,DAE,DAF,DAG,DA H,DAJ,DAL,DAW,DAX,V14,V15,V16, V17,V18,V19,V20,V21,V22,V24 .....	6
2	PAFZZ	5310-00-637-9541	00198	132661	WASHER,LOCK UOC: DAC,DAD,DAE,DAF,DAG,DA H,DAJ,DAL,DAW,DAX,V14,V15,V16, V17,V18,V19,V20,V21,V22,V24 .....	6
3	PAFZZ	4140-01-089-3058	61125	460516	IMPELLER,FAN,AXIAL RIGHT HAND SUCKER UOC: DAC,DAD,DAE,DAF,DAG,DA H,DAJ,DAL,DAW,DAX,V14,V15,V16, V17,V18,V19,V20,V21,V22,V24 .....	1
4	PAFZZ	5305-00-719-5235	80204	B1821BH050F175N	SCREW,CAP,HEXAGON H UOC: DAC,DAD,DAE,DAF,DAG,DA H,DAJ,DAL,DAW,DAX,V14,V15,V16, V17,V18,V19,V20,V21,V22,V24 .....	3
5	PAFZZ	5310-00-003-4094	80205	MS35338-48	WASHER,LOCK UOC: DAC,DAD,DAE,DAF,DAG,DA H,DAJ,DAL,DAW,DAX,V14,V15,V16, V17,V18,V19,V20,V21,V22,V24 .....	3
6	PAFZZ	5310-01-121-1703	24617	2436165	WASHER,FLAT UOC: DAC,DAD,DAE,DAF,DAG,DA H,DAJ,DAL,DAW,DAX,V14,V15,V16, V17,V18,V19,V20,V21,V22,V24 .....	2
7	PAFHH	2520-01-115-2285	21102	FC212000	CLUTCH ASSEMBLY,FRI ENGINE COOLING UOC: DAC,DAD,DAE,DAF,DAG,DA H,DAJ,DAL,DAW,DAX,V14,V15,V16, V17,V18,V19,V20,V21,V22,V24 .....	1
8	PBHZZ	3020-01-124-6079	21102	FC200007	. BRACKET AND SHAFT A UOC: DAC,DAD,DAE,DAF,DAG,DA H,DAJ,DAL,DAW,DAX,V14,V15,V16, V17,V18,V19,V20,V21,V22,V24 .....	1
9	PAHZZ	5365-01-126-5192	21102	FC030002	. SPACER,RING UOC: DAC,DAD,DAE,DAF,DAG,DA H,DAJ,DAL,DAW,DAX,V14,V15,V16, V17,V18,V19,V20,V21,V22,V24 .....	1
10	PAHZZ	5305-01-161-6000	21102	FC200010	. SCREW,CAP,HEXAGON H UOC: DAC,DAD,DAE,DAF,DAG,DA H,DAJ,DAL,DAW,DAX,V14,V15,V16, V17,V18,V19,V20,V21,V22,V24 .....	2

(1) ITEM NO.	(2) SMR CODE	(3) NSN	(4) CAGEC	(5) PART NUMBER	(6) DESCRIPTION AND USABLE ON CODE (UOC)	(7) QTY
11	PAHZZ	5305-01-120-8438	21102	FC030011	. SCREW,CAP,SOCKET HE UOC: DAC,DAD,DAE,DAF,DAG,DA H,DAJ,DAL,DAW,DAX,V14,V15,V16, V17,V18,V19,V20,V21,V22,V24 .....	8
12	PAHZZ	2930-01-122-5982	21102	FC030010	. PLATE,FAN,THRUST CA UOC: DAC,DAD,DAE,DAF,DAG,DA H,DAJ,DAL,DAW,DAX,V14,V15,V16, V17,V18,V19,V20,V21,V22,V24 .....	1
13	PAHZZ	5325-00-914-5837	96906	MS16631-1500	. RING,RETAINING UOC: DAC,DAD,DAE,DAF,DAG,DA H,DAJ,DAL,DAW,DAX,V14,V15,V16, V17,V18,V19,V20,V21,V22,V24 .....	1
14	PAHZZ	3110-01-126-1287	58536	AA59583-417JEBB	. BEARING,BALL,ANNULA UOC: DAC,DAD,DAE,DAF,DAG,DA H,DAJ,DAL,DAW,DAX,V14,V15,V16, V17,V18,V19,V20,V21,V22,V24 .....	1
15	PAHZZ	3020-01-124-9417	21102	FC200006	. PULLEY,CONE UOC: DAC,DAD,DAE,DAF,DAG,DA H,DAJ,DAL,DAW,DAX,V14,V15,V16, V17,V18,V19,V20,V21,V22,V24 .....	1
16	PAHZZ	2930-01-133-6948	21102	FC030035	. CAP,THRUST,FAN CLUT UOC: DAC,DAD,DAE,DAF,DAG,DA H,DAJ,DAL,DAW,DAX,V14,V15,V16, V17,V18,V19,V20,V21,V22,V24 .....	1
17	PAHZZ	5360-01-124-3373	21102	FD019	. SPRING,HELICAL,COMP UOC: DAC,DAD,DAE,DAF,DAG,DA H,DAJ,DAL,DAW,DAX,V14,V15,V16, V17,V18,V19,V20,V21,V22,V24 .....	1
18	PAHZZ	2520-01-077-4009	21102	FC030009	. LINING,FRICTION UOC: DAC,DAD,DAE,DAF,DAG,DA H,DAJ,DAL,DAW,DAX,V14,V15,V16, V17,V18,V19,V20,V21,V22,V24 .....	1
19	PAHZZ	5331-01-271-9374	21102	FC030028	. O-RING UOC: DAC,DAD,DAE,DAF,DAG,DA H,DAJ,DAL,DAW,DAX,V14,V15,V16, V17,V18,V19,V20,V21,V22,V24 .....	1
20	PAHZZ	2520-01-088-8172	34623	MA207-22-742	. PISTON UOC: DAC,DAD,DAE,DAF,DAG,DA H,DAJ,DAL,DAW,DAX,V14,V15,V16, V17,V18,V19,V20,V21,V22,V24 .....	1
21	PAHZZ	5331-01-079-6513	21102	FC030027	. O-RING UOC: DAC,DAD,DAE,DAF,DAG,DA H,DAJ,DAL,DAW,DAX,V14,V15,V16, V17,V18,V19,V20,V21,V22,V24 .....	1
22	PAHZZ	5365-01-123-1638	21102	FC030030	. SPACER,CLUTCH UOC: DAC,DAD,DAE,DAF,DAG,DA H,DAJ,DAL,DAW,DAX,V14,V15,V16, V17,V18,V19,V20,V21,V22,V24 .....	1



(1) ITEM NO.	(2) SMR CODE	(3) NSN	(4) CAGEC	(5) PART NUMBER	(6) DESCRIPTION AND USABLE ON CODE (UOC)	(7) QTY
23	PAHZZ	3110-00-109-1179	58536	AA59584-106JEBE	. BEARING,BALL,ANNULA UOC: DAC,DAD,DAE,DAF,DAG,DA H,DAJ,DAL,DAW,DAX,V14,V15,V16, V17,V18,V19,V20,V21,V22,V24 .....	2
24	PAHZZ	5365-01-123-1638	21102	FC030030	. SPACER,CLUTCH UOC: DAC,DAD,DAE,DAF,DAG,DA H,DAJ,DAL,DAW,DAX,V14,V15,V16, V17,V18,V19,V20,V21,V22,V24 .....	1
25	PAHZZ	5365-01-126-8689	21102	FC030029	. SPACER,SLEEVE UOC: DAC,DAD,DAE,DAF,DAG,DA H,DAJ,DAL,DAW,DAX,V14,V15,V16, V17,V18,V19,V20,V21,V22,V24 .....	1
26	PAHZZ	2520-01-123-8704	21102	FC200008	. HOUSING,CLUTCH UOC: DAC,DAD,DAE,DAF,DAG,DA H,DAJ,DAL,DAW,DAX,V14,V15,V16, V17,V18,V19,V20,V21,V22,V24 .....	1
27	PAHZZ	5365-01-270-8472	21102	FC030003	. SPACER,RING UOC: DAC,DAD,DAE,DAF,DAG,DA H,DAJ,DAL,DAW,DAX,V14,V15,V16, V17,V18,V19,V20,V21,V22,V24 .....	1
28	PAHZZ	5310-00-982-6810	80205	MS21044N12	. NUT,SELF-LOCKING,HE UOC: DAC,DAD,DAE,DAF,DAG,DA H,DAJ,DAL,DAW,DAX,V14,V15,V16, V17,V18,V19,V20,V21,V22,V24 .....	1
29	PAHZZ	5331-01-271-9372	21102	FC030020	. O-RING UOC: DAC,DAD,DAE,DAF,DAG,DA H,DAJ,DAL,DAW,DAX,V14,V15,V16, V17,V18,V19,V20,V21,V22,V24 .....	1
30	PAHZZ	5331-01-271-9371	21102	FC030021	. O-RING UOC: DAC,DAD,DAE,DAF,DAG,DA H,DAJ,DAL,DAW,DAX,V14,V15,V16, V17,V18,V19,V20,V21,V22,V24 .....	1
31	PAHZZ	5365-01-134-5534	21102	FC212143	. PLUG,MACHINE THREAD UOC: DAC,DAD,DAE,DAF,DAG,DA H,DAJ,DAL,DAW,DAX,V14,V15,V16, V17,V18,V19,V20,V21,V22,V24 .....	1
32	PAFZZ	3030-01-118-1318	81343	MS51069RC49-2	BELTS,V,MATCHED SET UOC: DAC,DAD,DAE,DAF,DAG,DA H,DAJ,DAL,DAW,DAX,V14,V15,V16, V17,V18,V19,V20,V21,V22,V24 .....	1

END OF FIGURE



**FIELD MAINTENANCE  
FAN ASSEMBLY (M939A2)**

---

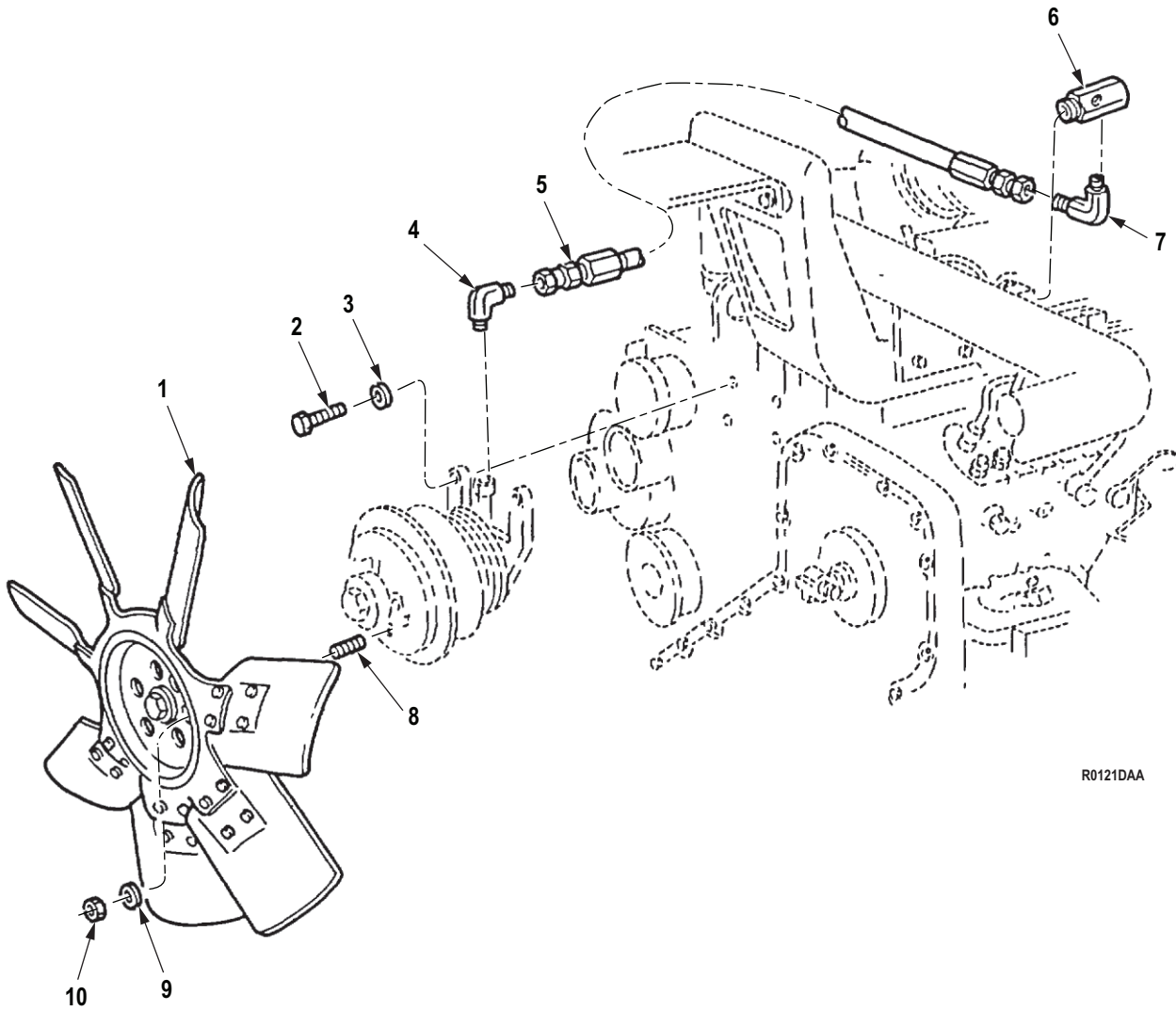

R0121DAA

Figure 121. Fan Assembly (M939A2).

(1) ITEM NO.	(2) SMR CODE	(3) NSN	(4) CAGEC	(5) PART NUMBER	(6) DESCRIPTION AND USABLE ON CODE (UOC)	(7) QTY
<b>GROUP 0505 FAN ASSEMBLY.</b>						
<b>FIG. 121. FAN ASSEMBLY (M939A2).</b>						
1	PAFZZ	2930-01-286-8357	05MG0	205109353	IMPELLER,FAN,AXIAL UOC: ZAA,ZAB,ZAC,ZAD,ZAE,ZAF, ZAG,ZAH,ZAJ,ZAL .....	1
2	PAFZZ	5306-01-276-1601	24617	11500869	BOLT,MACHINE UOC: ZAA,ZAB,ZAC,ZAD,ZAE,ZAF, ZAG,ZAH,ZAJ,ZAL .....	4
3	PAFZZ	5310-01-286-5452	24617	11511514	WASHER,FLAT UOC: ZAA,ZAB,ZAC,ZAD,ZAE,ZAF, ZAG,ZAH,ZAJ,ZAL .....	4
4	PAFZZ	4730-00-995-1568	96906	MS51508A4Z	ELBOW,PIPE TO TUBE UOC: ZAA,ZAB,ZAC,ZAD,ZAE,ZAF, ZAG,ZAH,ZAJ,ZAL .....	1
5	PAFZZ	4720-01-284-8184	98441	A3915-4	HOSE ASSEMBLY,NONME UOC: ZAA,ZAB,ZAC,ZAD,ZAE,ZAF, ZAG,ZAH,ZAJ,ZAL .....	1
6	PAFZZ	2930-01-285-5027	21102	CA200011	ACTUATOR,FAN CLUTCH UOC: ZAA,ZAB,ZAC,ZAD,ZAE,ZAF, ZAG,ZAH,ZAJ,ZAL .....	1
7	PAFZZ	4730-01-315-5596	1Z155	FRS-4-100	ELBOW,PIPE TO TUBE UOC: ZAA,ZAB,ZAC,ZAD,ZAE,ZAF, ZAG,ZAH,ZAJ,ZAL .....	1
8	PAFZZ	5305-01-283-8462	05MG0	20510978	SETSCREW UOC: ZAA,ZAB,ZAC,ZAD,ZAE,ZAF, ZAG,ZAH,ZAJ,ZAL .....	6
9	PAFZZ	5310-00-274-8041	06853	204235	WASHER,FLAT UOC: ZAA,ZAB,ZAC,ZAD,ZAE,ZAF, ZAG,ZAH,ZAJ,ZAL .....	6
10	PAFZZ	5310-01-126-9404	7X677	9422297	NUT,SELF-LOCKING,HE UOC: ZAA,ZAB,ZAC,ZAD,ZAE,ZAF, ZAG,ZAH,ZAJ,ZAL .....	6

**END OF FIGURE**



**FIELD MAINTENANCE  
FAN DRIVE CLUTCH ASSEMBLY (M939A2)**

---

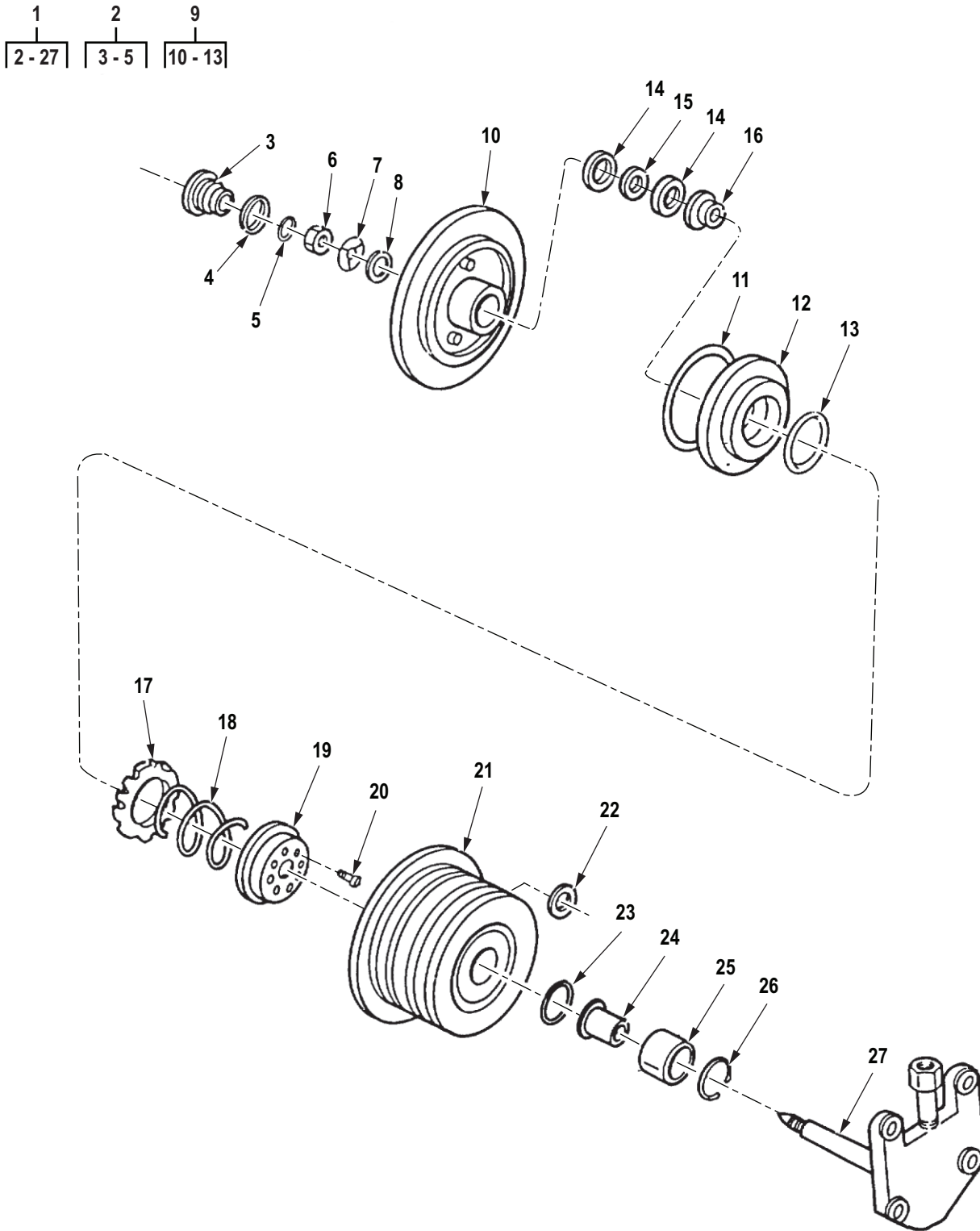

R0122DAA

Figure 122. Fan Drive Clutch Assembly (M939A2).



(1) ITEM NO.	(2) SMR CODE	(3) NSN	(4) CAGEC	(5) PART NUMBER	(6) DESCRIPTION AND USABLE ON CODE (UOC)	(7) QTY
<b>GROUP 0505 FAN ASSEMBLY.</b>						
<b>FIG. 122. FAN DRIVE CLUTCH ASSEMBLY (M939A2).</b>						
1	PAFHH	2930-01-268-8752	21102	FC200158	CLUTCH,FAN,ENGINE UOC: ZAA,ZAB,ZAC,ZAD,ZAE,ZAF, ZAG,ZAH,ZAJ,ZAL .....	1
2	PAHZZ	5365-01-134-5534	21102	FC212143	. PLUG,MACHINE THREAD PART OF KIT P/N FC212028 UOC: ZAA,ZAB,ZAC,ZAD,ZAE,ZAF, ZAG,ZAH,ZAJ,ZAL .....	1
3	XAHZZ		21102	FC200002XA	. . CAP,SPECIAL UOC: ZAA,ZAB,ZAC,ZAD,ZAE,ZAF, ZAG,ZAH,ZAJ,ZAL .....	1
4	PAHZZ	5331-01-271-9371	21102	FC030021	. . O-RING PART OF KIT P/N FC212028 UOC: ZAA,ZAB,ZAC,ZAD,ZAE,ZAF, ZAG,ZAH,ZAJ,ZAL .....	1
5	PAHZZ	5331-01-271-9372	21102	FC030020	. . O-RING PART OF KIT P/N FC212028 UOC: ZAA,ZAB,ZAC,ZAD,ZAE,ZAF, ZAG,ZAH,ZAJ,ZAL .....	1
6	PAHZZ	5310-00-982-6810	80205	MS21044N12	. NUT,SELF-LOCKING,HE PART OF KIT P/N FC212028 UOC: ZAA,ZAB,ZAC,ZAD,ZAE,ZAF, ZAG,ZAH,ZAJ,ZAL .....	1
7	PAHZZ	5310-01-271-1796	21102	FC030004	. WASHER,SPRING TENSIL PART OF KIT P/N FC212028 UOC: ZAA,ZAB,ZAC,ZAD,ZAE,ZAF, ZAG,ZAH,ZAJ,ZAL .....	1
8	PAHZZ	5365-01-270-8472	21102	FC030003	. SPACER,RING PART OF KIT P/ N FC212028 UOC: ZAA,ZAB,ZAC,ZAD,ZAE,ZAF, ZAG,ZAH,ZAJ,ZAL .....	1
9	PAHZZ	2520-01-123-8704	21102	FC200008	. HOUSING,CLUTCH UOC: ZAA,ZAB,ZAC,ZAD,ZAE,ZAF, ZAG,ZAH,ZAJ,ZAL .....	1
10	XAHZZ		21102	FC200008XA	. . PISTON UOC: ZAA,ZAB,ZAC,ZAD,ZAE,ZAF, ZAG,ZAH,ZAJ,ZAL .....	1
11	PAHZZ	5331-01-079-6513	21102	FC030027	. . O-RING PART OF KIT P/N FC212028 UOC: ZAA,ZAB,ZAC,ZAD,ZAE,ZAF, ZAG,ZAH,ZAJ,ZAL .....	1
12	PAHZZ	2520-01-088-8172	34623	MA207-22-742	. . PISTON UOC: ZAA,ZAB,ZAC,ZAD,ZAE,ZAF, ZAG,ZAH,ZAJ,ZAL .....	1
13	PAHZZ	5331-01-271-9374	21102	FC030028	. . O-RING PART OF KIT P/N FC212028 UOC: ZAA,ZAB,ZAC,ZAD,ZAE,ZAF, ZAG,ZAH,ZAJ,ZAL .....	1

(1) ITEM NO.	(2) SMR CODE	(3) NSN	(4) CAGEC	(5) PART NUMBER	(6) DESCRIPTION AND USABLE ON CODE (UOC)	(7) QTY
14	PAHZZ	5305-01-264-5886	21760	1206LT-1B1	. SCREW,CAP,HEXAGON H PART OF KIT P/N FC212028 UOC: ZAA,ZAB,ZAC,ZAD,ZAE,ZAF, ZAG,ZAH,ZAJ,ZAL .....	2
15	PAHZZ	5365-01-271-1854	21102	FC030043	. SPACER,RING PART OF KIT P/ N FC212028 UOC: ZAA,ZAB,ZAC,ZAD,ZAE,ZAF, ZAG,ZAH,ZAJ,ZAL .....	1
16	PAHZZ	5365-01-270-8459	21102	FC030060	. SPACER,STEPPED PART OF KIT P/N FC212028 UOC: ZAA,ZAB,ZAC,ZAD,ZAE,ZAF, ZAG,ZAH,ZAJ,ZAL .....	1
17	PAHZZ	2520-01-077-4009	21102	FC030009	. LINING,FRICTION PART OF KIT P/N FC212028 UOC: ZAA,ZAB,ZAC,ZAD,ZAE,ZAF, ZAG,ZAH,ZAJ,ZAL .....	1
18	PAHZZ	5360-01-271-5767	21102	FC030007	. SPRING,HELICAL,COMP UOC: ZAA,ZAB,ZAC,ZAD,ZAE,ZAF, ZAG,ZAH,ZAJ,ZAL .....	1
19	PAHZZ	2520-01-271-7152	21102	FC030061	. DISK,CLUTCH UOC: ZAA,ZAB,ZAC,ZAD,ZAE,ZAF, ZAG,ZAH,ZAJ,ZAL .....	1
20	PAHZZ	5305-01-256-3046	21102	FC030047	. SCREW,CAP,SOCKET HE UOC: ZAA,ZAB,ZAC,ZAD,ZAE,ZAF, ZAG,ZAH,ZAJ,ZAL .....	8
21	PAHZZ	3020-01-271-5126	21102	FC200161	. PULLEY,GROOVE UOC: ZAA,ZAB,ZAC,ZAD,ZAE,ZAF, ZAG,ZAH,ZAJ,ZAL .....	1
22	PAHZZ	5365-01-270-8473	21102	FC030098	. SPACER,RING UOC: ZAA,ZAB,ZAC,ZAD,ZAE,ZAF, ZAG,ZAH,ZAJ,ZAL .....	1
23	PAHZZ	5325-01-270-8363	21102	FC030064	. RING,RETAINING PART OF KIT P/N FC212028 UOC: ZAA,ZAB,ZAC,ZAD,ZAE,ZAF, ZAG,ZAH,ZAJ,ZAL .....	1
24	PAHZZ	3120-01-277-1036	21102	FC030065	. BUSHING,SLEEVE PART OF KIT P/N FC212028 UOC: ZAA,ZAB,ZAC,ZAD,ZAE,ZAF, ZAG,ZAH,ZAJ,ZAL .....	1
25	PAHZZ	3110-01-271-6353	23043	FC030066	. BEARING,ROLLER,CYLI PART OF KIT P/N FC212028 UOC: ZAA,ZAB,ZAC,ZAD,ZAE,ZAF, ZAG,ZAH,ZAJ,ZAL .....	1
26	PAHZZ	5325-01-270-8362	21102	FC030067	. RING,RETAINING UOC: ZAA,ZAB,ZAC,ZAD,ZAE,ZAF, ZAG,ZAH,ZAJ,ZAL .....	1

(1) ITEM NO.	(2) SMR CODE	(3) NSN	(4) CAGEC	(5) PART NUMBER	(6) DESCRIPTION AND USABLE ON CODE (UOC)	(7) QTY
27	PAHZZ	3040-01-271-3597	21102	FC200162	. BRACKET AND SHAFT A UOC: ZAA,ZAB,ZAC,ZAD,ZAE,ZAF, ZAG,ZAH,ZAJ,ZAL .....	1

END OF FIGURE



**FIELD MAINTENANCE  
BELT TENSIONER PULLEY (M939A2)**

---

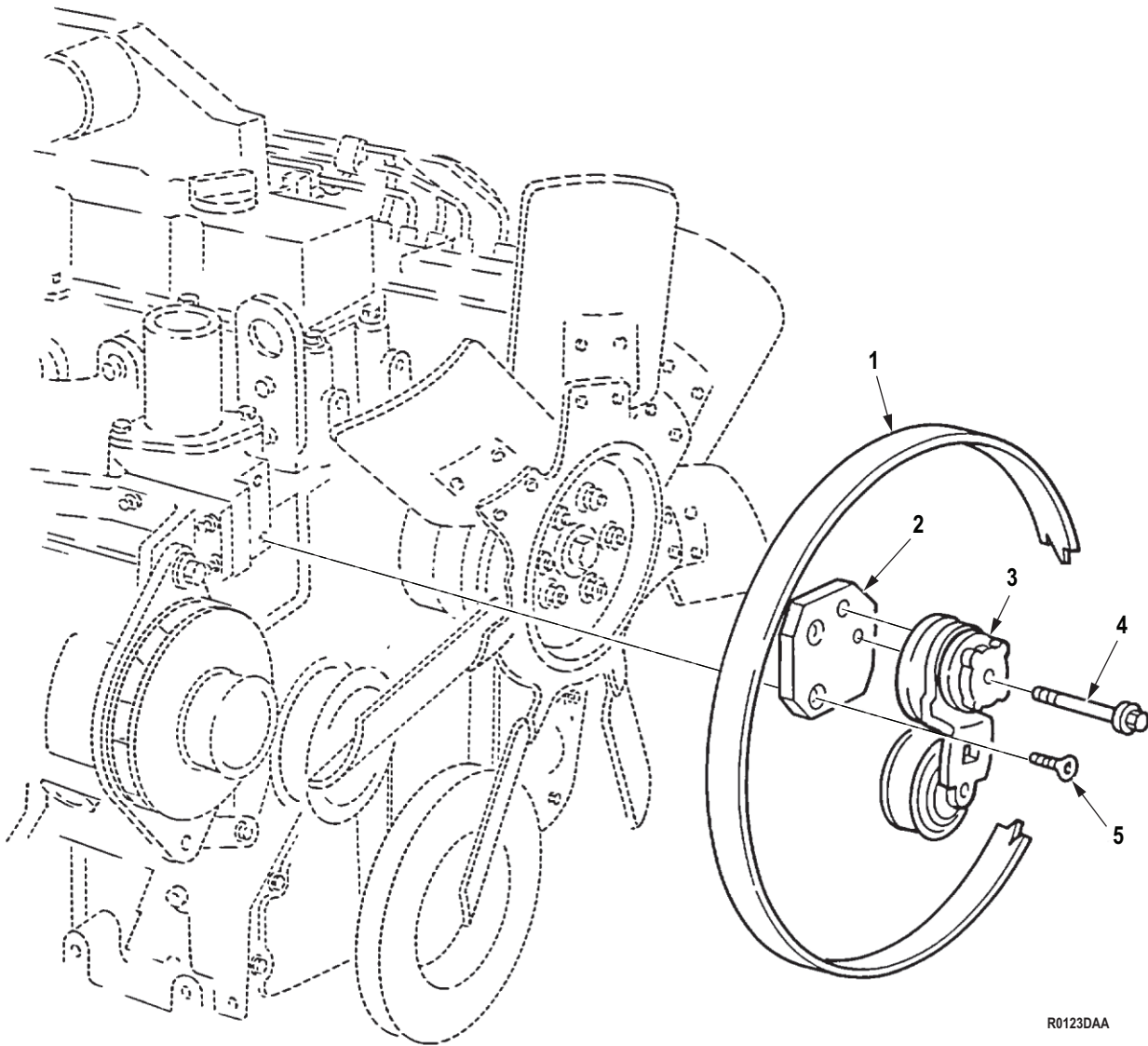

R0123DAA

Figure 123. Belt Tensioner Pulley (M939A2).

(1) ITEM NO.	(2) SMR CODE	(3) NSN	(4) CAGEC	(5) PART NUMBER	(6) DESCRIPTION AND USABLE ON CODE (UOC)	(7) QTY
<b>GROUP 0505 FAN ASSEMBLY.</b>						
<b>FIG. 123. BELT TENSIONER PULLEY (M939A2).</b>						
1	PAFZZ	3030-01-271-3754	15434	3912004	BELT,SERPENTINE UOC: ZAA,ZAB,ZAC,ZAD,ZAE,ZAF, ZAG,ZAH,ZAJ,ZAL .....	1
2	PAFZZ	5342-01-271-9818	15434	3925203	BRACKET,ENGINE ACCE UOC: ZAA,ZAB,ZAC,ZAD,ZAE,ZAF, ZAG,ZAH,ZAJ,ZAL .....	1
3	PAFZZ	2990-01-271-9816	15434	3976832	ADJUSTING DEVICE,BE UOC: ZAA,ZAB,ZAC,ZAD,ZAE,ZAF, ZAG,ZAH,ZAJ,ZAL .....	1
4	PAFZZ	5306-01-237-7531	15434	3901757	BOLT,MACHINE UOC: ZAA,ZAB,ZAC,ZAD,ZAE,ZAF, ZAG,ZAH,ZAJ,ZAL .....	1
5	PAFZZ	5305-01-406-9457	15434	3925186	SCREW,MACHINE UOC: ZAA,ZAB,ZAC,ZAD,ZAE,ZAF, ZAG,ZAH,ZAJ,ZAL .....	2

**END OF FIGURE**





**FIELD MAINTENANCE  
ENGINE AFTERCOOLER (M939A2)**

---

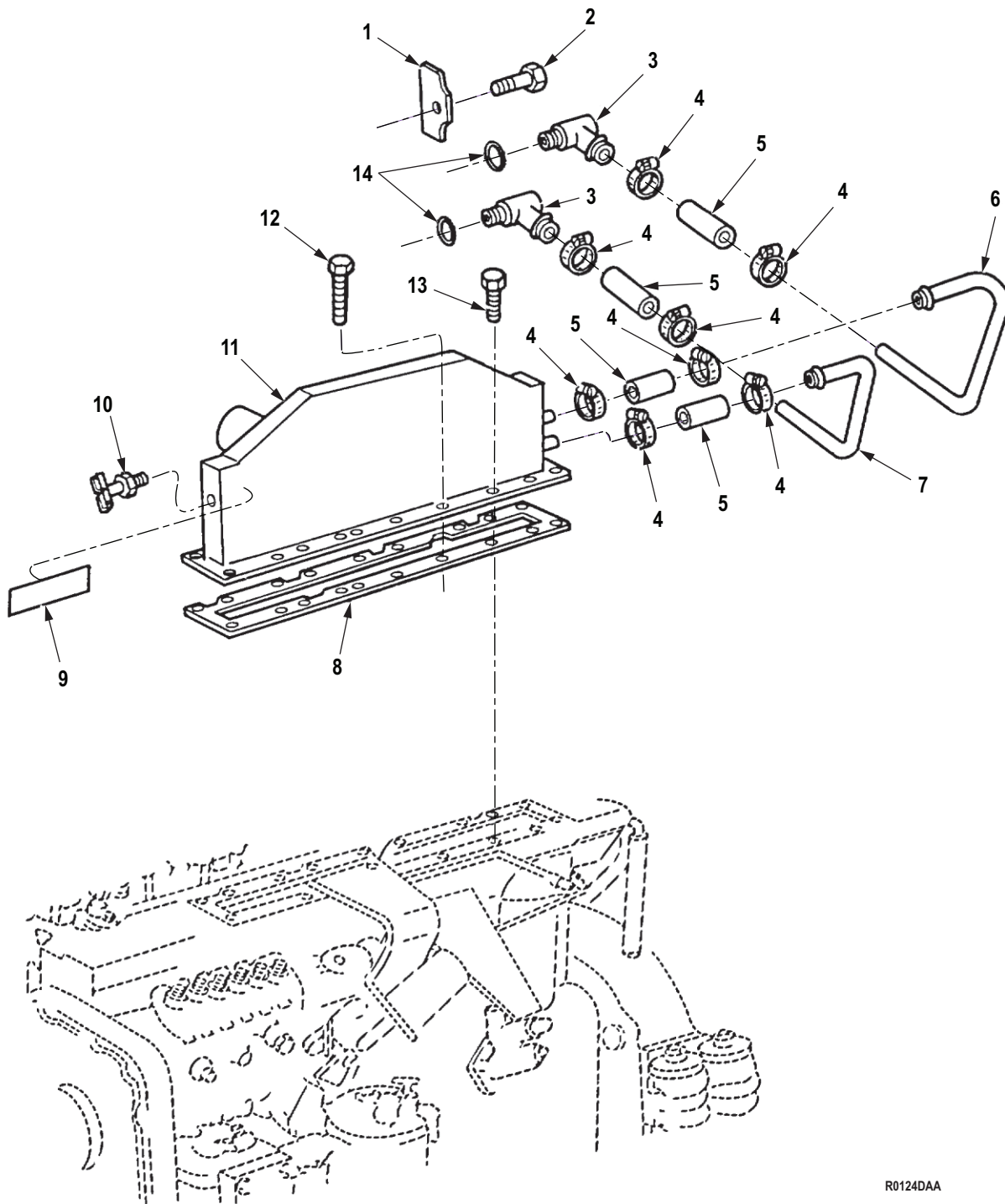

R0124DAA

Figure 124. Engine Aftercooler (M939A2).

(1) ITEM NO.	(2) SMR CODE	(3) NSN	(4) CAGEC	(5) PART NUMBER	(6) DESCRIPTION AND USABLE ON CODE (UOC)	(7) QTY
<b>GROUP 0507 AUXILIARY COOLING.</b>						
<b>FIG. 124. ENGINE AFTERCOOLER (M939A2).</b>						
1	PAFZZ	5340-01-271-2441	15434	3906439	PLATE,MENDING UOC: ZAA,ZAB,ZAC,ZAD,ZAE,ZAF, ZAG,ZAH,ZAJ,ZAL .....	1
2	PAFZZ	5305-01-237-4915	15434	3900629	SCREW,CAP,HEXAGON H UOC: ZAA,ZAB,ZAC,ZAD,ZAE,ZAF, ZAG,ZAH,ZAJ,ZAL .....	1
3	PAFZZ	4730-01-271-7874	15434	391739400	ELBOW,PIPE TO HOSE UOC: ZAA,ZAB,ZAC,ZAD,ZAE,ZAF, ZAG,ZAH,ZAJ,ZAL .....	2
4	XDFZZ	4730-01-291-8401	15434	3918163	CLAMP,HOSE UOC: ZAA,ZAB,ZAC,ZAD,ZAE,ZAF, ZAG,ZAH,ZAJ,ZAL .....	8
5	PAFZZ	4720-01-373-5652	15434	3918611	HOSE,NONMETALLIC UOC: ZAA,ZAB,ZAC,ZAD,ZAE,ZAF, ZAG,ZAH,ZAJ,ZAL .....	4
6	PAFZZ	4710-01-271-7940	15434	3908402	TUBE,BENT,METALLIC UOC: ZAA,ZAB,ZAC,ZAD,ZAE,ZAF, ZAG,ZAH,ZAJ,ZAL .....	1
7	PAFZZ	4710-01-272-2882	15434	3906436	TUBE,BENT,METALLIC UOC: ZAA,ZAB,ZAC,ZAD,ZAE,ZAF, ZAG,ZAH,ZAJ,ZAL .....	1
8	PAFZZ	5330-01-272-1138	15434	3936993	GASKET PART OF KIT P/N 3802622, PART OF KIT P/N 3800748, PART OF KIT P/N 402527100 UOC: ZAA,ZAB,ZAC,ZAD,ZAE,ZAF, ZAG,ZAH,ZAJ,ZAL .....	1
9	PAFZZ	7690-01-271-1926	15434	3910778	DECAL UOC: ZAA,ZAB,ZAC,ZAD,ZAE,ZAF, ZAG,ZAH,ZAJ,ZAL .....	1
10	PAFZZ	4820-00-684-0880	58536	AA59440/1-001	COCK,DRAIN UOC: ZAA,ZAB,ZAC,ZAD,ZAE,ZAF, ZAG,ZAH,ZAJ,ZAL .....	1
11	PAFZZ	2815-01-268-8737	15434	3924732	AFTERCOOLER,ENGINE UOC: ZAA,ZAB,ZAC,ZAD,ZAE,ZAF, ZAG,ZAH,ZAJ,ZAL .....	1
12	PAFZZ	5305-01-239-7202	0B8S3	3900632	SCREW,CAP,HEXAGON H UOC: ZAA,ZAB,ZAC,ZAD,ZAE,ZAF, ZAG,ZAH,ZAJ,ZAL .....	2
13	PAFZZ	5305-01-245-3192	15434	3918109	SCREW,CAP,HEXAGON H UOC: ZAA,ZAB,ZAC,ZAD,ZAE,ZAF, ZAG,ZAH,ZAJ,ZAL .....	16

(1) ITEM NO.	(2) SMR CODE	(3) NSN	(4) CAGEC	(5) PART NUMBER	(6) DESCRIPTION AND USABLE ON CODE (UOC)	(7) QTY
14	PAFZZ	5331-01-201-3623	15434	145530	O-RING PART OF KIT P/N 3802622, PART OF KIT P/N 3800748, PART OF KIT P/N 402527100 UOC: ZAA,ZAB,ZAC,ZAD,ZAE,ZAF, ZAG,ZAH,ZAJ,ZAL .....	2

END OF FIGURE

**FIELD MAINTENANCE**  
**ALTERNATOR ASSEMBLY, MOUNTING HARDWARE, BELTS, AND PULLEY (M939, M939A1)**

---

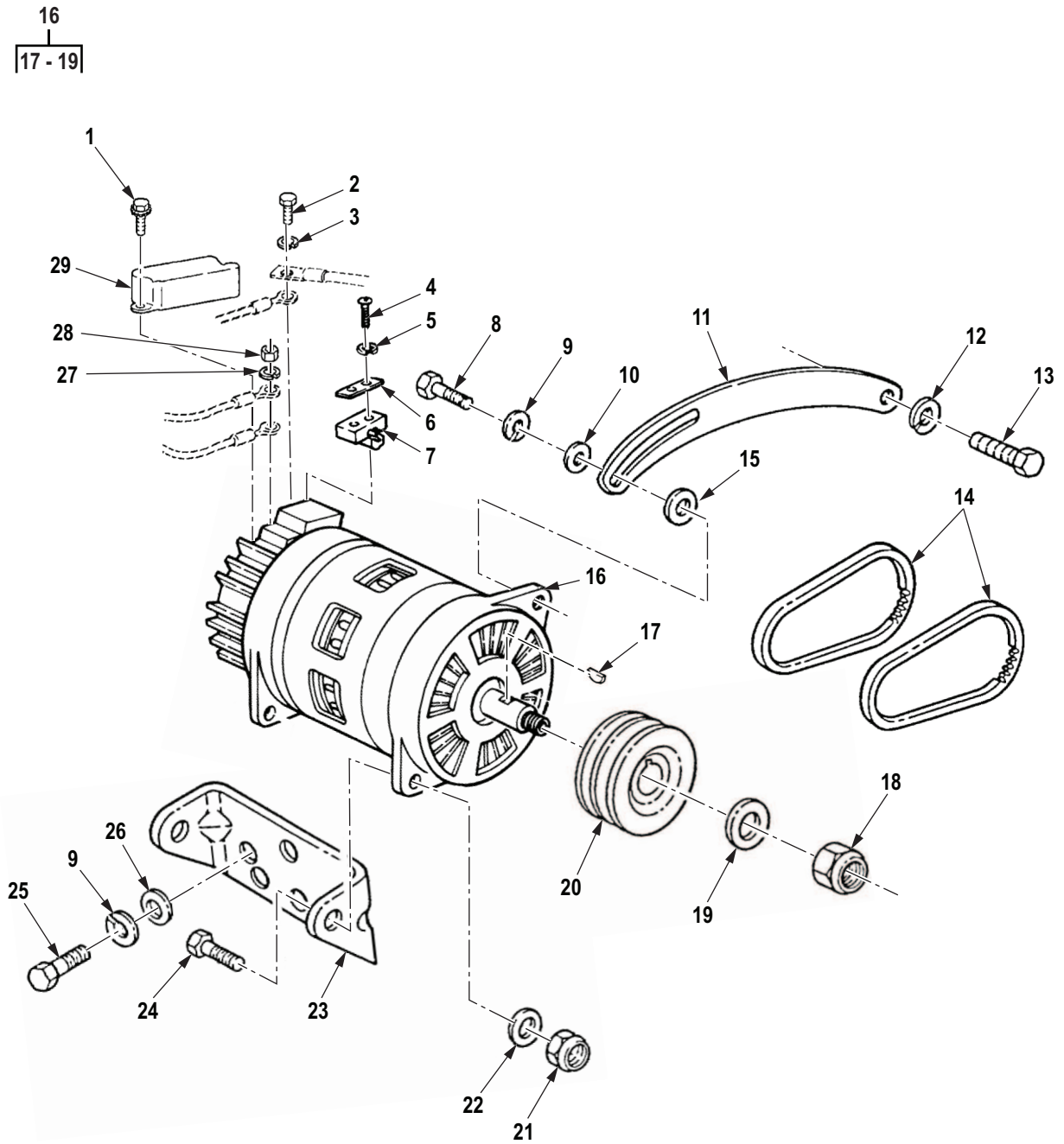

R0125DAA

Figure 125. Alternator Assembly, Mounting Hardware, Belts, and Pulley (M939, M939A1).

(1) ITEM NO.	(2) SMR CODE	(3) NSN	(4) CAGEC	(5) PART NUMBER	(6) DESCRIPTION AND USABLE ON CODE (UOC)	(7) QTY
<b>GROUP 0601 GENERATOR, ALTERNATOR.</b>						
<b>FIG. 125. ALTERNATOR ASSEMBLY, MOUNTING HARDWARE, BELTS, AND PULLEY (M939, M939A1).</b>						
1	PAFZZ	5305-00-638-0714	78189	6-32 1-4	SCREW,ASSEMBLED WAS UOC: DAC,DAD,DAE,DAF,DAG,DA H,DAJ,DAL,DAW,DAX,V14,V15,V16, V17,V18,V19,V20,V21,V22,V24 .....	2
2	PAFZZ	5306-00-226-4822	80204	B1821BH031C050N	BOLT,MACHINE UOC: ZAA,ZAB,ZAC,ZAD,ZAE,ZAF, ZAG,ZAH,ZAJ,ZAL .....	1
3	PAFZZ	5310-00-407-9566	80205	MS35338-45	WASHER,LOCK UOC: ZAA,ZAB,ZAC,ZAD,ZAE,ZAF, ZAG,ZAH,ZAJ,ZAL .....	1
4	PAFZZ	5305-00-984-6212	80205	MS35206-265	SCREW,MACHINE UOC: DAC,DAD,DAE,DAF,DAG,DA H,DAJ,DAL,DAW,DAX,V14,V15,V16, V17,V18,V19,V20,V21,V22,V24 .....	2
5	PAFZZ	5310-00-721-7809	96906	MS35340-43	WASHER,LOCK UOC: DAC,DAD,DAE,DAF,DAG,DA H,DAJ,DAL,DAW,DAX,V14,V15,V16, V17,V18,V19,V20,V21,V22,V24 .....	2
6	PAFZZ	5365-01-289-7852	19207	12357126	SPACER,PLATE UOC: DAC,DAD,DAE,DAF,DAG,DA H,DAJ,DAL,DAW,DAX,V14,V15,V16, V17,V18,V19,V20,V21,V22,V24 .....	1
7	PAFZZ	5365-01-289-4434	19207	12357116	SPACER,PLATE UOC: DAC,DAD,DAE,DAF,DAG,DA H,DAJ,DAL,DAW,DAX,V14,V15,V16, V17,V18,V19,V20,V21,V22,V24 .....	1
8	PAFZZ	5305-00-068-0511	80204	B1821BH038C125N	SCREW,CAP,HEXAGON H UOC: DAC,DAD,DAE,DAF,DAG,DA H,DAJ,DAL,DAW,DAX,V14,V15,V16, V17,V18,V19,V20,V21,V22,V24 .....	1
9	PAFZZ	5310-00-637-9541	00198	132661	WASHER,LOCK UOC: DAC,DAD,DAE,DAF,DAG,DA H,DAJ,DAL,DAW,DAX,V14,V15,V16, V17,V18,V19,V20,V21,V22,V24 .....	5
10	PAFZZ	5310-00-809-4061	96906	MS27183-15	WASHER,FLAT UOC: DAC,DAD,DAE,DAF,DAG,DA H,DAJ,DAL,DAW,DAX,V14,V15,V16, V17,V18,V19,V20,V21,V22,V24 .....	1
11	PAFZZ	2920-01-083-5408	19207	11669323	ARM,ADJUSTING,BELT UOC: DAC,DAD,DAE,DAF,DAG,DA H,DAJ,DAL,DAW,DAX,V14,V15,V16, V17,V18,V19,V20,V21,V22,V24 .....	1

(1) ITEM NO.	(2) SMR CODE	(3) NSN	(4) CAGEC	(5) PART NUMBER	(6) DESCRIPTION AND USABLE ON CODE (UOC)	(7) QTY
12	PAFZZ	5310-00-209-0965	80205	MS35338-47	WASHER,LOCK UOC: DAC,DAD,DAE,DAF,DAG,DA H,DAJ,DAL,DAW,DAX,V14,V15,V16, V17,V18,V19,V20,V21,V22,V24 .....	1
13	PAFZZ	5305-00-709-8482	80204	B1821BH044F325N	SCREW,CAP,HEXAGON H UOC: DAC,DAD,DAE,DAF,DAG,DA H,DAJ,DAL,DAW,DAX,V14,V15,V16, V17,V18,V19,V20,V21,V22,V24 .....	1
14	PAFZZ	3030-00-983-2873	96906	MS51065RP48-2	BELTS,V,MATCHED SET UOC: DAC,DAD,DAE,DAF,DAG,DA H,DAJ,DAL,DAW,DAX,V14,V15,V16, V17,V18,V19,V20,V21,V22,V24 .....	1
15	PAFZZ	5310-00-809-4085	96906	MS27183-16	WASHER,FLAT UOC: DAC,DAD,DAE,DAF,DAG,DA H,DAJ,DAL,DAW,DAX,V14,V15,V16, V17,V18,V19,V20,V21,V22,V24 .....	6
16	PAFZZ	2920-00-413-4337	19207	10947517-1	GENERATOR,ENGINE AC UOC: DAC,DAD,DAE,DAF,DAG,DA H,DAJ,DAL,DAW,DAX,V14,V15,V16, V17,V18,V19,V20,V21,V22,V24 .....	1
17	PAFZZ	5315-00-616-5526	80205	MS35756-8	. KEY,WOODRUFF UOC: DAC,DAD,DAE,DAF,DAG,DA H,DAJ,DAL,DAW,DAX,V14,V15,V16, V17,V18,V19,V20,V21,V22,V24 .....	1
18	PAFZZ	5310-00-449-2381	96906	MS21245L10	. NUT,SELF-LOCKING,HE UOC: DAC,DAD,DAE,DAF,DAG,DA H,DAJ,DAL,DAW,DAX,V14,V15,V16, V17,V18,V19,V20,V21,V22,V24 .....	1
19	PAFZZ	5310-00-614-3505	80205	MS15795-820	. WASHER,FLAT UOC: DAC,DAD,DAE,DAF,DAG,DA H,DAJ,DAL,DAW,DAX,V14,V15,V16, V17,V18,V19,V20,V21,V22,V24 .....	1
20	PAFZZ	3020-01-090-6695	19207	11669322	PULLEY,GROOVE UOC: DAC,DAD,DAE,DAF,DAG,DA H,DAJ,DAL,DAW,DAX,V14,V15,V16, V17,V18,V19,V20,V21,V22,V24 .....	1
21	PAFZZ	5310-00-274-9364	96906	MS21045-7	NUT,SELF-LOCKING,HE UOC: DAC,DAD,DAE,DAF,DAG,DA H,DAJ,DAL,DAW,DAX,V14,V15,V16, V17,V18,V19,V20,V21,V22,V24 .....	2
22	PAFZZ	5310-00-809-5997	96906	MS27183-17	WASHER,FLAT UOC: DAC,DAD,DAE,DAF,DAG,DA H,DAJ,DAL,DAW,DAX,V14,V15,V16, V17,V18,V19,V20,V21,V22,V24 .....	2
23	PFFZZ	5340-01-197-2183	19207	11669324-1	BRACKET UOC: DAC,DAD,DAE,DAF,DAG,DA H,DAJ,DAL,DAW,DAX,V14,V15,V16, V17,V18,V19,V20,V21,V22,V24 .....	1



(1) ITEM NO.	(2) SMR CODE	(3) NSN	(4) CAGEC	(5) PART NUMBER	(6) DESCRIPTION AND USABLE ON CODE (UOC)	(7) QTY
24	PAFZZ	5305-00-914-6133	80204	B1821BH044F150D	SCREW,CAP,HEXAGON H UOC: DAC,DAD,DAE,DAF,DAG,DA H,DAJ,DAL,DAW,DAX,V14,V15,V16, V17,V18,V19,V20,V21,V22,V24 .....	2
25	PAFZZ	5305-00-543-4372	80204	B1821BH038C075N	SCREW,CAP,HEXAGON H UOC: DAC,DAD,DAE,DAF,DAG,DA H,DAJ,DAL,DAW,DAX,V14,V15,V16, V17,V18,V19,V20,V21,V22,V24 .....	4
26	PAFZZ	5310-00-080-6004	96906	MS27183-14	WASHER,FLAT UOC: DAC,DAD,DAE,DAF,DAG,DA H,DAJ,DAL,DAW,DAX,V14,V15,V16, V17,V18,V19,V20,V21,V22,V24 .....	4
27	PAFZZ	5310-00-637-9541	00198	132661	WASHER,LOCK UOC: ZAA,ZAB,ZAC,ZAD,ZAE,ZAF, ZAG,ZAH,ZAJ,ZAL .....	1
28	PAFZZ	5310-00-768-0319	96906	MS51968-2	NUT,PLAIN,HEXAGON UOC: DAC,DAD,DAE,DAF,DAG,DA H,DAJ,DAL,DAW,DAX,V14,V15,V16, V17,V18,V19,V20,V21,V22,V24 .....	1
29	PAFZZ	2920-01-168-4127	68505	35-762	PARTS KIT,GENERATOR UOC: DAC,DAD,DAE,DAF,DAG,DA H,DAJ,DAL,DAW,DAX,V14,V15,V16, V17,V18,V19,V20,V21,V22,V24 .....	1

END OF FIGURE



**FIELD MAINTENANCE  
ALTERNATOR MOUNTING (M939A2)**

---

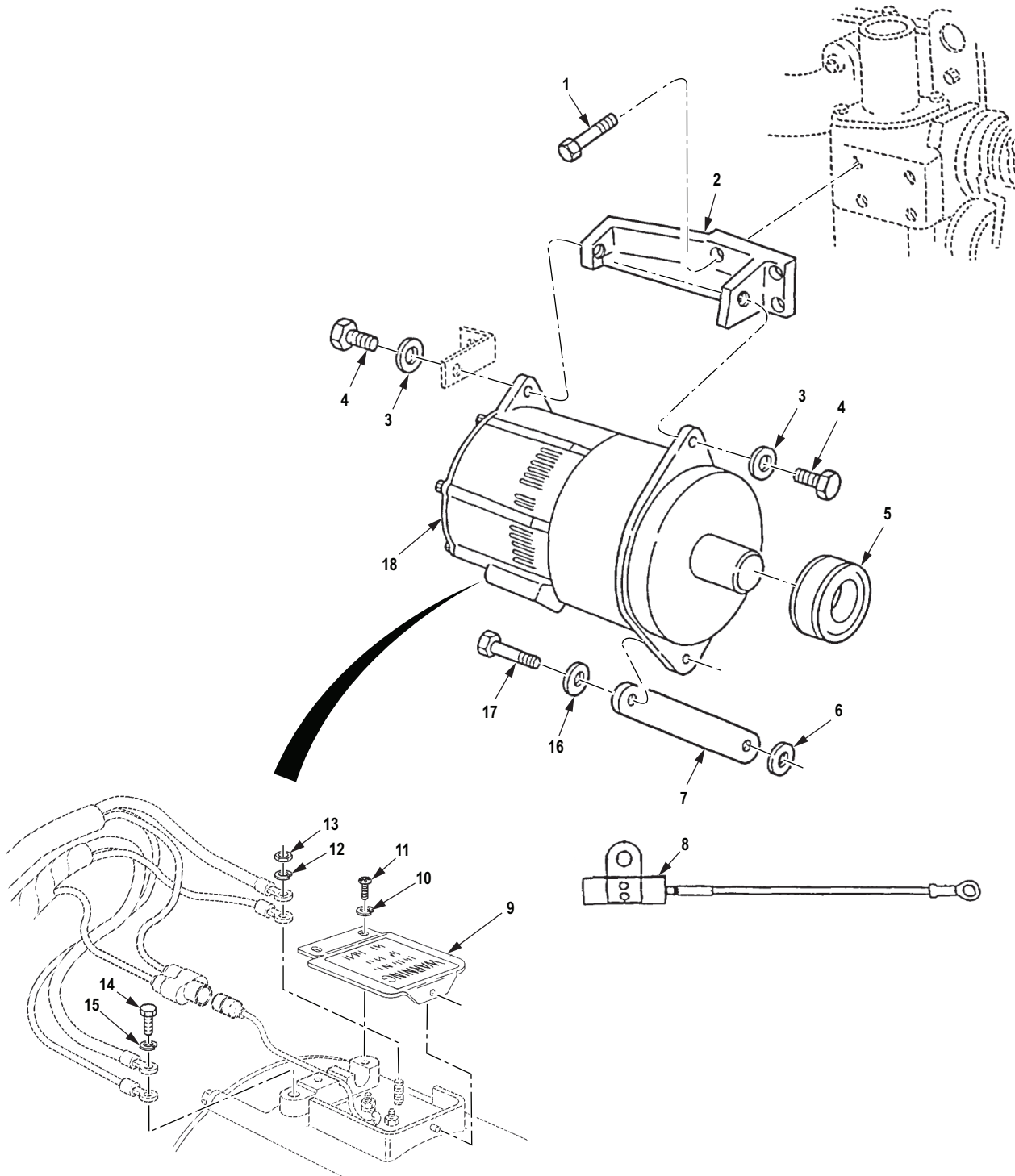

R0126DAA

Figure 126. Alternator Mounting (M939A2).

(1) ITEM NO.	(2) SMR CODE	(3) NSN	(4) CAGEC	(5) PART NUMBER	(6) DESCRIPTION AND USABLE ON CODE (UOC)	(7) QTY
<b>GROUP 0601 GENERATOR, ALTERNATOR.</b>						
<b>FIG. 126. ALTERNATOR MOUNTING (M939A2).</b>						
1	PAFZZ	5305-01-245-3193	15434	3900621	SCREW,CAP,HEXAGON H UOC: ZAA,ZAB,ZAC,ZAD,ZAE,ZAF, ZAG,ZAH,ZAJ,ZAL .....	4
2	PAFZZ	5342-01-271-5088	0B8S3	3909898	BRACKET,ENGINE ACCE UOC: ZAA,ZAB,ZAC,ZAD,ZAE,ZAF, ZAG,ZAH,ZAJ,ZAL .....	1
3	PAFZZ	5310-01-092-5495	19207	8356625-4	WASHER,FLAT UOC: ZAA,ZAB,ZAC,ZAD,ZAE,ZAF, ZAG,ZAH,ZAJ,ZAL .....	2
4	PAFZZ	5305-00-071-1788	80204	B1821BH044C125N	SCREW,CAP,HEXAGON H UOC: ZAA,ZAB,ZAC,ZAD,ZAE,ZAF, ZAG,ZAH,ZAJ,ZAL .....	2
5	PAFZZ	3020-01-271-3832	15434	3919390	PULLEY,GROOVE UOC: ZAA,ZAB,ZAC,ZAD,ZAE,ZAF, ZAG,ZAH,ZAJ,ZAL .....	1
6	PAFZZ	5310-01-286-5452	24617	11511514	WASHER,FLAT UOC: ZAA,ZAB,ZAC,ZAD,ZAE,ZAF, ZAG,ZAH,ZAJ,ZAL .....	1
7	PAFZZ	5342-01-271-5089	15434	3909899	BRACKET,ENGINE ACCE UOC: ZAA,ZAB,ZAC,ZAD,ZAE,ZAF, ZAG,ZAH,ZAJ,ZAL .....	1
8	PAFZZ	5910-01-218-1675	24975	AMA1096	CAPACITOR,FIXED,PLA UOC: ZAA,ZAB,ZAC,ZAD,ZAE,ZAF, ZAG,ZAH,ZAJ,ZAL .....	1
9	PAFZZ	2920-01-078-5769	1Y875	SAW-10785769	COVER,CAPACITOR,GEN UOC: ZAA,ZAB,ZAC,ZAD,ZAE,ZAF, ZAG,ZAH,ZAJ,ZAL .....	1
10	PAFZZ	5310-00-721-7809	96906	MS35340-43	WASHER,LOCK UOC: ZAA,ZAB,ZAC,ZAD,ZAE,ZAF, ZAG,ZAH,ZAJ,ZAL .....	2
11	PAFZZ	5305-00-984-6212	80205	MS35206-265	SCREW,MACHINE UOC: ZAA,ZAB,ZAC,ZAD,ZAE,ZAF, ZAG,ZAH,ZAJ,ZAL .....	2
12	PAFZZ	5310-00-637-9541	00198	132661	WASHER,LOCK UOC: ZAA,ZAB,ZAC,ZAD,ZAE,ZAF, ZAG,ZAH,ZAJ,ZAL .....	1
13	PAFZZ	5310-00-560-5576	18876	8170367	NUT,PLAIN,HEXAGON UOC: ZAA,ZAB,ZAC,ZAD,ZAE,ZAF, ZAG,ZAH,ZAJ,ZAL .....	1
14	PAFZZ	5306-00-226-4822	80204	B1821BH031C050N	BOLT,MACHINE UOC: ZAA,ZAB,ZAC,ZAD,ZAE,ZAF, ZAG,ZAH,ZAJ,ZAL .....	1

(1) ITEM NO.	(2) SMR CODE	(3) NSN	(4) CAGEC	(5) PART NUMBER	(6) DESCRIPTION AND USABLE ON CODE (UOC)	(7) QTY
15	PAFZZ	5310-00-407-9566	80205	MS35338-45	WASHER,LOCK UOC: ZAA,ZAB,ZAC,ZAD,ZAE,ZAF, ZAG,ZAH,ZAJ,ZAL .....	1
16	PAFZZ	5310-00-274-8041	06853	204235	WASHER,FLAT UOC: ZAA,ZAB,ZAC,ZAD,ZAE,ZAF, ZAG,ZAH,ZAJ,ZAL .....	1
17	PAFZZ	5305-00-068-0510	80204	B1821BH038C100N	SCREW,CAP,HEXAGON H UOC: ZAA,ZAB,ZAC,ZAD,ZAE,ZAF, ZAG,ZAH,ZAJ,ZAL .....	1
18	PAFZZ	2920-00-413-4337	19207	10947517-1	GENERATOR,ENGINE AC UOC: ZAA,ZAB,ZAC,ZAD,ZAE,ZAF, ZAG,ZAH,ZAJ,ZAL .....	1

END OF FIGURE

**FIELD MAINTENANCE  
STARTING MOTOR ASSEMBLY AND MOUNTING HARDWARE (M939, M939A1)**

---

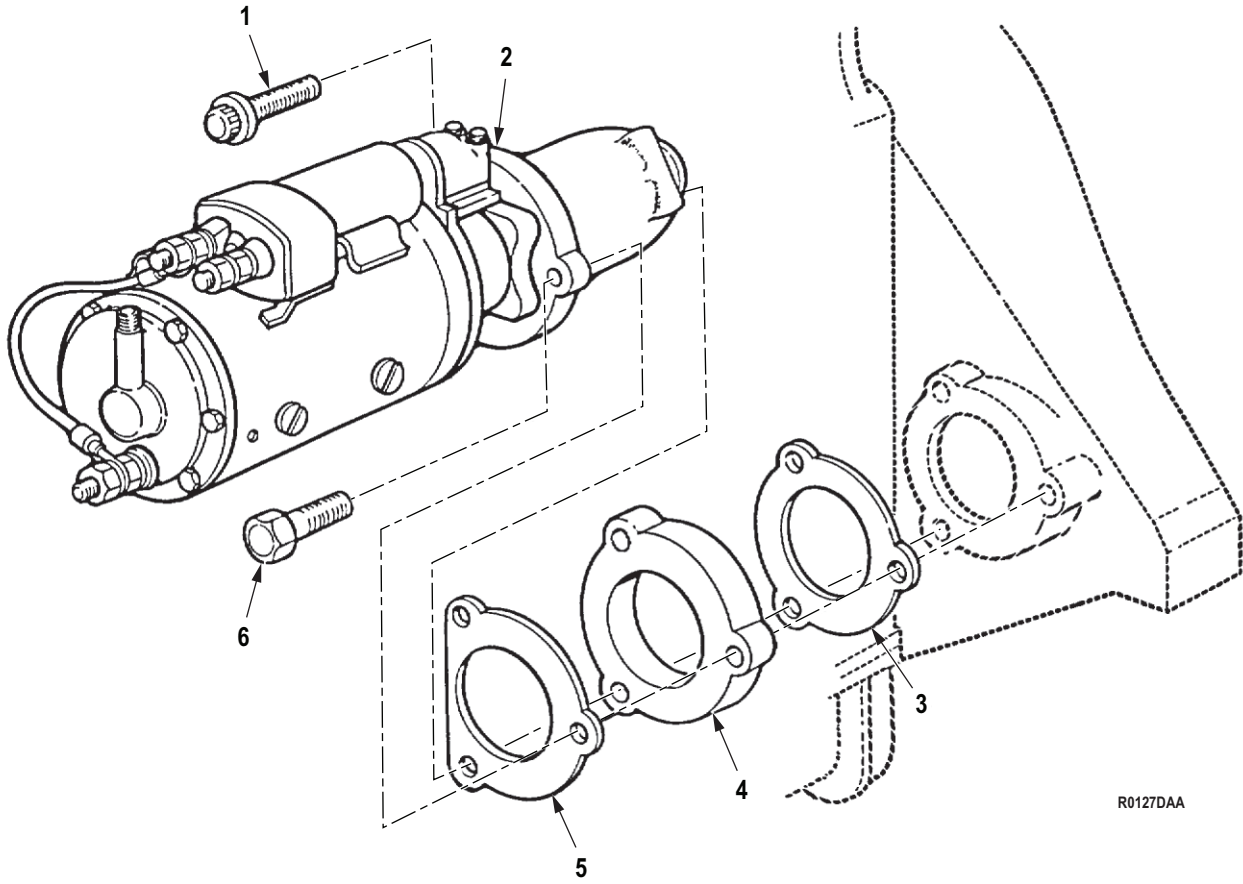

R0127DAA

Figure 127. Starting Motor Assembly and Mounting Hardware (M939, M939A1).



(1) ITEM NO.	(2) SMR CODE	(3) NSN	(4) CAGEC	(5) PART NUMBER	(6) DESCRIPTION AND USABLE ON CODE (UOC)	(7) QTY
<b>GROUP 0603 STARTING MOTOR.</b>						
<b>FIG. 127. STARTING MOTOR ASSEMBLY AND MOUNTING HARDWARE (M939, M939A1).</b>						
1	PAFZZ	5306-01-106-3850	19207	11664479-1	BOLT,MACHINE UOC: DAC,DAD,DAE,DAF,DAG,DA H,DAJ,DAL,DAW,DAX,V14,V15,V16, V17,V18,V19,V20,V21,V22,V24 .....	1
2	PAFZZ	2920-01-069-6997	81348	A-A-59294-1	STARTER,ENGINE,ELEC UOC: DAC,DAD,DAE,DAF,DAG,DA H,DAJ,DAL,DAW,DAX,V14,V15,V16, V17,V18,V19,V20,V21,V22,V24 .....	1
3	PAFZZ	5330-01-431-6771	14153	03070	GASKET UOC: DAC,DAD,DAE,DAF,DAG,DA H,DAJ,DAL,DAW,DAX,V14,V15,V16, V17,V18,V19,V20,V21,V22,V24 .....	1
4	PAFZZ	5310-01-104-3804	19207	11664432-1	WASHER,FLAT UOC: DAC,DAD,DAE,DAF,DAG,DA H,DAJ,DAL,DAW,DAX,V14,V15,V16, V17,V18,V19,V20,V21,V22,V24 .....	1
5	PAFZZ	5330-01-514-4992	19207	11664480 R87	GASKET PART OF KIT P/N 3011472 UOC: DAC,DAD,DAE,DAF,DAG,DA H,DAJ,DAL,DAW,DAX,V14,V15,V16, V17,V18,V19,V20,V21,V22,V24 .....	1
6	PAFZZ	5305-00-724-7221	80204	B1821BH063C175N	SCREW,CAP,HEXAGON H UOC: DAC,DAD,DAE,DAF,DAG,DA H,DAJ,DAL,DAW,DAX,V14,V15,V16, V17,V18,V19,V20,V21,V22,V24 .....	2
<b>END OF FIGURE</b>						



**FIELD MAINTENANCE  
STARTER ASSEMBLY (M939A2)**

---

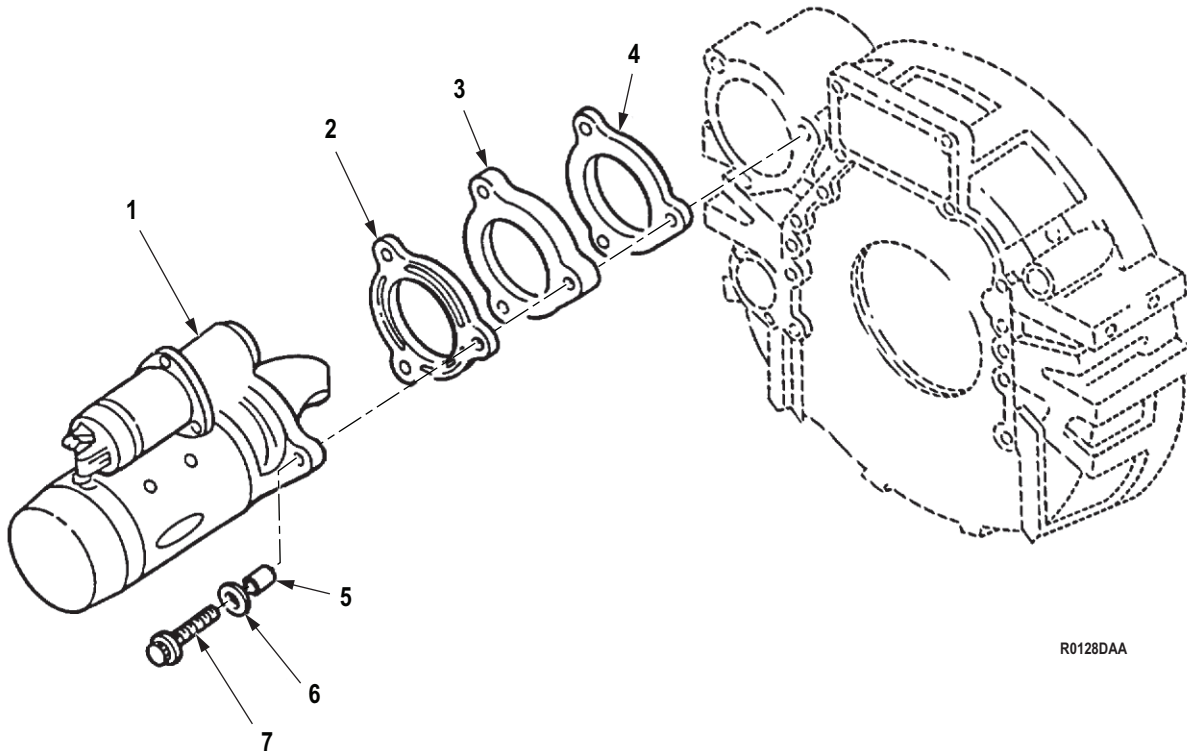

R0128DAA

Figure 128. Starter Assembly (M939A2).

(1) ITEM NO.	(2) SMR CODE	(3) NSN	(4) CAGEC	(5) PART NUMBER	(6) DESCRIPTION AND USABLE ON CODE (UOC)	(7) QTY
<b>GROUP 0603 STARTING MOTOR.</b>						
<b>FIG. 128. STARTER ASSEMBLY (M939A2).</b>						
1	PAFZZ	2920-01-515-8434	19207	12493624	STARTER,ENGINE,ELEC UOC: ZAA,ZAB,ZAC,ZAD,ZAE,ZAF, ZAG,ZAH,ZAJ,ZAL .....	1
2	PAFZZ	5330-01-137-4487	15434	33069826	GASKET UOC: ZAA,ZAB,ZAC,ZAD,ZAE,ZAF, ZAG,ZAH,ZAJ,ZAL .....	1
3	PAFZZ	5365-01-270-8481	15434	3908328	SPACER,PLATE UOC: ZAA,ZAB,ZAC,ZAD,ZAE,ZAF, ZAG,ZAH,ZAJ,ZAL .....	1
4	PAFZZ	5330-01-165-2314	15434	3031007	GASKET UOC: ZAA,ZAB,ZAC,ZAD,ZAE,ZAF, ZAG,ZAH,ZAJ,ZAL .....	1
5	PAFZZ	5365-01-280-6924	47457	20510304	SPACER,SLEEVE UOC: ZAA,ZAB,ZAC,ZAD,ZAE,ZAF, ZAG,ZAH,ZAJ,ZAL .....	3
6	PAFZZ	5310-01-282-3391	3T063	20510303	WASHER,FLAT UOC: ZAA,ZAB,ZAC,ZAD,ZAE,ZAF, ZAG,ZAH,ZAJ,ZAL .....	3
7	PAFZZ	5305-01-274-4406	15434	3968466	SCREW,CAP,HEXAGON H UOC: ZAA,ZAB,ZAC,ZAD,ZAE,ZAF, ZAG,ZAH,ZAJ,ZAL .....	3

**END OF FIGURE**



**FIELD MAINTENANCE  
SHUTDOWN VALVE AND MOUNTING HARDWARE (M939, M939A1)**

---

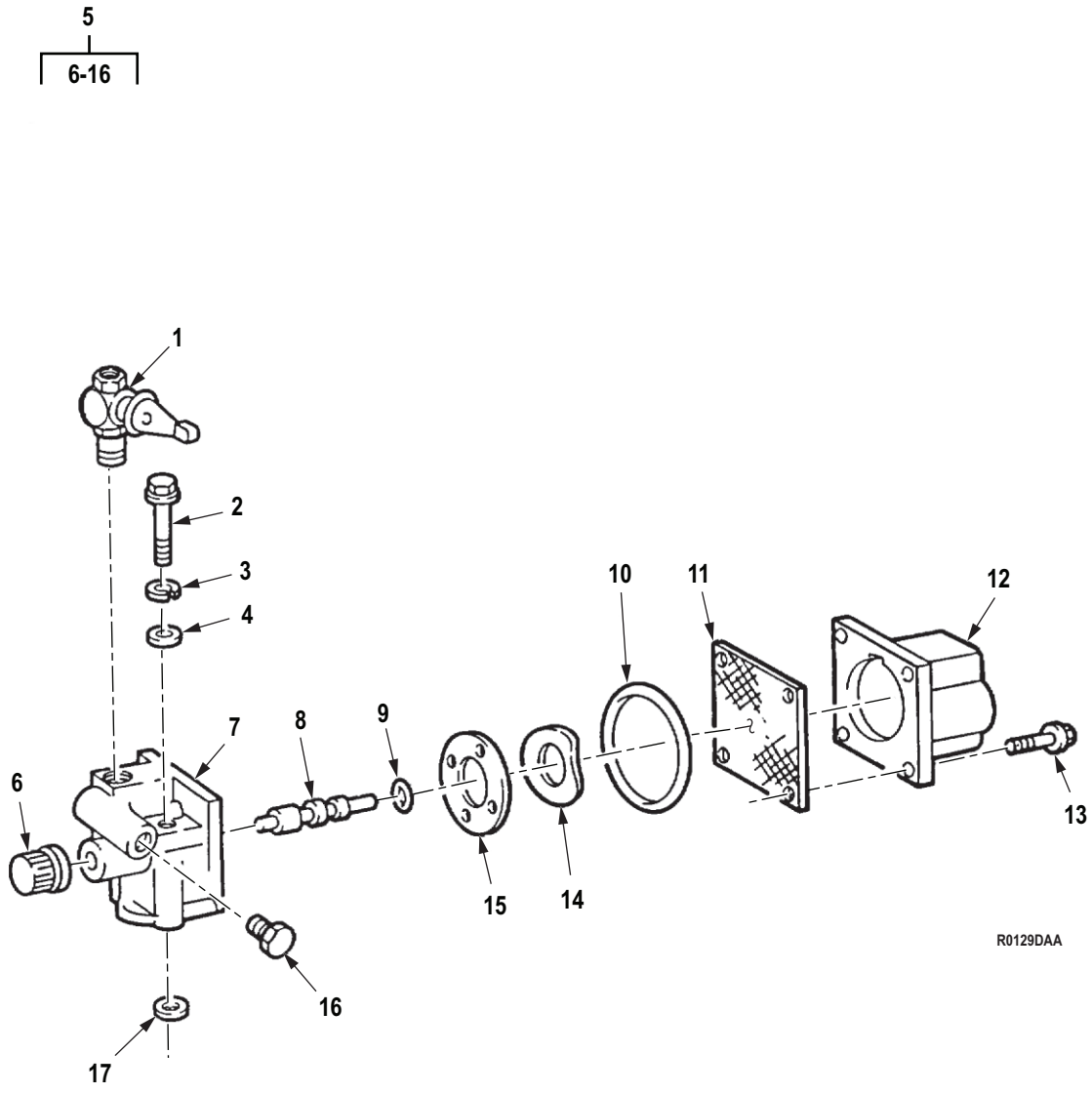

R0129DAA

Figure 129. Shutdown Valve and Mounting Hardware (M939, M939A1).



(1) ITEM NO.	(2) SMR CODE	(3) NSN	(4) CAGEC	(5) PART NUMBER	(6) DESCRIPTION AND USABLE ON CODE (UOC)	(7) QTY
<b>GROUP 0606 ENGINE SAFETY CONTROLS.</b>						
<b>FIG. 129. SHUTDOWN VALVE AND MOUNTING HARDWARE (M939, M939A1).</b>						
1	PAFZZ	4820-00-588-8604	15434	208087	VALVE,PLUG UOC: DAC,DAD,DAE,DAF,DAG,DAH,DAJ,DAL,DAW,DAX,V14,V15,V16,V17,V18,V19,V20,V21,V22,V24 .....	1
2	PAFZZ	5305-00-509-8106	15434	S189C	SCREW,CAP,SOCKET HE UOC: DAC,DAD,DAE,DAF,DAG,DAH,DAJ,DAL,DAW,DAX,V14,V15,V16,V17,V18,V19,V20,V21,V22,V24 .....	2
3	PAFZZ	5310-00-484-1718	15434	181466	WASHER,LOCK UOC: DAC,DAD,DAE,DAF,DAG,DAH,DAJ,DAL,DAW,DAX,V14,V15,V16,V17,V18,V19,V20,V21,V22,V24 .....	2
4	PAFZZ	5310-00-262-2986	15434	67684	WASHER,FLAT UOC: DAC,DAD,DAE,DAF,DAG,DAH,DAJ,DAL,DAW,DAX,V14,V15,V16,V17,V18,V19,V20,V21,V22,V24 .....	2
5	PAFFF	4810-01-187-4925	15434	3035362	VALVE,SOLENOID EMERGENCY FUEL SHUTOFF UOC: DAC,DAD,DAE,DAF,DAG,DAH,DAJ,DAL,DAW,DAX,V14,V15,V16,V17,V18,V19,V20,V21,V22,V24 .....	1
6	PAFZZ	5355-00-082-1189	15434	129838	. KNOB UOC: DAC,DAD,DAE,DAF,DAG,DAH,DAJ,DAL,DAW,DAX,V14,V15,V16,V17,V18,V19,V20,V21,V22,V24 .....	1
7	PAFZZ	4820-00-829-5600	15434	129826	. BODY,VALVE UOC: DAC,DAD,DAE,DAF,DAG,DAH,DAJ,DAL,DAW,DAX,V14,V15,V16,V17,V18,V19,V20,V21,V22,V24 .....	1
8	PAFZZ	3040-01-085-2616	15434	3000266	. SHAFT,SHOULDERED UOC: DAC,DAD,DAE,DAF,DAG,DAH,DAJ,DAL,DAW,DAX,V14,V15,V16,V17,V18,V19,V20,V21,V22,V24 .....	1
9	PAFZZ	5331-00-132-0274	15434	190876	. O-RING PART OF KIT P/N 3010240 UOC: DAC,DAD,DAE,DAF,DAG,DAH,DAJ,DAL,DAW,DAX,V14,V15,V16,V17,V18,V19,V20,V21,V22,V24 .....	1
10	PAFZZ	5331-00-081-9299	15434	129888	. O-RING PART OF KIT P/N 3010240 UOC: DAC,DAD,DAE,DAF,DAG,DAH,DAJ,DAL,DAW,DAX,V14,V15,V16,V17,V18,V19,V20,V21,V22,V24 .....	1

(1) ITEM NO.	(2) SMR CODE	(3) NSN	(4) CAGEC	(5) PART NUMBER	(6) DESCRIPTION AND USABLE ON CODE (UOC)	(7) QTY
11	PAFZZ	5340-00-084-7787	15434	129839	. COVER,ACCESS UOC: DAC,DAD,DAE,DAF,DAG,DA H,DAJ,DAL,DAW,DAX,V14,V15,V16, V17,V18,V19,V20,V21,V22,V24 .....	1
12	PAFZZ	2910-00-085-7436	15434	134074	. COIL ASSEMBLY,SHUT UOC: DAC,DAD,DAE,DAF,DAG,DA H,DAJ,DAL,DAW,DAX,V14,V15,V16, V17,V18,V19,V20,V21,V22,V24 .....	1
13	PAFZZ	5305-00-138-9848	15434	187556	. SCREW,MACHINE UOC: DAC,DAD,DAE,DAF,DAG,DA H,DAJ,DAL,DAW,DAX,V14,V15,V16, V17,V18,V19,V20,V21,V22,V24 .....	4
14	PAFZZ	5310-00-082-1888	15434	129768	. WASHER,SPRING TENSI UOC: DAC,DAD,DAE,DAF,DAG,DA H,DAJ,DAL,DAW,DAX,V14,V15,V16, V17,V18,V19,V20,V21,V22,V24 .....	1
15	PAFZZ	4820-01-146-1048	15434	3030970	. DISK,VALVE UOC: DAC,DAD,DAE,DAF,DAG,DA H,DAJ,DAL,DAW,DAX,V14,V15,V16, V17,V18,V19,V20,V21,V22,V24 .....	1
16	PAFZZ	4730-00-011-3175	15434	70295	. PLUG,PIPE UOC: DAC,DAD,DAE,DAF,DAG,DA H,DAJ,DAL,DAW,DAX,V14,V15,V16, V17,V18,V19,V20,V21,V22,V24 .....	1
17	PAFZZ	5330-01-291-6537	15434	3913994	PACKING,PREFORMED PART OF KIT P/N 3010240 UOC: DAC,DAD,DAE,DAF,DAG,DA H,DAJ,DAL,DAW,DAX,V14,V15,V16, V17,V18,V19,V20,V21,V22,V24 .....	1

END OF FIGURE

**FIELD MAINTENANCE  
THROTTLE CONTROL SOLENOID (M939A2)**

---

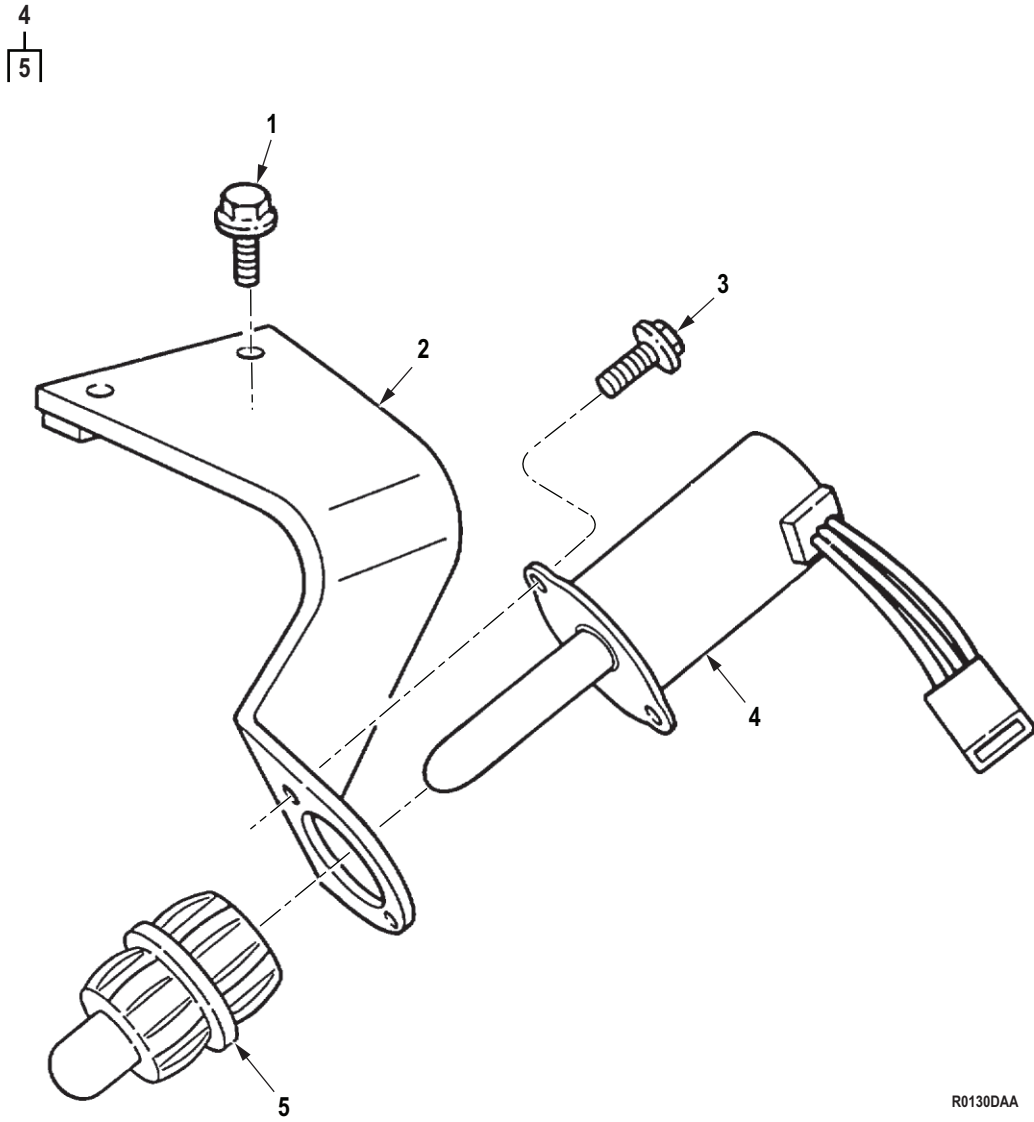

R0130DAA

Figure 130. Throttle Control Solenoid (M939A2).

(1) ITEM NO.	(2) SMR CODE	(3) NSN	(4) CAGEC	(5) PART NUMBER	(6) DESCRIPTION AND USABLE ON CODE (UOC)	(7) QTY
<b>GROUP 0606 ENGINE SAFETY CONTROLS.</b>						
<b>FIG. 130. THROTTLE CONTROL SOLENOID (M939A2).</b>						
1	PAFZZ	5305-01-239-7202	0B8S3	3900632	SCREW,CAP,HEXAGON H UOC: ZAA,ZAB,ZAC,ZAD,ZAE,ZAF, ZAG,ZAH,ZAJ,ZAL .....	1
2	PAFZZ	5340-01-271-2475	15434	3912487	BRACKET,DOUBLE ANGL UOC: ZAA,ZAB,ZAC,ZAD,ZAE,ZAF, ZAG,ZAH,ZAJ,ZAL .....	1
3	PAFZZ	5305-01-193-6839	15434	3900627	SCREW,CAP,HEXAGON H UOC: ZAA,ZAB,ZAC,ZAD,ZAE,ZAF, ZAG,ZAH,ZAJ,ZAL .....	2
4	PAFZZ	5945-01-279-4802	15434	3921980	SOLENOID,ELECTRICAL UOC: ZAA,ZAB,ZAC,ZAD,ZAE,ZAF, ZAG,ZAH,ZAJ,ZAL .....	1
5	PAFZZ	5340-01-331-9487	15434	3924912	. BOOT,DUST AND MOIST UOC: ZAA,ZAB,ZAC,ZAD,ZAE,ZAF, ZAG,ZAH,ZAJ,ZAL .....	1

**END OF FIGURE**



**FIELD MAINTENANCE  
CONTROL PANEL, LIGHT SWITCH, AND FUEL TANK SELECTOR SWITCH**

---

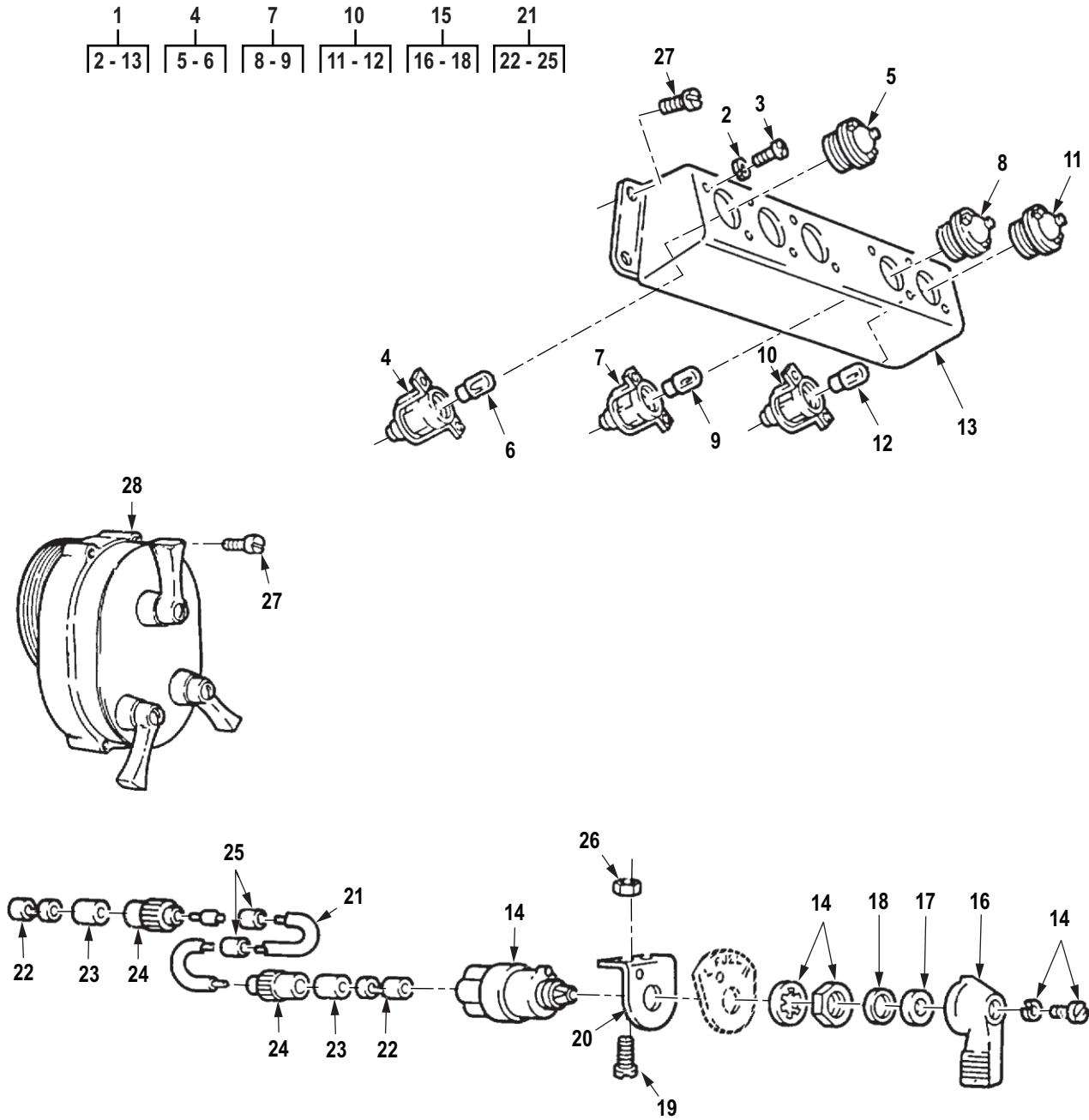

R0131DAA

Figure 131. Control Panel, Light Switch, and Fuel Tank Selector Switch.



(1) ITEM NO.	(2) SMR CODE	(3) NSN	(4) CAGEC	(5) PART NUMBER	(6) DESCRIPTION AND USABLE ON CODE (UOC)	(7) QTY
<p><b>GROUP 0607 INSTRUMENT OR ENGINE CONTROL PANEL.</b></p> <p><b>FIG. 131. CONTROL PANEL, LIGHT SWITCH, AND FUEL TANK SELECTOR SWITCH.</b></p>						
1	PAFZZ	6210-01-108-9125	19207	12277153-1	LIGHT SET,INDICATOR UOC: DAC,DAD,DAE,DAF,DAG,DAH,DAJ,DAL,DAW,DAX,V14,V15,V16,V17,V18,V19,V20,V21,V22,V24,ZAA,ZAB,ZAC,ZAD,ZAE,ZAF,ZAG,ZAH,ZAJ,ZAL .....	1
2	PAFZZ	5310-00-045-3299	80205	MS35338-42	. WASHER,LOCK UOC: DAC,DAD,DAE,DAF,DAG,DAH,DAJ,DAL,DAW,DAX,V14,V15,V16,V17,V18,V19,V20,V21,V22,V24,ZAA,ZAB,ZAC,ZAD,ZAE,ZAF,ZAG,ZAH,ZAJ,ZAL .....	10
3	PAFZZ	5305-00-984-6189	80205	MS35206-241	. SCREW,MACHINE UOC: DAC,DAD,DAE,DAF,DAG,DAH,DAJ,DAL,DAW,DAX,V14,V15,V16,V17,V18,V19,V20,V21,V22,V24,ZAA,ZAB,ZAC,ZAD,ZAE,ZAF,ZAG,ZAH,ZAJ,ZAL .....	10
4	PAFZZ	6210-00-635-5686	19207	7971111	. LIGHT,INDICATOR UOC: DAC,DAD,DAE,DAF,DAG,DAH,DAJ,DAL,DAW,DAX,V14,V15,V16,V17,V18,V19,V20,V21,V22,V24,ZAA,ZAB,ZAC,ZAD,ZAE,ZAF,ZAG,ZAH,ZAJ,ZAL .....	3
5	PAFZZ	6220-01-423-0209	19207	7358672-4	. . LENS,LIGHT CLEAR, USE W/RED LED, P/N 12360890-1 UOC: DAC,DAD,DAE,DAF,DAG,DAH,DAJ,DAL,DAW,DAX,V14,V15,V16,V17,V18,V19,V20,V21,V22,V24,ZAA,ZAB,ZAC,ZAD,ZAE,ZAF,ZAG,ZAH,ZAJ,ZAL .....	3
5	PAFZZ	6210-00-548-0504	19207	7358672	LENS,LIGHT RED, USE W/CLEAR INCANDESCENT LAMP, P/N MS25231-1829 UOC: DAC,DAD,DAE,DAF,DAG,DAH,DAJ,DAL,DAW,DAX,V14,V15,V16,V17,V18,V19,V20,V21,V22,V24,ZAA,ZAB,ZAC,ZAD,ZAE,ZAF,ZAG,ZAH,ZAJ,ZAL .....	3

(1) ITEM NO.	(2) SMR CODE	(3) NSN	(4) CAGEC	(5) PART NUMBER	(6) DESCRIPTION AND USABLE ON CODE (UOC)	(7) QTY
6	PAFZZ	6240-00-266-9940	96906	MS25231-1829	LAMP,INCANDESCENT CLEAR UOC: DAC,DAD,DAE,DAF,DAG,DA H,DAJ,DAL,DAW,DAX,V14,V15,V16, V17,V18,V19,V20,V21,V22,V24,ZAA, ZAB,ZAC,ZAD,ZAE,ZAF,ZAG,ZAH,Z AJ,ZAL .....	3
6	PAFZZ	5980-01-285-6688	19207	12360890-1	. . LIGHT EMITTING DIOD RED UOC: DAC,DAD,DAE,DAF,DAG,DA H,DAJ,DAL,DAW,DAX,V14,V15,V16, V17,V18,V19,V20,V21,V22,V24,ZAA, ZAB,ZAC,ZAD,ZAE,ZAF,ZAG,ZAH,Z AJ,ZAL .....	3
7	PAFZZ	6220-01-108-5108	19207	12277167	. INDICATOR,LIGHT UOC: DAC,DAD,DAE,DAF,DAG,DA H,DAJ,DAL,DAW,DAX,V14,V15,V16, V17,V18,V19,V20,V21,V22,V24,ZAA, ZAB,ZAC,ZAD,ZAE,ZAF,ZAG,ZAH,Z AJ,ZAL .....	1
8	PAFZZ	6220-01-129-5740	19207	12277166	. . LENS,LIGHT GREEN UOC: DAC,DAD,DAE,DAF,DAG,DA H,DAJ,DAL,DAW,DAX,V14,V15,V16, V17,V18,V19,V20,V21,V22,V24,ZAA, ZAB,ZAC,ZAD,ZAE,ZAF,ZAG,ZAH,Z AJ,ZAL .....	1
8	PAFZZ	6220-01-423-0209	19207	7358672-4	LENS,LIGHT CLEAR, USE W/ GREEN LED, P/N 12360890-3 UOC: DAC,DAD,DAE,DAF,DAG,DA H,DAJ,DAL,DAW,DAX,V14,V15,V16, V17,V18,V19,V20,V21,V22,V24,ZAA, ZAB,ZAC,ZAD,ZAE,ZAF,ZAG,ZAH,Z AJ,ZAL .....	1
9	PAFZZ	5980-01-296-2793	19207	12360890-3	LIGHT EMITTING DIOD GREEN UOC: DAC,DAD,DAE,DAF,DAG,DA H,DAJ,DAL,DAW,DAX,V14,V15,V16, V17,V18,V19,V20,V21,V22,V24,ZAA, ZAB,ZAC,ZAD,ZAE,ZAF,ZAG,ZAH,Z AJ,ZAL .....	1
9	PAFZZ	6240-00-266-9940	96906	MS25231-1829	LAMP,INCANDESCENT CLEAR, USE W/GREEN LED, P/N 12360890-3 UOC: DAC,DAD,DAE,DAF,DAG,DA H,DAJ,DAL,DAW,DAX,V14,V15,V16, V17,V18,V19,V20,V21,V22,V24,ZAA, ZAB,ZAC,ZAD,ZAE,ZAF,ZAG,ZAH,Z AJ,ZAL .....	1

(1) ITEM NO.	(2) SMR CODE	(3) NSN	(4) CAGEC	(5) PART NUMBER	(6) DESCRIPTION AND USABLE ON CODE (UOC)	(7) QTY
10	PAFZZ	6210-01-124-9301	19207	8376499-1	. LIGHT,INDICATOR UOC: DAC,DAD,DAE,DAF,DAG,DA H,DAJ,DAL,DAW,DAX,V14,V15,V16, V17,V18,V19,V20,V21,V22,V24,ZAA, ZAB,ZAC,ZAD,ZAE,ZAF,ZAG,ZAH,Z AJ,ZAL .....	1
11	PAFZZ	6220-00-451-8161	19207	7358622-1	LENS,LIGHT BLUE, USE W/ CLEAR INCANDESCENT LAMP, P/N MS25231-1829 UOC: DAC,DAD,DAE,DAF,DAG,DA H,DAJ,DAL,DAW,DAX,V14,V15,V16, V17,V18,V19,V20,V21,V22,V24,ZAA, ZAB,ZAC,ZAD,ZAE,ZAF,ZAG,ZAH,Z AJ,ZAL .....	1
11	PAFZZ	6220-01-423-0209	19207	7358672-4	LENS,LIGHT CLEAR, USE W/ YELLOW LED, P/N 12360890-2 UOC: DAC,DAD,DAE,DAF,DAG,DA H,DAJ,DAL,DAW,DAX,V14,V15,V16, V17,V18,V19,V20,V21,V22,V24,ZAA, ZAB,ZAC,ZAD,ZAE,ZAF,ZAG,ZAH,Z AJ,ZAL .....	1
12	PAFZZ	5980-01-381-7900	19207	12360890-2	LIGHT EMITTING DIOD YELLOW UOC: DAC,DAD,DAE,DAF,DAG,DA H,DAJ,DAL,DAW,DAX,V14,V15,V16, V17,V18,V19,V20,V21,V22,V24,ZAA, ZAB,ZAC,ZAD,ZAE,ZAF,ZAG,ZAH,Z AJ,ZAL .....	1
12	PAFZZ	6240-00-266-9940	96906	MS25231-1829	. . LAMP,INCANDESCENT CLEAR UOC: DAC,DAD,DAE,DAF,DAG,DA H,DAJ,DAL,DAW,DAX,V14,V15,V16, V17,V18,V19,V20,V21,V22,V24,ZAA, ZAB,ZAC,ZAD,ZAE,ZAF,ZAG,ZAH,Z AJ,ZAL .....	1
13	XAFZZ		19207	12277152	. PANEL,WARNING LIGHT UOC: DAC,DAD,DAE,DAF,DAG,DA H,DAJ,DAL,DAW,DAX,V14,V15,V16, V17,V18,V19,V20,V21,V22,V24,ZAA, ZAB,ZAC,ZAD,ZAE,ZAF,ZAG,ZAH,Z AJ,ZAL .....	1
14	PAFZZ	5930-00-898-0500	81349	MIL-S-13623/1-1	SWITCH,ROTARY UOC: DAE,DAF,DAG,DAH,DAL,V18, V19,V20,V21,V22,ZAE,ZAF,ZAG,ZA H,ZAJ,ZAL .....	1
15	PAFZZ	5930-00-130-5349	19207	5381088	HANDLE,SWITCH UOC: DAE,DAF,DAG,DAH,DAL,V18, V19,V20,V21,V22,ZAE,ZAF,ZAG,ZA H,ZAJ,ZAL .....	1

(1) ITEM NO.	(2) SMR CODE	(3) NSN	(4) CAGEC	(5) PART NUMBER	(6) DESCRIPTION AND USABLE ON CODE (UOC)	(7) QTY
16	PAFZZ	5930-01-197-8661	19207	5381051	. LEVER,MANUAL CONTRO UOC: DAE,DAF,DAG,DAH,DAL,V18, V19,V20,V21,V22,ZAE,ZAF,ZAG,ZA H,ZAJ,ZAL .....	1
17	XDFZZ		19207	7392454	. FELT,MECHANICAL,PRE UOC: DAE,DAF,DAG,DAH,DAL,V18, V19,V20,V21,V22,ZAE,ZAF,ZAG,ZA H,ZAJ,ZAL .....	1
18	PAFZZ	5310-01-108-5236	19207	5381087	. WASHER,SHOULDERED UOC: DAE,DAF,DAG,DAH,DAL,V18, V19,V20,V21,V22,ZAE,ZAF,ZAG,ZA H,ZAJ,ZAL .....	1
19	PAFZZ	5305-00-990-6444	80205	MS35207-261	SCREW,MACHINE UOC: DAE,DAF,DAG,DAH,DAL,V18, V19,V20,V21,V22,ZAE,ZAF,ZAG,ZA H,ZAJ,ZAL .....	2
20	PFFZZ	5340-00-176-0868	19207	7059461	BRACKET,ANGLE UOC: DAE,DAF,DAG,DAH,DAL,V18, V19,V20,V21,V22,ZAE,ZAF,ZAG,ZA H,ZAJ,ZAL .....	1
21	PFFZZ	6150-01-145-0361	19207	12277231	LEAD,ELECTRICAL UOC: DAC,DAE,DAF,DAG,DAH,DAL ,DAX,V14,V15,V16,V17,V18,V19,V20 ,V21,V22,V24,ZAA,ZAB,ZAC,ZAD,ZA E,ZAF,ZAG,ZAH,ZAJ,ZAL .....	1
22	PAFZZ	5940-00-399-6676	19207	8338564	. TERMINAL SET,QUICK FUEL TANK SWITCH LEAD UOC: DAE,DAX,V14,V15,V16,V17,V 18,V19,V20,V21,V22,V24,ZAA,ZAB,Z AC,ZAD,ZAE,ZAF,ZAG,ZAH,ZAJ,ZAL .....	2
23	PAFZZ	5970-00-833-8562	19207	8338562	. INSULATOR,BUSHING FUEL TANK SWITCH LEAD UOC: DAE,DAF,DAG,DAH,DAL,V18, V19,V20,V21,V22,ZAE,ZAF,ZAG,ZA H,ZAJ,ZAL .....	2
24	PFFZZ	5935-00-399-6673	19207	7982401	. SHELL,ELECTRICAL CO FUEL TANK SWITCH LEAD UOC: DAE,DAF,DAG,DAH,DAL,V18, V19,V20,V21,V22,ZAE,ZAF,ZAG,ZA H,ZAJ,ZAL .....	2
25	PAFZZ	9905-00-752-4649	24617	5939707	. BAND MRKER BLNK-ALU FUEL TANK SWITCH LEAD UOC: DAE,DAF,DAG,DAH,DAL,V18, V19,V20,V21,V22,ZAE,ZAF,ZAG,ZA H,ZAJ,ZAL .....	2

(1) ITEM NO.	(2) SMR CODE	(3) NSN	(4) CAGEC	(5) PART NUMBER	(6) DESCRIPTION AND USABLE ON CODE (UOC)	(7) QTY
26	PAFZZ	5310-00-877-5797	80205	MS21044N3	NUT,SELF-LOCKING,HE UOC: DAE,DAF,DAG,DAH,DAL,V18, V19,V20,V21,V22,ZAE,ZAF,ZAG,ZA H,ZAJ,ZAL .....	2
27	PAFZZ	5305-00-989-7435	80205	MS35207-264	SCREW,MACHINE UOC: DAC,DAD,DAE,DAF,DAG,DA H,DAJ,DAL,DAW,DAX,V14,V15,V16, V17,V18,V19,V20,V21,V22,V24,ZAA, ZAB,ZAC,ZAD,ZAE,ZAF,ZAG,ZAH,Z AJ,ZAL .....	8
28	PAFZZ	5930-00-307-8856	96906	MS51113-1	SWITCH ASSEMBLY UOC: DAC,DAD,DAE,DAF,DAG,DA H,DAJ,DAL,DAW,DAX,V14,V15,V16, V17,V18,V19,V20,V21,V22,V24,ZAA, ZAB,ZAC,ZAD,ZAE,ZAF,ZAG,ZAH,Z AJ,ZAL .....	1

END OF FIGURE



**FIELD MAINTENANCE  
INSTRUMENT CLUSTER ASSEMBLY**

---

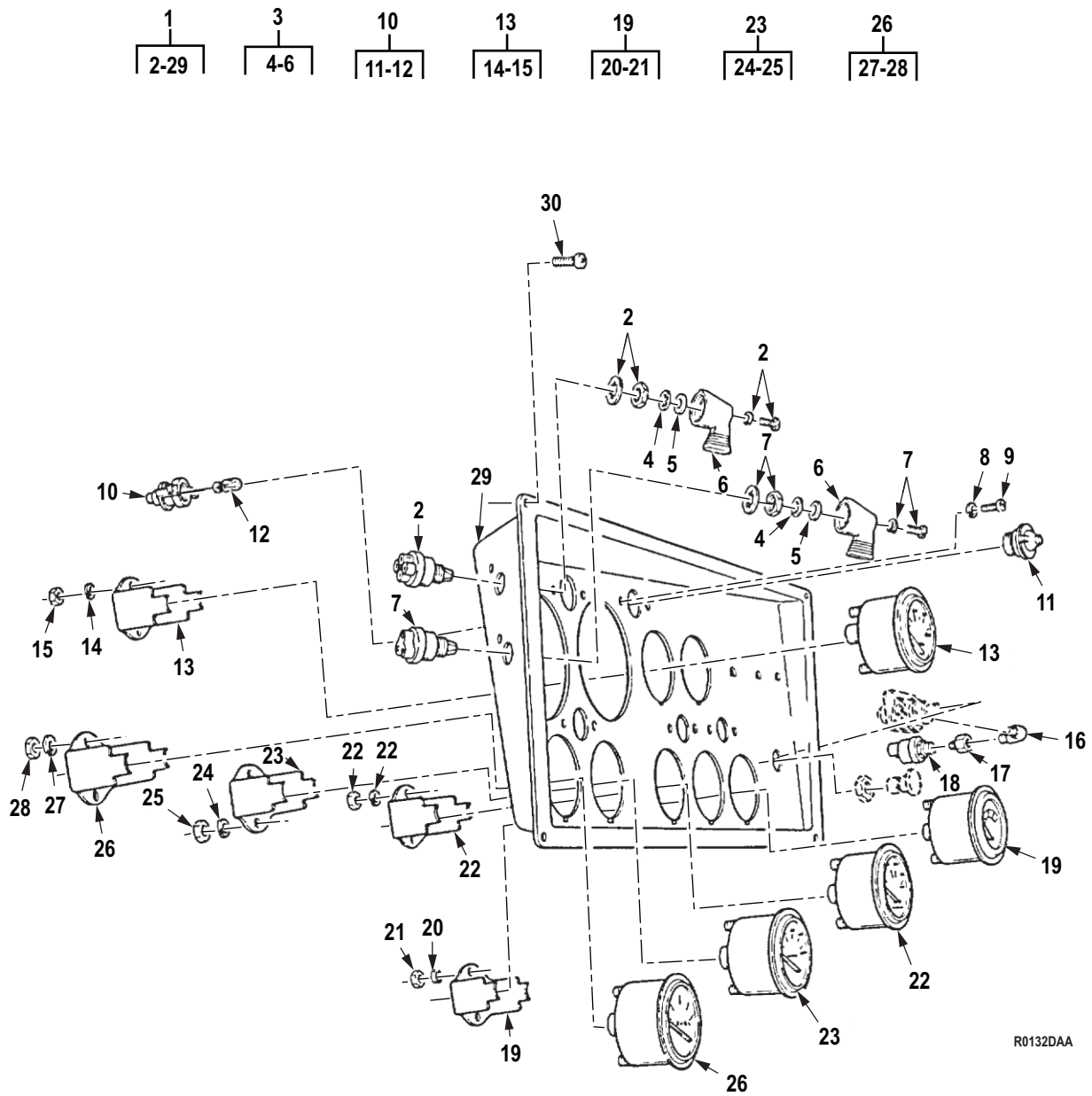

R0132DAA

Figure 132. Instrument Cluster Assembly.



(1) ITEM NO.	(2) SMR CODE	(3) NSN	(4) CAGEC	(5) PART NUMBER	(6) DESCRIPTION AND USABLE ON CODE (UOC)	(7) QTY
<b>GROUP 0607 INSTRUMENT OR ENGINE CONTROL PANEL.</b>						
<b>FIG. 132. INSTRUMENT CLUSTER ASSEMBLY.</b>						
1	AFFFF		19207	12277176-1	INDICATOR ASSEMBLY UOC: DAC,DAD,DAE,DAF,DAG,DAH,DAJ,DAL,DAW,DAX,V14,V15,V16,V17,V18,V19,V20,V21,V22,V24,ZAA,ZAB,ZAC,ZAD,ZAE,ZAF,ZAG,ZAH,ZAJ,ZAL .....	1
2	PAFZZ	5930-00-699-9438	81349	MIL-S-13623/1-2	. SWITCH,ROTARY UOC: DAC,DAD,DAE,DAF,DAG,DAH,DAJ,DAL,DAW,DAX,V14,V15,V16,V17,V18,V19,V20,V21,V22,V24,ZAA,ZAB,ZAC,ZAD,ZAE,ZAF,ZAG,ZAH,ZAJ,ZAL .....	1
3	PAFZZ	5930-00-130-5349	19207	5381088	. HANDLE,SWITCH UOC: DAC,DAD,DAE,DAF,DAG,DAH,DAJ,DAL,DAW,DAX,V14,V15,V16,V17,V18,V19,V20,V21,V22,V24,ZAA,ZAB,ZAC,ZAD,ZAE,ZAF,ZAG,ZAH,ZAJ,ZAL .....	2
4	PAFZZ	5310-01-108-5236	19207	5381087	. . WASHER,SHOULDERED UOC: DAC,DAD,DAE,DAF,DAG,DAH,DAJ,DAL,DAW,DAX,V14,V15,V16,V17,V18,V19,V20,V21,V22,V24,ZAA,ZAB,ZAC,ZAD,ZAE,ZAF,ZAG,ZAH,ZAJ,ZAL .....	2
5	XDFZZ		19207	7392454	. . FELT,MECHANICAL,PRE UOC: DAC,DAD,DAE,DAF,DAG,DAH,DAJ,DAL,DAW,DAX,V14,V15,V16,V17,V18,V19,V20,V21,V22,V24,ZAA,ZAB,ZAC,ZAD,ZAE,ZAF,ZAG,ZAH,ZAJ,ZAL .....	2
6	PAFZZ	5930-01-197-8661	19207	5381051	. . LEVER,MANUAL CONTRO UOC: DAC,DAD,DAE,DAF,DAG,DAH,DAJ,DAL,DAW,DAX,V14,V15,V16,V17,V18,V19,V20,V21,V22,V24,ZAA,ZAB,ZAC,ZAD,ZAE,ZAF,ZAG,ZAH,ZAJ,ZAL .....	2
7	PAFZZ	5930-00-134-5036	19207	11614131	SWITCH,ROTARY UOC: DAC,DAD,DAE,DAF,DAG,DAH,DAJ,DAL,DAW,DAX,V14,V15,V16,V17,V18,V19,V20,V21,V22,V24,ZAA,ZAB,ZAC,ZAD,ZAE,ZAF,ZAG,ZAH,ZAJ,ZAL .....	1

(1) ITEM NO.	(2) SMR CODE	(3) NSN	(4) CAGEC	(5) PART NUMBER	(6) DESCRIPTION AND USABLE ON CODE (UOC)	(7) QTY
8	PAFZZ	5310-00-045-3299	80205	MS35338-42	. WASHER, LOCK UOC: DAC, DAD, DAE, DAF, DAG, DA H, DAJ, DAL, DAW, DAX, V14, V15, V16, V17, V18, V19, V20, V21, V22, V24, ZAA, ZAB, ZAC, ZAD, ZAE, ZAF, ZAG, ZAH, Z AJ, ZAL .....	10
9	PAFZZ	5305-00-984-6189	80205	MS35206-241	. SCREW, MACHINE UOC: DAC, DAD, DAE, DAF, DAG, DA H, DAJ, DAL, DAW, DAX, V14, V15, V16, V17, V18, V19, V20, V21, V22, V24, ZAA, ZAB, ZAC, ZAD, ZAE, ZAF, ZAG, ZAH, Z AJ, ZAL .....	10
10	PAFZZ	6210-00-699-9458	5A910	8376500	. LIGHT, INDICATOR UOC: DAC, DAD, DAE, DAF, DAG, DA H, DAJ, DAL, DAW, DAX, V14, V15, V16, V17, V18, V19, V20, V21, V22, V24, ZAA, ZAB, ZAC, ZAD, ZAE, ZAF, ZAG, ZAH, Z AJ, ZAL .....	5
11	PPFZZ	6210-00-337-7345	19207	7358621	. . LENS, LIGHT UOC: DAC, DAD, DAE, DAF, DAG, DA H, DAJ, DAL, DAW, DAX, V14, V15, V16, V17, V18, V19, V20, V21, V22, V24, ZAA, ZAB, ZAC, ZAD, ZAE, ZAF, ZAG, ZAH, Z AJ, ZAL .....	5
12	PAFZZ	6240-00-266-9940	96906	MS25231-1829	. . LAMP, INCANDESCENT UOC: DAC, DAD, DAE, DAF, DAG, DA H, DAJ, DAL, DAW, DAX, V14, V15, V16, V17, V18, V19, V20, V21, V22, V24, ZAA, ZAB, ZAC, ZAD, ZAE, ZAF, ZAG, ZAH, Z AJ, ZAL .....	5
13	PAFZZ	6685-00-936-2139	96906	MS24543-2	. INDICATOR, TEMPERATU ENGINE TEMP UOC: DAC, DAD, DAE, DAF, DAG, DA H, DAJ, DAL, DAW, DAX, V14, V15, V16, V17, V18, V19, V20, V21, V22, V24, ZAA, ZAB, ZAC, ZAD, ZAE, ZAF, ZAG, ZAH, Z AJ, ZAL .....	1
14	PAFZZ	5310-00-045-3296	80205	MS35338-43	. . WASHER, LOCK UOC: DAC, DAD, DAE, DAF, DAG, DA H, DAJ, DAL, DAW, DAX, V14, V15, V16, V17, V18, V19, V20, V21, V22, V24, ZAA, ZAB, ZAC, ZAD, ZAE, ZAF, ZAG, ZAH, Z AJ, ZAL .....	2
15	PAFZZ	5310-00-934-9751	24975	8X-173	. . NUT, PLAIN, HEXAGON UOC: DAC, DAD, DAE, DAF, DAG, DA H, DAJ, DAL, DAW, DAX, V14, V15, V16, V17, V18, V19, V20, V21, V22, V24, ZAA, ZAB, ZAC, ZAD, ZAE, ZAF, ZAG, ZAH, Z AJ, ZAL .....	2

(1) ITEM NO.	(2) SMR CODE	(3) NSN	(4) CAGEC	(5) PART NUMBER	(6) DESCRIPTION AND USABLE ON CODE (UOC)	(7) QTY
16	PAFZZ	4730-00-287-1649	96906	MS39230-1	. ELBOW,PIPE UOC: DAC,DAD,DAE,DAF,DAG,DA H,DAJ,DAL,DAW,DAX,V14,V15,V16, V17,V18,V19,V20,V21,V22,V24,ZAA, ZAB,ZAC,ZAD,ZAE,ZAF,ZAG,ZAH,Z AJ,ZAL .....	1
17	PAFZZ	4730-00-226-8874	30780	1-4X1-8FGS	. REDUCER,PIPE UOC: DAC,DAD,DAE,DAF,DAG,DA H,DAJ,DAL,DAW,DAX,V14,V15,V16, V17,V18,V19,V20,V21,V22,V24,ZAA, ZAB,ZAC,ZAD,ZAE,ZAF,ZAG,ZAH,Z AJ,ZAL .....	1
18	PAFZZ	5930-01-189-0494	19207	12375453	. SWITCH,PRESSURE UOC: DAC,DAD,DAE,DAF,DAG,DA H,DAJ,DAL,DAW,DAX,V14,V15,V16, V17,V18,V19,V20,V21,V22,V24,ZAA, ZAB,ZAC,ZAD,ZAE,ZAF,ZAG,ZAH,Z AJ,ZAL .....	1
19	PAFZZ	6625-01-086-9580	58536	AA52508-1	. METER,SPECIAL SCALE VOLTAGE INDICATOR UOC: DAC,DAD,DAE,DAF,DAG,DA H,DAJ,DAL,DAW,DAX,V14,V15,V16, V17,V18,V19,V20,V21,V22,V24,ZAA, ZAB,ZAC,ZAD,ZAE,ZAF,ZAG,ZAH,Z AJ,ZAL .....	1
20	PAFZZ	5310-00-045-3296	80205	MS35338-43	. . WASHER,LOCK UOC: DAC,DAD,DAE,DAF,DAG,DA H,DAJ,DAL,DAW,DAX,V14,V15,V16, V17,V18,V19,V20,V21,V22,V24,ZAA, ZAB,ZAC,ZAD,ZAE,ZAF,ZAG,ZAH,Z AJ,ZAL .....	2
21	PAFZZ	5310-00-934-9751	24975	8X-173	. . NUT,PLAIN,HEXAGON UOC: DAC,DAD,DAE,DAF,DAG,DA H,DAJ,DAL,DAW,DAX,V14,V15,V16, V17,V18,V19,V20,V21,V22,V24,ZAA, ZAB,ZAC,ZAD,ZAE,ZAF,ZAG,ZAH,Z AJ,ZAL .....	2
22	PAFZZ	6685-01-098-5110	57733	11669355	. GAGE,PRESSURE,DIAL TRANS OIL TEMP GAGE UOC: DAC,DAD,DAE,DAF,DAG,DA H,DAJ,DAL,DAW,DAX,V14,V15,V16, V17,V18,V19,V20,V21,V22,V24,ZAA, ZAB,ZAC,ZAD,ZAE,ZAF,ZAG,ZAH,Z AJ,ZAL .....	1

(1) ITEM NO.	(2) SMR CODE	(3) NSN	(4) CAGEC	(5) PART NUMBER	(6) DESCRIPTION AND USABLE ON CODE (UOC)	(7) QTY
23	PAFZZ	6620-00-115-9042	96906	MS24540-2	. INDICATOR,PRESSURE OIL PRESSURE UOC: DAC,DAD,DAE,DAF,DAG,DA H,DAJ,DAL,DAW,DAX,V14,V15,V16, V17,V18,V19,V20,V21,V22,V24,ZAA, ZAB,ZAC,ZAD,ZAE,ZAF,ZAG,ZAH,Z AJ,ZAL .....	1
24	PAFZZ	5310-00-045-3296	80205	MS35338-43	. . WASHER,LOCK UOC: DAC,DAD,DAE,DAF,DAG,DA H,DAJ,DAL,DAW,DAX,V14,V15,V16, V17,V18,V19,V20,V21,V22,V24,ZAA, ZAB,ZAC,ZAD,ZAE,ZAF,ZAG,ZAH,Z AJ,ZAL .....	2
25	PAFZZ	5310-00-934-9751	24975	8X-173	. . NUT,PLAIN,HEXAGON UOC: DAC,DAD,DAE,DAF,DAG,DA H,DAJ,DAL,DAW,DAX,V14,V15,V16, V17,V18,V19,V20,V21,V22,V24,ZAA, ZAB,ZAC,ZAD,ZAE,ZAF,ZAG,ZAH,Z AJ,ZAL .....	2
26	PAFZZ	6680-00-933-3600	96906	MS24544-2	. INDICATOR,LIQUID QU FUEL GAGE UOC: DAC,DAD,DAE,DAF,DAG,DA H,DAJ,DAL,DAW,DAX,V14,V15,V16, V17,V18,V19,V20,V21,V22,V24,ZAA, ZAB,ZAC,ZAD,ZAE,ZAF,ZAG,ZAH,Z AJ,ZAL .....	1
27	PAFZZ	5310-00-045-3296	80205	MS35338-43	. . WASHER,LOCK UOC: DAC,DAD,DAE,DAF,DAG,DA H,DAJ,DAL,DAW,DAX,V14,V15,V16, V17,V18,V19,V20,V21,V22,V24,ZAA, ZAB,ZAC,ZAD,ZAE,ZAF,ZAG,ZAH,Z AJ,ZAL .....	2
28	PAFZZ	5310-00-934-9751	24975	8X-173	. . NUT,PLAIN,HEXAGON UOC: DAC,DAD,DAE,DAF,DAG,DA H,DAJ,DAL,DAW,DAX,V14,V15,V16, V17,V18,V19,V20,V21,V22,V24,ZAA, ZAB,ZAC,ZAD,ZAE,ZAF,ZAG,ZAH,Z AJ,ZAL .....	2
29	PFFZZ	2590-01-130-7935	19207	12277175	. PANEL,BLANK UOC: DAC,DAD,DAE,DAF,DAG,DA H,DAJ,DAL,DAW,DAX,V14,V15,V16, V17,V18,V19,V20,V21,V22,V24,ZAA, ZAB,ZAC,ZAD,ZAE,ZAF,ZAG,ZAH,Z AJ,ZAL .....	1

(1) ITEM NO.	(2) SMR CODE	(3) NSN	(4) CAGEC	(5) PART NUMBER	(6) DESCRIPTION AND USABLE ON CODE (UOC)	(7) QTY
30	PAFZZ	5305-00-989-7435	80205	MS35207-264	SCREW,MACHINE UOC: DAC,DAD,DAE,DAF,DAG,DA H,DAJ,DAL,DAW,DAX,V14,V15,V16, V17,V18,V19,V20,V21,V22,V24,ZAA, ZAB,ZAC,ZAD,ZAE,ZAF,ZAG,ZAH,Z AJ,ZAL .....	8

END OF FIGURE



**FIELD MAINTENANCE  
INSTRUMENT CLUSTER ASSEMBLY (M939A2)**

---

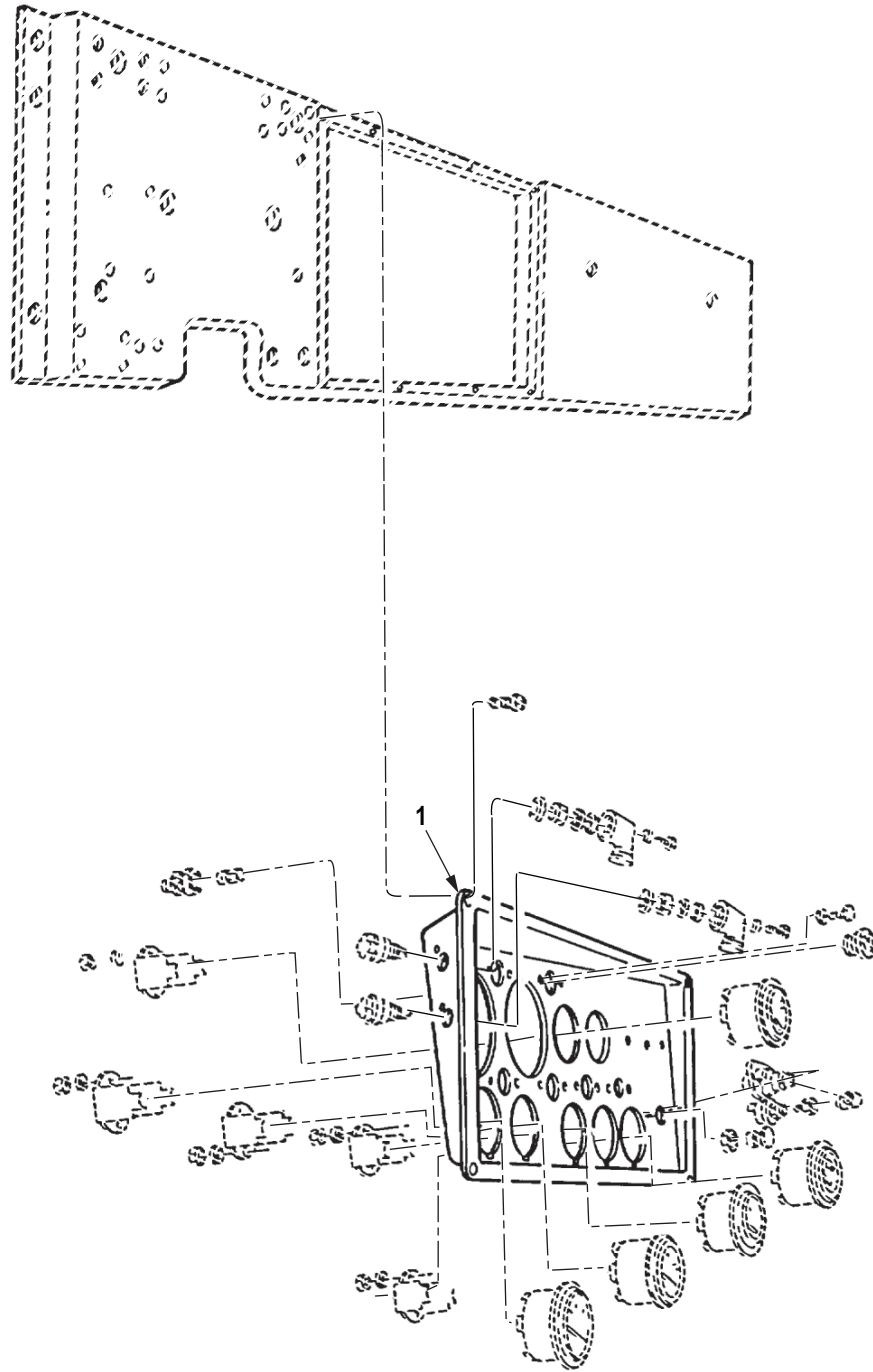

R0133DAA

Figure 133. Instrument Cluster Assembly (M939A2).



(1) ITEM NO.	(2) SMR CODE	(3) NSN	(4) CAGEC	(5) PART NUMBER	(6) DESCRIPTION AND USABLE ON CODE (UOC)	(7) QTY
--------------------	-----------------	------------	--------------	--------------------	--	------------

1	PFFZZ	2510-01-280-4155	05MG0	12277175A	<p><b>GROUP 0607 INSTRUMENT OR ENGINE CONTROL PANEL.</b></p> <p><b>FIG. 133. INSTRUMENT CLUSTER ASSEMBLY (M939A2).</b></p> <p>PANEL,VEHICULAR OPE                      UOC: ZAA,ZAB,ZAC,ZAD,ZAE,ZAF,                      ZAG,ZAH,ZAJ,ZAL ..... 1</p>	1
---	-------	------------------	-------	-----------	---	---

**END OF FIGURE**



**FIELD MAINTENANCE  
INSTRUMENT PANEL, FLOODLIGHT, HEATER, WARNING SWITCHES, LAMP HOLDER, AND AUXILIARY  
RECEPTACLE**

1	7	12	20	26	35
2-6	8-10	13-24	21-24	27-31	36-38

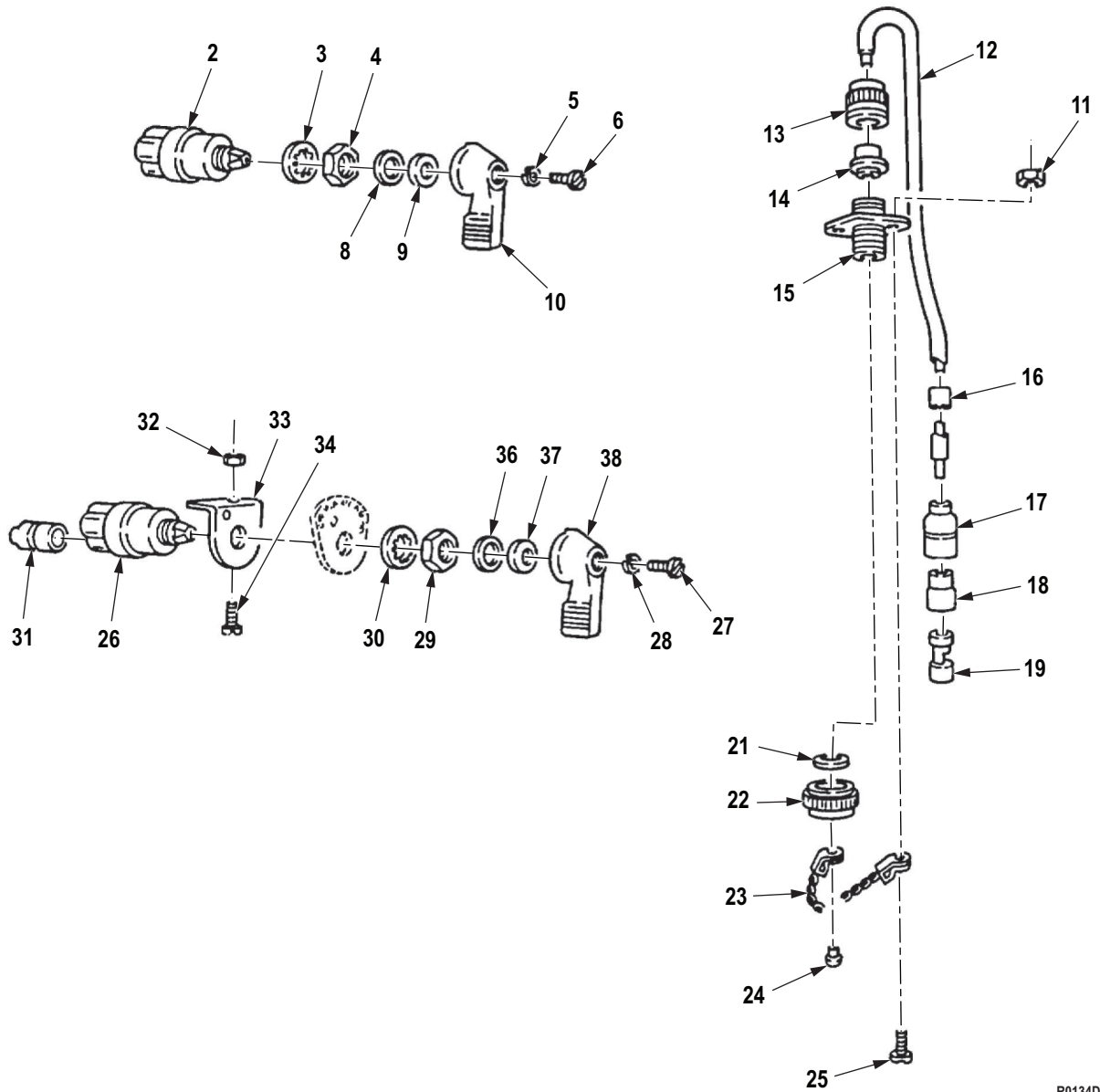

R0134DAA

Figure 134. Instrument Panel, Floodlight, Heater, Warning Switches, Lamp Holder, and Auxiliary Receptacle. (Sheet 1 of 2)

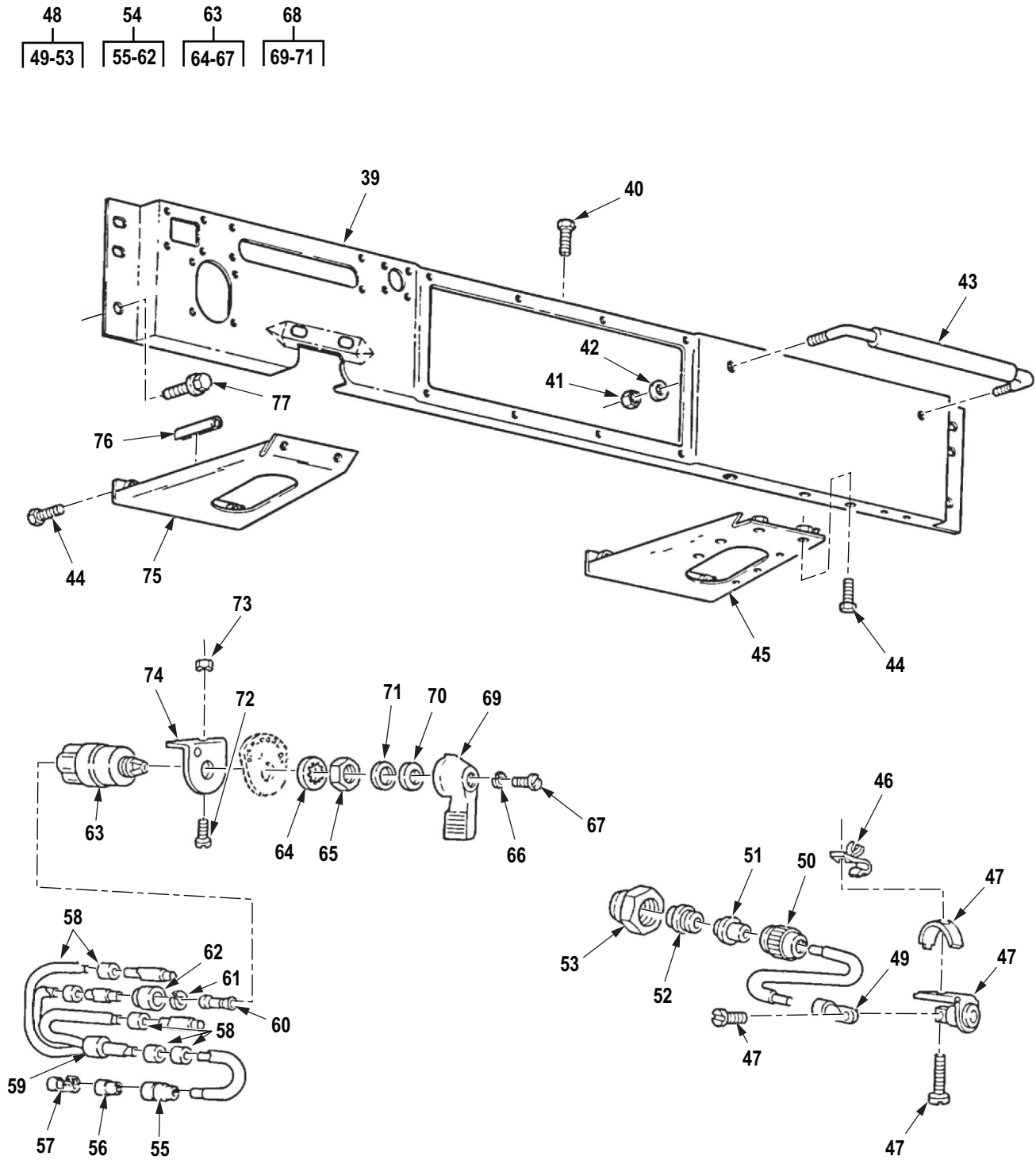

R0135DAA

Figure 134. Instrument Panel, Floodlight, Heater, Warning Switches, Lamp Holder, and Auxiliary Receptacle. (Sheet 2 of 2)

(1) ITEM NO.	(2) SMR CODE	(3) NSN	(4) CAGEC	(5) PART NUMBER	(6) DESCRIPTION AND USABLE ON CODE (UOC)	(7) QTY
					<b>GROUP 0607 INSTRUMENT OR ENGINE CONTROL PANEL.</b>	
					<b>FIG. 134. INSTRUMENT PANEL, FLOODLIGHT, HEATER, WARNING SWITCHES, LAMP HOLDER, AND AUXILIARY RECEPTACLE.</b>	
1	PGFZZ	5930-01-098-6743	19207	11669214	SWITCH,ROTARY UOC: DAC,DAD,DAE,DAF,DAG,DA H,DAJ,DAL,DAW,DAX,V14,V15,V16, V17,V18,V19,V20,V21,V22,V24,ZAA, ZAB,ZAC,ZAD,ZAE,ZAF,ZAG,ZAH,Z AJ,ZAL .....	1
2	XAFZZ		19207	12375495	. SWITCH,ROTARY UOC: DAC,DAD,DAE,DAF,DAG,DA H,DAJ,DAL,DAW,DAX,V14,V15,V16, V17,V18,V19,V20,V21,V22,V24,ZAA, ZAB,ZAC,ZAD,ZAE,ZAF,ZAG,ZAH,Z AJ,ZAL .....	1
3	PAFZZ	5310-00-194-1483	80205	MS35333-44	. WASHER,LOCK UOC: DAC,DAD,DAE,DAF,DAG,DA H,DAJ,DAL,DAW,DAX,V14,V15,V16, V17,V18,V19,V20,V21,V22,V24,ZAA, ZAB,ZAC,ZAD,ZAE,ZAF,ZAG,ZAH,Z AJ,ZAL .....	1
4	PAFZZ	5310-00-832-6852	19207	5381233	. NUT,PLAIN,HEXAGON UOC: DAC,DAD,DAE,DAF,DAG,DA H,DAJ,DAL,DAW,DAX,V14,V15,V16, V17,V18,V19,V20,V21,V22,V24,ZAA, ZAB,ZAC,ZAD,ZAE,ZAF,ZAG,ZAH,Z AJ,ZAL .....	1
5	PAFZZ	5310-00-045-3299	80205	MS35338-42	. WASHER,LOCK UOC: DAC,DAD,DAE,DAF,DAG,DA H,DAJ,DAL,DAW,DAX,V14,V15,V16, V17,V18,V19,V20,V21,V22,V24,ZAA, ZAB,ZAC,ZAD,ZAE,ZAF,ZAG,ZAH,Z AJ,ZAL .....	1
6	PAFZZ	5305-00-614-3423	96906	MS35265-43	. SCREW,MACHINE UOC: DAC,DAD,DAE,DAF,DAG,DA H,DAJ,DAL,DAW,DAX,V14,V15,V16, V17,V18,V19,V20,V21,V22,V24,ZAA, ZAB,ZAC,ZAD,ZAE,ZAF,ZAG,ZAH,Z AJ,ZAL .....	1
7	PAFFF	5930-00-130-5349	19207	5381088	HANDLE,SWITCH UOC: DAC,DAD,DAE,DAF,DAG,DA H,DAJ,DAL,DAW,DAX,V14,V15,V16, V17,V18,V19,V20,V21,V22,V24,ZAA, ZAB,ZAC,ZAD,ZAE,ZAF,ZAG,ZAH,Z AJ,ZAL .....	1

(1) ITEM NO.	(2) SMR CODE	(3) NSN	(4) CAGEC	(5) PART NUMBER	(6) DESCRIPTION AND USABLE ON CODE (UOC)	(7) QTY
8	PAFZZ	5310-01-108-5236	19207	5381087	. WASHER, SHOULDERED UOC: DAC,DAD,DAE,DAF,DAG,DAH,DAJ,DAL,DAW,DAX,V14,V15,V16,V17,V18,V19,V20,V21,V22,V24,ZAA,ZAB,ZAC,ZAD,ZAE,ZAF,ZAG,ZAH,ZAJ,ZAL .....	1
9	XDFZZ		19207	7392454	. FELT, MECHANICAL, PRE UOC: DAC,DAD,DAE,DAF,DAG,DAH,DAJ,DAL,DAW,DAX,V14,V15,V16,V17,V18,V19,V20,V21,V22,V24,ZAA,ZAB,ZAC,ZAD,ZAE,ZAF,ZAG,ZAH,ZAJ,ZAL .....	1
10	PAFZZ	5930-01-197-8661	19207	5381051	. LEVER, MANUAL CONTRO UOC: DAC,DAD,DAE,DAF,DAG,DAH,DAJ,DAL,DAW,DAX,V14,V15,V16,V17,V18,V19,V20,V21,V22,V24,ZAA,ZAB,ZAC,ZAD,ZAE,ZAF,ZAG,ZAH,ZAJ,ZAL .....	1
11	PAFZZ	5310-00-934-9755	80205	MS35650-362	NUT, PLAIN, HEXAGON UOC: DAL,V18,ZAL .....	4
12	PAFFF	5995-00-177-8220	19207	7363002	LEAD, ELECTRICAL UOC: DAL,V18,V24,ZAL .....	1
13	PAFZZ	5935-00-333-3088	19207	7723306	. NUT, BUSHING RETAINE UOC: DAL,V18,ZAL .....	1
14	PAFZZ	5365-00-772-2343	19207	7722343	. BUSHING, NONMETALLIC UOC: DAL,V18,ZAL .....	1
15	PAFZZ	5935-01-130-3536	19207	7720497	. CONNECTOR BODY, RECE UOC: DAL,V18,ZAL .....	1
16	PAFZZ	9905-00-752-4649	24617	5939707	. BAND MRKER BLNK-ALU UOC: DAL,V18,ZAL .....	1
17	PAFZZ	5935-00-833-8561	19207	8338561	. SHELL, ELECTRICAL CO UOC: DAL,V18,ZAL .....	1
18	PAFZZ	5970-00-833-8562	19207	8338562	. INSULATOR, BUSHING UOC: DAL,V18,ZAL .....	1
19	PAFZZ	1015-00-798-2997	19207	7982997	. TERMINAL, SOLDERED F UOC: DAL,V18,ZAL .....	1
20	PAFFF	5340-00-726-1670	77820	60-37398-12	. CAP, PROTECTIVE, DUST UOC: DAL,V18,ZAL .....	1
21	PAFZZ	5330-00-990-5804	19207	8701226	. . DISK, SOLID, PLAIN UOC: DAL,V18,ZAL .....	1
22	PAFZZ	5999-01-123-4557	19207	8701287	. . CAP, ELECTRICAL UOC: DAL,V18,ZAL .....	1
23	PAFZZ	4010-01-039-4831	19207	8701233	. . CHAIN, BEAD UOC: DAL,V18,ZAL .....	1
24	PFFZZ	5320-01-029-7722	19207	8701223	. . RIVET, SOLID UOC: DAL,V18,ZAL .....	1

(1) ITEM NO.	(2) SMR CODE	(3) NSN	(4) CAGEC	(5) PART NUMBER	(6) DESCRIPTION AND USABLE ON CODE (UOC)	(7) QTY
25	PAFZZ	5305-01-125-1181	21450	425544	SCREW,ASSEMBLED WAS UOC: DAL,V18,ZAL .....	4
26	PAFFF	5930-00-898-0500	81349	MIL-S-13623/1-1	SWITCH,ROTARY UOC: DAL,V18,ZAL .....	1
27	PAFZZ	5305-00-614-3423	96906	MS35265-43	. SCREW,MACHINE UOC: DAL,V18,ZAL .....	1
28	PAFZZ	5310-00-045-3299	80205	MS35338-42	. WASHER,LOCK UOC: DAL,V18,ZAL .....	1
29	PAFZZ	5310-00-832-6852	19207	5381233	. NUT,PLAIN,HEXAGON UOC: DAL,V18,ZAL .....	1
30	PAFZZ	5310-00-194-1483	80205	MS35333-44	. WASHER,LOCK UOC: DAL,V18,ZAL .....	1
31	PAFZZ	5935-00-833-8561	19207	8338561	. SHELL,ELECTRICAL CO UOC: DAL,V18,ZAL .....	1
32	PAFZZ	5310-00-877-5797	80205	MS21044N3	NUT,SELF-LOCKING,HE UOC: DAL,V18,ZAL .....	4
33	PFFZZ	5340-00-176-0868	19207	7059461	BRACKET,ANGLE UOC: DAL,V18,ZAL .....	2
34	PAFZZ	5305-00-990-6444	80205	MS35207-261	SCREW,MACHINE UOC: DAL,V18,ZAL .....	4
35	PAFFF	5930-00-130-5349	19207	5381088	HANDLE,SWITCH UOC: DAL,V18,ZAL .....	2
36	PAFZZ	5310-01-108-5236	19207	5381087	. WASHER,SHOULDERED UOC: DAL,V18,ZAL .....	2
37	XDFZZ		19207	7392454	. FELT,MECHANICAL,PRE UOC: DAL,V18,ZAL .....	2
38	PAFZZ	5930-01-197-8661	19207	5381051	. LEVER,MANUAL CONTRO UOC: DAL,V18,ZAL .....	2
39	PGFZZ	2510-01-189-6401	19207	12277177	PANEL,VEHICULAR OPE UOC: DAC,DAD,DAE,DAF,DAG,DA H,DAJ,DAL,DAW,DAX,V14,V15,V16, V17,V18,V19,V20,V21,V22,V24,ZAA, ZAB,ZAC,ZAD,ZAE,ZAF,ZAG,ZAH,Z AJ,ZAL .....	1
40	PAFZZ	5305-00-267-8953	80204	B1821BH025F063N	SCREW,CAP,HEXAGON H UOC: DAC,DAD,DAE,DAF,DAG,DA H,DAJ,DAL,DAW,DAX,V14,V15,V16, V17,V18,V19,V20,V21,V22,V24,ZAA, ZAB,ZAC,ZAD,ZAE,ZAF,ZAG,ZAH,Z AJ,ZAL .....	5
41	PAFZZ	5310-00-241-6658	81349	M45913/3-5FG8C	NUT,SELF-LOCKING,HE UOC: DAC,DAD,DAE,DAF,DAG,DA H,DAJ,DAL,DAW,DAX,V14,V15,V16, V17,V18,V19,V20,V21,V22,V24,ZAA, ZAB,ZAC,ZAD,ZAE,ZAF,ZAG,ZAH,Z AJ,ZAL .....	2

(1) ITEM NO.	(2) SMR CODE	(3) NSN	(4) CAGEC	(5) PART NUMBER	(6) DESCRIPTION AND USABLE ON CODE (UOC)	(7) QTY
42	PAFZZ	5310-00-081-4219	96906	MS27183-12	WASHER,FLAT UOC: DAC,DAD,DAE,DAF,DAG,DAH,DAJ,DAL,DAW,DAX,V14,V15,V16,V17,V18,V19,V20,V21,V22,V24,ZAA,ZAB,ZAC,ZAD,ZAE,ZAF,ZAG,ZAH,ZAJ,ZAL .....	2
43	PFFZZ	5340-01-131-0108	19207	12255921	HANDLE,MANUAL CONTR UOC: DAC,DAD,DAE,DAF,DAG,DAH,DAJ,DAL,DAW,DAX,V14,V15,V16,V17,V18,V19,V20,V21,V22,V24,ZAA,ZAB,ZAC,ZAD,ZAE,ZAF,ZAG,ZAH,ZAJ,ZAL .....	1
44	PAFZZ	5305-01-090-7626	19207	7372083-1	SCREW,ASSEMBLED WAS UOC: DAC,DAD,DAE,DAF,DAG,DAH,DAJ,DAL,DAW,DAX,V14,V15,V16,V17,V18,V19,V20,V21,V22,V24,ZAA,ZAB,ZAC,ZAD,ZAE,ZAF,ZAG,ZAH,ZAJ,ZAL .....	6
45	PFFZZ	5340-01-090-7644	19207	12255731-2	BRACKET,MOUNTING UOC: DAC,DAD,DAE,DAF,DAG,DAH,DAJ,DAL,DAW,DAX,V14,V15,V16,V17,V18,V19,V20,V21,V22,V24,ZAA,ZAB,ZAC,ZAD,ZAE,ZAF,ZAG,ZAH,ZAJ,ZAL .....	1
46	PAFZZ	5340-01-107-6971	96906	MS51928-1	CLIP,SPRING TENSION UOC: DAL,V18,ZAL .....	1
47	PAFZZ	6250-00-741-8960	13445	EX2235	LAMPHOLDER UOC: DAL,V18,ZAL .....	1
48	PFFFF	5995-00-057-1642	19207	7418959	LEAD,ELECTRICAL UOC: DAL,V18,ZAL .....	1
49	PAFZZ	5940-00-705-6708	56501	TG8	. TERMINAL,LUG UOC: DAL,V18,ZAL .....	1
50	PAFZA	5935-00-772-0495	19207	8724198	. CONNECTOR,PLUG,ELEC UOC: DAL,V18,ZAL .....	1
51	PFFZZ	5365-00-772-2343	19207	7722343	. BUSHING,NONMETALLIC AUXILIARY OUTLET CABLE UOC: DAL,V18,ZAL .....	1
52	PAFZZ	5935-00-333-3088	19207	7723306	. NUT,BUSHING RETAINE UOC: DAL,V18,ZAL .....	1
53	PAFZZ	5975-00-522-7125	77820	10-40457-12S	. NUT,COUPLING,ELECTR UOC: DAL,V18,ZAL .....	1
54	PAFFF	2590-01-157-6240	19207	12277230	LEAD ASSEMBLY,ELECT UOC: DAL,V18,ZAL .....	1
55	PAFZZ	5935-00-833-8561	19207	8338561	. SHELL,ELECTRICAL CO UOC: DAL,V18,ZAL .....	3
56	PAFZZ	5970-00-833-8562	19207	8338562	. INSULATOR,BUSHING UOC: DAL,V18,ZAL .....	3



(1) ITEM NO.	(2) SMR CODE	(3) NSN	(4) CAGEC	(5) PART NUMBER	(6) DESCRIPTION AND USABLE ON CODE (UOC)	(7) QTY
57	PAFZZ	5940-00-399-6676	19207	8338564	. TERMINAL SET,QUICK FLOODLIGHT SWITCH UOC: DAL,V18,ZAL .....	1
58	PAFZZ	9905-01-013-8723	81349	M43436/3-1	. BAND,MARKER UOC: DAL,V18,ZAL .....	5
59	PAFZA	5999-00-057-2929	58536	AA52536-2	. CONTACT,ELECTRICAL UOC: DAL,V18,ZAL .....	3
60	PAFZZ	5310-00-833-8567	19207	8338567	. WASHER,SLOTTED UOC: DAL,V18,ZAL .....	1
61	PAFZZ	5935-00-572-9180	19207	8338566	. SHELL,ELECTRICAL CO UOC: DAL,V18,ZAL .....	1
62	PAFZZ	9905-00-752-4649	24617	5939707	. BAND MRKER BLNK-ALU FLOODLIGHT SWITCH LEAD UOC: DAL,V18,ZAL .....	5
63	PAFFF	5930-00-699-9438	81349	MIL-S-13623/1-2	SWITCH,ROTARY UOC: DAL,V18,ZAL .....	1
64	PAFZZ	5310-00-194-1483	80205	MS35333-44	WASHER,LOCK UOC: DAL,V18,ZAL .....	1
65	PAFZZ	5310-00-832-6852	19207	5381233	NUT,PLAIN,HEXAGON UOC: DAL,V18,ZAL .....	1
66	PAFZZ	5310-00-045-3299	80205	MS35338-42	WASHER,LOCK UOC: DAL,V18,ZAL .....	1
67	PAFZZ	5305-00-614-3423	96906	MS35265-43	SCREW,MACHINE UOC: DAL,V18,ZAL .....	1
68	PAFFF	5930-00-130-5349	19207	5381088	HANDLE,SWITCH UOC: DAL,V18,ZAL .....	1
69	PAFZZ	5930-01-197-8661	19207	5381051	. LEVER,MANUAL CONTRO UOC: DAL,V18,ZAL .....	1
70	XDFZZ		19207	7392454	. FELT,MECHANICAL,PRE UOC: DAL,V18,ZAL .....	1
71	PAFZZ	5310-01-108-5236	19207	5381087	. WASHER,SHOULDERED UOC: DAL,V18,ZAL .....	1
72	PAFZZ	5305-00-990-6444	80205	MS35207-261	SCREW,MACHINE FUEL TANK GAGE SELECTOR UOC: DAL,V18,ZAL .....	1
73	PAFZZ	5310-00-877-5797	80205	MS21044N3	NUT,SELF-LOCKING,HE UOC: DAL,V18,ZAL .....	2
74	PFFZZ	5340-00-176-0868	19207	7059461	BRACKET,ANGLE UOC: DAL,V18,ZAL .....	1
75	PAFZZ	5340-01-090-7643	19207	12255731-1	PLATE,MENDING UOC: DAC,DAD,DAE,DAF,DAG,DA H,DAJ,DAL,DAW,DAX,V14,V15,V16, V17,V18,V19,V20,V21,V22,V24,ZAA, ZAB,ZAC,ZAD,ZAE,ZAF,ZAG,ZAH,Z AJ,ZAL .....	1

(1) ITEM NO.	(2) SMR CODE	(3) NSN	(4) CAGEC	(5) PART NUMBER	(6) DESCRIPTION AND USABLE ON CODE (UOC)	(7) QTY
76	XDFZZ	9330-00-165-6006	19207	11599001	TUBING, NONMETALLIC UOC: DAC, DAD, DAE, DAF, DAG, DA H, DAJ, DAL, DAW, DAX, V14, V15, V16, V17, V18, V19, V20, V21, V22, V24, ZAA, ZAB, ZAC, ZAD, ZAE, ZAF, ZAG, ZAH, Z AJ, ZAL .....	1
77	PAFZZ	5306-00-042-5859	24617	425859	BOLT, ASSEMBLED WASH UOC: DAC, DAD, DAE, DAF, DAG, DA H, DAJ, DAL, DAW, DAX, V14, V15, V16, V17, V18, V19, V20, V21, V22, V24, ZAA, ZAB, ZAC, ZAD, ZAE, ZAF, ZAG, ZAH, Z AJ, ZAL .....	2

END OF FIGURE

**FIELD MAINTENANCE  
CIRCUIT BREAKERS**

---

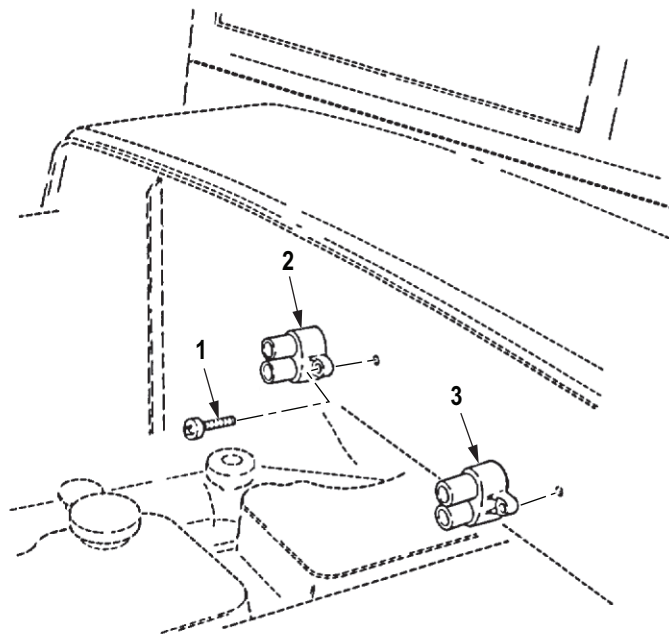

FRONT COWL

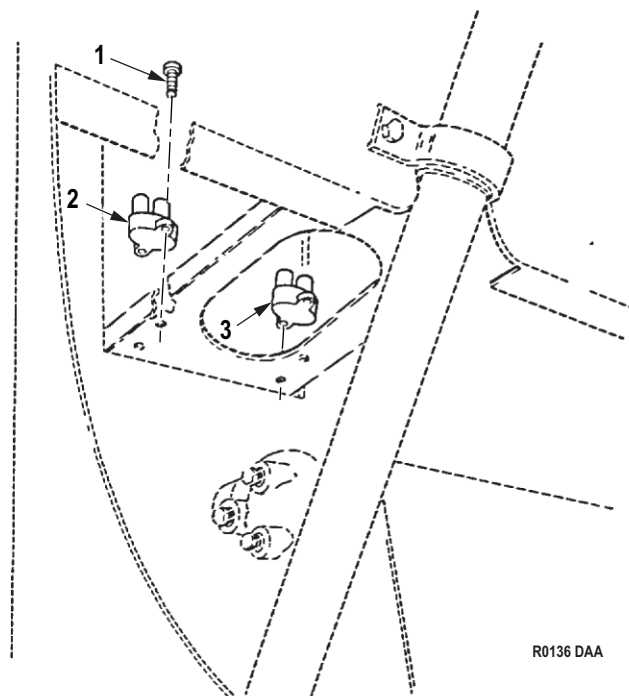

R0136 DAA

DASH UNDERSIDE

Figure 135. Circuit Breakers.

(1) ITEM NO.	(2) SMR CODE	(3) NSN	(4) CAGEC	(5) PART NUMBER	(6) DESCRIPTION AND USABLE ON CODE (UOC)	(7) QTY
<b>GROUP 0607 INSTRUMENT OR ENGINE CONTROL PANEL.</b>						
<b>FIG. 135. CIRCUIT BREAKERS.</b>						
1	PAFZZ	5305-00-855-0965	96906	MS24629-38	SCREW, TAPPING UOC: DAC, DAD, DAE, DAF, DAG, DAH, DAJ, DAL, DAW, DAX, V14, V15, V16, V17, V18, V19, V20, V21, V22, V24, ZAA, ZAB, ZAC, ZAD, ZAE, ZAF, ZAG, ZAH, ZAJ, ZAL .....	8
2	PAFZZ	5925-01-430-2318	58536	AA55571/01-001	CIRCUIT BREAKER UOC: DAC, DAD, DAE, DAF, DAG, DAH, DAJ, DAL, DAW, DAX, V14, V15, V16, V17, V18, V19, V20, V21, V22, V24, ZAA, ZAB, ZAC, ZAD, ZAE, ZAF, ZAG, ZAH, ZAJ, ZAL .....	2
3	PAFZZ	5925-00-333-1584	58536	AA55571/01-004	CIRCUIT BREAKER UOC: DAC, DAD, DAE, DAF, DAG, DAH, DAJ, DAL, DAW, DAX, V14, V15, V16, V17, V18, V19, V20, V21, V22, V24, ZAA, ZAB, ZAC, ZAD, ZAE, ZAF, ZAG, ZAH, ZAJ, ZAL .....	2

**END OF FIGURE**



**FIELD MAINTENANCE  
CONTROL UNIT AND DIRECTIONAL FLASHER**

---

1  
2-3

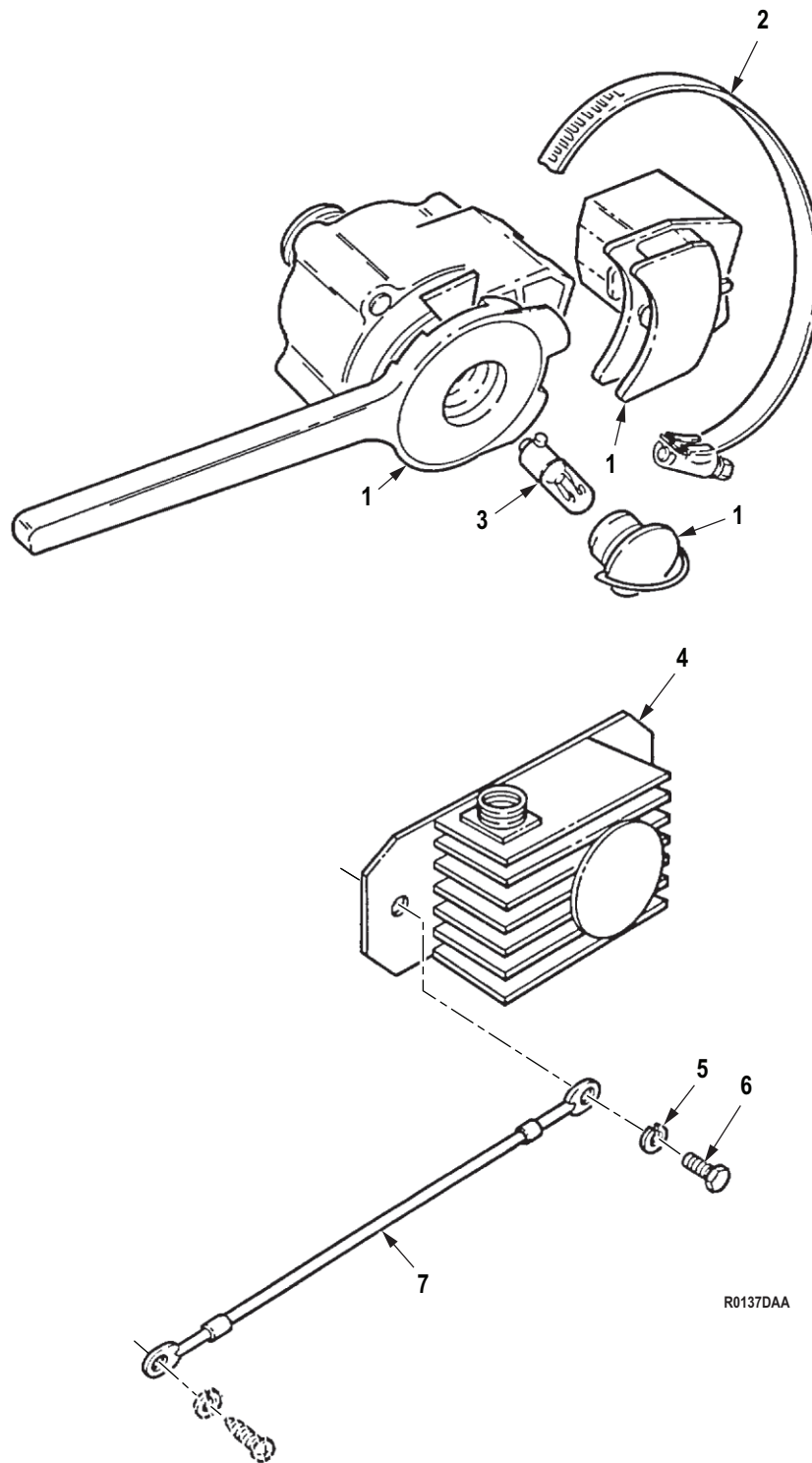

R0137DAA

Figure 136. Control Unit and Directional Flasher.



(1) ITEM NO.	(2) SMR CODE	(3) NSN	(4) CAGEC	(5) PART NUMBER	(6) DESCRIPTION AND USABLE ON CODE (UOC)	(7) QTY
<b>GROUP 0607 INSTRUMENT OR ENGINE CONTROL PANEL.</b>						
<b>FIG. 136. CONTROL UNIT AND DIRECTIONAL FLASHER.</b>						
1	PAFZZ	6220-00-808-6072	19207	11613632-3	CONTROL,DIRECTIONAL UOC: DAC,DAD,DAE,DAF,DAG,DAH,DAJ,DAL,DAW,DAX,V14,V15,V16,V17,V18,V19,V20,V21,V22,V24,ZAA,ZAB,ZAC,ZAD,ZAE,ZAF,ZAG,ZAH,ZAJ,ZAL .....	1
2	PAFZZ	4730-00-908-6292	58536	A-A-52506-F-48	. CLAMP,HOSE UOC: DAC,DAD,DAE,DAF,DAG,DAH,DAJ,DAL,DAW,DAX,V14,V15,V16,V17,V18,V19,V20,V21,V22,V24 .....	1
3	PAFZZ	6240-00-419-3185	96906	MS25231-1873	. LAMP,INCANDESCENT UOC: DAC,DAD,DAE,DAF,DAG,DAH,DAJ,DAL,DAW,DAX,V14,V15,V16,V17,V18,V19,V20,V21,V22,V24,ZAA,ZAB,ZAC,ZAD,ZAE,ZAF,ZAG,ZAH,ZAJ,ZAL .....	1
4	PAFZZ	5945-00-789-3706	19207	11613631	FLASHER,THERMAL UOC: DAC,DAD,DAE,DAF,DAG,DAH,DAJ,DAL,DAW,DAX,V14,V15,V16,V17,V18,V19,V20,V21,V22,V24,ZAA,ZAB,ZAC,ZAD,ZAE,ZAF,ZAG,ZAH,ZAJ,ZAL .....	1
5	PAFZZ	5310-00-550-1130	80205	MS35333-40	WASHER,LOCK UOC: DAC,DAD,DAE,DAF,DAG,DAH,DAJ,DAL,DAW,DAX,V14,V15,V16,V17,V18,V19,V20,V21,V22,V24,ZAA,ZAB,ZAC,ZAD,ZAE,ZAF,ZAG,ZAH,ZAJ,ZAL .....	2
6	PAFZZ	5305-00-068-0516	80204	B1821BH025F113N	SCREW,CAP,HEXAGON H UOC: DAC,DAD,DAE,DAF,DAG,DAH,DAJ,DAL,DAW,DAX,V14,V15,V16,V17,V18,V19,V20,V21,V22,V24,ZAA,ZAB,ZAC,ZAD,ZAE,ZAF,ZAG,ZAH,ZAJ,ZAL .....	2
7	PFFZZ	5995-01-147-5423	21530	12256051	LEAD,ELECTRICAL UOC: DAC,DAD,DAE,DAF,DAG,DAH,DAJ,DAL,DAW,DAX,V14,V15,V16,V17,V18,V19,V20,V21,V22,V24,ZAA,ZAB,ZAC,ZAD,ZAE,ZAF,ZAG,ZAH,ZAJ,ZAL .....	1

END OF FIGURE



**FIELD MAINTENANCE  
PROTECTIVE CONTROL BOX, HIGH BEAM SWITCH, AND MOUNTING HARDWARE**

---

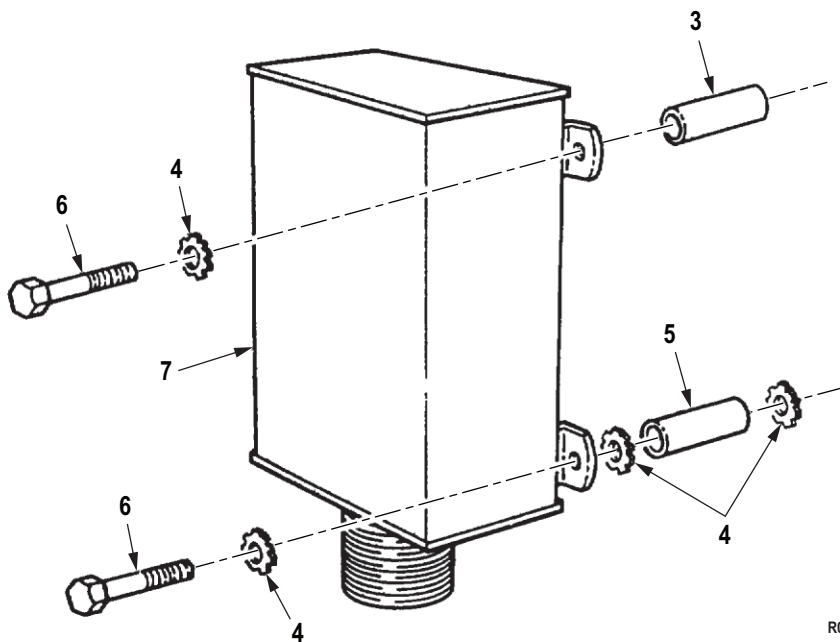
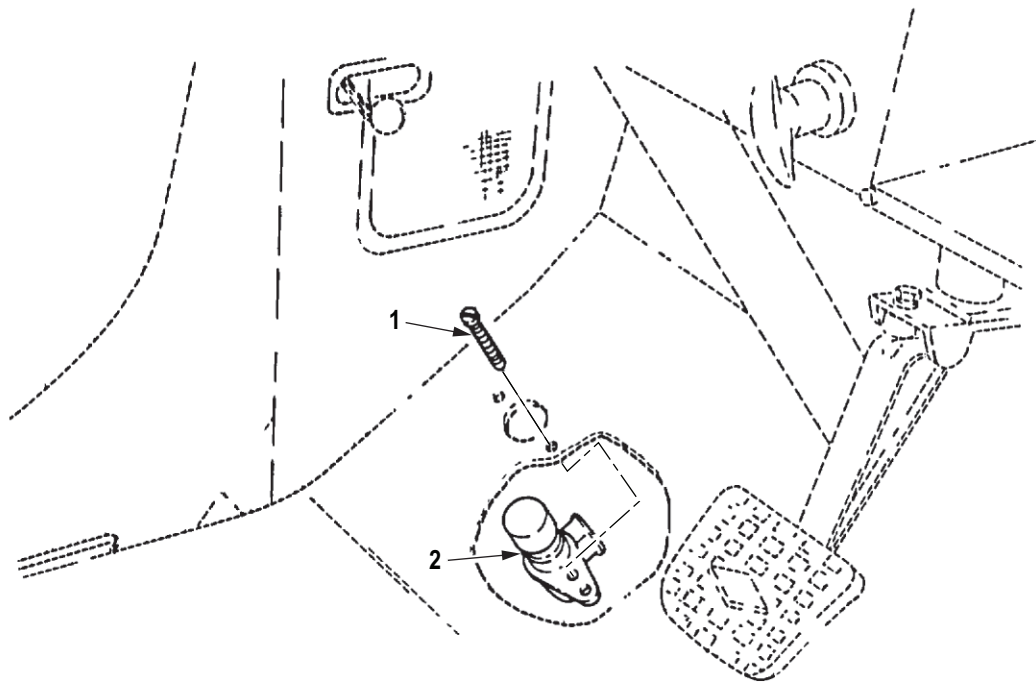

R0138DAA

Figure 137. Protective Control Box, High Beam Switch, and Mounting Hardware.

(1) ITEM NO.	(2) SMR CODE	(3) NSN	(4) CAGEC	(5) PART NUMBER	(6) DESCRIPTION AND USABLE ON CODE (UOC)	(7) QTY
<b>GROUP 0607 INSTRUMENT OR ENGINE CONTROL PANEL.</b>						
<b>FIG. 137. PROTECTIVE CONTROL BOX, HIGH BEAM SWITCH, AND MOUNTING HARDWARE.</b>						
1	PAFZZ	5305-00-988-1724	96906	MS35206-280	SCREW,MACHINE UOC: DAC,DAD,DAE,DAF,DAG,DAH,DAJ,DAL,DAW,DAX,V14,V15,V16,V17,V18,V19,V20,V21,V22,V24,ZAA,ZAB,ZAC,ZAD,ZAE,ZAF,ZAG,ZAH,ZAJ,ZAL .....	2
2	PAFZZ	2590-00-801-2355	19207	8396186	SWITCH,BEAM SELECTI UOC: DAC,DAD,DAE,DAF,DAG,DAH,DAJ,DAL,DAW,DAX,V14,V15,V16,V17,V18,V19,V20,V21,V22,V24,ZAA,ZAB,ZAC,ZAD,ZAE,ZAF,ZAG,ZAH,ZAJ,ZAL .....	1
3	PAFZZ	5365-01-106-6060	19207	12256063-1	SPACER,SLEEVE UOC: DAC,DAD,DAE,DAF,DAG,DAH,DAJ,DAL,DAW,DAX,V14,V15,V16,V17,V18,V19,V20,V21,V22,V24,ZAA,ZAB,ZAC,ZAD,ZAE,ZAF,ZAG,ZAH,ZAJ,ZAL .....	2
4	PAFZZ	5310-00-728-2044	96906	MS45904-73	WASHER,LOCK UOC: DAC,DAD,DAE,DAF,DAG,DAH,DAJ,DAL,DAW,DAX,V14,V15,V16,V17,V18,V19,V20,V21,V22,V24,ZAA,ZAB,ZAC,ZAD,ZAE,ZAF,ZAG,ZAH,ZAJ,ZAL .....	8
5	PAFZZ	5365-01-117-6655	19207	12256063-3	SPACER,SLEEVE UOC: DAC,DAD,DAE,DAF,DAG,DAH,DAJ,DAL,DAW,DAX,V14,V15,V16,V17,V18,V19,V20,V21,V22,V24,ZAA,ZAB,ZAC,ZAD,ZAE,ZAF,ZAG,ZAH,ZAJ,ZAL .....	2
6	PAFZZ	5306-00-051-4084	96906	MS90727-42	BOLT,MACHINE UOC: DAC,DAD,DAE,DAF,DAG,DAH,DAJ,DAL,DAW,DAX,V14,V15,V16,V17,V18,V19,V20,V21,V22,V24,ZAA,ZAB,ZAC,ZAD,ZAE,ZAF,ZAG,ZAH,ZAJ,ZAL .....	4

(1) ITEM NO.	(2) SMR CODE	(3) NSN	(4) CAGEC	(5) PART NUMBER	(6) DESCRIPTION AND USABLE ON CODE (UOC)	(7) QTY
7	PAFZZ	6110-01-444-2546	19207	12450333	CONTROL,LIGHT SOURC UOC: DAC,DAD,DAE,DAF,DAG,DA H,DAJ,DAL,DAW,DAX,V14,V15,V16, V17,V18,V19,V20,V21,V22,V24,ZAA, ZAB,ZAC,ZAD,ZAE,ZAF,ZAG,ZAH,Z AJ,ZAL .....	1

END OF FIGURE

**FIELD MAINTENANCE  
CTIS ELECTRICAL WIRING HARNESS (M939A2)**

---

1  
2 - 10

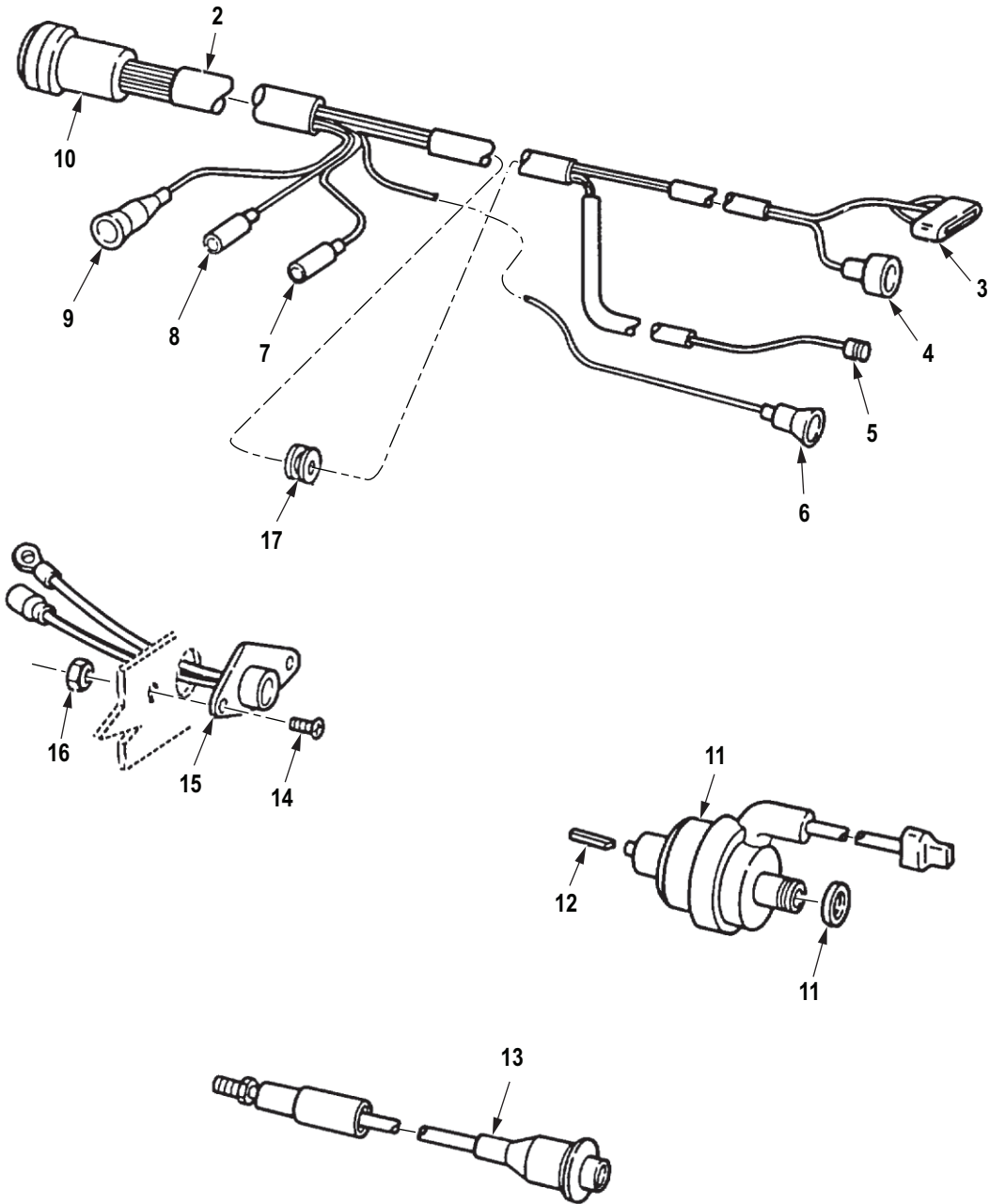

R0139DAA

Figure 138. CTIS Electrical Wiring Harness (M939A2).



(1) ITEM NO.	(2) SMR CODE	(3) NSN	(4) CAGEC	(5) PART NUMBER	(6) DESCRIPTION AND USABLE ON CODE (UOC)	(7) QTY
<b>GROUP 0608 MISCELLANEOUS ITEMS.</b>						
<b>FIG. 138. CTIS ELECTRICAL WIRING HARNESS (M939A2).</b>						
1	PAFFF	5995-01-290-1293	1MVZ1	599669	WIRING HARNESS UOC: ZAA,ZAB,ZAC,ZAD,ZAE,ZAF, ZAG,ZAH,ZAJ .....	1
1	PAFFF	5995-01-290-1294	52304	599763	WIRING HARNESS UOC: ZAL .....	1
2	XAFZZ		1MVZ1	599669-1	. WIRING HARNESS UOC: ZAA,ZAB,ZAC,ZAD,ZAE,ZAF, ZAG,ZAH,ZAJ,ZAL .....	1
3	XBFZZ		52304	599980	. LEAD,ELECTRICAL UOC: ZAL .....	1
3	XAFZZ	6150-01-282-1888	52304	599747	. LEAD,ELECTRICAL UOC: ZAA,ZAB,ZAC,ZAD,ZAE,ZAF, ZAG,ZAH,ZAJ .....	1
4	XAFZZ	6150-01-282-2785	52304	599752	. CABLE ASSEMBLY,SPEC TRANSDUCER UOC: ZAA,ZAB,ZAC,ZAD,ZAE,ZAF, ZAG,ZAH,ZAJ,ZAL .....	1
5	PAFZZ	5935-01-287-4286	52304	599753	. CONNECTOR,PLUG,ELEC COIL UOC: ZAA,ZAB,ZAC,ZAD,ZAE,ZAF, ZAG,ZAH,ZAJ,ZAL .....	1
6	XAFZZ	6150-01-282-2786	52304	599754	. CABLE ASSEMBLY,SPEC SWITCH UOC: ZAA,ZAB,ZAC,ZAD,ZAE,ZAF, ZAG,ZAH,ZAJ,ZAL .....	1
7	XAFZZ	6150-01-282-1885	52304	599971	. CABLE ASSEMBLY,SPEC SENSOR UOC: ZAA,ZAB,ZAC,ZAD,ZAE,ZAF, ZAG,ZAH,ZAJ,ZAL .....	1
8	XAFZZ		52304	599751	. LEAD,ELECTRICAL LIGHT UOC: ZAA,ZAB,ZAC,ZAD,ZAE,ZAF, ZAG,ZAH,ZAJ,ZAL .....	1
9	XAFZZ	6150-01-282-1890	52304	599982	. LEAD,ELECTRICAL UOC: ZAA,ZAB,ZAC,ZAD,ZAE,ZAF, ZAG,ZAH,ZAJ,ZAL .....	1
10	XAFZZ	5935-01-282-1881	65884	SIA-2017	. CONNECTOR,PLUG,ELEC AND GROUND UOC: ZAA,ZAB,ZAC,ZAD,ZAE,ZAF, ZAG,ZAH,ZAJ,ZAL .....	1
11	PAFZZ	6625-01-289-2062	19207	12363453	GENERATOR,SIGNAL SPEEDOMETER SHAFT ASSEMBLY UOC: ZAA,ZAB,ZAC,ZAD,ZAE,ZAF, ZAG,ZAH,ZAJ,ZAL .....	1

(1) ITEM NO.	(2) SMR CODE	(3) NSN	(4) CAGEC	(5) PART NUMBER	(6) DESCRIPTION AND USABLE ON CODE (UOC)	(7) QTY
12	PAFZZ	5315-01-384-2149	78388	SA-2677	PIN,SHOULDER,HEADLE SPEEDOMETER SHAFT ASSEMBLY UOC: ZAA,ZAB,ZAC,ZAD,ZAE,ZAF, ZAG,ZAH,ZAJ,ZAL .....	1
13	PAFZZ	5930-01-287-3965	52304	599603	SWITCH,PRESSURE UOC: ZAA,ZAB,ZAC,ZAD,ZAE,ZAF, ZAG,ZAH,ZAJ,ZAL .....	1
14	PAFZZ	5305-01-271-8332	24617	159358	SCREW,MACHINE UOC: ZAA,ZAB,ZAC,ZAD,ZAE,ZAF, ZAG,ZAH,ZAJ,ZAL .....	2
15	PAFZZ	6220-01-273-0177	96139	IRS-WP-1254AP	LIGHT,WARNING UOC: ZAA,ZAB,ZAC,ZAD,ZAE,ZAF, ZAG,ZAH,ZAJ,ZAL .....	1
16	PAFZZ	5310-00-982-4935	96906	MS27040-6	NUT,PLAIN,SQUARE UOC: ZAA,ZAB,ZAC,ZAD,ZAE,ZAF, ZAG,ZAH,ZAJ,ZAL .....	2
17	PAFZZ	5325-00-263-6648	96906	MS35489-135	GROMMET,NONMETALLIC UOC: ZAA,ZAB,ZAC,ZAD,ZAE,ZAF, ZAG,ZAH,ZAJ,ZAL .....	1

END OF FIGURE

**FIELD MAINTENANCE  
TAILLIGHT ASSEMBLY AND MOUNTING HARDWARE**

---

2  
3-11

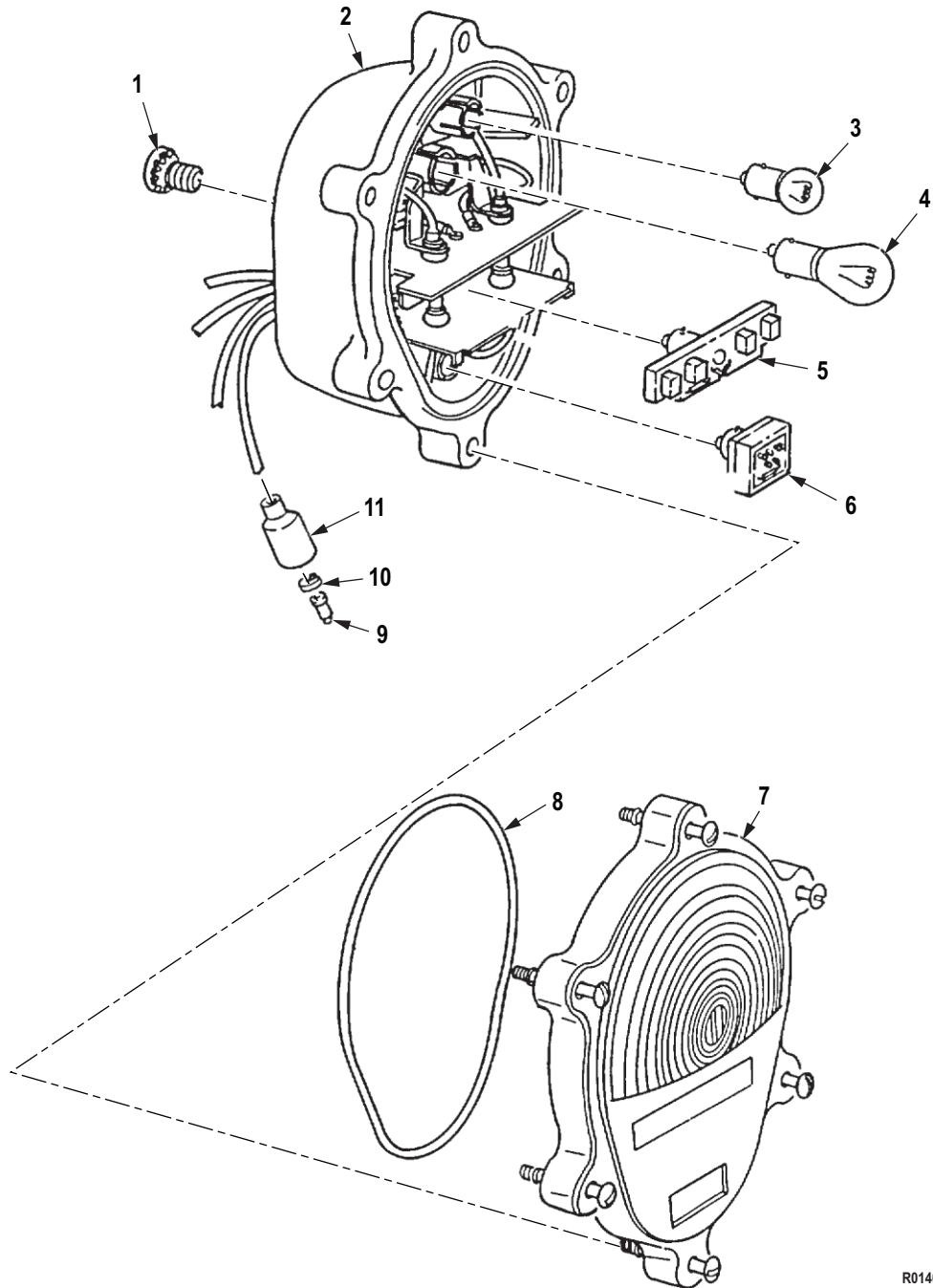

R0140DAA

Figure 139. Taillight Assembly and Mounting Hardware.

(1) ITEM NO.	(2) SMR CODE	(3) NSN	(4) CAGEC	(5) PART NUMBER	(6) DESCRIPTION AND USABLE ON CODE (UOC)	(7) QTY
<b>GROUP 0609 LIGHTS.</b>						
<b>FIG. 139. TAILLIGHT ASSEMBLY AND MOUNTING HARDWARE.</b>						
1	PAFZZ	5305-00-042-3568	21450	423568	SCREW,ASSEMBLED WAS UOC: DAC,DAD,DAE,DAF,DAG,DA H,DAJ,DAL,DAW,DAX,V14,V15,V16, V17,V18,V19,V20,V21,V22,V24,ZAA, ZAB,ZAC,ZAD,ZAE,ZAF,ZAG,ZAH,Z AJ,ZAL .....	4
2	PAFFF	6220-01-372-3883	19207	12375837	TAILLIGHT,VEHICULAR UOC: DAC,DAD,DAE,DAF,DAG,DA H,DAJ,DAL,DAW,DAX,V14,V15,V16, V17,V18,V19,V20,V21,V22,V24,ZAA, ZAB,ZAC,ZAD,ZAE,ZAF,ZAG,ZAH,Z AJ,ZAL .....	2
3	PAFZZ	6240-00-019-3093	58536	AA52463-A09	. LAMP,INCANDESCENT UOC: DAC,DAD,DAE,DAF,DAG,DA H,DAJ,DAL,DAW,DAX,V14,V15,V16, V17,V18,V19,V20,V21,V22,V24,ZAA, ZAB,ZAC,ZAD,ZAE,ZAF,ZAG,ZAH,Z AJ,ZAL .....	1
4	PAFZZ	6240-00-044-6914	08108	1683	. LAMP,INCANDESCENT UOC: DAC,DAD,DAE,DAF,DAG,DA H,DAJ,DAL,DAW,DAX,V14,V15,V16, V17,V18,V19,V20,V21,V22,V24,ZAA, ZAB,ZAC,ZAD,ZAE,ZAF,ZAG,ZAH,Z AJ,ZAL .....	1
5	PAFZZ	6220-01-284-2709	19207	12360850-1	. LIGHT,MARKER,CLEARA UOC: DAC,DAD,DAE,DAF,DAG,DA H,DAJ,DAL,DAW,DAX,V14,V15,V16, V17,V18,V19,V20,V21,V22,V24,ZAA, ZAB,ZAC,ZAD,ZAE,ZAF,ZAG,ZAH,Z AJ,ZAL .....	1
6	PAFZZ	6220-01-297-3217	19207	12360870-2	. STOP LIGHT,VEHICULA UOC: DAC,DAD,DAE,DAF,DAG,DA H,DAJ,DAL,DAW,DAX,V14,V15,V16, V17,V18,V19,V20,V21,V22,V24,ZAA, ZAB,ZAC,ZAD,ZAE,ZAF,ZAG,ZAH,Z AJ,ZAL .....	1
7	PAFZZ	6220-01-359-2870	19207	12375841	LENS,LIGHT USE WITH PLASTIC HOUSING ASSEMBLY ONLY UOC: DAC,DAD,DAE,DAF,DAG,DA H,DAJ,DAL,DAW,DAX,V14,V15,V16, V17,V18,V19,V20,V21,V22,V24,ZAA, ZAB,ZAC,ZAD,ZAE,ZAF,ZAG,ZAH,Z AJ,ZAL .....	1

(1) ITEM NO.	(2) SMR CODE	(3) NSN	(4) CAGEC	(5) PART NUMBER	(6) DESCRIPTION AND USABLE ON CODE (UOC)	(7) QTY
8	PAFZZ	5331-00-462-0907	19207	11639519-2	. O-RING UOC: DAC,DAD,DAE,DAF,DAG,DAH,DAJ,DAL,DAW,DAX,V14,V15,V16,V17,V18,V19,V20,V21,V22,V24,ZAA,ZAB,ZAC,ZAD,ZAE,ZAF,ZAG,ZAH,ZAJ,ZAL .....	1
9	PAFZA	5999-00-057-2929	58536	AA52536-2	. CONTACT,ELECTRICAL UOC: DAC,DAD,DAE,DAF,DAG,DAH,DAJ,DAL,DAW,DAX,V14,V15,V16,V17,V18,V19,V20,V21,V22,V24,ZAA,ZAB,ZAC,ZAD,ZAE,ZAF,ZAG,ZAH,ZAJ,ZAL .....	4
10	PAFZZ	5310-00-833-8567	19207	8338567	. WASHER,SLOTTED UOC: DAC,DAD,DAE,DAF,DAG,DAH,DAJ,DAL,DAW,DAX,V14,V15,V16,V17,V18,V19,V20,V21,V22,V24,ZAA,ZAB,ZAC,ZAD,ZAE,ZAF,ZAG,ZAH,ZAJ,ZAL .....	4
11	PAFZZ	5935-00-572-9180	19207	8338566	. SHELL,ELECTRICAL CO UOC: DAC,DAD,DAE,DAF,DAG,DAH,DAJ,DAL,DAW,DAX,V14,V15,V16,V17,V18,V19,V20,V21,V22,V24,ZAA,ZAB,ZAC,ZAD,ZAE,ZAF,ZAG,ZAH,ZAJ,ZAL .....	4

END OF FIGURE

**FIELD MAINTENANCE  
FRONT COMPOSITE LIGHT AND MOUNTING HARDWARE**

---

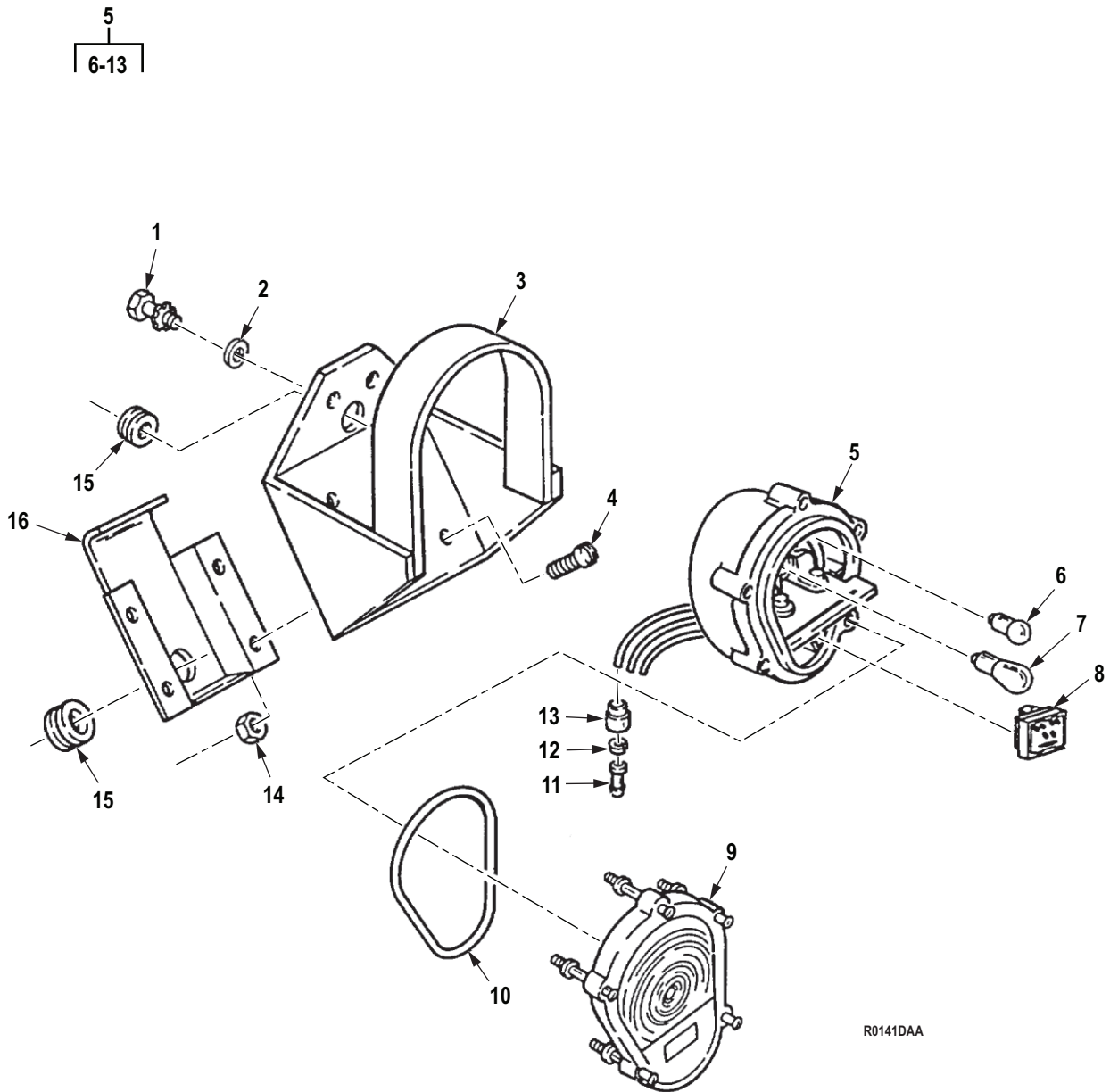

R0141DAA

Figure 140. Front Composite Light and Mounting Hardware.



(1) ITEM NO.	(2) SMR CODE	(3) NSN	(4) CAGEC	(5) PART NUMBER	(6) DESCRIPTION AND USABLE ON CODE (UOC)	(7) QTY
<b>GROUP 0609 LIGHTS.</b>						
<b>FIG. 140. FRONT COMPOSITE LIGHT AND MOUNTING HARDWARE.</b>						
1	PAFZZ	5305-00-042-3568	21450	423568	SCREW,ASSEMBLED WAS UOC: DAC,DAD,DAE,DAF,DAG,DA H,DAJ,DAL,DAW,DAX,V14,V15,V16, V17,V18,V19,V20,V21,V22,V24,ZAA, ZAB,ZAC,ZAD,ZAE,ZAF,ZAG,ZAH,Z AJ,ZAL .....	4
2	PAFZZ	5310-00-595-7237	80205	MS35333-42	WASHER,LOCK UOC: DAC,DAD,DAE,DAF,DAG,DA H,DAJ,DAL,DAW,DAX,V14,V15,V16, V17,V18,V19,V20,V21,V22,V24,ZAA, ZAB,ZAC,ZAD,ZAE,ZAF,ZAG,ZAH,Z AJ,ZAL .....	4
3	PAFZZ	6220-00-428-5943	19207	11658687	LIGHT,HOOD,VEHICLE UOC: DAC,DAD,DAE,DAF,DAG,DA H,DAJ,DAL,DAW,DAX,V14,V15,V16, V17,V18,V19,V20,V21,V22,V24,ZAA, ZAB,ZAC,ZAD,ZAE,ZAF,ZAG,ZAH,Z AJ,ZAL .....	2
4	PAFZZ	5306-00-050-1238	80204	B1821BH031F075N	BOLT,MACHINE UOC: DAC,DAD,DAE,DAF,DAG,DA H,DAJ,DAL,DAW,DAX,V14,V15,V16, V17,V18,V19,V20,V21,V22,V24,ZAA, ZAB,ZAC,ZAD,ZAE,ZAF,ZAG,ZAH,Z AJ,ZAL .....	8
5	PAFFF	6220-01-443-8813	19207	12432437-1	LIGHT,PARKING UOC: DAC,DAD,DAE,DAF,DAG,DA H,DAJ,DAL,DAW,DAX,V14,V15,V16, V17,V18,V19,V20,V21,V22,V24,ZAA, ZAB,ZAC,ZAD,ZAE,ZAF,ZAG,ZAH,Z AJ,ZAL .....	1
6	PAFZZ	6240-00-019-3093	58536	AA52463-A09	. LAMP,INCANDESCENT UOC: DAC,DAD,DAE,DAF,DAG,DA H,DAJ,DAL,DAW,DAX,V14,V15,V16, V17,V18,V19,V20,V21,V22,V24,ZAA, ZAB,ZAC,ZAD,ZAE,ZAF,ZAG,ZAH,Z AJ,ZAL .....	1
7	PAFZZ	6240-00-044-6914	08108	1683	. LAMP,INCANDESCENT UOC: DAC,DAD,DAE,DAF,DAG,DA H,DAJ,DAL,DAW,DAX,V14,V15,V16, V17,V18,V19,V20,V21,V22,V24,ZAA, ZAB,ZAC,ZAD,ZAE,ZAF,ZAG,ZAH,Z AJ,ZAL .....	1

(1) ITEM NO.	(2) SMR CODE	(3) NSN	(4) CAGEC	(5) PART NUMBER	(6) DESCRIPTION AND USABLE ON CODE (UOC)	(7) QTY
8	PAFZZ	5961-01-305-8848	19207	12360865	. SEMICONDUCTOR DEVIC UOC: DAC,DAD,DAE,DAF,DAG,DA H,DAJ,DAL,DAW,DAX,V14,V15,V16, V17,V18,V19,V20,V21,V22,V24,ZAA, ZAB,ZAC,ZAD,ZAE,ZAF,ZAG,ZAH,Z AJ,ZAL .....	1
9	PAFZZ	6220-01-443-8805	19207	12432440	. LENS,LIGHT USE WITH PLASTIC HOUSING ASSEMBLY ONLY UOC: DAC,DAD,DAE,DAF,DAG,DA H,DAJ,DAL,DAW,DAX,V14,V15,V16, V17,V18,V19,V20,V21,V22,V24,ZAA, ZAB,ZAC,ZAD,ZAE,ZAF,ZAG,ZAH,Z AJ,ZAL .....	1
10	PAFZZ	5331-00-463-0200	19207	11639519-1	. O-RING UOC: DAC,DAD,DAE,DAF,DAG,DA H,DAJ,DAL,DAW,DAX,V14,V15,V16, V17,V18,V19,V20,V21,V22,V24,ZAA, ZAB,ZAC,ZAD,ZAE,ZAF,ZAG,ZAH,Z AJ,ZAL .....	1
11	PAFZA	5999-00-057-2929	58536	AA52536-2	. CONTACT,ELECTRICAL UOC: DAC,DAD,DAE,DAF,DAG,DA H,DAJ,DAL,DAW,DAX,V14,V15,V16, V17,V18,V19,V20,V21,V22,V24,ZAA, ZAB,ZAC,ZAD,ZAE,ZAF,ZAG,ZAH,Z AJ,ZAL .....	3
12	PAFZZ	5310-00-833-8567	19207	8338567	. WASHER,SLOTTED UOC: DAC,DAD,DAE,DAF,DAG,DA H,DAJ,DAL,DAW,DAX,V14,V15,V16, V17,V18,V19,V20,V21,V22,V24,ZAA, ZAB,ZAC,ZAD,ZAE,ZAF,ZAG,ZAH,Z AJ,ZAL .....	3
13	PAFZZ	5935-00-572-9180	19207	8338566	. SHELL,ELECTRICAL CO UOC: DAC,DAD,DAE,DAF,DAG,DA H,DAJ,DAL,DAW,DAX,V14,V15,V16, V17,V18,V19,V20,V21,V22,V24,ZAA, ZAB,ZAC,ZAD,ZAE,ZAF,ZAG,ZAH,Z AJ,ZAL .....	3
14	PAFZZ	5310-01-409-1642	24617	9419479	NUT,SELF-LOCKING,HE UOC: DAC,DAD,DAE,DAF,DAG,DA H,DAJ,DAL,DAW,DAX,V14,V15,V16, V17,V18,V19,V20,V21,V22,V24,ZAA, ZAB,ZAC,ZAD,ZAE,ZAF,ZAG,ZAH,Z AJ,ZAL .....	8
15	PAFZZ	5325-00-276-6091	96906	MS35489-19	GROMMET,NONMETALLIC UOC: DAC,DAD,DAE,DAF,DAG,DA H,DAJ,DAL,DAW,DAX,V14,V15,V16, V17,V18,V19,V20,V21,V22,V24,ZAA, ZAB,ZAC,ZAD,ZAE,ZAF,ZAG,ZAH,Z AJ,ZAL .....	4

(1) ITEM NO.	(2) SMR CODE	(3) NSN	(4) CAGEC	(5) PART NUMBER	(6) DESCRIPTION AND USABLE ON CODE (UOC)	(7) QTY
16	PAFZZ	5340-00-178-1036	19207	7397758	COVER,ACCESS UOC: DAC,DAD,DAE,DAF,DAG,DA H,DAJ,DAL,DAW,DAX,V14,V15,V16, V17,V18,V19,V20,V21,V22,V24,ZAA, ZAB,ZAC,ZAD,ZAE,ZAF,ZAG,ZAH,Z AJ,ZAL .....	2

END OF FIGURE



**FIELD MAINTENANCE  
BLACKOUT LAMP AND HEADLIGHT**

---

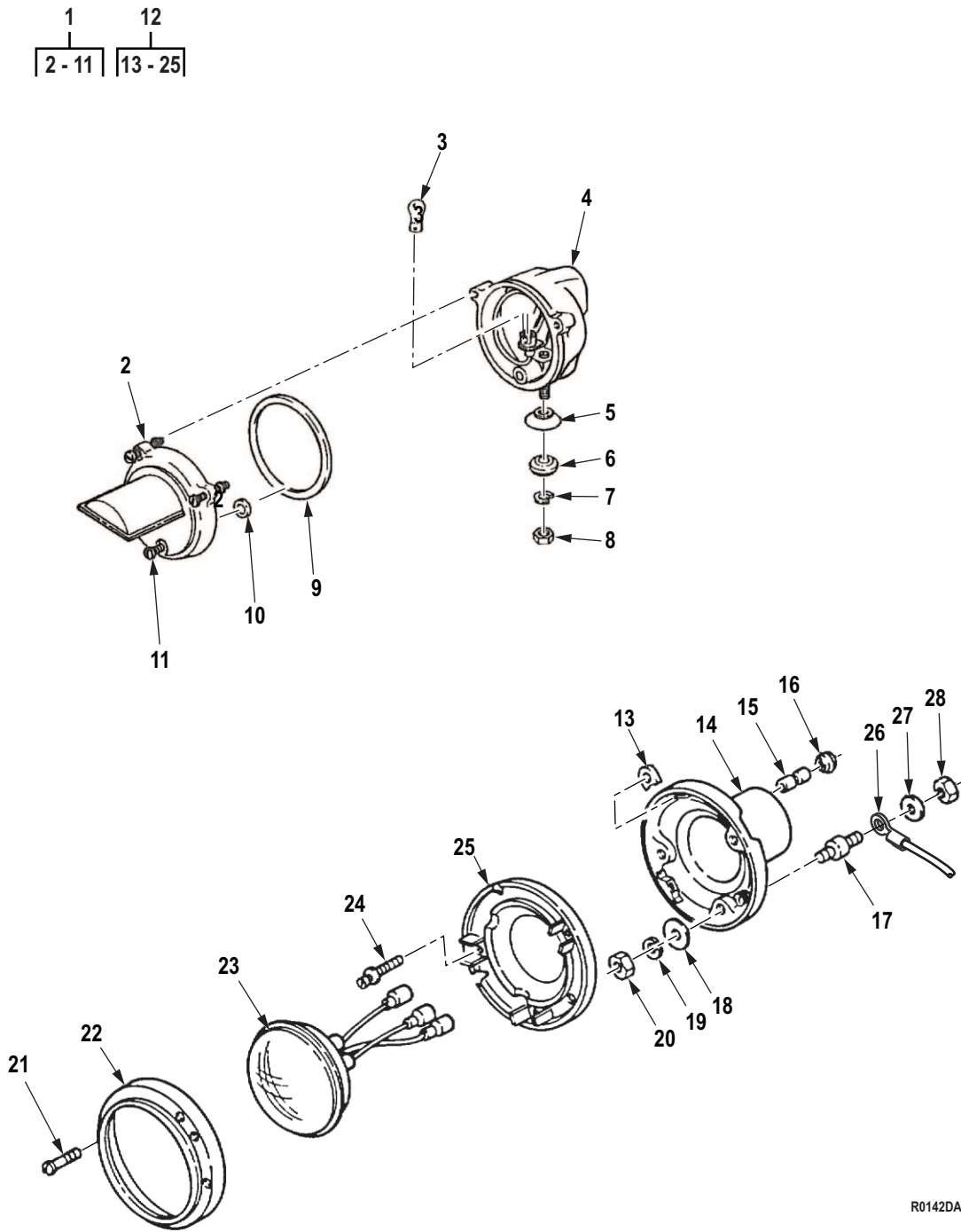

R0142DAA

Figure 141. Blackout Lamp and Headlight.

(1) ITEM NO.	(2) SMR CODE	(3) NSN	(4) CAGEC	(5) PART NUMBER	(6) DESCRIPTION AND USABLE ON CODE (UOC)	(7) QTY
<b>GROUP 0609 LIGHTS.</b>						
<b>FIG. 141. BLACKOUT LAMP AND HEADLIGHT.</b>						
1	PFFFF	6220-01-496-1925	19207	12423610	HEADLIGHT UOC: DAC,DAD,DAE,DAF,DAG,DAH,DAJ,DAL,DAW,DAX,V14,V15,V16,V17,V18,V19,V20,V21,V22,V24,ZAA,ZAB,ZAC,ZAD,ZAE,ZAF,ZAG,ZAH,ZAJ,ZAL .....	1
2	PAFZZ	6220-01-107-2613	5A910	DC8218	. RETAINER,LENS UOC: DAC,DAD,DAE,DAF,DAG,DAH,DAJ,DAL,DAW,DAX,V14,V15,V16,V17,V18,V19,V20,V21,V22,V24,ZAA,ZAB,ZAC,ZAD,ZAE,ZAF,ZAG,ZAH,ZAJ,ZAL .....	1
3	PAFZZ	6240-01-447-3779	19207	AA52463-B10	. LAMP,INCANDESCENT UOC: DAC,DAD,DAE,DAF,DAG,DAH,DAJ,DAL,DAW,DAX,V14,V15,V16,V17,V18,V19,V20,V21,V22,V24,ZAA,ZAB,ZAC,ZAD,ZAE,ZAF,ZAG,ZAH,ZAJ,ZAL .....	1
4	PAFZZ	6220-01-128-0087	13873	DGSCV-91-157	. HOUSING,LIGHT UOC: DAC,DAD,DAE,DAF,DAG,DAH,DAJ,DAL,DAW,DAX,V14,V15,V16,V17,V18,V19,V20,V21,V22,V24,ZAA,ZAB,ZAC,ZAD,ZAE,ZAF,ZAG,ZAH,ZAJ,ZAL .....	1
5	PAFZZ	5310-01-100-2067	19207	11668979	. WASHER,LOCK UOC: DAC,DAD,DAE,DAF,DAG,DAH,DAJ,DAL,DAW,DAX,V14,V15,V16,V17,V18,V19,V20,V21,V22,V24,ZAA,ZAB,ZAC,ZAD,ZAE,ZAF,ZAG,ZAH,ZAJ,ZAL .....	1
6	PAFZZ	5310-00-350-2655	19207	5294507	. WASHER,FINISHING UOC: DAC,DAD,DAE,DAF,DAG,DAH,DAJ,DAL,DAW,DAX,V14,V15,V16,V17,V18,V19,V20,V21,V22,V24,ZAA,ZAB,ZAC,ZAD,ZAE,ZAF,ZAG,ZAH,ZAJ,ZAL .....	1
7	PAFZZ	5310-00-637-9541	00198	132661	. WASHER,LOCK UOC: DAC,DAD,DAE,DAF,DAG,DAH,DAJ,DAL,DAW,DAX,V14,V15,V16,V17,V18,V19,V20,V21,V22,V24,ZAA,ZAB,ZAC,ZAD,ZAE,ZAF,ZAG,ZAH,ZAJ,ZAL .....	1

(1) ITEM NO.	(2) SMR CODE	(3) NSN	(4) CAGEC	(5) PART NUMBER	(6) DESCRIPTION AND USABLE ON CODE (UOC)	(7) QTY
8	PAFZZ	5310-00-732-0558	96906	MS51967-8	. NUT,PLAIN,HEXAGON UOC: DAC,DAD,DAE,DAF,DAG,DA H,DAJ,DAL,DAW,DAX,V14,V15,V16, V17,V18,V19,V20,V21,V22,V24,ZAA, ZAB,ZAC,ZAD,ZAE,ZAF,ZAG,ZAH,Z AJ,ZAL .....	1
9	PAFZZ	5330-01-037-0663	5A910	DC8211	. GASKET UOC: DAC,DAD,DAE,DAF,DAG,DA H,DAJ,DAL,DAW,DAX,V14,V15,V16, V17,V18,V19,V20,V21,V22,V24,ZAA, ZAB,ZAC,ZAD,ZAE,ZAF,ZAG,ZAH,Z AJ,ZAL .....	1
10	PAFZZ	5330-01-076-6172	34623	MA236-21103	. GASKET UOC: DAC,DAD,DAE,DAF,DAG,DA H,DAJ,DAL,DAW,DAX,V14,V15,V16, V17,V18,V19,V20,V21,V22,V24,ZAA, ZAB,ZAC,ZAD,ZAE,ZAF,ZAG,ZAH,Z AJ,ZAL .....	3
11	PAFZZ	5306-01-083-5536	19207	12287561-1	. BOLT,EXTERNALLY REL UOC: DAC,DAD,DAE,DAF,DAG,DA H,DAJ,DAL,DAW,DAX,V14,V15,V16, V17,V18,V19,V20,V21,V22,V24,ZAA, ZAB,ZAC,ZAD,ZAE,ZAF,ZAG,ZAH,Z AJ,ZAL .....	4
12	PAFFF	6220-01-193-1970	19207	12338611	HEADLIGHT UOC: DAC,DAD,DAE,DAF,DAG,DA H,DAJ,DAL,DAW,DAX,V14,V15,V16, V17,V18,V19,V20,V21,V22,V24,ZAA, ZAB,ZAC,ZAD,ZAE,ZAF,ZAG,ZAH,Z AJ,ZAL .....	2
13	PAFZZ	5310-00-241-6921	19207	8741435	. NUT BLANK UOC: DAC,DAD,DAE,DAF,DAG,DA H,DAJ,DAL,DAW,DAX,V14,V15,V16, V17,V18,V19,V20,V21,V22,V24,ZAA, ZAB,ZAC,ZAD,ZAE,ZAF,ZAG,ZAH,Z AJ,ZAL .....	2
14	PAFZZ	6220-00-443-0589	19207	8741461	. HOUSING,LIGHT UOC: DAC,DAD,DAE,DAF,DAG,DA H,DAJ,DAL,DAW,DAX,V14,V15,V16, V17,V18,V19,V20,V21,V22,V24,ZAA, ZAB,ZAC,ZAD,ZAE,ZAF,ZAG,ZAH,Z AJ,ZAL .....	1
15	PAFZZ	5935-00-807-4109	19207	8741492	. ADAPTER,CONNECTOR UOC: DAC,DAD,DAE,DAF,DAG,DA H,DAJ,DAL,DAW,DAX,V14,V15,V16, V17,V18,V19,V20,V21,V22,V24,ZAA, ZAB,ZAC,ZAD,ZAE,ZAF,ZAG,ZAH,Z AJ,ZAL .....	3



(1) ITEM NO.	(2) SMR CODE	(3) NSN	(4) CAGEC	(5) PART NUMBER	(6) DESCRIPTION AND USABLE ON CODE (UOC)	(7) QTY
16	PAFZZ	5325-00-088-6147	19207	8741442	. GROMMET, NONMETALLIC UOC: DAC, DAD, DAE, DAF, DAG, DA H, DAJ, DAL, DAW, DAX, V14, V15, V16, V17, V18, V19, V20, V21, V22, V24, ZAA, ZAB, ZAC, ZAD, ZAE, ZAF, ZAG, ZAH, Z AJ, ZAL .....	3
17	PAFZZ	5342-00-182-3726	19207	8741441	. MOUNT, RESILIENT, WEA UOC: DAC, DAD, DAE, DAF, DAG, DA H, DAJ, DAL, DAW, DAX, V14, V15, V16, V17, V18, V19, V20, V21, V22, V24, ZAA, ZAB, ZAC, ZAD, ZAE, ZAF, ZAG, ZAH, Z AJ, ZAL .....	3
18	PAFZZ	5310-00-463-0268	19207	5310615	. WASHER, FLAT UOC: DAC, DAD, DAE, DAF, DAG, DA H, DAJ, DAL, DAW, DAX, V14, V15, V16, V17, V18, V19, V20, V21, V22, V24, ZAA, ZAB, ZAC, ZAD, ZAE, ZAF, ZAG, ZAH, Z AJ, ZAL .....	3
19	PAFZZ	5310-00-582-5965	80205	MS35338-44	. WASHER, LOCK UOC: DAC, DAD, DAE, DAF, DAG, DA H, DAJ, DAL, DAW, DAX, V14, V15, V16, V17, V18, V19, V20, V21, V22, V24, ZAA, ZAB, ZAC, ZAD, ZAE, ZAF, ZAG, ZAH, Z AJ, ZAL .....	3
20	PAFZZ	5310-00-768-0319	96906	MS51968-2	. NUT, PLAIN, HEXAGON UOC: DAC, DAD, DAE, DAF, DAG, DA H, DAJ, DAL, DAW, DAX, V14, V15, V16, V17, V18, V19, V20, V21, V22, V24, ZAA, ZAB, ZAC, ZAD, ZAE, ZAF, ZAG, ZAH, Z AJ, ZAL .....	6
21	PAFZZ	5305-00-832-5743	19207	8741437	. SCREW, EXTERNALLY RE UOC: DAC, DAD, DAE, DAF, DAG, DA H, DAJ, DAL, DAW, DAX, V14, V15, V16, V17, V18, V19, V20, V21, V22, V24, ZAA, ZAB, ZAC, ZAD, ZAE, ZAF, ZAG, ZAH, Z AJ, ZAL .....	3
22	PAFZZ	5325-00-832-5650	19207	8741446	. RING, RETAINING UOC: DAC, DAD, DAE, DAF, DAG, DA H, DAJ, DAL, DAW, DAX, V14, V15, V16, V17, V18, V19, V20, V21, V22, V24, ZAA, ZAB, ZAC, ZAD, ZAE, ZAF, ZAG, ZAH, Z AJ, ZAL .....	1
23	PAFZZ	6240-00-966-3831	19207	8741491	. LAMP, INCANDESCENT UOC: DAC, DAD, DAE, DAF, DAG, DA H, DAJ, DAL, DAW, DAX, V14, V15, V16, V17, V18, V19, V20, V21, V22, V24, ZAA, ZAB, ZAC, ZAD, ZAE, ZAF, ZAG, ZAH, Z AJ, ZAL .....	1

(1) ITEM NO.	(2) SMR CODE	(3) NSN	(4) CAGEC	(5) PART NUMBER	(6) DESCRIPTION AND USABLE ON CODE (UOC)	(7) QTY
24	PAFZZ	5305-00-353-0969	19207	7538146	. SCREW,EXTERNALLY RE UOC: DAC,DAD,DAE,DAF,DAG,DA H,DAJ,DAL,DAW,DAX,V14,V15,V16, V17,V18,V19,V20,V21,V22,V24,ZAA, ZAB,ZAC,ZAD,ZAE,ZAF,ZAG,ZAH,Z AJ,ZAL .....	2
25	PAFZZ	6220-00-998-6142	19207	8741447	. RETAINER,LENS UOC: DAC,DAD,DAE,DAF,DAG,DA H,DAJ,DAL,DAW,DAX,V14,V15,V16, V17,V18,V19,V20,V21,V22,V24,ZAA, ZAB,ZAC,ZAD,ZAE,ZAF,ZAG,ZAH,Z AJ,ZAL .....	1
26	PFFZZ	6150-01-101-6741	19207	10938046-1	CABLE ASSEMBLY,SPEC HEAD LAMP GROUND UOC: DAC,DAD,DAE,DAF,DAG,DA H,DAJ,DAL,DAW,DAX,V14,V15,V16, V17,V18,V19,V20,V21,V22,V24,ZAA, ZAB,ZAC,ZAD,ZAE,ZAF,ZAG,ZAH,Z AJ,ZAL .....	1
27	PAFZZ	5310-00-209-0786	96906	MS35335-33	WASHER,LOCK UOC: DAC,DAD,DAE,DAF,DAG,DA H,DAJ,DAL,DAW,DAX,V14,V15,V16, V17,V18,V19,V20,V21,V22,V24,ZAA, ZAB,ZAC,ZAD,ZAE,ZAF,ZAG,ZAH,Z AJ,ZAL .....	6
28	PAFZZ	5310-00-768-0319	96906	MS51968-2	NUT,PLAIN,HEXAGON UOC: DAC,DAD,DAE,DAF,DAG,DA H,DAJ,DAL,DAW,DAX,V14,V15,V16, V17,V18,V19,V20,V21,V22,V24,ZAA, ZAB,ZAC,ZAD,ZAE,ZAF,ZAG,ZAH,Z AJ,ZAL .....	6

END OF FIGURE

**FIELD MAINTENANCE  
TAILLIGHT AND BLACKOUT LIGHT BRACKETS AND MOUNTING HARDWARE**

---

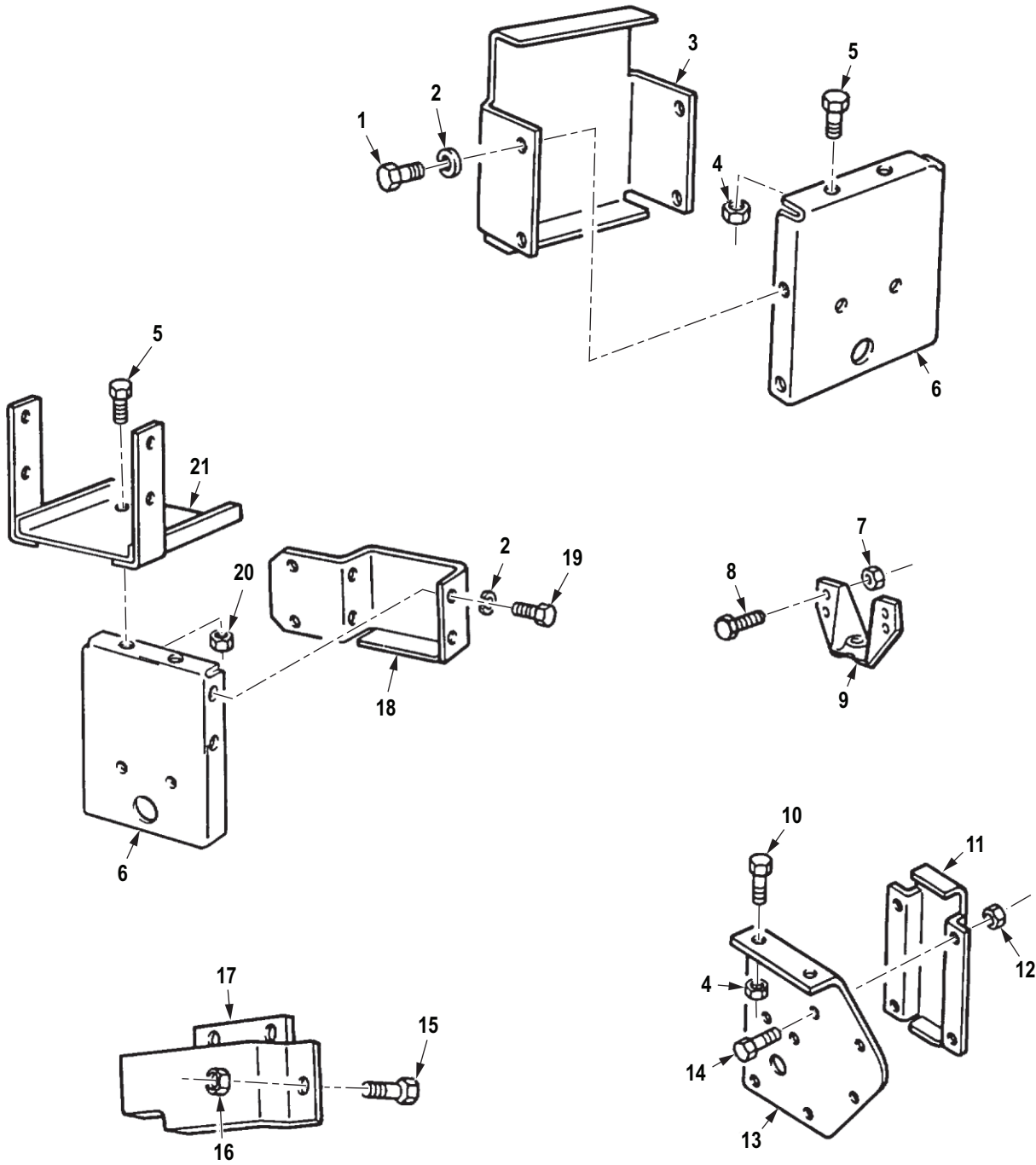

R0143DAA

Figure 142. Taillight and Blackout Light Brackets and Mounting Hardware.

(1) ITEM NO.	(2) SMR CODE	(3) NSN	(4) CAGEC	(5) PART NUMBER	(6) DESCRIPTION AND USABLE ON CODE (UOC)	(7) QTY
<b>GROUP 0609 LIGHTS.</b>						
<b>FIG. 142. TAILLIGHT AND BLACKOUT LIGHT BRACKETS AND MOUNTING HARDWARE.</b>						
1	PAFZZ	5305-00-052-6920	80205	MS24629-56	SCREW,TAPPING UOC: DAJ,DAL,V18,V24,ZAJ,ZAL .....	8
2	PAFZZ	5310-00-209-0786	96906	MS35335-33	WASHER,LOCK UOC: DAJ,DAL,V18,V24,ZAJ,ZAL .....	8
3	PAFZZ	5340-00-407-2612	19207	11658679	COVER,ACCESS UOC: DAC,DAD,DAE,DAF,DAG,DA H,DAJ,DAL,DAW,DAX,V14,V15,V16, V17,V18,V19,V20,V21,V22,V24,ZAA, ZAB,ZAC,ZAD,ZAE,ZAF,ZAG,ZAH,Z AJ,ZAL .....	2
4	PAFZZ	5310-00-959-1488	81349	M45913/2-6FG5C	NUT,SELF-LOCKING,HE UOC: DAC,DAD,DAE,DAF,DAG,DA H,DAJ,DAL,DAW,DAX,V14,V15,V16, V17,V18,V19,V20,V21,V22,V24,ZAA, ZAB,ZAC,ZAD,ZAE,ZAF,ZAG,ZAH,Z AJ,ZAL .....	4
5	PAFZZ	5305-00-912-5113	80205	MS51096-359	SCREW,CAP,HEXAGON H UOC: DAC,DAD,DAE,DAF,DAG,DA H,DAJ,DAL,DAW,DAX,V14,V15,V16, V17,V18,V19,V20,V21,V22,V24,ZAA, ZAB,ZAC,ZAD,ZAE,ZAF,ZAG,ZAH,Z AJ,ZAL .....	4
6	PFFZZ	2510-00-407-2617	19207	11658685	BRACKET,TAILLIGHT,V UOC: DAC,DAD,DAE,DAF,DAG,DA H,DAJ,DAL,DAW,DAX,V14,V15,V16, V17,V18,V19,V20,V21,V22,V24,ZAA, ZAB,ZAC,ZAD,ZAE,ZAF,ZAG,ZAH,Z AJ,ZAL .....	2
7	PAFZZ	5310-00-935-9022	81349	M45913/3-4FG8C	NUT,SELF-LOCKING,HE UOC: DAC,DAD,DAE,DAF,DAG,DA H,DAJ,DAL,DAW,DAX,V14,V15,V16, V17,V18,V19,V20,V21,V22,V24,ZAA, ZAB,ZAC,ZAD,ZAE,ZAF,ZAG,ZAH,Z AJ,ZAL .....	4
8	PAFZZ	5305-00-267-8953	80204	B1821BH025F063N	SCREW,CAP,HEXAGON H UOC: DAC,DAD,DAE,DAF,DAG,DA H,DAJ,DAL,DAW,DAX,V14,V15,V16, V17,V18,V19,V20,V21,V22,V24,ZAA, ZAB,ZAC,ZAD,ZAE,ZAF,ZAG,ZAH,Z AJ,ZAL .....	4

(1) ITEM NO.	(2) SMR CODE	(3) NSN	(4) CAGEC	(5) PART NUMBER	(6) DESCRIPTION AND USABLE ON CODE (UOC)	(7) QTY
9	PPFZZ	2590-00-753-9545	19207	7375699	BRACKET,MOUNTING,HE UOC: DAC,DAD,DAE,DAF,DAG,DA H,DAJ,DAL,DAW,DAX,V14,V15,V16, V17,V18,V19,V20,V21,V22,V24,ZAA, ZAB,ZAC,ZAD,ZAE,ZAF,ZAG,ZAH,Z AJ,ZAL .....	1
10	PAFZZ	5305-00-269-2803	80205	MS90726-60	SCREW,CAP,HEXAGON H UOC: DAG,DAH,V21,V22,ZAG,ZAH .....	4
11	PAFZZ	5340-00-407-5087	19207	10883106-1	COVER,ACCESS UOC: DAG,DAH,V21,V22,ZAG,ZAH .....	4
12	PAFZZ	5310-00-935-9022	81349	M45913/3-4FG8C	NUT,SELF-LOCKING,HE UOC: DAG,DAH,V21,V22,ZAG,ZAH .....	8
13	PPFZZ	2510-00-407-5095	19207	11658683-2	BRACKET,TAIL LIGHT RIGHT UOC: DAG,DAH,V21,V22,ZAG,ZAH .....	1
13	PPFZZ	2510-00-407-5093	19207	11658683-1	BRACKET,TAIL LIGHT LEFT UOC: DAG,DAH,V21,V22,ZAG,ZAH .....	1
14	PAFZZ	5305-00-269-2803	80205	MS90726-60	SCREW,CAP,HEXAGON H UOC: DAG,DAH,V21,V22,ZAG,ZAH .....	8
15	PAFZZ	5306-00-068-0513	80204	B1821BH025F075N	BOLT,MACHINE UOC: DAE,DAF,V19,V20,ZAE,ZAF .....	6
16	PAFZZ	5310-00-935-9022	81349	M45913/3-4FG8C	NUT,SELF-LOCKING,HE UOC: DAE,DAF,V19,V20,ZAE,ZAF .....	6
17	PAFZZ	2510-00-407-5085	19207	11658682-1	COVER,PROTECTOR,TAI RIGHT HAND TAILLIGHT UOC: DAE,DAF,V19,V20,ZAE,ZAF .....	1
17	PAFZZ	2510-00-407-5086	19207	11658682-2	COVER,PROTECTOR,TAI LEFT HAND TAILLIGHT UOC: DAE,DAF,V19,V20,ZAE,ZAF .....	1
18	PAFZZ	2510-00-231-7438	19207	11658686-2	GUARD,TAILLIGHT BRA RIGHT UOC: DAL,V18,ZAL .....	1
18	PAFZZ	2510-00-231-7437	19207	11658686-1	GUARD,TAILLIGHT BRA LEFT UOC: DAL,V18,ZAL .....	1
19	PAFZZ	5305-00-052-6920	80205	MS24629-56	SCREW,TAPPING UOC: DAL,V18,ZAL .....	8
20	PAFZZ	5310-00-814-0672	96906	M45913/3-6FG8C	NUT,SELF-LOCKING,HE UOC: DAL,V18,ZAL .....	4
21	PPFZZ	2510-00-222-8973	19207	10883450	BRACKET,TAIL LIGHT UOC: DAL,V18,ZAL .....	2

END OF FIGURE

**FIELD MAINTENANCE  
SIDE MARKER LIGHTS, BRACKETS, AND MOUNTING HARDWARE**

---

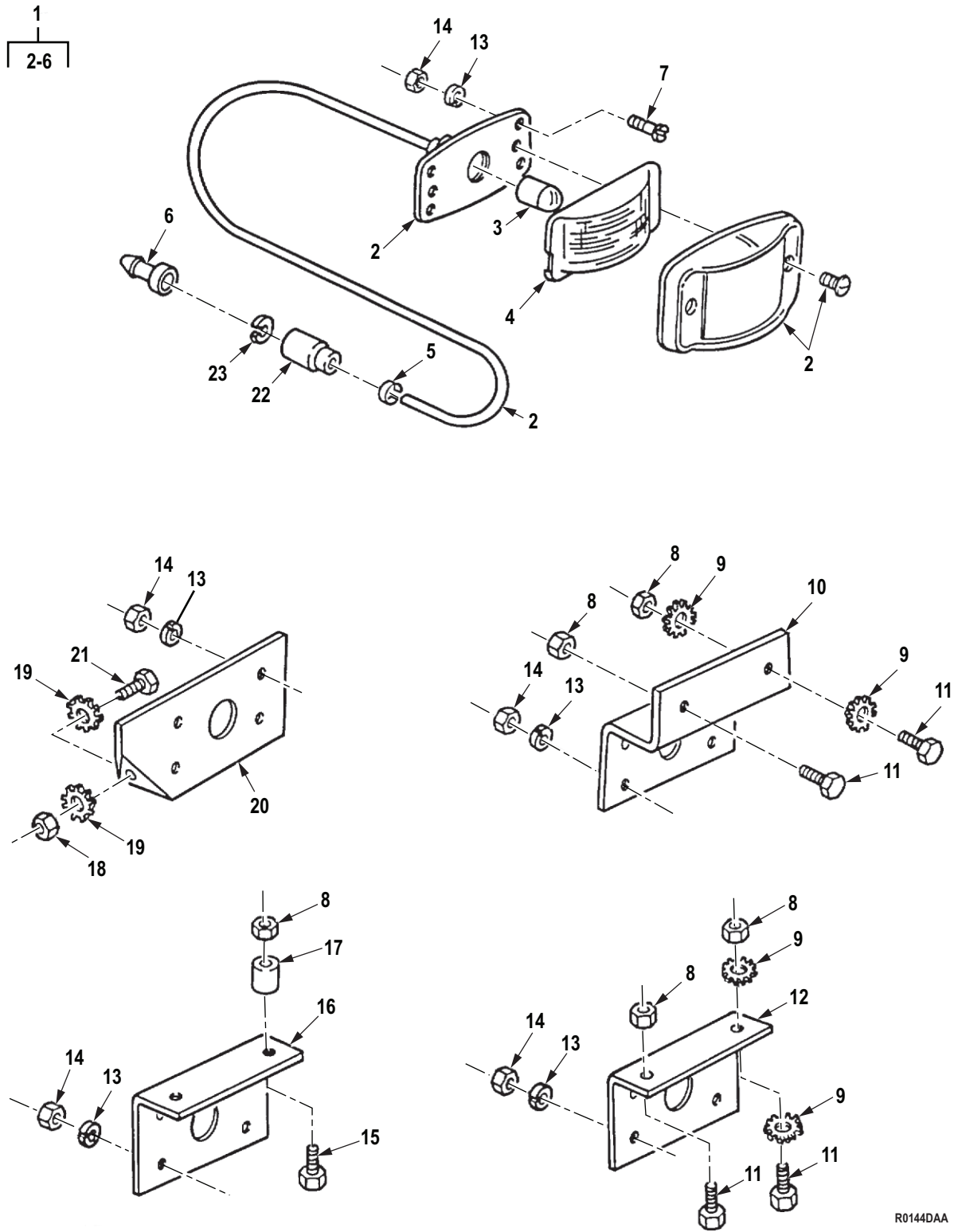

Figure 143. Side Marker Lights, Brackets, and Mounting Hardware.



(1) ITEM NO.	(2) SMR CODE	(3) NSN	(4) CAGEC	(5) PART NUMBER	(6) DESCRIPTION AND USABLE ON CODE (UOC)	(7) QTY
<b>GROUP 0609 LIGHTS.</b>						
<b>FIG. 143. SIDE MARKER LIGHTS, BRACKETS, AND MOUNTING HARDWARE.</b>						
1	PAFZZ	6220-00-577-3434	96906	MS35423-1	LIGHT,MARKER,CLEARA AMBER,BODY UOC: DAC,DAD,DAE,DAF,DAG,DA H,DAJ,DAL,DAW,DAX,V14,V15,V16, V17,V18,V19,V20,V21,V22,V24,ZAA, ZAB,ZAC,ZAD,ZAE,ZAF,ZAG,ZAH,Z AJ,ZAL .....	2
1	PAFZZ	6220-00-726-1916	96906	MS35423-2	LIGHT,MARKER,CLEARA RED,BODY UOC: DAC,DAD,DAE,DAF,DAG,DA H,DAJ,DAL,DAW,DAX,V14,V15,V16, V17,V18,V19,V20,V21,V22,V24,ZAA, ZAB,ZAC,ZAD,ZAE,ZAF,ZAG,ZAH,Z AJ,ZAL .....	2
2	PAFZZ	6250-00-729-9295	96906	MS35422-1	. LIGHT,MARKER,CLEARA UOC: DAC,DAD,DAE,DAF,DAG,DA H,DAJ,DAL,DAW,DAX,V14,V15,V16, V17,V18,V19,V20,V21,V22,V24,ZAA, ZAB,ZAC,ZAD,ZAE,ZAF,ZAG,ZAH,Z AJ,ZAL .....	1
3	PAFZZ	6240-00-019-0877	58536	AA52463-A08	. LAMP,INCANDESCENT UOC: DAC,DAD,DAE,DAF,DAG,DA H,DAJ,DAL,DAW,DAX,V14,V15,V16, V17,V18,V19,V20,V21,V22,V24,ZAA, ZAB,ZAC,ZAD,ZAE,ZAF,ZAG,ZAH,Z AJ,ZAL .....	1
4	PAFZZ	6220-00-299-7425	96906	MS35421-1	. LENS,LIGHT AMBER UOC: DAC,DAD,DAE,DAF,DAG,DA H,DAJ,DAL,DAW,DAX,V14,V15,V16, V17,V18,V19,V20,V21,V22,V24,ZAA, ZAB,ZAC,ZAD,ZAE,ZAF,ZAG,ZAH,Z AJ,ZAL .....	1
4	PAFZZ	6220-00-299-7426	96906	MS35421-2	. LENS,LIGHT RED UOC: DAC,DAD,DAE,DAF,DAG,DA H,DAJ,DAL,DAW,DAX,V14,V15,V16, V17,V18,V19,V20,V21,V22,V24,ZAA, ZAB,ZAC,ZAD,ZAE,ZAF,ZAG,ZAH,Z AJ,ZAL .....	1
5	PAFZZ	9905-00-752-4649	24617	5939707	. BAND MRKER BLNK-ALU UOC: DAC,DAD,DAE,DAF,DAG,DA H,DAJ,DAL,DAW,DAX,V14,V15,V16, V17,V18,V19,V20,V21,V22,V24,ZAA, ZAB,ZAC,ZAD,ZAE,ZAF,ZAG,ZAH,Z AJ,ZAL .....	1

(1) ITEM NO.	(2) SMR CODE	(3) NSN	(4) CAGEC	(5) PART NUMBER	(6) DESCRIPTION AND USABLE ON CODE (UOC)	(7) QTY
6	PAFZA	5999-00-057-2929	58536	AA52536-2	. CONTACT,ELECTRICAL UOC: DAC,DAD,DAE,DAF,DAG,DA H,DAJ,DAL,DAW,DAX,V14,V15,V16, V17,V18,V19,V20,V21,V22,V24,ZAA, ZAB,ZAC,ZAD,ZAE,ZAF,ZAG,ZAH,Z AJ,ZAL .....	1
7	PAFZZ	5305-00-984-6212	80205	MS35206-265	SCREW,MACHINE UOC: DAC,DAD,DAE,DAF,DAL,DA W,DAX,V14,V15,V16,V17,V18,V19,V 20,ZAA,ZAB,ZAC,ZAD,ZAE,ZAF,ZAL .....	16
7	PAFZZ	5305-00-984-6212	80205	MS35206-265	SCREW,MACHINE UOC: DAC,DAD,DAE,DAF,DAG,DA H,DAJ,DAL,DAW,DAX,V14,V15,V16, V17,V18,V19,V20,V21,V22,V24,ZAA, ZAB,ZAC,ZAD,ZAE,ZAF,ZAG,ZAH,Z AJ,ZAL .....	8
8	PAFZZ	5310-00-959-1488	81349	M45913/2-6FG5C	NUT,SELF-LOCKING,HE UOC: DAC,DAD,DAE,DAF,DAG,DA H,DAJ,DAL,DAW,DAX,V14,V15,V16, V17,V18,V19,V20,V21,V22,V24,ZAA, ZAB,ZAC,ZAD,ZAE,ZAF,ZAG,ZAH,Z AJ,ZAL .....	8
9	PAFZZ	5310-00-595-7237	80205	MS35333-42	WASHER,LOCK UOC: DAC,DAD,DAE,DAF,DAW,DA X,V14,V15,V16,V17,V19,V20,ZAA,ZA B,ZAC,ZAD,ZAE,ZAF .....	8
10	PFFZZ	5340-01-129-0474	19207	12277192	BRACKET,DOUBLE ANGL UOC: DAC,DAD,DAE,DAF,V16,V17, V19,V20,ZAC,ZAD,ZAE,ZAF .....	4
11	PAFZZ	5305-00-269-3234	80204	B1821BH038F075N	SCREW,CAP,HEXAGON H UOC: DAC,DAD,DAE,DAF,DAW,DA X,V14,V15,V16,V17,V18,V19,V20,ZA A,ZAB,ZAC,ZAD,ZAE,ZAF .....	8
12	PAFZZ	5340-01-108-9268	19207	12277002	BRACKET,ANGLE UOC: DAW,DAX,V14,V15,ZAA,ZAB .....	4
13	PAFZZ	5310-00-596-7691	96906	MS35335-32	WASHER,LOCK UOC: DAC,DAD,DAE,DAF,DAL,DA W,DAX,V14,V15,V16,V18,V19,V20,Z AA,ZAB,ZAC,ZAD,ZAE,ZAF,ZAL .....	16
13	PAFZZ	5310-00-596-7691	96906	MS35335-32	WASHER,LOCK UOC: DAC,DAD,DAE,DAF,DAG,DA H,DAJ,DAL,DAW,DAX,V14,V15,V16, V17,V18,V19,V20,V21,V22,V24,ZAA, ZAB,ZAC,ZAD,ZAE,ZAF,ZAG,ZAH,Z AJ,ZAL .....	8

(1) ITEM NO.	(2) SMR CODE	(3) NSN	(4) CAGEC	(5) PART NUMBER	(6) DESCRIPTION AND USABLE ON CODE (UOC)	(7) QTY
14	PAFZZ	5310-00-934-9758	80205	MS35649-202	NUT,PLAIN,HEXAGON UOC: DAC,DAD,DAE,DAF,DAG,DA H,DAJ,DAL,DAW,DAX,V14,V15,V16, V17,V18,V19,V20,V21,V22,V24,ZAA, ZAB,ZAC,ZAD,ZAE,ZAF,ZAG,ZAH,Z AJ,ZAL .....	8
14	PAFZZ	5310-00-934-9758	80205	MS35649-202	NUT,PLAIN,HEXAGON UOC: DAC,DAD,DAE,DAF,DAL,DA W,DAX,V14,V15,V16,V17,V18,V19,V 20,ZAA,ZAB,ZAC,ZAD,ZAE,ZAF,ZAL .....	16
15	PAFZZ	5305-00-269-3242	80204	B1821BH038F200N	SCREW,CAP,HEXAGON H UOC: DAL,V18,ZAL .....	8
15	PAFZZ	5305-00-269-2803	80205	MS90726-60	SCREW,CAP,HEXAGON H UOC: DAL,V18,ZAL .....	4
16	PBFZZ	5340-01-231-9291	19207	12277002-1	BRACKET,ANGLE UOC: DAL,V18,ZAL .....	4
17	PFFZZ	5365-01-108-9258	19207	12277047	SPACER,SLEEVE UOC: DAL,V18,ZAL .....	4
18	PAFZZ	5310-00-935-9022	81349	M45913/3-4FG8C	NUT,SELF-LOCKING,HE SIDE MARKER BRACKET UOC: DAC,DAD,DAE,DAF,DAG,DA H,DAJ,DAL,DAW,DAX,V14,V15,V16, V17,V18,V19,V20,V21,V22,V24,ZAA, ZAB,ZAC,ZAD,ZAE,ZAF,ZAG,ZAH,Z AJ,ZAL .....	8
19	PAFZZ	5310-00-889-2528	96906	MS45904-68	WASHER,LOCK UOC: DAC,DAD,DAE,DAF,DAG,DA H,DAJ,DAL,DAW,DAX,V14,V15,V16, V17,V18,V19,V20,V21,V22,V24,ZAA, ZAB,ZAC,ZAD,ZAE,ZAF,ZAG,ZAH,Z AJ,ZAL .....	4
20	PAFZZ	5340-01-106-2068	19207	12277042-2	BRACKET,MOUNTING SIDE MARKER UOC: DAC,DAD,DAE,DAF,DAG,DA H,DAJ,DAL,DAW,DAX,V14,V15,V16, V17,V18,V19,V20,V21,V22,V24,ZAA, ZAB,ZAC,ZAD,ZAE,ZAF,ZAG,ZAH,Z AJ,ZAL .....	1
20	PAFZZ	5340-01-121-7601	19207	12277042-1	BRACKET,MOUNTING RIGHT UOC: DAC,DAD,DAE,DAF,DAG,DA H,DAJ,DAL,DAW,DAX,V14,V15,V16, V17,V18,V19,V20,V21,V22,V24,ZAA, ZAB,ZAC,ZAD,ZAE,ZAF,ZAG,ZAH,Z AJ,ZAL .....	1

(1) ITEM NO.	(2) SMR CODE	(3) NSN	(4) CAGEC	(5) PART NUMBER	(6) DESCRIPTION AND USABLE ON CODE (UOC)	(7) QTY
21	PAFZZ	5306-00-068-0513	80204	B1821BH025F075N	BOLT,MACHINE SIDE MARKER BRACKET UOC: DAC,DAD,DAE,DAF,DAG,DA H,DAJ,DAL,DAW,DAX,V14,V15,V16, V17,V18,V19,V20,V21,V22,V24,ZAA, ZAB,ZAC,ZAD,ZAE,ZAF,ZAG,ZAH,Z AJ,ZAL .....	1
22	PAFZZ	5935-00-572-9180	19207	8338566	SHELL,ELECTRICAL CO UOC: DAC,DAD,DAE,DAF,DAL,DA W,DAX,V14,V15,V16,V17,V18,V19,V 20,ZAA,ZAB,ZAC,ZAD,ZAE,ZAF,ZAL .....	4
23	PAFZZ	5310-00-833-8567	19207	8338567	WASHER,SLOTTED UOC: DAC,DAD,DAE,DAF,DAL,DA W,DAX,V14,V15,V16,V17,V18,V19,V 20,ZAA,ZAB,ZAC,ZAD,ZAE,ZAF,ZAL .....	4

END OF FIGURE

**FIELD MAINTENANCE  
FLOODLIGHT ASSEMBLY**

---

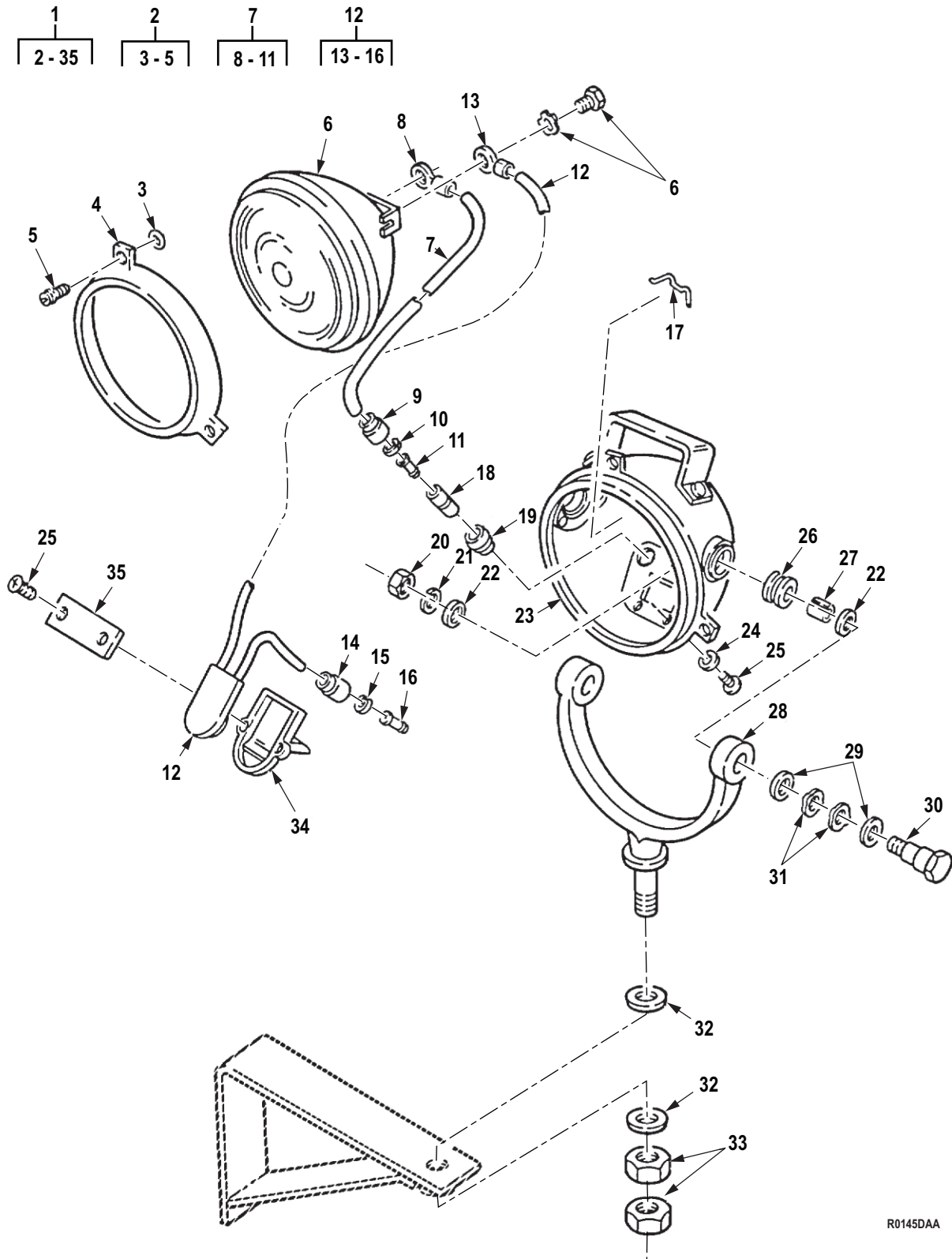

Figure 144. Floodlight Assembly.

(1) ITEM NO.	(2) SMR CODE	(3) NSN	(4) CAGEC	(5) PART NUMBER	(6) DESCRIPTION AND USABLE ON CODE (UOC)	(7) QTY
<b>GROUP 0609 LIGHTS.</b>						
<b>FIG. 144. FLOODLIGHT ASSEMBLY.</b>						
1	PAFFF	6220-00-878-7301	58536	A-A-52498-1	FLOODLIGHT,ELECTRIC UOC: DAL,V18,ZAL .....	3
2	PAFZZ	6220-01-155-2357	19207	7385905	. RETAINER,LENS UOC: DAL,V18,ZAL .....	1
3	PAFZZ	5340-00-732-0642	19207	7320642	. . CLIP,RETAINING UOC: DAL,V18,ZAL .....	3
4	XAFZZ		19207	7212871	. . DOOR UOC: DAL,V18,ZAL .....	1
5	PAFZZ	5305-00-752-5938	19207	7525938	. . SCREW,MACHINE UOC: DAL,V18,ZAL .....	3
6	PAFZZ	6240-00-295-2421	58536	A52409-4572	. LAMP,INCANDESCENT UOC: DAL,V18,ZAL .....	1
7	PFFFF	5995-00-991-6707	19207	8739552	. LEAD,ELECTRICAL UOC: DAL,V18,ZAL .....	1
8	PAFZZ	5940-00-050-6207	1NJK8	YAV14H1	. . TERMINAL,LUG FLOODLIGHT LEAD UOC: DAL,V18,ZAL .....	1
9	PAFZZ	5935-00-691-5591	97403	13207E6498-2	. . SHELL,ELECTRICAL CO FLOODLIGHT LEAD UOC: DAL,V18,ZAL .....	1
10	PAFZZ	5310-00-656-0067	19207	8724497	. . WASHER,SLOTTED FLOODLIGHT LEAD UOC: DAL,V18,ZAL .....	1
11	PAFZZ	5999-00-926-3144	58536	AA52536-3	. . CONTACT,ELECTRICAL FLOODLIGHT LEAD UOC: DAL,V18,ZAL .....	1
12	PFFFF	5930-00-991-6713	19207	8739573	. SWITCH,SENSITIVE UOC: DAL,V18,ZAL .....	1
13	PAFZZ	5940-00-050-6207	1NJK8	YAV14H1	. . TERMINAL,LUG FLOODLIGHT SWITCH UOC: DAL,V18,ZAL .....	1
14	PAFZZ	5935-00-691-5591	97403	13207E6498-2	. . SHELL,ELECTRICAL CO FLOODLIGHT SWITCH UOC: DAL,V18,ZAL .....	1
15	PAFZZ	5310-00-656-0067	19207	8724497	. . WASHER,SLOTTED FLOODLIGHT SWITCH UOC: DAL,V18,ZAL .....	1
16	PAFZZ	5999-00-926-3144	58536	AA52536-3	. . CONTACT,ELECTRICAL FLOODLIGHT SWITCH UOC: DAL,V18,ZAL .....	1
17	PAFZZ	5340-00-741-6869	19207	7416869	. CLIP,RETAINING UOC: DAL,V18,ZAL .....	4
18	PAFZZ	5935-00-807-4109	19207	8741492	. ADAPTER,CONNECTOR UOC: DAL,V18,ZAL .....	2

(1) ITEM NO.	(2) SMR CODE	(3) NSN	(4) CAGEC	(5) PART NUMBER	(6) DESCRIPTION AND USABLE ON CODE (UOC)	(7) QTY
19	PAFZZ	5325-00-088-6147	19207	8741442	. GROMMET, NONMETALLIC UOC: DAL, V18, ZAL .....	2
20	PAFZZ	5310-00-732-0558	96906	MS51967-8	. NUT, PLAIN, HEXAGON UOC: DAL, V18, ZAL .....	2
21	PAFZZ	5310-00-637-9541	00198	132661	. WASHER, LOCK UOC: DAL, V18, ZAL .....	2
22	PAFZZ	5310-00-741-6862	19207	7416862	. WASHER, FLAT UOC: DAL, V18, ZAL .....	4
23	PAFZZ	6220-00-397-3335	19207	8739559	. HOUSING, LIGHT UOC: DAL, V18, ZAL .....	1
24	PAFZZ	5310-00-045-3299	80205	MS35338-42	. WASHER, LOCK UOC: DAL, V18, ZAL .....	2
25	PAFZZ	5305-00-889-3002	96906	MS35206-242	. SCREW, MACHINE UOC: DAL, V18, ZAL .....	4
26	PAFZZ	5325-00-741-4180	19207	7414180	. GROMMET, NONMETALLIC UOC: DAL, V18, ZAL .....	2
27	PAFZZ	5365-00-923-4253	19207	7416861	. SPACER, SLEEVE UOC: DAL, V18, ZAL .....	2
28	PAFZZ	5340-01-008-6448	19207	7416866	. BRACKET, MOUNTING UOC: DAL, V18, ZAL .....	1
29	PAFZZ	5310-00-809-5998	96906	MS27183-18	. WASHER, FLAT UOC: DAL, V18, ZAL .....	4
30	PAFZZ	5306-00-741-6865	19207	7416865	. BOLT, SHOULDER UOC: DAL, V18, ZAL .....	2
31	PAFZZ	5310-00-079-9573	82679	WA132	. WASHER, SPRING TENS UOC: DAL, V18, ZAL .....	4
32	PAFZZ	5310-00-741-6867	19207	7416867	. WASHER, FLAT UOC: DAL, V18, ZAL .....	2
33	PAFZZ	5310-00-763-8905	96906	MS51968-20	. NUT, PLAIN, HEXAGON UOC: DAL, V18, ZAL .....	2
34	PAFZZ	2510-00-567-0130	19207	7414388	. HOUSING, SWITCH, FLOO UOC: DAL, V18, ZAL .....	1
35	PAFZZ	5935-00-991-6708	19207	8739556	. RETAINER, ELECTRICAL UOC: DAL, V18, ZAL .....	1

END OF FIGURE



**FIELD MAINTENANCE  
FUEL PRESSURE TRANSDUCER AND SUPPORT, FUEL LEVEL TRANSMITTER, PARKING BRAKE, AND  
WARNING CONTROL DEVICE**

---

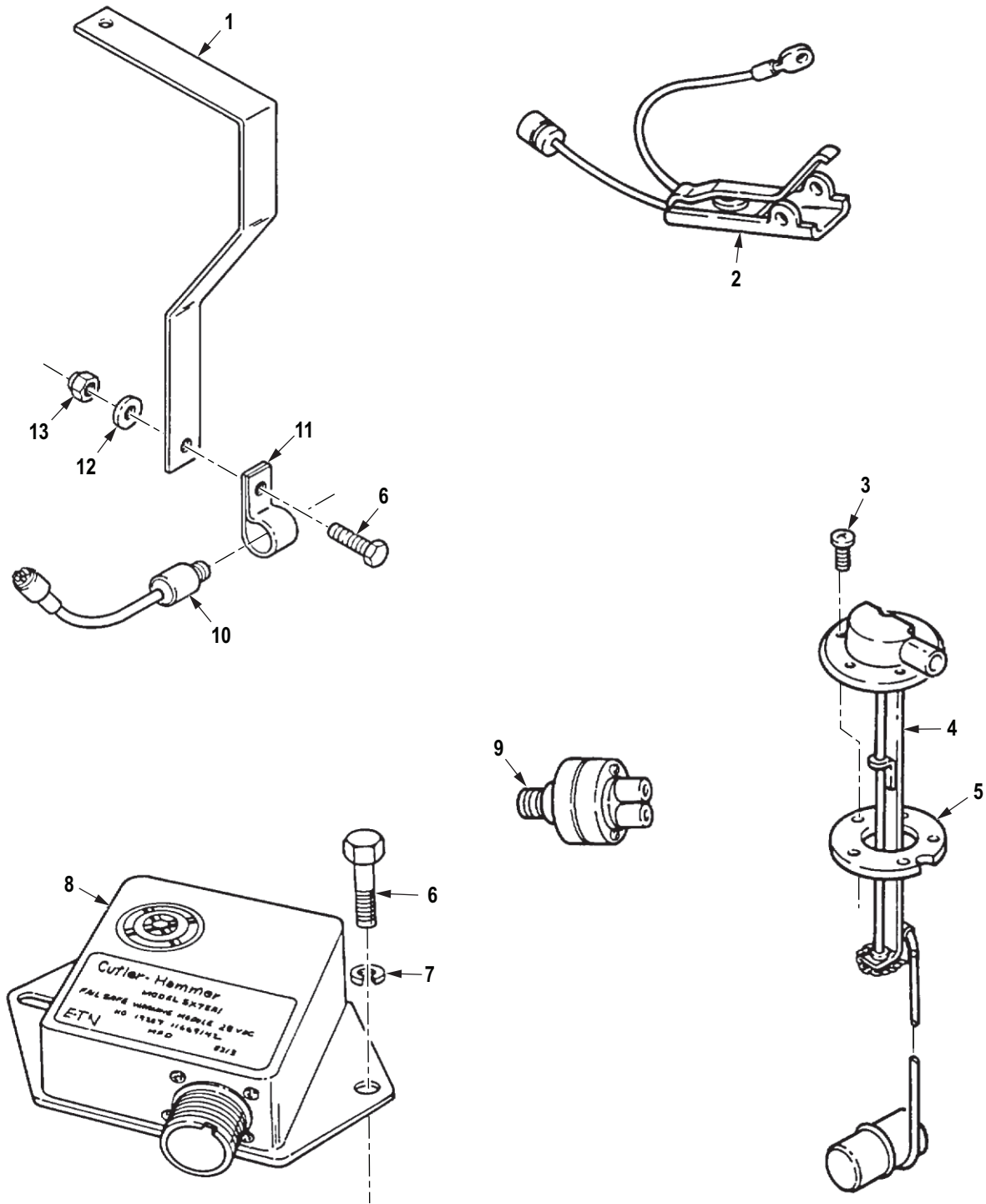

R0146DAA

Figure 145. Fuel Pressure Transducer and Support, Fuel Level Transmitter, Parking Brake, and Warning Control Device.

(1) ITEM NO.	(2) SMR CODE	(3) NSN	(4) CAGEC	(5) PART NUMBER	(6) DESCRIPTION AND USABLE ON CODE (UOC)	(7) QTY
<b>GROUP 0610 SENDING UNITS AND WARNING SWITCHES.</b>						
<b>FIG. 145. FUEL PRESSURE TRANSDUCER AND SUPPORT, FUEL LEVEL TRANSMITTER, PARKING BRAKE, AND WARNING CONTROL DEVICE.</b>						
1	PAFZZ	5340-01-205-9262	19207	12302859	BRACKET,ANGLE UOC: DAC,DAD,DAE,DAF,DAG,DAH,DAJ,DAL,DAW,DAX,V14,V15,V16,V17,V18,V19,V20,V21,V22,V24,ZAA,ZAB,ZAC,ZAD,ZAE,ZAF,ZAG,ZAH,ZAJ,ZAL .....	1
2	PAFZZ	2530-01-120-8441	81901	E-2038	SWITCH,BRAKE,PARKIN UOC: DAC,DAD,DAE,DAF,DAG,DAH,DAJ,DAL,DAW,DAX,V14,V15,V16,V17,V18,V19,V20,V21,V22,V24,ZAA,ZAB,ZAC,ZAD,ZAE,ZAF,ZAG,ZAH,ZAJ,ZAL .....	1
3	PAFZZ	5305-00-984-6194	80205	MS35206-246	SCREW,MACHINE #10-32 X 5/8 UNF-2A R/H UOC: DAE,DAF,DAG,DAH,DAL,V18,V19,V20,V21,V22,ZAE,ZAF,ZAG,ZAH,ZAL .....	10
3	PAFZZ	5305-01-031-5094	80205	MS3213-35	SCREW,MACHINE #10-32 X 5/8 UNF-2A R/H UOC: DAC,DAD,DAJ,DAW,DAX,V14,V15,V16,V17,V24,ZAA,ZAB,ZAC,ZAD,ZAJ	5
4	PAFZZ	6680-00-226-4574	96906	MS500040-6	TRANSMITTER,LIQUID UOC: DAC,DAD,DAJ,DAW,DAX,V14,V15,V16,V17,V24,ZAA,ZAB,ZAC,ZAD,ZAJ	1
4	PAFZZ	6680-00-226-4574	96906	MS500040-6	TRANSMITTER,LIQUID UOC: DAE,DAF,DAG,DAH,DAL,V18,V19,V20,V21,V22,ZAE,ZAF,ZAG,ZAH,ZAL	2
5	PAFZZ	5330-00-753-9072	19207	7539072	GASKET UOC: DAC,DAD,DAJ,DAW,DAX,V14,V15,V16,V17,V24,ZAA,ZAB,ZAC,ZAD,ZAJ	1
5	PAFZZ	5330-00-753-9072	19207	7539072	GASKET UOC: DAE,DAF,DAG,DAH,DAL,V18,V19,V20,V21,V22,ZAE,ZAF,ZAG,ZAH,ZAL	2
6	PAFZZ	5306-00-068-0513	80204	B1821BH025F075N	BOLT,MACHINE UOC: DAC,DAD,DAE,DAF,DAG,DAH,DAJ,DAL,DAW,DAX,V14,V15,V16,V17,V18,V19,V20,V21,V22,V24,ZAA,ZAB,ZAC,ZAD,ZAE,ZAF,ZAG,ZAH,ZAJ,ZAL .....	3

(1) ITEM NO.	(2) SMR CODE	(3) NSN	(4) CAGEC	(5) PART NUMBER	(6) DESCRIPTION AND USABLE ON CODE (UOC)	(7) QTY
7	PAFZZ	5310-00-550-1130	80205	MS35333-40	WASHER,LOCK UOC: DAC,DAD,DAE,DAF,DAG,DA H,DAJ,DAL,DAW,DAX,V14,V15,V16, V17,V18,V19,V20,V21,V22,V24,ZAA, ZAB,ZAC,ZAD,ZAE,ZAF,ZAG,ZAH,Z AJ,ZAL .....	2
8	PAFZZ	6350-01-089-2987	19207	11669142	ALARM-MONITOR FAILSAFE UOC: DAC,DAD,DAE,DAF,DAG,DA H,DAJ,DAL,DAW,DAX,V14,V15,V16, V17,V18,V19,V20,V21,V22,V24,ZAA, ZAB,ZAC,ZAD,ZAE,ZAF,ZAG,ZAH,Z AJ,ZAL .....	1
9	PAFZZ	5930-01-161-9580	19207	12302684	SWITCH,PRESSURE EITHER START UOC: DAC,DAD,DAE,DAF,DAG,DA H,DAJ,DAL,DAW,DAX,V14,V15,V16, V17,V18,V19,V20,V21,V22,V24,ZAA, ZAB,ZAC,ZAD,ZAE,ZAF,ZAG,ZAH,Z AJ,ZAL .....	1
10	PAFZZ	6695-01-146-7132	19207	12258932-7	TRANSDUCER,MOTIONAL UOC: DAC,DAD,DAE,DAF,DAG,DA H,DAJ,DAL,DAW,DAX,V14,V15,V16, V17,V18,V19,V20,V21,V22,V24,ZAA, ZAB,ZAC,ZAD,ZAE,ZAF,ZAG,ZAH,Z AJ,ZAL .....	1
11	PAFZZ	5340-00-809-1500	80205	MS21333-107	CLAMP,LOOP UOC: DAC,DAD,DAE,DAF,DAG,DA H,DAJ,DAL,DAW,DAX,V14,V15,V16, V17,V18,V19,V20,V21,V22,V24,ZAA, ZAB,ZAC,ZAD,ZAE,ZAF,ZAG,ZAH,Z AJ,ZAL .....	1
12	PAFZZ	5310-00-809-4058	96906	MS27183-10	WASHER,FLAT UOC: DAC,DAD,DAE,DAF,DAG,DA H,DAJ,DAL,DAW,DAX,V14,V15,V16, V17,V18,V19,V20,V21,V22,V24,ZAA, ZAB,ZAC,ZAD,ZAE,ZAF,ZAG,ZAH,Z AJ,ZAL .....	1
13	PAFZZ	5310-00-935-9022	81349	M45913/3-4FG8C	NUT,SELF-LOCKING,HE UOC: DAC,DAD,DAE,DAF,DAG,DA H,DAJ,DAL,DAW,DAX,V14,V15,V16, V17,V18,V19,V20,V21,V22,V24,ZAA, ZAB,ZAC,ZAD,ZAE,ZAF,ZAG,ZAH,Z AJ,ZAL .....	1

END OF FIGURE

**FIELD MAINTENANCE**  
**LOW AIR WARNING SWITCH, MECHANICAL TACHOMETER, TRANSMISSION TEMPERATURE**  
**TRANSMITTER, OIL PRESSURE TRANSMITTER, AND STOPLIGHT SWITCH**

---

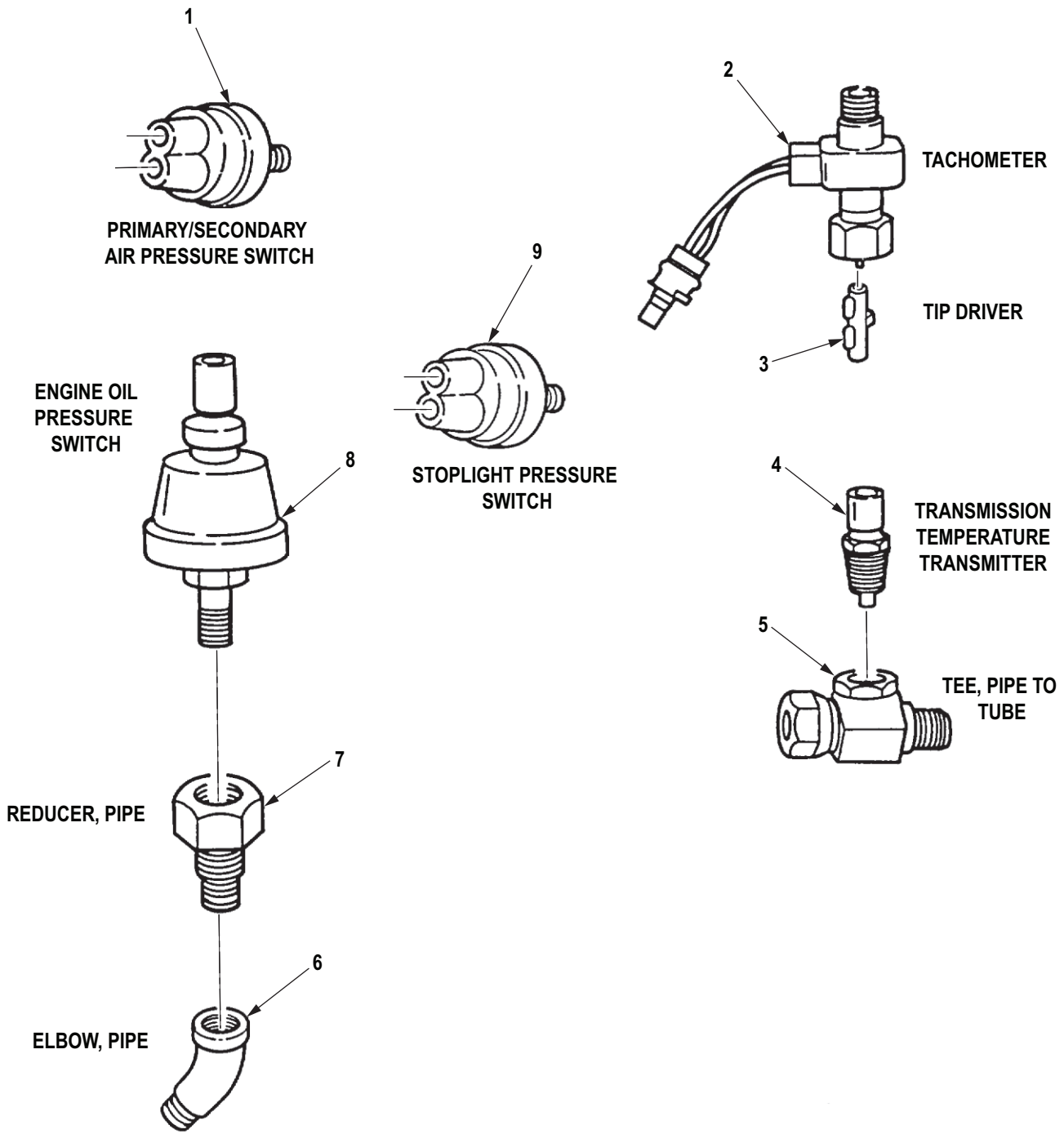

R0147DAA

Figure 146. Low Air Warning Switch, Mechanical Tachometer, Transmission Temperature Transmitter, Oil Pressure Transmitter, and Stoplight Switch.

(1) ITEM NO.	(2) SMR CODE	(3) NSN	(4) CAGEC	(5) PART NUMBER	(6) DESCRIPTION AND USABLE ON CODE (UOC)	(7) QTY
<b>GROUP 0610 SENDING UNITS AND WARNING SWITCHES.</b>						
<b>FIG. 146. LOW AIR WARNING SWITCH, MECHANICAL TACHOMETER, TRANSMISSION TEMPERATURE TRANSMITTER, OIL PRESSURE TRANSMITTER, AND STOPLIGHT SWITCH.</b>						
1	PAFZZ	5930-01-189-0494	19207	12375453	SWITCH,PRESSURE UOC: DAC,DAD,DAE,DAF,DAG,DAH,DAJ,DAL,DAW,DAX,V14,V15,V16,V17,V18,V19,V20,V21,V22,V24,ZAA,ZAB,ZAC,ZAD,ZAE,ZAF,ZAG,ZAH,ZAJ,ZAL .....	2
2	PAFZZ	6680-01-319-2354	7Z588	12258931-3	ADAPTER,SPEEDOMETER TACHOMETER PULSE,DCA UOC: DAC,DAD,DAE,DAF,DAG,DAH,DAJ,DAL,DAW,DAX,V14,V15,V16,V17,V18,V19,V20,V21,V22,V24,ZAA,ZAB,ZAC,ZAD,ZAE,ZAF,ZAG,ZAH,ZAJ,ZAL .....	1
3	PAFZZ	5340-01-290-1738	19207	12301264	PLUNGER,DETENT TIP DRIVE UOC: DAC,DAD,DAE,DAF,DAG,DAH,DAJ,DAL,DAW,DAX,V14,V15,V16,V17,V18,V19,V20,V21,V22,V24,ZAA,ZAB,ZAC,ZAD,ZAE,ZAF,ZAG,ZAH,ZAJ,ZAL .....	1
4	PAFZZ	6685-00-814-5271	96906	MS24537-1	TRANSMITTER,TEMPERA ELECTRICAL UOC: DAC,DAD,DAE,DAF,DAG,DAH,DAJ,DAL,DAW,DAX,V14,V15,V16,V17,V18,V19,V20,V21,V22,V24,ZAA,ZAB,ZAC,ZAD,ZAE,ZAF,ZAG,ZAH,ZAJ,ZAL .....	2
5	PAFZZ	4730-01-091-0266	19207	12256531	TEE,PIPE TO TUBE UOC: DAC,DAD,DAE,DAF,DAG,DAH,DAJ,DAL,DAW,DAX,V14,V15,V16,V17,V18,V19,V20,V21,V22,V24,ZAA,ZAB,ZAC,ZAD,ZAE,ZAF,ZAG,ZAH,ZAJ,ZAL .....	1
6	PAFZZ	4730-00-249-3932	96906	MS39231-1	ELBOW,PIPE UOC: DAC,DAD,DAE,DAF,DAG,DAH,DAJ,DAL,DAW,DAX,V14,V15,V16,V17,V18,V19,V20,V21,V22,V24,ZAA,ZAB,ZAC,ZAD,ZAE,ZAF,ZAG,ZAH,ZAJ,ZAL .....	1

(1) ITEM NO.	(2) SMR CODE	(3) NSN	(4) CAGEC	(5) PART NUMBER	(6) DESCRIPTION AND USABLE ON CODE (UOC)	(7) QTY
7	PAFZZ	4730-00-623-8303	81343	4-2 130139B	REDUCER,PIPE UOC: DAC,DAD,DAE,DAF,DAG,DA H,DAJ,DAL,DAW,DAX,V14,V15,V16, V17,V18,V19,V20,V21,V22,V24,ZAA, ZAB,ZAC,ZAD,ZAE,ZAF,ZAG,ZAH,Z AJ,ZAL .....	1
8	PAFZZ	6620-00-993-5546	96906	MS24539	TRANSMITTER,PRESSUR UOC: DAC,DAD,DAE,DAF,DAG,DA H,DAJ,DAL,DAW,DAX,V14,V15,V16, V17,V18,V19,V20,V21,V22,V24,ZAA, ZAB,ZAC,ZAD,ZAE,ZAF,ZAG,ZAH,Z AJ,ZAL .....	1
9	PAFZZ	2540-00-789-6192	19207	11602160	SWITCH,PRESSURE STOPLIGHT SWITCH UOC: DAC,DAD,DAE,DAF,DAG,DA H,DAJ,DAL,DAW,DAX,V14,V15,V16, V17,V18,V19,V20,V21,V22,V24,ZAA, ZAB,ZAC,ZAD,ZAE,ZAF,ZAG,ZAH,Z AJ,ZAL .....	1

END OF FIGURE



**FIELD MAINTENANCE  
TEMPERATURE TRANSMITTER AND TACHOMETER PULSE SENDER (M939A2)**

---

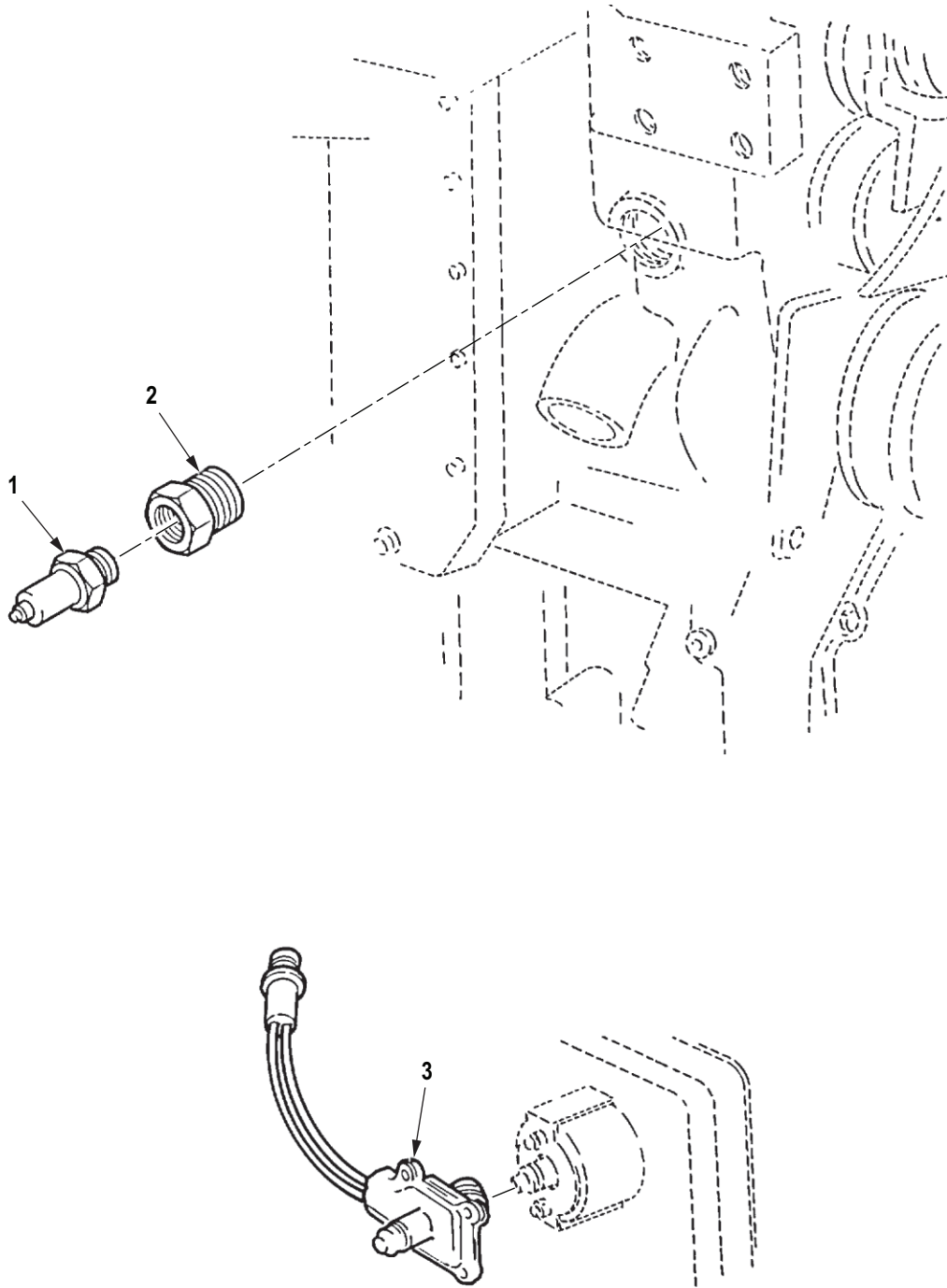

R0148DAA

Figure 147. Temperature Transmitter and Tachometer Pulse Sender (M939A2).

(1) ITEM NO.	(2) SMR CODE	(3) NSN	(4) CAGEC	(5) PART NUMBER	(6) DESCRIPTION AND USABLE ON CODE (UOC)	(7) QTY
<b>GROUP 0610 SENDING UNITS AND WARNING SWITCHES.</b>						
<b>FIG. 147. TEMPERATURE TRANSMITTER AND TACHOMETER PULSE SENDER (M939A2).</b>						
1	PAFZZ	6685-00-814-5271	96906	MS24537-1	TRANSMITTER,TEMPERA UOC: ZAA,ZAB,ZAC,ZAD,ZAE,ZAF, ZAG,ZAH,ZAJ,ZAL .....	1
2	PAFZZ	4730-00-196-0888	58536	AA59616BDQBCED	BUSHING,PIPE UOC: ZAA,ZAB,ZAC,ZAD,ZAE,ZAF, ZAG,ZAH,ZAJ,ZAL .....	1
3	PAFZZ	6680-01-272-9204	0UKB6	20511338	DRIVE UNIT,TACHOMET UOC: ZAA,ZAB,ZAC,ZAD,ZAE,ZAF, ZAG,ZAH,ZAJ,ZAL .....	1
<b>END OF FIGURE</b>						



**FIELD MAINTENANCE  
HORN ASSEMBLY, RELATED TUBING, AND MOUNTING BRACKET**

---

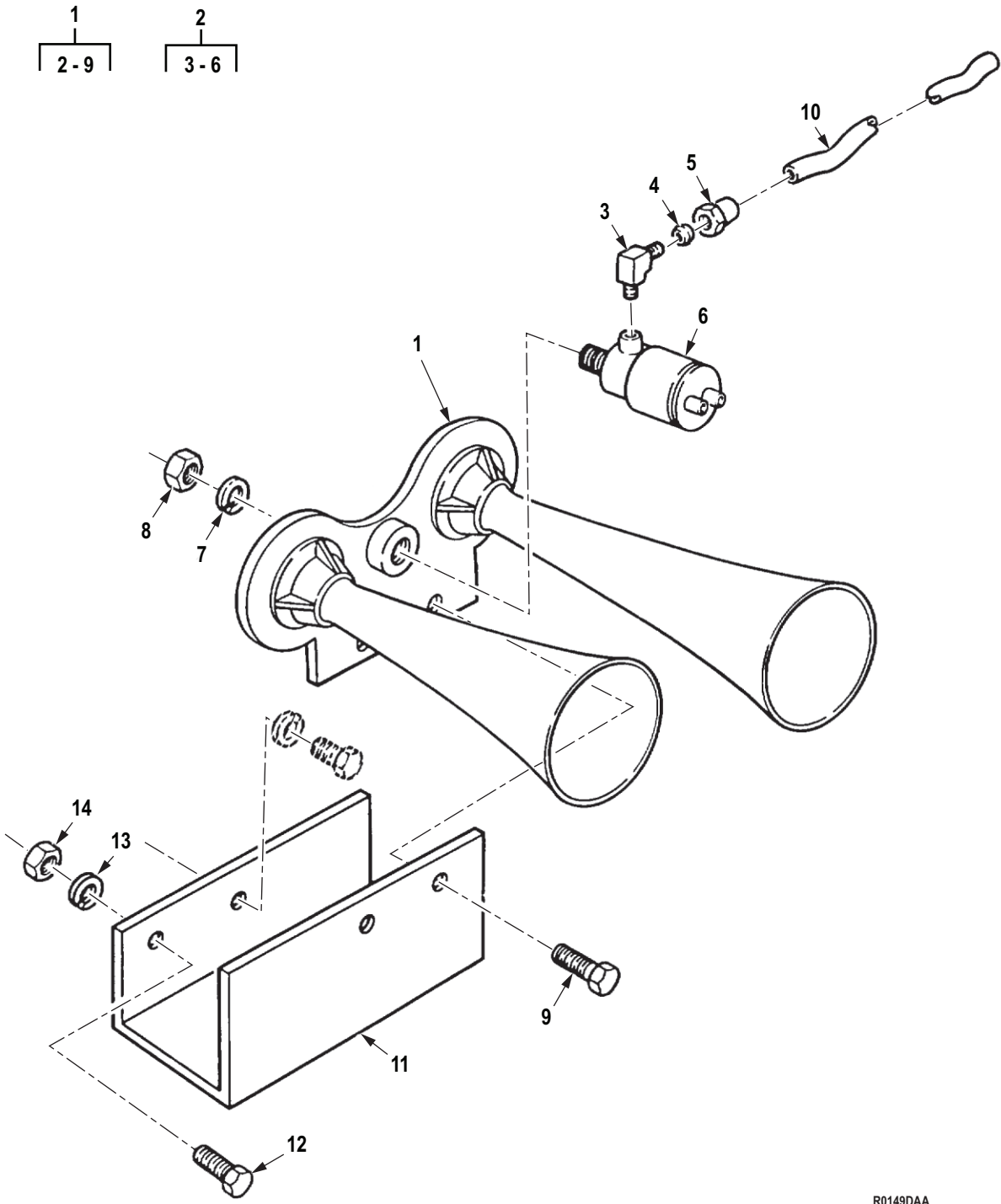

R0149DAA

Figure 148. Horn Assembly, Related Tubing, and Mounting Bracket.

(1) ITEM NO.	(2) SMR CODE	(3) NSN	(4) CAGEC	(5) PART NUMBER	(6) DESCRIPTION AND USABLE ON CODE (UOC)	(7) QTY
<b>GROUP 0611 HORN, SIREN.</b>						
<b>FIG. 148. HORN ASSEMBLY, RELATED TUBING, AND MOUNTING BRACKET.</b>						
1	PAFZZ	2590-00-900-1640	58536	AA52525-11	HORN,FLUID OPERATED UOC: DAC,DAD,DAE,DAF,DAG,DAH,DAJ,DAL,DAW,DAX,V14,V15,V16,V17,V18,V19,V20,V21,V22,V24,ZAA,ZAB,ZAC,ZAD,ZAE,ZAF,ZAG,ZAH,ZAJ,ZAL .....	1
2	PAFZZ	5945-00-240-1684	96906	MS17981-1	. SOLENOID,ELECTRICAL UOC: DAC,DAD,DAE,DAF,DAG,DAH,DAJ,DAL,DAW,DAX,V14,V15,V16,V17,V18,V19,V20,V21,V22,V24,ZAA,ZAB,ZAC,ZAD,ZAE,ZAF,ZAG,ZAH,ZAJ,ZAL .....	1
3	PAFZZ	4730-00-287-1604	81343	6-2 120202BA	. . ELBOW,PIPE TO TUBE UOC: DAC,DAD,DAE,DAF,DAG,DAH,DAJ,DAL,DAW,DAX,V14,V15,V16,V17,V18,V19,V20,V21,V22,V24,ZAA,ZAB,ZAC,ZAD,ZAE,ZAF,ZAG,ZAH,ZAJ,ZAL .....	1
4	PAFZZ	4730-00-293-7108	81343	SAE J246 6 120115B.	. SLEEVE,COMPRESSION, UOC: DAC,DAD,DAE,DAF,DAG,DAH,DAJ,DAL,DAW,DAX,V14,V15,V16,V17,V18,V19,V20,V21,V22,V24,ZAA,ZAB,ZAC,ZAD,ZAE,ZAF,ZAG,ZAH,ZAJ,ZAL .....	1
5	PAFZZ	4730-00-278-8824	06853	200455	. . NUT,TUBE COUPLING UOC: DAC,DAD,DAE,DAF,DAG,DAH,DAJ,DAL,DAW,DAX,V14,V15,V16,V17,V18,V19,V20,V21,V22,V24,ZAA,ZAB,ZAC,ZAD,ZAE,ZAF,ZAG,ZAH,ZAJ,ZAL .....	1
6	PAFZZ	5945-01-170-0553	96906	MS17981-2	. . SOLENOID,ELECTRICAL UOC: DAC,DAD,DAE,DAF,DAG,DAH,DAJ,DAL,DAW,DAX,V14,V15,V16,V17,V18,V19,V20,V21,V22,V24,ZAA,ZAB,ZAC,ZAD,ZAE,ZAF,ZAG,ZAH,ZAJ,ZAL .....	1
7	PAFZZ	5310-00-550-1130	80205	MS35333-40	. WASHER,LOCK UOC: DAC,DAD,DAE,DAF,DAG,DAH,DAJ,DAL,DAW,DAX,V14,V15,V16,V17,V18,V19,V20,V21,V22,V24,ZAA,ZAB,ZAC,ZAD,ZAE,ZAF,ZAG,ZAH,ZAJ,ZAL .....	2

(1) ITEM NO.	(2) SMR CODE	(3) NSN	(4) CAGEC	(5) PART NUMBER	(6) DESCRIPTION AND USABLE ON CODE (UOC)	(7) QTY
8	PAFZZ	5310-00-768-0319	96906	MS51968-2	. NUT,PLAIN,HEXAGON UOC: DAC,DAD,DAE,DAF,DAG,DA H,DAJ,DAL,DAW,DAX,V14,V15,V16, V17,V18,V19,V20,V21,V22,V24,ZAA, ZAB,ZAC,ZAD,ZAE,ZAF,ZAG,ZAH,Z AJ,ZAL .....	2
9	PAFZZ	5305-00-267-8954	80204	B1821BH025F125N	. SCREW,CAP,HEXAGON H HORN BRACKET UOC: V14,V15,V16,V17,V18,V19,V2 0,V21,V22,V24 .....	2
10	PAFZZ	4710-01-131-7529	19207	12256065	TUBE,BENT,METALLIC UOC: DAC,DAD,DAE,DAF,DAG,DA H,DAJ,DAL,DAW,DAX,V14,V15,V16, V17,V18,V19,V20,V21,V22,V24,ZAA, ZAB,ZAC,ZAD,ZAE,ZAF,ZAG,ZAH,Z AJ,ZAL .....	1
11	PPFZZ	5340-01-104-8946	19207	12256092	BRACKET,MOUNTING UOC: DAC,DAD,DAE,DAF,DAG,DA H,DAJ,DAL,DAW,DAX,V14,V15,V16, V17,V18,V19,V20,V21,V22,V24,ZAA, ZAB,ZAC,ZAD,ZAE,ZAF,ZAG,ZAH,Z AJ,ZAL .....	1
12	PAFZZ	5305-00-912-5113	80205	MS51096-359	SCREW,CAP,HEXAGON H UOC: DAC,DAD,DAE,DAF,DAG,DA H,DAJ,DAL,DAW,DAX,V14,V15,V16, V17,V18,V19,V20,V21,V22,V24,ZAA, ZAB,ZAC,ZAD,ZAE,ZAF,ZAG,ZAH,Z AJ,ZAL .....	1
13	PAFZZ	5310-00-595-7237	80205	MS35333-42	WASHER,LOCK UOC: DAC,DAD,DAE,DAF,DAG,DA H,DAJ,DAL,DAW,DAX,V14,V15,V16, V17,V18,V19,V20,V21,V22,V24,ZAA, ZAB,ZAC,ZAD,ZAE,ZAF,ZAG,ZAH,Z AJ,ZAL .....	1
14	PAFZZ	5310-00-732-0559	96906	MS51968-8	NUT,PLAIN,HEXAGON UOC: DAC,DAD,DAE,DAF,DAG,DA H,DAJ,DAL,DAW,DAX,V14,V15,V16, V17,V18,V19,V20,V21,V22,V24,ZAA, ZAB,ZAC,ZAD,ZAE,ZAF,ZAG,ZAH,Z AJ,ZAL .....	1

END OF FIGURE



**FIELD MAINTENANCE  
HORN BUTTON AND DIODE COUPLING ASSEMBLY**

---

7  
|  
8 - 11

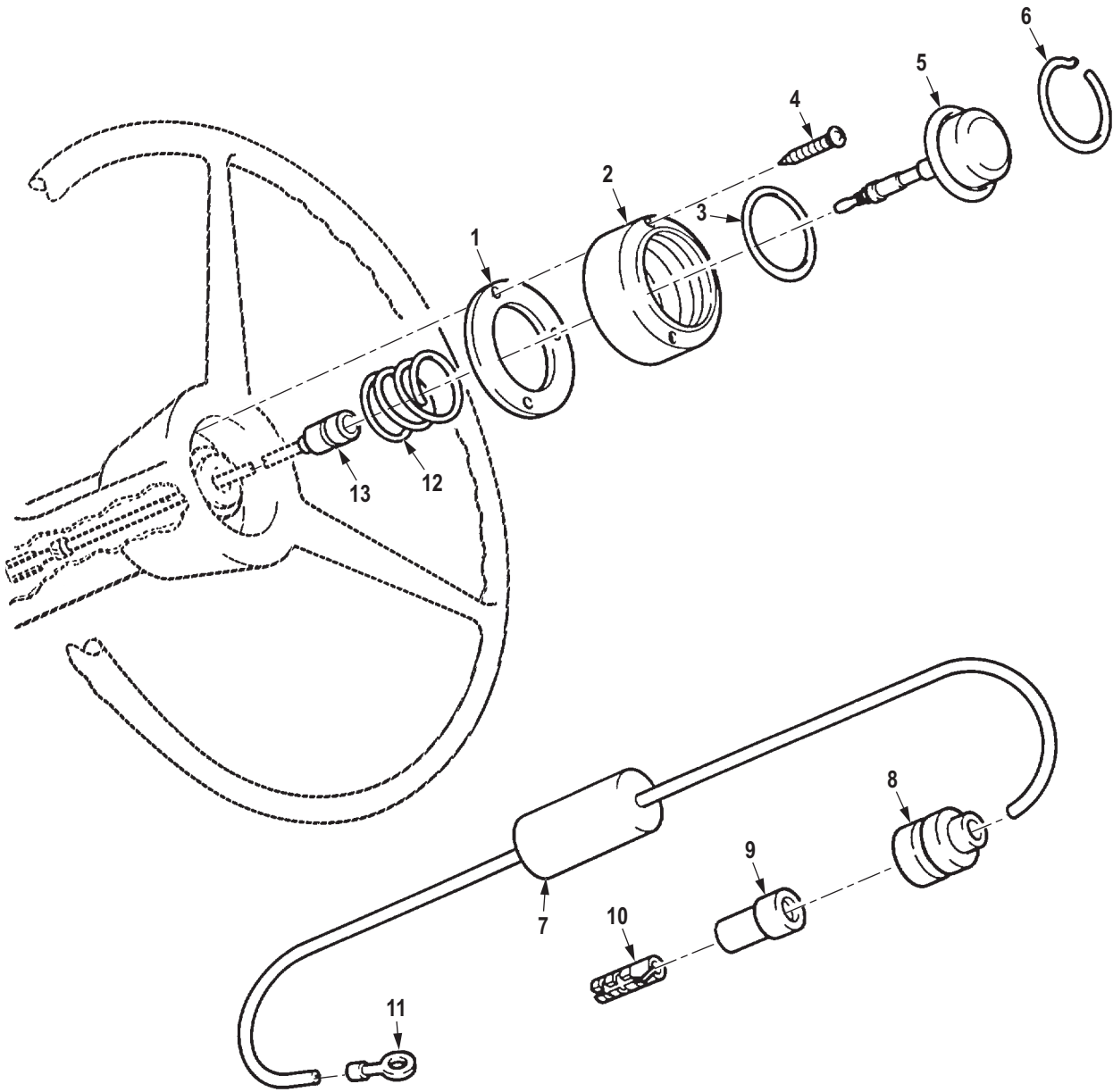

R0150DAA

Figure 149. Horn Button and Diode Coupling Assembly.

(1) ITEM NO.	(2) SMR CODE	(3) NSN	(4) CAGEC	(5) PART NUMBER	(6) DESCRIPTION AND USABLE ON CODE (UOC)	(7) QTY
<b>GROUP 0611 HORN, SIREN.</b>						
<b>FIG. 149. HORN BUTTON AND DIODE COUPLING ASSEMBLY.</b>						
1	PAFZZ	5330-01-099-0554	19207	12255677	GASKET UOC: DAC,DAD,DAE,DAF,DAG,DA H,DAJ,DAL,DAW,DAX,V14,V15,V16, V17,V18,V19,V20,V21,V22,V24,ZAA, ZAB,ZAC,ZAD,ZAE,ZAF,ZAG,ZAH,Z AJ,ZAL .....	1
2	PAFZZ	2590-01-111-5391	19207	11677306	ADAPTER,HORN BUTTON UOC: DAC,DAD,DAE,DAF,DAG,DA H,DAJ,DAL,DAW,DAX,V14,V15,V16, V17,V18,V19,V20,V21,V22,V24,ZAA, ZAB,ZAC,ZAD,ZAE,ZAF,ZAG,ZAH,Z AJ,ZAL .....	1
3	PAFZZ	5331-01-049-7374	81343	MS28775-032	O-RING UOC: DAC,DAD,DAE,DAF,DAG,DA H,DAJ,DAL,DAW,DAX,V14,V15,V16, V17,V18,V19,V20,V21,V22,V24,ZAA, ZAB,ZAC,ZAD,ZAE,ZAF,ZAG,ZAH,Z AJ,ZAL .....	1
4	PAFZZ	5305-00-432-7956	96906	MS51861-40	SCREW,TAPPING UOC: DAC,DAD,DAE,DAF,DAG,DA H,DAJ,DAL,DAW,DAX,V14,V15,V16, V17,V18,V19,V20,V21,V22,V24,ZAA, ZAB,ZAC,ZAD,ZAE,ZAF,ZAG,ZAH,Z AJ,ZAL .....	3
5	PAFZZ	2530-01-136-1098	19207	10921898-1	HORN BUTTON,VEHICLE UOC: DAC,DAD,DAE,DAF,DAG,DA H,DAJ,DAL,DAW,DAX,V14,V15,V16, V17,V18,V19,V20,V21,V22,V24,ZAA, ZAB,ZAC,ZAD,ZAE,ZAF,ZAG,ZAH,Z AJ,ZAL .....	1
6	PAFZZ	5325-01-144-4871	19207	8754124	RING,RETAINING UOC: DAC,DAD,DAE,DAF,DAG,DA H,DAJ,DAL,DAW,DAX,V14,V15,V16, V17,V18,V19,V20,V21,V22,V24,ZAA, ZAB,ZAC,ZAD,ZAE,ZAF,ZAG,ZAH,Z AJ,ZAL .....	1
7	PAFZZ	5961-01-180-5634	19207	12302643	SEMICONDUCTOR DEVIC UOC: DAC,DAD,DAE,DAF,DAG,DA H,DAJ,DAL,DAW,DAX,V14,V15,V16, V17,V18,V19,V20,V21,V22,V24,ZAA, ZAB,ZAC,ZAD,ZAE,ZAF,ZAG,ZAH,Z AJ,ZAL .....	1

(1) ITEM NO.	(2) SMR CODE	(3) NSN	(4) CAGEC	(5) PART NUMBER	(6) DESCRIPTION AND USABLE ON CODE (UOC)	(7) QTY
8	PAFZZ	5935-00-833-8561	19207	8338561	. SHELL,ELECTRICAL CO UOC: DAC,DAD,DAE,DAF,DAG,DA H,DAJ,DAL,DAW,DAX,V14,V15,V16, V17,V18,V19,V20,V21,V22,V24,ZAA, ZAB,ZAC,ZAD,ZAE,ZAF,ZAG,ZAH,Z AJ,ZAL .....	1
9	PAFZZ	5970-00-833-8562	19207	8338562	. INSULATOR,BUSHING UOC: DAC,DAD,DAE,DAF,DAG,DA H,DAJ,DAL,DAW,DAX,V14,V15,V16, V17,V18,V19,V20,V21,V22,V24,ZAA, ZAB,ZAC,ZAD,ZAE,ZAF,ZAG,ZAH,Z AJ,ZAL .....	1
10	PAFZZ	1015-00-798-2997	19207	7982997	. TERMINAL,SOLDERED F UOC: DAC,DAD,DAE,DAF,DAG,DA H,DAJ,DAL,DAW,DAX,V14,V15,V16, V17,V18,V19,V20,V21,V22,V24,ZAA, ZAB,ZAC,ZAD,ZAE,ZAF,ZAG,ZAH,Z AJ,ZAL .....	1
11	PAFZZ	5940-00-892-3151	96906	MS35436-9	. TERMINAL,LUG UOC: DAC,DAD,DAE,DAF,DAG,DA H,DAJ,DAL,DAW,DAX,V14,V15,V16, V17,V18,V19,V20,V21,V22,V24,ZAA, ZAB,ZAC,ZAD,ZAE,ZAF,ZAG,ZAH,Z AJ,ZAL .....	2
12	PAFZZ	5360-01-120-4610	19207	12255660	SPRING,HELICAL,COMP UOC: DAC,DAD,DAE,DAF,DAG,DA H,DAJ,DAL,DAW,DAX,V14,V15,V16, V17,V18,V19,V20,V21,V22,V24,ZAA, ZAB,ZAC,ZAD,ZAE,ZAF,ZAG,ZAH,Z AJ,ZAL .....	1
13	PAFZA	5999-00-925-6495	58536	AA52536-1	CONTACT,ELECTRICAL UOC: DAC,DAD,DAE,DAF,DAG,DA H,DAJ,DAL,DAW,DAX,V14,V15,V16, V17,V18,V19,V20,V21,V22,V24,ZAA, ZAB,ZAC,ZAD,ZAE,ZAF,ZAG,ZAH,Z AJ,ZAL .....	1

END OF FIGURE

**FIELD MAINTENANCE  
HORN COVER, BRUSH, AND CAPACITOR ASSEMBLY**

---

3      15  
4-9    16-17

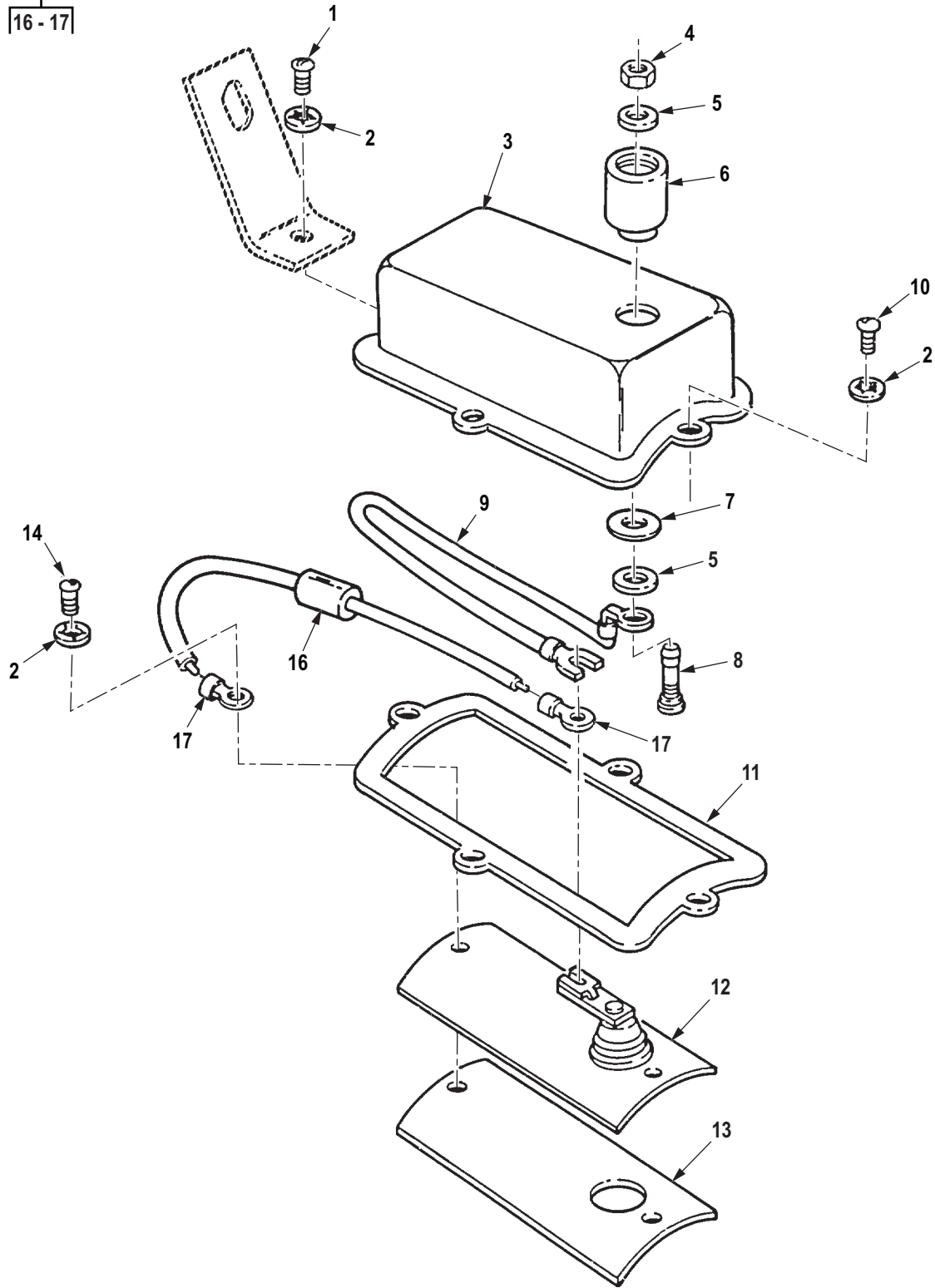

R0151DAA

Figure 150. Horn Cover, Brush, and Capacitor Assembly.

(1) ITEM NO.	(2) SMR CODE	(3) NSN	(4) CAGEC	(5) PART NUMBER	(6) DESCRIPTION AND USABLE ON CODE (UOC)	(7) QTY
<b>GROUP 0611 HORN, SIREN.</b>						
<b>FIG. 150. HORN COVER, BRUSH, AND CAPACITOR ASSEMBLY.</b>						
1	PAFZZ	5305-00-889-3002	96906	MS35206-242	SCREW,MACHINE UOC: DAC,DAD,DAE,DAF,DAG,DA H,DAJ,DAL,DAW,DAX,V14,V15,V16, V17,V18,V19,V20,V21,V22,V24,ZAA, ZAB,ZAC,ZAD,ZAE,ZAF,ZAG,ZAH,Z AJ,ZAL .....	1
2	PAFZZ	5310-00-559-0070	80205	MS35333-38	WASHER,LOCK UOC: DAC,DAD,DAE,DAF,DAG,DA H,DAJ,DAL,DAW,DAX,V14,V15,V16, V17,V18,V19,V20,V21,V22,V24,ZAA, ZAB,ZAC,ZAD,ZAE,ZAF,ZAG,ZAH,Z AJ,ZAL .....	6
3	PAFZZ	4320-00-922-4933	19207	7060038	COVER ASSEMBLY,CONT UOC: DAC,DAD,DAE,DAF,DAG,DA H,DAJ,DAL,DAW,DAX,V14,V15,V16, V17,V18,V19,V20,V21,V22,V24,ZAA, ZAB,ZAC,ZAD,ZAE,ZAF,ZAG,ZAH,Z AJ,ZAL .....	1
4	PAFZZ	5310-00-087-3946	96906	MS25082-12	. NUT,PLAIN,HEXAGON UOC: DAC,DAD,DAE,DAF,DAG,DA H,DAJ,DAL,DAW,DAX,V14,V15,V16, V17,V18,V19,V20,V21,V22,V24,ZAA, ZAB,ZAC,ZAD,ZAE,ZAF,ZAG,ZAH,Z AJ,ZAL .....	1
5	PAFZZ	5310-00-045-5207	80205	MS15795-908	. WASHER,FLAT UOC: DAC,DAD,DAE,DAF,DAG,DA H,DAJ,DAL,DAW,DAX,V14,V15,V16, V17,V18,V19,V20,V21,V22,V24,ZAA, ZAB,ZAC,ZAD,ZAE,ZAF,ZAG,ZAH,Z AJ,ZAL .....	2
6	PAFZZ	5970-00-906-0159	06853	235842N	. INSULATION SLEEVING UOC: DAC,DAD,DAE,DAF,DAG,DA H,DAJ,DAL,DAW,DAX,V14,V15,V16, V17,V18,V19,V20,V21,V22,V24,ZAA, ZAB,ZAC,ZAD,ZAE,ZAF,ZAG,ZAH,Z AJ,ZAL .....	1
7	PAFZZ	5970-01-121-6587	19207	7060041	. INSULATOR,WASHER UOC: DAC,DAD,DAE,DAF,DAG,DA H,DAJ,DAL,DAW,DAX,V14,V15,V16, V17,V18,V19,V20,V21,V22,V24,ZAA, ZAB,ZAC,ZAD,ZAE,ZAF,ZAG,ZAH,Z AJ,ZAL .....	1

(1) ITEM NO.	(2) SMR CODE	(3) NSN	(4) CAGEC	(5) PART NUMBER	(6) DESCRIPTION AND USABLE ON CODE (UOC)	(7) QTY
8	XDFZZ		19207	7060039	. TERMINAL,STUD UOC: DAC,DAD,DAE,DAF,DAG,DA H,DAJ,DAL,DAW,DAX,V14,V15,V16, V17,V18,V19,V20,V21,V22,V24,ZAA, ZAB,ZAC,ZAD,ZAE,ZAF,ZAG,ZAH,Z AJ,ZAL .....	1
9	PAFZZ	6150-01-114-3697	19207	7060040	. LEAD,ELECTRICAL UOC: DAC,DAD,DAE,DAF,DAG,DA H,DAJ,DAL,DAW,DAX,V14,V15,V16, V17,V18,V19,V20,V21,V22,V24,ZAA, ZAB,ZAC,ZAD,ZAE,ZAF,ZAG,ZAH,Z AJ,ZAL .....	1
10	PAFZZ	5305-00-984-6189	80205	MS35206-241	SCREW,MACHINE UOC: DAC,DAD,DAE,DAF,DAG,DA H,DAJ,DAL,DAW,DAX,V14,V15,V16, V17,V18,V19,V20,V21,V22,V24,ZAA, ZAB,ZAC,ZAD,ZAE,ZAF,ZAG,ZAH,Z AJ,ZAL .....	3
11	PAFZZ	5330-00-735-1272	19207	7351272	GASKET UOC: DAC,DAD,DAE,DAF,DAG,DA H,DAJ,DAL,DAW,DAX,V14,V15,V16, V17,V18,V19,V20,V21,V22,V24,ZAA, ZAB,ZAC,ZAD,ZAE,ZAF,ZAG,ZAH,Z AJ,ZAL .....	1
12	PAFZZ	5977-00-578-6495	7X677	1998757	ELECTRICAL CONTACT UOC: DAC,DAD,DAE,DAF,DAG,DA H,DAJ,DAL,DAW,DAX,V14,V15,V16, V17,V18,V19,V20,V21,V22,V24,ZAA, ZAB,ZAC,ZAD,ZAE,ZAF,ZAG,ZAH,Z AJ,ZAL .....	1
13	PAFZZ	2590-00-525-1352	77640	034059	PAD,CUSHIONING UOC: DAC,DAD,DAE,DAF,DAG,DA H,DAJ,DAL,DAW,DAX,V14,V15,V16, V17,V18,V19,V20,V21,V22,V24,ZAA, ZAB,ZAC,ZAD,ZAE,ZAF,ZAG,ZAH,Z AJ,ZAL .....	1
14	PAFZZ	5305-00-984-6226	80205	MS35206-240	SCREW,MACHINE UOC: DAC,DAD,DAE,DAF,DAG,DA H,DAJ,DAL,DAW,DAX,V14,V15,V16, V17,V18,V19,V20,V21,V22,V24,ZAA, ZAB,ZAC,ZAD,ZAE,ZAF,ZAG,ZAH,Z AJ,ZAL .....	2
15	PAFZZ	5910-01-096-5021	19207	12277055	CAPACITOR,FIXED,PLA UOC: DAC,DAD,DAE,DAF,DAG,DA H,DAJ,DAL,DAW,DAX,V14,V15,V16, V17,V18,V19,V20,V21,V22,V24,ZAA, ZAB,ZAC,ZAD,ZAE,ZAF,ZAG,ZAH,Z AJ,ZAL .....	1



(1) ITEM NO.	(2) SMR CODE	(3) NSN	(4) CAGEC	(5) PART NUMBER	(6) DESCRIPTION AND USABLE ON CODE (UOC)	(7) QTY
16	XAFZZ		19207	12277055-1	. CAPACITOR, FIXED, PLA UOC: DAC, DAD, DAE, DAF, DAG, DA H, DAJ, DAL, DAW, DAX, V14, V15, V16, V17, V18, V19, V20, V21, V22, V24, ZAA, ZAB, ZAC, ZAD, ZAE, ZAF, ZAG, ZAH, Z AJ, ZAL .....	1
17	PAFZZ	5940-00-113-3138	96906	MS20659-102	. TERMINAL, LUG UOC: DAC, DAD, DAE, DAF, DAG, DA H, DAJ, DAL, DAW, DAX, V14, V15, V16, V17, V18, V19, V20, V21, V22, V24, ZAA, ZAB, ZAC, ZAD, ZAE, ZAF, ZAG, ZAH, Z AJ, ZAL .....	2

END OF FIGURE



**FIELD MAINTENANCE  
BATTERIES, CABLES, AND RELATED PARTS**

---

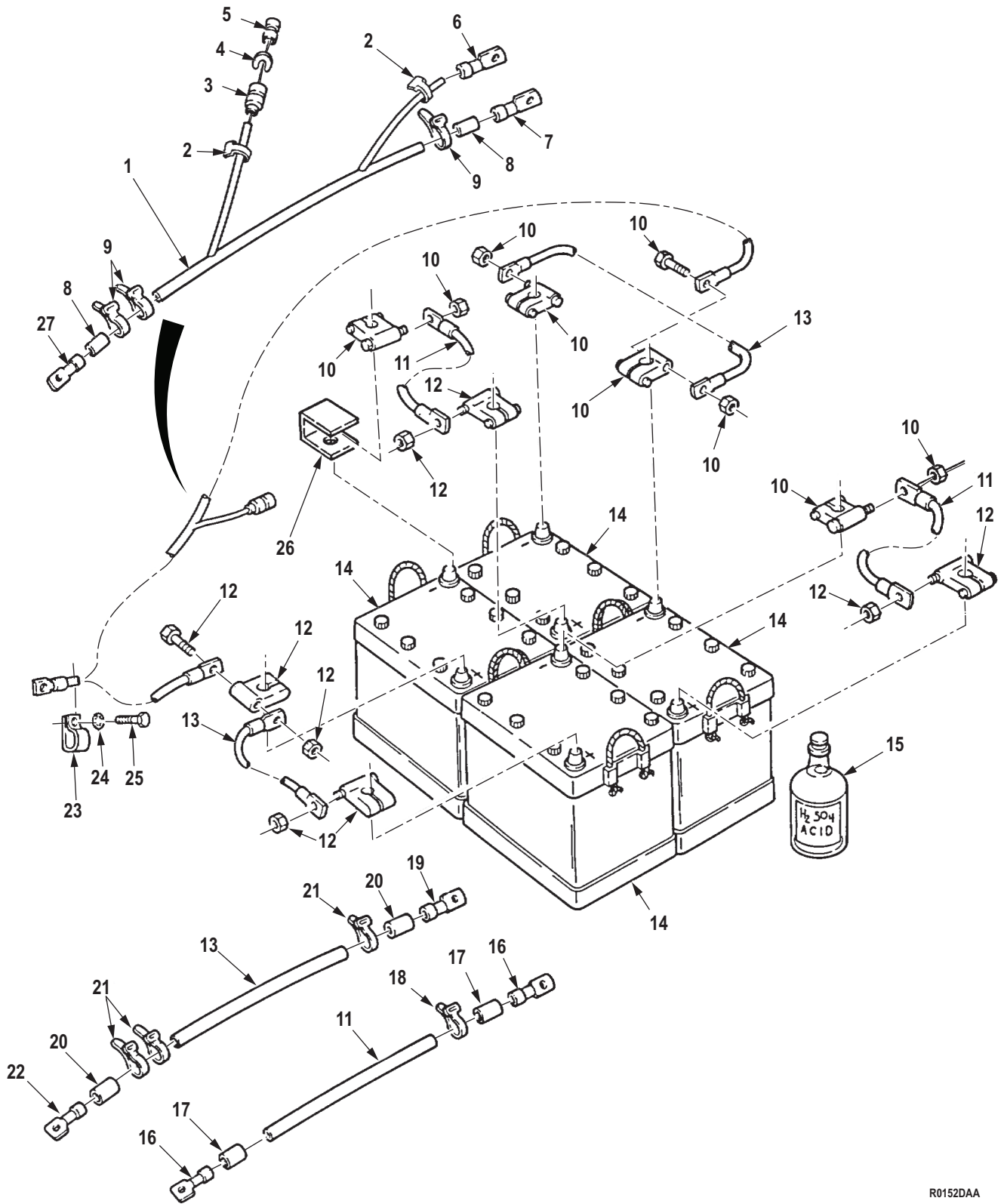

Figure 151. Batteries, Cables, and Related Parts.

R0152DAA

(1) ITEM NO.	(2) SMR CODE	(3) NSN	(4) CAGEC	(5) PART NUMBER	(6) DESCRIPTION AND USABLE ON CODE (UOC)	(7) QTY
<b>GROUP 0612 BATTERIES, STORAGE (WET OR DRY).</b>						
<b>FIG. 151. BATTERIES, CABLES, AND RELATED PARTS.</b>						
1	MFFZZ		19207	12277051	CABLE ASSY NEGATIVE,MAKE FROM P/N 13486-1-3,LENGTH AS REQUIRED UOC: DAC,DAD,DAE,DAF,DAG,DA H,DAJ,DAL,DAW,DAX,V14,V15,V16, V17,V18,V19,V20,V21,V22,V24 .....	1
1	MFFZZ		19207	12277050	LEAD,ELECTRICAL POSITIVE,MAKE FROM P/N M13486-1-3, LENGTH AS REQUIRED UOC: DAC,DAD,DAE,DAF,DAG,DA H,DAJ,DAL,DAW,DAX,V14,V15,V16, V17,V18,V19,V20,V21,V22,V24 .....	1
2	PAFZZ	9905-01-013-8723	81349	M43436/3-1	BAND,MARKER UOC: DAC,DAD,DAE,DAF,DAG,DA H,DAJ,DAL,DAW,DAX,V14,V15,V16, V17,V18,V19,V20,V21,V22,V24 .....	2
3	PAFZZ	5935-00-691-5591	97403	13207E6498-2	SHELL,ELECTRICAL CO UOC: DAC,DAD,DAE,DAF,DAG,DA H,DAJ,DAL,DAW,DAX,V14,V15,V16, V17,V18,V19,V20,V21,V22,V24 .....	1
4	PAFZZ	5310-00-656-0067	19207	8724497	WASHER,SLOTTED UOC: DAC,DAD,DAE,DAF,DAG,DA H,DAJ,DAL,DAW,DAX,V14,V15,V16, V17,V18,V19,V20,V21,V22,V24 .....	1
5	PAFZZ	5999-00-926-3144	58536	AA52536-3	CONTACT,ELECTRICAL UOC: DAC,DAD,DAE,DAF,DAG,DA H,DAJ,DAL,DAW,DAX,V14,V15,V16, V17,V18,V19,V20,V21,V22,V24 .....	1
6	PAFZZ	5940-01-035-4212	19207	7728780	TERMINAL,LUG UOC: DAC,DAD,DAE,DAF,DAG,DA H,DAJ,DAL,DAW,DAX,V14,V15,V16, V17,V18,V19,V20,V21,V22,V24 .....	1
7	PAFZZ	5940-00-115-5006	81343	MS25036-133	TERMINAL,LUG UOC: DAC,DAD,DAE,DAF,DAG,DA H,DAJ,DAL,DAW,DAX,V14,V15,V16, V17,V18,V19,V20,V21,V22,V24 .....	1
8	PAFZZ	5970-01-174-9449	19207	7056640	INSULATION SLEEVING UOC: DAC,DAD,DAE,DAF,DAG,DA H,DAJ,DAL,DAW,DAX,V14,V15,V16, V17,V18,V19,V20,V21,V22,V24 .....	2
9	PAFZZ	9905-00-893-3570	81349	M43436/1-3	BAND,MARKER UOC: DAC,DAD,DAE,DAF,DAG,DA H,DAJ,DAL,DAW,DAX,V14,V15,V16, V17,V18,V19,V20,V21,V22,V24 .....	2

(1) ITEM NO.	(2) SMR CODE	(3) NSN	(4) CAGEC	(5) PART NUMBER	(6) DESCRIPTION AND USABLE ON CODE (UOC)	(7) QTY
10	PAFZZ	5940-00-549-6581	58536	A52425-1	ADAPTER,BATTERY TER UOC: DAC,DAD,DAE,DAF,DAG,DA H,DAJ,DAL,DAW,DAX,V14,V15,V16, V17,V18,V19,V20,V21,V22,V24,ZAA, ZAB,ZAC,ZAD,ZAE,ZAF,ZAG,ZAH,Z AJ,ZAL .....	4
11	PAFZZ	6150-00-776-2738	19207	7762738	LEAD,ELECTRICAL UOC: DAC,DAD,DAE,DAF,DAG,DA H,DAJ,DAL,DAW,DAX,V14,V15,V16, V17,V18,V19,V20,V21,V22,V24,ZAA, ZAB,ZAC,ZAD,ZAE,ZAF,ZAG,ZAH,Z AJ,ZAL .....	2
12	PAFZZ	5940-00-549-6583	58536	AA-52425-2	ADAPTER,BATTERY TER UOC: DAC,DAD,DAE,DAF,DAG,DA H,DAJ,DAL,DAW,DAX,V14,V15,V16, V17,V18,V19,V20,V21,V22,V24,ZAA, ZAB,ZAC,ZAD,ZAE,ZAF,ZAG,ZAH,Z AJ,ZAL .....	4
13	PAFZZ	6150-01-083-1154	19207	12256008	CABLE ASSEMBLY,SPEC UOC: DAC,DAD,DAE,DAF,DAG,DA H,DAJ,DAL,DAW,DAX,V14,V15,V16, V17,V18,V19,V20,V21,V22,V24,ZAA, ZAB,ZAC,ZAD,ZAE,ZAF,ZAG,ZAH,Z AJ,ZAL .....	2
14	PAFHA	6140-01-446-9498	81349	6TMF/TYPEI	BATTERY,STORAGE UOC: DAC,DAD,DAE,DAF,DAG,DA H,DAJ,DAL,DAW,DAX,V14,V15,V16, V17,V18,V19,V20,V21,V22,V24,ZAA, ZAB,ZAC,ZAD,ZAE,ZAF,ZAG,ZAH,Z AJ,ZAL .....	4
15	PAFZZ	6810-00-249-9354	19207	10875529	SULFURIC ACID,ELECT UOC: DAC,DAD,DAE,DAF,DAG,DA H,DAJ,DAL,DAW,DAX,V14,V15,V16, V17,V18,V19,V20,V21,V22,V24,ZAA, ZAB,ZAC,ZAD,ZAE,ZAF,ZAG,ZAH,Z AJ,ZAL .....	1
16	PAFZZ	5940-00-115-5006	81343	MS25036-133	TERMINAL,LUG UOC: DAC,DAD,DAE,DAF,DAG,DA H,DAJ,DAL,DAW,DAX,V14,V15,V16, V17,V18,V19,V20,V21,V22,V24,ZAA, ZAB,ZAC,ZAD,ZAE,ZAF,ZAG,ZAH,Z AJ,ZAL .....	2
17	PAFZZ	5970-01-174-9449	19207	7056640	INSULATION SLEEVING UOC: DAC,DAD,DAE,DAF,DAG,DA H,DAJ,DAL,DAW,DAX,V14,V15,V16, V17,V18,V19,V20,V21,V22,V24,ZAA, ZAB,ZAC,ZAD,ZAE,ZAF,ZAG,ZAH,Z AJ,ZAL .....	2

(1) ITEM NO.	(2) SMR CODE	(3) NSN	(4) CAGEC	(5) PART NUMBER	(6) DESCRIPTION AND USABLE ON CODE (UOC)	(7) QTY
18	PAFZZ	9905-00-893-3570	81349	M43436/1-3	BAND,MARKER UOC: DAC,DAD,DAE,DAF,DAG,DA H,DAJ,DAL,DAW,DAX,V14,V15,V16, V17,V18,V19,V20,V21,V22,V24,ZAA, ZAB,ZAC,ZAD,ZAE,ZAF,ZAG,ZAH,Z AJ,ZAL .....	1
19	PAFZZ	5940-00-115-5006	81343	MS25036-133	TERMINAL,LUG UOC: DAC,DAD,DAE,DAF,DAG,DA H,DAJ,DAL,DAW,DAX,V14,V15,V16, V17,V18,V19,V20,V21,V22,V24,ZAA, ZAB,ZAC,ZAD,ZAE,ZAF,ZAG,ZAH,Z AJ,ZAL .....	2
20	PAFZZ	5970-01-174-9449	19207	7056640	INSULATION SLEEVING UOC: DAC,DAD,DAE,DAF,DAG,DA H,DAJ,DAL,DAW,DAX,V14,V15,V16, V17,V18,V19,V20,V21,V22,V24,ZAA, ZAB,ZAC,ZAD,ZAE,ZAF,ZAG,ZAH,Z AJ,ZAL .....	2
21	PAFZZ	9905-00-893-3570	81349	M43436/1-3	BAND,MARKER UOC: DAC,DAD,DAE,DAF,DAG,DA H,DAJ,DAL,DAW,DAX,V14,V15,V16, V17,V18,V19,V20,V21,V22,V24,ZAA, ZAB,ZAC,ZAD,ZAE,ZAF,ZAG,ZAH,Z AJ,ZAL .....	3
22	PAFZZ	5940-00-735-5520	19207	7355520	TERMINAL,LUG UOC: DAC,DAD,DAE,DAF,DAG,DA H,DAJ,DAL,DAW,DAX,V14,V15,V16, V17,V18,V19,V20,V21,V22,V24,ZAA, ZAB,ZAC,ZAD,ZAE,ZAF,ZAG,ZAH,Z AJ,ZAL .....	1
23	PAFZZ	5340-01-117-9876	19207	7397785	CLAMP,LOOP UOC: DAC,DAD,DAE,DAF,DAG,DA H,DAJ,DAL,DAW,DAX,V14,V15,V16, V17,V18,V19,V20,V21,V22,V24,ZAA, ZAB,ZAC,ZAD,ZAE,ZAF,ZAG,ZAH,Z AJ,ZAL .....	2
24	PAFZZ	5310-00-550-1130	80205	MS35333-40	WASHER,LOCK UOC: DAC,DAD,DAE,DAF,DAG,DA H,DAJ,DAL,DAW,DAX,V14,V15,V16, V17,V18,V19,V20,V21,V22,V24,ZAA, ZAB,ZAC,ZAD,ZAE,ZAF,ZAG,ZAH,Z AJ,ZAL .....	2
25	PAFZZ	5306-00-068-0513	80204	B1821BH025F075N	BOLT,MACHINE UOC: DAC,DAD,DAE,DAF,DAG,DA H,DAJ,DAL,DAW,DAX,V14,V15,V16, V17,V18,V19,V20,V21,V22,V24,ZAA, ZAB,ZAC,ZAD,ZAE,ZAF,ZAG,ZAH,Z AJ,ZAL .....	2

(1) ITEM NO.	(2) SMR CODE	(3) NSN	(4) CAGEC	(5) PART NUMBER	(6) DESCRIPTION AND USABLE ON CODE (UOC)	(7) QTY
26	PAFZZ	5940-00-738-6272	19207	10942521	COVER,BATTERY TERMI UOC: DAC,DAD,DAE,DAF,DAG,DA H,DAJ,DAL,DAW,DAX,V14,V15,V16, V17,V18,V19,V20,V21,V22,V24,ZAA, ZAB,ZAC,ZAD,ZAE,ZAF,ZAG,ZAH,Z AJ,ZAL .....	8
27	PAFZZ	5940-00-735-5520	19207	7355520	TERMINAL,LUG UOC: DAC,DAD,DAE,DAF,DAG,DA H,DAJ,DAL,DAW,DAX,V14,V15,V16, V17,V18,V19,V20,V21,V22,V24 .....	1

END OF FIGURE



**FIELD MAINTENANCE  
BATTERY CABLES (M939A2)**

---

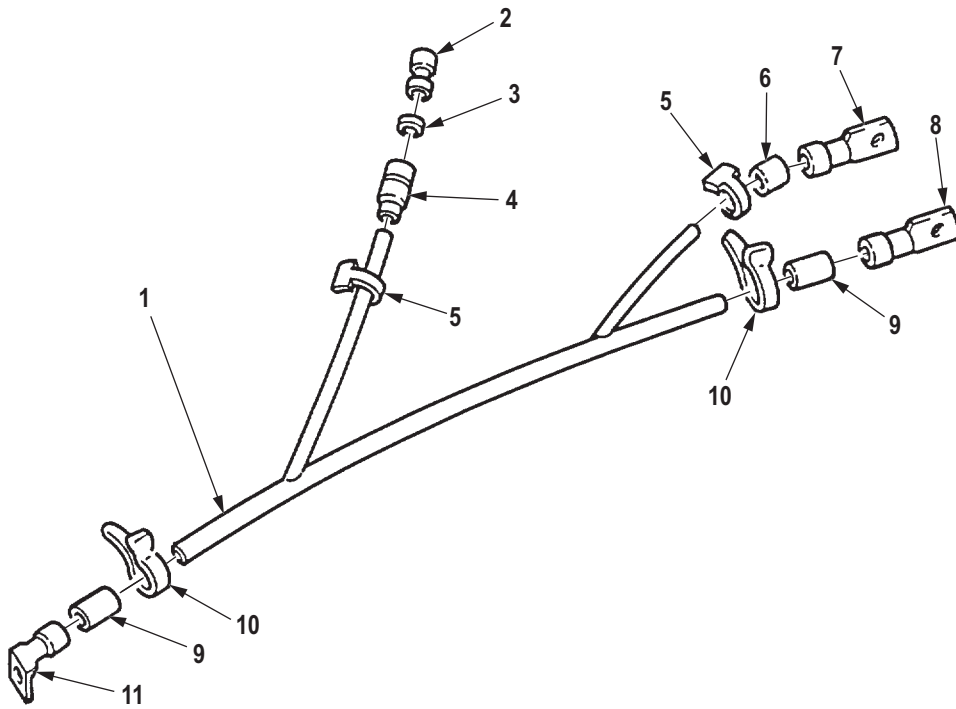

R0153DAA

Figure 152. Battery Cables (M939A2).

(1) ITEM NO.	(2) SMR CODE	(3) NSN	(4) CAGEC	(5) PART NUMBER	(6) DESCRIPTION AND USABLE ON CODE (UOC)	(7) QTY
<b>GROUP 0612 BATTERIES, STORAGE (WET OR DRY).</b>						
<b>FIG. 152. BATTERY CABLES (M939A2).</b>						
1	MFFZZ		1U238	12277051A XX	CABLE ASSEMBLY, POS BATTERY MAKE FROM WIRE, P/N M13486-1-3, 70 IN.LONG, AND P/N M13486-1-14, 102.50 IN.LONG UOC: ZAA,ZAB,ZAC,ZAD,ZAE,ZAF, ZAG,ZAH,ZAJ,ZAL .....	1
1	MFFZZ		1U238	12277050A XX	CABLE ASSEMBLY,SPEC POSITIVE BATTERY, MAKE FROM WIRE, P/N M13486/1-3, 73 IN.LONG, AND P/N M13486/1-14, 112.50 IN.LONG UOC: ZAA,ZAB,ZAC,ZAD,ZAE,ZAF, ZAG,ZAH,ZAJ,ZAL .....	1
2	PAFZZ	5999-00-926-3144	58536	AA52536-3	CONTACT,ELECTRICAL UOC: ZAA,ZAB,ZAC,ZAD,ZAE,ZAF, ZAG,ZAH,ZAJ,ZAL .....	2
3	PAFZZ	5310-00-656-0067	19207	8724497	WASHER,SLOTTED UOC: ZAA,ZAB,ZAC,ZAD,ZAE,ZAF, ZAG,ZAH,ZAJ,ZAL .....	1
4	PAFZZ	5935-00-691-5591	97403	13207E6498-2	SHELL,ELECTRICAL CO UOC: ZAA,ZAB,ZAC,ZAD,ZAE,ZAF, ZAG,ZAH,ZAJ,ZAL .....	1
5	PAFZZ	9905-01-013-8723	81349	M43436/3-1	BAND,MARKER UOC: ZAA,ZAB,ZAC,ZAD,ZAE,ZAF, ZAG,ZAH,ZAJ,ZAL .....	2
6	MFFZZ		81349	M23053/5 X 3 IN	INSULATION SLEEVING MAKE FROM INSULATION SLEEVING,P/N M23053/5-103-9,3 IN.LONG UOC: ZAA,ZAB,ZAC,ZAD,ZAE,ZAF, ZAG,ZAH,ZAJ,ZAL .....	1
7	PAFZZ	5940-01-035-4212	19207	7728780	TERMINAL,LUG UOC: ZAA,ZAB,ZAC,ZAD,ZAE,ZAF, ZAG,ZAH,ZAJ,ZAL .....	1
8	PAFZZ	5940-00-115-5006	81343	MS25036-133	TERMINAL,LUG UOC: ZAA,ZAB,ZAC,ZAD,ZAE,ZAF, ZAG,ZAH,ZAJ,ZAL .....	1
9	PAFZZ	5970-01-174-9449	19207	7056640	INSULATION SLEEVING UOC: ZAA,ZAB,ZAC,ZAD,ZAE,ZAF, ZAG,ZAH,ZAJ,ZAL .....	2
10	PAFZZ	9905-00-893-3570	81349	M43436/1-3	BAND,MARKER UOC: ZAA,ZAB,ZAC,ZAD,ZAE,ZAF, ZAG,ZAH,ZAJ,ZAL .....	2

(1) ITEM NO.	(2) SMR CODE	(3) NSN	(4) CAGEC	(5) PART NUMBER	(6) DESCRIPTION AND USABLE ON CODE (UOC)	(7) QTY
11	PAFZZ	5940-00-735-5520	19207	7355520	TERMINAL,LUG UOC: ZAA,ZAB,ZAC,ZAD,ZAE,ZAF, ZAG,ZAH,ZAJ,ZAL .....	1

END OF FIGURE

**FIELD MAINTENANCE  
BATTERY BOX ASSEMBLY, COVER, AND MOUNTING HARDWARE**

---

12 15  
 13 16 - 25

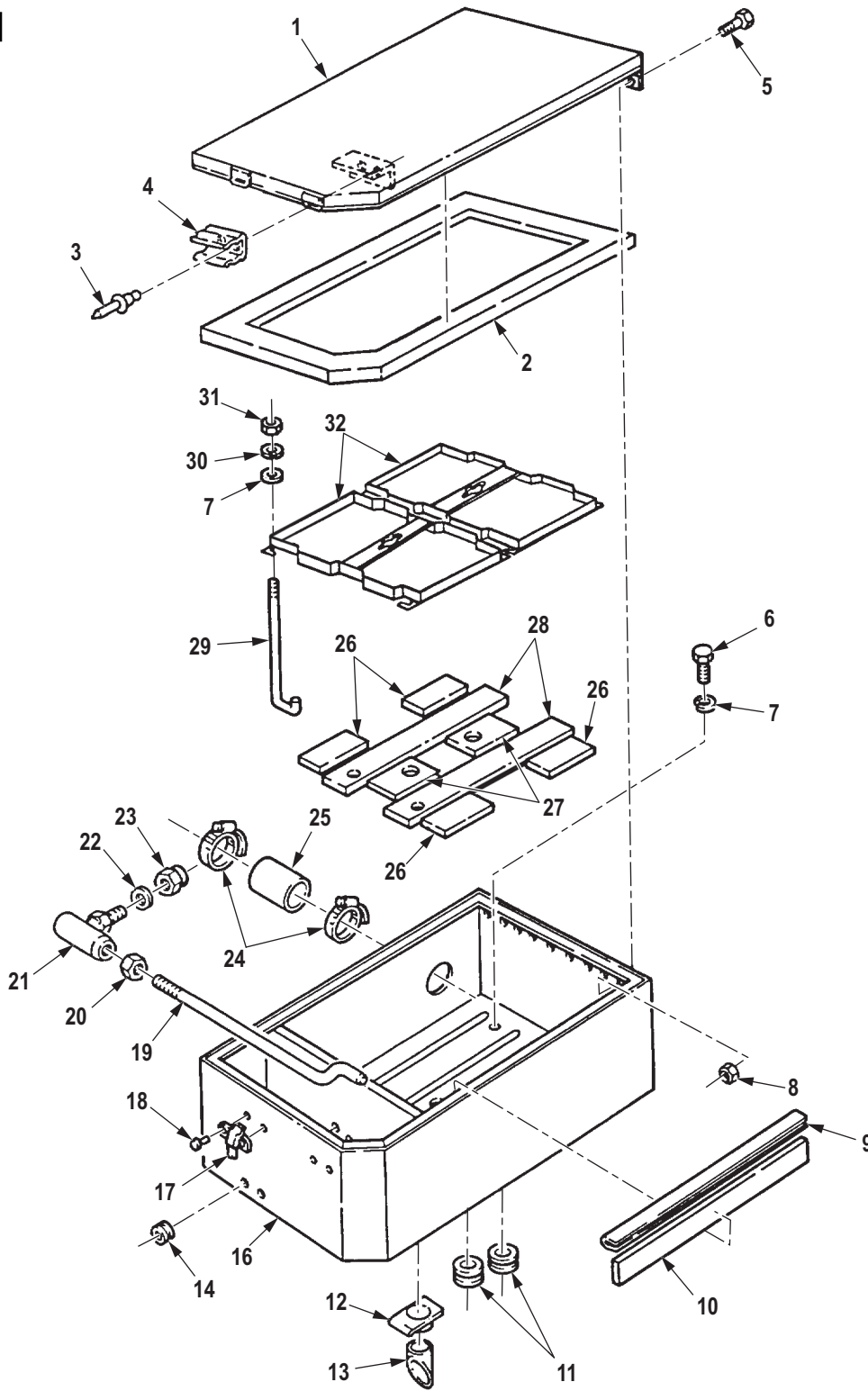

R0154DAA

Figure 153. Battery Box Assembly, Cover, and Mounting Hardware.

(1) ITEM NO.	(2) SMR CODE	(3) NSN	(4) CAGEC	(5) PART NUMBER	(6) DESCRIPTION AND USABLE ON CODE (UOC)	(7) QTY
<b>GROUP 0612 BATTERIES, STORAGE (WET OR DRY).</b>						
<b>FIG. 153. BATTERY BOX ASSEMBLY, COVER, AND MOUNTING HARDWARE.</b>						
1	PPFZZ	6160-01-130-8045	19207	12255880	COVER,BATTERY BOX UOC: DAC,DAD,DAE,DAF,DAG,DA H,DAJ,DAL,DAW,DAX,V14,V15,V16, V17,V18,V19,V20,V21,V22,V24,ZAA, ZAB,ZAC,ZAD,ZAE,ZAF,ZAG,ZAH,Z AJ,ZAL .....	1
2	PAFZZ	5330-01-104-7702	19207	12256041	RUBBER STRIP UOC: DAC,DAD,DAE,DAF,DAG,DA H,DAJ,DAL,DAW,DAX,V14,V15,V16, V17,V18,V19,V20,V21,V22,V24,ZAA, ZAB,ZAC,ZAD,ZAE,ZAF,ZAG,ZAH,Z AJ,ZAL .....	1
3	PAFZZ	5320-01-055-4452	81349	M24243/1-B304	RIVET,BLIND UOC: DAC,DAD,DAE,DAF,DAG,DA H,DAJ,DAL,DAW,DAX,V14,V15,V16, V17,V18,V19,V20,V21,V22,V24,ZAA, ZAB,ZAC,ZAD,ZAE,ZAF,ZAG,ZAH,Z AJ,ZAL .....	2
4	PAFZZ	5340-00-725-6033	80205	M24066/2-321	CLIP,SPRING TENSION UOC: DAC,DAD,DAE,DAF,DAG,DA H,DAJ,DAL,DAW,DAX,V14,V15,V16, V17,V18,V19,V20,V21,V22,V24,ZAA, ZAB,ZAC,ZAD,ZAE,ZAF,ZAG,ZAH,Z AJ,ZAL .....	1
5	PAFZZ	5305-00-989-7435	80205	MS35207-264	SCREW,MACHINE UOC: DAC,DAD,DAE,DAF,DAG,DA H,DAJ,DAL,DAW,DAX,V14,V15,V16, V17,V18,V19,V20,V21,V22,V24,ZAA, ZAB,ZAC,ZAD,ZAE,ZAF,ZAG,ZAH,Z AJ,ZAL .....	6
6	PAFZZ	5305-00-269-2803	80205	MS90726-60	SCREW,CAP,HEXAGON H UOC: DAC,DAD,DAE,DAF,DAG,DA H,DAJ,DAL,DAW,DAX,V14,V15,V16, V17,V18,V19,V20,V21,V22,V24,ZAA, ZAB,ZAC,ZAD,ZAE,ZAF,ZAG,ZAH,Z AJ,ZAL .....	4
7	PAFZZ	5310-00-080-6004	96906	MS27183-14	WASHER,FLAT UOC: DAC,DAD,DAE,DAF,DAG,DA H,DAJ,DAL,DAW,DAX,V14,V15,V16, V17,V18,V19,V20,V21,V22,V24,ZAA, ZAB,ZAC,ZAD,ZAE,ZAF,ZAG,ZAH,Z AJ,ZAL .....	10

(1) ITEM NO.	(2) SMR CODE	(3) NSN	(4) CAGEC	(5) PART NUMBER	(6) DESCRIPTION AND USABLE ON CODE (UOC)	(7) QTY
8	PAFZZ	5310-00-877-5797	80205	MS21044N3	NUT,SELF-LOCKING,HE UOC: DAC,DAD,DAE,DAF,DAG,DA H,DAJ,DAL,DAW,DAX,V14,V15,V16, V17,V18,V19,V20,V21,V22,V24,ZAA, ZAB,ZAC,ZAD,ZAE,ZAF,ZAG,ZAH,Z AJ,ZAL .....	6
9	PAFZZ	5970-01-144-4841	4L516	12257069	INSULATION SLEEVING UOC: DAC,DAD,DAE,DAF,DAG,DA H,DAJ,DAL,DAW,DAX,V14,V15,V16, V17,V18,V19,V20,V21,V22,V24,ZAA, ZAB,ZAC,ZAD,ZAE,ZAF,ZAG,ZAH,Z AJ,ZAL .....	1
10	PAFZZ	5970-01-134-5093	19207	12257070	INSULATOR,PLATE UOC: DAC,DAD,DAE,DAF,DAG,DA H,DAJ,DAL,DAW,DAX,V14,V15,V16, V17,V18,V19,V20,V21,V22,V24,ZAA, ZAB,ZAC,ZAD,ZAE,ZAF,ZAG,ZAH,Z AJ,ZAL .....	1
11	PAFZZ	5325-00-202-4005	96906	MS35489-110	GROMMET,NONMETALLIC UOC: DAC,DAD,DAE,DAF,DAG,DA H,DAJ,DAL,DAW,DAX,V14,V15,V16, V17,V18,V19,V20,V21,V22,V24,ZAA, ZAB,ZAC,ZAD,ZAE,ZAF,ZAG,ZAH,Z AJ,ZAL .....	2
12	PFFFF	6160-01-156-6187	19207	12277135	VENT TUBE,BATTERY UOC: DAC,DAD,DAE,DAF,DAG,DA H,DAJ,DAL,DAW,DAX,V14,V15,V16, V17,V18,V19,V20,V21,V22,V24,ZAA, ZAB,ZAC,ZAD,ZAE,ZAF,ZAG,ZAH,Z AJ,ZAL .....	1
13	PAFZZ	4720-01-122-3656	19207	12277138	. HOSE,NONMETALLIC UOC: DAC,DAD,DAE,DAF,DAG,DA H,DAJ,DAL,DAW,DAX,V14,V15,V16, V17,V18,V19,V20,V21,V22,V24,ZAA, ZAB,ZAC,ZAD,ZAE,ZAF,ZAG,ZAH,Z AJ,ZAL .....	1
14	PAFZZ	5325-01-242-7083	96906	MS35489-17	GROMMET,NONMETALLIC UOC: DAC,DAD,DAE,DAF,DAG,DA H,DAJ,DAL,DAW,DAX,V14,V15,V16, V17,V18,V19,V20,V21,V22,V24,ZAA, ZAB,ZAC,ZAD,ZAE,ZAF,ZAG,ZAH,Z AJ,ZAL .....	4
15	PAFZZ	6160-01-093-5836	19207	12255881	BATTERY BOX UOC: DAC,DAD,DAE,DAF,DAG,DA H,DAJ,DAL,DAW,DAX,V14,V15,V16, V17,V18,V19,V20,V21,V22,V24,ZAA, ZAB,ZAC,ZAD,ZAE,ZAF,ZAG,ZAH,Z AJ,ZAL .....	1



(1) ITEM NO.	(2) SMR CODE	(3) NSN	(4) CAGEC	(5) PART NUMBER	(6) DESCRIPTION AND USABLE ON CODE (UOC)	(7) QTY
16	XAFZZ		19207	12255882	. BATTERY BOX UOC: DAC,DAD,DAE,DAF,DAG,DA H,DAJ,DAL,DAW,DAX,V14,V15,V16, V17,V18,V19,V20,V21,V22,V24,ZAA, ZAB,ZAC,ZAD,ZAE,ZAF,ZAG,ZAH,Z AJ,ZAL .....	1
17	PAFZZ	5340-01-128-0191	19207	7413565	. CATCH,CLAMPING UOC: DAC,DAD,DAE,DAF,DAG,DA H,DAJ,DAL,DAW,DAX,V14,V15,V16, V17,V18,V19,V20,V21,V22,V24,ZAA, ZAB,ZAC,ZAD,ZAE,ZAF,ZAG,ZAH,Z AJ,ZAL .....	2
18	PFFZZ	5320-01-069-6365	96906	MS35743-16	. RIVET,SOLID UOC: DAC,DAD,DAE,DAF,DAG,DA H,DAJ,DAL,DAW,DAX,V14,V15,V16, V17,V18,V19,V20,V21,V22,V24,ZAA, ZAB,ZAC,ZAD,ZAE,ZAF,ZAG,ZAH,Z AJ,ZAL .....	4
19	PAFZZ	6160-01-093-4256	19207	12302883	. RETAINER,BATTERY UOC: DAC,DAD,DAE,DAF,DAG,DA H,DAJ,DAL,DAW,DAX,V14,V15,V16, V17,V18,V19,V20,V21,V22,V24,ZAA, ZAB,ZAC,ZAD,ZAE,ZAF,ZAG,ZAH,Z AJ,ZAL .....	1
20	PAFZZ	5310-00-891-1751	96906	MS35691-22	. NUT,PLAIN,HEXAGON UOC: DAC,DAD,DAE,DAF,DAG,DA H,DAJ,DAL,DAW,DAX,V14,V15,V16, V17,V18,V19,V20,V21,V22,V24,ZAA, ZAB,ZAC,ZAD,ZAE,ZAF,ZAG,ZAH,Z AJ,ZAL .....	1
21	PAFZZ	3040-00-541-0995	15434	210165	. BALLJOINT UOC: DAC,DAD,DAE,DAF,DAG,DA H,DAJ,DAL,DAW,DAX,V14,V15,V16, V17,V18,V19,V20,V21,V22,V24,ZAA, ZAB,ZAC,ZAD,ZAE,ZAF,ZAG,ZAH,Z AJ,ZAL .....	1
22	PAFZZ	5310-00-087-7493	96906	MS27183-13	. WASHER,FLAT UOC: DAC,DAD,DAE,DAF,DAG,DA H,DAJ,DAL,DAW,DAX,V14,V15,V16, V17,V18,V19,V20,V21,V22,V24,ZAA, ZAB,ZAC,ZAD,ZAE,ZAF,ZAG,ZAH,Z AJ,ZAL .....	1
23	PAFZZ	5310-00-814-0672	96906	M45913/3-6FG8C	. NUT,SELF-LOCKING,HE UOC: DAC,DAD,DAE,DAF,DAG,DA H,DAJ,DAL,DAW,DAX,V14,V15,V16, V17,V18,V19,V20,V21,V22,V24,ZAA, ZAB,ZAC,ZAD,ZAE,ZAF,ZAG,ZAH,Z AJ,ZAL .....	1

(1) ITEM NO.	(2) SMR CODE	(3) NSN	(4) CAGEC	(5) PART NUMBER	(6) DESCRIPTION AND USABLE ON CODE (UOC)	(7) QTY
24	PAFZZ	4730-00-909-8627	58536	AA52506-F-36	CLAMP,HOSE UOC: DAC,DAD,DAE,DAF,DAG,DA H,DAJ,DAL,DAW,DAX,V14,V15,V16, V17,V18,V19,V20,V21,V22,V24,ZAA, ZAB,ZAC,ZAD,ZAE,ZAF,ZAG,ZAH,Z AJ,ZAL .....	2
25	PAFZZ	4720-01-132-4868	19207	12277340	TUBING,NONMETALLIC UOC: DAC,DAD,DAE,DAF,DAG,DA H,DAJ,DAL,DAW,DAX,V14,V15,V16, V17,V18,V19,V20,V21,V22,V24,ZAA, ZAB,ZAC,ZAD,ZAE,ZAF,ZAG,ZAH,Z AJ,ZAL .....	1
26	PAFZZ	6160-01-125-6075	19207	12277132	BLOCK,SUPPORT,BATTE UOC: DAC,DAD,DAE,DAF,DAG,DA H,DAJ,DAL,DAW,DAX,V14,V15,V16, V17,V18,V19,V20,V21,V22,V24,ZAA, ZAB,ZAC,ZAD,ZAE,ZAF,ZAG,ZAH,Z AJ,ZAL .....	4
27	PAFZZ	6160-01-125-6074	19207	12277133	BLOCK,SUPPORT,BATTE UOC: DAC,DAD,DAE,DAF,DAG,DA H,DAJ,DAL,DAW,DAX,V14,V15,V16, V17,V18,V19,V20,V21,V22,V24,ZAA, ZAB,ZAC,ZAD,ZAE,ZAF,ZAG,ZAH,Z AJ,ZAL .....	2
28	PAFZZ	6160-01-125-6073	19207	12277134	BLOCK,SUPPORT,BATTE UOC: DAC,DAD,DAE,DAF,DAG,DA H,DAJ,DAL,DAW,DAX,V14,V15,V16, V17,V18,V19,V20,V21,V22,V24,ZAA, ZAB,ZAC,ZAD,ZAE,ZAF,ZAG,ZAH,Z AJ,ZAL .....	2
29	PAFZZ	5306-00-739-7754	19207	7397754	BOLT,HOOK UOC: DAC,DAD,DAE,DAF,DAG,DA H,DAJ,DAL,DAW,DAX,V14,V15,V16, V17,V18,V19,V20,V21,V22,V24,ZAA, ZAB,ZAC,ZAD,ZAE,ZAF,ZAG,ZAH,Z AJ,ZAL .....	10
30	PAFZZ	5310-00-637-9541	00198	132661	WASHER,LOCK UOC: DAC,DAD,DAE,DAF,DAG,DA H,DAJ,DAL,DAW,DAX,V14,V15,V16, V17,V18,V19,V20,V21,V22,V24,ZAA, ZAB,ZAC,ZAD,ZAE,ZAF,ZAG,ZAH,Z AJ,ZAL .....	10
31	PAFZZ	5310-00-655-9544	96906	MS35690-604	NUT,PLAIN,HEXAGON UOC: DAC,DAD,DAE,DAF,DAG,DA H,DAJ,DAL,DAW,DAX,V14,V15,V16, V17,V18,V19,V20,V21,V22,V24,ZAA, ZAB,ZAC,ZAD,ZAE,ZAF,ZAG,ZAH,Z AJ,ZAL .....	10

(1) ITEM NO.	(2) SMR CODE	(3) NSN	(4) CAGEC	(5) PART NUMBER	(6) DESCRIPTION AND USABLE ON CODE (UOC)	(7) QTY
32	PAFZZ	6160-00-404-2669	58536	A52505-C	RETAINER,BATTERY UOC: DAC,DAD,DAE,DAF,DAG,DA H,DAJ,DAL,DAW,DAX,V14,V15,V16, V17,V18,V19,V20,V21,V22,V24,ZAA, ZAB,ZAC,ZAD,ZAE,ZAF,ZAG,ZAH,Z AJ,ZAL .....	2

END OF FIGURE



**FIELD MAINTENANCE  
SLAVE RECEPTACLE, CABLE ASSEMBLIES, AND MOUNTING HARDWARE**

---

1  
2-12

6  
7-11

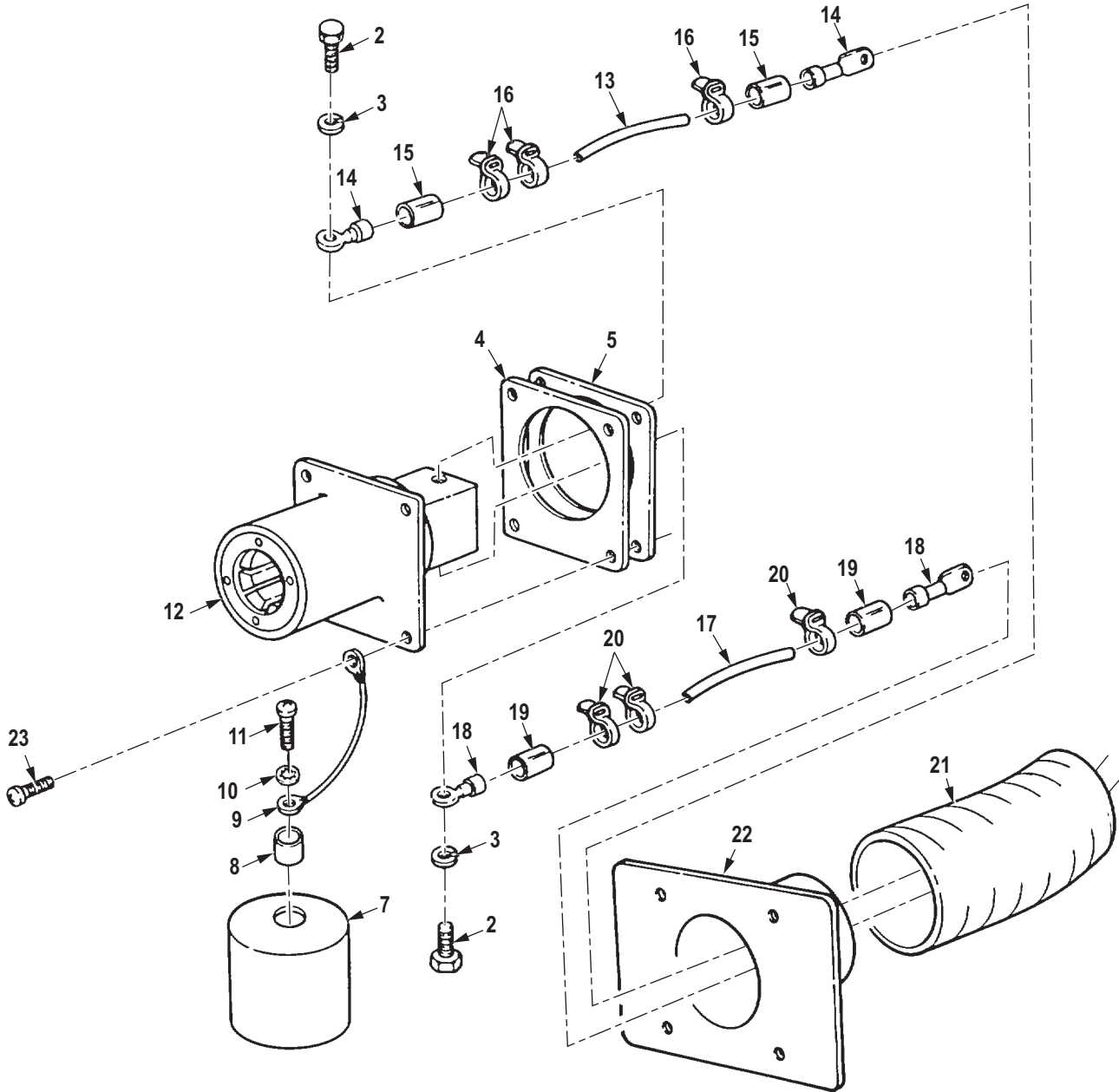

R0155DAA

Figure 154. Slave Receptacle, Cable Assemblies, and Mounting Hardware.

(1) ITEM NO.	(2) SMR CODE	(3) NSN	(4) CAGEC	(5) PART NUMBER	(6) DESCRIPTION AND USABLE ON CODE (UOC)	(7) QTY
<p><b>GROUP 0612 BATTERIES, STORAGE (WET OR DRY).</b></p> <p><b>FIG. 154. SLAVE RECEPTACLE, CABLE ASSEMBLIES, AND MOUNTING HARDWARE.</b></p>						
1	PAFZZ	5935-01-097-9974	19207	11674728	CONNECTOR,RECEPTACL UOC: DAC,DAD,DAE,DAF,DAG,DAH,DAJ,DAL,DAW,DAX,V14,V15,V16,V17,V18,V19,V20,V21,V22,V24,ZAA,ZAB,ZAC,ZAD,ZAE,ZAF,ZAG,ZAH,ZAJ,ZAL .....	1
2	PAFZZ	5305-00-269-3233	80204	B1821BH038F063N	. SCREW,CAP,HEXAGON H UOC: DAC,DAD,DAE,DAF,DAG,DAH,DAJ,DAL,DAW,DAX,V14,V15,V16,V17,V18,V19,V20,V21,V22,V24,ZAA,ZAB,ZAC,ZAD,ZAE,ZAF,ZAG,ZAH,ZAJ,ZAL .....	2
3	PAFZZ	5310-00-637-9541	00198	132661	. WASHER,LOCK UOC: DAC,DAD,DAE,DAF,DAG,DAH,DAJ,DAL,DAW,DAX,V14,V15,V16,V17,V18,V19,V20,V21,V22,V24,ZAA,ZAB,ZAC,ZAD,ZAE,ZAF,ZAG,ZAH,ZAJ,ZAL .....	2
4	PAFZZ	5970-01-044-8391	19207	11674730	. INSULATOR,PLATE UOC: DAC,DAD,DAE,DAF,DAG,DAH,DAJ,DAL,DAW,DAX,V14,V15,V16,V17,V18,V19,V20,V21,V22,V24,ZAA,ZAB,ZAC,ZAD,ZAE,ZAF,ZAG,ZAH,ZAJ,ZAL .....	1
5	PAFZZ	5330-01-059-4286	19207	11674729	. GASKET UOC: DAC,DAD,DAE,DAF,DAG,DAH,DAJ,DAL,DAW,DAX,V14,V15,V16,V17,V18,V19,V20,V21,V22,V24,ZAA,ZAB,ZAC,ZAD,ZAE,ZAF,ZAG,ZAH,ZAJ,ZAL .....	1
6	PAFFF	5340-01-059-0114	19207	11675004	. CAP,PROTECTIVE,DUST UOC: DAC,DAD,DAE,DAF,DAG,DAH,DAJ,DAL,DAW,DAX,V14,V15,V16,V17,V18,V19,V20,V21,V22,V24,ZAA,ZAB,ZAC,ZAD,ZAE,ZAF,ZAG,ZAH,ZAJ,ZAL .....	1
7	XAFZZ	5340-01-459-9722	19207	11675004-1	. . BODY UOC: DAC,DAD,DAE,DAF,DAG,DAH,DAJ,DAL,DAW,DAX,V14,V15,V16,V17,V18,V19,V20,V21,V22,V24,ZAA,ZAB,ZAC,ZAD,ZAE,ZAF,ZAG,ZAH,ZAJ,ZAL .....	1

(1) ITEM NO.	(2) SMR CODE	(3) NSN	(4) CAGEC	(5) PART NUMBER	(6) DESCRIPTION AND USABLE ON CODE (UOC)	(7) QTY
8	XAFZZ	5325-01-006-2246	96906	MS35914-148	. . INSERT,SCREW THREAD UOC: DAC,DAD,DAE,DAF,DAG,DA H,DAJ,DAL,DAW,DAX,V14,V15,V16, V17,V18,V19,V20,V21,V22,V24,ZAA, ZAB,ZAC,ZAD,ZAE,ZAF,ZAG,ZAH,Z AJ,ZAL .....	1
9	XAFZZ	4020-01-092-0331	19207	12269868	. . FIBER ROPE ASSEMBLY UOC: DAC,DAD,DAE,DAF,DAG,DA H,DAJ,DAL,DAW,DAX,V14,V15,V16, V17,V18,V19,V20,V21,V22,V24,ZAA, ZAB,ZAC,ZAD,ZAE,ZAF,ZAG,ZAH,Z AJ,ZAL .....	1
10	XAFZZ	5310-00-579-5554	80205	MS35333-35	. . WASHER,LOCK UOC: DAC,DAD,DAE,DAF,DAG,DA H,DAJ,DAL,DAW,DAX,V14,V15,V16, V17,V18,V19,V20,V21,V22,V24,ZAA, ZAB,ZAC,ZAD,ZAE,ZAF,ZAG,ZAH,Z AJ,ZAL .....	1
11	XAFZZ	5305-00-958-4357	96906	MS35207-242	. . SCREW,MACHINE UOC: DAC,DAD,DAE,DAF,DAG,DA H,DAJ,DAL,DAW,DAX,V14,V15,V16, V17,V18,V19,V20,V21,V22,V24,ZAA, ZAB,ZAC,ZAD,ZAE,ZAF,ZAG,ZAH,Z AJ,ZAL .....	1
12	PAFZZ	5935-01-044-8382	19207	11682345	. CONNECTOR,RECEPTACL UOC: DAC,DAD,DAE,DAF,DAG,DA H,DAJ,DAL,DAW,DAX,V14,V15,V16, V17,V18,V19,V20,V21,V22,V24,ZAA, ZAB,ZAC,ZAD,ZAE,ZAF,ZAG,ZAH,Z AJ,ZAL .....	1
13	MFFZZ		19207	12256699-2	LEAD ASSEMBLY,ELECT MAKE FROM WIRE, P/N M13486/1-12, AS REQUIRED UOC: DAC,DAD,DAE,DAF,DAG,DA H,DAJ,DAL,DAW,DAX,V14,V15,V16, V17,V18,V19,V20,V21,V22,V24,ZAA, ZAB,ZAC,ZAD,ZAE,ZAF,ZAG,ZAH,Z AJ,ZAL .....	1
14	PAFZZ	5940-00-705-6730	56501	TG30	TERMINAL,LUG UOC: DAC,DAD,DAE,DAF,DAG,DA H,DAJ,DAL,DAW,DAX,V14,V15,V16, V17,V18,V19,V20,V21,V22,V24,ZAA, ZAB,ZAC,ZAD,ZAE,ZAF,ZAG,ZAH,Z AJ,ZAL .....	2



(1) ITEM NO.	(2) SMR CODE	(3) NSN	(4) CAGEC	(5) PART NUMBER	(6) DESCRIPTION AND USABLE ON CODE (UOC)	(7) QTY
15	PAFZZ	5970-00-811-0640	19207	17-E-1728-651	INSULATION SLEEVING SLAVE LEAD UOC: DAC,DAD,DAE,DAF,DAG,DA H,DAJ,DAL,DAW,DAX,V14,V15,V16, V17,V18,V19,V20,V21,V22,V24,ZAA, ZAB,ZAC,ZAD,ZAE,ZAF,ZAG,ZAH,Z AJ,ZAL .....	2
16	PAFZZ	9905-00-893-3570	81349	M43436/1-3	BAND,MARKER UOC: DAC,DAD,DAE,DAF,DAG,DA H,DAJ,DAL,DAW,DAX,V14,V15,V16, V17,V18,V19,V20,V21,V22,V24,ZAA, ZAB,ZAC,ZAD,ZAE,ZAF,ZAG,ZAH,Z AJ,ZAL .....	3
17	MFFZZ		19207	12256699-1	LEAD ASSEMBLY,ELECT MAKE FROM WIRE, P/N M13486/1-12, AS REQUIRED UOC: DAC,DAD,DAE,DAF,DAG,DA H,DAJ,DAL,DAW,DAX,V14,V15,V16, V17,V18,V19,V20,V21,V22,V24,ZAA, ZAB,ZAC,ZAD,ZAE,ZAF,ZAG,ZAH,Z AJ,ZAL .....	1
18	PAFZZ	5940-00-705-6730	56501	TG30	TERMINAL,LUG UOC: DAC,DAD,DAE,DAF,DAG,DA H,DAJ,DAL,DAW,DAX,V14,V15,V16, V17,V18,V19,V20,V21,V22,V24,ZAA, ZAB,ZAC,ZAD,ZAE,ZAF,ZAG,ZAH,Z AJ,ZAL .....	2
19	PAFZZ	5970-00-705-6639	19207	7056639	INSULATOR,BUSHING UOC: DAC,DAD,DAE,DAF,DAG,DA H,DAJ,DAL,DAW,DAX,V14,V15,V16, V17,V18,V19,V20,V21,V22,V24,ZAA, ZAB,ZAC,ZAD,ZAE,ZAF,ZAG,ZAH,Z AJ,ZAL .....	2
20	PAFZZ	9905-00-893-3570	81349	M43436/1-3	BAND,MARKER UOC: DAC,DAD,DAE,DAF,DAG,DA H,DAJ,DAL,DAW,DAX,V14,V15,V16, V17,V18,V19,V20,V21,V22,V24,ZAA, ZAB,ZAC,ZAD,ZAE,ZAF,ZAG,ZAH,Z AJ,ZAL .....	3
21	PAFZZ	4720-01-195-7604	19207	12277340-1	HOSE,PREFORMED UOC: DAC,DAD,DAE,DAF,DAG,DA H,DAJ,DAL,DAW,DAX,V14,V15,V16, V17,V18,V19,V20,V21,V22,V24,ZAA, ZAB,ZAC,ZAD,ZAE,ZAF,ZAG,ZAH,Z AJ,ZAL .....	1

(1) ITEM NO.	(2) SMR CODE	(3) NSN	(4) CAGEC	(5) PART NUMBER	(6) DESCRIPTION AND USABLE ON CODE (UOC)	(7) QTY
22	PAFZZ	5340-01-212-2464	19207	12277338	PLATE,MOUNTING UOC: DAC,DAD,DAE,DAF,DAG,DA H,DAJ,DAL,DAW,DAX,V14,V15,V16, V17,V18,V19,V20,V21,V22,V24,ZAA, ZAB,ZAC,ZAD,ZAE,ZAF,ZAG,ZAH,Z AJ,ZAL .....	1
23	PAFZZ	5305-00-081-3728	96906	MS9316-08	SCREW,MACHINE UOC: DAC,DAD,DAE,DAF,DAG,DA H,DAJ,DAL,DAW,DAX,V14,V15,V16, V17,V18,V19,V20,V21,V22,V24,ZAA, ZAB,ZAC,ZAD,ZAE,ZAF,ZAG,ZAH,Z AJ,ZAL .....	4

END OF FIGURE

**FIELD MAINTENANCE  
ELECTRICAL GROUND STRAPS (M939, M939A1)**

---

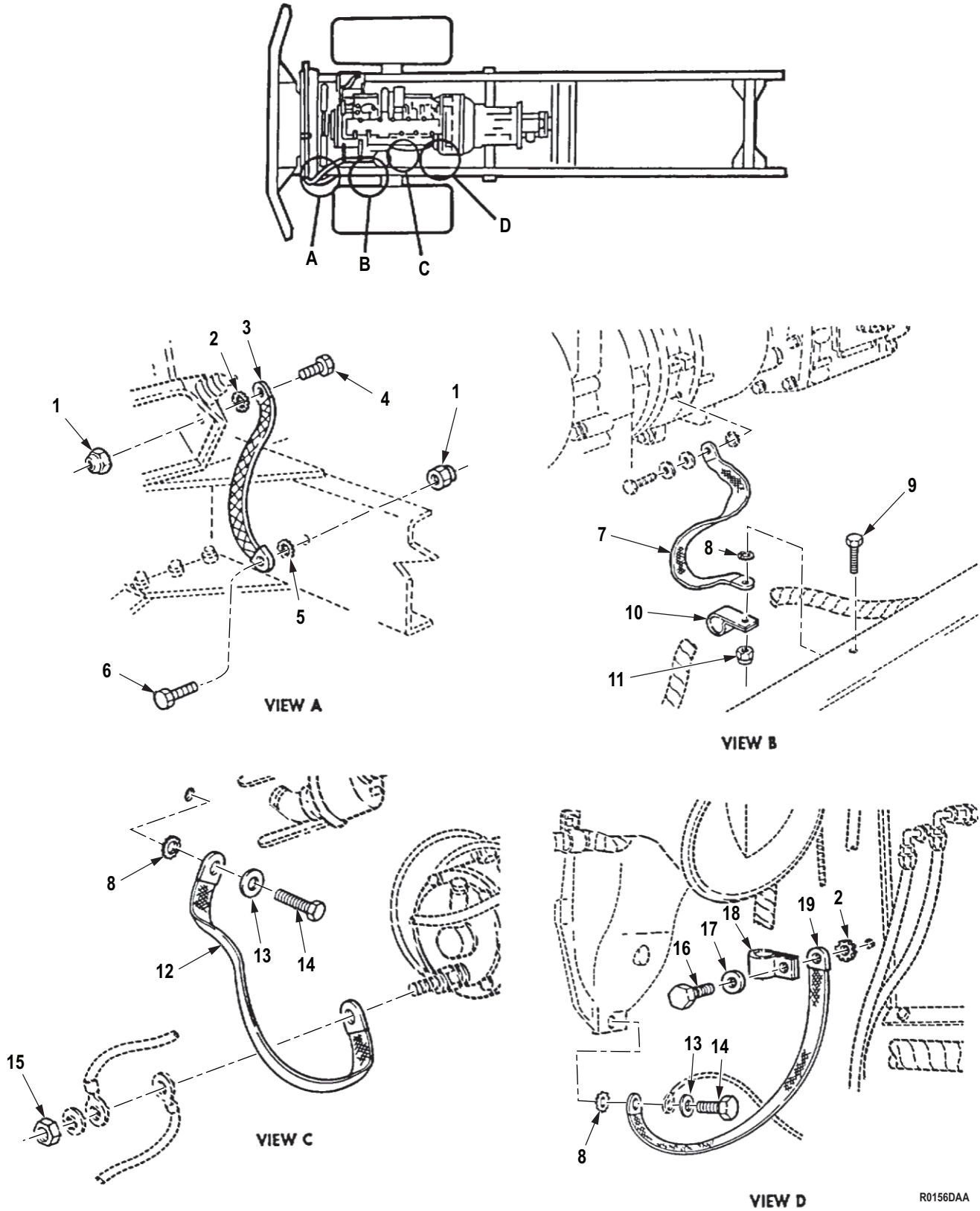

Figure 155. Electrical Ground Straps (M939, M939A1).

(1) ITEM NO.	(2) SMR CODE	(3) NSN	(4) CAGEC	(5) PART NUMBER	(6) DESCRIPTION AND USABLE ON CODE (UOC)	(7) QTY
<b>GROUP 0613 HULL OR CHASSIS WIRING HARNESS.</b>						
<b>FIG. 155. ELECTRICAL GROUND STRAPS (M939, M939A1).</b>						
1	PAFZZ	5310-00-488-3888	81349	M45913/3-8FG8C	NUT, SELF-LOCKING, HE UOC: DAC, DAD, DAE, DAF, DAG, DA H, DAJ, DAL, DAW, DAX, V14, V15, V16, V17, V18, V19, V20, V21, V22, V24 .....	2
2	PAFZZ	5310-00-935-8984	96906	MS45904-84	WASHER, LOCK UOC: DAC, DAD, DAE, DAF, DAG, DA H, DAJ, DAL, DAW, DAX, V14, V15, V16, V17, V18, V19, V20, V21, V22, V24 .....	1
3	PAFZZ	5999-01-128-2755	19207	12277229-2	STRIP, ELECTRICAL GR UOC: DAC, DAD, DAE, DAF, DAG, DA H, DAJ, DAL, DAW, DAX, V14, V15, V16, V17, V18, V19, V20, V21, V22, V24 .....	1
4	PAFZZ	5305-00-226-7767	H0001	0251588	SCREW, CAP, HEXAGON H UOC: DAC, DAD, DAE, DAF, DAG, DA H, DAJ, DAL, DAW, DAX, V14, V15, V16, V17, V18, V19, V20, V21, V22, V24 .....	1
5	PAFZZ	5310-00-901-1339	96906	MS45904-87	WASHER, LOCK UOC: DAC, DAD, DAE, DAF, DAG, DA H, DAJ, DAL, DAW, DAX, V14, V15, V16, V17, V18, V19, V20, V21, V22, V24 .....	4
6	PAFZZ	5305-00-719-5219	80204	B1821BH050F125N	SCREW, CAP, HEXAGON H UOC: DAC, DAD, DAE, DAF, DAG, DA H, DAJ, DAL, DAW, DAX, V14, V15, V16, V17, V18, V19, V20, V21, V22, V24 .....	1
7	XBFZZ		19207	10896285-4	LEAD, ELECTRICAL UOC: DAC, DAD, DAE, DAF, DAG, DA H, DAJ, DAL, DAW, DAX, V14, V15, V16, V17, V18, V19, V20, V21, V22, V24 .....	1
8	PAFZZ	5310-00-061-1258	96906	MS45904-76	WASHER, LOCK UOC: DAC, DAD, DAE, DAF, DAG, DA H, DAJ, DAL, DAW, DAX, V14, V15, V16, V17, V18, V19, V20, V21, V22, V24 .....	3
9	PAFZZ	5305-00-269-3238	80204	B1821BH038F125N	SCREW, CAP, HEXAGON H UOC: DAC, DAD, DAE, DAF, DAG, DA H, DAJ, DAL, DAW, DAX, V14, V15, V16, V17, V18, V19, V20, V21, V22, V24 .....	1
10	PAFZZ	5340-00-702-2848	80205	MS21333-128	CLAMP, LOOP UOC: DAC, DAD, DAE, DAF, DAG, DA H, DAJ, DAL, DAW, DAX, V14, V15, V16, V17, V18, V19, V20, V21, V22, V24 .....	1

(1) ITEM NO.	(2) SMR CODE	(3) NSN	(4) CAGEC	(5) PART NUMBER	(6) DESCRIPTION AND USABLE ON CODE (UOC)	(7) QTY
11	PAFZZ	5310-00-814-0672	96906	M45913/3-6FG8C	NUT, SELF-LOCKING, HE UOC: DAC, DAD, DAE, DAF, DAG, DA H, DAJ, DAL, DAW, DAX, V14, V15, V16, V17, V18, V19, V20, V21, V22, V24 .....	1
12	PAFZZ	6150-01-225-9535	19207	12302703	LEAD, ELECTRICAL UOC: DAC, DAD, DAE, DAF, DAG, DA H, DAJ, DAL, DAW, DAX, V14, V15, V16, V17, V18, V19, V20, V21, V22, V24 .....	1
13	PAFZZ	5310-00-087-7493	96906	MS27183-13	WASHER, FLAT UOC: DAC, DAD, DAE, DAF, DAG, DA H, DAJ, DAL, DAW, DAX, V14, V15, V16, V17, V18, V19, V20, V21, V22, V24 .....	2
14	PAFZZ	5305-00-269-3234	80204	B1821BH038F075N	SCREW, CAP, HEXAGON H UOC: DAC, DAD, DAE, DAF, DAG, DA H, DAJ, DAL, DAW, DAX, V14, V15, V16, V17, V18, V19, V20, V21, V22, V24 .....	2
15	PAFZZ	5310-00-989-5945	80205	MS35691-35	NUT, PLAIN, HEXAGON UOC: DAC, DAD, DAE, DAF, DAG, DA H, DAJ, DAL, DAW, DAX, V14, V15, V16, V17, V18, V19, V20, V21, V22, V24 .....	1
16	PAFZZ	5305-00-068-0515	80204	B1821BH025F100N	SCREW, CAP, HEXAGON H UOC: DAC, DAD, DAE, DAF, DAG, DA H, DAJ, DAL, DAW, DAX, V14, V15, V16, V17, V18, V19, V20, V21, V22, V24 .....	1
17	PAFZZ	5310-00-939-1061	80205	MS35333-104	WASHER, LOCK UOC: DAC, DAD, DAE, DAF, DAG, DA H, DAJ, DAL, DAW, DAX, V14, V15, V16, V17, V18, V19, V20, V21, V22, V24 .....	1
18	PAFZZ	5340-00-088-1254	80205	MS21333-104	CLAMP, LOOP UOC: DAC, DAD, DAE, DAF, DAG, DA H, DAJ, DAL, DAW, DAX, V14, V15, V16, V17, V18, V19, V20, V21, V22, V24 .....	1
19	PAFZZ	5999-01-331-8578	19207	10896285-2	STRIP, ELECTRICAL GR UOC: DAC, DAD, DAE, DAF, DAG, DA H, DAJ, DAL, DAW, DAX, V14, V15, V16, V17, V18, V19, V20, V21, V22, V24 .....	1

END OF FIGURE

**FIELD MAINTENANCE  
ELECTRICAL GROUND STRAPS (M939A2)**

---

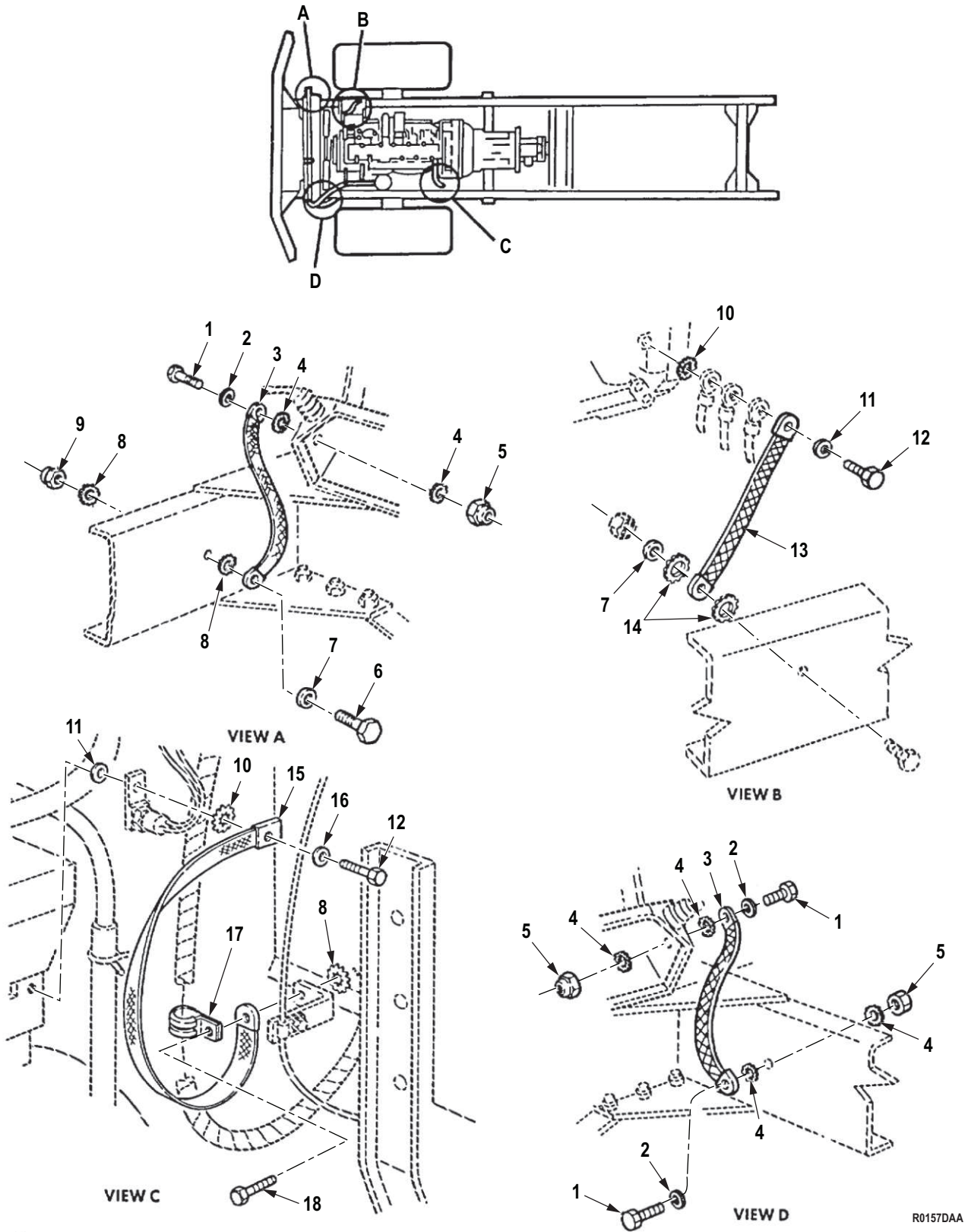

Figure 156. Electrical Ground Straps (M939A2).



(1) ITEM NO.	(2) SMR CODE	(3) NSN	(4) CAGEC	(5) PART NUMBER	(6) DESCRIPTION AND USABLE ON CODE (UOC)	(7) QTY
<b>GROUP 0613 HULL OR CHASSIS WIRING HARNESS.</b>						
<b>FIG. 156. ELECTRICAL GROUND STRAPS (M939A2).</b>						
1	PAFZZ	5305-00-719-5219	80204	B1821BH050F125N	SCREW,CAP,HEXAGON H UOC: ZAA,ZAB,ZAC,ZAD,ZAE,ZAF, ZAG,ZAH,ZAJ,ZAL .....	3
2	PAFZZ	5310-00-809-5998	96906	MS27183-18	WASHER,FLAT UOC: ZAA,ZAB,ZAC,ZAD,ZAE,ZAF, ZAG,ZAH,ZAJ,ZAL .....	3
3	PAFZZ	5999-01-128-2755	19207	12277229-2	STRIP,ELECTRICAL GR UOC: ZAA,ZAB,ZAC,ZAD,ZAE,ZAF, ZAG,ZAH,ZAJ,ZAL .....	2
4	PAFZZ	5310-00-935-8984	96906	MS45904-84	WASHER,LOCK UOC: ZAA,ZAB,ZAC,ZAD,ZAE,ZAF, ZAG,ZAH,ZAJ,ZAL .....	6
5	PAFZZ	5310-00-488-3888	81349	M45913/3-8FG8C	NUT,SELF-LOCKING,HE UOC: ZAA,ZAB,ZAC,ZAD,ZAE,ZAF, ZAG,ZAH,ZAJ,ZAL .....	3
6	PAFZZ	5305-00-269-3238	80204	B1821BH038F125N	SCREW,CAP,HEXAGON H UOC: ZAA,ZAB,ZAC,ZAD,ZAE,ZAF, ZAG,ZAH,ZAJ,ZAL .....	1
7	PAFZZ	5310-00-080-6004	96906	MS27183-14	WASHER,FLAT UOC: ZAA,ZAB,ZAC,ZAD,ZAE,ZAF, ZAG,ZAH,ZAJ,ZAL .....	2
8	PAFZZ	5310-00-061-1258	96906	MS45904-76	WASHER,LOCK UOC: ZAA,ZAB,ZAC,ZAD,ZAE,ZAF, ZAG,ZAH,ZAJ,ZAL .....	3
9	PAFZZ	5310-00-814-0672	96906	M45913/3-6FG8C	NUT,SELF-LOCKING,HE UOC: ZAA,ZAB,ZAC,ZAD,ZAE,ZAF, ZAG,ZAH,ZAJ,ZAL .....	1
10	PAFZZ	5310-00-514-6674	96906	MS35335-34	WASHER,LOCK UOC: ZAA,ZAB,ZAC,ZAD,ZAE,ZAF, ZAG,ZAH,ZAJ,ZAL .....	2
11	PAFZZ	5310-01-407-3451	3M915	9422772	WASHER,FLAT UOC: DAW,ZAA,ZAB,ZAC,ZAD,ZAE, ZAF,ZAG,ZAH,ZAJ,ZAL .....	2
12	PAFZZ	5306-01-197-1492	24617	11508687	BOLT,MACHINE UOC: ZAA,ZAB,ZAC,ZAD,ZAE,ZAF, ZAG,ZAH,ZAJ,ZAL .....	2
13	PAFZZ	5999-01-328-0524	19207	10896285-1	STRIP,ELECTRICAL GR UOC: DAW,ZAA,ZAB,ZAC,ZAD,ZAE, ZAF,ZAG,ZAH,ZAJ,ZAL .....	1
14	PAFZZ	5310-00-627-6128	96906	MS35335-35	WASHER,LOCK UOC: ZAA,ZAB,ZAC,ZAD,ZAE,ZAF, ZAG,ZAH,ZAJ,ZAL .....	2

(1) ITEM NO.	(2) SMR CODE	(3) NSN	(4) CAGEC	(5) PART NUMBER	(6) DESCRIPTION AND USABLE ON CODE (UOC)	(7) QTY
15	PAFZZ	5999-01-331-8578	19207	10896285-2	STRIP,ELECTRICAL GR UOC: DAC,DAD,DAE,DAF,DAG,DA H,DAJ,DAL,DAW,DAX,V14,V15,V16, V17,V18,V19,V20,V21,V22,V24 .....	1
16	PAFZZ	5310-00-081-4219	96906	MS27183-12	WASHER,FLAT UOC: ZAA,ZAB,ZAC,ZAD,ZAE,ZAF, ZAG,ZAH,ZAJ,ZAL .....	1
17	PAFZZ	5340-00-809-1500	80205	MS21333-107	CLAMP,LOOP UOC: ZAA,ZAB,ZAC,ZAD,ZAE,ZAF, ZAG,ZAH,ZAJ,ZAL .....	1
18	PAFZZ	5305-00-068-0515	80204	B1821BH025F100N	SCREW,CAP,HEXAGON H UOC: ZAA,ZAB,ZAC,ZAD,ZAE,ZAF, ZAG,ZAH,ZAJ,ZAL .....	1

END OF FIGURE

FIELD MAINTENANCE  
HARNES ASSEMBLY, FRONT VEHICLE LIGHTS

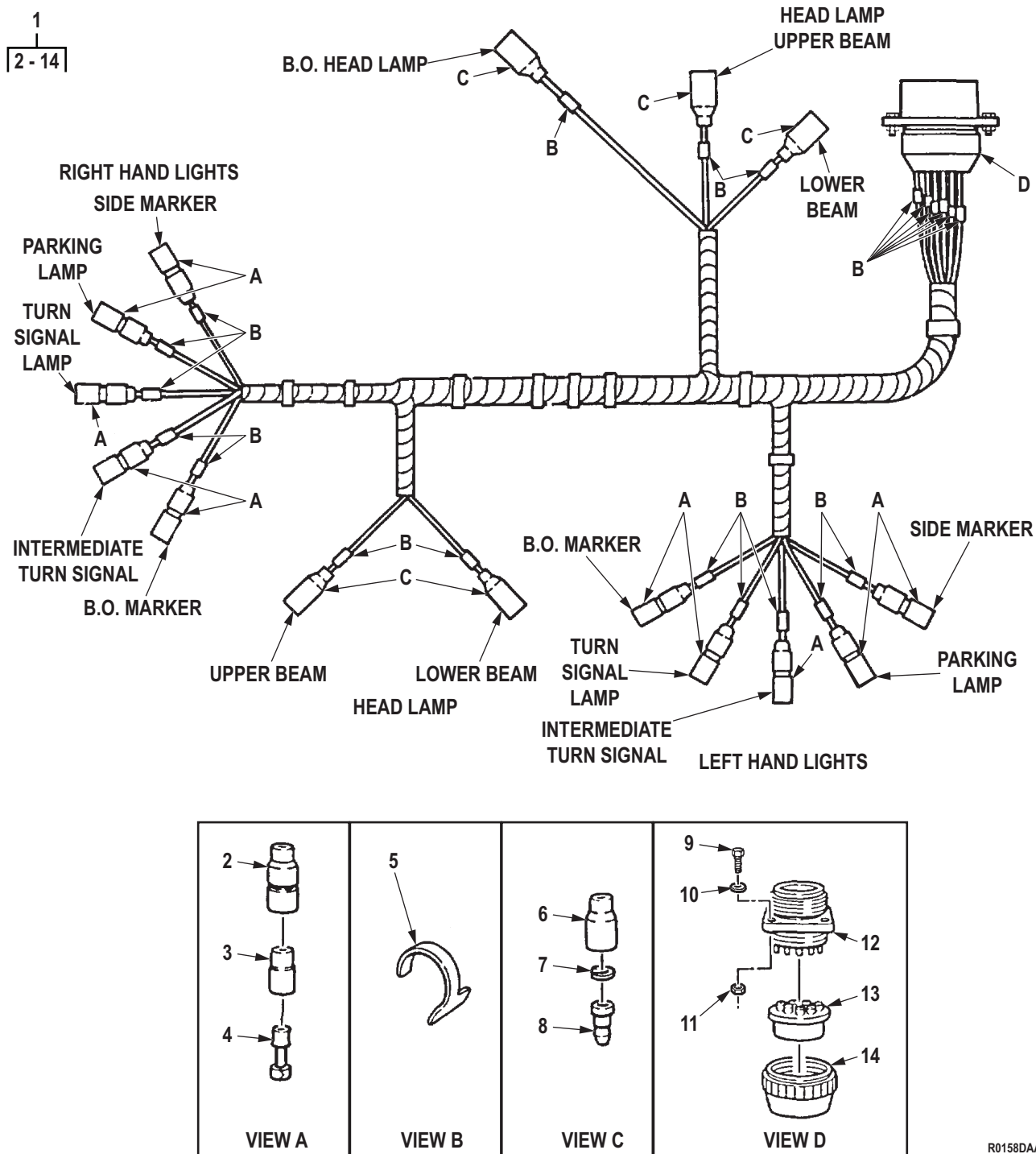

R0158DAA

Figure 157. Harness Assembly, Front Vehicle Lights. (Sheet 1 of 2)

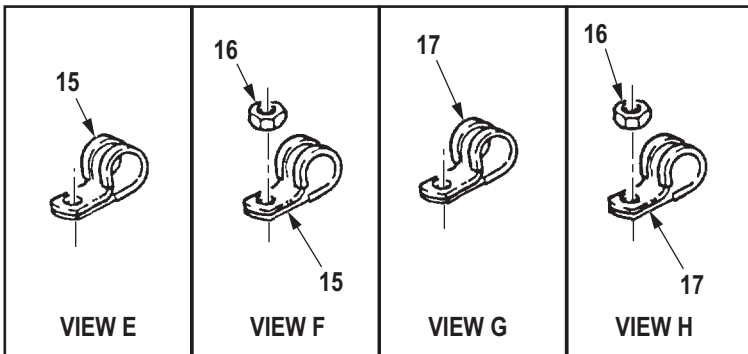
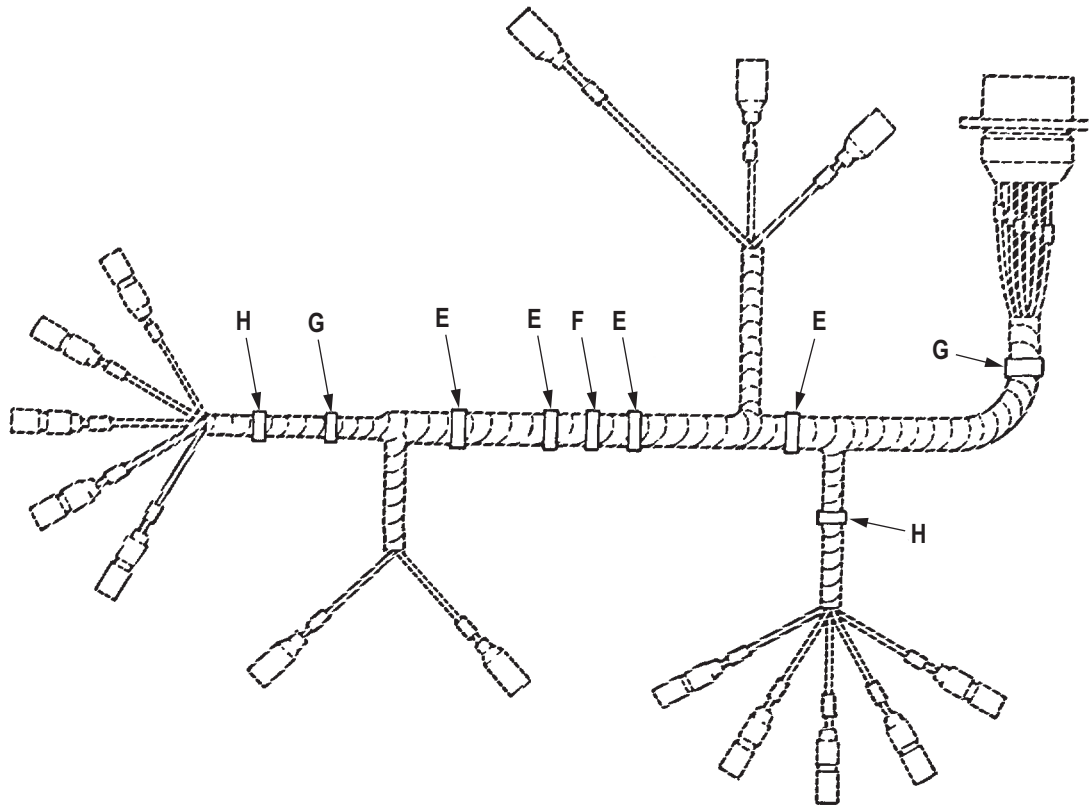

R0159DAA

Figure 157. Harness Assembly, Front Vehicle Lights. (Sheet 2 of 2)

(1) ITEM NO.	(2) SMR CODE	(3) NSN	(4) CAGEC	(5) PART NUMBER	(6) DESCRIPTION AND USABLE ON CODE (UOC)	(7) QTY
<b>GROUP 0613 HULL OR CHASSIS WIRING HARNESS.</b>						
<b>FIG. 157. HARNESS ASSEMBLY, FRONT VEHICLE LIGHTS.</b>						
1	PAFFF	2590-01-122-2419	19207	12277040	WIRING HARNESS,BRAN UOC: DAC,DAD,DAE,DAF,DAG,DA H,DAJ,DAL,DAW,DAX,V14,V15,V16, V17,V18,V19,V20,V21,V22,V24,ZAA, ZAB,ZAC,ZAD,ZAE,ZAF,ZAG,ZAH,Z AJ,ZAL .....	1
2	PAFZZ	5935-00-833-8561	19207	8338561	. SHELL,ELECTRICAL CO UOC: DAC,DAD,DAE,DAF,DAG,DA H,DAJ,DAL,DAW,DAX,V14,V15,V16, V17,V18,V19,V20,V21,V22,V24,ZAA, ZAB,ZAC,ZAD,ZAE,ZAF,ZAG,ZAH,Z AJ,ZAL .....	10
3	PAFZZ	5970-00-833-8562	19207	8338562	. INSULATOR,BUSHING UOC: DAC,DAD,DAE,DAF,DAG,DA H,DAJ,DAL,DAW,DAX,V14,V15,V16, V17,V18,V19,V20,V21,V22,V24,ZAA, ZAB,ZAC,ZAD,ZAE,ZAF,ZAG,ZAH,Z AJ,ZAL .....	10
4	PAFZZ	5940-00-399-6676	19207	8338564	. TERMINAL SET,QUICK UOC: DAC,DAD,DAE,DAF,DAG,DA H,DAJ,DAL,DAW,DAX,V14,V15,V16, V17,V18,V19,V20,V21,V22,V24,ZAA, ZAB,ZAC,ZAD,ZAE,ZAF,ZAG,ZAH,Z AJ,ZAL .....	10
5	PAFZZ	9905-00-752-4649	24617	5939707	. BAND MRKER BLNK-ALU UOC: DAC,DAD,DAE,DAF,DAG,DA H,DAJ,DAL,DAW,DAX,V14,V15,V16, V17,V18,V19,V20,V21,V22,V24,ZAA, ZAB,ZAC,ZAD,ZAE,ZAF,ZAG,ZAH,Z AJ,ZAL .....	23
6	PAFZZ	5935-00-572-9180	19207	8338566	. SHELL,ELECTRICAL CO UOC: DAC,DAD,DAE,DAF,DAG,DA H,DAJ,DAL,DAW,DAX,V14,V15,V16, V17,V18,V19,V20,V21,V22,V24,ZAA, ZAB,ZAC,ZAD,ZAE,ZAF,ZAG,ZAH,Z AJ,ZAL .....	5
7	PAFZZ	5310-00-833-8567	19207	8338567	. WASHER,SLOTTED UOC: DAC,DAD,DAE,DAF,DAG,DA H,DAJ,DAL,DAW,DAX,V14,V15,V16, V17,V18,V19,V20,V21,V22,V24,ZAA, ZAB,ZAC,ZAD,ZAE,ZAF,ZAG,ZAH,Z AJ,ZAL .....	5

(1) ITEM NO.	(2) SMR CODE	(3) NSN	(4) CAGEC	(5) PART NUMBER	(6) DESCRIPTION AND USABLE ON CODE (UOC)	(7) QTY
8	PAFZA	5999-00-057-2929	58536	AA52536-2	. CONTACT,ELECTRICAL UOC: DAC,DAD,DAE,DAF,DAG,DA H,DAJ,DAL,DAW,DAX,V14,V15,V16, V17,V18,V19,V20,V21,V22,V24,ZAA, ZAB,ZAC,ZAD,ZAE,ZAF,ZAG,ZAH,Z AJ,ZAL .....	5
9	PAFZZ	5305-00-984-6192	80205	MS35206-244	. SCREW,MACHINE UOC: DAC,DAD,DAE,DAF,DAG,DA H,DAJ,DAL,DAW,DAX,V14,V15,V16, V17,V18,V19,V20,V21,V22,V24,ZAA, ZAB,ZAC,ZAD,ZAE,ZAF,ZAG,ZAH,Z AJ,ZAL .....	4
10	PAFZZ	5310-00-596-7693	96906	MS35335-31	. WASHER,LOCK UOC: DAC,DAD,DAE,DAF,DAG,DA H,DAJ,DAL,DAW,DAX,V14,V15,V16, V17,V18,V19,V20,V21,V22,V24,ZAA, ZAB,ZAC,ZAD,ZAE,ZAF,ZAG,ZAH,Z AJ,ZAL .....	4
11	PAFZZ	5310-00-934-9757	80205	MS35649-282	. NUT,PLAIN,HEXAGON UOC: DAC,DAD,DAE,DAF,DAG,DA H,DAJ,DAL,DAW,DAX,V14,V15,V16, V17,V18,V19,V20,V21,V22,V24,ZAA, ZAB,ZAC,ZAD,ZAE,ZAF,ZAG,ZAH,Z AJ,ZAL .....	4
12	PAFZZ	5935-00-772-2353	19207	7722353	. CONNECTOR,RECEPTACL UOC: DAC,DAD,DAE,DAF,DAG,DA H,DAJ,DAL,DAW,DAX,V14,V15,V16, V17,V18,V19,V20,V21,V22,V24,ZAA, ZAB,ZAC,ZAD,ZAE,ZAF,ZAG,ZAH,Z AJ,ZAL .....	1
13	PAFZZ	5365-00-772-2322	19207	7722322	. BUSHING,NONMETALLIC UOC: DAC,DAD,DAE,DAF,DAG,DA H,DAJ,DAL,DAW,DAX,V14,V15,V16, V17,V18,V19,V20,V21,V22,V24,ZAA, ZAB,ZAC,ZAD,ZAE,ZAF,ZAG,ZAH,Z AJ,ZAL .....	1
14	PAFZZ	5935-00-333-9414	19207	7723308	. NUT,BUSHING RETAINE UOC: DAC,DAD,DAE,DAF,DAG,DA H,DAJ,DAL,DAW,DAX,V14,V15,V16, V17,V18,V19,V20,V21,V22,V24,ZAA, ZAB,ZAC,ZAD,ZAE,ZAF,ZAG,ZAH,Z AJ,ZAL .....	1
15	PAFZZ	5340-00-053-8994	80205	MS21333-126	CLAMP,LOOP UOC: DAC,DAD,DAE,DAF,DAG,DA H,DAJ,DAL,DAW,DAX,V14,V15,V16, V17,V18,V19,V20,V21,V22,V24,ZAA, ZAB,ZAC,ZAD,ZAE,ZAF,ZAG,ZAH,Z AJ,ZAL .....	5

(1) ITEM NO.	(2) SMR CODE	(3) NSN	(4) CAGEC	(5) PART NUMBER	(6) DESCRIPTION AND USABLE ON CODE (UOC)	(7) QTY
16	PAFZZ	5310-00-814-0672	96906	M45913/3-6FG8C	NUT,SELF-LOCKING,HE UOC: DAC,DAD,DAE,DAF,DAG,DA H,DAJ,DAL,DAW,DAX,V14,V15,V16, V17,V18,V19,V20,V21,V22,V24,ZAA, ZAB,ZAC,ZAD,ZAE,ZAF,ZAG,ZAH,Z AJ,ZAL .....	3
17	PAFZZ	5340-00-964-5267	80205	MS21333-120	CLAMP,LOOP UOC: DAC,DAD,DAE,DAF,DAG,DA H,DAJ,DAL,DAW,DAX,V14,V15,V16, V17,V18,V19,V20,V21,V22,V24,ZAA, ZAB,ZAC,ZAD,ZAE,ZAF,ZAG,ZAH,Z AJ,ZAL .....	4

END OF FIGURE





**FIELD MAINTENANCE  
FRONT WIRING HARNESS ASSEMBLY**

---

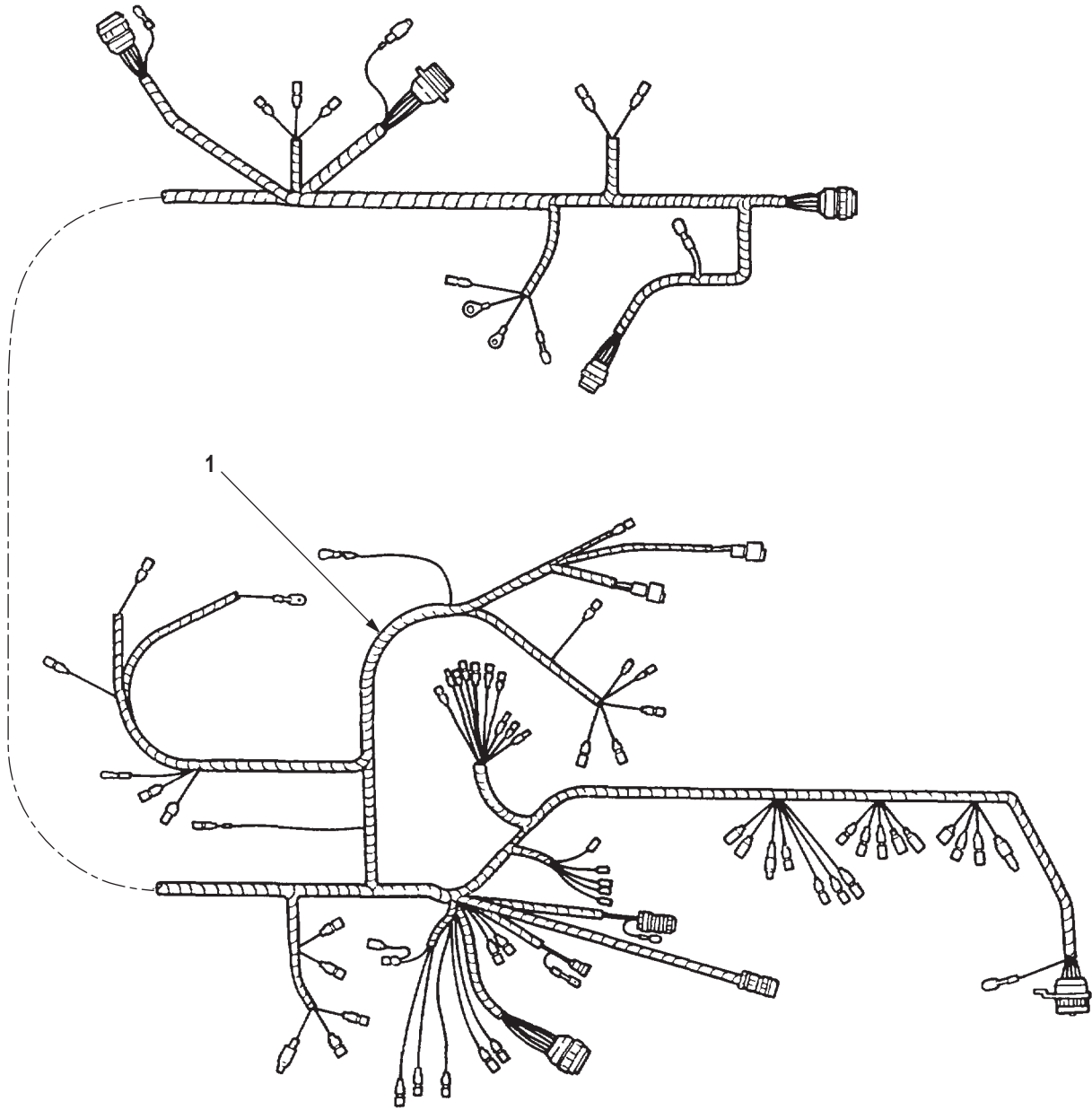

R0160DAA

Figure 158. Front Wiring Harness Assembly.

(1) ITEM NO.	(2) SMR CODE	(3) NSN	(4) CAGEC	(5) PART NUMBER	(6) DESCRIPTION AND USABLE ON CODE (UOC)	(7) QTY
					<b>GROUP 0613 HULL OR CHASSIS WIRING HARNESS.</b>	
					<b>FIG. 158. FRONT WIRING HARNESS ASSEMBLY.</b>	
1	PAFFF	2590-01-083-5728	19207	12256006	WIRING HARNESS, BRAN UOC: DAC, DAD, DAE, DAF, DAG, DA H, DAJ, DAL, DAW, DAX, V14, V15, V16, V17, V18, V19, V20, V21, V22, V24 .....	1
1	PBFFF	5995-01-287-3988	19207	12363340	WIRING HARNESS, BRAN UOC: ZAA, ZAB, ZAC, ZAD, ZAE, ZAF, ZAG, ZAH, ZAJ, ZAL .....	1

**END OF FIGURE**



**FIELD MAINTENANCE  
FRONT WIRING HARNESS, PARTIAL VIEW**

---

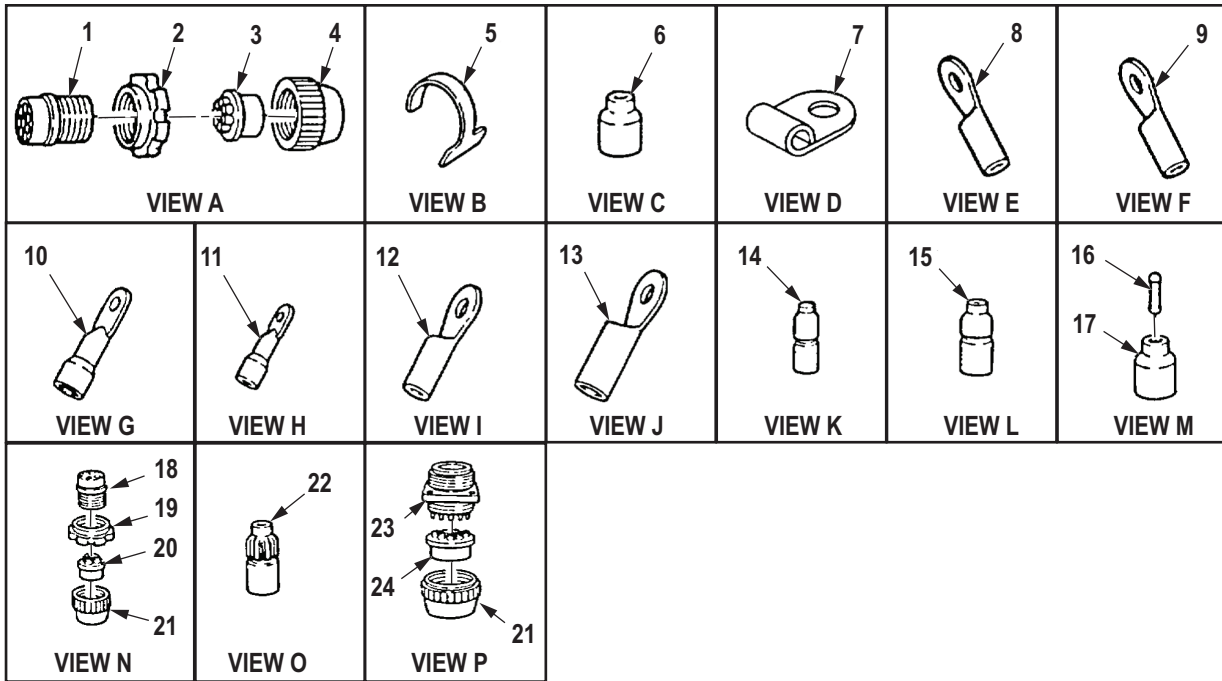
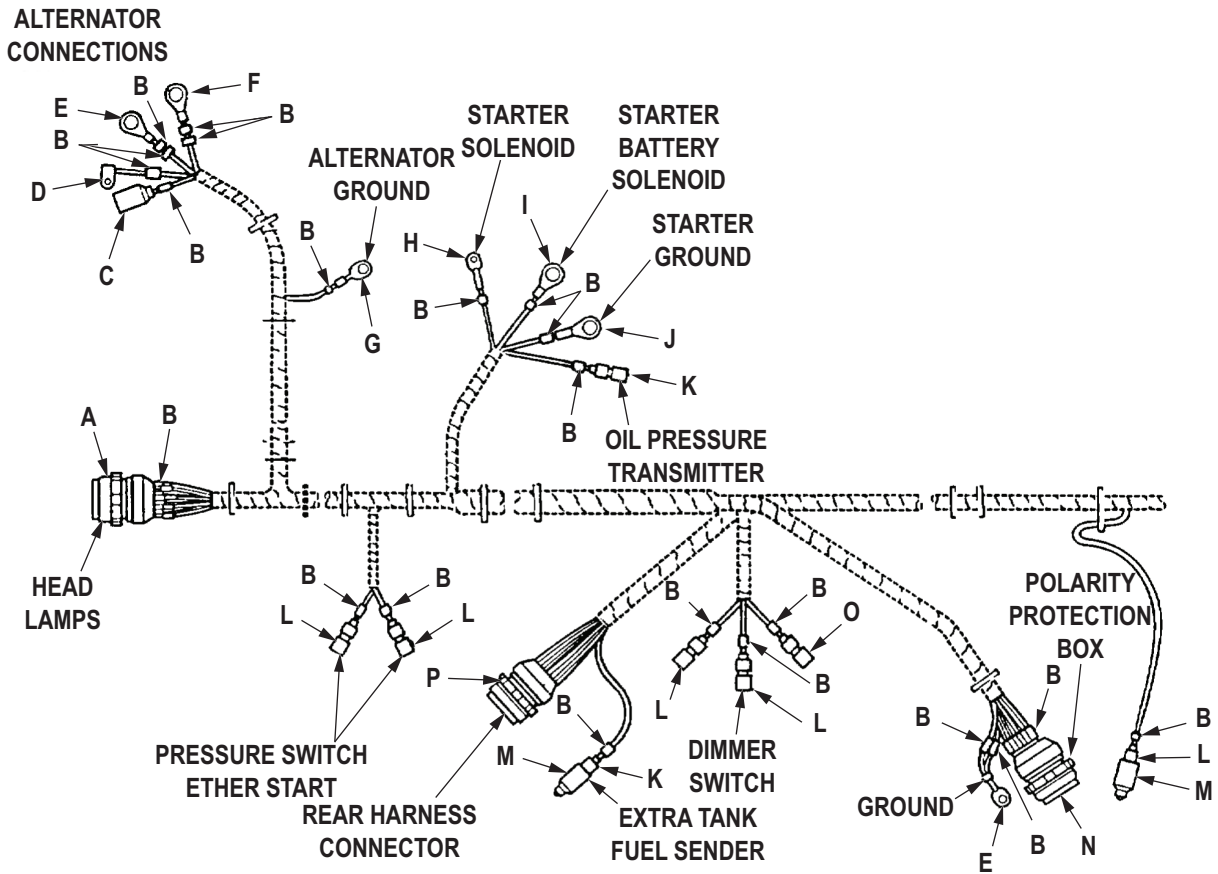

R0161DAA

Figure 159. Front Wiring Harness, Partial View. (Sheet 1 of 3)

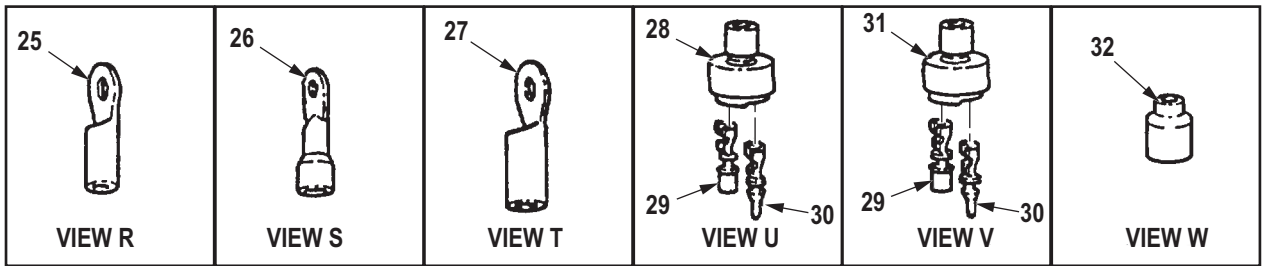
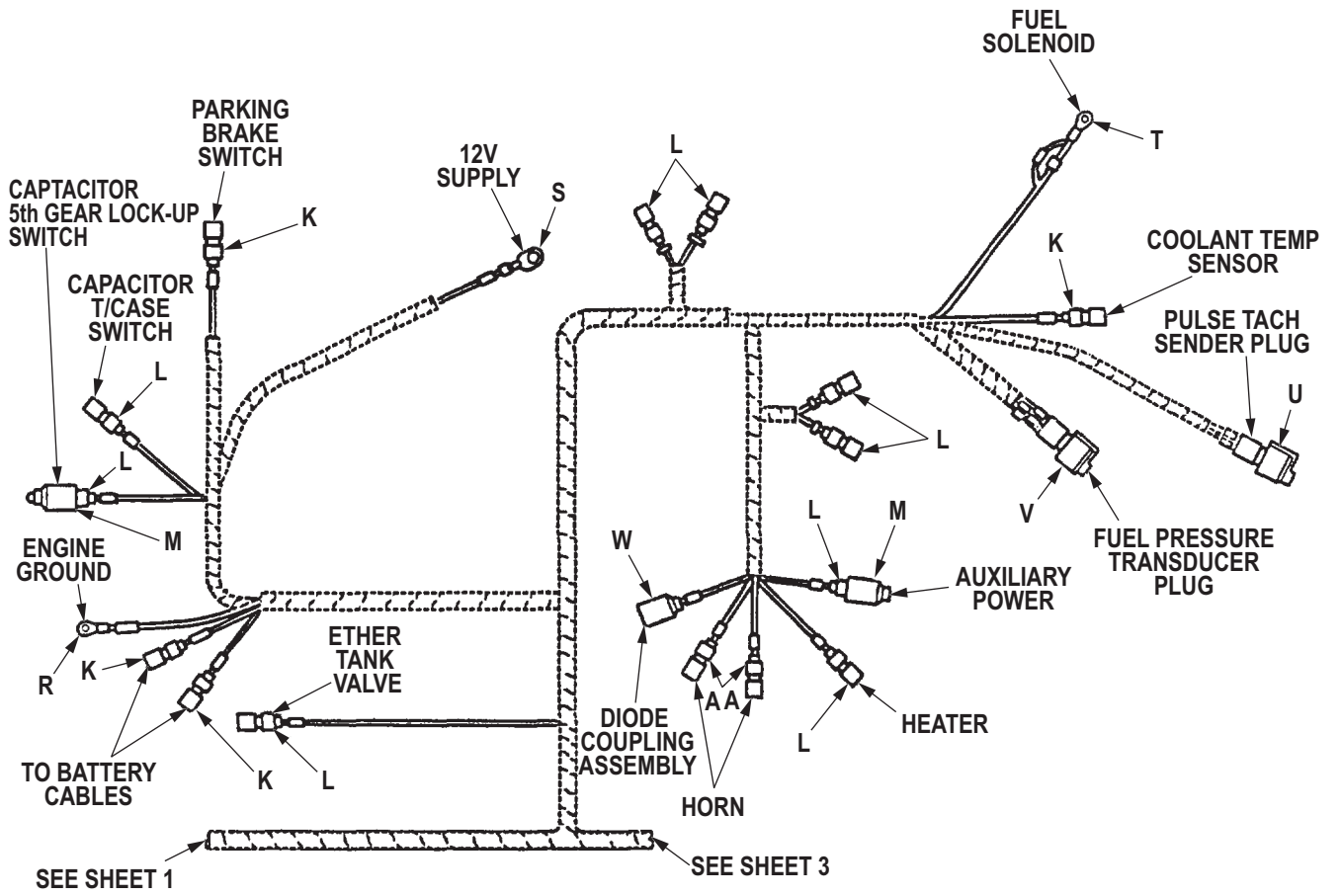

R0162DAA

Figure 159. Front Wiring Harness, Partial View. (Sheet 2 of 3)

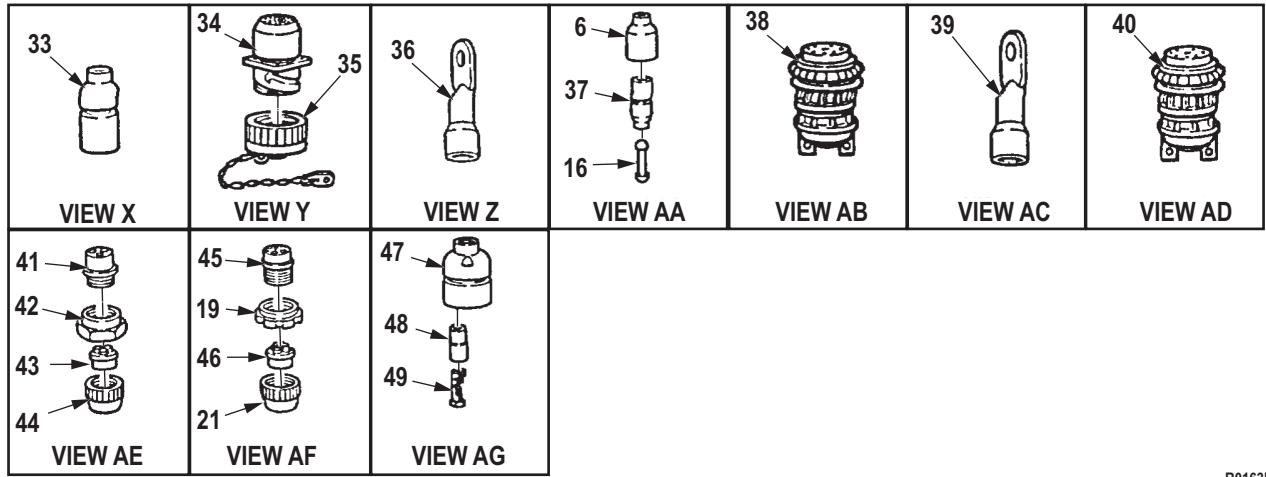
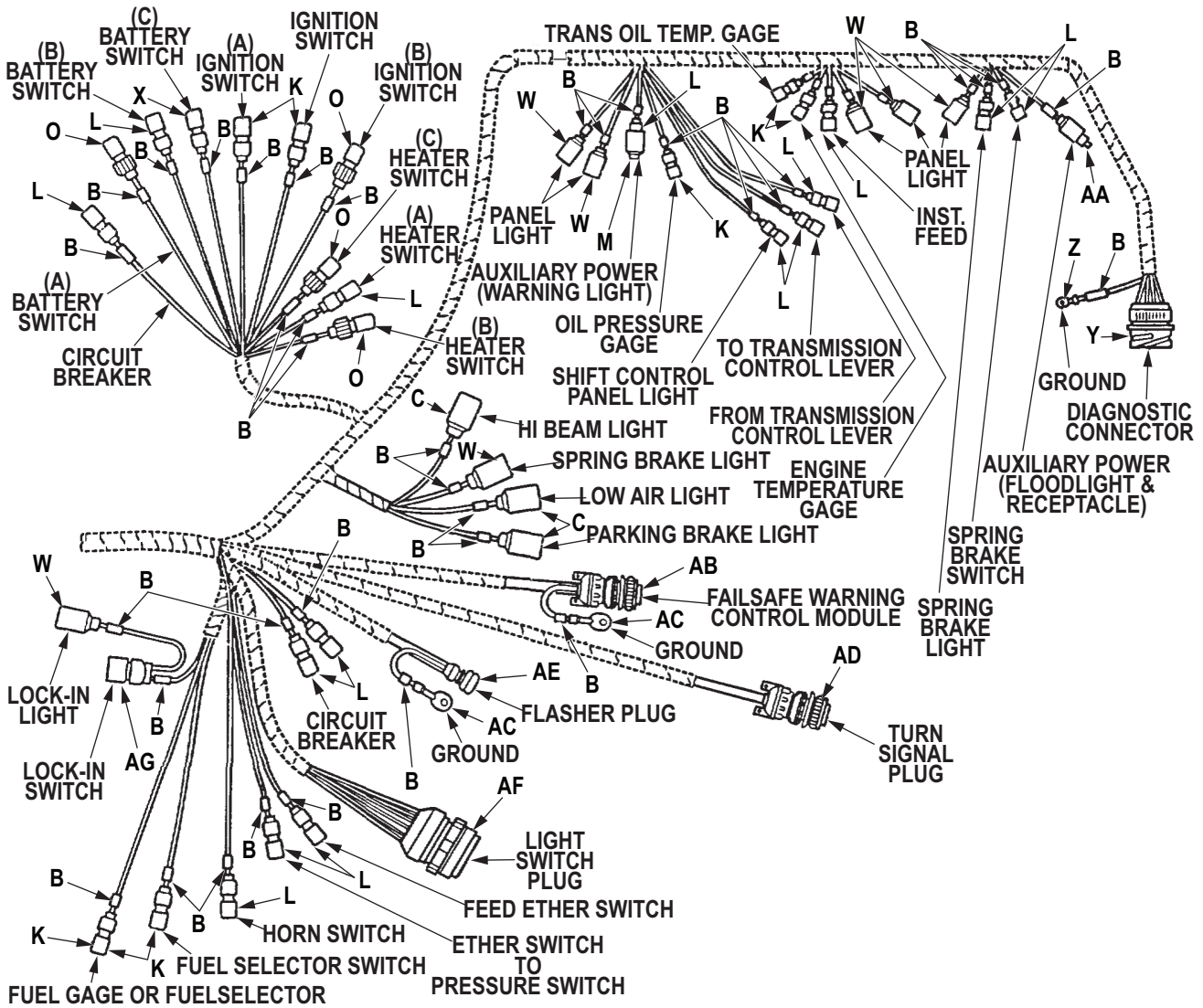

R0163DAA

Figure 159. Front Wiring Harness, Partial View. (Sheet 3 of 3)



(1) ITEM NO.	(2) SMR CODE	(3) NSN	(4) CAGEC	(5) PART NUMBER	(6) DESCRIPTION AND USABLE ON CODE (UOC)	(7) QTY
<b>GROUP 0613 HULL OR CHASSIS WIRING HARNESS.</b>						
<b>FIG. 159. FRONT WIRING HARNESS, PARTIAL VIEW.</b>						
1	PAFZZ	5935-00-614-3959	18876	8526701	CONNECTOR,PLUG,ELEC UOC: DAC,DAD,DAE,DAF,DAG,DA H,DAJ,DAL,DAW,DAX,V14,V15,V16, V17,V18,V19,V20,V21,V22,V24,ZAA, ZAB,ZAC,ZAD,ZAE,ZAF,ZAG,ZAH,Z AJ,ZAL .....	1
2	PAFZZ	5310-00-655-9860	19207	8701325	NUT,SLEEVE UOC: DAC,DAD,DAE,DAF,DAG,DA H,DAJ,DAL,DAW,DAX,V14,V15,V16, V17,V18,V19,V20,V21,V22,V24,ZAA, ZAB,ZAC,ZAD,ZAE,ZAF,ZAG,ZAH,Z AJ,ZAL .....	1
3	PAFZZ	5365-00-772-2322	19207	7722322	BUSHING,NONMETALLIC UOC: DAC,DAD,DAE,DAF,DAG,DA H,DAJ,DAL,DAW,DAX,V14,V15,V16, V17,V18,V19,V20,V21,V22,V24,ZAA, ZAB,ZAC,ZAD,ZAE,ZAF,ZAG,ZAH,Z AJ,ZAL .....	1
4	PAFZZ	5935-00-333-9414	19207	7723308	NUT,BUSHING RETAINE UOC: DAC,DAD,DAE,DAF,DAG,DA H,DAJ,DAL,DAW,DAX,V14,V15,V16, V17,V18,V19,V20,V21,V22,V24,ZAA, ZAB,ZAC,ZAD,ZAE,ZAF,ZAG,ZAH,Z AJ,ZAL .....	1
5	PAFZZ	9905-00-752-4649	24617	5939707	BAND MRKER BLNK-ALU UOC: DAC,DAD,DAE,DAF,DAG,DA H,DAJ,DAL,DAW,DAX,V14,V15,V16, V17,V18,V19,V20,V21,V22,V24,ZAA, ZAB,ZAC,ZAD,ZAE,ZAF,ZAG,ZAH,Z AJ,ZAL .....	138
6	PAFZZ	5935-00-115-2306	96906	MS27142-3	CONNECTOR,PLUG,ELEC UOC: DAC,DAD,DAE,DAF,DAG,DA H,DAJ,DAL,DAW,DAX,V14,V15,V16, V17,V18,V19,V20,V21,V22,V24,ZAA, ZAB,ZAC,ZAD,ZAE,ZAF,ZAG,ZAH,Z AJ,ZAL .....	5
7	PAFZZ	5940-01-021-1874	56501	AB53	TERMINAL,LUG UOC: DAC,DAD,DAE,DAF,DAG,DA H,DAJ,DAL,DAW,DAX,V14,V15,V16, V17,V18,V19,V20,V21,V22,V24,ZAA, ZAB,ZAC,ZAD,ZAE,ZAF,ZAG,ZAH,Z AJ,ZAL .....	1

(1) ITEM NO.	(2) SMR CODE	(3) NSN	(4) CAGEC	(5) PART NUMBER	(6) DESCRIPTION AND USABLE ON CODE (UOC)	(7) QTY
8	PAFZZ	5940-00-115-2674	96906	MS20659-108	TERMINAL,LUG UOC: DAC,DAD,DAE,DAF,DAG,DA H,DAJ,DAL,DAW,DAX,V14,V15,V16, V17,V18,V19,V20,V21,V22,V24 .....	2
9	PAFZZ	5940-00-113-9825	81343	MS20659-141	TERMINAL,LUG UOC: DAC,DAD,DAE,DAF,DAG,DA H,DAJ,DAL,DAW,DAX,V14,V15,V16, V17,V18,V19,V20,V21,V22,V24 .....	1
10	PAFZZ	5940-00-705-6715	56501	TG15	TERMINAL,LUG UOC: DAC,DAD,DAE,DAF,DAG,DA H,DAJ,DAL,DAW,DAX,V14,V15,V16, V17,V18,V19,V20,V21,V22,V24,ZAA, ZAB,ZAC,ZAD,ZAE,ZAF,ZAG,ZAH,Z AJ,ZAL .....	1
11	PAFZZ	5940-00-705-6702	24930	G360038-3	TERMINAL,LUG UOC: DAC,DAD,DAE,DAF,DAG,DA H,DAJ,DAL,DAW,DAX,V14,V15,V16, V17,V18,V19,V20,V21,V22,V24,ZAA, ZAB,ZAC,ZAD,ZAE,ZAF,ZAG,ZAH,Z AJ,ZAL .....	1
12	PAFZZ	5940-00-114-1315	96906	MS20659-142	TERMINAL,LUG UOC: DAC,DAD,DAE,DAF,DAG,DA H,DAJ,DAL,DAW,DAX,V14,V15,V16, V17,V18,V19,V20,V21,V22,V24 .....	1
13	PAFZZ	5940-00-113-9821	96906	MS20659-166	TERMINAL,LUG UOC: DAC,DAD,DAE,DAF,DAG,DA H,DAJ,DAL,DAW,DAX,V14,V15,V16, V17,V18,V19,V20,V21,V22,V24 .....	1
14	PAFZA	5935-00-115-2307	96906	MS27144-2	CONNECTOR,PLUG,ELEC UOC: DAC,DAD,DAE,DAF,DAG,DA H,DAJ,DAL,DAW,DAX,V14,V15,V16, V17,V18,V19,V20,V21,V22,V24,ZAA, ZAB,ZAC,ZAD,ZAE,ZAF,ZAG,ZAH,Z AJ,ZAL .....	2
15	PAFZZ	5935-00-167-7775	96906	MS27144-1	CONNECTOR,PLUG,ELEC UOC: DAC,DAD,DAE,DAF,DAG,DA H,DAJ,DAL,DAW,DAX,V14,V15,V16, V17,V18,V19,V20,V21,V22,V24,ZAA, ZAB,ZAC,ZAD,ZAE,ZAF,ZAG,ZAH,Z AJ,ZAL .....	28
16	PAFZZ	5935-00-214-0904	19207	7982907	DUMMY CONNECTOR,PLU UOC: DAC,DAD,DAE,DAF,DAG,DA H,DAJ,DAL,DAW,DAX,V14,V15,V16, V17,V18,V19,V20,V21,V22,V24,ZAA, ZAB,ZAC,ZAD,ZAE,ZAF,ZAG,ZAH,Z AJ,ZAL .....	4

(1) ITEM NO.	(2) SMR CODE	(3) NSN	(4) CAGEC	(5) PART NUMBER	(6) DESCRIPTION AND USABLE ON CODE (UOC)	(7) QTY
17	PAFZZ	5935-00-572-9180	19207	8338566	SHELL,ELECTRICAL CO UOC: DAC,DAD,DAE,DAF,DAG,DA H,DAJ,DAL,DAW,DAX,V14,V15,V16, V17,V18,V19,V20,V21,V22,V24,ZAA, ZAB,ZAC,ZAD,ZAE,ZAF,ZAG,ZAH,Z AJ,ZAL .....	2
18	PAFZZ	5935-00-081-0401	19207	8724260	CONNECTOR,PLUG,ELEC UOC: DAC,DAD,DAE,DAF,DAG,DA H,DAJ,DAL,DAW,DAX,V14,V15,V16, V17,V18,V19,V20,V21,V22,V24,ZAA, ZAB,ZAC,ZAD,ZAE,ZAF,ZAG,ZAH,Z AJ,ZAL .....	1
19	PAFZZ	5975-00-771-6634	19207	7716634	NUT,COUPLING,ELECTR UOC: DAC,DAD,DAE,DAF,DAG,DA H,DAJ,DAL,DAW,DAX,V14,V15,V16, V17,V18,V19,V20,V21,V22,V24,ZAA, ZAB,ZAC,ZAD,ZAE,ZAF,ZAG,ZAH,Z AJ,ZAL .....	1
20	PAFZZ	5325-00-678-8435	19207	8724264	GROMMET,NONMETALLIC UOC: DAC,DAD,DAE,DAF,DAG,DA H,DAJ,DAL,DAW,DAX,V14,V15,V16, V17,V18,V19,V20,V21,V22,V24,ZAA, ZAB,ZAC,ZAD,ZAE,ZAF,ZAG,ZAH,Z AJ,ZAL .....	1
21	PAFZZ	5310-00-393-6685	19207	7723309	NUT,PLAIN,KNURLED UOC: DAC,DAD,DAE,DAF,DAG,DA H,DAJ,DAL,DAW,DAX,V14,V15,V16, V17,V18,V19,V20,V21,V22,V24,ZAA, ZAB,ZAC,ZAD,ZAE,ZAF,ZAG,ZAH,Z AJ,ZAL .....	3
22	PAFZZ	5935-00-184-6707	96906	MS27144-3	CONNECTOR,PLUG,ELEC UOC: DAC,DAD,DAE,DAF,DAG,DA H,DAJ,DAL,DAW,DAX,V14,V15,V16, V17,V18,V19,V20,V21,V22,V24,ZAA, ZAB,ZAC,ZAD,ZAE,ZAF,ZAG,ZAH,Z AJ,ZAL .....	1
23	PAFZZ	5935-00-178-6075	19207	7388359	CONNECTOR,RECEPTACL UOC: DAC,DAD,DAE,DAF,DAG,DA H,DAJ,DAL,DAW,DAX,V14,V15,V16, V17,V18,V19,V20,V21,V22,V24,ZAA, ZAB,ZAC,ZAD,ZAE,ZAF,ZAG,ZAH,Z AJ,ZAL .....	1
24	PAFZZ	5365-00-507-8766	19207	7388366	BUSHING,NONMETALLIC UOC: DAC,DAD,DAE,DAF,DAG,DA H,DAJ,DAL,DAW,DAX,V14,V15,V16, V17,V18,V19,V20,V21,V22,V24,ZAA, ZAB,ZAC,ZAD,ZAE,ZAF,ZAG,ZAH,Z AJ,ZAL .....	1

(1) ITEM NO.	(2) SMR CODE	(3) NSN	(4) CAGEC	(5) PART NUMBER	(6) DESCRIPTION AND USABLE ON CODE (UOC)	(7) QTY
25	PAFZZ	5940-00-113-3148	81343	MS20659-164	TERMINAL,LUG UOC: DAC,DAD,DAE,DAF,DAG,DA H,DAJ,DAL,DAW,DAX,V14,V15,V16, V17,V18,V19,V20,V21,V22,V24,ZAA, ZAB,ZAC,ZAD,ZAE,ZAF,ZAG,ZAH,Z AJ,ZAL .....	1
26	PAFZZ	5940-00-113-9826	81343	MS25036-114	TERMINAL,LUG UOC: DAC,DAD,DAE,DAF,DAG,DA H,DAJ,DAL,DAW,DAX,V14,V15,V16, V17,V18,V19,V20,V21,V22,V24,ZAA, ZAB,ZAC,ZAD,ZAE,ZAF,ZAG,ZAH,Z AJ,ZAL .....	1
27	PAFZZ	5940-00-114-1300	96906	MS20659-105	TERMINAL,LUG UOC: DAC,DAD,DAE,DAF,DAG,DA H,DAJ,DAL,DAW,DAX,V14,V15,V16, V17,V18,V19,V20,V21,V22,V24,ZAA, ZAB,ZAC,ZAD,ZAE,ZAF,ZAG,ZAH,Z AJ,ZAL .....	1
28	PAFZZ	5935-01-149-5165	11083	7N9738	CONNECTOR BODY,PLUG UOC: DAC,DAD,DAE,DAF,DAG,DA H,DAJ,DAL,DAW,DAX,V14,V15,V16, V17,V18,V19,V20,V21,V22,V24,ZAA, ZAB,ZAC,ZAD,ZAE,ZAF,ZAG,ZAH,Z AJ,ZAL .....	1
29	PAFZZ	5999-01-150-8808	19207	12258939-2	CONTACT,ELECTRICAL UOC: DAC,DAD,DAE,DAF,DAG,DA H,DAJ,DAL,DAW,DAX,V14,V15,V16, V17,V18,V19,V20,V21,V22,V24,ZAA, ZAB,ZAC,ZAD,ZAE,ZAF,ZAG,ZAH,Z AJ,ZAL .....	3
30	PAFZZ	5999-01-156-6314	71468	110238-0195	PIN,GROOVED,HEADLES UOC: DAC,DAD,DAE,DAF,DAG,DA H,DAJ,DAL,DAW,DAX,V14,V15,V16, V17,V18,V19,V20,V21,V22,V24,ZAA, ZAB,ZAC,ZAD,ZAE,ZAF,ZAG,ZAH,Z AJ,ZAL .....	3
31	PAFZZ	5935-01-154-6233	19207	12258940-4	CONNECTOR,PLUG,ELEC UOC: DAC,DAD,DAE,DAF,DAG,DA H,DAJ,DAL,DAW,DAX,V14,V15,V16, V17,V18,V19,V20,V21,V22,V24,ZAA, ZAB,ZAC,ZAD,ZAE,ZAF,ZAG,ZAH,Z AJ,ZAL .....	1
32	PAFZZ	5935-00-462-6603	96906	MS27142-2	CONNECTOR,PLUG,ELEC UOC: DAC,DAD,DAE,DAF,DAG,DA H,DAJ,DAL,DAW,DAX,V14,V15,V16, V17,V18,V19,V20,V21,V22,V24,ZAA, ZAB,ZAC,ZAD,ZAE,ZAF,ZAG,ZAH,Z AJ,ZAL .....	8

(1) ITEM NO.	(2) SMR CODE	(3) NSN	(4) CAGEC	(5) PART NUMBER	(6) DESCRIPTION AND USABLE ON CODE (UOC)	(7) QTY
33	PAFZZ	5935-00-114-0607	16528	MS27143-1	CONNECTOR,PLUG,ELEC UOC: DAC,DAD,DAE,DAF,DAG,DA H,DAJ,DAL,DAW,DAX,V14,V15,V16, V17,V18,V19,V20,V21,V22,V24,ZAA, ZAB,ZAC,ZAD,ZAE,ZAF,ZAG,ZAH,Z AJ,ZAL .....	1
34	PAFZZ	5935-01-102-7124	11083	5R7840	CONNECTOR,RECEPTACL UOC: DAC,DAD,DAE,DAF,DAG,DA H,DAJ,DAL,DAW,DAX,V14,V15,V16, V17,V18,V19,V20,V21,V22,V24,ZAA, ZAB,ZAC,ZAD,ZAE,ZAF,ZAG,ZAH,Z AJ,ZAL .....	1
35	PAFZZ	5935-01-114-5354	80064	2601167	COVER,ELECTRICAL CO UOC: DAC,DAD,DAE,DAF,DAG,DA H,DAJ,DAL,DAW,DAX,V14,V15,V16, V17,V18,V19,V20,V21,V22,V24,ZAA, ZAB,ZAC,ZAD,ZAE,ZAF,ZAG,ZAH,Z AJ,ZAL .....	1
36	PAFZZ	5940-00-705-6707	56501	TG7	TERMINAL,LUG UOC: DAC,DAD,DAE,DAF,DAG,DA H,DAJ,DAL,DAW,DAX,V14,V15,V16, V17,V18,V19,V20,V21,V22,V24,ZAA, ZAB,ZAC,ZAD,ZAE,ZAF,ZAG,ZAH,Z AJ,ZAL .....	1
37	PAFZZ	5935-00-833-8561	19207	8338561	SHELL,ELECTRICAL CO UOC: DAC,DAD,DAE,DAF,DAG,DA H,DAJ,DAL,DAW,DAX,V14,V15,V16, V17,V18,V19,V20,V21,V22,V24,ZAA, ZAB,ZAC,ZAD,ZAE,ZAF,ZAG,ZAH,Z AJ,ZAL .....	1
38	PAFZZ	5935-00-622-2830	96906	MS3456W18-1S	CONNECTOR,PLUG,ELEC UOC: DAC,DAD,DAE,DAF,DAG,DA H,DAJ,DAL,DAW,DAX,V14,V15,V16, V17,V18,V19,V20,V21,V22,V24,ZAA, ZAB,ZAC,ZAD,ZAE,ZAF,ZAG,ZAH,Z AJ,ZAL .....	1
39	PAFZZ	5940-00-705-6709	56501	TG9	TERMINAL,LUG UOC: DAC,DAD,DAE,DAF,DAG,DA H,DAJ,DAL,DAW,DAX,V14,V15,V16, V17,V18,V19,V20,V21,V22,V24,ZAA, ZAB,ZAC,ZAD,ZAE,ZAF,ZAG,ZAH,Z AJ,ZAL .....	2
40	PAFZZ	5935-01-077-2622	96906	MS3456W18-8S	CONNECTOR,PLUG,ELEC UOC: DAC,DAD,DAE,DAF,DAG,DA H,DAJ,DAL,DAW,DAX,V14,V15,V16, V17,V18,V19,V20,V21,V22,V24,ZAA, ZAB,ZAC,ZAD,ZAE,ZAF,ZAG,ZAH,Z AJ,ZAL .....	1

(1) ITEM NO.	(2) SMR CODE	(3) NSN	(4) CAGEC	(5) PART NUMBER	(6) DESCRIPTION AND USABLE ON CODE (UOC)	(7) QTY
41	PAFZZ	5935-00-605-9322	80064	1755683	CONNECTOR,PLUG,ELEC UOC: DAC,DAD,DAE,DAF,DAG,DA H,DAJ,DAL,DAW,DAX,V14,V15,V16, V17,V18,V19,V20,V21,V22,V24,ZAA, ZAB,ZAC,ZAD,ZAE,ZAF,ZAG,ZAH,Z AJ,ZAL .....	1
42	PAFZZ	5975-00-697-7769	19207	7527645	NUT,COUPLING,ELECTR UOC: DAC,DAD,DAE,DAF,DAG,DA H,DAJ,DAL,DAW,DAX,V14,V15,V16, V17,V18,V19,V20,V21,V22,V24,ZAA, ZAB,ZAC,ZAD,ZAE,ZAF,ZAG,ZAH,Z AJ,ZAL .....	1
43	PAFZZ	5935-00-772-2344	18876	7722344	INSERT,ELECTRICAL C UOC: DAC,DAD,DAE,DAF,DAG,DA H,DAJ,DAL,DAW,DAX,V14,V15,V16, V17,V18,V19,V20,V21,V22,V24,ZAA, ZAB,ZAC,ZAD,ZAE,ZAF,ZAG,ZAH,Z AJ,ZAL .....	1
44	PAFZZ	5935-00-772-3307	19204	7723307	NUT,BUSHING RETAINE UOC: DAC,DAD,DAE,DAF,DAG,DA H,DAJ,DAL,DAW,DAX,V14,V15,V16, V17,V18,V19,V20,V21,V22,V24,ZAA, ZAB,ZAC,ZAD,ZAE,ZAF,ZAG,ZAH,Z AJ,ZAL .....	1
45	PAFZZ	5935-00-686-2599	19207	8724258	CONNECTOR,PLUG,ELEC UOC: DAC,DAD,DAE,DAF,DAG,DA H,DAJ,DAL,DAW,DAX,V14,V15,V16, V17,V18,V19,V20,V21,V22,V24,ZAA, ZAB,ZAC,ZAD,ZAE,ZAF,ZAG,ZAH,Z AJ,ZAL .....	1
46	PAFZZ	5365-00-090-5426	19207	7722333	BUSHING,NONMETALLIC UOC: DAC,DAD,DAE,DAF,DAG,DA H,DAJ,DAL,DAW,DAX,V14,V15,V16, V17,V18,V19,V20,V21,V22,V24,ZAA, ZAB,ZAC,ZAD,ZAE,ZAF,ZAG,ZAH,Z AJ,ZAL .....	1
47	PAFZA	5935-00-767-7936	96906	MS27145-1	CONNECTOR,PLUG,ELEC UOC: DAC,DAD,DAE,DAF,DAG,DA H,DAJ,DAL,DAW,DAX,V14,V15,V16, V17,V18,V19,V20,V21,V22,V24,ZAA, ZAB,ZAC,ZAD,ZAE,ZAF,ZAG,ZAH,Z AJ,ZAL .....	1
48	PAFZZ	5970-00-833-8562	19207	8338562	INSULATOR,BUSHING UOC: DAC,DAD,DAE,DAF,DAG,DA H,DAJ,DAL,DAW,DAX,V14,V15,V16, V17,V18,V19,V20,V21,V22,V24,ZAA, ZAB,ZAC,ZAD,ZAE,ZAF,ZAG,ZAH,Z AJ,ZAL .....	2

(1) ITEM NO.	(2) SMR CODE	(3) NSN	(4) CAGEC	(5) PART NUMBER	(6) DESCRIPTION AND USABLE ON CODE (UOC)	(7) QTY
49	PAFZZ	1015-00-798-2997	19207	7982997	TERMINAL,SOLDERED F UOC: DAC,DAD,DAE,DAF,DAG,DA H,DAJ,DAL,DAW,DAX,V14,V15,V16, V17,V18,V19,V20,V21,V22,V24,ZAA, ZAB,ZAC,ZAD,ZAE,ZAF,ZAG,ZAH,Z AJ,ZAL .....	2

END OF FIGURE





**FIELD MAINTENANCE  
FRONT WIRING HARNESS, PARTIAL VIEW (M939A2)**

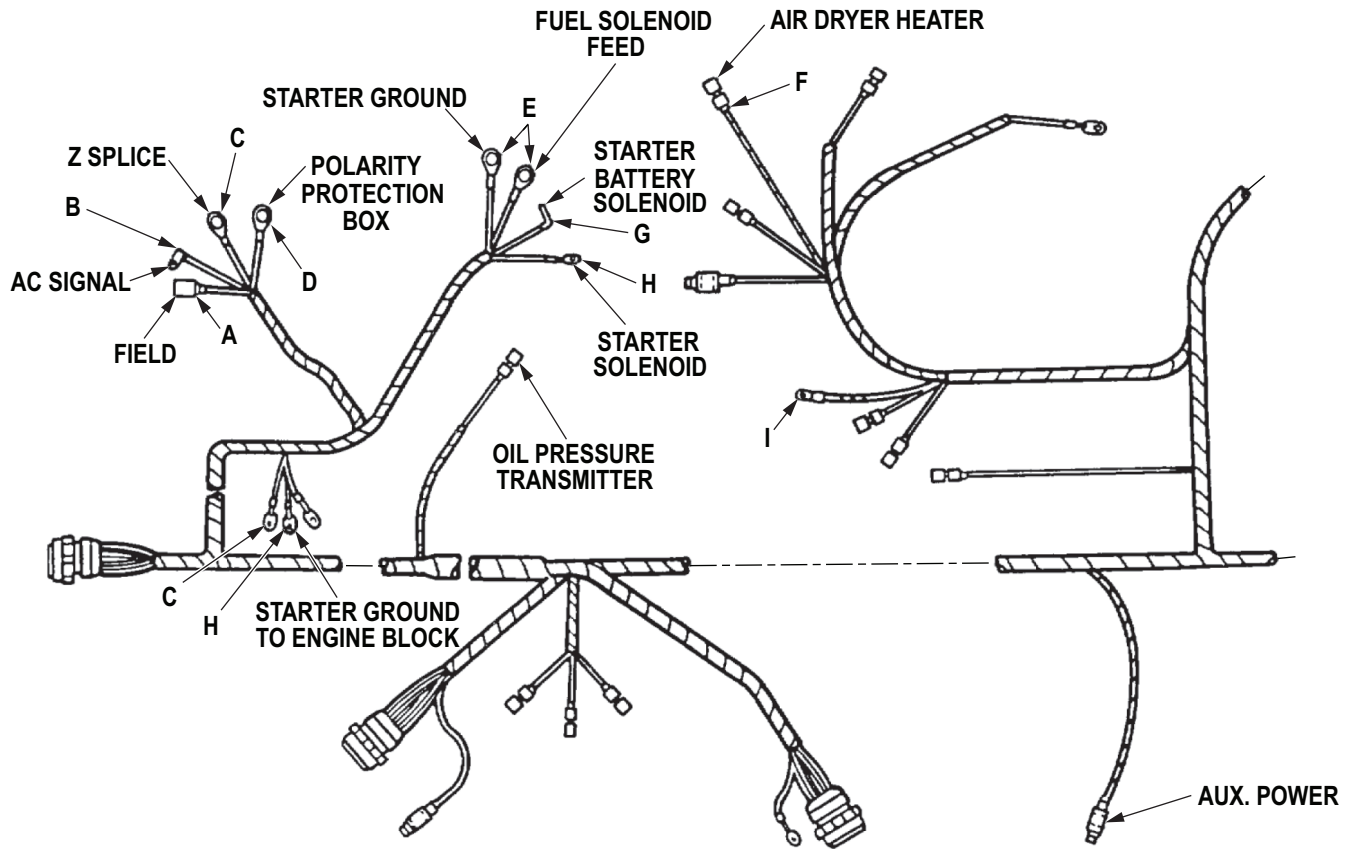

<p>1 2 3</p> <p><b>VIEW A</b></p>	<p>4</p> <p><b>VIEW B</b></p>	<p>5</p> <p><b>VIEW C</b></p>	<p>6</p> <p><b>VIEW D</b></p>	<p>7</p> <p><b>VIEW E</b></p>
<p>8 9 10</p> <p><b>VIEW F</b></p>	<p>11</p> <p><b>VIEW G</b></p>	<p>12</p> <p><b>VIEW H</b></p>	<p>13</p> <p><b>VIEW I</b></p>	

R0164DAA

Figure 160. Front Wiring Harness, Partial View (M939A2). (Sheet 1 of 2)

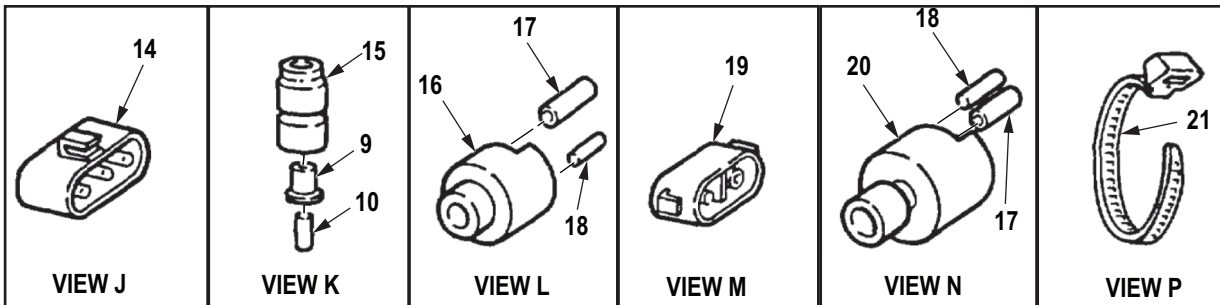
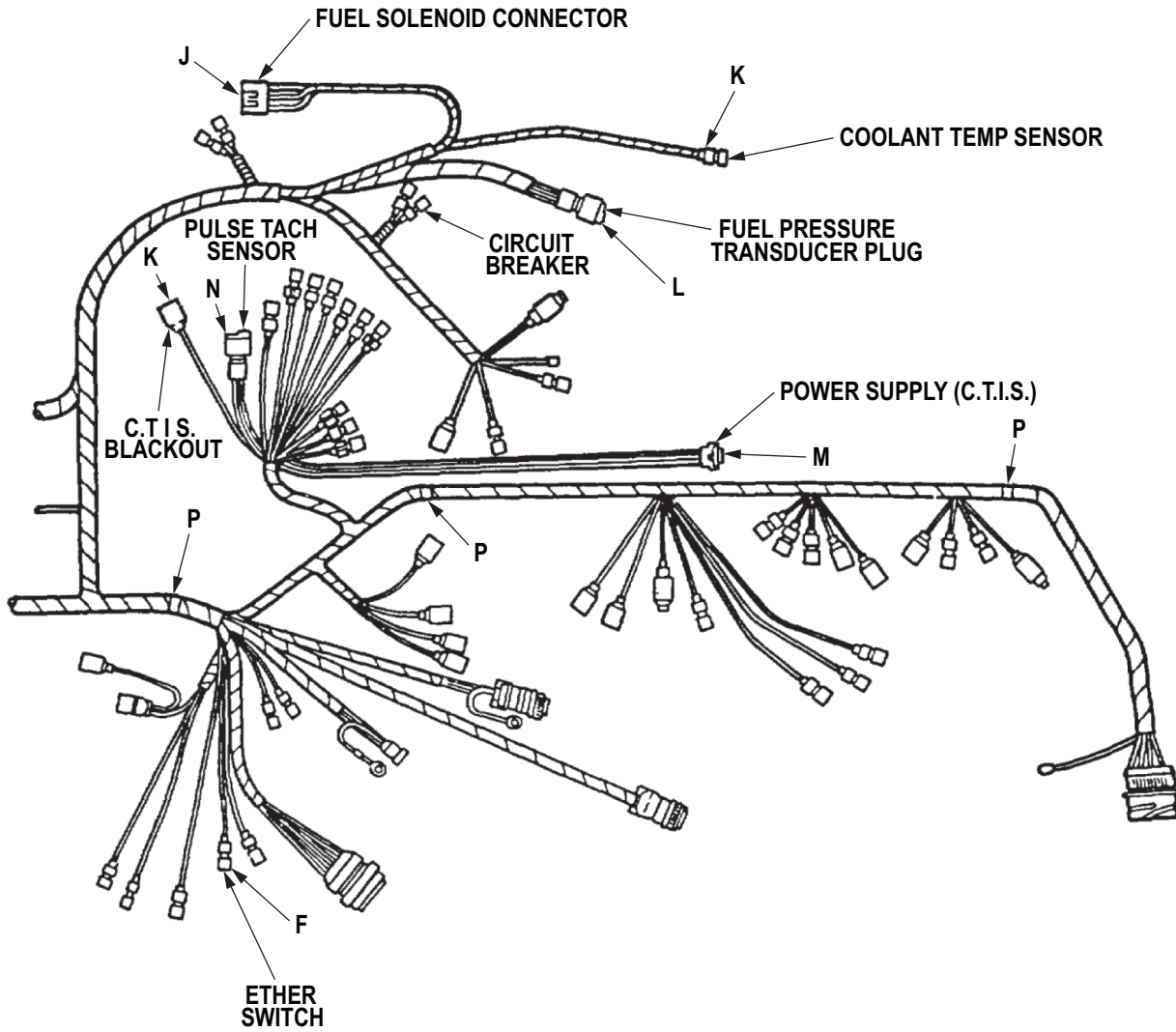

R0165DAA

Figure 160. Front Wiring Harness, Partial View (M939A2). (Sheet 2 of 2)

(1) ITEM NO.	(2) SMR CODE	(3) NSN	(4) CAGEC	(5) PART NUMBER	(6) DESCRIPTION AND USABLE ON CODE (UOC)	(7) QTY
<b>GROUP 0613 HULL OR CHASSIS WIRING HARNESS.</b>						
<b>FIG. 160. FRONT WIRING HARNESS, PARTIAL VIEW (M939A2).</b>						
1	PAFZZ	5935-00-691-5591	97403	13207E6498-2	. SHELL,ELECTRICAL CO UOC: ZAA,ZAB,ZAC,ZAD,ZAE,ZAF, ZAG,ZAH,ZAJ,ZAL .....	1
2	PAFZZ	5310-00-656-0067	19207	8724497	. WASHER,SLOTTED UOC: ZAA,ZAB,ZAC,ZAD,ZAE,ZAF, ZAG,ZAH,ZAJ,ZAL .....	1
3	PAFZZ	5999-00-926-3144	58536	AA52536-3	. CONTACT,ELECTRICAL UOC: ZAA,ZAB,ZAC,ZAD,ZAE,ZAF, ZAG,ZAH,ZAJ,ZAL .....	1
4	PAFZZ	5940-01-021-1874	56501	AB53	. TERMINAL,LUG UOC: ZAA,ZAB,ZAC,ZAD,ZAE,ZAF, ZAG,ZAH,ZAJ,ZAL .....	1
5	PAFZZ	5940-00-115-2674	96906	MS20659-108	. TERMINAL,LUG UOC: ZAA,ZAB,ZAC,ZAD,ZAE,ZAF, ZAG,ZAH,ZAJ,ZAL .....	2
6	PAFZZ	5940-00-113-9825	81343	MS20659-141	. TERMINAL,LUG UOC: ZAA,ZAB,ZAC,ZAD,ZAE,ZAF, ZAG,ZAH,ZAJ,ZAL .....	1
7	PAFZZ	5940-00-113-9821	96906	MS20659-166	. TERMINAL,LUG UOC: ZAA,ZAB,ZAC,ZAD,ZAE,ZAF, ZAG,ZAH,ZAJ,ZAL .....	2
8	PAFZZ	5935-00-833-8561	19207	8338561	. SHELL,ELECTRICAL CO UOC: ZAA,ZAB,ZAC,ZAD,ZAE,ZAF, ZAG,ZAH,ZAJ,ZAL .....	2
9	PAFZZ	5970-00-833-8562	19207	8338562	. INSULATOR,BUSHING UOC: ZAA,ZAB,ZAC,ZAD,ZAE,ZAF, ZAG,ZAH,ZAJ,ZAL .....	4
10	PAFZZ	5940-00-399-6676	19207	8338564	. TERMINAL SET,QUICK UOC: ZAA,ZAB,ZAC,ZAD,ZAE,ZAF, ZAG,ZAH,ZAJ,ZAL .....	4
11	PAFZZ	5940-00-114-1315	96906	MS20659-142	. TERMINAL,LUG UOC: ZAA,ZAB,ZAC,ZAD,ZAE,ZAF, ZAG,ZAH,ZAJ,ZAL .....	1
12	PAFZZ	5940-00-705-6702	24930	G360038-3	. TERMINAL,LUG UOC: ZAA,ZAB,ZAC,ZAD,ZAE,ZAF, ZAG,ZAH,ZAJ,ZAL .....	1
13	PAFZZ	5940-00-705-6715	19207	7056715	. TERMINAL,LUG UOC: ZAA,ZAB,ZAC,ZAD,ZAE,ZAF, ZAG,ZAH,ZAJ,ZAL .....	1
14	PAFZZ	5935-01-292-2336	45152	1618210	. CONNECTOR,PLUG,ELEC UOC: ZAA,ZAB,ZAC,ZAD,ZAE,ZAF, ZAG,ZAH,ZAJ,ZAL .....	1

(1) ITEM NO.	(2) SMR CODE	(3) NSN	(4) CAGEC	(5) PART NUMBER	(6) DESCRIPTION AND USABLE ON CODE (UOC)	(7) QTY
15	PAFZZ	5975-00-660-5962	19207	8724494	. CABLE NIPPLE,ELECTR UOC: ZAA,ZAB,ZAC,ZAD,ZAE,ZAF, ZAG,ZAH,ZAJ,ZAL .....	2
16	PAFZZ	5935-01-154-6233	19207	12258940-4	. CONNECTOR,PLUG,ELEC UOC: ZAA,ZAB,ZAC,ZAD,ZAE,ZAF, ZAG,ZAH,ZAJ,ZAL .....	1
17	PAFZZ	5999-01-150-8808	19207	12258939-2	. CONTACT,ELECTRICAL UOC: ZAA,ZAB,ZAC,ZAD,ZAE,ZAF, ZAG,ZAH,ZAJ,ZAL .....	3
18	PAFZZ	5999-01-156-6314	71468	110238-0195	. PIN,GROOVED,HEADLES UOC: ZAA,ZAB,ZAC,ZAD,ZAE,ZAF, ZAG,ZAH,ZAJ,ZAL .....	3
19	PAFZZ	5935-01-308-7866	77060	15300027	. CONNECTOR BODY,PLUG UOC: ZAA,ZAB,ZAC,ZAD,ZAE,ZAF, ZAG,ZAH,ZAJ,ZAL .....	1
20	PAFZZ	5935-01-149-5165	11083	7N9738	. CONNECTOR BODY,PLUG UOC: ZAA,ZAB,ZAC,ZAD,ZAE,ZAF, ZAG,ZAH,ZAJ,ZAL .....	1
21	PAFZZ	5975-00-156-3253	81343	MS3367-2-9	. STRAP,TIEDOWN,ELECT UOC: ZAA,ZAB,ZAC,ZAD,ZAE,ZAF, ZAG,ZAH,ZAJ,ZAL .....	1
21	PAFZZ	5975-00-984-6582	96906	MS3367-1-0	. STRAP,TIEDOWN,ELECT UOC: ZAA,ZAB,ZAC,ZAD,ZAE,ZAF, ZAG,ZAH,ZAJ,ZAL .....	1
21	PAFZZ	5975-00-451-5001	81343	MS3367-3-9	. STRAP,TIEDOWN,ELECT UOC: ZAA,ZAB,ZAC,ZAD,ZAE,ZAF, ZAG,ZAH,ZAJ,ZAL .....	1

END OF FIGURE

**FIELD MAINTENANCE  
FRONT WIRING HARNESS CLAMPS AND HARDWARE**

---

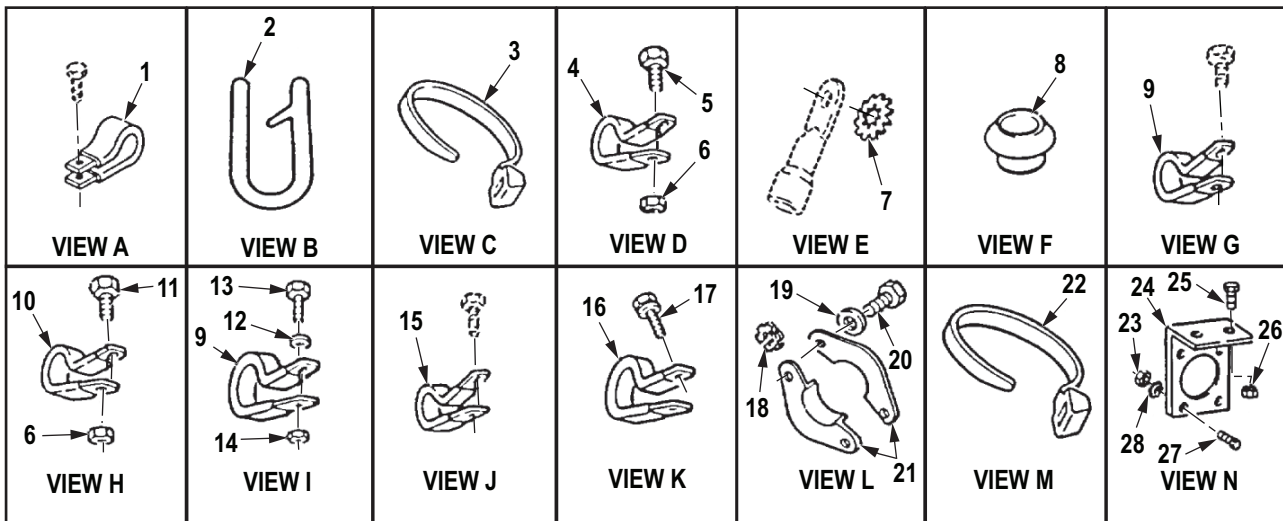
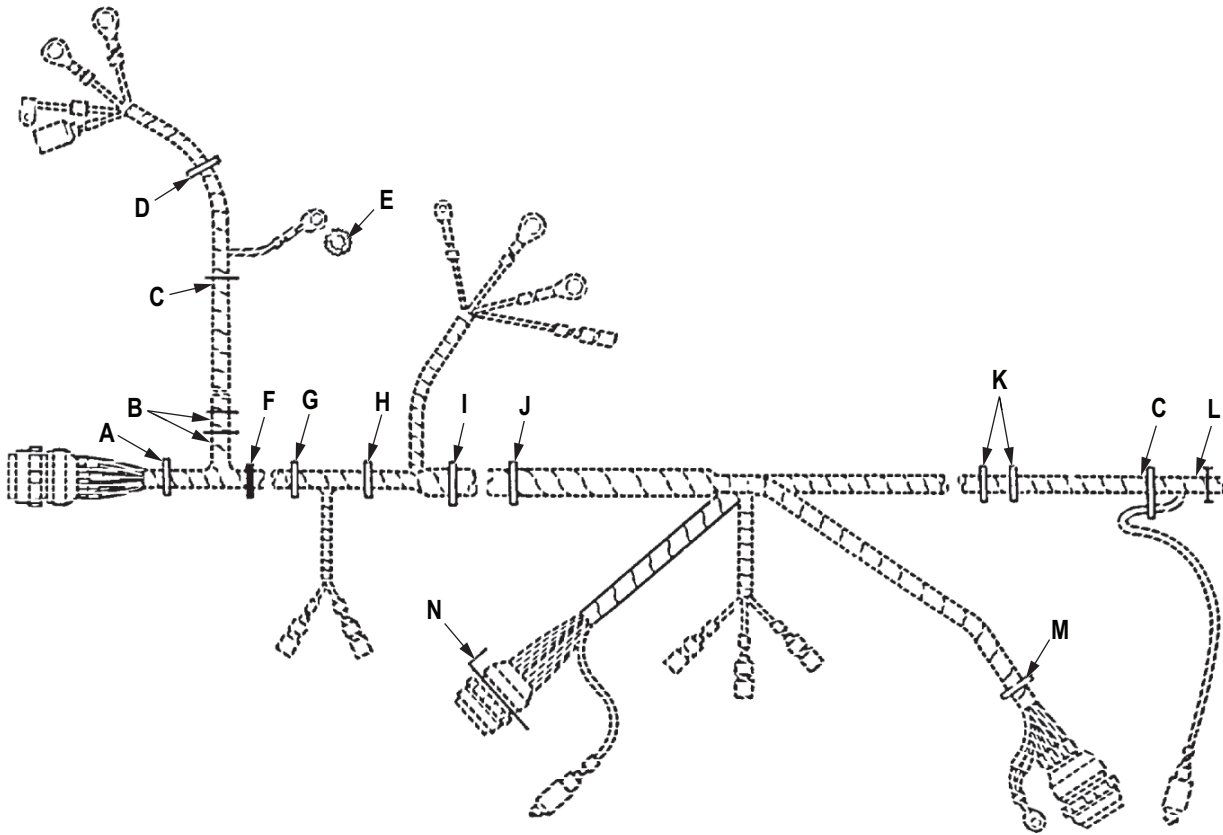

R0166DAA

Figure 161. Front Wiring Harness Clamps and Hardware.

(1) ITEM NO.	(2) SMR CODE	(3) NSN	(4) CAGEC	(5) PART NUMBER	(6) DESCRIPTION AND USABLE ON CODE (UOC)	(7) QTY
<b>GROUP 0613 HULL OR CHASSIS WIRING HARNESS.</b>						
<b>FIG. 161. FRONT WIRING HARNESS CLAMPS AND HARDWARE.</b>						
1	PAFZZ	5340-00-057-3043	96906	MS21333-112	CLAMP, LOOP UOC: DAC, DAD, DAE, DAF, DAG, DA H, DAJ, DAL, DAW, DAX, V14, V15, V16, V17, V18, V19, V20, V21, V22, V24, ZAA, ZAB, ZAC, ZAD, ZAE, ZAF, ZAG, ZAH, Z AJ, ZAL .....	1
2	PAFZZ	5340-01-188-5087	19207	12302768	CLIP, RETAINING UOC: DAC, DAD, DAE, DAF, DAG, DA H, DAJ, DAL, DAW, DAX, V14, V15, V16, V17, V18, V19, V20, V21, V22, V24, ZAA, ZAB, ZAC, ZAD, ZAE, ZAF, ZAG, ZAH, Z AJ, ZAL .....	2
3	PAFZZ	5975-00-156-3253	81343	MS3367-2-9	STRAP, TIEDOWN, ELECT UOC: DAC, DAD, DAE, DAF, DAG, DA H, DAJ, DAL, DAW, DAX, V14, V15, V16, V17, V18, V19, V20, V21, V22, V24, ZAA, ZAB, ZAC, ZAD, ZAE, ZAF, ZAG, ZAH, Z AJ, ZAL .....	2
4	PAFZZ	5340-00-053-8994	80205	MS21333-126	CLAMP, LOOP UOC: DAC, DAD, DAE, DAF, DAG, DA H, DAJ, DAL, DAW, DAX, V14, V15, V16, V17, V18, V19, V20, V21, V22, V24, ZAA, ZAB, ZAC, ZAD, ZAE, ZAF, ZAG, ZAH, Z AJ, ZAL .....	1
5	PAFZZ	5305-00-269-3238	80204	B1821BH038F125N	SCREW, CAP, HEXAGON H UOC: DAC, DAD, DAE, DAF, DAG, DA H, DAJ, DAL, DAW, DAX, V14, V15, V16, V17, V18, V19, V20, V21, V22, V24, ZAA, ZAB, ZAC, ZAD, ZAE, ZAF, ZAG, ZAH, Z AJ, ZAL .....	1
6	PAFZZ	5310-00-814-0672	96906	M45913/3-6FG8C	NUT, SELF-LOCKING, HE UOC: DAC, DAD, DAE, DAF, DAG, DA H, DAJ, DAL, DAW, DAX, V14, V15, V16, V17, V18, V19, V20, V21, V22, V24, ZAA, ZAB, ZAC, ZAD, ZAE, ZAF, ZAG, ZAH, Z AJ, ZAL .....	4
7	PAFZZ	5310-00-061-1258	96906	MS45904-76	WASHER, LOCK UOC: DAC, DAD, DAE, DAF, DAG, DA H, DAJ, DAL, DAW, DAX, V14, V15, V16, V17, V18, V19, V20, V21, V22, V24, ZAA, ZAB, ZAC, ZAD, ZAE, ZAF, ZAG, ZAH, Z AJ, ZAL .....	3

(1) ITEM NO.	(2) SMR CODE	(3) NSN	(4) CAGEC	(5) PART NUMBER	(6) DESCRIPTION AND USABLE ON CODE (UOC)	(7) QTY
8	PAFZZ	5325-00-739-7776	19207	7397776	EYELET,METALLIC UOC: DAC,DAD,DAE,DAF,DAG,DA H,DAJ,DAL,DAW,DAX,V14,V15,V16, V17,V18,V19,V20,V21,V22,V24,ZAA, ZAB,ZAC,ZAD,ZAE,ZAF,ZAG,ZAH,Z AJ,ZAL .....	1
9	PAFZZ	5340-00-764-7052	80205	MS21333-116	CLAMP,LOOP UOC: DAC,DAD,DAE,DAF,DAG,DA H,DAJ,DAL,DAW,DAX,V14,V15,V16, V17,V18,V19,V20,V21,V22,V24,ZAA, ZAB,ZAC,ZAD,ZAE,ZAF,ZAG,ZAH,Z AJ,ZAL .....	2
10	PAFZZ	5340-00-702-2848	80205	MS21333-128	CLAMP,LOOP UOC: DAC,DAD,DAE,DAF,DAG,DA H,DAJ,DAL,DAW,DAX,V14,V15,V16, V17,V18,V19,V20,V21,V22,V24,ZAA, ZAB,ZAC,ZAD,ZAE,ZAF,ZAG,ZAH,Z AJ,ZAL .....	1
11	PAFZZ	5305-00-912-5113	80205	MS51096-359	SCREW,CAP,HEXAGON H UOC: DAC,DAD,DAE,DAF,DAG,DA H,DAJ,DAL,DAW,DAX,V14,V15,V16, V17,V18,V19,V20,V21,V22,V24,ZAA, ZAB,ZAC,ZAD,ZAE,ZAF,ZAG,ZAH,Z AJ,ZAL .....	1
12	PAFZZ	5310-00-178-8631	80205	MS35333-75	WASHER,LOCK UOC: DAC,DAD,DAE,DAF,DAG,DA H,DAJ,DAL,DAW,DAX,V14,V15,V16, V17,V18,V19,V20,V21,V22,V24,ZAA, ZAB,ZAC,ZAD,ZAE,ZAF,ZAG,ZAH,Z AJ,ZAL .....	1
13	PAFZZ	5306-00-050-1238	80204	B1821BH031F075N	BOLT,MACHINE UOC: DAC,DAD,DAE,DAF,DAG,DA H,DAJ,DAL,DAW,DAX,V14,V15,V16, V17,V18,V19,V20,V21,V22,V24,ZAA, ZAB,ZAC,ZAD,ZAE,ZAF,ZAG,ZAH,Z AJ,ZAL .....	1
14	PAFZZ	5310-00-054-4892	80205	MS35650-3312	NUT,PLAIN,HEXAGON UOC: DAC,DAD,DAE,DAF,DAG,DA H,DAJ,DAL,DAW,DAX,V14,V15,V16, V17,V18,V19,V20,V21,V22,V24,ZAA, ZAB,ZAC,ZAD,ZAE,ZAF,ZAG,ZAH,Z AJ,ZAL .....	1
15	PAFZZ	5340-00-151-9651	80205	MS21333-129	CLAMP,LOOP UOC: DAC,DAD,DAE,DAF,DAG,DA H,DAJ,DAL,DAW,DAX,V14,V15,V16, V17,V18,V19,V20,V21,V22,V24,ZAA, ZAB,ZAC,ZAD,ZAE,ZAF,ZAG,ZAH,Z AJ,ZAL .....	1



(1) ITEM NO.	(2) SMR CODE	(3) NSN	(4) CAGEC	(5) PART NUMBER	(6) DESCRIPTION AND USABLE ON CODE (UOC)	(7) QTY
16	PAFZZ	5340-00-904-0933	80205	MS21333-80	CLAMP,LOOP UOC: DAC,DAD,DAE,DAF,DAG,DA H,DAJ,DAL,DAW,DAX,V14,V15,V16, V17,V18,V19,V20,V21,V22,V24,ZAA, ZAB,ZAC,ZAD,ZAE,ZAF,ZAG,ZAH,Z AJ,ZAL .....	2
17	PAFZZ	5306-00-042-5570	24617	425570	BOLT,ASSEMBLED WASH UOC: DAC,DAD,DAE,DAF,DAG,DA H,DAJ,DAL,DAW,DAX,V14,V15,V16, V17,V18,V19,V20,V21,V22,V24,ZAA, ZAB,ZAC,ZAD,ZAE,ZAF,ZAG,ZAH,Z AJ,ZAL .....	2
18	PAFZZ	5310-00-901-0279	96906	MS45904-74	WASHER,LOCK UOC: DAC,DAD,DAE,DAF,DAG,DA H,DAJ,DAL,DAW,DAX,V14,V15,V16, V17,V18,V19,V20,V21,V22,V24,ZAA, ZAB,ZAC,ZAD,ZAE,ZAF,ZAG,ZAH,Z AJ,ZAL .....	2
19	PAFZZ	5310-00-809-4058	96906	MS27183-10	WASHER,FLAT UOC: DAC,DAD,DAE,DAF,DAG,DA H,DAJ,DAL,DAW,DAX,V14,V15,V16, V17,V18,V19,V20,V21,V22,V24,ZAA, ZAB,ZAC,ZAD,ZAE,ZAF,ZAG,ZAH,Z AJ,ZAL .....	2
20	PAFZZ	5306-00-068-0513	80204	B1821BH025F075N	BOLT,MACHINE UOC: DAC,DAD,DAE,DAF,DAG,DA H,DAJ,DAL,DAW,DAX,V14,V15,V16, V17,V18,V19,V20,V21,V22,V24,ZAA, ZAB,ZAC,ZAD,ZAE,ZAF,ZAG,ZAH,Z AJ,ZAL .....	2
21	PAFZZ	5325-01-231-5963	84324	7397744-1	GROMMET,METALLIC UOC: DAC,DAD,DAE,DAF,DAG,DA H,DAJ,DAL,DAW,DAX,V14,V15,V16, V17,V18,V19,V20,V21,V22,V24,ZAA, ZAB,ZAC,ZAD,ZAE,ZAF,ZAG,ZAH,Z AJ,ZAL .....	2
22	PAFZZ	5975-00-451-5001	81343	MS3367-3-9	STRAP,TIEDOWN,ELECT UOC: DAC,DAD,DAE,DAF,DAG,DA H,DAJ,DAL,DAW,DAX,V14,V15,V16, V17,V18,V19,V20,V21,V22,V24,ZAA, ZAB,ZAC,ZAD,ZAE,ZAF,ZAG,ZAH,Z AJ,ZAL .....	1
23	PAFZZ	5310-00-934-9757	80205	MS35649-282	NUT,PLAIN,HEXAGON UOC: DAC,DAD,DAE,DAF,DAG,DA H,DAJ,DAL,DAW,DAX,V14,V15,V16, V17,V18,V19,V20,V21,V22,V24,ZAA, ZAB,ZAC,ZAD,ZAE,ZAF,ZAG,ZAH,Z AJ,ZAL .....	4

(1) ITEM NO.	(2) SMR CODE	(3) NSN	(4) CAGEC	(5) PART NUMBER	(6) DESCRIPTION AND USABLE ON CODE (UOC)	(7) QTY
24	PAFZZ	5340-00-158-4078	19207	10899434	BRACKET,ANGLE UOC: DAC,DAD,DAE,DAF,DAG,DA H,DAJ,DAL,DAW,DAX,V14,V15,V16, V17,V18,V19,V20,V21,V22,V24,ZAA, ZAB,ZAC,ZAD,ZAE,ZAF,ZAG,ZAH,Z AJ,ZAL .....	1
25	PAFZZ	5305-00-019-1675	24617	191675	SCREW,ASSEMBLED WAS UOC: DAC,DAD,DAE,DAF,DAG,DA H,DAJ,DAL,DAW,DAX,V14,V15,V16, V17,V18,V19,V20,V21,V22,V24,ZAA, ZAB,ZAC,ZAD,ZAE,ZAF,ZAG,ZAH,Z AJ,ZAL .....	2
26	PAFZZ	5310-00-400-5503	80205	MS35650-3254	NUT,PLAIN,HEXAGON UOC: DAC,DAD,DAE,DAF,DAG,DA H,DAJ,DAL,DAW,DAX,V14,V15,V16, V17,V18,V19,V20,V21,V22,V24,ZAA, ZAB,ZAC,ZAD,ZAE,ZAF,ZAG,ZAH,Z AJ,ZAL .....	2
27	PAFZZ	5305-00-984-6193	80205	MS35206-245	SCREW,MACHINE UOC: DAC,DAD,DAE,DAF,DAG,DA H,DAJ,DAL,DAW,DAX,V14,V15,V16, V17,V18,V19,V20,V21,V22,V24,ZAA, ZAB,ZAC,ZAD,ZAE,ZAF,ZAG,ZAH,Z AJ,ZAL .....	4
28	PAFZZ	5310-00-596-7693	96906	MS35335-31	WASHER,LOCK UOC: DAC,DAD,DAE,DAF,DAG,DA H,DAJ,DAL,DAW,DAX,V14,V15,V16, V17,V18,V19,V20,V21,V22,V24,ZAA, ZAB,ZAC,ZAD,ZAE,ZAF,ZAG,ZAH,Z AJ,ZAL .....	4

END OF FIGURE

**FIELD MAINTENANCE  
FRONT WIRING HARNESS CLAMPS AND HARDWARE**

---

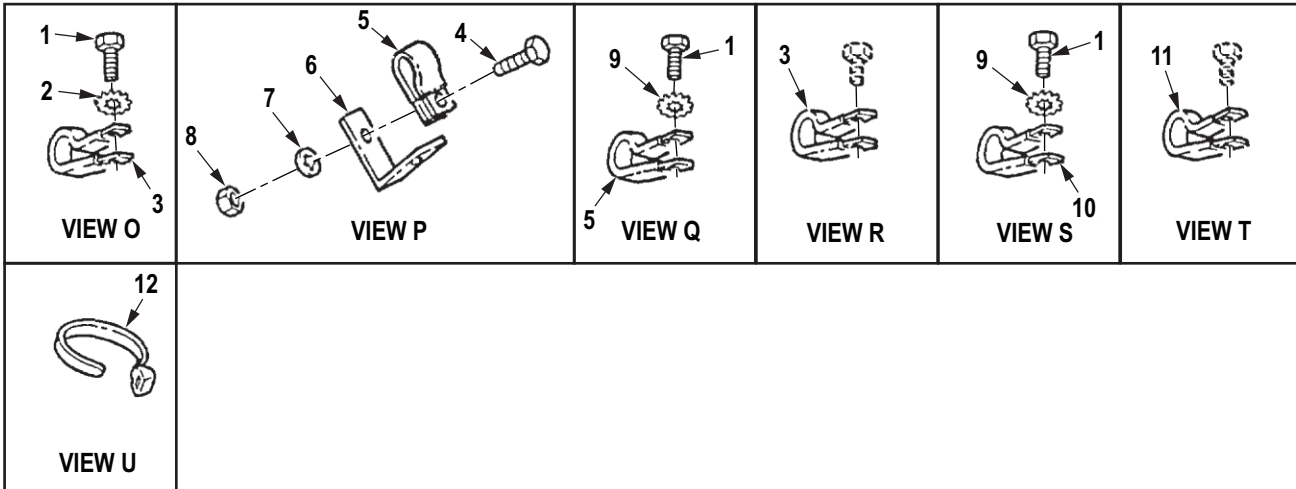
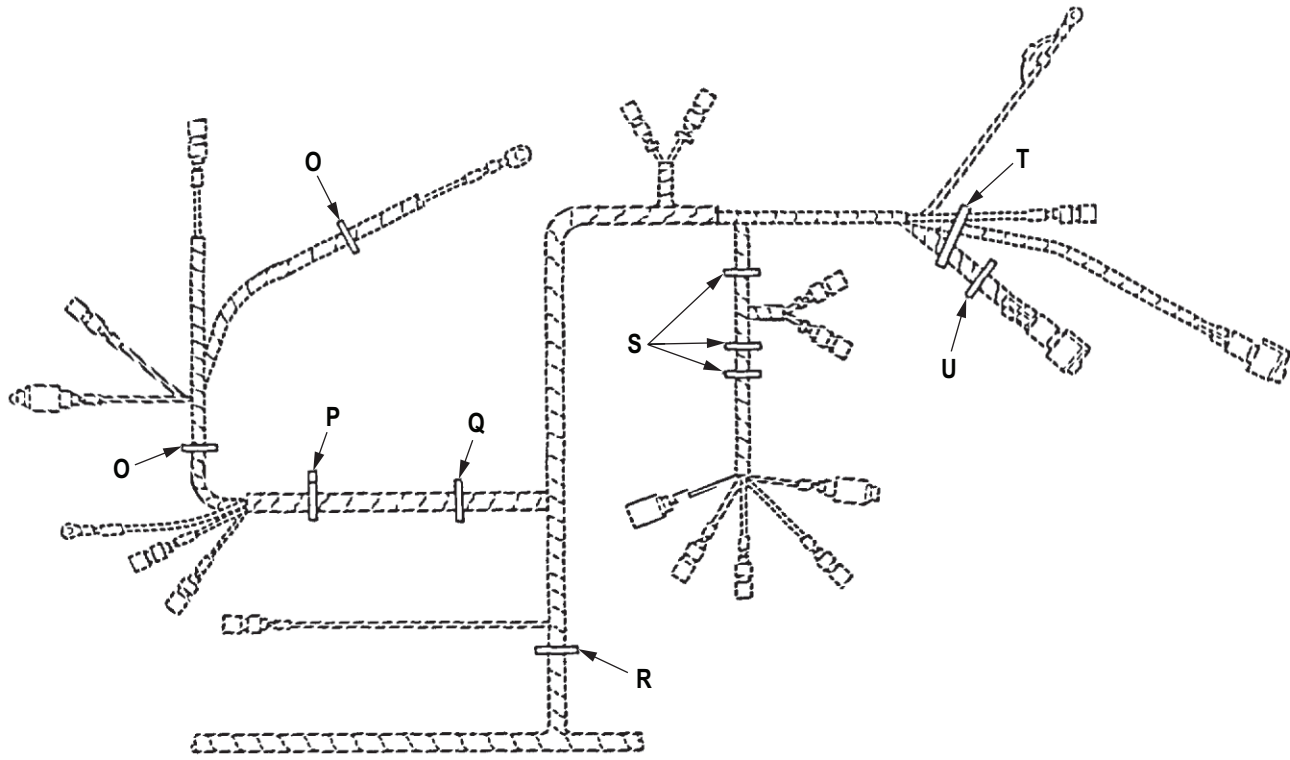

R0167DAA

Figure 162. Front Wiring Harness Clamps and Hardware.

(1) ITEM NO.	(2) SMR CODE	(3) NSN	(4) CAGEC	(5) PART NUMBER	(6) DESCRIPTION AND USABLE ON CODE (UOC)	(7) QTY
<b>GROUP 0613 HULL OR CHASSIS WIRING HARNESS.</b>						
<b>FIG. 162. FRONT WIRING HARNESS CLAMPS AND HARDWARE.</b>						
1	PAFZZ	5306-00-068-0513	80204	B1821BH025F075N	BOLT,MACHINE UOC: DAC,DAD,DAE,DAF,DAG,DA H,DAJ,DAL,DAW,DAX,V14,V15,V16, V17,V18,V19,V20,V21,V22,V24,ZAA, ZAB,ZAC,ZAD,ZAE,ZAF,ZAG,ZAH,Z AJ,ZAL .....	5
2	PAFZZ	5310-00-550-1130	80205	MS35333-40	WASHER,LOCK UOC: DAC,DAD,DAE,DAF,DAG,DA H,DAJ,DAL,DAW,DAX,V14,V15,V16, V17,V18,V19,V20,V21,V22,V24,ZAA, ZAB,ZAC,ZAD,ZAE,ZAF,ZAG,ZAH,Z AJ,ZAL .....	3
3	PAFZZ	5340-01-117-9876	19207	7397785	CLAMP,LOOP UOC: DAC,DAD,DAE,DAF,DAG,DA H,DAJ,DAL,DAW,DAX,V14,V15,V16, V17,V18,V19,V20,V21,V22,V24,ZAA, ZAB,ZAC,ZAD,ZAE,ZAF,ZAG,ZAH,Z AJ,ZAL .....	4
4	PAFZZ	5305-00-068-0515	80204	B1821BH025F100N	SCREW,CAP,HEXAGON H UOC: DAC,DAD,DAE,DAF,DAG,DA H,DAJ,DAL,DAW,DAX,V14,V15,V16, V17,V18,V19,V20,V21,V22,V24,ZAA, ZAB,ZAC,ZAD,ZAE,ZAF,ZAG,ZAH,Z AJ,ZAL .....	1
5	PAFZZ	5340-00-088-1254	80205	MS21333-104	CLAMP,LOOP UOC: DAC,DAD,DAE,DAF,DAG,DA H,DAJ,DAL,DAW,DAX,V14,V15,V16, V17,V18,V19,V20,V21,V22,V24,ZAA, ZAB,ZAC,ZAD,ZAE,ZAF,ZAG,ZAH,Z AJ,ZAL .....	2
6	PFFZZ	5340-01-147-6759	19207	12256266	BRACKET,ANGLE UOC: DAC,DAD,DAE,DAF,DAG,DA H,DAJ,DAL,DAW,DAX,V14,V15,V16, V18,V19,V20,V21,V22,V24,ZAA,ZAB, ZAC,ZAD,ZAE,ZAF,ZAG,ZAH,ZAJ,ZAL .....	1
7	PAFZZ	5310-00-022-8834	80205	MS35333-108	WASHER,LOCK UOC: DAC,DAD,DAE,DAF,DAG,DA H,DAJ,DAL,DAW,DAX,V14,V15,V16, V17,V18,V19,V20,V21,V22,V24,ZAA, ZAB,ZAC,ZAD,ZAE,ZAF,ZAG,ZAH,Z AJ,ZAL .....	1

(1) ITEM NO.	(2) SMR CODE	(3) NSN	(4) CAGEC	(5) PART NUMBER	(6) DESCRIPTION AND USABLE ON CODE (UOC)	(7) QTY
8	PAFZZ	5310-00-935-9022	81349	M45913/3-4FG8C	NUT,SELF-LOCKING,HE UOC: DAC,DAD,DAE,DAF,DAG,DA H,DAJ,DAL,DAW,DAX,V14,V15,V16, V18,V19,V20,V21,V22,V24,ZAA,ZAB, ZAC,ZAD,ZAE,ZAF,ZAG,ZAH,ZAJ,ZAL .....	1
9	PAFZZ	5310-00-901-0279	96906	MS45904-74	WASHER,LOCK UOC: DAC,DAD,DAE,DAF,DAG,DA H,DAJ,DAL,DAW,DAX,V14,V15,V16, V17,V18,V19,V20,V21,V22,V24,ZAA, ZAB,ZAC,ZAD,ZAE,ZAF,ZAG,ZAH,Z AJ,ZAL .....	4
10	PAFZZ	5340-00-993-6207	96906	MS21333-99	CLAMP,LOOP UOC: DAC,DAD,DAE,DAF,DAG,DA H,DAJ,DAL,DAW,DAX,V14,V15,V16, V17,V18,V19,V20,V21,V22,V24,ZAA, ZAB,ZAC,ZAD,ZAE,ZAF,ZAG,ZAH,Z AJ,ZAL .....	3
11	PAFZZ	5340-00-067-3868	80205	MS21333-109	CLAMP,LOOP UOC: DAC,DAD,DAE,DAF,DAG,DA H,DAJ,DAL,DAW,DAX,V14,V15,V16, V17,V18,V19,V20,V21,V22,V24,ZAA, ZAB,ZAC,ZAD,ZAE,ZAF,ZAG,ZAH,Z AJ,ZAL .....	1
12	PAFZZ	5975-00-727-5153	30554	88-20018-2	STRAP,TIEDOWN,ELECT UOC: DAC,DAD,DAE,DAF,DAG,DA H,DAJ,DAL,DAW,DAX,V14,V15,V16, V17,V18,V19,V20,V21,V22,V24,ZAA, ZAB,ZAC,ZAD,ZAE,ZAF,ZAG,ZAH,Z AJ,ZAL .....	1

END OF FIGURE

**FIELD MAINTENANCE  
FRONT WIRING HARNESS BRACKET AND HARDWARE**

---

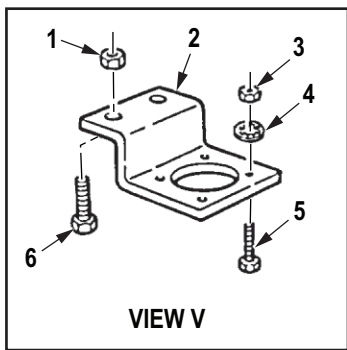
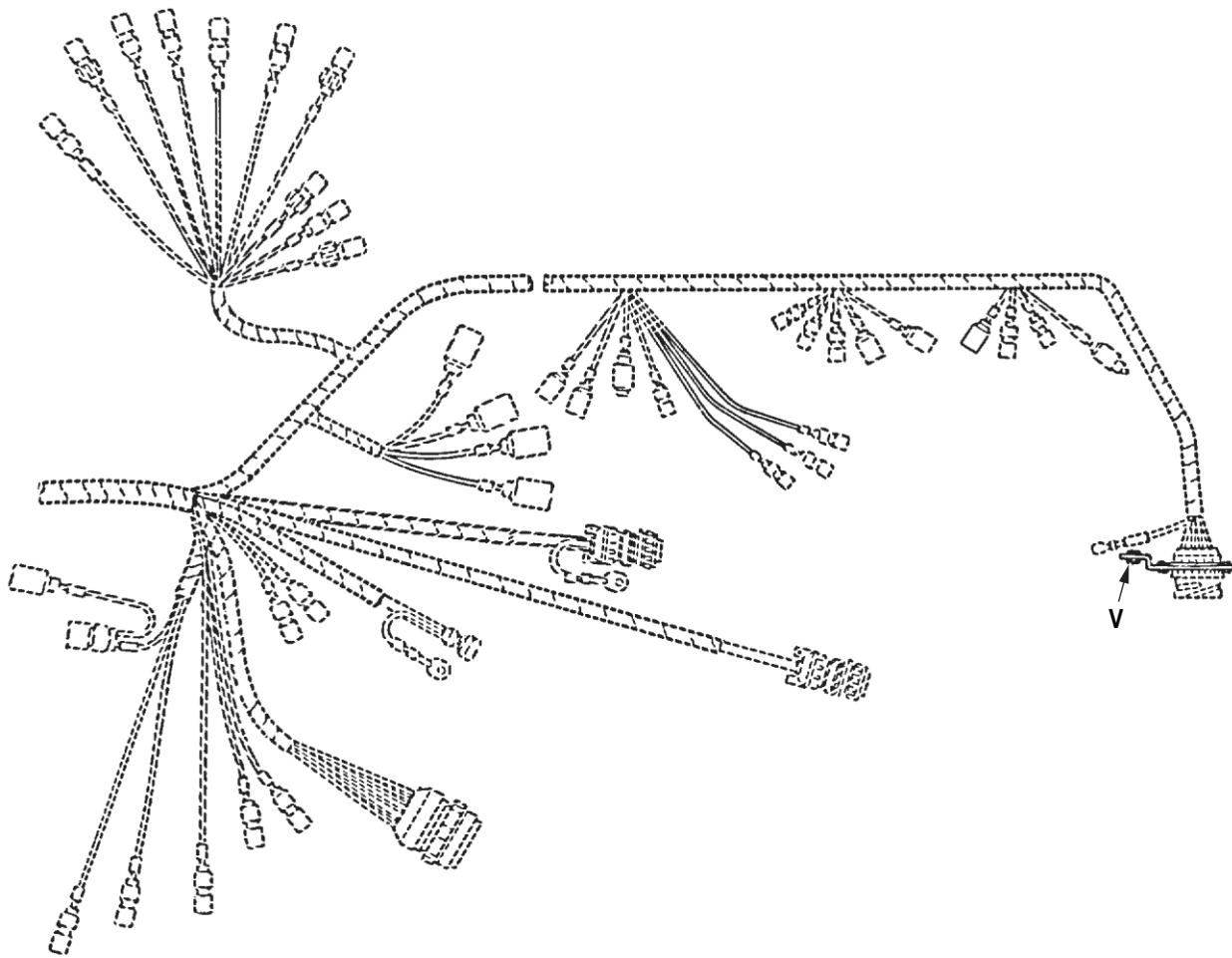

R0168DAA

Figure 163. Front Wiring Harness Bracket and Hardware.



(1) ITEM NO.	(2) SMR CODE	(3) NSN	(4) CAGEC	(5) PART NUMBER	(6) DESCRIPTION AND USABLE ON CODE (UOC)	(7) QTY
<b>GROUP 0613 HULL OR CHASSIS WIRING HARNESS.</b>						
<b>FIG. 163. FRONT WIRING HARNESS BRACKET AND HARDWARE.</b>						
1	PAFZZ	5310-00-814-0672	96906	M45913/3-6FG8C	NUT, SELF-LOCKING, HE UOC: DAC, DAD, DAE, DAF, DAG, DA H, DAJ, DAL, DAW, DAX, V14, V15, V16, V17, V18, V19, V20, V21, V22, V24, ZAA, ZAB, ZAC, ZAD, ZAE, ZAF, ZAG, ZAH, Z AJ, ZAL .....	2
2	PAFZZ	5935-01-120-3744	19207	12277052	BRACKET, ELECTRICAL UOC: DAC, DAD, DAE, DAF, DAG, DA H, DAJ, DAL, DAW, DAX, V14, V15, V16, V17, V18, V19, V20, V21, V22, V24, ZAA, ZAB, ZAC, ZAD, ZAE, ZAF, ZAG, ZAH, Z AJ, ZAL .....	1
3	PAFZZ	5310-00-934-9754	80205	MS35650-382	NUT, PLAIN, HEXAGON UOC: DAC, DAD, DAE, DAF, DAG, DA H, DAJ, DAL, DAW, DAX, V14, V15, V16, V17, V18, V19, V20, V21, V22, V24, ZAA, ZAB, ZAC, ZAD, ZAE, ZAF, ZAG, ZAH, Z AJ, ZAL .....	4
4	PAFZZ	5310-00-550-1130	80205	MS35333-40	WASHER, LOCK UOC: DAC, DAD, DAE, DAF, DAG, DA H, DAJ, DAL, DAW, DAX, V14, V15, V16, V17, V18, V19, V20, V21, V22, V24, ZAA, ZAB, ZAC, ZAD, ZAE, ZAF, ZAG, ZAH, Z AJ, ZAL .....	1
5	PAFZZ	5305-00-993-1848	80205	MS35207-265	SCREW, MACHINE UOC: DAC, DAD, DAE, DAF, DAG, DA H, DAJ, DAL, DAW, DAX, V14, V15, V16, V17, V18, V19, V20, V21, V22, V24, ZAA, ZAB, ZAC, ZAD, ZAE, ZAF, ZAG, ZAH, Z AJ, ZAL .....	4
6	PAFZZ	5305-00-269-3234	80204	B1821BH038F075N	SCREW, CAP, HEXAGON H UOC: DAC, DAD, DAE, DAF, DAG, DA H, DAJ, DAL, DAW, DAX, V14, V15, V16, V17, V18, V19, V20, V21, V22, V24, ZAA, ZAB, ZAC, ZAD, ZAE, ZAF, ZAG, ZAH, Z AJ, ZAL .....	2

END OF FIGURE



FIELD MAINTENANCE  
REAR WIRING HARNESS ASSEMBLY, CARGO

1  
2 - 16

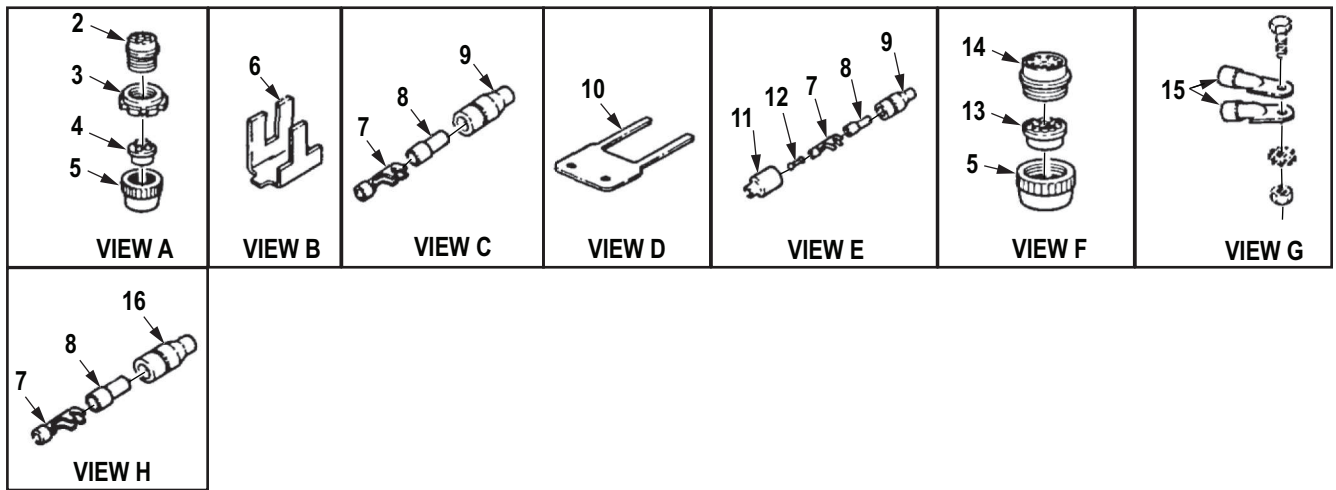
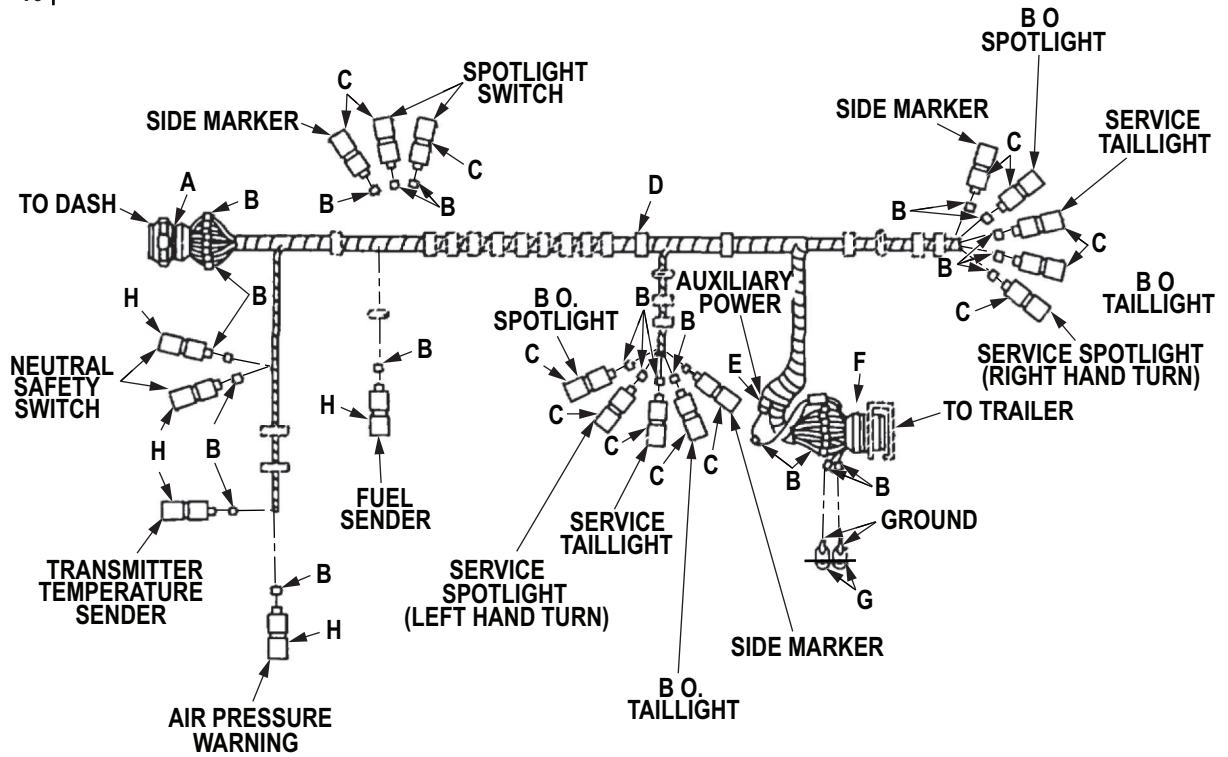

R0169DAA

Figure 164. Rear Wiring Harness Assembly, Cargo. (Sheet 1 of 2)

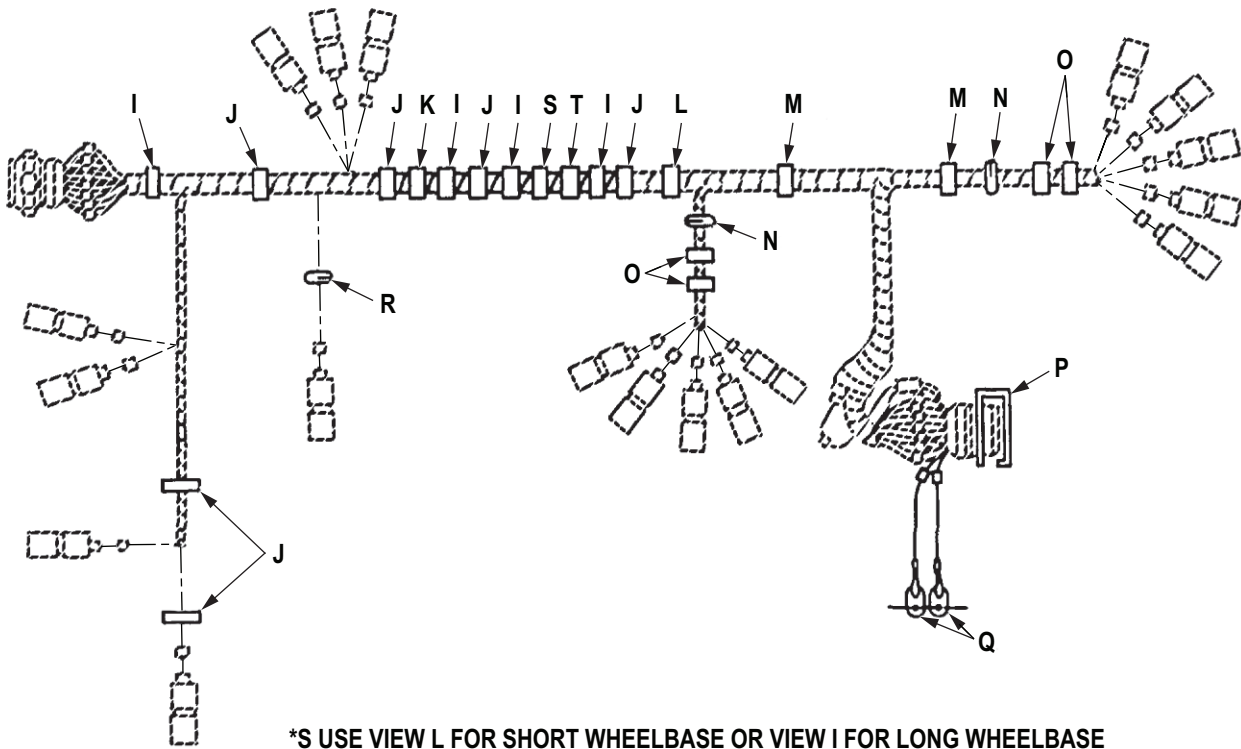

\*S USE VIEW L FOR SHORT WHEELBASE OR VIEW I FOR LONG WHEELBASE  
 \*T USE VIEW I FOR SHORT WHEELBASE OR VIEW L FOR LONG WHEELBASE

<p>VIEW I</p>	<p>VIEW J</p>	<p>VIEW K</p>	<p>VIEW L</p>	<p>VIEW M</p>
<p>VIEW N</p>	<p>VIEW O</p>	<p>VIEW P</p>	<p>VIEW Q</p>	<p>VIEW R</p>

R0170DAA

Figure 164. Rear Wiring Harness Assembly, Cargo. (Sheet 2 of 2)

(1) ITEM NO.	(2) SMR CODE	(3) NSN	(4) CAGEC	(5) PART NUMBER	(6) DESCRIPTION AND USABLE ON CODE (UOC)	(7) QTY
<b>GROUP 0613 HULL OR CHASSIS WIRING HARNESS.</b>						
<b>FIG. 164. REAR WIRING HARNESS ASSEMBLY, CARGO.</b>						
1	PBFFF	2590-01-085-3834	19207	12256002-2	WIRING HARNESS,BRAN UOC: DAC,DAD,V16,V17,ZAC,ZAD .....	1
2	PAFZZ	5935-00-080-1020	19207	8724255	. CONNECTOR,PLUG,ELEC UOC: DAC,DAD,DAW,DAX,V14,V15, V16,V17,ZAA,ZAB,ZAC,ZAD .....	1
3	PAFZZ	5975-00-771-6634	19207	7716634	. NUT,COUPLING,ELECTR UOC: DAC,DAD,DAW,DAX,V14,V15, V16,V17,ZAA,ZAB,ZAC,ZAD .....	1
4	PAFZZ	5365-00-507-8766	19207	7388366	. BUSHING,NONMETALLIC UOC: DAC,DAD,DAW,DAX,V14,V15, V16,V17,ZAA,ZAB,ZAC,ZAD .....	1
5	PAFZZ	5310-00-393-6685	19207	7723309	. NUT,PLAIN,KNURLED UOC: DAC,DAD,DAW,DAX,V14,V15, V16,V17,ZAA,ZAB,ZAC,ZAD .....	2
6	PAFZZ	9905-01-013-8723	81349	M43436/3-1	. BAND,MARKER UOC: DAC,DAD,DAW,DAX,V14,V15, V16,V17,ZAA,ZAB,ZAC,ZAD .....	49
7	PAFZZ	1015-00-798-2997	19207	7982997	. TERMINAL,SOLDERED F UOC: DAC,DAD,DAW,DAX,V14,V15, V16,V17,ZAA,ZAB,ZAC,ZAD .....	19
8	PAFZZ	5970-00-833-8562	19207	8338562	. INSULATOR,BUSHING UOC: DAC,DAD,DAW,DAX,V14,V15, V16,V17,ZAA,ZAB,ZAC,ZAD .....	19
9	PAFZZ	5935-00-833-8561	19207	8338561	. SHELL,ELECTRICAL CO UOC: DAC,DAD,DAW,DAX,V14,V15, V16,V17,ZAA,ZAB,ZAC,ZAD .....	14
10	XDFZZ	9905-00-114-1334	97403	13207E6882-1	. BAND,MARKER UOC: DAC,DAD,DAW,DAX,V14,V15, V16,V17,ZAA,ZAB,ZAC,ZAD .....	1
11	PAFZZ	5935-00-572-9180	19207	8338566	. SHELL,ELECTRICAL CO UOC: DAC,DAD,DAW,DAX,V14,V15, V16,V17,ZAA,ZAB,ZAC,ZAD .....	1
12	PAFZZ	5935-00-214-0904	19207	7982907	. DUMMY CONNECTOR,PLU UOC: DAC,DAD,DAW,DAX,V14,V15, V16,V17,ZAA,ZAB,ZAC,ZAD .....	1
13	PAFZZ	5365-00-090-5426	19207	7722333	. BUSHING,NONMETALLIC UOC: DAC,DAD,DAW,DAX,V14,V15, V16,V17,ZAA,ZAB,ZAC,ZAD .....	1
14	PAFZA	5935-00-846-3884	96906	MS75021-2	. CONNECTOR,RECEPTAC UOC: DAC,DAD,DAW,DAX,V14,V15, V16,V17,ZAA,ZAB,ZAC,ZAD .....	1

(1) ITEM NO.	(2) SMR CODE	(3) NSN	(4) CAGEC	(5) PART NUMBER	(6) DESCRIPTION AND USABLE ON CODE (UOC)	(7) QTY
15	PAFZZ	5940-00-705-6711	19207	7056711	. TERMINAL,LUG UOC: DAC,DAD,DAW,DAX,V14,V15, V16,V17,ZAA,ZAB,ZAC,ZAD .....	2
16	PAFZZ	5975-00-660-5962	19207	8724494	. CABLE NIPPLE,ELECTR UOC: DAC,DAD,DAW,DAX,V14,V15, V16,V17,ZAA,ZAB,ZAC,ZAD .....	5
17	PAFZZ	5340-00-053-8994	80205	MS21333-126	CLAMP,LOOP UOC: DAW,DAX,V14,V15,ZAA,ZAB .....	8
18	PAFZZ	5975-00-156-3253	81343	MS3367-2-9	STRAP,TIEDOWN,ELECT UOC: DAW,DAX,V14,V15,ZAA,ZAB .....	7
19	PAFZZ	5305-00-269-3240	80204	B1821BH038F150N	SCREW,CAP,HEXAGON H UOC: DAW,DAX,V14,V15,ZAA,ZAB .....	1
20	PAFZZ	5310-00-814-0672	96906	M45913/3-6FG8C	. NUT,SELF-LOCKING,HE UOC: DAW,DAX,V14,V15,ZAA,ZAB .....	1
21	PAFZZ	5305-00-269-3238	80204	B1821BH038F125N	. SCREW,CAP,HEXAGON H UOC: DAC,DAD,V16,V17,ZAC,ZAD .....	2
22	PAFZZ	5306-00-068-0513	80204	B1821BH025F075N	. BOLT,MACHINE UOC: DAC,DAD,DAW,DAX,V14,V15, V16,V17,ZAA,ZAB,ZAC,ZAD .....	2
23	PAFZZ	5340-00-809-1492	80205	MS21333-100	CLAMP,LOOP UOC: DAC,DAD,DAW,DAX,V14,V15, V16,V17,ZAA,ZAB,ZAC,ZAD .....	2
24	PAFZZ	5310-00-935-9022	81349	M45913/3-4FG8C	. NUT,SELF-LOCKING,HE UOC: DAC,DAD,DAW,DAX,V14,V15, V16,V17,ZAA,ZAB,ZAC,ZAD .....	2
25	PAFZZ	3120-00-073-3163	19207	7397775	. BUSHING,SLEEVE UOC: DAC,DAD,DAW,DAX,V14,V15, V16,V17,ZAA,ZAB,ZAC,ZAD .....	2
26	PAFZZ	5305-00-912-5113	80205	MS51096-359	SCREW,CAP,HEXAGON H UOC: DAC,DAD,DAW,DAX,V14,V15, V16,V17,ZAA,ZAB,ZAC,ZAD .....	4
27	PAFZZ	5340-00-954-6014	80205	MS21333-121	CLAMP,LOOP UOC: DAC,DAD,DAW,DAX,V14,V15, V16,V17,ZAA,ZAB,ZAC,ZAD .....	4
28	PAFZZ	5310-00-959-1488	81349	M45913/2-6FG5C	NUT,SELF-LOCKING,HE UOC: DAC,DAD,DAW,DAX,V14,V15, V16,V17,ZAA,ZAB,ZAC,ZAD .....	5
29	PAFZZ	5935-00-773-1428	19207	7731428	. COVER,ELECTRICAL CO UOC: DAC,DAD,DAW,DAX,V14,V15, V16,V17,ZAA,ZAB,ZAC,ZAD .....	1
30	PAFZZ	5310-00-877-5796	80205	MS21044N4	. NUT,SELF-LOCKING,HE 1/4-28 UNF-3B R.H. UOC: DAC,DAD,DAW,DAX,V14,V15, V16,V17,ZAA,ZAB,ZAC,ZAD .....	4
31	PAFZZ	5305-00-267-8957	80204	B1821BH025F175N	. SCREW,CAP,HEXAGON H UOC: DAC,DAD,DAW,DAX,V14,V15, V16,V17,ZAA,ZAB,ZAC,ZAD .....	4

(1) ITEM NO.	(2) SMR CODE	(3) NSN	(4) CAGEC	(5) PART NUMBER	(6) DESCRIPTION AND USABLE ON CODE (UOC)	(7) QTY
32	PAFZZ	5305-00-042-5603	24617	425603	SCREW,ASSEMBLED WAS UOC: DAC,DAD,DAW,DAX,V14,V15, V16,V17,ZAA,ZAB,ZAC,ZAD .....	1
33	PAFZZ	5310-00-627-6128	96906	MS35335-35	. WASHER,LOCK UOC: DAC,DAD,DAW,DAX,V14,V15, V16,V17,ZAA,ZAB,ZAC,ZAD .....	1
34	PAFZZ	5325-00-053-1116	19207	7397790	. GROMMET,REAR WIRING UOC: DAC,DAD,DAW,DAX,V14,V15, V16,V17,ZAA,ZAB,ZAC,ZAD .....	1

END OF FIGURE





**FIELD MAINTENANCE  
REAR WIRING HARNESS ASSEMBLY, WRECKER**

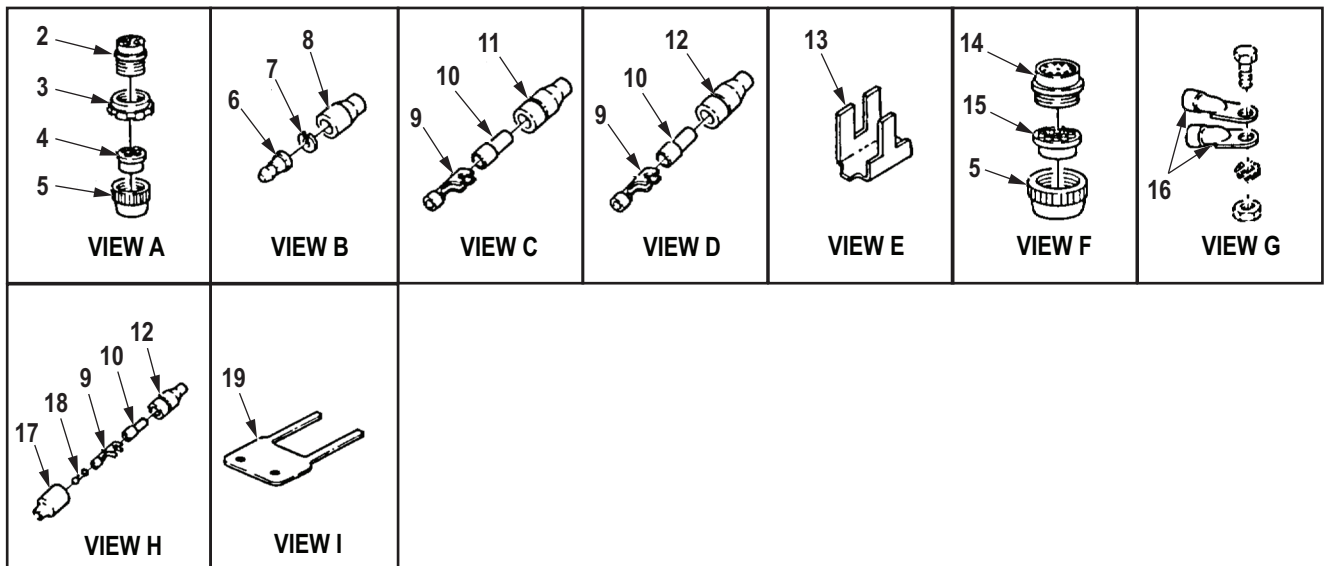
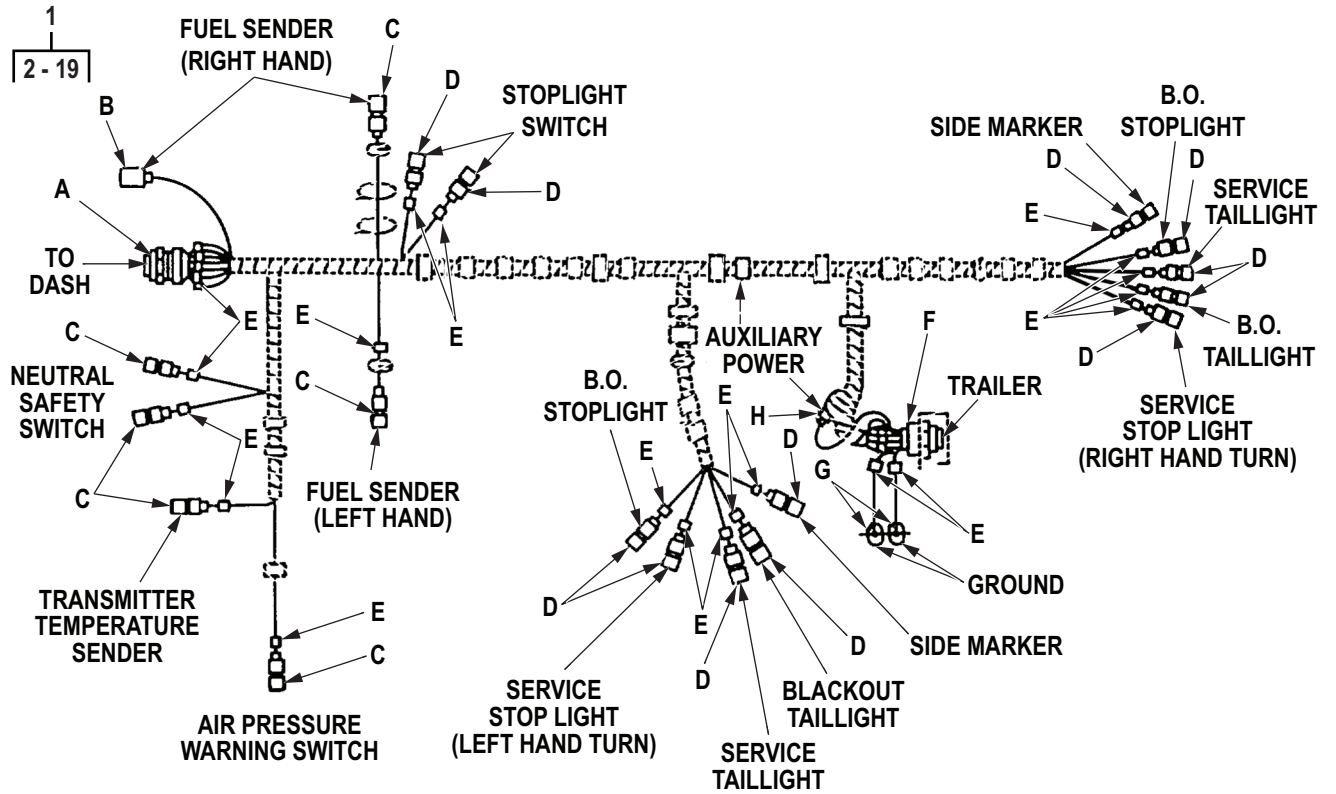

R0171DAA

Figure 165. Rear Wiring Harness Assembly, Wrecker. (Sheet 1 of 2)

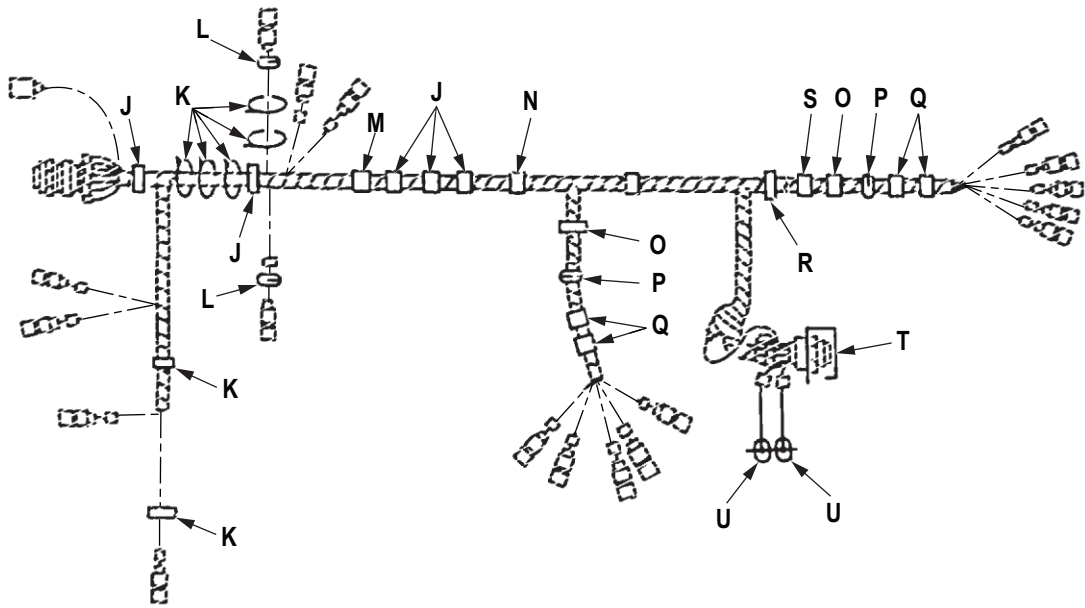

 20 VIEW J	 21 VIEW K	 22 VIEW L	 23 20 24 VIEW M	 25 VIEW N	 26 30 29 27 24 28 VIEW O	 31 VIEW P
 28 32 33 VIEW Q	 34 35 33 VIEW R	 34 32 33 VIEW S	 36 37 33 VIEW T	 38 39 24 VIEW U		

R0172DAA

Figure 165. Rear Wiring Harness Assembly, Wrecker. (Sheet 2 of 2)

(1) ITEM NO.	(2) SMR CODE	(3) NSN	(4) CAGEC	(5) PART NUMBER	(6) DESCRIPTION AND USABLE ON CODE (UOC)	(7) QTY
<b>GROUP 0613 HULL OR CHASSIS WIRING HARNESS.</b>						
<b>FIG. 165. REAR WIRING HARNESS ASSEMBLY, WRECKER.</b>						
1	PAFFF	6150-01-082-3828	19207	12256102	WIRING HARNESS,BRAN UOC: DAL,V18,ZAL .....	1
2	PAFZZ	5935-00-080-1020	19207	8724255	. CONNECTOR,PLUG,ELEC UOC: DAL,V18,ZAL .....	1
3	PAFZZ	5975-00-771-6634	19207	7716634	. NUT,COUPLING,ELECTR UOC: DAL,V18,ZAL .....	1
4	PAFZZ	5365-00-507-8766	19207	7388366	. BUSHING,NONMETALLIC UOC: DAL,V18,ZAL .....	1
5	PAFZZ	5310-00-393-6685	19207	7723309	. NUT,PLAIN,KNURLED UOC: DAL,V18,ZAL .....	2
6	PAFZZ	5999-00-926-3144	58536	AA52536-3	. CONTACT,ELECTRICAL UOC: DAL,V18,ZAL .....	1
7	PAFZZ	5310-00-656-0067	19207	8724497	. WASHER,SLOTTED UOC: DAL,V18,ZAL .....	1
8	PAFZZ	5935-00-691-5591	97403	13207E6498-2	. SHELL,ELECTRICAL CO UOC: DAL,V18,ZAL .....	1
9	PAFZZ	1015-00-798-2997	19207	7982997	. TERMINAL,SOLDERED F UOC: DAL,V18,ZAL .....	19
10	PAFZZ	5970-00-833-8562	19207	8338562	. INSULATOR,BUSHING UOC: DAL,V18,ZAL .....	19
11	PAFZZ	5975-00-660-5962	19207	8724494	. CABLE NIPPLE,ELECTR UOC: DAL,V18,ZAL .....	6
12	PAFZZ	5935-00-833-8561	19207	8338561	. SHELL,ELECTRICAL CO UOC: DAL,V18,ZAL .....	13
13	PAFZZ	9905-01-013-8723	81349	M43436/3-1	. BAND,MARKER WRECKER UOC: DAL,V18,ZAL .....	49
14	PAFZA	5935-00-846-3884	96906	MS75021-2	. CONNECTOR,RECEPTACL UOC: DAL,V18,ZAL .....	1
15	PAFZZ	5365-00-090-5426	19207	7722333	. BUSHING,NONMETALLIC UOC: DAL,V18,ZAL .....	1
16	PAFZZ	5940-00-705-6711	19207	7056711	. TERMINAL,LUG UOC: DAL,V18,ZAL .....	2
17	PAFZZ	5935-00-572-9180	19207	8338566	. SHELL,ELECTRICAL CO UOC: DAL,V18,ZAL .....	1
18	PAFZZ	5935-00-214-0904	19207	7982907	. DUMMY CONNECTOR,PLU UOC: DAL,V18,ZAL .....	1
19	XDFZZ	9905-00-114-1334	97403	13207E6882-1	. BAND,MARKER UOC: DAL,V18,ZAL .....	1
20	PAFZZ	5340-00-053-8994	80205	MS21333-126	CLAMP,LOOP UOC: DAL,V18,ZAL .....	5

(1) ITEM NO.	(2) SMR CODE	(3) NSN	(4) CAGEC	(5) PART NUMBER	(6) DESCRIPTION AND USABLE ON CODE (UOC)	(7) QTY
21	PAFZZ	5975-00-156-3253	81343	MS3367-2-9	. STRAP,TIEDOWN,ELECT UOC: DAL,V18,ZAL .....	6
22	PAFZZ	5325-00-053-1116	19207	7397790	GROMMET,REAR WIRING UOC: DAL,V18,ZAL .....	2
23	PAFZZ	5305-00-269-3239	80204	B1821BH038F138N	SCREW,CAP,HEXAGON H UOC: DAL,V18,ZAL .....	1
24	PAFZZ	5310-00-814-0672	96906	M45913/3-6FG8C	NUT,SELF-LOCKING,HE UOC: DAL,V18,ZAL .....	5
25	PAFZZ	5340-00-421-7254	19207	8352679	CLAMP,LOOP UOC: DAL,V18,ZAL .....	1
26	PAFZZ	5305-00-269-3234	80204	B1821BH038F075N	SCREW,CAP,HEXAGON H UOC: DAL,V18,ZAL .....	4
27	PAFZZ	5340-00-954-6014	80205	MS21333-121	CLAMP,LOOP UOC: DAL,V18,ZAL .....	4
28	PAFZZ	5306-00-068-0513	80204	B1821BH025F075N	BOLT,MACHINE UOC: DAL,V18,ZAL .....	6
29	PAFZZ	5310-00-935-9022	81349	M45913/3-4FG8C	NUT,SELF-LOCKING,HE UOC: DAL,V18,ZAL .....	2
30	PAFZZ	5340-00-419-9473	19207	7414917	BRACKET,ANGLE UOC: DAL,V18,ZAL .....	2
31	PAFZZ	3120-00-073-3163	19207	7397775	BUSHING,SLEEVE UOC: DAL,V18,ZAL .....	2
32	PAFZZ	5340-00-809-1492	80205	MS21333-100	CLAMP,LOOP UOC: DAL,V18,ZAL .....	5
33	PAFZZ	5310-00-877-5796	80205	MS21044N4	NUT,SELF-LOCKING,HE UOC: DAL,V18,ZAL .....	6
34	PAFZZ	5306-00-068-0514	80204	B1821BH025F088N	BOLT,MACHINE UOC: DAL,V18,ZAL .....	6
35	PAFZZ	5340-00-809-1494	80205	MS21333-105	CLAMP,LOOP UOC: DAL,V18,ZAL .....	1
36	PAFZZ	5935-00-773-1428	19207	7731428	COVER,ELECTRICAL CO UOC: DAL,V18,ZAL .....	1
37	PAFZZ	5305-00-267-8957	80204	B1821BH025F175N	SCREW,CAP,HEXAGON H UOC: DAL,V18,ZAL .....	4
38	PAFZZ	5305-00-042-5603	24617	425603	SCREW,ASSEMBLED WAS UOC: DAL,V18,ZAL .....	1
39	PAFZZ	5310-00-627-6128	96906	MS35335-35	WASHER,LOCK UOC: DAL,V18,ZAL .....	1

END OF FIGURE

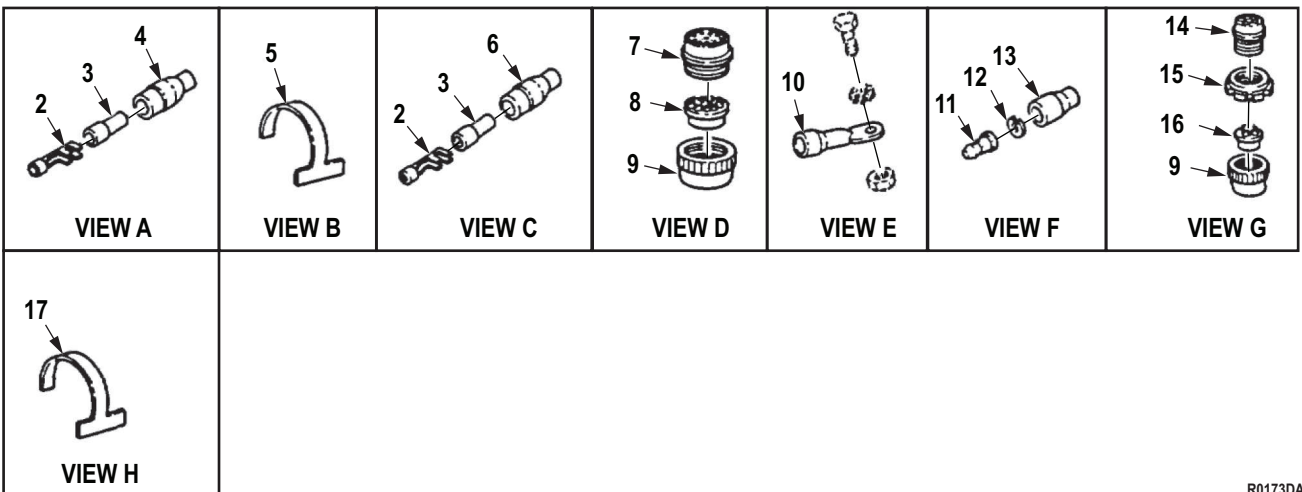
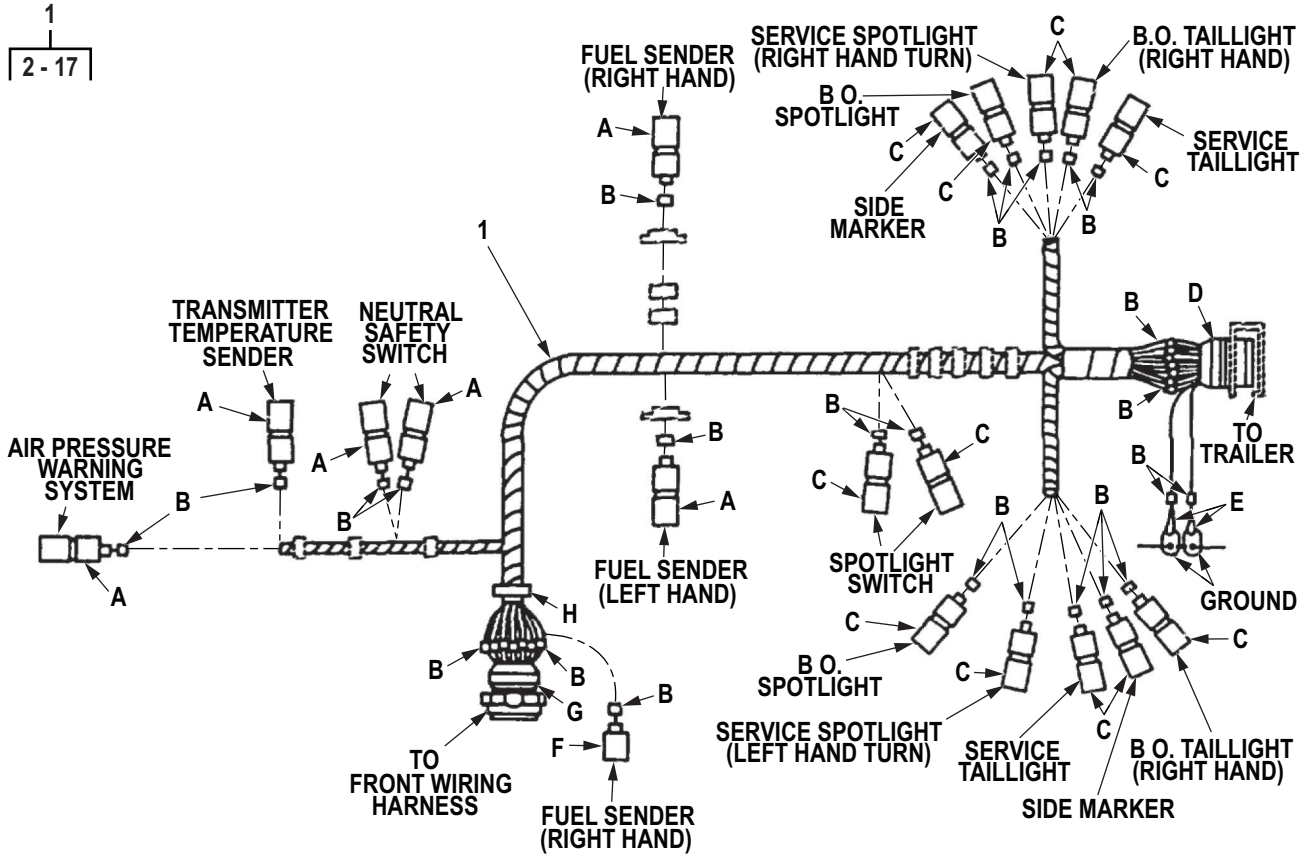

FIELD MAINTENANCE  
REAR WIRING HARNESS ASSEMBLY, DUMP

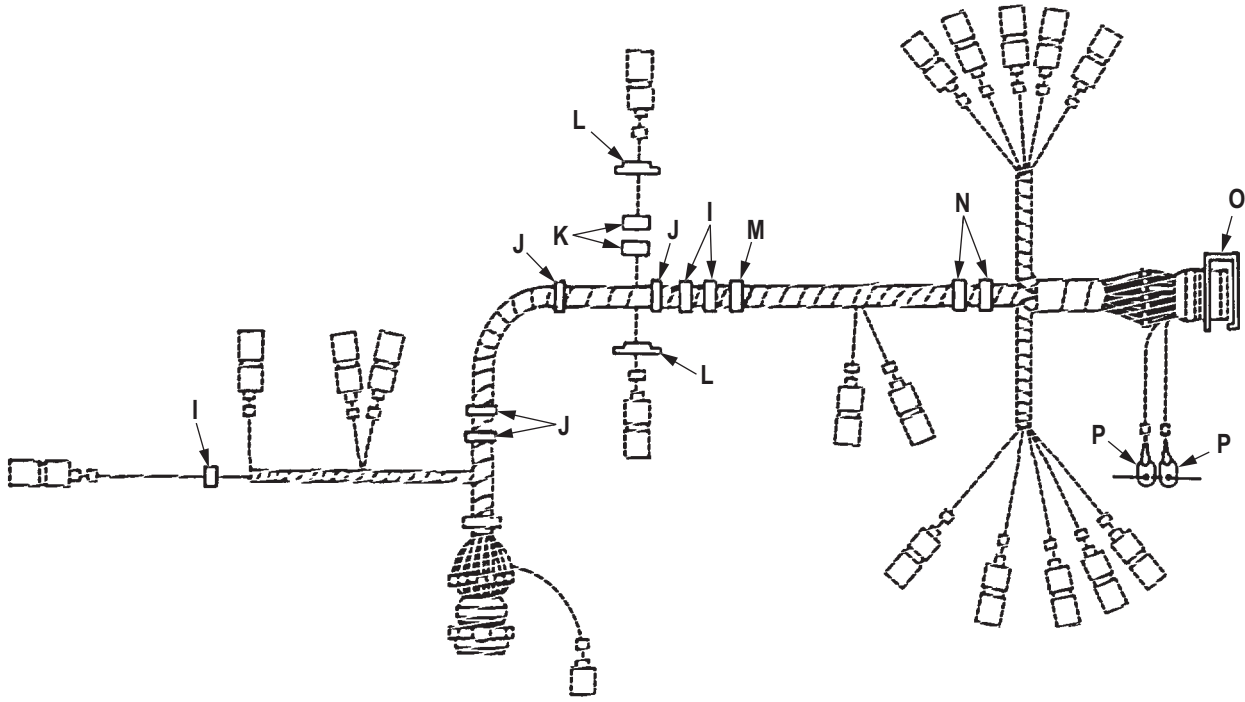

R0173DAA

Figure 166. Rear Wiring Harness Assembly, Dump. (Sheet 1 of 2)

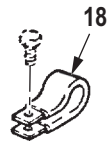
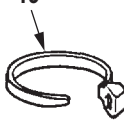
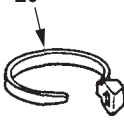

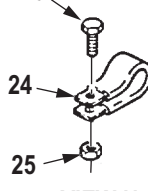
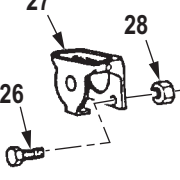
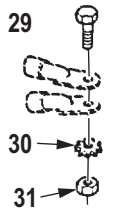
 <p>VIEW I</p>	 <p>VIEW J</p>	 <p>VIEW K</p>	 <p>VIEW L</p>	 <p>VIEW M</p>	 <p>VIEW N</p>
 <p>VIEW O</p>	 <p>VIEW P</p>				

R0174DAA

Figure 166. Rear Wiring Harness Assembly, Dump. (Sheet 2 of 2)

(1) ITEM NO.	(2) SMR CODE	(3) NSN	(4) CAGEC	(5) PART NUMBER	(6) DESCRIPTION AND USABLE ON CODE (UOC)	(7) QTY
<b>GROUP 0613 HULL OR CHASSIS WIRING HARNESS.</b>						
<b>FIG. 166. REAR WIRING HARNESS ASSEMBLY, DUMP.</b>						
1	PAFFF	2590-01-083-5729	19207	12256406	WIRING HARNESS,BRAN UOC: DAE,DAF,DAG,DAH,DAL,V18, V19,V20,V21,V22,ZAE,ZAF,ZAG,ZAH,ZAL	1
2	PAFZZ	1015-00-798-2997	19207	7982997	. TERMINAL,SOLDERED F UOC: DAE,DAF,V19,V20,ZAE,ZAF	18
3	PAFZZ	5970-00-833-8562	19207	8338562	. INSULATOR,BUSHING UOC: DAE,DAF,V19,V20,ZAE,ZAF	18
4	PAFZZ	5975-00-660-5962	19207	8724494	. CABLE NIPPLE,ELECTR UOC: DAE,DAF,V19,V20,ZAE,ZAF	6
5	PAFZZ	9905-01-013-8723	81349	M43436/3-1	. BAND,MARKER UOC: DAE,DAF,V19,V20,ZAE,ZAF	48
6	PAFZZ	5935-00-833-8561	19207	8338561	. SHELL,ELECTRICAL CO UOC: DAE,DAF,V19,V20,ZAE,ZAF	12
7	PAFZA	5935-00-846-3884	96906	MS75021-2	. CONNECTOR,RECEPTCL UOC: DAE,DAF,V19,V20,ZAE,ZAF	1
8	PAFZZ	5365-00-090-5426	19207	7722333	. BUSHING,NONMETALLIC UOC: DAE,DAF,V19,V20,ZAE,ZAF	1
9	PAFZZ	5310-00-393-6685	19207	7723309	. NUT,PLAIN,KNURLED UOC: DAE,DAF,V19,V20,ZAE,ZAF	2
10	PAFZZ	5940-00-705-6711	19207	7056711	. TERMINAL,LUG UOC: DAE,DAF,V19,V20,ZAE,ZAF	2
11	PAFZA	5999-00-057-2929	58536	AA52536-2	. CONTACT,ELECTRICAL UOC: DAE,DAF,V19,V20,ZAE,ZAF	1
12	PAFZZ	5310-00-833-8567	19207	8338567	. WASHER,SLOTTED UOC: DAE,DAF,V19,V20,ZAE,ZAF	1
13	PAFZZ	5935-00-572-9180	19207	8338566	. SHELL,ELECTRICAL CO UOC: DAE,DAF,V19,V20,ZAE,ZAF	1
14	PAFZZ	5935-00-080-1020	19207	8724255	. CONNECTOR,PLUG,ELEC UOC: DAE,DAF,V19,V20,ZAE,ZAF	1
15	PAFZZ	5975-00-771-6634	19207	7716634	. NUT,COUPLING,ELECTR UOC: DAE,DAF,V19,V20,ZAE,ZAF	1
16	PAFZZ	5365-00-507-8766	19207	7388366	. BUSHING,NONMETALLIC UOC: DAE,DAF,V19,V20,ZAE,ZAF	1
17	PAFZZ	9905-00-935-7777	81349	M43436/4-2	. BAND,MARKER UOC: DAE,DAF,V19,V20,ZAE,ZAF	1
18	PAFZZ	5340-00-088-1254	80205	MS21333-104	CLAMP,LOOP UOC: DAE,DAF,V19,V20,ZAE,ZAF	3
19	PAFZZ	5975-00-156-3253	81343	MS3367-2-9	STRAP,TIEDOWN,ELECT UOC: DAE,DAF,V19,V20,ZAE,ZAF	6
20	PAFZZ	5975-00-984-6582	96906	MS3367-1-0	STRAP,TIEDOWN,ELECT UOC: DAE,DAF,V19,V20,ZAE,ZAF	2

(1) ITEM NO.	(2) SMR CODE	(3) NSN	(4) CAGEC	(5) PART NUMBER	(6) DESCRIPTION AND USABLE ON CODE (UOC)	(7) QTY
21	PAFZZ	5325-00-053-1116	19207	7397790	GROMMET,REAR WIRING UOC: DAE,DAF,V19,V20,ZAE,ZAF .....	2
22	PAFZZ	5340-00-421-7254	19207	8352679	CLAMP,LOOP UOC: DAE,DAF,V19,V20,ZAE,ZAF .....	1
23	PAFZZ	5306-00-068-0514	80204	B1821BH025F088N	BOLT,MACHINE UOC: DAE,DAF,V19,V20,ZAE,ZAF .....	2
24	PAFZZ	5340-00-809-1492	80205	MS21333-100	CLAMP,LOOP UOC: DAE,DAF,V19,V20,ZAE,ZAF .....	2
25	PAFZZ	5310-00-935-9022	81349	M45913/3-4FG8C	NUT,SELF-LOCKING,HE UOC: DAE,DAF,V19,V20,ZAE,ZAF .....	6
26	PAFZZ	5305-00-267-8957	80204	B1821BH025F175N	SCREW,CAP,HEXAGON H UOC: DAE,DAF,V19,V20,ZAE,ZAF .....	4
27	PAFZZ	5935-00-773-1428	19207	7731428	COVER,ELECTRICAL CO UOC: DAE,DAF,V19,V20,ZAE,ZAF .....	1
28	PAFZZ	5310-00-877-5796	80205	MS21044N4	NUT,SELF-LOCKING,HE 1/4-28 UNF-3B R.H. UOC: DAE,DAF,V19,V20,ZAE,ZAF .....	4
29	PAFZZ	5305-00-042-5603	24617	425603	SCREW,ASSEMBLED WAS UOC: DAE,DAF,V19,V20,ZAE,ZAF .....	1
30	PAFZZ	5310-00-627-6128	96906	MS35335-35	WASHER,LOCK UOC: DAE,DAF,V19,V20,ZAE,ZAF .....	2
31	PAFZZ	5310-00-959-1488	81349	M45913/2-6FG5C	NUT,SELF-LOCKING,HE UOC: DAE,DAF,V19,V20,ZAE,ZAF .....	2

END OF FIGURE



**FIELD MAINTENANCE  
REAR WIRING HARNESS ASSEMBLY, TRACTOR**

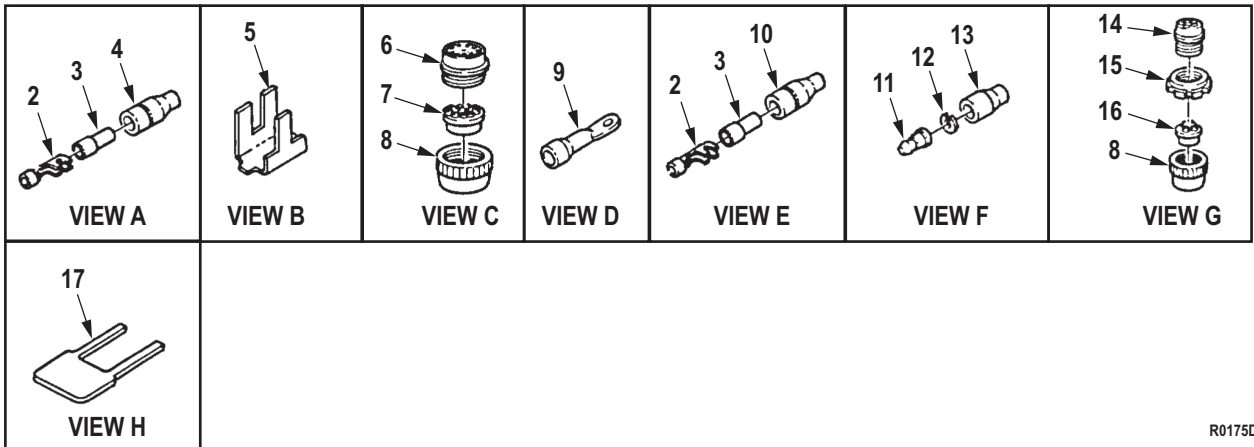
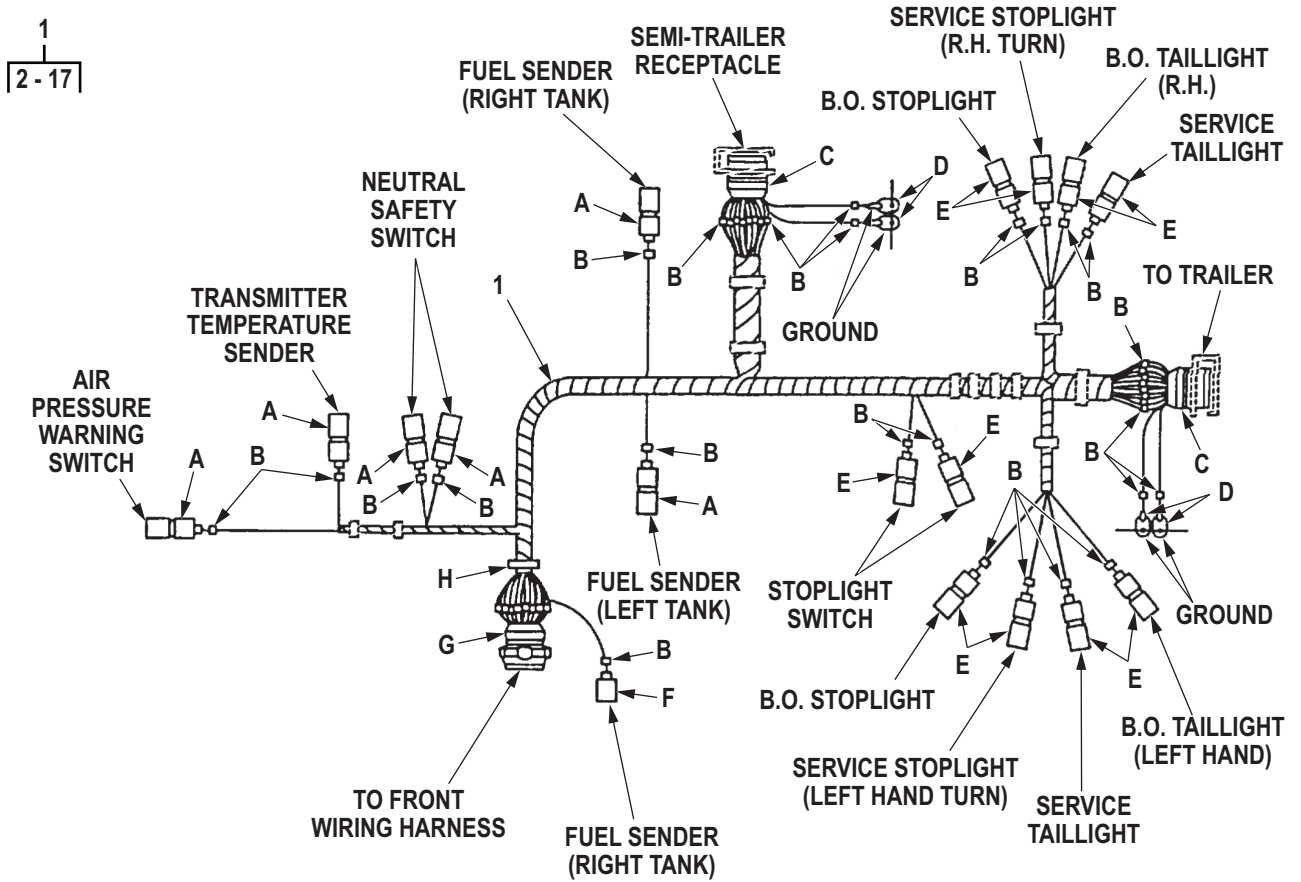

R0175DAA

Figure 167. Rear Wiring Harness Assembly, Tractor. (Sheet 1 of 2)

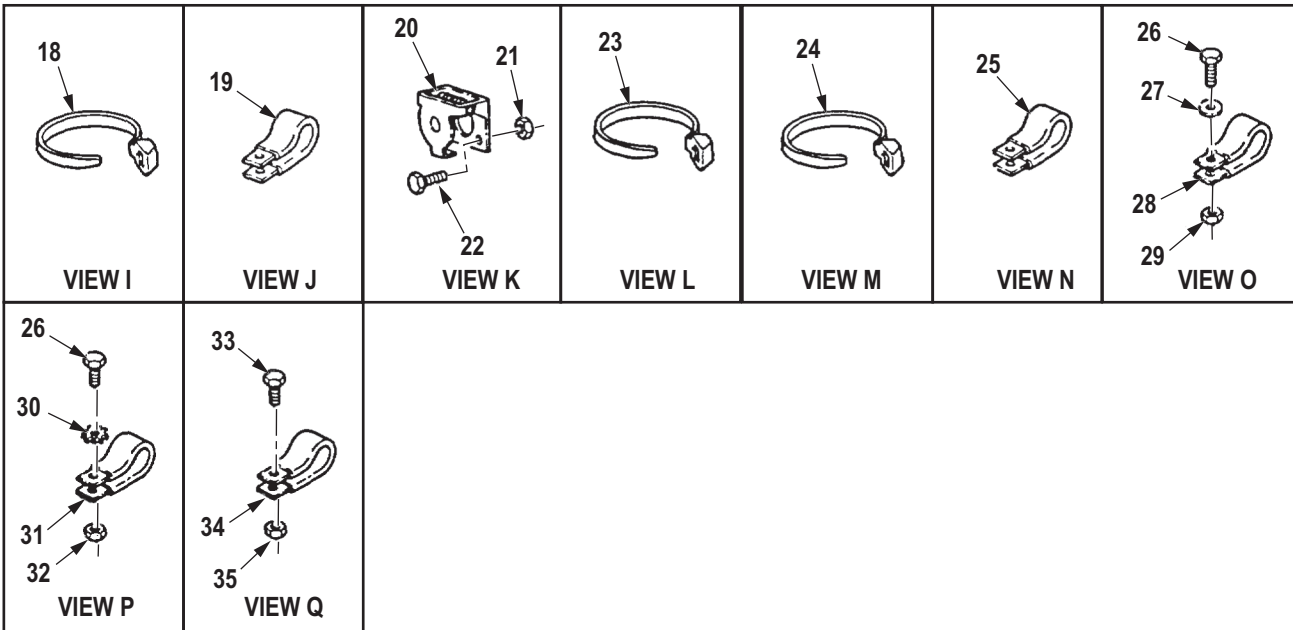
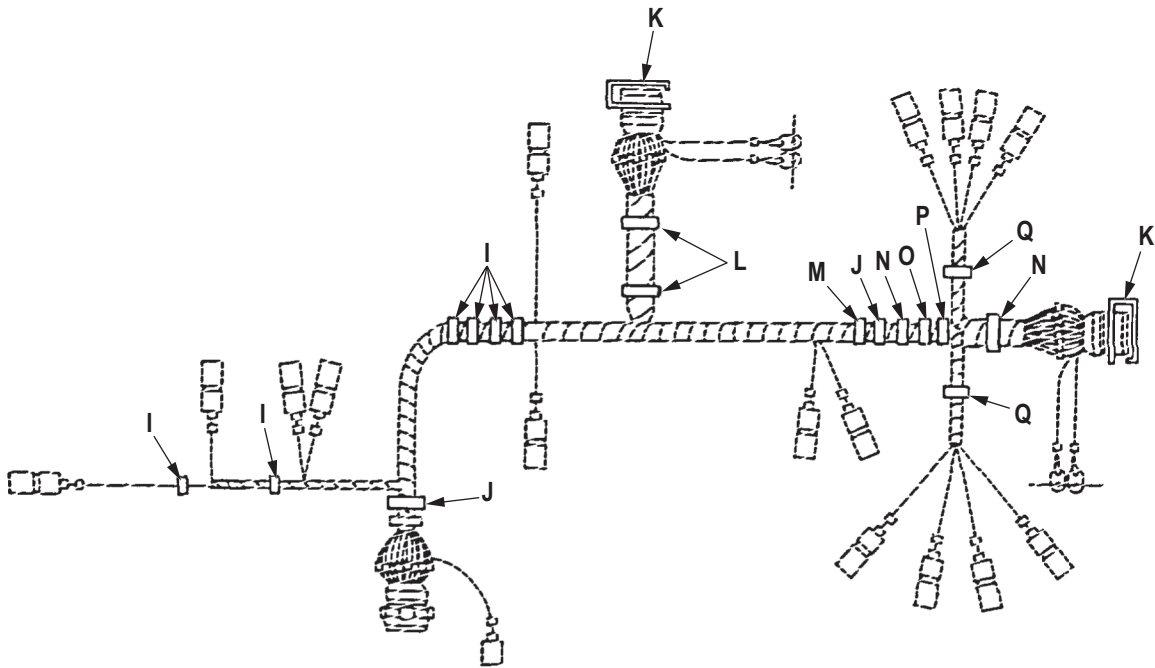

R0176DAA

Figure 167. Rear Wiring Harness Assembly, Tractor. (Sheet 2 of 2)

(1) ITEM NO.	(2) SMR CODE	(3) NSN	(4) CAGEC	(5) PART NUMBER	(6) DESCRIPTION AND USABLE ON CODE (UOC)	(7) QTY
<b>GROUP 0613 HULL OR CHASSIS WIRING HARNESS.</b>						
<b>FIG. 167. REAR WIRING HARNESS ASSEMBLY, TRACTOR.</b>						
1	PBFFF	6150-01-083-1152	19207	12256097	WIRING HARNESS,BRAN UOC: DAG,DAH,V21,V22,ZAG,ZAH .....	1
2	PAFZZ	1015-00-798-2997	19207	7982997	. TERMINAL,SOLDERED F UOC: DAG,DAH,V21,V22,ZAG,ZAH .....	16
3	PAFZZ	5970-00-833-8562	19207	8338562	. INSULATOR,BUSHING UOC: DAG,DAH,V21,V22,ZAG,ZAH .....	16
4	PAFZZ	5975-00-660-5962	19207	8724494	. CABLE NIPPLE,ELECTR UOC: DAG,DAH,V21,V22,ZAG,ZAH .....	6
5	PAFZZ	9905-01-013-8723	81349	M43436/3-1	. BAND,MARKER UOC: DAG,DAH,V21,V22,ZAG,ZAH .....	57
6	PAFZA	5935-00-846-3884	96906	MS75021-2	. CONNECTOR,RECEPTAC UOC: DAG,DAH,V21,V22,ZAG,ZAH .....	2
7	PAFZZ	5365-00-090-5426	19207	7722333	. BUSHING,NONMETALLIC UOC: DAG,DAH,V21,V22,ZAG,ZAH .....	2
8	PAFZZ	5310-00-393-6685	19207	7723309	. NUT,PLAIN,KNURLED UOC: DAG,DAH,V21,V22,ZAG,ZAH .....	3
9	PAFZZ	5940-00-705-6711	19207	7056711	. TERMINAL,LUG UOC: DAG,DAH,V21,V22,ZAG,ZAH .....	4
10	PAFZZ	5935-00-833-8561	19207	8338561	. SHELL,ELECTRICAL CO UOC: DAG,DAH,V21,V22,ZAG,ZAH .....	10
11	PAFZZ	5999-00-926-3144	58536	AA52536-3	. CONTACT,ELECTRICAL UOC: DAG,DAH,V21,V22,ZAG,ZAH .....	1
12	PAFZZ	5310-00-656-0067	19207	8724497	. WASHER,SLOTTED UOC: DAG,DAH,V21,V22,ZAG,ZAH .....	1
13	PAFZZ	5935-00-691-5591	97403	13207E6498-2	. SHELL,ELECTRICAL CO UOC: DAG,DAH,V21,V22,ZAG,ZAH .....	1
14	PAFZZ	5935-00-080-1020	19207	8724255	. CONNECTOR,PLUG,ELEC UOC: DAG,DAH,V21,V22,ZAG,ZAH .....	1
15	PAFZZ	5975-00-771-6634	19207	7716634	. NUT,COUPLING,ELECTR UOC: DAG,DAH,V21,V22,ZAG,ZAH .....	1
16	PAFZZ	5365-00-507-8766	19207	7388366	. BUSHING,NONMETALLIC UOC: DAG,DAH,V21,V22,ZAG,ZAH .....	1
17	XDFZZ	9905-00-114-1334	97403	13207E6882-1	. BAND,MARKER UOC: DAG,DAH,V21,V22,ZAG,ZAH .....	1
18	PAFZZ	5975-00-156-3253	81343	MS3367-2-9	STRAP,TIEDOWN,ELECT UOC: DAG,DAH,V21,V22,ZAG,ZAH .....	6
19	PAFZZ	5340-00-053-8994	80205	MS21333-126	CLAMP,LOOP UOC: DAG,DAH,V21,V22,ZAG,ZAH .....	2
20	PAFZZ	5935-00-773-1428	19207	7731428	COVER,ELECTRICAL CO UOC: DAG,DAH,DAL,V18,V21,V22,Z AG,ZAH .....	2

(1) ITEM NO.	(2) SMR CODE	(3) NSN	(4) CAGEC	(5) PART NUMBER	(6) DESCRIPTION AND USABLE ON CODE (UOC)	(7) QTY
21	PAFZZ	5310-00-877-5796	80205	MS21044N4	NUT,SELF-LOCKING,HE 1/4-28 UNF-3B R.H. UOC: DAG,DAH,V21,V22,ZAG,ZAH .....	8
22	PAFZZ	5305-00-267-8957	80204	B1821BH025F175N	SCREW,CAP,HEXAGON H UOC: DAG,DAH,V21,V22,ZAG,ZAH .....	8
23	PAFZZ	5975-00-984-6582	96906	MS3367-1-0	STRAP,TIEDOWN,ELECT UOC: DAG,DAH,V21,V22,ZAG,ZAH .....	2
24	PAFZZ	5975-01-205-5379	81343	MS3367-7	STRAP,TIEDOWN,ELECT UOC: DAG,DAH,V21,V22,ZAG,ZAH .....	1
25	PAFZZ	5340-00-421-7254	19207	8352679	CLAMP,LOOP UOC: DAG,DAH,V21,V22,ZAG,ZAH .....	1
26	PAFZZ	5305-00-068-0515	80204	B1821BH025F100N	SCREW,CAP,HEXAGON H UOC: DAG,DAH,V21,V22,ZAG,ZAH .....	1
27	PAFZZ	5310-00-809-4058	96906	MS27183-10	WASHER,FLAT UOC: DAG,DAH,V21,V22,ZAG,ZAH .....	1
28	PAFZZ	5340-00-809-1494	80205	MS21333-105	CLAMP,LOOP UOC: DAG,DAH,V21,V22,ZAG,ZAH .....	1
29	PAFZZ	5305-00-042-5603	24617	425603	SCREW,ASSEMBLED WAS UOC: DAG,DAH,V21,V22,ZAG,ZAH .....	1
30	PAFZZ	5310-00-627-6128	96906	MS35335-35	WASHER,LOCK UOC: DAG,DAH,V21,V22,ZAG,ZAH .....	1
31	PAFZZ	5340-00-702-2848	80205	MS21333-128	CLAMP,LOOP UOC: DAG,DAH,V21,V22,ZAG,ZAH .....	1
32	PAFZZ	5310-00-959-1488	81349	M45913/2-6FG5C	NUT,SELF-LOCKING,HE UOC: DAG,DAH,V21,V22,ZAG,ZAH .....	1
33	PAFZZ	5306-00-068-0513	80204	B1821BH025F075N	BOLT,MACHINE UOC: DAG,DAH,V21,V22,ZAG,ZAH .....	2
34	PAFZZ	5340-00-809-1492	80205	MS21333-100	CLAMP,LOOP UOC: DAG,DAH,V21,V22,ZAG,ZAH .....	2
35	PAFZZ	5310-00-935-9022	81349	M45913/3-4FG8C	NUT,SELF-LOCKING,HE UOC: DAG,DAH,V21,V22,ZAG,ZAH .....	2

END OF FIGURE

**FIELD MAINTENANCE  
REAR WIRING HARNESS ASSEMBLY, VAN**

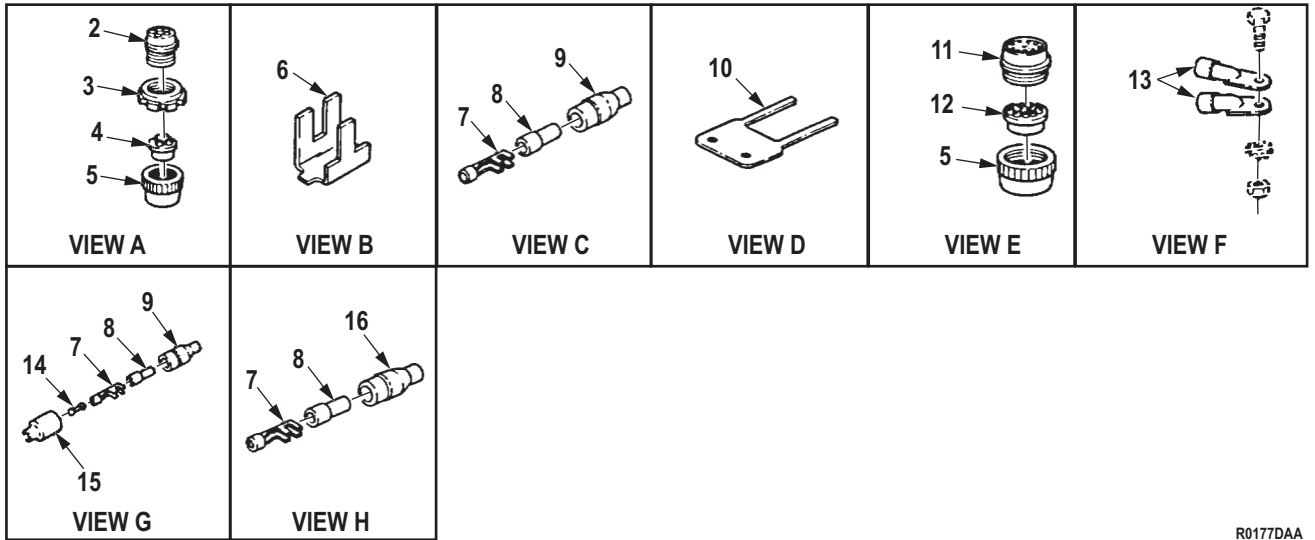
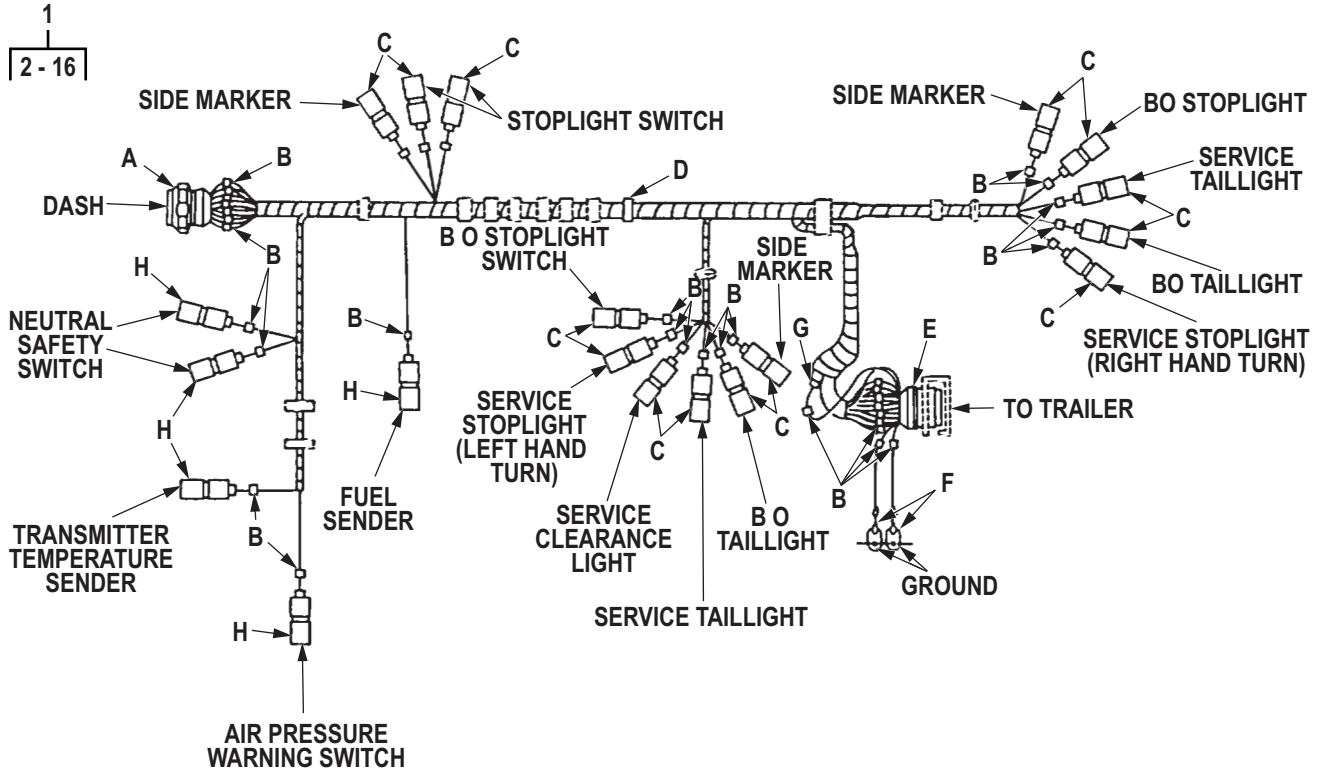

R0177DAA

Figure 168. Rear Wiring Harness Assembly, Van. (Sheet 1 of 2)

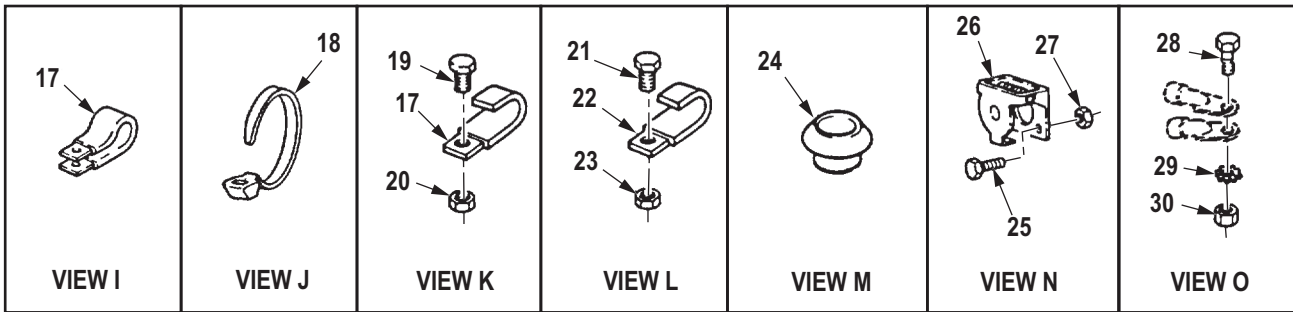
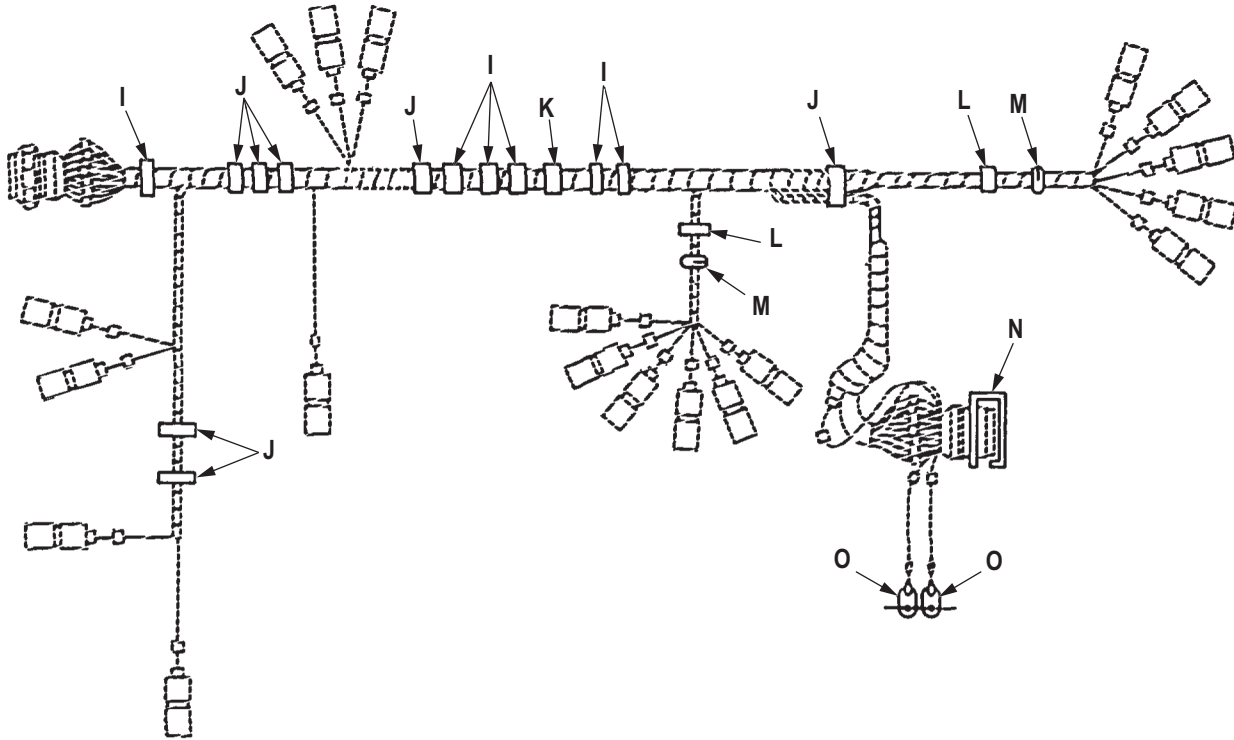

R0178DAA

Figure 168. Rear Wiring Harness Assembly, Van. (Sheet 2 of 2)

(1) ITEM NO.	(2) SMR CODE	(3) NSN	(4) CAGEC	(5) PART NUMBER	(6) DESCRIPTION AND USABLE ON CODE (UOC)	(7) QTY
<b>GROUP 0613 HULL OR CHASSIS WIRING HARNESS.</b>						
<b>FIG. 168. REAR WIRING HARNESS ASSEMBLY, VAN.</b>						
1	PAFFF	2590-01-084-9634	19207	12256002-3	WIRING HARNESS,BRAN UOC: DAJ,V24,ZAJ .....	1
2	PAFZZ	5935-00-080-1020	19207	8724255	. CONNECTOR,PLUG,ELEC UOC: DAJ,V24,ZAJ .....	1
3	PAFZZ	5975-00-771-6634	19207	7716634	. NUT,COUPLING,ELECTR UOC: DAJ,V24,ZAJ .....	1
4	PAFZZ	5365-00-507-8766	19207	7388366	. BUSHING,NONMETALLIC UOC: DAJ,V24,ZAJ .....	1
5	PAFZZ	5310-00-393-6685	19207	7723309	. NUT,PLAIN,KNURLED UOC: DAJ,V24,ZAJ .....	2
6	PAFZZ	9905-01-013-8723	81349	M43436/3-1	. BAND,MARKER UOC: DAJ,V24,ZAJ .....	49
7	PAFZZ	1015-00-798-2997	19207	7982997	. TERMINAL,SOLDERED F UOC: DAJ,V24,ZAJ .....	21
8	PAFZZ	5970-00-833-8562	19207	8338562	. INSULATOR,BUSHING UOC: DAJ,V24,ZAJ .....	21
9	PAFZZ	5935-00-833-8561	19207	8338561	. SHELL,ELECTRICAL CO UOC: DAJ,V24,ZAJ .....	16
10	XDFZZ	9905-00-114-1334	97403	13207E6882-1	. BAND,MARKER UOC: DAJ,V24,ZAJ .....	1
11	PAFZA	5935-00-846-3884	96906	MS75021-2	. CONNECTOR,RECEPTACL UOC: DAJ,V24,ZAJ .....	1
12	PAFZZ	5365-00-090-5426	19207	7722333	. BUSHING,NONMETALLIC UOC: DAJ,V24,ZAJ .....	1
13	PAFZZ	5940-00-705-6711	19207	7056711	. TERMINAL,LUG UOC: DAJ,V24,ZAJ .....	2
14	PAFZZ	5935-00-214-0904	19207	7982907	. DUMMY CONNECTOR,PLU UOC: DAJ,V24,ZAJ .....	4
15	PAFZZ	5935-00-572-9180	19207	8338566	. SHELL,ELECTRICAL CO UOC: DAJ,V24,ZAJ .....	4
16	PAFZZ	5975-00-660-5962	19207	8724494	. CABLE NIPPLE,ELECTR UOC: DAJ,V24,ZAJ .....	5
17	PAFZZ	5340-00-053-8994	80205	MS21333-126	CLAMP,LOOP UOC: DAJ,V24,ZAJ .....	7
18	PAFZZ	5975-00-156-3253	81343	MS3367-2-9	STRAP,TIEDOWN,ELECT UOC: DAJ,V24,ZAJ .....	7
19	PAFZZ	5305-00-068-0515	80204	B1821BH025F100N	SCREW,CAP,HEXAGON H UOC: DAJ,V24,ZAJ .....	1
20	PAFZZ	5310-00-814-0672	96906	M45913/3-6FG8C	NUT,SELF-LOCKING,HE UOC: DAJ,V24,ZAJ .....	1

(1) ITEM NO.	(2) SMR CODE	(3) NSN	(4) CAGEC	(5) PART NUMBER	(6) DESCRIPTION AND USABLE ON CODE (UOC)	(7) QTY
21	PAFZZ	5306-00-068-0513	80204	B1821BH025F075N	BOLT,MACHINE UOC: DAJ,V24,ZAJ .....	2
22	PAFZZ	5340-00-088-1254	80205	MS21333-104	CLAMP,LOOP UOC: DAJ,V24,ZAJ .....	7
23	PAFZZ	5310-00-935-9022	81349	M45913/3-4FG8C	NUT,SELF-LOCKING,HE UOC: DAJ,V24,ZAJ .....	2
24	PAFZZ	3120-00-073-3163	19207	7397775	BUSHING,SLEEVE UOC: DAJ,V24,ZAJ .....	2
25	PAFZZ	5305-00-267-8957	80204	B1821BH025F175N	SCREW,CAP,HEXAGON H UOC: DAJ,V24,ZAJ .....	4
26	PAFZZ	5935-00-773-1428	19207	7731428	COVER,ELECTRICAL CO UOC: DAJ,V24,ZAJ .....	1
27	PAFZZ	5310-00-877-5796	80205	MS21044N4	NUT,SELF-LOCKING,HE 1/4-28 UNF-3B R.H. UOC: DAJ,V24,ZAJ .....	4
28	PAFZZ	5305-00-042-5601	21450	425601	SCREW,ASSEMBLED WAS UOC: DAJ,V24,ZAJ .....	1
29	PAFZZ	5310-00-627-6128	96906	MS35335-35	WASHER,LOCK UOC: DAJ,V24,ZAJ .....	1
30	PAFZZ	5310-00-959-1488	81349	M45913/2-6FG5C	NUT,SELF-LOCKING,HE UOC: DAJ,V24,ZAJ .....	1

END OF FIGURE



FIELD MAINTENANCE  
REAR WIRING HARNESS ASSEMBLY, CHASSIS

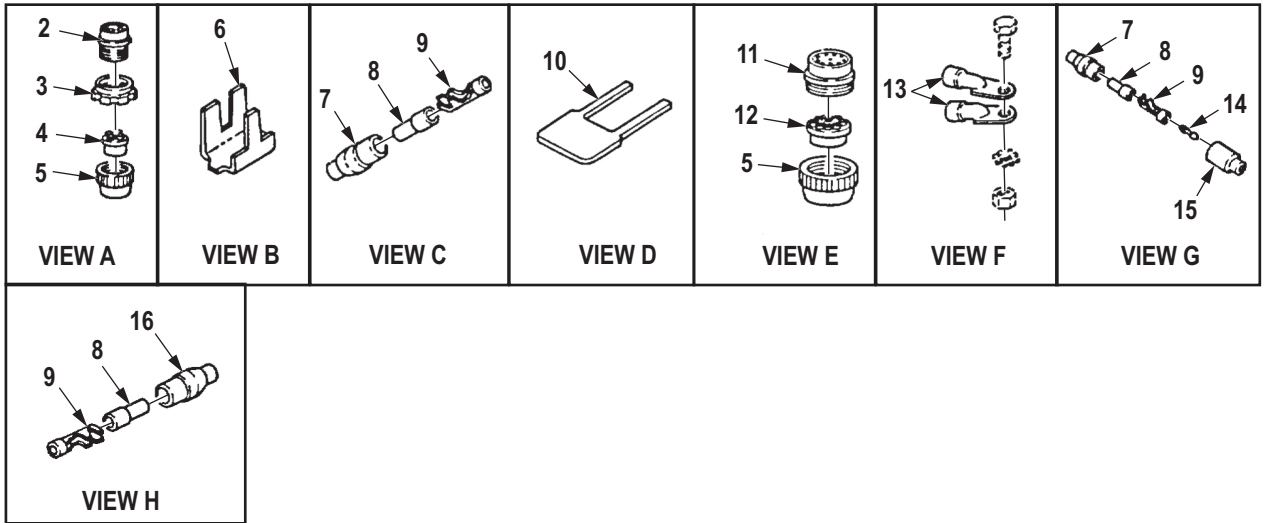
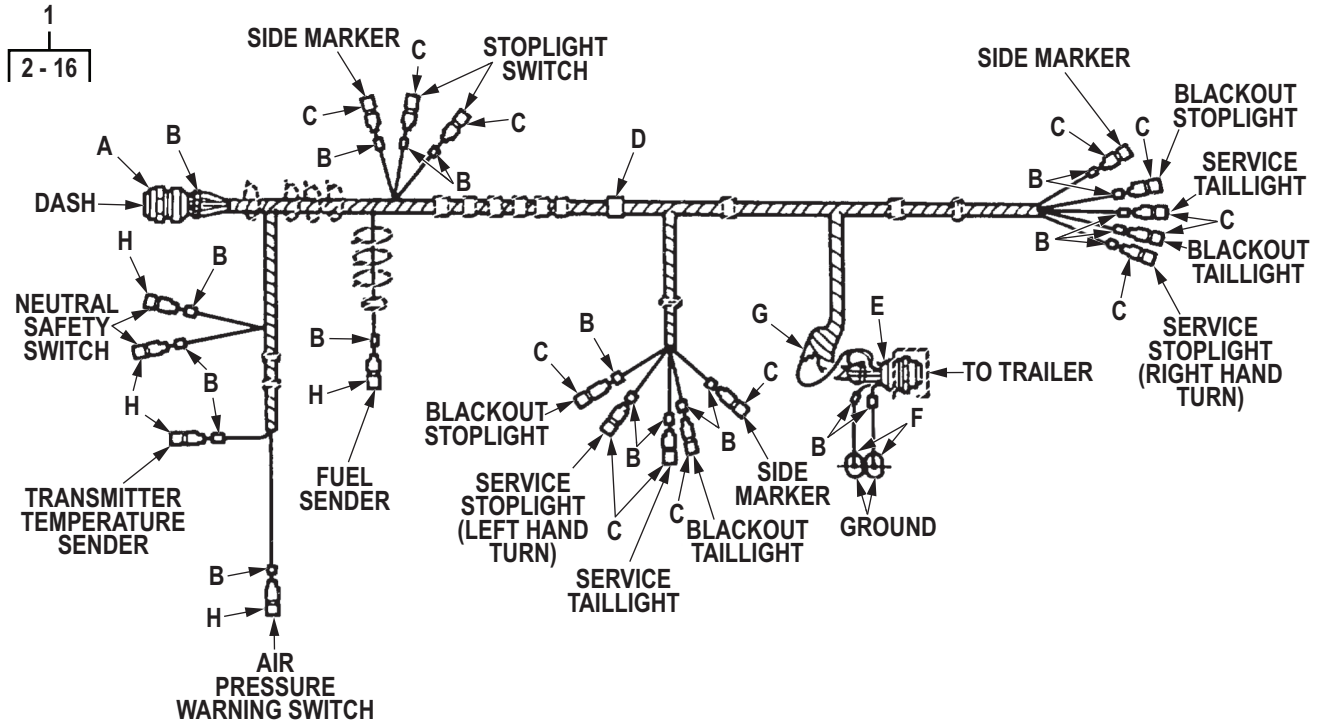

R0179DAA

Figure 169. Rear Wiring Harness Assembly, Chassis. (Sheet 1 of 2)

17  
18 - 23

FLOODLIGHT SWITCH

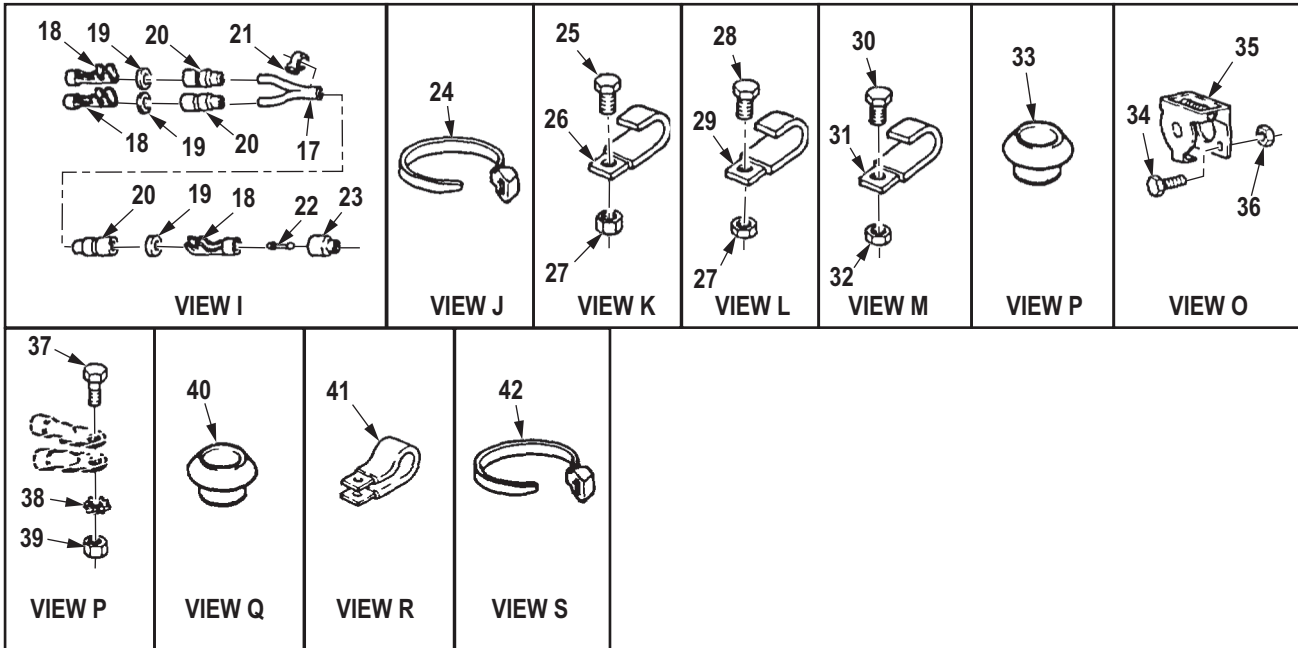
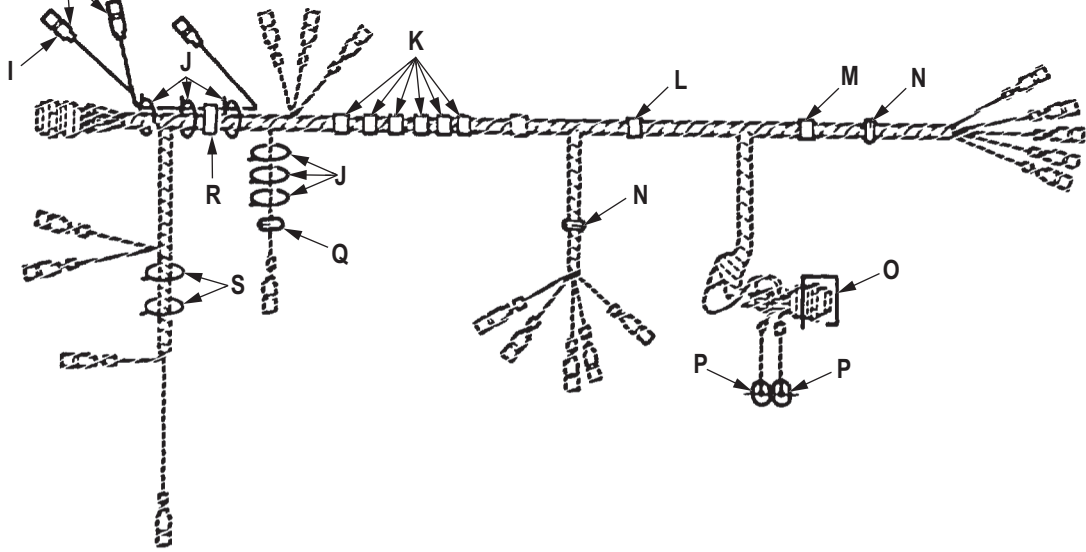

R0180DAA

Figure 169. Rear Wiring Harness Assembly, Chassis. (Sheet 2 of 2)

(1) ITEM NO.	(2) SMR CODE	(3) NSN	(4) CAGEC	(5) PART NUMBER	(6) DESCRIPTION AND USABLE ON CODE (UOC)	(7) QTY
<b>GROUP 0613 HULL OR CHASSIS WIRING HARNESS.</b>						
<b>FIG. 169. REAR WIRING HARNESS ASSEMBLY, CHASSIS.</b>						
1	PAFFF	2920-01-083-1188	19207	12256002-4	WIRING HARNESS,BRAN UOC: V39 .....	1
2	PAFZZ	5935-00-080-1020	19207	8724255	. CONNECTOR,PLUG,ELEC UOC: V39 .....	1
3	PAFZZ	5975-00-771-6634	19207	7716634	. NUT,COUPLING,ELECTR UOC: V39 .....	1
4	PAFZZ	5365-00-507-8766	19207	7388366	. BUSHING,NONMETALLIC UOC: V39 .....	1
5	PAFZZ	5310-00-393-6685	19207	7723309	. NUT,PLAIN,KNURLED UOC: V39 .....	2
6	PAFZZ	9905-01-013-8723	81349	M43436/3-1	. BAND,MARKER UOC: V39 .....	49
7	PAFZZ	5935-00-833-8561	19207	8338561	. SHELL,ELECTRICAL CO UOC: V39 .....	14
8	PAFZZ	5970-00-833-8562	19207	8338562	. INSULATOR,BUSHING UOC: V39 .....	19
9	PAFZZ	1015-00-798-2997	19207	7982997	. TERMINAL,SOLDERED F UOC: V39 .....	19
10	XDFZZ	9905-00-114-1334	97403	13207E6882-1	. BAND,MARKER UOC: V39 .....	1
11	PAFZA	5935-00-846-3884	96906	MS75021-2	. CONNECTOR,RECEPTACL UOC: V39 .....	1
12	PAFZZ	5365-00-090-5426	19207	7722333	. BUSHING,NONMETALLIC UOC: V39 .....	1
13	PAFZZ	5940-00-705-6711	19207	7056711	. TERMINAL,LUG UOC: V39 .....	2
14	PAFZZ	5935-00-214-0904	19207	7982907	. DUMMY CONNECTOR,PLU UOC: V39 .....	1
15	PAFZZ	5935-00-572-9180	19207	8338566	. SHELL,ELECTRICAL CO UOC: V39 .....	1
16	PAFZZ	5975-00-660-5962	19207	8724494	. CABLE NIPPLE,ELECTR UOC: V39 .....	5
17	PAFFF	6150-01-082-3818	19207	7363004-1	CABLE ASSEMBLY,SPEC UOC: V39 .....	1
18	PAFZZ	1015-00-798-2997	19207	7982997	. TERMINAL,SOLDERED F UOC: V39 .....	3
19	PAFZZ	5310-00-298-8903	19207	8338570	. WASHER,FLAT FLOODLIGHT SWITCH CABLE UOC: V39 .....	3

(1) ITEM NO.	(2) SMR CODE	(3) NSN	(4) CAGEC	(5) PART NUMBER	(6) DESCRIPTION AND USABLE ON CODE (UOC)	(7) QTY
20	PBFZZ	2590-00-695-9076	77060	5297084	. SHELL,HEAD LIGHT CI FLOODLIGHT SWITCH CABLE UOC: V39 .....	3
21	XDFZZ		81349	M43436/2-1	. BAND,MARKER FLOODLIGHT SWITCH CABLE UOC: V39 .....	3
22	PAFZZ	5935-00-214-0904	19207	7982907	. DUMMY CONNECTOR,PLU UOC: V39 .....	1
23	PAFZZ	5975-00-660-5962	19207	8724494	. CABLE NIPPLE,ELECTR UOC: V39 .....	1
24	PAFZZ	5975-00-984-6582	96906	MS3367-1-0	STRAP,TIEDOWN,ELECT UOC: V39 .....	6
25	PAFZZ	5305-00-068-0515	80204	B1821BH025F100N	SCREW,CAP,HEXAGON H UOC: V39 .....	6
26	PAFZZ	5340-00-445-4557	19207	8330341	STRAP,RETAINING UOC: V39 .....	6
27	PAFZZ	5310-00-935-9022	81349	M45913/3-4FG8C	NUT,SELF-LOCKING,HE UOC: V39 .....	7
28	PAFZZ	5306-00-068-0513	80204	B1821BH025F075N	BOLT,MACHINE UOC: V39 .....	1
29	PAFZZ	5340-00-419-3077	19207	8330343	STRAP,RETAINING UOC: V39 .....	1
30	PAFZZ	5305-00-225-9091	80205	MS90726-36	SCREW,CAP,HEXAGON H UOC: V39 .....	1
31	PAFZZ	5340-00-344-2767	19207	8330338	STRAP,RETAINING UOC: V39 .....	1
32	PAFZZ	5310-00-241-6658	81349	M45913/3-5FG8C	NUT,SELF-LOCKING,HE UOC: V39 .....	1
33	PAFZZ	3120-00-073-3163	19207	7397775	BUSHING,SLEEVE UOC: V39 .....	2
34	PAFZZ	5305-00-267-8957	80204	B1821BH025F175N	SCREW,CAP,HEXAGON H UOC: V39 .....	4
35	PAFZZ	5935-00-773-1428	19207	7731428	COVER,ELECTRICAL CO UOC: V39 .....	1
36	PAFZZ	5310-00-877-5796	80205	MS21044N4	NUT,SELF-LOCKING,HE 1/4-28 UNF-3B R.H. UOC: V39 .....	4
37	PAFZZ	5305-00-042-5603	24617	425603	SCREW,ASSEMBLED WAS UOC: V39 .....	1
38	PAFZZ	5310-00-627-6128	96906	MS35335-35	WASHER,LOCK UOC: V39 .....	1
39	PAFZZ	5310-00-959-1488	81349	M45913/2-6FG5C	NUT,SELF-LOCKING,HE UOC: V39 .....	1
40	PAFZZ	5325-00-053-1116	19207	7397790	GROMMET,REAR WIRING UOC: V39 .....	1

(1) ITEM NO.	(2) SMR CODE	(3) NSN	(4) CAGEC	(5) PART NUMBER	(6) DESCRIPTION AND USABLE ON CODE (UOC)	(7) QTY
41	PAFZZ	5340-00-725-5280	80205	MS21333-125	CLAMP,LOOP REAR WIRING HARNESS UOC: V39 .....	1
42	PAFZZ	5975-00-156-3253	81343	MS3367-2-9	STRAP,TIEDOWN,ELECT UOC: V39 .....	2

END OF FIGURE



FIELD MAINTENANCE  
CRANE WIRING LEADS

9	17
10 - 14	18 - 21

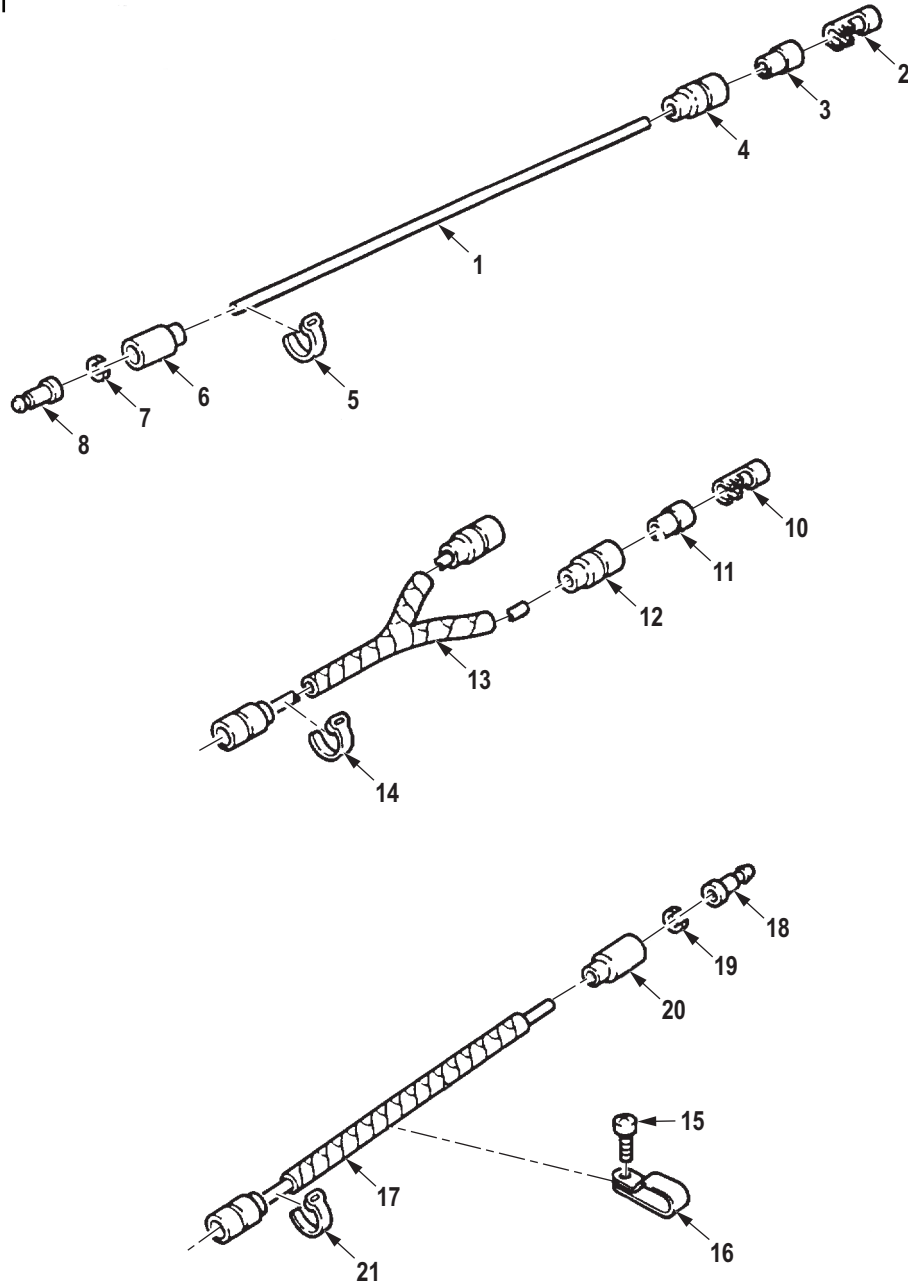

R0181DAA

Figure 170. Crane Wiring Leads. (Sheet 1 of 2)

22	27	39
23 - 26	28 - 34	40 - 45

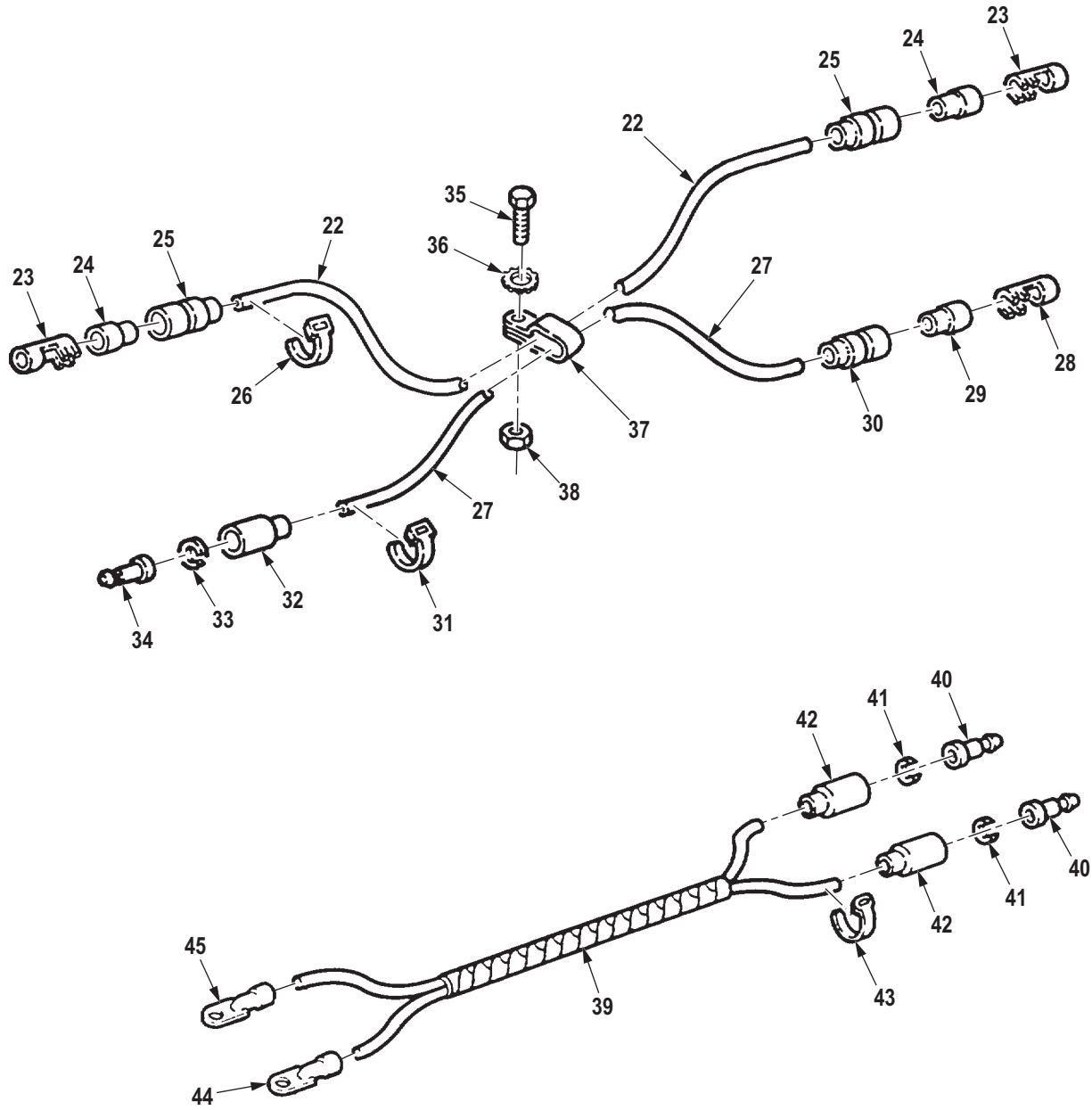

R0182DAA

Figure 170. Crane Wiring Leads. (Sheet 2 of 2)



(1) ITEM NO.	(2) SMR CODE	(3) NSN	(4) CAGEC	(5) PART NUMBER	(6) DESCRIPTION AND USABLE ON CODE (UOC)	(7) QTY
<b>GROUP 0613 HULL OR CHASSIS WIRING HARNESS.</b>						
<b>FIG. 170. CRANE WIRING LEADS.</b>						
1	MFFZZ		19207	12277326-3	LEAD,ELECTRICAL MAKE FROM PN M13486/1-5, CABLE LENGTH AS REQUIRED UOC: DAL,V18,ZAL .....	1
2	PAFZZ	5940-00-399-6676	19207	8338564	TERMINAL SET,QUICK CRANE SWIVEL VALVE LEAD UOC: DAL,V18,ZAL .....	1
3	PAFZZ	5970-00-833-8562	19207	8338562	INSULATOR,BUSHING CRANE SWIVEL VALVE LEAD UOC: DAL,V18,ZAL .....	1
4	PAFZZ	5935-00-833-8561	19207	8338561	SHELL,ELECTRICAL CO CRANE SWIVEL VALVE LEAD UOC: DAL,V18,ZAL .....	1
5	PAFZZ	9905-00-752-4649	24617	5939707	BAND MRKER BLNK-ALU CRANE SWIVEL VALVE LEAD UOC: DAL,V18,ZAL .....	2
6	PAFZZ	5935-00-572-9180	19207	8338566	SHELL,ELECTRICAL CO CRANE SWIVEL VALVE LEAD UOC: DAL,V18,ZAL .....	1
7	PAFZZ	5310-00-833-8567	19207	8338567	WASHER,SLOTTED CRANE SWIVEL VALVE LEAD UOC: DAL,V18,ZAL .....	1
8	PAFZA	5999-00-057-2929	58536	AA52536-2	CONTACT,ELECTRICAL CRANE SWIVEL VALVE LEAD UOC: DAL,V18,ZAL .....	1
9	XBFFF		19207	12277334	LEAD AND CONDUIT AS UOC: DAL,V18,ZAL .....	1
10	PAFZZ	5940-00-399-6676	19207	8338564	. TERMINAL SET,QUICK FLOODLIGHT LEAD UOC: DAL,V18,ZAL .....	3
11	PAFZZ	5970-00-833-8562	19207	8338562	. INSULATOR,BUSHING FLOODLIGHT LEAD UOC: DAL,V18,ZAL .....	3
12	PAFZZ	5935-00-833-8561	19207	8338561	. SHELL,ELECTRICAL CO FLOODLIGHT LEAD UOC: DAL,V18,ZAL .....	3
13	MFFZZ		80244	17-C-18035-50-119	. CONDUIT,NONMETALLIC MAKE FROM CONDUIT,P/N 17-C-18035-50 UOC: DAL,V18,ZAL .....	1
14	PAFZZ	9905-00-752-4649	24617	5939707	. BAND MRKER BLNK-ALU FLOODLIGHT LEAD UOC: DAL,V18,ZAL .....	3

(1) ITEM NO.	(2) SMR CODE	(3) NSN	(4) CAGEC	(5) PART NUMBER	(6) DESCRIPTION AND USABLE ON CODE (UOC)	(7) QTY
15	PAFZZ	5305-00-855-0957	45152	2477HX	SCREW,TAPPING UOC: DAL,V18,ZAL .....	4
16	PAFZZ	5340-00-930-1754	80205	MS21334-2	CLAMP,LOOP UOC: DAL,V18,ZAL .....	4
17	PAFFF	5995-00-231-7422	19207	10876527	LEAD,ELECTRICAL RIGHT UOC: DAC,DAD,DAE,DAF,DAG,DA H,DAJ,DAL,DAW,DAX,V14,V15,V16, V17,V18,V19,V20,V21,V22,V24,ZAA, ZAB,ZAC,ZAD,ZAE,ZAF,ZAG,ZAH,Z AJ,ZAL .....	1
17	PAFFF	5995-00-231-7423	19207	10876543	LEAD,ELECTRICAL LEFT, BOOM FLOODLIGHT UOC: DAC,DAD,DAE,DAF,DAG,DA H,DAJ,DAL,DAW,DAX,V14,V15,V16, V17,V18,V19,V20,V21,V22,V24,ZAL .....	1
18	PAFZA	5999-00-057-2929	58536	AA52536-2	. CONTACT,ELECTRICAL BOOM FLOODLIGHT LEAD UOC: DAL,V18,ZAL .....	2
19	PAFZZ	5310-00-833-8567	19207	8338567	. WASHER,SLOTTED BOOM FLOODLIGHT LEAD UOC: DAL,V18,ZAL .....	2
20	PAFZZ	5935-00-572-9180	19207	8338566	. SHELL,ELECTRICAL CO BOOM FLOODLIGHT LEAD UOC: DAL,V18,ZAL .....	2
21	PAFZZ	9905-00-752-4649	24617	5939707	. BAND MRKER BLNK-ALU BOOM FLOODLIGHT LEAD UOC: DAL,V18,ZAL .....	2
22	PAFFF	5995-01-166-2235	19207	12277328	LEAD,ELECTRICAL UOC: DAL,V18,ZAL .....	1
23	PAFZZ	5940-00-399-6676	19207	8338564	. TERMINAL SET,QUICK WARNING LIGHT LEAD UOC: DAL,V18,ZAL .....	2
24	PAFZZ	5970-00-833-8562	19207	8338562	. INSULATOR,BUSHING WARNING LIGHT LEAD UOC: DAL,V18,ZAL .....	2
25	PAFZZ	5975-00-660-5962	19207	8724494	. CABLE NIPPLE,ELECTR WARNING LIGHT LEAD UOC: DAL,V18,ZAL .....	2
26	PAFZZ	9905-00-752-4649	24617	5939707	. BAND MRKER BLNK-ALU WARNING LIGHT LEAD UOC: DAL,V18,ZAL .....	2
27	PAFFF	6150-01-164-3358	19207	12277327-1	LEAD,ELECTRICAL UOC: DAL,V18,ZAL .....	1
28	PAFZZ	5940-00-399-6676	19207	8338564	. TERMINAL SET,QUICK WARNING LIGHT LEAD UOC: DAL,V18,ZAL .....	1

(1) ITEM NO.	(2) SMR CODE	(3) NSN	(4) CAGEC	(5) PART NUMBER	(6) DESCRIPTION AND USABLE ON CODE (UOC)	(7) QTY
29	PAFZZ	5970-00-833-8562	19207	8338562	. INSULATOR,BUSHING WARNING LIGHT LEAD UOC: DAL,V18,ZAL .....	1
30	PAFZZ	5975-00-660-5962	19207	8724494	. CABLE NIPPLE,ELECTR WARNING LIGHT LEAD UOC: DAL,V18,ZAL .....	1
31	PAFZZ	9905-00-752-4649	24617	5939707	. BAND MRKER BLNK-ALU WARNING LIGHT LEAD UOC: DAL,V18,ZAL .....	2
32	PAFZZ	5935-00-691-5591	97403	13207E6498-2	. SHELL,ELECTRICAL CO WARNING LIGHT LEAD UOC: DAL,V18,ZAL .....	1
33	PAFZZ	5310-00-656-0067	19207	8724497	. WASHER,SLOTTED WARNING LIGHT LEAD UOC: DAL,V18,ZAL .....	1
34	PAFZZ	5999-00-926-3144	58536	AA52536-3	. CONTACT,ELECTRICAL WARNING LIGHT LEAD UOC: DAL,V18,ZAL .....	1
35	PAFZZ	5306-00-068-0514	80204	B1821BH025F088N	BOLT,MACHINE UOC: DAL,V18,ZAL .....	1
36	PAFZZ	5310-00-889-2528	96906	MS45904-68	WASHER,LOCK UOC: DAL,V18,ZAL .....	1
37	PAFZZ	5340-00-282-7544	96906	MS21333-35	CLAMP,LOOP UOC: DAL,V18,ZAL .....	1
38	PAFZZ	5310-00-935-9022	81349	M45913/3-4FG8C	NUT,SELF-LOCKING,HE UOC: DAL,V18,ZAL .....	1
39	PAFFF	5995-01-164-1900	19207	12277329	WIRING HARNESS,BRAN UOC: DAL,V18,ZAL .....	1
40	PAFZZ	5999-00-926-3144	58536	AA52536-3	. CONTACT,ELECTRICAL WARNING LIGHT LEAD UOC: DAL,V18,ZAL .....	2
41	PBFZZ	5310-00-656-0067	19207	8724497	. WASHER,SLOTTED WARNING LIGHT LEAD UOC: DAL,V18,ZAL .....	2
42	PAFZZ	5935-00-691-5591	97403	13207E6498-2	. SHELL,ELECTRICAL CO WARNING LIGHT LEAD UOC: DAL,V18,ZAL .....	2
43	PAFZZ	9905-00-752-4649	24617	5939707	. BAND MRKER BLNK-ALU WARNING LIGHT LEAD UOC: DAL,V18,ZAL .....	4
44	PAFZZ	5940-00-143-4780	81343	MS25036-108	. TERMINAL,LUG WARNING LIGHT LEAD UOC: DAL,V18,ZAL .....	1

(1) ITEM NO.	(2) SMR CODE	(3) NSN	(4) CAGEC	(5) PART NUMBER	(6) DESCRIPTION AND USABLE ON CODE (UOC)	(7) QTY
45	PBFZZ	5940-00-143-4774	81343	MS25036-153	. TERMINAL,LUG WARNING LIGHT LEAD UOC: DAL,V18,ZAL .....	1

END OF FIGURE

**FIELD MAINTENANCE  
WRECKER CRANE BOOM WIRING HARNESS**

---

1  
2-12

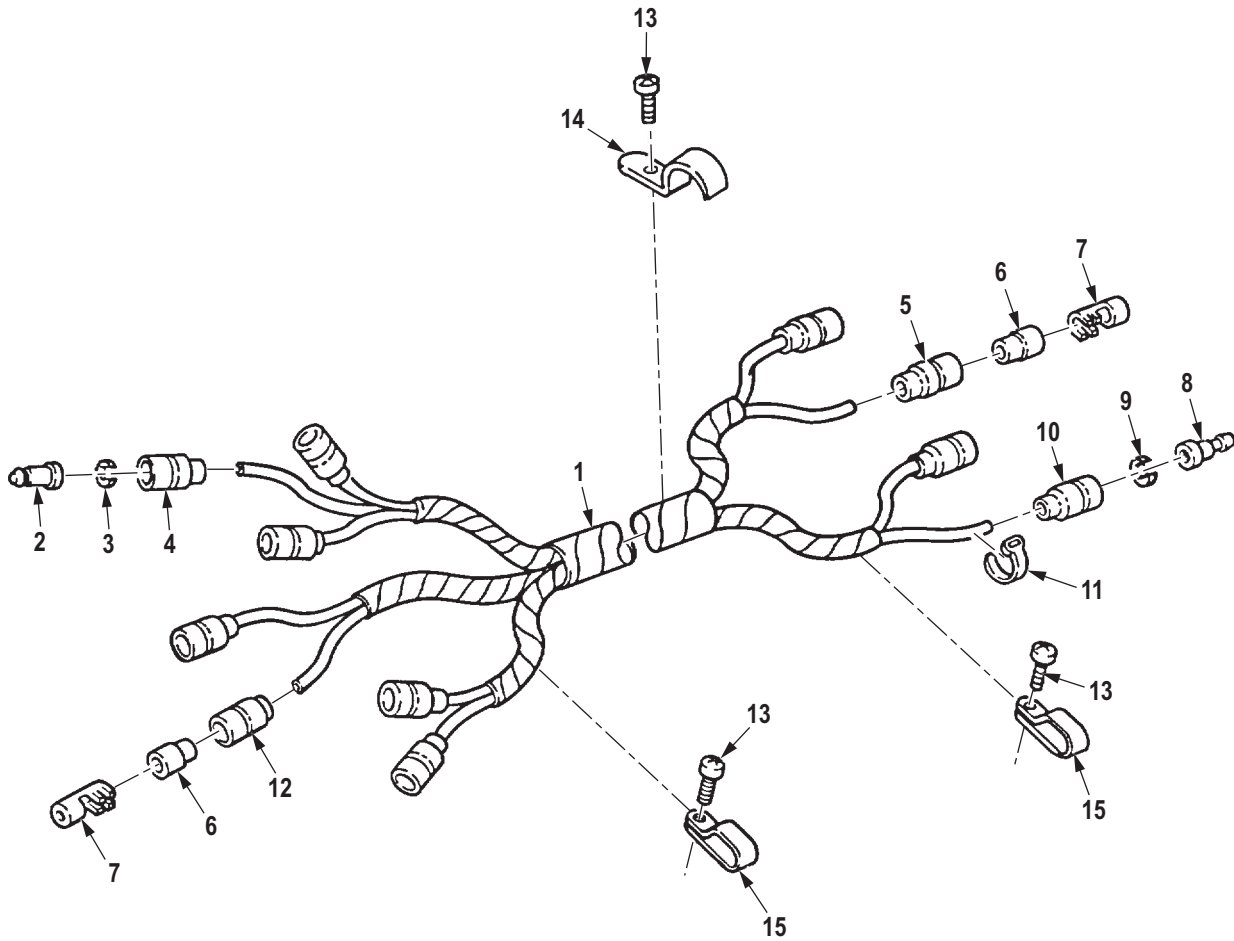

R0183DAA

Figure 171. Wrecker Crane Boom Wiring Harness.

(1) ITEM NO.	(2) SMR CODE	(3) NSN	(4) CAGEC	(5) PART NUMBER	(6) DESCRIPTION AND USABLE ON CODE (UOC)	(7) QTY
<b>GROUP 0613 HULL OR CHASSIS WIRING HARNESS.</b>						
<b>FIG. 171. WRECKER CRANE BOOM WIRING HARNESS.</b>						
1	PAFFF	2590-01-164-3440	19207	12277332	WIRING HARNESS,BRAN UOC: DAL,V18,ZAL .....	1
2	PAFZZ	5999-00-926-3144	58536	AA52536-3	. CONTACT,ELECTRICAL BOOM WIRING HARNESS UOC: DAL,V18,ZAL .....	1
3	PBFZZ	5310-00-656-0067	19207	8724497	. WASHER,SLOTTED BOOM WIRING HARNESS UOC: DAL,V18,ZAL .....	1
4	PAFZZ	5935-00-691-5591	97403	13207E6498-2	. SHELL,ELECTRICAL CO BOOM WIRING HARNESS UOC: DAL,V18,ZAL .....	1
5	PAFZZ	5935-00-833-8561	19207	8338561	. SHELL,ELECTRICAL CO CRANE WIRING HARNESS UOC: DAL,V18,ZAL .....	4
6	PAFZZ	5970-00-833-8562	19207	8338562	. INSULATOR,BUSHING CRANE WIRING HARNESS UOC: DAL,V18,ZAL .....	6
7	PAFZZ	5940-00-399-6676	19207	8338564	. TERMINAL SET,QUICK BOOM WIRING HARNESS UOC: DAL,V18,ZAL .....	6
8	PAFZA	5999-00-057-2929	58536	AA52536-2	. CONTACT,ELECTRICAL HARNESS ASSEMBLY,CRANE TO GONDOLA FLOODLIGHT UOC: DAL,V18,ZAL .....	4
9	PAFZZ	5310-00-833-8567	19207	8338567	. WASHER,SLOTTED UOC: DAL,V18,ZAL .....	4
10	PAFZZ	5935-00-572-9180	19207	8338566	. SHELL,ELECTRICAL CO UOC: DAL,V18,ZAL .....	4
11	PAFZZ	9905-00-752-4649	24617	5939707	. BAND MRKER BLNK-ALU BOOM WIRING HARNESS UOC: DAL,V18,ZAL .....	11
12	PAFZZ	5975-00-660-5962	19207	8724494	. CABLE NIPPLE,ELECTR BOOM WIRING HARNESS UOC: DAL,V18,ZAL .....	2
13	PAFZZ	5305-00-855-0957	45152	2477HX	SCREW,TAPPING UOC: DAL,V18,ZAL .....	17
14	PAFZZ	5340-00-282-7793	80205	MS35140-6	STRAP,RETAINING UOC: DAL,V18,ZAL .....	5
15	PAFZZ	5340-00-930-1754	80205	MS21334-2	CLAMP,LOOP UOC: DAL,V18,ZAL .....	18

**END OF FIGURE**





**FIELD MAINTENANCE  
SIDE MARKER LIGHT LEADS**

---

1	9	15
2-8	10-13	16-19

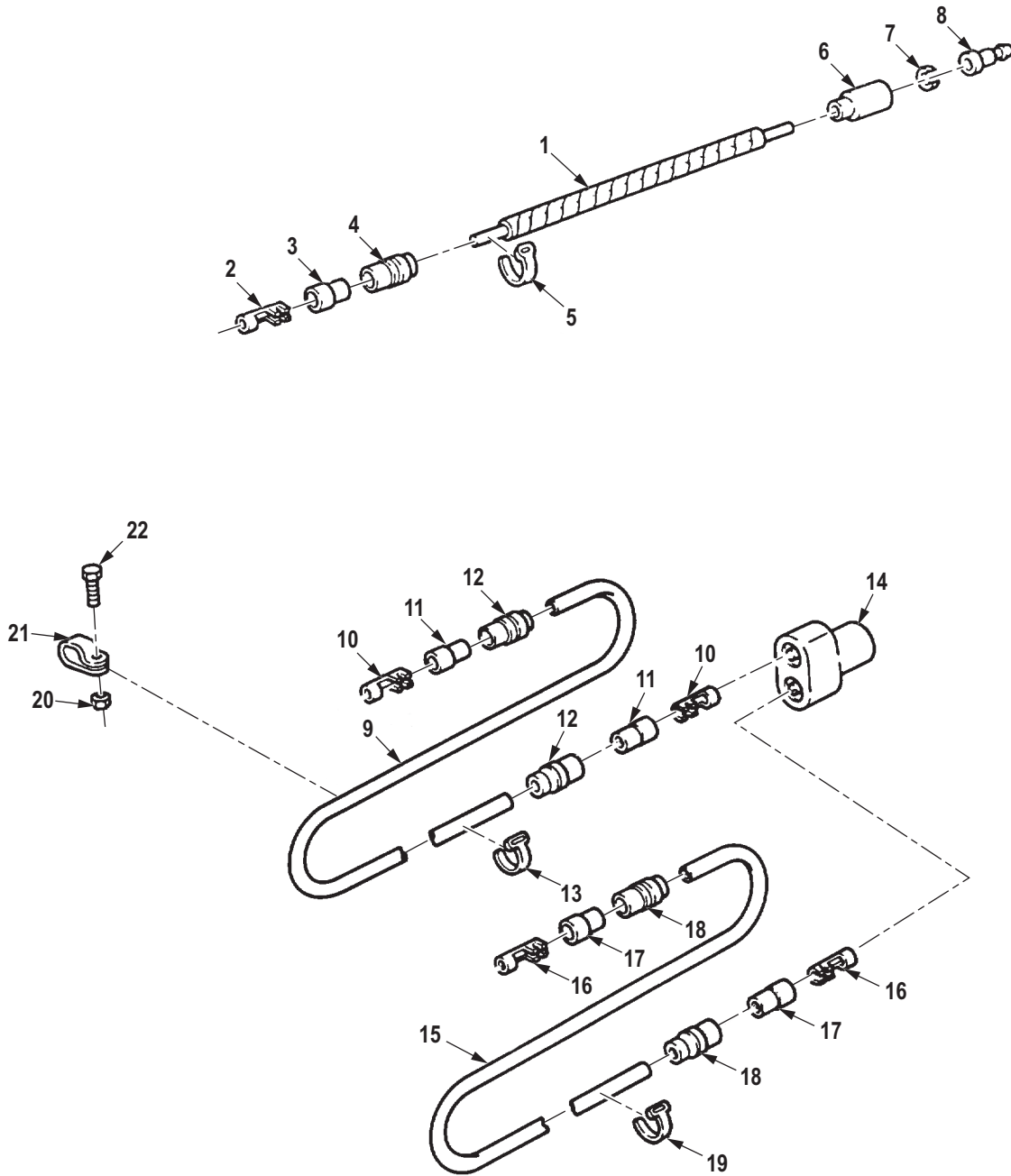

R0184DAA

Figure 172. Side Marker Light Leads.

(1) ITEM NO.	(2) SMR CODE	(3) NSN	(4) CAGEC	(5) PART NUMBER	(6) DESCRIPTION AND USABLE ON CODE (UOC)	(7) QTY
<b>GROUP 0613 HULL OR CHASSIS WIRING HARNESS.</b>						
<b>FIG. 172. SIDE MARKER LIGHT LEADS.</b>						
1	PAFFF	6150-01-130-8042	19207	12277005-2	LEAD,ELECTRICAL UOC: DAC,DAD,DAW,DAX,V14,V15, V16,V17,ZAA,ZAB,ZAC,ZAD .....	2
2	PAFZZ	1015-00-798-2997	19207	7982997	. TERMINAL,SOLDERED F SIDE MARKER TO TAILLIGHT LEAD UOC: DAC,DAD,DAW,DAX,V14,V15, V16,V17,ZAA,ZAB,ZAC,ZAD .....	1
3	PAFZZ	5970-00-833-8562	19207	8338562	. INSULATOR,BUSHING SIDE MARKER TO TAILLIGHT LEAD UOC: DAC,DAD,DAW,DAX,V14,V15, V16,V17,ZAA,ZAB,ZAC,ZAD .....	1
4	PAFZZ	5935-00-833-8561	19207	8338561	. SHELL,ELECTRICAL CO SIDE MARKER TO TAILLIGHT LEAD UOC: DAC,DAD,DAW,DAX,V14,V15, V16,V17,ZAA,ZAB,ZAC,ZAD .....	1
5	PAFZZ	9905-00-752-4649	24617	5939707	. BAND MRKER BLNK-ALU SIDE MARKER TO TAILLIGHT LEAD UOC: DAC,DAD,DAW,DAX,V14,V15, V16,V17,ZAA,ZAB,ZAC,ZAD .....	2
6	PAFZZ	5935-00-572-9180	19207	8338566	. SHELL,ELECTRICAL CO SIDE MARKER TO TAILLIGHT LEAD UOC: DAC,DAD,DAW,DAX,V14,V15, V16,V17,ZAA,ZAB,ZAC,ZAD .....	1
7	PAFZZ	5310-00-833-8567	19207	8338567	. WASHER,SLOTTED SIDE MARKER TO TAILLIGHT LEAD UOC: DAC,DAD,DAW,DAX,V14,V15, V16,V17,ZAA,ZAB,ZAC,ZAD .....	1
8	PAFZA	5999-00-057-2929	58536	AA52536-2	. CONTACT,ELECTRICAL SIDE MARKER TO TAILLIGHT LEAD UOC: DAC,DAD,DAW,DAX,V14,V15, V16,V17,ZAA,ZAB,ZAC,ZAD .....	1
9	PAFFF	6150-01-131-0147	19207	12277004-1	LEAD ASSEMBLY,ELECT UOC: DAC,DAD,DAW,DAX,V14,V15, V16,V17,ZAA,ZAB,ZAC,ZAD .....	1
10	PAFZZ	1015-00-798-2997	19207	7982997	. TERMINAL,SOLDERED F LEFT SIDE MARKER LIGHT LEAD UOC: DAC,DAD,DAW,DAX,V14,V15, V16,V17,ZAA,ZAB,ZAC,ZAD .....	2
11	PAFZZ	5970-00-833-8562	19207	8338562	. INSULATOR,BUSHING LEFT SIDE MARKER LIGHT LEAD UOC: DAC,DAD,DAW,DAX,V14,V15, V16,V17,ZAA,ZAB,ZAC,ZAD .....	2

(1) ITEM NO.	(2) SMR CODE	(3) NSN	(4) CAGEC	(5) PART NUMBER	(6) DESCRIPTION AND USABLE ON CODE (UOC)	(7) QTY
12	PAFZZ	5935-00-833-8561	19207	8338561	. SHELL,ELECTRICAL CO LEFT SIDE MARKER LIGHT LEAD UOC: DAC,DAD,DAW,DAX,V14,V15, V16,V17,ZAA,ZAB,ZAC,ZAD .....	2
13	PAFZZ	9905-00-752-4649	24617	5939707	. BAND MRKER BLNK-ALU LEFT SIDE MARKER LIGHT LEAD UOC: DAC,DAD,DAW,DAX,V14,V15, V16,V17,ZAA,ZAB,ZAC,ZAD .....	2
14	PAFZA	5935-00-900-6281	96906	MS27147-1	ADAPTER,CONNECTOR UOC: DAC,DAD,DAW,DAX,V14,V15, V16,V17,ZAA,ZAB,ZAC,ZAD .....	1
15	PFFFF	6150-01-131-0148	19207	12277004-2	LEAD ASSEMBLY,ELECT UOC: DAC,DAD,DAW,DAX,V14,V15, V16,V17,ZAA,ZAB,ZAC,ZAD .....	1
16	PAFZZ	1015-00-798-2997	19207	7982997	. TERMINAL,SOLDERED F RIGHT SIDE MARKER LIGHT UOC: DAC,DAD,DAW,DAX,V14,V15, V16,V17,ZAA,ZAB,ZAC,ZAD .....	2
17	PAFZZ	5970-00-833-8562	19207	8338562	. INSULATOR,BUSHING RIGHT SIDE MARKER LIGHT LEAD UOC: DAC,DAD,DAW,DAX,V14,V15, V16,V17,ZAA,ZAB,ZAC,ZAD .....	2
18	PAFZZ	5935-00-833-8561	19207	8338561	. SHELL,ELECTRICAL CO RIGHT SIDE MARKER LIGHT LEAD UOC: DAC,DAD,DAW,DAX,V14,V15, V16,V17,ZAA,ZAB,ZAC,ZAD .....	2
19	PAFZZ	9905-00-752-4649	24617	5939707	. BAND MRKER BLNK-ALU RIGHT SIDE MARKER LIGHT LEAD UOC: DAC,DAD,DAW,DAX,V14,V15, V16,V17,ZAA,ZAB,ZAC,ZAD .....	2
20	PAFZZ	5310-00-959-1488	81349	M45913/2-6FG5C	NUT,SELF-LOCKING,HE UOC: DAC,DAD,DAW,DAX,V14,V15, V16,V17,ZAA,ZAB,ZAC,ZAD .....	2
21	PAFZZ	5340-01-139-1002	19207	7539108	CLAMP,LOOP UOC: DAC,DAD,DAW,DAX,V14,V15, V16,V17,ZAA,ZAB,ZAC,ZAD .....	2
22	PAFZZ	5305-00-068-0515	80204	B1821BH025F100N	SCREW,CAP,HEXAGON H UOC: DAC,DAD,DAW,DAX,V14,V15, V16,V17,ZAA,ZAB,ZAC,ZAD .....	2

END OF FIGURE

**FIELD MAINTENANCE  
SIDE MARKER LIGHT LEADS**

---

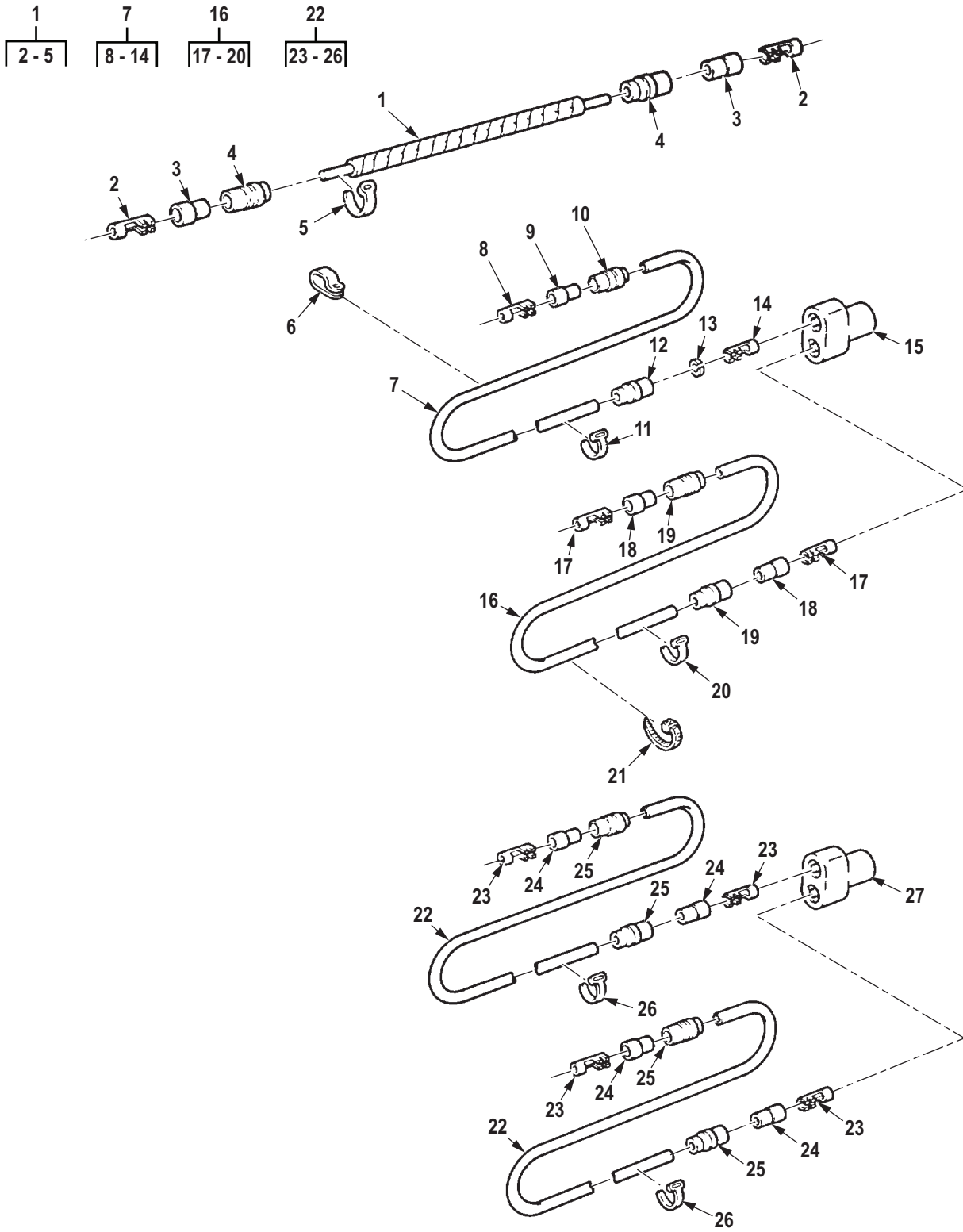

R0185DAA

Figure 173. Side Marker Light Leads.

(1) ITEM NO.	(2) SMR CODE	(3) NSN	(4) CAGEC	(5) PART NUMBER	(6) DESCRIPTION AND USABLE ON CODE (UOC)	(7) QTY
<b>GROUP 0613 HULL OR CHASSIS WIRING HARNESS.</b>						
<b>FIG. 173. SIDE MARKER LIGHT LEADS.</b>						
1	PAFFF	6150-01-095-8309	19207	12277004-5	CABLE ASSEMBLY,SPEC UOC: DAL,V18,ZAL .....	2
2	PAFZZ	1015-00-798-2997	19207	7982997	. TERMINAL,SOLDERED F SIDE MARKER LIGHT CABLE UOC: DAL,V18,ZAL .....	1
3	PAFZZ	5970-00-833-8562	19207	8338562	. INSULATOR,BUSHING SIDE MARKER LIGHT CABLE UOC: DAL,V18,ZAL .....	1
4	PAFZZ	5935-00-833-8561	19207	8338561	. SHELL,ELECTRICAL CO SIDE MARKER LIGHT CABLE UOC: DAL,V18,ZAL .....	1
5	PAFZZ	9905-00-752-4649	24617	5939707	. BAND MRKER BLNK-ALU SIDE MARKER LIGHT CABLE UOC: DAL,V18,ZAL .....	2
6	PAFZZ	5340-00-067-3868	80205	MS21333-109	CLAMP,LOOP UOC: DAL,V18,ZAL .....	2
7	PAFFF	6150-01-130-8042	19207	12277005-2	LEAD,ELECTRICAL UOC: DAL,V18,ZAL .....	2
8	PAFZZ	1015-00-798-2997	19207	7982997	. TERMINAL,SOLDERED F UOC: DAL,V18,ZAL .....	1
9	PAFZZ	5970-00-833-8562	19207	8338562	. INSULATOR,BUSHING UOC: DAL,V18,ZAL .....	1
10	PAFZZ	5935-00-833-8561	19207	8338561	. SHELL,ELECTRICAL CO UOC: DAL,V18,ZAL .....	1
11	PAFZZ	9905-00-752-4649	24617	5939707	. BAND MRKER BLNK-ALU UOC: DAL,V18,ZAL .....	2
12	PAFZZ	5935-00-572-9180	19207	8338566	. SHELL,ELECTRICAL CO UOC: DAL,V18,ZAL .....	1
13	PAFZZ	5310-00-833-8567	19207	8338567	. WASHER,SLOTTED UOC: DAL,V18,ZAL .....	1
14	PAFZA	5999-00-057-2929	58536	AA52536-2	. CONTACT,ELECTRICAL UOC: DAL,V18,ZAL .....	1
15	PAFZA	5935-00-900-6281	96906	MS27147-1	ADAPTER,CONNECTOR UOC: DAL,V18,ZAL .....	2
16	PAFFF	6150-01-095-8310	19207	12277004-6	LEAD,ELECTRICAL UOC: DAL,V18,ZAL .....	2
17	PAFZZ	1015-00-798-2997	19207	7982997	. TERMINAL,SOLDERED F UOC: DAL,V18,ZAL .....	2
18	PAFZZ	5970-00-833-8562	19207	8338562	. INSULATOR,BUSHING SIDE MARKER LIGHT CABLE UOC: DAL,V18,ZAL .....	2

(1) ITEM NO.	(2) SMR CODE	(3) NSN	(4) CAGEC	(5) PART NUMBER	(6) DESCRIPTION AND USABLE ON CODE (UOC)	(7) QTY
19	PAFZZ	5935-00-833-8561	19207	8338561	. SHELL,ELECTRICAL CO SIDE MARKER LIGHT CABLE UOC: DAL,V18,ZAL ..... 2	2
20	PAFZZ	9905-00-752-4649	24617	5939707	. BAND MRKER BLNK-ALU SIDE MARKER LIGHT CABLE UOC: DAL,V18,ZAL ..... 2	2
21	PAFZZ	5975-00-156-3253	81343	MS3367-2-9	STRAP,TIEDOWN,ELECT UOC: DAL,V18,ZAL ..... 2	2
22	PAFFF	6150-01-131-0150	19207	12277004-4	LEAD ASSEMBLY,ELECT UOC: DAE,DAF,V19,V20,ZAE,ZAF ..... 4	4
23	PAFZZ	1015-00-798-2997	19207	7982997	. TERMINAL,SOLDERED F SIDE MARKER LIGHT CABLE UOC: DAE,DAF,V19,V20,ZAE,ZAF ..... 2	2
24	PAFZZ	5970-00-833-8562	19207	8338562	. INSULATOR,BUSHING SIDE MARKER LIGHT CABLE UOC: DAE,DAF,V19,V20,ZAE,ZAF ..... 2	2
25	PAFZZ	5935-00-833-8561	19207	8338561	. SHELL,ELECTRICAL CO SIDE MARKER LIGHT CABLE UOC: DAE,DAF,V19,V20,ZAE,ZAF ..... 2	2
26	PAFZZ	9905-00-752-4649	24617	5939707	. BAND MRKER BLNK-ALU SIDE MARKER LIGHT CABLE UOC: DAE,DAF,V19,V20,ZAE,ZAF ..... 2	2
27	PAFZA	5935-00-900-6281	96906	MS27147-1	ADAPTER,CONNECTOR UOC: DAE,DAF,V19,V20,ZAE,ZAF ..... 2	2

END OF FIGURE



**FIELD MAINTENANCE  
INSTRUMENT CLUSTER HARNESS**

---

1  
2-8

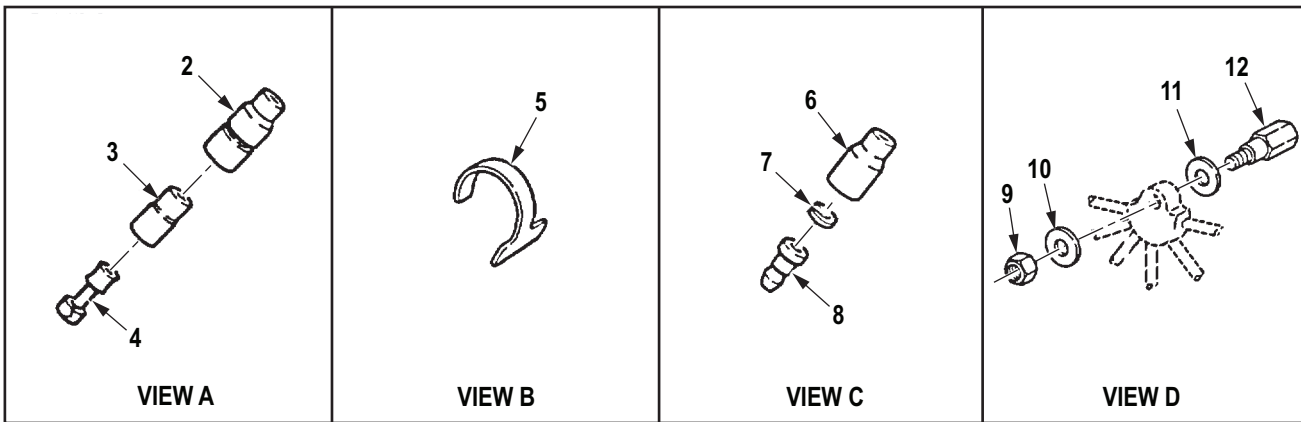
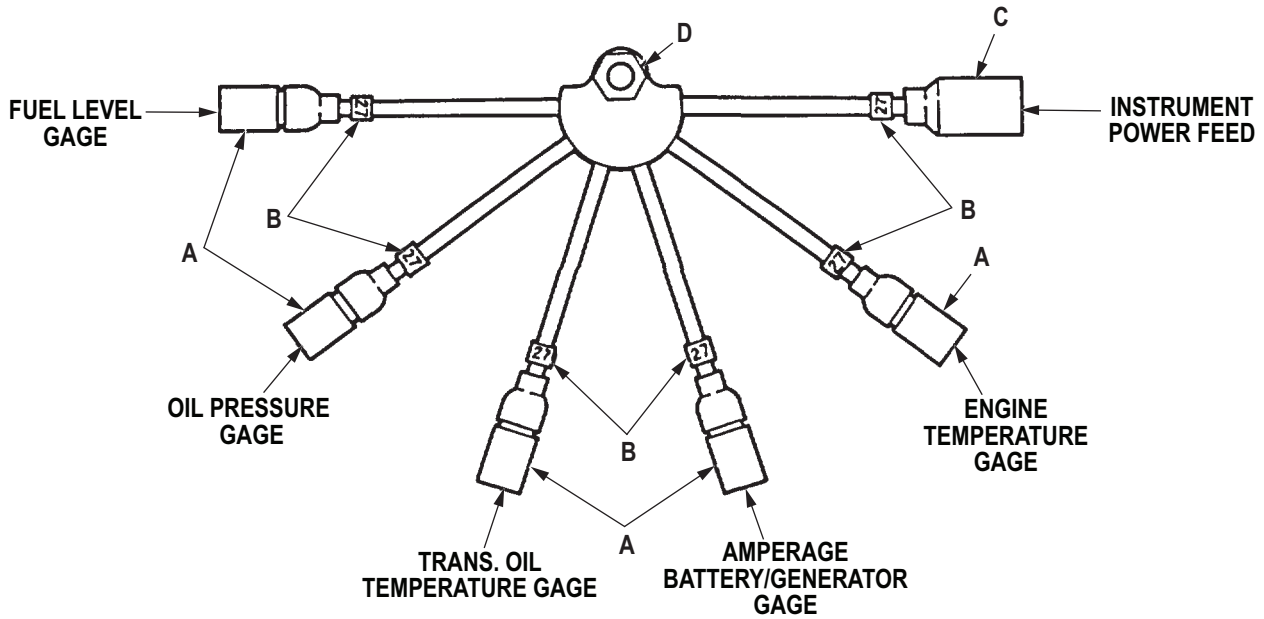

R0186DAA

Figure 174. Instrument Cluster Harness.

(1) ITEM NO.	(2) SMR CODE	(3) NSN	(4) CAGEC	(5) PART NUMBER	(6) DESCRIPTION AND USABLE ON CODE (UOC)	(7) QTY
<b>GROUP 0613 HULL OR CHASSIS WIRING HARNESS.</b>						
<b>FIG. 174. INSTRUMENT CLUSTER HARNESS.</b>						
1	PFFFF	6150-01-083-1161	19207	12256007	CABLE ASSEMBLY SET, UOC: DAC,DAD,DAE,DAF,DAG,DA H,DAJ,DAL,DAW,DAX,V14,V15,V16, V17,V18,V19,V20,V21,V22,V24,ZAA, ZAB,ZAC,ZAD,ZAE,ZAF,ZAG,ZAH,Z AJ,ZAL .....	1
2	PAFZZ	5935-00-833-8561	19207	8338561	. SHELL,ELECTRICAL CO UOC: DAC,DAD,DAE,DAF,DAG,DA H,DAJ,DAL,DAW,DAX,V14,V15,V16, V17,V18,V19,V20,V21,V22,V24,ZAA, ZAB,ZAC,ZAD,ZAE,ZAF,ZAG,ZAH,Z AJ,ZAL .....	5
3	PAFZZ	5970-00-833-8562	19207	8338562	. INSULATOR,BUSHING UOC: DAC,DAD,DAE,DAF,DAG,DA H,DAJ,DAL,DAW,DAX,V14,V15,V16, V17,V18,V19,V20,V21,V22,V24,ZAA, ZAB,ZAC,ZAD,ZAE,ZAF,ZAG,ZAH,Z AJ,ZAL .....	5
4	PAFZZ	1015-00-798-2997	19207	7982997	. TERMINAL,SOLDERED F CABLE ASSEMBLY UOC: DAC,DAD,DAE,DAF,DAG,DA H,DAJ,DAL,DAW,DAX,V14,V15,V16, V17,V18,V19,V20,V21,V22,V24,ZAA, ZAB,ZAC,ZAD,ZAE,ZAF,ZAG,ZAH,Z AJ,ZAL .....	5
5	PAFZZ	9905-00-752-4649	24617	5939707	. BAND MRKER BLNK-ALU CABLE ASSEMBLY UOC: DAC,DAD,DAE,DAF,DAG,DA H,DAJ,DAL,DAW,DAX,V14,V15,V16, V17,V18,V19,V20,V21,V22,V24,ZAA, ZAB,ZAC,ZAD,ZAE,ZAF,ZAG,ZAH,Z AJ,ZAL .....	6
6	PAFZZ	5935-00-572-9180	19207	8338566	. SHELL,ELECTRICAL CO UOC: DAC,DAD,DAE,DAF,DAG,DA H,DAJ,DAL,DAW,DAX,V14,V15,V16, V17,V18,V19,V20,V21,V22,V24,ZAA, ZAB,ZAC,ZAD,ZAE,ZAF,ZAG,ZAH,Z AJ,ZAL .....	1
7	PAFZZ	5310-00-833-8567	19207	8338567	. WASHER,SLOTTED CABLE ASSEMBLY UOC: DAC,DAD,DAE,DAF,DAG,DA H,DAJ,DAL,DAW,DAX,V14,V15,V16, V17,V18,V19,V20,V21,V22,V24,ZAA, ZAB,ZAC,ZAD,ZAE,ZAF,ZAG,ZAH,Z AJ,ZAL .....	1

(1) ITEM NO.	(2) SMR CODE	(3) NSN	(4) CAGEC	(5) PART NUMBER	(6) DESCRIPTION AND USABLE ON CODE (UOC)	(7) QTY
8	PAFZA	5999-00-057-2929	58536	AA52536-2	. CONTACT,ELECTRICAL CABLE ASSEMBLY UOC: DAC,DAD,DAE,DAF,DAG,DA H,DAJ,DAL,DAW,DAX,V14,V15,V16, V17,V18,V19,V20,V21,V22,V24,ZAA, ZAB,ZAC,ZAD,ZAE,ZAF,ZAG,ZAH,Z AJ,ZAL .....	1
9	PAFZZ	5310-00-934-9751	24975	8X-173	NUT,PLAIN,HEXAGON UOC: DAC,DAD,DAE,DAF,DAG,DA H,DAJ,DAL,DAW,DAX,V14,V15,V16, V17,V18,V19,V20,V21,V22,V24,ZAA, ZAB,ZAC,ZAD,ZAE,ZAF,ZAG,ZAH,Z AJ,ZAL .....	1
10	PAFZZ	5310-00-752-6593	19207	7526593	WASHER,FLAT UOC: DAC,DAD,DAE,DAF,DAG,DA H,DAJ,DAL,DAW,DAX,V14,V15,V16, V17,V18,V19,V20,V21,V22,V24,ZAA, ZAB,ZAC,ZAD,ZAE,ZAF,ZAG,ZAH,Z AJ,ZAL .....	1
11	XDFZZ		19207	7528592	WASHER,FLAT UOC: DAC,DAD,DAE,DAF,DAG,DA H,DAJ,DAL,DAW,DAX,V14,V15,V16, V17,V18,V19,V20,V21,V22,V24,ZAA, ZAB,ZAC,ZAD,ZAE,ZAF,ZAG,ZAH,Z AJ,ZAL .....	1
12	PAFZZ	5307-00-752-6594	19207	7526594	STANDOFF,THREADED S UOC: DAC,DAD,DAE,DAF,DAG,DA H,DAJ,DAL,DAW,DAX,V14,V15,V16, V17,V18,V19,V20,V21,V22,V24,ZAA, ZAB,ZAC,ZAD,ZAE,ZAF,ZAG,ZAH,Z AJ,ZAL .....	1

END OF FIGURE

**FIELD MAINTENANCE  
GROUND AND JUMPER CABLE ASSEMBLIES**

---

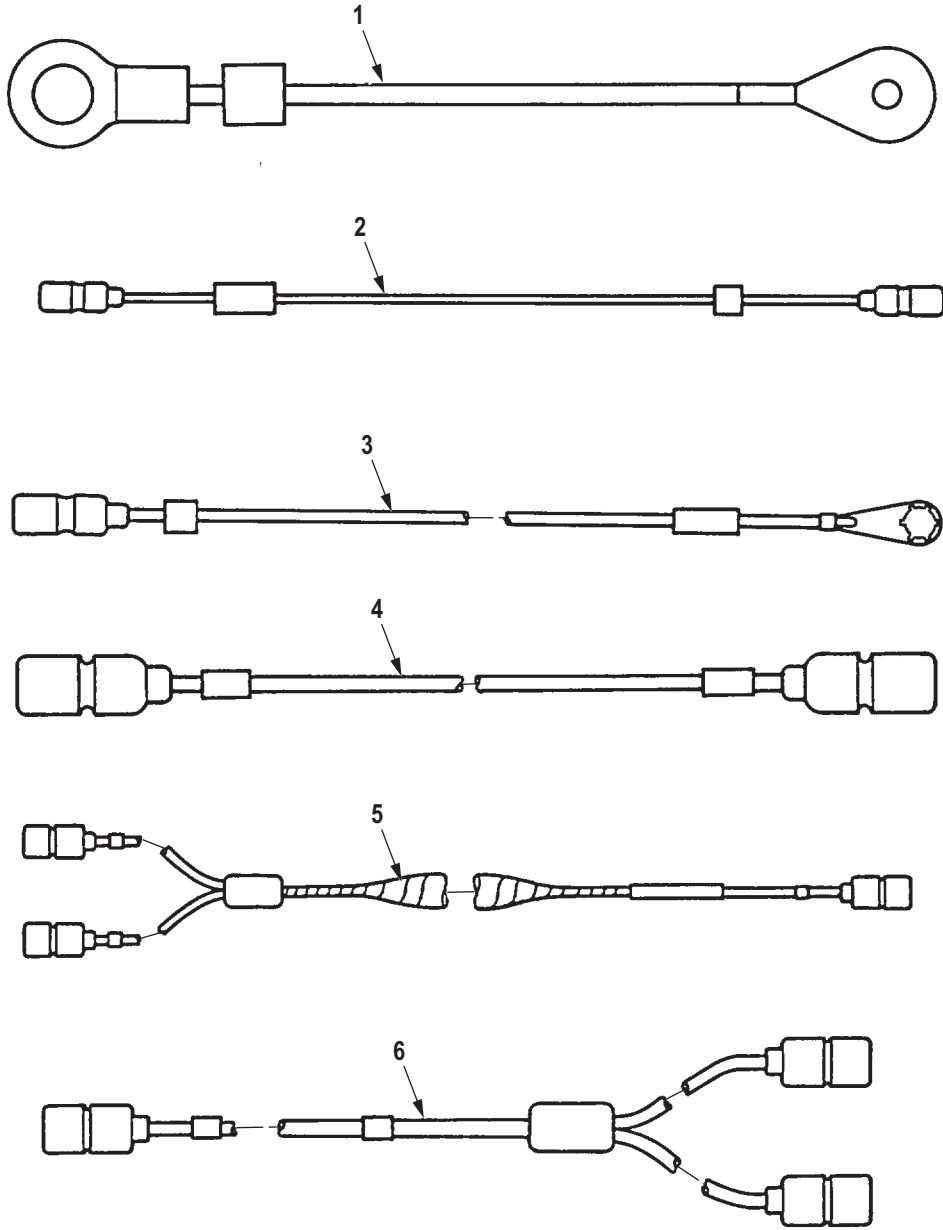

R0187DAA

Figure 175. Ground and Jumper Cable Assemblies.

(1) ITEM NO.	(2) SMR CODE	(3) NSN	(4) CAGEC	(5) PART NUMBER	(6) DESCRIPTION AND USABLE ON CODE (UOC)	(7) QTY
<b>GROUP 0613 HULL OR CHASSIS WIRING HARNESS.</b>						
<b>FIG. 175. GROUND AND JUMPER CABLE ASSEMBLIES.</b>						
1	PFFZZ	6150-01-083-1153	19207	12276953-2	CABLE ASSEMBLY,SPEC FUEL TANK GROUND CABLE UOC: DAE,DAF,DAG,DAH,DAL,V18, V19,V20,V21,V22,ZAE,ZAF,ZAG,ZAH,ZAL	1
1	PFFZZ	6150-01-082-9042	19207	12276953-1	LEAD,ELECTRICAL FUEL TANK GROUND CABLE UOC: DAC,DAD,DAE,DAF,DAG,DA H,DAJ,DAL,DAW,DAX,V14,V15,V16, V17,V18,V19,V20,V21,V22,V24,ZAA, ZAB,ZAC,ZAD,ZAE,ZAF,ZAG,ZAH,Z AJ,ZAL .....	1
2	PAFZZ	6150-01-082-9040	19207	12256098	LEAD,ELECTRICAL AIR TANK JUMPER CABLE UOC: DAC,DAD,DAE,DAF,DAG,DA H,DAJ,DAL,DAW,DAX,V14,V15,V16, V17,V18,V19,V20,V21,V22,V24,ZAA, ZAB,ZAC,ZAD,ZAE,ZAF,ZAG,ZAH,Z AJ,ZAL .....	1
3	PFFZZ	6150-01-083-5479	19207	12256099	LEAD,ELECTRICAL AIR TANK GROUND CABLE UOC: DAC,DAD,DAE,DAF,DAG,DA H,DAJ,DAL,DAW,DAX,V14,V15,V16, V17,V18,V19,V20,V21,V22,V24,ZAA, ZAB,ZAC,ZAD,ZAE,ZAF,ZAG,ZAH,Z AJ,ZAL .....	1
4	PFFZZ	6150-01-131-0141	19207	12256427-3	CABLE ASSEMBLY,SPEC CIRCUIT BREAKER TO BATTERY SWITCH UOC: DAC,DAD,DAE,DAF,DAG,DA H,DAJ,DAL,DAW,DAX,V14,V15,V16, V17,V18,V19,V20,V21,V22,V24,ZAA, ZAB,ZAC,ZAD,ZAE,ZAF,ZAG,ZAH,Z AJ,ZAL .....	1
5	PFFZZ	6150-01-082-3818	19207	7363004-1	CABLE ASSEMBLY,SPEC AIR TANK JUMPER UOC: DAV .....	1
6	PFFZZ	6150-01-130-8102	19207	7363005-1	CABLE ASSEMBLY,SPEC FLOODLIGHT SWITCH LEAD UOC: V39 .....	1

END OF FIGURE





**FIELD MAINTENANCE  
TRANSMISSION ASSEMBLY AND SHIPPING CONTAINER**

---

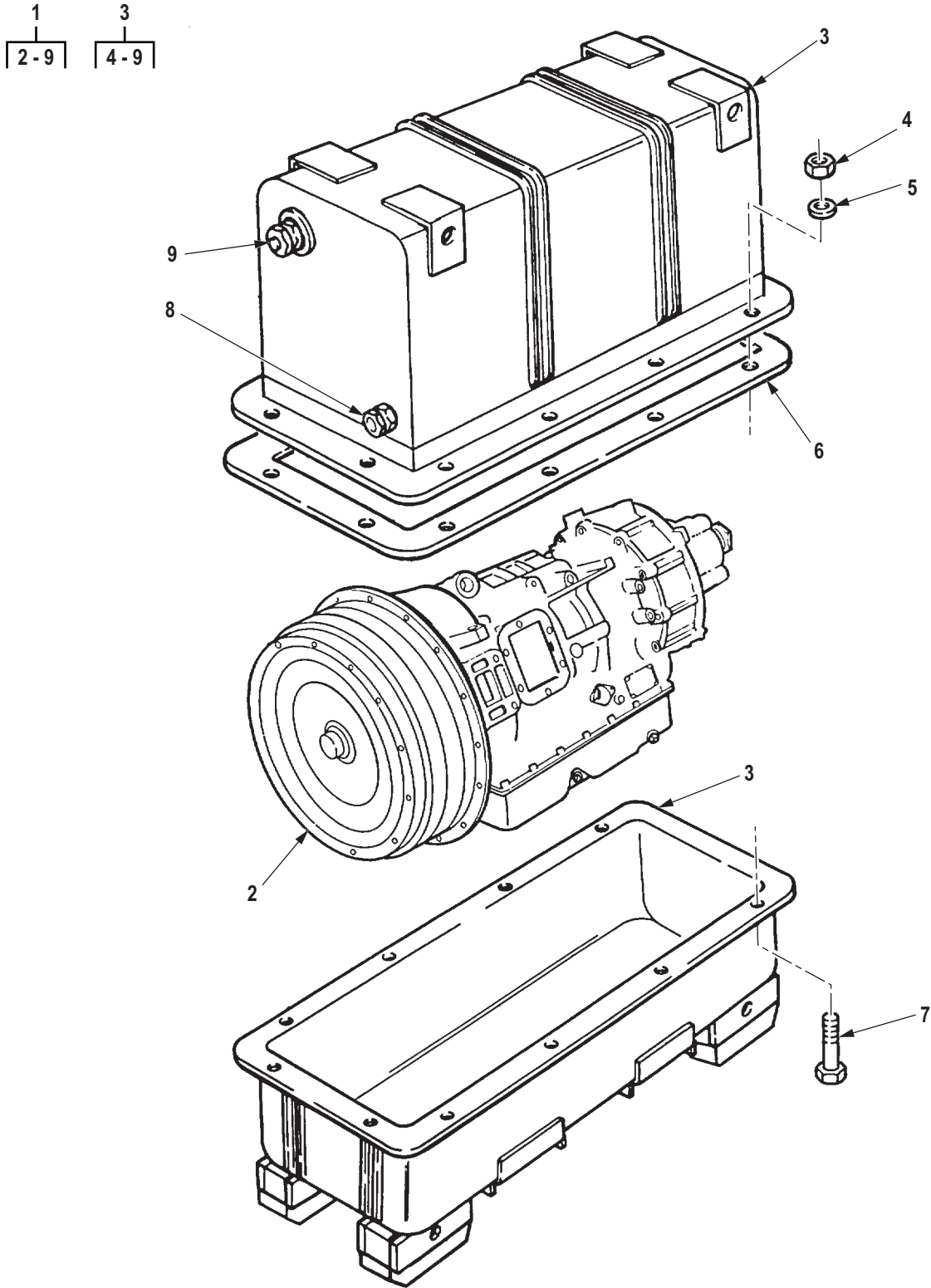

R0188DAA

Figure 176. Transmission Assembly and Shipping Container.

(1) ITEM NO.	(2) SMR CODE	(3) NSN	(4) CAGEC	(5) PART NUMBER	(6) DESCRIPTION AND USABLE ON CODE (UOC)	(7) QTY
<b>GROUP 0700 TRANSMISSION ASSEMBLY.</b>						
<b>FIG. 176. TRANSMISSION ASSEMBLY AND SHIPPING CONTAINER.</b>						
1	PBFHH	2520-01-117-3010	19207	5704512	TRANSMISSION WITH C UOC: DAC,DAD,DAE,DAF,DAG,DAH,DAJ,DAL,DAW,DAX,V14,V15,V16,V17,V18,V19,V20,V21,V22,V24,ZAA,ZAB,ZAC,ZAD,ZAE,ZAF,ZAG,ZAH,ZAJ,ZAL .....	1
2	XAFHH		19207	11669085	. TRANSMISSION,MECHAN UOC: DAC,DAD,DAE,DAF,DAG,DAH,DAJ,DAL,DAW,DAX,V14,V15,V16,V17,V18,V19,V20,V21,V22,V24,ZAA,ZAB,ZAC,ZAD,ZAE,ZAF,ZAG,ZAH,ZAJ,ZAL .....	1
3	PAFHH	8145-01-117-4978	19207	12277382	. SHIPPING AND STORAG UOC: DAC,DAD,DAE,DAF,DAG,DAH,DAJ,DAL,DAW,DAX,V14,V15,V16,V17,V18,V19,V20,V21,V22,V24,ZAA,ZAB,ZAC,ZAD,ZAE,ZAF,ZAG,ZAH,ZAJ,ZAL .....	1
4	PAFZZ	5310-00-768-0318	96906	MS51967-14	. . NUT,PLAIN,HEXAGON UOC: DAC,DAD,DAE,DAF,DAG,DAH,DAJ,DAL,DAW,DAX,V14,V15,V16,V17,V18,V19,V20,V21,V22,V24,ZAA,ZAB,ZAC,ZAD,ZAE,ZAF,ZAG,ZAH,ZAJ,ZAL .....	20
5	PAFZZ	5310-00-809-3079	96906	MS27183-19	. . WASHER,FLAT UOC: DAC,DAD,DAE,DAF,DAG,DAH,DAJ,DAL,DAW,DAX,V14,V15,V16,V17,V18,V19,V20,V21,V22,V24,ZAA,ZAB,ZAC,ZAD,ZAE,ZAF,ZAG,ZAH,ZAJ,ZAL .....	20
6	PAFZZ	5330-01-131-2066	19207	12302613	. . GASKET UOC: DAC,DAD,DAE,DAF,DAG,DAH,DAJ,DAL,DAW,DAX,V14,V15,V16,V17,V18,V19,V20,V21,V22,V24,ZAA,ZAB,ZAC,ZAD,ZAE,ZAF,ZAG,ZAH,ZAJ,ZAL .....	1
7	PAFZZ	5305-00-071-2069	80204	B1821BH050C150N	. . SCREW,CAP,HEXAGON H UOC: DAC,DAD,DAE,DAF,DAG,DAH,DAJ,DAL,DAW,DAX,V14,V15,V16,V17,V18,V19,V20,V21,V22,V24,ZAA,ZAB,ZAC,ZAD,ZAE,ZAF,ZAG,ZAH,ZAJ,ZAL .....	20

(1) ITEM NO.	(2) SMR CODE	(3) NSN	(4) CAGEC	(5) PART NUMBER	(6) DESCRIPTION AND USABLE ON CODE (UOC)	(7) QTY
8	PAFZZ	6685-00-618-1822	19207	10906697	. . INDICATOR,HUMIDITY, UOC: DAC,DAD,DAE,DAF,DAG,DA H,DAJ,DAL,DAW,DAX,V14,V15,V16, V17,V18,V19,V20,V21,V22,V24 .....	1
9	PAFZZ	4820-01-204-8364	08992	TA330-10-10-R	. . VALVE,PRESSURE UOC: DAC,DAD,DAE,DAF,DAG,DA H,DAJ,DAL,DAW,DAX,V14,V15,V16, V17,V18,V19,V20,V21,V22,V24,ZAA, ZAB,ZAC,ZAD,ZAE,ZAF,ZAG,ZAH,Z AJ,ZAL .....	1

END OF FIGURE

**FIELD MAINTENANCE  
TRANSMISSION MOUNTING HARDWARE, FLUID DIPSTICK, AND TUBE ASSEMBLY (M939, M939A1)**

---

11  
|  
[12 - 13]

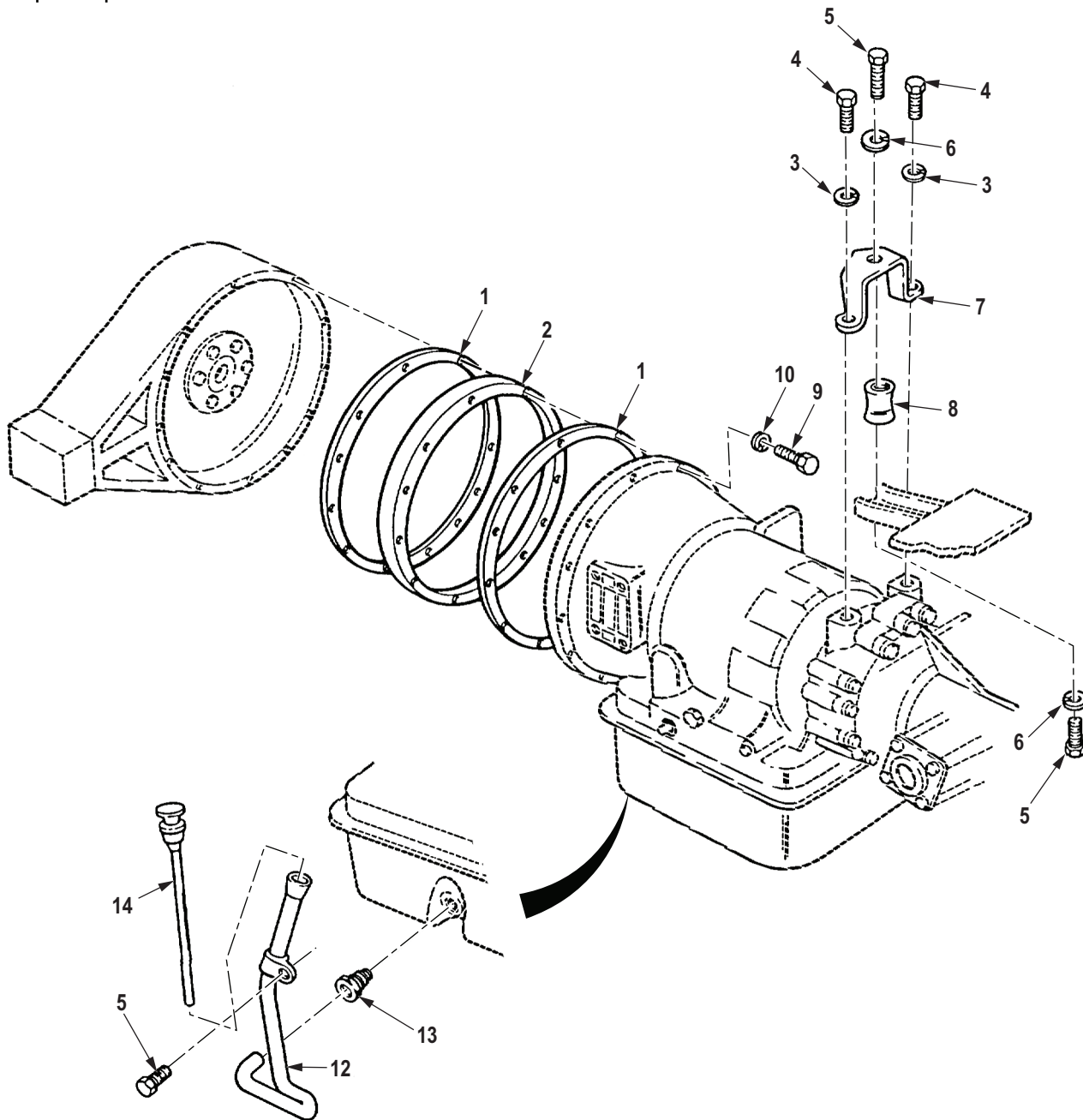

R0189DAA

Figure 177. Transmission Mounting Hardware, Fluid Dipstick, and Tube Assembly (M939, M939A1).

(1) ITEM NO.	(2) SMR CODE	(3) NSN	(4) CAGEC	(5) PART NUMBER	(6) DESCRIPTION AND USABLE ON CODE (UOC)	(7) QTY
<b>GROUP 0700 TRANSMISSION ASSEMBLY.</b>						
<b>FIG. 177. TRANSMISSION MOUNTING HARDWARE, FLUID DIPSTICK, AND TUBE ASSEMBLY (M939, M939A1).</b>						
1	PAFZZ	5330-00-737-6584	19207	7376584	GASKET UOC: DAC,DAD,DAE,DAF,DAG,DAH,DAJ,DAL,DAW,DAX,ZAA,ZAB,ZAC,ZAD,ZAE,ZAF,ZAG,ZAH,ZAJ,ZAL .....	2
2	PAFZZ	5365-01-066-7554	19207	12256997	SPACER,RING UOC: DAC,DAD,DAE,DAF,DAG,DAH,DAJ,DAL,DAW,DAX,V14,V15,V16,V17,V18,V19,V20,V21,V22,V24 .....	1
3	PAFZZ	5310-00-820-6653	80205	MS35338-50	WASHER,LOCK UOC: DAC,DAD,DAE,DAF,DAG,DAH,DAJ,DAL,DAW,DAX,V14,V15,V16,V17,V18,V19,V20,V21,V22,V24 .....	2
4	PAFZZ	5305-00-724-7221	80204	B1821BH063C175N	SCREW,CAP,HEXAGON H UOC: DAC,DAD,DAE,DAF,DAG,DAH,DAJ,DAL,DAW,DAX,V14,V15,V16,V17,V18,V19,V20,V21,V22,V24 .....	2
5	PAFZZ	5305-00-732-0512	80204	B1821BH050C075N	SCREW,CAP,HEXAGON H UOC: DAC,DAD,DAE,DAF,DAG,DAH,DAJ,DAL,DAW,DAX,V14,V15,V16,V17,V18,V19,V20,V21,V22,V24 .....	3
6	PAFZZ	5310-00-003-4094	80205	MS35338-48	WASHER,LOCK UOC: DAC,DAD,DAE,DAF,DAG,DAH,DAJ,DAL,DAW,DAX,V14,V15,V16,V17,V18,V19,V20,V21,V22,V24 .....	2
7	PAFZZ	5340-01-083-5443	19207	12255736	BRACKET,DOUBLE ANGL UOC: DAC,DAD,DAE,DAF,DAG,DAH,DAJ,DAL,DAW,DAX,V14,V15,V16,V17,V18,V19,V20,V21,V22,V24 .....	1
8	PAFZZ	5342-01-126-7910	76005	J-3424-190	MOUNT,RESILIENT,WEA UOC: DAC,DAD,DAE,DAF,DAG,DAH,DAJ,DAL,DAW,DAX,V14,V15,V16,V17,V18,V19,V20,V21,V22,V24 .....	1
9	PAFZZ	5305-00-638-8920	80204	B1821BH038C225N	SCREW,CAP,HEXAGON H UOC: DAC,DAD,DAE,DAF,DAG,DAH,DAJ,DAL,DAW,DAX,V14,V15,V16,V17,V18,V19,V20,V21,V22,V24 .....	12
10	PAFZZ	5310-00-637-9541	00198	132661	WASHER,LOCK UOC: DAC,DAD,DAE,DAF,DAG,DAH,DAJ,DAL,DAW,DAX,V14,V15,V16,V17,V18,V19,V20,V21,V22,V24 .....	12

(1) ITEM NO.	(2) SMR CODE	(3) NSN	(4) CAGEC	(5) PART NUMBER	(6) DESCRIPTION AND USABLE ON CODE (UOC)	(7) QTY
11	PAFZZ	4710-01-104-9099	19207	12256018	TUBE ASSEMBLY,METAL UOC: DAC,DAD,DAE,DAF,DAG,DA H,DAJ,DAL,DAW,DAX,V14,V15,V16, V17,V18,V19,V20,V21,V22,V24 .....	1
12	PAFZZ	4710-01-114-7761	19207	12256018-1	. TUBE ASSEMBLY,METAL UOC: DAC,DAD,DAE,DAF,DAG,DA H,DAJ,DAL,DAW,DAX,V14,V15,V16, V17,V18,V19,V20,V21,V22,V24 .....	1
13	PAFZZ	4730-00-019-0236	96906	MS51874-10	. INVERTED NUT,TUBE C UOC: DAC,DAD,DAE,DAF,DAG,DA H,DAJ,DAL,DAW,DAX,V14,V15,V16, V17,V18,V19,V20,V21,V22,V24 .....	1
14	PAFZZ	6680-01-296-2758	19207	11669173-1	GAGE ROD-CAP,LIQUID UOC: DAC,DAD,DAE,DAF,DAG,DA H,DAJ,DAL,DAW,DAX,V14,V15,V16, V17,V18,V19,V20,V21,V22,V24 .....	1

END OF FIGURE



**FIELD MAINTENANCE  
TRANSMISSION MOUNTING BRACKET (M939A2)**

---

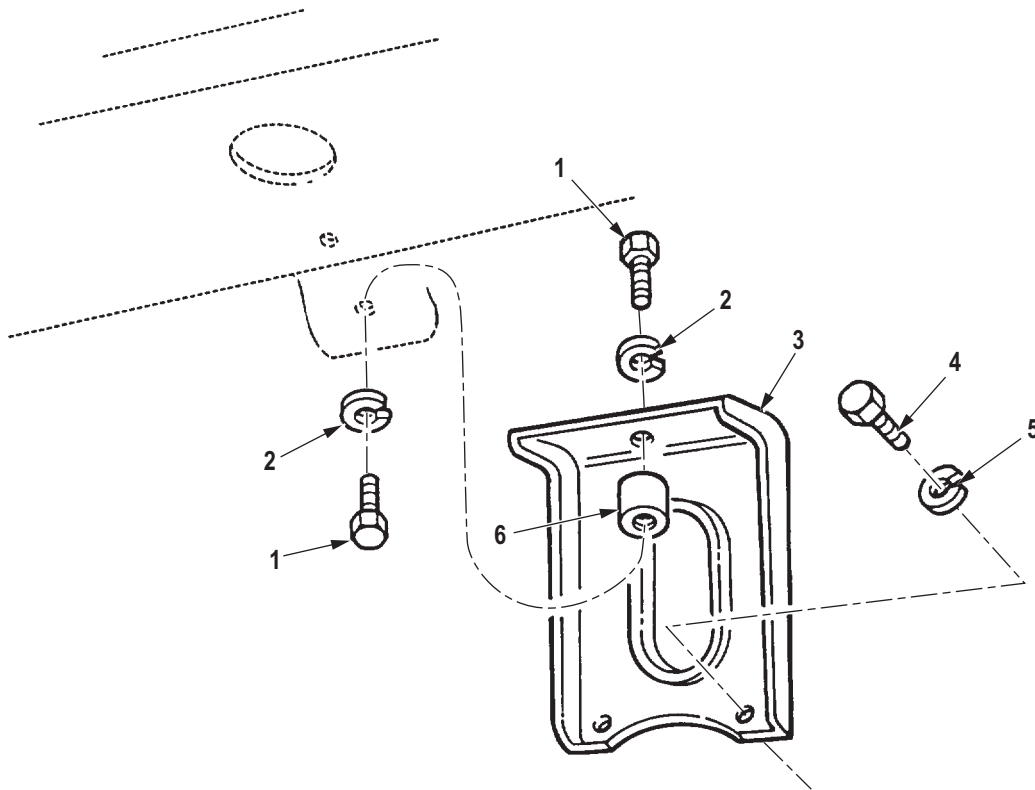

R0190DAA

Figure 178. Transmission Mounting Bracket (M939A2).

(1) ITEM NO.	(2) SMR CODE	(3) NSN	(4) CAGEC	(5) PART NUMBER	(6) DESCRIPTION AND USABLE ON CODE (UOC)	(7) QTY
<b>GROUP 0700 TRANSMISSION ASSEMBLY.</b>						
<b>FIG. 178. TRANSMISSION MOUNTING BRACKET (M939A2).</b>						
1	PAFZZ	5305-00-732-0512	80204	B1821BH050C075N	SCREW,CAP,HEXAGON H UOC: ZAA,ZAB,ZAC,ZAD,ZAE,ZAF, ZAG,ZAH,ZAJ,ZAL .....	2
2	PAFZZ	5310-00-003-4094	80205	MS35338-48	WASHER,LOCK UOC: ZAA,ZAB,ZAC,ZAD,ZAE,ZAF, ZAG,ZAH,ZAJ,ZAL .....	2
3	PGFZZ	5340-01-284-9652	05MG0	20510302	BRACKET,MOUNTING UOC: ZAA,ZAB,ZAC,ZAD,ZAE,ZAF, ZAG,ZAH,ZAJ,ZAL .....	1
4	PAFZZ	5305-00-724-7221	80204	B1821BH063C175N	SCREW,CAP,HEXAGON H UOC: ZAA,ZAB,ZAC,ZAD,ZAE,ZAF, ZAG,ZAH,ZAJ,ZAL .....	2
5	PAFZZ	5310-00-820-6653	80205	MS35338-50	WASHER,LOCK UOC: ZAA,ZAB,ZAC,ZAD,ZAE,ZAF, ZAG,ZAH,ZAJ,ZAL .....	2
6	PAFZZ	5342-01-126-7910	76005	J-3424-190	MOUNT,RESILIENT,WEA UOC: ZAA,ZAB,ZAC,ZAD,ZAE,ZAF, ZAG,ZAH,ZAJ,ZAL .....	1

**END OF FIGURE**



**FIELD MAINTENANCE  
TRANSMISSION DIPSTICK TUBE (M939A2)**

---

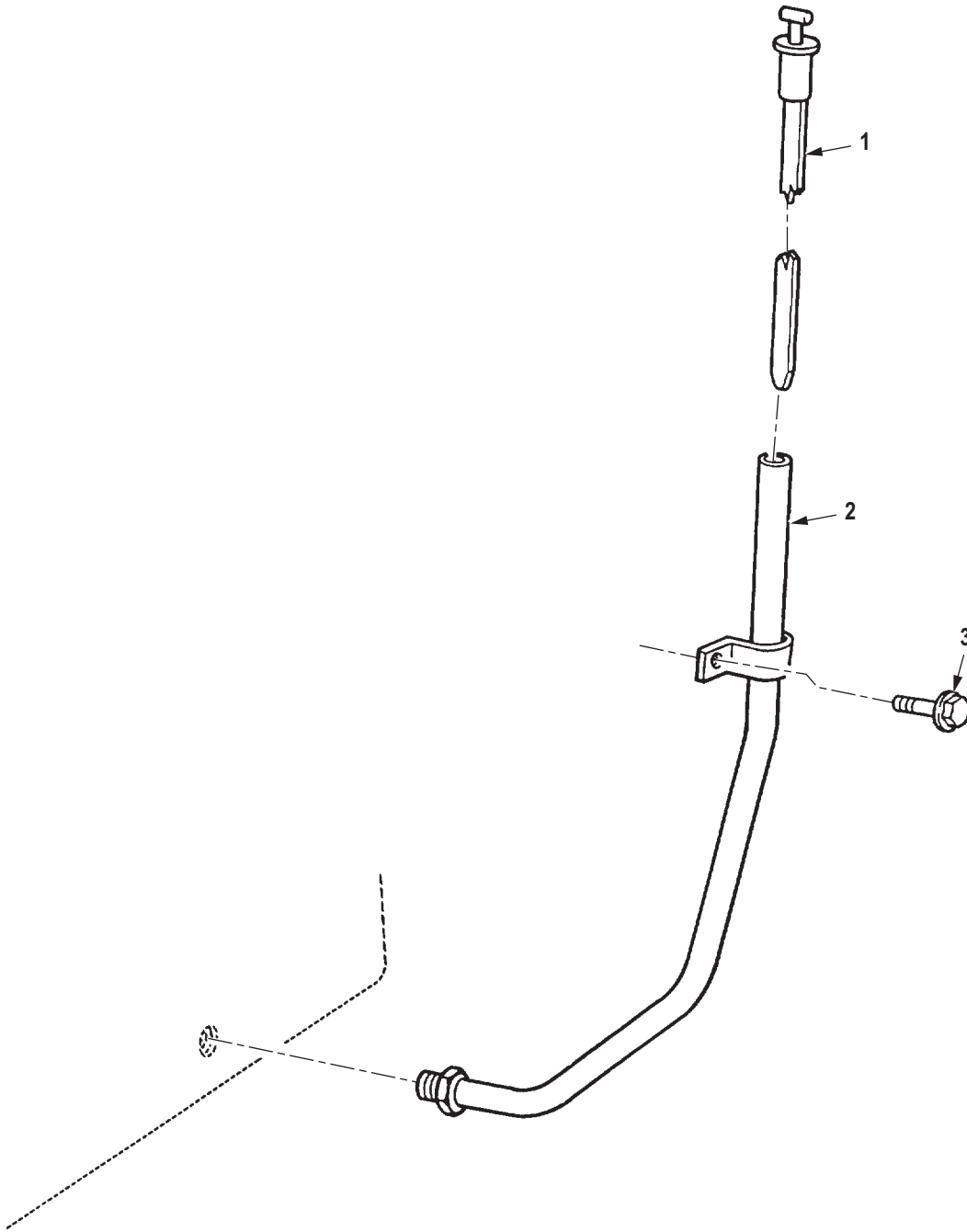

R0191DAA

Figure 179. Transmission Dipstick Tube (M939A2).

(1) ITEM NO.	(2) SMR CODE	(3) NSN	(4) CAGEC	(5) PART NUMBER	(6) DESCRIPTION AND USABLE ON CODE (UOC)	(7) QTY
<p><b>GROUP 0700 TRANSMISSION ASSEMBLY.</b></p> <p><b>FIG. 179. TRANSMISSION DIPSTICK TUBE (M939A2).</b></p>						
1	PAFZZ	6680-01-287-2153	0U276	42124	GAGE ROD-BREATHER,L UOC: ZAA,ZAB,ZAC,ZAD,ZAE,ZAF, ZAG,ZAH,ZAJ,ZAL .....	1
2	PAFZZ	2590-01-285-6261	19207	12363354	FILLER NECK,VEHICUL UOC: ZAA,ZAB,ZAC,ZAD,ZAE,ZAF, ZAG,ZAH,ZAJ,ZAL .....	1
3	PAFZZ	5305-01-192-2036	15434	3912072	SCREW UOC: ZAA,ZAB,ZAC,ZAD,ZAE,ZAF, ZAG,ZAH,ZAJ,ZAL .....	1
<p><b>END OF FIGURE</b></p>						





**FIELD MAINTENANCE**  
**TRANSMISSION SHIFT QUADRANT CONTROL CABLE AND NEUTRAL SAFETY SWITCH (M939, M939A1)**

---

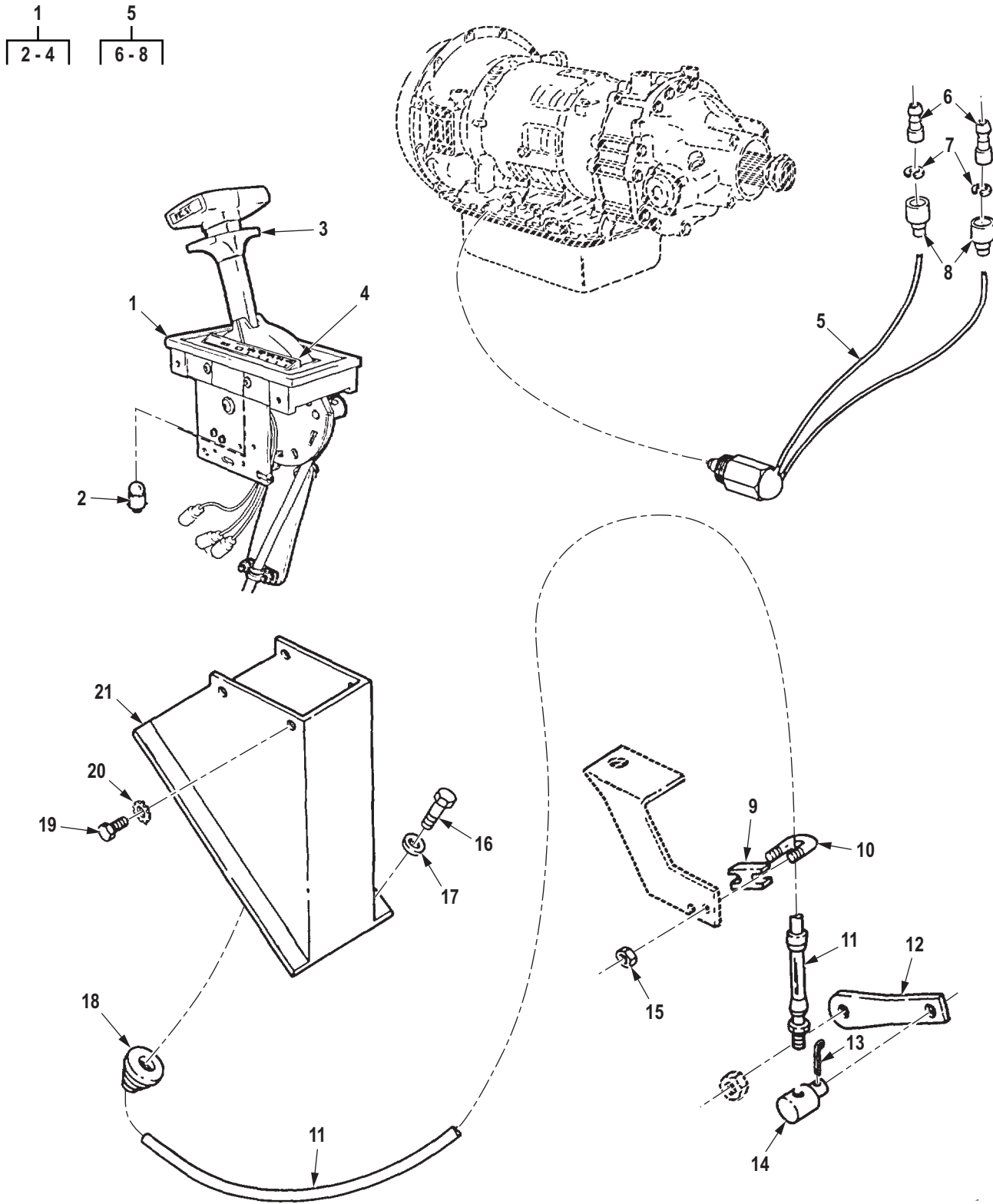

R0192DAA

Figure 180. Transmission Shift Quadrant Control Cable and Neutral Safety Switch (M939, M939A1).

(1) ITEM NO.	(2) SMR CODE	(3) NSN	(4) CAGEC	(5) PART NUMBER	(6) DESCRIPTION AND USABLE ON CODE (UOC)	(7) QTY
<b>GROUP 0705 TRANSMISSION SHIFTING COMPONENTS.</b>						
<b>FIG. 180. TRANSMISSION SHIFT QUADRANT CONTROL CABLE AND NEUTRAL SAFETY SWITCH (M939, M939A1).</b>						
1	PBFZZ	2520-01-090-7633	60602	55303-2342	TRANSMISSION CONTRO UOC: DAC,DAD,DAE,DAF,DAG,DA H,DAJ,DAL,DAW,DAX,V14,V15,V16, V17,V18,V19,V20,V21,V22,V24,ZAA, ZAB,ZAC,ZAD,ZAE,ZAF,ZAG,ZAH,Z AJ,ZAL .....	1
2	PAFZZ	6240-00-155-7866	96906	MS15573-3	. LAMP,INCANDESCENT UOC: DAC,DAD,DAE,DAF,DAG,DA H,DAJ,DAL,DAW,DAX,V14,V15,V16, V17,V18,V19,V20,V21,V22,V24,ZAA, ZAB,ZAC,ZAD,ZAE,ZAF,ZAG,ZAH,Z AJ,ZAL .....	1
3	PAFZZ	2520-01-367-7507	60602	59193	. CONTROL ASSEMBLY,GA UOC: DAC,DAD,DAE,DAF,DAG,DA H,DAJ,DAL,DAW,DAX,V14,V15,V16, V17,V18,V19,V20,V21,V22,V24,ZAA, ZAB,ZAC,ZAD,ZAE,ZAF,ZAG,ZAH,Z AJ,ZAL .....	1
4	XDFZZ		19207	00050081-0001	COVER,SHIFTER UOC: DAC,DAD,DAE,DAF,DAG,DA H,DAJ,DAL,DAW,DAX,V14,V15,V16, V17,V18,V19,V20,V21,V22,V24,ZAA, ZAB,ZAC,ZAD,ZAE,ZAF,ZAG,ZAH,Z AJ,ZAL .....	1
5	PAFZZ	2920-01-114-7538	73342	29511979	SWITCH,SAFETY,NEUTR TRANS CONTROL UOC: DAC,DAD,DAE,DAF,DAG,DA H,DAJ,DAL,DAW,DAX,V14,V15,V16, V17,V18,V19,V20,V21,V22,V24 .....	1
6	PAFZZ	5999-00-926-3144	58536	AA52536-3	. CONTACT,ELECTRICAL UOC: DAC,DAD,DAE,DAF,DAG,DA H,DAJ,DAL,DAW,DAX,V14,V15,V16, V17,V18,V19,V20,V21,V22,V24 .....	2
7	PAFZZ	5310-00-656-0067	19207	8724497	. WASHER,SLOTTED UOC: DAC,DAD,DAE,DAF,DAG,DA H,DAJ,DAL,DAW,DAX,V14,V15,V16, V17,V18,V19,V20,V21,V22,V24 .....	2
8	PAFZZ	5935-00-691-5591	97403	13207E6498-2	. SHELL,ELECTRICAL CO UOC: DAC,DAD,DAE,DAF,DAG,DA H,DAJ,DAL,DAW,DAX,V14,V15,V16, V17,V18,V19,V20,V21,V22,V24 .....	2

(1) ITEM NO.	(2) SMR CODE	(3) NSN	(4) CAGEC	(5) PART NUMBER	(6) DESCRIPTION AND USABLE ON CODE (UOC)	(7) QTY
9	PAFZZ	5340-01-090-9331	05MG0	12256023	STRAP,RETAINING UOC: DAC,DAD,DAE,DAF,DAG,DA H,DAJ,DAL,DAW,DAX,V14,V15,V16, V17,V18,V19,V20,V21,V22,V24 .....	1
10	PAFZZ	5306-01-112-6560	19207	12255984	BOLT,U UOC: DAC,DAD,DAE,DAF,DAG,DA H,DAJ,DAL,DAW,DAX,V14,V15,V16, V17,V18,V19,V20,V21,V22,V24 .....	1
11	PAFZZ	3040-01-208-5897	62809	03812-003-00600.0	CONTROL ASSEMBLY,PU UOC: DAC,DAD,DAE,DAF,DAG,DA H,DAJ,DAL,DAW,DAX,V14,V15,V16, V17,V18,V19,V20,V21,V22,V24 .....	1
12	PAFZZ	3040-01-104-9151	19207	11669346	LEVER,REMOTE CONTRO UOC: DAC,DAD,DAE,DAF,DAG,DA H,DAJ,DAL,DAW,DAX,V14,V15,V16, V17,V18,V19,V20,V21,V22,V24 .....	1
13	PAFZZ	5315-00-234-1863	80205	MS24665-300	PIN,COTTER UOC: DAC,DAD,DAE,DAF,DAG,DA H,DAJ,DAL,DAW,DAX,V14,V15,V16, V17,V18,V19,V20,V21,V22,V24 .....	1
14	PAFZZ	5315-01-144-8675	19207	11669345	PIN,SHOULDER,HEADLE UOC: DAC,DAD,DAE,DAF,DAG,DA H,DAJ,DAL,DAW,DAX,V14,V15,V16, V17,V18,V19,V20,V21,V22,V24 .....	1
15	PAFZZ	5310-00-877-5797	80205	MS21044N3	NUT,SELF-LOCKING,HE UOC: DAC,DAD,DAE,DAF,DAG,DA H,DAJ,DAL,DAW,DAX,V14,V15,V16, V17,V18,V19,V20,V21,V22,V24 .....	2
16	PAFZZ	5306-01-166-6895	21450	425736	BOLT,ASSEMBLED WASH UOC: DAC,DAD,DAE,DAF,DAG,DA H,DAJ,DAL,DAW,DAX,V14,V15,V16, V17,V18,V19,V20,V21,V22,V24 .....	4
17	PAFZZ	5310-00-080-6004	96906	MS27183-14	WASHER,FLAT UOC: DAC,DAD,DAE,DAF,DAG,DA H,DAJ,DAL,DAW,DAX,V14,V15,V16, V17,V18,V19,V20,V21,V22,V24 .....	4
18	PAFZZ	5325-01-106-4125	19207	12256578-5	GROMMET,NONMETALLIC BRACKET ASSEMBLY UOC: DAC,DAD,DAE,DAF,DAG,DA H,DAJ,DAL,DAW,DAX,V14,V15,V16, V17,V18,V19,V20,V21,V22,V24 .....	1
19	PAFZZ	5305-00-068-0500	11599	28988-4	SCREW,CAP,HEX HEAD UOC: DAC,DAD,DAE,DAF,DAG,DA H,DAJ,DAL,DAW,DAX,V14,V15,V16, V17,V18,V19,V20,V21,V22,V24 .....	4

(1) ITEM NO.	(2) SMR CODE	(3) NSN	(4) CAGEC	(5) PART NUMBER	(6) DESCRIPTION AND USABLE ON CODE (UOC)	(7) QTY
20	PAFZZ	5310-00-209-0786	96906	MS35335-33	WASHER,LOCK UOC: DAC,DAD,DAE,DAF,DAG,DA H,DAJ,DAL,DAW,DAX,V14,V15,V16, V17,V18,V19,V20,V21,V22,V24 .....	4
21	PFFZZ	5340-01-103-7587	19207	12255944	BRACKET,MOUNTING UOC: DAC,DAD,DAE,DAF,DAG,DA H,DAJ,DAL,DAW,DAX,V14,V15,V16, V17,V18,V19,V20,V21,V22,V24 .....	1

END OF FIGURE



**FIELD MAINTENANCE  
TRANSMISSION SHIFT CONTROL CABLE AND RELATED PARTS (M939A2)**

---

1	2	7
2-16	3-4	8-16

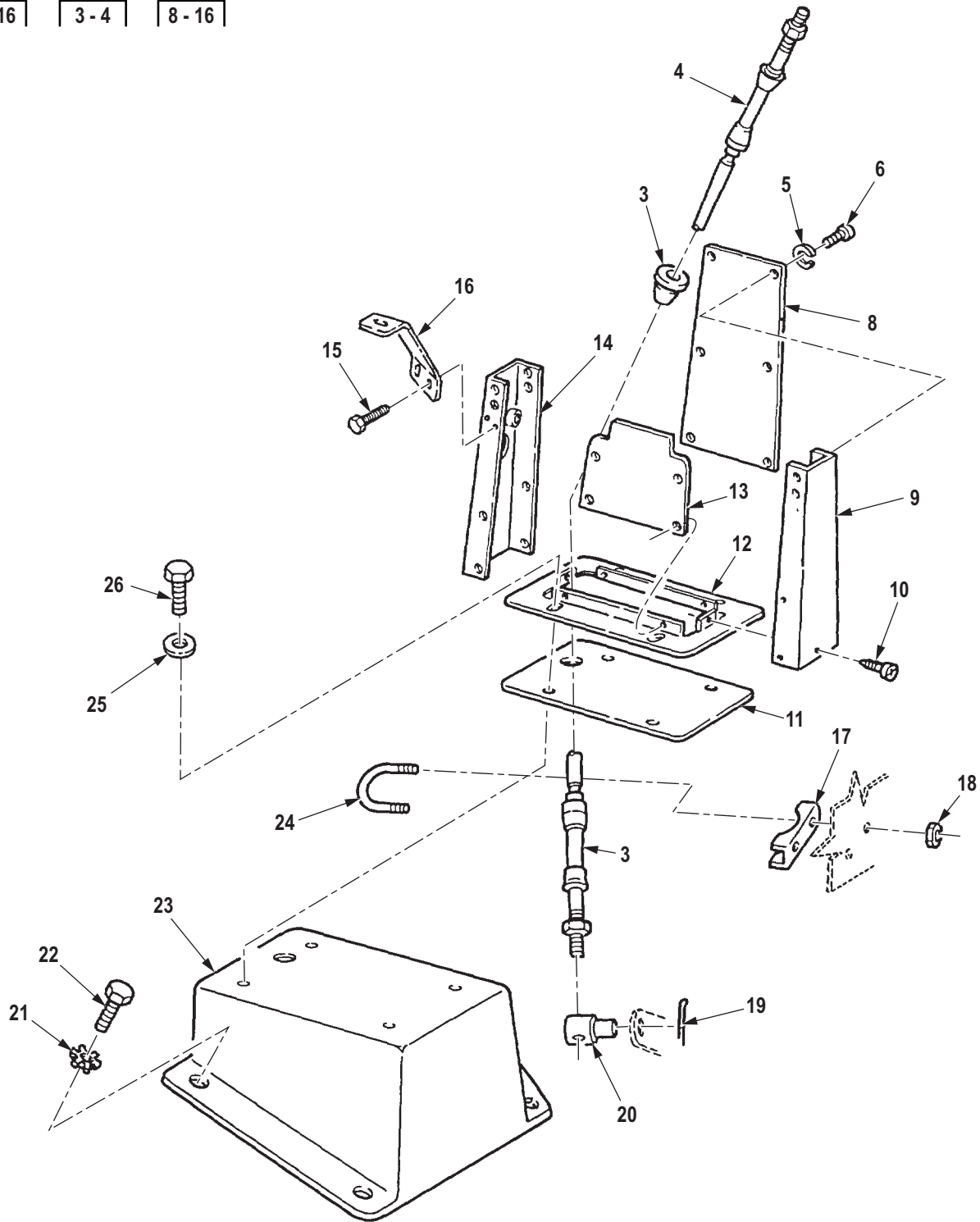

R0193DAA

Figure 181. Transmission Shift Control Cable and Related Parts (M939A2).



(1) ITEM NO.	(2) SMR CODE	(3) NSN	(4) CAGEC	(5) PART NUMBER	(6) DESCRIPTION AND USABLE ON CODE (UOC)	(7) QTY
<p><b>GROUP 0705 TRANSMISSION SHIFTING COMPONENTS.</b></p> <p><b>FIG. 181. TRANSMISSION SHIFT CONTROL CABLE AND RELATED PARTS (M939A2).</b></p>						
1	PAFZZ	5342-01-284-9246	60602	59188	BRACKET,SPECIAL TRANSMISSION SHIFT CONTROLS UOC: ZAA,ZAB,ZAC,ZAD,ZAE,ZAF, ZAG,ZAH,ZAJ,ZAL .....	1
2	PAFZZ	2520-01-286-5650	60602	000-45737-0040	. CONTROL ASSEMBLY,GA TRANS SHIFT CONTROL UOC: ZAA,ZAB,ZAC,ZAD,ZAE,ZAF, ZAG,ZAH,ZAJ,ZAL .....	1
3	PAFZZ	5325-01-461-2210	19207	12432431	. . GROMMET,NONMETALLIC CONTROL CABLE UOC: ZAA,ZAB,ZAC,ZAD,ZAE,ZAF, ZAG,ZAH,ZAJ,ZAL .....	1
4	PAFZZ	2520-01-461-4889	19207	12363371-1	. . CONTROL ASSEMBLY,TR TRANSMISSION CONTROL UOC: ZAA,ZAB,ZAC,ZAD,ZAE,ZAF, ZAG,ZAH,ZAJ,ZAL .....	1
5	PAFZZ	5310-00-582-5965	80205	MS35338-44	. WASHER,LOCK 1/4 UOC: ZAA,ZAB,ZAC,ZAD,ZAE,ZAF, ZAG,ZAH,ZAJ,ZAL .....	4
6	PAFZZ	5305-00-988-1723	80205	MS35206-279	. SCREW,MACHINE 1/4-20 X 1/2 UOC: ZAA,ZAB,ZAC,ZAD,ZAE,ZAF, ZAG,ZAH,ZAJ,ZAL .....	4
7	PAFZZ	5340-01-284-9247	60602	59189	. BRACKET,MOUNTING CONTROL TOWER UOC: ZAA,ZAB,ZAC,ZAD,ZAE,ZAF, ZAG,ZAH,ZAJ,ZAL .....	1
8	PAFZZ	5340-01-282-0452	05MG0	20510897	. . COVER,ACCESS RIGHT HAND UOC: ZAA,ZAB,ZAC,ZAD,ZAE,ZAF, ZAG,ZAH,ZAJ,ZAL .....	1
9	PAFZZ	5340-01-284-9655	05MG0	20510898-2	. . BRACKET,MOUNTING TOWER UOC: ZAA,ZAB,ZAC,ZAD,ZAE,ZAF, ZAG,ZAH,ZAJ,ZAL .....	1
10	PAFZZ	5305-01-271-8337	24617	9406129	. . SCREW,TAPPING THREA #10-32 X 5/16 UOC: ZAA,ZAB,ZAC,ZAD,ZAE,ZAF, ZAG,ZAH,ZAJ,ZAL .....	12
11	PAFZZ	5330-01-285-1601	60602	50161-2	. . GASKET UOC: ZAA,ZAB,ZAC,ZAD,ZAE,ZAF, ZAG,ZAH,ZAJ,ZAL .....	1
12	PAFZZ	5445-01-284-6173	60602	52442	. . PLATE,BASE,TOWER SU UOC: ZAA,ZAB,ZAC,ZAD,ZAE,ZAF, ZAG,ZAH,ZAJ,ZAL .....	1

(1) ITEM NO.	(2) SMR CODE	(3) NSN	(4) CAGEC	(5) PART NUMBER	(6) DESCRIPTION AND USABLE ON CODE (UOC)	(7) QTY
13	PAFZZ	5340-01-284-3789	60602	52478	. . COVER,ACCESS LEFT HAND UOC: ZAA,ZAB,ZAC,ZAD,ZAE,ZAF, ZAG,ZAH,ZAJ,ZAL .....	1
14	PAFZZ	5340-01-284-9654	05MG0	20510898-1	. . BRACKET,MOUNTING TOWER UOC: ZAA,ZAB,ZAC,ZAD,ZAE,ZAF, ZAG,ZAH,ZAJ,ZAL .....	1
15	PAFZZ	5305-01-459-9567	24617	9427724	. . SCREW,CAP,HEXAGON H 1/4-20 X 1/2 UOC: ZAA,ZAB,ZAC,ZAD,ZAE,ZAF, ZAG,ZAH,ZAJ,ZAL .....	20
16	PAFZZ	5340-01-460-1016	19207	12363442	. . BRACKET,MOUNTING SH SUPPORT UOC: ZAA,ZAB,ZAC,ZAD,ZAE,ZAF, ZAG,ZAH,ZAJ,ZAL .....	1
17	PAFZZ	5340-01-090-9331	05MG0	12256023	STRAP,RETAINING UOC: ZAA,ZAB,ZAC,ZAD,ZAE,ZAF, ZAG,ZAH,ZAJ,ZAL .....	1
18	PAFZZ	5310-00-061-7326	80205	MS21045-3	NUT,SELF-LOCKING,HE #10-32 UOC: ZAA,ZAB,ZAC,ZAD,ZAE,ZAF, ZAG,ZAH,ZAJ,ZAL .....	2
19	PAFZZ	5315-00-234-1863	80205	MS24665-300	PIN,COTTER 3/32 X 3/4 UOC: ZAA,ZAB,ZAC,ZAD,ZAE,ZAF, ZAG,ZAH,ZAJ,ZAL .....	1
20	PAFZZ	5315-01-144-8675	19207	11669345	PIN,SHOULDER,HEADLE UOC: ZAA,ZAB,ZAC,ZAD,ZAE,ZAF, ZAG,ZAH,ZAJ,ZAL .....	1
21	PAFZZ	5310-00-209-0786	96906	MS35335-33	WASHER,LOCK 17/64 UOC: ZAA,ZAB,ZAC,ZAD,ZAE,ZAF, ZAG,ZAH,ZAJ,ZAL .....	11
22	PAFZZ	5305-00-267-8954	80204	B1821BH025F125N	SCREW,CAP,HEXAGON H 1/4-24 X 1.25 UOC: ZAA,ZAB,ZAC,ZAD,ZAE,ZAF, ZAG,ZAH,ZAJ,ZAL .....	7
23	PAFZZ	5340-01-322-2906	7A964	20510403	BRACKET,MOUNTING UOC: ZAA,ZAB,ZAC,ZAD,ZAE,ZAF, ZAG,ZAH,ZAJ,ZAL .....	1
24	PAFZZ	5306-01-112-6560	19207	12255984	BOLT,U UOC: ZAA,ZAB,ZAC,ZAD,ZAE,ZAF, ZAG,ZAH,ZAJ,ZAL .....	1
25	PAFZZ	5310-00-809-4058	96906	MS27183-10	WASHER,FLAT 1/4 UOC: ZAA,ZAB,ZAC,ZAD,ZAE,ZAF, ZAG,ZAH,ZAJ,ZAL .....	7
26	PAFZZ	5305-00-267-8953	80204	B1821BH025F063N	SCREW,CAP,HEXAGON H 1/4-24 X 0.63 UOC: ZAA,ZAB,ZAC,ZAD,ZAE,ZAF, ZAG,ZAH,ZAJ,ZAL .....	4

END OF FIGURE

**FIELD MAINTENANCE  
WRECKER GOVERNOR PIPING AND CAPACITOR ASSEMBLY**

---

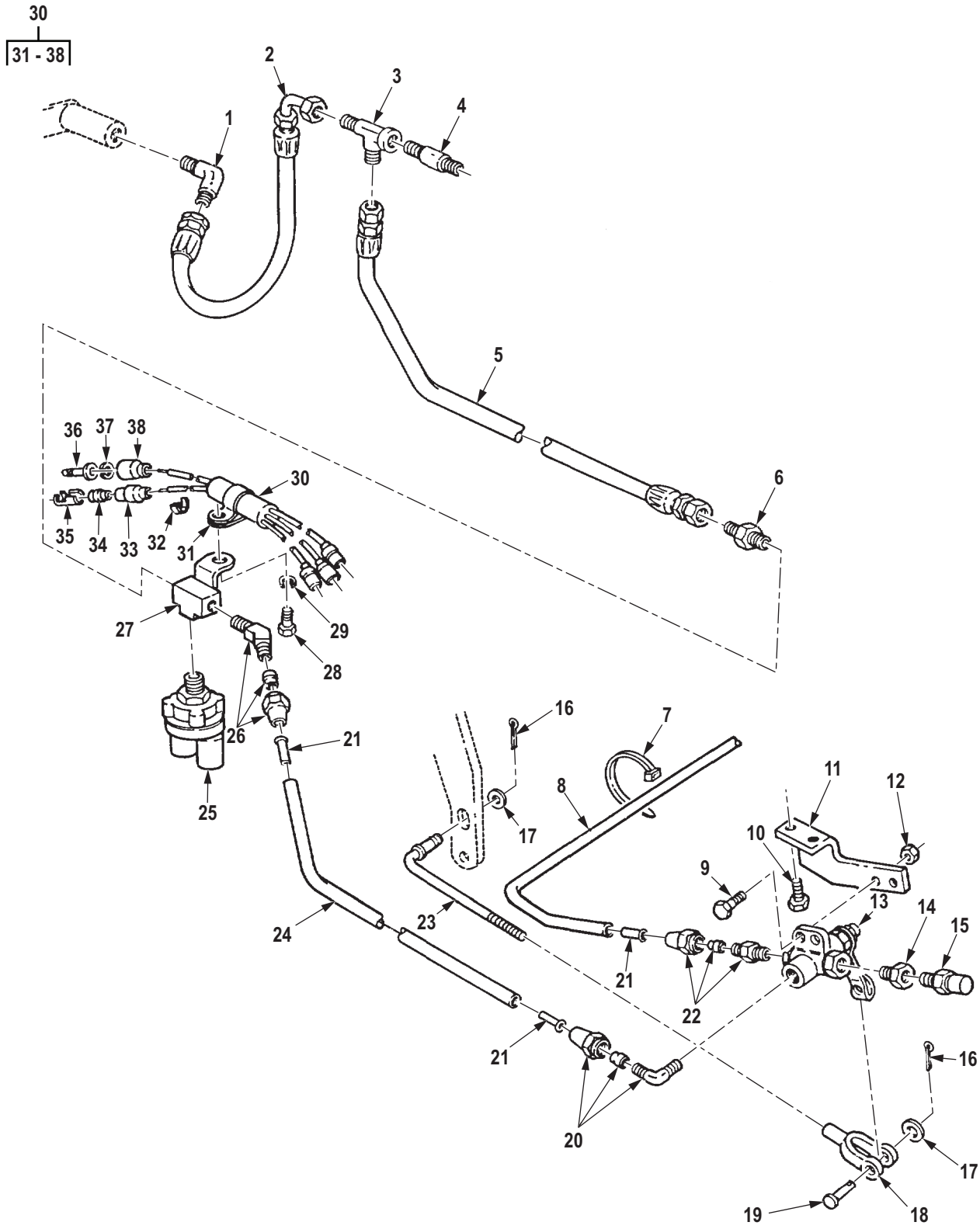

R0194DAA

Figure 182. Wrecker Governor Piping and Capacitor Assembly.

(1) ITEM NO.	(2) SMR CODE	(3) NSN	(4) CAGEC	(5) PART NUMBER	(6) DESCRIPTION AND USABLE ON CODE (UOC)	(7) QTY
<b>GROUP 0705 TRANSMISSION SHIFTING COMPONENTS.</b>						
<b>FIG. 182. WRECKER GOVERNOR PIPING AND CAPACITOR ASSEMBLY.</b>						
1	PAFZZ	4730-00-803-5765	96906	MS51504A6-2	ELBOW,PIPE TO TUBE UOC: DAL,V18,ZAL .....	1
2	PAFZZ	4720-01-304-0688	19207	12302866	HOSE ASSEMBLY,NONME UOC: DAL,V18,ZAL .....	1
3	PAFZZ	4730-01-146-4113	96906	MS51514A6	TEE,PIPE TO TUBE UOC: DAL,V18,ZAL .....	1
4	PAFZZ	4730-01-027-8943	96906	MS51873-32B	NIPPLE,PIPE UOC: DAL,V18,ZAL .....	1
5	PBFZZ	4720-01-276-1252	19207	12302867	HOSE ASSEMBLY,NONME UOC: DAL,V18,ZAL .....	1
6	PAFZZ	4730-00-322-8457	96906	MS51500A6-6	ADAPTER,STRAIGHT,PI UOC: DAL,V18,ZAL .....	1
7	PAFZZ	5975-00-984-6582	96906	MS3367-1-0	STRAP,TIEDOWN,ELECT UOC: DAL,V18,ZAL .....	3
8	MFFZZ		81343	J844TYBSIZE 3/8 BLACK-60	HOSE,NONMETALLIC AIR TANK TO VALVE, MAKE FROM HOSE, P/N J844TYBSIZE 3/8BLACK, 60 IN.LONG UOC: DAC,DAD,DAE,DAF,DAG,DA H,DAJ,DAL,DAW,DAX,V14,V15,V16, V17,V18,V19,V20,V21,V22,V24,ZAA, ZAB,ZAC,ZAD,ZAE,ZAF,ZAG,ZAH,Z AJ,ZAL .....	1
9	PAFZZ	5305-00-068-0515	80204	B1821BH025F100N	SCREW,CAP,HEXAGON H UOC: DAL,V18,ZAL .....	2
10	PAFZZ	5305-00-442-3217	80205	MS24629-66	SCREW,TAPPING UOC: DAL,V18,ZAL .....	2
11	PAFZZ	5340-01-167-5535	19207	12302646	BRACKET,ANGLE UOC: DAL,V18,ZAL .....	1
12	PAFZZ	5310-00-935-9022	81349	M45913/3-4FG8C	NUT,SELF-LOCKING,HE UOC: DAL,V18,ZAL .....	2
13	PAFZZ	4820-00-808-6905	70411	SP2346CM	VALVE,PLUG UOC: DAL,V18,ZAL .....	1
14	PAFZZ	4730-00-196-0930	96906	MS14315-1XA	BUSHING,PIPE UOC: DAL,V18,ZAL .....	1
15	PAFZZ	4820-00-726-4719	19207	5196397	VALVE,VENT UOC: DAL,V18,ZAL .....	1
16	PAFZZ	5315-00-839-2325	80205	MS24665-132	PIN,COTTER UOC: DAL,V18,ZAL .....	2
17	PAFZZ	5310-00-809-4058	96906	MS27183-10	WASHER,FLAT UOC: DAL,V18,ZAL .....	2
18	PAFZZ	5340-00-865-9496	06970	AC206	CLEVIS,ROD END UOC: DAL,V18,ZAL .....	1

(1) ITEM NO.	(2) SMR CODE	(3) NSN	(4) CAGEC	(5) PART NUMBER	(6) DESCRIPTION AND USABLE ON CODE (UOC)	(7) QTY
19	PAFZZ	5315-00-081-7874	80205	MS20392-3C23	PIN,STRAIGHT,HEADED UOC: DAL,V18,ZAL .....	1
20	PAFZZ	4730-00-069-1187	81343	SAE J246 6-4 100202BA	ELBOW,PIPE TO TUBE UOC: DAL,V18,ZAL .....	1
21	PAFZZ	4730-01-079-8821	19207	CPR102321-1	INSERT,TUBE FITTING UOC: DAL,V18,ZAL .....	6
22	PAFZZ	4730-00-069-1186	81343	6-4 120102BA	ADAPTER,STRAIGHT,PI UOC: DAL,V18,ZAL .....	1
23	PFFZZ	5315-01-173-0397	19207	12302647	PIN,STRAIGHT,HEADED UOC: DAL,V18,ZAL .....	1
24	MFFZZ		81343	J844TYBSIZE 3/8 BLACK-22	HOSE,NONMETALLIC MAKE FROM HOSE, P/N J844TYBSIZE 3/8 BLACK, 22 IN.LONG UOC: DAL,V18,ZAL .....	1
25	PAFZZ	2540-00-789-6192	19207	11602160	SWITCH,PRESSURE UOC: DAL,V18,ZAL .....	1
26	PAFZZ	4730-00-541-7500	81343	6-6 120302BA(LONG ELBOW,PIPE TO TUBE NUT)	UOC: DAL,V18,ZAL .....	1
27	PAFZZ	4730-01-114-7541	19207	11669081	TEE,PIPE UOC: DAL,V18,ZAL .....	1
28	PAFZZ	5305-00-990-0695	80205	B1821BH050F088N	SCREW,CAP,HEXAGON H UOC: DAL,V18,ZAL .....	1
29	PAFZZ	5310-00-003-4094	80205	MS35338-48	WASHER,LOCK UOC: DAL,V18,ZAL .....	1
30	PAFFF	5910-01-165-5255	19207	12302648	CAPACITOR,FIXED,MET UOC: DAL,V18,ZAL .....	1
31	PAFZZ	5340-01-170-5007	19207	8352678	. CLAMP,LOOP UOC: DAL,V18,ZAL .....	1
32	PAFZZ	9905-01-013-8723	81349	M43436/3-1	. BAND,MARKER UOC: DAL,V18,ZAL .....	5
33	PAFZZ	5975-00-660-5962	19207	8724494	. CABLE NIPPLE,ELECTR UOC: DAL,V18,ZAL .....	3
34	PAFZZ	5970-00-833-8562	19207	8338562	. INSULATOR,BUSHING UOC: DAL,V18,ZAL .....	3
35	PAFZZ	5940-00-399-6676	19207	8338564	. TERMINAL SET,QUICK UOC: DAL,V18,ZAL .....	3
36	PAFZZ	5999-00-926-3144	58536	AA52536-3	. CONTACT,ELECTRICAL UOC: DAL,V18,ZAL .....	2
37	PAFZZ	5310-00-656-0067	19207	8724497	. WASHER,SLOTTED UOC: DAL,V18,ZAL .....	2
38	PAFZZ	5935-00-691-5591	97403	13207E6498-2	. SHELL,ELECTRICAL CO UOC: DAL,V18,ZAL .....	2

END OF FIGURE

**FIELD MAINTENANCE  
TRANSMISSION MODULATOR AND CABLE ASSEMBLY (M939, M939A1)**

---

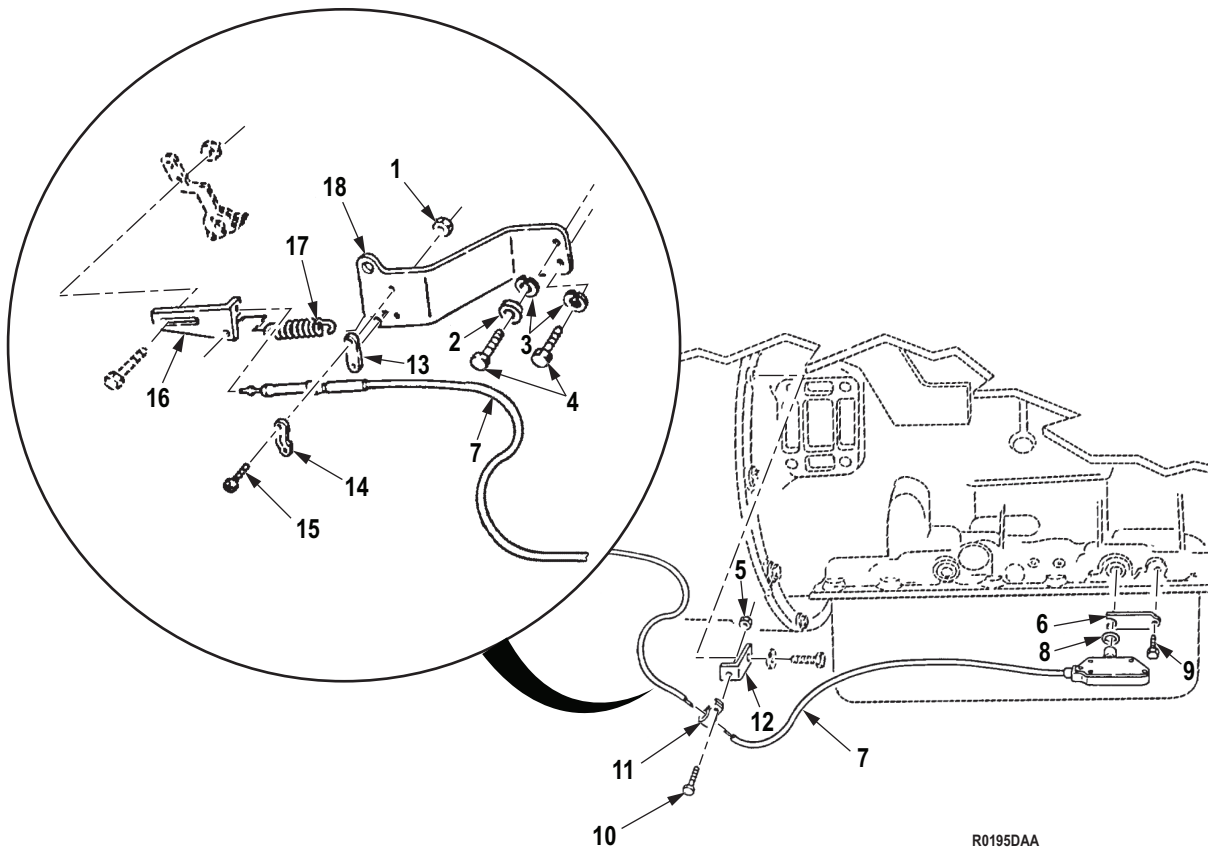

Figure 183. Transmission Modulator and Cable Assembly (M939, M939A1).



(1) ITEM NO.	(2) SMR CODE	(3) NSN	(4) CAGEC	(5) PART NUMBER	(6) DESCRIPTION AND USABLE ON CODE (UOC)	(7) QTY
<b>GROUP 0705 TRANSMISSION SHIFTING COMPONENTS.</b>						
<b>FIG. 183. TRANSMISSION MODULATOR AND CABLE ASSEMBLY (M939, M939A1).</b>						
1	PAFZZ	5310-00-877-5797	80205	MS21044N3	NUT,SELF-LOCKING,HE UOC: DAC,DAD,DAE,DAF,DAG,DA H,DAJ,DAL,DAW,DAX,V14,V15,V16, V17,V18,V19,V20,V21,V22,V24 .....	2
2	PAFZZ	5310-00-068-5285	96906	MS27183-20	WASHER,FLAT UOC: DAC,DAD,DAE,DAF,DAG,DA H,DAJ,DAL,DAW,DAX,V14,V15,V16, V17,V18,V19,V20,V21,V22,V24 .....	6
3	PAFZZ	5310-00-167-0680	80205	MS35338-49	WASHER,LOCK UOC: DAC,DAD,DAE,DAF,DAG,DA H,DAJ,DAL,DAW,DAX,V14,V15,V16, V17,V18,V19,V20,V21,V22,V24 .....	2
4	PAFZZ	5305-00-902-9338	80205	MS90726-134	SCREW,CAP,HEXAGON H UOC: DAC,DAD,DAE,DAF,DAG,DA H,DAJ,DAL,DAW,DAX,V14,V15,V16, V17,V18,V19,V20,V21,V22,V24 .....	2
5	PAFZZ	5310-00-087-4652	81349	M45913/1-6CG5C	NUT,SELF-LOCKING,HE UOC: DAC,DAD,DAE,DAF,DAG,DA H,DAJ,DAL,DAW,DAX,V14,V15,V16, V17,V18,V19,V20,V21,V22,V24 .....	1
6	PAFZZ	2520-00-557-6619	73342	8627650	RETAINER,MODULATOR UOC: DAC,DAD,DAE,DAF,DAG,DA H,DAJ,DAL,DAW,DAX,V14,V15,V16, V17,V18,V19,V20,V21,V22,V24 .....	1
7	PAFZZ	2590-01-079-1506	62809	310777-000-0060.0	MODULATOR AND CABLE UOC: DAC,DAD,DAE,DAF,DAG,DA H,DAJ,DAL,DAW,DAX,V14,V15,V16, V17,V18,V19,V20,V21,V22,V24 .....	1
8	PAFZZ	5331-00-248-3847	11599	8A9026	O-RING UOC: DAC,DAD,DAE,DAF,DAG,DA H,DAJ,DAL,DAW,DAX,V14,V15,V16, V17,V18,V19,V20,V21,V22,V24 .....	1
9	PAFZZ	5306-00-225-8496	80205	MS90725-31	BOLT,MACHINE UOC: DAC,DAD,DAE,DAF,DAG,DA H,DAJ,DAL,DAW,DAX,V14,V15,V16, V17,V18,V19,V20,V21,V22,V24 .....	1
10	PAFZZ	5305-00-269-2803	80205	MS90726-60	SCREW,CAP,HEXAGON H UOC: DAC,DAD,DAE,DAF,DAG,DA H,DAJ,DAL,DAW,DAX,V14,V15,V16, V17,V18,V19,V20,V21,V22,V24 .....	1

(1) ITEM NO.	(2) SMR CODE	(3) NSN	(4) CAGEC	(5) PART NUMBER	(6) DESCRIPTION AND USABLE ON CODE (UOC)	(7) QTY
11	PAFZZ	5340-00-523-5999	19207	7397783	CLAMP, LOOP UOC: DAC, DAD, DAE, DAF, DAG, DA H, DAJ, DAL, DAW, DAX, V14, V15, V16, V17, V18, V19, V20, V21, V22, V24 .....	1
12	PFFZZ	5340-01-312-1136	19207	12256026-1	BRACKET, ANGLE UOC: DAC, DAD, DAE, DAF, DAG, DA H, DAJ, DAL, DAW, DAX, V14, V15, V16, V17, V18, V19, V20, V21, V22, V24 .....	1
13	PAFZZ	5365-01-091-1630	19207	12256024	SPACER, PLATE UOC: DAC, DAD, DAE, DAF, DAG, DA H, DAJ, DAL, DAW, DAX, V14, V15, V16, V17, V18, V19, V20, V21, V22, V24 .....	1
14	PAFZZ	5340-01-090-9331	05MG0	12256023	STRAP, RETAINING UOC: DAC, DAD, DAE, DAF, DAG, DA H, DAJ, DAL, DAW, DAX, V14, V15, V16, V17, V18, V19, V20, V21, V22, V24 .....	1
15	PAFZZ	5305-00-993-1848	80205	MS35207-265	SCREW, MACHINE UOC: DAC, DAD, DAE, DAF, DAG, DA H, DAJ, DAL, DAW, DAX, V14, V15, V16, V17, V18, V19, V20, V21, V22, V24 .....	2
16	PAFZZ	5340-01-090-4484	19207	12256025	HOLDER, SPRING UOC: DAC, DAD, DAE, DAF, DAG, DA H, DAJ, DAL, DAW, DAX, V14, V15, V16, V17, V18, V19, V20, V21, V22, V24 .....	1
17	PAFZZ	5360-01-470-6574	19207	12256112	SPRING, HELICAL, EXTE UOC: DAC, DAD, DAE, DAF, DAG, DA H, DAJ, DAL, DAW, DAX, V14, V15, V16, V17, V18, V19, V20, V21, V22, V24 .....	1
18	PFFZZ	5342-01-090-9334	19207	12256094	BRACKET ASSEMBLY, MO UOC: DAC, DAD, DAE, DAF, DAG, DA H, DAJ, DAL, DAW, DAX, V14, V15, V16, V17, V18, V19, V20, V21, V22, V24 .....	1

END OF FIGURE

**FIELD MAINTENANCE  
TRANSMISSION MODULATOR AND CABLE ASSEMBLY (M939A2)**

---

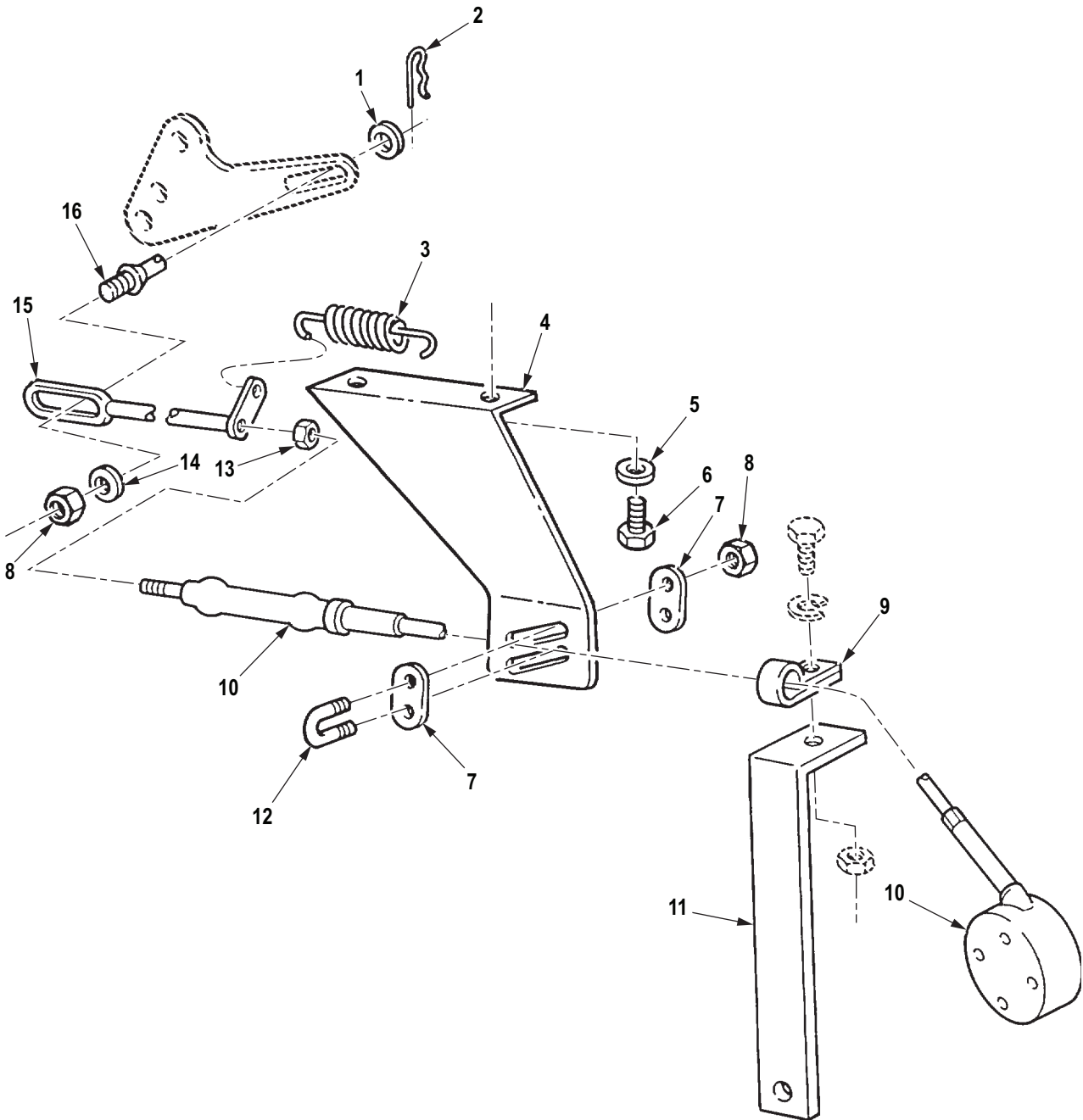

R0196DAA

Figure 184. Transmission Modulator and Cable Assembly (M939A2).

(1) ITEM NO.	(2) SMR CODE	(3) NSN	(4) CAGEC	(5) PART NUMBER	(6) DESCRIPTION AND USABLE ON CODE (UOC)	(7) QTY
<b>GROUP 0705 TRANSMISSION SHIFTING COMPONENTS.</b>						
<b>FIG. 184. TRANSMISSION MODULATOR AND CABLE ASSEMBLY (M939A2).</b>						
1	PAFZZ	5310-01-332-7265	24617	9421861	WASHER,FLAT UOC: ZAA,ZAB,ZAC,ZAD,ZAE,ZAF, ZAG,ZAH,ZAJ,ZAL .....	1
2	PAFZZ	5315-01-284-9812	60602	10166	PIN,LOCK UOC: ZAA,ZAB,ZAC,ZAD,ZAE,ZAF, ZAG,ZAH,ZAJ,ZAL .....	1
2	PAFZZ	5315-01-446-9007	58536	A-A-55487-8	PIN,LOCK FOR M939A2 VEHICLES WITH MODIFICATION KIT 57K0281 INSTALLED UOC: ZAA,ZAB,ZAC,ZAD,ZAE,ZAF, ZAG,ZAH,ZAJ,ZAL .....	1
3	PAFZZ	5360-01-550-8820	47457	20511227	SPRING,HELICAL,EXTE UOC: ZAA,ZAB,ZAC,ZAD,ZAE,ZAF, ZAG,ZAH,ZAJ,ZAL .....	1
4	PAFZZ	5340-01-280-7097	05MG0	20510476	BRACKET,MOUNTING CABLE UOC: ZAA,ZAB,ZAC,ZAD,ZAE,ZAF, ZAG,ZAH,ZAJ,ZAL .....	1
5	PAFZZ	5310-01-286-5452	24617	11511514	WASHER,FLAT UOC: ZAA,ZAB,ZAC,ZAD,ZAE,ZAF, ZAG,ZAH,ZAJ,ZAL .....	2
6	PAFZZ	5306-01-289-9197	24617	11500713	BOLT,MACHINE UOC: ZAA,ZAB,ZAC,ZAD,ZAE,ZAF, ZAG,ZAH,ZAJ,ZAL .....	2
7	PAFZZ	5365-01-284-8138	60602	000-39048-0000	SPACER,PLATE UOC: ZAA,ZAB,ZAC,ZAD,ZAE,ZAF, ZAG,ZAH,ZAJ,ZAL .....	2
8	PAFZZ	5310-00-877-5796	80205	MS21044N4	NUT,SELF-LOCKING,HE 1/4-28 UNF-3B R.H. UOC: ZAA,ZAB,ZAC,ZAD,ZAE,ZAF, ZAG,ZAH,ZAJ,ZAL .....	3
9	PAFZZ	5340-00-954-6014	80205	MS21333-121	CLAMP,LOOP UOC: ZAA,ZAB,ZAC,ZAD,ZAE,ZAF, ZAG,ZAH,ZAJ,ZAL .....	1
10	PAFZZ	2590-01-284-4547	60602	2242-54	CONTROL ASSEMBLY,PU UOC: ZAA,ZAB,ZAC,ZAD,ZAE,ZAF, ZAG,ZAH,ZAJ,ZAL .....	1
11	PAFZZ	5340-01-280-6874	05MG0	20511127	BRACKET,ANGLE UOC: ZAA,ZAB,ZAC,ZAD,ZAE,ZAF, ZAG,ZAH,ZAJ,ZAL .....	1
12	PAFZZ	5306-01-285-1703	60602	50662	BOLT,U UOC: ZAA,ZAB,ZAC,ZAD,ZAE,ZAF, ZAG,ZAH,ZAJ,ZAL .....	1

(1) ITEM NO.	(2) SMR CODE	(3) NSN	(4) CAGEC	(5) PART NUMBER	(6) DESCRIPTION AND USABLE ON CODE (UOC)	(7) QTY
13	PAFZZ	5310-00-768-0319	96906	MS51968-2	NUT,PLAIN,HEXAGON UOC: ZAA,ZAB,ZAC,ZAD,ZAE,ZAF, ZAG,ZAH,ZAJ,ZAL .....	1
14	PAFZZ	5310-00-209-0786	96906	MS35335-33	WASHER,LOCK UOC: ZAA,ZAB,ZAC,ZAD,ZAE,ZAF, ZAG,ZAH,ZAJ,ZAL .....	1
15	PAFZZ	3040-01-284-6232	60602	50452-2	CONNECTING LINK,RIG UOC: ZAA,ZAB,ZAC,ZAD,ZAE,ZAF, ZAG,ZAH,ZAJ,ZAL .....	1
16	PAFZZ	5315-01-285-5562	60602	50451	PIN,SHOULDER,HEADLE UOC: ZAA,ZAB,ZAC,ZAD,ZAE,ZAF, ZAG,ZAH,ZAJ,ZAL .....	1

END OF FIGURE

**FIELD MAINTENANCE  
TORQUE CONVERTER AND LOCKUP CLUTCH**

---

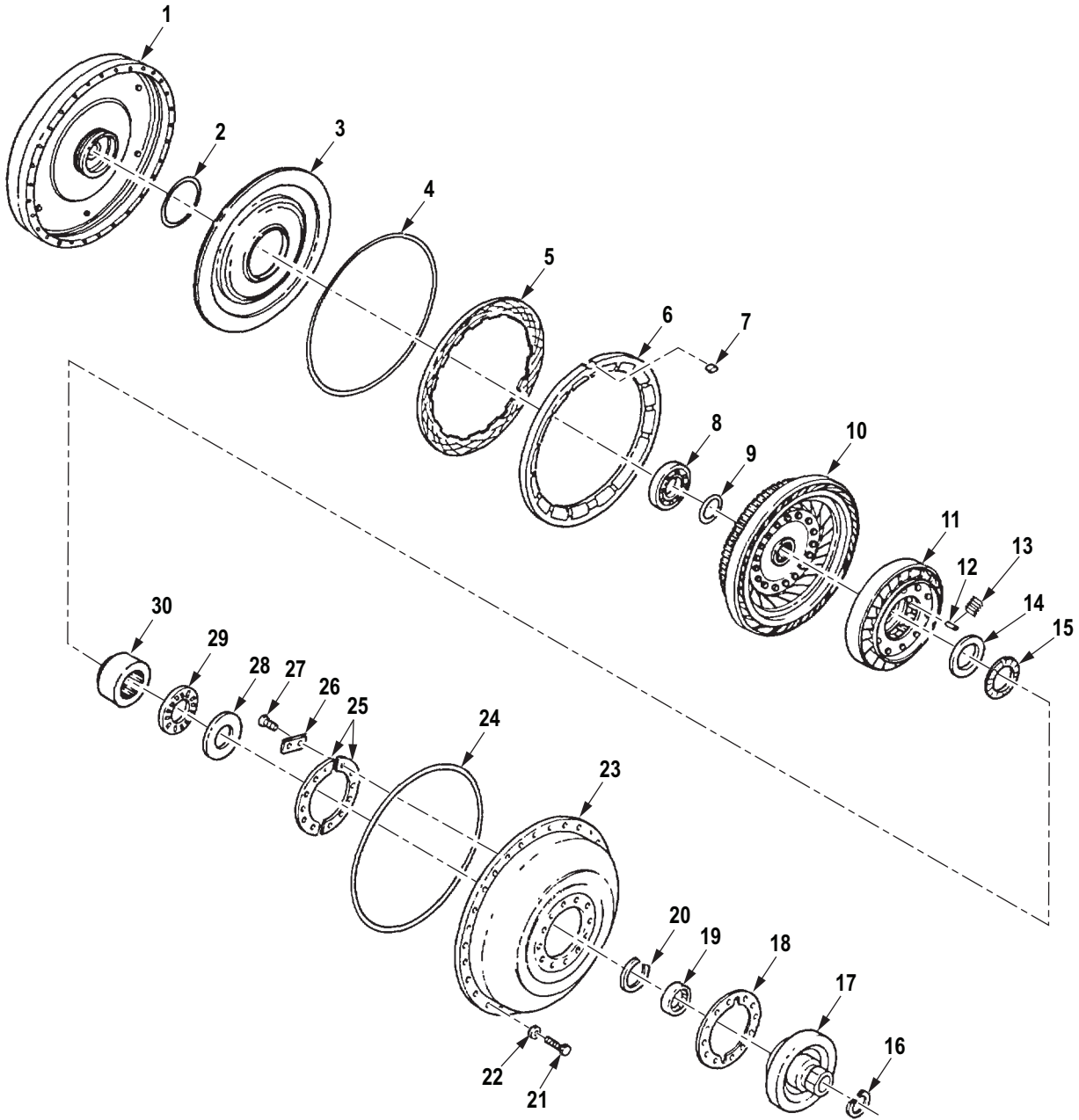

R0199DAA

Figure 185. Torque Converter and Lockup Clutch.



(1) ITEM NO.	(2) SMR CODE	(3) NSN	(4) CAGEC	(5) PART NUMBER	(6) DESCRIPTION AND USABLE ON CODE (UOC)	(7) QTY
<b>GROUP 0708 TORQUE CONVERTER OR FLUID COUPLING.</b>						
<b>FIG. 185. TORQUE CONVERTER AND LOCKUP CLUTCH.</b>						
1	PBH HH	2520-01-134-0898	73342	23016995	FLYWHEEL, TORQUE CON TRANSMISSION UOC: DAC, DAD, DAE, DAF, DAG, DA H, DAJ, DAL, DAW, DAX, V14, V15, V16, V17, V18, V19, V20, V21, V22, V24, ZAA, ZAB, ZAC, ZAD, ZAE, ZAF, ZAG, ZAH, Z AJ, ZAL .....	1
2	PAHZZ	5330-00-999-3760	73342	6770492	PACKING, PREFORMED UOC: DAC, DAD, DAE, DAF, DAG, DA H, DAJ, DAL, DAW, DAX, V14, V15, V16, V17, V18, V19, V20, V21, V22, V24, ZAA, ZAB, ZAC, ZAD, ZAE, ZAF, ZAG, ZAH, Z AJ, ZAL .....	1
3	PAHZZ	3040-01-255-4406	73342	29503808	PISTON, LINEAR ACTUA UOC: DAC, DAD, DAE, DAF, DAG, DA H, DAJ, DAL, DAW, DAX, V14, V15, V16, V17, V18, V19, V20, V21, V22, V24, ZAA, ZAB, ZAC, ZAD, ZAE, ZAF, ZAG, ZAH, Z AJ, ZAL .....	1
4	PAHZZ	5330-00-582-0456	73342	6758740	GASKET UOC: DAC, DAD, DAE, DAF, DAG, DA H, DAJ, DAL, DAW, DAX, V14, V15, V16, V17, V18, V19, V20, V21, V22, V24, ZAA, ZAB, ZAC, ZAD, ZAE, ZAF, ZAG, ZAH, Z AJ, ZAL .....	1
5	PAHZZ	2520-01-317-8288	73342	23048511	DISK, CLUTCH, VEHICUL UOC: DAC, DAD, DAE, DAF, DAG, DA H, DAJ, DAL, DAW, DAX, V14, V15, V16, V17, V18, V19, V20, V21, V22, V24, ZAA, ZAB, ZAC, ZAD, ZAE, ZAF, ZAG, ZAH, Z AJ, ZAL .....	1
6	PAHZZ	2520-00-406-2303	73342	23016957	PLATE, LOCKUP CLUTCH UOC: DAC, DAD, DAE, DAF, DAG, DA H, DAJ, DAL, DAW, DAX, V14, V15, V16, V17, V18, V19, V20, V21, V22, V24, ZAA, ZAB, ZAC, ZAD, ZAE, ZAF, ZAG, ZAH, Z AJ, ZAL .....	1
7	PAHZZ	5315-00-402-0421	73342	6772552	KEY, LOCKUP BACKING UOC: DAC, DAD, DAE, DAF, DAG, DA H, DAJ, DAL, DAW, DAX, V14, V15, V16, V17, V18, V19, V20, V21, V22, V24, ZAA, ZAB, ZAC, ZAD, ZAE, ZAF, ZAG, ZAH, Z AJ, ZAL .....	1

(1) ITEM NO.	(2) SMR CODE	(3) NSN	(4) CAGEC	(5) PART NUMBER	(6) DESCRIPTION AND USABLE ON CODE (UOC)	(7) QTY
8	PAHZZ	3110-00-198-2848	58536	AA59584-111JACT	BEARING,BALL,ANNULA UOC: DAC,DAD,DAE,DAF,DAG,DA H,DAJ,DAL,DAW,DAX,V14,V15,V16, V17,V18,V19,V20,V21,V22,V24,ZAA, ZAB,ZAC,ZAD,ZAE,ZAF,ZAG,ZAH,Z AJ,ZAL .....	1
9	PAHZZ	5365-01-080-0482	73342	6839976	SPACER BEARING,GOLD .015 UOC: DAC,DAD,DAE,DAF,DAG,DA H,DAJ,DAL,DAW,DAX,V14,V15,V16, V17,V18,V19,V20,V21,V22,V24,ZAA, ZAB,ZAC,ZAD,ZAE,ZAF,ZAG,ZAH,Z AJ,ZAL .....	1
9	PAHZZ	5365-01-080-0483	73342	6839977	SPACER BEARING,SILVER .030 UOC: DAC,DAD,DAE,DAF,DAG,DA H,DAJ,DAL,DAW,DAX,V14,V15,V16, V17,V18,V19,V20,V21,V22,V24,ZAA, ZAB,ZAC,ZAD,ZAE,ZAF,ZAG,ZAH,Z AJ,ZAL .....	1
9	PAHZZ	5365-01-080-0484	73342	6839978	SPACER BEARING,PLAIN .042 UOC: DAC,DAD,DAE,DAF,DAG,DA H,DAJ,DAL,DAW,DAX,V14,V15,V16, V17,V18,V19,V20,V21,V22,V24,ZAA, ZAB,ZAC,ZAD,ZAE,ZAF,ZAG,ZAH,Z AJ,ZAL .....	1
9	PAHZZ	5365-01-080-0486	73342	6839980	SPACER BEARING,COPPER .072 UOC: DAC,DAD,DAE,DAF,DAG,DA H,DAJ,DAL,DAW,DAX,V14,V15,V16, V17,V18,V19,V20,V21,V22,V24,ZAA, ZAB,ZAC,ZAD,ZAE,ZAF,ZAG,ZAH,Z AJ,ZAL .....	1
9	PAHZZ	5365-01-080-0485	73342	6839979	SPACER BEARING,BLACK .060 UOC: DAC,DAD,DAE,DAF,DAG,DA H,DAJ,DAL,DAW,DAX,V14,V15,V16, V17,V18,V19,V20,V21,V22,V24,ZAA, ZAB,ZAC,ZAD,ZAE,ZAF,ZAG,ZAH,Z AJ,ZAL .....	1
10	PAHZZ	2520-01-098-5117	73342	6839975	TURBINE UOC: DAC,DAD,DAE,DAF,DAG,DA H,DAJ,DAL,DAW,DAX,V14,V15,V16, V17,V18,V19,V20,V21,V22,V24,ZAA, ZAB,ZAC,ZAD,ZAE,ZAF,ZAG,ZAH,Z AJ,ZAL .....	1
11	PAHZZ	2520-01-094-4751	73342	6837167	STATOR ASSEMBLY UOC: DAC,DAD,DAE,DAF,DAG,DA H,DAJ,DAL,DAW,DAX,V14,V15,V16, V17,V18,V19,V20,V21,V22,V24,ZAA, ZAB,ZAC,ZAD,ZAE,ZAF,ZAG,ZAH,Z AJ,ZAL .....	1

(1) ITEM NO.	(2) SMR CODE	(3) NSN	(4) CAGEC	(5) PART NUMBER	(6) DESCRIPTION AND USABLE ON CODE (UOC)	(7) QTY
12	PAHZZ	3110-00-941-3830	73342	6837976	ROLLER, BEARING UOC: DAC, DAD, DAE, DAF, DAG, DA H, DAJ, DAL, DAW, DAX, V14, V15, V16, V17, V18, V19, V20, V21, V22, V24, ZAA, ZAB, ZAC, ZAD, ZAE, ZAF, ZAG, ZAH, Z AJ, ZAL .....	10
13	PAHZZ	5360-01-157-9921	63005	23012925	SPRING, FLAT UOC: DAC, DAD, DAE, DAF, DAG, DA H, DAJ, DAL, DAW, DAX, V14, V15, V16, V17, V18, V19, V20, V21, V22, V24, ZAA, ZAB, ZAC, ZAD, ZAE, ZAF, ZAG, ZAH, Z AJ, ZAL .....	10
14	PAHZZ	3110-00-916-9273	73342	9417722	SEAT, BEARING UOC: DAC, DAD, DAE, DAF, DAG, DA H, DAJ, DAL, DAW, DAX, V14, V15, V16, V17, V18, V19, V20, V21, V22, V24, ZAA, ZAB, ZAC, ZAD, ZAE, ZAF, ZAG, ZAH, Z AJ, ZAL .....	1
15	XDHZZ		73342	457118	RETAINER AND ROLLER UOC: DAC, DAD, DAE, DAF, DAG, DA H, DAJ, DAL, DAW, DAX, V14, V15, V16, V17, V18, V19, V20, V21, V22, V24, ZAA, ZAB, ZAC, ZAD, ZAE, ZAF, ZAG, ZAH, Z AJ, ZAL .....	1
16	PAHZZ	2520-00-405-1842	73342	6830187	RING, PISTON UOC: DAC, DAD, DAE, DAF, DAG, DA H, DAJ, DAL, DAW, DAX, V14, V15, V16, V17, V18, V19, V20, V21, V22, V24, ZAA, ZAB, ZAC, ZAD, ZAE, ZAF, ZAG, ZAH, Z AJ, ZAL .....	1
17	PAHZZ	2520-01-098-5108	73342	23017446	HUB, CONVERTER PUMP USE WITH TRANS P/N 6885292 UOC: DAC, DAD, DAE, DAF, DAG, DA H, DAJ, DAL, DAW, DAX, V14, V15, V16, V17, V18, V19, V20, V21, V22, V24, ZAA, ZAB, ZAC, ZAD, ZAE, ZAF, ZAG, ZAH, Z AJ, ZAL .....	1
18	PAHZZ	5330-00-911-9411	73342	6771366	GASKET UOC: DAC, DAD, DAE, DAF, DAG, DA H, DAJ, DAL, DAW, DAX, V14, V15, V16, V17, V18, V19, V20, V21, V22, V24, ZAA, ZAB, ZAC, ZAD, ZAE, ZAF, ZAG, ZAH, Z AJ, ZAL .....	1
19	PAHZZ	3110-01-179-1161	73342	23048030	BEARING, ROLLER, CYLI UOC: DAC, DAD, DAE, DAF, DAG, DA H, DAJ, DAL, DAW, DAX, V14, V15, V16, V17, V18, V19, V20, V21, V22, V24, ZAA, ZAB, ZAC, ZAD, ZAE, ZAF, ZAG, ZAH, Z AJ, ZAL .....	1

(1) ITEM NO.	(2) SMR CODE	(3) NSN	(4) CAGEC	(5) PART NUMBER	(6) DESCRIPTION AND USABLE ON CODE (UOC)	(7) QTY
20	PAHZZ	5325-01-079-6526	73342	6750020	RING,RETAINING UOC: DAC,DAD,DAE,DAF,DAG,DA H,DAJ,DAL,DAW,DAX,V14,V15,V16, V17,V18,V19,V20,V21,V22,V24,ZAA, ZAB,ZAC,ZAD,ZAE,ZAF,ZAG,ZAH,Z AJ,ZAL .....	1
21	PAHZZ	5305-00-292-4595	73342	9409037	SCREW,CAP,HEXAGON H UOC: DAC,DAD,DAE,DAF,DAG,DA H,DAJ,DAL,DAW,DAX,V14,V15,V16, V17,V18,V19,V20,V21,V22,V24,ZAA, ZAB,ZAC,ZAD,ZAE,ZAF,ZAG,ZAH,Z AJ,ZAL .....	30
22	PAHZZ	5310-00-776-7670	19207	7767670	WASHER,FLAT UOC: DAC,DAD,DAE,DAF,DAG,DA H,DAJ,DAL,DAW,DAX,V14,V15,V16, V17,V18,V19,V20,V21,V22,V24,ZAA, ZAB,ZAC,ZAD,ZAE,ZAF,ZAG,ZAH,Z AJ,ZAL .....	30
23	PAHZZ	4320-00-403-5223	73342	23010620	HOUSING,LIQUID PUMP UOC: DAC,DAD,DAE,DAF,DAG,DA H,DAJ,DAL,DAW,DAX,V14,V15,V16, V17,V18,V19,V20,V21,V22,V24,ZAA, ZAB,ZAC,ZAD,ZAE,ZAF,ZAG,ZAH,Z AJ,ZAL .....	1
24	PAHZZ	5330-01-141-9579	63005	6880389	GASKET UOC: DAC,DAD,DAE,DAF,DAG,DA H,DAJ,DAL,DAW,DAX,V14,V15,V16, V17,V18,V19,V20,V21,V22,V24,ZAA, ZAB,ZAC,ZAD,ZAE,ZAF,ZAG,ZAH,Z AJ,ZAL .....	1
25	PAHZZ	3110-00-916-4286	45152	2AX817	PLATE,RETAINING,BEA UOC: DAC,DAD,DAE,DAF,DAG,DA H,DAJ,DAL,DAW,DAX,V14,V15,V16, V17,V18,V19,V20,V21,V22,V24,ZAA, ZAB,ZAC,ZAD,ZAE,ZAF,ZAG,ZAH,Z AJ,ZAL .....	2
26	PAHZZ	5340-01-056-0037	73342	6880899	STRIP RETAINER UOC: DAC,DAD,DAE,DAF,DAG,DA H,DAJ,DAL,DAW,DAX,V14,V15,V16, V17,V18,V19,V20,V21,V22,V24,ZAA, ZAB,ZAC,ZAD,ZAE,ZAF,ZAG,ZAH,Z AJ,ZAL .....	6
27	PAHZZ	5305-00-269-3238	80204	B1821BH038F125N	SCREW,CAP,HEXAGON H UOC: DAC,DAD,DAE,DAF,DAG,DA H,DAJ,DAL,DAW,DAX,V14,V15,V16, V17,V18,V19,V20,V21,V22,V24,ZAA, ZAB,ZAC,ZAD,ZAE,ZAF,ZAG,ZAH,Z AJ,ZAL .....	12

(1) ITEM NO.	(2) SMR CODE	(3) NSN	(4) CAGEC	(5) PART NUMBER	(6) DESCRIPTION AND USABLE ON CODE (UOC)	(7) QTY
28	PAHZZ	3110-01-146-7144	73342	9436973	RACE, BEARING UOC: DAC, DAD, DAE, DAF, DAG, DA H, DAJ, DAL, DAW, DAX, V14, V15, V16, V17, V18, V19, V20, V21, V22, V24, ZAA, ZAB, ZAC, ZAD, ZAE, ZAF, ZAG, ZAH, Z AJ, ZAL .....	1
29	PAHZZ	3110-01-079-7049	73342	9436972	RETAINER AND ROLLER UOC: DAC, DAD, DAE, DAF, DAG, DA H, DAJ, DAL, DAW, DAX, V14, V15, V16, V17, V18, V19, V20, V21, V22, V24, ZAA, ZAB, ZAC, ZAD, ZAE, ZAF, ZAG, ZAH, Z AJ, ZAL .....	1
30	PAHZZ	2520-01-080-0448	73342	6839985	RACE UOC: DAC, DAD, DAE, DAF, DAG, DA H, DAJ, DAL, DAW, DAX, V14, V15, V16, V17, V18, V19, V20, V21, V22, V24, ZAA, ZAB, ZAC, ZAD, ZAE, ZAF, ZAG, ZAH, Z AJ, ZAL .....	1

END OF FIGURE



**FIELD MAINTENANCE  
ADAPTER HOUSING AND LOW PLANETARY CARRIER ASSEMBLY**

---

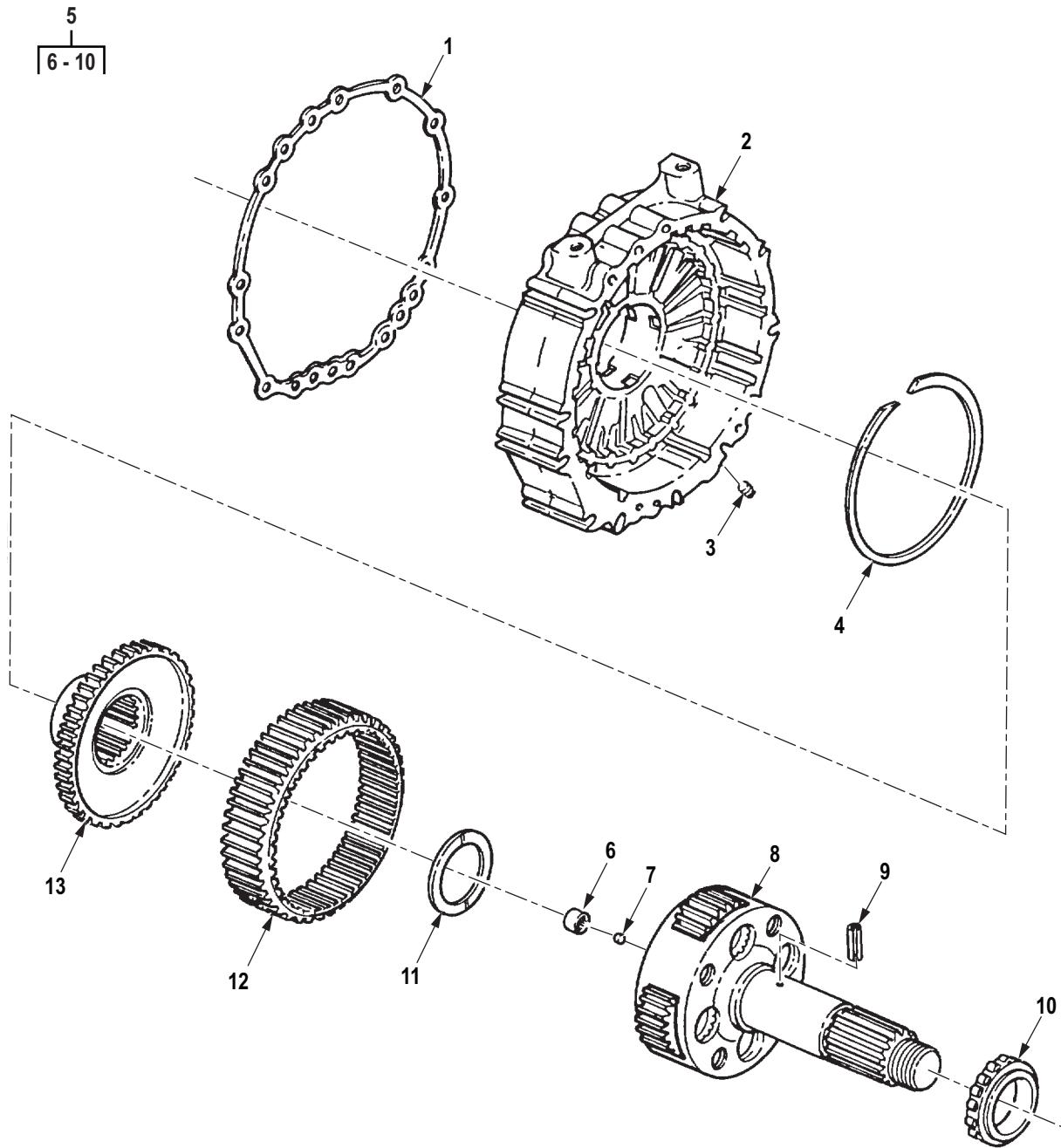

R0200DAA

Figure 186. Adapter Housing and Low Planetary Carrier Assembly.



(1) ITEM NO.	(2) SMR CODE	(3) NSN	(4) CAGEC	(5) PART NUMBER	(6) DESCRIPTION AND USABLE ON CODE (UOC)	(7) QTY
<p><b>GROUP 0710 TRANSMISSION ASSEMBLY AND ASSOCIATED PARTS.</b></p> <p><b>FIG. 186. ADAPTER HOUSING AND LOW PLANETARY CARRIER ASSEMBLY.</b></p>						
1	PAHZZ	5330-01-219-2555	73342	23045099	GASKET UOC: DAC,DAD,DAE,DAF,DAG,DAH,DAJ,DAL,DAW,DAX,V14,V15,V16,V17,V18,V19,V20,V21,V22,V24,ZAA,ZAB,ZAC,ZAD,ZAE,ZAF,ZAG,ZAH,ZAJ,ZAL .....	1
2	PAHZZ	3040-01-151-3568	73342	23045053	HOUSING,MECHANICAL UOC: DAC,DAD,DAE,DAF,DAG,DAH,DAJ,DAL,DAW,DAX,V14,V15,V16,V17,V18,V19,V20,V21,V22,V24,ZAA,ZAB,ZAC,ZAD,ZAE,ZAF,ZAG,ZAH,ZAJ,ZAL .....	1
3	PAHZZ	4730-01-206-6162	58536	AA59616ACABCD	PLUG,PIPE UOC: DAC,DAD,DAE,DAF,DAG,DAH,DAJ,DAL,DAW,DAX,V14,V15,V16,V17,V18,V19,V20,V21,V22,V24,ZAA,ZAB,ZAC,ZAD,ZAE,ZAF,ZAG,ZAH,ZAJ,ZAL .....	1
4	PAHZZ	5325-01-133-4679	63005	6881581	RING,RETAINING UOC: DAC,DAD,DAE,DAF,DAG,DAH,DAJ,DAL,DAW,DAX,V14,V15,V16,V17,V18,V19,V20,V21,V22,V24,ZAA,ZAB,ZAC,ZAD,ZAE,ZAF,ZAG,ZAH,ZAJ,ZAL .....	1
5	PAHHH	2520-01-123-1648	73342	23016862	CARRIER ASSEMBLY,TR UOC: DAC,DAD,DAE,DAF,DAG,DAH,DAJ,DAL,DAW,DAX,V14,V15,V16,V17,V18,V19,V20,V21,V22,V24,ZAA,ZAB,ZAC,ZAD,ZAE,ZAF,ZAG,ZAH,ZAJ,ZAL .....	1
6	PAHZZ	3110-01-007-2609	60380	B107	. BEARING,ROLLER,NEED UOC: DAC,DAD,DAE,DAF,DAG,DAH,DAJ,DAL,DAW,DAX,V14,V15,V16,V17,V18,V19,V20,V21,V22,V24,ZAA,ZAB,ZAC,ZAD,ZAE,ZAF,ZAG,ZAH,ZAJ,ZAL .....	1
7	PAHZZ	4730-01-007-0802	73342	8623484	. PLUG,CUP UOC: DAC,DAD,DAE,DAF,DAG,DAH,DAJ,DAL,DAW,DAX,V14,V15,V16,V17,V18,V19,V20,V21,V22,V24,ZAA,ZAB,ZAC,ZAD,ZAE,ZAF,ZAG,ZAH,ZAJ,ZAL .....	1

(1) ITEM NO.	(2) SMR CODE	(3) NSN	(4) CAGEC	(5) PART NUMBER	(6) DESCRIPTION AND USABLE ON CODE (UOC)	(7) QTY
8	PAHZZ	2520-01-122-5169	73342	23045372	. CARRIER ASSEMBLY,LO UOC: DAC,DAD,DAE,DAF,DAG,DA H,DAJ,DAL,DAW,DAX,V14,V15,V16, V17,V18,V19,V20,V21,V22,V24,ZAA, ZAB,ZAC,ZAD,ZAE,ZAF,ZAG,ZAH,Z AJ,ZAL .....	1
9	PAHZZ	5315-01-058-3487	80205	NAS561P6-12	. PIN,SPRING UOC: DAC,DAD,DAE,DAF,DAG,DA H,DAJ,DAL,DAW,DAX,V14,V15,V16, V17,V18,V19,V20,V21,V22,V24,ZAA, ZAB,ZAC,ZAD,ZAE,ZAF,ZAG,ZAH,Z AJ,ZAL .....	1
10	PFHZZ	3110-01-147-6681	73342	23048028	. RING,BEARING,OUTER UOC: DAC,DAD,DAE,DAF,DAG,DA H,DAJ,DAL,DAW,DAX,V14,V15,V16, V17,V18,V19,V20,V21,V22,V24,ZAA, ZAB,ZAC,ZAD,ZAE,ZAF,ZAG,ZAH,Z AJ,ZAL .....	1
11	PAHZZ	3120-01-126-1097	73342	6880024	BEARING,WASHER,THRU UOC: DAC,DAD,DAE,DAF,DAG,DA H,DAJ,DAL,DAW,DAX,V14,V15,V16, V17,V18,V19,V20,V21,V22,V24,ZAA, ZAB,ZAC,ZAD,ZAE,ZAF,ZAG,ZAH,Z AJ,ZAL .....	1
12	PAHZZ	3020-01-149-1239	73342	6883999	GEAR,SPUR UOC: DAC,DAD,DAE,DAF,DAG,DA H,DAJ,DAL,DAW,DAX,V14,V15,V16, V17,V18,V19,V20,V21,V22,V24,ZAA, ZAB,ZAC,ZAD,ZAE,ZAF,ZAG,ZAH,Z AJ,ZAL .....	1
13	PAHZZ	3020-01-122-5906	73342	6881580	GEAR,SPUR UOC: DAC,DAD,DAE,DAF,DAG,DA H,DAJ,DAL,DAW,DAX,V14,V15,V16, V17,V18,V19,V20,V21,V22,V24,ZAA, ZAB,ZAC,ZAD,ZAE,ZAF,ZAG,ZAH,Z AJ,ZAL .....	1

END OF FIGURE

**FIELD MAINTENANCE  
HOUSING ASSEMBLY AND FORWARD CLUTCH**

---

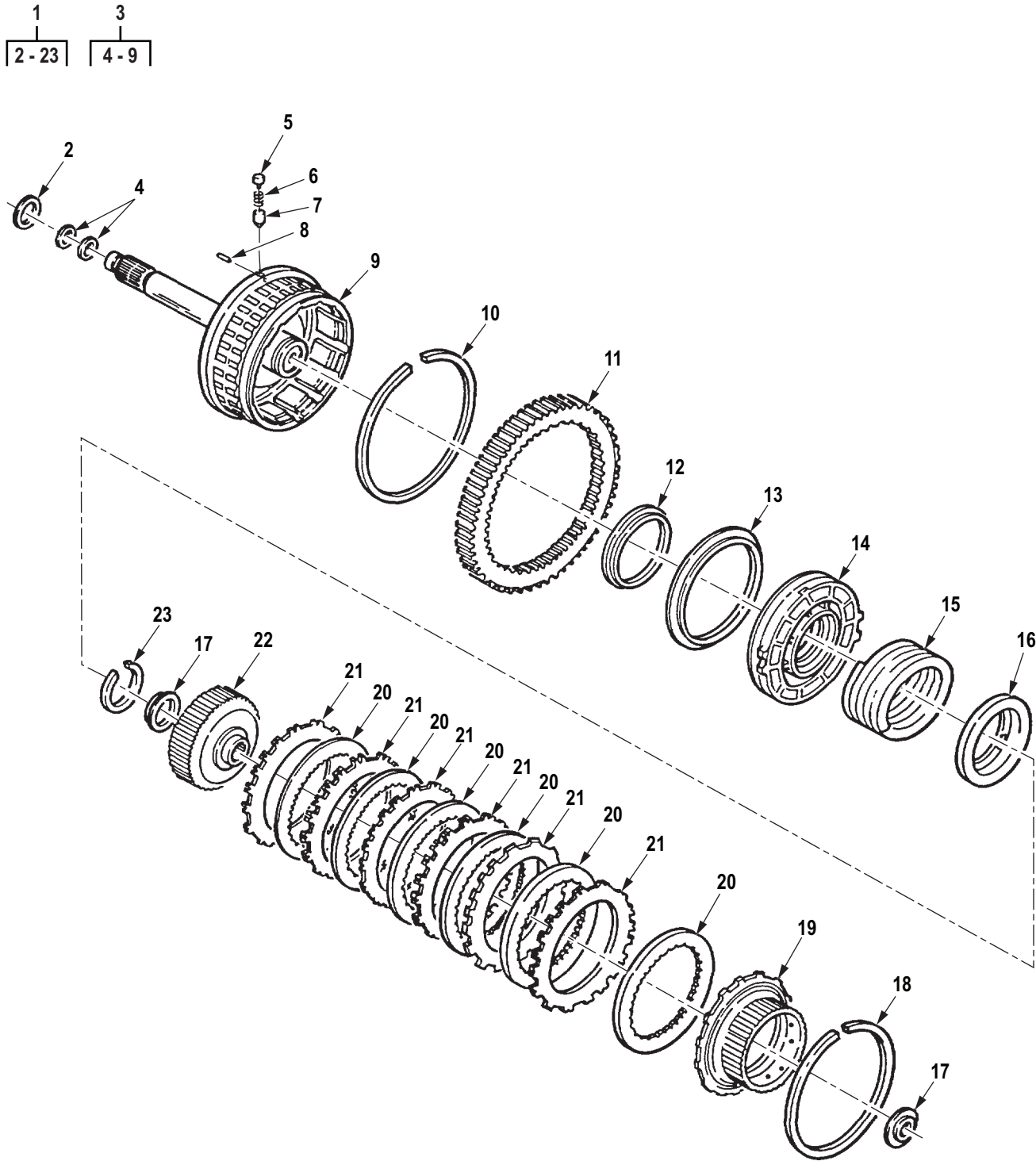

R0201DAA

Figure 187. Housing Assembly and Forward Clutch.

(1) ITEM NO.	(2) SMR CODE	(3) NSN	(4) CAGEC	(5) PART NUMBER	(6) DESCRIPTION AND USABLE ON CODE (UOC)	(7) QTY
<p><b>GROUP 0710 TRANSMISSION ASSEMBLY AND ASSOCIATED PARTS.</b></p> <p><b>FIG. 187. HOUSING ASSEMBLY AND FORWARD CLUTCH.</b></p>						
1	PAHHH	2520-01-149-1830	73342	23017701	CLUTCH ASSEMBLY,FRI UOC: DAC,DAD,DAE,DAF,DAG,DAH,DAJ,DAL,DAW,DAX,V14,V15,V16,V17,V18,V19,V20,V21,V22,V24,ZAA,ZAB,ZAC,ZAD,ZAE,ZAF,ZAG,ZAH,ZAJ,ZAL .....	1
2	PAHZZ	5330-00-374-4873	73342	6839163	. SEAL RING,METAL UOC: DAC,DAD,DAE,DAF,DAG,DAH,DAJ,DAL,DAW,DAX,V14,V15,V16,V17,V18,V19,V20,V21,V22,V24,ZAA,ZAB,ZAC,ZAD,ZAE,ZAF,ZAG,ZAH,ZAJ,ZAL .....	1
3	PAHHH	2520-01-130-5770	73342	23017696	. HOUSING ASSEMBLY,CL UOC: DAC,DAD,DAE,DAF,DAG,DAH,DAJ,DAL,DAW,DAX,V14,V15,V16,V17,V18,V19,V20,V21,V22,V24,ZAA,ZAB,ZAC,ZAD,ZAE,ZAF,ZAG,ZAH,ZAJ,ZAL .....	1
4	PAHZZ	5365-01-010-9688	73342	6833999	. . RING,HOOK TYPE SEAL UOC: DAC,DAD,DAE,DAF,DAG,DAH,DAJ,DAL,DAW,DAX,V14,V15,V16,V17,V18,V19,V20,V21,V22,V24,ZAA,ZAB,ZAC,ZAD,ZAE,ZAF,ZAG,ZAH,ZAJ,ZAL .....	2
5	PAHZZ	4820-01-148-9278	73342	23012446	. . PLUG,ROTARY,VALVE UOC: DAC,DAD,DAE,DAF,DAG,DAH,DAJ,DAL,DAW,DAX,V14,V15,V16,V17,V18,V19,V20,V21,V22,V24,ZAA,ZAB,ZAC,ZAD,ZAE,ZAF,ZAG,ZAH,ZAJ,ZAL .....	1
6	PAHZZ	5360-01-150-9693	63005	23013747	. . SPRING,HELICAL,COMP UOC: DAC,DAD,DAE,DAF,DAG,DAH,DAJ,DAL,DAW,DAX,V14,V15,V16,V17,V18,V19,V20,V21,V22,V24,ZAA,ZAB,ZAC,ZAD,ZAE,ZAF,ZAG,ZAH,ZAJ,ZAL .....	1
7	PAHZZ	2520-01-149-1785	73342	23013746	. . VALVE,CENTRIFUGAL UOC: DAC,DAD,DAE,DAF,DAG,DAH,DAJ,DAL,DAW,DAX,V14,V15,V16,V17,V18,V19,V20,V21,V22,V24,ZAA,ZAB,ZAC,ZAD,ZAE,ZAF,ZAG,ZAH,ZAJ,ZAL .....	1

(1) ITEM NO.	(2) SMR CODE	(3) NSN	(4) CAGEC	(5) PART NUMBER	(6) DESCRIPTION AND USABLE ON CODE (UOC)	(7) QTY
8	PAHZZ	5315-00-810-3701	80205	MS16562-36	. . PIN,SPRING UOC: DAC,DAD,DAE,DAF,DAG,DA H,DAJ,DAL,DAW,DAX,V14,V15,V16, V17,V18,V19,V20,V21,V22,V24,ZAA, ZAB,ZAC,ZAD,ZAE,ZAF,ZAG,ZAH,Z AJ,ZAL .....	1
9	XAHZZ		73342	23017172	. . HOUSING,MECHANICAL UOC: DAC,DAD,DAE,DAF,DAG,DA H,DAJ,DAL,DAW,DAX,V14,V15,V16, V17,V18,V19,V20,V21,V22,V24,ZAA, ZAB,ZAC,ZAD,ZAE,ZAF,ZAG,ZAH,Z AJ,ZAL .....	1
10	PAHZZ	5365-01-010-9687	73342	6838364	. RING,EXTERNAL SNAP UOC: DAC,DAD,DAE,DAF,DAG,DA H,DAJ,DAL,DAW,DAX,V14,V15,V16, V17,V18,V19,V20,V21,V22,V24,ZAA, ZAB,ZAC,ZAD,ZAE,ZAF,ZAG,ZAH,Z AJ,ZAL .....	1
11	PAHZZ	3020-01-065-0183	73342	6885146	. GEAR,SPUR UOC: DAC,DAD,DAE,DAF,DAG,DA H,DAJ,DAL,DAW,DAX,V14,V15,V16, V17,V18,V19,V20,V21,V22,V24,ZAA, ZAB,ZAC,ZAD,ZAE,ZAF,ZAG,ZAH,Z AJ,ZAL .....	1
12	PAHZZ	5330-01-146-6053	73342	23015880	. SEAL,PLAIN UOC: DAC,DAD,DAE,DAF,DAG,DA H,DAJ,DAL,DAW,DAX,V14,V15,V16, V17,V18,V19,V20,V21,V22,V24,ZAA, ZAB,ZAC,ZAD,ZAE,ZAF,ZAG,ZAH,Z AJ,ZAL .....	1
13	PAHZZ	5365-01-010-9689	73342	6833981	. RING,LIP TYPE SEAL PART OF KIT P/N 6884259 UOC: DAC,DAD,DAE,DAF,DAG,DA H,DAJ,DAL,DAW,DAX,V14,V15,V16, V17,V18,V19,V20,V21,V22,V24,ZAA, ZAB,ZAC,ZAD,ZAE,ZAF,ZAG,ZAH,Z AJ,ZAL .....	1
14	PAHZZ	2520-01-149-3438	73342	6885155	. PISTON,FOURTH CLUTC .777-.787 UOC: DAC,DAD,DAE,DAF,DAG,DA H,DAJ,DAL,DAW,DAX,V14,V15,V16, V17,V18,V19,V20,V21,V22,V24,ZAA, ZAB,ZAC,ZAD,ZAE,ZAF,ZAG,ZAH,Z AJ,ZAL .....	1
14	XDHZZ		73342	6885153	. PISTON,FOURTH CLUTC .837-.847 UOC: DAC,DAD,DAE,DAF,DAG,DA H,DAJ,DAL,DAW,DAX,V14,V15,V16, V17,V18,V19,V20,V21,V22,V24,ZAA, ZAB,ZAC,ZAD,ZAE,ZAF,ZAG,ZAH,Z AJ,ZAL .....	1

(1) ITEM NO.	(2) SMR CODE	(3) NSN	(4) CAGEC	(5) PART NUMBER	(6) DESCRIPTION AND USABLE ON CODE (UOC)	(7) QTY
14	XDHZZ	2520-01-150-0900	73342	6885154	. PISTON,FORWARD CLUT .807-.817 UOC: DAC,DAD,DAE,DAF,DAG,DA H,DAJ,DAL,DAW,DAX,V14,V15,V16, V17,V18,V19,V20,V21,V22,V24,ZAA, ZAB,ZAC,ZAD,ZAE,ZAF,ZAG,ZAH,Z AJ,ZAL .....	1
15	PAHZZ	5360-01-079-3096	73342	6836773	. SPRING,CLUTCH UOC: DAC,DAD,DAE,DAF,DAG,DA H,DAJ,DAL,DAW,DAX,V14,V15,V16, V17,V18,V19,V20,V21,V22,V24,ZAA, ZAB,ZAC,ZAD,ZAE,ZAF,ZAG,ZAH,Z AJ,ZAL .....	1
16	PAHZZ	2520-01-065-0841	73342	6834369	. RETAINER,CLUTCH SPR UOC: DAC,DAD,DAE,DAF,DAG,DA H,DAJ,DAL,DAW,DAX,V14,V15,V16, V17,V18,V19,V20,V21,V22,V24,ZAA, ZAB,ZAC,ZAD,ZAE,ZAF,ZAG,ZAH,Z AJ,ZAL .....	1
17	PAHZZ	3110-00-557-6163	73342	23015799	. RING,BEARING,INNER UOC: DAC,DAD,DAE,DAF,DAG,DA H,DAJ,DAL,DAW,DAX,V14,V15,V16, V17,V18,V19,V20,V21,V22,V24,ZAA, ZAB,ZAC,ZAD,ZAE,ZAF,ZAG,ZAH,Z AJ,ZAL .....	2
18	PAHZZ	5325-01-219-2580	73342	23018867	. RING,RETAINING UOC: DAC,DAD,DAE,DAF,DAG,DA H,DAJ,DAL,DAW,DAX,V14,V15,V16, V17,V18,V19,V20,V21,V22,V24,ZAA, ZAB,ZAC,ZAD,ZAE,ZAF,ZAG,ZAH,Z AJ,ZAL .....	1
19	PAHZZ	2520-01-148-9279	73342	6883090	. HUB,DRIVING,CLUTCH UOC: DAC,DAD,DAE,DAF,DAG,DA H,DAJ,DAL,DAW,DAX,V14,V15,V16, V17,V18,V19,V20,V21,V22,V24,ZAA, ZAB,ZAC,ZAD,ZAE,ZAF,ZAG,ZAH,Z AJ,ZAL .....	1
20	PAHZZ	2520-01-006-7116	79370	WPC-4946	. DISK,CLUTCH,VEHICUL UOC: DAC,DAD,DAE,DAF,DAG,DA H,DAJ,DAL,DAW,DAX,V14,V15,V16, V17,V18,V19,V20,V21,V22,V24,ZAA, ZAB,ZAC,ZAD,ZAE,ZAF,ZAG,ZAH,Z AJ,ZAL .....	6
21	PAHZZ	2520-01-065-0077	73342	23016610	. DISK,CLUTCH UOC: DAC,DAD,DAE,DAF,DAG,DA H,DAJ,DAL,DAW,DAX,V14,V15,V16, V17,V18,V19,V20,V21,V22,V24,ZAA, ZAB,ZAC,ZAD,ZAE,ZAF,ZAG,ZAH,Z AJ,ZAL .....	6

(1) ITEM NO.	(2) SMR CODE	(3) NSN	(4) CAGEC	(5) PART NUMBER	(6) DESCRIPTION AND USABLE ON CODE (UOC)	(7) QTY
22	PAHZZ	3020-01-149-3836	73342	6883020	. GEAR,SPUR UOC: DAC,DAD,DAE,DAF,DAG,DA H,DAJ,DAL,DAW,DAX,V14,V15,V16, V17,V18,V19,V20,V21,V22,V24,ZAA, ZAB,ZAC,ZAD,ZAE,ZAF,ZAG,ZAH,Z AJ,ZAL .....	1
23	PAHZZ	5325-01-145-6921	73342	6885156	. RING,RETAINING UOC: DAC,DAD,DAE,DAF,DAG,DA H,DAJ,DAL,DAW,DAX,V14,V15,V16, V17,V18,V19,V20,V21,V22,V24,ZAA, ZAB,ZAC,ZAD,ZAE,ZAF,ZAG,ZAH,Z AJ,ZAL .....	1

END OF FIGURE



**FIELD MAINTENANCE  
MAIN SHAFT AND CARRIER ASSEMBLY**

---

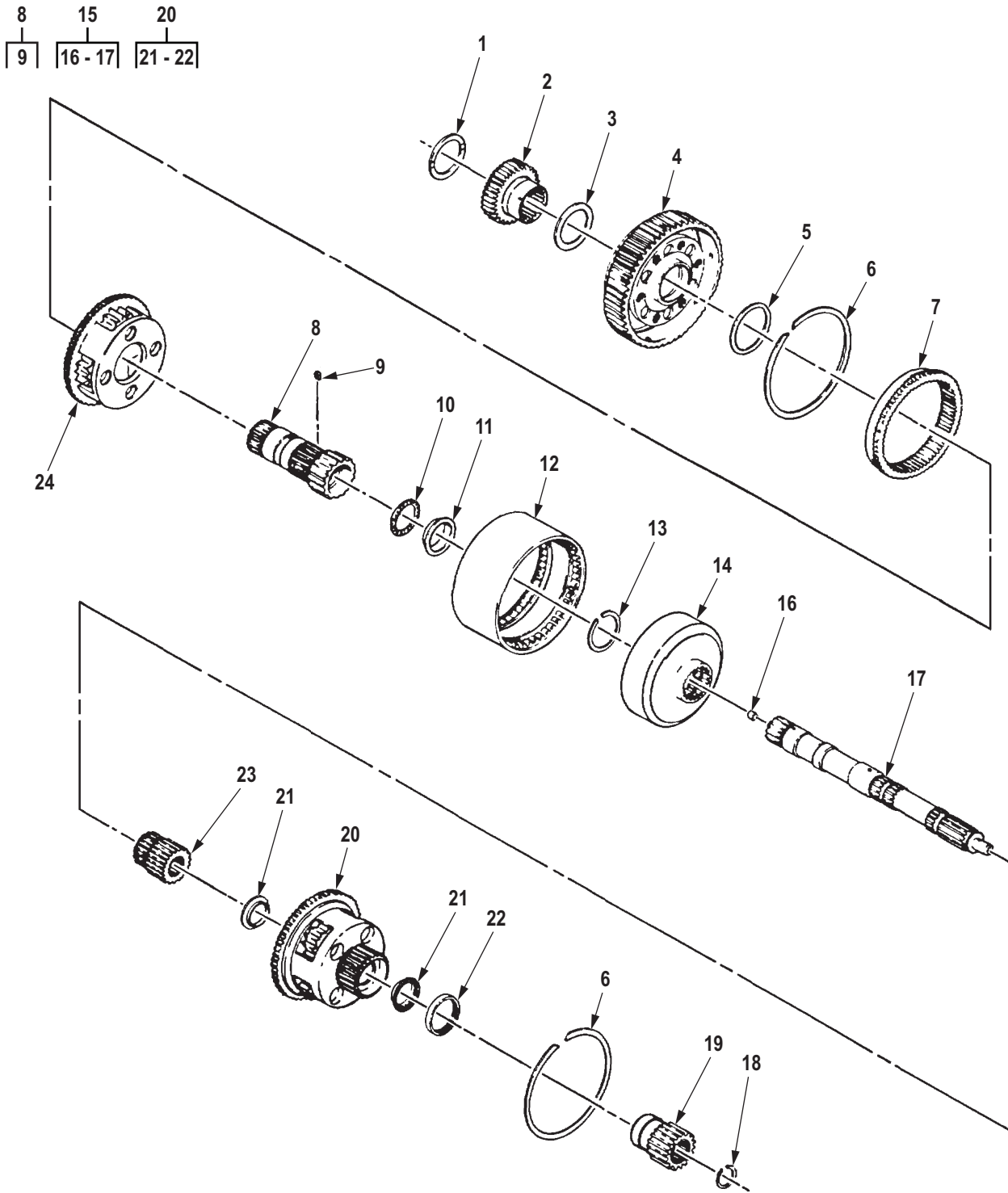

R0202DAA

Figure 188. Main Shaft and Carrier Assembly.

(1) ITEM NO.	(2) SMR CODE	(3) NSN	(4) CAGEC	(5) PART NUMBER	(6) DESCRIPTION AND USABLE ON CODE (UOC)	(7) QTY
<p><b>GROUP 0710 TRANSMISSION ASSEMBLY AND ASSOCIATED PARTS.</b></p> <p><b>FIG. 188. MAIN SHAFT AND CARRIER ASSEMBLY.</b></p>						
1	PAHZZ	5310-00-557-6568	73342	6839364	WASHER, THRUST UOC: DAC, DAD, DAE, DAF, DAG, DAH, DAJ, DAL, DAW, DAX, V14, V15, V16, V17, V18, V19, V20, V21, V22, V24, ZAA, ZAB, ZAC, ZAD, ZAE, ZAF, ZAG, ZAH, ZAJ, ZAL .....	1
2	PAHZZ	3020-01-065-0871	73342	6835574	GEAR, SPUR UOC: DAC, DAD, DAE, DAF, DAG, DAH, DAJ, DAL, DAW, DAX, V14, V15, V16, V17, V18, V19, V20, V21, V22, V24, ZAA, ZAB, ZAC, ZAD, ZAE, ZAF, ZAG, ZAH, ZAJ, ZAL .....	1
3	PAHZZ	5310-00-557-5943	73342	6835386	WASHER, THRUST UOC: DAC, DAD, DAE, DAF, DAG, DAH, DAJ, DAL, DAW, DAX, V14, V15, V16, V17, V18, V19, V20, V21, V22, V24, ZAA, ZAB, ZAC, ZAD, ZAE, ZAF, ZAG, ZAH, ZAJ, ZAL .....	1
4	PAHZZ	2520-00-557-5974	73342	6882565	CARRIER ASSEMBLY, FR UOC: DAC, DAD, DAE, DAF, DAG, DAH, DAJ, DAL, DAW, DAX, V14, V15, V16, V17, V18, V19, V20, V21, V22, V24, ZAA, ZAB, ZAC, ZAD, ZAE, ZAF, ZAG, ZAH, ZAJ, ZAL .....	1
5	PAHZZ	5310-00-568-6118	73342	6834389	WASHER, THRUST UOC: DAC, DAD, DAE, DAF, DAG, DAH, DAJ, DAL, DAW, DAX, V14, V15, V16, V17, V18, V19, V20, V21, V22, V24, ZAA, ZAB, ZAC, ZAD, ZAE, ZAF, ZAG, ZAH, ZAJ, ZAL .....	1
6	PAHZZ	5325-00-557-5835	73342	6834512	RING, RETAINING UOC: DAC, DAD, DAE, DAF, DAG, DAH, DAJ, DAL, DAW, DAX, V14, V15, V16, V17, V18, V19, V20, V21, V22, V24, ZAA, ZAB, ZAC, ZAD, ZAE, ZAF, ZAG, ZAH, ZAJ, ZAL .....	2
7	PAHZZ	3020-01-008-2769	73342	23045281	GEAR, RING UOC: DAC, DAD, DAE, DAF, DAG, DAH, DAJ, DAL, DAW, DAX, V14, V15, V16, V17, V18, V19, V20, V21, V22, V24, ZAA, ZAB, ZAC, ZAD, ZAE, ZAF, ZAG, ZAH, ZAJ, ZAL .....	1

(1) ITEM NO.	(2) SMR CODE	(3) NSN	(4) CAGEC	(5) PART NUMBER	(6) DESCRIPTION AND USABLE ON CODE (UOC)	(7) QTY
8	PAHZZ	2520-00-557-6549	7Y635	21606	SHAFT ASSY,SUN GEAR UOC: DAC,DAD,DAE,DAF,DAG,DA H,DAJ,DAL,DAW,DAX,V14,V15,V16, V17,V18,V19,V20,V21,V22,V24,ZAA, ZAB,ZAC,ZAD,ZAE,ZAF,ZAG,ZAH,Z AJ,ZAL .....	1
9	PAHZZ	5315-01-010-9777	63005	6834940	. PIN,SPRING UOC: DAC,DAD,DAE,DAF,DAG,DA H,DAJ,DAL,DAW,DAX,V14,V15,V16, V17,V18,V19,V20,V21,V22,V24,ZAA, ZAB,ZAC,ZAD,ZAE,ZAF,ZAG,ZAH,Z AJ,ZAL .....	2
10	PAHZZ	3110-00-557-6708	60380	9432513	RING,BEARING,OUTER UOC: DAC,DAD,DAE,DAF,DAG,DA H,DAJ,DAL,DAW,DAX,V14,V15,V16, V17,V18,V19,V20,V21,V24,ZAA,ZAB, ZAC,ZAD,ZAE,ZAF,ZAG,ZAH,ZAJ,ZAL .....	1
11	PAHZZ	3110-00-557-6666	60380	JF45496	RING,BEARING,INNER UOC: DAC,DAD,DAE,DAF,DAG,DA H,DAJ,DAL,DAW,DAX,V14,V15,V16, V17,V18,V19,V20,V21,V22,V24,ZAA, ZAB,ZAC,ZAD,ZAE,ZAF,ZAG,ZAH,Z AJ,ZAL .....	1
12	PAHZZ	2520-01-065-2530	73342	6835570	DRUM,PLANETARY CARR UOC: DAC,DAD,DAE,DAF,DAG,DA H,DAJ,DAL,DAW,DAX,V14,V15,V16, V17,V18,V19,V20,V21,V22,V24,ZAA, ZAB,ZAC,ZAD,ZAE,ZAF,ZAG,ZAH,Z AJ,ZAL .....	1
13	PAHZZ	5325-00-089-1262	63005	6769319	RING,RETAINING UOC: DAC,DAD,DAE,DAF,DAG,DA H,DAJ,DAL,DAW,DAX,V14,V15,V16, V17,V18,V19,V20,V21,V22,V24,ZAA, ZAB,ZAC,ZAD,ZAE,ZAF,ZAG,ZAH,Z AJ,ZAL .....	1
14	PAHZZ	3020-01-008-2770	73342	29523159	GEAR,INTERNAL UOC: DAC,DAD,DAE,DAF,DAG,DA H,DAJ,DAL,DAW,DAX,V14,V15,V16, V17,V18,V19,V20,V21,V22,V24,ZAA, ZAB,ZAC,ZAD,ZAE,ZAF,ZAG,ZAH,Z AJ,ZAL .....	1
15	PAHHH	2520-01-131-2694	73342	23017699	SHAFT ASSEMBLY,TRAN UOC: DAC,DAD,DAE,DAF,DAG,DA H,DAJ,DAL,DAW,DAX,V14,V15,V16, V17,V18,V19,V20,V21,V22,V24,ZAA, ZAB,ZAC,ZAD,ZAE,ZAF,ZAG,ZAH,Z AJ,ZAL .....	1

(1) ITEM NO.	(2) SMR CODE	(3) NSN	(4) CAGEC	(5) PART NUMBER	(6) DESCRIPTION AND USABLE ON CODE (UOC)	(7) QTY
16	PAHZZ	4730-01-127-6900	73342	6883707	. PLUG,PIPE UOC: DAC,DAD,DAE,DAF,DAG,DA H,DAJ,DAL,DAW,DAX,V14,V15,V16, V17,V18,V19,V20,V21,V22,V24,ZAA, ZAB,ZAC,ZAD,ZAE,ZAF,ZAG,ZAH,Z AJ,ZAL .....	1
17	PAHZZ	3040-01-292-4901	73342	23017700	. SHAFT,STRAIGHT UOC: DAC,DAD,DAE,DAF,DAG,DA H,DAJ,DAL,DAW,DAX,V14,V15,V16, V17,V18,V19,V20,V21,V22,V24,ZAA, ZAB,ZAC,ZAD,ZAE,ZAF,ZAG,ZAH,Z AJ,ZAL .....	1
18	PAHZZ	5325-00-566-6577	73342	6834583	RING,RETAINING UOC: DAC,DAD,DAE,DAF,DAG,DA H,DAJ,DAL,DAW,DAX,V14,V15,V16, V17,V18,V19,V20,V21,V22,V24,ZAA, ZAB,ZAC,ZAD,ZAE,ZAF,ZAG,ZAH,Z AJ,ZAL .....	1
19	PAHZZ	3020-01-124-3421	73342	6885151	GEAR,LOW SUN BRASS UOC: DAC,DAD,DAE,DAF,DAG,DA H,DAJ,DAL,DAW,DAX,V14,V15,V16, V17,V18,V19,V20,V21,V22,V24,ZAA, ZAB,ZAC,ZAD,ZAE,ZAF,ZAG,ZAH,Z AJ,ZAL .....	1
20	PAHHH	2520-01-122-9928	73342	6880008	CARRIER ASSEMBLY,RE UOC: DAC,DAD,DAE,DAF,DAG,DA H,DAJ,DAL,DAW,DAX,V14,V15,V16, V17,V18,V19,V20,V21,V22,V24,ZAA, ZAB,ZAC,ZAD,ZAE,ZAF,ZAG,ZAH,Z AJ,ZAL .....	1
21	PAHZZ	3110-01-065-2469	73342	9434057	. BEARING UOC: DAC,DAD,DAE,DAF,DAG,DA H,DAJ,DAL,DAW,DAX,V14,V15,V16, V17,V18,V19,V20,V21,V22,V24,ZAA, ZAB,ZAC,ZAD,ZAE,ZAF,ZAG,ZAH,Z AJ,ZAL .....	2
22	PAHZZ	3110-01-239-1253	73342	9436116	. BALL,BEARING UOC: DAC,DAD,DAE,DAF,DAG,DA H,DAJ,DAL,DAW,DAX,V14,V15,V16, V17,V18,V19,V20,V21,V22,V24,ZAA, ZAB,ZAC,ZAD,ZAE,ZAF,ZAG,ZAH,Z AJ,ZAL .....	1
23	PAHZZ	3020-01-152-8895	73342	6883901	GEAR CLUSTER,SPUR UOC: DAC,DAD,DAE,DAF,DAG,DA H,DAJ,DAL,DAW,DAX,V14,V15,V16, V17,V18,V19,V20,V21,V22,V24,ZAA, ZAB,ZAC,ZAD,ZAE,ZAF,ZAG,ZAH,Z AJ,ZAL .....	1

(1) ITEM NO.	(2) SMR CODE	(3) NSN	(4) CAGEC	(5) PART NUMBER	(6) DESCRIPTION AND USABLE ON CODE (UOC)	(7) QTY
24	PAHHH	2520-00-557-5980	89346	444965C1	CARRIER ASSEMBLY,CE UOC: DAC,DAD,DAE,DAF,DAG,DA H,DAJ,DAL,DAW,DAX,V14,V15,V16, V17,V18,V19,V20,V21,V22,V24,ZAA, ZAB,ZAC,ZAD,ZAE,ZAF,ZAG,ZAH,Z AJ,ZAL .....	1

END OF FIGURE

**FIELD MAINTENANCE  
TRANSMISSION HOUSING, OIL FILTER, OIL PAN, AND MOUNTING HARDWARE**

---

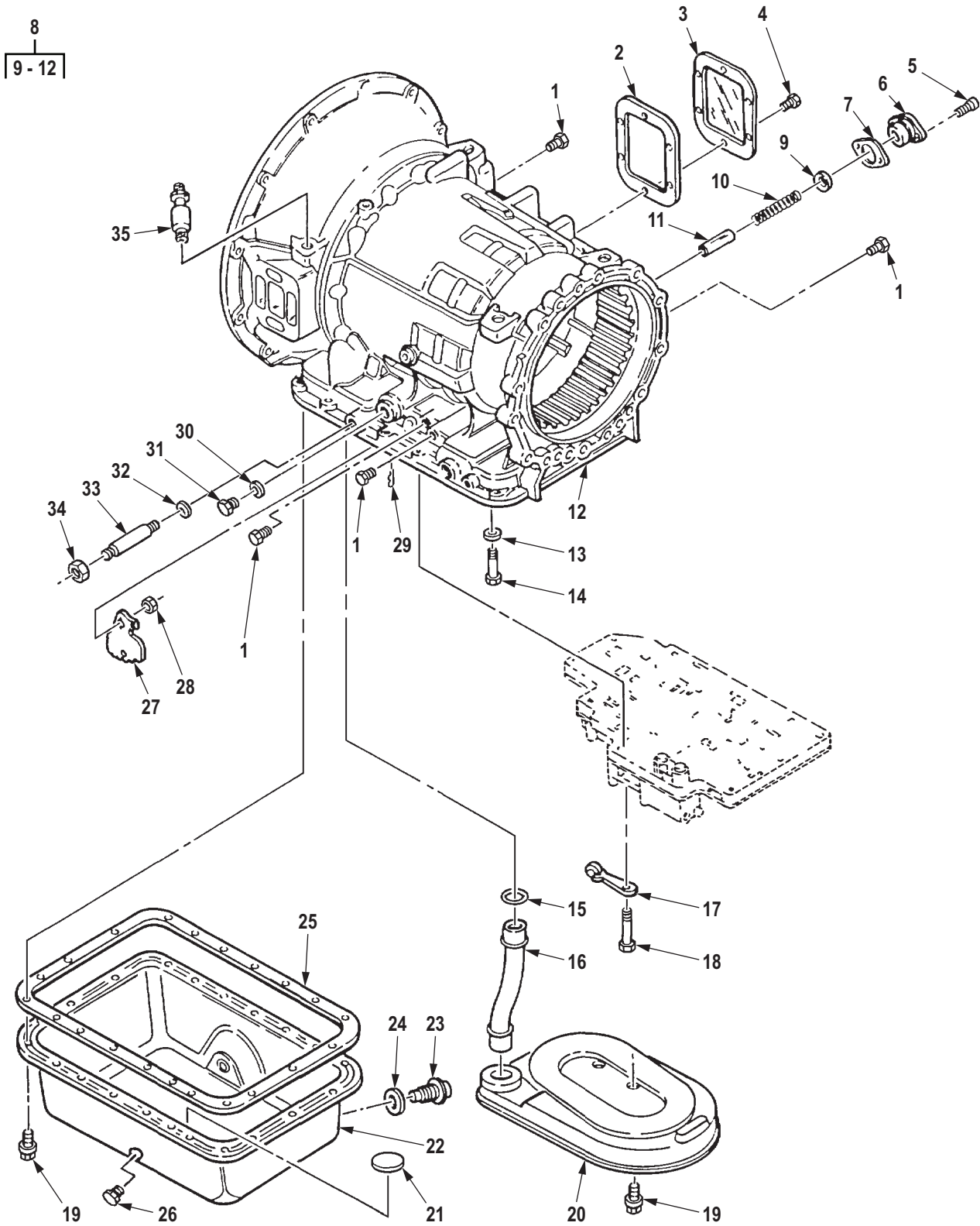

R0203DAA

Figure 189. Transmission Housing, Oil Filter, Oil Pan, and Mounting Hardware.



(1) ITEM NO.	(2) SMR CODE	(3) NSN	(4) CAGEC	(5) PART NUMBER	(6) DESCRIPTION AND USABLE ON CODE (UOC)	(7) QTY
<p><b>GROUP 0710 TRANSMISSION ASSEMBLY AND ASSOCIATED PARTS.</b></p> <p><b>FIG. 189. TRANSMISSION HOUSING, OIL FILTER, OIL PAN, AND MOUNTING HARDWARE.</b></p>						
1	PAFZZ	4730-01-146-1075	73342	23012036	PLUG,PIPE UOC: DAC,DAD,DAE,DAF,DAG,DAH,DAJ,DAL,DAW,DAX,V14,V15,V16,V17,V18,V19,V20,V21,V22,V24,ZAA,ZAB,ZAC,ZAD,ZAE,ZAF,ZAG,ZAH,ZAJ,ZAL .....	4
2	PAFZZ	5330-01-520-9770	19207	12288013 NON-ASBESTOS	GASKET PART OF KIT P/N 6884259 UOC: DAC,DAD,DAE,DAF,DAG,DAH,DAJ,DAL,DAW,DAX,V14,V15,V16,V17,V18,V19,V20,V21,V22,V24,ZAA,ZAB,ZAC,ZAD,ZAE,ZAF,ZAG,ZAH,ZAJ,ZAL .....	1
3	PAFZZ	2520-00-919-7240	73342	6774322	COVER UOC: DAC,DAD,DAE,DAF,DAG,DAH,DAJ,DAL,DAW,DAX,V14,V15,V16,V17,V18,V19,V20,V21,V22,V24,ZAA,ZAB,ZAC,ZAD,ZAE,ZAF,ZAG,ZAH,ZAJ,ZAL .....	1
4	PAFZZ	5305-00-543-4372	80204	B1821BH038C075N	SCREW,CAP,HEXAGON H UOC: DAC,DAD,DAE,DAF,DAG,DAH,DAJ,DAL,DAW,DAX,V14,V15,V16,V17,V18,V19,V20,V21,V22,V24,ZAA,ZAB,ZAC,ZAD,ZAE,ZAF,ZAG,ZAH,ZAJ,ZAL .....	6
5	PAFZZ	5305-01-124-5779	73342	6882586	SCREW,CAP,SOCKET HE UOC: DAC,DAD,DAE,DAF,DAG,DAH,DAJ,DAL,DAW,DAX,V14,V15,V16,V17,V18,V19,V20,V21,V22,V24,ZAA,ZAB,ZAC,ZAD,ZAE,ZAF,ZAG,ZAH,ZAJ,ZAL .....	2
6	PAFZZ	2520-01-106-0826	73342	6881227	ADAPTER,LUBE VALVE UOC: DAC,DAD,DAE,DAF,DAG,DAH,DAJ,DAL,DAW,DAX,V14,V15,V16,V17,V18,V19,V20,V21,V22,V24,ZAA,ZAB,ZAC,ZAD,ZAE,ZAF,ZAG,ZAH,ZAJ,ZAL .....	1
7	PAFZZ	5330-01-111-9291	73342	6884872	GASKET PART OF KIT P/N 23012502 UOC: DAC,DAD,DAE,DAF,DAG,DAH,DAJ,DAL,DAW,DAX,V14,V15,V16,V17,V18,V19,V20,V21,V22,V24,ZAA,ZAB,ZAC,ZAD,ZAE,ZAF,ZAG,ZAH,ZAJ,ZAL .....	1

(1) ITEM NO.	(2) SMR CODE	(3) NSN	(4) CAGEC	(5) PART NUMBER	(6) DESCRIPTION AND USABLE ON CODE (UOC)	(7) QTY
8	PFFZZ	2520-01-146-5254	73342	23011821	HOUSING ASSEMBLY,TR UOC: DAC,DAD,DAE,DAF,DAG,DA H,DAJ,DAL,DAW,DAX,V14,V15,V16, V17,V18,V19,V20,V21,V22,V24,ZAA, ZAB,ZAC,ZAD,ZAE,ZAF,ZAG,ZAH,Z AJ,ZAL .....	1
9	PAFZZ	2520-00-557-5900	73342	6834624	. VALVE,LUBE UOC: DAC,DAD,DAE,DAF,DAG,DA H,DAJ,DAL,DAW,DAX,V14,V15,V16, V17,V18,V19,V20,V21,V22,V24,ZAA, ZAB,ZAC,ZAD,ZAE,ZAF,ZAG,ZAH,Z AJ,ZAL .....	1
10	PAFZZ	5360-01-123-5483	73342	6836928	. SPRING,HELICAL,COMP UOC: DAC,DAD,DAE,DAF,DAG,DA H,DAJ,DAL,DAW,DAX,V14,V15,V16, V17,V18,V19,V20,V21,V22,V24,ZAA, ZAB,ZAC,ZAD,ZAE,ZAF,ZAG,ZAH,Z AJ,ZAL .....	1
11	PAFZZ	4710-00-557-5885	73342	23045085	. TUBE,VALVE GUIDE UOC: DAC,DAD,DAE,DAF,DAG,DA H,DAJ,DAL,DAW,DAX,V14,V15,V16, V17,V18,V19,V20,V21,V22,V24,ZAA, ZAB,ZAC,ZAD,ZAE,ZAF,ZAG,ZAH,Z AJ,ZAL .....	1
12	XAHZZ		73342	6880967	. HOUSING UOC: DAC,DAD,DAE,DAF,DAG,DA H,DAJ,DAL,DAW,DAX,V14,V15,V16, V17,V18,V19,V20,V21,V22,V24,ZAA, ZAB,ZAC,ZAD,ZAE,ZAF,ZAG,ZAH,Z AJ,ZAL .....	1
13	PAHZZ	5310-01-145-6923	63005	23014094	WASHER,FLAT PART OF KIT P/N 6884259 UOC: DAC,DAD,DAE,DAF,DAG,DA H,DAJ,DAL,DAW,DAX,V14,V15,V16, V17,V18,V19,V20,V21,V22,V24,ZAA, ZAB,ZAC,ZAD,ZAE,ZAF,ZAG,ZAH,Z AJ,ZAL .....	1
14	PAHZZ	5306-00-570-8942	63005	23013398	BOLT,MACHINE PART OF KIT P/ N 6884259 UOC: DAC,DAD,DAE,DAF,DAG,DA H,DAJ,DAL,DAW,DAX,V14,V15,V16, V17,V18,V19,V20,V21,V22,V24,ZAA, ZAB,ZAC,ZAD,ZAE,ZAF,ZAG,ZAH,Z AJ,ZAL .....	1

(1) ITEM NO.	(2) SMR CODE	(3) NSN	(4) CAGEC	(5) PART NUMBER	(6) DESCRIPTION AND USABLE ON CODE (UOC)	(7) QTY
15	PAHZZ	5331-01-010-9693	73342	6762127	O-RING PART OF KIT P/N 23019201, PART OF KIT P/N 6884259 UOC: DAC,DAD,DAE,DAF,DAG,DA H,DAJ,DAL,DAW,DAX,V14,V15,V16, V17,V18,V19,V20,V21,V22,V24,ZAA, ZAB,ZAC,ZAD,ZAE,ZAF,ZAG,ZAH,Z AJ,ZAL .....	1
16	PAHZZ	4710-01-078-8748	73342	6883046	TUBE,BENT,METALLIC UOC: DAC,DAD,DAE,DAF,DAG,DA H,DAJ,DAL,DAW,DAX,V14,V15,V16, V17,V18,V19,V20,V21,V22,V24,ZAA, ZAB,ZAC,ZAD,ZAE,ZAF,ZAG,ZAH,Z AJ,ZAL .....	1
17	PAHZZ	2520-00-008-7361	73342	8625431	ROLLER AND SPRING UOC: DAC,DAD,DAE,DAF,DAG,DA H,DAJ,DAL,DAW,DAX,V14,V15,V16, V17,V18,V19,V20,V21,V22,V24,ZAA, ZAB,ZAC,ZAD,ZAE,ZAF,ZAG,ZAH,Z AJ,ZAL .....	1
18	PAHZZ	5305-00-071-2513	80204	B1821BH025C250N	SCREW,CAP,HEXAGON H UOC: DAC,DAD,DAE,DAF,DAG,DA H,DAJ,DAL,DAW,DAX,V14,V15,V16, V17,V18,V19,V20,V21,V22,V24,ZAA, ZAB,ZAC,ZAD,ZAE,ZAF,ZAG,ZAH,Z AJ,ZAL .....	1
19	PAFZZ	5306-00-024-6580	73342	3829139	BOLT,MACHINE UOC: DAC,DAD,DAE,DAF,DAG,DA H,DAJ,DAL,DAW,DAX,V14,V15,V16, V17,V18,V19,V20,V21,V22,V24,ZAA, ZAB,ZAC,ZAD,ZAE,ZAF,ZAG,ZAH,Z AJ,ZAL .....	22
20	PAHZZ	2520-01-124-6469	73342	6883044	FILTER ELEMENT,FLUI PART OF KIT P/N 23019201, PART OF KIT P/N 6884259 UOC: DAC,DAD,DAE,DAF,DAG,DA H,DAJ,DAL,DAW,DAX,V14,V15,V16, V17,V18,V19,V20,V21,V22,V24,ZAA, ZAB,ZAC,ZAD,ZAE,ZAF,ZAG,ZAH,Z AJ,ZAL .....	1
21	PAHZZ	2920-01-143-1263	73342	29532686	MAGNET,OIL PAN PART OF KIT P/N 23012502 UOC: DAC,DAD,DAE,DAF,DAG,DA H,DAJ,DAL,DAW,DAX,V14,V15,V16, V17,V18,V19,V20,V21,V22,V24,ZAA, ZAB,ZAC,ZAD,ZAE,ZAF,ZAG,ZAH,Z AJ,ZAL .....	1

(1) ITEM NO.	(2) SMR CODE	(3) NSN	(4) CAGEC	(5) PART NUMBER	(6) DESCRIPTION AND USABLE ON CODE (UOC)	(7) QTY
22	PBFZZ	2520-01-206-9575	73342	23018884	OIL PAN UOC: DAC,DAD,DAE,DAF,DAG,DA H,DAJ,DAL,DAW,DAX,V14,V15,V16, V17,V18,V19,V20,V21,V22,V24,ZAA, ZAB,ZAC,ZAD,ZAE,ZAF,ZAG,ZAH,Z AJ,ZAL .....	1
23	PAFZZ	5363-01-085-7814	73342	23011420	PLUG,MACHINE THREAD PART OF KIT P/N 23012502 UOC: DAC,DAD,DAE,DAF,DAG,DA H,DAJ,DAL,DAW,DAX,V14,V15,V16, V17,V18,V19,V20,V21,V22,V24,ZAA, ZAB,ZAC,ZAD,ZAE,ZAF,ZAG,ZAH,Z AJ,ZAL .....	1
24	PAFZZ	5330-00-107-3925	7X677	14079550	GASKET PART OF KIT P/N 23012502 UOC: DAC,DAD,DAE,DAF,DAG,DA H,DAJ,DAL,DAW,DAX,V14,V15,V16, V17,V18,V19,V20,V21,V22,V24,ZAA, ZAB,ZAC,ZAD,ZAE,ZAF,ZAG,ZAH,Z AJ,ZAL .....	1
25	PAFZZ	5330-01-120-8090	73342	29501160	GASKET PART OF KIT P/N 23019201, PART OF KIT P/N 6884259 UOC: DAC,DAD,DAE,DAF,DAG,DA H,DAJ,DAL,DAW,DAX,V14,V15,V16, V17,V18,V19,V20,V21,V22,V24,ZAA, ZAB,ZAC,ZAD,ZAE,ZAF,ZAG,ZAH,Z AJ,ZAL .....	1
26	PAFZZ	4730-01-315-8280	81343	SAE J512 12 040109C	PLUG,TUBE FITTING,T UOC: DAC,DAD,DAE,DAF,DAG,DA H,DAJ,DAL,DAW,DAX,V14,V15,V16, V17,V18,V19,V20,V21,V22,V24,ZAA, ZAB,ZAC,ZAD,ZAE,ZAF,ZAG,ZAH,Z AJ,ZAL .....	1
27	PAFZZ	3040-01-122-5201	73342	6838278	LEVER,REMOTE CONTRO UOC: DAC,DAD,DAE,DAF,DAG,DA H,DAJ,DAL,DAW,DAX,V14,V15,V16, V17,V18,V19,V20,V21,V22,V24,ZAA, ZAB,ZAC,ZAD,ZAE,ZAF,ZAG,ZAH,Z AJ,ZAL .....	1
28	PAFZZ	5310-00-568-6077	24617	3978091	NUT,PLAIN,HEXAGON UOC: DAC,DAD,DAE,DAF,DAG,DA H,DAJ,DAL,DAW,DAX,V14,V15,V16, V17,V18,V19,V20,V21,V22,V24,ZAA, ZAB,ZAC,ZAD,ZAE,ZAF,ZAG,ZAH,Z AJ,ZAL .....	1

(1) ITEM NO.	(2) SMR CODE	(3) NSN	(4) CAGEC	(5) PART NUMBER	(6) DESCRIPTION AND USABLE ON CODE (UOC)	(7) QTY
29	PAFZZ	5315-00-108-1112	73342	6831774	PIN,RETAINING UOC: DAC,DAD,DAE,DAF,DAG,DA H,DAJ,DAL,DAW,DAX,V14,V15,V16, V17,V18,V19,V20,V21,V22,V24,ZAA, ZAB,ZAC,ZAD,ZAE,ZAF,ZAG,ZAH,Z AJ,ZAL .....	1
30	PAFZZ	5310-01-084-1768	73342	6839761	WASHER UOC: DAC,DAD,DAE,DAF,DAG,DA H,DAJ,DAL,DAW,DAX,V14,V15,V16, V17,V18,V19,V20,V21,V22,V24,ZAA, ZAB,ZAC,ZAD,ZAE,ZAF,ZAG,ZAH,Z AJ,ZAL .....	1
31	PAFZZ	5365-01-249-4343	73342	23046813	PLUG,MACHINE THREAD UOC: DAC,DAD,DAE,DAF,DAG,DA H,DAJ,DAL,DAW,DAX,V14,V15,V16, V17,V18,V19,V20,V21,V22,V24,ZAA, ZAB,ZAC,ZAD,ZAE,ZAF,ZAG,ZAH,Z AJ,ZAL .....	1
32	PAFZZ	5330-01-141-9503	73342	23010610	SEAL,PLAIN SELECTOR SHAFT PART OF KIT P/N 6884259 UOC: DAC,DAD,DAE,DAF,DAG,DA H,DAJ,DAL,DAW,DAX,V14,V15,V16, V17,V18,V19,V20,V21,V22,V24,ZAA, ZAB,ZAC,ZAD,ZAE,ZAF,ZAG,ZAH,Z AJ,ZAL .....	1
33	KBFZZ		73342	23017610 KIT	SHAFT,MANUAL PART OF KIT P/ N 6885213 UOC: DAC,DAD,DAE,DAF,DAG,DA H,DAJ,DAL,DAW,DAX,V14,V15,V16, V17,V18,V19,V20,V21,V22,V24,ZAA, ZAB,ZAC,ZAD,ZAE,ZAF,ZAG,ZAH,Z AJ,ZAL .....	1
34	PAFZZ	5310-01-143-0512	73342	29520052	NUT SELECTOR SHAFT PART OF KIT P/N 6885213 UOC: DAC,DAD,DAE,DAF,DAG,DA H,DAJ,DAL,DAW,DAX,V14,V15,V16, V17,V18,V19,V20,V21,V22,V24,ZAA, ZAB,ZAC,ZAD,ZAE,ZAF,ZAG,ZAH,Z AJ,ZAL .....	1
35	PAFZZ	4730-01-310-1137	19207	12368370	ADAPTER,STRAIGHT,PI UOC: DAC,DAD,DAE,DAF,DAG,DA H,DAJ,DAL,DAW,DAX,V14,V15,V16, V17,V18,V19,V20,V21,V22,V24,ZAA, ZAB,ZAC,ZAD,ZAE,ZAF,ZAG,ZAH,Z AJ,ZAL .....	1

END OF FIGURE



**FIELD MAINTENANCE  
REAR COVER ASSEMBLY AND RELATED PARTS**

---

5  
6 - 11

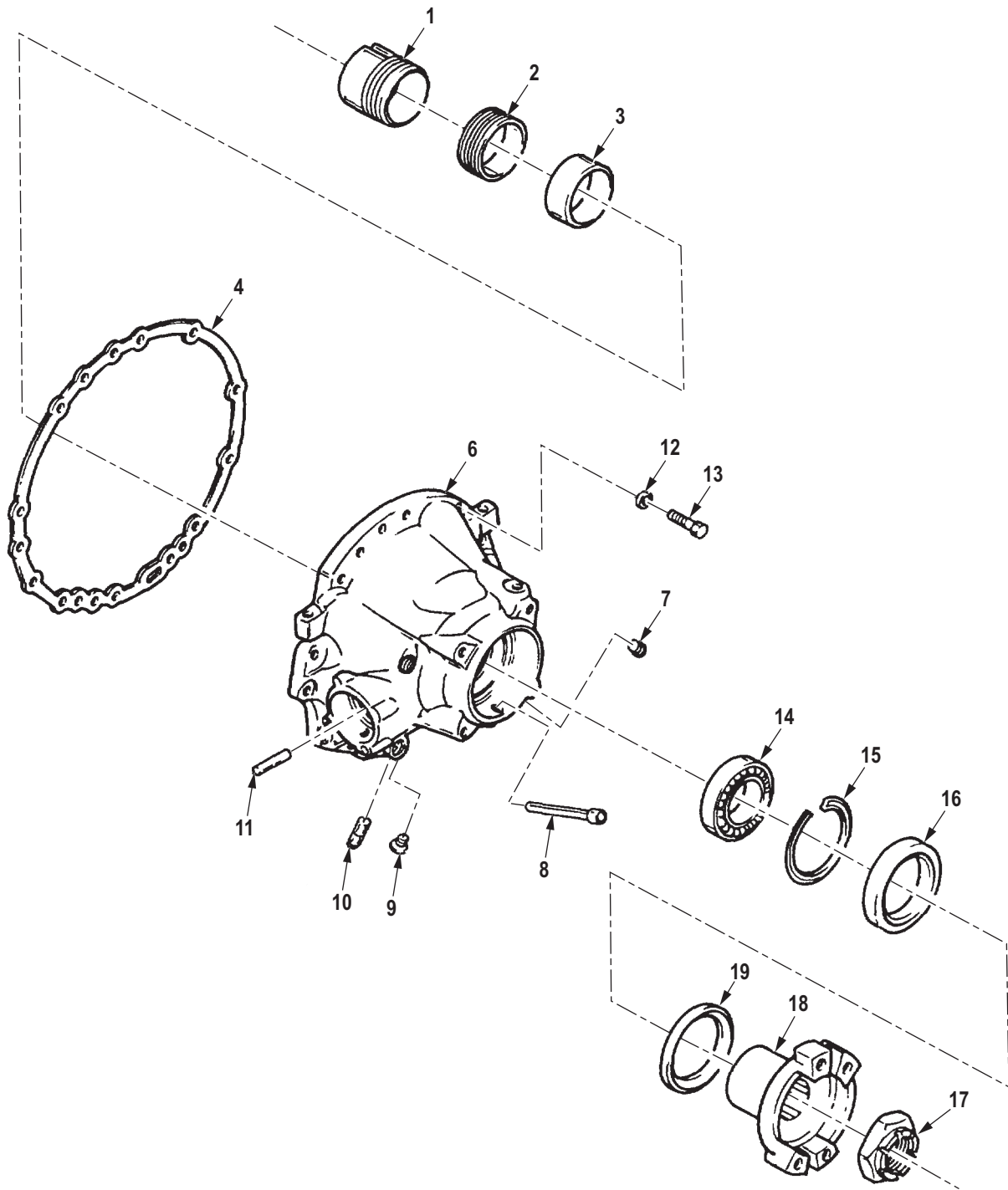

R0204DAA

Figure 190. Rear Cover Assembly and Related Parts.



(1) ITEM NO.	(2) SMR CODE	(3) NSN	(4) CAGEC	(5) PART NUMBER	(6) DESCRIPTION AND USABLE ON CODE (UOC)	(7) QTY
<p><b>GROUP 0710 TRANSMISSION ASSEMBLY AND ASSOCIATED PARTS.</b></p> <p><b>FIG. 190. REAR COVER ASSEMBLY AND RELATED PARTS.</b></p>						
1	PAHZZ	3020-01-179-7515	73342	29502387	GEAR,BEVEL UOC: DAC,DAD,DAE,DAF,DAG,DAH,DAJ,DAL,DAW,DAX,V14,V15,V16,V17,V18,V19,V20,V21,V22,V24,ZAA,ZAB,ZAC,ZAD,ZAE,ZAF,ZAG,ZAH,ZAJ,ZAL .....	1
2	PAHZZ	3020-01-134-1830	73342	29503795	GEAR,SPEEDOMETER DR UOC: DAC,DAD,DAE,DAF,DAG,DAH,DAJ,DAL,DAW,DAX,V14,V15,V16,V17,V18,V19,V20,V21,V22,V24,ZAA,ZAB,ZAC,ZAD,ZAE,ZAF,ZAG,ZAH,ZAJ,ZAL .....	1
3	PAHZZ	5365-01-124-2831	73342	6834556	SPACER,SLEEVE UOC: DAC,DAD,DAE,DAF,DAG,DAH,DAJ,DAL,DAW,DAX,V14,V15,V16,V17,V18,V19,V20,V21,V22,V24,ZAA,ZAB,ZAC,ZAD,ZAE,ZAF,ZAG,ZAH,ZAJ,ZAL .....	1
4	PAHZZ	5330-01-219-2555	73342	23045099	GASKET PART OF KIT P/N 6884259 UOC: DAC,DAD,DAE,DAF,DAG,DAH,DAJ,DAL,DAW,DAX,V14,V15,V16,V17,V18,V19,V20,V21,V22,V24,ZAA,ZAB,ZAC,ZAD,ZAE,ZAF,ZAG,ZAH,ZAJ,ZAL .....	1
5	PAHHH	2520-01-150-0899	73342	23016018	COVER ASSEMBLY,REAR UOC: DAC,DAD,DAE,DAF,DAG,DAH,DAJ,DAL,DAW,DAX,V14,V15,V16,V17,V18,V19,V20,V21,V22,V24,ZAA,ZAB,ZAC,ZAD,ZAE,ZAF,ZAG,ZAH,ZAJ,ZAL .....	1
6	XAHZZ		73342	23016019	. COVER,REAR UOC: DAC,DAD,DAE,DAF,DAG,DAH,DAJ,DAL,DAW,DAX,V14,V15,V16,V17,V18,V19,V20,V21,V22,V24,ZAA,ZAB,ZAC,ZAD,ZAE,ZAF,ZAG,ZAH,ZAJ,ZAL .....	1
7	PAHZZ	4730-00-057-5555	11083	7M7410	. PLUG,PIPE UOC: DAC,DAD,DAE,DAF,DAG,DAH,DAJ,DAL,DAW,DAX,V14,V15,V16,V17,V18,V19,V20,V21,V22,V24,ZAA,ZAB,ZAC,ZAD,ZAE,ZAF,ZAG,ZAH,ZAJ,ZAL .....	1

(1) ITEM NO.	(2) SMR CODE	(3) NSN	(4) CAGEC	(5) PART NUMBER	(6) DESCRIPTION AND USABLE ON CODE (UOC)	(7) QTY
8	PAHZZ	4710-01-131-2729	73342	6883974	. TUBE,DRAIN UOC: DAC,DAD,DAE,DAF,DAG,DAH,DAJ,DAL,DAW,DAX,V14,V15,V16,V17,V18,V19,V20,V21,V22,V24,ZAA,ZAB,ZAC,ZAD,ZAE,ZAF,ZAG,ZAH,ZAJ,ZAL .....	1
9	PAHZZ	4730-01-146-1075	73342	23012036	. PLUG,PIPE UOC: DAC,DAD,DAE,DAF,DAG,DAH,DAJ,DAL,DAW,DAX,V14,V15,V16,V17,V18,V19,V20,V21,V22,V24,ZAA,ZAB,ZAC,ZAD,ZAE,ZAF,ZAG,ZAH,ZAJ,ZAL .....	1
10	PAHZZ	4820-01-126-5379	73342	6882811	. VALVE,CHECK UOC: DAL,V18,ZAL .....	1
11	PAHZZ	5315-00-241-7523	21450	141231	. PIN,STRAIGHT,HEADLE UOC: DAC,DAD,DAE,DAF,DAG,DAH,DAJ,DAL,DAW,DAX,V14,V15,V16,V17,V18,V19,V20,V21,V22,V24,ZAA,ZAB,ZAC,ZAD,ZAE,ZAF,ZAG,ZAH,ZAJ,ZAL .....	1
12	PAHZZ	5310-00-799-4910	73342	6752556	WASHER,SPRING TENSI UOC: DAC,DAD,DAE,DAF,DAG,DAH,DAJ,DAL,DAW,DAX,V14,V15,V16,V17,V18,V19,V20,V21,V22,V24,ZAA,ZAB,ZAC,ZAD,ZAE,ZAF,ZAG,ZAH,ZAJ,ZAL .....	14
13	PAHZZ	5306-00-589-8133	73342	29505597	BOLT,MACHINE UOC: DAC,DAD,DAE,DAF,DAG,DAH,DAJ,DAL,DAW,DAX,V14,V15,V16,V17,V18,V19,V20,V21,V22,V24,ZAA,ZAB,ZAC,ZAD,ZAE,ZAF,ZAG,ZAH,ZAJ,ZAL .....	14
14	PAHZZ	3110-01-056-0031	43334	3212BAXR1A	BEARING,BALL,ANNULA UOC: DAC,DAD,DAE,DAF,DAG,DAH,DAJ,DAL,DAW,DAX,V14,V15,V16,V17,V18,V19,V20,V21,V22,V24,ZAA,ZAB,ZAC,ZAD,ZAE,ZAF,ZAG,ZAH,ZAJ,ZAL .....	1
15	PAHZZ	5325-00-557-5897	73342	6834567	RING,RETAINING UOC: DAC,DAD,DAE,DAF,DAG,DAH,DAJ,DAL,DAW,DAX,V14,V15,V16,V17,V18,V19,V20,V21,V22,V24,ZAA,ZAB,ZAC,ZAD,ZAE,ZAF,ZAG,ZAH,ZAJ,ZAL .....	1

(1) ITEM NO.	(2) SMR CODE	(3) NSN	(4) CAGEC	(5) PART NUMBER	(6) DESCRIPTION AND USABLE ON CODE (UOC)	(7) QTY
16	PAFZZ	5330-00-999-3752	73342	6773311	SEAL,PLAIN ENCASED PART OF KIT P/N 6884259 UOC: DAC,DAD,DAE,DAF,DAG,DA H,DAJ,DAL,DAW,DAX,V14,V15,V16, V17,V18,V19,V20,V21,V22,V24,ZAA, ZAB,ZAC,ZAD,ZAE,ZAF,ZAG,ZAH,Z AJ,ZAL .....	1
17	PAFZZ	5310-00-478-0548	73342	23040890	NUT,SELF-LOCKING,HE UOC: DAC,DAD,DAE,DAF,DAG,DA H,DAJ,DAL,DAW,DAX,V14,V15,V16, V17,V18,V19,V20,V21,V22,V24,ZAA, ZAB,ZAC,ZAD,ZAE,ZAF,ZAG,ZAH,Z AJ,ZAL .....	1
18	PAFZZ	2520-01-114-3691	78500	85WBYS38-10	YOKE,UNIVERSAL JOIN UOC: DAC,DAD,DAE,DAF,DAG,DA H,DAJ,DAL,DAW,DAX,V14,V15,V16, V17,V18,V19,V20,V21,V22,V24,ZAA, ZAB,ZAC,ZAD,ZAE,ZAF,ZAG,ZAH,Z AJ,ZAL .....	1
19	PAFZZ	5330-01-302-5092	73342	23016017	GASKET USE AFTER S/N 2410227062 PART OF KIT P/N 6884259 UOC: DAC,DAD,DAE,DAF,DAG,DA H,DAJ,DAL,DAW,DAX,V14,V15,V16, V17,V18,V19,V20,V21,V22,V24,ZAA, ZAB,ZAC,ZAD,ZAE,ZAF,ZAG,ZAH,Z AJ,ZAL .....	1
19	PAFZZ	5330-00-923-1409	73342	6757563	RETAINER,PACKING REAR COVER,USE PRIOR TO S/N 2410227062 PART OF KIT P/N 6884259 UOC: DAC,DAD,DAE,DAF,DAG,DA H,DAJ,DAL,DAW,DAX,V14,V15,V16, V17,V18,V19,V20,V21,V22,V24,ZAA, ZAB,ZAC,ZAD,ZAE,ZAF,ZAG,ZAH,Z AJ,ZAL .....	1

END OF FIGURE



**FIELD MAINTENANCE  
FIRST CLUTCH**

---

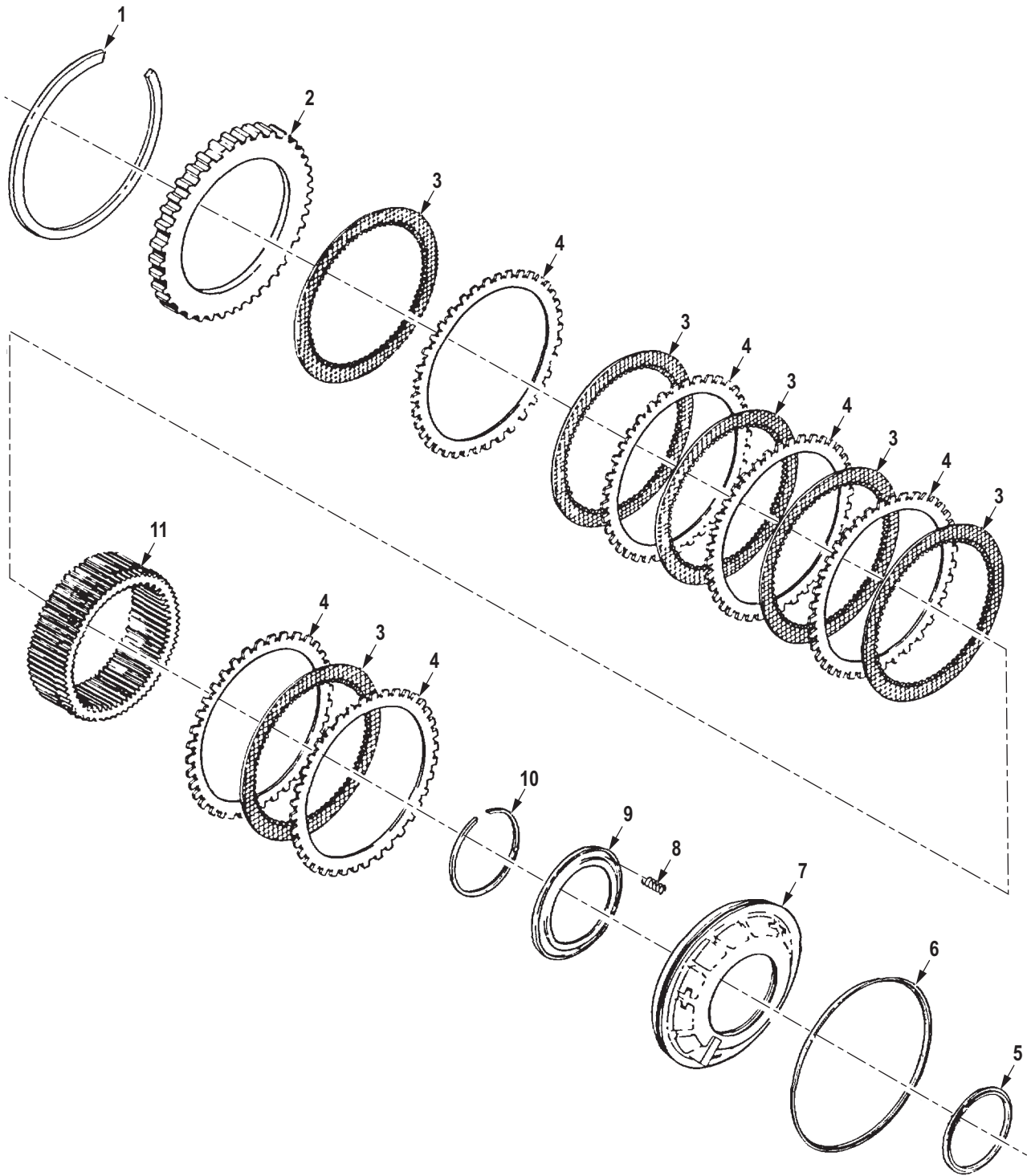

R0206DAA

Figure 191. First Clutch.

(1) ITEM NO.	(2) SMR CODE	(3) NSN	(4) CAGEC	(5) PART NUMBER	(6) DESCRIPTION AND USABLE ON CODE (UOC)	(7) QTY
<b>GROUP 0713 INTERMEDIATE CLUTCH.</b>						
<b>FIG. 191. FIRST CLUTCH.</b>						
1	PAHZZ	5325-00-007-2969	73342	6884275	RING,RETAINING UOC: DAC,DAD,DAE,DAF,DAG,DA H,DAJ,DAL,DAW,DAX,V14,V15,V16, V17,V18,V19,V20,V21,V22,V24,ZAA, ZAB,ZAC,ZAD,ZAE,ZAF,ZAG,ZAH,Z AJ,ZAL .....	1
2	PAHZZ	2520-01-064-8847	73342	29518132	DISK,CLUTCH 0.671-0.681 UOC: DAC,DAD,DAE,DAF,DAG,DA H,DAJ,DAL,DAW,DAX,V14,V15,V16, V17,V18,V19,V20,V21,V22,V24,ZAA, ZAB,ZAC,ZAD,ZAE,ZAF,ZAG,ZAH,Z AJ,ZAL .....	1
2	PAHZZ	2520-00-563-6041	73342	29518133	DISK,CLUTCH 0.640-0.650 UOC: DAC,DAD,DAE,DAF,DAG,DA H,DAJ,DAL,DAW,DAX,V14,V15,V16, V17,V18,V19,V20,V21,V22,V24,ZAA, ZAB,ZAC,ZAD,ZAE,ZAF,ZAG,ZAH,Z AJ,ZAL .....	1
2	PAHZZ	2520-00-557-5981	73342	29518131	DISK,CLUTCH 0.702-0.712 UOC: DAC,DAD,DAE,DAF,DAG,DA H,DAJ,DAL,DAW,DAX,V14,V15,V16, V17,V18,V19,V20,V21,V22,V24,ZAA, ZAB,ZAC,ZAD,ZAE,ZAF,ZAG,ZAH,Z AJ,ZAL .....	1
3	PAHZZ	2520-00-163-0713	13475	BD809990	DISK,CLUTCH,VEHICUL UOC: DAC,DAD,DAE,DAF,DAG,DA H,DAJ,DAL,DAW,DAX,V14,V15,V16, V17,V18,V19,V20,V21,V22,V24,ZAA, ZAB,ZAC,ZAD,ZAE,ZAF,ZAG,ZAH,Z AJ,ZAL .....	6
4	PAHZZ	2520-00-557-5807	73342	23016606	DISK,CLUTCH UOC: DAC,DAD,DAE,DAF,DAG,DA H,DAJ,DAL,DAW,DAX,V14,V15,V16, V17,V18,V19,V20,V21,V22,V24,ZAA, ZAB,ZAC,ZAD,ZAE,ZAF,ZAG,ZAH,Z AJ,ZAL .....	6
5	KBHZZ	5330-01-083-3065	73342	6883031	SEAL,PLAIN PART OF KIT P/N 6884259 UOC: DAC,DAD,DAE,DAF,DAG,DA H,DAJ,DAL,DAW,DAX,V14,V15,V16, V17,V18,V19,V20,V21,V22,V24,ZAA, ZAB,ZAC,ZAD,ZAE,ZAF,ZAG,ZAH,Z AJ,ZAL .....	1

(1) ITEM NO.	(2) SMR CODE	(3) NSN	(4) CAGEC	(5) PART NUMBER	(6) DESCRIPTION AND USABLE ON CODE (UOC)	(7) QTY
6	KBHZZ	2520-01-079-6700	73342	6883033	SEAL,AIR,AIRCRAFT G PART OF KIT P/N 6884259 UOC: DAC,DAD,DAE,DAF,DAG,DA H,DAJ,DAL,DAW,DAX,V14,V15,V16, V17,V18,V19,V20,V21,V22,V24,ZAA, ZAB,ZAC,ZAD,ZAE,ZAF,ZAG,ZAH,Z AJ,ZAL .....	1
7	PAHZZ	2520-01-146-1034	73342	23011665	PISTON,CLUTCH TRANS UOC: DAC,DAD,DAE,DAF,DAG,DA H,DAJ,DAL,DAW,DAX,V14,V15,V16, V17,V18,V19,V20,V21,V22,V24,ZAA, ZAB,ZAC,ZAD,ZAE,ZAF,ZAG,ZAH,Z AJ,ZAL .....	1
8	PAHZZ	5360-01-079-3097	73342	6880251	SPRING,PISTON RELEA UOC: DAC,DAD,DAE,DAF,DAG,DA H,DAJ,DAL,DAW,DAX,V14,V15,V16, V17,V18,V19,V20,V21,V22,V24,ZAA, ZAB,ZAC,ZAD,ZAE,ZAF,ZAG,ZAH,Z AJ,ZAL .....	26
9	PAHZZ	2520-01-064-8849	73342	6834339	RETAINER,PISTON SPR UOC: DAC,DAD,DAE,DAF,DAG,DA H,DAJ,DAL,DAW,DAX,V14,V15,V16, V17,V18,V19,V20,V21,V22,V24,ZAA, ZAB,ZAC,ZAD,ZAE,ZAF,ZAG,ZAH,Z AJ,ZAL .....	1
10	PAHZZ	5325-00-557-5794	73342	6833993	RING,RETAINING UOC: DAC,DAD,DAE,DAF,DAG,DA H,DAJ,DAL,DAW,DAX,V14,V15,V16, V17,V18,V19,V20,V21,V22,V24,ZAA, ZAB,ZAC,ZAD,ZAE,ZAF,ZAG,ZAH,Z AJ,ZAL .....	1
11	PAHZZ	3020-01-110-8251	73342	29538425	GEAR,CLUTCH UOC: DAC,DAD,DAE,DAF,DAG,DA H,DAJ,DAL,DAW,DAX,V14,V15,V16, V17,V18,V19,V20,V21,V22,V24,ZAA, ZAB,ZAC,ZAD,ZAE,ZAF,ZAG,ZAH,Z AJ,ZAL .....	1

END OF FIGURE



**FIELD MAINTENANCE  
SECOND, THIRD, AND FOURTH CLUTCH ASSEMBLY, AND CENTER SUPPORT (TRANSMISSION P/N  
6885292)**

---

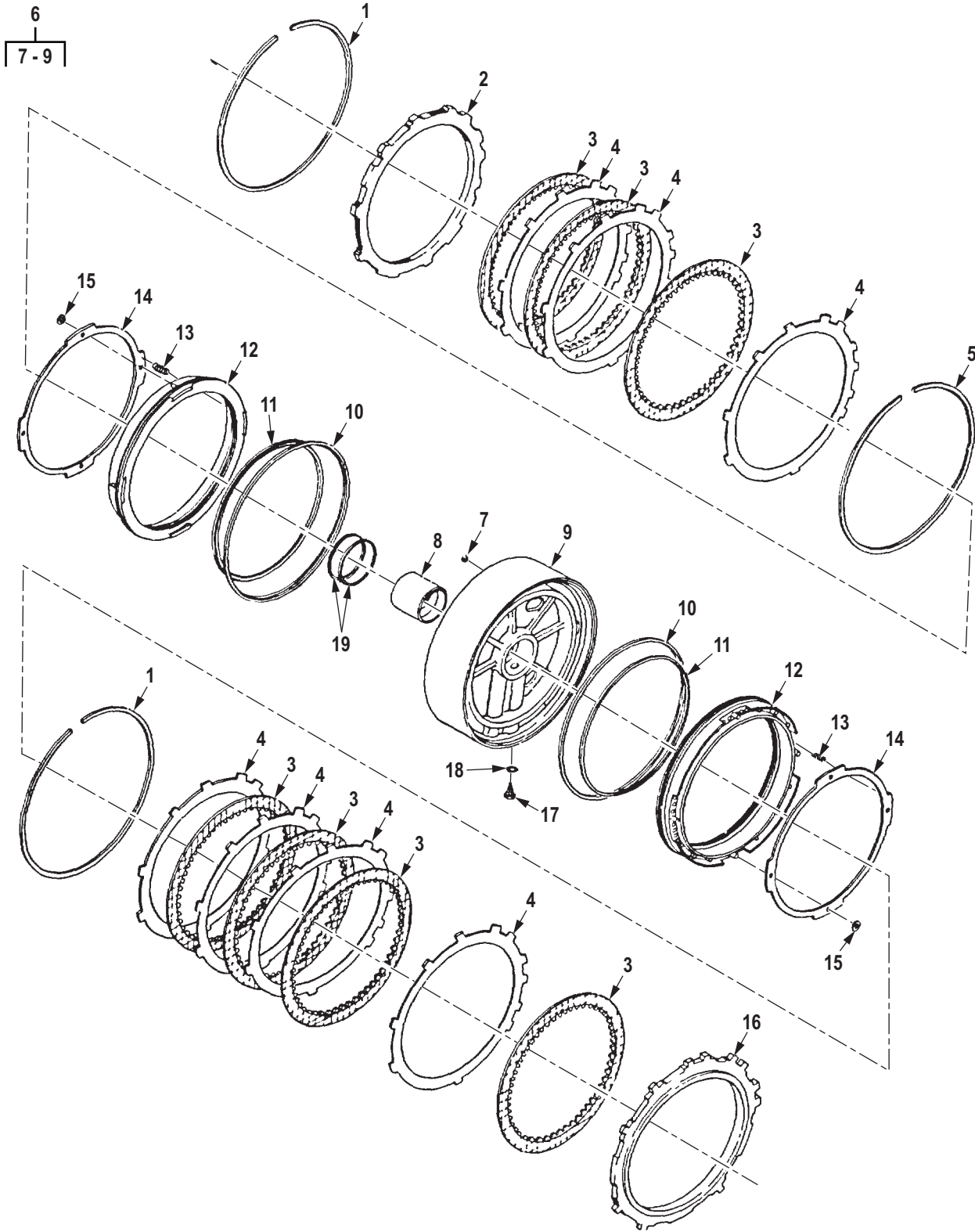

R0207DAA

Figure 192. Second, Third, and Fourth Clutch Assembly, and Center Support (Transmission P/N 6885292).

(1) ITEM NO.	(2) SMR CODE	(3) NSN	(4) CAGEC	(5) PART NUMBER	(6) DESCRIPTION AND USABLE ON CODE (UOC)	(7) QTY
<b>GROUP 0713 INTERMEDIATE CLUTCH.</b>						
<b>FIG. 192. SECOND, THIRD, AND FOURTH CLUTCH ASSEMBLY, AND CENTER SUPPORT (TRANSMISSION P/N 6885292).</b>						
1	PAHZZ	5325-00-557-6207	73342	6836267	RING,RETAINING UOC: DAC,DAD,DAE,DAF,DAG,DA H,DAJ,DAL,DAW,DAX,V14,V15,V16, V17,V18,V19,V20,V21,V22,V24,ZAA, ZAB,ZAC,ZAD,ZAE,ZAF,ZAG,ZAH,Z AJ,ZAL .....	2
2	PAHZZ	5365-01-277-9878	73342	23046718	SPACER,PLATE 0.463-0.473 UOC: DAC,DAD,DAE,DAF,DAG,DA H,DAJ,DAL,DAW,DAX,V14,V15,V16, V17,V18,V19,V20,V21,V22,V24,ZAA, ZAB,ZAC,ZAD,ZAE,ZAF,ZAG,ZAH,Z AJ,ZAL .....	1
2	PAHZZ	2520-00-557-5924	73342	23046746	DISK,CLUTCH 0.450-0.460 UOC: DAC,DAD,DAE,DAF,DAG,DA H,DAJ,DAL,DAW,DAX,V14,V15,V16, V17,V18,V19,V20,V21,V22,V24,ZAA, ZAB,ZAC,ZAD,ZAE,ZAF,ZAG,ZAH,Z AJ,ZAL .....	1
2	PAHZZ	2520-00-557-5799	73342	23046745	DISK,CLUTCH 0.476-0.486 UOC: DAC,DAD,DAE,DAF,DAG,DA H,DAJ,DAL,DAW,DAX,V14,V15,V16, V17,V18,V19,V20,V21,V22,V24,ZAA, ZAB,ZAC,ZAD,ZAE,ZAF,ZAG,ZAH,Z AJ,ZAL .....	1
3	PAHZZ	2520-00-557-6090	73342	6835720	DISK,CLUTCH UOC: DAC,DAD,DAE,DAF,DAG,DA H,DAJ,DAL,DAW,DAX,V14,V15,V16, V17,V18,V19,V20,V21,V22,V24,ZAA, ZAB,ZAC,ZAD,ZAE,ZAF,ZAG,ZAH,Z AJ,ZAL .....	7
4	PAHZZ	2520-00-557-6076	73342	23016608	DISK,CLUTCH UOC: DAC,DAD,DAE,DAF,DAG,DA H,DAJ,DAL,DAW,DAX,V14,V15,V16, V17,V18,V19,V20,V21,V22,V24,ZAA, ZAB,ZAC,ZAD,ZAE,ZAF,ZAG,ZAH,Z AJ,ZAL .....	7
5	PAHZZ	5325-00-557-6207	73342	6836267	RING,RETAINING 0.155-0.157 GREEN UOC: DAC,DAD,DAE,DAF,DAG,DA H,DAJ,DAL,DAW,DAX,V14,V15,V16, V17,V18,V19,V20,V21,V22,V24,ZAA, ZAB,ZAC,ZAD,ZAE,ZAF,ZAG,ZAH,Z AJ,ZAL .....	1

(1) ITEM NO.	(2) SMR CODE	(3) NSN	(4) CAGEC	(5) PART NUMBER	(6) DESCRIPTION AND USABLE ON CODE (UOC)	(7) QTY
5	PAHZZ	5325-00-557-6210	73342	6836268	RING,RETAINING 0.158-0.160 RED UOC: DAC,DAD,DAE,DAF,DAG,DA H,DAJ,DAL,DAW,DAX,V14,V15,V16, V17,V18,V19,V20,V21,V22,V24,ZAA, ZAB,ZAC,ZAD,ZAE,ZAF,ZAG,ZAH,Z AJ,ZAL .....	1
5	PAHZZ	5325-00-557-6164	73342	6836265	RING,RETAINING 0.148-0.150 WHITE UOC: DAC,DAD,DAE,DAF,DAG,DA H,DAJ,DAL,DAW,DAX,V14,V15,V16, V17,V18,V19,V20,V21,V22,V24,ZAA, ZAB,ZAC,ZAD,ZAE,ZAF,ZAG,ZAH,Z AJ,ZAL .....	1
5	PAHZZ	5325-00-557-6183	73342	6836266	RING,RETAINING 0.152-0.154 YELLOW UOC: DAC,DAD,DAE,DAF,DAG,DA H,DAJ,DAL,DAW,DAX,V14,V15,V16, V17,V18,V19,V20,V21,V22,V24,ZAA, ZAB,ZAC,ZAD,ZAE,ZAF,ZAG,ZAH,Z AJ,ZAL .....	1
6	PBHZZ	2520-01-168-1632	73342	23018593	SUPPORT,CENTER CLUT UOC: DAC,DAD,DAE,DAF,DAG,DA H,DAJ,DAL,DAW,DAX,V14,V15,V16, V17,V18,V19,V20,V21,V22,V24,ZAA, ZAB,ZAC,ZAD,ZAE,ZAF,ZAG,ZAH,Z AJ,ZAL .....	1
7	PFHZZ	3110-01-117-4893	81346	SATM F 2215	. BALL,BEARING UOC: DAC,DAD,DAE,DAF,DAG,DA H,DAJ,DAL,DAW,DAX,V14,V15,V16, V17,V18,V19,V20,V21,V22,V24,ZAA, ZAB,ZAC,ZAD,ZAE,ZAF,ZAG,ZAH,Z AJ,ZAL .....	1
8	PFHZZ	4730-01-078-2732	73342	23011924	. BUSHING,PIPE UOC: DAC,DAD,DAE,DAF,DAG,DA H,DAJ,DAL,DAW,DAX,V14,V15,V16, V17,V18,V19,V20,V21,V22,V24,ZAA, ZAB,ZAC,ZAD,ZAE,ZAF,ZAG,ZAH,Z AJ,ZAL .....	1
9	XAHZZ		73342	23017361	. CENTER SUPPORT UOC: DAC,DAD,DAE,DAF,DAG,DA H,DAJ,DAL,DAW,DAX,V14,V15,V16, V17,V18,V19,V20,V21,V22,V24,ZAA, ZAB,ZAC,ZAD,ZAE,ZAF,ZAG,ZAH,Z AJ,ZAL .....	1
10	KBHZZ	5330-01-104-8934	73342	6883035	SEAL,RING PART OF KIT P/N 6884259 UOC: DAC,DAD,DAE,DAF,DAG,DA H,DAJ,DAL,DAW,DAX,V14,V15,V16, V17,V18,V19,V20,V21,V22,V24,ZAA, ZAB,ZAC,ZAD,ZAE,ZAF,ZAG,ZAH,Z AJ,ZAL .....	2

(1) ITEM NO.	(2) SMR CODE	(3) NSN	(4) CAGEC	(5) PART NUMBER	(6) DESCRIPTION AND USABLE ON CODE (UOC)	(7) QTY
11	KBHZZ	4310-01-006-4952	73342	23011471	RING,PISTON PART OF KIT P/N 6884259 UOC: DAC,DAD,DAE,DAF,DAG,DA H,DAJ,DAL,DAW,DAX,V14,V15,V16, V17,V18,V19,V20,V21,V22,V24,ZAA, ZAB,ZAC,ZAD,ZAE,ZAF,ZAG,ZAH,Z AJ,ZAL .....	2
12	PAHZZ	2520-01-006-7120	73342	6834230	PISTON,TRANSMISSION UOC: DAC,DAD,DAE,DAF,DAG,DA H,DAJ,DAL,DAW,DAX,V14,V15,V16, V17,V18,V19,V20,V21,V22,V24,ZAA, ZAB,ZAC,ZAD,ZAE,ZAF,ZAG,ZAH,Z AJ,ZAL .....	2
13	PAHZZ	5360-00-211-9547	73342	6831656	SPRING,HELICAL,COMP UOC: DAC,DAD,DAE,DAF,DAG,DA H,DAJ,DAL,DAW,DAX,V14,V15,V16, V17,V18,V19,V20,V21,V22,V24,ZAA, ZAB,ZAC,ZAD,ZAE,ZAF,ZAG,ZAH,Z AJ,ZAL .....	40
14	PAHZZ	2520-01-065-0078	73342	6834354	RETAINER,CLUTCH SPR UOC: DAC,DAD,DAE,DAF,DAG,DA H,DAJ,DAL,DAW,DAX,V14,V15,V16, V17,V18,V19,V20,V21,V22,V24,ZAA, ZAB,ZAC,ZAD,ZAE,ZAF,ZAG,ZAH,Z AJ,ZAL .....	2
15	PAHZZ	5310-01-143-0542	73342	3909063	PUSH ON NUT UOC: DAC,DAD,DAE,DAF,DAG,DA H,DAJ,DAL,DAW,DAX,V14,V15,V16, V17,V18,V19,V20,V21,V22,V24,ZAA, ZAB,ZAC,ZAD,ZAE,ZAF,ZAG,ZAH,Z AJ,ZAL .....	8
16	PAHZZ	2520-01-078-6123	73342	6882321	DISK,CLUTCH 0.234-0.244 UOC: DAC,DAD,DAE,DAF,DAG,DA H,DAJ,DAL,DAW,DAX,V14,V15,V16, V17,V18,V19,V20,V21,V22,V24,ZAA, ZAB,ZAC,ZAD,ZAE,ZAF,ZAG,ZAH,Z AJ,ZAL .....	1
16	PAHZZ	2520-01-078-5564	73342	23046748	DISK,CLUTCH UOC: DAC,DAD,DAE,DAF,DAG,DA H,DAJ,DAL,DAW,DAX,V14,V15,V16, V17,V18,V19,V20,V21,V22,V24,ZAA, ZAB,ZAC,ZAD,ZAE,ZAF,ZAG,ZAH,Z AJ,ZAL .....	1
17	PAHZZ	2940-01-140-8227	73342	23010654	FILTER ELEMENT,FLUI UOC: DAC,DAD,DAE,DAF,DAG,DA H,DAJ,DAL,DAW,DAX,V14,V15,V16, V17,V18,V19,V20,V21,V22,V24,ZAA, ZAB,ZAC,ZAD,ZAE,ZAF,ZAG,ZAH,Z AJ,ZAL .....	1

(1) ITEM NO.	(2) SMR CODE	(3) NSN	(4) CAGEC	(5) PART NUMBER	(6) DESCRIPTION AND USABLE ON CODE (UOC)	(7) QTY
18	PAHZZ	5331-00-579-8108	81343	MS28775-111	O-RING UOC: DAC,DAD,DAE,DAF,DAG,DA H,DAJ,DAL,DAW,DAX,V14,V15,V16, V17,V18,V19,V20,V21,V22,V24,ZAA, ZAB,ZAC,ZAD,ZAE,ZAF,ZAG,ZAH,Z AJ,ZAL .....	1
19	PAHZZ	2520-00-557-6211	73342	23014632	RING,SEAL UOC: DAC,DAD,DAE,DAF,DAG,DA H,DAJ,DAL,DAW,DAX,V14,V15,V16, V17,V18,V19,V20,V21,V22,V24,ZAA, ZAB,ZAC,ZAD,ZAE,ZAF,ZAG,ZAH,Z AJ,ZAL .....	2

END OF FIGURE

**FIELD MAINTENANCE  
FOURTH CLUTCH ASSEMBLY**

---

1	11
2-14	12

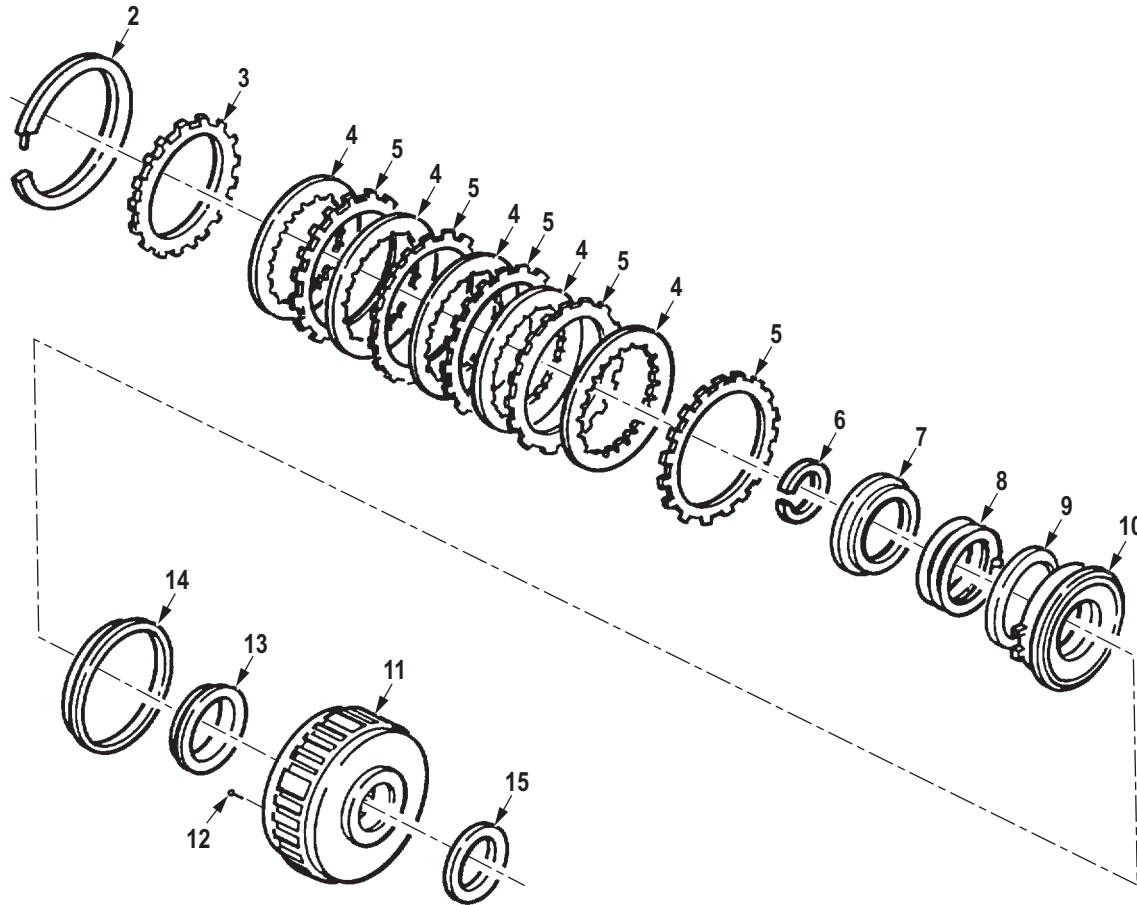

R0208DAA

Figure 193. Fourth Clutch Assembly.



(1) ITEM NO.	(2) SMR CODE	(3) NSN	(4) CAGEC	(5) PART NUMBER	(6) DESCRIPTION AND USABLE ON CODE (UOC)	(7) QTY
<b>GROUP 0713 INTERMEDIATE CLUTCH.</b>						
<b>FIG. 193. FOURTH CLUTCH ASSEMBLY.</b>						
1	PAHHH	2520-01-150-0901	73342	23013789	CLUTCH ASSEMBLY,VEH UOC: DAC,DAD,DAE,DAF,DAG,DA H,DAJ,DAL,DAW,DAX,V14,V15,V16, V17,V18,V19,V20,V21,V22,V24,ZAA, ZAB,ZAC,ZAD,ZAE,ZAF,ZAG,ZAH,Z AJ,ZAL .....	1
2	PAHZZ	5325-01-219-2580	73342	23018867	. RING,RETAINING UOC: DAC,DAD,DAE,DAF,DAG,DA H,DAJ,DAL,DAW,DAX,V14,V15,V16, V17,V18,V19,V20,V21,V22,V24,ZAA, ZAB,ZAC,ZAD,ZAE,ZAF,ZAG,ZAH,Z AJ,ZAL .....	1
3	PAHZZ	2520-01-006-7118	73342	29516333	. DISK,CLUTCH,VEHICUL UOC: DAC,DAD,DAE,DAF,DAG,DA H,DAJ,DAL,DAW,DAX,V14,V15,V16, V17,V18,V19,V20,V21,V22,V24,ZAA, ZAB,ZAC,ZAD,ZAE,ZAF,ZAG,ZAH,Z AJ,ZAL .....	1
4	PAHZZ	2520-01-006-7116	79370	WPC-4946	. DISK,CLUTCH,VEHICUL UOC: DAC,DAD,DAE,DAF,DAG,DA H,DAJ,DAL,DAW,DAX,V14,V15,V16, V17,V18,V19,V20,V21,V22,V24,ZAA, ZAB,ZAC,ZAD,ZAE,ZAF,ZAG,ZAH,Z AJ,ZAL .....	5
5	PAHZZ	2520-01-065-0077	73342	23016610	. DISK,CLUTCH UOC: DAC,DAD,DAE,DAF,DAG,DA H,DAJ,DAL,DAW,DAX,V14,V15,V16, V17,V18,V19,V20,V21,V22,V24,ZAA, ZAB,ZAC,ZAD,ZAE,ZAF,ZAG,ZAH,Z AJ,ZAL .....	5
6	PAHZZ	5325-01-145-6921	73342	6885156	. RING,RETAINING UOC: DAC,DAD,DAE,DAF,DAG,DA H,DAJ,DAL,DAW,DAX,V14,V15,V16, V17,V18,V19,V20,V21,V22,V24,ZAA, ZAB,ZAC,ZAD,ZAE,ZAF,ZAG,ZAH,Z AJ,ZAL .....	1
7	PAHZZ	2520-01-065-0841	73342	6834369	. RETAINER,CLUTCH SPR UOC: DAC,DAD,DAE,DAF,DAG,DA H,DAJ,DAL,DAW,DAX,V14,V15,V16, V17,V18,V19,V20,V21,V22,V24,ZAA, ZAB,ZAC,ZAD,ZAE,ZAF,ZAG,ZAH,Z AJ,ZAL .....	1

(1) ITEM NO.	(2) SMR CODE	(3) NSN	(4) CAGEC	(5) PART NUMBER	(6) DESCRIPTION AND USABLE ON CODE (UOC)	(7) QTY
8	PAHZZ	5360-01-079-3096	73342	6836773	. SPRING,CLUTCH UOC: DAC,DAD,DAE,DAF,DAG,DA H,DAJ,DAL,DAW,DAX,V14,V15,V16, V17,V18,V19,V20,V21,V22,V24,ZAA, ZAB,ZAC,ZAD,ZAE,ZAF,ZAG,ZAH,Z AJ,ZAL .....	1
9	PAHZZ	5365-01-197-4545	73342	6884653	. SPACER,RING UOC: DAC,DAD,DAE,DAF,DAG,DA H,DAJ,DAL,DAW,DAX,V14,V15,V16, V17,V18,V19,V20,V21,V22,V24,ZAA, ZAB,ZAC,ZAD,ZAE,ZAF,ZAG,ZAH,Z AJ,ZAL .....	1
10	XDHZZ		73342	6885153	. PISTON,FOURTH CLUTC FOURTH CLUTCH 0.837-0.847 THK PRIOR TO S/N 2420026502AND PISTON WITH A LETTER "C" AS AN IDENTIFIER UOC: DAC,DAD,DAE,DAF,DAG,DA H,DAJ,DAL,DAW,DAX,V14,V15,V16, V17,V18,V19,V20,V21,V22,V24,ZAA, ZAB,ZAC,ZAD,ZAE,ZAF,ZAG,ZAH,Z AJ,ZAL .....	1
10	PAHZZ	3040-01-336-8217	73342	23017260	. PISTON,LINEAR ACTUA FOURTH CLUTCH 0.970-0.980 UOC: DAC,DAD,DAE,DAF,DAG,DA H,DAJ,DAL,DAW,DAX,V14,V15,V16, V17,V18,V19,V20,V21,V22,V24,ZAA, ZAB,ZAC,ZAD,ZAE,ZAF,ZAG,ZAH,Z AJ,ZAL .....	1
10	PAHZZ	2520-01-149-3438	73342	6885155	. PISTON,FOURTH CLUTC FOURTH CLUTCH 0.777-0.787 THK PRIOR TO S/N 242002626502AND PISTON WITH A LETTER "A" AS AN IDENTIFIER UOC: DAC,DAD,DAE,DAF,DAG,DA H,DAJ,DAL,DAW,DAX,V14,V15,V16, V17,V18,V19,V20,V21,V22,V24,ZAA, ZAB,ZAC,ZAD,ZAE,ZAF,ZAG,ZAH,Z AJ,ZAL .....	1
10	PAHZZ	3040-01-337-4167	73342	23017262	. PISTON,LINEAR ACTUA FOURTH CLUTCH 1.020-1.030 THK USE AFTER S/N 2420026502 UOC: DAC,DAD,DAE,DAF,DAG,DA H,DAJ,DAL,DAW,DAX,V14,V15,V16, V17,V18,V19,V20,V21,V22,V24,ZAA, ZAB,ZAC,ZAD,ZAE,ZAF,ZAG,ZAH,Z AJ,ZAL .....	1

(1) ITEM NO.	(2) SMR CODE	(3) NSN	(4) CAGEC	(5) PART NUMBER	(6) DESCRIPTION AND USABLE ON CODE (UOC)	(7) QTY
10	PAHZZ	2520-01-150-0900	73342	6885154	. PISTON,FORWARD CLUT FOURTH CLUTCH 0.807-0.817 THK USE PRIOR S/N 2420026502AND A PISTON WITH A LETTER "B" AS A IDENTIFIER UOC: DAC,DAD,DAE,DAF,DAG,DA H,DAJ,DAL,DAW,DAX,V14,V15,V16, V17,V18,V19,V20,V21,V22,V24,ZAA, ZAB,ZAC,ZAD,ZAE,ZAF,ZAG,ZAH,Z AJ,ZAL .....	1
10	PAHZZ	3040-01-337-4168	73342	23017261	. PISTON,LINEAR ACTUA FOURTH CLUTCH 0.995-1.005 THK USE AFTER S/N 2420062502 UOC: DAC,DAD,DAE,DAF,DAG,DA H,DAJ,DAL,DAW,DAX,V14,V15,V16, V17,V18,V19,V20,V21,V22,V24,ZAA, ZAB,ZAC,ZAD,ZAE,ZAF,ZAG,ZAH,Z AJ,ZAL .....	1
11	PAHZZ	3040-01-337-4155	73342	23017257	. HOUSING,MECHANICAL UOC: DAC,DAD,DAE,DAF,DAG,DA H,DAJ,DAL,DAW,DAX,V14,V15,V16, V17,V18,V19,V20,V21,V22,V24,ZAA, ZAB,ZAC,ZAD,ZAE,ZAF,ZAG,ZAH,Z AJ,ZAL .....	1
11	PAHZZ	2520-01-130-5772	73342	23011825	. HOUSING ASSEMBLY TR USE PRIOR TO S/N 2420026502 UOC: DAC,DAD,DAE,DAF,DAG,DA H,DAJ,DAL,DAW,DAX,V14,V15,V16, V17,V18,V19,V20,V21,V22,V24,ZAA, ZAB,ZAC,ZAD,ZAE,ZAF,ZAG,ZAH,Z AJ,ZAL .....	1
12	PAHZZ	2520-00-008-7306	73342	8622757	. . BALL UOC: DAC,DAD,DAE,DAF,DAG,DA H,DAJ,DAL,DAW,DAX,V14,V15,V16, V17,V18,V19,V20,V21,V22,V24,ZAA, ZAB,ZAC,ZAD,ZAE,ZAF,ZAG,ZAH,Z AJ,ZAL .....	4
13	PAHZZ	5330-01-146-6053	73342	23015880	. SEAL,PLAIN FOURTH CLUTCH PART OF KIT P/N 6884259 UOC: DAC,DAD,DAE,DAF,DAG,DA H,DAJ,DAL,DAW,DAX,V14,V15,V16, V17,V18,V19,V20,V21,V22,V24,ZAA, ZAB,ZAC,ZAD,ZAE,ZAF,ZAG,ZAH,Z AJ,ZAL .....	1

(1) ITEM NO.	(2) SMR CODE	(3) NSN	(4) CAGEC	(5) PART NUMBER	(6) DESCRIPTION AND USABLE ON CODE (UOC)	(7) QTY
14	PAHZZ	5365-01-010-9689	73342	6833981	. RING,LIP TYPE SEAL PART OF KIT P/N 6884259 UOC: DAC,DAD,DAE,DAF,DAG,DA H,DAJ,DAL,DAW,DAX,V14,V15,V16, V17,V18,V19,V20,V21,V22,V24,ZAA, ZAB,ZAC,ZAD,ZAE,ZAF,ZAG,ZAH,Z AJ,ZAL .....	1
15	PAHZZ	3110-01-065-5842	2B524	23019782	BEARING UOC: DAC,DAD,DAE,DAF,DAG,DA H,DAJ,DAL,DAW,DAX,V14,V15,V16, V17,V18,V19,V20,V21,V22,V24,ZAA, ZAB,ZAC,ZAD,ZAE,ZAF,ZAG,ZAH,Z AJ,ZAL .....	1

END OF FIGURE

**FIELD MAINTENANCE  
LOW CLUTCH**

---

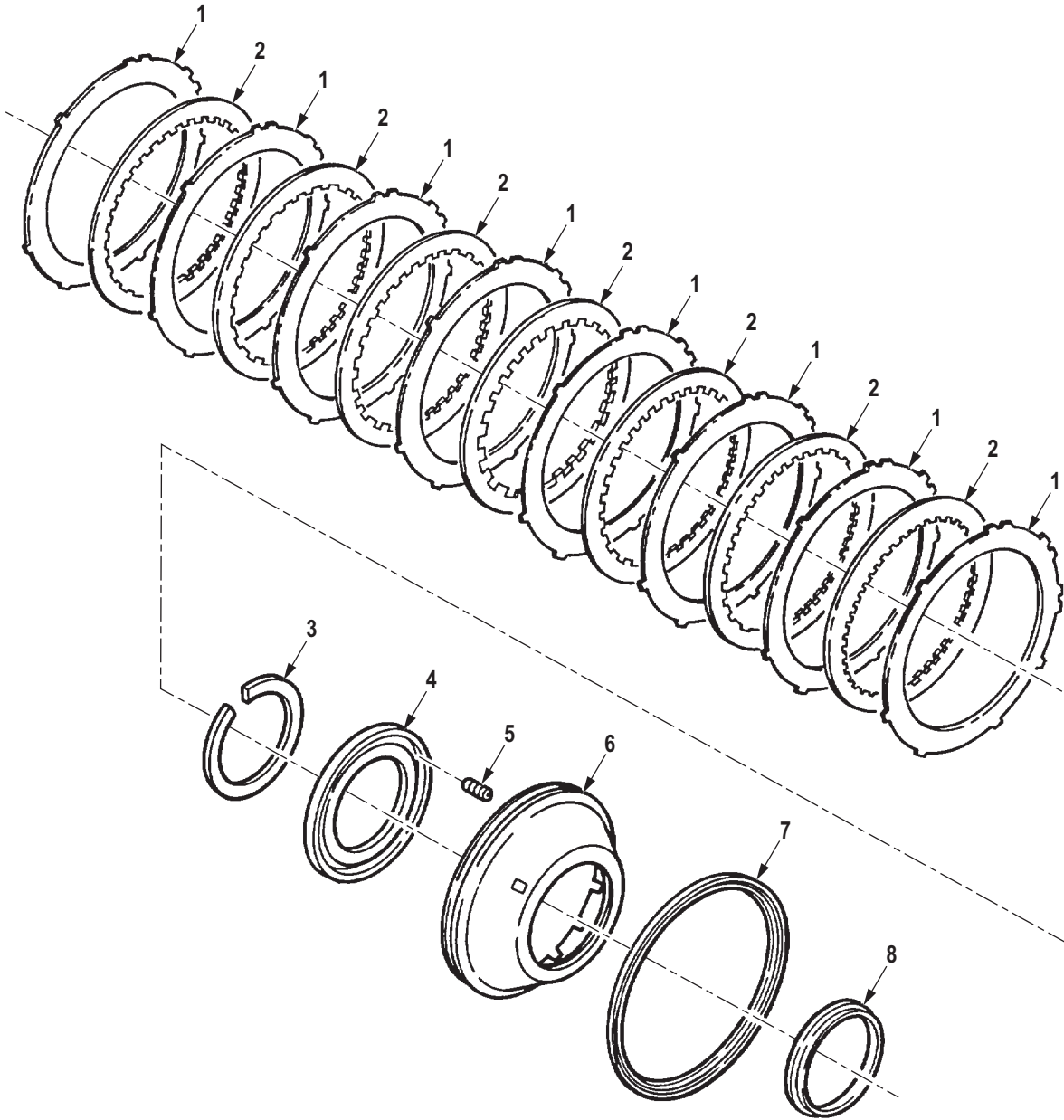

Figure 194. Low Clutch.

R0209DAA

(1) ITEM NO.	(2) SMR CODE	(3) NSN	(4) CAGEC	(5) PART NUMBER	(6) DESCRIPTION AND USABLE ON CODE (UOC)	(7) QTY
<b>GROUP 0713 INTERMEDIATE CLUTCH.</b>						
<b>FIG. 194. LOW CLUTCH.</b>						
1	PAHZZ	2520-01-226-3399	73342	23045054	DISK,CLUTCH,VEHICUL UOC: DAC,DAD,DAE,DAF,DAG,DA H,DAJ,DAL,DAW,DAX,V14,V15,V16, V17,V18,V19,V20,V21,V22,V24,ZAA, ZAB,ZAC,ZAD,ZAE,ZAF,ZAG,ZAH,Z AJ,ZAL .....	8
2	PAHZZ	2590-01-271-7861	73342	23042210	PLATE,TRANSMISSION UOC: DAC,DAD,DAE,DAF,DAG,DA H,DAJ,DAL,DAW,DAX,V14,V15,V16, V17,V18,V19,V20,V21,V22,V24,ZAA, ZAB,ZAC,ZAD,ZAE,ZAF,ZAG,ZAH,Z AJ,ZAL .....	7
3	PAHZZ	5325-00-557-5794	73342	6833993	RING,RETAINING UOC: DAC,DAD,DAE,DAF,DAG,DA H,DAJ,DAL,DAW,DAX,V14,V15,V16, V17,V18,V19,V20,V21,V22,V24,ZAA, ZAB,ZAC,ZAD,ZAE,ZAF,ZAG,ZAH,Z AJ,ZAL .....	1
4	PAHZZ	2520-01-064-8849	73342	6834339	RETAINER,PISTON SPR UOC: DAC,DAD,DAE,DAF,DAG,DA H,DAJ,DAL,DAW,DAX,V14,V15,V16, V17,V18,V19,V20,V21,V22,V24,ZAA, ZAB,ZAC,ZAD,ZAE,ZAF,ZAG,ZAH,Z AJ,ZAL .....	1
5	PAHZZ	5360-01-079-3097	73342	6880251	SPRING,PISTON RELEA UOC: DAC,DAD,DAE,DAF,DAG,DA H,DAJ,DAL,DAW,DAX,V14,V15,V16, V17,V18,V19,V20,V21,V22,V24,ZAA, ZAB,ZAC,ZAD,ZAE,ZAF,ZAG,ZAH,Z AJ,ZAL .....	26
6	PAHZZ	2520-01-151-2628	73342	23045496	PISTON,LOW CLUTCH 0.858-0.868 UOC: DAC,DAD,DAE,DAF,DAG,DA H,DAJ,DAL,DAW,DAX,V14,V15,V16, V17,V18,V19,V20,V21,V22,V24,ZAA, ZAB,ZAC,ZAD,ZAE,ZAF,ZAG,ZAH,Z AJ,ZAL .....	1
6	PAHZZ	2520-01-150-3690	73342	23045497	PISTON,LOW CLUTCH 0.829-0.839 UOC: DAC,DAD,DAE,DAF,DAG,DA H,DAJ,DAL,DAW,DAX,V14,V15,V16, V17,V18,V19,V20,V21,V22,V24,ZAA, ZAB,ZAC,ZAD,ZAE,ZAF,ZAG,ZAH,Z AJ,ZAL .....	1

(1) ITEM NO.	(2) SMR CODE	(3) NSN	(4) CAGEC	(5) PART NUMBER	(6) DESCRIPTION AND USABLE ON CODE (UOC)	(7) QTY
6	PAHZZ	2520-01-149-3439	73342	23045498	PISTON,LOW CLUTCH 0.800-0.810 UOC: DAC,DAD,DAE,DAF,DAG,DA H,DAJ,DAL,DAW,DAX,V14,V15,V16, V17,V18,V19,V20,V21,V22,V24,ZAA, ZAB,ZAC,ZAD,ZAE,ZAF,ZAG,ZAH,Z AJ,ZAL .....	1
7	KFFZZ	5330-01-104-8934	73342	6883035	SEAL,RING PART OF KIT P/N 6884259 UOC: DAC,DAD,DAE,DAF,DAG,DA H,DAJ,DAL,DAW,DAX,V14,V15,V16, V17,V18,V19,V20,V21,V22,V24,ZAA, ZAB,ZAC,ZAD,ZAE,ZAF,ZAG,ZAH,Z AJ,ZAL .....	1
8	KFFZZ	5330-01-083-3065	73342	6883031	SEAL,PLAIN PART OF KIT P/N 6884259 UOC: DAC,DAD,DAE,DAF,DAG,DA H,DAJ,DAL,DAW,DAX,V14,V15,V16, V17,V18,V19,V20,V21,V22,V24,ZAA, ZAB,ZAC,ZAD,ZAE,ZAF,ZAG,ZAH,Z AJ,ZAL .....	1

END OF FIGURE



**FIELD MAINTENANCE  
CONTROL VALVE ASSEMBLY AND MOUNTING HARDWARE**

---

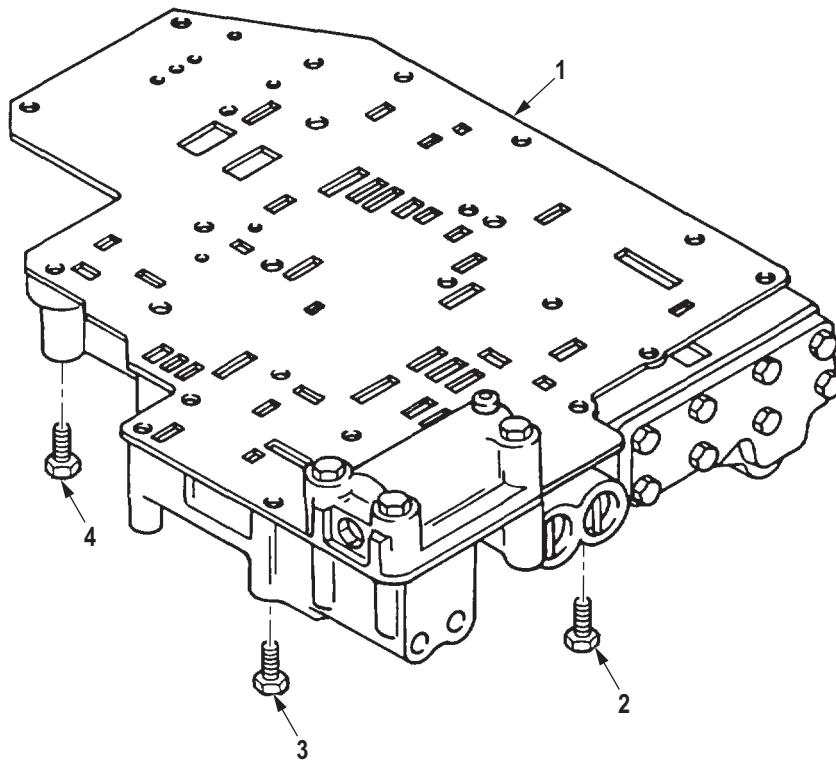

R0210DAA

Figure 195. Control Valve Assembly and Mounting Hardware.

(1) ITEM NO.	(2) SMR CODE	(3) NSN	(4) CAGEC	(5) PART NUMBER	(6) DESCRIPTION AND USABLE ON CODE (UOC)	(7) QTY
<b>GROUP 0714 SERVO UNIT.</b>						
<b>FIG. 195. CONTROL VALVE ASSEMBLY AND MOUNTING HARDWARE.</b>						
1	KBHHH		73342	23012443	CONTROL VALVE PART OF KIT P/N 23019596 UOC: DAC,DAD,DAE,DAF,DAG,DA H,DAJ,DAL,DAW,DAX,V14,V15,V16, V17,V18,V19,V20,V21,V22,V24,ZAA, ZAB,ZAC,ZAD,ZAE,ZAF,ZAG,ZAH,Z AJ,ZAL .....	1
2	PAHZZ	5305-01-057-4265	63005	454815	SCREW,CAP,HEXAGON H UOC: DAC,DAD,DAE,DAF,DAG,DA H,DAJ,DAL,DAW,DAX,V14,V15,V16, V17,V18,V19,V20,V21,V22,V24,ZAA, ZAB,ZAC,ZAD,ZAE,ZAF,ZAG,ZAH,Z AJ,ZAL .....	1
3	PAHZZ	5306-00-400-5541	73342	273340	BOLT,MACHINE UOC: DAC,DAD,DAE,DAF,DAG,DA H,DAJ,DAL,DAW,DAX,V14,V15,V16, V17,V18,V19,V20,V21,V22,V24,ZAA, ZAB,ZAC,ZAD,ZAE,ZAF,ZAG,ZAH,Z AJ,ZAL .....	3
4	PAHZZ	5305-00-071-2515	80204	B1821BH025C300N	SCREW,CAP,HEXAGON H UOC: DAC,DAD,DAE,DAF,DAG,DA H,DAJ,DAL,DAW,DAX,V14,V15,V16, V17,V18,V19,V20,V21,V22,V24,ZAA, ZAB,ZAC,ZAD,ZAE,ZAF,ZAG,ZAH,Z AJ,ZAL .....	15

**END OF FIGURE**



**FIELD MAINTENANCE  
MODULATED LOCKUP VALVE AND MOUNTING HARDWARE**

---

1  
2-7

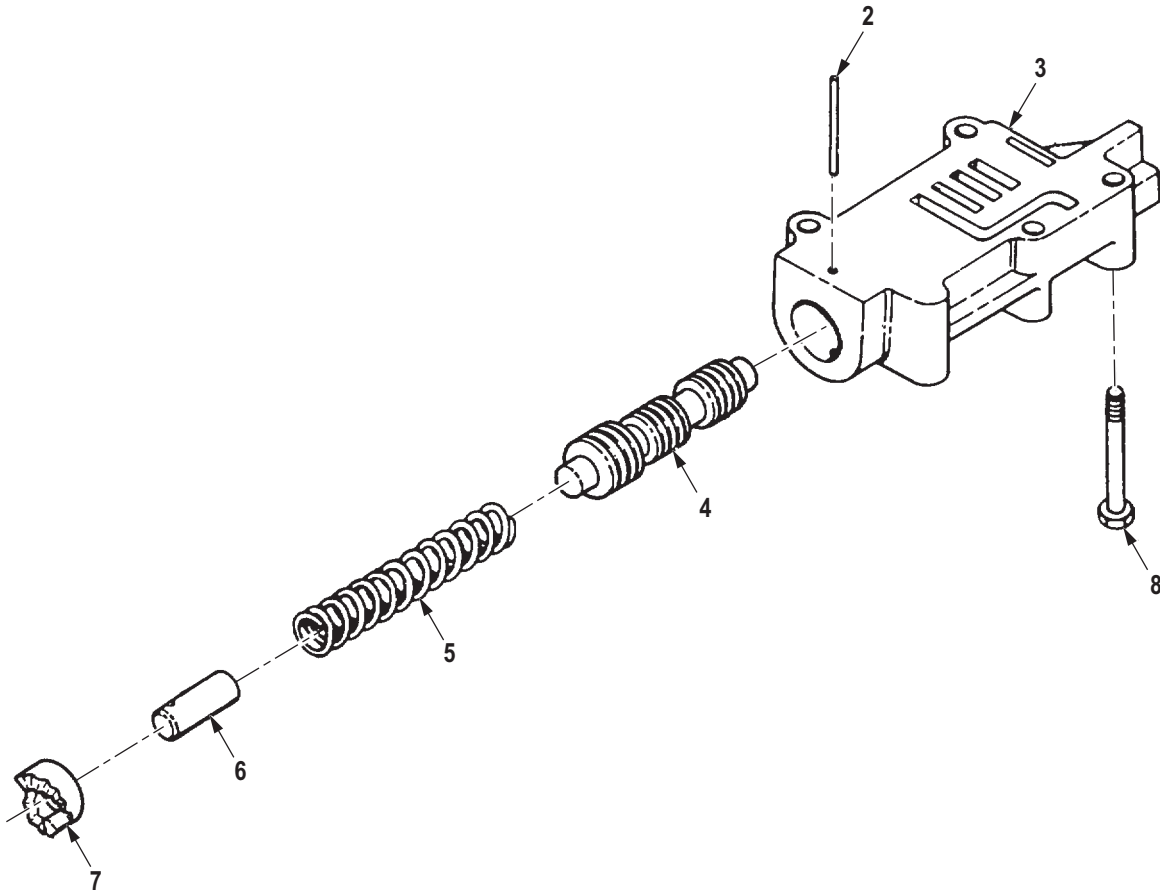

R0211DAA

Figure 196. Modulated Lockup Valve and Mounting Hardware.

(1) ITEM NO.	(2) SMR CODE	(3) NSN	(4) CAGEC	(5) PART NUMBER	(6) DESCRIPTION AND USABLE ON CODE (UOC)	(7) QTY
<b>GROUP 0714 SERVO UNIT.</b>						
<b>FIG. 196. MODULATED LOCKUP VALVE AND MOUNTING HARDWARE.</b>						
1	PAHHH	4820-01-221-5415	73342	23016413	LOCKUP,VALVE PART OF KIT P/ N 23019596 UOC: DAC,DAD,DAE,DAF,DAG,DA H,DAJ,DAL,DAW,DAX,V14,V15,V16, V17,V18,V19,V20,V21,V22,V24,ZAA, ZAB,ZAC,ZAD,ZAE,ZAF,ZAG,ZAH,Z AJ,ZAL .....	1
2	PBHZZ	3110-01-010-9779	73342	9428493	. BEARING,ROLLER,NEED UOC: DAC,DAD,DAE,DAF,DAG,DA H,DAJ,DAL,DAW,DAX,V14,V15,V16, V17,V18,V19,V20,V21,V22,V24,ZAA, ZAB,ZAC,ZAD,ZAE,ZAF,ZAG,ZAH,Z AJ,ZAL .....	1
3	PAHZZ	4810-01-220-1185	73342	6881007	. BODY,VALVE UOC: DAC,DAD,DAE,DAF,DAG,DA H,DAJ,DAL,DAW,DAX,V14,V15,V16, V17,V18,V19,V20,V21,V22,V24,ZAA, ZAB,ZAC,ZAD,ZAE,ZAF,ZAG,ZAH,Z AJ,ZAL .....	1
4	PBHZZ	3040-01-221-2092	73342	6883577	. VALVE,LOCKUP,TRANSM UOC: DAC,DAD,DAE,DAF,DAG,DA H,DAJ,DAL,DAW,DAX,V14,V15,V16, V17,V18,V19,V20,V21,V22,V24,ZAA, ZAB,ZAC,ZAD,ZAE,ZAF,ZAG,ZAH,Z AJ,ZAL .....	1
5	PBFZZ	5360-01-224-9218	73342	23016366	. SPRING,HELICAL,COMP UOC: DAC,DAD,DAE,DAF,DAG,DA H,DAJ,DAL,DAW,DAX,V14,V15,V16, V17,V18,V19,V20,V21,V22,V24,ZAA, ZAB,ZAC,ZAD,ZAE,ZAF,ZAG,ZAH,Z AJ,ZAL .....	1
6	PBHZZ	4820-01-007-0962	73342	6833896	. STOP,VALVE UOC: DAC,DAD,DAE,DAF,DAG,DA H,DAJ,DAL,DAW,DAX,V14,V15,V16, V17,V18,V19,V20,V21,V22,V24,ZAA, ZAB,ZAC,ZAD,ZAE,ZAF,ZAG,ZAH,Z AJ,ZAL .....	1
7	PBHZZ	5365-00-038-9592	19207	12267583	. RING,SPRING UOC: DAC,DAD,DAE,DAF,DAG,DA H,DAJ,DAL,DAW,DAX,V14,V15,V16, V17,V18,V19,V20,V21,V22,V24,ZAA, ZAB,ZAC,ZAD,ZAE,ZAF,ZAG,ZAH,Z AJ,ZAL .....	1

(1) ITEM NO.	(2) SMR CODE	(3) NSN	(4) CAGEC	(5) PART NUMBER	(6) DESCRIPTION AND USABLE ON CODE (UOC)	(7) QTY
8	PAHZZ	5306-00-570-8940	24617	454817	BOLT,MACHINE UOC: DAC,DAD,DAE,DAF,DAG,DA H,DAJ,DAL,DAW,DAX,V14,V15,V16, V17,V18,V19,V20,V21,V22,V24,ZAA, ZAB,ZAC,ZAD,ZAE,ZAF,ZAG,ZAH,Z AJ,ZAL .....	3

END OF FIGURE



**FIELD MAINTENANCE**  
**LOW SHIFT SIGNAL VALVE, LOW TRIMMER VALVE, AND MOUNTING HARDWARE**

---

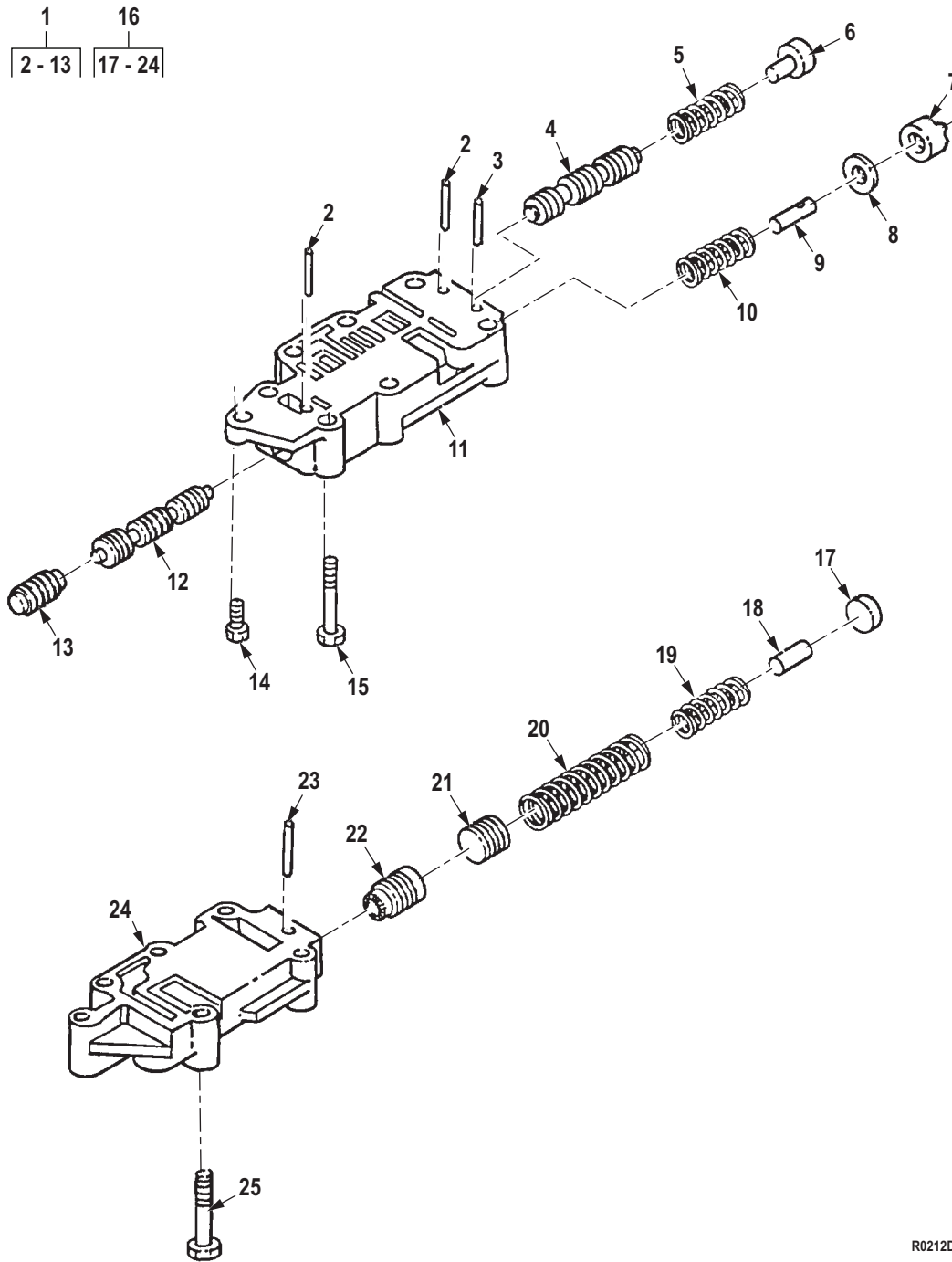

R0212DAA

Figure 197. Low Shift Signal Valve, Low Trimmer Valve, and Mounting Hardware.

(1) ITEM NO.	(2) SMR CODE	(3) NSN	(4) CAGEC	(5) PART NUMBER	(6) DESCRIPTION AND USABLE ON CODE (UOC)	(7) QTY
<b>GROUP 0714 SERVO UNIT.</b>						
<b>FIG. 197. LOW SHIFT SIGNAL VALVE, LOW TRIMMER VALVE, AND MOUNTING HARDWARE.</b>						
1	PAHHH	2520-01-127-1675	73342	6883579	VALVE ASSEMBLY,LOW PART OF KIT P/N 23019596 UOC: DAC,DAD,DAE,DAF,DAG,DA H,DAJ,DAL,DAW,DAX,V14,V15,V16, V17,V18,V19,V20,V21,V22,V24,ZAA, ZAB,ZAC,ZAD,ZAE,ZAF,ZAG,ZAH,Z AJ,ZAL .....	1
2	PBHZZ	5315-01-083-6352	63005	9420965	. PIN UOC: DAC,DAD,DAE,DAF,DAG,DA H,DAJ,DAL,DAW,DAX,V14,V15,V16, V17,V18,V19,V20,V21,V22,V24,ZAA, ZAB,ZAC,ZAD,ZAE,ZAF,ZAG,ZAH,Z AJ,ZAL .....	2
3	PBHZZ	3110-00-799-4903	19207	7709191	. ROLLER,BEARING UOC: DAC,DAD,DAE,DAF,DAG,DA H,DAJ,DAL,DAW,DAX,V14,V15,V16, V17,V18,V19,V20,V21,V22,V24,ZAA, ZAB,ZAC,ZAD,ZAE,ZAF,ZAG,ZAH,Z AJ,ZAL .....	1
4	PBHZZ	4730-01-133-1461	73342	6885188	. PLUG,PIPE UOC: DAC,DAD,DAE,DAF,DAG,DA H,DAJ,DAL,DAW,DAX,V14,V15,V16, V17,V18,V19,V20,V21,V22,V24,ZAA, ZAB,ZAC,ZAD,ZAE,ZAF,ZAG,ZAH,Z AJ,ZAL .....	1
5	PBHZZ	5360-01-074-8305	73342	6839214	. SPRING,HELICAL,COMP UOC: DAC,DAD,DAE,DAF,DAG,DA H,DAJ,DAL,DAW,DAX,V14,V15,V16, V17,V18,V19,V20,V21,V22,V24,ZAA, ZAB,ZAC,ZAD,ZAE,ZAF,ZAG,ZAH,Z AJ,ZAL .....	1
6	PBHZZ	4820-01-083-2127	73342	6881138	. STOP,RELAY VALVE UOC: DAC,DAD,DAE,DAF,DAG,DA H,DAJ,DAL,DAW,DAX,V14,V15,V16, V17,V18,V19,V20,V21,V22,V24,ZAA, ZAB,ZAC,ZAD,ZAE,ZAF,ZAG,ZAH,Z AJ,ZAL .....	1
7	PBHZZ	5365-00-038-9592	19207	12267583	. RING,SPRING UOC: DAC,DAD,DAE,DAF,DAG,DA H,DAJ,DAL,DAW,DAX,V14,V15,V16, V17,V18,V19,V20,V21,V22,V24,ZAA, ZAB,ZAC,ZAD,ZAE,ZAF,ZAG,ZAH,Z AJ,ZAL .....	1

(1) ITEM NO.	(2) SMR CODE	(3) NSN	(4) CAGEC	(5) PART NUMBER	(6) DESCRIPTION AND USABLE ON CODE (UOC)	(7) QTY
8	PBHZZ	5310-00-007-0260	73342	6833949	. WASHER,FLAT UOC: DAC,DAD,DAE,DAF,DAG,DA H,DAJ,DAL,DAW,DAX,V14,V15,V16, V17,V18,V19,V20,V21,V22,V24,ZAA, ZAB,ZAC,ZAD,ZAE,ZAF,ZAG,ZAH,Z AJ,ZAL .....	1
9	PBHZZ	5315-01-004-4836	19207	12267602	. PIN,STRAIGHT,HEADLE UOC: DAC,DAD,DAE,DAF,DAG,DA H,DAJ,DAL,DAW,DAX,V14,V15,V16, V17,V18,V19,V20,V21,V22,V24,ZAA, ZAB,ZAC,ZAD,ZAE,ZAF,ZAG,ZAH,Z AJ,ZAL .....	1
10	XDHZZ		73342	6778156	. SPRING,CUTOFF UOC: DAC,DAD,DAE,DAF,DAG,DA H,DAJ,DAL,DAW,DAX,V14,V15,V16, V17,V18,V19,V20,V21,V22,V24,ZAA, ZAB,ZAC,ZAD,ZAE,ZAF,ZAG,ZAH,Z AJ,ZAL .....	1
11	XAHZZ		73342	6881009	. BODY,VALVE UOC: DAC,DAD,DAE,DAF,DAG,DA H,DAJ,DAL,DAW,DAX,V14,V15,V16, V17,V18,V19,V20,V21,V22,V24,ZAA, ZAB,ZAC,ZAD,ZAE,ZAF,ZAG,ZAH,Z AJ,ZAL .....	1
12	PBHZZ	2520-01-130-5821	73342	6883581	. VALVE,LOW SHIFT SIG UOC: DAC,DAD,DAE,DAF,DAG,DA H,DAJ,DAL,DAW,DAX,V14,V15,V16, V17,V18,V19,V20,V21,V22,V24,ZAA, ZAB,ZAC,ZAD,ZAE,ZAF,ZAG,ZAH,Z AJ,ZAL .....	1
13	PBHZZ	4730-01-132-6849	73342	6880152	. PLUG,PIPE UOC: DAC,DAD,DAE,DAF,DAG,DA H,DAJ,DAL,DAW,DAX,V14,V15,V16, V17,V18,V19,V20,V21,V22,V24,ZAA, ZAB,ZAC,ZAD,ZAE,ZAF,ZAG,ZAH,Z AJ,ZAL .....	1
14	PAHZZ	5305-00-068-0509	80204	B1821BH025C125N	SCREW,CAP,HEXAGON H UOC: DAC,DAD,DAE,DAF,DAG,DA H,DAJ,DAL,DAW,DAX,V14,V15,V16, V17,V18,V19,V20,V21,V22,V24,ZAA, ZAB,ZAC,ZAD,ZAE,ZAF,ZAG,ZAH,Z AJ,ZAL .....	1
15	PAHZZ	5306-00-570-8940	24617	454817	BOLT,MACHINE UOC: DAC,DAD,DAE,DAF,DAG,DA H,DAJ,DAL,DAW,DAX,V14,V15,V16, V17,V18,V19,V20,V21,V22,V24,ZAA, ZAB,ZAC,ZAD,ZAE,ZAF,ZAG,ZAH,Z AJ,ZAL .....	2

(1) ITEM NO.	(2) SMR CODE	(3) NSN	(4) CAGEC	(5) PART NUMBER	(6) DESCRIPTION AND USABLE ON CODE (UOC)	(7) QTY
16	PAHHH	2520-01-127-5005	73342	6881386	VALVE ASSEMBLY,TRAN PART OF KIT P/N 23012465 UOC: DAC,DAD,DAE,DAF,DAG,DA H,DAJ,DAL,DAW,DAX,V14,V15,V16, V17,V18,V19,V20,V21,V22,V24,ZAA, ZAB,ZAC,ZAD,ZAE,ZAF,ZAG,ZAH,Z AJ,ZAL .....	1
17	PBHZZ	4730-01-083-9925	73342	6838750	. PLUG,PIPE UOC: DAC,DAD,DAE,DAF,DAG,DA H,DAJ,DAL,DAW,DAX,V14,V15,V16, V17,V18,V19,V20,V21,V22,V24,ZAA, ZAB,ZAC,ZAD,ZAE,ZAF,ZAG,ZAH,Z AJ,ZAL .....	1
18	PBHZZ	5315-01-004-4835	73342	6839122	. PIN,STRAIGHT,HEADLE UOC: DAC,DAD,DAE,DAF,DAG,DA H,DAJ,DAL,DAW,DAX,V14,V15,V16, V17,V18,V19,V20,V21,V22,V24,ZAA, ZAB,ZAC,ZAD,ZAE,ZAF,ZAG,ZAH,Z AJ,ZAL .....	1
19	PBHZZ	5360-01-113-9615	73342	6885166	. SPRING UOC: DAC,DAD,DAE,DAF,DAG,DA H,DAJ,DAL,DAW,DAX,V14,V15,V16, V17,V18,V19,V20,V21,V22,V24,ZAA, ZAB,ZAC,ZAD,ZAE,ZAF,ZAG,ZAH,Z AJ,ZAL .....	1
20	PBHZZ	5360-01-004-4863	73342	6839271	. SPRING,HELICAL,COMP UOC: DAC,DAD,DAE,DAF,DAG,DA H,DAJ,DAL,DAW,DAX,V14,V15,V16, V17,V18,V19,V20,V21,V22,V24,ZAA, ZAB,ZAC,ZAD,ZAE,ZAF,ZAG,ZAH,Z AJ,ZAL .....	1
21	PBHZZ	4730-01-006-9629	73342	6835921	. PLUG,TRIMMER UOC: DAC,DAD,DAE,DAF,DAG,DA H,DAJ,DAL,DAW,DAX,V14,V15,V16, V17,V18,V19,V20,V21,V22,V24,ZAA, ZAB,ZAC,ZAD,ZAE,ZAF,ZAG,ZAH,Z AJ,ZAL .....	1
22	PBHZZ	4820-01-007-0350	73342	23014097	. VALVE,TRIMMER UOC: DAC,DAD,DAE,DAF,DAG,DA H,DAJ,DAL,DAW,DAX,V14,V15,V16, V17,V18,V19,V20,V21,V22,V24,ZAA, ZAB,ZAC,ZAD,ZAE,ZAF,ZAG,ZAH,Z AJ,ZAL .....	1
23	PBHZZ	5315-01-083-6351	63005	9423346	. PIN UOC: DAC,DAD,DAE,DAF,DAG,DA H,DAJ,DAL,DAW,DAX,V14,V15,V16, V17,V18,V19,V20,V21,V22,V24,ZAA, ZAB,ZAC,ZAD,ZAE,ZAF,ZAG,ZAH,Z AJ,ZAL .....	1

(1) ITEM NO.	(2) SMR CODE	(3) NSN	(4) CAGEC	(5) PART NUMBER	(6) DESCRIPTION AND USABLE ON CODE (UOC)	(7) QTY
24	XAHZZ		73342	6881387	. BODY,VALVE UOC: DAC,DAD,DAE,DAF,DAG,DA H,DAJ,DAL,DAW,DAX,V14,V15,V16, V17,V18,V19,V20,V21,V22,V24,ZAA, ZAB,ZAC,ZAD,ZAE,ZAF,ZAG,ZAH,Z AJ,ZAL .....	1
25	PAHZZ	5305-01-084-5370	63005	9424899	SCREW,CAP,HEXAGON H UOC: DAC,DAD,DAE,DAF,DAG,DA H,DAJ,DAL,DAW,DAX,V14,V15,V16, V17,V18,V19,V20,V21,V22,V24,ZAA, ZAB,ZAC,ZAD,ZAE,ZAF,ZAG,ZAH,Z AJ,ZAL .....	6

END OF FIGURE

**FIELD MAINTENANCE  
TRANSMISSION TUBING, GOVERNOR, AND FILTER ASSEMBLY**

---

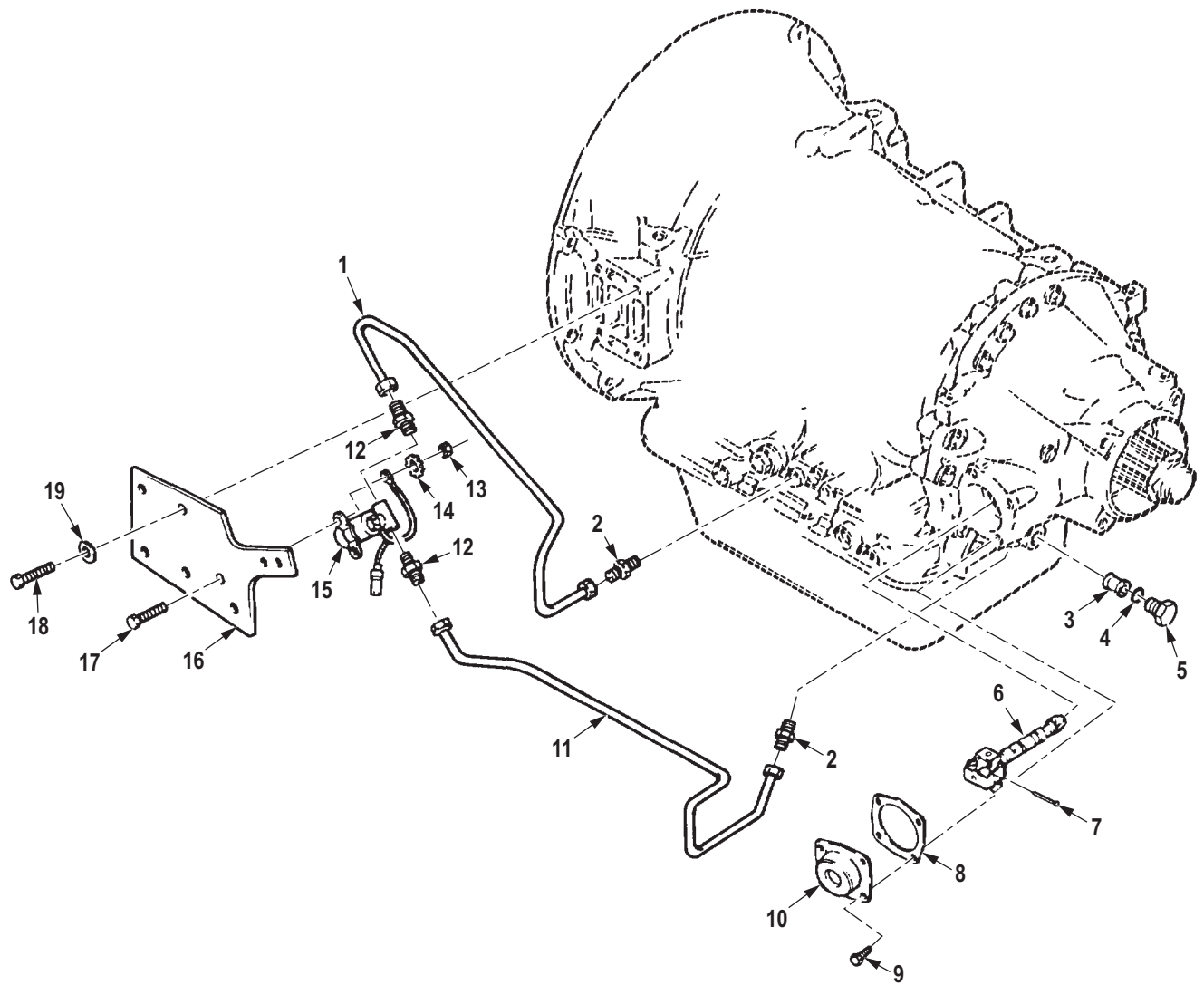

R0213DAA

Figure 198. Transmission Tubing, Governor, and Filter Assembly.



(1) ITEM NO.	(2) SMR CODE	(3) NSN	(4) CAGEC	(5) PART NUMBER	(6) DESCRIPTION AND USABLE ON CODE (UOC)	(7) QTY
<b>GROUP 0714 SERVO UNIT.</b>						
<b>FIG. 198. TRANSMISSION TUBING, GOVERNOR, AND FILTER ASSEMBLY.</b>						
1	PAHZZ	4710-01-195-7644	19207	12302660	TUBE ASSEMBLY,METAL UOC: DAC,DAD,DAE,DAF,DAG,DA H,DAJ,DAL,DAW,DAX,V14,V15,V16, V17,V18,V19,V20,V21,V22,V24,ZAA, ZAB,ZAC,ZAD,ZAE,ZAF,ZAG,ZAH,Z AJ,ZAL .....	1
2	PAHZZ	4730-00-618-8497	96906	MS51500A5	ADAPTER,STRAIGHT,PI UOC: DAC,DAD,DAE,DAF,DAG,DA H,DAJ,DAL,DAW,DAX,V14,V15,V16, V17,V18,V19,V20,V21,V22,V24,ZAA, ZAB,ZAC,ZAD,ZAE,ZAF,ZAG,ZAH,Z AJ,ZAL .....	2
3	PAFZZ	4330-01-074-9642	73342	6882687	PARTS KIT,FLUID PRE PART OF KIT P/N 6884749 UOC: DAC,DAD,DAE,DAF,DAG,DA H,DAJ,DAL,DAW,DAX,V14,V15,V16, V17,V18,V19,V20,V21,V22,V24,ZAA, ZAB,ZAC,ZAD,ZAE,ZAF,ZAG,ZAH,Z AJ,ZAL .....	1
4	PAFZZ	5331-01-080-3254	73342	6882689	O-RING PART OF KIT P/N 6884749 UOC: DAC,DAD,DAE,DAF,DAG,DA H,DAJ,DAL,DAW,DAX,V14,V15,V16, V17,V18,V19,V20,V21,V22,V24,ZAA, ZAB,ZAC,ZAD,ZAE,ZAF,ZAG,ZAH,Z AJ,ZAL .....	1
5	PAFZZ	5365-01-134-8660	24617	9410360	PLUG UOC: DAC,DAD,DAE,DAF,DAG,DA H,DAJ,DAL,DAW,DAX,V14,V15,V16, V17,V18,V19,V20,V21,V22,V24,ZAA, ZAB,ZAC,ZAD,ZAE,ZAF,ZAG,ZAH,Z AJ,ZAL .....	1
6	PAHZZ	2910-01-051-9444	73342	6885571	GOVERNOR,TRANSMISSI UOC: DAC,DAD,DAE,DAF,DAG,DA H,DAJ,DAL,DAW,DAX,V14,V15,V16, V17,V18,V19,V20,V21,V22,V24,ZAA, ZAB,ZAC,ZAD,ZAE,ZAF,ZAG,ZAH,Z AJ,ZAL .....	1
7	PFHZZ	5315-01-152-9029	73342	23017556	PIN,GOV,ASSY PART OF KIT P/N 6880353 UOC: DAC,DAD,DAE,DAF,DAG,DA H,DAJ,DAL,DAW,DAX,V14,V15,V16, V17,V18,V19,V20,V21,V22,V24,ZAA, ZAB,ZAC,ZAD,ZAE,ZAF,ZAG,ZAH,Z AJ,ZAL .....	2

(1) ITEM NO.	(2) SMR CODE	(3) NSN	(4) CAGEC	(5) PART NUMBER	(6) DESCRIPTION AND USABLE ON CODE (UOC)	(7) QTY
8	PFHZZ	5330-00-001-1984	7X677	8623263	GASKET PART OF KIT P/N 6880353 UOC: DAC,DAD,DAE,DAF,DAG,DA H,DAJ,DAL,DAW,DAX,V14,V15,V16, V17,V18,V19,V20,V21,V22,V24,ZAA, ZAB,ZAC,ZAD,ZAE,ZAF,ZAG,ZAH,Z AJ,ZAL .....	1
9	PAHZZ	5306-00-225-8496	80205	MS90725-31	BOLT,MACHINE UOC: DAC,DAD,DAE,DAF,DAG,DA H,DAJ,DAL,DAW,DAX,V14,V15,V16, V17,V18,V19,V20,V21,V22,V24,ZAA, ZAB,ZAC,ZAD,ZAE,ZAF,ZAG,ZAH,Z AJ,ZAL .....	4
10	PAHZZ	2520-01-127-3969	73342	23048869	COVER,GOVERNOR,TRAN UOC: DAC,DAD,DAE,DAF,DAG,DA H,DAJ,DAL,DAW,DAX,V14,V15,V16, V17,V18,V19,V20,V21,V22,V24,ZAA, ZAB,ZAC,ZAD,ZAE,ZAF,ZAG,ZAH,Z AJ,ZAL .....	1
11	PAHZZ	4710-01-195-7645	19207	12302661	TUBE ASSEMBLY,METAL UOC: DAC,DAD,DAE,DAF,DAG,DA H,DAJ,DAL,DAW,DAX,V14,V15,V16, V17,V18,V19,V20,V21,V22,V24,ZAA, ZAB,ZAC,ZAD,ZAE,ZAF,ZAG,ZAH,Z AJ,ZAL .....	1
12	PAHZZ	4730-00-620-6904	01276	2021A-4-5S	ADAPTER,STRAIGHT,PI UOC: DAC,DAD,DAE,DAF,DAG,DA H,DAJ,DAL,DAW,DAX,V14,V15,V16, V17,V18,V19,V20,V21,V22,V24,ZAA, ZAB,ZAC,ZAD,ZAE,ZAF,ZAG,ZAH,Z AJ,ZAL .....	2
13	PAFZZ	5310-00-061-7326	80205	MS21045-3	NUT,SELF-LOCKING,HE UOC: DAC,DAD,DAE,DAF,DAG,DA H,DAJ,DAL,DAW,DAX,V14,V15,V16, V17,V18,V19,V20,V21,V22,V24,ZAA, ZAB,ZAC,ZAD,ZAE,ZAF,ZAG,ZAH,Z AJ,ZAL .....	2
14	PAFZZ	5310-00-596-7691	96906	MS35335-32	WASHER,LOCK UOC: DAC,DAD,DAE,DAF,DAG,DA H,DAJ,DAL,DAW,DAX,V14,V15,V16, V17,V18,V19,V20,V21,V22,V24,ZAA, ZAB,ZAC,ZAD,ZAE,ZAF,ZAG,ZAH,Z AJ,ZAL .....	1
15	PAFZZ	4810-01-140-8221	19207	11669826	VALVE,SOLENOID UOC: DAC,DAD,DAE,DAF,DAG,DA H,DAJ,DAL,DAW,DAX,V14,V15,V16, V17,V18,V19,V20,V21,V22,V24,ZAA, ZAB,ZAC,ZAD,ZAE,ZAF,ZAG,ZAH,Z AJ,ZAL .....	1

(1) ITEM NO.	(2) SMR CODE	(3) NSN	(4) CAGEC	(5) PART NUMBER	(6) DESCRIPTION AND USABLE ON CODE (UOC)	(7) QTY
16	PFHZZ	5945-01-140-8242	19207	12302662	BRACKET,SOLENOID UOC: DAC,DAD,DAE,DAF,DAG,DA H,DAJ,DAL,DAW,DAX,V14,V15,V16, V17,V18,V19,V20,V21,V22,V24,ZAA, ZAB,ZAC,ZAD,ZAE,ZAF,ZAG,ZAH,Z AJ,ZAL .....	1
17	PAHZZ	5305-00-018-7838	24617	187838	SCREW,CAP,HEXAGON H UOC: DAC,DAD,DAE,DAF,DAG,DA H,DAJ,DAL,DAW,DAX,V14,V15,V16, V17,V18,V19,V20,V21,V22,V24,ZAA, ZAB,ZAC,ZAD,ZAE,ZAF,ZAG,ZAH,Z AJ,ZAL .....	2
18	PAHZZ	5306-01-118-4889	80204	B1821BH050C075L	BOLT,MACHINE UOC: DAC,DAD,DAE,DAF,DAG,DA H,DAJ,DAL,DAW,DAX,ZAA,ZAB,ZAC ,ZAD,ZAE,ZAF,ZAG,ZAH,ZAJ,ZAL .....	4
19	PAHZZ	5310-00-809-5998	96906	MS27183-18	WASHER,FLAT UOC: DAC,DAD,DAE,DAF,DAG,DA H,DAJ,DAL,DAW,DAX,V14,V15,V16, V17,V18,V19,V20,V21,V22,V24,ZAA, ZAB,ZAC,ZAD,ZAE,ZAF,ZAG,ZAH,Z AJ,ZAL .....	4

END OF FIGURE



**FIELD MAINTENANCE  
TRANSMISSION VENT LINE**

---

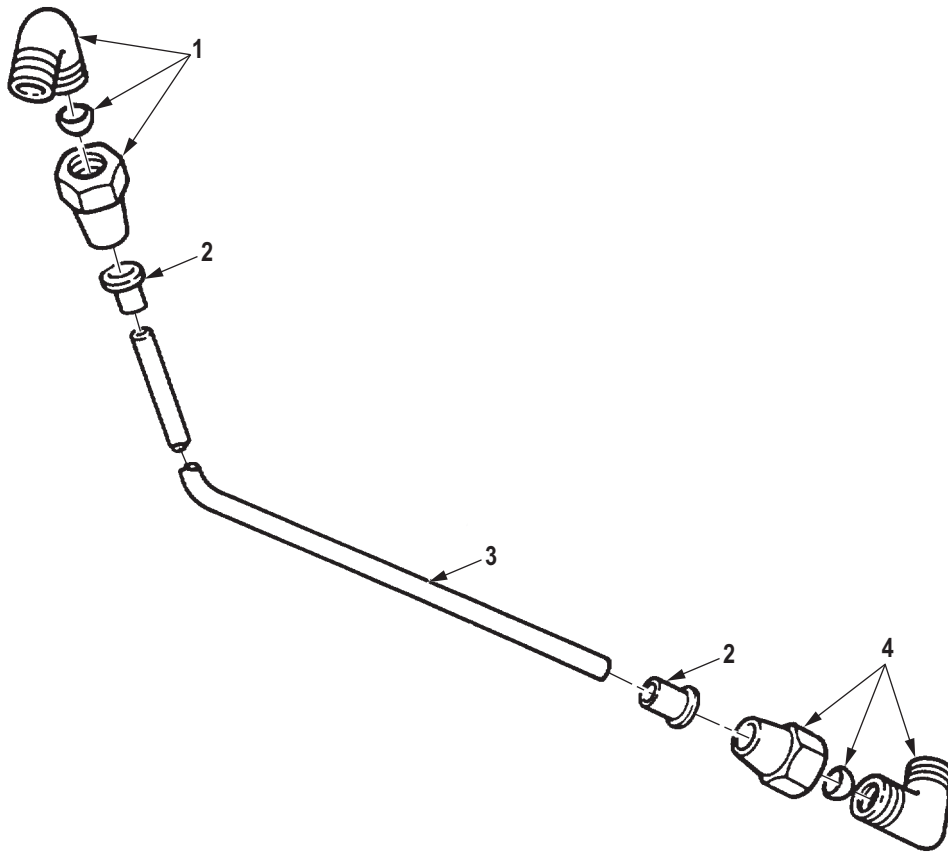

R0214DAA

Figure 199. Transmission Vent Line.

(1) ITEM NO.	(2) SMR CODE	(3) NSN	(4) CAGEC	(5) PART NUMBER	(6) DESCRIPTION AND USABLE ON CODE (UOC)	(7) QTY
<p><b>GROUP 0721 COOLERS, PUMPS, MOTORS.</b></p> <p><b>FIG. 199. TRANSMISSION VENT LINE.</b></p>						
1	PAFZZ	4730-00-287-1604	81343	6-2 120202BA	ELBOW,PIPE TO TUBE UOC: DAC,DAD,DAE,DAF,DAG,DAH,DAJ,DAL,DAW,DAX,V14,V15,V16,V17,V18,V19,V20,V21,V22,V24,ZAA,ZAB,ZAC,ZAD,ZAE,ZAF,ZAG,ZAH,ZAJ,ZAL .....	1
2	PAFZZ	4730-01-079-8821	19207	CPR102321-1	INSERT,TUBE FITTING UOC: DAC,DAD,DAE,DAF,DAG,DAH,DAJ,DAL,DAW,DAX,V14,V15,V16,V17,V18,V19,V20,V21,V22,V24,ZAA,ZAB,ZAC,ZAD,ZAE,ZAF,ZAG,ZAH,ZAJ,ZAL .....	2
3	MFFZZ		81343	J844TYBSIZE 3/8 BLACK-24	HOSE,NONMETALLIC MAKE FROM HOSE, P/N J844TYBSIZE 3/8 BLACK, 24 IN.LONG UOC: DAC,DAD,DAE,DAF,DAG,DAH,DAJ,DAL,DAW,DAX,V14,V15,V16,V17,V18,V19,V20,V21,V22,V24,ZAA,ZAB,ZAC,ZAD,ZAE,ZAF,ZAG,ZAH,ZAJ,ZAL .....	1
4	PAFZZ	4730-00-069-1187	81343	SAE J246 6-4 100202BA	ELBOW,PIPE TO TUBE UOC: DAC,DAD,DAE,DAF,DAG,DAH,DAJ,DAL,DAW,DAX,V14,V15,V16,V17,V18,V19,V20,V21,V22,V24,ZAA,ZAB,ZAC,ZAD,ZAE,ZAF,ZAG,ZAH,ZAJ,ZAL .....	1

**END OF FIGURE**





**FIELD MAINTENANCE  
OIL PUMP AND FRONT SUPPORT ASSEMBLY (TRANSMISSION P/N 6885292)**

---

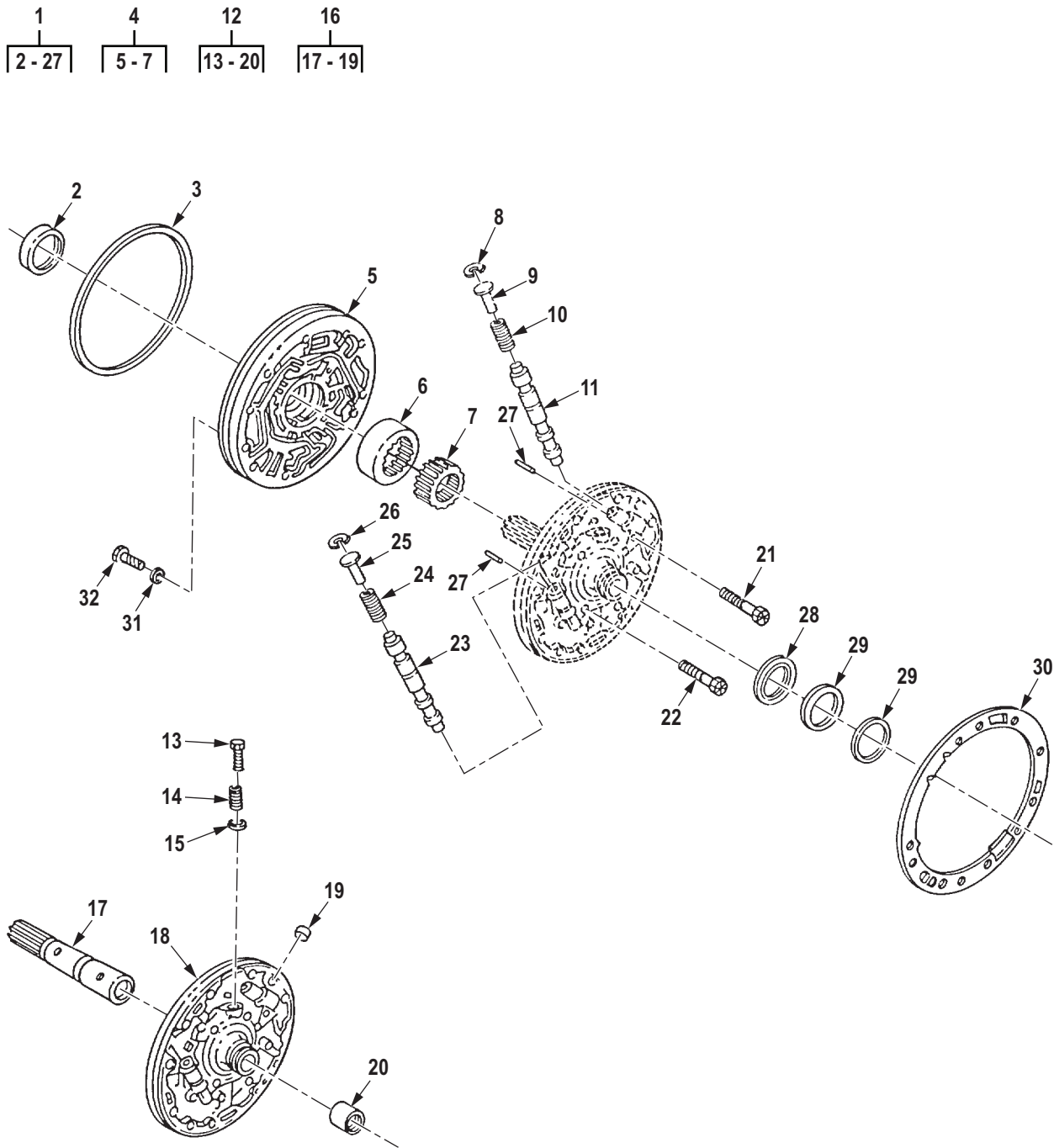

R0215DAA

Figure 200. Oil Pump and Front Support Assembly (Transmission P/N 6885292).

(1) ITEM NO.	(2) SMR CODE	(3) NSN	(4) CAGEC	(5) PART NUMBER	(6) DESCRIPTION AND USABLE ON CODE (UOC)	(7) QTY
<b>GROUP 0721 COOLERS, PUMPS, MOTORS.</b>						
<b>FIG. 200. OIL PUMP AND FRONT SUPPORT ASSEMBLY (TRANSMISSION P/N 6885292).</b>						
1	PAHHH	2520-01-146-3039	73342	23015870	PUMP ASSEMBLY, TRANS UOC: DAC,DAD,DAE,DAF,DAG,DA H,DAJ,DAL,DAW,DAX,V14,V15,V16, V17,V18,V19,V20,V21,V22,V24,ZAA, ZAB,ZAC,ZAD,ZAE,ZAF,ZAG,ZAH,Z AJ,ZAL .....	1
2	PAHZZ	5330-01-219-2375	73342	23016643	. SEAL PART OF KIT P/N 6884259 UOC: DAC,DAD,DAE,DAF,DAG,DA H,DAJ,DAL,DAW,DAX,V14,V15,V16, V17,V18,V19,V20,V21,V22,V24,ZAA, ZAB,ZAC,ZAD,ZAE,ZAF,ZAG,ZAH,Z AJ,ZAL .....	1
3	PAHZZ	5330-01-068-1713	73342	23016347	. SEAL,AIR,AIRCRAFT G PART OF KIT P/N 6884259 UOC: DAC,DAD,DAE,DAF,DAG,DA H,DAJ,DAL,DAW,DAX,V14,V15,V16, V17,V18,V19,V20,V21,V22,V24,ZAA, ZAB,ZAC,ZAD,ZAE,ZAF,ZAG,ZAH,Z AJ,ZAL .....	1
4	PAHHH	3020-01-098-6742	73342	29527509	. BODY,GEAR ASSEMBLY USE WITH TRANS. P/N 6885292 UOC: DAC,DAD,DAE,DAF,DAG,DA H,DAJ,DAL,DAW,DAX,V14,V15,V16, V17,V18,V19,V20,V21,V22,V24,ZAA, ZAB,ZAC,ZAD,ZAE,ZAF,ZAG,ZAH,Z AJ,ZAL .....	1
5	XAHZZ		73342	6881645	. . BODY UOC: DAC,DAD,DAE,DAF,DAG,DA H,DAJ,DAL,DAW,DAX,V14,V15,V16, V17,V18,V19,V20,V21,V22,V24,ZAA, ZAB,ZAC,ZAD,ZAE,ZAF,ZAG,ZAH,Z AJ,ZAL .....	1
6	PAHZZ	3020-01-078-0627	73342	29527497	. . GEAR,DRIVE MOTION UOC: DAC,DAD,DAE,DAF,DAG,DA H,DAJ,DAL,DAW,DAX,V14,V15,V16, V17,V18,V19,V20,V21,V22,V24,ZAA, ZAB,ZAC,ZAD,ZAE,ZAF,ZAG,ZAH,Z AJ,ZAL .....	1

(1) ITEM NO.	(2) SMR CODE	(3) NSN	(4) CAGEC	(5) PART NUMBER	(6) DESCRIPTION AND USABLE ON CODE (UOC)	(7) QTY
6	PAHZZ	3020-01-277-4635	73342	29527498	. . GEAR,INTERNAL .819-.820 UOC: DAC,DAD,DAE,DAF,DAG,DA H,DAJ,DAL,DAW,DAX,V14,V15,V16, V17,V18,V19,V20,V21,V22,V24,ZAA, ZAB,ZAC,ZAD,ZAE,ZAF,ZAG,ZAH,Z AJ,ZAL .....	1
7	PAHZZ	3020-01-277-4636	73342	29527492	. . GEAR,SPUR 0.8185-0.8190 UOC: DAC,DAD,DAE,DAF,DAG,DA H,DAJ,DAL,DAW,DAX,V14,V15,V16, V17,V18,V19,V20,V21,V22,V24,ZAA, ZAB,ZAC,ZAD,ZAE,ZAF,ZAG,ZAH,Z AJ,ZAL .....	1
7	PAHZZ	3020-01-277-4638	73342	29527494	. . GEAR,SPUR 0.8195-0.8200 UOC: DAC,DAD,DAE,DAF,DAG,DA H,DAJ,DAL,DAW,DAX,V14,V15,V16, V17,V18,V19,V20,V21,V22,V24,ZAA, ZAB,ZAC,ZAD,ZAE,ZAF,ZAG,ZAH,Z AJ,ZAL .....	1
7	PAHZZ	3020-01-104-3803	73342	29527495	. . GEAR,DRIVE .8200-.8205 UOC: DAC,DAD,DAE,DAF,DAG,DA H,DAJ,DAL,DAW,DAX,V14,V15,V16, V17,V18,V19,V20,V21,V22,V24,ZAA, ZAB,ZAC,ZAD,ZAE,ZAF,ZAG,ZAH,Z AJ,ZAL .....	1
7	PAHZZ	3020-01-277-4637	73342	29527493	. . GEAR,SPUR 0.8190-0.8195 UOC: DAC,DAD,DAE,DAF,DAG,DA H,DAJ,DAL,DAW,DAX,V14,V15,V16, V17,V18,V19,V20,V21,V22,V24,ZAA, ZAB,ZAC,ZAD,ZAE,ZAF,ZAG,ZAH,Z AJ,ZAL .....	1
8	PAHZZ	5325-00-804-4997	96906	MS16625-2077	. RING,RETAINING UOC: DAC,DAD,DAE,DAF,DAG,DA H,DAJ,DAL,DAW,DAX,V14,V15,V16, V17,V18,V19,V20,V21,V22,V24,ZAA, ZAB,ZAC,ZAD,ZAE,ZAF,ZAG,ZAH,Z AJ,ZAL .....	1
9	PAHZZ	2520-01-007-0345	73342	6834413	. STOP,VALVE UOC: DAC,DAD,DAE,DAF,DAG,DA H,DAJ,DAL,DAW,DAX,V14,V15,V16, V17,V18,V19,V20,V21,V22,V24,ZAA, ZAB,ZAC,ZAD,ZAE,ZAF,ZAG,ZAH,Z AJ,ZAL .....	1
10	PAHZZ	5360-01-079-6704	73342	6836277	. SPRING,HELICAL,COMP UOC: DAC,DAD,DAE,DAF,DAG,DA H,DAJ,DAL,DAW,DAX,V14,V15,V16, V17,V18,V19,V20,V21,V22,V24,ZAA, ZAB,ZAC,ZAD,ZAE,ZAF,ZAG,ZAH,Z AJ,ZAL .....	1

(1) ITEM NO.	(2) SMR CODE	(3) NSN	(4) CAGEC	(5) PART NUMBER	(6) DESCRIPTION AND USABLE ON CODE (UOC)	(7) QTY
11	PAHZZ	2520-01-007-0346	73342	6834414	. VALVE,LOCKUP UOC: DAC,DAD,DAE,DAF,DAG,DA H,DAJ,DAL,DAW,DAX,V14,V15,V16, V17,V18,V19,V20,V21,V22,V24,ZAA, ZAB,ZAC,ZAD,ZAE,ZAF,ZAG,ZAH,Z AJ,ZAL .....	1
12	PAHHH	2520-01-134-6534	73342	23015872	. SUPPORT,ASSEMBLY,TR USE WITH TRANS. P/N 6885292 UOC: DAC,DAD,DAE,DAF,DAG,DA H,DAJ,DAL,DAW,DAX,V14,V15,V16, V17,V18,V19,V20,V21,V22,V24,ZAA, ZAB,ZAC,ZAD,ZAE,ZAF,ZAG,ZAH,Z AJ,ZAL .....	1
13	PAHZZ	2520-01-011-1068	73342	6834410	. . GUIDE,VALVE UOC: DAC,DAD,DAE,DAF,DAG,DA H,DAJ,DAL,DAW,DAX,V14,V15,V16, V17,V18,V19,V20,V21,V22,V24,ZAA, ZAB,ZAC,ZAD,ZAE,ZAF,ZAG,ZAH,Z AJ,ZAL .....	1
14	PAHZZ	5360-01-079-6702	63005	6881072	. . SPRING UOC: DAC,DAD,DAE,DAF,DAG,DA H,DAJ,DAL,DAW,DAX,V14,V15,V16, V17,V18,V19,V20,V21,V22,V24,ZAA, ZAB,ZAC,ZAD,ZAE,ZAF,ZAG,ZAH,Z AJ,ZAL .....	1
15	PAHZZ	4820-01-011-1069	73342	6836202	. . SEAT,VALVE UOC: DAC,DAD,DAE,DAF,DAG,DA H,DAJ,DAL,DAW,DAX,V14,V15,V16, V17,V18,V19,V20,V21,V22,V24,ZAA, ZAB,ZAC,ZAD,ZAE,ZAF,ZAG,ZAH,Z AJ,ZAL .....	1
16	XAHHH		73342	23015874	. . SUPPORT,ASSY UOC: DAC,DAD,DAE,DAF,DAG,DA H,DAJ,DAL,DAW,DAX,V14,V15,V16, V17,V18,V19,V20,V21,V22,V24,ZAA, ZAB,ZAC,ZAD,ZAE,ZAF,ZAG,ZAH,Z AJ,ZAL .....	1
17	XAHZZ		73342	23013437	. . . SLEEVE,CONVERTER GR UOC: DAC,DAD,DAE,DAF,DAG,DA H,DAJ,DAL,DAW,DAX,V14,V15,V16, V17,V18,V19,V20,V21,V22,V24,ZAA, ZAB,ZAC,ZAD,ZAE,ZAF,ZAG,ZAH,Z AJ,ZAL .....	1
18	XAHZZ		73342	23015876	. . . SUPPORT UOC: DAC,DAD,DAE,DAF,DAG,DA H,DAJ,DAL,DAW,DAX,V14,V15,V16, V17,V18,V19,V20,V21,V22,V24,ZAA, ZAB,ZAC,ZAD,ZAE,ZAF,ZAG,ZAH,Z AJ,ZAL .....	1

(1) ITEM NO.	(2) SMR CODE	(3) NSN	(4) CAGEC	(5) PART NUMBER	(6) DESCRIPTION AND USABLE ON CODE (UOC)	(7) QTY
19	PAHZZ	5340-01-066-2794	19207	7707730	. . . PLUG,EXPANSION UOC: DAC,DAD,DAE,DAF,DAG,DA H,DAJ,DAL,DAW,DAX,V14,V15,V16, V17,V18,V19,V20,V21,V22,V24,ZAA, ZAB,ZAC,ZAD,ZAE,ZAF,ZAG,ZAH,Z AJ,ZAL .....	1
20	PAHZZ	3110-01-149-0876	73342	29517123	. . BEARING,ROLLER,NEED UOC: DAC,DAD,DAE,DAF,DAG,DA H,DAJ,DAL,DAW,DAX,V14,V15,V16, V17,V18,V19,V20,V21,V22,V24,ZAA, ZAB,ZAC,ZAD,ZAE,ZAF,ZAG,ZAH,Z AJ,ZAL .....	1
21	PAHZZ	5306-01-052-2402	96906	MS35764-1297	. BOLT,SELF-LOCKING UOC: DAC,DAD,DAE,DAF,DAG,DA H,DAJ,DAL,DAW,DAX,V14,V15,V16, V17,V18,V19,V20,V21,V22,V24,ZAA, ZAB,ZAC,ZAD,ZAE,ZAF,ZAG,ZAH,Z AJ,ZAL .....	2
22	PAHZZ	5305-00-638-2362	24617	9409225	. SCREW,CAP,HEXAGON H UOC: DAC,DAD,DAE,DAF,DAG,DA H,DAJ,DAL,DAW,DAX,V14,V15,V16, V17,V18,V19,V20,V21,V22,V24,ZAA, ZAB,ZAC,ZAD,ZAE,ZAF,ZAG,ZAH,Z AJ,ZAL .....	12
23	PAHZZ	2520-01-079-1615	73342	6881380	. VALVE,MAIN PRESSURE UOC: DAC,DAD,DAE,DAF,DAG,DA H,DAJ,DAL,DAW,DAX,V14,V15,V16, V17,V18,V19,V20,V21,V22,V24,ZAA, ZAB,ZAC,ZAD,ZAE,ZAF,ZAG,ZAH,Z AJ,ZAL .....	1
24	PAHZZ	5360-01-079-6703	73342	6881381	. SPRING UOC: DAC,DAD,DAE,DAF,DAG,DA H,DAJ,DAL,DAW,DAX,V14,V15,V16, V17,V18,V19,V20,V21,V22,V24,ZAA, ZAB,ZAC,ZAD,ZAE,ZAF,ZAG,ZAH,Z AJ,ZAL .....	1
25	PAHZZ	2520-01-011-1067	73342	6834412	. STOP,VALVE UOC: DAC,DAD,DAE,DAF,DAG,DA H,DAJ,DAL,DAW,DAX,V14,V15,V16, V17,V18,V19,V20,V21,V22,V24,ZAA, ZAB,ZAC,ZAD,ZAE,ZAF,ZAG,ZAH,Z AJ,ZAL .....	1
26	PAHZZ	5325-00-349-8518	73342	274613	. RING,RETAINING UOC: DAC,DAD,DAE,DAF,DAG,DA H,DAJ,DAL,DAW,DAX,V14,V15,V16, V17,V18,V19,V20,V21,V22,V24,ZAA, ZAB,ZAC,ZAD,ZAE,ZAF,ZAG,ZAH,Z AJ,ZAL .....	1

(1) ITEM NO.	(2) SMR CODE	(3) NSN	(4) CAGEC	(5) PART NUMBER	(6) DESCRIPTION AND USABLE ON CODE (UOC)	(7) QTY
27	PAHZZ	5315-01-155-7302	24617	9418910	. PIN,STRAIGHT,HEADLE USE STARTING WITH S/N2420021628 UOC: DAC,DAD,DAE,DAF,DAG,DA H,DAJ,DAL,DAW,DAX,V14,V15,V16, V17,V18,V19,V20,V21,V22,V24,ZAA, ZAB,ZAC,ZAD,ZAE,ZAF,ZAG,ZAH,Z AJ,ZAL .....	2
28	PAHZZ	3110-01-065-5842	2B524	23019782	BEARING UOC: DAC,DAD,DAE,DAF,DAG,DA H,DAJ,DAL,DAW,DAX,V14,V15,V16, V17,V18,V19,V20,V21,V22,V24,ZAA, ZAB,ZAC,ZAD,ZAE,ZAF,ZAG,ZAH,Z AJ,ZAL .....	1
29	PAHZZ	2520-00-557-6211	73342	23014632	RING,SEAL UOC: DAC,DAD,DAE,DAF,DAG,DA H,DAJ,DAL,DAW,DAX,V14,V15,V16, V17,V18,V19,V20,V21,V22,V24,ZAA, ZAB,ZAC,ZAD,ZAE,ZAF,ZAG,ZAH,Z AJ,ZAL .....	2
30	PAHZZ	5330-00-557-6518	73342	23046344	GASKET PART OF KIT P/N 6884259 UOC: DAC,DAD,DAE,DAF,DAG,DA H,DAJ,DAL,DAW,DAX,V14,V15,V16, V17,V18,V19,V20,V21,V22,V24,ZAA, ZAB,ZAC,ZAD,ZAE,ZAF,ZAG,ZAH,Z AJ,ZAL .....	1
31	PAHZZ	5310-00-557-5942	73342	6834908	WASHER,SPECIAL PART OF KIT P/N 6884259 UOC: DAC,DAD,DAE,DAF,DAG,DA H,DAJ,DAL,DAW,DAX,V14,V15,V16, V17,V18,V19,V20,V21,V22,V24,ZAA, ZAB,ZAC,ZAD,ZAE,ZAF,ZAG,ZAH,Z AJ,ZAL .....	12
32	PAHZZ	5305-00-559-1022	73342	179397	SCREW,CAP,HEXAGON H UOC: DAC,DAD,DAE,DAF,DAG,DA H,DAJ,DAL,DAW,DAX,V14,V15,V16, V17,V18,V19,V20,V21,V22,V24,ZAA, ZAB,ZAC,ZAD,ZAE,ZAF,ZAG,ZAH,Z AJ,ZAL .....	12

END OF FIGURE





**FIELD MAINTENANCE  
OIL PUMP AND FRONT SUPPORT ASSEMBLY (TRANSMISSION P/N 23040127)**

---

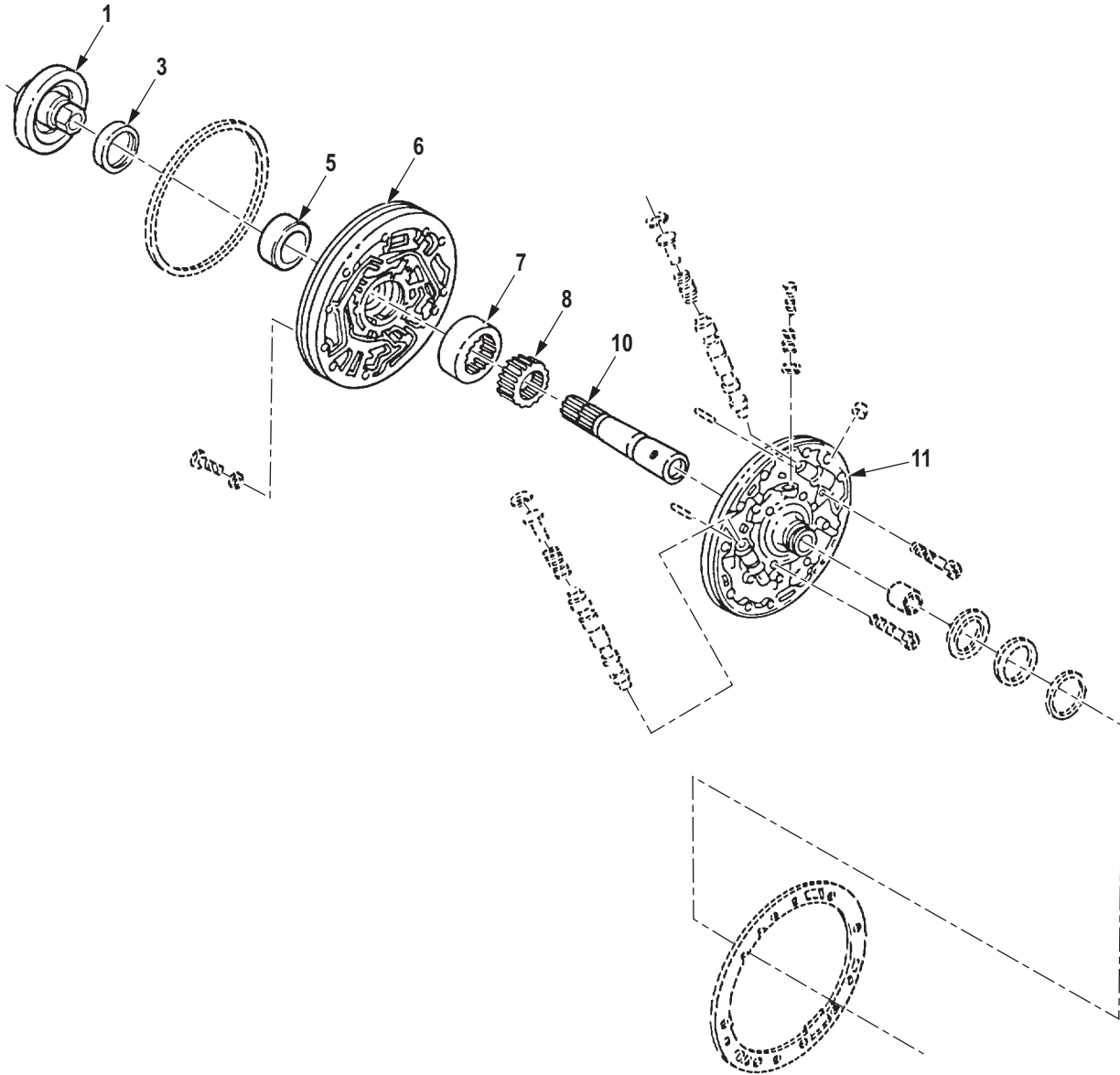
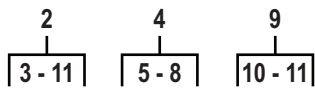

R0216DAA

Figure 201. Oil Pump and Front Support Assembly (Transmission P/N 23040127).

(1) ITEM NO.	(2) SMR CODE	(3) NSN	(4) CAGEC	(5) PART NUMBER	(6) DESCRIPTION AND USABLE ON CODE (UOC)	(7) QTY
					<b>GROUP 0721 COOLERS, PUMPS, MOTORS.</b>	
					<b>FIG. 201. OIL PUMP AND FRONT SUPPORT ASSEMBLY (TRANSMISSION P/N 23040127).</b>	
1	PAHZZ	3040-01-337-4379	73342	23016723	HUB,BODY USE WITH TRANSMISSION P/N 23040127 PART OF KIT P/N 23043043 UOC: DAC,DAD,DAE,DAF,DAG,DA H,DAJ,DAL,DAW,DAX,V14,V15,V16, V17,V18,V19,V20,V21,V22,V24,ZAA, ZAB,ZAC,ZAD,ZAE,ZAF,ZAG,ZAH,Z AJ,ZAL .....	1
2	PAHHH	2815-01-340-0377	73342	23017115	OIL PUMP ASSEMBLY,E PART OF KIT P/N 23043043 UOC: DAC,DAD,DAE,DAF,DAG,DA H,DAJ,DAL,DAW,DAX,V14,V15,V16, V17,V18,V19,V20,V21,V22,V24,ZAA, ZAB,ZAC,ZAD,ZAE,ZAF,ZAG,ZAH,Z AJ,ZAL .....	1
3	PAHZZ	5330-01-339-0708	73342	23045556	. SEAL,PLAIN PART OF KIT P/N 23043043 UOC: DAC,DAD,DAE,DAF,DAG,DA H,DAJ,DAL,DAW,DAX,V14,V15,V16, V17,V18,V19,V20,V21,V22,V24,ZAA, ZAB,ZAC,ZAD,ZAE,ZAF,ZAG,ZAH,Z AJ,ZAL .....	1
4	PAHHH	4320-01-337-0608	73342	29527481	. HOUSING,LIQUID PUMP USE WITH TRANSMISSION P/N 23040127 PART OF KIT P/N 23043043 UOC: DAC,DAD,DAE,DAF,DAG,DA H,DAJ,DAL,DAW,DAX,V14,V15,V16, V17,V18,V19,V20,V21,V22,V24,ZAA, ZAB,ZAC,ZAD,ZAE,ZAF,ZAG,ZAH,Z AJ,ZAL .....	1
5	PAHZZ	3120-01-341-6519	73342	23046152	. . BUSHING,SLEEVE PART OF KIT P/N 23043043 UOC: DAC,DAD,DAE,DAF,DAG,DA H,DAJ,DAL,DAW,DAX,V14,V15,V16, V17,V18,V19,V20,V21,V22,V24,ZAA, ZAB,ZAC,ZAD,ZAE,ZAF,ZAG,ZAH,Z AJ,ZAL .....	1
6	XAHZZ		73342	23017115XA	. . OIL PUMP ASSEMBLY,E UOC: DAC,DAD,DAE,DAF,DAG,DA H,DAJ,DAL,DAW,DAX,V14,V15,V16, V17,V18,V19,V20,V21,V22,V24,ZAA, ZAB,ZAC,ZAD,ZAE,ZAF,ZAG,ZAH,Z AJ,ZAL .....	1

(1) ITEM NO.	(2) SMR CODE	(3) NSN	(4) CAGEC	(5) PART NUMBER	(6) DESCRIPTION AND USABLE ON CODE (UOC)	(7) QTY
7	PAHZZ	3020-01-340-0402	73342	29527489	. . GEAR,HELICAL 0.999-1.000 PART OF KIT P/N 23043043 UOC: DAC,DAD,DAE,DAF,DAG,DA H,DAJ,DAL,DAW,DAX,V14,V15,V16, V17,V18,V19,V20,V21,V22,V24,ZAA, ZAB,ZAC,ZAD,ZAE,ZAF,ZAG,ZAH,Z AJ,ZAL .....	1
7	PAHZZ	3020-01-340-0403	73342	29527488	. . GEAR,INTERNAL 0.998-0.999 PART OF KIT P/N 23043043 UOC: DAC,DAD,DAE,DAF,DAG,DA H,DAJ,DAL,DAW,DAX,V14,V15,V16, V17,V18,V19,V20,V21,V22,V24,ZAA, ZAB,ZAC,ZAD,ZAE,ZAF,ZAG,ZAH,Z AJ,ZAL .....	1
8	PAHZZ	3020-01-340-0407	73342	29527483	. . GEAR,SPUR 0.9985-0.9990 PART OF KIT P/N 23043043 UOC: DAC,DAD,DAE,DAF,DAG,DA H,DAJ,DAL,DAW,DAX,V14,V15,V16, V17,V18,V19,V20,V21,V22,V24,ZAA, ZAB,ZAC,ZAD,ZAE,ZAF,ZAG,ZAH,Z AJ,ZAL .....	1
8	PAHZZ	3020-01-340-0408	73342	29527485	. . GEAR,SPUR 0.9995-1.0000 PART OF KIT P/N 23043043 UOC: DAC,DAD,DAE,DAF,DAG,DA H,DAJ,DAL,DAW,DAX,V14,V15,V16, V17,V18,V19,V20,V21,V22,V24,ZAA, ZAB,ZAC,ZAD,ZAE,ZAF,ZAG,ZAH,Z AJ,ZAL .....	1
8	PAHZZ	3020-01-340-0404	73342	29527486	. . GEAR,SPUR 1.0000-1.0005 PART OF KIT P/N 23043043 UOC: DAC,DAD,DAE,DAF,DAG,DA H,DAJ,DAL,DAW,DAX,V14,V15,V16, V17,V18,V19,V20,V21,V22,V24,ZAA, ZAB,ZAC,ZAD,ZAE,ZAF,ZAG,ZAH,Z AJ,ZAL .....	1
8	PAHZZ	3020-01-347-2855	73342	29527484	. . GEAR,SPUR 0.9990-0.9950 PART OF KIT P/N 23043043 UOC: DAC,DAD,DAE,DAF,DAG,DA H,DAJ,DAL,DAW,DAX,V14,V15,V16, V17,V18,V19,V20,V21,V22,V24,ZAA, ZAB,ZAC,ZAD,ZAE,ZAF,ZAG,ZAH,Z AJ,ZAL .....	1

(1) ITEM NO.	(2) SMR CODE	(3) NSN	(4) CAGEC	(5) PART NUMBER	(6) DESCRIPTION AND USABLE ON CODE (UOC)	(7) QTY
9	PAHHH	3040-01-337-4161	73342	23016763	. HOUSING,MECHANICAL USE WITH TRANSMISSION P/N 23040127 PART OF KIT P/N 23043043 UOC: DAC,DAD,DAE,DAF,DAG,DA H,DAJ,DAL,DAW,DAX,V14,V15,V16, V17,V18,V19,V20,V21,V22,V24,ZAA, ZAB,ZAC,ZAD,ZAE,ZAF,ZAG,ZAH,Z AJ,ZAL .....	1
10	XAHZZ		73342	23042126	. . SLEEVE,CONNECTOR PART OF KIT P/N 23043043 UOC: DAC,DAD,DAE,DAF,DAG,DA H,DAJ,DAL,DAW,DAX,V14,V15,V16, V17,V18,V19,V20,V21,V22,V24,ZAA, ZAB,ZAC,ZAD,ZAE,ZAF,ZAG,ZAH,Z AJ,ZAL .....	1
11	XAHZZ		73342	23016763-1	. . HOUSING,MECHANICAL USE WITH TRANSMISSION P/N 23040127 PART OF KIT P/N 23043043 UOC: DAC,DAD,DAE,DAF,DAG,DA H,DAJ,DAL,DAW,DAX,V14,V15,V16, V17,V18,V19,V20,V21,V22,V24,ZAA, ZAB,ZAC,ZAD,ZAE,ZAF,ZAG,ZAH,Z AJ,ZAL .....	1

END OF FIGURE



**FIELD MAINTENANCE  
TRANSMISSION OIL COOLER AND MOUNTING HARDWARE**

---

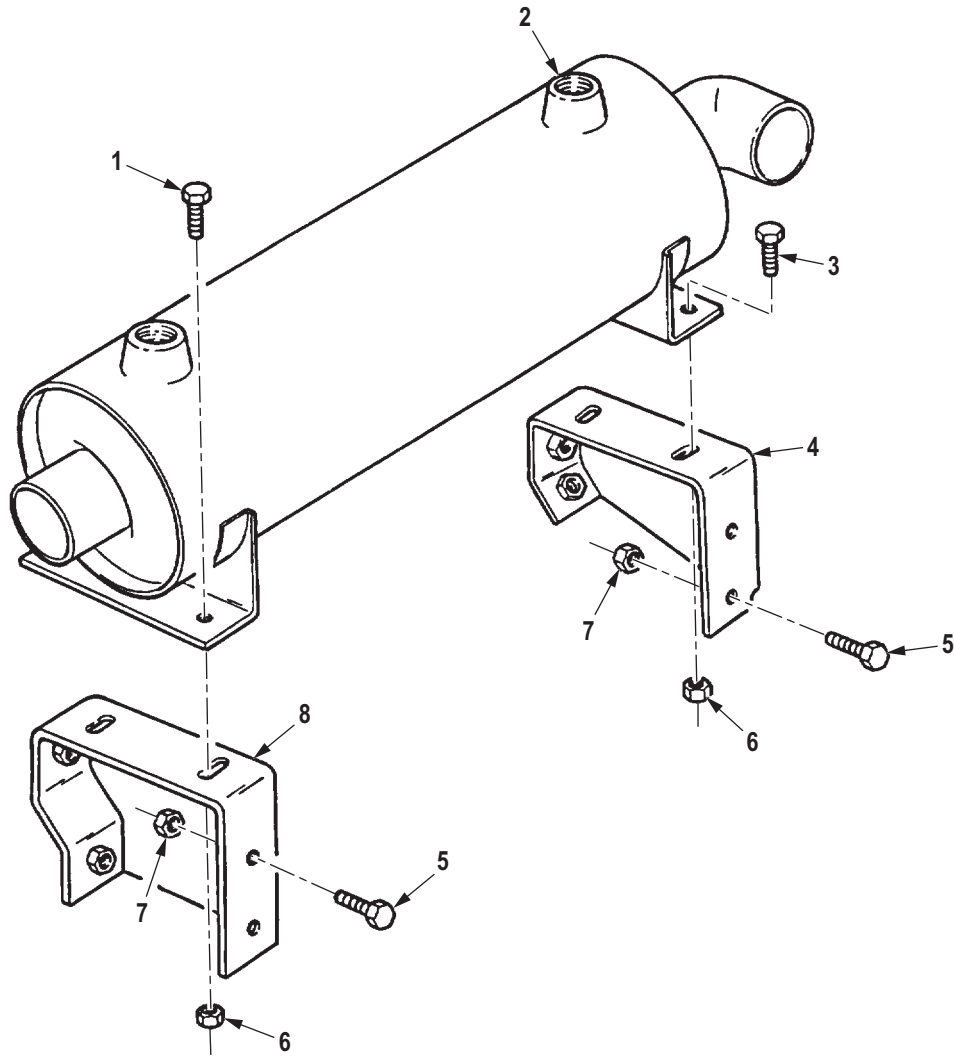

R0217DAA

Figure 202. Transmission Oil Cooler and Mounting Hardware.



(1) ITEM NO.	(2) SMR CODE	(3) NSN	(4) CAGEC	(5) PART NUMBER	(6) DESCRIPTION AND USABLE ON CODE (UOC)	(7) QTY
<b>GROUP 0721 COOLERS, PUMPS, MOTORS.</b>						
<b>FIG. 202. TRANSMISSION OIL COOLER AND MOUNTING HARDWARE.</b>						
1	PAFZZ	5305-00-269-3238	80204	B1821BH038F125N	SCREW,CAP,HEXAGON H UOC: DAC,DAD,DAE,DAF,DAG,DA H,DAJ,DAL,DAW,DAX,V14,V15,V16, V17,V18,V19,V20,V21,V22,V24,ZAA, ZAB,ZAC,ZAD,ZAE,ZAF,ZAG,ZAH,Z AJ,ZAL .....	4
2	PAFZZ	2520-01-098-5124	19207	11669164	COOLER,FLUID,TRANSM UOC: DAC,DAD,DAE,DAF,DAG,DA H,DAJ,DAL,DAW,DAX,V14,V15,V16, V17,V18,V19,V20,V21,V22,V24,ZAA, ZAB,ZAC,ZAD,ZAE,ZAF,ZAG,ZAH,Z AJ,ZAL .....	1
3	PAFZZ	5305-00-912-5113	80205	MS51096-359	SCREW,CAP,HEXAGON H UOC: DAC,DAD,DAE,DAF,DAG,DA H,DAJ,DAL,DAW,DAX,V14,V15,V16, V17,V18,V19,V20,V21,V22,V24,ZAA, ZAB,ZAC,ZAD,ZAE,ZAF,ZAG,ZAH,Z AJ,ZAL .....	2
4	PFFZZ	5342-01-231-9151	19207	12302629	BRACKET,ENGINE ACCE UOC: DAC,DAD,DAE,DAF,DAG,DA H,DAJ,DAL,DAW,DAX,V14,V15,V16, V17,V18,V19,V20,V21,V22,V24,ZAA, ZAB,ZAC,ZAD,ZAE,ZAF,ZAG,ZAH,Z AJ,ZAL .....	1
5	PAFZZ	5305-00-725-0154	80204	B1821BH050F138N	SCREW,CAP,HEXAGON H UOC: DAC,DAD,DAE,DAF,DAG,DA H,DAJ,DAL,DAW,DAX,V14,V15,V16, V17,V18,V19,V20,V21,V22,V24,ZAA, ZAB,ZAC,ZAD,ZAE,ZAF,ZAG,ZAH,Z AJ,ZAL .....	4
6	PAFZZ	5310-00-814-0672	96906	M45913/3-6FG8C	NUT,SELF-LOCKING,HE UOC: DAC,DAD,DAE,DAF,DAG,DA H,DAJ,DAL,DAW,DAX,V14,V15,V16, V17,V18,V19,V20,V21,V22,V24,ZAA, ZAB,ZAC,ZAD,ZAE,ZAF,ZAG,ZAH,Z AJ,ZAL .....	4
7	PAFZZ	5310-00-877-5795	80205	MS21044-N8	NUT,SELF-LOCKING,HE UOC: DAC,DAD,DAE,DAF,DAG,DA H,DAJ,DAL,DAW,DAX,V14,V15,V16, V17,V18,V19,V20,V21,V22,V24,ZAA, ZAB,ZAC,ZAD,ZAE,ZAF,ZAG,ZAH,Z AJ,ZAL .....	4

(1) ITEM NO.	(2) SMR CODE	(3) NSN	(4) CAGEC	(5) PART NUMBER	(6) DESCRIPTION AND USABLE ON CODE (UOC)	(7) QTY
8	PFFZZ	5342-01-106-6015	19207	12256165	BRACKET,SPECIAL UOC: DAC,DAD,DAE,DAF,DAG,DA H,DAJ,DAL,DAW,DAX,V14,V15,V16, V17,V18,V19,V20,V21,V22,V24,ZAA, ZAB,ZAC,ZAD,ZAE,ZAF,ZAG,ZAH,Z AJ,ZAL .....	1

END OF FIGURE

**FIELD MAINTENANCE  
TRANSMISSION OIL COOLER AND FITTINGS**

---

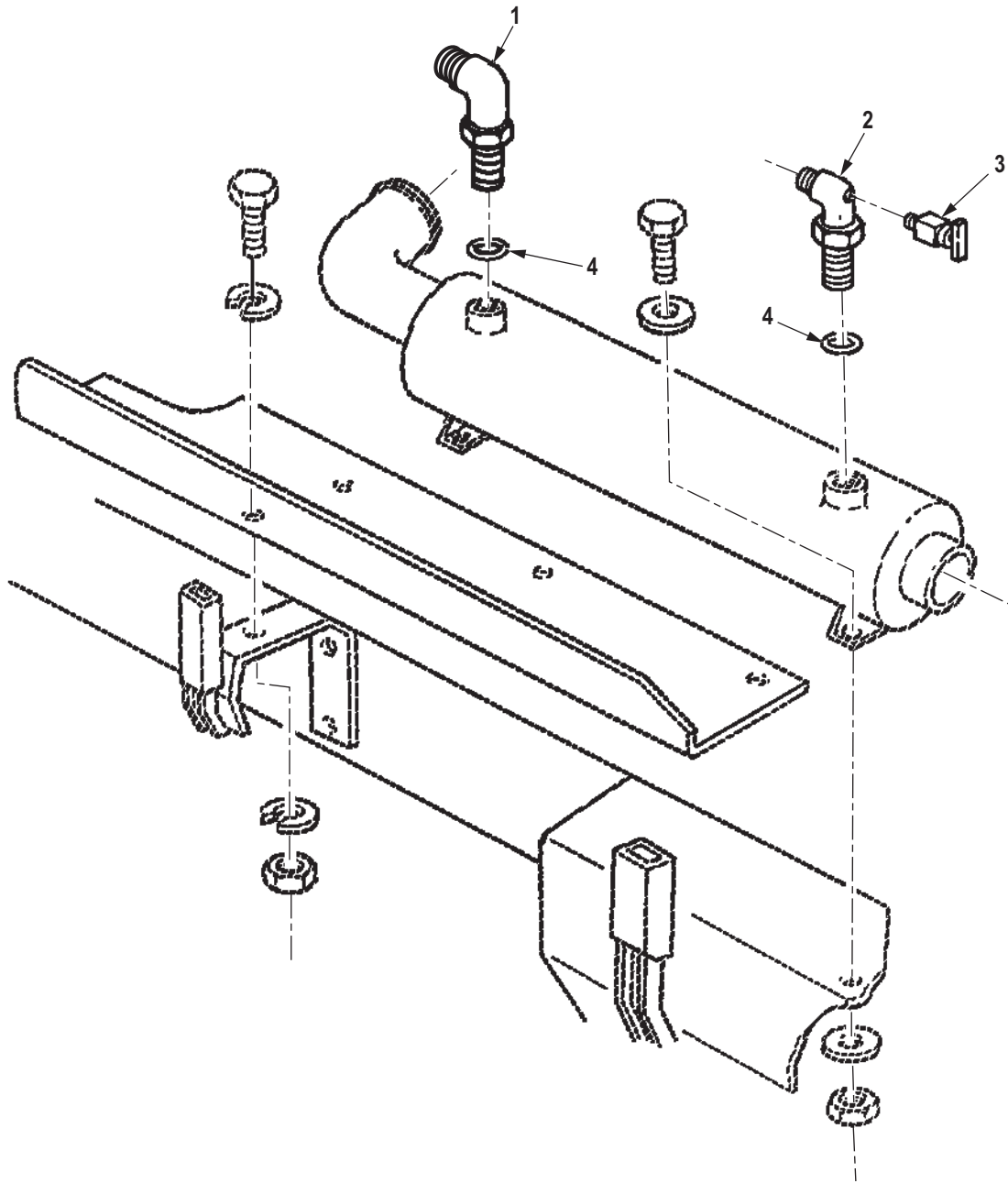

R0218DAA

Figure 203. Transmission Oil Cooler and Fittings.

(1) ITEM NO.	(2) SMR CODE	(3) NSN	(4) CAGEC	(5) PART NUMBER	(6) DESCRIPTION AND USABLE ON CODE (UOC)	(7) QTY
<b>GROUP 0721 COOLERS, PUMPS, MOTORS.</b>						
<b>FIG. 203. TRANSMISSION OIL COOLER AND FITTINGS.</b>						
1	PAFZZ	4730-01-110-4059	19207	12256456-4	ELBOW,TUBE TO BOSS UOC: ZAA,ZAB,ZAC,ZAD,ZAE,ZAF, ZAG,ZAH,ZAJ,ZAL .....	1
2	PAFZZ	4730-01-155-5449	19207	12256456-5	ELBOW,TUBE TO BOSS UOC: ZAA,ZAB,ZAC,ZAD,ZAE,ZAF, ZAG,ZAH,ZAJ,ZAL .....	1
3	PAFZZ	4820-00-845-1096	58536	AA59440/2-010	COCK,DRAIN UOC: ZAA,ZAB,ZAC,ZAD,ZAE,ZAF, ZAG,ZAH,ZAJ,ZAL .....	1
4	PAFZZ	5331-00-108-5691	81343	MS28778-10	O-RING UOC: ZAA,ZAB,ZAC,ZAD,ZAE,ZAF, ZAG,ZAH,ZAJ,ZAL .....	2
<b>END OF FIGURE</b>						



**FIELD MAINTENANCE  
OIL HOSES, FILTER, AND MOUNTING HARDWARE (M939, M939A1)**

---

15  
16-17

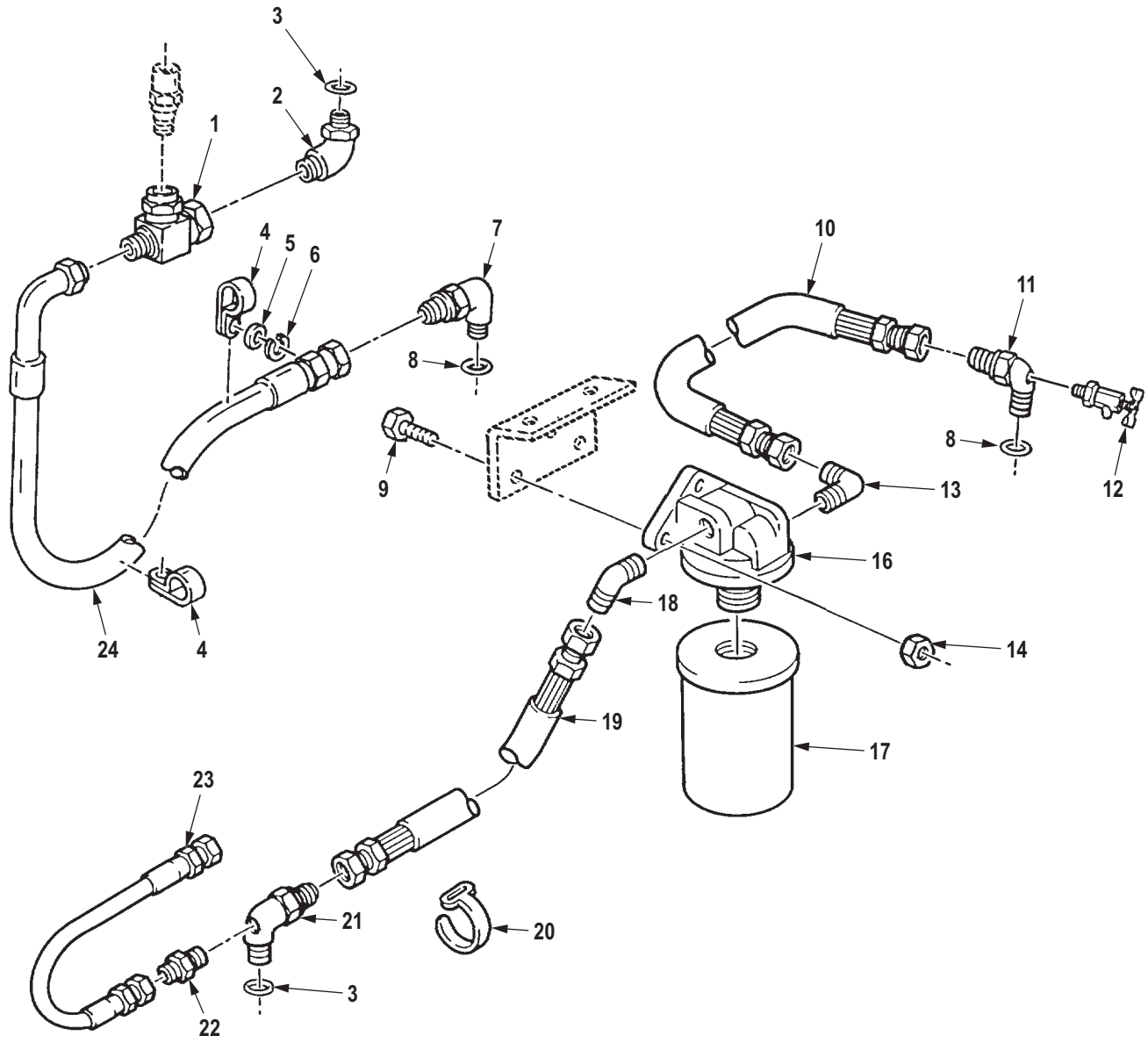

R0219DAA

Figure 204. Oil Hoses, Filter, and Mounting Hardware (M939, M939A1).



(1) ITEM NO.	(2) SMR CODE	(3) NSN	(4) CAGEC	(5) PART NUMBER	(6) DESCRIPTION AND USABLE ON CODE (UOC)	(7) QTY
<b>GROUP 0721 COOLERS, PUMPS, MOTORS.</b>						
<b>FIG. 204. OIL HOSES, FILTER, AND MOUNTING HARDWARE (M939, M939A1).</b>						
1	PAFZZ	4730-01-091-0266	19207	12256531	TEE,PIPE TO TUBE UOC: DAC,DAD,DAE,DAF,DAG,DA H,DAJ,DAL,DAW,DAX,V14,V15,V16, V17,V18,V19,V20,V21,V22,V24 .....	1
2	PAFZZ	4730-01-089-3071	19207	12256456-2	ELBOW ASSEMBLY,PIPE UOC: DAC,DAD,DAE,DAF,DAG,DA H,DAJ,DAL,DAW,DAX,V14,V15,V16, V17,V18,V19,V20,V21,V22,V24 .....	1
3	PAFZZ	5331-00-776-2830	81343	AS3551-912	O-RING UOC: DAC,DAD,DAE,DAF,DAG,DA H,DAJ,DAL,DAW,DAX,V14,V15,V16, V17,V18,V19,V20,V21,V22,V24 .....	2
4	PAFZZ	5340-01-106-8346	19207	7529133-5	CLAMP,LOOP UOC: DAC,DAD,DAE,DAF,DAG,DA H,DAJ,DAL,DAW,DAX,V14,V15,V16, V17,V18,V19,V20,V21,V22,V24 .....	2
5	PAFZZ	5310-00-080-6004	96906	MS27183-14	WASHER,FLAT UOC: DAC,DAD,DAE,DAF,DAG,DA H,DAJ,DAL,DAW,DAX,V14,V15,V16, V17,V18,V19,V20,V21,V22,V24 .....	1
6	PAFZZ	5310-00-003-4094	80205	MS35338-48	WASHER,LOCK UOC: DAC,DAD,DAE,DAF,DAG,DA H,DAJ,DAL,DAW,DAX,V14,V15,V16, V17,V18,V19,V20,V21,V22,V24 .....	1
7	PAFZZ	4730-01-110-4059	19207	12256456-4	ELBOW,TUBE TO BOSS UOC: DAC,DAD,DAE,DAF,DAG,DA H,DAJ,DAL,DAW,DAX,V14,V15,V16, V17,V18,V19,V20,V21,V22,V24 .....	1
8	PAFZZ	5331-00-108-5691	81343	MS28778-10	O-RING UOC: DAC,DAD,DAE,DAF,DAG,DA H,DAJ,DAL,DAW,DAX,V14,V15,V16, V17,V18,V19,V20,V21,V22,V24 .....	2
9	PAFZZ	5306-00-051-4077	80204	B1821BH031F113N	BOLT,MACHINE UOC: DAC,DAD,DAE,DAF,DAG,DA H,DAJ,DAL,DAW,DAX,V14,V15,V16, V17,V18,V19,V20,V21,V22,V24 .....	2
10	PAFZZ	4720-01-136-4454	19207	12277398-1	HOSE ASSEMBLY,NONME UOC: DAC,DAD,DAE,DAF,DAG,DA H,DAJ,DAL,DAW,DAX,V14,V15,V16, V17,V18,V19,V20,V21,V22,V24 .....	1

(1) ITEM NO.	(2) SMR CODE	(3) NSN	(4) CAGEC	(5) PART NUMBER	(6) DESCRIPTION AND USABLE ON CODE (UOC)	(7) QTY
11	PAFZZ	4730-01-155-5449	19207	12256456-5	ELBOW,TUBE TO BOSS UOC: DAC,DAD,DAE,DAF,DAG,DA H,DAJ,DAL,DAW,DAX,V14,V15,V16, V17,V18,V19,V20,V21,V22,V24 .....	1
12	PAFZZ	4820-00-845-1096	58536	AA59440/2-010	COCK,DRAIN UOC: DAC,DAD,DAE,DAF,DAG,DA H,DAJ,DAL,DAW,DAX,V14,V15,V16, V17,V18,V19,V20,V21,V22,V24 .....	1
13	PAFZZ	4730-00-289-4912	96906	MS51504A12	ELBOW,PIPE TO TUBE COVER UOC: DAC,DAD,DAE,DAF,DAG,DA H,DAJ,DAL,DAW,DAX,V14,V15,V16, V17,V18,V19,V20,V21,V22,V24 .....	1
14	PAFZZ	5310-00-241-6658	81349	M45913/3-5FG8C	NUT,SELF-LOCKING,HE UOC: DAC,DAD,DAE,DAF,DAG,DA H,DAJ,DAL,DAW,DAX,V14,V15,V16, V17,V18,V19,V20,V21,V22,V24 .....	2
15	PAFFF	2520-01-123-2649	70040	25011159	FILTER,FLUID,PRESSU TRANSMISSION UOC: DAC,DAD,DAE,DAF,DAG,DA H,DAJ,DAL,DAW,DAX,V14,V15,V16, V17,V18,V19,V20,V21,V22,V24,ZAA, ZAB,ZAC,ZAD,ZAE,ZAF,ZAG,ZAH,Z AJ,ZAL .....	1
16	PAFZZ	2940-01-164-5804	62860	25011151	. COVER,OIL FILTER UOC: DAC,DAD,DAE,DAF,DAG,DA H,DAJ,DAL,DAW,DAX,V14,V15,V16, V17,V18,V19,V20,V21,V22,V24,ZAA, ZAB,ZAC,ZAD,ZAE,ZAF,ZAG,ZAH,Z AJ,ZAL .....	1
17	PAFZZ	2940-01-110-2489	11083	1R0713	. FILTER ELEMENT,FLUI UOC: DAC,DAD,DAE,DAF,DAG,DA H,DAJ,DAL,DAW,DAX,V14,V15,V16, V17,V18,V19,V20,V21,V22,V24,ZAA, ZAB,ZAC,ZAD,ZAE,ZAF,ZAG,ZAH,Z AJ,ZAL .....	1
18	PAFZZ	4730-01-028-8147	96906	MS51508B12	ELBOW,PIPE TO TUBE UOC: DAC,DAD,DAE,DAF,DAG,DA H,DAJ,DAL,DAW,DAX,V14,V15,V16, V17,V18,V19,V20,V21,V22,V24 .....	1
19	PAFZZ	4720-01-137-1453	19207	12277398-2	HOSE ASSEMBLY,NONME UOC: DAC,DAD,DAE,DAF,DAG,DA H,DAJ,DAL,DAW,DAX,V14,V15,V16, V17,V18,V19,V20,V21,V22,V24 .....	1
20	PAFZZ	5975-00-985-6630	96906	MS3367-3-0	STRAP,TIEDOWN,ELECT UOC: DAC,DAD,DAE,DAF,DAG,DA H,DAJ,DAL,DAW,DAX,V14,V15,V16, V17,V18,V19,V20,V21,V22,V24 .....	2

(1) ITEM NO.	(2) SMR CODE	(3) NSN	(4) CAGEC	(5) PART NUMBER	(6) DESCRIPTION AND USABLE ON CODE (UOC)	(7) QTY
21	PAFZZ	4730-01-089-3072	19207	12256456-3	ELBOW ASSEMBLY,PIPE UOC: DAC,DAD,DAE,DAF,DAG,DA H,DAJ,DAL,DAW,DAX,V14,V15,V16, V17,V18,V19,V20,V21,V22,V24 .....	1
22	PAFZZ	4730-00-289-0383	96906	MS51500A4	ADAPTER,STRAIGHT,PI UOC: DAC,DAD,DAE,DAF,DAG,DA H,DAJ,DAL,DAW,DAX,V14,V15,V16, V17,V18,V19,V20,V21,V22,V24 .....	2
23	PAFZZ	4720-01-089-3074	19207	12256489	HOSE ASSEMBLY,NONME UOC: DAC,DAD,DAE,DAF,DAG,DA H,DAJ,DAL,DAW,DAX,V14,V15,V16, V17,V18,V19,V20,V21,V22,V24 .....	1
24	PAFZZ	4720-01-115-2274	19207	12277179	HOSE ASSEMBLY,NONME UOC: DAC,DAD,DAE,DAF,DAG,DA H,DAJ,DAL,DAW,DAX,V14,V15,V16, V17,V18,V19,V20,V21,V22,V24 .....	1

END OF FIGURE



**FIELD MAINTENANCE  
OIL HOSES (M939A2)**

---

6  
7-8

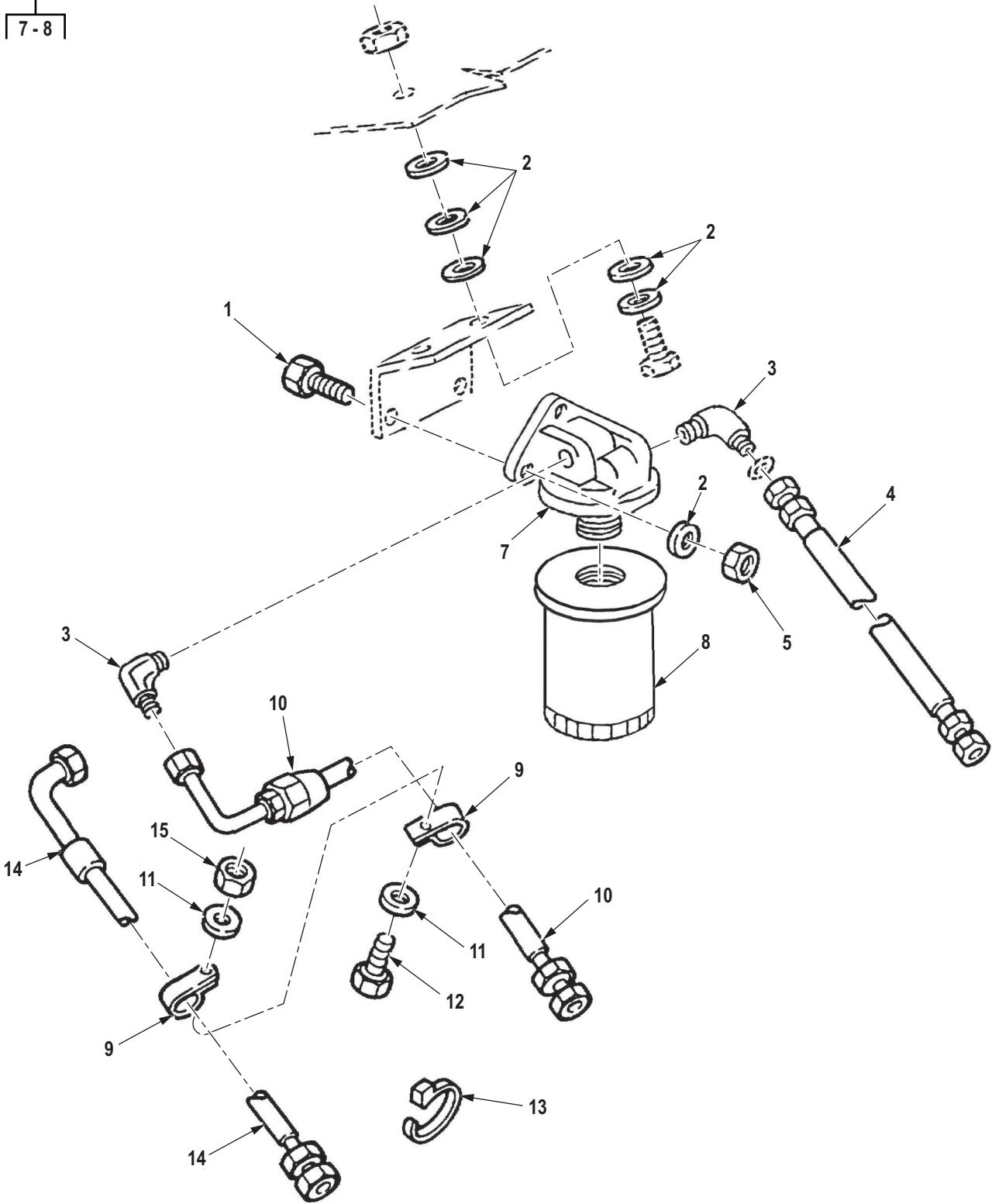

R0220DAA

Figure 205. Oil Hoses (M939A2).

(1) ITEM NO.	(2) SMR CODE	(3) NSN	(4) CAGEC	(5) PART NUMBER	(6) DESCRIPTION AND USABLE ON CODE (UOC)	(7) QTY
<b>GROUP 0721 COOLERS, PUMPS, MOTORS.</b>						
<b>FIG. 205. OIL HOSES (M939A2).</b>						
1	PAFZZ	5305-00-225-9091	80205	MS90726-36	SCREW,CAP,HEXAGON H UOC: ZAA,ZAB,ZAC,ZAD,ZAE,ZAF, ZAG,ZAH,ZAJ,ZAL .....	3
2	PAFZZ	5310-00-081-4219	96906	MS27183-12	WASHER,FLAT UOC: ZAA,ZAB,ZAC,ZAD,ZAE,ZAF, ZAG,ZAH,ZAJ,ZAL .....	11
3	PAFZZ	4730-00-640-0264	81343	SAE J514 12-12 070202BA	ELBOW,PIPE TO TUBE UOC: ZAA,ZAB,ZAC,ZAD,ZAE,ZAF, ZAG,ZAH,ZAJ,ZAL .....	2
4	PAFZZ	4720-01-272-0504	98441	A3917-1	HOSE ASSEMBLY,NONME OIL COOLER TO FILTER. 31 INCHES LONG. UOC: ZAA,ZAB,ZAC,ZAD,ZAE,ZAF, ZAG,ZAH,ZAJ,ZAL .....	1
5	PAFZZ	5310-00-241-6658	81349	M45913/3-5FG8C	NUT,SELF-LOCKING,HE UOC: ZAA,ZAB,ZAC,ZAD,ZAE,ZAF, ZAG,ZAH,ZAJ,ZAL .....	3
6	PAFFF	2520-01-123-2649	70040	25011159	FILTER,FLUID,PRESSU UOC: ZAA,ZAB,ZAC,ZAD,ZAE,ZAF, ZAG,ZAH,ZAJ,ZAL .....	1
7	PAFZZ	2940-01-164-5804	62860	25011151	. COVER,OIL FILTER UOC: ZAA,ZAB,ZAC,ZAD,ZAE,ZAF, ZAG,ZAH,ZAJ,ZAL .....	1
8	PAFZZ	2940-01-110-2489	11083	1R0713	. FILTER ELEMENT,FLUI UOC: ZAA,ZAB,ZAC,ZAD,ZAE,ZAF, ZAG,ZAH,ZAJ,ZAL .....	1
9	PAFZZ	5340-01-106-8346	19207	7529133-5	CLAMP,LOOP UOC: ZAA,ZAB,ZAC,ZAD,ZAE,ZAF, ZAG,ZAH,ZAJ,ZAL .....	2
10	PAFZZ	4720-01-271-7997	19207	12432427-2	HOSE ASSEMBLY,NOMEN TRANSMISSION TO OIL COLLER. 60 IN.LONG. UOC: ZAA,ZAB,ZAC,ZAD,ZAE,ZAF, ZAG,ZAH,ZAJ,ZAL .....	1
11	PAFZZ	5310-00-799-4910	73342	6752556	WASHER,SPRING TENSI UOC: ZAA,ZAB,ZAC,ZAD,ZAE,ZAF, ZAG,ZAH,ZAJ,ZAL .....	2
12	PAFZZ	5305-00-721-5492	80204	B1821BH038C063N	SCREW,CAP,HEXAGON H UOC: ZAA,ZAB,ZAC,ZAD,ZAE,ZAF, ZAG,ZAH,ZAJ,ZAL .....	1
13	PAFZZ	5975-00-451-5001	81343	MS3367-3-9	STRAP,TIEDOWN,ELECT UOC: ZAA,ZAB,ZAC,ZAD,ZAE,ZAF, ZAG,ZAH,ZAJ,ZAL .....	2

(1) ITEM NO.	(2) SMR CODE	(3) NSN	(4) CAGEC	(5) PART NUMBER	(6) DESCRIPTION AND USABLE ON CODE (UOC)	(7) QTY
14	PAFZZ	4720-01-271-7996	19207	12432427-1	HOSE ASSEMBLY, NONME OIL FILTER TO TRANSMISSION. 49 INCHES LONG. UOC: ZAA,ZAB,ZAC,ZAD,ZAE,ZAF, ZAG,ZAH,ZAJ,ZAL .....	1
15	PAFZZ	5310-00-935-9021	96906	MS51943-35	NUT, SELF-LOCKING, HE UOC: ZAA,ZAB,ZAC,ZAD,ZAE,ZAF, ZAG,ZAH,ZAJ,ZAL .....	1

END OF FIGURE



**FIELD MAINTENANCE  
TRANSFER CASE AND SHIPPING CONTAINER**

---

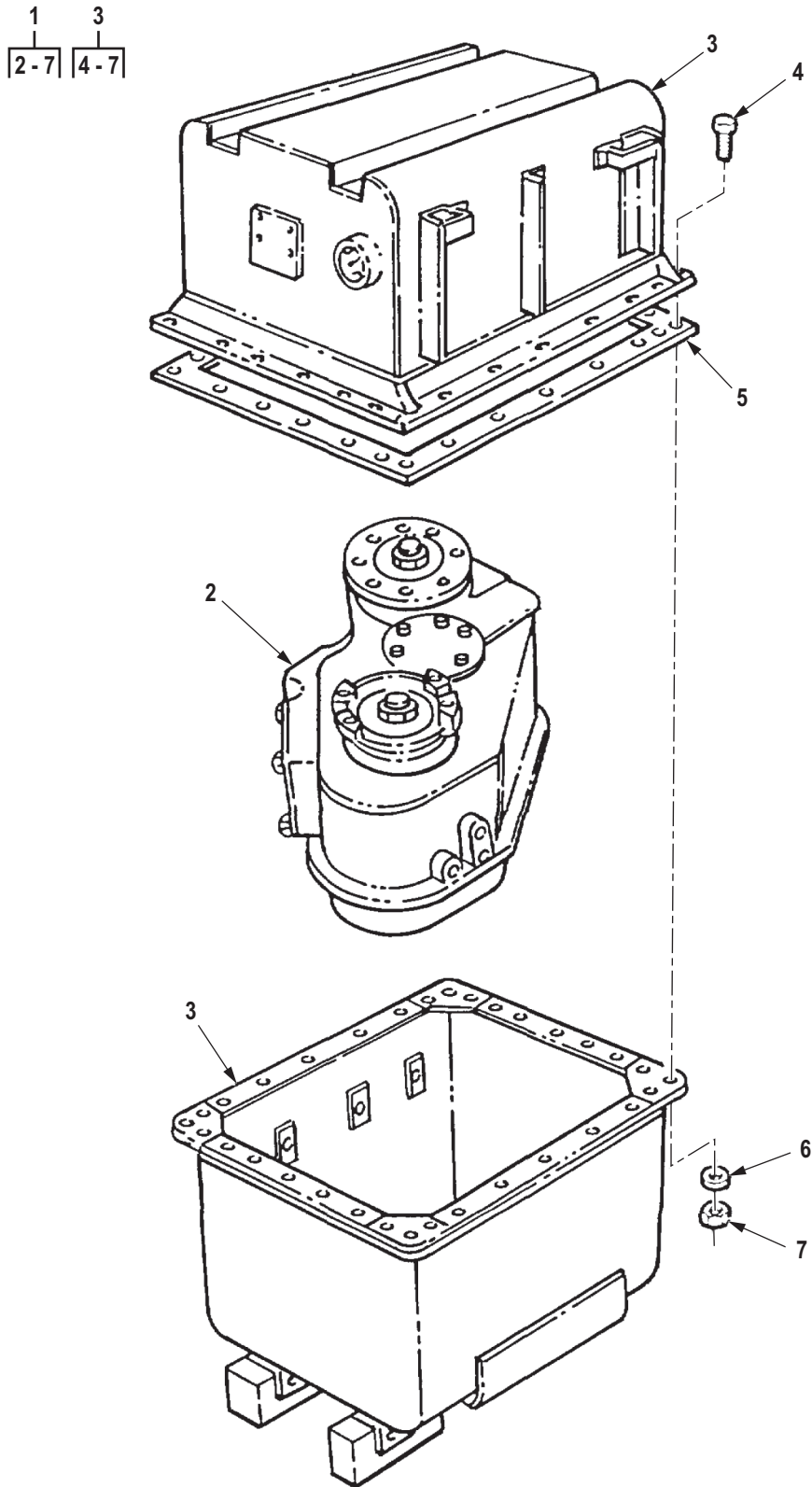

R0221DAA

Figure 206. Transfer Case and Shipping Container.

(1) ITEM NO.	(2) SMR CODE	(3) NSN	(4) CAGEC	(5) PART NUMBER	(6) DESCRIPTION AND USABLE ON CODE (UOC)	(7) QTY
<b>GROUP 0800 TRANSFER AND FINAL DRIVE ASSEMBLIES.</b>						
<b>FIG. 206. TRANSFER CASE AND SHIPPING CONTAINER.</b>						
1	PAFHH	2520-01-144-1528	19207	5704517	TRANSFER AND CONTAI UOC: DAC,DAD,DAE,DAF,DAG,DA H,DAJ,DAL,DAW,DAX,V14,V15,V16, V17,V18,V19,V20,V21,V22,V24,ZAA, ZAB,ZAC,ZAD,ZAE,ZAF,ZAG,ZAH,Z AJ,ZAL .....	1
2	XAFHH		19207	11669112	. TRANSFER,TRANSMISSI UOC: DAC,DAD,DAE,DAF,DAG,DA H,DAJ,DAL,DAW,DAX,V14,V15,V16, V17,V18,V19,V20,V21,V22,V24,ZAA, ZAB,ZAC,ZAD,ZAE,ZAF,ZAG,ZAH,Z AJ,ZAL .....	1
3	PAFHH	8145-01-134-6538	19207	10932088-1	. SHIPPING AND STORAG UOC: DAC,DAD,DAE,DAF,DAG,DA H,DAJ,DAL,DAW,DAX,V14,V15,V16, V17,V18,V19,V20,V21,V22,V24,ZAA, ZAB,ZAC,ZAD,ZAE,ZAF,ZAG,ZAH,Z AJ,ZAL .....	1
4	PAFZZ	5305-00-724-7222	80204	B1821BH063C200N	. . SCREW,CAP,HEXAGON H UOC: DAC,DAD,DAE,DAF,DAG,DA H,DAJ,DAL,DAW,DAX,V14,V15,V16, V17,V18,V19,V20,V21,V22,V24,ZAA, ZAB,ZAC,ZAD,ZAE,ZAF,ZAG,ZAH,Z AJ,ZAL .....	30
5	PAFZZ	5330-00-171-2776	19207	10932085	. . SEAL,NONMETALLIC RO UOC: DAC,DAD,DAE,DAF,DAG,DA H,DAJ,DAL,DAW,DAX,V14,V15,V16, V17,V18,V19,V20,V21,V22,V24,ZAA, ZAB,ZAC,ZAD,ZAE,ZAF,ZAG,ZAH,Z AJ,ZAL .....	1
6	PAFZZ	5310-00-820-6653	80205	MS35338-50	. . WASHER,LOCK UOC: DAC,DAD,DAE,DAF,DAG,DA H,DAJ,DAL,DAW,DAX,V14,V15,V16, V17,V18,V19,V20,V21,V22,V24,ZAA, ZAB,ZAC,ZAD,ZAE,ZAF,ZAG,ZAH,Z AJ,ZAL .....	30
7	PAFZZ	5310-00-763-8920	96906	MS51967-20	. . NUT,PLAIN,HEXAGON UOC: DAC,DAD,DAE,DAF,DAG,DA H,DAJ,DAL,DAW,DAX,V14,V15,V16, V17,V18,V19,V20,V21,V22,V24,ZAA, ZAB,ZAC,ZAD,ZAE,ZAF,ZAG,ZAH,Z AJ,ZAL .....	30

END OF FIGURE



**FIELD MAINTENANCE  
TRANSFER CASE MOUNTING HARDWARE, HOUSING, FLANGES, AND SPEEDOMETER DRIVE**

---

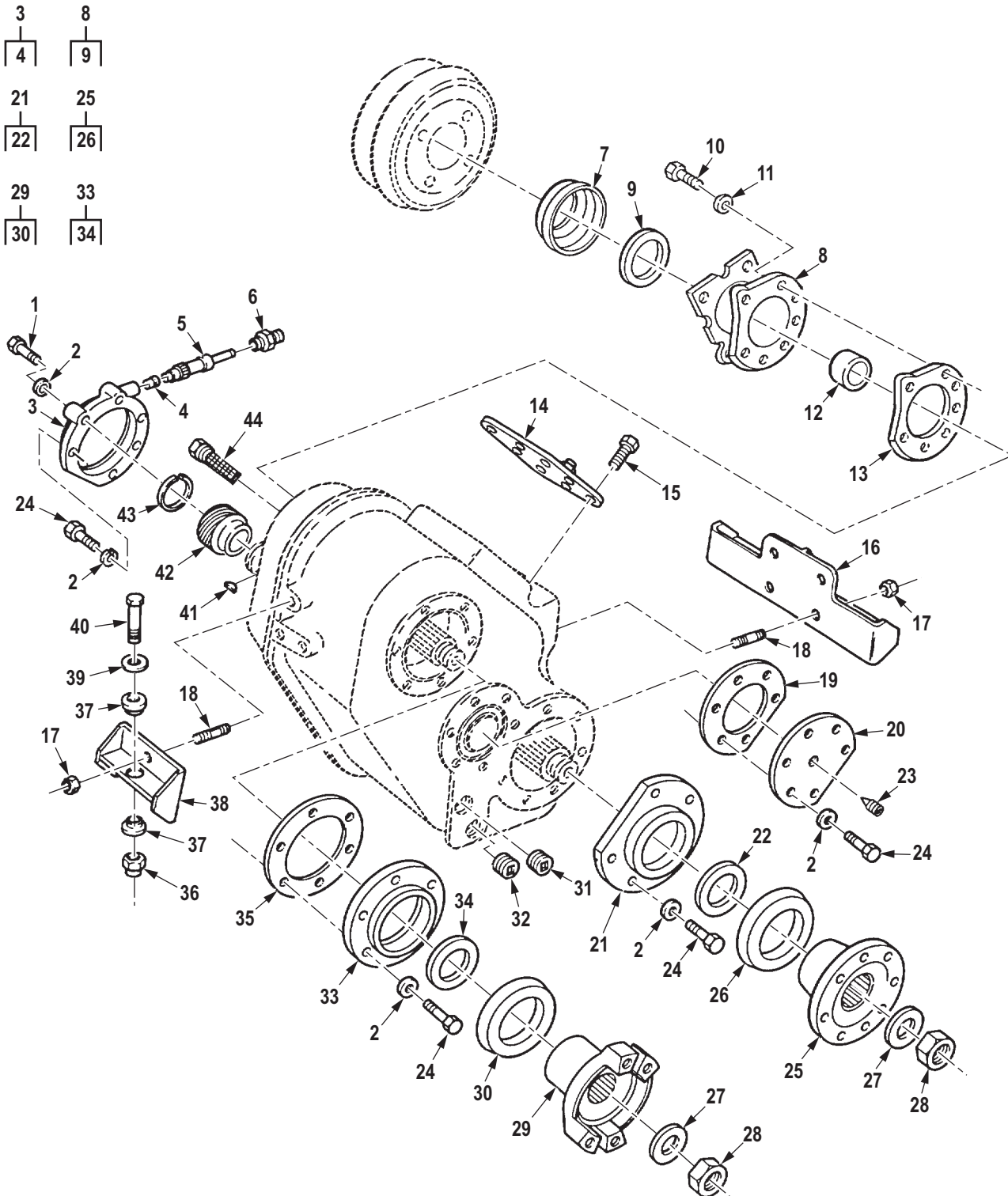

R0222DAA

Figure 207. Transfer Case Mounting Hardware, Housing, Flanges, and Speedometer Drive.

(1) ITEM NO.	(2) SMR CODE	(3) NSN	(4) CAGEC	(5) PART NUMBER	(6) DESCRIPTION AND USABLE ON CODE (UOC)	(7) QTY
<p><b>GROUP 0801 POWER TRANSFER, FINAL DRIVE, PLANETARY OR DROP GEAR BOX ASSEMBLIES.</b></p> <p><b>FIG. 207. TRANSFER CASE MOUNTING HARDWARE, HOUSING, FLANGES, AND SPEEDOMETER DRIVE.</b></p>						
1	PAFZZ	5305-00-071-2058	80204	B1821BH044C225N	SCREW,CAP,HEXAGON H UOC: DAC,DAD,DAE,DAF,DAG,DAH,DAJ,DAL,DAW,DAX,V14,V15,V16,V17,V18,V19,V20,V21,V22,V24,ZAA,ZAB,ZAC,ZAD,ZAE,ZAF,ZAG,ZAH,ZAJ,ZAL .....	2
2	PAFZZ	5310-00-893-3381	19207	7748744	WASHER,FLAT UOC: DAC,DAD,DAE,DAF,DAG,DAH,DAJ,DAL,DAW,DAX,V14,V15,V16,V17,V18,V19,V20,V21,V22,V24,ZAA,ZAB,ZAC,ZAD,ZAE,ZAF,ZAG,ZAH,ZAJ,ZAL .....	24
3	PAFZZ	2520-01-146-3447	3D6E9	A3266-W-621	COVER AND SEAL ASSE UOC: DAC,DAD,DAE,DAF,DAG,DAH,DAJ,DAL,DAW,DAX,V14,V15,V16,V17,V18,V19,V20,V21,V22,V24,ZAA,ZAB,ZAC,ZAD,ZAE,ZAF,ZAG,ZAH,ZAJ,ZAL .....	1
4	PAFZZ	3120-00-516-7516	19207	5284913	. BEARING,SLEEVE UOC: DAC,DAD,DAE,DAF,DAG,DAH,DAJ,DAL,DAW,DAX,V14,V15,V16,V17,V18,V19,V20,V21,V22,V24,ZAA,ZAB,ZAC,ZAD,ZAE,ZAF,ZAG,ZAH,ZAJ,ZAL .....	1
5	PAFZZ	2520-01-127-2624	0HZA7	890318	SHAFT,SPEEDOMETER,G UOC: DAC,DAD,DAE,DAF,DAG,DAH,DAJ,DAL,DAW,DAX,V14,V15,V16,V17,V18,V19,V20,V21,V22,V24,ZAA,ZAB,ZAC,ZAD,ZAE,ZAF,ZAG,ZAH,ZAJ,ZAL .....	1
6	PAFZZ	4730-00-202-9539	95019	55-454-1	REDUCER,TUBE UOC: DAC,DAD,DAE,DAF,DAG,DAH,DAJ,DAL,DAW,DAX,V14,V15,V16,V17,V18,V19,V20,V21,V22,V24,ZAA,ZAB,ZAC,ZAD,ZAE,ZAF,ZAG,ZAH,ZAJ,ZAL .....	1
7	PAFZZ	2520-01-137-4843	3D6E9	3264-W-101	SHIELD AND DEFLECTO UOC: DAC,DAD,DAE,DAF,DAG,DAH,DAJ,DAL,DAW,DAX,V14,V15,V16,V17,V18,V19,V20,V21,V22,V24,ZAA,ZAB,ZAC,ZAD,ZAE,ZAF,ZAG,ZAH,ZAJ,ZAL .....	1

(1) ITEM NO.	(2) SMR CODE	(3) NSN	(4) CAGEC	(5) PART NUMBER	(6) DESCRIPTION AND USABLE ON CODE (UOC)	(7) QTY
8	PAHZZ	2530-01-134-0900	78500	A3268-R-1084	SPIDER,BRAKE UOC: DAC,DAD,DAE,DAF,DAG,DA H,DAJ,DAL,DAW,DAX,V14,V15,V16, V17,V18,V19,V20,V21,V22,V24,ZAA, ZAB,ZAC,ZAD,ZAE,ZAF,ZAG,ZAH,Z AJ,ZAL .....	1
9	PAHZZ	5330-01-023-0269	19207	11669023	. SEAL,PLAIN ENCASED UOC: DAC,DAD,DAE,DAF,DAG,DA H,DAJ,DAL,DAW,DAX,V14,V15,V16, V17,V18,V19,V20,V21,V22,V24,ZAA, ZAB,ZAC,ZAD,ZAE,ZAF,ZAG,ZAH,Z AJ,ZAL .....	1
10	PAHZZ	5305-01-135-3536	78500	S2914-2-C	SCREW,CAP,HEXAGON H UOC: DAC,DAD,DAE,DAF,DAG,DA H,DAJ,DAL,DAW,DAX,V14,V15,V16, V17,V18,V19,V20,V21,V22,V24,ZAA, ZAB,ZAC,ZAD,ZAE,ZAF,ZAG,ZAH,Z AJ,ZAL .....	7
11	PAHZZ	5310-00-725-1983	81205	BACW10P53S	WASHER,FLAT UOC: DAC,DAD,DAE,DAF,DAG,DA H,DAJ,DAL,DAW,DAX,V14,V15,V16, V17,V18,V19,V20,V21,V22,V24,ZAA, ZAB,ZAC,ZAD,ZAE,ZAF,ZAG,ZAH,Z AJ,ZAL .....	7
12	PAHZZ	5365-01-129-6590	78500	1244-D-1590	SPACER UOC: DAC,DAD,DAE,DAF,DAG,DA H,DAJ,DAL,DAW,DAX,V14,V15,V16, V17,V18,V19,V20,V21,V22,V24,ZAA, ZAB,ZAC,ZAD,ZAE,ZAF,ZAG,ZAH,Z AJ,ZAL .....	1
13	PAHZZ	5365-01-135-2831	78500	2203-X-7850	SHIM .010 UOC: DAC,DAD,DAE,DAF,DAG,DA H,DAJ,DAL,DAW,DAX,V14,V15,V16, V17,V18,V19,V20,V21,V22,V24,ZAA, ZAB,ZAC,ZAD,ZAE,ZAF,ZAG,ZAH,Z AJ,ZAL .....	1
13	PAHZZ	5365-01-135-2830	78500	2203-W-7849	SHIM .005 UOC: DAC,DAD,DAE,DAF,DAG,DA H,DAJ,DAL,DAW,DAX,V14,V15,V16, V17,V18,V19,V20,V21,V22,V24,ZAA, ZAB,ZAC,ZAD,ZAE,ZAF,ZAG,ZAH,Z AJ,ZAL .....	1
13	PAHZZ	5365-01-135-2829	78500	2203-V-7848	SHIM .003 UOC: DAC,DAD,DAE,DAF,DAG,DA H,DAJ,DAL,DAW,DAX,V14,V15,V16, V17,V18,V19,V20,V21,V22,V24,ZAA, ZAB,ZAC,ZAD,ZAE,ZAF,ZAG,ZAH,Z AJ,ZAL .....	1



(1) ITEM NO.	(2) SMR CODE	(3) NSN	(4) CAGEC	(5) PART NUMBER	(6) DESCRIPTION AND USABLE ON CODE (UOC)	(7) QTY
14	XDFZZ		78500	A-3289-G-189	COVER,INSPECTION UOC: DAC,DAD,DAE,DAF,DAG,DA H,DAJ,DAL,DAW,DAX,V14,V15,V16, V17,V18,V19,V20,V21,V22,V24,ZAA, ZAB,ZAC,ZAD,ZAE,ZAF,ZAG,ZAH,Z AJ,ZAL .....	1
15	PAFZZ	5305-01-130-3267	3D6E9	S-265-2	SCREW,CAP,HEXAGON H UOC: DAC,DAD,DAE,DAF,DAG,DA H,DAJ,DAL,DAW,DAX,V14,V15,V16, V17,V18,V19,V20,V21,V22,V24,ZAA, ZAB,ZAC,ZAD,ZAE,ZAF,ZAG,ZAH,Z AJ,ZAL .....	8
16	PAFZZ	5340-01-089-2989	19207	12256188	BRACKET,MOUNTING UOC: DAC,DAD,DAE,DAF,DAG,DA H,DAJ,DAL,DAW,DAX,V14,V15,V16, V17,V18,V19,V20,V21,V22,V24,ZAA, ZAB,ZAC,ZAD,ZAE,ZAF,ZAG,ZAH,Z AJ,ZAL .....	1
17	PAFZZ	5310-00-241-6664	96906	M45913/3-10FG8C	NUT,SELF-LOCKING,HE UOC: DAC,DAD,DAE,DAF,DAG,DA H,DAJ,DAL,DAW,DAX,V14,V15,V16, V17,V18,V19,V20,V21,V22,V24,ZAA, ZAB,ZAC,ZAD,ZAE,ZAF,ZAG,ZAH,Z AJ,ZAL .....	7
18	PAFZZ	5307-01-121-9883	19207	8331791-1	STUD,PLAIN UOC: DAC,DAD,DAE,DAF,DAG,DA H,DAJ,DAL,DAW,DAX,V14,V15,V16, V17,V18,V19,V20,V21,V22,V24,ZAA, ZAB,ZAC,ZAD,ZAE,ZAF,ZAG,ZAH,Z AJ,ZAL .....	7
19	PAHZZ	5365-01-133-3749	78500	2203-M-7787	SHIM .005 UOC: DAC,DAD,DAE,DAF,DAG,DA H,DAJ,DAL,DAW,DAX,V14,V15,V16, V17,V18,V19,V20,V21,V22,V24,ZAA, ZAB,ZAC,ZAD,ZAE,ZAF,ZAG,ZAH,Z AJ,ZAL .....	1
19	PAHZZ	5365-01-133-3750	78500	2203-N-7788	SHIM .010 UOC: DAC,DAD,DAE,DAF,DAG,DA H,DAJ,DAL,DAW,DAX,V14,V15,V16, V17,V18,V19,V20,V21,V22,V24,ZAA, ZAB,ZAC,ZAD,ZAE,ZAF,ZAG,ZAH,Z AJ,ZAL .....	1
19	PAHZZ	5365-01-128-5061	78500	2203-L-7786	SHIM .003 UOC: DAC,DAD,DAE,DAF,DAG,DA H,DAJ,DAL,DAW,DAX,V14,V15,V16, V17,V18,V19,V20,V21,V22,V24,ZAA, ZAB,ZAC,ZAD,ZAE,ZAF,ZAG,ZAH,Z AJ,ZAL .....	1

(1) ITEM NO.	(2) SMR CODE	(3) NSN	(4) CAGEC	(5) PART NUMBER	(6) DESCRIPTION AND USABLE ON CODE (UOC)	(7) QTY
20	PAHZZ	2520-01-139-3124	3D6E9	3266-F-864	COVER,SHAFT UOC: DAC,DAD,DAE,DAF,DAG,DA H,DAJ,DAL,DAW,DAX,V14,V15,V16, V17,V18,V19,V20,V21,V22,V24,ZAA, ZAB,ZAC,ZAD,ZAE,ZAF,ZAG,ZAH,Z AJ,ZAL .....	1
21	PAHZZ	2520-01-126-9364	3D6E9	A3266-A-625	COVER AND SEAL ASSE UOC: DAC,DAD,DAE,DAF,DAG,DA H,DAJ,DAL,DAW,DAX,V14,V15,V16, V17,V18,V19,V20,V21,V22,V24,ZAA, ZAB,ZAC,ZAD,ZAE,ZAF,ZAG,ZAH,Z AJ,ZAL .....	1
22	PAHZZ	5330-01-023-0269	19207	11669023	. SEAL,PLAIN ENCASED UOC: DAC,DAD,DAE,DAF,DAG,DA H,DAJ,DAL,DAW,DAX,V14,V15,V16, V17,V18,V19,V20,V21,V22,V24,ZAA, ZAB,ZAC,ZAD,ZAE,ZAF,ZAG,ZAH,Z AJ,ZAL .....	1
23	PAHZZ	4730-00-010-3875	81348	WW-P-471ACBBUE	PLUG,PIPE UOC: DAC,DAD,DAE,DAF,DAG,DA H,DAJ,DAL,DAW,DAX,V14,V15,V16, V17,V18,V19,V20,V21,V22,V24,ZAA, ZAB,ZAC,ZAD,ZAE,ZAF,ZAG,ZAH,Z AJ,ZAL .....	1
24	PAHZZ	5305-00-338-5162	78500	S2710-2	SCREW,SPECIAL UOC: DAC,DAD,DAE,DAF,DAG,DA H,DAJ,DAL,DAW,DAX,V14,V15,V16, V17,V18,V19,V20,V21,V22,V24,ZAA, ZAB,ZAC,ZAD,ZAE,ZAF,ZAG,ZAH,Z AJ,ZAL .....	22
25	PAHZZ	2520-01-126-9363	78500	A-3280-U-7535	FLANGE,DEFLECTOR UOC: DAC,DAD,DAE,DAF,DAG,DA H,DAJ,DAL,DAW,DAX,V14,V15,V16, V17,V18,V19,V20,V21,V22,V24,ZAA, ZAB,ZAC,ZAD,ZAE,ZAF,ZAG,ZAH,Z AJ,ZAL .....	1
26	PAHZZ	2520-00-255-5149	78500	DEFR474	. SLINGER UOC: DAC,DAD,DAE,DAF,DAG,DA H,DAJ,DAL,DAW,DAX,V14,V15,V16, V17,V18,V19,V20,V21,V22,V24,ZAA, ZAB,ZAC,ZAD,ZAE,ZAF,ZAG,ZAH,Z AJ,ZAL .....	1
27	PAHZZ	5310-01-129-4373	3D6E9	1229-T-1450	WASHER,FLAT UOC: DAC,DAD,DAE,DAF,DAG,DA H,DAJ,DAL,DAW,DAX,V14,V15,V16, V17,V18,V19,V20,V21,V22,V24,ZAA, ZAB,ZAC,ZAD,ZAE,ZAF,ZAG,ZAH,Z AJ,ZAL .....	2

(1) ITEM NO.	(2) SMR CODE	(3) NSN	(4) CAGEC	(5) PART NUMBER	(6) DESCRIPTION AND USABLE ON CODE (UOC)	(7) QTY
28	PAHZZ	5310-01-099-0397	04627	287720	NUT UOC: DAC,DAD,DAE,DAF,DAG,DA H,DAJ,DAL,DAW,DAX,V14,V15,V16, V17,V18,V19,V20,V21,V22,V24,ZAA, ZAB,ZAC,ZAD,ZAE,ZAF,ZAG,ZAH,Z AJ,ZAL .....	2
29	PAHHH	2520-01-127-3595	78500	A-3260-A-79	YOKE AND DEFLECTOR UOC: DAC,DAD,DAE,DAF,DAG,DA H,DAJ,DAL,DAW,DAX,V14,V15,V16, V17,V18,V19,V20,V21,V22,V24,ZAA, ZAB,ZAC,ZAD,ZAE,ZAF,ZAG,ZAH,Z AJ,ZAL .....	1
30	PAHZZ	2520-00-255-5149	78500	DEFR474	. SLINGER UOC: DAC,DAD,DAE,DAF,DAG,DA H,DAJ,DAL,DAW,DAX,V14,V15,V16, V17,V18,V19,V20,V21,V22,V24,ZAA, ZAB,ZAC,ZAD,ZAE,ZAF,ZAG,ZAH,Z AJ,ZAL .....	1
31	PAFZZ	4730-00-187-4210	58536	AA59616AACBUE	PLUG,PIPE UOC: DAC,DAD,DAE,DAF,DAG,DA H,DAJ,DAL,DAW,DAX,V14,V15,V16, V17,V18,V19,V20,V21,V22,V24,ZAA, ZAB,ZAC,ZAD,ZAE,ZAF,ZAG,ZAH,Z AJ,ZAL .....	1
32	PAFZZ	4730-00-595-4827	36540	5054181	PLUG,PIPE,MAGNETIC UOC: DAC,DAD,DAE,DAF,DAG,DA H,DAJ,DAL,DAW,DAX,V14,V15,V16, V17,V18,V19,V20,V21,V22,V24,ZAA, ZAB,ZAC,ZAD,ZAE,ZAF,ZAG,ZAH,Z AJ,ZAL .....	1
33	PAHZZ	2520-01-134-3665	78500	A-3266-Y-623	COVER,TRANSFER CASE UOC: DAC,DAD,DAE,DAF,DAG,DA H,DAJ,DAL,DAW,DAX,V14,V15,V16, V17,V18,V19,V20,V21,V22,V24,ZAA, ZAB,ZAC,ZAD,ZAE,ZAF,ZAG,ZAH,Z AJ,ZAL .....	1
34	PAHZZ	5330-01-023-0269	19207	11669023	. SEAL,PLAIN ENCASED UOC: DAC,DAD,DAE,DAF,DAG,DA H,DAJ,DAL,DAW,DAX,V14,V15,V16, V17,V18,V19,V20,V21,V22,V24,ZAA, ZAB,ZAC,ZAD,ZAE,ZAF,ZAG,ZAH,Z AJ,ZAL .....	1
35	PAHZZ	5365-01-128-5064	78500	2203-R-7792	SHIM .010 UOC: DAC,DAD,DAE,DAF,DAG,DA H,DAJ,DAL,DAW,DAX,V14,V15,V16, V17,V18,V19,V20,V21,V22,V24,ZAA, ZAB,ZAC,ZAD,ZAE,ZAF,ZAG,ZAH,Z AJ,ZAL .....	1

(1) ITEM NO.	(2) SMR CODE	(3) NSN	(4) CAGEC	(5) PART NUMBER	(6) DESCRIPTION AND USABLE ON CODE (UOC)	(7) QTY
35	PAHZZ	5365-01-128-5063	78500	2203-Q-7791	SHIM .005 UOC: DAC,DAD,DAE,DAF,DAG,DA H,DAJ,DAL,DAW,DAX,V14,V15,V16, V17,V18,V19,V20,V21,V22,V24,ZAA, ZAB,ZAC,ZAD,ZAE,ZAF,ZAG,ZAH,Z AJ,ZAL .....	1
35	PAHZZ	5365-01-128-5062	78500	2203-P-7790	SHIM .003 UOC: DAC,DAD,DAE,DAF,DAG,DA H,DAJ,DAL,DAW,DAX,V14,V15,V16, V17,V18,V19,V20,V21,V22,V24,ZAA, ZAB,ZAC,ZAD,ZAE,ZAF,ZAG,ZAH,Z AJ,ZAL .....	1
36	PAFZZ	5310-00-241-6664	96906	M45913/3-10FG8C	NUT,SELF-LOCKING,HE UOC: DAC,DAD,DAE,DAF,DAG,DA H,DAJ,DAL,DAW,DAX,V14,V15,V16, V17,V18,V19,V20,V21,V22,V24,ZAA, ZAB,ZAC,ZAD,ZAE,ZAF,ZAG,ZAH,Z AJ,ZAL .....	3
37	PAFZZ	5342-00-741-1068	19207	7411068	MOUNT,RESILIENT,WEA UOC: DAC,DAD,DAE,DAF,DAG,DA H,DAJ,DAL,DAW,DAX,V14,V15,V16, V17,V18,V19,V20,V21,V22,V24,ZAA, ZAB,ZAC,ZAD,ZAE,ZAF,ZAG,ZAH,Z AJ,ZAL .....	6
38	PFFZZ	5340-01-089-2988	19207	12256083	BRACKET,DOUBLE ANGL UOC: DAC,DAD,DAE,DAF,DAG,DA H,DAJ,DAL,DAW,DAX,V14,V15,V16, V17,V18,V19,V20,V21,V22,V24,ZAA, ZAB,ZAC,ZAD,ZAE,ZAF,ZAG,ZAH,Z AJ,ZAL .....	1
39	PAFZZ	5310-00-531-9120	81348	FF-W-92-B	WASHER,FLAT UOC: DAC,DAD,DAE,DAF,DAG,DA H,DAJ,DAL,DAW,DAX,V14,V15,V16, V17,V18,V19,V20,V21,V22,V24,ZAA, ZAB,ZAC,ZAD,ZAE,ZAF,ZAG,ZAH,Z AJ,ZAL .....	3
40	PAFZZ	5305-00-726-2556	80204	B1821BH063F325N	SCREW,CAP,HEXAGON H UOC: DAC,DAD,DAE,DAF,DAG,DA H,DAJ,DAL,DAW,DAX,V14,V15,V16, V17,V18,V19,V20,V21,V22,V24,ZAA, ZAB,ZAC,ZAD,ZAE,ZAF,ZAG,ZAH,Z AJ,ZAL .....	3
41	PAFZZ	5315-00-616-5514	80205	MS35756-6	KEY,WOODRUFF UOC: DAC,DAD,DAE,DAF,DAG,DA H,DAJ,DAL,DAW,DAX,V14,V15,V16, V17,V18,V19,V20,V21,V22,V24,ZAA, ZAB,ZAC,ZAD,ZAE,ZAF,ZAG,ZAH,Z AJ,ZAL .....	1

(1) ITEM NO.	(2) SMR CODE	(3) NSN	(4) CAGEC	(5) PART NUMBER	(6) DESCRIPTION AND USABLE ON CODE (UOC)	(7) QTY
42	PAFZZ	3020-01-126-8444	78500	2297-T-3816	GEAR,SPEED DRIVE UOC: DAC,DAD,DAE,DAF,DAG,DA H,DAJ,DAL,DAW,DAX,V14,V15,V16, V17,V18,V19,V20,V21,V22,V24,ZAA, ZAB,ZAC,ZAD,ZAE,ZAF,ZAG,ZAH,Z AJ,ZAL .....	1
43	PAFZZ	5325-01-129-6849	78500	1229U-2829	RING,RETAINING UOC: DAC,DAD,DAE,DAF,DAG,DA H,DAJ,DAL,DAW,DAX,V14,V15,V16, V17,V18,V19,V20,V21,V22,V24,ZAA, ZAB,ZAC,ZAD,ZAE,ZAF,ZAG,ZAH,Z AJ,ZAL .....	1
44	PAFZZ	4730-01-132-6848	78500	A-2206-D-56	COUPLING,PIPE UOC: DAC,DAD,DAE,DAF,DAG,DA H,DAJ,DAL,DAW,DAX,V14,V15,V16, V17,V18,V19,V20,V21,V22,V24,ZAA, ZAB,ZAC,ZAD,ZAE,ZAF,ZAG,ZAH,Z AJ,ZAL .....	1

END OF FIGURE



**FIELD MAINTENANCE  
TRANSFER CASE HOUSING, OUTPUT SHAFT, AND COVER**

---

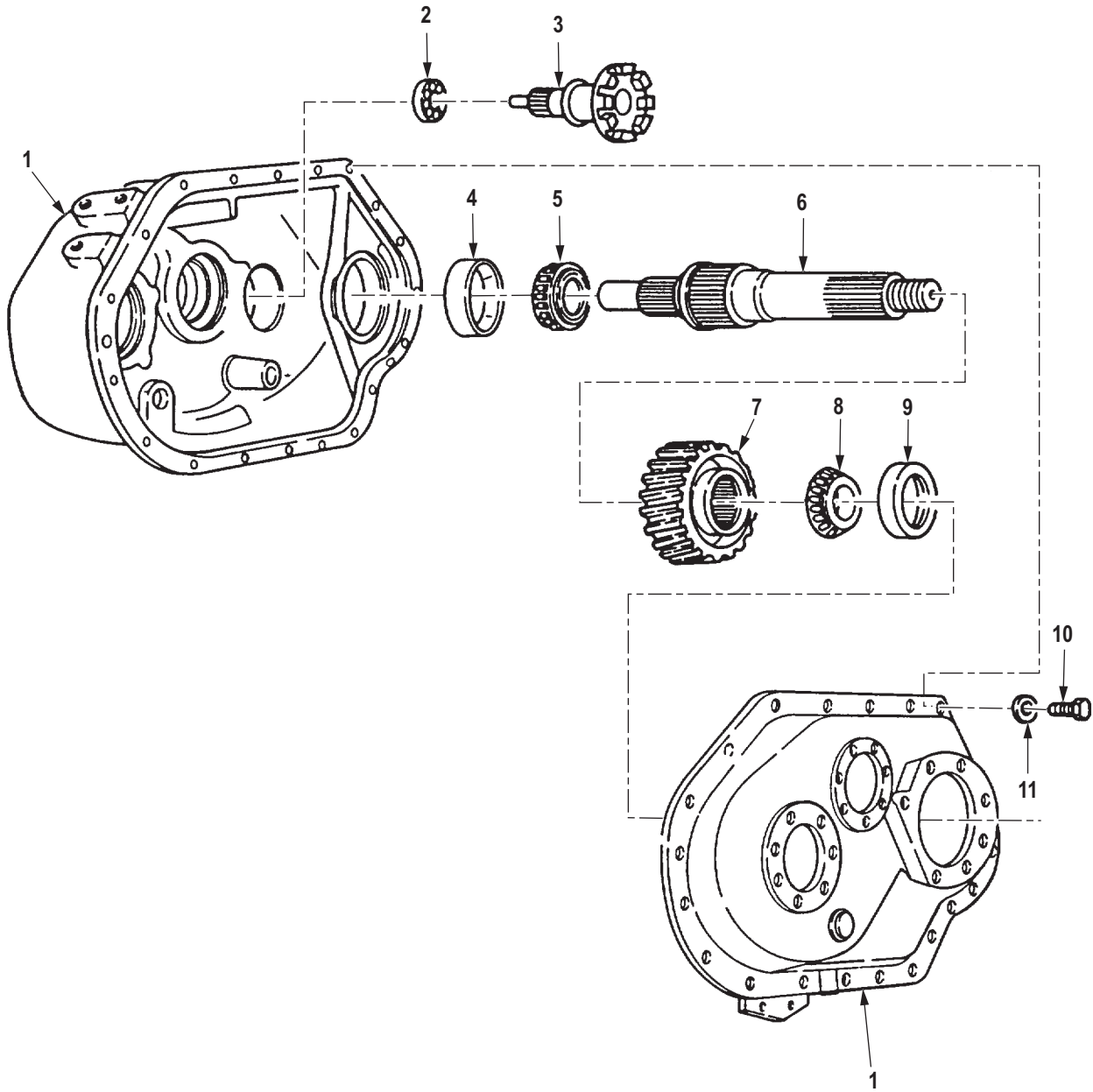

R0223DAA

Figure 208. Transfer Case Housing, Output Shaft, and Cover.



(1) ITEM NO.	(2) SMR CODE	(3) NSN	(4) CAGEC	(5) PART NUMBER	(6) DESCRIPTION AND USABLE ON CODE (UOC)	(7) QTY
					<b>GROUP 0801 POWER TRANSFER, FINAL DRIVE, PLANETARY OR DROP GEAR BOX ASSEMBLIES.</b>	
					<b>FIG. 208. TRANSFER CASE HOUSING, OUTPUT SHAFT, AND COVER.</b>	
1	PAHZZ	3040-01-248-3995	78500	A3290Y233	HOUSING,MECHANICAL UOC: DAC,DAD,DAE,DAF,DAG,DA H,DAJ,DAL,DAW,DAX,V14,V15,V16, V17,V18,V19,V20,V21,V22,V24,ZAA, ZAB,ZAC,ZAD,ZAE,ZAF,ZAG,ZAH,Z AJ,ZAL .....	1
2	PAHZZ	3110-00-293-8439	58536	AA59584-111JGBT	BEARING,BALL,ANNULA UOC: DAC,DAD,DAE,DAF,DAG,DA H,DAJ,DAL,DAW,DAX,V14,V15,V16, V17,V18,V19,V20,V21,V22,V24,ZAA, ZAB,ZAC,ZAD,ZAE,ZAF,ZAG,ZAH,Z AJ,ZAL .....	1
3	PAHZZ	2520-01-127-1676	78500	A-3297-K-63	SHAFT ASSEMBLY,TRAN FRONT OUTPUT UOC: DAC,DAD,DAE,DAF,DAG,DA H,DAJ,DAL,DAW,DAX,V14,V15,V16, V17,V18,V19,V20,V21,V22,V24,ZAA, ZAB,ZAC,ZAD,ZAE,ZAF,ZAG,ZAH,Z AJ,ZAL .....	1
4	PAHZZ	3110-00-100-0305	81348	FFB187/01-TYPE ABMA 394A	CUP,TAPERED ROLLER UOC: DAC,DAD,DAE,DAF,DAG,DA H,DAJ,DAL,DAW,DAX,V14,V15,V16, V17,V18,V19,V20,V21,V22,V24,ZAA, ZAB,ZAC,ZAD,ZAE,ZAF,ZAG,ZAH,Z AJ,ZAL .....	1
5	PAHZZ	3110-00-100-0231	24617	441294	CONE AND ROLLERS,TA UOC: DAC,DAD,DAE,DAF,DAG,DA H,DAJ,DAL,DAW,DAX,V14,V15,V16, V17,V18,V19,V20,V21,V22,V24,ZAA, ZAB,ZAC,ZAD,ZAE,ZAF,ZAG,ZAH,Z AJ,ZAL .....	1
6	PAHZZ	2520-01-127-2625	78500	3297L64	SHAFT,TRANSFER TRAN UOC: DAC,DAD,DAE,DAF,DAG,DA H,DAJ,DAL,DAW,DAX,V14,V15,V16, V17,V18,V19,V20,V21,V22,V24,ZAA, ZAB,ZAC,ZAD,ZAE,ZAF,ZAG,ZAH,Z AJ,ZAL .....	1
7	PAHZZ	3020-01-142-8090	78500	3892-A-4473	GEAR,HELICAL UOC: DAC,DAD,DAE,DAF,DAG,DA H,DAJ,DAL,DAW,DAX,V14,V15,V16, V17,V18,V19,V20,V21,V22,V24,ZAA, ZAB,ZAC,ZAD,ZAE,ZAF,ZAG,ZAH,Z AJ,ZAL .....	1

(1) ITEM NO.	(2) SMR CODE	(3) NSN	(4) CAGEC	(5) PART NUMBER	(6) DESCRIPTION AND USABLE ON CODE (UOC)	(7) QTY
8	PAHZZ	3110-01-143-9242	60038	39578	CONE AND ROLLERS,TA UOC: DAC,DAD,DAE,DAF,DAG,DA H,DAJ,DAL,DAW,DAX,V14,V15,V16, V17,V18,V19,V20,V21,V22,V24,ZAA, ZAB,ZAC,ZAD,ZAE,ZAF,ZAG,ZAH,Z AJ,ZAL .....	1
9	PAHZZ	3110-00-143-7586	60038	39520	CUP,TAPERED ROLLER UOC: DAC,DAD,DAE,DAF,DAG,DA H,DAJ,DAL,DAW,DAX,V14,V15,V16, V17,V18,V19,V20,V21,V22,V24,ZAA, ZAB,ZAC,ZAD,ZAE,ZAF,ZAG,ZAH,Z AJ,ZAL .....	1
10	PAHZZ	5306-01-084-5389	45152	1794HX1	BOLT,MACHINE UOC: DAC,DAD,DAE,DAF,DAG,DA H,DAJ,DAL,DAW,DAX,V14,V15,V16, V17,V18,V19,V20,V21,V22,V24,ZAA, ZAB,ZAC,ZAD,ZAE,ZAF,ZAG,ZAH,Z AJ,ZAL .....	19
11	PAHZZ	5310-00-893-3381	19207	7748744	WASHER,FLAT UOC: DAC,DAD,DAE,DAF,DAG,DA H,DAJ,DAL,DAW,DAX,V14,V15,V16, V17,V18,V19,V20,V21,V22,V24,ZAA, ZAB,ZAC,ZAD,ZAE,ZAF,ZAG,ZAH,Z AJ,ZAL .....	19

END OF FIGURE

**FIELD MAINTENANCE  
TRANSFER HOUSING INPUT AND INTERMEDIATE DRIVE SHAFTS**

---

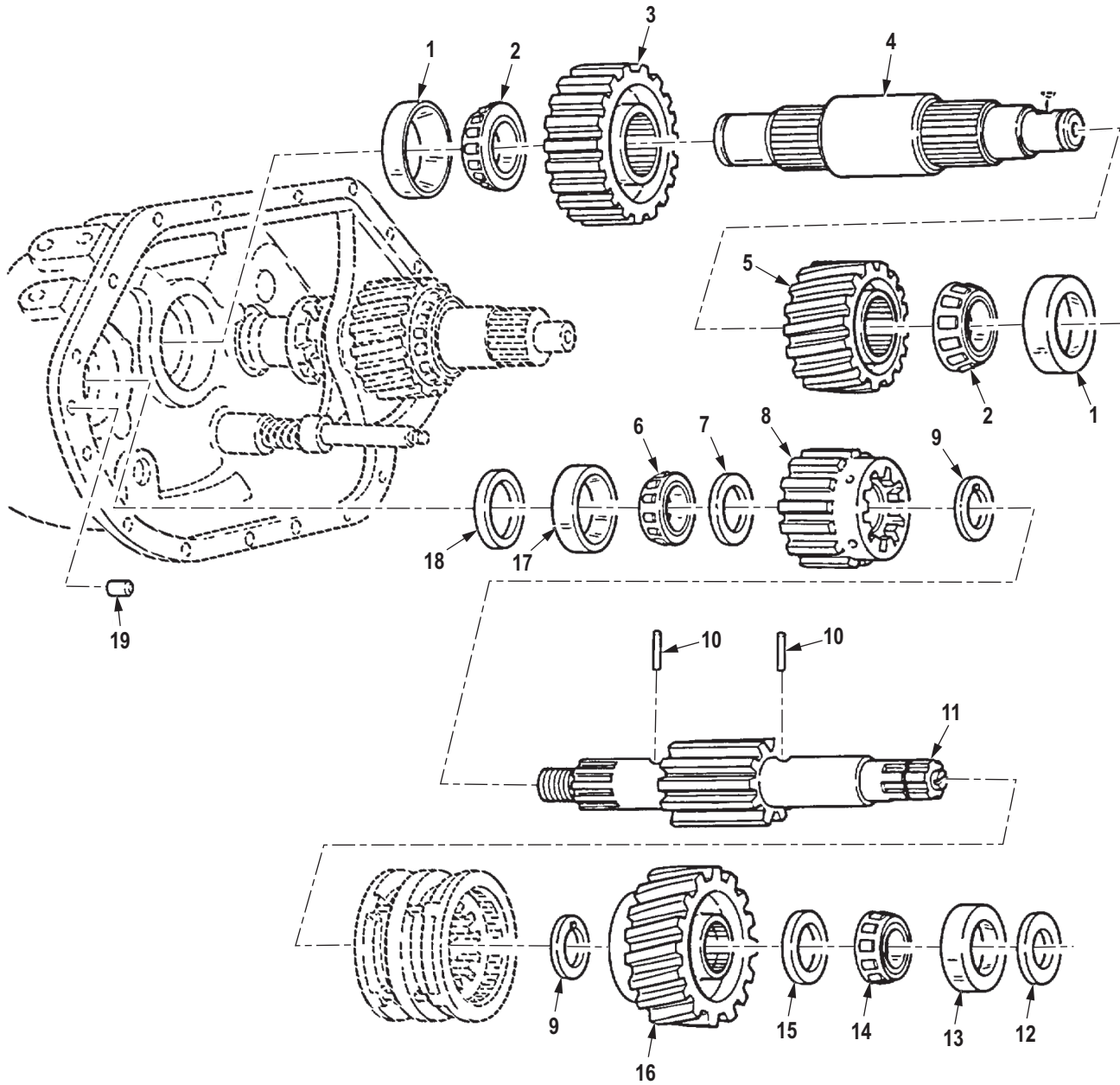

R0224DAA

Figure 209. Transfer Housing Input and Intermediate Drive Shafts.

(1) ITEM NO.	(2) SMR CODE	(3) NSN	(4) CAGEC	(5) PART NUMBER	(6) DESCRIPTION AND USABLE ON CODE (UOC)	(7) QTY
					<b>GROUP 0801 POWER TRANSFER, FINAL DRIVE, PLANETARY OR DROP GEAR BOX ASSEMBLIES.</b>	
					<b>FIG. 209. TRANSFER HOUSING INPUT AND INTERMEDIATE DRIVE SHAFTS.</b>	
1	PAHZZ	3110-00-227-4667	62265	181167	CUP,TAPERED ROLLER UOC: DAC,DAD,DAE,DAF,DAG,DA H,DAJ,DAL,DAW,DAX,V14,V15,V16, V17,V18,V19,V20,V21,V22,V24,ZAA, ZAB,ZAC,ZAD,ZAE,ZAF,ZAG,ZAH,Z AJ,ZAL .....	2
2	PAHZZ	3110-00-842-6572	60038	HM807049	CONE AND ROLLERS,TA UOC: DAC,DAD,DAE,DAF,DAG,DA H,DAJ,DAL,DAW,DAX,V14,V15,V16, V17,V18,V19,V20,V21,V22,V24,ZAA, ZAB,ZAC,ZAD,ZAE,ZAF,ZAG,ZAH,Z AJ,ZAL .....	2
3	PAHZZ	3020-01-141-1554	78500	3892-Y-4471	GEAR,SPUR UOC: DAC,DAD,DAE,DAF,DAG,DA H,DAJ,DAL,DAW,DAX,V14,V15,V16, V17,V18,V19,V20,V21,V22,V24,ZAA, ZAB,ZAC,ZAD,ZAE,ZAF,ZAG,ZAH,Z AJ,ZAL .....	1
4	PBHZZ	2520-01-127-2336	78500	3280-V-7536	SHAFT,GEAR TRANSFER UOC: DAC,DAD,DAE,DAF,DAG,DA H,DAJ,DAL,DAW,DAX,V14,V15,V16, V17,V18,V19,V20,V21,V22,V24,ZAA, ZAB,ZAC,ZAD,ZAE,ZAF,ZAG,ZAH,Z AJ,ZAL .....	1
5	PFHZZ	3020-01-146-4198	3D6E9	3892-B-4474	GEAR,SPUR UOC: DAC,DAD,DAE,DAF,DAG,DA H,DAJ,DAL,DAW,DAX,V14,V15,V16, V17,V18,V19,V20,V21,V22,V24,ZAA, ZAB,ZAC,ZAD,ZAE,ZAF,ZAG,ZAH,Z AJ,ZAL .....	1
6	PFHZZ	3110-00-519-7833	60038	JM207049	CONE AND ROLLERS,TA UOC: DAC,DAD,DAE,DAF,DAG,DA H,DAJ,DAL,DAW,DAX,V14,V15,V16, V17,V18,V19,V20,V21,V22,V24,ZAA, ZAB,ZAC,ZAD,ZAE,ZAF,ZAG,ZAH,Z AJ,ZAL .....	1
7	PAHZZ	5310-01-145-3991	78500	1229-U-2803	WASHER,FLAT UOC: DAC,DAD,DAE,DAF,DAG,DA H,DAJ,DAL,DAW,DAX,V14,V15,V16, V17,V18,V19,V20,V21,V22,V24,ZAA, ZAB,ZAC,ZAD,ZAE,ZAF,ZAG,ZAH,Z AJ,ZAL .....	1

(1) ITEM NO.	(2) SMR CODE	(3) NSN	(4) CAGEC	(5) PART NUMBER	(6) DESCRIPTION AND USABLE ON CODE (UOC)	(7) QTY
8	PAHZZ	3020-01-134-1015	3D6E9	A-3892-E-4555	GEAR, SPUR UOC: DAC,DAD,DAE,DAF,DAG,DA H,DAJ,DAL,DAW,DAX,V14,V15,V16, V17,V18,V19,V20,V21,V22,V24,ZAA, ZAB,ZAC,ZAD,ZAE,ZAF,ZAG,ZAH,Z AJ,ZAL .....	1
9	PAHZZ	5310-01-133-3614	78500	1229-N-2796	WASHER UOC: DAC,DAD,DAE,DAF,DAG,DA H,DAJ,DAL,DAW,DAX,V14,V15,V16, V17,V18,V19,V20,V21,V22,V24,ZAA, ZAB,ZAC,ZAD,ZAE,ZAF,ZAG,ZAH,Z AJ,ZAL .....	2
10	PFHZZ	5315-01-277-9765	3D6E9	1246-Q-615	PIN, STRAIGHT, HEADLE UOC: DAC,DAD,DAE,DAF,DAG,DA H,DAJ,DAL,DAW,DAX,V14,V15,V16, V17,V18,V19,V20,V21,V22,V24,ZAA, ZAB,ZAC,ZAD,ZAE,ZAF,ZAG,ZAH,Z AJ,ZAL .....	2
11	PAHZZ	2520-01-127-2623	3D6E9	A-3297-T-72	SHAFT, TRANSFER TRAN UOC: DAC,DAD,DAE,DAF,DAG,DA H,DAJ,DAL,DAW,DAX,V14,V15,V16, V17,V18,V19,V20,V21,V22,V24,ZAA, ZAB,ZAC,ZAD,ZAE,ZAF,ZAG,ZAH,Z AJ,ZAL .....	1
12	PAHZZ	5310-01-141-8464	78500	2221-B-2	WASHER, FLAT UOC: DAC,DAD,DAE,DAF,DAG,DA H,DAJ,DAL,DAW,DAX,V14,V15,V16, V17,V18,V19,V20,V21,V22,V24,ZAA, ZAB,ZAC,ZAD,ZAE,ZAF,ZAG,ZAH,Z AJ,ZAL .....	1
13	PAHZZ	3110-00-100-0316	60038	454	CUP, TAPERED ROLLER UOC: DAC,DAD,DAE,DAF,DAG,DA H,DAJ,DAL,DAW,DAX,V14,V15,V16, V17,V18,V19,V20,V21,V22,V24,ZAA, ZAB,ZAC,ZAD,ZAE,ZAF,ZAG,ZAH,Z AJ,ZAL .....	1
14	PAHZZ	3110-00-101-0836	01212	455S	CONE AND ROLLERS, TA UOC: DAC,DAD,DAE,DAF,DAG,DA H,DAJ,DAL,DAW,DAX,V14,V15,V16, V17,V18,V19,V20,V21,V22,V24,ZAA, ZAB,ZAC,ZAD,ZAE,ZAF,ZAG,ZAH,Z AJ,ZAL .....	1
15	PAHZZ	3120-01-143-9249	78500	1229-R-2800	BEARING, WASHER, THRU UOC: DAC,DAD,DAE,DAF,DAG,DA H,DAJ,DAL,DAW,DAX,V14,V15,V16, V17,V18,V19,V20,V21,V22,V24,ZAA, ZAB,ZAC,ZAD,ZAE,ZAF,ZAG,ZAH,Z AJ,ZAL .....	1

(1) ITEM NO.	(2) SMR CODE	(3) NSN	(4) CAGEC	(5) PART NUMBER	(6) DESCRIPTION AND USABLE ON CODE (UOC)	(7) QTY
16	PAHZZ	2520-01-127-5766	78500	A-3892-D-4554	GEAR AND BUSHING AS UOC: DAC,DAD,DAE,DAF,DAG,DA H,DAJ,DAL,DAW,DAX,V14,V15,V16, V17,V18,V19,V20,V21,V22,V24,ZAA, ZAB,ZAC,ZAD,ZAE,ZAF,ZAG,ZAH,Z AJ,ZAL .....	1
17	PAHZZ	3110-00-160-0338	60038	JM207010	CUP,TAPERED ROLLER UOC: DAC,DAD,DAE,DAF,DAG,DA H,DAJ,DAL,DAW,DAX,V14,V15,V16, V17,V18,V19,V20,V21,V22,V24,ZAA, ZAB,ZAC,ZAD,ZAE,ZAF,ZAG,ZAH,Z AJ,ZAL .....	1
18	PAHZZ	5365-01-133-0069	78500	1244-Y-1585	SPACER,RING UOC: DAC,DAD,DAE,DAF,DAG,DA H,DAJ,DAL,DAW,DAX,V14,V15,V16, V17,V18,V19,V20,V21,V22,V24,ZAA, ZAB,ZAC,ZAD,ZAE,ZAF,ZAG,ZAH,Z AJ,ZAL .....	1
19	PAHZZ	5315-01-143-4220	78500	1846-M-351	PIN,STRAIGHT,HEADLE TRANSFER TRANSMISSION HOUSING UOC: DAC,DAD,DAE,DAF,DAG,DA H,DAJ,DAL,DAW,DAX,V14,V15,V16, V17,V18,V19,V20,V21,V22,V24,ZAA, ZAB,ZAC,ZAD,ZAE,ZAF,ZAG,ZAH,Z AJ,ZAL .....	2

END OF FIGURE





**FIELD MAINTENANCE  
TRANSFER CLUTCH ASSEMBLY AND SYNCHRONIZER ASSEMBLY**

---

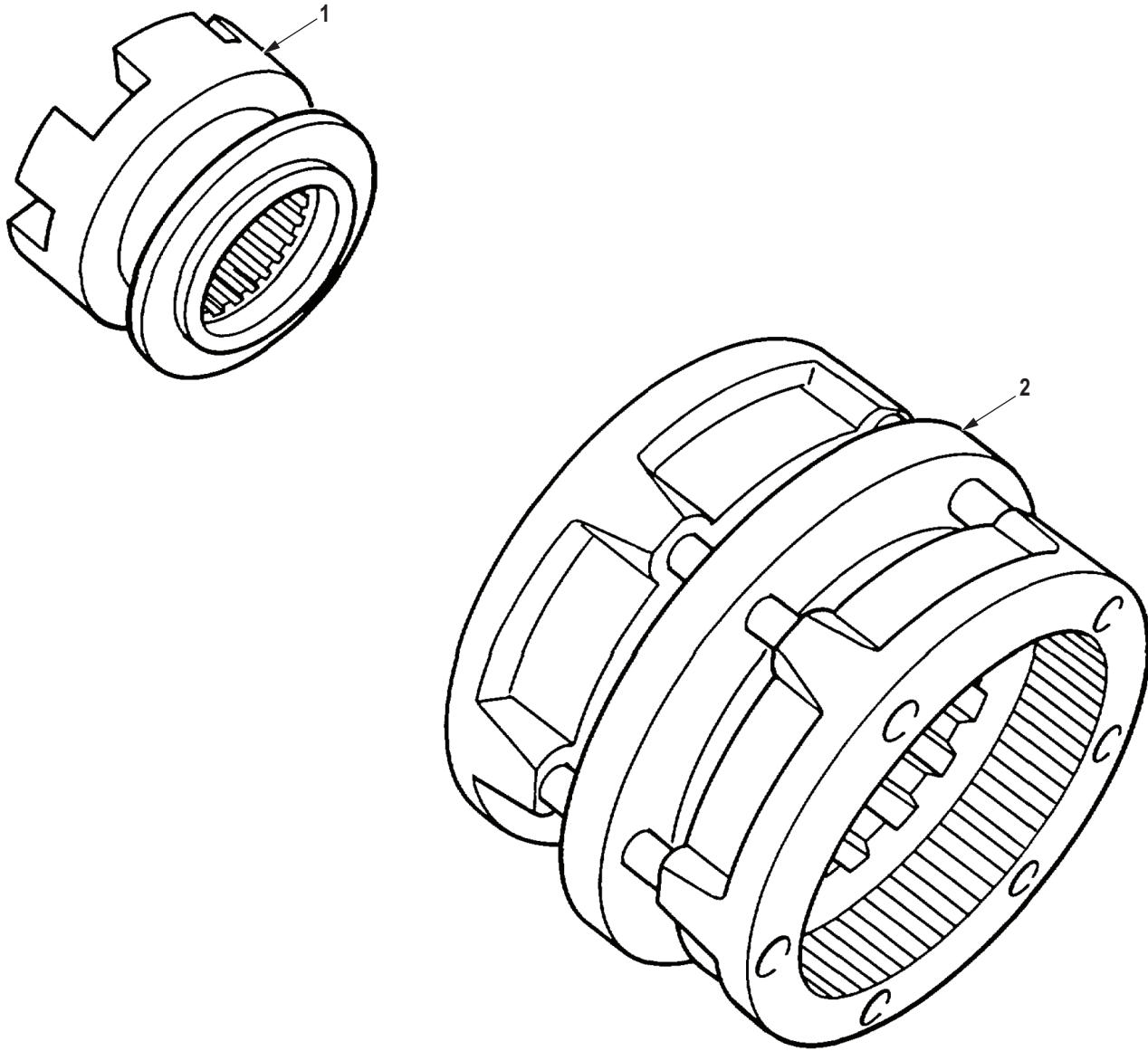

R0225DAA

Figure 210. Transfer Clutch Assembly and Synchronizer Assembly.

(1) ITEM NO.	(2) SMR CODE	(3) NSN	(4) CAGEC	(5) PART NUMBER	(6) DESCRIPTION AND USABLE ON CODE (UOC)	(7) QTY
					<b>GROUP 0802 CLUTCH AND CLUTCH CONTROLS.</b>	
					<b>FIG. 210. TRANSFER CLUTCH ASSEMBLY AND SYNCHRONIZER ASSEMBLY.</b>	
1	PAHZZ	2520-01-127-6901	78500	3107-E-31	CLUTCH ASSEMBLY,SL UOC: DAC,DAD,DAE,DAF,DAG,DAH,DAJ,DAL,DAW,DAX,V14,V15,V16,V17,V18,V19,V20,V21,V22,V24,ZAA,ZAB,ZAC,ZAD,ZAE,ZAF,ZAG,ZAH,ZAJ,ZAL .....	1
2	PAHZZ	2520-01-135-0085	3D6E9	A-3107-M-39	SYNCHRONIZER,HIGH A CLUTCH ASSEMBLY UOC: DAC,DAD,DAE,DAF,DAG,DAH,DAJ,DAL,DAW,DAX,V14,V15,V16,V17,V18,V19,V20,V21,V22,V24,ZAA,ZAB,ZAC,ZAD,ZAE,ZAF,ZAG,ZAH,ZAJ,ZAL .....	1

**END OF FIGURE**



**FIELD MAINTENANCE  
TRANSFER CONTROLS**

---

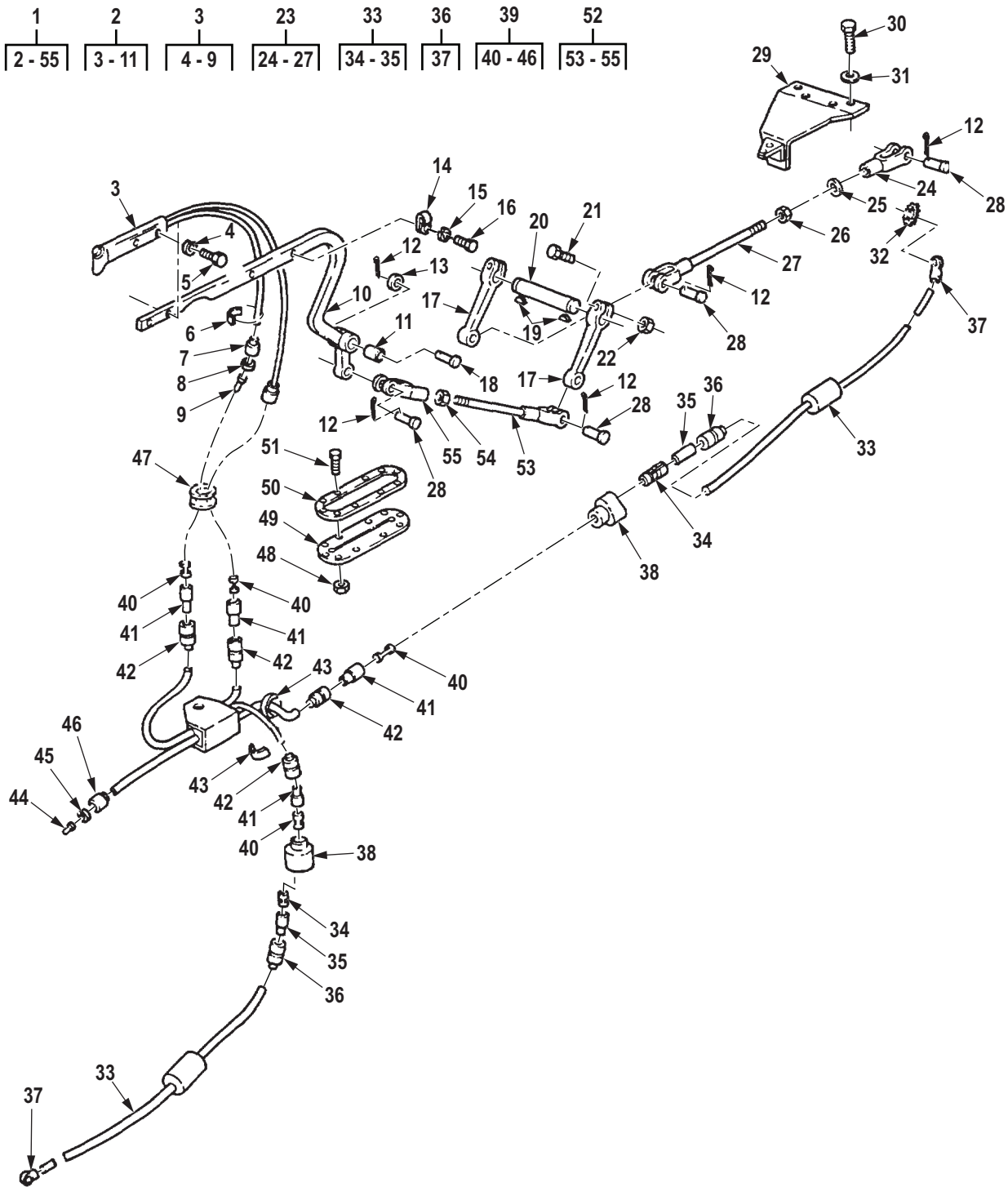

R0226DAA

Figure 211. Transfer Controls.

(1) ITEM NO.	(2) SMR CODE	(3) NSN	(4) CAGEC	(5) PART NUMBER	(6) DESCRIPTION AND USABLE ON CODE (UOC)	(7) QTY
<b>GROUP 0803 GEARSHIFT, VACUUM BOOSTER AND CONTROLS.</b>						
<b>FIG. 211. TRANSFER CONTROLS.</b>						
1	AFFFF		19207	12277363-ASSY	TRANSFER CONTROL AND LINKAGE ASSEMBLY UOC: DAC,DAD,DAE,DAF,DAG,DA H,DAJ,DAL,DAW,DAX,V14,V15,V16, V17,V18,V19,V20,V21,V22,V24,ZAA, ZAB,ZAC,ZAD,ZAE,ZAF,ZAG,ZAH,Z AJ,ZAL .....	1
2	PAFZZ	3040-01-123-9681	19207	12277363	. LEVER,MANUAL CONTRO UOC: DAC,DAD,DAE,DAF,DAG,DA H,DAJ,DAL,DAW,DAX,V14,V15,V16, V17,V18,V19,V20,V21,V22,V24,ZAA, ZAB,ZAC,ZAD,ZAE,ZAF,ZAG,ZAH,Z AJ,ZAL .....	1
3	PAFZZ	5930-01-141-8414	81901	K-1013-501	. . SWITCH,PUSH UOC: DAC,DAD,DAE,DAF,DAG,DA H,DAJ,DAL,DAW,DAX,V14,V15,V16, V17,V18,V19,V20,V21,V22,V24,ZAA, ZAB,ZAC,ZAD,ZAE,ZAF,ZAG,ZAH,Z AJ,ZAL .....	1
4	PAFZZ	5310-00-550-0284	96906	MS35336-9	. . . WASHER,LOCK UOC: DAC,DAD,DAE,DAF,DAG,DA H,DAJ,DAL,DAW,DAX,V14,V15,V16, V17,V18,V19,V20,V21,V22,V24,ZAA, ZAB,ZAC,ZAD,ZAE,ZAF,ZAG,ZAH,Z AJ,ZAL .....	4
5	PAFZZ	5305-00-959-2739	80205	MS35191-237	. . . SCREW,MACHINE UOC: DAC,DAD,DAE,DAF,DAG,DA H,DAJ,DAL,DAW,DAX,V14,V15,V16, V17,V18,V19,V20,V21,V22,V24,ZAA, ZAB,ZAC,ZAD,ZAE,ZAF,ZAG,ZAH,Z AJ,ZAL .....	4
6	PAFZZ	9905-00-752-4649	24617	5939707	. . . BAND MRKER BLNK-ALU UOC: DAC,DAD,DAE,DAF,DAG,DA H,DAJ,DAL,DAW,DAX,V14,V15,V16, V17,V18,V19,V20,V21,V22,V24,ZAA, ZAB,ZAC,ZAD,ZAE,ZAF,ZAG,ZAH,Z AJ,ZAL .....	2
7	PAFZZ	5935-00-691-5591	97403	13207E6498-2	. . . SHELL,ELECTRICAL CO UOC: DAC,DAD,DAE,DAF,DAG,DA H,DAJ,DAL,DAW,DAX,V14,V15,V16, V17,V18,V19,V20,V21,V22,V24,ZAA, ZAB,ZAC,ZAD,ZAE,ZAF,ZAG,ZAH,Z AJ,ZAL .....	2

(1) ITEM NO.	(2) SMR CODE	(3) NSN	(4) CAGEC	(5) PART NUMBER	(6) DESCRIPTION AND USABLE ON CODE (UOC)	(7) QTY
8	PAFZZ	5310-00-656-0067	19207	8724497	. . . WASHER,SLOTTED UOC: DAC,DAD,DAE,DAF,DAG,DA H,DAJ,DAL,DAW,DAX,V14,V15,V16, V17,V18,V19,V20,V21,V22,V24,ZAA, ZAB,ZAC,ZAD,ZAE,ZAF,ZAG,ZAH,Z AJ,ZAL .....	2
9	PAFZZ	5999-00-926-3144	58536	AA52536-3	. . . CONTACT,ELECTRICAL UOC: DAC,DAD,DAE,DAF,DAG,DA H,DAJ,DAL,DAW,DAX,V14,V15,V16, V17,V18,V19,V20,V21,V22,V24,ZAA, ZAB,ZAC,ZAD,ZAE,ZAF,ZAG,ZAH,Z AJ,ZAL .....	2
10	XAFZZ		19207	12277362	. . LEVER UOC: DAC,DAD,DAE,DAF,DAG,DA H,DAJ,DAL,DAW,DAX,V14,V15,V16, V17,V18,V19,V20,V21,V22,V24,ZAA, ZAB,ZAC,ZAD,ZAE,ZAF,ZAG,ZAH,Z AJ,ZAL .....	1
11	PAFZZ	3120-00-692-6153	89346	63942HA	. . BEARING,SLEEVE UOC: DAC,DAD,DAE,DAF,DAG,DA H,DAJ,DAL,DAW,DAX,V14,V15,V16, V17,V18,V19,V20,V21,V22,V24,ZAA, ZAB,ZAC,ZAD,ZAE,ZAF,ZAG,ZAH,Z AJ,ZAL .....	1
12	PAFZZ	5315-00-012-0123	79150	PK644	. PIN,COTTER UOC: DAC,DAD,DAE,DAF,DAG,DA H,DAJ,DAL,DAW,DAX,V14,V15,V16, V17,V18,V19,V20,V21,V22,V24,ZAA, ZAB,ZAC,ZAD,ZAE,ZAF,ZAG,ZAH,Z AJ,ZAL .....	5
13	PAFZZ	5310-00-809-8533	96906	MS27183-23	. WASHER,FLAT UOC: DAC,DAD,DAE,DAF,DAG,DA H,DAJ,DAL,DAW,DAX,V14,V15,V16, V17,V18,V19,V20,V21,V22,V24,ZAA, ZAB,ZAC,ZAD,ZAE,ZAF,ZAG,ZAH,Z AJ,ZAL .....	1
14	PAFZZ	5340-00-079-7837	80205	MS21333-67	. CLAMP,LOOP UOC: DAC,DAD,DAE,DAF,DAG,DA H,DAJ,DAL,DAW,DAX,V14,V15,V16, V17,V18,V19,V20,V21,V22,V24,ZAA, ZAB,ZAC,ZAD,ZAE,ZAF,ZAG,ZAH,Z AJ,ZAL .....	2
15	PAFZZ	5310-00-045-3296	80205	MS35338-43	. WASHER,LOCK UOC: DAC,DAD,DAE,DAF,DAG,DA H,DAJ,DAL,DAW,DAX,V14,V15,V16, V17,V18,V19,V20,V21,V22,V24,ZAA, ZAB,ZAC,ZAD,ZAE,ZAF,ZAG,ZAH,Z AJ,ZAL .....	2



(1) ITEM NO.	(2) SMR CODE	(3) NSN	(4) CAGEC	(5) PART NUMBER	(6) DESCRIPTION AND USABLE ON CODE (UOC)	(7) QTY
16	PAFZZ	5306-01-135-7202	11757	378431-42	. BOLT,MACHINE UOC: DAC,DAD,DAE,DAF,DAG,DA H,DAJ,DAL,DAW,DAX,V14,V15,V16, V17,V18,V19,V20,V21,V22,V24,ZAA, ZAB,ZAC,ZAD,ZAE,ZAF,ZAG,ZAH,Z AJ,ZAL .....	2
17	PAFZZ	3040-01-121-7744	19207	12277094	. LEVER,REMOTE CONTRO UOC: DAC,DAD,DAE,DAF,DAG,DA H,DAJ,DAL,DAW,DAX,V14,V15,V16, V17,V18,V19,V20,V21,V22,V24,ZAA, ZAB,ZAC,ZAD,ZAE,ZAF,ZAG,ZAH,Z AJ,ZAL .....	2
18	PAFZZ	5315-01-008-7084	96906	MS20392-10C91	. PIN,STRAIGHT,HEADED UOC: DAC,DAD,DAE,DAF,DAG,DA H,DAJ,DAL,DAW,DAX,V14,V15,V16, V17,V18,V19,V20,V21,V22,V24,ZAA, ZAB,ZAC,ZAD,ZAE,ZAF,ZAG,ZAH,Z AJ,ZAL .....	1
19	PAFZZ	5315-00-012-4553	80205	MS35756-17	. KEY,WOODRUFF UOC: DAC,DAD,DAE,DAF,DAG,DA H,DAJ,DAL,DAW,DAX,V14,V15,V16, V17,V18,V19,V20,V21,V22,V24,ZAA, ZAB,ZAC,ZAD,ZAE,ZAF,ZAG,ZAH,Z AJ,ZAL .....	2
20	PAFZZ	3040-01-088-9401	19207	12256551	. SHAFT,STRAIGHT UOC: DAC,DAD,DAE,DAF,DAG,DA H,DAJ,DAL,DAW,DAX,V14,V15,V16, V17,V18,V19,V20,V21,V22,V24,ZAA, ZAB,ZAC,ZAD,ZAE,ZAF,ZAG,ZAH,Z AJ,ZAL .....	1
21	PAFZZ	5305-00-269-2811	80205	MS90726-67	. SCREW,CAP,HEXAGON H UOC: DAC,DAD,DAE,DAF,DAG,DA H,DAJ,DAL,DAW,DAX,V14,V15,V16, V17,V18,V19,V20,V21,V22,V24,ZAA, ZAB,ZAC,ZAD,ZAE,ZAF,ZAG,ZAH,Z AJ,ZAL .....	2
22	PAFZZ	5310-00-814-0672	96906	M45913/3-6FG8C	. NUT,SELF-LOCKING,HE UOC: DAC,DAD,DAE,DAF,DAG,DA H,DAJ,DAL,DAW,DAX,V14,V15,V16, V17,V18,V19,V20,V21,V22,V24,ZAA, ZAB,ZAC,ZAD,ZAE,ZAF,ZAG,ZAH,Z AJ,ZAL .....	2
23	PAFZZ	3040-01-089-2991	19207	12256547-2	. CONNECTING LINK,RIG UOC: DAC,DAD,DAE,DAF,DAG,DA H,DAJ,DAL,DAW,DAX,V14,V15,V16, V17,V18,V19,V20,V21,V22,V24,ZAA, ZAB,ZAC,ZAD,ZAE,ZAF,ZAG,ZAH,Z AJ,ZAL .....	1

(1) ITEM NO.	(2) SMR CODE	(3) NSN	(4) CAGEC	(5) PART NUMBER	(6) DESCRIPTION AND USABLE ON CODE (UOC)	(7) QTY
24	PAFZZ	5340-00-466-4948	71843	2708-6A	. . CLEVIS,ROD END UOC: DAC,DAD,DAE,DAF,DAG,DA H,DAJ,DAL,DAW,DAX,V14,V15,V16, V17,V18,V19,V20,V21,V22,V24,ZAA, ZAB,ZAC,ZAD,ZAE,ZAF,ZAG,ZAH,Z AJ,ZAL .....	1
25	PAFZZ	5310-01-224-9142	19207	12302875	. . WASHER,FLAT UOC: DAC,DAD,DAE,DAF,DAG,DA H,DAJ,DAL,DAW,DAX,V14,V15,V16, V17,V18,V19,V20,V21,V22,V24,ZAA, ZAB,ZAC,ZAD,ZAE,ZAF,ZAG,ZAH,Z AJ,ZAL .....	1
26	PAFZZ	5310-01-192-5760	19207	12302874	. . NUT,SELF-LOCKING,HE UOC: DAC,DAD,DAE,DAF,DAG,DA H,DAJ,DAL,DAW,DAX,V14,V15,V16, V17,V18,V19,V20,V21,V22,V24,ZAA, ZAB,ZAC,ZAD,ZAE,ZAF,ZAG,ZAH,Z AJ,ZAL .....	1
27	PAFZZ	3040-01-121-7741	19207	12256548-2	. . CONNECTING LINK,RIG UOC: DAC,DAD,DAE,DAF,DAG,DA H,DAJ,DAL,DAW,DAX,V14,V15,V16, V17,V18,V19,V20,V21,V22,V24,ZAA, ZAB,ZAC,ZAD,ZAE,ZAF,ZAG,ZAH,Z AJ,ZAL .....	1
28	PAFZZ	5315-00-140-1938	96906	MS35810-6	. PIN,STRAIGHT,HEADED UOC: DAC,DAD,DAE,DAF,DAG,DA H,DAJ,DAL,DAW,DAX,V14,V15,V16, V17,V18,V19,V20,V21,V22,V24,ZAA, ZAB,ZAC,ZAD,ZAE,ZAF,ZAG,ZAH,Z AJ,ZAL .....	4
29	PFFZZ	5340-01-091-1608	19207	12276939	. BRACKET,ANGLE UOC: DAC,DAD,DAE,DAF,DAG,DA H,DAJ,DAL,DAW,DAX,V14,V15,V16, V17,V18,V19,V20,V21,V22,V24,ZAA, ZAB,ZAC,ZAD,ZAE,ZAF,ZAG,ZAH,Z AJ,ZAL .....	1
30	PAFZZ	5305-00-068-0511	80204	B1821BH038C125N	. SCREW,CAP,HEXAGON H UOC: DAC,DAD,DAE,DAF,DAG,DA H,DAJ,DAL,DAW,DAX,V14,V15,V16, V17,V18,V19,V20,V21,V22,V24,ZAA, ZAB,ZAC,ZAD,ZAE,ZAF,ZAG,ZAH,Z AJ,ZAL .....	4
31	PAFZZ	5310-00-080-6004	96906	MS27183-14	. WASHER,FLAT UOC: DAC,DAD,DAE,DAF,DAG,DA H,DAJ,DAL,DAW,DAX,V14,V15,V16, V17,V18,V19,V20,V21,V22,V24,ZAA, ZAB,ZAC,ZAD,ZAE,ZAF,ZAG,ZAH,Z AJ,ZAL .....	4

(1) ITEM NO.	(2) SMR CODE	(3) NSN	(4) CAGEC	(5) PART NUMBER	(6) DESCRIPTION AND USABLE ON CODE (UOC)	(7) QTY
32	PAFZZ	5310-00-889-2527	96906	MS45904-72	. WASHER, LOCK UOC: DAC, DAD, DAE, DAF, DAG, DA H, DAJ, DAL, DAW, DAX, V14, V15, V16, V17, V18, V19, V20, V21, V22, V24, ZAA, ZAB, ZAC, ZAD, ZAE, ZAF, ZAG, ZAH, Z AJ, ZAL .....	1
33	PFFZZ	5961-01-180-5634	19207	12302643	. SEMICONDUCTOR DEVIC UOC: DAC, DAD, DAE, DAF, DAG, DA H, DAJ, DAL, DAW, DAX, V14, V15, V16, V17, V18, V19, V20, V21, V22, V24, ZAA, ZAB, ZAC, ZAD, ZAE, ZAF, ZAG, ZAH, Z AJ, ZAL .....	2
34	PAFZZ	5940-00-399-6676	19207	8338564	. . TERMINAL SET, QUICK UOC: DAC, DAD, DAE, DAF, DAG, DA H, DAJ, DAL, DAW, DAX, V14, V15, V16, V17, V18, V19, V20, V21, V22, V24, ZAA, ZAB, ZAC, ZAD, ZAE, ZAF, ZAG, ZAH, Z AJ, ZAL .....	2
35	PAFZZ	5970-00-833-8562	19207	8338562	. . INSULATOR, BUSHING UOC: DAC, DAD, DAE, DAF, DAG, DA H, DAJ, DAL, DAW, DAX, V14, V15, V16, V17, V18, V19, V20, V21, V22, V24, ZAA, ZAB, ZAC, ZAD, ZAE, ZAF, ZAG, ZAH, Z AJ, ZAL .....	2
36	PAFZZ	5935-00-833-8561	19207	8338561	. SHELL, ELECTRICAL CO UOC: DAC, DAD, DAE, DAF, DAG, DA H, DAJ, DAL, DAW, DAX, V14, V15, V16, V17, V18, V19, V20, V21, V22, V24, ZAA, ZAB, ZAC, ZAD, ZAE, ZAF, ZAG, ZAH, Z AJ, ZAL .....	2
37	PAFZZ	5940-00-892-3151	96906	MS35436-9	. . TERMINAL, LUG UOC: DAC, DAD, DAE, DAF, DAG, DA H, DAJ, DAL, DAW, DAX, V14, V15, V16, V17, V18, V19, V20, V21, V22, V24, ZAA, ZAB, ZAC, ZAD, ZAE, ZAF, ZAG, ZAH, Z AJ, ZAL .....	2
38	PAFZA	5935-00-900-6281	96906	MS27147-1	. ADAPTER, CONNECTOR UOC: DAC, DAD, DAE, DAF, DAG, DA H, DAJ, DAL, DAW, DAX, V14, V15, V16, V17, V18, V19, V20, V21, V22, V24, ZAA, ZAB, ZAC, ZAD, ZAE, ZAF, ZAG, ZAH, Z AJ, ZAL .....	2
39	PAFZZ	5910-01-121-7603	19207	12277240	. CAPACITOR ASSEMBLY UOC: DAC, DAD, DAE, DAF, DAG, DA H, DAJ, DAL, DAW, DAX, V14, V15, V16, V17, V18, V19, V20, V21, V22, V24, ZAA, ZAB, ZAC, ZAD, ZAE, ZAF, ZAG, ZAH, Z AJ, ZAL .....	1

(1) ITEM NO.	(2) SMR CODE	(3) NSN	(4) CAGEC	(5) PART NUMBER	(6) DESCRIPTION AND USABLE ON CODE (UOC)	(7) QTY
40	PAFZZ	5940-00-399-6676	19207	8338564	. . TERMINAL SET,QUICK UOC: DAC,DAD,DAE,DAF,DAG,DA H,DAJ,DAL,DAW,DAX,V14,V15,V16, V17,V18,V19,V20,V21,V22,V24,ZAA, ZAB,ZAC,ZAD,ZAE,ZAF,ZAG,ZAH,Z AJ,ZAL .....	4
41	PAFZZ	5970-00-833-8562	19207	8338562	. . INSULATOR,BUSHING UOC: DAC,DAD,DAE,DAF,DAG,DA H,DAJ,DAL,DAW,DAX,V14,V15,V16, V17,V18,V19,V20,V21,V22,V24,ZAA, ZAB,ZAC,ZAD,ZAE,ZAF,ZAG,ZAH,Z AJ,ZAL .....	4
42	PAFZZ	5975-00-660-5962	19207	8724494	. . CABLE NIPPLE,ELECTR UOC: DAC,DAD,DAE,DAF,DAG,DA H,DAJ,DAL,DAW,DAX,V14,V15,V16, V17,V18,V19,V20,V21,V22,V24,ZAA, ZAB,ZAC,ZAD,ZAE,ZAF,ZAG,ZAH,Z AJ,ZAL .....	4
43	PAFZZ	9905-00-752-4649	24617	5939707	. . BAND MRKER BLNK-ALU UOC: DAC,DAD,DAE,DAF,DAG,DA H,DAJ,DAL,DAW,DAX,V14,V15,V16, V17,V18,V19,V20,V21,V22,V24,ZAA, ZAB,ZAC,ZAD,ZAE,ZAF,ZAG,ZAH,Z AJ,ZAL .....	5
44	PAFZZ	5999-00-926-3144	58536	AA52536-3	. . CONTACT,ELECTRICAL UOC: DAC,DAD,DAE,DAF,DAG,DA H,DAJ,DAL,DAW,DAX,V14,V15,V16, V17,V18,V19,V20,V21,V22,V24,ZAA, ZAB,ZAC,ZAD,ZAE,ZAF,ZAG,ZAH,Z AJ,ZAL .....	1
45	PAFZZ	5310-00-656-0067	19207	8724497	. . WASHER,SLOTTED UOC: DAC,DAD,DAE,DAF,DAG,DA H,DAJ,DAL,DAW,DAX,V14,V15,V16, V17,V18,V19,V20,V21,V22,V24,ZAA, ZAB,ZAC,ZAD,ZAE,ZAF,ZAG,ZAH,Z AJ,ZAL .....	1
46	PAFZZ	5935-00-691-5591	97403	13207E6498-2	. . SHELL,ELECTRICAL CO UOC: DAC,DAD,DAE,DAF,DAG,DA H,DAJ,DAL,DAW,DAX,V14,V15,V16, V17,V18,V19,V20,V21,V22,V24,ZAA, ZAB,ZAC,ZAD,ZAE,ZAF,ZAG,ZAH,Z AJ,ZAL .....	1
47	PAFZZ	5325-00-263-6651	96906	MS35489-12	. GROMMET,NONMETALLIC UOC: DAC,DAD,DAE,DAF,DAG,DA H,DAJ,DAL,DAW,DAX,V14,V15,V16, V17,V18,V19,V20,V21,V22,V24,ZAA, ZAB,ZAC,ZAD,ZAE,ZAF,ZAG,ZAH,Z AJ,ZAL .....	1

(1) ITEM NO.	(2) SMR CODE	(3) NSN	(4) CAGEC	(5) PART NUMBER	(6) DESCRIPTION AND USABLE ON CODE (UOC)	(7) QTY
48	PAFZZ	5310-00-208-1918	88044	AN365-1024A	. NUT,SELF-LOCKING,HE UOC: DAC,DAD,DAE,DAF,DAG,DA H,DAJ,DAL,DAW,DAX,V14,V15,V16, V17,V18,V19,V20,V21,V22,V24,ZAA, ZAB,ZAC,ZAD,ZAE,ZAF,ZAG,ZAH,Z AJ,ZAL .....	10
49	PAFZZ	5330-01-089-2992	19207	12256552	. SEAL,NONMETALLIC SP UOC: DAC,DAD,DAE,DAF,DAG,DA H,DAJ,DAL,DAW,DAX,V14,V15,V16, V17,V18,V19,V20,V21,V22,V24,ZAA, ZAB,ZAC,ZAD,ZAE,ZAF,ZAG,ZAH,Z AJ,ZAL .....	1
50	PAFZZ	5330-01-089-3046	19207	12256555	. GASKET UOC: DAC,DAD,DAE,DAF,DAG,DA H,DAJ,DAL,DAW,DAX,V14,V15,V16, V17,V18,V19,V20,V21,V22,V24,ZAA, ZAB,ZAC,ZAD,ZAE,ZAF,ZAG,ZAH,Z AJ,ZAL .....	1
51	PAFZZ	5306-00-044-0502	21450	440502	. BOLT,MACHINE UOC: DAC,DAD,DAE,DAF,DAG,DA H,DAJ,DAL,DAW,DAX,V14,V15,V16, V17,V18,V19,V20,V21,V22,V24,ZAA, ZAB,ZAC,ZAD,ZAE,ZAF,ZAG,ZAH,Z AJ,ZAL .....	10
52	PAFZZ	5342-01-089-2990	19207	12256547-1	. CLEVIS ASSEMBLY COM UOC: DAC,DAD,DAE,DAF,DAG,DA H,DAJ,DAL,DAW,DAX,V14,V15,V16, V17,V18,V19,V20,V21,V22,V24,ZAA, ZAB,ZAC,ZAD,ZAE,ZAF,ZAG,ZAH,Z AJ,ZAL .....	1
53	PAFZZ	5340-00-466-4948	71843	2708-6A	. . CLEVIS,ROD END UOC: DAC,DAD,DAE,DAF,DAG,DA H,DAJ,DAL,DAW,DAX,V14,V15,V16, V17,V18,V19,V20,V21,V22,V24,ZAA, ZAB,ZAC,ZAD,ZAE,ZAF,ZAG,ZAH,Z AJ,ZAL .....	1
54	PAFZZ	5310-00-891-1733	96906	MS35691-38	. . NUT,PLAIN,HEXAGON UOC: DAC,DAD,DAE,DAF,DAG,DA H,DAJ,DAL,DAW,DAX,V14,V15,V16, V17,V18,V19,V20,V21,V22,V24,ZAA, ZAB,ZAC,ZAD,ZAE,ZAF,ZAG,ZAH,Z AJ,ZAL .....	1

(1) ITEM NO.	(2) SMR CODE	(3) NSN	(4) CAGEC	(5) PART NUMBER	(6) DESCRIPTION AND USABLE ON CODE (UOC)	(7) QTY
55	PAFZZ	3040-01-121-7742	19207	12256548-1	. . CONNECTING LINK,RIG UOC: DAC,DAD,DAE,DAF,DAG,DA H,DAJ,DAL,DAW,DAX,V14,V15,V16, V17,V18,V19,V20,V21,V22,V24,ZAA, ZAB,ZAC,ZAD,ZAE,ZAF,ZAG,ZAH,Z AJ,ZAL .....	1

END OF FIGURE

**FIELD MAINTENANCE  
TRANSFER AIR CONTROL LINES**

---

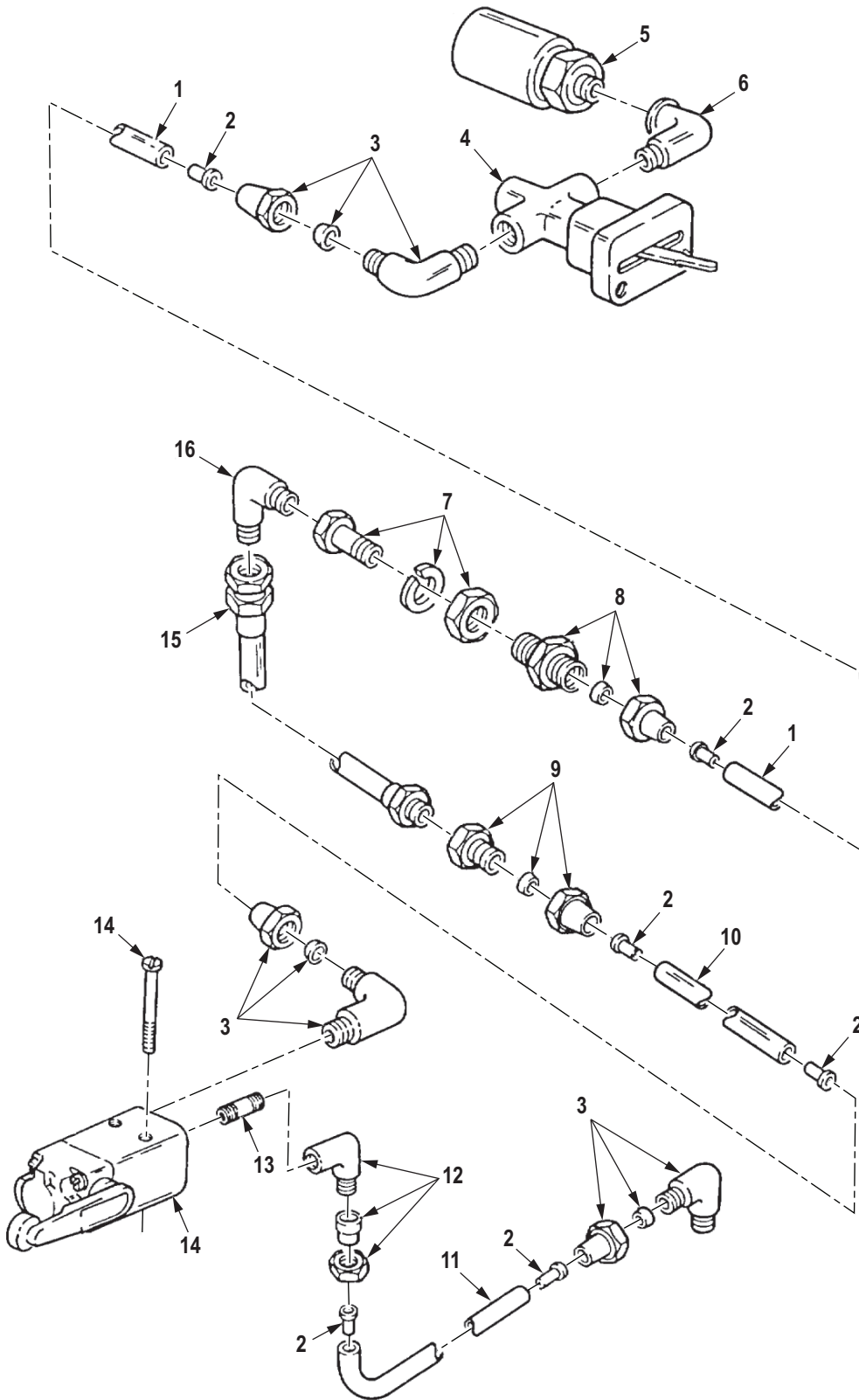

R0227DAA

Figure 212. Transfer Air Control Lines.



(1) ITEM NO.	(2) SMR CODE	(3) NSN	(4) CAGEC	(5) PART NUMBER	(6) DESCRIPTION AND USABLE ON CODE (UOC)	(7) QTY
<b>GROUP 0803 GEARSHIFT, VACUUM BOOSTER AND CONTROLS.</b>						
<b>FIG. 212. TRANSFER AIR CONTROL LINES.</b>						
1	MFFZZ		81343	J844TYBSIZE 3/8 BLACK-18	HOSE, NONMETALLIC CONTROL VALVE TO COUPLING, MAKE FROM HOSE, P/N J844TYBSIZE 3/8 BLACK, 18 IN. LONG UOC: DAC, DAD, DAE, DAF, DAG, DAH, DAJ, DAL, DAW, DAX, V14, V15, V16, V17, V18, V19, V20, V21, V22, V24, ZAA, ZAB, ZAC, ZAD, ZAE, ZAF, ZAG, ZAH, ZAJ, ZAL .....	1
2	PAFZZ	4730-01-079-8821	19207	CPR102321-1	INSERT, TUBE FITTING UOC: DAC, DAD, DAE, DAF, DAG, DAH, DAJ, DAL, DAW, DAX, V14, V15, V16, V17, V18, V19, V20, V21, V22, V24, ZAA, ZAB, ZAC, ZAD, ZAE, ZAF, ZAG, ZAH, ZAJ, ZAL .....	6
3	PAFZZ	4730-00-287-1604	81343	6-2 120202BA	ELBOW, PIPE TO TUBE UOC: DAC, DAD, DAE, DAF, DAG, DAH, DAJ, DAL, DAW, DAX, V14, V15, V16, V17, V18, V19, V20, V21, V22, V24, ZAA, ZAB, ZAC, ZAD, ZAE, ZAF, ZAG, ZAH, ZAJ, ZAL .....	3
4	PAFZZ	4820-00-832-8077	19207	10924753	VALVE, LINEAR, DIRECT UOC: DAC, DAD, DAE, DAF, DAG, DAH, DAJ, DAL, DAW, DAX, V14, V15, V16, V17, V18, V19, V20, V21, V22, V24, ZAA, ZAB, ZAC, ZAD, ZAE, ZAF, ZAG, ZAH, ZAJ, ZAL .....	1
5	PAFZA	5930-00-453-9367	58723	1702-0990	SWITCH, PRESSURE UOC: DAC, DAD, DAE, DAF, DAG, DAH, DAJ, DAL, DAW, DAX, V14, V15, V16, V17, V18, V19, V20, V21, V22, V24, ZAA, ZAB, ZAC, ZAD, ZAE, ZAF, ZAG, ZAH, ZAJ, ZAL .....	1
6	PAFZZ	4730-00-053-0266	96906	MS51952-1	ELBOW, PIPE UOC: DAC, DAD, DAE, DAF, DAG, DAH, DAJ, DAL, DAW, DAX, V14, V15, V16, V17, V18, V19, V20, V21, V22, V24, ZAA, ZAB, ZAC, ZAD, ZAE, ZAF, ZAG, ZAH, ZAJ, ZAL .....	1
7	PAFZZ	4730-00-278-6318	19207	8328782	COUPLING, PIPE UOC: DAC, DAD, DAE, DAF, DAG, DAH, DAJ, DAL, DAW, DAX, V14, V15, V16, V17, V18, V19, V20, V21, V22, V24, ZAA, ZAB, ZAC, ZAD, ZAE, ZAF, ZAG, ZAH, ZAJ, ZAL .....	1

(1) ITEM NO.	(2) SMR CODE	(3) NSN	(4) CAGEC	(5) PART NUMBER	(6) DESCRIPTION AND USABLE ON CODE (UOC)	(7) QTY
8	PAFZZ	4730-00-069-1186	81343	6-4 120102BA	ADAPTER,STRAIGHT,PI UOC: DAC,DAD,DAE,DAF,DAG,DA H,DAJ,DAL,DAW,DAX,V14,V15,V16, V17,V18,V19,V20,V21,V22,V24,ZAA, ZAB,ZAC,ZAD,ZAE,ZAF,ZAG,ZAH,Z AJ,ZAL .....	1
9	PAFZZ	4730-00-277-8770	81343	J246 6-6 120103BA	ADAPTER,STRAIGHT,PI UOC: DAC,DAD,DAE,DAF,DAG,DA H,DAJ,DAL,DAW,DAX,V14,V15,V16, V17,V18,V19,V20,V21,V22,V24,ZAA, ZAB,ZAC,ZAD,ZAE,ZAF,ZAG,ZAH,Z AJ,ZAL .....	1
10	MFFZZ		81343	J844TYBSIZE 3/8 BLACK-45	HOSE,NONMETALLIC MAKE FROM HOSE, P/N J844TYBSIZE 3/8 BLACK, 45 IN.LONG UOC: DAC,DAD,DAE,DAF,DAG,DA H,DAJ,DAL,DAW,DAX,V14,V15,V16, V17,V18,V19,V20,V21,V22,V24,ZAA, ZAB,ZAC,ZAD,ZAE,ZAF,ZAG,ZAH,Z AJ,ZAL .....	1
11	MFFZZ		81343	J844TYBSIZE 3/8 BLACK-26	HOSE,NONMETALLIC MAKE FROM HOSE, P/N J844TYBSIZE 3/8 BLACK, 26 IN.LONG UOC: DAC,DAD,DAE,DAF,DAG,DA H,DAJ,DAL,DAW,DAX,V14,V15,V16, V17,V18,V19,V20,V21,V22,V24,ZAA, ZAB,ZAC,ZAD,ZAE,ZAF,ZAG,ZAH,Z AJ,ZAL .....	1
12	PAFZZ	4730-00-289-4052	81343	6-2 120203BA	ELBOW,PIPE TO TUBE UOC: DAC,DAD,DAE,DAF,DAG,DA H,DAJ,DAL,DAW,DAX,V14,V15,V16, V17,V18,V19,V20,V21,V22,V24,ZAA, ZAB,ZAC,ZAD,ZAE,ZAF,ZAG,ZAH,Z AJ,ZAL .....	1
13	PAFZZ	4730-00-196-1966	81346	B687R-13B	NIPPLE,PIPE UOC: DAC,DAD,DAE,DAF,DAG,DA H,DAJ,DAL,DAW,DAX,V14,V15,V16, V17,V18,V19,V20,V21,V22,V24,ZAA, ZAB,ZAC,ZAD,ZAE,ZAF,ZAG,ZAH,Z AJ,ZAL .....	1
14	PAFZZ	4820-01-329-3245	97902	LSC-3270-S26022-1	VALVE,LINEAR,DIRECT UOC: DAC,DAD,DAE,DAF,DAG,DA H,DAJ,DAL,DAW,DAX,V14,V15,V16, V17,V18,V19,V20,V21,V22,V24,ZAA, ZAB,ZAC,ZAD,ZAE,ZAF,ZAG,ZAH,Z AJ,ZAL .....	1

(1) ITEM NO.	(2) SMR CODE	(3) NSN	(4) CAGEC	(5) PART NUMBER	(6) DESCRIPTION AND USABLE ON CODE (UOC)	(7) QTY
15	PAFZZ	4720-01-107-9939	19207	12256272	HOSE ASSEMBLY, NONME UOC: DAC, DAD, DAE, DAF, DAG, DA H, DAJ, DAL, DAW, DAX, V14, V15, V16, V17, V18, V19, V20, V21, V22, V24, ZAA, ZAB, ZAC, ZAD, ZAE, ZAF, ZAG, ZAH, Z AJ, ZAL .....	1
16	PAFZZ	4730-00-812-7999	96906	MS51504A6	ELBOW, PIPE TO TUBE UOC: DAC, DAD, DAE, DAF, DAG, DA H, DAJ, DAL, DAW, DAX, V14, V15, V16, V17, V18, V19, V20, V21, V22, V24, ZAA, ZAB, ZAC, ZAD, ZAE, ZAF, ZAG, ZAH, Z AJ, ZAL .....	1

END OF FIGURE



**FIELD MAINTENANCE  
TRANSFER AIR-ACTUATED CONTROLS AND INTERLOCK VALVE**

---

23  
24 - 28

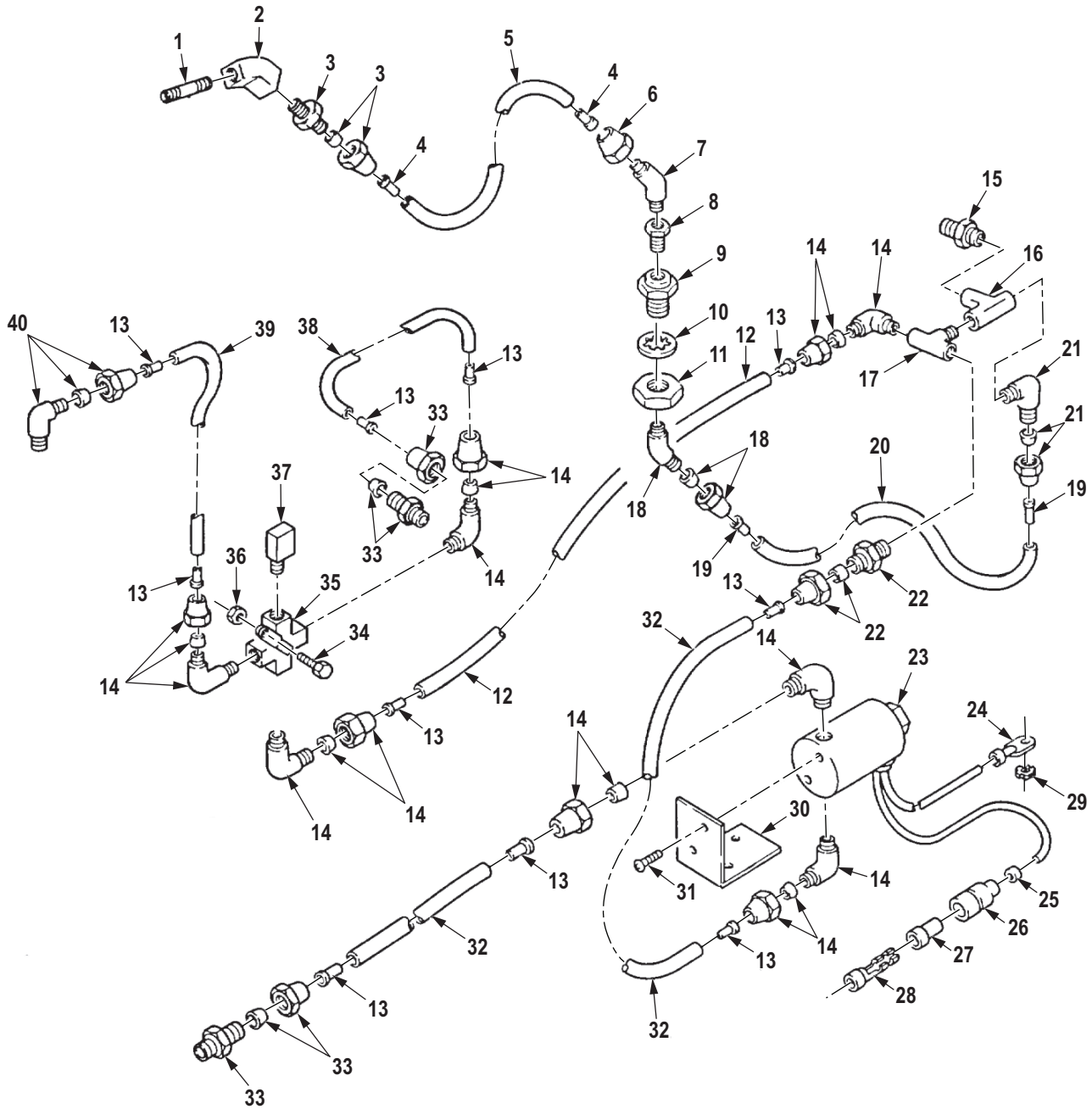

R0228DAA

Figure 213. Transfer Air-Actuated Controls and Interlock Valve.

(1) ITEM NO.	(2) SMR CODE	(3) NSN	(4) CAGEC	(5) PART NUMBER	(6) DESCRIPTION AND USABLE ON CODE (UOC)	(7) QTY
<b>GROUP 0803 GEARSHIFT, VACUUM BOOSTER AND CONTROLS.</b>						
<b>FIG. 213. TRANSFER AIR-ACTUATED CONTROLS AND INTERLOCK VALVE.</b>						
1	PAFZZ	4730-00-196-1966	81346	B687R-13B	NIPPLE,PIPE UOC: DAC,DAD,DAE,DAF,DAG,DAH,DAJ,DAL,DAW,DAX,V14,V15,V16,V17,V18,V19,V20,V21,V22,V24,ZAA,ZAB,ZAC,ZAD,ZAE,ZAF,ZAG,ZAH,ZAJ,ZAL .....	1
2	PAFZZ	4730-00-125-7979	72582	444136	TEE,PIPE UOC: DAC,DAD,DAE,DAF,DAG,DAH,DAJ,DAL,DAW,DAX,V14,V15,V16,V17,V18,V19,V20,V21,V22,V24,ZAA,ZAB,ZAC,ZAD,ZAE,ZAF,ZAG,ZAH,ZAJ,ZAL .....	1
3	XDFZZ		81343	4-2 120103BA	ADAPTER,STRAIGHT,PI UOC: DAC,DAD,DAE,DAF,DAG,DAH,DAJ,DAL,DAW,DAX,V14,V15,V16,V17,V18,V19,V20,V21,V22,V24,ZAA,ZAB,ZAC,ZAD,ZAE,ZAF,ZAG,ZAH,ZAJ,ZAL .....	1
4	PAFZZ	4730-00-132-4588	19207	11648703	INSERT,TUBE FITTING UOC: DAC,DAD,DAE,DAF,DAG,DAH,DAJ,DAL,DAW,DAX,V14,V15,V16,V17,V18,V19,V20,V21,V22,V24,ZAA,ZAB,ZAC,ZAD,ZAE,ZAF,ZAG,ZAH,ZAJ,ZAL .....	2
5	MFFZZ		19207	CPR104420-1-6	HOSE,NONMETALLIC MAKE FROM HOSE,P/N CPR104420-1, 6 IN. LONG UOC: DAC,DAD,DAE,DAF,DAG,DAH,DAJ,DAL,DAW,DAX,V14,V15,V16,V17,V18,V19,V20,V21,V22,V24,ZAA,ZAB,ZAC,ZAD,ZAE,ZAF,ZAG,ZAH,ZAJ,ZAL .....	1
6	PAFZZ	4730-00-011-6452	81343	4-010110B	NUT,TUBE COUPLING UOC: DAC,DAD,DAE,DAF,DAG,DAH,DAJ,DAL,DAW,DAX,V14,V15,V16,V17,V18,V19,V20,V21,V22,V24,ZAA,ZAB,ZAC,ZAD,ZAE,ZAF,ZAG,ZAH,ZAJ,ZAL .....	1
7	PAFZZ	4730-01-202-3351	81343	SAE J512 4-2 010302BA	ELBOW,PIPE TO TUBE UOC: DAC,DAD,DAE,DAF,DAG,DAH,DAJ,DAL,DAW,DAX,V14,V15,V16,V17,V18,V19,V20,V21,V22,V24,ZAA,ZAB,ZAC,ZAD,ZAE,ZAF,ZAG,ZAH,ZAJ,ZAL .....	1

(1) ITEM NO.	(2) SMR CODE	(3) NSN	(4) CAGEC	(5) PART NUMBER	(6) DESCRIPTION AND USABLE ON CODE (UOC)	(7) QTY
8	PAFZZ	4730-00-180-5038	81343	SAE J530 6-2 130140B	BUSHING,PIPE UOC: DAC,DAD,DAE,DAF,DAG,DA H,DAJ,DAL,DAW,DAX,V14,V15,V16, V17,V18,V19,V20,V21,V22,V24,ZAA, ZAB,ZAC,ZAD,ZAE,ZAF,ZAG,ZAH,Z AJ,ZAL .....	1
9	PAFZZ	4730-00-421-3924	19207	7339982	ADAPTER,STRAIGHT,PI UOC: DAC,DAD,DAE,DAF,DAG,DA H,DAJ,DAL,DAW,DAX,V14,V15,V16, V17,V18,V19,V20,V21,V22,V24,ZAA, ZAB,ZAC,ZAD,ZAE,ZAF,ZAG,ZAH,Z AJ,ZAL .....	1
10	PAFZZ	5310-00-582-6714	80205	MS35333-49	WASHER,LOCK UOC: DAC,DAD,DAE,DAF,DAG,DA H,DAJ,DAL,DAW,DAX,V14,V15,V16, V17,V18,V19,V20,V21,V22,V24,ZAA, ZAB,ZAC,ZAD,ZAE,ZAF,ZAG,ZAH,Z AJ,ZAL .....	1
11	PAFZZ	5310-00-241-0157	19207	5331179	NUT,PLAIN,HEXAGON UOC: DAC,DAD,DAE,DAF,DAG,DA H,DAJ,DAL,DAW,DAX,V14,V15,V16, V17,V18,V19,V20,V21,V22,V24,ZAA, ZAB,ZAC,ZAD,ZAE,ZAF,ZAG,ZAH,Z AJ,ZAL .....	1
12	MFFZZ		19207	CPR104420-3-55	HOSE,NONMETALIC MAKE FROM HOSE,P/N CPR104420-3, 55 IN.LONG UOC: DAC,DAD,DAE,DAF,DAG,DA H,DAJ,DAL,DAW,DAX,V14,V15,V16, V17,V18,V19,V20,V21,V22,V24,ZAA, ZAB,ZAC,ZAD,ZAE,ZAF,ZAG,ZAH,Z AJ,ZAL .....	1
13	PAFZZ	4730-01-079-8821	19207	CPR102321-1	INSERT,TUBE FITTING UOC: DAC,DAD,DAE,DAF,DAG,DA H,DAJ,DAL,DAW,DAX,V14,V15,V16, V17,V18,V19,V20,V21,V22,V24,ZAA, ZAB,ZAC,ZAD,ZAE,ZAF,ZAG,ZAH,Z AJ,ZAL .....	10
14	PAFZZ	4730-00-069-1187	81343	SAE J246 6-4 100202BA	ELBOW,PIPE TO TUBE UOC: DAC,DAD,DAE,DAF,DAG,DA H,DAJ,DAL,DAW,DAX,V14,V15,V16, V17,V18,V19,V20,V21,V22,V24,ZAA, ZAB,ZAC,ZAD,ZAE,ZAF,ZAG,ZAH,Z AJ,ZAL .....	6



(1) ITEM NO.	(2) SMR CODE	(3) NSN	(4) CAGEC	(5) PART NUMBER	(6) DESCRIPTION AND USABLE ON CODE (UOC)	(7) QTY
15	PAFZZ	4730-00-802-2560	81343	SAE J514 4-2 140137C	REDUCER,PIPE UOC: DAC,DAD,DAE,DAF,DAG,DA H,DAJ,DAL,DAW,DAX,V14,V15,V16, V17,V18,V19,V20,V21,V22,V24,ZAA, ZAB,ZAC,ZAD,ZAE,ZAF,ZAG,ZAH,Z AJ,ZAL .....	1
16	PAFZZ	4730-00-471-3102	81343	4-4-4 130438B	TEE,PIPE UOC: DAC,DAD,DAE,DAF,DAG,DA H,DAJ,DAL,DAW,DAX,V14,V15,V16, V17,V18,V19,V20,V21,V22,V24,ZAA, ZAB,ZAC,ZAD,ZAE,ZAF,ZAG,ZAH,Z AJ,ZAL .....	1
17	PAFZZ	4730-00-088-8666	81343	4-4-4 130425B	TEE,PIPE UOC: DAC,DAD,DAE,DAF,DAG,DA H,DAJ,DAL,DAW,DAX,V14,V15,V16, V17,V18,V19,V20,V21,V22,V24,ZAA, ZAB,ZAC,ZAD,ZAE,ZAF,ZAG,ZAH,Z AJ,ZAL .....	1
18	PAFZZ	4730-00-289-0051	81343	8-6 120202BA	ELBOW,PIPE TO TUBE UOC: DAC,DAD,DAE,DAF,DAG,DA H,DAJ,DAL,DAW,DAX,V14,V15,V16, V17,V18,V19,V20,V21,V22,V24,ZAA, ZAB,ZAC,ZAD,ZAE,ZAF,ZAG,ZAH,Z AJ,ZAL .....	1
19	PAFZZ	4730-01-032-6038	19207	CPR102321-4	INSERT,TUBE FITTING UOC: DAC,DAD,DAE,DAF,DAG,DA H,DAJ,DAL,DAW,DAX,V14,V15,V16, V17,V18,V19,V20,V21,V22,V24,ZAA, ZAB,ZAC,ZAD,ZAE,ZAF,ZAG,ZAH,Z AJ,ZAL .....	2
20	MFFZZ		19207	CPR104420-3-48	HOSE,NONMETALLIC MAKE FROM HOSE,P/N CPR104420-3, 48 IN.LONG UOC: DAC,DAD,DAE,DAF,DAG,DA H,DAJ,DAL,DAW,DAX,V14,V15,V16, V17,V18,V19,V20,V21,V22,V24,ZAA, ZAB,ZAC,ZAD,ZAE,ZAF,ZAG,ZAH,Z AJ,ZAL .....	1
21	PAFZZ	4730-00-409-7854	81343	J246 8-4 120202BA	ELBOW,PIPE TO TUBE UOC: DAC,DAD,DAE,DAF,DAG,DA H,DAJ,DAL,DAW,DAX,V14,V15,V16, V17,V18,V19,V20,V21,V22,V24,ZAA, ZAB,ZAC,ZAD,ZAE,ZAF,ZAG,ZAH,Z AJ,ZAL .....	1

(1) ITEM NO.	(2) SMR CODE	(3) NSN	(4) CAGEC	(5) PART NUMBER	(6) DESCRIPTION AND USABLE ON CODE (UOC)	(7) QTY
22	PAFZZ	4730-00-069-1186	81343	6-4 120102BA	ADAPTER,STRAIGHT,PI UOC: DAC,DAD,DAE,DAF,DAG,DA H,DAJ,DAL,DAW,DAX,V14,V15,V16, V17,V18,V19,V20,V21,V22,V24,ZAA, ZAB,ZAC,ZAD,ZAE,ZAF,ZAG,ZAH,Z AJ,ZAL .....	1
23	PAFZZ	5945-01-136-7640	97902	ESM-3302-S26021	SOLENOID,ELECTRICAL UOC: DAC,DAD,DAE,DAF,DAG,DA H,DAJ,DAL,DAW,DAX,V14,V15,V16, V17,V18,V19,V20,V21,V22,V24,ZAA, ZAB,ZAC,ZAD,ZAE,ZAF,ZAG,ZAH,Z AJ,ZAL .....	1
24	PAFZZ	5940-00-892-3151	96906	MS35436-9	. TERMINAL,LUG UOC: DAC,DAD,DAE,DAF,DAG,DA H,DAJ,DAL,DAW,DAX,V14,V15,V16, V17,V18,V19,V20,V21,V22,V24,ZAA, ZAB,ZAC,ZAD,ZAE,ZAF,ZAG,ZAH,Z AJ,ZAL .....	1
25	PAFZZ	9905-01-013-8723	81349	M43436/3-1	. BAND,MARKER UOC: DAC,DAD,DAE,DAF,DAG,DA H,DAJ,DAL,DAW,DAX,V14,V15,V16, V17,V18,V19,V20,V21,V22,V24,ZAA, ZAB,ZAC,ZAD,ZAE,ZAF,ZAG,ZAH,Z AJ,ZAL .....	2
26	PAFZZ	5975-00-660-5962	19207	8724494	. CABLE NIPPLE,ELECTR UOC: DAC,DAD,DAE,DAF,DAG,DA H,DAJ,DAL,DAW,DAX,V14,V15,V16, V17,V18,V19,V20,V21,V22,V24,ZAA, ZAB,ZAC,ZAD,ZAE,ZAF,ZAG,ZAH,Z AJ,ZAL .....	1
27	PAFZZ	5970-00-833-8562	19207	8338562	. INSULATOR,BUSHING UOC: DAC,DAD,DAE,DAF,DAG,DA H,DAJ,DAL,DAW,DAX,V14,V15,V16, V17,V18,V19,V20,V21,V22,V24,ZAA, ZAB,ZAC,ZAD,ZAE,ZAF,ZAG,ZAH,Z AJ,ZAL .....	1
28	PAFZZ	5940-00-399-6676	19207	8338564	. TERMINAL SET,QUICK UOC: DAC,DAD,DAE,DAF,DAG,DA H,DAJ,DAL,DAW,DAX,V14,V15,V16, V17,V18,V19,V20,V21,V22,V24,ZAA, ZAB,ZAC,ZAD,ZAE,ZAF,ZAG,ZAH,Z AJ,ZAL .....	1
29	PAFZZ	5310-00-061-1258	96906	MS45904-76	WASHER,LOCK UOC: DAC,DAD,DAE,DAF,DAG,DA H,DAJ,DAL,DAW,DAX,V14,V15,V16, V17,V18,V19,V20,V21,V22,V24,ZAA, ZAB,ZAC,ZAD,ZAE,ZAF,ZAG,ZAH,Z AJ,ZAL .....	1

(1) ITEM NO.	(2) SMR CODE	(3) NSN	(4) CAGEC	(5) PART NUMBER	(6) DESCRIPTION AND USABLE ON CODE (UOC)	(7) QTY
30	PAFZZ	5340-01-123-1333	19207	12277361	BRACKET,ANGLE UOC: DAC,DAD,DAE,DAF,DAG,DA H,DAJ,DAL,DAW,DAX,V14,V15,V16, V17,V18,V19,V20,V21,V22,V24,ZAA, ZAB,ZAC,ZAD,ZAE,ZAF,ZAG,ZAH,Z AJ,ZAL .....	1
31	PAFZZ	5305-00-088-9044	96906	MS35207-260	SCREW,MACHINE UOC: DAC,DAD,DAE,DAF,DAG,DA H,DAJ,DAL,DAW,DAX,V14,V15,V16, V17,V18,V19,V20,V21,V22,V24,ZAA, ZAB,ZAC,ZAD,ZAE,ZAF,ZAG,ZAH,Z AJ,ZAL .....	2
32	MFFZZ		81343	J844TYBSIZE 3/8 BLACK-15	HOSE,NONMETALLIC MAKE FROM HOSE, P/N J844TYBSIZE 3/8 BLACK, 15 IN.LONG UOC: DAC,DAD,DAE,DAF,DAG,DA H,DAJ,DAL,DAW,DAX,V14,V15,V16, V17,V18,V19,V20,V21,V22,V24,ZAA, ZAB,ZAC,ZAD,ZAE,ZAF,ZAG,ZAH,Z AJ,ZAL .....	2
33	PAFZZ	4730-00-837-1177	81343	6-8 120102BA	ADAPTER,STRAIGHT,PI UOC: DAC,DAD,DAE,DAF,DAG,DA H,DAJ,DAL,DAW,DAX,V14,V15,V16, V17,V18,V19,V20,V21,V22,V24,ZAA, ZAB,ZAC,ZAD,ZAE,ZAF,ZAG,ZAH,Z AJ,ZAL .....	2
34	PAFZZ	5305-00-269-3238	80204	B1821BH038F125N	SCREW,CAP,HEXAGON H UOC: DAL,V18,ZAL .....	1
34	PAFZZ	5305-00-269-2804	80205	MS90726-61	SCREW,CAP,HEXAGON H UOC: DAC,DAD,DAE,DAF,DAG,DA H,DAJ,DAW,V14,V15,V16,V17,V19,V 20,V21,V22,V24,ZAA,ZAB,ZAC,ZAD, ZAE,ZAF,ZAG,ZAH,ZAJ .....	1
35	PAFZZ	4730-01-112-6561	9S775	11669082	CROSS,PIPE UOC: DAC,DAD,DAE,DAF,DAG,DA H,DAJ,DAL,DAW,DAX,V14,V15,V16, V17,V18,V19,V20,V21,V22,V24,ZAA, ZAB,ZAC,ZAD,ZAE,ZAF,ZAG,ZAH,Z AJ,ZAL .....	1
36	PAFZZ	5310-00-814-0672	96906	M45913/3-6FG8C	NUT,SELF-LOCKING,HE UOC: DAC,DAD,DAE,DAF,DAG,DA H,DAJ,DAL,DAW,DAX,V14,V15,V16, V17,V18,V19,V20,V21,V22,V24,ZAA, ZAB,ZAC,ZAD,ZAE,ZAF,ZAG,ZAH,Z AJ,ZAL .....	1

(1) ITEM NO.	(2) SMR CODE	(3) NSN	(4) CAGEC	(5) PART NUMBER	(6) DESCRIPTION AND USABLE ON CODE (UOC)	(7) QTY
37	PAFZZ	4730-01-107-9692	19207	12255985	ELBOW,PIPE UOC: DAC,DAD,DAE,DAF,DAG,DA H,DAJ,DAL,DAW,DAX,V14,V15,V16, V17,V18,V19,V20,V21,V22,V24,ZAA, ZAB,ZAC,ZAD,ZAE,ZAF,ZAG,ZAH,Z AJ,ZAL .....	1
38	MFFZZ		81343	J844TYBSIZE 3/8 BLACK-17	HOSE,NONMETALLIC MAKE FROM HOSE, P/N J844TYBSIZE 3/8 BLACK, 17 IN.LONG UOC: DAC,DAD,DAE,DAF,DAG,DA H,DAJ,DAL,DAW,DAX,V14,V15,V16, V17,V18,V19,V20,V21,V22,V24,ZAA, ZAB,ZAC,ZAD,ZAE,ZAF,ZAG,ZAH,Z AJ,ZAL .....	1
39	MFFZZ		81343	J844TYBSIZE 3/8 BLACK-24	HOSE,NONMETALLIC MAKE FROM HOSE, P/N J844TYBSIZE 3/8 BLACK, 24 IN.LONG UOC: DAC,DAD,DAE,DAF,DAG,DA H,DAJ,DAL,DAW,DAX,V14,V15,V16, V17,V18,V19,V20,V21,V22,V24,ZAA, ZAB,ZAC,ZAD,ZAE,ZAF,ZAG,ZAH,Z AJ,ZAL .....	1
40	PAFZZ	4730-00-287-1604	81343	6-2 120202BA	ELBOW,PIPE TO TUBE UOC: DAC,DAD,DAE,DAF,DAG,DA H,DAJ,DAL,DAW,DAX,V14,V15,V16, V17,V18,V19,V20,V21,V22,V24,ZAA, ZAB,ZAC,ZAD,ZAE,ZAF,ZAG,ZAH,Z AJ,ZAL .....	1

END OF FIGURE

**FIELD MAINTENANCE  
TRANSFER AIR-ACTUATED CONTROLS AND MANIFOLD FITTINGS**

---

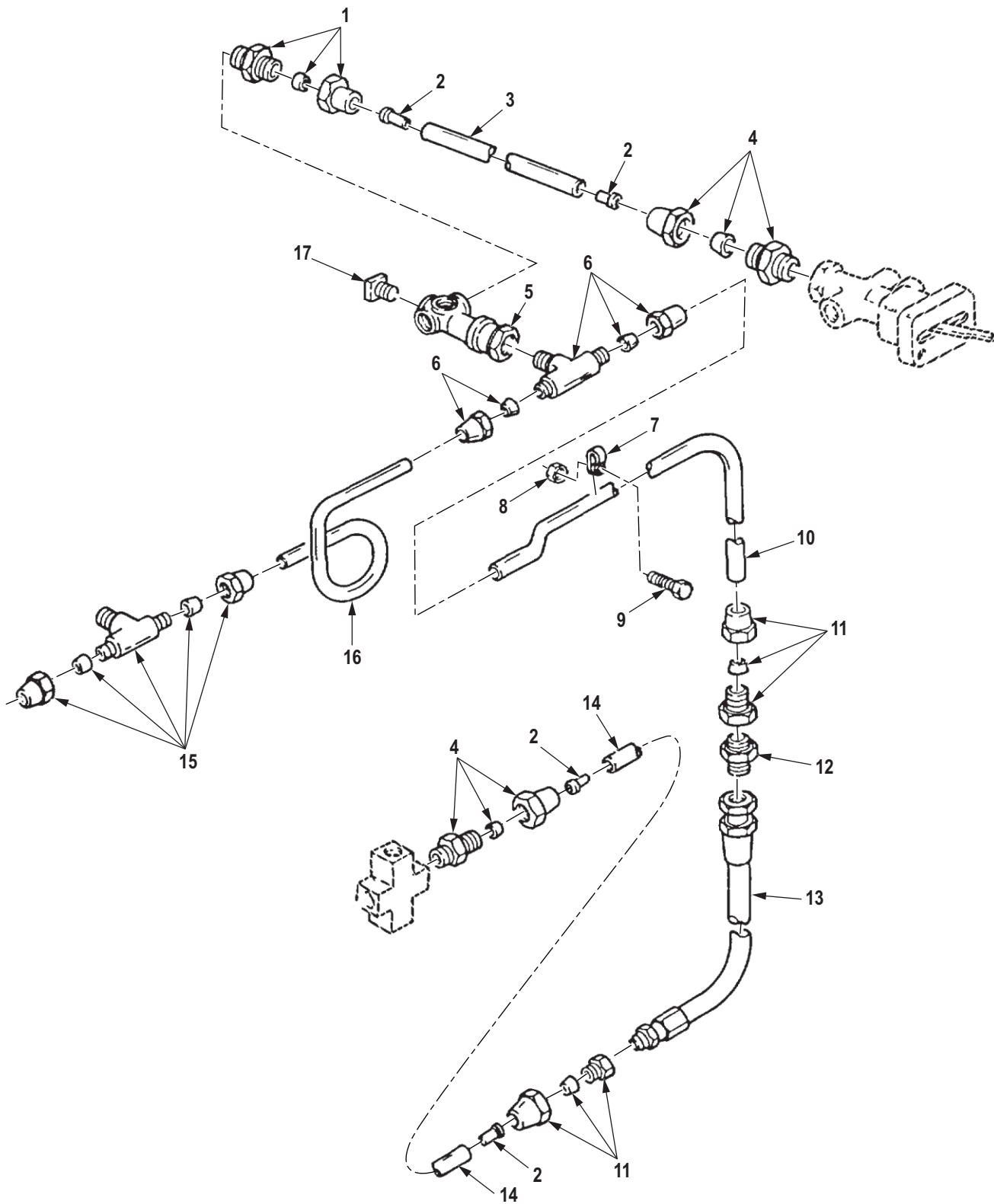

R0229DAA

Figure 214. Transfer Air-Actuated Controls and Manifold Fittings.

(1) ITEM NO.	(2) SMR CODE	(3) NSN	(4) CAGEC	(5) PART NUMBER	(6) DESCRIPTION AND USABLE ON CODE (UOC)	(7) QTY
<p><b>GROUP 0803 GEARSHIFT, VACUUM BOOSTER AND CONTROLS.</b></p> <p><b>FIG. 214. TRANSFER AIR-ACTUATED CONTROLS AND MANIFOLD FITTINGS.</b></p>						
1	PAFZZ	4730-00-069-1186	81343	6-4 120102BA	ADAPTER, STRAIGHT, PI UOC: DAC, DAD, DAE, DAF, DAG, DAH, DAJ, DAL, DAW, DAX, V14, V15, V16, V17, V18, V19, V20, V21, V22, V24, ZAA, ZAB, ZAC, ZAD, ZAE, ZAF, ZAG, ZAH, ZAJ, ZAL .....	1
2	PAFZZ	4730-01-079-8821	19207	CPR102321-1	INSERT, TUBE FITTING UOC: DAC, DAD, DAE, DAF, DAG, DAH, DAJ, DAL, DAW, DAX, V14, V15, V16, V17, V18, V19, V20, V21, V22, V24, ZAA, ZAB, ZAC, ZAD, ZAE, ZAF, ZAG, ZAH, ZAJ, ZAL .....	4
3	MFFZZ		81343	J844TYBSIZE 3/8 BLACK-30	HOSE, NONMETALLIC MAKE FROM HOSE, P/N J844TYBSIZE 3/8 BLACK, 30 IN. LONG UOC: DAC, DAD, DAE, DAF, DAG, DAH, DAJ, DAL, DAW, DAX, V14, V15, V16, V17, V18, V19, V20, V21, V22, V24, ZAA, ZAB, ZAC, ZAD, ZAE, ZAF, ZAG, ZAH, ZAJ, ZAL .....	1
4	PAFZZ	4730-00-142-3075	81343	6-2 120102BA	ADAPTER, STRAIGHT, PI UOC: DAC, DAD, DAE, DAF, DAG, DAH, DAJ, DAL, DAW, DAX, V14, V15, V16, V17, V18, V19, V20, V21, V22, V24, ZAA, ZAB, ZAC, ZAD, ZAE, ZAF, ZAG, ZAH, ZAJ, ZAL .....	1
5	PAFZZ	4730-00-753-9300	06853	223662N	CONNECTOR, MULTIPLE, UOC: DAC, DAD, DAE, DAF, DAG, DAH, DAJ, DAL, DAW, DAX, V14, V15, V16, V17, V18, V19, V20, V21, V22, V24, ZAA, ZAB, ZAC, ZAD, ZAE, ZAF, ZAG, ZAH, ZAJ, ZAL .....	1
6	PAFZZ	4730-00-494-6580	81343	6-6-4 120425BA	TEE, PIPE TO TUBE UOC: DAC, DAD, DAE, DAF, DAG, DAH, DAJ, DAL, DAW, DAX, V14, V15, V16, V17, V18, V19, V20, V21, V22, V24, ZAA, ZAB, ZAC, ZAD, ZAE, ZAF, ZAG, ZAH, ZAJ, ZAL .....	1
7	PAFZZ	5340-00-809-1492	80205	MS21333-100	CLAMP, LOOP UOC: DAC, DAD, DAE, DAF, DAG, DAH, DAJ, DAL, DAW, DAX, V14, V15, V16, V17, V18, V19, V20, V21, V22, V24, ZAA, ZAB, ZAC, ZAD, ZAE, ZAF, ZAG, ZAH, ZAJ, ZAL .....	1

(1) ITEM NO.	(2) SMR CODE	(3) NSN	(4) CAGEC	(5) PART NUMBER	(6) DESCRIPTION AND USABLE ON CODE (UOC)	(7) QTY
8	PAFZZ	5310-00-877-5796	80205	MS21044N4	NUT,SELF-LOCKING,HE 1/4-28 UNF-3B R.H. UOC: DAC,DAD,DAE,DAF,DAG,DA H,DAJ,DAL,DAW,DAX,V14,V15,V16, V17,V18,V19,V20,V21,V22,V24,ZAA, ZAB,ZAC,ZAD,ZAE,ZAF,ZAG,ZAH,Z AJ,ZAL .....	1
9	PAFZZ	5305-00-267-8953	80204	B1821BH025F063N	SCREW,CAP,HEXAGON H UOC: DAC,DAD,DAE,DAF,DAG,DA H,DAJ,DAL,DAW,DAX,V14,V15,V16, V17,V18,V19,V20,V21,V22,V24,ZAA, ZAB,ZAC,ZAD,ZAE,ZAF,ZAG,ZAH,Z AJ,ZAL .....	1
10	PAFZZ	4710-01-123-4576	19207	12256261	TUBE,BENT,METALLIC UOC: DAC,DAD,DAE,DAF,DAG,DA H,DAJ,DAL,DAW,DAX,V14,V15,V16, V17,V18,V19,V20,V21,V22,V24,ZAA, ZAB,ZAC,ZAD,ZAE,ZAF,ZAG,ZAH,Z AJ,ZAL .....	1
11	PAFZZ	4730-00-277-8770	81343	J246 6-6 120103BA	ADAPTER,STRAIGHT,PI UOC: DAC,DAD,DAE,DAF,DAG,DA H,DAJ,DAL,DAW,DAX,V14,V15,V16, V17,V18,V19,V20,V21,V22,V24,ZAA, ZAB,ZAC,ZAD,ZAE,ZAF,ZAG,ZAH,Z AJ,ZAL .....	2
12	PAFZZ	4730-00-322-8457	96906	MS51500A6-6	ADAPTER,STRAIGHT,PI UOC: DAC,DAD,DAE,DAF,DAG,DA H,DAJ,DAL,DAW,DAX,V14,V15,V16, V17,V18,V19,V20,V21,V22,V24,ZAA, ZAB,ZAC,ZAD,ZAE,ZAF,ZAG,ZAH,Z AJ,ZAL .....	1
13	PAFZZ	4720-01-107-9939	19207	12256272	HOSE ASSEMBLY,NONME UOC: DAC,DAD,DAE,DAF,DAG,DA H,DAJ,DAL,DAW,DAX,V14,V15,V16, V17,V18,V19,V20,V21,V22,V24,ZAA, ZAB,ZAC,ZAD,ZAE,ZAF,ZAG,ZAH,Z AJ,ZAL .....	1
14	MFFZZ		81343	J844TYBSIZE 3/8 BLACK-64	HOSE,NONMETALLIC MAKE FROM HOSE, P/N J844TYBSIZE 3/8 BLACK, 64 IN.LONG UOC: DAC,DAD,DAE,DAF,DAG,DA H,DAJ,DAL,DAW,DAX,V14,V15,V16, V17,V18,V19,V20,V21,V22,V24,ZAA, ZAB,ZAC,ZAD,ZAE,ZAF,ZAG,ZAH,Z AJ,ZAL .....	1



(1) ITEM NO.	(2) SMR CODE	(3) NSN	(4) CAGEC	(5) PART NUMBER	(6) DESCRIPTION AND USABLE ON CODE (UOC)	(7) QTY
15	PAFZZ	4730-00-782-5461	81343	J246 6-6-2 120425BA	TEE,PIPE TO TUBE UOC: DAC,DAD,DAE,DAF,DAG,DA H,DAJ,DAL,DAW,DAX,V14,V15,V16, V17,V18,V19,V20,V21,V22,V24,ZAA, ZAB,ZAC,ZAD,ZAE,ZAF,ZAG,ZAH,Z AJ,ZAL .....	1
16	PAFZZ	4710-01-125-3608	19207	12256262	TUBE,BENT,METALLIC UOC: DAC,DAD,DAE,DAF,DAG,DA H,DAJ,DAL,DAW,DAX,V14,V15,V16, V17,V18,V19,V20,V21,V22,V24,ZAA, ZAB,ZAC,ZAD,ZAE,ZAF,ZAG,ZAH,Z AJ,ZAL .....	1
17	PAFZZ	4730-00-954-1281	58536	AA59616ACABCB	PLUG,PIPE UOC: DAC,DAD,DAE,DAF,DAG,DA H,DAJ,DAL,DAW,DAX,V14,V15,V16, V17,V18,V19,V20,V21,V22,V24,ZAA, ZAB,ZAC,ZAD,ZAE,ZAF,ZAG,ZAH,Z AJ,ZAL .....	2

END OF FIGURE



**FIELD MAINTENANCE  
TRANSFER AIR-ACTUATED CONTROLS**

---

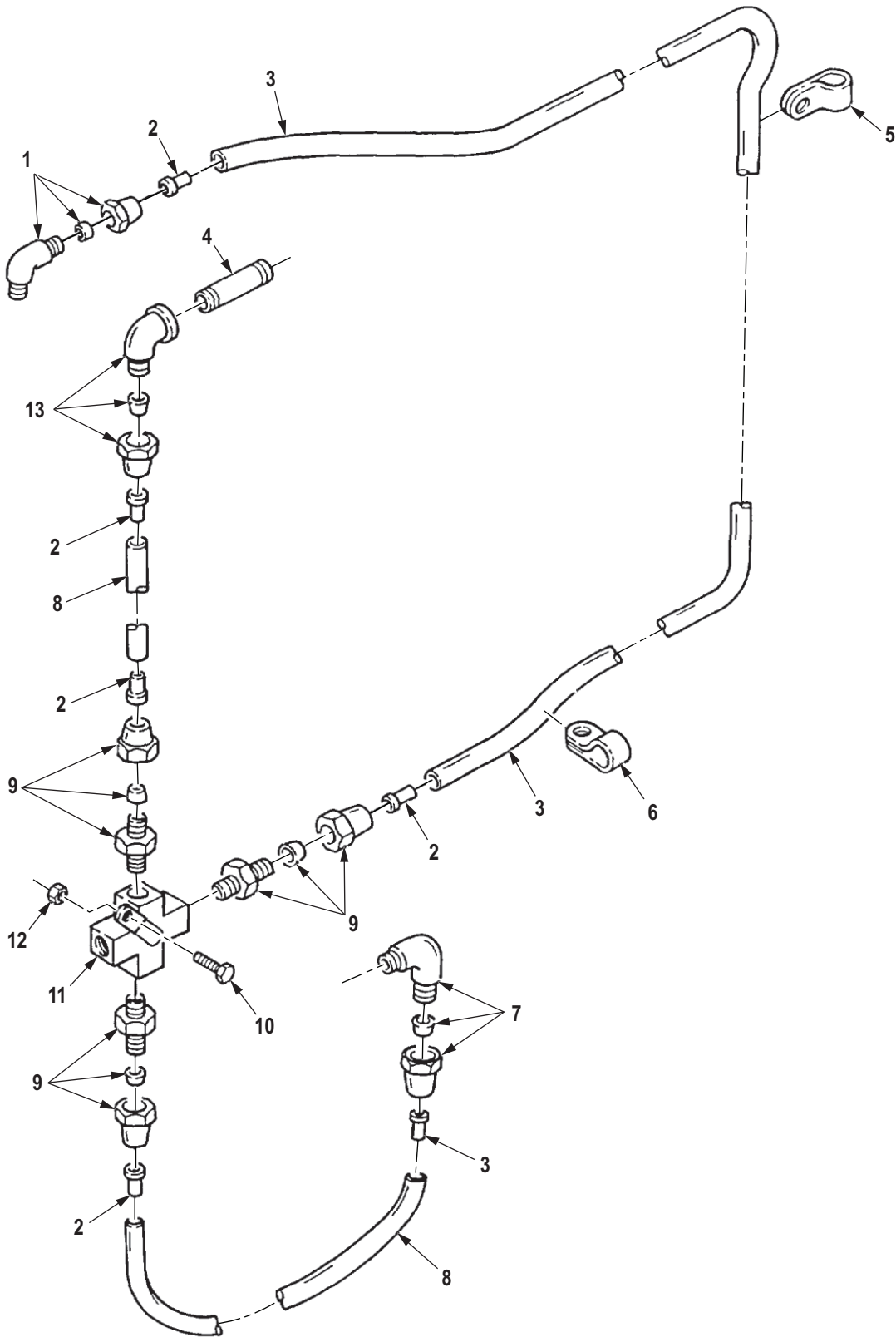

R0230DAA

Figure 215. Transfer Air-Actuated Controls.

(1) ITEM NO.	(2) SMR CODE	(3) NSN	(4) CAGEC	(5) PART NUMBER	(6) DESCRIPTION AND USABLE ON CODE (UOC)	(7) QTY
<b>GROUP 0803 GEARSHIFT, VACUUM BOOSTER AND CONTROLS.</b>						
<b>FIG. 215. TRANSFER AIR-ACTUATED CONTROLS.</b>						
1	PAFZZ	4730-00-701-7677	96906	MS39185-1	ELBOW,PIPE TO TUBE UOC: DAC,DAD,DAJ,V16,V17,V24,Z AC,ZAD,ZAJ .....	1
1	PAFZZ	4730-00-069-1187	81343	SAE J246 6-4 100202BA	ELBOW,PIPE TO TUBE UOC: DAE,DAF,DAG,DAH,DAW,DA X,V14,V15,V19,V20,V21,V22,ZAA,ZA B,ZAE,ZAF,ZAG,ZAH .....	1
2	PAFZZ	4730-01-079-8821	19207	CPR102321-1	INSERT,TUBE FITTING UOC: DAC,DAD,DAE,DAF,DAG,DA H,DAJ,DAL,DAW,DAX,V14,V15,V16, V17,V18,V19,V20,V21,V22,V24,ZAA, ZAB,ZAC,ZAD,ZAE,ZAF,ZAG,ZAH,Z AJ,ZAL .....	6
3	MFFZZ		81343	J844TYBSIZE 3/8 BLACK-146	HOSE,NONMETALLIC MAKE FROM HOSE, P/N J844TYBSIZE 3/8 BLACK, 146 IN.LONG UOC: DAW,DAX,V14,V15,ZAA,ZAB .....	1
3	MFFZZ		81343	J844TYBSIZE 3/8 BLACK-172	HOSE,NONMETALLIC MAKE FROM HOSE, P/N J844TYBSIZE 3/8 BLACK, 172 IN.LONG UOC: DAL,V18,ZAL .....	1
3	MFFZZ		81343	J844TYBSIZE 3/8 BLACK-159	HOSE,NONMETALLIC MAKE FROM HOSE, P/N J844TYBSIZE 3/8 BLACK, 159 IN.LONG UOC: DAE,DAF,DAG,DAH,V19,V20, V21,V22,ZAE,ZAF,ZAG,ZAH .....	1
3	MFFZZ		81343	J844TYBSIZE 3/8 BLACK-174	HOSE,NONMETALLIC MAKE FROM HOSE, P/N J844TYBSIZE 3/8 BLACK, 174 IN.LONG UOC: DAC,DAD,DAJ,V16,V17,ZAC, ZAD,ZAJ .....	1
4	PAFZZ	4730-00-196-1964	81346	B687R-10B	NIPPLE,PIPE UOC: DAC,DAD,DAE,DAF,DAG,DA H,DAJ,DAL,DAW,DAX,V14,V15,V16, V17,V18,V19,V20,V21,V22,V24,ZAA, ZAB,ZAC,ZAD,ZAE,ZAF,ZAG,ZAH,Z AJ,ZAL .....	1
5	PAFZZ	5340-00-151-9651	80205	MS21333-129	CLAMP,LOOP UOC: DAC,DAD,DAE,DAF,DAG,DA H,DAJ,DAL,DAW,DAX,V14,V15,V16, V17,V18,V19,V20,V21,V22,V24,ZAA, ZAB,ZAC,ZAD,ZAE,ZAF,ZAG,ZAH,Z AJ,ZAL .....	2

(1) ITEM NO.	(2) SMR CODE	(3) NSN	(4) CAGEC	(5) PART NUMBER	(6) DESCRIPTION AND USABLE ON CODE (UOC)	(7) QTY
6	PAFZZ	5340-01-197-7597	19207	7529133-7	CLAMP,LOOP UOC: DAC,DAD,DAE,DAF,DAG,DA H,DAJ,DAL,DAW,DAX,V14,V15,V16, V17,V18,V19,V20,V21,V22,V24,ZAA, ZAB,ZAC,ZAD,ZAE,ZAF,ZAG,ZAH,Z AJ,ZAL .....	1
7	PAFZZ	4730-00-069-1187	81343	SAE J246 6-4 100202BA	ELBOW,PIPE TO TUBE UOC: DAC,DAD,DAE,DAF,DAG,DA H,DAJ,DAL,DAW,DAX,V14,V15,V16, V17,V18,V19,V20,V21,V22,V24,ZAA, ZAB,ZAC,ZAD,ZAE,ZAF,ZAG,ZAH,Z AJ,ZAL .....	1
8	MFFZZ		81343	J844TYBSIZE 3/8 BLACK-24	HOSE,NONMETALLIC MAKE FROM HOSE, P/N J844TYBSIZE 3/8 BLACK, 24 IN.LONG UOC: DAC,DAD,DAE,DAF,DAG,DA H,DAJ,DAL,DAW,DAX,V14,V15,V16, V17,V18,V19,V20,V21,V22,V24,ZAA, ZAB,ZAC,ZAD,ZAE,ZAF,ZAG,ZAH,Z AJ,ZAL .....	2
9	PAFZZ	4730-00-069-1186	81343	6-4 120102BA	ADAPTER,STRAIGHT,PI UOC: DAC,DAD,DAE,DAF,DAG,DA H,DAJ,DAL,DAW,DAX,V14,V15,V16, V17,V18,V19,V20,V21,V22,V24,ZAA, ZAB,ZAC,ZAD,ZAE,ZAF,ZAG,ZAH,Z AJ,ZAL .....	3
10	PAFZZ	5305-00-269-2804	80205	MS90726-61	SCREW,CAP,HEXAGON H UOC: DAC,DAD,DAE,DAF,DAG,DA H,DAJ,DAL,DAW,DAX,V14,V15,V16, V17,V18,V19,V20,V21,V22,V24,ZAA, ZAB,ZAC,ZAD,ZAE,ZAF,ZAG,ZAH,Z AJ,ZAL .....	1
11	PAFZZ	4730-01-112-6561	9S775	11669082	CROSS,PIPE UOC: DAC,DAD,DAE,DAF,DAG,DA H,DAJ,DAL,DAW,DAX,V14,V15,V16, V17,V18,V19,V20,V21,V22,V24,ZAA, ZAB,ZAC,ZAD,ZAE,ZAF,ZAG,ZAH,Z AJ,ZAL .....	1
12	PAFZZ	5310-00-814-0672	96906	M45913/3-6FG8C	NUT,SELF-LOCKING,HE UOC: DAC,DAD,DAE,DAF,DAG,DA H,DAJ,DAL,DAW,DAX,V14,V15,V16, V17,V18,V19,V20,V21,V22,V24,ZAA, ZAB,ZAC,ZAD,ZAE,ZAF,ZAG,ZAH,Z AJ,ZAL .....	1

(1) ITEM NO.	(2) SMR CODE	(3) NSN	(4) CAGEC	(5) PART NUMBER	(6) DESCRIPTION AND USABLE ON CODE (UOC)	(7) QTY
13	PAFZZ	4730-00-289-4052	81343	6-2 120203BA	ELBOW,PIPE TO TUBE UOC: DAC,DAD,DAE,DAF,DAG,DA H,DAJ,DAL,DAW,DAX,V14,V15,V16, V17,V18,V19,V20,V21,V22,V24,ZAA, ZAB,ZAC,ZAD,ZAE,ZAF,ZAG,ZAH,Z AJ,ZAL .....	1

END OF FIGURE





**FIELD MAINTENANCE  
TRANSFER SHIFT MECHANISMS**

---

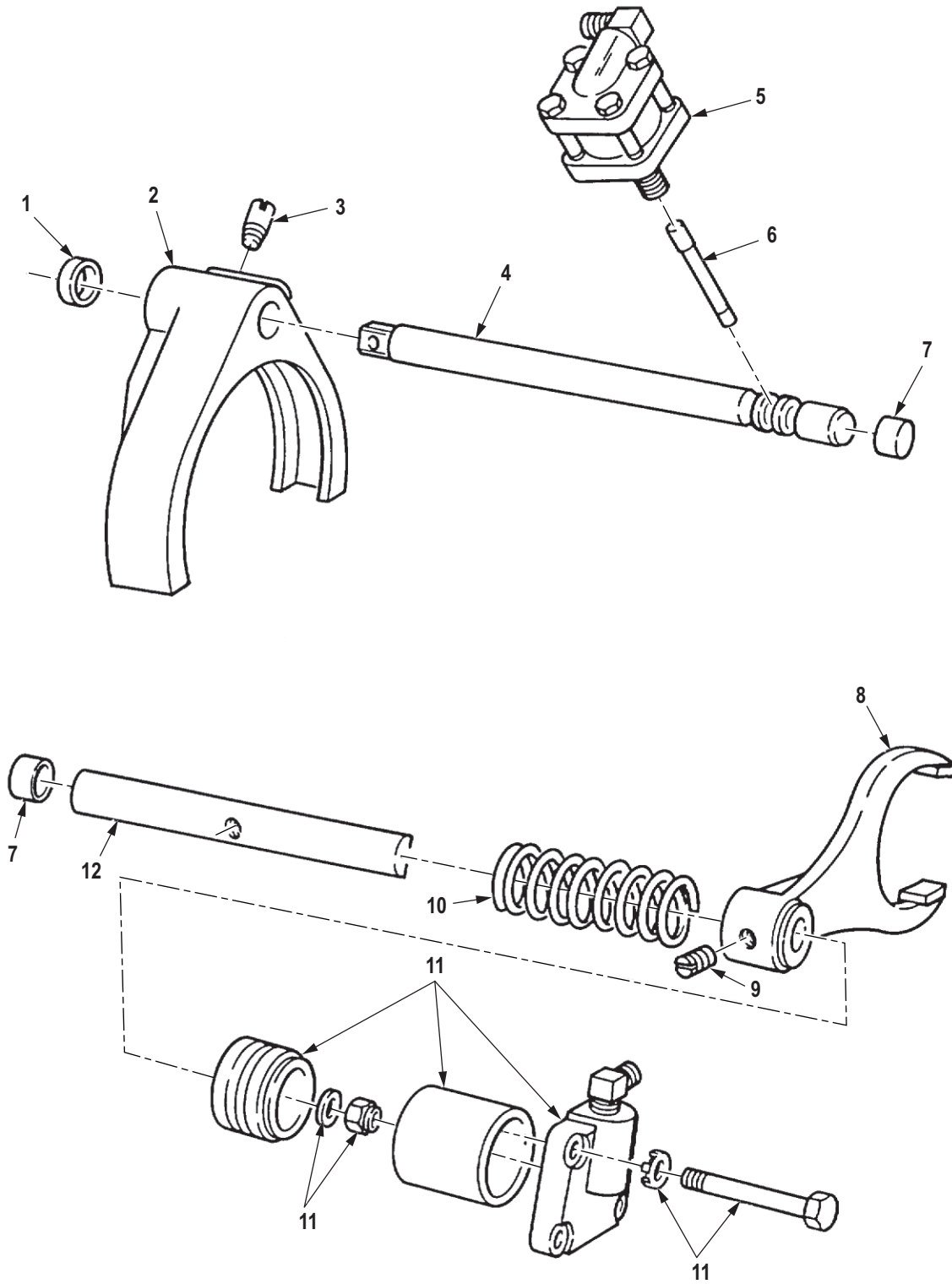

R0231DAA

Figure 216. Transfer Shift Mechanisms.

(1) ITEM NO.	(2) SMR CODE	(3) NSN	(4) CAGEC	(5) PART NUMBER	(6) DESCRIPTION AND USABLE ON CODE (UOC)	(7) QTY
<b>GROUP 0803 GEARSHIFT, VACUUM BOOSTER AND CONTROLS.</b>						
<b>FIG. 216. TRANSFER SHIFT MECHANISMS.</b>						
1	PAHZZ	5330-01-132-8346	3D6E9	A-1205-P-1758	SEAL,PLAIN ENCASED UOC: DAC,DAD,DAE,DAF,DAG,DA H,DAJ,DAL,DAW,DAX,V14,V15,V16, V17,V18,V19,V20,V21,V22,V24,ZAA, ZAB,ZAC,ZAD,ZAE,ZAF,ZAG,ZAH,Z AJ,ZAL .....	1
2	PAHZZ	2520-01-136-8717	78500	3296C-107	SHIFTER FORK,VEHICU UOC: DAC,DAD,DAE,DAF,DAG,DA H,DAJ,DAL,DAW,DAX,V14,V15,V16, V17,V18,V19,V20,V21,V22,V24,ZAA, ZAB,ZAC,ZAD,ZAE,ZAF,ZAG,ZAH,Z AJ,ZAL .....	1
3	PAHZZ	5305-01-142-2793	3D6E9	26X-235	SETSCREW UOC: DAC,DAD,DAE,DAF,DAG,DA H,DAJ,DAL,DAW,DAX,V14,V15,V16, V17,V18,V19,V20,V21,V22,V24,ZAA, ZAB,ZAC,ZAD,ZAE,ZAF,ZAG,ZAH,Z AJ,ZAL .....	1
4	PAHZZ	3040-01-134-1318	78500	2244-Z-26	SHAFT,STRAIGHT UOC: DAC,DAD,DAE,DAF,DAG,DA H,DAJ,DAL,DAW,DAX,V14,V15,V16, V17,V18,V19,V20,V21,V22,V24,ZAA, ZAB,ZAC,ZAD,ZAE,ZAF,ZAG,ZAH,Z AJ,ZAL .....	1
5	PAHZZ	2520-01-134-0899	3D6E9	A1-3261-D-290	INTERLOCK CYLINDER, UOC: DAC,DAD,DAE,DAF,DAG,DA H,DAJ,DAL,DAW,DAX,V14,V15,V16, V17,V18,V19,V20,V21,V22,V24,ZAA, ZAB,ZAC,ZAD,ZAE,ZAF,ZAG,ZAH,Z AJ,ZAL .....	1
6	PAHZZ	2520-01-134-7657	78500	2244-D-30	LOCK,PUSHROD UOC: DAC,DAD,DAE,DAF,DAG,DA H,DAJ,DAL,DAW,DAX,V14,V15,V16, V17,V18,V19,V20,V21,V22,V24,ZAA, ZAB,ZAC,ZAD,ZAE,ZAF,ZAG,ZAH,Z AJ,ZAL .....	1
7	PAHZZ	5340-00-752-1372	19207	7521372	PLUG,EXPANSION UOC: DAC,DAD,DAE,DAF,DAG,DA H,DAJ,DAL,DAW,DAX,V14,V15,V16, V17,V18,V19,V20,V21,V22,V24,ZAA, ZAB,ZAC,ZAD,ZAE,ZAF,ZAG,ZAH,Z AJ,ZAL .....	2

(1) ITEM NO.	(2) SMR CODE	(3) NSN	(4) CAGEC	(5) PART NUMBER	(6) DESCRIPTION AND USABLE ON CODE (UOC)	(7) QTY
8	PAHZZ	2520-01-136-8718	78500	3296-V-74	FORK,FRONT DECLUTCH UOC: DAC,DAD,DAE,DAF,DAG,DA H,DAJ,DAL,DAW,DAX,V14,V15,V16, V17,V18,V19,V20,V21,V22,V24,ZAA, ZAB,ZAC,ZAD,ZAE,ZAF,ZAG,ZAH,Z AJ,ZAL .....	1
9	PAHZZ	5305-01-142-2794	3D6E9	26X-230	SETSCREW UOC: DAC,DAD,DAE,DAF,DAG,DA H,DAJ,DAL,DAW,DAX,V14,V15,V16, V17,V18,V19,V20,V21,V22,V24,ZAA, ZAB,ZAC,ZAD,ZAE,ZAF,ZAG,ZAH,Z AJ,ZAL .....	1
10	PAHZZ	5360-01-147-4787	78500	2258-P-640	SPRING UOC: DAC,DAD,DAE,DAF,DAG,DA H,DAJ,DAL,DAW,DAX,V14,V15,V16, V17,V18,V19,V20,V21,V22,V24,ZAA, ZAB,ZAC,ZAD,ZAE,ZAF,ZAG,ZAH,Z AJ,ZAL .....	1
11	PAHZZ	3040-01-149-1111	78500	A-3261-S-253	CYLINDER ASSEMBLY,A UOC: DAC,DAD,DAE,DAF,DAG,DA H,DAJ,DAL,DAW,DAX,V14,V15,V16, V17,V18,V19,V20,V21,V22,V24,ZAA, ZAB,ZAC,ZAD,ZAE,ZAF,ZAG,ZAH,Z AJ,ZAL .....	1
12	PAHZZ	2520-01-136-8719	3D6E9	2244-Y-25	SHAFT,DECLUTCH UOC: DAC,DAD,DAE,DAF,DAG,DA H,DAJ,DAL,DAW,DAX,V14,V15,V16, V17,V18,V19,V20,V21,V22,V24,ZAA, ZAB,ZAC,ZAD,ZAE,ZAF,ZAG,ZAH,Z AJ,ZAL .....	1

END OF FIGURE

**FIELD MAINTENANCE  
TRANSFER OIL PUMP AND RELATED PARTS**

---

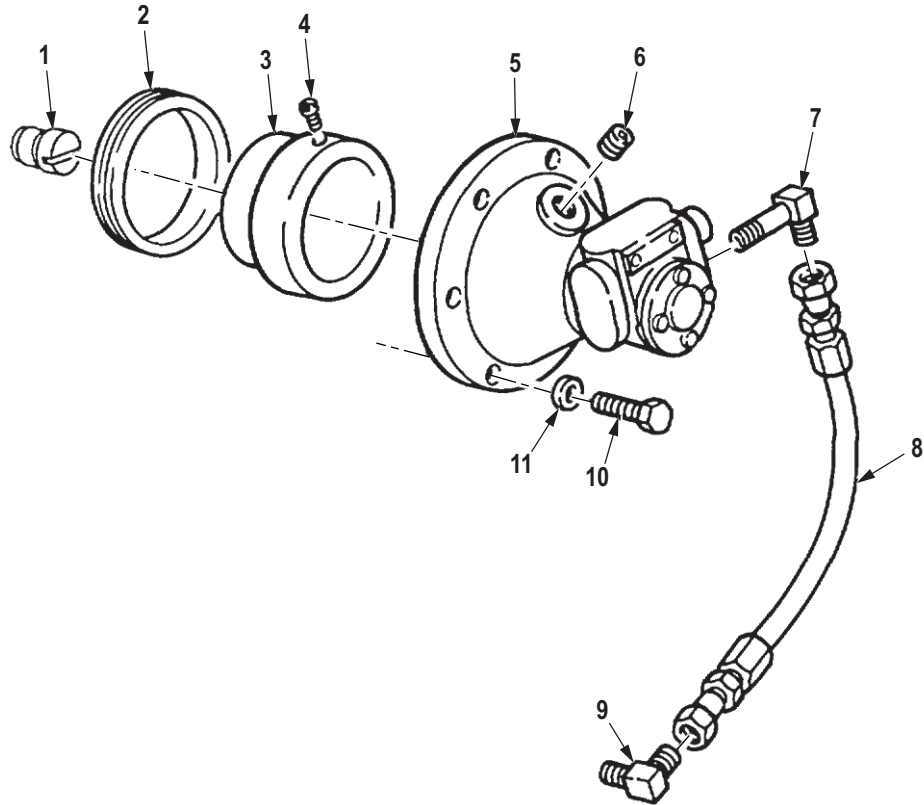

R0232DAA

Figure 217. Transfer Oil Pump and Related Parts.

(1) ITEM NO.	(2) SMR CODE	(3) NSN	(4) CAGEC	(5) PART NUMBER	(6) DESCRIPTION AND USABLE ON CODE (UOC)	(7) QTY
					<b>GROUP 0804 LUBRICATION, COOLING, OR HYDRAULIC COMPONENTS.</b>	
					<b>FIG. 217. TRANSFER OIL PUMP AND RELATED PARTS.</b>	
1	PAFZZ	2520-01-142-1979	78500	2297-J-3832	BUTTON,PUMP DRIVE UOC: DAC,DAD,DAE,DAF,DAG,DA H,DAJ,DAW,DAX,V14,V15,V16,V17, V20,V21,V22,V24,ZAA,ZAB,ZAC,ZA D,ZAE,ZAF,ZAG,ZAH,ZAJ .....	1
2	PAFZZ	5330-01-137-4799	78500	1205-Y-1663	SEAL,PACKING UOC: DAC,DAD,DAE,DAF,DAG,DA H,DAJ,DAW,DAX,V14,V15,V16,V20, V21,V22,V24,ZAA,ZAB,ZAC,ZAD,ZA E,ZAF,ZAG,ZAH,ZAJ .....	1
3	PAFZZ	3040-01-134-3605	78500	2207-K-11	COLLAR,SHAFT UOC: DAC,DAD,DAE,DAF,DAG,DA H,DAJ,DAW,DAX,V14,V15,V16,V20, V21,V22,V24,ZAA,ZAB,ZAC,ZAD,ZA E,ZAF,ZAG,ZAH,ZAJ .....	1
4	PAFZZ	5305-01-142-2792	78500	S-853	SETSCREW UOC: DAC,DAD,DAE,DAF,DAG,DA H,DAJ,DAW,DAX,V14,V15,V16,V17, V20,V21,V22,V24,ZAA,ZAB,ZAC,ZA D,ZAE,ZAF,ZAG,ZAH,ZAJ .....	1
5	PAFZZ	2815-01-136-8720	78500	A-3303-J-10	OIL PUMP ASSEMBLY TRANSFER TRANSMISSION UOC: DAC,DAD,DAE,DAF,DAG,DA H,DAJ,DAW,DAX,V14,V15,V16,V17, V19,V20,V21,V22,V24,ZAA,ZAB,ZAC ,ZAD,ZAE,ZAF,ZAG,ZAH,ZAJ .....	1
6	PAFZZ	5365-01-129-6777	78500	P-26	PLUG,MACHINE THREAD UOC: DAC,DAD,DAE,DAF,DAG,DA H,DAJ,DAW,DAX,V14,V15,V16,V17, V19,V20,V21,V22,V24,ZAA,ZAB,ZAC ,ZAD,ZAE,ZAF,ZAG,ZAH,ZAJ .....	1
7	PAFZZ	4730-01-127-7346	4N361	2501LL-06-06	ELBOW,PIPE TO HOSE UOC: DAC,DAD,DAE,DAF,DAG,DA H,DAJ,DAW,DAX,V14,V15,V16,V17, V20,V21,V22,V24,ZAA,ZAB,ZAC,ZA D,ZAE,ZAF,ZAG,ZAH,ZAJ .....	1
8	PAFZZ	4720-01-126-9555	3D6E9	A-2296-C-81	HOSE ASSEMBLY,NONME UOC: DAC,DAD,DAE,DAF,DAG,DA H,DAJ,DAW,DAX,V14,V15,V16,V17, V20,V21,V22,V24,ZAA,ZAB,ZAC,ZA D,ZAE,ZAF,ZAG,ZAH,ZAJ .....	1

(1) ITEM NO.	(2) SMR CODE	(3) NSN	(4) CAGEC	(5) PART NUMBER	(6) DESCRIPTION AND USABLE ON CODE (UOC)	(7) QTY
9	PAFZZ	4730-01-134-6988	78500	2206-F-58	ELBOW,PIPE TO TUBE UOC: DAC,DAD,DAE,DAF,DAG,DA H,DAJ,DAW,DAX,V14,V15,V16,V17, V19,V20,V21,V22,V24,ZAA,ZAB,ZAC ,ZAD,ZAE,ZAF,ZAG,ZAH,ZAJ .....	1
10	PAFZZ	5305-00-338-5162	78500	S2710-2	SCREW,SPECIAL UOC: DAC,DAD,DAE,DAF,DAG,DA H,DAJ,DAW,DAX,V14,V15,V16,V17, V20,V21,V22,V24,ZAA,ZAB,ZAC,ZA D,ZAE,ZAF,ZAG,ZAH,ZAJ .....	6
11	PAFZZ	5310-00-893-3381	19207	7748744	WASHER,FLAT UOC: DAC,DAD,DAE,DAF,DAG,DA H,DAJ,DAW,DAX,V14,V15,V16,V17, V20,V21,V22,V24,ZAA,ZAB,ZAC,ZA D,ZAE,ZAF,ZAG,ZAH,ZAJ .....	6

END OF FIGURE



**FIELD MAINTENANCE**  
**PROPELLER SHAFT ASSEMBLY, FRONT AXLE TO TRANSFER SHAFT (DANA) (M939, M939A1)**

---

1	6
2-11	7

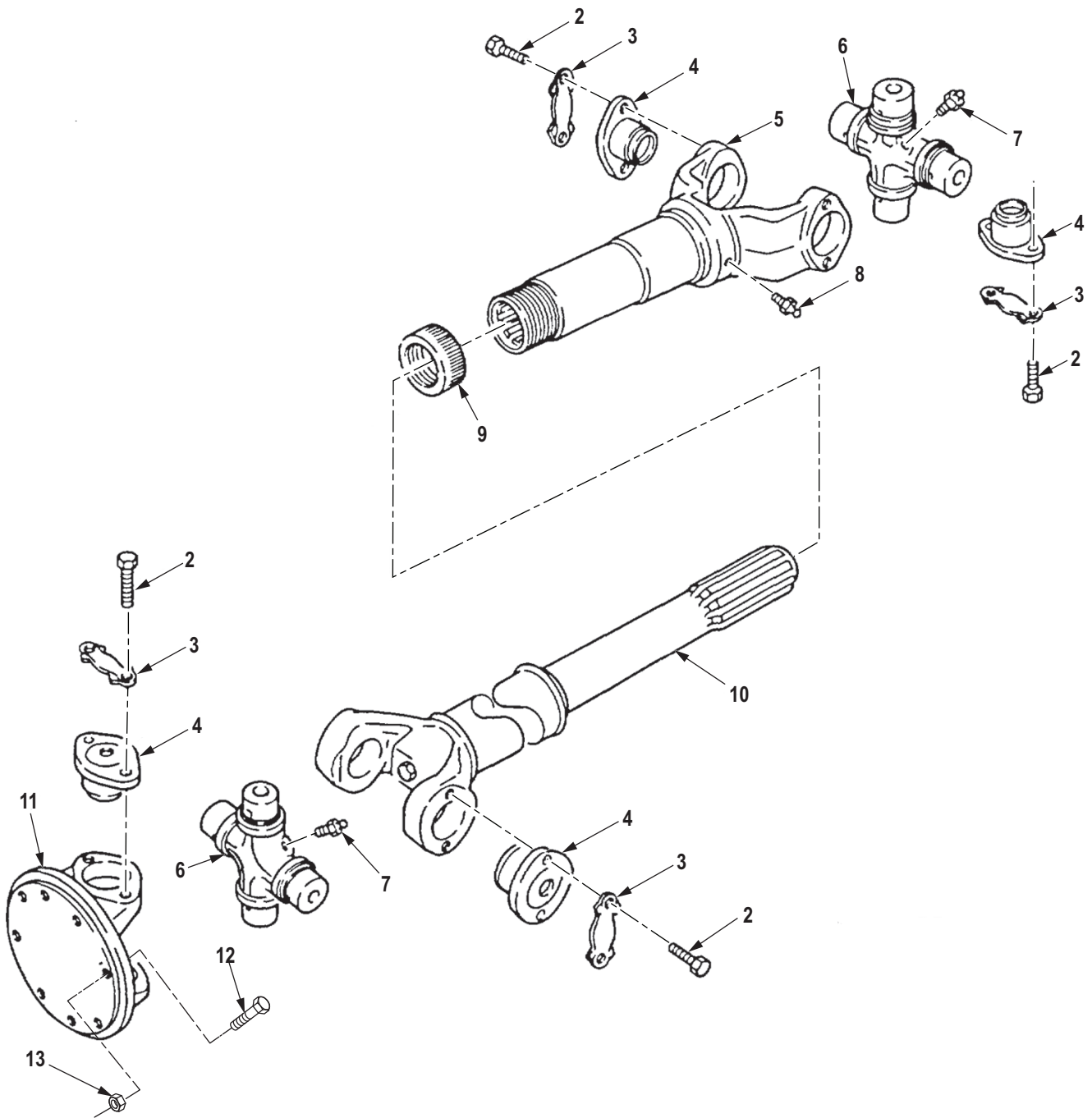

R0233DAA

Figure 218. Propeller Shaft Assembly, Front Axle to Transfer Shaft (Dana) (M939, M939A1).

(1) ITEM NO.	(2) SMR CODE	(3) NSN	(4) CAGEC	(5) PART NUMBER	(6) DESCRIPTION AND USABLE ON CODE (UOC)	(7) QTY
<b>GROUP 0900 PROPELLER SHAFTS.</b>						
<b>FIG. 218. PROPELLER SHAFT ASSEMBLY, FRONT AXLE TO TRANSFER SHAFT (DANA) (M939, M939A1).</b>						
1	PAFFF	2520-01-112-8366	95019	912257-0416	DRIVE SHAFT ASSEMBL USE WITH SHAFT ASSEMBLY P/N 908930-3716 UOC: DAC,DAD,DAE,DAF,DAG,DA H,DAJ,DAL,DAW,DAX,V14,V15,V16, V17,V18,V19,V20,V21,V22,V24 .....	1
2	KFFZZ	5306-00-679-8343	61822	920095-15	. BOLT,MACHINE PART OF KIT P/N CP16NS UOC: DAC,DAD,DAE,DAF,DAG,DA H,DAJ,DAL,DAW,DAX,V14,V15,V16, V17,V18,V19,V20,V21,V22,V24 .....	16
3	KFFZZ	5340-00-521-4479	95019	98-741	. LOCKING PLATE,NUT A PART OF KIT P/N CP16NS UOC: DAC,DAD,DAE,DAF,DAG,DA H,DAJ,DAL,DAW,DAX,V14,V15,V16, V17,V18,V19,V20,V21,V22,V24 .....	8
4	KFFZZ		19207	7066101	. BEARING,ASSY,NEEDLE SPIDER,UNIVERSAL NHA P/N 5190076 95019 PART OF KIT P/N CP16NS UOC: DAC,DAD,DAE,DAF,DAG,DA H,DAJ,DAL,DAW,DAX,V14,V15,V16, V17,V18,V19,V20,V21,V22,V24 .....	8
5	XAFZZ		95019	5-3-2751X	. YOKE,UNIVERSAL JOIN UOC: DAC,DAD,DAE,DAF,DAG,DA H,DAJ,DAL,DAW,DAX,V14,V15,V16, V17,V18,V19,V20,V21,V22,V24 .....	1
6	KFFZZ		19207	7066097	. CROSS,ASSEMBLY,UNIV PART OF KIT P/N CP16NS UOC: DAC,DAD,DAE,DAF,DAG,DA H,DAJ,DAL,DAW,DAX,V14,V15,V16, V17,V18,V19,V20,V21,V22,V24 .....	2
7	PAFZZ	4730-00-050-4203	81343	AS15001-1	. . FITTING,LUBRICATION PART OF KIT P/N CP16NS UOC: DAC,DAD,DAE,DAF,DAG,DA H,DAJ,DAL,DAW,DAX,V14,V15,V16, V17,V18,V19,V20,V21,V22,V24 .....	1
8	PAFZZ	4730-00-906-0982	16662	007-10-H-28	. FITTING,LUBRICATION PROPSHAFT YOKE UOC: DAC,DAD,DAE,DAF,DAG,DA H,DAJ,DAL,DAW,DAX,V14,V15,V16, V17,V18,V19,V20,V21,V22,V24 .....	1

(1) ITEM NO.	(2) SMR CODE	(3) NSN	(4) CAGEC	(5) PART NUMBER	(6) DESCRIPTION AND USABLE ON CODE (UOC)	(7) QTY
9	PAFZZ	2520-00-457-6660	72447	4-14-19	. CAP,DUST,PROPELLER UOC: DAC,DAD,DAE,DAF,DAG,DA H,DAJ,DAL,DAW,DAX,V14,V15,V16, V17,V18,V19,V20,V21,V22,V24 .....	1
10	XAFZZ		95019	5-60-354	. SHAFT,PROP,ASSEMBLY UOC: DAC,DAD,DAE,DAF,DAG,DA H,DAJ,DAL,DAW,DAX,V14,V15,V16, V17,V18,V19,V20,V21,V22,V24 .....	1
11	PAFZZ	2520-00-009-5304	19207	7066092	. YOKE,UNIVERSAL JOIN UOC: DAC,DAD,DAE,DAF,DAG,DA H,DAJ,DAL,DAW,DAX,V14,V15,V16, V17,V18,V19,V20,V21,V22,V24 .....	1
12	PAFZZ	5306-00-720-8747	80205	MS20073-06-12	BOLT,MACHINE UOC: DAC,DAD,DAE,DAF,DAG,DA H,DAJ,DAL,DAW,DAX,V14,V15,V16, V17,V18,V19,V20,V21,V22,V24 .....	8
13	PAFZZ	5310-00-814-0672	96906	M45913/3-6FG8C	NUT,SELF-LOCKING,HE UOC: DAC,DAD,DAE,DAF,DAG,DA H,DAJ,DAL,DAW,DAX,V14,V15,V16, V17,V18,V19,V20,V21,V22,V24 .....	8

END OF FIGURE

**FIELD MAINTENANCE**  
**PROPELLER SHAFT ASSEMBLY, FRONT AXLE TO TRANSFER SHAFT (ROCKWELL) (M939, M939A1)**

---

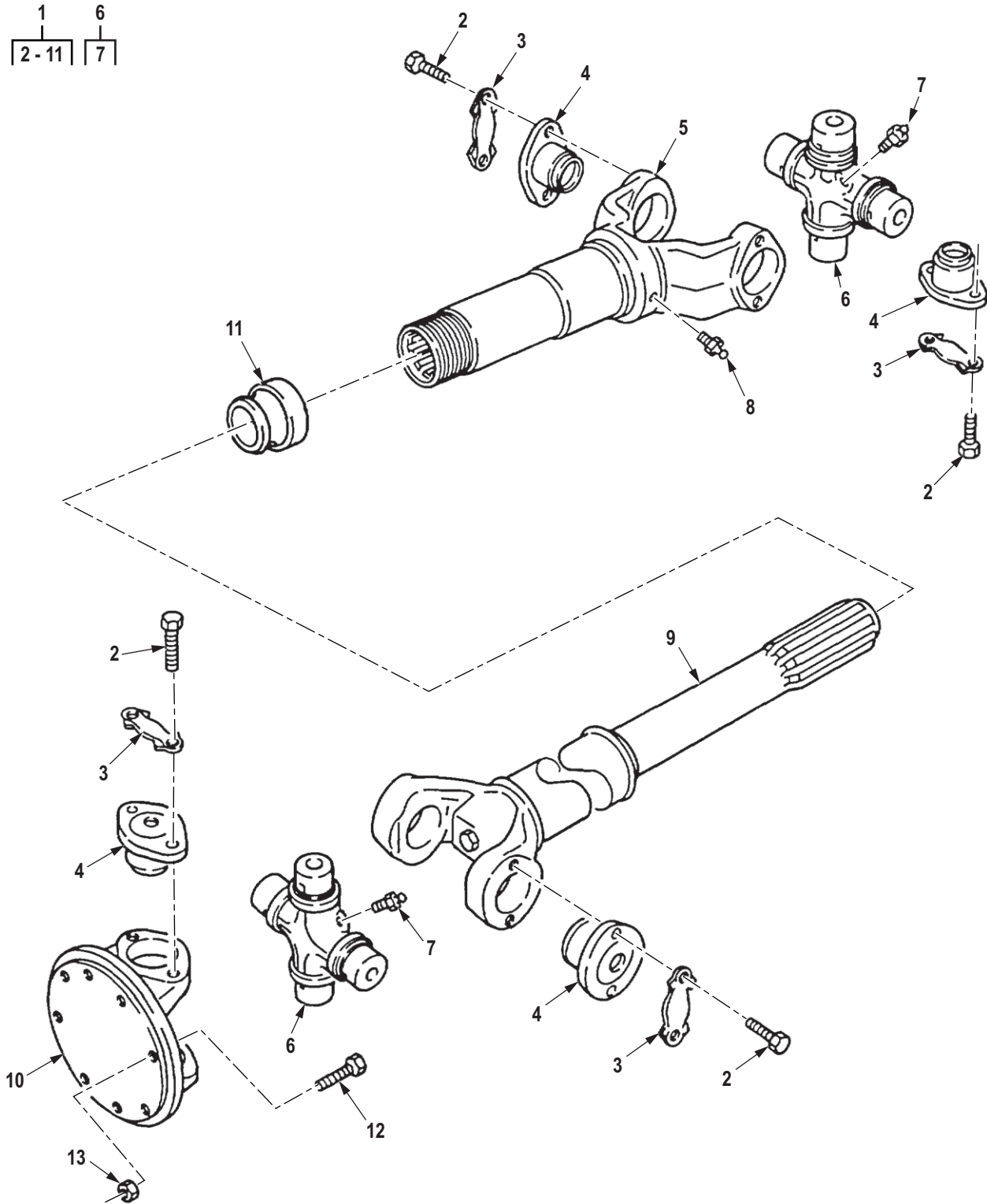

R0234DAA

Figure 219. Propeller Shaft Assembly, Front Axle to Transfer Shaft (Rockwell) (M939, M939A1).

(1) ITEM NO.	(2) SMR CODE	(3) NSN	(4) CAGEC	(5) PART NUMBER	(6) DESCRIPTION AND USABLE ON CODE (UOC)	(7) QTY
<b>GROUP 0900 PROPELLER SHAFTS.</b>						
<b>FIG. 219. PROPELLER SHAFT ASSEMBLY, FRONT AXLE TO TRANSFER SHAFT (ROCKWELL) (M939, M939A1).</b>						
1	PAFFF	2520-01-127-6950	78500	9830444760	PROPELLER SHAFT FRONT AXLE TO TRANSFER SHAFT,USE WITH SHAFT ASSEMBLYP/N 9836444761 UOC: DAC,DAD,DAE,DAF,DAG,DA H,DAJ,DAL,DAW,DAX,V14,V15,V16, V17,V18,V19,V20,V21,V22,V24 .....	1
2	KFFZZ		70960	CS-H5-24-15	. SCREW PART OF KIT P/N CP16NS UOC: DAC,DAD,DAE,DAF,DAG,DA H,DAJ,DAL,DAW,DAX,V14,V15,V16, V17,V18,V19,V20,V21,V22,V24 .....	16
3	KFFZZ		70960	LPHC37-1	. LOCKPLATE PART OF KIT P/N CP16NS UOC: DAC,DAD,DAE,DAF,DAG,DA H,DAJ,DAL,DAW,DAX,V14,V15,V16, V17,V18,V19,V20,V21,V22,V24 .....	8
4	KFFZZ		70960	16N4-3A	. BEARING ASSEMBLY PART OF KIT P/N CP16NS UOC: DAC,DAD,DAE,DAF,DAG,DA H,DAJ,DAL,DAW,DAX,V14,V15,V16, V17,V18,V19,V20,V21,V22,V24 .....	8
5	XAFZZ		70960	16NLS32-2	. YOKE UOC: DAC,DAD,DAE,DAF,DAG,DA H,DAJ,DAL,DAW,DAX,V14,V15,V16, V17,V18,V19,V20,V21,V22,V24 .....	1
6	KFFZZ		70960	16N1-1A	. CROSS ASSEMBLY PART OF KIT P/N CP16NS UOC: DAC,DAD,DAE,DAF,DAG,DA H,DAJ,DAL,DAW,DAX,V14,V15,V16, V17,V18,V19,V20,V21,V22,V24 .....	2
7	PAFZZ	4730-00-172-0031	81343	AS15003-5C	. . FITTING,LUBRICATION UOC: DAC,DAD,DAE,DAF,DAG,DA H,DAJ,DAL,DAW,DAX,V14,V15,V16, V17,V18,V19,V20,V21,V22,V24 .....	1
8	PAFZZ	4730-00-172-0031	81343	AS15003-5C	. FITTING,LUBRICATION UOC: DAC,DAD,DAE,DAF,DAG,DA H,DAJ,DAL,DAW,DAX,V14,V15,V16, V17,V18,V19,V20,V21,V22,V24 .....	1
9	XAFZZ		70960	983-55-44760	. SHAFT ASSEMBLY,PROP UOC: DAC,DAD,DAE,DAF,DAG,DA H,DAJ,DAL,DAW,DAX,V14,V15,V16, V17,V18,V19,V20,V21,V22,V24 .....	1

(1) ITEM NO.	(2) SMR CODE	(3) NSN	(4) CAGEC	(5) PART NUMBER	(6) DESCRIPTION AND USABLE ON CODE (UOC)	(7) QTY
10	XAFZZ		70960	16NF3	. YOKE, UNIVERSAL JOIN UOC: DAC, DAD, DAE, DAF, DAG, DA H, DAJ, DAL, DAW, DAX, V14, V15, V16, V17, V18, V19, V20, V21, V22, V24 .....	1
11	PAFZZ	5330-01-135-3376	78500	SE-RUR25-2	. SEAL, SHAFT UOC: DAC, DAD, DAE, DAF, DAG, DA H, DAJ, DAL, DAW, DAX, V14, V15, V16, V17, V18, V19, V20, V21, V22, V24 .....	1
12	PAFZZ	5306-00-720-8747	80205	MS20073-06-12	BOLT, MACHINE UOC: DAC, DAD, DAE, DAF, DAG, DA H, DAJ, DAL, DAW, DAX, V14, V15, V16, V17, V18, V19, V20, V21, V22, V24 .....	8
13	PAFZZ	5310-00-814-0672	96906	M45913/3-6FG8C	NUT, SELF-LOCKING, HE UOC: DAC, DAD, DAE, DAF, DAG, DA H, DAJ, DAL, DAW, DAX, V14, V15, V16, V17, V18, V19, V20, V21, V22, V24 .....	8

END OF FIGURE



**FIELD MAINTENANCE**  
**PROPELLER SHAFT ASSEMBLY, TRANSFER TO FRONT AXLE SHAFT (DANA) (M939, M939A1)**

---

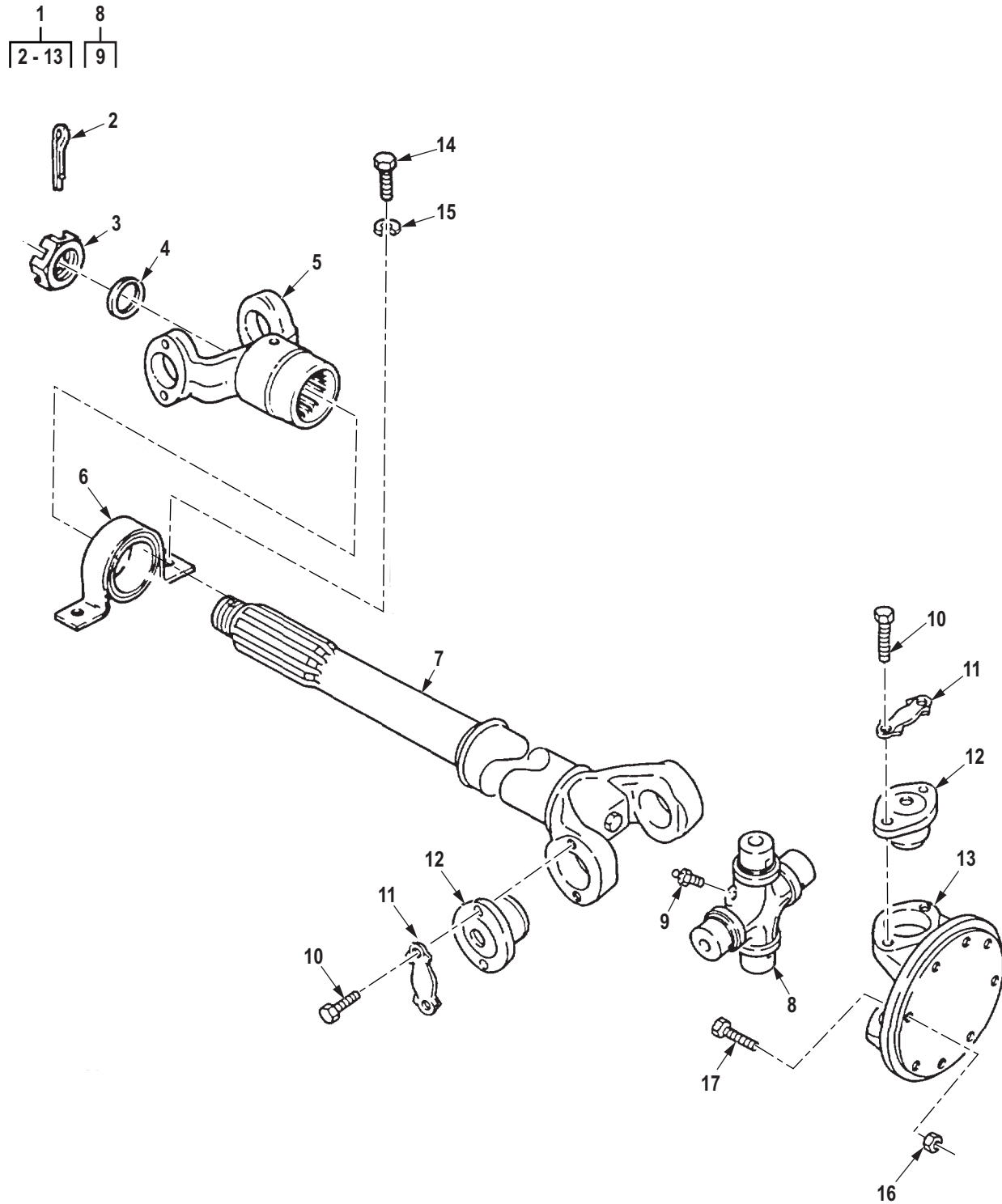

R0235DAA

Figure 220. Propeller Shaft Assembly, Transfer to Front Axle Shaft (Dana) (M939, M939A1).

(1) ITEM NO.	(2) SMR CODE	(3) NSN	(4) CAGEC	(5) PART NUMBER	(6) DESCRIPTION AND USABLE ON CODE (UOC)	(7) QTY
<b>GROUP 0900 PROPELLER SHAFTS.</b>						
<b>FIG. 220. PROPELLER SHAFT ASSEMBLY, TRANSFER TO FRONT AXLE SHAFT (DANA) (M939, M939A1).</b>						
1	PAFFF	2520-01-112-2157	72447	908930-3716	PROPELLER SHAFT ASS USE WITH SHAFT ASSEMBLY P/N 912257-0416 UOC: DAC,DAD,DAE,DAF,DAG,DA H,DAJ,DAL,DAW,DAX,V14,V15,V16, V17,V18,V19,V20,V21,V22,V24 .....	1
2	PAFZZ	5315-00-298-1498	80205	MS24665-362	. PIN,COTTER UOC: DAC,DAD,DAE,DAF,DAG,DA H,DAJ,DAL,DAW,DAX,V14,V15,V16, V17,V18,V19,V20,V21,V22,V24 .....	1
3	PAFZZ	5310-01-058-3772	78500	1227-Z-936	. NUT,PLAIN,SLOTTED,H UOC: DAC,DAD,DAE,DAF,DAG,DA H,DAJ,DAL,DAW,DAX,V14,V15,V16, V17,V18,V19,V20,V21,V22,V24 .....	1
4	PAFZZ	5310-01-217-0706	72447	231502	. WASHER,PLAIN,EXT W/WASHER UOC: DAC,DAD,DAE,DAF,DAG,DA H,DAJ,DAL,DAW,DAX,V14,V15,V16, V17,V18,V19,V20,V21,V22,V24 .....	1
5	XAFZZ		95019	5-4-1721	. END YOKE PROPELLOR SHAFT UOC: DAC,DAD,DAE,DAF,DAG,DA H,DAJ,DAL,DAW,DAX,V14,V15,V16, V17,V18,V19,V20,V21,V22,V24 .....	1
6	PAFZZ	3130-00-908-8589	72447	210084-2X	. HOUSING,BEARING UNI UOC: DAC,DAD,DAE,DAF,DAG,DA H,DAJ,DAL,DAW,DAX,V14,V15,V16, V17,V18,V19,V20,V21,V22,V24 .....	1
7	XAFZZ		95019	5-60-249	. SHAFT,PROP,AXLE UOC: DAC,DAD,DAE,DAF,DAG,DA H,DAJ,DAL,DAW,DAX,V14,V15,V16, V17,V18,V19,V20,V21,V22,V24 .....	1
8	KFFZZ		19207	7066097	. CROSS,ASSEMBLY,UNIV PART OF KIT P/N CP16NS UOC: DAC,DAD,DAE,DAF,DAG,DA H,DAJ,DAL,DAW,DAX,V14,V15,V16, V17,V18,V19,V20,V21,V22,V24 .....	1
9	PAFZZ	4730-00-050-4203	81343	AS15001-1	. . FITTING,LUBRICATION CROSS ASSEMBLY UOC: DAC,DAD,DAE,DAF,DAG,DA H,DAJ,DAL,DAW,DAX,V14,V15,V16, V17,V18,V19,V20,V21,V22,V24 .....	1
10	KFFZZ	5306-00-270-7387	19207	5214483	. BOLT,MACHINE PART OF KIT P/N CP16NS UOC: DAC,DAD,DAE,DAF,DAG,DA H,DAJ,DAL,DAW,DAX,V14,V15,V16, V17,V18,V19,V20,V21,V22,V24 .....	8

(1) ITEM NO.	(2) SMR CODE	(3) NSN	(4) CAGEC	(5) PART NUMBER	(6) DESCRIPTION AND USABLE ON CODE (UOC)	(7) QTY
11	KFFZZ	5340-00-521-4479	95019	98-741	. LOCKING PLATE,NUT A PART OF KIT P/N CP16NS UOC: DAC,DAD,DAE,DAF,DAG,DA H,DAJ,DAL,DAW,DAX,V14,V15,V16, V17,V18,V19,V20,V21,V22,V24 .....	4
12	KFFZZ		19207	7066101	. BEARING,ASSY,NEEDLE SPIDER,UNIVERSAL NHA P/N 5190076 95019 PART OF KIT P/N CP16NS UOC: DAC,DAD,DAE,DAF,DAG,DA H,DAJ,DAL,DAW,DAX,V14,V15,V16, V17,V18,V19,V20,V21,V22,V24 .....	4
13	PAFZZ	2520-00-009-5304	19207	7066092	. YOKE,UNIVERSAL JOIN UOC: DAC,DAD,DAE,DAF,DAG,DA H,DAJ,DAL,DAW,DAX,V14,V15,V16, V17,V18,V19,V20,V21,V22,V24 .....	1
14	PAFZZ	5305-00-269-2804	80205	MS90726-61	SCREW,CAP,HEXAGON H UOC: DAC,DAD,DAE,DAF,DAG,DA H,DAJ,DAL,DAW,DAX,V14,V15,V16, V17,V18,V19,V20,V21,V22,V24 .....	2
15	PAFZZ	5310-00-209-0965	80205	MS35338-47	WASHER,LOCK UOC: DAC,DAD,DAE,DAF,DAG,DA H,DAJ,DAL,DAW,DAX,V14,V15,V16, V17,V18,V19,V20,V21,V22,V24 .....	2
16	PAFZZ	5310-00-814-0672	96906	M45913/3-6FG8C	NUT,SELF-LOCKING,HE UOC: DAC,DAD,DAE,DAF,DAG,DA H,DAJ,DAL,DAW,DAX,V14,V15,V16, V17,V18,V19,V20,V21,V22,V24 .....	8
17	PAFZZ	5306-00-720-8747	80205	MS20073-06-12	BOLT,MACHINE UOC: DAC,DAD,DAE,DAF,DAG,DA H,DAJ,DAL,DAW,DAX,V14,V15,V16, V17,V18,V19,V20,V21,V22,V24 .....	8

END OF FIGURE

**FIELD MAINTENANCE**  
**PROPELLER SHAFT ASSEMBLY, TRANSFER TO FRONT AXLE SHAFT (ROCKWELL) (M939, M939A1)**

---

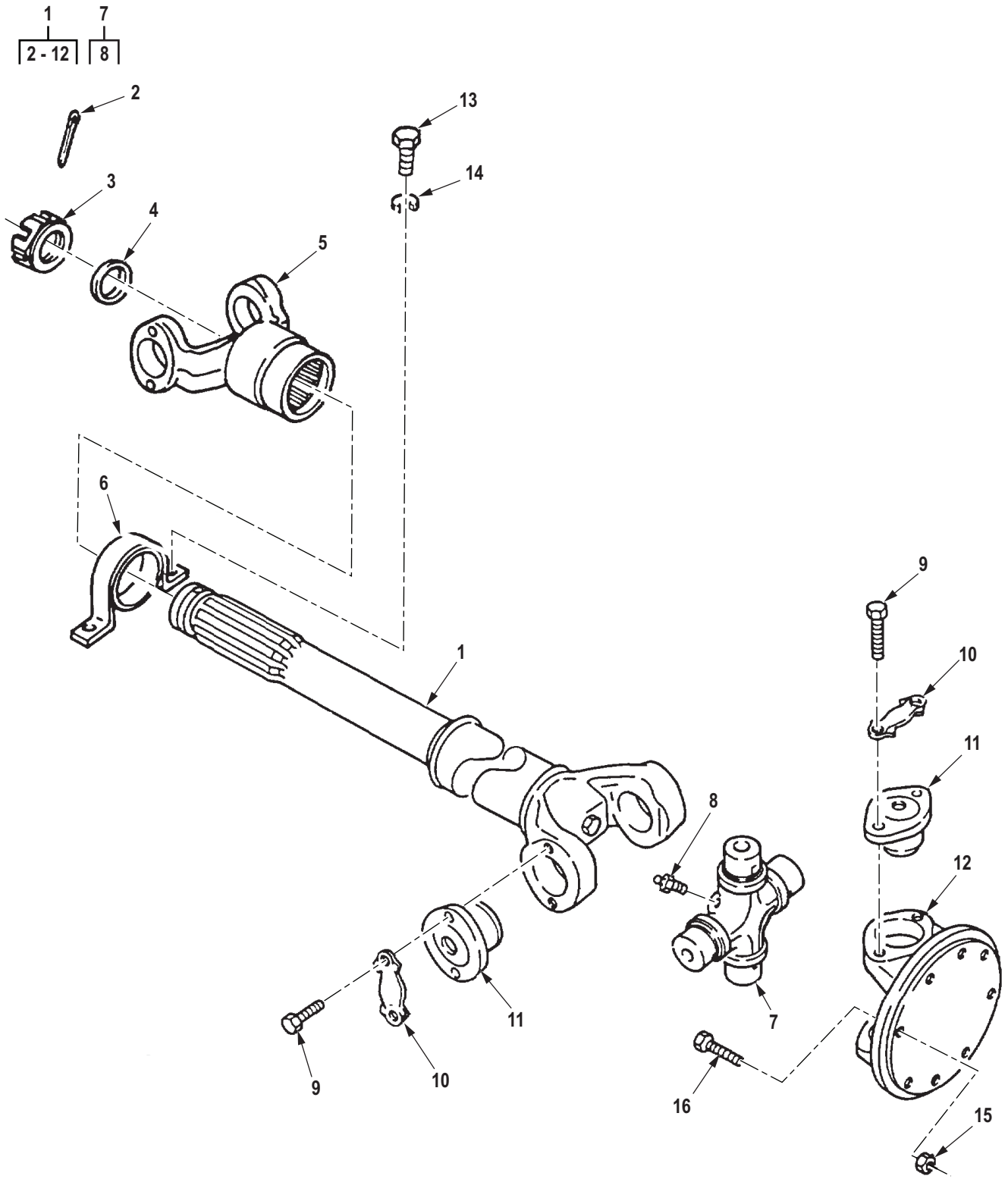

R0236DAA

Figure 221. Propeller Shaft Assembly, Transfer to Front Axle Shaft (Rockwell) (M939, M939A1).

(1) ITEM NO.	(2) SMR CODE	(3) NSN	(4) CAGEC	(5) PART NUMBER	(6) DESCRIPTION AND USABLE ON CODE (UOC)	(7) QTY
<b>GROUP 0900 PROPELLER SHAFTS.</b>						
<b>FIG. 221. PROPELLER SHAFT ASSEMBLY, TRANSFER TO FRONT AXLE SHAFT (ROCKWELL) (M939, M939A1).</b>						
1	PAFFF	2520-01-127-6951	78500	9836444761	PROPELLER SHAFT WIT USE WITH SHAFT ASSY P/N 9830444760 UOC: DAC,DAD,DAE,DAF,DAG,DA H,DAJ,DAL,DAW,DAX,V14,V15,V16, V17,V18,V19,V20,V21,V22,V24 .....	1
2	PAFZZ	5315-01-136-1659	78500	C02-40-4	. PIN,COTTER YOKE,SLOTTED NUT UOC: DAC,DAD,DAE,DAF,DAG,DA H,DAJ,DAL,DAW,DAX,V14,V15,V16, V17,V18,V19,V20,V21,V22,V24 .....	1
3	PAFZZ	5310-01-058-3772	78500	1227-Z-936	. NUT,PLAIN,SLOTTED,H UOC: DAC,DAD,DAE,DAF,DAG,DA H,DAJ,DAL,DAW,DAX,V14,V15,V16, V17,V18,V19,V20,V21,V22,V24 .....	1
4	PAFZZ	5310-01-135-6752	78500	WAR-21-3	. WASHER,FLAT UOC: DAC,DAD,DAE,DAF,DAG,DA H,DAJ,DAL,DAW,DAX,V14,V15,V16, V17,V18,V19,V20,V21,V22,V24 .....	4
5	XAFZZ		70960	16NYS28-21	. YOKE UOC: DAC,DAD,DAE,DAF,DAG,DA H,DAJ,DAL,DAW,DAX,V14,V15,V16, V17,V18,V19,V20,V21,V22,V24 .....	1
6	PAFZZ	3130-01-035-4287	3D6E9	UCB-104	. BEARING UNIT,ROLLER UOC: DAC,DAD,DAE,DAF,DAG,DA H,DAJ,DAL,DAW,DAX,V14,V15,V16, V17,V18,V19,V20,V21,V22,V24 .....	1
7	KFFZZ		70960	16N1-1A	. CROSS ASSEMBLY PART OF KIT P/N CP16NS UOC: DAC,DAD,DAE,DAF,DAG,DA H,DAJ,DAL,DAW,DAX,V14,V15,V16, V17,V18,V19,V20,V21,V22,V24 .....	1
8	PAFZZ	4730-00-172-0031	81343	AS15003-5C	. . FITTING,LUBRICATION UOC: DAC,DAD,DAE,DAF,DAG,DA H,DAJ,DAL,DAW,DAX,V14,V15,V16, V17,V18,V19,V20,V21,V22,V24 .....	1
9	KFFZZ		70960	CS-H5-24-15	. SCREW PART OF KIT P/N CP16NS UOC: DAC,DAD,DAE,DAF,DAG,DA H,DAJ,DAL,DAW,DAX,V14,V15,V16, V17,V18,V19,V20,V21,V22,V24 .....	1
10	KFFZZ		70960	LPHC37-1	. LOCKPLATE PART OF KIT P/N CP16NS UOC: DAC,DAD,DAE,DAF,DAG,DA H,DAJ,DAL,DAW,DAX,V14,V15,V16, V17,V18,V19,V20,V21,V22,V24 .....	1

(1) ITEM NO.	(2) SMR CODE	(3) NSN	(4) CAGEC	(5) PART NUMBER	(6) DESCRIPTION AND USABLE ON CODE (UOC)	(7) QTY
11	KFFZZ		70960	16N4-3A	. BEARING ASSEMBLY PART OF KIT P/N CP16NS UOC: DAC,DAD,DAE,DAF,DAG,DA H,DAJ,DAL,DAW,DAX,V14,V15,V16, V17,V18,V19,V20,V21,V22,V24 .....	1
12	XAFZZ		70960	16NF3	. YOKE,UNIVERSAL JOIN UOC: DAC,DAD,DAE,DAF,DAG,DA H,DAJ,DAL,DAW,DAX,V14,V15,V16, V17,V18,V19,V20,V21,V22,V24 .....	1
13	PAFZZ	5305-00-269-2804	80205	MS90726-61	. SCREW,CAP,HEXAGON H UOC: DAC,DAD,DAE,DAF,DAG,DA H,DAJ,DAL,DAW,DAX,V14,V15,V16, V17,V18,V19,V20,V21,V22,V24 .....	2
14	PAFZZ	5310-00-209-0965	80205	MS35338-47	WASHER,LOCK UOC: DAC,DAD,DAE,DAF,DAG,DA H,DAJ,DAL,DAW,DAX,V14,V15,V16, V17,V18,V19,V20,V21,V22,V24 .....	2
15	PAFZZ	5310-00-814-0672	96906	M45913/3-6FG8C	NUT,SELF-LOCKING,HE UOC: DAC,DAD,DAE,DAF,DAG,DA H,DAJ,DAL,DAW,DAX,V14,V15,V16, V17,V18,V19,V20,V21,V22,V24 .....	8
16	PAFZZ	5306-00-720-8747	80205	MS20073-06-12	BOLT,MACHINE UOC: DAC,DAD,DAE,DAF,DAG,DA H,DAJ,DAL,DAW,DAX,V14,V15,V16, V17,V18,V19,V20,V21,V22,V24 .....	8

END OF FIGURE



**FIELD MAINTENANCE  
PROPELLER SHAFT ASSEMBLY, TRANSFER TO FRONT AXLE SHAFT (M939A2)**

---

1  
2-7

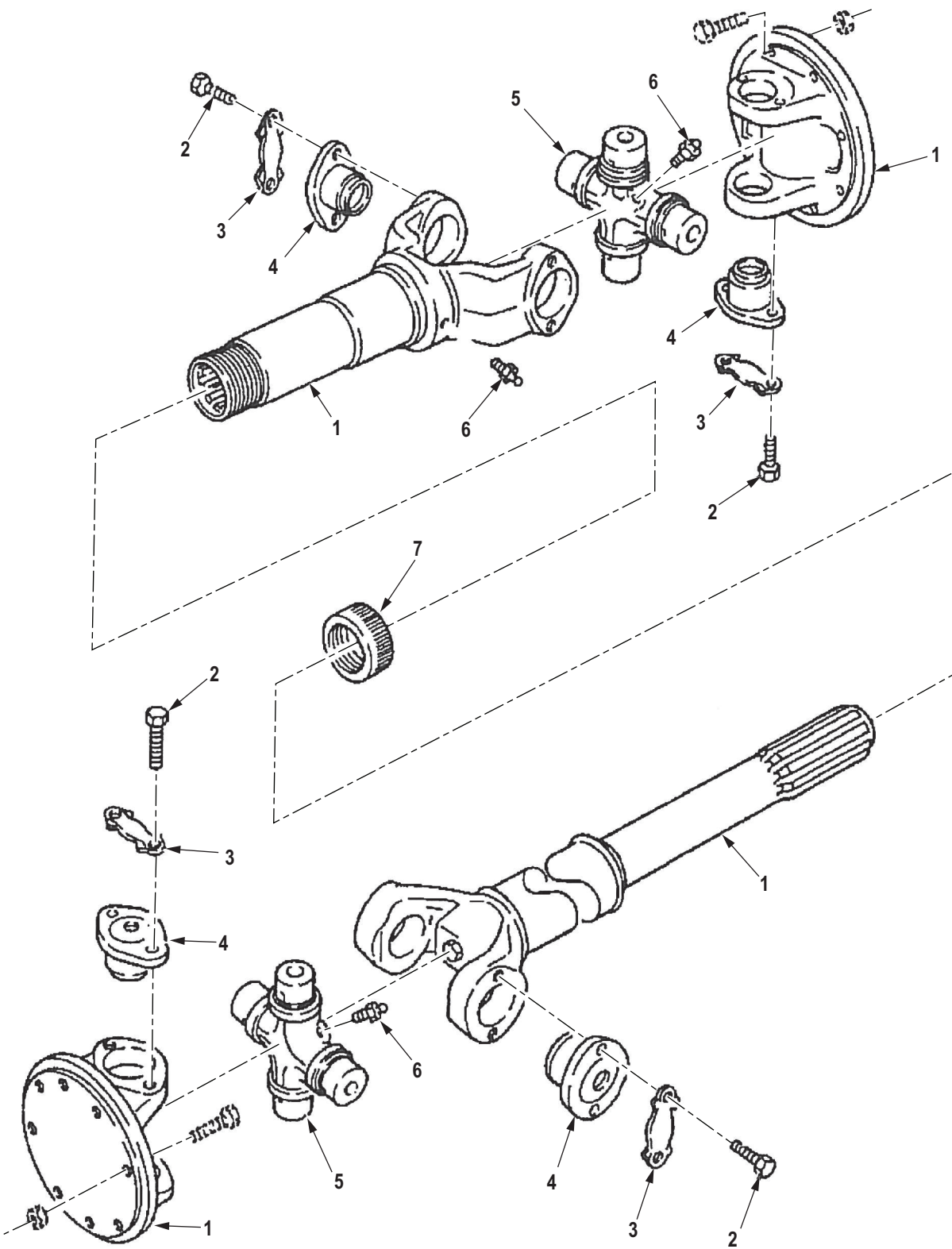

R0237DAA

Figure 222. Propeller Shaft Assembly, Transfer to Front Axle Shaft (M939A2).

(1) ITEM NO.	(2) SMR CODE	(3) NSN	(4) CAGEC	(5) PART NUMBER	(6) DESCRIPTION AND USABLE ON CODE (UOC)	(7) QTY
<b>GROUP 0900 PROPELLER SHAFTS.</b>						
<b>FIG. 222. PROPELLER SHAFT ASSEMBLY, TRANSFER TO FRONT AXLE SHAFT (M939A2).</b>						
1	PAFFF	2520-01-339-1648	78500	983-04-48-798	PROPELLER SHAFT UOC: ZAA,ZAB,ZAC,ZAD,ZAE,ZAF, ZAG,ZAH,ZAJ,ZAL .....	1
2	KFFZZ		70960	CS-H5-24-15	. SCREW PART OF KIT P/N CP16NS UOC: ZAA,ZAB,ZAC,ZAD,ZAE,ZAF, ZAG,ZAH,ZAJ,ZAL .....	16
3	KFFZZ		70960	LPHC37-1	. LOCKPLATE PART OF KIT P/N CP16NS UOC: ZAA,ZAB,ZAC,ZAD,ZAE,ZAF, ZAG,ZAH,ZAJ,ZAL .....	8
4	KFFZZ		70960	16N4-3A	. BEARING ASSEMBLY PART OF KIT P/N CP16NS UOC: ZAA,ZAB,ZAC,ZAD,ZAE,ZAF, ZAG,ZAH,ZAJ,ZAL .....	8
5	KFFZZ		70960	16N1-1A	. CROSS ASSEMBLY PART OF KIT P/N CP16NS UOC: ZAA,ZAB,ZAC,ZAD,ZAE,ZAF, ZAG,ZAH,ZAJ,ZAL .....	2
6	PAFZZ	4730-00-172-0031	81343	AS15003-5C	. FITTING,LUBRICATION UOC: ZAA,ZAB,ZAC,ZAD,ZAE,ZAF, ZAG,ZAH,ZAJ,ZAL .....	1
7	PAFZZ	5330-01-135-3376	78500	SE-RUR25-2	. SEAL,SHAFT UOC: ZAA,ZAB,ZAC,ZAD,ZAE,ZAF, ZAG,ZAH,ZAJ,ZAL .....	1

**END OF FIGURE**



**FIELD MAINTENANCE  
PROPELLER SHAFT ASSEMBLY, TRANSMISSION TO TRANSFER (M939, M939A1)**

---

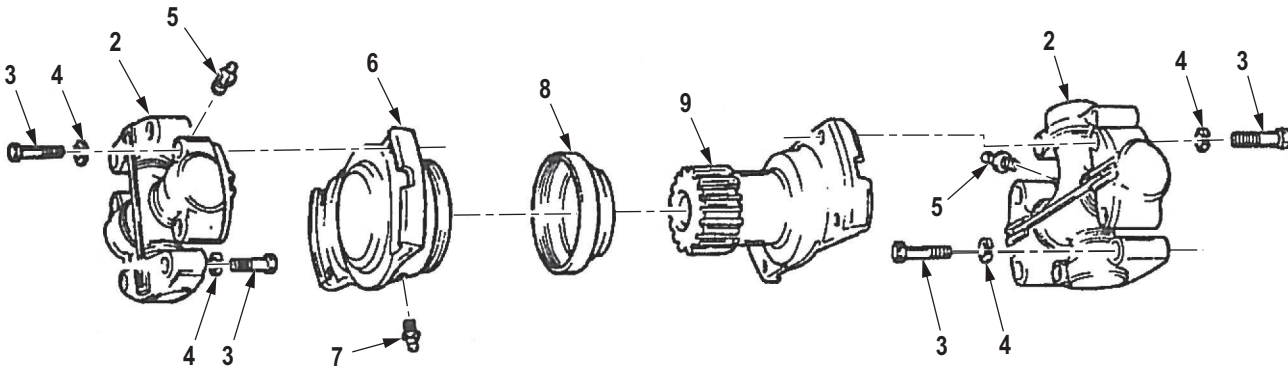
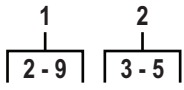

R0238DAA

Figure 223. Propeller Shaft Assembly, Transmission to Transfer (M939, M939A1).

(1) ITEM NO.	(2) SMR CODE	(3) NSN	(4) CAGEC	(5) PART NUMBER	(6) DESCRIPTION AND USABLE ON CODE (UOC)	(7) QTY
<b>GROUP 0900 PROPELLER SHAFTS.</b>						
<b>FIG. 223. PROPELLER SHAFT ASSEMBLY, TRANSMISSION TO TRANSFER (M939, M939A1).</b>						
1	PAFFF	2520-01-112-2156	19207	11669426-1	PROPELLER SHAFT UOC: DAC,DAD,DAE,DAF,DAG,DA H,DAJ,DAL,DAW,DAX,V14,V15,V16, V17,V18,V19,V20,V21,V22,V24 .....	1
2	PAFZZ	2520-01-132-4753	12361	9-364-100169	. SPIDER,UNIVERSAL JO UOC: DAC,DAD,DAE,DAF,DAG,DA H,DAJ,DAL,DAW,DAX,V14,V15,V16, V17,V18,V19,V20,V21,V22,V24 .....	2
3	KFFZZ	5306-01-119-5681	19207	7335054	. . BOLT,HEX HEAD PART OF KIT P/N 5-280X UOC: DAC,DAD,DAE,DAF,DAG,DA H,DAJ,DAL,DAW,DAX,V14,V15,V16, V17,V18,V19,V20,V21,V22,V24 .....	16
4	PAFZZ	5310-00-679-8346	95019	920095-4	. . WASHER,SPLIT UOC: DAC,DAD,DAE,DAF,DAG,DA H,DAJ,DAL,DAW,DAX,V14,V15,V16, V17,V18,V19,V20,V21,V22,V24 .....	2
5	PAFZZ	4730-00-050-4203	81343	AS15001-1	. . FITTING,LUBRICATION UOC: DAC,DAD,DAE,DAF,DAG,DA H,DAJ,DAL,DAW,DAX,V14,V15,V16, V17,V18,V19,V20,V21,V22,V24 .....	1
6	XAFZZ		19207	7335052	. YOKE,REAR UNIVERSAL UOC: DAC,DAD,DAE,DAF,DAG,DA H,DAJ,DAL,DAW,DAX,V14,V15,V16, V17,V18,V19,V20,V21,V22,V24 .....	1
7	PAFZZ	4730-00-050-4208	10001	297692PC104	. FITTING,LUBRICATION UOC: DAC,DAD,DAE,DAF,DAG,DA H,DAJ,DAL,DAW,DAX,V14,V15,V16, V17,V18,V19,V20,V21,V22,V24 .....	1
8	PAFZZ	2520-01-083-4404	78500	SE-RUR-40-3	. CAP,DUST,PROPELLER UOC: DAC,DAD,DAE,DAF,DAG,DA H,DAJ,DAL,DAW,DAX,V14,V15,V16, V17,V18,V19,V20,V21,V22,V24 .....	1
9	XAFZZ		19207	10883109	. YOKE,PROPELLER SHAF UOC: DAC,DAD,DAE,DAF,DAG,DA H,DAJ,DAL,DAW,DAX,V14,V15,V16, V17,V18,V19,V20,V21,V22,V24 .....	1

END OF FIGURE





**FIELD MAINTENANCE  
PROPELLER SHAFT ASSEMBLY, TRANSMISSION TO TRANSFER (M939A2)**

---

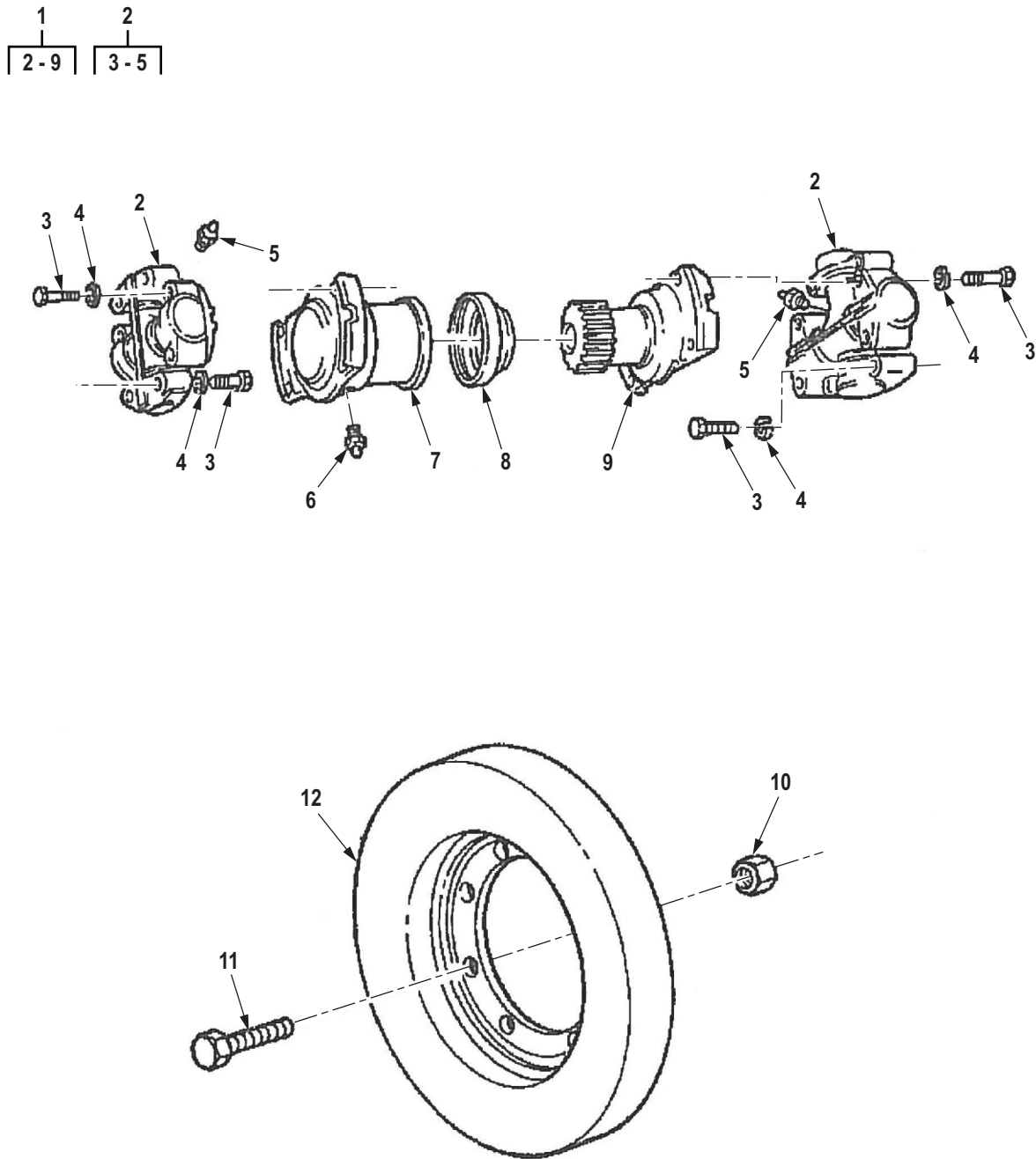

R0239DAA

Figure 224. Propeller Shaft Assembly, Transmission to Transfer (M939A2).

(1) ITEM NO.	(2) SMR CODE	(3) NSN	(4) CAGEC	(5) PART NUMBER	(6) DESCRIPTION AND USABLE ON CODE (UOC)	(7) QTY
<b>GROUP 0900 PROPELLER SHAFTS.</b>						
<b>FIG. 224. PROPELLER SHAFT ASSEMBLY, TRANSMISSION TO TRANSFER (M939A2).</b>						
1	PAFFF	2520-01-285-6283	1MBE8	2520012856283	PROPELLER SHAFT,VEH ASSEMBLY UOC: ZAA,ZAB,ZAC,ZAD,ZAE,ZAF, ZAG,ZAH,ZAJ,ZAL .....	1
2	PAFZZ	2520-01-132-4753	12361	9-364-100169	. SPIDER,UNIVERSAL JO UOC: ZAA,ZAB,ZAC,ZAD,ZAE,ZAF, ZAG,ZAH,ZAJ,ZAL .....	2
3	PAFZZ	5306-00-270-7387	19207	5214483	. . BOLT,MACHINE UOC: ZAA,ZAB,ZAC,ZAD,ZAE,ZAF, ZAG,ZAH,ZAJ,ZAL .....	16
4	PAFZZ	5310-00-276-3012	19207	7994440	. . WASHER,SPLIT UOC: ZAA,ZAB,ZAC,ZAD,ZAE,ZAF, ZAG,ZAH,ZAJ,ZAL .....	16
5	PAFZZ	4730-00-050-4203	81343	AS15001-1	. . FITTING,LUBRICATION CROSS ASSEMBLY UOC: ZAA,ZAB,ZAC,ZAD,ZAE,ZAF, ZAG,ZAH,ZAJ,ZAL .....	1
6	PAFZZ	4730-00-050-4208	10001	297692PC104	. FITTING,LUBRICATION UOC: ZAA,ZAB,ZAC,ZAD,ZAE,ZAF, ZAG,ZAH,ZAJ,ZAL .....	1
7	PBFZZ	2520-00-009-5304	19207	7066092	. YOKE,UNIVERSAL JOIN UOC: ZAA,ZAB,ZAC,ZAD,ZAE,ZAF, ZAG,ZAH,ZAJ,ZAL .....	1
8	PAFZZ	5330-01-082-1818	78500	SERUR33-4	. SEAL UOC: ZAA,ZAB,ZAC,ZAD,ZAE,ZAF, ZAG,ZAH,ZAJ,ZAL .....	1
9	XAFZZ		19207	7066093	. YOKE,HYDRAULIC MOTOR UOC: ZAA,ZAB,ZAC,ZAD,ZAE,ZAF, ZAG,ZAH,ZAJ,ZAL .....	1
10	PAFZZ	5310-00-814-0672	96906	M45913/3-6FG8C	NUT,SELF-LOCKING,HE UOC: ZAA,ZAB,ZAC,ZAD,ZAE,ZAF, ZAG,ZAH,ZAJ,ZAL .....	8
11	PAFZZ	5306-00-720-8747	80205	MS20073-06-12	BOLT,MACHINE UOC: ZAA,ZAB,ZAC,ZAD,ZAE,ZAF, ZAG,ZAH,ZAJ,ZAL .....	8
12	PAFZZ	2815-01-284-2284	74480	9711085-002	DAMPER,DRIVELINE TO UOC: ZAA,ZAB,ZAC,ZAD,ZAE,ZAF, ZAG,ZAH,ZAJ,ZAL .....	1

END OF FIGURE



**FIELD MAINTENANCE  
PROPELLER SHAFT ASSEMBLY, TRANSFER TO FORWARD REAR AXLE (LONG WHEELBASE)**

---

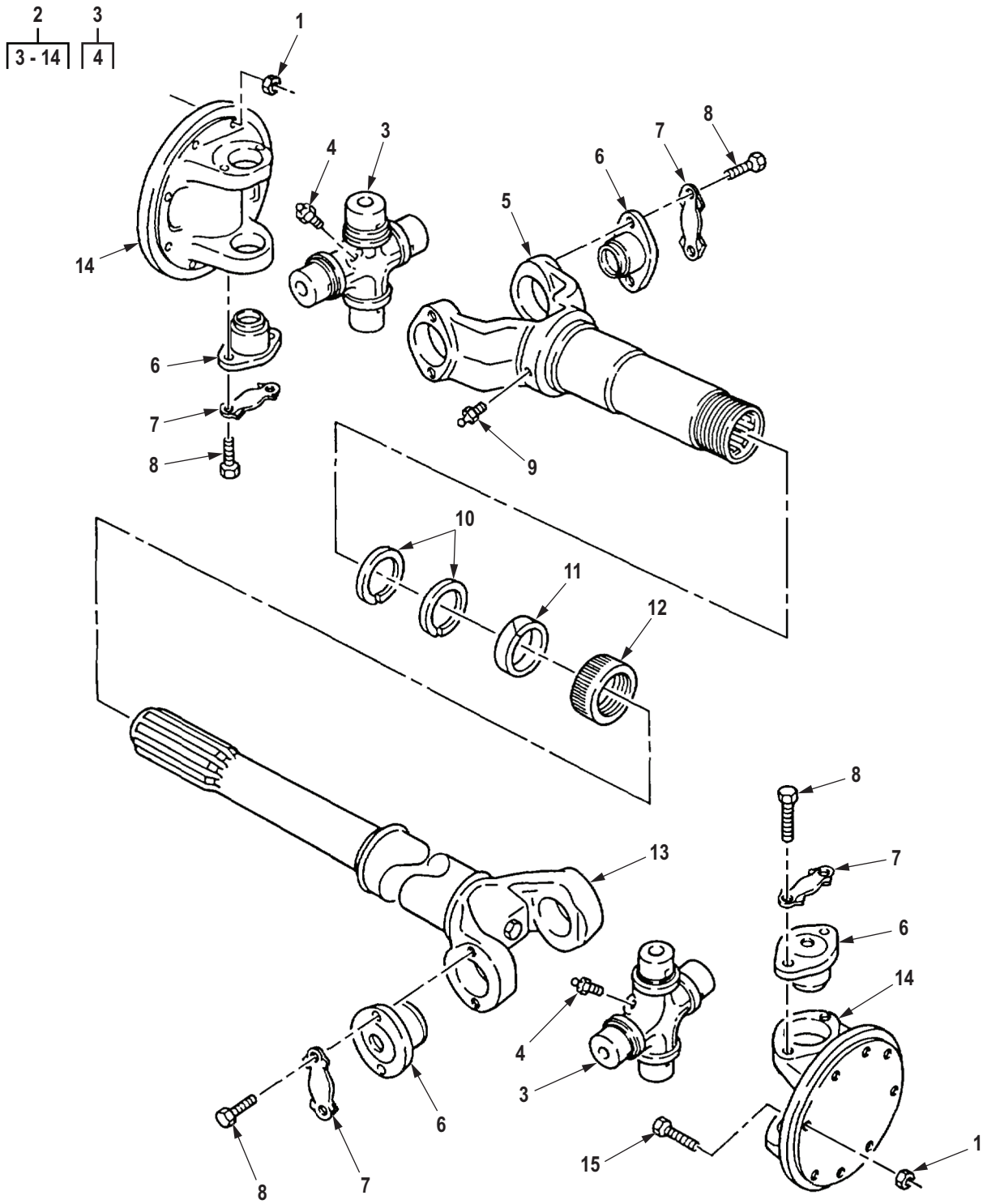

R0240DAA

Figure 225. Propeller Shaft Assembly, Transfer to Forward Rear Axle (Long Wheelbase).

(1) ITEM NO.	(2) SMR CODE	(3) NSN	(4) CAGEC	(5) PART NUMBER	(6) DESCRIPTION AND USABLE ON CODE (UOC)	(7) QTY
<b>GROUP 0900 PROPELLER SHAFTS.</b>						
<b>FIG. 225. PROPELLER SHAFT ASSEMBLY, TRANSFER TO FORWARD REAR AXLE (LONG WHEELBASE).</b>						
1	PAFZZ	5310-00-814-0672	96906	M45913/3-6FG8C	NUT,SELF-LOCKING,HE UOC: DAL,DAW,DAX,V15,V18,ZAA, ZAB,ZAL .....	16
2	PAFFF	2520-01-190-8485	78500	17NNS913D133	PROPELLER SHAFT ROCKWELL UOC: DAL,DAW,DAX,V15,V18,ZAA, ZAB,ZAL .....	1
2	PAFFF	2520-01-171-2360	72447	204581-3	PROPELLER SHAFT DANA UOC: DAL,DAW,DAX,V15,V18,ZAA, ZAB,ZAL .....	1
3	KFFZZ		81221	6-5-228X KF	. CROSS ASSEMBLY PART OF KIT P/N 5-280X UOC: DAL,DAW,DAX,V15,V18,ZAA, ZAB,ZAL .....	2
4	PAFZZ	4730-00-050-4203	81343	AS15001-1	. . FITTING,LUBRICATION UOC: DAL,DAW,DAX,V15,V18,ZAA, ZAB,ZAL .....	1
5	XAFZZ		19207	7335052	. YOKE,REAR UNIVERSAL UOC: DAL,DAW,DAX,V15,V18,ZAA, ZAB,ZAL .....	1
6	KFFZZ		81221	5-0280 KF	. BEARING ASSEMBLY PART OF KIT P/N 5-280X UOC: DAL,DAW,DAX,V15,V18,ZAA, ZAB,ZAL .....	2
7	PAFZZ	5340-01-119-5682	19207	7335053	. LOCKING PLATE,NUT A UOC: DAL,DAW,DAX,V15,V18,ZAA, ZAB,ZAL .....	4
8	PAFZZ	5306-01-119-5681	19207	7335054	. BOLT,HEX HEAD UOC: DAL,DAW,DAX,V15,V18,ZAA, ZAB,ZAL .....	4
9	PAFZZ	4730-00-172-0031	81343	AS15003-5C	. FITTING,LUBRICATION UOC: DAL,DAW,DAX,V15,V18,ZAA, ZAB,ZAL .....	1
10	PAFZZ	5310-00-679-8346	95019	920095-4	. WASHER,SPLIT UOC: DAL,DAW,DAX,V15,V18,ZAA, ZAB,ZAL .....	2
11	PAFZZ	5330-00-741-2636	19207	7412636	. PACKING,PREFORMED UOC: DAL,DAW,DAX,V15,V18,ZAA, ZAB,ZAL .....	1
12	PAFZZ	2520-00-734-8101	19207	7348101	. CAP,DUST,PROPELLER UOC: DAL,DAW,DAX,V15,V18,ZAA, ZAB,ZAL .....	1

(1) ITEM NO.	(2) SMR CODE	(3) NSN	(4) CAGEC	(5) PART NUMBER	(6) DESCRIPTION AND USABLE ON CODE (UOC)	(7) QTY
13	XAFZZ		19207	10883109	. YOKE, PROPELLER SHAF UOC: DAL, DAW, DAX, V15, V18, ZAA, ZAB, ZAL .....	1
14	PAFZZ	2520-00-734-8215	63117	1001132	. FLANGE, COMPANION, VE UOC: DAL, DAW, DAX, V15, V18, ZAA, ZAB, ZAL .....	2
15	PAFZZ	5306-00-720-8747	80205	MS20073-06-12	BOLT, MACHINE UOC: DAL, DAW, DAX, V15, V18, ZAA, ZAB, ZAL .....	8

END OF FIGURE



**FIELD MAINTENANCE**  
**PROPELLER SHAFT ASSEMBLY, FORWARD REAR AXLE TO REAR REAR AXLE (SHORT WHEELBASE)**

---

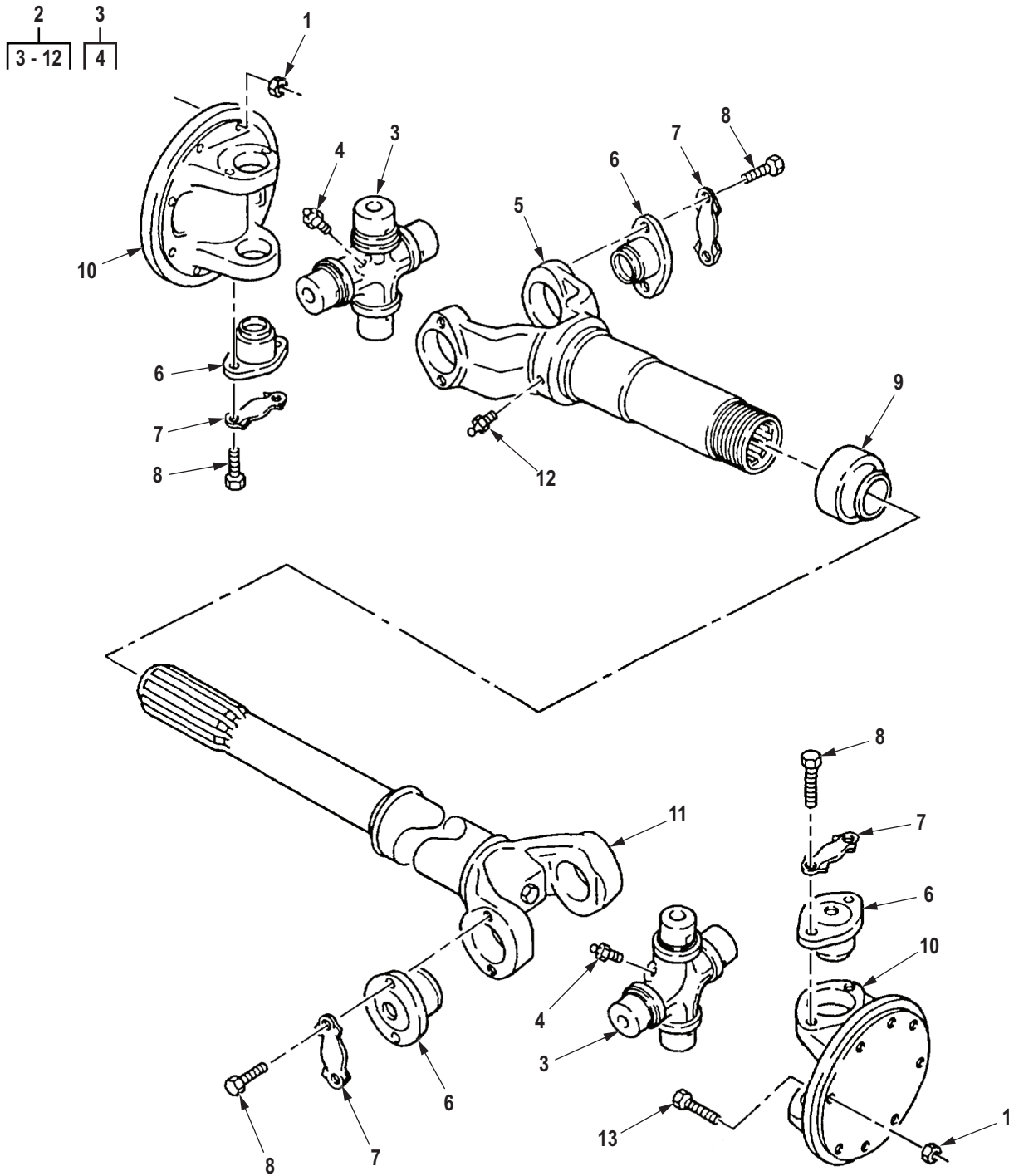

R0241DAA

Figure 226. Propeller Shaft Assembly, Forward Rear Axle to Rear Rear Axle (Short Wheelbase).

(1) ITEM NO.	(2) SMR CODE	(3) NSN	(4) CAGEC	(5) PART NUMBER	(6) DESCRIPTION AND USABLE ON CODE (UOC)	(7) QTY
<b>GROUP 0900 PROPELLER SHAFTS.</b>						
<b>FIG. 226. PROPELLER SHAFT ASSEMBLY, FORWARD REAR AXLE TO REAR REAR AXLE (SHORT WHEELBASE).</b>						
1	PAFZZ	5310-00-814-0672	96906	M45913/3-6FG8C	NUT,SELF-LOCKING,HE UOC: DAE,DAF,DAG,DAH,V19,V20, V21,V22,ZAE,ZAF,ZAG,ZAH .....	16
2	PAFFF	2520-01-323-6342	72447	916210-4823	PROPELLER SHAFT WIT ROCKWELL UOC: DAE,DAF,DAG,DAH,V19,V20, V21,V22,ZAE,ZAF,ZAG,ZAH .....	1
2	PAFFF	3010-01-127-6952	19207	11669144	PROPELLER SHAFT WIT DANA UOC: DAE,DAF,DAG,DAH,V19,V20, V21,V22,ZAE,ZAF,ZAG,ZAH .....	1
3	KFFZZ		70960	17N1-19A	. CROSS ASSEMBLY PART OF KIT P/N 5-0280 UOC: DAE,DAF,DAG,DAH,V19,V20, V21,V22,ZAE,ZAF,ZAG,ZAH .....	2
4	PAFZZ	4730-00-050-4203	81343	AS15001-1	. . FITTING,LUBRICATION UOC: DAE,DAF,DAG,DAH,V19,V20, V21,V22,ZAE,ZAF,ZAG,ZAH .....	1
5	XAFZZ		70960	17NLS40-24	. YOKE UOC: DAE,DAF,DAG,DAH,V19,V20, V21,V22,ZAE,ZAF,ZAG,ZAH .....	1
6	KFFZZ		70960	17N4-15A	. BEARING ASSEMBLY PART OF KIT P/N CP16NS UOC: DAE,DAF,DAG,DAH,V19,V20, V21,V22,ZAE,ZAF,ZAG,ZAH .....	8
7	KFFZZ		70960	LPHC39-3	. LOCKPLATE PART OF KIT P/N CP16NS UOC: DAE,DAF,DAG,DAH,V19,V20, V21,V22,ZAE,ZAF,ZAG,ZAH .....	8
8	KFFZZ		70960	CS-H6-24-49	. SCREW PART OF KIT P/N CP16NS UOC: DAE,DAF,DAG,DAH,V19,V20, V21,V22,ZAE,ZAF,ZAG,ZAH .....	16
9	PAFZZ	5330-01-082-1818	78500	SERUR33-4	SEAL UOC: DAE,DAF,DAG,DAH,V19,V20, V21,V22,ZAE,ZAF,ZAG,ZAH .....	1
10	XAFZZ		70960	17NF1	. YOKE SHAFT FLANGE UOC: DAE,DAF,DAG,DAH,V19,V20, V21,V22,ZAE,ZAF,ZAG,ZAH .....	2
11	XAFZZ		70960	984-55-44759	. SHAFT ASSEMBLY,PROP UOC: DAE,DAF,DAG,DAH,V19,V20, V21,V22,ZAE,ZAF,ZAG,ZAH .....	1
12	PAFZZ	4730-00-172-0031	81343	AS15003-5C	. FITTING,LUBRICATION UOC: DAE,DAF,DAG,DAH,V19,V20, V21,V22,ZAE,ZAF,ZAG,ZAH .....	1

(1) ITEM NO.	(2) SMR CODE	(3) NSN	(4) CAGEC	(5) PART NUMBER	(6) DESCRIPTION AND USABLE ON CODE (UOC)	(7) QTY
13	PAFZZ	5306-00-720-8747	80205	MS20073-06-12	BOLT,MACHINE UOC: DAE,DAF,DAG,DAH,V19,V20, V21,V22,ZAE,ZAF,ZAG,ZAH .....	1

END OF FIGURE

**FIELD MAINTENANCE**  
**PROPELLER SHAFT ASSEMBLY, TRANSFER TO FORWARD REAR AXLE (X-LONG WHEELBASE)**

---

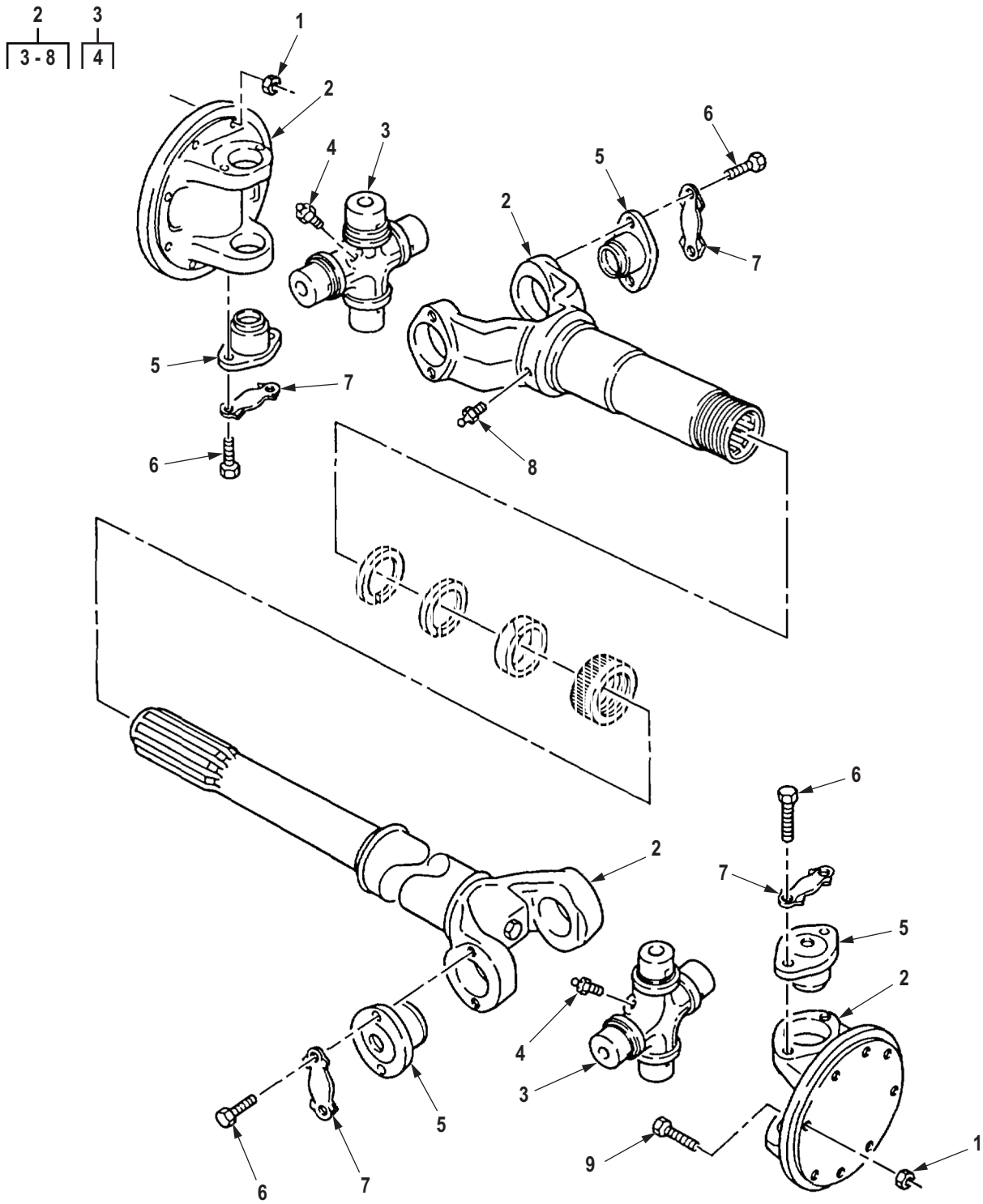

R0242DAA

Figure 227. Propeller Shaft Assembly, Transfer to Forward Rear Axle (X-Long Wheelbase).

(1) ITEM NO.	(2) SMR CODE	(3) NSN	(4) CAGEC	(5) PART NUMBER	(6) DESCRIPTION AND USABLE ON CODE (UOC)	(7) QTY
<b>GROUP 0900 PROPELLER SHAFTS.</b>						
<b>FIG. 227. PROPELLER SHAFT ASSEMBLY, TRANSFER TO FORWARD REAR AXLE (X-LONG WHEELBASE).</b>						
1	PAFZZ	5310-00-814-0672	96906	M45913/3-6FG8C	NUT,SELF-LOCKING,HE UOC: DAC,DAD,DAJ,V16,V17,V18,V 24,ZAC,ZAD,ZAJ .....	16
2	PAFFF	2520-01-323-6343	19207	12375585	PROPELLER SHAFT WIT DANA UOC: DAC,DAD,DAJ,V16,V17,V18,V 24,ZAC,ZAD,ZAJ .....	1
2	PAFFF	2520-01-323-6342	72447	916210-4823	PROPELLER SHAFT WIT ROCKWELL UOC: DAC,DAD,DAJ,V16,V17,V18,V 24,ZAC,ZAD,ZAJ .....	1
3	KFFZZ		19207	8764802	. CROSS,ASSEMBLY,UNIV PART OF KIT P/N 5-280X UOC: DAC,DAD,DAJ,V16,V17,V18,V 24,ZAC,ZAD,ZAJ .....	2
4	PAFZZ	4730-00-050-4203	81343	AS15001-1	. . FITTING,LUBRICATION UOC: DAC,DAD,DAJ,V16,V17,V18,V 24,ZAC,ZAD,ZAJ .....	2
5	KFFZZ		70960	17N4-15A	. BEARING ASSEMBLY PART OF KIT P/N 5-0280 UOC: DAC,DAD,DAJ,V16,V17,V18,V 24,ZAC,ZAD,ZAJ .....	8
6	KFFZZ	5306-01-119-5681	19207	7335054	. BOLT,HEX HEAD PART OF KIT P/N 5-0280 UOC: DAC,DAD,DAJ,V16,V17,V18,V 24,ZAC,ZAD,ZAJ .....	1
7	KFFZZ	5340-01-119-5682	19207	7335053	. LOCKING PLATE,NUT A PART OF KIT P/N 5-0280 UOC: DAC,DAD,DAJ,V16,V17,V18,V 24,ZAC,ZAD,ZAJ .....	8
8	PAFZZ	4730-00-172-0031	81343	AS15003-5C	. FITTING,LUBRICATION UOC: DAC,DAD,DAJ,V16,V17,V18,V 24,ZAC,ZAD,ZAJ .....	1
9	PAFZZ	5306-00-720-8747	80205	MS20073-06-12	BOLT,MACHINE UOC: DAC,DAD,DAJ,V16,V17,V18,V 24,ZAC,ZAD,ZAJ .....	8

**END OF FIGURE**





**FIELD MAINTENANCE**  
**PROPELLER SHAFT ASSEMBLY, FORWARD REAR AXLE TO REAR REAR AXLE (DANA)**

---

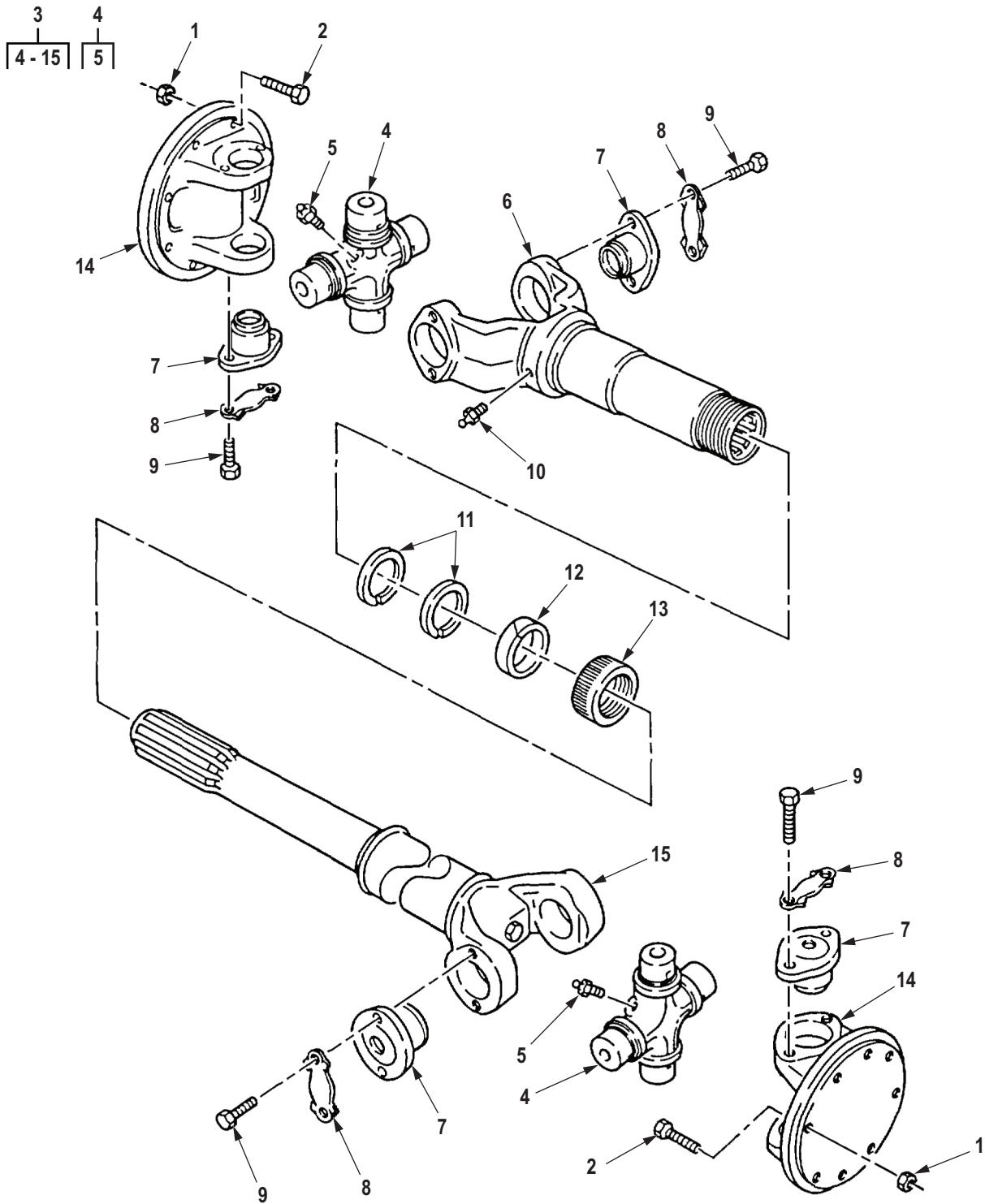

R0243DAA

Figure 228. Propeller Shaft Assembly, Forward Rear Axle to Rear Rear Axle (Dana).

(1) ITEM NO.	(2) SMR CODE	(3) NSN	(4) CAGEC	(5) PART NUMBER	(6) DESCRIPTION AND USABLE ON CODE (UOC)	(7) QTY
<b>GROUP 0900 PROPELLER SHAFTS.</b>						
<b>FIG. 228. PROPELLER SHAFT ASSEMBLY, FORWARD REAR AXLE TO REAR REAR AXLE (DANA).</b>						
1	PAFZZ	5310-00-814-0672	96906	M45913/3-6FG8C	NUT, SELF-LOCKING, HE UOC: DAC, DAD, DAE, DAF, DAG, DAH, DAJ, DAL , DAW, DAX, V14, V15, V16, V17, V18, V19, V20, V2 1, V22, V24, ZAA, ZAB, ZAC, ZAD, ZAE, ZAF, ZAG, ZAH, ZAJ, ZAL .....	16
2	PAFZZ	5306-00-720-8747	80205	MS20073-06-12	BOLT, MACHINE UOC: DAC, DAD, DAE, DAF, DAG, DAH, DAJ, DAL , DAW, DAX, V14, V15, V16, V17, V18, V19, V20, V2 1, V22, V24, ZAA, ZAB, ZAC, ZAD, ZAE, ZAF, ZAG, ZAH, ZAJ, ZAL .....	16
3	PAFFF	2520-00-318-0983	72447	200825-3	PROPELLER SHAFT WIT UOC: V39 .....	1
3	PAFFF	2520-01-093-4274	19207	8332248	PROPELLER SHAFT WIT UOC: DAC, DAD, DAE, DAF, DAG, DAH, DAJ, DAL , DAW, DAX, V14, V15, V16, V17, V18, V19, V20, V2 1, V22, V24, ZAA, ZAB, ZAC, ZAD, ZAE, ZAF, ZAG, ZAH, ZAJ, ZAL .....	1
4	KFFZZ		19207	7066097	. PART OF KIT P/N CROSS, ASSEMBLY, UNIV UOC: DAC, DAD, DAE, DAF, DAG, DAH, DAJ, DAL , DAW, DAX, V14, V15, V16, V17, V18, V19, V20, V2 1, V22, V24, ZAA, ZAB, ZAC, ZAD, ZAE, ZAF, ZAG, ZAH, ZAJ, ZAL .....	1
5	PAFZZ	4730-00-050-4203	81343	AS15001-1	. . FITTING, LUBRICATION UOC: DAC, DAD, DAE, DAF, DAG, DAH, DAJ, DAL , DAW, DAX, V14, V15, V16, V17, V18, V19, V20, V2 1, V22, V24, ZAA, ZAB, ZAC, ZAD, ZAE, ZAF, ZAG, ZAH, ZAJ, ZAL .....	2
6	XAFZZ		19207	7066093	. YOKE, HYDRAULIC UOC: DAC, DAD, DAE, DAF, DAG, DAH, DAJ, DAL , DAW, DAX, V14, V15, V16, V17, V18, V19, V20, V2 1, V22, V24, ZAA, ZAB, ZAC, ZAD, ZAE, ZAF, ZAG, ZAH, ZAJ, ZAL .....	1
7	XAFZZ		19207	7066101	. PART OF KIT P/N BEARING, ASSY, NEEDLE UOC: DAC, DAD, DAE, DAF, DAG, DAH, DAJ, DAL , DAW, DAX, V14, V15, V16, V17, V18, V19, V20, V2 1, V22, V24, ZAA, ZAB, ZAC, ZAD, ZAE, ZAF, ZAG, ZAH, ZAJ, ZAL .....	1
8	KFFZZ	5340-00-521-4479	92867	98-741	. PART OF KIT P/N LOCKING PLATE, NUT A UOC: DAC, DAD, DAE, DAF, DAG, DAH, DAJ, DAL , DAW, DAX, V14, V15, V16, V17, V18, V19, V20, V2 1, V22, V24, ZAA, ZAB, ZAC, ZAD, ZAE, ZAF, ZAG, ZAH, ZAJ, ZAL .....	1

(1) ITEM NO.	(2) SMR CODE	(3) NSN	(4) CAGEC	(5) PART NUMBER	(6) DESCRIPTION AND USABLE ON CODE (UOC)	(7) QTY
9	PAFZZ	5306-00-270-7387	19207	5214483	. PART OF KIT P/N BOLT,MACHINE UOC: DAC,DAD,DAE,DAF,DAG,DAH,DAJ,DAL ,DAW,DAX,V14,V15,V16,V17,V18,V19,V20,V2 1,V22,V24,ZAA,ZAB,ZAC,ZAD,ZAE,ZAF,ZAG, ZAH,ZAJ,ZAL .....	16
10	PAFZZ	4730-00-172-0031	81343	AS15003-5C	. FITTING,LUBRICATION UOC: DAC,DAD,DAE,DAF,DAG,DAH,DAJ,DAL ,DAW,DAX,V14,V15,V16,V17,V18,V19,V20,V2 1,V22,V24,ZAA,ZAB,ZAC,ZAD,ZAE,ZAF,ZAG, ZAH,ZAJ,ZAL .....	1
11	PAFZZ	5310-00-276-3012	19207	7994440	. WASHER,SPLIT UOC: DAC,DAD,DAE,DAF,DAG,DAH,DAJ,DAL ,DAW,DAX,V14,V15,V16,V17,V18,V19,V20,V2 1,V22,V24,ZAA,ZAB,ZAC,ZAD,ZAE,ZAF,ZAG, ZAH,ZAJ,ZAL .....	4
12	PAFZZ	5330-01-067-1740	19207	7066104	. SEAL,PROPELLER SHAF UOC: DAC,DAD,DAE,DAF,DAG,DAH,DAJ,DAL ,DAW,DAX,V14,V15,V16,V17,V18,V19,V20,V2 1,V22,V24,ZAA,ZAB,ZAC,ZAD,ZAE,ZAF,ZAG, ZAH,ZAJ,ZAL .....	4
13	PAFZZ	2520-00-457-6660	72447	4-14-19	. CAP,DUST,PROPELLER UOC: DAC,DAD,DAE,DAF,DAG,DAH,DAJ,DAL ,DAW,DAX,V14,V15,V16,V17,V18,V19,V20,V2 1,V22,V24,ZAA,ZAB,ZAC,ZAD,ZAE,ZAF,ZAG, ZAH,ZAJ,ZAL .....	1
14	PAFZZ	2520-00-009-5304	19207	7066092	. YOKE,UNIVERSAL JOIN UOC: DAC,DAD,DAE,DAF,DAG,DAH,DAJ,DAL ,DAW,DAX,V14,V15,V16,V17,V18,V19,V20,V2 1,V22,V24,ZAA,ZAB,ZAC,ZAD,ZAE,ZAF,ZAG, ZAH,ZAJ,ZAL .....	2
15	XAFZZ		19207	10883168	. PROPELLER SHAFT UOC: DAC,DAD,DAE,DAF,DAG,DAH,DAJ,DAL ,DAW,DAX,V14,V15,V16,V17,V18,V19,V20,V2 1,V22,V24,ZAA,ZAB,ZAC,ZAD,ZAE,ZAF,ZAG, ZAH,ZAJ,ZAL .....	2
15	XAFZZ		19207	10883167	. PROPELLER,SHAFT UOC: DAC,DAD,DAE,DAF,DAG,DAH,DAJ,DAL ,DAW,DAX,V14,V15,V16,V17,V18,V19,V20,V2 1,V22,V24,ZAA,ZAB,ZAC,ZAD,ZAE,ZAF,ZAG, ZAH,ZAJ,ZAL .....	1

END OF FIGURE

**FIELD MAINTENANCE  
PROPELLER SHAFT ASSEMBLY, FORWARD REAR AXLE TO REAR REAR AXLE (ROCKWELL)**

---

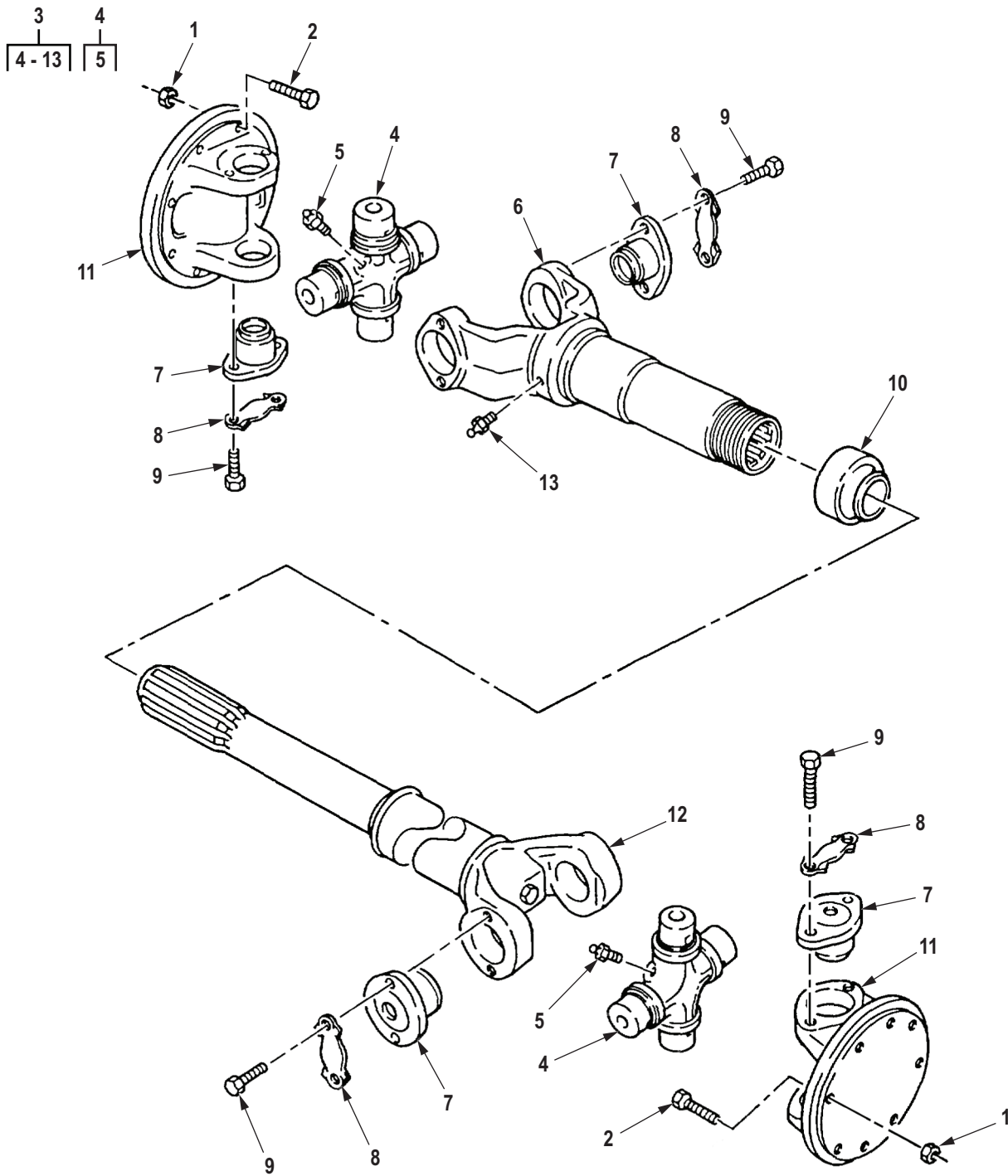

R0244DAA

Figure 229. Propeller Shaft Assembly, Forward Rear Axle to Rear Rear Axle (Rockwell).

(1) ITEM NO.	(2) SMR CODE	(3) NSN	(4) CAGEC	(5) PART NUMBER	(6) DESCRIPTION AND USABLE ON CODE (UOC)	(7) QTY
<b>GROUP 0900 PROPELLER SHAFTS.</b>						
<b>FIG. 229. PROPELLER SHAFT ASSEMBLY, FORWARD REAR AXLE TO REAR REAR AXLE (ROCKWELL).</b>						
1	PAFZZ	5310-00-814-0672	96906	M45913/3-6FG8C	NUT, SELF-LOCKING, HE UOC: DAC, DAD, DAE, DAF, DAG, DAH, DAJ, DAL , DAW, DAX, V14, V15, V16, V17, V18, V19, V20, V2 1, V22, V24, ZAA, ZAB, ZAC, ZAD, ZAE, ZAF, ZAG, ZAH, ZAJ, ZAL .....	8
2	PAFZZ	5306-00-720-8747	80205	MS20073-06-12	BOLT, MACHINE UOC: DAC, DAD, DAE, DAF, DAG, DAH, DAJ, DAL , DAW, DAX, V14, V15, V16, V17, V18, V19, V20, V2 1, V22, V24, ZAA, ZAB, ZAC, ZAD, ZAE, ZAF, ZAG, ZAH, ZAJ, ZAL .....	8
3	PAFFF	2520-01-127-6953	78500	16NNS907D083	PROPELLER SHAFT WIT UOC: DAC, DAD, DAE, DAF, DAG, DAH, DAJ, DAL , DAW, DAX, V14, V15, V16, V17, V18, V19, V20, V2 1, V22, V24, ZAA, ZAB, ZAC, ZAD, ZAE, ZAF, ZAG, ZAH, ZAJ, ZAL .....	1
3	PAFFF	2520-01-127-6954	78500	16NNS907D095	PROPELLER SHAFT WIT UOC: V39 .....	1
4	KFFZZ		70960	16N1-1A	. PART OF KIT P/N CROSS ASSEMBLY UOC: DAC, DAD, DAE, DAF, DAG, DAH, DAJ, DAL , DAW, DAX, V14, V15, V16, V17, V18, V19, V20, V2 1, V22, V24, ZAA, ZAB, ZAC, ZAD, ZAE, ZAF, ZAG, ZAH, ZAJ, ZAL .....	2
5	PAFZZ	4730-00-172-0031	81343	AS15003-5C	. . CROSS ASSEMBLY FITTING, LUBRICATION UOC: DAC, DAD, DAE, DAF, DAG, DAH, DAJ, DAL , DAW, DAX, V14, V15, V16, V17, V18, V19, V20, V2 1, V22, V24, ZAA, ZAB, ZAC, ZAD, ZAE, ZAF, ZAG, ZAH, ZAJ, ZAL .....	1
6	XAFZZ		70960	17NLS40-24	. YOKE UOC: DAC, DAD, DAE, DAF, DAG, DAH, DAJ, DAL , DAW, DAX, V14, V15, V16, V17, V18, V19, V20, V2 1, V22, V24, ZAA, ZAB, ZAC, ZAD, ZAE, ZAF, ZAG, ZAH, ZAJ, ZAL .....	1
7	KFFZZ		70960	17N4-15A	. PART OF KIT P/N BEARING ASSEMBLY UOC: DAC, DAD, DAE, DAF, DAG, DAH, DAJ, DAL , DAW, DAX, V14, V15, V16, V17, V18, V19, V20, V2 1, V22, V24, ZAA, ZAB, ZAC, ZAD, ZAE, ZAF, ZAG, ZAH, ZAJ, ZAL .....	8
8	KFFZZ		70960	LPHC39-3	. PART OF KIT P/N LOCKPLATE UOC: DAC, DAD, DAE, DAF, DAG, DAH, DAJ, DAL , DAW, DAX, V14, V15, V16, V17, V18, V19, V20, V2 1, V22, V24, ZAA, ZAB, ZAC, ZAD, ZAE, ZAF, ZAG, ZAH, ZAJ, ZAL .....	8

(1) ITEM NO.	(2) SMR CODE	(3) NSN	(4) CAGEC	(5) PART NUMBER	(6) DESCRIPTION AND USABLE ON CODE (UOC)	(7) QTY
9	KFFZZ		70960	CS-H6-24-49	. PART OF KIT P/N SCREW UOC: DAC,DAD,DAE,DAF,DAG,DAH,DAJ,DAL ,DAW,DAX,V14,V15,V16,V17,V18,V19,V20,V2 1,V22,V24,ZAA,ZAB,ZAC,ZAD,ZAE,ZAF,ZAG, ZAH,ZAJ,ZAL .....	16
10	PAFZZ	5330-01-135-3376	78500	SE-RUR25-2	. SEAL,SHAFT UOC: DAC,DAD,DAE,DAF,DAG,DAH,DAJ,DAL ,DAW,DAX,V14,V15,V16,V17,V18,V19,V20,V2 1,V22,V24,ZAA,ZAB,ZAC,ZAD,ZAE,ZAF,ZAG, ZAH,ZAJ,ZAL .....	1
11	XAFZZ		70960	17NF1	. YOKE SHAFT FLANGE UOC: DAC,DAD,DAE,DAF,DAG,DAH,DAJ,DAL ,DAW,DAX,V14,V15,V16,V17,V18,V19,V20,V2 1,V22,V24,ZAA,ZAB,ZAC,ZAD,ZAE,ZAF,ZAG, ZAH,ZAJ,ZAL .....	2
12	XAFZZ		70960	983-55-44478	. SHAFT ASSEMBLY,PROP UOC: DAC,DAD,DAE,DAF,DAG,DAH,DAJ,DAL ,DAW,DAX,V14,V15,V16,V17,V18,V19,V20,V2 1,V22,V24,ZAA,ZAB,ZAC,ZAD,ZAE,ZAF,ZAG, ZAH,ZAJ,ZAL .....	2
13	PAFZZ	4730-00-172-0031	81343	AS15003-5C	. FITTING,LUBRICATION UOC: DAC,DAD,DAE,DAF,DAG,DAH,DAJ,DAL ,DAW,DAX,V14,V15,V16,V17,V18,V19,V20,V2 1,V22,V24,ZAA,ZAB,ZAC,ZAD,ZAE,ZAF,ZAG, ZAH,ZAJ,ZAL .....	1

END OF FIGURE



**FIELD MAINTENANCE  
FRONT AXLE AND HOUSING ASSEMBLY (M939, M939A1)**

---

1	2
2-9	3-9

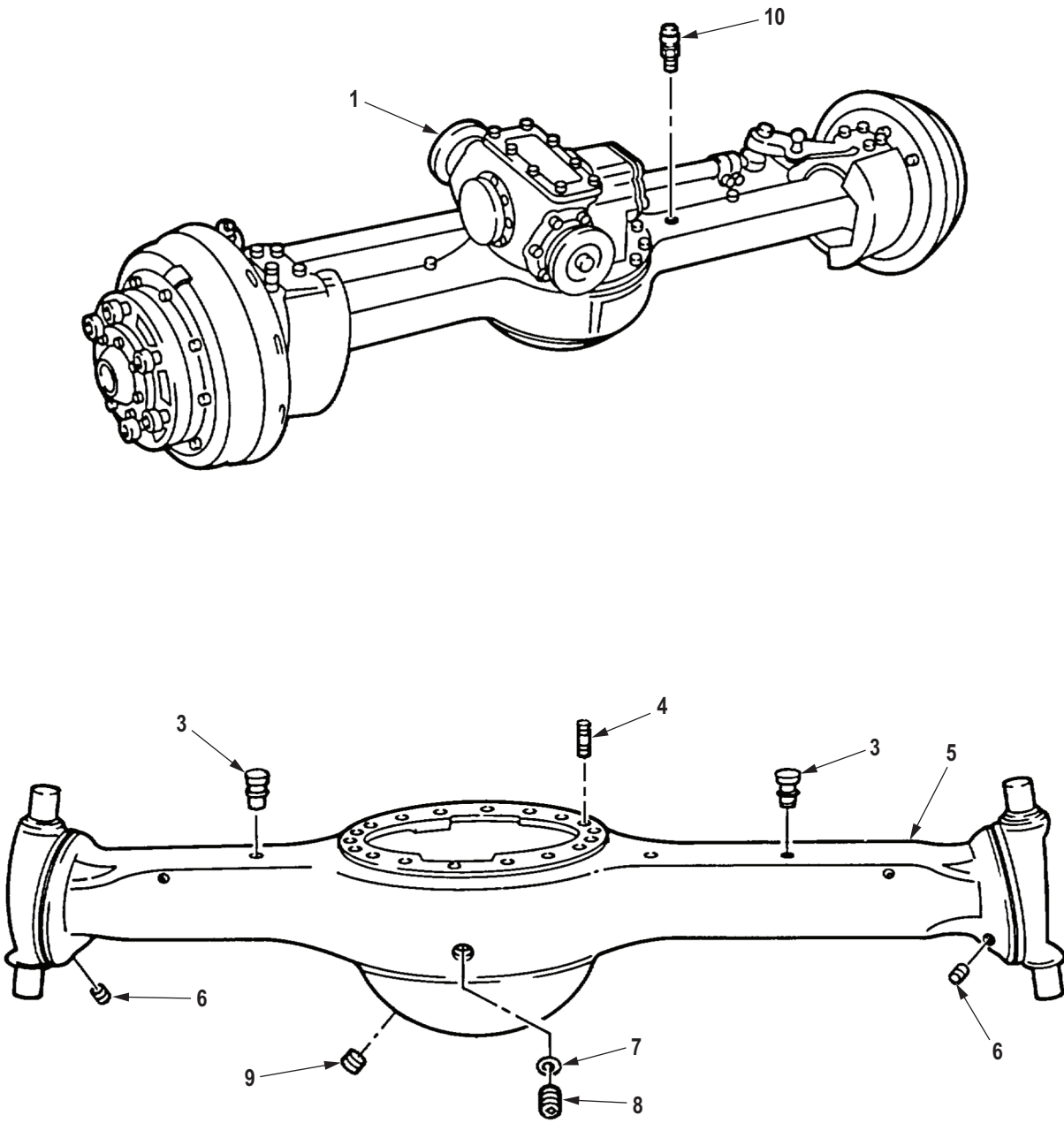

R0245DAA

Figure 230. Front Axle and Housing Assembly (M939, M939A1).

(1) ITEM NO.	(2) SMR CODE	(3) NSN	(4) CAGEC	(5) PART NUMBER	(6) DESCRIPTION AND USABLE ON CODE (UOC)	(7) QTY
<b>GROUP 1000 FRONT AXLE ASSEMBLY.</b>						
<b>FIG. 230. FRONT AXLE AND HOUSING ASSEMBLY (M939, M939A1).</b>						
1	PGFHH	2520-01-091-1660	19207	2256540-3	AXLE ASSEMBLY,AUTOM UOC: DAC,DAD,DAE,DAF,DAG,DAH,DAJ,DAL,DAW,DAX,V14,V15,V16,V17,V18,V19,V20,V21,V22,V24 .....	1
1	PGFHH	2520-01-091-1659	19207	12256540-2	AXLE ASSEMBLY,AUTOM UOC: DAC,DAD,DAE,DAF,DAG,DAH,DAJ,DAL,DAW,DAX,V14,V15,V16,V17,V18,V19,V20,V21,V22,V24 .....	1
2	XBFZZ	3040-00-930-7864	19207	8758345	. HOUSING,MECHANICAL UOC: DAC,DAD,DAE,DAF,DAG,DAH,DAJ,DAL,DAW,DAX,V14,V15,V16,V17,V18,V19,V20,V21,V22,V24 .....	1
3	PAFZZ	5315-00-752-1651	19207	7521651	. . PIN,SHOULDER,HEADLE UOC: DAC,DAD,DAE,DAF,DAG,DAH,DAJ,DAL,DAW,DAX,V14,V15,V16,V17,V18,V19,V20,V21,V22,V24 .....	2
4	PAFZZ	5307-00-434-1783	3D6E9	SN1020-1	. . STUD,PLAIN UOC: DAC,DAD,DAE,DAF,DAG,DAH,DAJ,DAL,DAW,DAX,V14,V15,V16,V17,V18,V19,V20,V21,V22,V24 .....	18
5	XAFZZ		19207	8758343	. . HOUSING UOC: DAC,DAD,DAE,DAF,DAG,DAH,DAJ,DAL,DAW,DAX,V14,V15,V16,V17,V18,V19,V20,V21,V22,V24 .....	1
6	PAFZZ	4730-00-954-1281	58536	AA59616ACABCB	. . PLUG,PIPE UOC: DAC,DAD,DAE,DAF,DAG,DAH,DAJ,DAL,DAW,DAX,V14,V15,V16,V17,V18,V19,V20,V21,V22,V24 .....	2
7	PAFZZ	5330-01-352-7768	81343	MS35769-21	. . GASKET UOC: DAC,DAD,DAE,DAF,DAG,DAH,DAJ,DAL,DAW,DAX,V14,V15,V16,V17,V18,V19,V20,V21,V22,V24 .....	1
8	PAFZZ	5365-00-732-6126	19207	7326126	. . PLUG,MACHINE THREAD UOC: DAC,DAD,DAE,DAF,DAG,DAH,DAJ,DAL,DAW,DAX,V14,V15,V16,V17,V18,V19,V20,V21,V22,V24 .....	1
9	PAFZZ	4730-00-968-6129	96906	MS49006-10	. PLUG,PIPE,MAGNETIC UOC: DAC,DAD,DAE,DAF,DAG,DAH,DAJ,DAL,DAW,DAX,V14,V15,V16,V17,V18,V19,V20,V21,V22,V24 .....	1

(1) ITEM NO.	(2) SMR CODE	(3) NSN	(4) CAGEC	(5) PART NUMBER	(6) DESCRIPTION AND USABLE ON CODE (UOC)	(7) QTY
10	PAFZZ	4820-00-726-4719	19207	5196397	VALVE,VENT UOC: DAC,DAD,DAE,DAF,DAG,DA H,DAJ,DAL,DAW,DAX,V14,V15,V16, V17,V18,V19,V20,V21,V22,V24 .....	1

END OF FIGURE

**FIELD MAINTENANCE  
FRONT AXLE AND HOUSING ASSEMBLY (M939A2)**

---

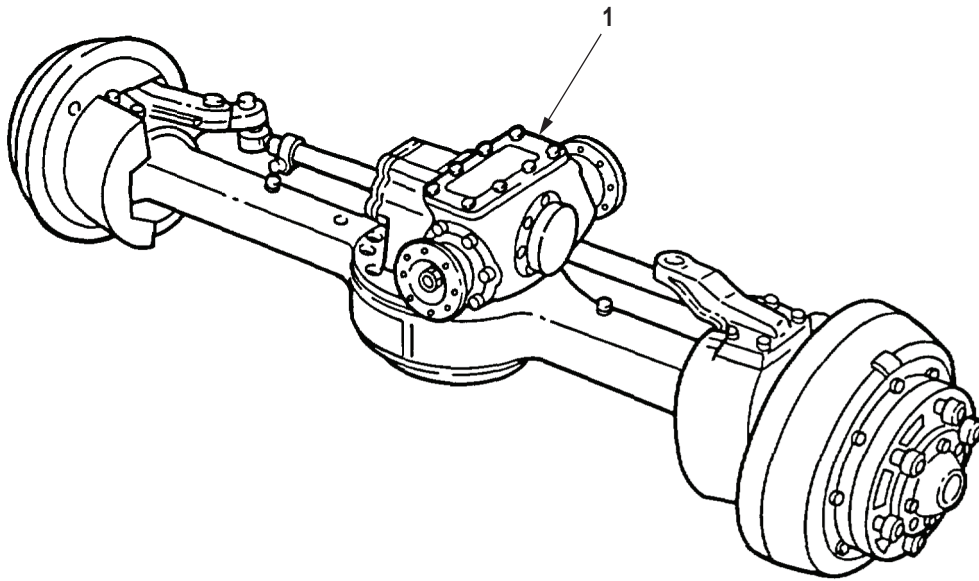

R0246DAA

Figure 231. Front Axle and Housing Assembly (M939A2).

(1) ITEM NO.	(2) SMR CODE	(3) NSN	(4) CAGEC	(5) PART NUMBER	(6) DESCRIPTION AND USABLE ON CODE (UOC)	(7) QTY
--------------------	-----------------	------------	--------------	--------------------	--	------------

					<b>GROUP 1000 FRONT AXLE ASSEMBLY.</b>	
					<b>FIG. 231. FRONT AXLE AND HOUSING ASSEMBLY (M939A2).</b>	
1	PGFHH	2520-01-291-9992	19207	12363375	AXLE ASSEMBLY,AUTOM FRONT,WITHOUT BRACKETS UOC: ZAA,ZAB,ZAC,ZAD,ZAE,ZAF, ZAG,ZAH,ZAJ,ZAL .....	1

**END OF FIGURE**





**FIELD MAINTENANCE  
FRONT AXLE DIFFERENTIAL ASSEMBLY**

---

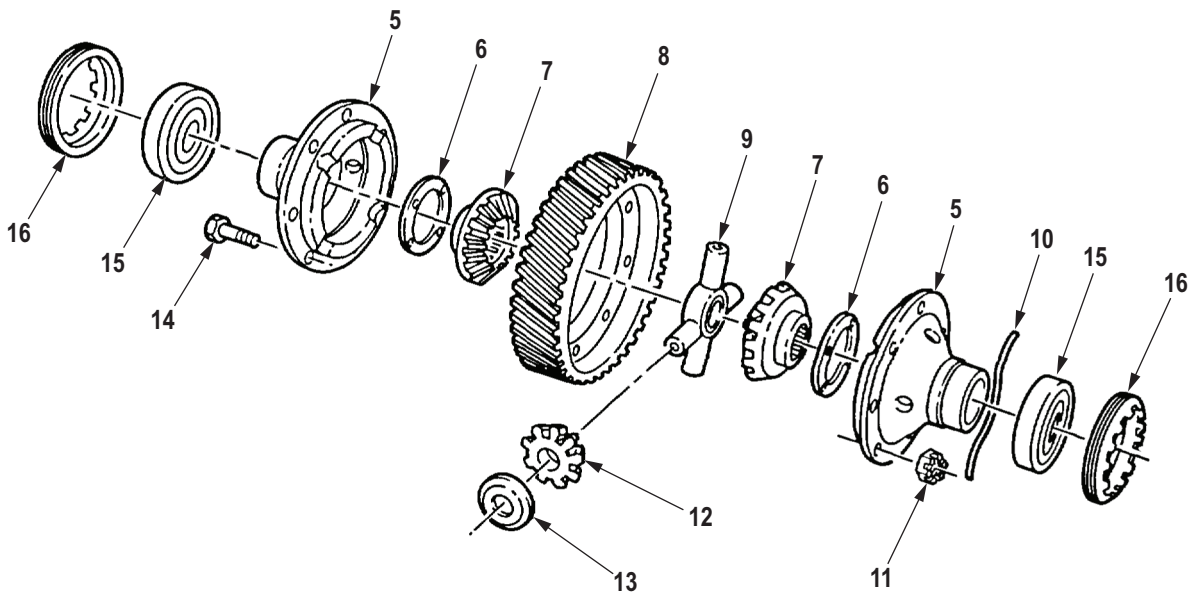
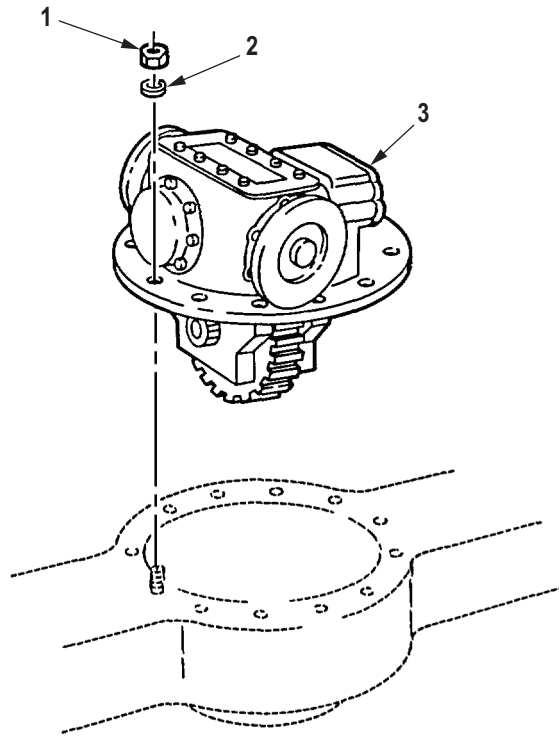
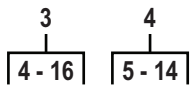

R0247DAA

Figure 232. Front Axle Differential Assembly.

(1) ITEM NO.	(2) SMR CODE	(3) NSN	(4) CAGEC	(5) PART NUMBER	(6) DESCRIPTION AND USABLE ON CODE (UOC)	(7) QTY
<b>GROUP 1002 DIFFERENTIAL.</b>						
<b>FIG. 232. FRONT AXLE DIFFERENTIAL ASSEMBLY.</b>						
1	PAFZZ	5310-00-274-7721	19207	7346813	NUT,PLAIN,HEXAGON UOC: DAC,DAD,DAE,DAF,DAG,DAH,DAJ,DAL,DAW,DAX,V14,V15,V16,V17,V18,V19,V20,V21,V22,V24,ZAA,ZAB,ZAC,ZAD,ZAE,ZAF,ZAG,ZAH,ZAJ,ZAL .....	18
2	PAFZZ	5310-00-483-2266	19207	10900409	WASHER,FLAT UOC: DAC,DAD,DAE,DAF,DAG,DAH,DAJ,DAL,DAW,DAX,V14,V15,V16,V17,V18,V19,V20,V21,V22,V24,ZAA,ZAB,ZAC,ZAD,ZAE,ZAF,ZAG,ZAH,ZAJ,ZAL .....	18
3	PAFHH	2520-00-734-6970	19207	7346970	DIFFERENTIAL,DRIVIN UOC: DAC,DAD,DAE,DAF,DAG,DAH,DAJ,DAL,DAW,DAX,V14,V15,V16,V17,V18,V19,V20,V21,V22,V24,ZAA,ZAB,ZAC,ZAD,ZAE,ZAF,ZAG,ZAH,ZAJ,ZAL .....	1
4	PAHHH	2520-00-419-9422	19207	8758285	. DIFFERENTIAL GEAR U UOC: DAC,DAD,DAE,DAF,DAG,DAH,DAJ,DAL,DAW,DAX,V14,V15,V16,V17,V18,V19,V20,V21,V22,V24,ZAA,ZAB,ZAC,ZAD,ZAE,ZAF,ZAG,ZAH,ZAJ,ZAL .....	1
5	XAHZZ		19207	8758252	. . CARRIER,DIFFERENTIA UOC: DAC,DAD,DAE,DAF,DAG,DAH,DAJ,DAL,DAW,DAX,V14,V15,V16,V17,V18,V19,V20,V21,V22,V24,ZAA,ZAB,ZAC,ZAD,ZAE,ZAF,ZAG,ZAH,ZAJ,ZAL .....	2
6	KBHZZ	3120-00-303-4977	3D6E9	1229H1022	. . BEARING,WASHER,THRU CARRIER PART OF KIT P/N 7346959 UOC: DAC,DAD,DAE,DAF,DAG,DAH,DAJ,DAL,DAW,DAX,V14,V15,V16,V17,V18,V19,V20,V21,V22,V24,ZAA,ZAB,ZAC,ZAD,ZAE,ZAF,ZAG,ZAH,ZAJ,ZAL .....	2
7	KBHZZ		19207	8758203	. . GEAR,BEVEL PART OF KIT P/N 7346959 UOC: DAC,DAD,DAE,DAF,DAG,DAH,DAJ,DAL,DAW,DAX,V14,V15,V16,V17,V18,V19,V20,V21,V22,V24,ZAA,ZAB,ZAC,ZAD,ZAE,ZAF,ZAG,ZAH,ZAJ,ZAL .....	2

(1) ITEM NO.	(2) SMR CODE	(3) NSN	(4) CAGEC	(5) PART NUMBER	(6) DESCRIPTION AND USABLE ON CODE (UOC)	(7) QTY
8	PAHZZ	3020-00-734-6824	78500	3892T1190	. . GEAR,HELICAL PART OF KIT P/N 10899232 UOC: DAC,DAD,DAE,DAF,DAG,DA H,DAJ,DAL,DAW,DAX,V14,V15,V16, V17,V18,V19,V20,V21,V22,V24,ZAA, ZAB,ZAC,ZAD,ZAE,ZAF,ZAG,ZAH,Z AJ,ZAL .....	1
9	KBHZZ		19207	8758206-KF	. . SPIDER,DIFFERENTIAL PART OF KIT P/N 10899232 UOC: DAC,DAD,DAE,DAF,DAG,DA H,DAJ,DAL,DAW,DAX,V14,V15,V16, V17,V18,V19,V20,V21,V22,V24,ZAA, ZAB,ZAC,ZAD,ZAE,ZAF,ZAG,ZAH,Z AJ,ZAL .....	1
10	MHHZZ		80244	22W1642125X36 IN	. . WIRE,NONELECTRICAL MAKE FROM WIRE, P/N 22W1642-125, 36 IN.LONG UOC: DAC,DAD,DAE,DAF,DAG,DA H,DAJ,DAL,DAW,DAX,V14,V15,V16, V17,V18,V19,V20,V21,V22,V24,ZAA, ZAB,ZAC,ZAD,ZAE,ZAF,ZAG,ZAH,Z AJ,ZAL .....	8
11	PAHZZ	5310-00-720-7627	19207	8761279	. . NUT,PLAIN,SLOTTED,H UOC: DAC,DAD,DAE,DAF,DAG,DA H,DAJ,DAL,DAW,DAX,V14,V15,V16, V17,V18,V19,V20,V21,V22,V24,ZAA, ZAB,ZAC,ZAD,ZAE,ZAF,ZAG,ZAH,Z AJ,ZAL .....	8
12	PAHZZ	3020-00-611-9536	78500	2233WT01	. . GEAR,BEVEL PART OF KIT P/ N 7346959 UOC: DAC,DAD,DAE,DAF,DAG,DA H,DAJ,DAL,DAW,DAX,V14,V15,V16, V17,V18,V19,V20,V21,V22,V24,ZAA, ZAB,ZAC,ZAD,ZAE,ZAF,ZAG,ZAH,Z AJ,ZAL .....	4
13	KBHZZ	5310-00-285-9402	3D6E9	1229Q1031	. . WASHER,THRUST PART OF KIT P/N 7346959 UOC: DAC,DAD,DAE,DAF,DAG,DA H,DAJ,DAL,DAW,DAX,V14,V15,V16, V17,V18,V19,V20,V21,V22,V24,ZAA, ZAB,ZAC,ZAD,ZAE,ZAF,ZAG,ZAH,Z AJ,ZAL .....	2
14	PAHZZ	5306-00-734-6822	19207	7346822	. . BOLT,MACHINE UOC: DAC,DAD,DAE,DAF,DAG,DA H,DAJ,DAL,DAW,DAX,V14,V15,V16, V17,V18,V19,V20,V21,V22,V24,ZAA, ZAB,ZAC,ZAD,ZAE,ZAF,ZAG,ZAH,Z AJ,ZAL .....	8

(1) ITEM NO.	(2) SMR CODE	(3) NSN	(4) CAGEC	(5) PART NUMBER	(6) DESCRIPTION AND USABLE ON CODE (UOC)	(7) QTY
15	PAHZZ	3110-00-100-4216	21450	712699	. BEARING,ROLLER,TAPE UOC: DAC,DAD,DAE,DAF,DAG,DA H,DAJ,DAL,DAW,DAX,V14,V15,V16, V17,V18,V19,V20,V21,V22,V24,ZAA, ZAB,ZAC,ZAD,ZAE,ZAF,ZAG,ZAH,Z AJ,ZAL .....	2
16	PAHZZ	5365-00-734-6818	19207	7346818	. RING,EXTERNALLY THR UOC: DAC,DAD,DAE,DAF,DAG,DA H,DAJ,DAL,DAW,DAX,V14,V15,V16, V17,V18,V19,V20,V21,V22,V24,ZAA, ZAB,ZAC,ZAD,ZAE,ZAF,ZAG,ZAH,Z AJ,ZAL .....	2

END OF FIGURE



**FIELD MAINTENANCE  
FRONT AXLE DIFFERENTIAL CARRIER ASSEMBLY, ACCESS COVERS, AND RELATED PARTS**

---

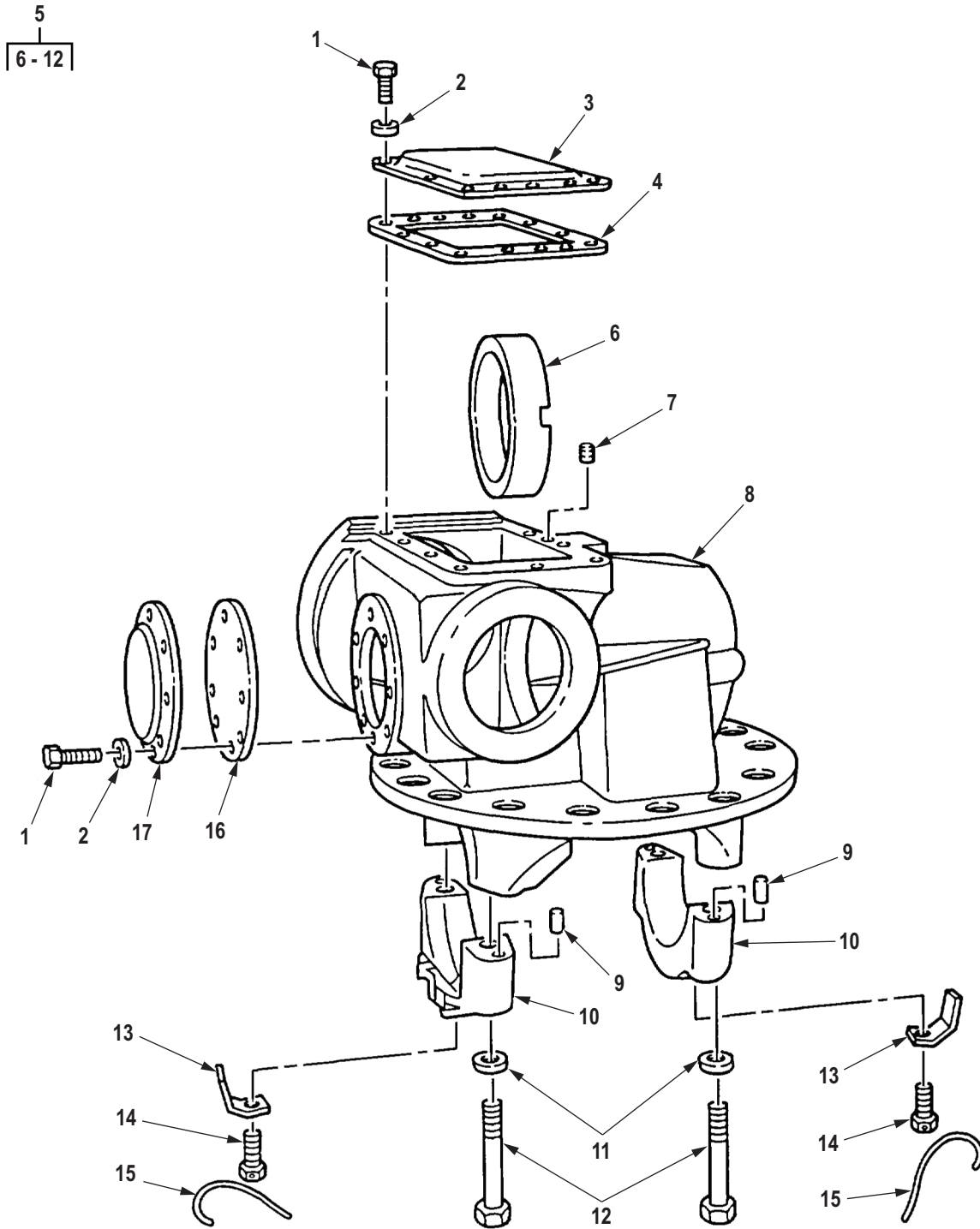

R0248DAA

Figure 233. Front Axle Differential Carrier Assembly, Access Covers, and Related Parts.



(1) ITEM NO.	(2) SMR CODE	(3) NSN	(4) CAGEC	(5) PART NUMBER	(6) DESCRIPTION AND USABLE ON CODE (UOC)	(7) QTY
<b>GROUP 1002 DIFFERENTIAL.</b>						
<b>FIG. 233. FRONT AXLE DIFFERENTIAL CARRIER ASSEMBLY, ACCESS COVERS, AND RELATED PARTS.</b>						
1	PAFZZ	5305-00-543-4372	80204	B1821BH038C075N	SCREW,CAP,HEXAGON H UOC: DAC,DAD,DAE,DAF,DAG,DA H,DAJ,DAL,DAW,DAX,V14,V15,V16, V17,V18,V19,V20,V21,V22,V24,ZAA, ZAB,ZAC,ZAD,ZAE,ZAF,ZAG,ZAH,Z AJ,ZAL .....	18
2	PAFZZ	5310-00-177-0892	19207	7748743	WASHER,FLAT UOC: DAC,DAD,DAE,DAF,DAG,DA H,DAJ,DAL,DAW,DAX,V14,V15,V16, V17,V18,V19,V20,V21,V22,V24,ZAA, ZAB,ZAC,ZAD,ZAE,ZAF,ZAG,ZAH,Z AJ,ZAL .....	18
3	PPFZZ	5340-00-734-6820	19207	7346820	COVER,ACCESS UOC: DAC,DAD,DAE,DAF,DAG,DA H,DAJ,DAL,DAW,DAX,V14,V15,V16, V17,V18,V19,V20,V21,V22,V24,ZAA, ZAB,ZAC,ZAD,ZAE,ZAF,ZAG,ZAH,Z AJ,ZAL .....	1
4	PAFZZ	5330-01-514-6882	19207	7535079 R87	GASKET PART OF KIT P/N 7346807 UOC: DAC,DAD,DAE,DAF,DAG,DA H,DAJ,DAL,DAW,DAX,V14,V15,V16, V17,V18,V19,V20,V21,V22,V24,ZAA, ZAB,ZAC,ZAD,ZAE,ZAF,ZAG,ZAH,Z AJ,ZAL .....	1
5	PAFHH	2520-00-734-7548	92679	483303C91	CARRIER AND CAP ASS UOC: DAC,DAD,DAE,DAF,DAG,DA H,DAJ,DAL,DAW,DAX,V14,V15,V16, V17,V18,V19,V20,V21,V22,V24,ZAA, ZAB,ZAC,ZAD,ZAE,ZAF,ZAG,ZAH,Z AJ,ZAL .....	1
6	PAHZZ	3120-00-734-6883	19207	7346883	. BEARING,SLEEVE UOC: DAC,DAD,DAE,DAF,DAG,DA H,DAJ,DAL,DAW,DAX,V14,V15,V16, V17,V18,V19,V20,V21,V22,V24,ZAA, ZAB,ZAC,ZAD,ZAE,ZAF,ZAG,ZAH,Z AJ,ZAL .....	1
7	PAHZZ	5305-00-752-1718	19207	7521718	. SETSCREW UOC: DAC,DAD,DAE,DAF,DAG,DA H,DAJ,DAL,DAW,DAX,V14,V15,V16, V17,V18,V19,V20,V21,V22,V24,ZAA, ZAB,ZAC,ZAD,ZAE,ZAF,ZAG,ZAH,Z AJ,ZAL .....	1

(1) ITEM NO.	(2) SMR CODE	(3) NSN	(4) CAGEC	(5) PART NUMBER	(6) DESCRIPTION AND USABLE ON CODE (UOC)	(7) QTY
8	XAHZZ		19207	8758260	. CARRIER,HOUSING UOC: DAC,DAD,DAE,DAF,DAG,DA H,DAJ,DAL,DAW,DAX,V14,V15,V16, V17,V18,V19,V20,V21,V22,V24,ZAA, ZAB,ZAC,ZAD,ZAE,ZAF,ZAG,ZAH,Z AJ,ZAL .....	1
9	PAHZZ	5315-00-597-2723	19207	7534717	. PIN,SHOULDER,HEADLE UOC: DAC,DAD,DAE,DAF,DAG,DA H,DAJ,DAL,DAW,DAX,V14,V15,V16, V17,V18,V19,V20,V21,V22,V24,ZAA, ZAB,ZAC,ZAD,ZAE,ZAF,ZAG,ZAH,Z AJ,ZAL .....	4
10	XBHZZ	2520-01-088-9158	19207	8758249	. CAP,DIFFERENTIAL SU UOC: DAC,DAD,DAE,DAF,DAG,DA H,DAJ,DAL,DAW,DAX,V14,V15,V16, V17,V18,V19,V20,V21,V22,V24,ZAA, ZAB,ZAC,ZAD,ZAE,ZAF,ZAG,ZAH,Z AJ,ZAL .....	2
11	PAHZZ	5310-00-355-5453	19207	10900408	. WASHER,FLAT UOC: DAC,DAD,DAE,DAF,DAG,DA H,DAJ,DAL,DAW,DAX,V14,V15,V16, V17,V18,V19,V20,V21,V22,V24,ZAA, ZAB,ZAC,ZAD,ZAE,ZAF,ZAG,ZAH,Z AJ,ZAL .....	4
12	PAHZZ	5306-00-734-6817	19207	7346817	. BOLT,MACHINE UOC: DAC,DAD,DAE,DAF,DAG,DA H,DAJ,DAL,DAW,DAX,V14,V15,V16, V17,V18,V19,V20,V21,V22,V24,ZAA, ZAB,ZAC,ZAD,ZAE,ZAF,ZAG,ZAH,Z AJ,ZAL .....	4
13	PAHZZ	2530-00-734-6819	19207	7346819	LOCK UOC: DAC,DAD,DAE,DAF,DAG,DA H,DAJ,DAL,DAW,DAX,V14,V15,V16, V17,V18,V19,V20,V21,V22,V24,ZAA, ZAB,ZAC,ZAD,ZAE,ZAF,ZAG,ZAH,Z AJ,ZAL .....	2
14	PAHZZ	5305-00-903-7794	96906	MS51095-410	SCREW,CAP,HEXAGON H UOC: DAC,DAD,DAE,DAF,DAG,DA H,DAJ,DAL,DAW,DAX,V14,V15,V16, V17,V18,V19,V20,V21,V22,V24,ZAA, ZAB,ZAC,ZAD,ZAE,ZAF,ZAG,ZAH,Z AJ,ZAL .....	2

(1) ITEM NO.	(2) SMR CODE	(3) NSN	(4) CAGEC	(5) PART NUMBER	(6) DESCRIPTION AND USABLE ON CODE (UOC)	(7) QTY
15	MHHZZ		80244	22W1642125X12 IN	WIRE,NONELECTRICAL MAKE FROM WIRE, P/N 22W1642-125, 12 IN.LONG UOC: DAC,DAD,DAE,DAF,DAG,DA H,DAJ,DAL,DAW,DAX,V14,V15,V16, V17,V18,V19,V20,V21,V22,V24,ZAA, ZAB,ZAC,ZAD,ZAE,ZAF,ZAG,ZAH,Z AJ,ZAL .....	1
16	PAFZZ	5330-01-388-3068	14153	02781	GASKET UOC: DAC,DAD,DAE,DAF,DAG,DA H,DAJ,DAL,DAW,DAX,V14,V15,V16, V17,V18,V19,V20,V21,V22,V24,ZAA, ZAB,ZAC,ZAD,ZAE,ZAF,ZAG,ZAH,Z AJ,ZAL .....	1
17	PFFZZ	5340-00-445-4555	19207	8758248	COVER,ACCESS CARRIER UOC: DAC,DAD,DAE,DAF,DAG,DA H,DAJ,DAL,DAW,DAX,V14,V15,V16, V17,V18,V19,V20,V21,V22,V24,ZAA, ZAB,ZAC,ZAD,ZAE,ZAF,ZAG,ZAH,Z AJ,ZAL .....	1

END OF FIGURE



**FIELD MAINTENANCE  
FRONT AXLE DIFFERENTIAL THROUGH SHAFT, GEARS, AND FLANGE ASSEMBLIES**

---

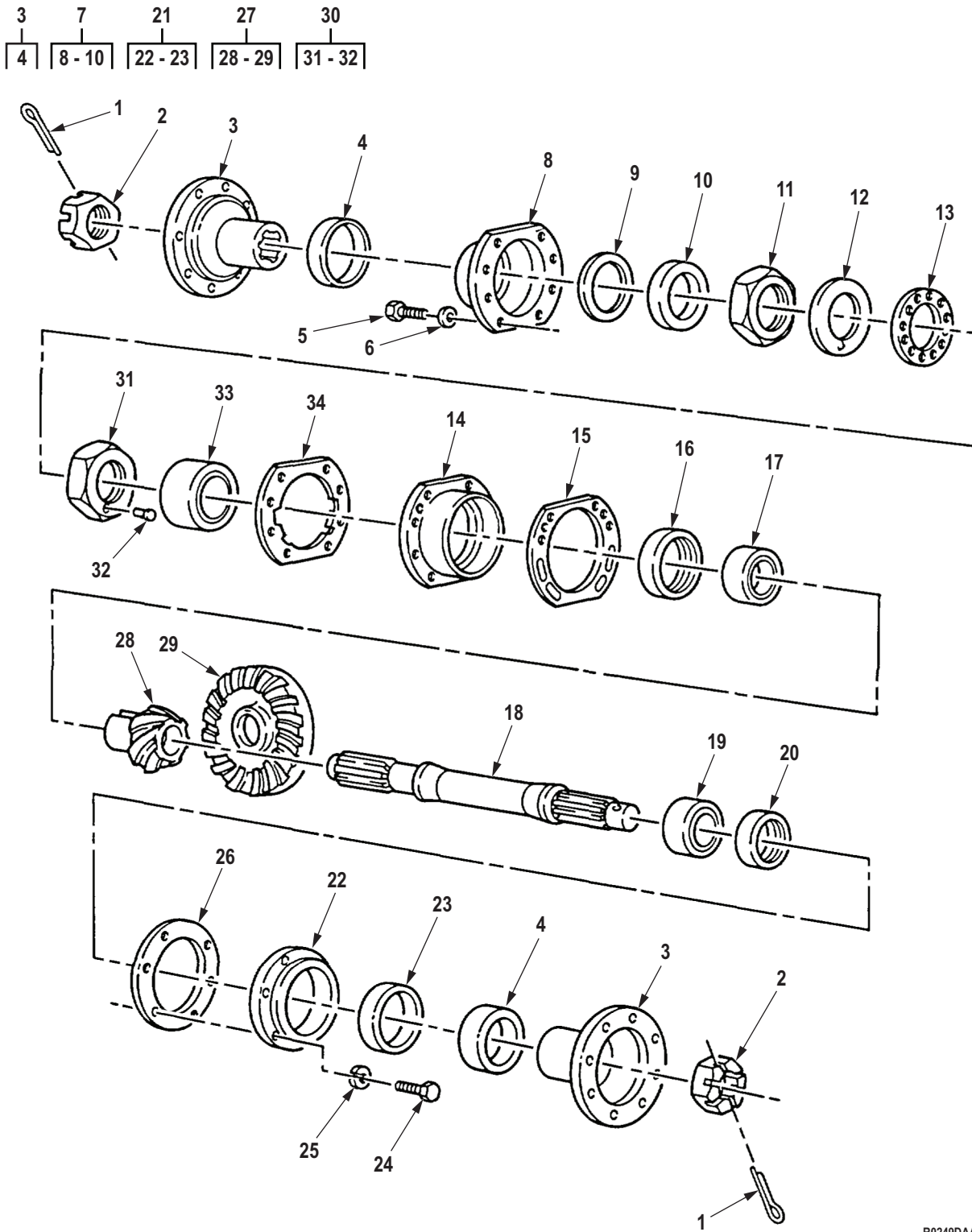

R0249DAA

Figure 234. Front Axle Differential Through Shaft, Gears, and Flange Assemblies.

(1) ITEM NO.	(2) SMR CODE	(3) NSN	(4) CAGEC	(5) PART NUMBER	(6) DESCRIPTION AND USABLE ON CODE (UOC)	(7) QTY
<b>GROUP 1002 DIFFERENTIAL.</b>						
<b>FIG. 234. FRONT AXLE DIFFERENTIAL THROUGH SHAFT, GEARS, AND FLANGE ASSEMBLIES.</b>						
1	PAFZZ	5315-00-059-0184	80205	MS24665-361	PIN,COTTER UOC: DAC,DAD,DAE,DAF,DAG,DA H,DAJ,DAL,DAW,DAX,V14,V15,V16, V17,V18,V19,V20,V21,V22,V24,ZAA, ZAB,ZAC,ZAD,ZAE,ZAF,ZAG,ZAH,Z AJ,ZAL .....	2
2	PAFZZ	5310-00-282-5661	19207	7346893	NUT,PLAIN,SLOTTED,H UOC: DAC,DAD,DAE,DAF,DAG,DA H,DAJ,DAL,DAW,DAX,V14,V15,V16, V17,V18,V19,V20,V21,V22,V24,ZAA, ZAB,ZAC,ZAD,ZAE,ZAF,ZAG,ZAH,Z AJ,ZAL .....	2
3	PAFZZ	2520-00-734-6802	19207	7346802	FLANGE,COMPANION,VE UOC: DAC,DAD,DAE,DAF,DAG,DA H,DAJ,DAL,DAW,DAX,V14,V15,V16, V17,V18,V19,V20,V21,V22,V24,ZAA, ZAB,ZAC,ZAD,ZAE,ZAF,ZAG,ZAH,Z AJ,ZAL .....	2
4	PAFZZ	2520-00-563-8309	19207	7535048	. DEFLECTOR,DIRT AND UOC: DAC,DAD,DAE,DAF,DAG,DA H,DAJ,DAL,DAW,DAX,V14,V15,V16, V17,V18,V19,V20,V21,V22,V24,ZAA, ZAB,ZAC,ZAD,ZAE,ZAF,ZAG,ZAH,Z AJ,ZAL .....	1
5	PAFZZ	5305-00-018-0178	24617	180178	SCREW,CAP,HEXAGON H UOC: DAC,DAD,DAE,DAF,DAG,DA H,DAJ,DAL,DAW,DAX,V14,V15,V16, V17,V18,V19,V20,V21,V22,V24,ZAA, ZAB,ZAC,ZAD,ZAE,ZAF,ZAG,ZAH,Z AJ,ZAL .....	8
6	PAFZZ	5310-00-515-9627	38597	50-4-18-17-7	WASHER,FLAT UOC: DAC,DAD,DAE,DAF,DAG,DA H,DAJ,DAL,DAW,DAX,V14,V15,V16, V17,V18,V19,V20,V21,V22,V24,ZAA, ZAB,ZAC,ZAD,ZAE,ZAF,ZAG,ZAH,Z AJ,ZAL .....	8
7	PAFZZ	3040-00-734-6897	78500	A4-3866-J-556	HOUSING PART,MECHAN UOC: DAC,DAD,DAE,DAF,DAG,DA H,DAJ,DAL,DAW,DAX,V14,V15,V16, V17,V18,V19,V20,V21,V22,V24,ZAA, ZAB,ZAC,ZAD,ZAE,ZAF,ZAG,ZAH,Z AJ,ZAL .....	1

(1) ITEM NO.	(2) SMR CODE	(3) NSN	(4) CAGEC	(5) PART NUMBER	(6) DESCRIPTION AND USABLE ON CODE (UOC)	(7) QTY
8	XAFZZ		19207	8758251	. COVER,BEARING RETAI UOC: DAC,DAD,DAE,DAF,DAG,DA H,DAJ,DAL,DAW,DAX,V14,V15,V16, V17,V18,V19,V20,V21,V22,V24,ZAA, ZAB,ZAC,ZAD,ZAE,ZAF,ZAG,ZAH,Z AJ,ZAL .....	1
9	PAFZZ	5330-01-382-1450	14153	02788	. GASKET UOC: DAC,DAD,DAE,DAF,DAG,DA H,DAJ,DAL,DAW,DAX,V14,V15,V16, V17,V18,V19,V20,V21,V22,V24,ZAA, ZAB,ZAC,ZAD,ZAE,ZAF,ZAG,ZAH,Z AJ,ZAL .....	1
10	PAFZZ	5330-01-023-0269	19207	11669023	. SEAL,PLAIN ENCASED UOC: DAC,DAD,DAE,DAF,DAG,DA H,DAJ,DAL,DAW,DAX,V14,V15,V16, V17,V18,V19,V20,V21,V22,V24,ZAA, ZAB,ZAC,ZAD,ZAE,ZAF,ZAG,ZAH,Z AJ,ZAL .....	1
11	PAFZZ	5310-00-353-2427	19207	7979263	NUT,PLAIN,OCTAGON UOC: DAC,DAD,DAE,DAF,DAG,DA H,DAJ,DAL,DAW,DAX,V14,V15,V16, V17,V18,V19,V20,V21,V22,V24,ZAA, ZAB,ZAC,ZAD,ZAE,ZAF,ZAG,ZAH,Z AJ,ZAL .....	1
12	PAHZZ	5310-00-147-3274	19207	8758258	WASHER,KEY UOC: DAC,DAD,DAE,DAF,DAG,DA H,DAJ,DAL,DAW,DAX,V14,V15,V16, V17,V18,V19,V20,V21,V22,V24,ZAA, ZAB,ZAC,ZAD,ZAE,ZAF,ZAG,ZAH,Z AJ,ZAL .....	1
13	PAHZZ	5310-00-700-7089	19207	5139123	WASHER,KEY UOC: DAC,DAD,DAE,DAF,DAG,DA H,DAJ,DAL,DAW,DAX,V14,V15,V16, V17,V18,V19,V20,V21,V22,V24,ZAA, ZAB,ZAC,ZAD,ZAE,ZAF,ZAG,ZAH,Z AJ,ZAL .....	1
14	PAHZZ	3110-00-419-9471	19207	8758202	PLATE,RETAINING,BEA UOC: DAC,DAD,DAE,DAF,DAG,DA H,DAJ,DAL,DAW,DAX,V14,V15,V16, V17,V18,V19,V20,V21,V22,V24,ZAA, ZAB,ZAC,ZAD,ZAE,ZAF,ZAG,ZAH,Z AJ,ZAL .....	1
15	KBHZZ	5365-00-734-6889	19207	7346889	SHIM .005 PART OF KIT P/N 7346807 UOC: DAC,DAD,DAE,DAF,DAG,DA H,DAJ,DAL,DAW,DAX,V14,V15,V16, V17,V18,V19,V20,V21,V22,V24,ZAA, ZAB,ZAC,ZAD,ZAE,ZAF,ZAG,ZAH,Z AJ,ZAL .....	1



(1) ITEM NO.	(2) SMR CODE	(3) NSN	(4) CAGEC	(5) PART NUMBER	(6) DESCRIPTION AND USABLE ON CODE (UOC)	(7) QTY
15	PAHZZ	5365-01-077-8564	19207	7346888	SHIM .003 PART OF KIT P/N 7346807 UOC: DAC,DAD,DAE,DAF,DAG,DA H,DAJ,DAL,DAW,DAX,V14,V15,V16, V17,V18,V19,V20,V21,V22,V24,ZAA, ZAB,ZAC,ZAD,ZAE,ZAF,ZAG,ZAH,Z AJ,ZAL .....	1
15	KBHZZ	5365-00-734-6890	89346	98683R1	SHIM .010 PART OF KIT P/N 7346807 UOC: DAC,DAD,DAE,DAF,DAG,DA H,DAJ,DAL,DAW,DAX,V14,V15,V16, V17,V18,V19,V20,V21,V22,V24,ZAA, ZAB,ZAC,ZAD,ZAE,ZAF,ZAG,ZAH,Z AJ,ZAL .....	1
16	KBHZZ		19207	8758223	COLLAR .381 PART OF KIT P/N 5704278 UOC: DAC,DAD,DAE,DAF,DAG,DA H,DAJ,DAL,DAW,DAX,V14,V15,V16, V17,V18,V19,V20,V21,V22,V24,ZAA, ZAB,ZAC,ZAD,ZAE,ZAF,ZAG,ZAH,Z AJ,ZAL .....	1
16	KBHZZ	3040-00-692-6123	19207	8758225	COLLAR,SHAFT .383 PART OF KIT P/N 5704278 UOC: DAC,DAD,DAE,DAF,DAG,DA H,DAJ,DAL,DAW,DAX,V14,V15,V16, V17,V18,V19,V20,V21,V22,V24,ZAA, ZAB,ZAC,ZAD,ZAE,ZAF,ZAG,ZAH,Z AJ,ZAL .....	1
16	KBHZZ		19207	8758227	COLLAR,BEARING .385 PART OF KIT P/N 5704278 UOC: DAC,DAD,DAE,DAF,DAG,DA H,DAJ,DAL,DAW,DAX,V14,V15,V16, V17,V18,V19,V20,V21,V22,V24,ZAA, ZAB,ZAC,ZAD,ZAE,ZAF,ZAG,ZAH,Z AJ,ZAL .....	1
16	KBHZZ	3120-00-692-6124	19207	8758229	BEARING,WASHER,THRU .387 PART OF KIT P/N 5704278 UOC: DAC,DAD,DAE,DAF,DAG,DA H,DAJ,DAL,DAW,DAX,V14,V15,V16, V17,V18,V19,V20,V21,V22,V24,ZAA, ZAB,ZAC,ZAD,ZAE,ZAF,ZAG,ZAH,Z AJ,ZAL .....	1
16	KBHZZ		19207	8758215	COLLAR,BEARING .373 PART OF KIT P/N 5704278 UOC: DAC,DAD,DAE,DAF,DAG,DA H,DAJ,DAL,DAW,DAX,V14,V15,V16, V17,V18,V19,V20,V21,V22,V24,ZAA, ZAB,ZAC,ZAD,ZAE,ZAF,ZAG,ZAH,Z AJ,ZAL .....	1

(1) ITEM NO.	(2) SMR CODE	(3) NSN	(4) CAGEC	(5) PART NUMBER	(6) DESCRIPTION AND USABLE ON CODE (UOC)	(7) QTY
16	KBHZZ	5365-00-692-6120	19207	8758213	COLLAR .371 PART OF KIT P/N 5704278 UOC: DAC,DAD,DAE,DAF,DAG,DA H,DAJ,DAL,DAW,DAX,V14,V15,V16, V17,V18,V19,V20,V21,V22,V24,ZAA, ZAB,ZAC,ZAD,ZAE,ZAF,ZAG,ZAH,Z AJ,ZAL .....	1
16	KBHZZ		19207	8758211	COLLAR .369 PART OF KIT P/N 5704278 UOC: DAC,DAD,DAE,DAF,DAG,DA H,DAJ,DAL,DAW,DAX,V14,V15,V16, V17,V18,V19,V20,V21,V22,V24,ZAA, ZAB,ZAC,ZAD,ZAE,ZAF,ZAG,ZAH,Z AJ,ZAL .....	1
16	KBHZZ		19207	8758221	COLLAR,BEARING .379 PART OF KIT P/N 5704278 UOC: DAC,DAD,DAE,DAF,DAG,DA H,DAJ,DAL,DAW,DAX,V14,V15,V16, V17,V18,V19,V20,V21,V22,V24,ZAA, ZAB,ZAC,ZAD,ZAE,ZAF,ZAG,ZAH,Z AJ,ZAL .....	1
16	KBHZZ		19207	8758219	COLLAR,BEARING .377 PART OF KIT P/N 5704278 UOC: DAC,DAD,DAE,DAF,DAG,DA H,DAJ,DAL,DAW,DAX,V14,V15,V16, V17,V18,V19,V20,V21,V22,V24,ZAA, ZAB,ZAC,ZAD,ZAE,ZAF,ZAG,ZAH,Z AJ,ZAL .....	1
16	KBHZZ	3040-00-692-6121	19207	8758217	COLLAR,SHAFT .375 PART OF KIT P/N 5704278 UOC: DAC,DAD,DAE,DAF,DAG,DA H,DAJ,DAL,DAW,DAX,V14,V15,V16, V17,V18,V19,V20,V21,V22,V24,ZAA, ZAB,ZAC,ZAD,ZAE,ZAF,ZAG,ZAH,Z AJ,ZAL .....	1
16	KBHZZ		19207	8758239	COLLAR,BEARING .397 PART OF KIT P/N 5704278 UOC: DAC,DAD,DAE,DAF,DAG,DA H,DAJ,DAL,DAW,DAX,V14,V15,V16, V17,V18,V19,V20,V21,V22,V24,ZAA, ZAB,ZAC,ZAD,ZAE,ZAF,ZAG,ZAH,Z AJ,ZAL .....	1
16	KBHZZ		19207	8758237	COLLAR,BEARING .395 PART OF KIT P/N 5704278 UOC: DAC,DAD,DAE,DAF,DAG,DA H,DAJ,DAL,DAW,DAX,V14,V15,V16, V17,V18,V19,V20,V21,V22,V24,ZAA, ZAB,ZAC,ZAD,ZAE,ZAF,ZAG,ZAH,Z AJ,ZAL .....	1

(1) ITEM NO.	(2) SMR CODE	(3) NSN	(4) CAGEC	(5) PART NUMBER	(6) DESCRIPTION AND USABLE ON CODE (UOC)	(7) QTY
16	KBHZZ		19207	8758241	COLLAR,BEARING .399 PART OF KIT P/N 5704278 UOC: DAC,DAD,DAE,DAF,DAG,DA H,DAJ,DAL,DAW,DAX,V14,V15,V16, V17,V18,V19,V20,V21,V22,V24,ZAA, ZAB,ZAC,ZAD,ZAE,ZAF,ZAG,ZAH,Z AJ,ZAL .....	1
16	KBHZZ		19207	8758245	COLLAR,BEARING .403 PART OF KIT P/N 5704278 UOC: DAC,DAD,DAE,DAF,DAG,DA H,DAJ,DAL,DAW,DAX,V14,V15,V16, V17,V18,V19,V20,V21,V22,V24,ZAA, ZAB,ZAC,ZAD,ZAE,ZAF,ZAG,ZAH,Z AJ,ZAL .....	1
16	KBHZZ		19207	8758243	COLLAR,BEARING .401 PART OF KIT P/N 5704278 UOC: DAC,DAD,DAE,DAF,DAG,DA H,DAJ,DAL,DAW,DAX,V14,V15,V16, V17,V18,V19,V20,V21,V22,V24,ZAA, ZAB,ZAC,ZAD,ZAE,ZAF,ZAG,ZAH,Z AJ,ZAL .....	1
16	KBHZZ		19207	8758231	COLLAR,BEARING .389 PART OF KIT P/N 5704278 UOC: DAC,DAD,DAE,DAF,DAG,DA H,DAJ,DAL,DAW,DAX,V14,V15,V16, V17,V18,V19,V20,V21,V22,V24,ZAA, ZAB,ZAC,ZAD,ZAE,ZAF,ZAG,ZAH,Z AJ,ZAL .....	1
16	KBHZZ		19207	8758233	COLLAR,BEARING .391 PART OF KIT P/N 5704278 UOC: DAC,DAD,DAE,DAF,DAG,DA H,DAJ,DAL,DAW,DAX,V14,V15,V16, V17,V18,V19,V20,V21,V22,V24,ZAA, ZAB,ZAC,ZAD,ZAE,ZAF,ZAG,ZAH,Z AJ,ZAL .....	1
16	KBHZZ		19207	8758235	COLLAR,BEARING .393 PART OF KIT P/N 5704278 UOC: DAC,DAD,DAE,DAF,DAG,DA H,DAJ,DAL,DAW,DAX,V14,V15,V16, V17,V18,V19,V20,V21,V22,V24,ZAA, ZAB,ZAC,ZAD,ZAE,ZAF,ZAG,ZAH,Z AJ,ZAL .....	1
16	PAHZZ	5365-00-692-6119	19207	8758209	SPACER,BEVEL PINION .367 PART OF KIT P/N 5704278 UOC: DAC,DAD,DAE,DAF,DAG,DA H,DAJ,DAL,DAW,DAX,V14,V15,V16, V17,V18,V19,V20,V21,V22,V24,ZAA, ZAB,ZAC,ZAD,ZAE,ZAF,ZAG,ZAH,Z AJ,ZAL .....	1

(1) ITEM NO.	(2) SMR CODE	(3) NSN	(4) CAGEC	(5) PART NUMBER	(6) DESCRIPTION AND USABLE ON CODE (UOC)	(7) QTY
17	PAHZZ	3110-00-100-5355	60038	42350-42584	BEARING,ROLLER,TAPE UOC: DAC,DAD,DAE,DAF,DAG,DA H,DAJ,DAL,DAW,DAX,V14,V15,V16, V17,V18,V19,V20,V21,V22,V24,ZAA, ZAB,ZAC,ZAD,ZAE,ZAF,ZAG,ZAH,Z AJ,ZAL .....	1
18	PAHZZ	3040-00-734-6892	19207	7346892	SHAFT,SHOULDERED UOC: DAC,DAD,DAE,DAF,DAG,DA H,DAJ,DAL,DAW,DAX,V14,V15,V16, V17,V18,V19,V20,V21,V22,V24,ZAA, ZAB,ZAC,ZAD,ZAE,ZAF,ZAG,ZAH,Z AJ,ZAL .....	1
19	PAHZZ	3110-00-195-0460	0LTL1	MR1212EL	BEARING,ROLLER,CYLI UOC: DAC,DAD,DAE,DAF,DAG,DA H,DAJ,DAL,DAW,DAX,V14,V15,V16, V17,V18,V19,V20,V21,V22,V24,ZAA, ZAB,ZAC,ZAD,ZAE,ZAF,ZAG,ZAH,Z AJ,ZAL .....	1
20	PAHZZ	3120-00-662-3370	78500	1244K557	BEARING,WASHER,THRU UOC: DAC,DAD,DAE,DAF,DAG,DA H,DAJ,DAL,DAW,DAX,V14,V15,V16, V17,V18,V19,V20,V21,V22,V24,ZAA, ZAB,ZAC,ZAD,ZAE,ZAF,ZAG,ZAH,Z AJ,ZAL .....	1
21	PAFZZ	3110-00-734-6895	78500	A3866H554	PLATE,RETAINING,BEA UOC: DAC,DAD,DAE,DAF,DAG,DA H,DAJ,DAL,DAW,DAX,V14,V15,V16, V17,V18,V19,V20,V21,V22,V24,ZAA, ZAB,ZAC,ZAD,ZAE,ZAF,ZAG,ZAH,Z AJ,ZAL .....	1
22	XAFZZ		19207	8758207	. CAP UOC: DAC,DAD,DAE,DAF,DAG,DA H,DAJ,DAL,DAW,DAX,V14,V15,V16, V17,V18,V19,V20,V21,V22,V24,ZAA, ZAB,ZAC,ZAD,ZAE,ZAF,ZAG,ZAH,Z AJ,ZAL .....	1
23	PAFZZ	5330-01-023-0269	19207	11669023	. SEAL,PLAIN ENCASED UOC: DAC,DAD,DAE,DAF,DAG,DA H,DAJ,DAL,DAW,DAX,V14,V15,V16, V17,V18,V19,V20,V21,V22,V24,ZAA, ZAB,ZAC,ZAD,ZAE,ZAF,ZAG,ZAH,Z AJ,ZAL .....	1
24	PAFZZ	5305-00-543-2419	80204	B1821BH038C113N	SCREW,CAP,HEXAGON H UOC: DAC,DAD,DAE,DAF,DAG,DA H,DAJ,DAL,DAW,DAX,V14,V15,V16, V17,V18,V19,V20,V21,V22,V24,ZAA, ZAB,ZAC,ZAD,ZAE,ZAF,ZAG,ZAH,Z AJ,ZAL .....	6

(1) ITEM NO.	(2) SMR CODE	(3) NSN	(4) CAGEC	(5) PART NUMBER	(6) DESCRIPTION AND USABLE ON CODE (UOC)	(7) QTY
25	PAFZZ	5310-00-637-9541	00198	132661	WASHER,LOCK UOC: DAC,DAD,DAE,DAF,DAG,DA H,DAJ,DAL,DAW,DAX,V14,V15,V16, V17,V18,V19,V20,V21,V22,V24,ZAA, ZAB,ZAC,ZAD,ZAE,ZAF,ZAG,ZAH,Z AJ,ZAL .....	6
26	PAHZZ	5330-01-077-8512	19207	7346896	GASKET CAP UOC: DAC,DAD,DAE,DAF,DAG,DA H,DAJ,DAL,DAW,V22,V24,ZAA,ZAB, ZAC,ZAD,ZAE,ZAF,ZAG,ZAH,ZAJ,ZAL .....	1
27	PAHZZ	3020-00-734-6881	19207	7346881	GEAR SET,BEVEL,MATC UOC: DAC,DAD,DAE,DAF,DAG,DA H,DAJ,DAL,DAW,DAX,V14,V15,V16, V17,V18,V19,V20,V21,V22,V24,ZAA, ZAB,ZAC,ZAD,ZAE,ZAF,ZAG,ZAH,Z AJ,ZAL .....	1
28	PAHZZ	3040-00-311-7875	19207	8758204	. GEARSHAFT,BEVEL UOC: DAC,DAD,DAE,DAF,DAG,DA H,DAJ,DAL,DAW,DAX,V14,V15,V16, V17,V18,V19,V20,V21,V22,V24,ZAA, ZAB,ZAC,ZAD,ZAE,ZAF,ZAG,ZAH,Z AJ,ZAL .....	1
29	XAHZZ		19207	8758205	. GEAR,BEVEL UOC: DAC,DAD,DAE,DAF,DAG,DA H,DAJ,DAL,DAW,DAX,V14,V15,V16, V17,V18,V19,V20,V21,V22,V24,ZAA, ZAB,ZAC,ZAD,ZAE,ZAF,ZAG,ZAH,Z AJ,ZAL .....	1
30	PAHZZ	5310-00-374-0836	24617	716649	NUT,PLAIN,OCTAGON UOC: DAC,DAD,DAE,DAF,DAG,DA H,DAJ,DAL,DAW,DAX,V14,V15,V16, V17,V18,V19,V20,V21,V22,V24,ZAA, ZAB,ZAC,ZAD,ZAE,ZAF,ZAG,ZAH,Z AJ,ZAL .....	1
31	XAHZZ	5310-01-135-0049	19207	7979309	. NUT,PLAIN,OCTAGON UOC: DAC,DAD,DAE,DAF,DAG,DA H,DAJ,DAL,DAW,DAX,V14,V15,V16, V17,V18,V19,V20,V21,V22,V24,ZAA, ZAB,ZAC,ZAD,ZAE,ZAF,ZAG,ZAH,Z AJ,ZAL .....	1
32	PAHZZ	5315-01-058-7268	19207	7979310	. PIN,ADJUSTMENT UOC: DAC,DAD,DAE,DAF,DAG,DA H,DAJ,DAL,DAW,DAX,V14,V15,V16, V17,V18,V19,V20,V21,V22,V24,ZAA, ZAB,ZAC,ZAD,ZAE,ZAF,ZAG,ZAH,Z AJ,ZAL .....	1

(1) ITEM NO.	(2) SMR CODE	(3) NSN	(4) CAGEC	(5) PART NUMBER	(6) DESCRIPTION AND USABLE ON CODE (UOC)	(7) QTY
33	PAHZZ	3110-00-100-4177	58536	AA59649-628	BEARING,ROLLER,TAPE UOC: DAC,DAD,DAE,DAF,DAG,DA H,DAJ,DAL,DAW,DAX,V14,V15,V16, V17,V18,V19,V20,V21,V22,V24,ZAA, ZAB,ZAC,ZAD,ZAE,ZAF,ZAG,ZAH,Z AJ,ZAL .....	1
34	PAHZZ	5330-01-413-8543	14153	02957	GASKET,COVER UOC: DAC,DAD,DAE,DAF,DAG,DA H,DAJ,DAL,DAW,DAX,V14,V15,V16, V17,V18,V19,V20,V21,V22,V24,ZAA, ZAB,ZAC,ZAD,ZAE,ZAF,ZAG,ZAH,Z AJ,ZAL .....	1

END OF FIGURE

**FIELD MAINTENANCE  
FRONT AXLE DIFFERENTIAL HELICAL DRIVE PINION AND RELATED PARTS**

---

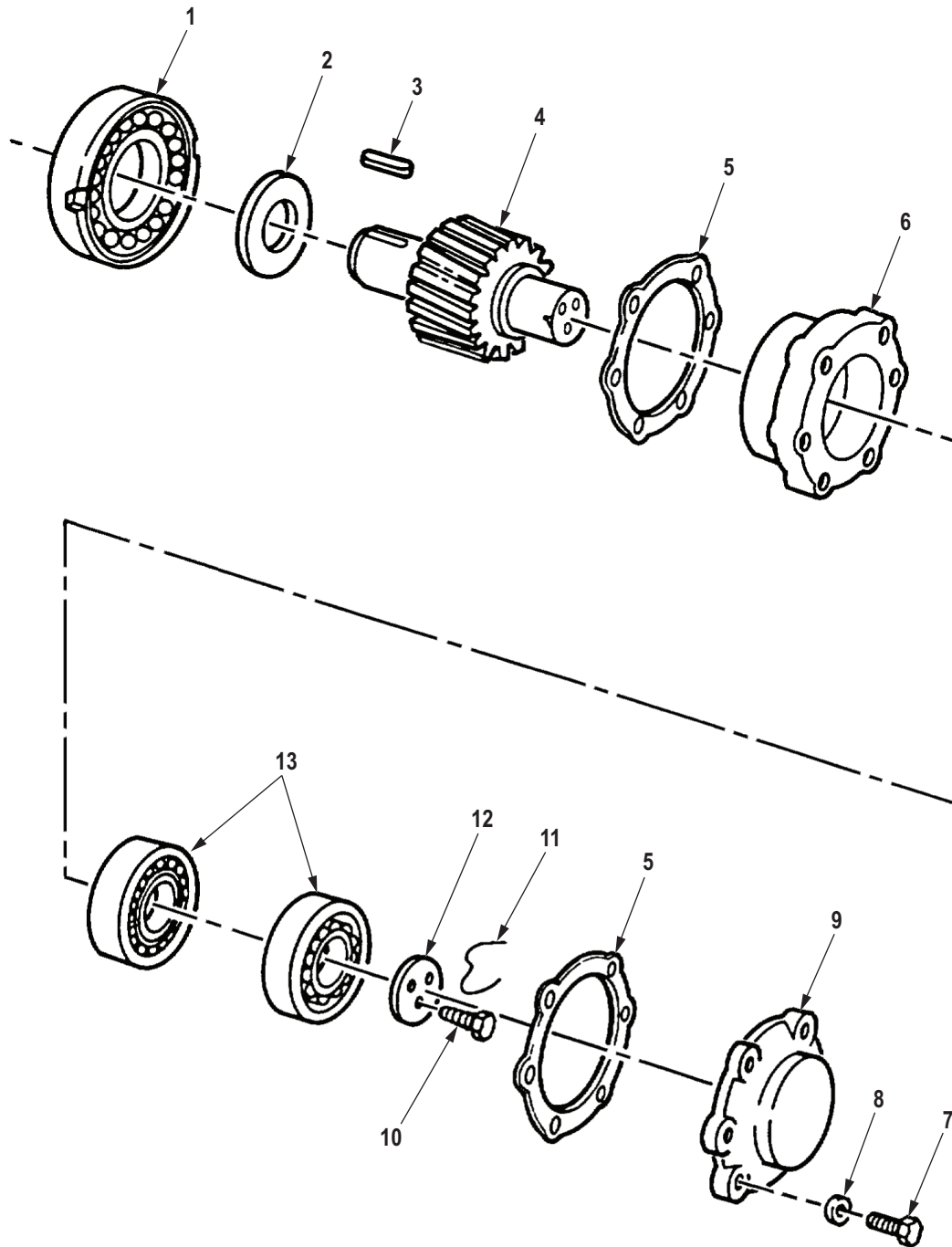

R0250DAA

Figure 235. Front Axle Differential Helical Drive Pinion and Related Parts.



(1) ITEM NO.	(2) SMR CODE	(3) NSN	(4) CAGEC	(5) PART NUMBER	(6) DESCRIPTION AND USABLE ON CODE (UOC)	(7) QTY
<b>GROUP 1002 DIFFERENTIAL.</b>						
<b>FIG. 235. FRONT AXLE DIFFERENTIAL HELICAL DRIVE PINION AND RELATED PARTS.</b>						
1	PAHZZ	3110-00-158-6011	OLTL1	11665824	BEARING,ROLLER,CYLI UOC: DAC,DAD,DAE,DAF,DAG,DA H,DAJ,DAL,DAW,DAX,V14,V15,V16, V17,V18,V19,V20,V21,V22,V24,ZAA, ZAB,ZAC,ZAD,ZAE,ZAF,ZAG,ZAH,Z AJ,ZAL .....	1
2	PAHZZ	5310-00-033-6012	19207	7346882	WASHER,RECESSED UOC: DAC,DAD,DAE,DAF,DAG,DA H,DAJ,DAL,DAW,DAX,V14,V15,V16, V17,V18,V19,V20,V21,V22,V24,ZAA, ZAB,ZAC,ZAD,ZAE,ZAF,ZAG,ZAH,Z AJ,ZAL .....	1
3	PAHZZ	5315-00-276-5385	19207	7534781	KEY,MACHINE UOC: DAC,DAD,DAE,DAF,DAG,DA H,DAJ,DAL,DAW,DAX,V14,V15,V16, V17,V18,V19,V20,V21,V22,V24,ZAA, ZAB,ZAC,ZAD,ZAE,ZAF,ZAG,ZAH,Z AJ,ZAL .....	1
4	KBHZZ	3040-00-734-6825	89346	98683R3	GEARSHAFT,HELICAL PART OF KIT P/N 10899232 UOC: DAC,DAD,DAE,DAF,DAG,DA H,DAJ,DAL,DAW,DAX,V14,V15,V16, V17,V18,V19,V20,V21,V22,V24,ZAA, ZAB,ZAC,ZAD,ZAE,ZAF,ZAG,ZAH,Z AJ,ZAL .....	1
5	PAHZZ	5365-00-734-6880	19207	7346880	SHIM PART OF KIT P/N 7346807 UOC: DAC,DAD,DAE,DAF,DAG,DA H,DAJ,DAL,DAW,DAX,V14,V15,V16, V17,V18,V19,V20,V21,V22,V24,ZAA, ZAB,ZAC,ZAD,ZAE,ZAF,ZAG,ZAH,Z AJ,ZAL .....	2
5	PAHZZ	5365-00-734-6879	78500	2803J1440	SHIM .005 PART OF KIT P/N 7346807 UOC: DAC,DAD,DAE,DAF,DAG,DA H,DAJ,DAL,DAW,DAX,V14,V15,V16, V17,V18,V19,V20,V21,V22,V24,ZAA, ZAB,ZAC,ZAD,ZAE,ZAF,ZAG,ZAH,Z AJ,ZAL .....	2
5	PAHZZ	5365-00-734-6878	19207	7346878	GASKET .010 PART OF KIT P/N 7346807 UOC: DAC,DAD,DAE,DAF,DAG,DA H,DAJ,DAL,DAW,DAX,V14,V15,V16, V17,V18,V19,V20,V21,V22,V24,ZAA, ZAB,ZAC,ZAD,ZAE,ZAF,ZAG,ZAH,Z AJ,ZAL .....	2

(1) ITEM NO.	(2) SMR CODE	(3) NSN	(4) CAGEC	(5) PART NUMBER	(6) DESCRIPTION AND USABLE ON CODE (UOC)	(7) QTY
6	PAHZZ	3110-00-182-7957	19207	8758208	PLATE,RETAINING,BEA UOC: DAC,DAD,DAE,DAF,DAG,DA H,DAJ,DAL,DAW,DAX,V14,V15,V16, V17,V18,V19,V20,V21,V22,V24,ZAA, ZAB,ZAC,ZAD,ZAE,ZAF,ZAG,ZAH,Z AJ,ZAL .....	1
7	PAHZZ	5305-00-071-2071	80204	B1821BH050C200N	SCREW,CAP,HEXAGON H UOC: DAC,DAD,DAE,DAF,DAG,DA H,DAJ,DAL,DAW,DAX,V14,V15,V16, V17,V18,V19,V20,V21,V22,V24,ZAA, ZAB,ZAC,ZAD,ZAE,ZAF,ZAG,ZAH,Z AJ,ZAL .....	6
8	PAHZZ	5310-00-003-4094	80205	MS35338-48	WASHER,LOCK UOC: DAC,DAD,DAE,DAF,DAG,DA H,DAJ,DAL,DAW,DAX,V14,V15,V16, V17,V18,V19,V20,V21,V22,V24,ZAA, ZAB,ZAC,ZAD,ZAE,ZAF,ZAG,ZAH,Z AJ,ZAL .....	6
9	PAHZZ	3110-00-734-6877	19207	7346877	PLATE,RETAINING,BEA UOC: DAC,DAD,DAE,DAF,DAG,DA H,DAJ,DAL,DAW,DAX,V14,V15,V16, V17,V18,V19,V20,V21,V22,V24,ZAA, ZAB,ZAC,ZAD,ZAE,ZAF,ZAG,ZAH,Z AJ,ZAL .....	1
10	PAHZZ	5305-00-941-9460	96906	MS51095-386	SCREW,CAP,HEXAGON H UOC: DAC,DAD,DAE,DAF,DAG,DA H,DAJ,DAL,DAW,DAX,V14,V15,V16, V17,V18,V19,V20,V21,V22,V24,ZAA, ZAB,ZAC,ZAD,ZAE,ZAF,ZAG,ZAH,Z AJ,ZAL .....	3
11	MHHZZ		80244	22W1642125X12 IN	WIRE,NONELECTRICAL MAKE FROM WIRE,P/N 22W1642-125, 12 IN.LONG UOC: DAC,DAD,DAE,DAF,DAG,DA H,DAJ,DAL,DAW,DAX,V14,V15,V16, V17,V18,V19,V20,V21,V22,V24,ZAA, ZAB,ZAC,ZAD,ZAE,ZAF,ZAG,ZAH,Z AJ,ZAL .....	1
12	PAHZZ	3110-00-350-5407	3D6E9	1829S149	PLATE,RETAINING,BEA UOC: DAC,DAD,DAE,DAF,DAG,DA H,DAJ,DAL,DAW,DAX,V14,V15,V16, V17,V18,V19,V20,V21,V22,V24,ZAA, ZAB,ZAC,ZAD,ZAE,ZAF,ZAG,ZAH,Z AJ,ZAL .....	1

(1) ITEM NO.	(2) SMR CODE	(3) NSN	(4) CAGEC	(5) PART NUMBER	(6) DESCRIPTION AND USABLE ON CODE (UOC)	(7) QTY
13	PAHZZ	3110-00-100-5825	60038	66225-66462	BEARING,ROLLER,TAPE UOC: DAC,DAD,DAE,DAF,DAG,DA H,DAJ,DAL,DAW,DAX,V14,V15,V16, V17,V18,V19,V20,V21,V22,V24,ZAA, ZAB,ZAC,ZAD,ZAE,ZAF,ZAG,ZAH,Z AJ,ZAL .....	2

END OF FIGURE



**FIELD MAINTENANCE  
SPINDLE SHAFT ASSEMBLY, UNIVERSAL SHAFT, AND KNUCKLE ASSEMBLY**

---

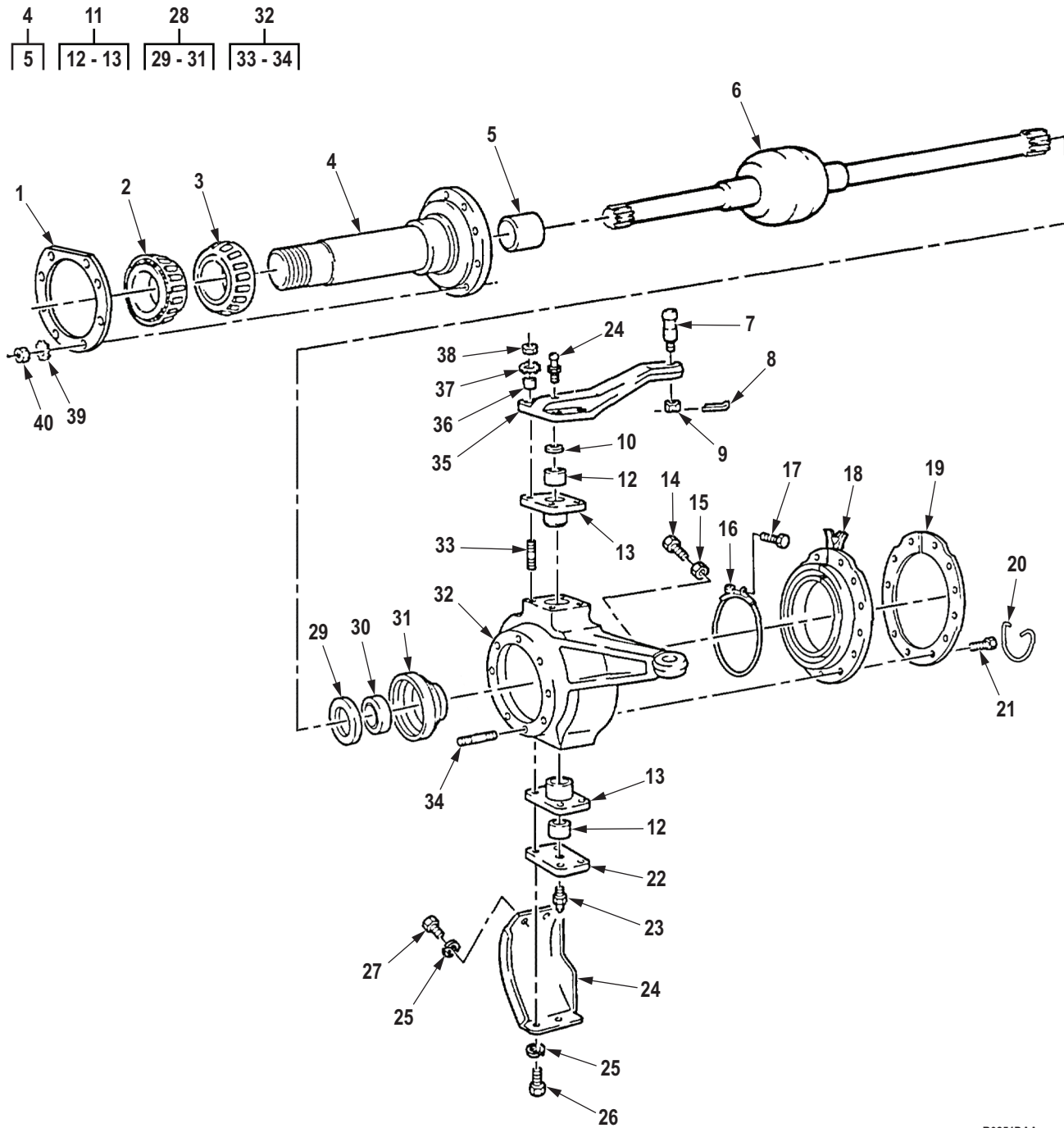

R0251DAA

Figure 236. Spindle Shaft Assembly, Universal Shaft, and Knuckle Assembly.

(1) ITEM NO.	(2) SMR CODE	(3) NSN	(4) CAGEC	(5) PART NUMBER	(6) DESCRIPTION AND USABLE ON CODE (UOC)	(7) QTY
<b>GROUP 1004 STEERING AND LEANING WHEEL MECHANISM.</b>						
<b>FIG. 236. SPINDLE SHAFT ASSEMBLY, UNIVERSAL SHAFT, AND KNUCKLE ASSEMBLY.</b>						
1	PAFZZ	5330-01-271-5151	3D6E9	3286-N-1054	SEAL,PLAIN UOC: DAC,DAD,DAE,DAF,DAG,DA H,DAJ,DAL,DAW,DAX,V14,V15,V16, V17,V18,V19,V20,V21,V22,V24,ZAA, ZAB,ZAC,ZAD,ZAE,ZAF,ZAG,ZAH,Z AJ,ZAL .....	2
2	PAFZZ	3110-00-100-0650	60038	598	CONE AND ROLLERS,TA UOC: ZAA,ZAB,ZAC,ZAD,ZAE,ZAF, ZAG,ZAH,ZAJ,ZAL .....	2
3	PAFZZ	3110-00-950-9700	60038	594A	CONE AND ROLLERS,TA UOC: ZAA,ZAB,ZAC,ZAD,ZAE,ZAF, ZAG,ZAH,ZAJ,ZAL .....	2
4	PAFZZ	2530-01-272-0542	3D6E9	A3213X1558	SPINDLE,WHEEL,DRIVI UOC: ZAA,ZAB,ZAC,ZAD,ZAE,ZAF, ZAG,ZAH,ZAJ,ZAL .....	2
4	PAFZZ	2530-00-734-6982	19207	7346982	SPINDLE,WHEEL,DRIVI UOC: DAC,DAD,DAE,DAF,DAG,DA H,DAJ,DAL,DAW,DAX,V14,V15,V16, V17,V18,V19,V20,V21,V22,V24,ZAA, ZAB,ZAC,ZAD,ZAE,ZAF,ZAG,ZAH,Z AJ,ZAL .....	2
5	PAFZZ	3120-00-537-0614	19207	7346983	. BEARING,SLEEVE UOC: DAC,DAD,DAE,DAF,DAG,DA H,DAJ,DAL,DAW,DAX,V14,V15,V16, V17,V18,V19,V20,V21,V22,V24,ZAA, ZAB,ZAC,ZAD,ZAE,ZAF,ZAG,ZAH,Z AJ,ZAL .....	1
6	PAFZZ	2520-00-734-6985	19207	7348985	SHAFT,AXLE,AUTOMOTI LEFT HAND FRONT AXLE ASSEMBLY UOC: DAC,DAD,DAE,DAF,DAG,DA H,DAJ,DAL,DAW,DAX,V14,V15,V16, V17,V18,V19,V20,V21,V22,V24,ZAA, ZAB,ZAC,ZAD,ZAE,ZAF,ZAG,ZAH,Z AJ,ZAL .....	1
6	PAFZZ	2520-00-734-6984	13038	J950112-6	SHAFT,AXLE,AUTOMOTI RIGHT HAND FRONT AXLE ASSEMBLY UOC: DAC,DAD,DAE,DAF,DAG,DA H,DAJ,DAL,DAW,DAX,V14,V15,V16, V17,V18,V19,V20,V21,V22,V24,ZAA, ZAB,ZAC,ZAD,ZAE,ZAF,ZAG,ZAH,Z AJ,ZAL .....	1

(1) ITEM NO.	(2) SMR CODE	(3) NSN	(4) CAGEC	(5) PART NUMBER	(6) DESCRIPTION AND USABLE ON CODE (UOC)	(7) QTY
7	PAFZZ	5307-00-483-1105	19207	11664599	STUD,BALL UOC: DAC,DAD,DAE,DAF,DAG,DA H,DAJ,DAL,DAW,DAX,V14,V15,V16, V17,V18,V19,V20,V21,V22,V24,ZAA, ZAB,ZAC,ZAD,ZAE,ZAF,ZAG,ZAH,Z AJ,ZAL .....	1
8	PAFZZ	5315-00-298-1481	80205	MS24665-357	PIN,COTTER UOC: DAC,DAD,DAE,DAF,DAG,DA H,DAJ,DAL,DAW,DAX,V14,V15,V16, V17,V18,V19,V20,V21,V22,V24,ZAA, ZAB,ZAC,ZAD,ZAE,ZAF,ZAG,ZAH,Z AJ,ZAL .....	2
9	PAFZZ	5310-00-835-2140	96906	MS35692-69	NUT,PLAIN,SLOTTED,H UOC: DAC,DAD,DAE,DAF,DAG,DA H,DAJ,DAL,DAW,DAX,V14,V15,V16, V17,V18,V19,V20,V21,V22,V24,ZAA, ZAB,ZAC,ZAD,ZAE,ZAF,ZAG,ZAH,Z AJ,ZAL .....	2
10	PAFZZ	5310-01-128-1592	78500	1244-D-550	WASHER,FLAT .145 UOC: DAC,DAD,DAE,DAF,DAG,DA H,DAJ,DAL,DAW,DAX,V14,V15,V16, V17,V18,V19,V20,V21,V22,V24,ZAA, ZAB,ZAC,ZAD,ZAE,ZAF,ZAG,ZAH,Z AJ,ZAL .....	1
10	PAFZZ	5365-01-055-8769	78500	1244-G-553	SHIM .175 UOC: DAC,DAD,DAE,DAF,DAG,DA H,DAJ,DAL,DAW,DAX,V14,V15,V16, V17,V18,V19,V20,V21,V22,V24,ZAA, ZAB,ZAC,ZAD,ZAE,ZAF,ZAG,ZAH,Z AJ,ZAL .....	1
10	PAFZZ	5310-01-134-5791	78500	1244-F-553	WASHER,FLAT .165 UOC: DAC,DAD,DAE,DAF,DAG,DA H,DAJ,DAL,DAW,DAX,V14,V15,V16, V17,V18,V19,V20,V21,V22,V24,ZAA, ZAB,ZAC,ZAD,ZAE,ZAF,ZAG,ZAH,Z AJ,ZAL .....	1
10	PAFZZ	5310-01-134-0209	19207	8758282	WASHER,FLAT .155 UOC: DAC,DAD,DAE,DAF,DAG,DA H,DAJ,DAL,DAW,DAX,V14,V15,V16, V17,V18,V19,V20,V21,V22,V24,ZAA, ZAB,ZAC,ZAD,ZAE,ZAF,ZAG,ZAH,Z AJ,ZAL .....	1
10	PAFZZ	5310-01-054-2568	19207	8758280	WASHER,FLAT .135 UOC: DAC,DAD,DAE,DAF,DAG,DA H,DAJ,DAL,DAW,DAX,V14,V15,V16, V17,V18,V19,V20,V21,V22,V24,ZAA, ZAB,ZAC,ZAD,ZAE,ZAF,ZAG,ZAH,Z AJ,ZAL .....	1



(1) ITEM NO.	(2) SMR CODE	(3) NSN	(4) CAGEC	(5) PART NUMBER	(6) DESCRIPTION AND USABLE ON CODE (UOC)	(7) QTY
11	PAFZZ	2530-00-734-6971	19207	7346971	SLEEVE ASSEMBLY UOC: DAC,DAD,DAE,DAF,DAG,DA H,DAJ,DAL,DAW,DAX,V14,V15,V16, V17,V18,V19,V20,V21,V22,V24,ZAA, ZAB,ZAC,ZAD,ZAE,ZAF,ZAG,ZAH,Z AJ,ZAL .....	4
12	PAFZZ	3120-00-288-1889	19207	7346972	. BEARING,SLEEVE UOC: DAC,DAD,DAE,DAF,DAG,DA H,DAJ,DAL,DAW,DAX,V14,V15,V16, V17,V18,V19,V20,V21,V22,V24,ZAA, ZAB,ZAC,ZAD,ZAE,ZAF,ZAG,ZAH,Z AJ,ZAL .....	1
13	XAFZZ		19207	8758253	. SLEEVE,STEERING KNU UOC: DAC,DAD,DAE,DAF,DAG,DA H,DAJ,DAL,DAW,DAX,V14,V15,V16, V17,V18,V19,V20,V21,V22,V24,ZAA, ZAB,ZAC,ZAD,ZAE,ZAF,ZAG,ZAH,Z AJ,ZAL .....	1
14	PAFZZ	5306-00-281-1651	19207	5225875	BOLT,MACHINE UOC: DAC,DAD,DAE,DAF,DAG,DA H,DAJ,DAL,DAW,DAX,V14,V15,V16, V17,V18,V19,V20,V21,V22,V24,ZAA, ZAB,ZAC,ZAD,ZAE,ZAF,ZAG,ZAH,Z AJ,ZAL .....	2
15	PAFZZ	5310-00-763-8919	96906	MS51967-18	NUT,PLAIN,HEXAGON UOC: DAC,DAD,DAE,DAF,DAG,DA H,DAJ,DAL,DAW,DAX,V14,V15,V16, V17,V18,V19,V20,V21,V22,V24,ZAA, ZAB,ZAC,ZAD,ZAE,ZAF,ZAG,ZAH,Z AJ,ZAL .....	2
16	PAFZZ	4730-01-118-5972	19207	12300575	CLAMP,HOSE PART OF KIT P/N 5704510 UOC: DAC,DAD,DAE,DAF,DAG,DA H,DAJ,DAL,DAW,DAX,V14,V15,V16, V17,V18,V19,V20,V21,V22,V24 .....	2
17	PAFZZ	5305-00-752-1693	19207	7071098	SCREW,MACHINE UOC: V15 .....	2
17	PAFZZ	5305-00-143-3266	80205	MS27039-0825	SCREW,MACHINE PART OF KIT P/N 5704510 UOC: DAC,DAD,DAE,DAF,DAG,DA H,DAJ,DAL,DAW,DAX,V14,V15,V16, V17,V18,V19,V20,V21,V22,V24,ZAA, ZAB,ZAC,ZAD,ZAE,ZAF,ZAG,ZAH,Z AJ,ZAL .....	2

(1) ITEM NO.	(2) SMR CODE	(3) NSN	(4) CAGEC	(5) PART NUMBER	(6) DESCRIPTION AND USABLE ON CODE (UOC)	(7) QTY
18	PAFZZ	2530-00-832-7123	19207	8327123	BOOT,VEHICULAR COMP PART OF KIT P/N 5704510 UOC: DAC,DAD,DAE,DAF,DAG,DA H,DAJ,DAL,DAW,DAX,V14,V15,V16, V17,V18,V19,V20,V21,V22,V24,ZAA, ZAB,ZAC,ZAD,ZAE,ZAF,ZAG,ZAH,Z AJ,ZAL .....	2
19	PAFZZ	2520-00-734-6975	89346	98887R1	RING,DIFFERENTIAL C UOC: DAC,DAD,DAE,DAF,DAG,DA H,DAJ,DAL,DAW,DAX,V14,V15,V16, V17,V18,V19,V20,V21,V22,V24,ZAA, ZAB,ZAC,ZAD,ZAE,ZAF,ZAG,ZAH,Z AJ,ZAL .....	2
20	MFFZZ		10001	22-W-1642-100-40	WIRE,NONELECTRICAL MAKE FROM WIRE, P/N 22W1642-100, 40 INCHES LONG UOC: DAC,DAD,DAE,DAF,DAG,DA H,DAJ,DAL,DAW,DAX,V14,V15,V16, V17,V18,V19,V20,V21,V22,V24,ZAA, ZAB,ZAC,ZAD,ZAE,ZAF,ZAG,ZAH,Z AJ,ZAL .....	2
21	PAFZZ	5305-00-551-5097	96906	MS35265-94	SCREW,MACHINE UOC: DAC,DAD,DAE,DAF,DAG,DA H,DAJ,DAL,DAW,DAX,V14,V15,V16, V17,V18,V19,V20,V21,V22,V24,ZAA, ZAB,ZAC,ZAD,ZAE,ZAF,ZAG,ZAH,Z AJ,ZAL .....	24
22	PAFZZ	5340-00-734-6974	19207	7346974	COVER,ACCESS UOC: DAC,DAD,DAE,DAF,DAG,DA H,DAJ,DAL,DAW,DAX,V14,V15,V16, V17,V18,V19,V20,V21,V22,V24,ZAA, ZAB,ZAC,ZAD,ZAE,ZAF,ZAG,ZAH,Z AJ,ZAL .....	2
23	PAFZZ	4730-00-050-4208	10001	297692PC104	FITTING,LUBRICATION UOC: DAC,DAD,DAE,DAF,DAG,DA H,DAJ,DAL,DAW,DAX,V14,V15,V16, V17,V18,V19,V20,V21,V22,V24,ZAA, ZAB,ZAC,ZAD,ZAE,ZAF,ZAG,ZAH,Z AJ,ZAL .....	4
24	PAFZZ	2530-00-734-6978	19207	7346978	GUARD,BRUSH KNUCKLE AND STUD ASSEMBLY,RIGHT SIDE UOC: DAC,DAD,DAE,DAF,DAG,DA H,DAJ,DAL,DAW,DAX,V14,V15,V16, V17,V18,V19,V20,V21,V22,V24,ZAA, ZAB,ZAC,ZAD,ZAE,ZAF,ZAG,ZAH,Z AJ,ZAL .....	1

(1) ITEM NO.	(2) SMR CODE	(3) NSN	(4) CAGEC	(5) PART NUMBER	(6) DESCRIPTION AND USABLE ON CODE (UOC)	(7) QTY
24	PAFZZ	2530-00-734-6977	19207	7346977	GUARD,BRUSH KNUCKLE AND STUD ASSEMBLY,LEFT SIDE UOC: DAC,DAD,DAE,DAF,DAG,DA H,DAJ,DAL,DAW,DAX,V14,V15,V16, V17,V18,V19,V20,V21,V22,V24,ZAA, ZAB,ZAC,ZAD,ZAE,ZAF,ZAG,ZAH,Z AJ,ZAL .....	1
25	PAFZZ	5310-00-820-6653	80205	MS35338-50	WASHER,LOCK UOC: DAC,DAD,DAE,DAF,DAG,DA H,DAJ,DAL,DAW,DAX,V14,V15,V16, V17,V18,V19,V20,V21,V22,V24,ZAA, ZAB,ZAC,ZAD,ZAE,ZAF,ZAG,ZAH,Z AJ,ZAL .....	12
26	PAFZZ	5305-00-724-7223	80204	B1821BH063C225N	SCREW,CAP,HEXAGON H UOC: DAC,DAD,DAE,DAF,DAG,DA H,DAJ,DAL,DAW,DAX,V14,V15,V16, V17,V18,V19,V20,V21,V22,V24,ZAA, ZAB,ZAC,ZAD,ZAE,ZAF,ZAG,ZAH,Z AJ,ZAL .....	8
27	PAFZZ	5305-00-724-7219	80204	B1821BH063C125N	SCREW,CAP,HEXAGON H UOC: DAC,DAD,DAE,DAF,DAG,DA H,DAJ,DAL,DAW,DAX,V14,V15,V16, V17,V18,V19,V20,V21,V22,V24,ZAA, ZAB,ZAC,ZAD,ZAE,ZAF,ZAG,ZAH,Z AJ,ZAL .....	4
28	PAFFF	4320-00-734-6951	19207	7346951	SEAL ASSEMBLY,SHAFT UOC: DAC,DAD,DAE,DAF,DAG,DA H,DAJ,DAL,DAW,DAX,V14,V15,V16, V17,V18,V19,V20,V21,V22,V24,ZAA, ZAB,ZAC,ZAD,ZAE,ZAF,ZAG,ZAH,Z AJ,ZAL .....	2
29	PAFZZ	5310-00-033-6007	78500	1229T1346	. WASHER,FLAT UOC: DAC,DAD,DAE,DAF,DAG,DA H,DAJ,DAL,DAW,DAX,V14,V15,V16, V17,V18,V19,V20,V21,V22,V24,ZAA, ZAB,ZAC,ZAD,ZAE,ZAF,ZAG,ZAH,Z AJ,ZAL .....	1
30	PAFZZ	5330-00-145-8355	19207	10938292	. SEAL,PLAIN ENCASED UOC: DAC,DAD,DAE,DAF,DAG,DA H,DAJ,DAL,DAW,DAX,V14,V15,V16, V17,V18,V19,V20,V21,V22,V24,ZAA, ZAB,ZAC,ZAD,ZAE,ZAF,ZAG,ZAH,Z AJ,ZAL .....	1
31	PAFZZ	5330-01-098-6668	19207	8758268	. RETAINER,OIL SEAL UOC: DAC,DAD,DAE,DAF,DAG,DA H,DAJ,DAL,DAW,DAX,V14,V15,V16, V17,V18,V19,V20,V21,V22,V24,ZAA, ZAB,ZAC,ZAD,ZAE,ZAF,ZAG,ZAH,Z AJ,ZAL .....	1

(1) ITEM NO.	(2) SMR CODE	(3) NSN	(4) CAGEC	(5) PART NUMBER	(6) DESCRIPTION AND USABLE ON CODE (UOC)	(7) QTY
32	PAFZZ	2530-01-271-9824	3D6E9	A2-3111-E-2605	SPINDLE,WHEEL,DRIVI LEFT HAND UOC: ZAA,ZAB,ZAC,ZAD,ZAE,ZAF, ZAG,ZAH,ZAJ,ZAL .....	1
32	PAFZZ	2530-00-006-7469	19207	7346816-1	SPINDLE,WHEEL,DRIVI RIGHT HAND UOC: DAC,DAD,DAE,DAF,DAG,DA H,DAJ,DAL,DAW,DAX,V14,V15,V16, V17,V18,V19,V20,V21,V22,V24,ZAA, ZAB,ZAC,ZAD,ZAE,ZAF,ZAG,ZAH,Z AJ,ZAL .....	1
32	PAFZZ	2530-01-272-2926	78500	A2-3111-D-2604	SPINDLE,WHEEL,DRIVI RIGHT HAND UOC: ZAA,ZAB,ZAC,ZAD,ZAE,ZAF, ZAG,ZAH,ZAJ,ZAL .....	1
32	PAFZZ	2530-00-734-6815	19207	7346815	SPINDLE,WHEEL,DRIVI LEFT HAND UOC: DAC,DAD,DAE,DAF,DAG,DA H,DAJ,DAL,DAW,DAX,V14,V15,V16, V17,V18,V19,V20,V21,V22,V24 .....	1
33	PAFZZ	5307-00-734-6900	19207	7346900	. STUD,PLAIN UOC: DAC,DAD,DAE,DAF,DAG,DA H,DAJ,DAL,DAW,DAX,V14,V15,V16, V17,V18,V19,V20,V21,V22,V24,ZAA, ZAB,ZAC,ZAD,ZAE,ZAF,ZAG,ZAH,Z AJ,ZAL .....	4
34	PAFZZ	5307-01-277-5053	78500	SN-921-1	. STUD,PLAIN UOC: DAC,DAD,DAE,DAF,DAG,DA H,DAJ,DAL,DAW,DAX,V14,V15,V16, V17,V18,V19,V20,V21,V22,V24 .....	9
34	PAFZZ	5307-01-281-7219	19207	7346811-1	. STUD,PLAIN UOC: ZAA,ZAB,ZAC,ZAD,ZAE,ZAF, ZAG,ZAH,ZAJ,ZAL .....	9
35	PAFZZ	2530-01-088-9357	19207	11664597-1	ARM,STEERING GEAR LEFT HAND UOC: DAC,DAD,DAE,DAF,DAG,DA H,DAJ,DAL,DAW,DAX,V14,V15,V16, V17,V18,V19,V20,V21,V22,V24,ZAA, ZAB,ZAC,ZAD,ZAE,ZAF,ZAG,ZAH,Z AJ,ZAL .....	1
35	PAFZZ	2530-00-231-0178	19207	11664598	ARM,STEERING RIGHT HAND UOC: DAC,DAD,DAE,DAF,DAG,DA H,DAJ,DAL,DAW,DAX,V14,V15,V16, V17,V18,V19,V20,V21,V22,V24,ZAA, ZAB,ZAC,ZAD,ZAE,ZAF,ZAG,ZAH,Z AJ,ZAL .....	1
36	PAFZZ	5365-00-427-2282	19207	7346812	BUSHING,TAPERED UOC: DAC,DAD,DAE,DAF,DAG,DA H,DAJ,DAL,DAW,DAX,V14,V15,V16, V17,V18,V19,V20,V21,V22,V24,ZAA, ZAB,ZAC,ZAD,ZAE,ZAF,ZAG,ZAH,Z AJ,ZAL .....	8

(1) ITEM NO.	(2) SMR CODE	(3) NSN	(4) CAGEC	(5) PART NUMBER	(6) DESCRIPTION AND USABLE ON CODE (UOC)	(7) QTY
37	PAFZZ	5310-00-800-0695	96906	MS35335-39	WASHER,LOCK UOC: DAC,DAD,DAE,DAF,DAG,DA H,DAJ,DAL,DAW,DAX,V14,V15,V16, V17,V18,V19,V20,V21,V22,V24,ZAA, ZAB,ZAC,ZAD,ZAE,ZAF,ZAG,ZAH,Z AJ,ZAL .....	8
38	PAFZZ	5310-00-274-7721	19207	7346813	NUT,PLAIN,HEXAGON UOC: DAC,DAD,DAE,DAF,DAG,DA H,DAJ,DAL,DAW,DAX,V14,V15,V16, V17,V18,V19,V20,V21,V22,V24,ZAA, ZAB,ZAC,ZAD,ZAE,ZAF,ZAG,ZAH,Z AJ,ZAL .....	8
39	PAFZZ	5310-00-616-6354	96906	MS35335-38	WASHER,LOCK UOC: DAC,DAD,DAE,DAF,DAG,DA H,DAJ,DAL,DAW,DAX,V14,V15,V16, V17,V18,V19,V20,V21,V22,V24,ZAA, ZAB,ZAC,ZAD,ZAE,ZAF,ZAG,ZAH,Z AJ,ZAL .....	20
40	PAFZZ	5310-00-763-8911	96906	MS51968-17	NUT,PLAIN,HEXAGON UOC: DAC,DAD,DAE,DAF,DAG,DA H,DAJ,DAL,DAW,DAX,V14,V15,V16, V17,V18,V19,V20,V21,V22,V24,ZAA, ZAB,ZAC,ZAD,ZAE,ZAF,ZAG,ZAH,Z AJ,ZAL .....	20

END OF FIGURE



**FIELD MAINTENANCE  
FORWARD REAR AND REAR REAR AXLE ASSEMBLIES (M939, M939A1)**

---

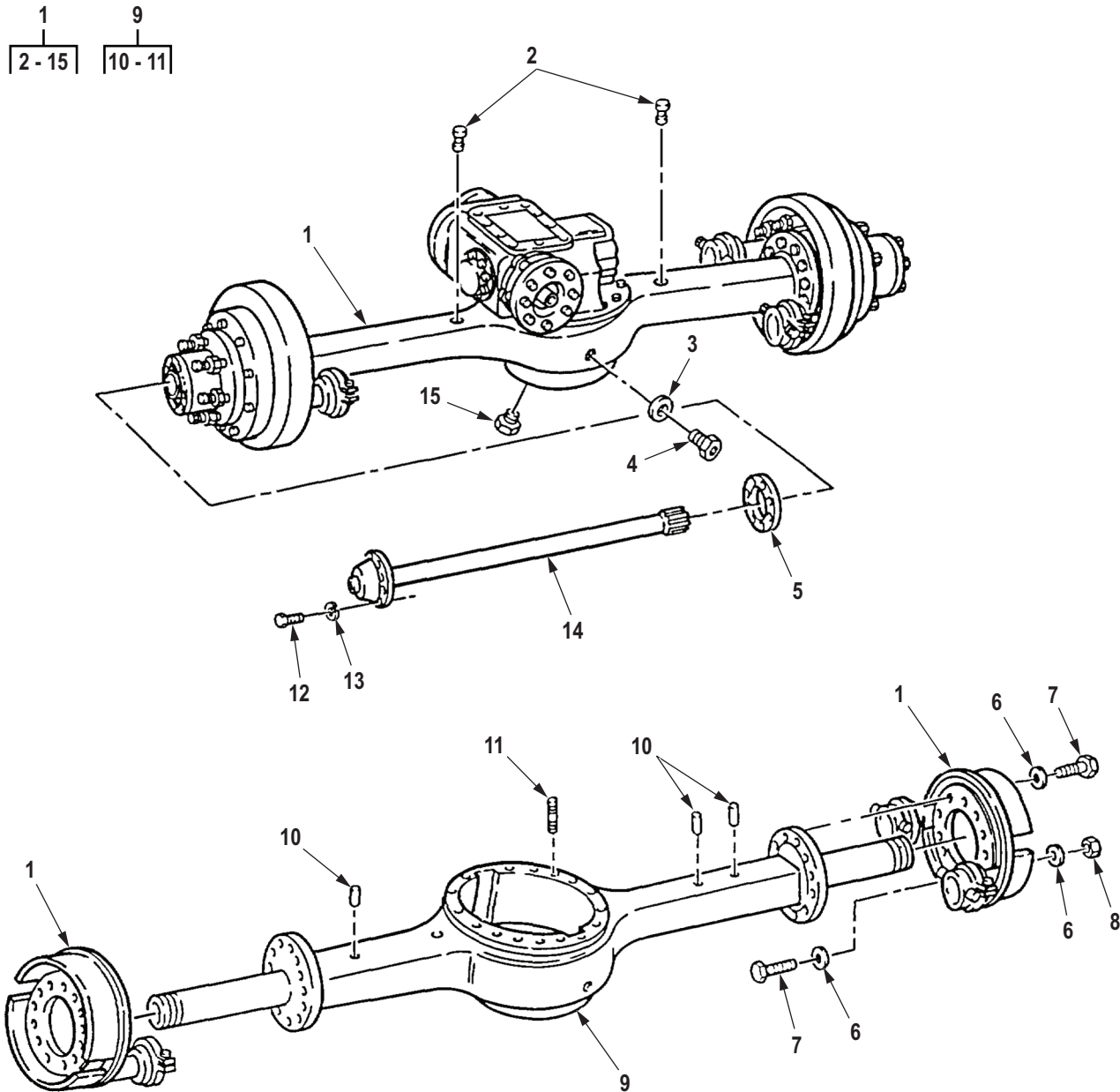

R0252DAA

Figure 237. Forward Rear and Rear Rear Axle Assemblies (M939, M939A1).



(1) ITEM NO.	(2) SMR CODE	(3) NSN	(4) CAGEC	(5) PART NUMBER	(6) DESCRIPTION AND USABLE ON CODE (UOC)	(7) QTY
<b>GROUP 1100 REAR AXLE ASSEMBLY.</b>						
<b>FIG. 237. FORWARD REAR AND REAR REAR AXLE ASSEMBLIES (M939, M939A1).</b>						
1	PAFHH	2520-01-117-6592	19207	12256156-5	AXLE ASSEMBLY,AUTOM REAR REAR UOC: DAC,DAD,DAE,DAF,DAG,DA H,DAJ,DAL,DAW,DAX,V14,V15,V16, V17,V18,V19,V20,V21,V22,V24 .....	1
1	PAFHH	2520-01-117-3015	19207	12256156-4	AXLE ASSEMBLY,AUTOM DUAL WHEEL,REAR AXLE UOC: V39 .....	1
1	PAFHH	2520-01-117-4933	19207	12256156-6	AXLE ASSEMBLY,AUTOM DUAL REAR,REAR UOC: V39 .....	1
1	PAFHH	2520-01-117-3014	19207	12256156-2	AXLE ASSEMBLY,AUTOM FORWARD REAR UOC: DAC,DAD,DAE,DAF,DAG,DA H,DAJ,DAL,DAW,DAX,V14,V15,V16, V17,V18,V19,V20,V21,V22,V24 .....	1
2	PAFZZ	4820-00-726-4719	19207	5196397	. VALVE,VENT UOC: DAC,DAD,DAE,DAF,DAG,DA H,DAJ,DAL,DAW,DAX,V14,V15,V16, V17,V18,V19,V20,V21,V22,V24 .....	2
3	PAFZZ	5330-01-352-7768	81343	MS35769-21	. GASKET UOC: DAC,DAD,DAE,DAF,DAG,DA H,DAJ,DAL,DAW,DAX,V14,V15,V16, V17,V18,V19,V20,V21,V22,V24 .....	1
4	PAFZZ	5365-00-732-6126	19207	7326126	. PLUG,MACHINE THREAD UOC: DAC,DAD,DAE,DAF,DAG,DA H,DAJ,DAL,DAW,DAX,V14,V15,V16, V17,V18,V19,V20,V21,V22,V24 .....	1
5	PAFZZ	5330-01-377-9775	14153	02764	. GASKET UOC: DAC,DAD,DAE,DAF,DAG,DA H,DAJ,DAL,DAW,DAX,V14,V15,V16, V17,V18,V19,V20,V21,V22,V24 .....	2
6	PAFZZ	5310-01-205-2830	3D6E9	1229-Y-1507	. WASHER,FLAT UOC: DAC,DAD,DAE,DAF,DAG,DA H,DAJ,DAL,DAW,DAX,V14,V15,V16, V17,V18,V19,V20,V21,V22,V24 .....	36
7	PAFZZ	5305-00-716-7454	80204	B1821BH056C175N	. SCREW,CAP,HEXAGON H UOC: DAC,DAD,DAE,DAF,DAG,DA H,DAJ,DAL,DAW,DAX,V14,V15,V16, V17,V18,V19,V20,V21,V22,V24 .....	20
8	PAFZZ	5310-00-465-9341	3D6E9	N19-1	. NUT,PLAIN,HEXAGON UOC: DAC,DAD,DAE,DAF,DAG,DA H,DAJ,DAL,DAW,DAX,V14,V15,V16, V17,V18,V19,V20,V21,V22,V24 .....	20

(1) ITEM NO.	(2) SMR CODE	(3) NSN	(4) CAGEC	(5) PART NUMBER	(6) DESCRIPTION AND USABLE ON CODE (UOC)	(7) QTY
9	XAFZZ		19207	8758344	. HOUSING WITH STUDS UOC: DAC,DAD,DAE,DAF,DAG,DA H,DAJ,DAL,DAW,DAX,V14,V15,V16, V17,V18,V19,V20,V21,V22,V24 .....	1
9	XAFZZ		19207	8758322	. HOUSING WITH STUDS UOC: V39 .....	1
10	PAFZZ	5315-00-752-1651	19207	7521651	. . PIN,SHOULDER,HEADLE UOC: DAC,DAD,DAE,DAF,DAG,DA H,DAJ,DAL,DAW,DAX,V14,V15,V16, V17,V18,V19,V20,V21,V22,V24 .....	3
11	PAFZZ	5307-00-434-1783	3D6E9	SN1020-1	. . STUD,PLAIN UOC: DAC,DAD,DAE,DAF,DAG,DA H,DAJ,DAL,DAW,DAX,V14,V15,V16, V17,V18,V19,V20,V21,V22,V24 .....	18
12	PAFZZ	5306-00-182-9267	19207	10896726	. BOLT,MACHINE UOC: DAC,DAD,DAE,DAF,DAG,DA H,DAJ,DAL,DAW,DAX,V14,V15,V16, V17,V18,V19,V20,V21,V22,V24 .....	20
13	PAFZZ	5310-00-003-4094	80205	MS35338-48	. WASHER,LOCK UOC: DAC,DAD,DAE,DAF,DAG,DA H,DAJ,DAL,DAW,DAX,V14,V15,V16, V17,V18,V19,V20,V21,V22,V24 .....	20
14	PAFZZ	2520-00-734-6960	19207	7346960	. SHAFT,AXLE,AUTOMOTI UOC: DAC,DAD,DAE,DAF,DAG,DA H,DAJ,DAL,DAW,DAX,V14,V15,V16, V17,V18,V19,V20,V21,V22,V24 .....	2
14	PAFZZ	2520-00-741-1142	19207	7411142	. SHAFT,AXLE,AUTOMOTI REAR REAR HOUSING ASSEMBLY UOC: V39 .....	2
15	PAFZZ	4730-00-595-4827	36540	5054181	. PLUG,PIPE,MAGNETIC UOC: DAC,DAD,DAE,DAF,DAG,DA H,DAJ,DAL,DAW,DAX,V14,V15,V16, V17,V18,V19,V20,V21,V22,V24 .....	1

END OF FIGURE

**FIELD MAINTENANCE  
FORWARD REAR AND REAR REAR AXLE ASSEMBLIES (M939A2)**

---

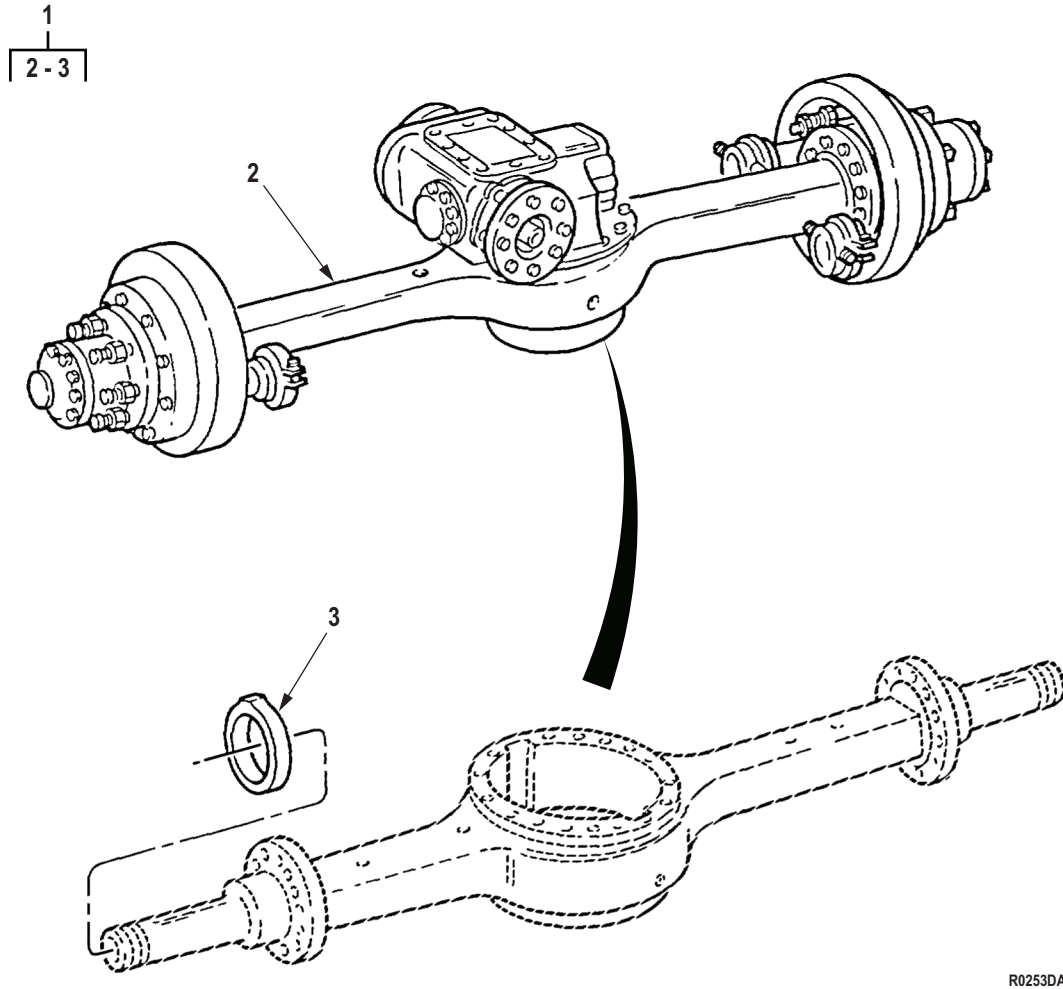

R0253DAA

Figure 238. Forward Rear and Rear Rear Axle Assemblies (M939A2).

(1) ITEM NO.	(2) SMR CODE	(3) NSN	(4) CAGEC	(5) PART NUMBER	(6) DESCRIPTION AND USABLE ON CODE (UOC)	(7) QTY
<b>GROUP 1100 REAR AXLE ASSEMBLY.</b>						
<b>FIG. 238. FORWARD REAR AND REAR REAR AXLE ASSEMBLIES (M939A2).</b>						
1	PAFHH	2520-01-291-9994	3D6E9	M-1240- RDAX-30-644	AXLE ASSEMBLY,AUTOM FORWARD REAR,WITHOUT BRACKETS UOC: ZAA,ZAB,ZAC,ZAD,ZAE,ZAF, ZAG,ZAH,ZAJ,ZAL .....	1
1	PAFHH	2520-01-291-9993	19207	12363376-1	AXLE ASSEMBLY,AUTOM REAR REAR,WITHOUT BRACKETS UOC: ZAA,ZAB,ZAC,ZAD,ZAE,ZAF, ZAG,ZAH,ZAJ,ZAL .....	1
2	XAFZZ		78500	C3-3201-W-7589	. HOUSING, AXLE UOC: ZAA,ZAB,ZAC,ZAD,ZAE,ZAF, ZAG,ZAH,ZAJ,ZAL .....	1
3	PAFZZ	2520-01-271-7007	3D6E9	3268-L-1338	. ADAPTER,FIN UOC: ZAA,ZAB,ZAC,ZAD,ZAE,ZAF, ZAG,ZAH,ZAJ,ZAL .....	1

**END OF FIGURE**



**FIELD MAINTENANCE  
REAR AXLE DIFFERENTIAL ASSEMBLY AND MOUNTING HARDWARE**

---

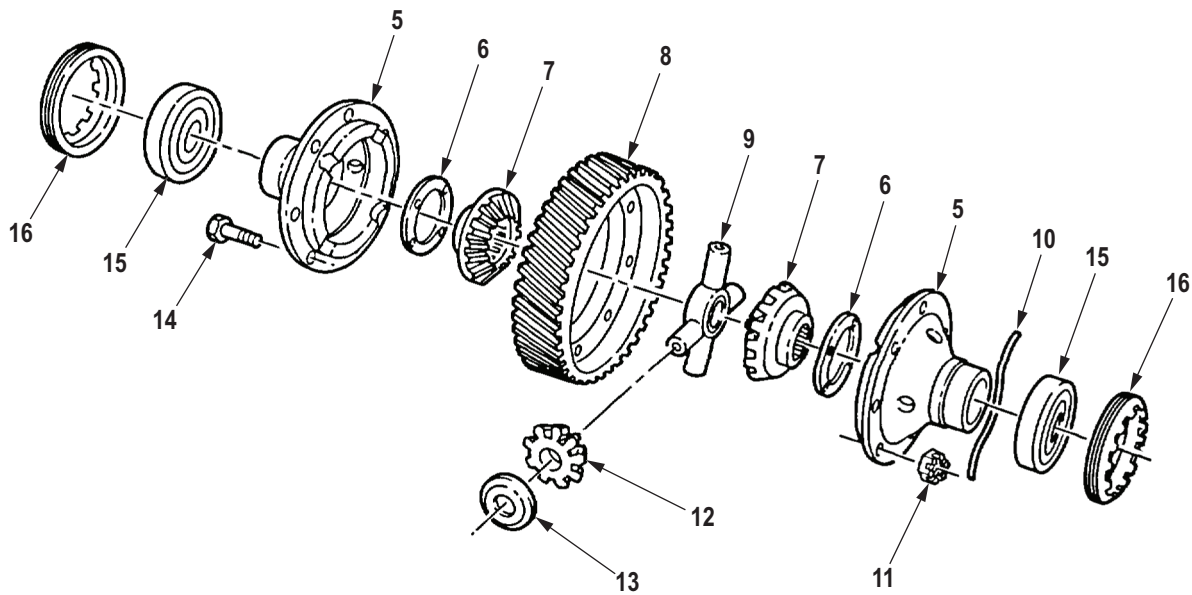
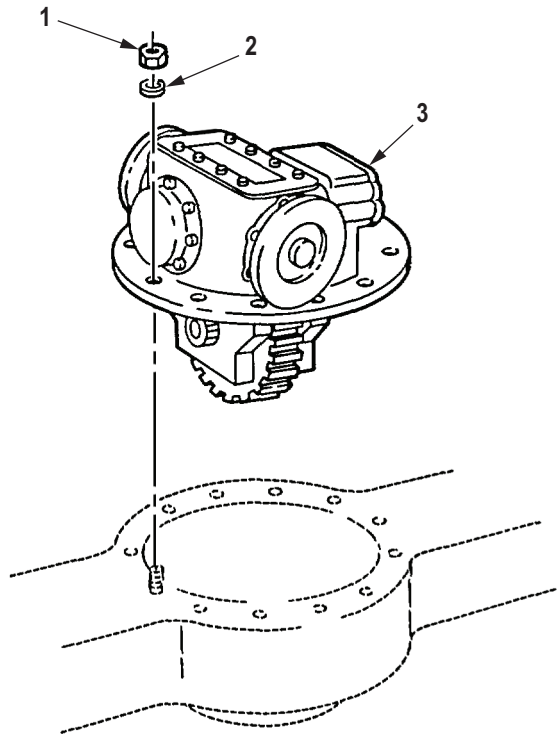
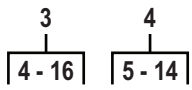

R0254DAA

Figure 239. Rear Axle Differential Assembly and Mounting Hardware.



(1) ITEM NO.	(2) SMR CODE	(3) NSN	(4) CAGEC	(5) PART NUMBER	(6) DESCRIPTION AND USABLE ON CODE (UOC)	(7) QTY
<b>GROUP 1102 DIFFERENTIAL.</b>						
<b>FIG. 239. REAR AXLE DIFFERENTIAL ASSEMBLY AND MOUNTING HARDWARE.</b>						
1	PAFZZ	5310-00-274-7721	19207	7346813	NUT,PLAIN,HEXAGON UOC: DAC,DAD,DAE,DAF,DAG,DA H,DAJ,DAL,DAW,DAX,V14,V15,V16, V17,V18,V19,V20,V21,V22,V24,ZAA, ZAB,ZAC,ZAD,ZAE,ZAF,ZAG,ZAH,Z AJ,ZAL .....	18
2	PAFZZ	5310-00-483-2266	19207	10900409	WASHER,FLAT UOC: DAC,DAD,DAE,DAF,DAG,DA H,DAJ,DAL,DAW,DAX,V14,V15,V16, V17,V18,V19,V20,V21,V22,V24,ZAA, ZAB,ZAC,ZAD,ZAE,ZAF,ZAG,ZAH,Z AJ,ZAL .....	18
3	PAFHH	2520-00-734-6970	19207	7346970	DIFFERENTIAL,DRIVIN UOC: DAC,DAD,DAE,DAF,DAG,DA H,DAJ,DAL,DAW,DAX,V14,V15,V16, V17,V18,V19,V20,V21,V22,V24,ZAA, ZAB,ZAC,ZAD,ZAE,ZAF,ZAG,ZAH,Z AJ,ZAL .....	2
4	PAHHH	2520-00-419-9422	19207	8758285	. DIFFERENTIAL GEAR U UOC: DAC,DAD,DAE,DAF,DAG,DA H,DAJ,DAL,DAW,DAX,V14,V15,V16, V17,V18,V19,V20,V21,V22,V24,ZAA, ZAB,ZAC,ZAD,ZAE,ZAF,ZAG,ZAH,Z AJ,ZAL .....	1
5	XAHZZ		19207	8758252	. . CARRIER,DIFFERENTIA UOC: DAC,DAD,DAE,DAF,DAG,DA H,DAJ,DAL,DAW,DAX,V14,V15,V16, V17,V18,V19,V20,V21,V22,V24,ZAA, ZAB,ZAC,ZAD,ZAE,ZAF,ZAG,ZAH,Z AJ,ZAL .....	2
6	KBHZZ	3120-00-303-4977	3D6E9	1229H1022	. . BEARING,WASHER,THRU PART OF KIT P/N 7346959 UOC: DAC,DAD,DAE,DAF,DAG,DA H,DAJ,DAL,DAW,DAX,V14,V15,V16, V17,V18,V19,V20,V21,V22,V24,ZAA, ZAB,ZAC,ZAD,ZAE,ZAF,ZAG,ZAH,Z AJ,ZAL .....	2
7	KBHZZ		19207	8758203	. . GEAR,BEVEL PART OF KIT P/ N 7346959 UOC: DAC,DAD,DAE,DAF,DAG,DA H,DAJ,DAL,DAW,DAX,V14,V15,V16, V17,V18,V19,V20,V21,V22,V24,ZAA, ZAB,ZAC,ZAD,ZAE,ZAF,ZAG,ZAH,Z AJ,ZAL .....	2

(1) ITEM NO.	(2) SMR CODE	(3) NSN	(4) CAGEC	(5) PART NUMBER	(6) DESCRIPTION AND USABLE ON CODE (UOC)	(7) QTY
8	PAHZZ	3020-00-734-6824	78500	3892T1190	. . GEAR,HELICAL PART OF KIT P/N 10899232 UOC: DAC,DAD,DAE,DAF,DAG,DA H,DAJ,DAL,DAW,DAX,V14,V15,V16, V17,V18,V19,V20,V21,V22,V24,ZAA, ZAB,ZAC,ZAD,ZAE,ZAF,ZAG,ZAH,Z AJ,ZAL .....	1
9	XDHZZ		19207	8758206-KF	. . SPIDER,DIFFERENTIAL CARRIER PART OF KIT P/N 7346959 UOC: DAC,DAD,DAE,DAF,DAG,DA H,DAJ,DAL,DAW,DAX,V14,V15,V16, V17,V18,V19,V20,V21,V22,V24,ZAA, ZAB,ZAC,ZAD,ZAE,ZAF,ZAG,ZAH,Z AJ,ZAL .....	1
10	MHHZZ		80244	22W1642125X36 IN	. . WIRE,NONELECTRICAL DIFFERENTIAL CARRIER, MAKE FROM WIRE P/N 22W1642-125, 36 IN.LONG UOC: DAC,DAD,DAE,DAF,DAG,DA H,DAJ,DAL,DAW,DAX,V14,V15,V16, V17,V18,V19,V20,V21,V22,V24,ZAA, ZAB,ZAC,ZAD,ZAE,ZAF,ZAG,ZAH,Z AJ,ZAL .....	1
11	PAHZZ	5310-00-720-7627	19207	8761279	. . NUT,PLAIN,SLOTTED,H UOC: DAC,DAD,DAE,DAF,DAG,DA H,DAJ,DAL,DAW,DAX,V14,V15,V16, V17,V18,V19,V20,V21,V22,V24,ZAA, ZAB,ZAC,ZAD,ZAE,ZAF,ZAG,ZAH,Z AJ,ZAL .....	8
12	PAHZZ	3020-00-611-9536	78500	2233WT01	. . GEAR,BEVEL PART OF KIT P/ N 7346959 UOC: DAC,DAD,DAE,DAF,DAG,DA H,DAJ,DAL,DAW,DAX,V14,V15,V16, V17,V18,V19,V20,V21,V22,V24,ZAA, ZAB,ZAC,ZAD,ZAE,ZAF,ZAG,ZAH,Z AJ,ZAL .....	4
13	PAHZZ	5310-00-285-9402	3D6E9	1229Q1031	. . WASHER,THRUST PART OF KIT P/N 7346959 UOC: DAC,DAD,DAE,DAF,DAG,DA H,DAJ,DAL,DAW,DAX,V14,V15,V16, V17,V18,V19,V20,V21,V22,V24,ZAA, ZAB,ZAC,ZAD,ZAE,ZAF,ZAG,ZAH,Z AJ,ZAL .....	4
14	PAHZZ	5306-00-734-6822	19207	7346822	. . BOLT,MACHINE UOC: DAC,DAD,DAE,DAF,DAG,DA H,DAJ,DAL,DAW,DAX,V14,V15,V16, V17,V18,V19,V20,V21,V22,V24,ZAA, ZAB,ZAC,ZAD,ZAE,ZAF,ZAG,ZAH,Z AJ,ZAL .....	8

(1) ITEM NO.	(2) SMR CODE	(3) NSN	(4) CAGEC	(5) PART NUMBER	(6) DESCRIPTION AND USABLE ON CODE (UOC)	(7) QTY
15	PAHZZ	3110-00-100-4216	21450	712699	. BEARING,ROLLER,TAPE UOC: DAC,DAD,DAE,DAF,DAG,DA H,DAJ,DAL,DAW,DAX,V14,V15,V16, V17,V18,V19,V20,V21,V22,V24,ZAA, ZAB,ZAC,ZAD,ZAE,ZAF,ZAG,ZAH,Z AJ,ZAL .....	2
16	PAHZZ	5365-00-734-6818	19207	7346818	. RING,EXTERNALLY THR CARRIER UOC: DAC,DAD,DAE,DAF,DAG,DA H,DAJ,DAL,DAW,DAX,V14,V15,V16, V17,V18,V19,V20,V21,V22,V24,ZAA, ZAB,ZAC,ZAD,ZAE,ZAF,ZAG,ZAH,Z AJ,ZAL .....	2

END OF FIGURE



**FIELD MAINTENANCE**  
**REAR AXLE DIFFERENTIAL CARRIER ASSEMBLY, ACCESS COVER, AND RELATED PARTS**

---

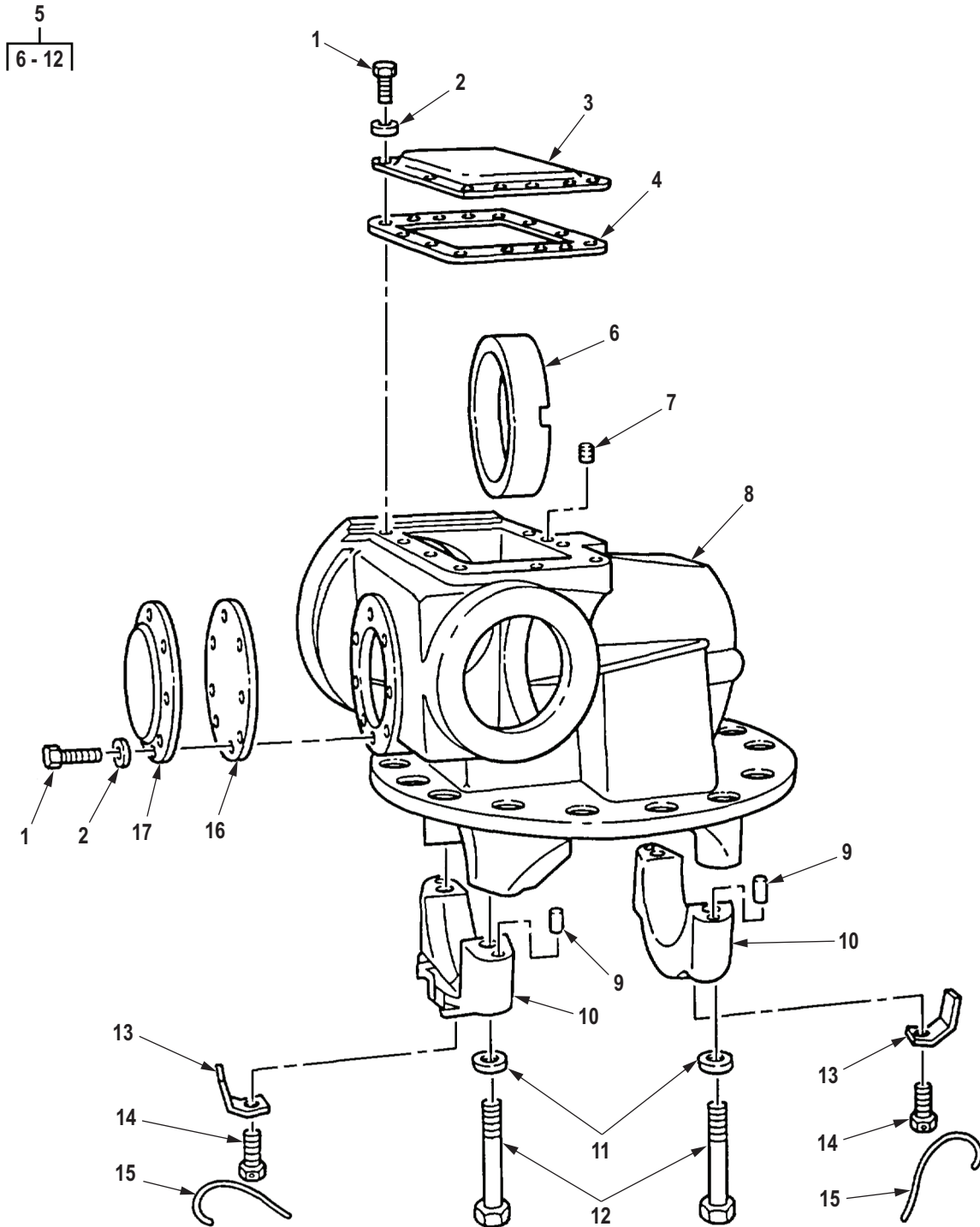

R0255DAA

Figure 240. Rear Axle Differential Carrier Assembly, Access Cover, and Related Parts.

(1) ITEM NO.	(2) SMR CODE	(3) NSN	(4) CAGEC	(5) PART NUMBER	(6) DESCRIPTION AND USABLE ON CODE (UOC)	(7) QTY
<b>GROUP 1102 DIFFERENTIAL.</b>						
<b>FIG. 240. REAR AXLE DIFFERENTIAL CARRIER ASSEMBLY, ACCESS COVER, AND RELATED PARTS.</b>						
1	PAFZZ	5305-00-115-9526	80204	B1821BH038C075D	SCREW,CAP,HEXAGON H UOC: DAC,DAD,DAE,DAF,DAG,DA H,DAJ,DAL,DAW,DAX,V14,V15,V16, V17,V18,V19,V20,V21,V22,V24,ZAA, ZAB,ZAC,ZAD,ZAE,ZAF,ZAG,ZAH,Z AJ,ZAL .....	18
2	PAFZZ	5310-00-177-0892	19207	7748743	WASHER,FLAT UOC: DAC,DAD,DAE,DAF,DAG,DA H,DAJ,DAL,DAW,DAX,V14,V15,V16, V17,V18,V19,V20,V21,V22,V24,ZAA, ZAB,ZAC,ZAD,ZAE,ZAF,ZAG,ZAH,Z AJ,ZAL .....	18
3	PFZZ	5340-00-734-6820	19207	7346820	COVER,ACCESS UOC: DAC,DAD,DAE,DAF,DAG,DA H,DAJ,DAL,DAW,DAX,V14,V15,V16, V17,V18,V19,V20,V21,V22,V24,ZAA, ZAB,ZAC,ZAD,ZAE,ZAF,ZAG,ZAH,Z AJ,ZAL .....	1
4	PAFZZ	5330-01-514-6882	19207	7535079 R87	GASKET PART OF KIT P/N 7346807 UOC: DAC,DAD,DAE,DAF,DAG,DA H,DAJ,DAL,DAW,DAX,V14,V15,V16, V17,V18,V19,V20,V21,V22,V24,ZAA, ZAB,ZAC,ZAD,ZAE,ZAF,ZAG,ZAH,Z AJ,ZAL .....	1
5	PAHHH	2520-00-734-7548	92679	483303C91	CARRIER AND CAP ASS UOC: DAC,DAD,DAE,DAF,DAG,DA H,DAJ,DAL,DAW,DAX,V14,V15,V16, V17,V18,V19,V20,V21,V22,V24,ZAA, ZAB,ZAC,ZAD,ZAE,ZAF,ZAG,ZAH,Z AJ,ZAL .....	2
6	PAHZZ	3120-00-734-6883	19207	7346883	. BEARING,SLEEVE UOC: DAC,DAD,DAE,DAF,DAG,DA H,DAJ,DAL,DAW,DAX,V14,V15,V16, V17,V18,V19,V20,V21,V22,V24,ZAA, ZAB,ZAC,ZAD,ZAE,ZAF,ZAG,ZAH,Z AJ,ZAL .....	1
7	PAHZZ	5305-00-752-1718	19207	7521718	. SETSCREW UOC: DAC,DAD,DAE,DAF,DAG,DA H,DAJ,DAL,DAW,DAX,V14,V15,V16, V17,V18,V19,V20,V21,V22,V24,ZAA, ZAB,ZAC,ZAD,ZAE,ZAF,ZAG,ZAH,Z AJ,ZAL .....	1

(1) ITEM NO.	(2) SMR CODE	(3) NSN	(4) CAGEC	(5) PART NUMBER	(6) DESCRIPTION AND USABLE ON CODE (UOC)	(7) QTY
8	XAHZZ		19207	8758260	. CARRIER,HOUSING UOC: DAC,DAD,DAE,DAF,DAG,DA H,DAJ,DAL,DAW,DAX,V14,V15,V16, V17,V18,V19,V20,V21,V22,V24,ZAA, ZAB,ZAC,ZAD,ZAE,ZAF,ZAG,ZAH,Z AJ,ZAL .....	1
9	PAHZZ	5315-00-597-2723	19207	7534717	. PIN,SHOULDER,HEADLE UOC: DAC,DAD,DAE,DAF,DAG,DA H,DAJ,DAL,DAW,DAX,V14,V15,V16, V17,V18,V19,V20,V21,V22,V24,ZAA, ZAB,ZAC,ZAD,ZAE,ZAF,ZAG,ZAH,Z AJ,ZAL .....	4
10	PAHZZ	2520-01-088-9158	19207	8758249	. CAP,DIFFERENTIAL SU CARRIER UOC: DAC,DAD,DAE,DAF,DAG,DA H,DAJ,DAL,DAW,DAX,V14,V15,V16, V17,V18,V19,V20,V21,V22,V24,ZAA, ZAB,ZAC,ZAD,ZAE,ZAF,ZAG,ZAH,Z AJ,ZAL .....	1
11	PAHZZ	5310-00-355-5453	19207	10900408	. WASHER,FLAT UOC: DAC,DAD,DAE,DAF,DAG,DA H,DAJ,DAL,DAW,DAX,V14,V15,V16, V17,V18,V19,V20,V21,V22,V24,ZAA, ZAB,ZAC,ZAD,ZAE,ZAF,ZAG,ZAH,Z AJ,ZAL .....	4
12	PAHZZ	5306-00-734-6817	19207	7346817	. BOLT,MACHINE UOC: DAC,DAD,DAE,DAF,DAG,DA H,DAJ,DAL,DAW,DAX,V14,V15,V16, V17,V18,V19,V20,V21,V22,V24,ZAA, ZAB,ZAC,ZAD,ZAE,ZAF,ZAG,ZAH,Z AJ,ZAL .....	4
13	PAHZZ	2530-00-734-6819	19207	7346819	LOCK UOC: DAC,DAD,DAE,DAF,DAG,DA H,DAJ,DAL,DAW,DAX,V14,V15,V16, V17,V18,V19,V20,V21,V22,V24,ZAA, ZAB,ZAC,ZAD,ZAE,ZAF,ZAG,ZAH,Z AJ,ZAL .....	2
14	PAHZZ	5305-00-903-7794	96906	MS51095-410	SCREW,CAP,HEXAGON H UOC: DAC,DAD,DAE,DAF,DAG,DA H,DAJ,DAL,DAW,DAX,V14,V15,V16, V17,V18,V19,V20,V21,V22,V24,ZAA, ZAB,ZAC,ZAD,ZAE,ZAF,ZAG,ZAH,Z AJ,ZAL .....	2



(1) ITEM NO.	(2) SMR CODE	(3) NSN	(4) CAGEC	(5) PART NUMBER	(6) DESCRIPTION AND USABLE ON CODE (UOC)	(7) QTY
15	MFFZZ		80244	22W1642125X12 IN	WIRE,NONELECTRICAL MAKE FROM WIRE, P/N 22W1642-125, 12 IN.LONG UOC: DAC,DAD,DAE,DAF,DAG,DA H,DAJ,DAL,DAW,DAX,V14,V15,V16, V17,V18,V19,V20,V21,V22,V24,ZAA, ZAB,ZAC,ZAD,ZAE,ZAF,ZAG,ZAH,Z AJ,ZAL .....	2
16	PAFZZ	5330-01-388-3068	14153	02781	GASKET UOC: DAC,DAD,DAE,DAF,DAG,DA H,DAJ,DAL,DAW,DAX,V14,V15,V16, V17,V18,V19,V20,V21,V22,V24,ZAA, ZAB,ZAC,ZAD,ZAE,ZAF,ZAG,ZAH,Z AJ,ZAL .....	1
17	PFFZZ	5340-00-445-4555	19207	8758248	COVER,ACCESS UOC: DAC,DAD,DAE,DAF,DAG,DA H,DAJ,DAL,DAW,DAX,V14,V15,V16, V17,V18,V19,V20,V21,V22,V24,ZAA, ZAB,ZAC,ZAD,ZAE,ZAF,ZAG,ZAH,Z AJ,ZAL .....	1

END OF FIGURE



**FIELD MAINTENANCE  
REAR AXLE DIFFERENTIAL THROUGH SHAFT, GEARS, AND FLANGE ASSEMBLIES**

---

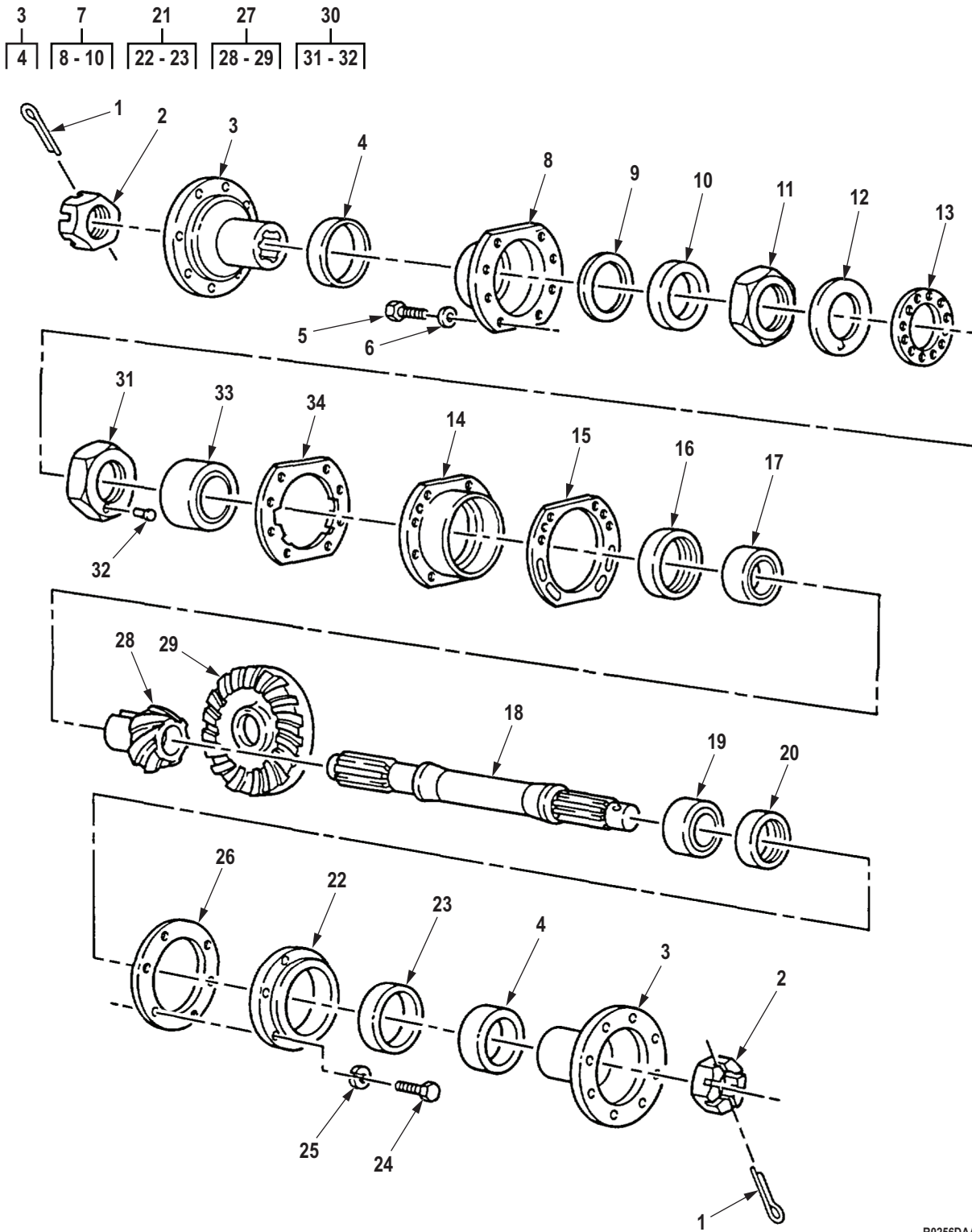

R0256DAA

Figure 241. Rear Axle Differential Through Shaft, Gears, and Flange Assemblies.

(1) ITEM NO.	(2) SMR CODE	(3) NSN	(4) CAGEC	(5) PART NUMBER	(6) DESCRIPTION AND USABLE ON CODE (UOC)	(7) QTY
<b>GROUP 1102 DIFFERENTIAL.</b>						
<b>FIG. 241. REAR AXLE DIFFERENTIAL THROUGH SHAFT, GEARS, AND FLANGE ASSEMBLIES.</b>						
1	PAFZZ	5315-00-059-0184	80205	MS24665-361	PIN,COTTER UOC: DAC,DAD,DAE,DAF,DAG,DA H,DAJ,DAL,DAW,DAX,V14,V15,V16, V17,V18,V19,V20,V21,V22,V24,ZAA, ZAB,ZAC,ZAD,ZAE,ZAF,ZAG,ZAH,Z AJ,ZAL .....	2
2	PAFZZ	5310-00-282-5661	19207	7346893	NUT,PLAIN,SLOTTED,H UOC: DAC,DAD,DAE,DAF,DAG,DA H,DAJ,DAL,DAW,DAX,V14,V15,V16, V17,V18,V19,V20,V21,V22,V24,ZAA, ZAB,ZAC,ZAD,ZAE,ZAF,ZAG,ZAH,Z AJ,ZAL .....	2
3	PAFZZ	2520-00-734-6802	19207	7346802	FLANGE,COMPANION,VE UOC: DAC,DAD,DAE,DAF,DAG,DA H,DAJ,DAL,DAW,DAX,V14,V15,V16, V17,V18,V19,V20,V21,V22,V24,ZAA, ZAB,ZAC,ZAD,ZAE,ZAF,ZAG,ZAH,Z AJ,ZAL .....	2
4	PAFZZ	2520-00-563-8309	19207	7535048	. DEFLECTOR,DIRT AND UOC: DAC,DAD,DAE,DAF,DAG,DA H,DAJ,DAL,DAW,DAX,V14,V15,V16, V17,V18,V19,V20,V21,V22,V24,ZAA, ZAB,ZAC,ZAD,ZAE,ZAF,ZAG,ZAH,Z AJ,ZAL .....	1
5	PAFZZ	5305-00-018-0178	24617	180178	SCREW,CAP,HEXAGON H UOC: DAC,DAD,DAE,DAF,DAG,DA H,DAJ,DAL,DAW,DAX,V14,V15,V16, V17,V18,V19,V20,V21,V22,V24,ZAA, ZAB,ZAC,ZAD,ZAE,ZAF,ZAG,ZAH,Z AJ,ZAL .....	8
6	PAFZZ	5310-00-515-9627	38597	50-4-18-17-7	WASHER,FLAT UOC: DAC,DAD,DAE,DAF,DAG,DA H,DAJ,DAL,DAW,DAX,V14,V15,V16, V17,V18,V19,V20,V21,V22,V24,ZAA, ZAB,ZAC,ZAD,ZAE,ZAF,ZAG,ZAH,Z AJ,ZAL .....	8
7	PAFZZ	3040-00-734-6897	78500	A4-3866-J-556	HOUSING PART,MECHAN UOC: DAC,DAD,DAE,DAF,DAG,DA H,DAJ,DAL,DAW,DAX,V14,V15,V16, V17,V18,V19,V20,V21,V22,V24,ZAA, ZAB,ZAC,ZAD,ZAE,ZAF,ZAG,ZAH,Z AJ,ZAL .....	1

(1) ITEM NO.	(2) SMR CODE	(3) NSN	(4) CAGEC	(5) PART NUMBER	(6) DESCRIPTION AND USABLE ON CODE (UOC)	(7) QTY
8	XAFZZ		19207	8758251	. COVER,BEARING RETAI UOC: DAC,DAD,DAE,DAF,DAG,DA H,DAJ,DAL,DAW,DAX,V14,V15,V16, V17,V18,V19,V20,V21,V22,V24,ZAA, ZAB,ZAC,ZAD,ZAE,ZAF,ZAG,ZAH,Z AJ,ZAL .....	1
9	XDFZZ	5330-01-382-1450	14153	02788	. GASKET UOC: DAC,DAD,DAE,DAF,DAG,DA H,DAJ,DAL,DAW,DAX,V14,V15,V16, V17,V18,V19,V20,V21,V22,V24,ZAA, ZAB,ZAC,ZAD,ZAE,ZAF,ZAG,ZAH,Z AJ,ZAL .....	1
10	PAFZZ	5330-01-023-0269	19207	11669023	. SEAL,PLAIN ENCASED UOC: DAC,DAD,DAE,DAF,DAG,DA H,DAJ,DAL,DAW,DAX,V14,V15,V16, V17,V18,V19,V20,V21,V22,V24,ZAA, ZAB,ZAC,ZAD,ZAE,ZAF,ZAG,ZAH,Z AJ,ZAL .....	1
11	PAHZZ	5310-00-353-2427	19207	7979263	NUT,PLAIN,OCTAGON UOC: DAC,DAD,DAE,DAF,DAG,DA H,DAJ,DAL,DAW,DAX,V14,V15,V16, V17,V18,V19,V20,V21,V22,V24,ZAA, ZAB,ZAC,ZAD,ZAE,ZAF,ZAG,ZAH,Z AJ,ZAL .....	1
12	PAHZZ	5310-00-147-3274	19207	8758258	WASHER,KEY UOC: DAC,DAD,DAE,DAF,DAG,DA H,DAJ,DAL,DAW,DAX,V14,V15,V16, V17,V18,V19,V20,V21,V22,V24,ZAA, ZAB,ZAC,ZAD,ZAE,ZAF,ZAG,ZAH,Z AJ,ZAL .....	1
13	PAHZZ	5310-00-700-7089	19207	5139123	WASHER,KEY UOC: DAC,DAD,DAE,DAF,DAG,DA H,DAJ,DAL,DAW,DAX,V14,V15,V16, V17,V18,V19,V20,V21,V22,V24,ZAA, ZAB,ZAC,ZAD,ZAE,ZAF,ZAG,ZAH,Z AJ,ZAL .....	1
14	PAHZZ	3110-00-419-9471	19207	8758202	PLATE,RETAINING,BEA UOC: DAC,DAD,DAE,DAF,DAG,DA H,DAJ,DAL,DAW,DAX,V14,V15,V16, V17,V18,V19,V20,V21,V22,V24,ZAA, ZAB,ZAC,ZAD,ZAE,ZAF,ZAG,ZAH,Z AJ,ZAL .....	1
15	KBHZZ	5365-00-734-6890	89346	98683R1	SHIM .010 PART OF KIT P/N 7346807 UOC: DAC,DAD,DAE,DAF,DAG,DA H,DAJ,DAL,DAW,DAX,V14,V15,V16, V17,V18,V19,V20,V21,V22,V24,ZAA, ZAB,ZAC,ZAD,ZAE,ZAF,ZAG,ZAH,Z AJ,ZAL .....	1

(1) ITEM NO.	(2) SMR CODE	(3) NSN	(4) CAGEC	(5) PART NUMBER	(6) DESCRIPTION AND USABLE ON CODE (UOC)	(7) QTY
15	KBHZZ	5365-01-077-8564	19207	7346888	SHIM .003 PART OF KIT P/N 7346807 UOC: DAC,DAD,DAE,DAF,DAG,DA H,DAJ,DAL,DAW,DAX,V14,V15,V16, V17,V18,V19,V20,V21,V22,V24,ZAA, ZAB,ZAC,ZAD,ZAE,ZAF,ZAG,ZAH,Z AJ,ZAL .....	1
15	KBHZZ	5365-00-734-6889	19207	7346889	SHIM .005 PART OF KIT P/N 7346807 UOC: DAC,DAD,DAE,DAF,DAG,DA H,DAJ,DAL,DAW,DAX,V14,V15,V16, V17,V18,V19,V20,V21,V22,V24,ZAA, ZAB,ZAC,ZAD,ZAE,ZAF,ZAG,ZAH,Z AJ,ZAL .....	5
16	KBHZZ		19207	8758237	COLLAR,BEARING .395 PART OF KIT P/N 5704278 UOC: DAC,DAD,DAE,DAF,DAG,DA H,DAJ,DAL,DAW,DAX,V14,V15,V16, V17,V18,V19,V20,V21,V22,V24,ZAA, ZAB,ZAC,ZAD,ZAE,ZAF,ZAG,ZAH,Z AJ,ZAL .....	1
16	KBHZZ		19207	8758245	COLLAR,BEARING .403 PART OF KIT P/N 5704278 UOC: DAC,DAD,DAE,DAF,DAG,DA H,DAJ,DAL,DAW,DAX,V14,V15,V16, V17,V18,V19,V20,V21,V22,V24,ZAA, ZAB,ZAC,ZAD,ZAE,ZAF,ZAG,ZAH,Z AJ,ZAL .....	1
16	KBHZZ		19207	8758243	COLLAR,BEARING .401 PART OF KIT P/N 5704278 UOC: DAC,DAD,DAE,DAF,DAG,DA H,DAJ,DAL,DAW,DAX,V14,V15,V16, V17,V18,V19,V20,V21,V22,V24,ZAA, ZAB,ZAC,ZAD,ZAE,ZAF,ZAG,ZAH,Z AJ,ZAL .....	1
16	KBHZZ		19207	8758233	COLLAR,BEARING .391 PART OF KIT P/N 5704278 UOC: DAC,DAD,DAE,DAF,DAG,DA H,DAJ,DAL,DAW,DAX,V14,V15,V16, V17,V18,V19,V20,V21,V22,V24,ZAA, ZAB,ZAC,ZAD,ZAE,ZAF,ZAG,ZAH,Z AJ,ZAL .....	1
16	KBHZZ		19207	8758211	COLLAR .369 PART OF KIT P/N 5704278 UOC: DAC,DAD,DAE,DAF,DAG,DA H,DAJ,DAL,DAW,DAX,V14,V15,V16, V17,V18,V19,V20,V21,V22,V24,ZAA, ZAB,ZAC,ZAD,ZAE,ZAF,ZAG,ZAH,Z AJ,ZAL .....	1

(1) ITEM NO.	(2) SMR CODE	(3) NSN	(4) CAGEC	(5) PART NUMBER	(6) DESCRIPTION AND USABLE ON CODE (UOC)	(7) QTY
16	PAHZZ	3040-00-692-6121	19207	8758217	COLLAR,SHAFT .375 PART OF KIT P/N 5704278 UOC: DAC,DAD,DAE,DAF,DAG,DA H,DAJ,DAL,DAW,DAX,V14,V15,V16, V17,V18,V19,V20,V21,V22,V24,ZAA, ZAB,ZAC,ZAD,ZAE,ZAF,ZAG,ZAH,Z AJ,ZAL .....	1
16	KBHZZ		19207	8758215	COLLAR,BEARING .373 PART OF KIT P/N 5704278 UOC: DAC,DAD,DAE,DAF,DAG,DA H,DAJ,DAL,DAW,DAX,V14,V15,V16, V17,V18,V19,V20,V21,V22,V24,ZAA, ZAB,ZAC,ZAD,ZAE,ZAF,ZAG,ZAH,Z AJ,ZAL .....	1
16	PAHZZ	5365-00-692-6119	19207	8758209	SPACER,BEVEL PINION .367 PART OF KIT P/N 5704278 UOC: DAC,DAD,DAE,DAF,DAG,DA H,DAJ,DAL,DAW,DAX,V14,V15,V16, V17,V18,V19,V20,V21,V22,V24,ZAA, ZAB,ZAC,ZAD,ZAE,ZAF,ZAG,ZAH,Z AJ,ZAL .....	1
16	PAHZZ	5365-00-692-6120	19207	8758213	COLLAR .371 PART OF KIT P/N 5704278 UOC: DAC,DAD,DAE,DAF,DAG,DA H,DAJ,DAL,DAW,DAX,V14,V15,V16, V17,V18,V19,V20,V21,V22,V24,ZAA, ZAB,ZAC,ZAD,ZAE,ZAF,ZAG,ZAH,Z AJ,ZAL .....	1
16	KBHZZ		19207	8758239	COLLAR,BEARING .397 PART OF KIT P/N 5704278 UOC: DAC,DAD,DAE,DAF,DAG,DA H,DAJ,DAL,DAW,DAX,V14,V15,V16, V17,V18,V19,V20,V21,V22,V24,ZAA, ZAB,ZAC,ZAD,ZAE,ZAF,ZAG,ZAH,Z AJ,ZAL .....	1
16	KBHZZ	3120-00-692-6124	19207	8758229	BEARING,WASHER,THRU .387 PART OF KIT P/N 5704278 UOC: DAC,DAD,DAE,DAF,DAG,DA H,DAJ,DAL,DAW,DAX,V14,V15,V16, V17,V18,V19,V20,V21,V22,V24,ZAA, ZAB,ZAC,ZAD,ZAE,ZAF,ZAG,ZAH,Z AJ,ZAL .....	1
16	PAHZZ	3040-00-692-6123	19207	8758225	COLLAR,SHAFT .383 PART OF KIT P/N 5704278 UOC: DAC,DAD,DAE,DAF,DAG,DA H,DAJ,DAL,DAW,DAX,V14,V15,V16, V17,V18,V19,V20,V21,V22,V24,ZAA, ZAB,ZAC,ZAD,ZAE,ZAF,ZAG,ZAH,Z AJ,ZAL .....	1



(1) ITEM NO.	(2) SMR CODE	(3) NSN	(4) CAGEC	(5) PART NUMBER	(6) DESCRIPTION AND USABLE ON CODE (UOC)	(7) QTY
16	KBHZZ		19207	8758227	COLLAR,BEARING .385 PART OF KIT P/N 5704278 UOC: DAC,DAD,DAE,DAF,DAG,DA H,DAJ,DAL,DAW,DAX,V14,V15,V16, V17,V18,V19,V20,V21,V22,V24,ZAA, ZAB,ZAC,ZAD,ZAE,ZAF,ZAG,ZAH,Z AJ,ZAL .....	1
16	KBHZZ		19207	8758231	COLLAR,BEARING .389 PART OF KIT P/N 5704278 UOC: DAC,DAD,DAE,DAF,DAG,DA H,DAJ,DAL,DAW,DAX,V14,V15,V16, V17,V18,V19,V20,V21,V22,V24,ZAA, ZAB,ZAC,ZAD,ZAE,ZAF,ZAG,ZAH,Z AJ,ZAL .....	1
16	KBHZZ		19207	8758219	COLLAR,BEARING .377 PART OF KIT P/N 5704278 UOC: DAC,DAD,DAE,DAF,DAG,DA H,DAJ,DAL,DAW,DAX,V14,V15,V16, V17,V18,V19,V20,V21,V22,V24,ZAA, ZAB,ZAC,ZAD,ZAE,ZAF,ZAG,ZAH,Z AJ,ZAL .....	1
16	KBHZZ		19207	8758235	COLLAR,BEARING .393 PART OF KIT P/N 5704278 UOC: DAC,DAD,DAE,DAF,DAG,DA H,DAJ,DAL,DAW,DAX,V14,V15,V16, V17,V18,V19,V20,V21,V22,V24,ZAA, ZAB,ZAC,ZAD,ZAE,ZAF,ZAG,ZAH,Z AJ,ZAL .....	1
16	KBHZZ		19207	8758241	COLLAR,BEARING .399 PART OF KIT P/N 5704278 UOC: DAC,DAD,DAE,DAF,DAG,DA H,DAJ,DAL,DAW,DAX,V14,V15,V16, V17,V18,V19,V20,V21,V22,V24,ZAA, ZAB,ZAC,ZAD,ZAE,ZAF,ZAG,ZAH,Z AJ,ZAL .....	1
16	XDHZZ		19207	8758221	COLLAR,BEARING .379 PART OF KIT P/N 5704278 UOC: DAC,DAD,DAE,DAF,DAG,DA H,DAJ,DAL,DAW,DAX,V14,V15,V16, V17,V18,V19,V20,V21,V22,V24,ZAA, ZAB,ZAC,ZAD,ZAE,ZAF,ZAG,ZAH,Z AJ,ZAL .....	1
16	KBHZZ		19207	8758223	COLLAR .381 PART OF KIT P/N 5704278 UOC: DAC,DAD,DAE,DAF,DAG,DA H,DAJ,DAL,DAW,DAX,V14,V15,V16, V17,V18,V19,V20,V21,V22,V24,ZAA, ZAB,ZAC,ZAD,ZAE,ZAF,ZAG,ZAH,Z AJ,ZAL .....	1

(1) ITEM NO.	(2) SMR CODE	(3) NSN	(4) CAGEC	(5) PART NUMBER	(6) DESCRIPTION AND USABLE ON CODE (UOC)	(7) QTY
17	PAHZZ	3110-00-100-5355	60038	42350-42584	BEARING,ROLLER,TAPE UOC: DAC,DAD,DAE,DAF,DAG,DA H,DAJ,DAL,DAW,DAX,V14,V15,V16, V17,V18,V19,V20,V21,V22,V24,ZAA, ZAB,ZAC,ZAD,ZAE,ZAF,ZAG,ZAH,Z AJ,ZAL .....	1
18	PAHZZ	3040-00-734-6892	19207	7346892	SHAFT,SHOULDERED UOC: DAC,DAD,DAE,DAF,DAG,DA H,DAJ,DAL,DAW,DAX,V14,V15,V16, V17,V18,V19,V20,V21,V22,V24,ZAA, ZAB,ZAC,ZAD,ZAE,ZAF,ZAG,ZAH,Z AJ,ZAL .....	1
19	PAHZZ	3110-00-195-0460	0LTL1	MR1212EL	BEARING,ROLLER,CYLI UOC: DAC,DAD,DAE,DAF,DAG,DA H,DAJ,DAL,DAW,DAX,V14,V15,V16, V17,V18,V19,V20,V21,V22,V24,ZAA, ZAB,ZAC,ZAD,ZAE,ZAF,ZAG,ZAH,Z AJ,ZAL .....	1
20	PAHZZ	3120-00-662-3370	78500	1244K557	BEARING,WASHER,THRU UOC: DAC,DAD,DAE,DAF,DAG,DA H,DAJ,DAL,DAW,DAX,V14,V15,V16, V17,V18,V19,V20,V21,V22,V24,ZAA, ZAB,ZAC,ZAD,ZAE,ZAF,ZAG,ZAH,Z AJ,ZAL .....	1
21	PAFZZ	3110-00-734-6895	19207	7346895	PLATE,RETAINING,BEA UOC: DAC,DAD,DAE,DAF,DAG,DA H,DAJ,DAL,DAW,DAX,V14,V15,V16, V17,V18,V19,V20,V21,V22,V24,ZAA, ZAB,ZAC,ZAD,ZAE,ZAF,ZAG,ZAH,Z AJ,ZAL .....	1
22	XAFZZ		19207	8758207	. CAP UOC: DAC,DAD,DAE,DAF,DAG,DA H,DAJ,DAL,DAW,DAX,V14,V15,V16, V17,V18,V19,V20,V21,V22,V24,ZAA, ZAB,ZAC,ZAD,ZAE,ZAF,ZAG,ZAH,Z AJ,ZAL .....	1
23	PAFZZ	5330-01-023-0269	19207	11669023	. SEAL,PLAIN ENCASED UOC: DAC,DAD,DAE,DAF,DAG,DA H,DAJ,DAL,DAW,DAX,V14,V15,V16, V17,V18,V19,V20,V21,V22,V24,ZAA, ZAB,ZAC,ZAD,ZAE,ZAF,ZAG,ZAH,Z AJ,ZAL .....	1
24	PAFZZ	5305-00-543-2419	80204	B1821BH038C113N	SCREW,CAP,HEXAGON H UOC: DAC,DAD,DAE,DAF,DAG,DA H,DAJ,DAL,DAW,DAX,V14,V15,V16, V17,V18,V19,V20,V21,V22,V24,ZAA, ZAB,ZAC,ZAD,ZAE,ZAF,ZAG,ZAH,Z AJ,ZAL .....	6

(1) ITEM NO.	(2) SMR CODE	(3) NSN	(4) CAGEC	(5) PART NUMBER	(6) DESCRIPTION AND USABLE ON CODE (UOC)	(7) QTY
25	PAFZZ	5310-00-637-9541	00198	132661	WASHER,LOCK UOC: DAC,DAD,DAE,DAF,DAG,DA H,DAJ,DAL,DAW,DAX,V14,V15,V16, V17,V18,V19,V20,V21,V22,V24,ZAA, ZAB,ZAC,ZAD,ZAE,ZAF,ZAG,ZAH,Z AJ,ZAL .....	6
26	PAHZZ	5330-01-077-8512	19207	7346896	GASKET PART OF KIT P/N 7346807 UOC: DAC,DAD,DAE,DAF,DAG,DA H,DAJ,DAL,DAW,DAX,V14,V15,V16, V17,V18,V19,V20,V21,V22,V24,ZAA, ZAB,ZAC,ZAD,ZAE,ZAF,ZAG,ZAH,Z AJ,ZAL .....	1
27	PAHZZ	3020-00-734-6881	19207	7346881	GEAR SET,BEVEL,MATC UOC: DAC,DAD,DAE,DAF,DAG,DA H,DAJ,DAL,DAW,DAX,V14,V15,V16, V17,V18,V19,V20,V21,V22,V24,ZAA, ZAB,ZAC,ZAD,ZAE,ZAF,ZAG,ZAH,Z AJ,ZAL .....	1
28	PAHZZ	3040-00-311-7875	19207	8758204	. GEARSHAFT,BEVEL UOC: DAC,DAD,DAE,DAF,DAG,DA H,DAJ,DAL,DAW,DAX,V14,V15,V16, V17,V18,V19,V20,V21,V22,V24,ZAA, ZAB,ZAC,ZAD,ZAE,ZAF,ZAG,ZAH,Z AJ,ZAL .....	1
29	XAHZZ		19207	8758205	. GEAR,BEVEL UOC: DAC,DAD,DAE,DAF,DAG,DA H,DAJ,DAL,DAW,DAX,V14,V15,V16, V17,V18,V19,V20,V21,V22,V24,ZAA, ZAB,ZAC,ZAD,ZAE,ZAF,ZAG,ZAH,Z AJ,ZAL .....	1
30	PAHZZ	5310-00-374-0836	24617	716649	NUT,PLAIN,OCTAGON UOC: DAC,DAD,DAE,DAF,DAG,DA H,DAJ,DAL,DAW,DAX,V14,V15,V16, V17,V18,V19,V20,V21,V22,V24,ZAA, ZAB,ZAC,ZAD,ZAE,ZAF,ZAG,ZAH,Z AJ,ZAL .....	1
31	XAHZZ	5310-01-135-0049	19207	7979309	. NUT,PLAIN,OCTAGON UOC: DAC,DAD,DAE,DAF,DAG,DA H,DAJ,DAL,DAW,DAX,V14,V15,V16, V17,V18,V19,V20,V21,V22,V24,ZAA, ZAB,ZAC,ZAD,ZAE,ZAF,ZAG,ZAH,Z AJ,ZAL .....	1
32	PAHZZ	5315-01-058-7268	19207	7979310	. PIN,ADJUSTMENT UOC: DAC,DAD,DAE,DAF,DAG,DA H,DAJ,DAL,DAW,DAX,V14,V15,V16, V17,V18,V19,V20,V21,V22,V24,ZAA, ZAB,ZAC,ZAD,ZAE,ZAF,ZAG,ZAH,Z AJ,ZAL .....	1

(1) ITEM NO.	(2) SMR CODE	(3) NSN	(4) CAGEC	(5) PART NUMBER	(6) DESCRIPTION AND USABLE ON CODE (UOC)	(7) QTY
33	PAHZZ	3110-00-100-4177	58536	AA59649-628	BEARING,ROLLER,TAPE UOC: DAC,DAD,DAE,DAF,DAG,DA H,DAJ,DAL,DAW,DAX,V14,V15,V16, V17,V18,V19,V20,V21,V22,V24,ZAA, ZAB,ZAC,ZAD,ZAE,ZAF,ZAG,ZAH,Z AJ,ZAL .....	1
34	PAHZZ	5330-01-413-8543	14153	02957	GASKET,COVER PART OF KIT P/ N 7346807 UOC: DAC,DAD,DAE,DAF,DAG,DA H,DAJ,DAL,DAW,DAX,V14,V15,V16, V17,V18,V19,V20,V21,V22,V24,ZAA, ZAB,ZAC,ZAD,ZAE,ZAF,ZAG,ZAH,Z AJ,ZAL .....	1

END OF FIGURE

**FIELD MAINTENANCE**  
**REAR AXLE DIFFERENTIAL HELICAL DRIVE PINION AND RELATED PARTS**

---

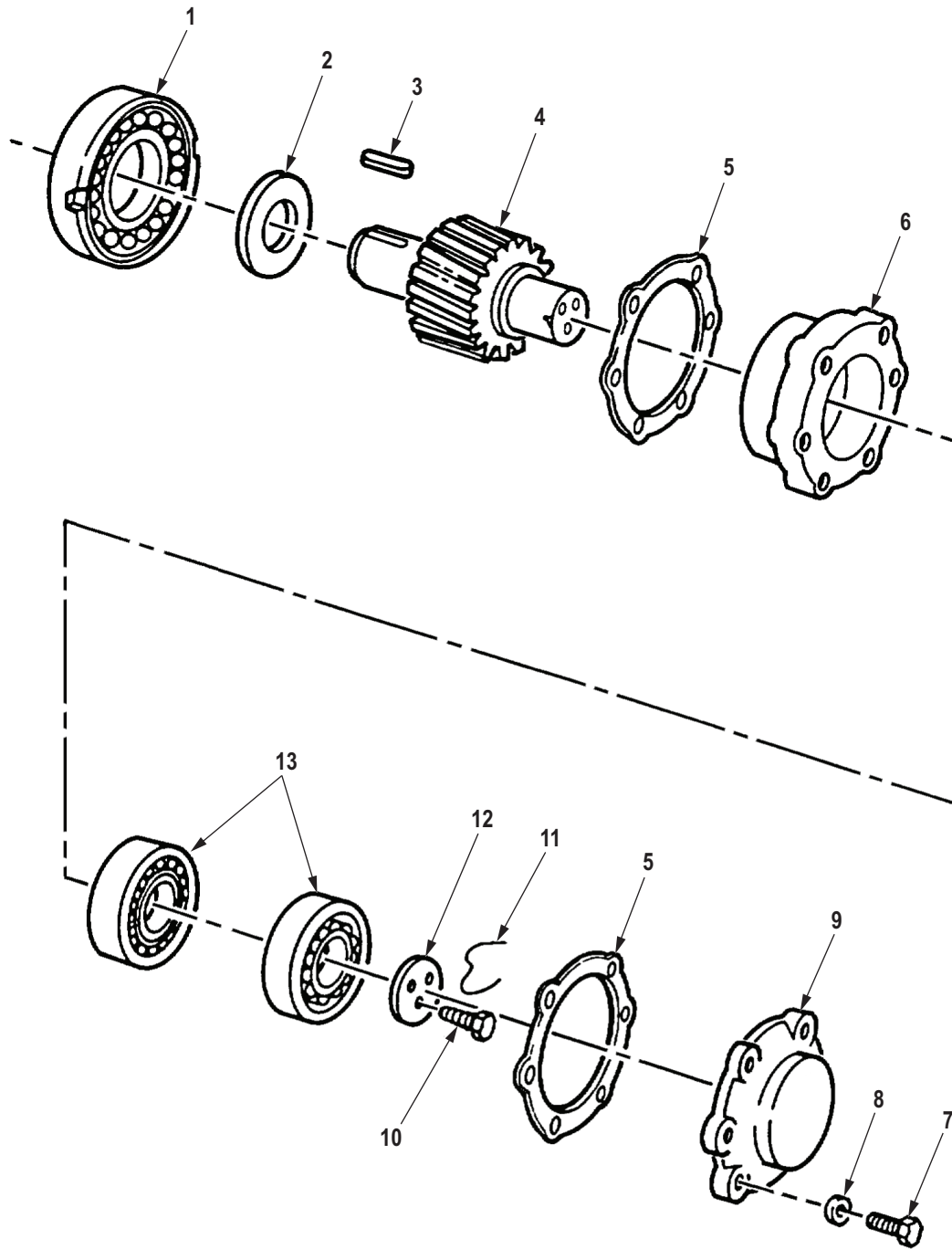

R0257DAA

Figure 242. Rear Axle Differential Helical Drive Pinion and Related Parts.

(1) ITEM NO.	(2) SMR CODE	(3) NSN	(4) CAGEC	(5) PART NUMBER	(6) DESCRIPTION AND USABLE ON CODE (UOC)	(7) QTY
<b>GROUP 1102 DIFFERENTIAL.</b>						
<b>FIG. 242. REAR AXLE DIFFERENTIAL HELICAL DRIVE PINION AND RELATED PARTS.</b>						
1	PAHZZ	3110-00-158-6011	OLTL1	11665824	BEARING,ROLLER,CYLI UOC: DAC,DAD,DAE,DAF,DAG,DA H,DAJ,DAL,DAW,DAX,V14,V15,V16, V17,V18,V19,V20,V21,V22,V24,ZAA, ZAB,ZAC,ZAD,ZAE,ZAF,ZAG,ZAH,Z AJ,ZAL .....	1
2	PAHZZ	5310-00-033-6012	19207	7346882	WASHER,RECESSED UOC: DAC,DAD,DAE,DAF,DAG,DA H,DAJ,DAL,DAW,DAX,V14,V15,V16, V17,V18,V19,V20,V21,V22,V24,ZAA, ZAB,ZAC,ZAD,ZAE,ZAF,ZAG,ZAH,Z AJ,ZAL .....	1
3	PAHZZ	5315-00-276-5385	19207	7534781	KEY,MACHINE UOC: DAC,DAD,DAE,DAF,DAG,DA H,DAJ,DAL,DAW,DAX,V14,V15,V16, V17,V18,V19,V20,V21,V22,V24,ZAA, ZAB,ZAC,ZAD,ZAE,ZAF,ZAG,ZAH,Z AJ,ZAL .....	1
4	KBHZZ	3040-00-734-6825	89346	98683R3	GEARSHAFT,HELICAL PART OF KIT P/N 10899232 UOC: DAC,DAD,DAE,DAF,DAG,DA H,DAJ,DAL,DAW,DAX,V14,V15,V16, V17,V18,V19,V20,V21,V22,V24,ZAA, ZAB,ZAC,ZAD,ZAE,ZAF,ZAG,ZAH,Z AJ,ZAL .....	1
5	KBHZZ	5365-00-734-6878	19207	7346878	GASKET .010 PART OF KIT P/N 7346807 UOC: DAC,DAD,DAE,DAF,DAG,DA H,DAJ,DAL,DAW,DAX,V14,V15,V16, V17,V18,V19,V20,V21,V22,V24,ZAA, ZAB,ZAC,ZAD,ZAE,ZAF,ZAG,ZAH,Z AJ,ZAL .....	2
5	KBHZZ	5365-00-734-6880	19207	7346880	SHIM .003 PART OF KIT P/N 7346807 UOC: DAC,DAD,DAE,DAF,DAG,DA H,DAJ,DAL,DAW,DAX,V14,V15,V16, V17,V18,V19,V20,V21,V22,V24,ZAA, ZAB,ZAC,ZAD,ZAE,ZAF,ZAG,ZAH,Z AJ,ZAL .....	2
5	PAHZZ	5365-00-734-6879	78500	2803J1440	SHIM .005 PART OF KIT P/N 7346807 UOC: DAC,DAD,DAE,DAF,DAG,DA H,DAJ,DAL,DAW,DAX,V14,V15,V16, V17,V18,V19,V20,V21,V22,V24,ZAA, ZAB,ZAC,ZAD,ZAE,ZAF,ZAG,ZAH,Z AJ,ZAL .....	2

(1) ITEM NO.	(2) SMR CODE	(3) NSN	(4) CAGEC	(5) PART NUMBER	(6) DESCRIPTION AND USABLE ON CODE (UOC)	(7) QTY
6	PAHZZ	3110-00-182-7957	19207	8758208	PLATE,RETAINING,BEA UOC: DAC,DAD,DAE,DAF,DAG,DA H,DAJ,DAL,DAW,DAX,V14,V15,V16, V17,V18,V19,V20,V21,V22,V24,ZAA, ZAB,ZAC,ZAD,ZAE,ZAF,ZAG,ZAH,Z AJ,ZAL .....	1
7	PAHZZ	5305-00-071-2071	80204	B1821BH050C200N	SCREW,CAP,HEXAGON H UOC: DAC,DAD,DAE,DAF,DAG,DA H,DAJ,DAL,DAW,DAX,V14,V15,V16, V17,V18,V19,V20,V21,V22,V24,ZAA, ZAB,ZAC,ZAD,ZAE,ZAF,ZAG,ZAH,Z AJ,ZAL .....	6
8	PAHZZ	5310-00-003-4094	80205	MS35338-48	WASHER,LOCK UOC: DAC,DAD,DAE,DAF,DAG,DA H,DAJ,DAL,DAW,DAX,V14,V15,V16, V17,V18,V19,V20,V21,V22,V24,ZAA, ZAB,ZAC,ZAD,ZAE,ZAF,ZAG,ZAH,Z AJ,ZAL .....	6
9	PAHZZ	3110-00-734-6877	19207	7346877	PLATE,RETAINING,BEA UOC: DAC,DAD,DAE,DAF,DAG,DA H,DAJ,DAL,DAW,DAX,V14,V15,V16, V17,V18,V19,V20,V21,V22,V24,ZAA, ZAB,ZAC,ZAD,ZAE,ZAF,ZAG,ZAH,Z AJ,ZAL .....	1
10	PAHZZ	5305-00-941-9460	96906	MS51095-386	SCREW,CAP,HEXAGON H UOC: DAC,DAD,DAE,DAF,DAG,DA H,DAJ,DAL,DAW,DAX,V14,V15,V16, V17,V18,V19,V20,V21,V22,V24,ZAA, ZAB,ZAC,ZAD,ZAE,ZAF,ZAG,ZAH,Z AJ,ZAL .....	3
11	MHHZZ		80244	22W1642125X12 IN	WIRE,NONELECTRICAL RETAINING PLATE, MAKE FROM WIRE,P/N 22W1642-125, 12 IN.LONG UOC: DAC,DAD,DAE,DAF,DAG,DA H,DAJ,DAL,DAW,DAX,V14,V15,V16, V17,V18,V19,V20,V21,V22,V24,ZAA, ZAB,ZAC,ZAD,ZAE,ZAF,ZAG,ZAH,Z AJ,ZAL .....	1
12	PAHZZ	3110-00-350-5407	3D6E9	1829S149	PLATE,RETAINING,BEA UOC: DAC,DAD,DAE,DAF,DAG,DA H,DAJ,DAL,DAW,DAX,V14,V15,V16, V17,V18,V19,V20,V21,V22,V24,ZAA, ZAB,ZAC,ZAD,ZAE,ZAF,ZAG,ZAH,Z AJ,ZAL .....	1



(1) ITEM NO.	(2) SMR CODE	(3) NSN	(4) CAGEC	(5) PART NUMBER	(6) DESCRIPTION AND USABLE ON CODE (UOC)	(7) QTY
13	PAHZZ	3110-00-100-5825	60038	66225-66462	BEARING,ROLLER,TAPE UOC: DAC,DAD,DAE,DAF,DAG,DA H,DAJ,DAL,DAW,DAX,V14,V15,V16, V17,V18,V19,V20,V21,V22,V24,ZAA, ZAB,ZAC,ZAD,ZAE,ZAF,ZAG,ZAH,Z AJ,ZAL .....	2

END OF FIGURE



**FIELD MAINTENANCE  
PARKING BRAKE LEVER ASSEMBLY, CABLE, AND MOUNTING HARDWARE**

---

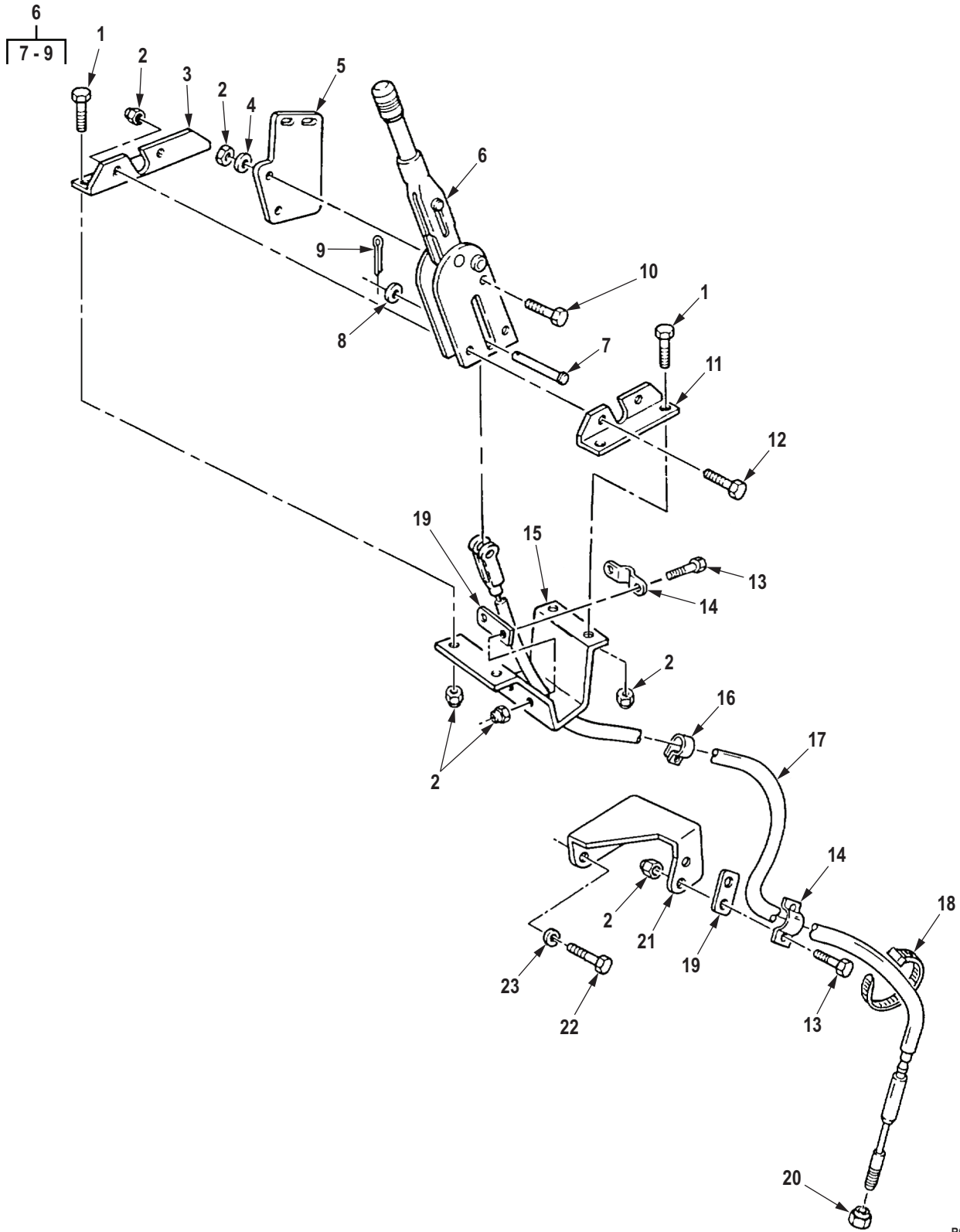

R0258DAA

Figure 243. Parking Brake Lever Assembly, Cable, and Mounting Hardware.

(1) ITEM NO.	(2) SMR CODE	(3) NSN	(4) CAGEC	(5) PART NUMBER	(6) DESCRIPTION AND USABLE ON CODE (UOC)	(7) QTY
<b>GROUP 1201 HAND BRAKES.</b>						
<b>FIG. 243. PARKING BRAKE LEVER ASSEMBLY, CABLE, AND MOUNTING HARDWARE.</b>						
1	PAFZZ	5305-00-269-2803	80205	MS90726-60	SCREW,CAP,HEXAGON H UOC: DAC,DAD,DAE,DAF,DAG,DA H,DAJ,DAL,DAW,DAX,V14,V15,V16, V17,V18,V19,V20,V21,V22,V24,ZAA, ZAB,ZAC,ZAD,ZAE,ZAF,ZAG,ZAH,Z AJ,ZAL .....	4
2	PAFZZ	5310-00-814-0672	96906	M45913/3-6FG8C	NUT,SELF-LOCKING,HE UOC: DAC,DAD,DAE,DAF,DAG,DA H,DAJ,DAL,DAW,DAX,V14,V15,V16, V17,V18,V19,V20,V21,V22,V24,ZAA, ZAB,ZAC,ZAD,ZAE,ZAF,ZAG,ZAH,Z AJ,ZAL .....	14
3	PFFZZ	5340-00-480-7608	19207	11608772	BRACKET,ANGLE UOC: DAC,DAD,DAE,DAF,DAG,DA H,DAJ,DAL,DAW,DAX,V14,V15,V16, V17,V18,V19,V20,V21,V22,V24,ZAA, ZAB,ZAC,ZAD,ZAE,ZAF,ZAG,ZAH,Z AJ,ZAL .....	1
4	PAFZZ	5310-00-080-6004	96906	MS27183-14	WASHER,FLAT UOC: DAC,DAD,DAE,DAF,DAG,DA H,DAJ,DAL,DAW,DAX,V14,V15,V16, V17,V18,V19,V20,V21,V22,V24,ZAA, ZAB,ZAC,ZAD,ZAE,ZAF,ZAG,ZAH,Z AJ,ZAL .....	1
5	PFFZZ	5340-01-333-8147	19207	12375362	BRACKET,ANGLE UOC: DAC,DAD,DAE,DAF,DAG,DA H,DAJ,DAL,DAW,DAX,V14,V15,V16, V17,V18,V19,V20,V21,V22,V24,ZAA, ZAB,ZAC,ZAD,ZAE,ZAF,ZAG,ZAH,Z AJ,ZAL .....	1
6	PAFZZ	3040-00-040-2401	92867	01166202	LEVER,MANUAL CONTRO UOC: DAC,DAD,DAE,DAF,DAG,DA H,DAJ,DAL,DAW,DAX,V14,V15,V16, V17,V18,V19,V20,V21,V22,V24,ZAA, ZAB,ZAC,ZAD,ZAE,ZAF,ZAG,ZAH,Z AJ,ZAL .....	1
7	PAFZZ	5315-00-741-5746	19207	7415746	. PIN,STRAIGHT,HEADED UOC: DAC,DAD,DAE,DAF,DAG,DA H,DAJ,DAL,DAW,DAX,V14,V15,V16, V17,V18,V19,V20,V21,V22,V24,ZAA, ZAB,ZAC,ZAD,ZAE,ZAF,ZAG,ZAH,Z AJ,ZAL .....	1

(1) ITEM NO.	(2) SMR CODE	(3) NSN	(4) CAGEC	(5) PART NUMBER	(6) DESCRIPTION AND USABLE ON CODE (UOC)	(7) QTY
8	PAFZZ	5310-00-625-5756	80205	MS15795-812	. WASHER,FLAT UOC: DAC,DAD,DAE,DAF,DAG,DA H,DAJ,DAL,DAW,DAX,V14,V15,V16, V17,V18,V19,V20,V21,V22,V24,ZAA, ZAB,ZAC,ZAD,ZAE,ZAF,ZAG,ZAH,Z AJ,ZAL .....	1
9	PAFZZ	5315-00-842-3044	80205	MS24665-283	. PIN,COTTER UOC: DAC,DAD,DAE,DAF,DAG,DA H,DAJ,DAL,DAW,DAX,V14,V15,V16, V17,V18,V19,V20,V21,V22,V24,ZAA, ZAB,ZAC,ZAD,ZAE,ZAF,ZAG,ZAH,Z AJ,ZAL .....	1
10	PAFZZ	5305-00-269-2811	80205	MS90726-67	SCREW,CAP,HEXAGON H UOC: DAC,DAD,DAE,DAF,DAG,DA H,DAJ,DAL,DAW,DAX,V14,V15,V16, V17,V18,V19,V20,V21,V22,V24,ZAA, ZAB,ZAC,ZAD,ZAE,ZAF,ZAG,ZAH,Z AJ,ZAL .....	2
11	PFFZZ	5340-00-740-9361	19207	7409361	BRACKET,ANGLE UOC: DAC,DAD,DAE,DAF,DAG,DA H,DAJ,DAL,DAW,DAX,V14,V15,V16, V17,V18,V19,V20,V21,V22,V24,ZAA, ZAB,ZAC,ZAD,ZAE,ZAF,ZAG,ZAH,Z AJ,ZAL .....	1
12	PAFZZ	5305-00-269-3242	80204	B1821BH038F200N	SCREW,CAP,HEXAGON H UOC: DAC,DAD,DAE,DAF,DAG,DA H,DAJ,DAL,DAW,DAX,V14,V15,V16, V17,V18,V19,V20,V21,V22,V24,ZAA, ZAB,ZAC,ZAD,ZAE,ZAF,ZAG,ZAH,Z AJ,ZAL .....	1
13	PAFZZ	5305-00-269-3238	80204	B1821BH038F125N	SCREW,CAP,HEXAGON H UOC: DAC,DAD,DAE,DAF,DAG,DA H,DAJ,DAL,DAW,DAX,V14,V15,V16, V17,V18,V19,V20,V21,V22,V24,ZAA, ZAB,ZAC,ZAD,ZAE,ZAF,ZAG,ZAH,Z AJ,ZAL .....	2
14	PAFZZ	5340-00-740-9366	19207	7409366	STRAP,RETAINING UOC: DAC,DAD,DAE,DAF,DAG,DA H,DAJ,DAL,DAW,DAX,V14,V15,V16, V17,V18,V19,V20,V21,V22,V24,ZAA, ZAB,ZAC,ZAD,ZAE,ZAF,ZAG,ZAH,Z AJ,ZAL .....	2
15	PFFZZ	5342-00-999-8591	19207	10883130	BRACKET,CLAMP UOC: DAC,DAD,DAE,DAF,DAG,DA H,DAJ,DAL,DAW,DAX,V14,V15,V16, V17,V18,V19,V20,V21,V22,V24,ZAA, ZAB,ZAC,ZAD,ZAE,ZAF,ZAG,ZAH,Z AJ,ZAL .....	2

(1) ITEM NO.	(2) SMR CODE	(3) NSN	(4) CAGEC	(5) PART NUMBER	(6) DESCRIPTION AND USABLE ON CODE (UOC)	(7) QTY
16	PAFZZ	5340-00-053-8994	80205	MS21333-126	CLAMP,LOOP UOC: DAC,DAD,DAE,DAF,DAG,DA H,DAJ,DAL,DAW,DAX,V14,V15,V16, V17,V18,V19,V20,V21,V22,V24,ZAA, ZAB,ZAC,ZAD,ZAE,ZAF,ZAG,ZAH,Z AJ,ZAL .....	1
17	PAFZZ	2590-01-136-8721	19207	12255644-1	CONTROL ASSEMBLY,PU UOC: DAC,DAD,DAE,DAF,DAG,DA H,DAJ,DAL,DAW,DAX,V14,V15,V16, V17,V18,V19,V20,V21,V22,V24,ZAA, ZAB,ZAC,ZAD,ZAE,ZAF,ZAG,ZAH,Z AJ,ZAL .....	1
18	PAFZZ	5975-00-156-3253	81343	MS3367-2-9	STRAP,TIEDOWN,ELECT UOC: DAC,DAD,DAE,DAF,DAG,DA H,DAJ,DAL,DAW,DAX,V14,V15,V16, V17,V18,V19,V20,V21,V22,V24,ZAA, ZAB,ZAC,ZAD,ZAE,ZAF,ZAG,ZAH,Z AJ,ZAL .....	1
19	PAFZZ	3040-00-740-9372	19207	7409372	CONNECTING LINK,RIG UOC: DAC,DAD,DAE,DAF,DAG,DA H,DAJ,DAL,DAW,DAX,V14,V15,V16, V17,V18,V19,V20,V21,V22,V24,ZAA, ZAB,ZAC,ZAD,ZAE,ZAF,ZAG,ZAH,Z AJ,ZAL .....	2
20	PAFZZ	5310-00-269-7044	19207	7373244	NUT,SELF-LOCKING,SI UOC: DAC,DAD,DAE,DAF,DAG,DA H,DAJ,DAL,DAW,DAX,V14,V15,V16, V17,V18,V19,V20,V21,V22,V24,ZAA, ZAB,ZAC,ZAD,ZAE,ZAF,ZAG,ZAH,Z AJ,ZAL .....	1
21	PFFZZ	2590-01-112-2167	19207	12302657	BRACKET,VEHICULAR C UOC: DAC,DAD,DAE,DAF,DAG,DA H,DAJ,DAL,DAW,DAX,V14,V15,V16, V17,V18,V19,V20,V21,V22,V24,ZAA, ZAB,ZAC,ZAD,ZAE,ZAF,ZAG,ZAH,Z AJ,ZAL .....	1
22	PAFZZ	5305-00-709-8516	80204	B1821BH044F113N	SCREW,CAP,HEXAGON H UOC: DAC,DAD,DAE,DAF,DAG,DA H,DAJ,DAL,DAW,DAX,V14,V15,V16, V17,V18,V19,V20,V21,V22,V24,ZAA, ZAB,ZAC,ZAD,ZAE,ZAF,ZAG,ZAH,Z AJ,ZAL .....	2

(1) ITEM NO.	(2) SMR CODE	(3) NSN	(4) CAGEC	(5) PART NUMBER	(6) DESCRIPTION AND USABLE ON CODE (UOC)	(7) QTY
23	PAFZZ	5310-00-209-0965	80205	MS35338-47	WASHER,LOCK UOC: DAC,DAD,DAE,DAF,DAG,DA H,DAJ,DAL,DAW,DAX,V14,V15,V16, V17,V18,V19,V20,V21,V22,V24,ZAA, ZAB,ZAC,ZAD,ZAE,ZAF,ZAG,ZAH,Z AJ,ZAL .....	2

END OF FIGURE



**FIELD MAINTENANCE**  
**PARKING BRAKE SHOE ASSEMBLY, DRUM, DUST SHIELD, AND RELATED PARTS**

---

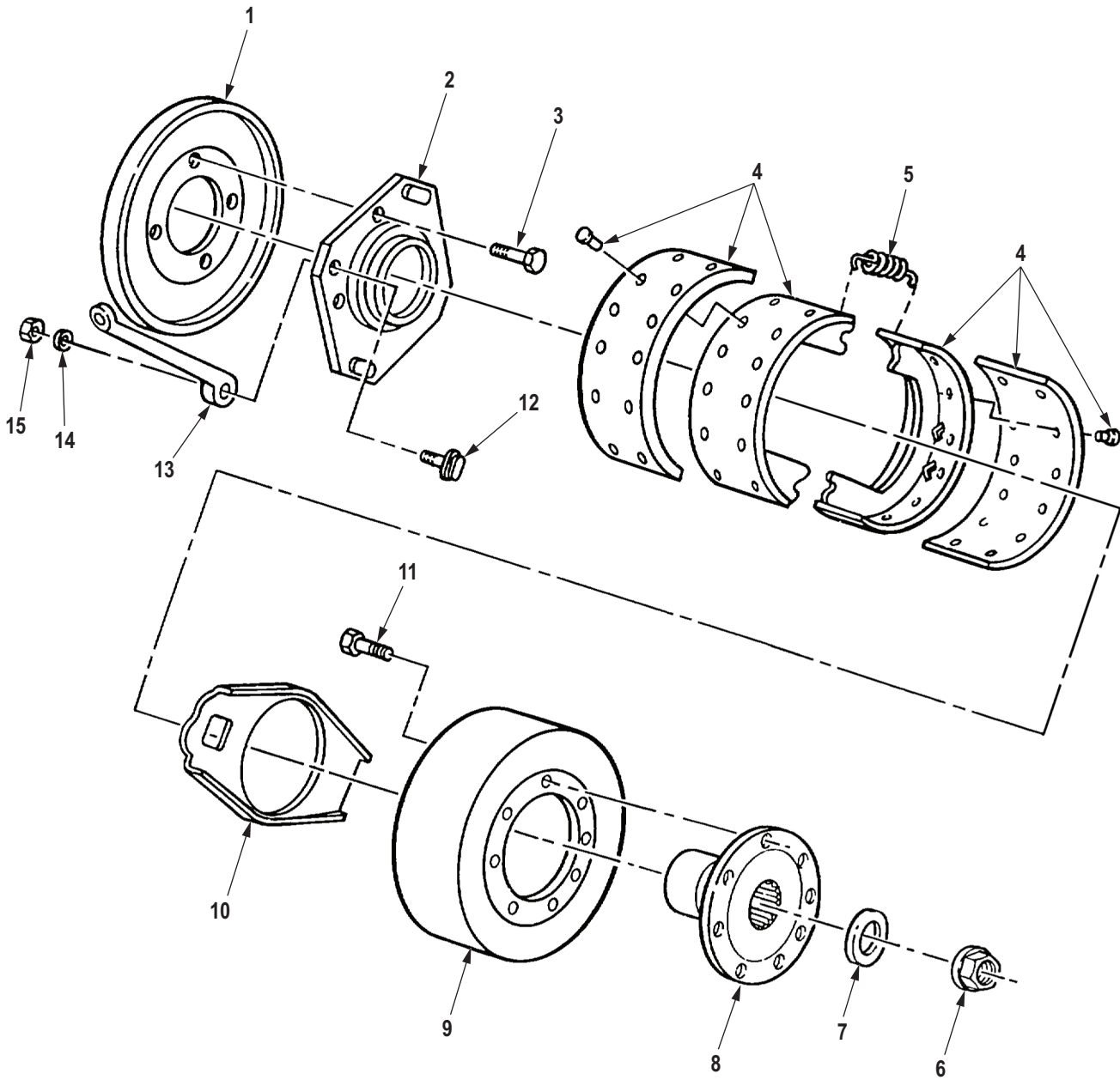

R0259DAA

Figure 244. Parking Brake Shoe Assembly, Drum, Dust Shield, and Related Parts.

(1) ITEM NO.	(2) SMR CODE	(3) NSN	(4) CAGEC	(5) PART NUMBER	(6) DESCRIPTION AND USABLE ON CODE (UOC)	(7) QTY
<b>GROUP 1201 HAND BRAKES.</b>						
<b>FIG. 244. PARKING BRAKE SHOE ASSEMBLY, DRUM, DUST SHIELD, AND RELATED PARTS.</b>						
1	PAFZZ	2530-01-138-2016	78500	3264-V-100	DUST SHIELD,BRAKE UOC: DAC,DAD,DAE,DAF,DAG,DA H,DAJ,DAL,DAW,DAX,V14,V15,V16, V17,V18,V19,V20,V21,V22,V24,ZAA, ZAB,ZAC,ZAD,ZAE,ZAF,ZAG,ZAH,Z AJ,ZAL .....	1
2	PAFZZ	2530-01-134-6626	78500	A3736-K-375	PLATE,BACKING,BRAKE UOC: DAC,DAD,DAE,DAF,DAG,DA H,DAJ,DAL,DAW,DAX,V14,V15,V16, V17,V18,V19,V20,V21,V22,V24,ZAA, ZAB,ZAC,ZAD,ZAE,ZAF,ZAG,ZAH,Z AJ,ZAL .....	1
3	PAFZZ	5306-01-132-8271	78500	10X-1250	BOLT,MACHINE UOC: DAC,DAD,DAE,DAF,DAG,DA H,DAJ,DAL,DAW,DAX,V14,V15,V16, V17,V18,V19,V20,V21,V22,V24,ZAA, ZAB,ZAC,ZAD,ZAE,ZAF,ZAG,ZAH,Z AJ,ZAL .....	4
4	PAFZZ	2530-01-140-0107	78500	A3-3722-D-420	BRAKE SHOE UOC: DAC,DAD,DAE,DAF,DAG,DA H,DAJ,DAL,DAW,DAX,V14,V15,V16, V17,V18,V19,V20,V21,V22,V24,ZAA, ZAB,ZAC,ZAD,ZAE,ZAF,ZAG,ZAH,Z AJ,ZAL .....	2
5	PAFZZ	5360-00-758-6456	11083	5D3261	SPRING,HELICAL,EXTE UOC: DAC,DAD,DAE,DAF,DAG,DA H,DAJ,DAL,DAW,DAX,V14,V15,V16, V17,V18,V19,V20,V21,V22,V24,ZAA, ZAB,ZAC,ZAD,ZAE,ZAF,ZAG,ZAH,Z AJ,ZAL .....	2
6	PAFZZ	5310-01-099-0397	04627	287720	NUT UOC: DAC,DAD,DAE,DAF,DAG,DA H,DAJ,DAL,DAW,DAX,V14,V15,V16, V17,V18,V19,V20,V21,V22,V24,ZAA, ZAB,ZAC,ZAD,ZAE,ZAF,ZAG,ZAH,Z AJ,ZAL .....	1
7	PAFZZ	5310-01-129-4373	3D6E9	1229-T-1450	WASHER,FLAT UOC: DAC,DAD,DAE,DAF,DAG,DA H,DAJ,DAL,DAW,DAX,V14,V15,V16, V17,V18,V19,V20,V21,V22,V24,ZAA, ZAB,ZAC,ZAD,ZAE,ZAF,ZAG,ZAH,Z AJ,ZAL .....	1

(1) ITEM NO.	(2) SMR CODE	(3) NSN	(4) CAGEC	(5) PART NUMBER	(6) DESCRIPTION AND USABLE ON CODE (UOC)	(7) QTY
8	PAFZZ	2520-01-126-9363	78500	A-3280-U-7535	FLANGE,DEFLECTOR UOC: DAC,DAD,DAE,DAF,DAG,DA H,DAJ,DAL,DAW,DAX,V14,V15,V16, V17,V18,V19,V20,V21,V22,V24,ZAA, ZAB,ZAC,ZAD,ZAE,ZAF,ZAG,ZAH,Z AJ,ZAL .....	1
9	PAFZZ	2530-01-138-2015	78500	3219H4064	BRAKE DRUM UOC: DAC,DAD,DAE,DAF,DAG,DA H,DAJ,DAL,DAW,DAX,V14,V15,V16, V17,V18,V19,V20,V21,V22,V24,ZAA, ZAB,ZAC,ZAD,ZAE,ZAF,ZAG,ZAH,Z AJ,ZAL .....	1
10	PAFZZ	2530-01-134-1332	3D6E9	A-3787-N-14	PLATE,BACKING,BRAKE UOC: DAC,DAD,DAE,DAF,DAG,DA H,DAJ,DAL,DAW,DAX,V14,V15,V16, V17,V18,V19,V20,V21,V22,V24,ZAA, ZAB,ZAC,ZAD,ZAE,ZAF,ZAG,ZAH,Z AJ,ZAL .....	1
11	PAFZZ	5306-01-129-0327	78500	10X507Z	BOLT,MACHINE BRAKE DRUM UOC: DAC,DAD,DAE,DAF,DAG,DA H,DAJ,DAL,DAW,DAX,V14,V15,V16, V17,V18,V19,V20,V21,V22,V24,ZAA, ZAB,ZAC,ZAD,ZAE,ZAF,ZAG,ZAH,Z AJ,ZAL .....	8
12	PAFZZ	3040-01-132-8272	3D6E9	2710-U-151	STUD UOC: DAC,DAD,DAE,DAF,DAG,DA H,DAJ,DAL,DAW,DAX,V14,V15,V16, V17,V18,V19,V20,V21,V22,V24,ZAA, ZAB,ZAC,ZAD,ZAE,ZAF,ZAG,ZAH,Z AJ,ZAL .....	1
13	PAFZZ	3040-01-138-8578	3D6E9	302-Z-676	LEVER,MANUAL CONTRO UOC: DAC,DAD,DAE,DAF,DAG,DA H,DAJ,DAL,DAW,DAX,V14,V15,V16, V17,V18,V19,V20,V21,V22,V24,ZAA, ZAB,ZAC,ZAD,ZAE,ZAF,ZAG,ZAH,Z AJ,ZAL .....	1
14	PAFZZ	5310-00-068-5285	96906	MS27183-20	WASHER,FLAT UOC: DAC,DAD,DAE,DAF,DAG,DA H,DAJ,DAL,DAW,DAX,V14,V15,V16, V17,V18,V19,V20,V21,V22,V24,ZAA, ZAB,ZAC,ZAD,ZAE,ZAF,ZAG,ZAH,Z AJ,ZAL .....	1

(1) ITEM NO.	(2) SMR CODE	(3) NSN	(4) CAGEC	(5) PART NUMBER	(6) DESCRIPTION AND USABLE ON CODE (UOC)	(7) QTY
15	PAFZZ	5310-00-949-6280	78500	1227L1702	NUT,LOCK UOC: DAC,DAD,DAE,DAF,DAG,DA H,DAJ,DAL,DAW,DAX,V14,V15,V16, V17,V18,V19,V20,V21,V22,V24,ZAA, ZAB,ZAC,ZAD,ZAE,ZAF,ZAG,ZAH,Z AJ,ZAL .....	1

END OF FIGURE



**FIELD MAINTENANCE  
FRONT AXLE BRAKE AND SPIDER ASSEMBLY**

---

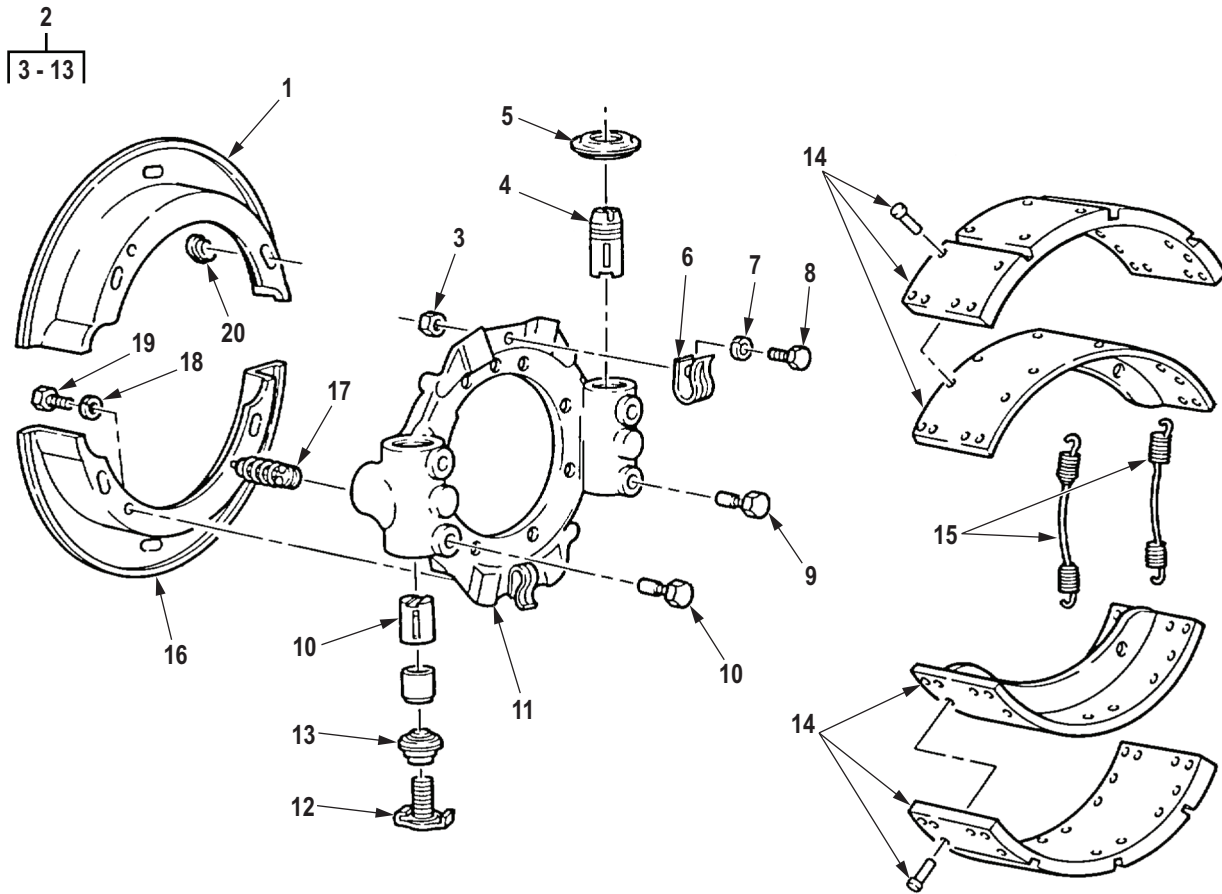

R0260DAA

Figure 245. Front Axle Brake and Spider Assembly.



(1) ITEM NO.	(2) SMR CODE	(3) NSN	(4) CAGEC	(5) PART NUMBER	(6) DESCRIPTION AND USABLE ON CODE (UOC)	(7) QTY
<b>GROUP 1202 SERVICE BRAKES.</b>						
<b>FIG. 245. FRONT AXLE BRAKE AND SPIDER ASSEMBLY.</b>						
1	PAFZZ	2530-01-271-7074	78500	3264-B-1068	SHIELD,BRAKE DISK UOC: DAC,DAD,DAE,DAF,DAG,DAH,DAJ,DAL,DAW,DAX,V14,V15,V16,V17,V18,V19,V20,V21,V22,V24 .....	2
2	PAFFF	2530-01-134-1333	78500	A-3211-L-2872	SPIDER,BRAKE RIGHT HAND UOC: DAC,DAD,DAE,DAF,DAG,DAH,DAJ,DAL,DAW,DAX,V14,V15,V16,V17,V18,V19,V20,V21,V22,V24,ZAA,ZAB,ZAC,ZAD,ZAE,ZAF,ZAG,ZAH,ZAJ,ZAL .....	1
2	PAFFF	2530-01-134-0901	3D6E9	A-3211-H-2868	SPIDER,BRAKE LEFT HAND UOC: DAC,DAD,DAE,DAF,DAG,DAH,DAJ,DAL,DAW,DAX,V14,V15,V16,V17,V18,V19,V20,V21,V22,V24,ZAA,ZAB,ZAC,ZAD,ZAE,ZAF,ZAG,ZAH,ZAJ,ZAL .....	1
3	PAFZZ	5310-00-768-0319	96906	MS51968-2	. NUT,PLAIN,HEXAGON UOC: DAC,DAD,DAE,DAF,DAG,DAH,DAJ,DAL,DAW,DAX,V14,V15,V16,V18,V19,V20,V21,V22,V24,ZAA,ZAB,ZAC,ZAD,ZAE,ZAF,ZAG,ZAH,ZAJ,ZAL .....	2
4	PAFZZ	2530-01-127-3596	78500	2297-K-3885	. PISTON,HYDRAULIC BR L.H. PART OF KIT P/N KIT1105B UOC: DAC,DAD,DAE,DAF,DAG,DAH,DAJ,DAL,DAW,DAX,V14,V15,V16,V17,V18,V19,V20,V21,V22,V24 .....	2
4	PAFZZ	2530-01-131-7741	78500	2297-L-3886	. PLUNGER,ANCHOR SPID RIGHT HAND PART OF KIT P/N KIT1105B UOC: DAC,DAD,DAE,DAF,DAG,DAH,DAJ,DAL,DAW,DAX,V14,V15,V16,V17,V18,V19,V20,V21,V22,V24,ZAA,ZAB,ZAC,ZAD,ZAE,ZAF,ZAG,ZAH,ZAJ,ZAL .....	2
5	PAFZZ	5330-01-292-9573	78500	1205-B-2004	. SEAL,PLAIN ENCASED PART OF KIT P/N KIT1105B, PART OF KIT P/N 3202P8362, PART OF KIT P/N KIT 1174RH UOC: DAC,DAD,DAE,DAF,DAG,DAH,DAJ,DAL,DAW,DAX,V14,V15,V16,V17,V18,V19,V20,V21,V22,V24,ZAA,ZAB,ZAC,ZAD,ZAE,ZAF,ZAG,ZAH,ZAJ,ZAL .....	2

(1) ITEM NO.	(2) SMR CODE	(3) NSN	(4) CAGEC	(5) PART NUMBER	(6) DESCRIPTION AND USABLE ON CODE (UOC)	(7) QTY
6	PAFZZ	5340-01-292-5552	78500	2257-M-1001	. CLIP,SPRING TENSION UOC: DAC,DAD,DAE,DAF,DAG,DA H,DAJ,DAL,DAW,DAX,V14,V15,V16, V18,V19,V20,V21,V22,V24,ZAA,ZAB, ZAC,ZAD,ZAE,ZAF,ZAG,ZAH,ZAJ,ZAL .....	2
7	PAFZZ	5310-01-063-2299	78500	WA142	. WASHER,LOCK UOC: DAC,DAD,DAE,DAF,DAG,DA H,DAJ,DAL,DAW,DAX,V14,V15,V16, V18,V19,V20,V21,V22,V24,ZAA,ZAB, ZAC,ZAD,ZAE,ZAF,ZAG,ZAH,ZAJ,ZAL .....	2
8	PAFZZ	5306-01-062-3148	78500	S-146-C	. BOLT,MACHINE UOC: DAC,DAD,DAE,DAF,DAG,DA H,DAJ,DAL,DAW,DAX,V14,V15,V16, V18,V19,V20,V21,V22,V24,ZAA,ZAB, ZAC,ZAD,ZAE,ZAF,ZAG,ZAH,ZAJ,ZAL .....	2
9	KFFZZ	2530-01-351-4061	78500	A1779M195	. GUIDE,PLUNGER PART OF KIT P/N KIT1105B, PART OF KIT P/N 3202P8362, PART OF KIT P/N KIT 1174RH UOC: DAC,DAD,DAE,DAF,DAG,DA H,DAJ,DAL,DAW,DAX,V14,V15,V16, V17,V18,V19,V20,V21,V22,V24,ZAA, ZAB,ZAC,ZAD,ZAE,ZAF,ZAG,ZAH,Z AJ,ZAL .....	2
10	PAFZZ	3040-01-280-4156	3D6E9	A-3280-V-8186	. PAWL PART OF KIT P/N KIT1105B, PART OF KIT P/N KIT1164 UOC: DAC,DAD,DAE,DAF,DAG,DA H,DAJ,DAL,DAW,DAX,V14,V15,V16, V17,V18,V19,V20,V21,V22,V24,ZAA, ZAB,ZAC,ZAD,ZAE,ZAF,ZAG,ZAH,Z AJ,ZAL .....	2
11	XAFZZ		78500	3211-L-2872	. SPIDER R.H. UOC: DAC,DAD,DAE,DAF,DAG,DA H,DAJ,DAL,DAW,DAX,V14,V15,V16, V18,V19,V20,V21,V22,V24,ZAA,ZAB, ZAC,ZAD,ZAE,ZAF,ZAG,ZAH,ZAJ,ZAL .....	1
11	XAFZZ		78500	3211-H-2868	. SPIDER L.H. UOC: DAC,DAD,DAE,DAF,DAG,DA H,DAJ,DAL,DAW,DAX,V14,V15,V16, V18,V19,V20,V21,V22,V24,ZAA,ZAB, ZAC,ZAD,ZAE,ZAF,ZAG,ZAH,ZAJ,ZAL .....	1
12	KFFZZ	2530-01-271-7084	3D6E9	A-2297-V-5326	. ADJUSTING SCREW ASS PART OF KIT P/N KIT1105B, PART OF KIT P/N KIT1164 UOC: DAC,DAD,DAE,DAF,DAG,DA H,DAJ,DAL,DAW,DAX,V14,V15,V16, V17,V18,V19,V20,V21,V22,V24,ZAA, ZAB,ZAC,ZAD,ZAE,ZAF,ZAG,ZAH,Z AJ,ZAL .....	2

(1) ITEM NO.	(2) SMR CODE	(3) NSN	(4) CAGEC	(5) PART NUMBER	(6) DESCRIPTION AND USABLE ON CODE (UOC)	(7) QTY
13	KFFZZ	5330-01-271-9347	3D6E9	1205-C-2005	. SEAL,PLAIN ENCASED PART OF KIT P/N KIT1105B, PART OF KIT P/N KIT1164 UOC: DAC,DAD,DAE,DAF,DAG,DA H,DAJ,DAL,DAW,DAX,V14,V15,V16, V17,V18,V19,V20,V21,V22,V24,ZAA, ZAB,ZAC,ZAD,ZAE,ZAF,ZAG,ZAH,Z AJ,ZAL .....	2
14	PAFZZ	2530-01-286-3257	19207	5705696	PARTS KIT,BRAKE SHO UOC: DAC,DAD,DAE,DAF,DAG,DA H,DAJ,DAL,DAW,DAX,V14,V15,V16, V17,V18,V19,V20,V21,V22,V24,ZAA, ZAB,ZAC,ZAD,ZAE,ZAF,ZAG,ZAH,Z AJ,ZAL .....	1
15	PAFZZ	5360-00-482-4422	78500	2758W127	SPRING PART OF KIT P/N KIT1105B UOC: DAC,DAD,DAE,DAF,DAG,DA H,DAJ,DAL,DAW,DAX,V14,V15,V16, V18,V19,V20,V21,V22,V24,ZAA,ZAB, ZAC,ZAD,ZAE,ZAF,ZAG,ZAH,ZAJ,ZAL .....	2
16	PAFZZ	2530-01-271-7074	78500	3264-B-1068	SHIELD,BRAKE DISK UOC: DAC,DAD,DAE,DAF,DAG,DA H,DAJ,DAL,DAW,DAX,V14,V15,V16, V18,V19,V20,V21,V22,V24 .....	2
17	PAFZZ	2530-00-117-9144	60528	L-773	. WEDGE ASSEMBLY UOC: DAC,DAD,DAE,DAF,DAG,DA H,DAJ,DAL,DAW,DAX,V14,V15,V16, V18,V19,V20,V21,V22,V24,ZAA,ZAB, ZAC,ZAD,ZAE,ZAF,ZAG,ZAH,ZAJ,ZAL .....	4
18	XDFZZ		78500	1229-S-513-C	. WASHER,LOCK UOC: DAC,DAD,DAE,DAF,DAG,DA H,DAJ,DAL,DAW,DAX,V14,V15,V16, V18,V19,V20,V21,V22,V24,ZAA,ZAB, ZAC,ZAD,ZAE,ZAF,ZAG,ZAH,ZAJ,ZAL .....	8
19	PAFZZ	5305-01-357-1656	3D6E9	S255Z	. SCREW,CAP,HEXAGON H UOC: DAC,DAD,DAE,DAF,DAG,DA H,DAJ,DAL,DAW,DAX,V14,V15,V16, V18,V19,V20,V21,V22,V24,ZAA,ZAB, ZAC,ZAD,ZAE,ZAF,ZAG,ZAH,ZAJ,ZAL .....	8
20	PAFZZ	5340-00-181-1546	78500	1707C3	. CAP-PLUG,PROTECTIVE UOC: DAC,DAD,DAE,DAF,DAG,DA H,DAJ,DAL,DAW,DAX,V14,V15,V16, V18,V19,V20,V21,V22,V24,ZAA,ZAB, ZAC,ZAD,ZAE,ZAF,ZAG,ZAH,ZAJ,ZAL .....	2

END OF FIGURE



**FIELD MAINTENANCE  
REAR AXLE BRAKE AND SPIDER ASSEMBLY**

---

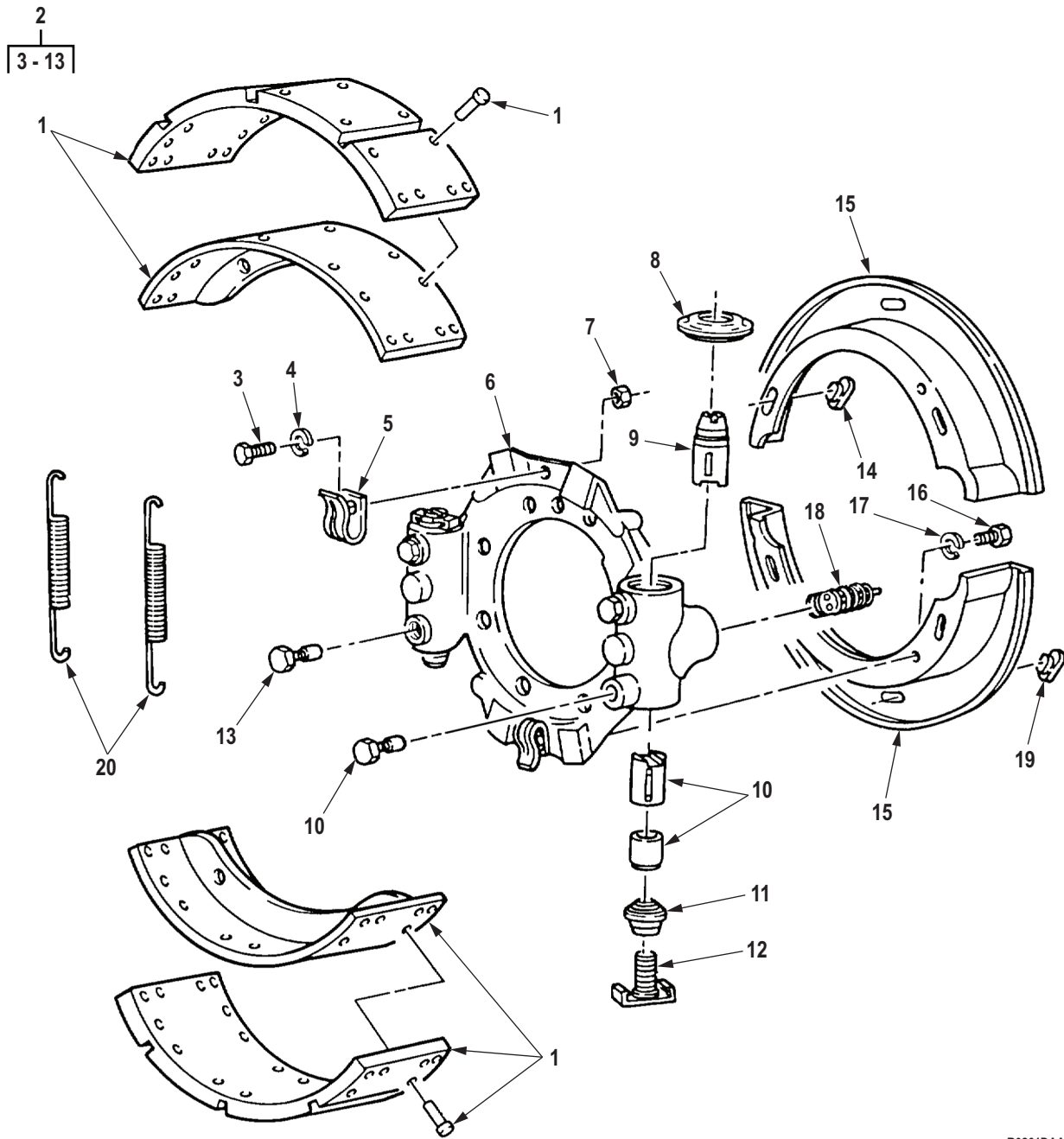

R0261DAA

Figure 246. Rear Axle Brake and Spider Assembly.

(1) ITEM NO.	(2) SMR CODE	(3) NSN	(4) CAGEC	(5) PART NUMBER	(6) DESCRIPTION AND USABLE ON CODE (UOC)	(7) QTY
<b>GROUP 1202 SERVICE BRAKES.</b>						
<b>FIG. 246. REAR AXLE BRAKE AND SPIDER ASSEMBLY.</b>						
1	PAFZZ	2530-01-286-3257	19207	5705696	PARTS KIT,BRAKE SHO QTY-4 PER SET UOC: DAC,DAD,DAE,DAF,DAG,DAH,DAJ,DAL,DAW,DAX,V14,V15,V16,V17,V18,V19,V20,V21,V22,V24,ZAA,ZAB,ZAC,ZAD,ZAE,ZAF,ZAG,ZAH,ZAJ,ZAL .....	2
2	PAFFF	2530-01-125-4280	78500	A-3211-D-2994	SPIDER,BRAKE FWD REAR,R.H. AND REAR REAR, LH. UOC: DAC,DAD,DAE,DAF,DAG,DAH,DAJ,DAL,DAW,DAX,V14,V15,V16,V17,V18,V19,V20,V21,V22,V24,ZAA,ZAB,ZAC,ZAD,ZAE,ZAF,ZAG,ZAH,ZAJ,ZAL .....	2
2	PAFFF	2530-01-124-6530	78500	A-3211-K-2871	SPIDER,BRAKE FWD REAR,L.H. AND REAR REAR, R.H. UOC: DAC,DAD,DAE,DAF,DAG,DAH,DAJ,DAL,DAW,DAX,V14,V15,V16,V17,V18,V19,V20,V21,V22,V24,ZAA,ZAB,ZAC,ZAD,ZAE,ZAF,ZAG,ZAH,ZAJ,ZAL .....	1
3	PAFZZ	5306-01-062-3148	78500	S-146-C	. BOLT,MACHINE UOC: DAC,DAD,DAE,DAF,DAG,DAH,DAJ,DAL,DAW,DAX,V14,V15,V16,V18,V19,V20,V21,V22,V24,ZAA,ZAB,ZAC,ZAD,ZAE,ZAF,ZAG,ZAH,ZAJ,ZAL .....	2
4	PAFZZ	5310-01-063-2299	78500	WA142	. WASHER,LOCK UOC: DAC,DAD,DAE,DAF,DAG,DAH,DAJ,DAL,DAW,DAX,V14,V15,V16,V18,V19,V20,V21,V22,V24,ZAA,ZAB,ZAC,ZAD,ZAE,ZAF,ZAG,ZAH,ZAJ,ZAL .....	2
5	PAFZZ	5340-01-292-5552	78500	2257-M-1001	. CLIP,SPRING TENSION UOC: DAC,DAD,DAE,DAF,DAG,DAH,DAJ,DAL,DAW,DAX,V14,V15,V16,V18,V19,V20,V21,V22,V24,ZAA,ZAB,ZAC,ZAD,ZAE,ZAF,ZAG,ZAH,ZAJ,ZAL .....	2
6	PAFZZ	2590-01-168-7939	78500	A13-3211-K-2871	. BRAKE SPIDER AND CL FWD. REAR L.H. AND REAR REAR R.H. UOC: DAC,DAD,DAE,DAF,DAG,DAH,DAJ,DAL,DAW,DAX,V14,V15,V16,V17,V18,V19,V20,V21,V22,V24,ZAA,ZAB,ZAC,ZAD,ZAE,ZAF,ZAG,ZAH,ZAJ,ZAL .....	1

(1) ITEM NO.	(2) SMR CODE	(3) NSN	(4) CAGEC	(5) PART NUMBER	(6) DESCRIPTION AND USABLE ON CODE (UOC)	(7) QTY
6	PAFFF	2530-01-123-1229	78500	A1-3211-D-2994	. SPIDER,BRAKE FWD. REAR R.H. AND REAR REAR, L.H. UOC: DAC,DAD,DAE,DAF,DAG,DA H,DAJ,DAL,DAW,DAX,V14,V15,V16, V17,V18,V19,V20,V21,V22,V24,ZAA, ZAB,ZAC,ZAD,ZAE,ZAF,ZAG,ZAH,Z AJ,ZAL .....	1
7	PAFZZ	5310-01-237-2615	78500	N14C	. NUT,HEXAGON UOC: DAC,DAD,DAE,DAF,DAG,DA H,DAJ,DAL,DAW,DAX,V14,V15,V16, V17,V18,V19,V20,V21,V22,V24,ZAA, ZAB,ZAC,ZAD,ZAE,ZAF,ZAG,ZAH,Z AJ,ZAL .....	2
8	PAFZZ	5330-01-292-9573	78500	1205-B-2004	. SEAL,PLAIN ENCASED PART OF KIT P/N KIT1105B, PART OF KIT P/N 3202P8362, PART OF KIT P/N KIT 1174RH UOC: DAC,DAD,DAE,DAF,DAG,DA H,DAJ,DAL,DAW,DAX,V14,V15,V16, V17,V18,V19,V20,V21,V22,V24,ZAA, ZAB,ZAC,ZAD,ZAE,ZAF,ZAG,ZAH,Z AJ,ZAL .....	2
9	PAFZZ	5315-01-270-8268	3D6E9	2297-Y-5329	. PIN,GROOVED,HEADLES L.H. PART OF KIT P/N KIT1105B, PART OF KIT P/N 3202P8362 UOC: DAC,DAD,DAE,DAF,DAG,DA H,DAJ,DAL,DAW,DAX,V14,V15,V16, V17,V18,V19,V20,V21,V22,V24,ZAA, ZAB,ZAC,ZAD,ZAE,ZAF,ZAG,ZAH,Z AJ,ZAL .....	2
9	PAFZZ	5315-01-270-8269	3D6E9	2297-Z-5330	. PIN,GROOVED,HEADLES PART OF KIT P/N KIT1105B, PART OF KIT P/N KIT 1174RH UOC: DAC,DAD,DAE,DAF,DAG,DA H,DAJ,DAL,DAW,DAX,V14,V15,V16, V17,V18,V19,V20,V21,V22,V24,ZAA, ZAB,ZAC,ZAD,ZAE,ZAF,ZAG,ZAH,Z AJ,ZAL .....	2
10	PAFZZ	3040-01-280-4156	3D6E9	A-3280-V-8186	. PAWL PART OF KIT P/N KIT1105B, PART OF KIT P/N KIT1164 UOC: DAC,DAD,DAE,DAF,DAG,DA H,DAJ,DAL,DAW,DAX,V14,V15,V16, V17,V18,V19,V20,V21,V22,V24,ZAA, ZAB,ZAC,ZAD,ZAE,ZAF,ZAG,ZAH,Z AJ,ZAL .....	2



(1) ITEM NO.	(2) SMR CODE	(3) NSN	(4) CAGEC	(5) PART NUMBER	(6) DESCRIPTION AND USABLE ON CODE (UOC)	(7) QTY
11	PAFZZ	5330-01-271-9347	3D6E9	1205-C-2005	. SEAL,PLAIN ENCASED PART OF KIT P/N KIT1105B, PART OF KIT P/N KIT1164 UOC: DAC,DAD,DAE,DAF,DAG,DA H,DAJ,DAL,DAW,DAX,V14,V15,V16, V17,V18,V19,V20,V21,V22,V24,ZAA, ZAB,ZAC,ZAD,ZAE,ZAF,ZAG,ZAH,Z AJ,ZAL .....	2
12	KFFZZ	2530-01-271-7084	3D6E9	A-2297-V-5326	. ADJUSTING SCREW ASS PART OF KIT P/N KIT1105B, PART OF KIT P/N KIT1164 UOC: DAC,DAD,DAE,DAF,DAG,DA H,DAJ,DAL,DAW,DAX,V14,V15,V16, V17,V18,V19,V20,V21,V22,V24,ZAA, ZAB,ZAC,ZAD,ZAE,ZAF,ZAG,ZAH,Z AJ,ZAL .....	2
13	KFFZZ	2530-01-351-4061	78500	A1779M195	. GUIDE,PLUNGER PART OF KIT P/N KIT1105B, PART OF KIT P/N 3202P8362, PART OF KIT P/N KIT 1174RH UOC: DAC,DAD,DAE,DAF,DAG,DA H,DAJ,DAL,DAW,DAX,V14,V15,V16, V17,V18,V19,V20,V21,V22,V24,ZAA, ZAB,ZAC,ZAD,ZAE,ZAF,ZAG,ZAH,Z AJ,ZAL .....	2
14	PAFZZ	5340-00-181-1546	78500	1707C3	CAP-PLUG,PROTECTIVE UOC: DAC,DAD,DAE,DAF,DAG,DA H,DAJ,DAL,DAW,DAX,V14,V15,V16, V18,V19,V20,V21,V22,V24,ZAA,ZAB, ZAC,ZAD,ZAE,ZAF,ZAG,ZAH,ZAJ,ZAL .....	8
15	PAFZZ	2530-01-271-7075	78500	3264-A-1067	SHIELD,BRAKE DISK UOC: DAC,DAD,DAE,DAF,DAG,DA H,DAJ,DAL,DAW,DAX,V14,V15,V16, V18,V19,V20,V21,V22,V24 .....	8
16	PAFZZ	5305-01-357-1656	3D6E9	S255Z	SCREW,CAP,HEXAGON H UOC: DAC,DAD,DAE,DAF,DAG,DA H,DAJ,DAL,DAW,DAX,V14,V15,V16, V17,V18,V19,V20,V21,V22,V24,ZAA, ZAB,ZAC,ZAD,ZAE,ZAF,ZAG,ZAH,Z AJ,ZAL .....	12
17	PAFZZ		78500	1229-S-513-C	WASHER,LOCK UOC: DAC,DAD,DAE,DAF,DAG,DA H,DAJ,DAL,DAW,DAX,V14,V15,V16, V18,V19,V20,V21,V22,V24,ZAA,ZAB, ZAC,ZAD,ZAE,ZAF,ZAG,ZAH,ZAJ,ZAL ...	12

(1) ITEM NO.	(2) SMR CODE	(3) NSN	(4) CAGEC	(5) PART NUMBER	(6) DESCRIPTION AND USABLE ON CODE (UOC)	(7) QTY
18	PAFZZ	2530-00-117-9144	60528	L-773	WEDGE ASSEMBLY PART OF KIT P/N KIT1105B UOC: DAC,DAD,DAE,DAF,DAG,DA H,DAJ,DAL,DAW,DAX,V14,V15,V16, V17,V18,V19,V20,V21,V22,V24,ZAA, ZAB,ZAC,ZAD,ZAE,ZAF,ZAG,ZAH,Z AJ,ZAL .....	8
19	PAFZZ	2530-00-406-6785	78500	1707B2	COVER,DUST UOC: DAC,DAD,DAE,DAF,DAG,DA H,DAJ,DAL,DAW,DAX,V14,V15,V16, V18,V19,V20,V21,V22,V24,ZAA,ZAB, ZAC,ZAD,ZAE,ZAF,ZAG,ZAH,ZAJ,ZAL .....	8
20	PAFZZ	5360-01-275-0545	78500	2258S1033	SPRING,HELICAL,EXTE PART OF KIT P/N KIT1105B, PART OF KIT P/N KIT1164 UOC: DAC,DAD,DAE,DAF,DAG,DA H,DAJ,DAL,DAW,DAX,V14,V15,V16, V18,V19,V20,V21,V22,V24,ZAA,ZAB, ZAC,ZAD,ZAE,ZAF,ZAG,ZAH,ZAJ,ZAL .....	2

END OF FIGURE

**FIELD MAINTENANCE  
SERVICE BRAKE MOUNTING PLATE (M939A2)**

---

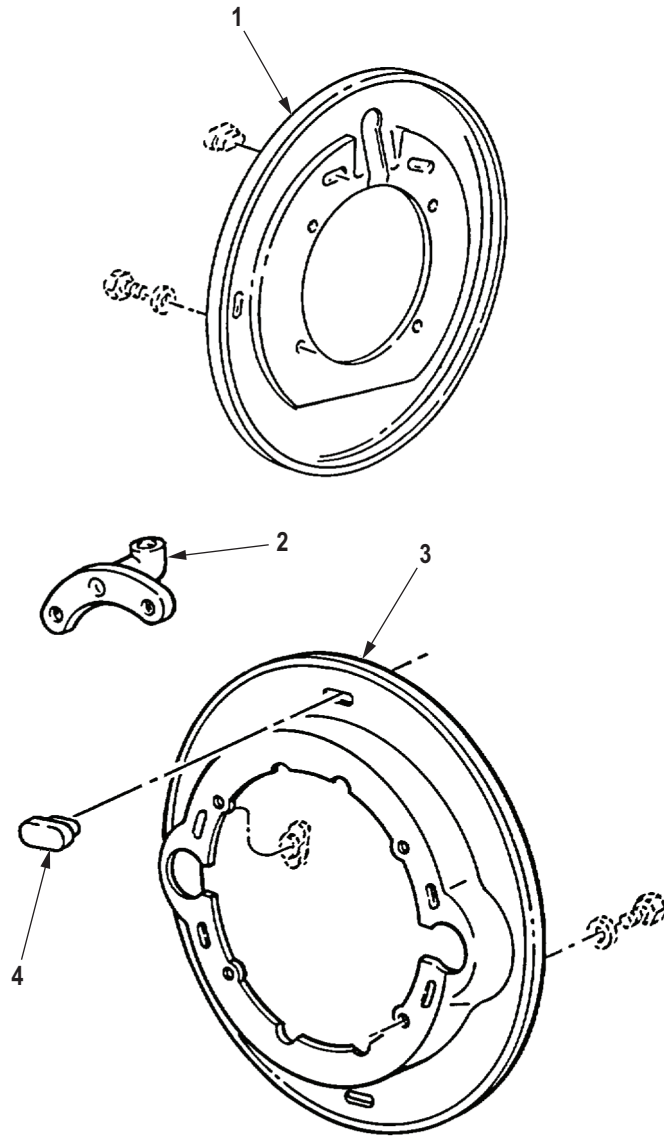

R0262DAA

Figure 247. Service Brake Mounting Plate (M939A2).

(1) ITEM NO.	(2) SMR CODE	(3) NSN	(4) CAGEC	(5) PART NUMBER	(6) DESCRIPTION AND USABLE ON CODE (UOC)	(7) QTY
<b>GROUP 1202 SERVICE BRAKES.</b>						
<b>FIG. 247. SERVICE BRAKE MOUNTING PLATE (M939A2).</b>						
1	PAFZZ	2530-01-271-7074	78500	3264-B-1068	SHIELD,BRAKE DISK UOC: ZAA,ZAB,ZAC,ZAD,ZAE,ZAF, ZAG,ZAH,ZAJ,ZAL .....	2
2	PAFZZ	4730-01-271-7187	0XJ81	BCS091102-A	MANIFOLD,AIR LINE UOC: ZAA,ZAB,ZAC,ZAD,ZAE,ZAF, ZAG,ZAH,ZAJ,ZAL .....	2
3	PAFZZ	2530-01-271-7075	78500	3264-A-1067	SHIELD,BRAKE DISK UOC: ZAA,ZAB,ZAC,ZAD,ZAE,ZAF, ZAG,ZAH,ZAJ,ZAL .....	2
4	PAFZZ	2530-00-406-6785	78500	1707B2	COVER,DUST UOC: DAC,DAD,DAE,DAF,DAG,DA H,DAJ,DAL,DAW,DAX,V14,V15,V16, V18,V19,V20,V21,V22,V24,ZAA,ZAB, ZAC,ZAD,ZAE,ZAF,ZAG,ZAH,ZAJ,ZAL .....	4

**END OF FIGURE**



**FIELD MAINTENANCE  
TREADLE VALVE ASSEMBLY**

---

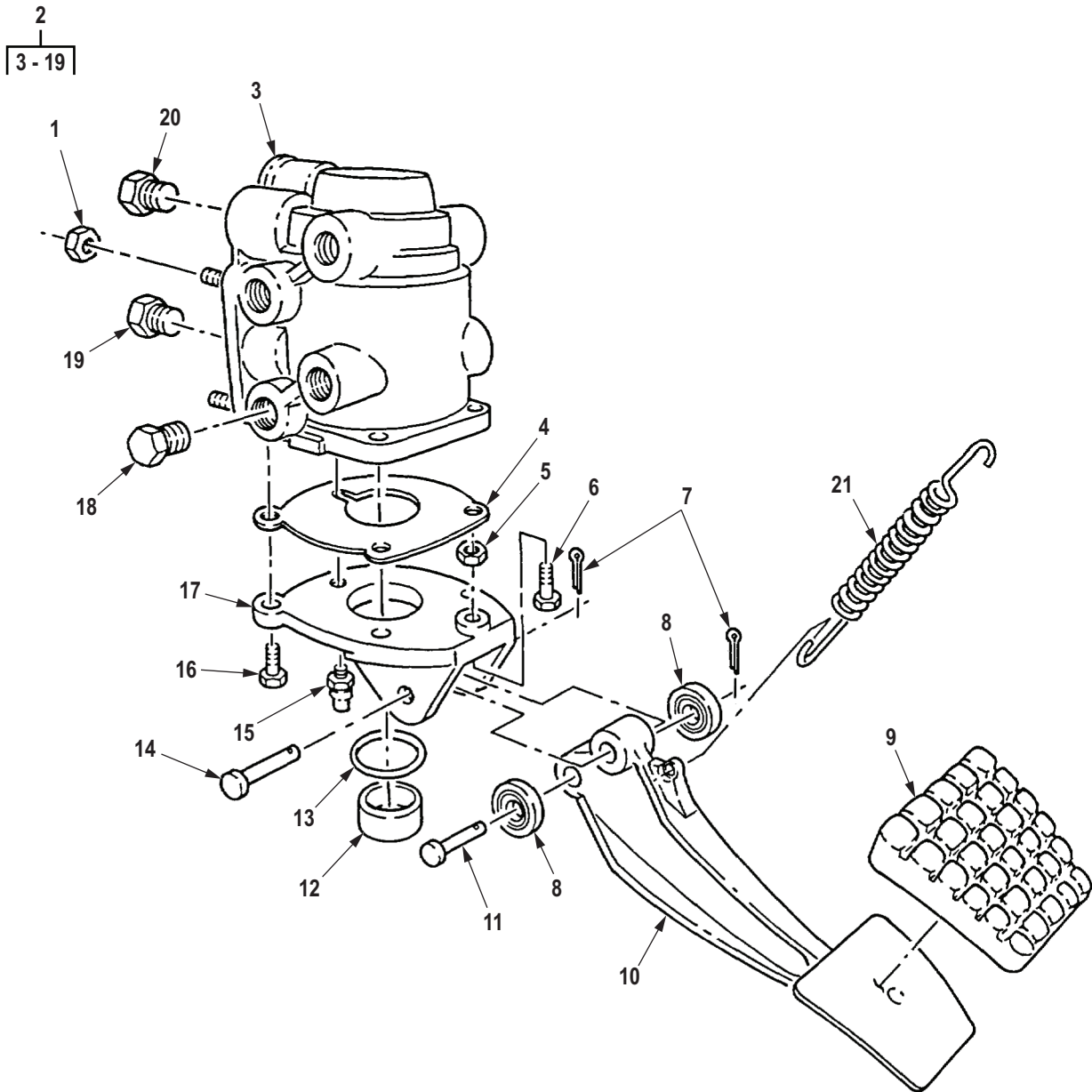

R0264DAA

Figure 248. Treadle Valve Assembly.



(1) ITEM NO.	(2) SMR CODE	(3) NSN	(4) CAGEC	(5) PART NUMBER	(6) DESCRIPTION AND USABLE ON CODE (UOC)	(7) QTY
<b>GROUP 1206 MECHANICAL BRAKE SYSTEM.</b>						
<b>FIG. 248. TREADLE VALVE ASSEMBLY.</b>						
1	PAFZZ	5310-00-959-1488	81349	M45913/2-6FG5C	NUT, SELF-LOCKING, HE UOC: DAC, DAD, DAE, DAF, DAG, DAH, DAJ, DAL, DAW, DAX, V14, V15, V16, V17, V18, V19, V20, V21, V22, V24, ZAA, ZAB, ZAC, ZAD, ZAE, ZAF, ZAG, ZAH, ZAJ, ZAL .....	3
2	PAFHH	2530-01-112-6435	06853	102352	VALVE, BRAKE PNEUMAT UOC: DAC, DAD, DAE, DAF, DAG, DAH, DAJ, DAL, DAW, DAX, V14, V15, V16, V17, V18, V19, V20, V21, V22, V24, ZAA, ZAB, ZAC, ZAD, ZAE, ZAF, ZAG, ZAH, ZAJ, ZAL .....	1
3	PAFZZ	2530-01-127-1677	06853	5009254	. VALVE, BRAKE PNEUMAT UOC: DAC, DAD, DAE, DAF, DAG, DAH, DAJ, DAL, DAW, DAX, V14, V15, V16, V17, V18, V19, V20, V21, V22, V24, ZAA, ZAB, ZAC, ZAD, ZAE, ZAF, ZAG, ZAH, ZAJ, ZAL .....	1
4	PAFZZ	5330-01-123-6409	06853	291882	. GASKET UOC: DAC, DAD, DAE, DAF, DAG, DAH, DAJ, DAL, DAW, DAX, V14, V15, V16, V17, V18, V19, V20, V21, V22, V24, ZAA, ZAB, ZAC, ZAD, ZAE, ZAF, ZAG, ZAH, ZAJ, ZAL .....	1
5	PAFZZ	5310-01-133-7216	06853	230250	. NUT, PLAIN, HEXAGON UOC: DAC, DAD, DAE, DAF, DAG, DAH, DAJ, DAL, DAW, DAX, V14, V15, V16, V17, V18, V19, V20, V21, V22, V24, ZAA, ZAB, ZAC, ZAD, ZAE, ZAF, ZAG, ZAH, ZAJ, ZAL .....	1
6	PAFZZ	5305-01-133-7193	06853	243890N	. THUMBSCREW UOC: DAC, DAD, DAE, DAF, DAG, DAH, DAJ, DAL, DAW, DAX, V14, V15, V16, V17, V18, V19, V20, V21, V22, V24, ZAA, ZAB, ZAC, ZAD, ZAE, ZAF, ZAG, ZAH, ZAJ, ZAL .....	1
7	PAFZZ	5315-01-246-4339	06853	210492N	. PIN, COTTER UOC: DAC, DAD, DAE, DAF, DAG, DAH, DAJ, DAL, DAW, DAX, V14, V15, V16, V17, V18, V19, V20, V21, V22, V24, ZAA, ZAB, ZAC, ZAD, ZAE, ZAF, ZAG, ZAH, ZAJ, ZAL .....	1

(1) ITEM NO.	(2) SMR CODE	(3) NSN	(4) CAGEC	(5) PART NUMBER	(6) DESCRIPTION AND USABLE ON CODE (UOC)	(7) QTY
8	PAFZZ	3120-01-132-5579	06853	245118N	. ROLLER,LINEAR-ROTAR UOC: DAC,DAD,DAE,DAF,DAG,DA H,DAJ,DAL,DAW,DAX,V14,V15,V16, V17,V18,V19,V20,V21,V22,V24,ZAA, ZAB,ZAC,ZAD,ZAE,ZAF,ZAG,ZAH,Z AJ,ZAL .....	2
9	PAFZZ	2540-01-103-9128	06853	244682N	. PAD,PEDAL UOC: DAC,DAD,DAE,DAF,DAG,DA H,DAJ,DAL,DAW,DAX,V14,V15,V16, V17,V18,V19,V20,V21,V22,V24,ZAA, ZAB,ZAC,ZAD,ZAE,ZAF,ZAG,ZAH,Z AJ,ZAL .....	1
10	PFZZ	2540-01-131-9639	06853	292532	. PEDAL,BRAKE VALVE UOC: DAC,DAD,DAE,DAF,DAG,DA H,DAJ,DAL,DAW,DAX,V14,V15,V16, V17,V18,V19,V20,V21,V22,V24,ZAA, ZAB,ZAC,ZAD,ZAE,ZAF,ZAG,ZAH,Z AJ,ZAL .....	1
11	PAFZZ	5315-01-105-9475	06853	200981N	. PIN,STRAIGHT,HEADED UOC: DAC,DAD,DAE,DAF,DAG,DA H,DAJ,DAL,DAW,DAX,V14,V15,V16, V17,V18,V19,V20,V21,V22,V24,ZAA, ZAB,ZAC,ZAD,ZAE,ZAF,ZAG,ZAH,Z AJ,ZAL .....	1
12	PFHZZ	4820-01-104-9313	06853	244680N	. SLEEVE,DIRECTIONAL UOC: DAC,DAD,DAE,DAF,DAG,DA H,DAJ,DAL,DAW,DAX,V14,V15,V16, V17,V18,V19,V20,V21,V22,V24,ZAA, ZAB,ZAC,ZAD,ZAE,ZAF,ZAG,ZAH,Z AJ,ZAL .....	1
13	PFHZZ	5331-00-074-2692	06853	233955	. O-RING UOC: DAC,DAD,DAE,DAF,DAG,DA H,DAJ,DAL,DAW,DAX,V14,V15,V16, V17,V18,V19,V20,V21,V22,V24,ZAA, ZAB,ZAC,ZAD,ZAE,ZAF,ZAG,ZAH,Z AJ,ZAL .....	1
14	PAFZZ	5315-01-112-4507	06853	240445N	. PIN,STRAIGHT,HEADED UOC: DAC,DAD,DAE,DAF,DAG,DA H,DAJ,DAL,DAW,DAX,V14,V15,V16, V17,V18,V19,V20,V21,V22,V24,ZAA, ZAB,ZAC,ZAD,ZAE,ZAF,ZAG,ZAH,Z AJ,ZAL .....	1
15	PAFZZ	4820-00-726-4719	19207	5196397	. VALVE,VENT UOC: DAC,DAD,DAE,DAF,DAG,DA H,DAJ,DAL,DAW,DAX,V14,V15,V16, V17,V18,V19,V20,V21,V22,V24,ZAA, ZAB,ZAC,ZAD,ZAE,ZAF,ZAG,ZAH,Z AJ,ZAL .....	1

(1) ITEM NO.	(2) SMR CODE	(3) NSN	(4) CAGEC	(5) PART NUMBER	(6) DESCRIPTION AND USABLE ON CODE (UOC)	(7) QTY
16	PAFZZ	5306-01-124-1225	06853	113052	. BOLT,ASSEMBLED WASH UOC: DAC,DAD,DAE,DAF,DAG,DA H,DAJ,DAL,DAW,DAX,V14,V15,V16, V17,V18,V19,V20,V21,V22,V24,ZAA, ZAB,ZAC,ZAD,ZAE,ZAF,ZAG,ZAH,Z AJ,ZAL .....	3
17	PAFZZ	2530-01-123-3105	06853	291883	. PLATE,MOUNTING,BRAK UOC: DAC,DAD,DAE,DAF,DAG,DA H,DAJ,DAL,DAW,DAX,V14,V15,V16, V17,V18,V19,V20,V21,V22,V24,ZAA, ZAB,ZAC,ZAD,ZAE,ZAF,ZAG,ZAH,Z AJ,ZAL .....	1
18	PAFZZ	4730-01-030-4950	58536	AA59616ACABDA	. PLUG,PIPE UOC: DAC,DAD,DAE,DAF,DAG,DA H,DAJ,DAL,DAW,DAX,V14,V15,V16, V17,V18,V19,V20,V21,V22,V24,ZAA, ZAB,ZAC,ZAD,ZAE,ZAF,ZAG,ZAH,Z AJ,ZAL .....	2
19	PAFZZ	4730-00-012-7951	01276	2082-4B	. PLUG,PIPE UOC: DAC,DAD,DAE,DAF,DAG,DA H,DAJ,DAL,DAW,DAX,V14,V15,V16, V17,V18,V19,V20,V21,V22,V24,ZAA, ZAB,ZAC,ZAD,ZAE,ZAF,ZAG,ZAH,Z AJ,ZAL .....	6
20	PAFZZ	4730-01-030-4950	58536	AA59616ACABDA	. PLUG,PIPE UOC: DAC,DAD,DAE,DAF,DAG,DA H,DAJ,DAL,DAW,DAX,V14,V15,V16, V17,V18,V19,V20,V21,V22,V24,ZAA, ZAB,ZAC,ZAD,ZAE,ZAF,ZAG,ZAH,Z AJ,ZAL .....	2
21	PAFZZ	5360-01-112-6546	19207	12255975	SPRING,HELICAL,EXTE UOC: DAC,DAD,DAE,DAF,DAG,DA H,DAJ,DAL,DAW,DAX,V14,V15,V16, V17,V18,V19,V20,V21,V22,V24,ZAA, ZAB,ZAC,ZAD,ZAE,ZAF,ZAG,ZAH,Z AJ,ZAL .....	1

END OF FIGURE



**FIELD MAINTENANCE  
AIR CHAMBERS, FRONT AND REAR BRAKES**

---

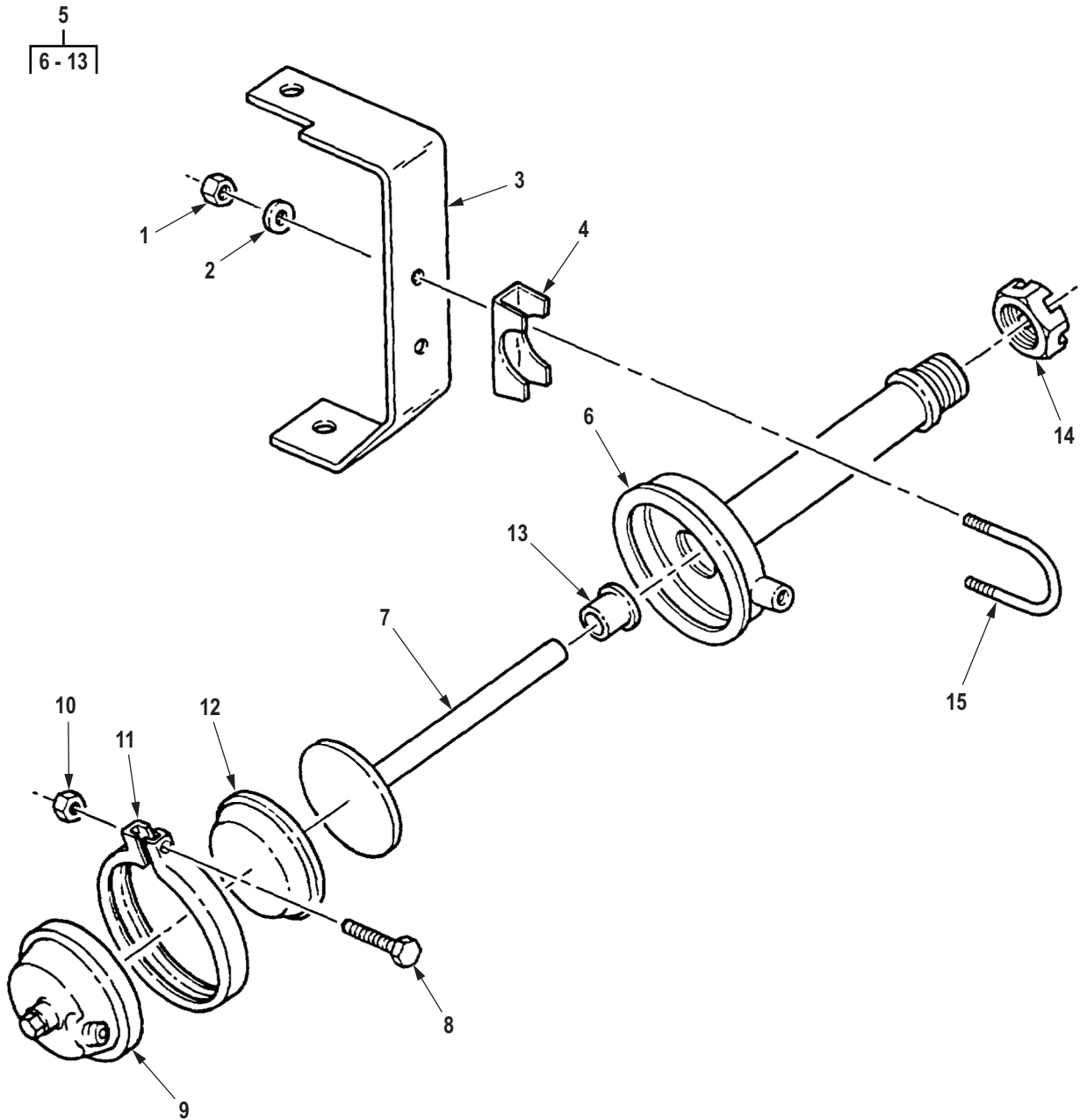

R0265DAA

Figure 249. Air Chambers, Front and Rear Brakes.

(1) ITEM NO.	(2) SMR CODE	(3) NSN	(4) CAGEC	(5) PART NUMBER	(6) DESCRIPTION AND USABLE ON CODE (UOC)	(7) QTY
<b>GROUP 1208 AIR BRAKE SYSTEM.</b>						
<b>FIG. 249. AIR CHAMBERS, FRONT AND REAR BRAKES.</b>						
1	PAFZZ	5310-01-126-0566	78500	NL25Z1	NUT UOC: DAC,DAD,DAE,DAF,DAG,DAH,DAJ,DAL,DAW,DAX,V14,V15,V16,V17,V18,V19,V20,V21,V22,V24,ZAA,ZAB,ZAC,ZAD,ZAE,ZAF,ZAG,ZAH,ZAJ,ZAL .....	8
2	PAFZZ	5310-01-200-9879	78500	1229-E-1669	WASHER,FLAT UOC: DAC,DAD,DAE,DAF,DAG,DAH,DAJ,DAL,DAW,DAX,V14,V15,V16,V17,V18,V19,V20,V21,V22,V24,ZAA,ZAB,ZAC,ZAD,ZAE,ZAF,ZAG,ZAH,ZAJ,ZAL .....	8
3	XDFZZ	5340-01-290-8882	14153	03205-1	BRACKET,MOUNTING UOC: DAC,DAD,DAE,DAF,DAG,DAH,DAJ,DAL,DAW,DAX,V14,V15,V16,V17,V18,V19,V20,V21,V22,V24,ZAA,ZAB,ZAC,ZAD,ZAE,ZAF,ZAG,ZAH,ZAJ,ZAL .....	4
4	PAFZZ	5340-01-289-5030	19207	5932849	BRACKET,DOUBLE ANGL UOC: DAC,DAD,DAE,DAF,DAG,DAH,DAJ,DAL,DAW,DAX,V14,V15,V16,V17,V18,V19,V20,V21,V22,V24,ZAA,ZAB,ZAC,ZAD,ZAE,ZAF,ZAG,ZAH,ZAJ,ZAL .....	4
5	PAFZZ	2530-01-126-7869	1JX42	TA-0009CA	BRAKE CHAMBER ASSY FRONT UOC: DAC,DAD,DAE,DAF,DAG,DAH,DAJ,DAL,DAW,DAX,V14,V15,V16,V17,V18,V19,V20,V21,V22,V24,ZAA,ZAB,ZAC,ZAD,ZAE,ZAF,ZAG,ZAH,ZAJ,ZAL .....	2
5	PAFZZ	2530-01-091-7814	19207	12450340-1	CHAMBER,AIR BRAKE REAR UOC: DAC,DAD,DAE,DAF,DAG,DAH,DAJ,DAL,DAW,DAX,V14,V15,V16,V17,V18,V19,V20,V21,V22,V24,ZAA,ZAB,ZAC,ZAD,ZAE,ZAF,ZAG,ZAH,ZAJ,ZAL .....	4
5	PAFZZ	2530-01-425-9520	78500	E23-3276L-12	CHAMBER,AIR BRAKE REAR UOC: V39 .....	4
6	XAFZZ		78500	A5-3280-F-5232	. HSG ASSY,NON-PRESS FRONT AIR BRAKE CHAMBER UOC: DAC,DAD,DAE,DAF,DAG,DAH,DAJ,DAL,DAW,DAX,V14,V15,V16,V17,V18,V19,V20,V21,V22,V24,ZAA,ZAB,ZAC,ZAD,ZAE,ZAF,ZAG,ZAH,ZAJ,ZAL .....	1

(1) ITEM NO.	(2) SMR CODE	(3) NSN	(4) CAGEC	(5) PART NUMBER	(6) DESCRIPTION AND USABLE ON CODE (UOC)	(7) QTY
6	XAFZZ		78500	A9-3280-F-5232	. HSG,ASSY,NON-PRESS FRONT/REAR BRAKE CHAMBER UOC: V39 .....	1
6	XAFZZ		78500	A4-3280-F-5232	. HOUSING,NON-PRESS REAR AIR BRAKE CHAMBER UOC: DAC,DAD,DAE,DAF,DAG,DA H,DAJ,DAL,DAW,DAX,V14,V15,V16, V17,V18,V19,V20,V21,V22,V24,ZAA, ZAB,ZAC,ZAD,ZAE,ZAF,ZAG,ZAH,Z AJ,ZAL .....	1
7	PAFZZ	2530-01-064-2630	78500	A45-1779V230	. ROD,CHAMBER,AIR BRA FRONT REAR,REAR REAR AXLE UOC: DAC,DAD,DAE,DAF,DAG,DA H,DAJ,DAL,DAW,DAX,V14,V15,V16, V17,V18,V19,V20,V21,V22,V24,ZAA, ZAB,ZAC,ZAD,ZAE,ZAF,ZAG,ZAH,Z AJ,ZAL .....	1
7	PAFZZ	2530-01-134-1336	3D6E9	A71-1779-V-230	. PUSH ROD,CHAMBER BR FRONT AXLE UOC: DAC,DAD,DAE,DAF,DAG,DA H,DAJ,DAL,DAW,DAX,V14,V15,V16, V17,V18,V19,V20,V21,V22,V24,ZAA, ZAB,ZAC,ZAD,ZAE,ZAF,ZAG,ZAH,Z AJ,ZAL .....	1
7	PAFZZ	2530-01-417-1645	3D6E9	A59 1779V 230	. PUSH ROD,CHAMBER BR FRONT REAR,REAR REAR AXLE UOC: V39 .....	1
8	PAFZZ	5306-00-498-7209	78500	15X725	. BOLT,SPECIAL RIM CLENCHING CLAMP UOC: DAC,DAD,DAE,DAF,DAG,DA H,DAJ,DAL,DAW,DAX,V14,V15,V16, V17,V18,V19,V20,V21,V22,V24,ZAA, ZAB,ZAC,ZAD,ZAE,ZAF,ZAG,ZAH,Z AJ,ZAL .....	1
9	XAFZZ	2530-01-289-8359	3D6E9	A2-3780-J-62	. HOUSING,AIR BRAKE C AIR BRAKE CHAMBER UOC: DAC,DAD,DAE,DAF,DAG,DA H,DAJ,DAL,DAW,DAX,V14,V15,V16, V17,V18,V19,V20,V21,V22,V24,ZAA, ZAB,ZAC,ZAD,ZAE,ZAF,ZAG,ZAH,Z AJ,ZAL .....	1
10	PAFZZ	5310-00-177-1258	3D6E9	N35P	. NUT,PLAIN,HEXAGON PRESSURE HOUSING CLAMP UOC: DAC,DAD,DAE,DAF,DAG,DA H,DAJ,DAL,DAW,DAX,V14,V15,V16, V17,V18,V19,V20,V21,V22,V24,ZAA, ZAB,ZAC,ZAD,ZAE,ZAF,ZAG,ZAH,Z AJ,ZAL .....	1



(1) ITEM NO.	(2) SMR CODE	(3) NSN	(4) CAGEC	(5) PART NUMBER	(6) DESCRIPTION AND USABLE ON CODE (UOC)	(7) QTY
11	PAFZZ	5340-00-015-7560	3D6E9	A2257M1079	. CLAMP,SYNCHRO PRESSURE HOUSING UOC: DAC,DAD,DAE,DAF,DAG,DAH,DAJ,DAL,DAW,DAX,V14,V15,V16,V17,V18,V19,V20,V21,V22,V24,ZAA,ZAB,ZAC,ZAD,ZAE,ZAF,ZAG,ZAH,ZAJ,ZAL .....	1
12	PAFZZ	2530-00-430-2392	79146	031023	. DIAPHRAGM,CHAMBER,B UOC: DAC,DAD,DAE,DAF,DAG,DAH,DAJ,DAL,DAW,DAX,V14,V15,V16,V17,V18,V19,V20,V21,V22,V24,ZAA,ZAB,ZAC,ZAD,ZAE,ZAF,ZAG,ZAH,ZAJ,ZAL .....	1
13	PAFZZ	2530-00-087-0163	78500	1779-Q-433	. GUIDE,BRAKE ASSEMBL HOUSING ASSEMBLY UOC: DAC,DAD,DAE,DAF,DAG,DAH,DAJ,DAL,DAW,DAX,V14,V15,V16,V17,V18,V19,V20,V21,V22,V24,ZAA,ZAB,ZAC,ZAD,ZAE,ZAF,ZAG,ZAH,ZAJ,ZAL .....	1
14	PAFZZ	5310-01-391-5248	78500	1727N40	NUT,PLAIN,ROUND HOUSING ASSEMBLY UOC: DAC,DAD,DAE,DAF,DAG,DAH,DAJ,DAL,DAW,DAX,V14,V15,V16,V17,V18,V19,V20,V21,V22,V24,ZAA,ZAB,ZAC,ZAD,ZAE,ZAF,ZAG,ZAH,ZAJ,ZAL .....	1
15	PAFZZ	5306-01-196-6632	3D6E9	2297-Y-4341	BOLT,U UOC: DAC,DAD,DAE,DAF,DAG,DAH,DAJ,DAL,DAW,DAX,V14,V15,V16,V17,V18,V19,V20,V21,V22,V24,ZAA,ZAB,ZAC,ZAD,ZAE,ZAF,ZAG,ZAH,ZAJ,ZAL .....	8

END OF FIGURE



**FIELD MAINTENANCE  
REAR AXLE FAIL-SAFE BRAKE CHAMBER ASSEMBLY**

---

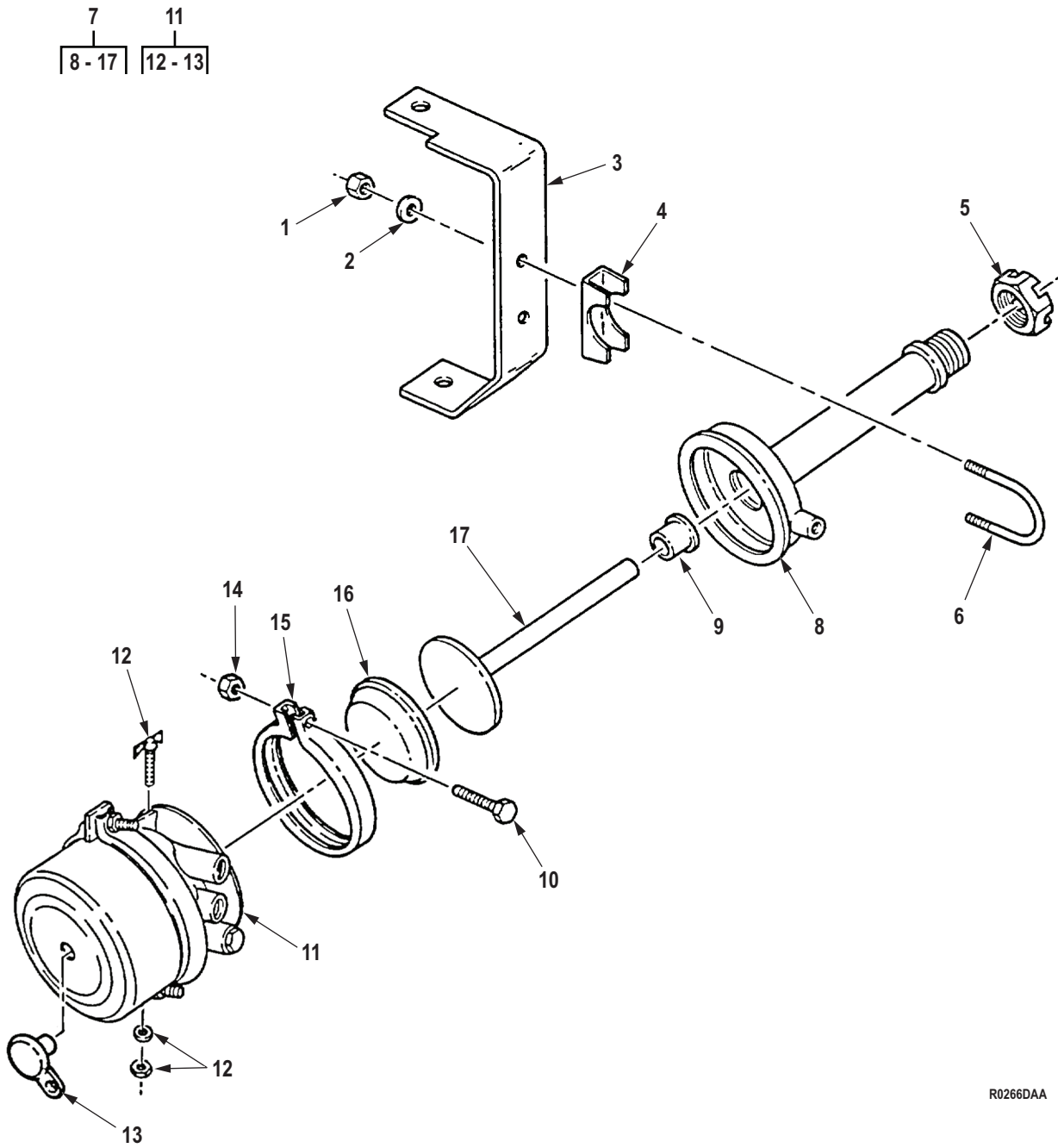

R0266DAA

Figure 250. Rear Axle Fail-Safe Brake Chamber Assembly.

(1) ITEM NO.	(2) SMR CODE	(3) NSN	(4) CAGEC	(5) PART NUMBER	(6) DESCRIPTION AND USABLE ON CODE (UOC)	(7) QTY
<b>GROUP 1208 AIR BRAKE SYSTEM.</b>						
<b>FIG. 250. REAR AXLE FAIL-SAFE BRAKE CHAMBER ASSEMBLY.</b>						
1	PAFZZ	5310-01-126-0566	78500	NL25Z1	NUT UOC: DAC,DAD,DAE,DAF,DAG,DA H,DAJ,DAL,DAW,DAX,V14,V15,V16, V17,V18,V19,V20,V21,V22,V24 .....	8
2	PAFZZ	5310-01-200-9879	78500	1229-E-1669	WASHER,FLAT UOC: DAC,DAD,DAE,DAF,DAG,DA H,DAJ,DAL,DAW,DAX,V14,V15,V16, V17,V18,V19,V20,V21,V22,V24,ZAA, ZAB,ZAC,ZAD,ZAE,ZAF,ZAG,ZAH,Z AJ,ZAL .....	8
3	PAFZZ	5340-01-290-8882	14153	03205-1	BRACKET,MOUNTING UOC: DAC,DAD,DAE,DAF,DAG,DA H,DAJ,DAL,DAW,DAX,V14,V15,V16, V17,V18,V19,V20,V21,V22,V24,ZAA, ZAB,ZAC,ZAD,ZAE,ZAF,ZAG,ZAH,Z AJ,ZAL .....	4
4	PAFZZ	5340-01-289-5030	19207	5932849	BRACKET,DOUBLE ANGL UOC: DAC,DAD,DAE,DAF,DAG,DA H,DAJ,DAL,DAW,DAX,V14,V15,V16, V17,V18,V19,V20,V21,V22,V24,ZAA, ZAB,ZAC,ZAD,ZAE,ZAF,ZAG,ZAH,Z AJ,ZAL .....	4
5	PAFZZ	5310-01-391-5248	78500	1727N40	NUT,PLAIN,ROUND UOC: DAC,DAD,DAE,DAF,DAG,DA H,DAJ,DAL,DAW,DAX,V14,V15,V16, V17,V18,V19,V20,V21,V22,V24,ZAA, ZAB,ZAC,ZAD,ZAE,ZAF,ZAG,ZAH,Z AJ,ZAL .....	1
6	PAFZZ	5306-01-196-6632	3D6E9	2297-Y-4341	BOLT,U UOC: DAC,DAD,DAE,DAF,DAG,DA H,DAJ,DAL,DAW,DAX,V14,V15,V16, V17,V18,V19,V20,V21,V22,V24,ZAA, ZAB,ZAC,ZAD,ZAE,ZAF,ZAG,ZAH,Z AJ,ZAL .....	4
7	PAFFF	2530-01-125-6076	78500	Y86 3276L12	BRAKE CHAMBER,FAIL REAR UOC: DAC,DAD,DAE,DAF,DAG,DA H,DAJ,DAL,DAW,DAX,V14,V15,V16, V17,V18,V19,V20,V21,V22,V24,ZAA, ZAB,ZAC,ZAD,ZAE,ZAF,ZAG,ZAH,Z AJ,ZAL .....	4

(1) ITEM NO.	(2) SMR CODE	(3) NSN	(4) CAGEC	(5) PART NUMBER	(6) DESCRIPTION AND USABLE ON CODE (UOC)	(7) QTY
8	XAFZZ		78500	A4-3280-F-5232	. HOUSING, NON-PRESS BRAKE CHAMBER UOC: DAC, DAD, DAE, DAF, DAG, DA H, DAJ, DAL, DAW, DAX, V14, V15, V16, V17, V18, V19, V20, V21, V22, V24, ZAA, ZAB, ZAC, ZAD, ZAE, ZAF, ZAG, ZAH, Z AJ, ZAL .....	1
9	PAFZZ	2530-00-087-0163	78500	1779-Q-433	. GUIDE, BRAKE ASSEMBL PUSH ROD UOC: DAC, DAD, DAE, DAF, DAG, DA H, DAJ, DAL, DAW, DAX, V14, V15, V16, V17, V18, V19, V20, V21, V22, V24, ZAA, ZAB, ZAC, ZAD, ZAE, ZAF, ZAG, ZAH, Z AJ, ZAL .....	1
10	PAFZZ	5306-00-498-7209	78500	15X725	. BOLT, SPECIAL RIM CLENCHING CLAMP UOC: DAC, DAD, DAE, DAF, DAG, DA H, DAJ, DAL, DAW, DAX, V14, V15, V16, V17, V18, V19, V20, V21, V22, V24, ZAA, ZAB, ZAC, ZAD, ZAE, ZAF, ZAG, ZAH, Z AJ, ZAL .....	1
11	PAFZZ	2530-01-134-3417	78500	A-3280-E-6817	. HOUSING ASSEMBL, BRA BRAKE CHAMBER UOC: DAC, DAD, DAE, DAF, DAG, DA H, DAJ, DAL, DAW, DAX, V14, V15, V16, V17, V18, V19, V20, V21, V22, V24, ZAA, ZAB, ZAC, ZAD, ZAE, ZAF, ZAG, ZAH, Z AJ, ZAL .....	1
12	PAFZZ	2530-01-095-3561	06721	9999036	. . STUD ASSEMBLY, RELEA HOUSING UOC: DAC, DAD, DAE, DAF, DAG, DA H, DAJ, DAL, DAW, DAX, V14, V15, V16, V17, V18, V19, V20, V21, V22, V24, ZAA, ZAB, ZAC, ZAD, ZAE, ZAF, ZAG, ZAH, Z AJ, ZAL .....	1
13	PAFZZ	2530-01-084-6975	98171	9999039	. . PLUG, CHAMBER TOP FAIL SAFE HOUSING UOC: DAC, DAD, DAE, DAF, DAG, DA H, DAJ, DAL, DAW, DAX, V14, V15, V16, V17, V18, V19, V20, V21, V22, V24, ZAH, ZAJ, ZAL .....	1
14	PAFZZ	5310-00-177-1258	3D6E9	N35P	. NUT, PLAIN, HEXAGON RIM CLENCHING CLAMP UOC: DAC, DAD, DAE, DAF, DAG, DA H, DAJ, DAL, DAW, DAX, V14, V15, V16, V17, V18, V19, V20, V21, V22, V24, ZAA, ZAB, ZAC, ZAD, ZAE, ZAF, ZAG, ZAH, Z AJ, ZAL .....	1

(1) ITEM NO.	(2) SMR CODE	(3) NSN	(4) CAGEC	(5) PART NUMBER	(6) DESCRIPTION AND USABLE ON CODE (UOC)	(7) QTY
15	PAFZZ	5340-00-015-7560	3D6E9	A2257M1079	. CLAMP,SYNCHRO PRESSURE HOUSING UOC: DAC,DAD,DAE,DAF,DAG,DA H,DAJ,DAL,DAW,DAX,V14,V15,V16, V17,V18,V19,V20,V21,V22,V24,ZAA, ZAB,ZAC,ZAD,ZAE,ZAF,ZAG,ZAH,Z AJ,ZAL .....	1
16	PAFZZ	2530-00-430-2392	79146	031023	. DIAPHRAGM,CHAMBER,B AIR BRAKE PUSH ROD UOC: DAC,DAD,DAE,DAF,DAG,DA H,DAJ,DAL,DAW,DAX,V14,V15,V16, V17,V18,V19,V20,V21,V22,V24,ZAA, ZAB,ZAC,ZAD,ZAE,ZAF,ZAG,ZAH,Z AJ,ZAL .....	1
17	PAFZZ	2530-01-064-2630	78500	A45-1779V230	. ROD,CHAMBER,AIR BRA HOUSING UOC: DAC,DAD,DAE,DAF,DAG,DA H,DAJ,DAL,DAW,DAX,V14,V15,V16, V17,V18,V19,V20,V21,V22,V24,ZAA, ZAB,ZAC,ZAD,ZAE,ZAF,ZAG,ZAH,Z AJ,ZAL .....	1

END OF FIGURE





**FIELD MAINTENANCE  
FRONT SERVICE HALF COUPLING, AIR BRAKE VALVE, AND RELATED PARTS**

---

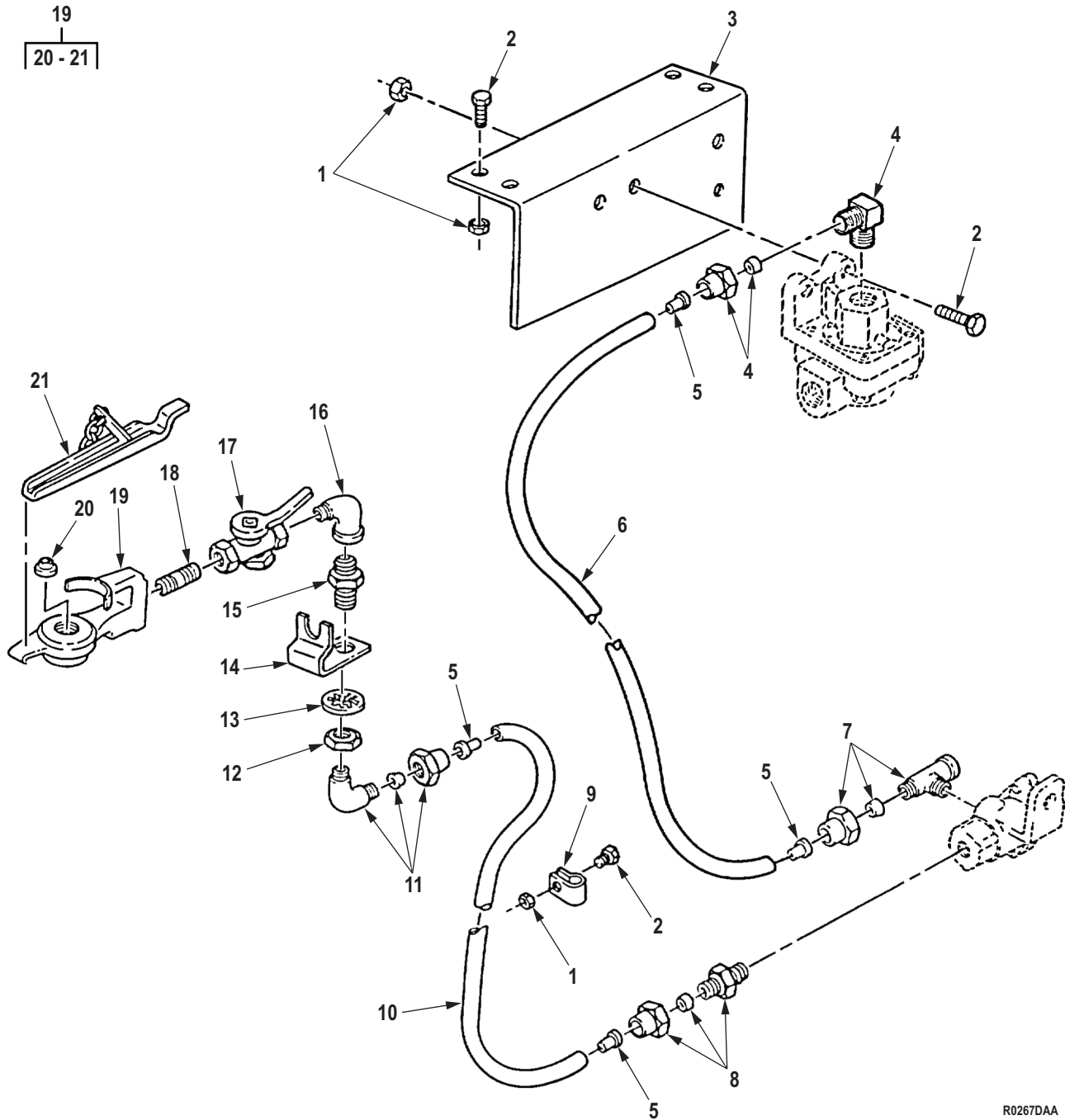

R0267DAA

Figure 251. Front Service Half Coupling, Air Brake Valve, and Related Parts.

(1) ITEM NO.	(2) SMR CODE	(3) NSN	(4) CAGEC	(5) PART NUMBER	(6) DESCRIPTION AND USABLE ON CODE (UOC)	(7) QTY
<b>GROUP 1208 AIR BRAKE SYSTEM.</b>						
<b>FIG. 251. FRONT SERVICE HALF COUPLING, AIR BRAKE VALVE, AND RELATED PARTS.</b>						
1	PPFZZ	5310-00-241-6658	81349	M45913/3-5FG8C	NUT, SELF-LOCKING, HE UOC: DAC, DAD, DAE, DAF, DAG, DA H, DAJ, DAL, DAW, DAX, V14, V15, V16, V17, V18, V19, V20, V21, V22, V24, ZAA, ZAB, ZAC, ZAD, ZAE, ZAF, ZAG, ZAH, Z AJ, ZAL .....	7
2	PAFZZ	5306-00-225-9088	80205	MS90726-33	BOLT, MACHINE UOC: DAC, DAD, DAE, DAF, DAG, DA H, DAJ, DAL, DAW, DAX, V14, V15, V16, V17, V18, V19, V20, V21, V22, V24, ZAA, ZAB, ZAC, ZAD, ZAE, ZAF, ZAG, ZAH, Z AJ, ZAL .....	7
3	PPFZZ	5340-01-107-9691	19207	12255970	BRACKET, ANGLE UOC: DAC, DAD, DAE, DAF, DAG, DA H, DAJ, DAL, DAW, DAX, V14, V15, V16, V17, V18, V19, V20, V21, V22, V24, ZAA, ZAB, ZAC, ZAD, ZAE, ZAF, ZAG, ZAH, Z AJ, ZAL .....	1
4	PAFZZ	4730-00-289-0051	81343	8-6 120202BA	ELBOW, PIPE TO TUBE UOC: DAC, DAD, DAE, DAF, DAG, DA H, DAJ, DAL, DAW, DAX, V14, V15, V16, V17, V18, V19, V20, V21, V22, V24, ZAA, ZAB, ZAC, ZAD, ZAE, ZAF, ZAG, ZAH, Z AJ, ZAL .....	1
5	PAFZZ	4730-01-032-6038	19207	CPR102321-4	INSERT, TUBE FITTING UOC: DAC, DAD, DAE, DAF, DAG, DA H, DAJ, DAL, DAW, DAX, V14, V15, V16, V17, V18, V19, V20, V21, V22, V24, ZAA, ZAB, ZAC, ZAD, ZAE, ZAF, ZAG, ZAH, Z AJ, ZAL .....	4
6	MFFZZ		19207	CPR104420-3-23	HOSE, NONMETALLIC MAKE FROM HOSE, P/N CPR104420-3, 23 IN. LONG UOC: DAC, DAD, DAE, DAF, DAG, DA H, DAJ, DAL, DAW, DAX, V14, V15, V16, V17, ZAE, ZAF, ZAG, ZAH, ZAJ, ZAL .....	1
6	MFFZZ		19207	CPR104420-3-25	HOSE, NONMETALLIC MAKE FROM HOSE, P/N CPR104420-3, 25 IN. LONG UOC: DAW, DAX, V14, V15, V16, V17, V 18, V19, V20, V21, V22, V24, ZAA, ZAB .....	1

(1) ITEM NO.	(2) SMR CODE	(3) NSN	(4) CAGEC	(5) PART NUMBER	(6) DESCRIPTION AND USABLE ON CODE (UOC)	(7) QTY
7	PAFZZ	4730-00-278-8902	96906	MS39189-2	TEE,PIPE TO TUBE UOC: DAC,DAD,DAE,DAF,DAG,DA H,DAJ,DAL,DAW,DAX,V14,V15,V16, V17,V18,V19,V20,V21,V22,V24,ZAA, ZAB,ZAC,ZAD,ZAE,ZAF,ZAG,ZAH,Z AJ,ZAL .....	1
8	PAFZZ	4730-00-142-3076	81343	8-6 120102BA	ADAPTER,STRAIGHT,PI UOC: DAC,DAD,DAE,DAF,DAG,DA H,DAJ,DAL,DAW,DAX,V14,V15,V16, V17,V18,V19,V20,V21,V22,V24,ZAA, ZAB,ZAC,ZAD,ZAE,ZAF,ZAG,ZAH,Z AJ,ZAL .....	1
9	PAFZZ	5340-00-725-5267	80205	MS21333-115	CLAMP,LOOP UOC: DAC,DAD,DAE,DAF,DAG,DA H,DAJ,DAL,DAW,DAX,V14,V15,V16, V17,V18,V19,V20,V21,V22,V24,ZAA, ZAB,ZAC,ZAD,ZAE,ZAF,ZAG,ZAH,Z AJ,ZAL .....	2
10	MFFZZ		19207	CPR104420-3-45	HOSE,NONMETALLIC MAKE FROM HOSE P/N CPR104420-3,45 IN.LONG UOC: DAC,DAD,DAE,DAF,DAG,DA H,DAJ,DAL,V16,V17,V18,V19,V20,V 21,V22,V24 .....	1
10	MFFZZ		19207	CPR104420-3-46	HOSE MAKE FROM HOSE P/N CPR104420-3,46 IN.LONG UOC: DAW,DAX,V14,V15,ZAA,ZAB .....	1
11	PAFZZ	4730-00-409-7854	81343	J246 8-4 120202BA	ELBOW,PIPE TO TUBE UOC: DAC,DAD,DAE,DAF,DAG,DA H,DAJ,DAL,DAW,DAX,V14,V15,V16, V17,V18,V19,V20,V21,V22,V24,ZAA, ZAB,ZAC,ZAD,ZAE,ZAF,ZAG,ZAH,Z AJ,ZAL .....	1
12	PAFZZ	5310-00-891-3428	96906	MS35691-77	NUT,PLAIN,HEXAGON UOC: DAC,DAD,DAE,DAF,DAG,DA H,DAJ,DAL,DAW,DAX,V14,V15,V16, V17,V18,V19,V20,V21,V22,V24,ZAA, ZAB,ZAC,ZAD,ZAE,ZAF,ZAG,ZAH,Z AJ,ZAL .....	1
13	PAFZZ	5310-00-582-6714	80205	MS35333-49	WASHER,LOCK UOC: DAC,DAD,DAE,DAF,DAG,DA H,DAJ,DAL,DAW,DAX,V14,V15,V16, V17,V18,V19,V20,V21,V22,V24,ZAA, ZAB,ZAC,ZAD,ZAE,ZAF,ZAG,ZAH,Z AJ,ZAL .....	1

(1) ITEM NO.	(2) SMR CODE	(3) NSN	(4) CAGEC	(5) PART NUMBER	(6) DESCRIPTION AND USABLE ON CODE (UOC)	(7) QTY
14	PAFZZ	5340-01-107-9929	19207	12256265	BRACKET,ANGLE UOC: DAC,DAD,DAE,DAF,DAG,DA H,DAJ,DAL,DAW,DAX,V14,V15,V16, V17,V18,V19,V20,V21,V22,V24,ZAA, ZAB,ZAC,ZAD,ZAE,ZAF,ZAG,ZAH,Z AJ,ZAL .....	1
15	PAFZZ	4730-00-419-9424	19207	8376311	REDUCER,PIPE UOC: DAC,DAD,DAE,DAF,DAG,DA H,DAJ,DAL,DAW,DAX,V14,V15,V16, V17,V18,V19,V20,V21,V22,V24,ZAA, ZAB,ZAC,ZAD,ZAE,ZAF,ZAG,ZAH,Z AJ,ZAL .....	1
16	PAFZZ	4730-00-277-5555	96906	MS51952-4	ELBOW,PIPE UOC: DAC,DAD,DAE,DAF,DAG,DA H,DAJ,DAL,DAW,DAX,V14,V15,V16, V17,V18,V19,V20,V21,V22,V24,ZAA, ZAB,ZAC,ZAD,ZAE,ZAF,ZAG,ZAH,Z AJ,ZAL .....	1
17	PAFZZ	4820-00-420-5499	06853	285172N	VALVE,BALL UOC: DAC,DAD,DAE,DAF,DAG,DA H,DAJ,DAL,DAW,DAX,V14,V15,V16, V17,V18,V19,V20,V21,V22,V24,ZAA, ZAB,ZAC,ZAD,ZAE,ZAF,ZAG,ZAH,Z AJ,ZAL .....	1
18	PAFZZ	4730-00-196-1504	81346	A733S-75CFG	NIPPLE,PIPE UOC: DAC,DAD,DAE,DAF,DAG,DA H,DAJ,DAL,DAW,DAX,V14,V15,V16, V17,V18,V19,V20,V21,V22,V24,ZAA, ZAB,ZAC,ZAD,ZAE,ZAF,ZAG,ZAH,Z AJ,ZAL .....	1
19	PAFZZ	4730-00-595-0083	58536	A52484-1	COUPLING HALF,QUICK UOC: DAC,DAD,DAE,DAF,DAG,DA H,DAJ,DAL,DAW,DAX,V14,V15,V16, V17,V18,V19,V20,V21,V22,V24,ZAA, ZAB,ZAC,ZAD,ZAE,ZAF,ZAG,ZAH,Z AJ,ZAL .....	1
20	PAFZZ	5330-00-090-2128	58536	A52484-2	. PACKING,PREFORMED UOC: DAC,DAD,DAE,DAF,DAG,DA H,DAJ,DAL,DAW,DAX,V14,V15,V16, V17,V18,V19,V20,V21,V22,V24,ZAA, ZAB,ZAC,ZAD,ZAE,ZAF,ZAG,ZAH,Z AJ,ZAL .....	1

(1) ITEM NO.	(2) SMR CODE	(3) NSN	(4) CAGEC	(5) PART NUMBER	(6) DESCRIPTION AND USABLE ON CODE (UOC)	(7) QTY
21	PAFZZ	2530-00-740-9445	19207	7409445	. DUMMY COUPLING,AUTO UOC: DAC,DAD,DAE,DAF,DAG,DA H,DAJ,DAL,DAW,DAX,V14,V15,V16, V17,V18,V19,V20,V21,V22,V24,ZAA, ZAB,ZAC,ZAD,ZAE,ZAF,ZAG,ZAH,Z AJ,ZAL .....	1

END OF FIGURE

**FIELD MAINTENANCE**  
**AIR CONTROL LINES, FRONT SERVICE CHECK VALVE TO BRAKE CHAMBERS**

---

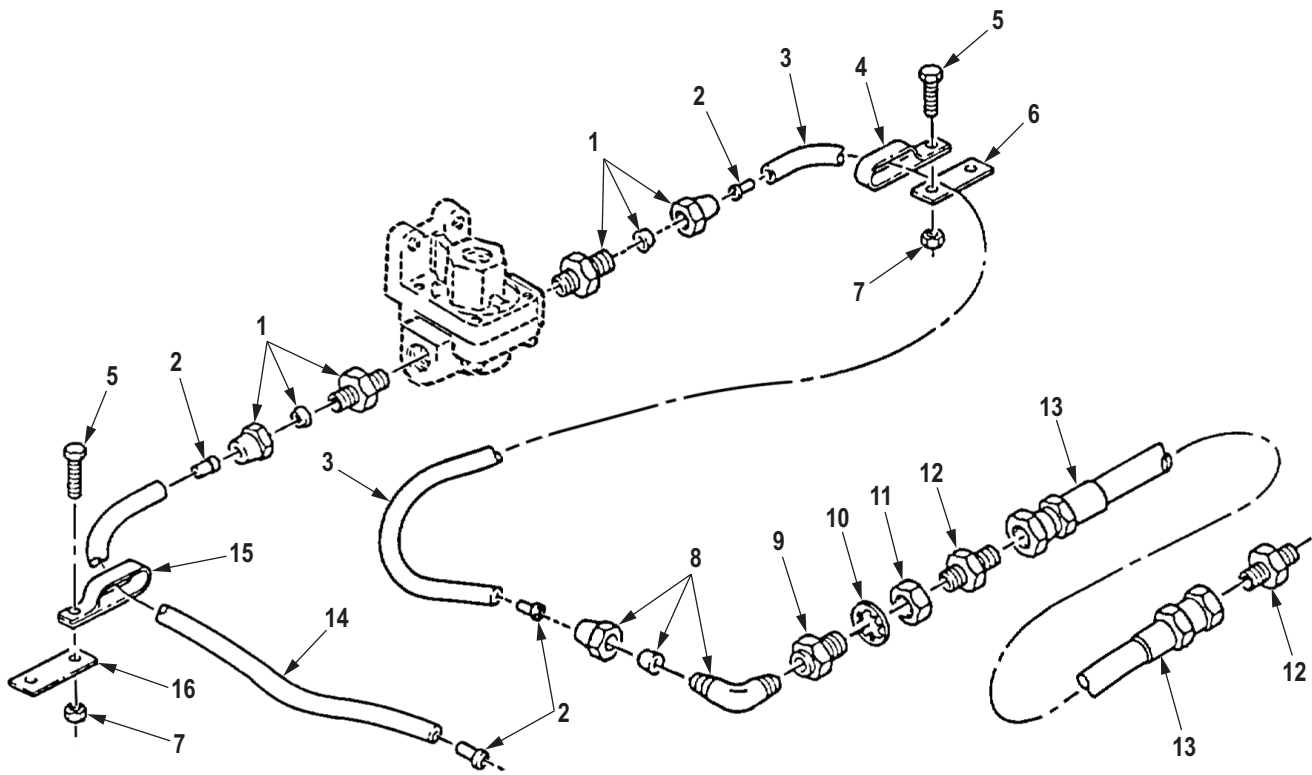

R0268DAA

Figure 252. Air Control Lines, Front Service Check Valve to Brake Chambers.



(1) ITEM NO.	(2) SMR CODE	(3) NSN	(4) CAGEC	(5) PART NUMBER	(6) DESCRIPTION AND USABLE ON CODE (UOC)	(7) QTY
<b>GROUP 1208 AIR BRAKE SYSTEM.</b>						
<b>FIG. 252. AIR CONTROL LINES, FRONT SERVICE CHECK VALVE TO BRAKE CHAMBERS.</b>						
1	PAFZZ	4730-01-091-8032	81343	J246 8-6 100102BA	ADAPTER,STRAIGHT,PI UOC: DAC,DAD,DAE,DAF,DAG,DAH,DAJ,DAL,DAW,DAX,V14,V15,V16,V17,V18,V19,V20,V21,V22,V24,ZAA,ZAB,ZAC,ZAD,ZAE,ZAF,ZAG,ZAH,ZAJ,ZAL .....	2
2	PAFZZ	4730-01-032-6038	19207	CPR102321-4	INSERT,TUBE FITTING UOC: DAC,DAD,DAE,DAF,DAG,DAH,DAJ,DAL,DAW,DAX,V14,V15,V16,V17,V18,V19,V20,V21,V22,V24,ZAA,ZAB,ZAC,ZAD,ZAE,ZAF,ZAG,ZAH,ZAJ,ZAL .....	4
3	MFFZZ		19207	CPR104420-3-37	HOSE,NONMETALLIC MAKE FROM HOSE, P/N CPR104420-3, 37 IN.LONG UOC: DAC,DAD,DAE,DAF,DAG,DAH,DAJ,DAL,DAW,DAX,V14,V15,V16,V17,V18,V19,V20,V21,V22,V24,ZAA,ZAB,ZAC,ZAD,ZAE,ZAF,ZAG,ZAH,ZAJ,ZAL .....	1
4	PAFZZ	5340-00-989-1771	80205	MS21333-123	CLAMP,LOOP UOC: DAC,DAD,DAE,DAF,DAG,DAH,DAJ,DAL,DAW,DAX,V14,V15,V16,V17,V18,V19,V20,V21,V22,V24,ZAA,ZAB,ZAC,ZAD,ZAE,ZAF,ZAG,ZAH,ZAJ,ZAL .....	1
5	PAFZZ	5305-00-269-2803	80205	MS90726-60	SCREW,CAP,HEXAGON H UOC: DAC,DAD,DAE,DAF,DAG,DAH,DAJ,DAL,DAW,DAX,V14,V15,V16,V17,V18,V19,V20,V21,V22,V24,ZAA,ZAB,ZAC,ZAD,ZAE,ZAF,ZAG,ZAH,ZAJ,ZAL .....	4
6	PAFZZ	5340-01-197-9300	19207	12302694	PLATE,MENDING UOC: DAC,DAD,DAE,DAF,DAG,DAH,DAJ,DAL,DAW,DAX,V14,V15,V16,V17,V18,V19,V20,V21,V22,V24,ZAA,ZAB,ZAC,ZAD,ZAE,ZAF,ZAG,ZAH,ZAJ,ZAL .....	2
7	PAFZZ	5310-00-814-0672	96906	M45913/3-6FG8C	NUT,SELF-LOCKING,HE UOC: DAC,DAD,DAE,DAF,DAG,DAH,DAJ,DAL,DAW,DAX,V14,V15,V16,V17,V18,V19,V20,V21,V22,V24,ZAA,ZAB,ZAC,ZAD,ZAE,ZAF,ZAG,ZAH,ZAJ,ZAL .....	4

(1) ITEM NO.	(2) SMR CODE	(3) NSN	(4) CAGEC	(5) PART NUMBER	(6) DESCRIPTION AND USABLE ON CODE (UOC)	(7) QTY
8	PAFZZ	4730-00-289-0051	81343	8-6 120202BA	ELBOW,PIPE TO TUBE FRONT LEFT AND RIGHT HAND BRAKE CHAMBER HOSE UOC: DAC,DAD,DAE,DAF,DAG,DA H,DAJ,DAL,DAW,DAX,V14,V15,V16, V17,V18,V19,V20,V21,V22,V24,ZAA, ZAB,ZAC,ZAD,ZAE,ZAF,ZAG,ZAH,Z AJ,ZAL .....	2
9	PAFZZ	4730-00-421-3924	19207	7339982	ADAPTER,STRAIGHT,PI FRONT LEFT AND RIGHT HAND BRAKE CHAMBER ELBOW UOC: DAC,DAD,DAE,DAF,DAG,DA H,DAJ,DAL,DAW,DAX,V14,V15,V16, V17,V18,V19,V20,V21,V22,V24,ZAA, ZAB,ZAC,ZAD,ZAE,ZAF,ZAG,ZAH,Z AJ,ZAL .....	2
10	PAFZZ	5310-00-582-6714	80205	MS35333-49	WASHER,LOCK UOC: DAC,DAD,DAE,DAF,DAG,DA H,DAJ,DAL,DAW,DAX,V14,V15,V16, V17,V18,V19,V20,V21,V22,V24,ZAA, ZAB,ZAC,ZAD,ZAE,ZAF,ZAG,ZAH,Z AJ,ZAL .....	2
11	PAFZZ	5310-00-241-0157	19207	5331179	NUT,PLAIN,HEXAGON UOC: DAC,DAD,DAE,DAF,DAG,DA H,DAJ,DAL,DAW,DAX,V14,V15,V16, V17,V18,V19,V20,V21,V22,V24,ZAA, ZAB,ZAC,ZAD,ZAE,ZAF,ZAG,ZAH,Z AJ,ZAL .....	2
12	PAFZZ	4730-00-813-9611	81343	J514 8-6 070102CA	ADAPTER,STRAIGHT,PI FRONT LEFT AND RIGHT HAND BRAKE CHAMBER HOSE ASSEMBLY UOC: DAC,DAD,DAE,DAF,DAG,DA H,DAJ,DAL,DAW,DAX,V14,V15,V16, V17,V18,V19,V20,V21,V22,V24,ZAA, ZAB,ZAC,ZAD,ZAE,ZAF,ZAG,ZAH,Z AJ,ZAL .....	4
13	PAFZZ	4720-01-145-0371	19207	12256270-1	HOSE ASSEMBLY,NONME UOC: DAC,DAD,DAE,DAF,DAG,DA H,DAJ,DAL,DAW,DAX,V14,V15,V16, V17,V18,V19,V20,V21,V22,V24,ZAA, ZAB,ZAC,ZAD,ZAE,ZAF,ZAG,ZAH,Z AJ,ZAL .....	2
14	MFFZZ		19207	CPR104420-3-38	HOSE,NONMETALLIC MAKE FROM HOSE, P/N CPR104420-3, 38 IN.LONG UOC: DAC,DAD,DAE,DAF,DAG,DA H,DAJ,DAL,DAW,DAX,V14,V15,V16, V17,V18,V19,V20,V21,V22,V24,ZAA, ZAB,ZAC,ZAD,ZAE,ZAF,ZAG,ZAH,Z AJ,ZAL .....	1

(1) ITEM NO.	(2) SMR CODE	(3) NSN	(4) CAGEC	(5) PART NUMBER	(6) DESCRIPTION AND USABLE ON CODE (UOC)	(7) QTY
15	PAFZZ	5340-01-117-9876	19207	7397785	CLAMP,LOOP UOC: DAC,DAD,DAE,DAF,DAG,DA H,DAJ,DAL,DAW,DAX,V14,V15,V16, V17,V18,V19,V20,V21,V22,V24,ZAA, ZAB,ZAC,ZAD,ZAE,ZAF,ZAG,ZAH,Z AJ,ZAL .....	1

END OF FIGURE



**FIELD MAINTENANCE  
DASH CONTROL AIR SUPPLY LINES, SPRING BRAKE CONTROL VALVE TO PRIMARY AND SECONDARY  
AIR RESERVOIRS**

---

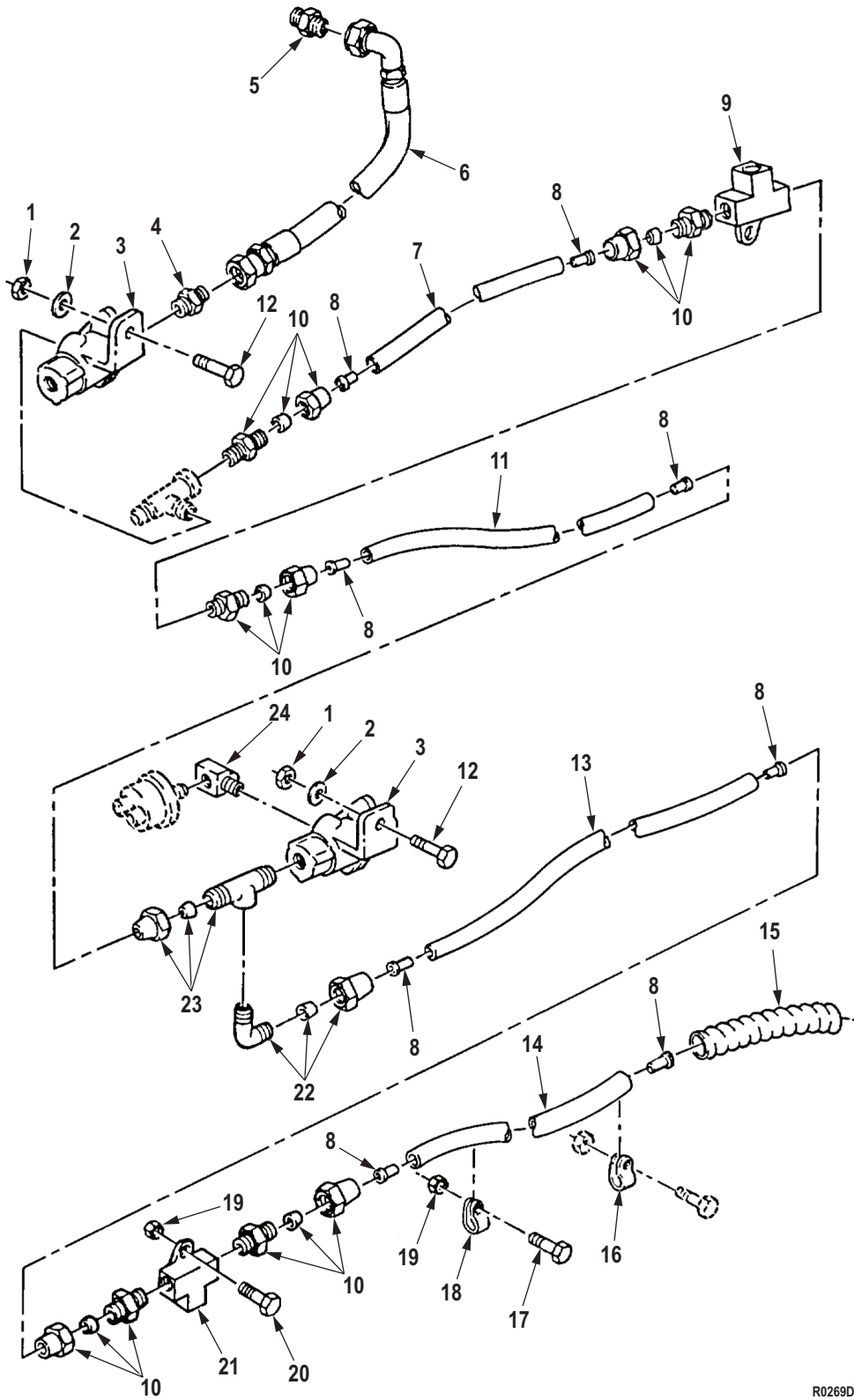

R0269DAA

Figure 253. Dash Control Air Supply Lines, Spring Brake Control Valve to Primary and Secondary Air Reservoirs.

(1) ITEM NO.	(2) SMR CODE	(3) NSN	(4) CAGEC	(5) PART NUMBER	(6) DESCRIPTION AND USABLE ON CODE (UOC)	(7) QTY
<b>GROUP 1208 AIR BRAKE SYSTEM.</b>						
<b>FIG. 253. DASH CONTROL AIR SUPPLY LINES, SPRING BRAKE CONTROL VALVE TO PRIMARY AND SECONDARY AIR RESERVOIRS.</b>						
1	PAFZZ	5310-00-241-6658	81349	M45913/3-5FG8C	NUT,SELF-LOCKING,HE UOC: DAC,DAD,DAE,DAF,DAG,DA H,DAJ,DAL,DAW,DAX,V14,V15,V16, V17,V18,V19,V20,V21,V22,V24,ZAA, ZAB,ZAC,ZAD,ZAE,ZAF,ZAG,ZAH,Z AJ,ZAL .....	2
2	PAFZZ	5310-00-081-4219	96906	MS27183-12	WASHER,FLAT UOC: DAC,DAD,DAE,DAF,DAG,DA H,DAJ,DAL,DAW,DAX,V14,V15,V16, V17,V18,V19,V20,V21,V22,V24,ZAA, ZAB,ZAC,ZAD,ZAE,ZAF,ZAG,ZAH,Z AJ,ZAL .....	2
3	PAFZZ	4820-00-728-7467	06853	278614N	VALVE,LINEAR,DIRECT UOC: DAC,DAD,DAE,DAF,DAG,DA H,DAJ,DAL,DAW,DAX,V14,V15,V16, V17,V18,V19,V20,V21,V22,V24,ZAA, ZAB,ZAC,ZAD,ZAE,ZAF,ZAG,ZAH,Z AJ,ZAL .....	1
4	PAFZZ	4730-00-813-9611	81343	J514 8-6 070102CA	ADAPTER,STRAIGHT,PI UOC: DAC,DAD,DAE,DAF,DAG,DA H,DAJ,DAL,DAW,DAX,V14,V15,V16, V17,V18,V19,V20,V21,V22,V24,ZAA, ZAB,ZAC,ZAD,ZAE,ZAF,ZAG,ZAH,Z AJ,ZAL .....	1
5	PAFZZ	4730-00-809-9427	81343	MS51500A8-8	ADAPTER,STRAIGHT,PI UOC: DAC,DAD,DAE,DAF,DAG,DA H,DAJ,DAL,DAW,DAX,V14,V15,V16, V17,V18,V19,V20,V21,V22,V24,ZAA, ZAB,ZAC,ZAD,ZAE,ZAF,ZAG,ZAH,Z AJ,ZAL .....	1
6	PAFZZ	4720-01-290-2510	19207	12302893	HOSE ASSEMBLY,NONME UOC: DAL,V18 .....	1
6	PAFZZ	4720-01-112-2329	19207	12256269-3	HOSE ASSEMBLY,NONME UOC: DAC,DAD,DAE,DAF,DAG,DA H,DAJ,DAW,DAX,V14,V15,V16,V21, V22,V24,ZAA,ZAB,ZAC,ZAD,ZAE,ZA F,ZAG,ZAH,ZAJ,ZAL .....	1
7	MFFZZ		81343	J844TYBSIZE 3/8 BLACK-80	HOSE,NONMETALLIC MAKE FROM HOSE, P/N J844TYBSIZE 3/8 BLACK 80 IN LONG UOC: DAW,DAX,V14,V15,ZAA,ZAB .....	1

(1) ITEM NO.	(2) SMR CODE	(3) NSN	(4) CAGEC	(5) PART NUMBER	(6) DESCRIPTION AND USABLE ON CODE (UOC)	(7) QTY
8	PAFZZ	4730-01-079-8821	19207	CPR102321-1	INSERT,TUBE FITTING UOC: DAC,DAD,DAE,DAF,DAG,DA H,DAJ,DAL,DAW,DAX,V14,V15,V16, V17,V18,V19,V20,V21,V22,V24,ZAA, ZAB,ZAC,ZAD,ZAE,ZAF,ZAG,ZAH,Z AJ,ZAL .....	8
9	PAFZZ	4730-01-108-5103	19207	10937774-1	TEE,PIPE UOC: DAC,DAD,DAE,DAF,DAG,DA H,DAJ,DAL,DAW,DAX,V14,V15,V16, V17,V18,V19,V20,V21,V22,V24,ZAA, ZAB,ZAC,ZAD,ZAE,ZAF,ZAG,ZAH,Z AJ,ZAL .....	1
10	PAFZZ	4730-00-069-1186	81343	6-4 120102BA	ADAPTER,STRAIGHT,PI UOC: DAC,DAD,DAE,DAF,DAG,DA H,DAJ,DAL,DAW,DAX,V14,V15,V16, V17,V18,V19,V20,V21,V22,V24,ZAA, ZAB,ZAC,ZAD,ZAE,ZAF,ZAG,ZAH,Z AJ,ZAL .....	5
11	MFFZZ		81343	J844TYBSIZE 3/8 BLACK-43	HOSE,NONMETALLIC TEE TO VALVE ASSEMBLY,MAKE FROM HOSE, P/N J844TYBSIZE 3/8 BLACK, 43 INCH LONG UOC: DAC,DAD,DAE,DAF,DAG,DA H,DAJ,DAL,DAW,DAX,V14,V15,V16, V17,V18,V19,V20,V21,V22,V24,ZAA, ZAB,ZAC,ZAD,ZAE,ZAF,ZAG,ZAH,Z AJ,ZAL .....	1
12	PAFZZ	5305-00-225-9093	80205	NASM90726-38	SCREW,CAP,HEXAGON H UOC: DAC,DAD,DAE,DAF,DAG,DA H,DAJ,DAL,DAW,DAX,V14,V15,V16, V17,V18,V19,V20,V21,V22,V24,ZAA, ZAB,ZAC,ZAD,ZAE,ZAF,ZAG,ZAH,Z AJ,ZAL .....	2
13	MFFZZ		81343	J844TYBSIZE 3/8 BLACK-83	HOSE,NONMETALLIC AIR BRAKE VALVE TO TEE ASSEMBLY,MAKE FROM HOSE, P/N J844TYBSIZE 3/8 BLACK 83 IN LONG UOC: DAW,DAX,V14,V15,ZAA,ZAB .....	1
13	MFFZZ		81343	J844TYBSIZE 3/8 BLACK-77	HOSE,NONMETALLIC MAKE FROM HOSE, P/N J844TYBSIZE 3/8 BLACK 77 IN LONG UOC: DAL,V18,ZAL .....	1
13	MFFZZ		81343	J844TYBSIZE 3/8 BLACK-70	HOSE,NONMETALLIC MAKE FROM HOSE, P/N J844TYBSIZE 3/8 BLACK, 70 IN.LONG UOC: DAE,DAF,V19,V20 .....	1



(1) ITEM NO.	(2) SMR CODE	(3) NSN	(4) CAGEC	(5) PART NUMBER	(6) DESCRIPTION AND USABLE ON CODE (UOC)	(7) QTY
13	MFFZZ		81343	J844TYBSIZE 3/8 BLACK-54	HOSE, NONMETALLIC AIR BRAKE VALVE TO TEE ASSEMBLY, MAKE FROM HOSE, P/N J844TYBSIZE 3/8 BLACK 54 IN LONG UOC: DAG, DAH, V21, V22, ZAG, ZAH ..... 1	1
13	MFFZZ		81343	J844TYBSIZE 3/8 BLACK-113	HOSE, NONMETALLIC AIR BRAKE VALVE TO TEE ASSEMBLY, MAKE FROM HOSE, P/N J844TYBSIZE 3/8 BLACK, 113 IN LONG UOC: DAC, DAD, DAJ, V16, V17, V24, Z AC, ZAD, ZAJ ..... 1	1
14	MFFZZ		81343	J844TYBSIZE 3/8 BLACK-80	HOSE, NONMETALLIC TEE TO DOUBLE CHECK VALVE, MAKE FROM HOSE, P/N J844TYBSIZE 3/8 BLACK 80 IN LONG UOC: ZAP ..... 1	1
14	MFFZZ		81343	J844TYBSIZE 3/8 BLACK-73	HOSE, NONMETALLIC TEE TO DOUBLE CHECK VALVE, MAKE FROM HOSE, P/N J844TYBSIZE 3/8 BLACK 73 IN LONG UOC: DAJ, V24, ZAJ ..... 1	1
14	MFFZZ		81343	J844TYBSIZE 3/8 BLACK-94	HOSE, NONMETALLIC MAKE FROM HOSE, P/N J844TYBSIZE 3/8 BLACK 94 IN LONG UOC: DAC, DAD, V16, V17, ZAC, ZAD ..... 1	1
14	MFFZZ		81343	J844TYBSIZE 3/8 BLACK-28	HOSE, NONMETALLIC MAKE FROM HOSE, P/N J844TYBSIZE 3/8 BLACK 28 IN LONG UOC: DAL, V18, ZAL ..... 1	1
14	MFFZZ		81343	J844TYBSIZE 3/8 BLACK-13	HOSE, NONMETALLIC TEE TO DOUBLE CHECK VALVE, MAKE FROM HOSE, P/N J844TYBSIZE 3/8 BLACK, 13 IN LONG UOC: DAE, DAF, V19, V20, ZAE, ZAF ..... 1	1
14	MFFZZ		81343	J844TYBSIZE 3/8 BLACK-41	HOSE, NONMETALLIC TEE TO DOUBLE CHECK VALVE, MAKE FROM HOSE, P/N J844TYBSIZE 3/8 BLACK 41 IN LONG UOC: DAE, DAF, DAW, DAX, V14, V15, V19, V20, ZAA, ZAB, ZAE, ZAF ..... 1	1
15	MFFZZ		19207	12302690-6	TUBING, PLASTIC, SPIR MAKE FROM TUBING, P/N 12302690, 6 IN. LONG UOC: DAC, DAD, DAE, DAF, DAG, DA H, DAJ, DAL, DAW, DAX, V14, V15, V16, V17, V18, V19, V20, V21, V22, V24, ZAA, ZAB, ZAC, ZAD, ZAE, ZAF, ZAG, ZAH, Z AJ, ZAL ..... 1	1
16	PAFZZ	5340-00-222-1653	19207	7415752	CLAMP, LOOP UOC: DAL, V18, ZAL ..... 1	1

(1) ITEM NO.	(2) SMR CODE	(3) NSN	(4) CAGEC	(5) PART NUMBER	(6) DESCRIPTION AND USABLE ON CODE (UOC)	(7) QTY
16	PAFZZ	5340-00-222-1653	19207	7415752	CLAMP,LOOP UOC: DAC,DAD,DAE,DAF,DAG,DA H,DAJ,DAL,DAW,DAX,V14,V15,V16, V17,V18,V19,V20,V21,V22,V24,ZAA, ZAB,ZAC,ZAD,ZAE,ZAF,ZAG,ZAH,Z AJ,ZAL .....	2
17	PAFZZ	5305-00-269-2804	80205	MS90726-61	SCREW,CAP,HEXAGON H UOC: DAC,DAD,DAJ,V16,V17,V24,Z AC,ZAD,ZAJ .....	2
17	PAFZZ	5305-00-269-2804	80205	MS90726-61	SCREW,CAP,HEXAGON H UOC: DAW,DAX,V14,V15,ZAA,ZAB .....	1
18	PAFZZ	5340-00-954-6014	80205	MS21333-121	CLAMP,LOOP UOC: DAW,DAX,V14,V15,V16,V17,V 18,V19,V20,V21,V22,V24,ZAA,ZAB .....	1
18	PAFZZ	5340-00-954-6014	80205	MS21333-121	CLAMP,LOOP UOC: DAC,DAD,DAJ,V16,V17,V24,Z AC,ZAD,ZAJ .....	2
19	PAFZZ	5310-00-814-0672	96906	M45913/3-6FG8C	NUT,SELF-LOCKING,HE UOC: DAC,DAD,DAE,DAF,DAG,DA H,DAJ,DAL,DAW,DAX,V14,V15,V16, V17,V18,V19,V20,V21,V22,V24 .....	2
19	PAFZZ	5310-00-814-0672	96906	M45913/3-6FG8C	NUT,SELF-LOCKING,HE UOC: DAW,DAX,V14,V15,ZAA,ZAB .....	3
20	PAFZZ	5305-00-269-3238	80204	B1821BH038F125N	SCREW,CAP,HEXAGON H UOC: DAC,DAD,DAE,DAF,DAG,DA H,DAJ,DAL,DAW,DAX,V14,V15,V16, V17,V18,V19,V20,V21,V22,V24,ZAA, ZAB,ZAC,ZAD,ZAE,ZAF,ZAG,ZAH,Z AJ,ZAL .....	1
21	PAFZZ	4730-01-107-9690	19207	10937774	TEE,PIPE UOC: DAC,DAD,DAE,DAF,DAG,DA H,DAJ,DAL,DAW,DAX,V14,V15,V16, V17,V18,V19,V20,V21,V22,V24,ZAA, ZAB,ZAC,ZAD,ZAE,ZAF,ZAG,ZAH,Z AJ,ZAL .....	1
22	PAFZZ	4730-00-069-1187	81343	SAE J246 6-4 100202BA	ELBOW,PIPE TO TUBE UOC: DAC,DAD,DAE,DAF,DAG,DA H,DAJ,DAL,DAW,DAX,V14,V15,V16, V17,V18,V19,V20,V21,V22,V24,ZAA, ZAB,ZAC,ZAD,ZAE,ZAF,ZAG,ZAH,Z AJ,ZAL .....	1
23	PAFZZ	4730-01-195-0095	19207	12302759	TEE,PIPE TO TUBE UOC: DAC,DAD,DAE,DAF,DAG,DA H,DAJ,DAL,DAW,DAX,V14,V15,V16, V17,V18,V19,V20,V21,V22,V24,ZAA, ZAB,ZAC,ZAD,ZAE,ZAF,ZAG,ZAH,Z AJ,ZAL .....	1

(1) ITEM NO.	(2) SMR CODE	(3) NSN	(4) CAGEC	(5) PART NUMBER	(6) DESCRIPTION AND USABLE ON CODE (UOC)	(7) QTY
24	PAFZZ	4730-00-278-4822	92679	444042	ELBOW,PIPE UOC: DAC,DAD,DAE,DAF,DAG,DA H,DAJ,DAL,DAW,V15,V24,ZAA,ZAB, ZAC,ZAD,ZAE,ZAF,ZAJ,ZAL .....	1

END OF FIGURE



**FIELD MAINTENANCE  
DOUBLECHECK VALVE NO. 5 (ABS)**

---

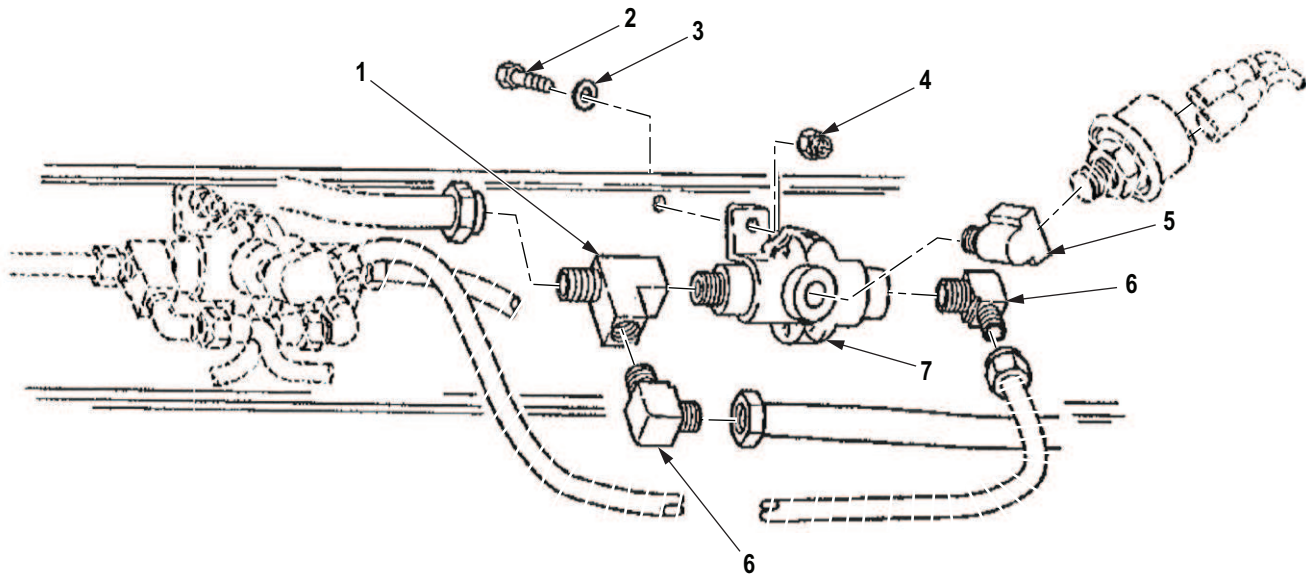

R0270DAA

Figure 254. Doublecheck Valve No. 5 (ABS).

(1) ITEM NO.	(2) SMR CODE	(3) NSN	(4) CAGEC	(5) PART NUMBER	(6) DESCRIPTION AND USABLE ON CODE (UOC)	(7) QTY
<b>GROUP 1208 AIR BRAKE SYSTEM.</b>						
<b>FIG. 254. DOUBLECHECK VALVE NO. 5 (ABS).</b>						
1	PAFZZ	4730-01-391-8317	81343	8-8-8 130425B	TEE,PIPE UOC: DAC,DAD,DAE,DAF,DAG,DAH,DAJ,DAL,DAW,DAX,V14,V15,V16,V17,V18,V19,V20,V21,V22,V24,ZAA,ZAB,ZAC,ZAD,ZAE,ZAF,ZAG,ZAH,ZAJ,ZAL .....	1
2	PAFZZ	5305-00-269-3238	80204	B1821BH038F125N	SCREW,CAP,HEXAGON H UOC: DAC,DAD,DAE,DAF,DAG,DAH,DAJ,DAL,DAW,DAX,V14,V15,V16,V17,V18,V19,V20,V21,V22,V24,ZAA,ZAB,ZAC,ZAD,ZAE,ZAF,ZAG,ZAH,ZAJ,ZAL .....	1
3	PAFZZ	5310-01-280-5796	96906	MS27183-57	WASHER,FLAT UOC: DAC,DAD,DAE,DAF,DAG,DAH,DAJ,DAL,DAW,DAX,V14,V15,V16,V17,V18,V19,V20,V21,V22,V24,ZAA,ZAB,ZAC,ZAD,ZAE,ZAF,ZAG,ZAH,ZAJ,ZAL .....	1
4	PAFZZ	5310-00-814-0672	96906	M45913/3-6FG8C	NUT,SELF-LOCKING,HE UOC: DAC,DAD,DAE,DAF,DAG,DAH,DAJ,DAL,DAW,DAX,V14,V15,V16,V17,V18,V19,V20,V21,V22,V24,ZAA,ZAB,ZAC,ZAD,ZAE,ZAF,ZAG,ZAH,ZAJ,ZAL .....	1
5	PAFZZ	4730-00-278-4822	92679	444042	ELBOW,PIPE UOC: DAC,DAD,DAE,DAF,DAG,DAH,DAJ,DAL,DAW,DAX,V14,V15,V16,V17,V18,V19,V20,V21,V22,V24,ZAA,ZAB,ZAC,ZAD,ZAE,ZAF,ZAG,ZAH,ZAJ,ZAL .....	1
6	PAFZZ	4730-00-289-0155	81343	6-6 120202BA	ELBOW,PIPE TO TUBE UOC: DAC,DAD,DAE,DAF,DAG,DAH,DAJ,DAL,DAW,DAX,V14,V15,V16,V17,V18,V19,V20,V21,V22,V24,ZAA,ZAB,ZAC,ZAD,ZAE,ZAF,ZAG,ZAH,ZAJ,ZAL .....	1
7	PAFZZ	4820-01-478-4650	06721	N20954A	VALVE,DOUBLE CHECK UOC: DAC,DAD,DAE,DAF,DAG,DAH,DAJ,DAL,DAW,DAX,V14,V15,V16,V17,V18,V19,V20,V21,V22,V24,ZAA,ZAB,ZAC,ZAD,ZAE,ZAF,ZAG,ZAH,ZAJ,ZAL .....	1

END OF FIGURE





**FIELD MAINTENANCE  
DOUBLECHECK VALVE NO. 6 (ABS)**

---

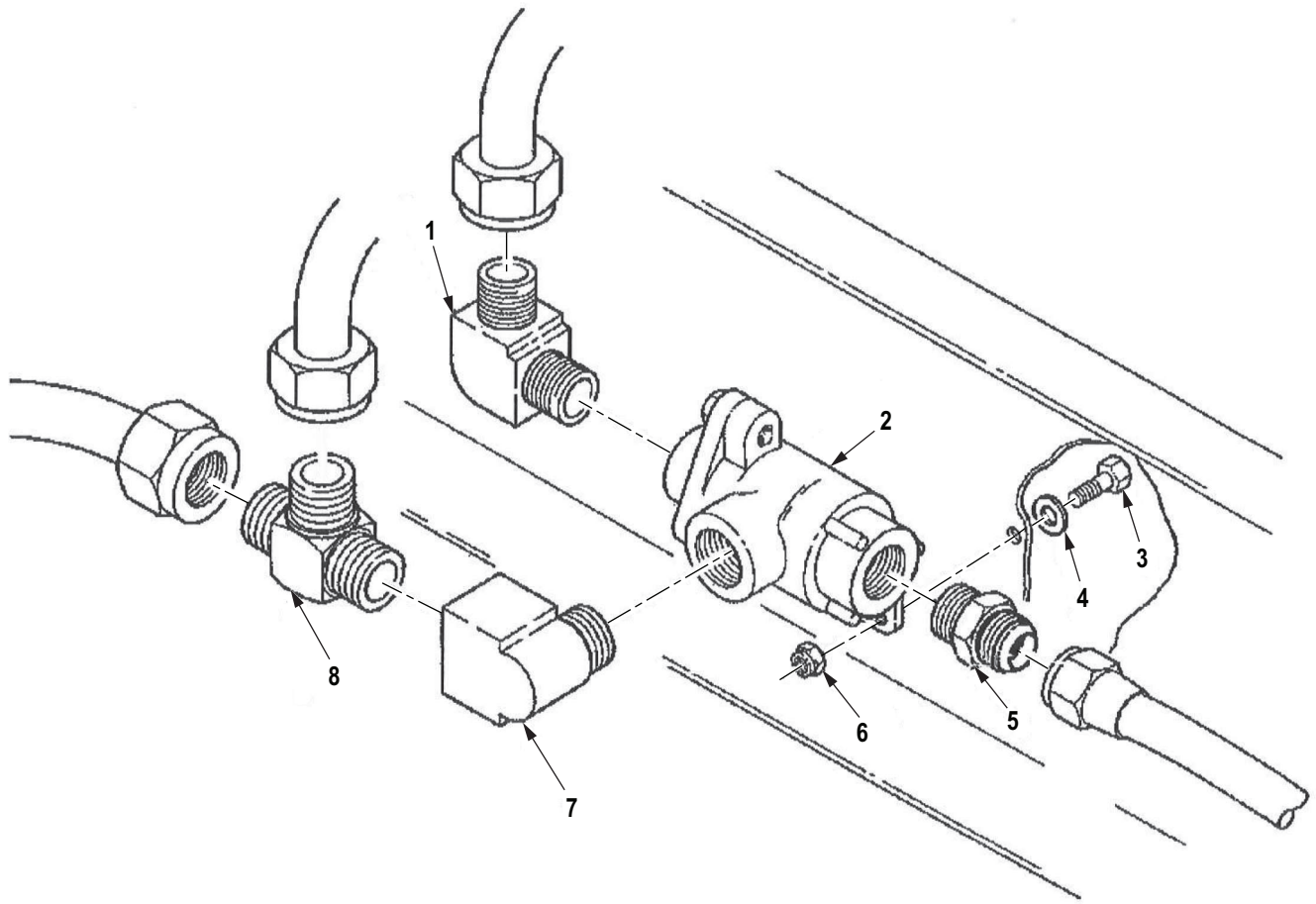

R0271DAA

Figure 255. Doublecheck Valve No. 6 (ABS).

(1) ITEM NO.	(2) SMR CODE	(3) NSN	(4) CAGEC	(5) PART NUMBER	(6) DESCRIPTION AND USABLE ON CODE (UOC)	(7) QTY
<b>GROUP 1208 AIR BRAKE SYSTEM.</b>						
<b>FIG. 255. DOUBLECHECK VALVE NO. 6 (ABS).</b>						
1	PAFZZ	4730-00-289-0155	81343	6-6 120202BA	ELBOW,PIPE TO TUBE UOC: DAC,DAD,DAE,DAF,DAG,DAH,DAJ,DAL,DAW,DAX,V14,V15,V16,V17,V18,V19,V20,V21,V22,V24,ZAA,ZAB,ZAC,ZAD,ZAE,ZAF,ZAG,ZAH,ZAJ,ZAL .....	1
2	PAFZZ	4820-01-478-4650	06721	N20954A	VALVE,DOUBLE CHECK UOC: DAC,DAD,DAE,DAF,DAG,DAH,DAJ,DAL,DAW,DAX,V14,V15,V16,V17,V18,V19,V20,V21,V22,V24,ZAA,ZAB,ZAC,ZAD,ZAE,ZAF,ZAG,ZAH,ZAJ,ZAL .....	1
3	PAFZZ	5305-00-269-3238	80204	B1821BH038F125N	SCREW,CAP,HEXAGON H UOC: DAC,DAD,DAE,DAF,DAG,DAH,DAJ,DAL,DAW,DAX,V14,V15,V16,V17,V18,V19,V20,V21,V22,V24,ZAA,ZAB,ZAC,ZAD,ZAE,ZAF,ZAG,ZAH,ZAJ,ZAL .....	1
4	PAFZZ	5310-01-280-5796	96906	MS27183-57	WASHER,FLAT UOC: DAC,DAD,DAE,DAF,DAG,DAH,DAJ,DAL,DAW,DAX,V14,V15,V16,V17,V18,V19,V20,V21,V22,V24,ZAA,ZAB,ZAC,ZAD,ZAE,ZAF,ZAG,ZAH,ZAJ,ZAL .....	1
5	PAFZZ	4730-00-813-9611	81343	J514 8-6 070102CA	ADAPTER,STRAIGHT,PI UOC: DAC,DAD,DAE,DAF,DAG,DAH,DAJ,DAL,DAW,DAX,V14,V15,V16,V17,V18,V19,V20,V21,V22,V24,ZAA,ZAB,ZAC,ZAD,ZAE,ZAF,ZAG,ZAH,ZAJ,ZAL .....	1
6	PAFZZ	5310-00-814-0672	96906	M45913/3-6FG8C	NUT,SELF-LOCKING,HE UOC: DAC,DAD,DAE,DAF,DAG,DAH,DAJ,DAL,DAW,DAX,V14,V15,V16,V17,V18,V19,V20,V21,V22,V24,ZAA,ZAB,ZAC,ZAD,ZAE,ZAF,ZAG,ZAH,ZAJ,ZAL .....	1
7	PAFZZ	4730-00-278-4822	92679	444042	ELBOW,PIPE UOC: DAC,DAD,DAE,DAF,DAG,DAH,DAJ,DAL,DAW,DAX,V14,V15,V16,V17,V18,V19,V20,V21,V22,V24,ZAA,ZAB,ZAC,ZAD,ZAE,ZAF,ZAG,ZAH,ZAJ,ZAL .....	1

(1) ITEM NO.	(2) SMR CODE	(3) NSN	(4) CAGEC	(5) PART NUMBER	(6) DESCRIPTION AND USABLE ON CODE (UOC)	(7) QTY
8	PAFZZ	4730-01-086-4068	81343	SAE J246 6-6 100424BA	TEE,PIPE TO TUBE UOC: DAC,DAD,DAE,DAF,DAG,DA H,DAJ,DAL,DAW,DAX,V14,V15,V16, V17,V18,V19,V20,V21,V22,V24,ZAA, ZAB,ZAC,ZAD,ZAE,ZAF,ZAG,ZAH,Z AJ,ZAL .....	1

END OF FIGURE

**FIELD MAINTENANCE  
DOUBLECHECK VALVE NO. 7 (ABS)**

---

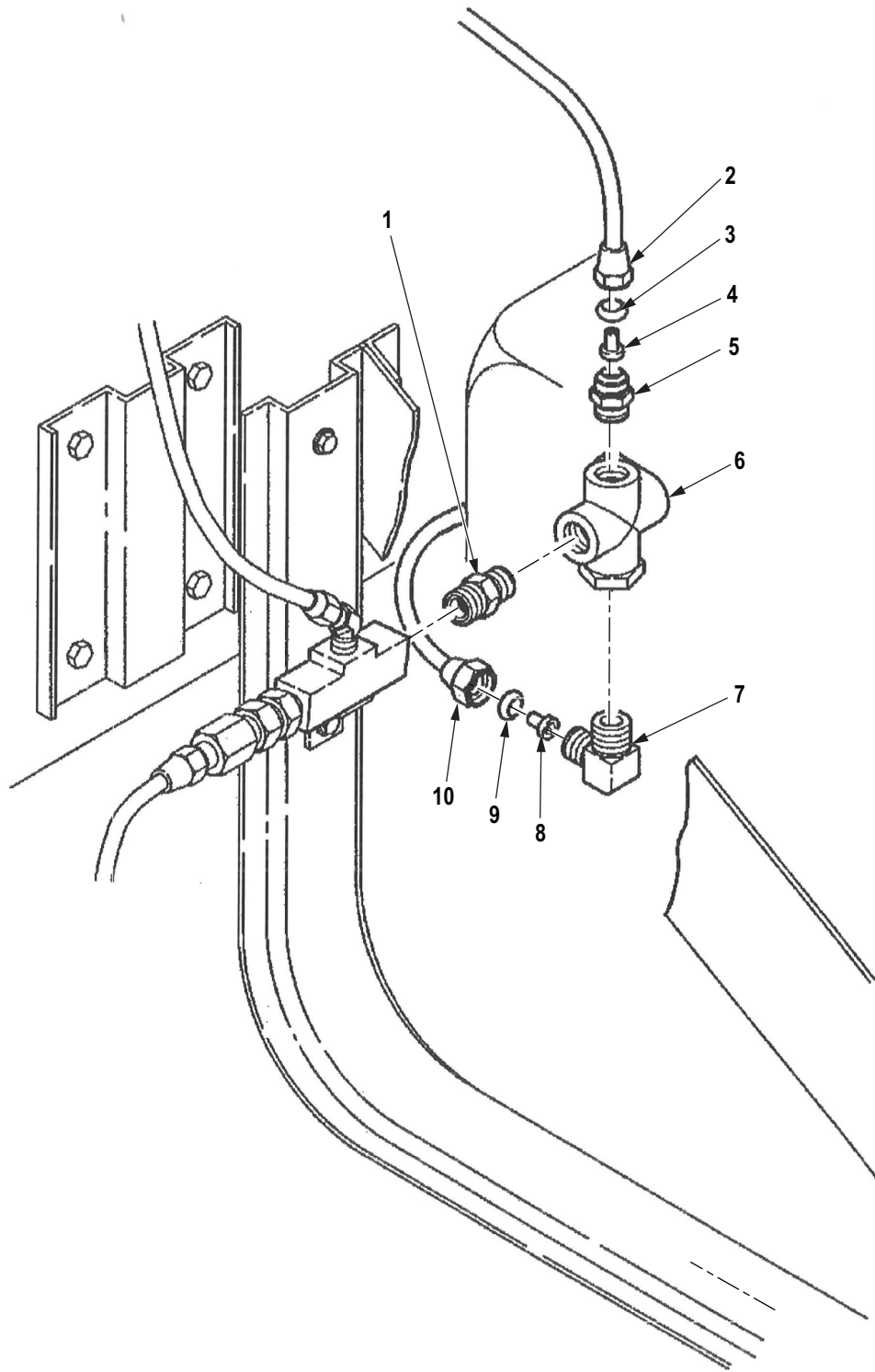

R0272DAA

Figure 256. Doublecheck Valve No. 7 (ABS).

(1) ITEM NO.	(2) SMR CODE	(3) NSN	(4) CAGEC	(5) PART NUMBER	(6) DESCRIPTION AND USABLE ON CODE (UOC)	(7) QTY
<b>GROUP 1208 AIR BRAKE SYSTEM.</b>						
<b>FIG. 256. DOUBLECHECK VALVE NO. 7 (ABS).</b>						
1	PAFZZ	4730-00-419-9424	81343	SAE J530 8-6 130137B	REDUCER,PIPE UOC: DAC,DAD,DAE,DAF,DAG,DA H,DAJ,DAL,DAW,DAX,V14,V15,V16, V17,V18,V19,V20,V21,V22,V24,ZAA, ZAB,ZAC,ZAD,ZAE,ZAF,ZAG,ZAH,Z AJ,ZAL .....	1
2	PAFZZ	4730-01-048-7874	93061	61NTA-8	NUT,TUBE COUPLING UOC: DAC,DAD,DAE,DAF,DAG,DA H,DAJ,DAL,DAW,DAX,V14,V15,V16, V17,V18,V19,V20,V21,V22,V24,ZAA, ZAB,ZAC,ZAD,ZAE,ZAF,ZAG,ZAH,Z AJ,ZAL .....	1
3	PAFZZ	4730-01-049-1559	81343	J246 8 100115B	SLEEVE,COMPRESSION, UOC: DAC,DAD,DAE,DAF,DAG,DA H,DAJ,DAL,DAW,DAX,V14,V15,V16, V17,V18,V19,V20,V21,V22,V24,ZAA, ZAB,ZAC,ZAD,ZAE,ZAF,ZAG,ZAH,Z AJ,ZAL .....	1
4	PAFZZ	4730-01-095-7717	81343	SAE J246 8-6 100202BA	ELBOW,PIPE TO TUBE UOC: DAC,DAD,DAE,DAF,DAG,DA H,DAJ,DAL,DAW,DAX,V14,V15,V16, V17,V18,V19,V20,V21,V22,V24,ZAA, ZAB,ZAC,ZAD,ZAE,ZAF,ZAG,ZAH,Z AJ,ZAL .....	1
5	PAFZZ	4730-01-048-5261	93061	63NTA-8	INSERT,TUBE FITTING UOC: DAC,DAD,DAE,DAF,DAG,DA H,DAJ,DAL,DAW,DAX,V14,V15,V16, V17,V18,V19,V20,V21,V22,V24,ZAA, ZAB,ZAC,ZAD,ZAE,ZAF,ZAG,ZAH,Z AJ,ZAL .....	1
6	PAFZZ	4820-01-478-4650	06721	N20954A	VALVE,DOUBLE CHECK UOC: DAC,DAD,DAE,DAF,DAG,DA H,DAJ,DAL,DAW,DAX,V14,V15,V16, V17,V18,V19,V20,V21,V22,V24,ZAA, ZAB,ZAC,ZAD,ZAE,ZAF,ZAG,ZAH,Z AJ,ZAL .....	1
7	PAFZZ	4730-00-289-0155	81343	6-6 120202BA	ELBOW,PIPE TO TUBE UOC: DAC,DAD,DAE,DAF,DAG,DA H,DAJ,DAL,DAW,DAX,V14,V15,V16, V17,V18,V19,V20,V21,V22,V24,ZAA, ZAB,ZAC,ZAD,ZAE,ZAF,ZAG,ZAH,Z AJ,ZAL .....	1

(1) ITEM NO.	(2) SMR CODE	(3) NSN	(4) CAGEC	(5) PART NUMBER	(6) DESCRIPTION AND USABLE ON CODE (UOC)	(7) QTY
8	PAFZZ	4730-01-056-4990	93061	63NTA-6	INSERT,TUBE FITTING UOC: DAC,DAD,DAE,DAF,DAG,DA H,DAJ,DAL,DAW,DAX,V14,V15,V16, V17,V18,V19,V20,V21,V22,V24,ZAA, ZAB,ZAC,ZAD,ZAE,ZAF,ZAG,ZAH,Z AJ,ZAL .....	1
9	PAFZZ	4730-01-048-5260	81343	SAE J246 6 100115	SLEEVE,COMPRESSION, UOC: DAC,DAD,DAE,DAF,DAG,DA H,DAJ,DAL,DAW,DAX,V14,V15,V16, V17,V18,V19,V20,V21,V22,V24,ZAA, ZAB,ZAC,ZAD,ZAE,ZAF,ZAG,ZAH,Z AJ,ZAL .....	1
10	PAFZZ	4730-01-048-7873	93061	61NTA-6	NUT,TUBE COUPLING UOC: DAC,DAD,DAE,DAF,DAG,DA H,DAJ,DAL,DAW,DAX,V14,V15,V16, V17,V18,V19,V20,V21,V22,V24,ZAA, ZAB,ZAC,ZAD,ZAE,ZAF,ZAG,ZAH,Z AJ,ZAL .....	1

END OF FIGURE



**FIELD MAINTENANCE  
REAR SERVICE HALF COUPLING AND MOUNTING HARDWARE**

---

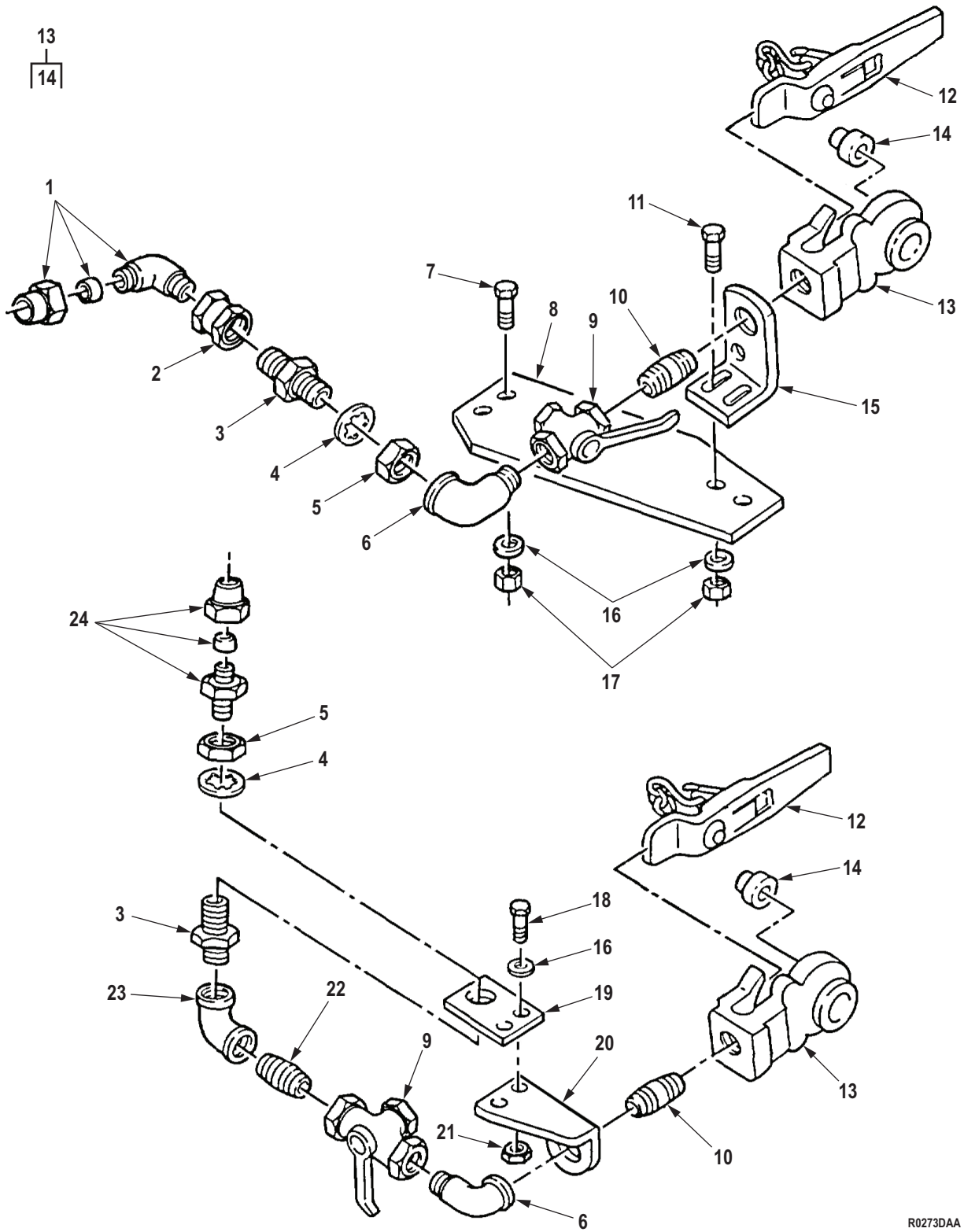

Figure 257. Rear Service Half Coupling and Mounting Hardware.

R0273DAA

(1) ITEM NO.	(2) SMR CODE	(3) NSN	(4) CAGEC	(5) PART NUMBER	(6) DESCRIPTION AND USABLE ON CODE (UOC)	(7) QTY
<b>GROUP 1208 AIR BRAKE SYSTEM.</b>						
<b>FIG. 257. REAR SERVICE HALF COUPLING AND MOUNTING HARDWARE.</b>						
1	PAFZZ	4730-00-143-9282	81343	J246 6-8 120202BA	ELBOW,PIPE TO TUBE UOC: DAW,DAX,V14,V15,ZAA,ZAB .....	1
2	PAFZZ	4730-00-278-2648	96906	MS14305-4Y	COUPLING,PIPE UOC: DAW,DAX,V14,V15,ZAA,ZAB .....	1
3	PAFZZ	4730-00-419-9424	19207	8376311	REDUCER,PIPE UOC: DAC,DAD,DAE,DAF,DAG,DA H,DAJ,DAL,DAW,DAX,V14,V15,V16, V17,V18,V19,V20,V21,V22,V24,ZAA, ZAB,ZAC,ZAD,ZAE,ZAF,ZAG,ZAH,Z AJ,ZAL .....	1
4	PAFZZ	5310-00-582-6714	80205	MS35333-49	WASHER,LOCK UOC: DAC,DAD,DAE,DAF,DAG,DA H,DAJ,DAL,DAW,DAX,V14,V15,V16, V17,V18,V19,V20,V21,V22,V24,ZAA, ZAB,ZAC,ZAD,ZAE,ZAF,ZAG,ZAH,Z AJ,ZAL .....	1
5	PAFZZ	5310-00-021-9760	0AHU0	24569D	NUT,PLAIN,HEXAGON UOC: DAC,DAD,DAE,DAF,DAG,DA H,DAJ,DAL,DAW,DAX,V14,V15,V16, V17,V18,V19,V20,V21,V22,V24,ZAA, ZAB,ZAC,ZAD,ZAE,ZAF,ZAG,ZAH,Z AJ,ZAL .....	1
6	PAFZZ	4730-00-277-5555	96906	MS51952-4	ELBOW,PIPE UOC: DAC,DAD,DAE,DAF,DAG,DA H,DAJ,DAL,DAW,DAX,V14,V15,V16, V17,V18,V19,V20,V21,V22,V24 .....	1
7	PAFZZ	5306-00-068-0514	80204	B1821BH025F088N	BOLT,MACHINE UOC: DAW,DAX,V14,V15,ZAA,ZAB .....	2
8	PFFZZ	2530-00-478-5865	19207	11593371	PLATE,MOUNTING UOC: DAW,DAX,V14,V15,ZAA,ZAB .....	1
9	PAFZZ	4820-00-420-5499	06853	285172N	VALVE,BALL UOC: DAC,DAD,DAE,DAF,DAG,DA H,DAJ,DAL,DAW,DAX,V14,V15,V16, ZAC,ZAD,ZAE,ZAF,ZAG,ZAH,ZAJ,ZAL .....	1
10	PAFZZ	4730-00-196-1504	81346	A733S-75CFG	NIPPLE,PIPE UOC: DAC,DAD,DAE,DAF,DAG,DA H,DAJ,DAL,DAW,DAX,V14,V15,V16, V17,V18,V19,V20,V21,V22,V24,ZAA, ZAB,ZAC,ZAD,ZAE,ZAF,ZAG,ZAH,Z AJ,ZAL .....	1
11	PAFZZ	5305-00-269-3239	80204	B1821BH038F138N	SCREW,CAP,HEXAGON H UOC: DAW,DAX,V14,V15,ZAA,ZAB .....	2

(1) ITEM NO.	(2) SMR CODE	(3) NSN	(4) CAGEC	(5) PART NUMBER	(6) DESCRIPTION AND USABLE ON CODE (UOC)	(7) QTY
12	PAFZZ	2530-00-270-3878	06721	N13048	DUMMY COUPLING,AUTO UOC: DAC,DAD,DAE,DAF,DAG,DA H,DAJ,DAL,DAW,DAX,V14,V15,V16, V17,V18,V19,V20,V21,V22,V24,ZAA, ZAB,ZAC,ZAD,ZAE,ZAF,ZAG,ZAH,Z AJ,ZAL .....	1
13	PAFZZ	4730-00-595-0083	58536	A52484-1	COUPLING HALF,QUICK UOC: DAC,DAD,DAE,DAF,DAG,DA H,DAJ,DAL,DAW,DAX,V14,V15,V16, V17,V18,V19,V20,V21,V22,V24,ZAA, ZAB,ZAC,ZAD,ZAE,ZAF,ZAG,ZAH,Z AJ,ZAL .....	1
14	PAFZZ	5330-00-090-2128	58536	A52484-2	. PACKING,PREFORMED UOC: DAC,DAD,DAE,DAF,DAG,DA H,DAJ,DAL,DAW,DAX,V14,V15,V16, V17,V18,V19,V20,V21,V22,V24,ZAA, ZAB,ZAC,ZAD,ZAE,ZAF,ZAG,ZAH,Z AJ,ZAL .....	1
15	PFFZZ	5340-00-419-9487	19207	10883438	BRACKET,ANGLE UOC: DAW,DAX,V14,V15,ZAA,ZAB .....	1
16	PAFZZ	5310-00-809-4058	96906	MS27183-10	WASHER,FLAT UOC: DAW,DAX,V14,V15,ZAA,ZAB .....	4
16	PAFZZ	5310-00-809-4058	96906	MS27183-10	WASHER,FLAT UOC: DAC,DAD,DAE,DAF,DAG,DA H,DAJ,DAL,V16,V17,V18,V19,V20,V 21,V22,V24,ZAC,ZAD,ZAE,ZAF,ZAG, ZAH,ZAJ,ZAL .....	2
17	PAFZZ	5310-00-935-9022	81349	M45913/3-4FG8C	NUT,SELF-LOCKING,HE UOC: DAW,DAX,V14,V15,ZAA,ZAB .....	4
18	PAFZZ	5305-00-267-8954	80204	B1821BH025F125N	SCREW,CAP,HEXAGON H UOC: DAC,DAD,DAE,DAF,DAG,DA H,DAJ,DAL,V16,V17,V18,V19,V20,V 21,V22,V24,ZAC,ZAD,ZAE,ZAF,ZAG, ZAH,ZAJ,ZAL .....	2
19	PFFZZ	5340-00-157-7938	19207	10883331	PLATE,MENDING UOC: DAC,DAD,DAE,DAF,DAG,DA H,DAJ,DAL,V16,V17,V18,V19,V20,V 21,V22,V24 .....	1
20	PFFZZ	5342-00-179-7123	19207	10883328	BRACKET,COUPLING AI UOC: DAC,DAD,DAE,DAF,DAG,DA H,DAJ,DAL,V16,V17,V18,V19,V20,V 21,V22,V24,ZAC,ZAD,ZAE,ZAF,ZAG, ZAH,ZAJ,ZAL .....	1
21	PAFZZ	5310-00-935-9022	81349	M45913/3-4FG8C	NUT,SELF-LOCKING,HE UOC: DAC,DAD,DAE,DAF,DAG,DA H,DAJ,DAL,V16,V17,V18,V19,V20,V 21,V22,V24,ZAC,ZAD,ZAE,ZAF,ZAG, ZAH,ZAJ,ZAL .....	2

(1) ITEM NO.	(2) SMR CODE	(3) NSN	(4) CAGEC	(5) PART NUMBER	(6) DESCRIPTION AND USABLE ON CODE (UOC)	(7) QTY
22	PAFZZ	4730-00-196-1993	81346	B687R-67B	NIPPLE,PIPE UOC: DAL,V18,ZAL .....	1
23	PAFZZ	4730-00-249-3885	96906	MS51845-4	ELBOW,PIPE UOC: DAC,DAD,DAE,DAF,DAG,DA H,DAJ,DAL,V16,V17,V18,V19,V20,V 21,V22,V24,ZAC,ZAD,ZAE,ZAF,ZAG, ZAH,ZAJ,ZAL .....	1
24	PAFZZ	4730-00-069-1186	81343	6-4 120102BA	ADAPTER,STRAIGHT,PI UOC: DAC,DAD,DAE,DAF,DAG,DA H,DAJ,DAL,V16,V17,V18,V19,V20,V 21,V22,V24,ZAC,ZAD,ZAE,ZAF,ZAG, ZAH,ZAJ,ZAL .....	1

END OF FIGURE



**FIELD MAINTENANCE  
QUICK RELEASE VALVE, AIR BRAKE VALVES, AND RELATED LINES**

---

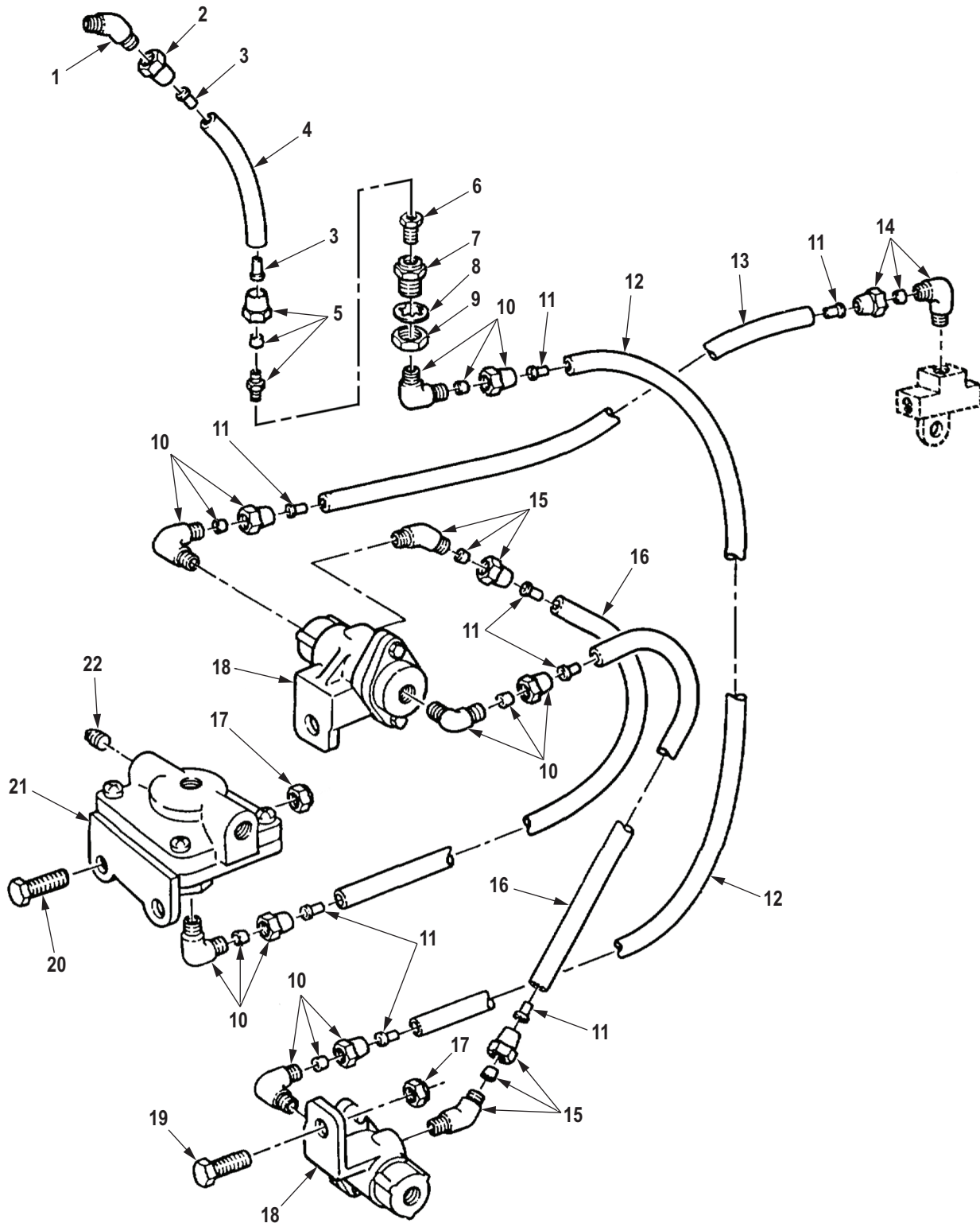

R0274DAA

Figure 258. Quick Release Valve, Air Brake Valves, and Related Lines.



(1) ITEM NO.	(2) SMR CODE	(3) NSN	(4) CAGEC	(5) PART NUMBER	(6) DESCRIPTION AND USABLE ON CODE (UOC)	(7) QTY
<b>GROUP 1208 AIR BRAKE SYSTEM.</b>						
<b>FIG. 258. QUICK RELEASE VALVE, AIR BRAKE VALVES, AND RELATED LINES.</b>						
1	PAFZZ	4730-01-134-6991	81343	4-2 100302BA	ELBOW,PIPE TO TUBE UOC: DAC,DAD,DAE,DAF,DAG,DAH,DAJ,DAL,DAW,DAX,V14,V15,V16,V17,V18,V19,V20,V21,V22,V24,ZAA,ZAB,ZAC,ZAD,ZAE,ZAF,ZAG,ZAH,ZAJ,ZAL .....	1
2	PAFZZ	4730-00-011-6452	81343	4-010110B	NUT,TUBE COUPLING UOC: DAC,DAD,DAE,DAF,DAG,DAH,DAJ,DAL,DAW,DAX,V14,V15,V16,V17,V18,V19,V20,V21,V22,V24,ZAA,ZAB,ZAC,ZAD,ZAE,ZAF,ZAG,ZAH,ZAJ,ZAL .....	2
3	PAFZZ	4730-00-132-4588	19207	11648703	INSERT,TUBE FITTING UOC: DAC,DAD,DAE,DAF,DAG,DAH,DAJ,DAL,DAW,DAX,V14,V15,V16,V17,V18,V19,V20,V21,V22,V24,ZAA,ZAB,ZAC,ZAD,ZAE,ZAF,ZAG,ZAH,ZAJ,ZAL .....	2
4	MFFZZ		81343	J844TYBSIZE 3/8 BLACK-6	HOSE,NONMETALLIC MAKE FROM HOSE,P/N J844TYBSIZE 3/8 BLACK, 6 IN. LONG UOC: DAC,DAD,DAE,DAF,DAG,DAH,DAJ,DAL,DAW,DAX,V14,V15,V16,V17,V18,V19,V20,V21,V22,V24,ZAA,ZAB,ZAC,ZAD,ZAE,ZAF,ZAG,ZAH,ZAJ,ZAL .....	1
5	PAFZZ	4730-00-277-8750	81343	SAE J246 4-2 120102BA	ADAPTER,STRAIGHT,PI UOC: DAC,DAD,DAE,DAF,DAG,DAH,DAJ,DAL,DAW,DAX,V14,V15,V16,V17,V18,V19,V20,V21,V22,V24,ZAA,ZAB,ZAC,ZAD,ZAE,ZAF,ZAG,ZAH,ZAJ,ZAL .....	1
6	PAFZZ	4730-00-180-5038	81343	SAE J530 6-2 130140B	BUSHING,PIPE UOC: DAC,DAD,DAE,DAF,DAG,DAH,DAJ,DAL,DAW,DAX,V14,V15,V16,V17,V18,V19,V20,V21,V22,V24,ZAA,ZAB,ZAC,ZAD,ZAE,ZAF,ZAG,ZAH,ZAJ,ZAL .....	1
7	PAFZZ	4730-00-421-3924	19207	7339982	ADAPTER,STRAIGHT,PI UOC: DAC,DAD,DAE,DAF,DAG,DAH,DAJ,DAL,DAW,DAX,V14,V15,V16,V17,V18,V19,V20,V21,V22,V24,ZAA,ZAB,ZAC,ZAD,ZAE,ZAF,ZAG,ZAH,ZAJ,ZAL .....	1

(1) ITEM NO.	(2) SMR CODE	(3) NSN	(4) CAGEC	(5) PART NUMBER	(6) DESCRIPTION AND USABLE ON CODE (UOC)	(7) QTY
8	PAFZZ	5310-00-582-6714	80205	MS35333-49	WASHER,LOCK UOC: DAC,DAD,DAE,DAF,DAG,DA H,DAJ,DAL,DAW,DAX,V14,V15,V16, V17,V18,V19,V20,V21,V22,V24,ZAA, ZAB,ZAC,ZAD,ZAE,ZAF,ZAG,ZAH,Z AJ,ZAL .....	1
9	PAFZZ	5310-00-241-0157	19207	5331179	NUT,PLAIN,HEXAGON UOC: DAC,DAD,DAE,DAF,DAG,DA H,DAJ,DAL,DAW,DAX,V14,V15,V16, V17,V18,V19,V20,V21,V22,V24,ZAA, ZAB,ZAC,ZAD,ZAE,ZAF,ZAG,ZAH,Z AJ,ZAL .....	1
10	PAFZZ	4730-00-289-0051	81343	8-6 120202BA	ELBOW,PIPE TO TUBE UOC: DAC,DAD,DAE,DAF,DAG,DA H,DAJ,DAL,DAW,DAX,V14,V15,V16, V17,V18,V19,V20,V21,V22,V24,ZAA, ZAB,ZAC,ZAD,ZAE,ZAF,ZAG,ZAH,Z AJ,ZAL .....	2
11	PAFZZ	4730-01-032-6038	19207	CPR102321-4	INSERT,TUBE FITTING UOC: DAC,DAD,DAE,DAF,DAG,DA H,DAJ,DAL,DAW,DAX,V14,V15,V16, V17,V18,V19,V20,V21,V22,V24,ZAA, ZAB,ZAC,ZAD,ZAE,ZAF,ZAG,ZAH,Z AJ,ZAL .....	8
12	MFFZZ		19207	CPR104420-3-83	HOSE,NONMETALLIC MAKE FROM HOSE, P/N CPR104420-3, 83 IN.LONG UOC: DAC,DAD,DAE,DAF,DAG,DA H,DAJ,DAL,DAW,DAX,V14,V15,V16, V17,V18,V19,V20,V21,V22,V24,ZAA, ZAB,ZAC,ZAD,ZAE,ZAF,ZAG,ZAH,Z AJ,ZAL .....	1
13	MFFZZ		19207	CPR104420-3-69	HOSE,NONMETALLIC MAKE FROM HOSE, P/N CPR104420-3, 69 IN.LONG UOC: DAC,DAD,DAE,DAF,DAG,DA H,DAJ,DAL,V16,V17,V18,V19,V20,V 21,V22,V24,ZAC,ZAD,ZAE,ZAF,ZAG, ZAH,ZAJ,ZAL .....	1
13	MFFZZ		19207	CPR104420-3-74	HOSE,NONMETALLIC MAKE FROM HOSE,P/N CPR104420-3, 74 IN.LONG UOC: DAW,DAX,V14,V15,ZAA,ZAB .....	1
14	PAFZZ	4730-00-409-7854	81343	J246 8-4 120202BA	ELBOW,PIPE TO TUBE UOC: DAC,DAD,DAE,DAF,DAG,DA H,DAJ,DAL,DAW,DAX,V14,V15,V16, V17,V18,V19,V20,V21,V22,V24,ZAA, ZAB,ZAC,ZAD,ZAE,ZAF,ZAG,ZAH,Z AJ,ZAL .....	1

(1) ITEM NO.	(2) SMR CODE	(3) NSN	(4) CAGEC	(5) PART NUMBER	(6) DESCRIPTION AND USABLE ON CODE (UOC)	(7) QTY
15	PAFZZ	4730-01-117-1614	81343	8-6 120302BA	ELBOW,PIPE TO TUBE UOC: DAC,DAD,DAE,DAF,DAG,DA H,DAJ,DAL,DAW,DAX,V14,V15,V16, V17,V18,V19,V20,V21,V22,V24,ZAA, ZAB,ZAC,ZAD,ZAE,ZAF,ZAG,ZAH,Z AJ,ZAL .....	2
16	MFFZZ		19207	CPR104420-3-9	HOSE,NONMETALLIC MAKE FROM HOSE P/N CPR104420-3 UOC: DAC,DAD,DAE,DAF,DAG,DA H,DAJ,DAL,DAW,DAX,V14,V15,V16, V17,V18,V19,V20,V21,V22,V24,ZAA, ZAB,ZAC,ZAD,ZAE,ZAF,ZAG,ZAH,Z AJ,ZAL .....	2
17	PAFZZ	5310-00-241-6658	81349	M45913/3-5FG8C	NUT,SELF-LOCKING,HE UOC: DAC,DAD,DAE,DAF,DAG,DA H,DAJ,DAL,DAW,DAX,V14,V15,V16, V17,V18,V19,V20,V21,V22,V24,ZAA, ZAB,ZAC,ZAD,ZAE,ZAF,ZAG,ZAH,Z AJ,ZAL .....	4
18	PAFZZ	4820-00-728-7467	06853	278614N	VALVE,LINEAR,DIRECT UOC: DAC,DAD,DAE,DAF,DAG,DA H,DAJ,DAL,DAW,DAX,V14,V15,V16, V17,V18,V19,V20,V21,V22,V24,ZAA, ZAB,ZAC,ZAD,ZAE,ZAF,ZAG,ZAH,Z AJ,ZAL .....	2
19	PAFZZ	5305-00-225-9093	80205	NASM90726-38	SCREW,CAP,HEXAGON H UOC: DAC,DAD,DAE,DAF,DAG,DA H,DAJ,DAL,DAW,DAX,V14,V15,V16, V17,V18,V19,V20,V21,V22,V24,ZAA, ZAB,ZAC,ZAD,ZAE,ZAF,ZAG,ZAH,Z AJ,ZAL .....	2
20	PAFZZ	5306-00-050-1238	80204	B1821BH031F075N	BOLT,MACHINE UOC: DAC,DAD,DAE,DAF,DAG,DA H,DAJ,DAL,DAW,DAX,V14,V15,V16, V17,V18,V19,V20,V21,V22,V24,ZAA, ZAB,ZAC,ZAD,ZAE,ZAF,ZAG,ZAH,Z AJ,ZAL .....	2
21	PFFZZ	4820-00-857-2737	06853	288251N	VALVE,LINEAR,DIRECT UOC: DAC,DAD,DAE,DAF,DAG,DA H,DAJ,DAL,DAW,DAX,V14,V15,V16, V17,V18,V19,V20,V21,V22,V24,ZAA, ZAB,ZAC,ZAD,ZAE,ZAF,ZAG,ZAH,Z AJ,ZAL .....	1

(1) ITEM NO.	(2) SMR CODE	(3) NSN	(4) CAGEC	(5) PART NUMBER	(6) DESCRIPTION AND USABLE ON CODE (UOC)	(7) QTY
22	PAFZZ	4730-00-050-0730	81348	WW-P-471ACABCC	PLUG,PIPE UOC: DAC,DAD,DAE,DAF,DAG,DA H,DAJ,DAL,DAW,DAX,V14,V15,V16, V17,V18,V19,V20,V21,V22,V24,ZAA, ZAB,ZAC,ZAD,ZAE,ZAF,ZAG,ZAH,Z AJ,ZAL .....	2

END OF FIGURE

**FIELD MAINTENANCE  
BRAKE LQ-2 VALVE (ABS)**

---

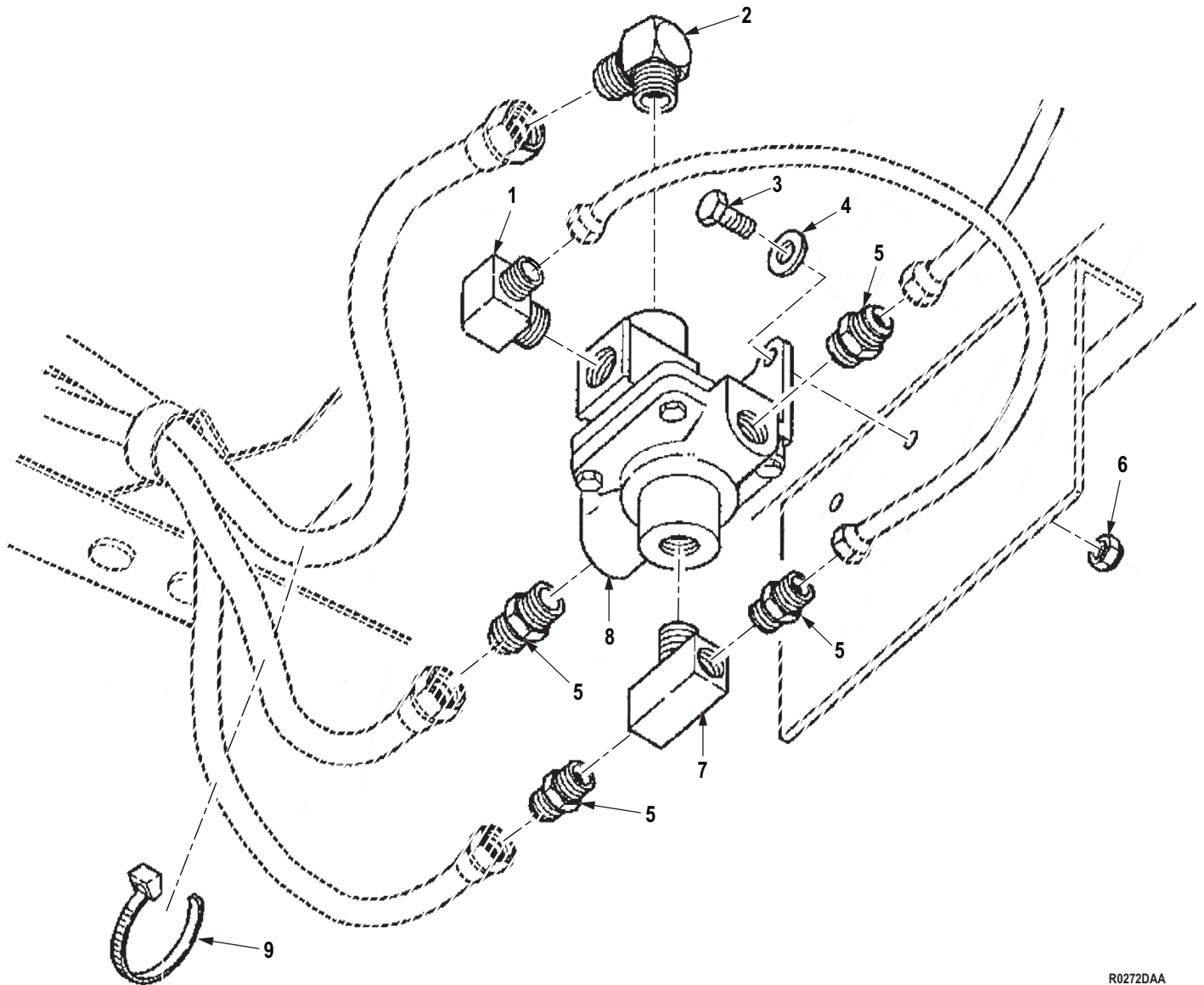

R0272DAA

Figure 259. Brake LQ-2 Valve (ABS).

(1) ITEM NO.	(2) SMR CODE	(3) NSN	(4) CAGEC	(5) PART NUMBER	(6) DESCRIPTION AND USABLE ON CODE (UOC)	(7) QTY
<b>GROUP 1208 AIR BRAKE SYSTEM.</b>						
<b>FIG. 259. BRAKE LQ-2 VALVE (ABS).</b>						
1	PAFZZ	4730-00-289-0155	81343	6-6 120202BA	ELBOW,PIPE TO TUBE UOC: DAC,DAD,DAE,DAF,DAG,DA H,DAJ,DAL,DAW,DAX,V14,V15,V16, V17,V18,V19,V20,V21,V22,V24,ZAA, ZAB,ZAC,ZAD,ZAE,ZAF,ZAG,ZAH,Z AJ,ZAL .....	1
2	PAFZZ	4730-01-095-7717	81343	SAE J246 8-6 100202BA	ELBOW,PIPE TO TUBE UOC: DAC,DAD,DAE,DAF,DAG,DA H,DAJ,DAL,DAW,DAX,V14,V15,V16, V17,V18,V19,V20,V21,V22,V24,ZAA, ZAB,ZAC,ZAD,ZAE,ZAF,ZAG,ZAH,Z AJ,ZAL .....	1
3	PAFZZ	5305-00-051-4076	96906	MS90727-34	SCREW,CAP,HEXAGON H UOC: DAC,DAD,DAE,DAF,DAG,DA H,DAJ,DAL,DAW,DAX,V14,V15,V16, V17,V18,V19,V20,V21,V22,V24,ZAA, ZAB,ZAC,ZAD,ZAE,ZAF,ZAG,ZAH,Z AJ,ZAL .....	1
4	PAFZZ	5310-00-081-4219	96906	MS27183-12	WASHER,FLAT UOC: DAC,DAD,DAE,DAF,DAG,DA H,DAJ,DAL,DAW,DAX,V14,V15,V16, V17,V18,V19,V20,V21,V22,V24,ZAA, ZAB,ZAC,ZAD,ZAE,ZAF,ZAG,ZAH,Z AJ,ZAL .....	1
5	PAFZZ	4730-01-091-8032	81343	J246 8-6 100102BA	ADAPTER,STRAIGHT,PI UOC: DAC,DAD,DAE,DAF,DAG,DA H,DAJ,DAL,DAW,DAX,V14,V15,V16, V17,V18,V19,V20,V21,V22,V24,ZAA, ZAB,ZAC,ZAD,ZAE,ZAF,ZAG,ZAH,Z AJ,ZAL .....	1
6	PAFZZ	5310-00-241-6658	81349	M45913/3-5FG8C	NUT,SELF-LOCKING,HE UOC: DAC,DAD,DAE,DAF,DAG,DA H,DAJ,DAL,DAW,DAX,V14,V15,V16, V17,V18,V19,V20,V21,V22,V24,ZAA, ZAB,ZAC,ZAD,ZAE,ZAF,ZAG,ZAH,Z AJ,ZAL .....	1
7	PAFZZ	4730-01-288-3883	93061	2205P-6	CROSS,PIPE UOC: DAC,DAD,DAE,DAF,DAG,DA H,DAJ,DAL,DAW,DAX,V14,V15,V16, V17,V18,V19,V20,V21,V22,V24,ZAA, ZAB,ZAC,ZAD,ZAE,ZAF,ZAG,ZAH,Z AJ,ZAL .....	1

(1) ITEM NO.	(2) SMR CODE	(3) NSN	(4) CAGEC	(5) PART NUMBER	(6) DESCRIPTION AND USABLE ON CODE (UOC)	(7) QTY
8	PAFZZ	2530-01-515-6392	0UKB6	WCDFAPL-100	VALVE,BRAKE PNEUMAT ABS L2- Q VALVE UOC: DAC,DAD,DAE,DAF,DAG,DA H,DAJ,DAL,DAW,V14,V15,V16,V17, V18,V19,V20,V21,V22,V24,ZAA,ZAB, ZAC,ZAD,ZAE,ZAF,ZAG,ZAH,ZAJ,ZAL	..... 1
9	PAFZZ	5975-01-205-5379	81343	MS3367-7	STRAP,TIEDOWN,ELECT UOC: DAC,DAD,DAE,DAF,DAG,DA H,DAJ,DAL,DAW,DAX,V14,V15,V16, V17,V18,V19,V20,V21,V22,V24,ZAA, ZAB,ZAC,ZAD,ZAE,ZAF,ZAG,ZAH,Z AJ,ZAL	..... 1

END OF FIGURE



**FIELD MAINTENANCE  
INVERSION VALVE (ABS)**

---

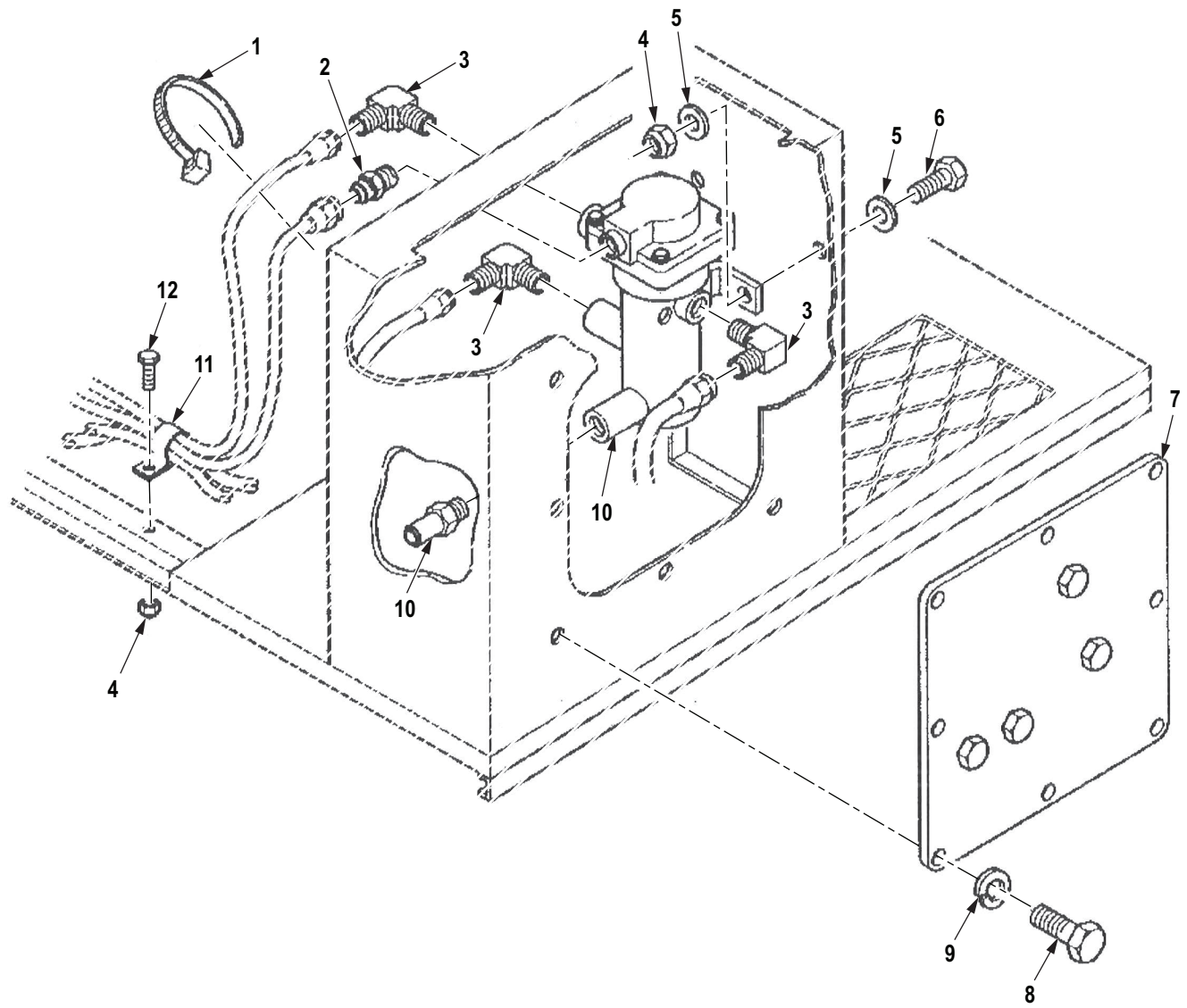

R0276DAA

Figure 260. Inversion Valve (ABS).

(1) ITEM NO.	(2) SMR CODE	(3) NSN	(4) CAGEC	(5) PART NUMBER	(6) DESCRIPTION AND USABLE ON CODE (UOC)	(7) QTY
<b>GROUP 1208 AIR BRAKE SYSTEM.</b>						
<b>FIG. 260. INVERSION VALVE (ABS).</b>						
1	PAFZZ	5975-01-205-5379	81343	MS3367-7	STRAP,TIEDOWN,ELECT UOC: DAC,DAD,DAE,DAF,DAG,DA H,DAJ,DAL,DAW,DAX,V14,V15,V16, V17,V18,V19,V20,V21,V22,V24,ZAA, ZAB,ZAC,ZAD,ZAE,ZAF,ZAG,ZAH,Z AJ,ZAL .....	1
2	PAFZZ	4730-01-062-2570	93061	68NTA-6-4	ADAPTER,STRAIGHT,PI UOC: DAC,DAD,DAE,DAF,DAG,DA H,DAJ,DAL,DAW,DAX,V14,V15,V16, V17,V18,V19,V20,V21,V22,V24,ZAA, ZAB,ZAC,ZAD,ZAE,ZAF,ZAG,ZAH,Z AJ,ZAL .....	1
3	PAFZZ	4730-00-069-1187	93061	269NTA-6-4	ELBOW,PIPE TO TUBE UOC: DAC,DAD,DAE,DAF,DAG,DA H,DAJ,DAL,DAW,DAX,V14,V15,V16, V17,V18,V19,V20,V21,V22,V24,ZAA, ZAB,ZAC,ZAD,ZAE,ZAF,ZAG,ZAH,Z AJ,ZAL .....	2
4	PAFZZ	5310-00-814-0672	96906	M45913/3-6FG8C	NUT,SELF-LOCKING,HE UOC: DAC,DAD,DAE,DAF,DAG,DA H,DAJ,DAL,DAW,DAX,V14,V15,V16, V17,V18,V19,V20,V21,V22,V24,ZAA, ZAB,ZAC,ZAD,ZAE,ZAF,ZAG,ZAH,Z AJ,ZAL .....	3
5	PAFZZ	5310-01-280-5796	96906	MS27183-57	WASHER,FLAT UOC: DAC,DAD,DAE,DAF,DAG,DA H,DAJ,DAL,DAW,DAX,V14,V15,V16, V17,V18,V19,V20,V21,V22,V24,ZAA, ZAB,ZAC,ZAD,ZAE,ZAF,ZAG,ZAH,Z AJ,ZAL .....	4
6	PAFZZ	5305-00-269-3238	80204	B1821BH038F125N	SCREW,CAP,HEXAGON H UOC: DAC,DAD,DAE,DAF,DAG,DA H,DAJ,DAL,DAW,DAX,V14,V15,V16, V17,V18,V19,V20,V21,V22,V24,ZAA, ZAB,ZAC,ZAD,ZAE,ZAF,ZAG,ZAH,Z AJ,ZAL .....	1
7	PFFZZ	5340-01-103-6010	19207	12276933	COVER,ACCESS UOC: DAC,DAD,DAE,DAF,DAG,DA H,DAJ,DAL,DAW,DAX,V14,V15,V16, V17,V18,V19,V20,V21,V22,V24,ZAA, ZAB,ZAC,ZAD,ZAE,ZAF,ZAG,ZAH,Z AJ,ZAL .....	1

(1) ITEM NO.	(2) SMR CODE	(3) NSN	(4) CAGEC	(5) PART NUMBER	(6) DESCRIPTION AND USABLE ON CODE (UOC)	(7) QTY
8	PAFZZ	5305-00-269-2803	80205	MS90726-60	SCREW,CAP,HEXAGON H UOC: DAC,DAD,DAE,DAF,DAG,DA H,DAJ,DAL,DAW,DAX,V14,V15,V16, V17,V18,V19,V20,V21,V22,V24,ZAA, ZAB,ZAC,ZAD,ZAE,ZAF,ZAG,ZAH,Z AJ,ZAL .....	8
9	PAFZZ	5310-00-637-9541	00198	132661	WASHER,LOCK UOC: DAC,DAD,DAE,DAF,DAG,DA H,DAJ,DAL,DAW,DAX,V14,V15,V16, V17,V18,V19,V20,V21,V22,V24,ZAA, ZAB,ZAC,ZAD,ZAE,ZAF,ZAG,ZAH,Z AJ,ZAL .....	8
10	PAFZZ	2530-01-478-3877	0UKB6	WHMBN50002B	VALVE,BRAKE,PNEUMAT UOC: DAC,DAD,DAE,DAF,DAG,DA H,DAJ,DAL,DAW,DAX,V14,V15,V16, V17,V18,V19,V20,V21,V22,V24,ZAA, ZAB,ZAC,ZAD,ZAE,ZAF,ZAG,ZAH,Z AJ,ZAL .....	1
11	PAFZZ	5340-01-231-5357	19207	7529133-9	CLAMP,LOOP UOC: DAC,DAD,DAE,DAF,DAG,DA H,DAJ,DAL,DAW,DAX,V14,V15,V16, V17,V18,V19,V20,V21,V22,V24,ZAA, ZAB,ZAC,ZAD,ZAE,ZAF,ZAG,ZAH,Z AJ,ZAL .....	2
12	PAFZZ	5305-00-269-3235	80204	B1821BH038F088N	SCREW,CAP,HEXAGON H UOC: DAC,DAD,DAE,DAF,DAG,DA H,DAJ,DAL,DAW,DAX,V14,V15,V16, V17,V18,V19,V20,V21,V22,V24,ZAA, ZAB,ZAC,ZAD,ZAE,ZAF,ZAG,ZAH,Z AJ,ZAL .....	1

END OF FIGURE

**FIELD MAINTENANCE  
AIR LINE CROSS FITTING (ABS)**

---

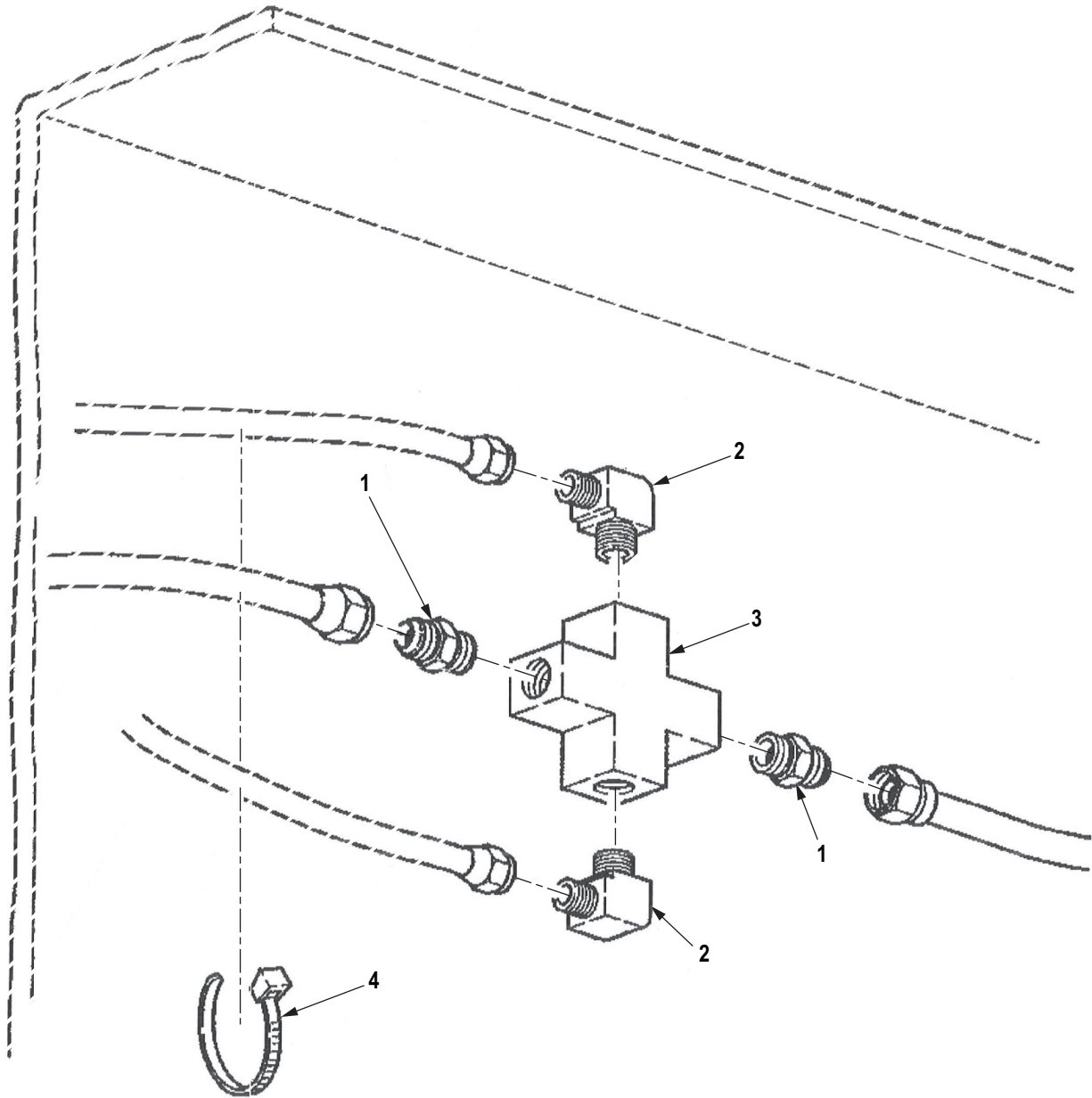

R0277DAA

Figure 261. Air Line Cross Fitting (ABS).

(1) ITEM NO.	(2) SMR CODE	(3) NSN	(4) CAGEC	(5) PART NUMBER	(6) DESCRIPTION AND USABLE ON CODE (UOC)	(7) QTY
<b>GROUP 1208 AIR BRAKE SYSTEM.</b>						
<b>FIG. 261. AIR LINE CROSS FITTING (ABS).</b>						
1	PAFZZ	4730-01-091-8032	81343	J246 8-6 100102BA	ADAPTER, STRAIGHT, PI UOC: DAC, DAD, DAE, DAF, DAG, DA H, DAJ, DAL, DAW, DAX, V14, V15, V16, V17, V18, V19, V20, V21, V22, V24, ZAA, ZAB, ZAC, ZAD, ZAE, ZAF, ZAG, ZAH, Z AJ, ZAL .....	2
2	PAFZZ	4730-00-289-0155	81343	6-6 120202BA	ELBOW, PIPE TO TUBE UOC: DAC, DAD, DAE, DAF, DAG, DA H, DAJ, DAL, DAW, DAX, V14, V15, V16, V17, V18, V19, V20, V21, V22, V24, ZAA, ZAB, ZAC, ZAD, ZAE, ZAF, ZAG, ZAH, Z AJ, ZAL .....	2
3	PAFZZ	4730-01-288-3883	93061	2205P-6	CROSS, PIPE UOC: DAC, DAD, DAE, DAF, DAG, DA H, DAJ, DAL, DAW, DAX, V14, V15, V16, V17, V18, V19, V20, V21, V22, V24, ZAA, ZAB, ZAC, ZAD, ZAE, ZAF, ZAG, ZAH, Z AJ, ZAL .....	1
4	PAFZZ	5975-01-205-5379	81343	MS3367-7	STRAP, TIEDOWN, ELECT UOC: DAC, DAD, DAE, DAF, DAG, DA H, DAJ, DAL, DAW, DAX, V14, V15, V16, V17, V18, V19, V20, V21, V22, V24, ZAA, ZAB, ZAC, ZAD, ZAE, ZAF, ZAG, ZAH, Z AJ, ZAL .....	1

**END OF FIGURE**





**FIELD MAINTENANCE  
TREADLE VALVE TO SECONDARY RELAY VALVE AND PRIMARY RELAY VALVE TO HALF COUPLING  
LINES**

---

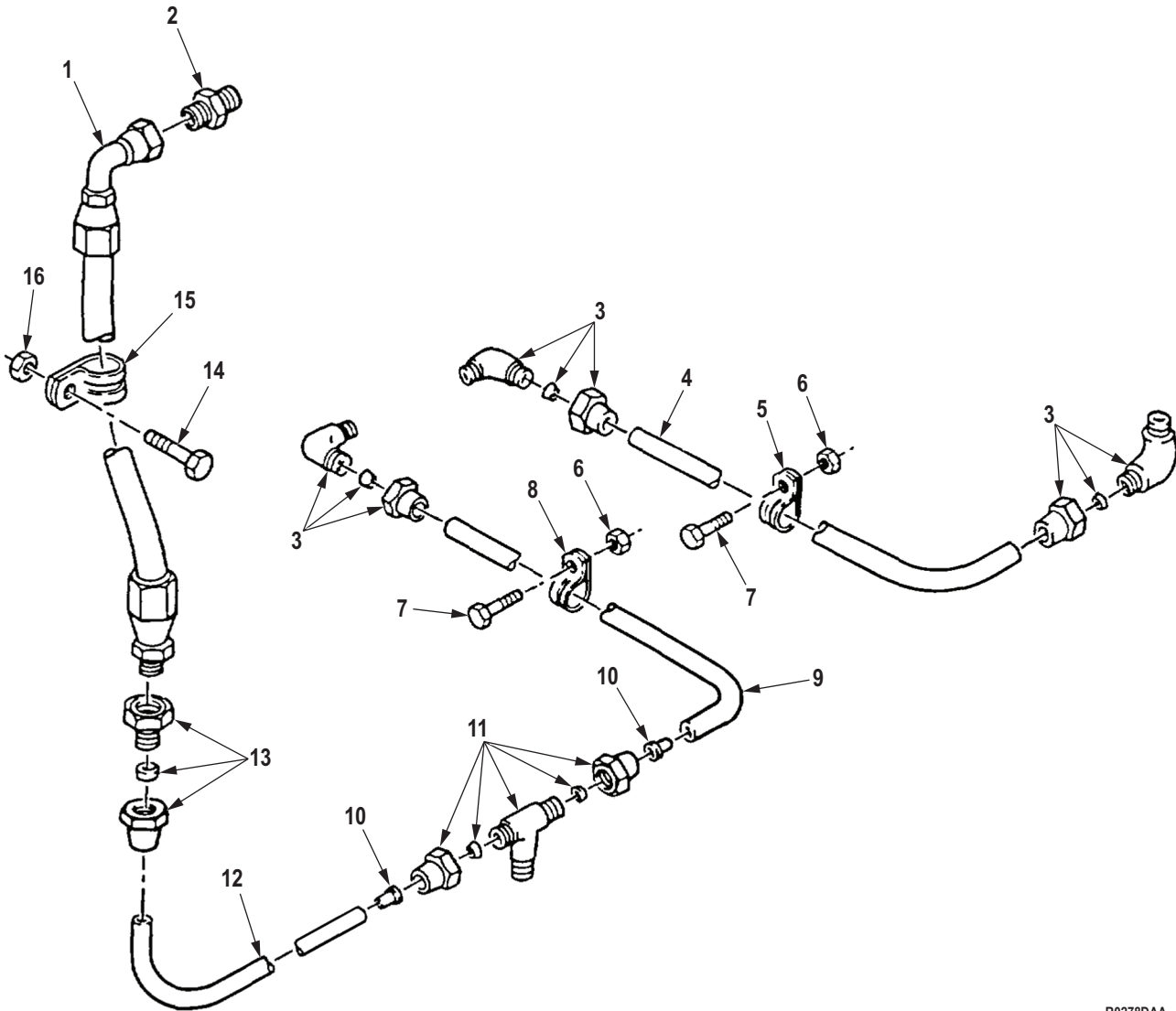

R0278DAA

Figure 262. Treadle Valve to Secondary Relay Valve and Primary Relay Valve to Half Coupling Lines.

(1) ITEM NO.	(2) SMR CODE	(3) NSN	(4) CAGEC	(5) PART NUMBER	(6) DESCRIPTION AND USABLE ON CODE (UOC)	(7) QTY
<b>GROUP 1208 AIR BRAKE SYSTEM.</b>						
<b>FIG. 262. TREADLE VALVE TO SECONDARY RELAY VALVE AND PRIMARY RELAY VALVE TO HALF COUPLING LINES.</b>						
1	PAFZZ	4720-01-112-2325	19207	12256263	HOSE ASSEMBLY, NONME UOC: DAC, DAD, DAE, DAF, DAG, DA H, DAJ, DAL, DAW, DAX, V14, V15, V16, V17, V18, V19, V20, V21, V22, V24, ZAA, ZAB, ZAC, ZAD, ZAE, ZAF, ZAG, ZAH, Z AJ, ZAL .....	1
2	PAFZZ	4730-00-809-9427	81343	MS51500A8-8	ADAPTER, STRAIGHT, PI UOC: DAC, DAD, DAE, DAF, DAG, DA H, DAJ, DAL, DAW, DAX, V14, V15, V16, V18, V21, V22, V24, ZAA, ZAB, ZAC, ZA D, ZAE, ZAF, ZAG, ZAH, ZAJ, ZAL .....	1
3	PAFZZ	4730-00-069-1187	81343	SAE J246 6-4 100202BA	ELBOW, PIPE TO TUBE UOC: DAC, DAD, DAE, DAF, DAG, DA H, DAJ, DAL, DAW, DAX, V14, V15, V16, V17, V18, V19, V20, V21, V22, V24, ZAA, ZAB, ZAC, ZAD, ZAE, ZAF, ZAG, ZAH, Z AJ, ZAL .....	3
4	MFFZZ		81343	J844TYBSIZE 3/8 BLACK-37	HOSE, NONMETALLIC MAKE FROM HOSE, P/N J844TYBSIZE 3/8 BLACK, 37 IN. LONG UOC: DAC, DAD, DAE, DAF, DAG, DA H, DAJ, DAL, V16, V17, V18, V19, V20, V 21, V22, V24, ZAC, ZAD, ZAE, ZAF, ZAG, ZAH, ZAJ, ZAL .....	1
4	MFFZZ		81343	J844TYBSIZE 3/8 BLACK-35	HOSE, NONMETALLIC MAKE FROM HOSE, P/N J844TYBSIZE 3/8 BLACK, 35 IN. LONG UOC: DAC, DAD, DAE, DAF, DAG, DA H, DAJ, DAL, DAW, DAX, V14, V15, V16, V17, V18, V19, V20, V21, V22, V24, ZAA, ZAB, ZAC, ZAD, ZAE, ZAF, ZAG, ZAH, Z AJ, ZAL .....	1
5	PAFZZ	5340-00-954-6014	80205	MS21333-121	CLAMP, LOOP UOC: DAC, DAD, DAE, DAF, DAG, DA H, DAJ, DAL, DAW, DAX, V14, V15, V16, V17, V18, V19, V20, V21, V22, V24, ZAA, ZAB, ZAC, ZAD, ZAE, ZAF, ZAG, ZAH, Z AJ, ZAL .....	0001
6	PAFZZ	5310-00-814-0672	96906	M45913/3-6FG8C	NUT, SELF-LOCKING, HE UOC: DAC, DAD, DAE, DAF, DAG, DA H, DAJ, DAL, DAW, DAX, V14, V15, V16, V17, V18, V19, V20, V21, V22, V24, ZAA, ZAB, ZAC, ZAD, ZAE, ZAF, ZAG, ZAH, Z AJ, ZAL .....	2

(1) ITEM NO.	(2) SMR CODE	(3) NSN	(4) CAGEC	(5) PART NUMBER	(6) DESCRIPTION AND USABLE ON CODE (UOC)	(7) QTY
7	PAFZZ	5305-00-269-2804	80205	MS90726-61	SCREW,CAP,HEXAGON H UOC: DAC,DAD,DAE,DAF,DAG,DA H,DAJ,DAL,DAW,DAX,V14,V15,V16, V17,V18,V19,V20,V21,V22,V24,ZAA, ZAB,ZAC,ZAD,ZAE,ZAF,ZAG,ZAH,Z AJ,ZAL .....	2
8	PAFZZ	5340-00-954-6014	80205	MS21333-121	CLAMP,LOOP UOC: DAC,DAD,DAE,DAF,DAG,DA H,DAJ,DAL,DAW,DAX,V14,V15,V16, V17,V18,V19,V20,V21,V22,V24,ZAA, ZAB,ZAC,ZAD,ZAE,ZAF,ZAG,ZAH,Z AJ,ZAL .....	1
9	MFFZZ		81343	J844TYBSIZE 3/8 BLACK-78	HOSE,NONMETALLIC CHECK VALVE TO FRONT RELAY VALVE,MAKE FROM HOSE, P/N J844TYBSIZE 3/8 BLACK, 78 INCH LONG UOC: DAC,DAD,DAE,DAF,DAJ,DAL, V16,V17,V18,V19,V20,V24 .....	1
9	MFFZZ		81343	J844TYBSIZE 3/8 BLACK-50	HOSE,NONMETALLIC MAKE FROM HOSE, P/N J844TYBSIZE 3/8 BLACK, 50 IN.LONG UOC: DAG,DAH,V21,V22,ZAG,ZAH .....	1
10	PAFZZ	4730-01-079-8821	19207	CPR102321-1	INSERT,TUBE FITTING UOC: DAC,DAD,DAE,DAF,DAG,DA H,DAJ,DAL,DAW,DAX,V14,V15,V16, V17,V18,V19,V20,V21,V22,V24,ZAA, ZAB,ZAC,ZAD,ZAE,ZAF,ZAG,ZAH,Z AJ,ZAL .....	6
11	PAFZZ	4730-01-195-0095	19207	12302759	TEE,PIPE TO TUBE UOC: DAC,DAD,DAE,DAF,DAG,DA H,DAJ,DAL,DAW,DAX,V14,V15,V16, V17,V18,V19,V20,V21,V22,V24,ZAA, ZAB,ZAC,ZAD,ZAE,ZAF,ZAG,ZAH,Z AJ,ZAL .....	1
12	MFFZZ		81343	J844TYBSIZE 3/8 BLACK-66	HOSE,NONMETALLIC MAKE FROM HOSE, P/N J844TYBSIZE 3/8 BLACK, 66 IN.LONG UOC: DAW,DAX,V14,V15,ZAA,ZAB .....	1
12	MFFZZ		81343	J844TYBSIZE 3/8 BLACK-56	HOSE,NONMETALLIC MAKE FROM HOSE, P/N J844TYBSIZE 3/8 BLACK 56 IN. LONG UOC: DAC,DAD,DAE,DAF,DAJ,DAL, DAW,V16,V17,V18,V19,V20,V24 .....	1
13	PAFZZ	4730-00-277-8770	81343	J246 6-6 120103BA	ADAPTER,STRAIGHT,PI UOC: DAC,DAD,DAE,DAF,DAG,DA H,DAJ,DAL,DAW,DAX,V14,V15,V16, V17,V18,V19,V20,V21,V22,V24,ZAA, ZAB,ZAC,ZAD,ZAE,ZAF,ZAG,ZAH,Z AJ,ZAL .....	1

(1) ITEM NO.	(2) SMR CODE	(3) NSN	(4) CAGEC	(5) PART NUMBER	(6) DESCRIPTION AND USABLE ON CODE (UOC)	(7) QTY
14	PAFZZ	5305-00-857-3367	96906	MS9316-13	SCREW,MACHINE UOC: DAC,DAD,DAE,DAF,DAG,DA H,DAJ,DAL,DAW,DAX,V14,V15,V16, V17,V18,V19,V20,V21,V22,V24,ZAA, ZAB,ZAC,ZAD,ZAE,ZAF,ZAG,ZAH,Z AJ,ZAL .....	1
15	PAFZZ	5340-01-105-9143	80205	MS21334-42	CLAMP,LOOP UOC: DAC,DAD,DAE,DAF,DAG,DA H,DAJ,DAL,DAW,DAX,V14,V15,V16, V17,V18,V19,V20,V21,V22,V24,ZAA, ZAB,ZAC,ZAD,ZAE,ZAF,ZAG,ZAH,Z AJ,ZAL .....	1
16	PAFZZ	5310-00-061-7326	80205	MS21045-3	NUT,SELF-LOCKING,HE UOC: DAC,DAD,DAE,DAF,DAG,DA H,DAJ,DAL,DAW,DAX,V14,V15,V16, V17,V18,V19,V20,V21,V22,V24,ZAA, ZAB,ZAC,ZAD,ZAE,ZAF,ZAG,ZAH,Z AJ,ZAL .....	1

END OF FIGURE



**FIELD MAINTENANCE  
PRIMARY AND SECONDARY RELAY VALVE, MOUNTING HARDWARE, AND RELATED LINES**

---

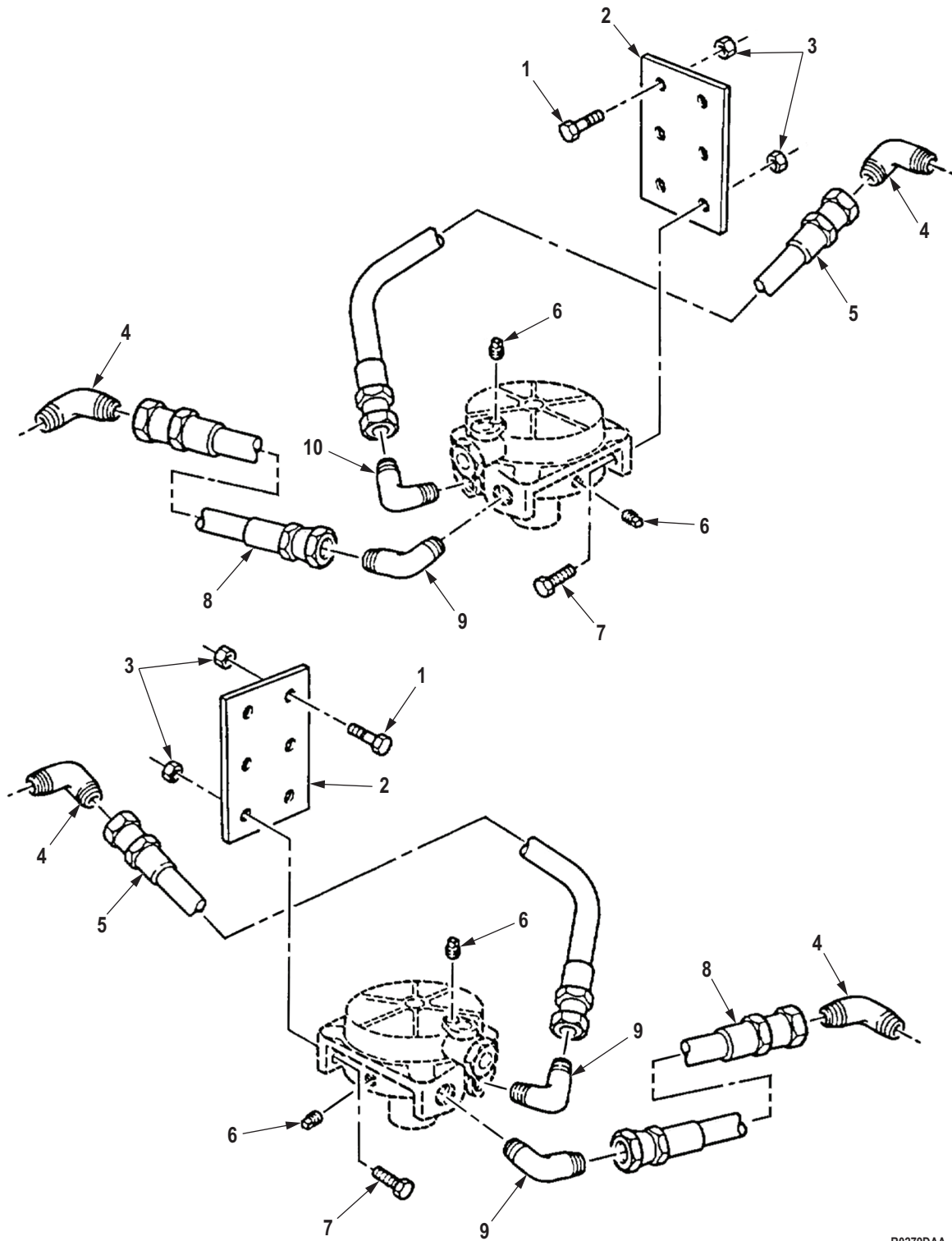

R0279DAA

Figure 263. Primary and Secondary Relay Valve, Mounting Hardware, and Related Lines.



(1) ITEM NO.	(2) SMR CODE	(3) NSN	(4) CAGEC	(5) PART NUMBER	(6) DESCRIPTION AND USABLE ON CODE (UOC)	(7) QTY
<b>GROUP 1208 AIR BRAKE SYSTEM.</b>						
<b>FIG. 263. PRIMARY AND SECONDARY RELAY VALVE, MOUNTING HARDWARE, AND RELATED LINES.</b>						
1	PAFZZ	5305-00-269-2804	80205	MS90726-61	SCREW,CAP,HEXAGON H UOC: DAC,DAD,DAE,DAF,DAG,DA H,DAJ,DAL,DAW,DAX,V14,V15,V16, V17,V18,V19,V20,V21,V22,V24,ZAA, ZAB,ZAC,ZAD,ZAE,ZAF,ZAG,ZAH,Z AJ,ZAL .....	8
2	PFFZZ	5340-01-112-2164	19207	12256288	BRACKET,MOUNTING UOC: DAC,DAD,DAE,DAF,DAG,DA H,DAJ,DAL,DAW,DAX,V14,V15,V16, V17,V18,V19,V20,V21,V22,V24,ZAA, ZAB,ZAC,ZAD,ZAE,ZAF,ZAG,ZAH,Z AJ,ZAL .....	2
3	PAFZZ	5310-00-814-0672	96906	M45913/3-6FG8C	NUT,SELF-LOCKING,HE UOC: DAC,DAD,DAE,DAF,DAG,DA H,DAJ,DAL,DAW,DAX,V14,V15,V16, V17,V18,V19,V20,V21,V22,V24,ZAA, ZAB,ZAC,ZAD,ZAE,ZAF,ZAG,ZAH,Z AJ,ZAL .....	12
4	PAFZZ	4730-00-555-1764	96906	MS51504A8	ELBOW,PIPE TO TUBE UOC: DAC,DAD,DAE,DAF,DAG,DA H,DAJ,DAL,DAW,DAX,V14,V15,V16, V17,V18,V19,V20,V21,V22,V24,ZAA, ZAB,ZAC,ZAD,ZAE,ZAF,ZAG,ZAH,Z AJ,ZAL .....	4
5	PAFZZ	4720-01-188-5139	19207	12256271-6	HOSE ASSEMBLY,NONME UOC: DAC,DAD,DAE,DAF,DAG,DA H,DAJ,DAL,DAW,DAX,V14,V15,V16, V17,V18,V19,V20,V21,V22,V24,ZAA, ZAB,ZAC,ZAD,ZAE,ZAF,ZAG,ZAH,Z AJ,ZAL .....	2
6	PAFZZ	4730-00-359-3872	58536	AA59616ACABCE	PLUG,PIPE UOC: DAC,DAD,DAE,DAF,DAG,DA H,DAJ,DAL,DAW,DAX,V14,V15,V16, V17,V18,V19,V20,V21,V22,V24,ZAA, ZAB,ZAC,ZAD,ZAE,ZAF,ZAG,ZAH,Z AJ,ZAL .....	4
7	PAFZZ	5305-00-269-3239	80204	B1821BH038F138N	SCREW,CAP,HEXAGON H UOC: DAC,DAD,DAE,DAF,DAG,DA H,DAJ,DAL,DAW,DAX,V14,V15,V16, V17,V18,V19,V20,V21,V22,V24,ZAA, ZAB,ZAC,ZAD,ZAE,ZAF,ZAG,ZAH,Z AJ,ZAL .....	4

(1) ITEM NO.	(2) SMR CODE	(3) NSN	(4) CAGEC	(5) PART NUMBER	(6) DESCRIPTION AND USABLE ON CODE (UOC)	(7) QTY
8	PAFZZ	4720-01-112-2333	19207	12256271-1	HOSE ASSEMBLY, NONME UOC: DAC, DAD, DAE, DAF, DAG, DA H, DAJ, DAL, DAW, DAX, V14, V15, V16, V17, V18, V19, V20, V21, V22, V24, ZAA, ZAB, ZAC, ZAD, ZAE, ZAF, ZAG, ZAH, Z AJ, ZAL .....	2
9	PAFZZ	4730-00-052-3420	96906	MS51508A8-8	ELBOW, PIPE TO TUBE UOC: DAC, DAD, DAE, DAF, DAG, DA H, DAJ, DAL, DAW, DAX, V14, V15, V16, V17, V18, V19, V20, V21, V22, V24, ZAA, ZAB, ZAC, ZAD, ZAE, ZAF, ZAG, ZAH, Z AJ, ZAL .....	3
10	PAFZZ	4730-00-273-6686	96906	MS51504A8-8	ELBOW, PIPE TO TUBE UOC: DAC, DAD, DAE, DAF, DAG, DA H, DAJ, DAL, DAW, DAX, V14, V15, V16, V17, V18, V19, V20, V21, V22, V24, ZAA, ZAB, ZAC, ZAD, ZAE, ZAF, ZAG, ZAH, Z AJ, ZAL .....	1

END OF FIGURE

**FIELD MAINTENANCE  
FORWARD REAR AXLE AIR BRAKE CHAMBER CONTROL LINES AND MOUNTING HARDWARE**

---

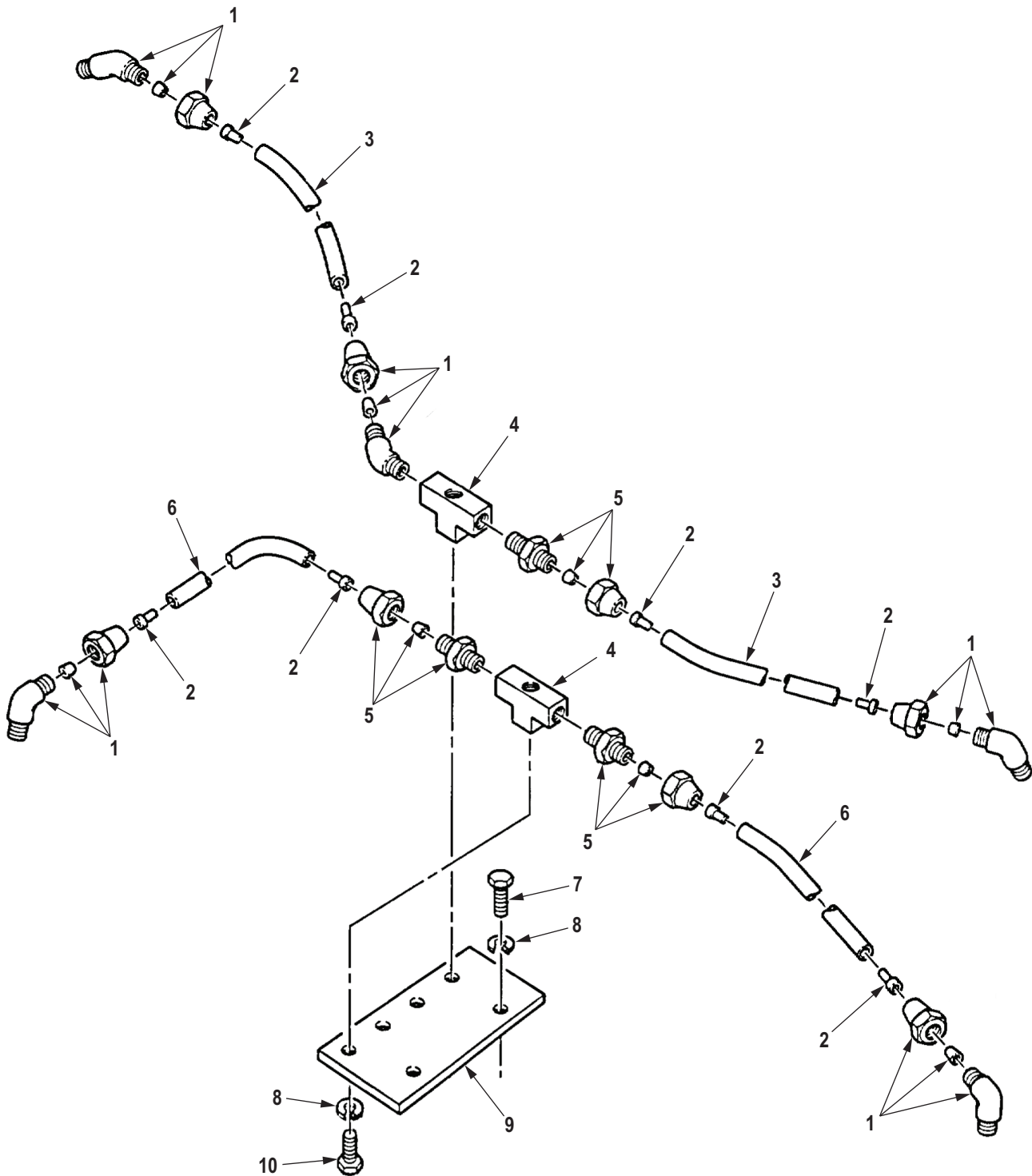

R0280DAA

Figure 264. Forward Rear Axle Air Brake Chamber Control Lines and Mounting Hardware.

(1) ITEM NO.	(2) SMR CODE	(3) NSN	(4) CAGEC	(5) PART NUMBER	(6) DESCRIPTION AND USABLE ON CODE (UOC)	(7) QTY
<b>GROUP 1208 AIR BRAKE SYSTEM.</b>						
<b>FIG. 264. FORWARD REAR AXLE AIR BRAKE CHAMBER CONTROL LINES AND MOUNTING HARDWARE.</b>						
1	PAFZZ	4730-01-117-1614	81343	8-6 120302BA	ELBOW,PIPE TO TUBE UOC: DAC,DAD,DAE,DAF,DAG,DA H,DAJ,DAL,DAW,DAX,V14,V15,V16, V17,V18,V19,V20,V21,V22,V24,ZAA, ZAB,ZAC,ZAD,ZAE,ZAF,ZAG,ZAH,Z AJ,ZAL .....	5
2	PAFZZ	4730-01-032-6038	19207	CPR102321-4	INSERT,TUBE FITTING UOC: DAC,DAD,DAE,DAF,DAG,DA H,DAJ,DAL,DAW,DAX,V14,V15,V16, V17,V18,V19,V20,V21,V22,V24,ZAA, ZAB,ZAC,ZAD,ZAE,ZAF,ZAG,ZAH,Z AJ,ZAL .....	8
3	MFFZZ		19207	CPR104420-3-21	HOSE,NONMETALLIC MAKE FROM HOSE,P/N CPR104420-3,21 IN.LONG UOC: DAC,DAD,DAE,DAF,DAG,DA H,DAJ,DAL,DAW,DAX,V14,V15,V16, V17,V18,V19,V20,V21,V22,V24,ZAA, ZAB,ZAC,ZAD,ZAE,ZAF,ZAG,ZAH,Z AJ,ZAL .....	2
4	PAFZZ	4730-01-195-1884	19207	12302675	TEE,PIPE UOC: DAC,DAD,DAE,DAF,DAG,DA H,DAJ,DAL,DAW,DAX,V14,V15,V16, V17,V18,V19,V20,V21,V22,V24,ZAA, ZAB,ZAC,ZAD,ZAE,ZAF,ZAG,ZAH,Z AJ,ZAL .....	4
5	PAFZZ	4730-00-142-3076	81343	8-6 120102BA	ADAPTER,STRAIGHT,PI UOC: DAC,DAD,DAE,DAF,DAG,DA H,DAJ,DAL,DAW,DAX,V14,V15,V16, V17,V18,V19,V20,V21,V22,V24,ZAA, ZAB,ZAC,ZAD,ZAE,ZAF,ZAG,ZAH,Z AJ,ZAL .....	3
6	MFFZZ		19207	CPR104420-3-23	HOSE,NONMETALLIC MAKE FROM HOSE,P/N CPR104420-3,23 IN.LONG UOC: DAC,DAD,DAE,DAF,DAG,DA H,DAJ,DAL,DAW,DAX,V14,V15,V16, V17,V18,V19,V20,V21,V22,V24,ZAA, ZAB,ZAC,ZAD,ZAE,ZAF,ZAG,ZAH,Z AJ,ZAL .....	2
7	PAFZZ	5305-00-942-2196	80204	B1821BH038C100D	SCREW,CAP,HEXAGON H UOC: DAC,DAD,DAE,DAF,DAG,DA H,DAJ,DAL,DAW,DAX,V14,V15,V16, V17,V18,V19,V20,V21,V22,V24,ZAA, ZAB,ZAC,ZAD,ZAE,ZAF,ZAG,ZAH,Z AJ,ZAL .....	2

(1) ITEM NO.	(2) SMR CODE	(3) NSN	(4) CAGEC	(5) PART NUMBER	(6) DESCRIPTION AND USABLE ON CODE (UOC)	(7) QTY
8	PAFZZ	5310-00-637-9541	00198	132661	WASHER,LOCK UOC: DAC,DAD,DAE,DAF,DAG,DA H,DAJ,DAL,DAW,DAX,V14,V15,V16, V17,V18,V19,V20,V21,V22,V24,ZAA, ZAB,ZAC,ZAD,ZAE,ZAF,ZAG,ZAH,Z AJ,ZAL .....	6
9	PAFZZ	5340-01-188-5086	19207	12302691	BRACKET,MOUNTING UOC: DAC,DAD,DAE,DAF,DAG,DA H,DAJ,DAL,DAW,DAX,V14,V15,V16, V17,V18,V19,V20,V21,V22,V24,ZAA, ZAB,ZAC,ZAD,ZAE,ZAF,ZAG,ZAH,Z AJ,ZAL .....	1
10	PAFZZ	5305-00-269-2803	80205	MS90726-60	SCREW,CAP,HEXAGON H UOC: DAC,DAD,DAE,DAF,DAG,DA H,DAJ,DAL,DAW,DAX,V14,V15,V16, V17,V18,V19,V20,V21,V22,V24,ZAA, ZAB,ZAC,ZAD,ZAE,ZAF,ZAG,ZAH,Z AJ,ZAL .....	4

END OF FIGURE

**FIELD MAINTENANCE**  
**REAR REAR AXLE AIR BRAKE CHAMBER CONTROL LINES AND MOUNTING HARDWARE**

---

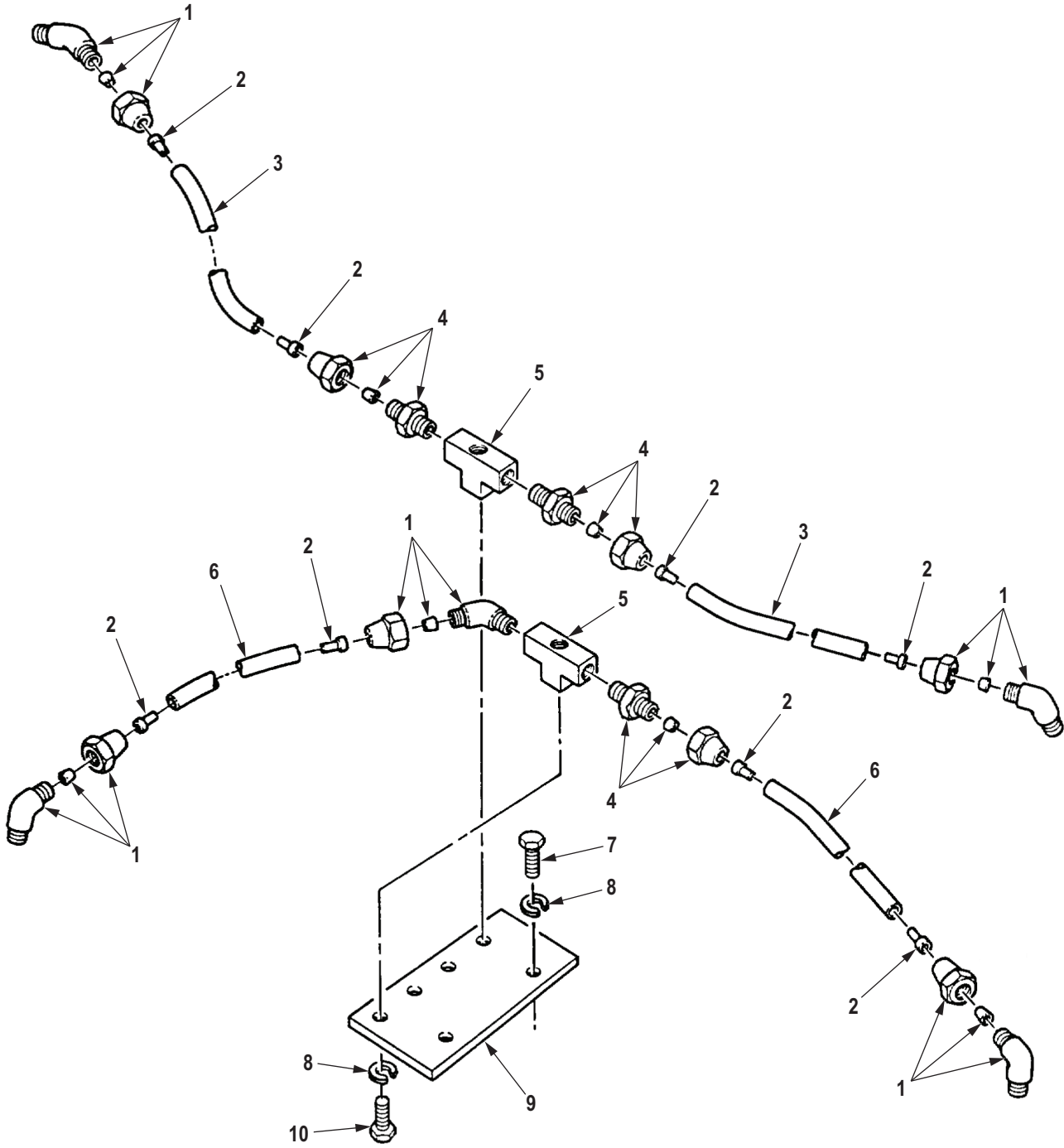

R0281DAA

Figure 265. Rear Rear Axle Air Brake Chamber Control Lines and Mounting Hardware.



(1) ITEM NO.	(2) SMR CODE	(3) NSN	(4) CAGEC	(5) PART NUMBER	(6) DESCRIPTION AND USABLE ON CODE (UOC)	(7) QTY
<b>GROUP 1208 AIR BRAKE SYSTEM.</b>						
<b>FIG. 265. REAR REAR AXLE AIR BRAKE CHAMBER CONTROL LINES AND MOUNTING HARDWARE.</b>						
1	PAFZZ	4730-01-117-1614	81343	8-6 120302BA	ELBOW,PIPE TO TUBE UOC: DAC,DAD,DAE,DAF,DAG,DA H,DAJ,DAL,DAW,DAX,V14,V15,V16, V17,V18,V19,V20,V21,V22,V24 .....	5
2	PAFZZ	4730-01-032-6038	19207	CPR102321-4	INSERT,TUBE FITTING UOC: DAC,DAD,DAE,DAF,DAG,DA H,DAJ,DAL,DAW,DAX,V14,V15,V16, V17,V18,V19,V20,V21,V22,V24,ZAA, ZAB,ZAC,ZAD,ZAE,ZAF,ZAG,ZAH,Z AJ,ZAL .....	8
3	MFFZZ		19207	CPR104420-3-23	HOSE,NONMETALLIC MAKE FROM HOSE,P/N CPR104420-3,23 IN.LONG UOC: DAC,DAD,DAE,DAF,DAG,DA H,DAJ,DAL,DAW,DAX,V14,V15,V16, V17,V18,V19,V20,V21,V22,V24,ZAA, ZAB,ZAC,ZAD,ZAE,ZAF,ZAG,ZAH,Z AJ,ZAL .....	2
4	PAFZZ	4730-00-142-3076	81343	8-6 120102BA	ADAPTER,STRAIGHT,PI UOC: DAC,DAD,DAE,DAF,DAG,DA H,DAJ,DAL,DAW,DAX,V14,V15,V16, V17,V18,V19,V20,V21,V22,V24,ZAA, ZAB,ZAC,ZAD,ZAE,ZAF,ZAG,ZAH,Z AJ,ZAL .....	3
5	PAFZZ	4730-01-195-1884	19207	12302675	TEE,PIPE UOC: DAC,DAD,DAE,DAF,DAG,DA H,DAJ,DAL,DAW,DAX,V14,V15,V16, V17,V18,V19,V20,V21,V22,V24,ZAA, ZAB,ZAC,ZAD,ZAE,ZAF,ZAG,ZAH,Z AJ,ZAL .....	4
6	MFFZZ		19207	CPR104420-3-19	HOSE,NONMETALLIC MAKE FROM HOSE,P/N CPR104420-3,19 IN.LONG UOC: DAC,DAD,DAE,DAF,DAG,DA H,DAJ,DAL,DAW,DAX,V14,V15,V16, V17,V18,V19,V20,V21,V22,V24,ZAA, ZAB,ZAC,ZAD,ZAE,ZAF,ZAG,ZAH,Z AJ,ZAL .....	2
7	PAFZZ	5305-00-942-2196	80204	B1821BH038C100D	SCREW,CAP,HEXAGON H UOC: DAC,DAD,DAE,DAF,DAG,DA H,DAJ,DAL,DAW,DAX,V14,V15,V16, V17,V18,V19,V20,V21,V22,V24,ZAA, ZAB,ZAC,ZAD,ZAE,ZAF,ZAG,ZAH,Z AJ,ZAL .....	2

(1) ITEM NO.	(2) SMR CODE	(3) NSN	(4) CAGEC	(5) PART NUMBER	(6) DESCRIPTION AND USABLE ON CODE (UOC)	(7) QTY
8	PAFZZ	5310-00-637-9541	00198	132661	WASHER,LOCK UOC: DAC,DAD,DAE,DAF,DAG,DA H,DAJ,DAL,DAW,DAX,V14,V15,V16, V17,V18,V19,V20,V21,V22,V24,ZAA, ZAB,ZAC,ZAD,ZAE,ZAF,ZAG,ZAH,Z AJ,ZAL .....	6
9	PAFZZ	5340-01-188-5086	19207	12302691	BRACKET,MOUNTING UOC: DAC,DAD,DAE,DAF,DAG,DA H,DAJ,DAL,DAW,DAX,V14,V15,V16, V17,V18,V19,V20,V21,V22,V24,ZAA, ZAB,ZAC,ZAD,ZAE,ZAF,ZAG,ZAH,Z AJ,ZAL .....	1
10	PAFZZ	5305-00-269-2803	80205	MS90726-60	SCREW,CAP,HEXAGON H UOC: DAC,DAD,DAE,DAF,DAG,DA H,DAJ,DAL,DAW,DAX,V14,V15,V16, V17,V18,V19,V20,V21,V22,V24,ZAA, ZAB,ZAC,ZAD,ZAE,ZAF,ZAG,ZAH,Z AJ,ZAL .....	4

END OF FIGURE

**FIELD MAINTENANCE  
FRONT EMERGENCY HALF COUPLING AND RELATED LINES**

---

22  
23

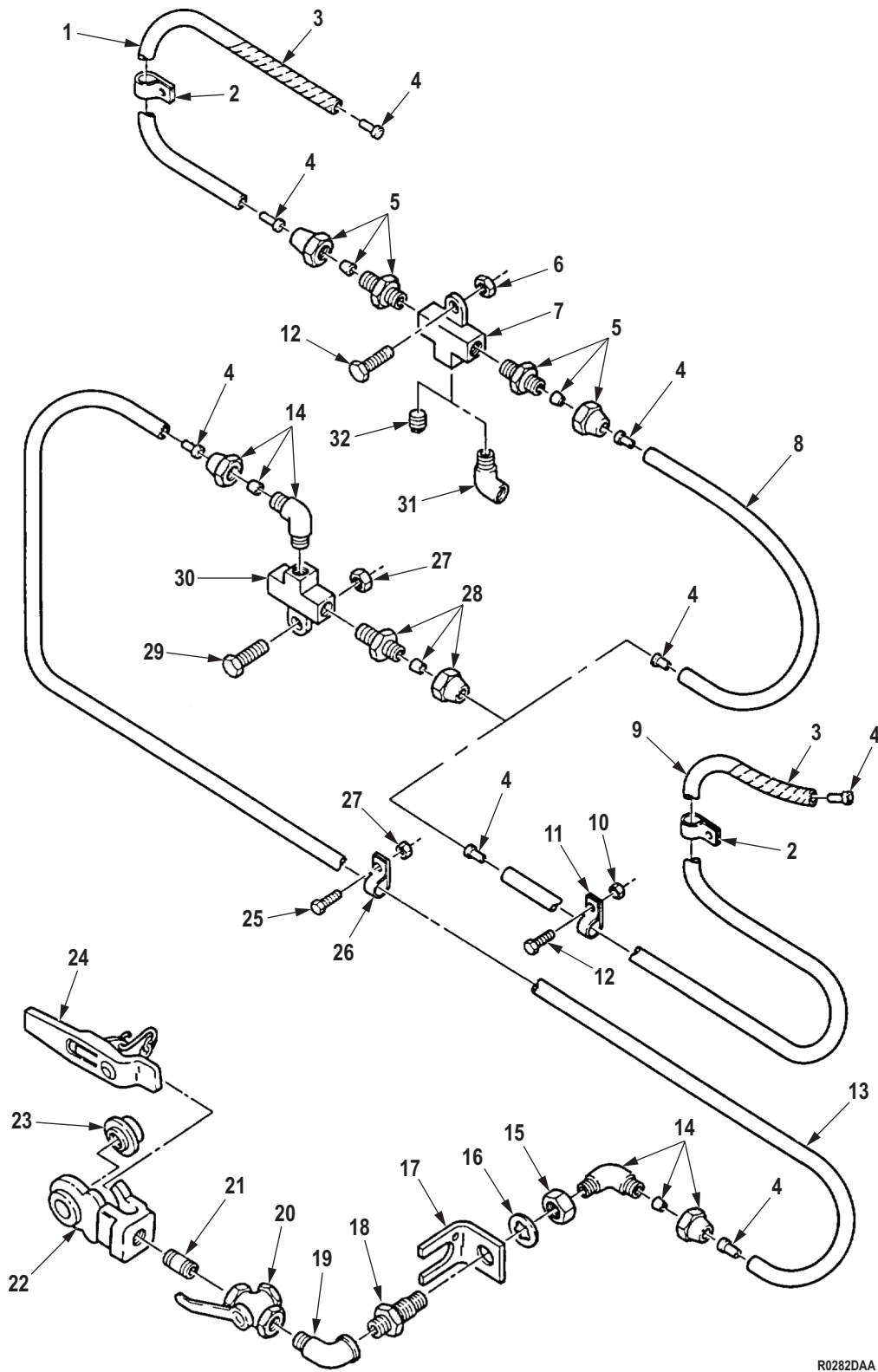

R0282DAA

Figure 266. Front Emergency Half Coupling and Related Lines.

(1) ITEM NO.	(2) SMR CODE	(3) NSN	(4) CAGEC	(5) PART NUMBER	(6) DESCRIPTION AND USABLE ON CODE (UOC)	(7) QTY
<b>GROUP 1208 AIR BRAKE SYSTEM.</b>						
<b>FIG. 266. FRONT EMERGENCY HALF COUPLING AND RELATED LINES.</b>						
1	MFFZZ		81343	J844TYBSIZE 3/8 BLACK-38	HOSE, NONMETALLIC MAKE FROM HOSE, P/N J844TYBSIZE 3/8 BLACK 38 IN LONG UOC: DAL, V18 .....	1
2	PAFZZ	5340-00-222-1653	19207	7415752	CLAMP, LOOP UOC: DAC, DAD, DAE, DAF, DAG, DA H, DAJ, DAL, DAW, DAX, V14, V15, V16, V17, V18, V19, V20, V21, V22, V24, ZAA, ZAB, ZAC, ZAD, ZAE, ZAF, ZAG, ZAH, Z AJ, ZAL .....	1
3	MFFZZ		19207	12302690-6	TUBING, PLASTIC, SPIR MAKE FROM TUBING, P/N 12302690, 6 IN. LONG UOC: DAC, DAD, DAE, DAF, DAG, DA H, DAJ, DAL, DAW, DAX, V14, V15, V16, V17, V18, V19, V20, V21, V22, V24, ZAA, ZAB, ZAC, ZAD, ZAE, ZAF, ZAG, ZAH, Z AJ, ZAL .....	1
4	PAFZZ	4730-01-079-8821	19207	CPR102321-1	INSERT, TUBE FITTING UOC: DAC, DAD, DAE, DAF, DAG, DA H, DAJ, DAL, DAW, DAX, V14, V15, V16, V17, V18, V19, V20, V21, V22, V24, ZAA, ZAB, ZAC, ZAD, ZAE, ZAF, ZAG, ZAH, Z AJ, ZAL .....	8
5	PAFZZ	4730-00-069-1186	81343	6-4 120102BA	ADAPTER, STRAIGHT, PI UOC: DAL, V18, ZAL .....	3
6	PAFZZ	5310-00-814-0672	96906	M45913/3-6FG8C	NUT, SELF-LOCKING, HE UOC: DAL, V18, ZAL .....	1
7	PAFZZ	4730-01-107-9690	19207	10937774	TEE, PIPE UOC: DAL, V18, ZAL .....	2
8	MFFZZ		81343	J844TYBSIZE 3/8 BLACK-66	HOSE, NONMETALLIC MAKE FROM HOSE, P/N J844TYBSIZE 3/8 BLACK, 66 IN. LONG UOC: DAL, V18, ZAL .....	1
9	MFFZZ		81343	J844TYBSIZE 3/8 BLACK-169	HOSE, NONMETALLIC MAKE FROM HOSE, P/N J844TYBSIZE 3/8 BLACK, 169 IN. LONG UOC: DAJ, V24, ZAJ .....	1
9	MFFZZ		81343	J844TYBSIZE 3/8 BLACK-77	HOSE, NONMETALLIC MAKE FROM HOSE, P/N J844TYBSIZE 3/8 BLACK, 77 IN. LONG UOC: DAE, DAF, DAG, DAH, V19, V20, V21, V22, ZAG, ZAH .....	1

(1) ITEM NO.	(2) SMR CODE	(3) NSN	(4) CAGEC	(5) PART NUMBER	(6) DESCRIPTION AND USABLE ON CODE (UOC)	(7) QTY
9	MFFZZ		81343	J844TYBSIZE 3/8 BLACK-148	HOSE, NONMETALLIC MAKE FROM HOSE, P/N J844TYBSIZE 3/8 BLACK, 148 IN. LONG UOC: DAC, DAD, V16, V17, ZAC, ZAD ..... 1	1
9	MFFZZ		81343	J844TYBSIZE 3/8 BLACK-101	HOSE, NONMETALLIC MAKE FROM HOSE, P/N J844TYBSIZE 3/8 BLACK, 101 IN. LONG UOC: DAW, DAX, V14, V15, ZAA, ZAB ..... 1	1
10	PAFZZ	5310-00-814-0672	96906	M45913/3-6FG8C	NUT, SELF-LOCKING, HE UOC: DAC, DAD, DAE, DAF, DAG, DA H, DAJ, DAL, DAW, DAX, V14, V15, V16, V17, V18, V19, V20, V21, V22, V24, ZAA, ZAB, ZAC, ZAD, ZAE, ZAF, ZAG, ZAH, Z AJ, ZAL ..... 1	1
11	PAFZZ	5340-00-954-6014	80205	MS21333-121	CLAMP, LOOP UOC: DAG, DAH, DAW, DAX, ZAA, ZA B, ZAG, ZAH ..... 1	1
11	PAFZZ	5340-00-954-6014	80205	MS21333-121	CLAMP, LOOP UOC: DAC, DAD, DAJ, V16, V17, V24, Z AC, ZAD, ZAJ ..... 3	3
12	PAFZZ	5305-00-269-3238	80204	B1821BH038F125N	SCREW, CAP, HEXAGON H UOC: DAC, DAD, DAJ, V16, V17, V18, V 24, ZAC, ZAD, ZAJ ..... 3	3
12	PAFZZ	5305-00-269-3238	80204	B1821BH038F125N	SCREW, CAP, HEXAGON H UOC: DAW, DAX, V14, V15, ZAA, ZAB ..... 2	2
13	MFFZZ		81343	J844TYBSIZE 3/8 BLACK-178	HOSE, NONMETALLIC MAKE FROM HOSE, P/N J844TYBSIZE 3/8 BLACK, 178 IN. LONG UOC: DAE, DAF, DAG, DAH, V19, V20, V21, V22 ..... 1	1
13	MFFZZ		81343	J844TYBSIZE 3/8 BLACK-229	HOSE, NONMETALLIC MAKE FROM HOSE, P/N J844TYBSIZE 3/8 BLACK, 229 IN. LONG UOC: DAC, DAD, DAE, DAF, DAG, DA H, DAJ, DAL, DAW, DAX, V14, V15, V16, V17, V18, V19, V20, V21, V22, V24, ZAA, ZAB, ZAC, ZAD, ZAE, ZAF, ZAG, ZAH, Z AJ, ZAL ..... 1	1
13	MFFZZ		81343	J844TYBSIZE 3/8 BLACK-191	HOSE, NONMETALLIC MAKE FROM HOSE, P/N J844TYBSIZE 3/8 BLACK, 191 IN. LONG UOC: DAL, V18, ZAL ..... 1	1
13	MFFZZ		81343	J844TYBSIZE 3/8 BLACK-203	HOSE, NONMETALLIC MAKE FROM HOSE, P/N J844TYBSIZE 3/8 BLACK, 203 IN. LONG UOC: DAW, DAX, V14, V15, ZAA, ZAB ..... 1	1

(1) ITEM NO.	(2) SMR CODE	(3) NSN	(4) CAGEC	(5) PART NUMBER	(6) DESCRIPTION AND USABLE ON CODE (UOC)	(7) QTY
14	PAFZZ	4730-00-069-1187	81343	SAE J246 6-4 100202BA	ELBOW,PIPE TO TUBE UOC: DAC,DAD,DAE,DAF,DAG,DA H,DAJ,DAL,DAW,DAX,V14,V15,V16, V17,V18,V19,V20,V21,V22,V24,ZAA, ZAB,ZAC,ZAD,ZAE,ZAF,ZAG,ZAH,Z AJ,ZAL .....	2
15	PAFZZ	5310-00-891-3428	96906	MS35691-77	NUT,PLAIN,HEXAGON UOC: DAC,DAD,DAE,DAF,DAG,DA H,DAJ,DAL,DAW,DAX,V14,V15,V16, V17,V18,V19,V20,V21,V22,V24,ZAA, ZAB,ZAC,ZAD,ZAE,ZAF,ZAG,ZAH,Z AJ,ZAL .....	1
16	PAFZZ	5310-00-582-6714	80205	MS35333-49	WASHER,LOCK UOC: DAC,DAD,DAE,DAF,DAG,DA H,DAJ,DAL,DAW,DAX,V14,V15,V16, V17,V18,V19,V20,V21,V22,V24,ZAA, ZAB,ZAC,ZAD,ZAE,ZAF,ZAG,ZAH,Z AJ,ZAL .....	1
17	PAFZZ	5340-01-107-9929	19207	12256265	BRACKET,ANGLE UOC: DAC,DAD,DAE,DAF,DAG,DA H,DAJ,DAL,DAW,DAX,V14,V15,V16, V17,V18,V19,V20,V21,V22,V24,ZAA, ZAB,ZAC,ZAD,ZAE,ZAF,ZAG,ZAH,Z AJ,ZAL .....	1
18	PAFZZ	4730-00-419-9424	19207	8376311	REDUCER,PIPE UOC: DAC,DAD,DAE,DAF,DAG,DA H,DAJ,DAL,DAW,DAX,V14,V15,V16, V17,V18,V19,V20,V21,V22,V24,ZAA, ZAB,ZAC,ZAD,ZAE,ZAF,ZAG,ZAH,Z AJ,ZAL .....	1
19	PAFZZ	4730-00-277-5555	96906	MS51952-4	ELBOW,PIPE UOC: DAC,DAD,DAE,DAF,DAG,DA H,DAJ,DAL,DAW,DAX,V14,V15,V16, V17,V18,V19,V20,V21,V22,V24,ZAA, ZAB,ZAC,ZAD,ZAE,ZAF,ZAG,ZAH,Z AJ,ZAL .....	1
20	PAFZZ	4820-00-420-5499	06853	285172N	VALVE,BALL UOC: DAC,DAD,DAE,DAF,DAG,DA H,DAJ,DAL,DAW,DAX,V14,V15,V16, V17,V18,V19,V20,V21,V22,V24,ZAA, ZAB,ZAC,ZAD,ZAE,ZAF,ZAG,ZAH,Z AJ,ZAL .....	1
21	PAFZZ	4730-00-196-1504	81346	A733S-75CFG	NIPPLE,PIPE UOC: DAC,DAD,DAE,DAF,DAG,DA H,DAJ,DAL,DAW,DAX,V14,V15,V16, V17,V18,V19,V20,V21,V22,V24,ZAA, ZAB,ZAC,ZAD,ZAE,ZAF,ZAG,ZAH,Z AJ,ZAL .....	1

(1) ITEM NO.	(2) SMR CODE	(3) NSN	(4) CAGEC	(5) PART NUMBER	(6) DESCRIPTION AND USABLE ON CODE (UOC)	(7) QTY
22	PAFZZ	4730-00-595-0083	58536	A52484-1	COUPLING HALF,QUICK UOC: DAC,DAD,DAE,DAF,DAG,DA H,DAJ,DAL,DAW,DAX,V14,V15,V16, V17,V18,V19,V20,V21,V22,V24,ZAA, ZAB,ZAC,ZAD,ZAE,ZAF,ZAG,ZAH,Z AJ,ZAL .....	1
23	PAFZZ	5330-00-090-2128	58536	A52484-2	. PACKING,PREFORMED UOC: DAC,DAD,DAE,DAF,DAG,DA H,DAJ,DAL,DAW,DAX,V14,V15,V16, V17,V18,V19,V20,V21,V22,V24,ZAA, ZAB,ZAC,ZAD,ZAE,ZAF,ZAG,ZAH,Z AJ,ZAL .....	1
24	PAFZZ	2530-00-270-3878	06721	N13048	DUMMY COUPLING,AUTO UOC: DAC,DAD,DAE,DAF,DAG,DA H,DAJ,DAL,DAW,DAX,V14,V15,V16, V17,V18,V19,V20,V21,V22,V24,ZAA, ZAB,ZAC,ZAD,ZAE,ZAF,ZAG,ZAH,Z AJ,ZAL .....	1
25	PAFZZ	5305-00-269-2804	80205	MS90726-61	SCREW,CAP,HEXAGON H UOC: DAC,DAD,DAE,DAF,DAG,DA H,DAJ,DAL,DAW,DAX,V14,V15,V16, V17,V18,V19,V20,V21,V22,V24,ZAA, ZAB,ZAC,ZAD,ZAE,ZAF,ZAG,ZAH,Z AJ,ZAL .....	1
26	PAFZZ	5340-00-053-8994	80205	MS21333-126	CLAMP,LOOP UOC: DAC,DAD,DAE,DAF,DAG,DA H,DAJ,DAL,DAW,DAX,V14,V15,V16, V17,V18,V19,V20,V21,V22,V24,ZAA, ZAB,ZAC,ZAD,ZAE,ZAF,ZAG,ZAH,Z AJ,ZAL .....	1
27	PAFZZ	5310-00-814-0672	96906	M45913/3-6FG8C	NUT,SELF-LOCKING,HE UOC: DAC,DAD,DAE,DAF,DAG,DA H,DAJ,DAL,DAW,DAX,V14,V15,V16, V17,V18,V19,V20,V21,V22,V24,ZAA, ZAB,ZAC,ZAD,ZAE,ZAF,ZAG,ZAH,Z AJ,ZAL .....	2
28	PAFZZ	4730-00-069-1186	81343	6-4 120102BA	ADAPTER,STRAIGHT,PI UOC: DAC,DAD,DAE,DAF,DAG,DA H,DAJ,DAL,DAW,DAX,V14,V15,V16, V17,V18,V19,V20,V21,V22,V24,ZAA, ZAB,ZAC,ZAD,ZAE,ZAF,ZAG,ZAH,Z AJ,ZAL .....	1
29	PAFZZ	5305-00-269-3240	80204	B1821BH038F150N	SCREW,CAP,HEXAGON H UOC: DAC,DAD,DAE,DAF,DAG,DA H,DAJ,DAL,DAW,DAX,V14,V15,V16, V17,V18,V19,V20,V21,V22,V24 .....	1



(1) ITEM NO.	(2) SMR CODE	(3) NSN	(4) CAGEC	(5) PART NUMBER	(6) DESCRIPTION AND USABLE ON CODE (UOC)	(7) QTY
30	PAFZZ	4730-01-107-9690	19207	10937774	TEE,PIPE UOC: DAC,DAD,DAE,DAF,DAG,DAH,DAJ,DAL,DAW,DAX,V14,V15,V16,V17,V18,V19,V20,V21,V22,V24,ZAA,ZAB,ZAC,ZAD,ZAE,ZAF,ZAG,ZAH,ZAJ,ZAL .....	1
31	PAFZZ	4730-00-231-5598	81343	AS4854-04	ELBOW,PIPE UOC: DAL,V18,ZAL .....	1
32	PAFZZ	4730-00-221-2137	81343	AS4863SIZE02	MODPLUG,PIPE UOC: DAL,V18,ZAL .....	1

END OF FIGURE



**FIELD MAINTENANCE  
REAR EMERGENCY HALF COUPLINGS AND MOUNTING HARDWARE**

---

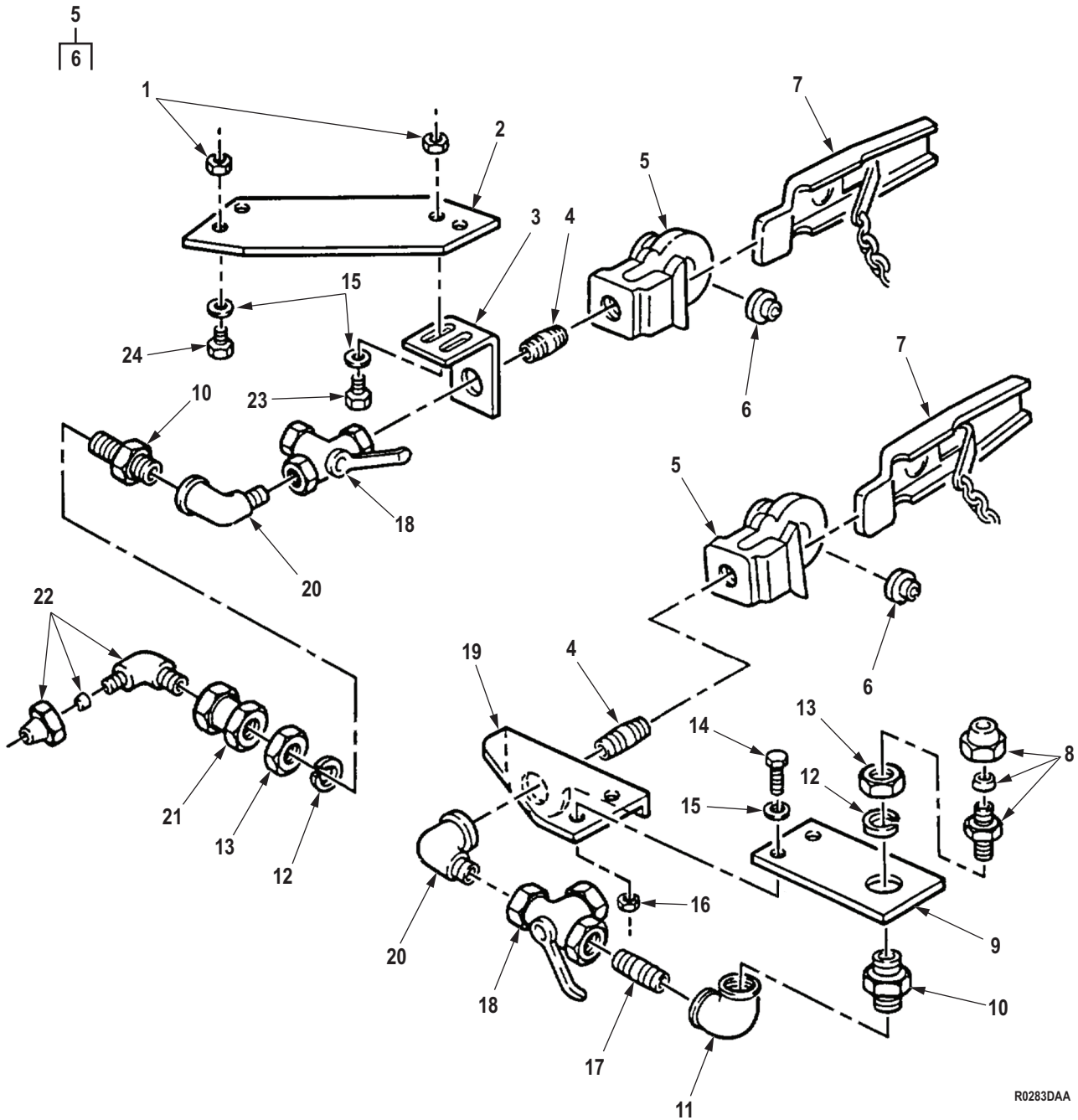

R0283DAA

Figure 267. Rear Emergency Half Couplings and Mounting Hardware.

(1) ITEM NO.	(2) SMR CODE	(3) NSN	(4) CAGEC	(5) PART NUMBER	(6) DESCRIPTION AND USABLE ON CODE (UOC)	(7) QTY
<b>GROUP 1208 AIR BRAKE SYSTEM.</b>						
<b>FIG. 267. REAR EMERGENCY HALF COUPLINGS AND MOUNTING HARDWARE.</b>						
1	PAFZZ	5310-00-935-9022	81349	M45913/3-4FG8C	NUT,SELF-LOCKING,HE UOC: DAW,DAX,V14,V15,ZAA,ZAB .....	4
2	PFFZZ	2510-00-127-4768	19207	10883437	PLATE,REAR,SUPPORT UOC: DAW,DAX,V14,V15,ZAA,ZAB .....	1
3	PFFZZ	5340-00-419-9487	19207	10883438	BRACKET,ANGLE UOC: DAW,DAX,V14,V15,ZAA,ZAB .....	1
4	PAFZZ	4730-00-196-1504	81346	A733S-75CFG	NIPPLE,PIPE UOC: DAC,DAD,DAE,DAF,DAG,DA H,DAJ,DAL,DAW,DAX,V14,V15,V16, V17,V18,V19,V20,V21,V22,V24,ZAA, ZAB,ZAC,ZAD,ZAE,ZAF,ZAG,ZAH,Z AJ,ZAL .....	1
5	PAFZZ	4730-00-595-0083	58536	A52484-1	COUPLING HALF,QUICK UOC: DAC,DAD,DAE,DAF,DAG,DA H,DAJ,DAL,DAW,DAX,V14,V15,V16, V17,V18,V19,V20,V21,V22,V24,ZAA, ZAB,ZAC,ZAD,ZAE,ZAF,ZAG,ZAH,Z AJ,ZAL .....	1
6	PAFZZ	5330-00-090-2128	58536	A52484-2	. PACKING,PREFORMED UOC: DAC,DAD,DAE,DAF,DAG,DA H,DAJ,DAL,DAW,DAX,V14,V15,V16, V17,V18,V19,V20,V21,V22,V24,ZAA, ZAB,ZAC,ZAD,ZAE,ZAF,ZAG,ZAH,Z AJ,ZAL .....	1
7	PAFZZ	2530-00-270-3878	06721	N13048	DUMMY COUPLING,AUTO UOC: DAC,DAD,DAE,DAF,DAG,DA H,DAJ,DAL,DAW,DAX,V14,V15,V16, V17,V18,V19,V20,V21,V22,V24,ZAA, ZAB,ZAC,ZAD,ZAE,ZAF,ZAG,ZAH,Z AJ,ZAL .....	1
8	PAFZZ	4730-00-069-1186	81343	6-4 120102BA	ADAPTER,STRAIGHT,PI UOC: V14,V15,V16,V17,V18,V19,V2 0,V21,V22,V24,ZAC,ZAD,ZAE,ZAF,Z AG,ZAH,ZAJ,ZAL .....	1
9	PFFZZ	5340-00-157-7938	19207	10883331	PLATE,MENDING UOC: DAC,DAD,DAE,DAF,DAG,DA H,DAJ,DAL,V16,V17,V18,V19,V20,V 21,V22,V24,ZAC,ZAD,ZAE,ZAF,ZAG, ZAH,ZAJ,ZAL .....	1

(1) ITEM NO.	(2) SMR CODE	(3) NSN	(4) CAGEC	(5) PART NUMBER	(6) DESCRIPTION AND USABLE ON CODE (UOC)	(7) QTY
10	PAFZZ	4730-00-419-9424	19207	8376311	REDUCER,PIPE UOC: DAC,DAD,DAE,DAF,DAG,DA H,DAJ,DAL,DAW,DAX,V14,V15,V16, V17,V18,V19,V20,V21,V22,V24,ZAA, ZAB,ZAC,ZAD,ZAE,ZAF,ZAG,ZAH,Z AJ,ZAL .....	2
11	PAFZZ	4730-00-249-3885	96906	MS51845-4	ELBOW,PIPE UOC: DAC,DAD,DAE,DAF,DAG,DA H,DAJ,DAL,V16,V17,V18,V19,V20,V 21,V22,V24,ZAC,ZAD,ZAE,ZAF,ZAG, ZAH,ZAJ,ZAL .....	1
12	PAFZZ	5310-00-582-6714	80205	MS35333-49	WASHER,LOCK UOC: DAC,DAD,DAE,DAF,DAG,DA H,DAJ,DAL,DAW,DAX,V14,V15,V16, V17,V18,V19,V20,V21,V22,V24,ZAA, ZAB,ZAC,ZAD,ZAE,ZAF,ZAG,ZAH,Z AJ,ZAL .....	2
13	PAFZZ	5310-00-021-9760	21450	219760	NUT,PLAIN,HEXAGON UOC: DAC,DAD,DAE,DAF,DAG,DA H,DAJ,DAL,DAW,DAX,V14,V15,V16, V17,V18,V19,V20,V21,V22,V24,ZAA, ZAB,ZAC,ZAD,ZAE,ZAF,ZAG,ZAH,Z AJ,ZAL .....	2
14	PAFZZ	5305-00-267-8954	80204	B1821BH025F125N	SCREW,CAP,HEXAGON H UOC: DAC,DAD,DAE,DAF,DAG,DA H,DAJ,DAL,V16,V17,V18,V19,V20,V 21,V22,V24,ZAC,ZAD,ZAE,ZAF,ZAG, ZAH,ZAJ,ZAL .....	2
15	PAFZZ	5310-00-809-4058	96906	MS27183-10	WASHER,FLAT UOC: DAC,DAD,DAE,DAF,DAG,DA H,DAJ,DAL,DAW,DAX,V14,V15,V16, V17,V18,V19,V20,V21,V22,V24,ZAA, ZAB,ZAC,ZAD,ZAE,ZAF,ZAG,ZAH,Z AJ,ZAL .....	4
16	PAFZZ	5310-00-935-9022	81349	M45913/3-4FG8C	NUT,SELF-LOCKING,HE UOC: DAC,DAD,DAE,DAF,DAG,DA H,DAJ,DAL,DAX,V14,V15,V16,V17,V 18,V19,V20,V21,V22,V24 .....	2
17	PAFZZ	4730-00-196-1991	96906	MS51846-64	NIPPLE,PIPE UOC: DAC,DAD,DAE,DAF,DAG,DA H,DAJ,DAL,V16,V17,V18,V19,V20,V 21,V22,V24,ZAC,ZAD,ZAE,ZAF,ZAG, ZAH,ZAJ,ZAL .....	1
18	PAFZZ	4820-00-420-5499	06853	285172N	VALVE,BALL UOC: DAC,DAD,DAE,DAF,DAG,DA H,DAJ,DAL,DAW,DAX,V14,V15,V16, V17,V18,V19,V20,V21,V22,V24,ZAA, ZAB,ZAC,ZAD,ZAE,ZAF,ZAG,ZAH,Z AJ,ZAL .....	1

(1) ITEM NO.	(2) SMR CODE	(3) NSN	(4) CAGEC	(5) PART NUMBER	(6) DESCRIPTION AND USABLE ON CODE (UOC)	(7) QTY
19	PFFZZ	5340-00-448-4073	19207	10883329	BRACKET,ANGLE UOC: DAC,DAD,DAE,DAF,DAG,DA H,DAJ,DAL,V16,V17,V18,V19,V20,V 21,V22,V24,ZAC,ZAD,ZAE,ZAF,ZAG, ZAH,ZAJ,ZAL .....	1
20	PAFZZ	4730-00-277-5555	96906	MS51952-4	ELBOW,PIPE UOC: DAC,DAD,DAE,DAF,DAG,DA H,DAJ,DAL,DAW,DAX,V14,V15,V16, V17,V18,V19,V20,V21,V22,V24,ZAA, ZAB,ZAC,ZAD,ZAE,ZAF,ZAG,ZAH,Z AJ,ZAL .....	2
21	PAFZZ	4730-00-278-2648	96906	MS14305-4Y	COUPLING,PIPE UOC: DAW,DAX,V14,V15,ZAA,ZAB .....	1
22	PAFZZ	4730-00-143-9282	81343	J246 6-8 120202BA	ELBOW,PIPE TO TUBE UOC: DAW,DAX,V14,V15,ZAA,ZAB .....	1
23	PAFZZ	5306-00-068-0514	80204	B1821BH025F088N	BOLT,MACHINE UOC: DAW,DAX,V14,V15,ZAA,ZAB .....	2
24	PAFZZ	5305-00-269-3239	80204	B1821BH038F138N	SCREW,CAP,HEXAGON H UOC: DAW,DAX,V14,V15,ZAA,ZAB .....	2

END OF FIGURE





**FIELD MAINTENANCE  
AIR COMPRESSOR TO WET RESERVOIR AIR SUPPLY LINES**

---

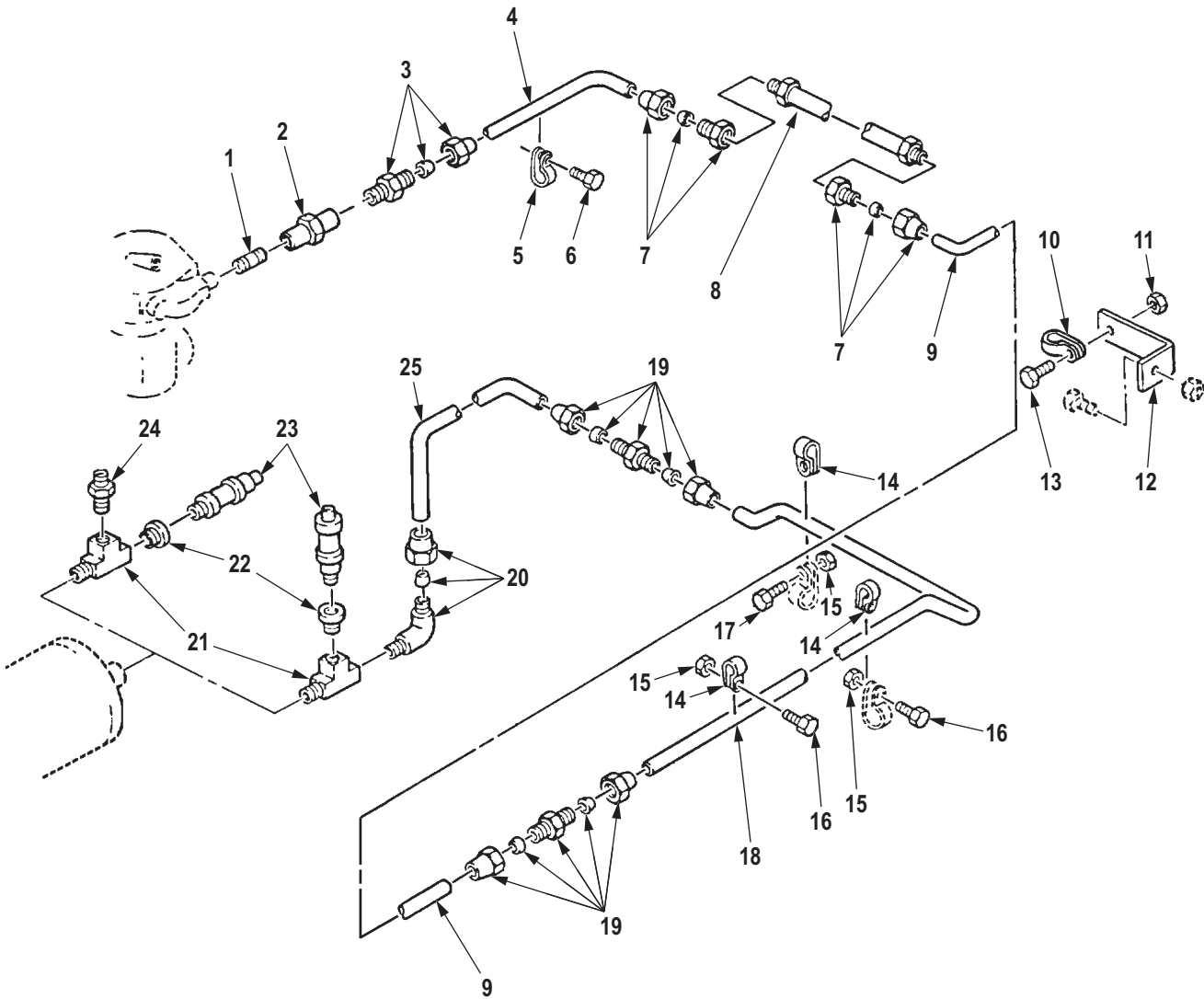

R0284DAA

Figure 268. Air Compressor to Wet Reservoir Air Supply Lines.

(1) ITEM NO.	(2) SMR CODE	(3) NSN	(4) CAGEC	(5) PART NUMBER	(6) DESCRIPTION AND USABLE ON CODE (UOC)	(7) QTY
<b>GROUP 1208 AIR BRAKE SYSTEM.</b>						
<b>FIG. 268. AIR COMPRESSOR TO WET RESERVOIR AIR SUPPLY LINES.</b>						
1	PAFZZ	4730-00-196-1495	81346	A733-80CF8	NIPPLE,PIPE UOC: DAC,DAD,DAE,DAF,DAG,DA H,DAJ,DAL,DAW,DAX,V14,V15,V16, V17,V18,V19,V20,V21,V22,V24,ZAA, ZAB,ZAC,ZAD,ZAE,ZAF,ZAG,ZAH,Z AJ,ZAL .....	1
2	PAFZZ	4730-00-542-5598	81343	SAE J514 8-8 140138C	COUPLING,PIPE UOC: DAC,DAD,DAE,DAF,DAG,DA H,DAJ,DAL,DAW,DAX,V14,V15,V16, V17,V18,V19,V20,V21,V22,V24,ZAA, ZAB,ZAC,ZAD,ZAE,ZAF,ZAG,ZAH,Z AJ,ZAL .....	1
3	PAFZZ	4730-00-202-9036	81343	SAE J246 8-8 120102BA	ADAPTER,STRAIGHT,PI UOC: DAC,DAD,DAE,DAF,DAG,DA H,DAJ,DAL,DAW,DAX,V14,V15,V16, V17,V18,V19,V20,V21,V22,V24,ZAA, ZAB,ZAC,ZAD,ZAE,ZAF,ZAG,ZAH,Z AJ,ZAL .....	1
4	MFFZZ		24617	12302615	TUBE,COPPER MAKE FROM TUBE,P/N ASTM B280, LENGTH AS REQUIRED UOC: DAC,DAD,DAE,DAF,DAG,DA H,DAJ,DAL,DAW,DAX,V14,V15,V16, V17,V18,V19,V20,V21,V22,V24,ZAA, ZAB,ZAC,ZAD,ZAE,ZAF,ZAG,ZAH,Z AJ,ZAL .....	1
5	PAFZZ	5340-01-112-8909	19207	11648730	CLAMP,LOOP UOC: DAC,DAD,DAE,DAF,DAG,DA H,DAJ,DAL,DAW,DAX,V14,V15,V16, V17,V18,V19,V20,V21,V22,V24,ZAB, ZAC,ZAD,ZAE,ZAF,ZAG,ZAH,ZAJ,ZAL .....	1
6	PAFZZ	5305-01-277-0461	96906	MS90727-130	SCREW,CAP,HEXAGON H UOC: DAC,DAD,DAE,DAF,DAG,DA H,DAJ,DAL,DAW,DAX,V14,V15,V16, V17,V18,V19,V20,V21,V22,V24,ZAA, ZAB,ZAC,ZAD,ZAE,ZAF,ZAG,ZAH,Z AJ,ZAL .....	1
7	PAFZZ	4730-00-173-1867	81343	8-6 120103BA	ADAPTER,STRAIGHT,PI UOC: DAC,DAD,DAE,DAF,DAG,DA H,DAJ,DAL,DAW,DAX,V14,V15,V16, V17,V18,V19,V20,V21,V22,V24,ZAA, ZAB,ZAC,ZAD,ZAE,ZAF,ZAG,ZAH,Z AJ,ZAL .....	2

(1) ITEM NO.	(2) SMR CODE	(3) NSN	(4) CAGEC	(5) PART NUMBER	(6) DESCRIPTION AND USABLE ON CODE (UOC)	(7) QTY
8	PAFZZ	4720-00-096-9630	19207	11648644	HOSE ASSEMBLY, NONME UOC: DAC, DAD, DAE, DAF, DAG, DA H, DAJ, DAL, DAW, DAX, V14, V15, V16, V17, V18, V19, V20, V21, V22, V24, ZAA, ZAB, ZAC, ZAD, ZAE, ZAF, ZAG, ZAH, Z AJ, ZAL .....	1
9	MFFZZ		19207	12255962	TUBE, COPPER MAKE FROM TUBE, P/N ASTM B280, LENGTH AS REQUIRED UOC: DAC, DAD, DAE, DAF, DAG, DA H, DAJ, DAL, DAW, DAX, V14, V15, V16, V17, V18, V19, V20, V21, V22, V24, ZAA, ZAB, ZAC, ZAD, ZAE, ZAF, ZAG, ZAH, Z AJ, ZAL .....	1
10	PAFZZ	5340-00-057-3043	96906	MS21333-112	CLAMP, LOOP UOC: DAC, DAD, DAE, DAF, DAG, DA H, DAJ, DAL, DAW, DAX, V14, V15, V16, V17, V18, V19, V20, V21, V22, V24, ZAA, ZAB, ZAC, ZAD, ZAE, ZAF, ZAG, ZAH, Z AJ, ZAL .....	1
11	PAFZZ	5310-00-814-0673	81349	M45913/3-5CG8C	NUT, SELF-LOCKING, HE UOC: DAC, DAD, DAE, DAF, DAG, DA H, DAJ, DAL, DAW, DAX, V14, V15, V16, V17, V18, V19, V20, V21, V22, V24, ZAA, ZAB, ZAC, ZAD, ZAE, ZAF, ZAG, ZAH, Z AJ, ZAL .....	1
12	PAFZZ	5340-01-147-6759	19207	12256266	BRACKET, ANGLE UOC: DAC, DAD, DAE, DAF, DAG, DA H, DAJ, DAL, DAW, DAX, V14, V15, V16, V17, V18, V19, V20, V21, V22, V24, ZAA, ZAB, ZAC, ZAD, ZAE, ZAF, ZAG, ZAH, Z AJ, ZAL .....	1
13	PAFZZ	5306-00-050-1238	80204	B1821BH031F075N	BOLT, MACHINE UOC: DAC, DAD, DAE, DAF, DAG, DA H, DAJ, DAL, DAW, DAX, V14, V15, V16, V17, V18, V19, V20, V21, V22, V24, ZAA, ZAB, ZAC, ZAD, ZAE, ZAF, ZAG, ZAH, Z AJ, ZAL .....	1
14	PAFZZ	5340-00-989-1771	80205	MS21333-123	CLAMP, LOOP UOC: DAC, DAD, DAE, DAF, DAG, DA H, DAJ, DAL, DAW, DAX, V14, V15, V16, V17, V18, V19, V20, V21, V22, V24, ZAA, ZAB, ZAC, ZAD, ZAE, ZAF, ZAG, ZAH, Z AJ, ZAL .....	5

(1) ITEM NO.	(2) SMR CODE	(3) NSN	(4) CAGEC	(5) PART NUMBER	(6) DESCRIPTION AND USABLE ON CODE (UOC)	(7) QTY
15	PAFZZ	5310-00-814-0672	96906	M45913/3-6FG8C	NUT,SELF-LOCKING,HE UOC: DAC,DAD,DAE,DAF,DAG,DA H,DAJ,DAL,DAW,DAX,V14,V15,V16, V17,V18,V19,V20,V21,V22,V24,ZAA, ZAB,ZAC,ZAD,ZAE,ZAF,ZAG,ZAH,Z AJ,ZAL .....	5
16	PAFZZ	5305-00-269-3238	80204	B1821BH038F125N	SCREW,CAP,HEXAGON H UOC: DAL,V18,ZAL .....	1
16	PAFZZ	5305-00-269-3238	80204	B1821BH038F125N	SCREW,CAP,HEXAGON H UOC: DAC,DAD,DAE,DAF,DAG,DA H,DAJ,DAW,V14,V15,V16,V17,V19,V 20,V21,V22,V24,ZAA,ZAB,ZAC,ZAD, ZAE,ZAF,ZAG,ZAH,ZAJ .....	2
17	PAFZZ	5305-00-269-2804	80205	MS90726-61	SCREW,CAP,HEXAGON H UOC: DAC,DAD,DAE,DAF,DAG,DA H,DAJ,DAL,DAW,DAX,V14,V15,V16, V17,V18,V19,V20,V21,V22,V24,ZAA, ZAB,ZAC,ZAD,ZAE,ZAF,ZAG,ZAH,Z AJ,ZAL .....	5
18	MFFZZ		19207	12255968-3	TUBE,COPPER AIR SUPPLY,MAKE FROM TUBE,P/N ASTM B280, LENGTH AS REQUIRED UOC: DAC,DAD,DAJ,V16,V17,V24,Z AC,ZAD,ZAJ .....	1
18	MFFZZ		19207	12255968-1	TUBE,COPPER AIR COMPRESSOR TO WET RESERVOIR,MAKE FROM TUBE,P/ N ASTM B280, LENGTH AS REQUIRED UOC: DAL,DAW,DAX,V14,V15,V18, ZAA,ZAB,ZAL .....	1
18	MFFZZ		19207	12255968-2	TUBE,COPPER AIR COMPRESSOR TO WET RESERVOIR MAKE FROM TUBE,P/ N ASTM B280, LENGTH AS REQUIRED UOC: DAE,DAF,V19,V20,V21,V22,Z AC,ZAD,ZAE,ZAF .....	1
19	PAFZZ	4730-00-278-3220	81343	8-8 120101BA	NIPPLE,TUBE UOC: DAC,DAD,DAE,DAF,DAG,DA H,DAJ,DAL,DAW,DAX,V14,V15,V16, V17,V18,V19,V20,V21,V22,V24,ZAA, ZAB,ZAC,ZAD,ZAE,ZAF,ZAG,ZAH,Z AJ,ZAL .....	2
20	PAFZZ	4730-00-595-2572	81343	SAE J246 8-8 120202BA	ELBOW,PIPE TO TUBE WET RESERVOIR TEE UOC: DAC,DAD,DAE,DAF,DAG,DA H,DAJ,DAW,DAX,V14,V15,V16,V17, V19,V20,V21,V22,V24,ZAA,ZAB,ZAC ,ZAD,ZAE,ZAF,ZAG,ZAH,ZAJ .....	1

(1) ITEM NO.	(2) SMR CODE	(3) NSN	(4) CAGEC	(5) PART NUMBER	(6) DESCRIPTION AND USABLE ON CODE (UOC)	(7) QTY
21	PAFZZ	4730-01-095-2034	81343	SAE J530 8-8-8 130424BA	TEE,PIPE UOC: DAC,DAD,DAE,DAF,DAG,DA H,DAJ,DAL,DAW,DAX,V14,V15,V16, V17,V18,V19,V20,V21,V22,V24,ZAA, ZAB,ZAC,ZAD,ZAE,ZAF,ZAG,ZAH,Z AJ,ZAL .....	1
22	PAFZZ	4730-01-192-4729	58536	AA59616BDQBCDB	BUSHING,PIPE UOC: DAC,DAD,DAE,DAF,DAG,DA H,DAJ,DAL,DAW,DAX,V14,V15,V16, V17,V18,V19,V20,V21,V22,V24,ZAA, ZAB,ZAC,ZAD,ZAE,ZAF,ZAG,ZAH,Z AJ,ZAL .....	1
23	PAFZZ	4820-00-595-2761	06853	284142N	VALVE,SAFETY RELIEF UOC: DAC,DAD,DAE,DAF,DAG,DA H,DAJ,DAL,DAW,DAX,V14,V15,V16, V17,V18,V19,V20,V21,V22,V24,ZAA, ZAB,ZAC,ZAD,ZAE,ZAF,ZAG,ZAH,Z AJ,ZAL .....	1
24	PAFZZ	4730-00-202-9036	81343	SAE J246 8-8 120102BA	ADAPTER,STRAIGHT,PI UOC: DAL,V18,ZAL .....	3
25	MFFZZ		19207	12255967-3	TUBE,COPPER AIR COMPRESSOR TO WET RESERVOIR,MAKE FROM TUBING P/N ASTM B280, LENGTH AS REQUIRED UOC: DAC,DAJ,V24,ZAJ .....	1
25	MFFZZ		19207	12256101	TUBE,COPPER MAKE FROM TUBING,P/N ASTM B280, LENGTH AS REQUIRED UOC: DAE,DAF,DAG,DAH,V19,V20, V21,V22,ZAE,ZAF,ZAG,ZAH .....	1
25	MFFZZ		19207	12255967-1	TUBE,COPPER AIR COMPRESSOR TO WET RESERVOIR,MAKE FROM TUBING P/N ASTM B280, LENGTH AS REQUIRED UOC: DAL,DAW,DAX,V14,V15,V18, ZAA,ZAB,ZAL .....	1

END OF FIGURE

**FIELD MAINTENANCE  
AIR SUPPLY LINE SAFETY VALVE (ABS)**

---

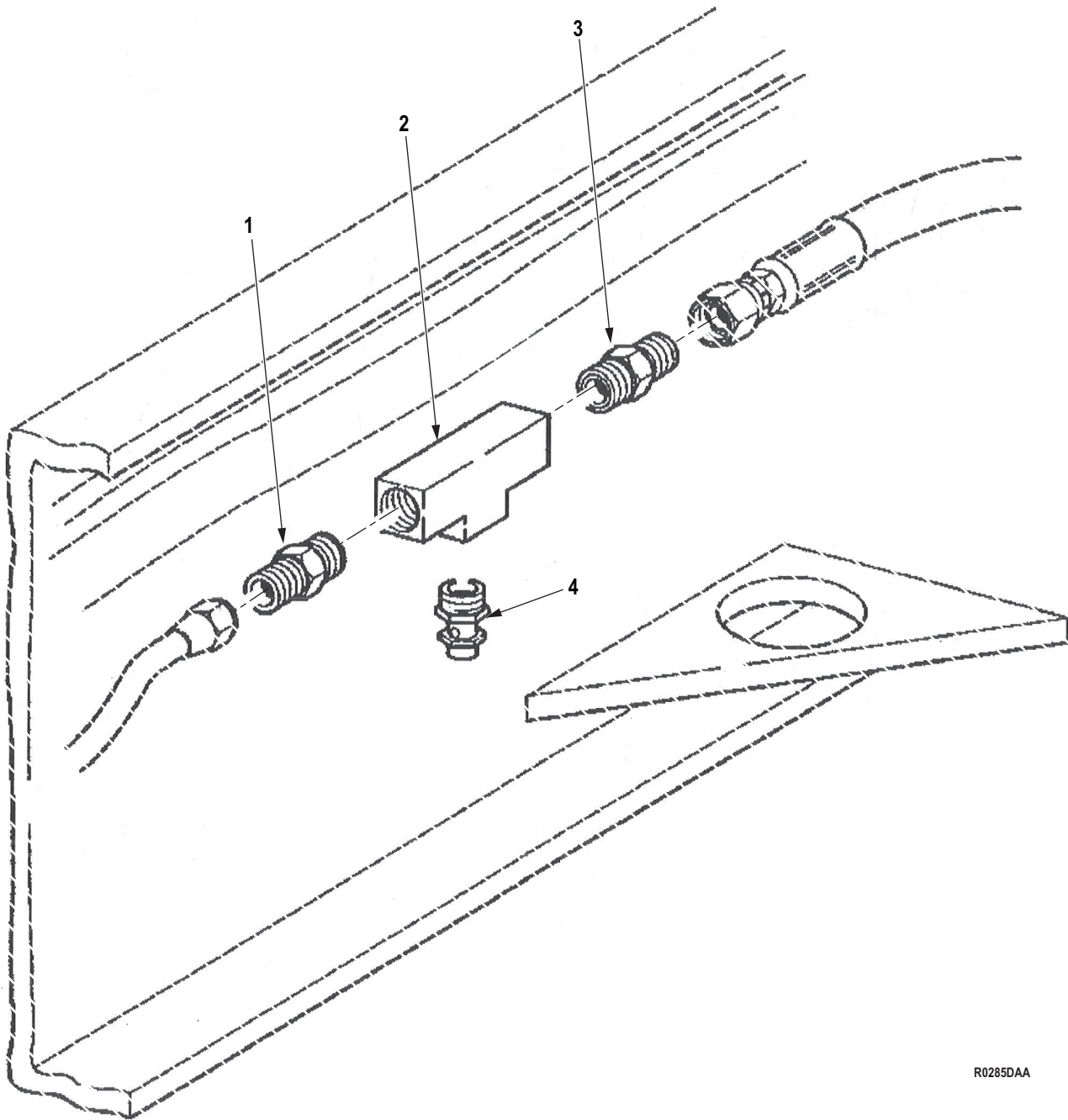

R0285DAA

Figure 269. Air Supply Line Safety Valve (ABS).



(1) ITEM NO.	(2) SMR CODE	(3) NSN	(4) CAGEC	(5) PART NUMBER	(6) DESCRIPTION AND USABLE ON CODE (UOC)	(7) QTY
<b>GROUP 1208 AIR BRAKE SYSTEM.</b>						
<b>FIG. 269. AIR SUPPLY LINE SAFETY VALVE (ABS).</b>						
1	PAFZZ	4730-00-126-8445	93061	68AB-8-8	ADAPTER, STRAIGHT, PI UOC: DAC, DAD, DAE, DAF, DAG, DA H, DAJ, DAL, DAW, DAX, V14, V15, V16, V17, V18, V19, V20, V21, V22, V24, ZAA, ZAB, ZAC, ZAD, ZAE, ZAF, ZAG, ZAH, Z AJ, ZAL .....	1
2	PAFZZ	4730-01-235-3007	81343	8-8-8 130438B	TEE, PIPE UOC: DAC, DAD, DAE, DAF, DAG, DA H, DAJ, DAL, DAW, DAX, V14, V15, V16, V17, V18, V19, V20, V21, V22, V24, ZAA, ZAB, ZAC, ZAD, ZAE, ZAF, ZAG, ZAH, Z AJ, ZAL .....	1
3	PAFZZ	4730-01-382-1646	93061	222P-8-8	COUPLING, PIPE UOC: DAC, DAD, DAE, DAF, DAG, DA H, DAJ, DAL, DAW, DAX, V14, V15, V16, V17, V18, V19, V20, V21, V22, V24, ZAA, ZAB, ZAC, ZAD, ZAE, ZAF, ZAG, ZAH, Z AJ, ZAL .....	1
4	PAFZZ	4820-01-478-3710	0UKB6	WHMBN1178DF	VALVE, RELIEF UOC: DAC, DAD, DAE, DAF, DAG, DA H, DAJ, DAL, DAW, DAX, V14, V15, V16, V17, V18, V19, V20, V21, V22, V24, ZAA, ZAB, ZAC, ZAD, ZAE, ZAF, ZAG, ZAH, Z AJ, ZAL .....	1

**END OF FIGURE**



**FIELD MAINTENANCE  
PRIMARY, SECONDARY, WET RESERVOIRS, AND RELATED LINES**

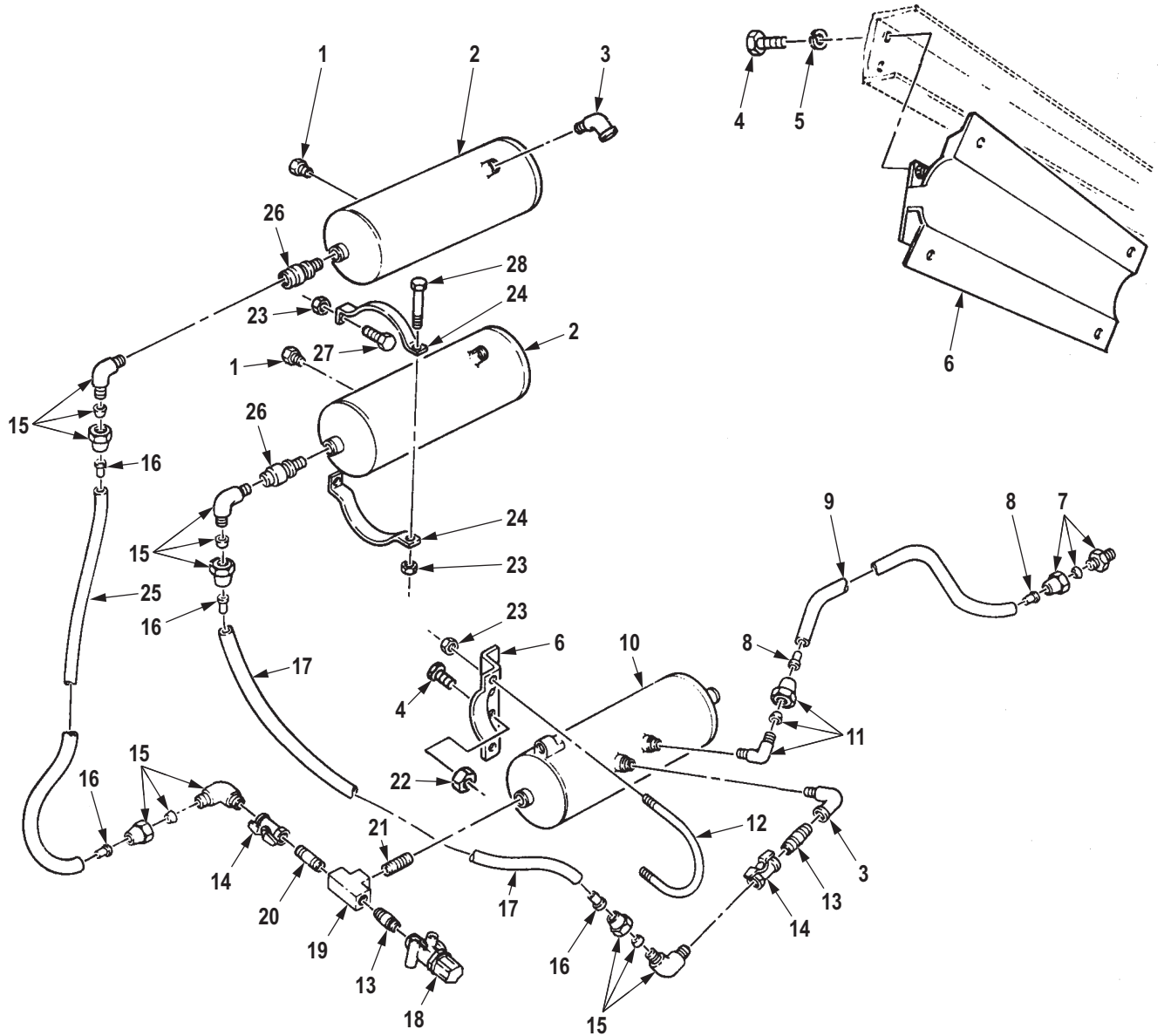

R0286DAA

Figure 270. Primary, Secondary, Wet Reservoirs, and Related Lines. (Sheet 1 of 2)

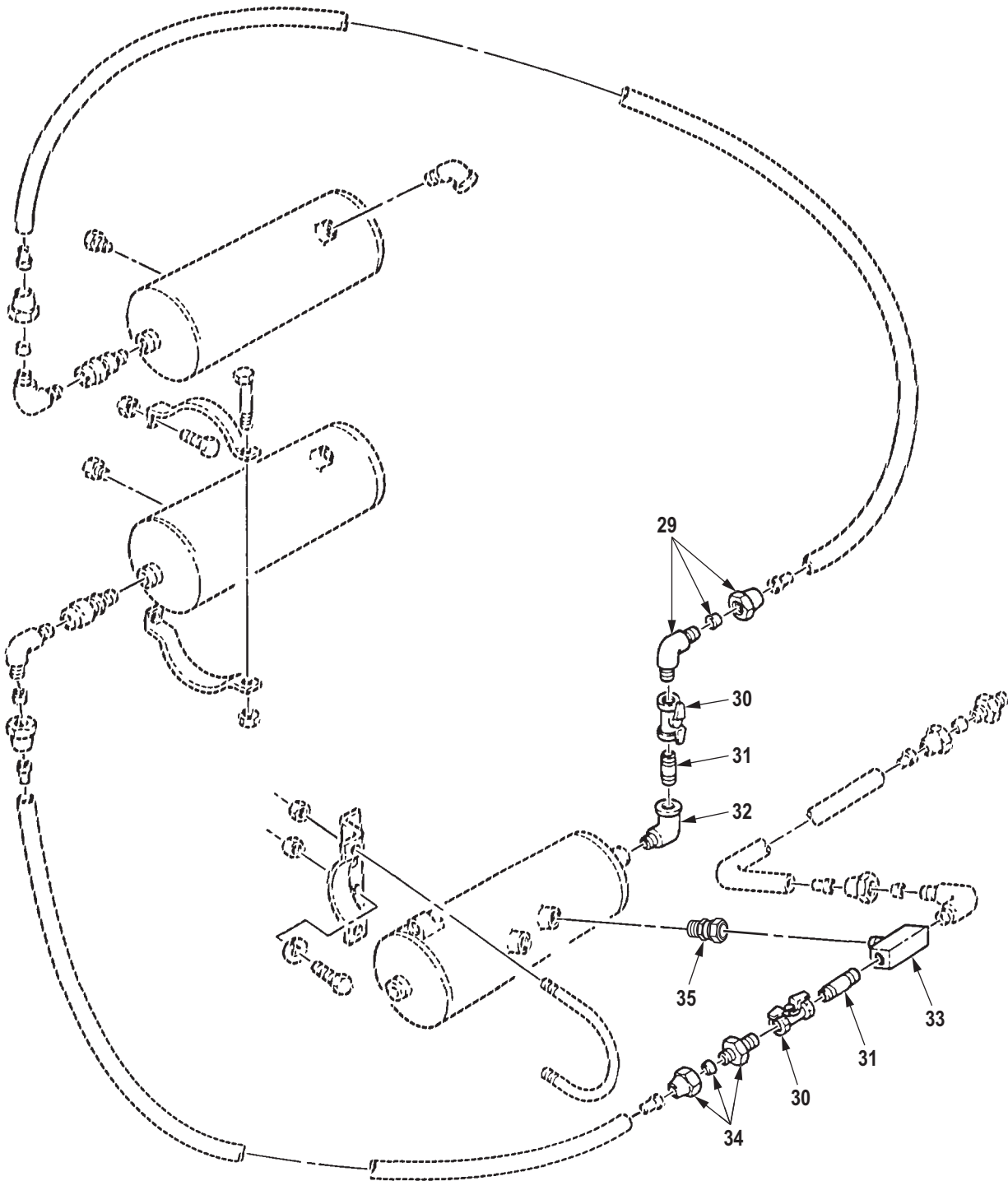

R0287DAA

Figure 270. Primary, Secondary, Wet Reservoirs, and Related Lines. (Sheet 2 of 2)

(1) ITEM NO.	(2) SMR CODE	(3) NSN	(4) CAGEC	(5) PART NUMBER	(6) DESCRIPTION AND USABLE ON CODE (UOC)	(7) QTY
<b>GROUP 1208 AIR BRAKE SYSTEM.</b>						
<b>FIG. 270. PRIMARY, SECONDARY, WET RESERVOIRS, AND RELATED LINES.</b>						
1	PAFZZ	4730-01-206-6162	58536	AA59616ACABCD	PLUG,PIPE UOC: DAC,DAD,DAE,DAF,DAG,DA H,DAJ,DAL,DAW,DAX,V14,V15,V16, V17,V18,V19,V20,V21,V22,V24,ZAA, ZAB,ZAC,ZAD,ZAE,ZAF,ZAG,ZAH,Z AJ,ZAL .....	2
2	PAFZZ	2530-01-111-2260	19207	12255982	RESERVOIR,AIR UOC: DAC,DAD,DAE,DAF,DAG,DA H,DAJ,DAL,DAW,DAX,V14,V15,V16, V17,V18,V19,V20,V21,V22,V24,ZAA, ZAB,ZAC,ZAD,ZAE,ZAF,ZAG,ZAH,Z AJ,ZAL .....	2
3	PAFZZ	4730-00-277-5555	96906	MS51952-4	ELBOW,PIPE UOC: DAC,DAD,DAE,DAF,DAG,DA H,DAJ,DAW,DAX,V14,V15,V16,V17, V19,V20,V21,V22,V24,ZAA,ZAB,ZAC ,ZAD,ZAE,ZAF,ZAG,ZAH,ZAJ .....	3
4	PAFZZ	5305-00-269-2803	80205	MS90726-60	SCREW,CAP,HEXAGON H UOC: DAC,DAD,DAJ,DAL,V16,V17, V18,V24,ZAC,ZAD,ZAJ,ZAL .....	4
5	PAFZZ	5310-00-637-9541	00198	132661	WASHER,LOCK UOC: DAC,DAD,DAJ,DAL,V16,V17, V18,V24,ZAC,ZAD,ZAJ,ZAL .....	4
6	PAFZZ	5340-01-112-6436	19207	12255974	BRACKET,MOUNTING UOC: DAE,DAF,DAG,DAH,DAW,DA X,V14,V15,V19,V20,V21,V22 .....	2
6	PAFZZ	5340-01-188-5088	19207	12302755	BRACKET,MOUNTING UOC: DAC,DAD,DAJ,DAL,V16,V17, V18,V24,ZAC,ZAD,ZAJ,ZAL .....	1
7	PAFZZ	4730-00-069-1186	81343	6-4 120102BA	ADAPTER,STRAIGHT,PI UOC: DAC,DAD,DAE,DAF,DAG,DA H,DAJ,DAL,DAW,DAX,V14,V15,V16, V17,V18,V19,V20,V21,V22,V24,ZAA, ZAB,ZAC,ZAD,ZAE,ZAF,ZAG,ZAH,Z AJ,ZAL .....	1
8	PAFZZ	4730-01-079-8821	19207	CPR102321-1	INSERT,TUBE FITTING UOC: DAC,DAD,DAE,DAF,DAG,DA H,DAJ,DAL,DAW,DAX,V14,V15,V16, V17,V18,V19,V20,V21,V22,V24,ZAA, ZAB,ZAC,ZAD,ZAE,ZAF,ZAG,ZAH,Z AJ,ZAL .....	2

(1) ITEM NO.	(2) SMR CODE	(3) NSN	(4) CAGEC	(5) PART NUMBER	(6) DESCRIPTION AND USABLE ON CODE (UOC)	(7) QTY
9	MFFZZ		81343	J844TYBSIZE 3/8 BLACK-49	HOSE, NONMETALLIC WET RESERVOIR, MAKE FROM HOSE, P/ N J844TYBSIZE 3/8 BLACK, 49 IN. LONG UOC: DAL, DAW, DAX, V14, V15, V18, ZAA, ZAB, ZAL .....	1
9	MFFZZ		81343	J844TYBSIZE 3/8 BLACK-39	HOSE, NONMETALLIC WET RESERVOIR, MAKE FROM HOSE, P/ N J844TYBSIZE 3/8 BLACK, 39 IN. LONG UOC: DAL, DAW, DAX, V14, V15, V18, V19, V20, V21, V22, ZAA, ZAB, ZAE, ZAF , ZAH, ZAJ, ZAL .....	1
9	MFFZZ		81343	J844TYBSIZE 3/8 BLACK-89	HOSE, NONMETALLIC WET RESERVOIR, MAKE FROM HOSE, P/ N J844TYBSIZE 3/8 BLACK, 89 IN. LONG UOC: DAC, DAD, DAJ, V16, V17, V24, Z AC, ZAD, ZAJ, ZAL .....	1
10	PAFZZ	2530-01-111-2261	19207	12255983	RESERVOIR, AIR UOC: DAC, DAD, DAE, DAF, DAG, DA H, DAJ, DAL, DAW, DAX, V14, V15, V16, V17, V18, V19, V20, V21, V22, V24, ZAA, ZAB, ZAC, ZAD, ZAE, ZAF, ZAG, ZAH, Z AJ, ZAL .....	1
11	PAFZZ	4730-00-143-9282	81343	J246 6-8 120202BA	ELBOW, PIPE TO TUBE UOC: DAC, DAD, DAE, DAF, DAG, DA H, DAJ, DAW, DAX, V14, V15, V16, V17, V19, V20, V21, V22, V24, ZAA, ZAB, ZAC , ZAD, ZAE, ZAF, ZAG, ZAH, ZAJ .....	1
12	PAFZZ	5306-00-207-4932	19207	8327473	BOLT, U UOC: DAC, DAD, DAE, DAF, DAG, DA H, DAJ, DAL, DAW, DAX, V14, V15, V16, V17, V18, V19, V20, V21, V22, V24, ZAA, ZAB, ZAC, ZAD, ZAE, ZAF, ZAG, ZAH, Z AJ, ZAL .....	1
13	PAFZZ	4730-00-222-1839	81346	B687R-58B	NIPPLE, PIPE UOC: DAC, DAD, DAE, DAF, DAG, DA H, DAJ, DAW, DAX, V14, V15, V16, V17, V19, V20, V21, V22, V24, ZAA, ZAB, ZAC , ZAD, ZAE, ZAF, ZAG, ZAH, ZAJ .....	2
14	PAFZZ	4820-00-420-5499	06853	285172N	VALVE, BALL UOC: DAC, DAD, DAE, DAF, DAG, DA H, DAJ, DAW, DAX, V14, V15, V16, V17, V19, V20, V21, V22, V24, ZAA, ZAB, ZAC , ZAD, ZAE, ZAF, ZAG, ZAH, ZAJ .....	2
15	PAFZZ	4730-00-595-2572	81343	SAE J246 8-8 120202BA	ELBOW, PIPE TO TUBE UOC: DAC, DAD, DAE, DAF, DAG, DA H, DAJ, DAW, DAX, V14, V15, V16, V17, V19, V20, V21, V22, V24, ZAA, ZAB, ZAC , ZAD, ZAE, ZAF, ZAG, ZAH, ZAJ .....	2

(1) ITEM NO.	(2) SMR CODE	(3) NSN	(4) CAGEC	(5) PART NUMBER	(6) DESCRIPTION AND USABLE ON CODE (UOC)	(7) QTY
16	PAFZZ	4730-01-032-6038	19207	CPR102321-4	INSERT,TUBE FITTING UOC: DAC,DAD,DAE,DAF,DAG,DA H,DAJ,DAL,DAW,DAX,V14,V15,V16, V17,V18,V19,V20,V21,V22,V24,ZAA, ZAB,ZAC,ZAD,ZAE,ZAF,ZAG,ZAH,Z AJ,ZAL .....	4
17	MFFZZ		19207	CPR104420-3-64	HOSE,NONMETALLIC MAKE FROM HOSE P/N CPR104420-3,64 IN.LONG UOC: DAW,DAX,V14,V15,ZAA,ZAB .....	1
17	MFFZZ		19207	J844TYBSIZE 3/8 BLACK-68	HOSE,NONMETALLIC MAKE FROM HOSE, P/N J844TYBSIZE 3/8 BLACK,68 IN.LONG UOC: DAC,DAD,DAE,DAF,DAG,DA H,DAJ,DAL,V16,V17,V18,V19,V20,V 21,V22,V24,ZAC,ZAD,ZAE,ZAF,ZAG, ZAH,ZAJ,ZAL .....	1
18	PAFZZ	4820-01-114-7543	19207	11669104	VALVE,SAFETY RELIEF UOC: DAC,DAD,DAE,DAF,DAG,DA H,DAJ,DAW,DAX,V14,V15,V16,V17, V19,V20,V21,V22,V24,ZAA,ZAB,ZAC ,ZAD,ZAE,ZAF,ZAG,ZAH,ZAJ,ZAL .....	1
19	PAFZZ	4730-01-095-2034	81343	SAE J530 8-8-8 130424BA	TEE,PIPE UOC: DAC,DAD,DAE,DAF,DAG,DA H,DAJ,DAW,DAX,V14,V15,V16,V17, V19,V20,V21,V22,V24,ZAA,ZAB,ZAC ,ZAD,ZAE,ZAF,ZAG,ZAH,ZAJ .....	1
20	PAFZZ	4730-00-193-2709	81346	B687R-24B	NIPPLE,PIPE UOC: DAC,DAD,DAE,DAF,DAG,DA H,DAJ,DAW,DAX,V14,V15,V16,V17, V18,V19,V20,V21,V22,V24 .....	1
21	PAFZZ	4730-01-192-4729	58536	AA59616BDQBCDB	BUSHING,PIPE UOC: DAC,DAD,DAE,DAF,DAG,DA H,DAJ,DAW,DAX,V14,V15,V16,V17, V19,V20,V21,V22,V24,ZAA,ZAB,ZAC ,ZAD,ZAE,ZAF,ZAG,ZAH,ZAJ .....	1
22	PAFZZ	5310-00-814-0672	96906	M45913/3-6FG8C	NUT,SELF-LOCKING,HE UOC: DAC,DAD,DAE,DAF,DAG,DA H,DAJ,DAL,DAW,DAX,V14,V15,V16, V17,V18,V19,V20,V21,V22,V24,ZAA, ZAB,ZAC,ZAD,ZAE,ZAF,ZAG,ZAH,Z AJ,ZAL .....	4
23	PAFZZ	5310-00-814-0672	96906	M45913/3-6FG8C	NUT,SELF-LOCKING,HE UOC: DAC,DAD,DAE,DAF,DAG,DA H,DAJ,DAL,DAW,DAX,V21,V22,V24, ZAA,ZAB,ZAC,ZAD,ZAE,ZAF,ZAG,Z AH,ZAJ,ZAL .....	14

(1) ITEM NO.	(2) SMR CODE	(3) NSN	(4) CAGEC	(5) PART NUMBER	(6) DESCRIPTION AND USABLE ON CODE (UOC)	(7) QTY
24	PAFZZ	5340-01-112-6554	19207	12255969-1	STRAP,RETAINING UOC: DAC,DAD,DAE,DAF,DAG,DA H,DAJ,DAL,DAW,DAX,V14,V15,V16, V17,V18,V19,V20,V21,V22,V24,ZAA, ZAB,ZAC,ZAD,ZAE,ZAF,ZAG,ZAH,Z AJ,ZAL .....	8
25	MFFZZ		19207	CPR104420-3-45	HOSE,NONMETALLIC MAKE FROM HOSE P/N CPR104420-3,45 IN.LONG UOC: DAW,DAX,V14,V15,ZAA,ZAB .....	1
25	MFFZZ		19207	CPR104420-3-54	HOSE,NONMETALLIC MAKE FROM HOSE, P/N CPR104420-3, 54 IN.LONG UOC: DAC,DAD,DAE,DAF,DAG,DA H,DAJ,DAL,V15,V16,V17,V18,V19,V 20,V21,V22,V24,ZAC,ZAD,ZAE,ZAF, ZAG,ZAH,ZAJ,ZAL .....	1
26	PAFZZ	4820-00-633-3523	06721	N-30252	VALVE,CHECK UOC: DAC,DAD,DAE,DAF,DAG,DA H,DAJ,DAL,DAW,DAX,V14,V15,V16, V17,V18,V19,V20,V21,V22,V24,ZAA, ZAB,ZAC,ZAD,ZAE,ZAF,ZAG,ZAH,Z AJ,ZAL .....	2
27	PAFZZ	5305-00-269-2803	80205	MS90726-60	SCREW,CAP,HEXAGON H UOC: DAC,DAD,DAE,DAF,DAG,DA H,DAJ,DAL,DAW,DAX,V14,V15,V16, V17,V18,V19,V20,V21,V22,V24,ZAA, ZAB,ZAC,ZAD,ZAE,ZAF,ZAG,ZAH,Z AJ,ZAL .....	8
28	PAFZZ	5305-01-133-7201	24617	147601	SCREW,CAP,HEXAGON H UOC: DAC,DAD,DAE,DAF,DAG,DA H,DAJ,DAL,DAW,DAX,V14,V15,V16, V17,V18,V19,V20,V21,V22,V24,ZAA, ZAB,ZAC,ZAD,ZAE,ZAF,ZAG,ZAH,Z AJ,ZAL .....	4
29	PAFZZ	4730-00-595-2572	81343	SAE J246 8-8 120202BA	ELBOW,PIPE TO TUBE UOC: DAL,V18,ZAL .....	1
30	PAFZZ	4820-00-420-5499	06853	285172N	VALVE,BALL UOC: DAL,V18,ZAL .....	2
31	PAFZZ	4730-00-222-1839	81346	B687R-58B	NIPPLE,PIPE UOC: DAL,V18,ZAL .....	2
32	PAFZZ	4730-00-277-5555	96906	MS51952-4	ELBOW,PIPE UOC: DAL,V18,ZAL .....	1
33	PAFZZ	4730-01-095-2034	81343	SAE J530 8-8-8 130424BA	TEE,PIPE UOC: DAL,V18,ZAL .....	1
34	PAFZZ	4730-00-202-9036	81343	SAE J246 8-8 120102BA	ADAPTER,STRAIGHT,PI UOC: DAL,V18,ZAL .....	1



(1) ITEM NO.	(2) SMR CODE	(3) NSN	(4) CAGEC	(5) PART NUMBER	(6) DESCRIPTION AND USABLE ON CODE (UOC)	(7) QTY
35	PAFZZ	4730-01-192-4729	58536	AA59616BDQBCDB	BUSHING,PIPE UOC: DAL,V18,ZAL .....	1

END OF FIGURE



**FIELD MAINTENANCE  
AIR TANK RESERVOIRS, DRAINVALVES, AND RELATE LINES**

---

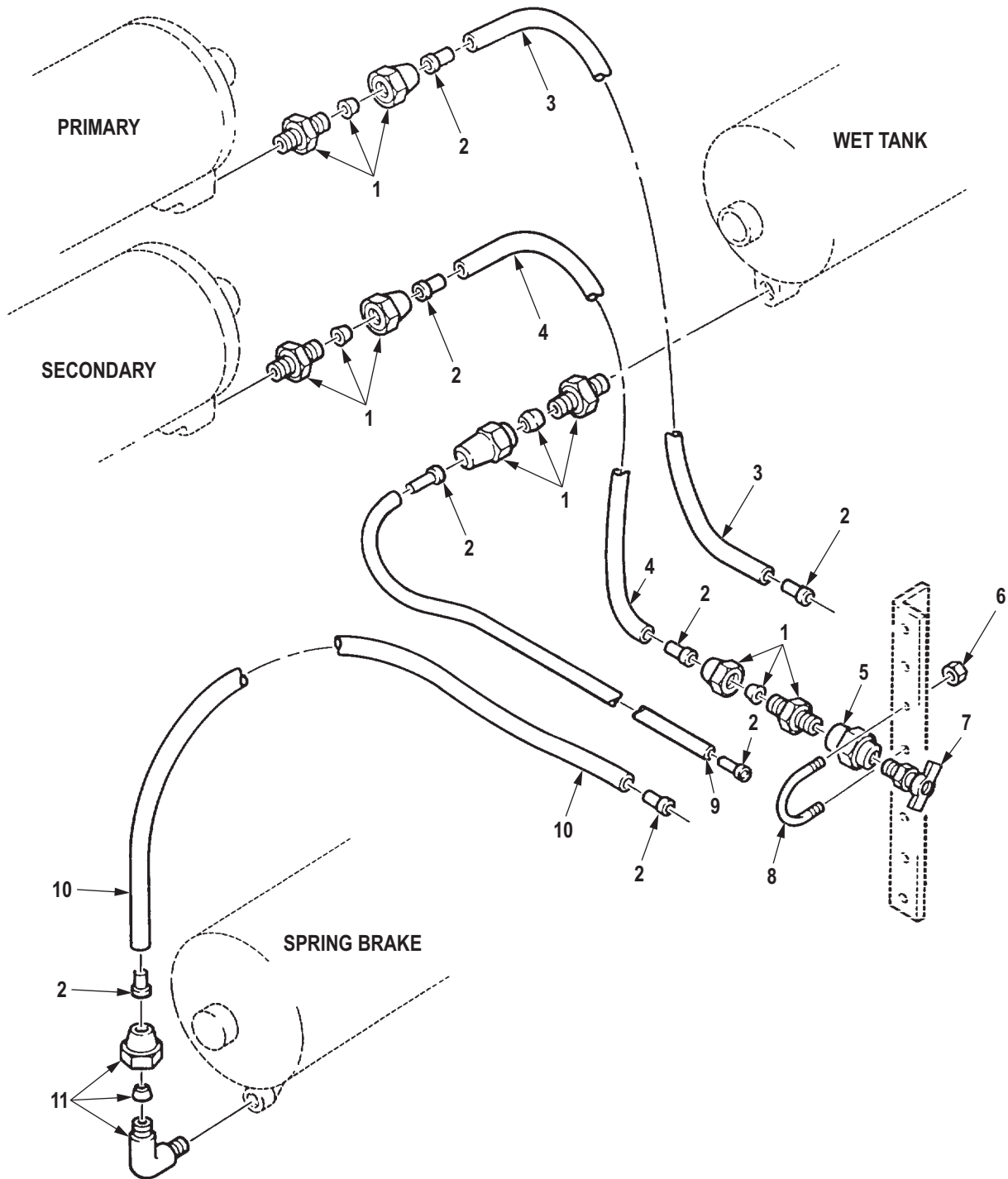

R0288DAA

Figure 271. Air Tank Reservoirs, Drainvalves, and Relate Lines.

(1) ITEM NO.	(2) SMR CODE	(3) NSN	(4) CAGEC	(5) PART NUMBER	(6) DESCRIPTION AND USABLE ON CODE (UOC)	(7) QTY
<b>GROUP 1208 AIR BRAKE SYSTEM.</b>						
<b>FIG. 271. AIR TANK RESERVOIRS, DRAINVALVES, AND RELATE LINES.</b>						
1	PAFZZ	4730-00-069-1186	81343	6-4 120102BA	ADAPTER,STRAIGHT,PI UOC: DAC,DAD,DAE,DAF,DAG,DA H,DAJ,DAL,DAW,DAX,V14,V15,V16, V17,V18,V19,V20,V21,V22,V24,ZAA, ZAB,ZAC,ZAD,ZAE,ZAF,ZAG,ZAH,Z AJ,ZAL .....	6
2	PAFZZ	4730-01-079-8821	19207	CPR102321-1	INSERT,TUBE FITTING UOC: DAC,DAD,DAE,DAF,DAG,DA H,DAJ,DAL,DAW,DAX,V14,V15,V16, V17,V18,V19,V20,V21,V22,V24,ZAA, ZAB,ZAC,ZAD,ZAE,ZAF,ZAG,ZAH,Z AJ,ZAL .....	8
3	MFFZZ		81343	J844TYBSIZE 3/8 BLACK-11	HOSE,NONMETALLIC PRIMARY RESERVOIR, MAKE FROM HOSE, P/ N J844TYBSIZE 3/8BLACK, 11 IN.LONG UOC: DAC,DAD,DAE,DAF,DAG,DA H,DAJ,DAL,DAW,DAX,V14,V15,V16, V17,V18,V19,V20,V21,V22,V24,ZAA, ZAB,ZAC,ZAD,ZAE,ZAF,ZAG,ZAH,Z AJ,ZAL .....	1
4	MFFZZ		81343	J844TYBSIZE 3/8 BLACK-16	HOSE,NONMETALLIC SECONDARY RESERVOIR,MAKE FROM HOSE, P/N J844TYBSIZE 3/8 BLACK,16 IN.LONG UOC: DAC,DAD,DAE,DAF,DAG,DA H,DAJ,DAL,DAW,DAX,V14,V15,V16, V17,V18,V19,V20,V21,V22,V24,ZAA, ZAB,ZAC,ZAD,ZAE,ZAF,ZAG,ZAH,Z AJ,ZAL .....	1
5	PAFZZ	4730-00-580-7408	04164	272M0075P004	COUPLING,PIPE UOC: DAC,DAD,DAE,DAF,DAG,DA H,DAJ,DAL,DAW,DAX,V14,V15,V16, V17,V18,V19,V20,V21,V22,V24,ZAA, ZAB,ZAC,ZAD,ZAE,ZAF,ZAG,ZAH,Z AJ,ZAL .....	4
6	PAFZZ	5310-00-061-7326	80205	MS21045-3	NUT,SELF-LOCKING,HE UOC: DAC,DAD,DAE,DAF,DAG,DA H,DAJ,DAL,DAW,DAX,V14,V15,V16, V17,V18,V19,V20,V21,V22,V24,ZAA, ZAB,ZAC,ZAD,ZAE,ZAF,ZAG,ZAH,Z AJ,ZAL .....	8

(1) ITEM NO.	(2) SMR CODE	(3) NSN	(4) CAGEC	(5) PART NUMBER	(6) DESCRIPTION AND USABLE ON CODE (UOC)	(7) QTY
7	PAFZZ	4820-00-849-1220	58536	A-A-59440/1-005	COCK,DRAIN UOC: DAC,DAD,DAE,DAF,DAG,DA H,DAJ,DAL,DAW,DAX,V14,V15,V16, V17,V18,V19,V20,V21,V22,V24,ZAA, ZAB,ZAC,ZAD,ZAE,ZAF,ZAG,ZAH,Z AJ,ZAL .....	4
8	PAFZZ	5306-01-112-6560	19207	12255984	BOLT,U UOC: DAC,DAD,DAE,DAF,DAG,DA H,DAJ,DAL,DAW,DAX,V14,V15,V16, V17,V18,V19,V20,V21,V22,V24,ZAA, ZAB,ZAC,ZAD,ZAE,ZAF,ZAG,ZAH,Z AJ,ZAL .....	4
9	MFFZZ		81343	J844TYBSIZE 3/8 BLACK-26	HOSE,NONMETALLIC MAKE FROM HOSE, P/N J844TYBSIZE 3/8 BLACK,26 IN.LONG UOC: DAC,DAD,DAE,DAF,DAG,DA H,DAJ,DAL,DAW,DAX,V14,V15,V16, V17,V18,V19,V20,V21,V22,V24,ZAA, ZAB,ZAC,ZAD,ZAE,ZAF,ZAG,ZAH,Z AJ,ZAL .....	1
10	MFFZZ		81343	J844TYBSIZE 3/8 BLACK-115	HOSE,NONMETALLIC SPRING BRAKE RESERVOIR,MAKE FROM HOSE, P/N J844TYBSIZE3/8 BLACK, 115 IN.LONG UOC: DAC,DAD,DAJ,V16,V17,V24,Z AC,ZAD,ZAJ .....	1
10	MFFZZ		81343	J844TYBSIZE 3/8 BLACK-110	HOSE,NONMETALLIC SPRING BRAKE RESERVOIR,MAKE FROM HOSE, P/N J844TYBSIZE3/8 BLACK, 110 IN.LONG UOC: DAE,DAF,DAG,DAH,DAL,DA W,DAX,V14,V15,V18,V19,V20,V21,V 22,ZAA,ZAB,ZAE,ZAF,ZAG,ZAH,ZAL .....	1
11	PAFZZ	4730-00-069-1187	81343	SAE J246 6-4 100202BA	ELBOW,PIPE TO TUBE UOC: DAC,DAD,DAE,DAF,DAG,DA H,DAJ,DAL,DAW,DAX,V14,V15,V16, V17,V18,V19,V20,V21,V22,V24,ZAA, ZAB,ZAC,ZAD,ZAE,ZAF,ZAG,ZAH,Z AJ,ZAL .....	2

END OF FIGURE

**FIELD MAINTENANCE  
SPRING BRAKE RESERVOIR, MOUNTING HARDWARE, SPRING BRAKE RELEASE VALVE, AND RELATED  
AIR SUPPLY LINES**

---

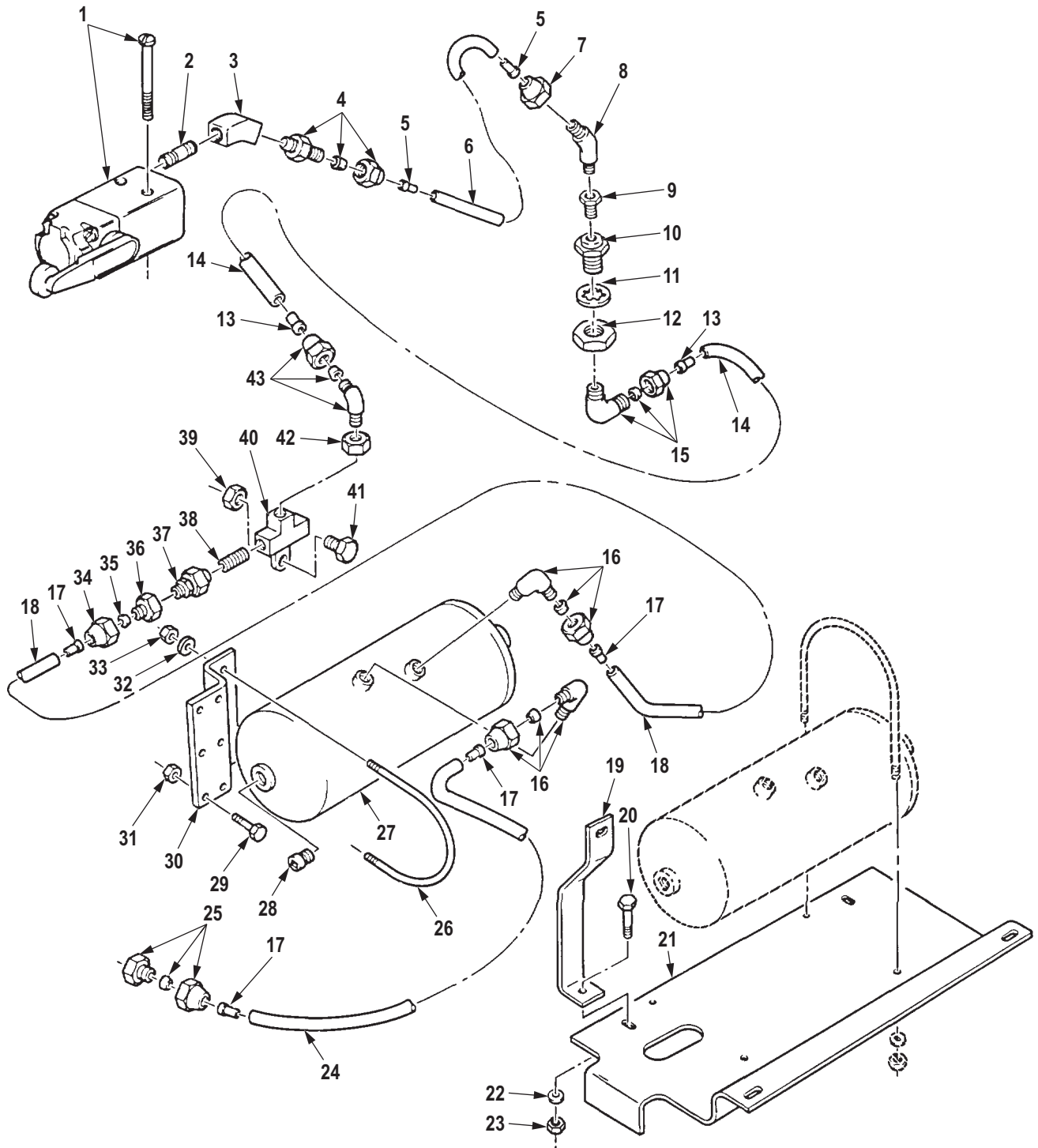

R0289DAA

Figure 272. Spring Brake Reservoir, Mounting Hardware, Spring Brake Release Valve, and Related Air Supply Lines.



(1) ITEM NO.	(2) SMR CODE	(3) NSN	(4) CAGEC	(5) PART NUMBER	(6) DESCRIPTION AND USABLE ON CODE (UOC)	(7) QTY
<b>GROUP 1208 AIR BRAKE SYSTEM.</b>						
<b>FIG. 272. SPRING BRAKE RESERVOIR, MOUNTING HARDWARE, SPRING BRAKE RELEASE VALVE, AND RELATED AIR SUPPLY LINES.</b>						
1	PAFZZ	4820-01-329-3245	97902	LSC-3270-S26022-1	VALVE,LINEAR,DIRECT UOC: DAC,DAD,DAE,DAF,DAG,DA H,DAJ,DAL,DAW,DAX,V14,V15,V16, V17,V18,V19,V20,V21,V22,V24,ZAA, ZAB,ZAC,ZAD,ZAE,ZAF,ZAG,ZAH,Z AJ,ZAL .....	1
2	PAFZZ	4730-00-196-1966	81346	B687R-13B	NIPPLE,PIPE UOC: DAC,DAD,DAE,DAF,DAG,DA H,DAJ,DAL,DAW,DAX,V14,V15,V16, V17,V18,V19,V20,V21,V22,V24,ZAA, ZAB,ZAC,ZAD,ZAE,ZAF,ZAG,ZAH,Z AJ,ZAL .....	1
3	PAFZZ	4730-00-125-7979	72582	444136	TEE,PIPE UOC: DAC,DAD,DAE,DAF,DAG,DA H,DAJ,DAL,DAW,DAX,V14,V15,V16, V17,V18,V19,V20,V21,V22,V24,ZAA, ZAB,ZAC,ZAD,ZAE,ZAF,ZAG,ZAH,Z AJ,ZAL .....	1
4	PAFZZ	4730-00-270-4580	81343	SAE J246 4-4 120102BA	ADAPTER,STRAIGHT,PI UOC: DAC,DAD,DAE,DAF,DAG,DA H,DAJ,DAL,DAW,DAX,V14,V15,V16, V17,V18,V19,V20,V21,V22,V24,ZAA, ZAB,ZAC,ZAD,ZAE,ZAF,ZAG,ZAH,Z AJ,ZAL .....	1
6	MFFZZ		19207	CPR104420-1-6	HOSE,NONMETALLIC MAKE FROM HOSE,P/N CPR104420-1, 6 IN. LONG UOC: DAC,DAD,DAE,DAF,DAG,DA H,DAJ,DAL,DAW,DAX,V14,V15,V16, V17,V18,V19,V20,V21,V22,V24,ZAA, ZAB,ZAC,ZAD,ZAE,ZAF,ZAG,ZAH,Z AJ,ZAL .....	1
7	PAFZZ	4730-00-011-6452	81343	4-010110B	NUT,TUBE COUPLING UOC: DAC,DAD,DAE,DAF,DAG,DA H,DAJ,DAL,DAW,DAX,V14,V15,V16, V17,V18,V19,V20,V21,V22,V24,ZAA, ZAB,ZAC,ZAD,ZAE,ZAF,ZAG,ZAH,Z AJ,ZAL .....	1
8	PAFZZ	4730-01-202-3351	81343	SAE J512 4-2 010302BA	ELBOW,PIPE TO TUBE UOC: DAC,DAD,DAE,DAF,DAG,DA H,DAJ,DAL,DAW,DAX,V14,V15,V16, V17,V18,V19,V20,V21,V22,V24,ZAA, ZAB,ZAC,ZAD,ZAE,ZAF,ZAG,ZAH,Z AJ,ZAL .....	1

(1) ITEM NO.	(2) SMR CODE	(3) NSN	(4) CAGEC	(5) PART NUMBER	(6) DESCRIPTION AND USABLE ON CODE (UOC)	(7) QTY
9	PAFZZ	4730-00-180-5038	81343	SAE J530 6-2 130140B	BUSHING,PIPE UOC: DAC,DAD,DAE,DAF,DAG,DA H,DAJ,DAL,DAW,DAX,V14,V15,V16, V17,V18,V19,V20,V21,V22,V24,ZAA, ZAB,ZAC,ZAD,ZAE,ZAF,ZAG,ZAH,Z AJ,ZAL .....	1
10	PAFZZ	4730-00-421-3924	19207	7339982	ADAPTER,STRAIGHT,PI UOC: DAC,DAD,DAE,DAF,DAG,DA H,DAJ,DAL,DAW,DAX,V14,V15,V16, V17,V18,V19,V20,V21,V22,V24,ZAA, ZAB,ZAC,ZAD,ZAE,ZAF,ZAG,ZAH,Z AJ,ZAL .....	1
11	PAFZZ	5310-00-582-6714	80205	MS35333-49	WASHER,LOCK UOC: DAC,DAD,DAE,DAF,DAG,DA H,DAJ,DAL,DAW,DAX,V14,V15,V16, V17,V18,V19,V20,V21,V22,V24,ZAA, ZAB,ZAC,ZAD,ZAE,ZAF,ZAG,ZAH,Z AJ,ZAL .....	1
12	PAFZZ	5310-00-241-0157	19207	5331179	NUT,PLAIN,HEXAGON UOC: DAC,DAD,DAE,DAF,DAG,DA H,DAJ,DAL,DAW,DAX,V14,V15,V16, V17,V18,V19,V20,V21,V22,V24,ZAA, ZAB,ZAC,ZAD,ZAE,ZAF,ZAG,ZAH,Z AJ,ZAL .....	1
13	PAFZZ	4730-01-032-6038	19207	CPR102321-4	INSERT,TUBE FITTING UOC: DAC,DAD,DAE,DAF,DAG,DA H,DAJ,DAL,DAW,DAX,V14,V15,V16, V17,V18,V19,V20,V21,V22,V24,ZAA, ZAB,ZAC,ZAD,ZAE,ZAF,ZAG,ZAH,Z AJ,ZAL .....	2
14	MFFZZ		19207	CPR104420-3-25	HOSE,NONMETALLIC MAKE FROM HOSE, P/N CPR104420-1,25 IN.LONG UOC: DAC,DAD,DAE,DAF,DAG,DA H,DAJ,DAL,DAW,DAX,V14,V15,V16, V17,V18,V19,V20,V21,V22,V24,ZAA, ZAB,ZAC,ZAD,ZAE,ZAF,ZAG,ZAH,Z AJ,ZAL .....	1
15	PAFZZ	4730-00-289-0051	81343	8-6 120202BA	ELBOW,PIPE TO TUBE UOC: DAC,DAD,DAE,DAF,DAG,DA H,DAJ,DAL,DAW,DAX,V14,V15,V16, V17,V18,V19,V20,V21,V22,V24,ZAA, ZAB,ZAC,ZAD,ZAE,ZAF,ZAG,ZAH,Z AJ,ZAL .....	1

(1) ITEM NO.	(2) SMR CODE	(3) NSN	(4) CAGEC	(5) PART NUMBER	(6) DESCRIPTION AND USABLE ON CODE (UOC)	(7) QTY
16	PAFZZ	4730-00-595-2572	81343	SAE J246 8-8 120202BA	ELBOW,PIPE TO TUBE UOC: DAC,DAD,DAE,DAF,DAG,DA H,DAJ,DAL,DAW,DAX,V14,V15,V16, V17,V18,V19,V20,V21,V22,V24,ZAA, ZAB,ZAC,ZAD,ZAE,ZAF,ZAG,ZAH,Z AJ,ZAL .....	2
17	PAFZZ	4730-00-132-4588	19207	11648703	INSERT,TUBE FITTING UOC: DAC,DAD,DAE,DAF,DAG,DA H,DAJ,DAL,DAW,DAX,V14,V15,V16, V17,V18,V19,V20,V21,V22,V24,ZAA, ZAB,ZAC,ZAD,ZAE,ZAF,ZAG,ZAH,Z AJ,ZAL .....	4
18	MFFZZ		19207	CPR104420-3-7	HOSE,NONMETALLIC MAKE FROM HOSE,P/N CPR104420-3,7 IN.LONG UOC: DAC,DAD,DAE,DAF,DAG,DA H,DAJ,DAL,DAW,DAX,V14,V15,V16, V17,V18,V19,V20,V21,V22,V24,ZAA, ZAB,ZAC,ZAD,ZAE,ZAF,ZAG,ZAH,Z AJ,ZAL .....	1
19	PFFZZ	5340-01-229-8365	19207	12302870	BRACKET,MOUNTING UOC: DAD,DAJ,DAL,V16,V17,V18,V 24,ZAC,ZAD,ZAJ,ZAL .....	2
20	PAFZZ	5305-00-269-2804	80205	MS90726-61	SCREW,CAP,HEXAGON H UOC: DAC,DAD,DAJ,DAL,V16,V17, V18,V24,ZAC,ZAD,ZAJ,ZAL .....	6
21	PFFZZ	5340-01-198-2415	19207	12302756	BRACKET,DOUBLE ANGL UOC: DAC,DAD,DAJ,DAL,V16,V17, V18,V24,ZAC,ZAD,ZAJ,ZAL .....	1
22	PAFZZ	5310-00-080-6004	96906	MS27183-14	WASHER,FLAT RESERVOIR BRACKET UOC: DAC,DAD,DAJ,DAL,V16,V17, V18,V24,ZAC,ZAD,ZAJ,ZAL .....	6
23	PAFZZ	5310-00-959-1488	81349	M45913/2-6FG5C	NUT,SELF-LOCKING,HE UOC: DAC,DAD,DAJ,DAL,V16,V17, V18,V24,ZAC,ZAD,ZAJ,ZAL .....	6
24	MFFZZ		19207	CPR104420-3-20	HOSE,NONMETALLIC MAKE FROM TUBING,P/N CPR104420-3,20 IN.LONG UOC: DAC,DAD,DAE,DAF,DAG,DA H,DAJ,DAL,DAW,DAX,V14,V15,V16, V17,V18,V19,V20,V21,V22,V24,ZAA, ZAB,ZAC,ZAD,ZAE,ZAF,ZAG,ZAH,Z AJ,ZAL .....	1
25	PAFZZ	4730-00-173-1867	81343	8-6 120103BA	ADAPTER,STRAIGHT,PI UOC: DAC,DAD,DAE,DAF,DAG,DA H,DAJ,DAL,DAW,DAX,V14,V15,V16, V17,V18,V19,V20,V21,V22,V24,ZAA, ZAB,ZAC,ZAD,ZAE,ZAF,ZAG,ZAH,Z AJ,ZAL .....	1

(1) ITEM NO.	(2) SMR CODE	(3) NSN	(4) CAGEC	(5) PART NUMBER	(6) DESCRIPTION AND USABLE ON CODE (UOC)	(7) QTY
26	PAFZZ	5306-00-753-9242	19207	7539242	BOLT,U UOC: DAC,DAD,DAE,DAF,DAG,DA H,DAJ,DAL,DAW,DAX,V14,V15,V16, V17,V18,V19,V20,V21,V22,V24,ZAA, ZAB,ZAC,ZAD,ZAE,ZAF,ZAG,ZAH,Z AJ,ZAL .....	2
27	PAFZZ	2530-01-111-2261	19207	12255983	RESERVOIR,AIR UOC: DAC,DAD,DAE,DAF,DAG,DA H,DAJ,DAL,DAW,DAX,V14,V15,V16, V17,V18,V19,V20,V21,V22,V24,ZAA, ZAB,ZAC,ZAD,ZAE,ZAF,ZAG,ZAH,Z AJ,ZAL .....	1
28	PAFZZ	4730-01-206-6162	58536	AA59616ACABCD	PLUG,PIPE UOC: DAC,DAD,DAE,DAF,DAG,DA H,DAJ,DAL,DAW,DAX,V14,V15,V16, V17,V18,V19,V20,V21,V22,V24,ZAA, ZAB,ZAC,ZAD,ZAE,ZAF,ZAG,ZAH,Z AJ,ZAL .....	2
29	PAFZZ	5305-00-269-2804	80205	MS90726-61	SCREW,CAP,HEXAGON H UOC: DAE,DAF,DAG,DAH,DAW,DA X,V14,V15,V19,V20,V21,V22,ZAA,ZA B,ZAE,ZAF,ZAG,ZAH .....	8
30	PFFZZ	2510-01-114-7542	19207	12276929	SUPPORT,AIR TANK UOC: DAE,DAF,DAG,DAH,DAW,DA X,V14,V15,V19,V20,V21,V22,ZAA,ZA B,ZAE,ZAF,ZAG,ZAH .....	2
31	PAFZZ	5310-00-814-0672	96906	M45913/3-6FG8C	NUT,SELF-LOCKING,HE UOC: DAE,DAF,DAG,DAH,DAW,DA X,V14,V15,V19,V20,V21,V22,ZAA,ZA B,ZAE,ZAF,ZAG,ZAH .....	8
32	PAFZZ	4730-00-647-3207	96906	MS51504A4	ELBOW,PIPE TO TUBE UOC: DAC,DAD,DAE,DAF,DAG,DA H,DAJ,DAL,DAW,DAX,V14,V15,V16, V17,V18,V19,V20,V21,V22,V24,ZAA, ZAB,ZAC,ZAD,ZAE,ZAF,ZAG,ZAH,Z AJ,ZAL .....	4
33	PAFZZ	5310-00-877-5796	80205	MS21044N4	NUT,SELF-LOCKING,HE 1/4-28 UNF-3B R.H. UOC: DAC,DAD,DAE,DAF,DAG,DA H,DAJ,DAL,DAW,DAX,V14,V15,V16, V17,V18,V19,V20,V21,V22,V24,ZAA, ZAB,ZAC,ZAD,ZAE,ZAF,ZAG,ZAH,Z AJ,ZAL .....	4
34	PAFZZ	4730-00-054-2572	81343	8 120111B	NUT,TUBE COUPLING UOC: DAC,DAD,DAE,DAF,DAG,DA H,DAJ,DAL,DAW,DAX,V14,V15,V16, V17,V18,V19,V20,V21,V22,V24,ZAA, ZAB,ZAC,ZAD,ZAE,ZAF,ZAG,ZAH,Z AJ,ZAL .....	1

(1) ITEM NO.	(2) SMR CODE	(3) NSN	(4) CAGEC	(5) PART NUMBER	(6) DESCRIPTION AND USABLE ON CODE (UOC)	(7) QTY
35	PAFZZ	4730-00-054-2571	81343	8 120115B	SLEEVE, COMPRESSION, UOC: DAC,DAD,DAE,DAF,DAG,DA H,DAJ,DAL,DAW,DAX,V14,V15,V16, V17,V18,V19,V20,V21,V22,V24,ZAA, ZAB,ZAC,ZAD,ZAE,ZAF,ZAG,ZAH,Z AJ,ZAL .....	1
36	PAFZZ	4730-01-116-7886	19207	12276950	ADAPTER, STRAIGHT, PI UOC: DAC,DAD,DAE,DAF,DAG,DA H,DAJ,DAL,DAW,DAX,V14,V15,V16, V17,V18,V19,V20,V21,V22,V24,ZAA, ZAB,ZAC,ZAD,ZAE,ZAF,ZAG,ZAH,Z AJ,ZAL .....	1
37	PAFZZ	4820-00-633-3523	06721	N-30252	VALVE, CHECK UOC: DAC,DAD,DAE,DAF,DAG,DA H,DAJ,DAL,DAW,DAX,V14,V15,V16, V17,V18,V19,V20,V21,V22,V24,ZAA, ZAB,ZAC,ZAD,ZAE,ZAF,ZAG,ZAH,Z AJ,ZAL .....	1
38	PAFZZ	4730-00-196-1504	81346	A733S-75CFG	NIPPLE, PIPE UOC: DAC,DAD,DAE,DAF,DAG,DA H,DAJ,DAL,DAW,DAX,V14,V15,V16, V17,V18,V19,V20,V21,V22,V24,ZAA, ZAB,ZAC,ZAD,ZAE,ZAF,ZAG,ZAH,Z AJ,ZAL .....	1
39	PAFZZ	5310-00-241-6658	81349	M45913/3-5FG8C	NUT, SELF-LOCKING, HE UOC: DAC,DAD,DAE,DAF,DAG,DA H,DAJ,DAL,DAW,DAX,V14,V15,V16, V17,V18,V19,V20,V21,V22,V24,ZAA, ZAB,ZAC,ZAD,ZAE,ZAF,ZAG,ZAH,Z AJ,ZAL .....	1
40	PAFZZ	4730-01-112-2168	19207	12256594	TEE ASSEMBLY, PIPE UOC: DAC,DAD,DAE,DAF,DAG,DA H,DAJ,DAL,DAW,DAX,V14,V15,V16, V17,V18,V19,V20,V21,V22,V24,ZAA, ZAB,ZAC,ZAD,ZAE,ZAF,ZAG,ZAH,Z AJ,ZAL .....	1
41	PAFZZ	5306-00-225-9089	80205	MS90726-34	BOLT, MACHINE UOC: DAC,DAD,DAE,DAF,DAG,DA H,DAJ,DAL,DAW,DAX,V14,V15,V16, V17,V18,V19,V20,V21,V22,V24,ZAA, ZAB,ZAC,ZAD,ZAE,ZAF,ZAG,ZAH,Z AJ,ZAL .....	1
42	PAFZZ	4730-01-100-0109	96906	MS51887-7C	BUSHING, PIPE UOC: DAC,DAD,DAE,DAF,DAG,DA H,DAJ,DAL,DAW,DAX,V14,V15,V16, V17,V18,V19,V20,V21,V22,V24,ZAA, ZAB,ZAC,ZAD,ZAE,ZAF,ZAG,ZAH,Z AJ,ZAL .....	1

(1) ITEM NO.	(2) SMR CODE	(3) NSN	(4) CAGEC	(5) PART NUMBER	(6) DESCRIPTION AND USABLE ON CODE (UOC)	(7) QTY
43	PAFZZ	4730-01-117-1614	81343	8-6 120302BA	ELBOW,PIPE TO TUBE UOC: DAC,DAD,DAE,DAF,DAG,DA H,DAJ,DAL,DAW,DAX,V14,V15,V16, V17,V18,V19,V20,V21,V22,V24,ZAA, ZAB,ZAC,ZAD,ZAE,ZAF,ZAG,ZAH,Z AJ,ZAL .....	1

END OF FIGURE

**FIELD MAINTENANCE  
AIR SUPPLY LINES, DOUBLECHECK VALVE TO COUPLING TO PUSH-PULL VALVE, AND SUPPLY LINE  
QUICK RELEASE VALVE TO TEE TO FAIL-SAFE TEE**

---

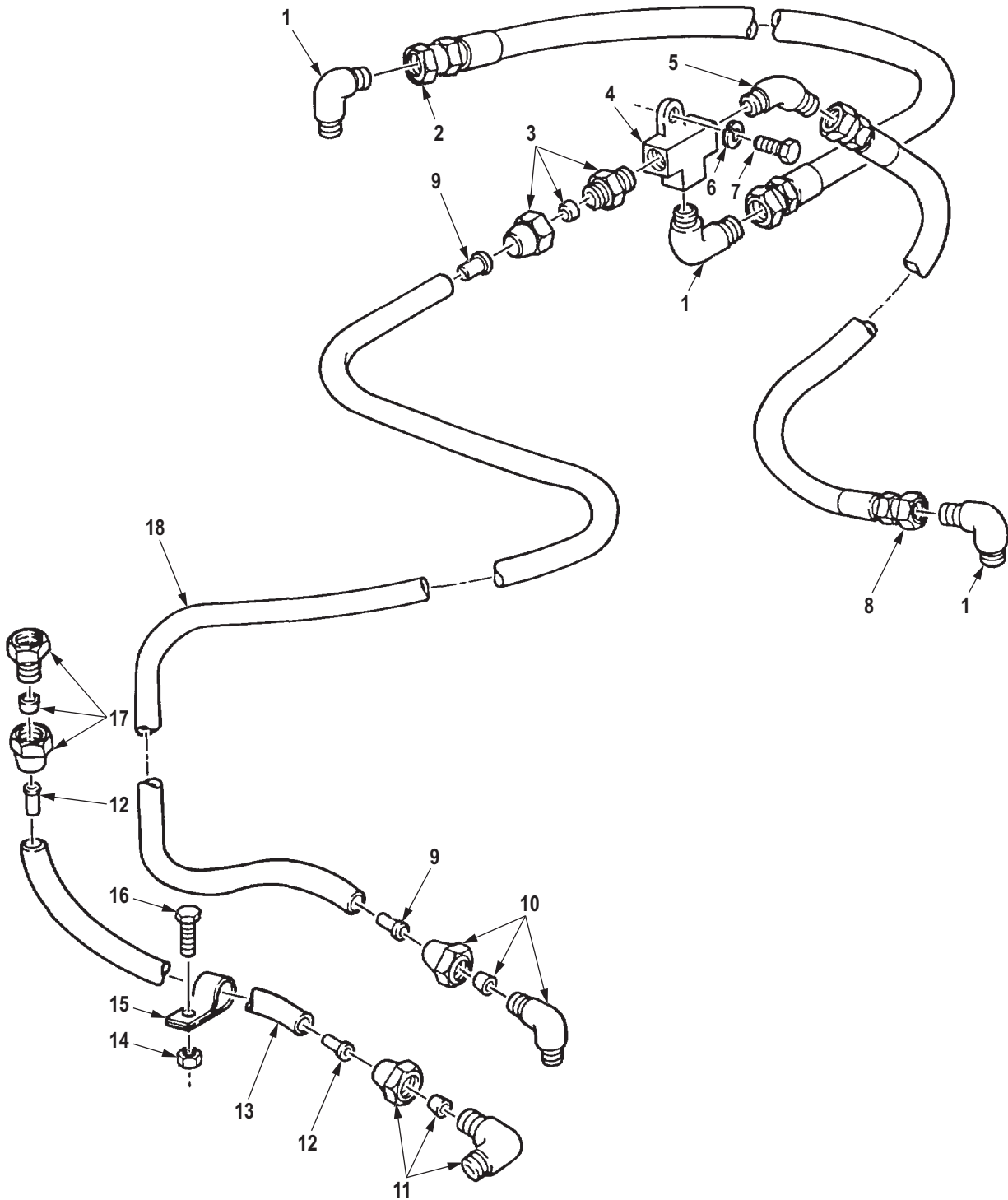

R0290DAA

Figure 273. Air Supply Lines, Double-Check Valve to Coupling to Push-Pull Valve, and Supply Line Quick Release Valve to Tee to Fail-Safe Tee.



(1) ITEM NO.	(2) SMR CODE	(3) NSN	(4) CAGEC	(5) PART NUMBER	(6) DESCRIPTION AND USABLE ON CODE (UOC)	(7) QTY
<b>GROUP 1208 AIR BRAKE SYSTEM.</b>						
<b>FIG. 273. AIR SUPPLY LINES, DOUBLE-CHECK VALVE TO COUPLING TO PUSH-PULL VALVE, AND SUPPLY LINE QUICK RELEASE VALVE TO TEE TO FAIL-SAFE TEE.</b>						
1	PAFZZ	4730-00-555-1764	96906	MS51504A8	ELBOW,PIPE TO TUBE FRONT REAR BRAKE CHAMBER UOC: DAC,DAD,DAE,DAF,DAG,DAH,DAJ,DAL,DAW,DAX,V14,V15,V16,V17,V18,V19,V20,V21,V22,V24,ZAA,ZAB,ZAC,ZAD,ZAE,ZAF,ZAG,ZAH,ZAJ,ZAL .....	3
2	PAFZZ	4720-01-112-6577	19207	12256271-5	HOSE ASSEMBLY,NONME FRONT REAR BRAKE CHAMBER UOC: DAC,DAD,DAE,DAF,DAG,DAH,DAJ,DAL,DAW,DAX,V14,V15,V16,V17,V18,V19,V20,V21,V22,V24,ZAA,ZAB,ZAC,ZAD,ZAE,ZAF,ZAG,ZAH,ZAJ,ZAL .....	1
3	PAFZZ	4730-00-270-4616	81343	6-6120102BA	ADAPTER,STRAIGHT,PI FRONT REAR BRAKE CHAMBER UOC: DAC,DAD,DAE,DAF,DAG,DAH,DAJ,DAL,DAW,DAX,V14,V15,V16,V17,V18,V19,V20,V21,V22,V24,ZAA,ZAB,ZAC,ZAD,ZAE,ZAF,ZAG,ZAH,ZAJ,ZAL .....	1
4	PAFZZ	4730-01-195-1884	19207	12302675	TEE,PIPE UOC: DAC,DAD,DAE,DAF,DAG,DAH,DAJ,DAL,DAW,DAX,V14,V15,V16,V17,V18,V19,V20,V21,V22,V24,ZAA,ZAB,ZAC,ZAD,ZAE,ZAF,ZAG,ZAH,ZAJ,ZAL .....	1
5	PAFZZ	4730-01-324-5071	96906	MS51508A8Z	ELBOW,PIPE TO TUBE FRONT REAR BRAKE CHAMBER UOC: DAC,DAD,DAE,DAF,DAG,DAH,DAJ,DAL,DAW,DAX,V14,V15,V16,V17,V18,V19,V20,V21,V22,V24,ZAA,ZAB,ZAC,ZAD,ZAE,ZAF,ZAG,ZAH,ZAJ,ZAL .....	1
6	PAFZZ	5310-00-637-9541	00198	132661	WASHER,LOCK UOC: DAC,DAD,DAE,DAF,DAG,DAH,DAJ,DAL,DAW,DAX,V14,V15,V16,V17,V18,V19,V20,V21,V22,V24,ZAA,ZAB,ZAC,ZAD,ZAE,ZAF,ZAG,ZAH,ZAJ,ZAL .....	1

(1) ITEM NO.	(2) SMR CODE	(3) NSN	(4) CAGEC	(5) PART NUMBER	(6) DESCRIPTION AND USABLE ON CODE (UOC)	(7) QTY
7	PAFZZ	5305-00-269-3239	80204	B1821BH038F138N	SCREW,CAP,HEXAGON H UOC: DAC,DAD,DAE,DAF,DAG,DA H,DAJ,DAL,DAW,DAX,V14,V15,V16, V17,V18,V19,V20,V21,V22,V24,ZAA, ZAB,ZAC,ZAD,ZAE,ZAF,ZAG,ZAH,Z AJ,ZAL .....	1
8	PAFZZ	4720-01-112-2332	19207	12256271-2	HOSE ASSEMBLY,NONME REAR REAR BRAKE CHAMBER UOC: DAC,DAD,DAE,DAF,DAG,DA H,DAJ,DAL,DAW,DAX,V14,V15,V16, V17,V18,V19,V20,V21,V22,V24,ZAA, ZAB,ZAC,ZAD,ZAE,ZAF,ZAG,ZAH,Z AJ,ZAL .....	1
9	PAFZZ	4730-01-079-8821	19207	CPR102321-1	INSERT,TUBE FITTING UOC: DAC,DAD,DAE,DAF,DAG,DA H,DAJ,DAL,DAW,DAX,V14,V15,V16, V17,V18,V19,V20,V21,V22,V24,ZAA, ZAB,ZAC,ZAD,ZAE,ZAF,ZAG,ZAH,Z AJ,ZAL .....	2
10	PAFZZ	4730-00-289-0155	81343	6-6 120202BA	ELBOW,PIPE TO TUBE UOC: DAC,DAD,DAE,DAF,DAG,DA H,DAJ,DAL,DAW,DAX,V14,V15,V16, V17,V18,V19,V20,V21,V22,V24,ZAA, ZAB,ZAC,ZAD,ZAE,ZAF,ZAG,ZAH,Z AJ,ZAL .....	1
11	PAFZZ	4730-00-289-0051	81343	8-6 120202BA	ELBOW,PIPE TO TUBE UOC: DAC,DAD,DAE,DAF,DAG,DA H,DAJ,DAL,DAW,DAX,V14,V15,V16, V17,V18,V19,V20,V21,V22,V24,ZAA, ZAB,ZAC,ZAD,ZAE,ZAF,ZAG,ZAH,Z AJ,ZAL .....	1
12	PAFZZ	4730-01-032-6038	19207	CPR102321-4	INSERT,TUBE FITTING UOC: DAC,DAD,DAE,DAF,DAG,DA H,DAJ,DAL,DAW,DAX,V14,V15,V16, V17,V18,V19,V20,V21,V22,V24,ZAA, ZAB,ZAC,ZAD,ZAE,ZAF,ZAG,ZAH,Z AJ,ZAL .....	2
13	MFFZZ		19207	CPR104420-3-44	HOSE,NONMETALLIC MAKE FROM HOSE P/N CPR104420-3,44 IN.LONG UOC: DAC,DAD,DAE,DAF,DAG,DA H,DAJ,DAL,DAW,DAX,V14,V15,V16, V17,V18,V19,V20,V21,V22,V24,ZAA, ZAB,ZAC,ZAD,ZAE,ZAF,ZAG,ZAH,Z AJ,ZAL .....	1

(1) ITEM NO.	(2) SMR CODE	(3) NSN	(4) CAGEC	(5) PART NUMBER	(6) DESCRIPTION AND USABLE ON CODE (UOC)	(7) QTY
14	PAFZZ	5310-00-814-0672	96906	M45913/3-6FG8C	NUT,SELF-LOCKING,HE UOC: DAC,DAD,DAE,DAF,DAG,DA H,DAJ,DAL,DAW,DAX,V14,V15,V16, V17,V18,V19,V20,V21,V22,V24,ZAA, ZAB,ZAC,ZAD,ZAE,ZAF,ZAG,ZAH,Z AJ,ZAL .....	2
15	PAFZZ	5340-01-231-5357	19207	7529133-9	CLAMP,LOOP UOC: DAC,DAD,DAE,DAF,DAG,DA H,DAJ,DAL,DAW,DAX,V14,V15,V16, V17,V18,V19,V20,V21,V22,V24,ZAA, ZAB,ZAC,ZAD,ZAE,ZAF,ZAG,ZAH,Z AJ,ZAL .....	2
16	PAFZZ	5305-00-912-5113	80205	MS51096-359	SCREW,CAP,HEXAGON H UOC: DAC,DAD,DAE,DAF,DAG,DA H,DAJ,DAL,DAW,DAX,V14,V15,V16, V17,V18,V19,V20,V21,V22,V24,ZAA, ZAB,ZAC,ZAD,ZAE,ZAF,ZAG,ZAH,Z AJ,ZAL .....	2
17	PAFZZ	4730-00-173-1867	81343	8-6 120103BA	ADAPTER,STRAIGHT,PI UOC: DAC,DAD,DAE,DAF,DAG,DA H,DAJ,DAL,DAW,DAX,V14,V15,V16, V17,V18,V19,V20,V21,V22,V24,ZAA, ZAB,ZAC,ZAD,ZAE,ZAF,ZAG,ZAH,Z AJ,ZAL .....	1
18	MFFZZ		81343	J844TYBSIZE 3/8 BLACK-206	HOSE,NONMETALLIC MAKE FROM HOSE, P/N J844TYBSIZE 3/8 BLACK, 206 IN.LONG UOC: DAW,DAX,V14,V15,ZAA,ZAB .....	1
18	MFFZZ		81343	J844TYBSIZE 3/8 BLACK-191	HOSE,NONMETALLIC MAKE FROM HOSE, P/N J844TYBSIZE 3/8 BLACK, 191 IN.LONG UOC: DAL,V18,ZAL .....	1
18	MFFZZ		81343	J844TYBSIZE 3/8 BLACK-229	HOSE,NONMETALLIC MAKE FROM HOSE, P/N J844TYBSIZE 3/8 BLACK, 229 IN. LONG UOC: DAC,DAD,DAJ,V16,V17,V24,Z AC,ZAD,ZAJ .....	1
18	MFFZZ		81343	J844TYBSIZE 3/8 BLACK-178	HOSE,NONMETALLIC MAKE FROM HOSE, P/N J844TYBSIZE 3/8 BLACK, 178 IN.LONG UOC: DAE,DAF,DAG,DAH,V19,V20, V21,V22 .....	1

END OF FIGURE



**FIELD MAINTENANCE  
FAIL-SAFE AIR BRAKE CHAMBER LINES**

---

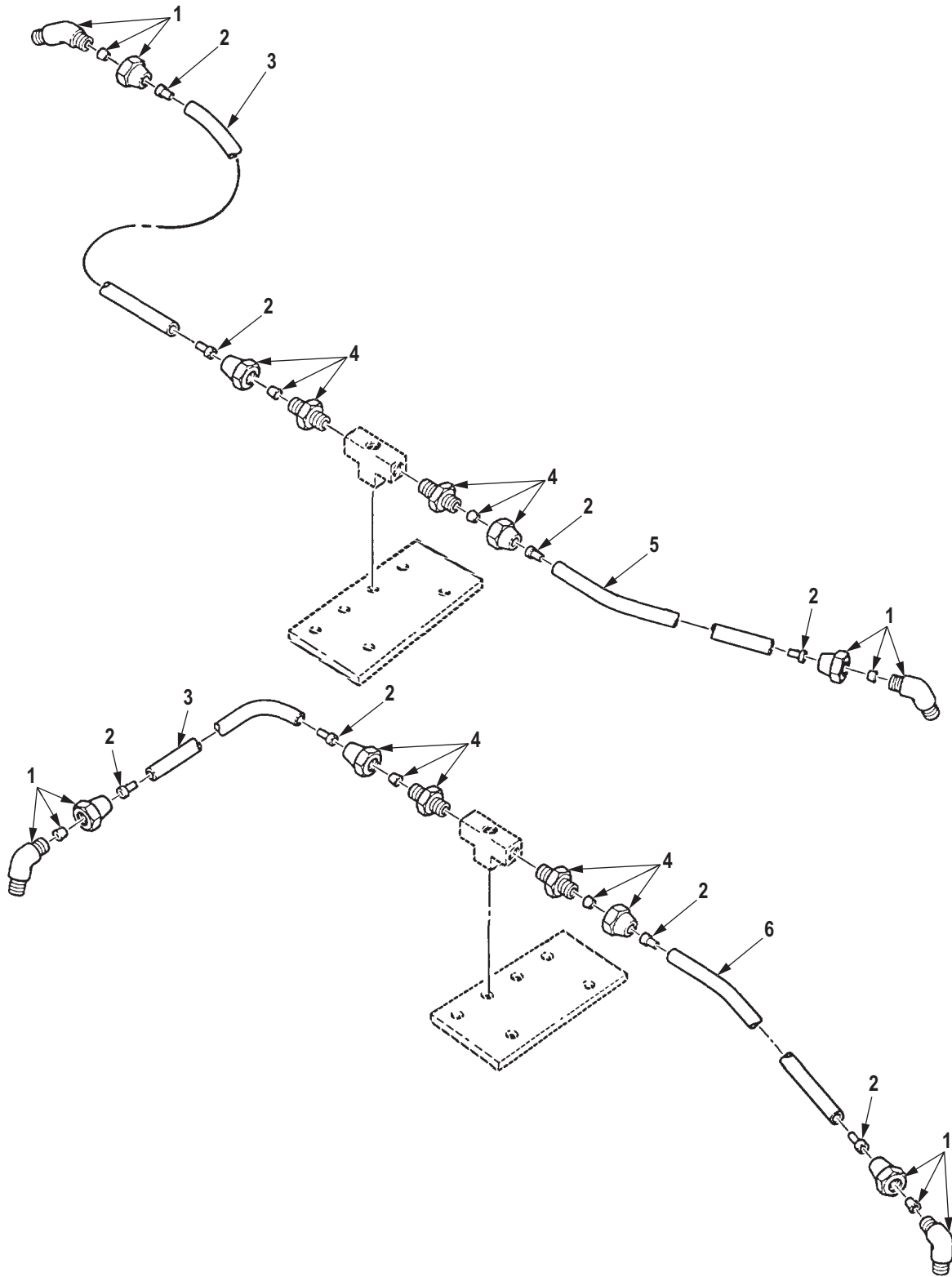

R0291DAA

Figure 274. Fail-Safe Air Brake Chamber Lines.

(1) ITEM NO.	(2) SMR CODE	(3) NSN	(4) CAGEC	(5) PART NUMBER	(6) DESCRIPTION AND USABLE ON CODE (UOC)	(7) QTY
<b>GROUP 1208 AIR BRAKE SYSTEM.</b>						
<b>FIG. 274. FAIL-SAFE AIR BRAKE CHAMBER LINES.</b>						
1	PAFZZ	4730-00-541-7500	81343	6-6 120302BA(LONGELBOW,PIPE TO TUBE NUT)	UOC: DAC,DAD,DAE,DAF,DAG,DA H,DAJ,DAL,DAW,DAX,V14,V15,V16, V17,V18,V19,V20,V21,V22,V24,ZAA, ZAB,ZAC,ZAD,ZAE,ZAF,ZAG,ZAH,Z AJ,ZAL .....	4
2	PAFZZ	4730-01-079-8821	19207	CPR102321-1	INSERT,TUBE FITTING UOC: DAC,DAD,DAE,DAF,DAG,DA H,DAJ,DAL,DAW,DAX,V14,V15,V16, V17,V18,V19,V20,V21,V22,V24,ZAA, ZAB,ZAC,ZAD,ZAE,ZAF,ZAG,ZAH,Z AJ,ZAL .....	8
3	MFFZZ		81343	J844TYBSIZE 3/8 BLACK-18	HOSE,NONMETALLIC MAKE FROM HOSE,NSN 4720-01-014-4915, 18 IN.LONG UOC: DAC,DAD,DAG,DAH,DAJ,DAL ,DAW,DAX,V14,V15,V16,V17,V18,V2 1,V22,V24,ZAA,ZAB,ZAC,ZAD,ZAG, ZAH,ZAJ,ZAL .....	1
3	MFFZZ		81343	J844TYBSIZE 3/8 BLACK-14	HOSE,NONMETALLIC MAKE FROM HOSE, P/N J844TYBSIZE 3/8 BLACK, 14 IN.LONG UOC: DAE,DAF,V19,V20,ZAE,ZAF .....	2
4	PAFZZ	4730-00-270-4616	81343	6-6120102BA	ADAPTER,STRAIGHT,PI UOC: DAC,DAD,DAE,DAF,DAG,DA H,DAJ,DAL,DAW,DAX,V14,V15,V16, V17,V18,V19,V20,V21,V22,V24,ZAA, ZAB,ZAC,ZAD,ZAE,ZAF,ZAG,ZAH,Z AJ,ZAL .....	4
5	MFFZZ		81343	J844TYBSIZE 3/8 BLACK-20	HOSE,NONMETALLIC MAKE FROM HOSE, P/N J844TYBSIZE 3/8 BLACK, 20 IN.LONG UOC: DAC,DAD,DAG,DAH,DAJ,DAL ,DAW,DAX,V14,V15,V16,V17,V18,V2 1,V22,V24,ZAA,ZAB,ZAC,ZAD,ZAG, ZAH,ZAJ,ZAL .....	1
5	MFFZZ		81343	J844TYBSIZE 3/8 BLACK-16	HOSE,NONMETALLIC MAKE FROM HOSE, P/N J844TYBSIZE 3/8 BLACK, 16 IN.LONG UOC: DAE,DAF,V19,V20 .....	1
6	MFFZZ		81343	J844TYBSIZE 3/8 BLACK-20	HOSE,NONMETALLIC MAKE FROM HOSE, P/N J844TYBSIZE 3/8 BLACK,20 IN.LONG UOC: DAE,DAF,V19,V20,ZAE,ZAF .....	1

(1)	(2)	(3)	(4)	(5)	(6)	(7)
ITEM	SMR CODE	NSN	CAGEC	PART NUMBER	DESCRIPTION AND USABLE ON	QTY
NO.					CODE (UOC)	
6	MFFZZ		81343	J844TYBSIZE 3/8 BLACK-19	HOSE, NONMETALLIC MAKE FROM HOSE, P/N J844TYBSIZE 3/8 BLACK, 19 IN. LONG UOC: DAC, DAD, DAG, DAH, DAJ, DAL , DAW, DAX, V14, V15, V16, V17, V18, V2 1, V22, V24 .....	1

END OF FIGURE



**FIELD MAINTENANCE**  
**AIR SUPPLY LINES, TREADLE VALVE TO PRIMARY AND SECONDARY AIR TANKS, AND RELAY VALVES**

---

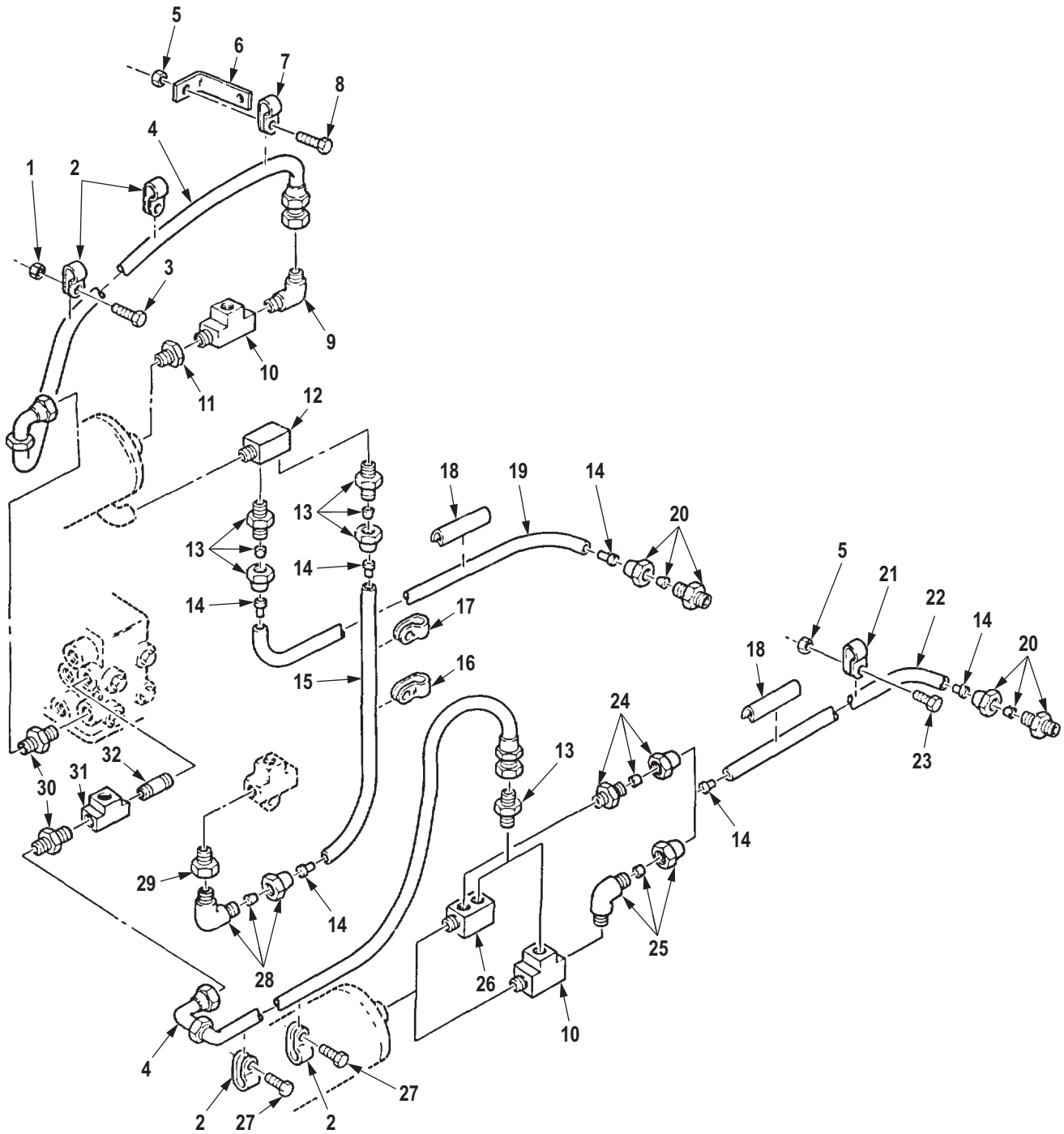

R0292DAA

Figure 275. Air Supply Lines, Treadle Valve to Primary and Secondary Air Tanks, and Relay Valves.

(1) ITEM NO.	(2) SMR CODE	(3) NSN	(4) CAGEC	(5) PART NUMBER	(6) DESCRIPTION AND USABLE ON CODE (UOC)	(7) QTY
<b>GROUP 1208 AIR BRAKE SYSTEM.</b>						
<b>FIG. 275. AIR SUPPLY LINES, TREADLE VALVE TO PRIMARY AND SECONDARY AIR TANKS, AND RELAY VALVES.</b>						
1	PAFZZ	5310-00-935-9022	81349	M45913/3-4FG8C	NUT, SELF-LOCKING, HE UOC: DAC, DAD, DAE, DAF, DAG, DA H, DAJ, DAL, DAW, DAX, V14, V15, V16, V17, V18, V19, V20, V21, V22, V24, ZAA, ZAB, ZAC, ZAD, ZAE, ZAF, ZAG, ZAH, Z AJ, ZAL .....	1
2	PAFZZ	5340-00-809-1494	80205	MS21333-105	CLAMP, LOOP UOC: DAC, DAD, DAE, DAF, DAG, DA H, DAJ, DAL, DAW, DAX, V14, V15, V16, V17, V18, V19, V20, V21, V22, V24, ZAA, ZAB, ZAC, ZAD, ZAE, ZAF, ZAG, ZAH, Z AJ, ZAL .....	6
3	PAFZZ	5305-00-269-3239	80204	B1821BH038F138N	SCREW, CAP, HEXAGON H UOC: DAC, DAD, DAE, DAF, DAG, DA H, DAJ, DAL, DAW, DAX, V14, V15, V16, V17, V18, V19, V20, V21, V22, V24, ZAA, ZAB, ZAC, ZAD, ZAE, ZAF, ZAG, ZAH, Z AJ, ZAL .....	1
4	PAFZZ	4720-01-112-2328	19207	12256269-1	HOSE ASSEMBLY, NONME UOC: DAC, DAD, DAE, DAF, DAG, DA H, DAJ, DAL, DAW, DAX, V14, V15, V16, V17, V18, V19, V20, V21, V22, V24, ZAA, ZAB, ZAC, ZAD, ZAE, ZAF, ZAG, ZAH, Z AJ, ZAL .....	2
5	PAFZZ	5310-00-814-0672	96906	M45913/3-6FG8C	NUT, SELF-LOCKING, HE UOC: DAC, DAD, DAE, DAF, DAG, DA H, DAJ, DAL, DAW, DAX, V14, V15, V16, V17, V18, V19, V20, V21, V22, V24, ZAA, ZAB, ZAC, ZAD, ZAE, ZAF, ZAG, ZAH, Z AJ, ZAL .....	2
6	PAFZZ	5340-01-197-8214	19207	12302693	BRACKET, ANGLE UOC: DAC, DAD, DAE, DAF, DAG, DA H, DAJ, DAL, DAW, DAX, V14, V15, V16, V17, V18, V19, V20, V21, V22, V24, ZAA, ZAB, ZAC, ZAD, ZAE, ZAF, ZAG, ZAH, Z AJ, ZAL .....	1
7	PAFZZ	5340-00-053-8994	80205	MS21333-126	CLAMP, LOOP UOC: DAC, DAD, DAE, DAF, DAG, DA H, DAJ, DAL, DAW, DAX, V14, V15, V16, V17, V18, V19, V20, V21, V22, V24, ZAA, ZAB, ZAC, ZAD, ZAE, ZAF, ZAG, ZAH, Z AJ, ZAL .....	2

(1) ITEM NO.	(2) SMR CODE	(3) NSN	(4) CAGEC	(5) PART NUMBER	(6) DESCRIPTION AND USABLE ON CODE (UOC)	(7) QTY
8	PAFZZ	5305-00-269-2803	80205	MS90726-60	SCREW,CAP,HEXAGON H UOC: DAC,DAD,DAE,DAF,DAG,DA H,DAJ,DAL,DAW,DAX,V14,V15,V16, V17,V18,V19,V20,V21,V22,V24,ZAA, ZAB,ZAC,ZAD,ZAE,ZAF,ZAG,ZAH,Z AJ,ZAL .....	1
9	PAFZZ	4730-00-273-6686	96906	MS51504A8-8	ELBOW,PIPE TO TUBE UOC: DAC,DAD,DAE,DAF,DAG,DA H,DAJ,DAL,DAW,DAX,V14,V15,V16, V17,V18,V19,V20,V21,V22,V24,ZAA, ZAB,ZAC,ZAD,ZAE,ZAF,ZAG,ZAH,Z AJ,ZAL .....	1
10	PAFZZ	4730-01-095-2034	81343	SAE J530 8-8-8 130424BA	TEE,PIPE UOC: DAL,V18,ZAL .....	2
10	PAFZZ	4730-01-095-2034	81343	SAE J530 8-8-8 130424BA	TEE,PIPE UOC: DAC,DAD,DAE,DAF,DAG,DA H,DAJ,DAW,DAX,V14,V15,V16,V17, V19,V21,V22,V24,ZAA,ZAB,ZAC,ZA D,ZAE,ZAF,ZAG,ZAH,ZAJ .....	1
11	PAFZZ	4730-01-192-4729	58536	AA59616BDQBCDB	BUSHING,PIPE UOC: DAC,DAD,DAE,DAF,DAG,DA H,DAJ,DAL,DAW,DAX,V14,V15,V16, V17,V18,V19,V20,V21,V22,V24,ZAA, ZAB,ZAC,ZAD,ZAE,ZAF,ZAG,ZAH,Z AJ,ZAL .....	1
12	PAFZZ	4730-01-115-0433	19207	12255986	CONNECTOR,MULTIPLE, UOC: DAC,DAD,DAE,DAF,DAG,DA H,DAJ,DAL,DAW,DAX,V14,V15,V16, V17,V18,V19,V20,V21,V22,V24,ZAA, ZAB,ZAC,ZAD,ZAE,ZAF,ZAG,ZAH,Z AJ,ZAL .....	1
13	PAFZZ	4730-00-202-9036	81343	SAE J246 8-8 120102BA	ADAPTER,STRAIGHT,PI UOC: DAC,DAD,DAE,DAF,DAG,DA H,DAJ,DAL,DAW,DAX,V14,V15,V16, V17,V18,V19,V20,V21,V22,V24,ZAA, ZAB,ZAC,ZAD,ZAE,ZAF,ZAG,ZAH,Z AJ,ZAL .....	3
14	PAFZZ	4730-01-032-6038	19207	CPR102321-4	INSERT,TUBE FITTING UOC: DAC,DAD,DAE,DAF,DAG,DA H,DAJ,DAL,DAW,DAX,V14,V15,V16, V17,V18,V19,V20,V21,V22,V24,ZAA, ZAB,ZAC,ZAD,ZAE,ZAF,ZAG,ZAH,Z AJ,ZAL .....	6
15	MFFZZ		19207	CPR104420-3-166	HOSE,NONMETALLIC MAKE FROM HOSE P/N CPR104420-3,166 IN.LONG UOC: DAL,DAW,DAX,V14,V15,V18, ZAA,ZAB,ZAL .....	1

(1) ITEM NO.	(2) SMR CODE	(3) NSN	(4) CAGEC	(5) PART NUMBER	(6) DESCRIPTION AND USABLE ON CODE (UOC)	(7) QTY
15	MFFZZ		19207	CPR104420-3-192	HOSE, NONMETALLIC PRIMARY TO SECONDARY RESERVOIR, MAKE FROM HOSE, P/ N CPR104420-3, 192 IN. LONG UOC: DAC, DAD, DAJ, V16, V17, V24, Z AC, ZAD, ZAJ .....	1
15	MFFZZ		19207	CPR104420-3-143	HOSE, NONMETALLIC PRIMARY TO SECONDARY RESERVOIR, MAKE FROM HOSE, P/ N CPR104420-3, 143 IN. LONG UOC: DAE, DAF, DAG, DAH, V19, V20, V21, V22, ZAE, ZAF, ZAG, ZAH .....	1
16	PAFZZ	5340-01-197-9350	19207	7529133-8	CLAMP, LOOP UOC: DAC, DAD, DAJ, V16, V17, V24, Z AC, ZAD, ZAJ .....	2
16	PAFZZ	5340-01-197-9350	19207	7529133-8	CLAMP, LOOP UOC: DAE, DAF, DAG, DAH, DAL, DA W, DAX, V14, V15, V18, V19, V20, V21, V 22, ZAA, ZAB, ZAE, ZAF, ZAG, ZAH, ZAL .....	1
17	PAFZZ	5340-00-337-9619	19207	7373381	CLAMP, LOOP UOC: DAC, DAD, DAE, DAF, DAG, DA H, DAJ, DAL, DAW, DAX, V14, V15, V16, V17, V18, V19, V20, V21, V22, V24, ZAA, ZAB, ZAC, ZAD, ZAE, ZAF, ZAG, ZAH, Z AJ, ZAL .....	1
18	PAFZZ	5340-01-188-5087	19207	12302768	CLIP, RETAINING UOC: DAC, DAD, DAE, DAF, DAG, DA H, DAJ, DAL, DAW, DAX, V14, V15, V16, V17, V18, V19, V20, V21, V22, V24, ZAA, ZAB, ZAC, ZAD, ZAE, ZAF, ZAG, ZAH, Z AJ, ZAL .....	4
19	MFFZZ		19207	CPR104420-3-126	HOSE, NONMETALLIC PRIMARY RESERVOIR TO REAR RELAY VALVE, MAKE FROM HOSE, P/N CPR104420-3, 126 IN. LONG UOC: DAL, DAW, DAX, V14, V15, V18, ZAA, ZAB, ZAL .....	1
19	MFFZZ		19207	CPR104420-3-107	HOSE, NONMETALLIC MAKE FROM HOSE, P/N CPR104420-3, 107 IN. LONG UOC: DAC, DAD, DAE, DAF, DAG, DA H, DAJ, DAL, DAW, DAX, V14, V15, V16, V17, V18, V19, V20, V21, V22, V24, ZAL .....	1
19	MFFZZ		19207	CPR104420-3-95	HOSE, NONMETALLIC PRIMARY RESERVOIR TO REAR RELAY VALVE, MAKE FROM HOSE, P/N CPR 104420-3, 95 IN. LONG UOC: DAE, DAF, DAG, DAH, V19, V20, V21, V22, ZAE, ZAF, ZAG, ZAH .....	1

(1) ITEM NO.	(2) SMR CODE	(3) NSN	(4) CAGEC	(5) PART NUMBER	(6) DESCRIPTION AND USABLE ON CODE (UOC)	(7) QTY
19	MFFZZ		19207	CPR104420-3-145	HOSE, NONMETALLIC PRIMARY RESERVOIR TO REAR RELAY VALVE, MAKE FROM HOSE, P/N CPR104420-3, 145 IN. LONG UOC: DAC, DAJ, V16, V17, V24, ZAC, ZAJ ....	1
19	MFFZZ		19207	CPR104420-3-187	HOSE, NONMETALLIC MAKE FROM TUBING, P/N CPR104420-3, 187 IN. LONG UOC: DAL, V18, ZAL .....	1
20	PAFZZ	4730-00-050-4358	81343	SAE J246 8-12 120102BA	ADAPTER, STRAIGHT, PI UOC: DAC, DAD, DAE, DAF, DAG, DA H, DAJ, DAL, DAW, DAX, V14, V15, V16, V17, V18, V19, V20, V21, V22, V24, ZAA, ZAB, ZAC, ZAD, ZAE, ZAF, ZAG, ZAH, Z AJ, ZAL .....	2
21	PAFZZ	5340-00-151-9651	80205	MS21333-129	CLAMP, LOOP UOC: V16, V17, V24 .....	1
21	PAFZZ	5340-00-151-9651	80205	MS21333-129	CLAMP, LOOP UOC: DAE, DAF, DAG, DAH, V19, V20, V21, V22, ZAE, ZAF, ZAG, ZAH .....	1
22	MFFZZ		19207	CPR104420-3-80	HOSE, NONMETALLIC SECONDARY RESERVOIR TO FRONT RELAY VALVE, MAKE FROM HOSE, P/N CPR104420-3, 80 IN. LONG UOC: DAE, DAF, DAG, DAH, V19, V20, V21, V22, ZAE, ZAF, ZAG, ZAH .....	1
22	MFFZZ		19207	CPR104420-3-92	HOSE, NONMETALLIC SECONDARY RESERVOIR TO FRONT RELAY VALVE, MAKE FROM HOSE, P/N CPR104420-3, 92 IN. LONG UOC: DAE, DAF, DAG, DAH, DAL, DA W, DAX, V14, V15, V18, V19, V20, V21, V 22, ZAA, ZAB, ZAE, ZAF, ZAG, ZAH, ZAL .....	1
22	MFFZZ		19207	CPR104420-3-130	HOSE, NONMETALLIC SECONDARY RESERVOIR TO FRONT RELAY VALVE, MAKE FROM HOSE, P/N CPR104420-3, 130 IN. LONG UOC: DAC, DAD, DAJ, V15, V16, V17, V 24, ZAA, ZAB, ZAC, ZAD, ZAE, ZAF, ZA G, ZAH, ZAJ, ZAL .....	1
23	PAFZZ	5305-00-269-3238	80204	B1821BH038F125N	SCREW, CAP, HEXAGON H UOC: DAC, DAD, DAJ, V14, V15, V16, V 17, V18, V24 .....	3
24	PAFZZ	4730-00-202-9036	81343	SAE J246 8-8 120102BA	ADAPTER, STRAIGHT, PI UOC: DAL, V18, V21, V22, V24, ZAA, Z AB, ZAC, ZAD, ZAE, ZAF, ZAG, ZAH, ZAJ .....	1

(1) ITEM NO.	(2) SMR CODE	(3) NSN	(4) CAGEC	(5) PART NUMBER	(6) DESCRIPTION AND USABLE ON CODE (UOC)	(7) QTY
25	PAFZZ	4730-00-273-6686	96906	MS51504A8-8	ELBOW,PIPE TO TUBE UOC: DAC,DAD,DAE,DAF,DAG,DA H,DAJ,DAL,DAW,DAX,V14,V15,V16, V17,V18,V19,V20,V21,V22,V24 .....	1
26	PAFZZ	4730-01-115-0433	19207	12255986	CONNECTOR,MULTIPLE, UOC: DAC,DAD,DAE,DAF,DAG,DA H,DAJ,DAW,DAX,V14,V15,V16,V17, V19,V21,V22,V24,ZAA,ZAB,ZAC,ZA D,ZAE,ZAF,ZAG,ZAH,ZAJ .....	1
27	PAFZZ	5306-00-068-0513	80204	B1821BH025F075N	BOLT,MACHINE UOC: DAC,DAD,DAE,DAF,DAG,DA H,DAJ,DAL,DAW,DAX,V14,V15,V16, V17,V18,V19,V20,V21,V22,V24,ZAA, ZAB,ZAC,ZAD,ZAE,ZAF,ZAG,ZAH,Z AJ,ZAL .....	2
28	PAFZZ	4730-01-117-1614	81343	8-6 120302BA	ELBOW,PIPE TO TUBE UOC: DAC,DAD,DAE,DAF,DAG,DA H,DAJ,DAL,DAW,DAX,V14,V15,V16, V17,V18,V19,V20,V21,V22,V24,ZAA, ZAB,ZAC,ZAD,ZAE,ZAF,ZAG,ZAH,Z AJ,ZAL .....	1
29	PAFZZ	4730-01-192-4729	58536	AA59616BDQBCDB	BUSHING,PIPE UOC: DAC,DAD,DAE,DAF,DAG,DA H,DAJ,DAL,DAW,DAX,V14,V15,V16, V17,V18,V19,V20,V21,V22,V24,ZAA, ZAB,ZAC,ZAD,ZAE,ZAF,ZAG,ZAH,Z AJ,ZAL .....	1
30	PAFZZ	4730-00-809-9427	81343	MS51500A8-8	ADAPTER,STRAIGHT,PI UOC: DAC,DAD,DAE,DAF,DAG,DA H,DAJ,DAL,DAW,DAX,V14,V15,V16, V17,V18,V19,V20,V21,V22,V24,ZAA, ZAB,ZAC,ZAD,ZAE,ZAF,ZAG,ZAH,Z AJ,ZAL .....	2
31	PAFZZ	4730-00-765-9102	13174	101B1-2IN	TEE,PIPE UOC: DAC,DAD,DAE,DAF,DAG,DA H,DAJ,DAL,DAW,DAX,V14,V15,V16, V17,V21,V22,V24,ZAA,ZAB,ZAC,ZA D,ZAE,ZAF,ZAG,ZAH,ZAJ .....	1
32	PAFZZ	4730-00-196-1495	81346	A733-80CF8	NIPPLE,PIPE UOC: DAC,DAD,DAE,DAF,DAG,DA H,DAJ,DAL,DAW,DAX,V14,V15,V16, V17,V21,V22,V24,ZAA,ZAB,ZAC,ZA D,ZAE,ZAF,ZAG,ZAH,ZAJ .....	1

END OF FIGURE





**FIELD MAINTENANCE  
DASH CONTROL AIR SUPPLY LINES, SPRING BRAKE CONTROL VALVE TO PRIMARY AND SECONDARY  
AIR RESERVOIRS**

---

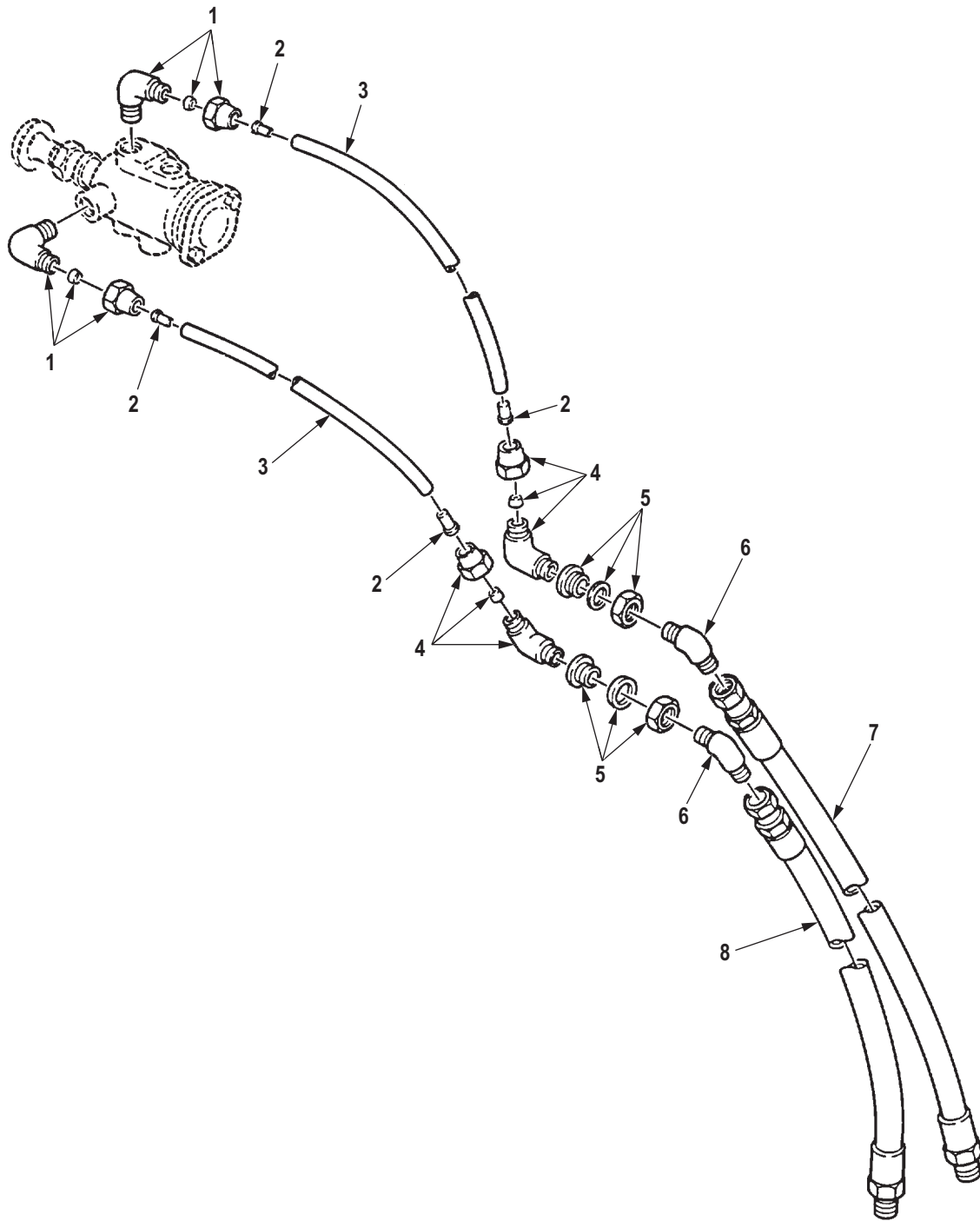

R0293DAA

Figure 276. Dash Control Air Supply Lines, Spring Brake Control Valve to Primary and Secondary Air Reservoirs.

(1) ITEM NO.	(2) SMR CODE	(3) NSN	(4) CAGEC	(5) PART NUMBER	(6) DESCRIPTION AND USABLE ON CODE (UOC)	(7) QTY
<b>GROUP 1208 AIR BRAKE SYSTEM.</b>						
<b>FIG. 276. DASH CONTROL AIR SUPPLY LINES, SPRING BRAKE CONTROL VALVE TO PRIMARY AND SECONDARY AIR RESERVOIRS.</b>						
1	PAFZZ	4730-00-287-1604	81343	6-2 120202BA	ELBOW,PIPE TO TUBE UOC: DAC,DAD,DAE,DAF,DAG,DA H,DAJ,DAL,DAW,DAX,V14,V15,V16, V17,V18,V19,V20,V21,V22,V24,ZAA, ZAB,ZAC,ZAD,ZAE,ZAF,ZAG,ZAH,Z AJ,ZAL .....	2
2	PAFZZ	4730-01-079-8821	19207	CPR102321-1	INSERT,TUBE FITTING UOC: DAC,DAD,DAE,DAF,DAG,DA H,DAJ,DAL,DAW,DAX,V14,V15,V16, V17,V18,V19,V20,V21,V22,V24,ZAA, ZAB,ZAC,ZAD,ZAE,ZAF,ZAG,ZAH,Z AJ,ZAL .....	4
3	MFFZZ		81343	J844TYBSIZE 3/8 BLACK-29	HOSE,NONMETALLIC MAKE FROM HOSE, P/N J844TYBSIZE 3/8 BLACK, 29 IN.LONG UOC: DAC,DAD,DAE,DAF,DAG,DA H,DAJ,DAL,DAW,DAX,V14,V15,V16, V17,V18,V19,V20,V21,V22,V24,ZAA, ZAB,ZAC,ZAD,ZAE,ZAF,ZAG,ZAH,Z AJ,ZAL .....	2
4	PAFZZ	4730-00-069-1187	81343	SAE J246 6-4 100202BA	ELBOW,PIPE TO TUBE UOC: DAC,DAD,DAE,DAF,DAG,DA H,DAJ,DAL,DAW,DAX,V14,V15,V16, V17,V18,V19,V20,V21,V22,V24,ZAA, ZAB,ZAC,ZAD,ZAE,ZAF,ZAG,ZAH,Z AJ,ZAL .....	2
5	PAFZZ	4730-00-278-6318	19207	8328782	COUPLING,PIPE UOC: DAC,DAD,DAE,DAF,DAG,DA H,DAJ,DAL,DAW,DAX,V14,V15,V16, V17,V18,V19,V20,V21,V22,V24,ZAA, ZAB,ZAC,ZAD,ZAE,ZAF,ZAG,ZAH,Z AJ,ZAL .....	2
6	PAFZZ	4730-00-930-0982	96906	MS20823-6B	ELBOW,PIPE TO TUBE UOC: DAC,DAD,DAE,DAF,DAG,DA H,DAJ,DAL,DAW,DAX,V14,V15,V16, V17,V18,V19,V20,V21,V22,V24,ZAA, ZAB,ZAC,ZAD,ZAE,ZAF,ZAG,ZAH,Z AJ,ZAL .....	2
7	PAFZZ	4720-01-119-5844	19207	12256272-2	HOSE ASSEMBLY,NONME UOC: DAC,DAD,DAE,DAF,DAG,DA H,DAJ,DAL,DAW,DAX,V14,V15,V16, V17,V18,V19,V20,V21,V22,V24,ZAA, ZAB,ZAC,ZAD,ZAE,ZAF,ZAG,ZAH,Z AJ,ZAL .....	1

(1) ITEM NO.	(2) SMR CODE	(3) NSN	(4) CAGEC	(5) PART NUMBER	(6) DESCRIPTION AND USABLE ON CODE (UOC)	(7) QTY
8	PAFZZ	4720-01-119-5843	19207	12256272-1	HOSE ASSEMBLY, NONME UOC: DAC, DAD, DAE, DAF, DAG, DA H, DAJ, DAL, DAW, DAX, V14, V15, V16, V17, V18, V19, V20, V21, V22, V24, ZAA, ZAB, ZAC, ZAD, ZAE, ZAF, ZAG, ZAH, Z AJ, ZAL .....	1

END OF FIGURE

**FIELD MAINTENANCE  
TREADLE VALVE TO QUICK RELEASE VALVE AND AIR INTAKE TUBING**

---

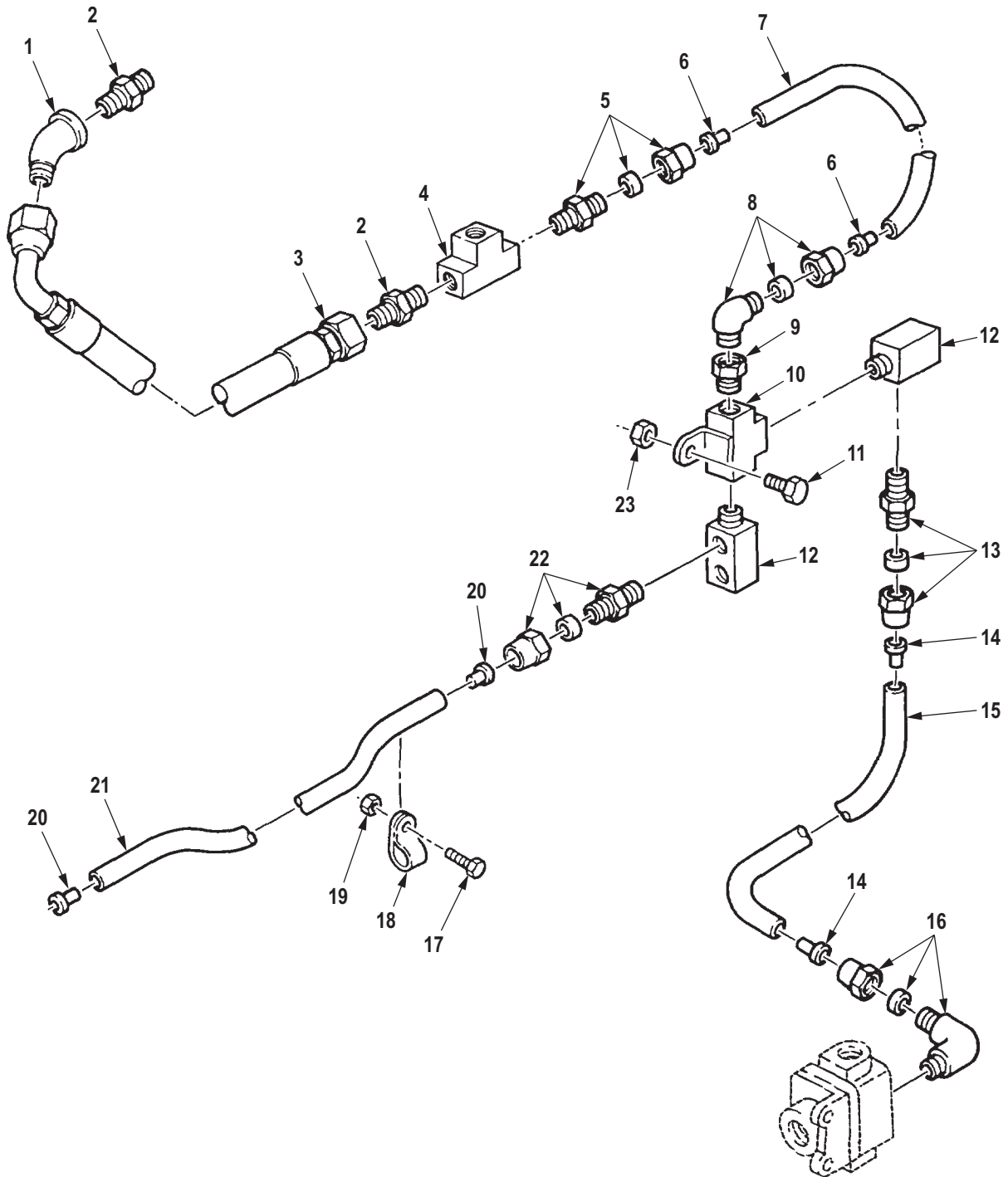

R0294DAA

Figure 277. Treadle Valve to Quick Release Valve and Air Intake Tubing.

(1) ITEM NO.	(2) SMR CODE	(3) NSN	(4) CAGEC	(5) PART NUMBER	(6) DESCRIPTION AND USABLE ON CODE (UOC)	(7) QTY
<b>GROUP 1208 AIR BRAKE SYSTEM.</b>						
<b>FIG. 277. TREADLE VALVE TO QUICK RELEASE VALVE AND AIR INTAKE TUBING.</b>						
1	PAFZZ	4730-00-249-3935	96906	MS39231-4	ELBOW,PIPE UOC: DAC,DAD,DAE,DAF,DAG,DA H,DAJ,DAL,DAW,DAX,V14,V15,V16, V17,V18,V19,V20,V21,V22,V24,ZAA, ZAB,ZAC,ZAD,ZAE,ZAF,ZAG,ZAH,Z AJ,ZAL .....	1
2	PAFZZ	4730-00-865-9251	96906	MS51500A12-8	ADAPTER,STRAIGHT,PI UOC: DAC,DAD,DAE,DAF,DAG,DA H,DAJ,DAL,DAW,DAX,V14,V15,V16, V17,V18,V19,V20,V21,V22,V24,ZAA, ZAB,ZAC,ZAD,ZAE,ZAF,ZAG,ZAH,Z AJ,ZAL .....	2
3	PAFZZ	4720-01-195-9518	19207	12302873	HOSE ASSEMBLY,NONME UOC: DAC,DAD,DAE,DAF,DAG,DA H,DAJ,DAL,DAW,DAX,V14,V15,V16, V17,V18,V19,V20,V21,V22,V24,ZAA, ZAB,ZAC,ZAD,ZAE,ZAF,ZAG,ZAH,Z AJ,ZAL .....	1
4	PAFZZ	4730-01-095-2034	81343	SAE J530 8-8-8 130424BA	TEE,PIPE UOC: DAC,DAD,DAE,DAF,DAG,DA H,DAJ,DAL,DAW,DAX,V14,V15,V16, V17,V18,V19,V20,V21,V22,V24,ZAA, ZAB,ZAC,ZAD,ZAE,ZAF,ZAG,ZAH,Z AJ,ZAL .....	1
5	PAFZZ	4730-00-202-9035	81343	12-8 120102BA	ADAPTER,STRAIGHT,PI UOC: DAC,DAD,DAE,DAF,DAG,DA H,DAJ,DAL,DAW,DAX,V14,V15,V16, V17,V18,V19,V20,V21,V22,V24,ZAA, ZAB,ZAC,ZAD,ZAE,ZAF,ZAG,ZAH,Z AJ,ZAL .....	1
6	PAFZZ	4730-00-180-7031	06853	246091	INSERT,TUBE FITTING UOC: DAC,DAD,DAE,DAF,DAG,DA H,DAJ,DAL,DAW,DAX,V14,V15,V16, V17,V18,V19,V20,V21,V22,V24,ZAA, ZAB,ZAC,ZAD,ZAE,ZAF,ZAG,ZAH,Z AJ,ZAL .....	2
7	MFFZZ		19207	CPR104420-5-15	HOSE,NONMETALLIC MAKE FROM HOSE,P/N 247607,17 IN.LONG UOC: DAC,DAD,DAE,DAF,DAG,DA H,DAJ,DAL,DAW,DAX,V14,V15,V16, V17,V18,V19,V20,V21,V22,V24,ZAA, ZAB,ZAC,ZAD,ZAE,ZAF,ZAG,ZAH,Z AJ,ZAL .....	1

(1) ITEM NO.	(2) SMR CODE	(3) NSN	(4) CAGEC	(5) PART NUMBER	(6) DESCRIPTION AND USABLE ON CODE (UOC)	(7) QTY
8	PAFZZ	4730-00-289-0155	81343	6-6 120202BA	ELBOW,PIPE TO TUBE UOC: DAC,DAD,DAE,DAF,DAG,DA H,DAJ,DAL,DAW,DAX,V14,V15,V16, V17,V18,V19,V20,V21,V22,V24,ZAA, ZAB,ZAC,ZAD,ZAE,ZAF,ZAG,ZAH,Z AJ,ZAL .....	1
9	PAFZZ	4730-00-457-6295	93061	222P-12-8	REDUCER,PIPE UOC: DAC,DAD,DAE,DAF,DAG,DA H,DAJ,DAL,DAW,DAX,V14,V15,V16, V17,V18,V19,V20,V21,V22,V24,ZAA, ZAB,ZAC,ZAD,ZAE,ZAF,ZAG,ZAH,Z AJ,ZAL .....	1
10	PAFZZ	4730-01-112-2168	19207	12256594	TEE ASSEMBLY,PIPE UOC: DAC,DAD,DAE,DAF,DAG,DA H,DAJ,DAL,DAW,DAX,V14,V15,V16, V17,V18,V19,V20,V21,V22,V24,ZAA, ZAB,ZAC,ZAD,ZAE,ZAF,ZAG,ZAH,Z AJ,ZAL .....	1
11	PAFZZ	5306-00-051-4077	80204	B1821BH031F113N	BOLT,MACHINE UOC: DAC,DAD,DAE,DAF,DAG,DA H,DAJ,DAL,DAW,DAX,V14,V15,V16, V17,V18,V19,V20,V21,V22,V24,ZAA, ZAB,ZAC,ZAD,ZAE,ZAF,ZAG,ZAH,Z AJ,ZAL .....	1
12	PAFZZ	4730-01-115-0433	19207	12255986	CONNECTOR,MULTIPLE, UOC: DAC,DAD,DAE,DAF,DAG,DA H,DAJ,DAL,DAW,DAX,V14,V15,V16, V17,V18,V19,V20,V21,V22,V24,ZAA, ZAB,ZAC,ZAD,ZAE,ZAF,ZAG,ZAH,Z AJ,ZAL .....	2
13	PAFZZ	4730-00-202-9036	81343	SAE J246 8-8 120102BA	ADAPTER,STRAIGHT,PI UOC: DAC,DAD,DAE,DAF,DAG,DA H,DAJ,DAL,DAW,DAX,V14,V15,V16, V17,V18,V19,V20,V21,V22,V24,ZAA, ZAB,ZAC,ZAD,ZAE,ZAF,ZAG,ZAH,Z AJ,ZAL .....	1
14	PAFZZ	4730-01-032-6038	19207	CPR102321-4	INSERT,TUBE FITTING UOC: DAC,DAD,DAE,DAF,DAG,DA H,DAJ,DAL,DAW,DAX,V14,V15,V16, V17,V18,V19,V20,V21,V22,V24,ZAA, ZAB,ZAC,ZAD,ZAE,ZAF,ZAG,ZAH,Z AJ,ZAL .....	2
15	MFFZZ		19207	CPR104420-3-22	HOSE,NONMETALLIC MAKE FROM HOSE,P/N CPR104420-3,22 IN.LONG UOC: DAC,DAD,DAE,DAF,DAG,DA H,DAJ,DAL,DAW,DAX,V14,V15,V16, V17,V18,V19,V20,V21,V22,V24,ZAA, ZAB,ZAC,ZAD,ZAE,ZAF,ZAG,ZAH,Z AJ,ZAL .....	1



(1) ITEM NO.	(2) SMR CODE	(3) NSN	(4) CAGEC	(5) PART NUMBER	(6) DESCRIPTION AND USABLE ON CODE (UOC)	(7) QTY
16	PAFZZ	4730-00-289-0051	81343	8-6 120202BA	ELBOW,PIPE TO TUBE UOC: DAC,DAD,DAE,DAF,DAG,DA H,DAJ,DAL,DAW,DAX,V14,V15,V16, V17,V18,V19,V20,V21,V22,V24,ZAA, ZAB,ZAC,ZAD,ZAE,ZAF,ZAG,ZAH,Z AJ,ZAL .....	1
17	PAFZZ	5305-00-269-2804	80205	MS90726-61	SCREW,CAP,HEXAGON H UOC: DAC,DAD,DAE,DAF,DAG,DA H,DAJ,DAL,DAW,DAX,V14,V15,V16, V17,V18,V19,V20,V21,V22,V24,ZAA, ZAB,ZAC,ZAD,ZAE,ZAF,ZAG,ZAH,Z AJ,ZAL .....	1
18	PAFZZ	5340-00-053-8994	80205	MS21333-126	CLAMP,LOOP UOC: DAC,DAD,DAE,DAF,DAG,DA H,DAJ,DAL,DAW,DAX,V14,V15,V16, V17,V18,V19,V20,V21,V22,V24,ZAA, ZAB,ZAC,ZAD,ZAE,ZAF,ZAG,ZAH,Z AJ,ZAL .....	1
19	PAFZZ	5310-00-814-0672	96906	M45913/3-6FG8C	NUT,SELF-LOCKING,HE UOC: DAC,DAD,DAE,DAF,DAG,DA H,DAJ,DAL,DAW,DAX,V14,V15,V16, V17,V18,V19,V20,V21,V22,V24,ZAA, ZAB,ZAC,ZAD,ZAE,ZAF,ZAG,ZAH,Z AJ,ZAL .....	1
20	PAFZZ	4730-01-079-8821	19207	CPR102321-1	INSERT,TUBE FITTING UOC: DAC,DAD,DAE,DAF,DAG,DA H,DAJ,DAL,DAW,DAX,V14,V15,V16, V17,V18,V19,V20,V21,V22,V24,ZAA, ZAB,ZAC,ZAD,ZAE,ZAF,ZAG,ZAH,Z AJ,ZAL .....	2
21	MFFZZ		81343	J844TYBSIZE 3/8 BLACK-45	HOSE,NONMETALLIC MAKE FROM HOSE, P/N J844TYBSIZE 3/8 BLACK, 45 IN.LONG UOC: DAC,DAD,DAE,DAF,DAG,DA H,DAJ,DAL,DAW,DAX,V14,V15,V16, V17,V18,V19,V20,V21,V22,V24,ZAA, ZAB,ZAC,ZAD,ZAE,ZAF,ZAG,ZAH,Z AJ,ZAL .....	1
22	PAFZZ	4730-00-837-1177	81343	6-8 120102BA	ADAPTER,STRAIGHT,PI UOC: DAC,DAD,DAE,DAF,DAG,DA H,DAJ,DAL,DAW,DAX,V14,V15,V16, V17,V18,V19,V20,V21,V22,V24,ZAA, ZAB,ZAC,ZAD,ZAE,ZAF,ZAG,ZAH,Z AJ,ZAL .....	1

(1) ITEM NO.	(2) SMR CODE	(3) NSN	(4) CAGEC	(5) PART NUMBER	(6) DESCRIPTION AND USABLE ON CODE (UOC)	(7) QTY
23	PAFZZ	4730-01-079-8821	19207	CPR102321-1	INSERT,TUBE FITTING UOC: DAC,DAD,DAE,DAF,DAG,DA H,DAJ,DAL,DAW,DAX,V14,V15,V16, V17,V18,V19,V20,V21,V22,V24,ZAA, ZAB,ZAC,ZAD,ZAE,ZAF,ZAG,ZAH,Z AJ,ZAL .....	2

END OF FIGURE

**FIELD MAINTENANCE  
FRONT BRAKE CHAMBER VENT LINES AND LIMITING VALVE**

---

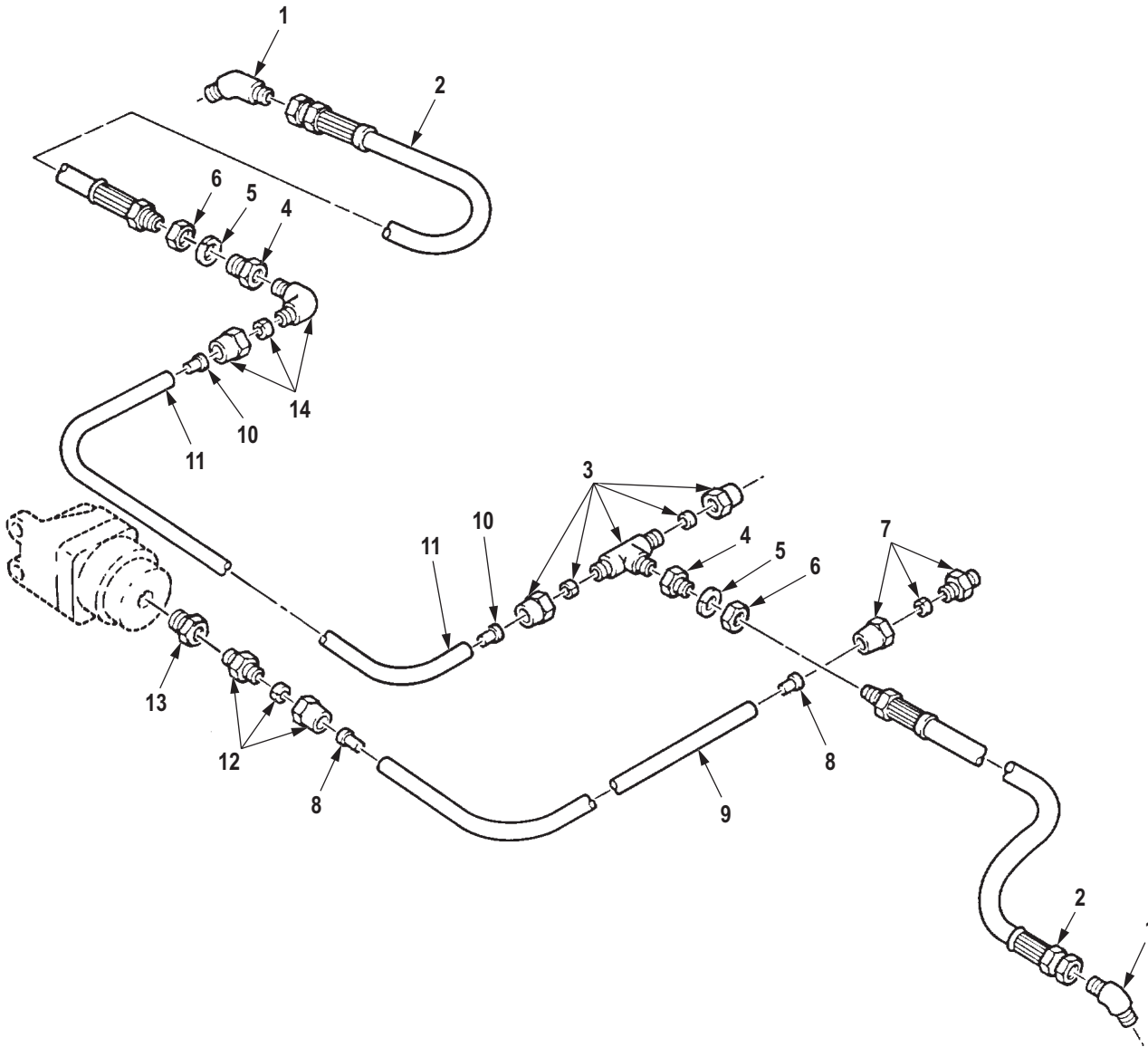

R0295DAA

Figure 278. Front Brake Chamber Vent Lines and Limiting Valve.

(1) ITEM NO.	(2) SMR CODE	(3) NSN	(4) CAGEC	(5) PART NUMBER	(6) DESCRIPTION AND USABLE ON CODE (UOC)	(7) QTY
<b>GROUP 1208 AIR BRAKE SYSTEM.</b>						
<b>FIG. 278. FRONT BRAKE CHAMBER VENT LINES AND LIMITING VALVE.</b>						
1	PAFZZ	4730-01-005-0623	96906	MS51508A6-6S	ELBOW,PIPE TO TUBE UOC: DAC,DAD,DAE,DAF,DAG,DA H,DAJ,DAL,DAW,DAX,V14,V15,V16, V17,V18,V19,V20,V21,V22,V24,ZAA, ZAB,ZAC,ZAD,ZAE,ZAF,ZAG,ZAH,Z AJ,ZAL .....	2
2	PAFZZ	4720-01-153-8240	19207	12276944-4	HOSE ASSEMBLY,NONME UOC: DAC,DAD,DAE,DAF,DAG,DA H,DAJ,DAL,DAW,DAX,V14,V15,V16, V17,V18,V19,V20,V21,V22,V24,ZAA, ZAB,ZAC,ZAD,ZAE,ZAF,ZAG,ZAH,Z AJ,ZAL .....	2
3	PAFZZ	4730-01-095-5833	81343	SAE J246 6-6-6 120425BA	TEE,PIPE TO TUBE UOC: DAC,DAD,DAE,DAF,DAG,DA H,DAJ,DAL,DAW,DAX,V14,V15,V16, V17,V18,V19,V20,V21,V22,V24,ZAA, ZAB,ZAC,ZAD,ZAE,ZAF,ZAG,ZAH,Z AJ,ZAL .....	1
4	PAFZZ	4730-00-421-3924	19207	7339982	ADAPTER,STRAIGHT,PI UOC: DAC,DAD,DAE,DAF,DAG,DA H,DAJ,DAL,DAW,DAX,V14,V15,V16, V17,V18,V19,V20,V21,V22,V24,ZAA, ZAB,ZAC,ZAD,ZAE,ZAF,ZAG,ZAH,Z AJ,ZAL .....	2
5	PAFZZ	5310-00-582-6714	80205	MS35333-49	WASHER,LOCK UOC: DAC,DAD,DAE,DAF,DAG,DA H,DAJ,DAL,DAW,DAX,V14,V15,V16, V17,V18,V19,V20,V21,V22,V24,ZAA, ZAB,ZAC,ZAD,ZAE,ZAF,ZAG,ZAH,Z AJ,ZAL .....	2
6	PAFZZ	5310-00-241-0157	19207	5331179	NUT,PLAIN,HEXAGON UOC: DAC,DAD,DAE,DAF,DAG,DA H,DAJ,DAL,DAW,DAX,V14,V15,V16, V17,V18,V19,V20,V21,V22,V24,ZAA, ZAB,ZAC,ZAD,ZAE,ZAF,ZAG,ZAH,Z AJ,ZAL .....	2
7	PAFZZ	4730-00-202-9036	81343	SAE J246 8-8 120102BA	ADAPTER,STRAIGHT,PI UOC: DAC,DAD,DAE,DAF,DAG,DA H,DAJ,DAL,DAW,DAX,V14,V15,V16, V17,V18,V19,V20,V21,V22,V24,ZAA, ZAB,ZAC,ZAD,ZAE,ZAF,ZAG,ZAH,Z AJ,ZAL .....	1

(1) ITEM NO.	(2) SMR CODE	(3) NSN	(4) CAGEC	(5) PART NUMBER	(6) DESCRIPTION AND USABLE ON CODE (UOC)	(7) QTY
8	PAFZZ	4730-01-032-6038	19207	CPR102321-4	INSERT,TUBE FITTING UOC: DAC,DAD,DAE,DAF,DAG,DA H,DAJ,DAL,DAW,DAX,V14,V15,V16, V17,V18,V19,V20,V21,V22,V24,ZAA, ZAB,ZAC,ZAD,ZAE,ZAF,ZAG,ZAH,Z AJ,ZAL .....	2
9	MFFZZ		19207	CPR104420-3-80	HOSE,NONMETALLIC MAKE FROM HOSE,P/N CPR104420-3,80 IN.LONG UOC: DAC,DAD,DAE,DAF,DAG,DA H,DAJ,DAL,DAW,DAX,V14,V15,V16, V17,V18,V19,V20,V21,V22,V24,ZAA, ZAB,ZAC,ZAD,ZAE,ZAF,ZAG,ZAH,Z AJ,ZAL .....	1
10	PAFZZ	4730-01-079-8821	19207	CPR102321-1	INSERT,TUBE FITTING UOC: DAC,DAD,DAE,DAF,DAG,DA H,DAJ,DAL,DAW,DAX,V14,V15,V16, V17,V18,V19,V20,V21,V22,V24,ZAA, ZAB,ZAC,ZAD,ZAE,ZAF,ZAG,ZAH,Z AJ,ZAL .....	2
11	MFFZZ		81343	J844TYBSIZE 3/8 BLACK-100	HOSE,NONMETALLIC MAKE FROM HOSE, P/N J844TYBSIZE 3/8 BLACK, 100 IN.LONG UOC: DAC,DAD,DAE,DAF,DAG,DA H,DAJ,DAL,DAW,DAX,V14,V15,V16, V17,V18,V19,V20,V21,V22,V24,ZAA, ZAB,ZAC,ZAD,ZAE,ZAF,ZAG,ZAH,Z AJ,ZAL .....	1
12	PAFZZ	4730-00-526-0284	06853	217690N	ADAPTER,STRAIGHT,PI UOC: DAC,DAD,DAE,DAF,DAG,DA H,DAJ,DAL,DAW,DAX,V14,V15,V16, V17,V18,V19,V20,V21,V22,V24,ZAA, ZAB,ZAC,ZAD,ZAE,ZAF,ZAG,ZAH,Z AJ,ZAL .....	1
13	XDFZZ		24617	444012	REDUCER,PIPE UOC: DAC,DAD,DAE,DAF,DAG,DA H,DAJ,DAL,DAW,DAX,V14,V15,V16, V17,V18,V19,V20,V21,V22,V24,ZAA, ZAB,ZAC,ZAD,ZAE,ZAF,ZAG,ZAH,Z AJ,ZAL .....	1
14	PAFZZ	4730-00-289-0155	81343	6-6 120202BA	ELBOW,PIPE TO TUBE UOC: DAC,DAD,DAE,DAF,DAG,DA H,DAJ,DAL,DAW,DAX,V14,V15,V16, V17,V18,V19,V20,V21,V22,V24,ZAA, ZAB,ZAC,ZAD,ZAE,ZAF,ZAG,ZAH,Z AJ,ZAL .....	1

END OF FIGURE

**FIELD MAINTENANCE  
VENT LINES, AIR INTAKE MANIFOLD TO PRIMARY AND SECONDARY RELAY VALVES, AND REAR AXLE  
VENT LINES**

---

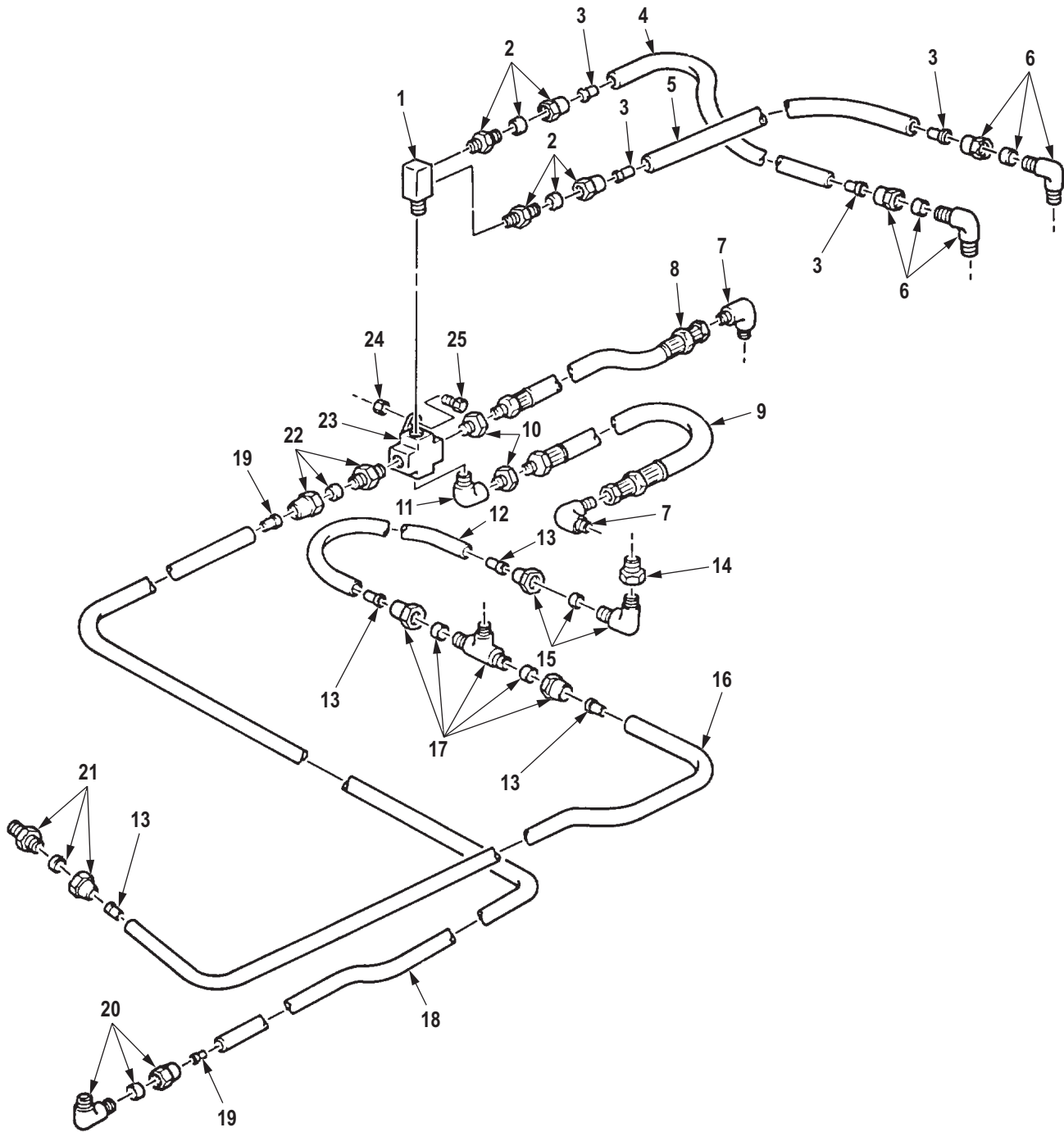

R0296DAA

Figure 279. Vent Lines, Air Intake Manifold to Primary and Secondary Relay Valves, and Rear Axle Vent Lines.



(1) ITEM NO.	(2) SMR CODE	(3) NSN	(4) CAGEC	(5) PART NUMBER	(6) DESCRIPTION AND USABLE ON CODE (UOC)	(7) QTY
<b>GROUP 1208 AIR BRAKE SYSTEM.</b>						
<b>FIG. 279. VENT LINES, AIR INTAKE MANIFOLD TO PRIMARY AND SECONDARY RELAY VALVES, AND REAR AXLE VENT LINES.</b>						
1	PAFZZ	4730-01-107-9692	19207	12255985	ELBOW,PIPE UOC: DAC,DAD,DAE,DAF,DAG,DA H,DAJ,DAL,DAW,DAX,V14,V15,V16, V17,V18,V19,V20,V21,V22,V24,ZAA, ZAB,ZAC,ZAD,ZAE,ZAF,ZAG,ZAH,Z AJ,ZAL .....	1
2	PAFZZ	4730-00-069-1186	81343	6-4 120102BA	ADAPTER,STRAIGHT,PI UOC: DAC,DAD,DAE,DAF,DAG,DA H,DAJ,DAL,DAW,DAX,V14,V15,V16, V17,V18,V19,V20,V21,V22,V24,ZAA, ZAB,ZAC,ZAD,ZAE,ZAF,ZAG,ZAH,Z AJ,ZAL .....	2
3	PAFZZ	4730-01-079-8821	19207	CPR102321-1	INSERT,TUBE FITTING UOC: DAC,DAD,DAE,DAF,DAG,DA H,DAJ,DAL,DAW,DAX,V14,V15,V16, V17,V18,V19,V20,V21,V22,V24,ZAA, ZAB,ZAC,ZAD,ZAE,ZAF,ZAG,ZAH,Z AJ,ZAL .....	4
4	MFFZZ		81343	J844TYBSIZE 3/8 BLACK-14	HOSE,NONMETALLIC MAKE FROM HOSE,P/N J844TYBSIZE 3/8 BLACK, 14 IN.LONG UOC: DAC,DAD,DAE,DAF,DAG,DA H,DAJ,DAL,DAW,DAX,V14,V15,V16, V17,V18,V19,V20,V21,V22,V24,ZAA, ZAB,ZAC,ZAD,ZAE,ZAF,ZAG,ZAH,Z AJ,ZAL .....	1
5	MFFZZ		81343	J844TYBSIZE 3/8 BLACK-33	HOSE,NONMETALLIC MAKE FROM HOSE, P/N J844TYBSIZE 3/8 BLACK, 33 IN.LONG UOC: DAC,DAD,DAE,DAF,DAG,DA H,DAJ,DAL,DAW,DAX,V14,V15,V16, V17,V18,V19,V20,V21,V22,V24,ZAA, ZAB,ZAC,ZAD,ZAE,ZAF,ZAG,ZAH,Z AJ,ZAL .....	1
6	PAFZZ	4730-00-287-1604	81343	6-2 120202BA	ELBOW,PIPE TO TUBE UOC: DAC,DAD,DAE,DAF,DAG,DA H,DAJ,DAL,DAW,DAX,V14,V15,V16, V17,V18,V19,V20,V21,V22,V24,ZAA, ZAB,ZAC,ZAD,ZAE,ZAF,ZAG,ZAH,Z AJ,ZAL .....	2

(1) ITEM NO.	(2) SMR CODE	(3) NSN	(4) CAGEC	(5) PART NUMBER	(6) DESCRIPTION AND USABLE ON CODE (UOC)	(7) QTY
7	PAFZZ	4730-00-835-3003	96906	MS51504A6-6	ELBOW,PIPE TO TUBE UOC: DAC,DAD,DAE,DAF,DAG,DA H,DAJ,DAL,DAW,DAX,V14,V15,V16, V17,V18,V19,V20,V21,V22,V24,ZAA, ZAB,ZAC,ZAD,ZAE,ZAF,ZAG,ZAH,Z AJ,ZAL .....	2
8	PAFZZ	4720-01-188-5140	19207	12276944-5	HOSE ASSEMBLY,NONME UOC: DAC,DAD,DAE,DAF,DAG,DA H,DAJ,DAL,DAW,DAX,V14,V15,V16, V17,V18,V19,V20,V21,V22,V24,ZAA, ZAB,ZAC,ZAD,ZAE,ZAF,ZAG,ZAH,Z AJ,ZAL .....	1
9	PAFZZ	4720-01-112-2326	19207	12276944-1	HOSE ASSEMBLY,NONME UOC: DAC,DAD,DAG,DAH,DAJ,V16, V17,V21,V22,V24 .....	1
10	PAFZZ	4730-00-200-0257	81343	SAE J530 6-4 130139B	REDUCER,PIPE UOC: DAC,DAD,DAE,DAF,DAG,DA H,DAJ,DAL,DAW,DAX,V14,V15,V16, V17,V18,V19,V20,V21,V22,V24,ZAA, ZAB,ZAC,ZAD,ZAE,ZAF,ZAG,ZAH,Z AJ,ZAL .....	2
11	PAFZZ	4730-01-240-6108	93061	2202PA-4-4	ELBOW,PIPE UOC: DAC,DAD,DAE,DAF,DAG,DA H,DAJ,DAL,DAW,DAX,V14,V15,V16, V17,V18,V19,V20,V21,V22,V24,ZAA, ZAB,ZAC,ZAD,ZAE,ZAF,ZAG,ZAH,Z AJ,ZAL .....	1
12	MFFZZ		19207	CPR104420-5-37	HOSE,NONMETALLIC MAKE FROM HOSE,P/N 247607,37 IN.LONG UOC: DAC,DAD,DAE,DAF,DAG,DA H,DAJ,DAL,DAW,DAX,V14,V15,V16, V17,V18,V19,V20,V21,V22,V24,ZAA, ZAB,ZAC,ZAD,ZAE,ZAF,ZAG,ZAH,Z AJ,ZAL .....	1
13	PAFZZ	4730-00-180-7031	06853	246091	INSERT,TUBE FITTING UOC: DAC,DAD,DAE,DAF,DAG,DA H,DAJ,DAL,DAW,DAX,V14,V15,V16, V17,V18,V19,V20,V21,V22,V24,ZAA, ZAB,ZAC,ZAD,ZAE,ZAF,ZAG,ZAH,Z AJ,ZAL .....	4
14	PAFZZ	4730-00-457-6295	93061	222P-12-8	REDUCER,PIPE UOC: DAC,DAD,DAE,DAF,DAG,DA H,DAJ,DAL,DAW,DAX,V14,V15,V16, V17,V18,V19,V20,V21,V22,V24,ZAA, ZAB,ZAC,ZAD,ZAE,ZAF,ZAG,ZAH,Z AJ,ZAL .....	1

(1) ITEM NO.	(2) SMR CODE	(3) NSN	(4) CAGEC	(5) PART NUMBER	(6) DESCRIPTION AND USABLE ON CODE (UOC)	(7) QTY
15	PAFZZ	4730-01-123-8824	81343	12-12 120202BA	ELBOW,PIPE TO TUBE UOC: DAC,DAD,DAE,DAF,DAG,DA H,DAJ,DAL,DAW,DAX,V14,V15,V16, V17,V18,V19,V20,V21,V22,V24,ZAA, ZAB,ZAC,ZAD,ZAE,ZAF,ZAG,ZAH,Z AJ,ZAL .....	1
16	MFFZZ		19207	CPR104420-5-144	HOSE,NONMETALLIC AIR INTAKE VALVE TO FRONT RELAY VALVE,MAKE FROM HOSE,P/N 247607,144 IN.LONG UOC: DAW,DAX,V14,V15,ZAA,ZAB .....	1
16	MFFZZ		19207	CPR104420-5-200	HOSE,NONMETALLIC AIR INTAKE TO FRONT RELAY VALVE,MAKE FROM HOSE,P/N 247607,200 IN.LONG UOC: DAC,DAD,DAJ,V16,V17,V24,Z AC,ZAD,ZAJ .....	1
16	MFFZZ		19207	CPR104420-5-140	HOSE,NONMETALLIC AIR INTAKE TO FRONT RELAY VALVE,MAKE FROM HOSE,P/N 247607,140 IN.LONG UOC: DAG,DAH,V21,V22,ZAG,ZAH .....	1
16	MFFZZ		19207	CPR104420-5-151	HOSE,NONMETALLIC AIR INTAKE TO FRONT RELAY VALVE,MAKE FROM HOSE,P/N 247607,151 IN.LONG UOC: DAE,DAF,DAG,DAL,V18,V19, V20,V22,ZAD,ZAF,ZAG,ZAL .....	1
17	PAFZZ	4730-01-442-6120	24617	144387	TEE,PIPE TO TUBE UOC: DAC,DAD,DAE,DAF,DAG,DA H,DAJ,DAL,DAW,DAX,V14,V15,V16, V17,V18,V19,V20,V21,V22,V24,ZAA, ZAB,ZAC,ZAD,ZAE,ZAF,ZAG,ZAH,Z AJ,ZAL .....	1
18	MFFZZ		19207	CPR104420-3-136	TUBE,NYLON DOUBLE PIPE ELBOW TO REAR BRAKE CHAMBER TEE,MAKE FROM HOSE,P/N CPR104420-3,136 IN.LONG UOC: DAL,DAW,DAX,V14,V15,V18, ZAA,ZAB,ZAL .....	1
18	MFFZZ		19207	CPR104420-3-124	HOSE,NONMETALLIC DOUBLE PIPE ELBOW TO REAR BRAKE CHAMBER TEE,MAKE FROM HOSE,P/N CPR104420-3,124 IN.LONG UOC: DAG,DAH,V21,V22,ZAG,ZAH .....	1

(1) ITEM NO.	(2) SMR CODE	(3) NSN	(4) CAGEC	(5) PART NUMBER	(6) DESCRIPTION AND USABLE ON CODE (UOC)	(7) QTY
18	MFFZZ		19207	CPR104420-3-120	HOSE, NONMETALLIC AIR COMPRESSOR TO WET RESERVOIR, MAKE FROM TUBING, P/N CPR104420-3, 120 IN. LONG UOC: DAE, DAF, V19, V20, ZAE, ZAF .....	1
18	MFFZZ		19207	CPR104420-3-180	HOSE, NONMETALLIC DOUBLE PIPE ELBOW TO REAR BRAKE CHAMBER TEE, MAKE FROM HOSE, P/N CPR104420-3, 180 IN. LONG UOC: DAC, DAD, DAJ, V16, V17, V24, Z AC, ZAD, ZAJ .....	1
19	PAFZZ	4730-01-032-6038	19207	CPR102321-4	INSERT, TUBE FITTING UOC: DAC, DAD, DAE, DAF, DAG, DA H, DAJ, DAL, DAW, DAX, V14, V15, V16, V17, V18, V19, V20, V21, V22, V24, ZAA, ZAB, ZAC, ZAD, ZAE, ZAF, ZAG, ZAH, Z AJ, ZAL .....	2
20	PAFZZ	4730-00-595-2572	81343	SAE J246 8-8 120202BA	ELBOW, PIPE TO TUBE UOC: DAC, DAD, DAE, DAF, DAG, DA H, DAJ, DAL, DAW, DAX, V14, V15, V16, V17, V18, V19, V20, V21, V22, V24, ZAA, ZAB, ZAC, ZAD, ZAE, ZAF, ZAG, ZAH, Z AJ, ZAL .....	1
21	PAFZZ	4730-00-202-9035	81343	12-8 120102BA	ADAPTER, STRAIGHT, PI UOC: DAC, DAD, DAE, DAF, DAG, DA H, DAJ, DAL, DAW, DAX, V14, V15, V16, V17, V18, V19, V20, V21, V22, V24, ZAA, ZAB, ZAC, ZAD, ZAE, ZAF, ZAG, ZAH, Z AJ, ZAL .....	1
22	PAFZZ	4730-00-526-0284	06853	217690N	ADAPTER, STRAIGHT, PI UOC: DAC, DAD, DAE, DAF, DAG, DA H, DAJ, DAL, DAW, DAX, V14, V15, V16, V17, V18, V19, V20, V21, V22, V24, ZAA, ZAB, ZAC, ZAD, ZAE, ZAF, ZAG, ZAH, Z AJ, ZAL .....	1
23	PAFZZ	4730-01-112-6561	9S775	11669082	CROSS, PIPE UOC: DAC, DAD, DAE, DAF, DAG, DA H, DAJ, DAL, DAW, DAX, V14, V15, V16, V17, V18, V19, V20, V21, V22, V24, ZAA, ZAB, ZAC, ZAD, ZAE, ZAF, ZAG, ZAH, Z AJ, ZAL .....	1
24	PAFZZ	5310-00-814-0672	96906	M45913/3-6FG8C	NUT, SELF-LOCKING, HE UOC: DAC, DAD, DAE, DAF, DAG, DA H, DAJ, DAL, DAW, DAX, V14, V15, V16, V17, V18, V19, V20, V21, V22, V24, ZAA, ZAB, ZAC, ZAD, ZAE, ZAF, ZAG, ZAH, Z AJ, ZAL .....	1

(1) ITEM NO.	(2) SMR CODE	(3) NSN	(4) CAGEC	(5) PART NUMBER	(6) DESCRIPTION AND USABLE ON CODE (UOC)	(7) QTY
25	PAFZZ	5305-00-269-3238	80204	B1821BH038F125N	SCREW,CAP,HEXAGON H UOC: DAC,DAD,DAE,DAF,DAG,DA H,DAJ,DAL,DAW,DAX,V14,V15,V16, V17,V18,V19,V20,V21,V22,V24,ZAA, ZAB,ZAC,ZAD,ZAE,ZAF,ZAG,ZAH,Z AJ,ZAL .....	1

END OF FIGURE



**FIELD MAINTENANCE  
SECONDARY VENT LINES, REAR AXLE BRAKE CHAMBERS TO FAIL-SAFE BRAKE CHAMBER**

---

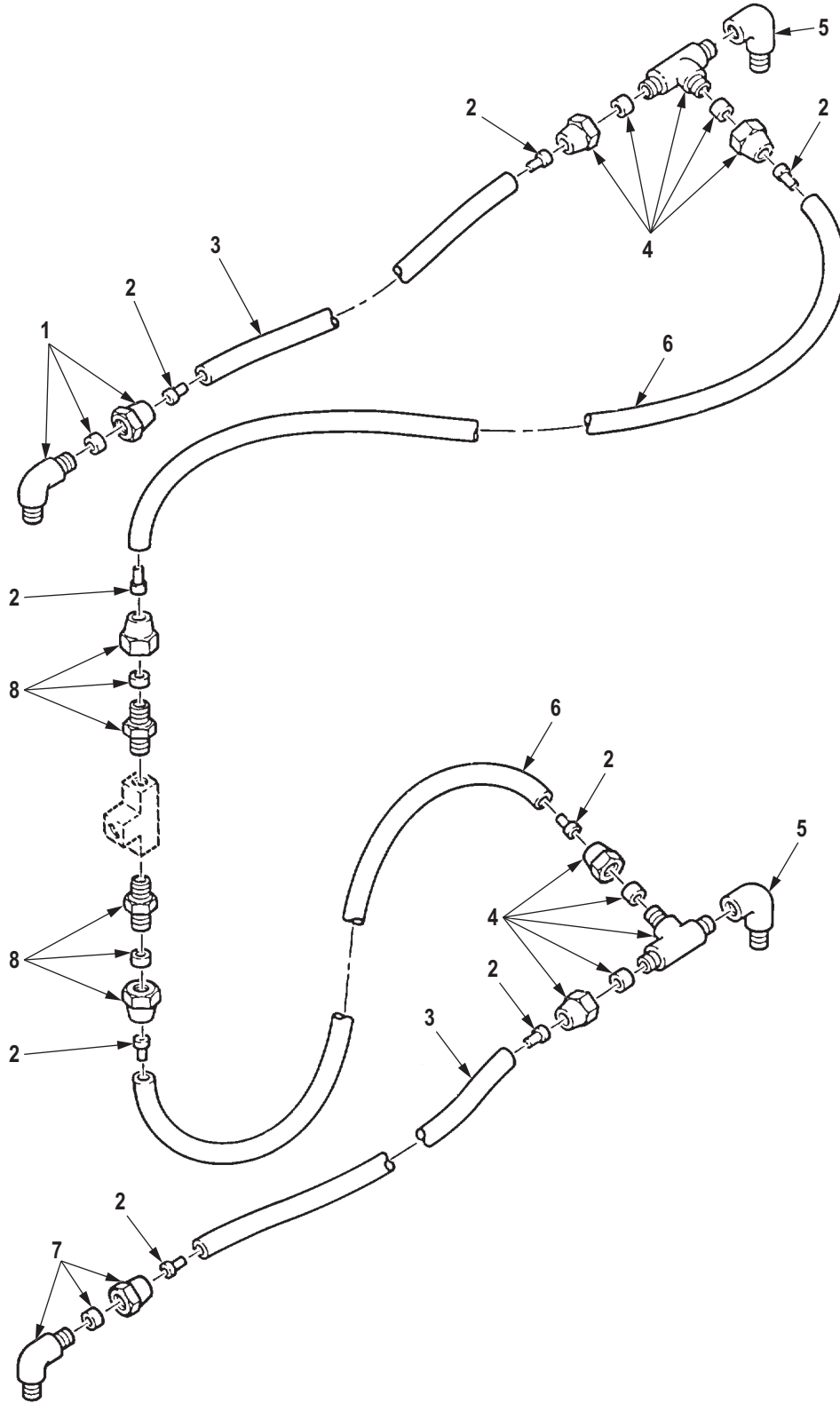

R0297DAA

Figure 280. Secondary Vent Lines, Rear Axle Brake Chambers to Fail-Safe Brake Chamber.



(1) ITEM NO.	(2) SMR CODE	(3) NSN	(4) CAGEC	(5) PART NUMBER	(6) DESCRIPTION AND USABLE ON CODE (UOC)	(7) QTY
<b>GROUP 1208 AIR BRAKE SYSTEM.</b>						
<b>FIG. 280. SECONDARY VENT LINES, REAR AXLE BRAKE CHAMBERS TO FAIL-SAFE BRAKE CHAMBER.</b>						
1	PAFZZ	4730-01-354-8977	81343	6-6 120302BA	ELBOW,PIPE TO TUBE UOC: DAC,DAD,DAE,DAF,DAG,DA H,DAJ,DAL,DAW,DAX,V14,V15,V16, V17,V18,V19,V20,V21,V22,V24,ZAA, ZAB,ZAC,ZAD,ZAE,ZAF,ZAG,ZAH,Z AJ,ZAL .....	1
2	PAFZZ	4730-01-079-8821	19207	CPR102321-1	INSERT,TUBE FITTING UOC: DAC,DAD,DAE,DAF,DAG,DA H,DAJ,DAL,DAW,DAX,V14,V15,V16, V17,V18,V19,V20,V21,V22,V24,ZAA, ZAB,ZAC,ZAD,ZAE,ZAF,ZAG,ZAH,Z AJ,ZAL .....	8
3	MFFZZ		81343	J844TYBSIZE 3/8 BLACK-17	HOSE,NONMETALLIC MAKE FROM HOSE, P/N J844TYBSIZE 3/8 BLACK, 17 IN.LONG UOC: DAC,DAD,DAE,DAF,DAG,DA H,DAJ,DAL,DAW,DAX,V14,V15,V16, V17,V18,V19,V20,V21,V22,V24,ZAA, ZAB,ZAC,ZAD,ZAE,ZAF,ZAG,ZAH,Z AJ,ZAL .....	2
4	PAFZZ	4730-00-930-6354	81343	SAE J246 6-6-6 120424B	TEE,PIPE TO TUBE UOC: DAC,DAD,DAE,DAF,DAG,DA H,DAJ,DAL,DAW,DAX,V14,V15,V16, V17,V18,V19,V20,V21,V22,V24,ZAA, ZAB,ZAC,ZAD,ZAE,ZAF,ZAG,ZAH,Z AJ,ZAL .....	2
5	PAFZZ	4730-00-278-4822	19207	7364214	ELBOW,PIPE UOC: DAC,DAD,DAE,DAF,DAG,DA H,DAJ,DAL,DAW,DAX,V14,V15,V16, V17,V18,V19,V20,V21,V22,V24,ZAA, ZAB,ZAC,ZAD,ZAE,ZAF,ZAG,ZAH,Z AJ,ZAL .....	2
6	MFFZZ		81343	J844TYBSIZE 3/8 BLACK-23	HOSE,NONMETALLIC MAKE FROM HOSE, P/N J844TYBSIZE 3/8 BLACK, 23 IN. LONG UOC: DAC,DAD,DAE,DAF,DAG,DA H,DAJ,DAL,DAW,DAX,V14,V15,V16, V17,V18,V19,V20,V21,V22,V24,ZAA, ZAB,ZAC,ZAD,ZAE,ZAF,ZAG,ZAH,Z AJ,ZAL .....	2

(1) ITEM NO.	(2) SMR CODE	(3) NSN	(4) CAGEC	(5) PART NUMBER	(6) DESCRIPTION AND USABLE ON CODE (UOC)	(7) QTY
7	PAFZZ	4730-00-289-0155	81343	6-6 120202BA	ELBOW,PIPE TO TUBE UOC: DAC,DAD,DAE,DAF,DAG,DA H,DAJ,DAL,DAW,DAX,V14,V15,V16, V17,V18,V19,V20,V21,V22,V24,ZAA, ZAB,ZAC,ZAD,ZAE,ZAF,ZAG,ZAH,Z AJ,ZAL .....	1
8	PAFZZ	4730-00-270-4616	81343	6-6120102BA	ADAPTER,STRAIGHT,PI UOC: DAC,DAD,DAE,DAF,DAG,DA H,DAJ,DAL,DAW,DAX,V14,V15,V16, V17,V18,V19,V20,V21,V22,V24,ZAA, ZAB,ZAC,ZAD,ZAE,ZAF,ZAG,ZAH,Z AJ,ZAL .....	2

END OF FIGURE

**FIELD MAINTENANCE  
PRIMARY VENT LINES, REAR AXLE AIR BRAKE**

---

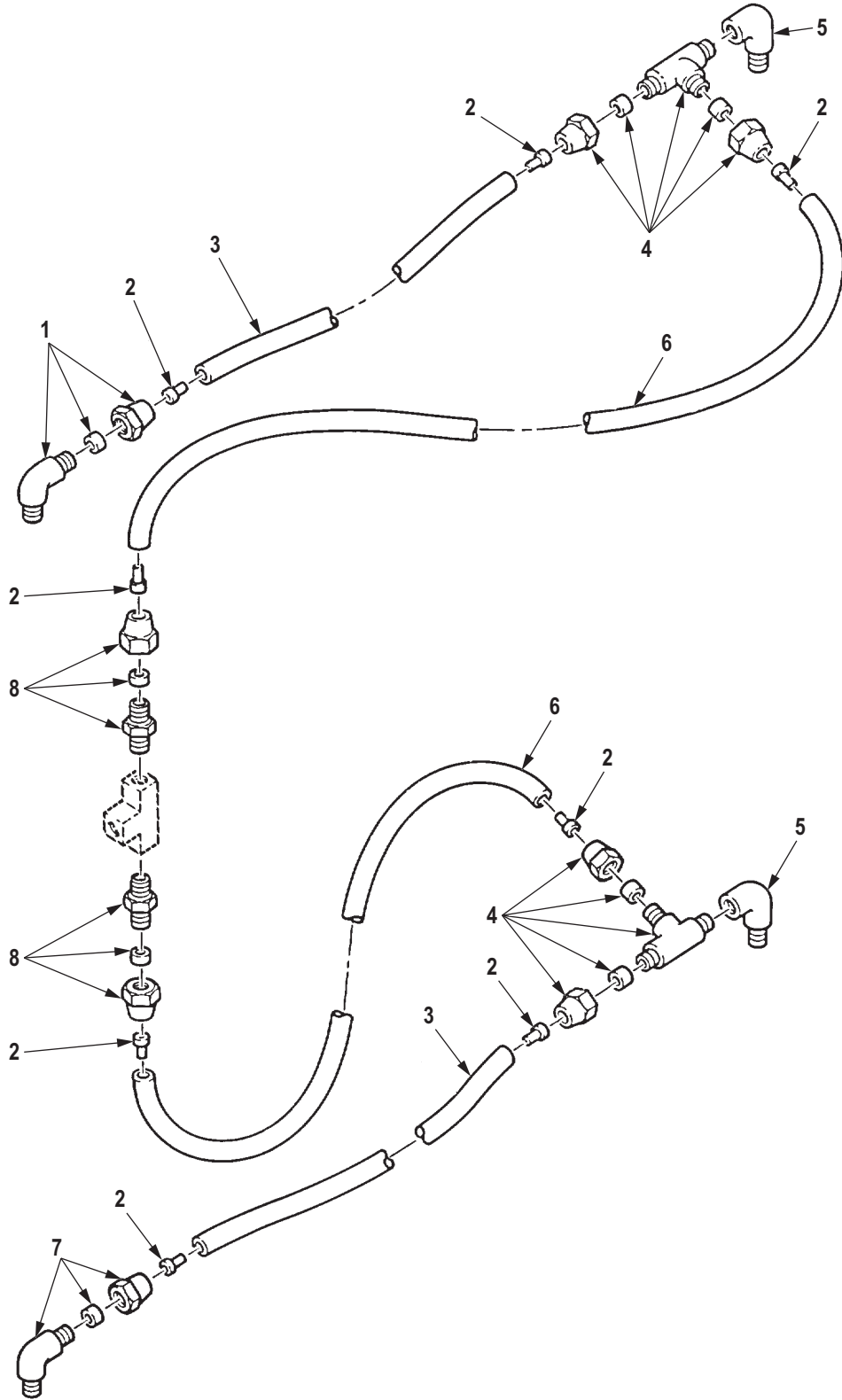

R0298DAA

Figure 281. Primary Vent Lines, Rear Axle Air Brake.

(1) ITEM NO.	(2) SMR CODE	(3) NSN	(4) CAGEC	(5) PART NUMBER	(6) DESCRIPTION AND USABLE ON CODE (UOC)	(7) QTY
<b>GROUP 1208 AIR BRAKE SYSTEM.</b>						
<b>FIG. 281. PRIMARY VENT LINES, REAR AXLE AIR BRAKE.</b>						
1	PAFZZ	4730-00-541-7500	81343	6-6 120302BA(LONGELBOW,PIPE TO TUBE NUT)	UOC: DAC,DAD,DAE,DAF,DAG,DAH,DAJ,DAL,DAW,DAX,V14,V15,V16,V17,V18,V19,V20,V21,V22,V24,ZAA,ZAB,ZAC,ZAD,ZAE,ZAF,ZAG,ZAH,ZAJ,ZAL .....	2
2	PAFZZ	4730-01-079-8821	19207	CPR102321-1	INSERT,TUBE FITTING UOC: DAC,DAD,DAE,DAF,DAG,DAH,DAJ,DAL,DAW,DAX,V14,V15,V16,V17,V18,V19,V20,V21,V22,V24,ZAA,ZAB,ZAC,ZAD,ZAE,ZAF,ZAG,ZAH,ZAJ,ZAL .....	16
3	MFFZZ		81343	J844TYBSIZE 3/8 BLACK-17	HOSE,NONMETALLIC MAKE FROM HOSE, P/N J844TYBSIZE 3/8 BLACK, 17 IN.LONG UOC: DAC,DAD,DAE,DAF,DAG,DAH,DAJ,DAL,DAW,DAX,V14,V15,V16,V17,V18,V19,V20,V21,V22,V24,ZAA,ZAB,ZAC,ZAD,ZAE,ZAF,ZAG,ZAH,ZAJ,ZAL .....	4
4	PAFZZ	4730-00-930-6354	81343	SAE J246 6-6-6 120424B	TEE,PIPE TO TUBE UOC: DAC,DAD,DAE,DAF,DAG,DAH,DAJ,DAL,DAW,DAX,V14,V15,V16,V17,V18,V19,V20,V21,V22,V24,ZAA,ZAB,ZAC,ZAD,ZAE,ZAF,ZAG,ZAH,ZAJ,ZAL .....	4
5	PAFZZ	4730-00-278-4822	19207	7364214	ELBOW,PIPE UOC: DAC,DAD,DAE,DAF,DAG,DAH,DAJ,DAL,DAW,DAX,V14,V15,V16,V17,V18,V19,V20,V21,V22,V24,ZAA,ZAB,ZAC,ZAD,ZAE,ZAF,ZAG,ZAH,ZAJ,ZAL .....	4
6	MFFZZ		81343	J844TYBSIZE 3/8 BLACK-23	HOSE,NONMETALLIC MAKE FROM HOSE, P/N J844TYBSIZE 3/8 BLACK, 23 IN.LONG UOC: DAC,DAD,DAE,DAF,DAG,DAH,DAJ,DAL,DAW,DAX,V14,V15,V16,V17,V18,V19,V20,V21,V22,V24,ZAA,ZAB,ZAC,ZAD,ZAE,ZAF,ZAG,ZAH,ZAJ,ZAL .....	4
7	PAFZZ	4730-00-289-0155	81343	6-6 120202BA	ELBOW,PIPE TO TUBE UOC: DAC,DAD,DAE,DAF,DAG,DAH,DAJ,DAL,DAW,DAX,V14,V15,V16,V17,V18,V19,V20,V21,V22,V24,ZAA,ZAB,ZAC,ZAD,ZAE,ZAF,ZAG,ZAH,ZAJ,ZAL .....	2

(1) ITEM NO.	(2) SMR CODE	(3) NSN	(4) CAGEC	(5) PART NUMBER	(6) DESCRIPTION AND USABLE ON CODE (UOC)	(7) QTY
8	PAFZZ	4730-00-270-4616	81343	6-6120102BA	ADAPTER,STRAIGHT,PI UOC: DAC,DAD,DAE,DAF,DAG,DA H,DAJ,DAL,DAW,DAX,V14,V15,V16, V17,V18,V19,V20,V21,V22,V24,ZAA, ZAB,ZAC,ZAD,ZAE,ZAF,ZAG,ZAH,Z AJ,ZAL .....	4

END OF FIGURE

**FIELD MAINTENANCE  
ALCOHOL EVAPORATOR AND AIR COMPRESSOR TO AIR GOVERNOR LINES**

---

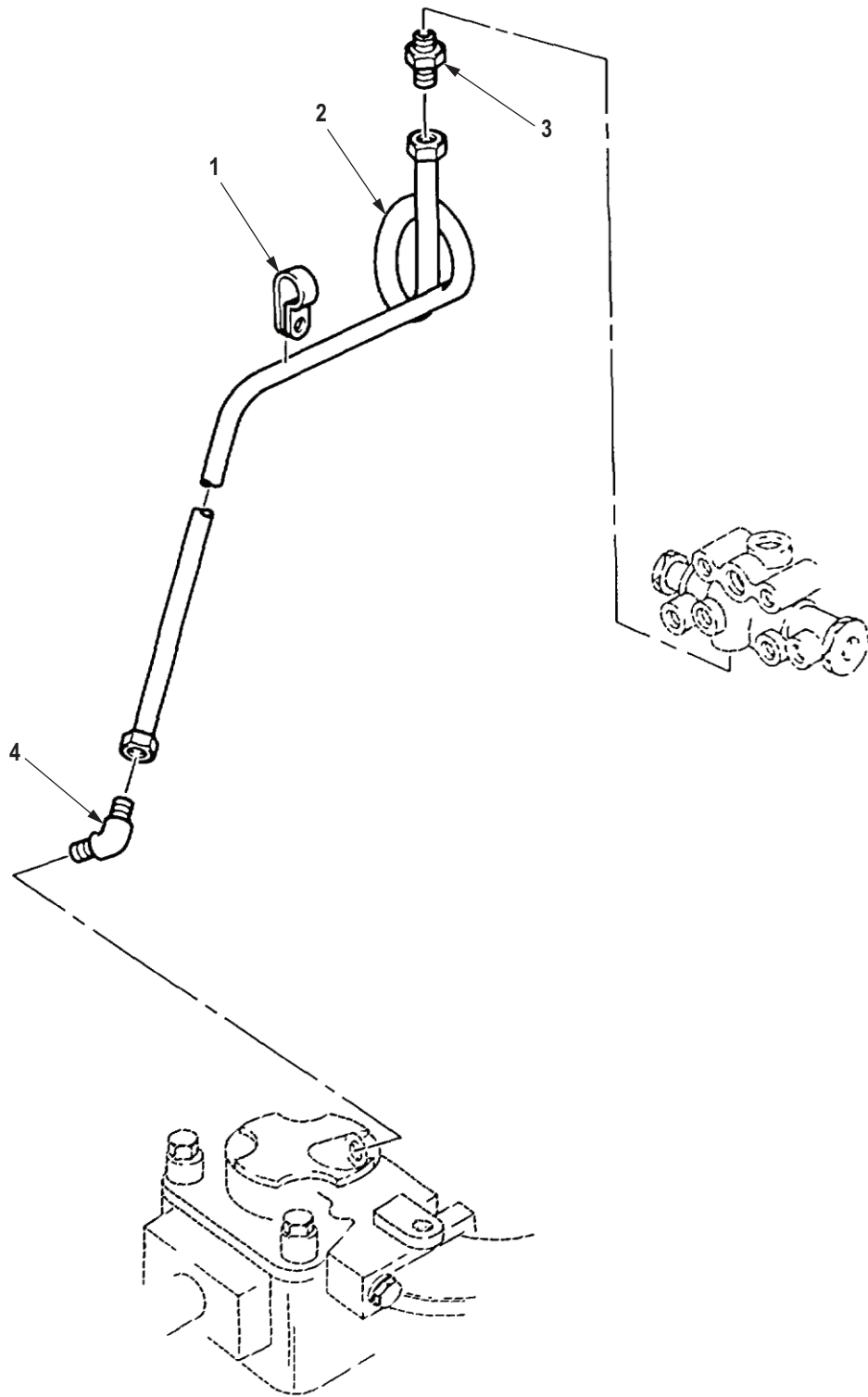

R0299DAA

Figure 282. Alcohol Evaporator and Air Compressor to Air Governor Lines.



(1) ITEM NO.	(2) SMR CODE	(3) NSN	(4) CAGEC	(5) PART NUMBER	(6) DESCRIPTION AND USABLE ON CODE (UOC)	(7) QTY
<b>GROUP 1208 AIR BRAKE SYSTEM.</b>						
<b>FIG. 282. ALCOHOL EVAPORATOR AND AIR COMPRESSOR TO AIR GOVERNOR LINES.</b>						
1	PAFZZ	5340-00-050-9077	96906	MS21333-119	CLAMP, LOOP UOC: DAC,DAD,DAE,DAF,DAG,DA H,DAJ,DAL,DAW,DAX,V14,V15,V16, V17,V18,V19,V20,V21,V22,V24,ZAA, ZAB,ZAC,ZAD,ZAE,ZAF,ZAG,ZAH,Z AJ,ZAL .....	1
2	PAFZZ	4710-01-120-8538	19207	12256264	TUBE ASSEMBLY,METAL UOC: DAC,DAD,DAE,DAF,DAG,DA H,DAJ,DAL,DAW,DAX,V14,V15,V16, V17,V18,V19,V20,V21,V22,V24 .....	1
3	PAFZZ	4730-00-289-0383	96906	MS51500A4	ADAPTER, STRAIGHT, PI UOC: DAC,DAD,DAE,DAF,DAG,DA H,DAJ,DAL,DAW,DAX,V14,V15,V16, V17,V18,V19,V20,V21,V22,V24,ZAA, ZAB,ZAC,ZAD,ZAE,ZAF,ZAG,ZAH,Z AJ,ZAL .....	1
4	PAFZZ	4730-00-647-3207	96906	MS51504A4	ELBOW, PIPE TO TUBE UOC: DAC,DAD,DAE,DAF,DAG,DA H,DAJ,DAL,DAW,DAX,V14,V15,V16, V17,V18,V19,V20,V21,V22,V24 .....	1

**END OF FIGURE**



**FIELD MAINTENANCE  
GOVERNOR CONTROL AIR LINE (ABS)**

---

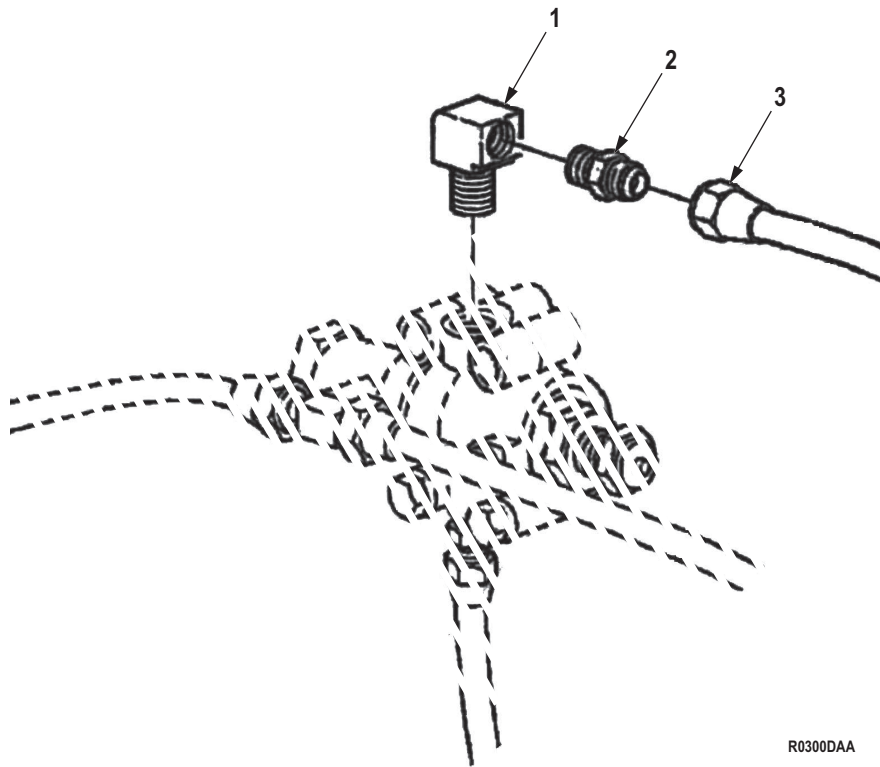

R0300DAA

Figure 283. Governor Control Air Line (ABS).

(1) ITEM NO.	(2) SMR CODE	(3) NSN	(4) CAGEC	(5) PART NUMBER	(6) DESCRIPTION AND USABLE ON CODE (UOC)	(7) QTY
<b>GROUP 1208 AIR BRAKE SYSTEM.</b>						
<b>FIG. 283. GOVERNOR CONTROL AIR LINE (ABS).</b>						
1	PAFZZ	4730-00-254-6211	81343	J5124-2010202B	ELBOW,PIPE TO TUBE UOC: DAC,DAD,DAE,DAF,DAG,DA H,DAJ,DAL,DAW,DAX,V14,V15,V16, V17,V18,V19,V20,V21,V22,V24,ZAA, ZAB,ZAC,ZAD,ZAE,ZAF,ZAG,ZAH,Z AJ,ZAL .....	1
2	PAFZZ	4730-00-415-3172	81343	2-2 130139B	COUPLING,PIPE UOC: DAC,DAD,DAE,DAF,DAG,DA H,DAJ,DAL,DAW,DAX,V14,V15,V16, V17,V18,V19,V20,V21,V22,V24,ZAA, ZAB,ZAC,ZAD,ZAE,ZAF,ZAG,ZAH,Z AJ,ZAL .....	1
3	PAFZZ	4730-00-277-6988	93061	42F-4	NIPPLE,TUBE UOC: DAC,DAD,DAE,DAF,DAG,DA H,DAJ,DAL,DAW,DAX,V14,V15,V16, V17,V18,V19,V20,V21,V22,V24,ZAA, ZAB,ZAC,ZAD,ZAE,ZAF,ZAG,ZAH,Z AJ,ZAL .....	1

**END OF FIGURE**



**FIELD MAINTENANCE  
CLUTCH FAN ACTUATOR AND RELATED AIR LINES**

---

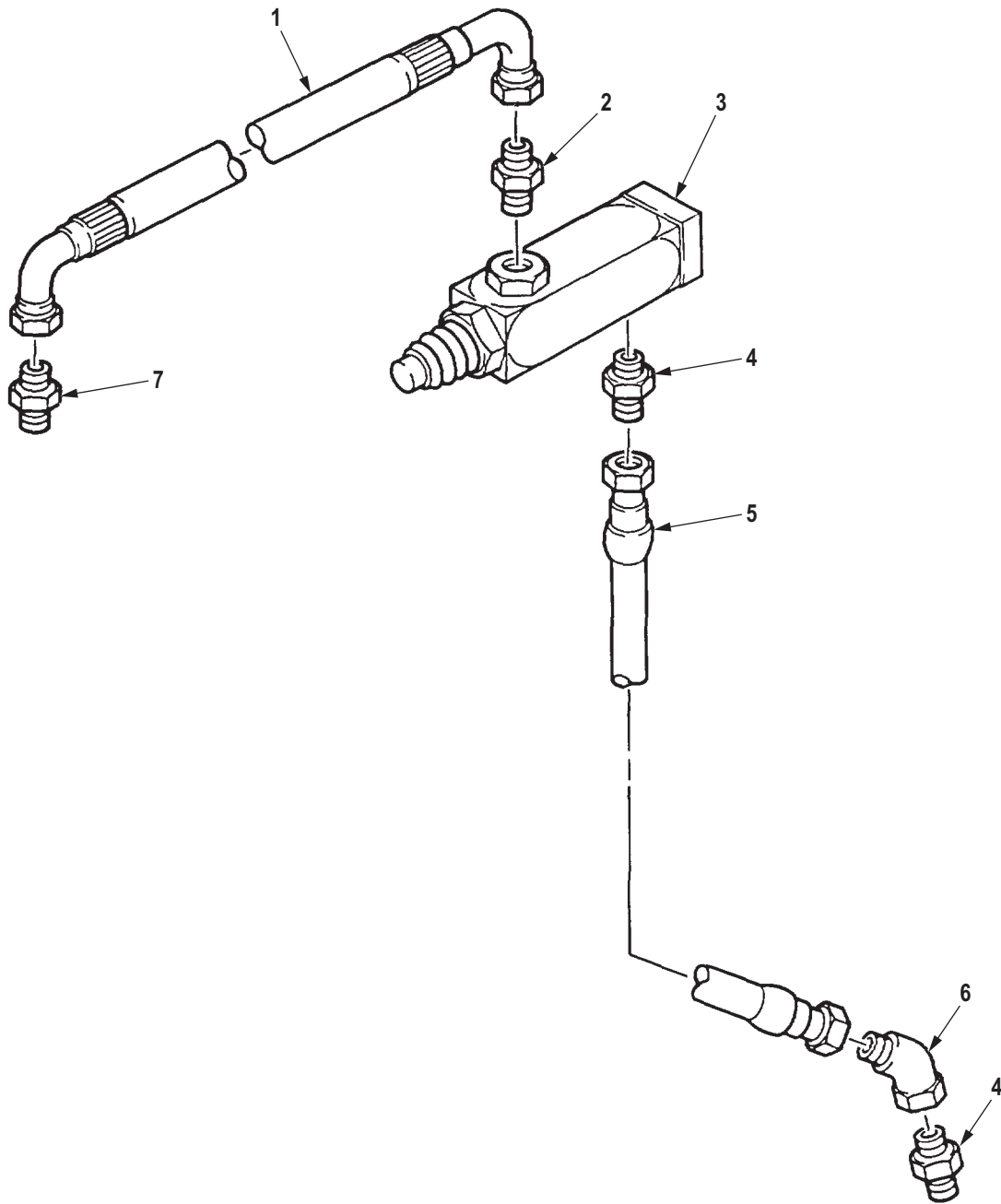

R0301DAA

Figure 284. Clutch Fan Actuator and Related Air Lines.



(1) ITEM NO.	(2) SMR CODE	(3) NSN	(4) CAGEC	(5) PART NUMBER	(6) DESCRIPTION AND USABLE ON CODE (UOC)	(7) QTY
<b>GROUP 1208 AIR BRAKE SYSTEM.</b>						
<b>FIG. 284. CLUTCH FAN ACTUATOR AND RELATED AIR LINES.</b>						
1	PAFZZ	4720-01-134-3847	19207	12277227	HOSE ASSEMBLY, NONME UOC: DAC, DAD, DAE, DAF, DAG, DA H, DAJ, DAL, DAW, DAX, V14, V15, V16, V17, V18, V19, V20, V21, V22, V24 .....	1
2	PAFZZ	4730-00-803-5776	96906	MS51500A6-2	ADAPTER, STRAIGHT, PI UOC: DAC, DAD, DAE, DAF, DAG, DA H, DAJ, DAL, DAW, DAX, V14, V15, V16, V17, V18, V19, V20, V21, V22, V24 .....	1
3	PAFZZ	4820-01-149-1317	21102	CA200046	VALVE, REGULATING, FL UOC: DAC, DAD, DAE, DAF, DAG, DA H, DAJ, DAL, DAW, DAX, V14, V15, V16, V17, V18, V19, V20, V21, V22, V24, ZAA, ZAB, ZAC, ZAD, ZAE, ZAF, ZAG, ZAH, Z AJ, ZAL .....	1
4	PAFZZ	4730-00-618-8497	96906	MS51500A5	ADAPTER, STRAIGHT, PI UOC: DAC, DAD, DAE, DAF, DAG, DA H, DAJ, DAL, DAW, DAX, V14, V15, V16, V17, V18, V19, V20, V21, V22, V24 .....	2
5	PAFZZ	4720-01-130-8086	19207	12256281-3	HOSE ASSEMBLY, NONME UOC: DAC, DAD, DAE, DAF, DAG, DA H, DAJ, DAL, DAW, DAX, V14, V15, V16, V17, V18, V19, V20, V21, V22, V24, ZAA, ZAB, ZAC, ZAD, ZAE, ZAF, ZAG, ZAH, Z AJ, ZAL .....	1
6	PAFZZ	4730-01-139-4231	96906	MS51522A5	ELBOW, TUBE UOC: DAC, DAD, DAE, DAF, DAG, DA H, DAJ, DAL, DAW, DAX, V14, V15, V16, V17, V18, V19, V20, V21, V22, V24, ZAA, ZAB, ZAC, ZAD, ZAE, ZAF, ZAG, ZAH, Z AJ, ZAL .....	1
7	PAFZZ	4730-00-289-0382	96906	MS51500A6-8	ADAPTER, STRAIGHT, PI UOC: DAC, DAD, DAE, DAF, DAG, DA H, DAJ, DAL, DAW, DAX, V14, V15, V16, V17, V18, V19, V20, V21, V22, V24 .....	1

**END OF FIGURE**



**FIELD MAINTENANCE  
PRESSURE REGULATOR, DOUBLE-CHECK VALVES, AND AIR LINES**

---

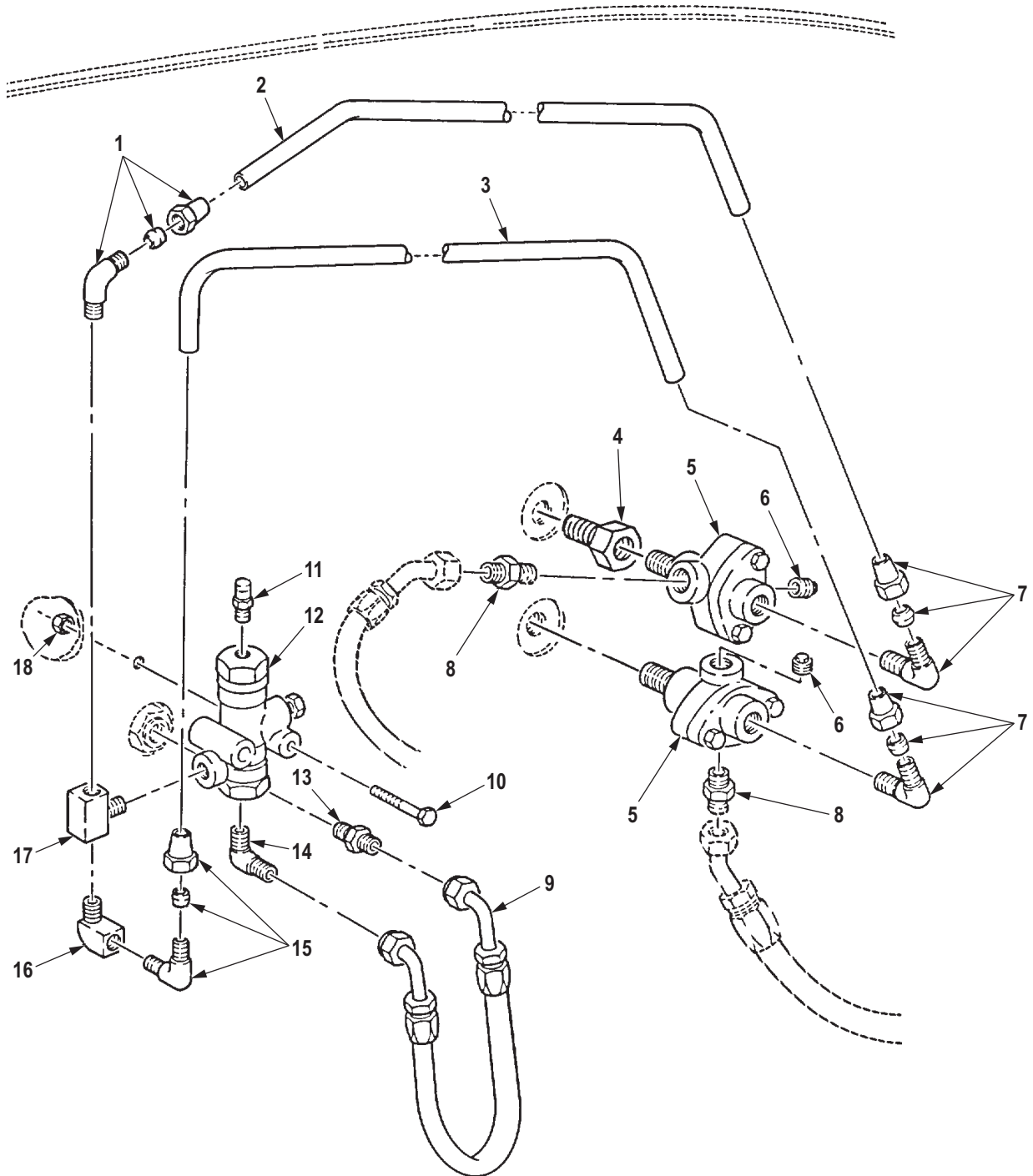

R0302DAA

Figure 285. Pressure Regulator, Double-Check Valves, and Air Lines.

(1) ITEM NO.	(2) SMR CODE	(3) NSN	(4) CAGEC	(5) PART NUMBER	(6) DESCRIPTION AND USABLE ON CODE (UOC)	(7) QTY
<b>GROUP 1208 AIR BRAKE SYSTEM.</b>						
<b>FIG. 285. PRESSURE REGULATOR, DOUBLE-CHECK VALVES, AND AIR LINES.</b>						
1	PAFZZ	4730-01-066-9484	81343	6-4 120302BA	ELBOW,PIPE TO TUBE UOC: DAL,V18,ZAL .....	1
2	MFFZZ		19207	12302864-AR	TUBE MAKE FROM TUBING, P/N 5174K5 UOC: DAL,V18,ZAL .....	1
3	MFFZZ		19207	12302865-AR	TUBE MAKE FROM TUBING, P/N 5174K5. UOC: DAL,V18,ZAL .....	1
4	PAFZZ	4730-00-475-5168	24617	444004	COUPLING,PIPE UOC: DAL,V18,ZAL .....	1
5	PAFZZ	2530-00-981-8736	06853	278599N	VALVE,BRAKE PNEUMAT UOC: DAL,V18,ZAL .....	2
6	PAFZZ	4730-00-187-4202	58536	AA59616AASBCC	PLUG,PIPE UOC: DAL,V18,ZAL .....	2
7	PAFZZ	4730-00-289-0155	81343	6-6 120202BA	ELBOW,PIPE TO TUBE UOC: DAL,V18 .....	2
8	PAFZZ	4730-00-813-9611	81343	J514 8-6 070102CA	ADAPTER,STRAIGHT,PI UOC: DAL,V18,ZAL .....	2
9	PFFZZ	4720-01-276-1253	19207	12302894	HOSE ASSEMBLY,NONME UOC: DAL,V18,ZAL .....	1
10	PAFZZ	5305-00-267-8958	80204	B1821BH025F200N	SCREW,CAP,HEXAGON H UOC: DAL,V18,ZAL .....	2
11	PFFZZ	4820-00-726-4719	19207	5196397	VALVE,VENT UOC: DAL,V18,ZAL .....	1
12	PAFZZ	4820-01-251-1699	06853	103998	VALVE,CALIBRATED FL UOC: DAL,V18,ZAL .....	1
13	PAFZZ	4730-00-088-8908	96906	MS51500-A6	ADAPTER FRONT CAB MOUNT UOC: V14,V15,V16,V17,V18,V19,V2 0,V21,V24 .....	2
14	PAFZZ	4730-00-812-7999	96906	MS51504A6	ELBOW,PIPE TO TUBE UOC: DAL,V18,ZAL .....	1
15	PAFZZ	4730-00-069-1187	81343	SAE J246 6-4 100202BA	ELBOW,PIPE TO TUBE UOC: DAL,V18,ZAL .....	1
16	PAFZZ	4730-00-277-5553	96906	MS51952-2	ELBOW,PIPE UOC: DAL,V18,ZAL .....	1
17	PAFZZ	4730-00-088-8666	81343	4-4-4 130425B	TEE,PIPE UOC: DAL,V18,ZAL .....	1
18	PAFZZ	5310-00-935-9022	81349	M45913/3-4FG8C	NUT,SELF-LOCKING,HE UOC: DAL,V18,ZAL .....	2

END OF FIGURE



**FIELD MAINTENANCE  
BRAKE LOCK VALVE AND AIR LINES**

---

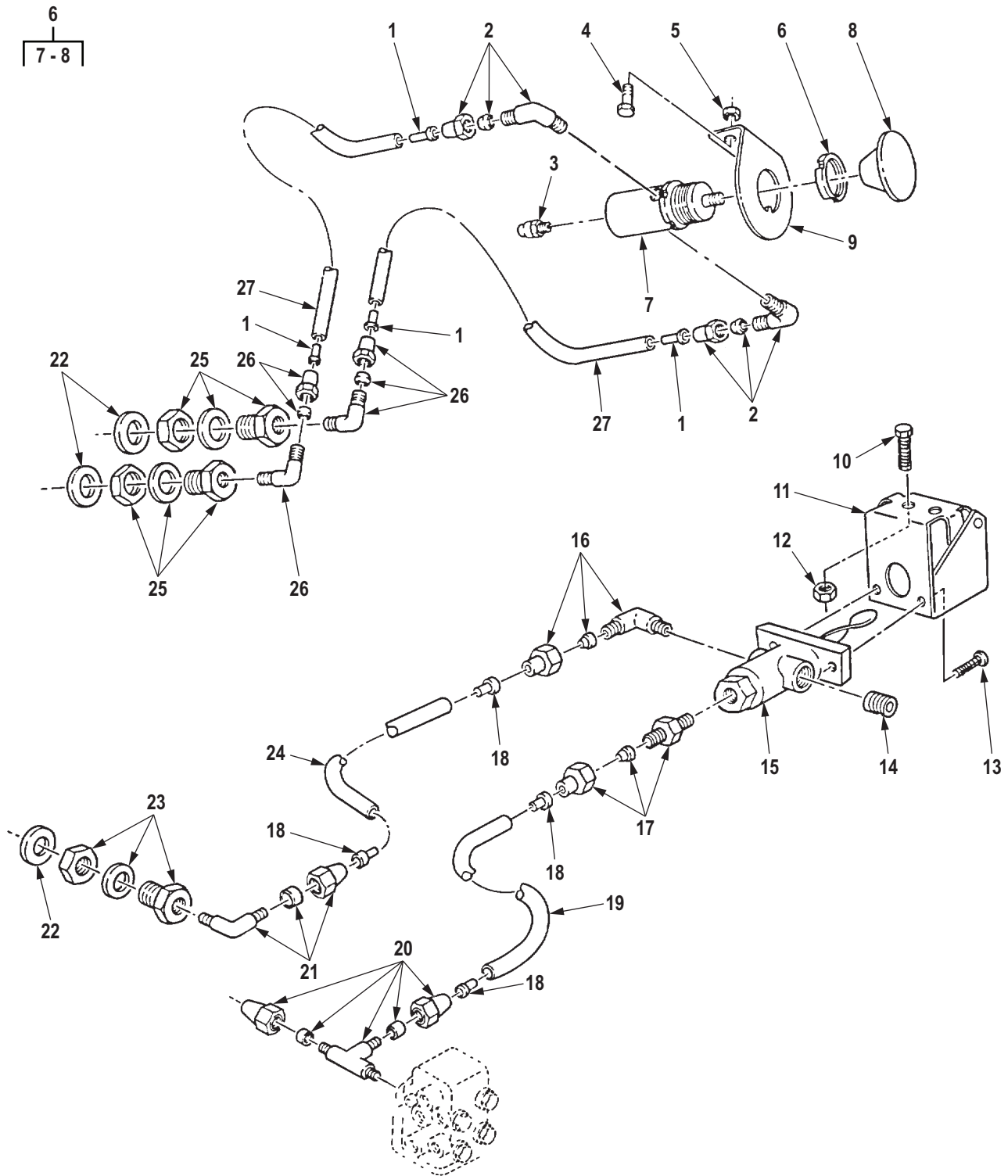

R0303DAA

Figure 286. Brake Lock Valve and Air Lines.



(1) ITEM NO.	(2) SMR CODE	(3) NSN	(4) CAGEC	(5) PART NUMBER	(6) DESCRIPTION AND USABLE ON CODE (UOC)	(7) QTY
<b>GROUP 1208 AIR BRAKE SYSTEM.</b>						
<b>FIG. 286. BRAKE LOCK VALVE AND AIR LINES.</b>						
1	PAFZZ	4730-01-079-8821	19207	CPR102321-1	INSERT,TUBE FITTING UOC: DAL,V18,ZAL .....	4
2	PAFZZ	4730-00-287-1604	81343	6-2 120202BA	ELBOW,PIPE TO TUBE UOC: DAL,V18,ZAL .....	2
3	PFFZZ	4820-00-726-4719	19207	5196397	VALVE,VENT UOC: DAL,V18,ZAL .....	1
4	PAFZZ	5305-00-267-8953	80204	B1821BH025F063N	SCREW,CAP,HEXAGON H UOC: DAL,V18,ZAL .....	2
5	PAFZZ	5310-00-935-9022	81349	M45913/3-4FG8C	NUT,SELF-LOCKING,HE UOC: DAL,V18,ZAL .....	2
6	PFFZZ	4820-01-277-1486	34623	12302904	VALVE,LINEAR,DIRECT UOC: DAL,V18,ZAL .....	1
7	XAFZZ		34623	12302904XA	. VALVE,LINEAR,DIRECT UOC: DAL,V18,ZAL .....	1
8	PFFZZ	5355-01-318-2811	19207	12302904-1	. KNOB UOC: DAL,V18,ZAL .....	1
9	PFFZZ	5340-01-277-3023	19207	12302898	BRACKET,ANGLE UOC: DAL,V18,ZAL .....	1
10	PAFZZ	5305-00-267-8953	80204	B1821BH025F063N	SCREW,CAP,HEXAGON H UOC: V39 .....	2
11	XDFZZ		19207	12302896	GUARD,SWITCH UOC: DAL,V18 .....	1
12	PAFZZ	5310-00-935-9022	81349	M45913/3-4FG8C	NUT,SELF-LOCKING,HE UOC: V39 .....	2
13	PAFZZ	5305-00-984-6208	95105	343-0586-000	SCREW,MACHINE UOC: V39 .....	2
14	PAFZZ	4730-01-030-4950	58536	AA59616ACABDA	PLUG,PIPE UOC: V39 .....	1
15	PAFZZ	4820-00-832-8077	19207	10924753	VALVE,LINEAR,DIRECT UOC: V39 .....	1
16	PAFZZ	4730-00-287-1604	81343	6-2 120202BA	ELBOW,PIPE TO TUBE UOC: V39 .....	1
17	PAFZZ	4730-00-142-3075	81343	6-2 120102BA	ADAPTER,STRAIGHT,PI UOC: V39 .....	1
18	PAFZZ	4730-01-079-8821	19207	CPR102321-1	INSERT,TUBE FITTING UOC: V39 .....	4
19	MFFZZ		81343	J844TYBSIZE 3/8 BLACK-14	HOSE,NONMETALLIC MAKE FROM TUBING,P/N J844TYBSIZE 3/8 BLACK,14 IN.LONG UOC: V39 .....	1
20	PAFZZ	4730-00-813-7811	81343	6-4-6 120424BA	TEE,PIPE TO TUBE UOC: V39 .....	1

(1) ITEM NO.	(2) SMR CODE	(3) NSN	(4) CAGEC	(5) PART NUMBER	(6) DESCRIPTION AND USABLE ON CODE (UOC)	(7) QTY
21	PAFZZ	4730-00-069-1187	81343	SAE J246 6-4 100202BA	ELBOW,PIPE TO TUBE UOC: V39 .....	1
22	PAFZZ	5310-00-809-8533	96906	MS27183-23	WASHER,FLAT UOC: V18,ZAL .....	3
23	PFFZZ	4730-00-278-6318	19207	8328782	COUPLING,PIPE UOC: V39 .....	2
24	MFFZZ		81343	J844TYBSIZE 3/8 BLACK-9	HOSE,NONMETALLIC MAKE FROM HOSE, P/N J844TYBSIZE 3/8 BLACK,9 IN.LONG UOC: V39 .....	1
25	PFFZZ	4730-00-278-6318	19207	8328782	COUPLING,PIPE UOC: DAL,V18,ZAL .....	2
26	PAFZZ	4730-00-069-1187	81343	SAE J246 6-4 100202BA	ELBOW,PIPE TO TUBE UOC: DAL,V18,ZAL .....	2
27	MFFZZ		81343	J844TYBSIZE 3/8 BLACK-18	HOSE,NONMETALLIC MAKE FROM HOSE, P/N J844TYBSIZE 3/8 BLACK,18 IN.LONG UOC: DAL,V18,ZAL .....	4

END OF FIGURE

<b>RECOMMENDED CHANGES TO PUBLICATIONS AND BLANK FORMS</b>						Use Part II (reverse) for Repair Parts and Special Tool Lists (RPSTL) and Supply Catalogs/Supply Manuals (SC/SM).	DATE <i>Date you filled out this form.</i>	
For use of this form, see AR 25-30; the proponent agency is OAASA.								
<b>TO</b> (Forward to proponent of publication or form) (Include ZIP Code) U.S. Army TACOM Life Cycle Management Command ATTN: AMSTA-LCL-MPP/TECH PUBS 6501 E. 11 Mile Road, Warren, MI 48397-5000						<b>FROM</b> (Activity and location) (Include ZIP Code)  <i>Your mailing address</i>		
<b>PART I – ALL PUBLICATIONS (EXCEPT RPSTL AND SC/SM) AND BLANK FORMS</b>								
PUBLICATION/FORM NUMBER <i>TM Number</i>						DATE <i>Date of the TM</i>	TITLE <i>Title of the TM</i>	
ITEM	PAGE	PARA-GRAPH	LINE	FIGURE NO.	TABLE	RECOMMENDED CHANGES AND REASON (Exact wording of recommended change must be given)		
	0007-3					<i>Figure 2, Item 9 should show a lockwasher. Currently shows a flat washer.</i>		
	0018-2					<i>Cleaning and inspection, Step 6, reference to governor support pin (14) is wrong reference. Reference should be change to (12).</i>		
SAMPLE								
TYPED NAME, GRADE OR TITLE						TELEPHONE EXCHANGE/AUTOVON, PLUS EXTENSION		SIGNATURE
<i>Your Name</i>						<i>Your Phone Number</i>		<i>Your Signature</i>

<b>TO</b> (Forward direct to addressee listed in publication) U.S. Army TACOM Life Cycle Management Command ATTN: AMSTA-LCL-MPP/TECH PUBS 6501 E. 11 Mile Road, Warren, MI 48397-5000	<b>FROM</b> (Activity and location) (Include ZIP Code)  <i>Your Address</i>	<b>DATE</b> <i>Date you filled out this form</i>
--	---	---

**PART II – REPAIR PARTS AND SPECIAL TOOL LISTS AND SUPPLY CATALOGS/SUPPLY MANUALS**

PUBLICATION NUMBER <i>TM Number</i>	DATE <i>Date of the TM</i>	TITLE <i>Title of the TM</i>
--	-------------------------------	---------------------------------

PAGE NO.	COLM NO.	LINE NO.	NATIONAL STOCK NUMBER	REFERENCE NO.	FIGURE NO.	ITEM NO.	TOTAL NO. OF MAJOR ITEMS SUPPORTED	RECOMMENDED ACTION
<h1>SAMPLE</h1>								

**PART III – REMARKS** (Any general remarks, or recommendations, or suggestions for improvement of publications and blank forms. Additional blank sheets may be used if more space is needed.)

TYPED NAME, GRADE OR TITLE <i>Your Name</i>	TELEPHONE EXCHANGE/AUTOVON, PLUS EXTENSION <i>Your Phone Number</i>	SIGNATURE <i>Your Signature</i>
--	--	------------------------------------

<b>RECOMMENDED CHANGES TO PUBLICATIONS AND BLANK FORMS</b>						Use Part II (reverse) for Repair Parts and Special Tool Lists (RPSTL) and Supply Catalogs/Supply Manuals (SC/SM).	<b>DATE</b>
For use of this form, see AR 25-30; the proponent agency is OAASA							
<b>TO</b> (Forward to proponent of publication or form) (Include ZIP Code) U.S. Army TACOM Life Cycle Management Command ATTN: AMSTA-LCL-MPP/TECH PUBS 6501 E. 11 Mile Road, Warren, MI 48397-5000						<b>FROM</b> (Activity and location) (Include ZIP Code)	
<b>PART I – ALL PUBLICATIONS (EXCEPT RPSTL AND SC/SM) AND BLANK FORMS</b>							
PUBLICATION/FORM NUMBER TM 9-2320-272-24P-1						DATE 27 August 2012	TITLE Truck, 5-Ton, 6X6, M939A1, And M939A2 Series Trucks (Diesel), Field Maintenance Manual
	PAGE	PARA-GRAPH	LINE	FIGURE NO.	TABLE	RECOMMENDED CHANGES AND REASON	
TYPED NAME, GRADE OR TITLE					TELEPHONE EXCHANGE/AUTOVON, PLUS EXTENSION		SIGNATURE

<b>TO</b> <i>(Forward direct to addressee listed in publication)</i> U.S. Army TACOM Life Cycle Management Command ATTN: AMSTA-LCL-MPP/TECH PUBS 6501 E. 11 Mile Road, Warren, MI 48397-5000	<b>FROM</b> <i>(Activity and location) (Include ZIP Code)</i>	<b>DATE</b>
---	---	-------------

**PART II – REPAIR PARTS AND SPECIAL TOOL LISTS AND SUPPLY CATALOGS/SUPPLY MANUALS**

<b>PUBLICATION/FORM NUMBER</b> TM 9-2320-272-24P-1	<b>DATE</b> 27 August 2012	<b>TITLE</b> Truck, 5-Ton, 6X6, M939A1, And M939A2 Series Trucks (Diesel), Field Maintenance Manual
---	-------------------------------	--

PAGE NO.	COLM NO.	LINE NO.	NATIONAL STOCK NUMBER	REFERENCE NO.	FIGURE NO.	ITEM NO.	TOTAL NO. OF MAJOR ITEMS SUPPORTED	RECOMMENDED ACTION

**PART III – REMARKS** *(Any general remarks, or recommendations, or suggestions for improvement of publications and blank forms. Additional blank sheets may be used if more space is needed.)*

TYPED NAME, GRADE OR TITLE	TELEPHONE EXCHANGE/AUTOVON, PLUS EXTENSION	SIGNATURE
----------------------------	--	-----------

<b>RECOMMENDED CHANGES TO PUBLICATIONS AND BLANK FORMS</b>						Use Part II (reverse) for Repair Parts and Special Tool Lists (RPSTL) and Supply Catalogs/Supply Manuals (SC/SM).	<b>DATE</b>
For use of this form, see AR 25-30; the proponent agency is OAASA							
<b>TO</b> (Forward to proponent of publication or form) (Include ZIP Code) U.S. Army TACOM Life Cycle Management Command ATTN: AMSTA-LCL-MPP/TECH PUBS 6501 E. 11 Mile Road, Warren, MI 48397-5000						<b>FROM</b> (Activity and location) (Include ZIP Code)	
<b>PART I – ALL PUBLICATIONS (EXCEPT RPSTL AND SC/SM) AND BLANK FORMS</b>							
PUBLICATION/FORM NUMBER TM 9-2320-272-24P-1						DATE 27 August 2012	TITLE Truck, 5-Ton, 6X6, M939A1, And M939A2 Series Trucks (Diesel), Field Maintenance Manual
ITEM	PAGE	PARA-GRAPH	LINE	FIGURE NO.	TABLE	RECOMMENDED CHANGES AND REASON	
TYPED NAME, GRADE OR TITLE					TELEPHONE EXCHANGE/AUTOVON, PLUS EXTENSION		SIGNATURE

<b>TO</b> <i>(Forward direct to addressee listed in publication)</i> U.S. Army TACOM Life Cycle Management Command ATTN: AMSTA-LCL-MPP/TECH PUBS 6501 E. 11 Mile Road, Warren, MI 48397-5000	<b>FROM</b> <i>(Activity and location) (Include ZIP Code)</i>	<b>DATE</b>
---	---	-------------

**PART II – REPAIR PARTS AND SPECIAL TOOL LISTS AND SUPPLY CATALOGS/SUPPLY MANUALS**

<b>PUBLICATION/FORM NUMBER</b> TM 9-2320-272-24P-1	<b>DATE</b> 27 August 2012	<b>TITLE</b> Truck, 5-Ton, 6X6, M939A1, And M939A2 Series Trucks (Diesel), Field Maintenance Manual
---	-------------------------------	--

PAGE NO.	COLM NO.	LINE NO.	NATIONAL STOCK NUMBER	REFERENCE NO.	FIGURE NO.	ITEM NO.	TOTAL NO. OF MAJOR ITEMS SUPPORTED	RECOMMENDED ACTION

**PART III – REMARKS** *(Any general remark, or recommendations, or suggestions for improvement of publications and blank forms. Additional blank sheets may be used if more space is needed.)*

TYPED NAME, GRADE OR TITLE	TELEPHONE EXCHANGE/AUTOVON, PLUS EXTENSION	SIGNATURE
----------------------------	--	-----------



<b>RECOMMENDED CHANGES TO PUBLICATIONS AND BLANK FORMS</b>						Use Part II (reverse) for Repair Parts and Special Tool Lists (RPSTL) and Supply Catalogs/Supply Manuals (SC/SM).	<b>DATE</b>
For use of this form, see AR 25-30; the proponent agency is OAASA							
<b>TO</b> (Forward to proponent of publication or form) (Include ZIP Code) U.S. Army TACOM Life Cycle Management Command ATTN: AMSTA-LCL-MPP/TECH PUBS 6501 E. 11 Mile Road, Warren, MI 48397-5000						<b>FROM</b> (Activity and location) (Include ZIP Code)	
<b>PART I – ALL PUBLICATIONS (EXCEPT RPSTL AND SC/SM) AND BLANK FORMS</b>							
PUBLICATION/FORM NUMBER TM 9-2320-272-24P-1						DATE 27 August 2012	TITLE Truck, 5-Ton, 6X6, M939A1, And M939A2 Series Trucks (Diesel), Field Maintenance Manual
ITEM	PAGE	PARA-GRAPH	LINE	FIGURE NO.	TABLE	RECOMMENDED CHANGES AND REASON	
TYPED NAME, GRADE OR TITLE					TELEPHONE EXCHANGE/AUTOVON, PLUS EXTENSION		SIGNATURE

<b>TO</b> <i>(Forward direct to addressee listed in publication)</i> U.S. Army TACOM Life Cycle Management Command ATTN: AMSTA-LCL-MPP/TECH PUBS 6501 E. 11 Mile Road, Warren, MI 48397-5000	<b>FROM</b> <i>(Activity and location) (Include ZIP Code)</i>	<b>DATE</b>
---	---	-------------

**PART II – REPAIR PARTS AND SPECIAL TOOL LISTS AND SUPPLY CATALOGS/SUPPLY MANUALS**

<b>PUBLICATION/FORM NUMBER</b> TM 9-2320-272-24P-1	<b>DATE</b> 27 August 2012	<b>TITLE</b> Truck, 5-Ton, 6X6, M939A1, And M939A2 Series Trucks (Diesel), Field Maintenance Manual
---	-------------------------------	--

PAGE NO.	COLM NO.	LINE NO.	NATIONAL STOCK NUMBER	REFERENCE NO.	FIGURE NO.	ITEM NO.	TOTAL NO. OF MAJOR ITEMS SUPPORTED	RECOMMENDED ACTION

**PART III – REMARKS** *(Any general remarks, recommendations, or suggestions for improvement of publications and blank forms. Additional blank sheets may be used if more space is needed.)*

TYPED NAME, GRADE OR TITLE	TELEPHONE EXCHANGE/AUTOVON, PLUS EXTENSION	SIGNATURE
----------------------------	--	-----------

By Order of the Secretary of the Army:

Official:



JOYCE E. MORROW  
*Administrative Assistant to the  
Secretary of the Army*

1220807

RAYMOND T. ODIERNO  
*General, United States Army  
Chief of Staff*

By Order of the Secretary of the Air Force:

DONALD J. HOFFMAN  
*General, United States Air Force  
Commander, AFMC*

NORTON A. SCHWARTZ  
*General, United States Air Force  
Chief of Staff*

Distribution:

To be distributed in accordance with the initial distribution number (IDN) 381081 requirements for TM 9-2320-272-24P-1.



## THE METRIC SYSTEM AND EQUIVALENTS

### LINEAR MEASURE

1 Centimeter=10 Millimeters=0.01 Meters=0.3937 Inches  
 1 Meter=100 Centimeters=1000 Millimeters=39.37 Inches  
 1 Kilometer=1000 Meters=0.621 Miles

### WEIGHTS

1 Gram=0.001 Kilograms=1000 Milligrams=0.035 Ounces  
 1 Kilogram=1000 Grams=2.2 Lb  
 1 Metric Ton=1000 Kilograms=1 Megagram=1.1 Short Tons

### LIQUID MEASURE

1 Milliliter=0.001 Liters=0.0338 Fluid Ounces  
 1 Liter=1000 Milliliters=33.82 Fluid Ounces

### SQUARE MEASURE

1 Sq Centimeter=100 Sq Millimeters=0.155 Sq Inches  
 1 Sq Meter=10,000 Sq Centimeters=10.76 Sq Feet  
 1 Sq Kilometer=1,000,000 Sq Meters=0.386 Sq Miles

### CUBIC MEASURE

1 Cu Centimeter=1000 Cu Millimeters=0.06 Cu Inches  
 1 Cu Meter=1,000,000 Cu Centimeters=35.31 Cu Feet

### TEMPERATURE

$5/9 (^{\circ}\text{F} - 32) = ^{\circ}\text{C}$   
 212°Fahrenheit is equivalent to 100°Celsius  
 90°Fahrenheit is equivalent to 32.2°Celsius  
 32°Fahrenheit is equivalent to 0°Celsius  
 $9/5 (^{\circ}\text{C} + 32) = ^{\circ}\text{F}$

### APPROXIMATE CONVERSION FACTORS

<u>TO CHANGE</u>	<u>TO</u>	<u>MULTIPLY BY</u>
Inches . . . . .	Centimeters . . . . .	2.540
Feet . . . . .	Meters . . . . .	0.305
Yards . . . . .	Meters . . . . .	0.914
Miles . . . . .	Kilometers . . . . .	1.609
Square Inches . . . . .	Square Centimeters . . . . .	6.451
Square Feet . . . . .	Square Meters . . . . .	0.093
Square Yards . . . . .	Square Meters . . . . .	0.836
Square Miles . . . . .	Square Kilometers . . . . .	2.590
Acres . . . . .	Square Hectometers . . . . .	0.405
Cubic Feet . . . . .	Cubic Meters . . . . .	0.028
Cubic Yards . . . . .	Cubic Meters . . . . .	0.765
Fluid Ounces . . . . .	Milliliters . . . . .	29.573
Pints . . . . .	Liters . . . . .	0.473
Quarts . . . . .	Liters . . . . .	0.946
Gallons . . . . .	Liters . . . . .	3.785
Ounces . . . . .	Grams . . . . .	28.349
Pounds . . . . .	Kilograms . . . . .	0.454
Short Tons . . . . .	Metric Tons . . . . .	0.907
Pound-Feet . . . . .	Newton-Meters . . . . .	1.356
Pounds/Sq Inch . . . . .	Kilopascals . . . . .	6.895
Miles per Gallon . . . . .	Kilometers per Liter . . . . .	0.425
Miles per Hour . . . . .	Kilometers per Hour . . . . .	1.609

<u>TO CHANGE</u>	<u>TO</u>	<u>MULTIPLY BY</u>
Centimeters . . . . .	Inches . . . . .	0.394
Meters . . . . .	Feet . . . . .	3.280
Meters . . . . .	Yards . . . . .	1.094
Kilometers . . . . .	Miles . . . . .	0.621
Sq Centimeters . . . . .	Square Inches . . . . .	0.155
Square Meters . . . . .	Square Feet . . . . .	10.764
Square Meters . . . . .	Square Yards . . . . .	1.196
Square Kilometers . . . . .	Square Miles . . . . .	0.386
Sq Hectometers . . . . .	Acres . . . . .	2.471
Cubic Meters . . . . .	Cubic Feet . . . . .	35.315
Cubic Meters . . . . .	Cubic Yards . . . . .	1.308
Milliliters . . . . .	Fluid Ounces . . . . .	0.034
Liters . . . . .	Pints . . . . .	2.113
Liters . . . . .	Quarts . . . . .	1.057
Liters . . . . .	Gallons . . . . .	0.264
Grams . . . . .	Ounces . . . . .	0.035
Kilograms . . . . .	Pounds . . . . .	2.205
Metric Tons . . . . .	Short Tons . . . . .	1.102
Newton-Meters . . . . .	Pound-Feet . . . . .	0.738
Kilopascals . . . . .	Pounds per Sq Inch . . . . .	0.145
Km per Liter . . . . .	Miles per Gallon . . . . .	2.354
Km per Hour . . . . .	Miles per Hour . . . . .	0.621

