

**TM 9-2320-209-10-1**  
**TO 36A12-1B-1091-1**

---

TECHNICAL MANUAL

**OPERATION, INSTALLATION AND  
REFERENCE DATA**

OPERATOR LEVEL

**2 1/2-TON, 6X6, M44A1 AND M44A2 SERIES TRUCKS  
(MULTIFUEL)**

**TRUCK, CARGO: M35A1 ,  
M35A2, M35A2C, M36A2; TRUCK,  
TANK, FUEL: M49A1C, M49A2C; TRUCK, TANK,  
WATER: M50A1, M50A2, M50A3; TRUCK, VAN,  
SHOP: M109A2, M109A3; TRUCK, REPAIR SHOP:  
M185A2, M185A3; TRUCK, TRACTOR: M275A1,  
M275A2; TRUCK, DUMP: M342A2; TRUCK,  
MAINTENANCE, PIPELINE CONSTRUCTION:  
M756A2; TRUCK, MAINTENANCE,  
EARTH BORING AND POLESETTING: M764**

Chapter 1  
Introduction

Chapter 2  
Description  
and Data

Chapter 3  
Service Upon  
Receipt of  
Equipment

Chapter 4  
Operating  
Procedures

Appendix A  
References

Appendix B  
Components  
of End Item  
List

Appendix C  
Additional  
Authorization  
List

Appendix D  
Expendable  
Supplies and  
Materials  
List

---

**DEPARTMENTS OF THE ARMY AND THE AIR FORCE**  
**SEPTEMBER 1980**

## WARNING

### EXHAUST GASES CAN BE DEADLY

Exposure to exhaust gases produces symptoms of headache, dizziness, loss of muscular control, apparent drowsiness, and coma. Permanent brain damage or death can result from severe exposure.

Carbon monoxide occurs in the exhaust fumes of fuel burning heaters and internal combustion engines, and becomes dangerously concentrated under conditions of inadequate ventilation. The following precautions must be observed to insure the safety of personnel whenever fuel burning heater(s) or engine of any vehicle is operated for maintenance purposes or tactical use.

Do not operate heater or engine of vehicle in an enclosed area unless it is adequately ventilated.

Do not idle engine for long periods without maintaining adequate ventilation in personnel compartments.

Do not drive any vehicle with inspection plates or cover plates removed unless necessary for maintenance purposes.

Be alert at all times during vehicle operation for exhaust odors and exposure symptoms. If either are present, immediately ventilate personnel compartments. If symptoms persist, remove affected personnel from vehicle and treat as follows: expose to fresh air; keep warm; do not permit physical exercise; if necessary, administer artificial respiration.

If exposed, seek prompt medical attention for possible delayed onset of acute lung congestion. Administer oxygen if available.

The best defense against exhaust gas poisoning is adequate ventilation.

Use extreme care when removing radiator cap, especially when temperature gage shows above 180°F.

Always wear leather gloves when handling winch cable. Never allow cable to slip through hands. Do not operate winch with less than four turns of cable on drum.

Do not drive truck until the low air pressure warning buzzer is silent and the air pressure gage shows at least 65 PSI. This is the minimum pressure required for safe braking action.

Do not use hand throttle to drive the vehicle.

Do not park truck with front transmission gearshift lever in gear.

If your vehicle class number is greater than the bridge class number, do not cross.

This vehicle has been designed to operate safely and efficiently within the limits specified in this TM. Operation beyond these limits is prohibited IAW AR 70-1 without written approval from the Commander, U.S. Army Tank-Automotive Command, ATTN: AMSTA-CM-S, Warren, MI 48397-5000.

**TECHNICAL MANUAL  
NO. TM 9-2320-209-10-1**

**TM 9-2320-209-10-1**

**C2**

**TECHNICAL ORDER  
NO. 36A12-1B-1091-1**

**CHANGE**

**No. 2**

**HEADQUARTERS  
DEPARTMENT OF THE ARMY  
Washington D. C., 30 November 1989**

OPERATION, INSTALLATION AND  
REFERENCE DATA  
OPERATOR LEVEL  
2-1/2 TON, 6X6, M44A1 AND M44A2 SERIES TRUCKS  
(MULTIFUEL)  
TRUCK, CARGO: M35A1,  
M35A2, M35A2C, M36A2; TRUCK,  
TANK, FUEL: M49A1C, M49A2C; TRUCK, TANK,  
WATER M50A1, M50A2, M50A3; TRUCK, VAN,  
SHOP: M109A2, M109A3; TRUCK, REPAIR SHOP:  
M185A2, M185A3; TRUCK, TRACTOR: M275A1,  
M275A2; TRUCK, DUMP: M342A2; TRUCK,  
MAINTENANCE, PIPELINE CONSTRUCTION:  
M756A2; TRUCK, MAINTENANCE,  
EARTH BORING AND POLESETTING: M764

TM 9-2320-209-10-1/TO 36A12-1B-1091-1, dated 26 September 1980, is changed as follows:

1. Change to narrative material is indicated by a vertical bar in the outside margin of the page. Added or revised illustrations are indicated by a vertical bar adjacent to the identification number.
2. Remove old pages and insert new pages as indicated below..
3. File this change sheet in front of the publication for reference purposes.

Remove Pages

2-1 and 2-2  
4-29 and 4-30

Cover and Warning

Insert Pages

2-1 and 2-2  
4-29 and 4-30

Cover and Warning

By Order of the Secretary of the Army

CARL E. VUONO  
*General, United States Army*  
*Chief of Staff*

Official:

WILLIAM J. MEEHAN II  
*Brigadier General, United States Army*  
*The Adjutant General*

Distribution:

To be distributed in accordance with DA Form 12-38-R (Block 201) Operator maintenance requirements for Truck, Gasoline, 2 1/4-ton, 6x6, M44-series.

CHANGE

NO. 1

DEPARTMENTS OF THE ARMY  
AND THE AIR FORCE  
Washington, D.C., 7 July 1988

OPERATION, INSTALLATION AND  
REFERENCE DATA  
OPERATOR LEVEL  
2-1/2 TON, 6X6, M44A1 AND M44A2 SERIES TRUCKS  
(MULTIFUEL)

TRUCK, CARGO: M35A1,  
M35A2, M35A2C, M36A2; TRUCK,  
TANK, FUEL: M49A1C, M49A2C; TRUCK, TANK,  
WATER: M50A1, M50A2, M50A3; TRUCK, VAN,  
SHOP: M109A2, M109A3; TRUCK, REPAIR SHOP:  
M185A2, M185A3; TRUCK, TRACTOR: M275A1,  
M275A2; TRUCK, DUMP: M342A2; TRUCK,  
MAINTENANCE, PIPELINE CONSTRUCTION:  
M756A2; TRUCK, MAINTENANCE,  
EARTH BORING AND POLESETTING: M764

TM 9-2320-209-10-1/TO 36A12-1B-1091-1, 26 September 1980, is changed as follows:

1. Remove old pages and insert new pages as indicated below.
2. New or changed material is indicated by a vertical bar in the margin of the page.

Remove Pages

Insert Page

4-365 and 4-366

4-365 and 4-366

File this change in front of the publication for reference purposes.

By Order of the Secretary of the Army:

CARL E. VUONO  
*General, United States Army*  
*Chief of Staff*

Official:

R. L. DILWORTH  
*Brigadier General, United States Army*  
*The Adjutant General*

Distribution:

To be distributed in accordance with DA Form 12-38, Operator Maintenance requirements for Trucks, Gasoline, 2 1/2-ton, 6X6, M44-Series.

TECHNICAL MANUAL  
NO. 9-2320 -209-10-1  
TECHNICAL ORDER  
NO. 36A12-1B-1091-1

DEPARTMENTS OF THE ARMY  
AND  
THE AIR FORCE  
Washington, DC, 26 September 1980

TECHNICAL MANUAL

OPERATION, INSTALLATION AND REFERENCE DATA  
OPERATOR LEVEL  
2 1/2-TON, 6X6, M44A1 AND M44A2 SERIES TRUCKS  
(MULTIFUEL)

Model		NSN without Winch	NSN with Winch
Truck, Cargo	M35A1	2320-00-542-5633	2320-00-542-5634
	M35A2	2320-00-077-1616	2320-00-077-1617
	M35A2C	2320-00-926-0873	2320-00-926-0875
	M36A2	2320-00-077-1618	2320-00-077-1619
Truck, Tank, Fuel	M49A1C	2320-00-440-3349	2320-00-440-3346
	M49A2C	2320-00-077-1631	2320-00-077-1632
Truck, Tank, Water	M50A1	2320-00-440-8307	2320-00-440-8305
	M50A2	2320-00-077-1633	2320-00-077-1634
	M50A3	2320-00-937-4036	2320-00-937-5264
Truck, Van, Shop	M109A2	2320-00-440-8313	2320-00-440-8308
	M109A3	2320-00-077-1636	2320-00-077-1637
Truck, Repair Shop	M185A2	4940-00-987-8799	4940-00-987-8800
	M185A3	4940-00-077-1638	4940-00-077-1639
Truck, Tractor	M275A1	2320-00-446-2479	
	M275A2	2320-00-077-1640	2320-00-077-1641
Truck, Dump	M342A2	2320-00-077-1643	2320-00-077-1644
Truck, Maintenance, Pipeline Construction	M756A2		2320-00-904-3277
Truck, Maintenance, Earth Boring and Polesetting	M764		2320-00-937-5980

\* This manual, together with TM 9-2320-209-10-2, 26 September 1980; TM 9-2320-209-10-3, 26 September 1980; and TM 9-2320-209-10-4, 26 September 1980, supersedes TM 9-2320-209-10/1, 29 October 1976.

## REPORTING OF ERRORS AND RECOMMENDING IMPROVEMENTS

You can help improve this manual. If you find any mistakes or if you know of a way to improve the procedure, please let us know. Mail your letter, DA Form 2028 (Recommended Changes to Publication and Blank Forms) , or DA Form 2028-2 located in the back of this manual direct to: Commander, U.S. Army Tank Automotive Materiel Readiness Command, ATTN : DRSTA-MBA, Warren, Michigan 48090. A reply will be furnished to you.

	Paragraph	Page
CHAPTER 1. INTRODUCTION		
Scope . . . . .	1-1	1-1
Forms and Records . . . . .	1-2	1-1
Equipment Improvement Report and Maintenance Digest (EIR MD) and Equipment Improvement Report and Maintenance Summary (EIR MS) . . . . .	1-3	1-1
Reporting Improvement Recommendations . . . . .	1-4	1-1
Metric System . . . . .	1-5	1-1
Destruction to Prevent Enemy Use . . . . .	1-6	1-1
Manual Organization . . . . .	1-7	1-6
Vehicle /Bridge Classification . . . . .	1-8	1-6
CHAPTER 2. DESCRIPTION AND DATA		
Section I. Functional Description		2-1
General . . . . .	2-1	2-1
Overall Equipment Functional Description . . . . .	2-2	2-1
Engine . . . . .	2-2a	2-1
Clutch . . . . .	2-2b	2-1
Electrical System . . . . .	2-2c	2-1
Fuel System . . . . .	2-2d	2-1
Cooling System. . . . .	2-2e	2-1
Exhaust System . . . . .	2-2f	2-1
Transmission System . . . . .	2-2g	2-1
Transfer System . . . . .	2-2h	2-1
Transmission Power Takeoff System . . . . .	2-2i	2-1
Transfer Power Takeoff System . . . . .	2-2j	2-1
Propeller Shafts . . . . .	2-2k	2-1
Steering System . . . . .	2-2l	2-2
Brake System . . . . .	2-2m	2-2
Axle, Wheels and Hubs . . . . .	2-2n	2-2
Auxiliary Equipment and Accessories . . . . .	2-2o	2-2
Section II. Physical Description . . . . .		2-2
General . . . . .	2-3	2-2
Overall Equipment Physical Description . . . . .	2-4	2-2
Engine . . . . .	2-4a	2-2
Clutch. . . . .	2-4b	2-5
Electrical System . . . . .	2-4c	2-6
Fuel and Air Intake System . . . . .	2-4d	2-7



	Paragraph	Page
	Cooling System . . . . .	2-4e 2-8
	Exhaust System . . . . .	2-4f 2-9
	Transmission . . . . .	2-4g 2-14
	Transmission Power Takeoff . . . . .	2-4h 2-14
	Transfer . . . . .	2-4i 2-14
	Transfer Power Takeoff . . . . .	2-4j 2-14
	Propeller and Drive Shaft Systems . . . . .	2-4k 2-15
	Steering System . . . . .	2-4l 2-18
	Brake System . . . . .	2-4m 2-19
	Axles, Wheels, and Hubs . . . . .	2-4n 2-20
Section III.	Tabulated Data . . . . .	2-21
	General . . . . .	2-5 2-21
	Weight . . . . .	2-6 2-21
	Dimensions: . . . . .	2-7 2-21
	Capacities . . . . .	2-8 2-21
	Tire Inflation Data . . . . .	2-9 2-21
	Environmental Characteristics . . . . .	2-10 2-21
	Functional Characteristics . . . . .	2-11 2-21
	Components of End Item List . . . . .	2-12 2-21
	Additional Authorization List . . . . .	2-13 2-21
	Expendable Supplies and Materials List . . . . .	2-14 2-21
CHAPTER 3.	SERVICE UPON RECEIPT OF EQUIPMENT	
	General . . . . .	3-1 3-1
	Break-in Operation . . . . .	3-2 3-1
	General . . . . .	3-2a 3-1
	Break-in . . . . .	3-2b 3-1
	Road Test . . . . .	3-2c 3-2
	After the Road Test . . . . .	3-2d 3-2
CHAPTER 4.	OPERATING PROCEDURES . . . . .	
Section I.	Description and Use of Operator's Controls and Indicators . . . . .	4-1
	General . . . . .	4-1 4-1
	Chassis Controls and Indicators . . . . .	4-2 4-2
	Instrument Panel Controls and Indicators . . . . .	4-2a 4-2
	Windshield Controls and Indicators . . . . .	4-2b 4-4
	Driver's Compartment Controls and Indicators . . . . .	4-2c 4-5
	Front Winch Controls and Indicators . . . . .	4-2d 4-9
	Trailer Brake Controls and Indicators . . . . .	4-2e 4-10
	Equipment Body Controls and Indicators . . . . .	4-3 4-11
	Fuel Tank Trucks (M49A1C and M49A2C) Controls and Indicators . . . . .	4-3a 4-11
	Water Tank Trucks Controls and Indicators . . . . .	4-3b 4-13
	Shop Van and Instrument Repair Shop Trucks Controls and Indicators . . . . .	4-3c 4-15

	Paragraph	Page
Tractor Trucks Controls and Indicators . . . . .	4-3d	4-17
Dump Truck Controls and Indicators . . . . .	4-3e	4-18
Pipeline Construction Truck Controls and Indicators . . . . .	4-3f	4-19
Earth Boring Machine and Polesetter Truck Controls and Indicators . . . . .	4-3g	4-20
Special Kits Controls and Indicators . . . . .	4-4	4-23
Hot Water Personnel Heater Kit Controls and Indicators . . . . .	4-4a	4-23
Arctic Winterization Kit Controls and Indicators . . . . .	4-4b	4-24
Deep Water Fording Kit Controls and Indicators . . . . .	4-4c	4-27
Electric Brake Kit Controls and Indicators . . . . .	4-4d	4-28
Section II. Operation Under Usual Conditions . . . . .		4-29
Scope . . . . .	4-5	4-29
General Operating Procedures . . . . .	4-6	4-29
Before Engine Startup . . . . .	4-6a	4-30
Starting the Engine Above +20°F . . . . .	4-6b	4-37
Cold Weather Starting Below +20°F . . . . .	4-6c	4-41
Placing and Keeping the Truck in Motion. . . . .	4-6d	4-43
Stopping the Truck and Engine . . . . .	4-6e	4-55
Operation of Front Winch . . . . .	4-7	4-58
General . . . . .	4-7a	4-58
Before Operating . . . . .	4-7b	4-58
Unwinding the Winch Line . . . . .	4-7c	4-59
Lifting or Pulling . . . . .	4-7d	4-65
Stopping the Winch . . . . .	4-7e	4-69
Lowering Load or Unwinding Slack Cable. . . . .	4-7f	4-70
Winding the Winch Line on the Drum . . . . .	4-7g	4-72
Locking the Front Winch for Travel . . . . .	4-7h	4-75
Operation of Cargo Trucks . . . . .	4-8	4-77
General . . . . .	4-8a	4-77
Removing the Front and Side Racks . . . . .	4-8b	4-77
Installing the Front and Side Racks . . . . .	4-8c	4-80
Removing the Front and Side Racks from Dropside Type Cargo Trucks . . . . .	4-8d	4-83
Lowering the Dropsides on Dropside Type Cargo Trucks . . . . .	4-8e	4-88
Removing the Dropsides, Tailgate or Both. . . . .	4-8f	4-93
Installing the Dropsides, Tailgate, Side Racks and Front Racks . . . . .	4-8g	4-95
Operation of Fuel Tank Trucks . . . . .	4-9	4-98
General . . . . .	4-9a	4-98
Gravity Filling the Tank Sections . . . . .	4-9b	4-98
Suction Filling the Tank Sections or Trans- ferring Fuel from One Source to Another through Pump . . . . .	4-9c	4-110

	Paragraph	Page
Power Discharging the Tank Sections . . . . .	4-9d	4-131
Checking Condition of Filter . . . . .	4-9e	4-139
Gravity Discharging the Tank Sections . . . . .	4-9f	4-143
Fording . . . . .	4-9g	4-151
Operation of Water Tank Trucks . . . . .	4-10	4-156
General . . . . .	4-10a	4-156
Gravity Filling the Tank Sections . . . . .	4-10b	4-157
Suction Filling the Tank Sections and Transferring Water from One Location to Another . . . . .	4-10c	4-161
Hydrant Filling the Tank Sections . . . . .	4-10d	4-175
Power Discharging the Tank Sections . . . . .	4-10e	4-186
Gravity Discharging the Tank Sections . . . . .	4-10f	4-192
Operating Water Tank Trucks During Freezing Temperatures . . . . .	4-10g	4-195
Operation of Shop Van and Instrument Repair Shop Van Trucks. . . . .	4-11	4-202
Preparing Shop Van and Instrument Repair Shop Van for Use. . . . .	4-11a	4-202
Supplying 115-Volt AC Power to Shop Van . . . . .	4-11b	4-209
Operating the Exhaust Blower . . . . .	4-11c	4-210
Operating the Dome and Blackout Dome Lights . . . . .	4-11d	4-212
Supplying Power to Moulding Receptacles . . . . .	4-11e	4-216
Operation of Tractor Trucks . . . . .	4-12	4-217
General . . . . .	4-12a	4-217
Coupling the Semitrailer . . . . .	4-12b	4-217
Uncoupling the Semitrailer . . . . .	4-12c	4-231
Operation of Dump Trucks . . . . .	4-13	4-235
General . . . . .	4-13a	4-235
Rigging the Tailgate . . . . .	4-13b	4-236
Loading the Dump Truck . . . . .	4-13c	4-238
Unloading the Dump Truck with Body Down . . . . .	4-13d	4-244
Unloading the Dump Truck by Dumping . . . . .	4-13e	4-247
Unloading the Dump Truck by Spreading . . . . .	4-13f	4-252
Operation of Pipeline Construction Truck . . . . .	4-14	4-257
General . . . . .	4-14a	4-257
Operating the Rear Winch . . . . .	4-14b	4-257
Rigging the A-Frame for Rear Operation . . . . .	4-14c	4-271
Lowering the A-Frame and Preparing . . . . . Truck for Travel after Rear Operation . . . . .	4-14d	4-278
Rigging the A-Frame for Side Operation . . . . .	4-14e	4-291
Lowering the A-Frame and Preparing Truck for Travel after Side Operation . . . . .	4-14f	4-302
Operation of Earth Boring Machine and Polesetter Trucks . . . . .	4-15	4-311
General . . . . .	4-15a	4-311
Preparing the Truck for Boring Operation . . . . .	4-15b	4-311

	Paragraph	
Raising, Leveling, and Lowering the Derrick Tube . . . . .	4-15c	4-315
Operating and Securing the Rear Winch... . . . .	4-15d	4-322
Installing 9-inch, 12-inch, and 16-inch Augers . . . . .	4-15e	4-329
Installing 20-inch and 30-inch Augers . . . . .	4-15f	4-331
Operating the Earth Boring Machine. . . . .	4-15g	4-337
Boring in Various Soils . . . . .	4-15h	4-347
Preparing Boring Machine for Travel . . . . .	4-15i	4-352
Dragging Poles. . . . .	4-15j	4-362
Setting Poles. . . . .	4-15k	4-365
Pulling Poles. . . . .	4-15l	4-369
Operating Collapsible Cable Reel . . . . .	4-15m	4-373
Operation of Hot Water Personnel Heater Kit. . . . .	4-16	4-383
Operation of Arctic Winterization Kit . . . . .	4-17	4-384
General . . . . .	4-17a	4-384
Operating the Winterfront Cover . . . . .	4-17b	4-384
Using the Quilted Engine Compartment Cover . . . . .	4-17c	4-385
Operating the Fuel Burning Personnel Heater . . . . .	4-17d	4-386
Operating the Fuel Burning Power Plant Heater . . . . .	4-17e	4-391
Using the Slave Receptacle . . . . .	4-17f	4-395
Operating the Deep Water Fording Kit . . . . .	4-18	4-398
Operating the Electric Brake Kit . . . . .	4-19	4-403
Section III. Operation Under Unusual Conditions . . . . .		4-404
Scope . . . . .	4-20	4-404
General . . . . .	4-21	4-404
Operation in Extremely Cold Weather . . . . .	4-22	4-404
General . . . . .	4-22a	4-404
Related Publications . . . . .	4-22b	4-404
Winterization Kits . . . . .	4-22c	4-404
Moving the Truck . . . . .	4-22d	4-405
Parking . . . . .	4-22e	4-406
Refueling . . . . .	4-22f	4-407
Operation in Extreme Hot Weather . . . . .	4-23	4-408
General . . . . .	4-23a	4-408
Cooling System . . . . .	4-23b	4-408
Batteries . . . . .	4-23c	4-408
Body and Chassis . . . . .	4-23d	4-408
Parking the Truck . . . . .	4-23e	4-409
Operation on Unusual Terrain . . . . .	4-24	4-409
Deep Snow or Mud . . . . .	4-24a	4-409
Hard Baked Sand. . . . .	4-24b	4-409
Ice . . . . .	4-24c	4-409
Dusty or Sandy Roads . . . . .	4-24d	4-410
Rocks and Boulders . . . . .	4-24e	4-410
High Altitudes . . . . .	4-24f	4-410

	Paragraph	Page
Fording Operation . . . . .	4-25	4-410
General . . . . .	4-25a	4-410
Fording . . . . .	4-25b	4-411
Fording, Water Tank Trucks . . . . .	4-25c	4-413
After Fording . . . . .	4-25d	4-417
Care of Vehicle After Fording . . . . .	4-25e	4-418
Accidental Submersion. . . . .	4-25f	4-418
Emergency Procedures . . . . .	4-26	4-419
Using Slave Receptacle to Start the Engine . . . . .	4-26a	4-419
Using Jumper Cables to Start the Engine . . . . .	4-26b	4-419
Towing the Truck to Start Engine . . . . .	4-26c	4-423
Highway Towing (M44A2 Series Trucks) . . . . .	4-26d	4-426
Highway Towing (M44A1 Series Trucks) . . . . .	4-26e	4-428
 APPENDIX A. REFERENCES		
Publication Indexes and General Reference . . . . .	A-1	A-1
Military Publications Indexes . . . . .	A-1a	A-1
General Reference . . . . .	A-1b	A-1
Forms . . . . .	A-2	A-1
Other Publications . . . . .	A-3	A-1
Truck . . . . .	A-3a	A-1
General . . . . .	A-3b	A-2
 APPENDIX B . COMPONENTS OF END ITEM LIST		
Section I . Introduction . . . . .		B-1
Scope . . . . .	B-1	B-1
General . . . . .	B-2	B-1
Explanation of Columns . . . . .	B-3	B-1
Abbreviations . . . . .	B-4	B-3
Section II. Integral Components of the End Item . . . . .		B-4
Section III. Basic Issue Items . . . . .		B-6
 APPENDIX C . ADDITIONAL AUTHORIZATION LIST		
Section 1. Introduction . . . . .		
Scope . . . . .	C-1	C-1
General . . . . .	C-2	C-1
Explanation of Listing . . . . .	C-3	C-1
Section II. Additional Authorization List . . . . .		C-3
 APPENDIX D. EXPENDABLE SUPPLIES AND MATERIALS LIST.		
Section 1. Introduction . . . . .		D-1
Scope . . . . .	D-1	D-1
Explanation of Columns . . . . .	D-2	D-1
Section II. Expendable Supplies and Materials List. . . . .		D-2
 <b>INDEX</b> . . . . .		 Index 1

VOLUME 2 of 4

SCHEDULED MAINTENANCE

	Page
CHAPTER 1.	PREVENTIVE MAINTENANCE . . . . . 1-1
2.	CHECKOUT , ALINEMENT , AND ADJUSTMENT . . . . . 2-1
3.	LUBRICATION . . . . . 3-1
4.	SCHEDULED MAINTENANCE OF MATERIAL USED IN CONJUNCTION WITH MAJOR ITEMS . . . . . 4-1

VOLUME 3 of 4

TROUBLESHOOTING

CHAPTER 1.	GENERAL INFORMATION . . . . . 1-1
2.	TROUBLESHOOTING APPROACH . . . . . 2-1
3.	TROUBLESHOOTING INDEX . . . . . 3-1
4.	TEST EQUIPMENT PROCEDURES INDEX . . . . . 4-1
5.	TROUBLESHOOTING ROADMAPS . . . . . 5-1
6.	FAULT SYMPTOM INDEXES . . . . . 6-1
7.	SAMPLE TROUBLESHOOTING PROCEDURE . . . . . 7-1
8.	FUEL SYSTEM TROUBLESHOOTING PROCEDURES . . . . . 8-1
9.	COOLING SYSTEM TROUBLESHOOTING PROCEDURE . . . . . 9-1
10.	TRANSMISSION SYSTEM TROUBLESHOOTING PROCEDURES . . . . . 10-1
11.	TRANSFER SYSTEM TROUBLESHOOTING PROCEDURES . . . . . ...11-1
12.	FRONT AXLE SYSTEM TROUBLESHOOTING PROCEDURES . . . . . 12-1
13.	REAR AXLE SYSTEM TROUBLESHOOTING PROCEDURES . . . . . ...13-1
14.	BRAKE SYSTEM TROUBLESHOOTING PROCEDURES . . . . . 14-1
15.	WHEEL SYSTEM TROUBLESHOOTING PROCEDURES . . . . . 15-1
16.	STEERING SYSTEM TROUBLESHOOTING PROCEDURES . . . . . 16-1
17.	OUTRIGGER TROUBLESHOOTING PROCEDURES, TRUCK M764 . . . . . ...17-1
18.	FRONT WINCH TROUBLESHOOTING PROCEDURES . . . . . 18-1
19.	REAR WINCH TROUBLESHOOTING PROCEDURES TRUCK M764 . . . . . ...19-1
20.	REAR WINCH TROUBLESHOOTING PROCEDURES, TRUCK M756A2 . . . . . ...20-1
21.	DUMP TRUCK TROUBLESHOOTING PROCEDURES . . . . . 21-1

VOLUME 4 of 4

MAINTENANCE

		Page
CHAPTER 1.	GENERAL MAINTENANCE INFORMATION. . . . .	1-1
2.	EQUIPMENT GROUP MAINTENANCE. . . . .	2-1
Section I.	Scope . . . . .	2-1
II.	Engine Equipment Items Maintenance . . . . .	2-2
III.	Wheels Equipment Items Maintenance . . . . .	2-14
IV.	Electrical Equipment Items Maintenance . . . . .	2-32
V.	Winch Equipment Items Maintenance. . . . .	2-35
VI.	Body Equipment Items Maintenance . . . . .	2-43
VII.	Special Purpose Kits Equipment Items . . . . .	
	Maintenance . . . . .	2-54

**LIST OF ILLUSTRATIONS**

Figure	Title	Page
1-1	Typical 2 1/2-Ton 6 x 6 Cargo Truck, M35A1, M35A2, M35A2C , M36A2) . . . . .	1-2
1-2	Typical 2 1/2-Ton 6 x 6 Fuel Servicing Tank Truck (M49A1C , M49A2C) . . . . .	1-2
1-3	Typical 2 1/2-Ton 6 x 6 Water Tank Truck (M50A1, M50A2, M50A3) . . . . .	1-3
1-4	Typical 2 1/2-Ton 6 x 6 Truck Mounted Instrument Repair Shop (M185A2, M185A3) or Truck Mounted Van (M109A2, M109A3) . . . . .	1-3
1-5	Typical 2 1/2-Ton 6 x 6 Tractor Truck, (M275A1, M275A2). . . . .	1-4
1-6	Typical 2 1/2-Ton 6 x 6 Dump Truck (M342A2) . . . . .	1-4
1-7	Typical 2 1/2-Ton 6 x 6 Pipeline Construction Truck (M756A2) . . . . .	1-5
1-8	Typical 2 1/2-Ton 6 x 6 Earth Boring Machine and Polesetter Truck (M764) . . . . .	1-5
2-1	Overall Equipment Block Diagram . . . . .	2-3
2-2	Engine Components Location . . . . .	2-4
2-3	Clutch Components Location . . . . .	2-5
2-4	Electrical System Component Location . . . . .	2-6
2-5	Fuel and Air Intake System Components Location . . . . .	2-7

Figure	Title	Page
2-6	Cooling System Components Location . . . . .	2-8
2-7	Exhaust System Component Location (LDS 427-2 Engines). . . .	2-9
2-8	Exhaust System Component Location (M50A1 and M50A2 Trucks) . . . . .	2-10
2-9	Exhaust System Component Location (LD 465-1-IC Engine). . .	2-11
2-10	Exhaust System , Stack Type, Components Location (LD 465-1C and LDT 465-1C Engines) . . . . .	2-12
2-11	Exhaust System Component Location (M49A 2C Fuel Tankers and M275 Tractor Trucks) . . . . .	2-13
2-12	Transmission Power Takeoff Systems Component Location . . . . .	2-14
2-13	Propeller and Drive Shafts System Component Location (Trucks with Winch except M49, M50, and M764). . . . .	2-15
2-14	Propeller and Drive Shafts System Component Location (M49, M50) . . . . .	2-16
2-15	Propeller and Drive Shafts System Component Location (M764) . . . . .	2-17
2-16	Steering System Component Location . . . . .	2-18
2-17	Brake System Component Location . . . . .	2-19
2-18	Axles, Wheels, and Hubs System Component Location . . . . .	2-20
B-1	Repair Shop Truck (M185A2, M185A3) Tools and Equipment . . . . .	B-4
B-2	Miscellaneous Tools and Equipment ( Sheet 1 of 2) . . . . .	B-6
B-2	Miscellaneous Tools and Equipment (Sheet 2 of 2) . . . . .	B-8
B-3	Fuel Truck (M49A1C , M49A2C) Tools and Equipment. . . . .	B-10
B-4	Water Truck (M50A1, M50A2, M50A3) Tools and Equipment (Sheet 1 of 2) . . . . .	B-12
B-4	Water Truck (M50A1, M50A2, M50A3) Tools and Equipment (Sheet 2 of 2) . . . . .	B-14
B-5	Shop Van (M185A2, M185A3) Tools and Equipment (Sheet 1 of 4) . . . . .	B-16
B-5	Shop Van (M185A2, M185A3) Tools and Equipment (Sheet 2 of 4) . . . . .	B-18
B-5	Shop Van (M185A2, M185A3) Tools and Equipment (Sheet 3 of 4) . . . . .	B-20
B-5	Shop Van (M185A2, M185A3) Tools and Equipment (Sheet 4 of 4) . . . . .	B-22
B-6	Pipeline Construction Truck (M765A 2) Tools and Equipment (Sheet 1 of 2) . . . . .	B-24
B-6	Pipeline Construction Truck ( M756A 2) Tools and Equipment (Sheet 20 of 2) . . . . .	B-26
B-7	Earth Boring and Polesetting Truck (M764) Tools and Equipment ( Sheet 1 of 3) . . . . .	B-28



Figure	Title	Page
B-7	Earth Boring and Polesetting Truck (M764) Tools and Equipment (Sheet 2 of 3) . . . . .	B-30
B-7	Earth Boring and Polesetting Truck (M764) Tools and Equipment (Sheet 3 of 3) . . . . .	B-32
B-8	Pipeline Construction Truck (M 756A 2) and Earth Boring and Polesetting Truck (M764) Tools and Equipment . . . . .	B-34

### LIST OF TABLES

Number	Title	Page
1-1	Vehicle Class Information . . . . .	1-6
2-1	Weight (Pounds) . . . . .	2-22
2-2	Dimensions (Inches) . . . . .	2-22
2-3	Operating Dimensions . . . . .	2-23
2-4	Capacities . . . . .	2-23
2-5	Tire Inflation Data . . . . .	2-24
2-6	Permissible Fuels . . . . .	2-24
2-7	Shifting Speeds in Mph . . . . .	2-26
2-8	Engine and Radiator Data . . . . .	2-26
4-1	Vehicle Lights Chart . . . . .	4-45
4-2	Weight of Material in Truck . . . . .	4-235
4-3	Boring Machine Controls . . . . .	4-339
4-4	Gear Speed Settings for Soil Conditions . . . . .	4-341



# CHAPTER 1

## INTRODUCTION

---

1-1. **SCOPE.** This Technical Manual contains operating instructions for the 2 1/2-ton, 6x6 M44A1 and M44A2 series trucks (figures 1-1 through 1-8) equipped with multifuel engines, and operator level maintenance instructions in accordance with the Maintenance Allocation Chart. Operating instructions for special purpose kits used with these trucks are also included. The purpose of this manual is to give the operator the information he needs for safe, trouble-free operation of the equipment under usual and unusual conditions.

1-2. **FORMS AND RECORDS.** Maintenance forms, records, and reports which are to be used by maintenance personnel at all levels are listed in and prescribed by TM 38-750.

1-3. **EQUIPMENT IMPROVEMENT REPORT AND MAINTENANCE DIGEST (EIR MD) AND EQUIPMENT IMPROVEMENT REPORT AND MAINTENANCE E SUMMARY (EIR MS).** The quarterly Equipment Improvement Report and Maintenance Digest, TB 43-0001-39 series, contains valuable field information on the equipment covered in this manual. The information in the TB 43-0001-39 series is compiled from some of the Equipment Improvement Reports that you prepared on the vehicles covered in this manual. Many of these articles result from comments, suggestions, and improvement recommendations that you submitted to the EIR program. The TB 43-0001-39 series contains information on equipment improvements, minor alterations, proposed Modification Work Orders (MWO's), warranties (if applicable), actions taken on some of your DA Form 2028's (Recommended Changes to Publications), and advance information on proposed changes that may affect this manual. In addition, the more maintenance significant articles, including minor alterations, field-fixes, etc, that have a more permanent and continuing need in the field are republished in the Equipment Improvement Report and Maintenance Summary (EIR MS) for TARCOM Equipment (TM 43-0143). Refer to both of these publications (TB 43-0001-39 series and TM 43-0143) periodically, especially the TB 43-0001-39 series, for the most current and authoritative information on your equipment. The information will help you in doing your job better and will help in keeping you advised of the latest changes to this manual. Also refer to DA Pam 310-4, Index of Technical Publications, and Appendix A, References, of this manual.

1-4. **REPORTING IMPROVEMENT RECOMMENDATIONS.** If your truck needs improvement, let us know. Send us an EIR. YOU, the user, are the only one who can tell us what you don't like about your equipment. Let us know why you don't like the design. Tell us why a procedure is hard to perform. Put it on an SF 368 (Quality Deficiency Report). Mail it to us at: Commander, U. S. Army Tank Automotive Materiel Readiness Command, ATTN: DRSTA-MT, Warren, Michigan 48090. We'll send you a reply.

1-5. **METRIC SYSTEM.** The equipment/system described herein is nonmetric and does not require metric common or special tools. Therefore, metric units are not supplied. Tactical instructions, for sake of clarity, will also remain nonmetric.

1-6. **DESTRUCTION TO PREVENT ENEMY USE.** Follow procedures given in TM 750-244-6 for destruction of Army materiel to prevent enemy use.

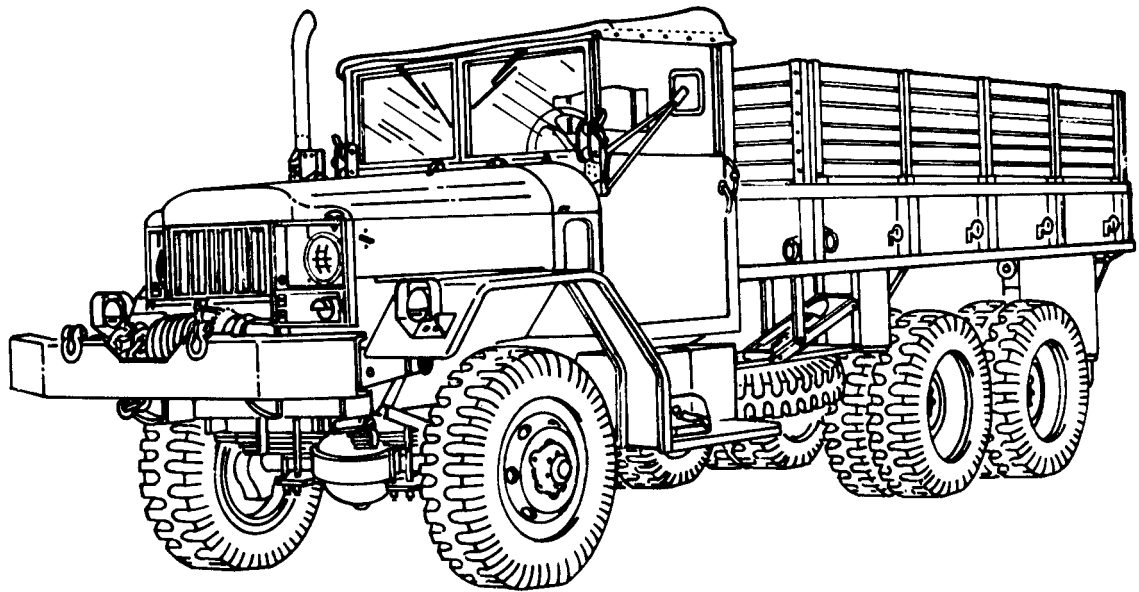

TA 044886

Figure 1-1. Typical 2 1/2-Ton 6x6 Cargo Truck (M35A1, M35A2, M35A2C, M36A2) .

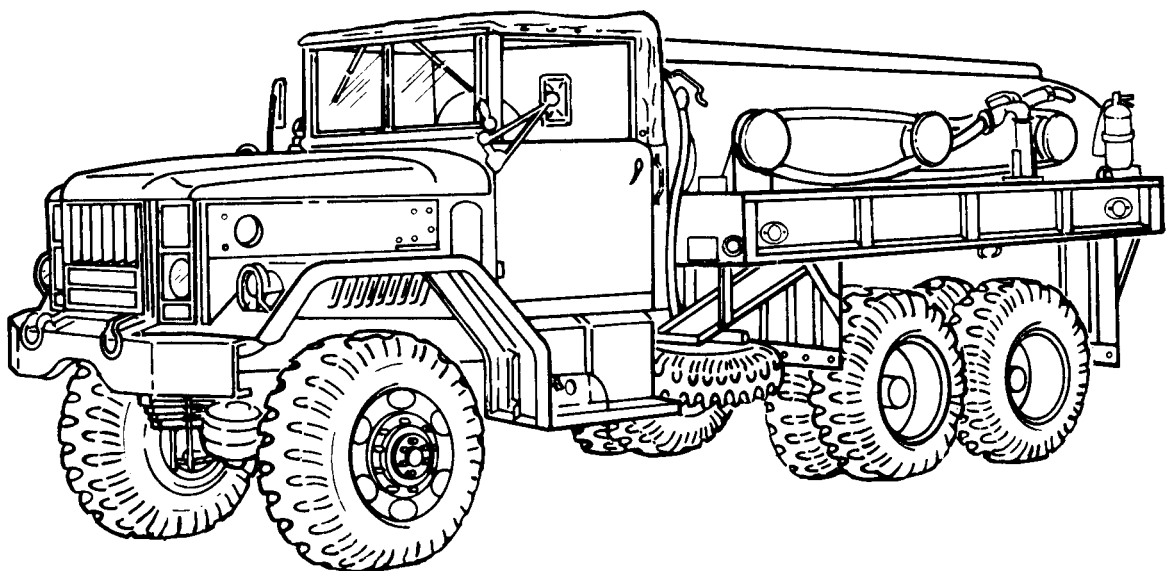

TA 044887

Figure 1-2. Typical 2 1/2-Ton 6x6 Fuel Servicing Tank Truck (M49A1C, M49A2C).

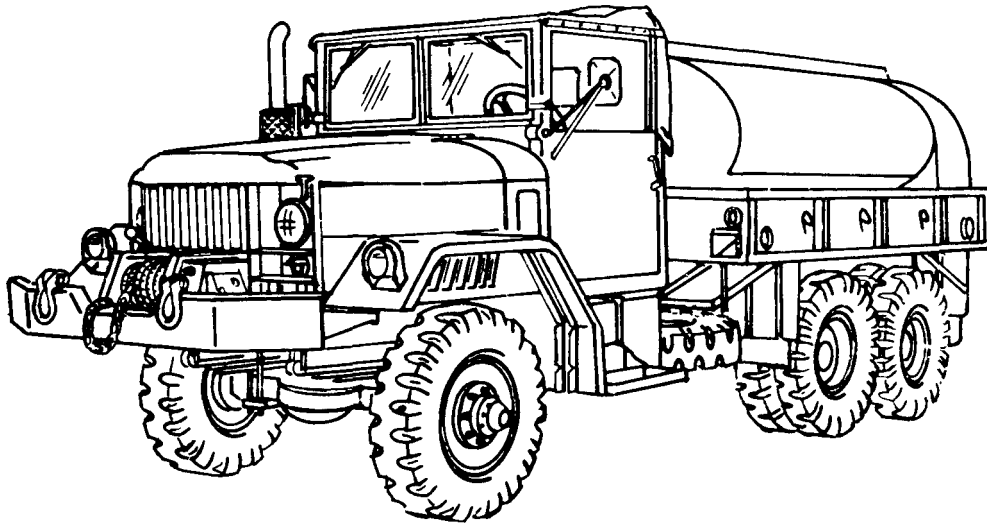

TA 044888

Figure 1-3. Typical 2 1/2-Ton 6x6 Water Tank Truck (M50A1, M50A2, M50A3).

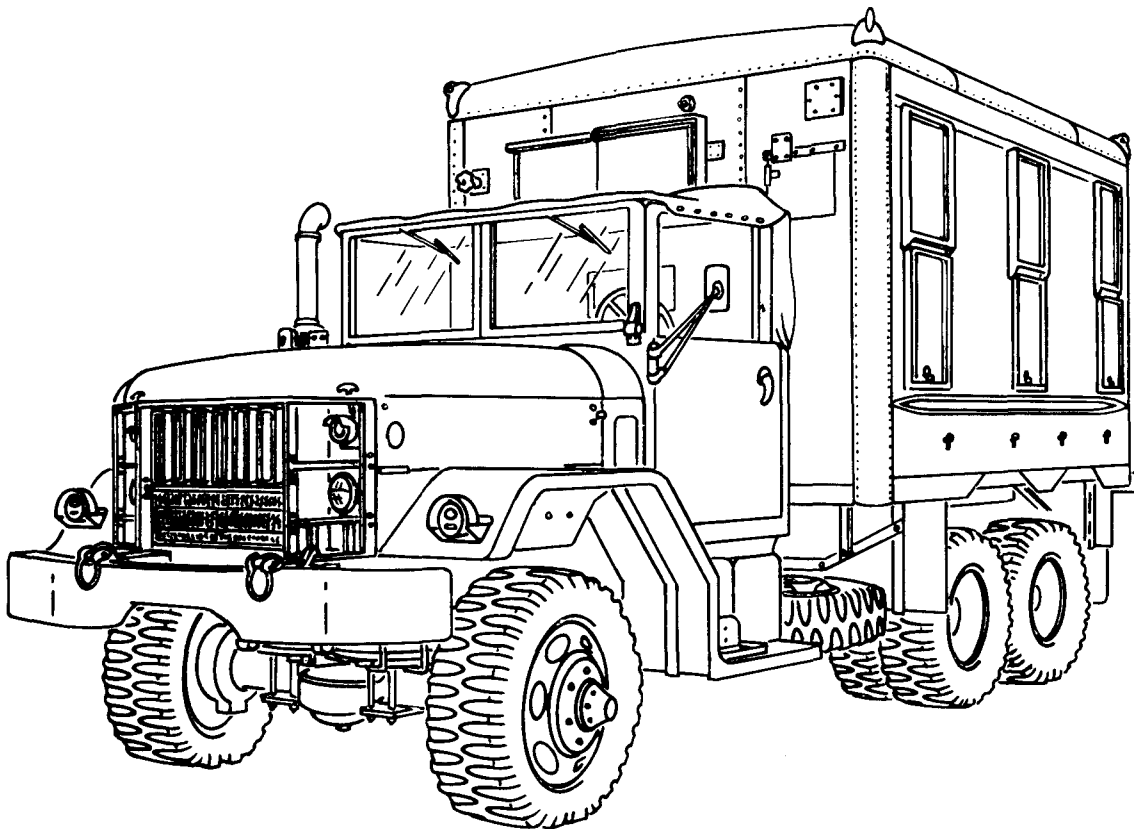

TA 044889

Figure 1-4, Typical 2 1/2-Ton 6x6 Truck Mounted Instrument Repair Shop (M185A2, M185A3) or Truck Mounted Van (M109A2, M109A3).

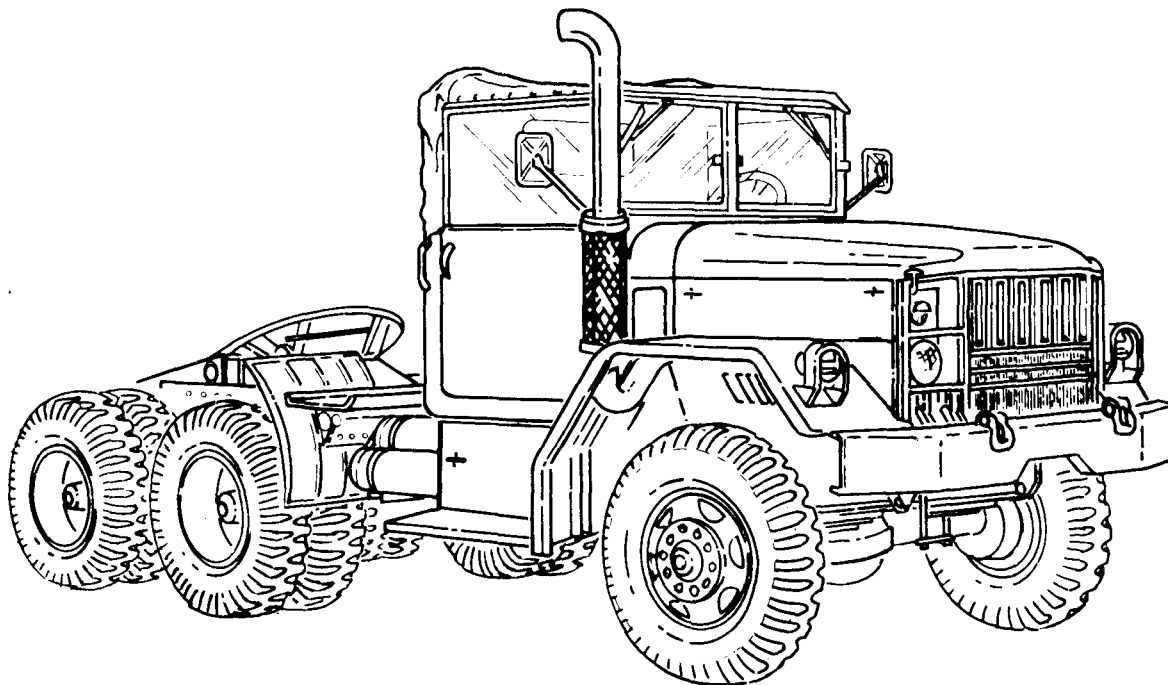

TA 044890

Figure 1-5. Typical 2 1/2-Ton 6x6 Tractor Truck (M275A1, M275A2) .

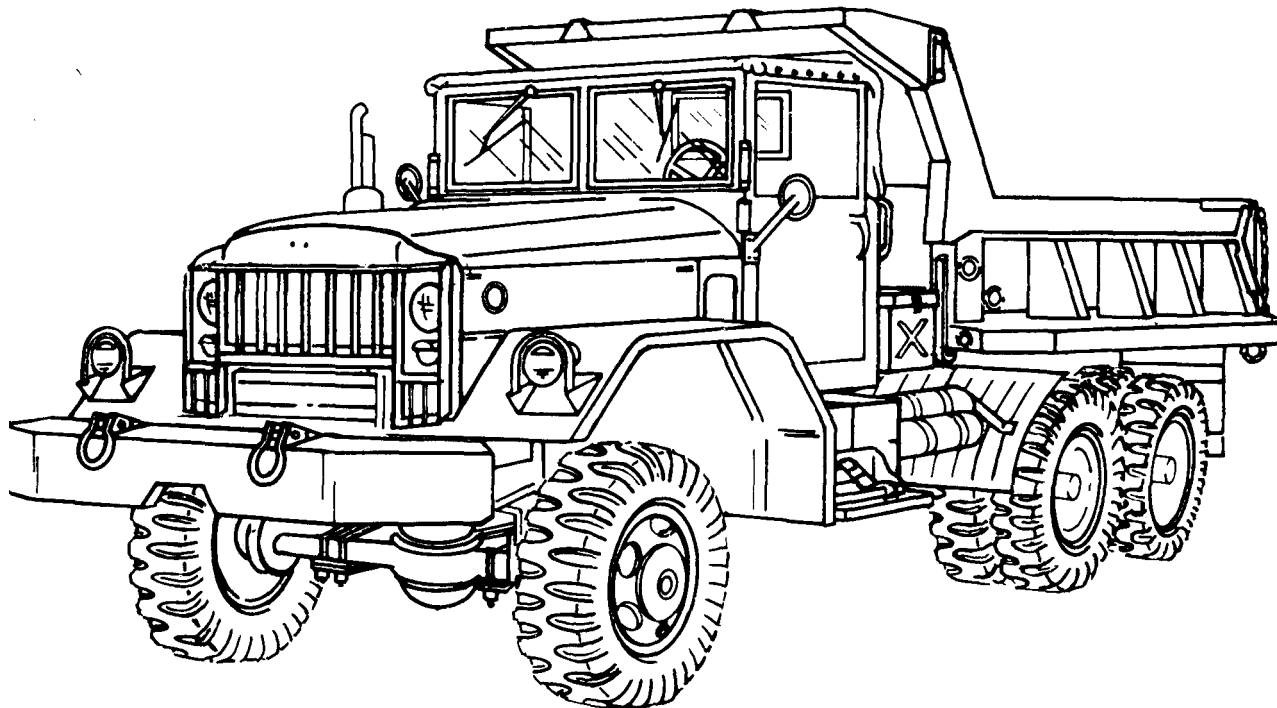

TA 044891

Figure 1-6. Typical 2 1/2-Ton 6x6 Dump Truck (M342A2).

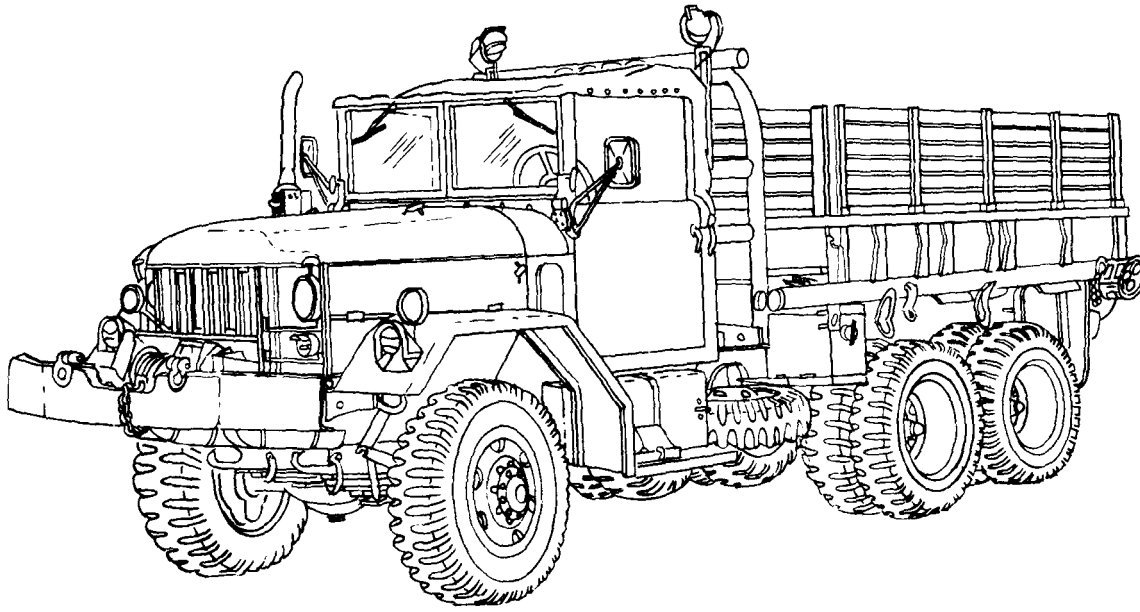

TA 044892

Figure 1-7. Typical 2 1/2-Ton 6x6 Pipeline Construction Truck (M756A2).

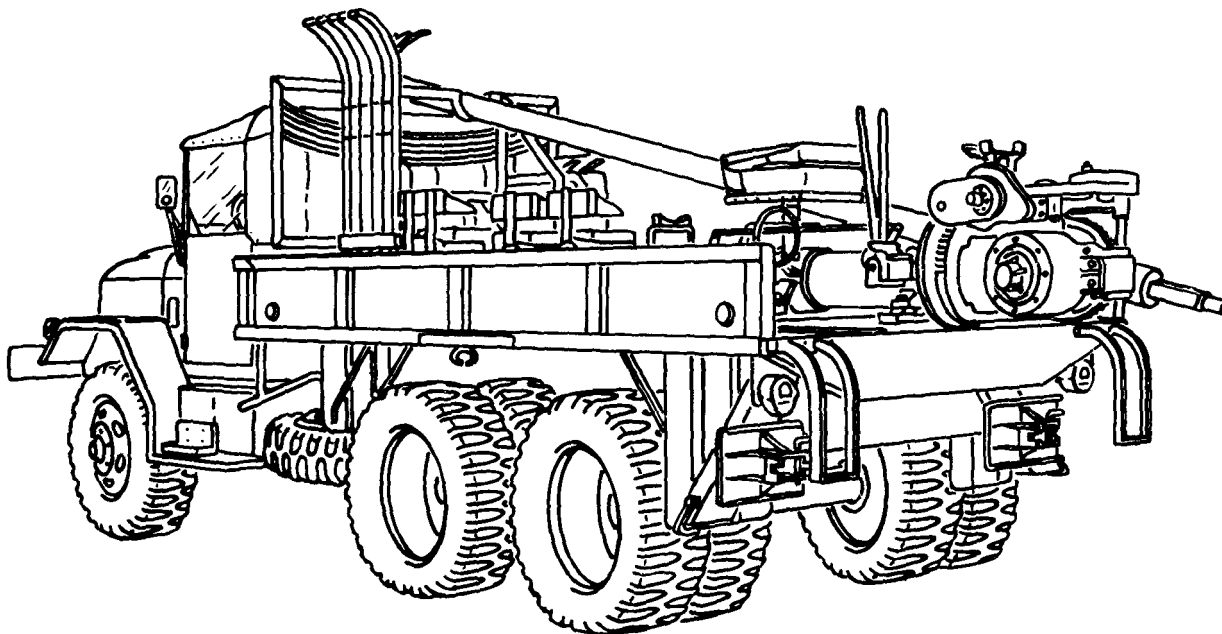

TA 044893

Figure 1-8. Typical 2 1/2-Ton 6x6 Earth Boring Machine and Polesetter Truck (M764)

1-7. **MANUAL ORGANIZATION.** This manual is divided into four volumes. Volumes are divided into chapters and sections depending on the amount of subject material. The content of each volume is as follows:

Volume 1. TM 9-2320-209-10-1, Operation, Installation, and Reference Data.

Volume 2. TM 9-2320-209-10-2, Scheduled Maintenance.

Volume 3. TM 9-2320-209-10-3, Troubleshooting.

Volume 4. TM 9-2320-209-10-4, Maintenance.

1-8. **VEHICLE /BRIDGE CLASSIFICATION.** Refer to table 1-1 and find your vehicle class number. Table columns are marked as follows:

E - Class number of vehicle with no payload.

C - Class number of vehicle with cross-country payload.

H - Class number of vehicle with highway payload.

a. Bridges along your route may be marked with a class number. The bridge class number shows the safe capacity of the bridge. If your vehicle class number is equal to or less than the bridge class number, the bridge will hold your vehicle. If your vehicle class number is greater than the bridge class number, your vehicle is too heavy for the bridge; **DO NOT CROSS.**

b. For more information refer to FM 5-36.

Table 1-1. Vehicle Class Information

Vehicle	Model	NSN	Class Number		
			E	C	H
Cargo	M35A1	2320-00-542-5633 and	5	8	10
		2320-00-542-5634	5	8	10
	M35A2	2320-00-077-1616 and	6	8	11
		2320-00-077-1617	6	8	11
M35A2C	2320-00-926-0873 and	6	8	10	
	2320-00-926-0875	6	8	11	
	M36A2	2320-00-077-1618 and	6	8	11
		2320-00-077-1619	6	9	11
Fuel Tank	M49A1C	2320-00-440-3349 and	6	8	11
		2320-00-440-3346	7	9	11
	M49A2C	2320-00-077-1631 and	6	8	11
		2320-00-077-1632	6	9	11
Water Tank	M50A1	2320-00-440-8307 and	7	9	11
		2320-00-440-8305	7	9	11



Table 1-1. Vehicle Class Information - Cont

Vehicle	Model	NSN	Class Number		
			E	C	H
Water Tank - Cont	M50A2	2320-00-077-1633 and	7	9	11
		2320-00-077-1634	7	9	11
	M50A3	2320-00-037-4036 and	6	8	10
		2320-00-937-5264	6	8	10
Shop Van	M109A2	2320-00-440-8313 and	7	9	10
		2320-00-440-8308	7	9	10
	M109A3	2320-00-077-1636 and	7	9	10
		2320-00-077-1637	7	9	10
Repair Shop	M185A2	4940-00-987-8799 and	7	10	10
		4940-00-987-8800	*	*	*
	M185A3	4940-00-077-1638 and	7	10	11
		4940-00-077-1639	8	10	11
Tractor	M275A1	2320-00-446-2479	5†	◆	◆
	M275A2	2320-00-077-1640 and	5	8	11
		2320-00-077-1641	5	9	11
Dump	M342A2	2320-00-077-1643 and	7	9	12
		2320-00-077-1644	7	9	12
Pipeline Construction	M756A2	2320-00-904-3277	7	10	13
Earth Boring and Polesetting	M764	2320-00-937-5980	9	9	10

\* Information to be supplied when it becomes available.

† Tractor only (without semitrailer).

◆ Weight of semitrailer and payload must be known to determine class number.



## CHAPTER 2

### DESCRIPTION AND DATA

---

#### Section I. FUNCTIONAL DESCRIPTION

2-1. **GENERAL.** The 2 1/2-ton, 6x6 M44A1 and M44A2 series trucks are tactical vehicles designed for use on all types of roads, highways, and cross country terrain. They will ford hard bottom water crossings up to 30 inches deep without special fording equipment. The following paragraphs are provided to give the operator an overall understanding of the equipment and its main functions. The descriptive text is keyed to an overall equipment block diagram, which shows each functional group of the equipment as a block, Arrows are used to show the flow of power to and from each functional block on the diagram,

#### WARNING

This vehicle has been designed to operate safely and efficiently within the limits specified in this TM. Operation beyond these limits is prohibited IAW AR 70-1 without written approval from the Commander, U.S. Army Tank-Automotive Command, ATTN: AMSTA-CM-S, Warren, MI 48397-5000.

2-2. **OVERALL EQUIPMENT FUNCTIONAL DESCRIPTION.** (See Fig. 2-1.)

- a. Engine. The engine functions to supply power to move the truck and operate equipment and accessories.
- b. Clutch. The clutch by means of mechanical linkage, connects power produced by the engine, to the transmission. The clutch also separates power from the transmission when not needed, or while shifting transmission gears.
- c. Electrical System. The electrical system supplies electrical current to start the engine, operate lights, equipment and accessories, and to charge the batteries.
- d. Fuel System. The fuel system functions to store fuel in tanks, deliver fuel to the engine, as required, and return excess fuel to the tanks.
- e. Cooling System. The cooling system functions to remove excess heat produced while the engine is running, and to keep the engine at normal operating temperature. The cooling system also supplies heat to warm the cab or personnel compartment, when required.
- f. Exhaust System. The exhaust system functions to collect and remove exhaust gasses produced when the engine is operating. The exhaust system also supplies heat necessary to heat water in water tank trucks, when required.
- g. Transmission System. The transmission system gives the operator a choice of five forward gear combinations (speeds), reverse, and neutral position for operating the truck efficiently at all speeds and conditions.
- h. Transfer System. The transfer system sends power from transmission to propeller shafts to drive front and rear wheels. The system gives an additional gear combination (speed) for each transmission speed.
- i. Transmission Power Take-off System. This system transmits power to propeller shafts to operate auxiliary equipment.
- j. Transfer Power Take-off System. This system transmits power from the transfer unit to propeller shafts to operate auxiliary equipment and accessories.
- k. Propeller Shafts. Propeller shafts are used to transmit power from transmission to the transfer system and from transfer system to axles. Propeller shafts also transmit power from power take-off assemblies to auxiliary equipment and accessories.

l. Steering System. When the operator turns steering wheel, the steering system sends this action to front wheels. This system functions to control direction of truck while in motion.

m. Brake System. When the operator steps on service brake pedal, brake system functions to slow down or stop truck. A handbrake, when set to up position by the operator, is used for parking vehicle.

n. Axles, Wheels, and Hubs. The axles support the weight of the truck and transmit power to the hubs to turn the wheels. The front and both rear axles are powered (live) axles.

o. Auxiliary Equipment and Accessories. These components perform required tasks, such as pulling, lifting, earth boring, heating, towing and fording.

## Section II. PHYSICAL DESCRIPTION

2-3. GENERAL. Three basic wheelbase chassis are available for mounting various body types, (cargo, dump, tankers, vans, tractor, earth boring and pole setting, and pipeline construction bodies). The following paragraph will describe systems, units, and components of the various trucks. The diagrams show location of these items on the vehicle.

### 2-4. OVERALL EQUIPMENT PHYSICAL DESCRIPTION.

a. Engine. M44A1 and M44A2 series trucks are equipped with US Army LDS 427-2, LD 465-1, and LD465-1C six-cylinder in-line, liquid-cooled, multifuel engines. The multifuel engine (fig. 2-2) uses the fuel injection compression ignition principle which permits the use of various grades of fuel. Refer to Table 2-6, for fuel grades to be used.

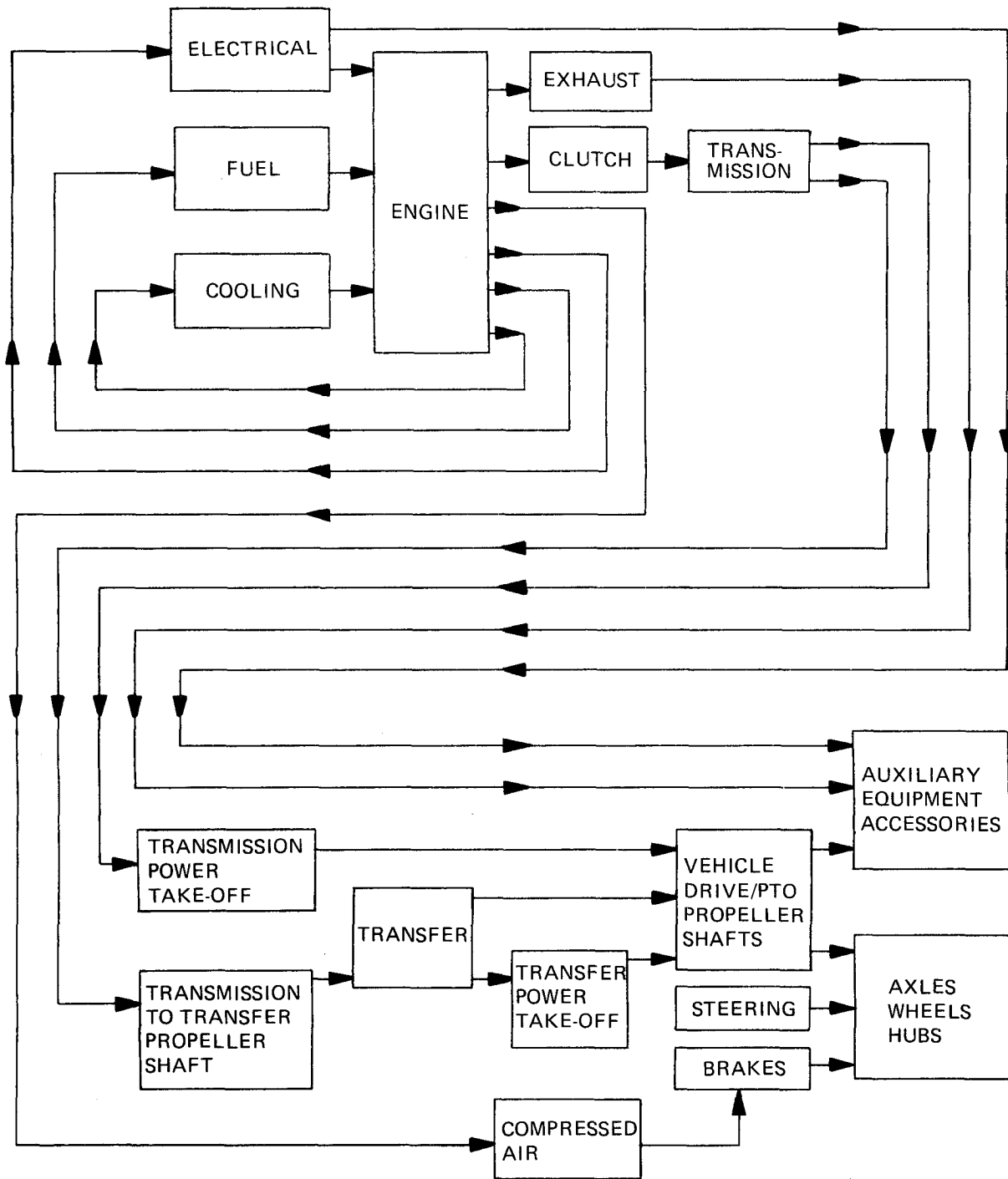

TA 044894

Figure 2-1. Overall Equipment Block Diagram.

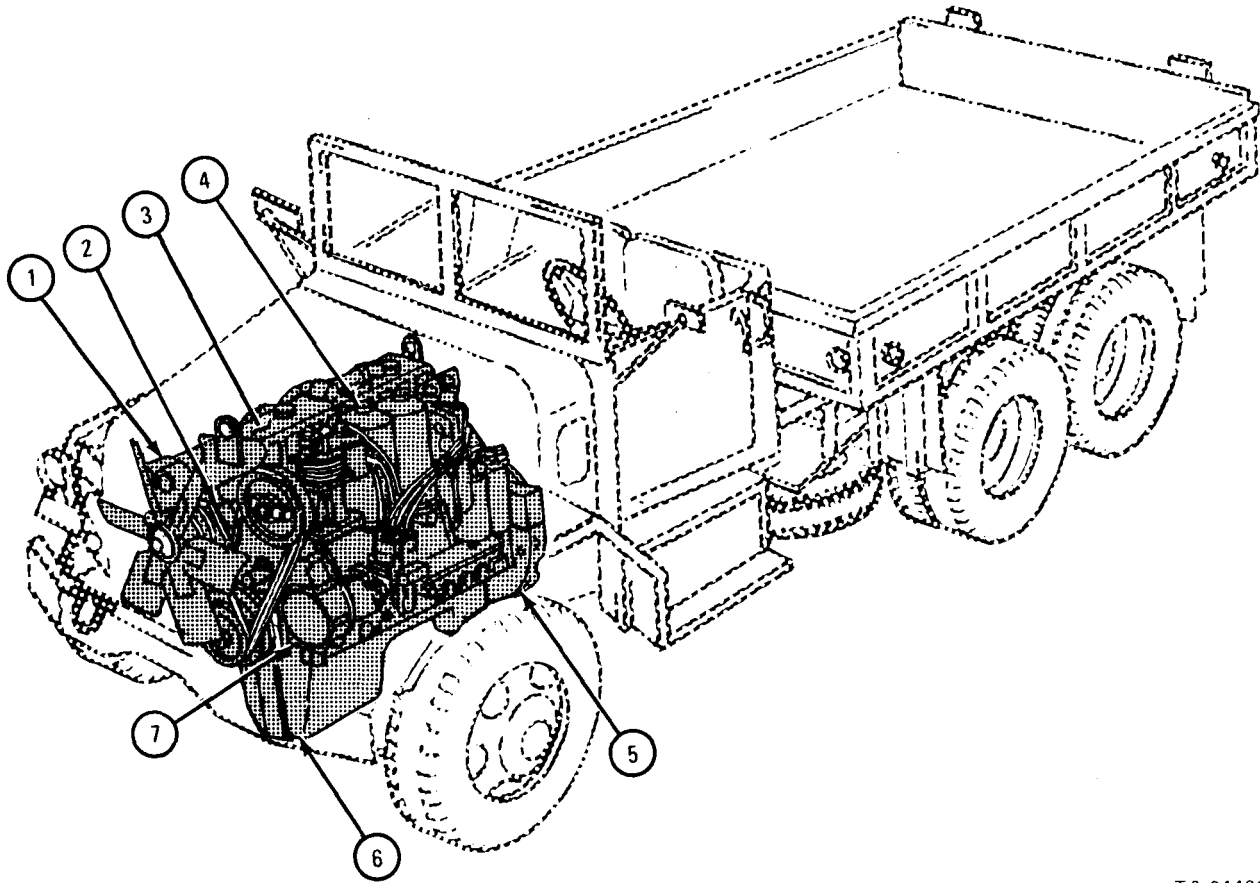

TA 044895

- |                  |                     |
|------------------|---------------------|
| 1. Manifold      | 5. Flywheel housing |
| 2. Block         | 6. Oil pan          |
| 3. Cylinder head | 7. Crankcase        |
| 4. Oil filter    |                     |

Figure 2-2. Engine Components Location.

b. Clutch. The clutch (fig. 2-3) has two plates (disks), one attached to the flywheel of the engine, the other connected to the transmission. The disks are pressed together by a pressure plate. When the engine is running, the disk attached to the flywheel drives the disk attached to the transmission, turning the gears in the transmission. The plates are separated when the operator steps down on the clutch pedal. The gears in the transmission stop turning to let the operator shift gears.

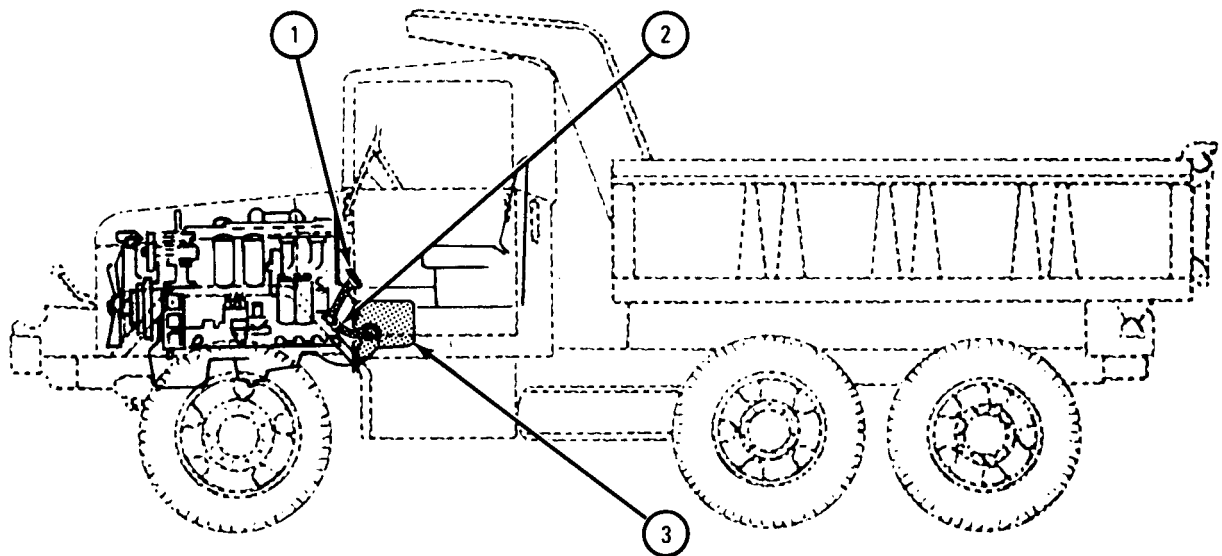

TA 044896

- |                   |           |
|-------------------|-----------|
| 1. Clutch pedal   | 3. Clutch |
| 2. Clutch linkage |           |

Figure 2-3. Clutch Components Location.

c. Electrical System. The electrical system (fig. 2-4) is a 24-volt dc system . Two 12-volt storage batteries are connected in series with the negative terminal grounded. The engine starter motor operates directly from the 24-volt source. The system uses a belt-driven, 24-volt generator having an output capacity of 25 amperes. A battery-generator indicator is located on the instrument panel. Wiring harnesses are used to carry current to operate equipment and accessories. Circuit breakers are included to protect circuits from overload.

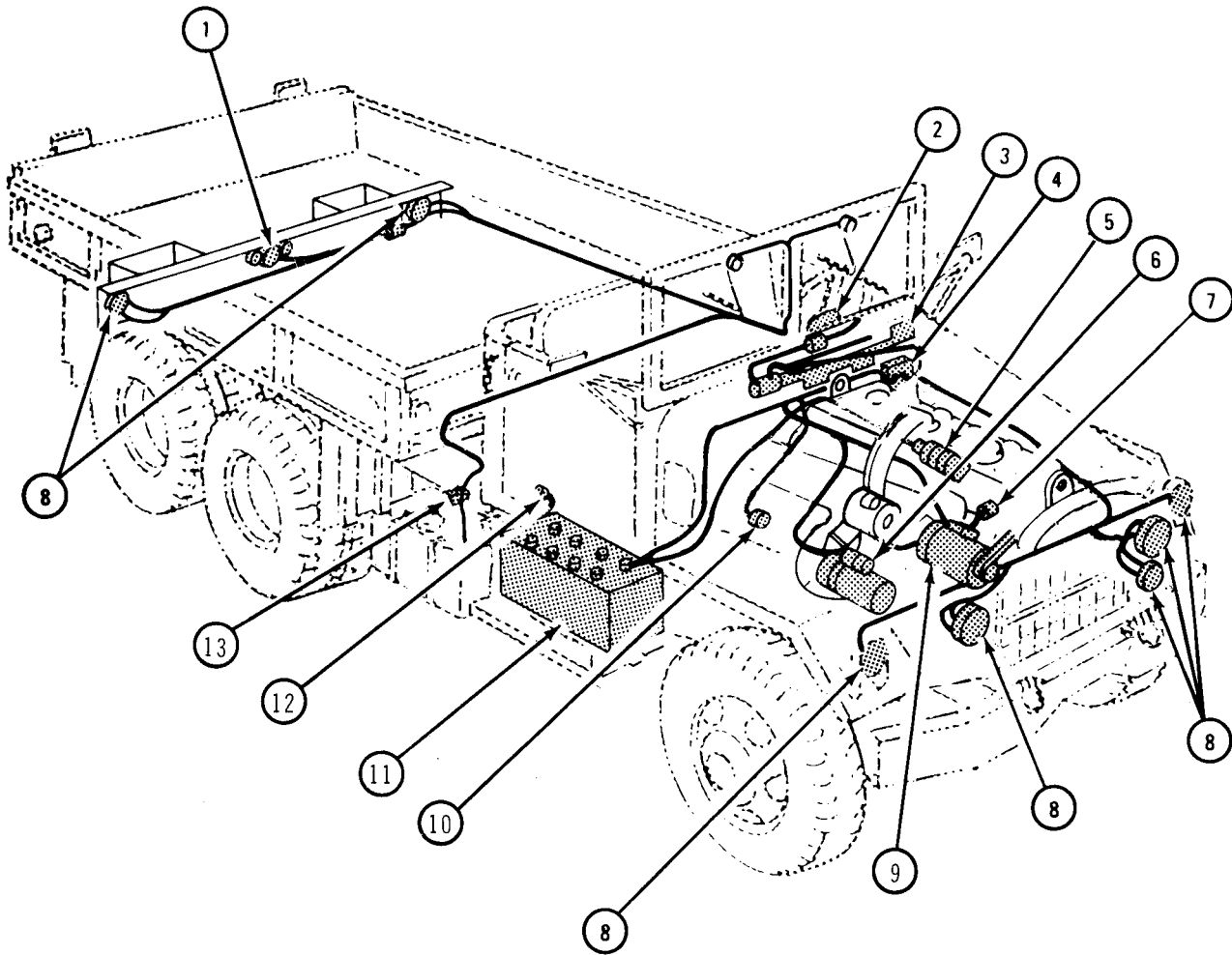

- |  |                                    |
|--|------------------------------------|
| 1. Trailer coupling                    | 8. Lights                          |
| 2. Horn button                         | 9. Generator                       |
| 3. Gages and controls                  | 10. Oil pressure gage sending unit |
| 4. Regulator                           | 11. Batteries                      |
| 5. Manifold air heater ignition unit   | 12. Ground strap                   |
| 6. Starter                             | 13. Fuel level gage sending unit   |
| 7. Water temperature gage sending unit |                                    |

Figure 2-4. Electrical System Component Location



d. Fuel and Air Intake System. The fuel and air intake system (fig. 2-5) includes an intake manifold heater, air cleaner, fuel tanks, fuel pump, primary and secondary fuel filters, injection pump, nozzle, fuel lines and fittings, accelerator pedal and linkage, engine stop, and hand throttle.

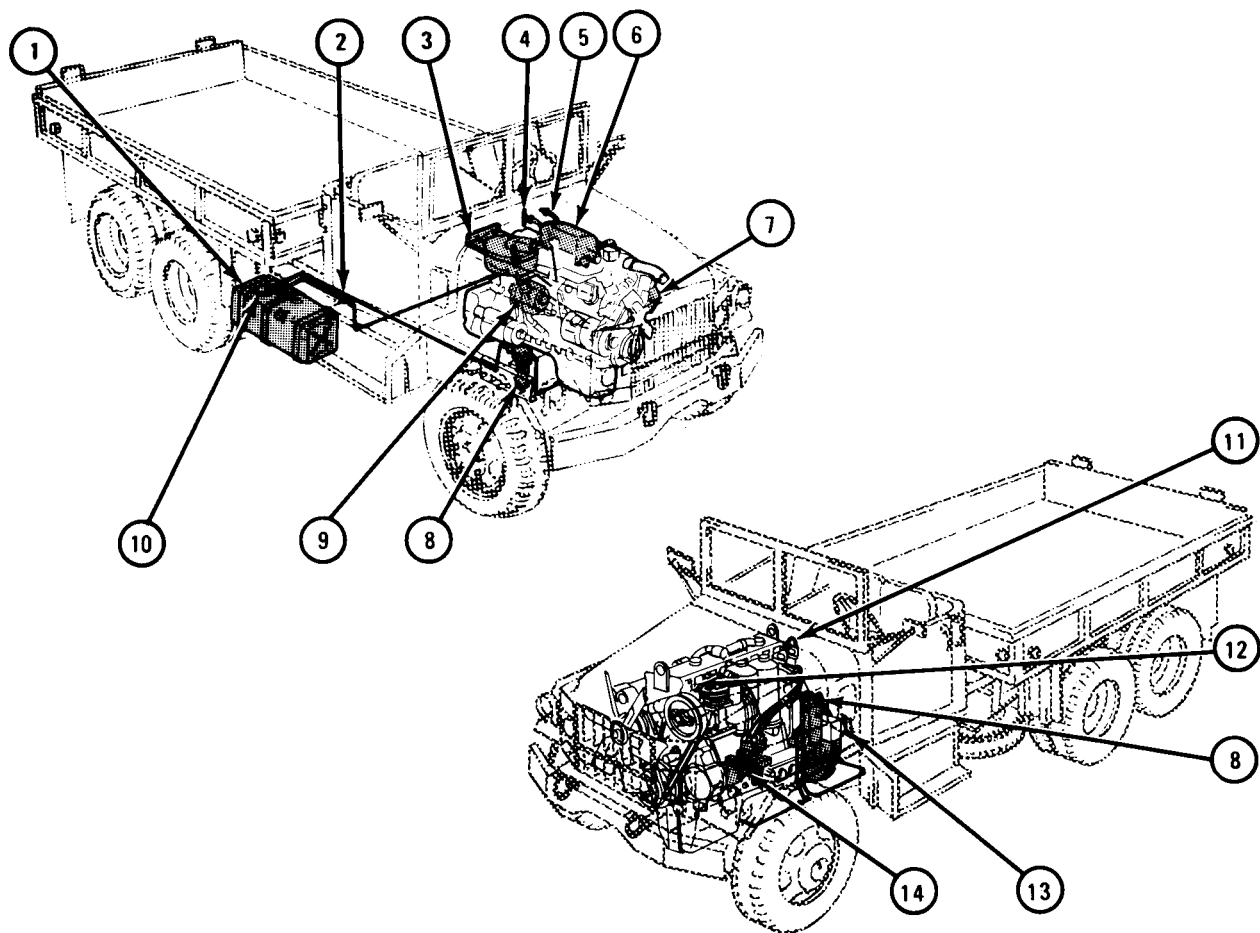

TA 044898

- |                        |                                       |
|------------------------|---------------------------------------|
| 1. Fuel tank           | 8. Filters                            |
| 2. Fuel lines          | 9. Turbocharger                       |
| 3. Air cleaner         | 10. supply pump                       |
| 4. Throttle control    | 11. Fuel injector nozzles and holder  |
| 5. Engine stop control | 12. Fuel return connectors            |
| 6. Manifold heater     | 13. Accelerator controls and linkages |
| 7. Injection pump      | 14. Fuel pump                         |

Figure 2-5. Fuel and Air Intake System Components Location.

e. Cooling System. The cooling system (fig. 2-6) is a sealed-type system made up of the radiator, fan, drive belts, thermostat, water pump, temperature gage, pressure-type filler cap, thermostat bypass line connecting the radiator to the engine, and the water pump.

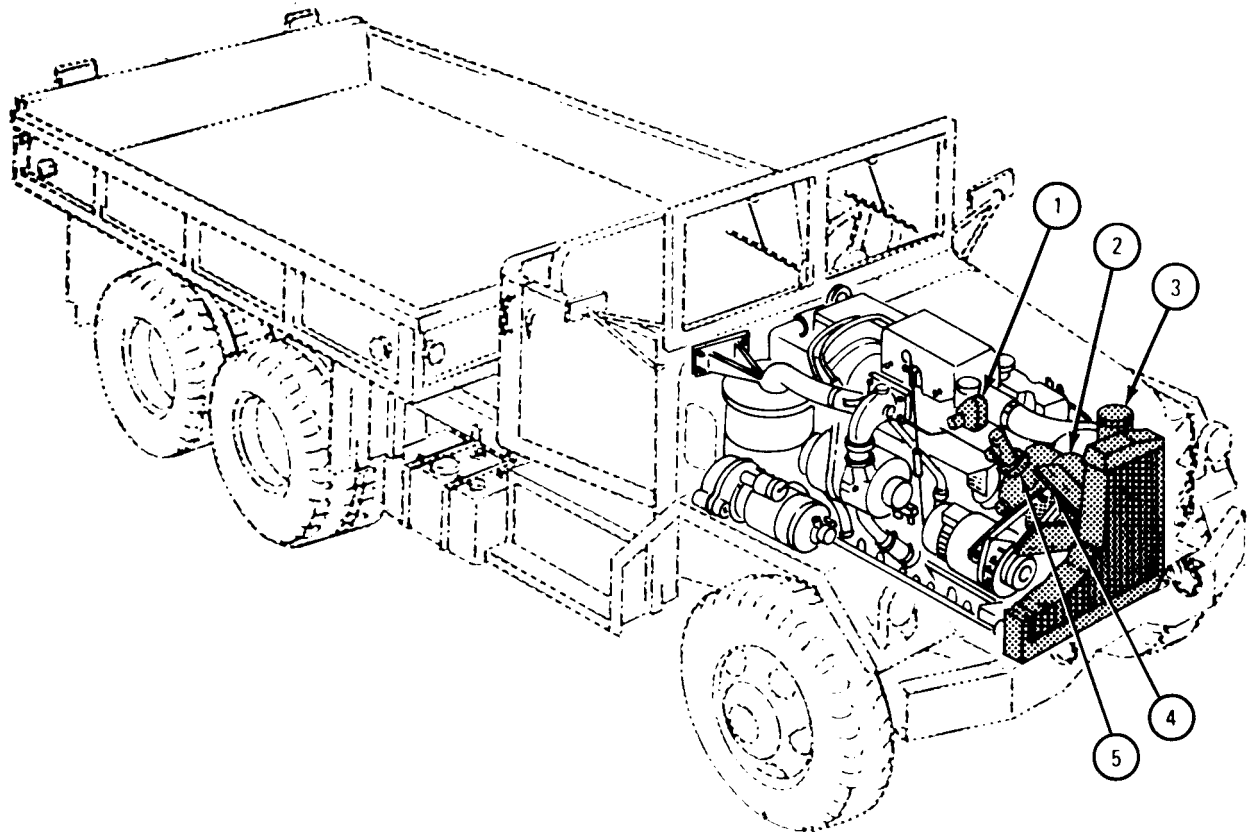

TA 044899

- |                       |                     |
|-----------------------|---------------------|
| 1. Thermostat housing | 4. Fan and fan belt |
| 2. Shroud             | 5. Water pump       |
| 3. Radiator and cap   |                     |

Figure 2-6. Cooling System Components Location.

f. Exhaust System. There are different exhaust system setups used on the trucks covered in this manual. The following paragraphs note the differences in exhaust systems used with particular engines, or with certain trucks.

(1) On vehicles with LDS 427-2 engines (fig. 2-7), the exhaust manifold empties directly into the turbo-supercharger. The pressurized exhaust gasses drive the turbo-supercharger and pass from the turbo-supercharger outlet through an exhaust pipe assembly. The pipe assembly extends back along the right side of the truck, to the outlet, located between the right tandem wheels.

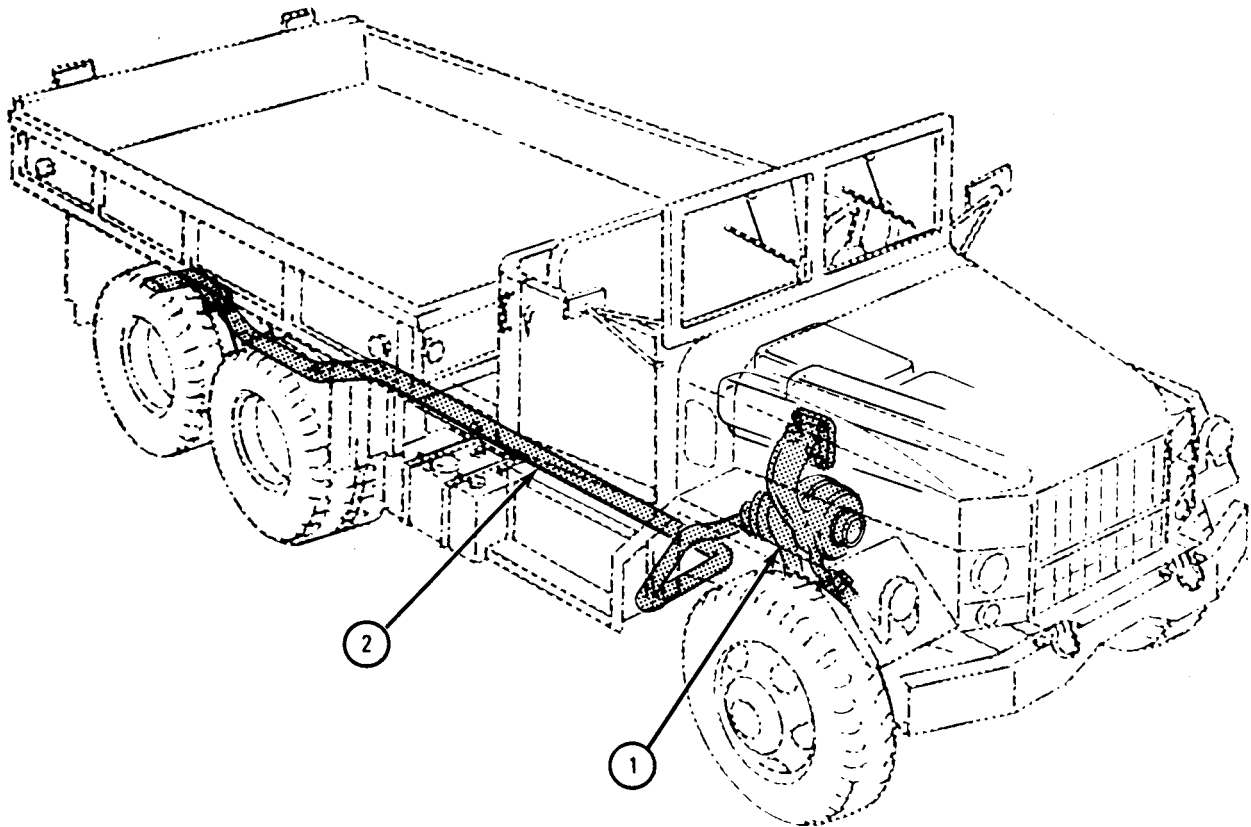

TA 044900

1. Turbo-supercharger

2. Exhaust pipes

Figure 2-7. Exhaust System Component Location (LDS 427-2 Engines).

(2) The M50A1 and M50A2 (fig. 2-8) water tank trucks have an exhaust bypass valve and a bypass fording valve. The exhaust bypass valve is opened to let exhaust gasses heat the water in the tanks. The bypass fording valve is used to close off the heating chamber under the tanks, while fording.

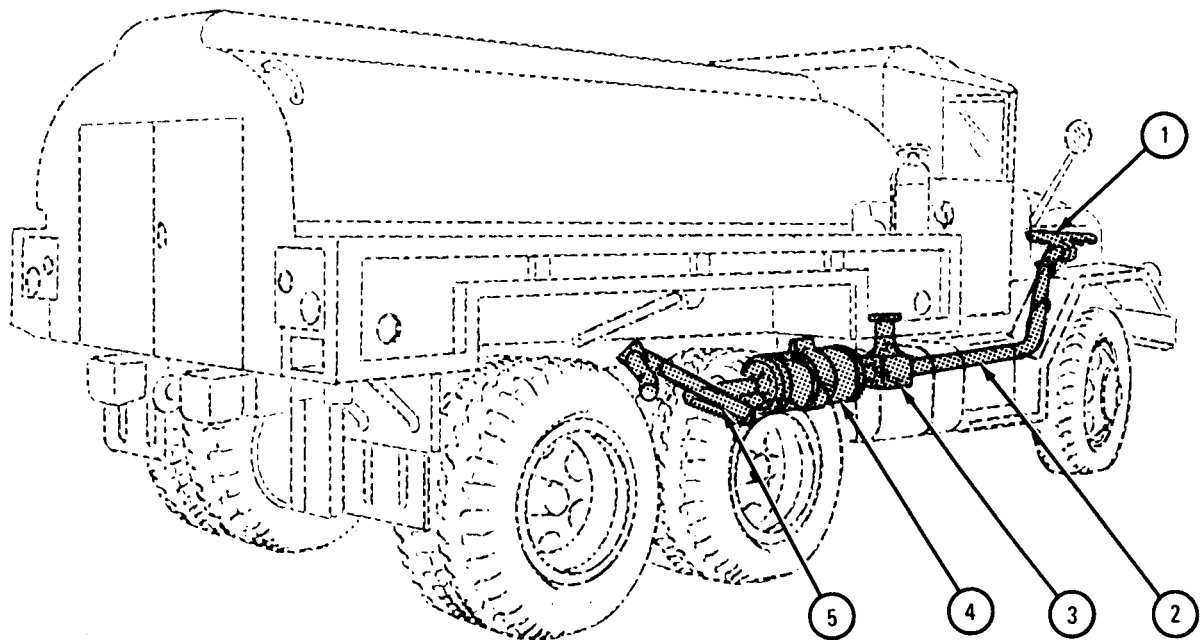

TA 044901

- |  |             |
|--|-------------|
| 1. Manifold  | 4. Muffler  |
| 2. Exhaust pipe  | 5. Tailpipe |
| 3. Exhaust bypass valve<br>Bypass fording valve<br>(deep water fording only) |             |

Figure 2-8. Exhaust System Component Location (M50A1 and M50A2 Trucks).

(3) On earlier model M44A2 series trucks with LD465-1 and LD465-1C engines, the exhaust system (fig. 2-9) is made up of front and rear exhaust pipes, muffler, and tailpipe. The exhaust pipes are connected directly to the manifold.

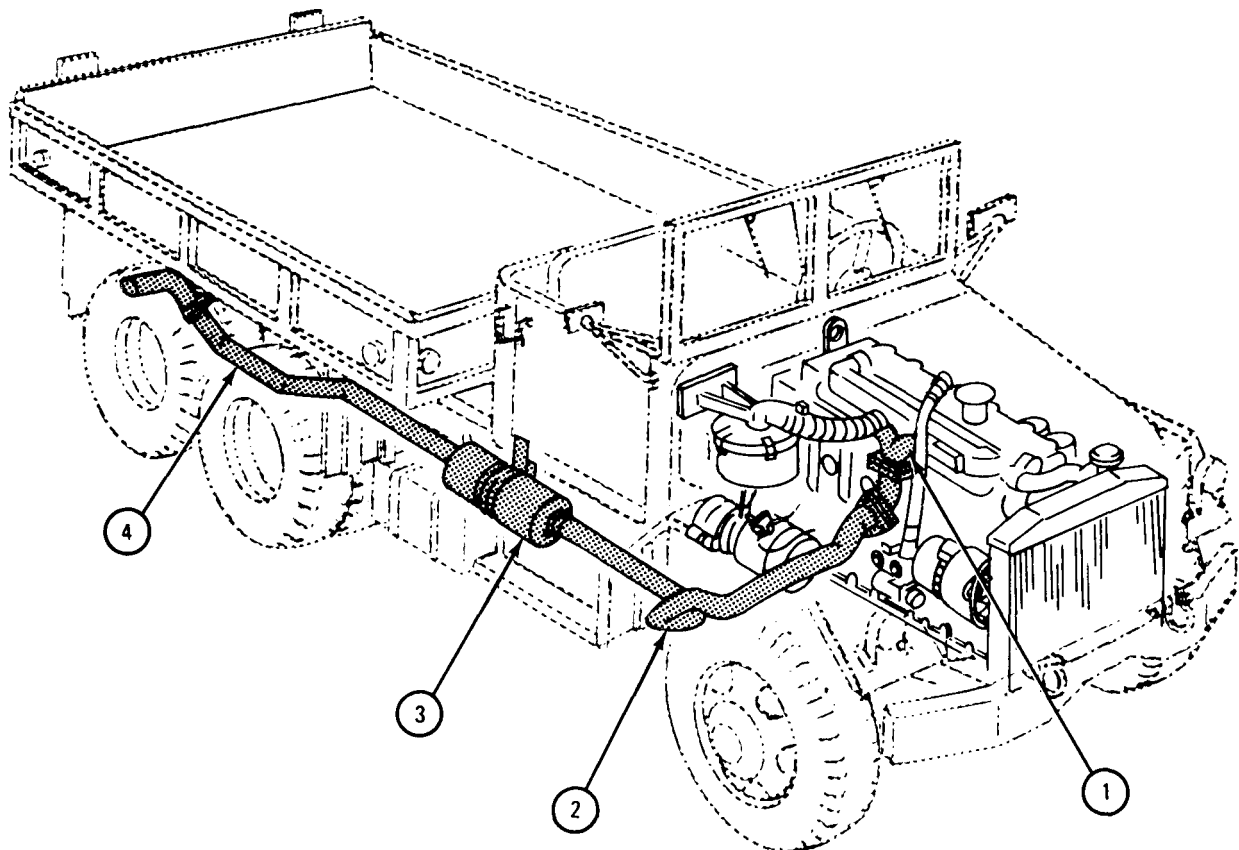

TA 044902

- |                 |             |
|-----------------|-------------|
| 1. Manifold     | 3. Muffler  |
| 2. Exhaust pipe | 4. Tailpipe |

Figure 2-9. Exhaust System Component Location (LD 465-1-1C Engine).

(4) On later model M44A2 series trucks with LD465-1C and LDT 465-1C engines (except M50A2 water tankers), a stack-type exhaust system is used. The upper exhaust pipe (stack) is mounted on the right side of truck and extends above cab top.

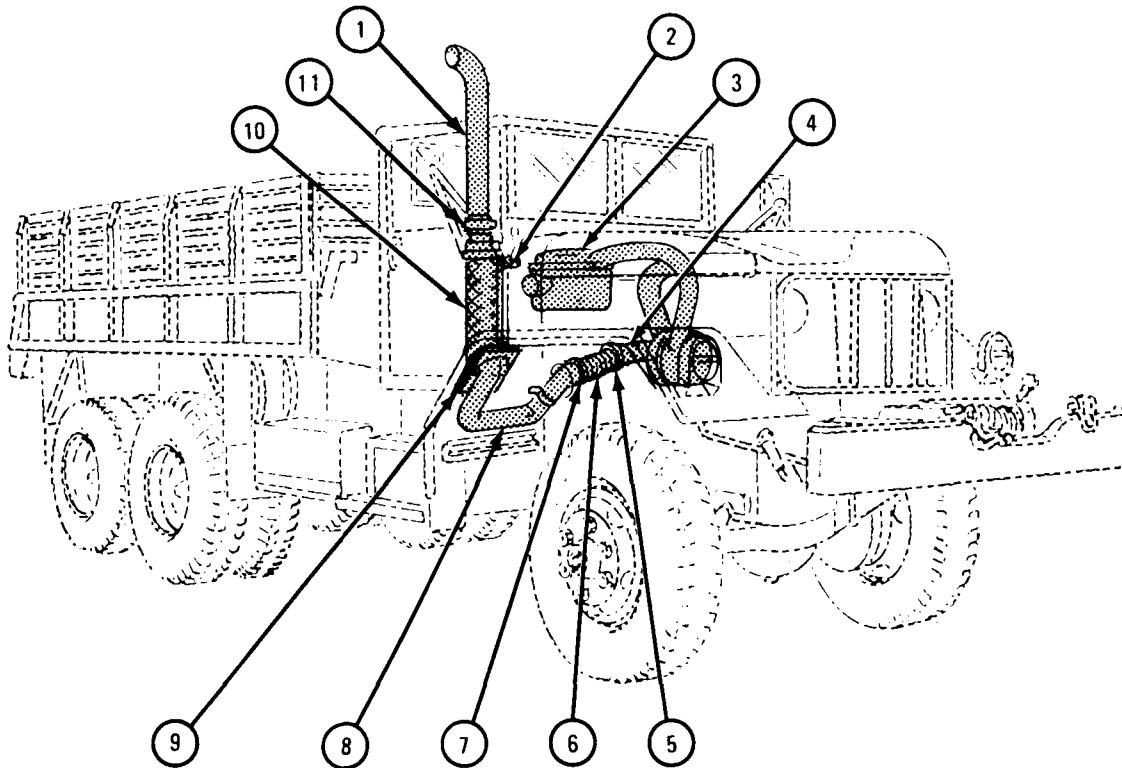

TA 044903

- |                       |                       |
|-----------------------|-----------------------|
| 1. Upper exhaust pipe | 7. Lower coupling     |
| 2. Clamp assembly     | 8. Lower exhaust pipe |
| 3. Air cleaner        | 9. Cover plate        |
| 4. Elbow              | 10. Exhaust shield    |
| 5. Coupling           | 11. Coupling          |
| 6. Exhaust flex tube  |                       |

Figure 2-10. Exhaust System Stack Type, Component location, (LD 465-1C and LDT 465-1C Engines).

(5) The exhaust system on M49A2C fuel tanker and M275 tractor trucks (fig. 2-11) includes a spark-arrestor-type muffler, which traps exhaust sparks from the engine.

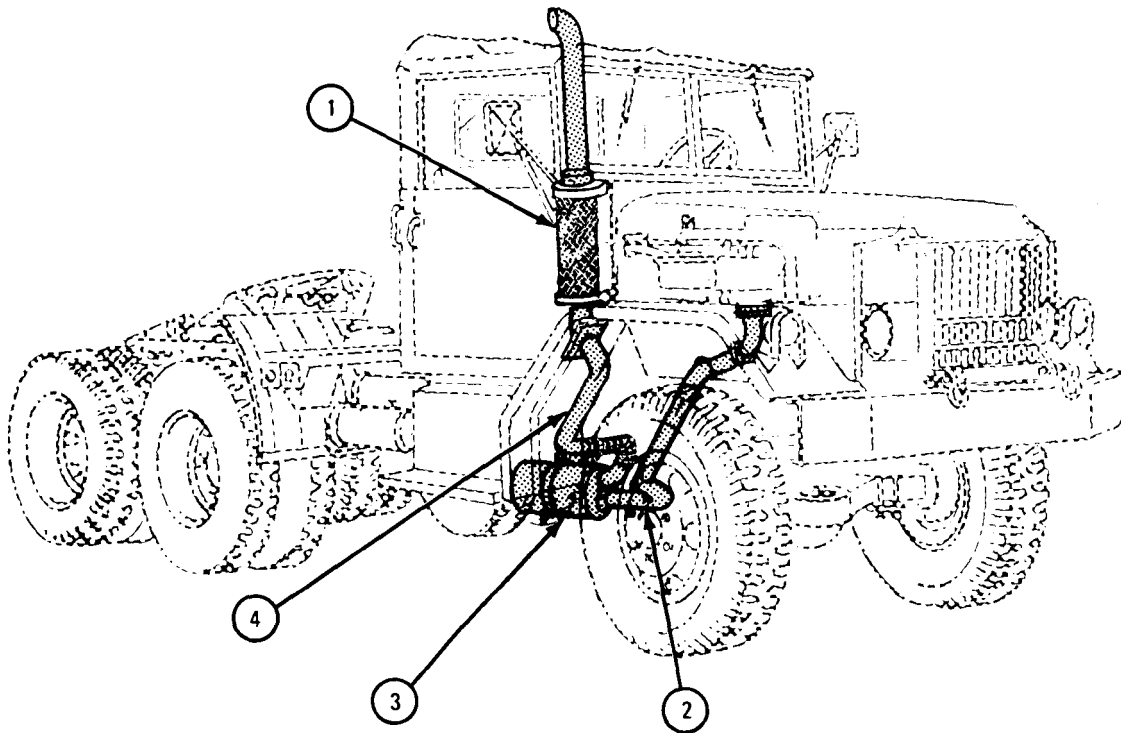

TA 044904

- |                       |                       |
|-----------------------|-----------------------|
| 1. Exhaust shield     | 3. Muffler            |
| 2. Lower exhaust pipe | 4. Upper exhaust pipe |

Figure 2-11. Exhaust System Component Location (M49A2C Fuel Tankers and M275 Tractor Trucks).

g. Transmission. The transmission (fig. 2-12) is a manually operated synchromesh type, mounted on the rear of the engine. The transmission supplies one reverse and five forward speeds.

h. Transmission Power Takeoff (Fig. 2-12). All trucks except dump truck, have single-ended transmission power takeoff units. The dump truck has a double-ended unit.

(1) Single-ended unit is a two-speed-and-reverse drive, mounted on the left side of the transmission. The power takeoff supplies power to the front winch. The power takeoff is controlled by a shifting lever in the cab.

(2) Double-ended unit is mounted on the left side of the transmission. The forward output shaft is a two-speed-and-reverse drive to the front winch with shifting lever in the cab. The rear accessory drive shaft drives the hydraulic hoist pump on dump trucks and is controlled by the drivers hydraulic hoist control lever in the cab.

i. Transfer. The transfer (fig. 2-12) is a two-speed synchromesh unit driven by the transmission through a propeller shaft. The transfer drives propeller shafts connected to the front and rear wheels. The handbrake drum is mounted on the transfer rear output companion shaft.

j. Transfer Power Takeoff. The transfer power takeoff (fig. 2-12) is attached to the rear of the transfer, and is controlled by a lever in the cab. The unit functions to supply power to auxiliary equipment.

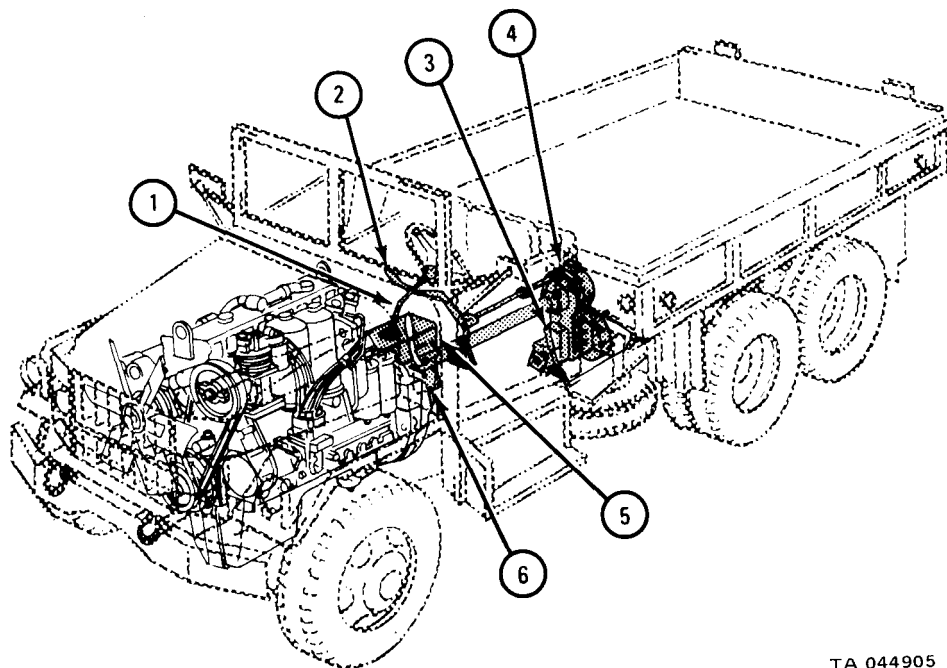

TA 044905

- |   |  |
|---|--|
| 1. Front transmission gear shift lever              | 4. Transfer assembly                   |
| 2. Transmission power takeoff shifting lever        | 5. Transmission assembly               |
| 3. Transfer power takeoff lever (all except M342A2) | 6. Transmission power takeoff assembly |
| 4. Hydraulic hoist control lever (on M342A2)        |  |

Figure 2-12. Transmission Power Takeoff System Component Location.



k. Propeller and Drive Shaft Systems. Except on M49 and M50 tank trucks, all drive shafts are double universal joint type. Tank trucks shafts are solid and supported on each end by a flange and pillow-block with a bearing assembly. Figures 2-13, 2-14, and 2-15 give the shafts and locations for the different model trucks.

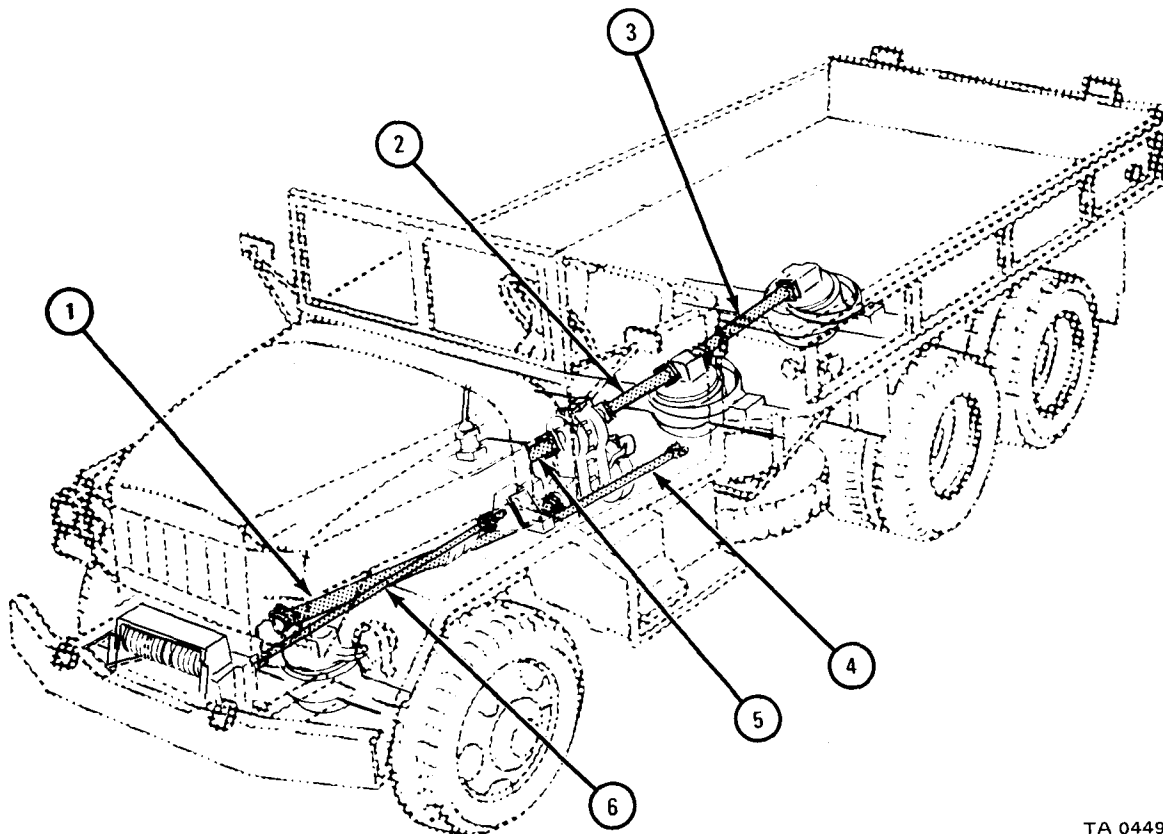

TA 044906

- |  |  |
|--|--|
| 1. Front axle propeller shaft assembly             | 4. Hydraulic hoist pump drive shaft<br>(on M342A2) |
| 2. Intermediate propeller shaft<br>(except M342A2) | 5. Transfer propeller shaft assembly               |
| 3. Rear axle propeller drive shaft                 | 6. Front drive shaft assembly                      |

Figure 2-13. Propeller and Drive Shafts System Component Location (Trucks with Winch except M49, M50, and M764).

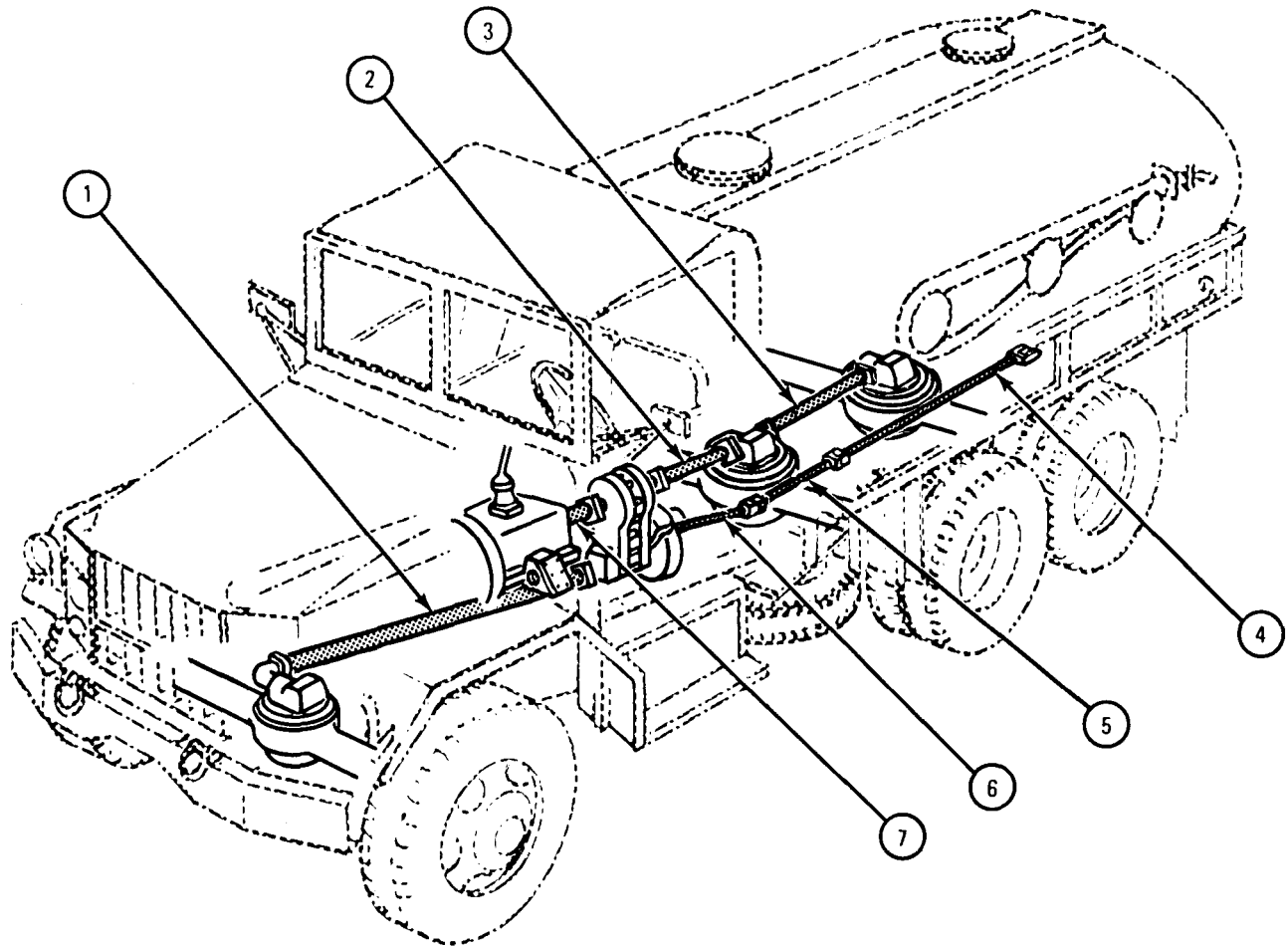

TA 045535

- |  |  |
|--|--|
| 1. Front axle propeller shaft assembly | 5. Delivery pump intermediate drive shaft (M49 only) |
| 2. Forward rear axle propeller shaft   | 6. Delivery pump front drive shaft (M50 only)        |
| 3. Rear rear axle drive shaft          | 7. Transfer propeller shaft assembly                 |
| 4. Delivery pump rear drive shaft      |  |

Figure 2-14. Propeller and Drive Shafts System Component Location (M49, M50).

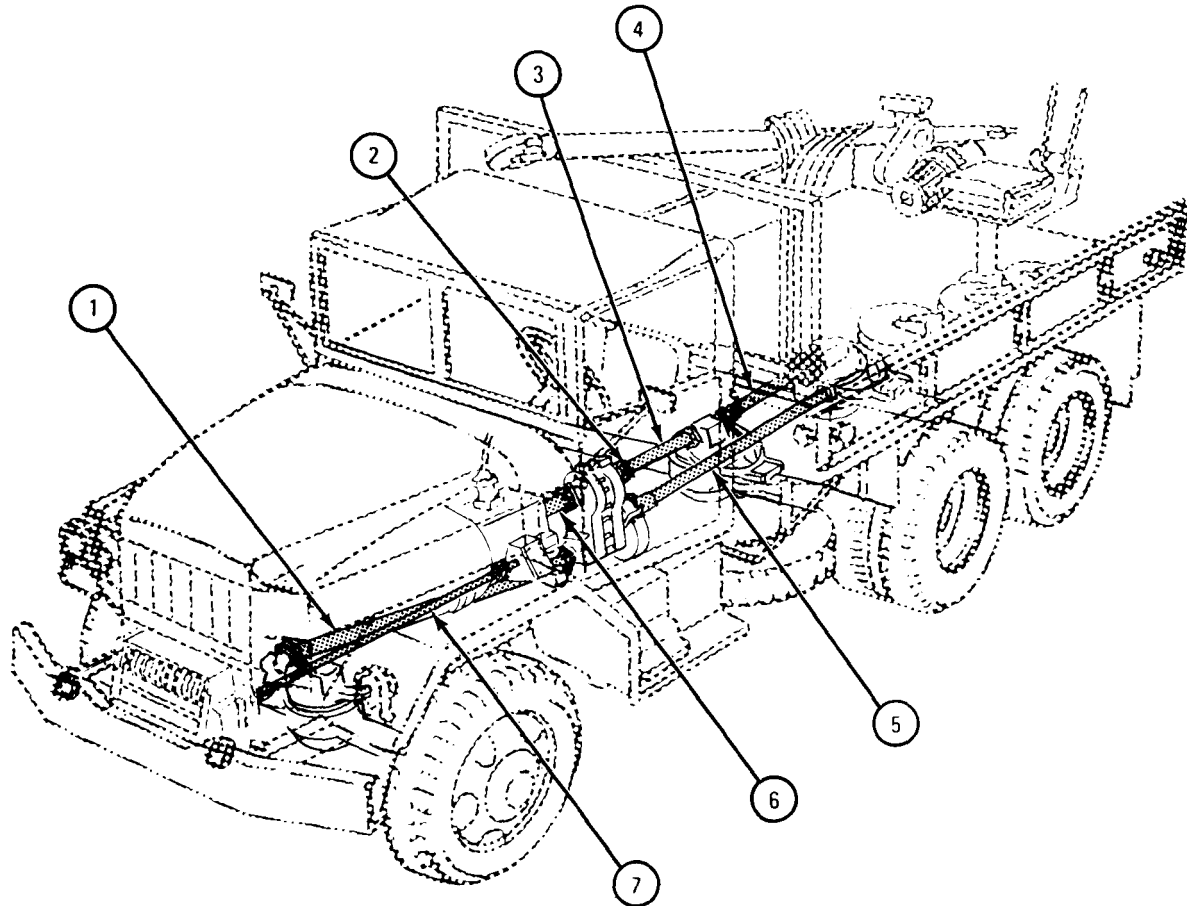

TA 045542

- |  |                                      |
|--|--------------------------------------|
| 1. Front axle propeller shaft assembly | 5. Earth boring machine drive shaft  |
| 2. Power-divider drive shaft assembly  | 6. Transfer propeller shaft assembly |
| 3. Forward rear axle drive shaft       | 7. Front winch drive shaft assembly  |
| 4. Rear rear axle drive shaft          |                                      |

Figure 2-15. Propeller and Drive Shafts System Component Location (M764).

1. Steering System. The steering system (fig. 2-16) consists of a steering wheel, a helical cam and lever-type steering gear, pitman arm, drag link and tie rods. Turning motion applied to the steering wheel is sent through these components to steer the front wheels.

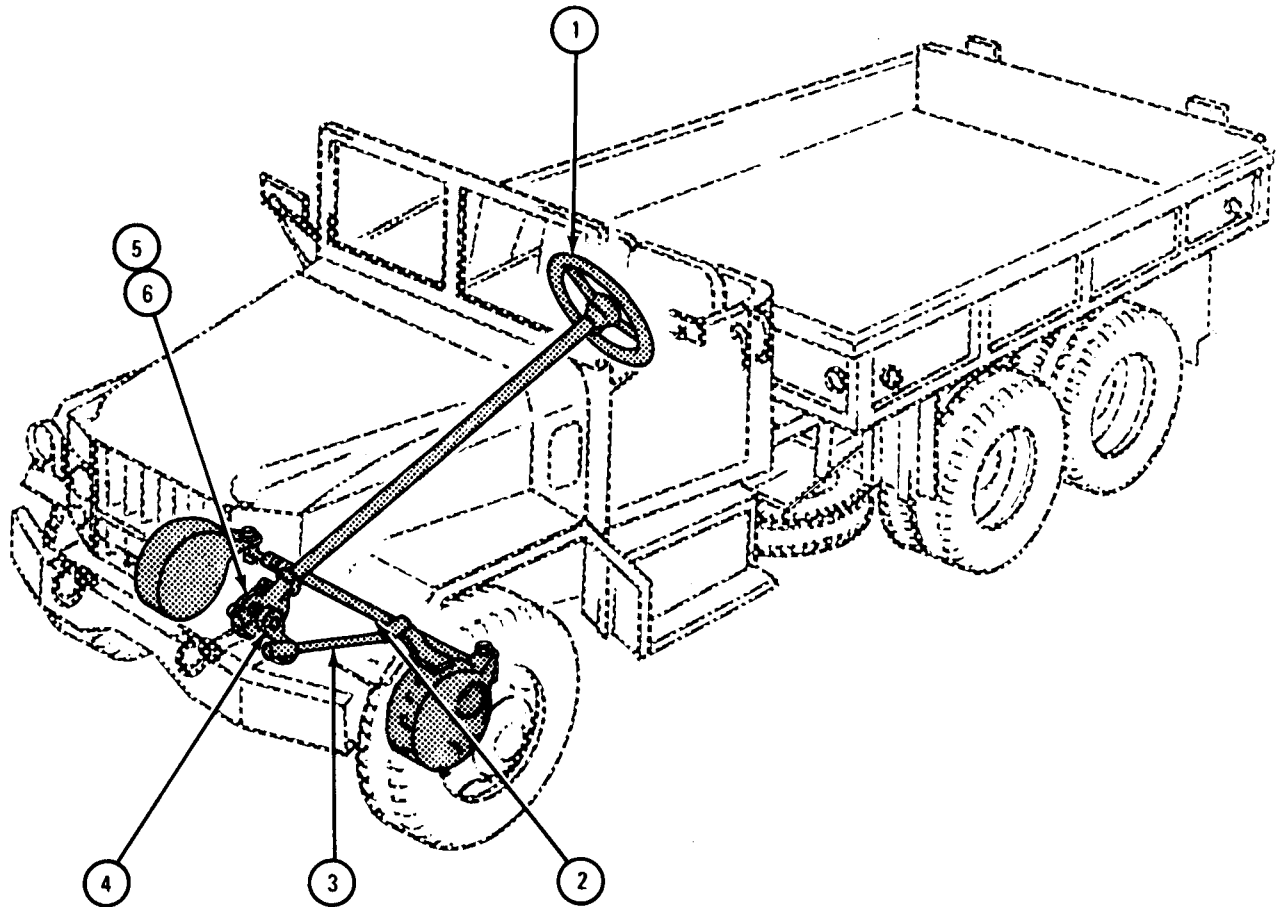

TA 044907

- |                   |                  |
|-------------------|------------------|
| 1. Steering wheel | 4. Pitman arm    |
| 2. Tie rods       | 5. Helical cam   |
| 3. Drag link      | 6. Steering gear |

Figure 2-16. Steering System Component Location.

m. **Brake System.** The brake system (fig. 2-17) includes the service brakes and a hand-brake. The compressed air system is covered here since it is part of the brake system.

(1) The service brake system, is an air-hydraulic system made up of a master cylinder, air-hydraulic cylinder, individual hydraulic wheel cylinders, an air compressor, air reservoirs, air lines, hydraulic lines and linkage, and trailer brake connections and controls. The master cylinder contains hydraulic fluid. Pressure on the brake pedal is transmitted to the air-hydraulic cylinder. The air-hydraulic cylinder increases pressure to the wheel cylinders. The wheel cylinders expand and press the brake shoes against the drum to slow or stop the truck.

(2) The handbrake system consists of a brake drum, mounted on the rear output shaft of the transfer, and inner and outer brakeshoes operated by a single shoe lever. A cable attached to the brake shoe lever runs through a protective casing to the handbrake lever at the left of the driver's seat.

(3) The compressed air system is used to supply air to the air-hydraulic cylinder, windshield wiper motors, and trailer airbrakes. This system can also be used in an emergency to clean the air cleaner and inflate tires. When air pressure in the air reservoir tanks is low, a buzzer is set off in the driver's compartment to warn the operator.

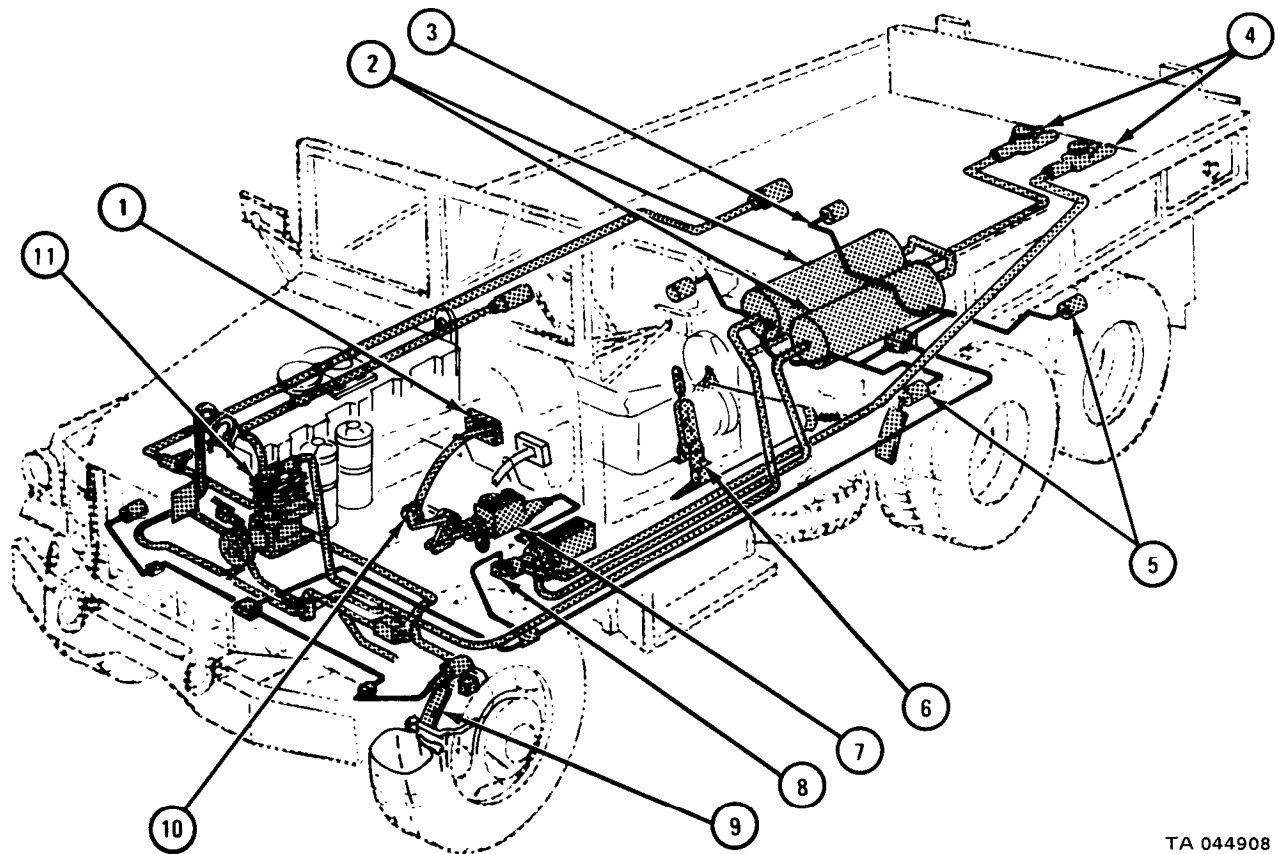

TA 044908

- |                             |                                  |
|-----------------------------|----------------------------------|
| 1. Brake pedal              | 7. Master cylinder               |
| 2. Air reservoir tanks      | 8. Air hydraulic master cylinder |
| 3. Brake lines              | 9. Service brake shoe            |
| 4. Trailer brake connection | 10. Linkage                      |
| 5. Wheel cylinder           | 11. Compressor                   |
| 6. Handbrake assembly       |                                  |

Figure 2-17. Brake System Component Location.

n. Axles, Wheels and Hubs (Fig. 2-18).

(1) The front axle is made up of a housing, differential and pinion, axle shaft, with universal joint, and steering knuckle. Power is sent from the differential to the wheels, through the axle shaft. Universal joints **permit continuous delivery of power to the wheels** while the truck is turning right or left.

(2) Both rear axles are made up of a housing, differential and carrier assembly, and an axle shaft. Forward rear and rear rear axles are mounted, one behind the other, with torque rods on each side of the interconnecting axles. Power is sent from the transfer to the front rear differential by a propeller shaft, and from the forward rear axle to the rear rear axle differential by another propeller shaft. Axle shafts transmit power from the differential to the wheels.

(3) The wheels are disk-type, secured to six studs on the wheel hubs. The wheels are completely interchangeable. Trucks with dual wheels use 9x20 size tires. Single wheels use 11x20 tires. Single wheels can be used on dual wheel trucks if there is enough clearance between the tire and body under full payload.

(4) The wheel hubs are mounted on roller bearings. Each hub is secured to its axle with two adjusting nuts and an adjusting nut lock. All hubs have inner seals, and rear hubs also have an outer seal.

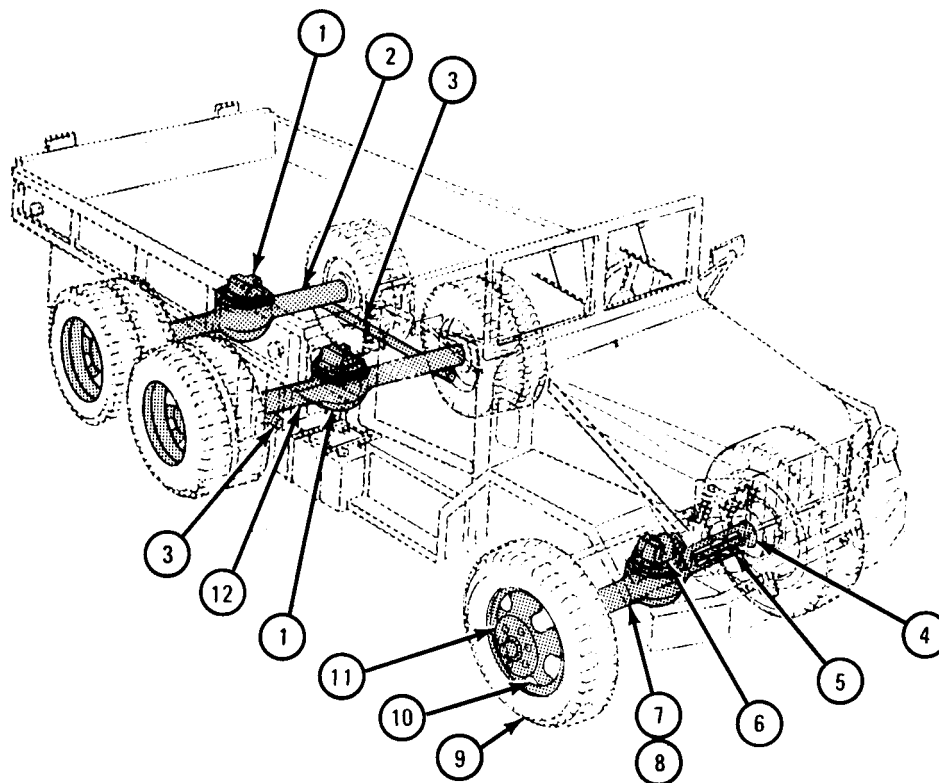

TA 044909

- |                                    |                          |
|------------------------------------|--------------------------|
| 1. Differential and carrier        | 7. Front axle            |
| 2. Rear rear axle                  | 8. Housing               |
| 3. Torque rods                     | 9. Tires                 |
| 4. Steering knuckle                | 10. Wheels               |
| 5. Axle shaft with universal joint | 11. Hubs (behind wheels) |
| 6. Differential                    | 12. Front rear axle      |

Figure 2-18. Axles, Wheels, and Hubs System Component Location.

### Section III. TABULATED DATA

2-5. **GENERAL.** This section contains reference data, in table form, for use by the operator when using the equipment. Data is given for the following areas:

- a. Physical data
- b. Functional characteristics
- c. Capabilities and limitations
- d. Environmental characteristics

2-6. **WEIGHT.** Table 2-1 gives the weight of all trucks covered in this manual under various conditions. Column "Net w/wn" means trucks with winch.

2-7. **DIMENSIONS.** Tables 2-2 and 2-3 give overall and operating dimensions for all trucks covered in this manual.

2-8. **CAPACITIES.** Table 2-4 gives the liquid capacities for various systems.

2-9. **TIRE INFLATION DATA.** Table 2-5 gives tire inflation data for all trucks covered in this manual.

2-10. **ENVIRONMENTAL CHARACTERISTICS.** Table 2-6 lists the fuels that can be used in all trucks under various temperature conditions.

2-11. **FUNCTIONAL CHARACTERISTICS.** Tables 2-7 and 2-8 give data relating to the functional characteristics of all trucks covered in this manual.

2-12. **COMPONENTS OF END ITEM LIST.** Integral components and basic issue items required for 2 1/2-ton trucks are listed in appendix B.

2-13. **ADDITIONAL AUTHORIZATION LIST.** Additional items authorized for the support of 2 1/2-ton trucks are listed in appendix C.

2-14. **EXPENDABLE SUPPLIES AND MATERIALS LIST.** Expendable supplies and materials needed to operate and maintain the 2 1/2-ton trucks are listed in appendix D.

Table 2-1. Weight (Pounds)

Truck Type	Net w/wn	Gross Highway	Gross Cross-Country	Payload Highway	Payload Cross-Country	Towed Load Highway	Towed Load Cross-Country
M35A1	13,530	23,530	18,530	10,000	5,000	10,000	6,000
M35A2	13,530	23,530	18,530	10,000	5,000	10,000	6,000
M35A2C	13,530	23,530	18,530	10,000	5,000	10,000	6,000
M36A2	15,750	25,510	20,750	10,000	5,000	10,000	6,000
M49A1C	16,107	23,665		1,200 gal	600 gal	10,000	6,000
M49A2C	14,740	22,840		1,200 gal	600 gal	10,000	6,000
M50A1	15,255	23,855		1,000 gal	400 gal	10,000	6,000
M50A2	14,589	22,930		1,000 gal	400 gal	10,000	6,000
M50A3	15,150	23,450		1,000 gal	500 gal	10,000	6,000
M109A2	16,296	20,642	19,992	7,500	5,000	10,000	6,000
M109A3	15,430	22,930	19,930	7,500	5,000	8,000	6,000
M185A2	17,485	22,487	22,067	5,350	5,000	10,000	6,000
M185A3	17,300	24,800	22,300	7,500	5,000	8,000	6,000
M275A1	12,534	23,124	19,124	12,000	7,000	36,000	17,000
M275A2	12,226	24,226	18,790	12,000	7,000	36,000	17,000
M342A2	15,500	25,500	20,500	10,000	5,000	10,000	6,000
M756A2	16,960	24,020	18,960	8,000	2,000	10,000	6,000
M764	19,490	24,690	18,690	8,000	2,000	10,000	6,000

Subtract 500 pounds for trucks not equipped with front winch.

Table 2-2. Dimensions (Inches)

Truck Type	Length Overall w/wn	Height Overall	Height Reduced Minimum	Width Overall	Pintle Height	Ground Clearance
M35A1	277	112	81	96	35	12 1/2
M35A2	278 1/4	112	81	96	36 1/8	10 15/16
M35A2C	278 1/4	112	81	96	36 1/8	10 15/16
M36A2	343 1/2	124 3/8	81	96	36 1/8	10 15/16
M49A1C	277	97	88	96	37	12 1/2
M49A2C	277	101 1/2	92	96	36 1/8	10 15/16
M50A1	277	97	90	95	36	13
M50A2	277	101 1/2	92	95	36 1/8	10 15/16
M50A3	277	101 1/2	92	95	36 1/8	10 15/16
M109A2	277	130	130	99	34	13
M109A3	282	130	130	98	26 1/8	10 15/16
M185A2	277	130	90	95	36	13
M185A3	282	130	130	98	36 1/8	10 15/16
M275A1	242	99	81	93	35	12 1/2
M275A2	242	101 1/2	81	93	36 1/8	10 15/16
M342A2	274	105	81	96	36 1/8	10 15/16
M756A2	287	113	108	96	36 1/2	10 15/16
M764	305	108	94	96		10 15/16

Subtract 14 inches from length for trucks not equipped with front winch.



Table 2-3. Operating Dimensions

Truck Type	Wheel Base (in. )	Departure Angle (deg)	Turning Radius	
			W/WN	WO/WN (ft)
Cargo M35 type	154	40	37 ft 6 in.	36
Cargo M36 type	190	24	46 ft	45
Fuel tank	154	40	37 ft 6 in.	36
Water tank	154	40	37 ft 6 in.	36
Shop van	154	40	37 ft 6 in.	36
Repair shop	154	40	37 ft 6 in.	36
Tractor	142	73	36 ft	35
Dump	154	70	37 ft 6 in.	36
Pipeline construction	154	40	37 ft 6 in.	36
Earthboring and polesetter	154	40	37 ft 6 in.	36

Note: The approach angle for all trucks covered in this manual is 40 degrees with winch and 47 degrees without winch.

Table 2-4. Capacities

Description	Capacity	Truck(s)
Cooling system		All trucks
LDS427-2	34 qt	
LD-465 & LDT465	28-32 qt	
Crankcase	22 qt	All trucks
Differentials (each)	6 qt	All trucks
Fuel tank	50 gal	All trucks
Transmission 1. W/PTO	10-1/2 pt	All trucks
Transmission 2. WO/PTO	8-1/2 pt	All trucks
Transfer	7 qt	All trucks
Front winch worm housing	1-1/4 pt	All trucks equipped with front winch
Front winch end bearing frame	1 pt	All trucks equipped with front winch
Rear winch worm housing	7 pt	M764
Power divider	3-1/2 qt	M764
Earth boring machine intermediate case	5 qt	M764
Earth boring machine clutch and brake case	5 qt	M764
Earth boring machine boring case	10 qt	M764
Outrigger hydraulic system	6 gal	M764
Rear winch cable level winder speed reducer housing	1-3/4 pt	M764
Rear winch jaw clutch housing	1-3/4 pt	M756A2
Rear winch worm gear housing	2-3/4 pt	M756A2

Table 2-5. Tire Inflation Data

Condition/Tire Size	Pressure (psi)
Highway 9 x 20	50
Highway 11 x 20	70
Cross-country	35
Mud, snow, and sand	15

Table 2-6. Permissible Fuels

Ambient Temperature	Fuel
	<u>Primary Fuels</u>
No Limit	Diesel fuel, VV-F-800, grade DF-A (NATO code no. F-54)
Above -51° F	Turbine fuel, MIL-T-5624, grade JP-5 (NATO code no. F-44)
Above -10°F	Diesel fuel, VV-F -800, grade DF-1 (NATO code no. F-54)
Above +32 °F	Diesel fuel, VV-F-800, grade DF-2 (NATO code no. F-54)
	<u>Alternate Fuels</u>
Above -76°F	Aviation gasoline, MIL-G-5572, AVGAS 80/87 (NATO code no. F-12)
*	Commercial aviation gasoline (ASTM D910), grade 80/87
*	Commercial gasoline, leaded, low - lead, or unleaded, when research octane number (RON) is 89 or below, or octane number displayed on retail gasoline pumps in CONUS is 85 or below

Table 2-6. Permissible Fuels - Cont

Ambient Temperature	Fuel
<p>Above -58° F</p> <p>Above -46° F</p> <p>*</p> <p>Above -10° F</p> <p>Above +15°F</p> <p>Above +32° F</p> <p>Above +40° F</p> <p>*</p>	<p><u>Alternate Fuels</u></p> <p>Turbine fuel, aviation, kerosene-type, MIL-T-83133, grade JP-8 (NATO code no. F-34)</p> <p>Turbine fuel, low volatility, MIL-T-38219, grade JP-7</p> <p>Commercial aviation turbine fuel (ASTM D1655), jet A and jet A-1</p> <p>Commercial diesel fuel (ASTM D975) 1-D and no. 1</p> <p>Diesel fuel, MIL-F-16884 (NATO code no. F-75 or F-76)</p> <p>Commercial diesel fuel (ASTM D975), 2-D and no. 2</p> <p>Distillate fuel, MIL-F-24397, ND (NATO code no. F-85)</p> <p>Any mixture of primary and/or alternate fuels listed above</p>

\* Any temperature at which the fuel will flow.

**CAUTION**

Other fuels may be used to run multifuel engines. If engine runs rough when using a new fuel, add 10% to 30% diesel fuel to smooth engine performance. Failure to add diesel fuel to smooth engine performance will result in burned pistons.

Table 2-7. Shifting Speeds in Mph

Transmission	Transfer Low	Transfer High
1st gear	5	9
2nd gear	8	16
3rd gear	14	27
4th gear	22	44
5th gear	28	56
Reverse	5	9

Table 2-8. Engine and Radiator Data

Attribute	Specification
Cylinders (in-line)	6
Brake horsepower	126-140 (gross at 2,600 rpm)
Ignition system	Compression
Firing order	1-5-3 -6-2-4
Cooling	Liquid
Thermostat:	
Start to open	180° F
Fully open	200° F

## CHAPTER 3

### SERVICE UPON RECEIPT OF EQUIPMENT

3-1. **GENERAL.** When a new, used or reconditioned truck is first received by the using organization, it is the responsibility of the using organization to see that the truck has been inspected and prepared for service by the supporting service unit. This will be shown on DA Forms 2408-5, 2408-6, 2408-7 and 2408-8, which are a record of all services and corrective maintenance. If not done before, the following services must be done before placing truck into service:

a. Lubricate the truck in accordance with lubrication order, LO 9-2320-209-12/1, regardless of interval, except for gearcases and engine crankcase.

b. Check processing tag for gearcase and engine oil, If tag shows that engine oil is good for 500 miles of operation, and is the proper grade for local climate, check oil level but do not change oil.

c. Schedule a second S preventive maintenance service on DD Form 314 Preventive Maintenance Schedule and Record, and arrange for an oil change at 500 miles.

d. Services to be done by organizational maintenance personnel when trucks are received are designated in TM 9-2320-209-20. Whenever possible the operator will assist organizational maintenance personnel in performing these services.

3-2. **BREAK IN OPERATION.**

a. **General.** Before operating the truck, the operator must become familiar with the truck controls and operation as given in chapter 4.

b. **Break-in.** When break-in of a new or rebuilt truck is done in normal service, the operator is cautioned to take special care in performing all before-operation checks and inspections given in Preventive Maintenance Checks and Services, volume 2, chapter 2, of this manual. The following precautions must be taken during break-in:

(1) Do not go above the speed shown on the truck instruction and data plate, located on the instrument panel, directly in front of the driver.

(2) Pick the best gear selection for the driving conditions. Do not skip speeds when shifting gears.

(3) Avoid fast starts and stops.

(4) Avoid sudden stops (unless in an emergency).

(5) Avoid long runs under other than normal weather, and on rough terrain.

(6) Avoid sudden forced movement of an operating control.

(7) Avoid overheating the engine.

- (8) Avoid operating the engine or the power train at full speed.

**CAUTION**

During road test, do not go faster or operate the truck continuously at the maximum allowable speeds shown on the truck instruction and caution data plate.

c. Road test. All trucks received by the using organization must be road tested to check their operation and condition. For all new or reconditioned trucks, except those driven 50 miles or more during delivery, the road test will be a minimum of 50 miles. For used trucks and trucks driven 50 miles or more during delivery, the road test will be long enough to observe truck operation and conditions. The operator will look at the instrument panel and gages, as often as possible, for signs of unsatisfactory performance. Stops will be made at least every 10 miles to give the operator a chance to inspect the truck for possible coolant, oil, fuel or exhaust leaks and any signs that may show the engine, transmission, wheel hubs, brakedrums, axle differential or transfer assemblies are overheated. The truck must be checked thoroughly for any control hard to operate and any instrument not operating properly. Unusual noises and vibrations will be noted. All unusual conditions will be reported to organizational maintenance unit.

d. After the Road Test. After the road test, fix any faulty condition which can be done at operator's maintenance level. Tell organizational maintenance unit about any other faulty conditions.

## CHAPTER 4

# OPERATING PROCEDURES

---

### Section 1. DESCRIPTION AND USE OF OPERATOR'S CONTROLS AND INDICATORS

4-1. GENERAL. Before trying to operate equipment, be sure you know where all controls and indicators are located, what each control does, and what information each indicator is giving.

#### NOTE

Controls and indicators described in this section are generally the same for all trucks covered in this manual, except where specifically noted.

In this manual the term "left" is the driver's side. The term "right" is the opposite side.



4-2. CHASSIS CONTROLS AND INDICATORS.

a. Instrument Panel Controls and Indicators.

INSTRUMENT PANEL LEFT SIDE

1. Hand THROTTLE control. Sets engine to any speed without stepping on accelerator pedal. When hand THROTTLE control knob is pulled out it locks in any position. Turning knob right or left unlocks it.
2. ENG. STOP control. When pulled out, stops engine by cutting off fuel.
3. ACCESSORY power switch. When in the ON position, routes power to the starter system, instrument panel gages, fuel pump and low pressure warning buzzer.
4. Light switch. Turns truck lights on or off.
5. Engine START button (on trucks with LD 465-1 engines). When pressed in, routes current to starter to crank engine. On trucks with LDS 427-2 engines the start button is mounted on the cab floor. (Refer to para 4-2c, Driver's Compartment Controls and Indicators.)
6. Air filter indicator. Shows red when engine air filter needs cleaning.
7. Windshield wiper control knob. When turned to on position, starts windshield wipers.
8. MANIFOLD HEATER SWITCH. When set to ON position, starts manifold heater. Manifold heater is used to help start and warmup the engine when outside temperature is below +20°F .

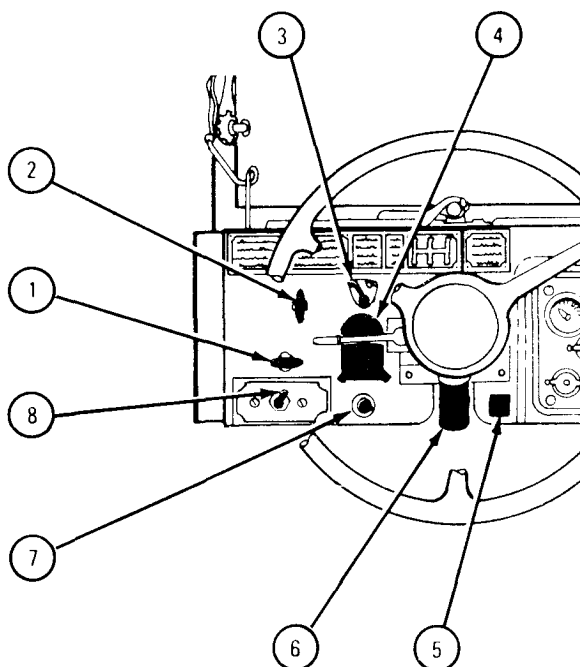
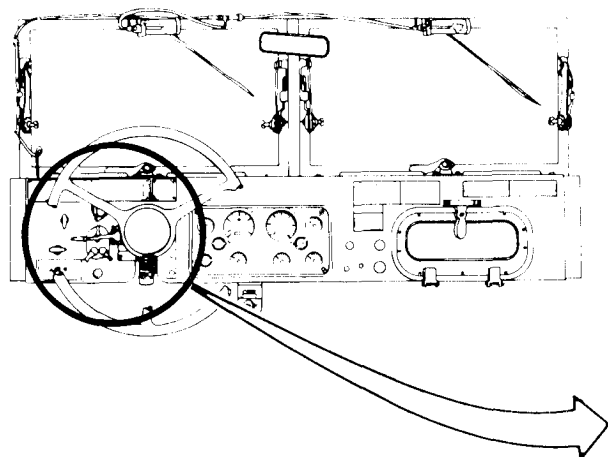

TA 044922



a. Instrument Panel Controls and indicators - Cont.

INSTRUMENT PANEL CENTER

1. FUEL level gage. Shows fuel level in fuel tank.
2. Speedometer/Odometer. Shows speed and total mileage.
3. Tachometer. Shows engine speed in revolutions per minute (rpm). Shows engine operation time in hours and tenths of hours.
4. Water temperature gage. Shows temperature of engine coolant. Normal operating temperature is between 180°F and 200° F.
5. Battery generator indicator. Shows when the battery is charging or discharging.
6. AIR pressure gage. Shows pressure in the air reservoir tanks. Normal pressure is 105 pounds per square inch (psi).

**NOTE**

A warning buzzer will be heard when engine is started and will stop when safe operating pressure is reached.

7. FRONT WHEEL DRIVE lever. When in the IN position, starts front wheel driving power.
8. FRONT WHEEL DRIVE indicator light. Goes on when front wheel drive is operating.
9. OIL pressure gage. Shows engine oil pressure when engine is running.
10. HIGH BEAM indicator. Goes on when headlights are on high beam.

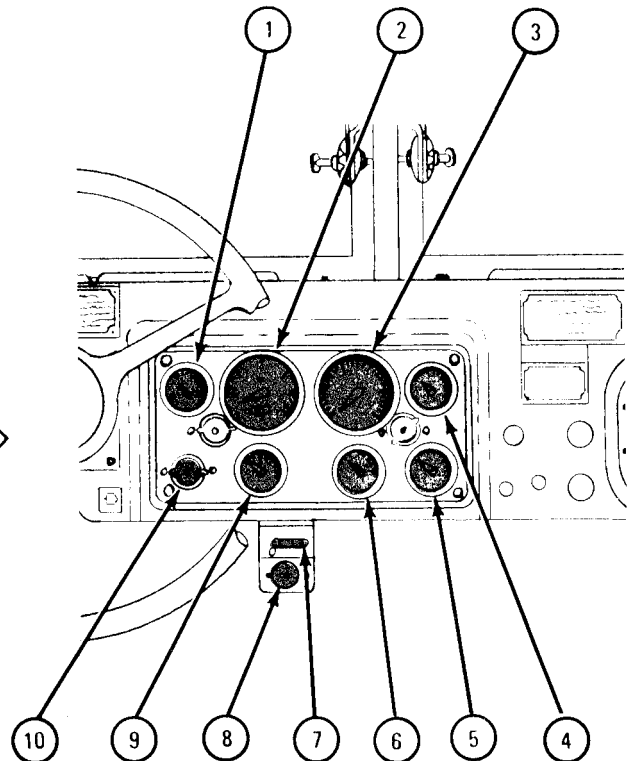
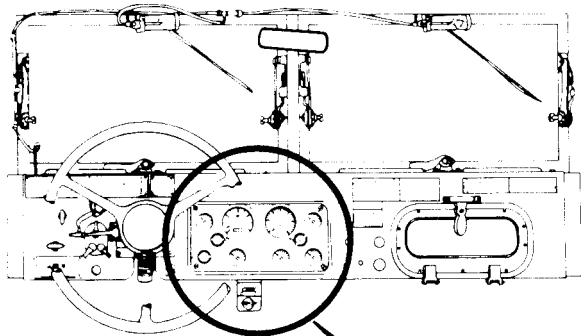

TA 044923

b. Windshield Controls and Indicators.

1. Windshield locking handle. Locks windshield in closed position.
2. Windshield wiper lever. Gives a way to move the windshield wiper manually.
3. Windshield clamping screws. Locks wind shield in any open position.
4. Windshield wiper motor reset button. When in the out position, wiper motor will not operate. Press in before turning windshield wiper control knob to on position.

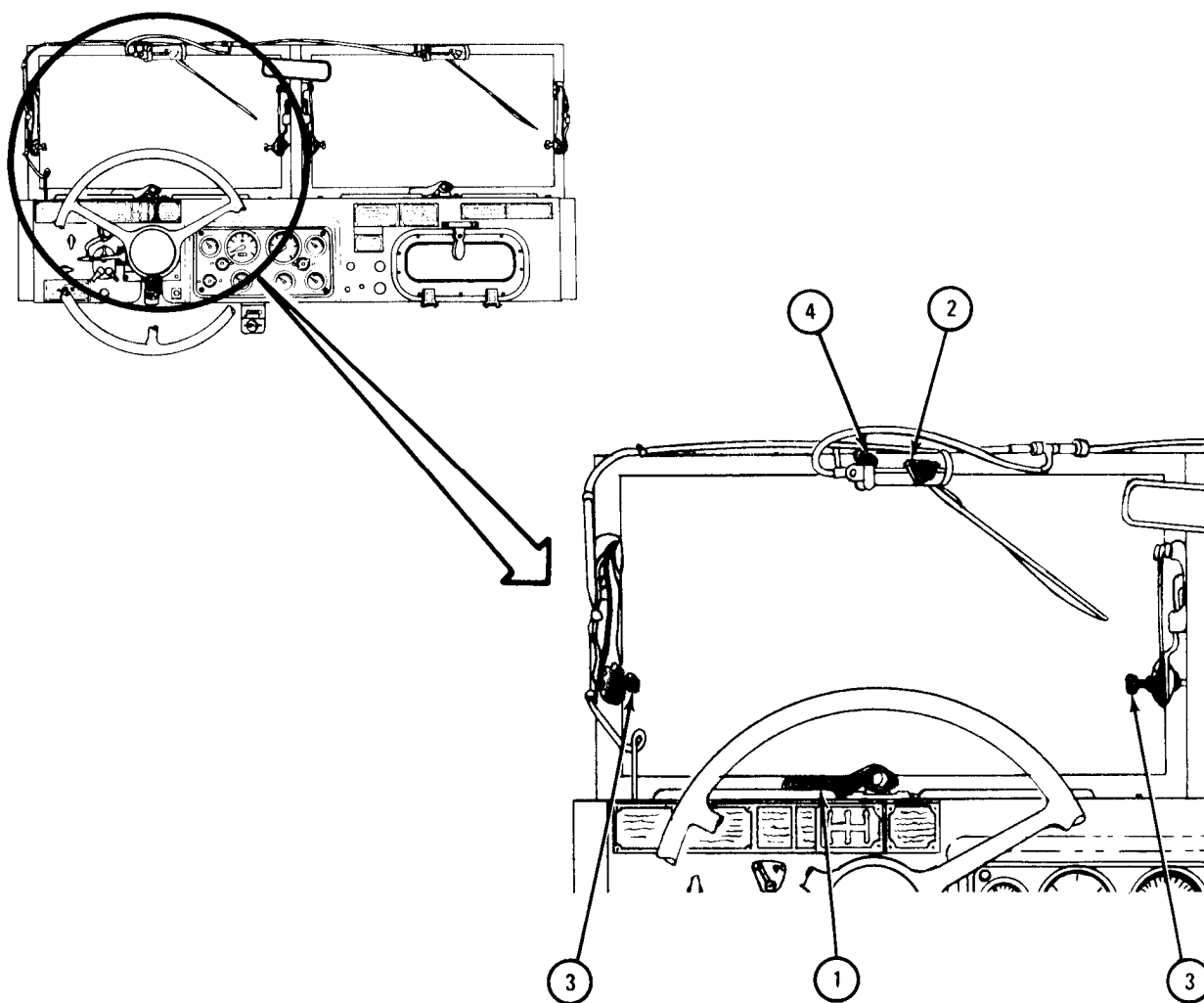

TA 044924

c. Driver's Compartment Controls and Indicators.

- |  |   |
|--|---|
| <ol style="list-style-type: none"> <li>1. Accelerator pedal. Controls engine speed.</li> <li>2. Dimmer switch. Raises or lowers head light beam.</li> <li>3. Clutch pedal. Is pressed in before shifting gears.</li> </ol> | <ol style="list-style-type: none"> <li>4. Engine STAR T button (on trucks with LDS 427-2 engines). When pressed in, routes current to starter to crank engine. (On trucks with LD 465-1 engines the start button is mounted on the instrument panel. Refer to para 4-2a, Instrument Panel Left Side Controls and Indicators.)</li> <li>5. Service foot brake. When pressed in, slows down and stops truck.</li> </ol> |
|--|---|

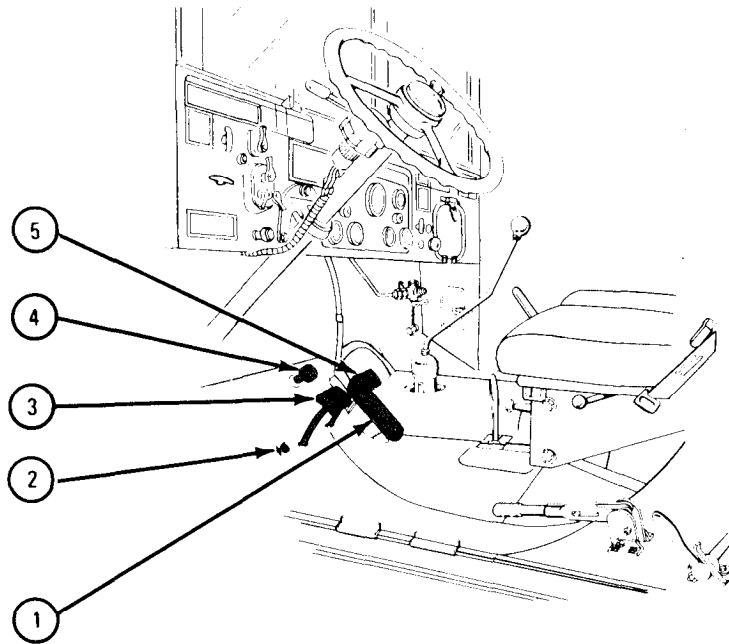

TA 044925

c. Driver's Compartment Controls and Indicators - Cont.

- |  |  |
|--|--|
| <p>1. Horn button. When pressed in, sounds horn.</p> <p>2. Directional turn signal and flasher control lever. Turns on turn signal and emergency flasher lights.</p> | <p>3. Steering wheel. Controls direction of the truck.</p> |
|--|--|

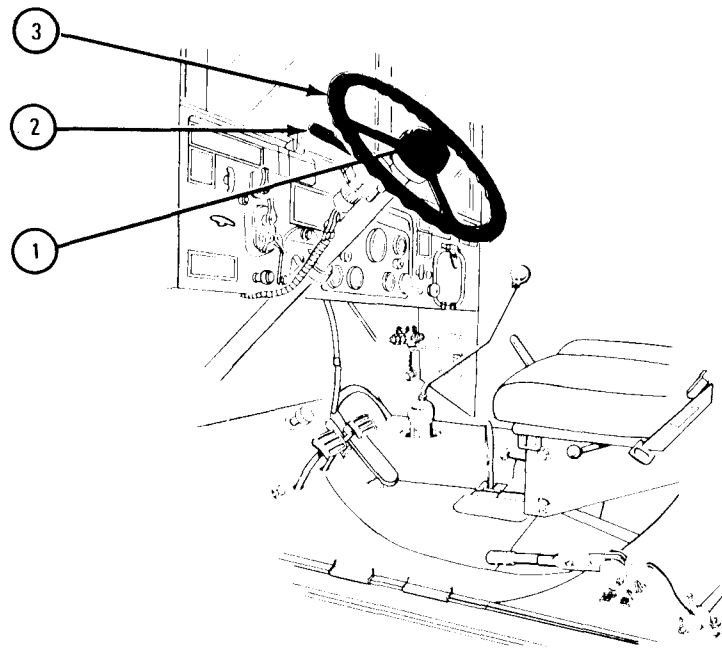

TA 044945

c. Driver's Compartment Controls and Indicators - Cont.

- |  |   |
|--|---|
| <ol style="list-style-type: none"> <li>1. Cowl ventilator. When open, lets air flow into the driver's compartment.</li> <li>2. Air supply valve. Is an emergency source of compressed air for inflating tires, cleaning air filters, etc.</li> </ol> | <ol style="list-style-type: none"> <li>3. FRONT TRANSMISSION gearshift lever. Used to place the transmission in one of five forward positions, reverse or neutral.</li> <li>4. Spring tension control lever. Turned to make seat harder or softer.</li> </ol> |
|--|---|

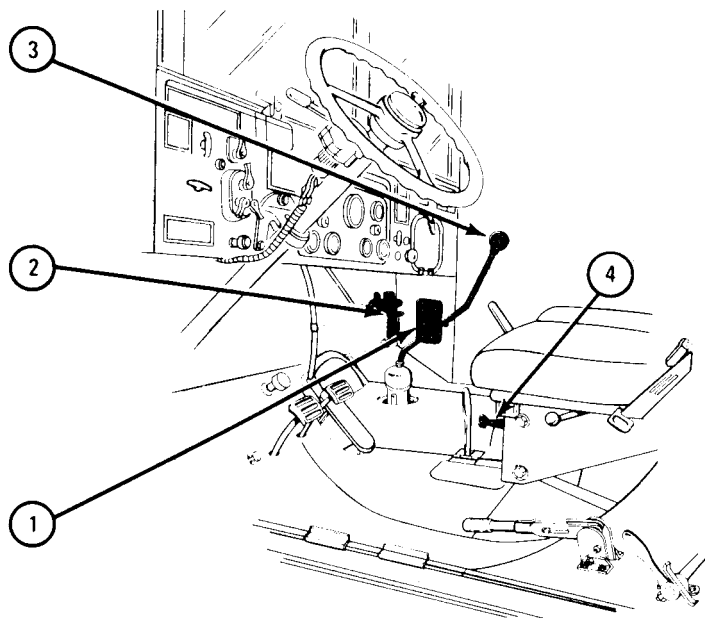

TA 044946

c. Driver's Compartment Controls and Indicators - Cont.

- |   |   |
|---|---|
| <ol style="list-style-type: none"> <li>1. TRANSFER CASE shift lever. Moved to (DOWN) LOW for heavy load conditions and to (UP) HIGH for light load conditions.</li> <li>2. Backrest control lever. Used to change position of the lower section of the backrest.</li> <li>3. Seat cushion control lever. Used to move rear portion of seat cushion up or down.</li> <li>4. Seat horizontal control lever. Used to move seat forward or backward.</li> <li>5. Slotted bracket. Used to move front of seat cushion up or down.</li> <li>6. Locking bar. Locks power take-off lever in off position when bar is turned to up and down position.</li> </ol> | <ol style="list-style-type: none"> <li>7. Transfer POWER TAKE OFF LEVER. Supplies power to operate auxiliary equipment when in the up position.</li> <li>8. Handbrake control lever. Is pulled up to set handbrake. The knob at the top of the handle is turned to set brake cable tension.</li> <li>9. Shifting lever hinge lock. Locks transmission power take-off lever in neutral position.</li> <li>10. POWER TAKE OFF SHIFTS LEVER. Is moved forward to HIGH or LOW position to give power to front winch for reeling in a load. Moved to REV (reverse) position to release or lower a load.</li> </ol> |
|---|---|

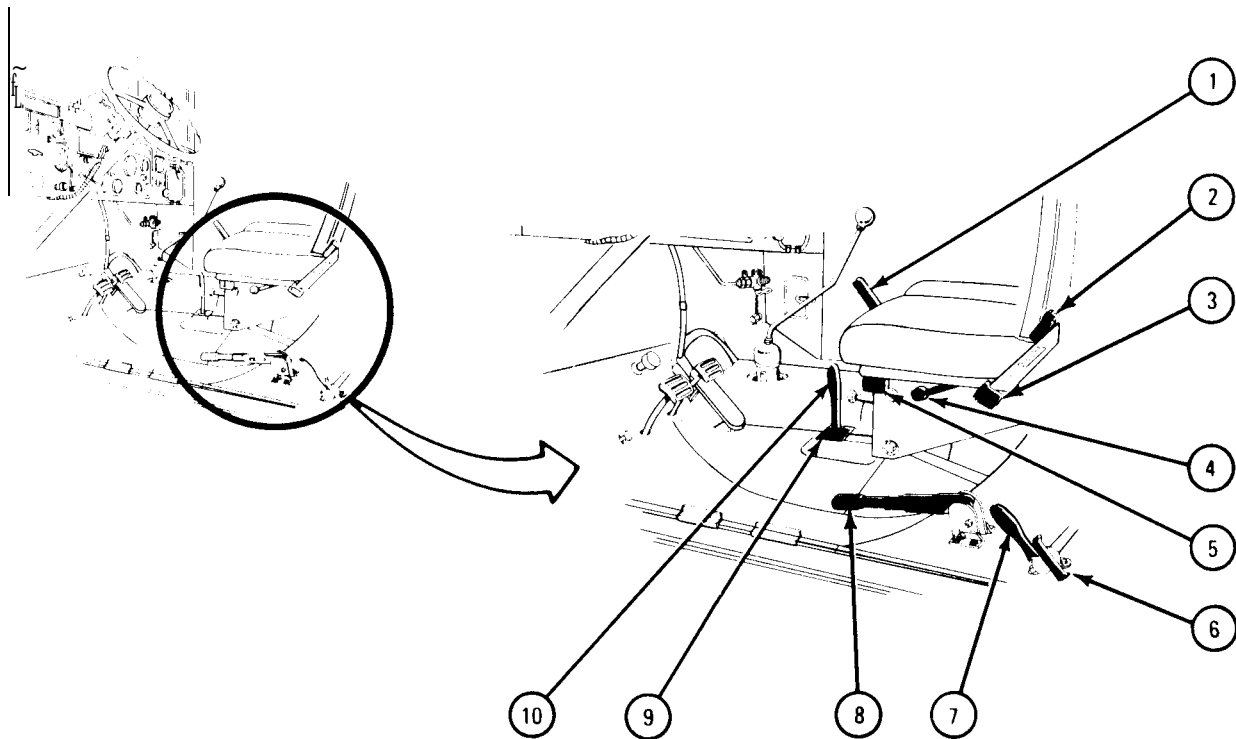

TA 044947

d. Front Winch Controls and Indicators.

1. Front winch drum lock knob. Is used to lock drum when winch is not in use. When knob is pulled out and drum is unlocked.

2. Front winch CLUTCH control lever. Is moved to IN position (toward right side of truck) to put winch into gear and to OUT position (left side of truck) to take it out of gear.

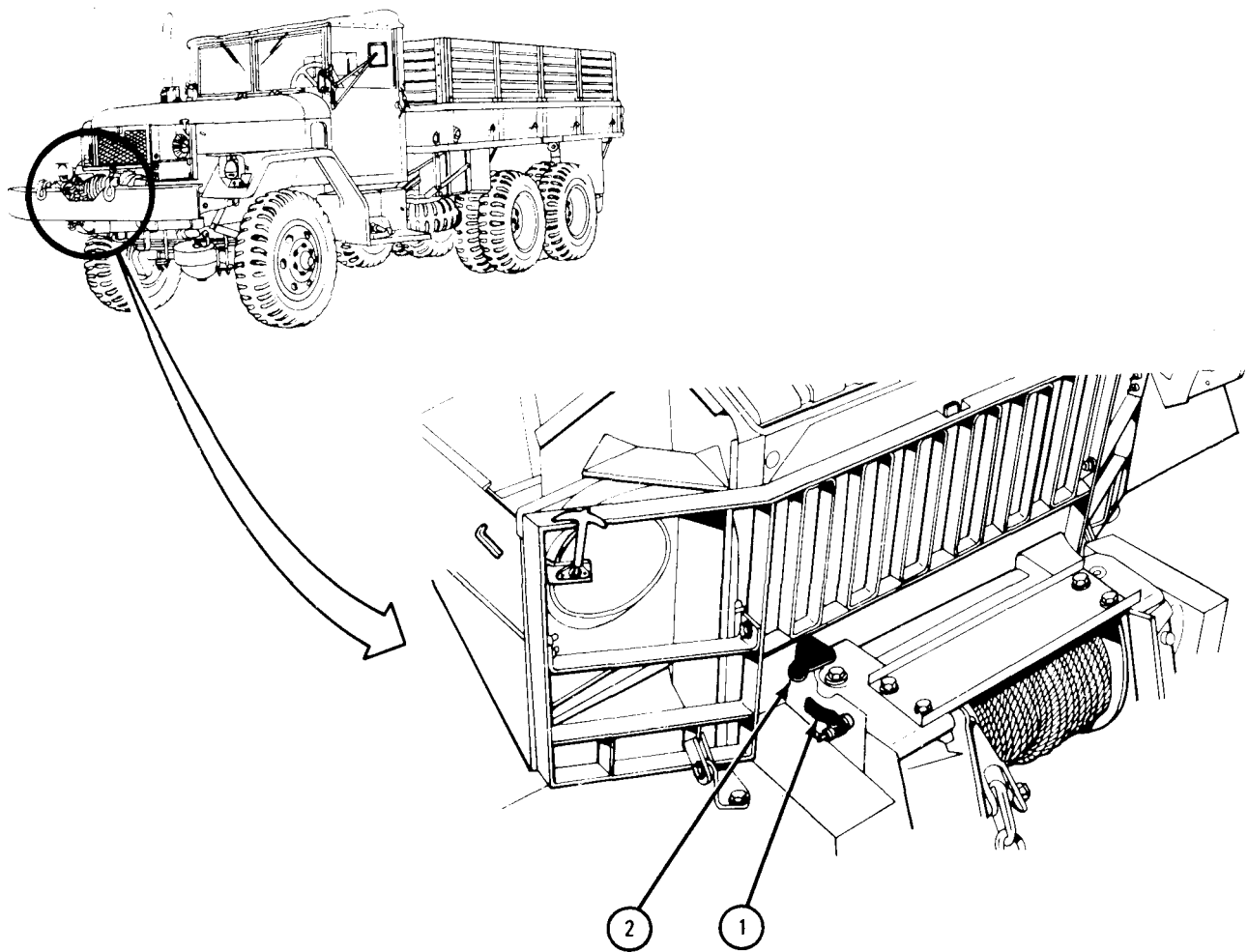

TA 044926

e. Trailer Brake Controls and Indicators.

1. Trailer air valve handles (two). Are turned to send compressed air to the trailer brake system.

**NOTE**

The trailer air valve handles are located on rear part of chassis frame on right and left sides. Position of valve handle is different on some trucks.

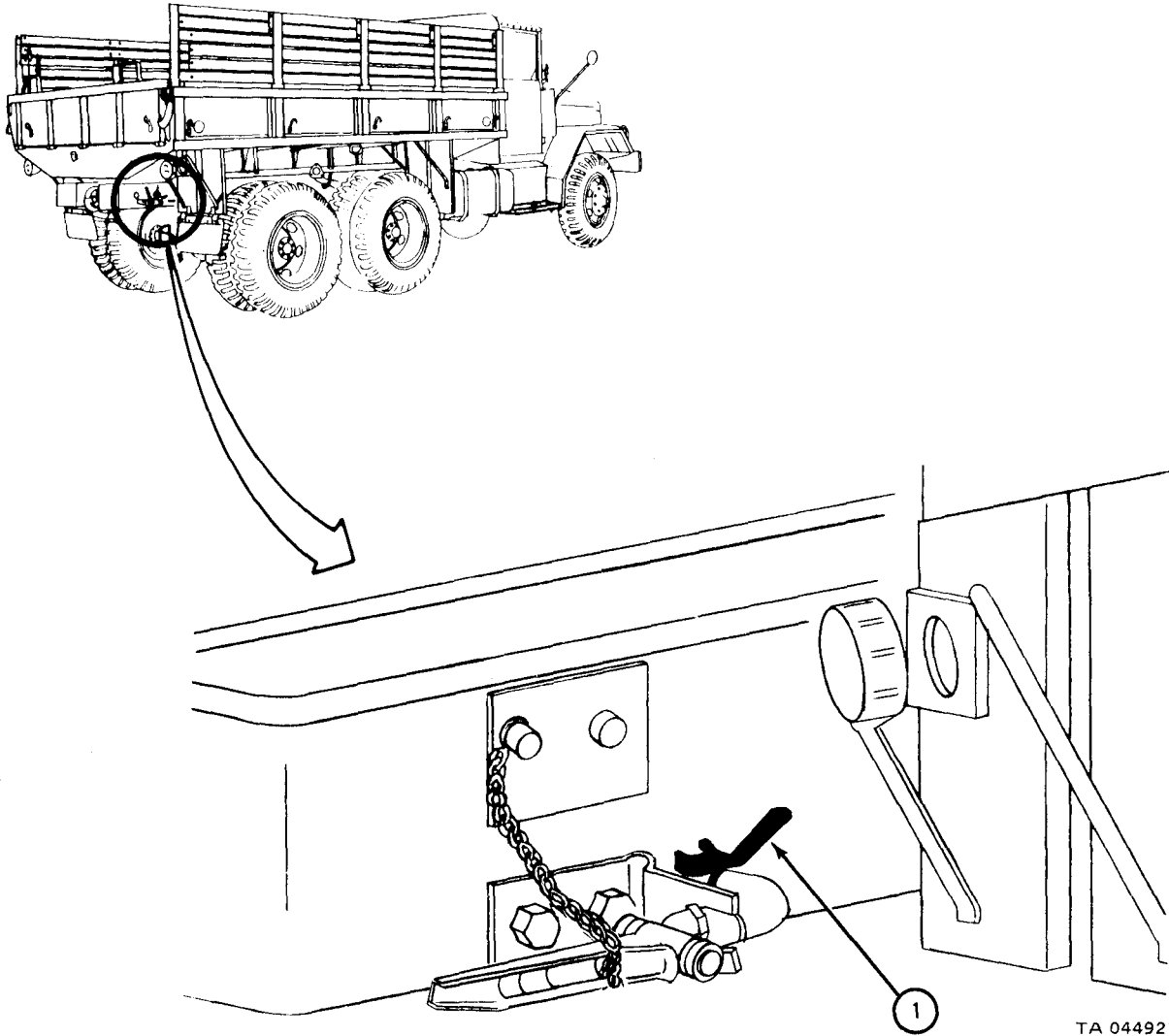

TA 044927



4-3. EQUIPMENT BODY CONTROLS AND INDICATORS.

a. Fuel Tank Trucks (M49A1C and M49A2C) Controls and Indicators.

M49A1C

- |  |  |
|--|--|
| <ol style="list-style-type: none"> <li>1. Meter. Records amount (no. of gallons) of fuel pumped out.</li> <li>2. Counter control lever. Is moved up or down to return numbers on meter to zero.</li> <li>3. Pressure gage. Shows condition of filter elements by showing difference in pressure between inlet and outlet side of filter.</li> <li>4. Pressure gage handle. Is turned to No. 1 position (right) to take pressure readings on inlet side of valve. Is turned to No. 3 position (left) to take readings on outlet side of valve.</li> <li>5. Dump valve control (1-inch line). Is turned left to open automatic dump valve, which dumps water separated from fuel by filter segregator unit.</li> <li>6. Manual drain valve control (1/2-inch line). Is turned left to open manual drain valve to drain sump assembly.</li> </ol> | <ol style="list-style-type: none"> <li>7. Gravity delivery line gate valve. Is turned left to let fuel flow through gravity delivery line.</li> <li>8. Pump delivery line gate valve. Is turned left to let fuel flow through pump and dispenser line.</li> <li>9. Discharge valve control levers. Are pulled back to open discharge valves which control flow of fuel from tank sections.</li> <li>10. Liquid level gage. Is dipped into tank sections to measure liquid level.</li> <li>11. Remote control handle. Is pulled forward in an emergency to trip operating levers and return them to the closed position.</li> </ol> |
|--|--|

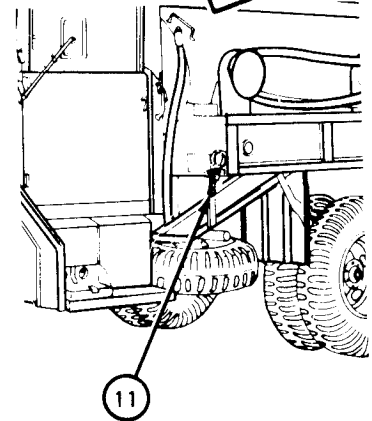
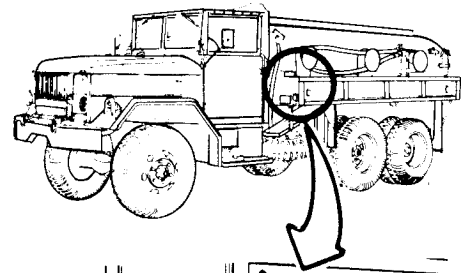
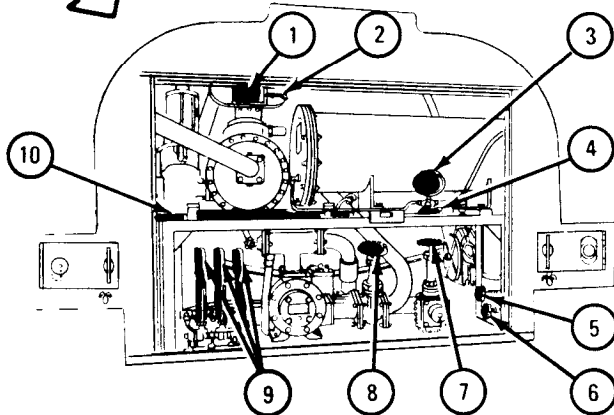
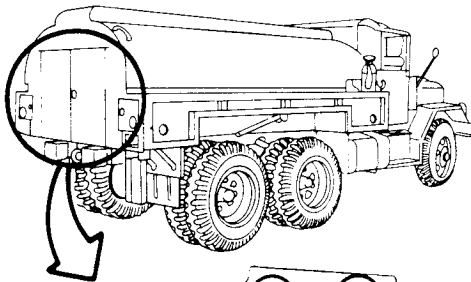

TA 044928

a. Fuel Tank Trucks (M49A1C and M49A2C ) Controls and Indicators - Cent,

M49A2C

- |  |  |
|--|--|
| <ol style="list-style-type: none"> <li>1. Meter. Records amount (no. of gallons ) of fuel pumped out.</li> <li>2. Counter control lever. Is moved up or down to return numbers on meter to zero.</li> <li>3. Pressure gage. Shows condition of filter elements by showing difference in pressure between inlet and outlet side of filter.</li> <li>4. Pressure gage handle. Is turned to No. 1 position (right) to take pressure readings on inlet side of valve. Is turned to No. 2 position (left) to take readings on outlet side of valve.</li> <li>5. Dump valve control (1-inch line). Is turned left to open automatic dump valve, which dumps water separated from fuel by filter segregator unit.</li> <li>6. Manual drain valve control (1/2 -inch line). Is turned left to open manual drain valve to drain the sump assembly.</li> </ol> | <ol style="list-style-type: none"> <li>7. Gravity delivery line gate valve. Is turned left to let fuel flow through gravity delivery line.</li> <li>8. Pump delivery line gate valve. Is turned left to let fuel flow through pump and dispenser line.</li> <li>9. Discharge valve control levers. Are pulled back to open discharge valves which control flow of fuel from tank sections.</li> <li>10. Liquid level gage. Is dipped into tank sections to measure fuel level.</li> <li>11. Remote control handle. Is pulled forward in an emergency to trip operating levers and return them to closed position.</li> </ol> |
|--|--|

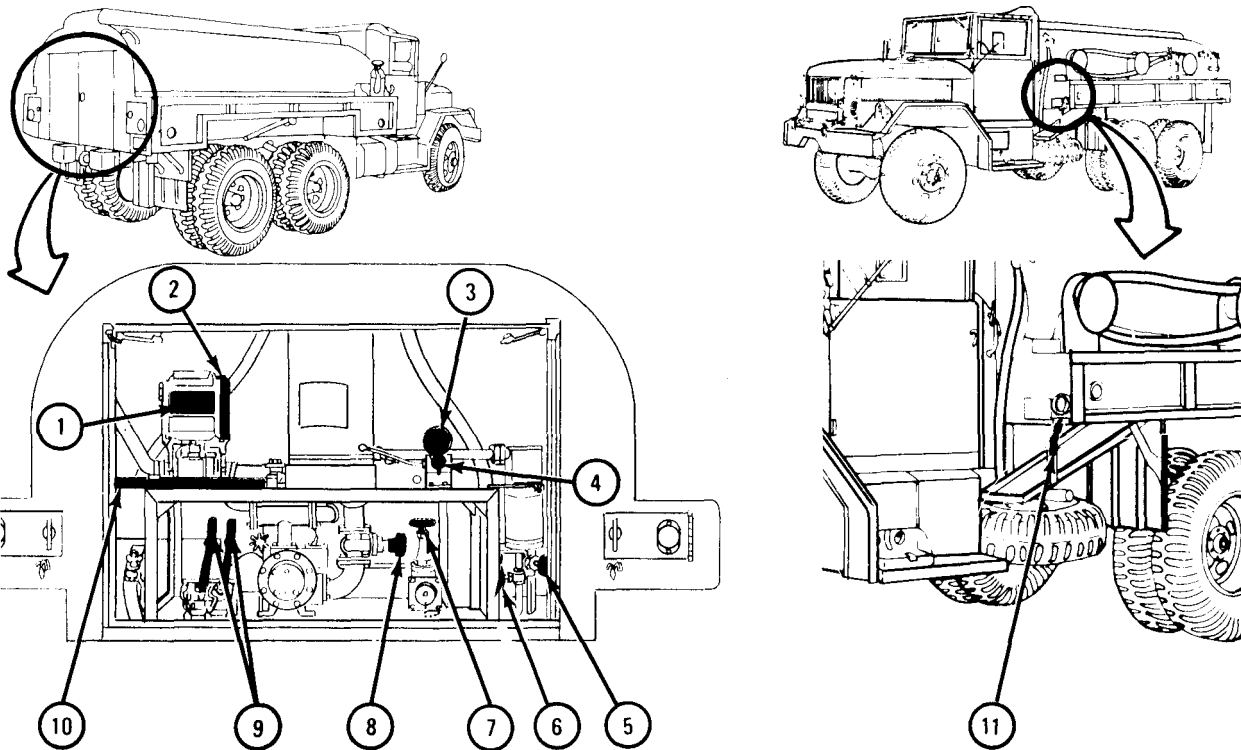

TA 044929

b. Water Tank Trucks Controls and Indicators.

- |   |   |
|---|---|
| <p>1. Gravity delivery line suction valve. Is turned left to let water flow through gravity delivery line.</p> <p>2. Pump delivery line discharge valve. Is turned left to let water flow through pump delivery line.</p> | <p>3. 400 gallon compartment valve lever and 600 gallon compartment valve lever. Are pulled back to open discharge valves which control flow of water.</p> <p>4. Water level gage. Is dipped into tank sections to measure water level.</p> |
|---|---|

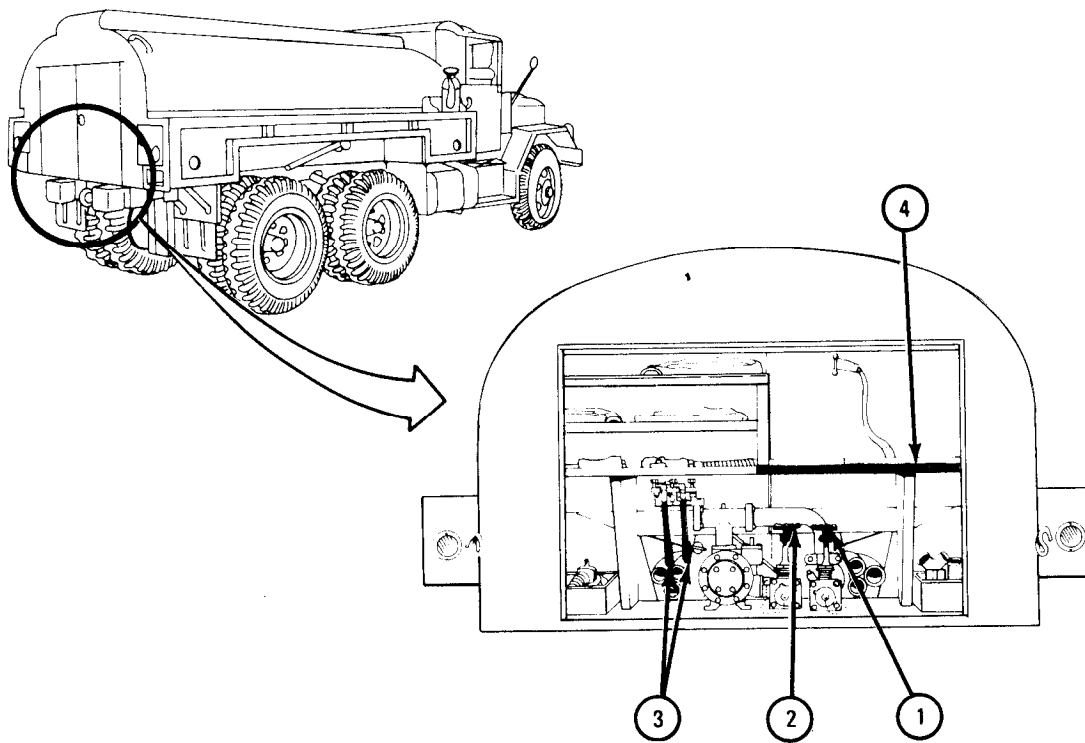

TA 044931

b. Water Tank Trucks Controls and Indicators - Cont.

1. Exhaust bypass valve control. Is pulled out to open exhaust bypass valve and allow exhaust gases to enter heating chamber under tank.

2. Exhaust bypass fording valve. Is closed to prevent outside water from entering tank heating chamber during fording operations.

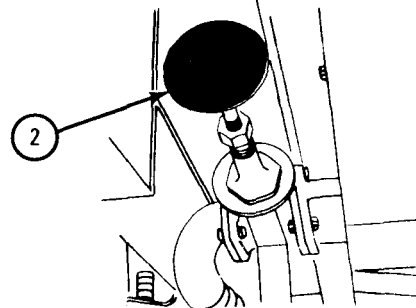
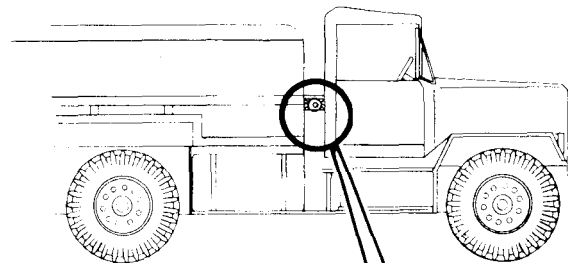
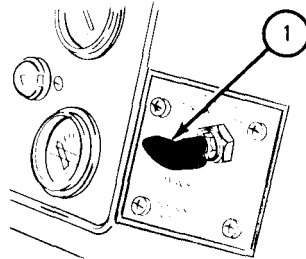
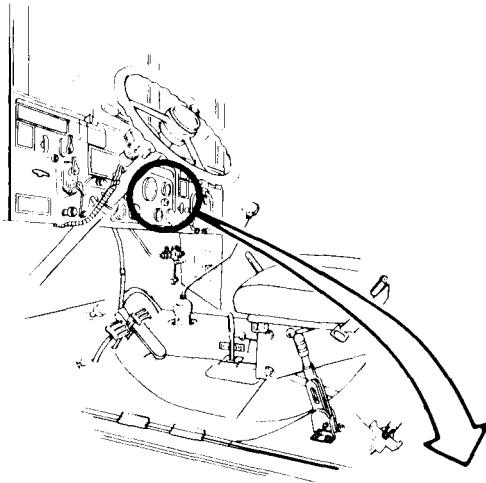

TA 044930

c. Shop Van and Instrument Repair Shop Trucks Controls and Indicators.

- |   |   |
|---|---|
| <p>1. OPERATION BLACKOUT SWITCH 115V. -A. C. SYSTEM. Controls dome lights in the 115 volt AC system.</p> <p>2. Circuit breaker box. Has four circuit breakers which control van body circuits.</p> <p>3. POWER SWITCH 115V. -A. C. Controls all power to van body electrical circuits except the 24 volt AC-to-DC converter for exhaust blower.</p> | <p>4. EXH. BLOWER switch. Controls power to exhaust blower.</p> <p>5. Converter SELECTOR switch. Is used to choose desired voltage.</p> |
|---|---|

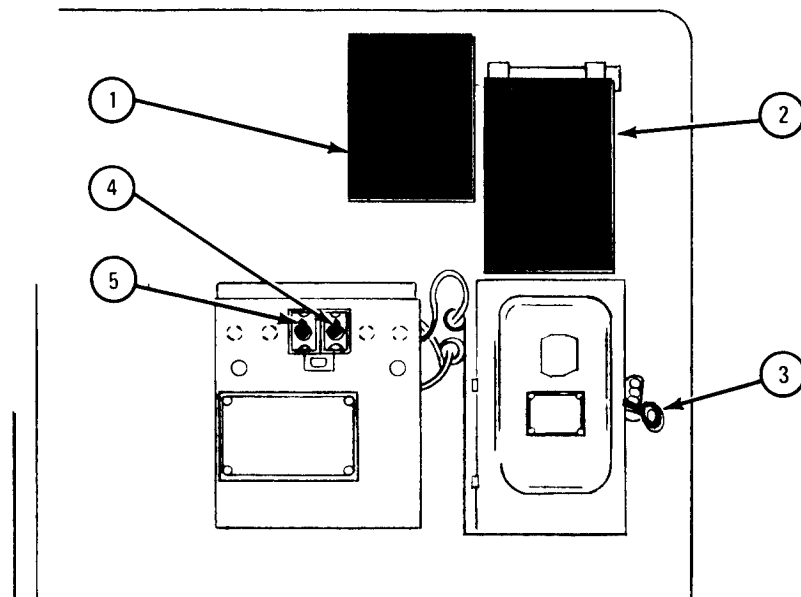
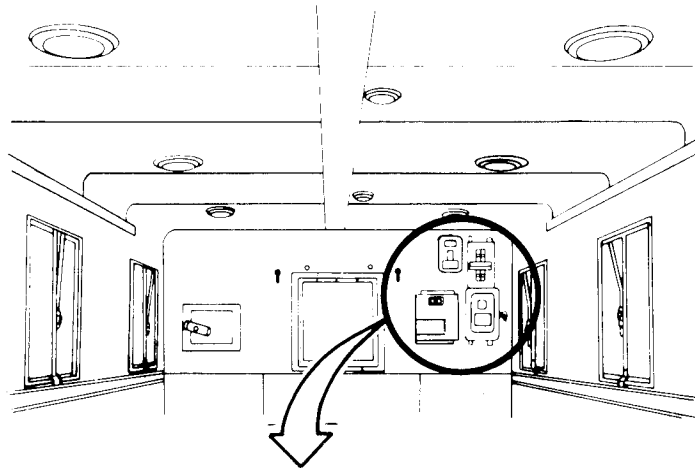

c. Shop Van and Instrument Repair Shop Trucks Controls and Indicators - Cont.

- |  |  |
|--|--|
| 1. DOME LIGHT SWITCHES 24 VOLTS ON-OFF switch. Controls the 24-volt dome light system. | 2. DOME LIGHTS SWITCHES 24 VOLTS NORMAL-BLACKOUT switch. Lets you control dome lights in normal or blackout condition. |
|--|--|

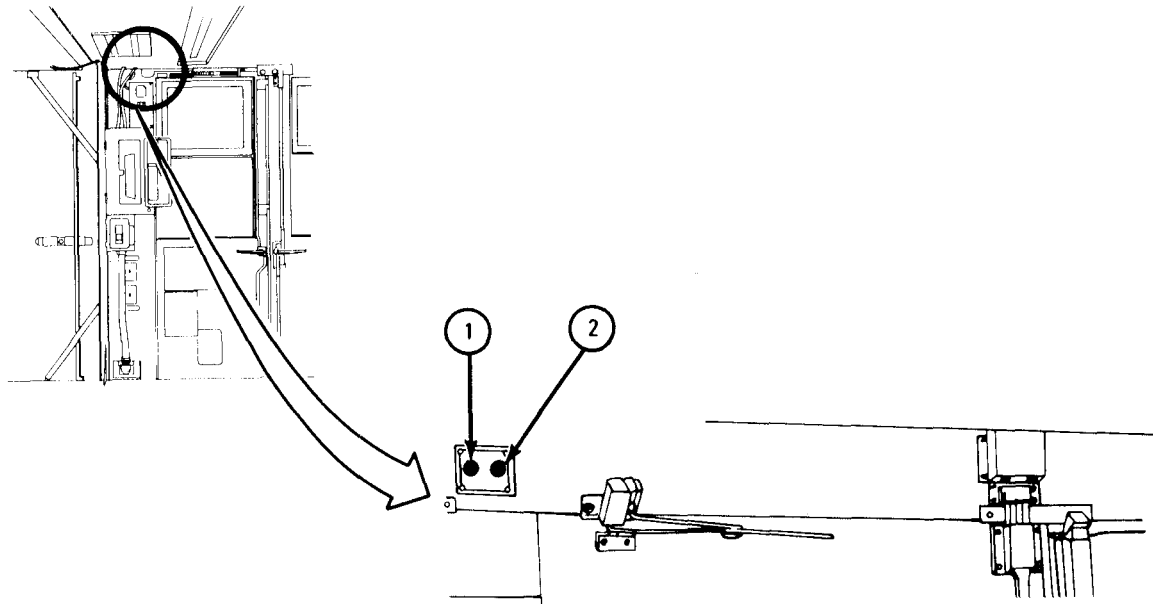

TA 044932

d. Tractor Trucks Controls and Indicators.

1. Airbrake hand control lever. Controls semitrailer airbrake system. When lever is moved down, brakes are on.
2. Airbrake hose coupling shut-off-cocks. Are turned on (up position) to let air enter semitrailer brake system after it is hooked up and must be turned off (position shown) before trailer is unhooked.
3. Fifth wheel operating handle. Is pulled forward to unlock jaws and separate semitrailer from tractor.
4. Safety latch. Makes sure that there is a positive locking of the fifth wheel jaws. The safety latch must be moved left or right to move operating handle.

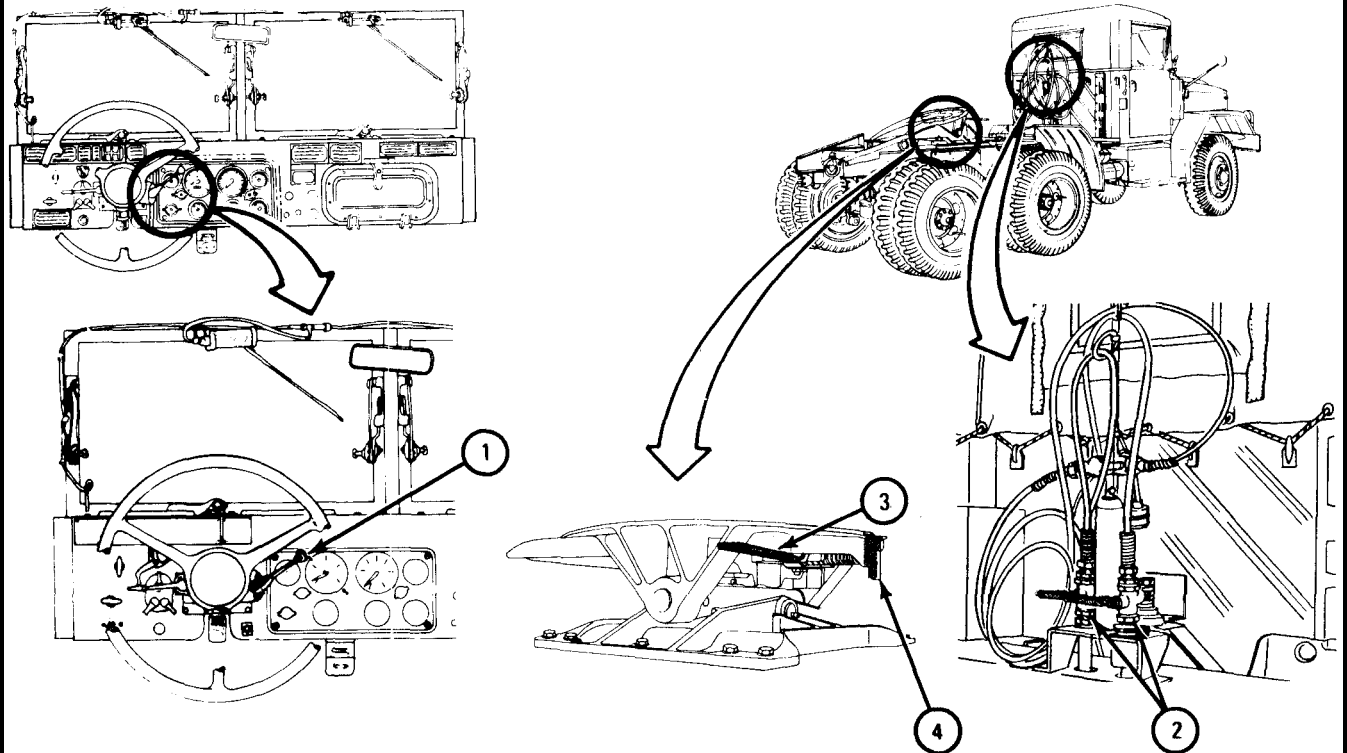

TA 044934

e. Dump Truck Controls and Indicators.

1. Tailgate hand lever. Is pulled forward and down to open tailgate.
2. Hydraulic hoist control lever. Is moved forward to raise dump body, and backward to lower dump body.
3. Safety lock. Locks control lever in dump body down position when turned to side position.

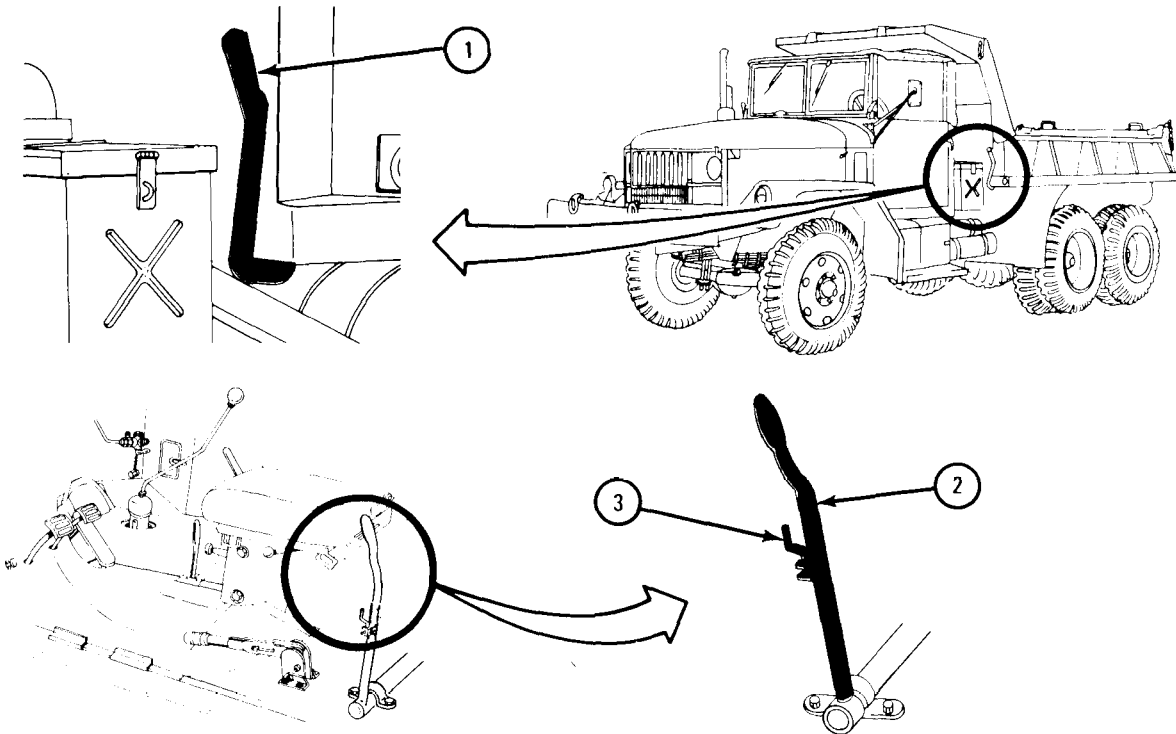

TA 044935



f. Pipeline Construction Truck Controls and Indicators.

- |  |   |
|--|---|
| <p>1. Safety brake adjustment screw. Is turned right (from under the truck) to tighten brake bands which prevent lowering of the load when the clutch is set free.</p> <p>2. Drag brake adjustment screw. Is turned right (from under the truck) to increase drag and prevent free spooling.</p> | <p>3. Drum clutch lever. Is placed right to make drum ready to turn and left to set drum free.</p> <p>4. Winch drumlock. Is pulled out and turned 90° to unlock drum.</p> |
|--|---|

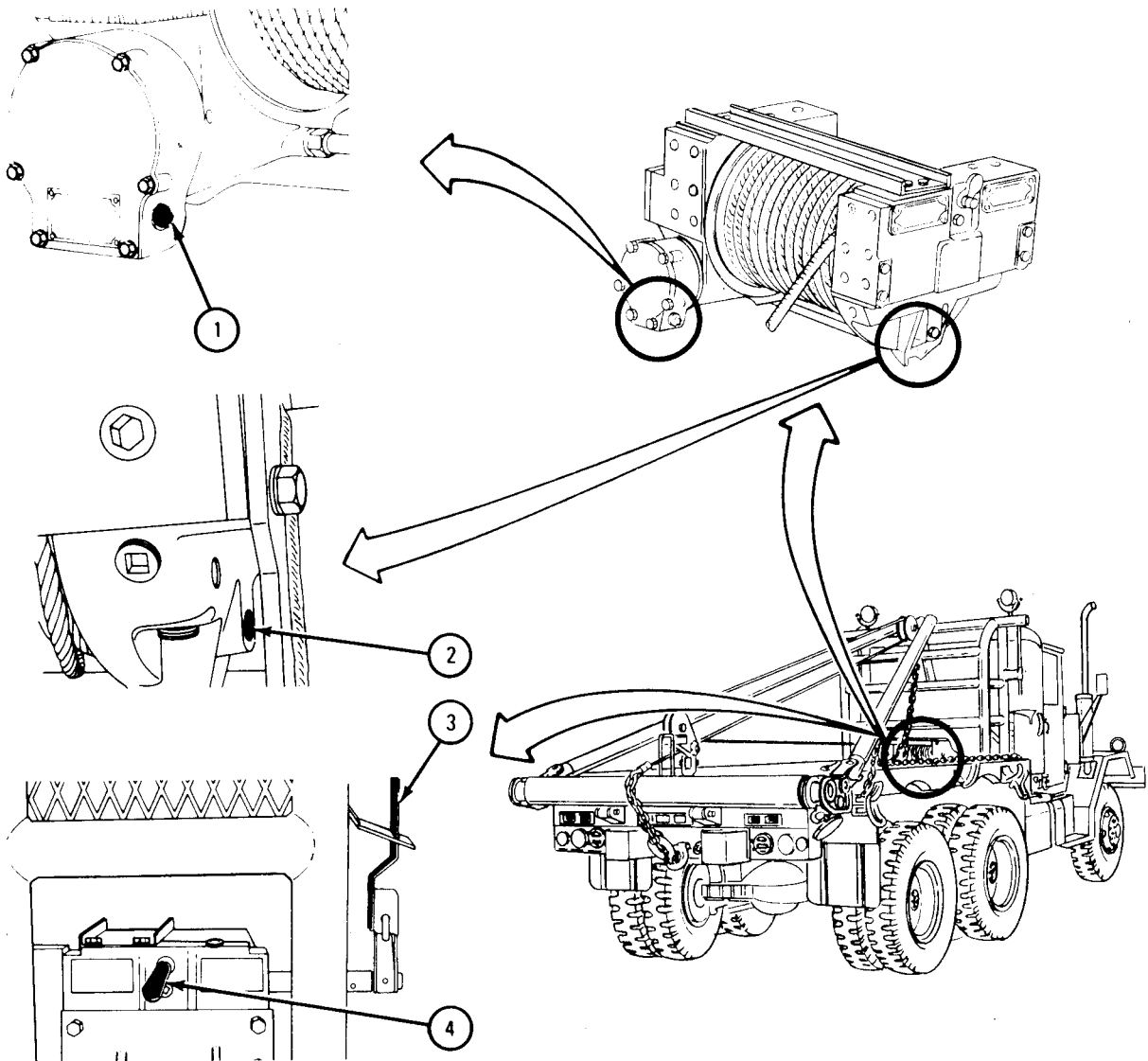

TA 044936

g. Earth Boring Machine and Polesetter Truck Controls and Indicators.

1. Rear winch control lever. Is moved forward to operate rear winch, and to the rear to stop rear winch.
2. Hinge lock. Locks rear winch control lever in the off position when not in use.
3. Power divider control lever. Is shifted as needed to give power to rear winch or earth boring machine.

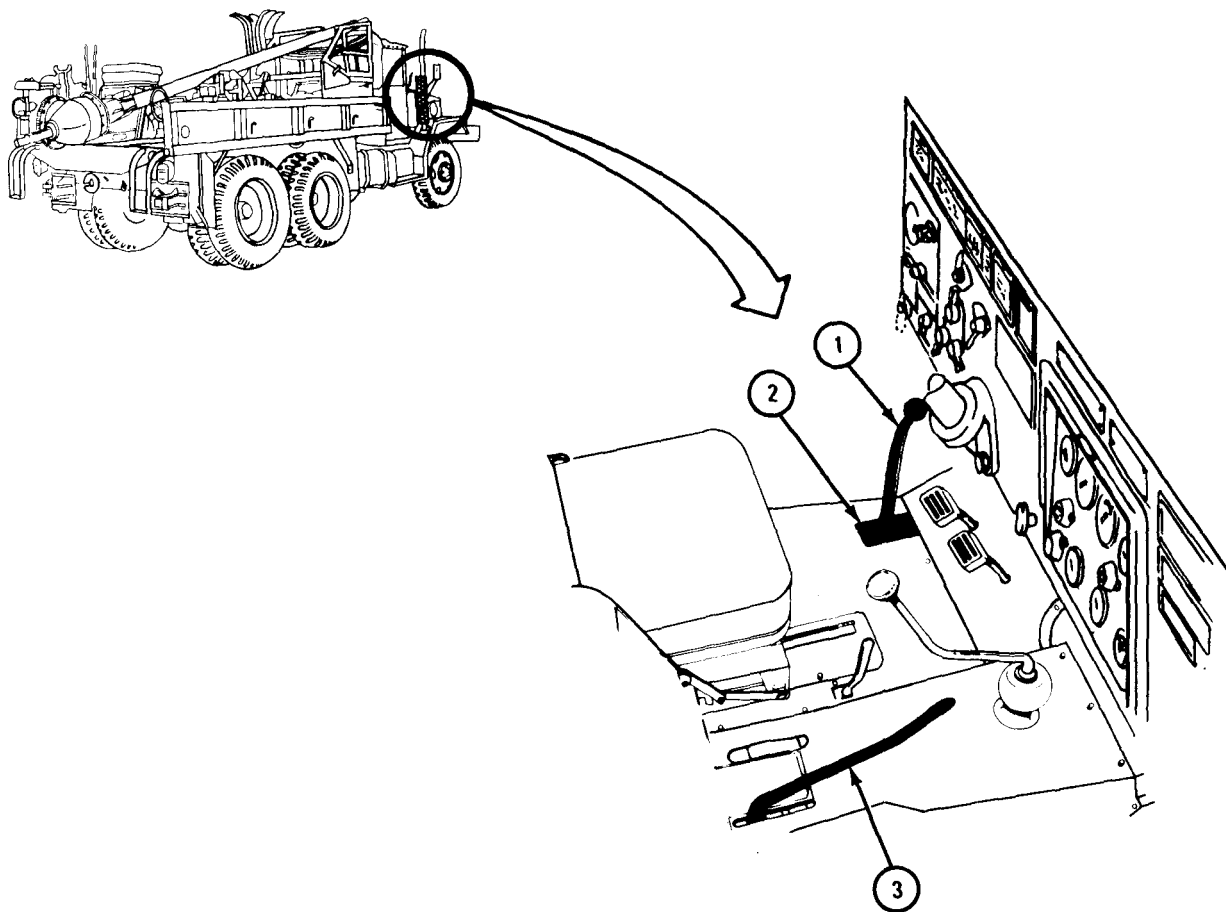

TA 044937

g. Earth Boring Machine and Polesetter Truck Controls and Indicators -Cont.

1. **OUTRIGGERS** control valve levers. Are moved forward (DOWN) to lower outrigger legs and to the rear (UP) to raise legs.

From operator's position, right lever controls left outrigger leg and left lever controls right leg.

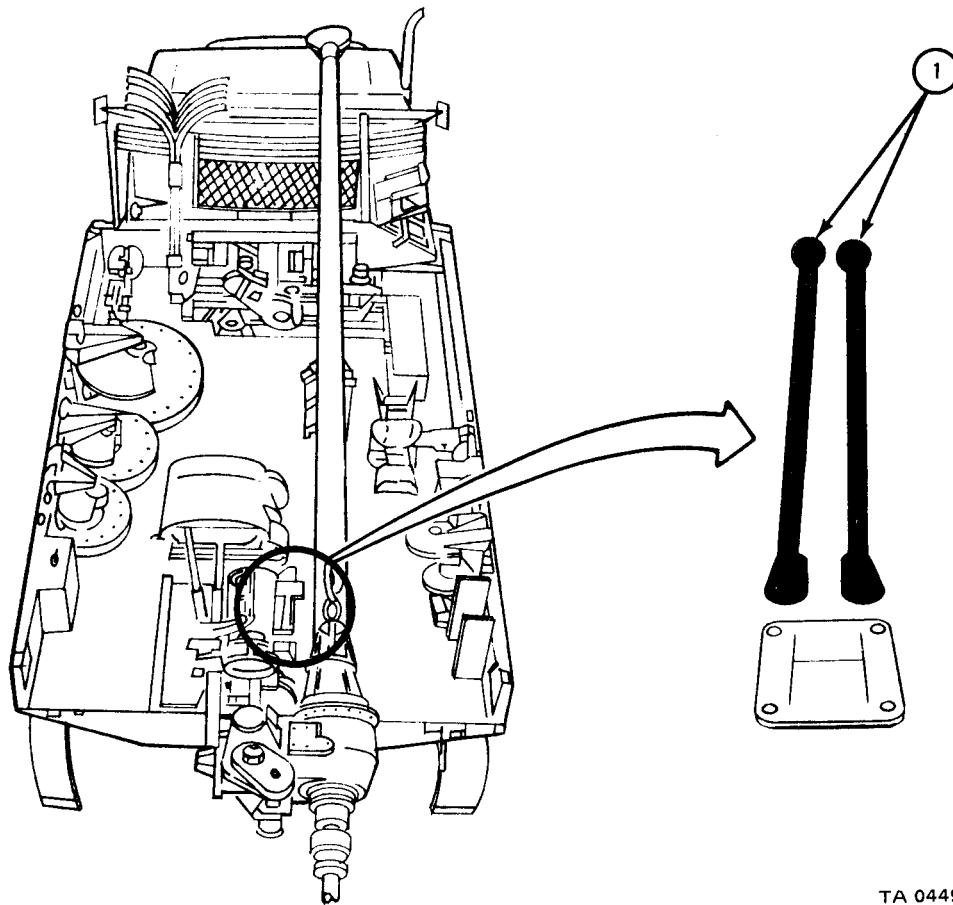

TA 044938

g. Earth Boring Machine and Polesetter Truck Controls and Indicators - Cont.

- |  |  |
|--|--|
| <ol style="list-style-type: none"> <li>1. Leveling bubble. Shows that earth auger is in straight up and down position when bubble is centered.</li> <li>2. Power-leveler shifting handle. Used with boring machine feed and drive control levers, to control up and down and side to side movements of earth boring machine and polesetter derrick.</li> <li>3. Earth boring machine feed control lever. Controls up and down movement of earth auger, when used together with the drive control lever.</li> </ol> | <ol style="list-style-type: none"> <li>4. Earth boring machine drive control lever. Controls the turning of the earth auger. Is used together with the feed control lever.</li> <li>5. Locking latch. Gives positive locking of drive and feed control levers in braking position.</li> <li>6. Outrigger safety latch. Gives positive locking of outrigger leg when in up position.</li> </ol> |
|--|--|

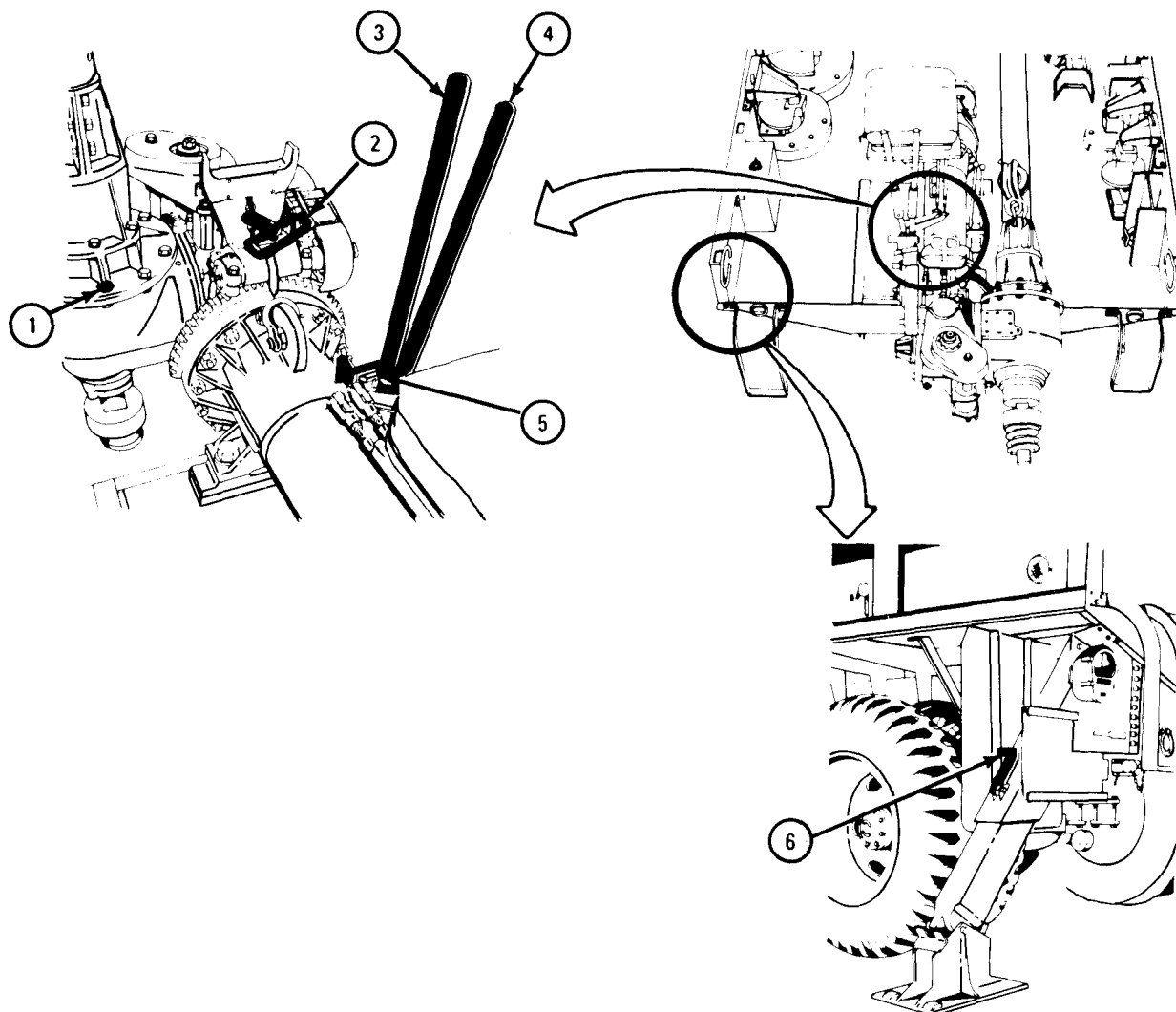

TA 044939

4-4. SPECIAL KITS CONTROLS AND INDICATORS.

a. Hot Water Personnel Heater Kit Controls and Indicators.

- |   |   |
|---|---|
| <ol style="list-style-type: none"> <li>1. HEATER blower switch. Is placed in HI or LO position to control flow of forced air into personnel compartment.</li> <li>2. Damper control knob. Is pulled out all the way to give maximum amount of heat to personnel compartment.</li> </ol> | <ol style="list-style-type: none"> <li>3. DEFROSTER knob. Is pulled out all the way to send the flow of hot air onto windshield to prevent frosting.</li> <li>4. Air bleeder valve. Is opened (turned to left) while coolant is flowing through the cooling system to let air out and prevent an air pocket from forming in heater hot water tank.</li> </ol> |
|---|---|

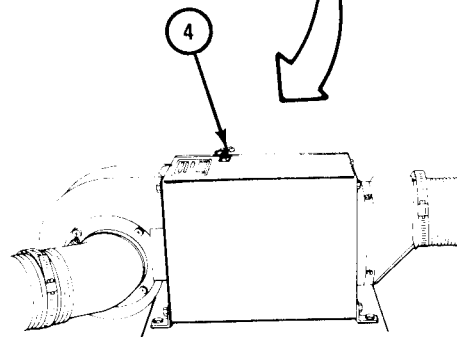
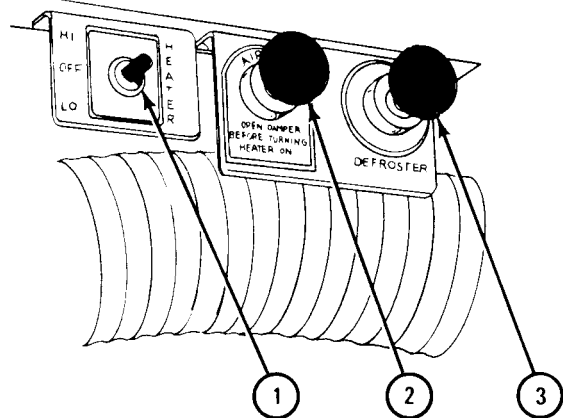
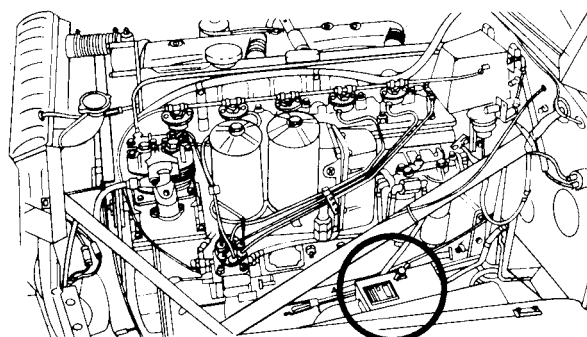
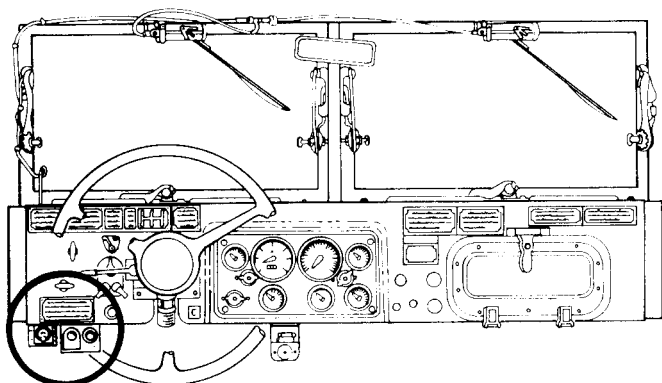

TA 044940

b. Arctic Winterization Kit Controls and Indicators.

- |   |  |
|---|--|
| <ol style="list-style-type: none"> <li>1. HI-LO switch. Controls the rate of fuel burning and speed of blower in personnel heater.</li> <li>2. Red indicator light. Is on when the personnel heater is operating.</li> <li>3. START-OFF-RUN switch. Is set to START position to start personnel heater. Set to RUN position to run heater and to OFF to stop heater.</li> <li>4. Air control knob. Is pulled all the way out to get maximum air flow, is pushed in to lower or shut off air flow.</li> <li>5. DEFROSTER control knob. Is pulled all the way out for maximum defroster operation. Is pushed in for maximum heater operation; is placed half way out for combination defroster heater operation.</li> </ol> | <ol style="list-style-type: none"> <li>6. EMERGENCY switch. Is for emergency conditions only. When switch is placed in down position, fuel flow to heater stops immediately and blower motor is shut off.</li> <li>7. HI-LO switch. Controls rate of fuel burning and speed of blower in power plant (engine) heater.</li> <li>8. Red indicator light. Is on when power plant heater is operating.</li> <li>9. START-OFF-RUN switch. Is set to START position to start power plant heater, to RUN position to run heater and to OFF to stop heater.</li> </ol> |
|---|--|

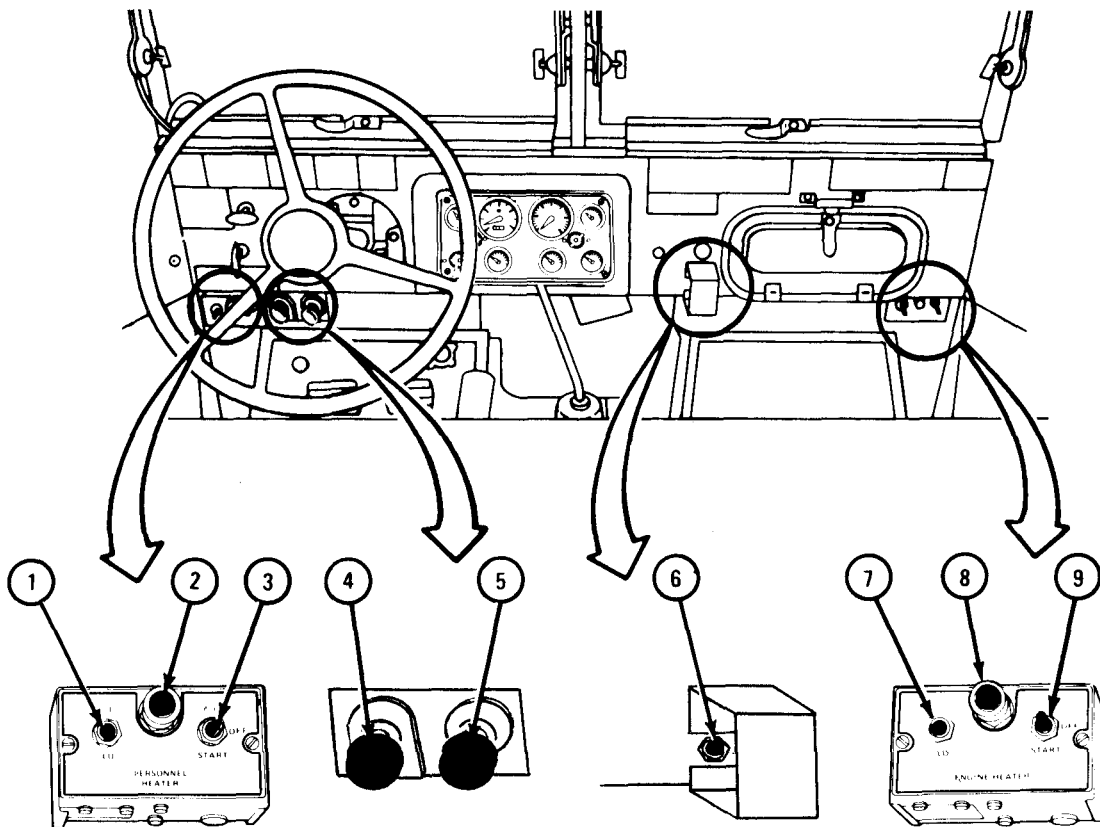

TA 044941

b. Arctic Winterization Kit Controls and Indicators -Cont.

1. Power plant heater shutoff cock. Is opened (turned left) to let fuel enter power plant heater combustion chamber.

2. Personnel heater shutoff cock. Is opened (turned left) to let fuel enter personnel heater combustion chamber.

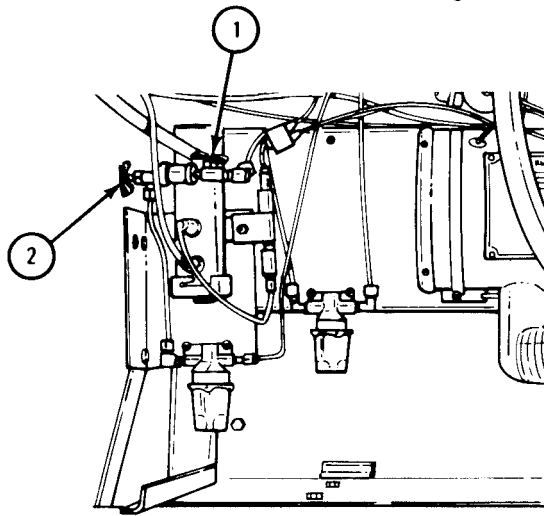
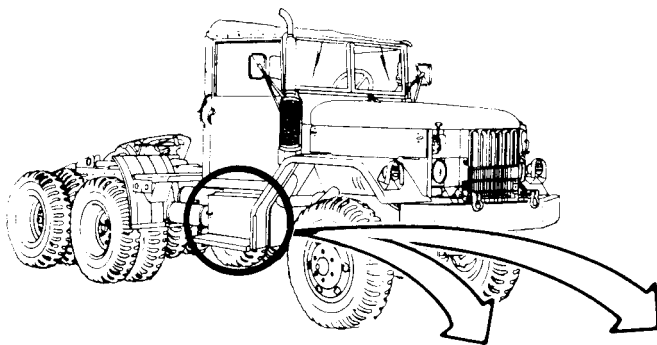

EARLIER MODEL TRUCKS

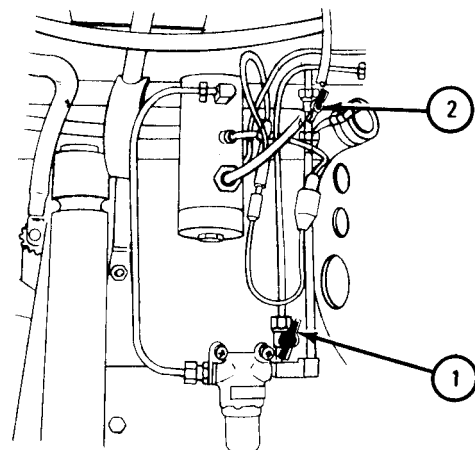

LATER MODEL TRUCKS

TA 044942

b. Arctic Winterization Kit Controls and Indicators -Cont.

1. Inlet coolant shutoff cock. Is opened (turned left) to let coolant from power plant cooling system enter heating chamber of power plant heater.

2. Outlet coolant shutoff cock. Is opened (turned left) to let coolant from heating chamber of power plant heater enter power plant cooling system.

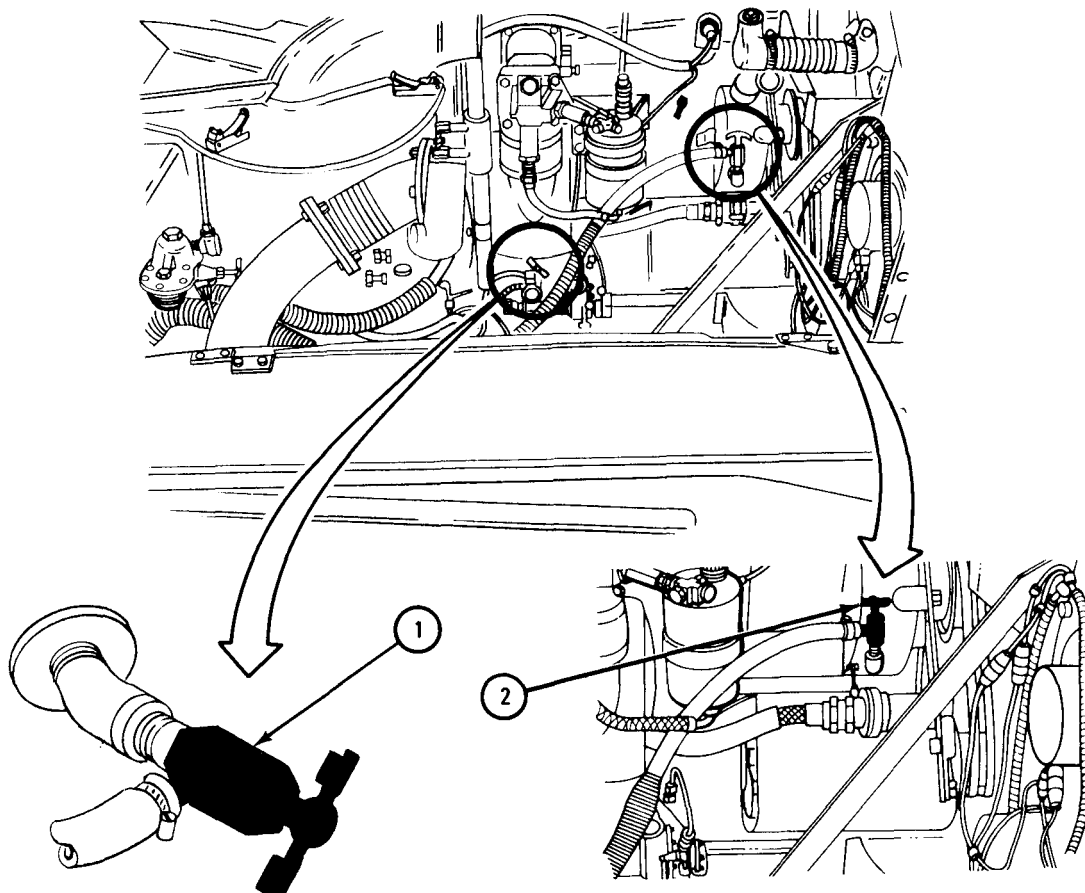

TA 044948



c. Deep Water Fording Kit Controls and Indicators.

1. Fording valve control. When placed left (on later model trucks) or pulled out (earlier model trucks), starts the air pressure system and forces air into flywheel housing to stop water seepage when fording.

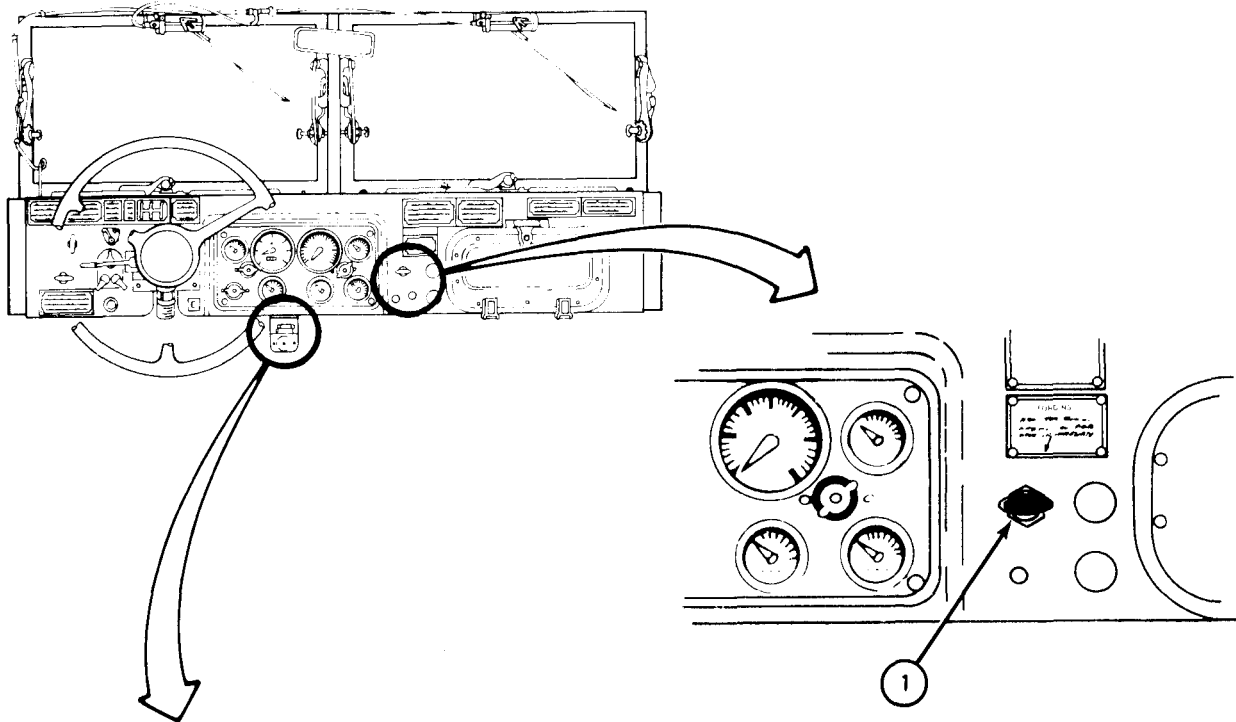

EARLIER MODEL TRUCKS

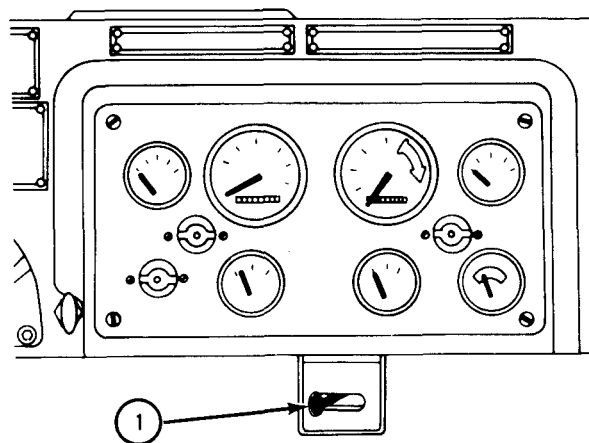

LATER MODEL TRUCKS

TA 044943

d. Electric Brake Kit Controls and Indicators.

1. Rheostat control handle. Is turned right to increase electric brake system braking action.

2. Data plate. Shows number setting of rheostat. The lighter the towed load, the lower the number; the heavier the towed load, the higher the number.

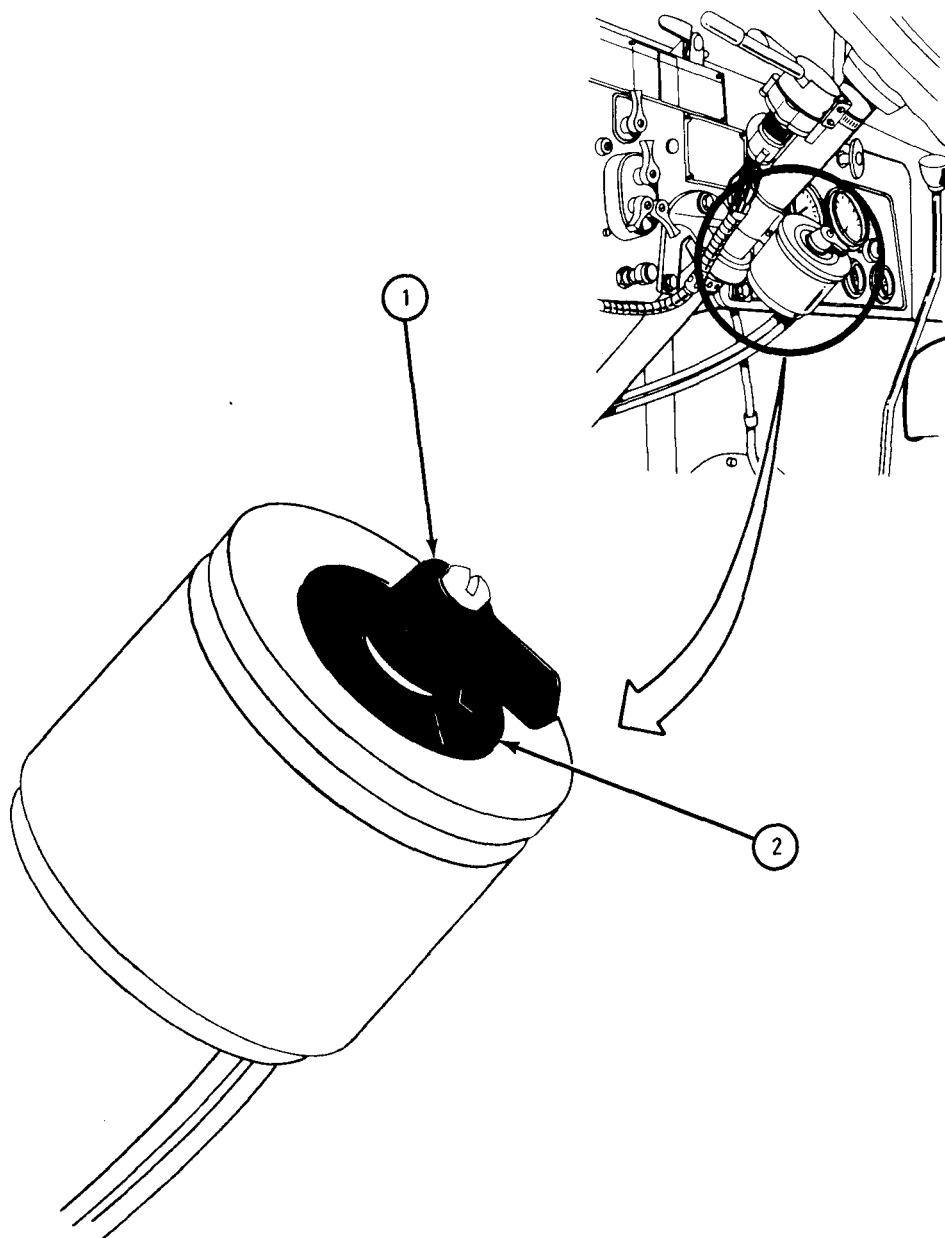

TA 044944

## Section II. OPERATION UNDER USUAL CONDITIONS

4-5. SCOPE. This section describes general operating procedures which are the same for all trucks. Operating procedures that apply only to some models will follow under separate paragraph headings. Each frame gives step-by-step instructions and detailed illustrations to cover all operating controls and show how these controls are set for each function.

4-6. GENERAL OPERATING PROCEDURES.

**WARNING**

This vehicle has been designed to operate safely and efficiently within the limits specified in this TM. Operation beyond these limits is prohibited IAW AR 70-1 without written approval from the Commander, U.S. Army Tank-Automotive Command, ATTN: AMSTA-CM-S, Warren, MI 48397-5000.

**NOTE**

Before engine start up, be sure that you know where all controls and indicators are, what the purpose of each one is and what it does. (Refer to section 1.) Make sure that all preventive maintenance checks and services (PMCS) were done. (Refer to PMCS, volume 2, chapter 1. )

a. Before Engine Startup.

FRAME 1

1. Pull handbrake lever (1) up to position.

**NOTE**

The handbrake must click into place when handbrake lever (1) is being pulled up. If you do not hear a click adjust handbrake as given in steps 2 through 5.

2. Push handbrake lever (1) forward to off position.
3. If the handbrake is loose (not enough tension) turn knob (2) to the right one or two turns. If the handbrake is tight (too much tension) turn knob (2) to the left one or two turns.
4. Pull handbrake lever (1) up again.
5. If handbrake clicks into place it is properly adjusted. If click is not heard, do steps 2, 3 and 4 again until handbrake clicks into place.
6. If handbrake cannot be properly adjusted tell organizational maintenance.
7. Set FRONT TRANSMISSION gearshift lever (3) to N position.

GO TO FRAME 2

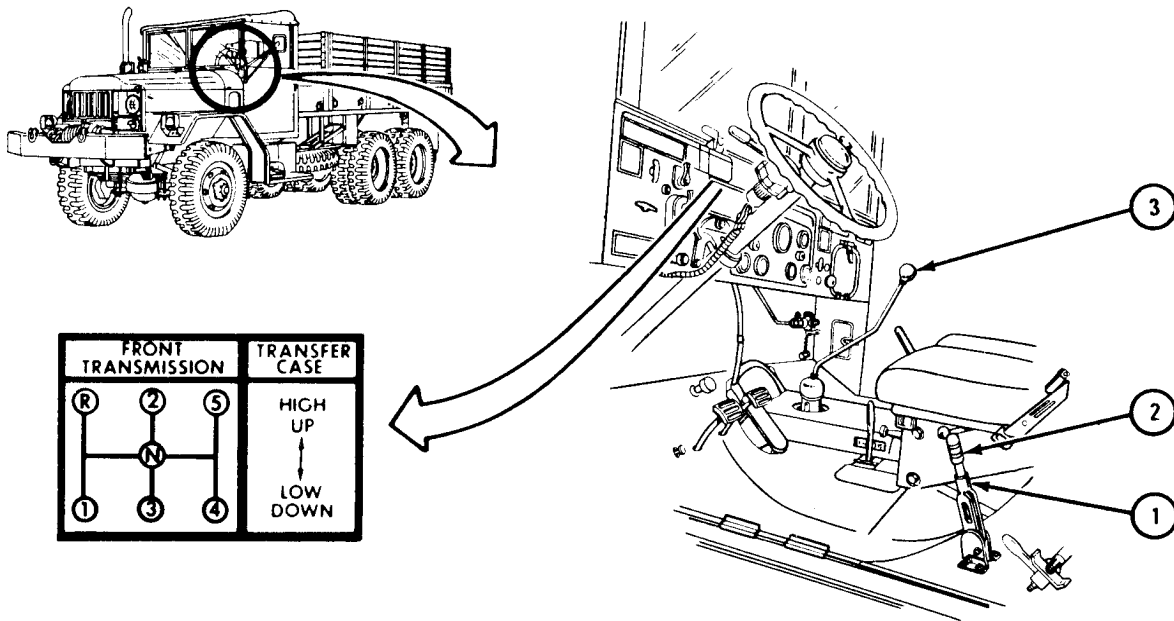

TA 044949

FRAME 2

1. Place transmission power takeoff lever (1) to NEU position and lock it with hinge lock (2).

GO TO FRAME 3

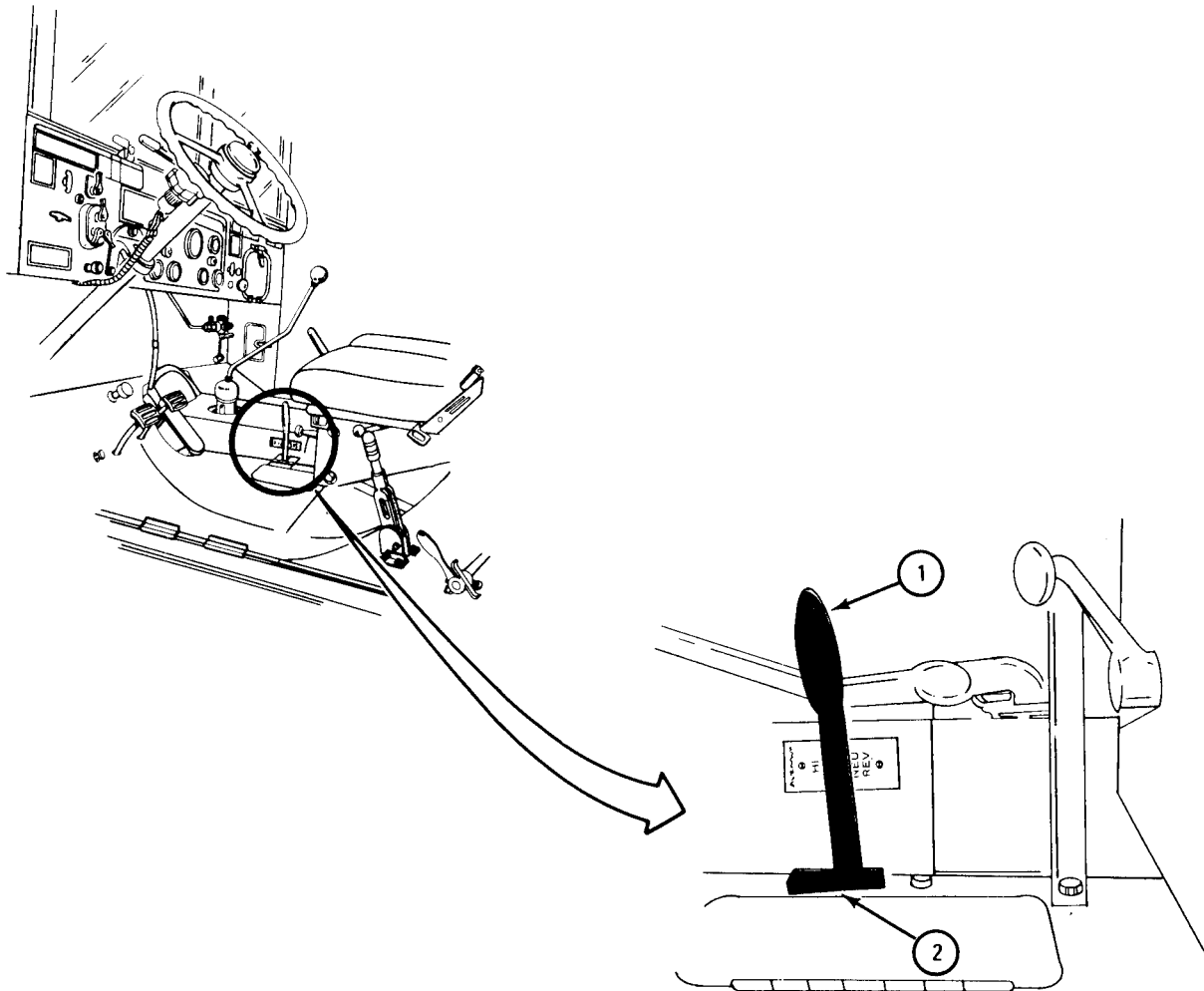

T A 044951

FRAME 3

1. Place TRANSFER CASE lever (1) in either:
  - (a) LOW (for greater power, lower speed) or
  - (b) HIGH (for greater speed, lower power).

GO TO FRAME 4

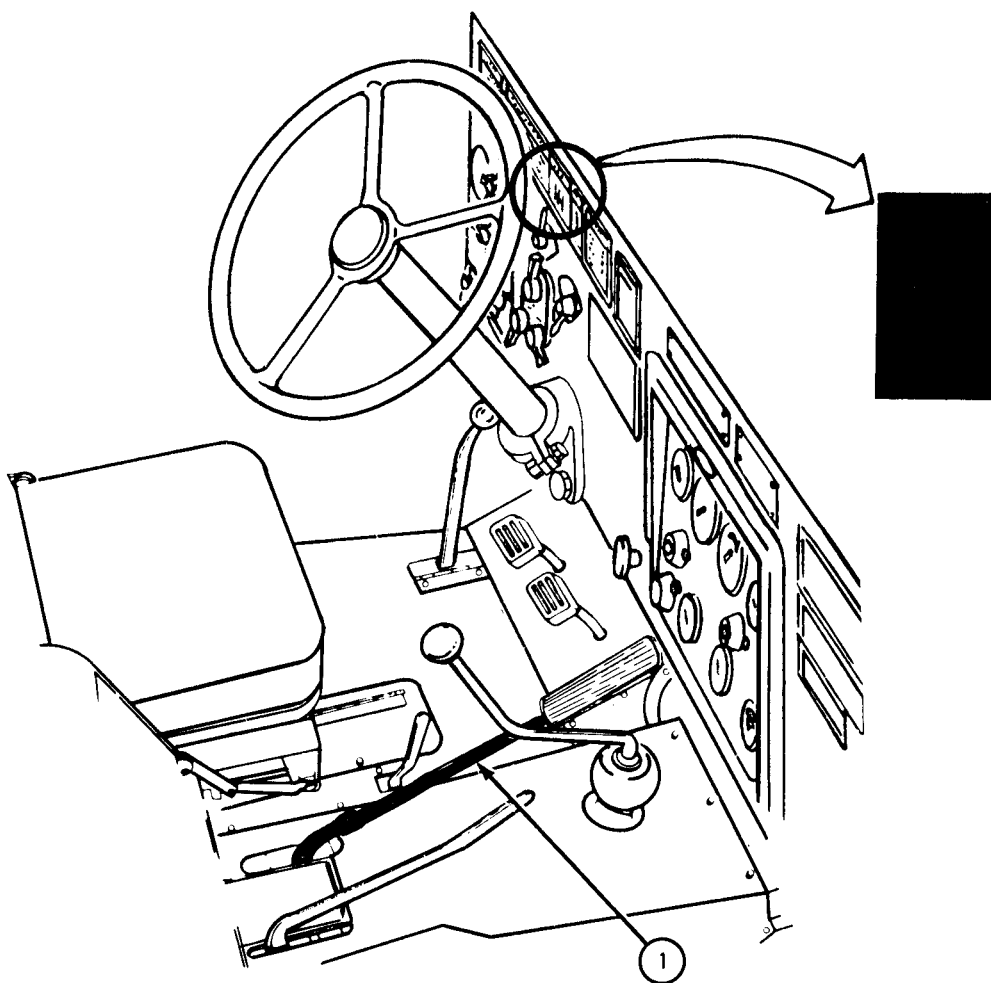

TA 044952

## FRAME 4

1. On trucks with a transfer power takeoff, place POWER TAKEOFF LEVER (1) to DISENGAGE (off) position, toward front of truck, and turn lock (2) to lock (up) position.

GO TO FRAME 5

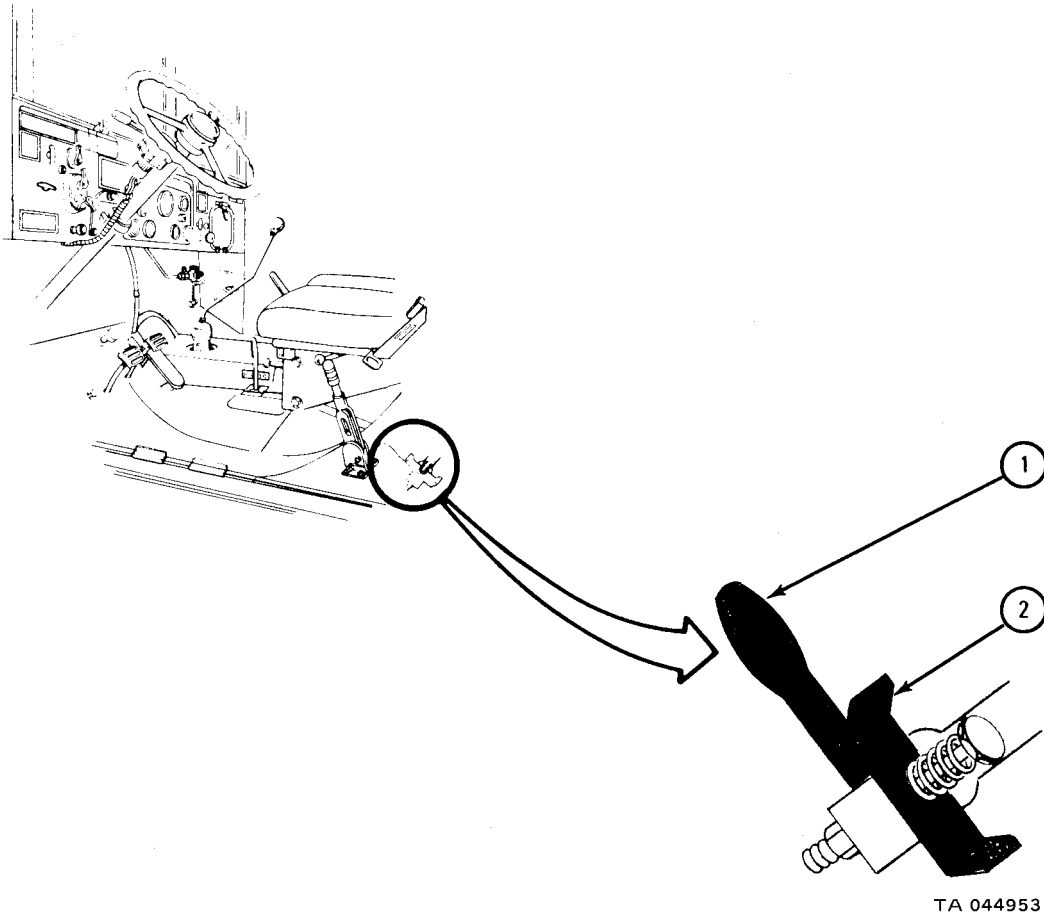

FRAME 5

1. On dump trucks, place hydraulic control lever(1) in the full up (body down) position and set lock (2).

GO TO FRAME 6

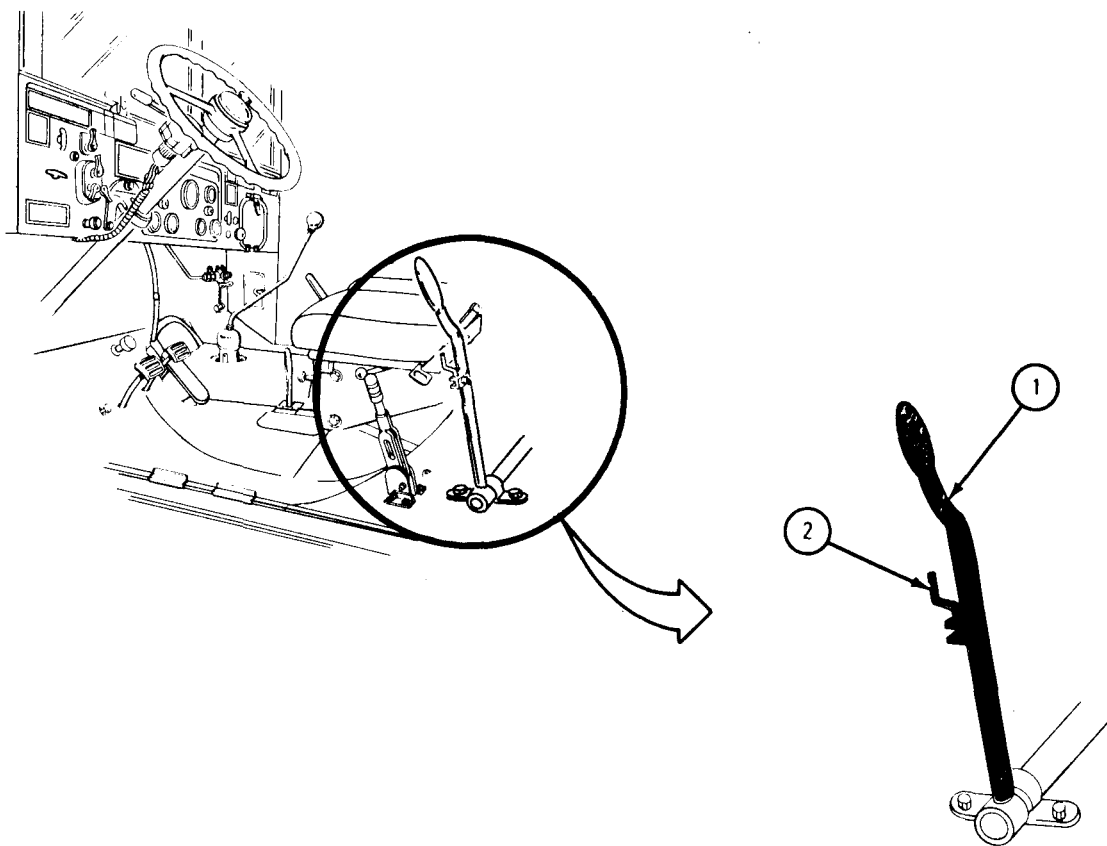

TA 044954



## FRAME 6

1. On earth boring machines and polesetter trucks, place power-divider control lever (1) in NEUTRAL position. Place rear winch control lever (2) in off (mid) position and set hinge lock (3).

GO TO FRAME 7

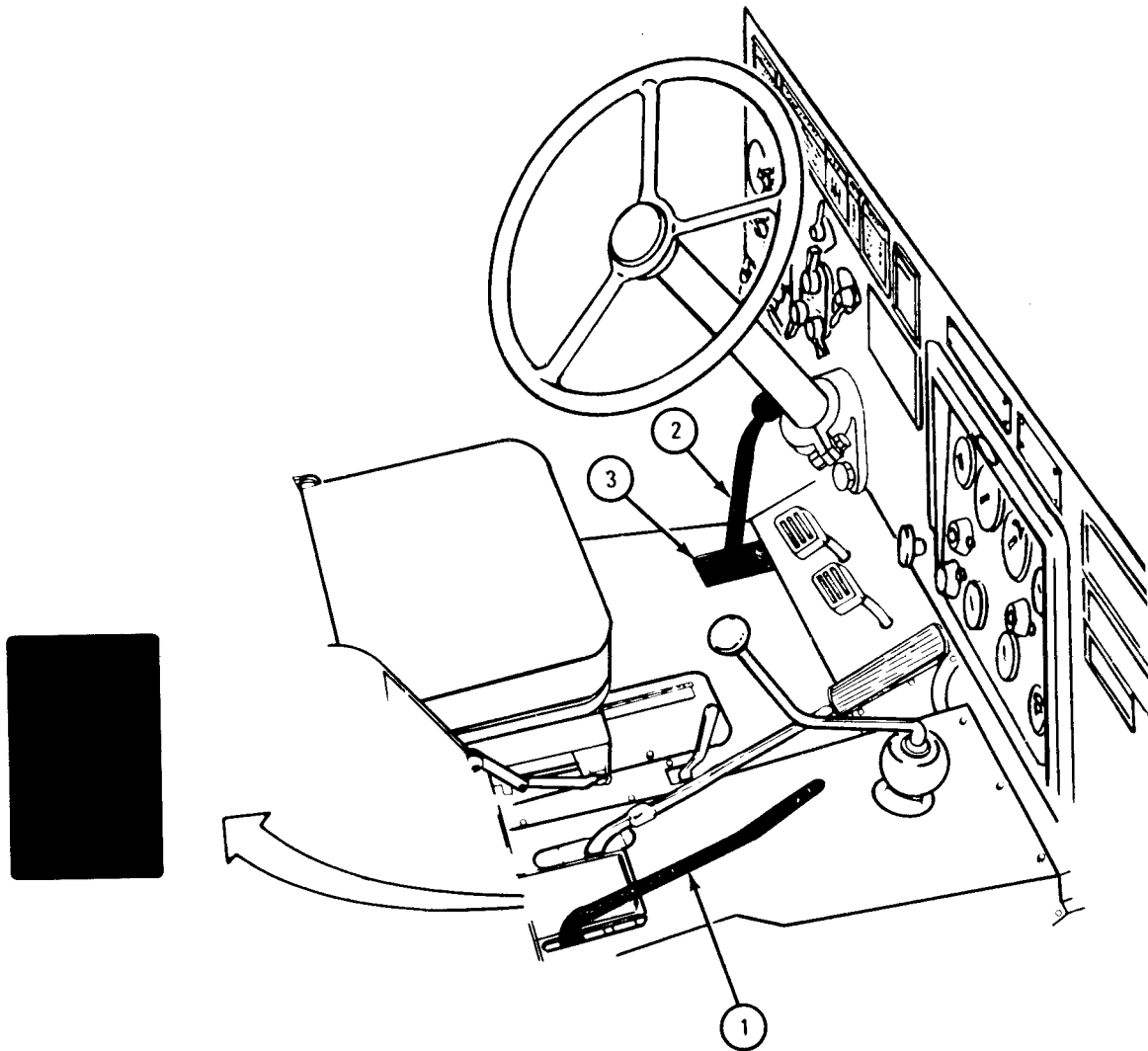

TA 044955

FRAME 7

1. Check for hydrostatic lock as follows:
  - (a) Turn ACCESSORY switch (1) to ON.
  - (b) Pull ENG. STOP control knob (2) out as far as it will go and hold it out to stop fuel flow.
  - (c) On trucks with engine START button (3) on instrument panel, press and quickly let go of START button several times. On trucks with floor mounted starter button (3) step on button and quickly let it go several times.
2. If any of the following happen, stop cranking immediately and tell organizational maintenance:
  - (a) Engine starts to turn over with starter and stops.
  - (b) Starter sounds as if it is straining when cranking.
  - (c) Engine appears to be binding.
3. If there is no sign of hydrostatic lock, let ENG. STOP control knob (2) return to normal fuel on position.

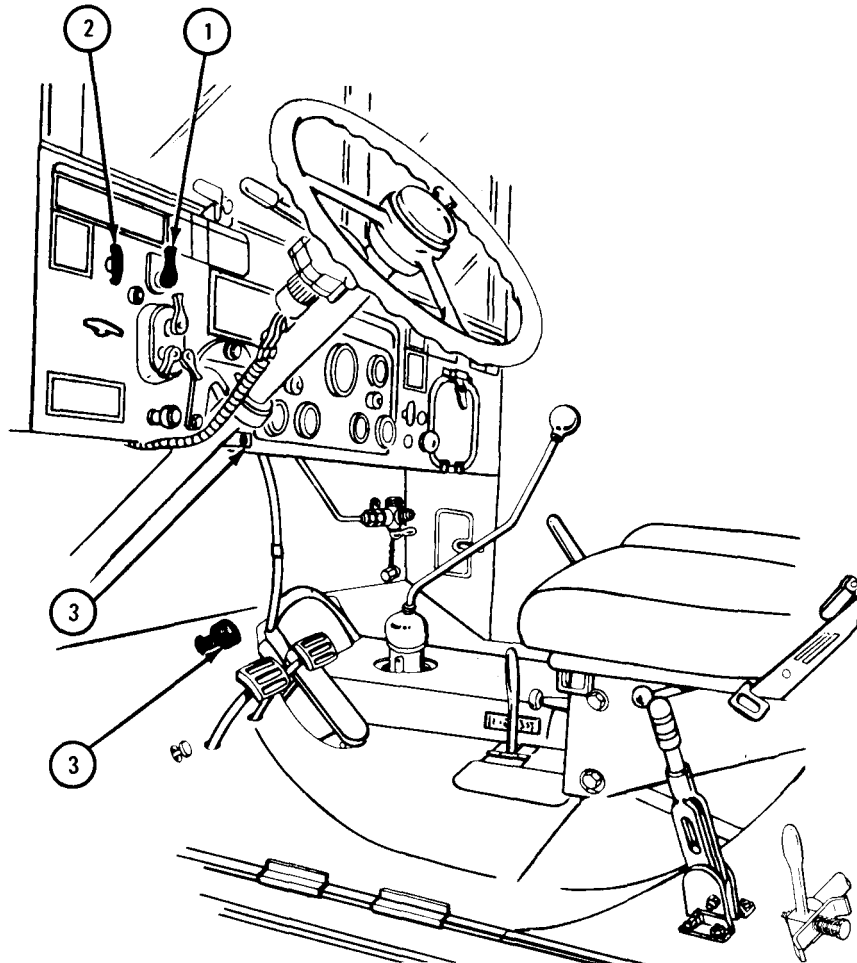

TA 044956

b. Starting the Engine Above + 20°F.

## FRAME 1

1. Step on clutch pedal (1) press it all the way down and hold it down.

**CAUTION**

Do not hold starter button in for more than 10 seconds at one time. If engine does not start in 10 seconds, wait two minutes before pressing starter button again.

Do not press starter button while headlights are on. Either of the above may cause damage to battery, starter or both.

1. On trucks with engine START button (2) on instrument panel, press START button and step down on accelerator pedal (3) until engine starts. On trucks with floor mounted starter button (2), step down on button and step down on accelerator pedal (3) using same foot until engine starts.
2. Let clutch pedal (1) up slowly as soon as engine starts.

GO TO FRAME 2

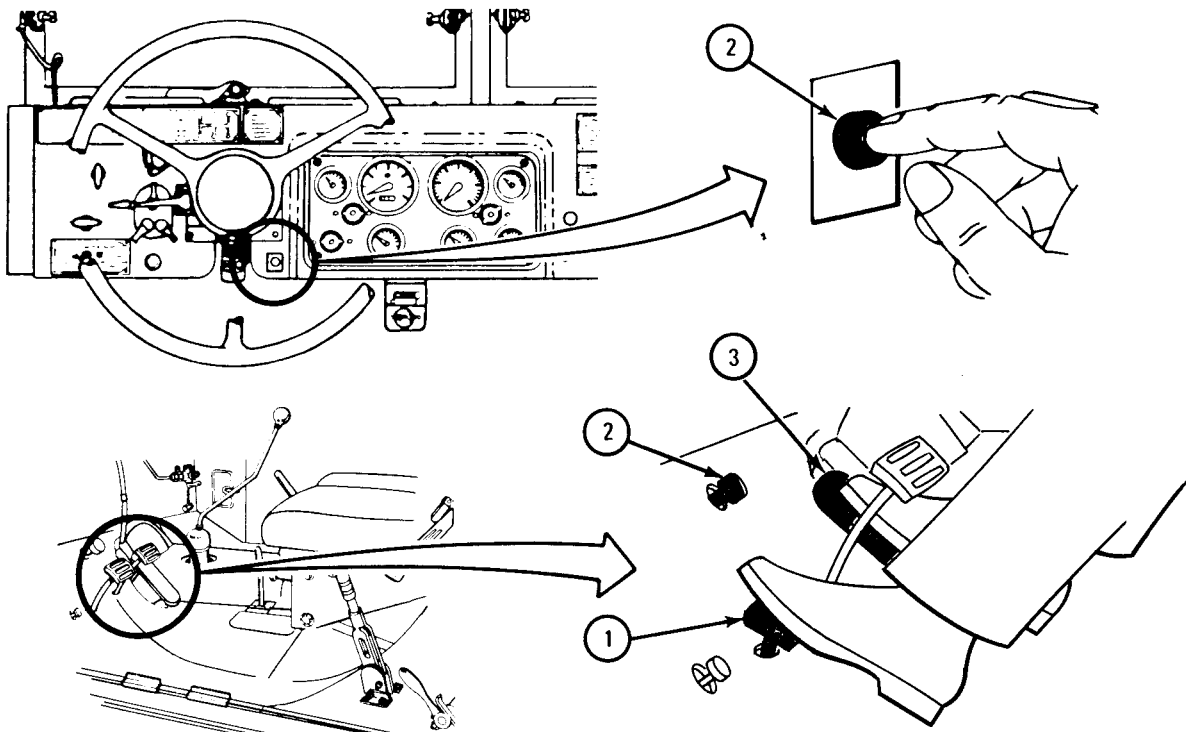

TA 044958

FRAME 2

**WARNING**

Use hand THROTTLE (1) for cold engine starting and warm up only. Never use it to drive truck.

1. To warm up engine, pull hand THROTTLE (1) out until engine is running at 800 rpm as shown on tachometer (2).

GO TO FRAME 3

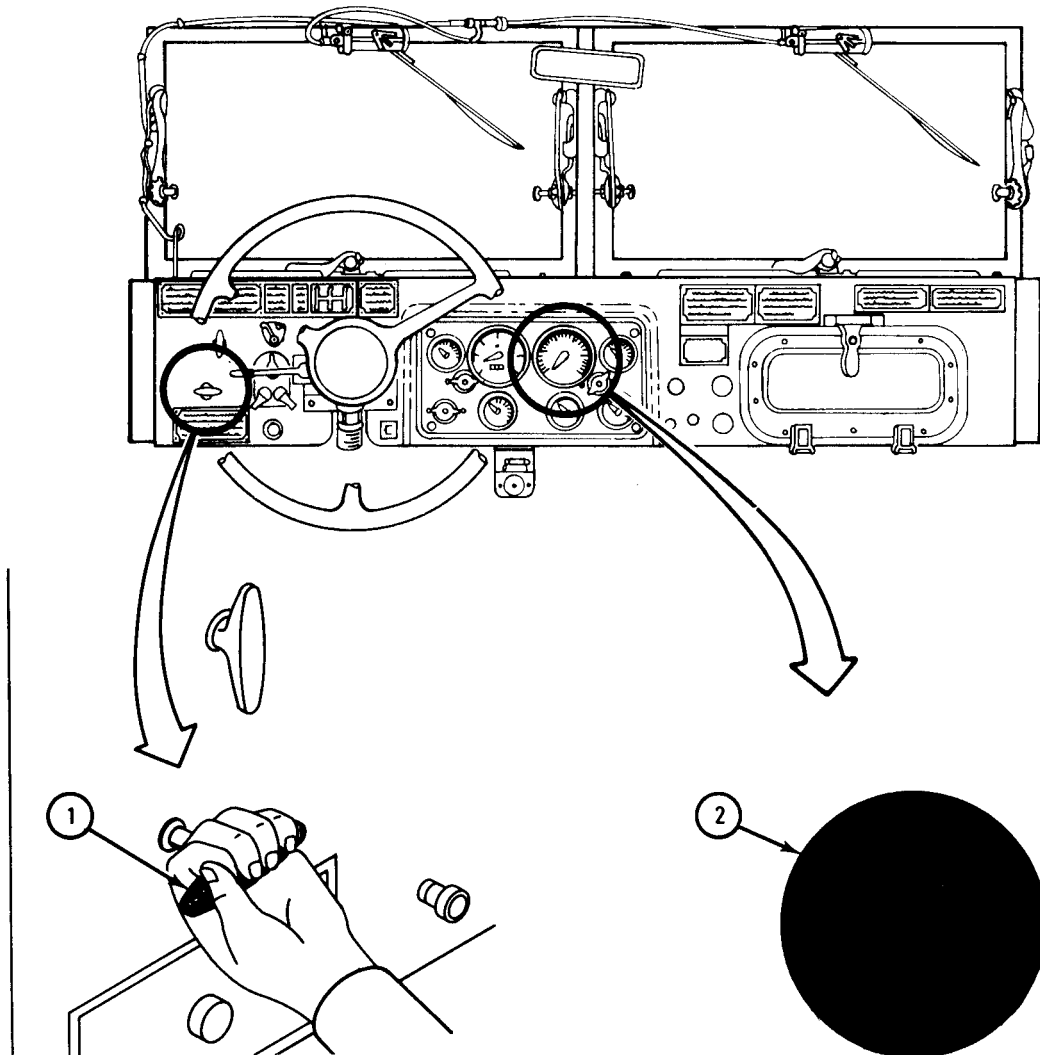

TA 044959

## FRAME 3

**CAUTION**

If OIL pressure gage (1) does not show correct pressure within 20 seconds or if you notice any unusual noises or vibrations, pull ENG. STOP control knob (2) out and hold it out until engine stops to avoid serious engine damage.

1. Check OIL pressure gage (1). It should show 30 to 40 psi. If it does not show correct pressure, stop engine and tell organizational maintenance.
2. Check battery generator indicator (3). Pointer should be in green area. If it is not in green area, stop engine and tell organizational maintenance.

GO TO FRAME 4

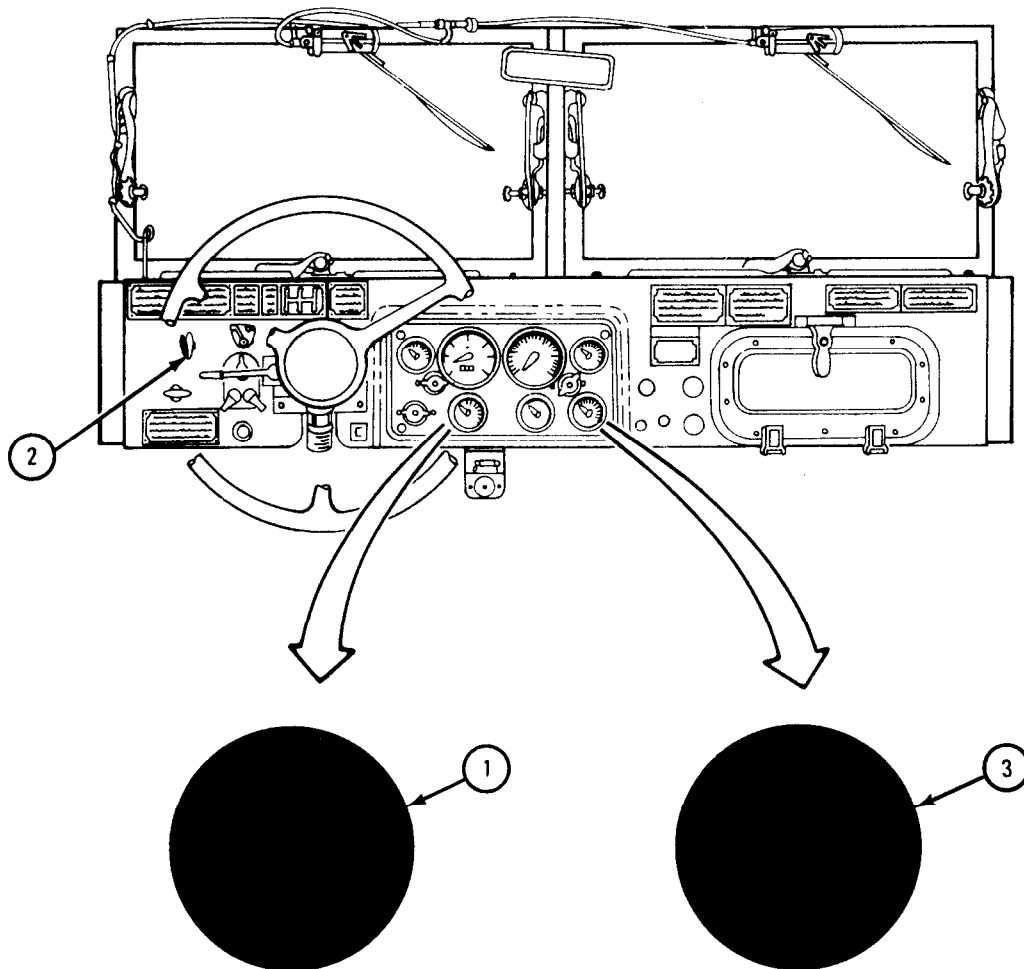

TA 044960

FRAME 4

**WARNING**

Trucks described in this manual are equipped with a low air pressure buzzer system. Do not place vehicle in motion until buzzer stops and AIR pressure gage (1) shows at least 65 psi. Air brakes may not function properly when air pressure is low.

1. Check AIR pressure gage (1) . It should show 65 psi. If it does not show between 65 and 120 psi, stop engine and tell organizational maintenance.
2. Check air filter indicator (2) . It should not show red. If indicator shows red, stop engine.
3. Check temperature gage (3) . It should show between 180°F and 200°F when engine is at normal operating temperature. If engine temperature rises sharply to 210°F or more, or if temperature stays below 160°F, stop engine.

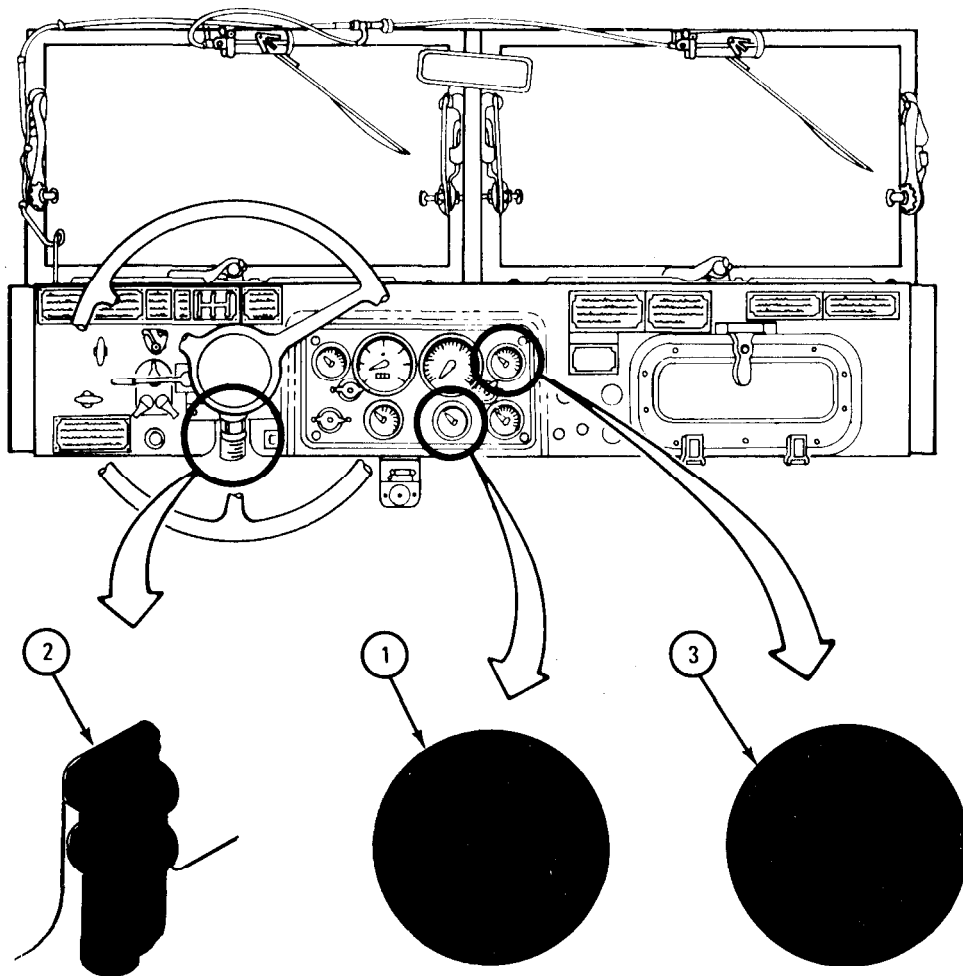

TA 044962

c. Cold Weather Starting Below +20°F.

## FRAME 1

1. Step on clutch pedal (1) , press it all the way down, and hold it down.
2. Pull hand THROTTLE (2) out half way.
3. Step on the accelerator pedal (3). Press it down two-thirds of the way. On trucks with floor mounted starter button (4) , using same foot, step down on button. On trucks with START button (4) on instrument panel, press START button.

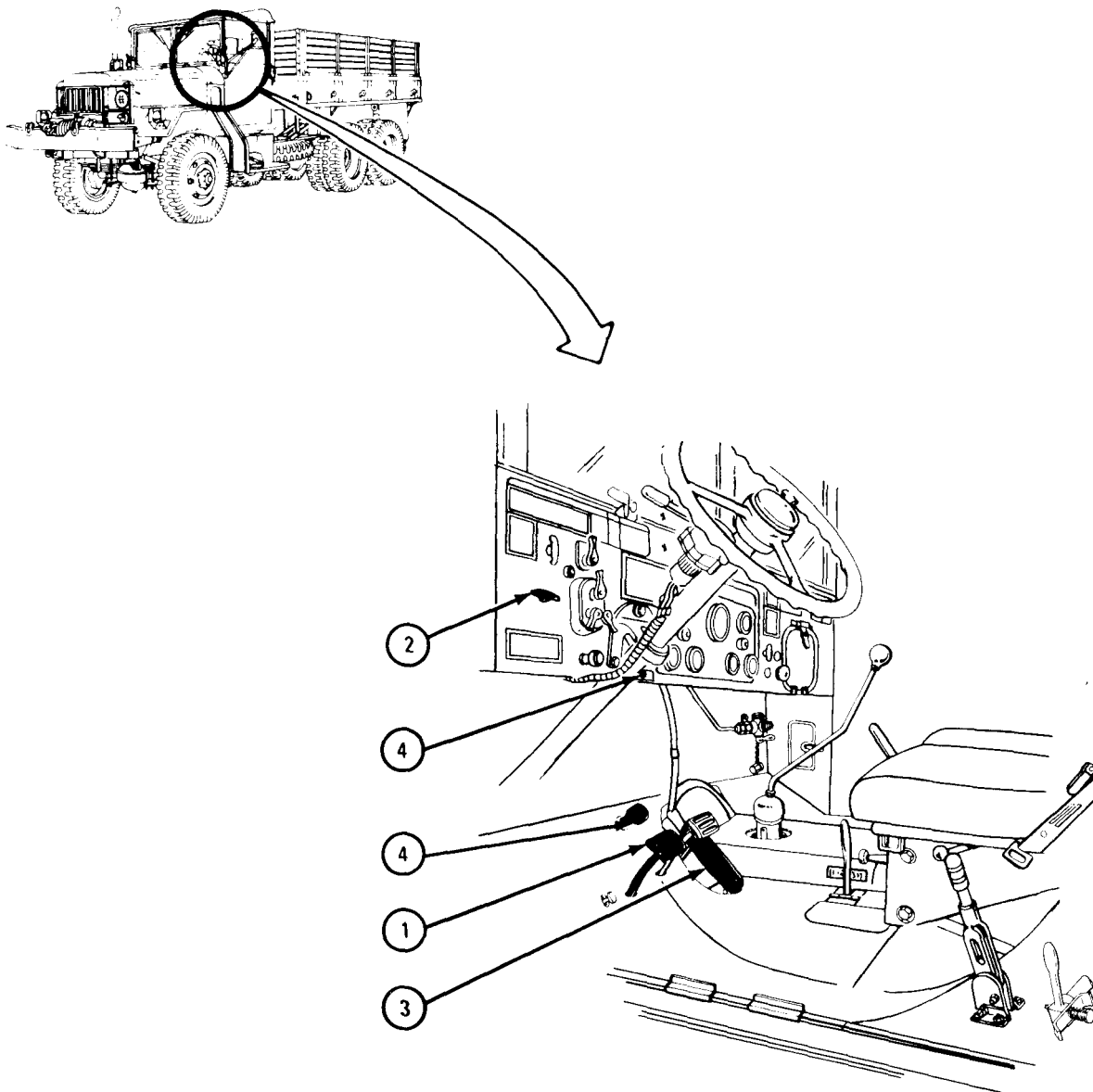

TA 044965

FRAME 2

**CAUTION**

Do not operate manifold heater unless engine is idling or being cranked. Engine can be damaged.

1. While engine is being cranked, turn MANIFOLD HEATER SWITCH (1) to ON. The engine should start and run within 30 seconds.
2. If engine does not start in 30 seconds, turn MANIFOLD HEATER SWITCH (1) to OFF and stop cranking engine.
3. Wait two minutes and do steps 1 and 2 again above.

**NOTE**

If engine misses or does not run smoothly after starting, turn MANIFOLD HEATER SWITCH (1) ON for 30 seconds, then OFF. Wait a few seconds and do it again until engine runs smoothly.

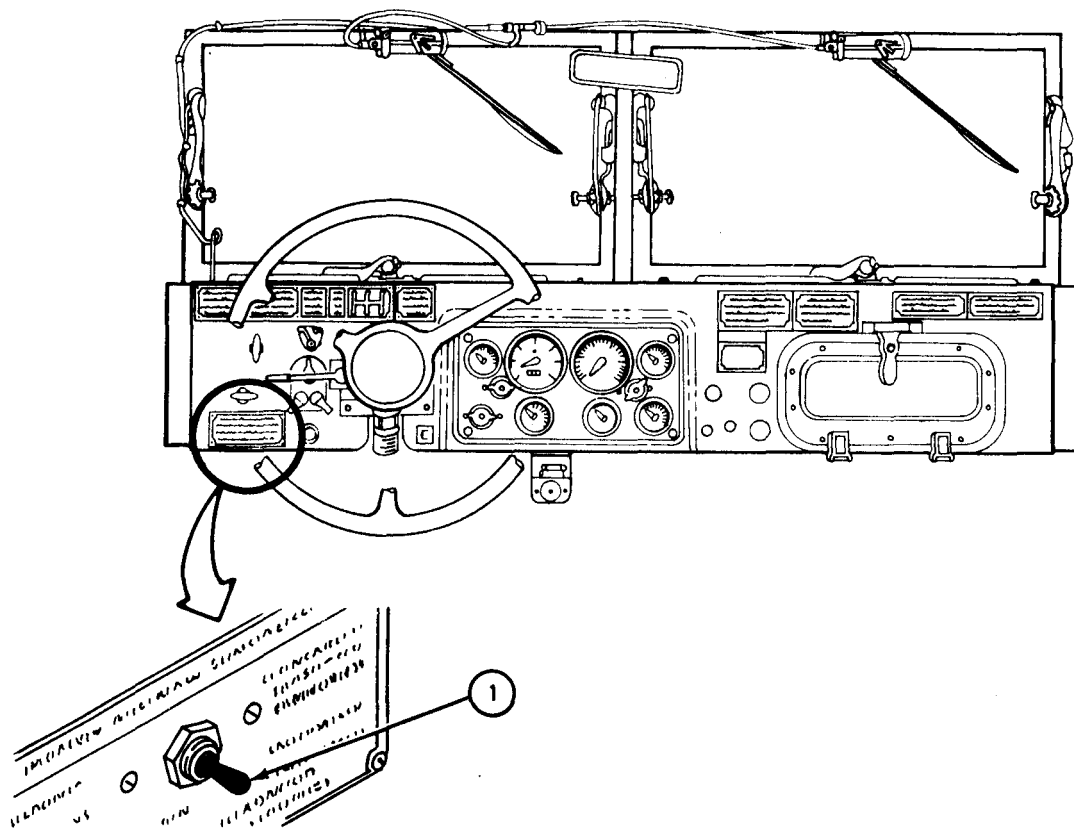

TA 044968



d. Placing and Keeping the Truck in Motion.

FRAME 1

1. Make sure that front winch (1), auxiliary equipment, and tools are locked and stowed for travel.

GO TO FRAME 2

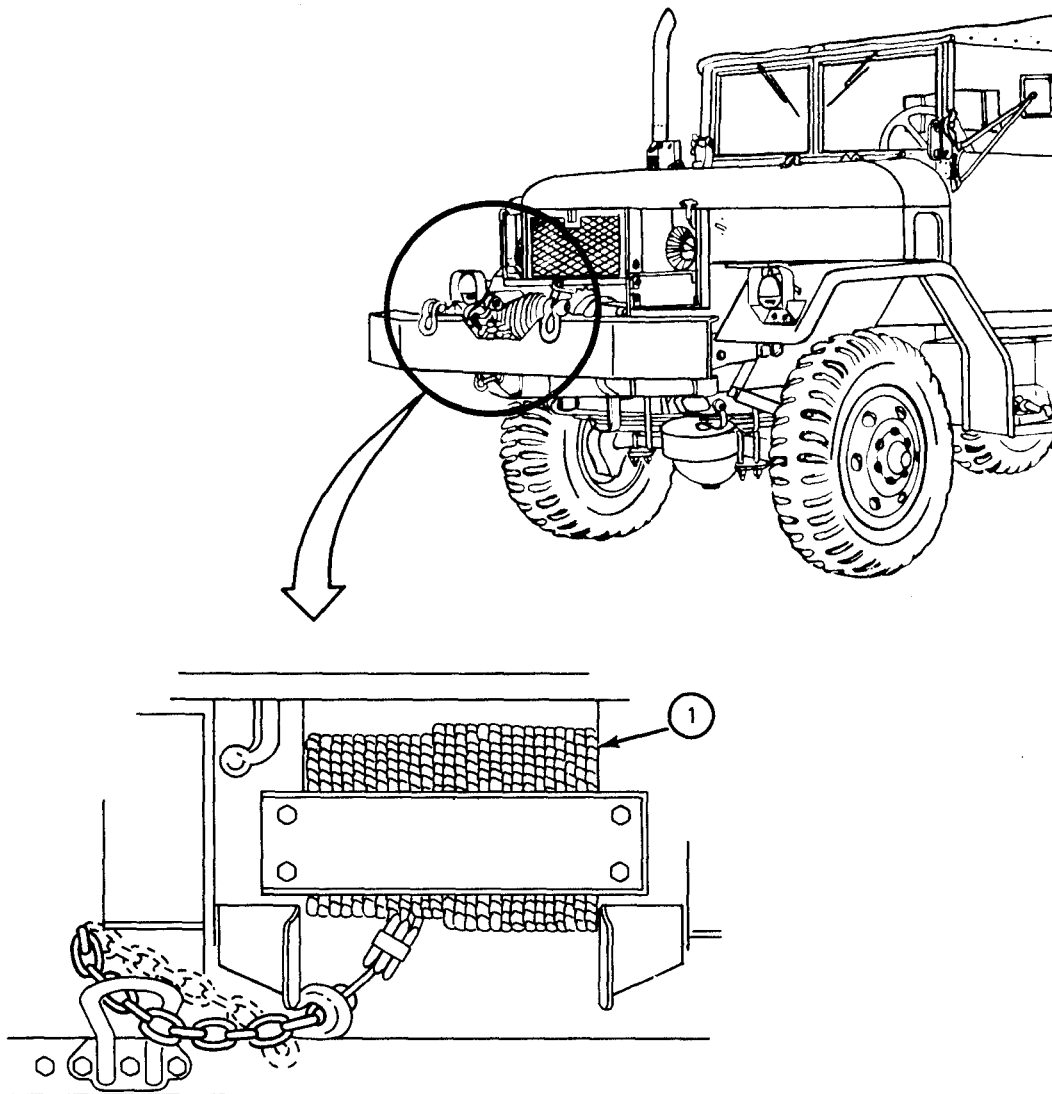

TA 044969

FRAME 2

1. Set hand THROTTLE (1) in off position, all the way in.
2. Set light switch (2) for lighting as needed. Refer to table 4-1 for switch positions.

GO TO FRAME 3

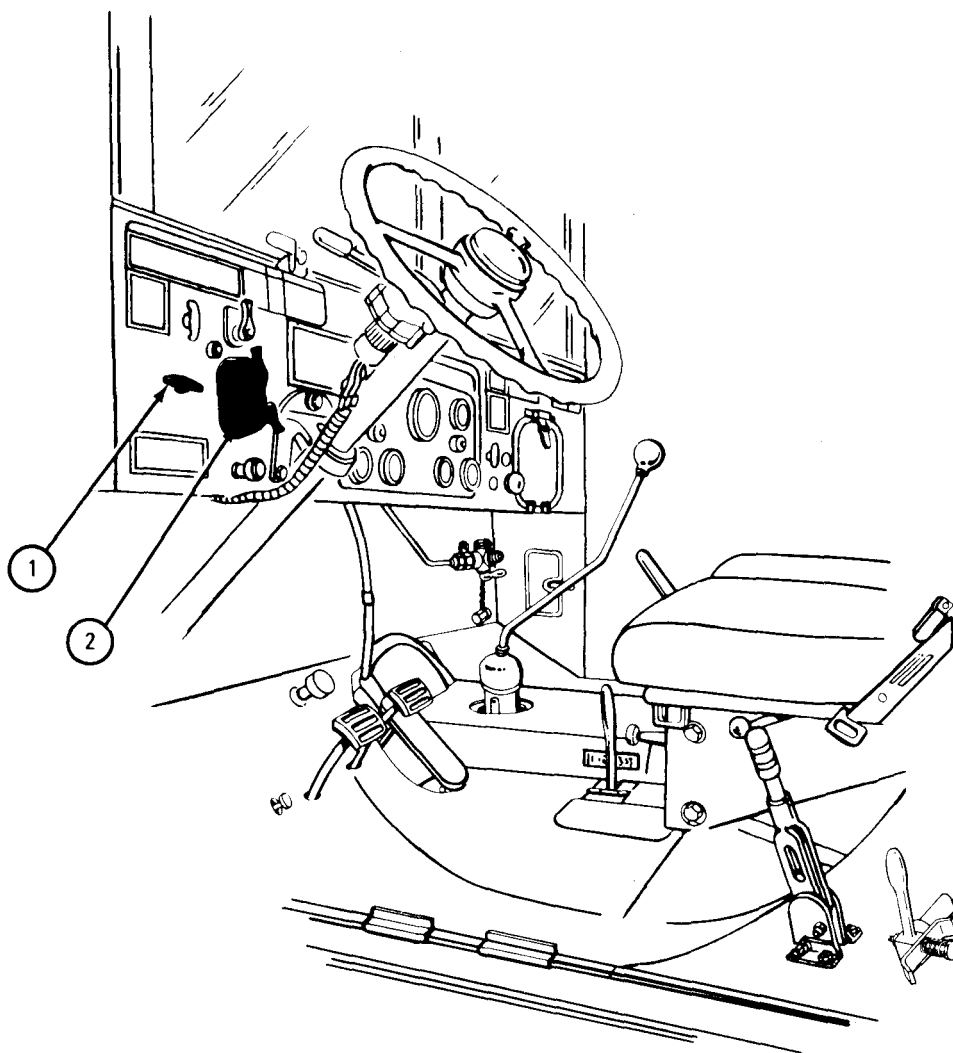

TA 044970

Table 4-1. Vehicle Lights Chart

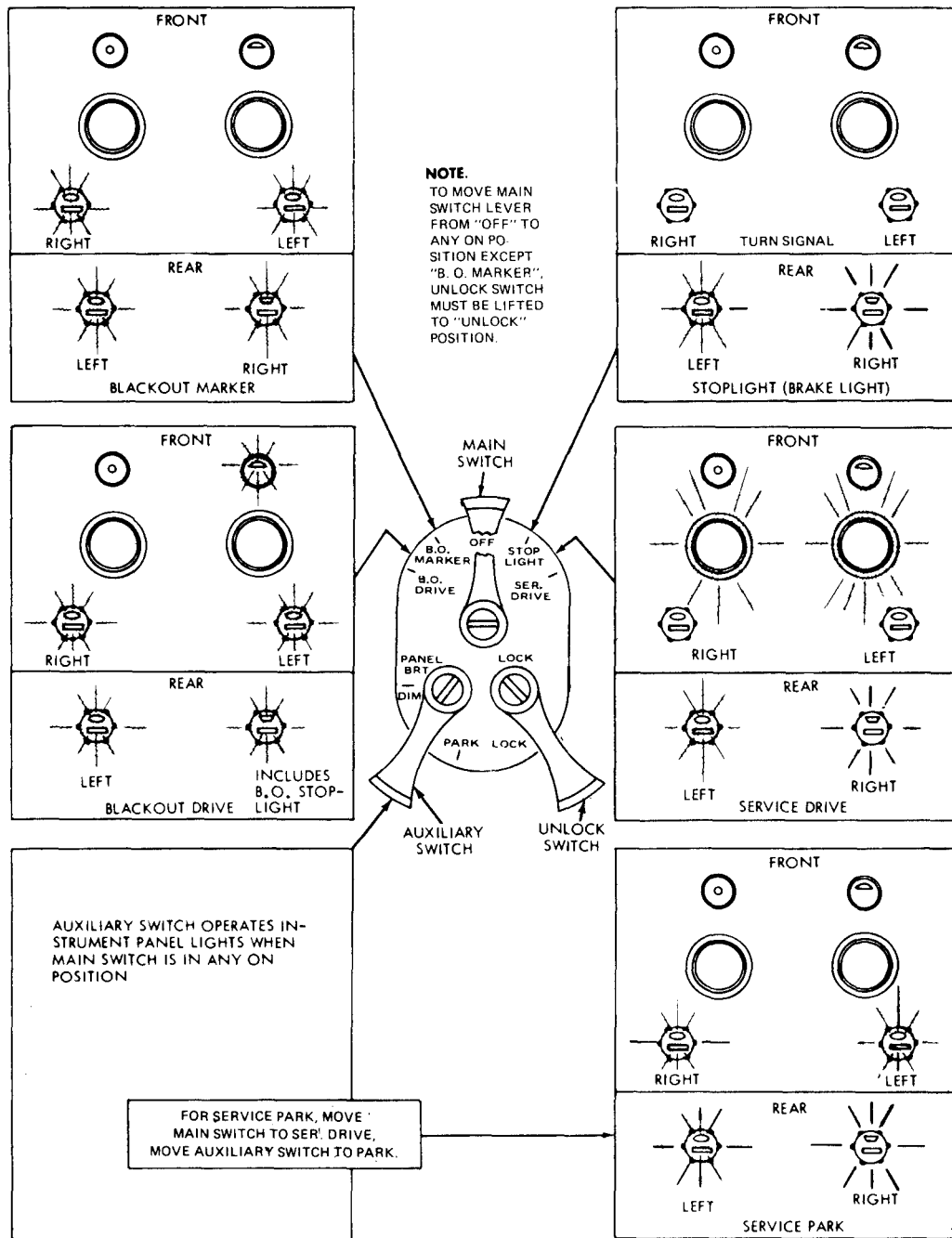

TA 084651

FRAME 3

**NOTE**

If you are going to backup truck, get a second soldier to use as a guide.

1. Step on clutch pedal (1) and press it all the way down.
2. Place FRONT TRANSMISSION gearshift lever (2) in position 1 or R, depending on direction that you want to go.

**NOTE**

Position 1 (low gear) must always be used to place vehicle in forward motion. Position R (reverse) is for backward motion.

GO TO FRAME 4

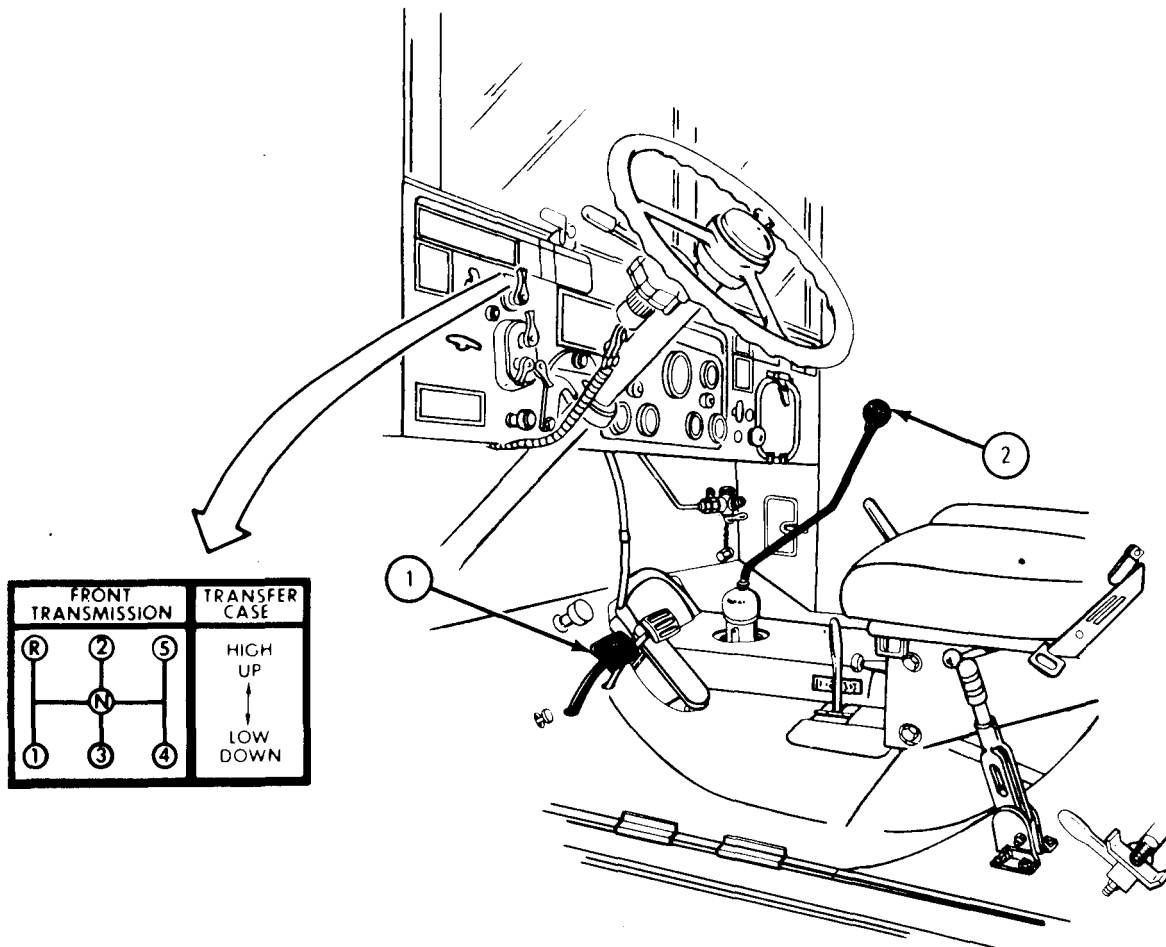

TA 044972

## FRAME 4

1. If truck is on level ground, set handbrake lever (1) free (down position).
2. Let clutch pedal (2) come up slowly, while stepping down on accelerator pedal (3) lightly.
3. Keep pressing down on accelerator pedal (3) to move truck slowly and keep from stalling.

GO TO FRAME 5

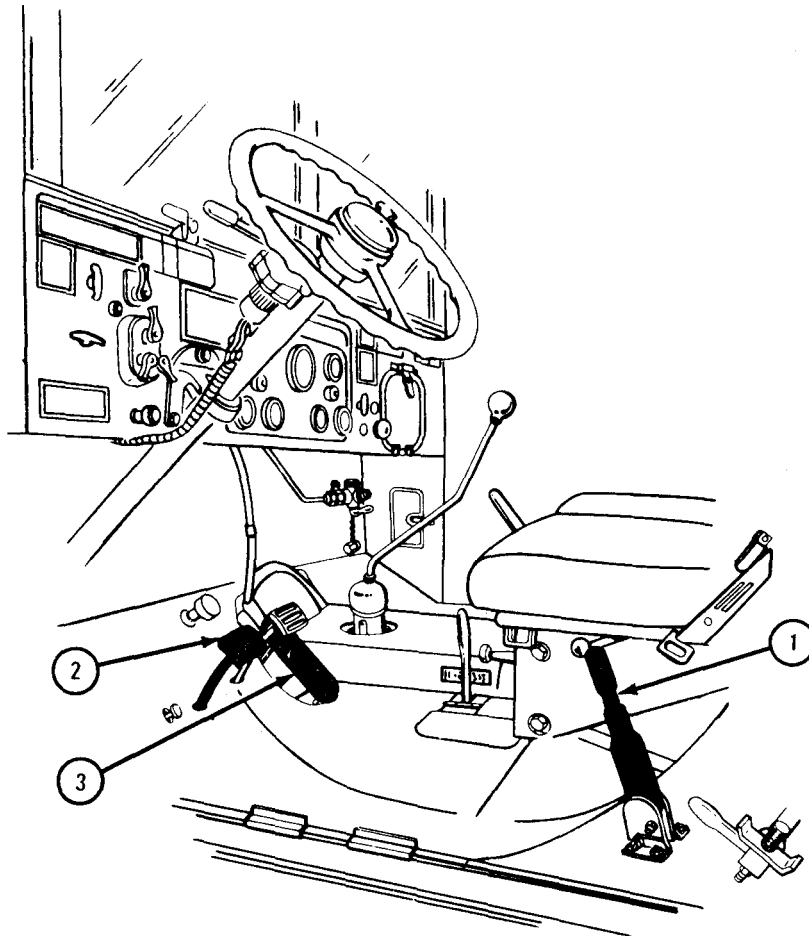

TA 044973

FRAME 5

1. To go forward on upgrade terrain:
  - (a) Keep handbrake lever (1) up.
  - (b) Step on and press clutch pedal (2) all the way down.
  - (c) Place FRONT TRANSMISSION gearshift lever (3) in position 1.
  - (d) Let clutch pedal (2) up slowly until truck starts to move forward.
  - (e) Move handbrake lever (1) down to off position.
  - (f) Step down on accelerator pedal (4) slowly to increase speed.

GO TO FRAME 6

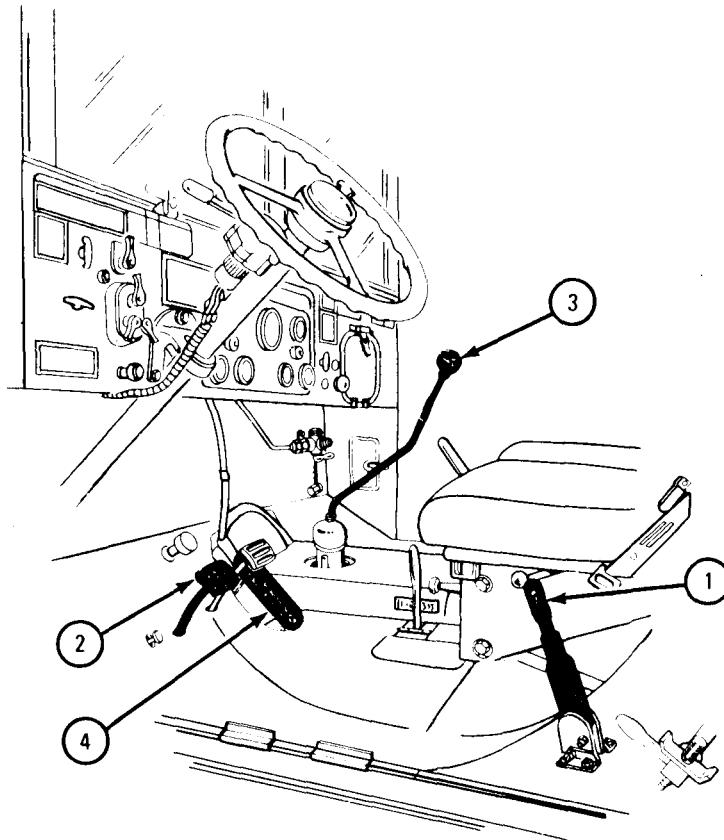

TA 044974

## FRAME 6

**NOTE**

When possible, use a second soldier as a guide when you are backing up truck.

1. To go backward on downgrade terrain:
  - (a) Keep handbrake lever (1) in up (on) position.
  - (b) Step on and press clutch pedal (2) all the way down.
  - (c) Place FRONT TRANSMISSION gear shift lever (3) in R position.
  - (d) Let clutch pedal (2) up slowly until vehicle starts to move.
  - (e) Move handbrake lever (1) to down (off) position.
  - (f) Step down on accelerator pedal (4) slowly to increase speed.

GO TO FRAME 7

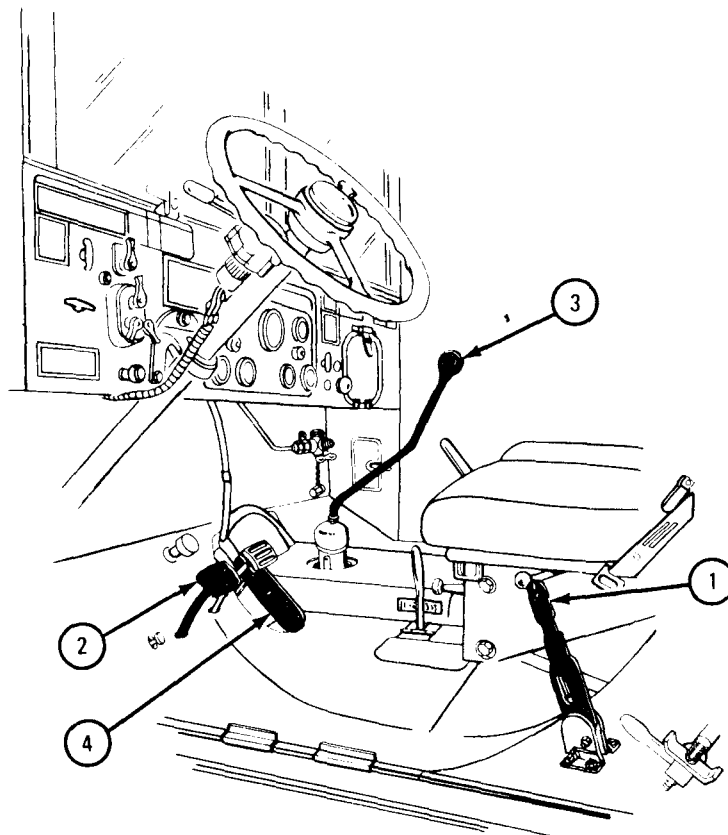

TA 044974

FRAME 7

**CAUTION**

Shift to next highest gear position when truck has reached a speed just below maximum shown on data plate for the position being used. Shifting too soon or too late causes extra heavy wear on engine, transmission and other parts of the truck.

1. When truck speed shown on speedometer (1) is just below maximum speed shown on data plate (2) for first gear, step on clutch pedal (3), press it all the way down.
2. Let accelerator pedal (4) up.
3. Move the FRONT TRANSMISSION gear shift lever (5) to position 2.
4. Let clutch pedal (3) up slowly, press down on accelerator pedal (4), bring truck to just below maximum speed for second gear.
5. Repeat above procedure to shift to third, fourth, and fifth gear.

GO TO FRAME 8

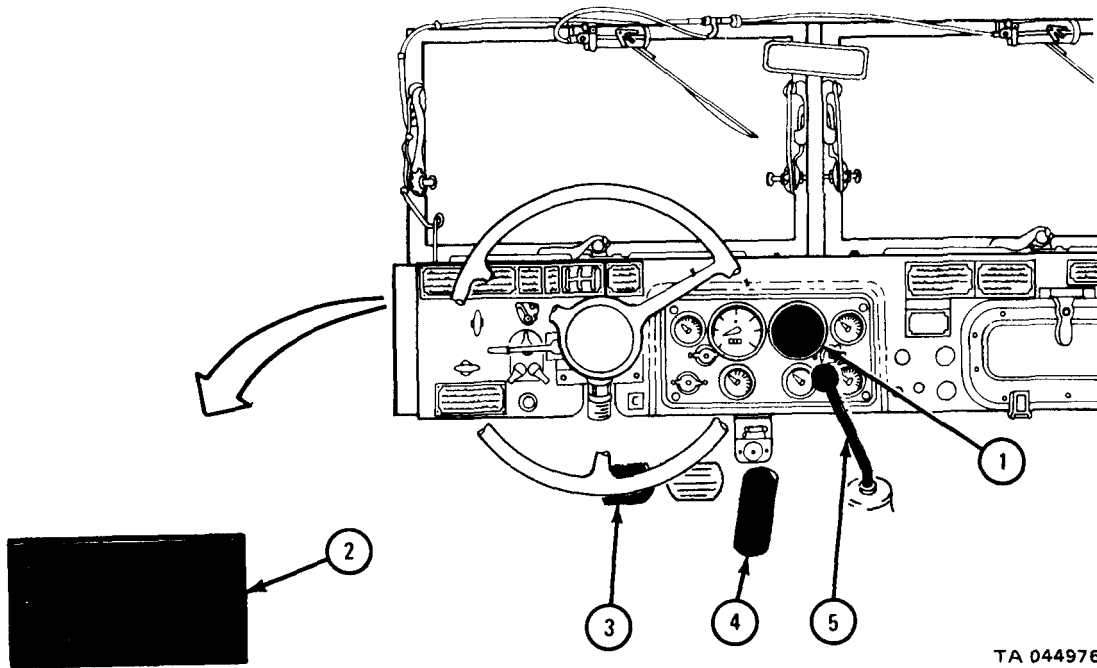

TA 044976



## FRAME 8

1. To shift from HIGH to LOW range when truck is heavily loaded or terrain is hilly, soft or rough:
  - (a) Reduce truck speed below speed shown on data plate (1) for FRONT TRANSMISSION position in use.
  - (b) Step on and press clutch pedal (2) down all the way.
  - (c) Move TRANSFER CASE shift lever (3) down to LOW.
  - (d) Let clutch (2) up slowly.
  - (e) Step down on accelerator pedal (4) to bring truck to the speed you want.

GO TO FRAME 9

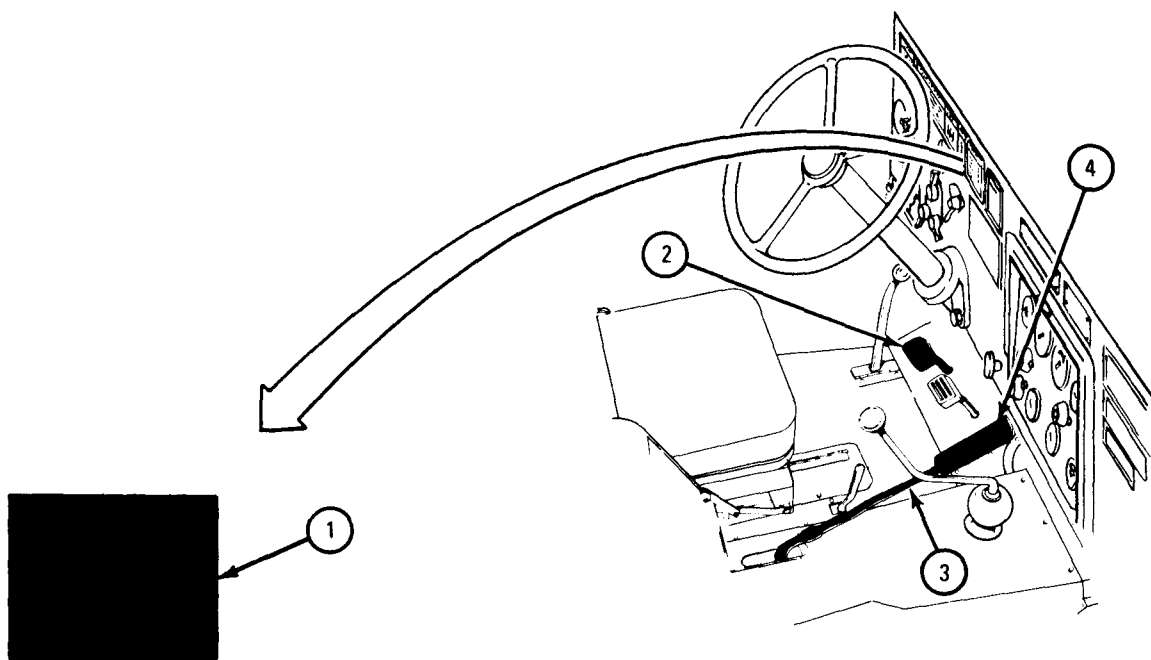

TA 044977

FRAME 9

1. To shift from LOW to HIGH range at any speed:
  - (a) Step on clutch pedal (1) and press it all the way down.
  - (b) Move TRANSFER CASE shift lever (2) up to HIGH range.
  - (c) Press down on accelerator (3) to increase speed of the engine to match the truck speed.
  - (d) Let clutch pedal (1) come up slowly.

GO TO FRAME 10

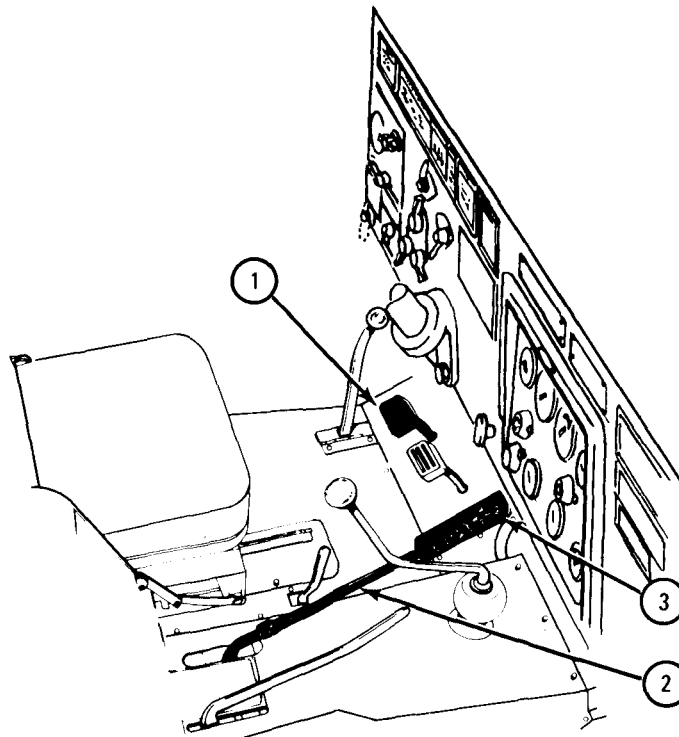

TA 044978

## FRAME 10

**CAUTION**

Do not use engine alone without help of service brake to slow down or stop truck. To do so would overspeed and cause damage to the engine.

1. To downshift, when truck is unable to maintain speed or for going down a steep hill:
  - (a) Let accelerator pedal (1) up and quickly step down on clutch pedal (2).
  - (b) Let front transmission gears slow down.
  - (c) Step down on accelerator pedal (1) to speed engine up slightly (1,400 rpm to 1,800 rpm) as shown on tachometer (3).
  - (d) Move FRONT TRANSMISSION gearshift lever (4) to lower gear position.
  - (e) Let clutch pedal (2) up slowly.

**NOTE**

To prevent overheating brakeshoe linings when going down a steep hill, press brake pedal (5) down, let it come up and press down again. If it becomes necessary to double clutch to shift gears, tell direct support maintenance unit.

GO TO FRAME 11

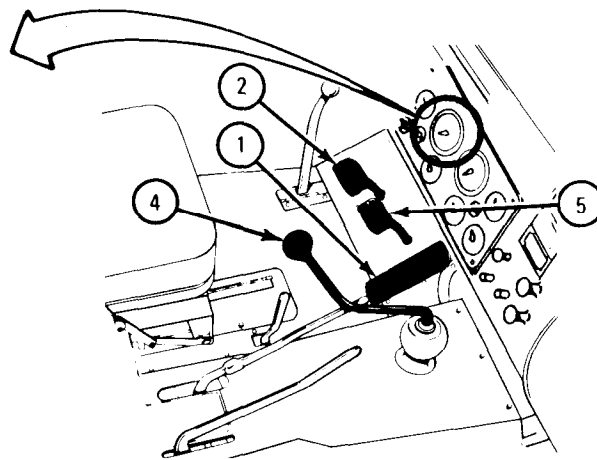
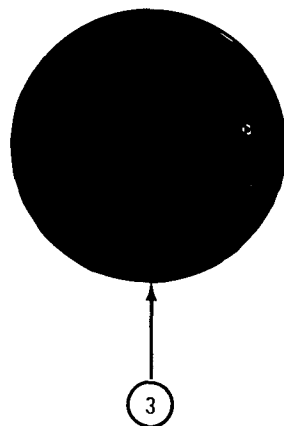

TA 044979

FRAME 11

1. Trucks covered in this manual should be operated within the following rpm limits, as shown on tachometer (1):
  - (a) 1200. Lowest engine rpm when operating under load.
  - (b) 1400-1800. Engine rpm recommended for downshifting.
  - (c) 1400-2200. Engine rpm recommended for cruising.
  - (d) 2600. Highest engine rpm recommended when pulling a very heavy load and when going up a very steep hill.

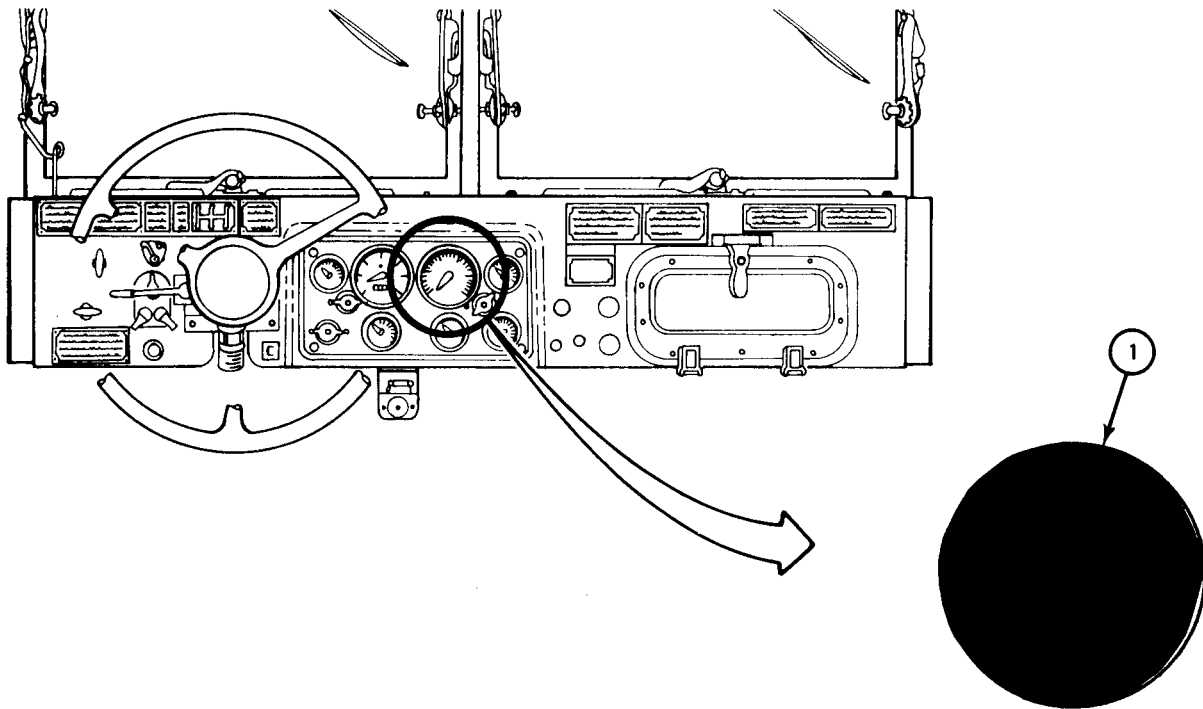

TA 044980

e. Stopping the Truck and Engine.

## FRAME 1

1. To stop truck, take foot off accelerator pedal (1).
2. Step on brake pedal (2) and press down evenly.

**NOTE**

Do not pump brake pedal (2) or shift FRONT TRANSMISSION gearshift lever (3) into N position. With truck in gear, engine helps to slow truck speed.

3. Slow truck until engine runs at idle speed (600 rpm) as shown on tachometer (4).
4. Step on clutch pedal (5) and press it all the way down.
5. Move FRONT TRANSMISSION gearshift lever (3) to N.

GO TO FRAME 2

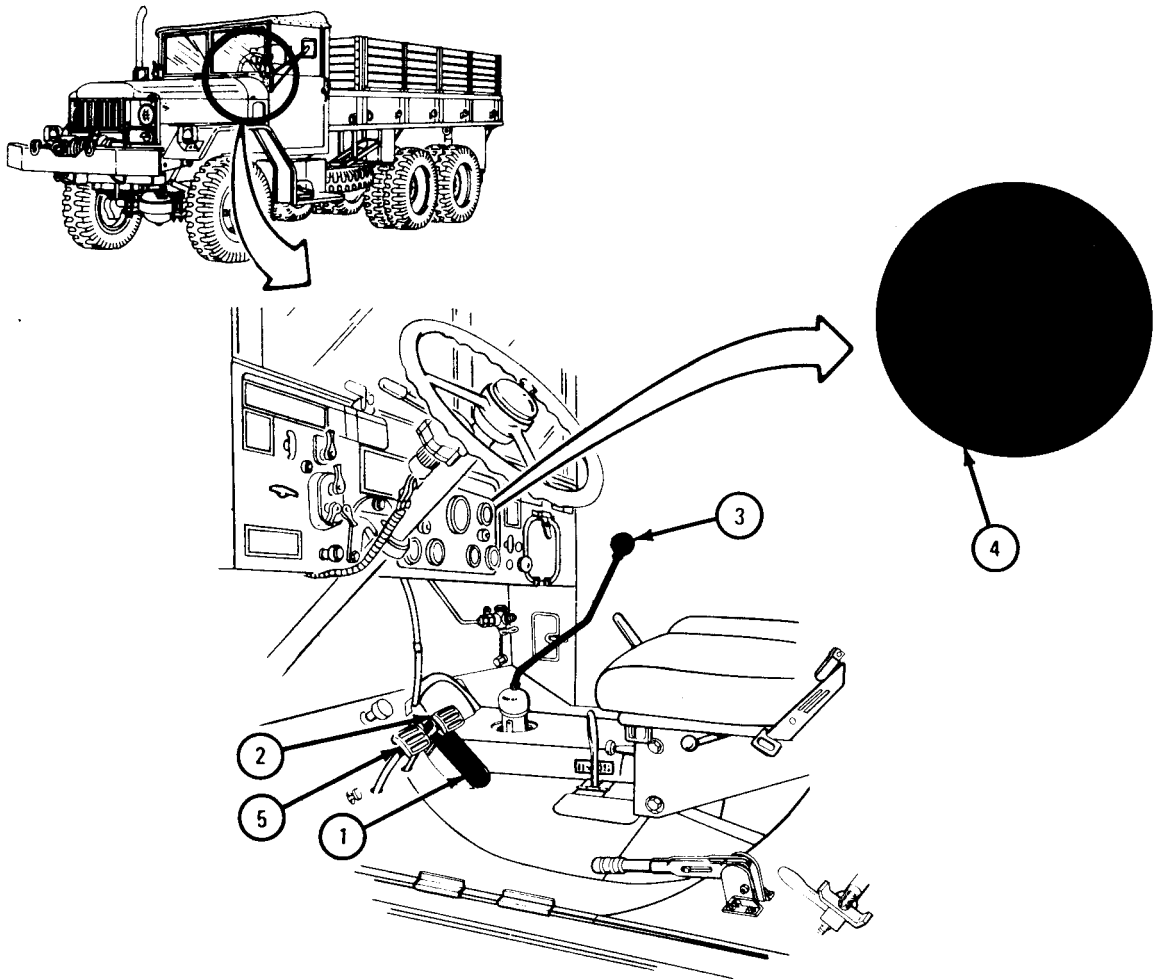

TA 044981

FRAME 2

1. When truck has come to a complete stop, pull handbrake lever (1) up.
2. Take your foot off brake pedal (2).
3. Let clutch pedal (3) come up.

**CAUTION**

Do not let truck roll backward. This could cause strain in the transfer unit which could make it hard to shift gears in the front transmission.

GO TO FRAME 3

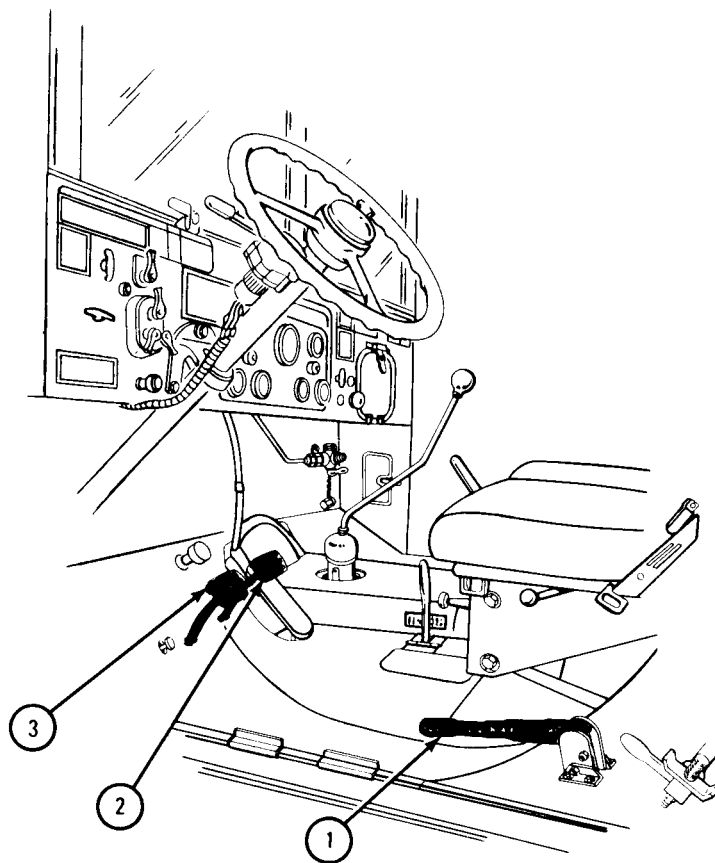

TA 044983

## FRAME 3

1. To stop engine, place ACCESSORY switch (1) and all other switches in off position.

**WARNING**

If engine does not stop after you have pulled the ENG. STOP control knob out, leave the truck immediately and take cover to avoid personal injury.

2. Pull ENG. STOP control knob (2) out to cut off flow of fuel. Leave it in out Position.
3. Do all after-operation preventive maintenance checks and services. (Refer to vol 2, chapter 1 for procedures. )

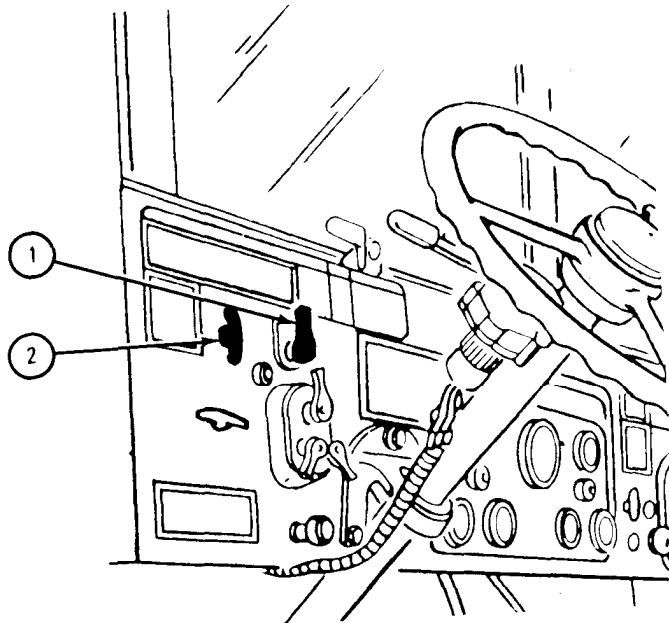

TA 044984

4-7. OPERATION OF FRONT WINCH.

a. General. Any of the 2 1/2-ton 6 x 6 trucks covered in this manual can be equipped with a front winch. The front winch is mounted on the front of the truck on support brackets attached to the left and right side rail extensions. Power for operation is supplied through a propeller shaft extending from the transmission power takeoff. The transmission power takeoff has high, low, and reverse gears, with neutral points between these positions. It has an internal automatic safety brake to hold the winch load when the power takeoff is being shifted.

b. Before Operating.

FRAME 1

**WARNING**

Do not operate winch with a shear pin other than the aluminum pin shown in the parts list for winch being used. Always stand clear of the winch cable under load. A snapped cable can cause serious injury.

1. Check shear pin (1) and make sure that it is the aluminum pin called for in parts list.

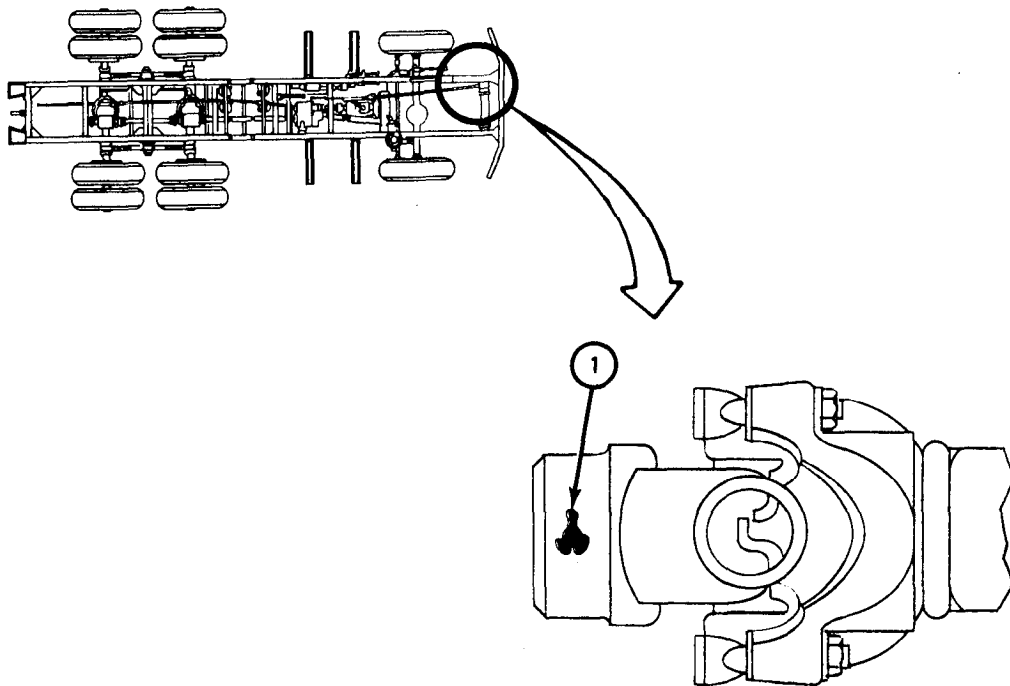

TA 044985



c. Unwinding the Winch Line.

## FRAME 1

1. Start engine. (Refer to para 4-6 b.)
  2. Place truck so that front winch (1) is in a direct line with object (2) to be pulled.
- GO TO FRAME 2

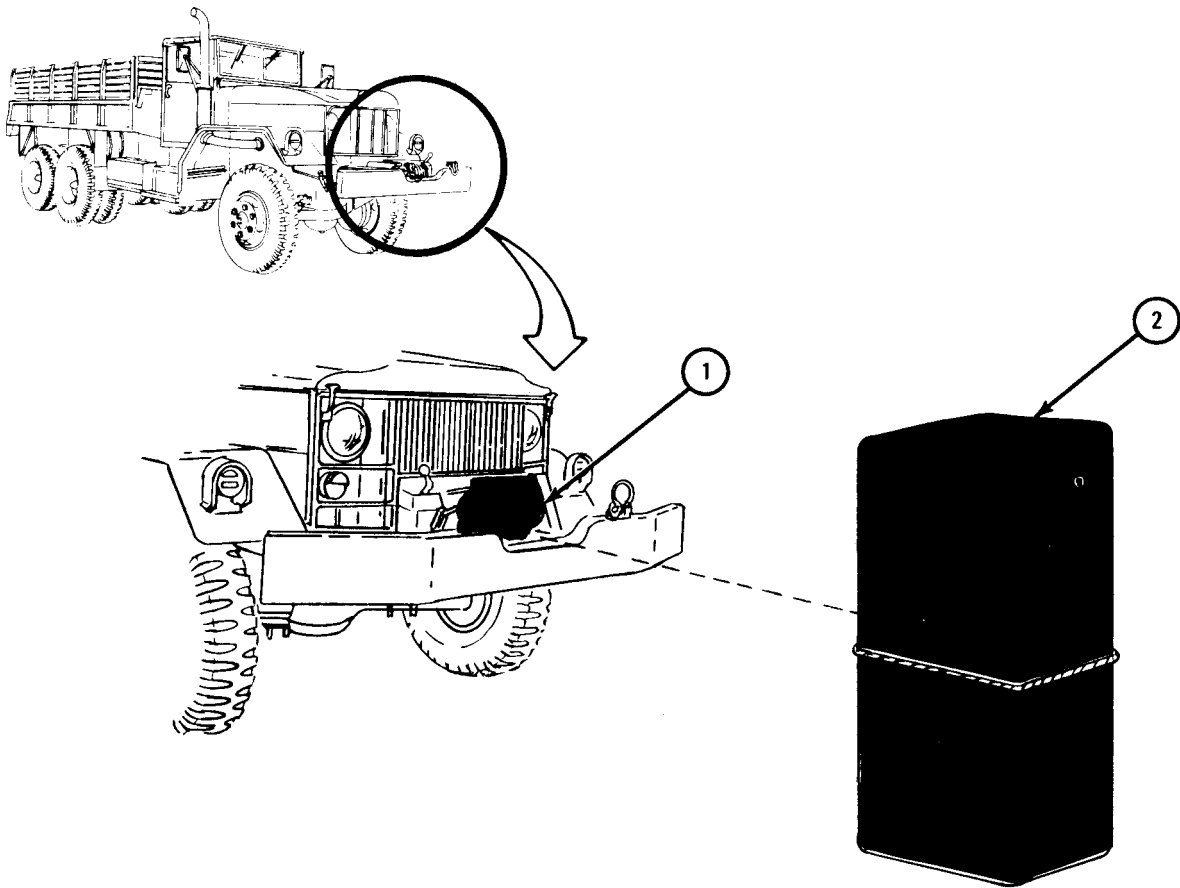

TA 044986

FRAME 2

1. Pull handbrake (1) up to on position.
2. Place FRONT TRANSMISSION gearshift lever (2) in N position.
3. Place POWER TAKEOFF SHIFTS lever (3) in NEU position.
4. Place hinge lock (4) in lock position.

GO TO FRAME 3

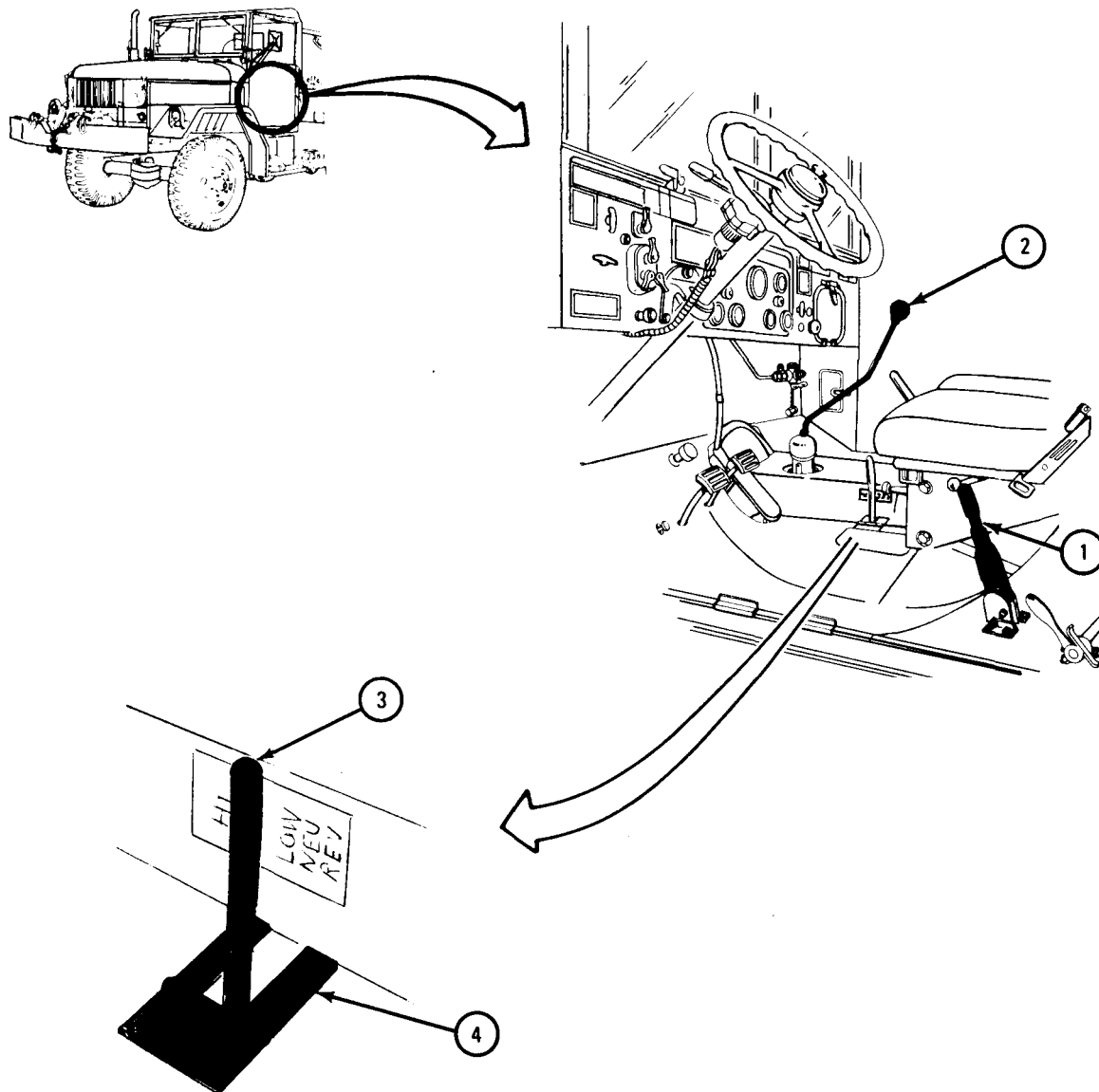

TA 044987

FRAME 3

1. Move winch CLUTCH control lever (1) as far as it will go toward center of truck.
2. Pull front winch drum lock knob (2) out, give it a quarter turn and let it go into shallow slot on nut (3).

GO TO FRAME 4

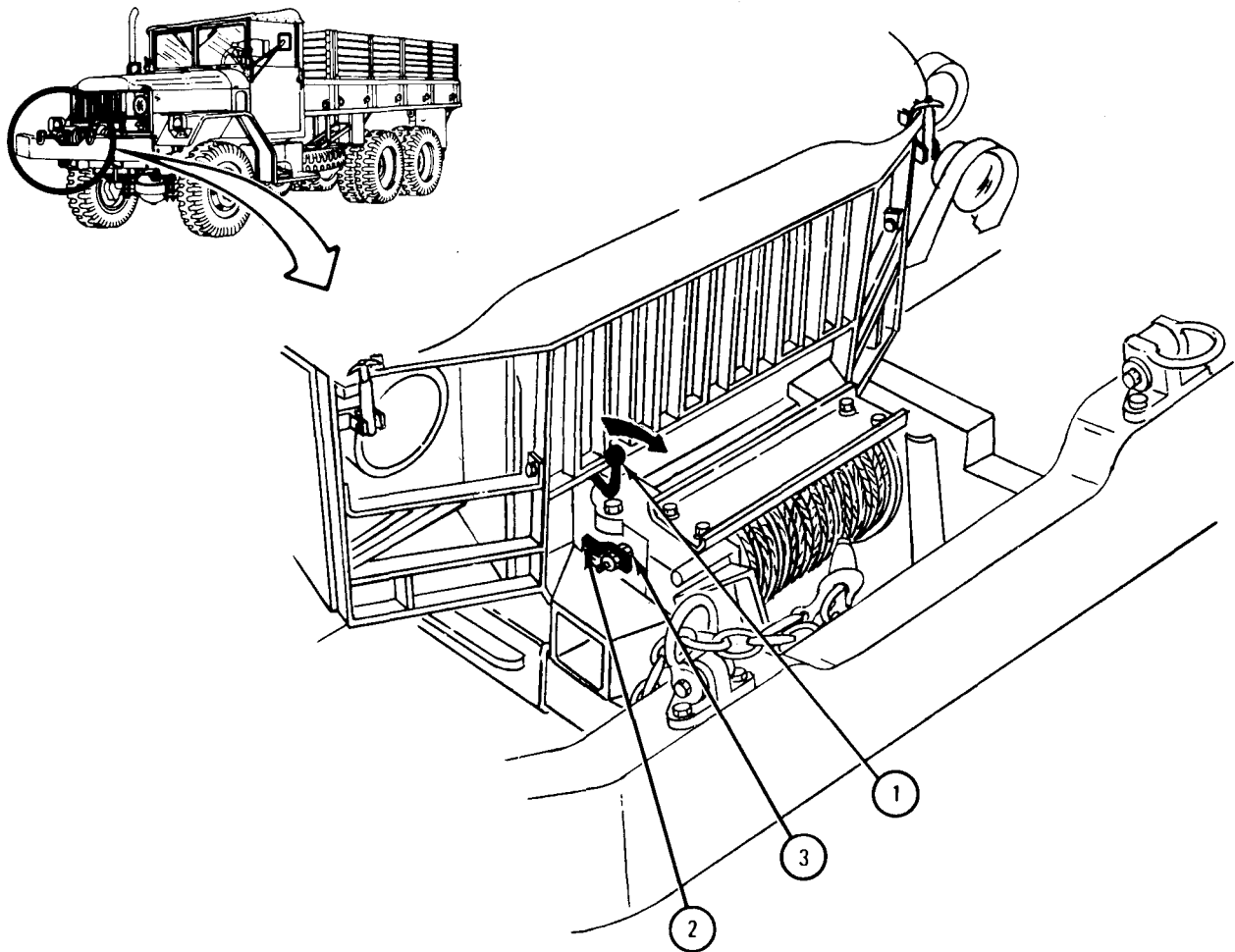

TA 044988

FRAME 4

**WARNING**

Always wear protective gloves when handling winch cable. Do not let winch cable slip through hands. Rusty or broken wires can cause serious injury.

**CAUTION**

Do not operate winch with less than four turns of cable on drum.

**NOTE**

Do not kink winch cable.

1. Pull end of winch cable (1) out to reach object to be pulled (2).
2. Hook winch cable (1) to object to be pulled (2) and make it fast.

GO TO FRAME 5

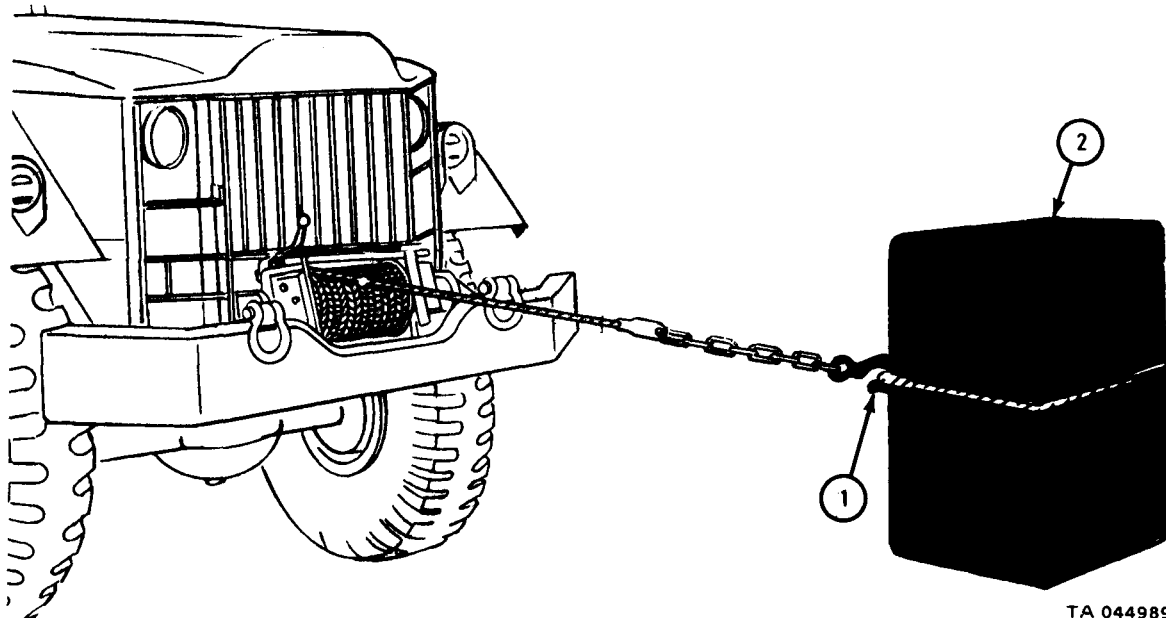

TA 044989

## FRAME 5

1. For very heavy loads (1) always use a snatch block (2) as shown.

**NOTE**

The truck's brakes will hold under a load only as much as the shear pin will hold. Always use a snatch block for very heavy loads. Never anchor the truck to a tree or other object.

GO TO FRAME 6

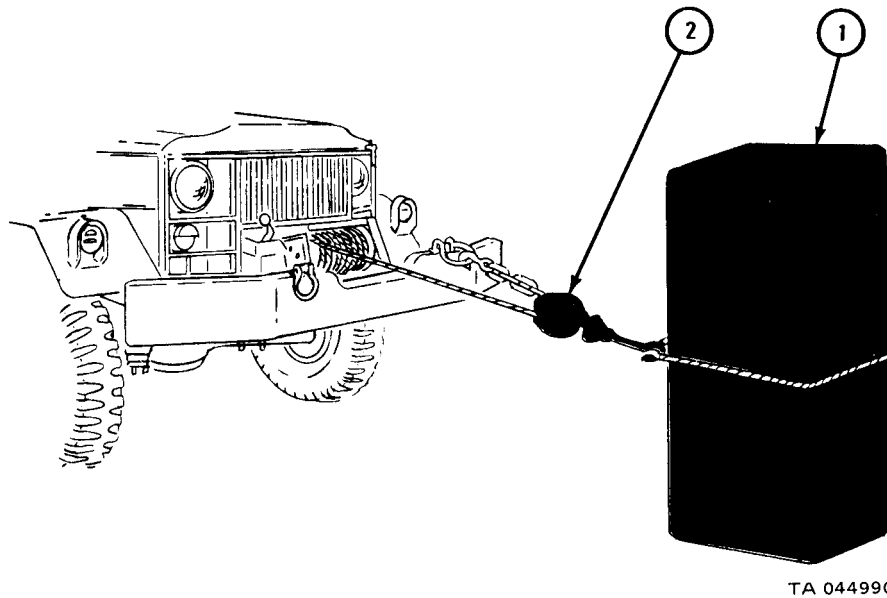

TA 044990

FRAME 6

1. To pull an object (1) that is not in a straight line (directional pull), use snatch block (2) and utility chain (3), as shown.

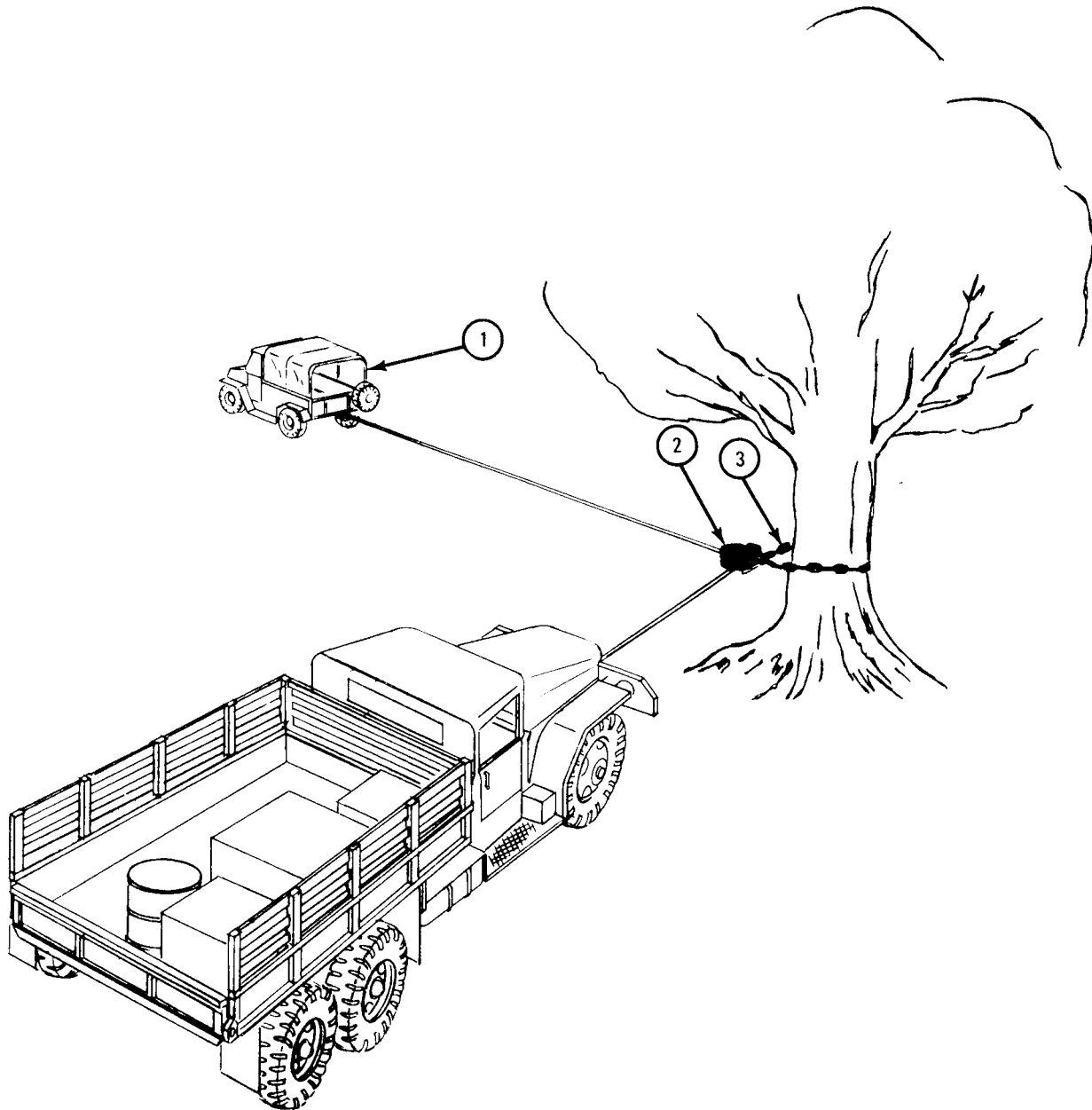

TA 044991

d. Lifting or Pulling.

## FRAME 1

**WARNING**

During all winch operations, the instant that slack in winch line (1) is taken up is critical. Tell all personnel to stand clear of winch line and load (2).

A snapped winch line or shifting load can be very dangerous. If load shifts to present a hazard, stop pulling and spread load. If any part of the equipment fails, stop operations and tell organizational maintenance.

1. Take up slack in winch line (1) by backing truck slowly, if there is room behind truck and conditions permit.

GO TO FRAME 2

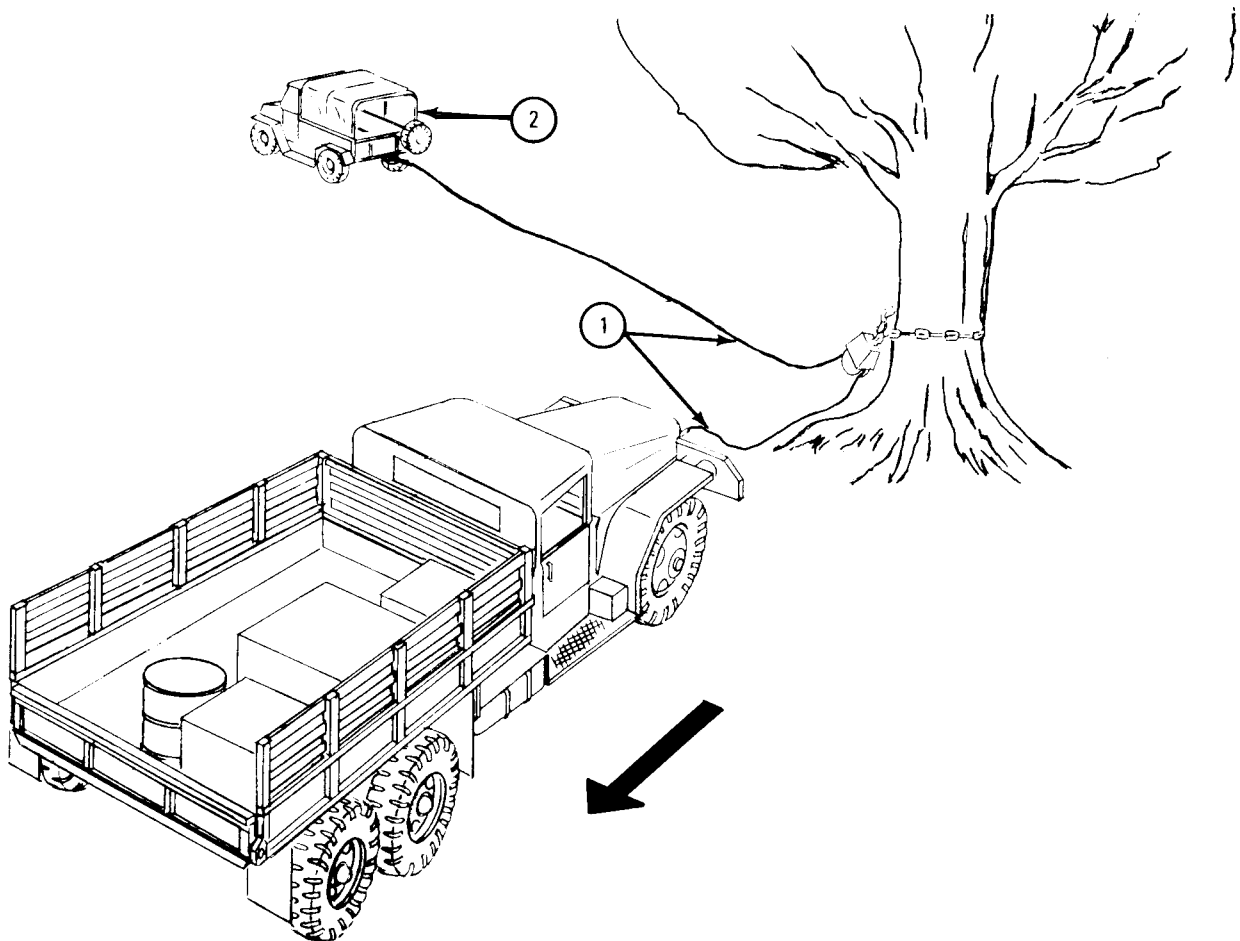

TA 044992

FRAME 2

1. If conditions do not permit backing up truck, take up slack in cable with winch.
2. Move CLUTCH control lever (1) as far as it will go toward right side of truck to IN position to take up slack in cable.

**NOTE**

Never use winch CLUTCH control lever (1) to control winch.  
Always use POWER TAKEOFF SHIFTS lever and engine clutch.

GO TO FRAME 3

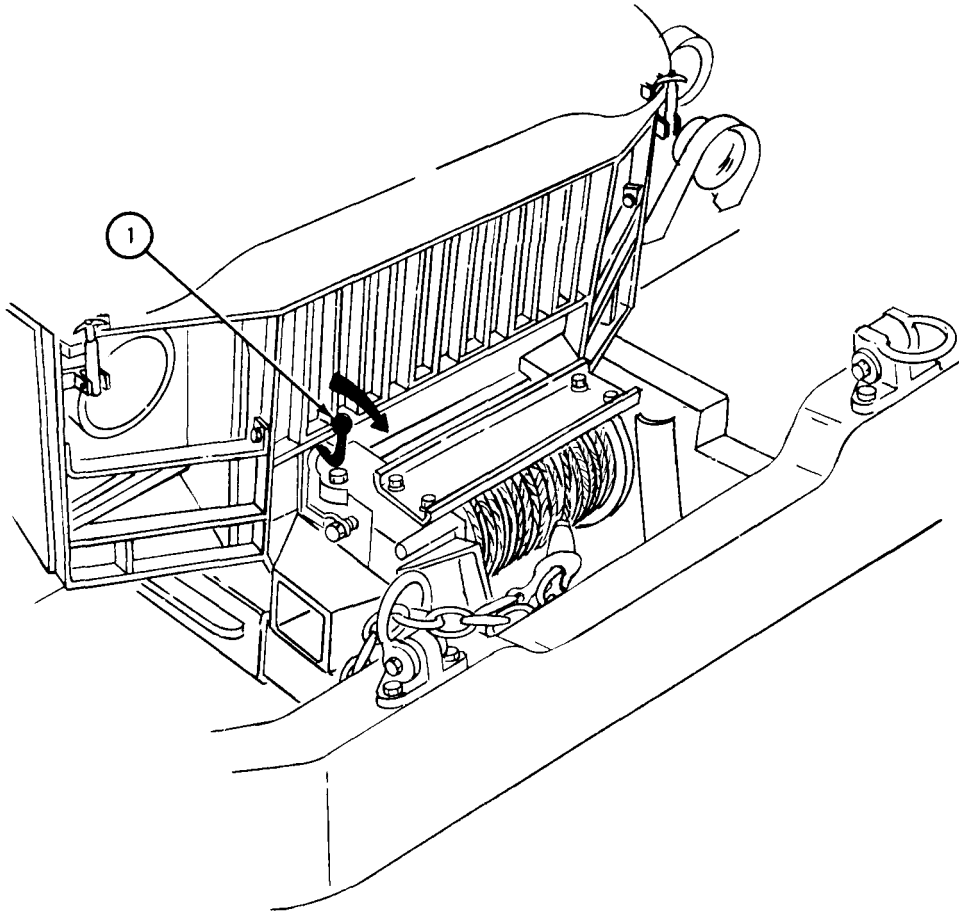

TA 044993



**FRAME 4**

1. With engine running, leave FRONT TRANSMISSION gearshift lever (1) in position N.

**WARNING**

Always use hand THROTTLE (2) to control engine speed when operating winch. Avoid sudden changes in speed or high speed. Do not run engine faster than 1,200 rpm as shown on tachometer (3).

Rough, jerky operation may cause broken shear pins and snapped cables, damage to vehicle or injury to personnel.

2. Press down on clutch pedal (4).
3. Lift POWER TAKEOFF SHIFTS lever hinge lock (5) and move POWER TAKEOFF SHIFTS lever (6) to LOW for heavy loads, HI for normal loads. When in doubt, use LOW position.

GO TO FRAME 4

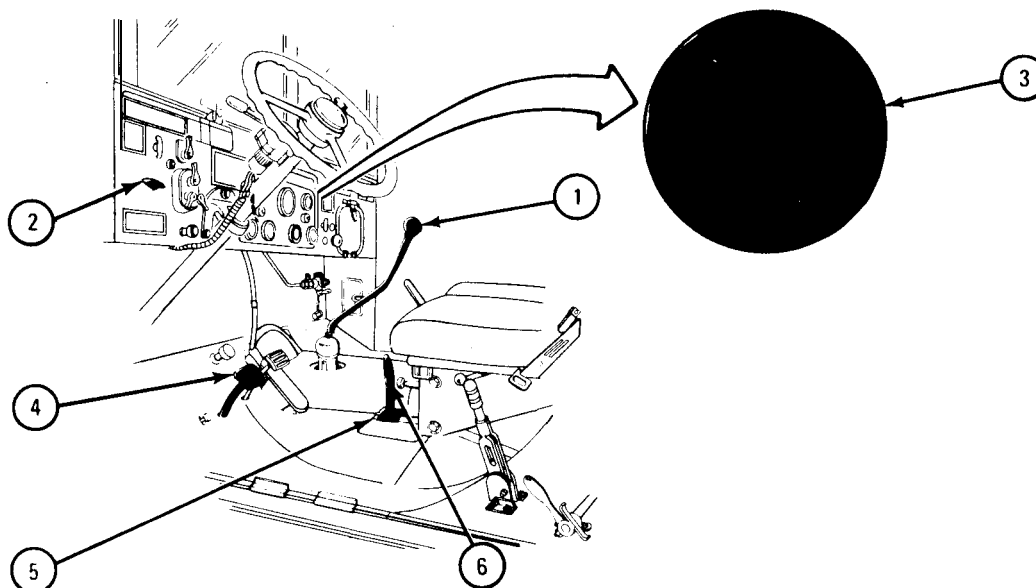

TA 044994

FRAME 4

1. Let clutch pedal (1) come up slowly.
2. Wind in winch cable to take up slack.
3. Use hand THROTTLE (2) to control speed and continue smooth operation. Wind in winch cable as needed to pull or lift load.

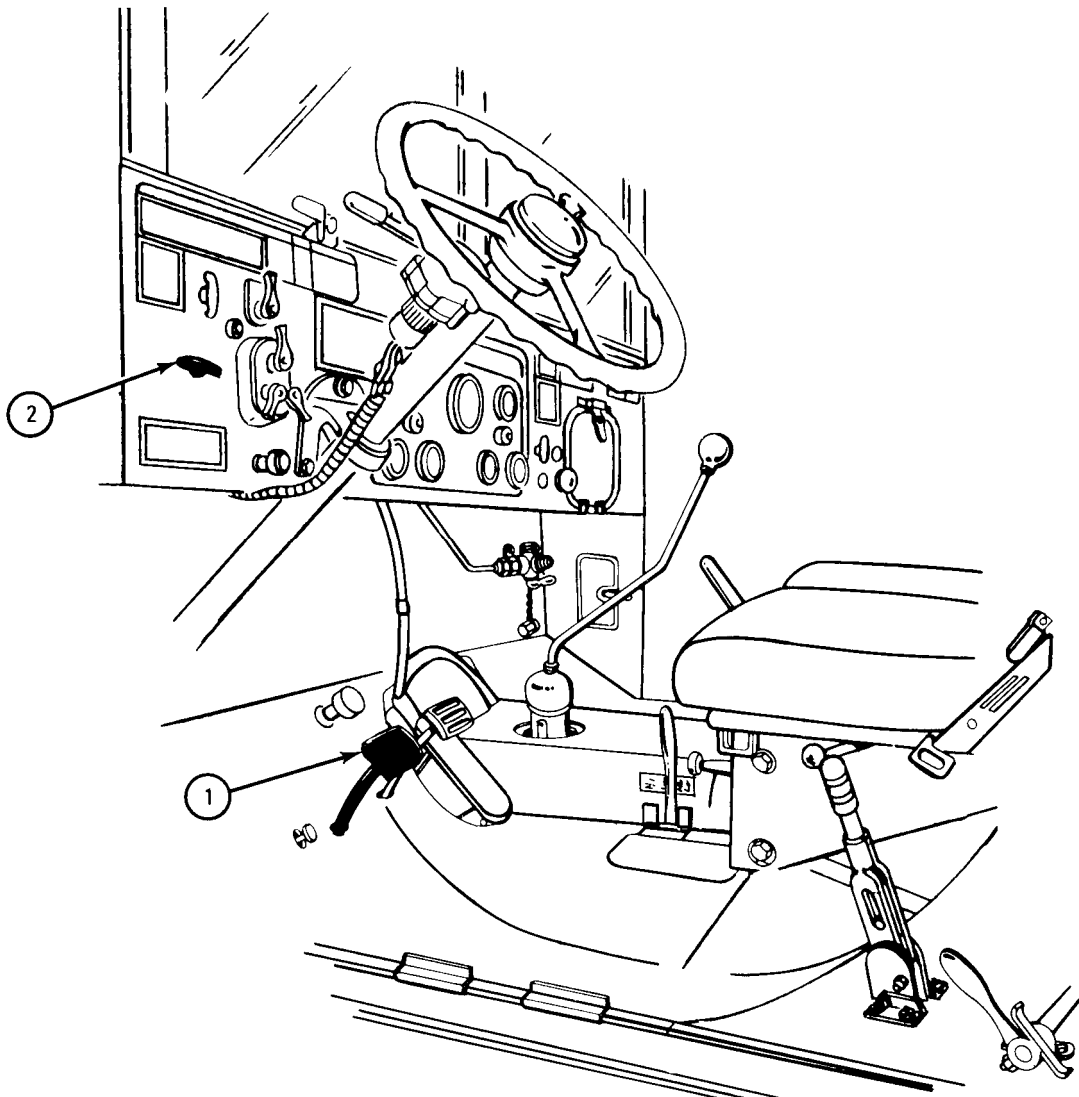

e. Stopping the Winch.

## FRAME 1

1. Step on and press clutch pedal (1) all the way down.
2. Place POWER TAKEOFF SHIFTS lever (2) in NEU position.
3. Let clutch pedal (1) come up slowly.

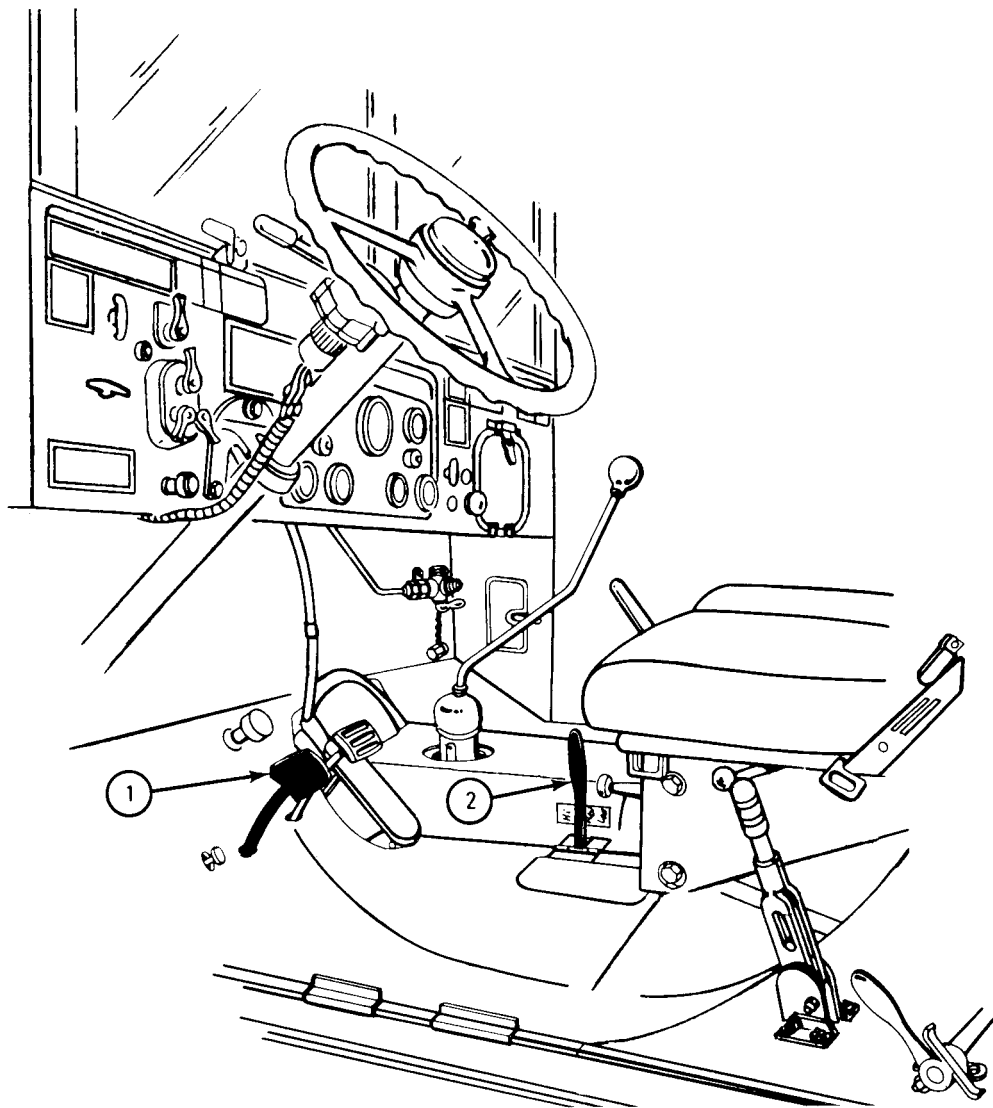

TA 044996

f. Lowering Load or Unwinding Slack Cable.

PERSONNEL: Two

FRAME 1

- Soldier A
1. Step on and press clutch pedal (1) all the way down.
  2. Check to be sure that FRONT TRANSMISSION gearshift lever (2) is in N position.
  3. Place POWER TAKEOFF SHIFTS lever (3) in REV position.
  4. Let clutch pedal (1) come up slowly.
  5. As winch begins to operate, control speed with hand THROTTLE (4) to give smooth operation at moderate speed.

GO TO FRAME 2

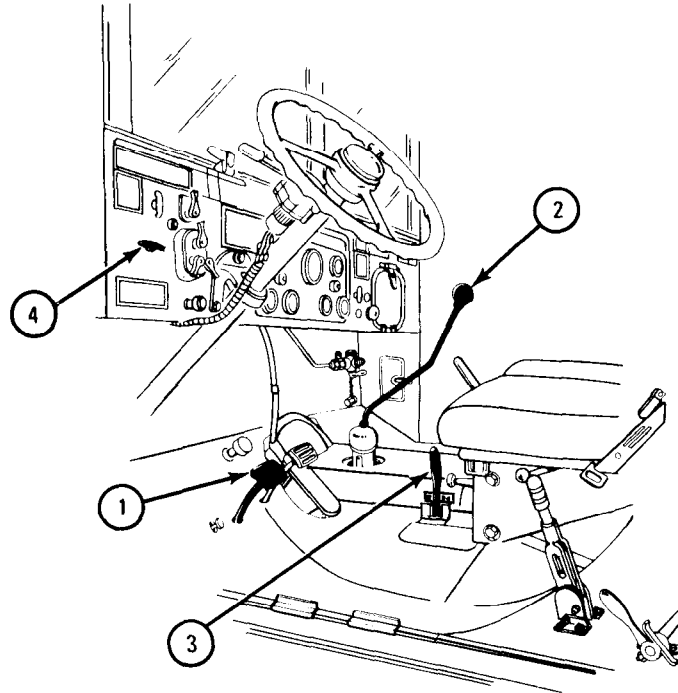

TA 044997

**CAUTION**

Do not leave less than four turns of winch cable (1) on winch drum (2) when lowering or unreeling cable. The cable clamp alone will not hold against a load.

**FRAME 2**

Soldier B 1. Pull on winch cable hook (3) and unwind cable as needed.

**NOTE**

When unwinding winch cable (1) under power without a load, keep tension on cable. This keeps cable from crossing coils.

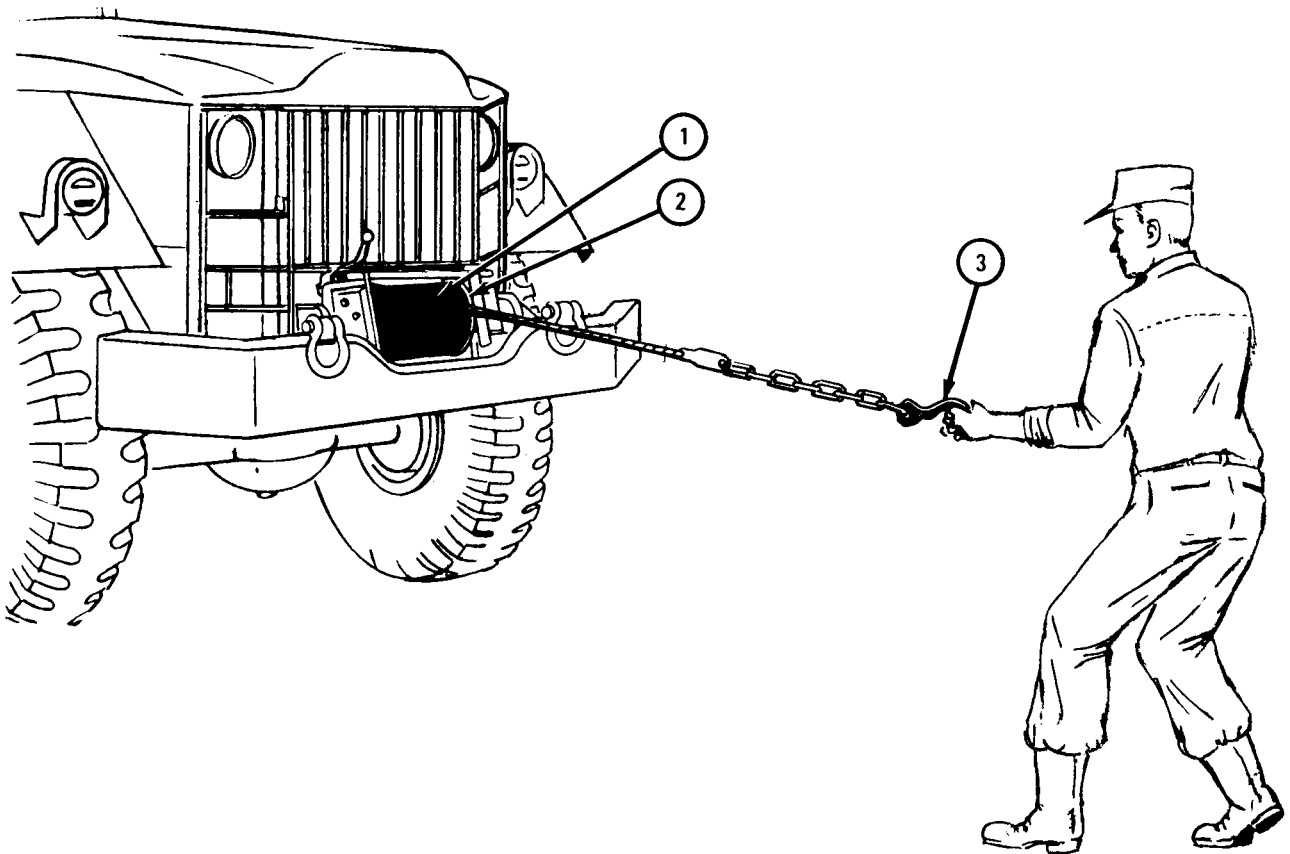

TA 044998

g. Winding the Winch Line on the Drum.

FRAME 1

**WARNING**

Always wear protective gloves when handling winch cable.  
Do not allow winch cable to run through hands. Rusty or  
broken wires can cause serious injury.

1. Attach a load to end of winch cable (1). If no load is available, attach the cable to a tree or another truck with brakes set.

**GO TO FRAME 2**

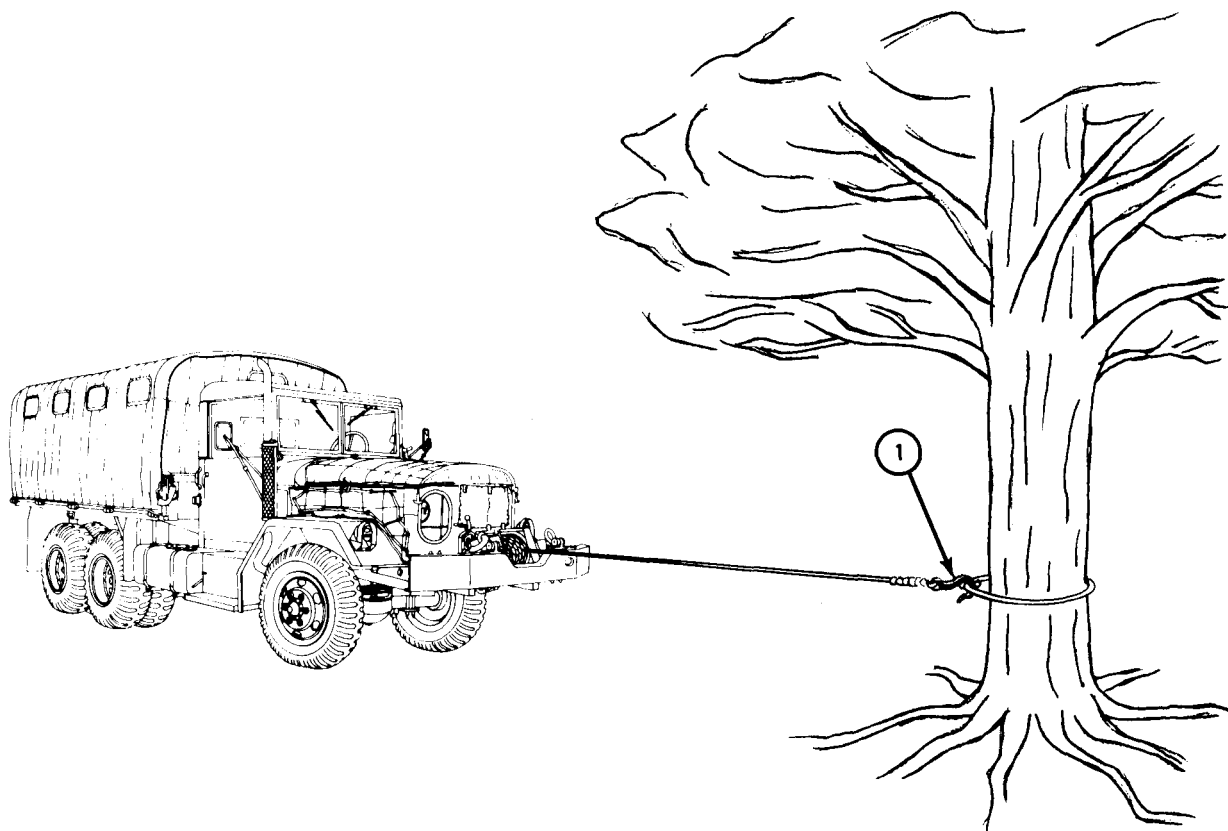

TA 044999

## FRAME 2

1. Step on and press clutch pedal (1) all the way down.
2. Make sure that FRONT TRANSMISSION gearshift lever (2) is in N position.
3. Place POWER TAKEOFF SHIFTS lever (3) in LOW position.
4. Set handbrake lever (4) off to down position.
5. Let clutch pedal (1) come up slowly. The front winch will pull vehicle forward and wind winch line onto drum.
6. Step on brake pedal (5) and press down lightly to make sure of a tight, neat wind.

**NOTE**

Make sure that first layer of winch line goes onto drum in order and that each additional layer starts back across drum. If necessary, use wooden block to push or hammer line closely wrapped. If truck is equipped with a load winding device, this will not be necessary.

GO TO FRAME 3

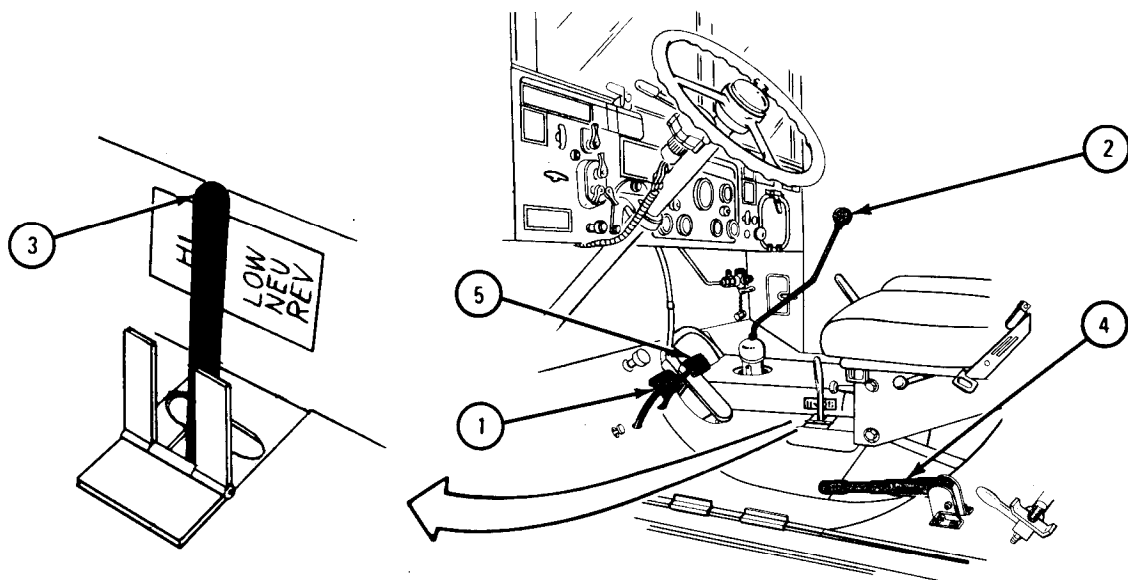

TA 045000

FRAME 3

1. When winch line is fully wound on drum, step on clutch pedal (1) and press it all the way down.
2. Place POWER TAKEOFF SHIFTS lever (2) in NEU position. Lock in position with lock hinge (3).
3. Pull handbrake lever (4) to up (on) position.
4. Stop engine. (Refer to para 4-6e.)

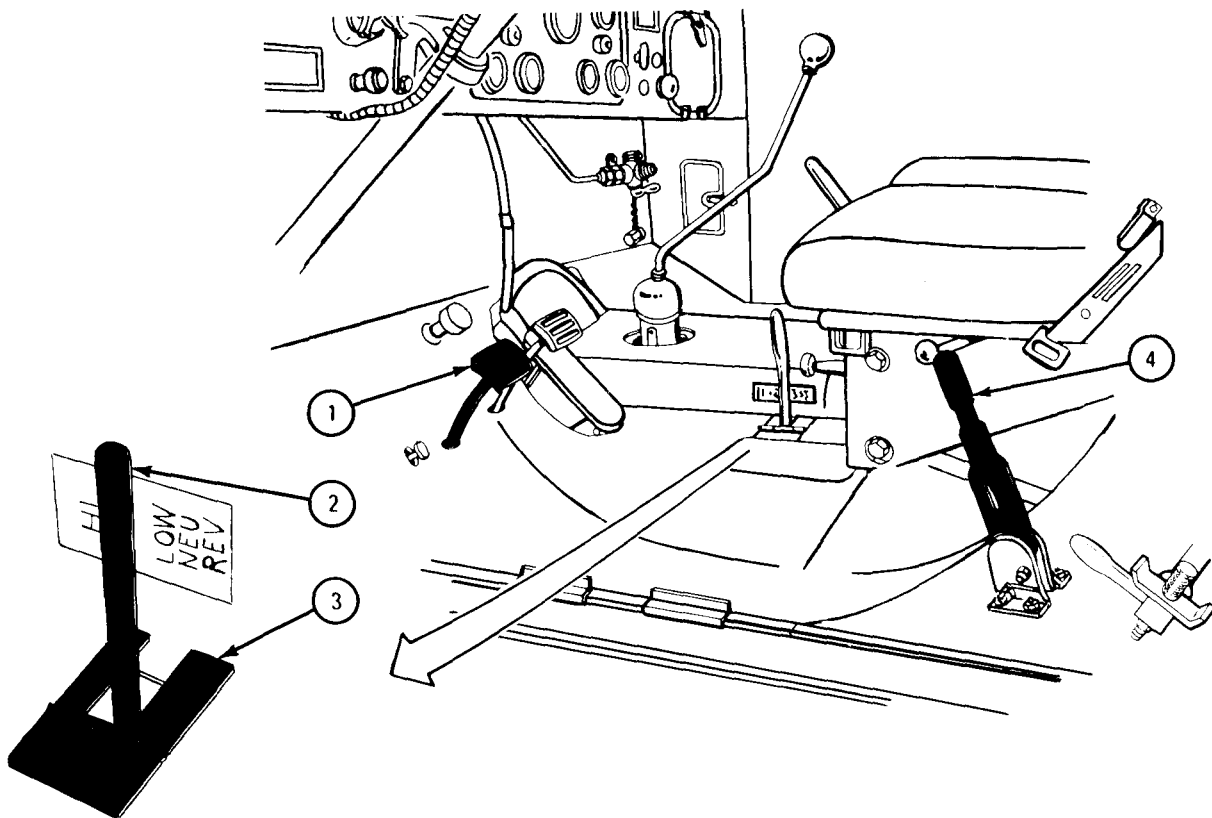

TA 045001



h. Locking the Front Winch for Travel.

## FRAME 1

1. Place cable chain (1) above bumper (2) and up through left shackle (3).
2. Place cable chain (1) across front of bumper (2) and hook to right lifting shackle (4).

GO TO FRAME 2

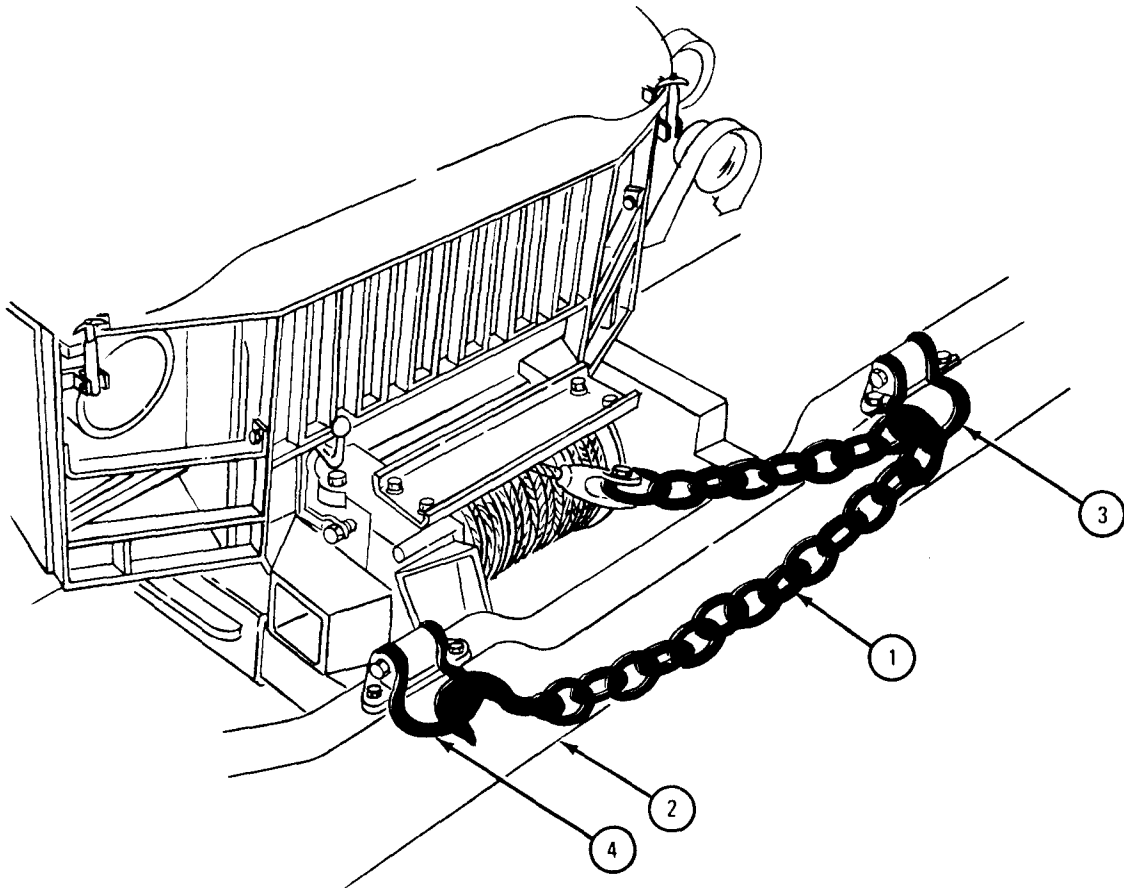

TA 045002

FRAME 2

1. Move winch CLUTCH control lever (1) toward left side (driver's side) of vehicle, to OUT position to set drum (2) free.
2. Pull drum lock knob (3) out, turn a quarter-turn, (90°), and let wing on knob go into deep slot on nut.
3. Turn drum left until lock knob (3) plunger slips into nearest hole on drum flange (4).

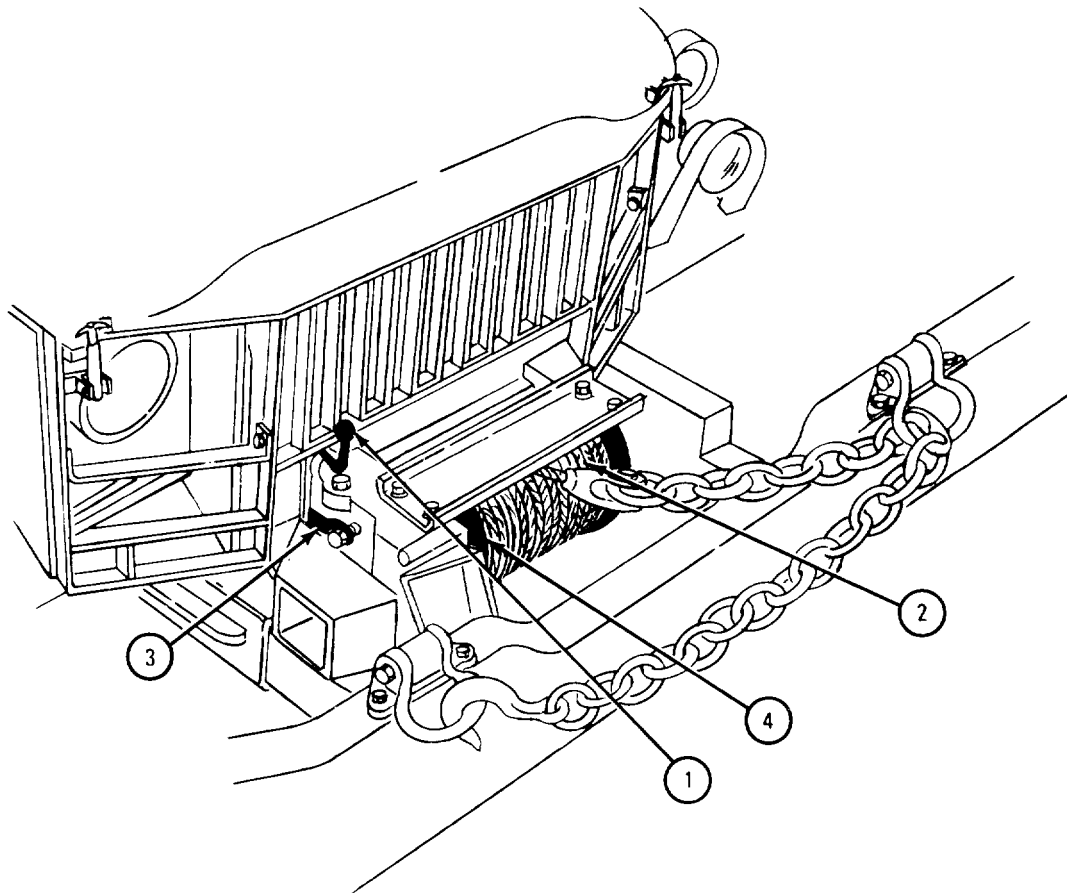

TA 045003

4-8. OPERATION OF CARGO TRUCKS.

a. General. The cargo trucks covered in this manual are equipped with a 12-foot steel bed, removable front and side racks, and a hinged tailgate. They are designed to accept a tarpaulin cover for cargo protection.

b. Removing the Front and Side Racks.

FRAME 1

1. Take hooks (1) out of retainer slots (2) on both sides of truck.

GO TO FRAME 2

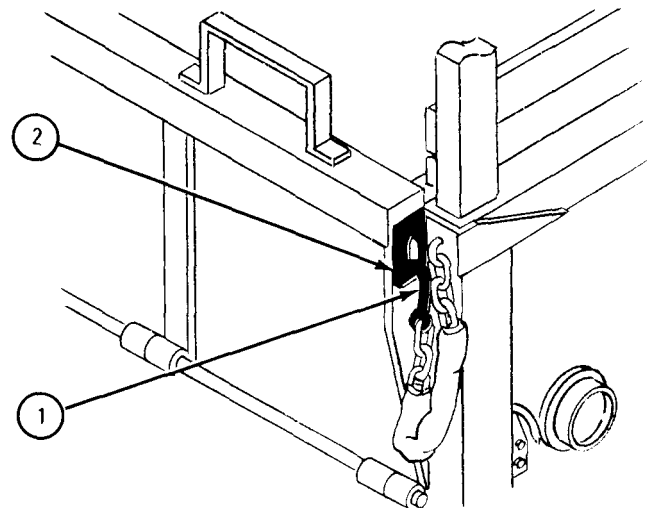
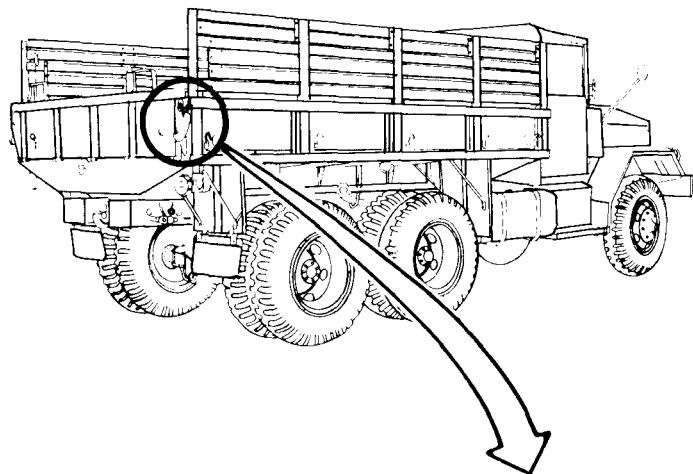

TA 045063

FRAME 2

1. Grasp top of tailgate (1) and pull it toward rear of truck.
2. Let tailgate (1) come down slowly, do not let it drop.

GO TO FRAME 3

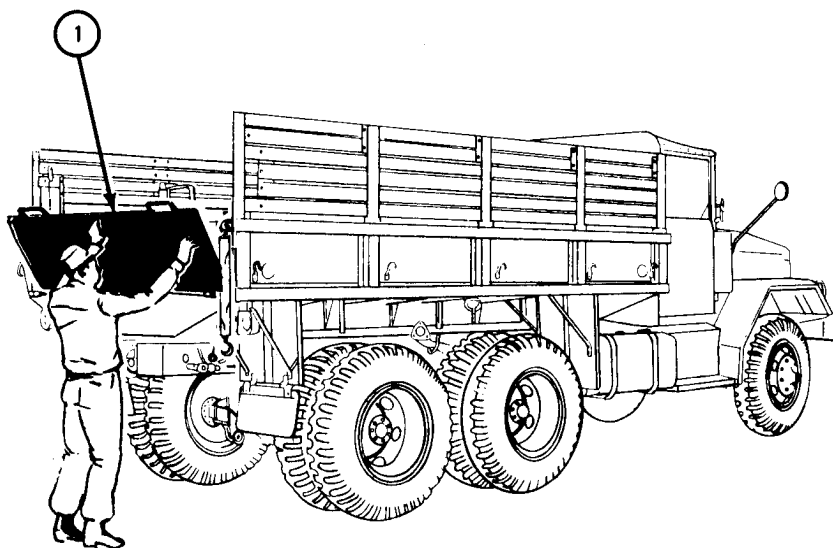

TA 045064

FRAME 3

1. Fold troop seat (1) up and lock it in place with retainers (2).
2. Lift and take off front rack (3).
3. Lift and take off side racks with seats (4).

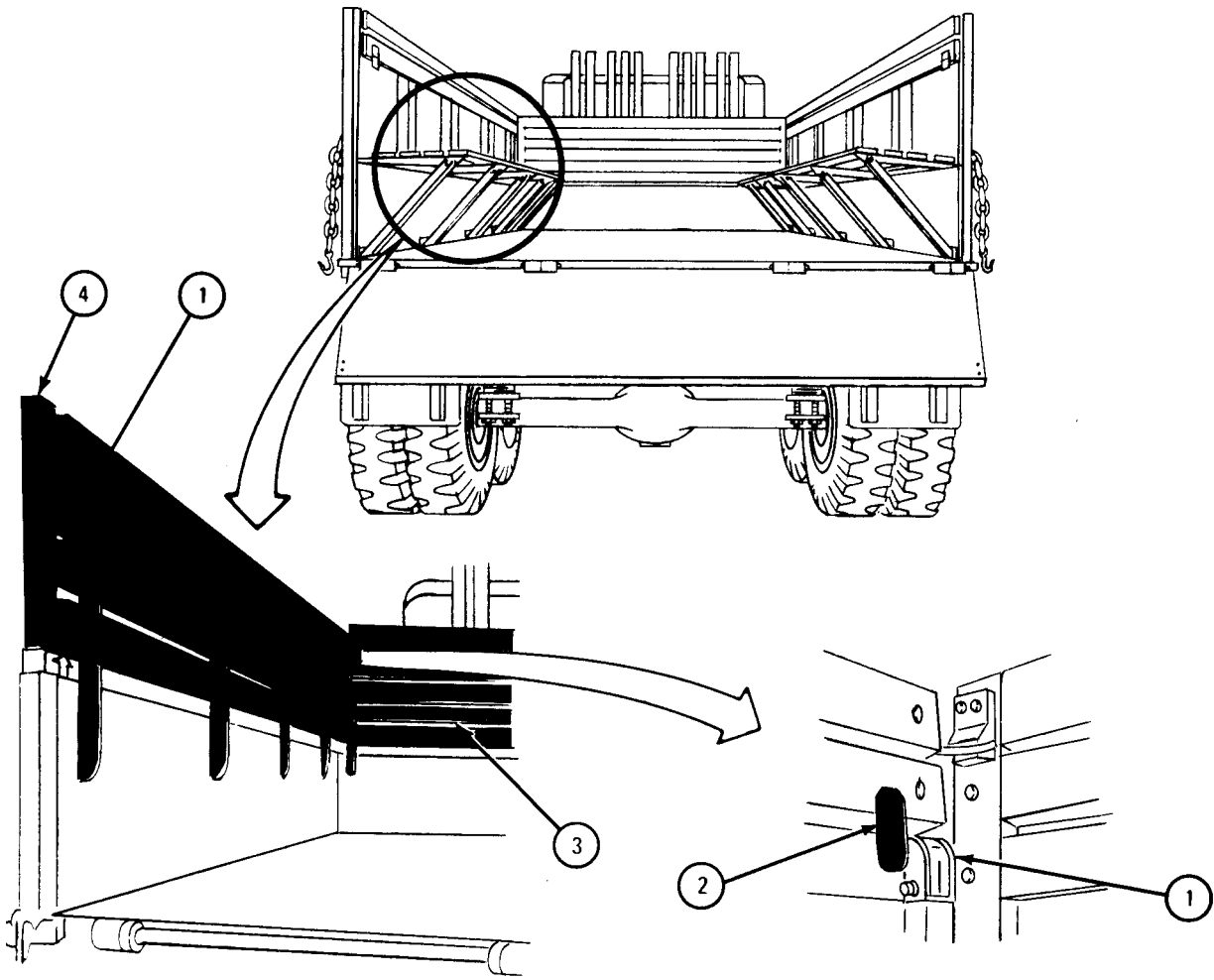

TA 045065

c. Installing the Front and Side Racks.

FRAME 1

1. Put side racks with seats (1) into sockets (2) on right and left sides of truck.
  2. Put front rack (3) into front rack sockets (4).
  3. Make sure that retainers (5) on front rack go into retainer rings (6) on side rack.
- GO TO FRAME 2

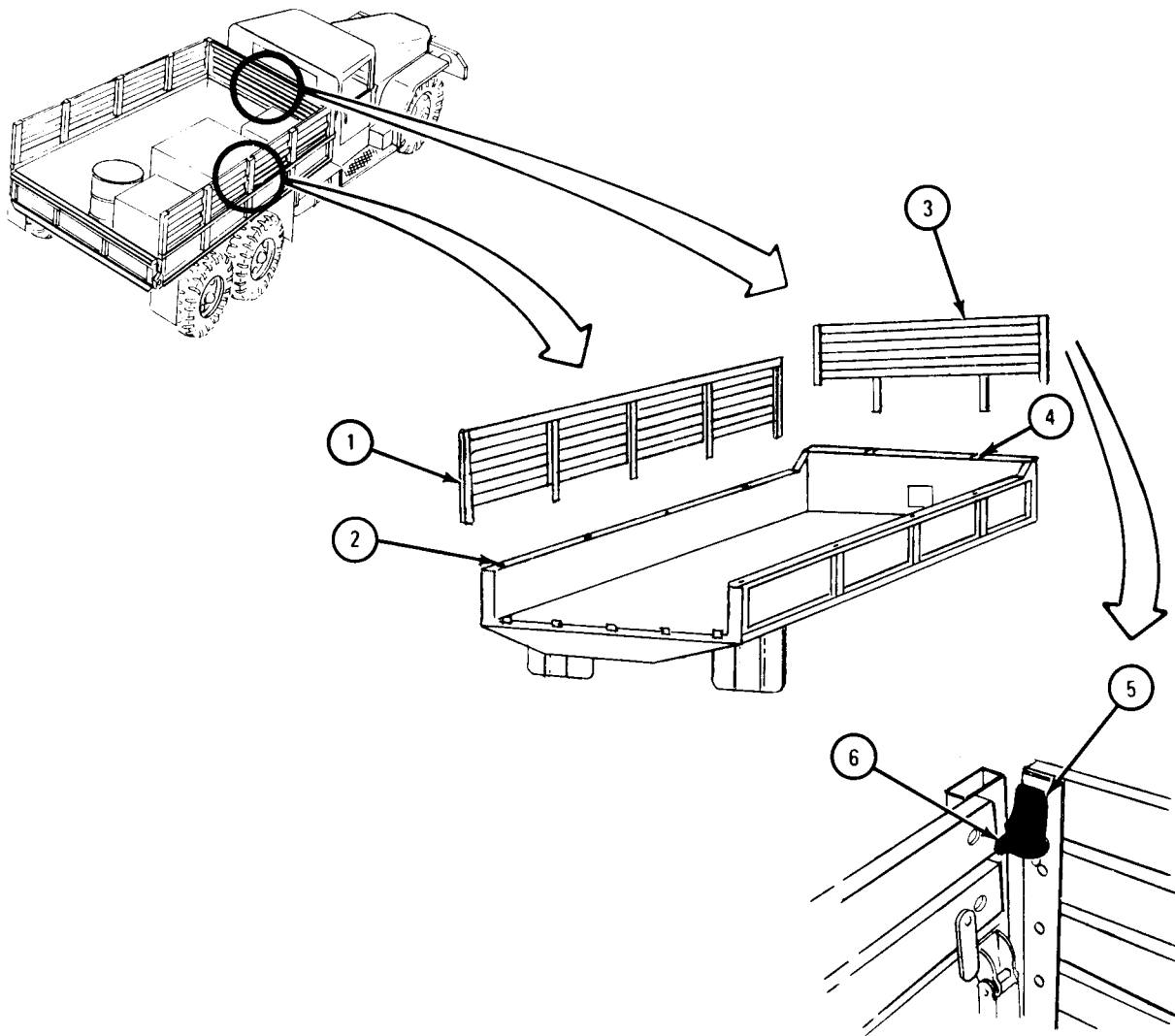

TA 045066

## FRAME 2

1. Turn troop seat retainers (1) up.
2. Move seats (2) down into position slowly. Do not let them drop.

GO TO FRAME 3

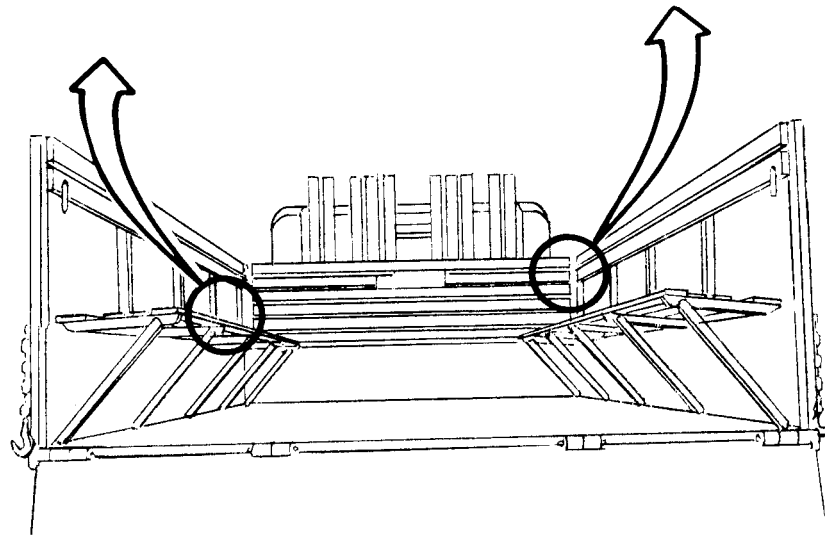
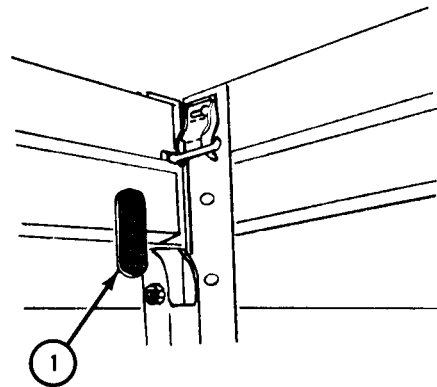
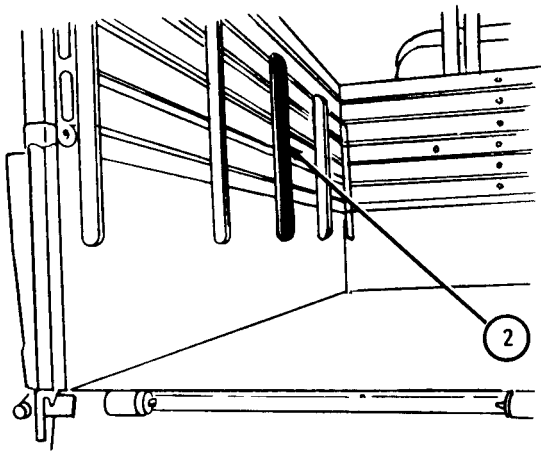

TA 045067

FRAME 3

1. Lift tailgate (1) up to closed position.
2. Place hooks (2) through retainer slots (3).

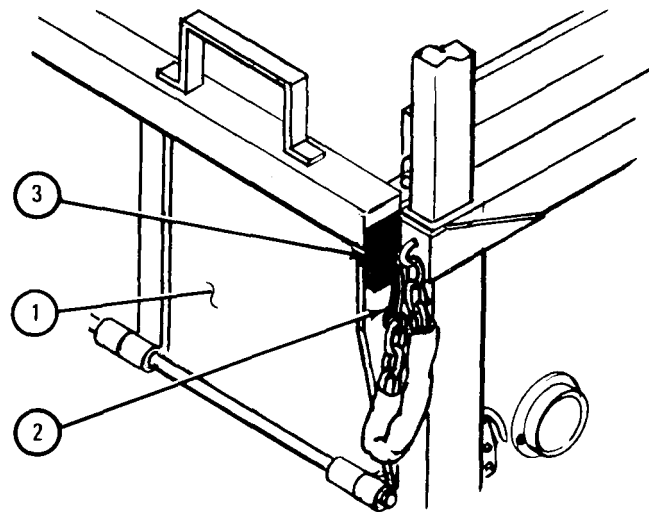
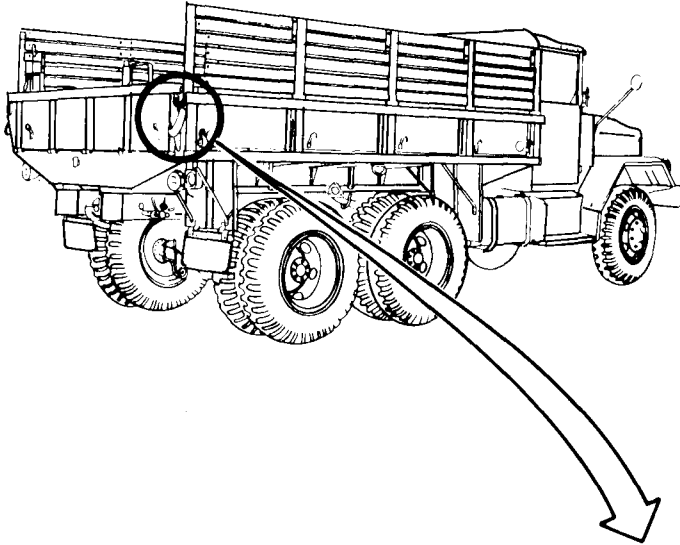

TA 045068



d. Removing the Front and Side Racks from Dropside Type Cargo Trucks.

PERSONNEL: Two

FRAME 1

1. Turn left and loosen locking handles (1) on each side of tailgate.
  2. Turn handle locking pins (2), align pins with slots (3), pull handles through slots.
- GO TO FRAME 2

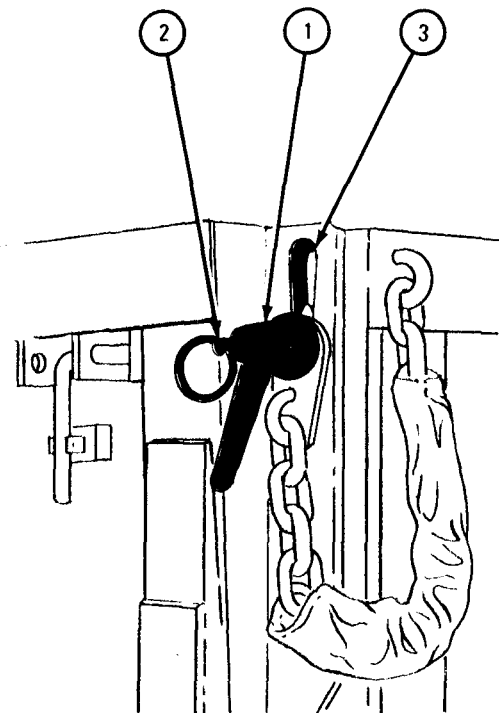
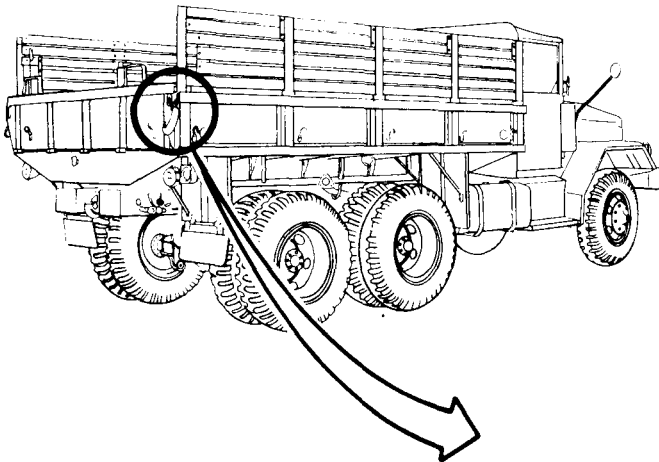

TA 045069

FRAME 2

1. Move tailgate (1) down by gripping it on top and pulling toward rear. Let it come down slowly, do not let it drop.

GO TO FRAME 3

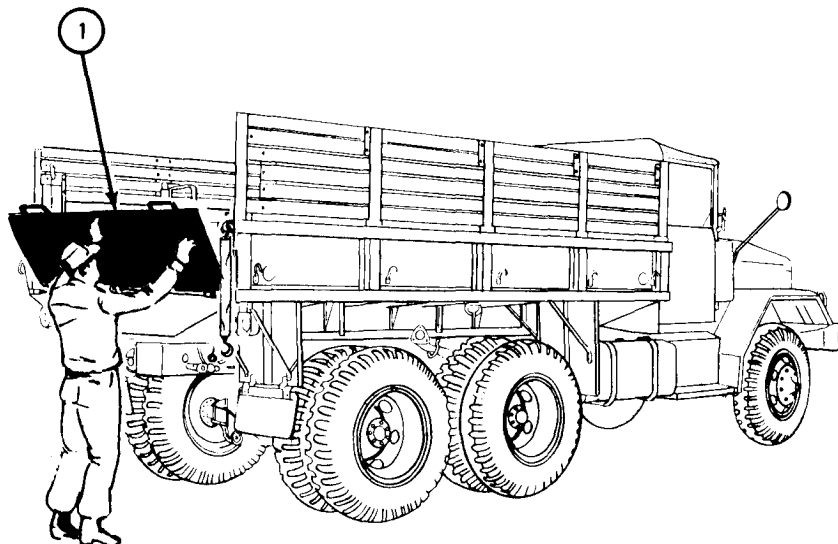

TA 045064

FRAME 3

1. Pull side rack locking pin handles (1) from retainers (2).
2. Move them away from rack sockets (3).

GO TO FRAME 4

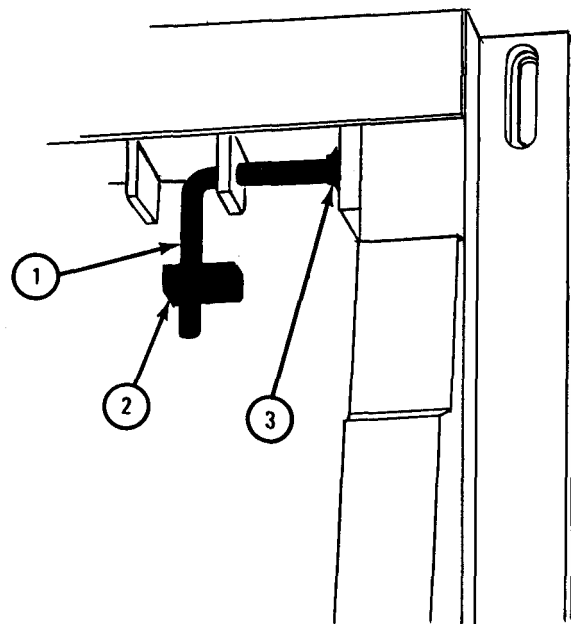
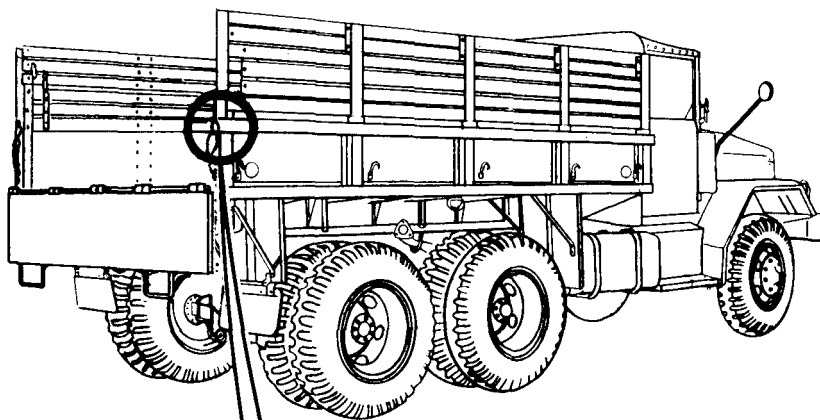

TA 045071

FRAME 4

1. Fold the troop seats (1) up and lock them in place with retainers (2).  
GO TO FRAME 5

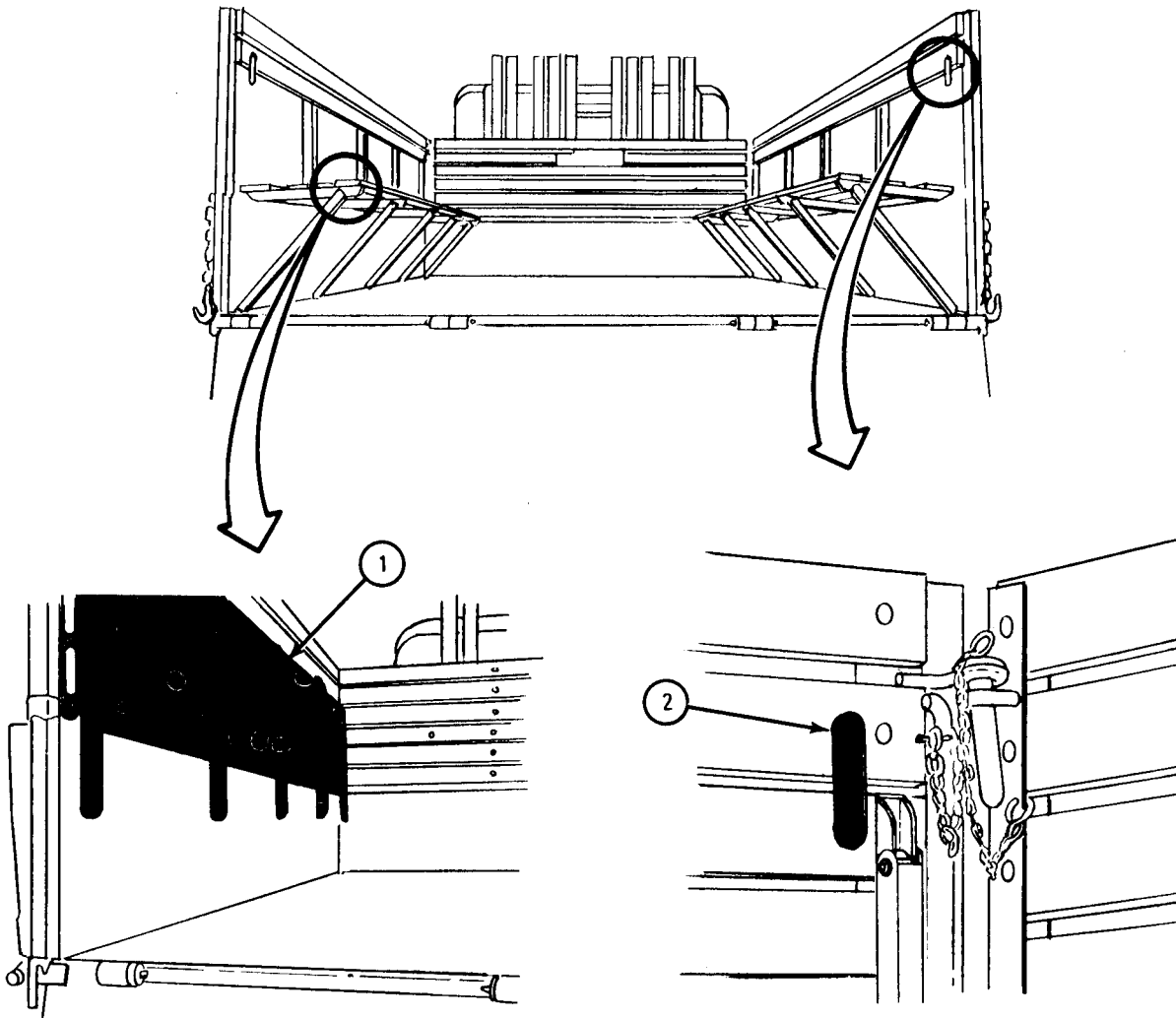

TA 045072

FRAME 5

- Soldier A 1. Lift front and side rack locking pins(1) out of retainer rings (2).
- Soldiers A and B 2. Lift front rack (3) out of its sockets.
3. Lift side rack (4) with seats out of its sockets.

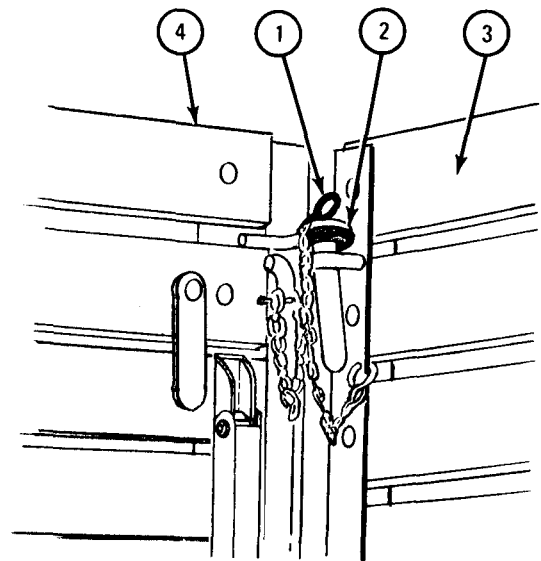
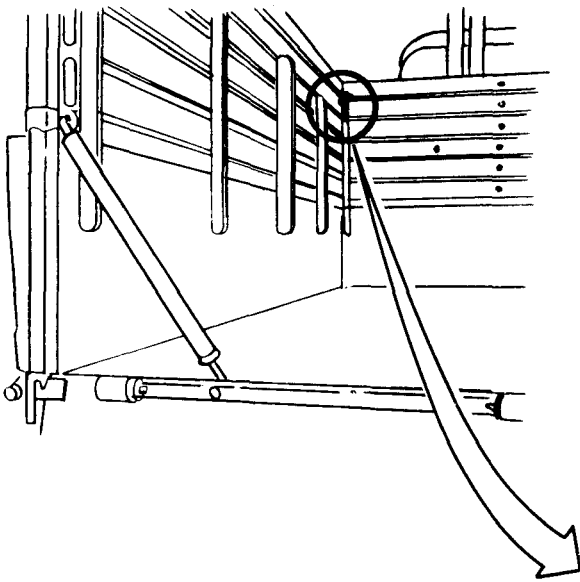

TA 045073

e. Lowering the Dropsides on Dropside Type Cargo Trucks.

TOOLS: Pliers

PERSONNEL: Two

FRAME 1

**CAUTION**

Use extreme care when moving drop sides down. Move them down slowly. Do not let them fall free. Letting sides fall can cause damage to side racks, mud guards, or both.

If truck is moved with sides in down position; be sure that cargo is made fast. Clearance between sides and ground when they are down with racks attached is 15 inches. Without side racks attached, clearance is about 38 inches. When sides are down, move truck slowly on even terrain only.

1. Turn left, loosen, locking handles (1) on each side of tailgate.
2. Turn handle locking pins (2) to aline pins with slots (3), and pull handles through slots .

GO TO FRAME 2

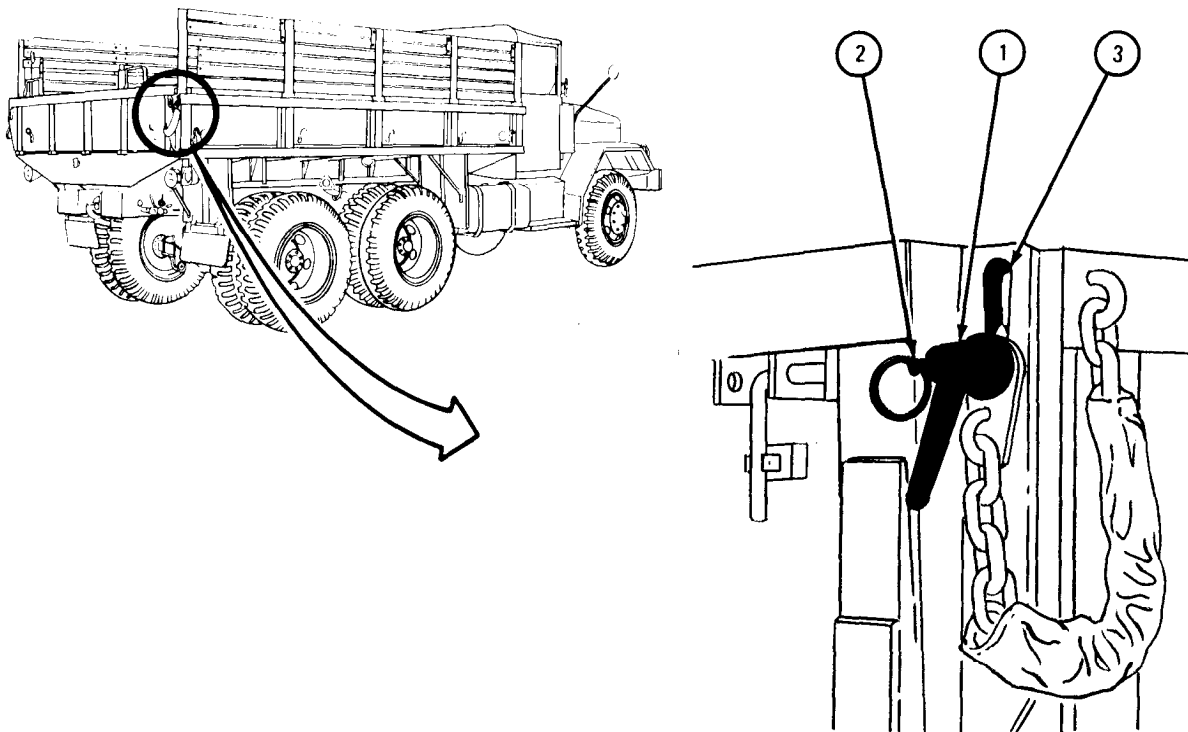

TA 045069

FRAME 2

1. Move tailgate (1) down by gripping it on top and pulling toward the rear. Move down slowly, do not let tailgate drop.

GO TO FRAME 3

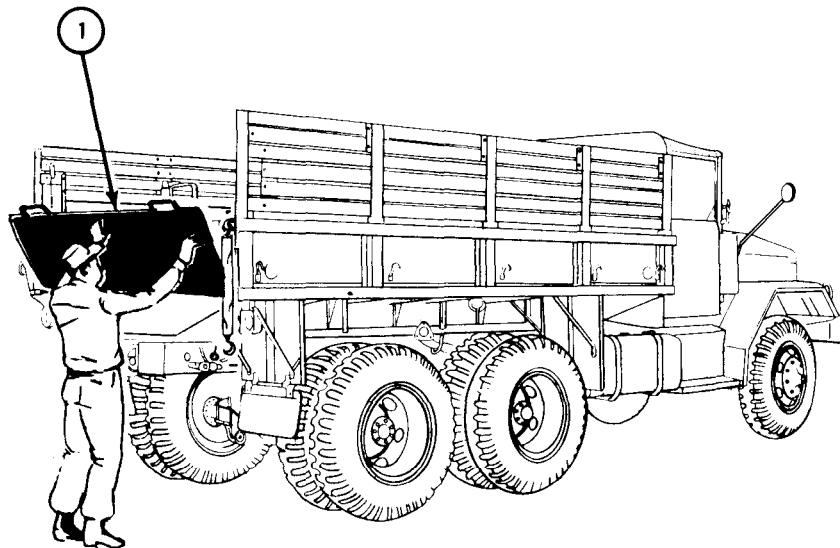

TA 045064

FRAME 3

**NOTE**

Dropsides can be let down either with side racks in position or after side racks have been taken off.

1. Straighten open end of cotter pin (1) and take cotter pin out of hole in top end of stabilizer (2).
2. Take washer (3) off end of stabilizer (2).
3. Take stabilizer (2) out of its mounting holes.

GO TO FRAME 4

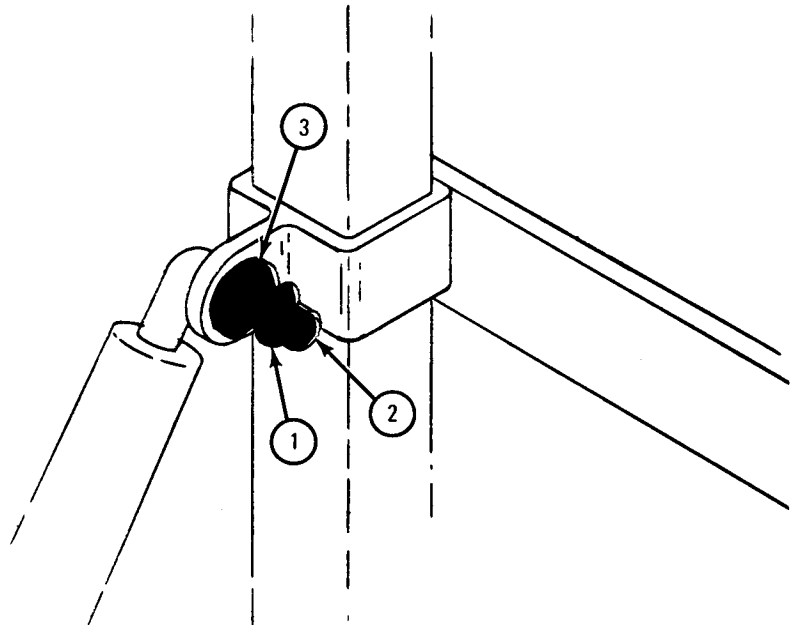
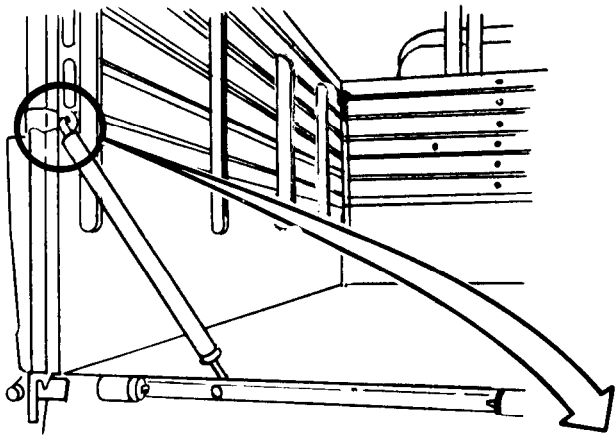

TA 045075



FRAME 4

- Soldier A
1. To move dropsides down with side rack (1) in place, lift front and side rack locking pins (2) out of retainer rings (3).
  2. Hold side rack (1).

GO TO FRAME 5

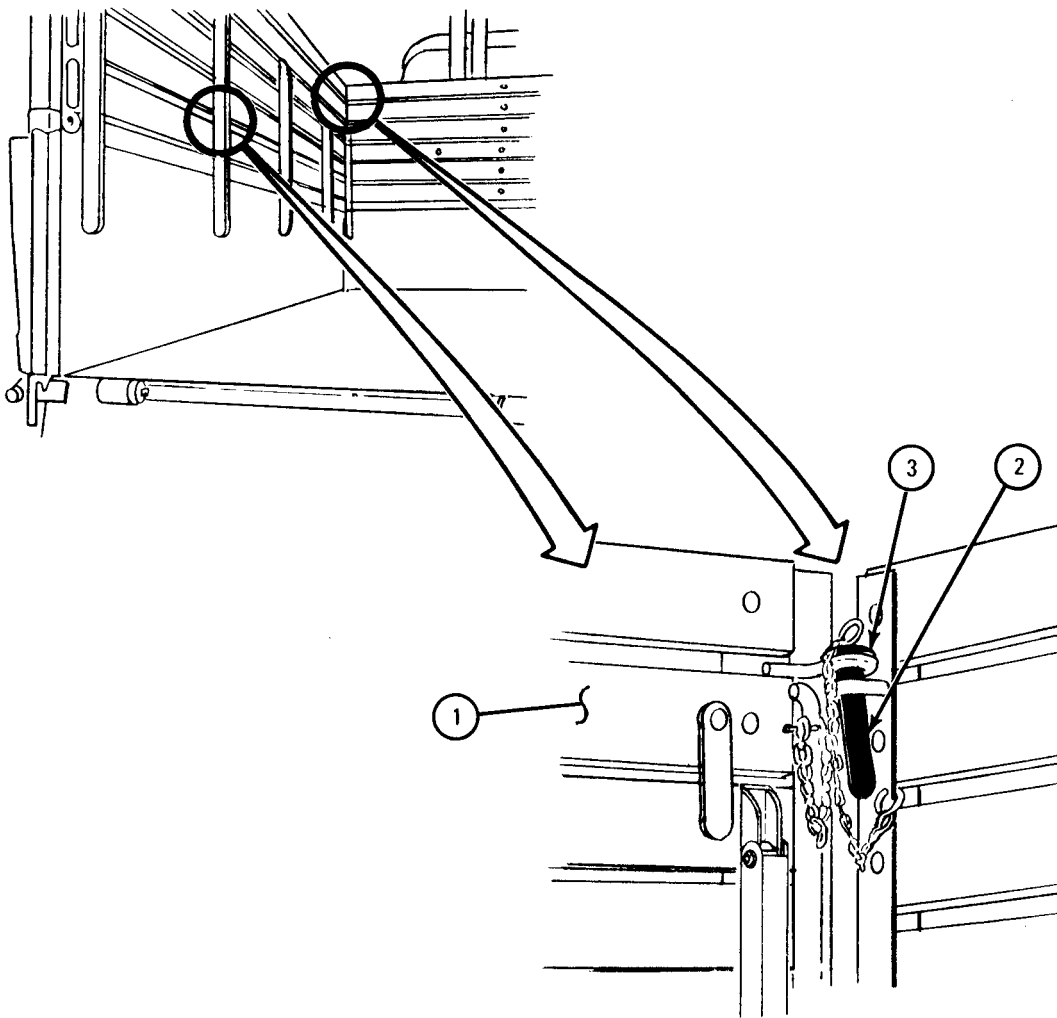

TA 045076

FRAME 5

- Soldier B
1. At front of truck, turn left, and loosen locking handle (1) on drop-side (2) to be lowered.
  2. Turn locking handle ring (3) to align pin (4) with slots (5), and pull handle (1) from slots.
- Soldiers A and B
3. Grip center of side (2) to be lowered firmly.
  4. Pull side (2) toward you and let it come down slowly. Do not let it drop.

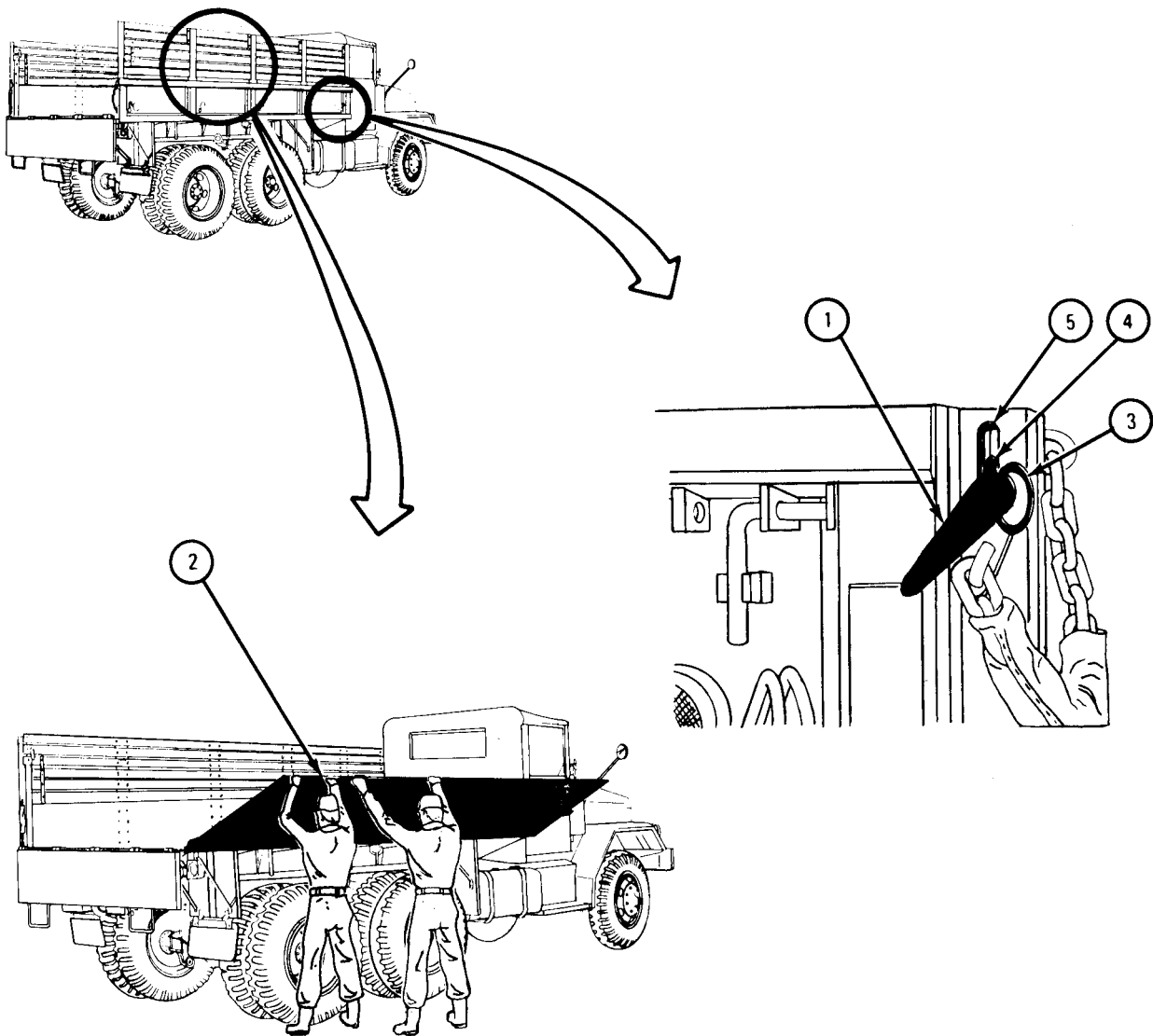

TA 045077

f. Removing the Dropsides, Tailgate or Both.

TOOLS: Pliers

PERSONNEL: Two

- (1) Preliminary procedure. Take off side racks. (Refer to para 4-8 d.)
- (2) Removal.

## FRAME 1

1. Unlock tailgate (1) or dropside (2) to be taken off as in para 4-8 e.
2. Use two soldiers to do this job. One soldier is needed to keep tailgate (1) or dropside (2) steady while other takes cotter pins (3) and washers (4) off of hinge pins (5).

GO TO FRAME 2

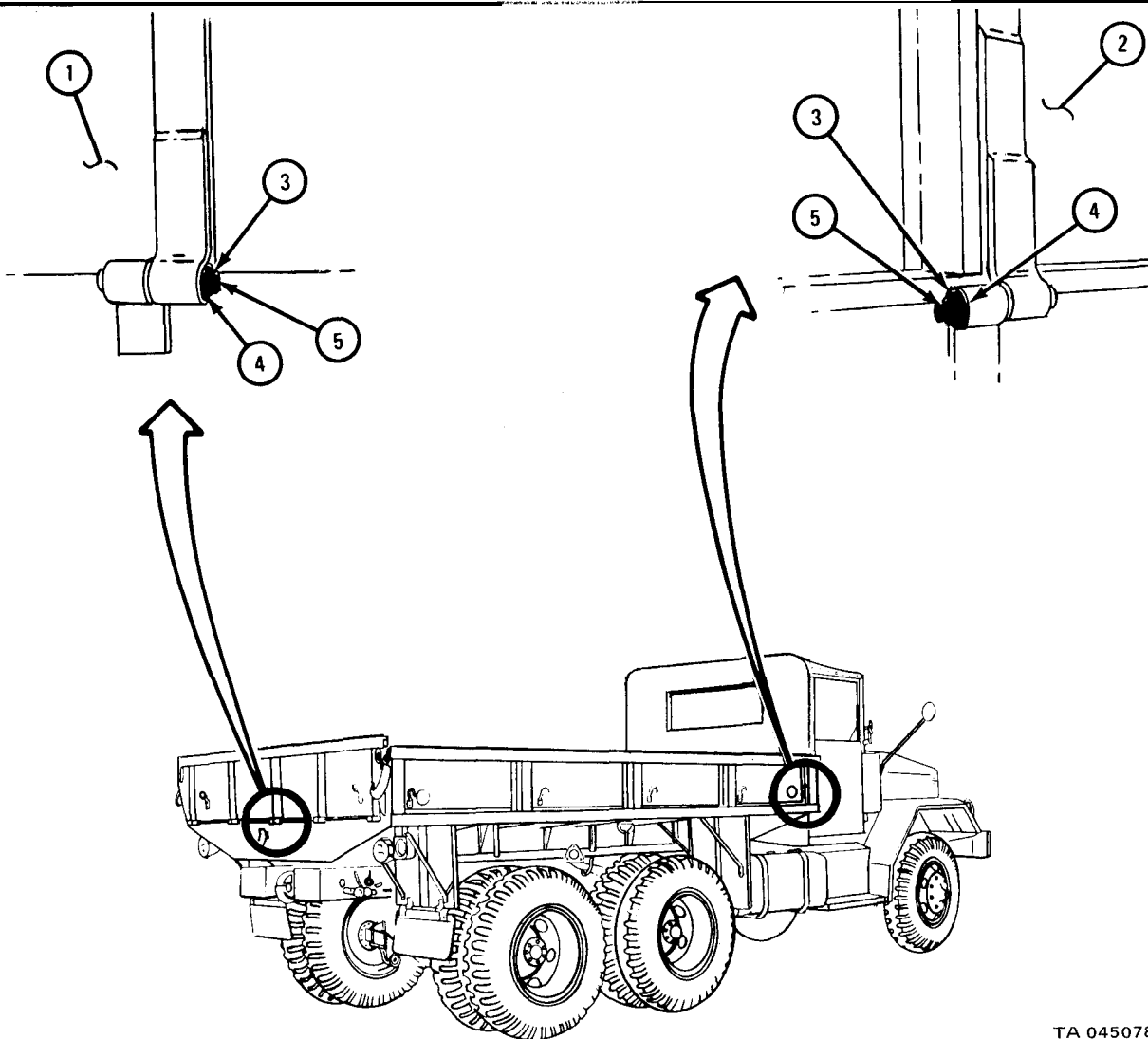

TA 045078

FRAME 2

1. Take hinge pins (1) out with fingers or pliers.
2. Use one soldier at each end of tailgate or dropside to move tailgate or dropside down from cargo bed.

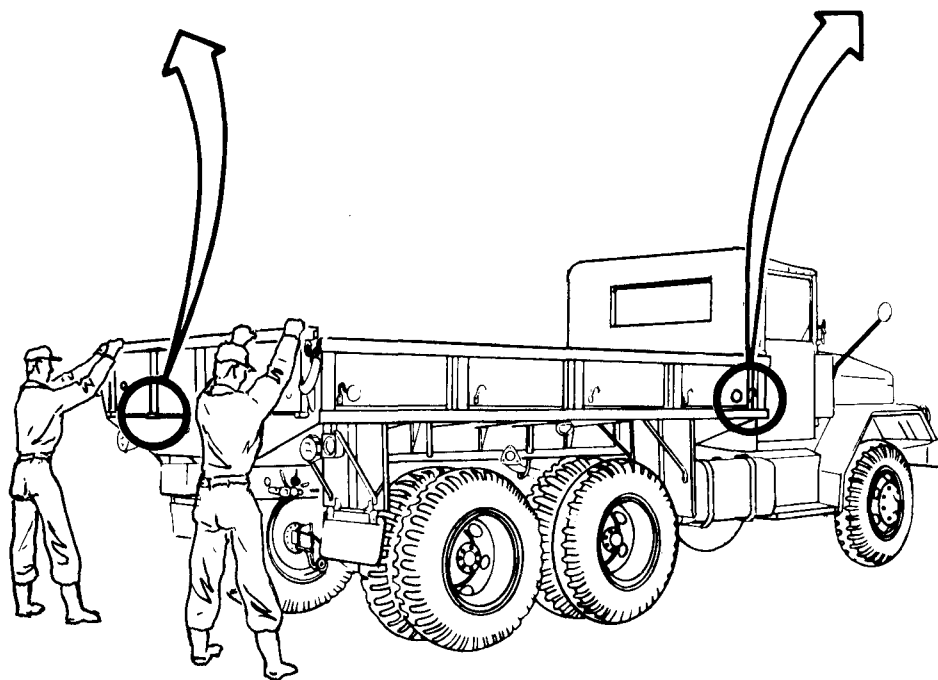
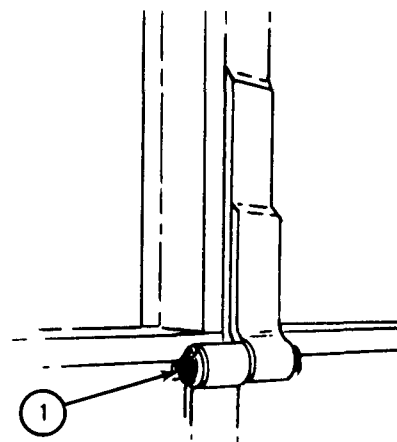
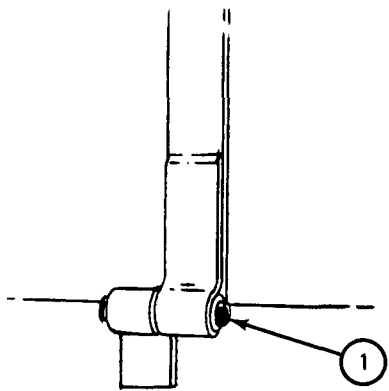

TA 045079

g. Installing the Dropside, Tailgate, Side Racks, and Front Racks.

PERSONNEL: Two

## FRAME 1

**CAUTION**

Sides of drop side cargo body are interchangeable. When putting back sides, be sure that amber reflectors (1) are at front of body and red reflectors (2) are at rear of body.

1. Use two soldiers, one at each end of tailgate (3) or dropside (4) to lift them into place and put hinge pins (5) back into hinge (6).

GO TO FRAME 2

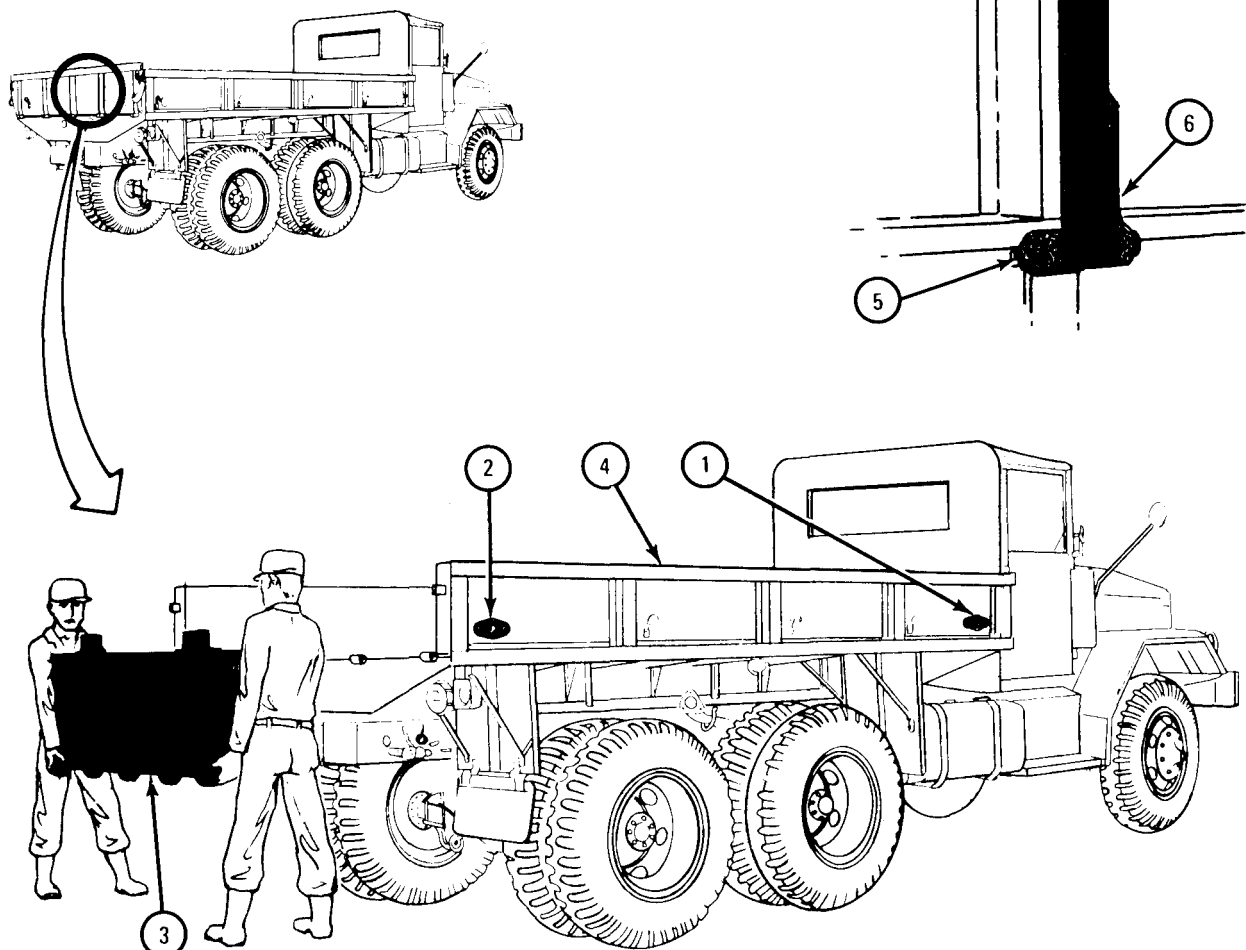

TA 045080

FRAME 2

1. Put washers (1) and cotter pins (2) back onto hinge pin (3).
2. Spread open ends of cotter pin (2) to keep them from falling out.
3. Lock both ends of tailgate (4) on side (5):
  - (a) Aline pins (6) with slots (7) and place pins in slots.
  - (b) Turn rings (8) 90°.
  - (c) Hold rings (8) and turn handles (9) right to tighten.

GO TO FRAME 3

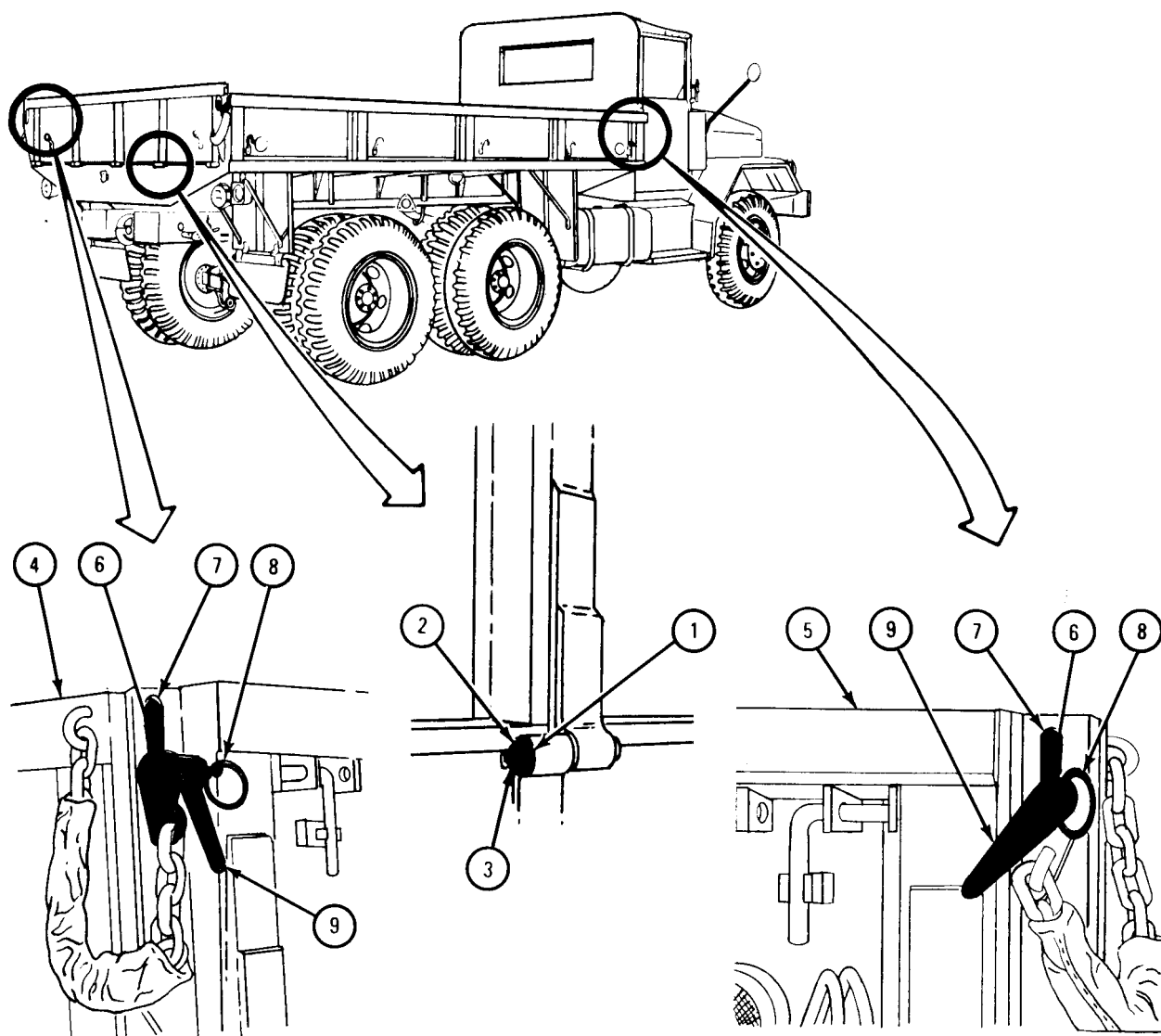

.TA 045081

## FRAME 3

1. Put stabilizer rods (1) back in place.
2. Put washer (2) back on upper end of stabilizer (1).
3. Put cotter pin (3) into hole on upper end of stabilizer (1).
4. Spread open end of cotter pin (3) to keep it from falling out.

Follow-on Maintenance Action Required:  
Put back side racks. (Refer to para 4-8c. )

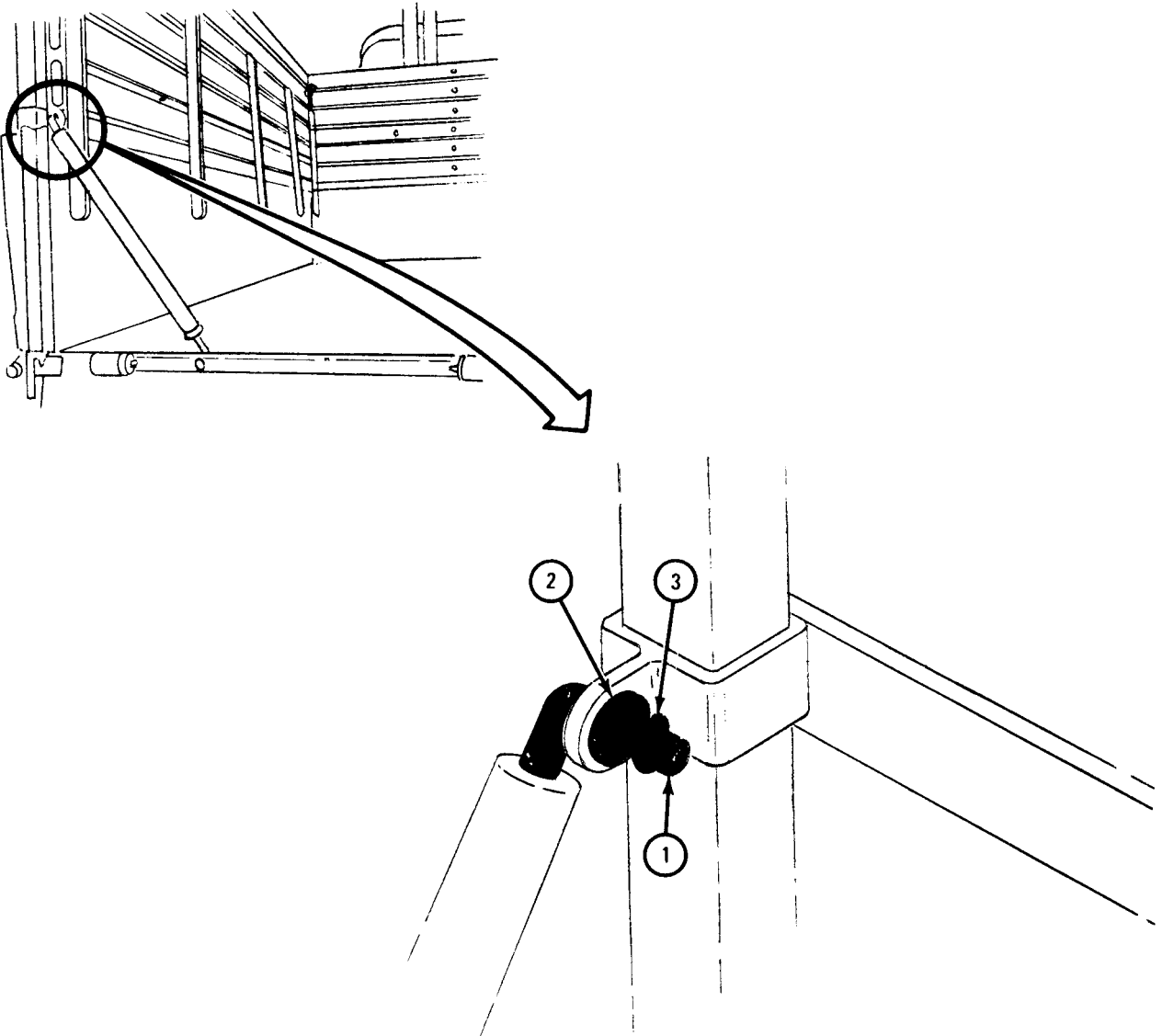

TA 045082

4-9. OPERATION OF FUEL TANK TRUCKS.

General. M49A1C fuel trucks are equipped with a 200-gallon tank, a 400-gallon center tank, and a 600-gallon rear tank. M49A2C fuel trucks are equipped with two 600-gallon tanks. Operating procedures described in this paragraph are for both M49A1C and M49A2C fuel trucks. It should be noted that illustrations given are for the M49A2C configuration. Certain procedures where discharge valve control levers are operated will note two levers on M49A2C trucks and three levers on M49A1C trucks.

b. Gravity Filling the Fuel Tank Sections.

FRAME 1

**WARNING**

To prevent fire or explosion, smoking, flame, sparks, and glowing or hot objects are not allowed near truck during filling and delivery of fuel. Make sure that rear and dispenser nozzle grounding wires are properly connected for static discharge before transferring of fuel.

**NOTE**

Drain compartments and piping system, including filter/separator, when changing to a fuel or grade different from the one last carried. Flush with 50 gallons of new product, and circulate new product back to each compartment twice. Circulate new product through all fuel handling components, including meter, filter/separator, and hose reels when applicable. Get rid of this fuel in the approved area after flushing.

1. Start engine. (Refer to para 4-6 b.)
2. Place truck near fuel supply with filler hole (1) in an easy to reach position.

GO TO FRAME 2

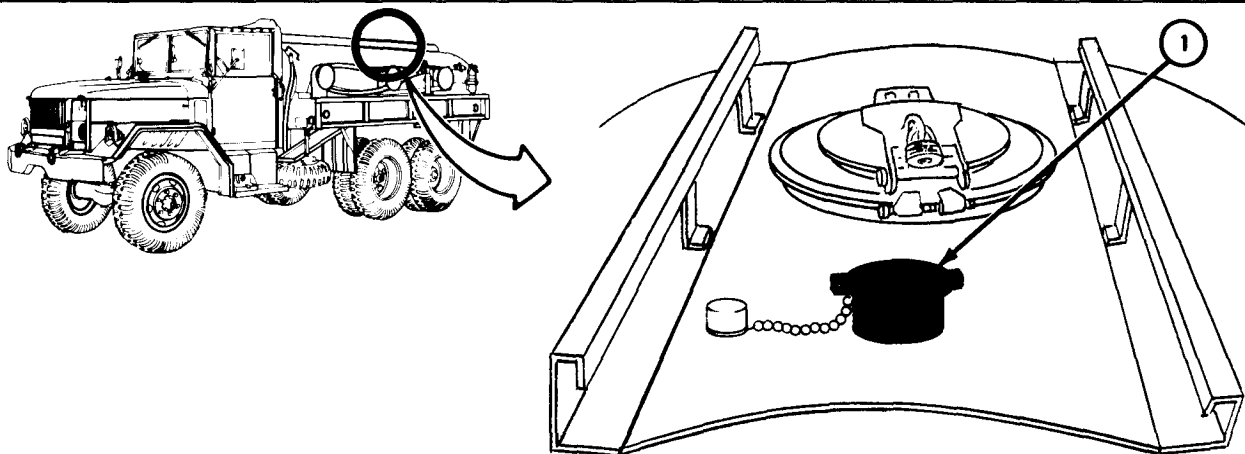

TA 045083



## FRAME 2

1. Pull handbrake lever (1) up to on position.
2. Set ACCESSORY switch (2) and all other switches to off position.
3. Pull ENG. STOP control knob (3) out to stop engine.

GO TO FRAME 3

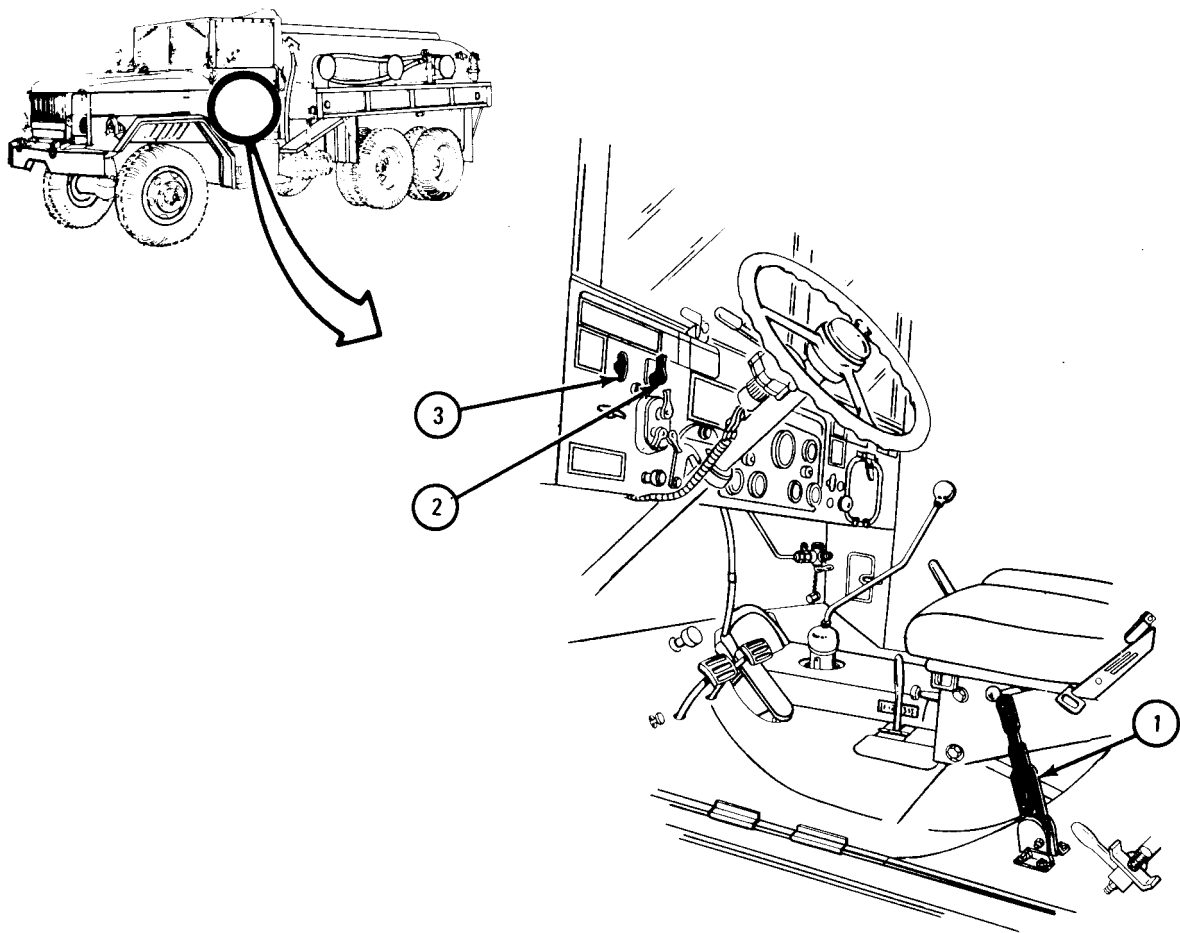

TA 045084

FRAME 3

1. Open rear compartment door, pull ground wire (1) out and clip it to suitable ground.

GO TO FRAME 4

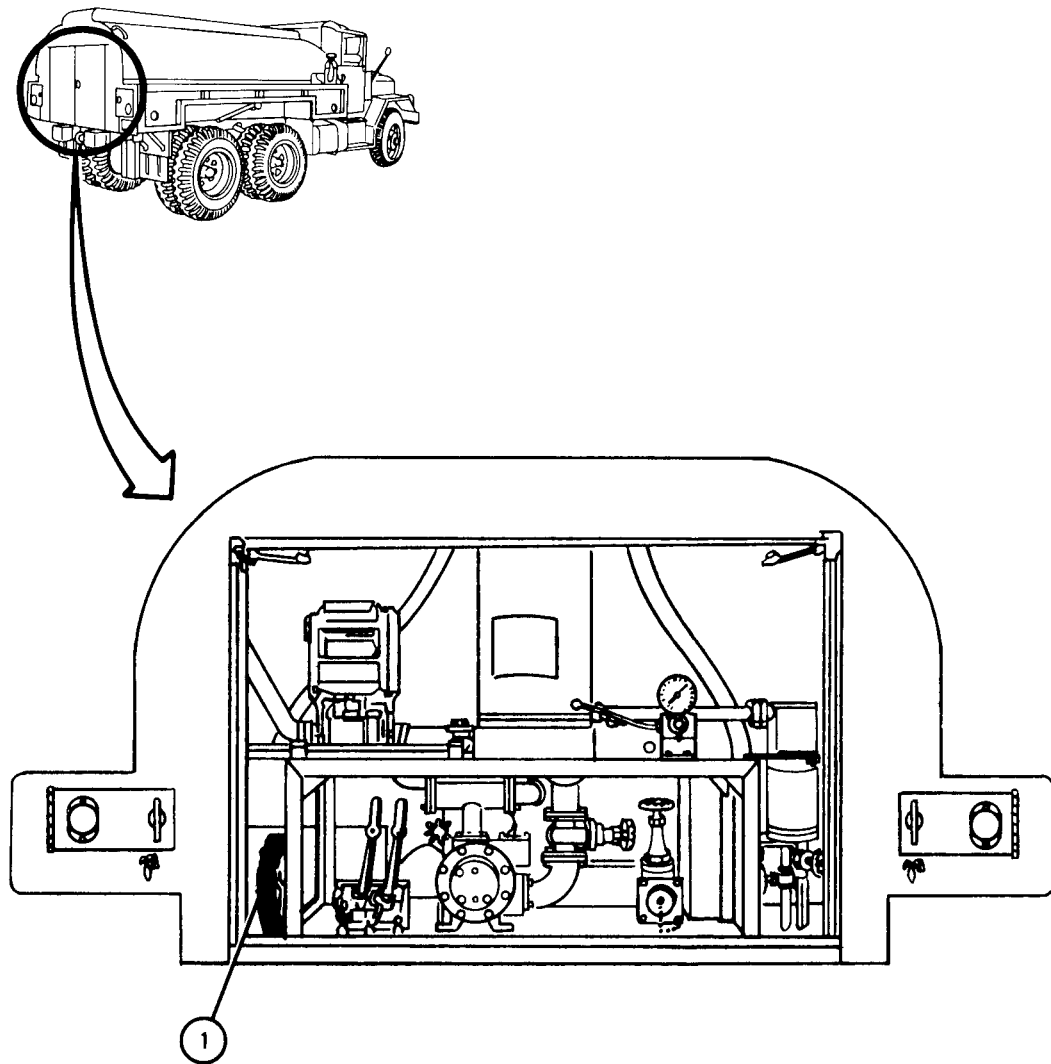

TA 045085

## FRAME 4

1. Place discharge valve control levers (1) in closed position (toward front of truck).  
GO TO FRAME 5

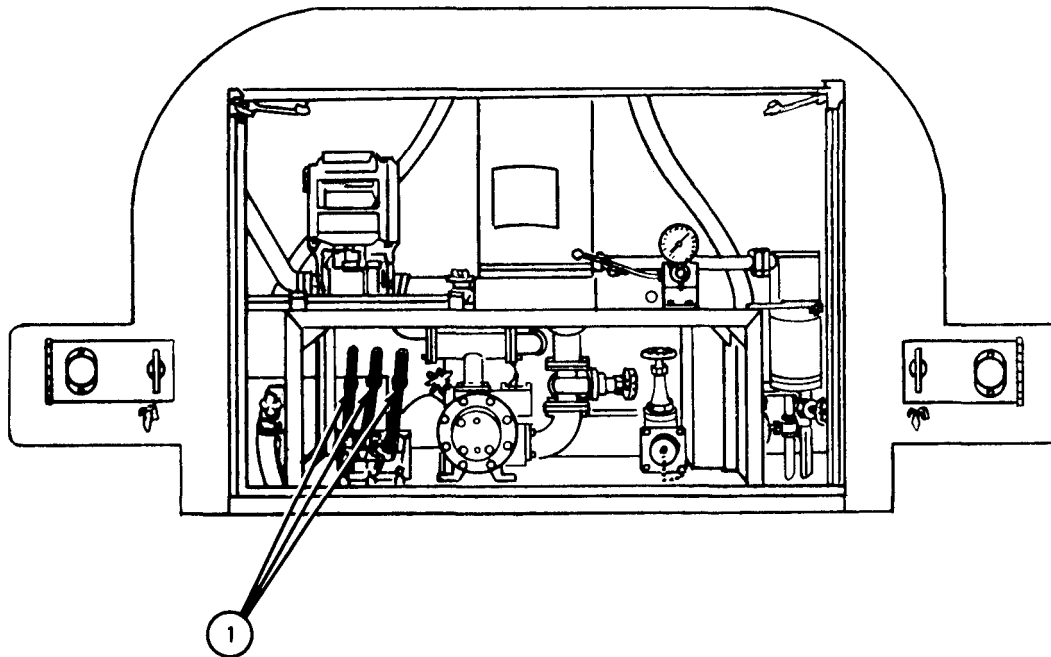

TA 045086

FRAME 5

1. Turn delivery pump draincock (1) right, to closed position.  
GO TO FRAME 6

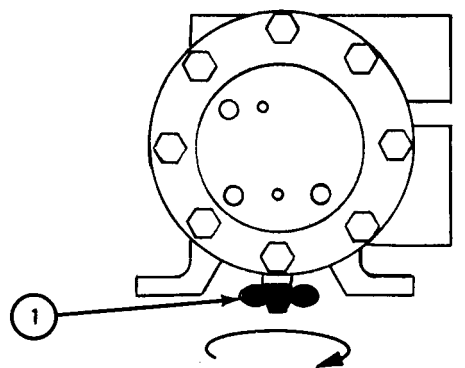
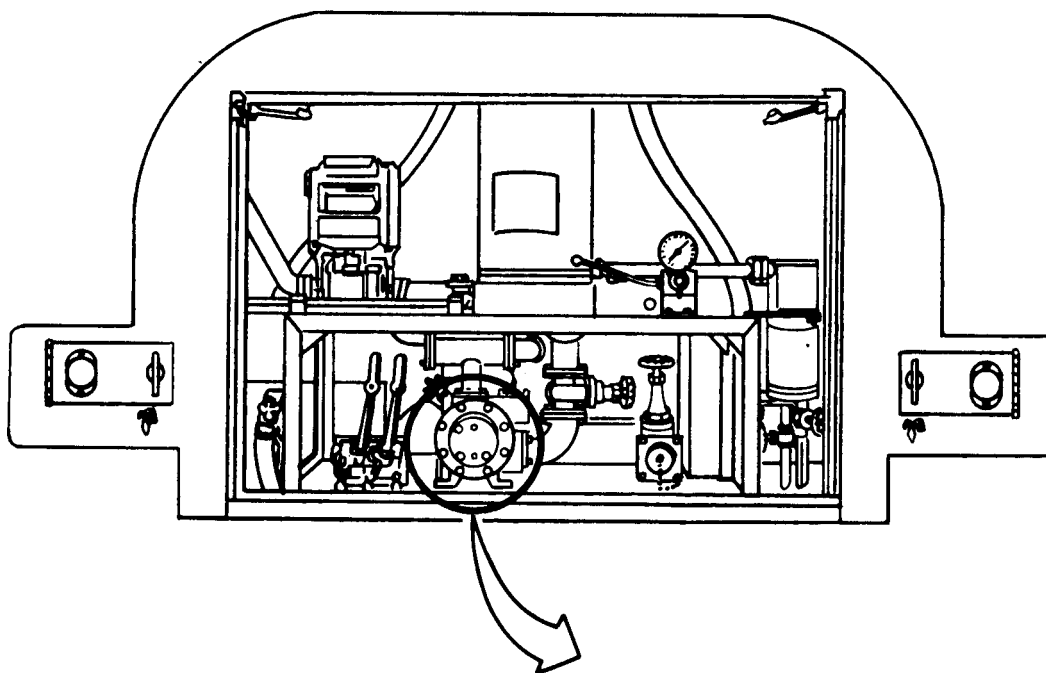

TA 045087

## FRAME 6

1. Turn meter drain knob (1) right, to closed position.

GO TO FRAME 7

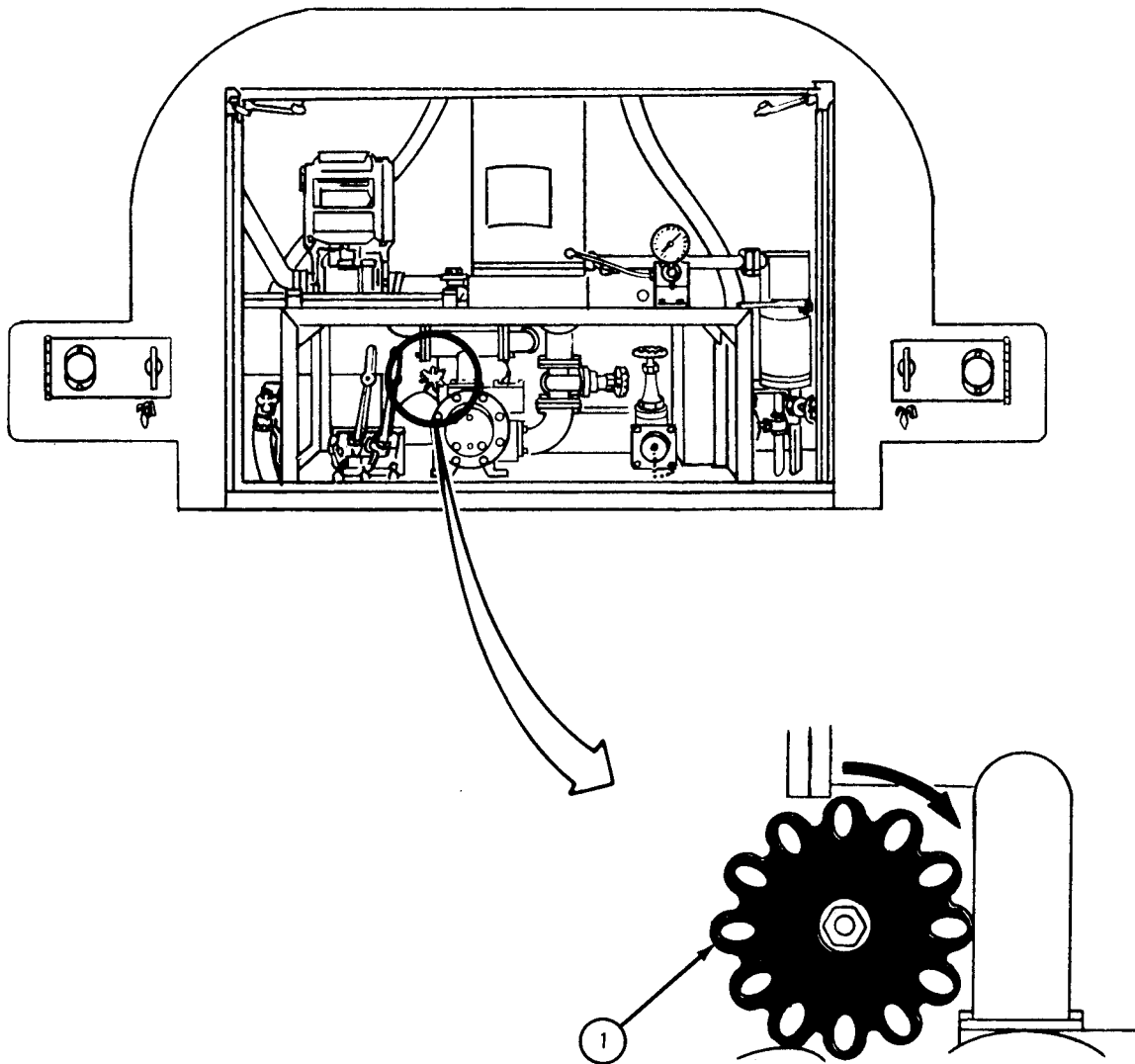

TA 045088

FRAME 7

1. Turn pump delivery line gate valve knob (1) and gravity line gate valve knob (2) right, to closed position.

GO TO FRAME 8

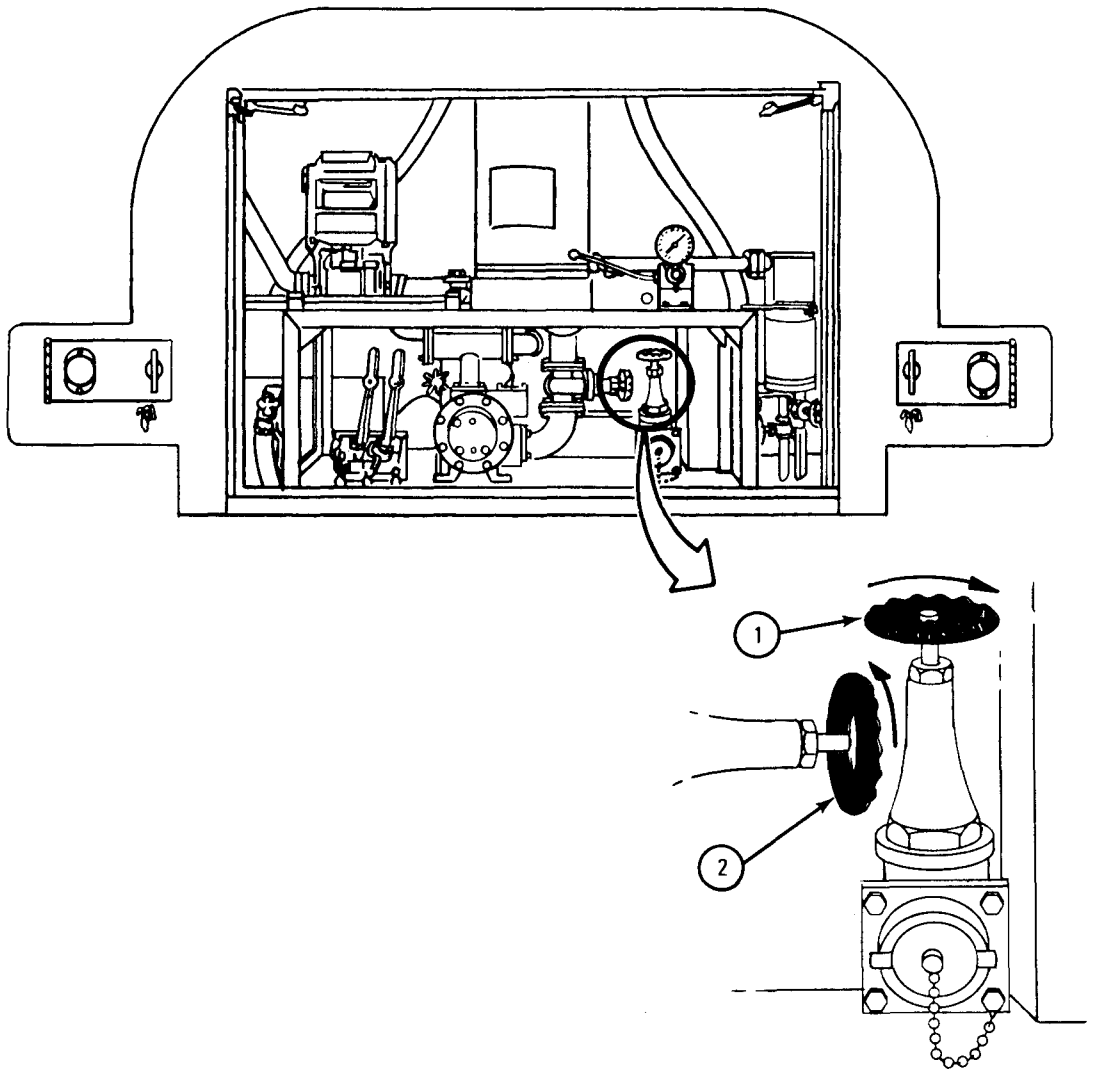

TA 045089

## FRAME 8

1. Turn water segregator drain valve knob (1) and dump valve knob (2) right, to closed position.
2. Take fuel level gage (3) out of stowed position in compartment.

GO TO FRAME 9

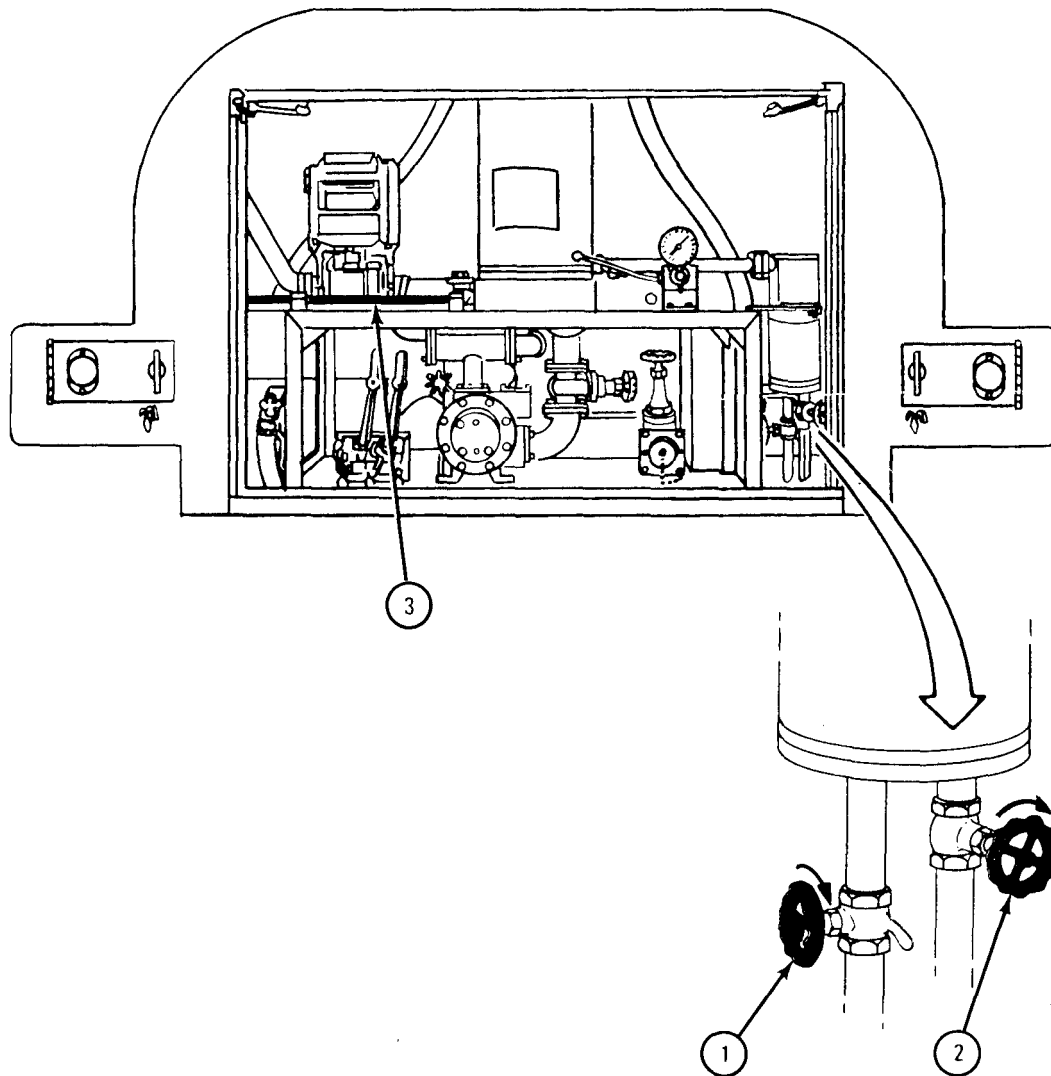

TA 045090

FRAME 9

1. Takeoff filler cover (1) by turning it to the left.
  2. Take off padlock (2).
  3. Lift cover clamp (3) and open manhole cover (4).
- GO TO FRAME 10

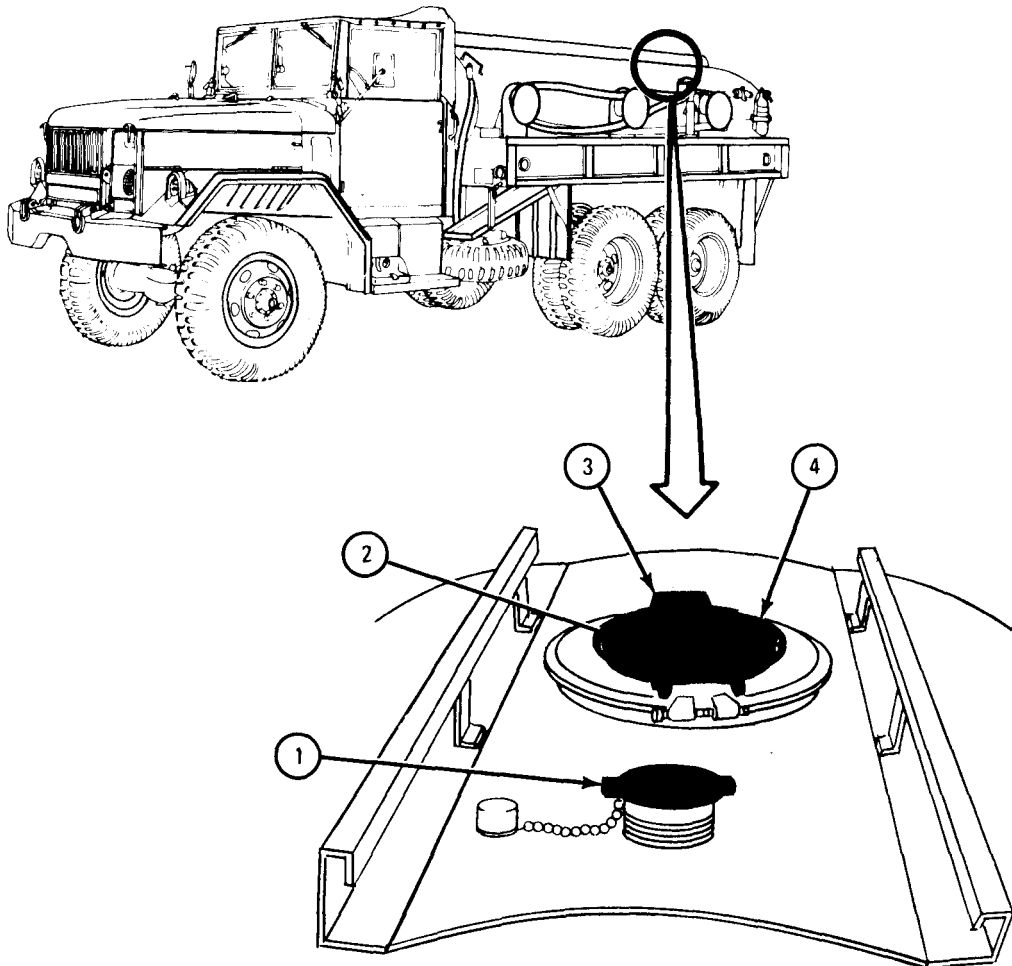

TA 045091



## FRAME 10

1. Make sure dispenser nozzle (1) is properly grounded.
2. Place dispenser nozzle (1) into filler hole (2).
3. Press operating lever (3).
4. Fill tank as needed. Check level of tank using fuel level gage (4).

**NOTE**

Payload capacity of M49A1C trucks for off the road travel is 200-gallons in center tank and 400-gallons in rear tank, with forward tank empty. Payload capacity of M49A2C tank truck for off the road travel is 600-gallons in rear tank with forward tank empty.

GO TO FRAME 11

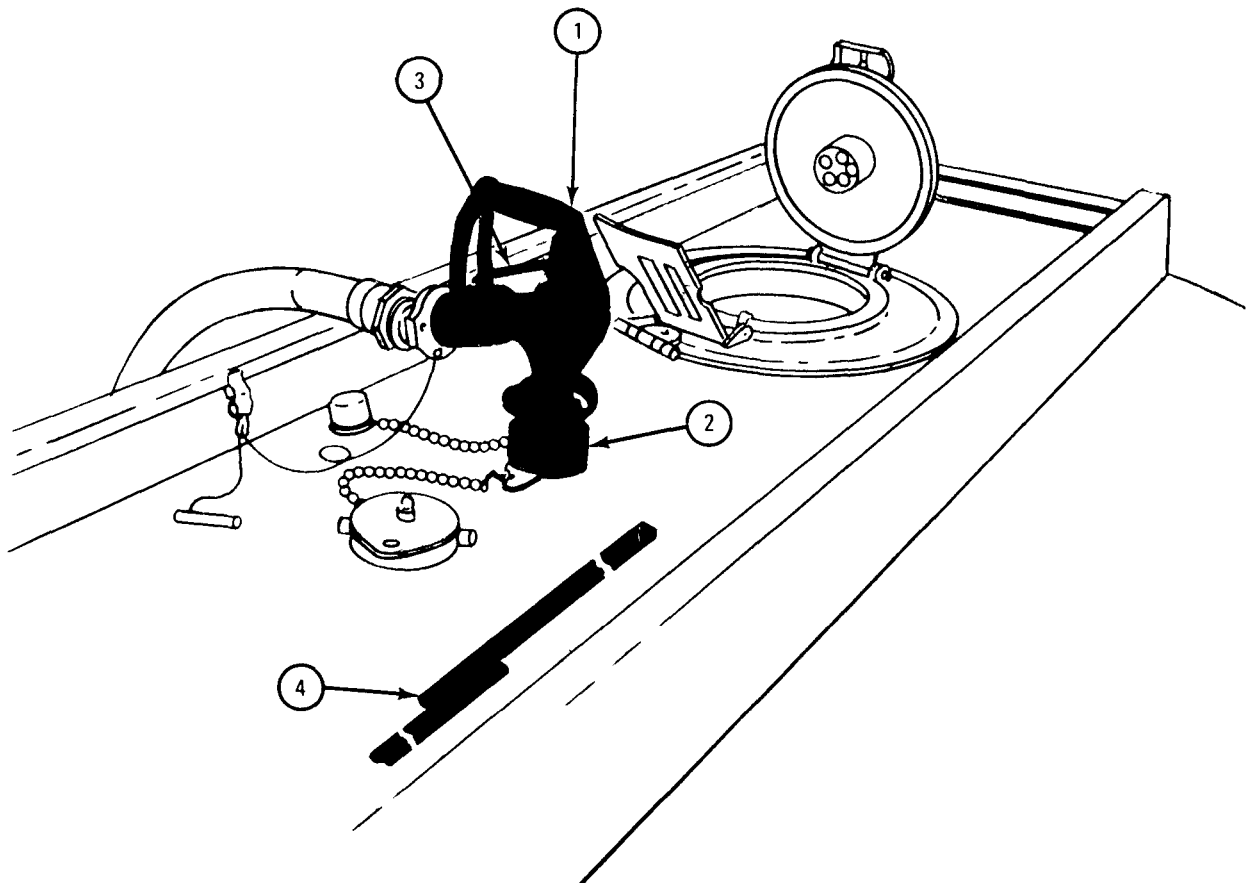

TA 045092

FRAME 11

1. Take filler nozzle (1) out of filler hole.
2. Take filler nozzle ground clip (2) off grounding rail.
3. Put filler hole cover (3) back on filler hole and tighten it.
4. Close manhole cover (4) and lock it with cover clamp (5).
5. Put on padlock (6).

GO TO FRAME 12

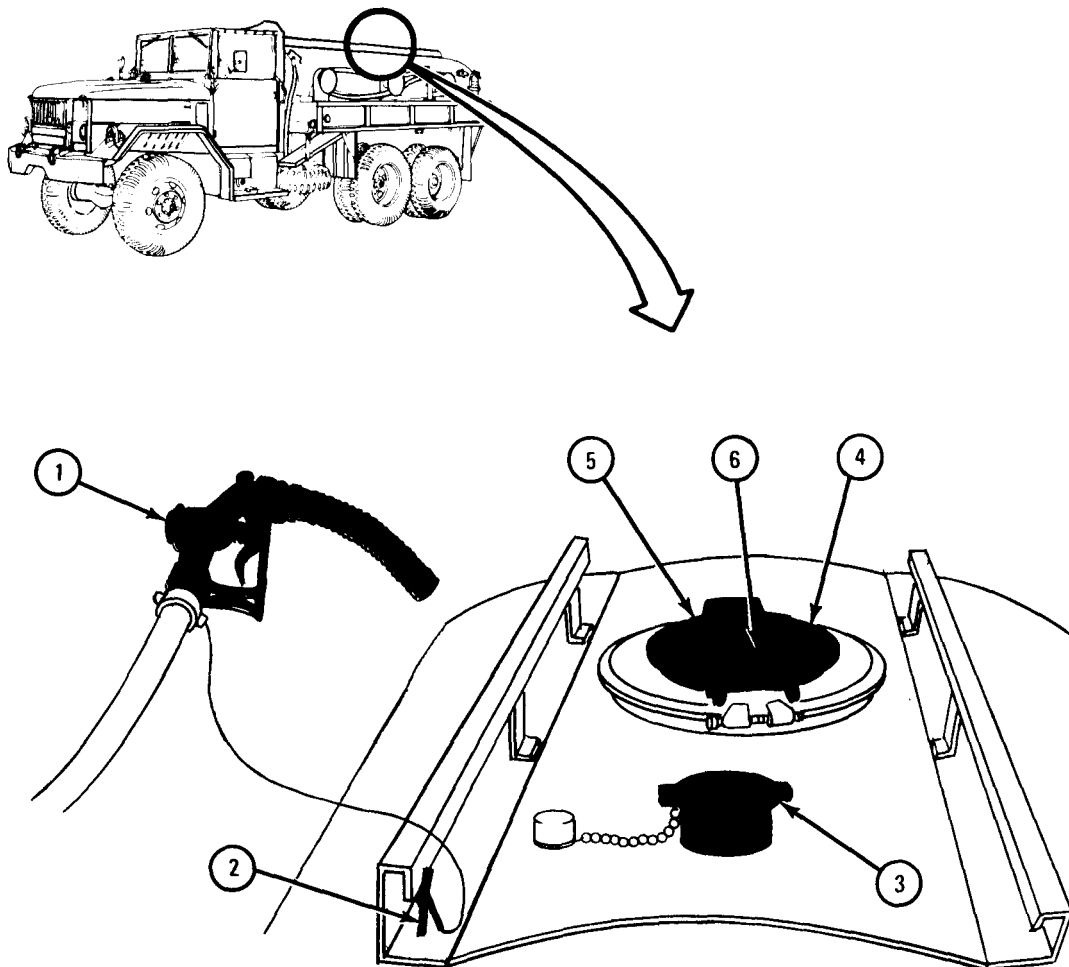

TA 045093

## FRAME 12

1. Take ground wire clip (1) off ground and let ground wire rewind onto its reel (2).
2. Put fuel level gage (3) back in its stowed position.
3. Close and lock rear compartment door.

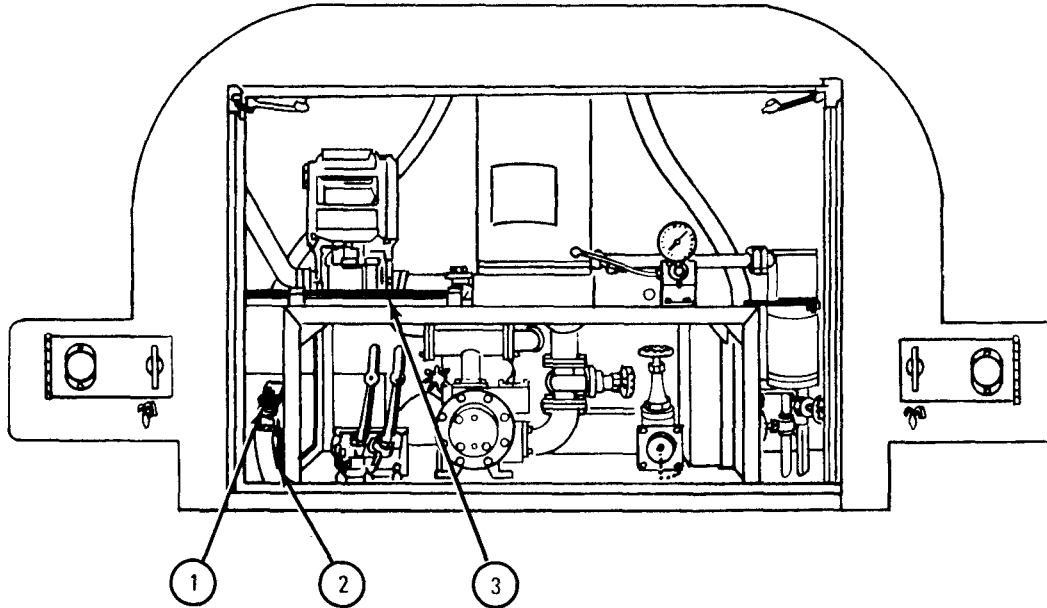
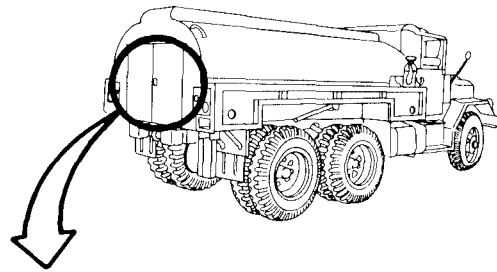

TA 045094

c. Suction Filling the Tank Sections or Transferring Fuel from One Source to Another Through Pump.

TOOLS: 2-inch spanner wrench

FRAME 1

1. Start engine. (Refer to para 4-6b. )
2. Place truck near fuel supply with filler hole (1) in an easy to reach position.

GO TO FRAME 2

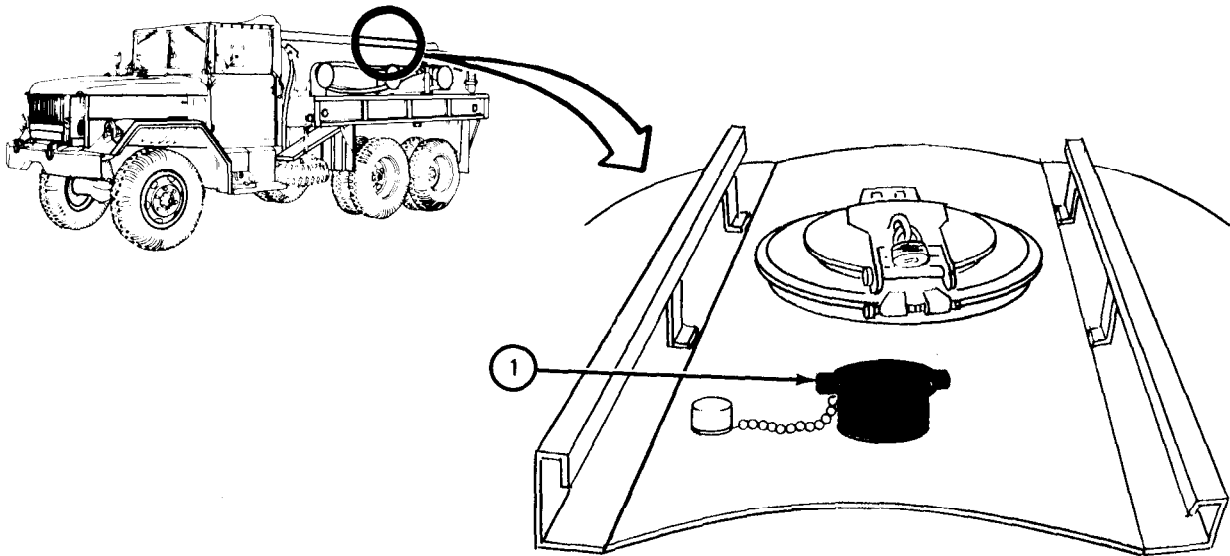

TA 045083

## FRAME 2

1. Pull handbrake lever (1) to (up) on position.
2. Set ACCESSORY switch (2) and all other switches to off position.
3. Pull ENG. STOP control knob (3) out to stop engine.

GO TO FRAME 3

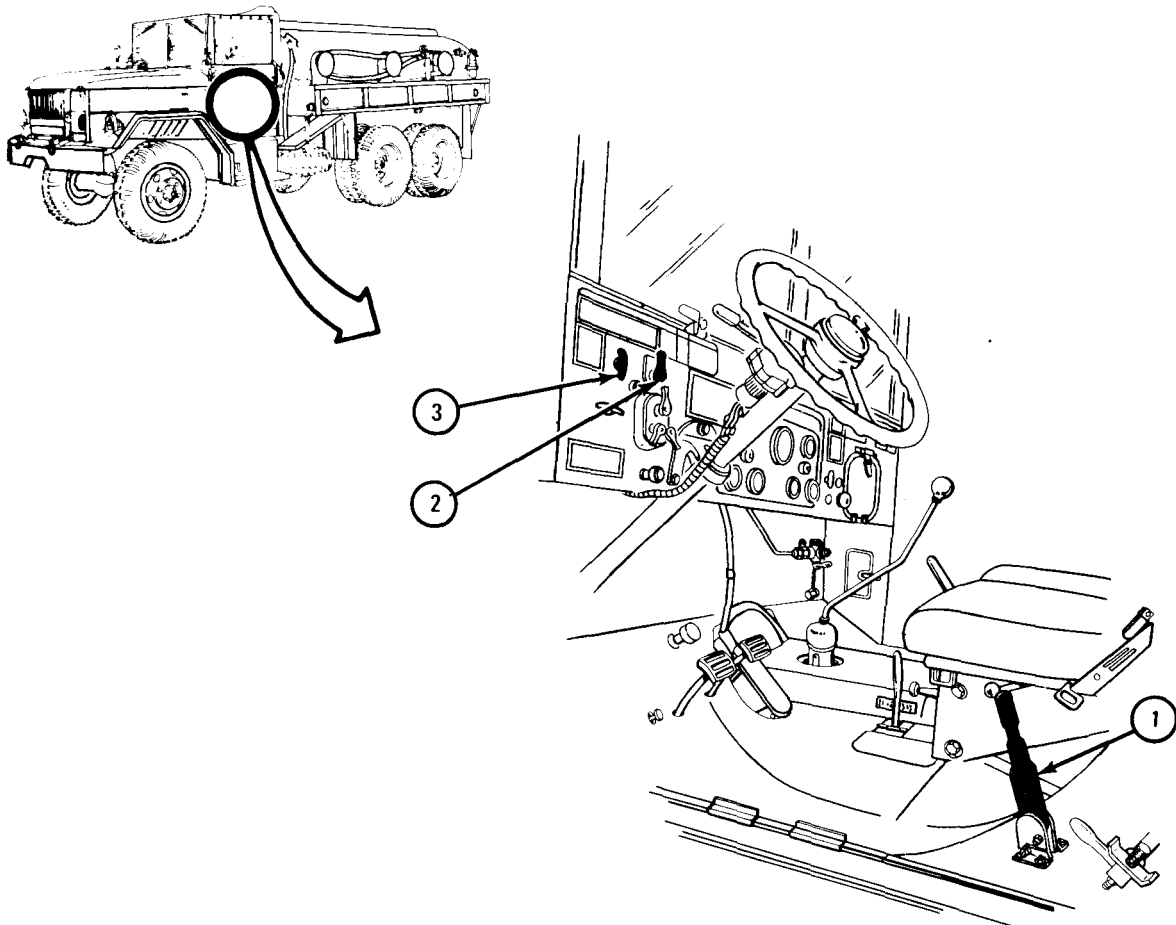

TA 045084

FRAME 3

1. Open rear compartment door, pull ground wire (1) out, and clip it to suitable ground.  
GO TO FRAME 4

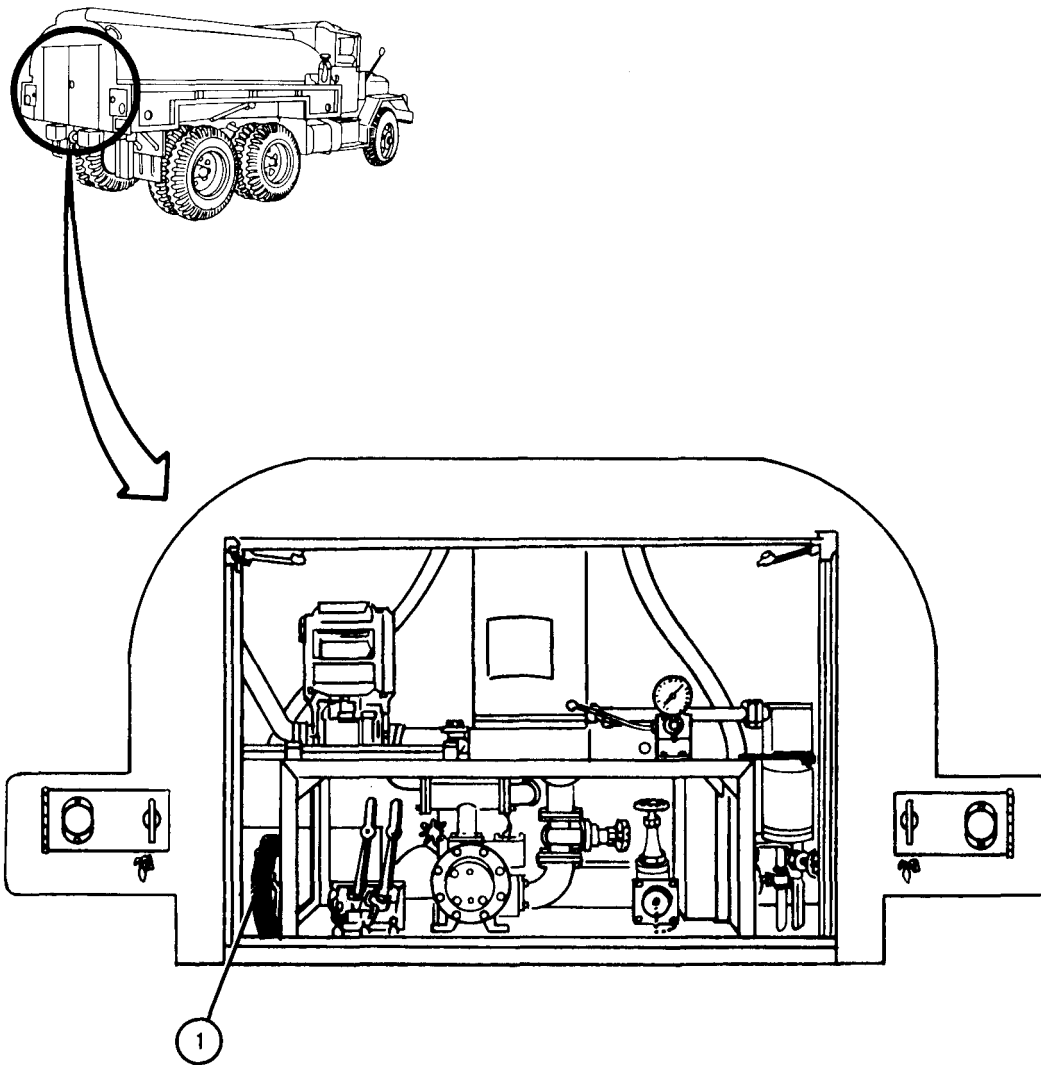

TA 045085

## FRAME 4

1. Turn to left and take off gravity delivery line gate valve dust cap (1).  
GO TO FRAME 5

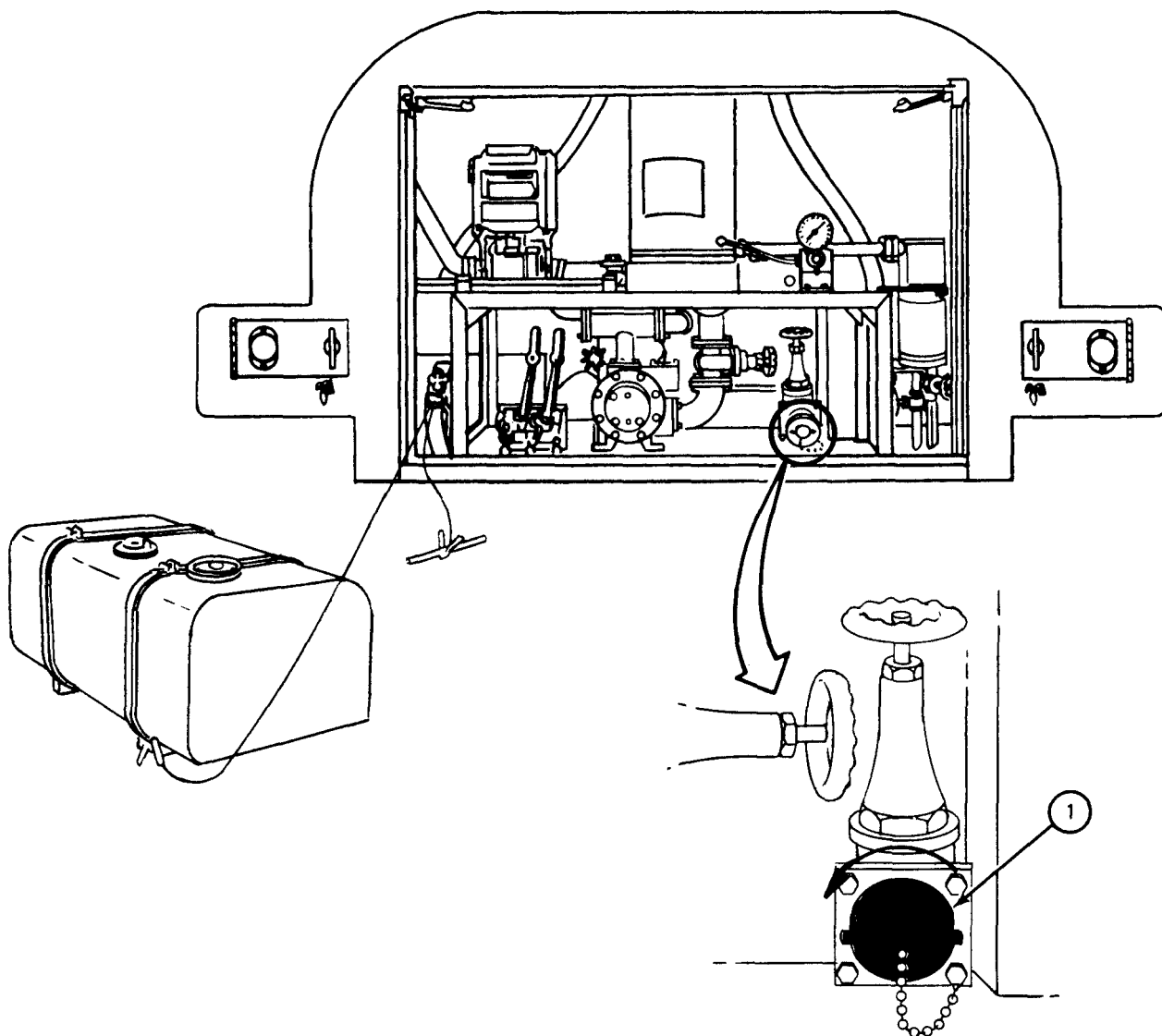

TA 045095

FRAME 5

1. Open hose compartment doors (1), take out one or both lengths of hose (2) as needed to reach fuel supply.
2. Turn right and screw one end of hose (2) onto gravity delivery valve adapter (3), Tighten with 2-inch spanner wrench.
3. Put other end of hose (2) into fuel supply.

**NOTE**

Two lengths of hose can be joined together to form a longer hose when needed.

4. Take fuel gage (4) out of its stowed position.

GO TO FRAME 6

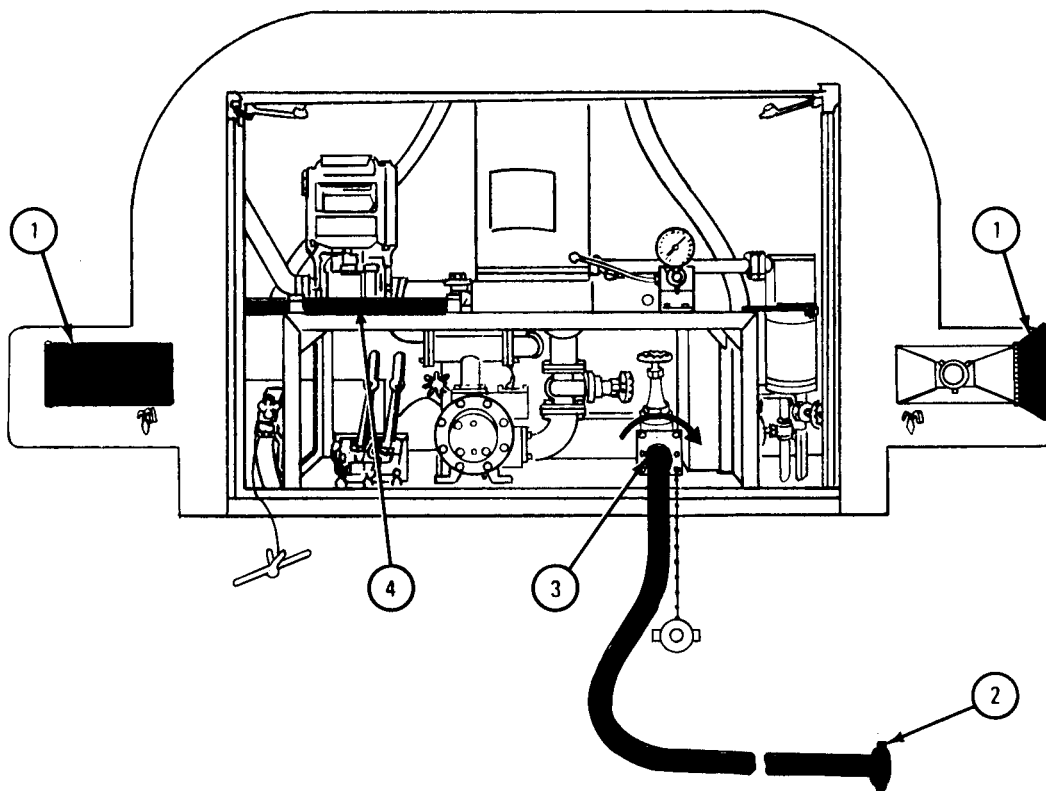

TA 045096



FRAME 6

1. Place discharge valve control levers (1) in closed position (toward front of truck).  
GO TO FRAME 7

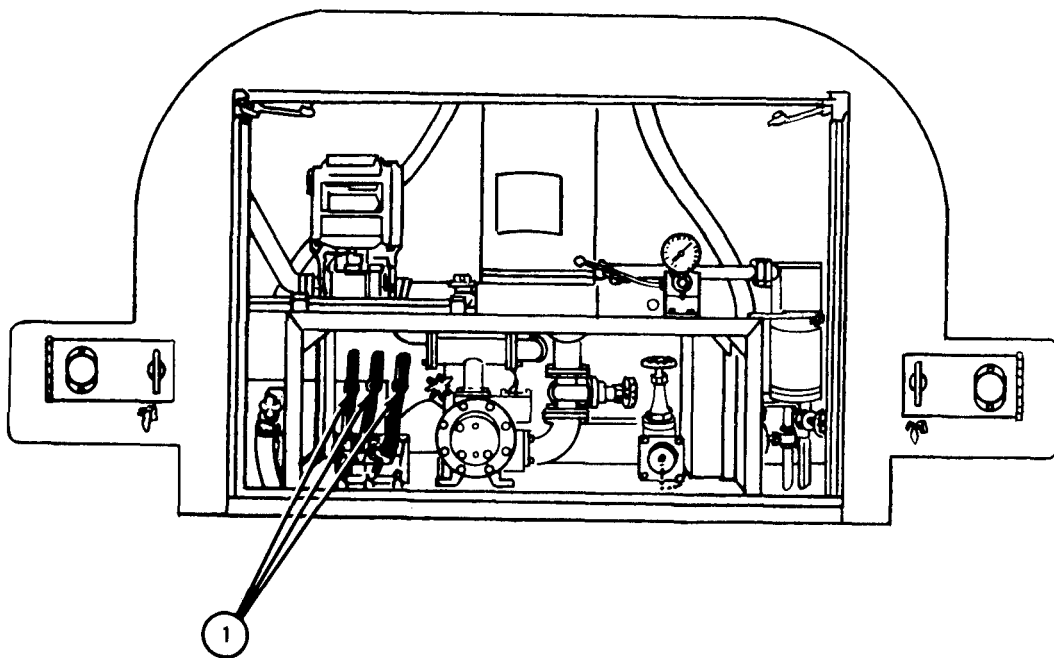

TA 045086

FRAME 7

1. Turn meter drain knob (1) right, to closed position.
- GO TO FRAME 8

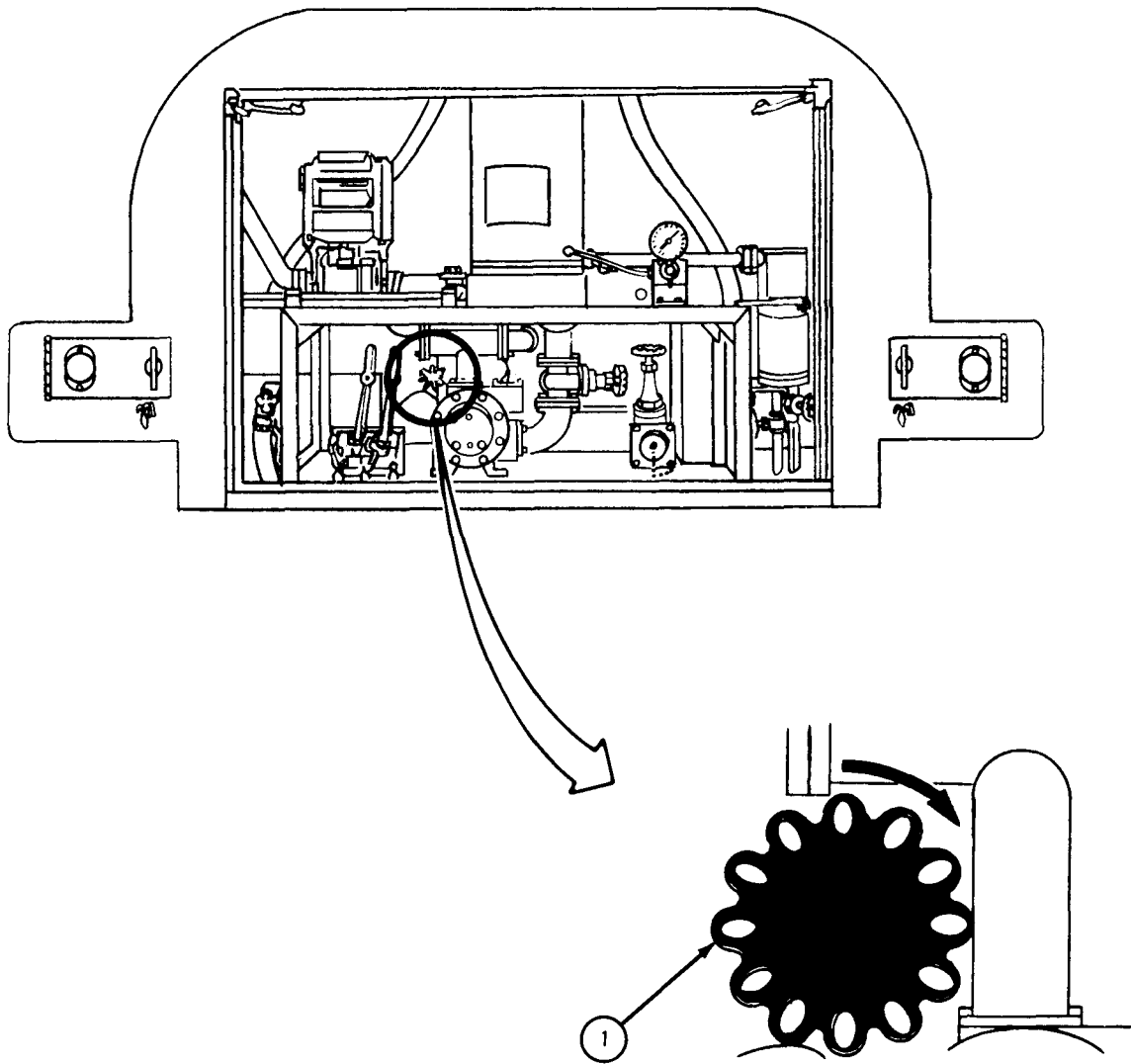

TA 045088

FRAME 8

1. Turn water segregator drain valve knob (1) and delivery pump drain cock (2) right, to closed position.

GO TO FRAME 9

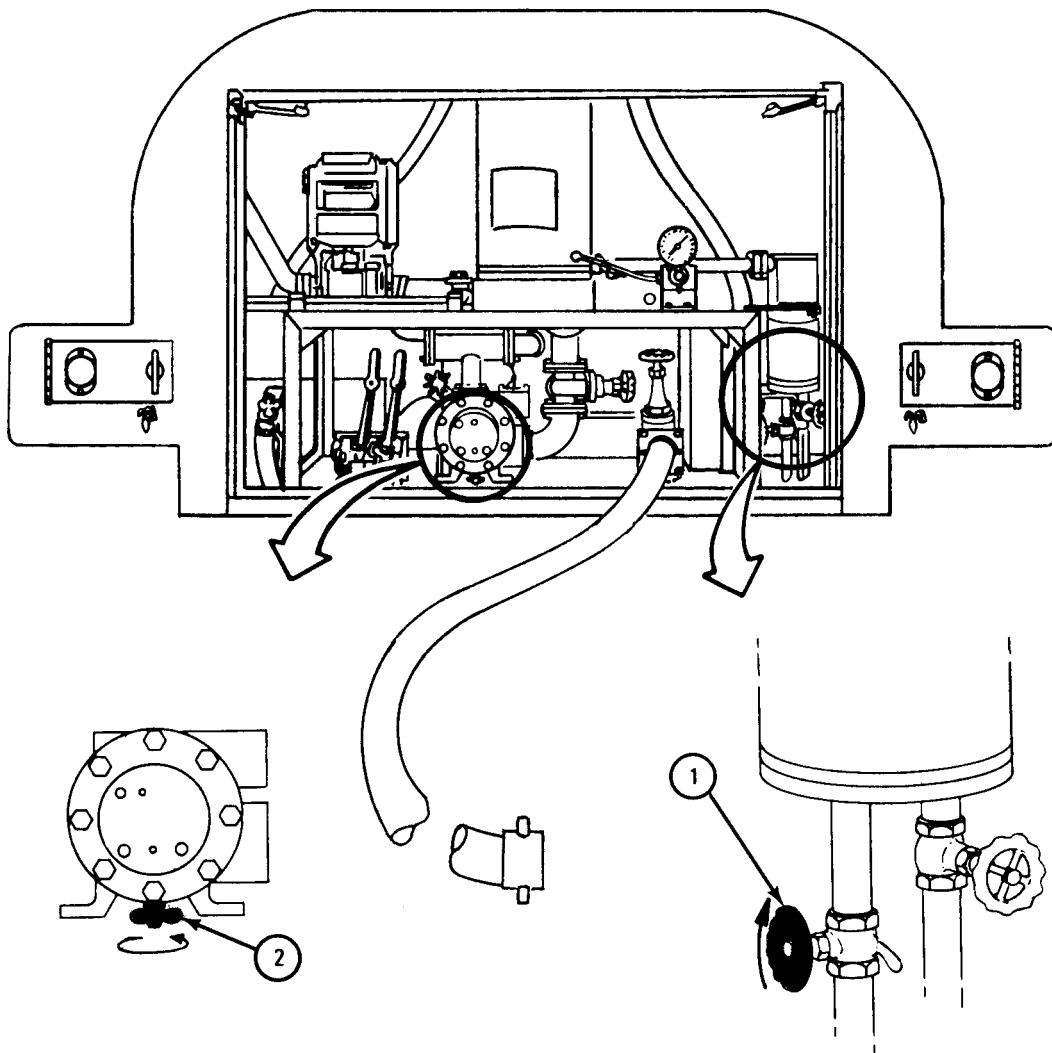

TA 045097

FRAME 9

1. Turn automatic dump valve knob (1), pump delivery line gate valve knob (2), and gravity delivery line gate valve knob (3) left, to open position.

GO TO FRAME 10

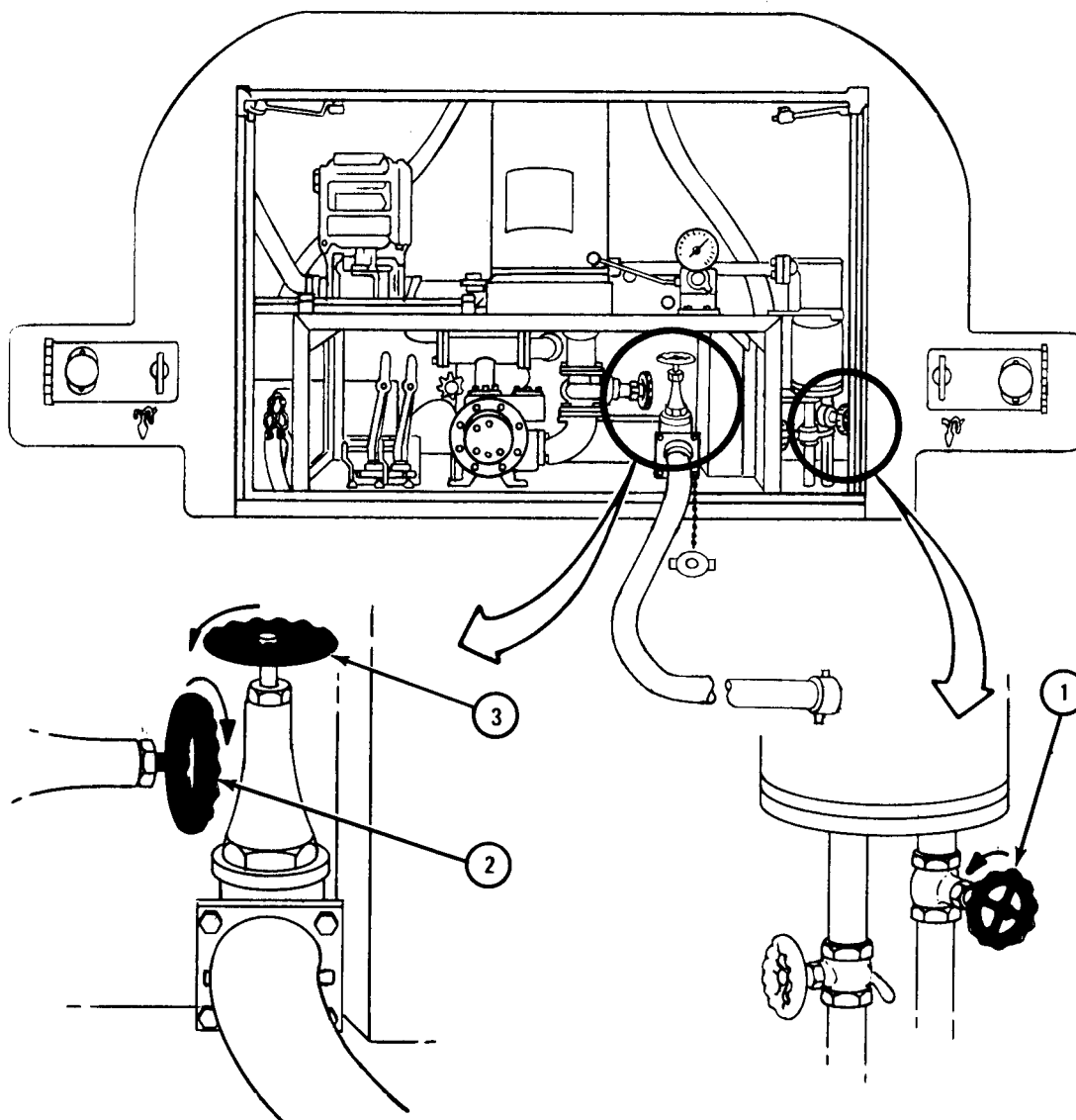

TA 045098

## FRAME 10

1. Start engine. (Refer to para 4-6 b.)
  2. Place FRONT TRANSMISSION gear shift lever (1) in position 2.
  3. Place TRANSFER CASE shift lever (2) in the middle (neutral position).
- GO TO FRAME 11

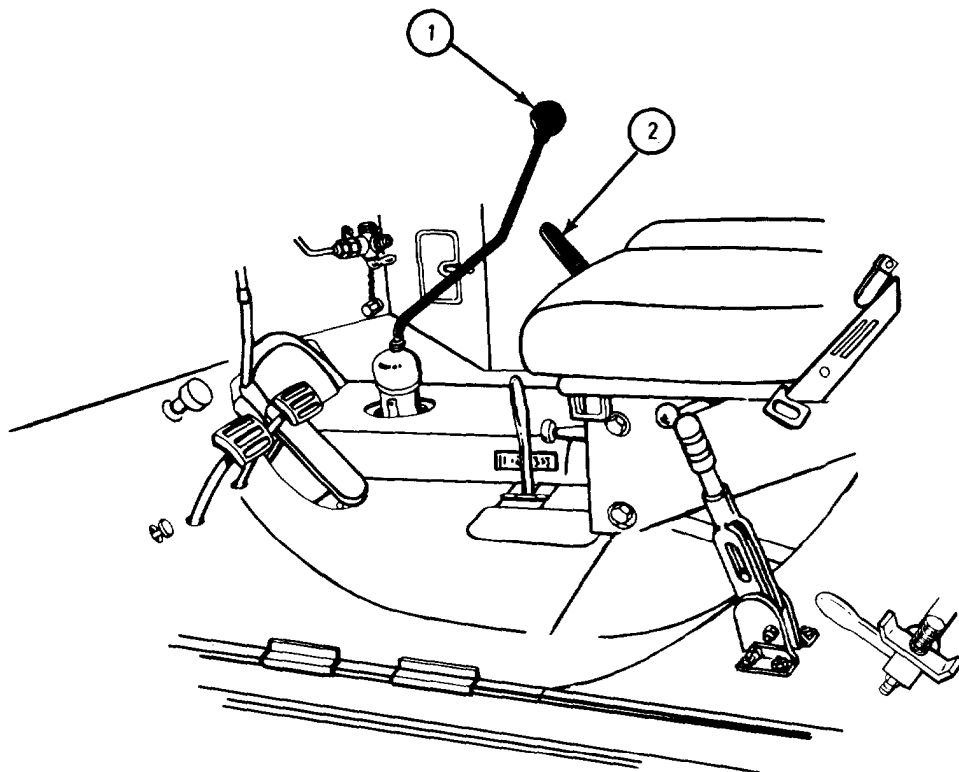

TA 045099

FRAME 11

1. Turn locking bar (1) to off (up) position.
2. Move transfer POWER TAKE OFF LEVER (2) toward rear of truck to ENGAGE (on) POSITION.

GO TO FRAME 12

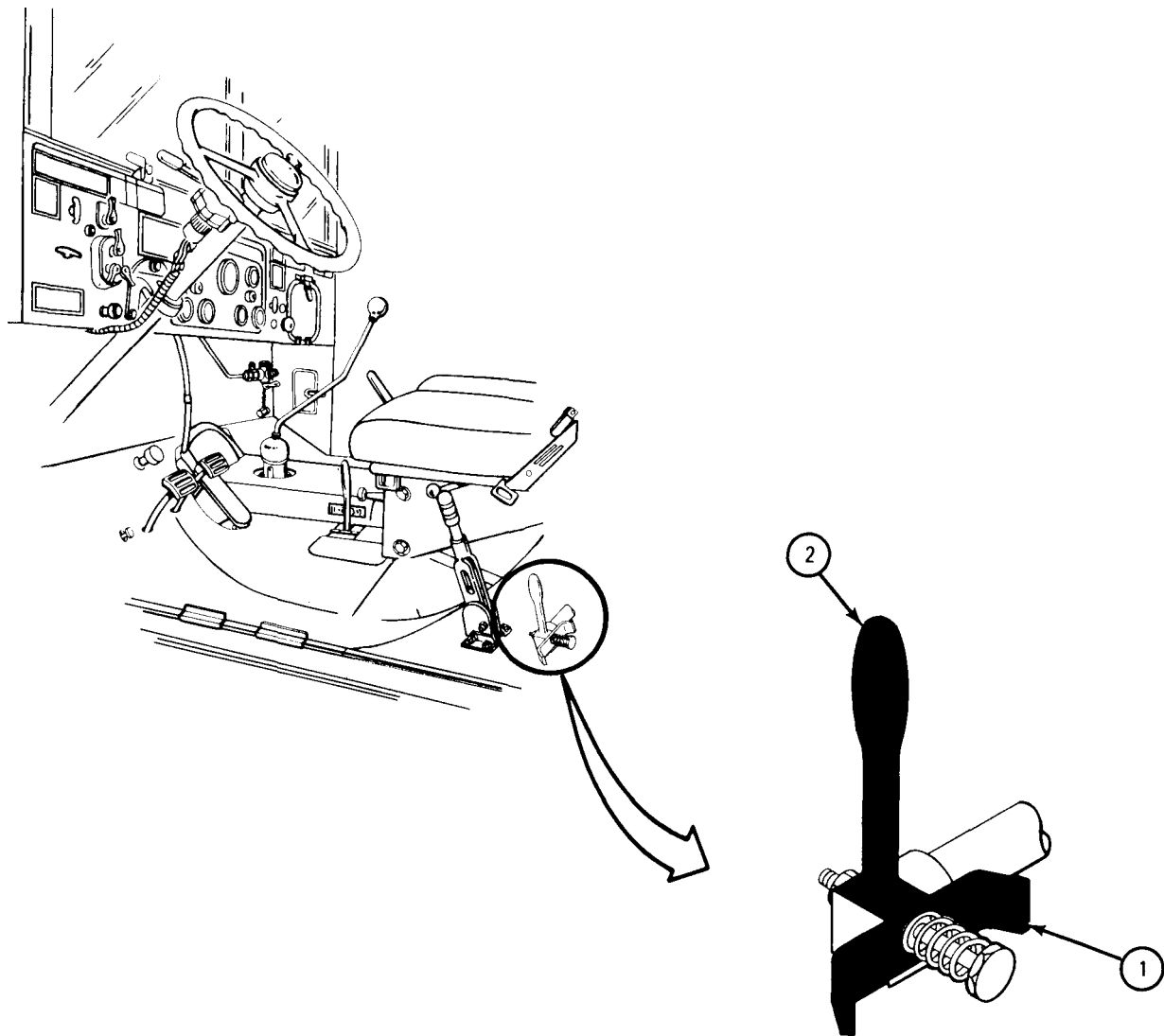

TA 045100

## FRAME 12

1. Slowly pull hand THROTTLE (1) out as far as it will go.  
GO TO FRAME 13

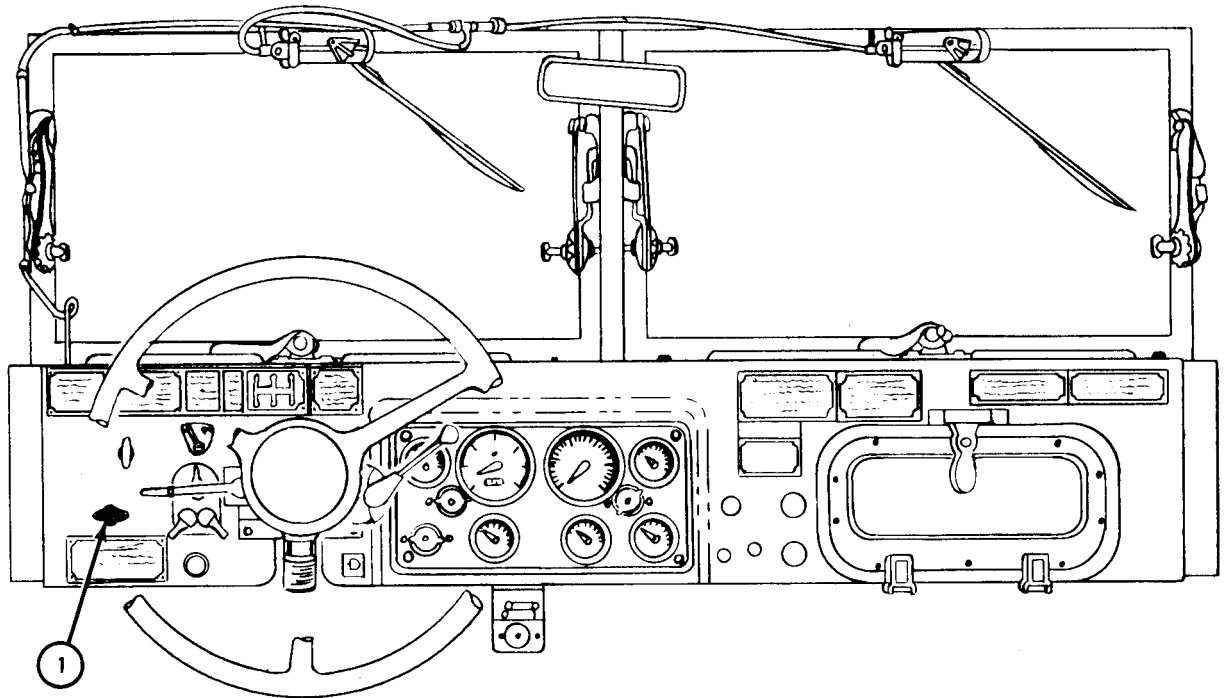

TA 045101

FRAME 13

1. Unwind dispenser line and nozzle (1) from its mountings, on side of truck.  
GO TO FRAME 14

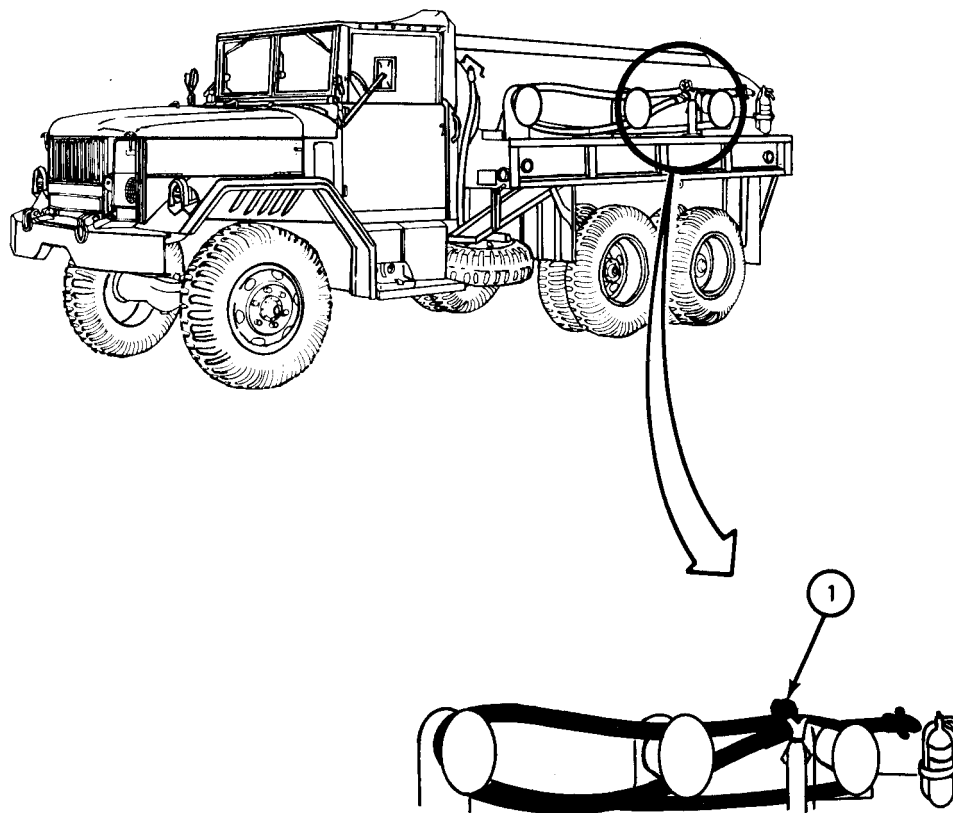

TA 045102



## FRAME 14

**WARNING**

Do not remove any filler covers or manhole covers before all grounding clips have been attached to prevent a static spark from causing a fire or explosion.

1. Clip dispenser nozzle ground wire (1) to tank rail (2).
2. Unscrew and take off filler cover (3).
3. Take off padlock (4).
4. Open manhole cover (5).

GO TO FRAME 15

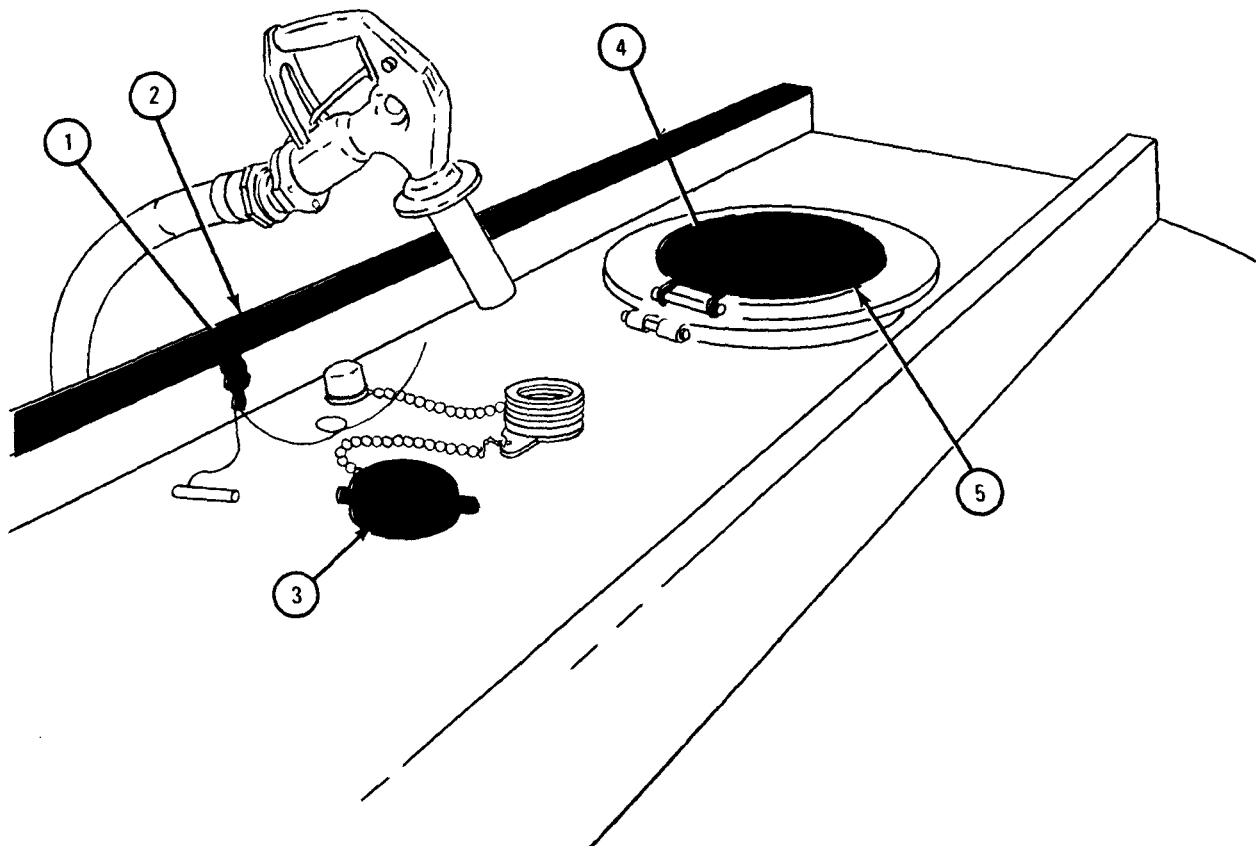

TA 045103

FRAME 15

1. Put dispenser nozzle (1) into filler hole (2) of tank section to be refilled.
2. Press nozzle operating lever (3) to fill section of tank.
3. Use fuel level gage (4) and fill tank to fill mark shown on gage for either the 200-, 400-, or 600-gallon tank.

GO TO FRAME 16

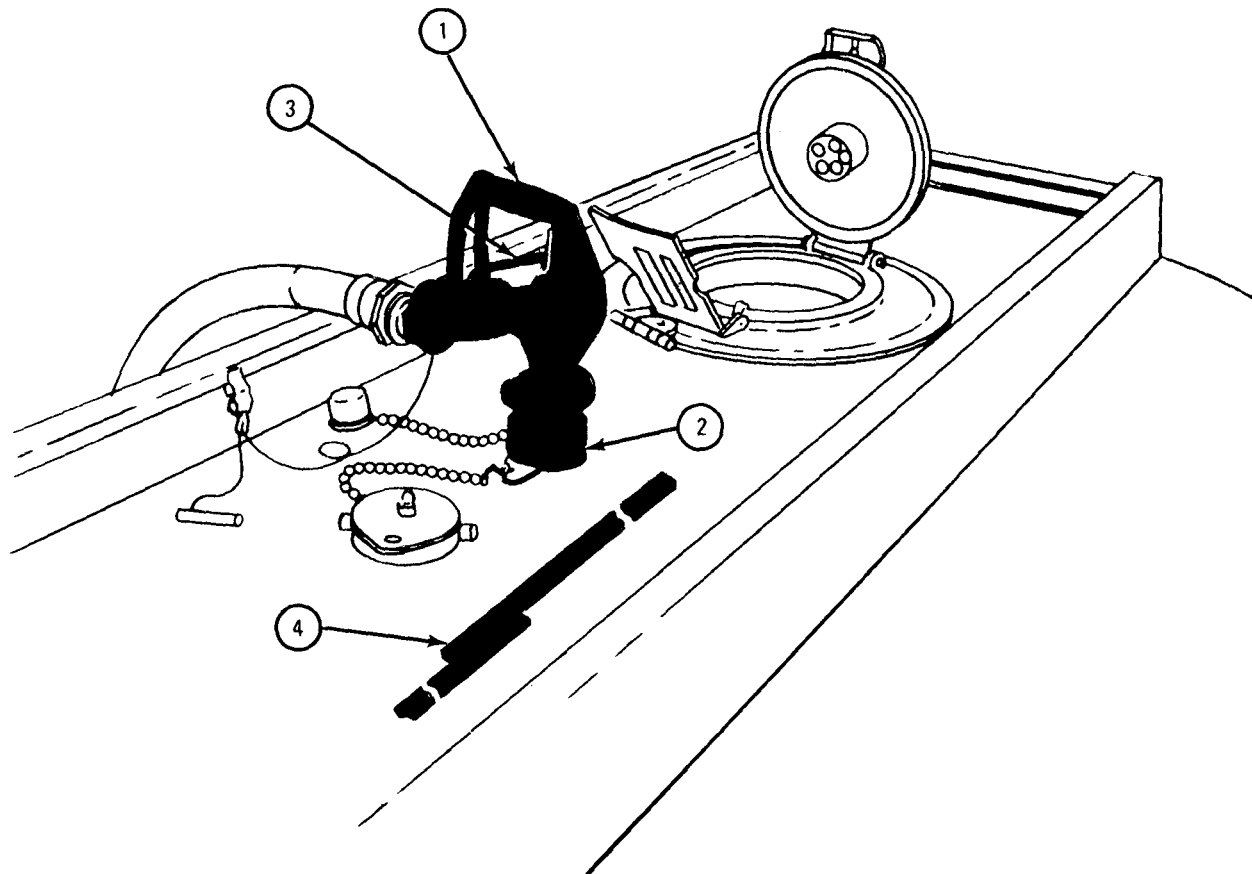

TA 045104

## FRAME 16

1. After filling each section, close and make filler cover (1) and manhole cover (2) fast.
2. Put on padlock (3).
3. Stow dispenser line (4) in traveling position on side of truck.

GO TO FRAME 17

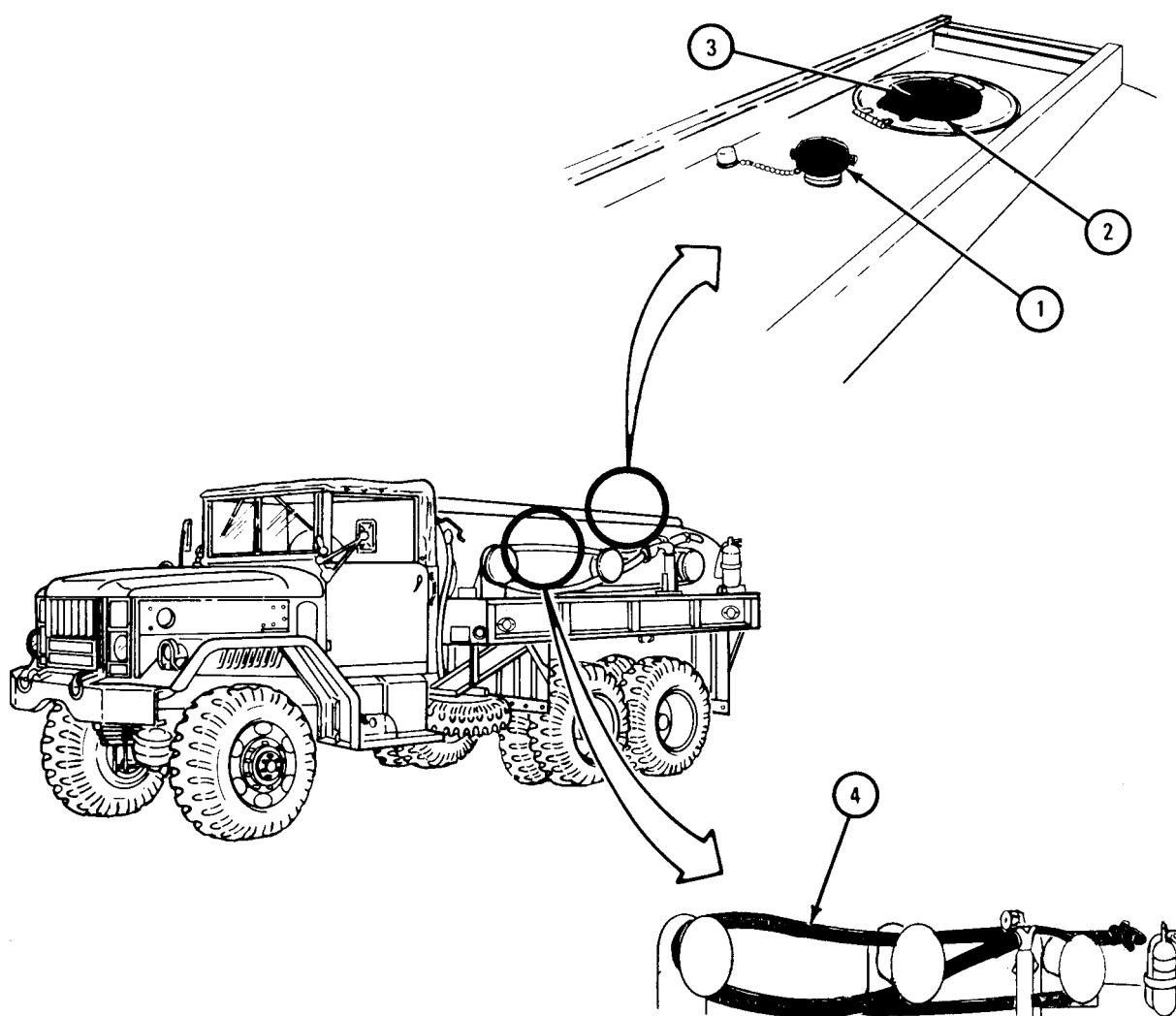

TA 045105

FRAME 17

1. Turn gravity delivery line gate valve knob (1) and pump delivery line gate valve knob (2) right to closed position.

GO TO FRAME 18

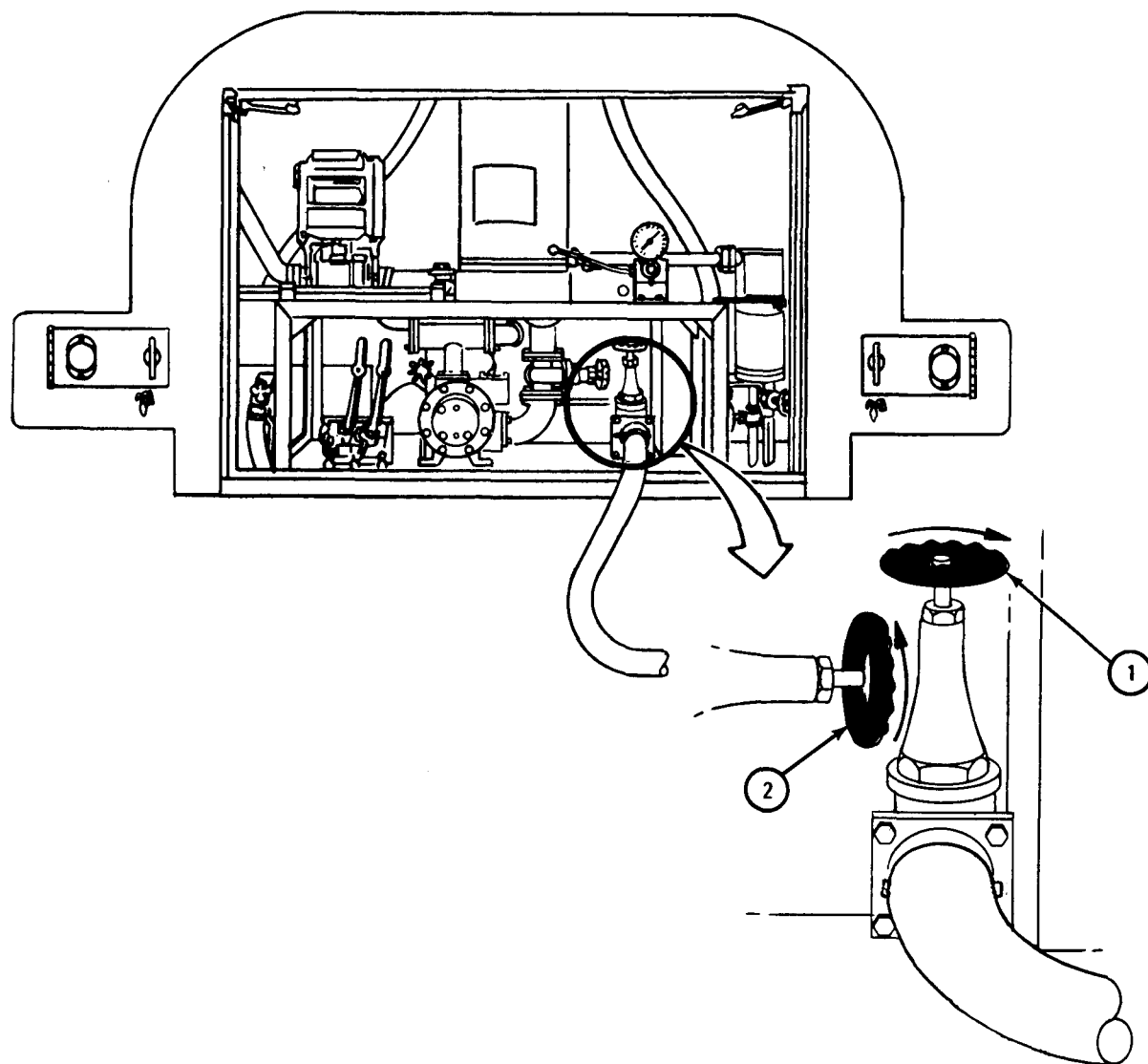

TA 045106

## FRAME 18

1. Turn hand THROTTLE control knob (1) to unlock it and let it return to closed position.
2. Pull ENG. STOP control (2) out to stop engine.

GO TO FRAME 19

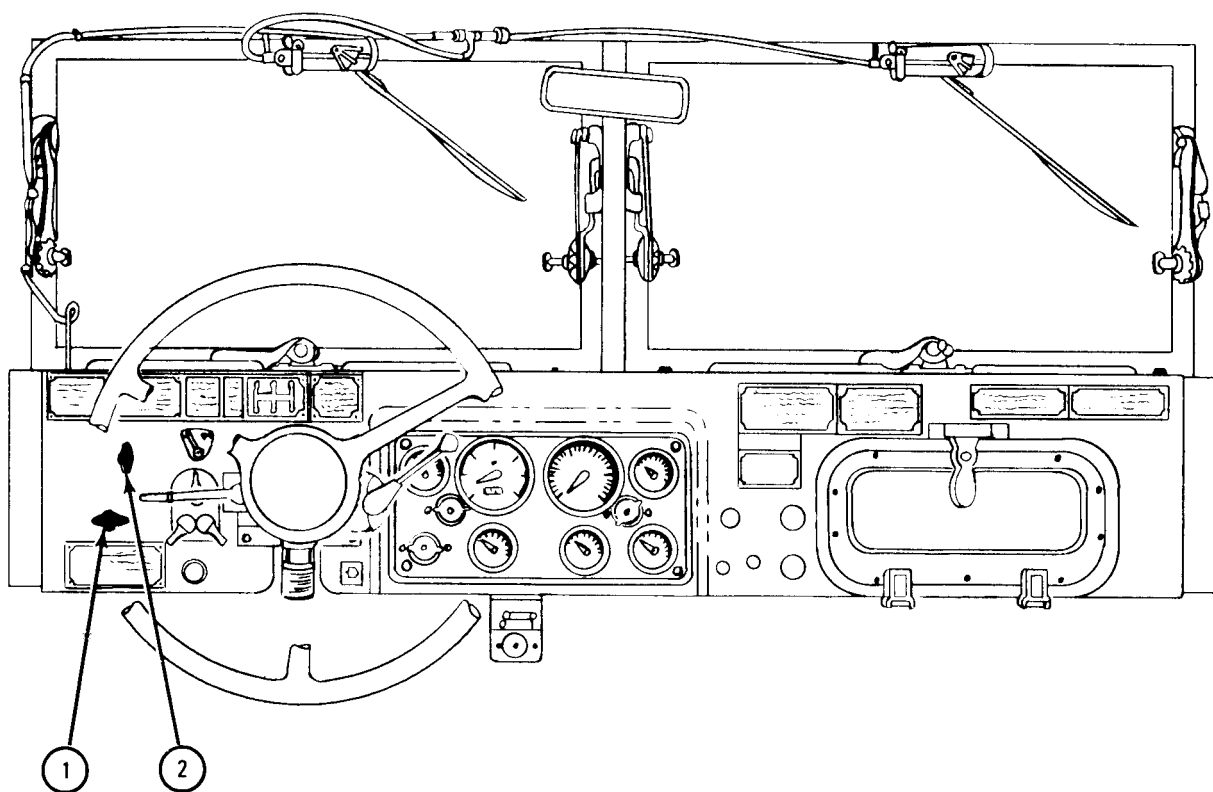

TA 045107

FRAME 19

1. Place transfer POWER TAKEOFF LEVER (1) in off position, (toward front of truck).
2. Turn locking bar (2) up to lock position.
3. Place FRONT TRANSMISSION gearshift lever (3) in N position.

GO TO FRAME 20

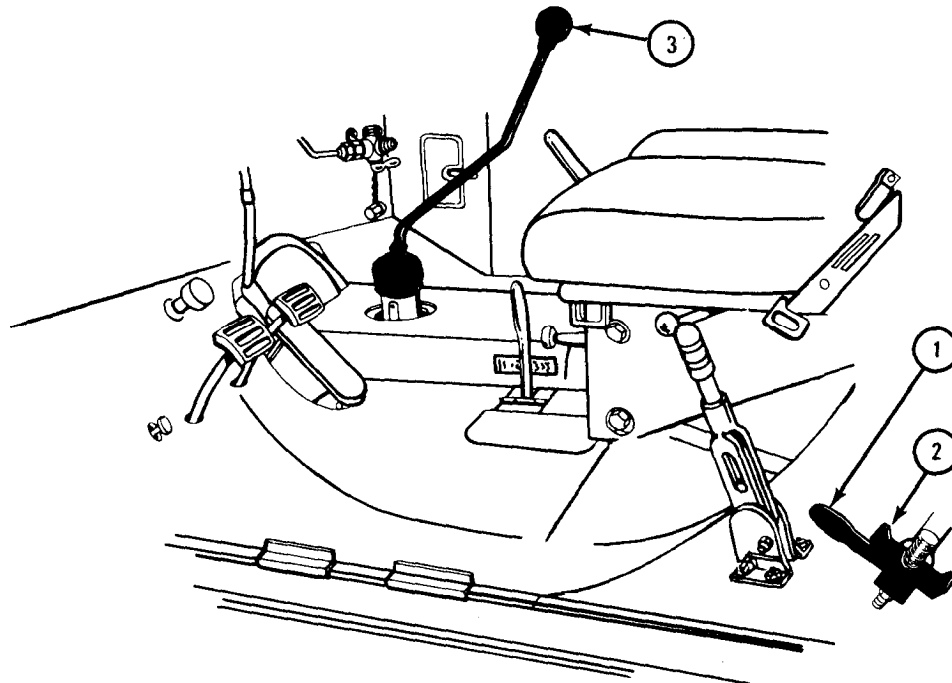

TA 045108

## FRAME 20

**CAUTION**

Authorized procedures must be used to dispose of fuel drained from hose lines.

1. Turn hose coupling left and take hose section (1) off gravity delivery line gate valve adapter (2).
2. Put dust cover (3) back onto delivery line gate valve adapter (2).
3. Drain and stow hose line (1).
4. Close hose line compartment door (4).

GO TO FRAME 21

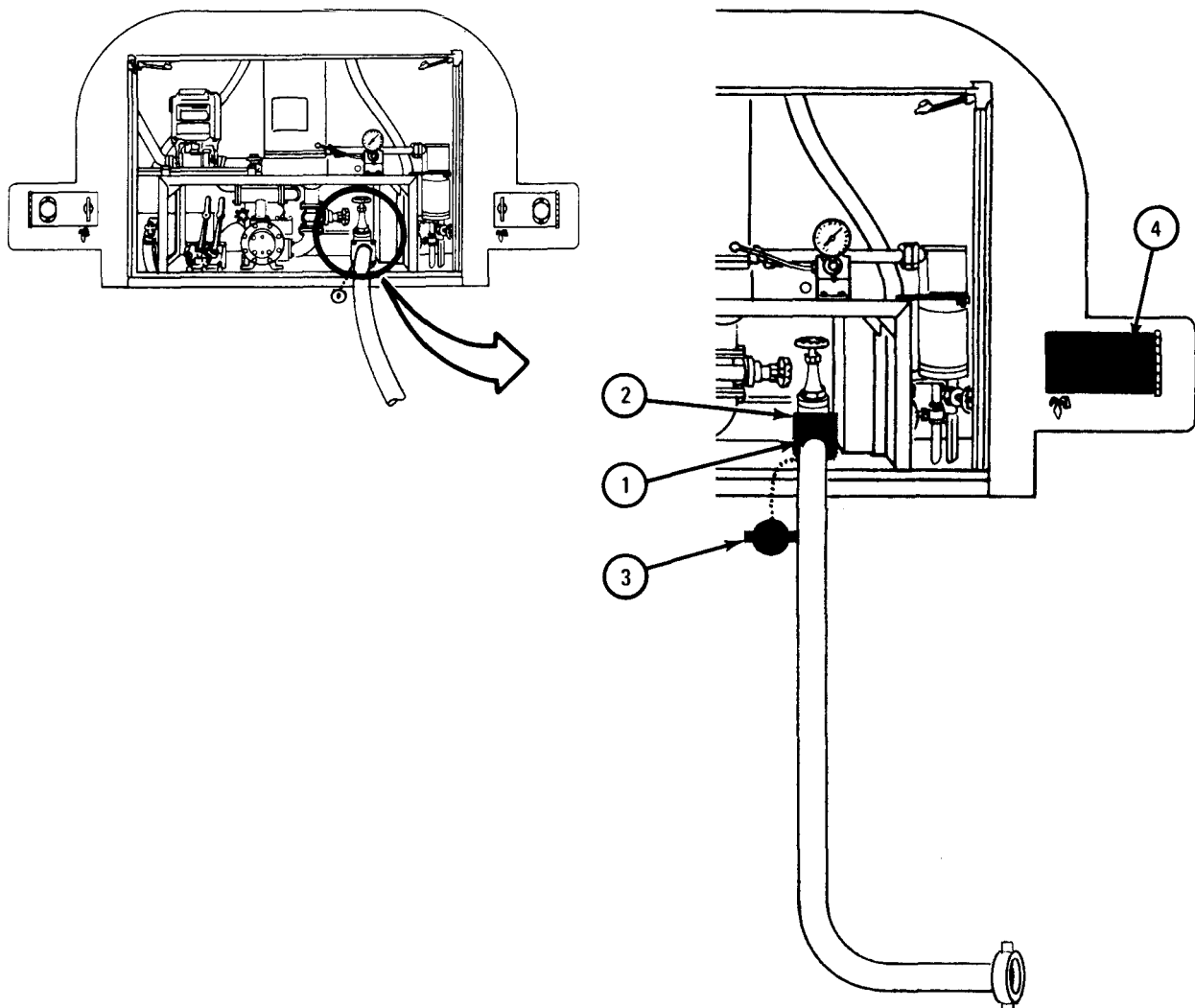

TA 045109

FRAME 21

1. Unclip ground wire (1) from ground connection and let wire rewind on its reel (2).
2. Put fuel level gage (3) back in its stowed position.
3. Close and make rear compartment door fast.

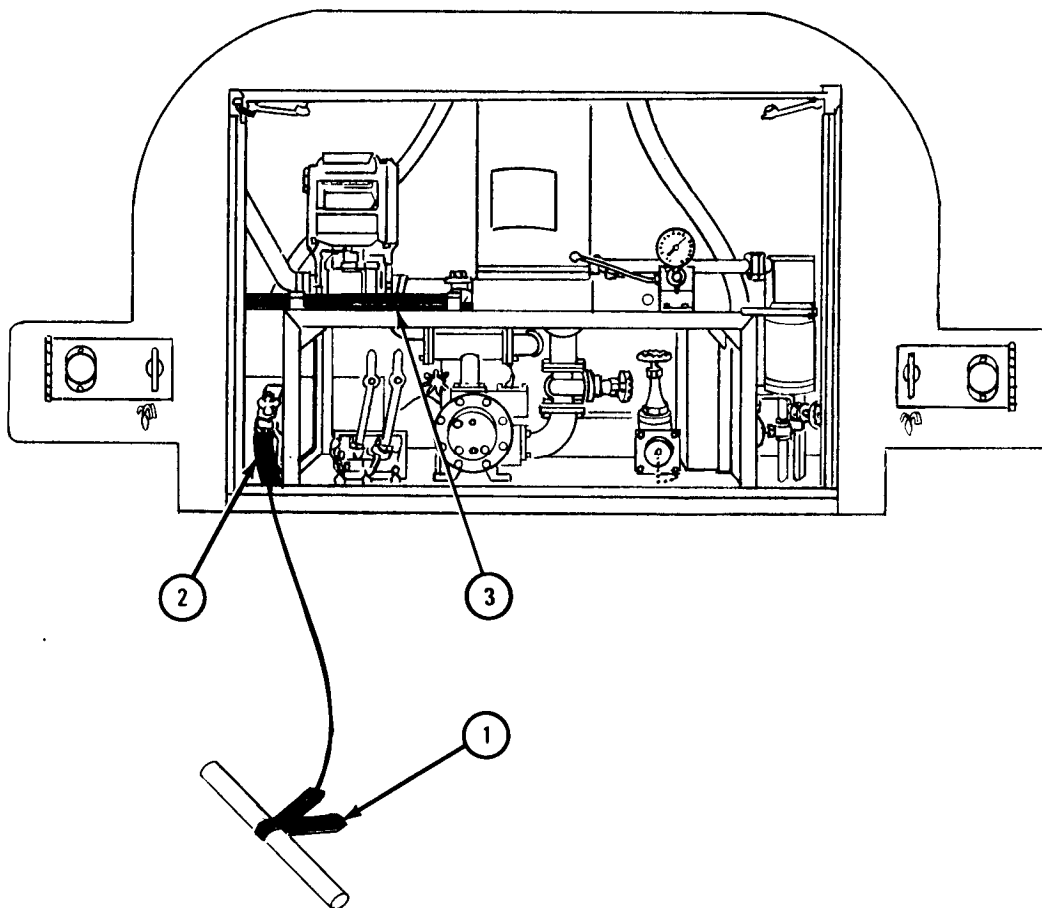

TA 045110



d. Power Discharging the Tank Sections.

FRAME 1

1. Start engine. (Refer to para 4-6b.)
2. Place truck in position to let discharge hose (1) reach filler hole of unit to be serviced.

GO TO FRAME 2

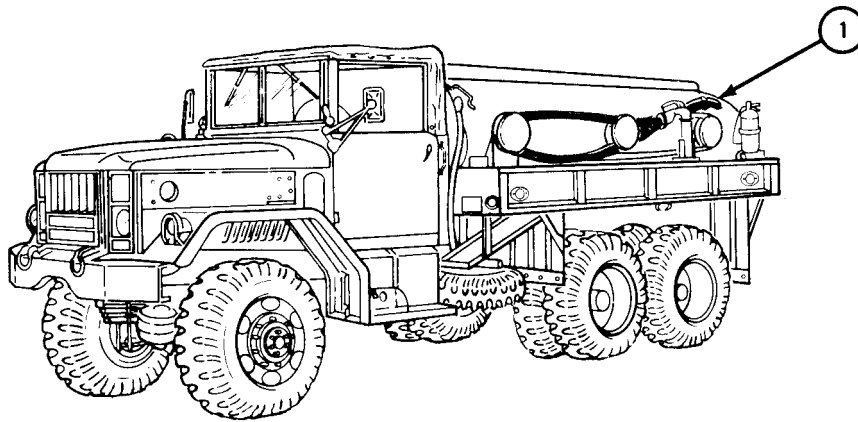

TA 045111

FRAME 2

1. Pull handbrake lever (1) up to on position.
2. Place FRONT TRANSMISSION gearshift lever (2) in position 2.
3. Place TRANSFER CASE shift lever (3) in middle (neutral) position.
4. Turn locking bar (4) to off (down) position.
5. Move transfer POWER TAKEOFF LEVER (5) to on (toward rear of truck) position.
6. Slowly pull hand THROTTLE control knob (6) out all the way.

GO TO FRAME 3.

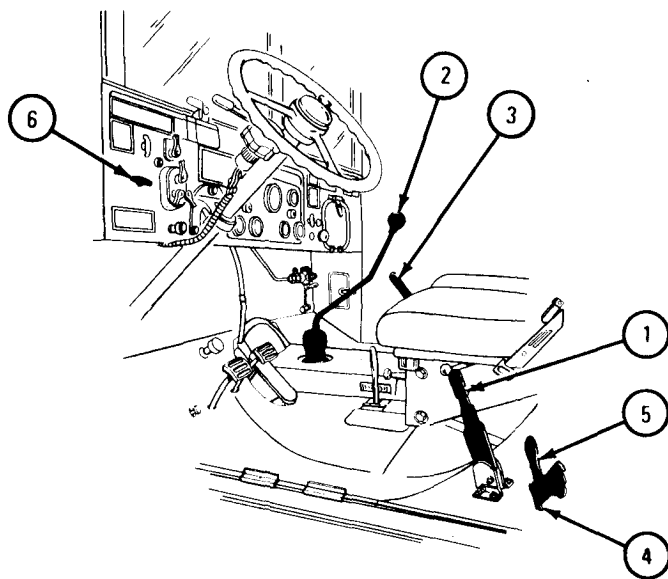

TA 045112

## FRAME 3

1. Open rear compartment doors (1).
  2. Pull ground wire (2) out and clip it to a suitable ground.
  3. Pull other ground wire (3) out and clip it to unit to be filled.
- GO TO FRAME 4

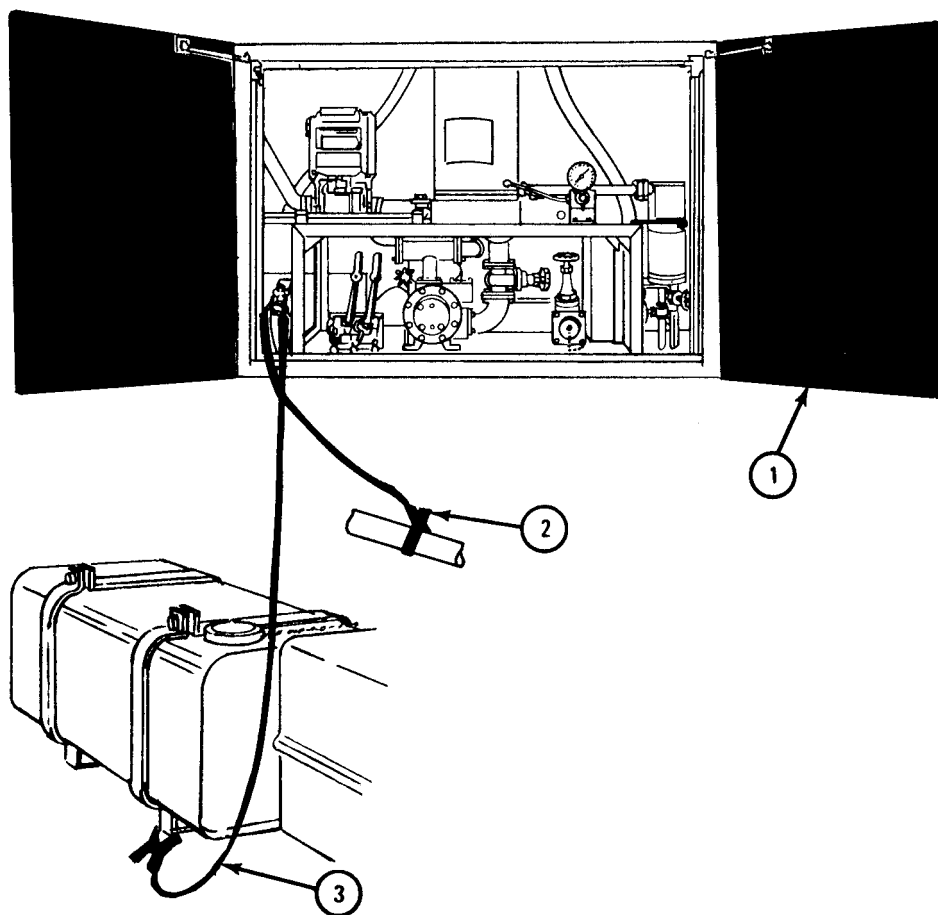

TA 045113

FRAME 4

1. Turn dump valve knob (1) left, to open position.
2. Turn pump delivery line valve knob (2) left, to open position.
3. Move discharge valve control lever for tank to be discharged to open position (toward rear of truck). Lever (3) controls forward tank section. Lever (4) controls rear tank section.

**NOTE**

On M49A1C truck lever (5) controls mid-section tank.

GO TO FRAME 5

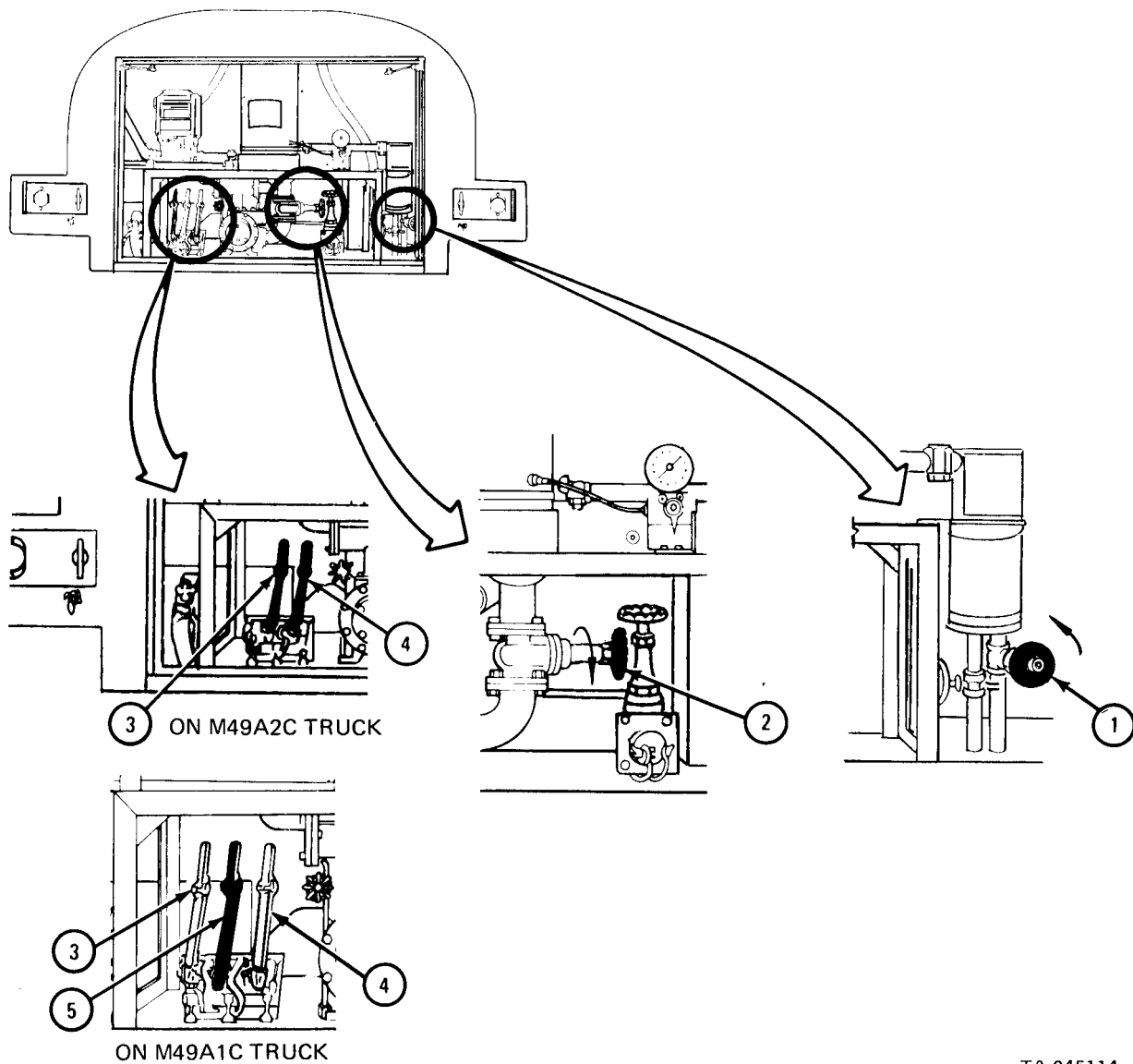

## FRAME 5

1. Unwind dispenser line and nozzle (1) from left side of truck.
2. Clip dispenser nozzle grounding wire (2) to unit being serviced.
3. Open filler cover (3), put nozzle (4) in, and fill as needed.
4. After discharging fuel, unclip nozzle grounding wire (2).
5. Put dispenser line and nozzle (1) in stowed position.

GO TO FRAME 6

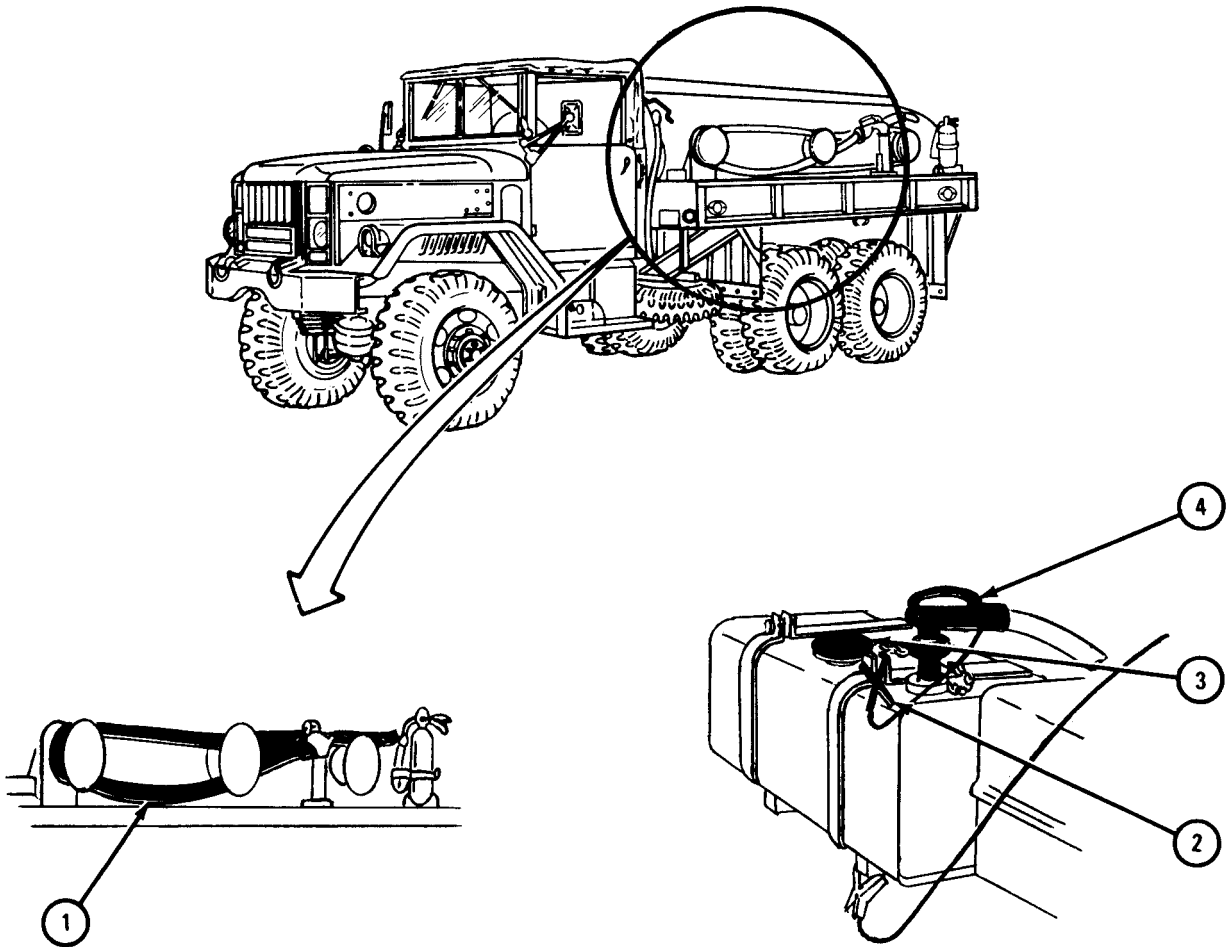

TA 045115

FRAME 6

1. Turn pump delivery line gate valve knob (1) right to closed position.
2. Turn dump valve knob (2) right to closed position.

GO TO FRAME 7

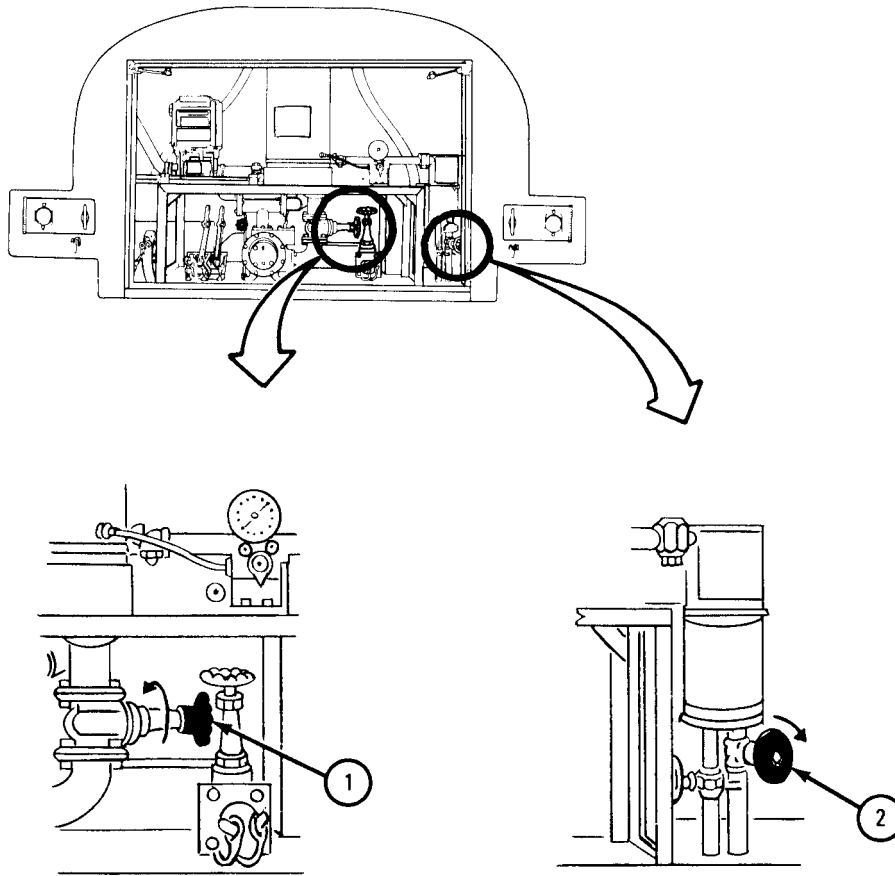

TA 045116

## FRAME 7

1. On M49A2C truck, move discharge valve control operating lever (1) or (2) (or on M49A1C truck levers 1, 2, or 3) to closed position (toward front of truck).
2. Unclip grounding wires (4) and (5); let them rewind on reel.
3. Close and lock rear compartment doors (6).

GO TO FRAME 8

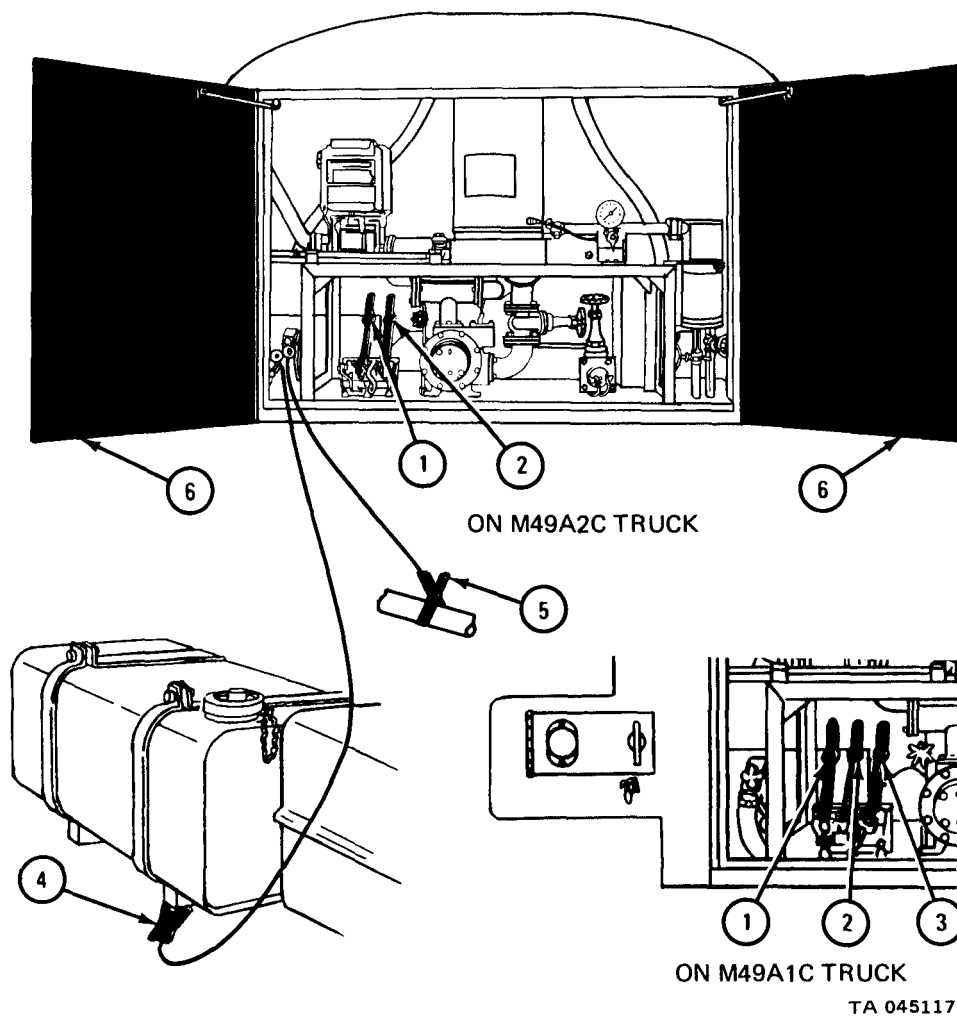

FRAME 8

1. Turn hand THROTTLE control knob (1) until it unlocks and let it return to closed position.
2. Place ACCESSORY switch (2) and all other switches in off position.
3. Pull ENG. STOP control (3) out to cut off fuel flow. Leave it in out position.
4. Place transfer POWER TAKEOFF LEVER (4) in off position (toward front of truck.)
5. Turn locking bar (5) to lock (up) position.
6. Place FRONT TRANSMISSION gearshift lever (6) in N position.

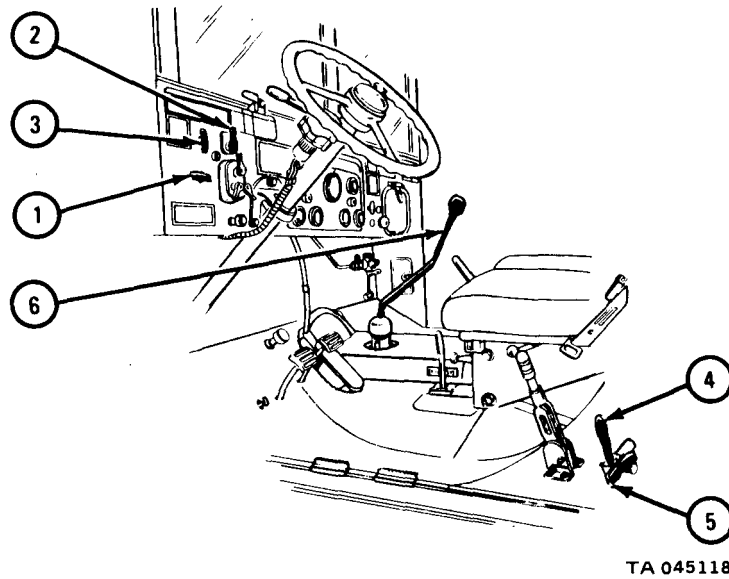



e. Checking Condition of Filter. Filter should be checked as follows once a day during pumping operation.

**FRAME 1**

1. Start engine. (Refer to para 4-6b. )
2. Transfer power to the pump. (Refer to para 4-9d, frame 2 for procedures).
3. Open rear compartment doors and hook up ground wires. (Refer to para 4-9d, frame 3 for procedures).
4. Take a pressure reading on inlet side of filter.
  - (a) Turn pressure gage control handle (1) right, to position NO. 1.
  - (b) Write reading down.

GO TO FRAME 2

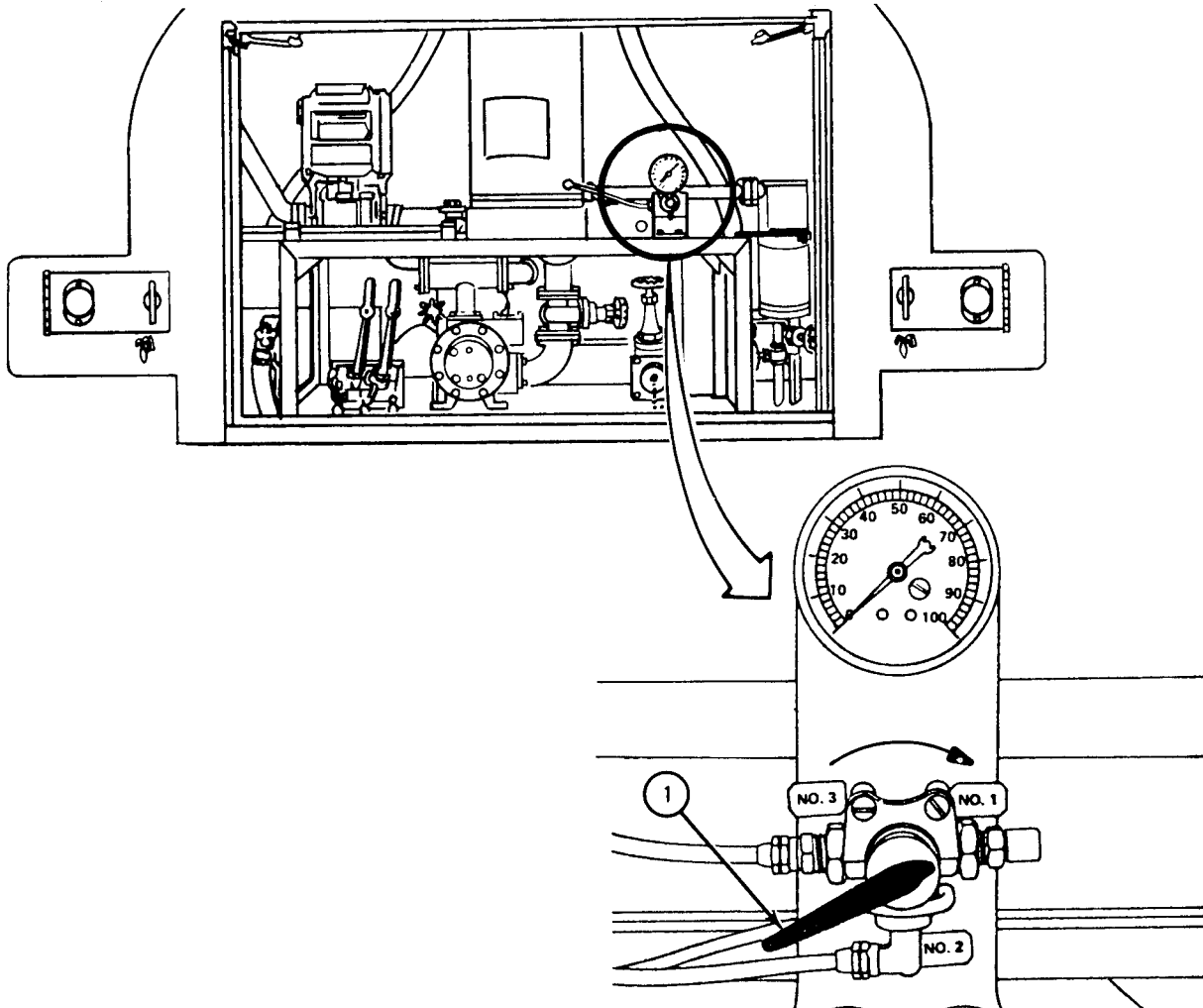

TA 045119

FRAME 2

1. Take a pressure reading on outlet side of filter.
  - (a) Turn pressure gage control handle (1) right, to position NO. 2.
  - (b) Write reading down.

GO TO FRAME 3

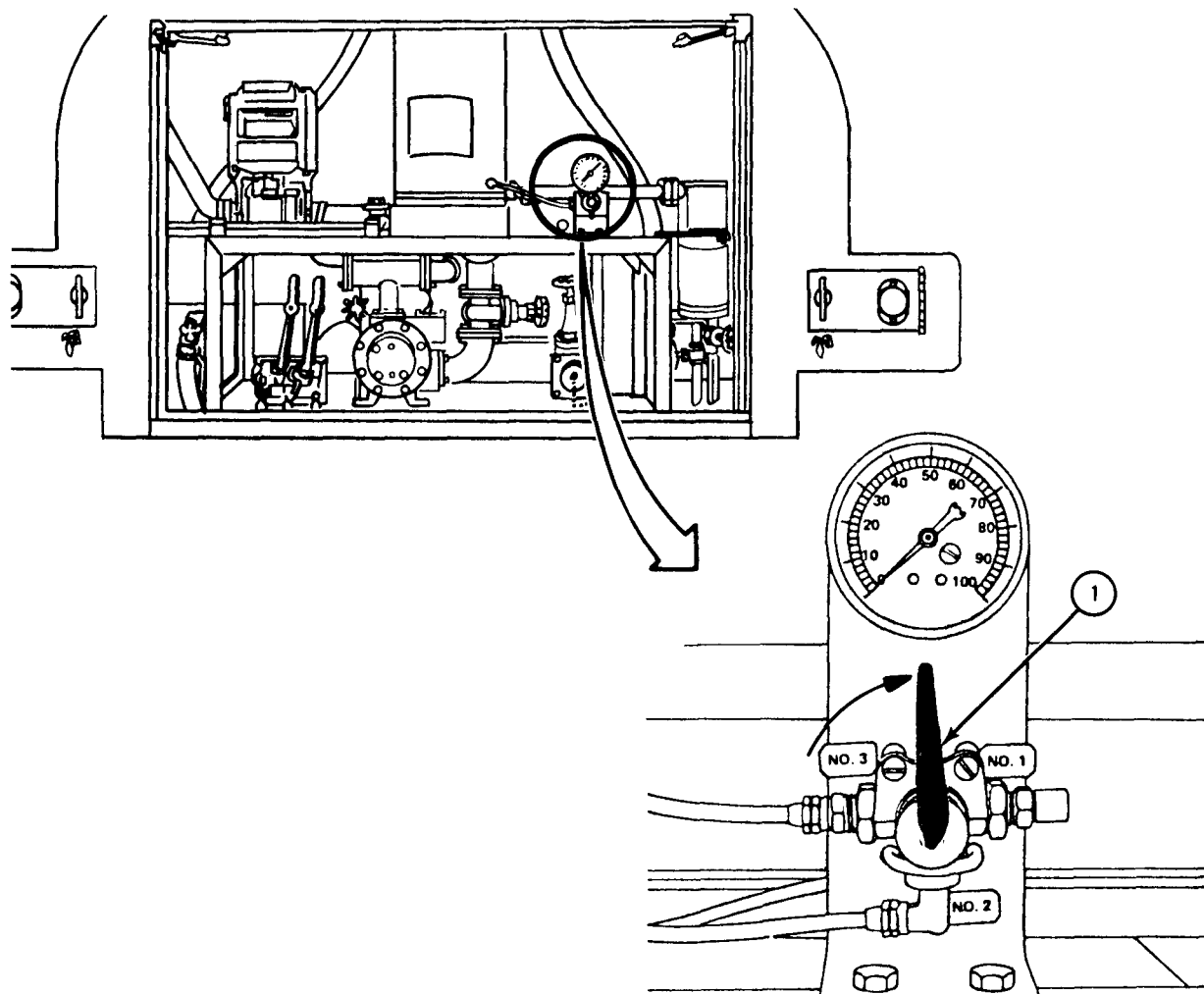

TA 045120

## FRAME 3

1. Take a pressure reading on internal pressure side of valve.
  - (a) Turn pressure gage control handle (1) right, to position NO. 3.
  - (b) Write reading down.

GO TO FRAME 4

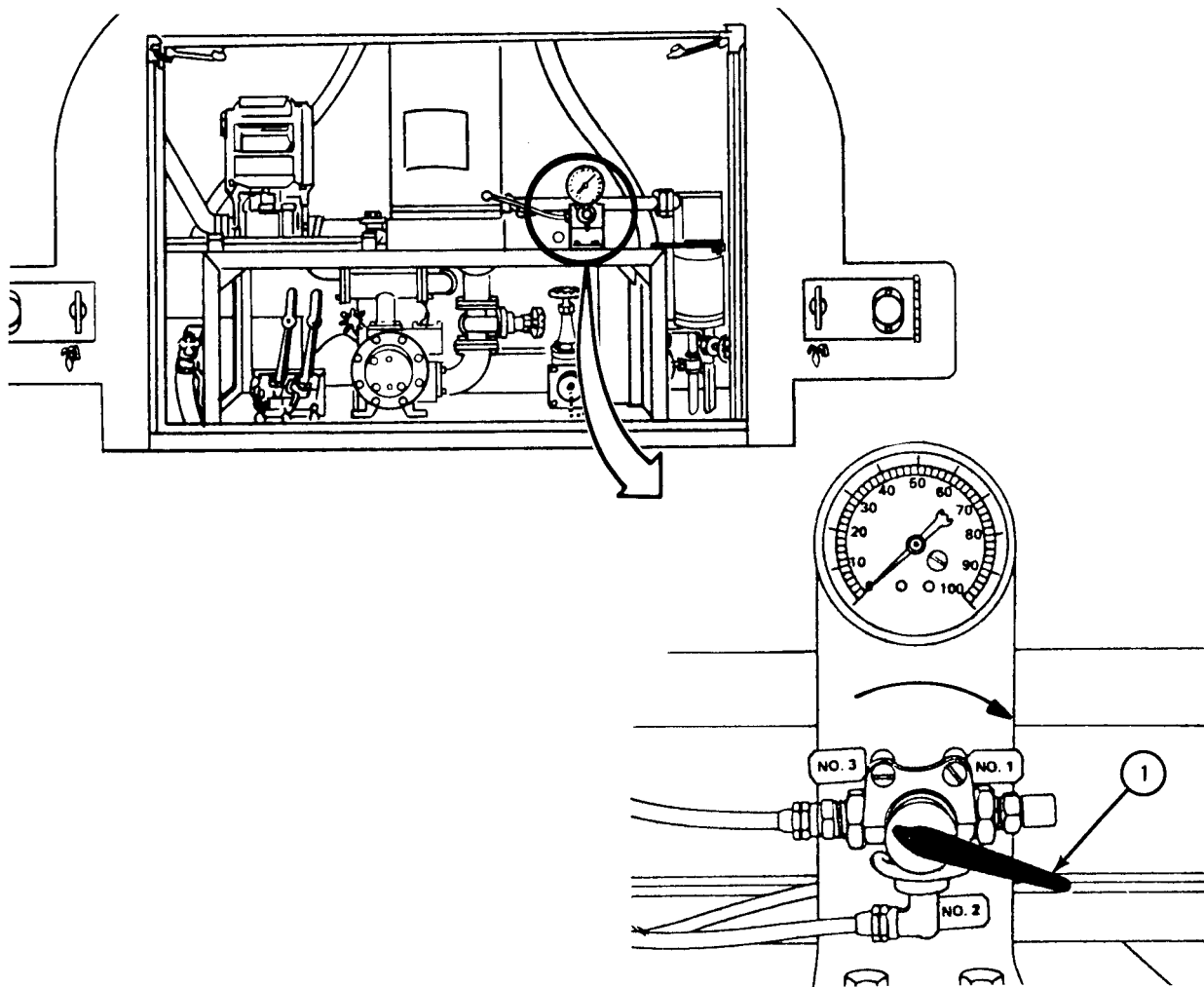

TA 045121

FRAME 4

1. Close valve by turning pressure gage control handle (1) left and placing pointer between position NO. 1 and position NO. 2.
2. Tell organizational maintenance if any of following conditions exist:
  - (a) Difference between readings taken in position NO. 1 (inlet pressure) and position NO. 2 (outlet pressure) is more than 20 psi.
  - (b) Difference between readings taken in position NO. 1 (inlet pressure) and position NO. 3 (internal pressure) is more than 15 psi.
  - (c) Difference between readings taken in position NO. 2 (outlet pressure) , and position NO. 3 (internal pressure) is more than 15 psi.
3. Take off ground wires and close rear compartment doors. (Refer to para 4-9d frame 7).
4. Take off power to pump. (Refer to para 4-9d, frame 8).

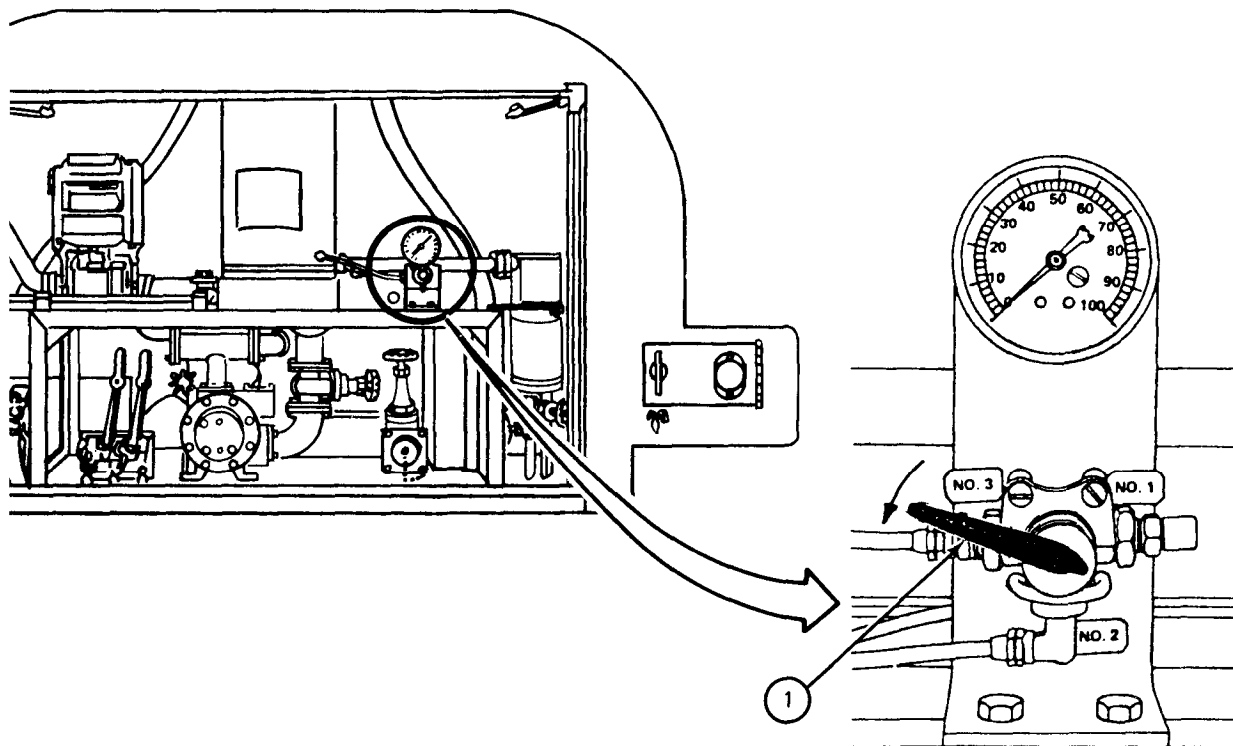

TA 045122

f. Gravity Discharging the Tank Sections.

TOOLS: 2-inch spanner wrench

## FRAME 1

1. Start engine. (Refer to para 4-6b. )
  2. Place truck in position, with rear compartment (1) near unit to be serviced (2).
- GO TO FRAME 2

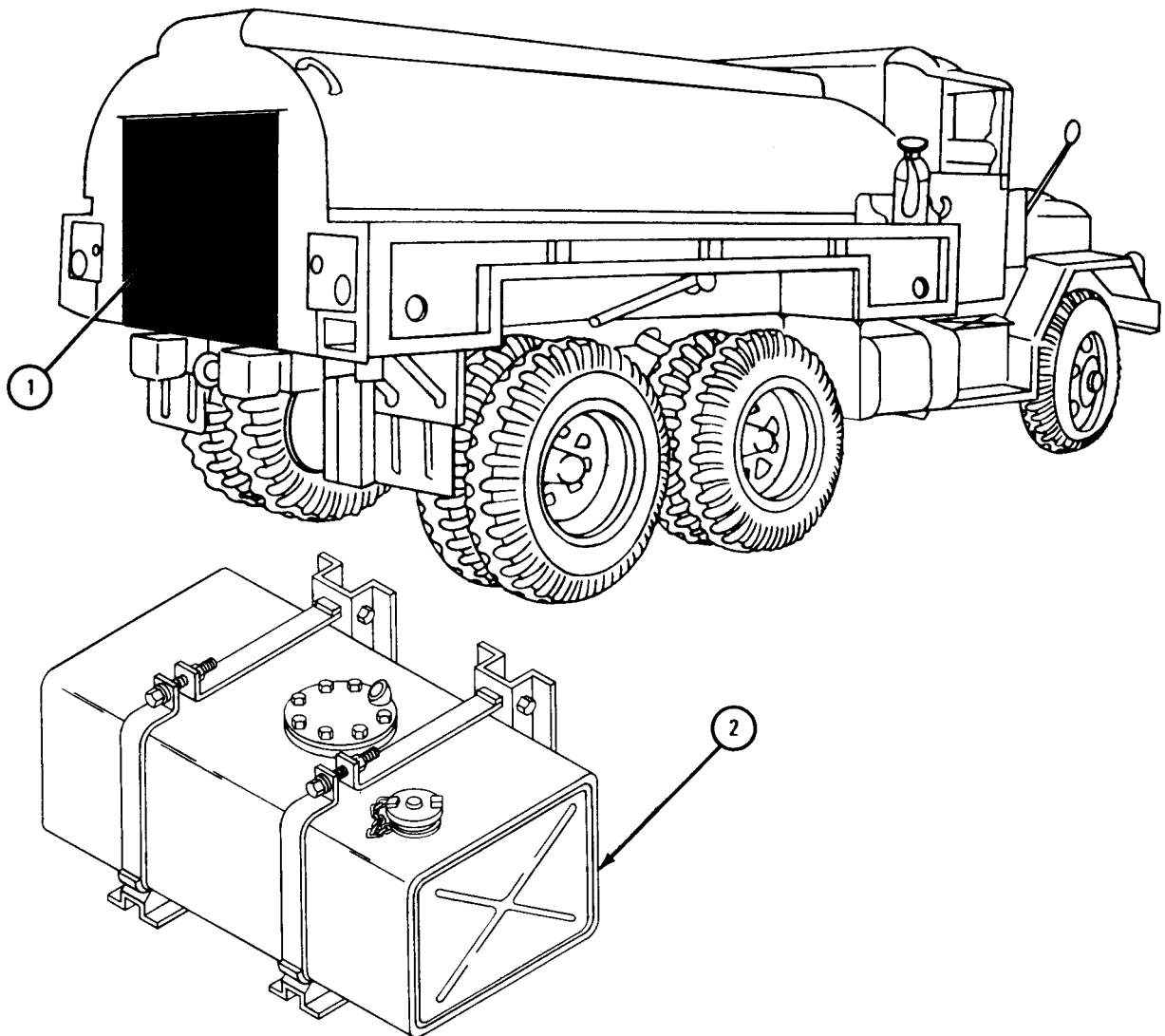

TA 045123

FRAME 2

1. Pull handbrake lever (1) up to on position.
2. Set ACCESSORY switch (2) and all other switches to off position.
3. Pull ENG. STOP control knob (3) out to stop engine.

GO TO FRAME 3

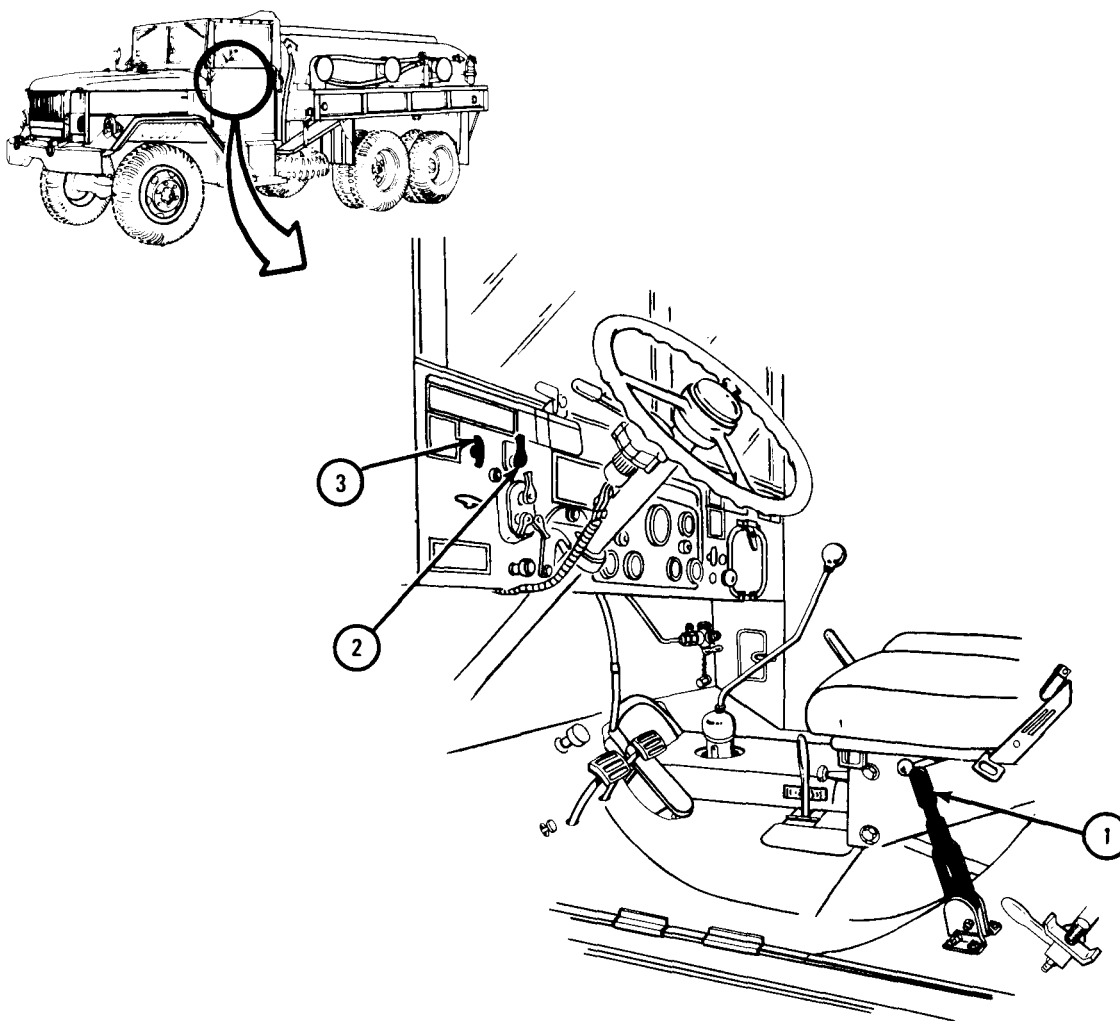

TA 045124

## FRAME 1

1. Open rear compartment doors (1).
2. Pull ground wire (2) out and clip it to a suitable ground.
3. Pull other ground wire (3) out and clip it to unit to be filled.

GO TO FRAME 4

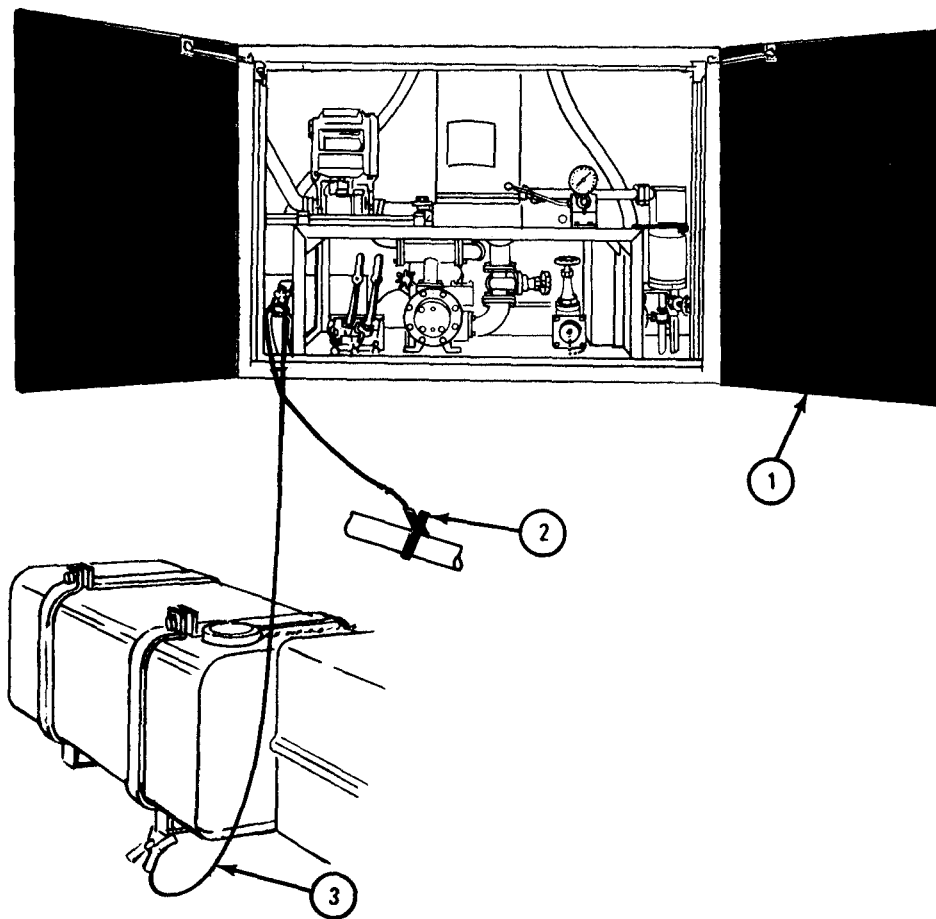

TA 045113

FRAME 4

1. Turn left and take gravity delivery line gate valve, dust cover (1) off.  
GO TO FRAME 5

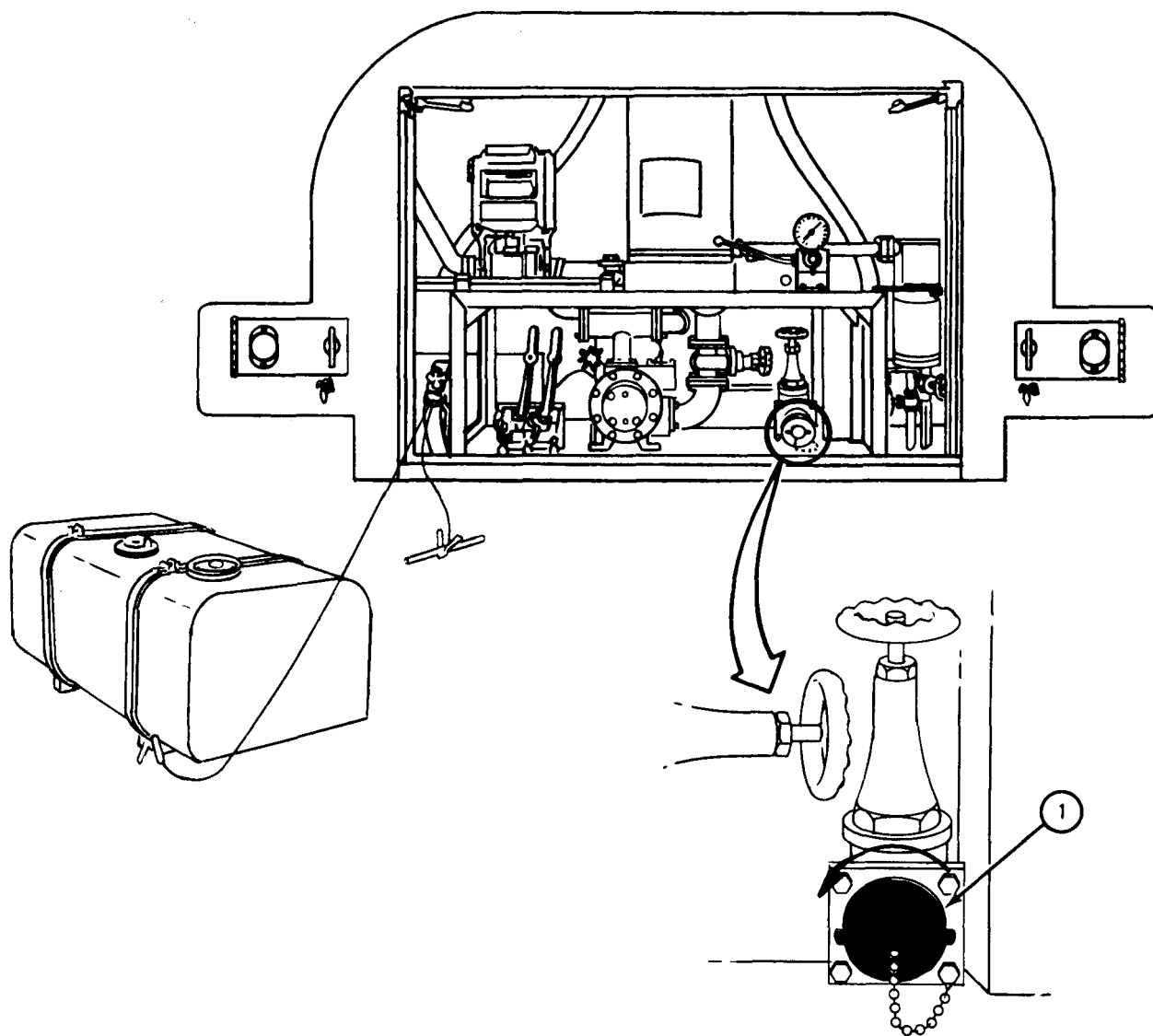

TA 045095



## FRAME 5

1. Open hose compartment doors (1), take out one or both lengths of hose (2), as needed, to reach tank to be filled.
2. Turn right and screw one end of hose onto gravity delivery valve adapter (3). Tighten with 2-inch spanner wrench.
3. Take dispenser nozzle (4) from rear compartment, put it onto other end of hose (2).
4. Turn right to tighten. After it is hand tight, use spanner wrench to complete tightening.

**NOTE**

Two lengths of hose can be joined together to form a longer hose when needed.

GO TO FRAME 6

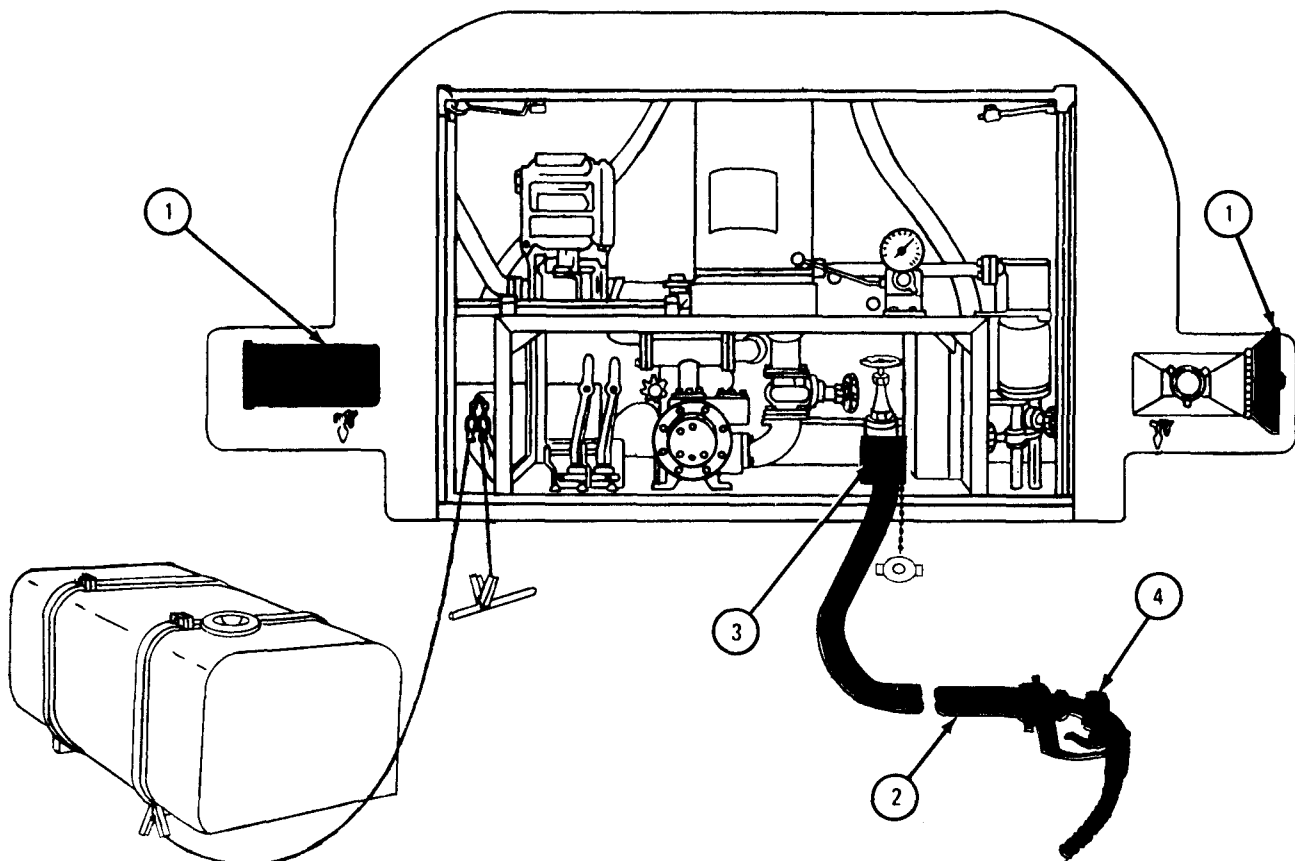

TA 045125

FRAME 6

1. Turn left and open gravity delivery line gate valve (1).
2. Move discharge valve control lever for tank to be discharged to open position (toward rear of truck).
  - (a) Lever (2) on left controls forward tank.
  - (b) Lever (3) on right controls rear tank.
3. Open filler cover (4) on tank to be filled.
4. Place dispenser nozzle (5) into tank.
5. Press operating lever (6) to let fuel flow into tank.

GO TO FRAME 7

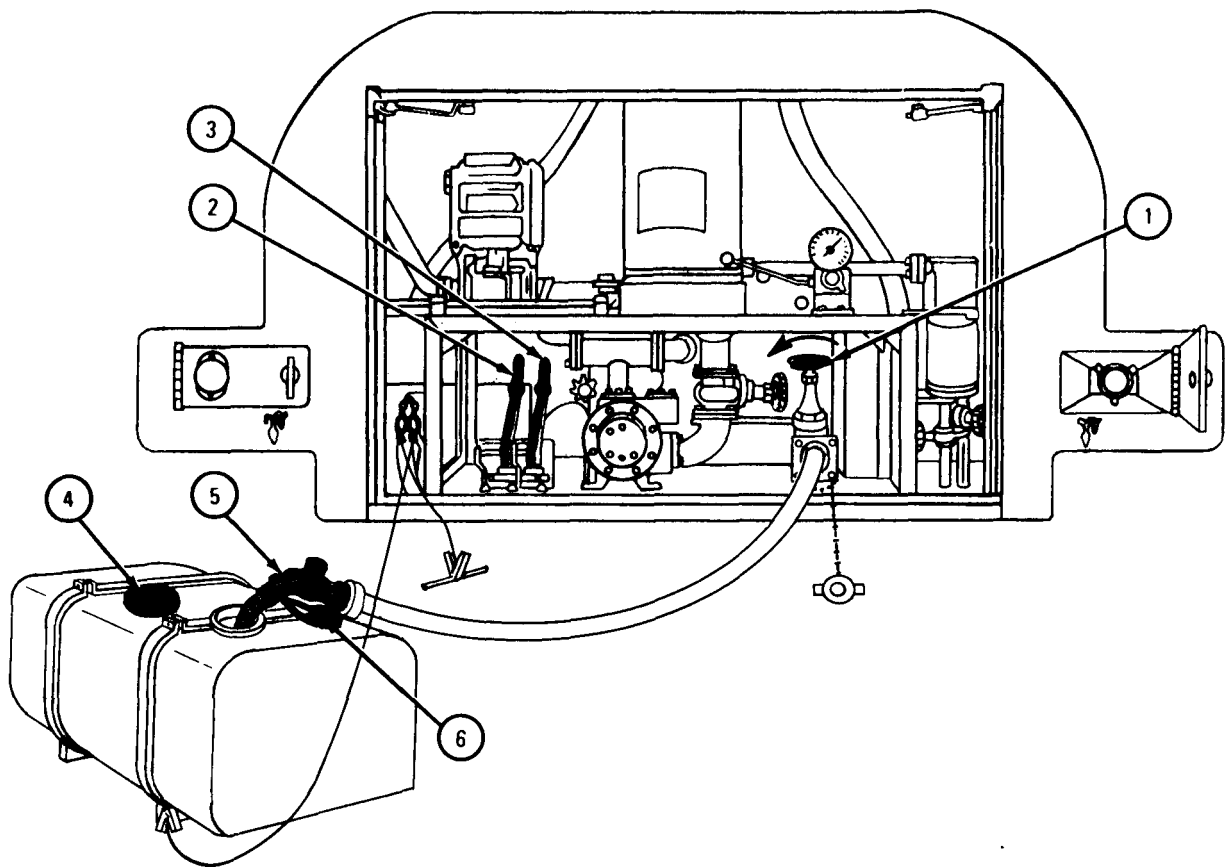

TA 045126

## FRAME 7

1. When needed amount of fuel has been put into tank, set operating lever (1) free.
2. Move discharge valve control levers (2) and (3) to closed position (toward front of truck).
3. Turn gravity delivery line gate valve knob (4) right, to closed position.
4. Take dispenser nozzle (5) out of tank.
5. Put filler cover (6) onto filler hole, turn right to tighten.

GO TO FRAME 8

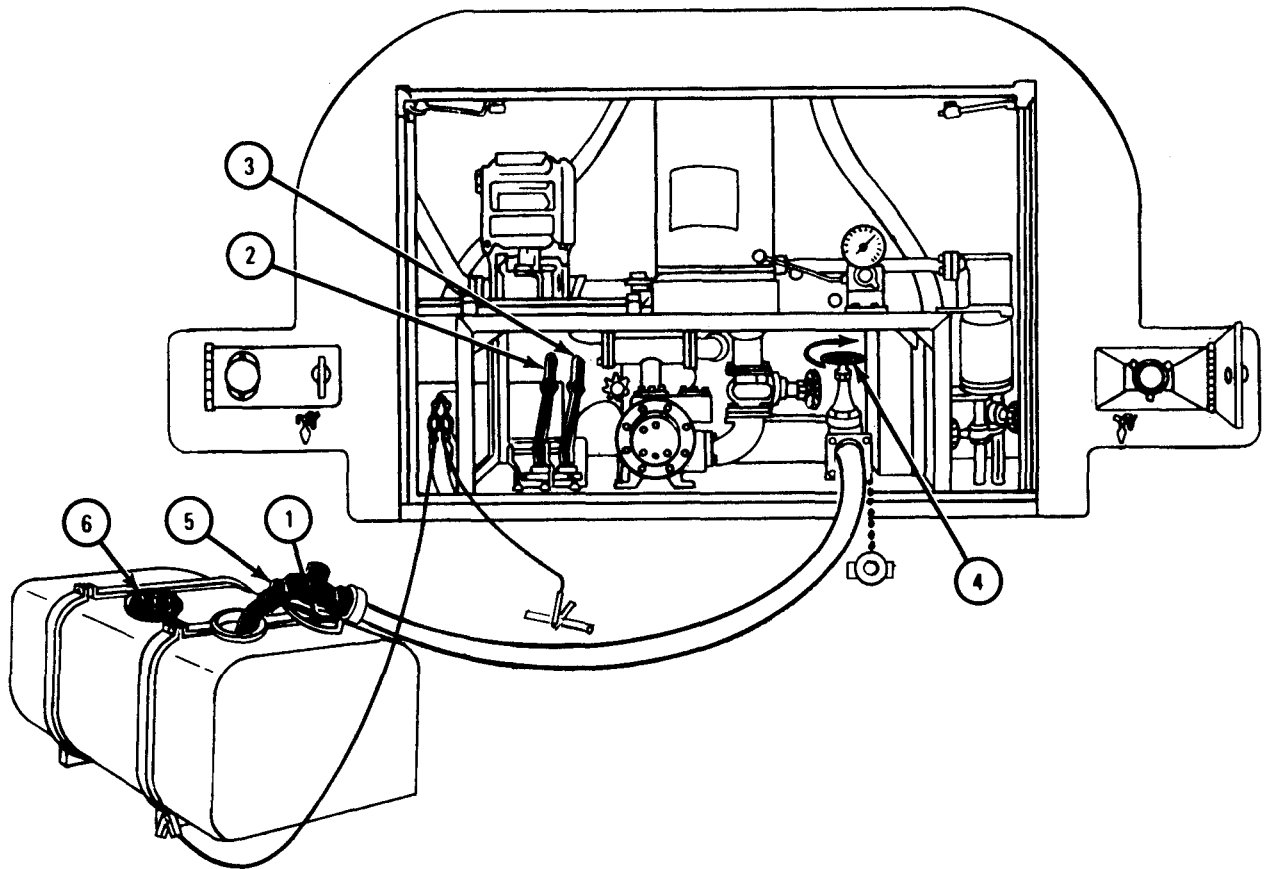

TA 045127

FRAME 8

1. Loosen nozzle (1) using spanner wrench, take it off end of hose (2), and return it to place in rear compartment.
2. Loosen hose (2) using spanner wrench. Take it off gravity valve adapter (3).
3. Drain hose using authorized procedures, and return it to hose compartment.
4. Put dust cover (4) back onto valve adapter (3). Turn clockwise (right) to tighten.
5. Unclip grounding wires (5) and (6) from tank and ground, let them rewind on reel.
6. Close rear compartment doors (7).

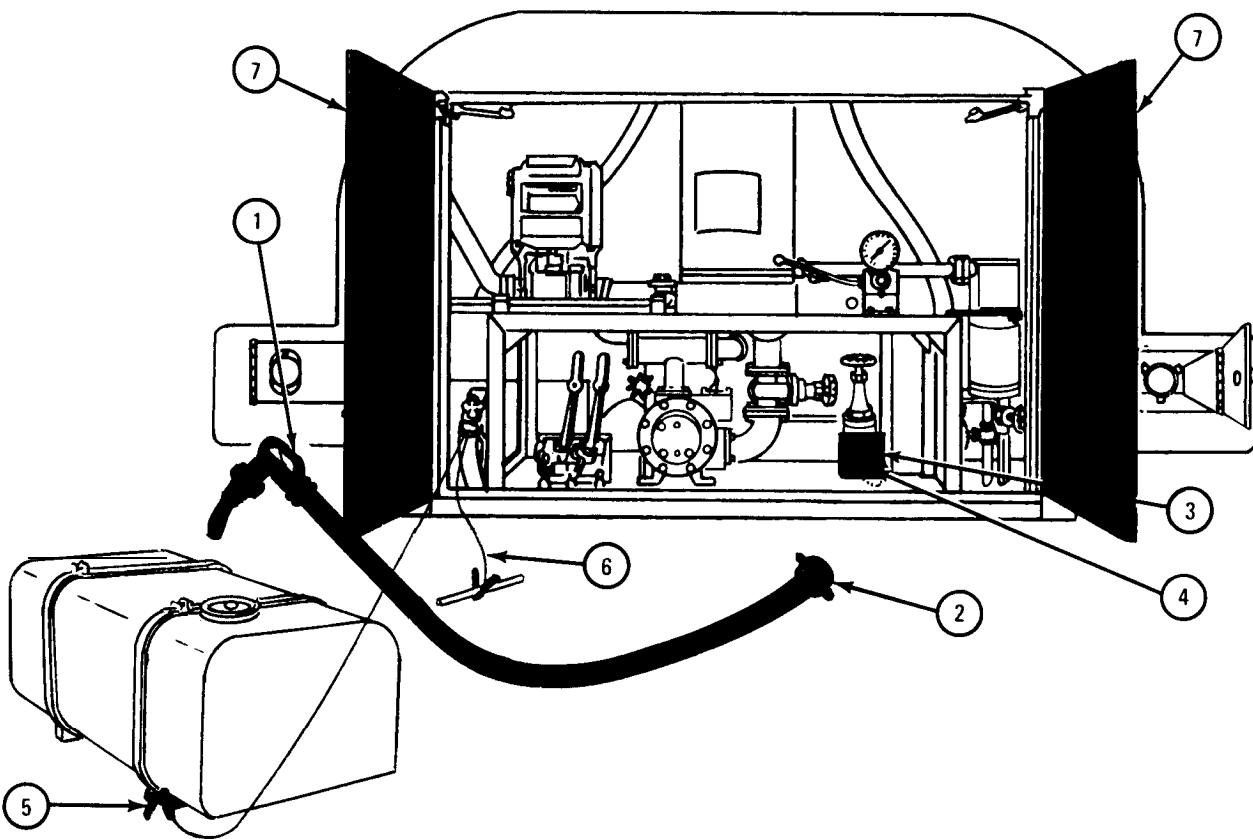

TA 045128

g. Fording

TOOLS: Ratchet wrench  
 1/2-inch straight bar plug wrench

SUPPLIES: Container, suitable for fuel

FRAME 7

1. Open rear compartment doors (1).
  2. Make sure that dust cover (2) is in place and made fast.
  3. Refer to para 4-18 and 4-25 for complete fording procedures.
- GO TO FRAME 2

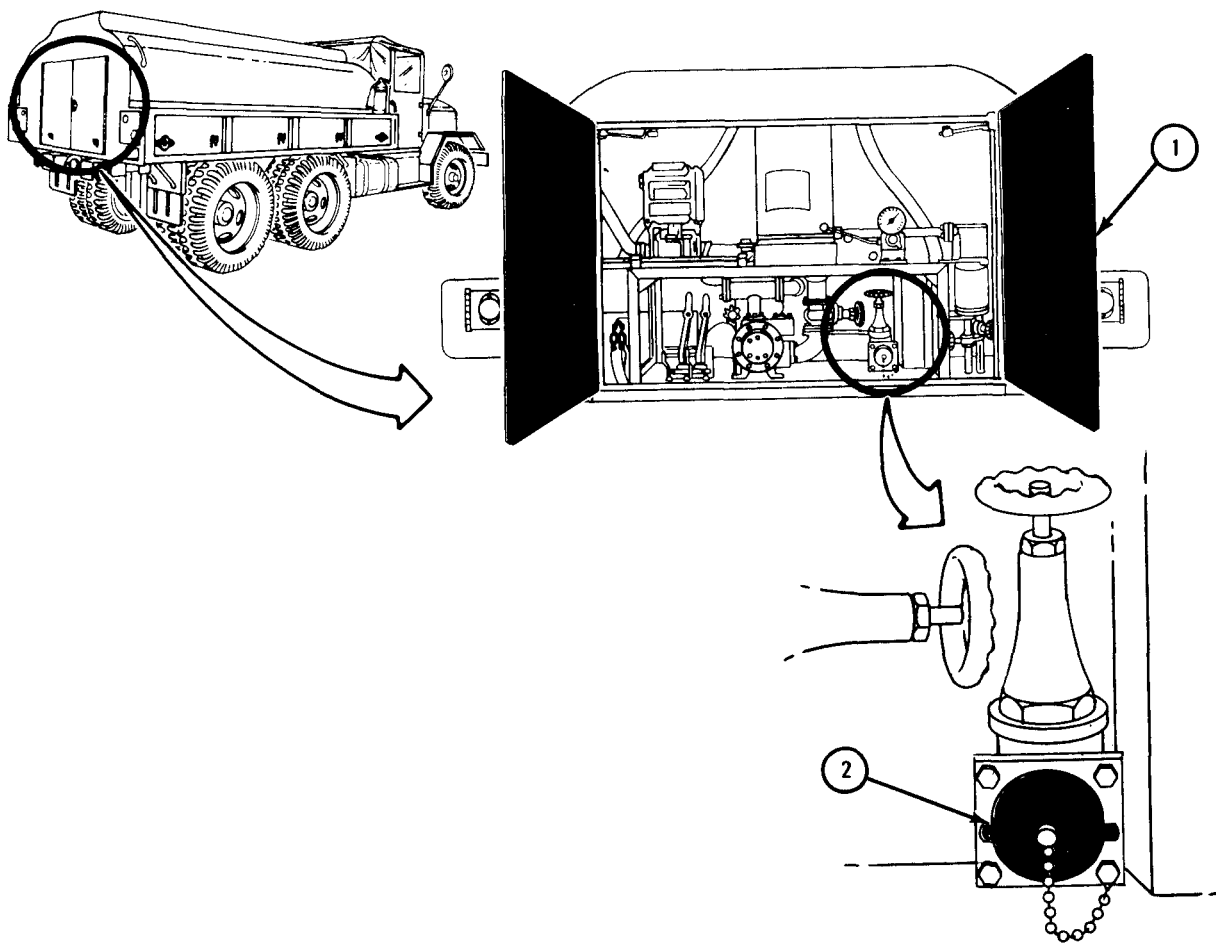

TA 045129

FRAME 2

**WARNING**

To prevent fire or explosion, smoking, sparks, or open flame are not allowed within 50 feet of working area during this operation.

1. After fording, park truck and stop engine. (Refer to para 4-6 e.)
2. Clip truck ground wire (1) to container (2).
3. Check to make sure that there is no water in delivery lines (3). Let fuel and/or water drain into container.
4. If necessary drain segregator (4), meter (5), delivery pump (6), and manifold pipes (7).

GO TO FRAME 3

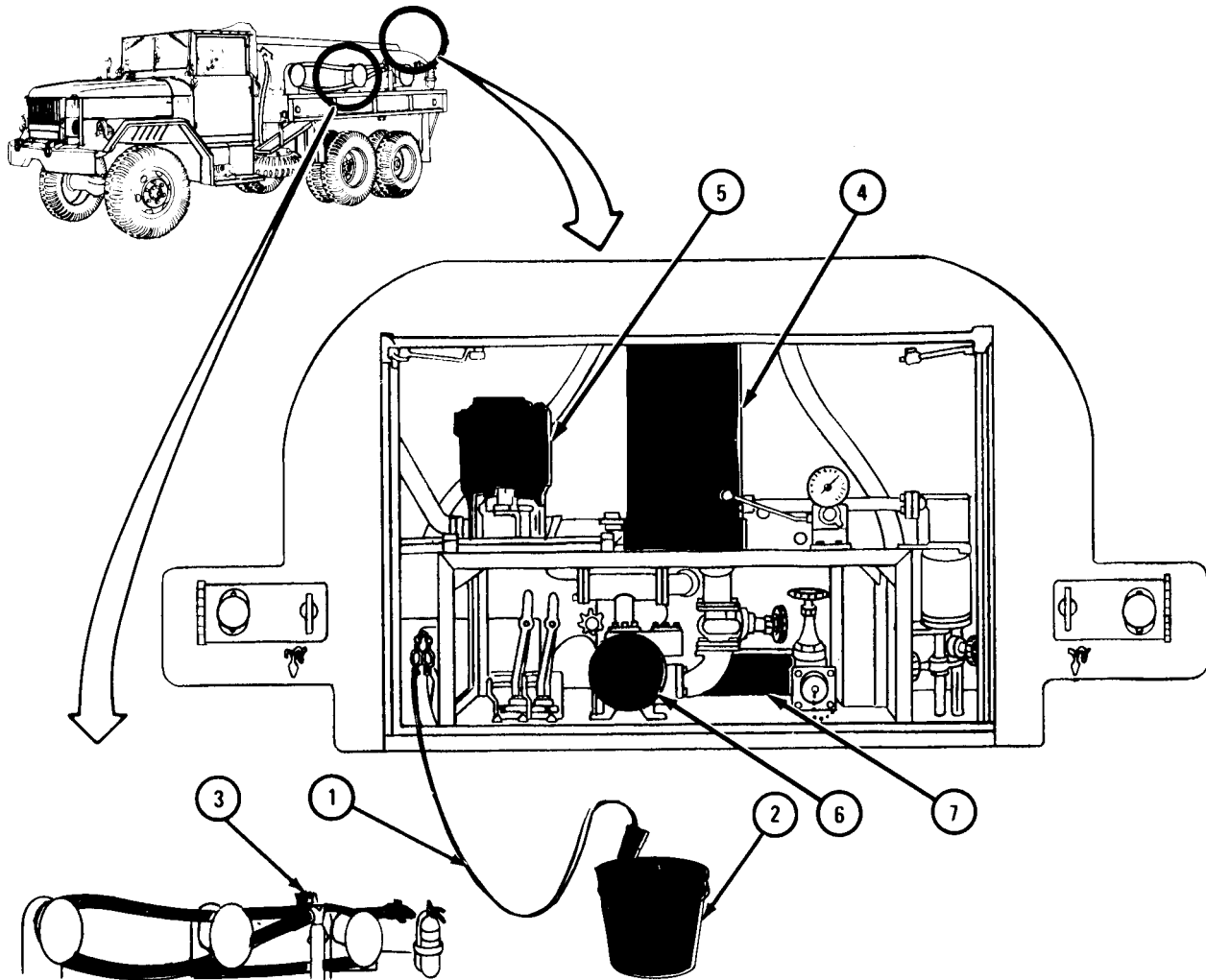

TA 045130

## FRAME 3

1. To drain segregator (1):
  - (a) Place container (2) under truck and under water separator drain pipe (3) and automatic dump pipe (4).
  - (b) Turn both water separator drain valve (5) and automatic dump valve (6) left to open position.
  - (c) After fuel and/or water has drained into container (2), turn water separator drain valve (5) and automatic dump valve (6) right to closed position.
2. To drain meter (7):
  - (a) Place container (2) under truck and under meter drain pipe (8).
  - (b) Turn knob of meter drain valve (9) left to open position.
  - (c) After fuel and/or water has drained out, turn knob of meter drain valve (9) to right to closed position.

GO TO FRAME 4

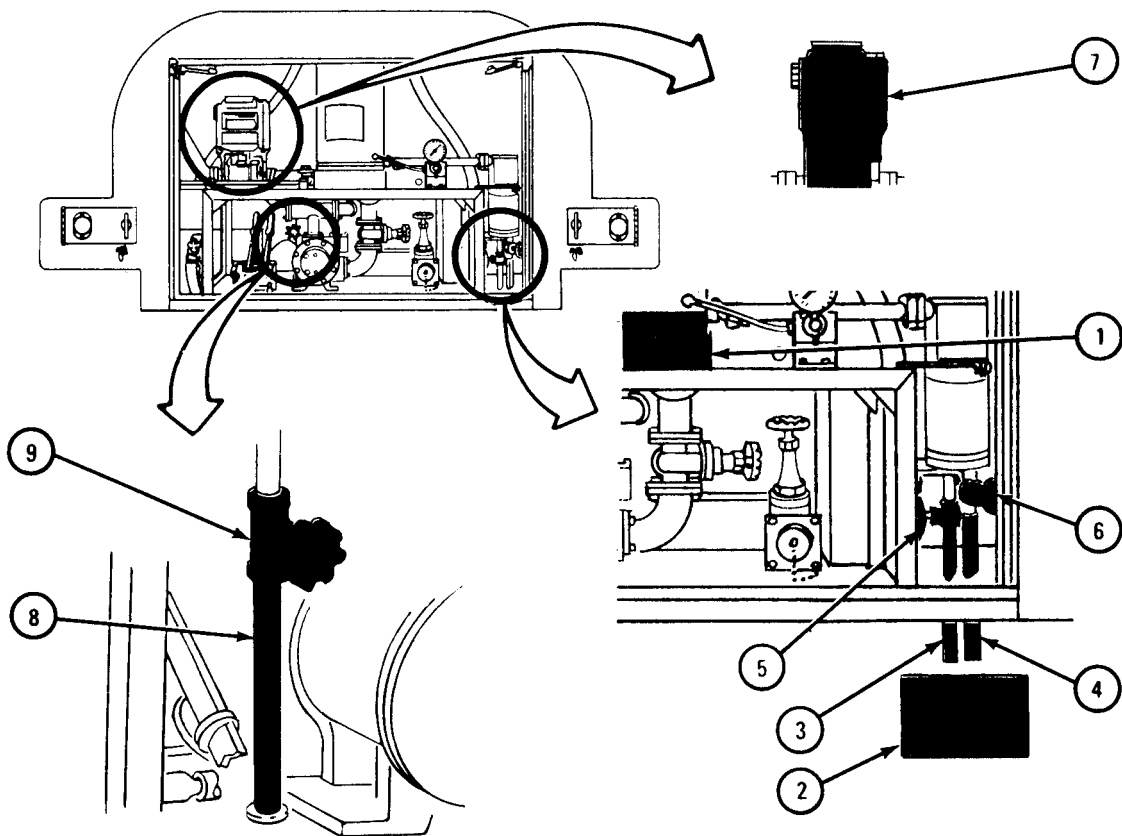

TA 084646

FRAME 4

1. To drain delivery pump (1):
  - (a) Place container (2) under truck, and under delivery pump (1).
  - (b) For M49A2C trucks turn drain valve (3) left to open position.
  - (c) For M49A1C trucks, using ratchet wrench and straight bar plug wrench, turn plug (4) left to loosen and take it out.
  - (d) Turn pump delivery line gate valve (5) left to open position.
  - (e) Let fuel and/or water drain into container.
  - (f) For M49A2C trucks, turn drain valve (3) right to closed position.
  - (g) For M49A1C trucks, using ratchet wrench and straight bar plug wrench, screw drain plug (4) back into delivery pump (1).
  - (h) Turn pump delivery line gate valve (5) right to closed position.

GO TO FRAME 5

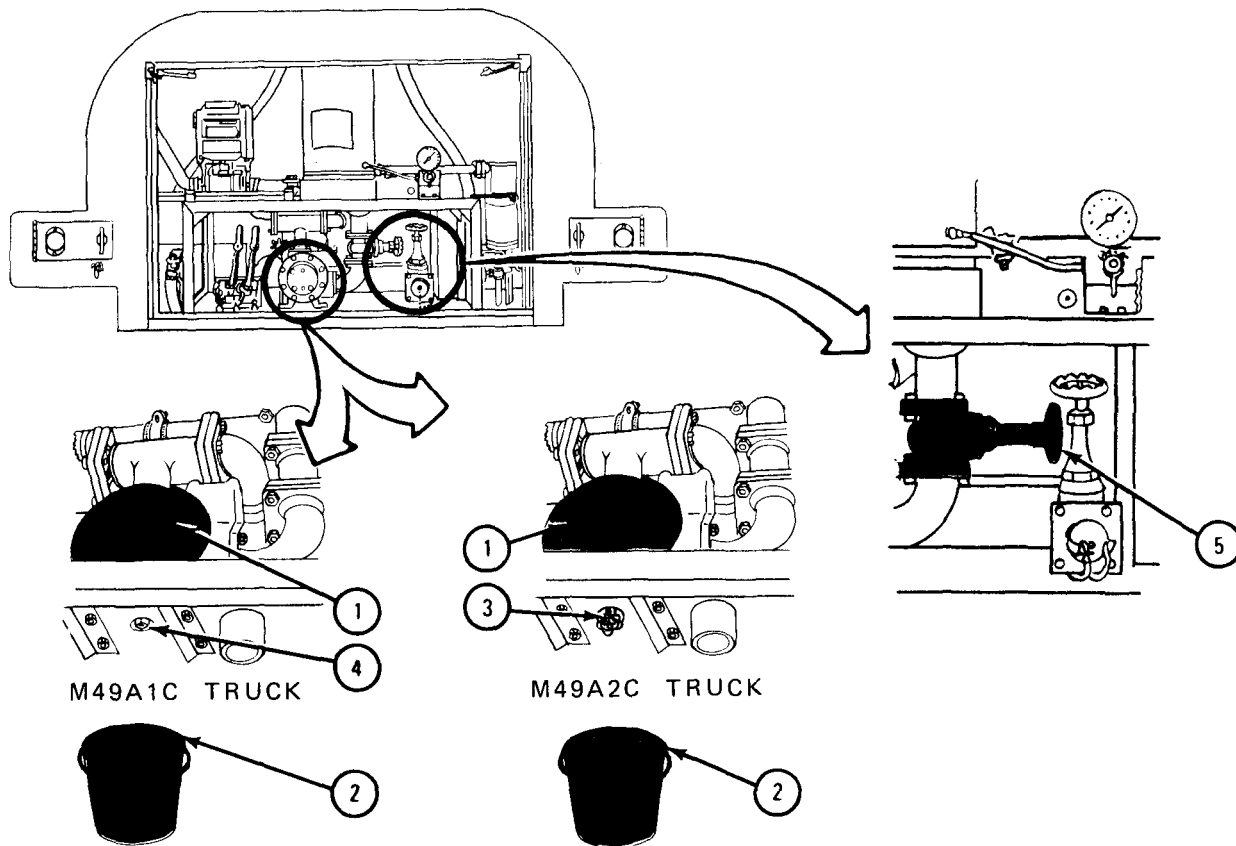

TA 084647



## FRAME 5

1. To drain manifold pipes (1):
  - (a) Place delivery line (2) on gravity delivery line gate valve (3). (Refer to para 4-9 f.)
  - (b) Check that discharge valve control levers (4) are in closed (forward) position.
  - (c) Turn left and open gravity delivery line gate valve (3).
  - (d) Let water and fuel drain from manifold pipes (1) into container (5).
  - (e) Turn right and close gravity delivery line gate valve (3).
  - (f) Take delivery line (2) from gravity delivery line gate valve (3). (Refer to para 4-9 f.)
  - (g) Unclip ground wire (6) and let it rewind on reel.
  - (h) Close rear compartment doors (7).

**CAUTION**

Authorized procedures must be used to get rid of the fuel drained into the container.

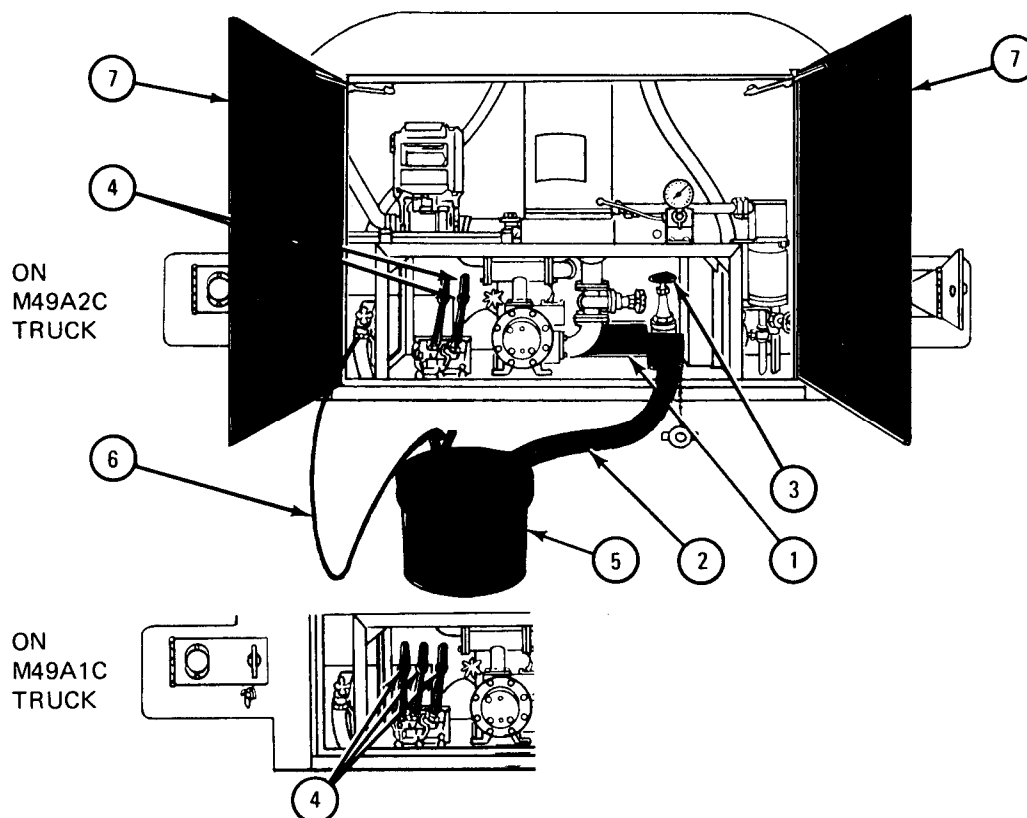

TA 084648

4-10. OPERATION OF WATER TANK TRUCKS.

a. General. Water tank trucks covered in this manual are equipped with a 400-gallon front tank and a 600-gallon rear tank for a total payload capacity of 1,000 gallons when operating on smooth roads. Payload capacity for off-the-road travel is 400-gallons in rear compartment.

**CAUTION**

Sanitary precautions must be observed at all times, when handling water and equipment, to keep water clean.

At freezing temperatures, delivery pump must be run 60 seconds, with delivery line gate valves open, to drain manifold pipes and delivery pump dry. Water in system could freeze up and cause damage to components.

b. Gravity Filling the Tank Sections.

TOOLS: Stick gages

FRAME 1

1. Start engine. (Refer to para 4-6b. )
2. Place truck near filling device or filling hose.
3. Place FRONT TRANSMISSION gearshift lever in N position.
4. Put handbrake lever in on (up) position.
5. Stop engine. (Refer to para 4-6e.)
6. Take off padlock (1), lift cover clamp (2) and open cover (3).
7. Open rear compartment doors (4).

GO TO FRAME 2

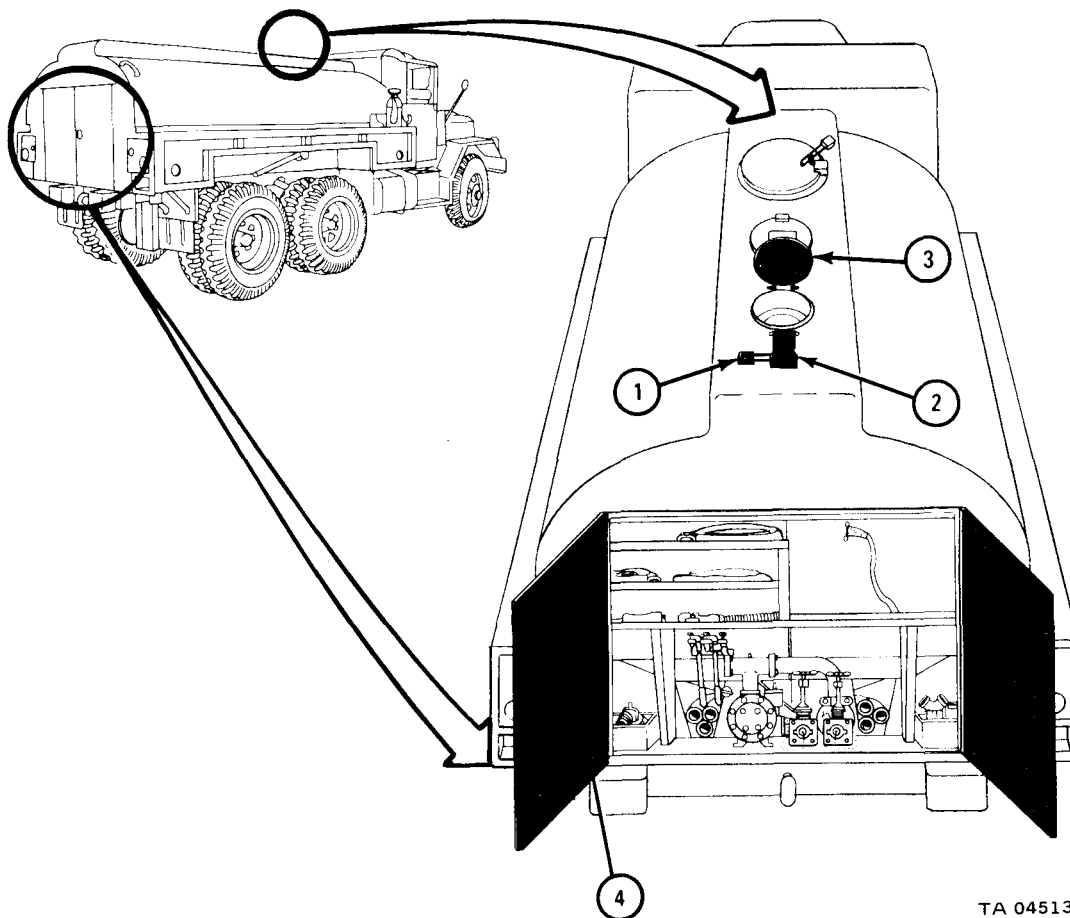

FRAME 2

1. Turn right and close pump delivery line discharge valve (1) and gravity delivery line suction valve (2).
2. Make sure that 400 gallon compartment valve and 600 gallon compartment valve levers (3) are in closed position (toward front of truck).

GO TO FRAME 3

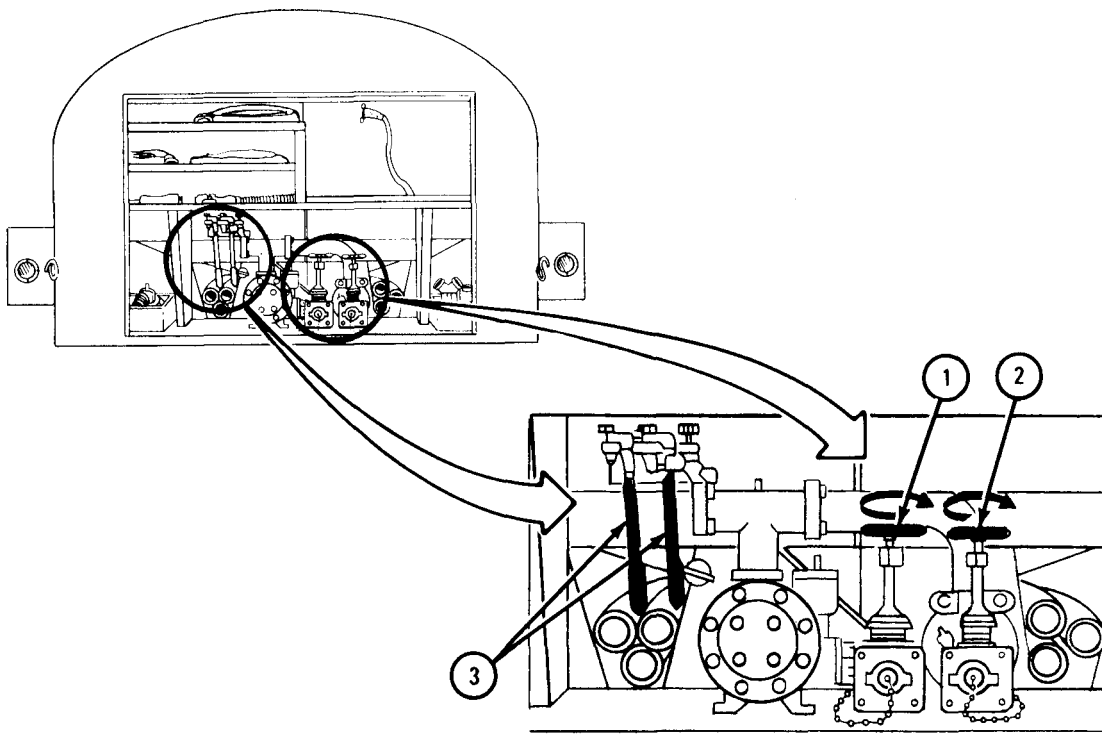

TA 045132

FRAME 3

1. Place nozzle (1) into filler hole. Press operating lever (2) to let water into tank section.
  2. Take water level gages (3) and (4) out of rear compartment.
  3. Check water level using gage (3) for rear section and gage (4) for front section.
- GO TO FRAME 4

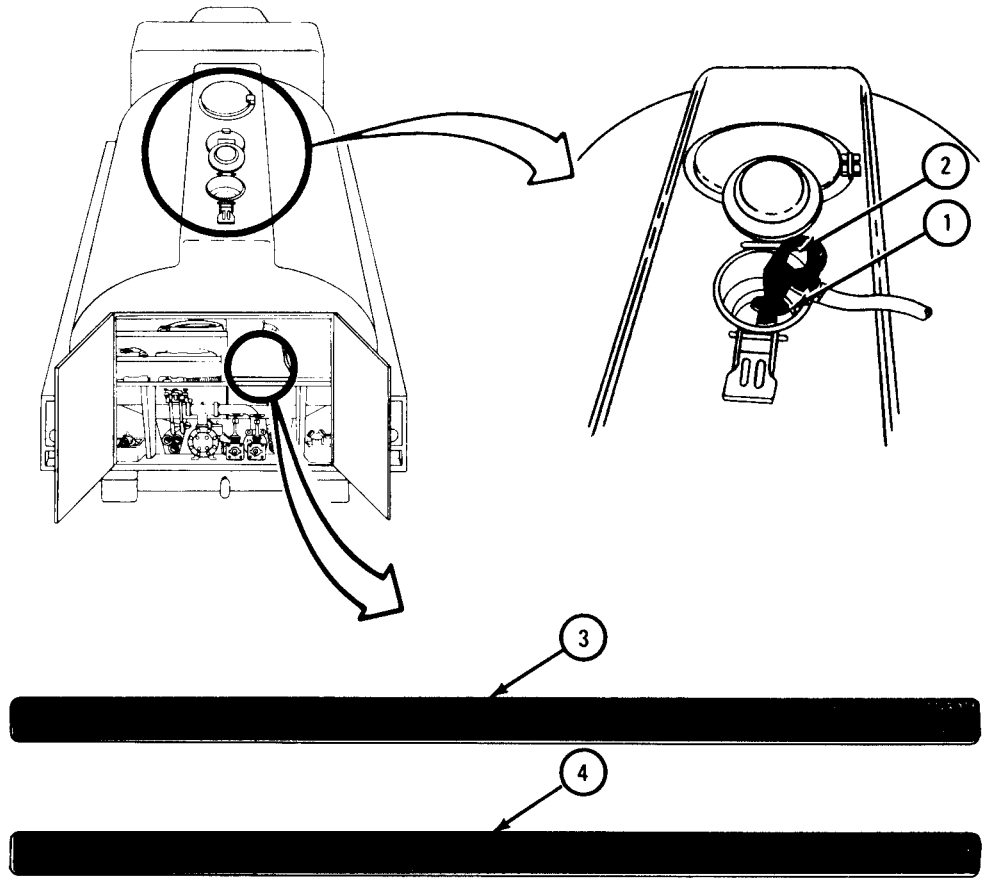

TA 045133

FRAME 4

1. After filling each section as needed, close filler cover (1). Lock it with cover clamp (2). Put on padlock (3).
2. Put water level gages (4 and 5) back in rear compartment.
3. Close rear compartment doors (6).

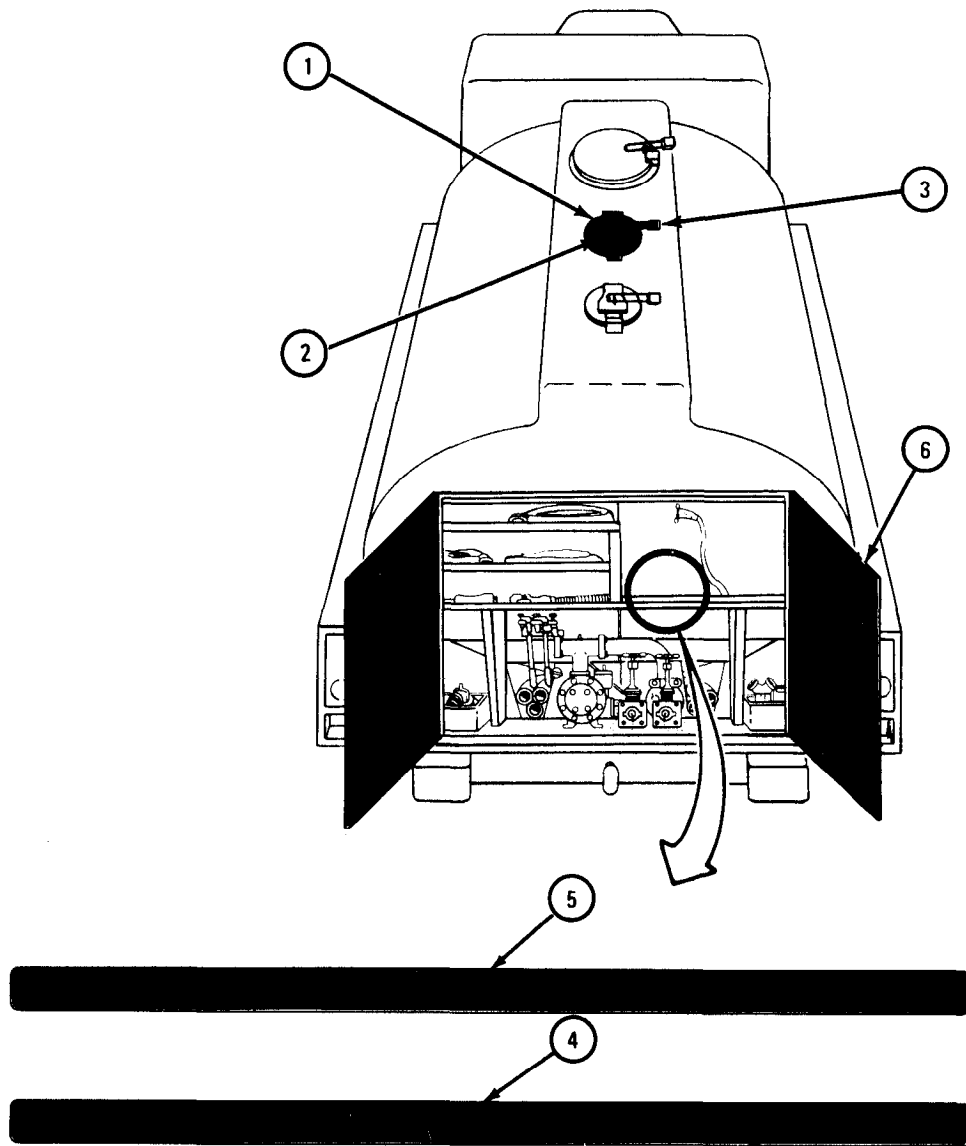

TA 045134

c. Suction Filling the Tank Sections and Transferring Water from One Location to Another.

TOOLS: 1 1/2-inch spanner wrench

## FRAME 1

1. Start engine. (Refer to para 4-6b.)
2. Place truck near water source.
3. Place FRONT TRANSMISSION gearshift lever in position N.
4. Pull handbrake lever to on (up) position.
5. Open rear compartment doors (1).
6. Turn left and take gravity delivery line suction valve dust cover (2) and pump delivery line discharge valve dust cover (3) off.

GO TO FRAME 2

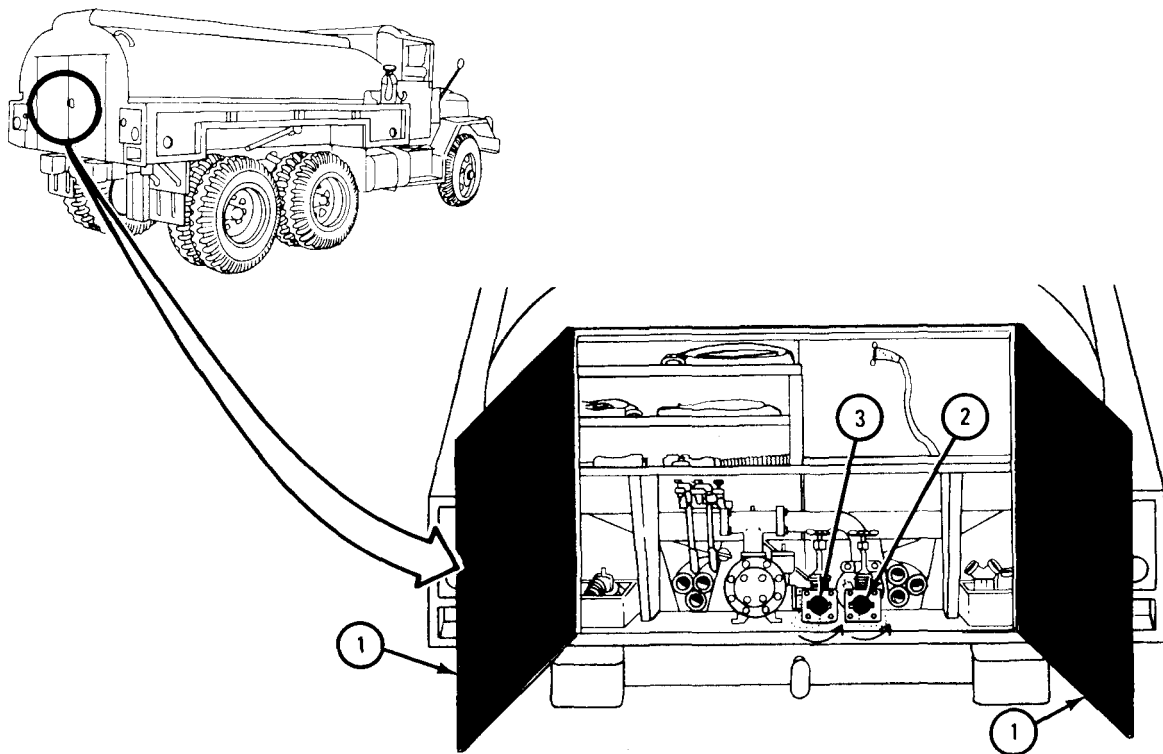

TA 045135

FRAME 2

1. Take suction hose (1) out of rear compartment (2).
2. Put one end of hose onto gravity delivery line suction valve (3). Using spanner wrench, turn hose (1) to right to tighten.
3. Take strainer (4) from rear compartment, put it onto other end of hose (1). Using spanner wrench, turn strainer to right to tighten.
4. Place strainer end of hose (1) into water source.

GO TO FRAME 3

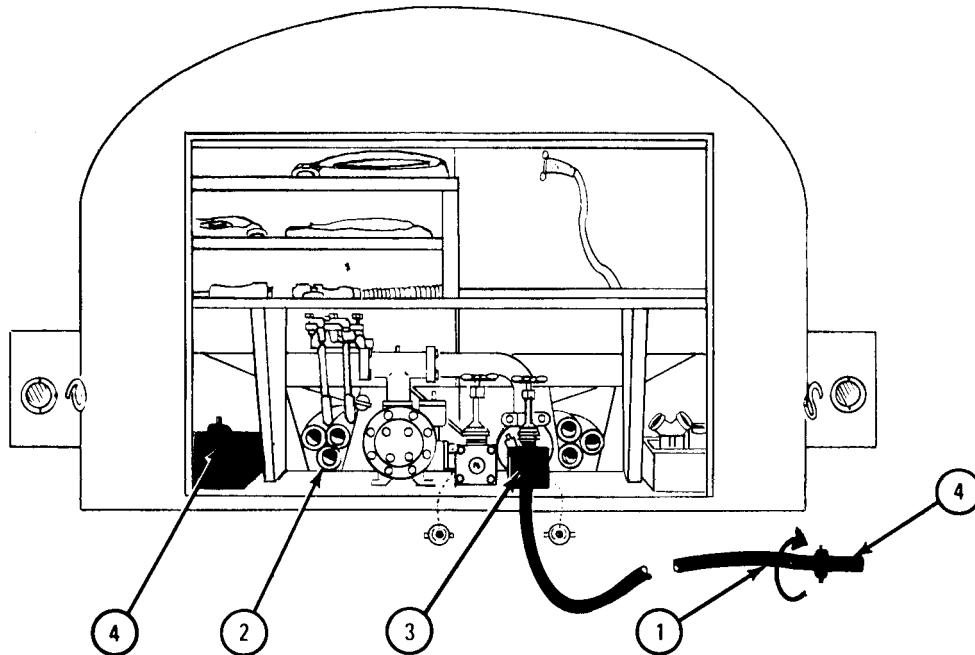

TA 045136



## FRAME 3

1. Take 1 1/2 x 2-inch reducer coupling (1) from rear compartment (2).
2. Put coupling (1) onto pump delivery line discharge valve adapter (3).
3. Using spanner wrench, turn coupling (1) to right to tighten.

GO TO FRAME 4

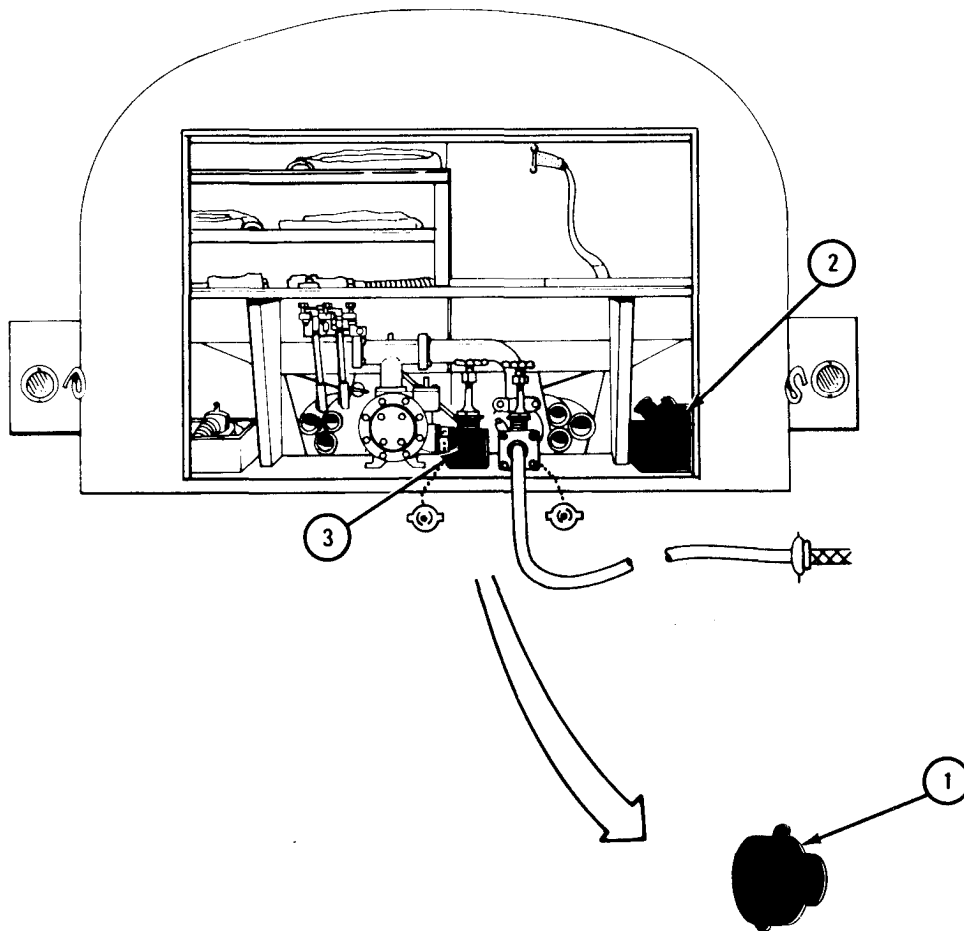

TA 045137

FRAME 4

1. Take discharge hose (1) from left side of rear compartment (2).
  2. Put one end of hose onto reducer coupling (3).
  3. Using spanner wrench, turn reducer coupling (3) to right to tighten.
- GO TO FRAME 5

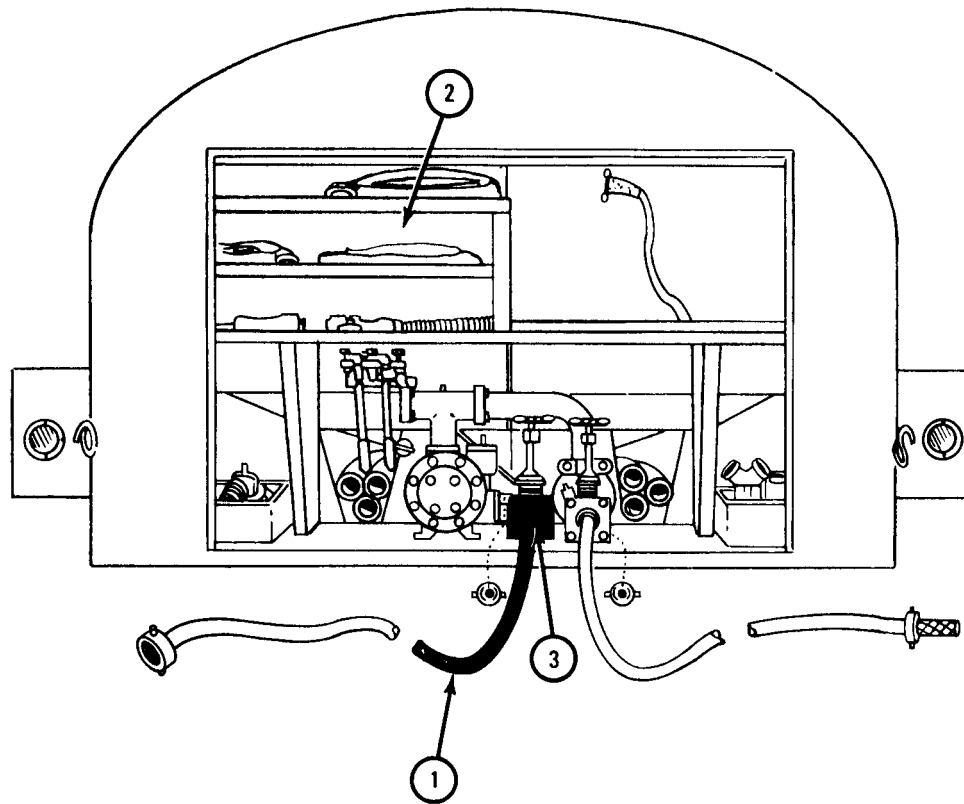

TA 045138

## FRAME 5

1. Take discharge nozzle (1) from rear compartment (2), place it onto end of discharge hose (3).
2. Using spanner wrench, turn discharge nozzle (1) to right to tighten.

GO TO FRAME 6

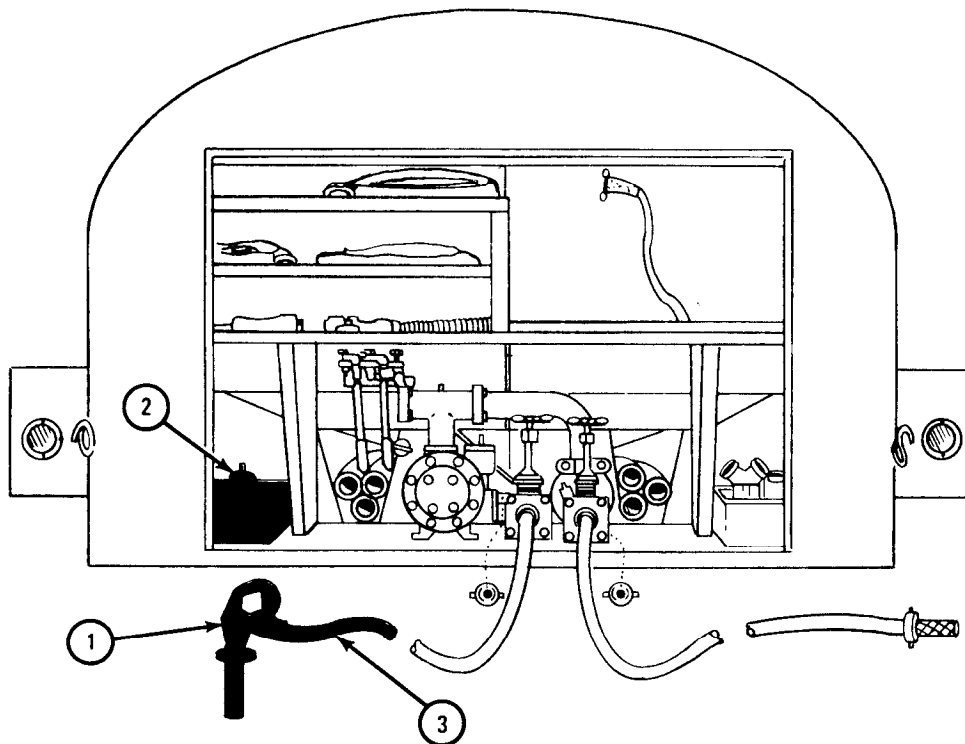

TA 045139

FRAME 6

1. Turn gravity delivery line suction valve knob (1) and pump delivery line discharge valve knob (2) left, to open position.
2. Make sure that 400 gallon and 600 gallon compartment valve levers (3) are in closed position (toward front of truck).

GO TO FRAME 7

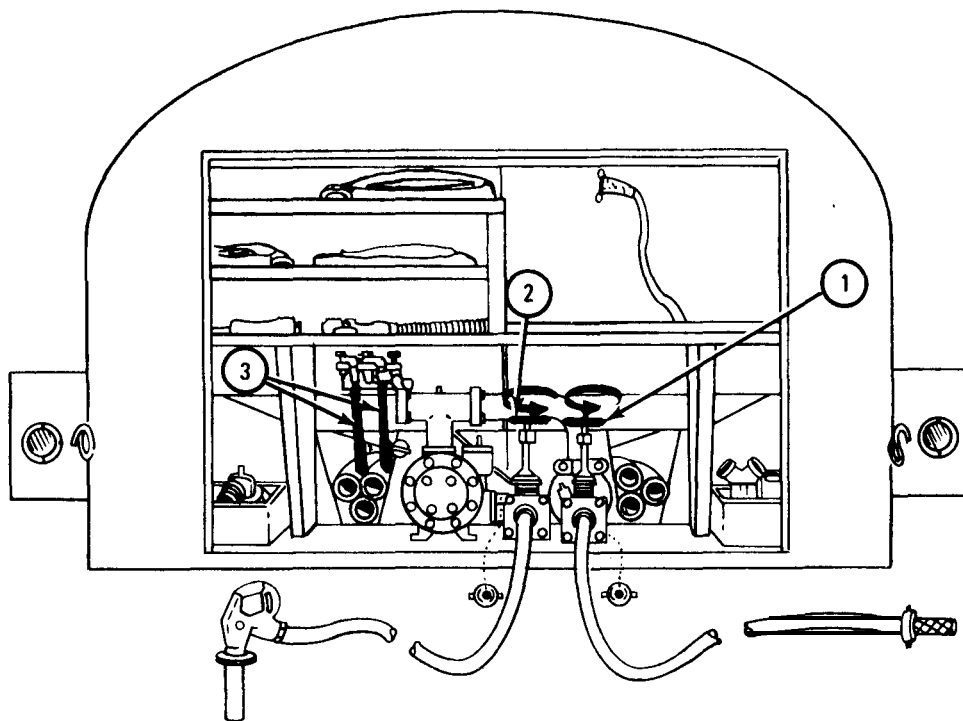

TA 045140

## FRAME 7

1. Press clutch pedal (1) all the way down.
2. Place TRANSFER CASE shift lever (2) in middle (neutral) position.
3. Turn locking bar (3) down and move transfer POWER TAKEOFF LEVER (4) to ENGAGE (on) POSITION (toward rear of truck).
4. Place FRONT TRANSMISSION gearshift lever (5) in position 2, and let clutch pedal (1) up slowly.
5. Pull hand THROTTLE (6) out all the way slowly.

GO TO FRAME 8 to suction fill tanks.

GO TO FRAME 10 to transfer water from one place to another.

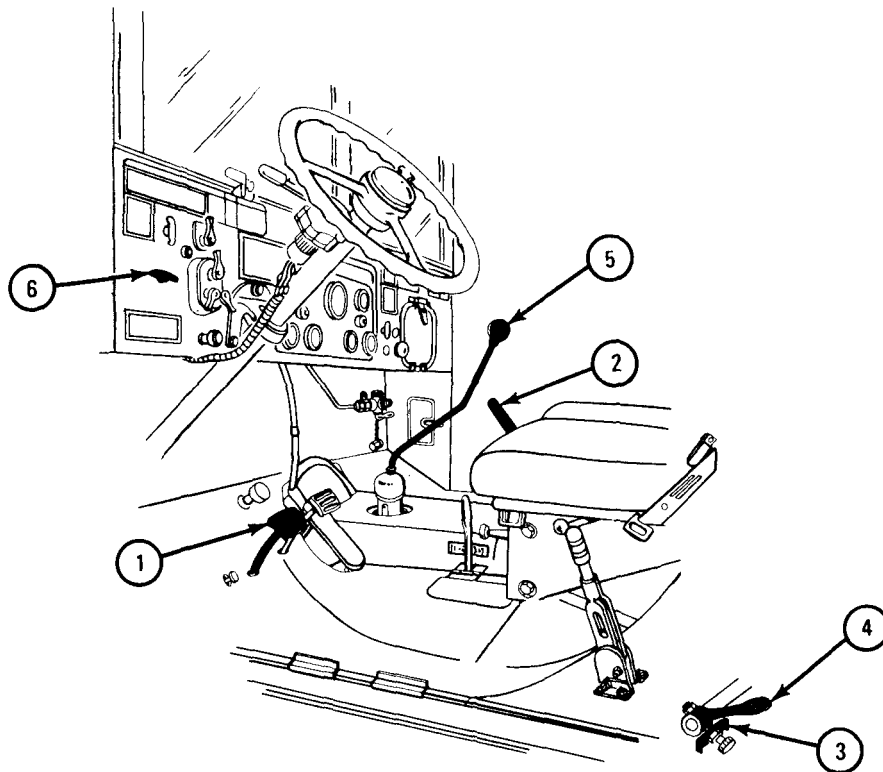

TA 045141

FRAME 8

1. To suction fill tank sections:
  - (a) Take off padlock (1), lift cover clamp (2), and open filler cover (3) of tank section to be filled.
  - (b) Place nozzle (4) into filler hole, press operating lever (5), and fill tank with amount of water required.
  - (c) Use water level gage (6) (in rear compartment) to measure amount of water in rear section or water level gage (7) to measure amount of water in front section of tank.
  - (d) Refer to para 4-10a for payload capacity.

GO TO FRAME 9

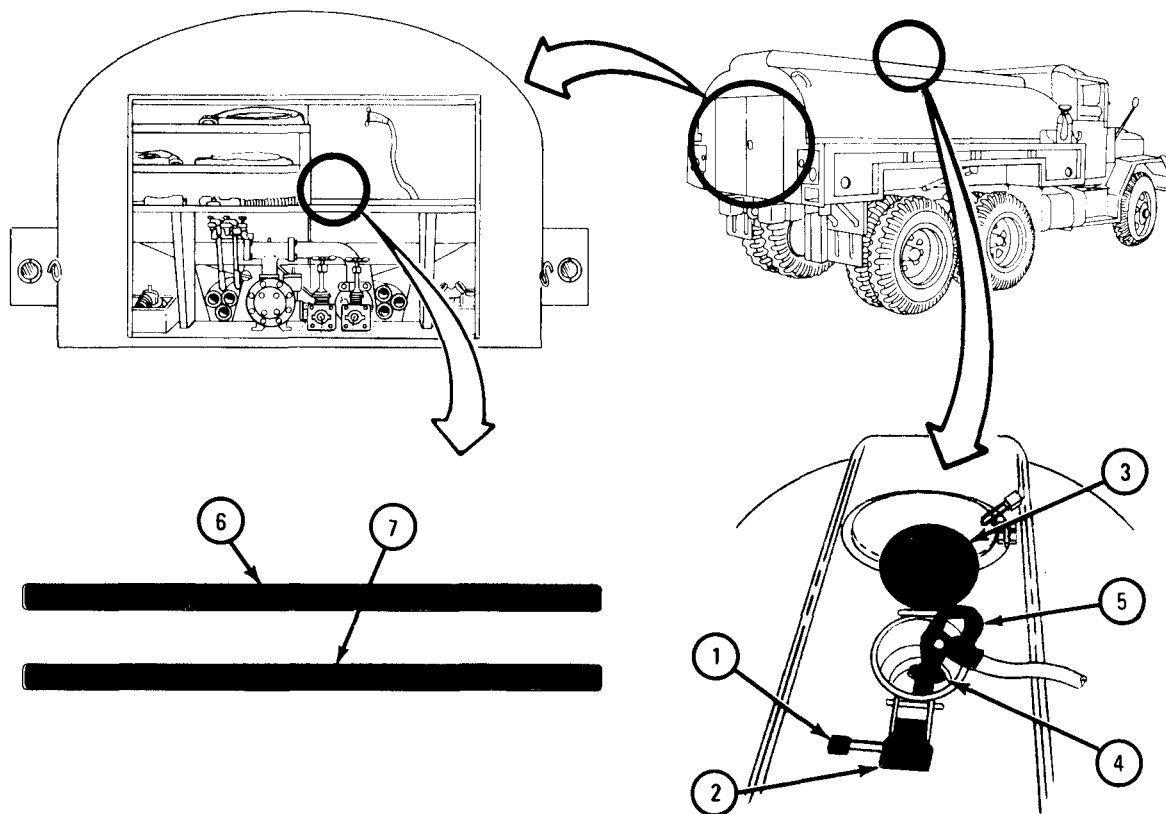

TA 045142

FRAME 9

1. After filling, take dispenser nozzle (1) out of filler hole and suction hose with strainer end (2) out of water source.
2. Close filler cover (3) and lock with cover clamp (4). Put on padlock (5).
3. Turn pump delivery line discharge valve knob (6) and gravity delivery line suction valve knob (7) right, to closed position.

TO TRANSFER WATER, IF NEEDED, GO TO FRAME 10

IF WATER TRANSFER IS NOT NEEDED GO TO FRAME 11

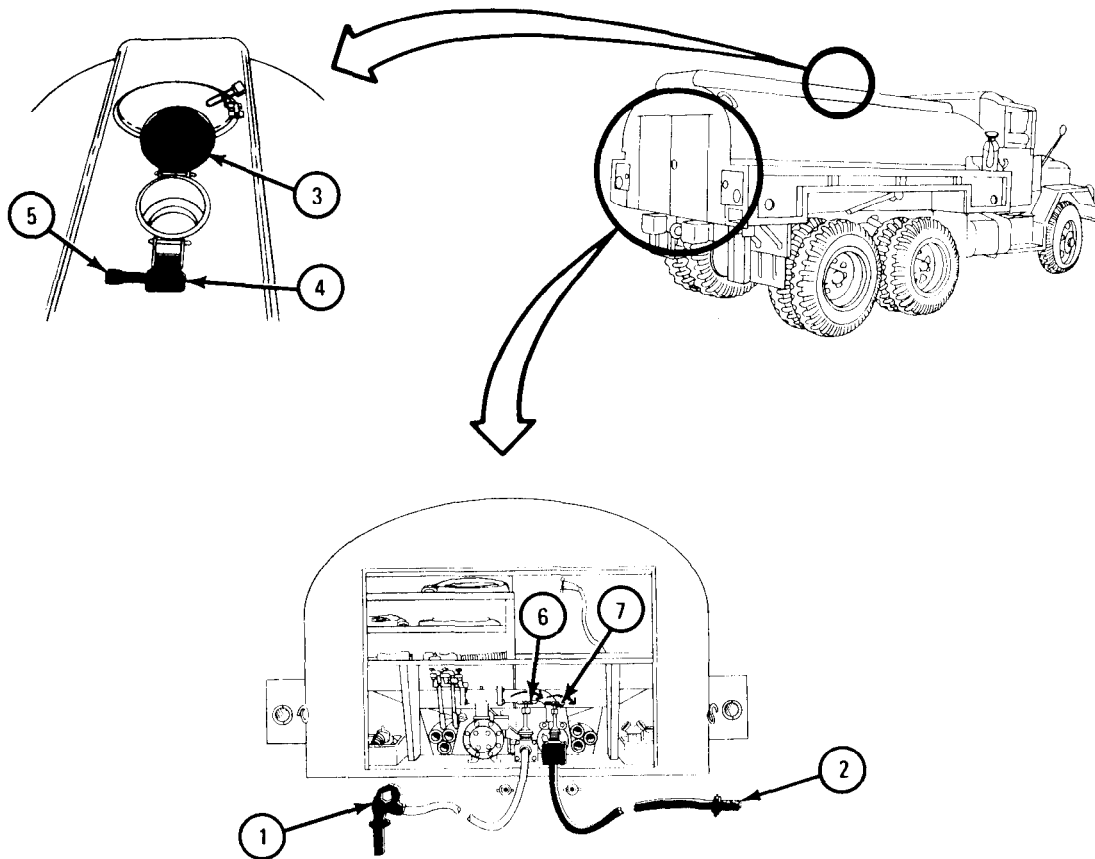

TA 045143

FRAME 10

1. To transfer water from one location to another:
  - (a) Place strainer end of suction hose (1) into source of water.
  - (b) Place dispenser nozzle (2) into water container (3) to be filled.
  - (c) Press dispenser handle operating lever (4) to let water flow.
  - (d) When water container (3) is full, take dispenser nozzle (2) out of container (3), and strainer end of suction hose (1) out of water source. Cover containers.

GO TO FRAME 11

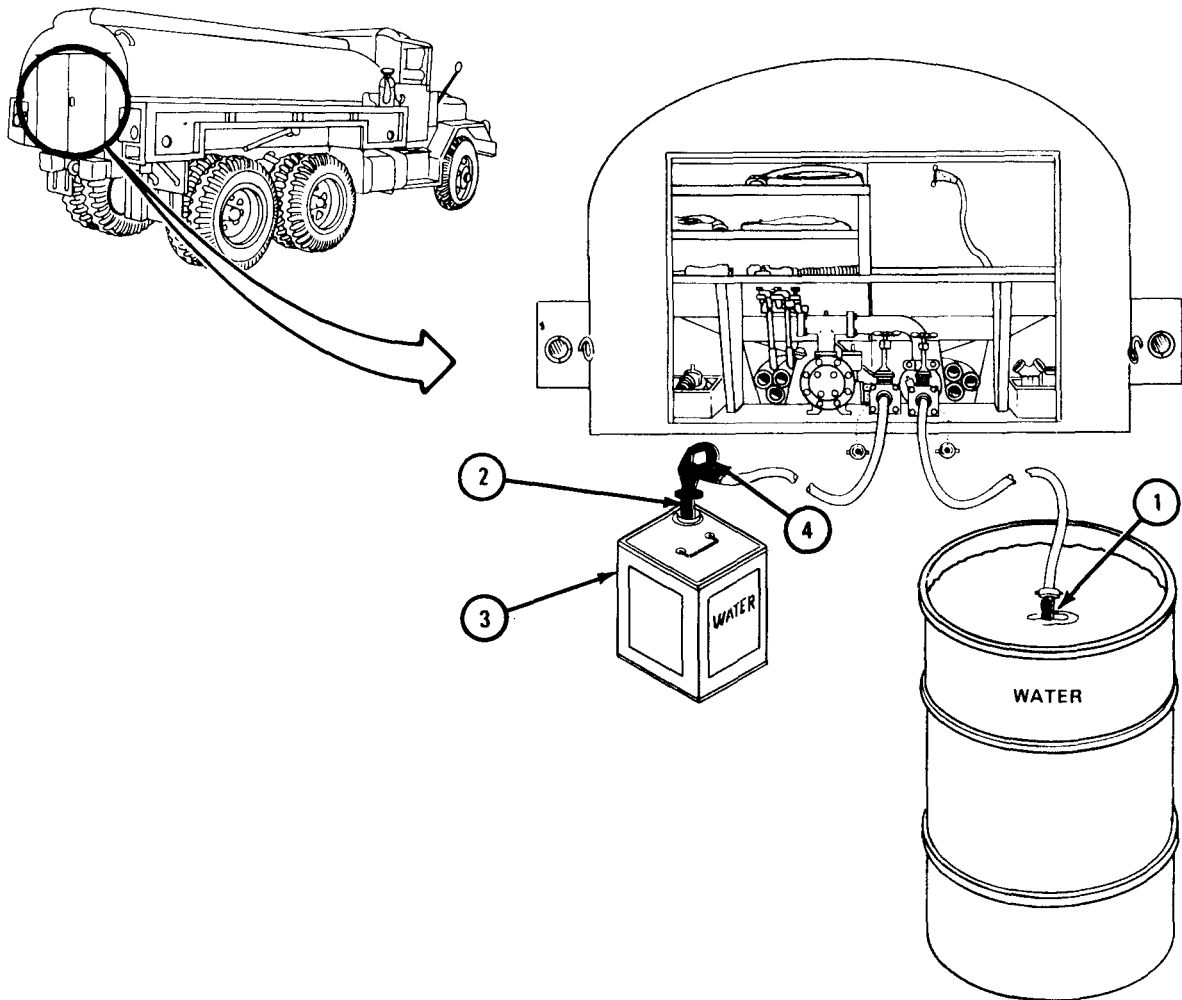

TA 045144



## FRAME 11

1. After filling tank sections or transferring water:
  - (a) Turn hand THROTTLE knob (1) and let it go back to closed position.
  - (b) Press clutch pedal (2) all the way down.
  - (c) Move transfer POWER TAKEOFF LEVER (3) forward to DISENGAGE (off) POSITION.
  - (d) Turn locking bar (4) up to lock position.
  - (e) Place FRONT TRANSMISSION gearshift lever (5) in N position and let clutch pedal (2) up slowly.
  - (f) Stop engine. (Refer to para 4-6e.)

GO TO FRAME 12

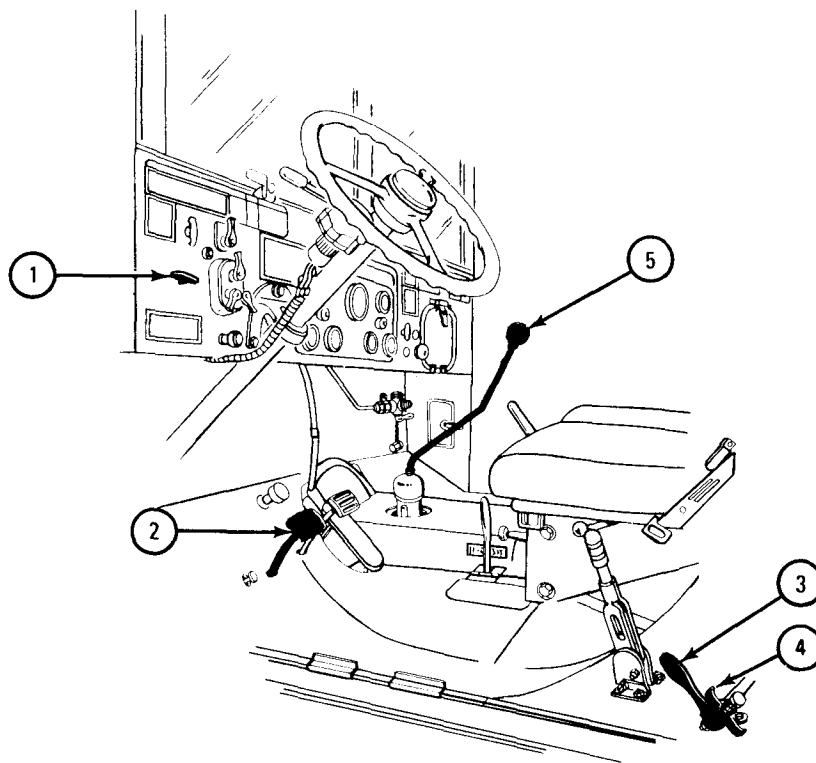

TA 045145

FRAME 12

1. Using spanner wrench, turn left and separate discharge nozzle (1) from end of hose (2).
2. Using spanner wrench, turn left and separate strainer (3) from end of hose (4).
3. Put strainer (3) and nozzle (1) back into place in rear compartment (5).

GO TO FRAME 13

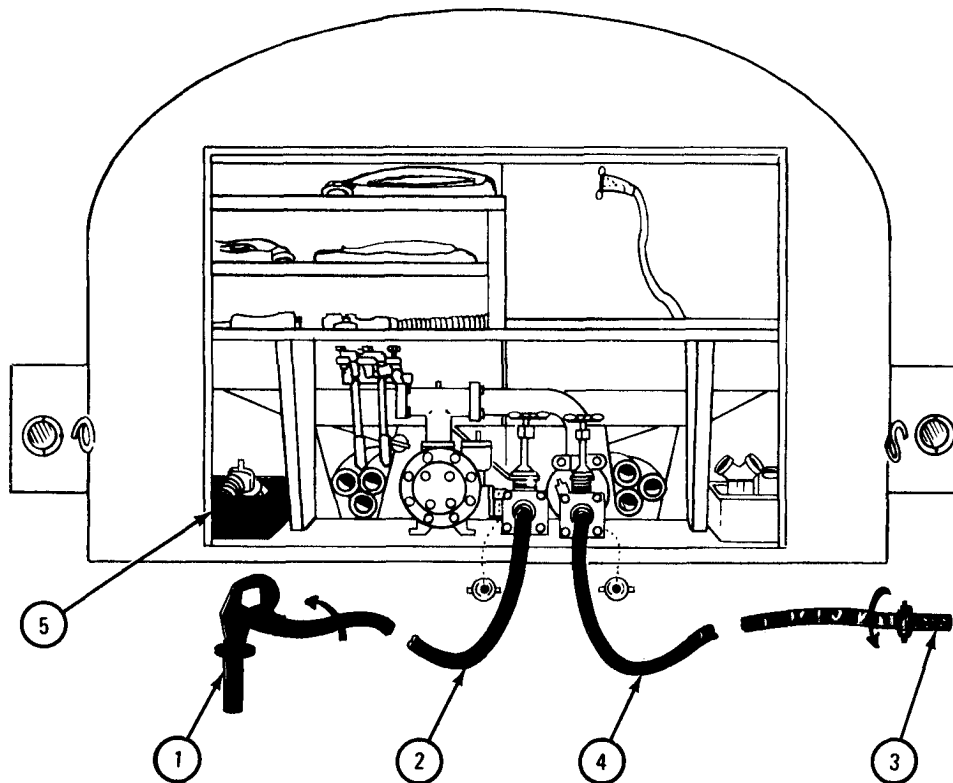

TA 045146

## FRAME 13

1. Using spanner wrench, turn left and separate hose (1) from gravity delivery line suction valve (2).
2. Using spanner wrench, turn left, and take discharge hose (3) from pump delivery line discharge valve (4).
3. Drain hoses and return to place in rear compartment (5).

GO TO FRAME 14

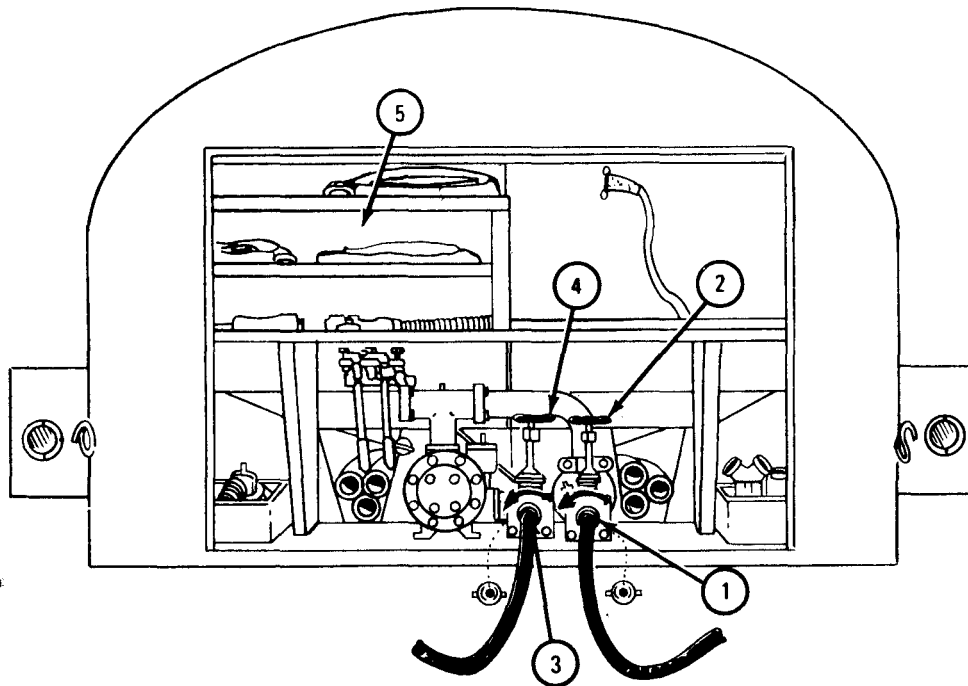

TA 045147

FRAME 14

1. Using spanner wrench, turn left and take coupling (1) from pump delivery line discharge valve (2).
2. Put coupling (1) back into place in rear compartment (3).
3. Put dust covers (4) onto pump delivery line discharge valve adapter (2) and gravity delivery line suction valve adapter (5). Turn right to tighten.
4. Close rear compartment doors (6).

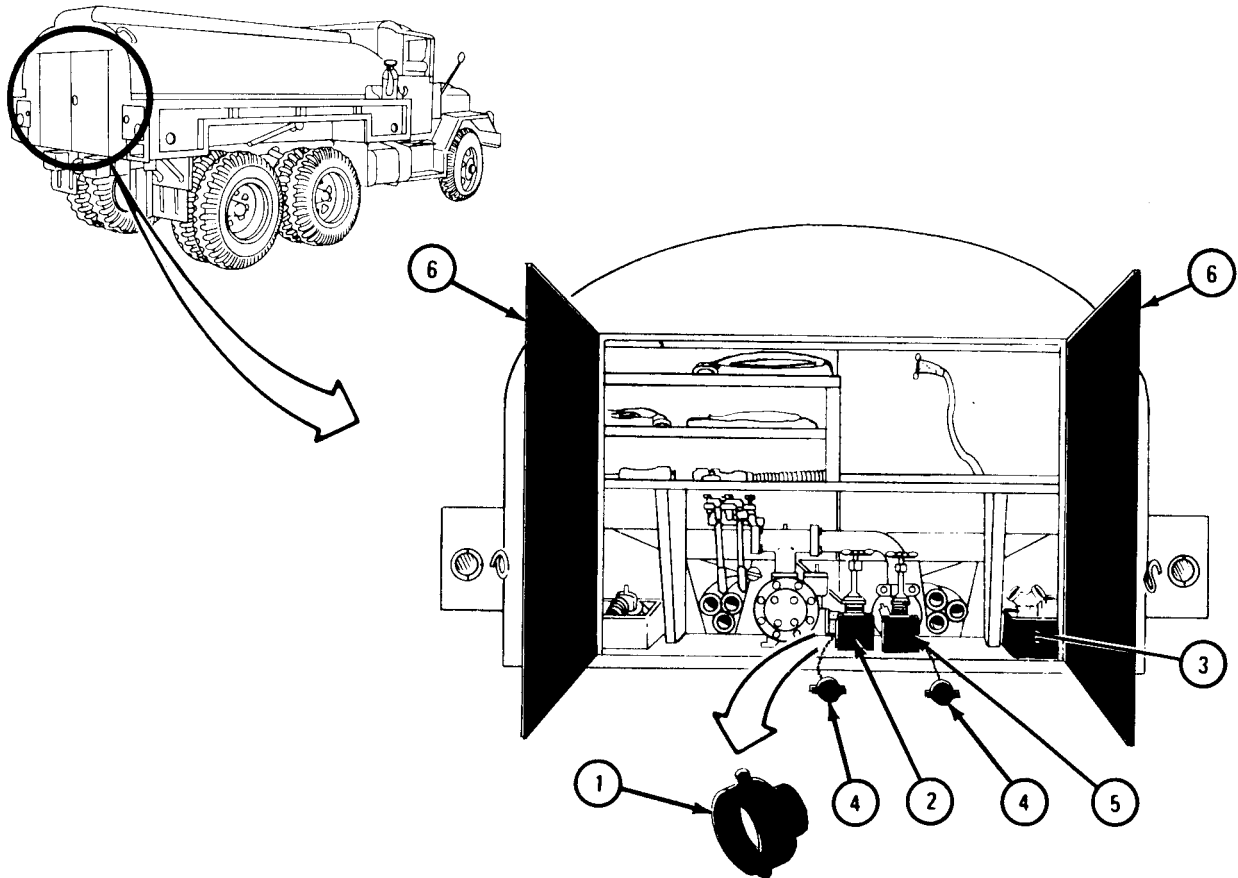

TA 045148

d. Hydrant Filling the Tank Sections.

TOOLS: Hydrant wrench  
2-inch spanner wrench

## FRAME 1

1. Start engine. (Refer to para 4-6b.)
2. Place truck near hydrant.
3. Stop engine. (Refer to para 4-6e.)
4. Place FRONT TRANSMISSION gearshift lever in N position.
5. Put handbrake lever up (on) position.
6. Take off padlock (1), lift cover clamp (2), and open cover (3).
7. Open rear compartment doors (4).

GO TO FRAME 2

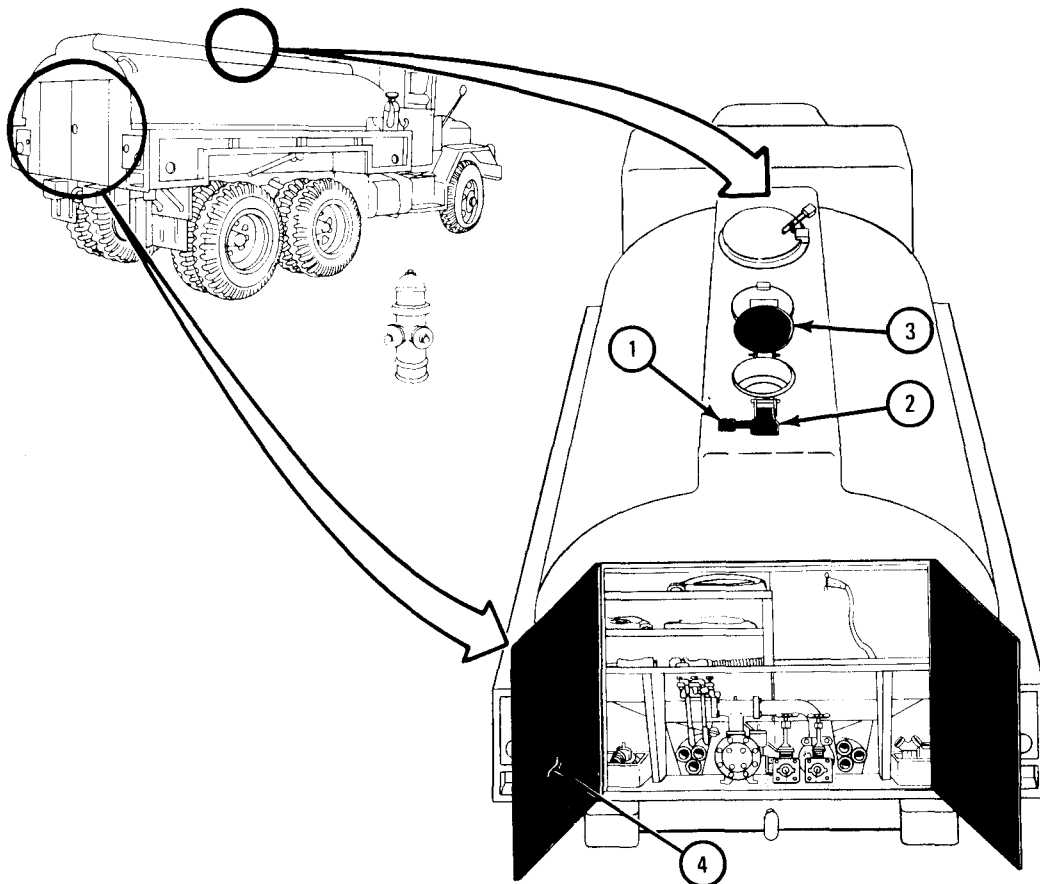

TA 045149

FRAME 2

1. Take hydrant wrench (1) from rear compartment.
  2. Place wrench on hydrant cap (2), turn wrench to left, and take cap off,
- GO TO FRAME 3

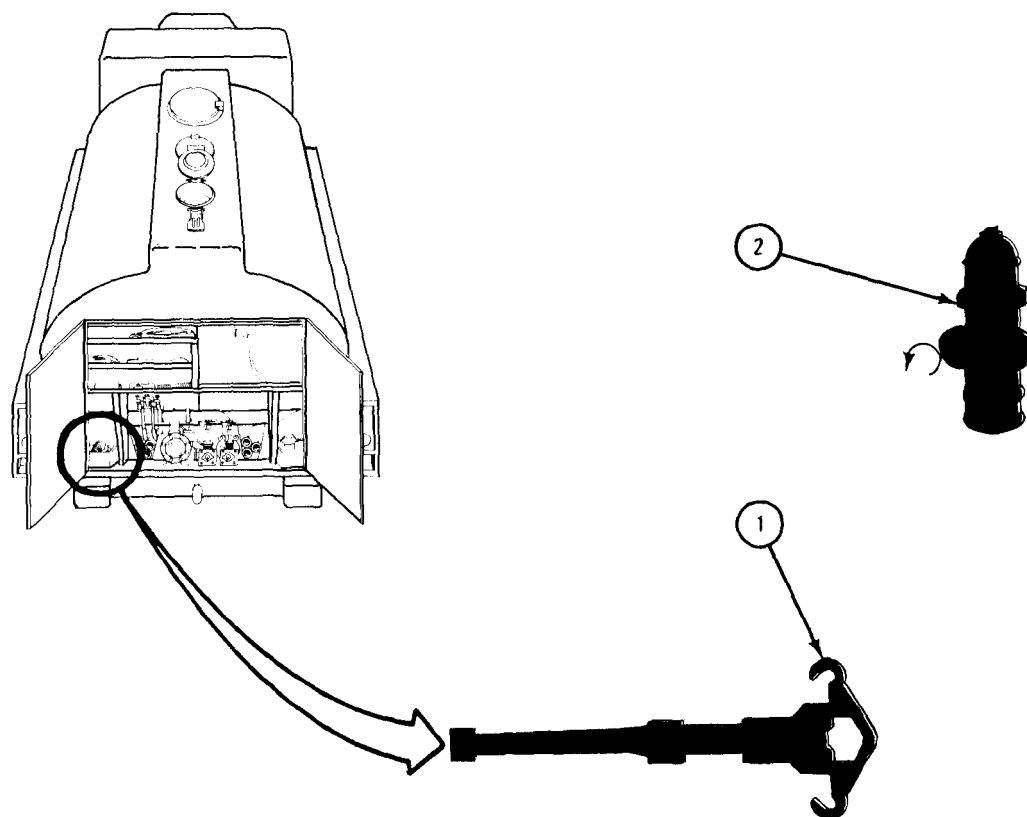

TA 045150

## FRAME 3

1. Take 2 1/2 x 1 1/2-inch reducer coupling (1) from rear compartment.
2. Put reducer coupling onto hydrant threads, turn right, and tighten with 2-inch spanner wrench.

GO TO FRAME 4

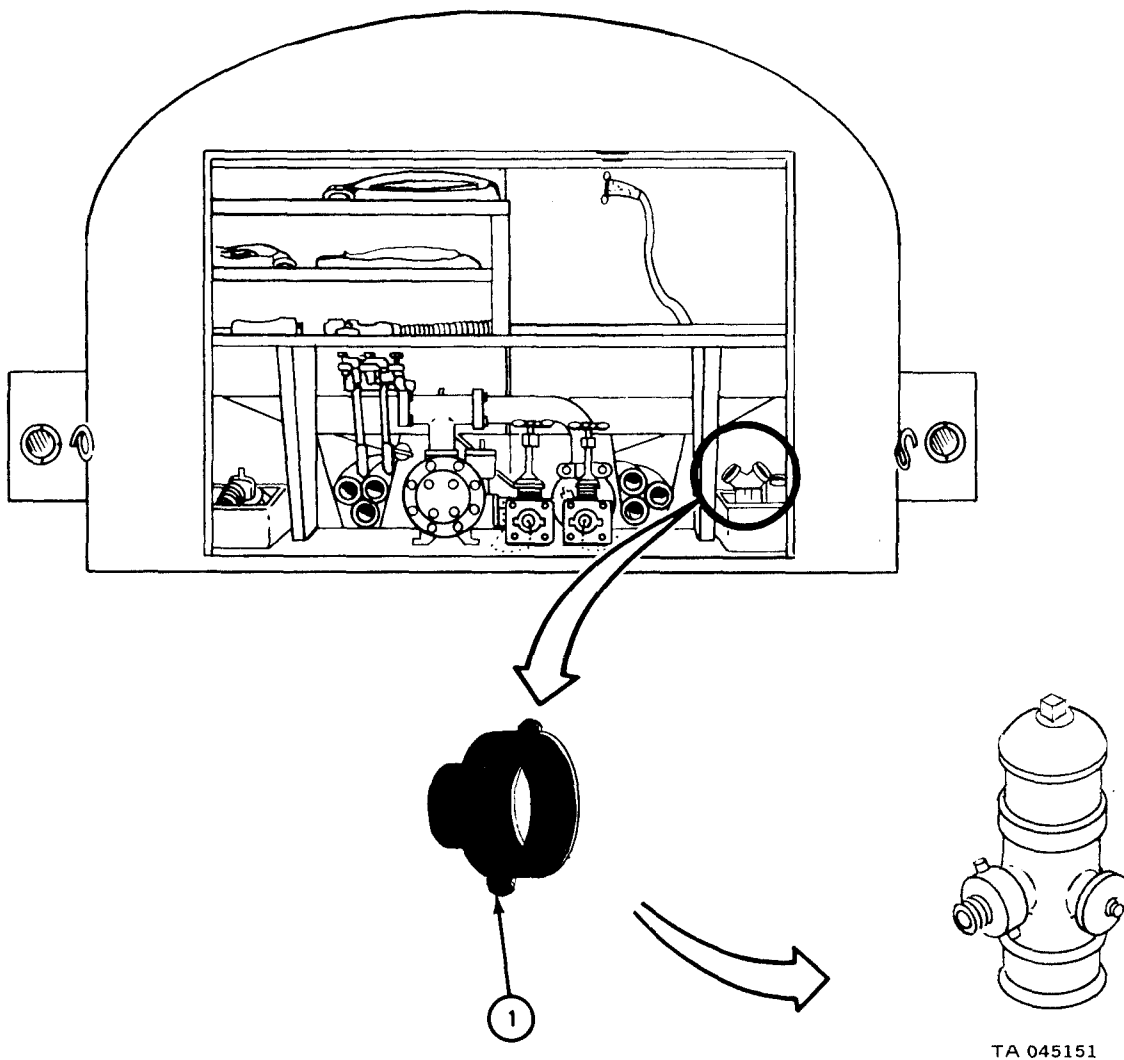

FRAME 4

1. Take discharge hose (1) from rear compartment.
2. Put one end of hose onto coupling (2), turn right, and use spanner wrench to tighten.
3. Take discharge nozzle (3) from rear compartment, put it onto other end of hose (1), turn right, and use spanner wrench to tighten.

GO TO FRAME 5

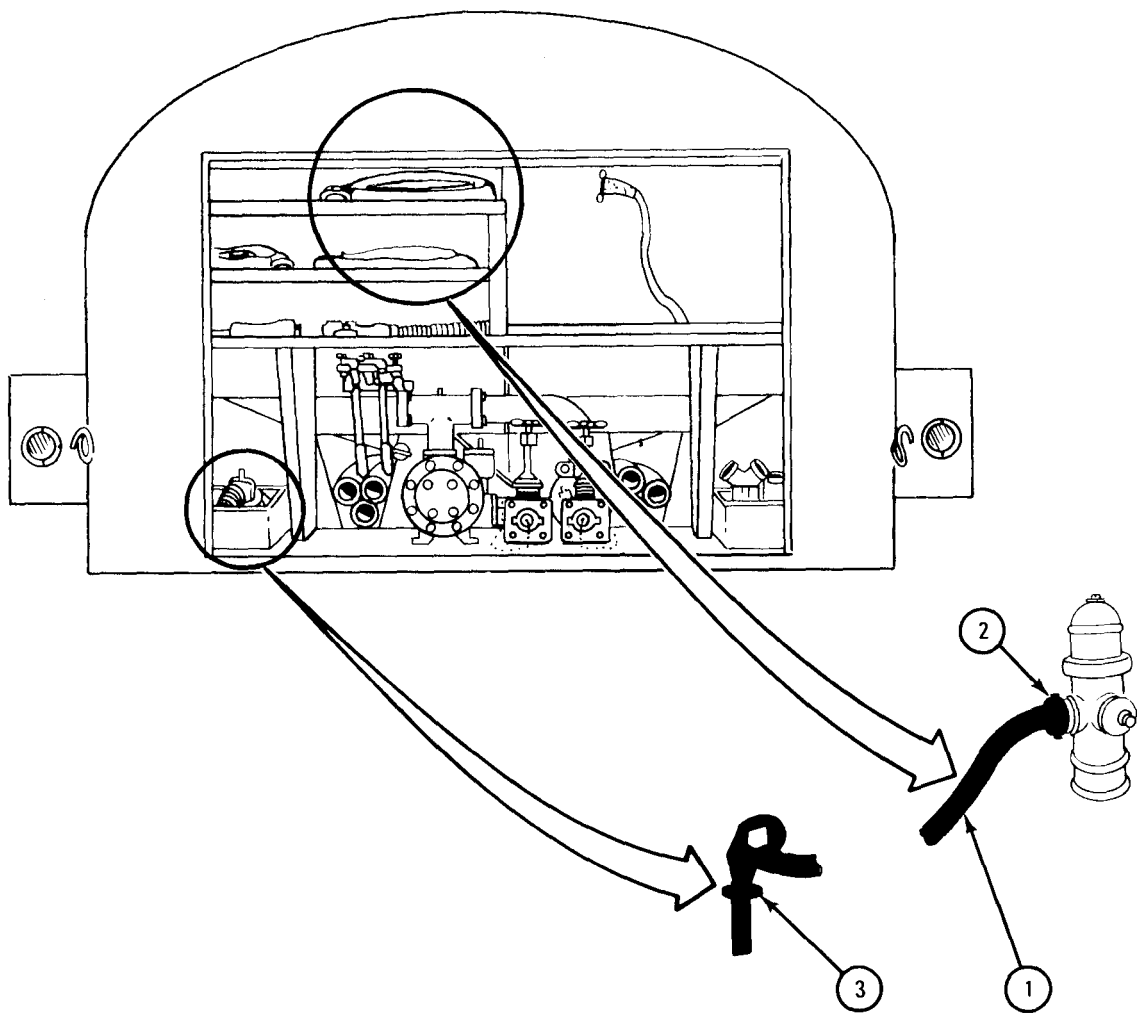

TA 045152



FRAME 5

1. Make sure that 400 gallon and 600 gallon compartment valve levers (1) are in closed position (toward front of truck).
2. Make sure that pump delivery line discharge and gravity delivery line suction valves (2) are in closed position (turn knob right to close).

GO TO FRAME 6

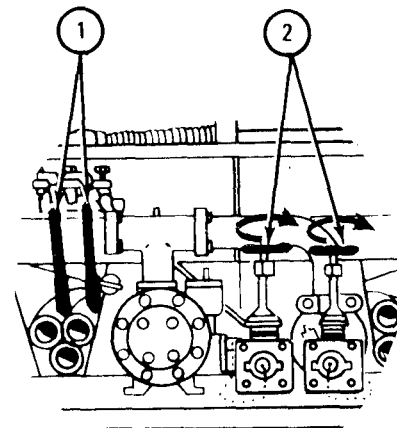
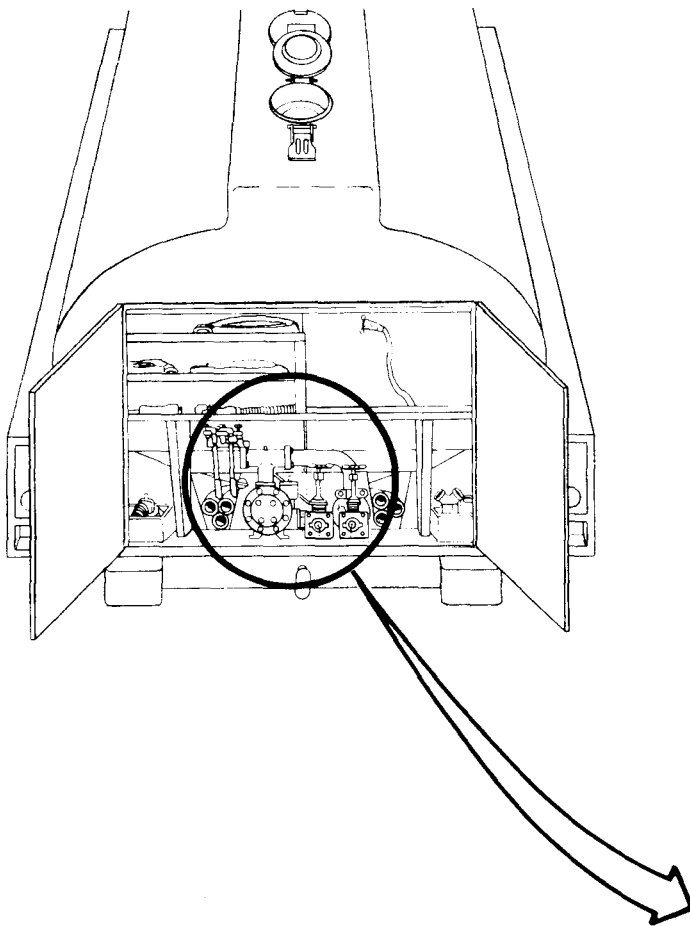

TA 045153

FRAME 6

1. Place hydrant wrench (1) on hydrant valve (2) and turn in direction of arrows to open.

GO TO FRAME 7

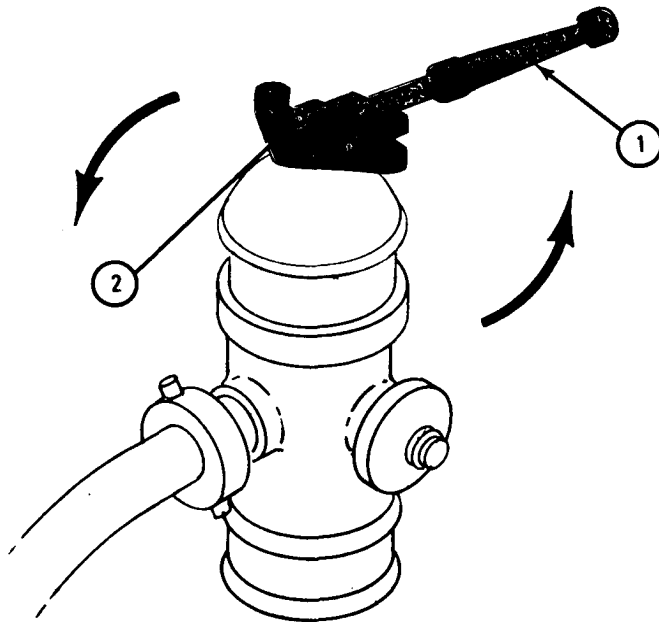

TA 045154

## FRAME 7

1. Put nozzle (1) into tank section to refilled.
2. Press operating lever (2) to let water flow into tank.
3. Check water level in tank with water level gages (3 and 4) found in rear compartment. Use gage (3) for front tank, and gage (4) for rear tank.
4. Refer to para 4-10a for payload data.

GO TO FRAME 8

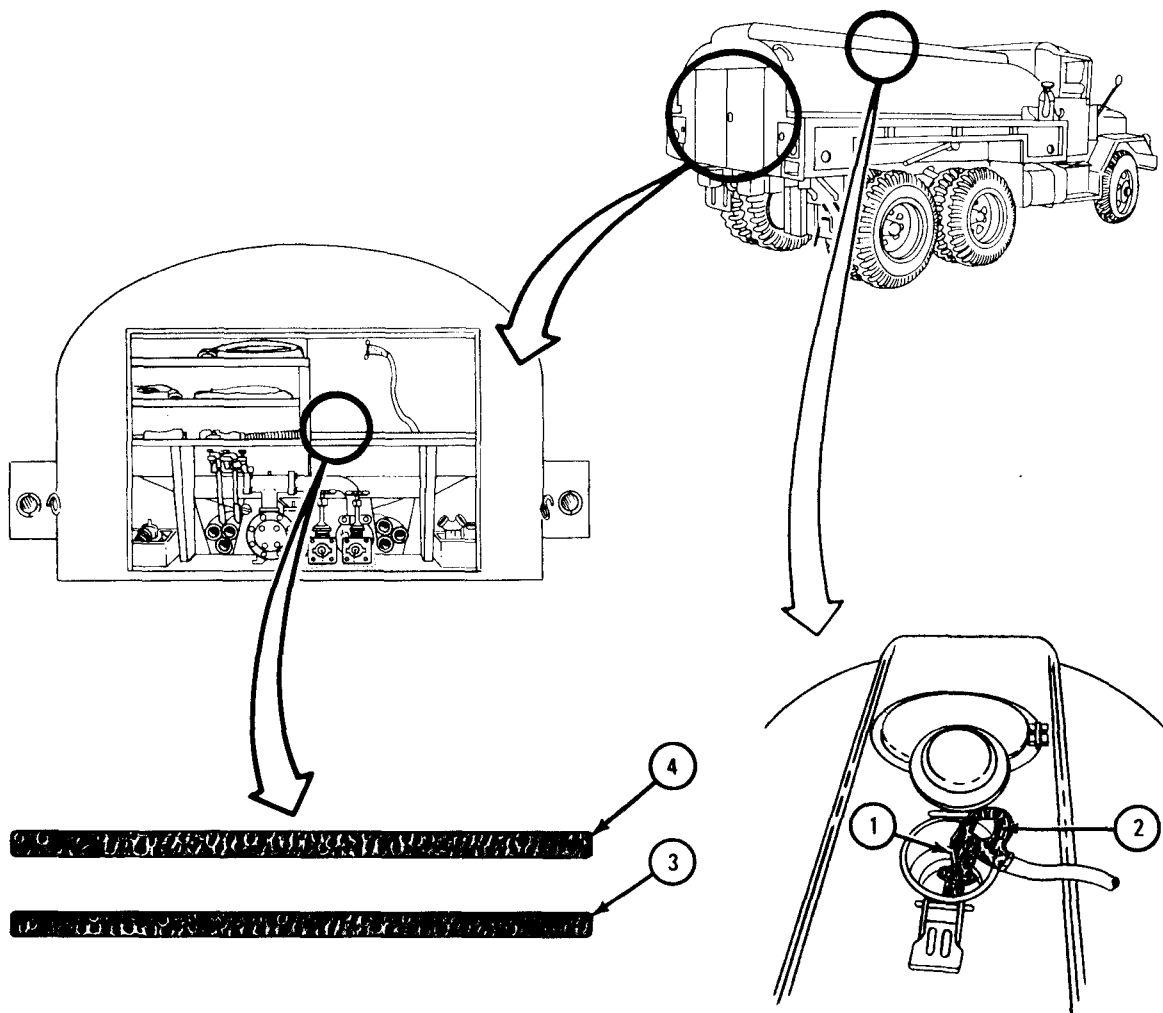

TA 045155

FRAME 8

1. After filling tank section, take dispenser nozzle (1) out of tank.
2. Close filler cover (2) and lock with clamp (3). Put on padlock (4).

GO TO FRAME 9

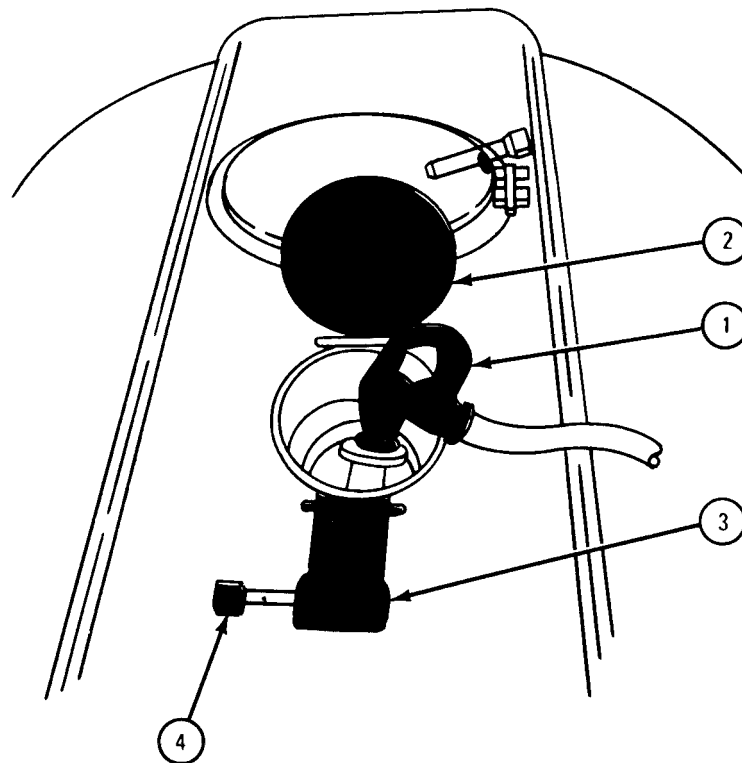

TA 045156

## FRAME 9

1. Place hydrant wrench (1) on hydrant valve (2) and turn in direction of arrows to close valve.

GO TO FRAME 10

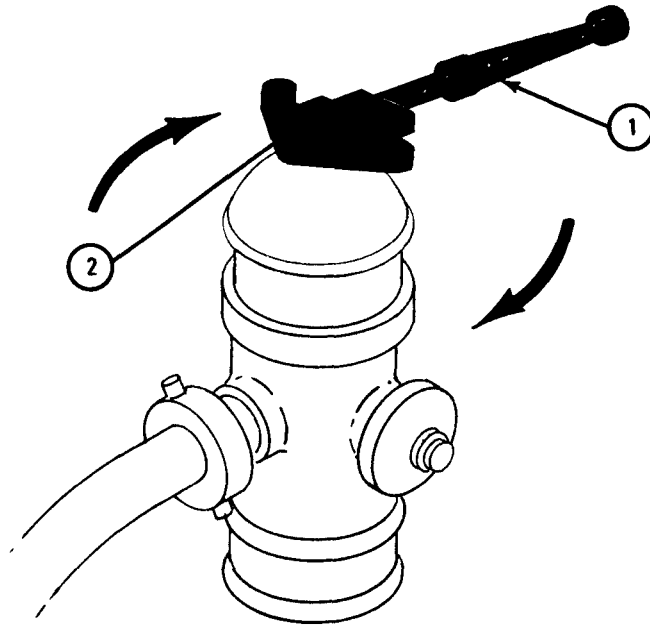

TA 045157

FRAME 10

1. Press nozzle operating lever (1) to relieve pressure.
2. Using spanner wrench, loosen and then separate the following:
  - (a) Nozzle (2) from hose (3).
  - (b) Hose (3) from reducer coupling (4).
  - (c) Reducer coupling (4) from hydrant (5).
3. Put hydrant cap (6) back onto hydrant (5). Using hydrant wrench, turn cap to right to tighten.

GO TO FRAME 11

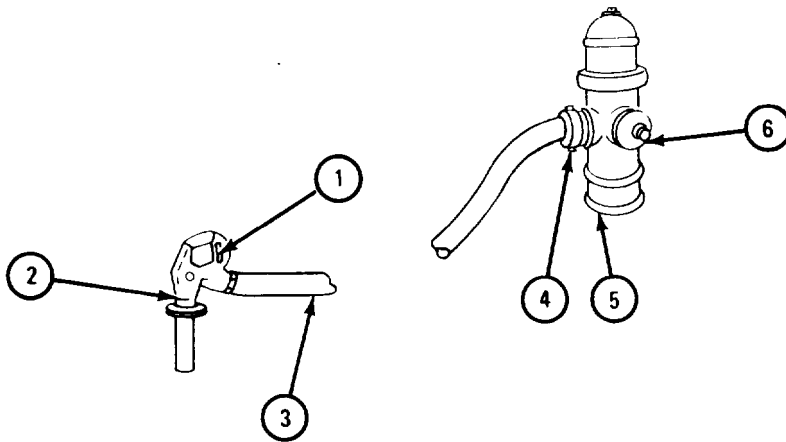

TA 045158

FRAME 11

1. Drain discharge hose (1).
2. Stow all equipment in proper place in rear compartment (2).
3. Close rear compartment doors (3).

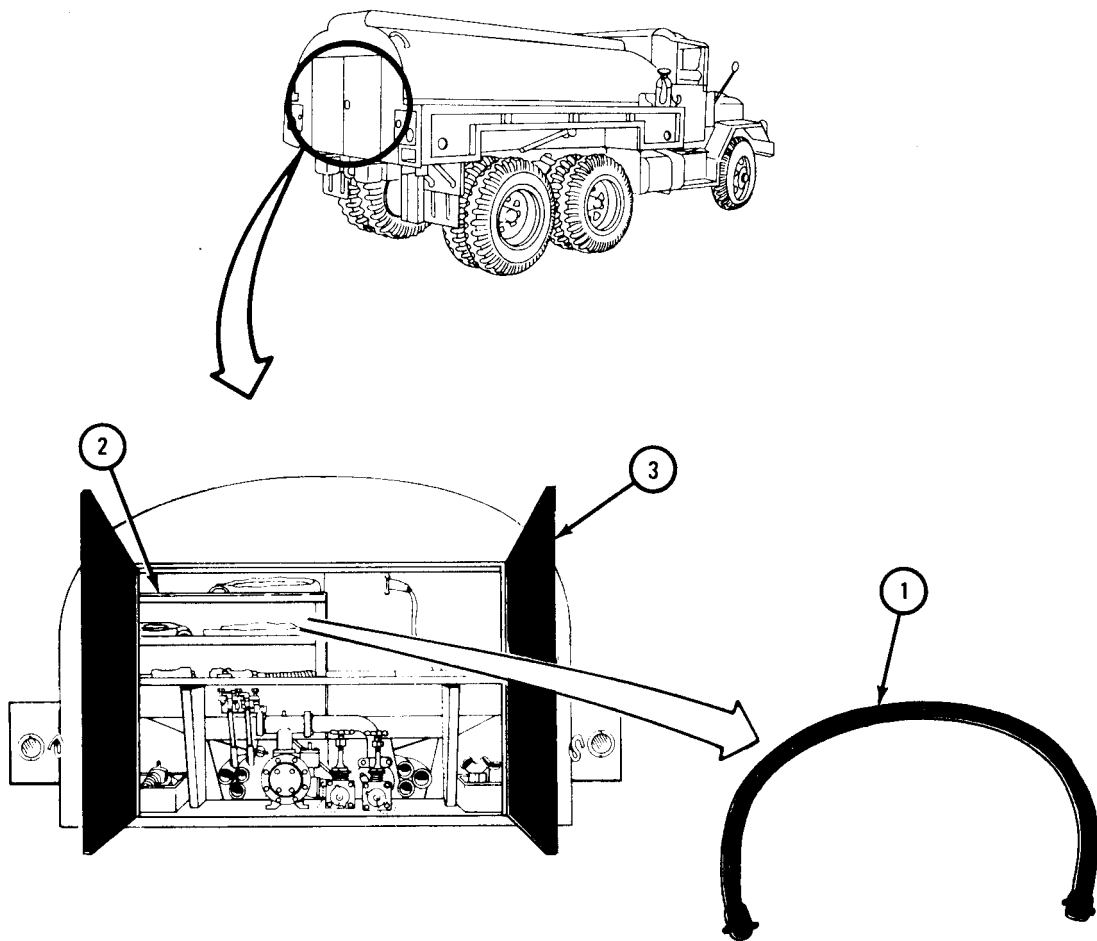

TA 045159

e. Power Discharging the Tank Sections.

TOOLS: 2-inch spanner wrench

FRAME 1

1. Start engine. (Refer to para 4-6b.)
2. Park truck near area where water is to be let out.
3. Stop engine. (Refer to para 4-6e.)
4. Open rear compartment doors (1). Turn dust cover (2) left and take it off pump delivery line discharge valve adapter (3).
5. Put 1 1/2 x 2-inch reducer coupling (4) onto pump delivery line discharge valve adapter (3), turn right, and use spanner wrench to tighten.
6. Place one end of discharge hose (5) onto coupling (4), turn right, and use spanner wrench to tighten.
7. Place discharge nozzle (6) onto other end of hose (5), turn right, and use spanner wrench to tighten.

GO TO FRAME 2

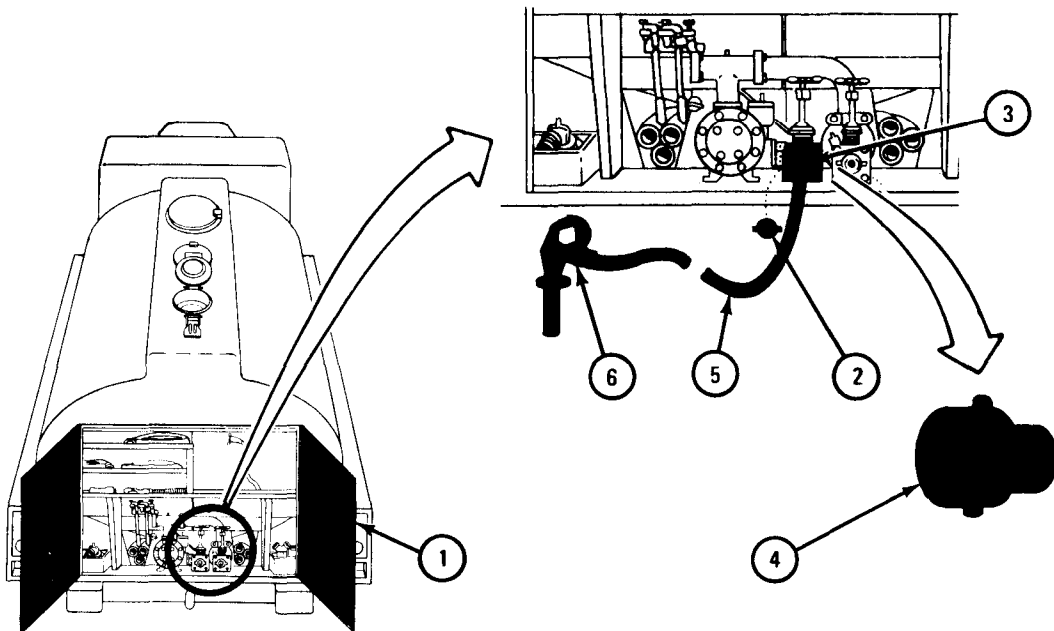

TA 045160



## FRAME 2

1. Start engine. (Refer to para 4-6b.)
2. Place TRANSFER CASE shift lever (1) in neutral position.
3. Turn locking bar (2) down and place transfer POWER TAKEOFF LEVER (3) in ENGAGE (on) POSITION (toward rear of truck).
4. Place FRONT TRANSMISSION gearshift lever (4) in position 2.
5. Pull hand THROTTLE (5) out as far as it will go.

GO TO FRAME 3

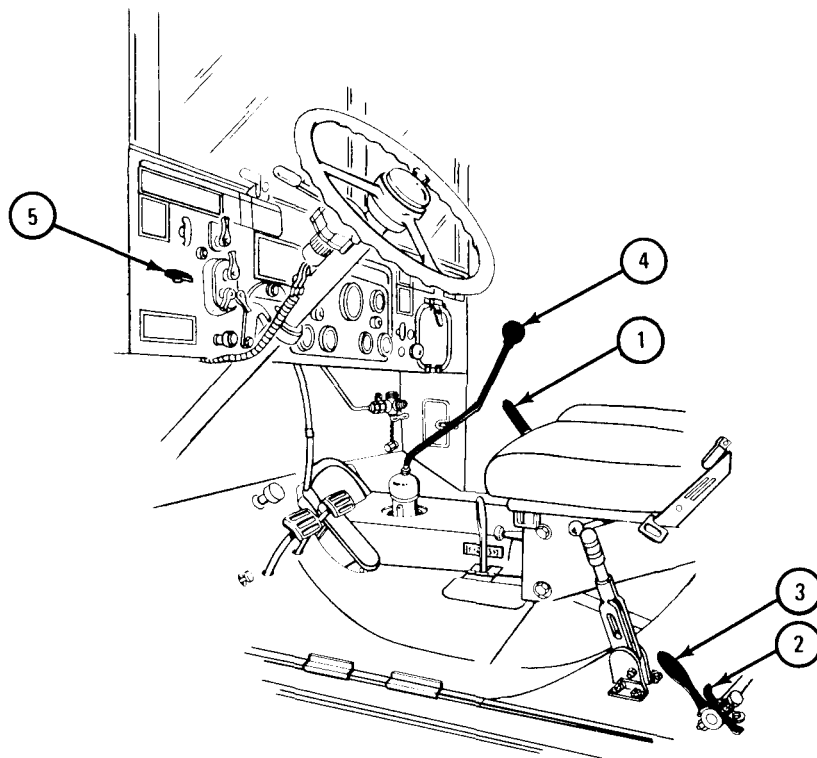

TA 045161

FRAME 3

1. Place either 400 gallon front tank compartment valve lever (1) or 600 gallon rear tank compartment valve lever (2) in open position (toward rear of truck).

**CAUTION**

Always empty front tank compartment first when discharging water on any kind of terrain or road conditions. This will keep load properly distributed (even) for vehicle operation.

2. Turn pump delivery line discharge valve knob (3) left, to open position.
3. Press nozzle operating lever (4) and let water come out as needed.

GO TO FRAME 4

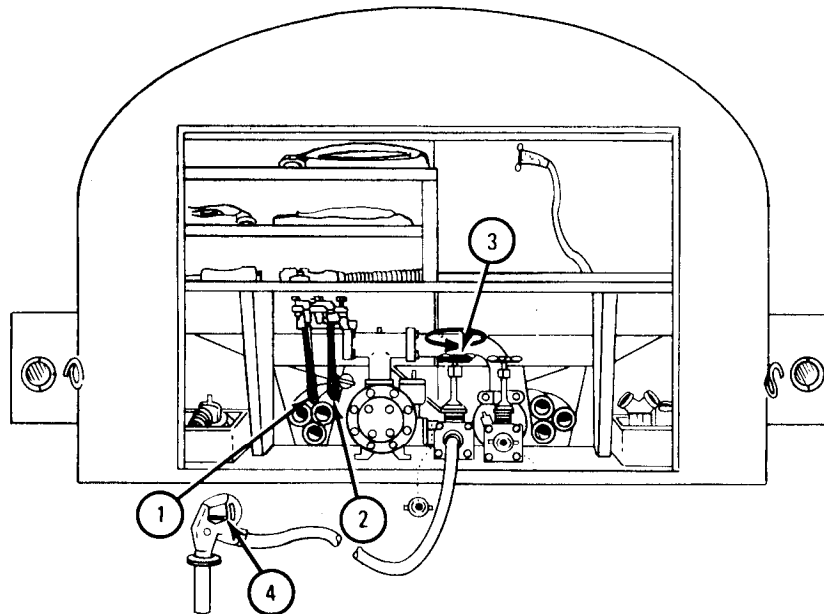

TA 045162

## FRAME 4

1. After letting out water, turn pump delivery line discharge valve knob (1) right to closed position.
2. Place 400 gallon compartment valve lever and 600 gallon compartment valve lever (2) in closed position (toward front of truck).

GO TO FRAME 5

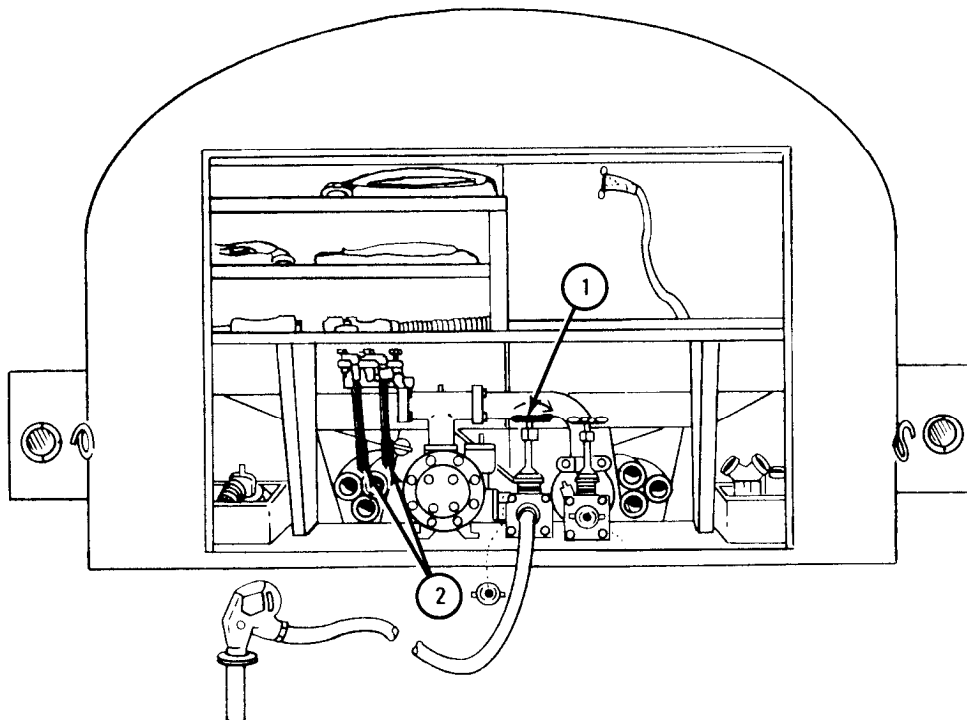

TA 045163

FRAME 5

1. Turn hand THROTTLE (1) and let it go back to closed position.
2. Pull ENG. STOP control (2) out to stop engine.
3. Place FRONT TRANSMISSION gearshift lever (3) in N position.
4. Place transfer POWER TAKEOFF LEVER (4) in DISENGAGE (off) POSITION, (toward front of truck).
5. Turn locking bar (5) up (locked position).

GO TO FRAME 6

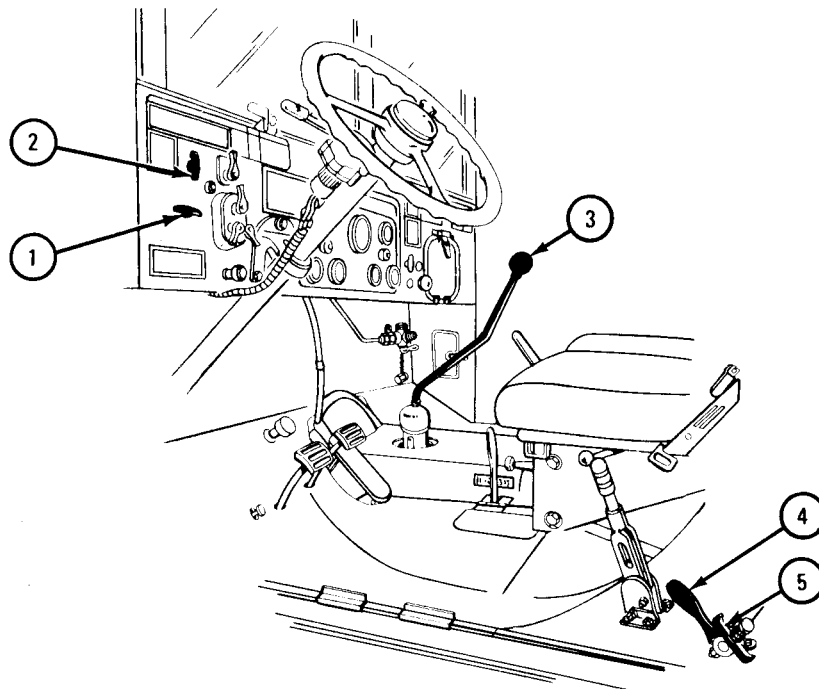

TA 045164

## FRAME 6

1. Press discharge nozzle operating lever (1) to ease off pressure.
2. Use spanner wrench, turn left, loosen and separate the following:
  - (a) Nozzle (2) from hose (3).
  - (b) Hose (3) from reducer coupling (4).
  - (c) Reducer coupling (4) from pump delivery line discharge valve adapter (5).
3. Put dust cover (6) onto pump delivery line discharge valve adapter (5). Turn right to tighten.
4. Stow all equipment in place in rear compartment. Close compartment doors (7).

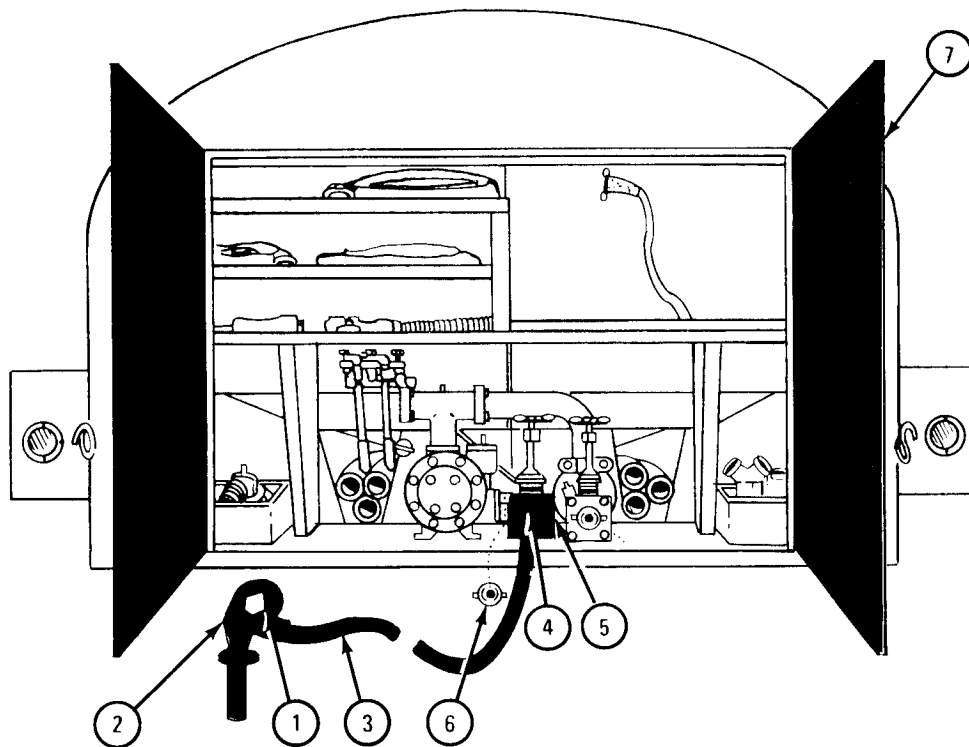

TA 045165

f. Gravity Discharging the Tank Sections.

TOOLS: 2-inch spanner wrench

FRAME 1

1. Start engine. (Refer to para 4-6b.)
2. Park truck near area where water is to be let out.
3. Stop engine. (Refer to para 4-6e.)
4. Open rear compartment doors. Turn left, and take dust cover (1) off gravity delivery line suction valve adapter (2).
5. Put 1 1/2 x 2-inch reducer coupling (3) onto gravity delivery line suction valve adapter (2), turn right, and use 2-inch spanner wrench to tighten.
6. Place one end of discharge hose (4) onto coupling (3), turn right, and use spanner wrench to tighten.
7. Place discharge nozzle (5) onto other end of hose, and turn to right to tighten.

GO TO FRAME 2

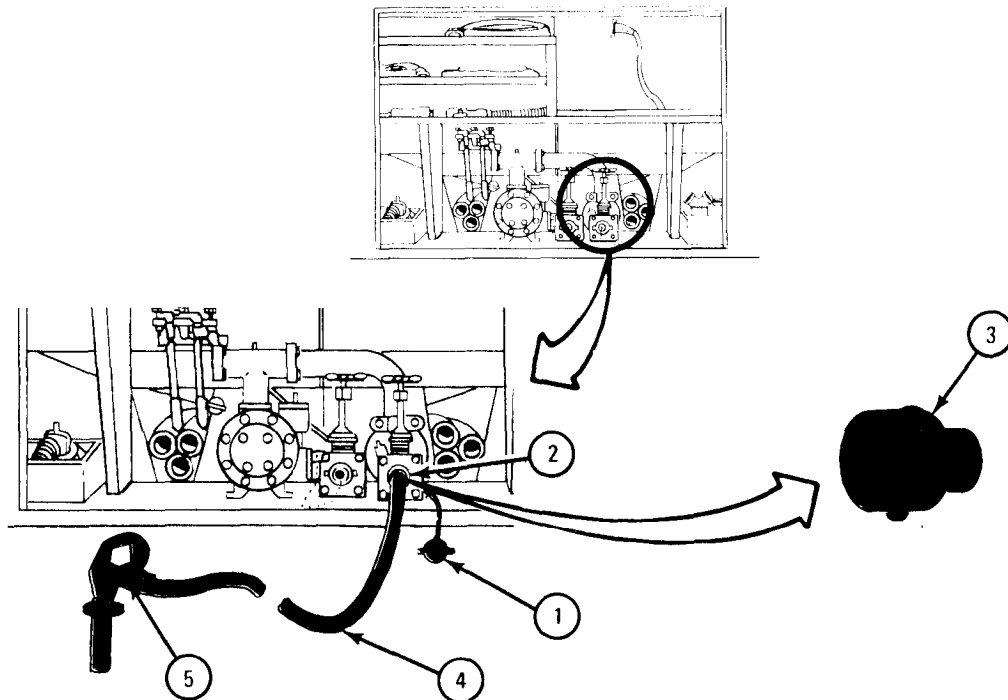

TA 045166

## FRAME 2

1. Turn gravity delivery line suction valve knob (1) left, to open position.
2. Place either 400 gallon compartment valve lever (2) in open position, (left lever controls 400 gallon front tank, right lever controls 600 gallon rear tank).

**CAUTION**

Always empty front tank compartment first when letting out water, on any kind of terrain or road condition. This will keep the load properly distributed (even) for vehicle operation.

3. Press discharge nozzle operating lever (3) to let water flow as needed.

GO TO FRAME 3

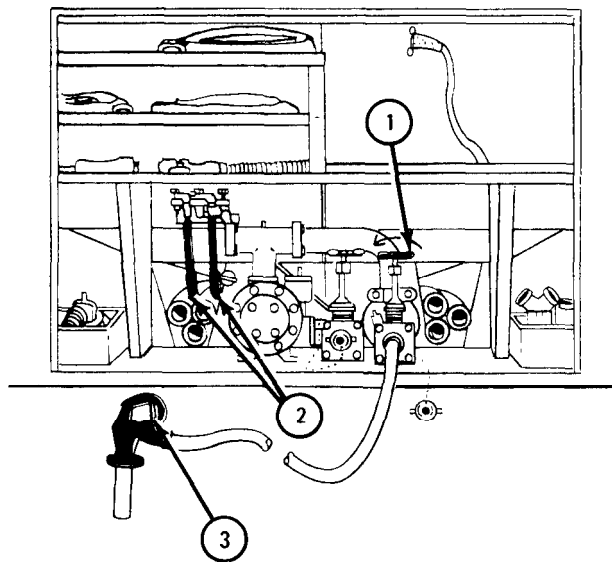

TA 045167

FRAME 3

1. When needed amount of water has been discharged, place 400 gallon compartment valve lever and 600 gallon compartment valve lever (1) in closed position (toward front of truck).
2. Turn gravity delivery line suction valve (2) right, to closed position.
3. Press dispenser nozzle operating lever (3) to let water out of hose.
4. Using a spanner wrench, turn left, loosen and then separate the following:
  - (a) Discharge nozzle (4) from hose (5).
  - (b) Hose (5) from reducer coupling (6).
  - (c) Coupling (6) from gravity delivery line suction valve adapter (7).
5. Put dust cover (8) onto gravity delivery line suction valve adapter (7) and turn right to tighten.
6. Drain hose (5).
7. Stow all equipment in proper places in rear compartment.

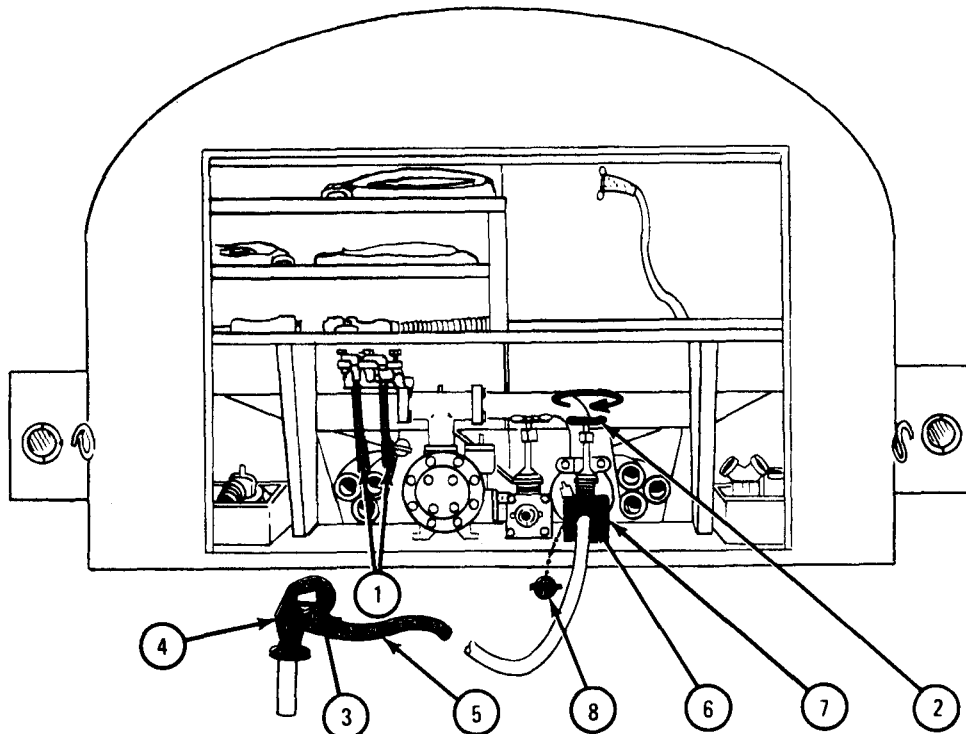

TA 045168



g. Operating Water Tank Trucks During Freezing Temperatures.

FRAME 1

**CAUTION**

Do not heat water tank with less than 10 inches of water in both front and rear tank sections. The 10 inches of water prevents heat from building up in parts of the tank. Metal expansion due to the heat could cause cracks in seams and welds.

1. Take off padlocks (1) open tank section filler covers (2).
2. Measure water level in each tank section using water level gage (3) for front section and water level gage (4) for rear section.

GO TO FRAME 2

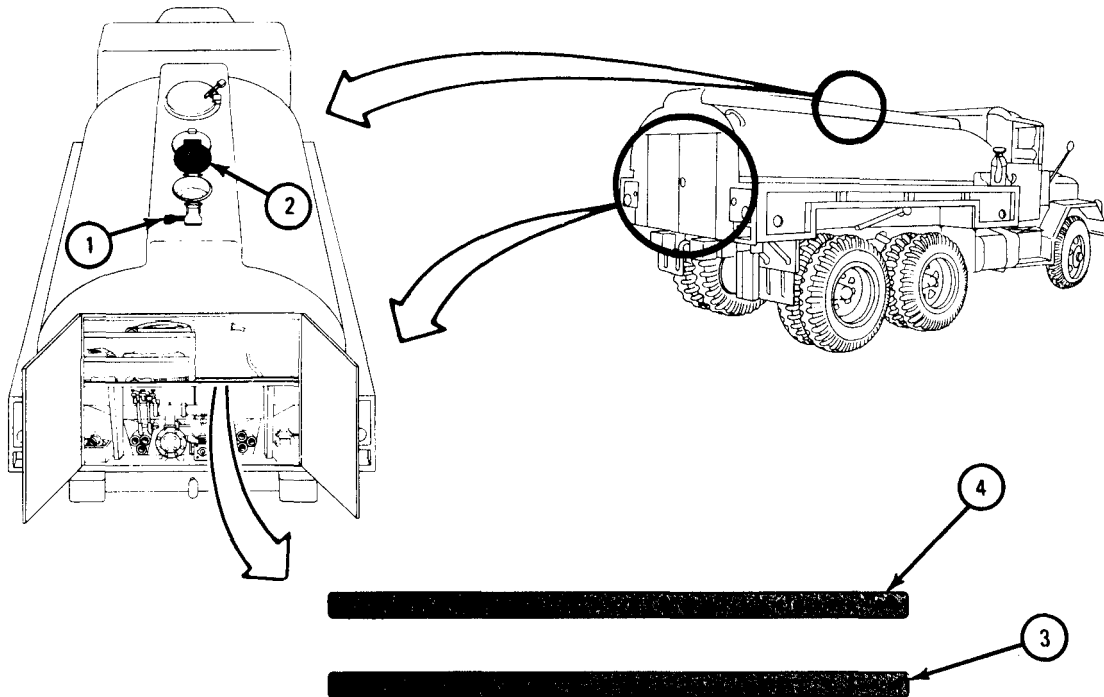

TA 045169

FRAME 2

1. If there is less than 10 inches of water in either section, add water following procedures given in para 4-10b, c, d, or move water from one section to another.
2. To move water from one tank section to another, turn pump delivery line discharge valve (1) and gravity delivery line suction valve (2) knobs right to closed position.
3. Move 400 gallon and 600 gallon compartment valve levers (3) to open position (toward rear of truck).
4. When low tank section reaches a minimum 10-inch water level, move 400 gallon and 600 gallon compartment valve levers (3) to closed position.

GO TO FRAME 3

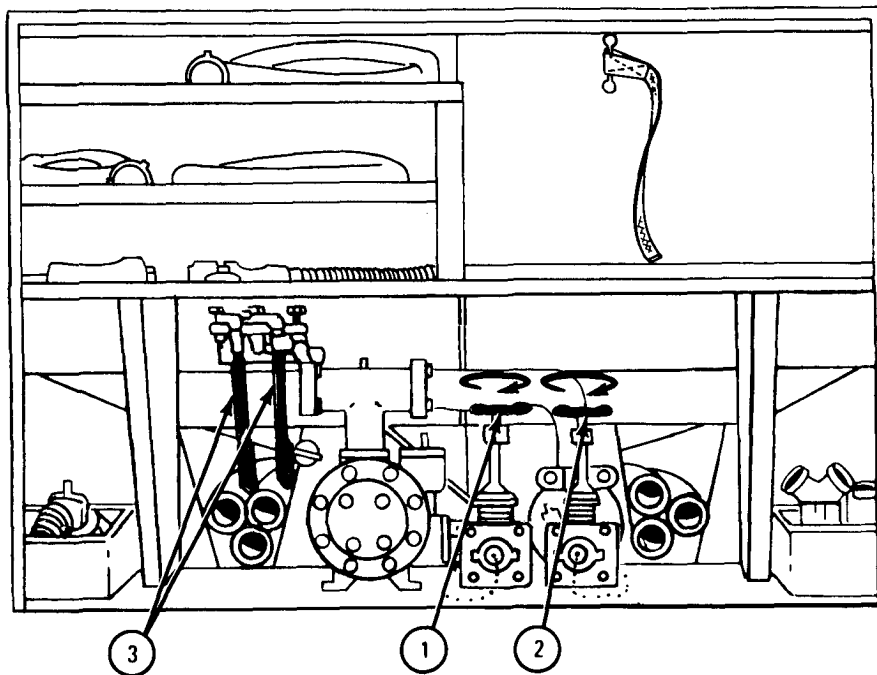

TA 045170

## FRAME 3

**CAUTION**

During freezing temperatures, always keep delivery lines, compartment drain pipes, manifold pipes and delivery pump free of water except during water discharging operations. Water in system could freeze and cause damage to components.

1. Turn left and take dust covers (1) off.
2. Turn pump delivery line discharge valve knob (2) and gravity delivery line suction valve knob (3) left, to open position.

GO TO FRAME 4

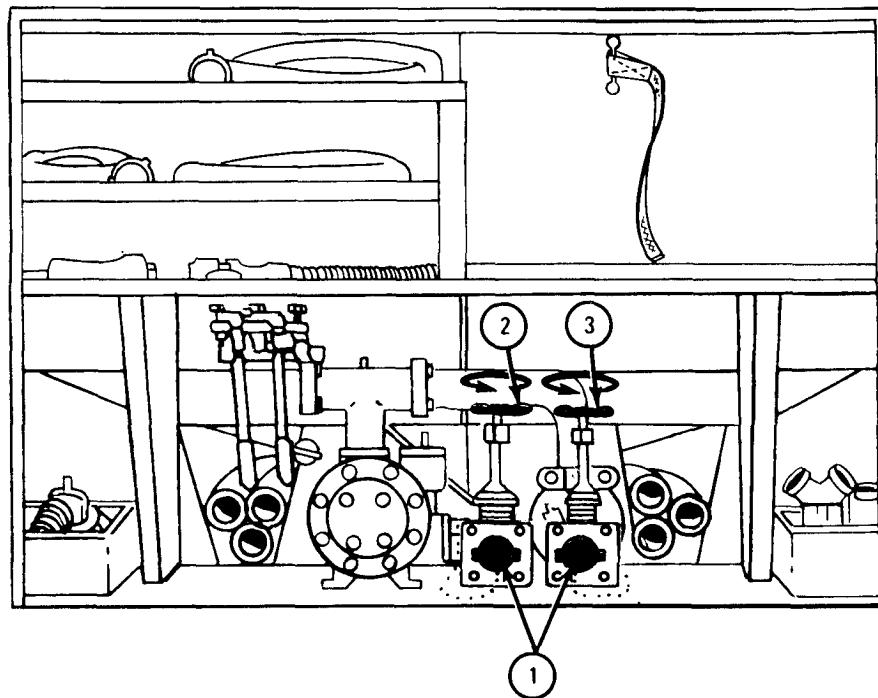

TA 045171

FRAME 4

1. Start engine. (Refer to para 4-6b.)
2. Press down on clutch pedal (1) and place TRANSFER CASE shift lever (2) in neutral position.
3. Turn locking bar (3) down and pull transfer POWER TAKEOFF LEVER (4) to ENGAGE (on) POSITION (toward rear of truck).
4. Place FRONT TRANSMISSION gearshift lever (5) in position 2.
5. Let clutch pedal (1) come up slowly.
6. Set hand THROTTLE (6) to run engine at 1,000 rpm.

GO TO FRAME 5

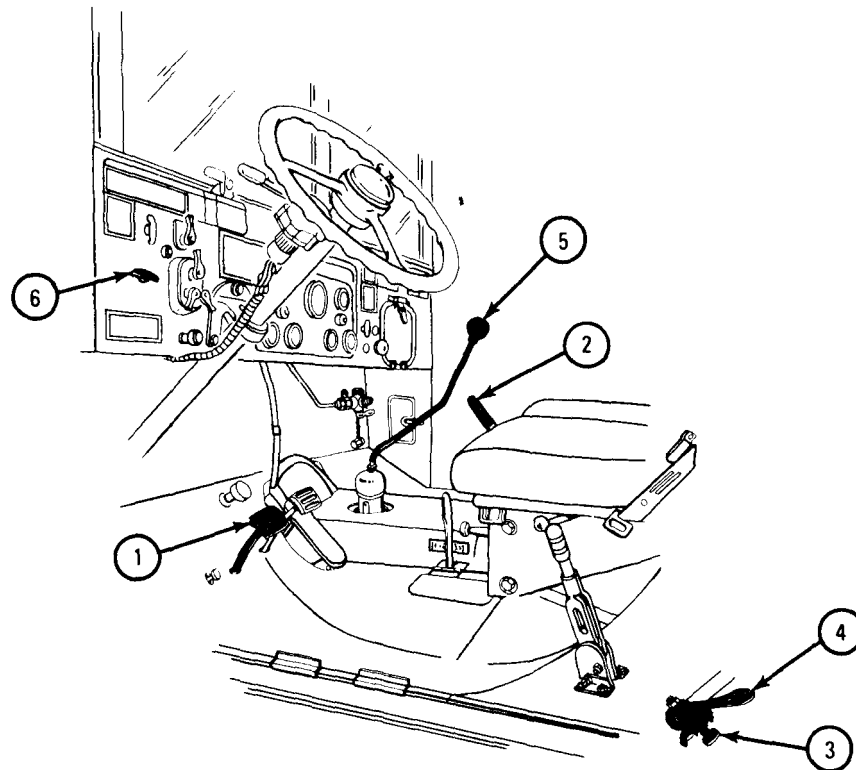

TA 045172

## FRAME 5

1. Let pump run for 60 seconds to drain delivery lines, compartment drain pipes, manifold pipes and delivery pump.
2. Turn hand THROTTLE (1) and let it go all the way in.
3. Press clutch pedal (2) all the way down.
4. Move transfer POWER TAKEOFF LEVER (3) forward to DISENGAGE (off) POSITION and lock with locking bar (4).
5. Place FRONT TRANSMISSION gearshift lever (5) in N position.

GO TO FRAME 6

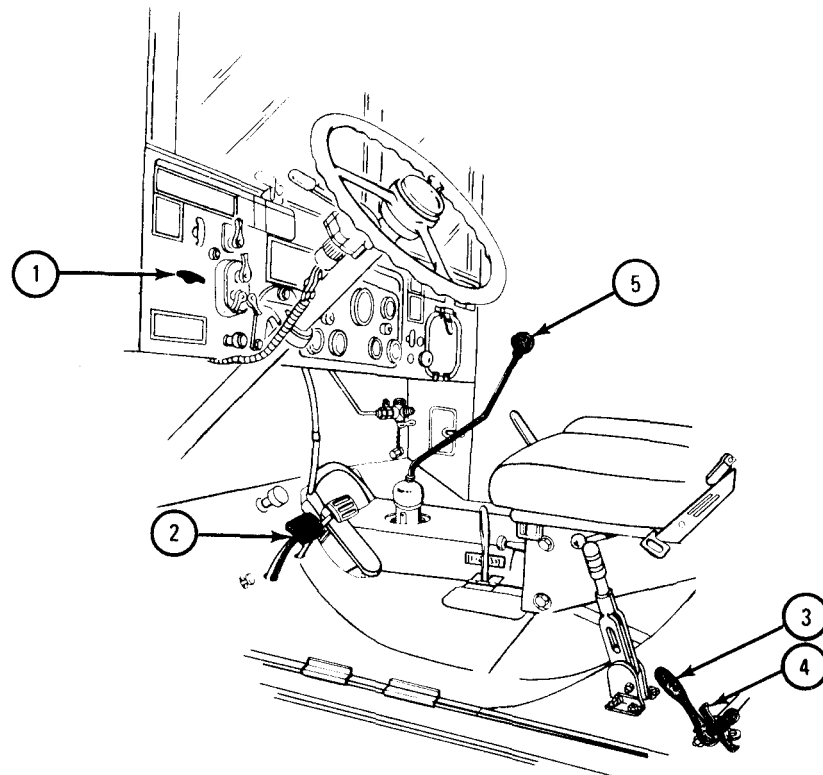

TA 045173

FRAME 6

1. Make sure that exhaust bypass fording valve (1) is in open position (in direction of arrow).

GO TO FRAME 7

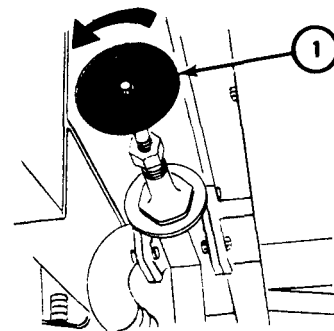
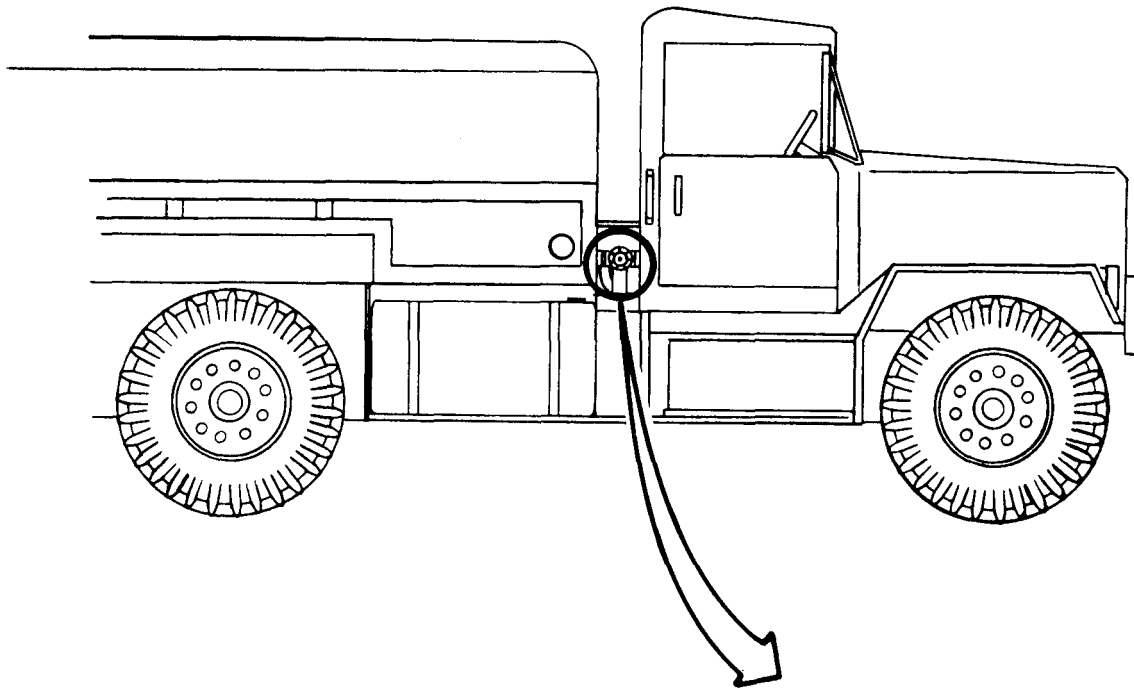

TA 045174

## FRAME 7

1. Pull exhaust bypass fording valve control (1) out, turn it to side-to-side position. This will lock control and keep valve open.
2. When outside temperature goes above freezing (32 ° F), turn bypass fording valve control (1) to up and down position. Let it go back to close valve and stop heating.
3. Stop engine. (Refer to para 4-6e.)

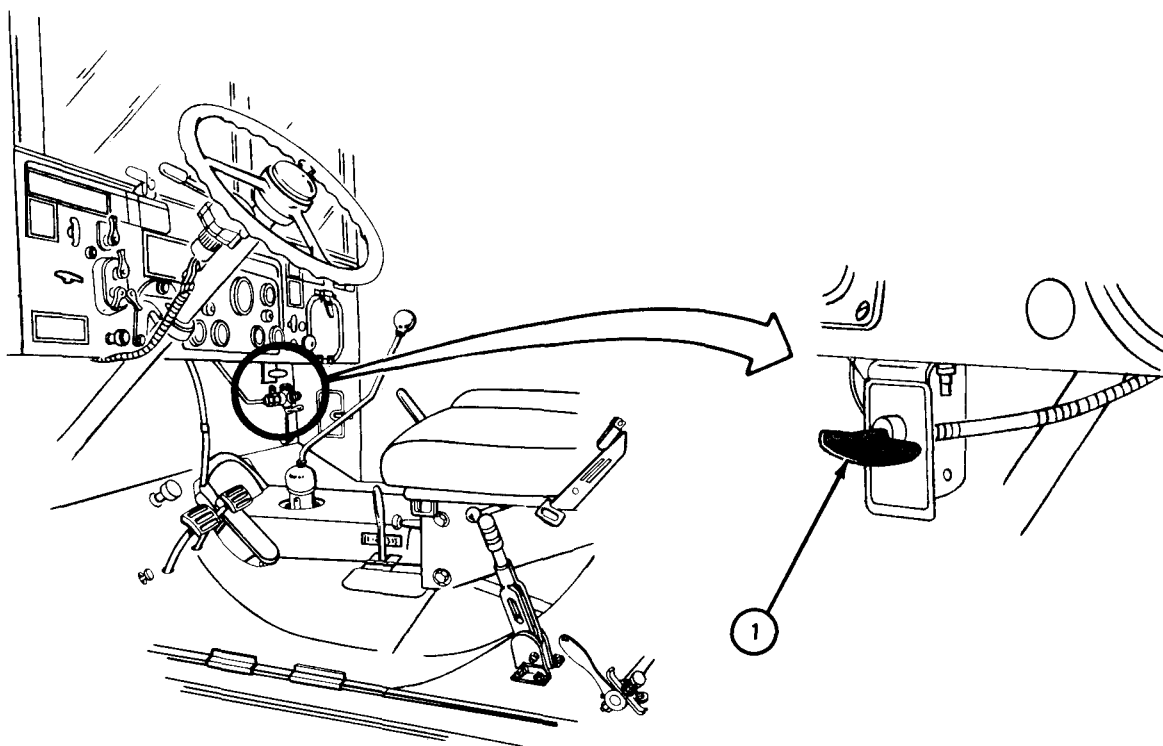

TA 045175

4-11. OPERATION OF SHOP VAN AND INSTRUMENT REPAIR SHOP VAN TRUCKS.

a. Preparing Shop Van and Instrument Repair Shop Van for Use.

FRAME 1

1. Place access ladder (1) into position.
  - (a) Unsnap ladder lock (2).
  - (b) Take ladder out of its storage sockets (3).
  - (c) Place top end of ladder into mounting brackets (4) and place bottom end firmly on the ground.

GO TO FRAME 2

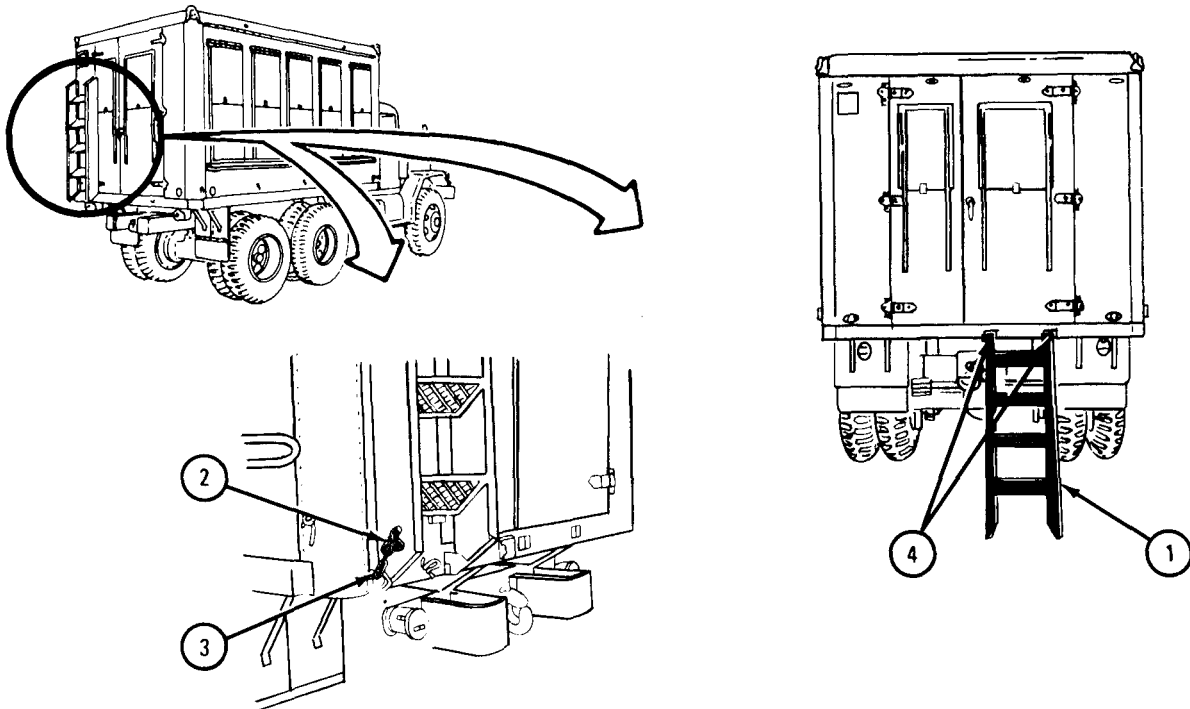

TA 045178



FRAME 2

1. Open right rear door (1).
  - (a) Unlock and take padlock (2) off.
  - (b) Turn door handle (3) to side-to-side position.

GO TO FRAME 3

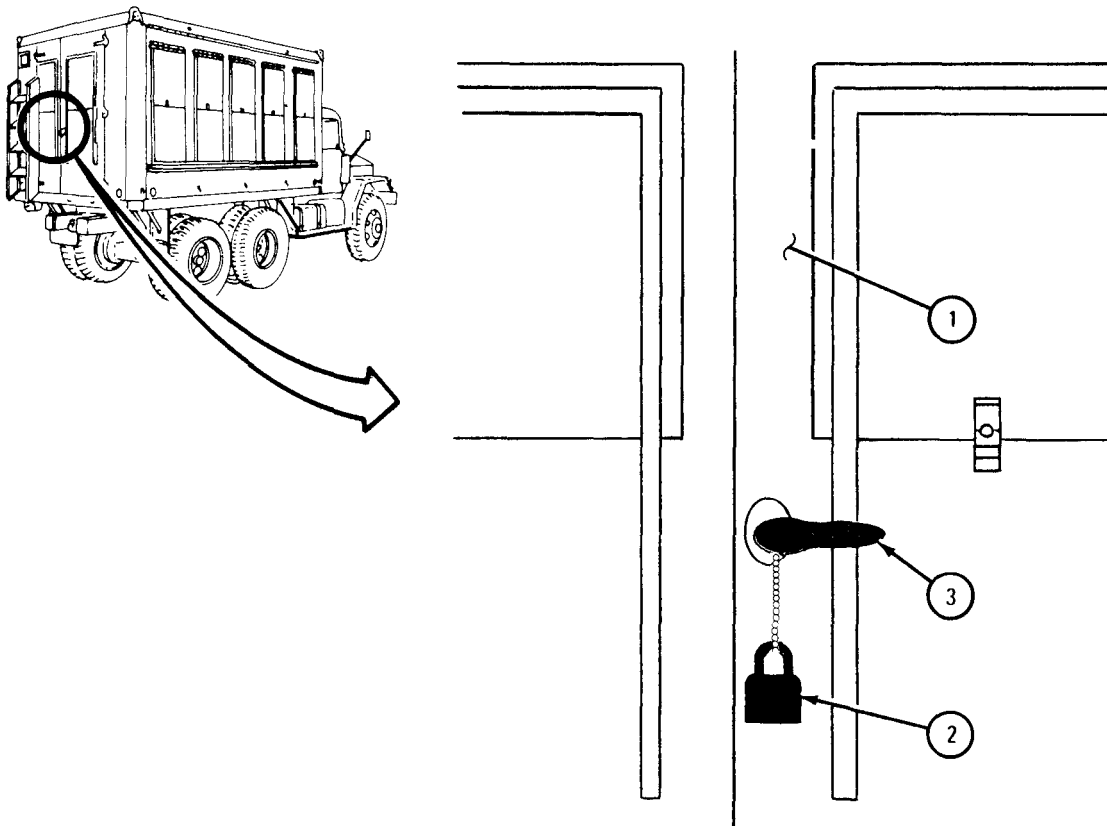

TA 045179

FRAME 3

1. Open left rear door (1) front inside of van.
  - (a) Pull down on upper latch rod ring (2) and lift up on lower latch (3).
  - (b) Press each door against door retainer (4) to keep door in open position.

GO TO FRAME 4

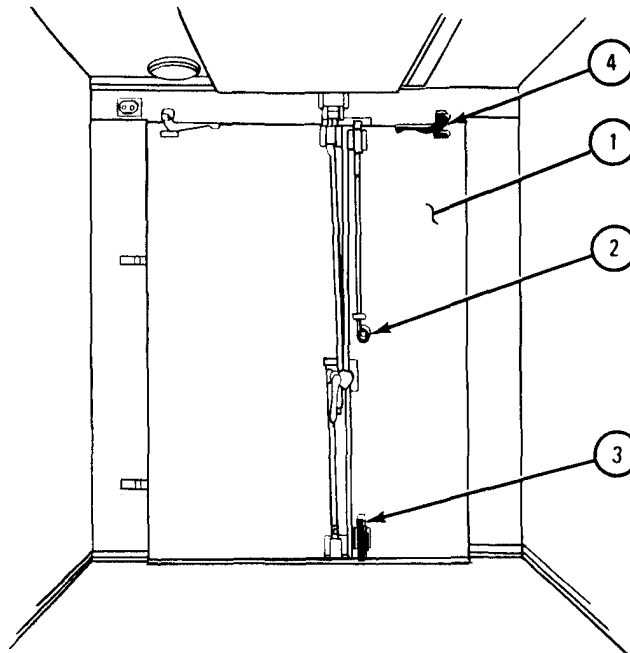

TA 045180

## FRAME 4

1. Open blackout panels (1),
  - (a) Lift latch (2).
  - (b) Slide panels (1) down.

GO TO FRAME 5

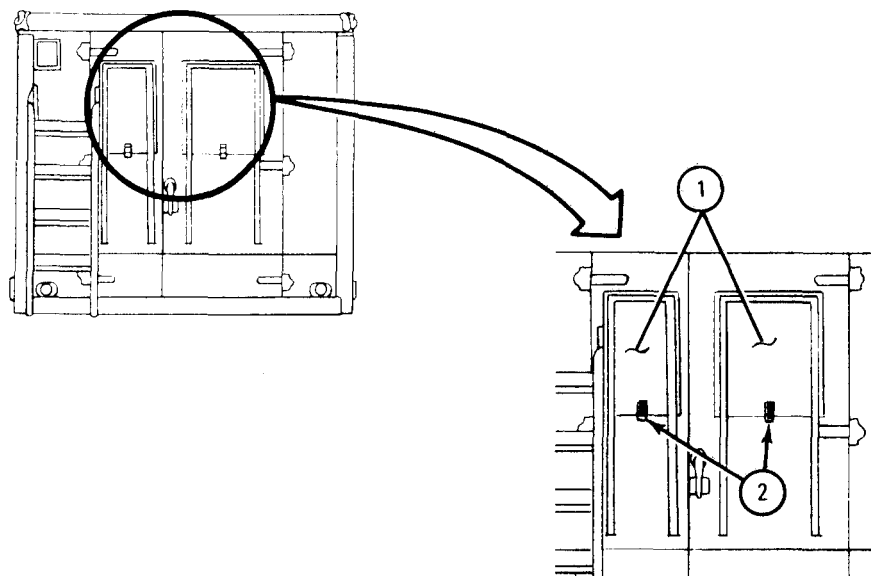

TA 045181

FRAME 5

1. Open side window (1) from inside with blackout panels in fully open or fully closed position.
2. Press sliding member (2) and lift ring (3) from retainer (4).

GO TO FRAME 6

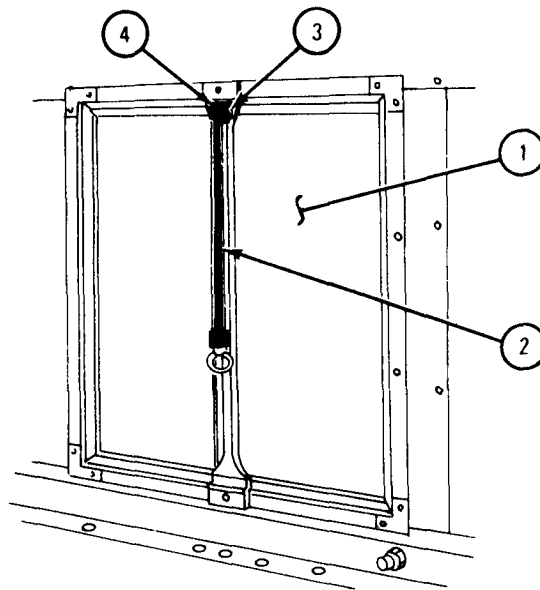

TA 04518z

## FRAME 6

1. Lower sliding member (1), push it outward to open window while pulling down on window latch ring (2).
2. Let window latch ring (2) go, continue to push outward until latch pin snaps into hole in sliding member (1), to hold window open.

GO TO FRAME 7

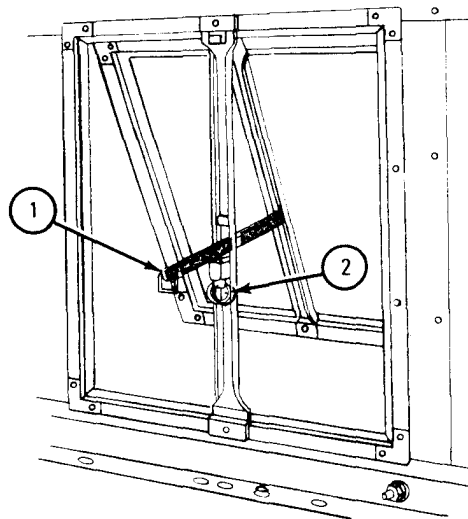

TA 045183

FRAME 7

1. Close side window (1) by holding sliding member (2) and pulling window latch ring (3). Let window come back to closed position and let ring go,
2. Lift sliding member (2), and fold it flat against window frame (4).
3. Lift ring (5) and slip it over retainer (6).

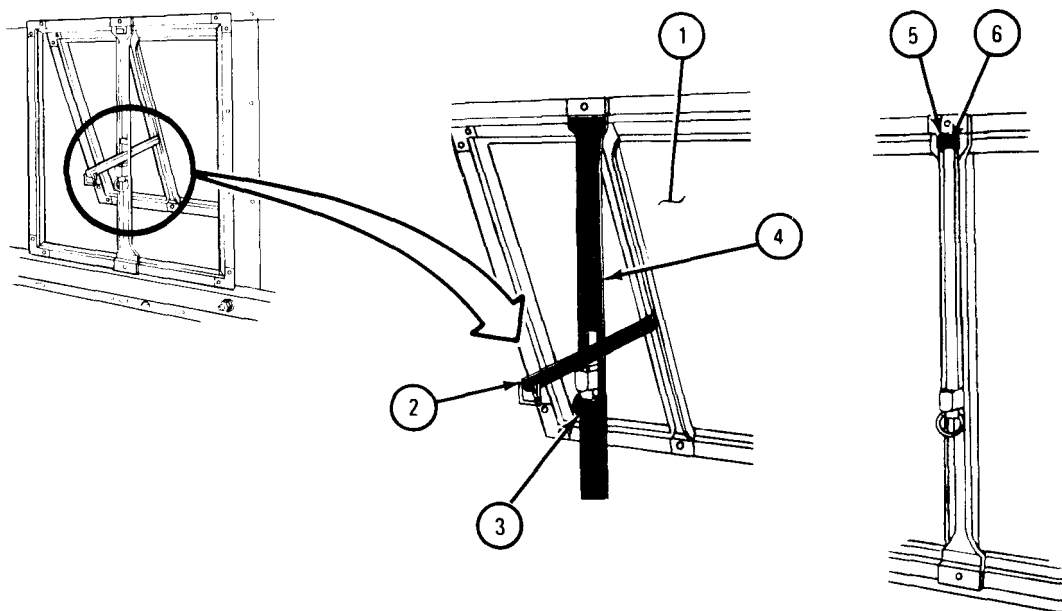

b. Supplying 115-Volt AC Power to Shop Van.

## FRAME 1

1. Inside van, check that power switch (1) is in off (down) position.
2. Turn dust cover (2) to left and take it off.
3. Plug cable connector (3) from outside 115-volt ac power source into receptacle (4) on front of van.
4. When van is to be moved to another location, take cable connector (3) out of receptacle (4). Put on dust cover (2).

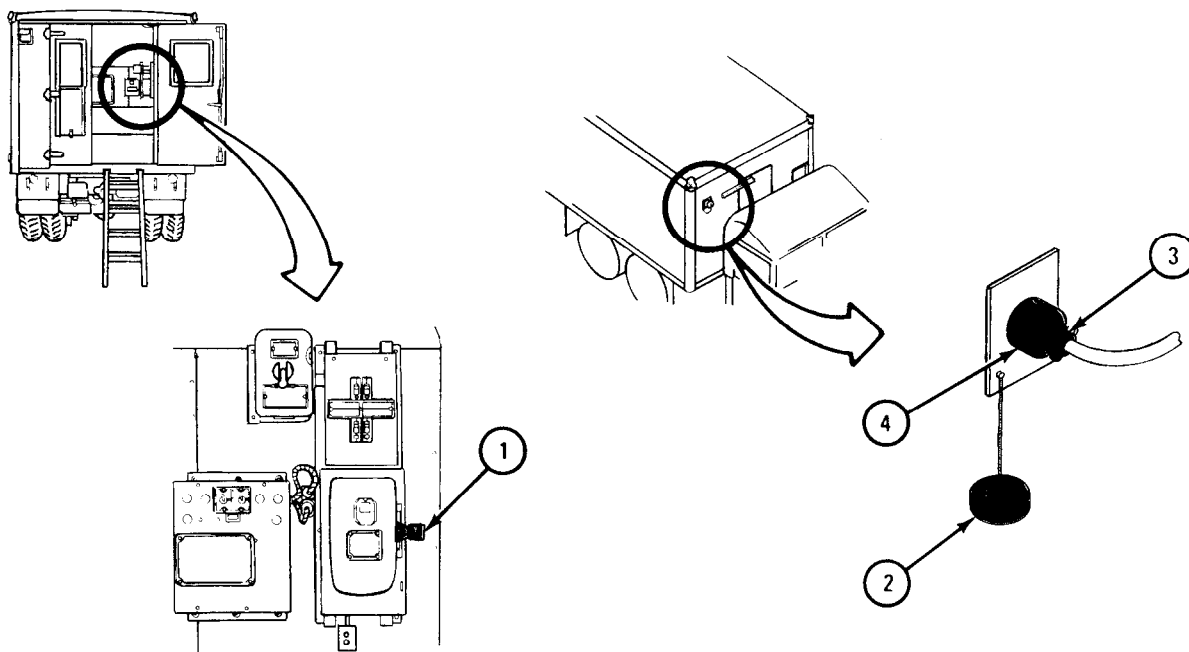

TA 045177

c. Operating the Exhaust Blower.

(1) Operating from 24-volt source

FRAME 1

1. Place POWER SWITCH 115-VAC (1) handle in OFF (down) position.
2. Place converter SELECTOR switch (2) in 24V position.
3. Place EXH BLOWER switch (3) in desired HI or LOW speed position.

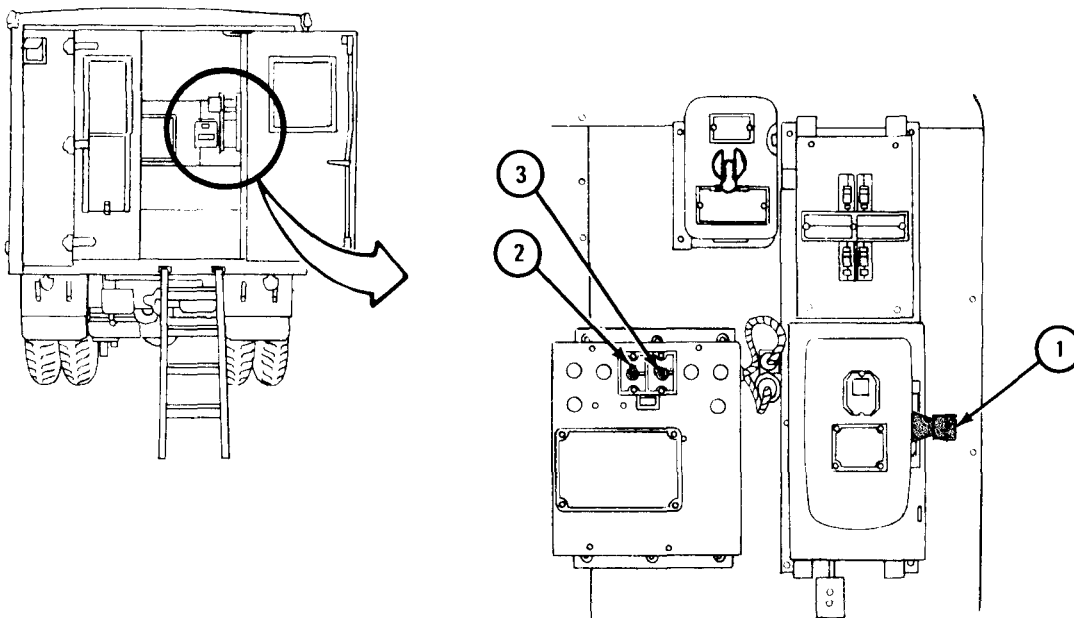

TA 045185



(2) Operating from 115-volt source.

FRAME 2

1. Place POWER SWITCH 115-VAC handle (1) in ON (up) position.
2. Place NO. 3 CIRCUIT BREAKER HEATER CIRCUIT (2) in ON position.
3. Place converter SELECTOR switch (3) in 115V position. Red light (4) will light.
4. Place EXH BLOWER switch (5) in desired HI or LO speed position.

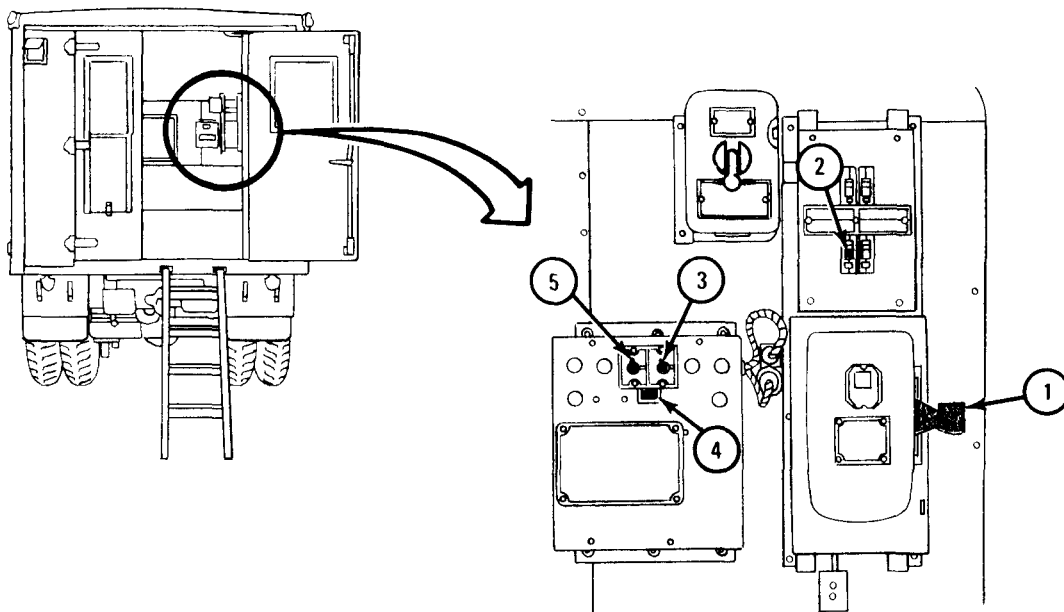

TA 045186

d. Operating the Dome and Blackout Dome Lights.

(1) Operating 115-volt dome lights under normal conditions.

FRAME 1

1. Place POWER SWITCH 115-VAC handle (1) in ON (up) position.
2. Place NO. 4 CIRCUIT BREAKER CEILING LAMP CIRCUIT (2) in ON position.
3. Place OPERATION BLACKOUT SWITCH 115-VAC SYSTEM (3) in down position.

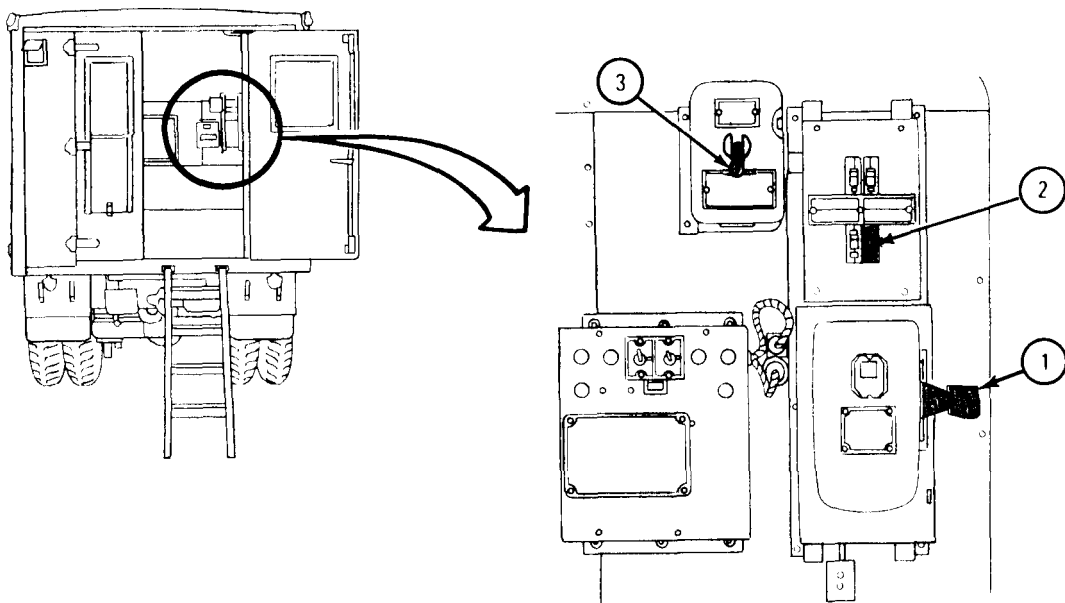

TA 045187

(2) Operating 115-volt dome and blackout lights under blackout conditions.

**FRAME 1**

1. Place POWER SWITCH 115-VAC handle (1) in ON (up) position.
2. Place NO. 4 circuit breaker CEILING LAMP CIRCUIT (2) in ON position.
3. Place OPERATION BLACKOUT SWITCH 115-VAC SYSTEM (3) in up (on) position.

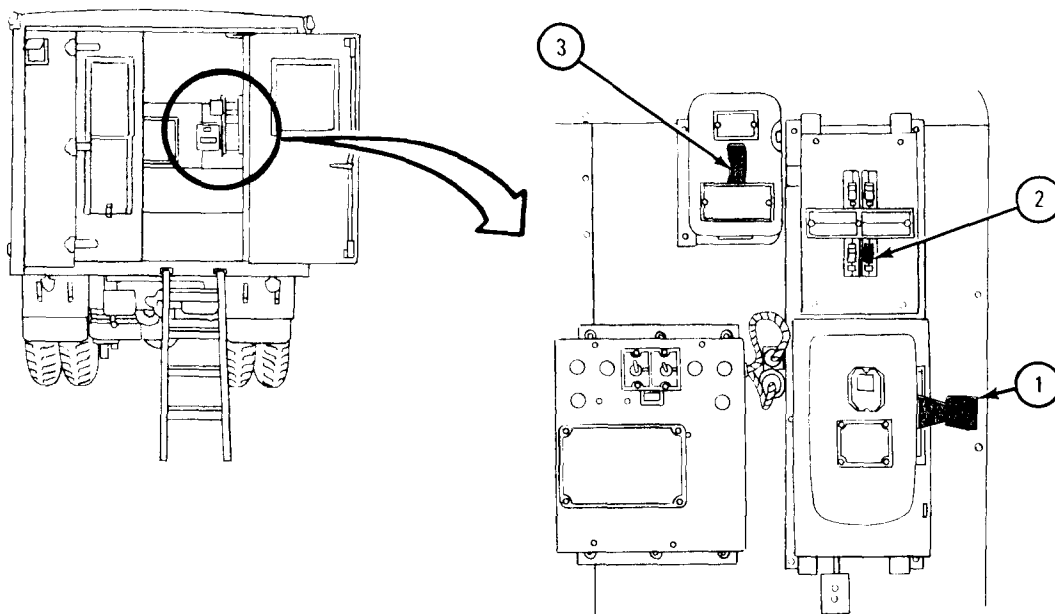

TA 045188

(3) Operating 24-volt dome light under normal conditions.

FRAME 1

1. Place POWER SWITCH 115-VAC handle (1) in OFF (down) position.
2. Place BLACKOUT dome light toggle switch (2) in ON position.
3. Place dome light toggle switch (3) in NORMAL position.

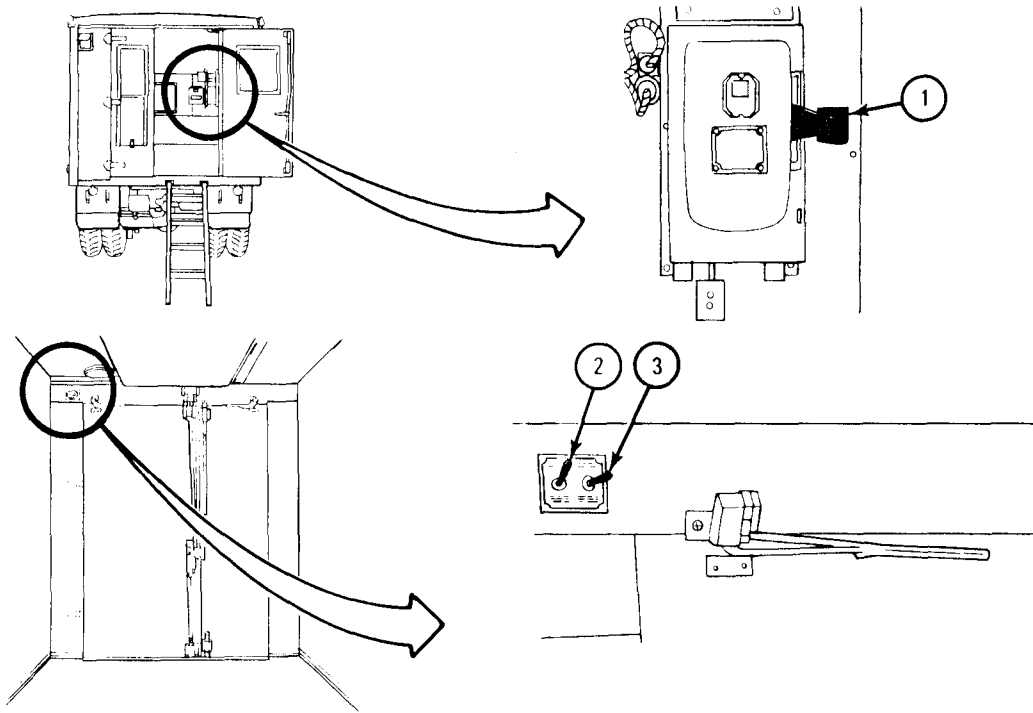

TA 045189

(4) Operating 24-volt dome lights under blackout conditions.

FRAME 1

1. Place POWER SWITCH 115-VAC handle (1) in ON (up) position.
2. Place dome light toggle switch (2) in ON position.
3. Place OPERATION BLACKOUT SWITCH 115-VAC SYSTEM (3) in (up) ON position.
4. Place dome light toggle switch (4) in BLACKOUT position.
5. Open and close rear door to check blackout action.

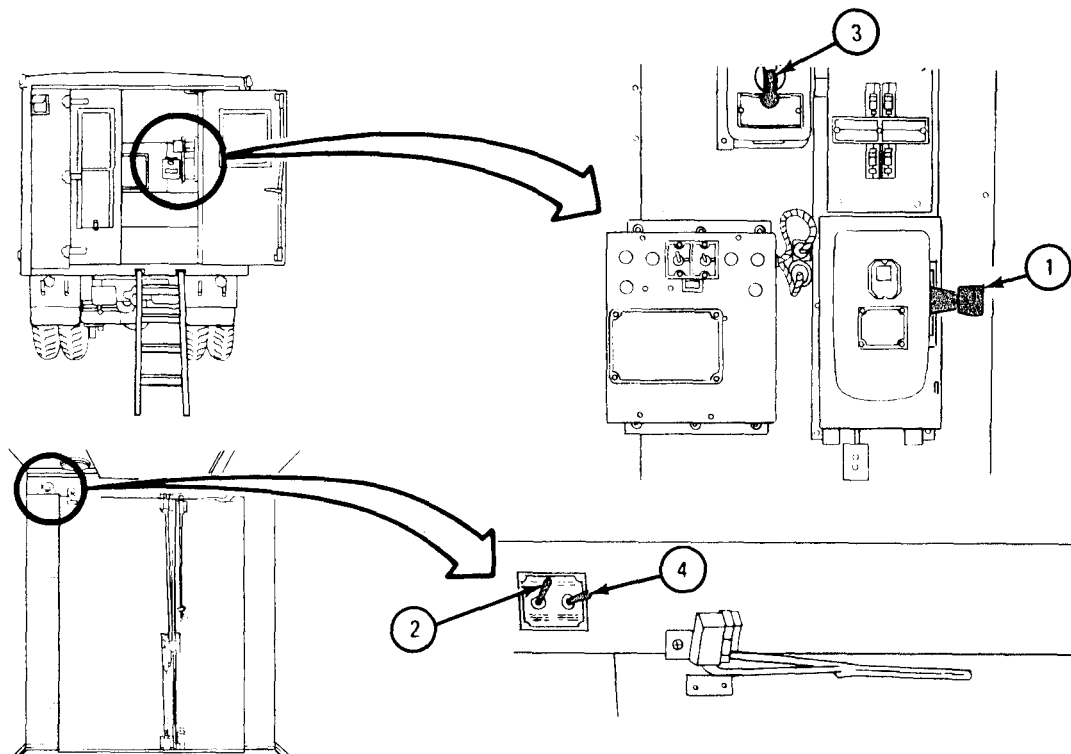

TA 045190

e. Supplying Power to Moulding Receptacles.

FRAME 1

1. Place POWER SWITCH 115-VAC handle (1) in ON (up) position.
2. To supply power to moulding receptacles (2), on right side of shop van, set NO. 1 CIRCUIT BREAKER R. H. POWER CIRCUIT (3) to ON position.
3. To supply power to moulding receptacles (4), on left side of shop van, set NO. 2 CIRCUIT BREAKER L. H. POWER CIRCUIT (5) to ON position.

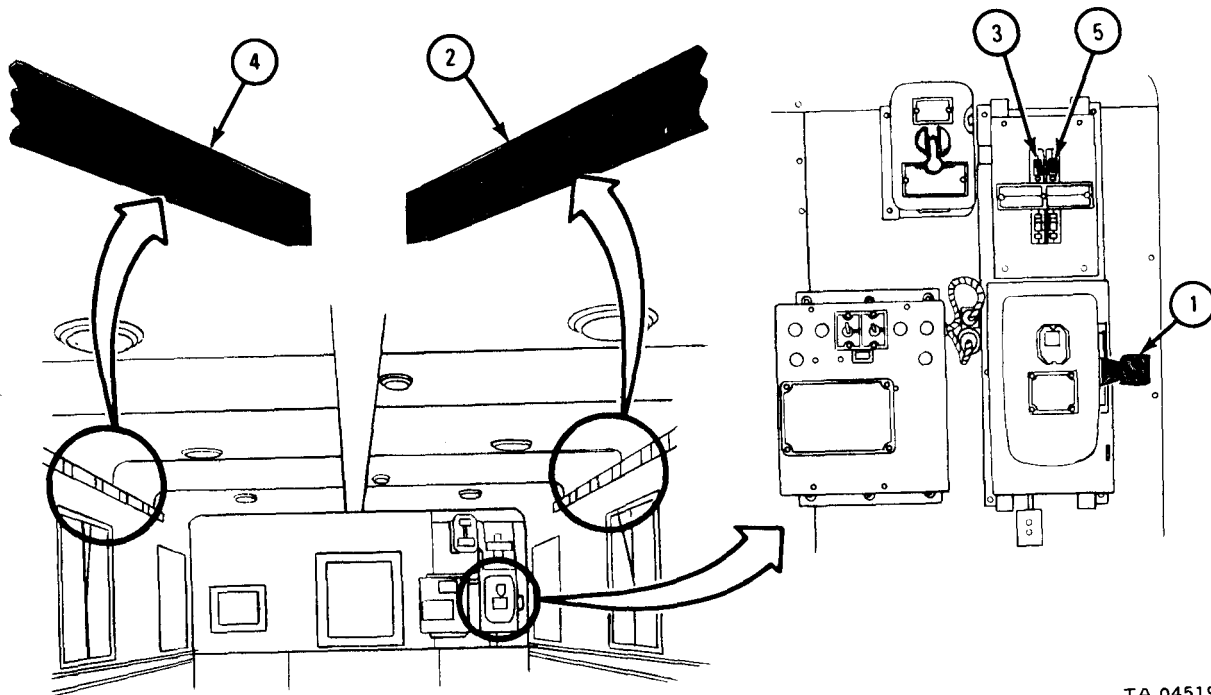

TA 045191

## 4-12. OPERATION OF TRACTOR TRUCKS.

a. General. Tractor trucks covered in this manual are made to tow a semitrailer with a maximum travel load of 17,000 pounds for cross-country travel and 36,000 pounds for prepared road travel.

b. Coupling the Semitrailer.

PERSONNEL: TWO

## FRAME 1

1. Start engine. (Refer to para 4-6b.)
2. Place tractor truck in front of trailer with wheel coupler jaws (1) almost touching and directly in line with semitrailer king pin (2).
3. Place FRONT TRANSMISSION gearshift lever (3) in N position.
4. Pull handbrake lever (4) up to on position.

GO TO FRAME 2

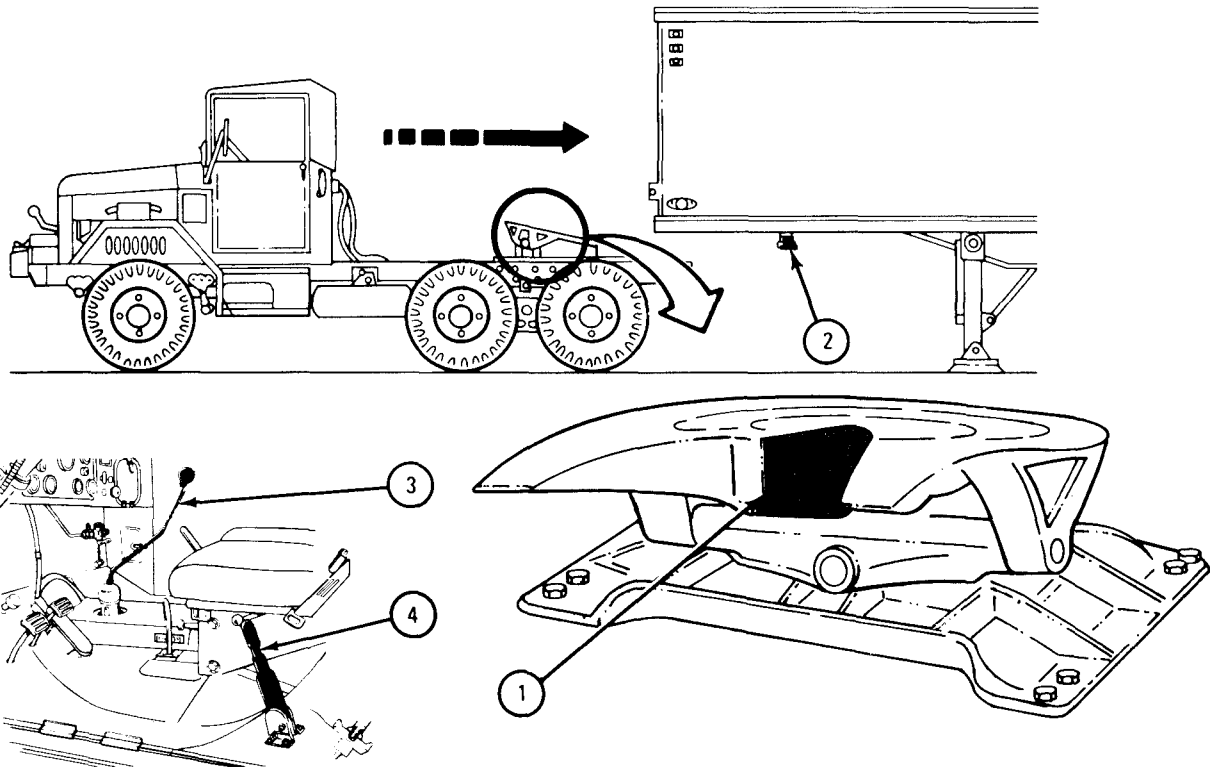

TA 045192

FRAME 2

1. Adjust trailer landing gear (1) to raise or lower semitrailer skid plate (2). Skid plate should be slightly lower than tractor fifth wheel (3).
2. Check to see that semitrailer wheel chocks (4) are in place.

**NOTE**

Refer to the operator's manual, for the trailer to be coupled, for instructions on how to raise or lower landing gear.

GO TO FRAME 3

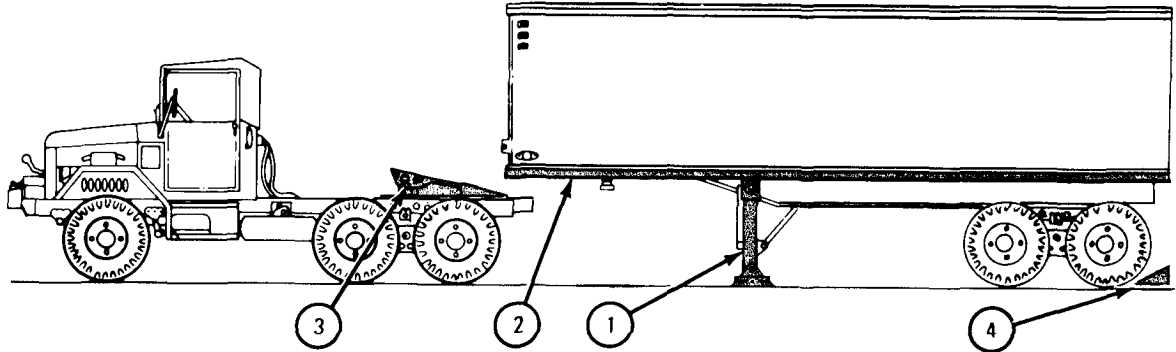

TA 045022



## FRAME 3

1. Turn safety latch (1) to right or left to set locking plunger free.
2. Move operating handle (2) forward until it stays in forward position. Coupler jaws (3) are now unlocked.

GO TO FRAME 4

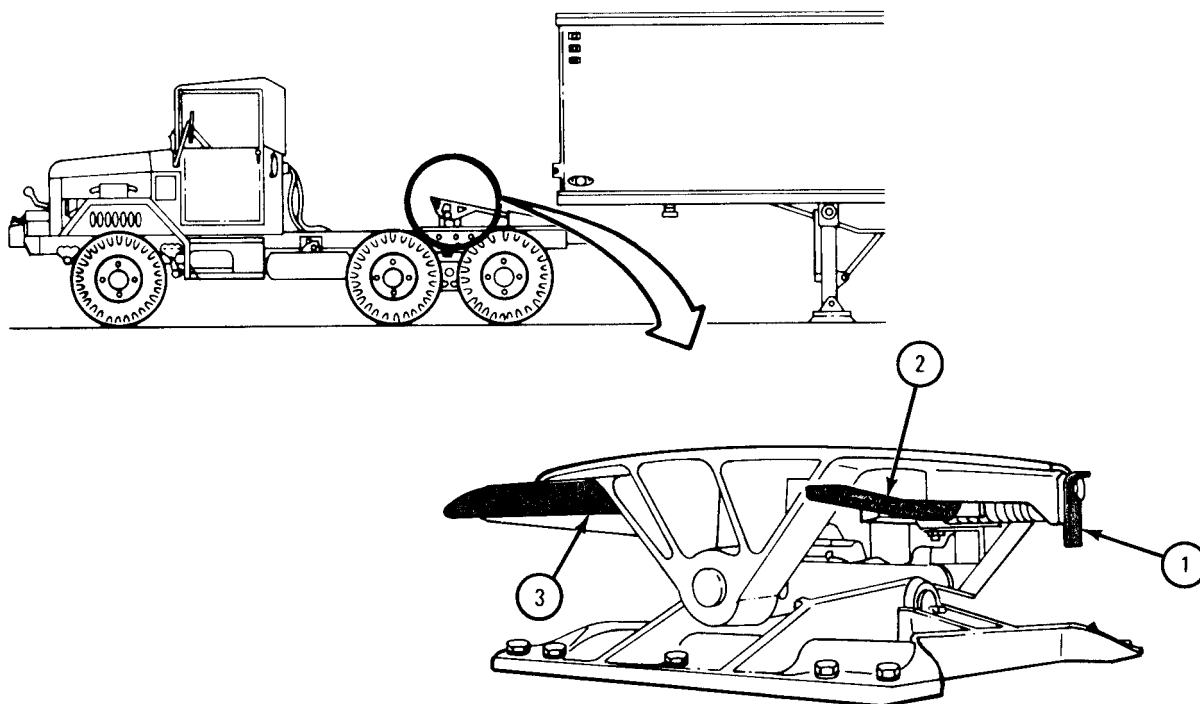

TA 045194

FRAME 4

1. Pull up on coupling half (1) of emergency airbrake hose (2) and take it from stowage bracket (3).

GO TO FRAME 5

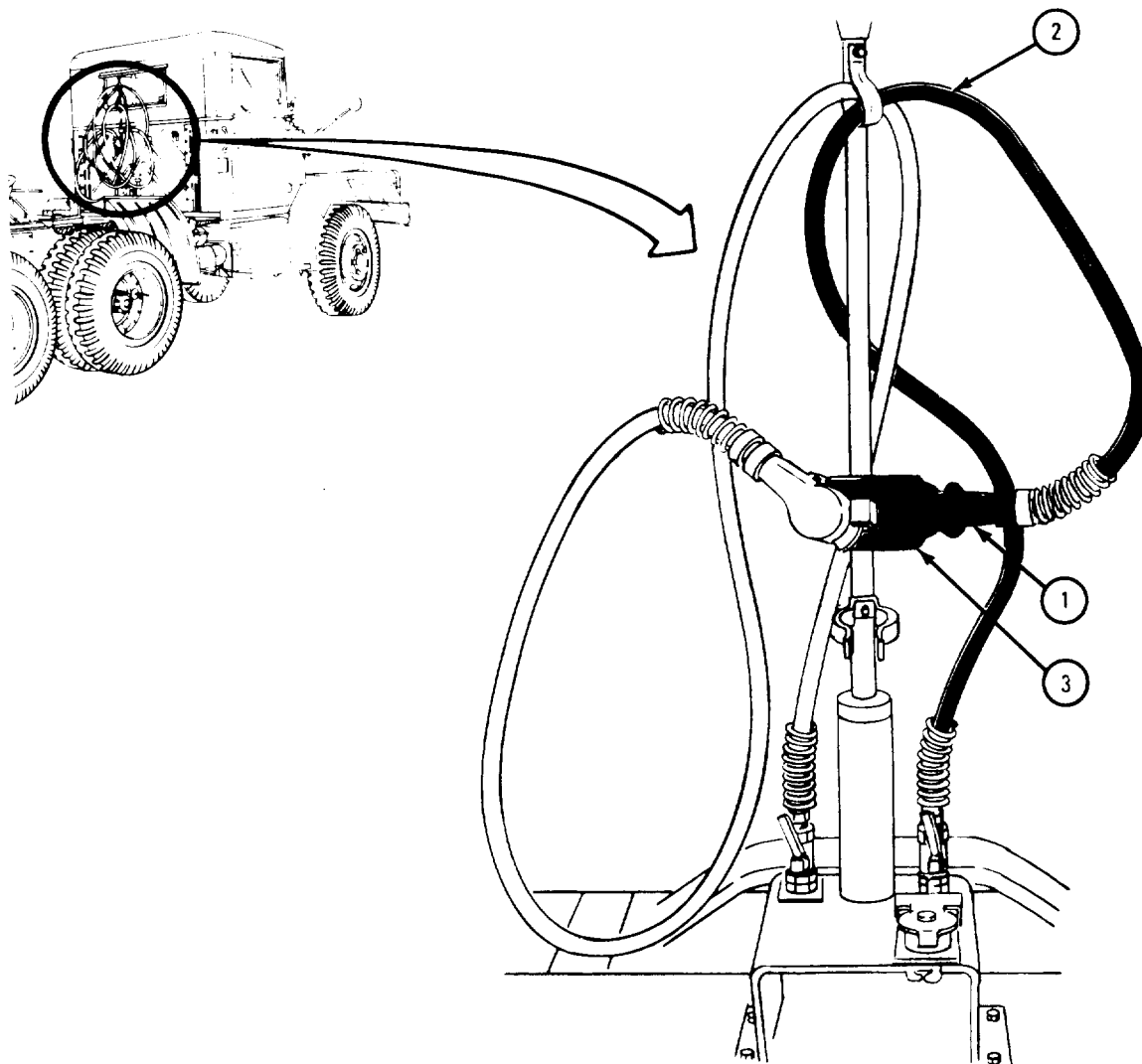

TA 045195

FRAME 5

1. Pull up on dummy coupling (1) and take it off semitrailer emergency airbrake coupling half (2).

**CAUTION**

Be sure to plug tractor emergency airbrake hose to semitrailer emergency coupling and service airbrake hose to service coupling. Hoses not hooked up right can cause brakes not to operate.

2. Place tractor emergency airbrake hose coupling half (3) to semitrailer emergency coupling half (2) and turn it down to lock.

GO TO FRAME 6

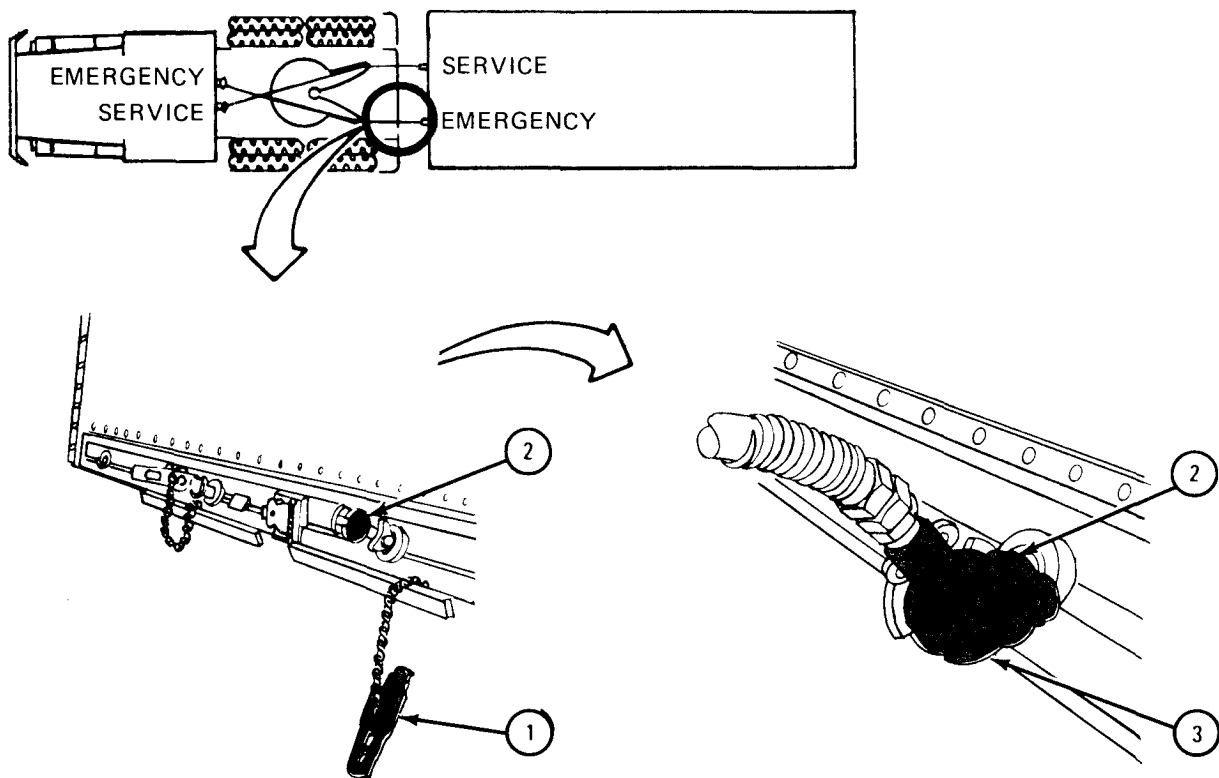

TA 045259

FRAME 6

1. Pull up on coupling half (1) of service airbrake hose (2) to take it from stowage bracket (3).

GO TO FRAME 7

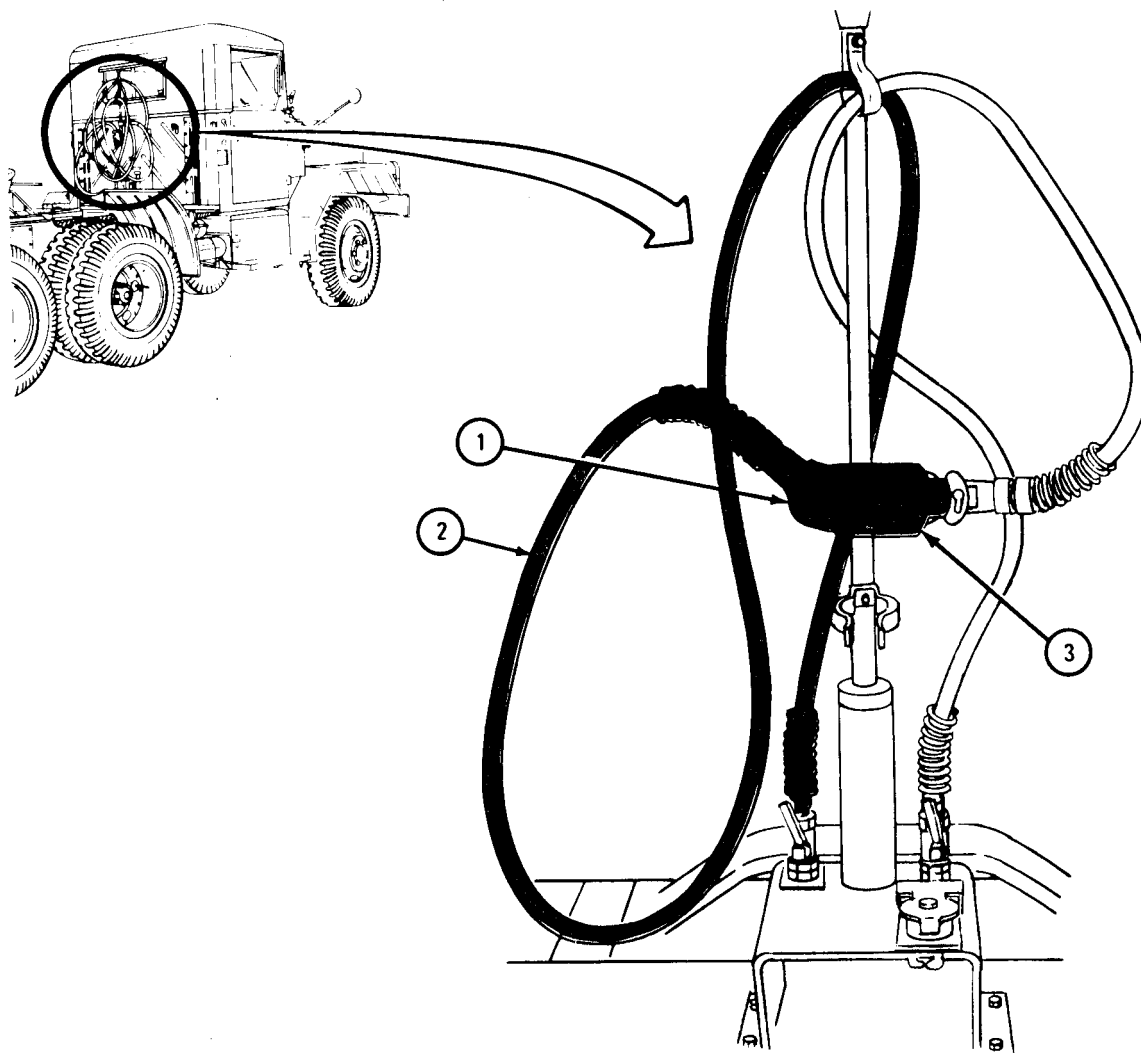

TA 102059

## FRAME 7

1. Pull up on dummy coupling (1) to take it off semitrailer service airbrake coupling half (2).
2. Place tractor service airbrake hose coupling half (3) to semitrailer service airbrake coupling half (2) and turn down to lock.

GO TO FRAME 8

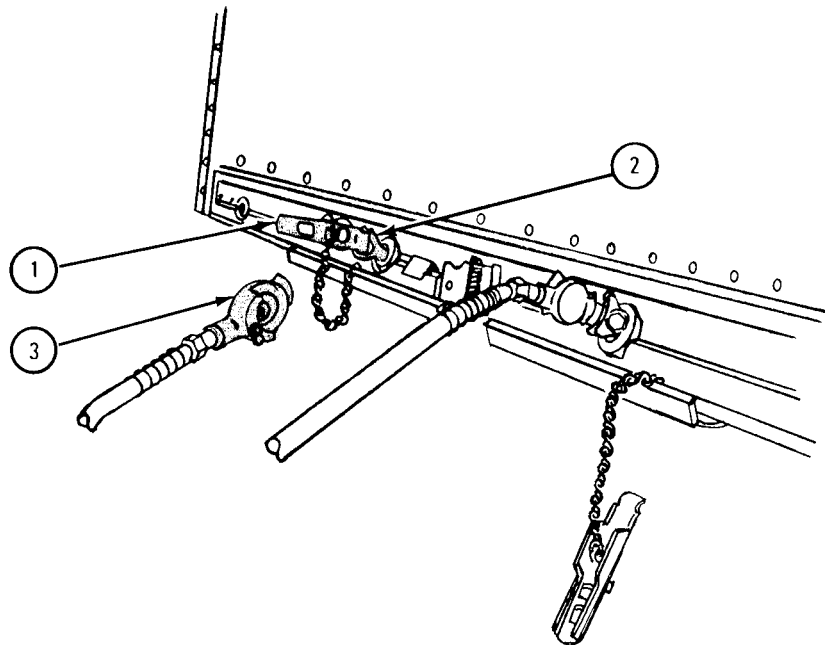
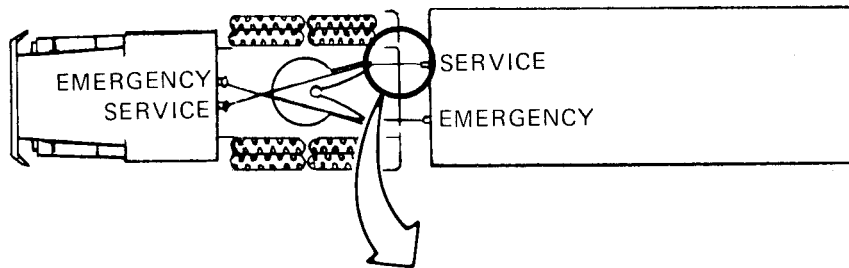

TA 045201

FRAME 8

1. Place both service and emergency cutout cocks (1) in side-to-side position, to turn on air supply.

GO TO FRAME 9

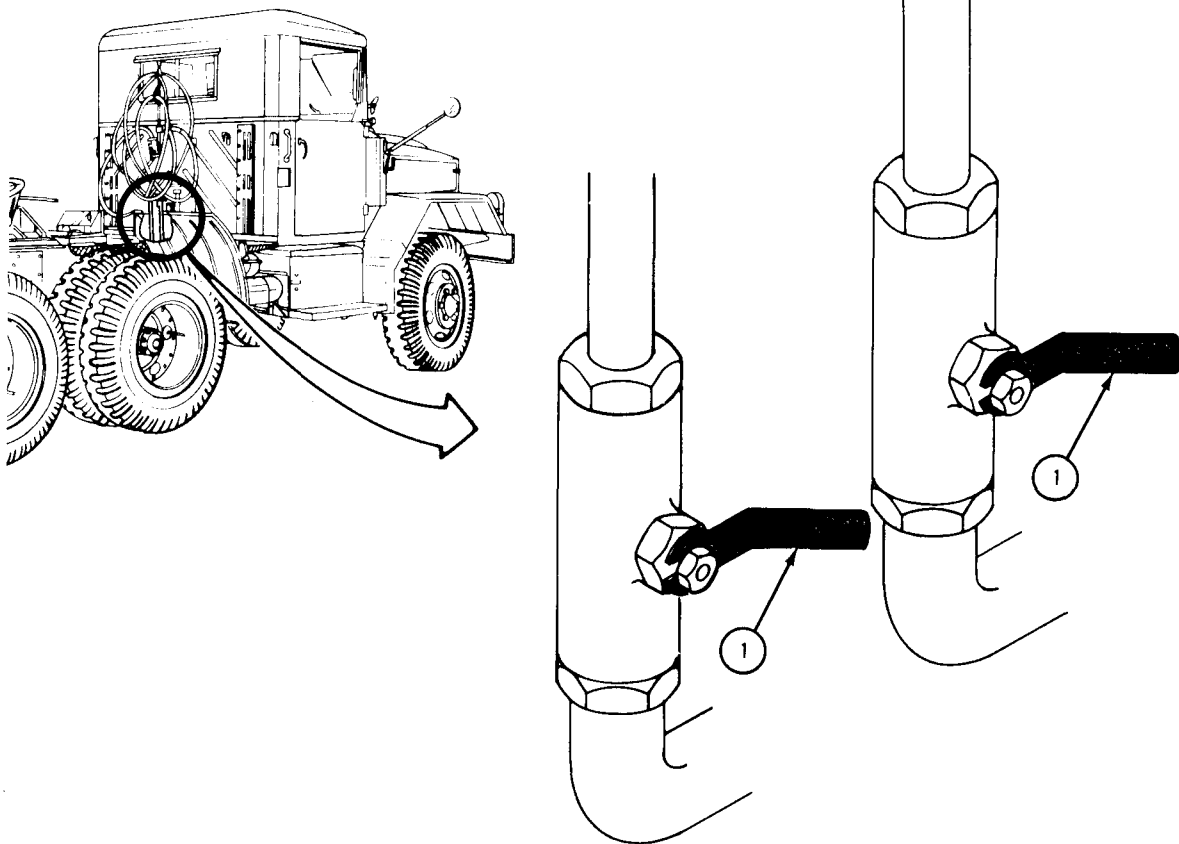

TA 045197

## FRAME 9

1. Pull down on airbrake hand control lever (1) to check service airbrake system. Air should be heard passing through control valve.

**NOTE**

If air flow is not heard, recheck hose connections and position of cutout cocks. If they are correct, tell organizational maintenance.

GO TO FRAME 10

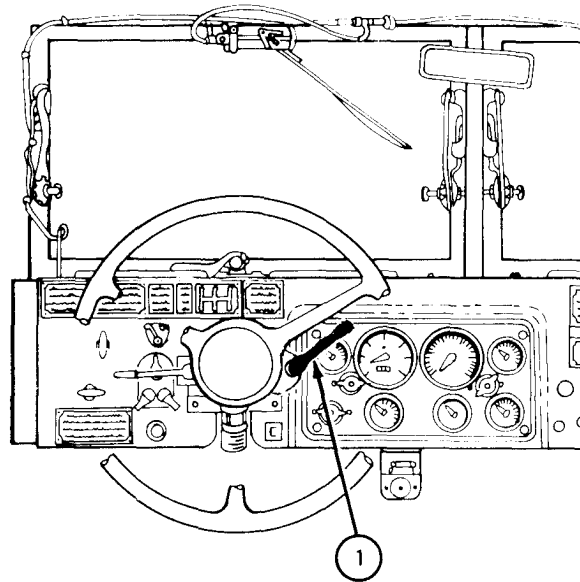

TA 045198

FRAME 10

1. Set handbrake lever (1) to off (down) position.
2. Slowly back tractor under semitrailer until fifth wheel locking jaws (2) are securely locked around semitrailer king pin (3). Place FRONT TRANSMISSION gear shift lever (4) in N position.
3. Set handbrake lever (1) to on (up) position.
4. Check fifth wheel to make sure that operating lever (5) is in rearward (locked) position; and that safety latch (6) is in vertical position.

GO TO FRAME 11

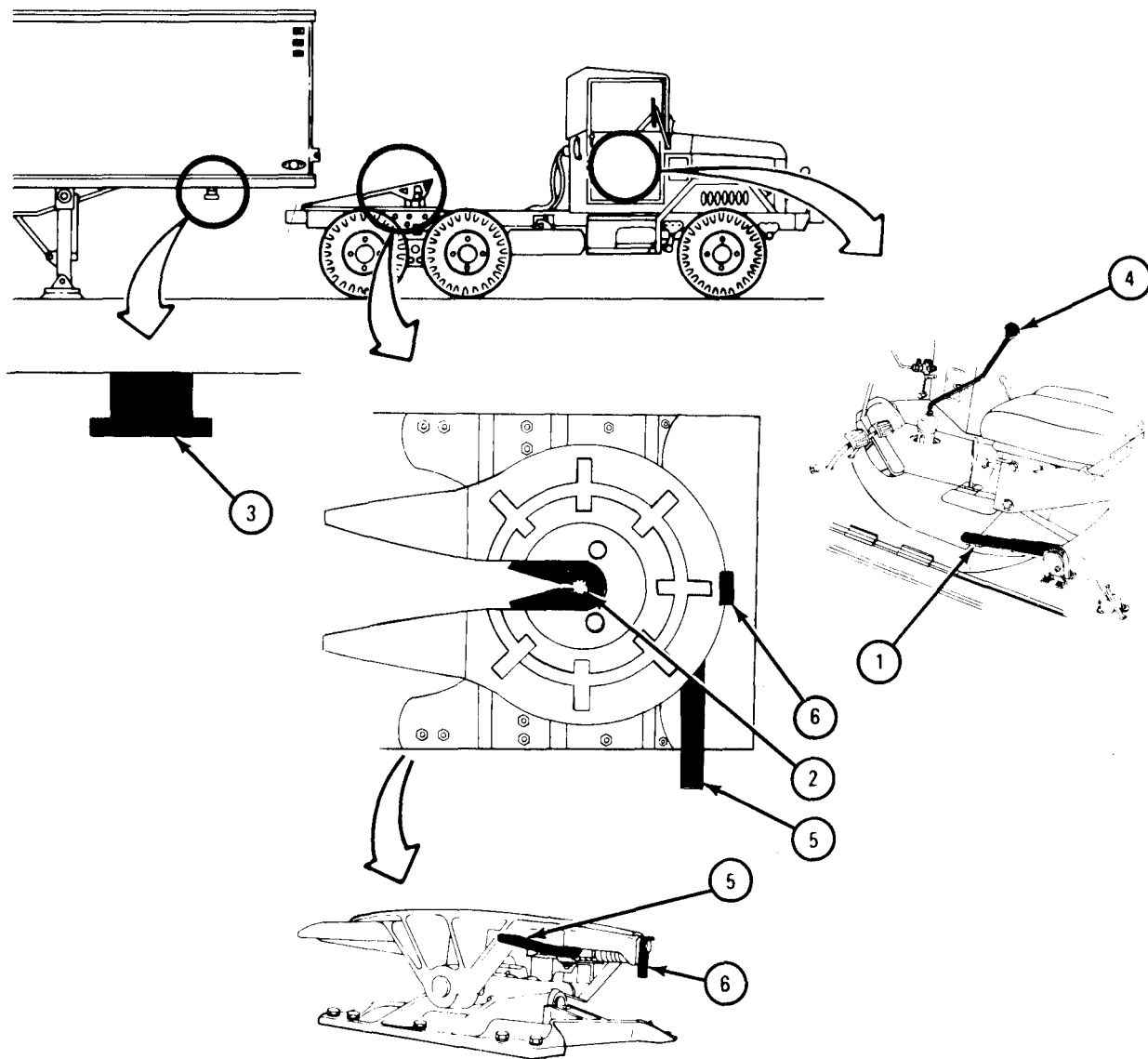

TA 045199



FRAME 11

1. Set handbrake lever (1) to off (down) position.
2. With semitrailer airbrake hand control lever (2) in down (on) position, slowly move tractor forward to get positive locking of semitrailer king pin (3) with fifth wheel (4).
3. When you are sure that locking is positive, place FRONT TRANSMISSION gearshift lever (5) in N position.
4. Stop engine, (refer to para 4-6e) and set handbrake lever (1) to on (up) position.
5. Raise trailer landing gear (6).

GO TO FRAME 12

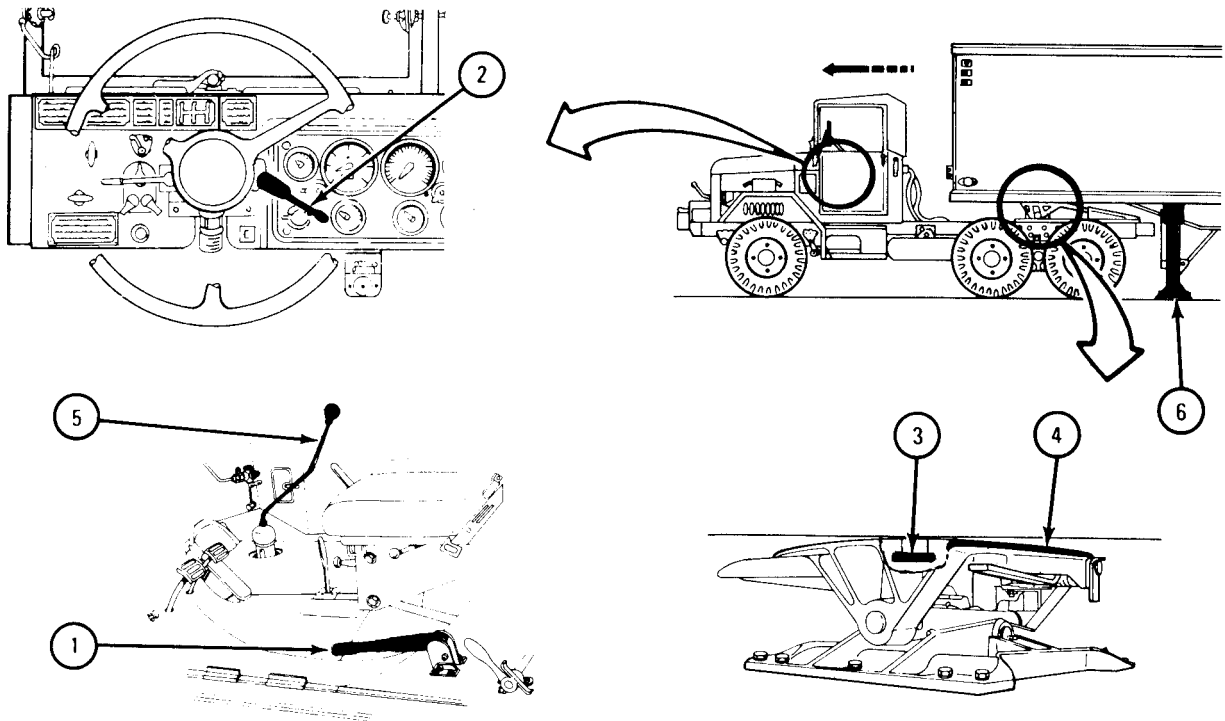

TA 045200

FRAME 12

1. Take electrical cable connector (1) from stowage clamp (2).
2. Pull back on cap (3) on connector (1) until it locks open.

GO TO FRAME 13

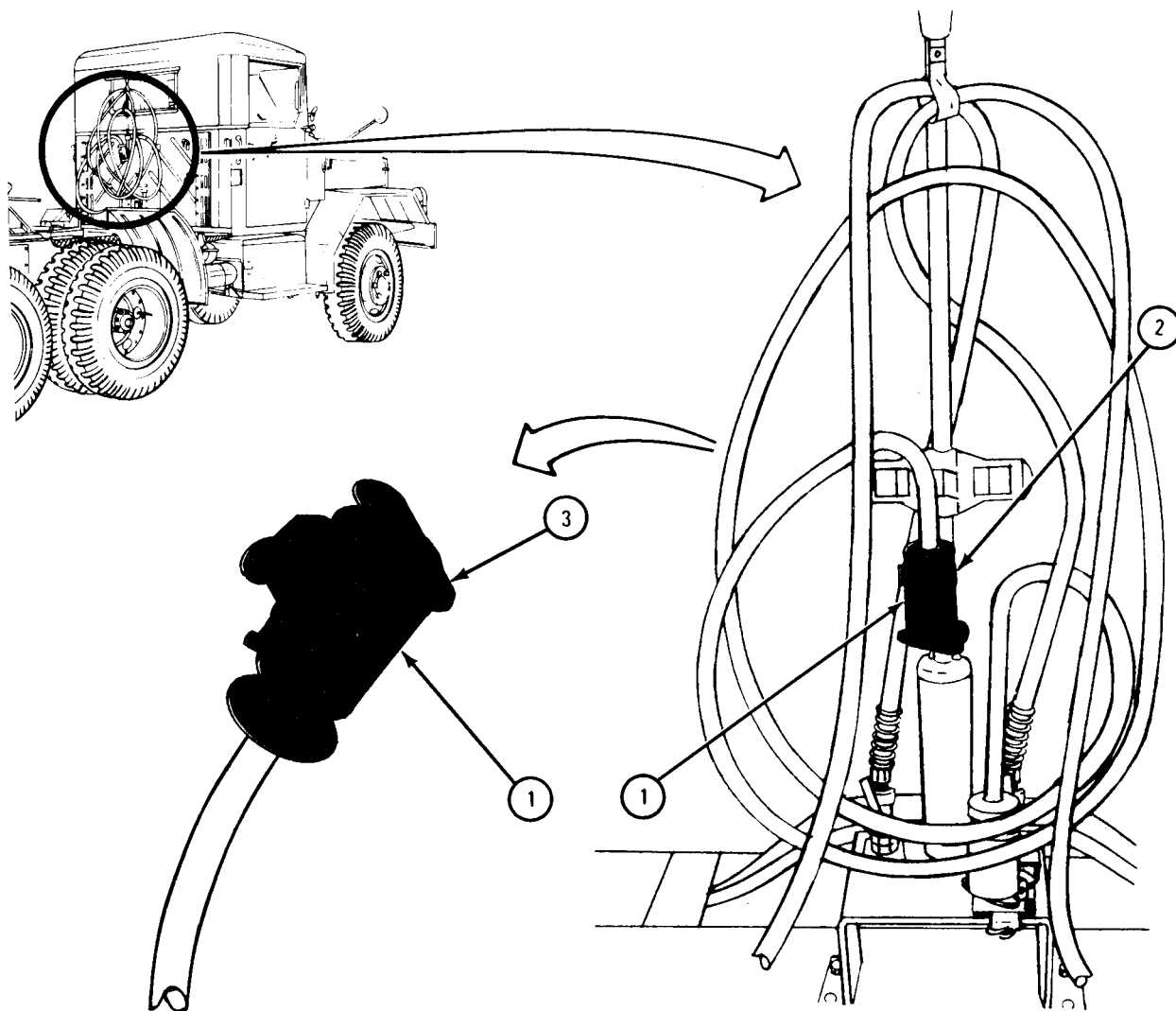

TA 084650

FRAME 13

1. Pull back and hold cap (1) of trailer electrical receptacle (2).

**CAUTION**

When plugging the tractor electrical cable connector (3) into the trailer receptacle do not force the connector. Forcing the connector could damage pins.

2. Plug tractor electrical cable connector (3) into trailer receptacle (2).
3. Let lip (4) on trailer receptacle cap (1) go into slot (5) in cable connector (3).

GO TO FRAME 14

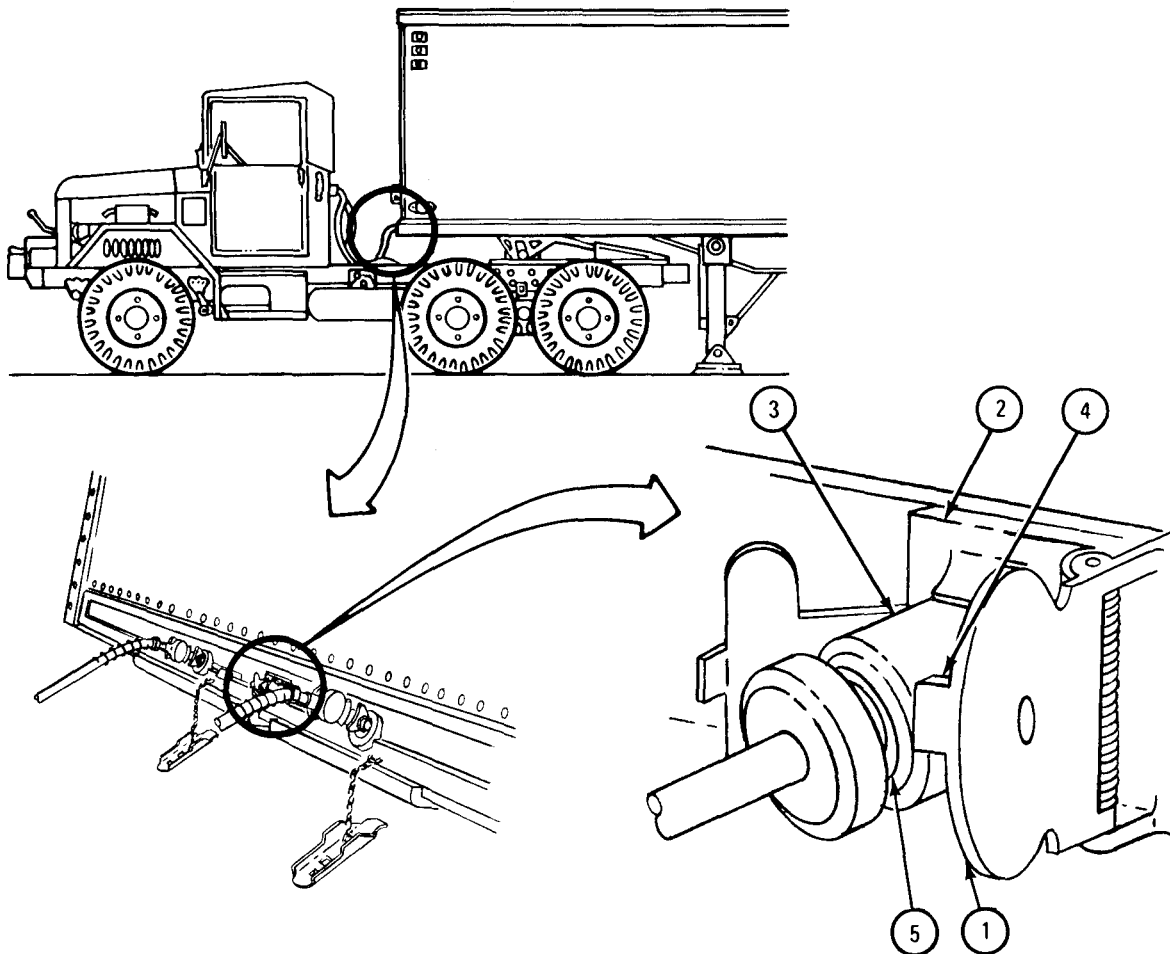

TA 045196

FRAME 14

- Soldier A 1. Using thumb, lift up on unlock lever (1) and hold it up.  
 2. Using forefinger, pull down main switch (2) to DRIVE position. Let go of unlock lever (1).
- Soldier B 3. Check semitrailer running lights (3) to see if they are on.
- Soldier A 4. Press service foot brake (4) .
- Soldier B 5. Check semitrailer stop lights (5) to see if they go on.
- Soldier A 6. Turn main switch (2) to STOP position.

**NOTE**

If lights do not work right tell organizational maintenance.

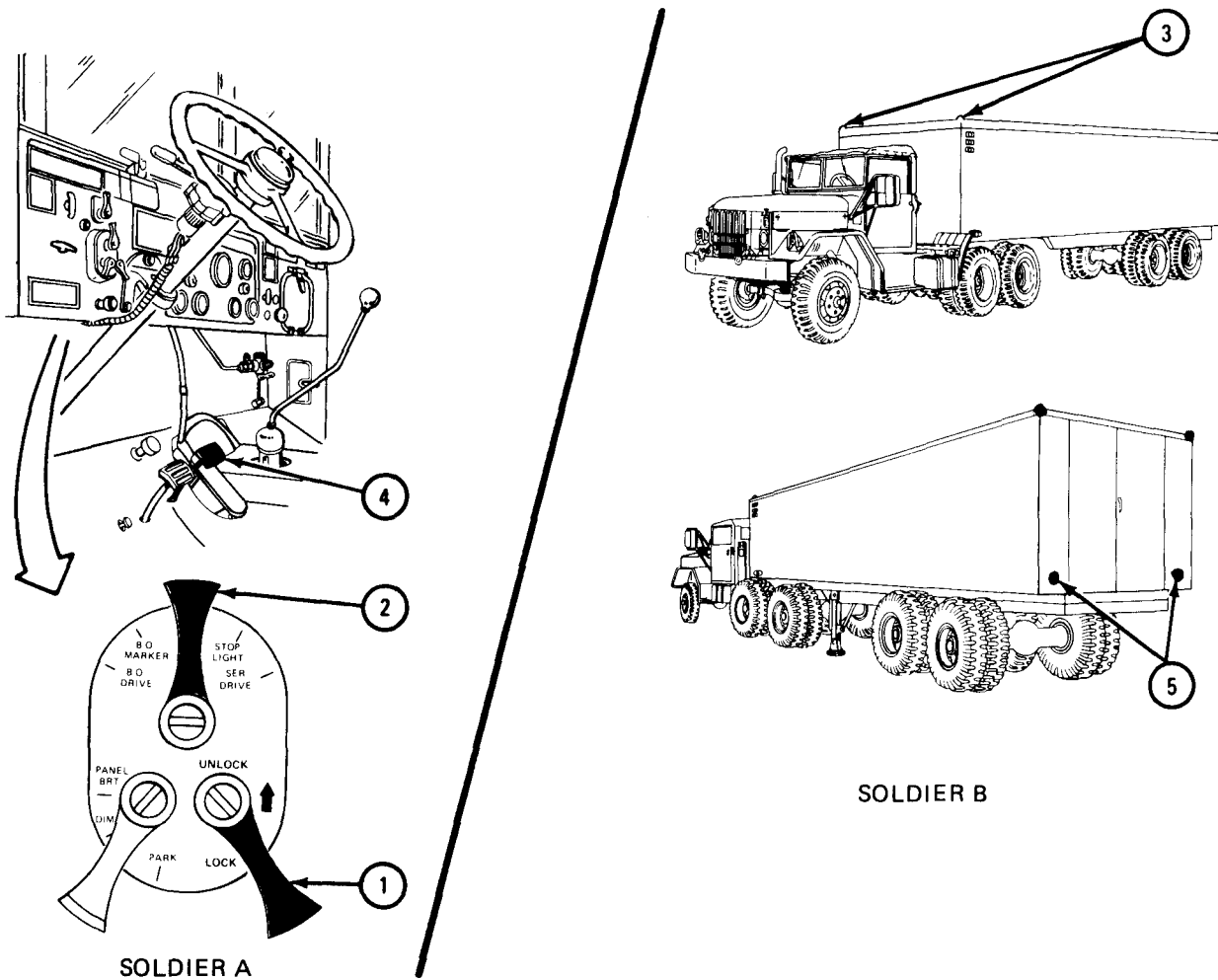

SOLDIER B

TA 045193

c. Uncoupling the Semitrailer.

FRAME 1

1. Start engine. (Refer to para 4-6b.)
2. Place truck where you want to leave semitrailer.
3. Set semitrailer airbrake hand control (1) to on (down) position.
4. Set handbrake lever (2) to on (up) position.
5. Place FRONT TRANSMISSION lever (3) in N position.
6. Lower semitrailer landing gear (4). (Refer to TM for trailer).
7. Pull back on hinged cap (5) and take out electrical connector (6) from receptacle (7).
8. Push cap (8) closed on connector (6).
9. Place connector (6) in stowage clamp (9) on hose support (10).

GO TO FRAME 2

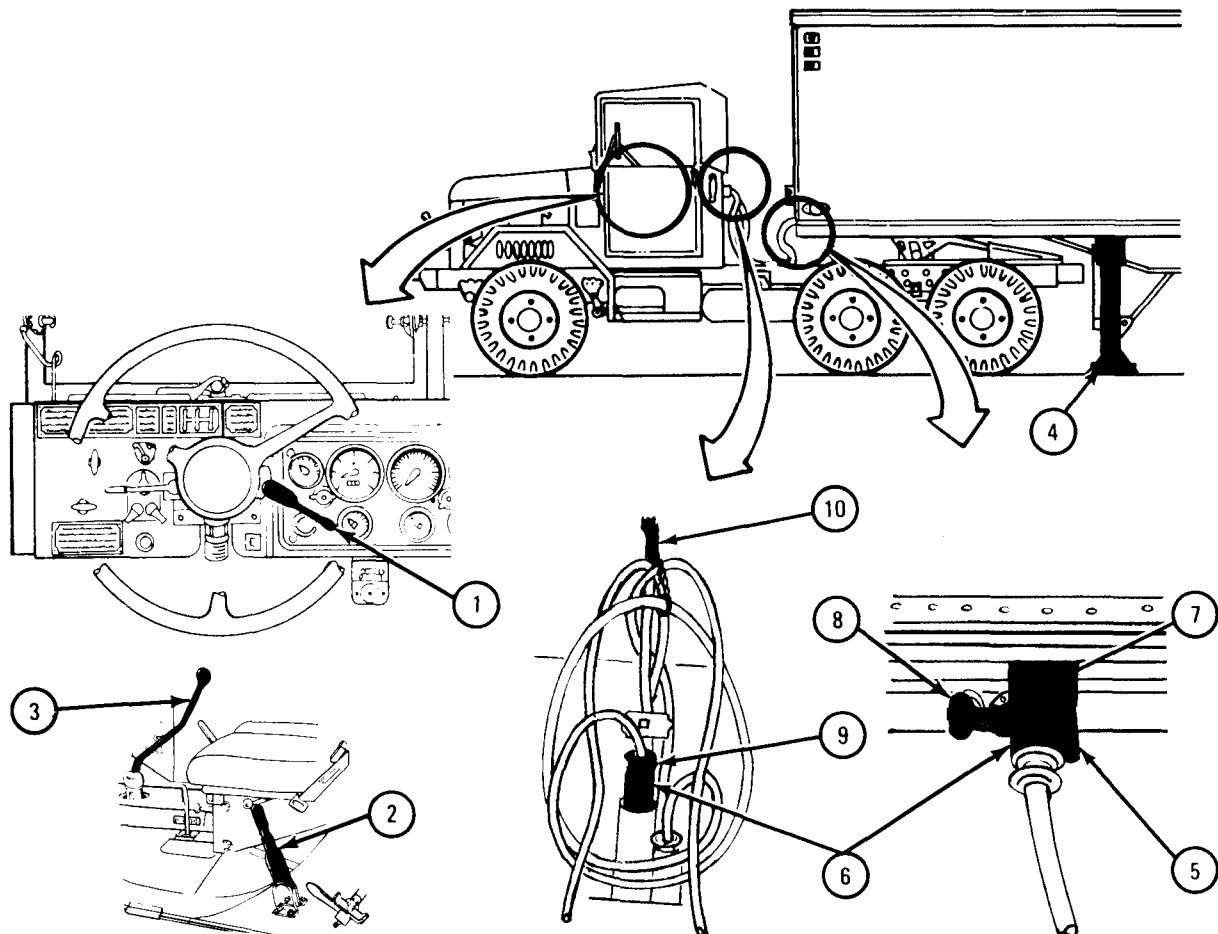

TA 045202

FRAME 2

1. Turn safety latch (1) to set locking plunger free.
2. Move operating handle (2) forward until it remains in forward position.
3. Coupler jaws (3) are now unlocked.

GO TO FRAME 3

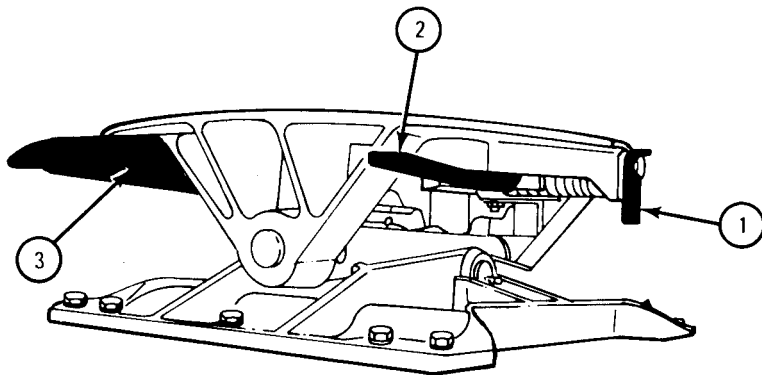
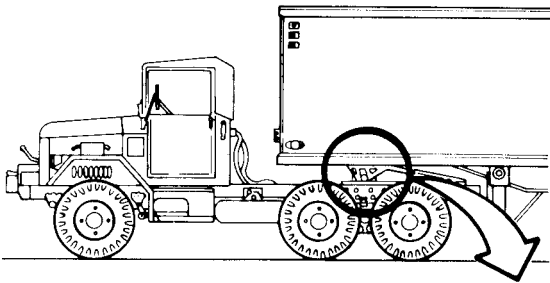

TA 045203

## FRAME 3

1. Move handbrake lever (1) to off (down) position.
2. Slowly move tractor forward until fifth wheel (2) is clear of semitrailer skid plates (3).
3. Stop engine. (Refer to para 4-6e.)

GO TO FRAME 4

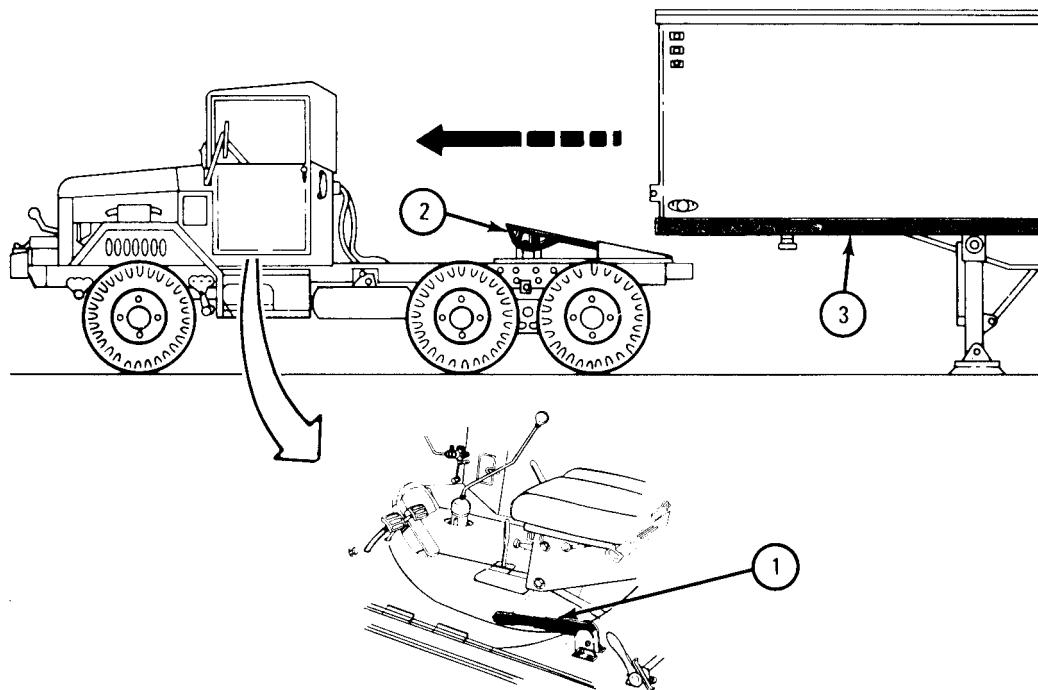

TA 045204

FRAME 4

1. Set handbrake lever (1) to on (up) position.
2. Move FRONT TRANSMISSION gear shift lever (2) to N position.
3. Set semitrailer airbrake hand control lever (3) to off (up) position.
4. Turn both cutout cocks (4) to off (up and down) position to turn off the air supply.
5. Unlock and separate emergency and service hose coupling halves (5) from semitrailer coupling halves (6).
6. Place emergency and service hose coupling halves (5) on stowage bracket (7) on hose support (8).

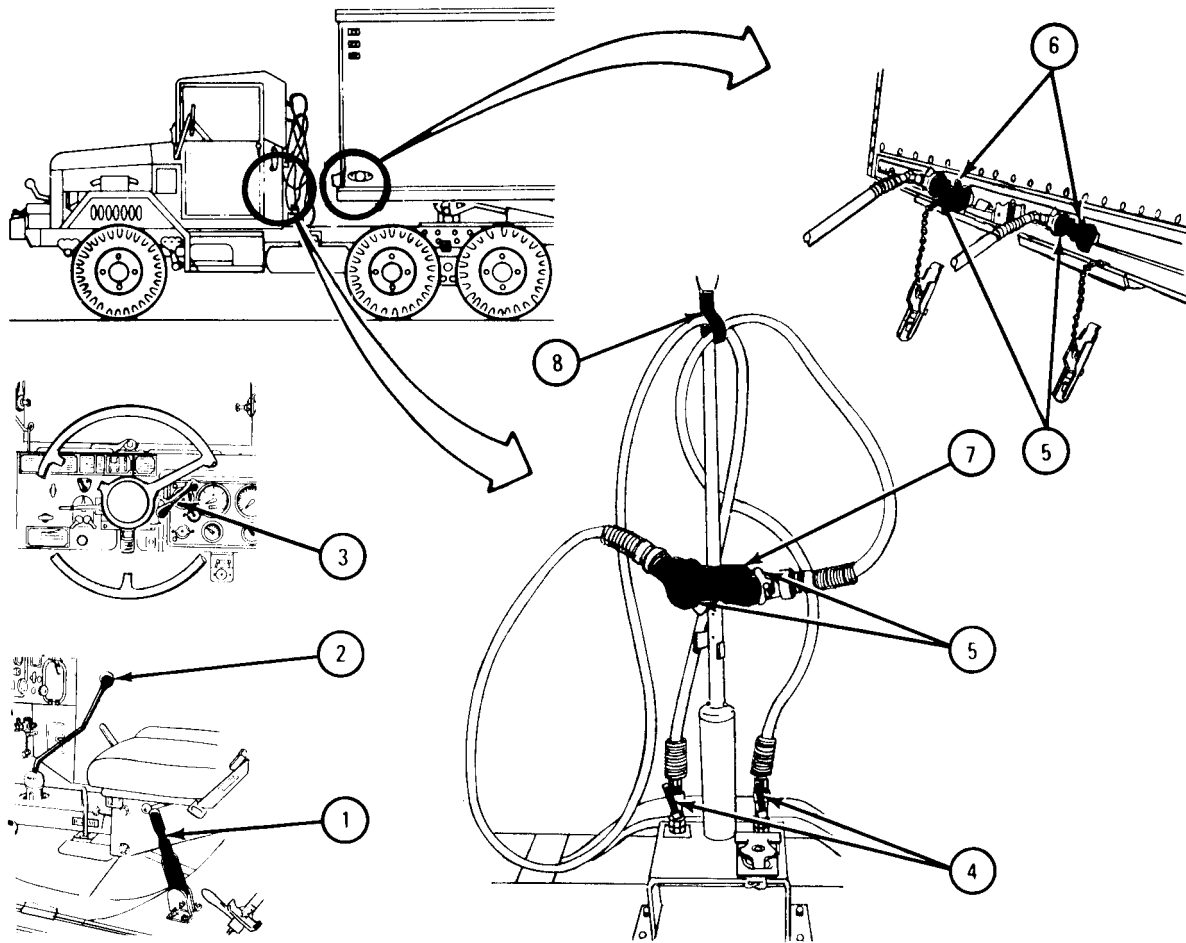

TA 045205



4-13. OPERATION OF DUMP TRUCKS.

a. **General.** Dump trucks covered in this manual may be used as regular cargo carriers, or for dumping and spreading operations. Payload capacity for cross country operation is 5,000 pounds. Payload capacity for prepared roads is 10,000 pounds. Refer to table 4-2, weight chart for typical materials.

Table 4-2. Weight of Material in Truck

Material	Weight of Material (lb)		Capacity	
			Level Full (2. 51 cu yd or 67.79 tuft)	Heaping Full (3. 76 cu yd or 101.50 cu ft)
	Per cu-ft	Per cu-yd	Loaded Weight (lb approx)	Loaded Weight (lb approx)
Ashes (soft coal)	44	1,188	2,985	4,470
Cinders	46	1,242	3,120	4,675
Clay:				
Dry	63	1,701	4,270	6,400*
Wet	110	2,970	7,460	11,175†
Coal:				
Anthracite	52	1,404	3,525	5,280
Bituminous	47	1,269	3,190	4,775
Coke	28	756	1,900	2,845
Concrete mix (wet)	124	3,618	9,095*	13,615†
Coral rock	25	675	1,695	2,540
Earth:				
Dry or moist (loose)	80	2,160	5,425*	8,125*
Dry or moist (packed)	96	2,592	6,510	9,750*
Garbage:				
Wet	47	1,269	3,190	4,775
Dry (paper wrapped)	13	351	881	1,320
Gravel	110	2,970	7,460*	11,175†
Limestone (crushed)	95	2,565	6,435*	9,650*
Masonry (dry rubble)	122	3,294	8,280*	12,390†
Mortar	100	2,700	6,780*	10,150†
Mortar (dry rubble)	138	3,726	9,360*	14,025†
Mud	115	3,105	7,800*	11,690
Sand:				
Dry (loose)	98	2,646	6,645*	9,950*
Dry (packed)	110	2,970	7,460*	11,175†
Wet or moist	122	3,294	8,280*	12,390†
Stones (loose)	95	2,565	6,435*	9,650*

\* Over the rated cross-country payload.  
† Over the rated cross-country and highway payload.

b. Rigging the Tailgate.

(1) Rigging to swing open at bottom for dumping and spreading operations.

FRAME 1

1. Pass free end of chains (1) through retainers (2) and through holes at top of locking slots (3).
2. Leave enough slack in chains (1) to let tailgate (4) swing open. Opening must be wide enough for material to slip through when body is lifted.
3. Lock chains (1) in place by slipping them down to bottom of locking slots (3).

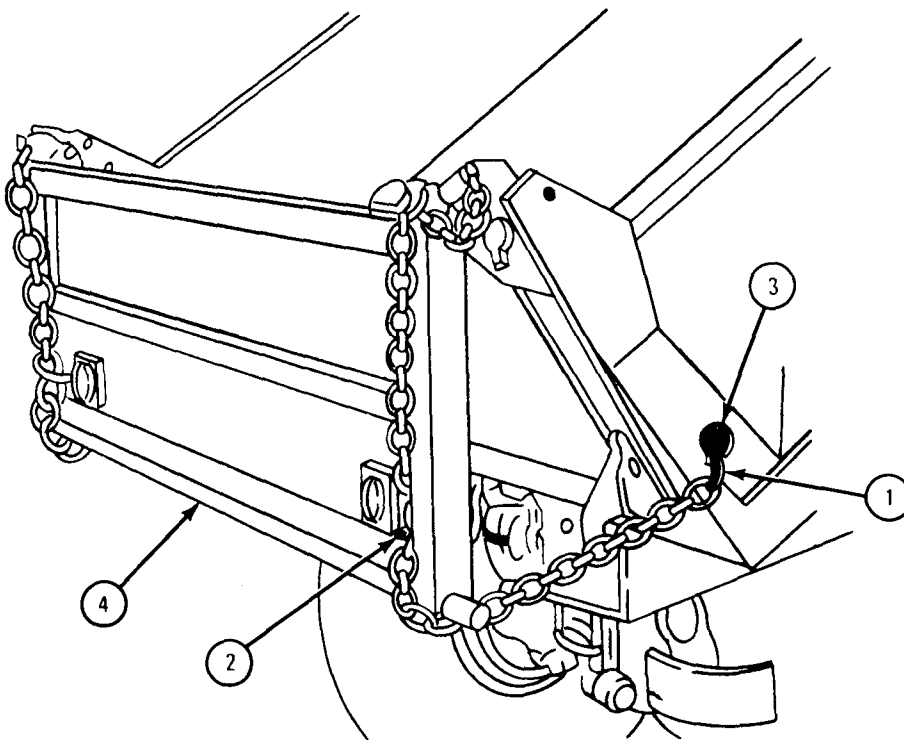

TA 045206

(2) Rigging to swing open at top for regular loading or unloading.

FRAME 1

1. Move chains (1) up, from locking position at bottom of lower locking slot (2) to hole at top of slot. Take chains out of slots and retainers (3).
2. Put chains (1) through holes at top of upper locking slots (4).
3. Pull locking pins (5) out and move tailgate (6) down slowly. Do not let it drop.
4. Pull chains (1) through until they hold weight of tailgate (6) in open position, in line with truck bed (7).
5. Slip chains (1) to bottom of locking slots (4) to lock them in position.

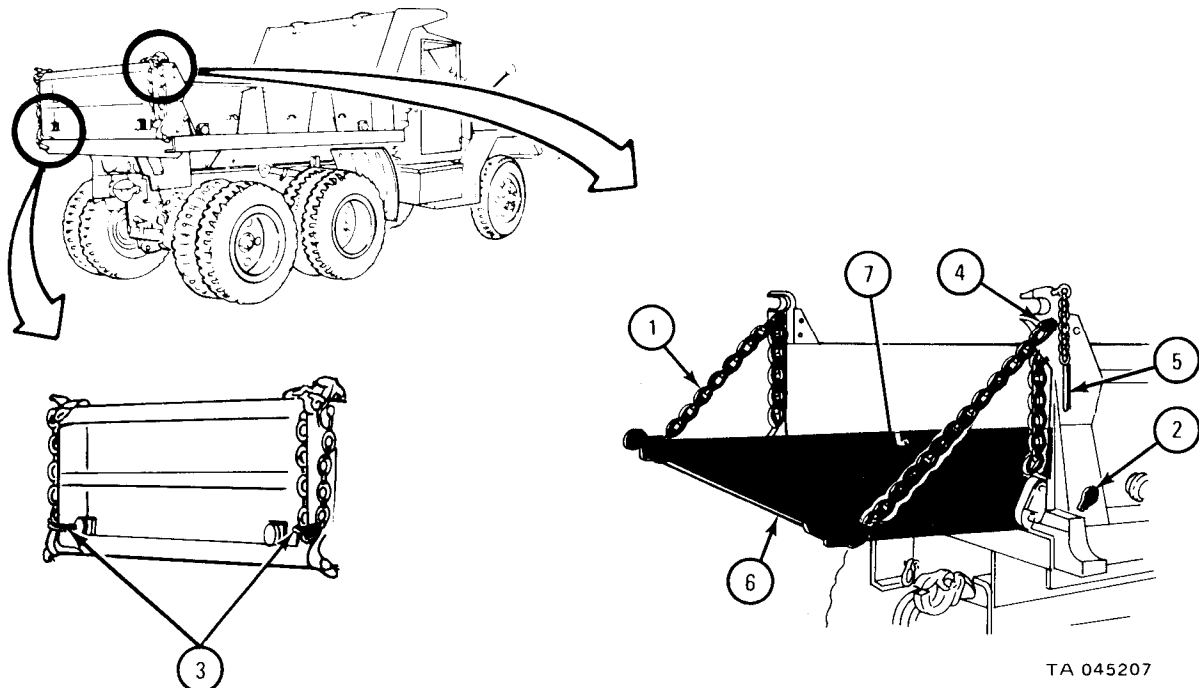

- c. Loading the Dump Truck.  
(1) Loading from the top.

**FRAME 1**

1. Start engine. (Refer to para 4-6b.)
  2. Move truck so that dump body (1) is under loading device (2).
- GO TO FRAME 2

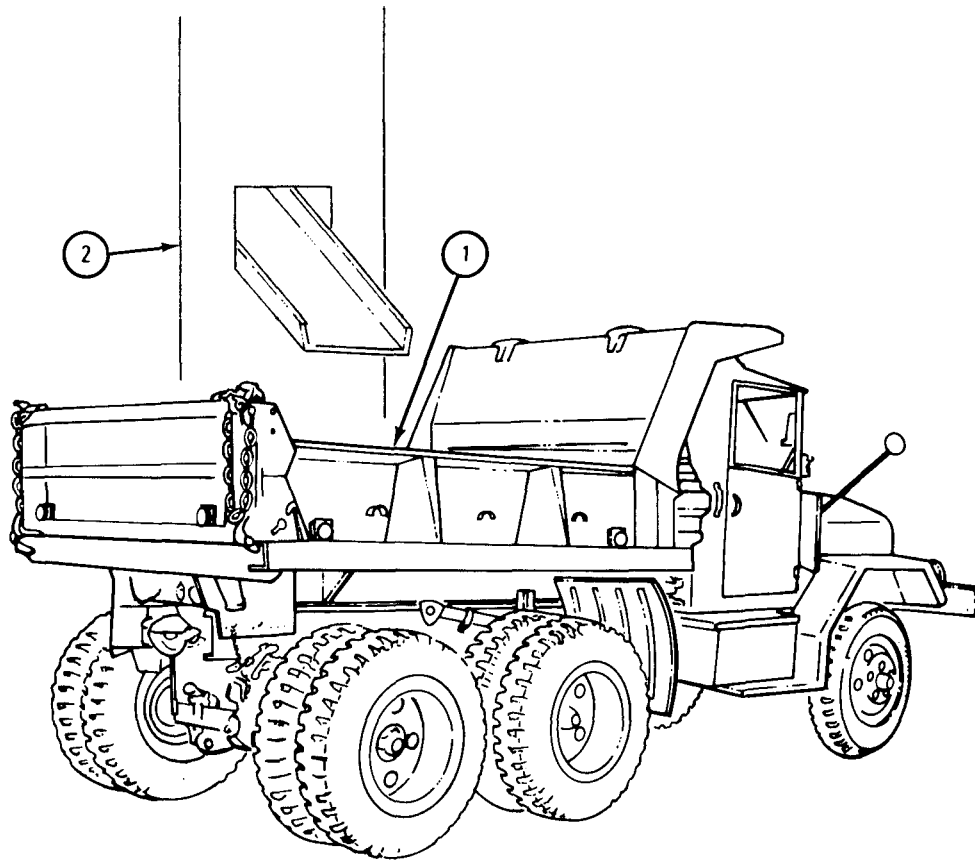

TA 045208

## FRAME 2

1. Pull handbrake lever (1) up, to on position.
2. Press down on clutch pedal (2) all the way.
3. Place FRONT TRANSMISSION gearshift lever (3) in position N, and let clutch pedal (2) come up.
4. Stop engine. (Refer to para 4-6e.)

GO TO FRAME 3

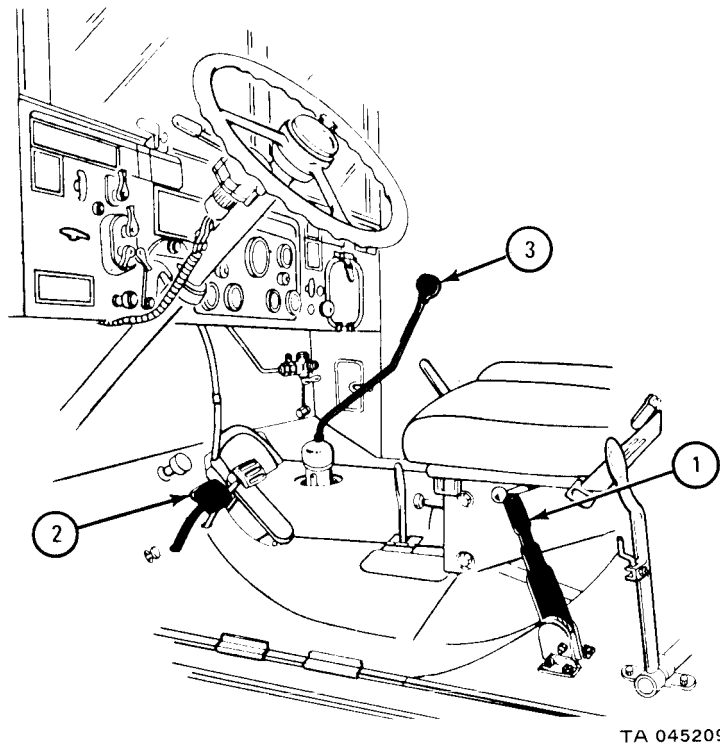

FRAME 3

1. Rig tailgate (1) for loading. Refer to para 4-13b.
2. Load truck, following payload capacity given in table 4-2, and standard safety precautions.

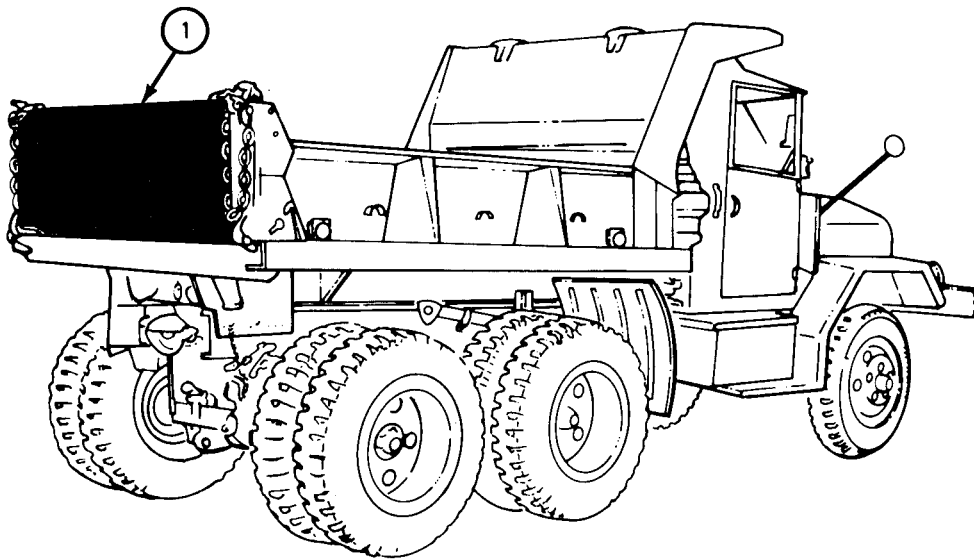

TA 045210

(2) Loading from the end.

FRAME 1

1. Rig for loading and lower tailgate (1). Refer to para 4-13b.
  2. Start engine. (Refer to para 4-6b.)
  3. Back truck into position near loading ramp or platform.
- GO TO FRAME 2

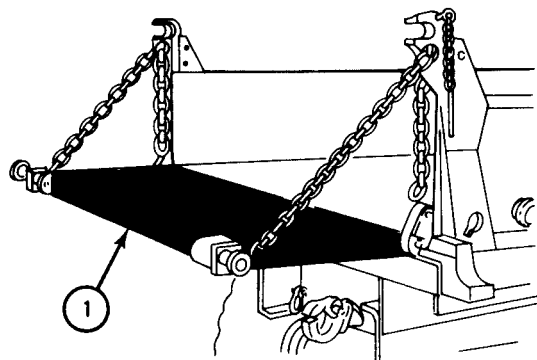
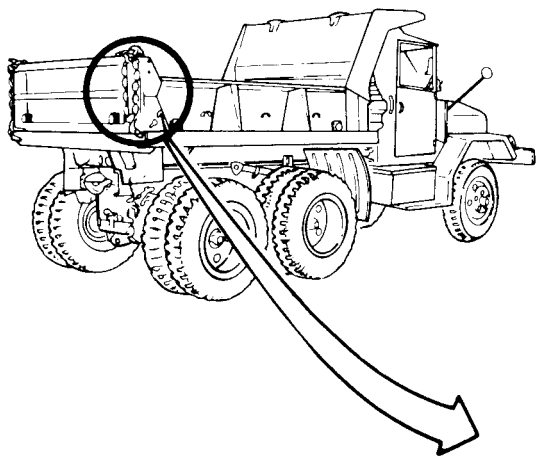

TA 045211

FRAME 2

1. Pull handbrake lever (1) up, to on position.
2. Press down on clutch pedal (2) all the way.
3. Place FRONT TRANSMISSION gearshift lever (3) in position N, and let clutch pedal (2) come up.
4. Stop engine. (Refer to para 4-6e.)

GO TO FRAME 3

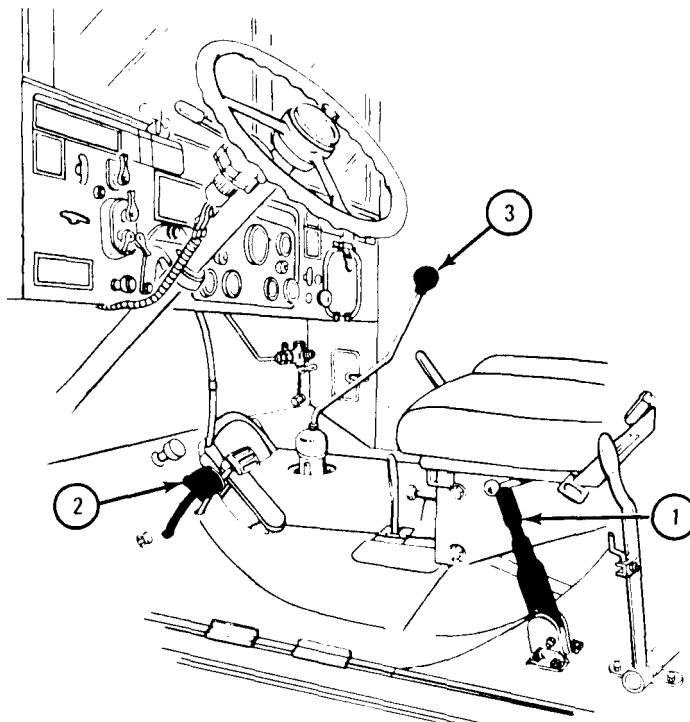

TA 045212



## FRAME 3

1. Load truck, following payload capacity given in table 4-2, and standard safety precautions.
2. After loading is finished, lift tailgate (1) to closed position, and lock it in place with locking pins (2).

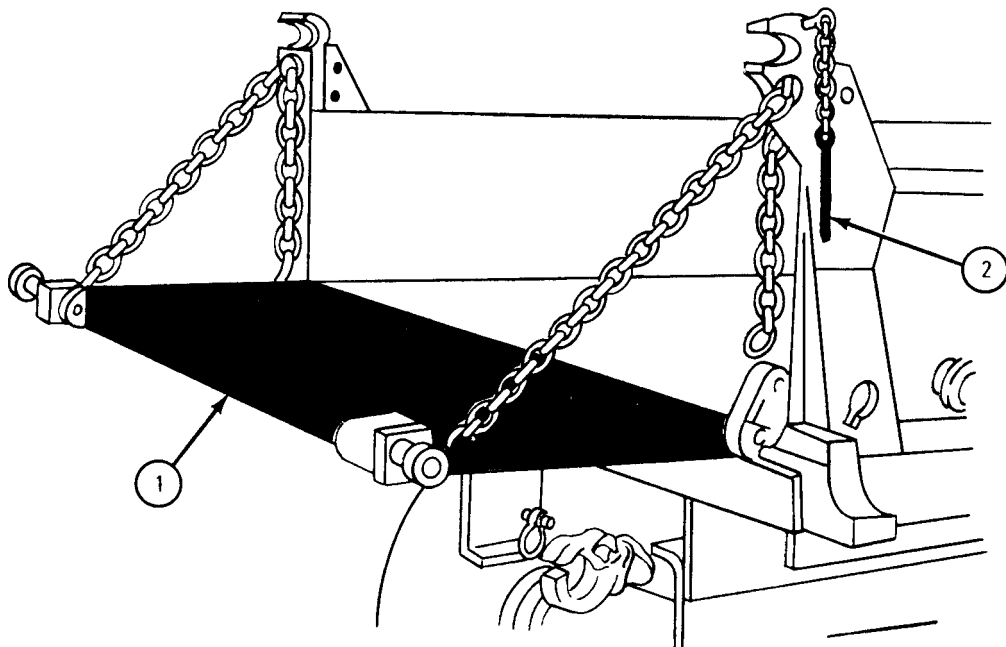

TA 045213

d. Unloading the Dump Truck with Body Down.

FRAME 1

1. Rig for unloading and lower tailgate (1) to flat position. (Refer to para 4-13b.)
  2. Start engine. (Refer to para 4-6b.)
  3. Back truck up to unloading dock or platform.
- GO TO FRAME 2

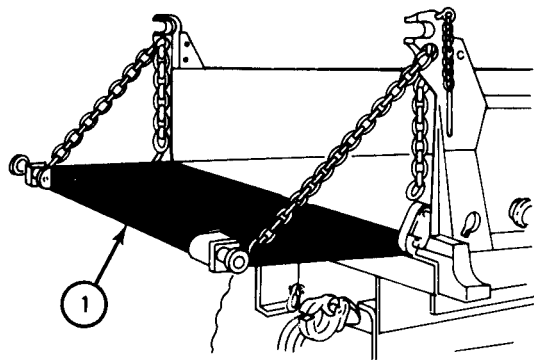
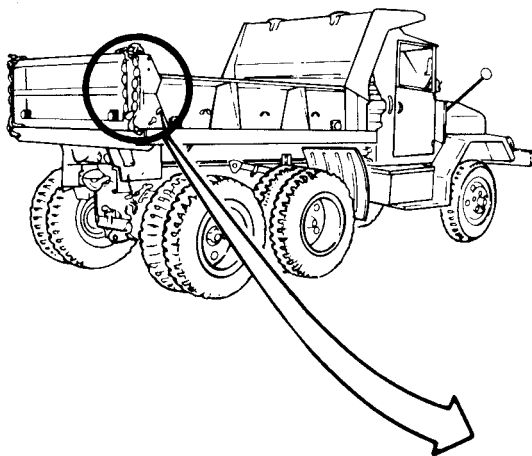

TA 045211

## FRAME 2

1. Pull handbrake lever (1) up, to on position.
2. Press down on clutch pedal (2) all the way down.
3. Place FRONT TRANSMISSION gearshift lever (3) in position N, and let clutch pedal (2) come up.
4. Stop engine. (Refer to para 4-6e.)

GO TO FRAME 3

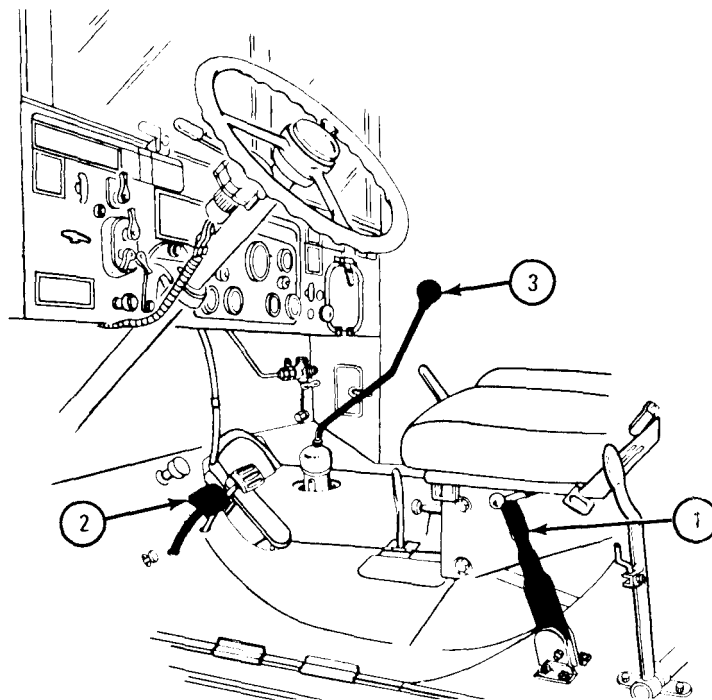

TA 045214

FRAME 3

1. Unload truck, following all safety precautions.
2. After unloading, lift tailgate (1) and lock in place with locking pins (2) on both sides of tailgate.

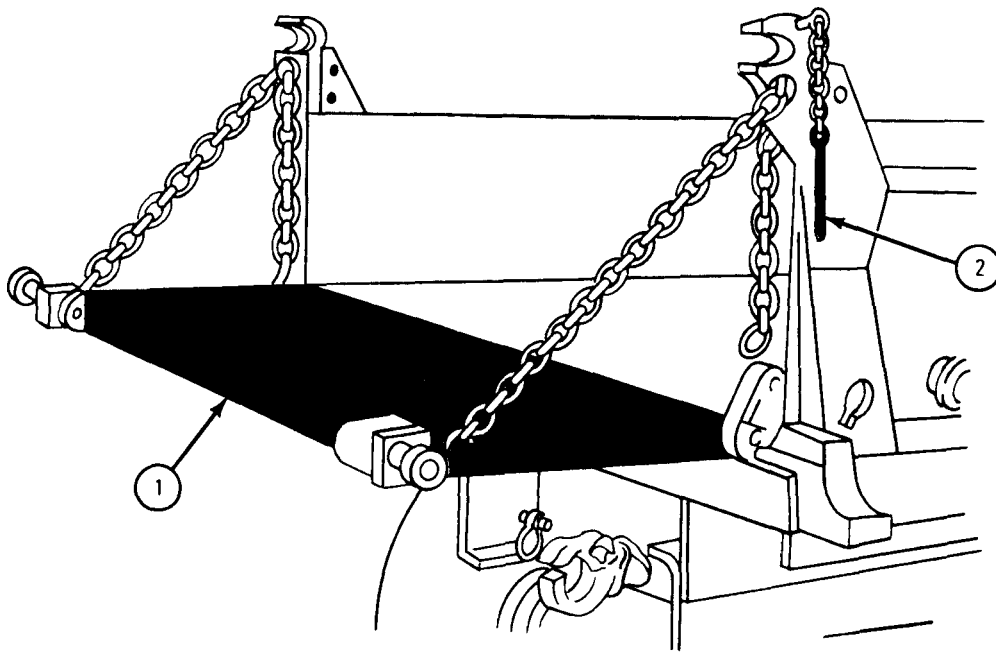

TA 045213

e. Unloading the Dump Truck by Dumping.

## FRAME 1

1. Start engine. (Refer to para 4-6b.)
2. Place truck so that tailgate (1) is over dumping area.
3. Pull handbrake lever (2) up to on position.
4. Press down on clutch pedal (3) all the way.
5. Place FRONT TRANSMISSION gearshift lever (4) in N position and let clutch pedal (3) come up.

GO TO FRAME 2

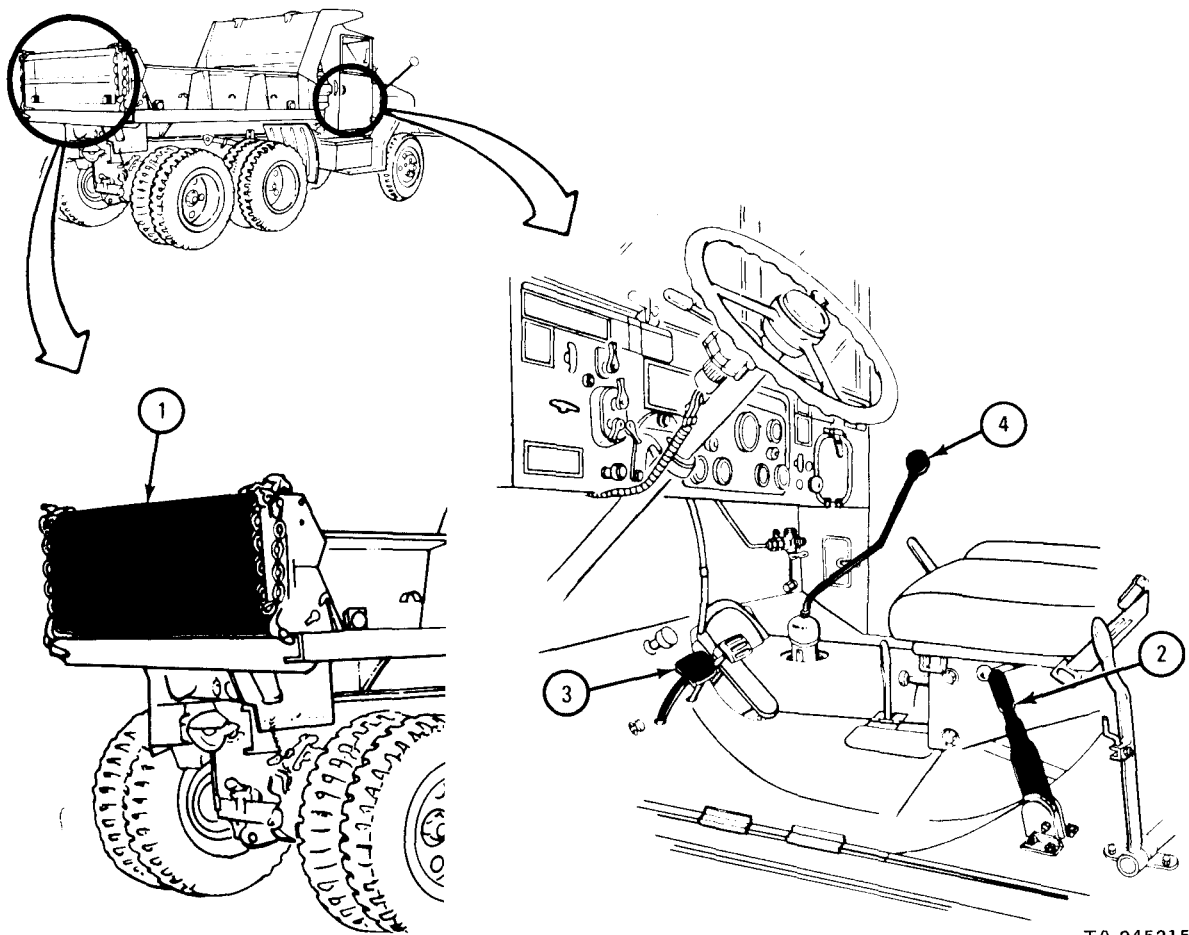

TA 045215

FRAME 2

1. Rig tailgate (1) to swing open at bottom. (Refer to para 4-13b.)
  2. Open tailgate lock by pulling tailgate hand lever (2) forward and down.
- GO TO FRAME 3

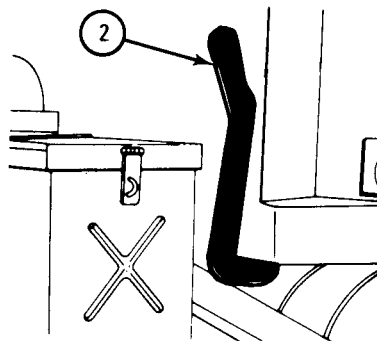
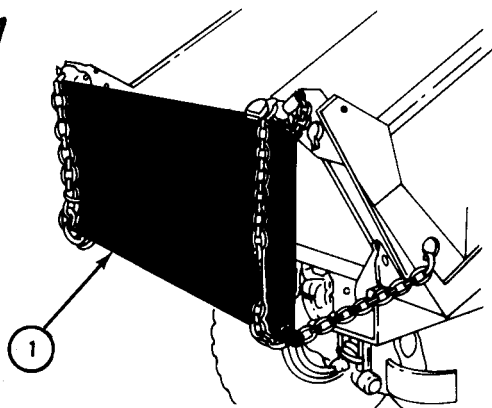
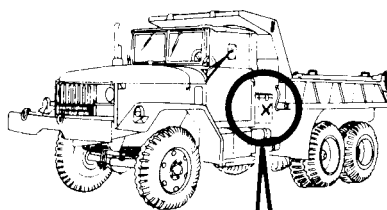
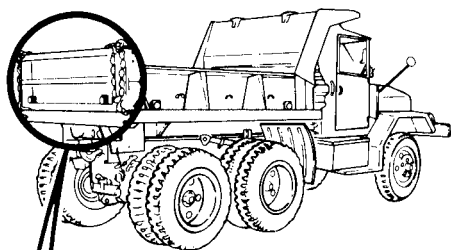

TA 045216

## FRAME 3

1. Set safety lock (1) on hoist control lever (2) free.
2. Step down on accelerator pedal (3) far enough to keep engine from stalling.
3. Press down on clutch pedal (4) all the way.
4. Move hoist control lever (2) forward, all the way to position D, to lift dump body.
5. Let clutch pedal (4) up.
6. When dump body is up as high as needed to dump load, move hoist control lever (2) back, to position C. This will stop lifting and will hold dump body position.
7. Dump load.

GO TO FRAME 4

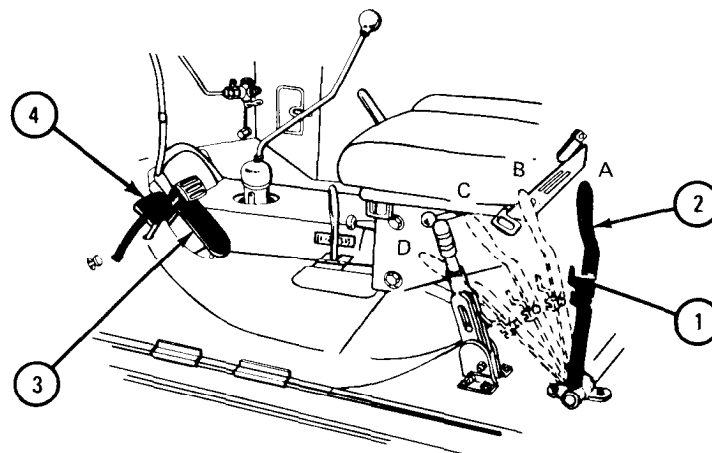

TA 045217

FRAME 4

1. After dumping load, clear area near tailgate (1) of all material.
2. Move hoist control lever (2) to position B, to let dump body down.
3. After dump body is down, move hoist control lever (2) to position A.
4. Put safety lock (3) on.
5. Stop engine. (Refer to para 4-6e.)

GO TO FRAME 5

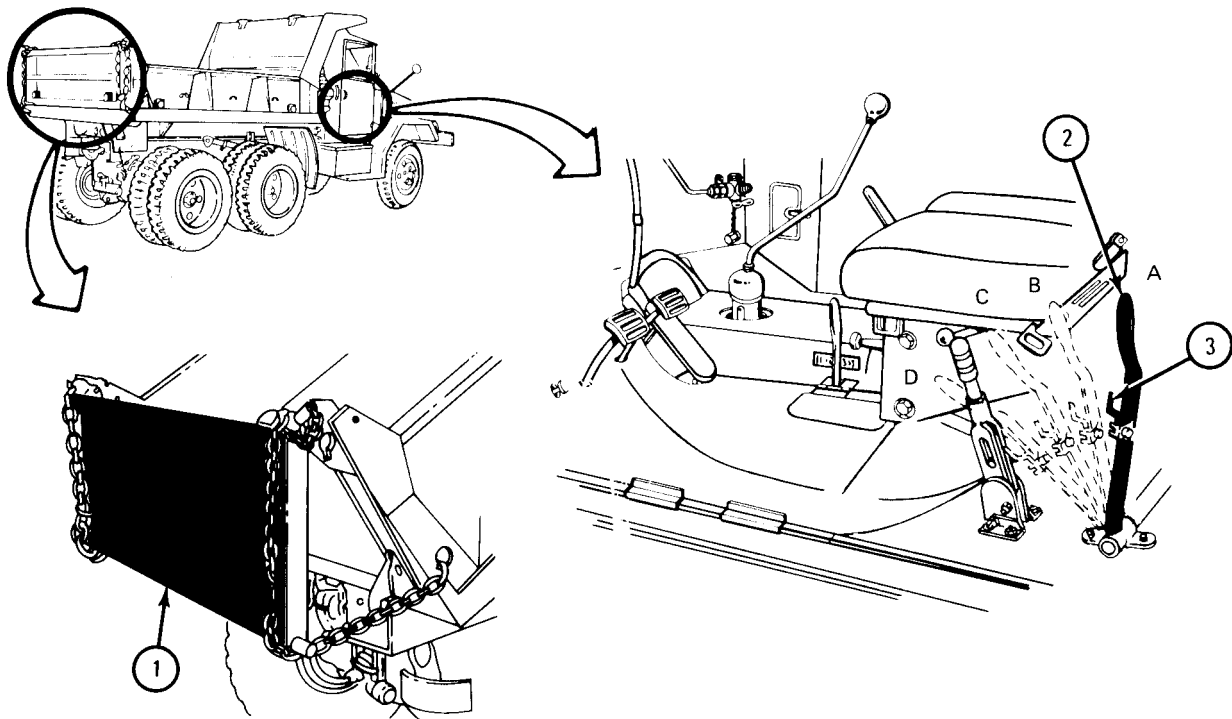

TA 045218



FRAME 5

1. Push tailgate hand lever (1), up and toward rear of truck to lock tailgate in closed position.

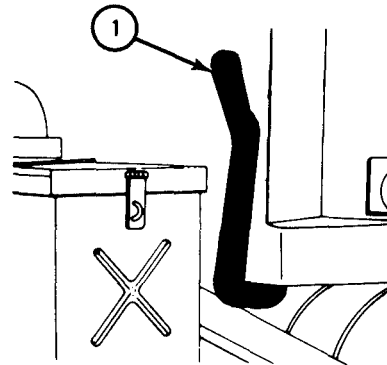
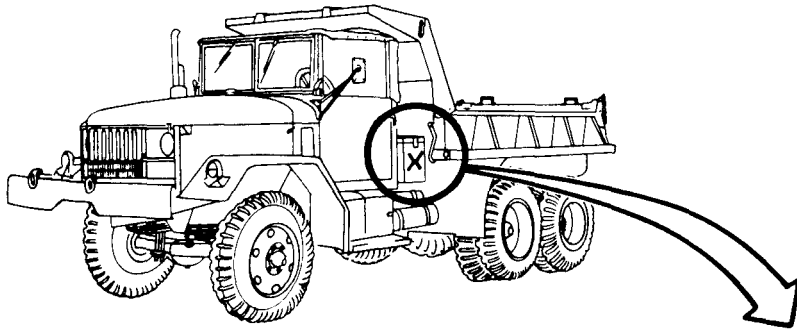

TA 045219

f. Unloading the Dump Truck by Spreading.

FRAME 1

1. Start engine. (Refer to para 4-6b.)
2. Place truck so that tailgate (1) is over starting point of area to be spread.
3. pull handbrake lever (2) up, to on position.
4. Press clutch pedal (3) all the way down.
5. Place FRONT TRANSMISSION gearshift lever (4) in position N, and let clutch pedal (3) come up.
6. Rig tailgate (1) to swing open at bottom. (Refer to para. 4-13b.) Adjust tailgate chains (5) to control opening for material to be spread.

GO TO FRAME 2

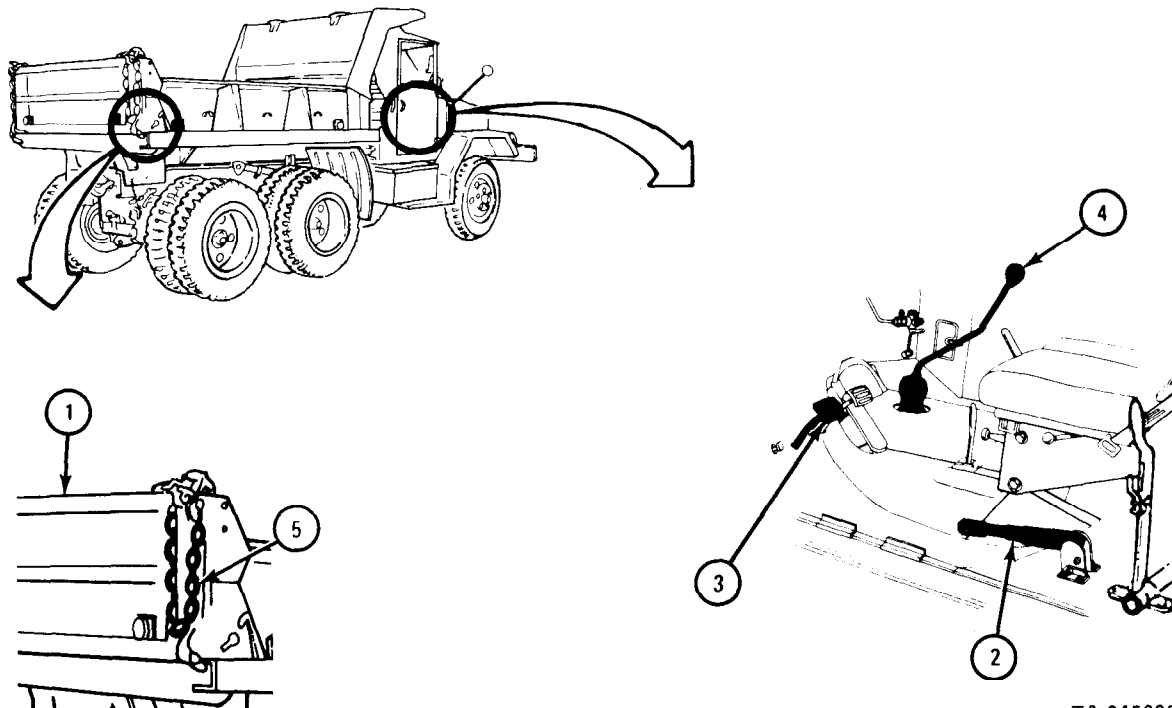

## FRAME 2

1. Open tailgate lock by pushing tailgate hand lever (1) forward and down.  
GO TO FRAME 3

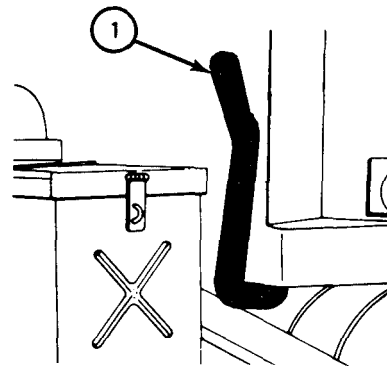
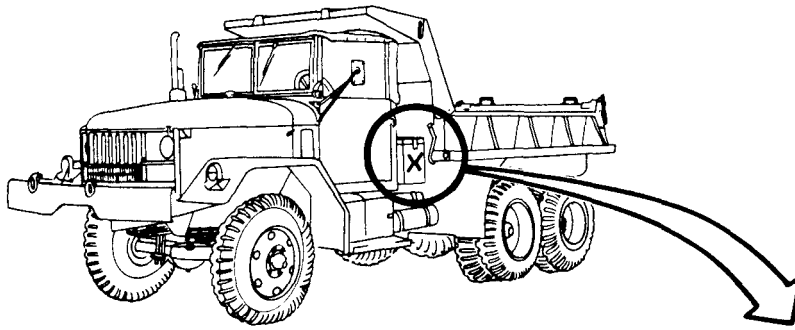

TA 045219

FRAME 3

1. Set safety lock (1) on hoist control lever (2) free.
2. Step down on accelerator pedal (3) far enough to keep engine from stalling.
3. Press down on clutch pedal (4) all of the way.
4. Move hoist control lever (2) forward, all the way to position D, to lift dump body.
5. Let clutch pedal (4) up.
6. When dump body is up high enough to begin spreading, move hoist control lever (2) to position C. This will stop lifting and will hold dump body in position.

GO TO FRAME 4

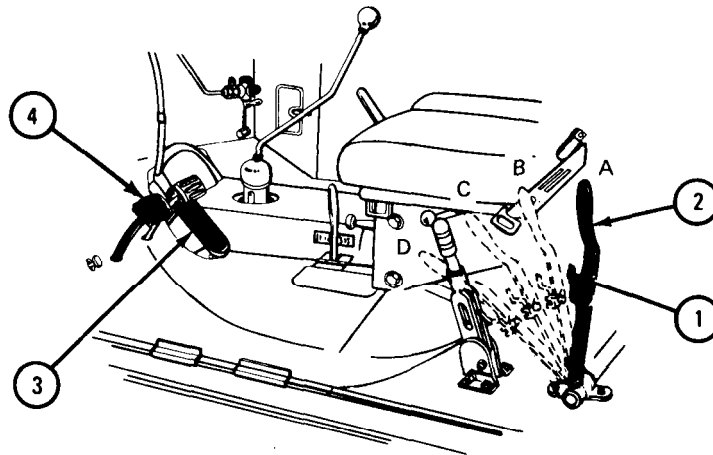

TA 045217

## FRAME 4

1. Set handbrake (1) free and slowly move truck along spreading area. Move hoist control lever (2) forward, to position D, or back to position B, to control the flow of material.
2. After material has been spread, stop truck and move hoist control lever (2) to position B, to lower dump body.
3. When dump body is all the way down, move hoist control lever (2) to position A, and lock lever in place with safety lock (3).
4. Stop engine. (Refer to para 4-6e.)

GO TO FRAME 5

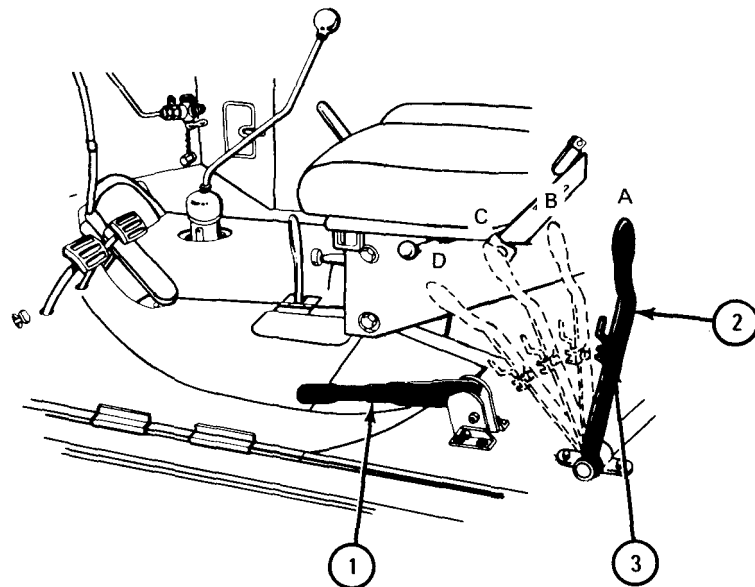

TA 045221

FRAME 5

1. Move tailgate hand lever (1) up and toward back of truck to lock tailgate in place.

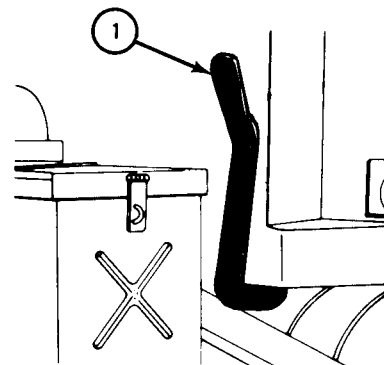
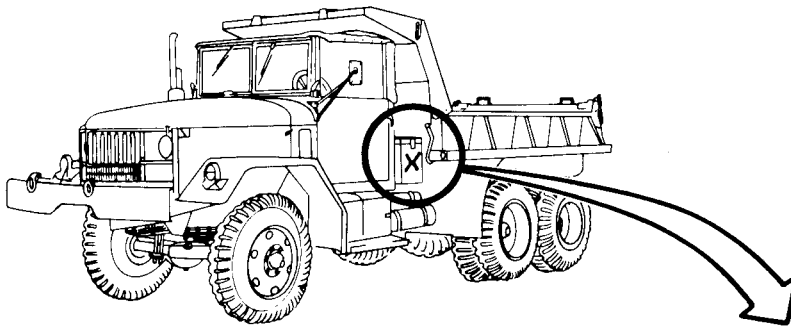

TA 045219

## 4-14. OPERATION OF PIPELINE CONSTRUCTION TRUCK.

a. General. The M756A2 Pipeline Construction Truck has an open top metal body with a wood-metal reinforced flat-bed. The truck is equipped with a rear winch, a winch and cab protector, two gin poles for constructing an A-frame, two 24-volt flood lights, a tailboard roller, a custom made tool box, and stiff leg jacks for additional support. Weather protection for personnel and equipment is provided by a cargo body tarpaulin, with end curtains supported by top bows. Front and side cargo body panels with racks support the top bows. These panels and racks are easily removable for side loading. The side cargo racks have built-in troop seats so that the truck can be used as a personnel carrier when necessary.

b. Operating the Rear Winch.

TOOLS: Offset flat tip screw driver  
9/16-inch wrench

## FRAME 1

1. Start engine. (Refer to para 4-6b.)
2. Place vehicle so that winch (1) is in a direct line with object to be pulled or lifted (2).
3. Pull handbrake lever (3) up, to on position, and place FRONT TRANSMISSION gearshift lever (4) in N position.
4. Stop engine. (Refer to para 4-6e.)
5. Place wheel chocks (5) against rear wheels.
6. Lower tailgate (6). (Refer to para 4-8b.)

GO TO FRAME 2

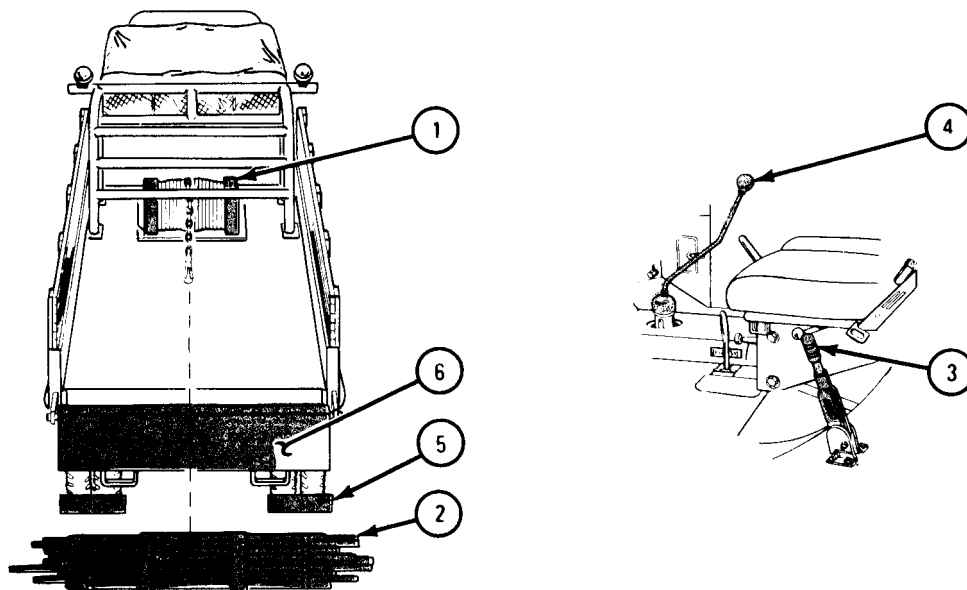

TA 045009

FRAME 2

1. Unhook safety pins (1), pull out tee locking pins (2), and pull stiff leg jacks (3) from their compartments on each side of truck.

GO TO FRAME 3

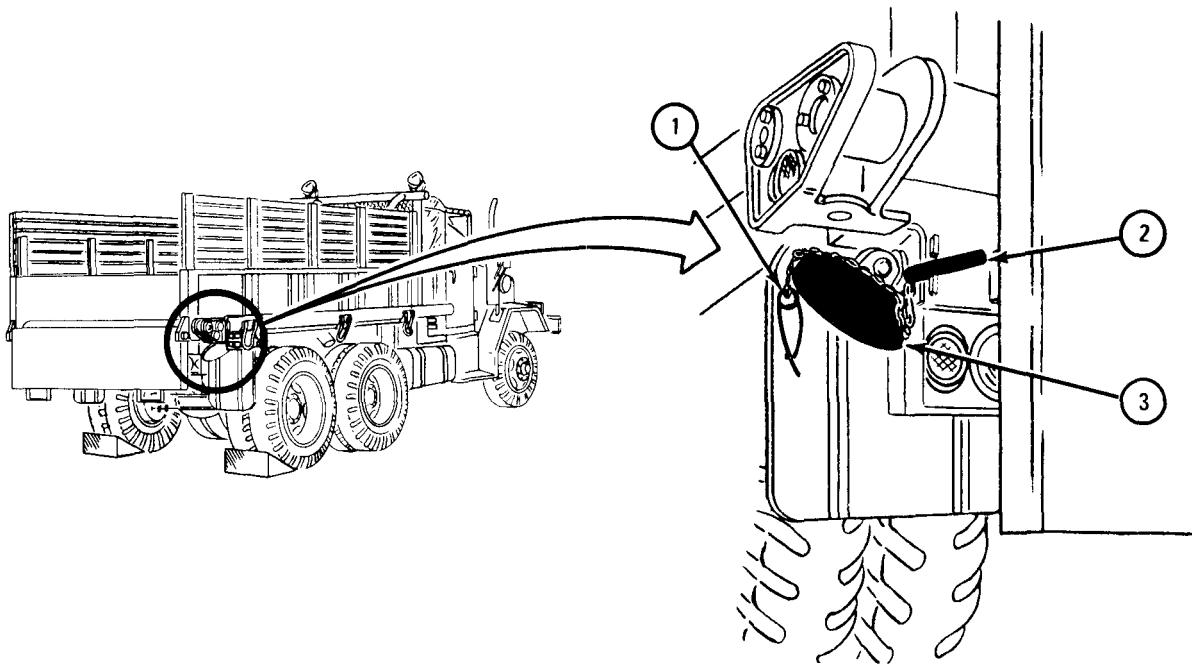

TA 045010



## FRAME 3

1. Move lower leg (1) up or down in upper leg (2) until bottom of lower leg rests firmly on ground.
2. Put tee locking pin (3) into highest visible hole in lower leg (1).
3. Make legs (1 and 2) fast by putting safety pin (4) into hole at end of tee locking pin (3).
4. Do steps 1 through 3 on other side of truck.

GO TO FRAME 4

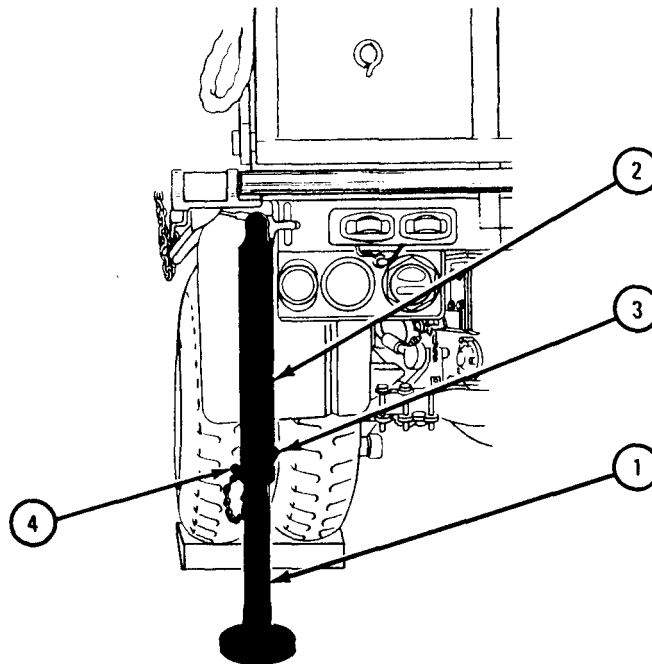

TA 045011

FRAME 4

1. Pullout drum lock (1), turn it 90° (one-quarter turn) until wing on knob (2) slips into shallow groove on poppet nut (3).
2. Place drum clutch lever (4) in off position, toward center of truck.

GO TO FRAME 5

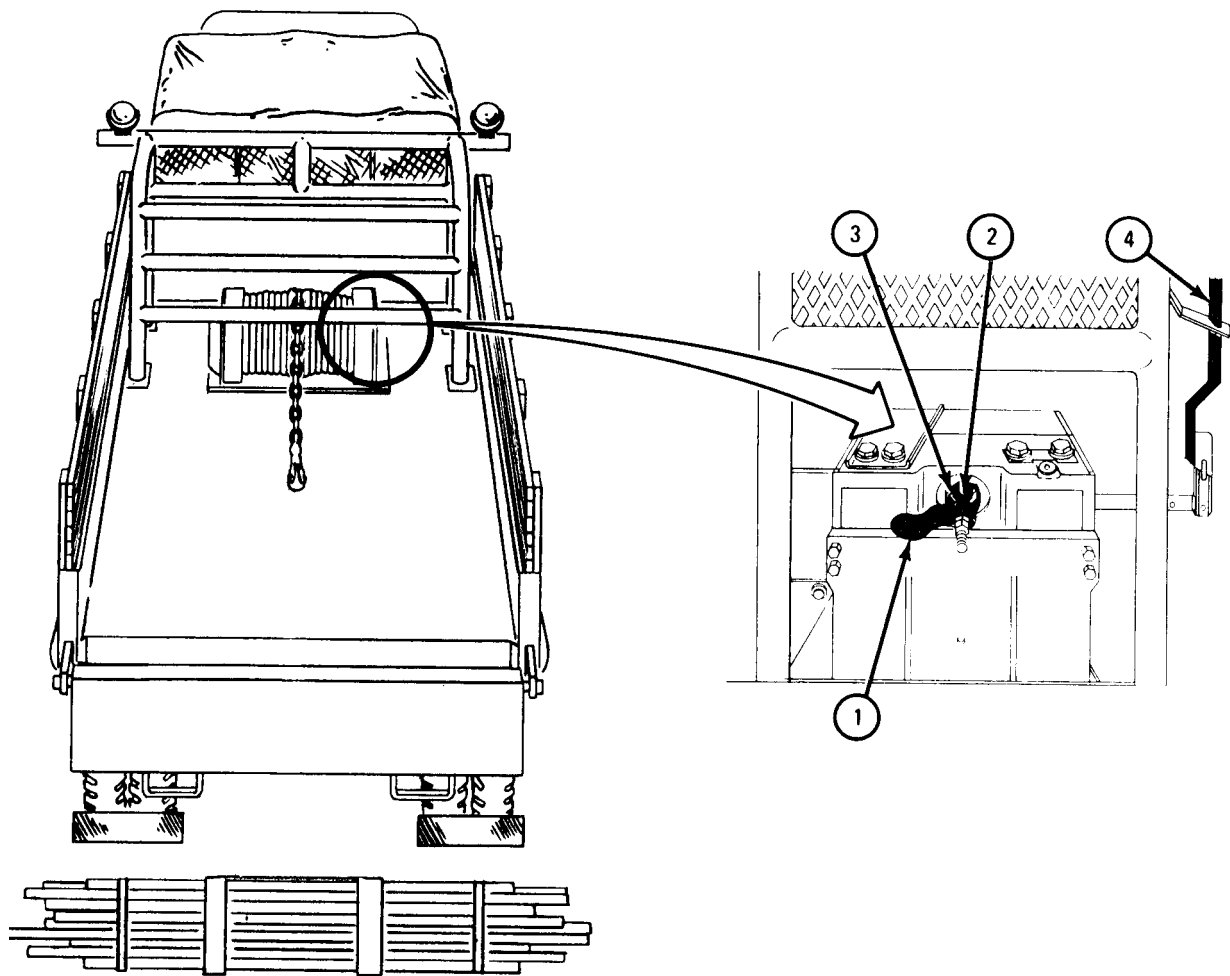

TA 045012

## FRAME 5

**WARNING**

Always wear protective gloves when handling winch cable. Do not let winch cable slip through hands. Rusty or broken wires can cause serious injury.

1. Pull end of winch cable (1) out far enough to reach load (2). Make it fast to load.
2. Always keep tension on cable. If drum overspins working underneath truck, using offset screwdriver, turn adjusting screw (3) right, to tighten drag brake.

GO TO FRAME 6

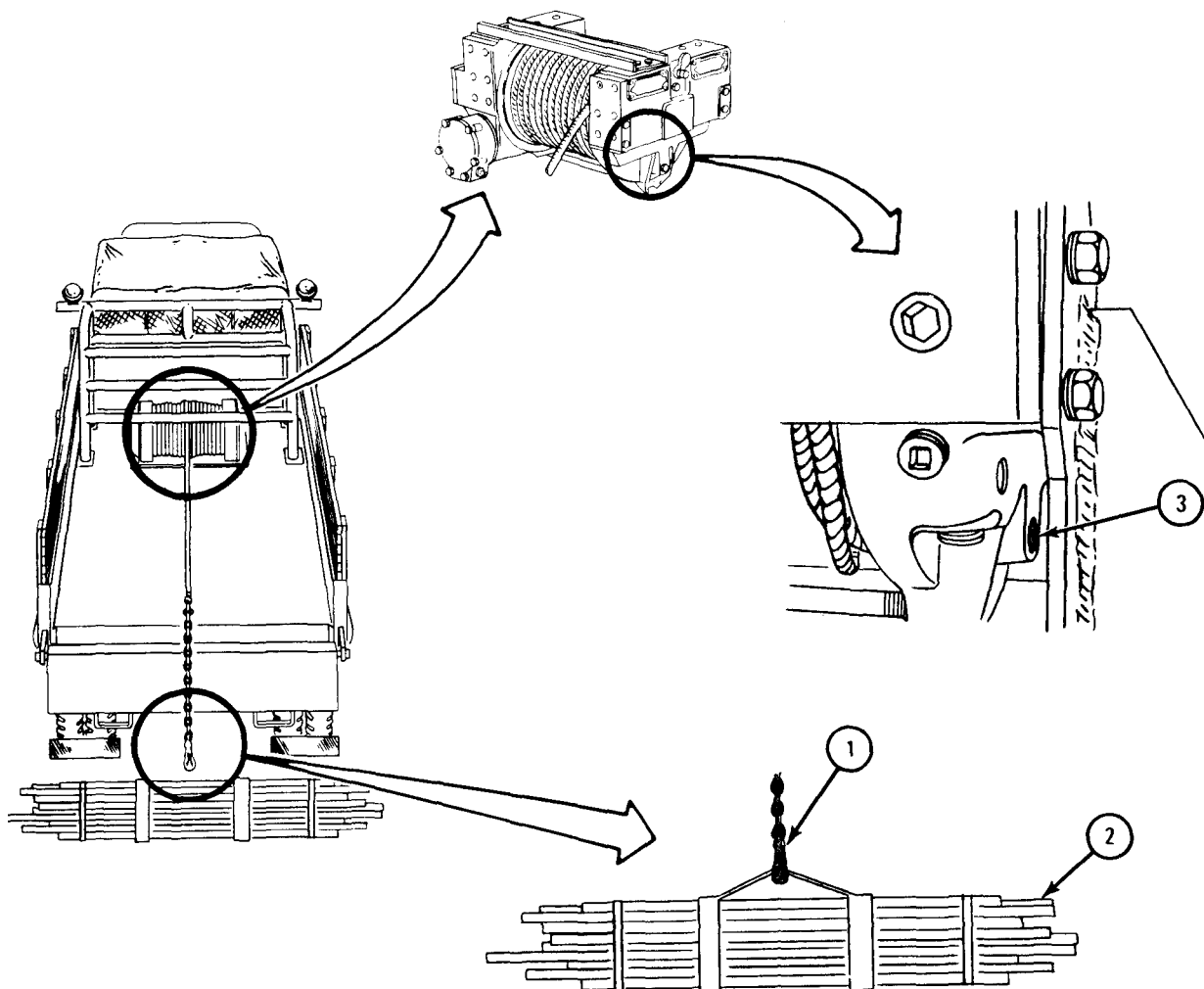

TA 045013

## FRAME 6

**CAUTION**

Do not let engine run with FRONT TRANSMISSION gearshift lever (1) in gear and TRANSFER CASE shifting lever (2) in neutral position without the transfer POWER TAKEOFF LEVER (3) in ON position. This could cause bearing failure in transfer. Always shift FRONT TRANSMISSION gearshift lever (1) to N when not operating the transfer power takeoff.

1. Start engine. (Refer to para 4-6b.)
2. Place FRONT TRANSMISSION gearshift lever (1) in N position.
3. Turn locking bar (4) and pull transfer POWER TAKEOFF LEVER (3) back to on position.
4. Place TRANSFER CASE shifting lever (2) in neutral position.

GO TO FRAME 7

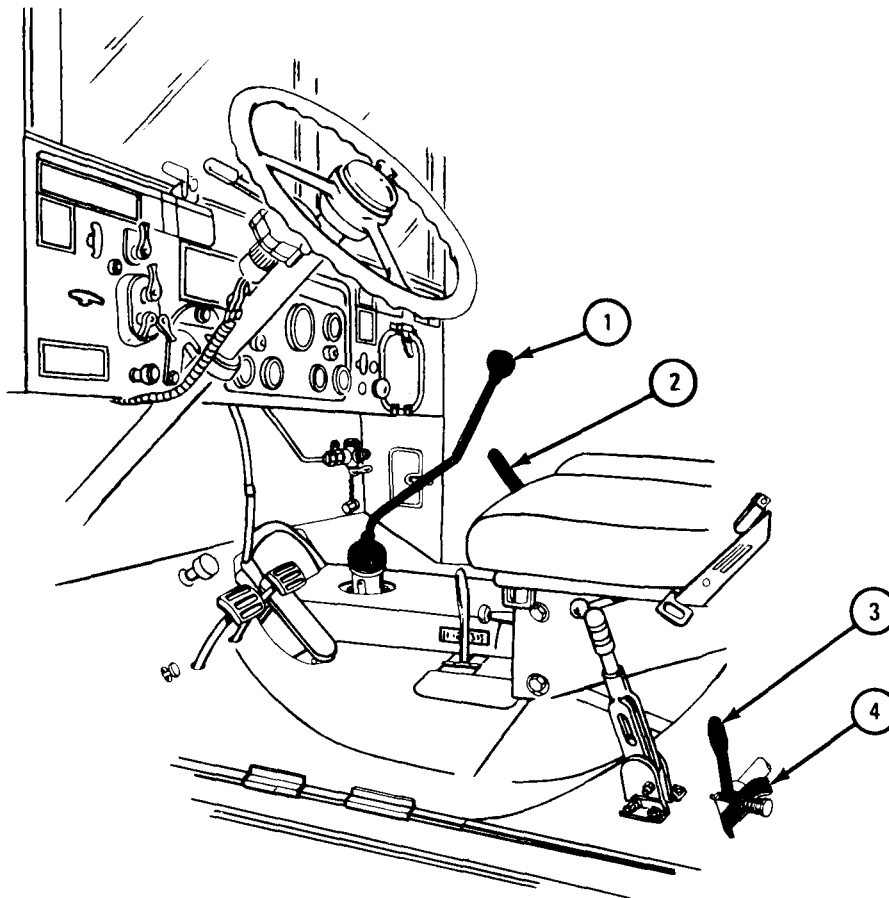

TA 045014

## FRAME 7

**WARNING**

Do not overload winch or operate it with less than four turns of cable on drum; either condition can damage winch.

Do not allow personnel near cable during winch operation. If cable should snap or fray it can cause serious injury.

**CAUTION**

Do not force winch clutch lever (1) or the clutch and get damaged.

1. Shift winch clutch lever (1) to on position, (toward left side of truck).

**NOTE**

If winch clutch lever (1) is hard to shift, with powertake off shifting lever in on position, place transmission in gear and slip engine clutch slightly.

GO TO FRAME 8

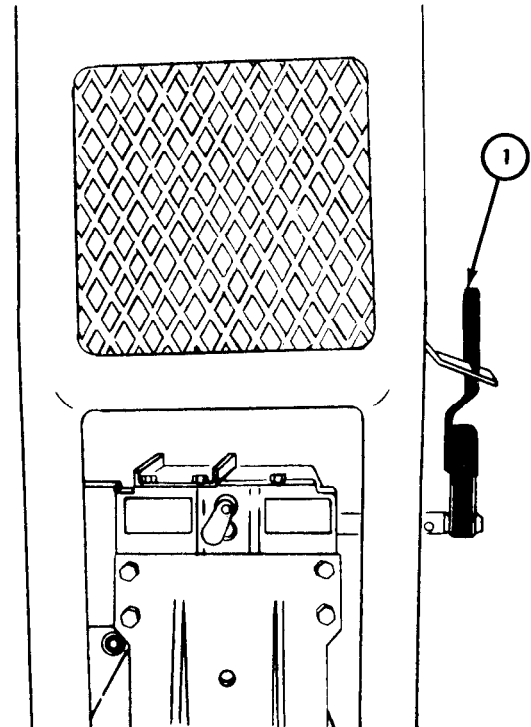
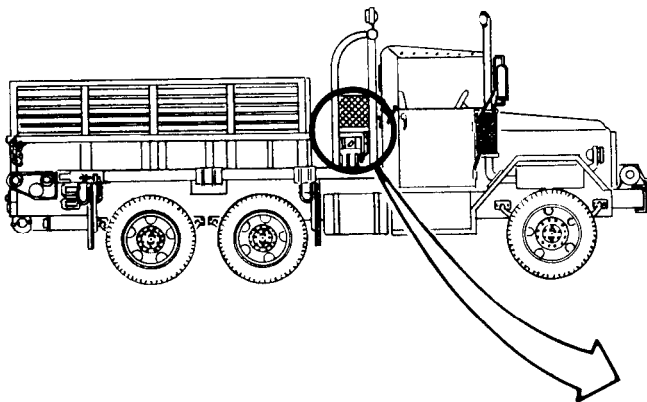

TA 045015

FRAME 8

**NOTE**

Distance between truck and load has an effect on maximum rated pull. Maximum (20, 000 lbs) is available only when enough cable is run out to completely show the first layer on winch drum.

1. Step on and press clutch pedal (1) all the way down.
2. Move FRONT TRANSMISSION gearshift lever (2) to a forward position.
  - (a) Use position 3 for average load.
  - (b) Use lower gearshift positions for extra heavy loads.

GO TO FRAME 9

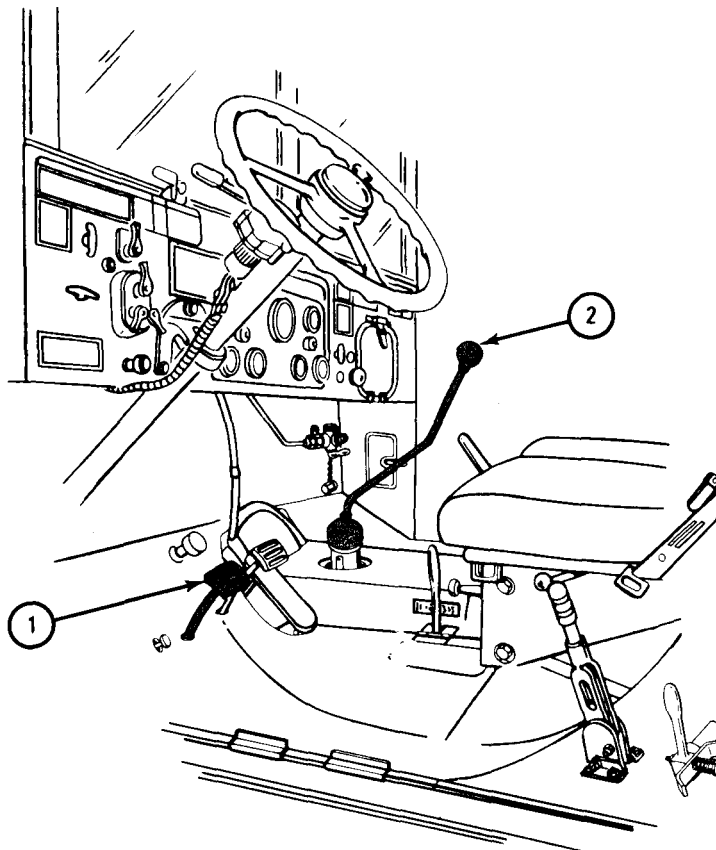

TA 045016

## FRAME 9

**WARNING**

Before letting clutch pedal up, make sure that there is no loose cable on winch drum. Loose cable can cause damage to cable and serious injury to personnel.

**CAUTION**

When drawing in slack cable, do not let loops form in cable. Loops will become kinks as load pulls cable tight. A kinked cable is a weak cable.

1. Let clutch pedal (1) up slowly and wind in slack cable.

GO TO FRAME 10

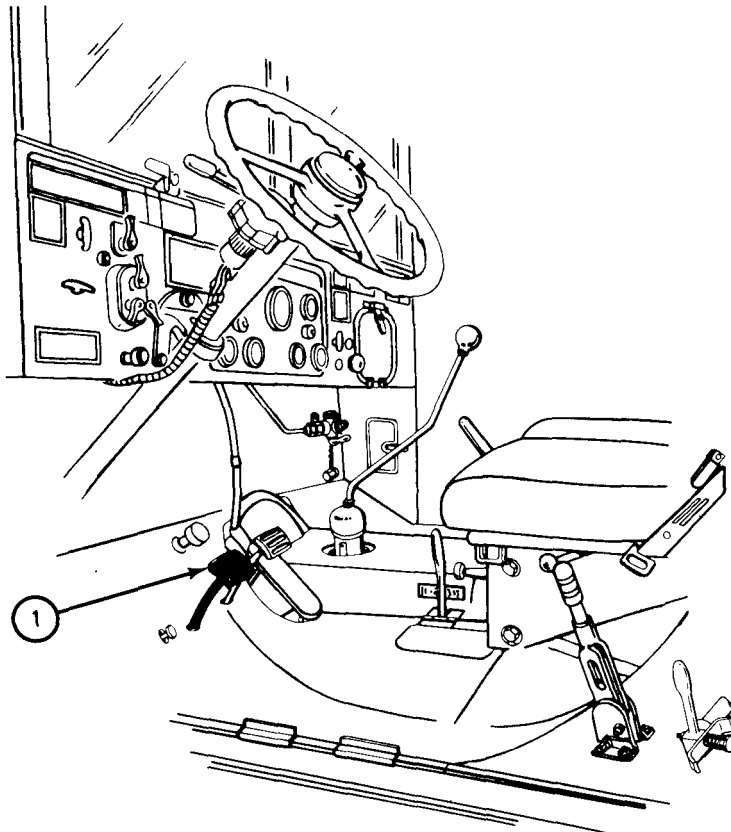

TA 045017

**FRAME 10**

1. When all slack cable has been drawn in, lift load just off the ground.
2. Step on, and press clutch pedal all the way down to stop winch.
3. Safety brake should hold load.

**CAUTION**

Do not turn brake adjusting screw (1) out (to the left) more than one full turn. Screw will come out of brake drum and brake drum will have to be taken apart to fix.

4. If safety brake does not hold, working underneath truck, using wrench, turn brake adjustment screw (1) right to tighten brake.
5. Do steps 1 through 3 again. If safety brake still does not hold, tell organizational maintenance.

GO TO FRAME 11

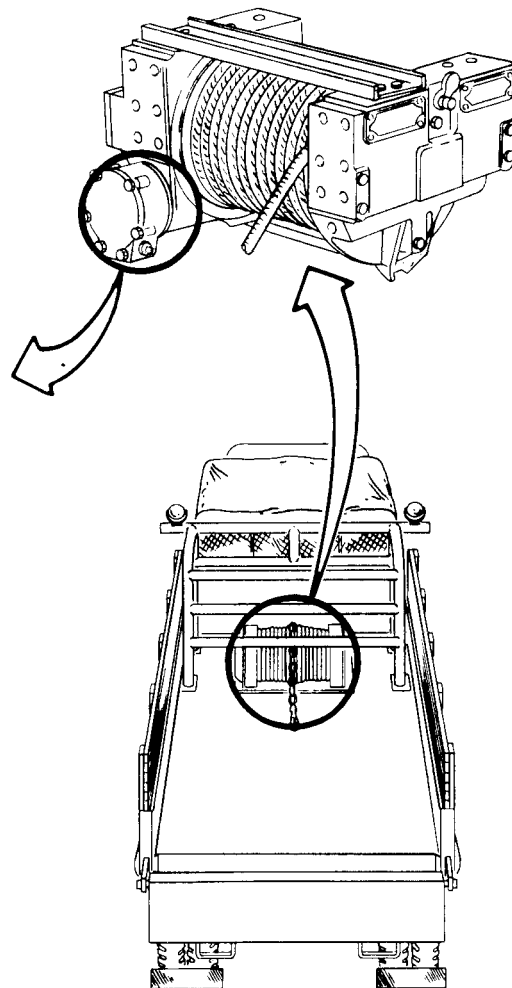
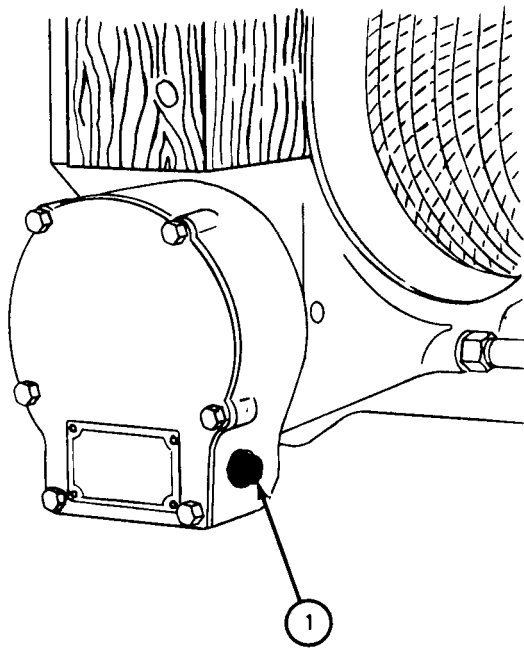

TA 045018



## FRAME 11

1. To lower load or unwind winch cable under power:
  - (a) Press clutch pedal (1) in all the way.
  - (b) Place FRONT TRANSMISSION gearshift lever (2) in R position.
  - (c) Let clutch pedal (1) up slowly.

**NOTE**

When unwinding cable under power, always keep tension on cable so that cable does not crossover.

GO TO FRAME 12

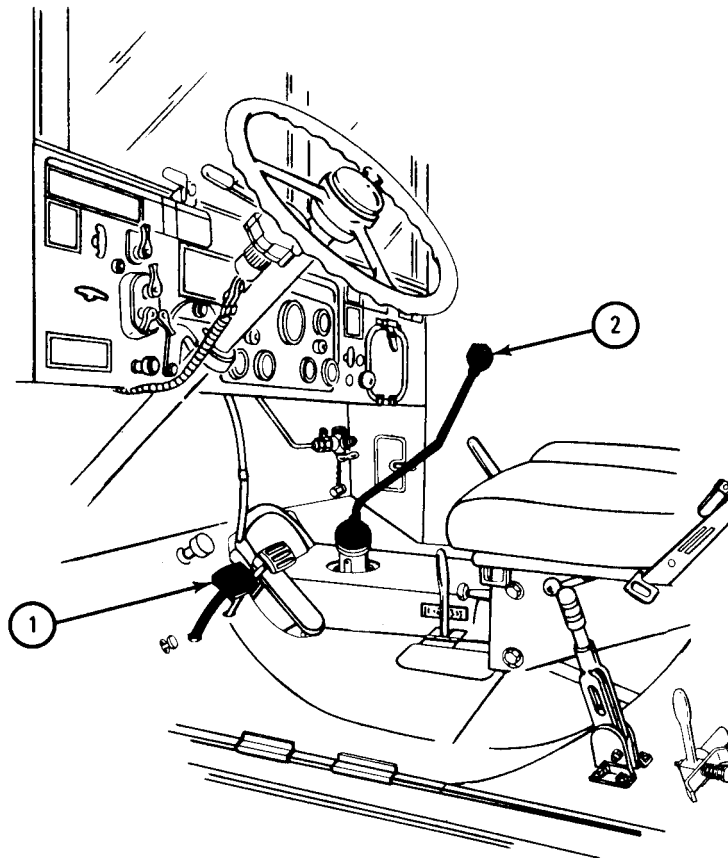

TA 045019

FRAME 12

1. At end of winch operations:
    - (a) Step on clutch pedal (1) and press it all the way down.
    - (b) Place FRONT TRANSMISSION gearshift lever (2) in N position.
    - (c) Place transfer POWER TAKE OFF LEVER, (3) in off position and lock in place with locking bar (4).
  2. Stop engine. (Refer to para 4-6e.)
- GO TO FRAME 13

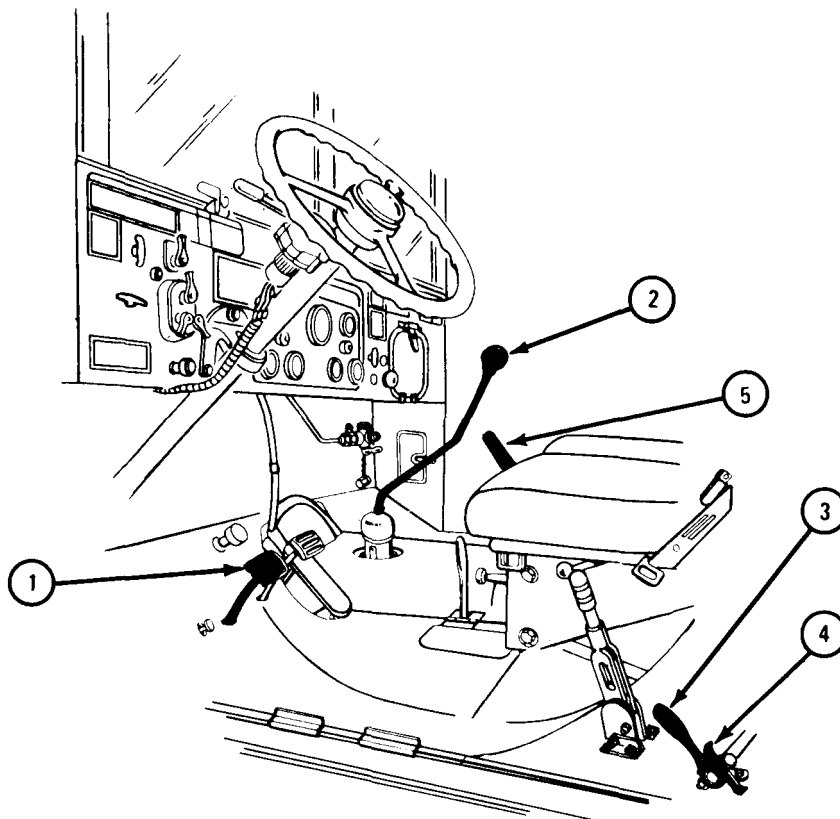

TA 045020

FRAME 13

1. Pull out drum lock (1) and turn it 90° (one-quarter turn) until wing on knob (2) slips into deep groove on poppet nut (3).
2. Let drum lock (1) mesh with poppet nut (3).
3. Turn winch drum (4) until poppet meshes with winch drum flange.

GO TO FRAME 14

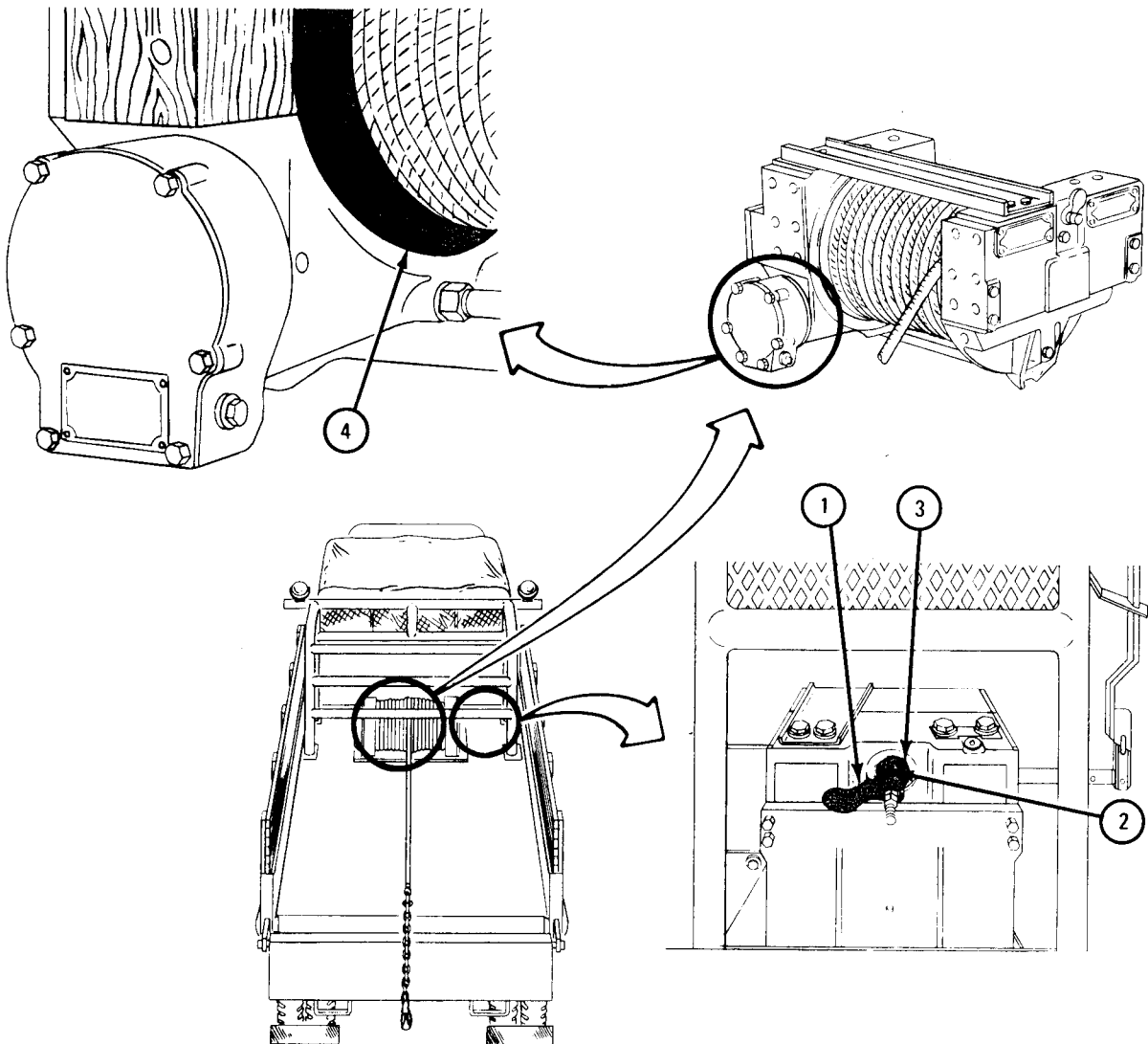

TA 045021

FRAME 14

1. Lift jack legs (1) and (2) up to level position and push legs about 1 foot into stowage compartments (3).
2. Take safety pins (4) out of tee locking pins (5) and pull locking pins out.
3. Push leg (1) into leg (2) and aline last holes.
4. Push tee locking pins (5) through hole but do not let pins extend out of other side of leg (2).
5. Push jack legs (1) and (2) all the way into stowage compartment (3).
6. Turn tee locking pin (5) handles to up and down position and push pins all the way in.
7. Put safety pins (4) through holes in end of tee locking pins (5) and lock safety pins.

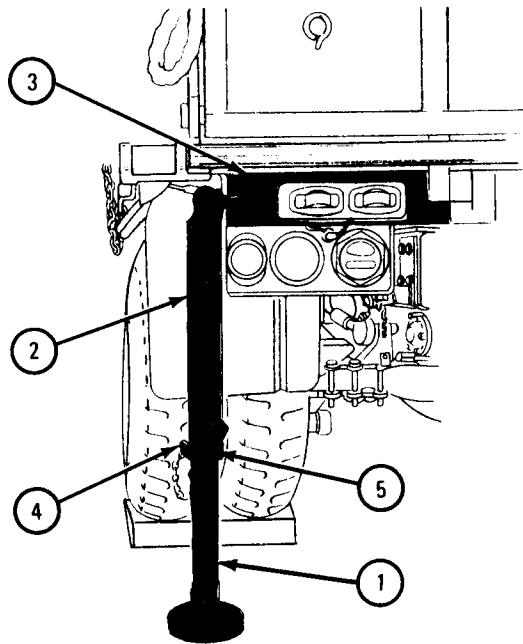

TA 087001

c. Rigging the A-Frame for Rear Operation.

TOOLS: Pliers

FRAME 1

1. Take off tailgate, front and side racks. (Refer to para 4-8b, f).
2. Loosen wing nuts (1) and free gin poles (2) from side clamps (3).
3. Lift gin poles (2) and place them on top of cab protector (4).

GO TO FRAME 2

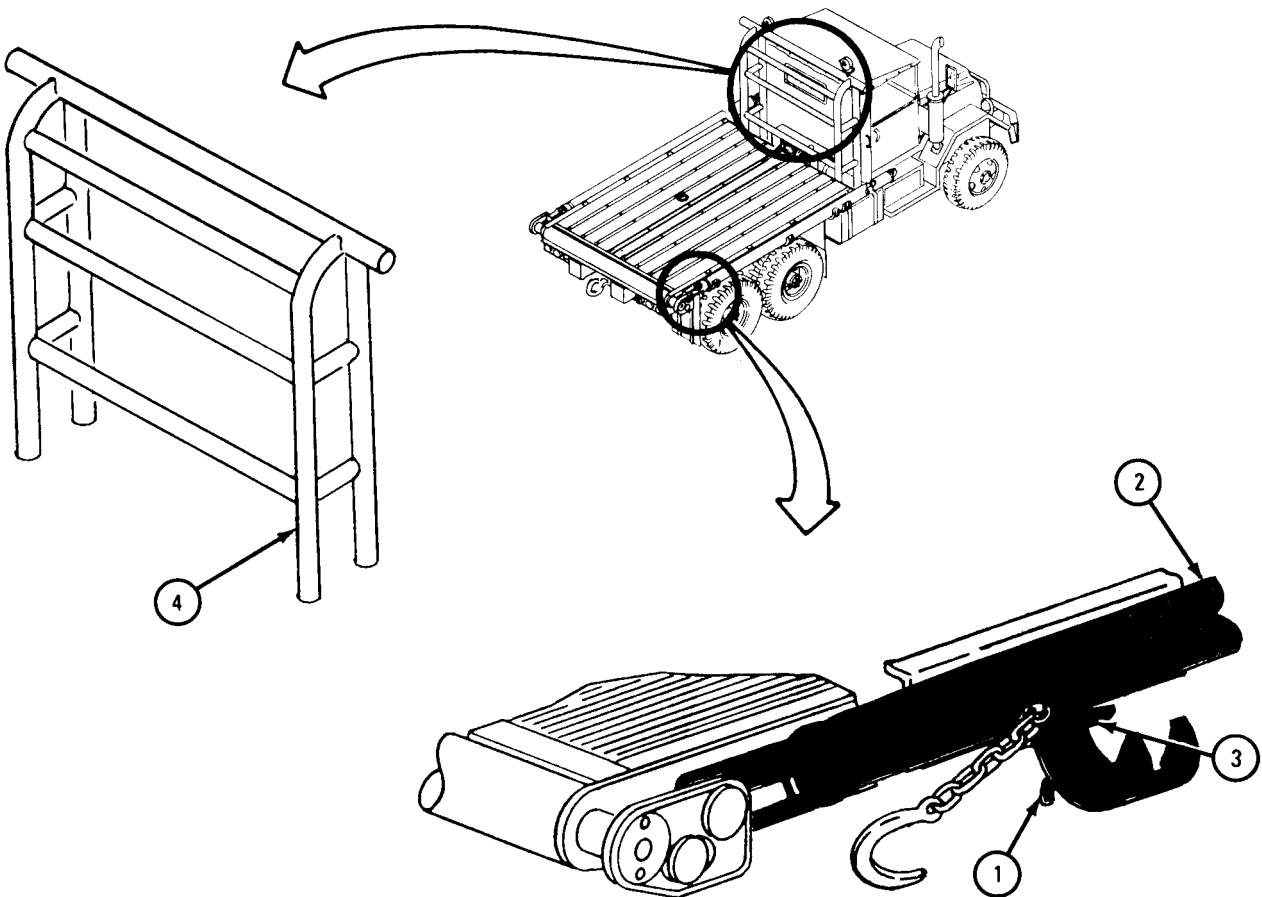

TA 045023

FRAME 2

1. Put trunion (1) through ring ends (2) of both boom chains.
2. Put trunion (1) through yoke ends (3) of both gin poles.
3. Turn trunion (1) until it locks into place.
4. Lock hook end of boom chains (4) into boom chain bracket (5), thirty links from hook.

**NOTE**

Chain lengths must be the same.

GO TO FRAME 3

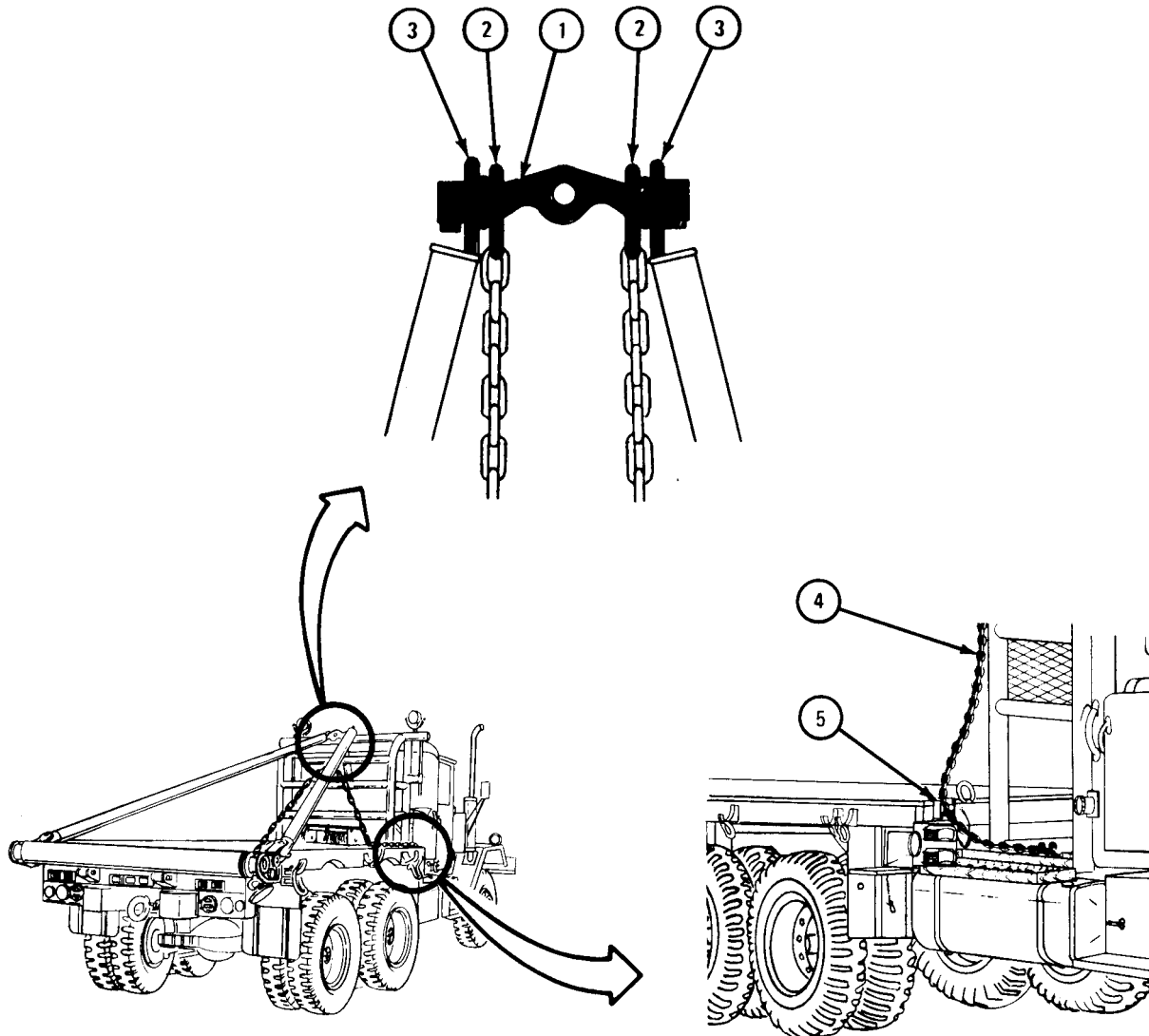

TA 045024

## FRAME 3

1. Place gin pole sheave assembly (1) into trunion (2).
2. Put retaining pin (3) through trunion (2) and sheave assembly (1).
3. Put cotter pins (4) into holes at both ends of retaining pin (3) and using pliers, bend open ends of cotter pins out.
4. Place tailboard sheave assembly (5) in rear well and make it fast with retaining pin (6) and two cotter pins (7).

GO TO FRAME 4

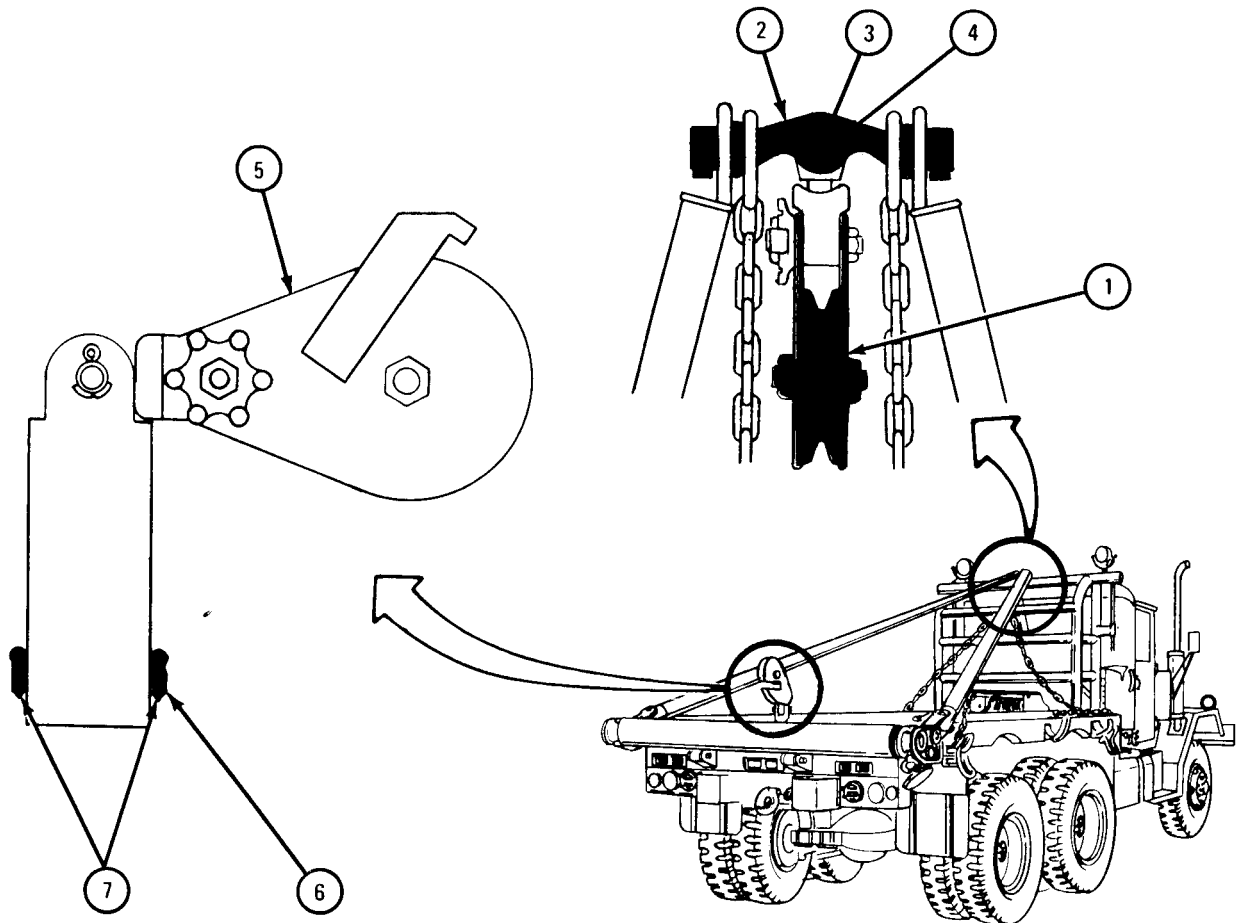

TA 045025

FRAME 4

1. Turn handnuts (1) and (2) to unscrew retaining pins (3) and (4) from side plate (5) and (6).
2. Turn side plates (5) and (6) left or right 90°.

GO TO FRAME 5

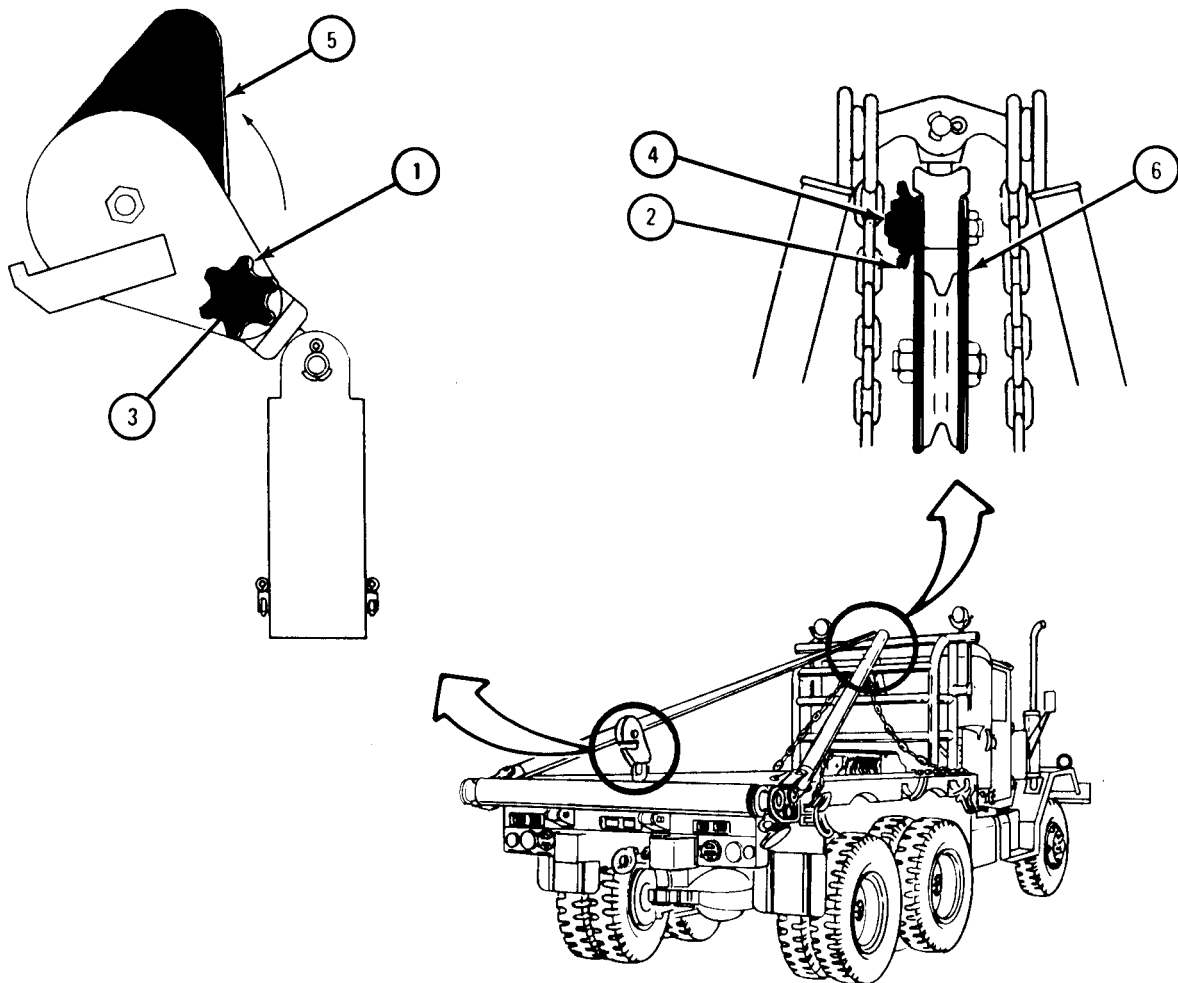

TA 045026



FRAME 5

1. Pull winch cable (1) out from winch (2). (Refer to para 4-14.)
2. Place cable (1) under, around, and over tailboard sheave (3).
3. Bring end of winch cable (1) straight back and place it under, around, and over A-frame sheave (4).
4. Turn pintle (5) so that hook (6) is on top.
5. Bring hook end of winch cable (1) straight back and hook it to pintle (5).

GO TO FRAME 6

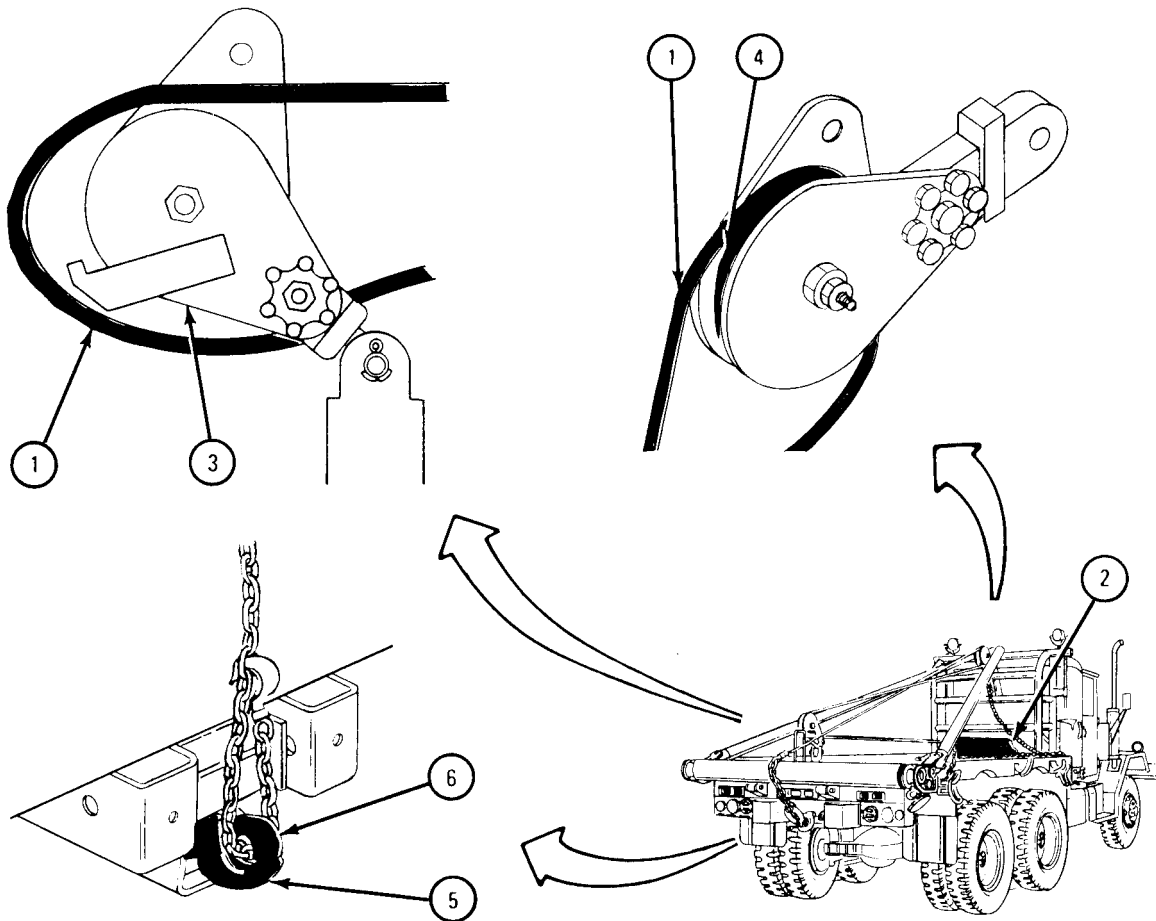

TA 045027

FRAME 6

1. Move side plates (1 and 2) back into place.
2. Make side plates (1 and 2) fast with retaining pins (3 and 4), and handnuts (5 and 6).
3. Pull U-bolt (7) up and hook it over tailboard sheave bracket (8).

GO TO FRAME 7

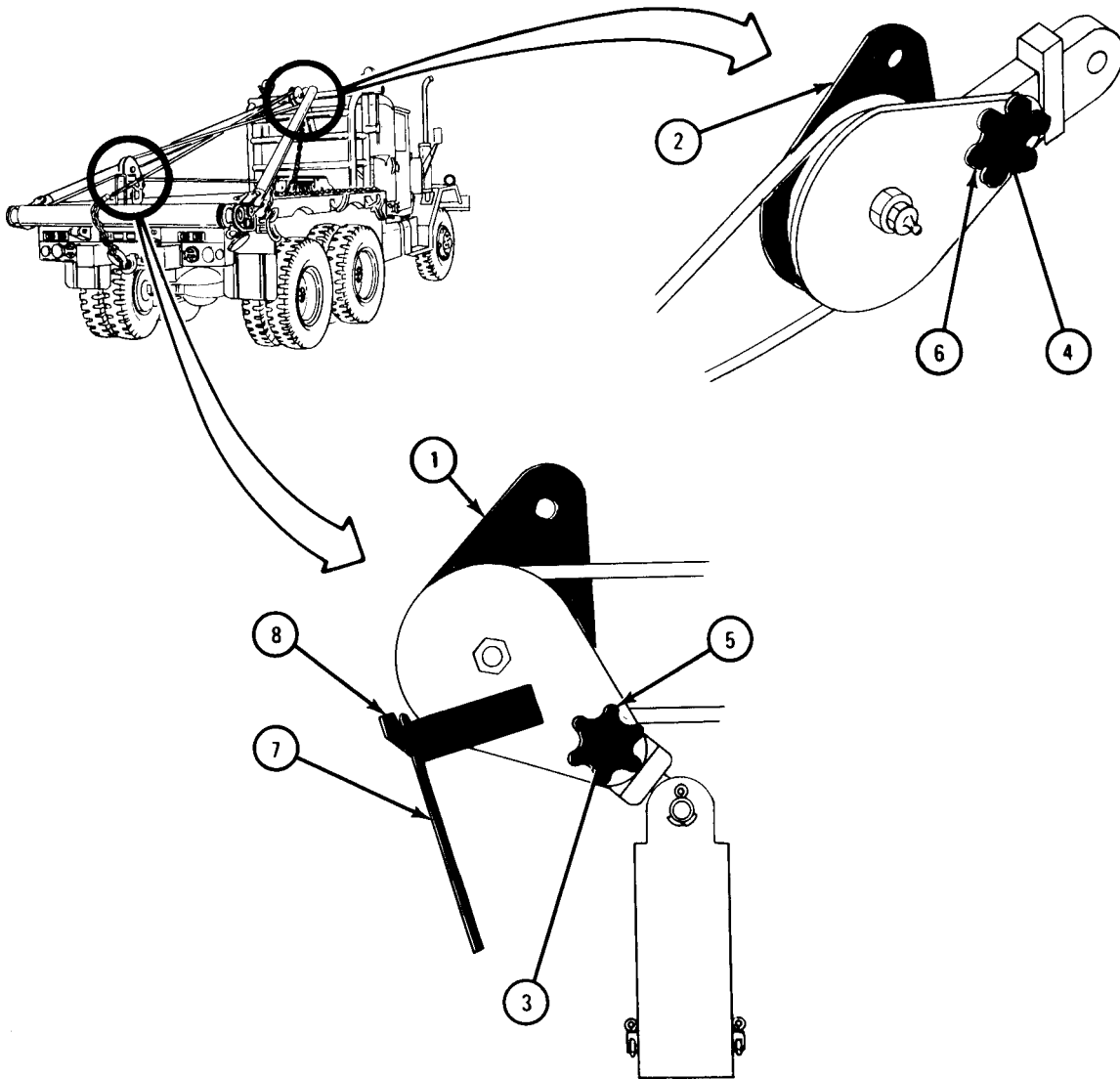

TA 045028

## FRAME 7

1. Take up slack in winch cable (1) and slowly operate winch, refer to para 4-14b, until A-frame (2) reaches operating position.
2. If necessary, by hand, push A-frame (2) over center, until it is in operating position.
3. Let winch cable (1) go slack, and unhook U-bolt (3) from tailboard sheave assembly (4). Push U-bolt down even with truck bed.
4. Unhook winch cable (1) from pintle hook (5).

**NOTE**

Height of the A-frame (2) can be changed by making boom chains (6) longer or shorter. Place A-frame at a higher angle for heavy loads. Make a second (auxiliary) chain (7) fast to each safety chain (8) and to bumpers (9), so that there wont be any backlash.

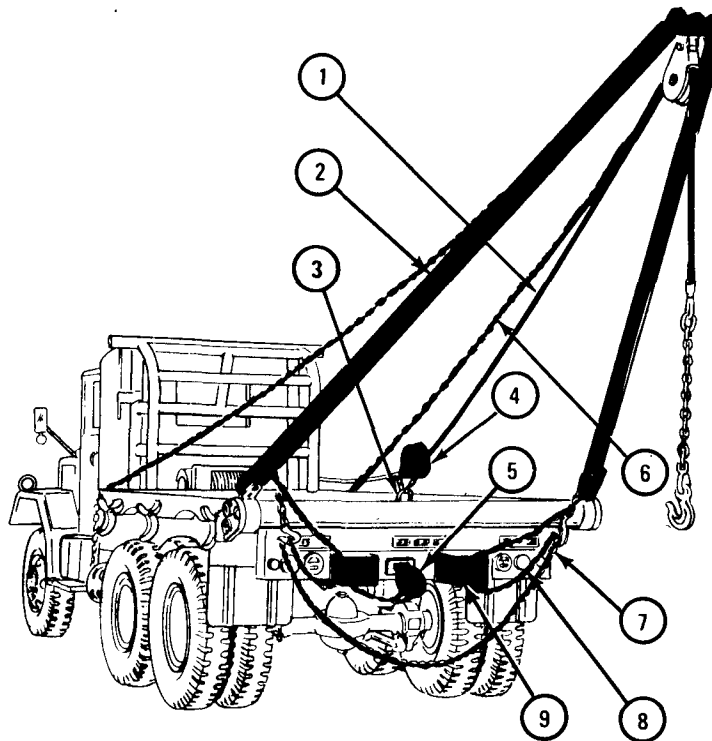

TA 045029

d. Lowering the A-Frame and Preparing Truck for Travel after Rear Operation.

TOOLS: Pliers

FRAME 1

1. Lift U-bolt (1) and hook it to tailboard sheave bracket (2).
  2. Put hook end (3) of winch cable onto left center lashing ring (4).
- GO TO FRAME 2

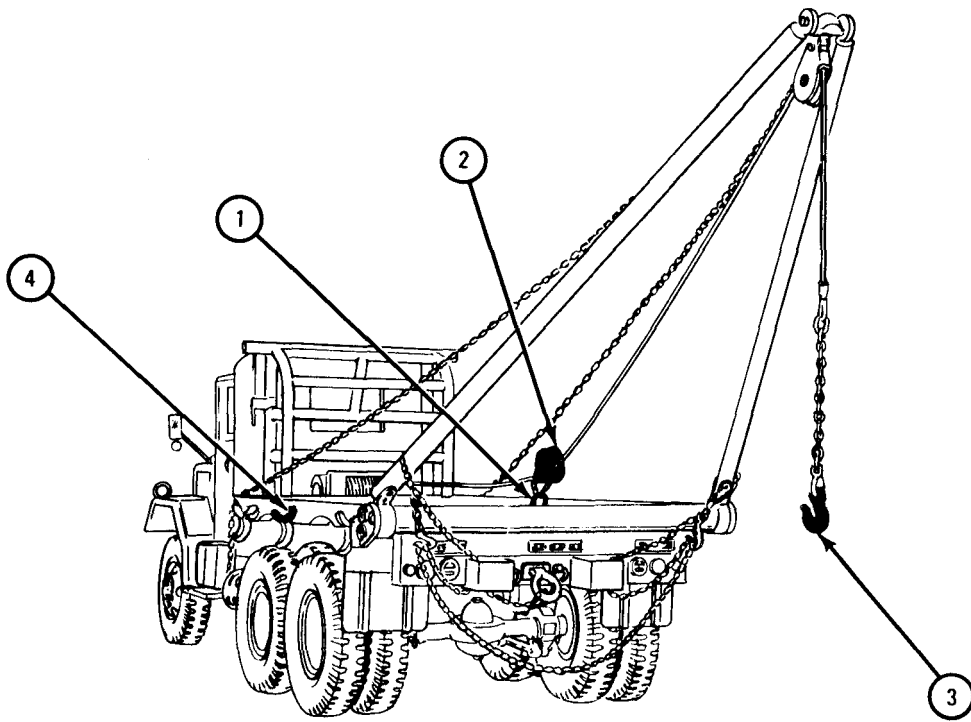

TA 045030

## FRAME 2

**CAUTION**

Do not let A-frame go past center. It will free and damage equipment.

1. Operate rear winch, refer to paragraph 4-14b, to raise A-frame (1) up to about an 80° position.
2. Reset boom chains (2) to support A-frame (1) in this position.

**CAUTION**

Too much slack will allow A-frame to smash down on cab roof.

3. Take hook end of winch cable (3) from left center lashing ring (4) and hook it onto pintle (5). Leave a small amount of slack (about 2 feet) in winch cable.

GO TO FRAME 3

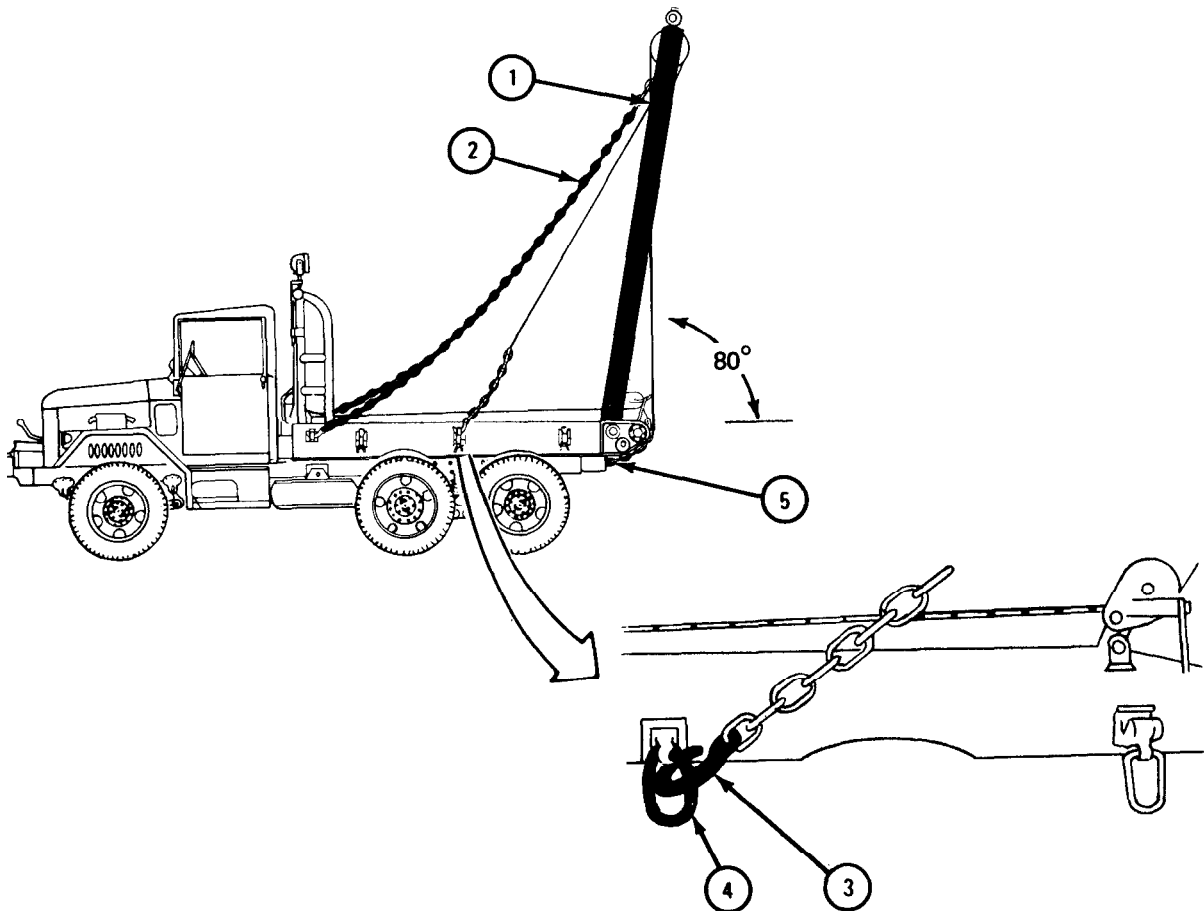

TA 045031

FRAME 3

1. Hand pull boom chain (1) and bring A-frame (2) to an angle of about 80°.
  2. Using winch, slowly lower A-frame (2) until it rests on top of cab protector (3).
- GO TO FRAME 4

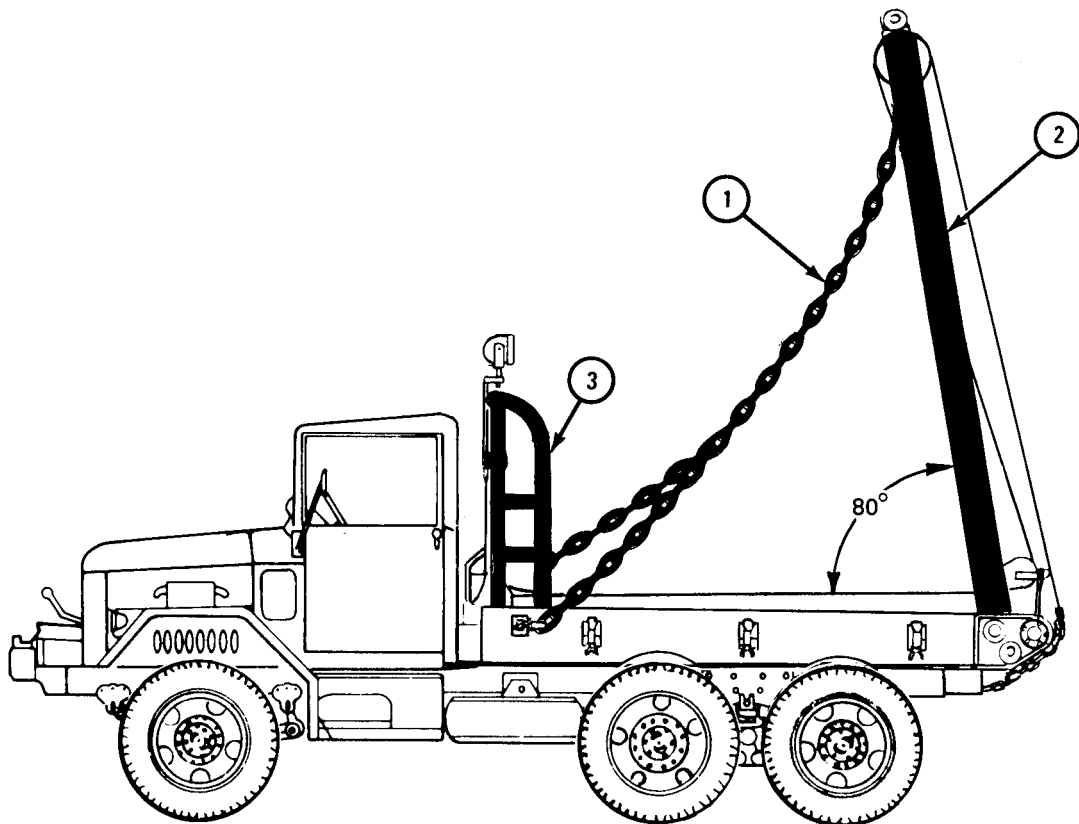

TA 045032

FRAME 4

1. Run winch until winch cable (1) is slack, stop winch, unhook end of winch cable from pintle (2).
2. Unhook U-bolt (3) from tailboard sheave bracket (4).
3. Lower U-bolt (3) until it is even with truck bed.

GO TO FRAME 5

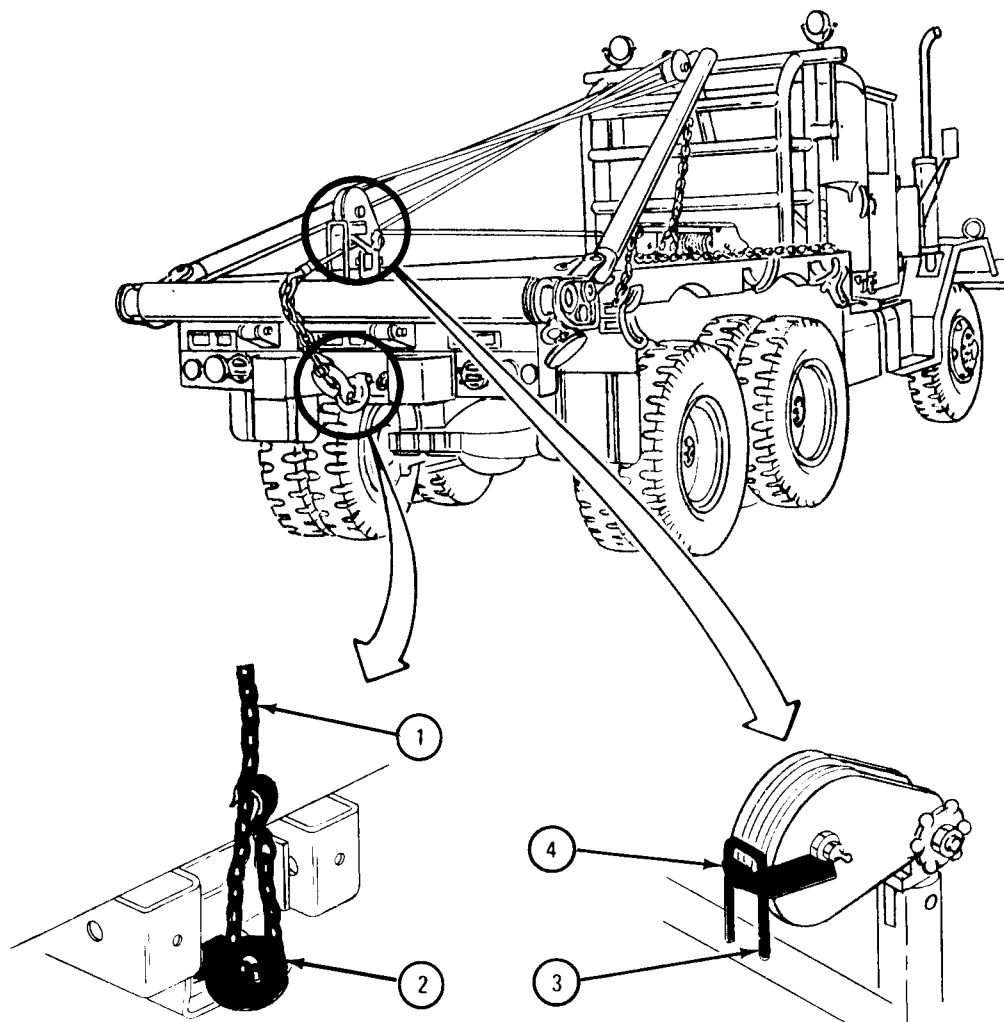

TA 045033

FRAME 5

1. Turn handnuts (1) and (2) to unscrew retaining pins (3) and (4) from side plates (5) and (6).
2. Turn sideplates (5) and (6) left or right 90°.

GO TO FRAME 6

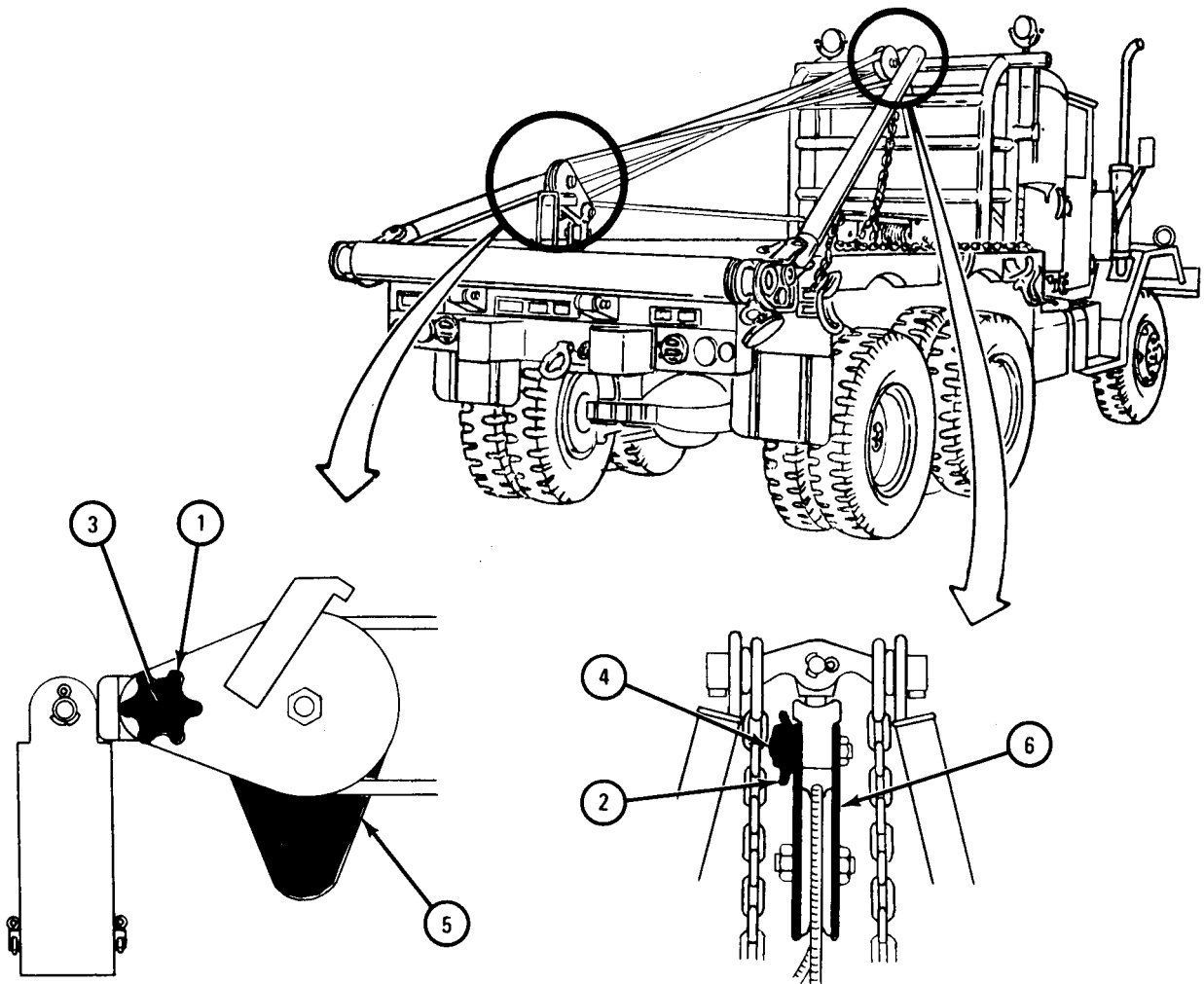

TA 045034



FRAME 6

- 1. Slip cable (1) out of A-frame sheave (2) and tailboard sheave (3).
- GO TO FRAME 7

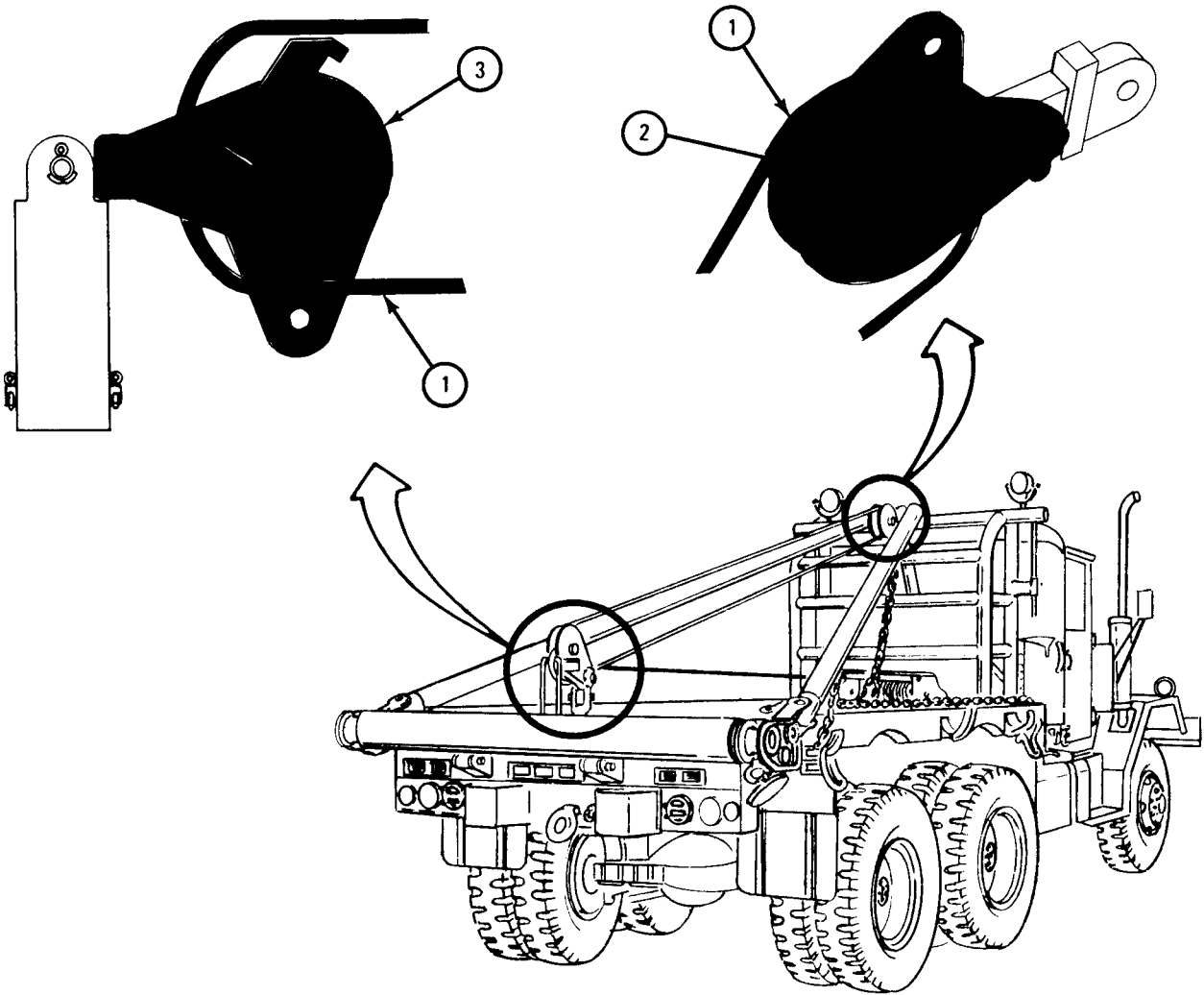

TA 045035

FRAME 7

1. Move side plates (1 and 2) back to closed position.
  2. Put retaining pins (3 and 4) into place and tighten with handnuts (5 and 6).
- GO TO FRAME 8

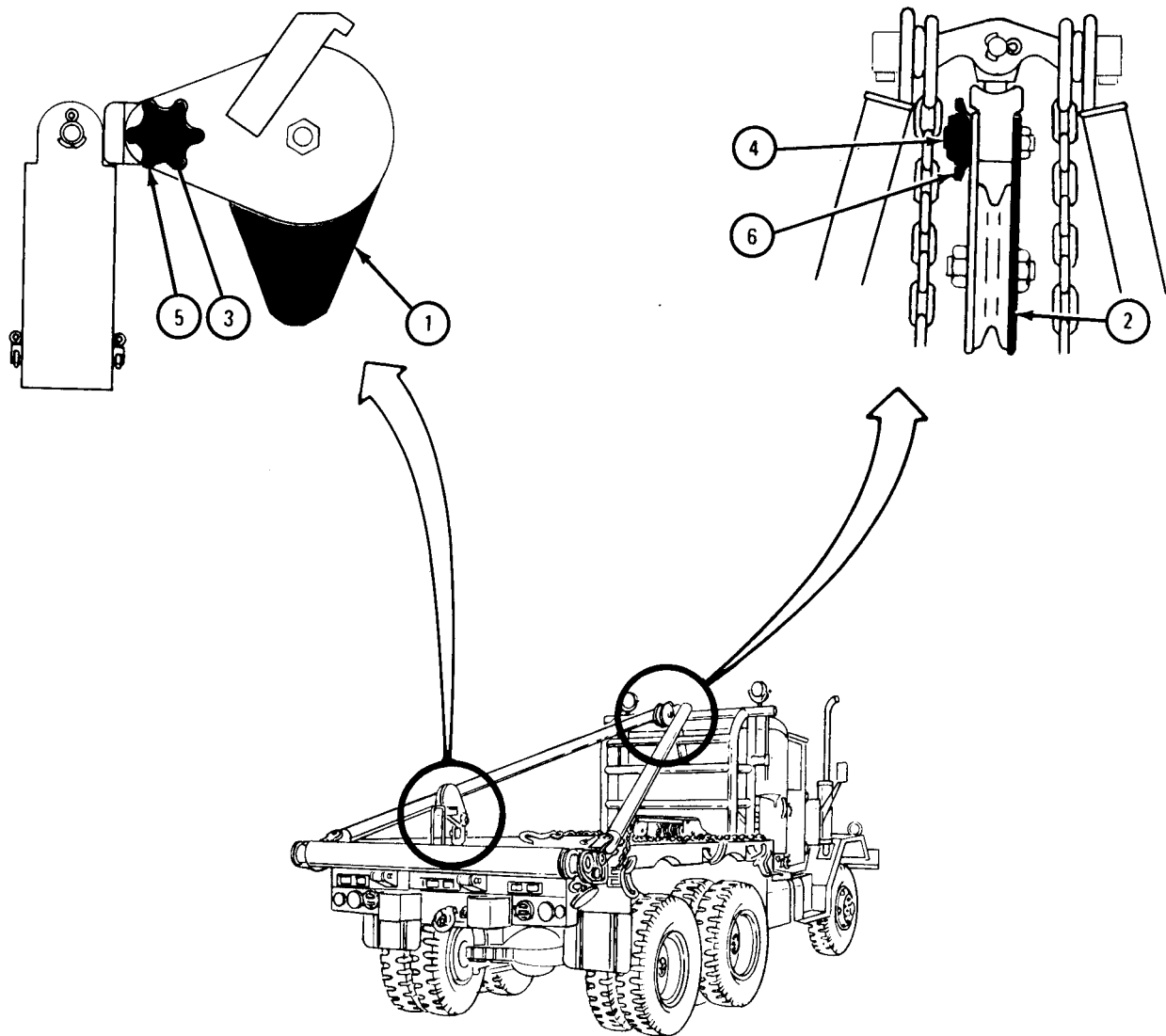

TA 045036

## FRAME 8

1. Step on clutch pedal (1) and press it all the way down.
2. Move FRONT TRANSMISSION gearshift lever (2) to N position.
3. Move transfer POWER TAKEOFF LEVER (3) to off position and lock, in place with locking bar (4).
4. Stop engine. (Refer to para 4-6b.)

GO TO FRAME 9

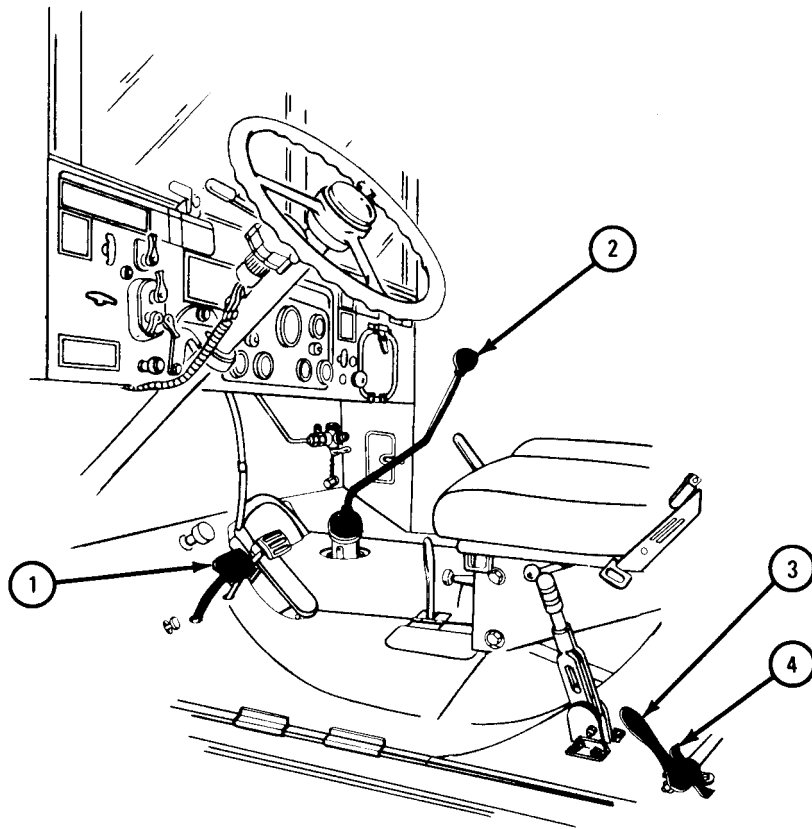

TA 045037

FRAME 9

1. Turn winch drum (1) by hand and wind in winch cable.
2. Pull winch drum lock knob (2) out and turn it 90° (one-quarter turn).
3. Let wing on winch drum lock knob (2) slip into deep slot on poppet seat.
3. Turn winch drum (1) until poppet meshes with winch drum flange.

Go TO FRAME 10

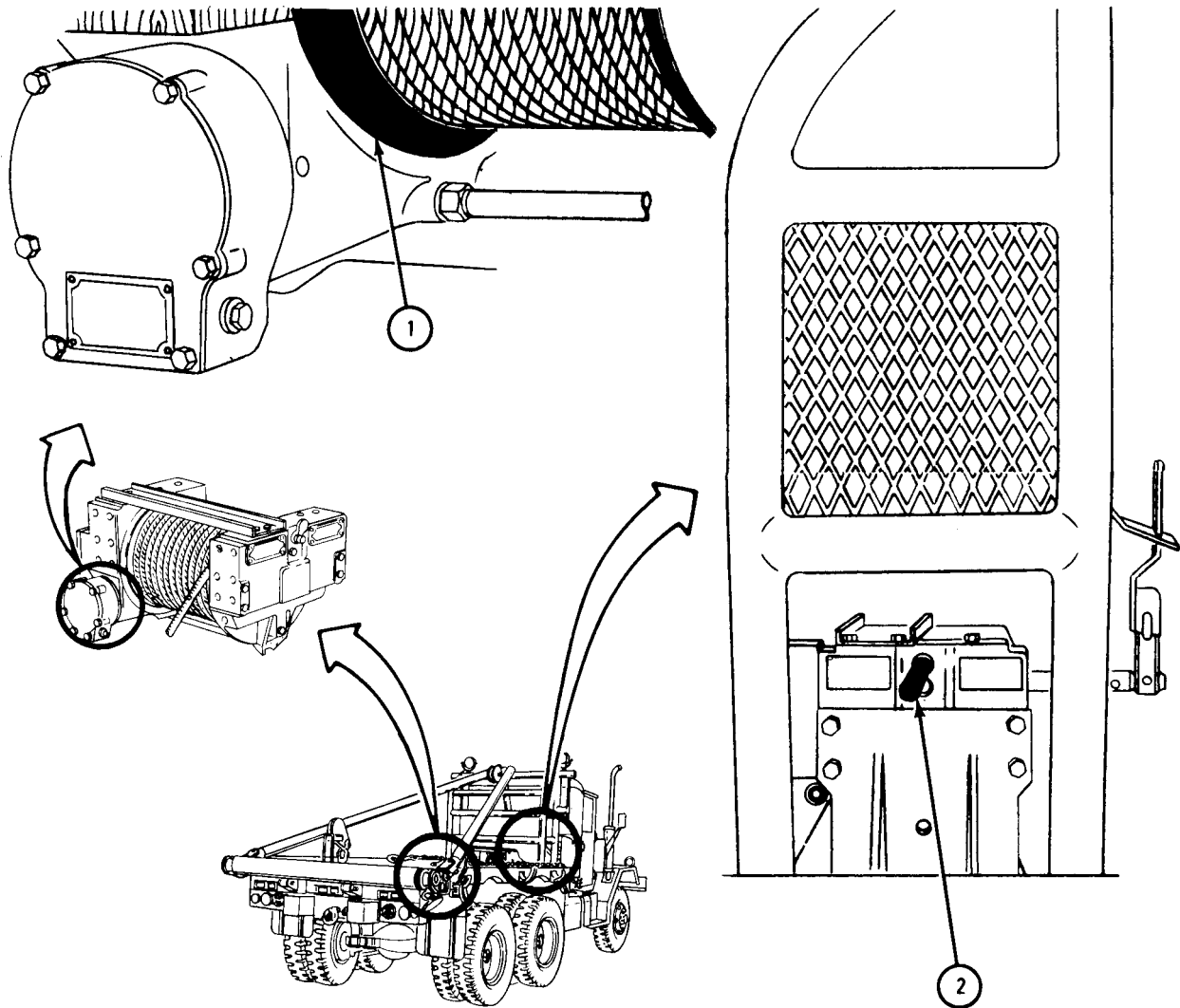

TA 045038

## FRAME 10

1. Using pliers, straighten ends of cotter pin (1) and take it out of retaining pin (2).
2. Take retaining pin (2) out of trunion (3) and A-frame sheave assembly (4).
3. Take A-frame sheave assembly (4) out of trunion (3).

GO TO FRAME 11

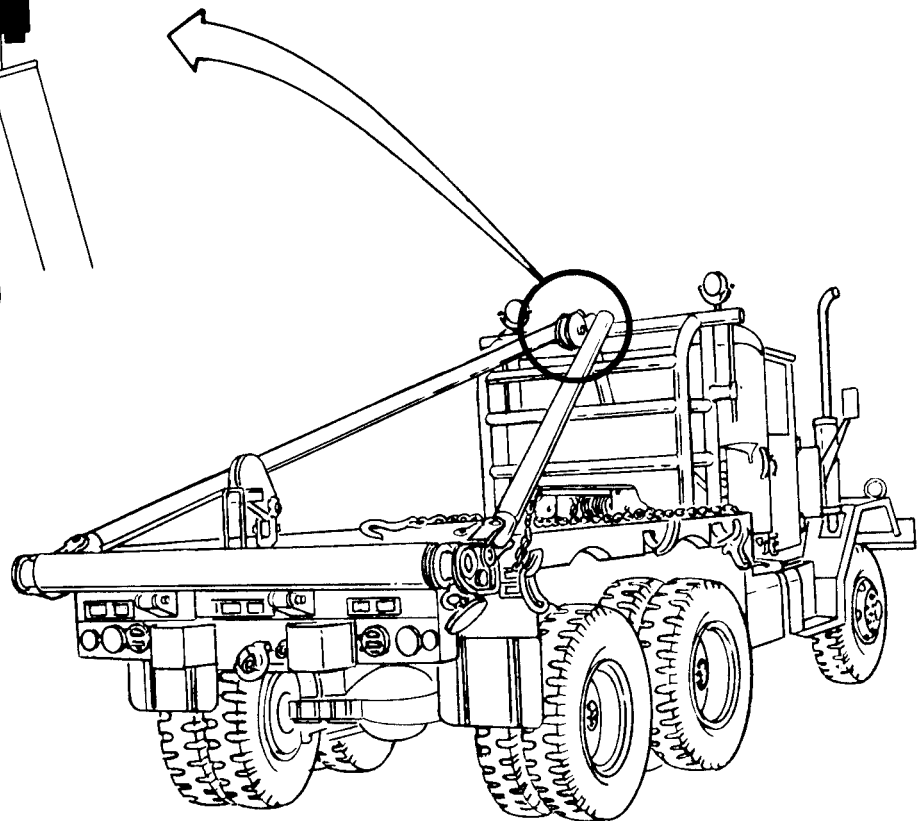
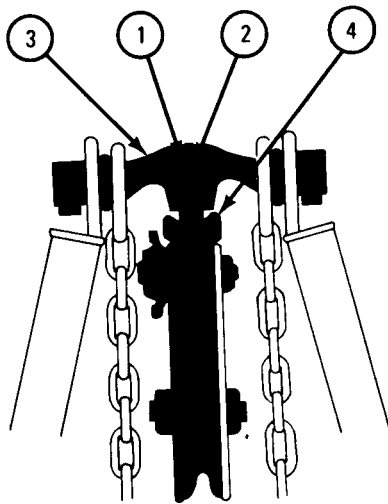

TA 045039

FRAME 11

1. Unhook end of boom chains (1) from boom chain brackets (2).
2. Turn trunion (3) to unlock it.
3. Take trunion (3) out of yoke of each of both gin poles (4).
4. Take ring ends of both boom chains (5) off ends of trunion (3).

GO TO FRAME 12

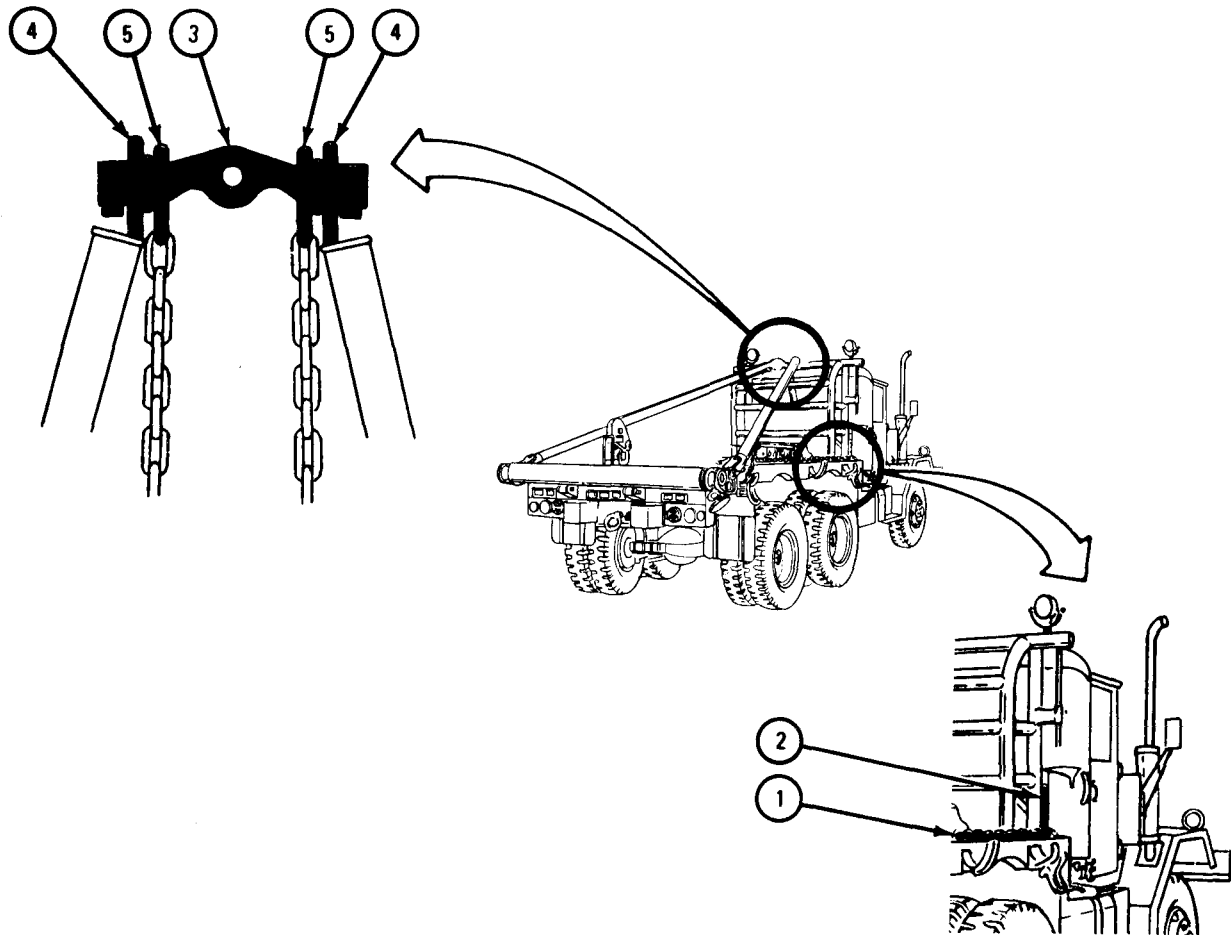

TA 045040

## FRAME 12

1. Lower gin poles (1), and place them onto bracket (2).
  2. Lock gin poles (1) in place with clamp (3), and tighten wig nuts (4).
- GO TO FRAME 13

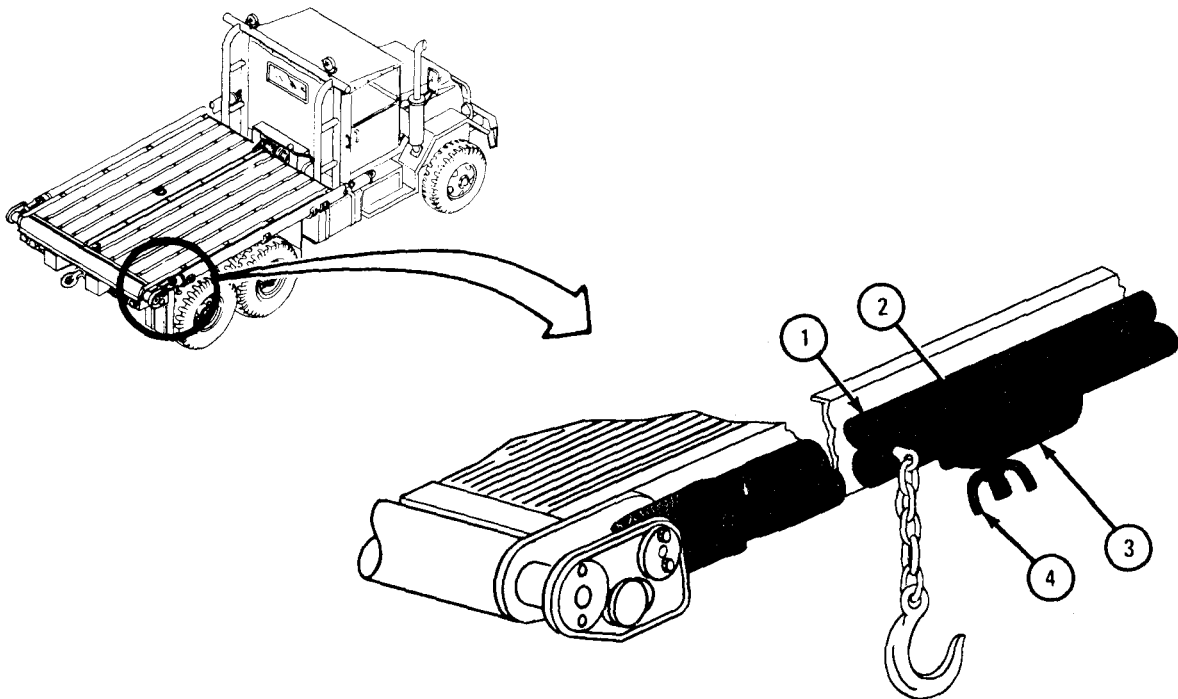

TA 045041

FRAME 13

1. Using pliers, straighten ends of cotter pins (1), and remove them from retaining pin (2).
2. Take tailboard sheave (3) out of mount in truck bed.
3. Front rack, side racks and tailgate can now be put back into place, if required.  
(Refer to para 4-8.)

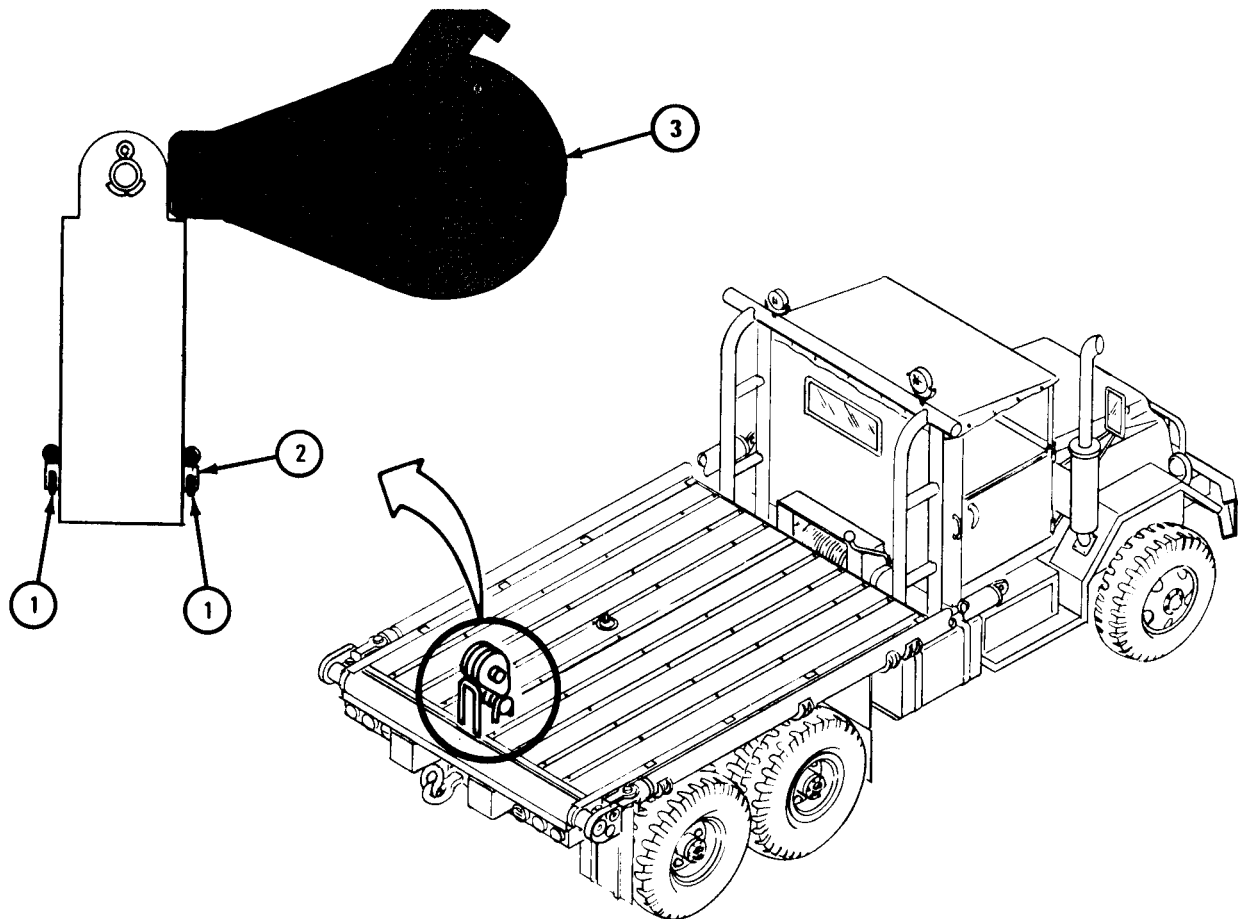

TA 045042



e. Rigging the A-Frame for Side Operation.

TOOLS : 1/2-inch wrench  
5/8-inch wrench

## FRAME 1

1. Using 1/2-inch wrench, take out four machine screws (1) from gin pole link holding pins (2) on both sides of truck.
2. Take out two link pins (2).
3. Loosen two wing nuts (3), on each side of truck and take gin poles (4), out of two side clamps (5).

GO TO FRAME 2

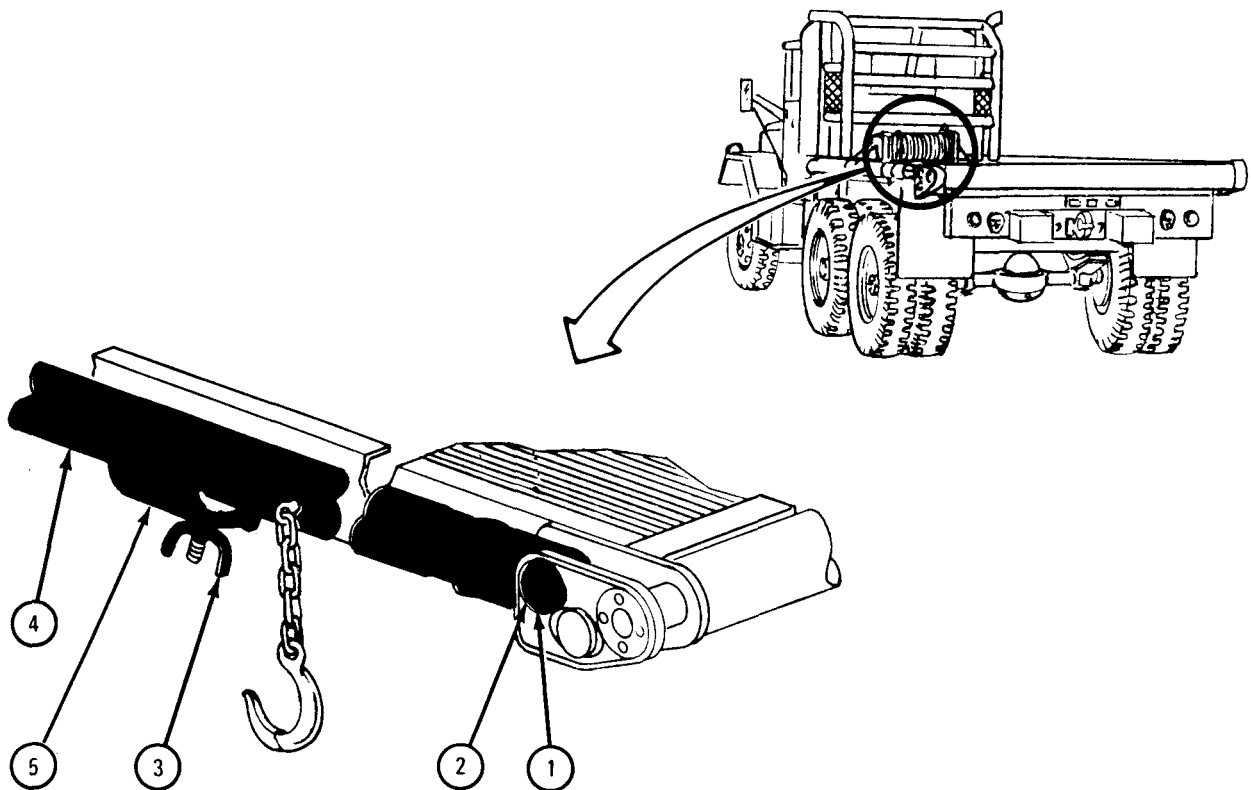

TA 045043

FRAME 2

1. Get two gin pole side mounting adapters (1) from storage compartment.
2. Find stake pockets with bolt holes at front and rear end of truck bed.
3. Place adapters (1) into front and rear stake pockets on side of truck to be used.
4. Using 5/8-inch wrench, make adapters (1) fast with capscrews and lockwashers (2).

GO TO FRAME 3

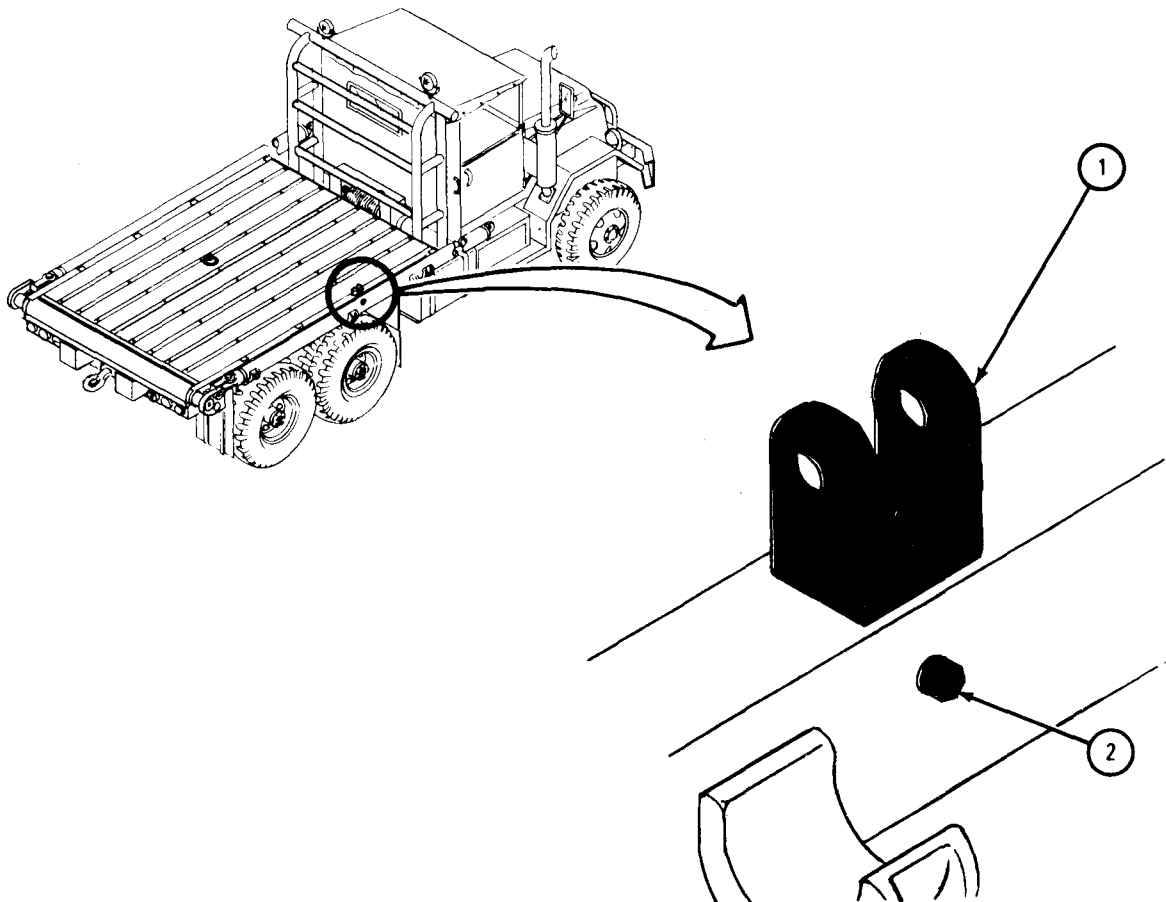

TA 045044

## FRAME 3

1. Place gin pole holding links (1) into adapter slots (2).
2. Using 1/2-inch wrench, make links (1) fast with holding pins (3), and machine screws and lockwashers (4).

GO TO FRAME 4

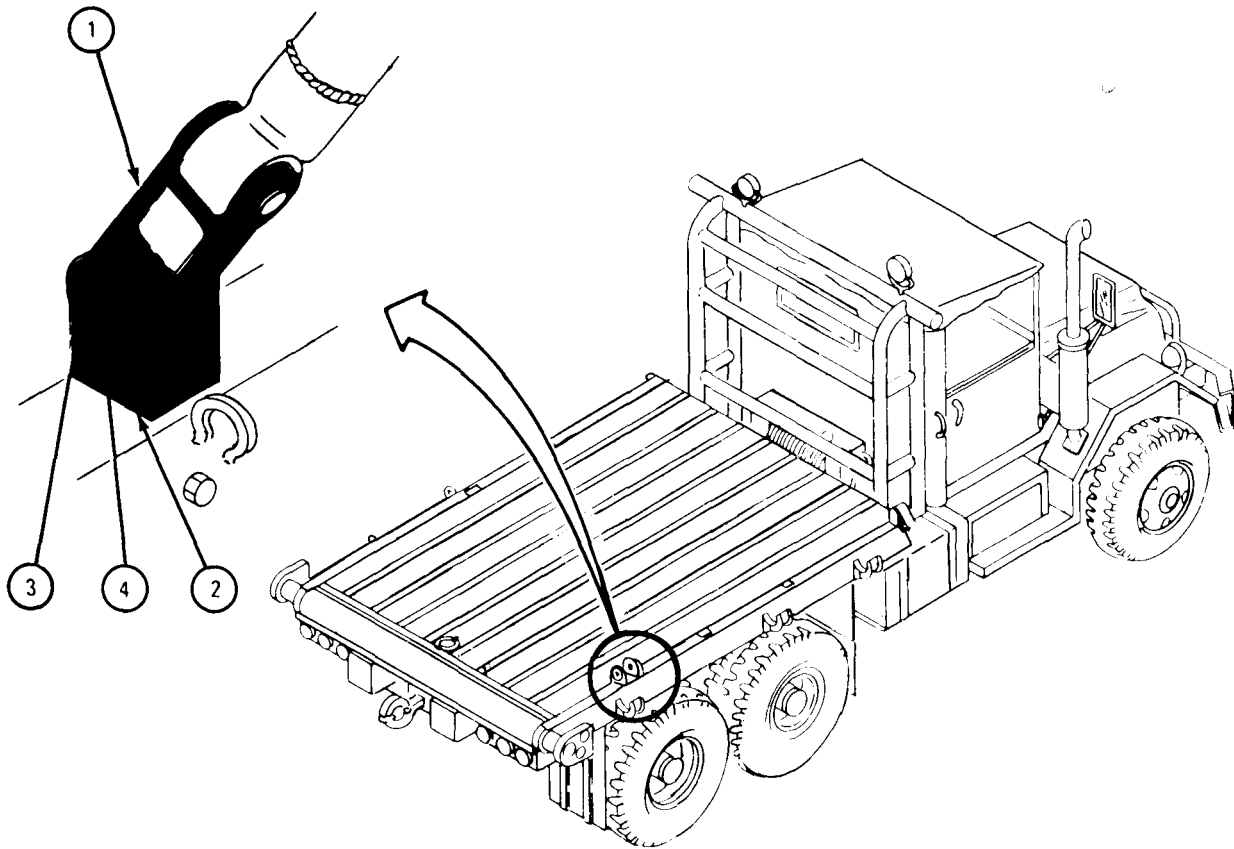

TA 045045

FRAME 4

1. Put trunion (1) through ring ends (2) of boom chains and yoke ends (3) of both gin poles.
2. Turn trunion (1) to right until it is locked into position.
3. Put A-frame sheave (4) into trunion (1), make it fast with retaining pin (5) and two cotter pins (6).

GO TO FRAME 5

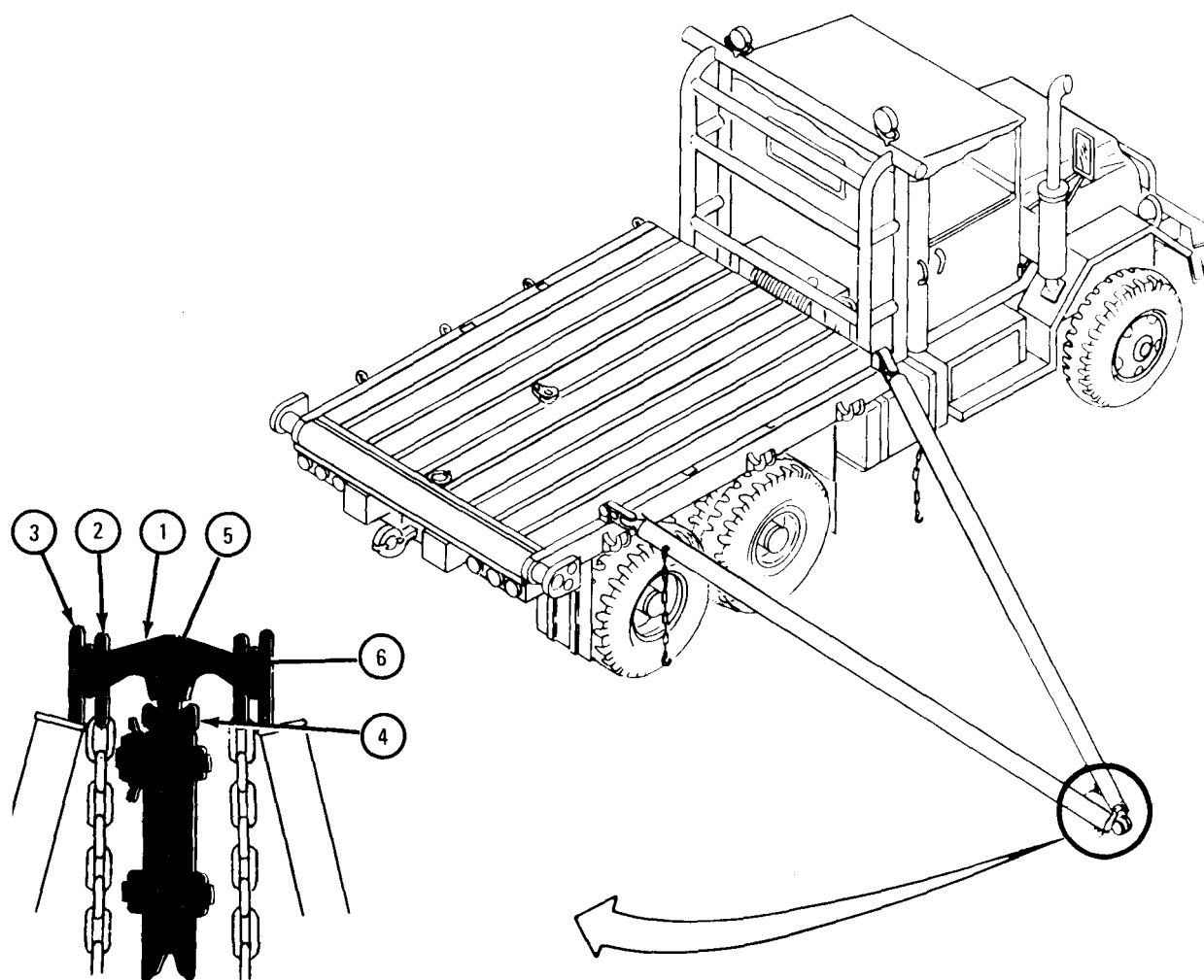

TA 045046

## FRAME 5

1. Place boom chains (1) over truck bed and through lashing rings (2) on end of truck bed.
2. Double boom chains (1) back and place hook into chain about fifteen links from lashing ring (2).

GO TO FRAME 6

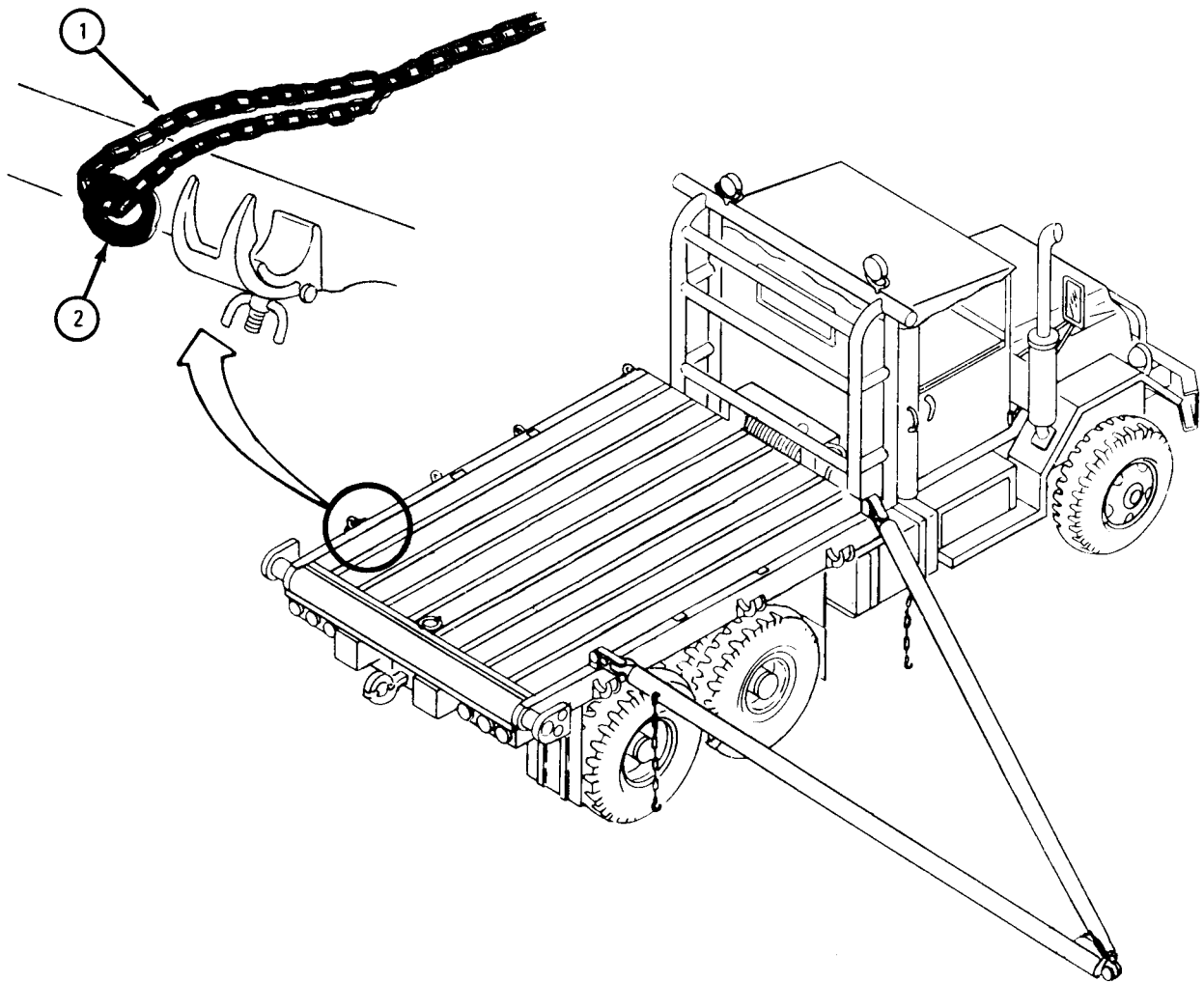

TA 045047

FRAME 6

1. Place tailboard sheave mount (1) into center sheave mount well.
2. Make sheave mount (1) fast with retaining pin (2) and two cotter pins (3).

GO TO FRAME 7

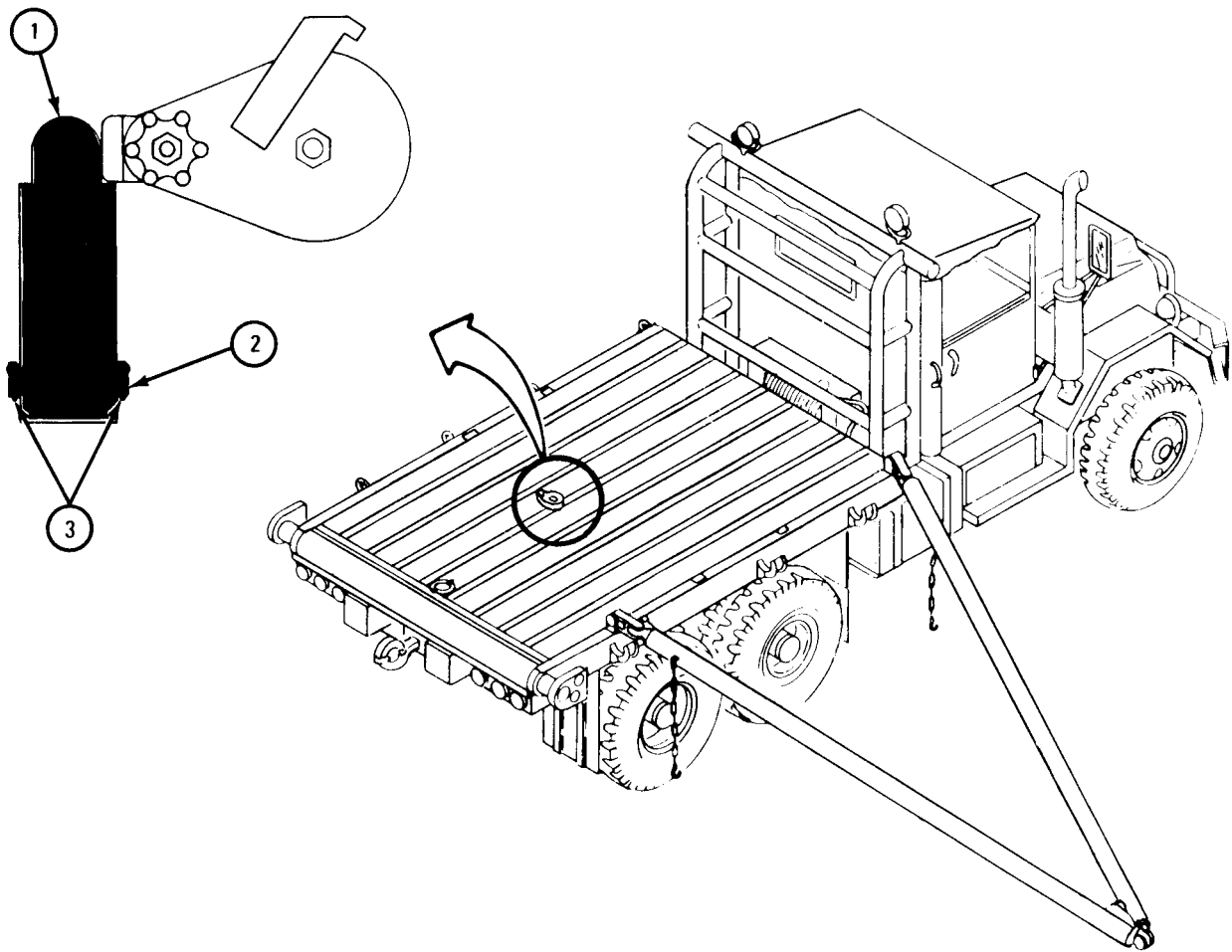

TA 045048

## FRAME 7

1. Loosen two handnuts (1), on sheave assembly (2) and A-frame sheave (3), to unscrew retaining pin (4) from side plate (5).
2. Turn side plate (5) left or right 90°.

GO TO FRAME 8

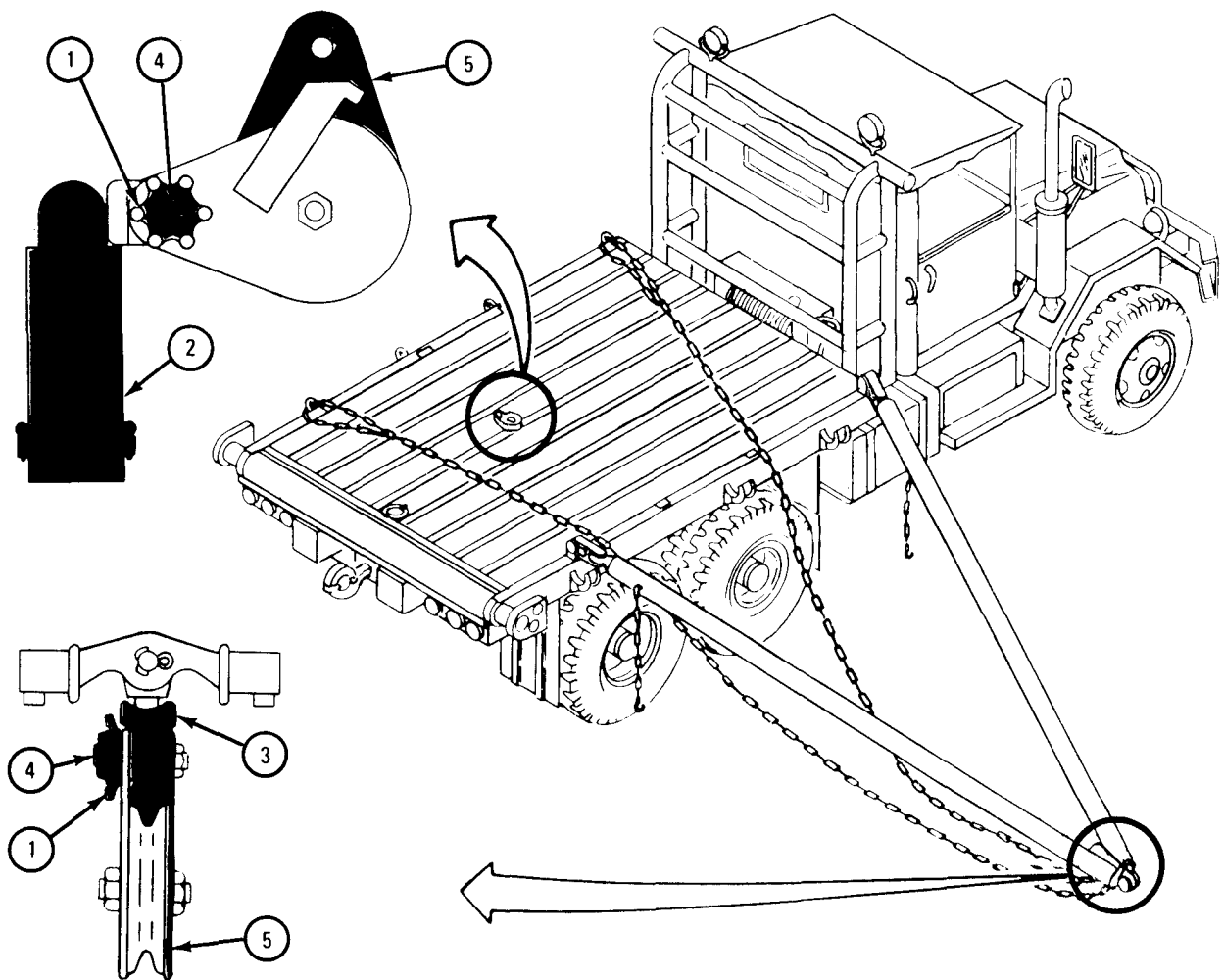

TA 045049

FRAME 8

1. Free spool winch cable. (Refer to para 4-14 b.)
2. Run winch cable (1) under forward boom chain, and under, around, and over sheave assembly (2).
3. Run winch cable (1) over and under A-frame sheave (3).
4. Hook end (4) to lashing ring (5).

GO TO FRAME 9

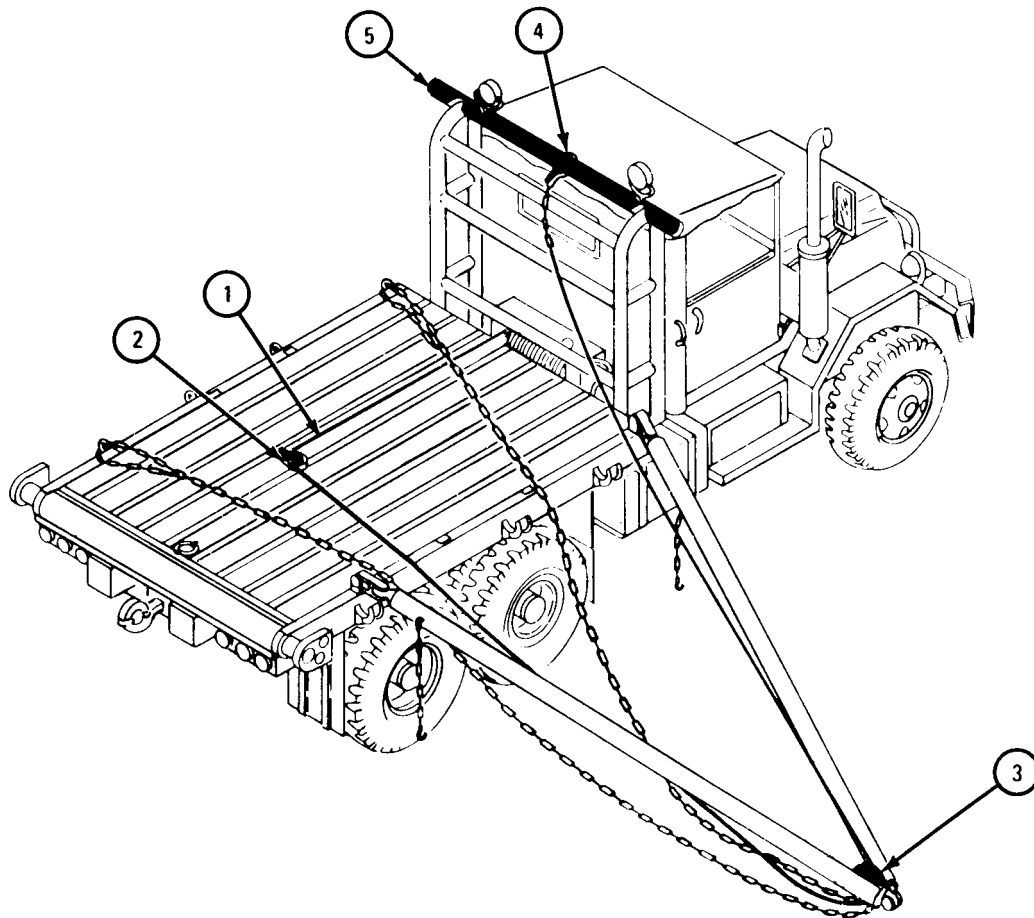

TA 045050



FRAME 9

1. Move side plate (1) on sheave assembly (2) and A-frame sheave (3) back into place.
2. Put retaining pins (4) back into sheave assembly (2) and A-frame sheave (3).
3. Tighten with two handnuts (5).

GO TO FRAME 10

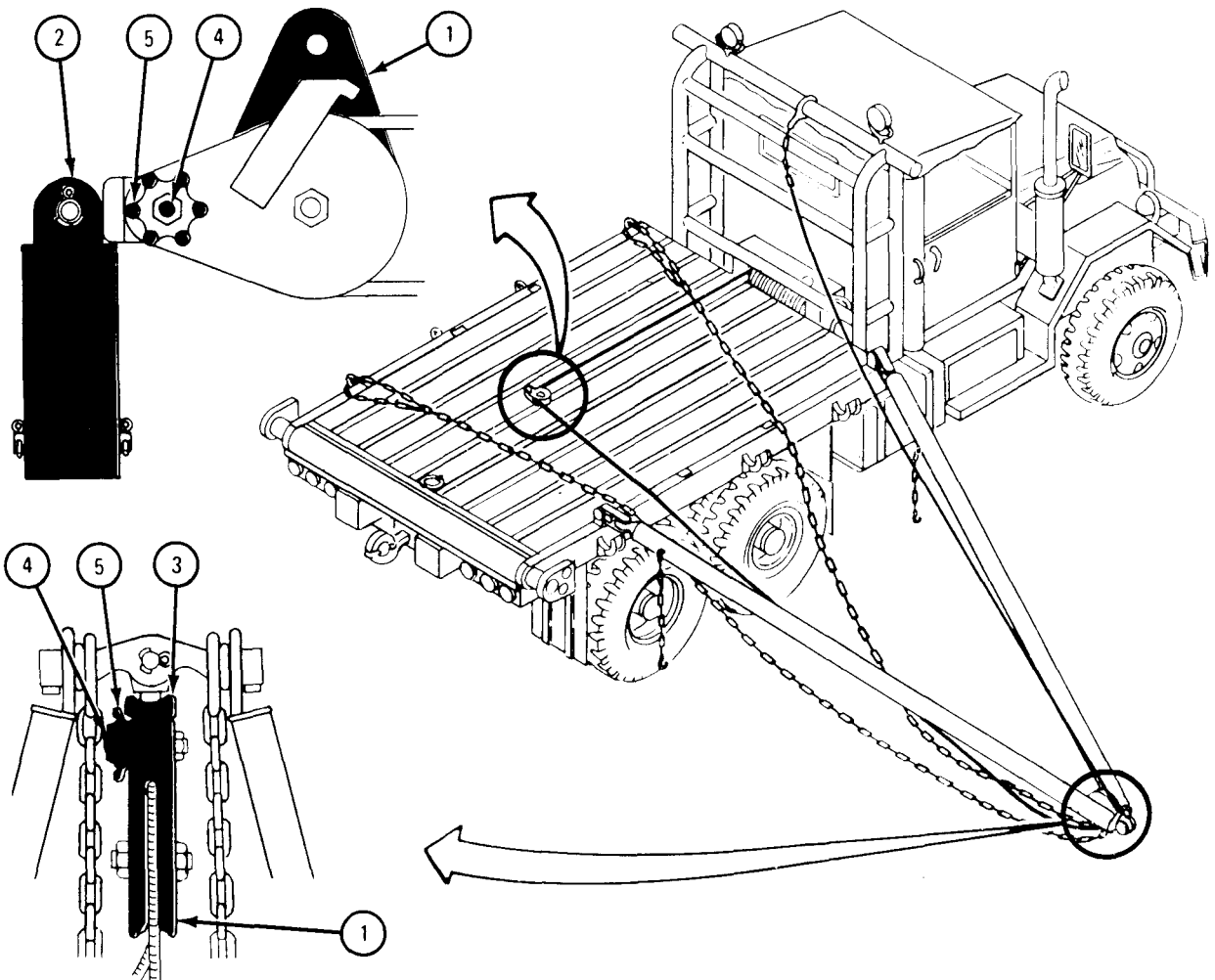

TA 045051

FRAME 10

1. Take up slack in winch cable, and raise A-frame (1) to position shown. (Refer to para 4-14 b.)
2. Adjust boom chains (2) to hold A-frame (1) in position shown.

**NOTE**

Height of the A-frame (1) can be changed by making boom chains (2) longer or shorter. Place A-frame at a high angle for heavy loads.

GO TO FRAME 11

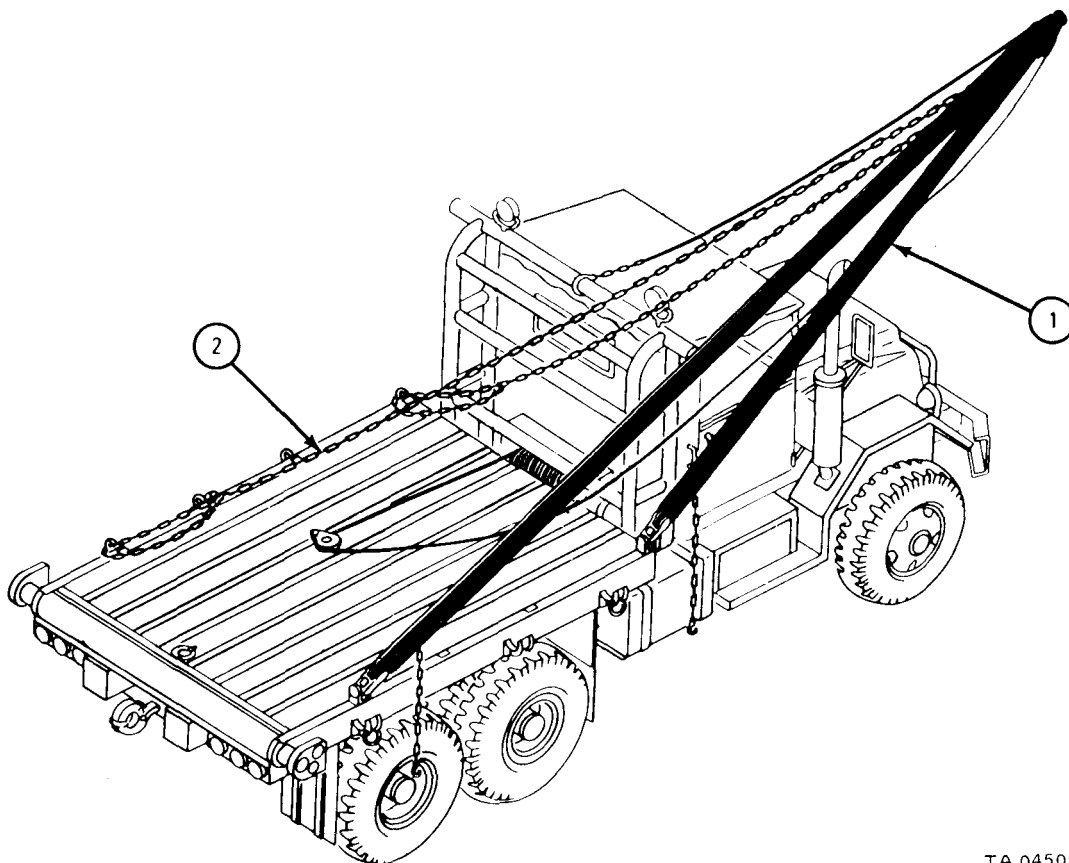

TA 045052

## FRAME 11

1. Place an adapter ring (1) onto lashing ring (2) on each end of A-frame side of truck bed.
2. Put a safety chain (3) onto each adapter ring (1).
3. Take the end of winch cable (4) from lashing ring (5).

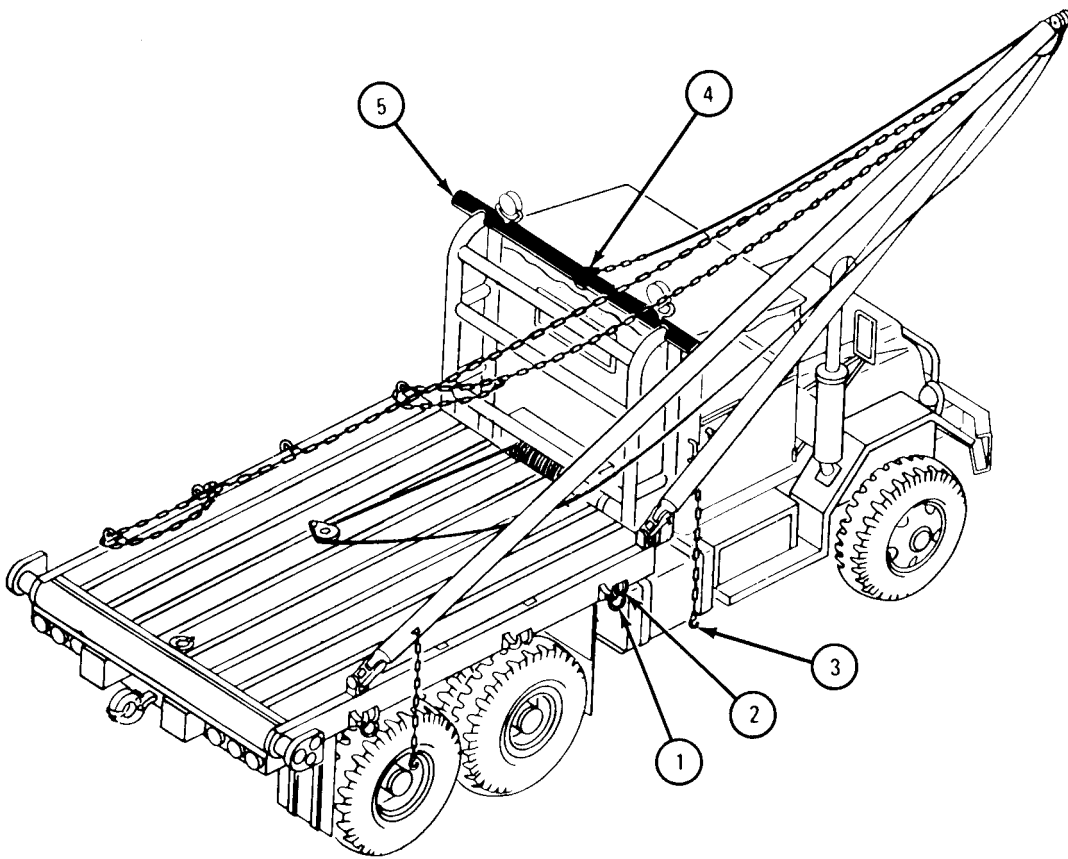

TA 045053

f. Lowering the A-Frame and Preparing Truck for Travel after Side Operation.

TOOLS : Pliers  
1/2-inch wrench  
5/8-inch wrench

FRAME 1

1. Hook end of winch cable (1) to lashing ring (2). Take up slack in cable. (Refer to para 4-14 b.)
2. Unhook boom chains (3) and safety chains (4), then, slowly lower A-frame to ground.
3. Take off chain adapter (5), safety chains (4), and boom chain (3).

GO TO FRAME 2

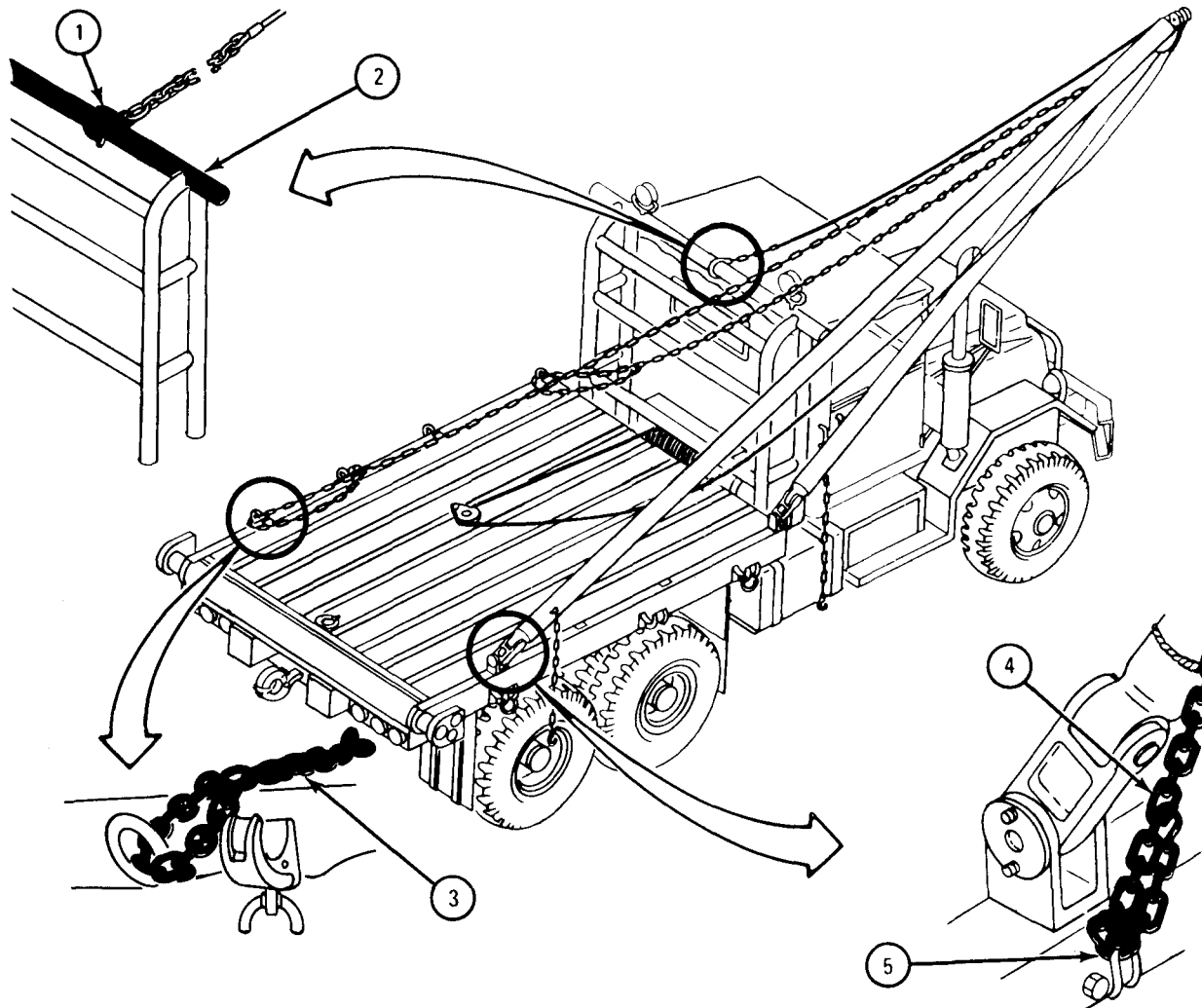

TA 045054

## FRAME 2

1. Turn handnuts (1 and 2) to unscrew retaining pins (3 and 4) from side plates (5 and 6).
2. Turn side plates (5 and 6) left or right 90°

GO TO FRAME 3

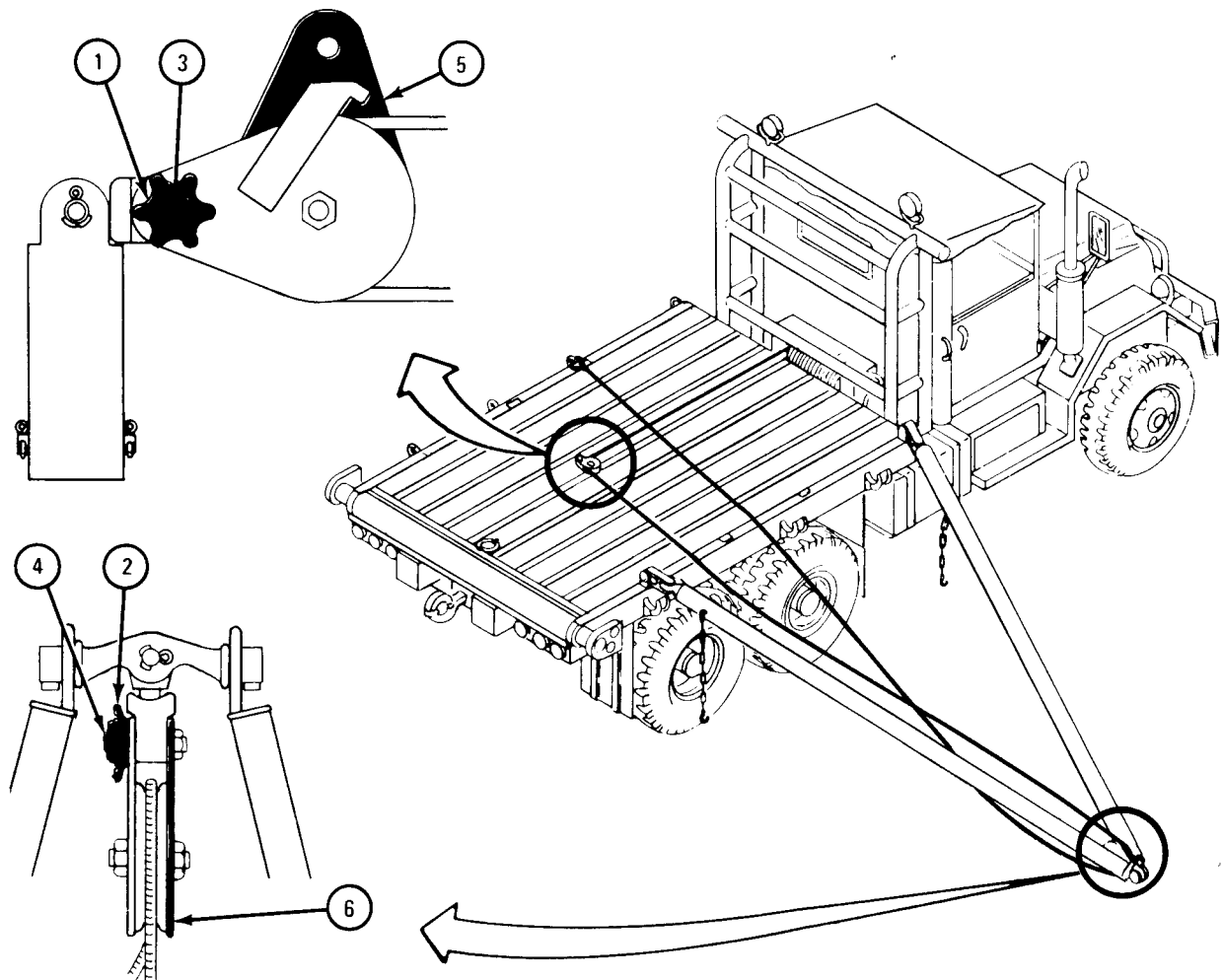

TA 045055

FRAME 3

1. Take winch cable (1) out of A-frame sheave (2), and sheave assembly (3).
2. Unhook end of winch cable (1) from lashing ring (4).
3. Wind winch cable (1) onto winch drum. (Refer to para 4-14 b.)

GO TO FRAME 4

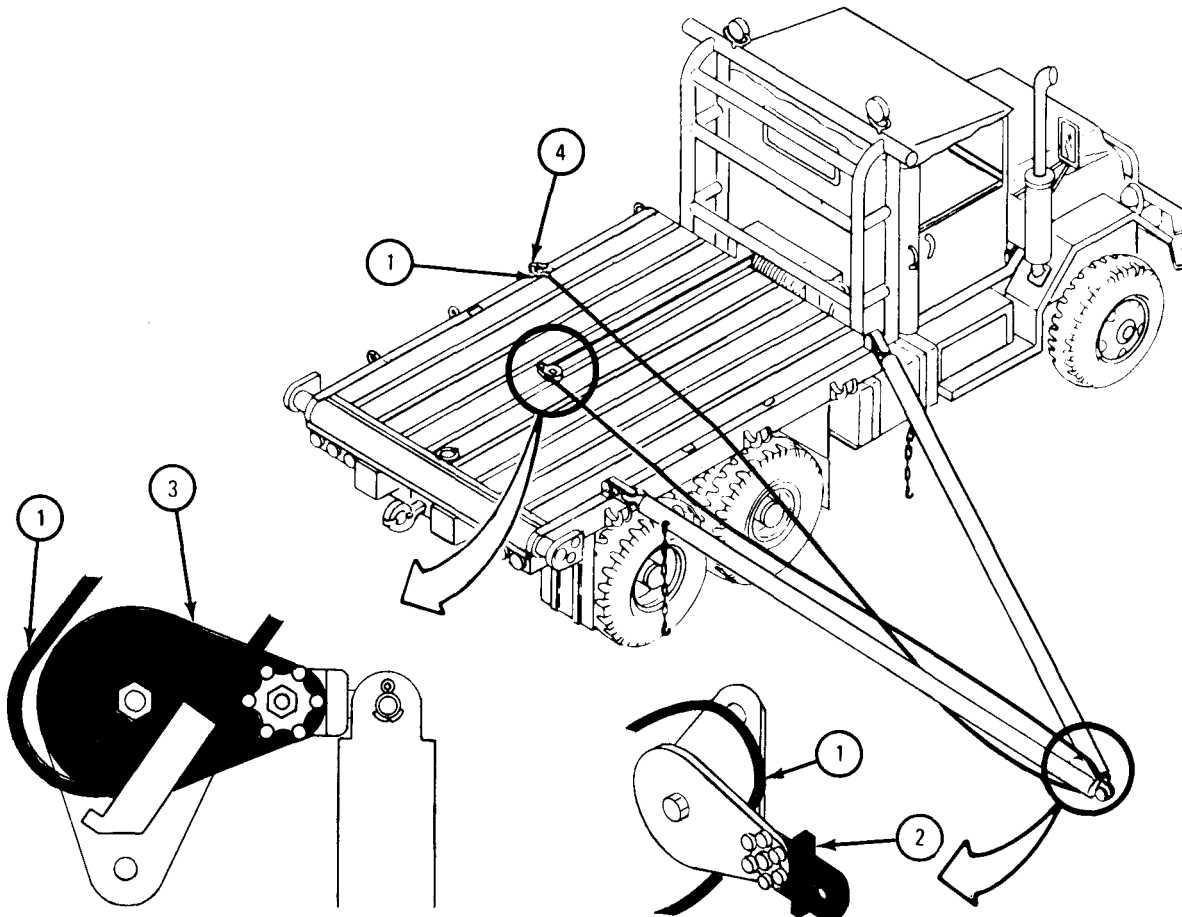

TA 045056

FRAME 4

1. Move side plates (1) back into closed position on A-frame sheave (2) and sheave assembly (3).
  2. Make side plates (1) fast with retaining pins (4) and tighten handnuts (5).
- GO TO FRAME 5

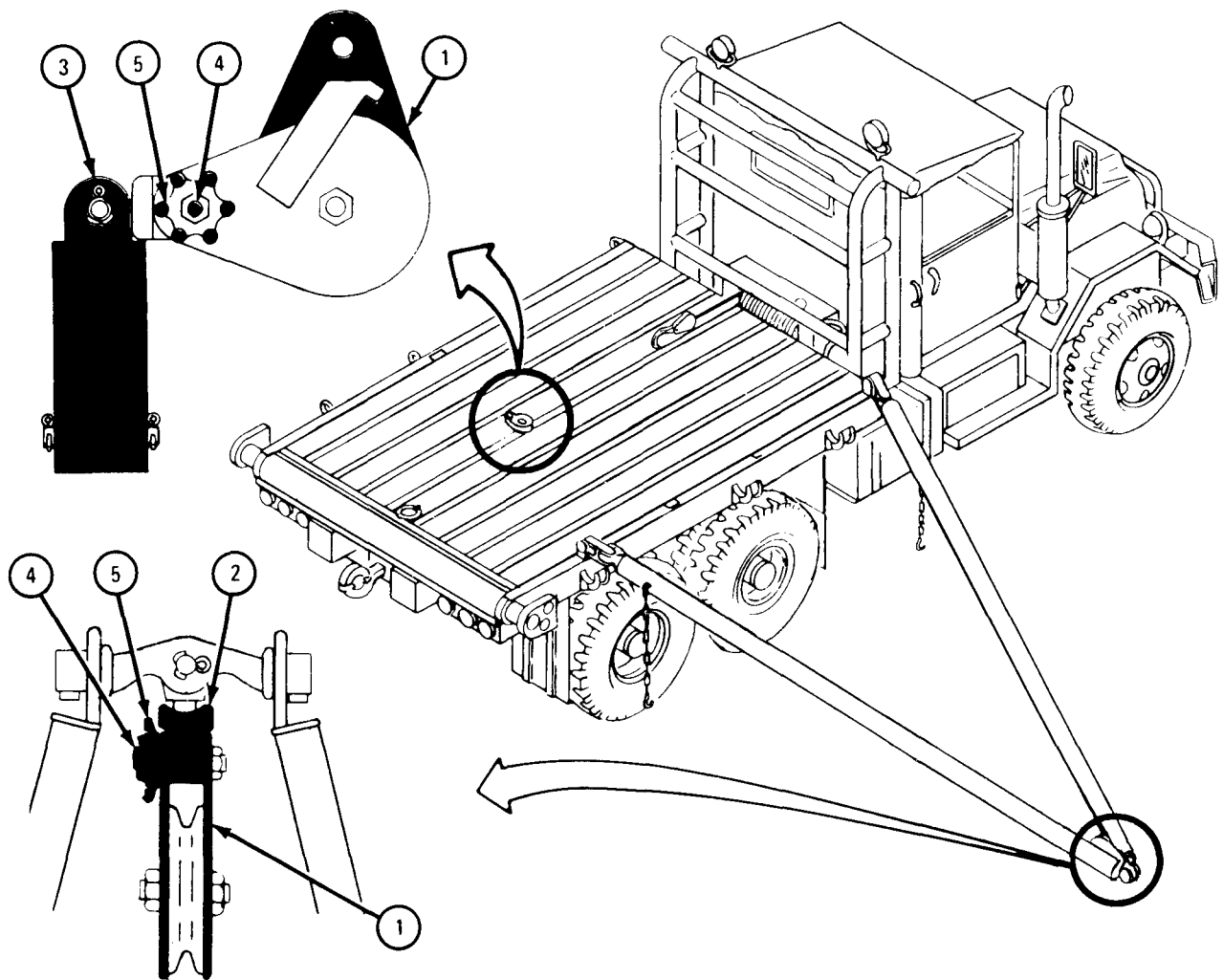

TA 045057

FRAME 5

1. Using pliers, straighten bent ends of cotter pins (1) and remove them from retaining pin (2).
2. Take retaining pin (2) out of trunion (3) and A-frame sheave (4).
3. Take A-frame sheave (4) out of trunion (3).

GO TO FRAME 6

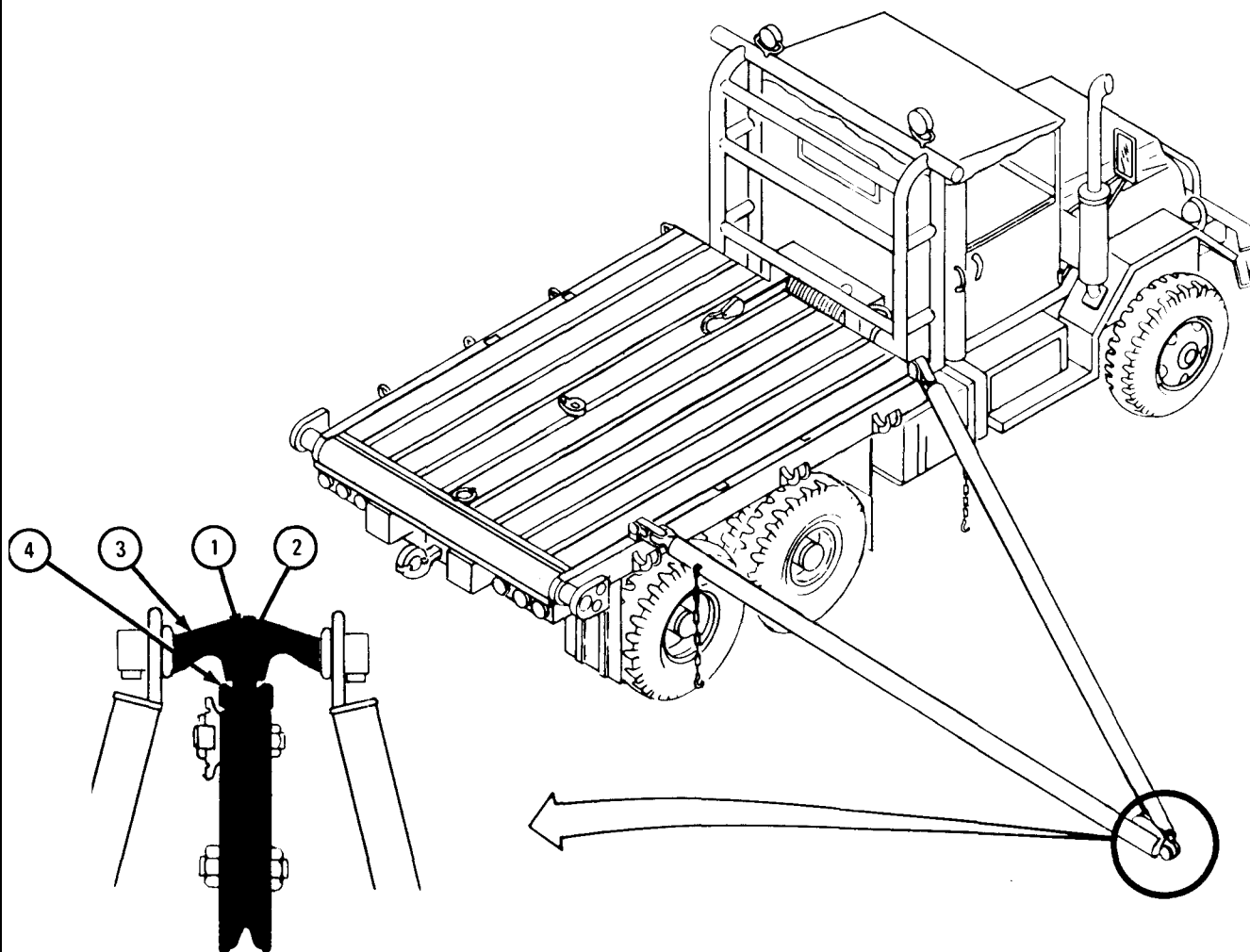

TA 045058



## FRAME 6

1. Using 1/2-inch wrench, loosen and takeout four machine screws (1).
2. Pull two link holding pins (2) from both gin pole adapters (3) and links (4).
3. Lift gin poles (5) out of adapters (3).
4. Using 5/8-inch wrench, takeout capscrews (6), and lift out adapters (3).

GO TO FRAME 7

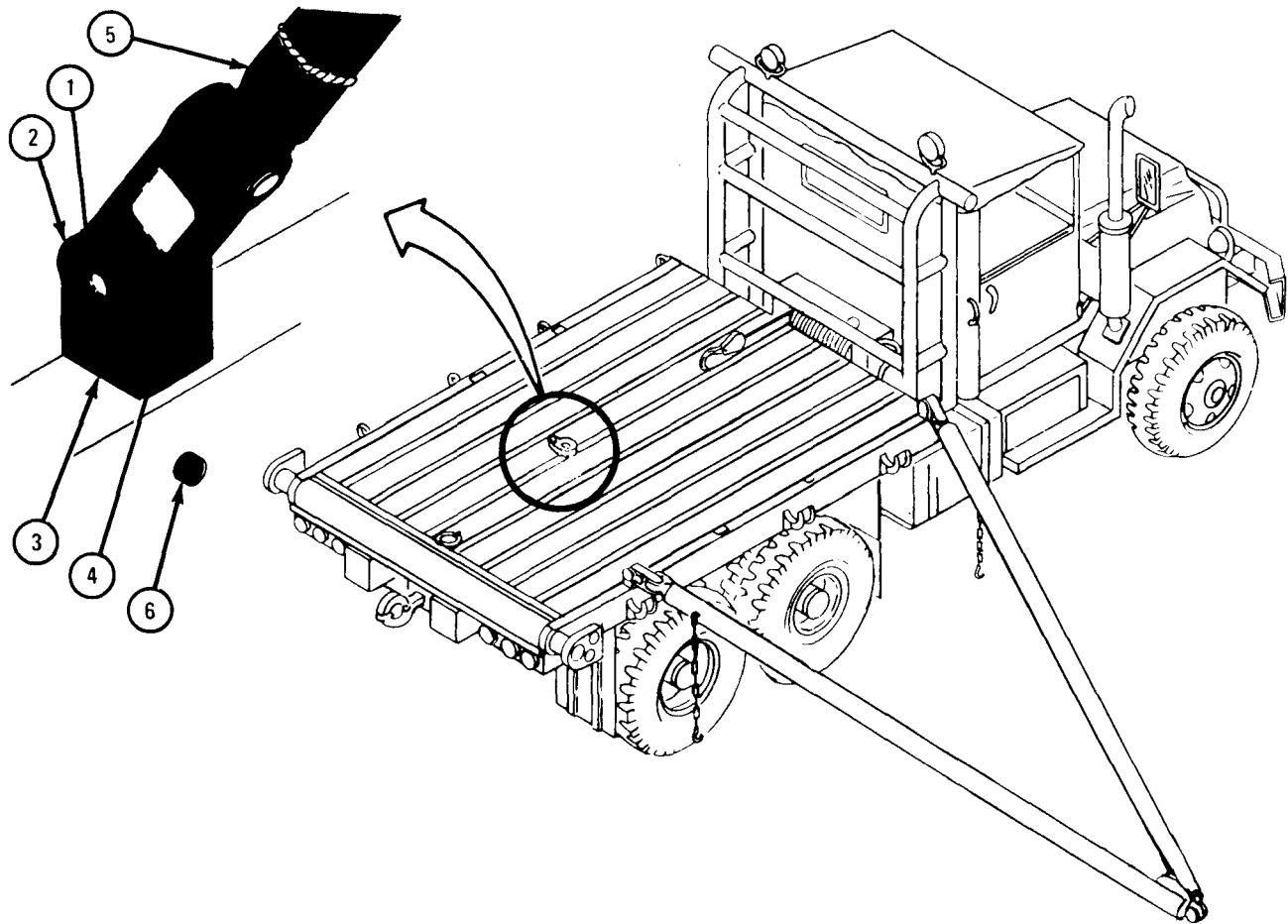

TA 045059

FRAME 7

1. Put link ends of gin poles (1) back into tailboard bracket (2).
2. Put gin pole link holding pins (3) back into place in tailboard bracket (2) and through gin pole links (4).
3. Using 1/2-inch wrench, make gin pole link holding pins (3) fast with machine screws (5).

GO TO FRAME 8

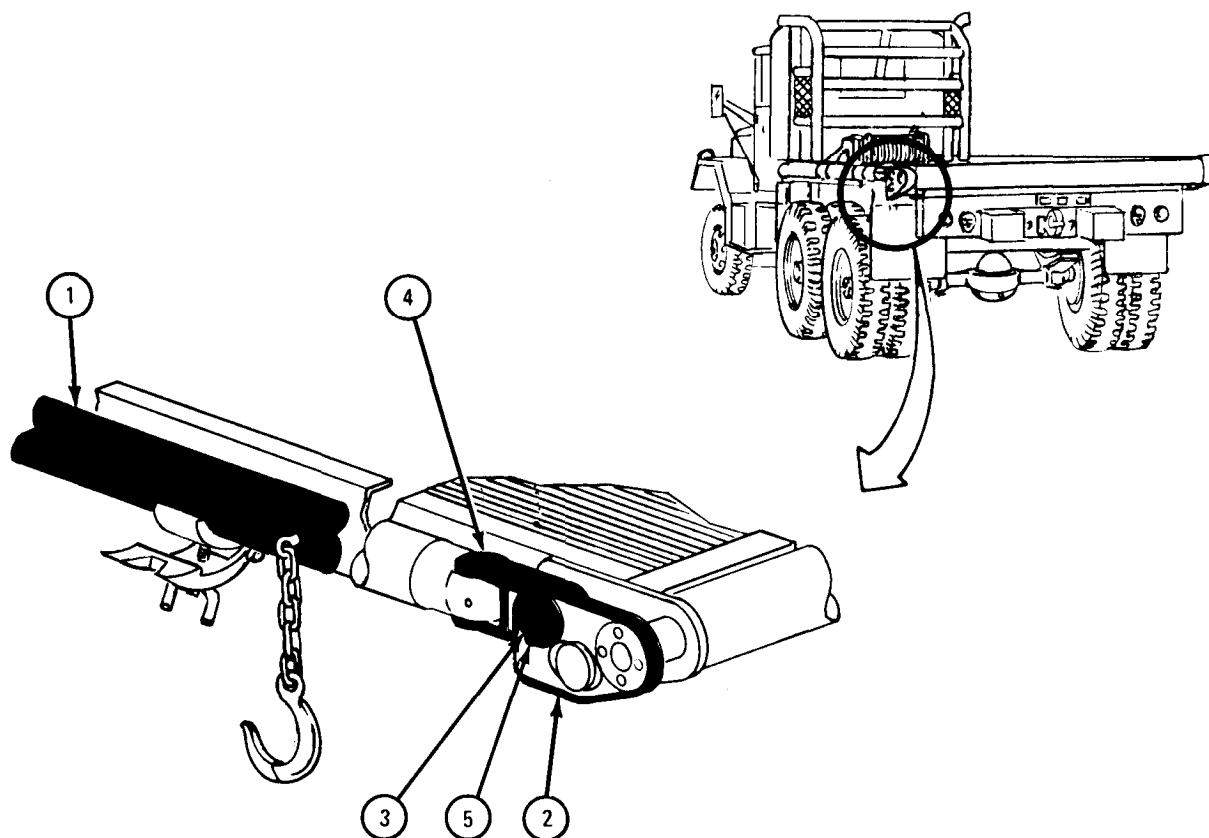

TA 045060

FRAME 8

- 1. Place gin poles (1) on side clamp brackets (2).
  - 2. Make gin poles (1) fast with clamps (3) and wing nuts (4).
- GO TO FRAME 9

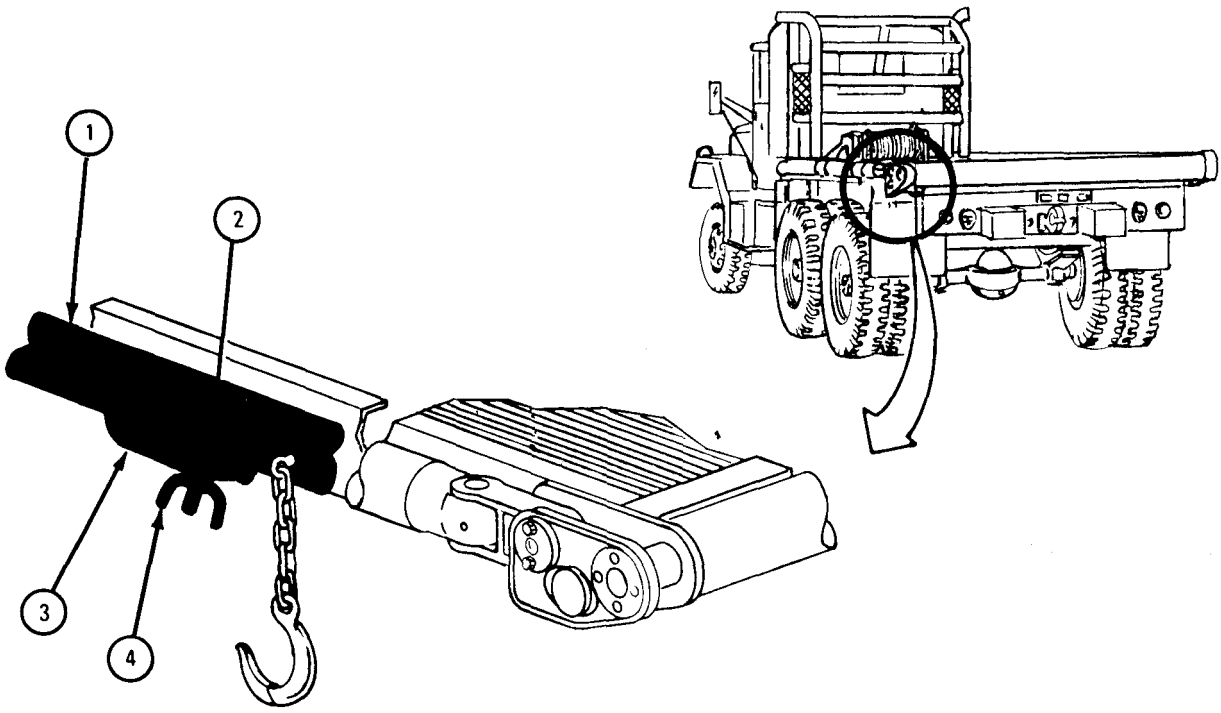

TA 045061

FRAME 9

1. Using pliers, straighten bent ends of cotter pins (1) and take them out of retaining pin (2).
2. Take retaining pin (2) out to sheave assembly mount (3).
3. Lift sheave and mount assembly (4) out of center sheave mount well.
4. Put all parts back into proper storage places.

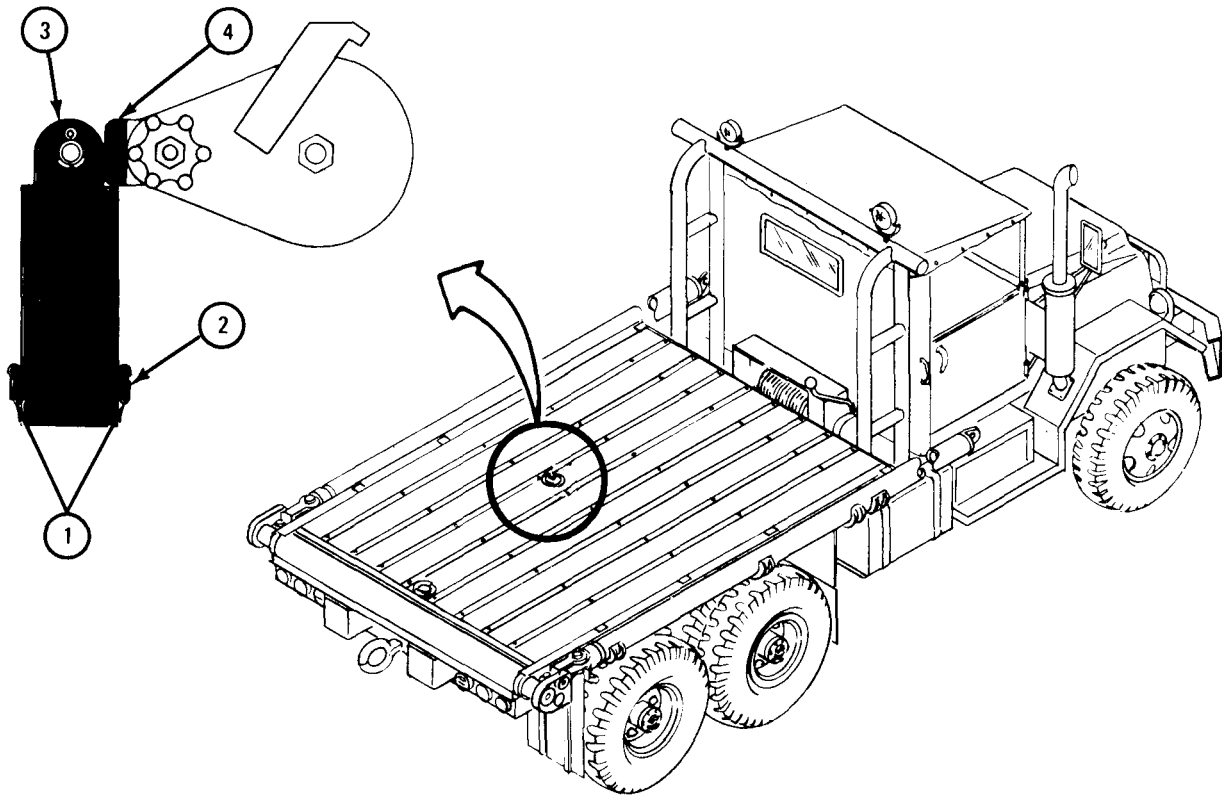

TA 045062

## 4-15. OPERATION OF EARTH BORING MACHINE AND POLESETTER TRUCKS.

a. General. M764 earth boring machine and polesetter trucks are equipped with a rear earth boring machine, rear winch, and collapsible cable reel. The rear winch is used with the earth boring machine derrick to set and pull poles, and with collapsible cable reel to take up or lay wire and light cable.

b. Preparing the Truck for Boring Operation.

FRAME 1
---------

1. Start engine. (Refer to para 4-6b.)
2. Place truck so rack bar (1) will be directly over hole location when in boring position.
3. Press clutch pedal (2) down.
4. Place FRONT TRANSMISSION gear shift lever (3) in N position. Let clutch pedal (2) up slowly.
5. Pull handbrake (4) up to on position.
6. Take wheel chocks (5) from side of truck and place them against rear wheels.

GO TO FRAME 2

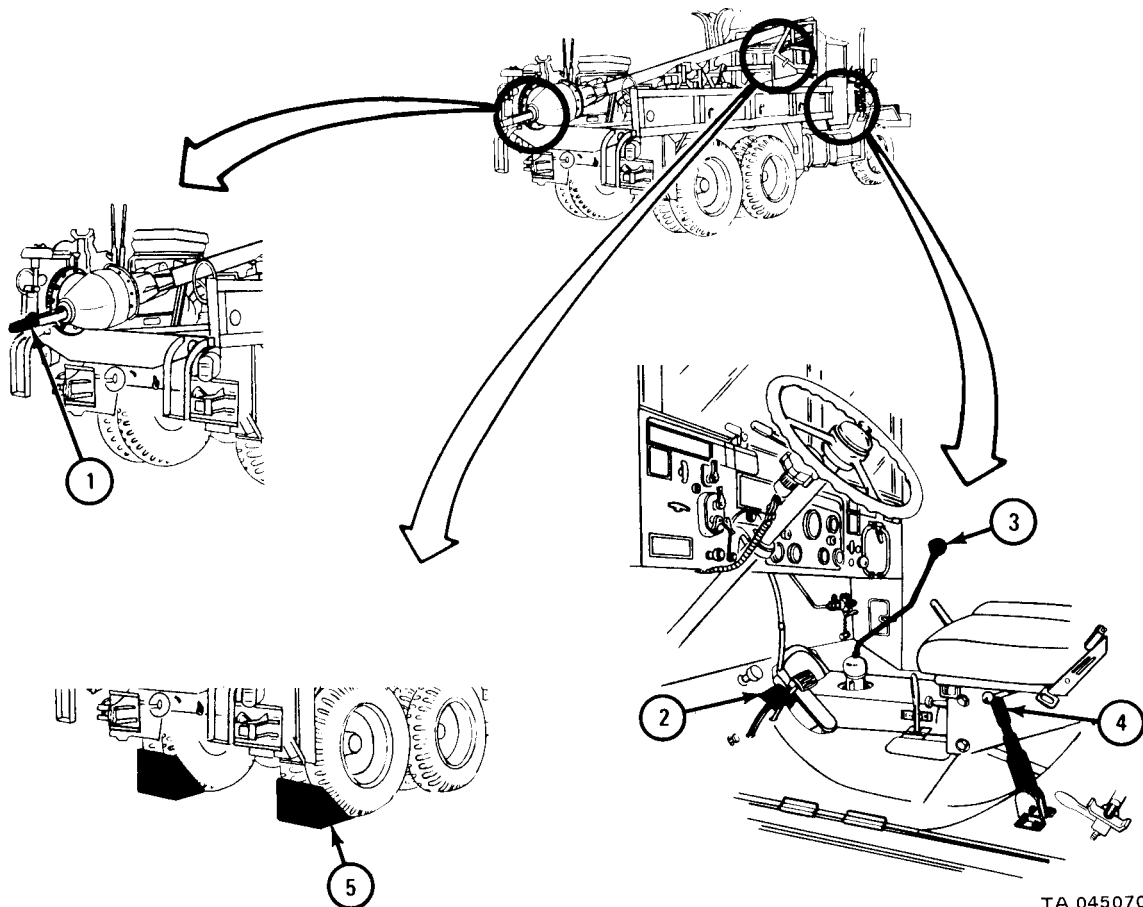

FRAME 2

1. Let engine run at idle speed, press clutch pedal (1) all the way down.
2. Place TRANSFER CASE gearshift lever (2) in neutral position.
3. Place FRONT TRANSMISSION gearshift lever (3) in position 1.
4. Turn locking bar (4) to off position.
5. Place transfer POWER TAKE OFF LEVER (5) all the way to rear to ENGAGE (on) position.
6. Place control lever (6) in EARTH AUGER position.
7. Let clutch pedal (1) up slowly.

GO TO FRAME 3

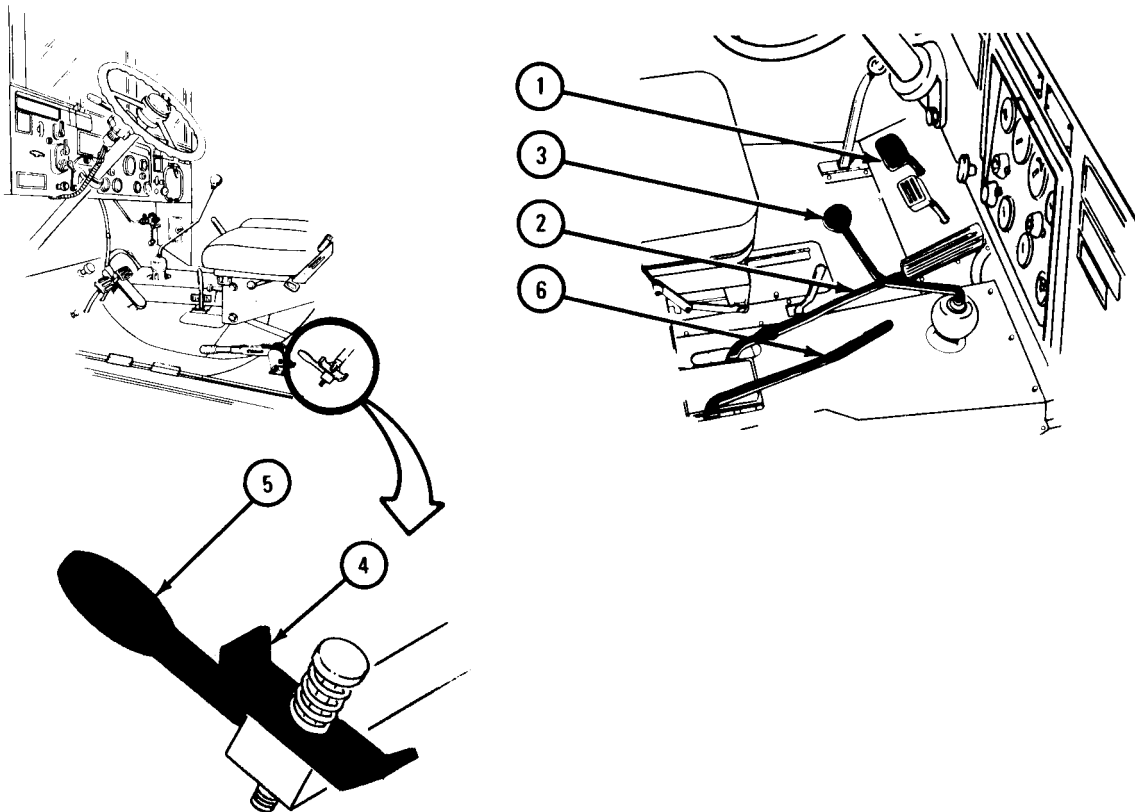

TA 045373

FRAME 3

**NOTE**

OUTRIGGERS control levers (1) and (2) are spring loaded and will return to NEUTRAL when let go.

1. Move OUTRIGGERS control levers (1) and (2) to UP position one at a time to raise inner outrigger legs (3) a little to free safety latches (4).
2. Pull safety latches (4) out and turn to up position against upper outrigger legs (5).
3. Move OUTRIGGERS control levers (1) and (2) to DOWN position one at a time to lower inner outrigger legs (3) about halfway.

GO TO FRAME 4

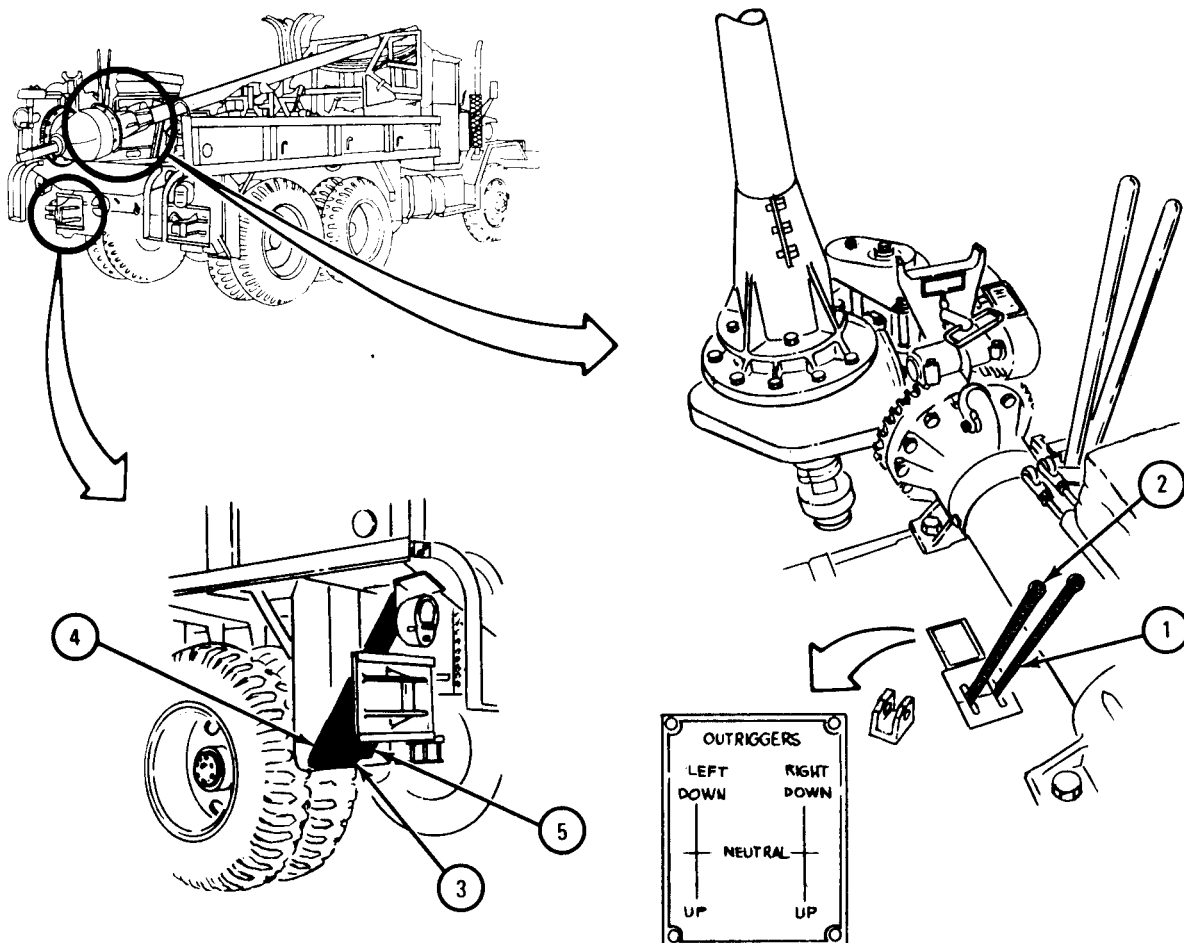

TA 045222

FRAME 4

1. Take outrigger shoes (1) from stowage brackets (2), (right and left sides).
2. Place outrigger shoes (1) on end of inner outrigger legs (3) and make them fast with retaining pins (4).
3. Operate OUTRIGGER S control levers (5 and 6) until outrigger shoes (1) press against ground to make machine steady and level.

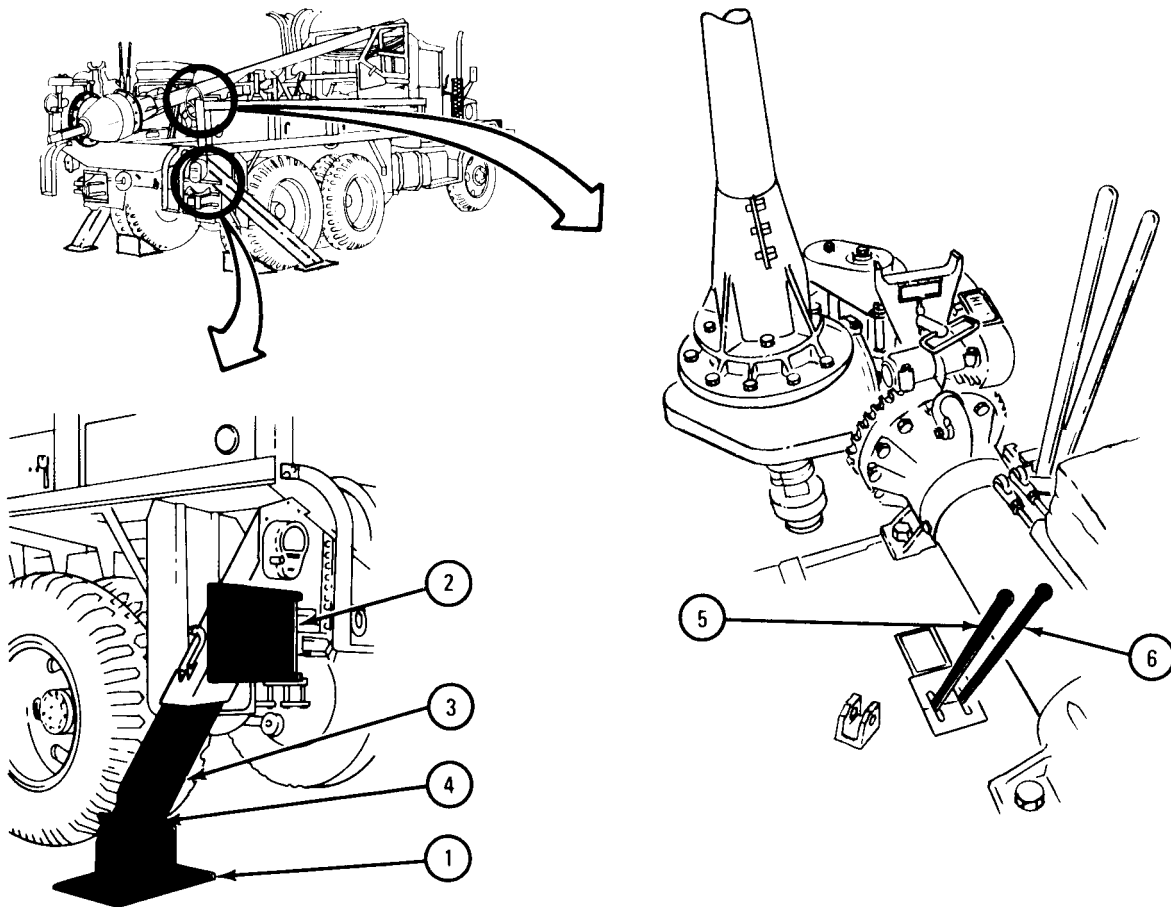

TA 045223



c. Raising, Leveling, and Lowering the Derrick Tube.

TOOLS: 1-inch ratchet wrench

FRAME 1

**WARNING**

Be certain there are no overhead power lines or other obstructions before raising derrick from travel position, accidental contact can cause serious injury and damage.

1. Step on and press clutch pedal (1) in all of the way.
2. Check that TRANSFER CASE shift lever (2) is in neutral position.
3. Check that transfer POWER TAKEOFF LEVER (3) is in ENGAGE position.
4. Check that power divider control lever (4) is in EARTH AUGER position.
5. Check that FRONT TRANSMISSION gearshift lever (5) is in position 1.
6. Let clutch pedal (1) up slowly.

GO TO FRAME 2

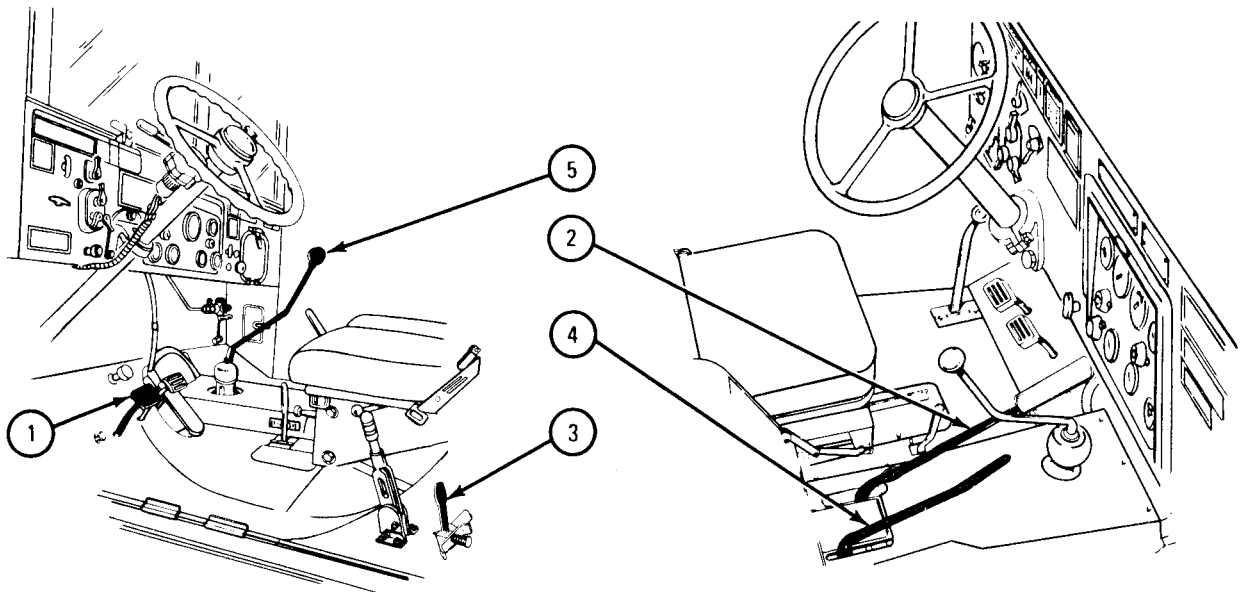

TA 045227

FRAME 2

**WARNING**

Whenever you leave the operator's area lock the feed and drive control levers (1 and 2). This will prevent movement of the boring machine and possible injury to personnel or damage to equipment. Refer to frame (8) for locking procedures.

1. To unlock feed and drive control levers (1 and 2):
  - (a) Pull and hold feed and drive control levers (1 and 2) toward operator.
  - (b) Lift locking latch (3) by hand and turn it away from operator.
  - (c) Let go of levers (1 and 2).

GO TO FRAME 3

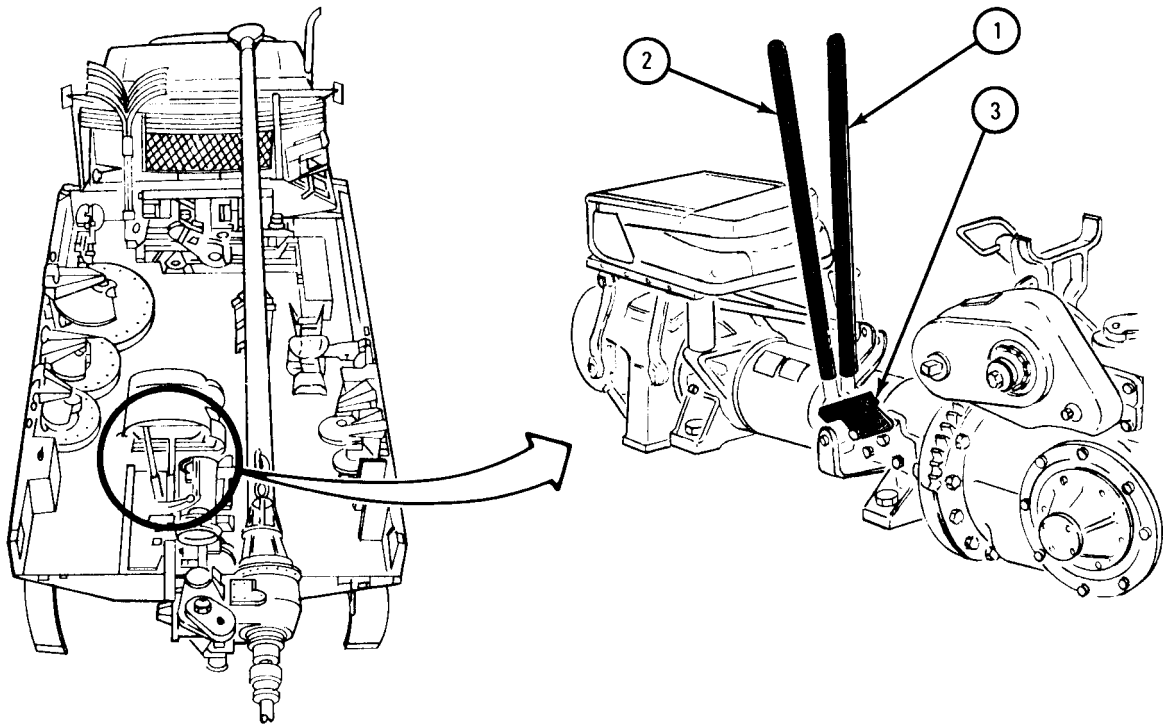

TA 045226

## FRAME 3

**NOTE**

Auger end of rack bar will tend to move away from boring case when derrick is raised. Raise auger rack bar from time to time to prevent it from hitting the ground. However, do not raise it high enough to compress the bumper spring against the boring case.

1. To raise derrick:
  - (a) Move power leveler shifting handle (1) down.
  - (b) Place feed control lever (2) in NEUTRAL position.
  - (c) Move drive control lever (3) forward to raise derrick (4).
  - (d) If rack bar (5) gets too close to ground, push feed control lever (2) forward to raise it. Let feed control lever come back to NEUTRAL position.
  - (e) Hold drive control lever (3) in forward position until leveling bubble (6) is nearly centered.

GO TO FRAME 4

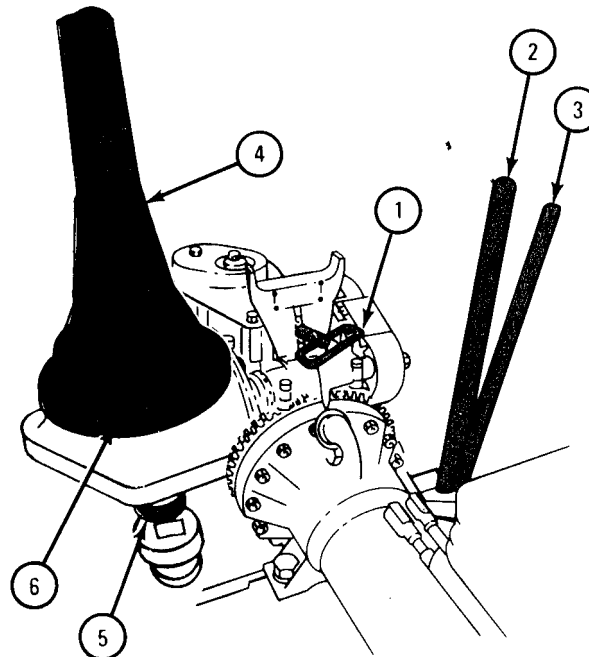

TA 045228

FRAME 4

1. To move derrick to operator's right:
  - (a) Move power-leveler shifting handle (1) up.
  - (b) Check that FRONT TRANSMISSION gearshift lever (2) is in position 1.
  - (c) Keep feed control lever (3) in NEUTRAL position.
  - (d) Move drive control lever (4) forward to move derrick (5) to right. Let handle (4) come back to NEUTRAL when derrick gets to position you want.

GO TO FRAME 5

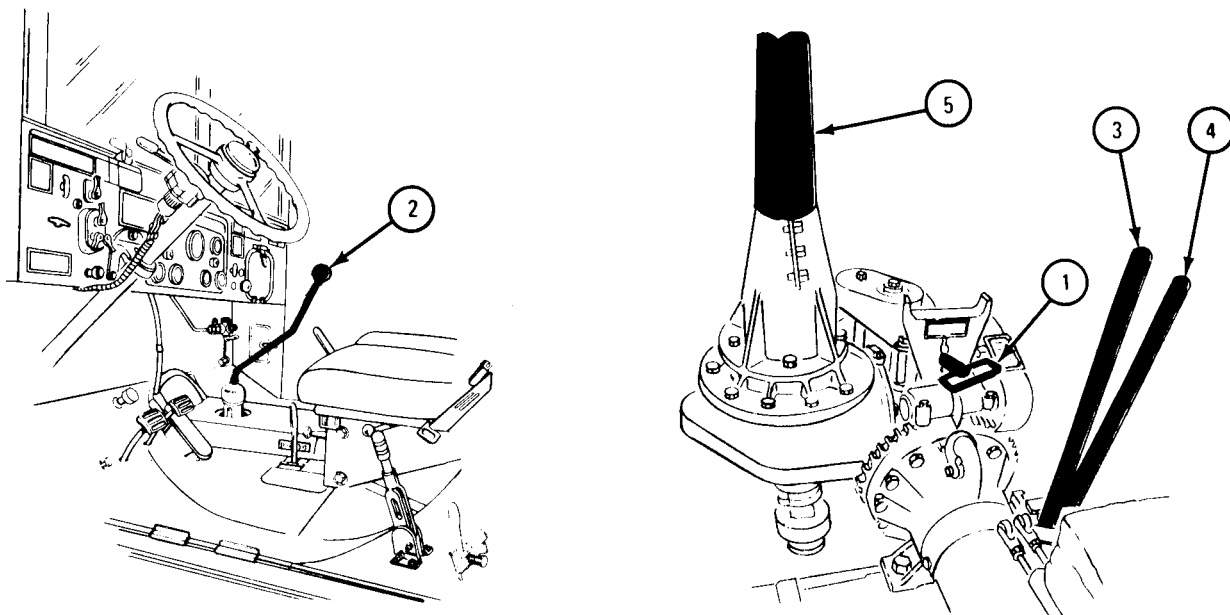

TA 084652

## FRAME 5

1. To move derrick to operator's left:
  - (a) Step on clutch pedal (1) all the way down.
  - (b) Place FRONT TRANSMISSION gearshift lever (2) in R position.
  - (c) Let clutch pedal (1) up.
  - (d) Keep power-leveler shifting handle (3) up.
  - (e) Keep feed control lever (4) in NEUTRAL position.
  - (f) Move and hold drive control lever (5) forward until derrick (6) moves left to position you want.

GO TO FRAME 6

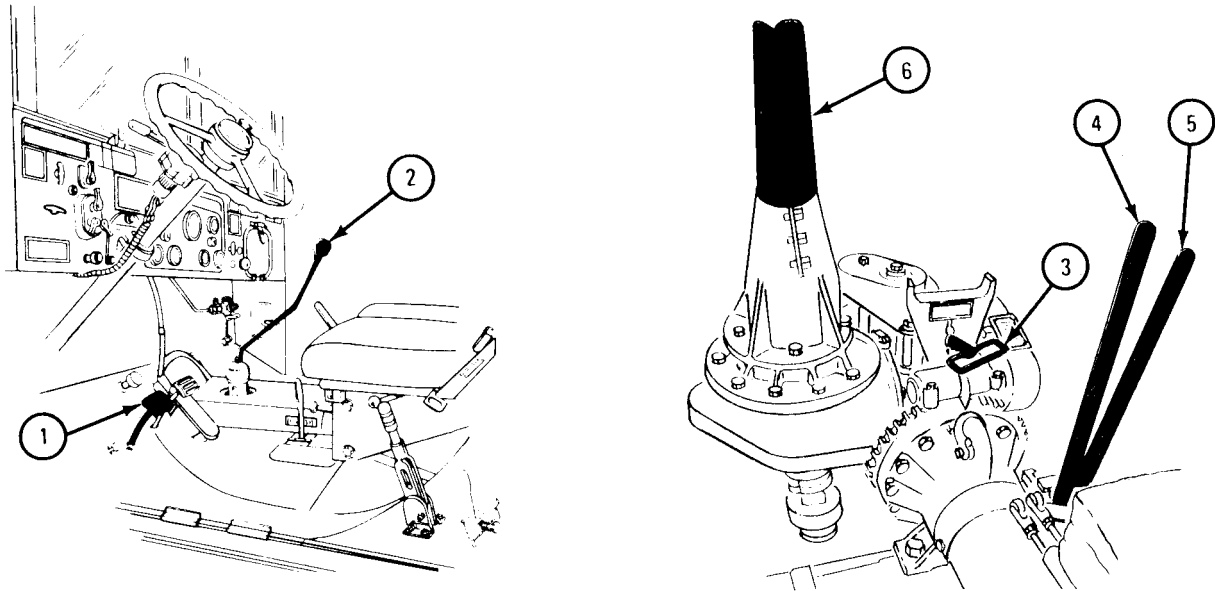

TA 084653

FRAME 6

**NOTE**

Always level boring machine with engine operating at idle speed. Leveling adjustments are easier to make at idle speed.

1. To level boring machine:
  - (a) Move derrick (1) so that leveling bubble (2) is near center. Refer to frames 3, 4, and 5.
  - (b) Using ratchet wrench, turn-front-to-back leveling adjustment (3) and side-to-side leveling adjustment (4) to center leveling bubble (2).
  - (c) When leveling bubble (2) is centered in circle pull out power leveler shifting handle (5). Set handle in neutral position.

GO TO FRAME 7

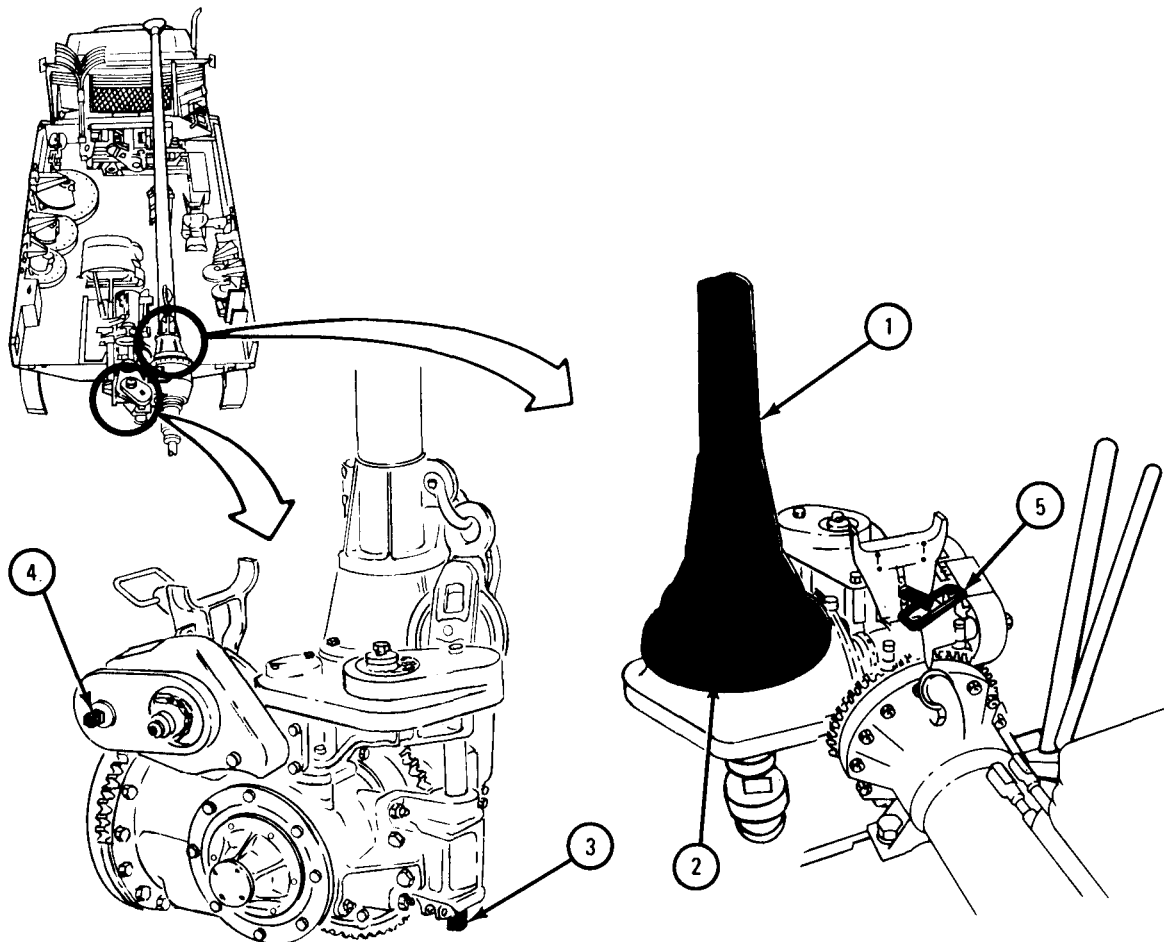

TA 045229

## FRAME 7

## 1. To lower derrick:

- (a) Step on clutch pedal (1). Place FRONT TRANSMISSION gearshift lever (2) in R position. Let clutch pedal (1) up.
- (b) Place power leveler shifting handle (3) in down position and keep feed control lever (4) in NEUTRAL position.
- (c) Place drive control lever (5) in forward position to lower derrick (6) into cradle (7) on a protector (8).

**CAUTION**

Before locking latch (9) against feed and drive control levers (4) and (5), let machine run with levers in neutral position. This will let heat escape from brake assemblies in clutch case.

- (d) Place power leveler shifting handle (3) in NEUTRAL position.

## 2. To lock feed (4) and drive (5) control levers:

- (a) Pull and hold feed and drive control levers (4) and (5) toward operator.
- (b) Turn locking latch (9) to locked position.
- (c) Let go of feed and drive control levers (4) and (5).

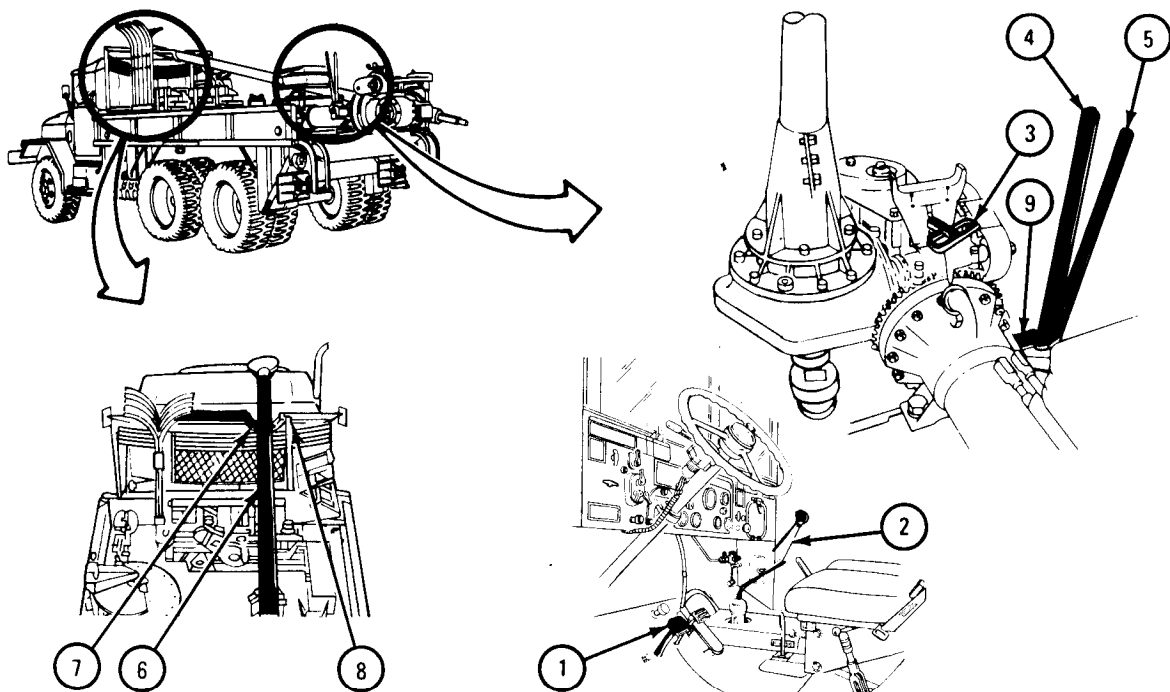

TA 084018

d. Operating and Securing the Rear Winch.

FRAME 1

1. Lift locking latch (1).
2. Pull winch control lever (2) back as needed to control rear winch brake and prevent free spooling.

GO TO FRAME 2

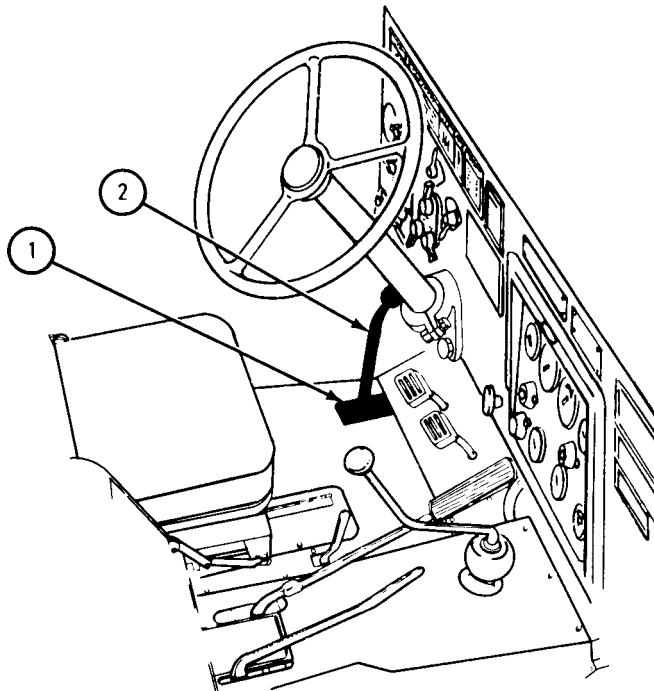

TA 045252



## FRAME 2

**WARNING**

When using derrick tube and rear winch together, do not go over pulling capacity shown on CAUTION plate mounted on derrick tube. Examine derrick tube carefully for damage before using. A tube bend or flat surface can cause collapse under load. If tube is damaged, tell organizational maintenance.

Always leave TRANSFER CASE gearshift lever (1) in neutral position during winch operations to avoid movement of truck.

1. Press clutch pedal (2) all the way in.
2. Place FRONT TRANSMISSION gearshift lever (3) in N position.
3. Place TRANSFER CASE gearshift lever (1) in neutral position.

GO TO FRAME 3

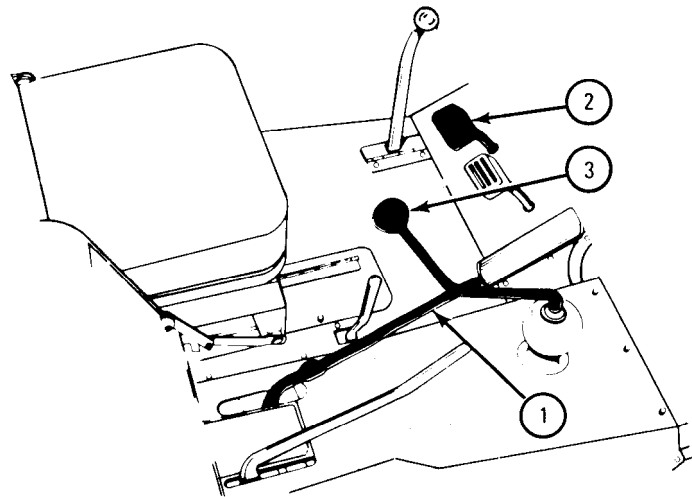

TA 045253

FRAME 3

**WARNING**

Always wear leather gloves when handling winch cable to prevent injury from brakes or loose wires. Do not let cable slide through hands. Do not let personnel stand near winch cable during winch operation. A snapped cable can cause series injury. Do not go over load limits shown on winch load chart on cab door to prevent shearing of winch shear pin.

1. Pull rear winch cable (1) out by hand.
2. Rig cable (1) on sheaves (2) as needed. (Refer to para 4-15j.)
3. Raise derrick tube (3) if needed. (Refer to para 4- 15c.)

GO TO FRAME 4

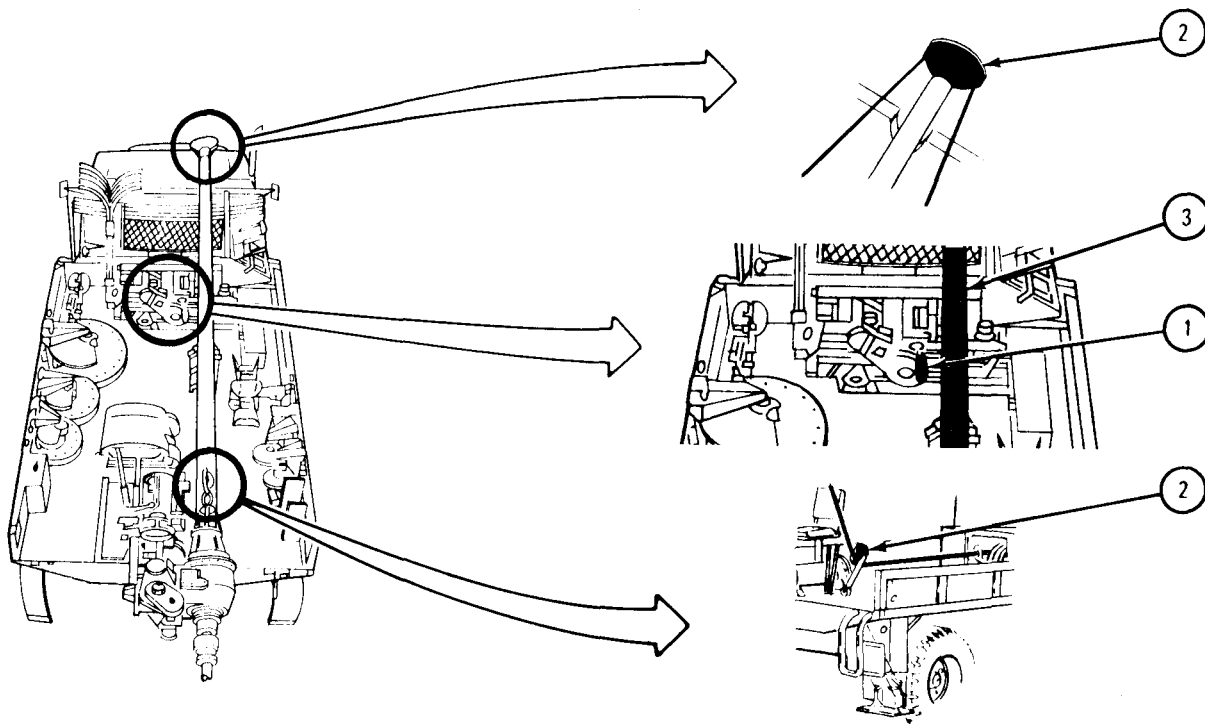

TA 045251

## FRAME 4

1. Turn locking bar (1) and place transfer POWER TAKEOFF LEVER (2) to rear to ENGAGE (on) position.
2. Move rear winch control lever (3) forward to on position.
3. Place power divider control lever (4) in REAR WINCH FWD position to wind in the load.
4. Place power divider control lever (4) in REAR WINCH REV position to lower load or unwind winch cable.
5. Place FRONT TRANSMISSION gearshift lever (5) in position 2.
6. Let clutch pedal (6) up slowly and press down on accelerator pedal (7). Press down just enough to operate winch without racing or stalling engine.

GO TO FRAME 5

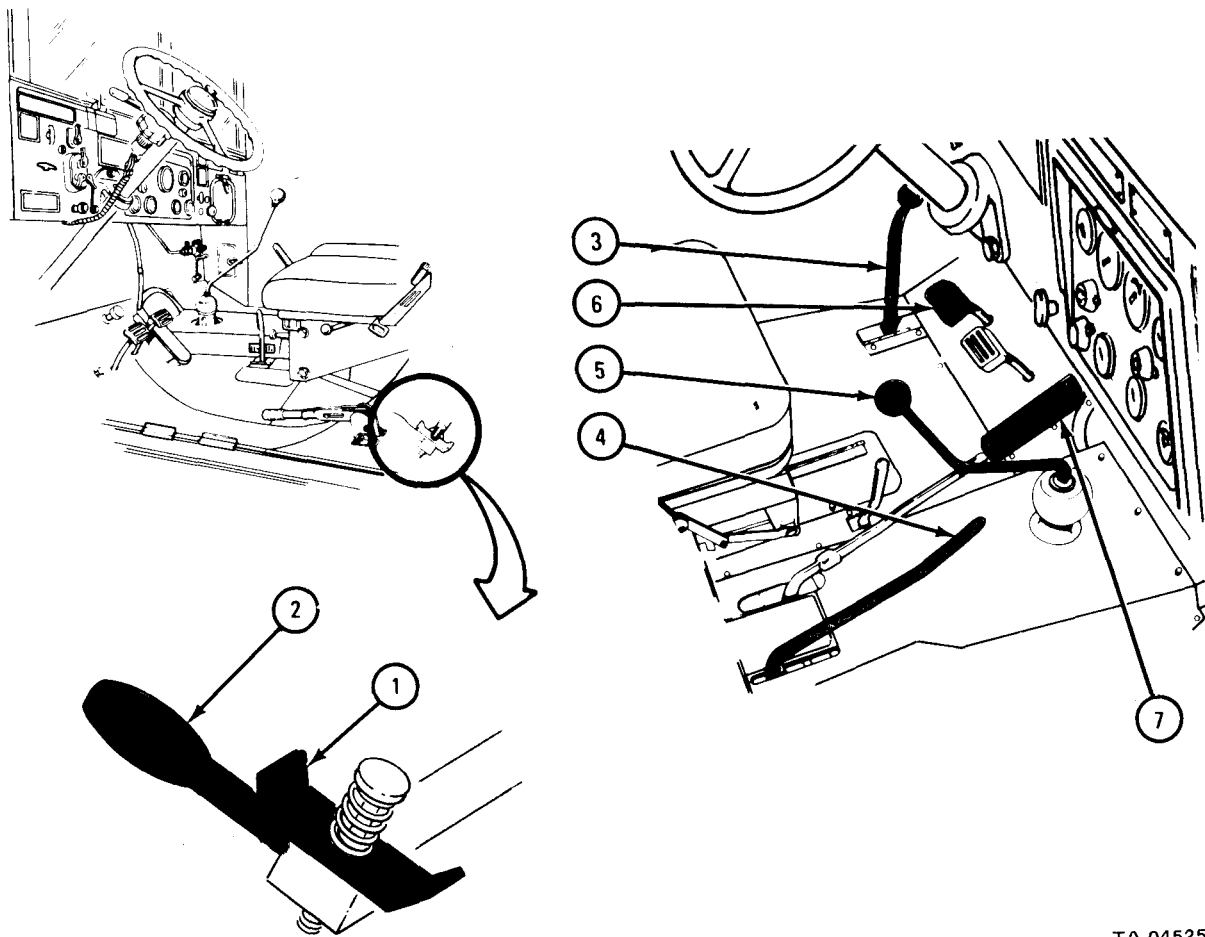

TA 045254

FRAME 5

1. To stop winch drum from turning, press down on clutch pedal (1) and let accelerator pedal (2) up.
2. Move power divider control lever (3) to NEUTRAL position.
3. Let clutch pedal (1) come up slowly.

GO TO FRAME 6

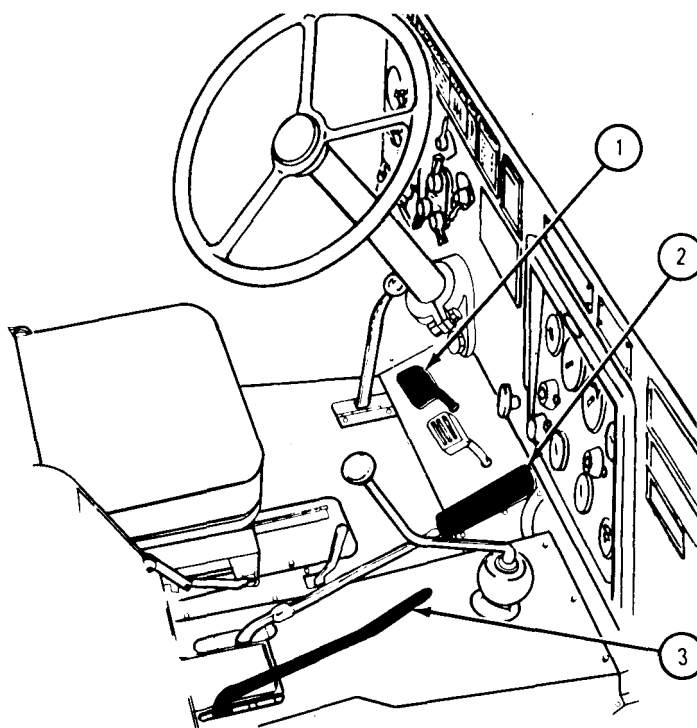

TA 045256

## FRAME 6

**WARNING**

Do not pull winch control lever (1) back while a load is still hanging on cable. Taking winch control lever out of forward position will cause load to drop.

1. If there is a load attached to end of winch cable (2) do the following steps:
  - (a) Press clutch pedal (3) all of the way in.
  - (b) Place the power divider control lever (4) in the REAR WINCH REV position.
  - (c) Lower the load and unhook cable (2) from the load. Refer to frames 5 and 6.
2. Lower derrick tube (5) if it was raised. (Refer to para 4-15c.)
3. Remove winch cable (2) from sheaves (6) that were used. (Refer to para 4-15j.)
4. Press clutch pedal (3) all of the way in.
5. Place power divider control lever (4) in REAR WINCH FWD position.
6. Let clutch pedal (3) up and wind in cable (2).
7. Press clutch pedal (3) all of the way in.
8. Place rear winch control lever (1) in NEUTRAL position and set locking latch (7).

GO TO FRAME 7

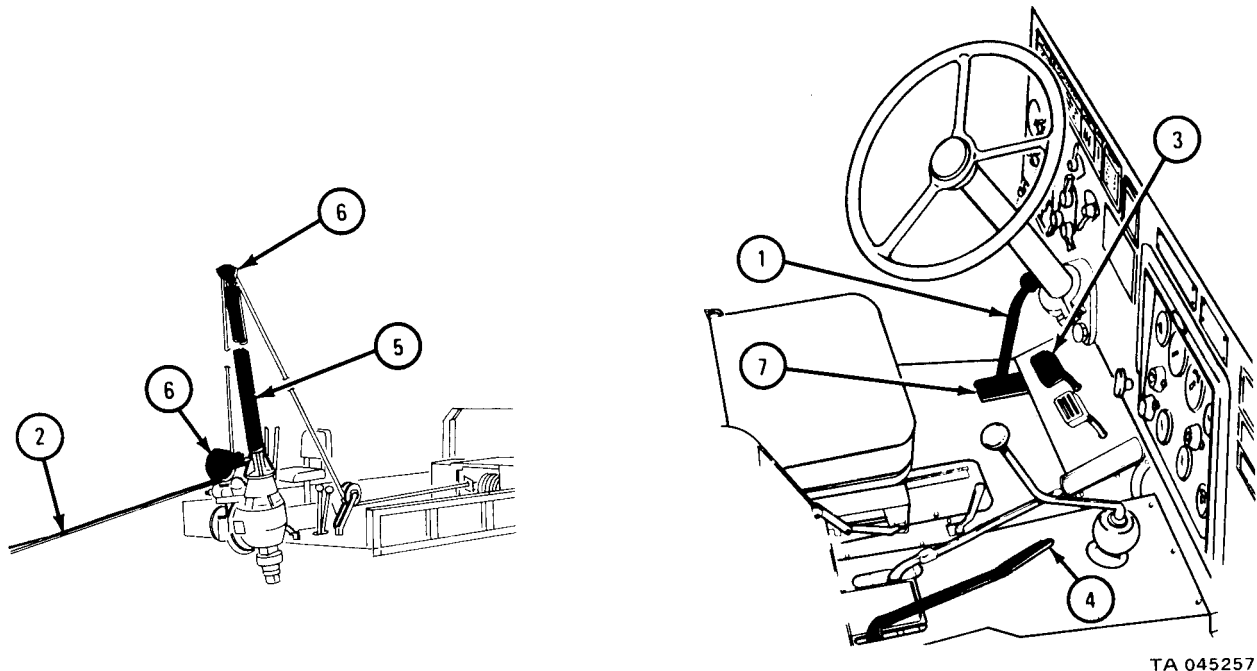

TA 045257

FRAME 7

1. Place FRONT TRANSMISSION gearshift lever (1) in N position.
2. Move transfer POWER TAKE OFF LEVER (2) to off position and turn locking bar (3) to lock position.
3. Let clutch pedal (4) up.
4. Stop engine. (Refer to para 4-6e.)

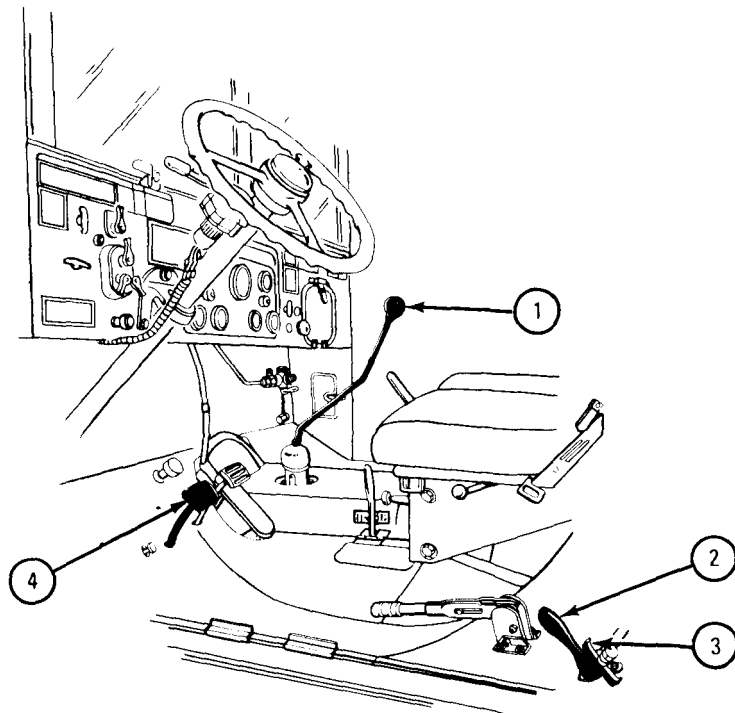

TA 045258

- e. Installing 9-inch, 12-inch, and 16-inch Augers.  
 (1) Lifting auger from stowed position.

## FRAME 1

**WARNING**

To avoid injury to personnel and damage to equipment, do not try to lift the 20-inch and 30-inch augers from their holders by hand. These augers should be lifted with the rear winch and boring machine integral derrick.

1. Pick the size auger (1) to be installed on rack bar (2).
2. Lift holder locking handle (3) out of bracket (4) and holder (5).
3. Pull auger to holder pin (6) out of auger (1) and holder (5).
4. Lift auger (1) out of stowed position.

GO TO FRAME 2

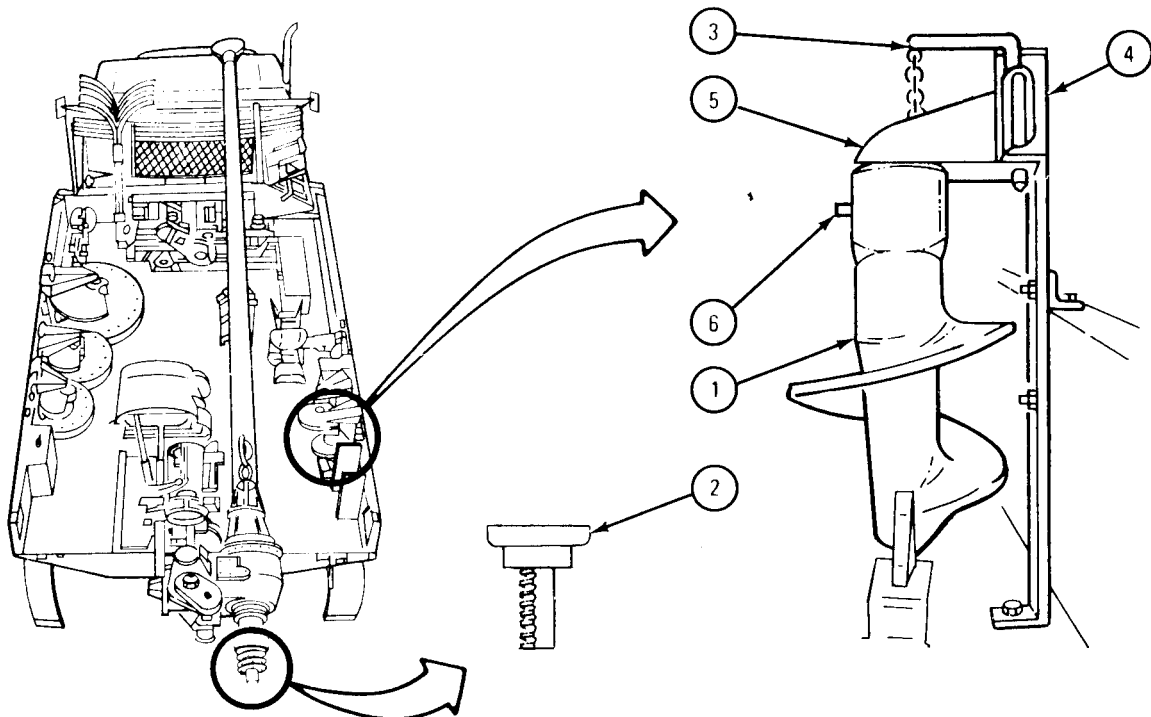

TA 045224

(2) Installing auger onto the rack bar.

FRAME 2

1. Put rubber bumper (1) and bumper spring (2) onto rack bar (3).
2. Put auger (4) onto rack bar (3).
3. Make it fast with pin (5) and cotter pin (6).

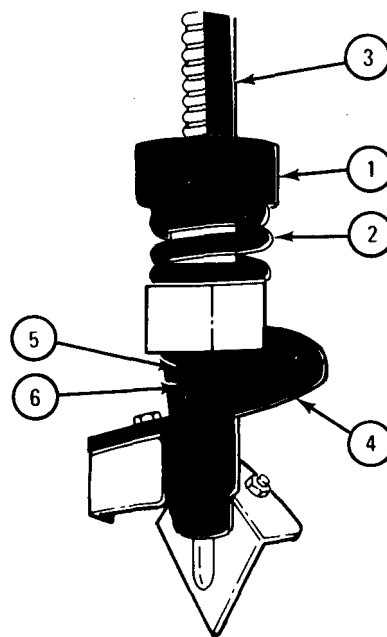

TA 045225



f. Installing 20-inch or 30-inch Augers.

(1) Lifting auger from stowed position.

PERSONNEL: Two

## FRAME 1

Pick the size auger (1) to be installed on rack bar (2).

Pull winch cable (3) out from winch.

Place cable (3) under, around, and over strap sheave (4).

Bring end of cable forward and over derrick sheave (5).

Start engine. (Refer to para 4-6b.)

Raise and position derrick tube (6) so that end of winch cable (3) is directly over auger (1) to be used. (Refer to para 4-15c and 4-15d.)

If seat (7) gets in the way of derrick (6) take seat off truck.

(a) Take safety pin (8) out.

(b) Pull retainer pin (9) out.

(c) Pull seat (7) up and take out of truck.

GO TO FRAME 2

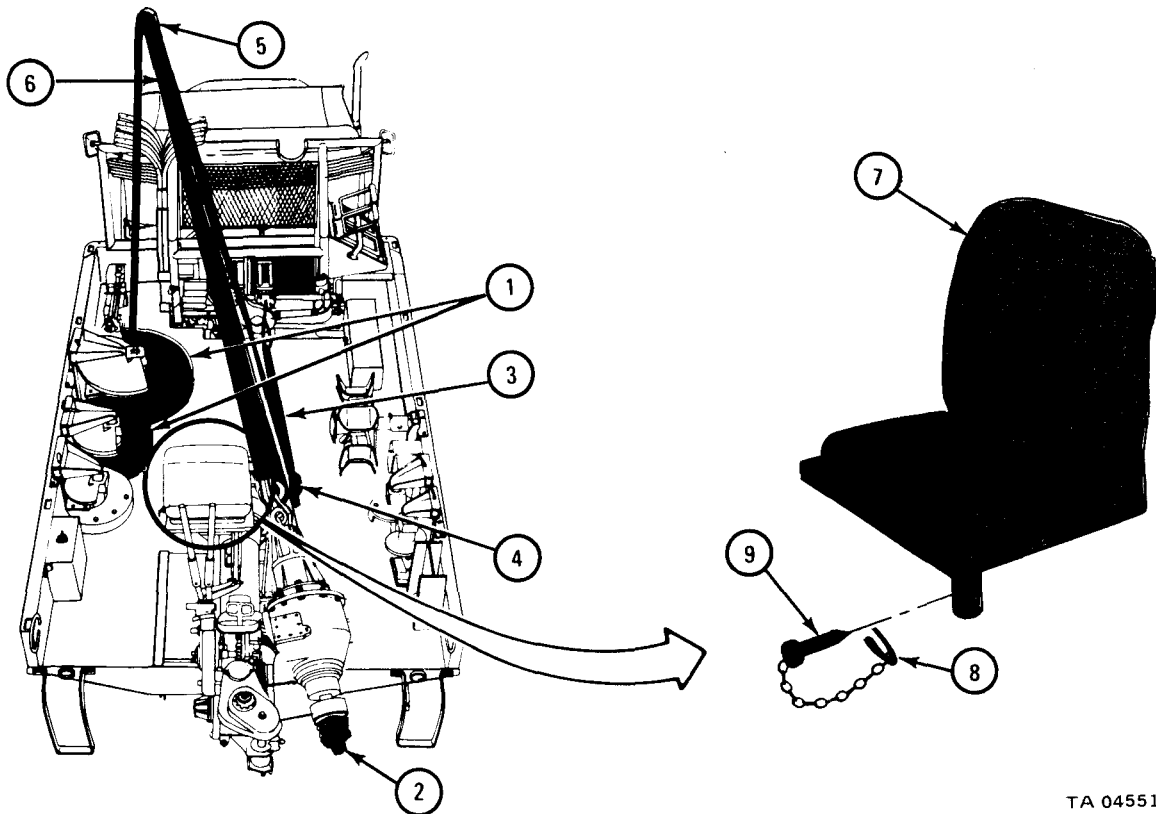

TA 045518

FRAME 2

**WARNING**

Be sure your feet are clear before pulling holder locking handle out on 20-and/or 30-inch augers. Augers tilt to side once handle has been taken out.

1. Lift holder locking handle (1) out of bracket (2) and holder (3).
2. Pull auger-to-holder pin (4) out of auger (5) and holder (3).
3. Lift holder (3) out of auger (5).

GO TO FRAME 3

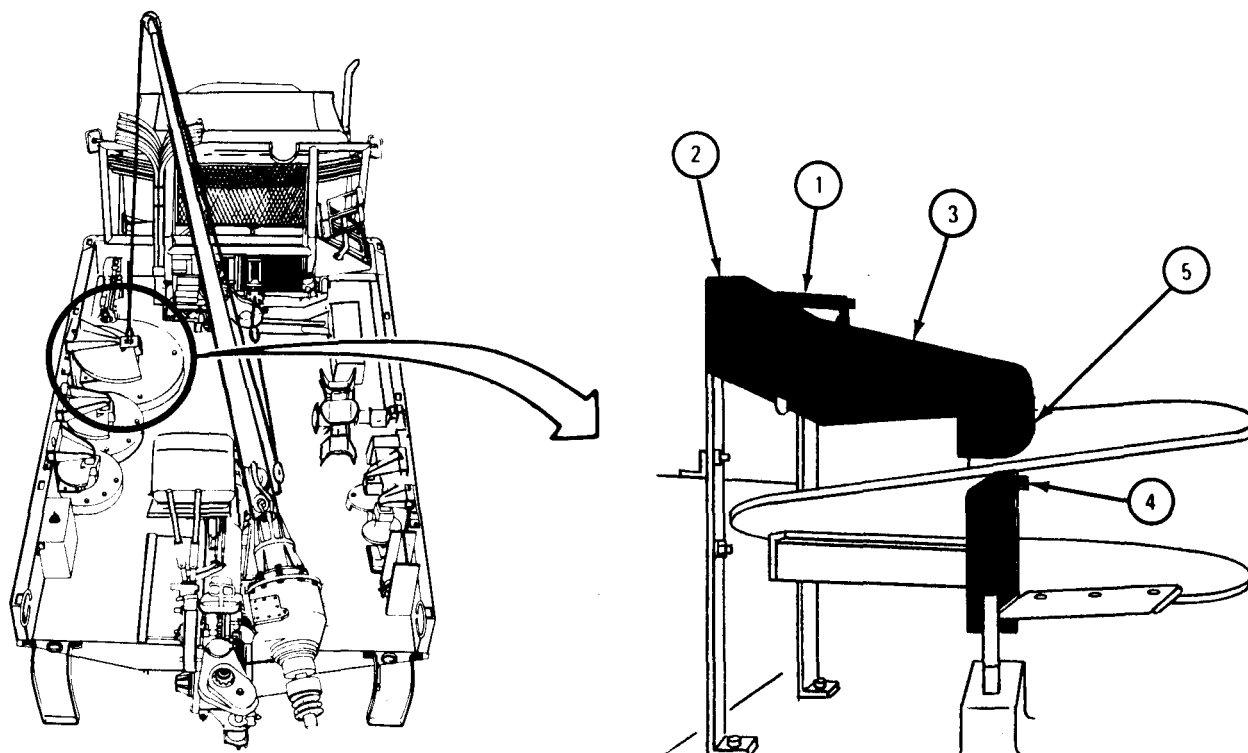

TA 045519

## FRAME 3

- Soldier A 1. Put winch cable loop (1) into square auger mounting hole (2).
2. Put auger-to-holder pin (3) into hole in auger (4), through loop (1) and into other side of hole in auger.

**CAUTION**

Never move winch control lever to off position when there is a load on winch. This will cause the load to drop.

Be sure that winch cable does not bind against derrick sheave cover while lifting auger and moving auger to rear of truck. Guide auger with a tag line after auger is lifted from body.

- Soldier B 3. Operate rear winch. Refer to para 4-15d. Lift auger no higher than necessary to move it to rear of truck.

- Soldier A 4. Guide auger with tag line.

GO TO FRAME 4

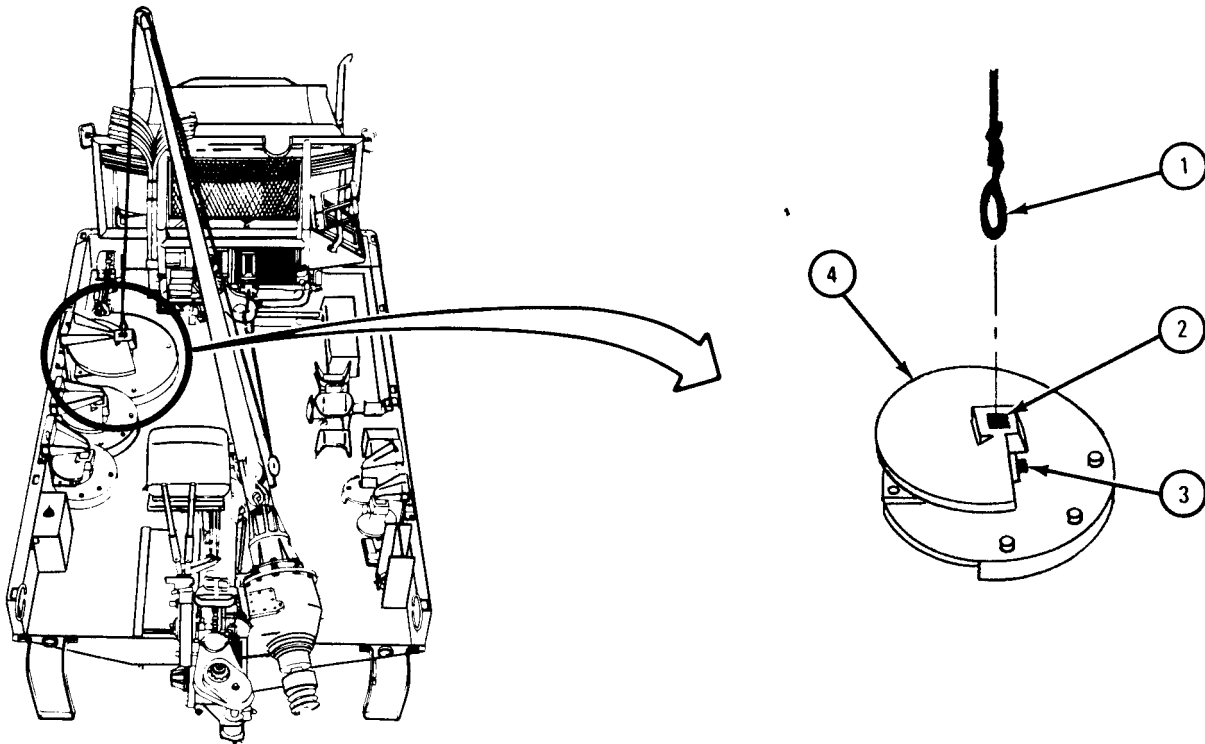

TA 045520

FRAME 4

1. Raise derrick (1) past straight up and down position so winch cable (2) will clear boring case (3) when derrick is moved left.
2. Operate rear winch, lower auger (4) to about one foot off ground.
3. Move derrick (1) left until derrick and winch cable (2) are in line.
4. Operate rear winch to lower auger (4) to ground.
5. If seat (5) was taken off, put seat back:
  - (a) Place seat mounting tube (6) on seat mounting bracket (7) and aline holes.
  - (b) Place retaining pin (8) through holes and lock with safety pin (9).

GO TO FRAME 5

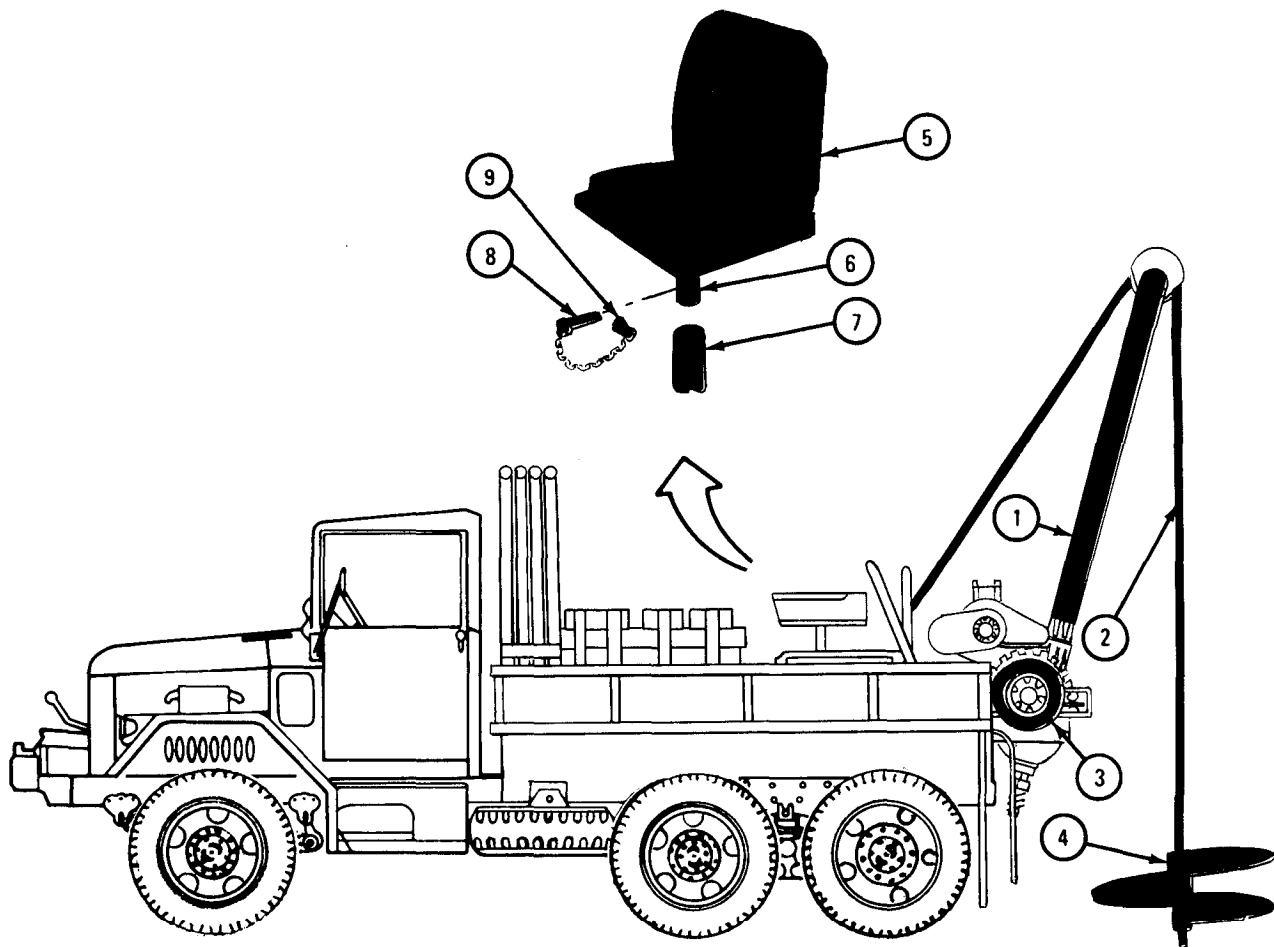

TA 045521

FRAME 5

1. Lock boring machine control levers (1) in back position with locking latch (2).
2. Take auger-to-holder pin (3) out of auger (4).
3. Lift cable (5) out of auger (4).
4. Operate rear winch to take up cable. (Refer to para 4-15d.)
5. Secure winch from operation.

GO TO FRAME 6

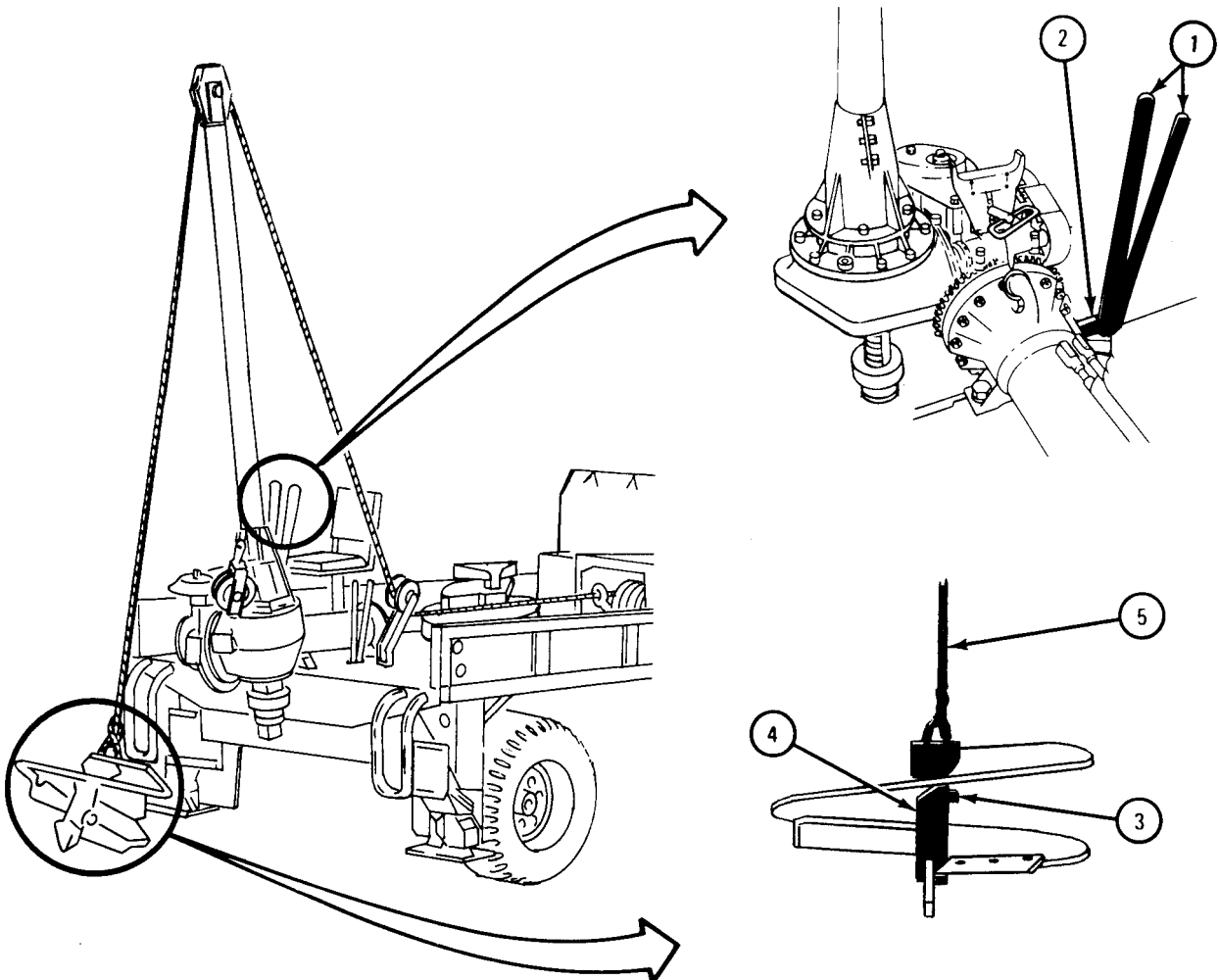

TA 045522

(2) Installing 20-inch or 30-inch auger onto rack bar.

FRAME 6

1. Place the derrick (1) in 45° position. (Refer to para 4-15c.)
2. Align the rack bar (2) with the auger (3).
3. Put rubber bumper (4) and spring (5) onto rack bar (2).
4. Move feed control lever (6) forward to lower rack bar (2) into auger (3).
5. Make auger (3) fast with pin (7) and cotter pin (8).
6. Stop engine. (Refer to para 4-6e.)

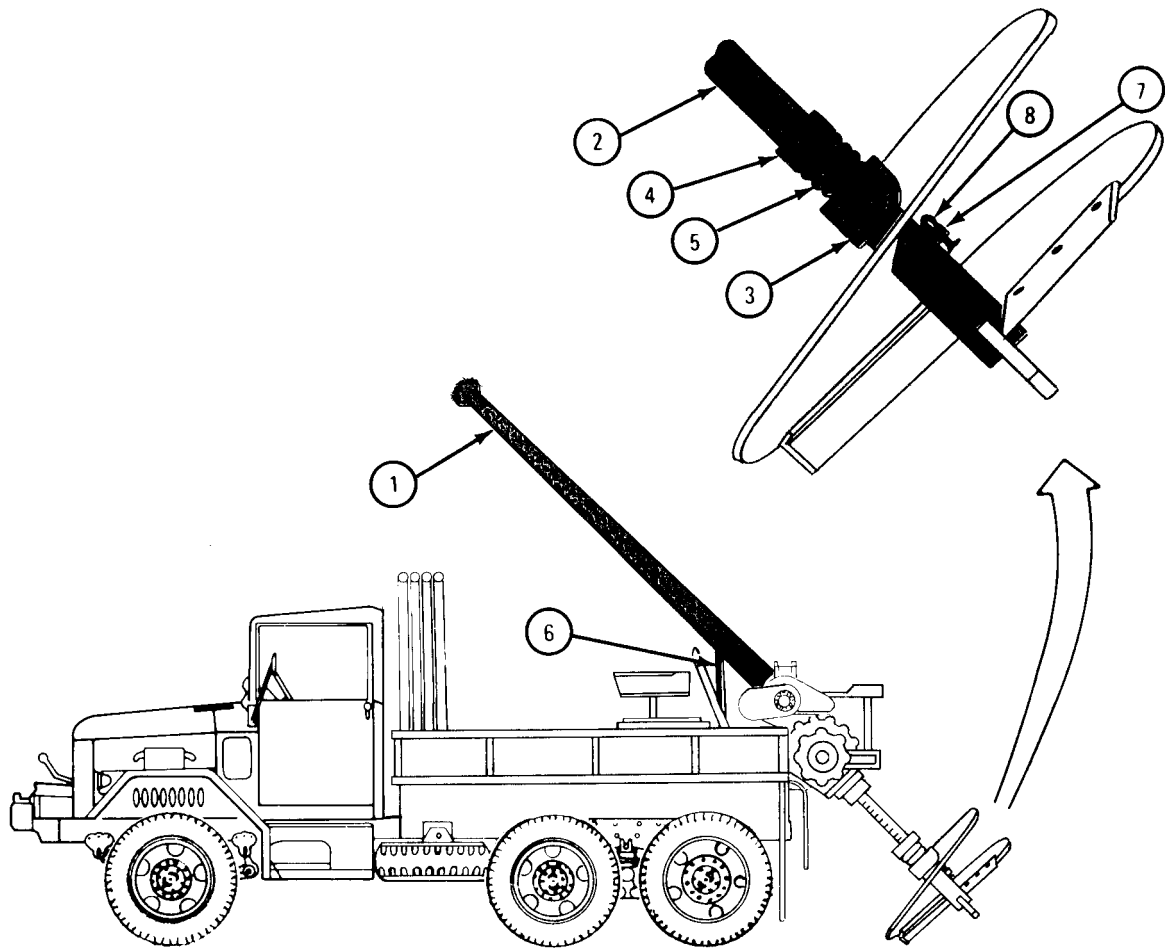

TA 045523

g. Operating the Earth Boring Machine.

TOOLS: 1-inch ratchet wrench

## FRAME 1

1. Start engine. (Refer to para 4-6b.)
2. Step on and press clutch pedal (1) in all of the way.
3. Check that TRANSFER CASE shift lever (2) is in neutral position.
4. Check that transfer POWER TAKEOFF LEVER (3) is in ENGAGE position.
5. Check that power divider control lever (4) is in EARTH AUGER position.
6. Place FRONT TRANSMISSION gearshift lever (5) in position 1.
7. Let clutch pedal (1) up slowly.
8. Set hand THROTTLE (6) to let engine run at 1800 rpm as shown on tachometer (7).

GO TO FRAME 2

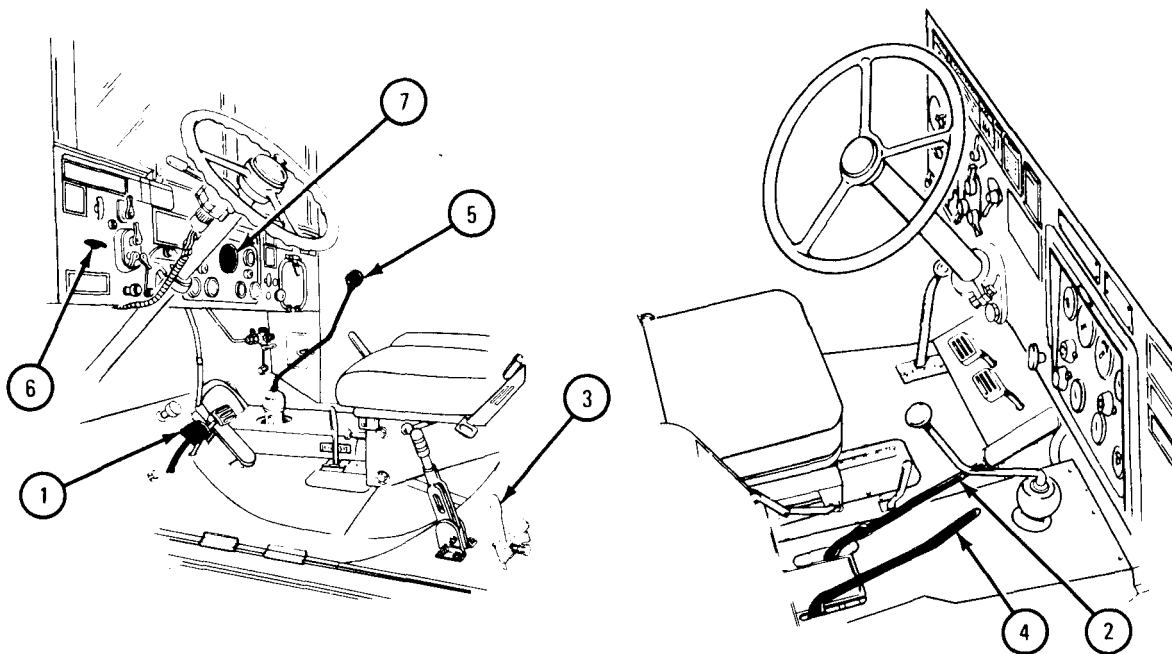

TA 045231

FRAME 2

1. Lift boring machine control lever locking latch (1).
2. Let feed control lever (2) and drive control lever (3) go to NEUTRAL (position 1, table 4-3).

**NOTE**

Avoid moving both feed and drive control levers (2 and 3) quickly at the same time. Move handles one at a time and pause at NEUTRAL position.



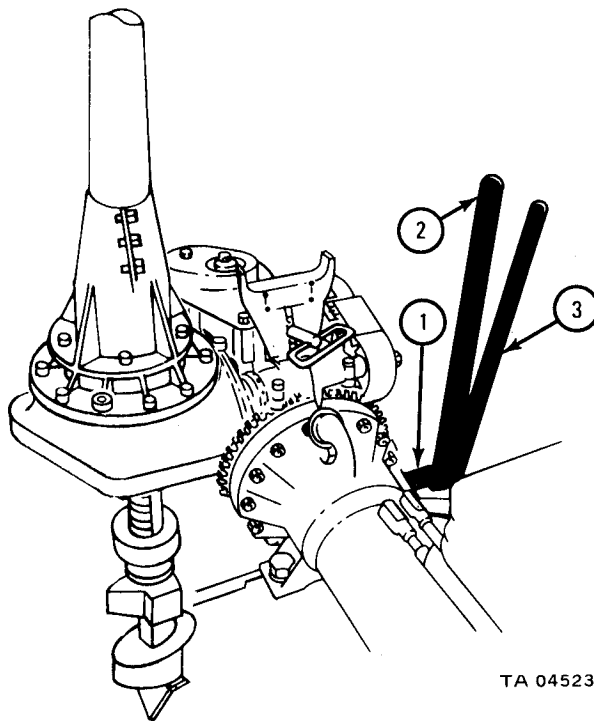









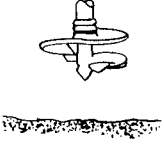

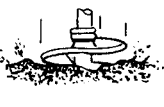

GO TO FRAME 3



TA 045232

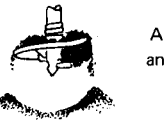

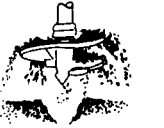
Table 4-3. Boring Machine Controls

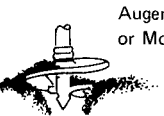
BORING MACHINE LEVER POSITIONS		AUGER ACTION
LEFT HAND LEVER	RIGHT HAND LEVER	
FEED - NEUTRAL 	DRIVE - NEUTRAL POSITION 1 	 <p>Auger Stationary</p>
FEED - BACK 	DRIVE - FORWARD POSITION 2 	 <p>Auger Turning and Moving Down Fast</p>
FEED - NEUTRAL 	DRIVE - FORWARD POSITION 3 	 <p>Auger Turning and Moving Down Slowly</p>
FEED - FORWARD 	DRIVE - FORWARD POSITION 4 	 <p>Auger Turning and Moving Down at Normal Digging Speed</p>
FEED - FORWARD 	DRIVE - BACK POSITION 5 	 <p>Auger Cannot Turn and Will Come Up</p>
FEED - FORWARD 	DRIVE - NEUTRAL POSITION 6 	 <p>Auger Will Turn and Will Come Up</p>
FEED - BACK 	DRIVE - BACK POSITION 7 	 <p>Auger Cannot Turn or Move Up and Down</p>

FRAME 3

**CAUTION**

Do not use position 2 table 4-3 for boring. It will overload equipment and can cause serious damage.

1. Push drive control lever (1) forward while pulling back on feed control lever (2) (position 2, table 4-3).
2. Let auger (3) come down to ground.

**NOTE**

Inexperienced operators should hold feed control (2) in NEUTRAL while pushing drive control (1) forward (position 3, table 4-3).

GO TO FRAME 4

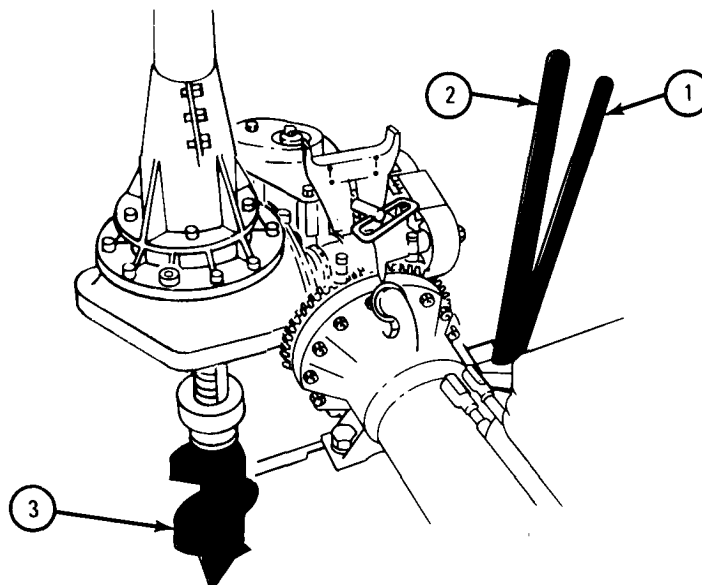

TA 045233

FRAME 4

**WARNING**

Do not let personnel stand near auger while boring or spinning soil off auger. Soil spun off may contain objects that can cause injuries.

**CAUTION**

To prevent damage to boring machine, do not make sudden starts (impact loads) when starting to bore. Do not load auger above bumper spring.

1. When auger point (1) enters ground, push drive control lever (2) and feed control lever (3) forward to start boring (position 4, table 4-3).
2. Keep auger turning speed down to 25 rpm (1800 engine rpm) until hole is about 18-inches deep.
3. If auger is working smoothly, set auger turning speed for type of soil. (Refer to table 4-4 and para 4-15h.)

GO TO FRAME 5

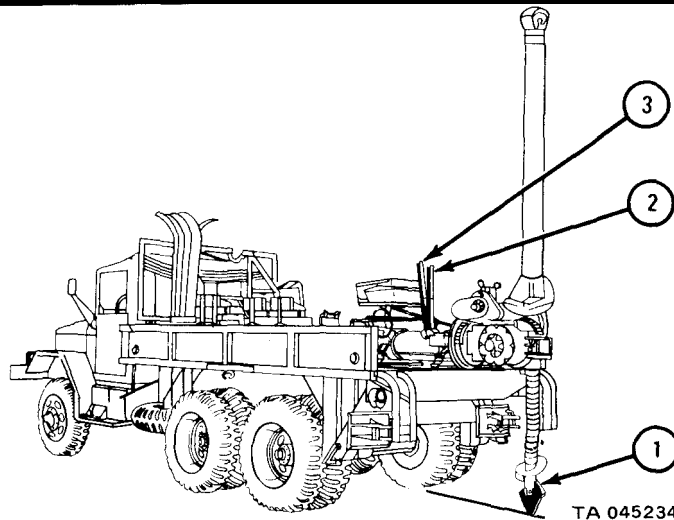

Table 4-4. Gear, Speed Settings for Soil Conditions

Soil Type	Transmission Gear	Engine Speed (rpm)	Auger Speed (rpm)
Sandy Clay, Ordinary Soil	3rd	2200-2650	90-110
Disintegrated Shale, Similar	1st	1800	25
Sandstone, Frozen Soil	2nd	1700-2400	40-60

FRAME 5

1. When auger (1) is loaded, let go of both driver lever (2) and feed lever (3). Levers will automatically go back to neutral position as shown in (position 1, table 4-3) and auger will stop.
2. Pull drive control lever (2) back and push feed control lever (3) forward as shown in position 5 (table 4-3) to raise auger above ground level.
3. Move drive control lever (2) into and out of neutral position to spin soil from auger. Do not press down bumper spring.
4. Let go of both drive control lever (2) and feed control lever (3) and let levers go back to neutral position.
5. Repeat frames 4 and 5 to drill hole as deep as needed.

GO TO FRAME 6

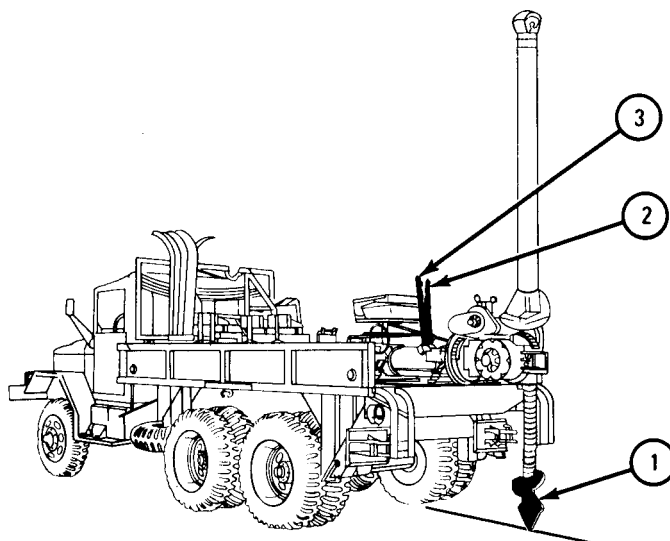

TA 045234

## FRAME 6

1. If auger (1) accidentally becomes overloaded:
  - (a) Step on clutch pedal (2) and press it all the way down.
  - (b) Place FRONT TRANSMISSION gearshift lever (3) in R position.
  - (c) Let clutch pedal (2) up.
  - (d) Pull feed control lever (4) back and push drive control lever (5) forward (position 2 table 4-3). Auger (1) will back out of the hole.

GO TO FRAME 7

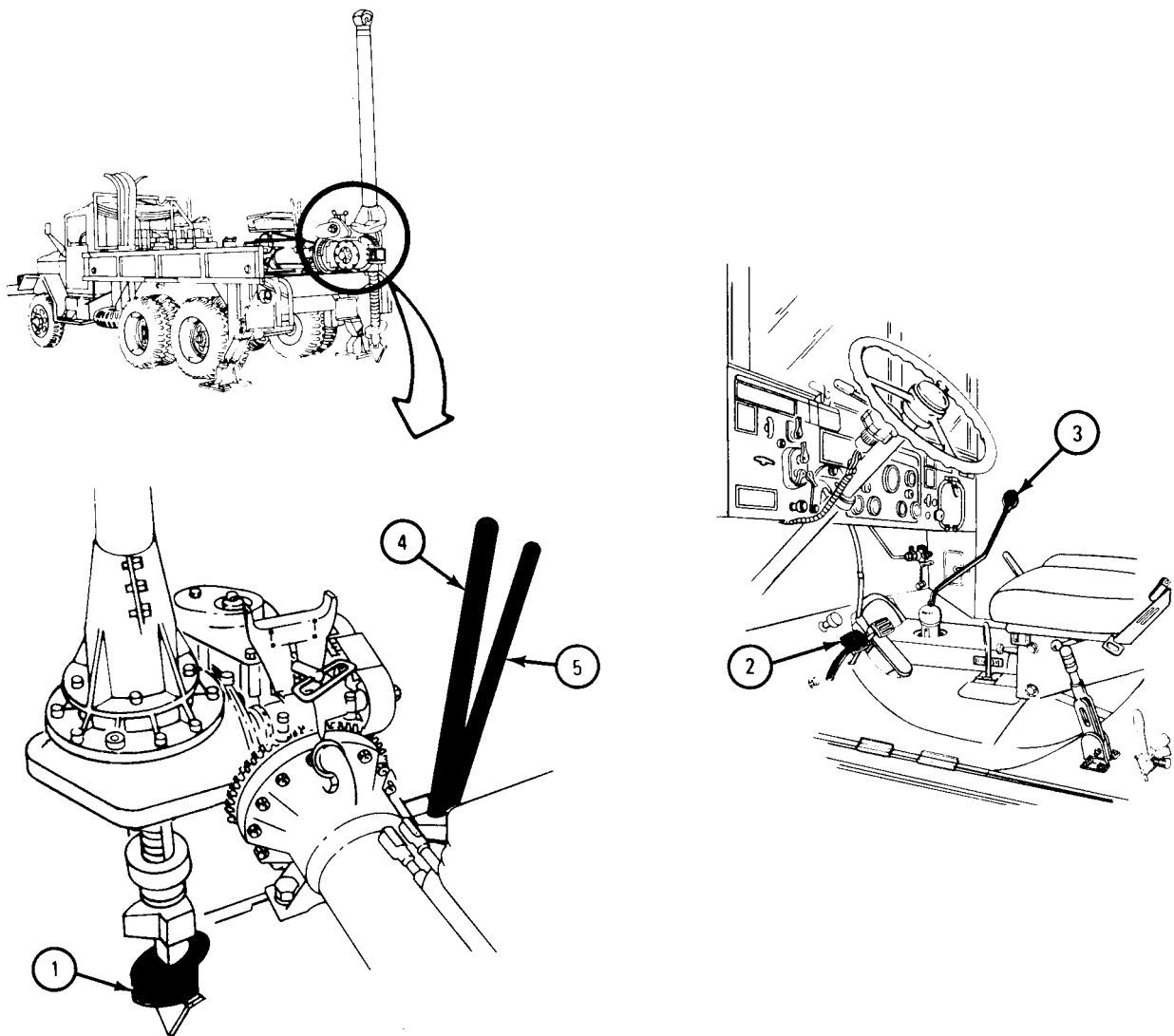

TA 045235

**FRAME 7**

1. Depth of hole bored is checked through sighting holes (1, 2, and 3) in derrick tube (4).
2. When you can see bar guide (5) through sighting hole (1), bored hole is 8 feet deep.
3. When bar guide (5) reaches sighting hole (2), bored hole is 9 feet deep.
4. When bar guide (5) reaches sighting hole (3), bored hole is 10 feet deep.

GO TO FRAME 8

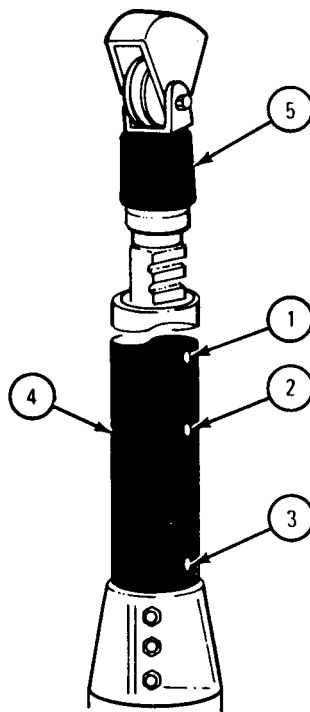

TA 045236

## FRAME 8

1. After hole is dug, place feed control (1) forward and drive control (2) back as shown in position 5, table 4-3.
2. Raise auger (3) as far as possible without pressing down bumper springs (4).
3. Pull back on both feed control (1) and drive control (2) as shown in position 7, table 4-3.
4. Place locking latch (5) in lock position.

GO TO FRAME 9

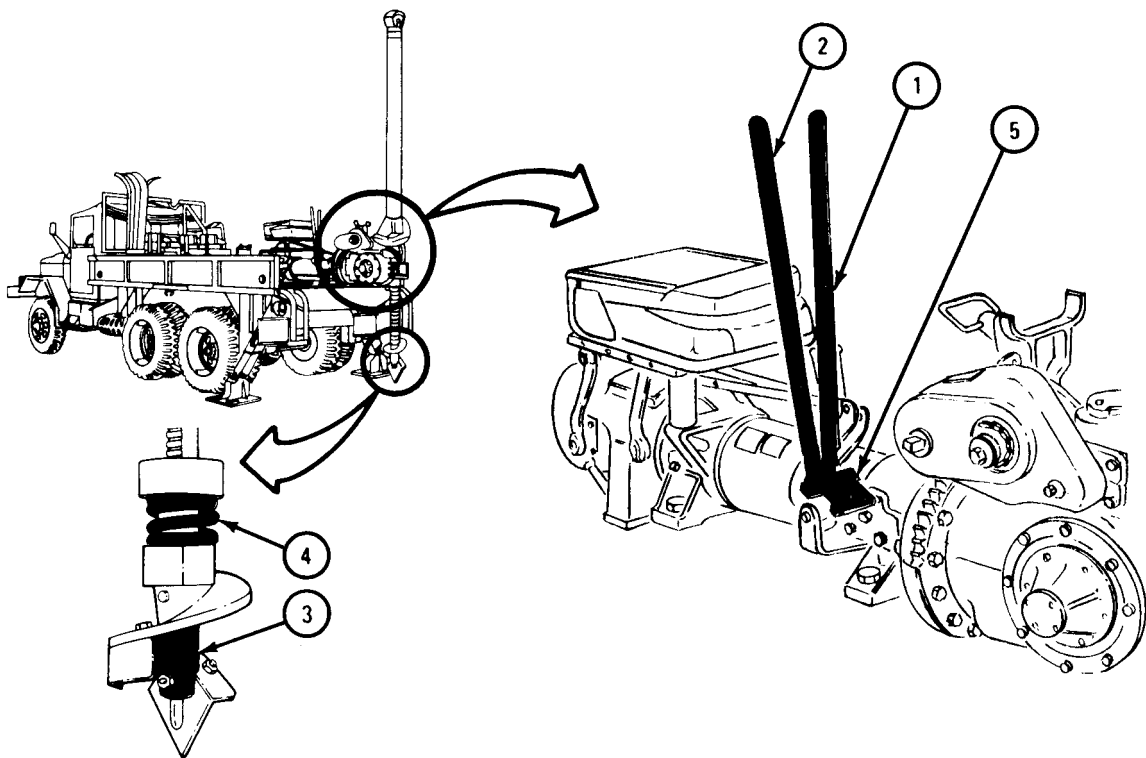

TA 045237

FRAME 9

1. Set hand THROTTLE (1) at engine idle speed.
2. Move OUTRIGGERS control levers (2) back to raise outrigger legs (3).
3. Move truck until auger is no longer over hole.

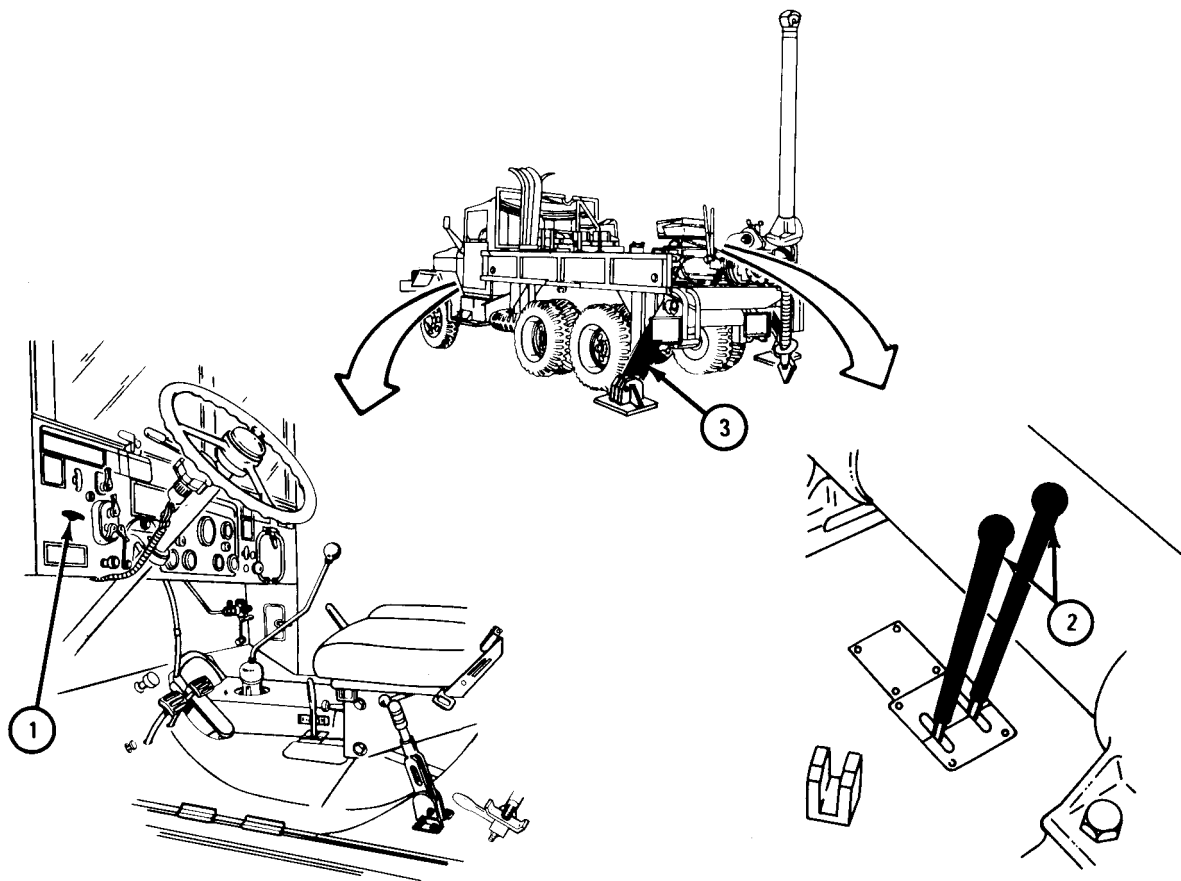

TA 045238



h. Boring in Various Soils.

## FRAME 1

**CAUTION**

Use care so that auger and boring machine are not damaged when boring in soil containing loose rock. Take loose rocks larger than 10-inches in diameter out by hand or other means.

1. To bore in disintegrated shale or similar soil, step on clutch pedal (1). Set FRONT TRANSMISSION gearshift lever (2) in position 1 and let clutch pedal (1) up.
2. Set hand THROTTLE (3) to let engine run at 1800 rpm, as shown on tachometer (4). Auger will turn at about 25 rpm. (Refer to tables 4-3 and 4-4.)

GO TO FRAME 2

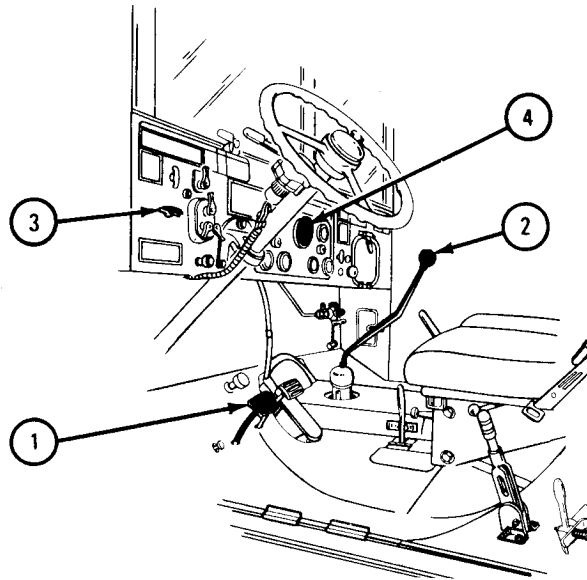

TA 084654

FRAME 2

1. Boring in disintegrated shale or similar rock requires sharp auger blades (1).
2. If boring seems slower than usual check auger blade (1) and point (2). If either or both blade and point are badly worn replace them.
3. Blades (1) may be good for only 5 to 7 holes when boring in this type of soil.
4. Auger points (2) may be good for one or two more holes.
5. If there is too much vibration in derrick tube (3) when boring tell organizational maintenance.

GO TO FRAME 3

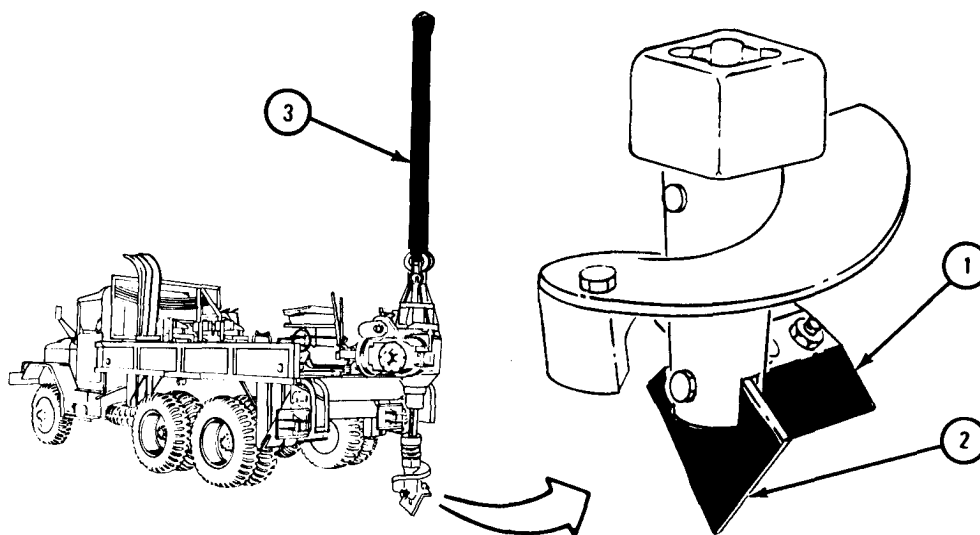

TA 045239

## FRAME 3

1. To bore in sandstone or frozen ground step on clutch pedal (1). Place FRONT TRANSMISSION gearshift lever (2) in position 2 and let clutch pedal (1) up.
2. Pull hand THROTTLE (3) out to run engine at 1700-2400 rpm as shown on tachometer (4). Auger will turn at 40-60 rpm. (Refer to tables 4-3 and 4-4.)

GO TO FRAME 4

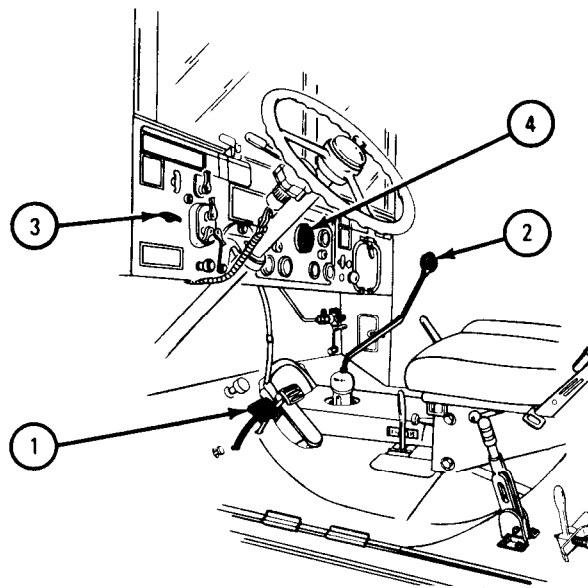

TA 084654

FRAME 4

1. To bore in sandy clay or ordinary soil step on clutch pedal (1). Place FRONT TRANSMISSION gearshift lever (2) in position 3 and let clutch pedal (1) up.
2. Pull hand THROTTLE (3) out to run engine at 2,200 to 2,650 rpm as shown on Tachometer (4). Auger will turn at 90-110 rpm. (Refer to tables 4-3 and 4-4.)

GO TO FRAME 5

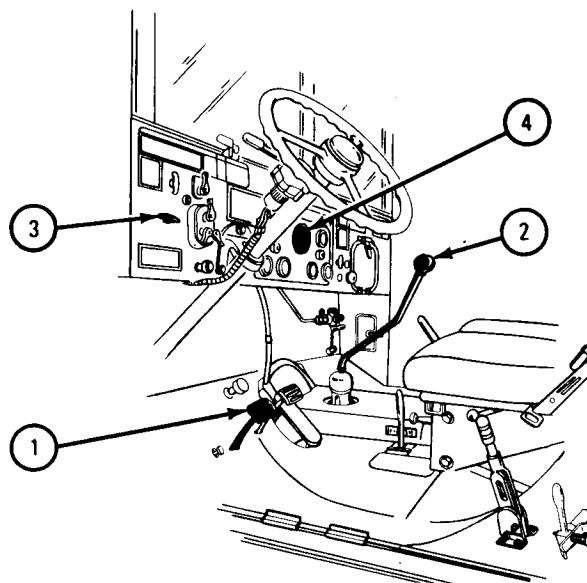

TA 084654

## FRAME 5

**CAUTION**

Brush rack teeth (1) with wire brush as necessary when boring soil that sticks to rack teeth. This will prevent dirt from getting into and damaging thrust plate inside of rack carriers (2). Keep leveling worms and gears (3) free of sand and dirt to prevent damage to gears.

1. Take less load on auger (4) before lifting when boring in sandy clay or wet soil. Too much suction will make load too heavy and strain the machine.

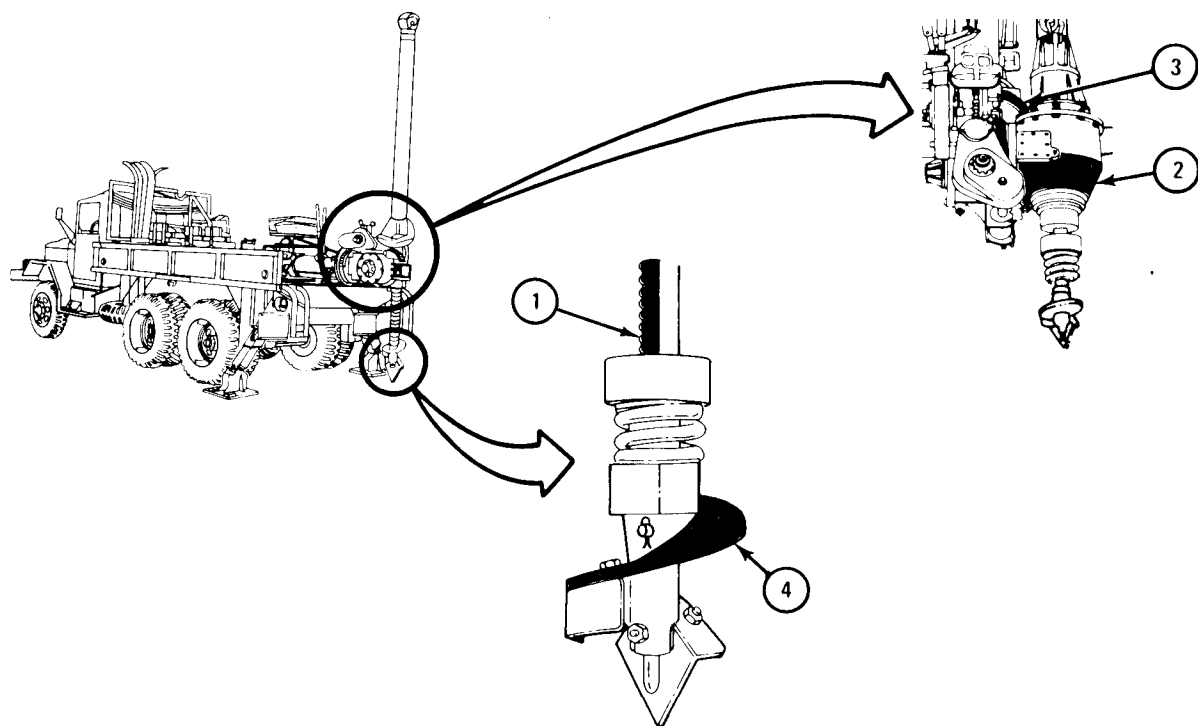

TA 045240

i. Preparing Boring Machine for Travel.

TOOLS: Pliers

FRAME 1

1. Set engine to idle speed.
2. Move truck away from hole.
3. Place feed control lever (1) in NEUTRAL, drive control lever (2) forward (position 3, table 4-3).
4. Lower auger (3) until it is resting on top of level ground.

GO TO FRAME 2

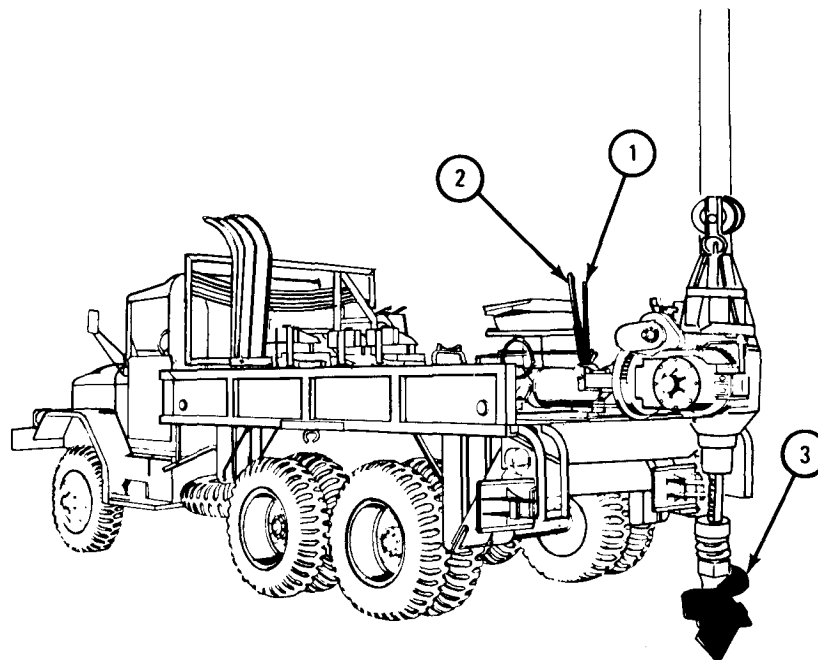

TA 045241

## FRAME 2

1. Using pliers, straighten bent ends and take cotter pin (1) out of retaining pin (2).
2. Pull retaining pin (2) out of auger (3) and rack bar (4).

GO TO FRAME 3

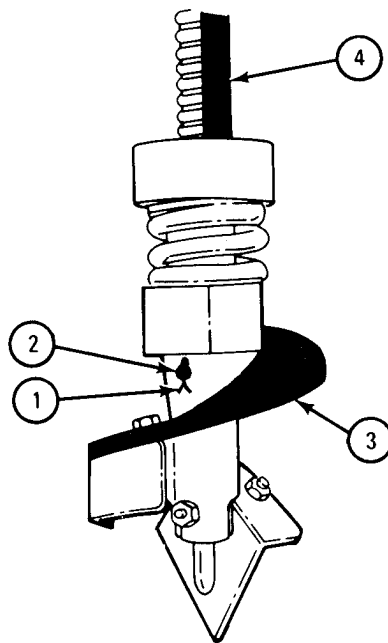

TA 045242

FRAME 3

1. Lift boring machine control lever locking latch (1).
2. Let feed control lever (2) and drive control lever (3) go to NEUTRAL position.
3. Move feed control lever (2) forward and drive control lever (3) back (position 5, table 4-3). Let rack bar (4) move up until it is out of auger.
4. Let feed control lever (2) and drive control lever (3) return to NEUTRAL.

GO TO FRAME 4

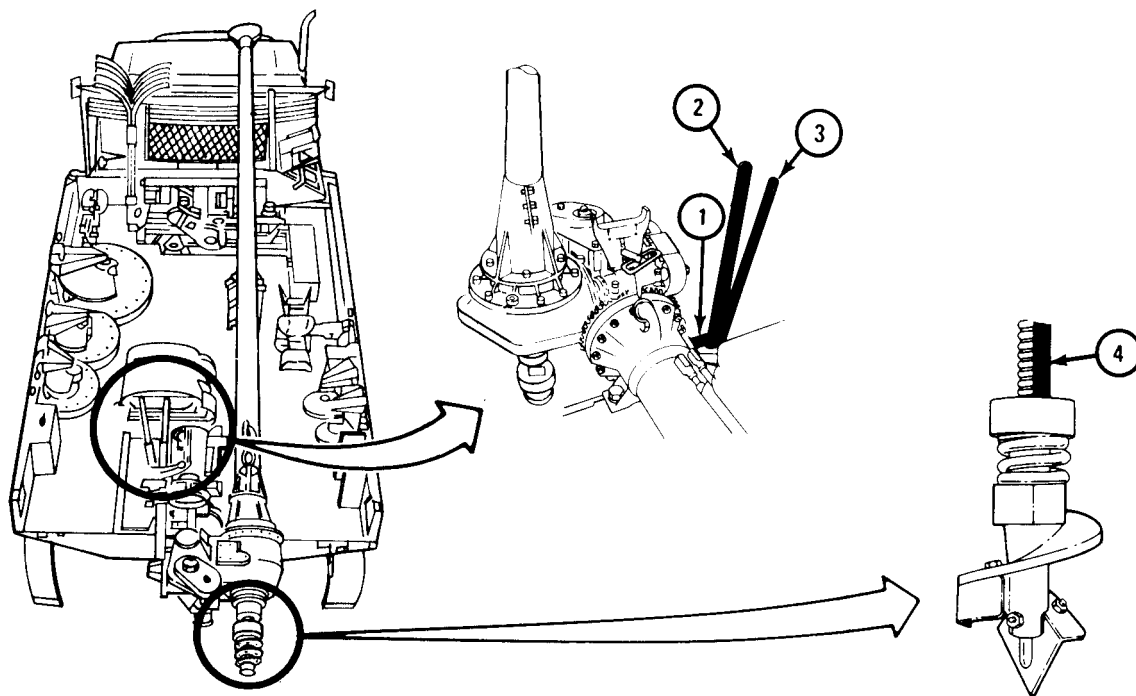

TA 045243



FRAME 4

1. Slide bumper (1) and spring (2) upon rack bar (3).
2. Put retaining pin (4) and cotter pin (5) back into hole in rack bar (3).
3. Move feed control lever (6) forward and drive control lever (7) back (position 5, table 4-3).
4. Let rack bar (3) move up until rubber bumper (1) touches lower thrust platecap (8). Do not press down spring (2).
5. Pull feed control lever (6) and drive control lever (7) back and lock with latch (9).

GO TO FRAME 5

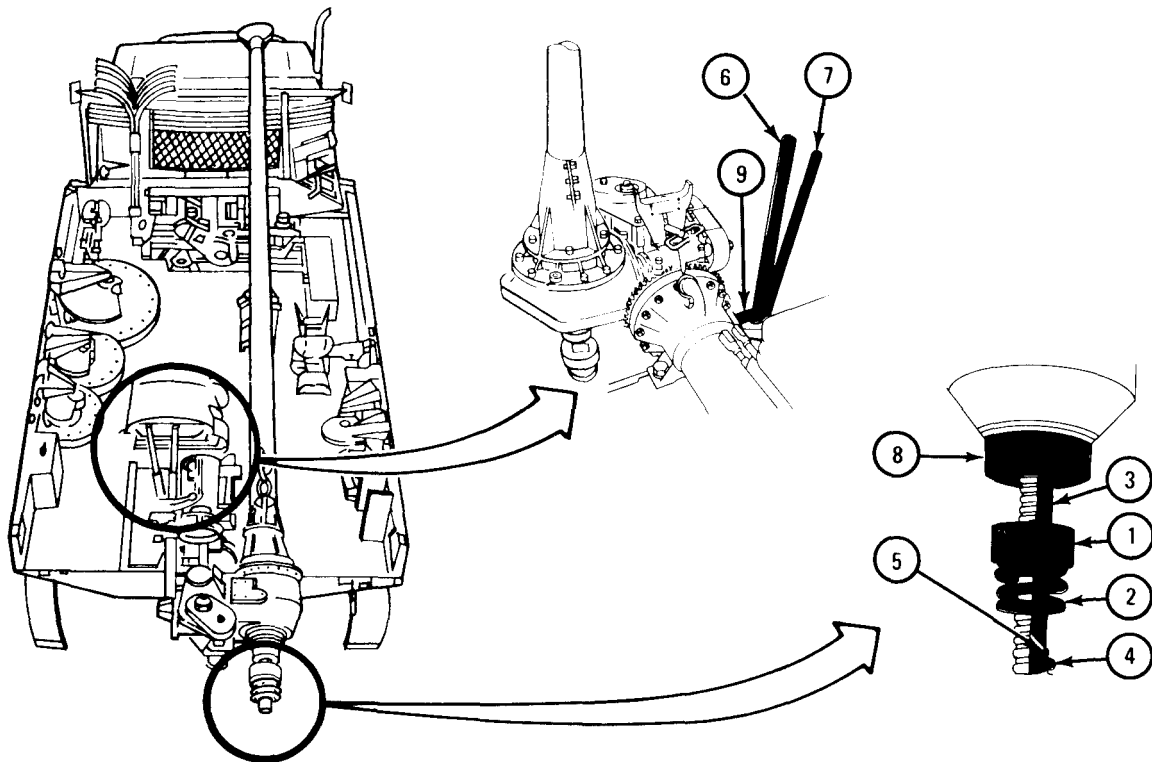

TA 045244

FRAME 5

**WARNING**

Do not lift 20-inch or 30-inch augers by hand. Use the rear winch and the derrick for lifting these augers. Personnel may be injured or equipment damaged if you try to lift these augers by hand. ( Refer to para 4-15f.)

1. Lift the 9-inch (1), 12-inch (2) and 16-inch (3) auger onto truck body.
2. Stow and make fast augers (1, 2, and 3) in proper holders.

GO TO FRAME 6

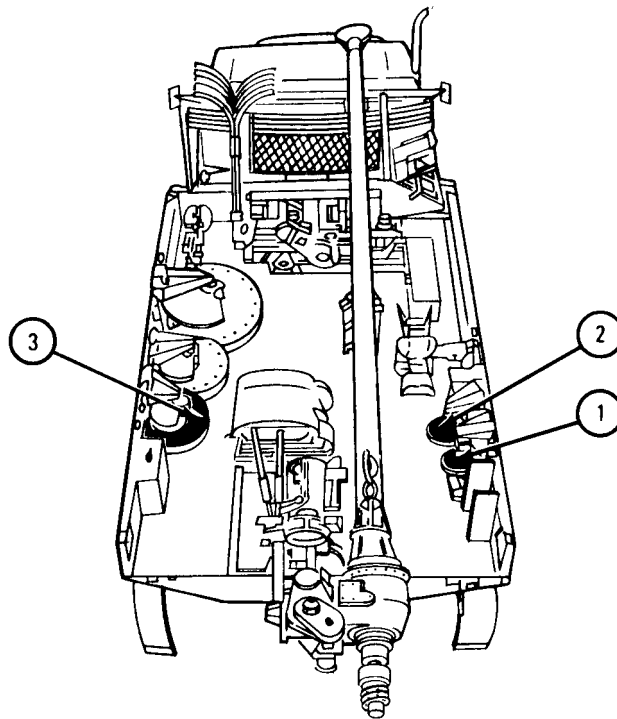

TA 045245

## FRAME 6

1. Position derrick (1) so that pointer (2) is directly over key (3) on support tube (4).  
(Refer to para 4-15c.)

GO TO FRAME 7

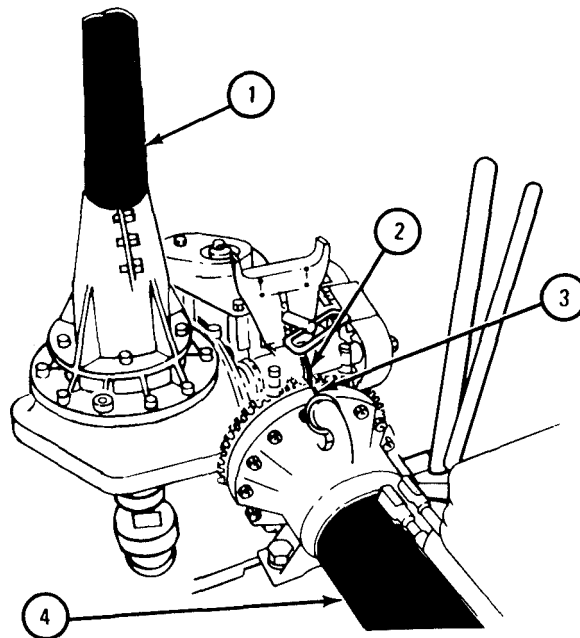

TA 045246

FRAME 7

1. Step on clutch pedal (1) and press it all the way down.
2. Place FRONT TRANSMISSION gearshift lever (2) in position R.
3. Let clutch pedal (1) up.

GO TO FRAME 8

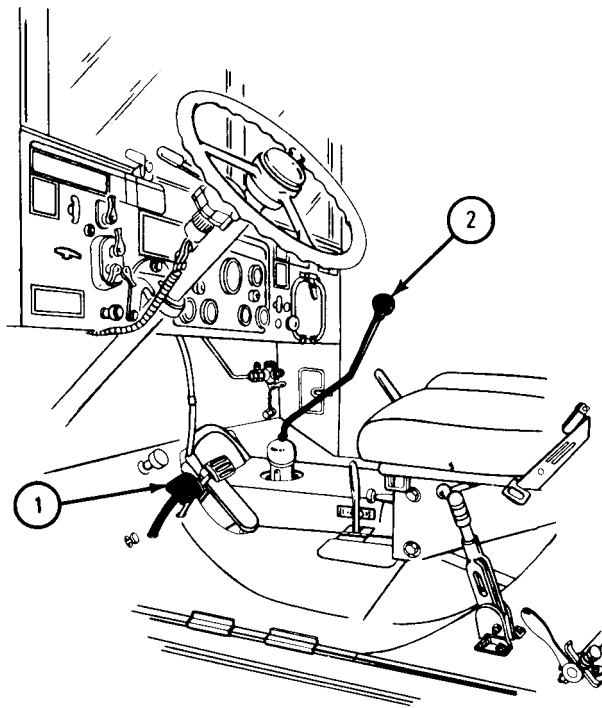

TA 045247

## FRAME 8

1. Pull feed control lever (1) and drive control lever (2) back and place latch (3) in locked position.
2. Place power leveler shifting handle (4) in down position.
3. Place latch (3) in unlocked position.
4. Keep feed control lever (1) in NEUTRAL position.
5. Place drive control lever (2) in forward position to lower derrick (5) into cradle (6) on cab protector (7).

**NOTE**

Before locking latch (3) against boring machine feed control lever (1) and drive control lever (2), let machine run with both levers in NEUTRAL position. This will let heat escape from brake assemblies in clutch case.

6. Pull both feed control lever (1) and drive control lever (2) to the rear and lock in place with locking latch (3).

GO TO FRAME 9

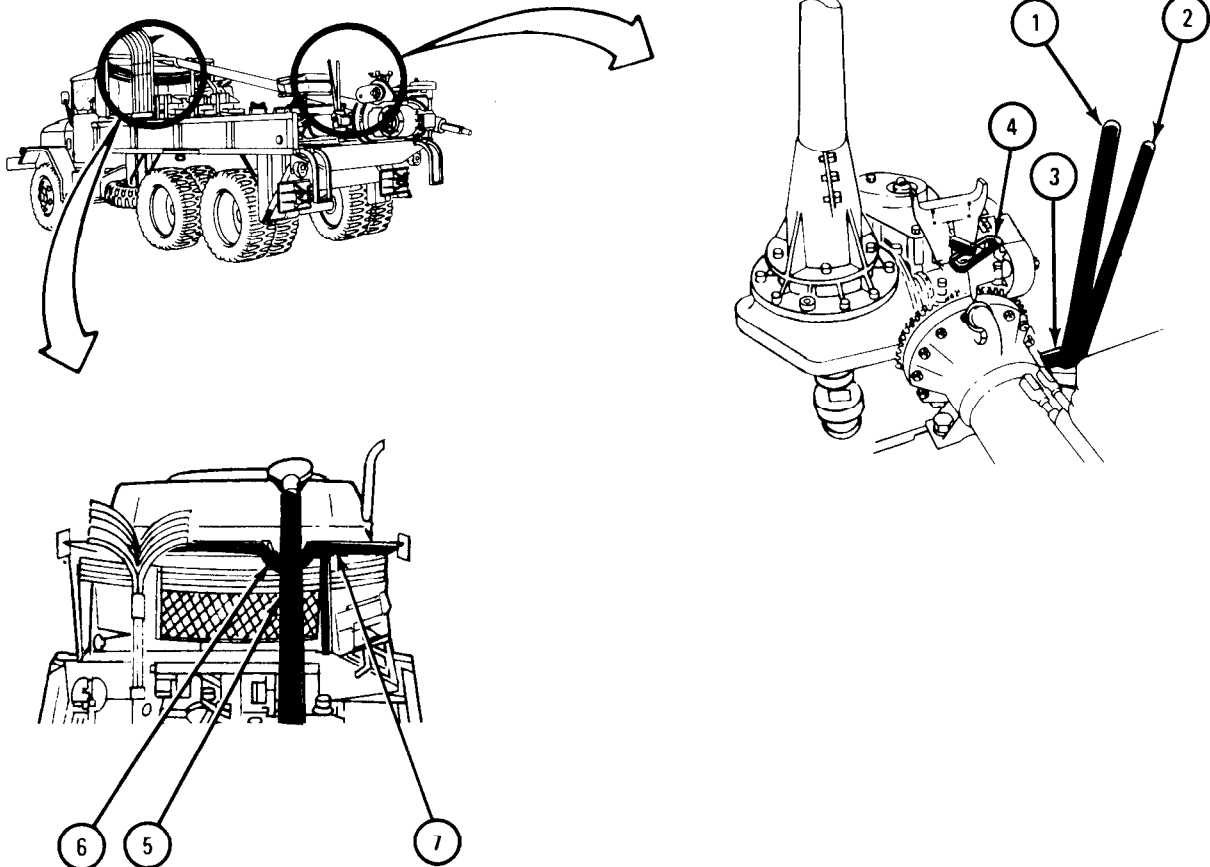

TA 045248

FRAME 9

1. Move OUTRIGGERS control levers (1) one at a time to pull in outrigger legs (2) half way.
2. Take out retaining pins (3) and take off outrigger shoes (4).
3. Stow shoes in stowage brackets (5).
4. Move OUTRIGGERS control levers (1) one at a time to pull in outrigger legs (2) all the way.
5. Hook safety latch (6) over lug on end of each outrigger leg.

GO TO FRAME 10

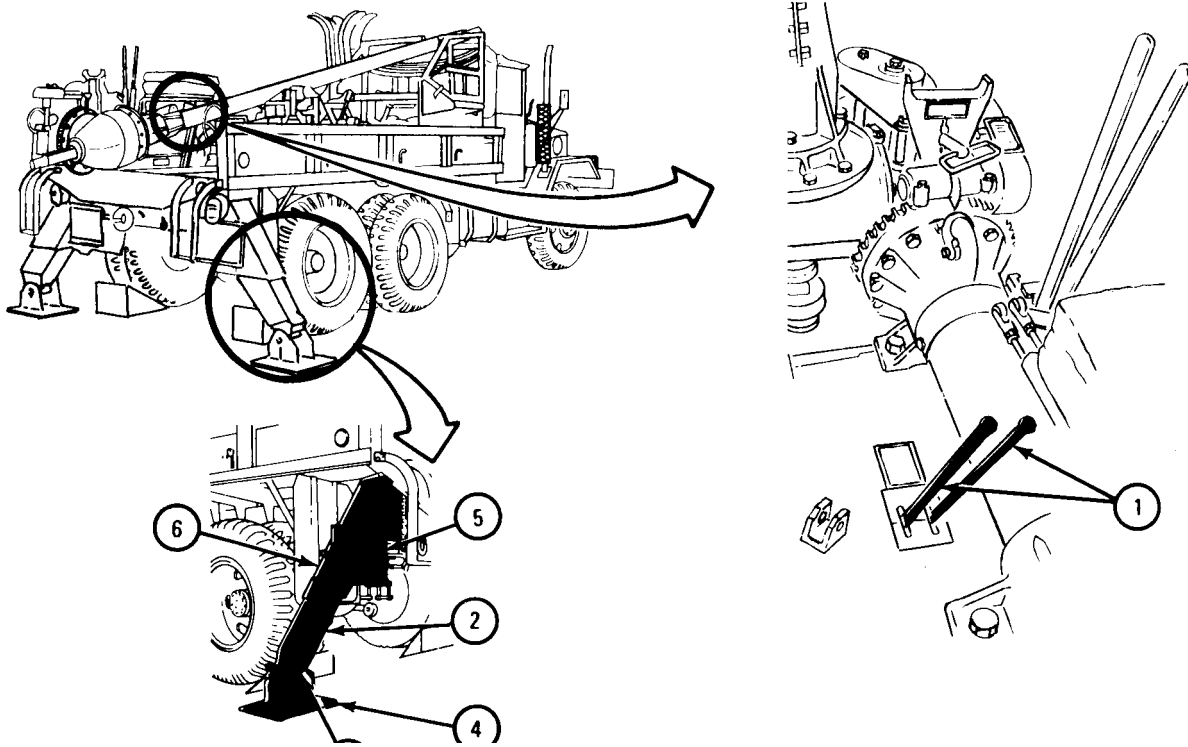

## FRAME 10

1. Step on clutch pedal (1) and press it all the way down.
2. Place FRONT TRANSMISSION gear shift lever (2) in N position.
3. Move transfer POWER TAKE OFF LEVER (3) to off position and set locking latch (4).
4. Place power divider shifting lever (5) in NEUTRAL position.
5. Stop engine. (Refer to para 4-6e.)

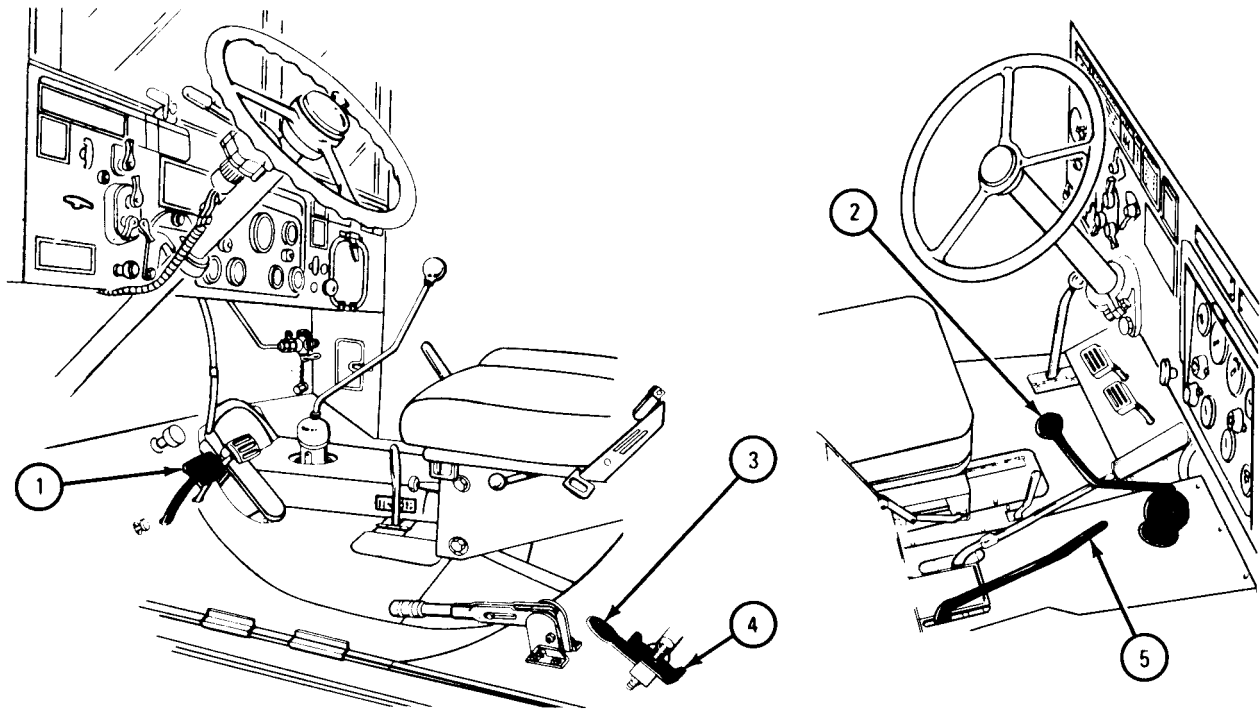

TA 045250

j. Dragging Poles.

FRAME 1

**CAUTION**

Poles 20 feet or more from the derrick must be dragged to the derrick using the snatch sheave. Dragging without using snatch sheave will damage the derrick tube.

**NOTE**

Dragging the pole can be done with the derrick tube raised or lowered. Raising the derrick tube will place the snatch sheave a little higher.

1. Rigging for dragging with derrick lowered:
  - (a) Pull winch cable (1) out from rear winch (2). (Refer to para 4-15d.)
  - (b) Place winch cable around snatch sheave (3) and tie cable to end of pole (4).

GO TO FRAME 2

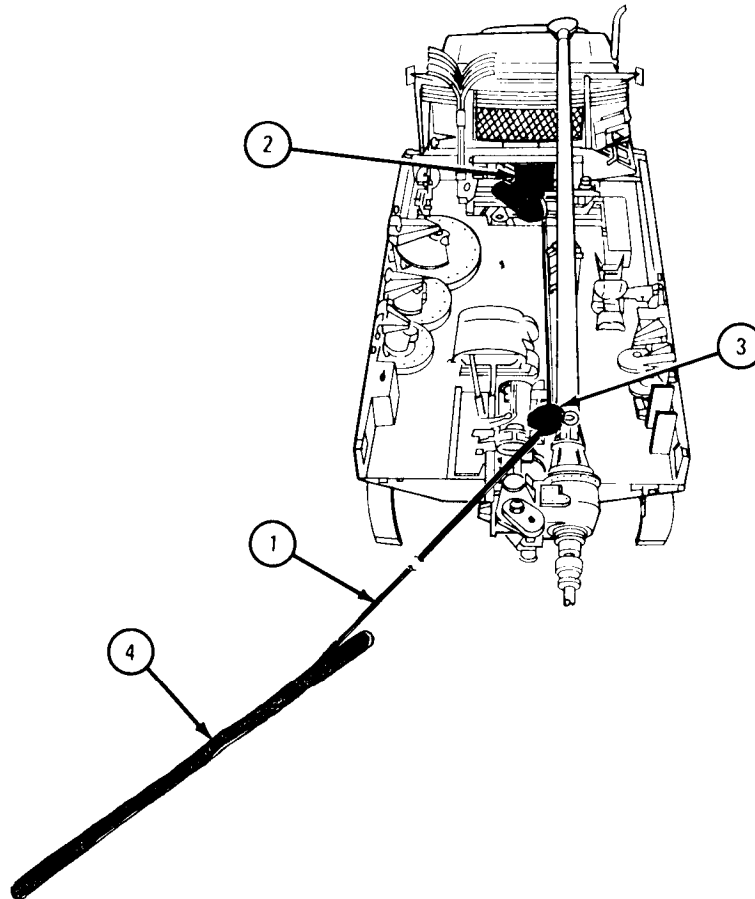

TA 084655



## FRAME 2

1. Rigging for dragging with derrick raised:
  - (a) Pull winch cable (1) out from rear winch (2). (Refer to para 4-15d.)
  - (b) Place winch cable (1) under and around strap sheave (3).
  - (c) Bring end of cable (1) forward, over and around derrick sheave (4).
  - (d) Raise derrick (5) to full apposition. (Refer to para4-15c.)
  - (e) Bring end of cable (1) around snatch sheave (6) and tie cable to end of pole (7).

GO T O FRAME 3

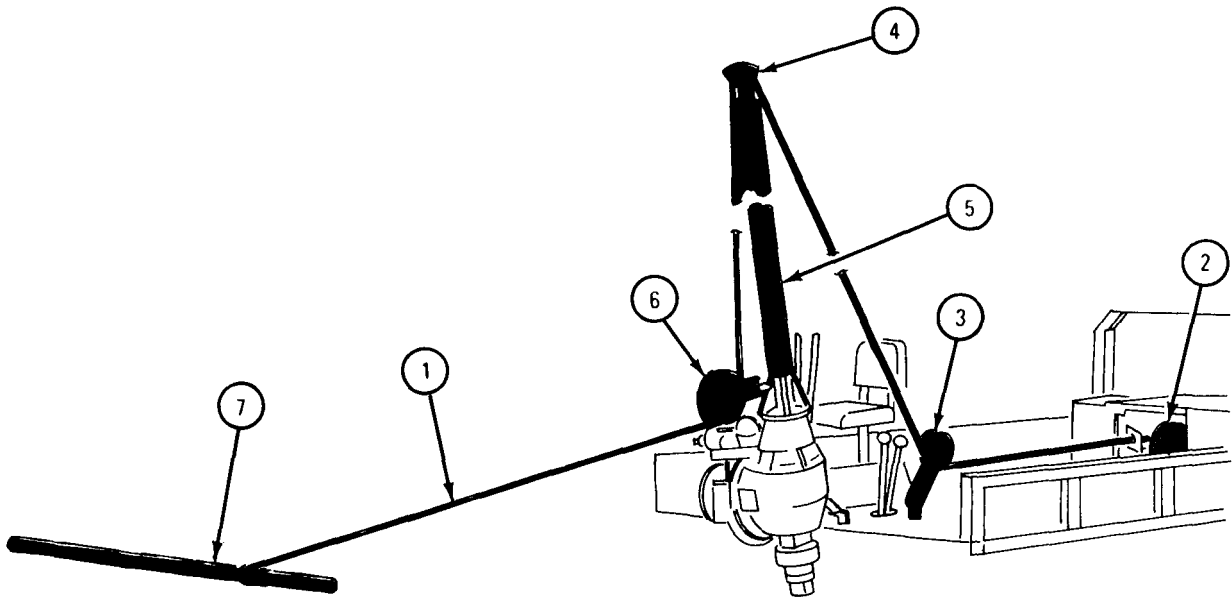

TA 045262

FRAME 3

1. Dragging (with derrick lowered or raised):
  - (a) Operate winch (1) to pull pole (2) toward truck. (Refer to para 4-15d.)
  - (b) Stop winch (1) when pole (2) gets close to truck.
  - (c) Slack off winch cable (3). (Refer to para 4-15d.)
  - (d) Take cable (3) off pole (2).
2. Secure from dragging:
  - (a) Lower derrick (4) if it was raised. (Refer to para 4-15c.)
  - (b) Take winch cable (3) from sheaves (5, 6, or 7) if used.
  - (c) Operate winch to reel in winch cable (3). (Refer to para 4-15d.)

GO TO FRAME 4

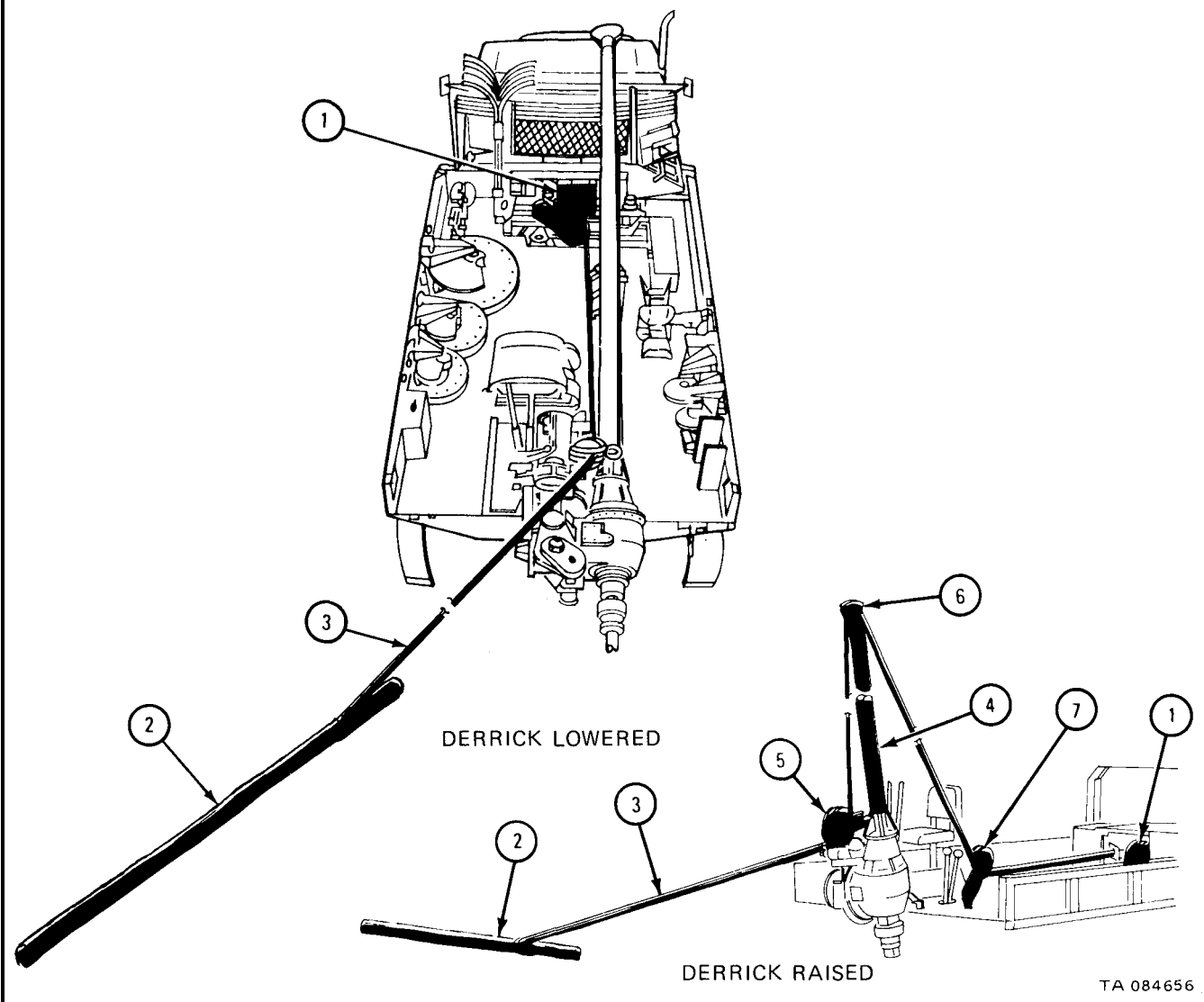

TA 084656

k. Setting Poles.

TOOLS: Pike, pole, wood, 12 ft long  
 Spoon, hand, telegraph, 8 ft long, size 2  
 Tamp, backfill, 8 ft long, type III  
 Bar, digging and tamping, 8 ft long  
 Tagline

PERSONNEL: Two

FRAME 1

**WARNING**

Check derrick tube (1) carefully for damage before using. A tube bend or flat spot can cause collapse under load. If tube is damaged tell organizational maintenance.

When using derrick tube to lift loads, do not exceed pulling capacities given on caution plate (2), mounted on derrick tube.

1. Place the truck so that the derrick sheave (3) will be in position above hole (4) when derrick is placed for lifting.
2. Place outriggers (5) in position on ground. (Refer to para 4-15b.)

GO TO FRAME 2

**CAUTION**

DO NOT EXCEED THE  
PULLING CAPACITY SPECIFIED

A	PULLING CAP
VERT	5,000 LBS
3'	4,100 LBS
4'	3,000 LBS
5'	2,500 LBS
6'	2,100 LBS
8'	1,600 LBS
C	1,300 LBS

PULLING CAPACITY 5,000LBS IN  
ANY DIRECTION AT ALL ANGLES  
WHEN SNATCH SHEAVE IS USED

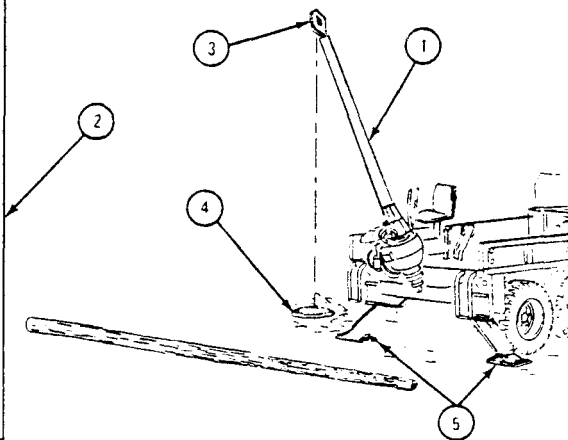

TA 084657

FRAME 2

1. Rig the winch cable (1) for derrick operation. (Refer to para 4-15f.)
2. Raise the derrick tube (2). (Refer to para 4-15c.)
3. Make winch cable (1) fast to pole (3), slightly above balance point (4).
4. Operate rear winch (5) slowly to lift pole (3). (Refer to para 4-15d.)
5. Stop the winch when pole (3) is just clear of ground and in position over hole (6).

GO TO FRAME 3

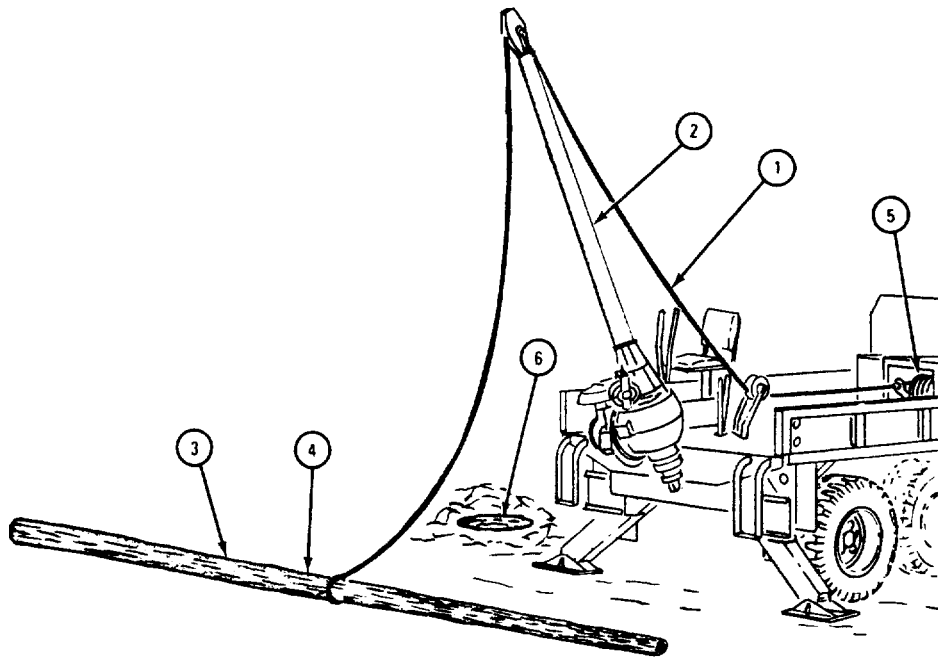

TA 084658

FRAME 3

**CAUTION**

Be very careful in handling pole (1). Make sure it does not get out of control.

Soldier A 1. Operate rear winch (2) slowly to lower pole (1) into hole (3).  
(Refer to para 4-15d.)

Soldier B 2. Using tagline (4), guide lower end of pole (1) into hole (3). Take off tagline.

Soldier A 3. Stop winch (2) when pole (1) reaches bottom of hole (3). Do not put any slack in winch cable (5).

GO TO FRAME 4

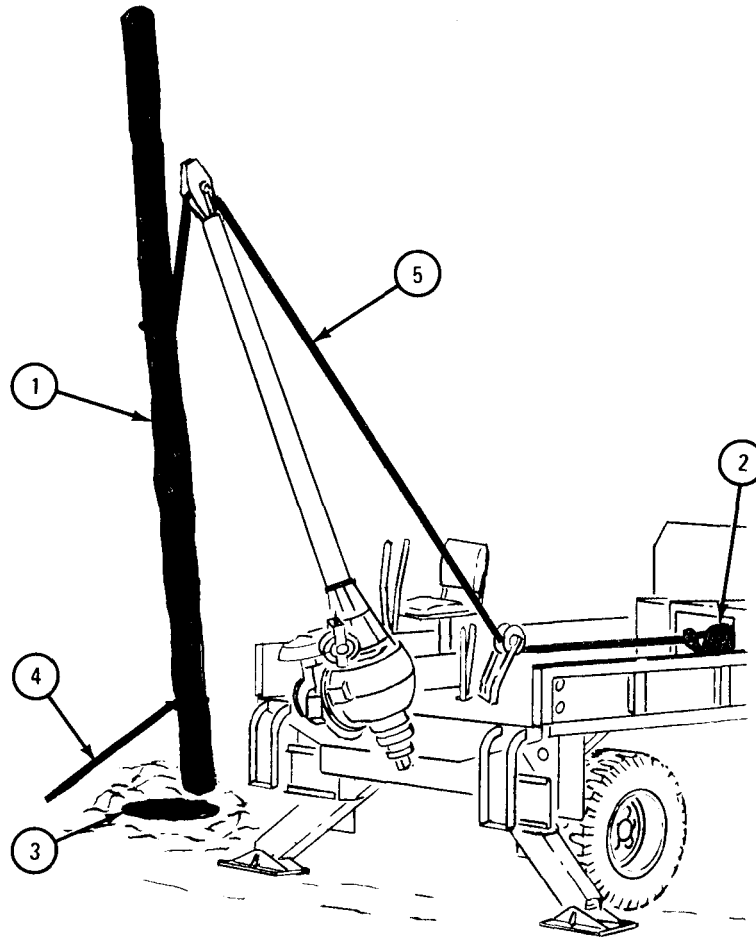

TA 084659

FRAME 4

- Soldier A 1. Using pole pike, push and hold upper part of pole (1) in position.
- Soldier B 2. Using telegraph hand spoon, shovel 4 or 5 loads of dirt into hole (2) and tamp with back fill tamp.
3. Repeat step 2 until hole is filled.
- Soldier A 4. Take pole pike away from pole (1).
- Soldier B 5. Using telegraph hand spoon, pile the left over dirt around pole (1).
- Soldier A 6. Using digging and tamping bar, tamp dirt around pole (1).
7. Operate rear winch (3) to put slack in winch cable (4). (Refer to par 4-15d.)
- Soldier B 8. Take winch cable (4) from pole (1).
9. Pull in and secure outriggers (5). (Refer to para 4- 15i.)

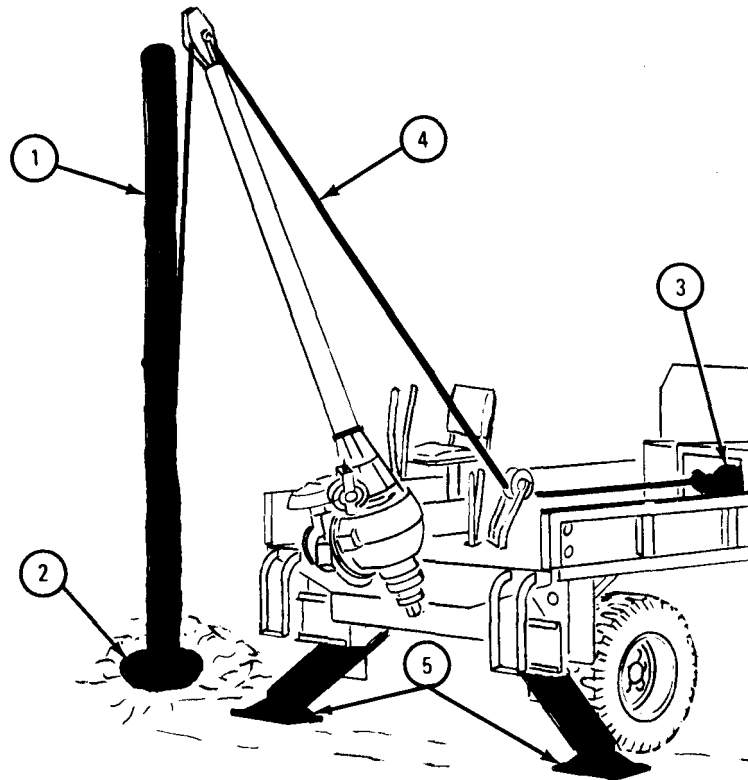

TA 084660

1. Pulling Pole.

TOOLS: Jack, rack bar with chain, 15 ton rated capacity  
Spoon, hand, telegraph, 8 ft long, size 2  
Bar, tamping and digging, 8 ft long  
Tagline

PERSONNEL: Two

FRAME 1

**CAUTION**

Make sure wood pole (1) is strong enough to take pull without breaking, before pulling pole. Use pole pulling jack (2) or dig hole alongside pole to loosen pole as required. Great suction can be created under pole unless pole is loose in hole.

1. Wrap jack chain (3) around pole (1).
2. Operate jack handle (4) in an up and down motion to loosen pole (1).

GO TO FRAME 2

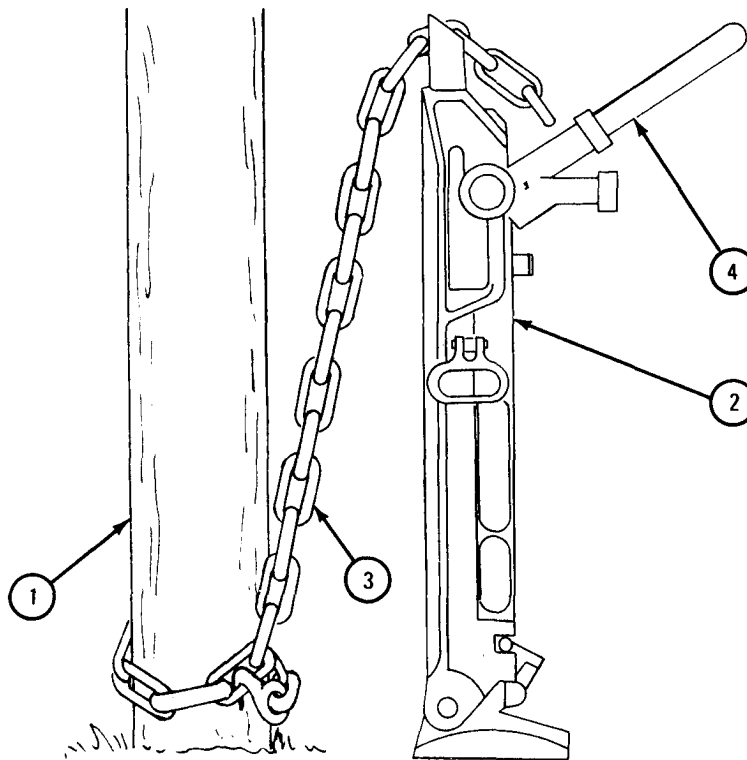

TA 045263

FRAME 2

1. Place truck so that derrick sheave (1) is almost touching pole (2).
2. Operate rear winch (3) to let out some slack in winch cable (4). (Refer to para 4-15d.)
3. Tie winch cable (4) to pole (2) about 2 feet above the balance point.
4. Place outriggers (5) in position on ground. (Refer to para 4-15b.)

GO TO FRAME 3

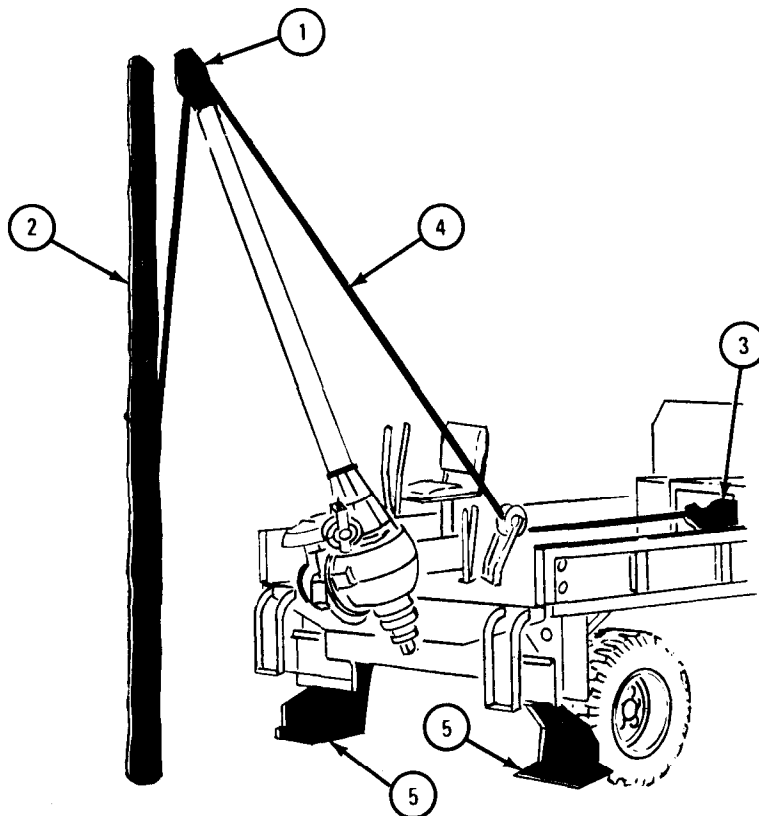

TA 084661



FRAME 3

- Soldier A 1. Place tagline (1) on lower part of pole (2).
- Soldier B 2. Operate rear winch (3) and slowly lift pole (2) until it is clear of hole (4). (Refer to para 4-15d.)
- Soldier A 3. Guide lower part of pole (2) as needed with tagline (1).
- Soldier B 4. Operate rear winch (3) to lower pole (2) to the ground. (Refer to para 4-15d.)
- Soldier A 5. Block pole (2) to keep it from rolling.
6. Take tagline (1) and winch cable (5) from pole (2).

GO TO FRAME 4

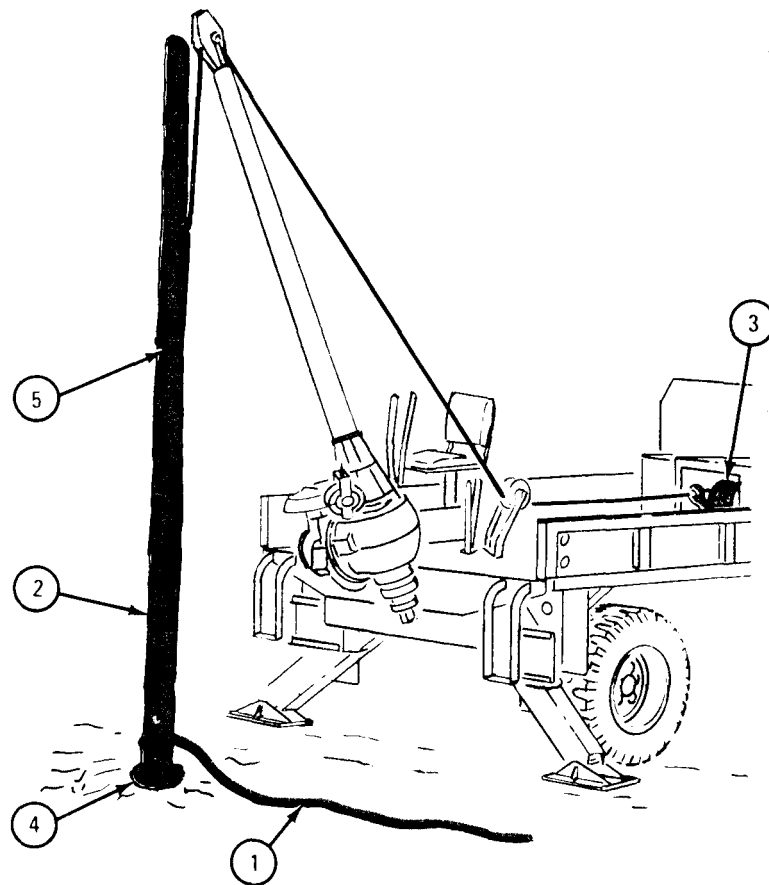

TA 084662

FRAME 4

1. If hole (1) will not be used:
  - (a) Using telegraph hand spoon, fill hole (1) with dirt.
  - (b) Using digging and tamping bar, tamp dirt down.
2. Pull in and secure outriggers (2). (Refer to para 4-15i.)
3. Lower derrick (3) to secured position. (Refer to para 4-15c.)
4. Secure rear winch (4). (Refer to para 4-15d.)

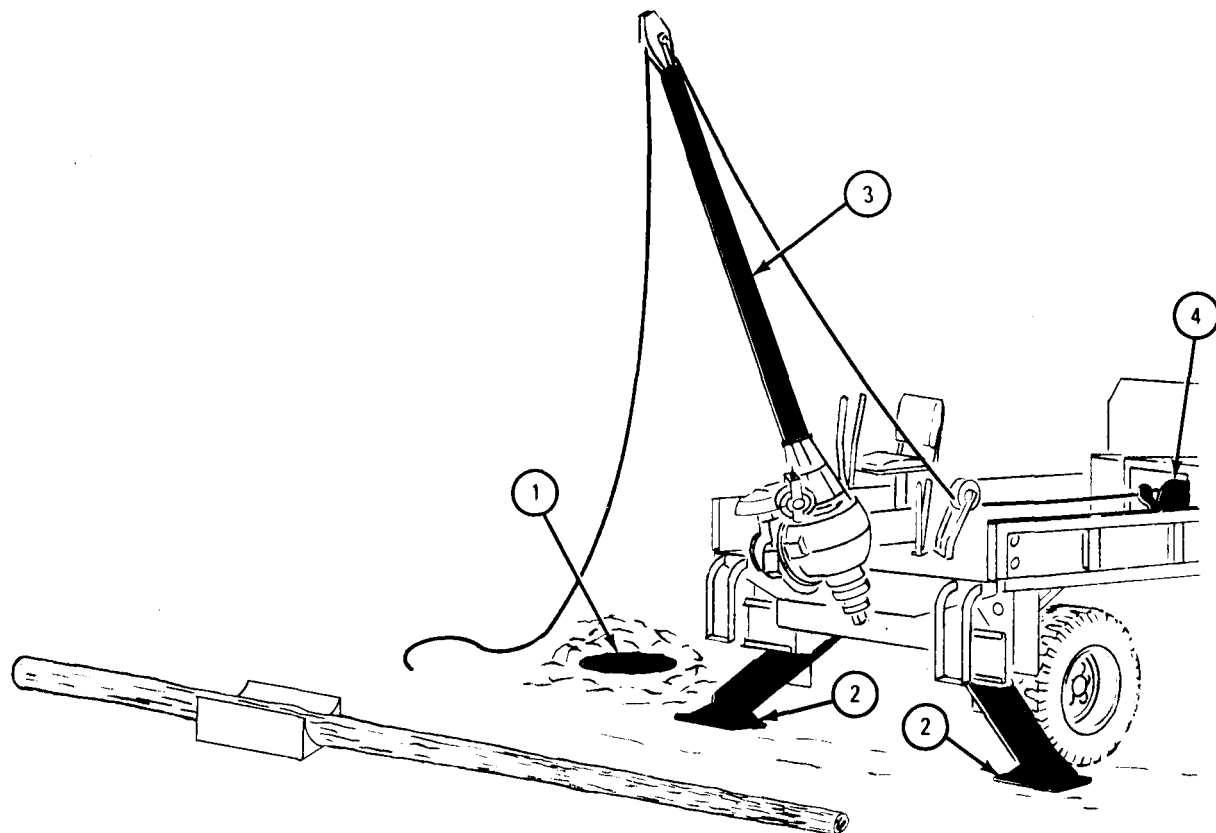

TA 084663

m. Operating Collapsible Cable Reel.

## FRAME 1

Depending on the amount of cable or wire on the reel, one soldier, two soldiers, or the derrick tube and winch might be required to handle it. If the derrick tube and rear winch are needed, refer to lifting the 20- and 30-inch augers, para 4-15f.

1. Take out retaining pin (1) and take collapsible reel (2) from its stowed position.

GO TO FRAME 2

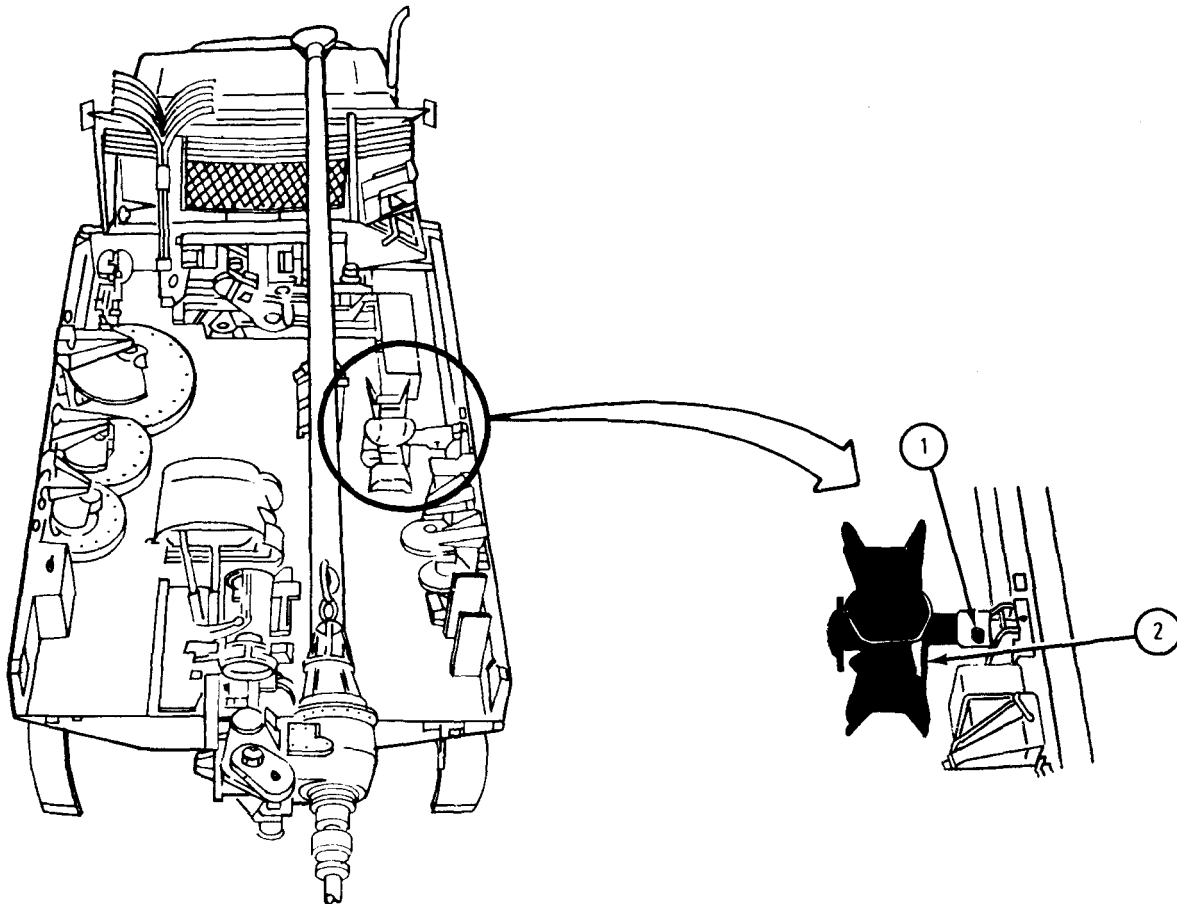

TA 045265

FRAME 2

1. Place collapsible reel (1) on rear winch shaft (2).
2. Press reel (1) against spindle spring and turn it to the right until shaft dowel pins (3) go into grooves (4) in the reel spindle shaft (5).

GO TO FRAME 3

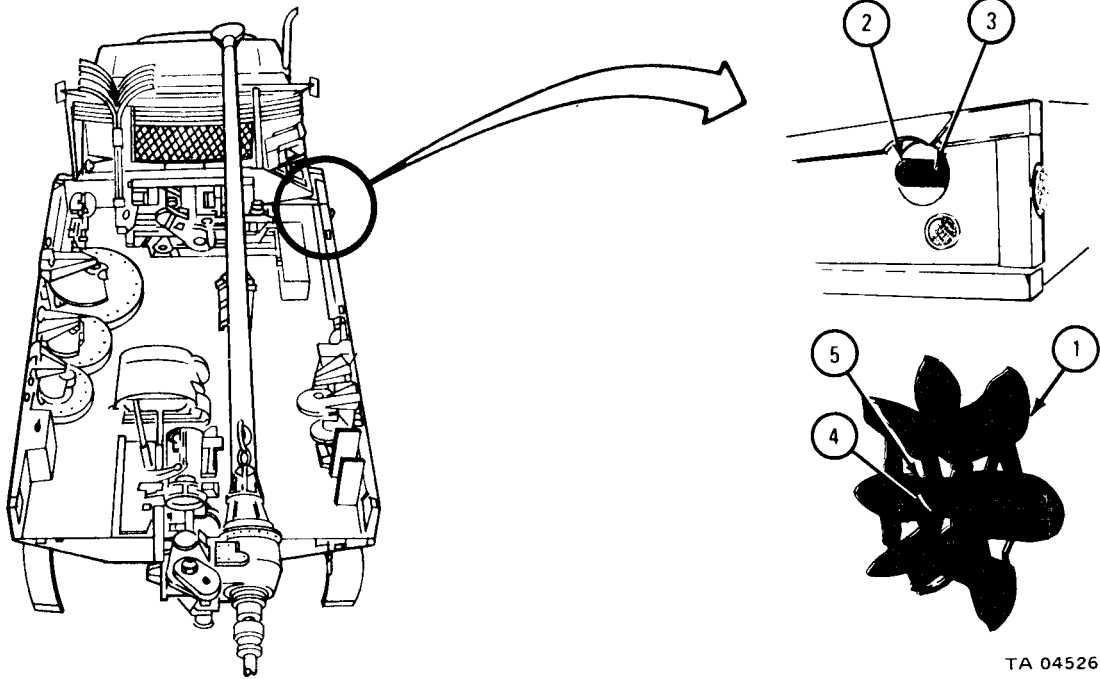

## FRAME 3

**WARNING**

Make sure collapsible cable reel (1) is properly mounted on rear winch shaft before operating reel. Do not overload cable reel. Maximum pull on reel must not be more than 4,000 pounds. Stand clear of reel and cable during operation. Do not touch cable unless absolutely necessary. Wear leather gloves to avoid injury.

**CAUTION**

Make sure ends of cable are made fast before installing or removing cable from reel. If the cable gets tangled it could cause damage to equipment.

1. Collapse cable reel (1) by turning operating handle (2) left until sliding spider (3) separates from handle.
2. Push in sliding spider (3) to completely collapse cable reel (1). Wire coil may now be placed onto or taken off of rim segments (4).
3. Pull sliding spider (3) forward and turn operating handle (2) right to mesh with spider. Continue to turn handle as far as it will go.

GO TO FRAME 4

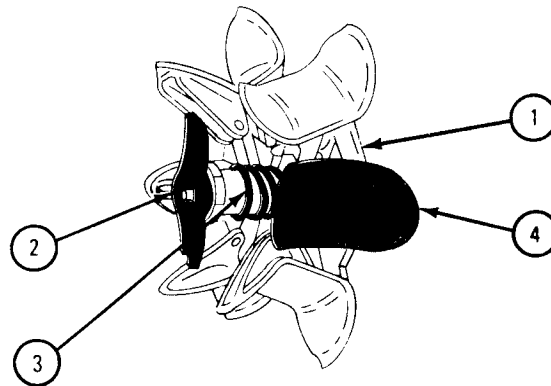

TA 045267

FRAME 4

1. Start engine. (Refer to para 4-6b.)
2. Press clutch pedal (1) down.
3. Place TRANSFER CASE gear shift lever (2) in neutral position.
4. Turn locking bar (3) and move transfer POWER TAKEOFF LEVER (4) to rear to on position.

GO TO FRAME 5

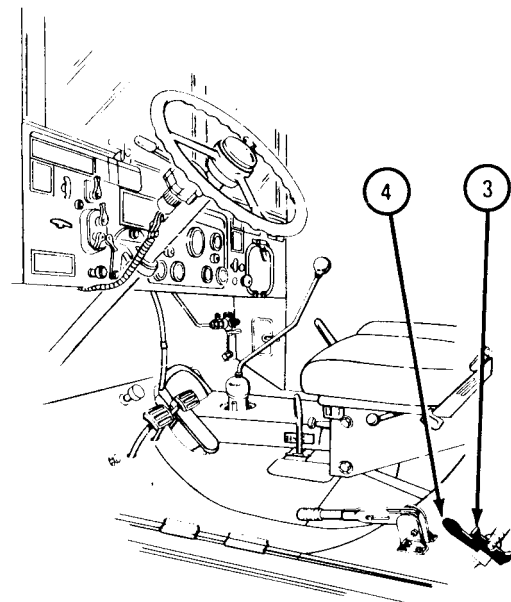
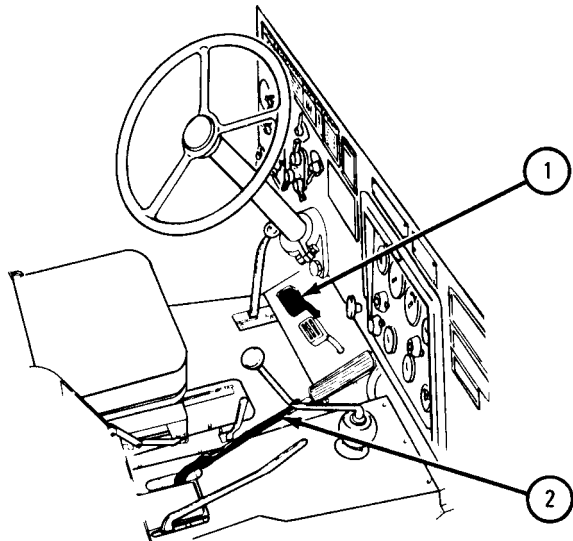

TA 045268

## FRAME 5

**CAUTION**

Make sure that winch control lever (1) is locked in neutral position by hingelock (2).

1. Place power divider control lever (3) in REAR WINCH FWD position.
2. Place FRONT TRANSMISSION gearshift lever (4) in a forward position (not above 3), then let clutch pedal (5) come up slowly.
3. Press down on accelerator pedal (6) enough to keep engine from stalling.

GO TO FRAME 6

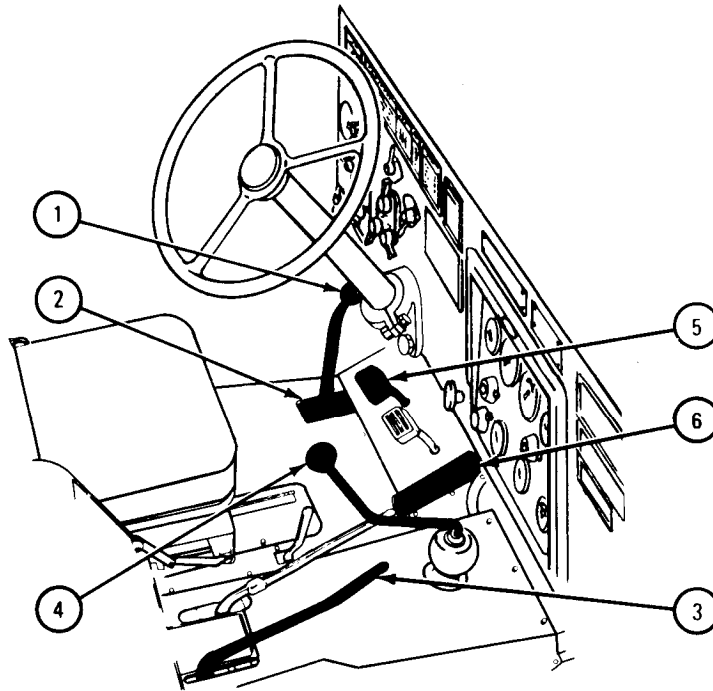

TA 045269

FRAME 6

1. To stop reel action; press clutch pedal (1) down and let up on accelerator pedal (2).
2. Place power divider control lever (3) in NEUTRAL position.

GO TO FRAME 7

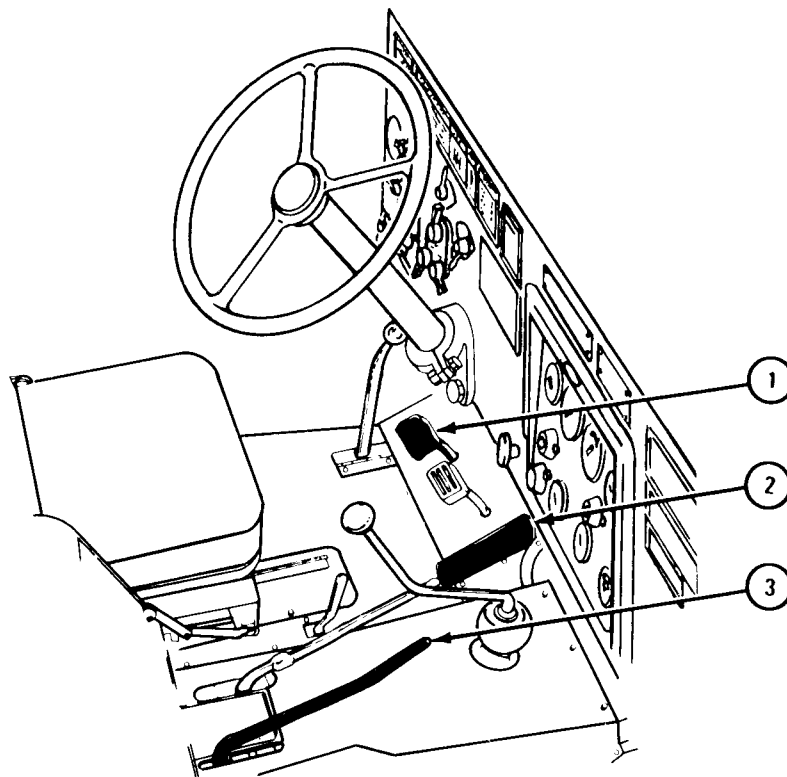

TA 045270



## FRAME 7

1. To secure from operations; move transfer POWER TAKEOFF LEVER (1) forward to off position.
2. Turn locking bar (2) to lock position.
3. Stop the engine. (Refer to para 4-6e.)

GO TO FRAME 8

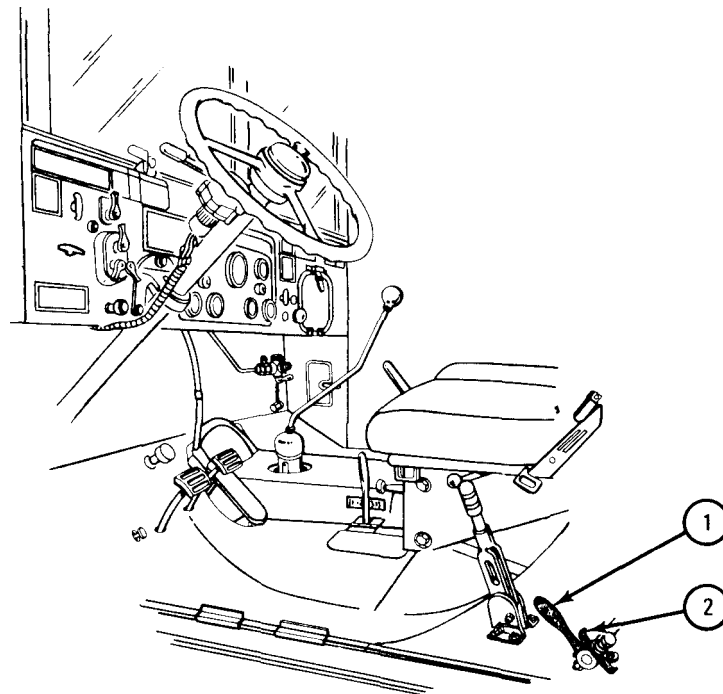

TA 045271

FRAME 8

1. Turn operating handle (1) left until sliding spider (2) separates from handle.
2. Push in sliding spider (2) to completely collapse reel (3).
3. Take off coil of wire if there is one on reel (3).

GO TO FRAME 9

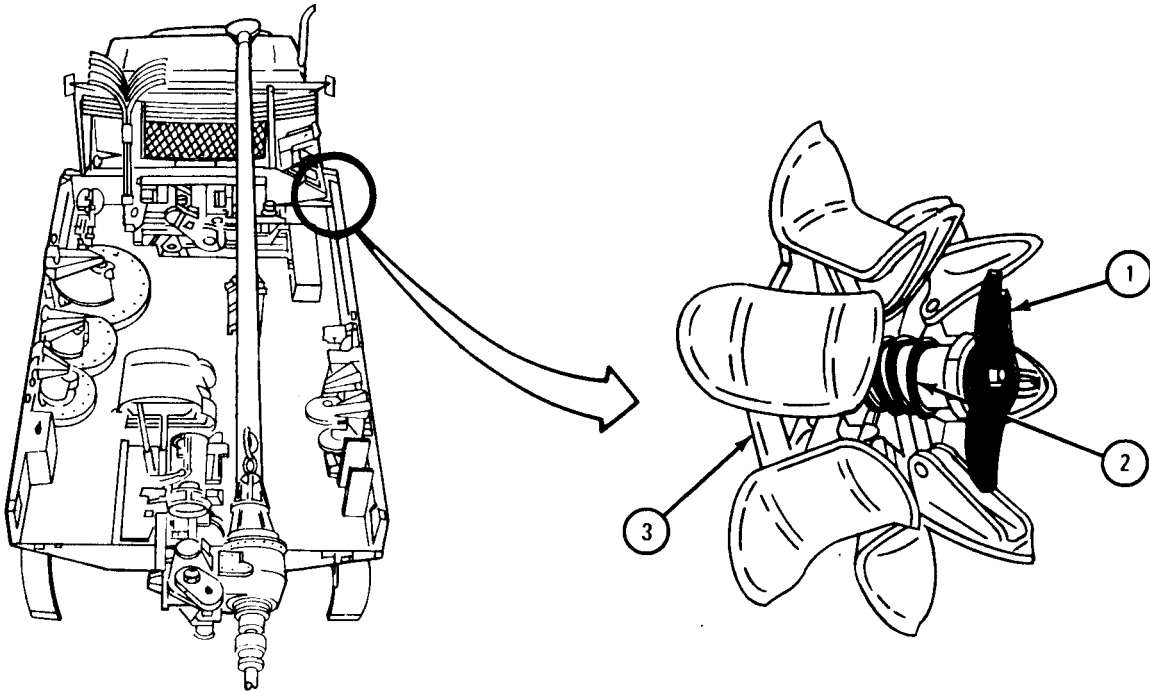

TA 045272

## FRAME 9

1. Pull forward on sliding spider (1) and turn operating handle (2) right to mesh with spider (1). Continue to turn handle as far as it will go.

GO TO FRAME 10

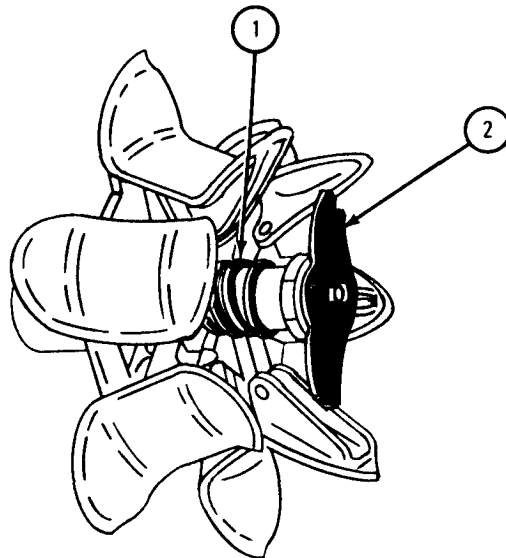

TA 045273

FRAME 10

1. Press reel (1) against spindle spring and turn reel to the right. Continue to turn reel until dowl pins (2) on shaft (3) separate from grooves in spindle shaft (4).
2. Put reel (1) back onto stowing shaft (5) and put back retaining pin (6).

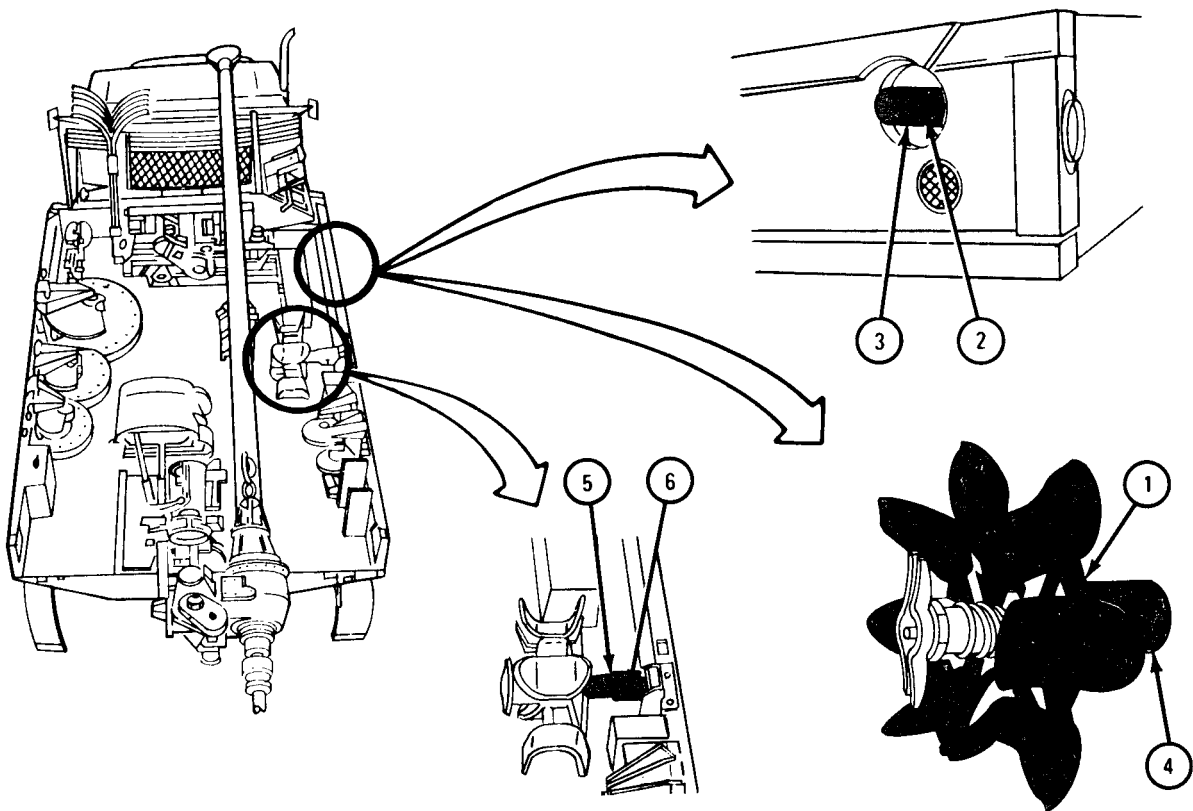

TA 045274

## 4-16. OPERATION OF HOT WATER PERSONNEL HEATER KIT.

## FRAME 1

1. Start engine and let it warmup. (Refer to para 4-6b.)

**CAUTION**

In ice, snow, or 0°F weather do not damage glass by making sudden changes in temperature. Let more heated air flow to personnel compartment than to the windshield.

2. Pull DAMPER knob (1) out to let warm air flow to personnel compartment.
3. Pull DEFROSTER knob (2) out to let warm air flow to windshield.
4. Move DAMPER knob (1) and DEFROSTER knob (2) in or out to control amount of warm air to windshield or personnel compartment.
5. Set HEATER (blower motor) switch (3) in HI or LO position as needed.
6. To stop heating or defrosting action, set HEATER (blower motor) switch (3) in OFF position.
7. Stop engine. (Refer to para 4-6e.)

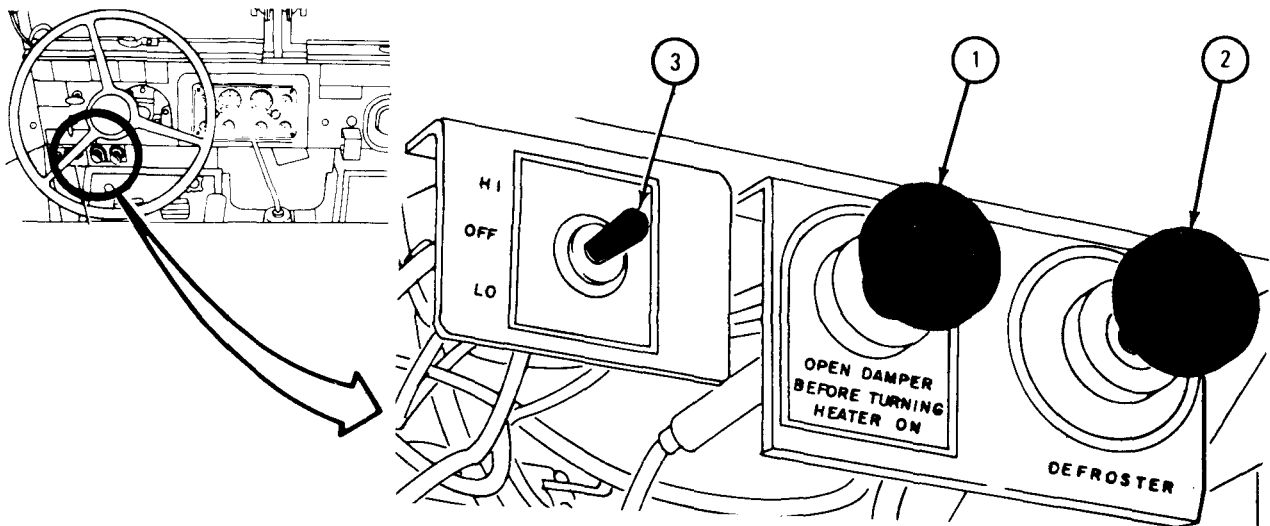

TA 045275

4-17. OPERATION OF ARCTIC WINTERIZATION KIT.

a. General. The arctic winterization kit is designed for use in areas where the average temperature is -25 °F to -65 °F.

**NOTE**

Installation of quilted cargo compartment cover and quilted engine compartment cover is done at direct support maintenance level.

b. Operating the Winterfront Cover.

FRAME 1

1. During cold weather when engine cannot hold normal operating temperatures, attach a winterfront cover (1) to radiator brushguard.
2. Open aperture flap (2) when engine temperature goes above 180 °F.

**CAUTION**

If engine temperature continues to rise after opening aperture flap (2), take off winterfront cover (1) completely so that engine does not overheat. Failure to remove the winterfront cover may cause damage to the engine.

3. Close aperture flap (2) when engine operating temperature stays below 180 °F.
4. Close aperture flap (2) during standby periods and overnight.

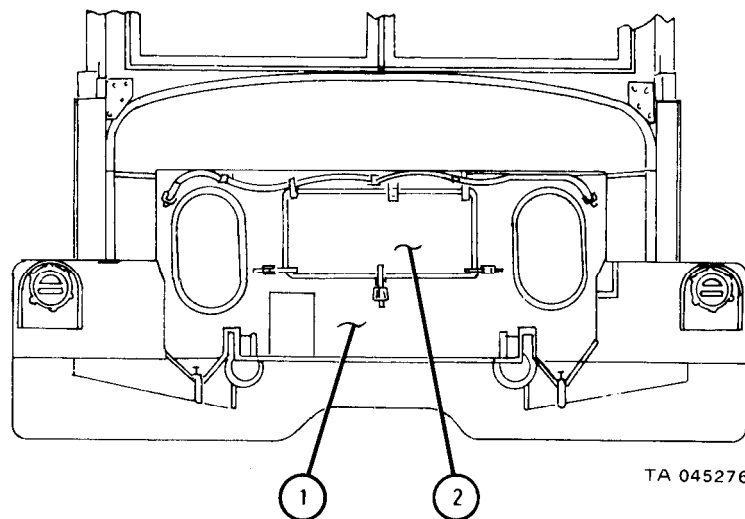

c. Using the Quilted Engine Compartment Cover.

FRAME 1

**CAUTION**

Open aperture flap (1) when engine temperature goes above 180 °F. If engine temperature keeps going up, take off quilted engine compartment cover (2) completely, so that engine does not overheat. Failure to remove quilted engine compartment cover may cause damage to the engine.

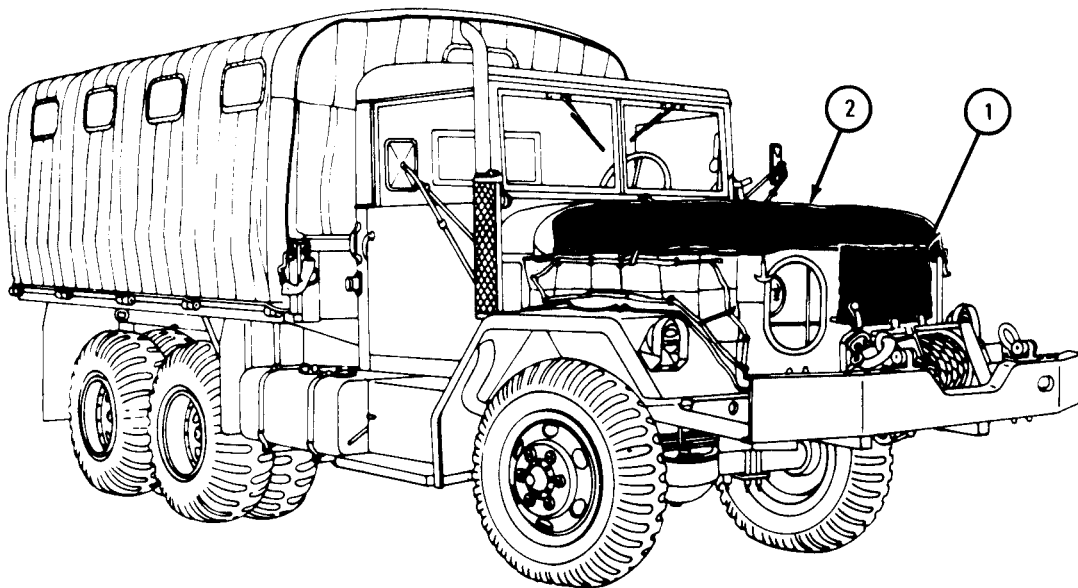

TA 045277

d. Operating the Fuel Burning Personnel Heater.

FRAME 1

1. Open the fuel shutoff cock (1) by turning it to the left.
- GO TO FRAME 2

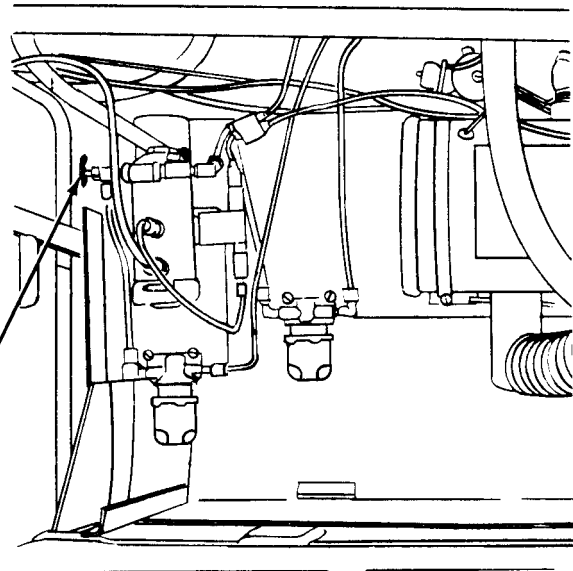
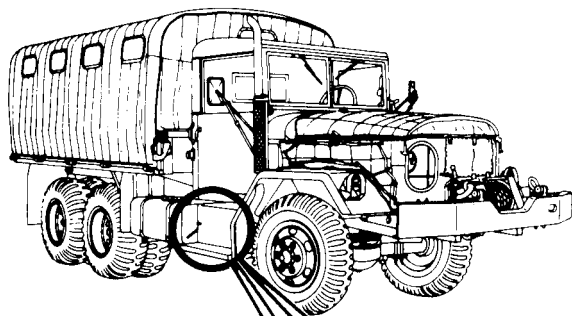

EARLIER MODEL TRUCKS

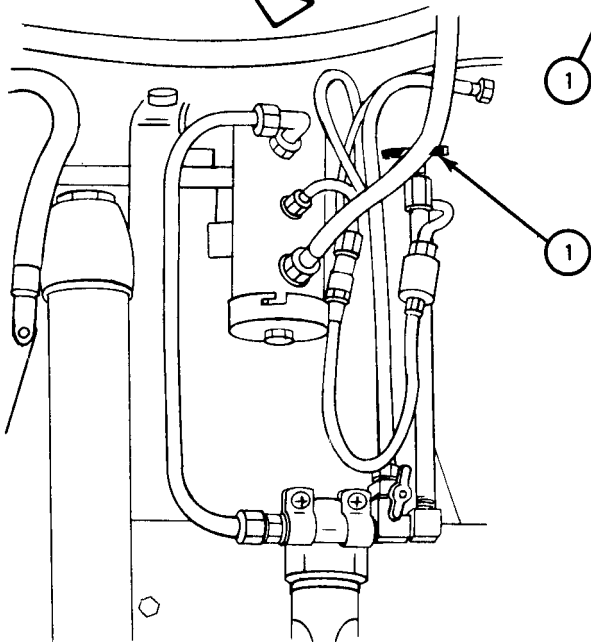

LATER MODEL TRUCKS

TA 045278



## FRAME 2

1. Make sure that personnel heater EMERGENCY switch (1) is in the up position.
2. Pull DAMPER knob (2) to full out position.
3. Place HI-LO switch (3) in HI or LO position, depending on heat needed.
4. Hold START-OFF-RUN switch (4) in START position until indicator light (5) comes on. START-OFF-RUN switch (4) is spring loaded and must be held in position.
5. As soon as the indicator light (5) comes on, move START-OFF-RUN switch (4) quickly to RUN position.

**NOTE**

Moving START-OFF-RUN switch (4) lever from START position to RUN position too slowly will result in a heater shutdown. Move switch lever quickly. Warm air should be felt at the heat outlet within three minutes. If heater fails to start within two minutes (indicator light (5) remains off), move START-OFF-RUN switch (4) to OFF position. Wait three minutes before trying to start heater again.

GO TO FRAME 3

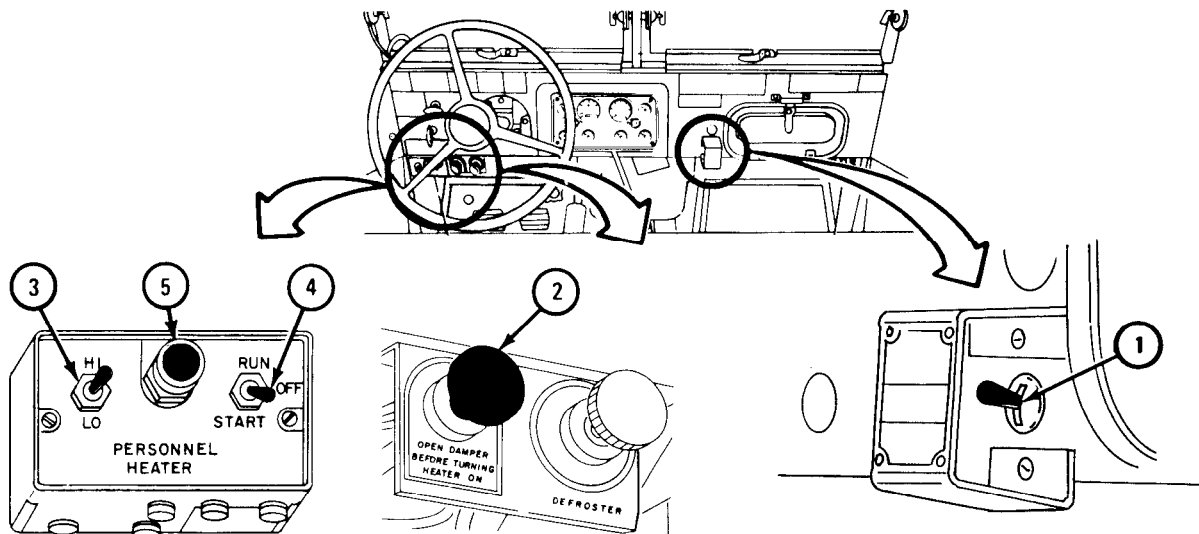

TA 045279

FRAME 3

1. Pull DAMPER knob (1) out to get more heated air from the heat outlet.
2. Push DAMPER control knob (1) into lower amount of hot air coming from the heat outlet.

**NOTE**

Do not operate the heater with the DAMPER knob (1) pushed all the way in. The unit does not work best with knob in this position.

GO TO FRAME 4

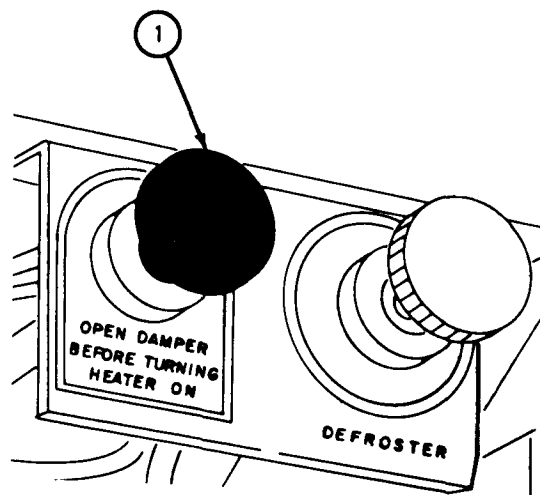

TA 045280

## FRAME 4

1. Pull DEFROSTER knob (1) out all the way for maximum defrosting. For even heating and defrosting, push DEFROSTER knob half way in.
2. To stop the heater, set the HI-LO switch (2) in the LO position, and set the START-OFF-RUN switch (3) to OFF position.
3. The burner will stop in a few seconds but indicator light (4) will stay on.
4. When burner is cool and all unused fuel is out, indicator light will go out.

**NOTE**

Wait until indicator light (4) goes out before trying to restart heater.

GO TO FRAME 5

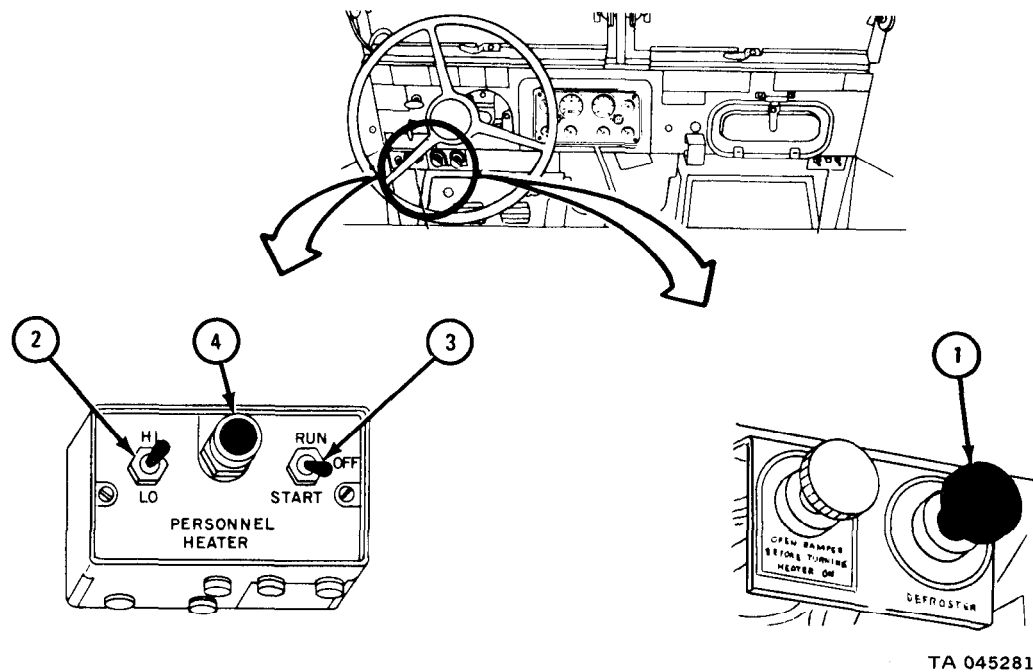

FRAME 5

**CAUTION**

Under normal conditions do not stop heater by setting personnel heater EMERGENCY switch (1) in off (down) position. Damage to equipment may result.

In case of an emergency condition, set personnel heater EMERGENCY switch (1) in off (down) position. This may cause damage to equipment but crew compartment personnel will be better protected.

1. If heater fails to start or goes out after a short run, wait until indicator light (2) goes out.
2. Try to restart. If heater fails to operate after third try, notify direct support maintenance unit.

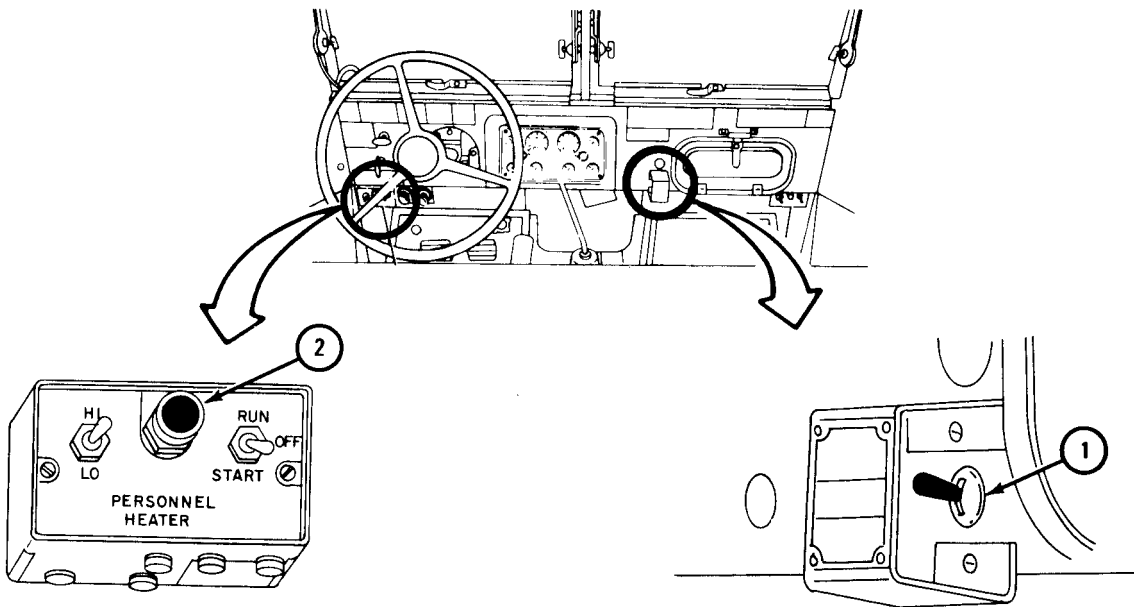

TA 045282

e. Operating the Fuel Burning Power Plant Heater.

## FRAME 1

**NOTE**

The fuel burning power plant heater is designed to keep the engine compartment warm when vehicle is not in use. This heater should not be used while operating the vehicle.

1. Make sure heater coolant outlet shutoff cock (1) is fully open (turn left).
2. Make sure heater coolant inlet shutoff cock (2) is fully open (turn left).

GO TO FRAME 2

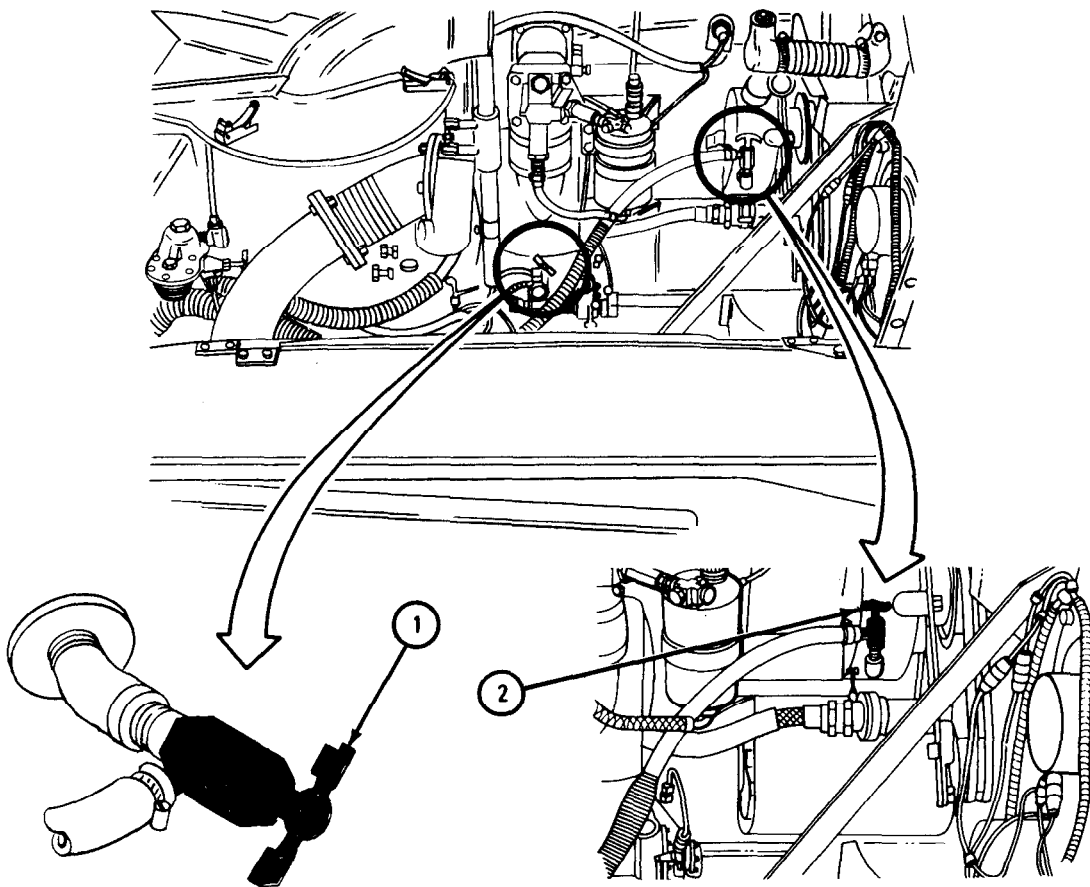

TA 044948

FRAME 2

- 1. Turn engine heater fuel shutoff cock (1) left to open position.
- GO TO FRAME 3

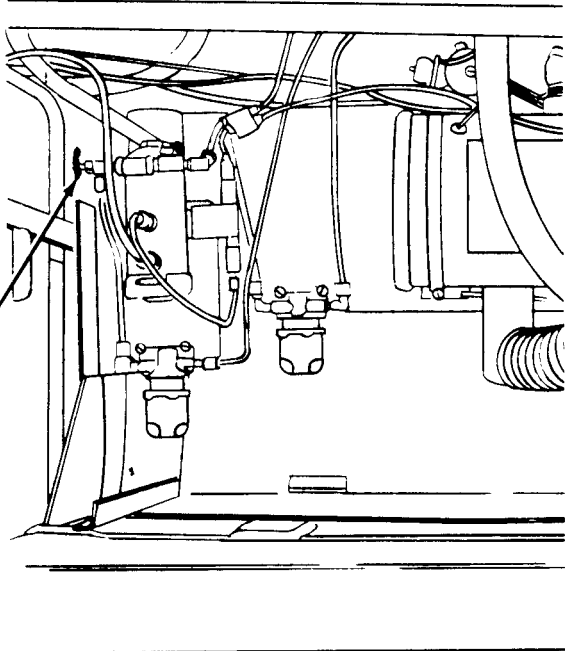
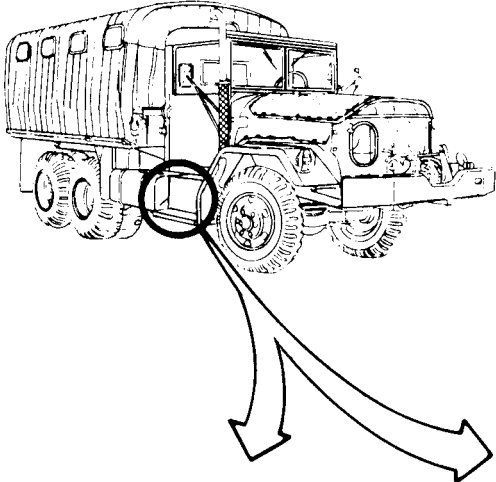

EARLIER MODEL TRUCKS

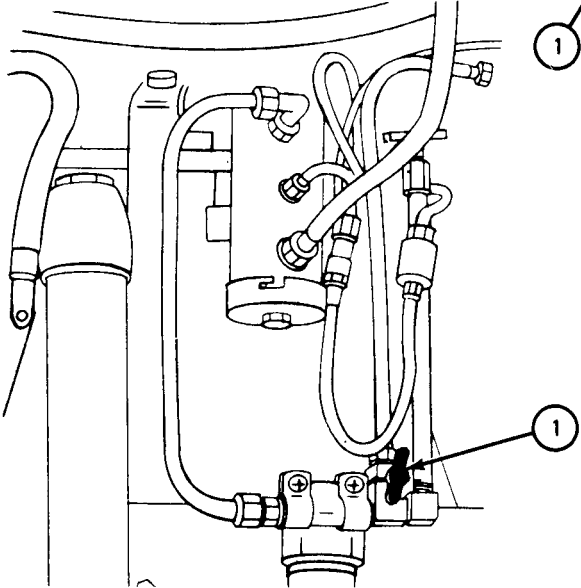

LATER MODEL TRUCKS

TA 084664

## FRAME 3

1. Set Hi-LO switch (1) to LO position.
2. Hold START-OFF-RUN switch (2) in START position until indicator light (3) comes on. Indicator light should come on within two minutes.

**NOTE**

START-OFF-RUN switch (2) is spring loaded and must be held in position.

3. As soon as indicator light (3) comes on, quickly move START-OFF-RUN switch (2) to RUN position.

**NOTE**

Moving switch (2) lever from START to RUN too slowly will result in a heater shutdown. Warm air should be felt at the heat outlet within three minutes.

4. If heater fails to start within two-minutes, (indicator light (3) remains off), move STAR T-OFF-RUN switch (2) to OFF position. Wait until three minutes before trying again to start.
5. Set HI-LO switch (1) to HI or LO depending on heat needed.

**NOTE**

LO position of HI-LO switch (1) is suitable for standby periods when heater will operate for a long period of time.

GO TO FRAME 4

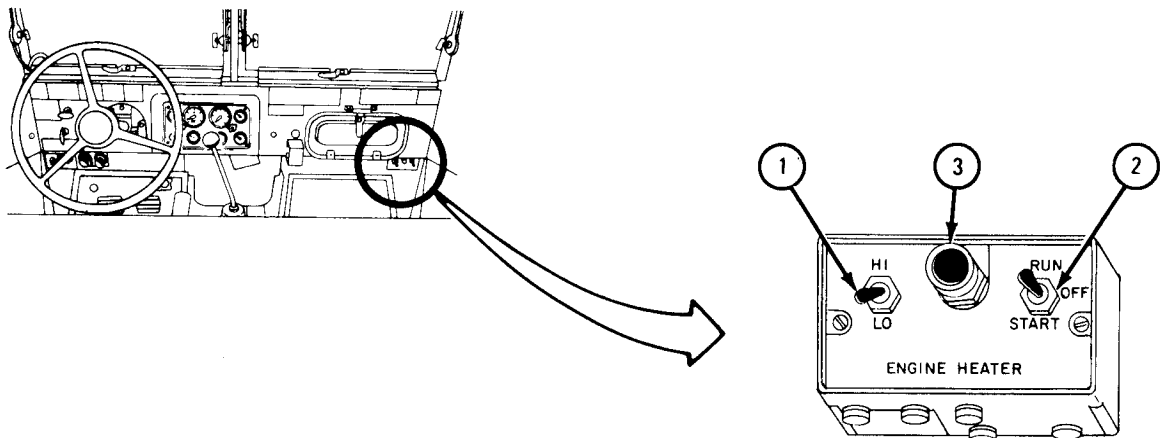

TA 045284

FRAME 4

1. To stop the engine heater, set the HI-LO switch (1) to LO position.
2. Set START -OFF -RUN switch (2) to OFF position, burner will stop within a few seconds.
3. Indicator light (3) will remain on, blower will keep running until burner cools and unburned gases are out.

**NOTE**

Always wait until indicator light (3) goes out before trying to restart engine heater.

4. If heater fails to start after three tries or stops after a short run, tell direct support maintenance.

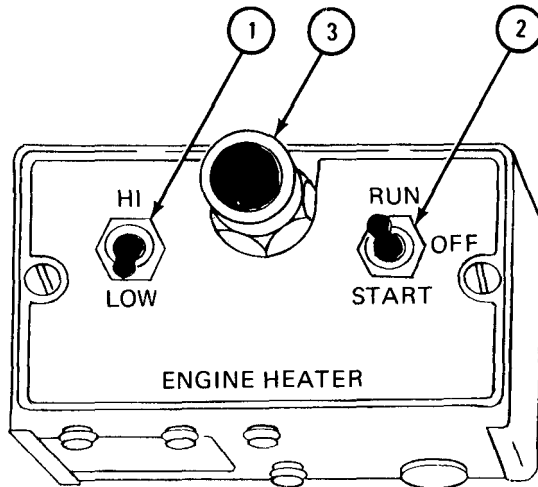

TA 045285



f. Using the Slave Receptacle.

FRAME 1

**NOTE**

A vehicle with discharged batteries can get power from another vehicle through the slave receptacle.

1. Start engine. (Refer to para 4-6b.)
2. Place vehicle so that slave receptacle (1) faces slave receptacle of disabled vehicle.
3. Stop engine. (Refer to para 4-6e.)
4. Turn left, unscrew protective cap (2) and swing it to the side.

GO TO FRAME 2

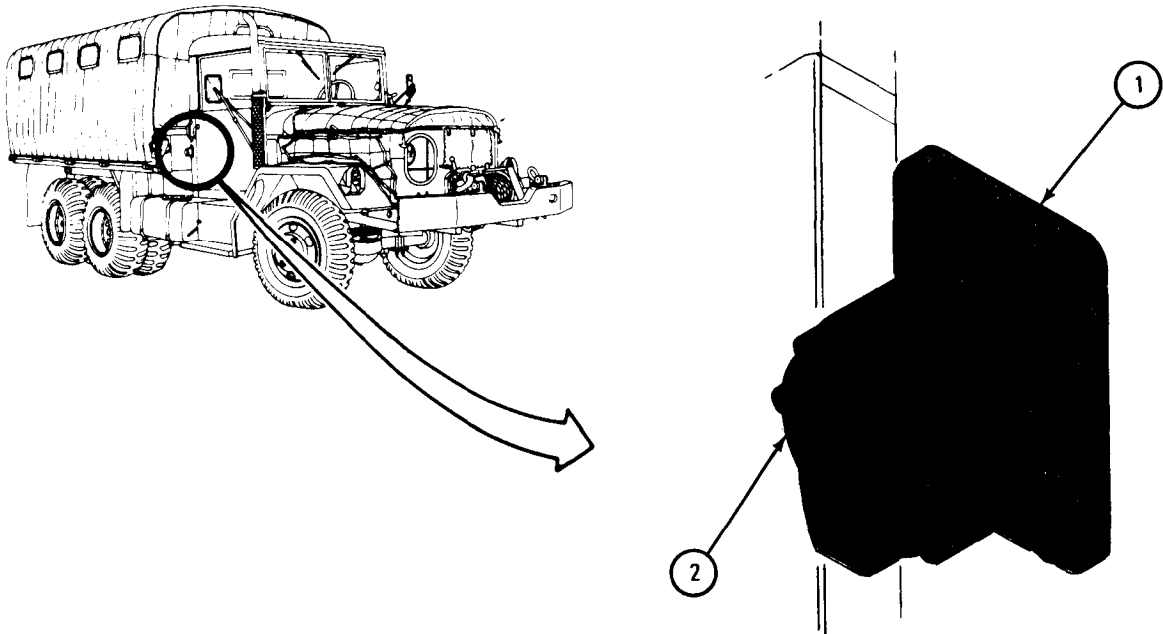

TA 045286

FRAME 2

1. Plug service cable connectors (1) into slave receptacle (2) on each vehicle.
2. Start engine of slaving vehicle. (Refer to para 4-6b.)
3. Set idle speed at 1,000-1100 rpm.
4. Start engine of disabled vehicle. (Refer to para 4-6b.)
5. As soon as engine is running smoothly, remove service cable connectors (1) from receptacles (2).
6. Swing protective caps (3) back into position and screw cap onto receptacle.
7. Stop engine on slaving vehicle. (Refer to para 4-6e.)

GO TO FRAME 3

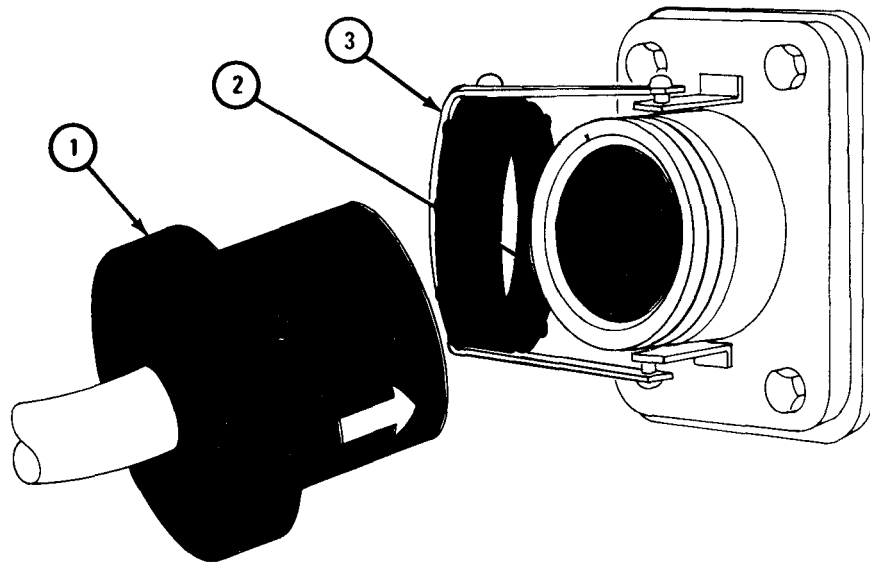

TA 045287

## FRAME 3

1. Check battery generator indicator (1) on slaved vehicle. If indicator reading is in the yellow or red, stop engine, refer to para 4-6e, and tell organizational maintenance.

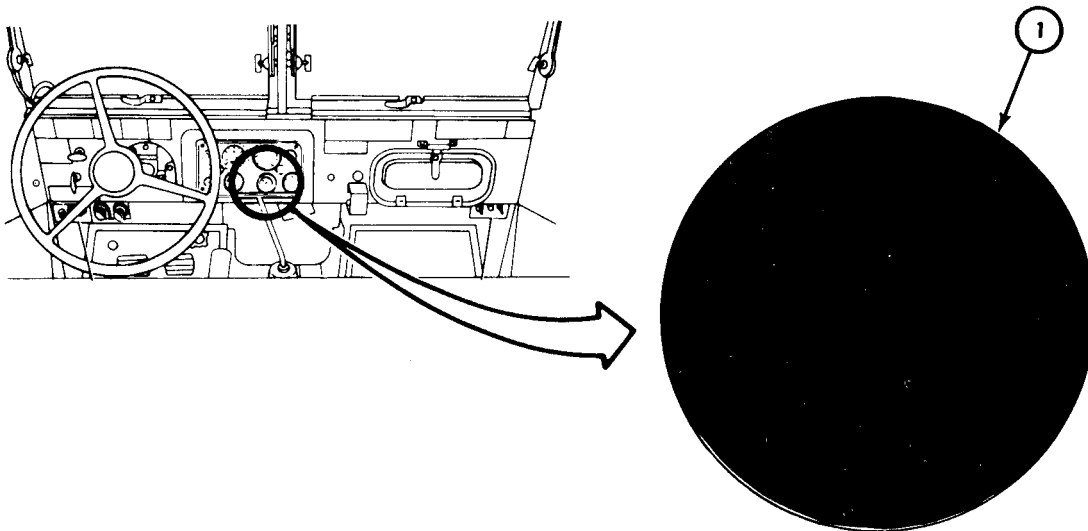

TA 045288

4-18. OPERATING THE DEEP WATER FORDING KIT.

TOOLS: Straight bar plug wrench  
Ratchet wrench

FRAME 1

**NOTE**

Trucks with deep water fording kits can ford hard bottom crossings up to 72 inches deep.

1. Using straight bar plug wrench and ratchet wrench, unscrew drain plug (1) from storage boss (2) on flywheel housing.
2. Screw drain plug (1) into drain port (3).

GO TO FRAME 2

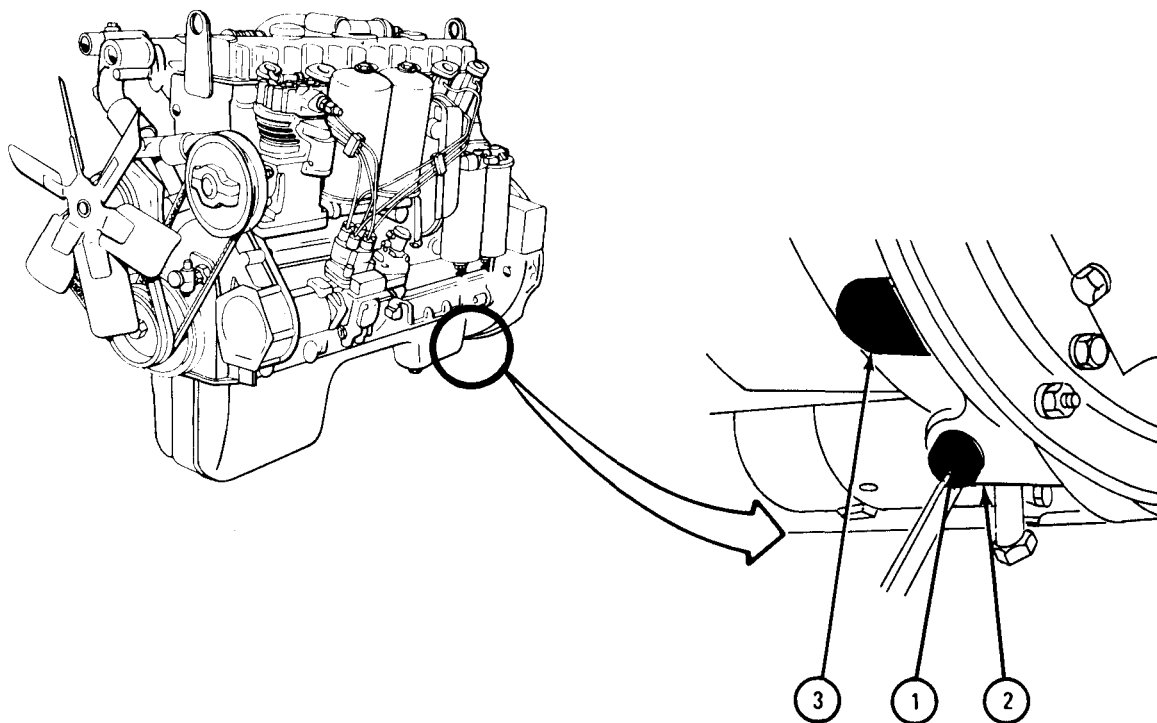

TA 045289

FRAME 2

1. Make fast all loose objects to the vehicle.
2. Start engine. (Refer to para 4-6b.)
3. On trucks with bracket-mounted FORDING control, move fording valve control lever (1) left to IN. On trucks with panel-mounted fording control, pull FORDING valve cable control handle (2) out.

GO TO FRAME 3

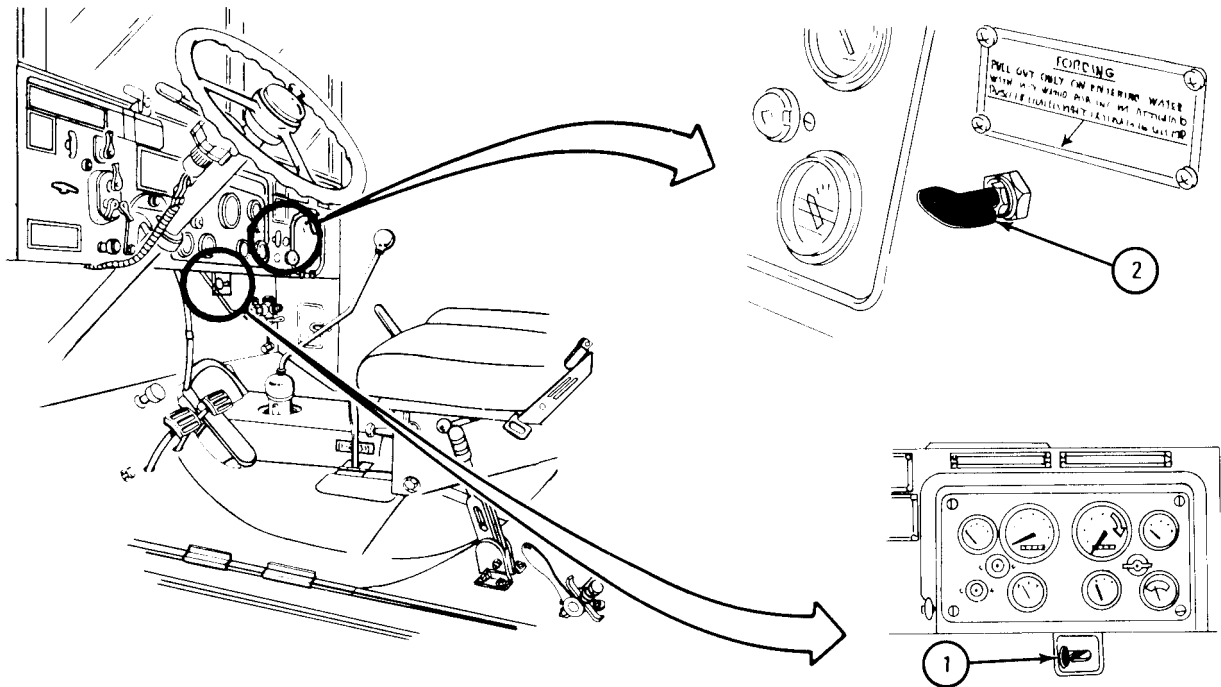

TA 045290

FRAME 3

1. Step on clutch pedal (1) and press it all the way down.
2. Place FRONT TRANSMISSION gearshift levers (2) in position 1.
3. Move TRANSFER CASE shifting lever (3) down to LOW position.
4. Let clutch pedal (1) up.

GO TO FRAME 4

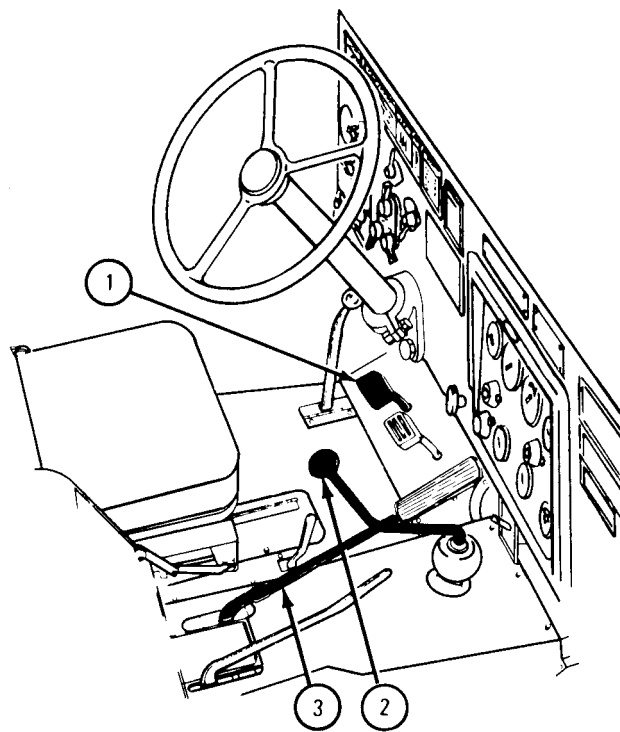

TA 045291

## FRAME 4

**WARNING**

Do not attempt to ford your truck in depths greater than 72 inches. While fording, keep your speed down to 3 to 4 miles per hour.

After fording, do not rely on brakes until they dry out. Keep putting them on and releasing them until vehicle stops without brakes grabbing.

Failure to observe these warnings could result in injury to personnel and damage to equipment.

1. Make sure your engine is running correctly and start fording.
2. After leaving the water, on trucks with bracket-mounted FORDING control, move FORDING valve control lever (1) to the right, OUT position. On trucks with panel-mounted fording control, push FORDING valve cable control handle (2) in.
3. Stop engine. (Refer to para 4-6e.)

GO TO FRAME 5

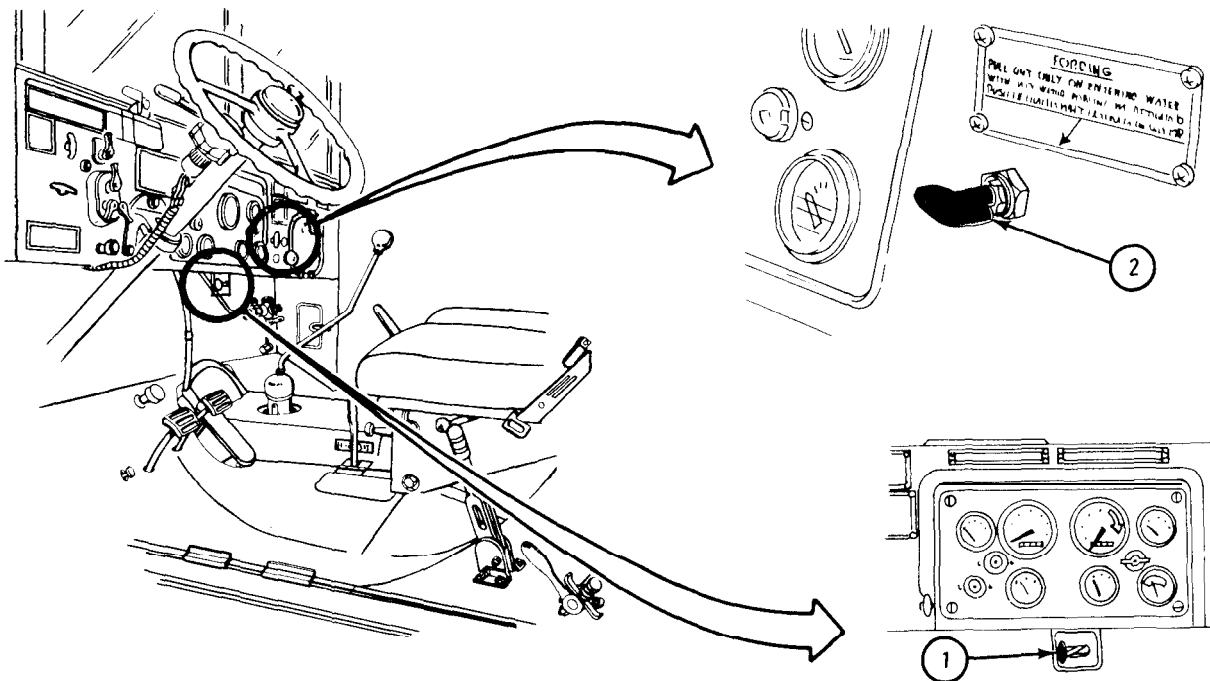

TA 045290

FRAME 5

1. Using straight bar plug wrench and ratchet wrench, unscrew flywheel housing drain plug (1) from drain port (2).
2. Screw drain plug (1) into storage boss (3).
3. Wash off all salt water and salt deposits from every part of truck.
4. As soon after fording as possible, take truck to organizational maintenance for lubrication and servicing. Be sure to tell organizational maintenance that truck has been used in fording operations.

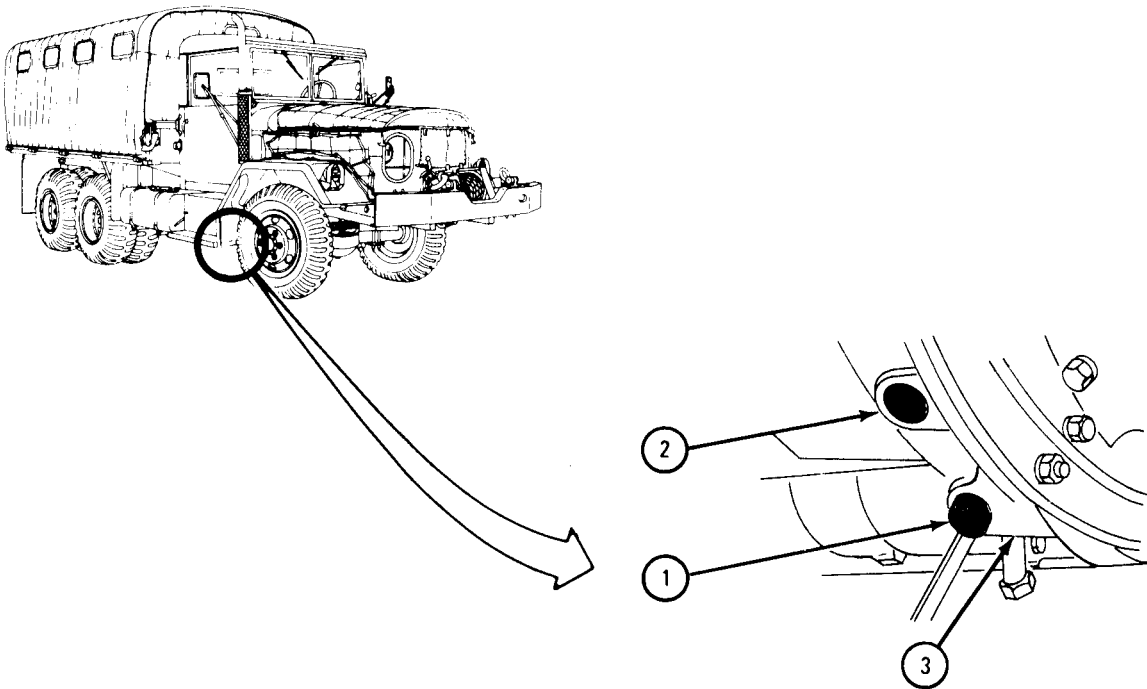

TA 045293



## 4-19. OPERATING THE ELECTRIC BRAKE KIT.

FRAME 1

**NOTE**

The electric brake kit is installed on trucks used to move trailers or semitrailers.

**WARNING**

Electric brakes on towed trucks operate when service brake pedal is pressed down, not when rheostat control handle (1) is turned. Make sure brakes work correctly at the number you set on the rheostat. Failure to make sure brakes work correctly may result in injury to personnel and damage to equipment.

1. Turn rheostat control handle (1) to setting shown on data plate (2).

**NOTE**

Exact setting needed for each load must be found by experience. Heavier loads need higher number setting.

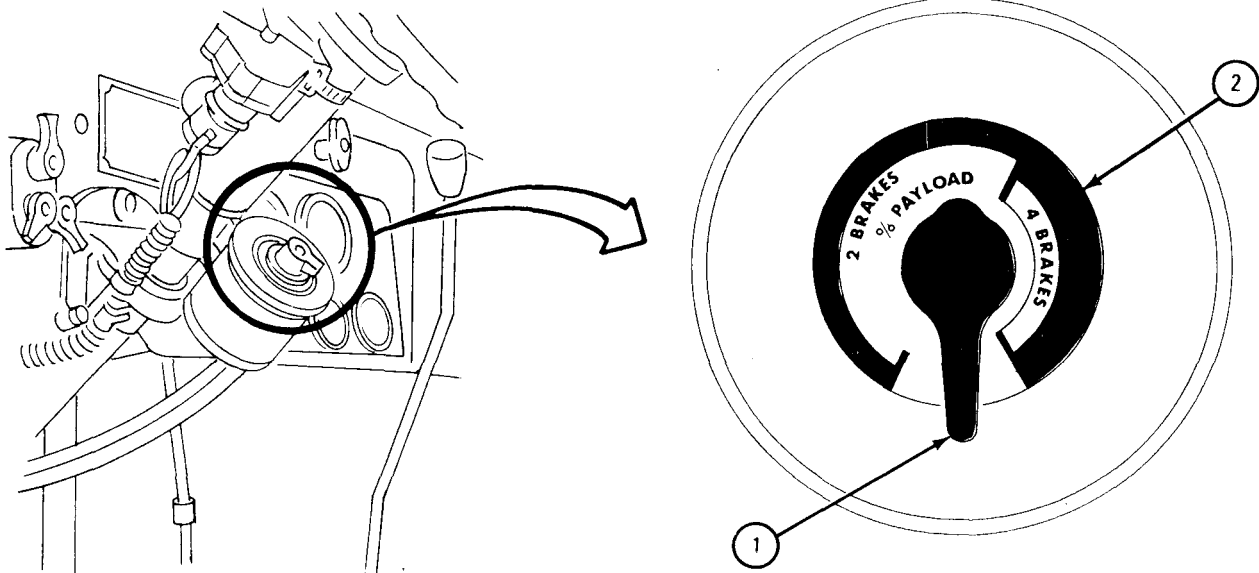

TA 045294

### SECTION III. OPERATION UNDER UNUSUAL CONDITIONS

4-20. SCOPE. Extremes of temperature, humidity and terrain conditions require special operating procedures. Instructions for operating under these unusual conditions are contained in this section.

a. Refer to FM 55-30 for instruction on driver selection, training and supervision.

b. Refer to FM 21-305 for special driving instructions for operation of wheeled trucks under unusual conditions.

4-21. GENERAL. When operating under unusual conditions, pay particular attention to all gages and indicators for signs of trouble.

4-22. OPERATION IN EXTREME COLD WEATHER.

a. General. Extreme cold weather will cause:

(1) Lubricants to thicken or get hard.

(2) Batteries to freeze and keep from supplying enough current for starting.

(3) Electrical insulation to crack and cause short circuits.

(4) Fuel not to vaporize and mix with air to form a combustible mixture, for starting, that will burn.

b. Related Publications. Refer to the following for information relating to operation of a truck in cold weather conditions.

FM 31-70 Basic Cold Weather Manual

FM 31-71 Northern Operations

FM 90-6 (HTF) Mountain Operations

FM 9-207 Operation and Maintenance of Army Materiel  
in Extreme Cold Weather (0° F to -65° F)

#### WARNING

FM 9-207 contains general information which applies to all Army materiel. This information must be considered part of this manual.

Approved practices and precautions must be followed for safe cold weather operation so that personnel will not be injured or equipment damaged.

c. Winterization Kits. Special winterization equipment is provided in kit form when protection against extreme cold (0° F to -65° F) is needed.

(1) Refer to para 4-16 for hot water personnel heater kit operating instructions.

(2) Refer to para 4-17 for arctic winterization kit operating instructions.

d. Moving the Truck.

FRAME 1

**CAUTION**

After shutdown for long periods of time, lubricants harden and brakes and tires may freeze fast. Take each condition into account before moving truck so that equipment will not be damaged.

**NOTE**

Check that PMCS that apply to operation in extreme cold weather have been done.

1. Start engine. (Refer to para 4-6 b), and let it warm up thoroughly.
2. Step on clutch pedal (1) and press it all the way down.
3. Place FRONT TRANSMISSION gearshift lever (2) in position 1.
4. Place TRANSFER CASE gearshift lever (3) to LOW (DOWN) position.
5. Let clutch pedal (1) up.
6. Drive truck at lowest speed possible for about 100 yards. Be careful not to stall engine. This should heat gears and tires for normal operation.
7. Stop engine. (Refer to para 4-6e.)

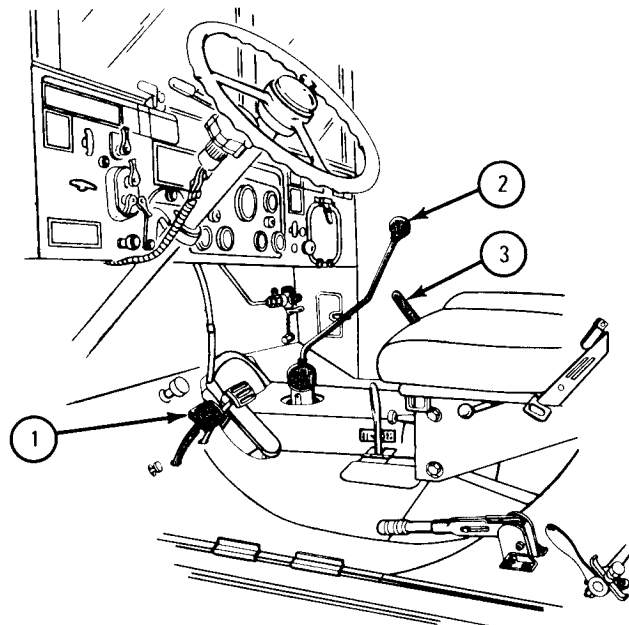

TA 045295

e. Parking.

(1) Park truck in a sheltered area out of the wind, where possible. If no shelter is available, park truck so that it does not face into the wind.

(2) Park truck on high dry ground, if possible. If high dry ground is not available, spread out planks or brush and put wheel chocks in place, if necessary.

(3) Park truck on level ground so that body does not twist.

(4) Place all control lever in neutral position to stop freezing in gear due to water condensation.

(5) In areas where temperatures reach -50°F or colder, put an extra 20 pounds of air (above normal) in tires for long standby periods or overnight. (Refer to volume 2, chapter 1, table 1-1.)

(6) Let the extra air out of tires before starting normal operations. Do not lower pressure when tires are hot.

(7) Turn power plant heater on. (Refer to para 4-17e.)

(8) If truck does not have an arctic kit, tell organizational maintenance to take batteries out. Store batteries in a warm place.

(9) The cooling system must be serviced and protected for temperatures below 32 °F. Refer to TM 9-750-651 and TM 9-207 for special procedures.

(10) If no approved antifreeze solution is available, tell organizational maintenance to drain radiator and block.

f. Refueling.

FRAME 1

**WARNING**

Authorized procedures must be used to get rid of drained fuel. Serious injury to personnel and damage to equipment may result if correct procedure is not used.

**NOTE**

Before refueling, tell organizational maintenance to drain fuel tank of any water.

1. Refuel immediately after operations to reduce condensation that may form in fuel tank.
2. Drain water from primary (1), secondary (2), and final (3) fuel filters before fuel system cools below freezing point (refer to TM 9-2320-209-10-2).

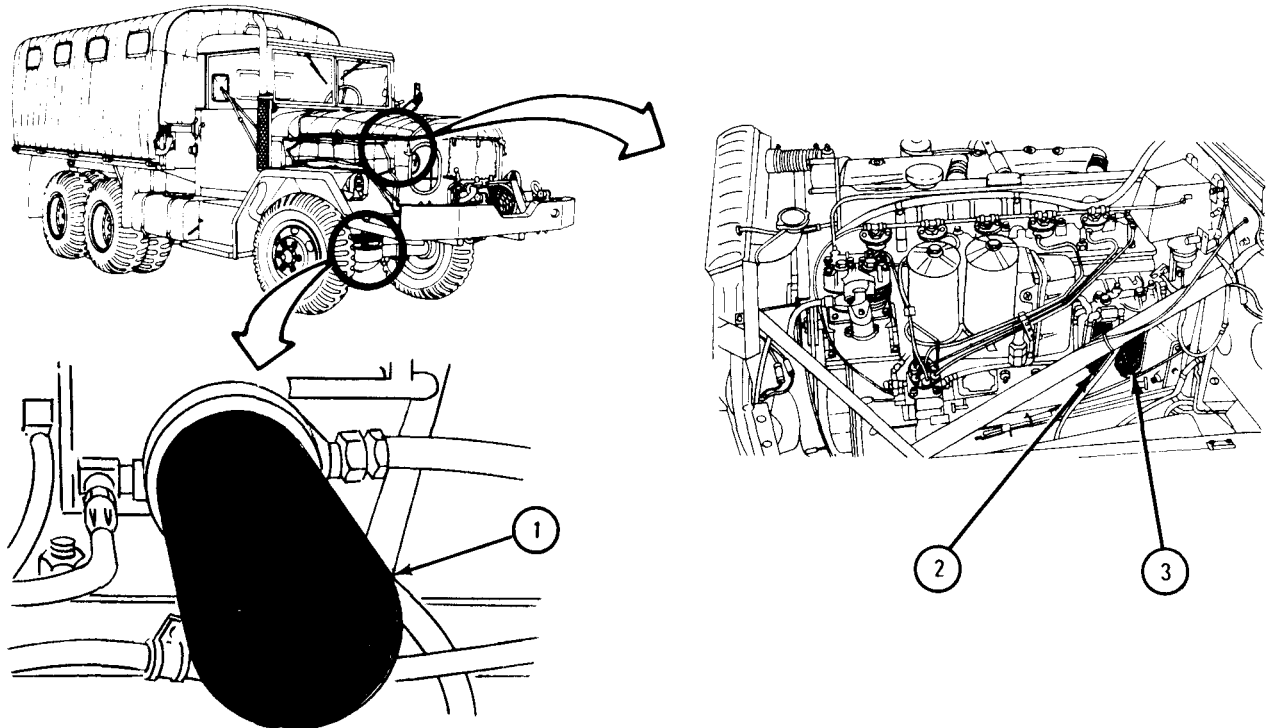

TA 045296

4-23. OPERATION IN EXTREME HOT WEATHER.

**WARNING**

When engine temperature is above 180° F use extreme care in taking off cooling system pressure cap so that you do not get burned/scalded. Turn cap one-half turn to left to relieve pressure before removing. Use a heavy rag or gloves to protect hands.

a. **General.** Continuous operation of truck at high speeds, or under long hard pulls in low gear ratios on steep grades or in soft terrain may cause engine to overheat. Try not to use low gear ratios for long periods, when possible. Always watch for overheating. Stop truck for a cooling-off period whenever necessary and tactical situation permits. If necessary, raise hood to help in cooling.

b. **Cooling System.** Scale and rust forms quicker in extremely high temperatures. Always add corrosion-inhibiter compound to cooling liquid. Don't use water that contains minerals. Fill radiator with rain water whenever possible. Refer to TM 750-651 for engine cleaning compound to be used.

(1) Check cooling system often, look for following:

- (a) Proper coolant level in radiator (refer to TM 9-2320-209-10-2).
- (b) Leaking hose connections
- (c) Proper fan belt tension (refer to TM 9-2320-209-10-2).
- (d) Cracked or leaking hose lines

(2) If truck is always overheating inspect and clean radiator fins with compressed air to get rid of sand, dust, and inspect.

(3) If engine still overheats tell organizational maintenance.

c. **Batteries.**

(1) In very hot zones, check level of electrolyte in battery cells daily. If they are low, add distilled water. If distilled water is not available, use rain or drinking water. Use of water with a high mineral content will damage batteries.

**NOTE**

The use of water with high mineral content will do less damage to a battery than letting electrolyte level drop below the plates. A battery left dry has a short life.

(2) A battery will discharge faster if left standing for long periods at high temperatures. If necessary to park for several days, tell organizational maintenance to take out batteries and store them in a cool place.

d. **Body and Chassis.** In hot, damp climates, corrosion takes place quickly, especially during rainy seasons. Check often for the following:

- (1) Signs of pitting or paint blistering on metal surfaces.
- (2) Signs of mildew, mold or fungus on fabrics, rubber and glass.

If you find signs of any of these, tell organizational maintenance.

e. Parking the Truck.

(1) Do not park truck in the sun for long periods; heat and sunlight will shorten the life of tires. When possible, park under cover to keep truck from sun, sand, and dust.

(2) Cover trucks not being used with paulins if no other suitable shelter is available. When entire truck cannot be covered, cover window glass to stop etching of glass by sand, and cover engine compartment to keep out sand.

(3) Check that tires are properly inflated. (Refer to table 2-5.)

**NOTE**

When checking tire pressure, do not let out air if tire is hot.

4-24. OPERATION ON UNUSUAL TERRAIN.

a. Deep Snow or Mud.

(1) Choose a FRONT TRANSMISSION position low enough to keep engine speed above recommended minimum speed (rpm) without making the wheels spin.

(2) Take care to keep spinning wheels from becoming buried up to the axle housing.

**CAUTION**

Do not lower tire pressure enough to damage equipment. Refill tires to recommended pressure after emergency.

(3) If necessary, lower tire pressure. (Refer to table 2-5.)

**CAUTION**

Do not drive with chains on only one wheel of a driving axle. This may result in damage to the tire and/or power train.

(4) Tire chains should be used at all times when driving in deep snow, mud, or soft sand.

**WARNING**

Do not jam sticks or stones under a spinning wheel. This can cause injury to personnel or unnecessary tire wear.

(5) If one or more tires become stuck, use another truck to tow or winch the stuck truck. If a truck is not available jack up stuck truck and put planking or matting under the wheel.

(6) After operating truck on muddy or snowy surfaces, clean ice, snow or mud from wheels, axles, radiator core, engine compartment steering knuckles and arms, air cleaner intake, and electrical connections.

b. Hard Baked Sand. When driving on hard baked sand, try not to break through the crust. A roadbed of canvas or planking should be set down for short distances.

c. Ice.

(1) General. Skidding and loss of steering control are the main troubles found when driving on icy roads. Due to lack of traction, the truck may continue in a straight direction no matter which way you turn the wheels. When the wheels reach a point where you get traction back the truck may veer sharply to left or right or stall.

(2) Skidding. When the rear end of the truck skids to either right or left, instantly turn the front wheels in the same direction in which the rear end is skidding. Take your foot off the accelerator pedal but do not step down on the clutch pedal. Pump down on brakes lightly.

d. Dusty or Sandy Roads.

(1) When operating truck on dusty or sandy terrain, clean air filter daily. (Refer to TM 9-2320-209-10-4.)

e. Rocks and Boulders.

**CAUTION**

Too much pressure in tires will cause more shock through the moving truck. Not enough pressure in tires can cause internal breaking of the tires or damage to the tube.

(1) Refer to table 2-5 and inflate tires properly.

(2) Check tire pressure when tires are cold.

(3) Do not let out air when tires are hot.

f. High Altitudes.

(1) High altitude operation requires careful maintenance of the cooling system. As you go to a higher altitude, the boiling point of your coolant will become lower. The pressurized cooling system of your truck will operate at 220° F when taken care of in the right way.

(2) Check all hose connections for leaks daily and be sure that radiator cap is closed properly.

4-25. FORDING OPERATION.

a. General. Your truck can ford bodies of water up to a depth of 30 inches without the use of special equipment. Special kits are available for deep water fording. (Refer to para 4-18.)



b. Fording.

TOOLS: Straight bar plug wrench  
Ratchet wrench

## FRAME 1

1. Make sure that water is not deeper than 30 inches.
2. Using a straight bar plug wrench and ratchet handle, unscrew flywheel housing drain plug (1) from storage boss (2).
3. Screw drain plug (1) into drain port (3).

GO TO FRAME 2

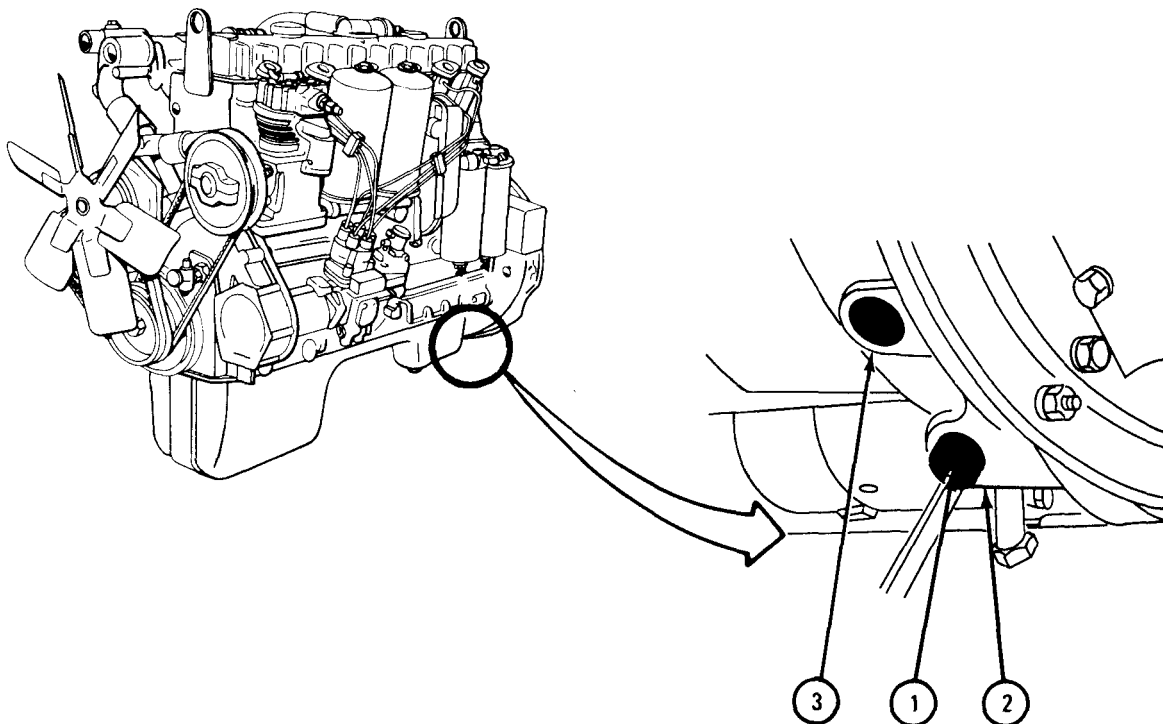

TA 045289

FRAME 2

1. Start engine, refer to para 4-6b, and make sure it is operating right.

**WARNING**

Limit speed to 3 to 4 miles per hour while fording. Do not try to ford your truck at depths greater than 30 inches.

2. Step on clutch pedal (1) and press it all the way down.
3. Place FRONT TRANSMISSION gear shift lever (2) in position 1.
4. Push TRANSFER CASE gearshift lever (3) to LOW DOWN position.
5. Let clutch pedal (1) up.
6. Enter water slowly.

**WARNING**

Do not rely on brakes until they dry out. After fording, remove water from brake lining by pressing and letting go of brake pedal. Keep stepping down and letting go of brake pedal until truck stops without grabbing.

7. Complete fording without stopping. Avoid too much use of clutch.
8. Stop engine. (Refer to para 4-6e.)

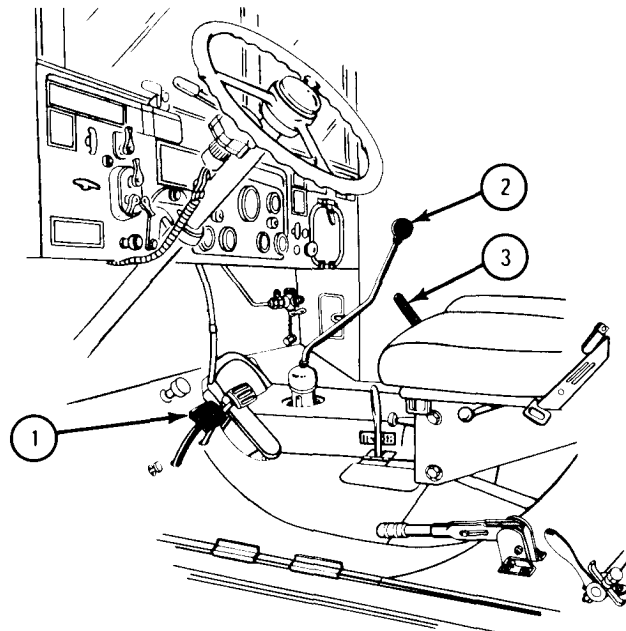

TA 045295

c. Fording, Water Tank Trucks.

## FRAME 1

1. Before fording, open rear compartment doors and drain delivery lines, manifold pipes and delivery pump.
  - (a) Push 400 gallon and 600 gallon compartment levers (1) forward to closed position.
  - (b) Turn to left and take dust covers (2) off of delivery line discharge and suction valves (3).
  - (c) Turn delivery line discharge and suction valve knobs (4) left all the way, to open valves.

GO TO FRAME 2

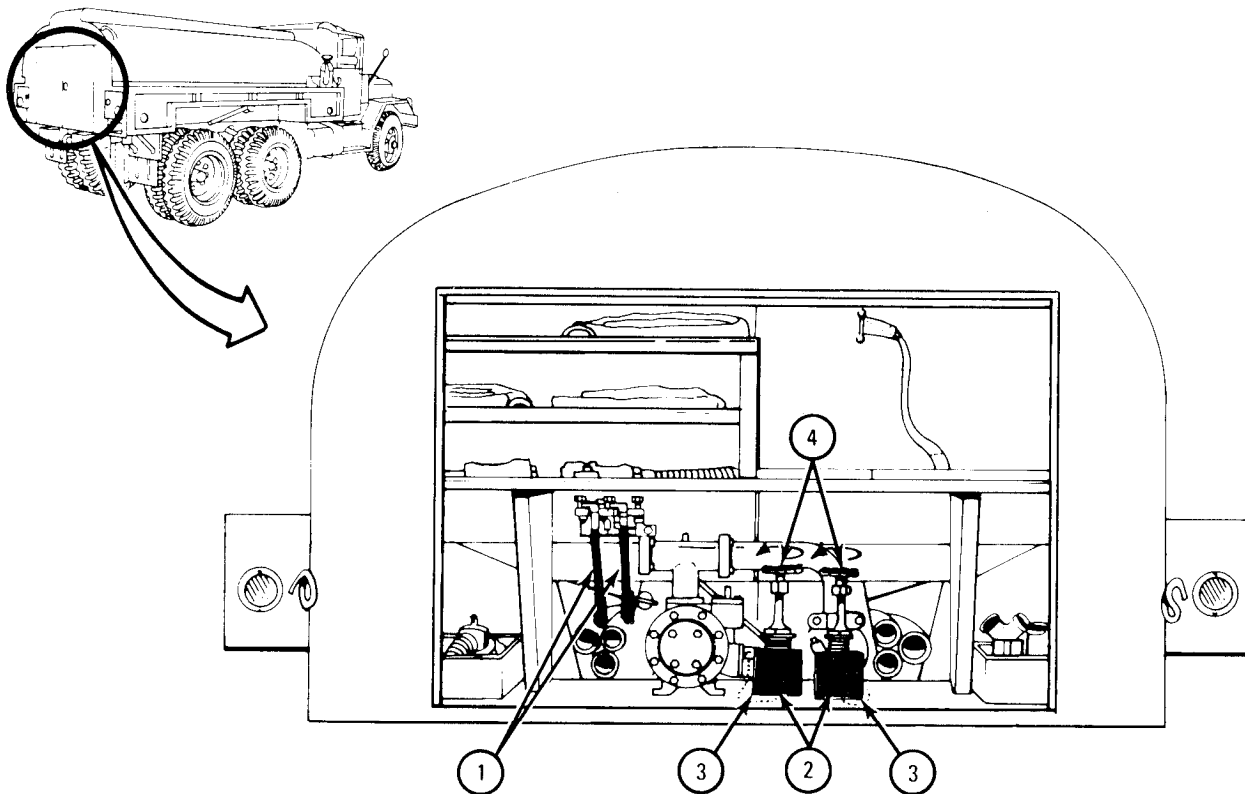

TA 045298

FRAME 2

1. Start engine. (Refer to para 4-6b.)
2. Press down on clutch pedal (1) and place TRANSFER CASE gearshift lever (2) in neutral position.
3. Turn locking bar (3) and pull transfer POWER TAKEOFF LEVER (4) back to on position.
4. Place FRONT TRANSMISSION gearshift lever (5) in position 2.
5. Let clutch pedal (1) up.
6. Pull hand THROTTLE (6) out to run engine at 1100 RPM for 60 seconds.
7. Turn hand THROTTLE (6) and put it in.

GO TO FRAME 3

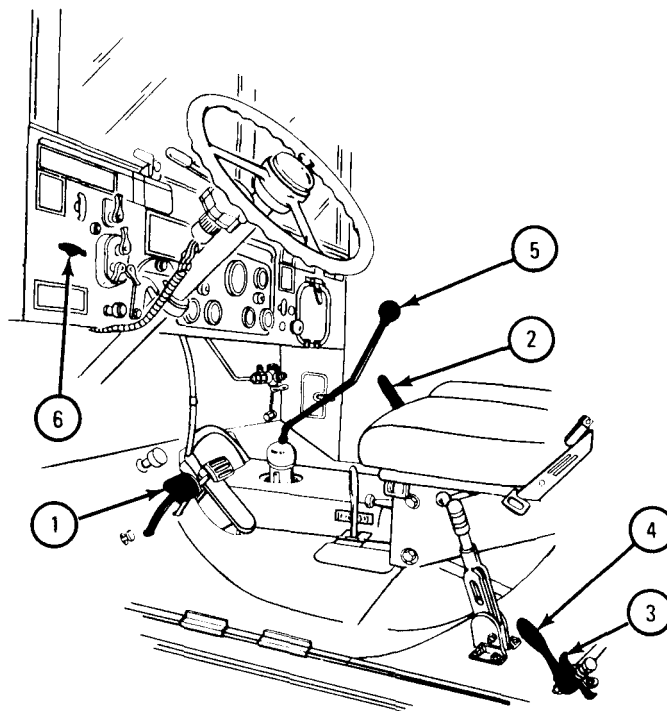

TA 045299

## FRAME 3

1. Put dust covers (1) onto delivery line discharge and suction valve adapters (2), turn right to tighten.
2. Turn delivery line discharge and suction valve knobs (3) right all the way to close valves.
3. Close and lock rear compartment doors (4).

GO TO FRAME 4

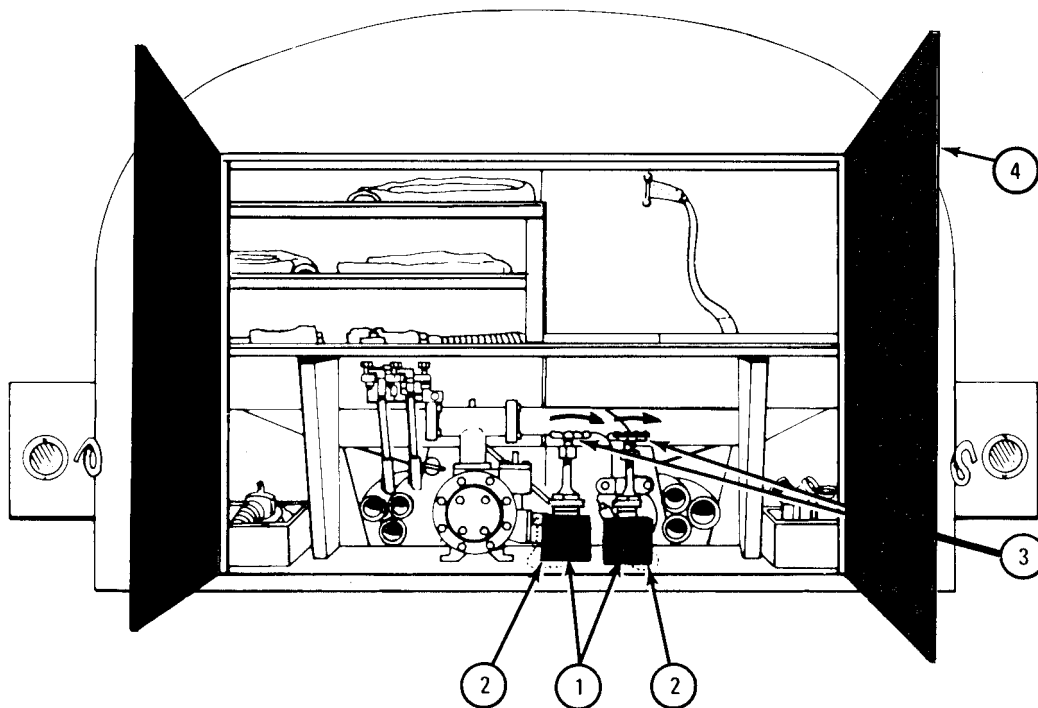

TA 045310

FRAME 4

1. Turn exhaust bypass fording valve (1) right, all the way, to closed position.
2. Before fording refer to para 4-25b, frames 1 and 2.

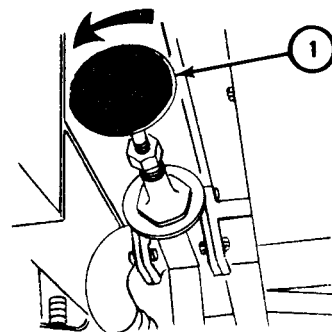
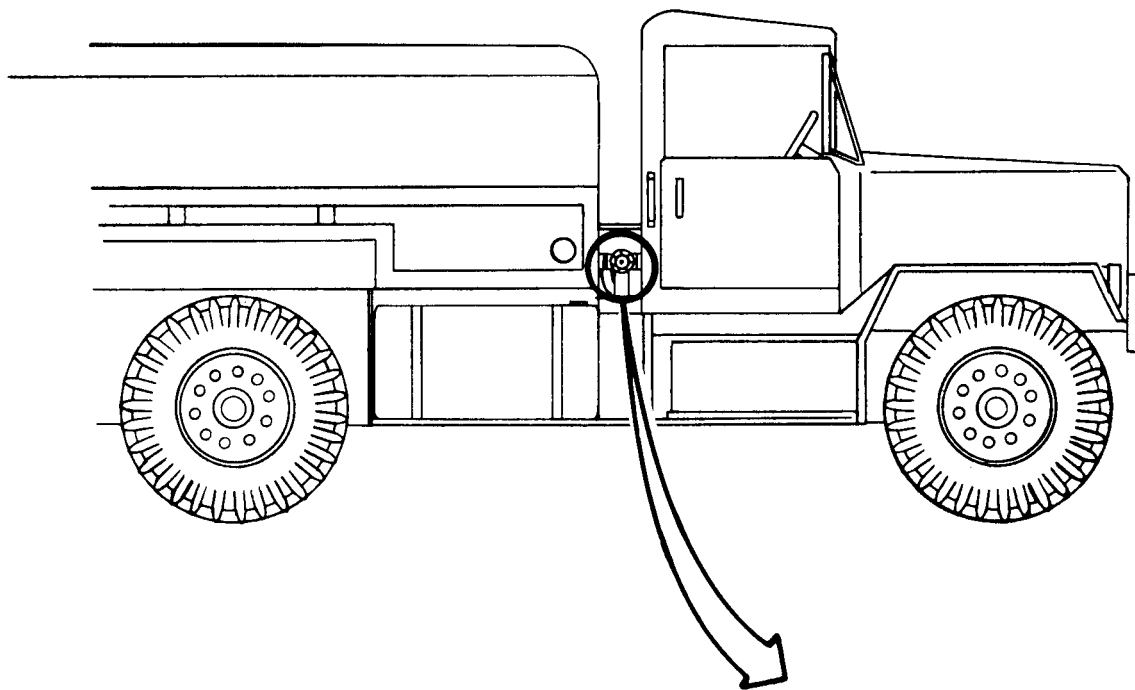

TA 045174

d. After Fording.

TOOLS: Straight bar plug wrench  
Ratchet wrench

## FRAME 1

1. Dry brakes out by stepping down and letting go of brake pedal until truck stops without grabbing.
2. Stop vehicle and shut down engine. (Refer to para 4-6e.)
3. Using a straight bar plug wrench and ratchet handle, unscrew drain plug (1) from flywheel housing drain port (2).
4. Screw drain plug (1) into storage boss (3).

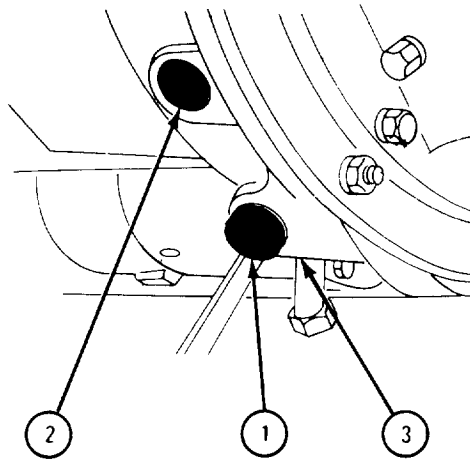

TA 045311

e. Care of Vehicle After Fording.

(1) Clean all surfaces that have been in the water. Coat all unpainted metal parts with engine lubricating oil (OE).

(2) When necessary return to organizational maintenance for paint touch up.

**NOTE**

Salt water fording causes rust, especially on unpainted surfaces. Clean salt water and salt deposits from all parts of truck as soon as possible. Deliver truck as soon as possible to direct support maintenance regardless of maintenance done.

f. Accidental Submersion. If truck is accidently submerged in water deeper than 30 inches do the following:

(1) Salvage truck.

(2) Preserve truck temporarily.

(3) As soon as possible, send truck to direct support maintenance for complete maintenance.



## 4-26. EMERGENCY PROCEDURES.

- a. Using Slave Receptacle to Start the Engine. (Refer to para 4-17f.)
- b. Using Jumper Cables to Start the Engine.

TOOLS: Jumper cables

## FRAME 1

1. Position slave truck so that its batteries (1) are directly opposite batteries (2) of disabled truck.
2. Stop engine. (Refer to para 4-6e.)

GO TO FRAME 2

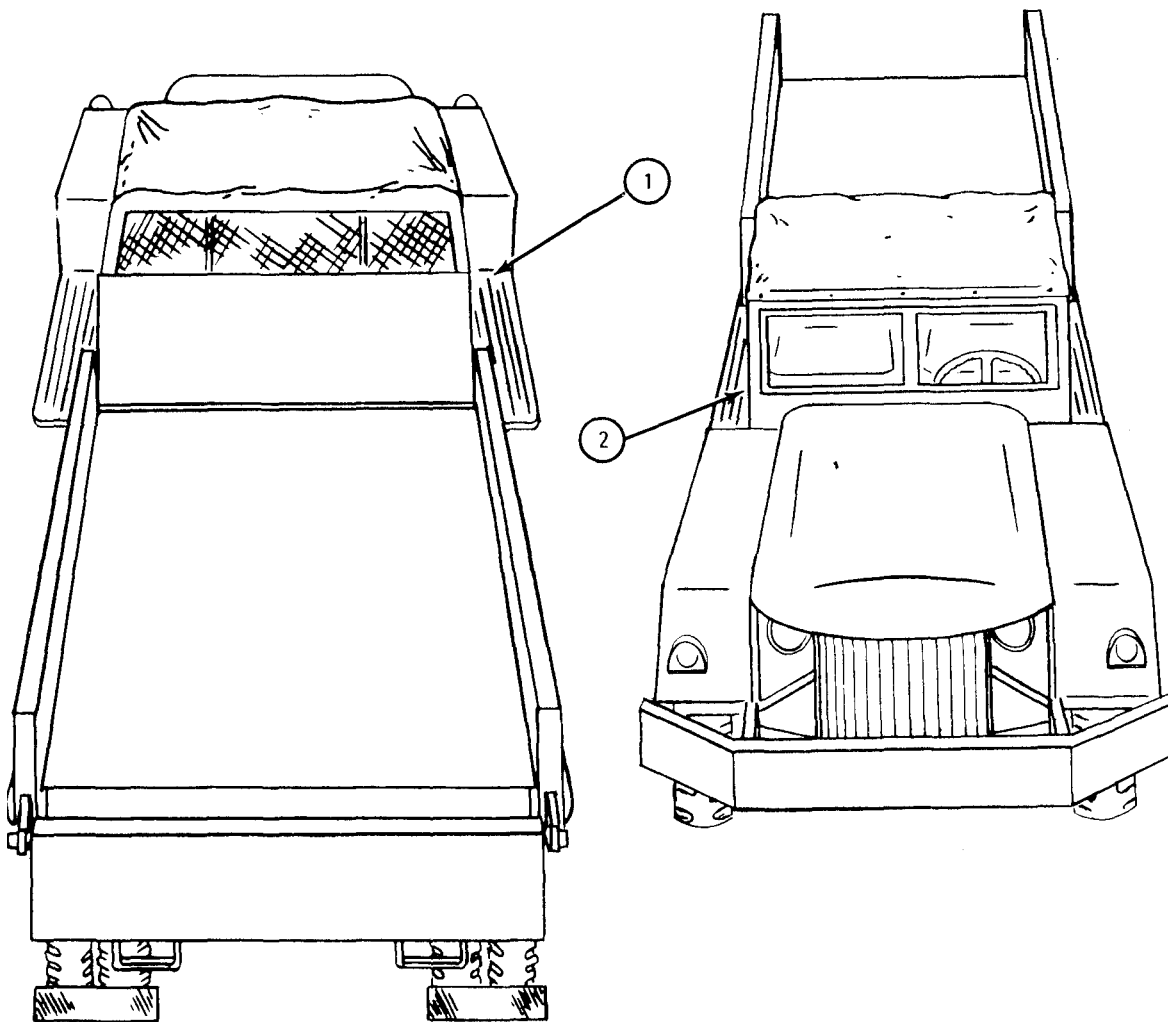

FRAME 2

1. Open battery compartment doors (1) of both trucks.
  2. Loosen thumbscrews (2).
  3. Move clamps (3) as far as they go to the right.
- GO TO FRAME 3

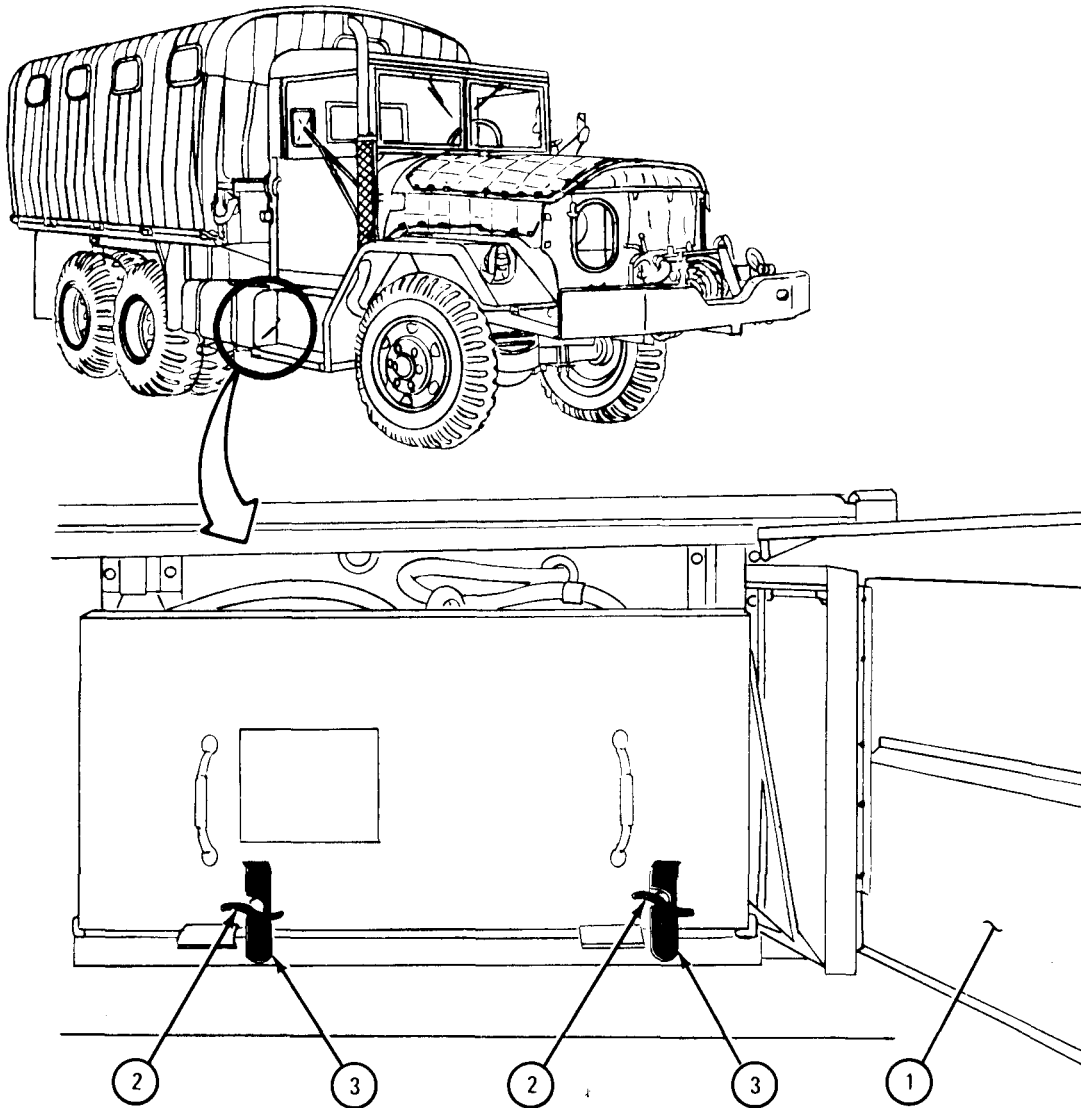

TA 044911

## FRAME 3

1. Pull battery boxes (1) of both trucks out far enough for battery posts to be reached.

**CAUTION**

Be sure to connect positive post of disabled truck to positive post of slave truck, and negative post of disabled truck to negative post of slave truck. This will prevent damage to alternator and other equipment.

2. Clamp one end of positive (red) jumper cable (2) to positive battery post (battery B) of disabled truck. Clamp other end to positive battery post (battery B) of slave truck.
3. Clamp one end of negative (black) jumper cable (3) to negative battery post (battery A) of disabled truck. Clamp other end of jumper cable (3) to negative battery post (battery A) of slave truck.

GO TO FRAME 4

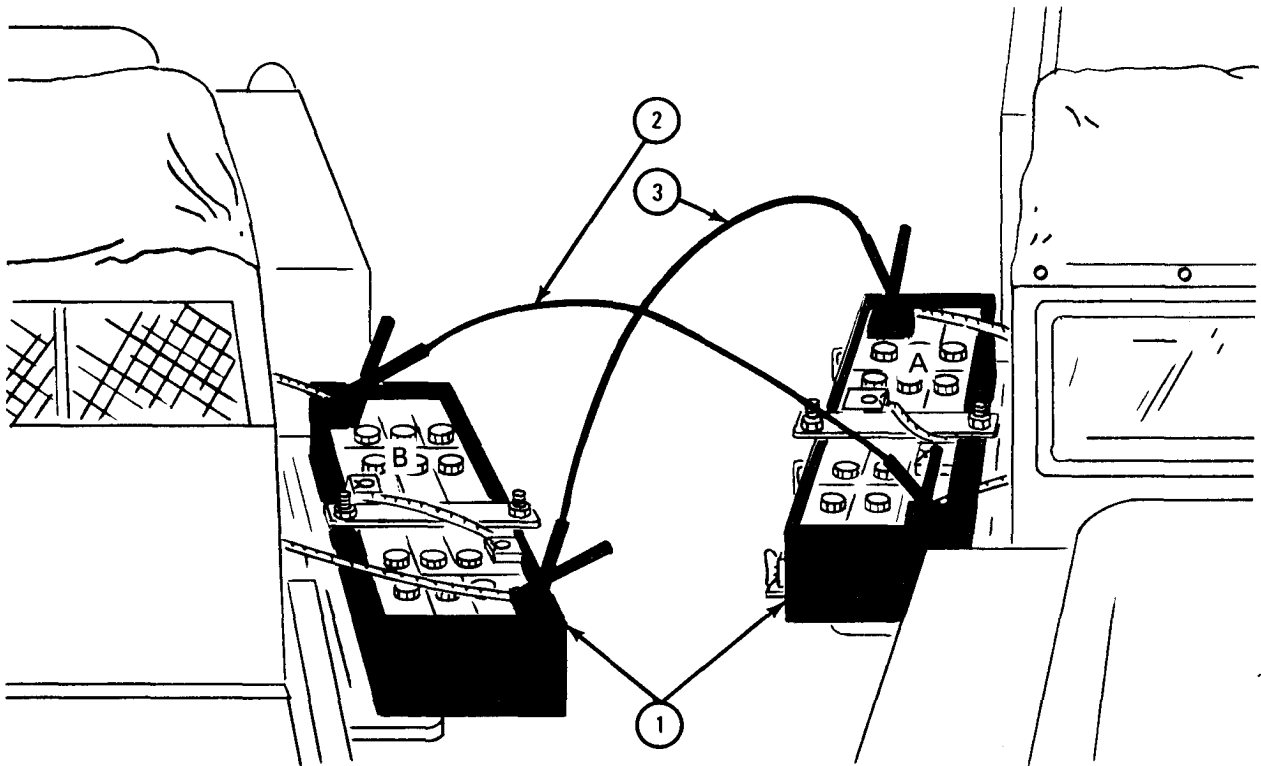

TA 044912

FRAME 4

1. Start engine of slave truck. (Refer to para 4-6b.)
2. Start engine of disabled truck. (Refer to para 4-6e.)

**NOTE**

If engine of disabled truck does not start after three or four tries, notify organizational maintenance.

**CAUTION**

Completely remove one jumper cable at a time to prevent contact of positive (red) and negative (black) ends of cables. Shorting of battery can cause serious damage to alternator.

3. Remove jumper cables (1).
4. Push battery boxes (2) back into place.
5. Secure battery boxes (2) with clamps (3) and thumbscrews (4).
6. Close battery compartment doors.

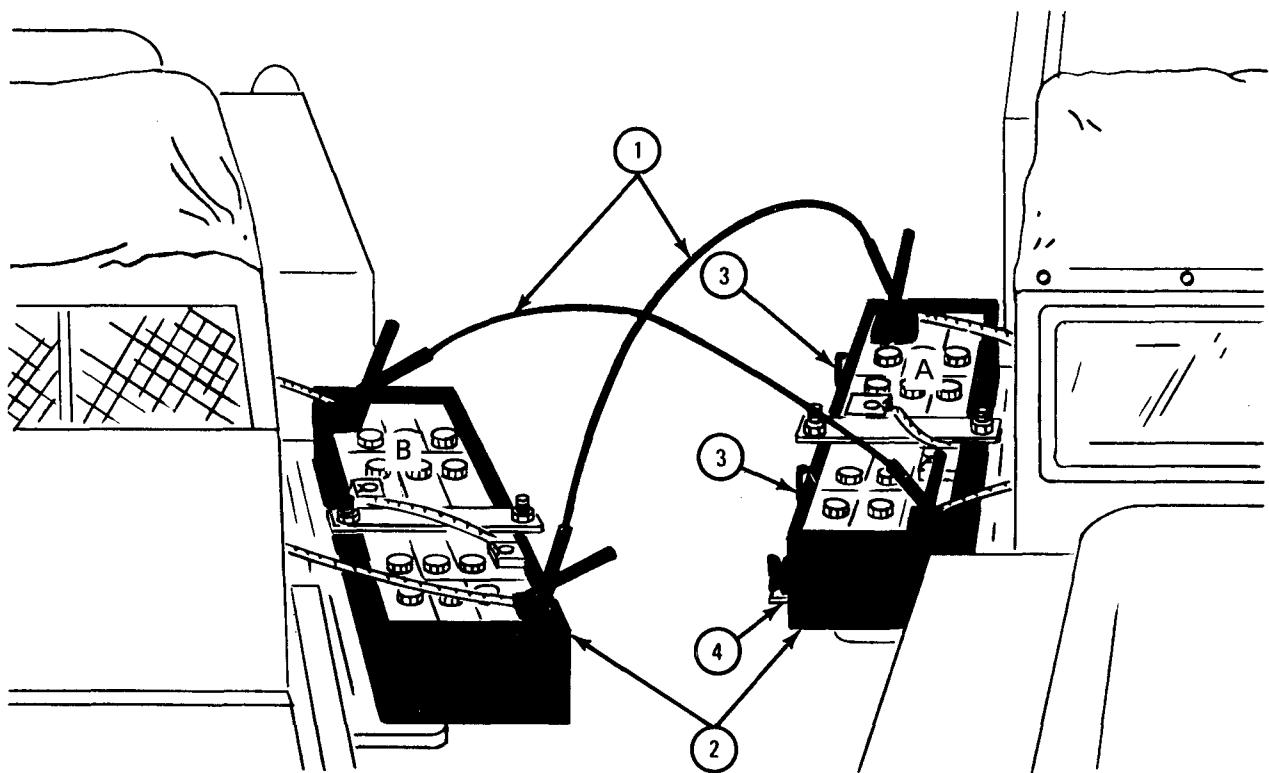

TA 044913

c. Towing the Truck to Start Engine.

PERSONNEL: Two

FRAME 1

**CAUTION**

Do not try to tow a disabled truck with two chains wrapped around center of bumper. This may cause damage to bumper.

Be sure that service brakes are operating properly before towing.

**NOTE**

Approval from maintenance officer must be obtained before towing your truck to start engine.

1. Hook each end of tow chain (1) to lifting shackles (2) of truck to be towed. Chain should be long enough for both trucks to be able to move around.
2. Slip center of tow chain into pintle (3) of towing truck.

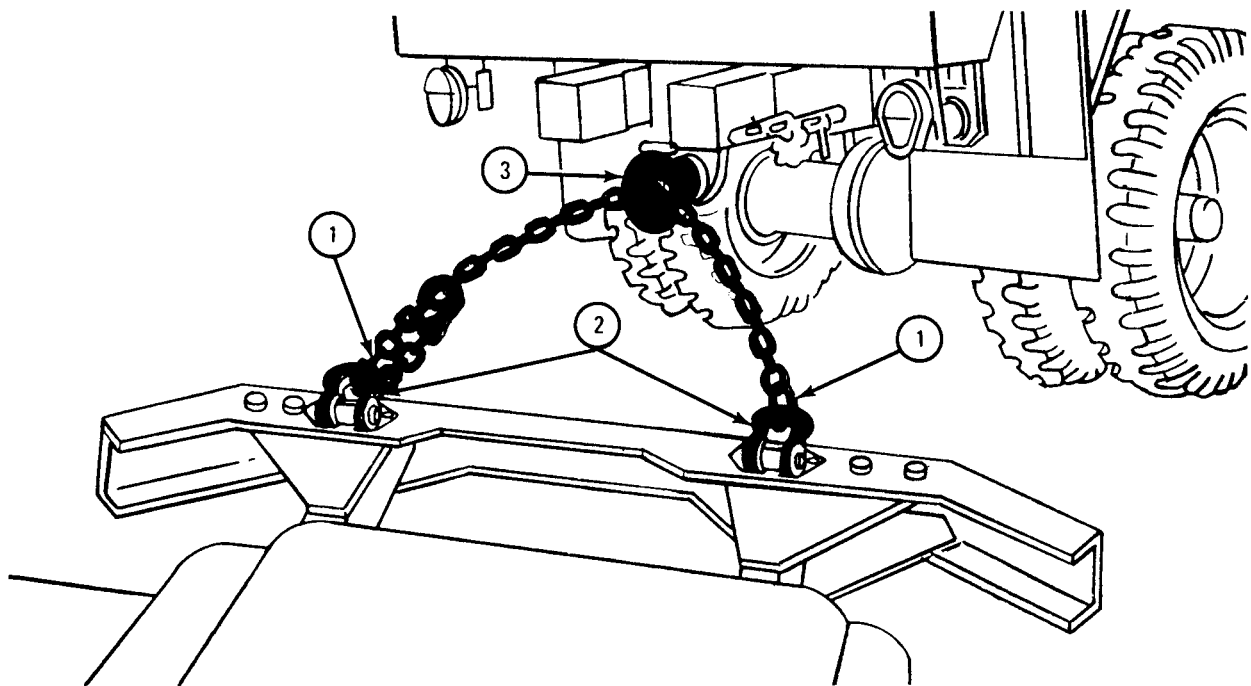

TA 044914

FRAME 2

**NOTE**

Steps 1 through 9 are done on the towed (disabled) truck.

1. Step on clutch pedal (1) and press it all the way down.
2. Place TRANSFER CASE gearshift lever (2) in HIGH UP position.
3. Place FRONT TRANSMISSION gear shift lever (3) in position 5.
4. Let clutch pedal (1) up.
5. Push ENG. STOP control (4) all the way in.
6. Pull hand THROTTLE (5) out three-fourths of an inch.
7. Turn ACCESSORY switch (6) to ON position.
8. Step down on service brake pedal (7) to keep truck from coasting.
9. Push handbrake (8) down to off position.
10. Step down on clutch pedal (1) all the way.

GO TO FRAME 3

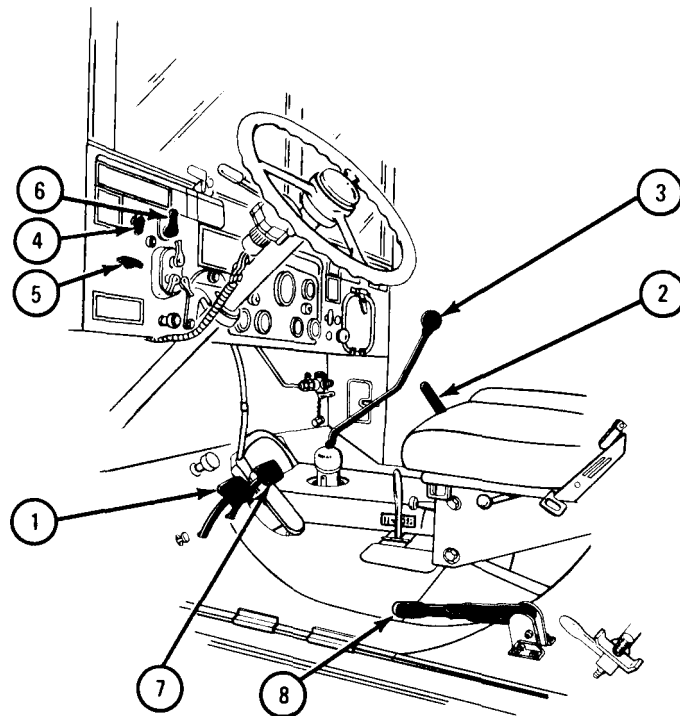

TA 044915

## FRAME 3

**NOTE**

Steps 1 through 7 are done on the towed (disabled) truck.

1. As soon as towing begins, let service brake pedal (1) up.
2. Hold clutch pedal (2) in until truck speed reaches 10 miles per hour.
3. Let clutch pedal (2) up slowly and operate accelerator pedal (3) as necessary.

**NOTE**

For cold weather starting, move MANIFOLD HEATER switch (4) to ON position as soon as clutch pedal (2) is up.

4. When engine starts, step down on clutch pedal (2).
5. Put FRONT TRANSMISSION gearshift lever (5) to N position.
6. Bring truck to a stop.
7. Release clutch pedal (2).

**NOTE**

During cold weather turn MANIFOLD HEATER switch (4) ON and OFF until engine is warm.

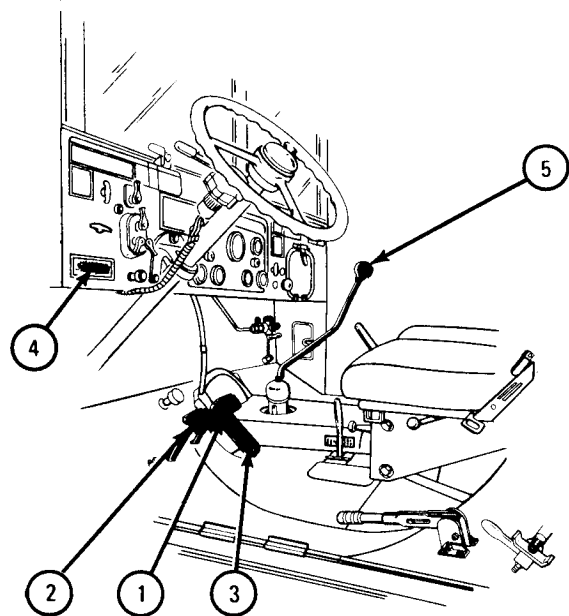

TA 044916

d. Highway Towing (M44A2 Series Trucks).

TOOLS : Tow Bar  
Pliers

FRAME 1

CAUTION

Do not tow a truck that has become disabled because of a damaged transfer, axle or transmission. Tell direct support maintenance.

Do not try to tow with front or rear wheels off the ground. Tell direct support maintenance.

Do not push a disabled truck. Use towing procedure only.

1. Using pliers take cotter pins (1) from right and left shackle retainer pins (2) on front bumper (3) of truck to be towed.
2. Take off retainer pins (2) and lifting shackles (4).
3. Install tow bar (5) on lifting shackle brackets (6) with retainer pins (2) and cotter pins (1).
4. Install tow bar (5) ring on pintle hook (7) of towing vehicle.

GO TO FRAME 2

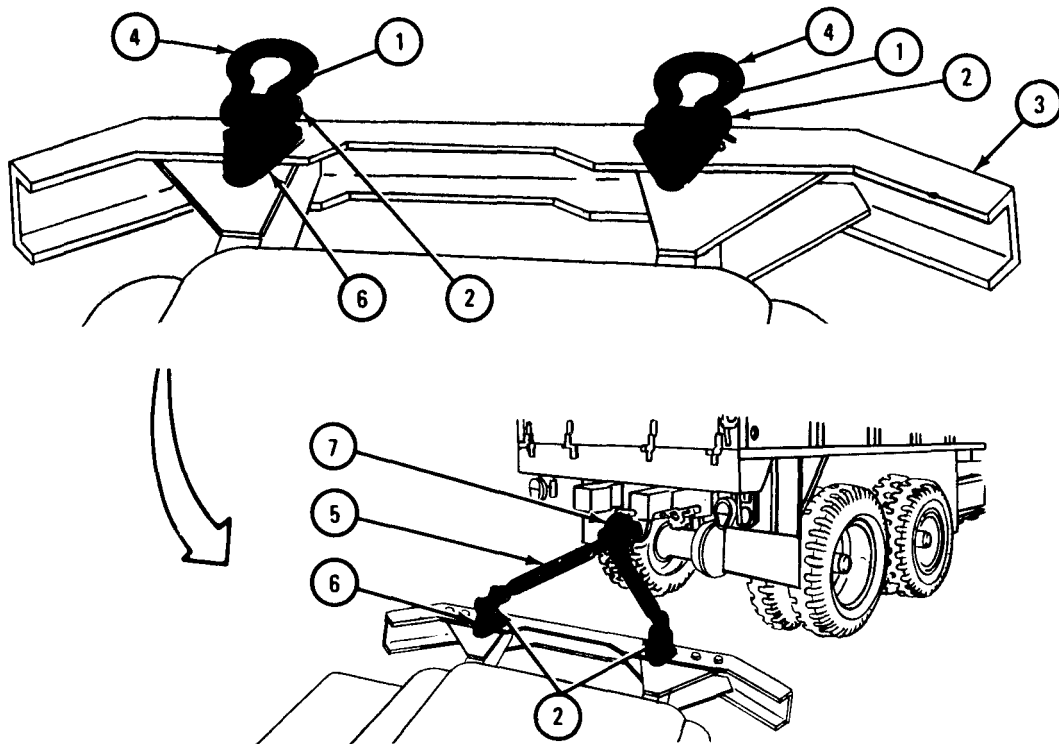

TA 044917



## FRAME 2

1. Step on clutch pedal (1) and press it all the way down.
2. Place TRANSFER CASE gear shift lever (2) in neutral (mid) position.
3. Place FRONT TRANSMISSION gearshift lever (3) to N position.
4. Let clutch pedal (1) up.
5. Set handbrake (4) free (down position).
6. Tow truck following procedure given in para 4- 26c.

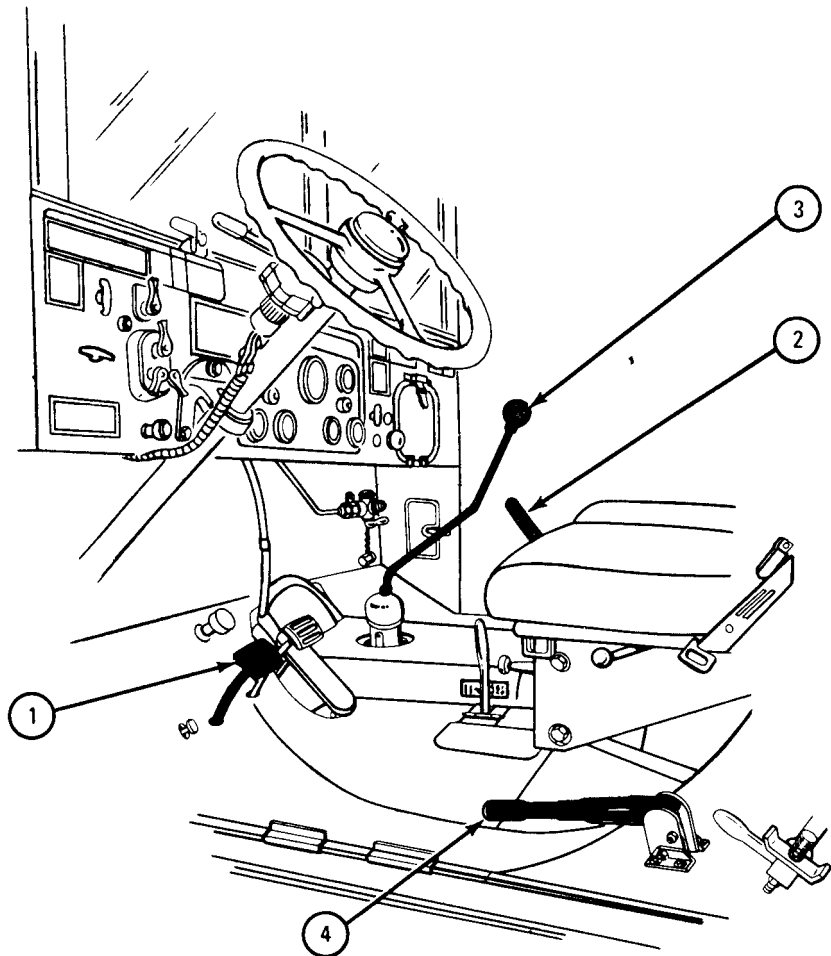

TA 044918

e. Highway Towing (M44A1 Series Trucks).

FRAME 1

**CAUTION**

M44A1 series trucks are equipped with a sprag unit (over-spinning clutch). In order to prevent damage to the drive train, the following procedure must be followed closely.

1. Mark one corner of mating flanges (1) of front axle drive shaft (2) at front axle with paint.
2. Mark one corner of mating flanges (3) of front axle drive shaft (2) at transfer case with paint.
3. Take out four bolts (4) from each end. Store drive shaft and connecting hardware with truck.

GO TO FRAME 2

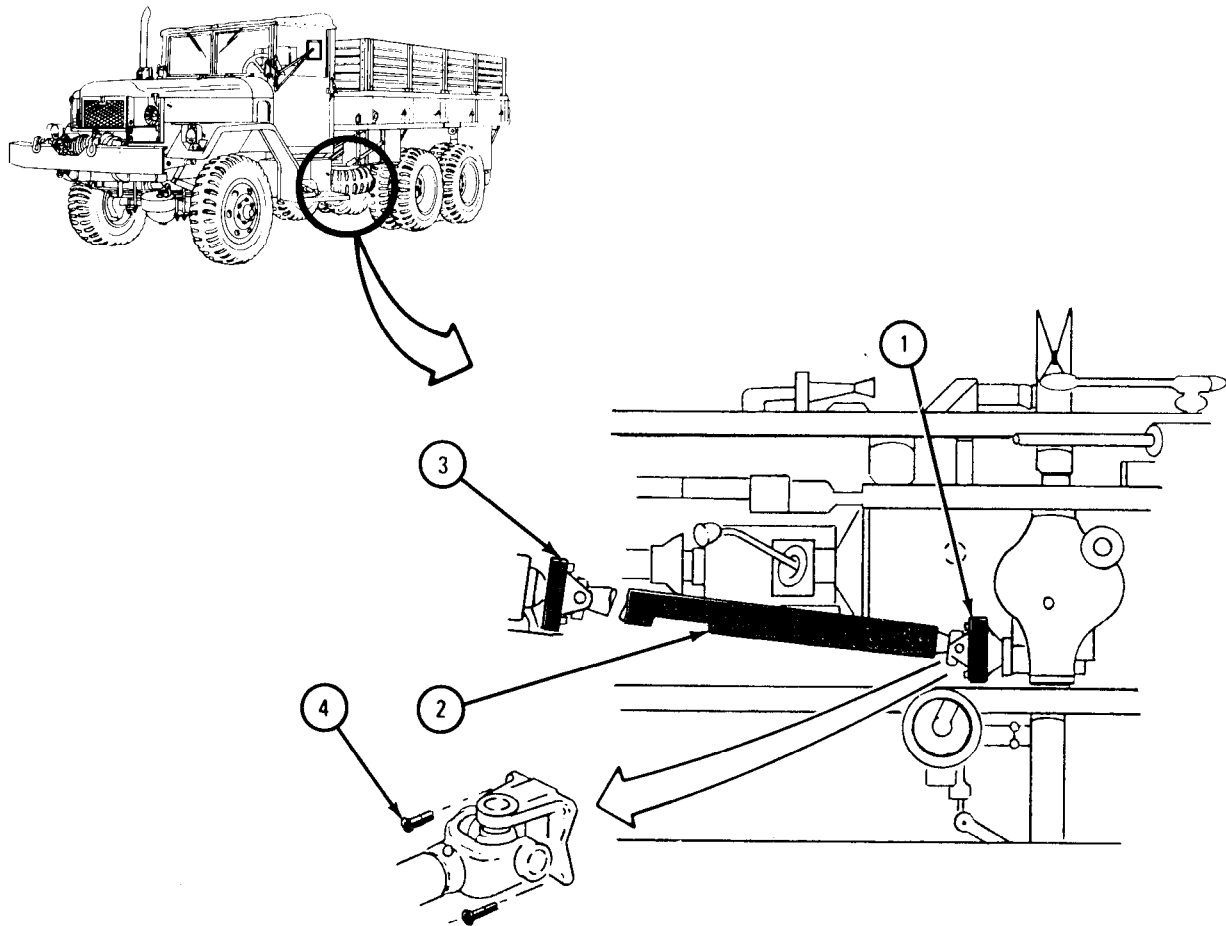

TA 044919

## FRAME 2

1. Match mark on corner of mating flanges (1) of forward rear axle drive shaft (2) and forward rear axle.
2. Take out four bolts (3) and separate drive shaft (2) from axle.
3. Tie down loose end of drive shaft (2) to frame crossmembers (4) so it will not loosen during towing.
4. Tow truck following procedure given in para 4-26c.

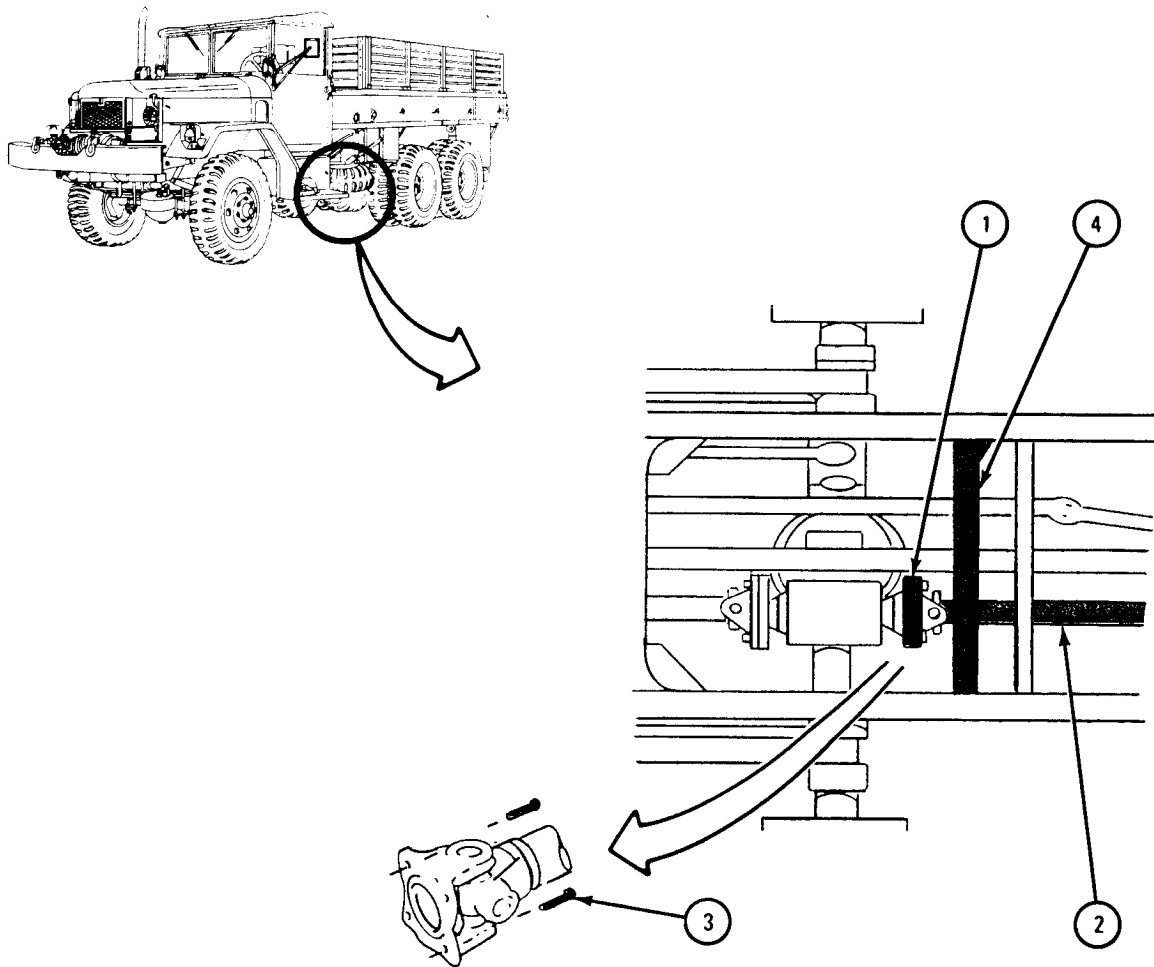

TA 044920



## APPENDIX A REFERENCES

---

**A-1. PUBLICATION INDEXES and GENERAL REFERENCE.**

Indexes should be checked often for the latest changes or revisions of references given in this appendix and for new publications on materiel covered in this technical manual.

**a. Military Publications Indexes.**

Index of Blank Forms . . . . . DA Pam 310-2

Military Publications:

Index of Technical Manuals, Technical  
Bulletins, Supply Bulletins, and  
Lubrication Orders . . . . . DA Pam 310-4

**b. General Reference.**

Authorization Abbreviations and Brevity  
Codes . . . . . AR 310-50

Dictionary of United States Army Terms . . . . . AR 310-25

**A-2. FORMS.**

The following forms are for this materiel (refer to DA Pamphlet 310-2 for index of blank forms and to TM 38-750 for explanation of their use).

Recommended Changes to Publications and Blank Forms .. DA Form 2028

Maintenance Request - Continuation Sheet . . . . . DA Form 2407-1

Equipment Log Assembly (Records) .. . . . . DA Form 2408

**A-3. OTHER PUBLICATIONS.**

**a. Truck.**

Lubrication Order . . . . . LO 9-2320-209-12/1

Organizational Maintenance Manual  
(Multifuel Engine) . . . . . TM 9-2320-209-20-1  
-2, -3

b. General.

Basic Cold Weather Manual . . . . .	FM 31-70
Northern Operations . . . . .	FM 31-71
Mountain Operations . . . . .	FM 490-6
Security of Tactical Wheeled Vehicles . . . . .	TB 9-2300-422-20
Use of Antifreeze Solutions and Cleaning Compounds in Engine Cooling Systems . . . . .	TB 750-651
Operation and Maintenance of Ordnance Materiel in Cold Weather (0° to -65 °F) . . . . .	FM 9-207
Deep Water Fording . . . . .	TM 9-238
Petroleum Tank Vehicle Operation . . . . .	FM 10-71
Driver Selection and Training (Wheeled Vehicles) . . . . .	FM 55-30
Drivers Manual, Wheeled Vehicle . . . . .	FM 21-305
Army Maintenance Management System . . . . .	TM 38-750
Route Reconnaissance and Classification . . . . .	FM 5-36

## APPENDIX B

### COMPONENTS OF END ITEM LIST

---

#### Section I. INTRODUCTION

B-1. SCOPE. This appendix lists integral components of and basic issue items for the 2 1/2-ton, 6 x 6, M44A1 and M44A2 series trucks (multifuel) to help you find items needed for safe and efficient operation.

B-2. GENERAL. This Components of End Item List is broken down into the following sections:

- a. Section II. Integral Components of the End Item. These items, when put on the truck, are part of the truck and must go with it whenever it is moved to another site or turned in. The illustrations will help you find these items.
- b. Section III. Basic Issue Items. These are the minimum basic items needed to place the truck in operation, to operate it, and to do emergency repairs. Although packed and shipped separately, they must go with the truck during operation and whenever it is turned over to another accountable officer. The illustrations will help you with hard-to-find items. This manual is your authority to order replacement BII, based on TOE/MTOE authorization of the end item.

B-3. EXPLANATION OF COLUMNS.

- a. Illustration. This column is broken down as follows:
  - (1) Figure Number. The number of the illustration on which the item is shown.
  - (2) Item Number. The number of the item called out in the illustration.
- b. National Stock Number. The National Stock Number given to the item which will be used to order the item.
- c. Part Number. The primary number used by the manufacturer which controls the design and characteristics of the item by means of its engineering drawings, specifications, standards, and inspection requirements to pin point the item or range of items.
- d. Description. Gives the Federal Item Name and, if needed, a minimum description of the item.
- e. Location. The location on the truck of each item listed is given in this column.

- f. Usable on Code. Usable On codes are given to help you find which component items are used on the different models. The codes used in these lists are as follows:

<u>Code</u>	<u>Used On</u>
A	All trucks
AA	All trucks w/winch
AB	Model M35A1
AC	Model M35A2
AD	Model M35A2C
AE	Model M36A2
AF	Model M49A1C
AG	Model M49A2C
AH	Model M50A1
AI	Model M50A2
AJ	Model M50A3
AK	Model M109A2
AL	Model M109A3
AM	Model M185A2
AN	Model M185A3
AO	Model M275A1
AP	Model M275A2
AR	Model M342A2
AS	Model M756A2
AT	Model M764



- g. Quantity Required (Reqd Qty). This column lists the quantity of each item needed for a complete major item.
- h. Quantity. This column is left blank and is to be used during an inventory. In the Rev' d column, list the quantity you actually get on your major item. The Date columns are for your use when you make an inventory of the major item at a later date, such as for shipment to another site.

**B-4. ABBREVLATIONS.** The following abbreviations are found in the lists:

<u>Abbreviation</u>	<u>Explanation</u>
assy	assembly
compt	compartment
dbl	double
dia	diameter
ea	each
ft	foot, feet
gal	gallon(s)
hex	hexagon
in.	inch(es)
L	left
lb	pound(s)
lg	long
max	maximum
oz	ounce
R	right
rd	round
sq	square
thd	thread
w/	with
wo/	without

Section II. INTEGRAL COMPONENTS OF THE END ITEM

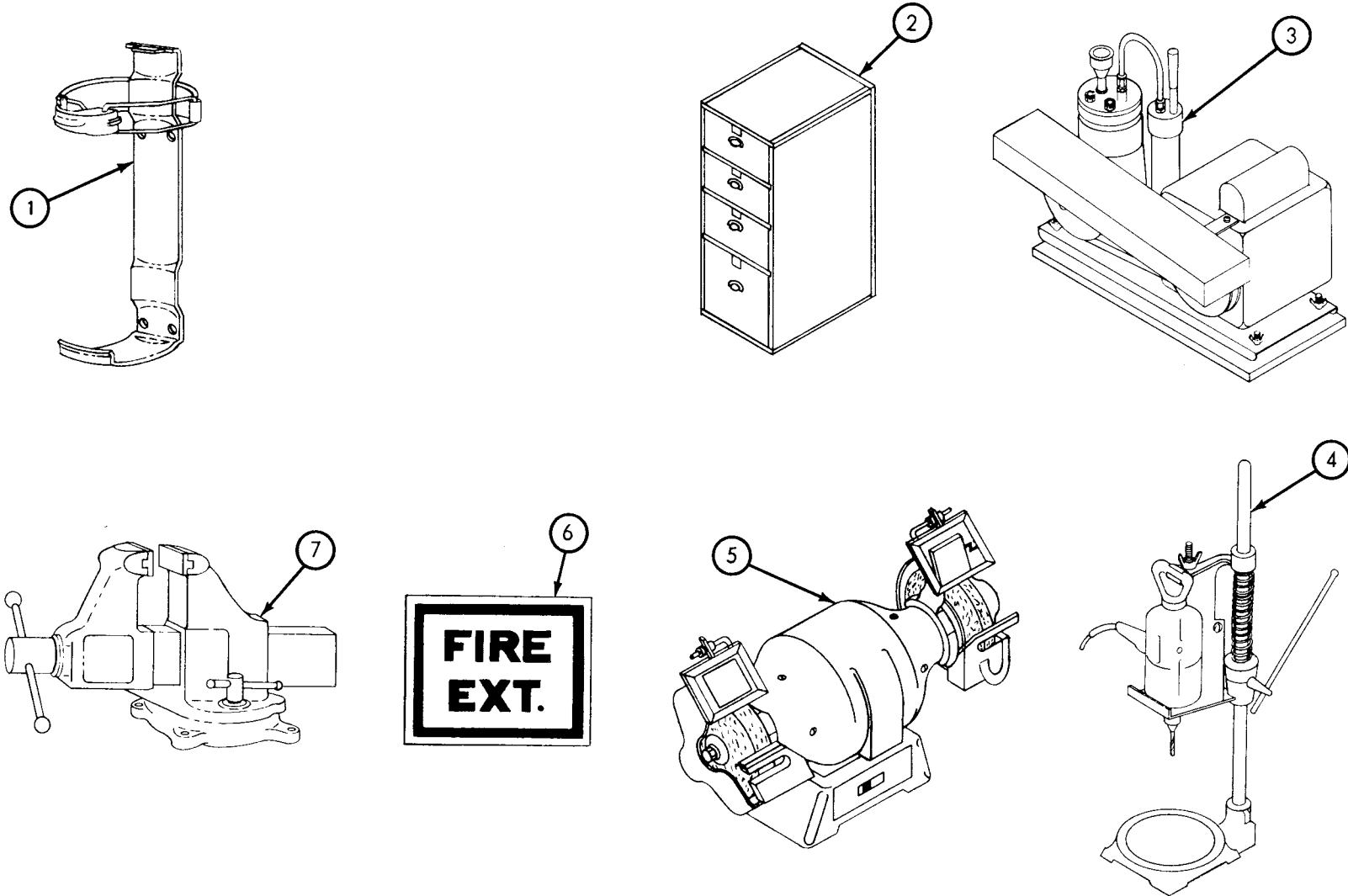

TA 088586

Figure B-1. Repair Shop Truck (M185A2, M185A3) Tools and Equipment.

Section II. INTEGRAL COMPONENTS OF THE END ITEM - Cont

(1)		(2)	(3)	(4)	(5)	(6)	(7)	(8)			
ILLUSTRATION		NATIONAL STOCK NUMBER	PART NO.	DESCRIPTION	LOCATION	USABLE ON CODE	REQD QTY	QUANTITY			
(a) FIGURE NO.	(b) ITEM NO.							RCV'D	DATE	DATE	DATE
B-1	1		12255634	BRACKET: Fire extinguisher	L side, rear wall	AM, AN	1				
	2	7110-00-634-2860	7063095	CABINET ASSY: Filing	Rear body, L and R side	AM, AN	2				
	3	4310-00-631-5693	MIL-C-3925	COMPRESSOR: Reciprocating, Power Driven; Type 1, style 1, group A, size 1	Rear cabinet, L side	AM, AN	1				
	4	5130-00-853-4480	W-D-661B	DRILL: Electric, w/stand, type IV, 3/8-in. drill	Front table, L side	AM, AN	1				
	5	3415-00-517-7754	W-G-656B	GRINDING MACHINE: Utility, bench mounting, type 1, size 7	Front table, L side	AM, AN	1				
	6	7690-00-489-8322	7053776	SIGN, DECAL: Fire extinguisher	Rear wall, L side	AM, AN	1				
	7	5120-00-293-1439	GGG-V-410	WISE: Machinists, swivel base, type VI, class II	Rear table, L side	AM, AN	1				

B-5

TM 9-2320-209-10-1

Section III. BASIC ISSUE ITEMS - Cont

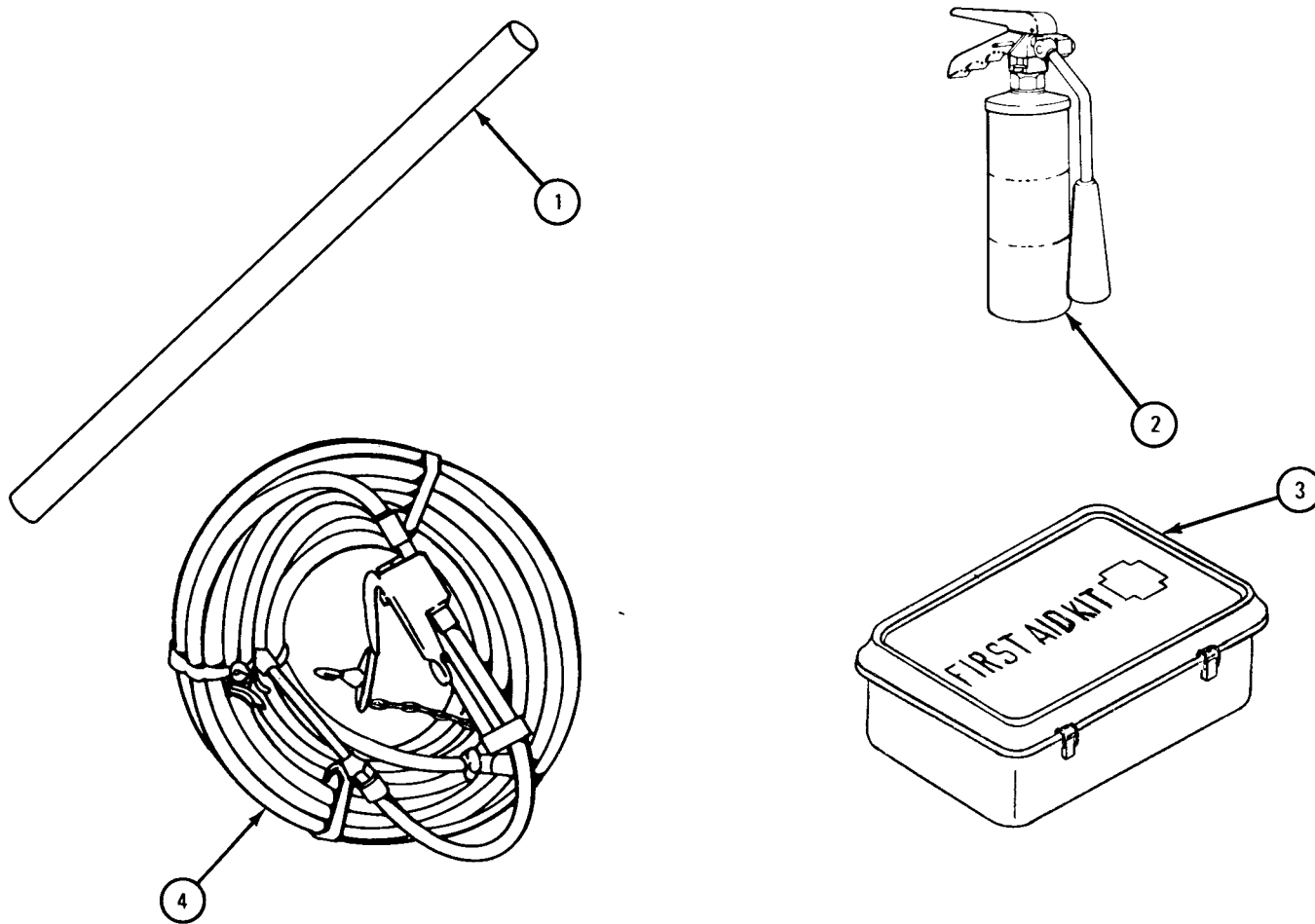

TA 088587-1

Figure B-2. Miscellaneous Tools and Equipment (Sheet 1 of 2).

Section III. BASIC ISSUE ITEMS - Cont

(1)		(2)	(3)	(4)	(5)	(6)	(7)	(8)			
ILLUSTRATION		NATIONAL STOCK NUMBER	PART NO.	DESCRIPTION	LOCATION	USABLE ON CODE	REQD QTY	QUANTITY			
(a) FIGURE NO.	(b) ITEM NO.							RCV'D	DATE	DATE	DATE
B-2	1	5120-00-243-2419	6196147	BAR: Socket wrench handle	Tool box above L running board	A	1				
	2	4210-01-063-7893	12255633-1	FIRE EXTINGUISHER	L rear tank body	AF, AF	1				
					R front tank body	AF, AG	1				
					L rear interior	AM, AN	1				
				Lower R cab panel	AF, AG AO, AP AS, AT	1 ea					
3	6545-00-922-1200	11677011	FIRST AID KIT: General purpose, 12-unit	Map compt Rack, R wall panel towards rear	AS, AT AM, AN	1 1					
4	4910-01-038-2820	11677140-5	GAGE AND HOSE ASSY: Tire inflation, in-line gage, 30-ft lg	Tool box above L running board	A	1					

Section III. BASIC ISSUE ITEMS - Cont

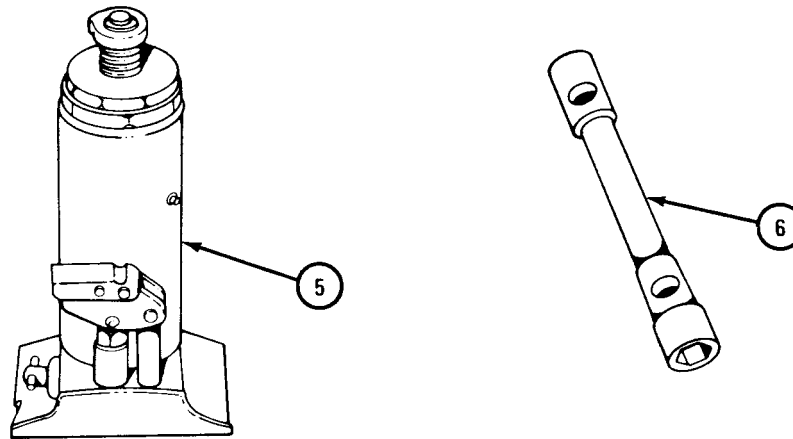

TA 088587-2

Figure B-2. Miscellaneous Tools and Equipment (Sheet 2 of 2).

Section III. BASIC ISSUE ITEMS - Cont

(1)		(2)	(3)	(4)	(5)	(6)	(7)	(8)			
ILLUSTRATION		NATIONAL STOCK NUMBER	PART NO.	DESCRIPTION	LOCATION	USABLE ON CODE	REQD QTY	QUANTITY			
(a) FIGURE NO.	(b) ITEM NO.							RCV'D	DATE	DATE	DATE
B-2	5	5120-00-403-0953	7529492	JACK ASSY: 3-ton, hydraulic, w/handle	Tool box above L running board	A	1				
	6	5120-00-293-1289	11677000	WRENCH: Wheel stud nut, dbl head socket, 1 1/2-in. hex opening, 13/16-in. sq opening	Tool box above L running board	A	1				
		5120-00-293-2452	7083293	WRENCH: Wheel stud nut, spare tire, 1 1/2-in. hex	Tool box above L running board	AF, AG, AH, AI, AJ, AK, AL, AM, AN, AS, AT	1				

Section III. BASIC ISSUE ITEMS - Cont

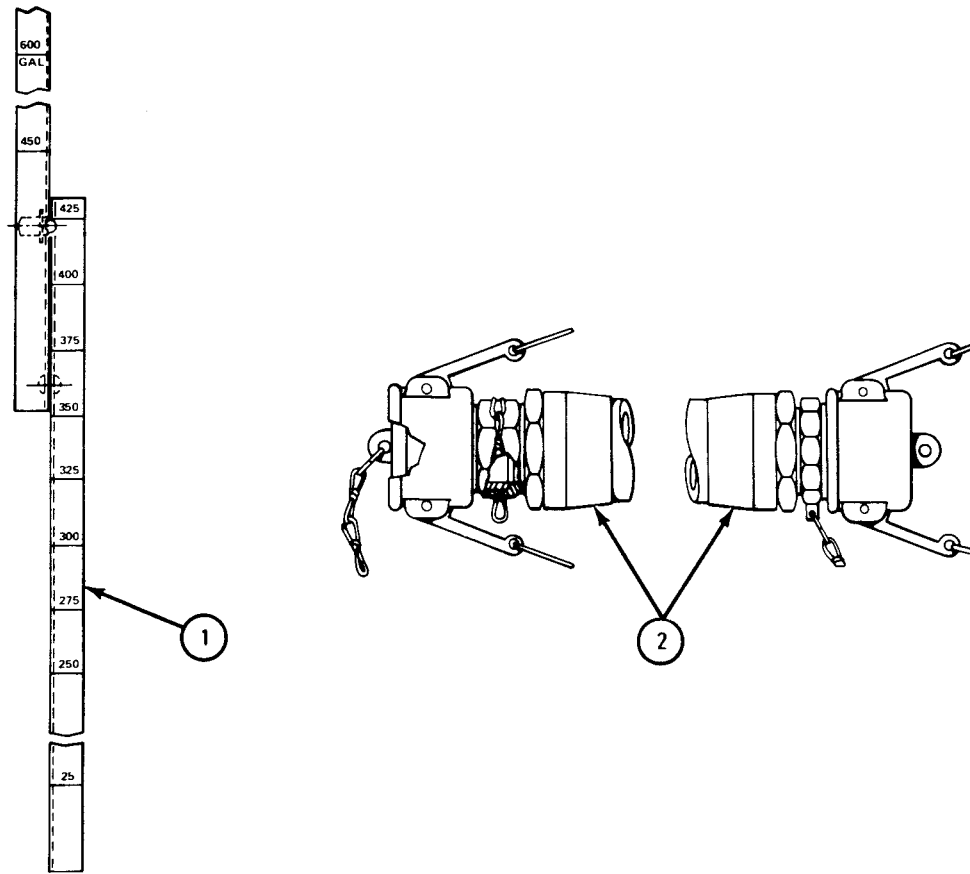

TA 088588

Figure B-3. Fuel Truck (M49A1C, M49A2C) Tools and Equipment.



Section III. BASIC ISSUE ITEMS - Cont

(1)		(2)	(3)	(4)	(5)	(6)	(7)	(8)			
ILLUSTRATION		NATIONAL STOCK NUMBER	PART NO.	DESCRIPTION	LOCATION	USABLE ON CODE	REQD QTY	QUANTITY			
(a) FIGURE NO.	(b) ITEM NO.							RCV'D	DATE	DATE	DATE
B-3	1	5210-00-884-4840	10872403	GAGE ASSY: Fuel	Rear compt, L side	AF, AG	1				
	2	4720-01 029-5046	11672535	HOSE ASSY: W/dust caps	Rear compt, L and R side	AF, AG	2				

B-11

T/M 9-2320-209-10-1

Section III. BASIC ISSUE ITEMS - Cont

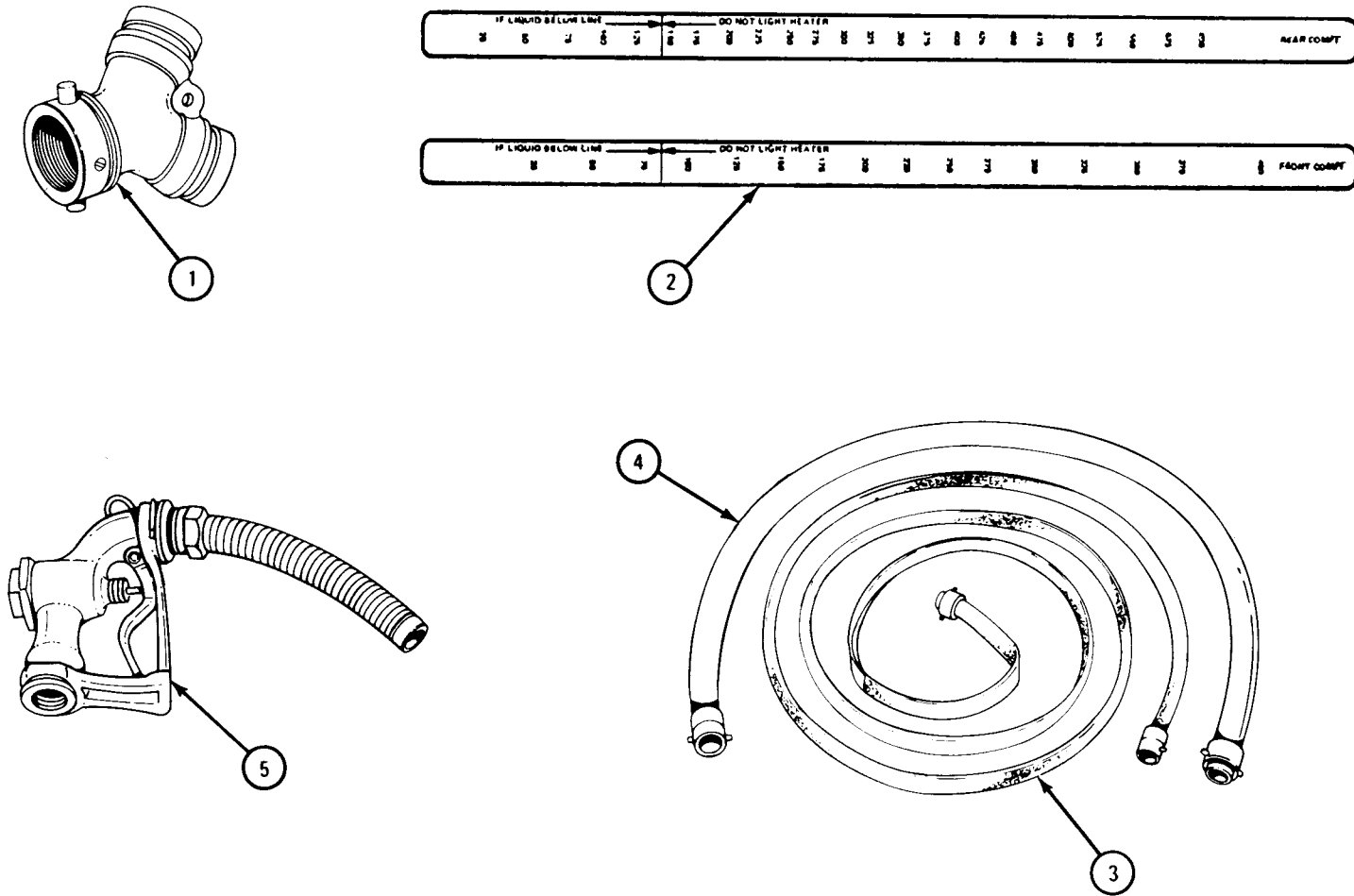

TA 088589-1

Figure B-4. Water Truck (M50A1, M50A2, M50A3) Tools and Equipment (Sheet 1 of 2).

Section III. BASIC ISSUE ITEMS - Cont

(1)		(2)	(3)	(4)	(5)	(6)	(7)	(8)			
ILLUSTRATION		NATIONAL STOCK NUMBER	PART NO.	DESCRIPTION	LOCATION	USABLE ON CODE	REQD QTY	QUANTITY			
(a) FIGURE NO.	(b) ITEM NO.							RCV'D	DATE	DATE	DATE
B-4	1	4730-00-322-9636	8332729	COUPLING, Y: 2-in. female inlet to 1 1/2-in. male outlets	Tool box, rear compt	AH, AI, AJ	1				
	2	5210-00-532-9058	8329924	GAGE STICK ASSY: Calibrated in increments of 25-gal	Shelf, rear compt	AH, AI	1				
		2590-00-566-1440	11609128	GAGE STICK ASSY: Calibrated in increments of 25-gal	Shelf, rear compt	AJ	1				
	3	4720-00-318-0941	8330012	HOSE ASSY: Discharge	Shelf, rear compt	AH, AI, AJ	3				
	4	4720-00-318-0940	8330011	HOSE ASSY: Rubber, suction	In rear compt under tank	AH, AI, AJ	6				
	5	4930-00-563-4642	8329947	NOZZLE ASSY: Fuel type, w/flexible spout	In box, rear compt	AH, AI, AJ	1 2				

Section III. BASIC ISSUE ITEMS - Cont

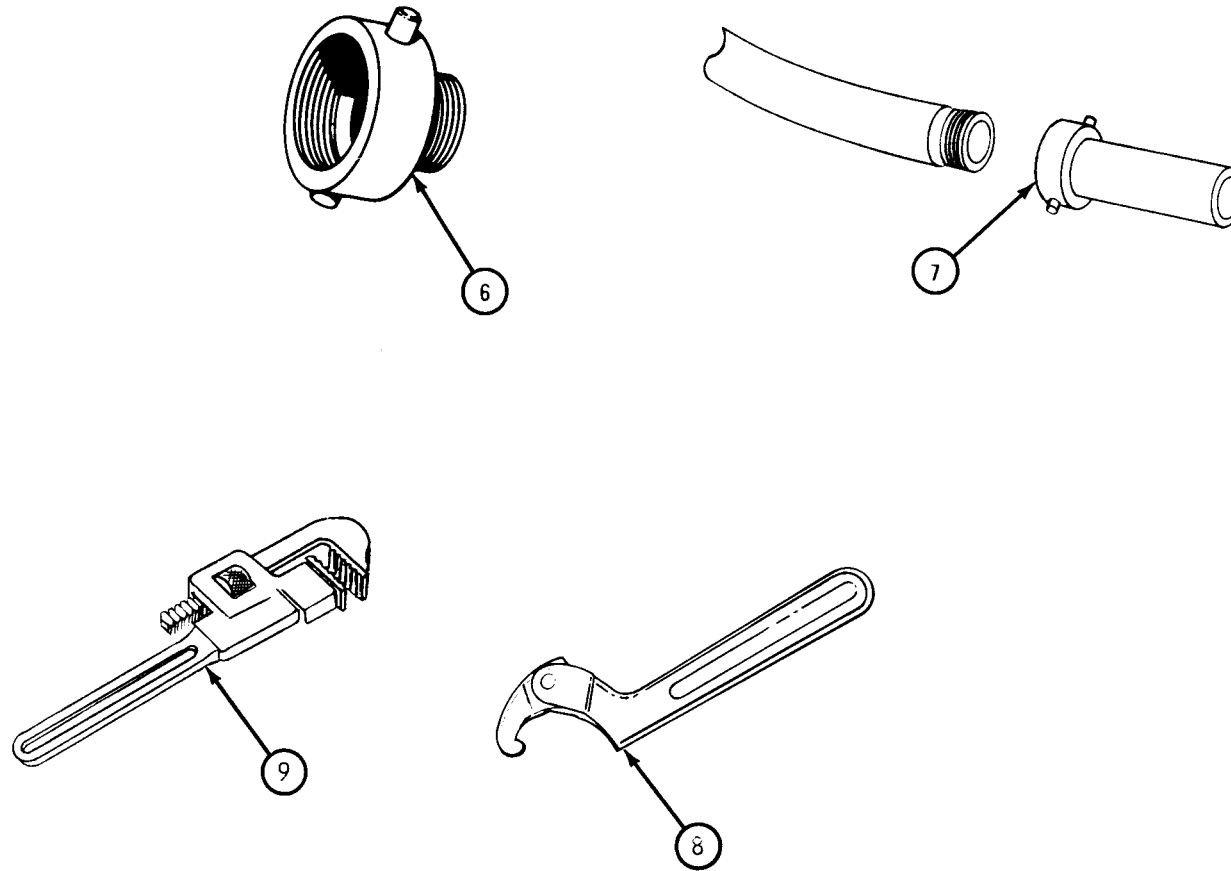

TA 088589-2

Figure B-4. Water Truck (M50A1, M50A2, M50A3) Tools and Equipment (Sheet 2 of 2).

Section III. BASIC ISSUE ITEMS - Cont

(1)		(2)	(3)	(4)	(5)	(6)	(7)	(8)			
ILLUSTRATION		NATIONAL STOCK NUMBER	PART NO.	DESCRIPTION	LOCATION	USABLE ON CODE	REQD QTY	QUANTITY			
(a) FIGURE NO.	(b) ITEM NO.							RCV'D	DATE	DATE	DATE
B-4	6	4730-00-335-1814	8330014	REDUCER, HOSE: Brass, pin plug coupling, 2-in.	In box, rear compt	AH, AI, AJ	1				
		4730-00-090-9228	8330013	REDUCER, PIPE: Brass, pin lug coupling, 2 1/2-in.	In box, rear compt	AH, AI, AJ	1				
	7	4730-00-314-0747	8330015	STRAINER: Suction, brass, pin lug coupling	Tool box, rear compt	AH, AI, AJ	1				
	8	5120-00-516-2981	33443	WRENCH, SPANNER: Combination, hydrant and hose	Tool box, rear compt	AH, AI, AJ	2				
	8	5120-00-293-1602	GGG-W-665 (81348)	WRENCH, SPANNER: Hose coupling, 11-in., overall length	Tool box, rear compt	AH, AI, AJ	2				
	9	5120-00-277-1461	11655780-5	WRENCH: Pipe	Tool box, rear compt	AH, AI, AJ	2				

Section III. BASIC ISSUE ITEMS - Cont

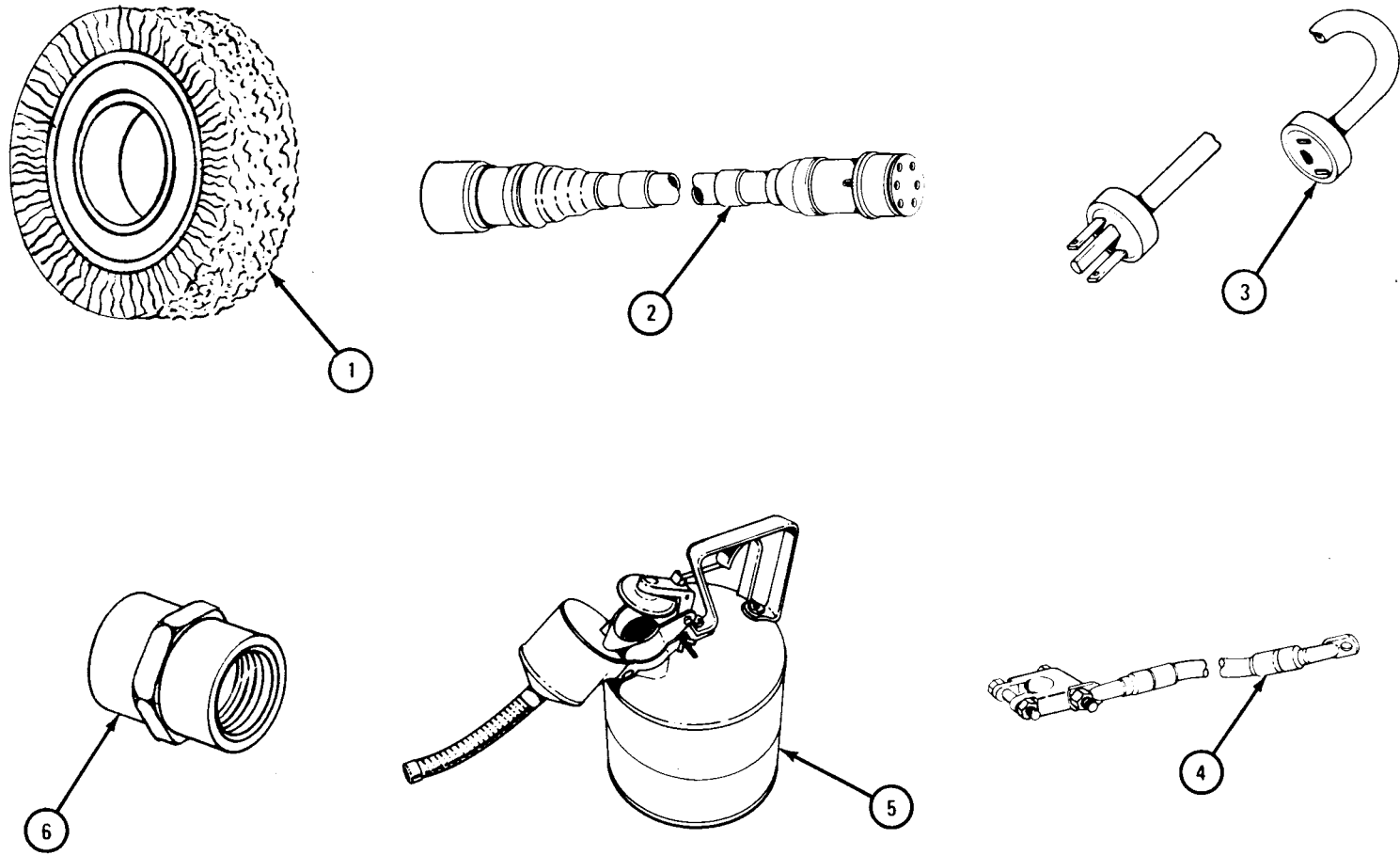

TA 088590-1

Figure B-5. Shop Van (M185A2, M185A3) Tools and Equipment (Sheet 1 of 4).

Section III. BASIC ISSUE ITEMS - Cont

(1) ILLUSTRATION		(2)	(3)	(4)	(5)	(6)	(7)	(8) QUANTITY			
(a) FIGURE NO.	(b) ITEM NO.	NATIONAL STOCK NUMBER	PART NO.	DESCRIPTION	LOCATION	USABLE ON CODE	REQD QTY	RCV'D	DATE	DATE	DATE
B-5	1	5130-00-473-6444	11677006 HB771 (81348)	BRUSH: Wire, rotary, wheel	Bench drawer, L side, near grinder	AM, AN	1				
	2	5995-00-539-8758	11677008 SCD27398- 101 (80063)	CABLE ASSY	Bench shelf, L rear table	AM, AN	1				
	3	6150-00-682-3460	11647741	CABLE ASSY: Power	Bench shelf, L rear table	AM, AN	1				
	4	6140-00-851-4573	7017575	LEAD: Storage battery U/W 2510-00-790-2296	Tool box, running board, L side	AK, AL, AM, AN	1				
	5	7240-00-222-3084	RR-S-30 (81348)	CAN, SAFETY	Strapped in bracket, top R side, rear table	AM, AN	1				
	6	4730-00-142-2717	444097	COUPLING: Auto- motive pipe, air hose to compressor	L filing cabinet, top drawer	AM, AN	1				

Section III. BASIC ISSUE ITEMS - Cont

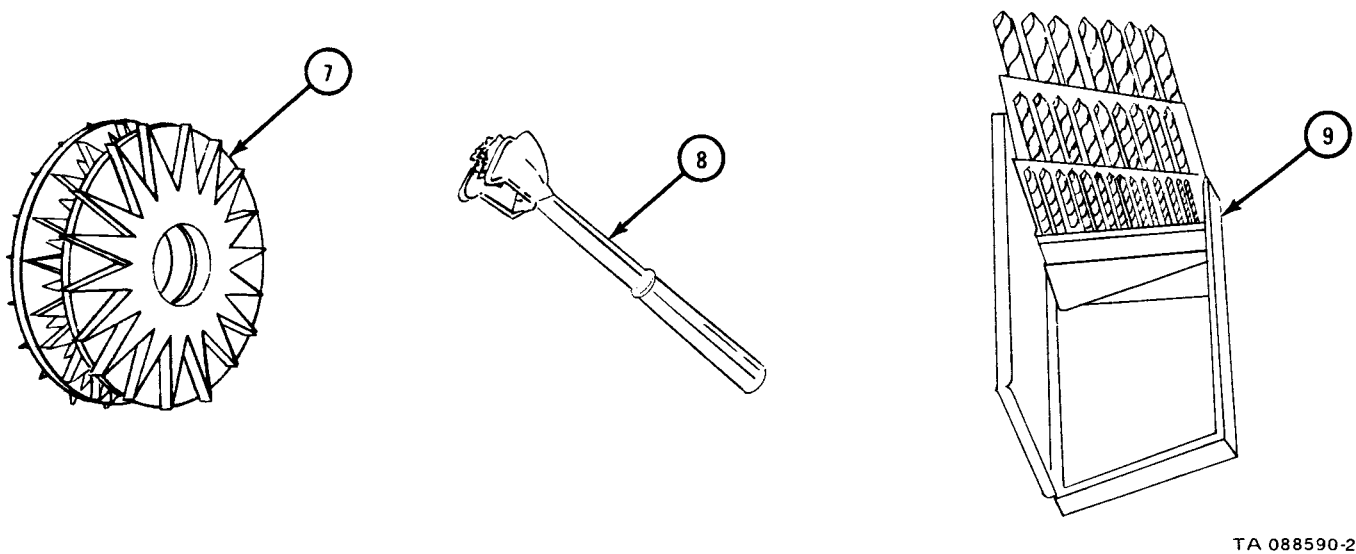

TA 088590-2

Figure B-5. Shop Van (M185A2, M185A3) Tools and Equipment (Sheet 2 of 4).



Section III. BASIC ISSUE ITEMS - Cont

(1)		(2)	(3)	(4)	(5)	(6)	(7)	(8)			
ILLUSTRATION		NATIONAL STOCK NUMBER	PART NO.	DESCRIPTION	LOCATION	USABLE ON CODE	REQD QTY	QUANTITY			
(a) FIGURE NO.	(b) ITEM NO.							RCV'D	DATE	DATE	DATE
B-5	7	5120-00-278-6641	MS15796-1	CUTTER SET: Dresser, abrasive wheel	Bench drawer, L side, near grinder	AM, AN	2				
	8	5120-00-223-9952	11655781 GGG-D-631 (81348)	DRESSER, ABRASIVE WHEEL: Hand, size 0, 1/4-in. dia, revolving cutter wheel	Bench drawer, L side, near grinder	AM, AN	1				
	9	5133-00-449-6775	11677009-2	DRILL SET: Twist, high speed, straight rd shank, wire gage size, short length, R-hand, w/indexed case, (60 drills)	Case, bench drawer, L side, near grinder	AM, AN	1				

Section III. BASIC ISSUE ITEMS - Cont

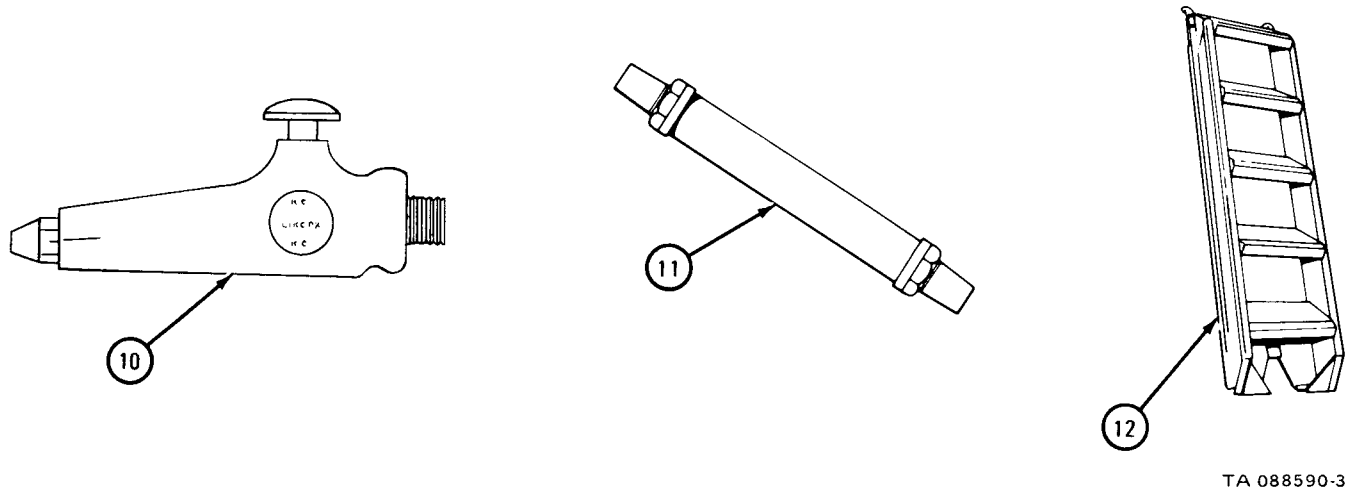
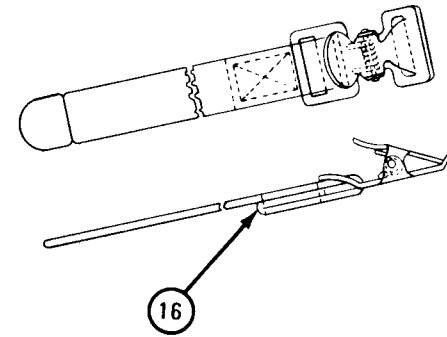
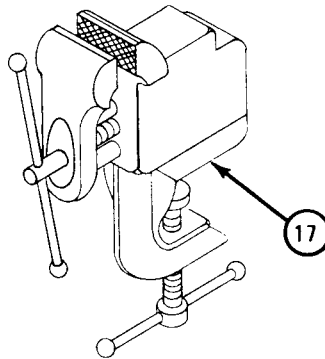
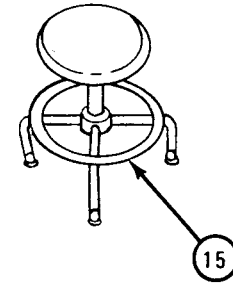
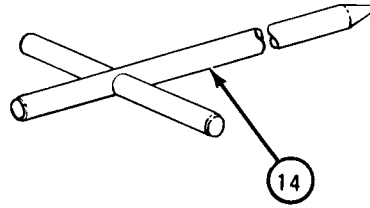
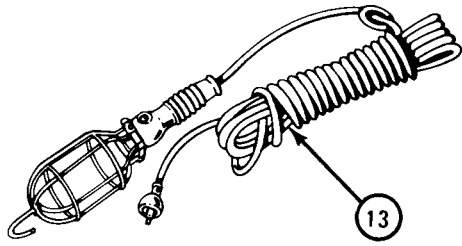

Figure B-5. Shop Van (M185A2, M185A3) Tools and Equipment (Sheet 3 of 4).

Section III. BASIC ISSUE ITEMS - Cont

(1)		(2)	(3)	(4)	(5)	(6)	(7)	(8)			
ILLUSTRATION		NATIONAL STOCK NUMBER	PART NO.	DESCRIPTION	LOCATION	USABLE ON CODE	REQD QTY	QUANTITY			
(a) FIGURE NO.	(b) ITEM NO.							RCV'D	DATE	DATE	DATE
B-5	10	4940-00-333-5541	GGG-G-770 (81348)	GUN, AIR BLOW: Straight design, button operated, rated for automatic reduction to 30 psi at nozzle, removable tip, 1/4-18 male thd	L filing cabinet, top drawer	AM, AN	1				
	11	4720-00-422-8540	PH 5032-1	HOSE, AIR: 1/4-in. male (NPT) coupling, 15-ft lg	L filing cabinet, top drawer	AM, AN	1				
	12	2540-00-735-6179	8757809	LADDER ASSY: Boarding	Van body, L rear side	AK, AL, AM, AN	1				

Section III. BASIC ISSUE ITEMS - Cont



TA 088590-4

Figure B-5. Shop Van (M185A2, M185A3) Tools and Equipment (Sheet 4 of 4).

Section III. BASIC TOOLS - Cont

(1)		(2)	(3)	(4)	(5)	(6)	(7)	(8)			
ILLUSTRATION		NATIONAL STOCK NUMBER	PART NO.	DESCRIPTION	LOCATION	USABLE ON CODE	REQD QTY	QUANTITY			
(a) FIGURE NO.	(b) ITEM NO.							RCV'D	DATE	DATE	DATE
B-5	13	6230-00-901-9755	11677014	LIGHT: Extension, 25-ft cord set, 100 W lamp	Bench shelf	AM, AN	2				
	14	2510-00-790-2296	8380403	ROD: Ground, 30-in. lg U/W 6140-00-851-4573	Tool box, running board, L side	AK, AL, AM, AN	1				
	15	7110-00-634-8596	AA-S-700 (81348)	STOOL: Revolving	Strapped in front of van body	AM, AN	3				
	16	5340-01-012-2607	501288 (19204)	STRAP: Webbing, secure safety can	Top R, rear table	AM, AN	1				
			5340-00-126-9011	8690449	STRAP: Webbing, secure stools	Front of van body, securing 3 stools	AM, AN	1			
	17	5120-00-243-1372	116557823 GGG-V-436	WISE: Bench, clamp base, utility, stationary base	Table drawer	AM, AN	2				

Section III. BASIC ISSUE ITEMS - Cont

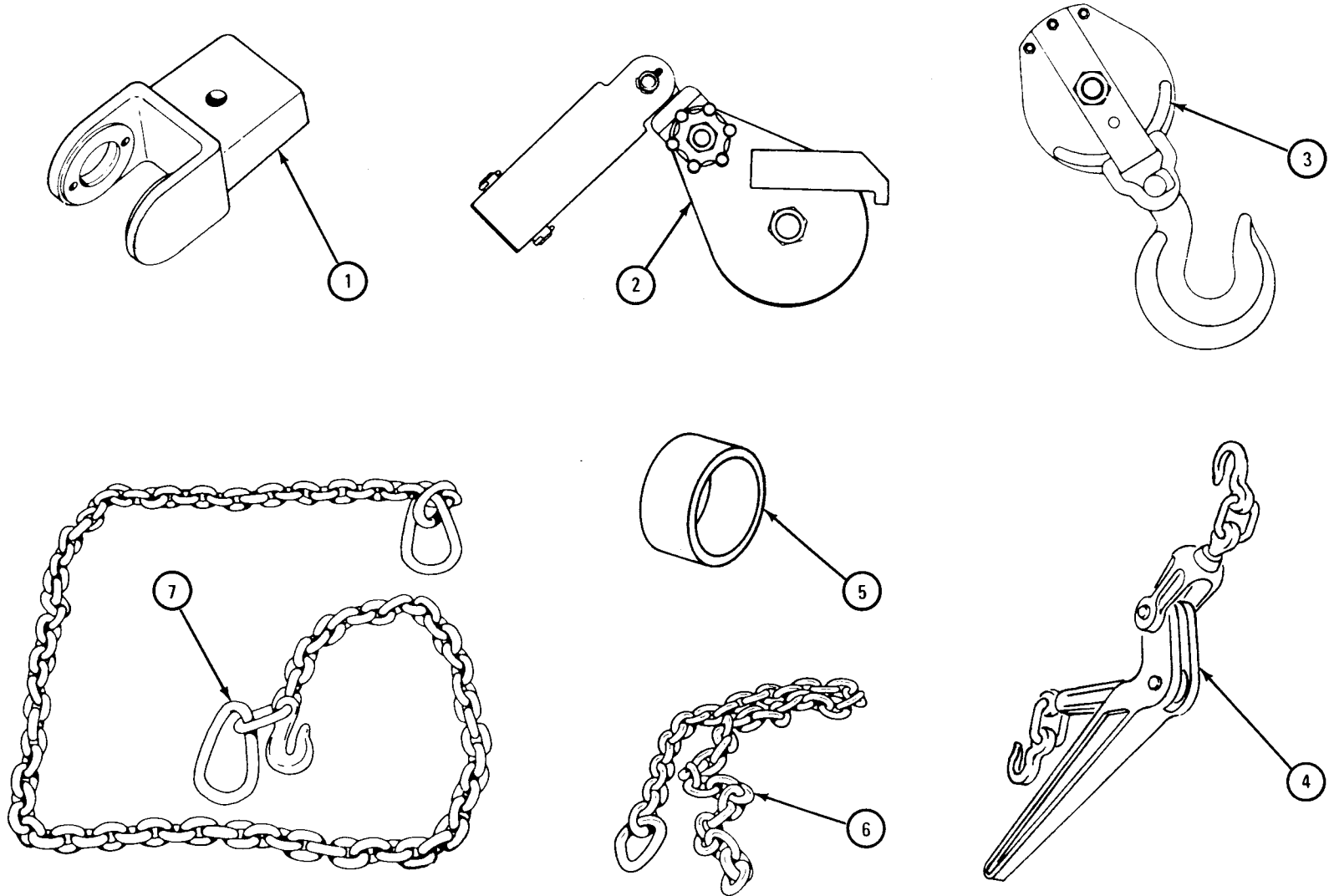

TA 088591-1

Figure B-6. Pipeline Construction Truck (M756A2) Tools and Equipment (Sheet 1 of 2).

Section III. BASIC ISSUES - Cont

(1)		(2)	(3)	(4)	(5)	(6)	(7)	(8)			
ILLUSTRATION		NATIONAL STOCK NUMBER	PART NO.	DESCRIPTION	LOCATION	USABLE ON CODE	REQD QTY	QUANTITY			
(a) FIGURE NO.	(b) ITEM NO.							RCV'D	DATE	DATE	DATE
B-6	1	5340-00-425-0610	11647843	GIN POLE ADAPTER: Side mounting	Tool box, L side body	AS	2				
	2	3940-00-151-6770	116478402	BLOCK, TACKLE: Universal, center mount	Tool box, L side body	AS	1				
	3	3940-00-151-6769	11676932	BLOCK, TACKLE: W/hook	Tool box, L side body	AS	1				
	4	-	11677040	BINDER, LOAD: Lever type, heavy duty, 1/4-in. to 1/2-in. chain capacity	Tool box, R side body	AS	2				
	5	3120-00-702-6039	11647839	BUSHING	Tool box, L side body	AS	2				
	6	4010-00-158-5618	11647877	CHAIN ASSY: Boom tie	Lower cab protector	AS	2				
	7	4010-010-033-2811	11677052	CHAIN, LOG: W/ standard grab hook one end, slip hook w/parallel eye other end, 7/6-in. x 12-ft	Tool box, R side body	AS	2				

Section III. BASIC ISSUE ITEMS - Cont

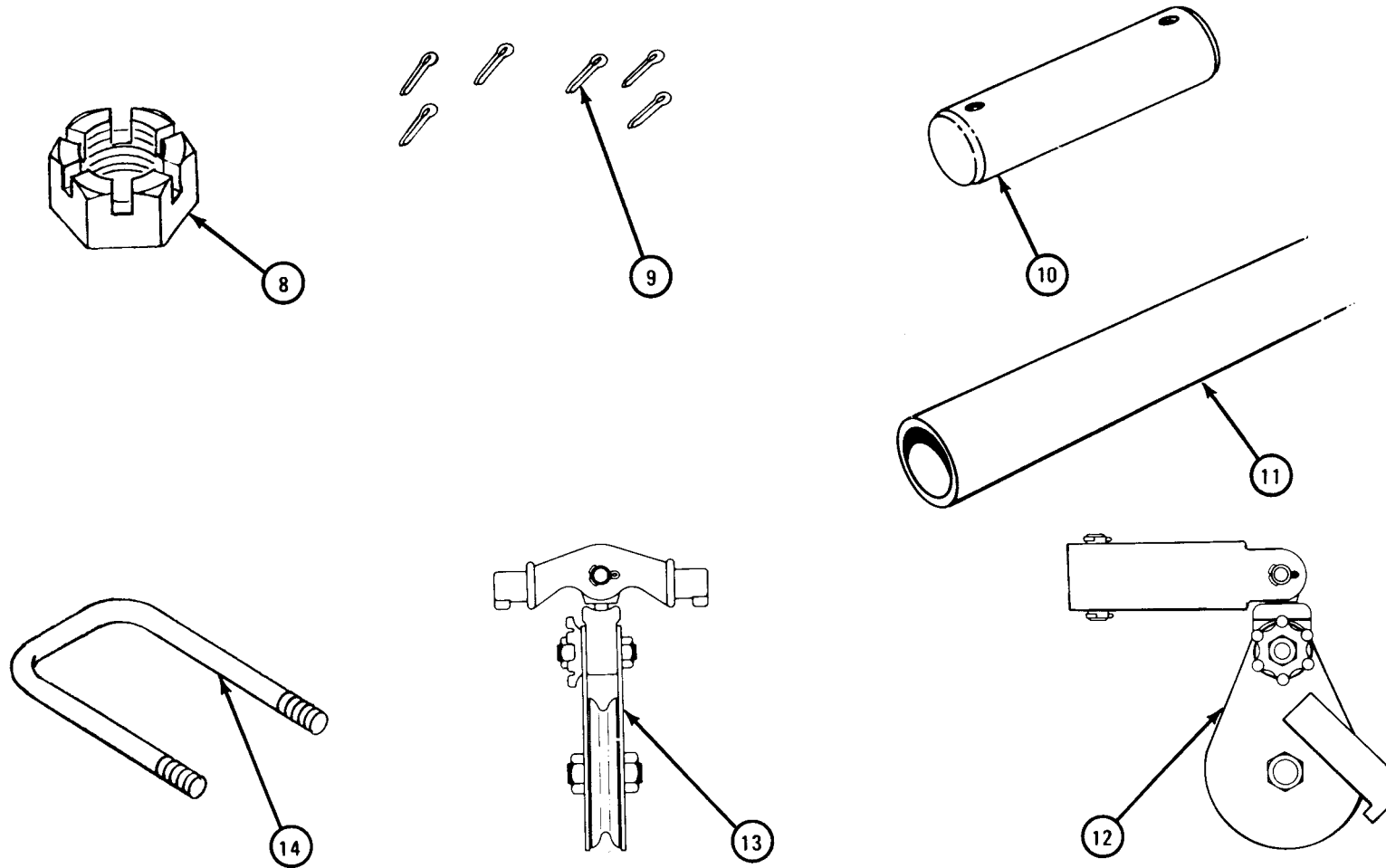

TA 088591-2

Figure B-6. Pipeline Construction Truck (M756A2) Tools and Equipment (Sheet 2 of 2).



Section III. BASIC ISSUE ITEMS - Cont

(1)		(2)	(3)	(4)	(5)	(6)	(7)	(8)			
ILLUSTRATION		NATIONAL STOCK NUMBER	PART NO.	DESCRIPTION	LOCATION	USABLE ON CODE	REQD QTY	QUANTITY			
(a) FIGURE NO.	(b) ITEM NO.							RCV'D	DATE	DATE	DATE
B-6	8	5310-00-850-6881	MS35692-57	NUT: Slotted, hex	Tool box, L side body	AS	2				
	9	5315-00-013-7238	MS24665-425	PIN, COTTER	Tool box, L side body	AS	2				
		5315-00-013-7228	MS24665-423	PIN, COTTER: Sheave assy	Tool box, L side body	AS	8				
	10	5315-00-140-4775	11647875	PIN: Straight, headless, sheave assy	Tool box, L side body	AS	4				
	11		11677041	ROLLER: Load, pipe, plain ends, 2-in. dia, 48-in. lg	Tool box, L side body	AS	3				
	12	2590-00-147-5280	11647840-1	SHEAVE ASSY: Universal, rear mount	Tool box, L side body	AS	1				
	13	3940-00-162-4201	11647841	SHEAVE ASSY: W/ trunnion boom	Tool box, L side body	AS	1				
	14	5306-00-099-5706	11647876	U-BOLT	Tool box, L side body	AS	1				

Section III. BASIC ISSUE ITEMS - Cont

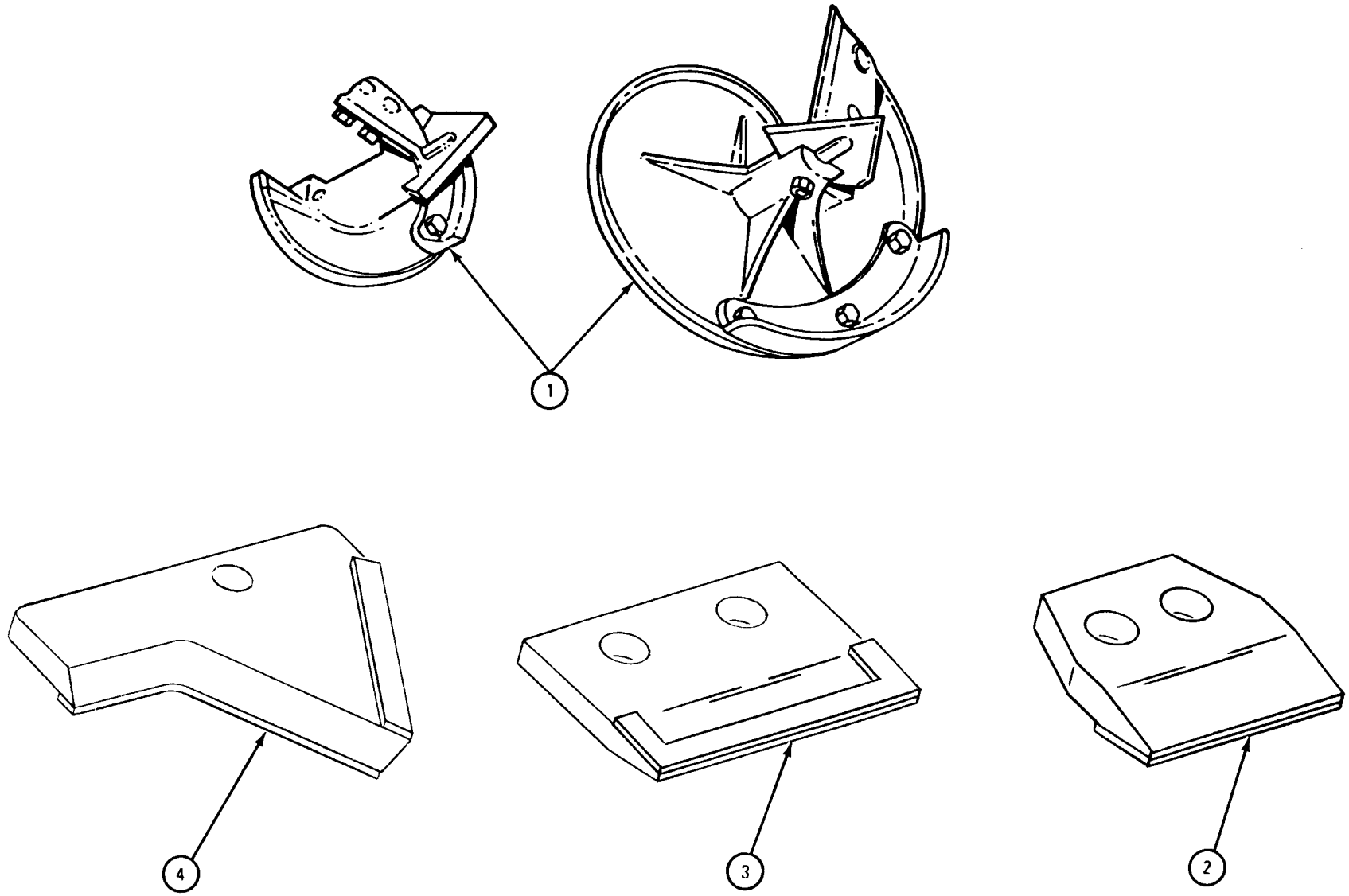

TA 088592-1

Figure B-7. Earth Boring and Polesetting Truck (M764) Tools and Equipment (Sheet 1 of 3).

Section III. BASIC E ITEMS - Cont

(1)		(2)	(3)	(4)	(5)	(6)	(7)	(8)			
ILLUSTRATION		NATIONAL STOCK NUMBER	PART NO.	DESCRIPTION	LOCATION	USABLE ON CODE	REQD QTY	QUANTITY			
(a) FIGURE NO.	(b) ITEM NO.							RCV'D	DATE	DATE	DATE
B-7	1	3820-00-733-6160	7336160	AUGER ASSY: 9-in.	Auger holder, R side body	AT	1				
		3820-00-695-7217	8332447	AUGER ASSY: 12-in.	Auger holder, R side body	AT	1				
		3820-00-695-7218	8332448	AUGER ASSY: 16-in.	Auger holder, L side body	AT	1				
		3830-00-695-7219	8332449	AUGER ASSY: 20-in.	Auger holder, L side body	AT	1				
		3820-00-477-9897	11623812	AUGER ASSY: 30-in.	Auger holder, L side body	AT	1				
	2	3820-00-161-4874	7005090	BLADE: Auger, 12-in.	Tool box, R side body	AT	2				
	3	3820-00-161-4883	7410556	BLADE: Auger, 16-in. and 30-in.	Tool box, R side body	AT	4				
		3820-00-161-4882	7005253	BLADE: Auger, 20-in.	Tool box, R side body	AT	2				
	4	3820-00-125-8640	7005256	BLADE POINT: Auger, 9-in.	Tool box, R side body	AT	1				

B-29

TM 9-2320-209-10-1

Section III. BASIC ISSUE ITEMS - Cont

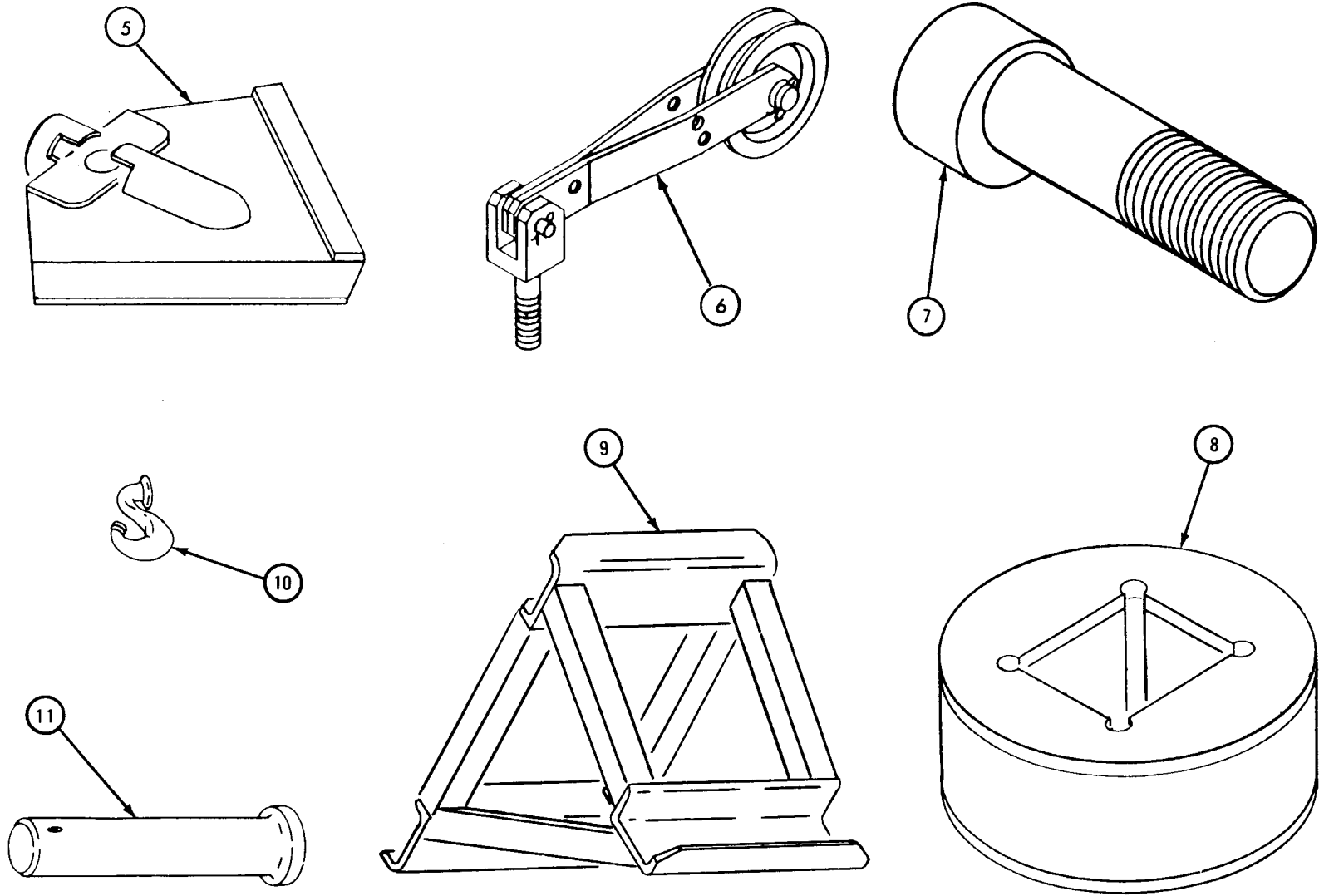

TA 088592-2

Figure B-7. Earth Boring and Polesetting Truck (M764) Tools and Equipment (Sheet 2 of 3).

Section III. BASIC ITEMS - Cont

(1)		(2)	(3)	(4)	(5)	(6)	(7)	(8)				
ILLUSTRATION		NATIONAL STOCK NUMBER	PART NO.	DESCRIPTION	LOCATION	USABLE ON CODE	REQD QTY	QUANTITY				
(a) FIGURE NO.	(b) ITEM NO.							RCV'D	DATE	DATE	DATE	
B-7	5	3820-00-125-2906	7005254	BLADE POINT: Auger, 12-in., 16-in., 20-in. and 30-in.	Tool box, R side body	AT	1					
	6	3940-00-740-6154	EA 2991 (744370)	BLOCK: Tackle, derrick	Space at rear of body	AT	1					
	7	5630-00-407-2779	7005242	BOLT: Eccentric head	Tool box, R side body	AT	5					
	8	5360-00-429-7390	7374019	BOLT: Eccentric head	Tool box, R side body	AT	6					
			5340-00-111-3603	116233 82	BUMPER: Rubber	Tool box, R side body	AT	1				
	9		2540-00-406-4588	116234 08	CHOCK BLOCK	Chock block holder, R front body	AT	4				
	10		4030-00-693-0649	8332403	HOOK, HOIST: Quick disconnect to winch line	Body tool box	AT	1				
	11		5315-00-276-5728	7005041	PIN: Auger retaining	Tool box, R side body	AT	3				

Section III. BASIC ISSUE ITEMS - Cont

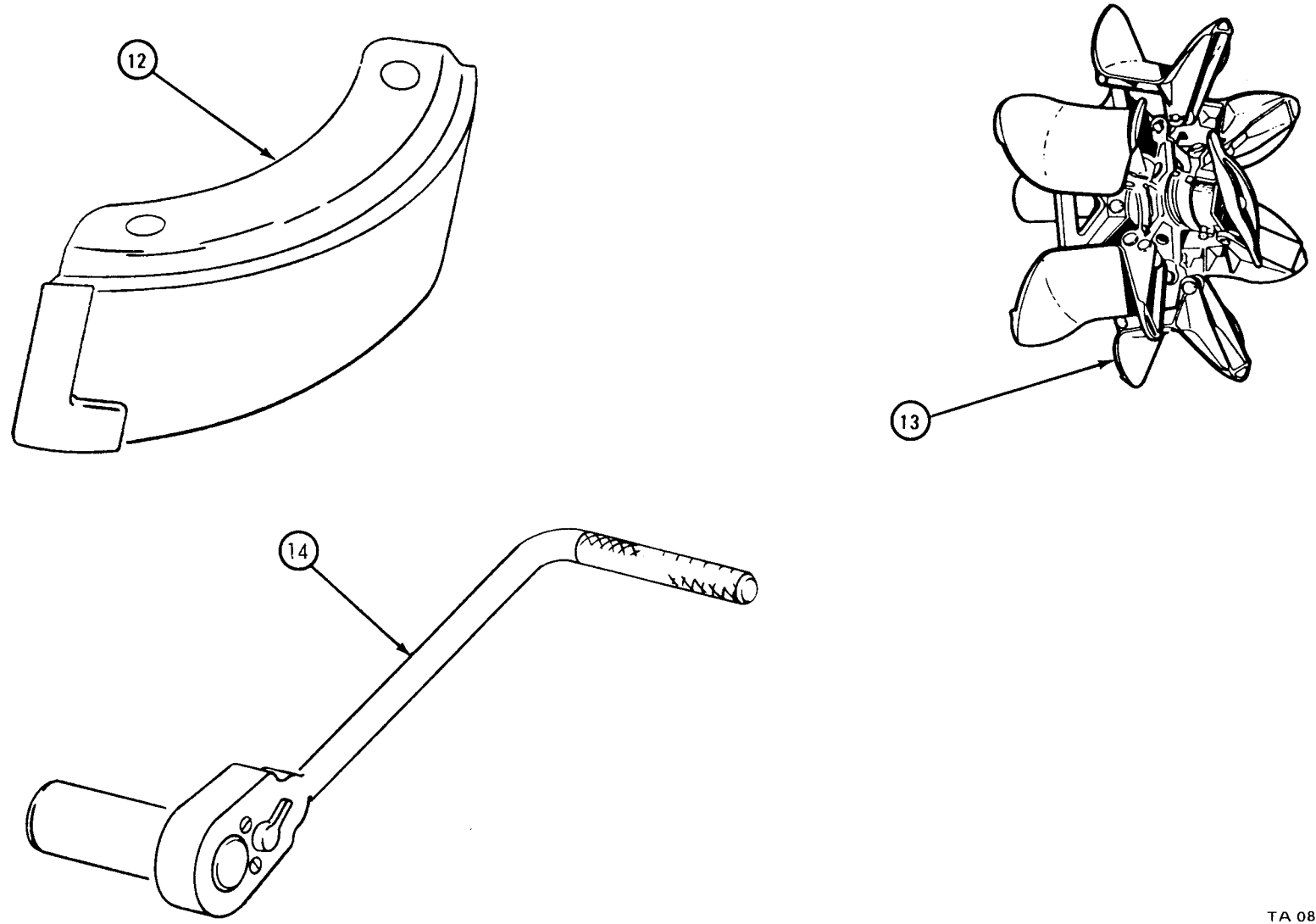

TA 088592-3

Figure B-7. Earth Boring and Polesetting Truck (M764) Tools and Equipment (Sheet 3 of 3).

Section III. BASIC IS ITEMS - Cont

(1)		(2)	(3)	(4)	(5)	(6)	(7)	(8)			
ILLUSTRATION		NATIONAL STOCK NUMBER	PART NO.	DESCRIPTION	LOCATION	USABLE ON CODE	REQD QTY	QUANTITY			
(a) FIGURE NO.	(b) ITEM NO.							RCV'D	DATE	DATE	DATE
B-7	12	3820-00-161-4881	7005250	PLATE: Auger, 12-in.	Tool box, R side body	AT	1				
		3820-00-161-4879	7005247	PLATE: Auger, 16-in.	Tool box, R side body	AT	1				
		3820-00-161-4876	7005246	PLATE: Auger, 20-in.	Tool box, R side body	AT	1				
		3820-00-477-9898	11623811	PLATE: Auger, 30-in.	Tool box, R side body	AT	1				
	13	2590-00-924-5896	7329291	REEL ASSY: Cable, collapsible	Holder, R side body	AT	1				
	14	5360-00-597-3795	7005146	SPRING: Helical, compression	Tool box, R side body	AT	1				
	15	5120-00-247-3261	116770 48 GGG-W-653 (81348)	WRENCH, RATCHET: Reversible, reversing mechanism in handle, 1 7/16-in. (max) thick head, 24-in. lg, 1-in. sq female socket drive (used for horizontal leveling of worm assy on auger machine)	Body tool box	AT	1				

Section III. BASIC ISSUE ITEMS - Cont

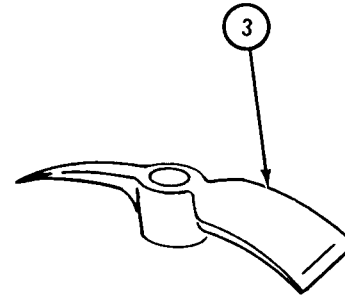
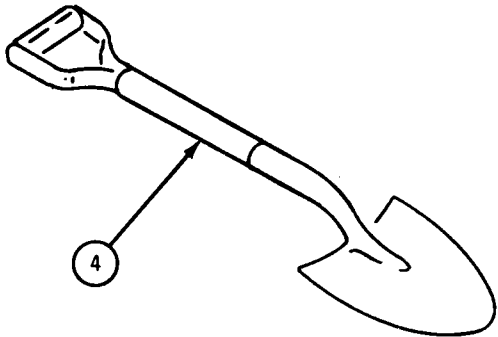
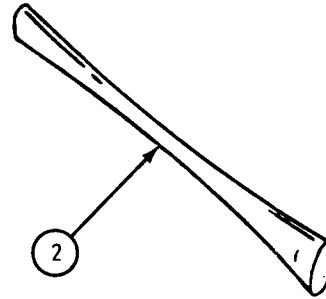
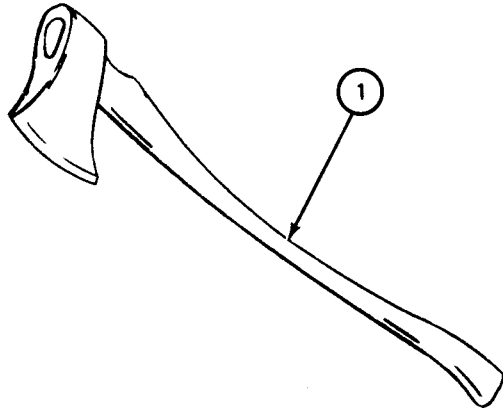

TA 088593

Figure B-8. Pipeline Construction Truck (M756A2) and Earth Boring and Polesetting Truck (M764) Tools and Equipment.



Section III. BASIC ISSUES ITEMS - Cont

(1)		(2)	(3)	(4)	(5)	(6)	(7)	(8)			
ILLUSTRATION		NATIONAL STOCK NUMBER	PART NO.	DESCRIPTION	LOCATION	USABLE ON CODE	REQD QTY	QUANTITY			
(a) FIGURE NO.	(b) ITEM NO.							RCV'D	DATE	DATE	DATE
B-8	1	5110-00-293-2336	6150925	AXE: Single bit, 4-lb, w/handle	Pioneer bracket, midship mounted, winch protector basket	AS	1				
					Pioneer bracket, under body, R front side	AT	1				
	2	5120-00-288-6574	11677021	HANDLE: Mattock pick, 36-in. lg	Pioneer bracket	AS, AT	1				
	3	5120-00-243-2395	11677022	MATTOCK PICK: Wo/handle, 5-lb	Pioneer bracket	AS, AT	1				
	4	5120-00-293-3336	MS170 88-1 GGG-S-326 (81348)	SHOVEL: Hand, general purpose, round point	Pioneer bracket	AS, AT	1				

B-35/(B-36 blank)

TM 9-2320-209-10-1



# APPENDIX C ADDITIONAL AUTHORIZATION LIST

## Section I. INTRODUCTION

C-1. SCOPE. This appendix lists additional items you are authorized for the support of the 2 1/2-ton, 6 x 6, M44A1 and M44A2 series trucks (multifuel).

C-2. GENERAL. This list is made up of items that do not have to stay with the truck and that do not have to be turned in with it. Authorization for these items is given by CTA, MTOE, TDA or JTA.

C-3. EXPLANATION OF LISTING. National stock numbers, descriptions, and quantities give all details needed to order the additional items for support of this equipment. If item needed is different for different models of this equipment, the model using this item is shown under the Usable On Code heading in the Description column. These codes are as follows:

<u>Code</u>	<u>Used On</u>
A	All trucks
AA	All trucks w/winch
AB	Model M35A1
AC	Model M35A2
AD	Model M35A2C
AE	Model M36A2
AF	Model M49A1C
AG	Model M49A2C
AH	Model M50A1
AI	Model M50A2
AJ	Model M50A3
AK	Model M109A2



<u>Code</u>	<u>Used On</u>
A L	Model M109A3
AM	Model M185A2
AN	Model M185A3
AO	Model M275A1
AP	Model M275A2
AR	Model M342A2
AS	Model M756A2
AT	Model M764

## Section II. ADDITIONAL AUTHORIZATION LIST

(1) NATIONAL STOCK NUMBER	(2) DESCRIPTION PART NUMBER & FSCM                      USABLE ON CODE	(3) U/M	(4) QTY AUTH
4930-00-288-1511	ADAPTER: Extension, grease gun 6300333 (19207)                      AT	Ea	1
2540-00-670-2459	BAG, PAMPHLET: For publications 7961712 (19207)                      A	Ea	1
5150-00-772-4142	BAG: Tool 7724142 (19207)                      A	Ea	1
5120-00-240-6040	BAR: Crow, pinch piont, 48-in. 11677049 (19207)                      AS	Ea	2
5120-00-237-8256	BAR: Digging and tamping GGG-B-101                      AT	Ea	2
5120-00-242-3417	BAR: Tamping, back fill, 8-ft GGG-T-0040                      (80244)                      AT	Ea	2
7530-01-065-0166	FOLDER: Equipment Record                      A	Ea	1
3940-00-111-6693	BLOCK RIGGING: Wire rope 11631700 (19207)                      AA	Ea	1
7240-00-222-3088	CAN: Gas, military, 5-gallon 11677019 (19207)                      A	Ea	1
5120-00-247-2834	CANT HOOK: 4-ft MIL-H-20638 (81349)                      AT	Ea	2
4010-00-473-6166	CHAIN: Utility, single leg 7077063 (19207)                      AA	Ea	1
9905-00-148-9546	WARNING DEVICE KIT: RR-W-1817 (81348)                      AS, AT	Ea	1
4930-00-253-2478	GREASE GUN: Hand, lever operated 5644803 (19207) MIL-G-3859 Size 1 (81349)                      AT	Ea	1
5120-00-061-8543	HAMMER: Machinist, 1-lb 11677028 (19207)                      AA	Ea	1
5120-00-900-6103	HAMMER: Machinist, 3-lb 11677042 (19207)                      AS	Ea	1
5120-00-900-6095	HAMMER: Machinist, 6-lb 11677050 (19207)                      AS	Ea	1

Section II. ADDITIONAL AUTHORIZATION LIST - Cont

(1) NATIONAL STOCK NUMBER	(2) DESCRIPTION PART NUMBER & FSCM      USABLE ON CODE		(3) U/M	(4) QTY AUTH
5120-00-595-8381	JACK: Pole pulling assy 8329902 (19207)      AT		Ea	1
1930-00-266-9182	OILER: Hand, pushbutton 6008514 (19207) GGG-O-591 (81348)      AT		Ea	1
5120-00-596-1112	PIKE, POLE: Wood, 12-ft GGG-P-335 (80244)      AT		Ea	4
5315-00-839-2325	PIN, COTTER: MS 24665-132 (96906)      AS		Ea	6
5315-00-839-5820	PIN, COTTER: MS 24665-134 (96906)      AA, AT		Ea	6
5315-00-064-2701	PIN, SHEAR: MS 20392-3C37 (19207)      AS		Ea	3
5315-00-252-5669	PIN, SHEAR: 11609886 (19207)      AT		Ea	3
5315-00-736-8685	PIN, SHEAR: 7538740 (19207)      AA		Ea	3
5120-00-223-7397	PLIERS: 8-in., w/cutter GGG-P-471 (81348)      A		Ea	1
5120-00-752-9031	PUNCH, DRIVE: 11677010 (19207)      AA		Ea	1
5120-00-222-8852	SCREWDRIVER: 1/4-in. w, 4-in. blade GGG-S-121 (81348)      A		Ea	1
5120-00-240-8716	SCREWDRIVER: x-point, #1 GGG-S-121 (81348)      A		Ea	1
5120-00-234-8913	SCREWDRIVER: x-point, #2 GGG-S-121 (81348)      A		Ea	1
5120-00-188-8440	SHOVEL: Hand, telegraph, 8-ft GGG-S-326 (81348)      AT		Ea	2
5120-00-188-8444	SPOON: Hand, telegraph, 8-ft GGG-S-326 (81348)      AT		Ea	2

Section II. ADDITIONAL AUTHORIZATION LIST - Cont

(1) NATIONAL STOCK NUMBER	(2) DESCRIPTION		(3) U/M	(4) QTY AUTH
	PART NUMBER & FSCM	USABLE ON CODE		
7240-00-177-6154	SPOUT: Can, flexible nozzle 11677020 (19207)	A	Ea	1
5120-00-242-3417	TAMP: Back fill, 8-ft GGG-T-0040 (80244)	AT	Ea	2
5120-00-240-5328	WRENCH: Adjustable, open end, 0.947-in. jaw opening GGG-W-631 (81348)	A	Ea	1
5120-00-423-6728	WRENCH: Adjustable, open end, 1.698-in. jaw opening GGG-W-631 (81348)	AT	Ea	1
5315-00-732-1019	WRENCH, PLUG: 1/2-in. sq drive, 2 1/2-in. lg MS20066-543 (96906)	A	Ea	1
<p>NOTE</p> <p>The following tool bracket assembly is issued on AS and AT trucks as noted. At the commanders discretion it is authorized for installation on all other model trucks.</p>				
2540-00-409-8891	BRACKET ASSY : Tool MS53053-1 (96906)	AS, AT	Ea	1





## APPENDIX D

### EXPENDABLE SUPPLIES AND MATERIALS LIST

---

#### Section I. INTRODUCTION

D-1. SCOPE. This appendix lists expendable supplies and materials you will need to operate and maintain the 2 1/2-ton, 6 x 6, M44A1 and M44A2 series trucks (multifuel). These items are authorized by CTA 50-970, Expendable Items (Except Medical, Class V, Repair Parts, and Heraldic Items).

#### D-2. EXPLANATION OF COLUMNS.

- a. Column 1 - Item number. This number is given to the entry in the listing.
- b. Column 2- Level. This is the lowest level of maintenance that needs the listed item.  
  
C - Operator/Crew  
O - Organizational Maintenance
- c. Column 3 - National Stock Number. This is the National Stock Number given to the item; use it to order the item.
- d. Column 4 - Description. Shows the Federal Item Name and, if needed, a description to give more details about the item. The last line for each item shows the part number, followed by the Federal Supply Code for Manufacturer (FSCM) in brackets, if it applies.
- e. Column 5 - Unit of Measure (U/M). Shows the measure used in doing the actual maintenance function. This measure is shown by an alphabetical abbreviation (es, in, qt). If the unit of measure is different from the unit of issue, order the lowest unit of issue that will give you what you need.

Section II. EXPENDABLE SUPPLIES AND MATERIAL LIST

(1) ITEM NUMBER	(2) LEVEL	(3) NATIONAL STOCK NUMBER	(4) DESCRIPTION	(5) U/M
1	O	6850-00-181-7929	ANTIFREEZE: Permanent, ethylene glycol (-60° F) inhibited (MIL-A-46153) 1-gal container	Gal
2	O	6850-00-181-7933	ANTIFREEZE: Permanent, ethylene glycol (-60° F) inhibited (MIL-A-46153) 5-gal container	Gal
3	O	6850-00-181-7940	ANTIFREEZE: Permanent, ethylene glycol (-60° F) inhibited (MIL-A-46153) 55-gal drum	Gal
4	O	6850-00-174-1806	ANTIFREEZE: Permanent, arctic grade (-90° F) (0-1-490) (MIL-C-11755) 55-gal drum	Gal
5	C	9150-00-252-6375	FLUID, HYDRAULIC: Non-petroleum base, automotive, arctic type (MIL-H-13910) 1-gal can	Gal
6	C	9150-00-190-0932	FLUID, HYDRAULIC: Non-petroleum base, automotive (HB) (VV-B-680) 1-pt can	Pt
7	C	9150-00-231-9071	FLUID, HYDRAULIC: Non-petroleum base, automotive (HB) (VV-B-680) 1-gal can	Gal
8	C	9150-00-065-0029	GREASE: GAA, automotive and artillery (MIL-G-10924) 2 1/2-oz tube	Oz
9	C	9150-00-935-1017	GREASE: GAA, automotive and artillery (MIL-G-10924) 14-oz cartridge	Oz
10	C	9150-00-190-0904	GREASE: GAA, automotive and artillery (MIL-G-10924) 1-lb can	Lb
11	C	9150-00-190-0905	GREASE: GAA, automotive and artillery (MIL-G-10924) 5-lb can	Lb

## Section II. EXPENDABLE SUPPLIES AND MATERIAL LIST - Cont

(1) ITEM NUMBER	(2) LEVEL	(3) NATIONAL STOCK NUMBER	(4) DESCRIPTION	(5) U/M
12	C	9150-00- 190-0907	GREASE: GAA, automotive and artillery (MIL-G- 10924) 35-lb pail	Lb
13	C	9150-00- 530-7369	GREASE: GAA, automotive and artillery (MIL-G-10924) 120-lb drum	Lb
14	O	6850-00- 753-4967	INHIBITOR: Corrosion, liquid, cooling system, powder form, 6-oz can	Oz
15	C	9150-00- 286-5286	OIL, FUEL: Diesel, DF-1, winter (VV-F-800) bulk	Gal
16	C	9150-00- 286-5287	OIL, FUEL: Diesel, DF-1, winter (VV-F-800) 5-gal drum	Gal
17	C	9150-00- 286-5288	OIL, FUEL: Diesel, DF-1, winter (VV-F-800) 55-gal drum, 16 gage	Gal
18	C	9150-00- 286-5289	OIL, FUEL: Diesel, DF-1, winter (VV-F-800) 55-gal drum, 18 gage	Gal
19	C	9150-00- 286-5294	OIL, FUEL: Diesel, DF-2, regular (VV-F-800) bulk	Gal
20	C	9150-00- 286-5295	OIL, FUEL: Diesel, DF-2, regular (VV-F-800) 5-gal can	Gal
21	C	9150-00- 286-5296	OIL, FUEL: Diesel, DF-2, regular (VV-F-800) 55-gal drum, 16 gage	Gal
22	C	9150-00- 286-5297	OIL, FUEL: Diesel, DF-2, regular (VV-F-800) 55-gal drum, 18 gage	Gal
23	C	9150-00- 286-5283	OIL, FUEL: Diesel, DF-A (arctic) A, bulk	Gal
24	C	9150-00- 286-5282	OIL, FUEL: Diesel, DF-A (arctic) A, 5-gal drum	Gal

## Section II. EXPENDABLE SUPPLIES AND MATERIAL LIST - Cont

(1) ITEM NUMBER	(2) LEVEL	(3) NATIONAL STOCK NUMBER	(4) DESCRIPTION	(5) U/M
25	C	9150-00- 286-5284	OIL, FUEL: Diesel, DF-A (arctic) A, 55-gal drum, 16 gage	Gal
26	C	9150-00- 286-5285	OIL, FUEL: Diesel, DF-A (arctic) A, 55-gal drum, 18 gage	Gal
27	O	9150-00- 234-5197	OIL, LUBRICATING: Exposed gear, CW, (VV-L-751) 5-lb can	Lb
28	O	9150-00- 261-7891	OIL, LUBRICATING: Exposed gear, CW (VV-L-751) 35-lb pail	Lb
29	O	9150-01- 035-5392	OIL, LUBRICATING: Gear, GO 80/90 (MIL-L-2105) 1-qt can	Qt
30	O	9150-01- 035-5393	OIL, LUBRICATING: Gear, GO 80/90 (MIL-L-2105) 5-gal drum	Gal
31	O	9150-01- 035-5394	OIL, LUBRICATING: Gear, GO 80/90 (MIL-L-2105) 55-gal drum, 18 gage	Gal
32	O	9150-01- 035-5390	OIL, LUBRICATING: Gear, GO 75 (MIL-L-2105) 1-qt	Qt
33	O	9150-01- 035-5391	OIL, LUBRICATING: Gear, GO 75 (MIL-L-2105) 5-gal drum	Gal
34	O	9150-00- 402-4478	OIL, LUBRICATING: OEA (MIL-L-46167) A, 1-qt	Qt
35	O	9150-00- 402-2372	OIL, LUBRICATING: OEA (MIL-L-46167) A, Pail	Gal
36	O	9150-00- 491-7197	OIL, LUBRICATING: OEA (MIL-L-46167) A, 55-gal drum	Gal
37	C	9150-00- 183-7807	OIL, LUBRICATING: OE/HDO 10 (MIL-L-2104) bulk	Gal
38	C	9150-00- 189-6727	OIL, LUBRICATING: OE/HDO 10 (MIL-L-2104) 1-qt can	Qt

Section II. EXPENDABLE SUPPLIES AND MATERIAL LIST - Cont

(1)	(2)	(3) NATIONAL STOCK NUMBER	(4) DESCRIPTION	(5) U/M
39	C	9150-00- 191-2772	OIL, LUBRICATING: OE/HDO 10 (MIL-L-2104) 55-gal drum, 18 gage	Gal
40	C	9150-00- 183-7808	OIL, LUBRICATING: OE/HDO 30 (MIL-L-2104) A, bulk	Gal
41	C	9150-00- 186-6681	OIL, LUBRICATING : OE/HDO 30 (MIL-L-2104) A 1-qt can	Qt
42	C	9150-00- 189-6729	OIL, LUBRICATING: OE/HDO 30 (MIL-L-2104) A, 55-gal drum, 18 gage	Gal



# INDEX

Subject	Paragraph	Page
A		
Additional authorization list . . . . .	2-13	2-21
Arctic winterization kit controls and indicators . . . . .	4- 4b	4-24
Arctic winterization kit, operation . . . . .	4-17	4-384
B		
Before engine startup . . . . .	4-6a	4-30
Break-in operation . . . . .	3-2	3-1
After the road test. . . . .	3-2d	3-2
Break-in . . . . .	3-2b	3-1
General . . . . .	3-2a	3-1
Road test . . . . .	3-2c	3-2
C		
Capacities data . . . . .	2-8	2-21
Cargo trucks . . . . .	4-8	4-77
Dropsides, dropside cargo trucks, lowering . . . . .	4-8e	4-88
Dropsides and tailgate, removing . . . . .	4-8f	4-93
Dropsides, tailgate, side and front racks, installing . . . . .	4-8g	4-95
General . . . . .	4-8a	4-77
Racks, front and side, dropside cargo trucks, removing . . . . .	4-8d	4-83
Racks, front and side, installing . . . . .	4-8c	4-80
Racks, front and side, removing . . . . .	4-8b	4-77
Classification, vehicle/bridge . . . . .	1-8	1-6
Cold weather starting below +20F . . . . .	4-6c	4-41
Controls and indicators, chassis . . . . .	4-2	4-2
Controls and indicators, equipment . . . . .	4-3	4-11
Cover, quilted engine compartment. . . . .	4-17c	4-385
D		
Deep water fording kit controls and indicators . . . . .	4-4c	4-27
Deep water fording kit, operating the . . . . .	4-18	4-398
Description, functional, general . . . . .	2-1	2-1
Description, functional, overall . . . . .	2-2	2-2
Auxiliary equipment and accessories . . . . .	2-2o	2-2
Axles, wheels, and hubs . . . . .	2-2n	2-2
Brake system . . . . .	2-2m	2-2

## INDEX-CONT

Subject	Paragraph	Page
<b>D - cont</b>		
Description, functional, overall - cont		
Clutch . . . . .	2-2b	2-1
Cooling system . . . . .	2-2e	2-1
Electrical system . . . . .	2-2c	2-1
Engine . . . . .	2-2a	2-1
Exhaust system . . . . .	2-2f	2-1
Fuel System . . . . .	2-2d	2-1
Propeller shafts . . . . .	2-2k	2-1
Steering system . . . . .	2-2d	2-1
Transfer power takeoff system . . . . .	2-2j	2-1
Transfer system . . . . .	2-2h	2-1
Transmission power takeoff system . . . . .	2-2i	2-1
Transmission system . . . . .	2-2g	2-1
Description, physical, general . . . . .	2-3	2-2
Description, physical, overall . . . . .	2-4	2-2
Axles, wheels, and hubs . . . . .	2-4n	2-20
Brake system . . . . .	2-4m	2-19
Clutch . . . . .	2-4b	2-5
Cooling system . . . . .	2-4e	2-8
Electrical system . . . . .	2-4c	2-6
Engine . . . . .	2-4a	2-2
Exhaust system . . . . .	2-4f	2-9
Fuel and air intake system . . . . .	2-4d	2-7
Propeller and drive shaft systems . . . . .	2-4k	2-15
Steering system . . . . .	2-4l	2-18
Transfer . . . . .	2-4i	2-14
Transfer power takeoff . . . . .	2-4j	2-14
Transmission . . . . .	2-4g	2-14
Transmission power takeoff . . . . .	2-4h	2-14
Destruction to prevent enemy use . . . . .	1-6	1-1
Dimensions data . . . . .	2-7	2-21
Driver's compartment controls and indicators . . . . .	4-2c	4-5
Dump truck controls and indicators . . . . .	4-3e	4-18
Dump trucks . . . . .	4-13	4-235
General . . . . .	4-13a	4-235
Loading . . . . .	4-13c	4-238
Tailgate, rigging . . . . .	4-13b	4-236
Unloading, body down . . . . .	4-13d	4-244
Unloading by dumping . . . . .	4-13e	4-247
Unloading by spreading . . . . .	4-13f	4-252



## INDEX-CONT

Subject	Paragraph	Page
E		
Earth boring machine and polesetter truck controls and indicators . . . . .	4-3g	4-20
Earth boring machines and polesetter trucks . . . . .	4-15	4-311
Augers, 12-inch, and 16-inch, installing . . . . .	4-15e	4-329
Augers, and 30-inch, installing . . . . .	4-15f	4-331
Boring in various soils . . . . .	4-15h	4-347
Collapsible cable reel, operation . . . . .	4-15m	4-373
Derrick tube, raising, leveling, and lowering . . . . .	4-15c	4-315
Earth boring machine, operating . . . . .	4-15g	4-337
General . . . . .	4-15a	4-311
Poles, dragging . . . . .	4-15j	4-362
Poles, pulling . . . . .	4-15l	4-369
Poles, setting . . . . .	4-15k	4-365
Preparing boring machine for travel . . . . .	4-15i	4-352
Preparing truck for boring operation . . . . .	4-15b	4-311
Rear winch, operating and securing . . . . .	4-15d	4-322
Electric brake kit controls and indicators . . . . .	4-4d	4-28
Electric brake kit, operating the . . . . .	4-19	4-403
Emergency procedures . . . . .	4-26	4-419
Highway towing, M44A2 series trucks . . . . .	4-26d	4-426
Towing truck to start engine . . . . .	4-26c	4-423
Using jumper cables to start the engine . . . . .	4-26b	4-419
Using slave receptacle to start the engine . . . . .	4-26a	4-419
End item list, components . . . . .	2-12	2-21
Environmental characteristics . . . . .	2-10	2-21
Equipment improvement report and maintenance digest (EIR MD) and equipment improvement report and maintenance summary (EIR MS) . . . . .	1-2	1-1
Extremely cold weather, operation in . . . . .	4-22	4-404
General . . . . .	4-22a	4-404
Moving the truck . . . . .	4-22d	4-405
Parking . . . . .	4-22e	4-406
Refueling . . . . .	4-22f	4-407
Related publications . . . . .	4-22b	4-404
Winterization kits . . . . .	4-22c	4-404
Extremely hot weather, operation in . . . . .	4-23	4-408
Batteries . . . . .	4-23c	4-408
Body and chassis . . . . .	4-23d	4-408
Cooling system . . . . .	4-23b	4-408
General . . . . .	4-23a	4-408
Parking the truck. . . . .	4-23e	4-409

## INDEX-CONT

Subject	Paragraph	Page
F		
Fording operation . . . . .	4-25	4-410
Accidental submersion . . . . .	4-25f	4-418
After fording . . . . .	4-25d	4-417
Care of vehicle after fording . . . . .	4-25e	4-418
Fording . . . . .	4-25b	4-411
Fording, water tank trucks . . . . .	4-25c	4-413
General . . . . .	4-25a	4-410
Forms and records . . . . .	1-2	1-1
Front winch controls and indicators . . . . .	4-2d	4-9
Fuel burning personnel heater . . . . .	4-17d	4-386
Fuel burning power plant heater . . . . .	4-17e	4-391
Fuel tank trucks . . . . .	4-9	4-98
Checking condition of filter. . . . .	4-9e	4-139
Fording . . . . .	4-9g	4-151
General . . . . .	4-9a	4-98
Gravity discharging the tank sections . . . . .	4-9f	4-143
Gravity filling the tank sections . . . . .	4-9b	4-98
Power discharging the tank sections . . . . .	4-9d	4-131
Suction filling the tank sections or transferring fuel through pump . . . . .	4-9c	4-110
Fuel tank, trucks M49A1C and M49A2C, controls and indicators . . . . .	4-3a	4-11
Functional characteristics . . . . .	2-11	2-21
H		
Hot water personnel heater kit controls and indicators . . . . .	4-4a	4-23
Hot water personnel heater kit, operation . . . . .	4-16	4-383
I		
Instrument panel controls and indicators . . . . .	4-2a	4-2
Introduction, scope. . . . .	1-1	1-1
M		
Manual organization . . . . .	1-7	1-6
Metric system . . . . .	1-5	1-1

## INDEX-CONT

Subject	Paragraph	Page
P		
Pipeline construction truck . . . . .	4-14	4-257
A-frame, lowering, and preparing truck for travel after rear operation . . . . .	4-14d	4-278
A-frame, lowering, and preparing truck for travel after side operation . . . . .	4-14f	4-302
A-frame, rigging for rear operation . . . . .	4-14c	4-271
A-frame, rigging for side operation . . . . .	4-14e	4-291
General . . . . .	4-14a	4-257
Rear winch, operating . . . . .	4-14b	4-257
Pipeline construction truck controls and indicators . . . . .	4-3f	4-19
Placing and keeping the truck in motion . . . . .	4-6d	4-43
R		
Reporting improvement recommendations . . . . .	1-4	1-1
S		
Service upon receipt of equipment, general . . . . .	3-1	3-1
Shop van and instrument repair shop trucks controls and indicators . . . . .	4-3c	4-15
Shop van and instrument repair van trucks . . . . .	4-11	4-202
Dome and blackout dome lights . . . . .	4-11d	4-212
Exhaust blower, operating . . . . .	4-11c	4-210
Preparing shop van and instrument repair shop van for use . . . . .	4-11a	4-202
Supplying 115-volt ac power to shop van . . . . .	4-11b	4-209
Supplying power to moulding receptacles . . . . .	4-11e	4-216
Slave receptacle . . . . .	4-17f	4-395
Special kits controls and indicators . . . . .	4-4	4-23
Starting the engine above +20°F . . . . .	4-6b	4-37
Stopping the truck and engine . . . . .	4-6e	4-55
Supplies and materials list, expendable . . . . .	2-14	2-21

## INDEX-CONT

Subject	Paragraph	Page
T		
Tabulated data, general . . . . .	2-5	2-21
Tire inflation data . . . . .	2-9	2-21
Trailer brake controls and indicators . . . . .	4-2e	4-10
Tractor trucks . . . . .	4-12	4-217
General . . . . .	4-12a	4-217
Semitrailer, coupling . . . . .	4-12b	4-217
Semitrailer, uncoupling . . . . .	4-12c	4-231
Tractor trucks controls and indicators . . . . .	4-3d	4-17
U		
Unusual terrain, operation on . . . . .	4-24	4-409
Deep snow or mud . . . . .	4-24a	4-409
Dusty or sandy roads . . . . .	4-24d	4-410
Hard baked sand . . . . .	4-24b	4-409
High altitudes.. . . .	4-24f	4-410
Ice . . . . .	4-24c	4-409
Rocks and boulders . . . . .	4-24e	4-410
W		
Water tank trucks, . . . . .	4-10	4-156
General. . . . .	4-10a	4-156
Gravity discharging the tank sections . . . . .	4-10f	4-192
Gravity filling the tank sections . . . . .	4-10b	4-157
Hydrant filling the tank sections . . . . .	4-10d	4-175
Operating during freezing temperatures . . . . .	4-10g	4-195
Power discharging the tank sections . . . . .	4-10e	4-186
Suction filling the tank sections or transferring water . . . . .	4-10c	4-161
Water tank trucks controls and indicators . . . . .	4-3b	4-13
Weight data . . . . .	2-6	2-21
Winch, front . . . . .	4-7	4-58
Before operating. . . . .	4-7b	4-58
General . . . . .	4-7a	4-58
Lifting or pulling . . . . .	4-7d	4-65
Locking for travel . . . . .	4-7h	4-75
Lowering load or unwinding slack cable . . . . .	4-7f	4-70
Stopping . . . . .	4-7e	4-69
Winch line, unwinding . . . . .	4-7c	4-59
Winch line, winding on drum . . . . .	4-7g	4-72
Windshield controls and indicators . . . . .	4-2b	4-4
Winterfront cover, operating . . . . .	4-17b	4-384

By Order of the Secretaries of the Army and the Air Force:

Official:

E. C. MEYER  
General, United States Army  
Chief of Staff

J. C. PENNINGTON  
Major General, United States Army  
The Adjutant General

Official:

LEW ALLEN, JR., General, USAF  
Chief of Staff

VAN L. CRAWFORD, JR., Colonel, USAF  
Director of Administration

Distribution:

To be distributed in accordance with DA Form 12-38,  
Operator Maintenance requirements for 2-1/2 Ton Truck  
Cargo, and 2-1/2 Ton Truck Van.





THEN... JOT DOWN THE DOPE ABOUT IT ON THIS FORM, CAREFULLY TEAR IT OUT, FOLD IT AND DROP IT IN THE MAIL!

SOMETHING WRONG WITH THIS PUBLICATION?

FROM (PRINT YOUR UNIT'S COMPLETE ADDRESS)

CDR, 1st Bn, 65th ADA

Attn: SP4 Jane Idone

Key West, FL 33040

DATE SENT

(Date sent in)

PUBLICATION NUMBER

TM 9-2320-209-10-1

PUBLICATION DATE

26 Sep 80

PUBLICATION TITLE OPERATOR

INSTL, OPN, AND REF DATA MANUAL

BE EXACT PIN-POINT WHERE IT IS

PAGE NO	PARA-GRAPH	FIGURE NO	TABLE NO
2-5		2-3	
2-19	2-4		
4-40			4-1

IN THIS SPACE TELL WHAT IS WRONG AND WHAT SHOULD BE DONE ABOUT IT:

Change illustration callouts.  
Reason: callouts for clutch pedal (1) and clutch (2) are reversed.

Subparagraph m refers to figure 2-15.  
Should refer to figure 2-17.

Chart does not show stoplights.  
Chart should be changed to add -  
STOPLIGHT (BRAKE LIGHT) LEFT and RIGHT.

SAMPLE

PRINTED NAME GRADE OR TITLE AND TELEPHONE NUMBER

SP4 Jane Idone Anderson 444-4444

SIGN HERE

Jane Idone

FILL IN YOUR  
UNIT'S ADDRESS

FOLD BACK

DEPARTMENT OF THE ARMY

\_\_\_\_\_  
\_\_\_\_\_

OFFICIAL BUSINESS  
PENALTY FOR PRIVATE USE \$300

POSTAGE AND FEES PAID  
DEPARTMENT OF THE ARMY  
DOD 314



TEAR ALONG PERFORATED LINE

COMMANDER  
U S ARMY TANK – AUTOMOTIVE  
MATERIEL READINESS COMMAND  
ATTN: DRSTA-MB  
WARREN, MI 48090





FILL IN YOUR  
UNIT'S ADDRESS

FOLD BACK

TEAR ALONG PERFORATED LINE

DEPARTMENT OF THE ARMY

POSTAGE AND FEES PAID  
DEPARTMENT OF THE ARMY  
DOD 314



OFFICIAL BUSINESS  
PENALTY FOR PRIVATE USE \$300

Commander  
US Army Tank-Automotive Materiel Readiness Command  
ATTN: DRSTA-MB  
Warren, MI 48090



FILL IN YOUR  
UNIT'S ADDRESS

FOLD BACK

DEPARTMENT OF THE ARMY

\_\_\_\_\_  
\_\_\_\_\_

OFFICIAL BUSINESS  
PENALTY FOR PRIVATE USE \$300

POSTAGE AND FEES PAID  
DEPARTMENT OF THE ARMY  
DOD 314



TEAR ALONG PERFORATED LINE

Commander  
US Army Tank-Automotive Materiel Readiness Command  
ATTN: DRSTA-MB  
Warren, MI 48090

## THE METRIC SYSTEM AND EQUIVALENTS

### LINEAR MEASURE

1 Centimeter = 10 Millimeters = 0.01 Meters = 0.3937 Inches  
 1 Meter = 100 Centimeters = 1,000 Millimeters = 39.37 Inches  
 1 Kilo Meter = 1,000 Meters = 0.621 Miles

### WEIGHTS

1 Gram = 0.001 Kilograms = 1,000 Milligrams = 0.035 Ounces  
 1 Kilogram = 1,000 Grams = 2.2 Lb  
 1 Metric Ton = 1,000 Kilograms = 1 Megagram = 1.1 Short  
 Tons

### LIQUID MEASURE

1 Milliliter = 0.001 Liters = 0.0338 Fluid Ounces  
 1 Liter = 1,000 Milliliters = 33.82 Fluid Ounces

### SQUARE MEASURE

1 Sq Centimeter = 100 Sq Millimeters = 0.155 Sq Inches  
 1 Sq Meter = 10,000 Sq Centimeters = 10.76 Sq Feet  
 1 Sq Kilometer = 1,000,000 Sq Meters = 0.386 Sq Miles

### CUBIC MEASURE

1 Cu Centimeter = 1,000 Cu Millimeters = 0.06 Cu Inches  
 1 Cu Meter = 1,000,000 Cu Centimeters = 35.31 Cu Feet

### TEMPERATURE

$5/9 (^{\circ}\text{F} - 32) = ^{\circ}\text{C}$   
 121° Fahrenheit is equivalent to 100° Celsius  
 90° Fahrenheit is equivalent to 32.2° Celsius  
 32° Fahrenheit is equivalent to 0° Celsius  
 $9/5 \text{ C}^{\circ} + 32 = \text{F}^{\circ}$

## APPROXIMATE CONVERSION FACTORS

TO CHANGE	TO	MULTIPLY BY
Inches . . . . .	Centimeters . . . . .	2.540
Feet . . . . .	Meters . . . . .	0.305
Yards . . . . .	Meters . . . . .	0.914
Miles . . . . .	Kilometers . . . . .	1.609
Square Inches . . . . .	Square Centimeters . . . . .	6.451
Square Feet . . . . .	Square Meters . . . . .	0.093
Square Yards . . . . .	Square Meters . . . . .	0.836
Square Miles . . . . .	Square Kilometers . . . . .	2.590
Acres . . . . .	Square Hectometers . . . . .	0.405
Cubic Feet . . . . .	Cubic Meters . . . . .	0.028
Cubic Yards . . . . .	Cubic Meters . . . . .	0.765
Fluid Ounces . . . . .	Milliliters . . . . .	29.573
Pints . . . . .	Liters . . . . .	0.473
Quarts . . . . .	Liters . . . . .	0.946
Gallons . . . . .	Liters . . . . .	3.785
Ounces . . . . .	Grams . . . . .	28.349
Pounds . . . . .	Kilograms . . . . .	0.454
Short Tons . . . . .	Metric Tons . . . . .	0.907
Pound-Feet . . . . .	Newton-Meters . . . . .	1.356
Pounds Per Square Inch . . . . .	Kilopascals . . . . .	6.895
Miles Per Gallon . . . . .	Kilometers Per Liter . . . . .	0.425
Miles Per Hour . . . . .	Kilometers Per Hour . . . . .	1.609
TO CHANGE	TO	MULTIPLY BY
Centimeters . . . . .	Inches . . . . .	0.394
Meters . . . . .	Feet . . . . .	3.280
Meters . . . . .	Yards . . . . .	1.094
Kilometers . . . . .	Miles . . . . .	0.621
Square Centimeters . . . . .	Square Inches . . . . .	0.155
Square Meters . . . . .	Square Feet . . . . .	10.764
Square Meters . . . . .	Square Yards . . . . .	1.196
Square Kilometers . . . . .	Square Miles . . . . .	0.386
Square Hectometers . . . . .	Acres . . . . .	2.471
Cubic Meters . . . . .	Cubic Feet . . . . .	35.315
Cubic Meters . . . . .	Cubic Yards . . . . .	1.308
Millimeters . . . . .	Fluid Ounces . . . . .	0.034
Liters . . . . .	Pints . . . . .	2.113
Liters . . . . .	Quarts . . . . .	1.057
Liters . . . . .	Gallons . . . . .	0.264
Grams . . . . .	Ounces . . . . .	0.035
Kilograms . . . . .	Pounds . . . . .	2.205
Metric Tons . . . . .	Short Tons . . . . .	1.102
Newton-Meters . . . . .	Pound-Feet . . . . .	0.738
Kilopascals . . . . .	Pounds Per Square Inch . . . . .	0.145
Kilometers Per Liter . . . . .	Miles Per Gallon . . . . .	2.354
Kilometers Per Hour . . . . .	Miles Per Hour . . . . .	0.621

