

**LUBRICATION**

**ORDER  
LI-00664G-12**

**LO 5-4210-217-12**

15 MAY 1975 (Supersedes L05-4210-217-12 dated 6 APRIL 1973)

**TRUCK, FIRE FIGHTING: POWERED PUMPER; FOAM AND WATER 750 G.P.M. CAP.; CENTRIFUGAL PUMP, POWER TAKE OFF DRIVEN; 400 GAL. WATER TANK, 40 GAL. FOAM CHEMICAL TANK, (ENGINEERED DEVICES INC. MODEL 0814) FSN 4210-150-1426, (AMERICAN AIR FILTER MODEL FT 750) FSN 4210-106-7432 AND WINTERIZED (AMERICAN AIR FILTER MODEL FT 750W) FSN 4210-106-7433**

Reference: TM5-4210-217-12, LO9-2320-209-12, and FEDERAL SUPPLY CATALOG C9100-IL

Intervals are based on normal hours of operation. Adjust to compensate for abnormal operations and severe conditions.

During inactive periods sufficient lubrication must be performed for adequate preservation.

Clean fittings before lubricating.

A dotted circle indicates a drain below.

Clean parts with SOLVENT, dry-cleaning, Type II (SD-2).

Dry before lubricating.

Lubricate points indicated by dotted arrow shafts on both sides of equipment.

\* The times specified are the hours required to perform 311 services at the particular interval.

*TOTAL MAN-HR		* TOTAL MAN-HR	
INTERVAL	MAN-HR	INTERVAL	MAN-HR
50	1.0	250	1.1
100	1.5	500	1.1

**LUBRICANT • INTERVAL**

**INTERVAL • LUBRICANT**

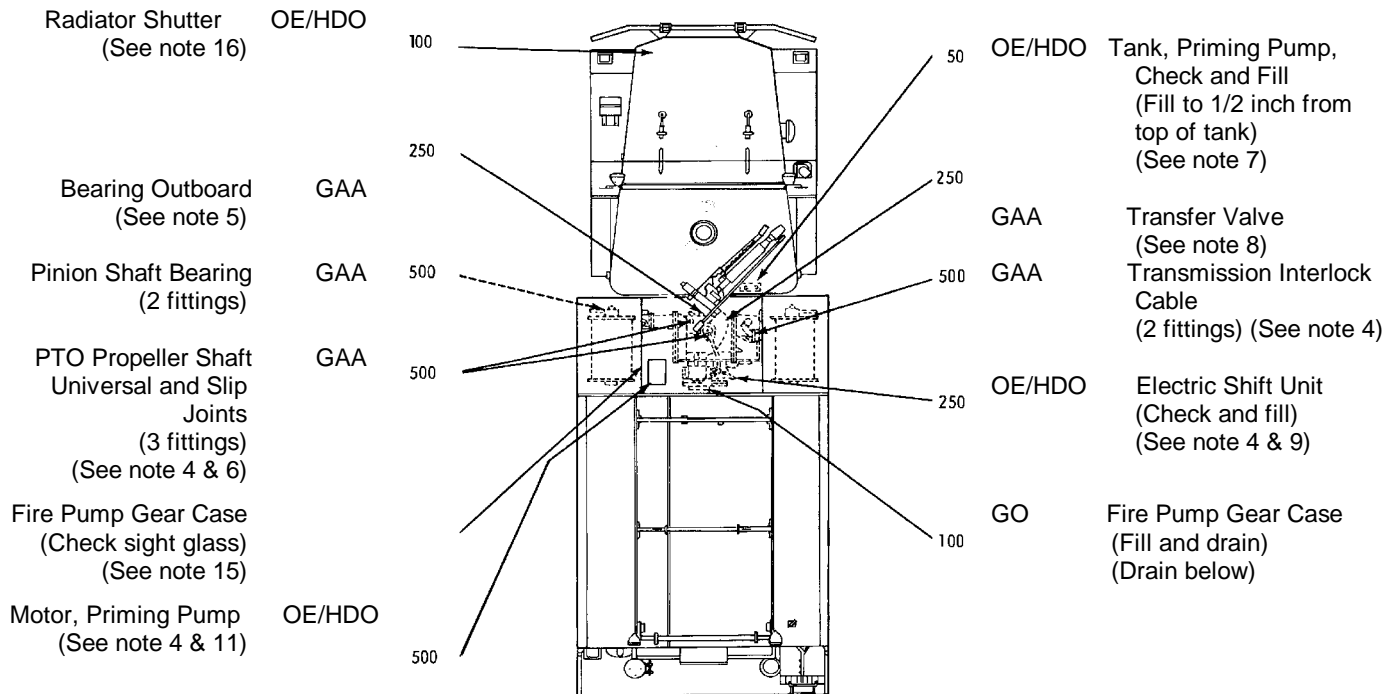

**KEY**

LUBRICANTS	CAPACITY	EXPECTED TEMPERATURES			INTERVALS
		Above + 32°F Above 0°C	+ 40°F to -10°F + 5°C to -23°C	0°F to -65°F -18°C to -50°C	
<b>OE/HDO-LUBRICATING OIL, Engine</b>		OE/HDO 30	OE/HDO 10	OEA	Intervals given are in hours of normal operation
Tank, Priming Pump	4 qts (3.8L)				
Oil Can Points					
Electric Shift Unit	1 oz (30cc)	OE/HDO 10			
Motor, Priming Pump					
<b>OEA-LUBRICATING OIL, Engine, Arctic</b>		GO 90		GOS	
<b>GO-LUBRICATION OIL, Gear</b>					
Gear Case, Fire Pump	5 pts (1.4L)				
<b>GOS-LUBRICATION OIL, Gear, Sub-zero</b>		ALL TEMPERATURES			
<b>GAA-GREASE, Automotive and Artillery</b>					

**NOTES:**

- FOR OPERATION OF EQUIPMENT IN PROTRACTED COLD TEMPERATURES BELOW 10°F. (-23°C). Remove lubricants prescribed in the key for temperatures above 10°F. (-23°C). Relubricate with lubricants specified in the key for temperatures below -10°F. (-23°C).
- OIL CAN POINTS.** Every 250 hours or quarterly, whichever occurs first, clean and lightly coat door hinges and locks, push-pull operating control rods, throttle control, latches, springs, and pinion gear, and all exposed threads with OE/HDO.
- LUBRICANTS.** The following is a list of lubricants with Military Symbols and applicable Specification numbers.

GO	MIL-L-2105	GOS
	MIL-L-10324	
OE/HDO	MIL-L-2104C	OEA
	MIL-L-46167	
GAA	MIL-G-10924	
- PUMP COMPARTMENT PANEL.** Remove bottom cover panel of pump compartment for access to PTO propeller shaft universal and slip joints, transmission interlock cable, electric shift unit, priming pump motor, and draining fire pump gear case.
- BEARING OUTBOARD (IMPELLER SHAFT).** Every 250 hours of operation or quarterly, whichever occurs first, lubricate until lubricant appears at relief fitting. The relief fitting is located directly below the lubrication fitting.
- PTO PROPELLER SHAFT UNIVERSAL JOINTS.** To prevent damage to journal seals, use relief fitting with grease gun.
- TANK, PRIMING PUMP.** Check and fill the tank every fifty hours or after each use, whichever occurs first. When changing from one grade of oil to another, remove the tank and empty through fill opening.
- TRANSFER VALVE..** During lubrication, operate transfer valve control several times to distribute the grease.
- ELECTRIC SHIFT UNIT.** Routine oil changes are not necessary. Changing the lubricant is required only for cold weather operation or when shift unit is removed. To drain the shift unit remove cover plate. During reassembly, install new cover plate gasket. To fill shift unit, use pump type oil can. Fill until oil flows from fill opening.

- HOSE REEL.** The motor, drum shaft bearings, and swivel connection, do not require lubrication. Lubricate hose reel drive chain with cloth saturated with OE/HDO.
- PRIMING PUMP MOTOR.** Every 500 hours or semiannually, whichever occurs first, lubricate the priming pump motor. The oil can point is located on top of motor shaft housing. Use only a few drops of oil, do not over lubricate.
- FIRE PUMP.** Every 500 hours or semiannually, whichever occurs first, lubricate the 5 gear sector racks with GAA. The racks are installed on the 3 discharge and 2 suction valves.
- BATTERY COMPARTMENT.** Every 500 hours or semiannually, whichever occurs first, lubricate the sliding trays, channels of top cover, and battery terminals with GAA.
- FIRE PUMP PACKING GLANDS.** The stuffing boxes (2 each) are designed to leak slightly during operation to cool and lubricate the packing. Acceptable leakage rates are 10 drops minimum to 60 drops maximum of water per minute at 150 psig discharge pressure. To adjust packing glands, refer to TM 5-4210-217-12.
- PUMP GEAR CASE.** Check oil level after each use. Add if required. Note: Area of check located under left operator's panel on chassis member.
- RADIATOR SHUTTER.** Position control assembly screw to full exposure and apply OE/HDO to surface.

Copy of this Lubrication Order will remain with the equipment at all times; instructions contained herein are mandatory.

**By Order of the Secretaries of the Army and the Navy:**

**FRED C. WEYAND**  
General, United States Army  
Chief of Staff

**Official:**  
**VERNE L. BOWERS**  
Major General, United States Army  
The Adjutant General

**E.J. MILLER**  
Major General, U. S. Marine  
Corps Deputy Chief of Staff  
for Installations & Logistics

**DISTRIBUTION:**

Active Army: To be distributed in accordance with DA Form 12-25A, (qty rqr block no. 121) Operator maintenance requirements for Fire Fighting.  
Marine Corps: MARCORPS LIST: AO plus 7000161 (2)

RECOMMENDED CHANGES TO EQUIPMENT TECHNICAL PUBLICATIONS

 <div style="border: 1px solid black; border-radius: 15px; padding: 5px; margin: 10px auto; width: 80%; text-align: center;"> <p><i>THEN...JOT DOWN THE DOPE ABOUT IT ON THIS FORM. CAREFULLY TEAR IT OUT, FOLD IT AND DROP IT IN THE MAIL.</i></p> </div>		SOMETHING WRONG WITH PUBLICATION		
		FROM: (PRINT YOUR UNIT'S COMPLETE ADDRESS)		
PUBLICATION NUMBER		PUBLICATION DATE		
PUBLICATION TITLE		DATE SENT		
BE EXACT PIN-POINT WHERE IT IS				
PAGE NO.	PARA-GRAPH	FIGURE NO.	TABLE NO.	<p style="text-align: center; font-weight: bold;">                     IN THIS SPACE, TELL WHAT IS WRONG AND WHAT SHOULD BE DONE ABOUT IT.                 </p>
PRINTED NAME, GRADE OR TITLE AND TELEPHONE NUMBER			SIGN HERE	

## The Metric System and Equivalents

### Linear Measure

1 centimeter = 10 millimeters = .39 inch  
 1 decimeter = 10 centimeters = 3.94 inches  
 1 meter = 10 decimeters = 39.37 inches  
 1 dekameter = 10 meters = 32.8 feet  
 1 hectometer = 10 dekameters = 328.08 feet  
 1 kilometer = 10 hectometers = 3,280.8 feet

### Weights

1 centigram = 10 milligrams = .15 grain  
 1 decigram = 10 centigrams = 1.54 grains  
 1 gram = 10 decigrams = .035 ounce  
 1 decagram = 10 grams = .35 ounce  
 1 hectogram = 10 decagrams = 3.52 ounces  
 1 kilogram = 10 hectograms = 2.2 pounds  
 1 quintal = 100 kilograms = 220.46 pounds  
 1 metric ton = 10 quintals = 1.1 short tons

### Liquid Measure

1 centiliter = 10 milliliters = .34 fl. ounce  
 1 deciliter = 10 centiliters = 3.38 fl. ounces  
 1 liter = 10 deciliters = 33.81 fl. ounces  
 1 dekaliter = 10 liters = 2.64 gallons  
 1 hectoliter = 10 dekaliters = 26.42 gallons  
 1 kiloliter = 10 hectoliters = 264.18 gallons

### Square Measure

1 sq. centimeter = 100 sq. millimeters = .155 sq. inch  
 1 sq. decimeter = 100 sq. centimeters = 15.5 sq. inches  
 1 sq. meter (centare) = 100 sq. decimeters = 10.76 sq. feet  
 1 sq. dekameter (are) = 100 sq. meters = 1,076.4 sq. feet  
 1 sq. hectometer (hectare) = 100 sq. dekameters = 2.47 acres  
 1 sq. kilometer = 100 sq. hectometers = .386 sq. mile

### Cubic Measure

1 cu. centimeter = 1000 cu. millimeters = .06 cu. inch  
 1 cu. decimeter = 1000 cu. centimeters = 61.02 cu. inches  
 1 cu. meter = 1000 cu. decimeters = 35.31 cu. feet

## Approximate Conversion Factors

<i>To change</i>	<i>To</i>	<i>Multiply by</i>	<i>To change</i>	<i>To</i>	<i>Multiply by</i>
inches	centimeters	2.540	ounce-inches	Newton-meters	.007062
feet	meters	.305	centimeters	inches	.394
yards	meters	.914	meters	feet	3.280
miles	kilometers	1.609	meters	yards	1.094
square inches	square centimeters	6.451	kilometers	miles	.621
square feet	square meters	.093	square centimeters	square inches	.155
square yards	square meters	.836	square meters	square feet	10.764
square miles	square kilometers	2.590	square meters	square yards	1.196
acres	square hectometers	.405	square kilometers	square miles	.386
cubic feet	cubic meters	.028	square hectometers	acres	2.471
cubic yards	cubic meters	.765	cubic meters	cubic feet	35.315
fluid ounces	milliliters	29.573	cubic meters	cubic yards	1.308
pints	liters	.473	milliliters	fluid ounces	.034
quarts	liters	.946	liters	pints	2.113
gallons	liters	3.785	liters	quarts	1.057
ounces	grams	28.349	liters	gallons	.264
pounds	kilograms	.454	grams	ounces	.035
short tons	metric tons	.907	kilograms	pounds	2.205
pound-feet	Newton-meters	1.356	metric tons	short tons	1.102
pound-inches	Newton-meters	.11296			

### Temperature (Exact)

°F	Fahrenheit temperature	5/9 (after subtracting 32)	Celsius temperature	°C
----	---------------------------	-------------------------------	------------------------	----

PIN: 030056-000